

76 - CHASSIS AND BODY

CONTENTS

	Page
DESCRIPTION AND OPERATION	
BODY CONSTRUCTION	1
PAINT CODES - 1993	3
REPAIR	
BODY REPAIRS, GENERAL INFORMATION	1
PAINTWORK	2
BODY	4
WELDING	4
PREPARATION	4
INNER BODY SHELL ASSEMBLY	5
HEADLINING	11
ROOF PANEL	11
BONNET	12
DECKER PANEL	12
FRONT WING	13
ASSISTED BONNET LIFT	14
FUEL FILLER FLAP	15
REAR CORNER PANEL AND WING	16
REAR QUARTER PANEL-INTERIOR	17
REAR QUARTER PANEL-EXTERIOR	17
TAILGATE UPPER	18
TAILGATE UPPER LOCK	18
TAILGATE UPPER GLASS	19
TAILGATE LOWER STRIKER	19
TAILGATE LOWER	20
TAILGATE LOWER RELEASE MECHANISM	20
RADIATOR GRILLE	21
FRONT DOOR	22
FRONT DOOR GLASS AND REGULATOR	23
FRONT DOOR - TRIM PANEL	24
FRONT DOOR LOCK, OUTSIDE AND INSIDE DOOR RELEASE HANDLES	25
FRONT DOOR HEATED LOCK ASSEMBLY - 1991 MODEL YEAR	26
FRONT DOOR LOCK AND HANDLE ASSEMBLY	26
FRONT WHEEL ARCH LINER	27
SILL FINISHER	27
ENGINE UNDERTRAY	28



76 - CHASSIS AND BODY

CONTENTS

	Page
REAR DOOR	28
REAR DOOR - TRIM PANEL	29
REAR DOOR LOCK, OUTSIDE AND INSIDE DOOR RELEASE HANDLES	30
REAR DOOR LOCK AND HANDLE ASSEMBLY	31
REAR DOOR GLASS AND REGULATOR	31
WINDSCREEN GLASS	32
REAR QUARTER LIGHT GLASS	34
FRONT SEAT ELECTRICAL	35
FRONT SEAT MANUAL	36
ASYMMETRIC SPLIT REAR SEAT	37
ASYMMETRIC SPLIT REAR SEAT - LOCKING MECHANISM	37
FRONT SEAT HEATED CUSHION AND SQUAB	38
SEAT BELTS	39
FRONT SEAT BELT	40
REAR SEAT BELT	41
GLOVE BOX AND FLOOR MOUNTED CONSOLE ASSEMBLY	42
LOWER DASH PANEL	43
RADIO HOUSING	43
CENTRE DASH PANEL	44
LOUVRE DASH PANEL	44
DASHBOARD	45
FRONT SPOILER	46
METAL SUNROOF ASSEMBLY	47
OPERATING MOTOR, MICRO-SWITCH AND RELAY	48
SUNROOF PANEL SEALS	49
SUNROOF ASSEMBLY	49
SUNROOF HEADLINER ASSEMBLY	52
GLASS SUNROOF 1991 MODEL YEAR	53
GLASS PANEL ASSEMBLY	53
WIND DEFLECTOR ASSEMBLY	54
MANUAL OPERATION	54
MOTOR DRIVE ASSEMBLY AND CONTROL UNIT	55
GLASS SUNROOF COMPLETE ASSEMBLY	56
SLIDE AND GUIDE CHANNEL ASSEMBLIES OR SUNSHADE PANEL	57
TIMING OF CONTROL UNIT TO SUNROOF OPERATION	58
STEERING COLUMN SHROUD	59
CHASSIS AMERICA ONLY - 1990 ONWARDS	60
CHASSIS NON AMERICAN - 1990 ONWARDS	63
CHASSIS - AMERICAN COUNTY LWB (108") MODELS	66
CHASSIS - LSE (108") AIR SUSPENSION MODELS	69



BODY CONSTRUCTION

Description

The Range Rover body consists of a steel frame to which alloy outer panels are attached. The decker panel, front wings, side door outer panels, body side outer panels and roof are made from a special light magnesium aluminium alloy.

The manufacture of body panels from aluminium has two distinct advantages, the first of which is a much better resistance to corrosion, the second being a decrease in the gross vehicle weight.

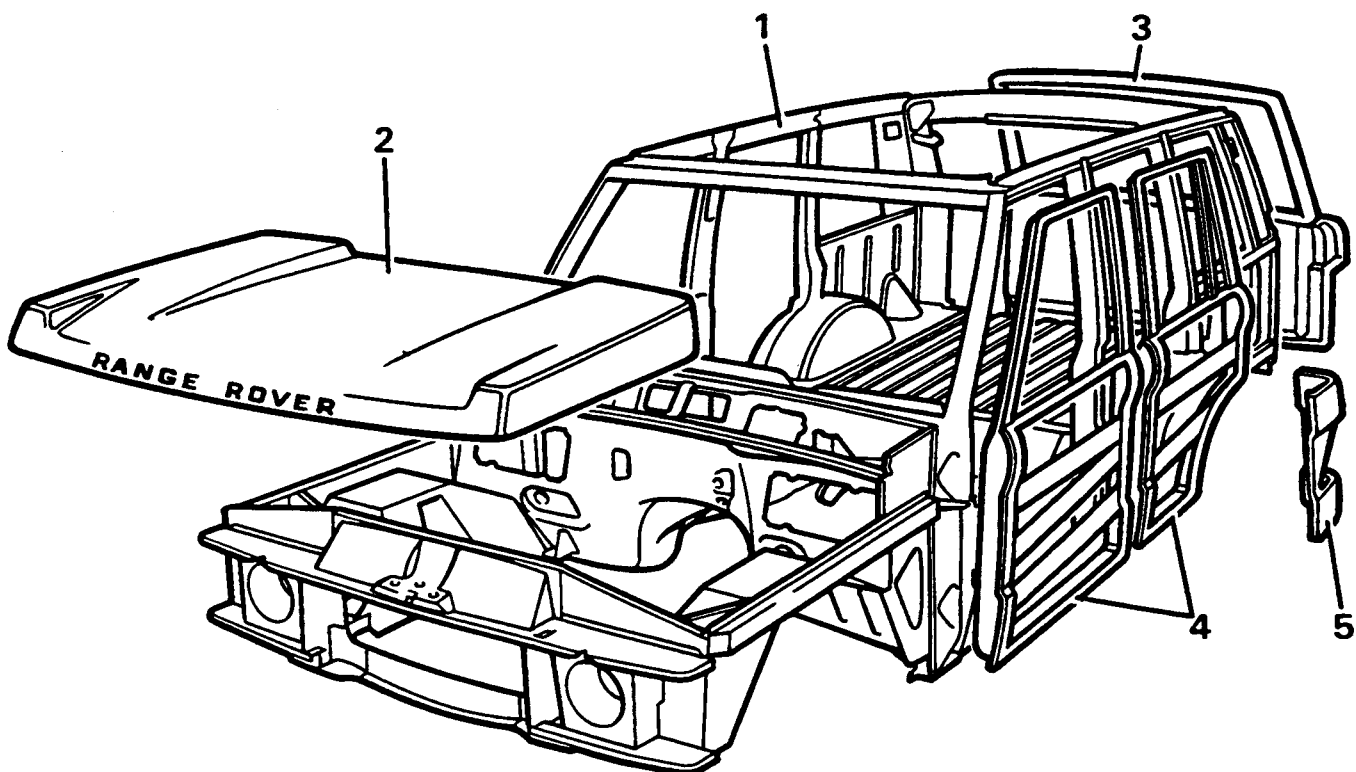

RR3577M

Steel components

1. Body shell.
2. Bonnet.
3. Tailgate.
4. Door frames
5. Quarter panel.

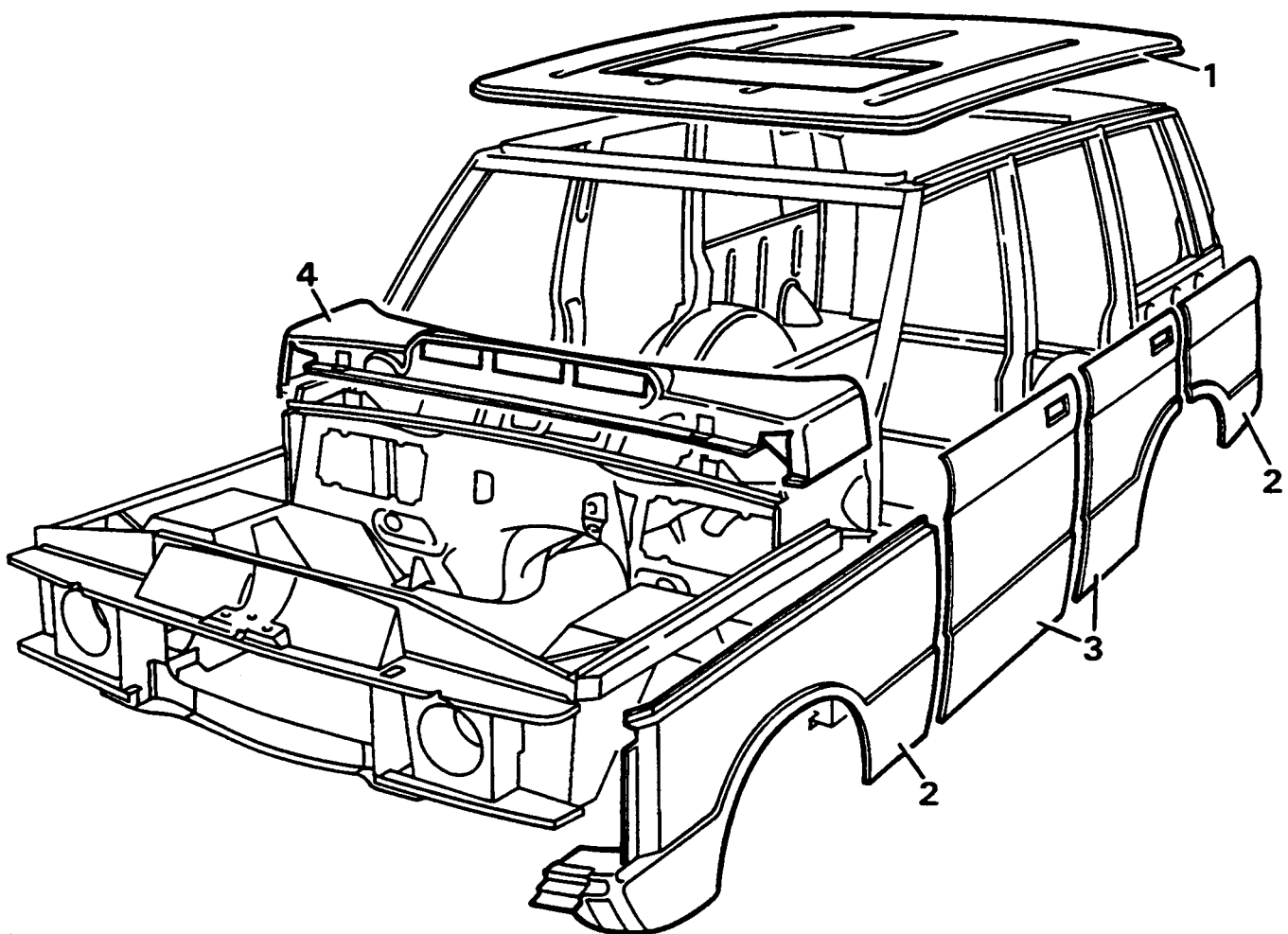

RR3578M

Aluminium alloy components

1. Roof.
2. Wings.
3. Door panels.
4. Decker panel.



PAINT CODES - 1993

The following information should be used when ordering paint for 1993 model year vehicles.

COLOUR	TYPE	LRC	INTERIOR	DECALS
100"				
ARLES	SOLID	424	W	MS
ALPINE	SOLID	456	W S	DG
EASTNOR	SOLID	419	S	MS
PEMBROKE	SOLID	476	W	MS
PORTOFINO	SOLID	390	W S	MS
BELUGA	SOLID COB	416	W S	MS
ARDENNES	MICATALLIC	413	W S	MS
SONORAN	MICATALLIC	508	S	MS
TROCADERO	MICATALLIC	467	W S	MS
ROMAN BRONZE	METALLIC	479	S	DG
ASPEN	METALLIC	458	S	DG
PLYMOUTH BLUE	MICATALLIC	434	W	MS
AEGEAN BLUE	MICATALLIC	490	W	MS
WESTMINSTER	MICATALLIC	445	W	MS
VOGUE SE				
ALPINE	SOLID	456	W S DS	DG
BELUGA	SOLID COB	416	W S	MS
ARDENNES	MICATALLIC	413	W S	MS
ASPEN	METALLIC	458	S	DG
PLYMOUTH BLUE	MICATALLIC	434	W	MS
WESTMINSTER	MICATALLIC	445	W	MS
LSE 108"				
ALPINE	SOLID	456	SA	DG
BELUGA	SOLID COB	416	SA	MS
ARDENNES	MICATALLIC	413	SA	MS
MOSSWOOD	MICATALLIC	987	SA	MS
ROMAN BRONZE	MICATALLIC	479	SA	DG
PLYMOUTH BLUE	MICATALLIC	434	SA	MS
KEY TO COLOURS:				
INTERIOR:		S - SORREL, W - WINCHESTER, DS - DARK SABLE, SA - SADDLE		
DECALS:		MS - MID SILVER, DG - DARK GREY		



BODY REPAIRS, GENERAL INFORMATION

Aluminium panels can be effectively repaired using the 'Argon Arc' process of welding, because the afore mentioned is a specialist operation it is necessary that only a skilled operator or specialist body shop undertake such repairs.

Under certain conditions it may not be practical to repair an exterior damaged panel, if this is the case, then panels can be easily removed and replaced with new ones.

Panel beating

 **WARNING: Before applying heat to any panel ensure that the panel is clean and free from underseal and that the area to be worked on is well clear of any combustible materials. Ensure that all precautions are taken against fire. On pre 1991 model year vehicles a fuel expansion tank is located between the rear right wing and inner body side.**

1. Aluminium alloy panels can be beaten out after accidental damage in the same way as sheet steel. Hammering causes metal to work harden, and requires annealing to prevent the possibility of cracking. To anneal, apply spread of heat to the area, until the heated metal will char a piece of soft wood when touched on it. Followed by slow air cooling.

Welding



WARNING: The battery ground lead MUST be disconnected before commencing welding.



WARNING: Before applying heat to any panel ensure that the panel is clean and free from underseal and that the area to be worked on is well clear of any combustible materials. Ensure that all precautions are taken against fire. On pre 1991 model year vehicles a fuel expansion tank is located between the rear right wing and inner body side.

1. Clean off all grease and paint, dry thoroughly and then clean the edges to be welded, and an area at least half an inch on either side of the weld, with a stiff wire scratch brush or wire wool. Cleanliness is essential. Also clean the welding rod or strip with steel wool.
2. It is strongly recommended that a few welds are made on scrap metal before the actual repair is undertaken if the operator is not already experienced in welding aluminium and its alloys.
3. Use only 5 per cent magnesium aluminium welding rod (5 Mg/A).

Welding tears and patching

1. If a tear extends to the edge of a panel, start the weld from the end away from the edge and also at this point drill a small hole to prevent the crack spreading, then work towards the edge.
2. When welding a long tear, or making a long welded joint, tack the edges to be welded at intervals of 50 to 100 mm. After this, weld continuously along the joint, increasing the speed of the weld as the material heats up.
3. When patching, cut the patch to the correct shape for the hole to be filled, but of such sizes as to leave a gap 0.80 mm between it and the panel, and then weld as described above. Never apply an 'overlay' patch.

Spot welding

1. Spot welding is mainly used in the manufacture of the Range-Rover inner steel body frame and exterior magnesium-aluminium alloy panels, and is a process which can be carried out satisfactorily by the use of the proper apparatus in a specialist body shop. Aluminium and its alloys are very good conductors of heat and electricity, and thus it is most important to maintain the right conditions for successful spot welding. The correct current density must be maintained, and so must the 'dwell' of the electrodes. Special spot welding machines have been developed, but they are expensive, and though the actual work can be carried out by comparatively unskilled labour, supervision and machine maintenance must be in the hands of properly qualified persons.

Riveting

1. Where both sides of the metal are accessible and it is possible to use an anvil or 'dolly' solid aluminium rivets may be used, with a suitable punch or 'pop' to ensure clean rounded head on the work. For riveting blind holes, 'pop-rivets' must be used. These are inserted and closed by special 'Lazy-Tong' 'pop-rivet' pliers.

PAINTWORK

General Information

Before undertaking any paintwork process on the exterior body of Range Rover, firstly ascertain which is the best method of repair either by panel repair or replacement.

The initial preparation of a panel is very important to ensure that when finished it is of a standard that meets and matches existing bodywork. Panels must be thoroughly degreased with Berger Preclean 802.0516 or a suitable equivalent, any unsound paint to be stripped using Berger Double strength Meltic 301.8051. Always refer to the paint manufacturers instructions.

Paintwork processes should be performed by a specialist bodyshop where paint spraying can be undertaken in a controlled environment whereby temperatures are kept constant and the atmosphere dust free.

The flow chart on the following page gives a guide to preparing and painting a panel. Wherever possible refer to the Berger Vehicle Refinishes Product Data and Application Sheets for further information.



SUBSTRATE	ALUMINIUM PANELS	
	PANEL REPAIR	REPLACEMENT PANEL
PREPARATION	Wet for using P60 Grade paper or dry sand using P240 grit discs.	Wet flat using P60 Grade paper or dry sand using P240 grit discs. Care must be taken to avoid cutting through to bare aluminium.
BODY FILLING	If filling is required, thoroughly abrade bare aluminium area to be filled and apply Standox Polyester	If filling is required, fill small indentations with Standox Polyester stopper 430-5029.
ETCHING	<p style="text-align: right;">This process is not required if the original electrocoat primer is in sound condition. IF NOT</p> <p>Etch the bare aluminium and filler with auto-speed self etch primer 414-1171, mixed 1:1 with activator 801-7995. Apply one coat and allow to dry for approximately 20 minutes. Recoat within 1 hour.</p>	
PRIMING	To obtain maximum adhesion and excellent build, apply Standox 2K 4:1 full primer 405-0381. Coats of 30-40 microns can be wet flatted with P60 grade paper after 45 minutes at 20°C.	
COLOUR COATING	Apply either Standox 2K Standocryl or Standox Metallic Basislack to the colour required. Hardeners and thinners will vary depending upon system employed, conditions available, temperature and size of vehicle etc. Refer to paint manufacturers Technical Information Sheet for correct selection.	

BODY

Introduction:

The information which follows is concerned solely with the 'Monocoque' assembly of the inner body shell on Range Rover models.

Body repairs often require the removal of mechanical and electrical units and associated wiring. Where necessary, reference should be made to the relevant section of the Repair Manual for removal and refitting instructions.

The inner body shell is of 'Monocoque' construction and to gain access to the repair area, it may be necessary to remove exterior body panels, all exterior body panels are bolted to the inner body shell to facilitate easier panel removal and replacement or repair.

It is expected that a repairer will select the best and most economic repair method possible, making use of the facilities available. The instructions given are intended to assist a skilled body repairer by expanding approved procedures for panel replacement with the objective of restoring the car to a safe running condition and effecting a repair which is visually acceptable.

WELDING

The following charts and illustrations show the locations and types of weld for securing the body side assembly, tailgate frame assembly and the front valance and wheel arch assembly. Before undertaking any spot weld joints to the inner body, it is advisable to make a test joint using offcuts of the damaged components, and to use this test piece to perform a weld integrity test.

Spot welding is satisfactory if the joints do not pull apart. If the weld pulls a hole or tears the metal the weld is satisfactory. It is defective if the weld joint pulls apart or if there are signs of burning, porosity or cracking evident.

PREPARATION

Thoroughly clean all areas to be welded, remove any sealants and corrosion protectives from around original panels. Align and clamp all new panels in position and check relationship to one another.



INNER BODY SHELL ASSEMBLY

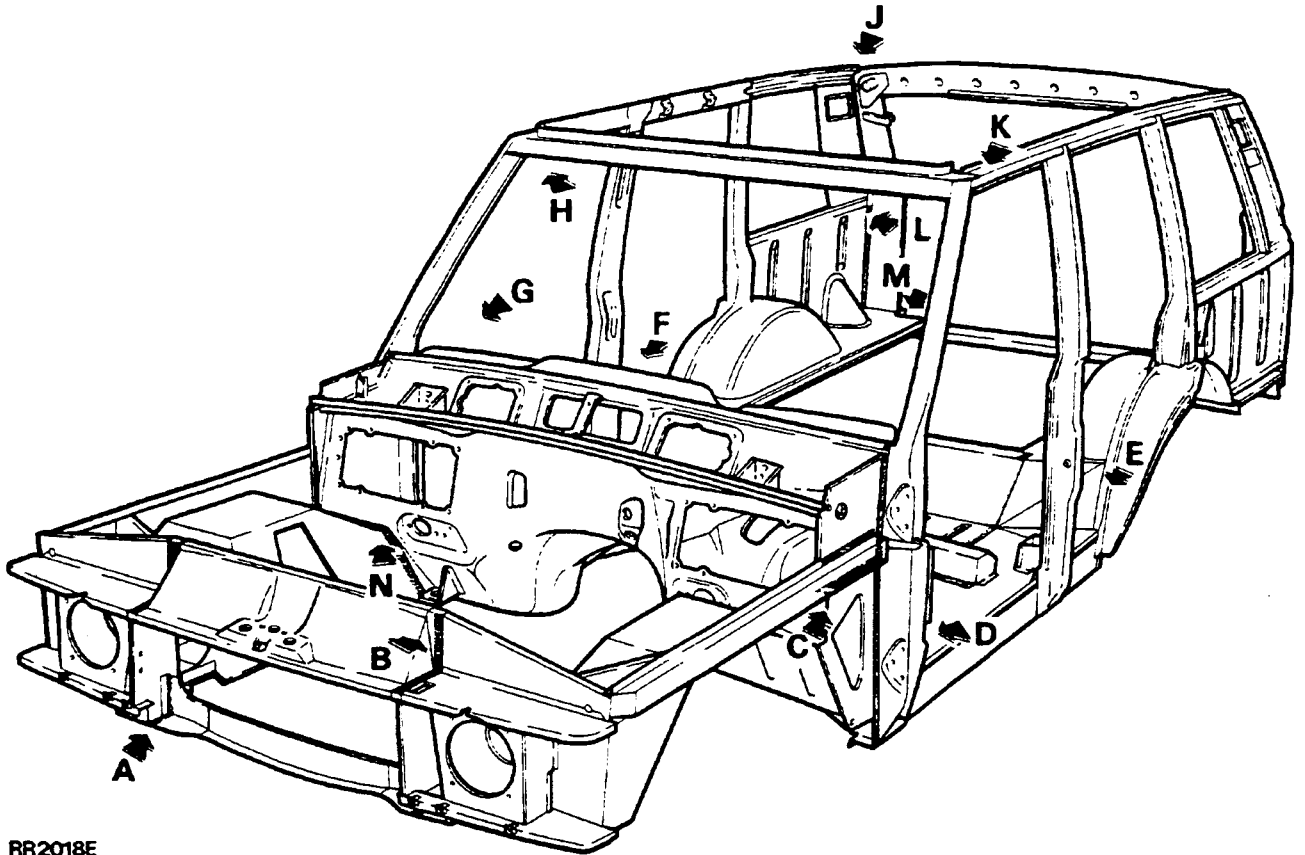

RR2018E

LOCATION	FACTORY JOINT (minimum number of spot welds quoted)
A. Front cross member to valance and wheel arch assembly	6 spot welds, 20 mm pitch
B. Bonnet locking platform to valance and wheel arch assembly	10 spot welds, 25 mm pitch
C. Valance and wheel arch assembly to dash and tunnel assembly	16 spot welds, 25 mm pitch
D. Body side complete to dash and tunnel assembly	10 spot welds, 65 mm pitch

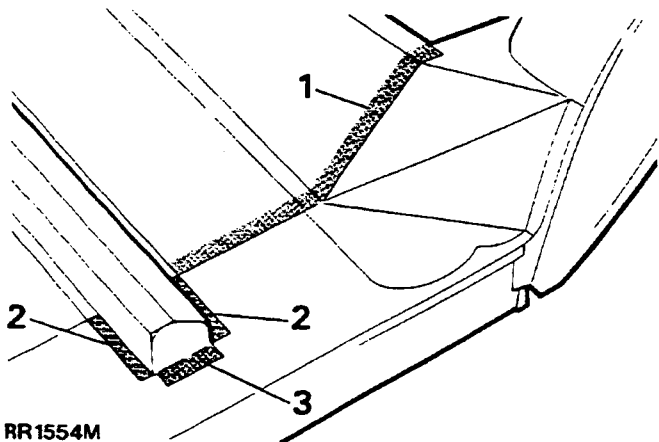

LOCATION E

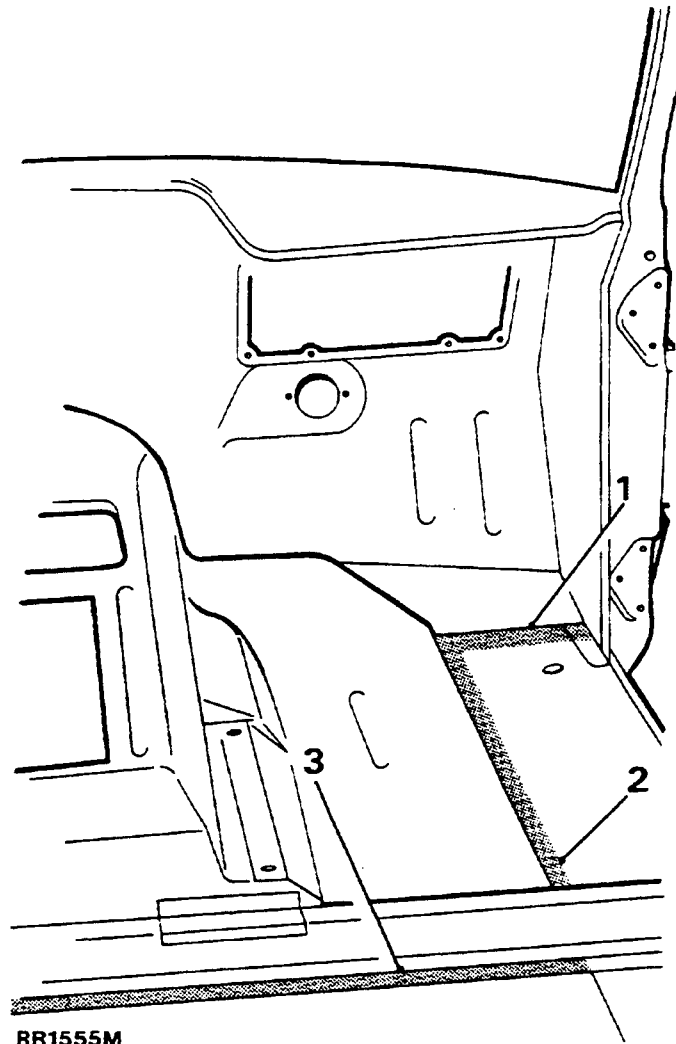

LOCATION F

LOCATION	
E. 1. Body side complete to heelboard panel assembly. 2. Body side complete to dash and tunnel assembly complete. 3. Body side complete to dash and tunnel assembly	14 spot welds, 35 mm pitch 10 spot welds, 25 mm pitch 3 spot welds, 30 mm pitch
F. 1. Body side complete to dash and tunnel assembly complete 2. Body side complete to dash and tunnel assembly complete 3. Body side complete to dash and tunnel assembly complete	7 spot welds, 30 mm pitch 18 spot welds, 40 mm pitch 30 spot welds, 34 mm pitch

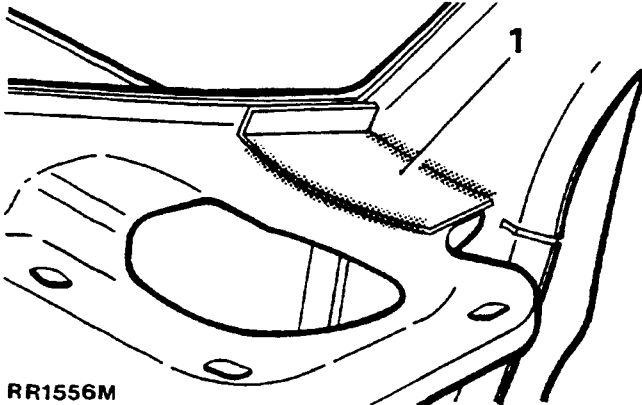

RR1556M

LOCATION G

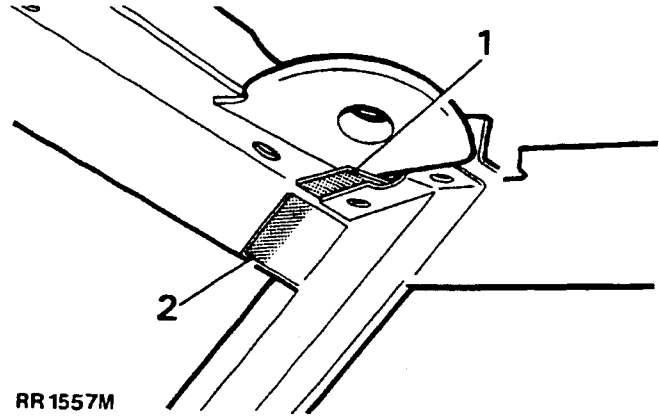

RR1557M

LOCATION H

LOCATION	FACTORY JOINT (minimum weld requirement quoted)
G. 1. Reinforcement plate to dash and tunnel assembly and body side assembly complete	CO ² weld, 2 places 75 mm long each weld
H. 1. Body side complete to roof header panel assembly (internal joint) 2. Body side complete to roof header panel assembly (internal joint)	3 spot welds, 15 mm pitch 3 spot welds, 15 mm pitch

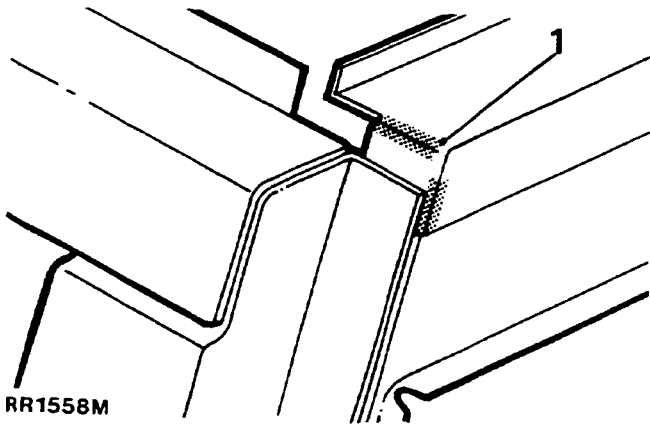

LOCATION J

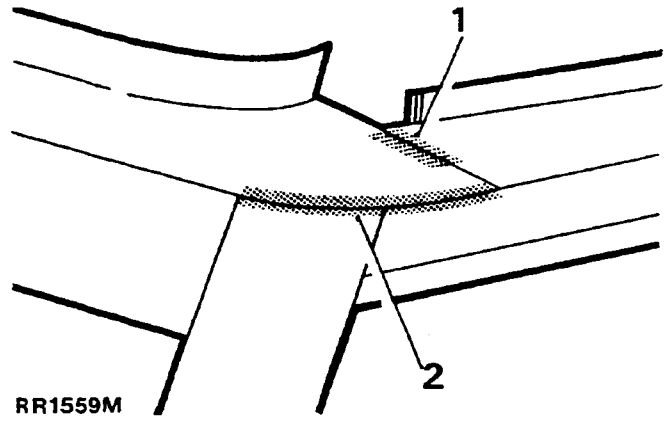

LOCATION K

LOCATION	FACTORY JOINT (minimum weld requirement quoted)
J. 1. Body side complete to rear tailgate frame assembly	CO ² weld, one run 40 mm long
K. 1. Body side complete to roof header panel assembly (external joint) 2. Body side complete to roof header panel assembly (external joint)	CO ² weld, one run 20 mm long CO ² weld, one run 100 mm long

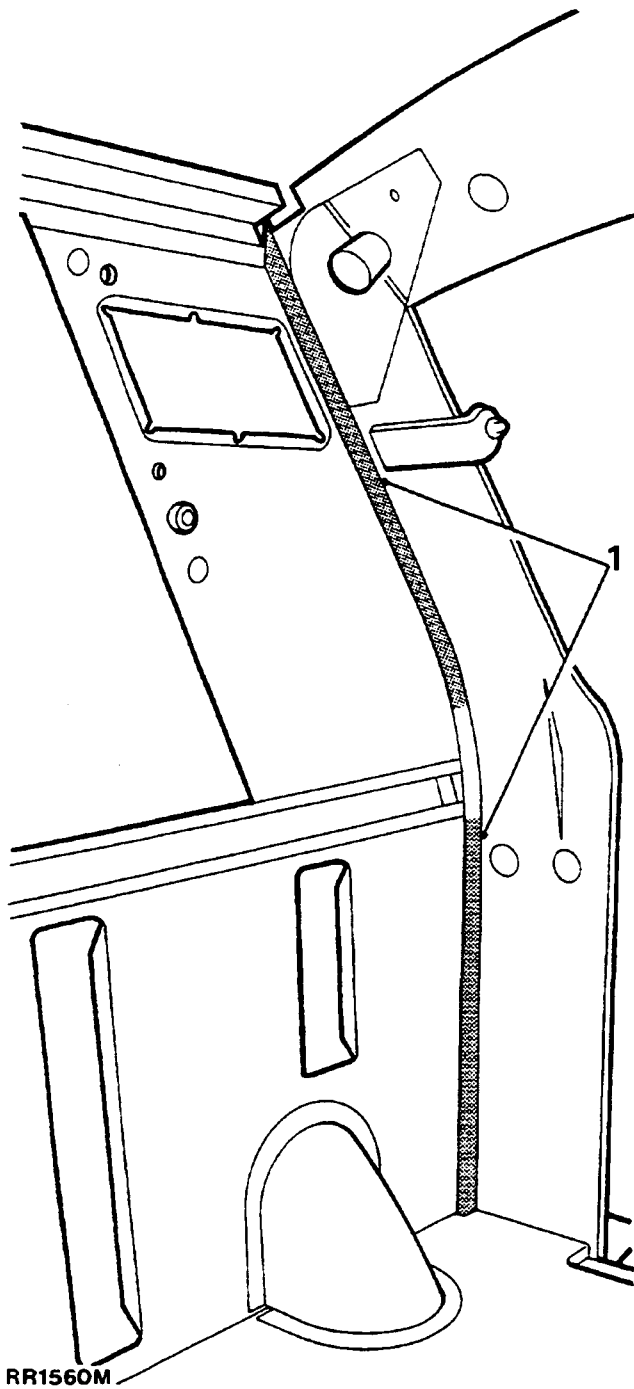

LOCATION L

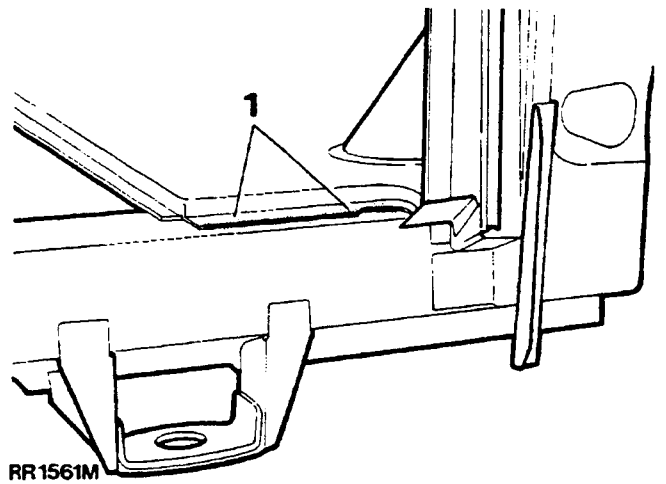

LOCATION M

LOCATION	FACTORY JOINT (minimum weld requirement quoted)
L. 1. Body side complete to rear tailgate side member	32 spot welds, 30 mm pitch
M. 1. Body side complete to rear tailgate bottom cross member	CO ² weld, 2 runs 40 mm long

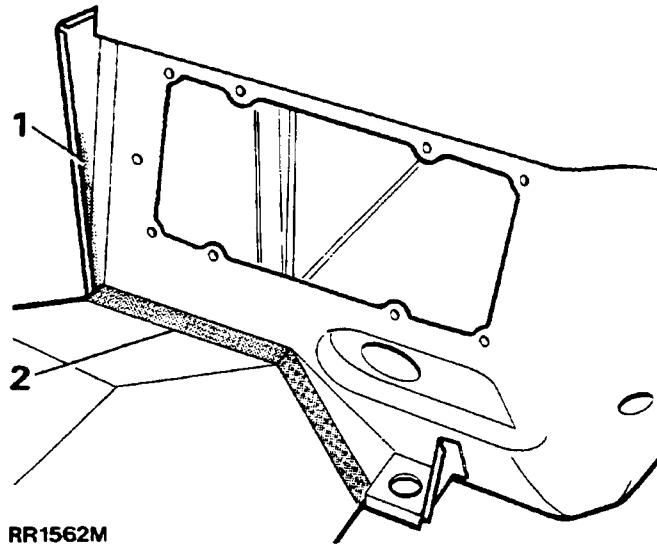

LOCATION N

LOCATION	FACTORY JOINT (minimum number of spot welds quoted)
N. 1. Valance and wheel arch assembly to dash and tunnel assembly 2. Valance and wheel arch assembly to dash and tunnel assembly.	4 spot welds, 45 mm pitch 15 spot welds, 25 mm pitch



HEADLINING

Service repair no - 76.64.01.

Remove and refit

Remove

1. Remove spare wheel.
2. Remove rear seat belt upper guide brackets and inertia reel assemblies.
3. Fold rear seat backrest forward. Recline front seats.
4. Disconnect the battery negative lead.
5. Remove two roof lamp assemblies. Remove interior lamp mounting panel if sunroof is fitted.
6. Remove rear view mirror.
7. Remove two sun visors and centre retaining bracket.
8. Remove passenger grab handles.
Sunroof vehicles: Remove edge trim and clips from roof opening.
9. With assistance support front of headlining. Remove two plastic retaining clips above rear door.
10. Remove two plastic retaining clips securing rear end of headlining near upper tailgate hinges.
11. Pull headlining forward to clear rear quarter trim. Lower headlining, disconnect electrical leads from speakers.
12. Remove headlining through tailgate.



CAUTION: To assist removal tilt headlining at an angle. **DO NOT** flex headlining as damage may occur.

Refit

13. Reverse removal procedure.
Sunroof vehicles: Secure headlining around roof opening with edging finisher.

ROOF PANEL

Service repair no - 76.10.13.

Remove and refit

Remove

1. Remove headlining. *See Headlining*
2. Remove blanking plugs from rail above door frames to access screws.
3. Remove the screws washers from around inner edge of roof panel.

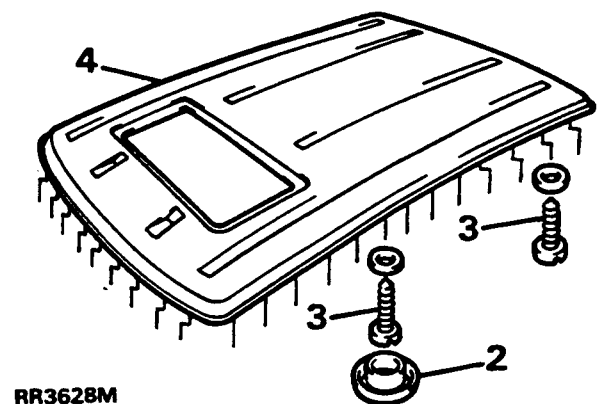

RR3628M

4. With assistance lift roof panel from body. Remove sealant from roof and body mating faces.

Refit

5. Apply sealant to roof and body mating faces.
6. Reverse removal procedure.

BONNET

Service repair no - 76.16.01.

Remove and refit**Remove**

1. Disconnect the battery negative lead.

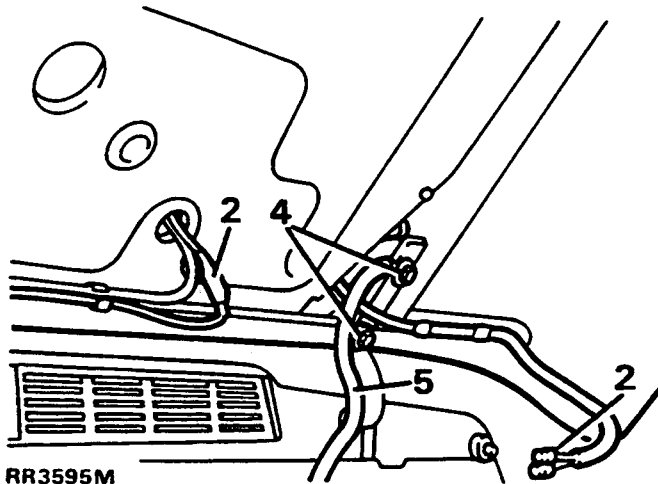

RR3595M

2. Disconnect electrical leads to under bonnet lamp and heated washer jets.
3. Disconnect windscreen washer tube at 'T' joint.
4. With assistance release four bolts securing bonnet to hinges. Note ground strap located onto left hinge for reassembly. Lift bonnet clear of vehicle.

Refit

5. Fit bonnet ensure ground strap is refitted. Before final tightening of bolts align bonnet with decker panel, wing and front grille.
6. Reverse the remaining removal instructions.

DECKER PANEL

Service repair no - 76.10.35.

Remove and refit**Remove**

1. Disconnect the battery negative lead.
2. Remove bonnet. *See Bonnet*
3. Remove wiper arms and two nuts securing wheel boxes to decker panel. Remove two exterior sealing rubbers.
4. Remove nine screws securing front of decker panel.
5. Remove four bolts, spring and plain washers retaining decker panel to wings.

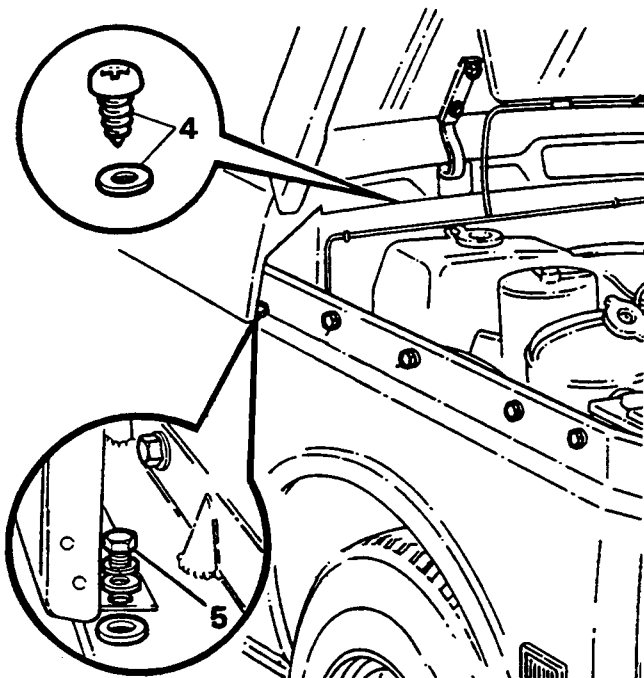

RR2686M

6. With assistance place a tube over each hinge and lower to enable decker panel to be removed. Slowly return hinges to upright position.



WARNING: Gradually let hinges return to upright position to prevent possibility of personal injury or damage.

Refit

7. Reverse removal procedure.
8. Using a soft blunt instrument ease windscreen rubber onto top of decker panel.

FRONT WING

Service repair no - 76.10.24.

Remove and refit

Remove

1. Remove wheel arch liner. *See Front wheel arch liner*
2. Remove side light and flash lamp assembly. *See ELECTRICAL, Repair, Side light and flasher lamp assembly and bulb.*

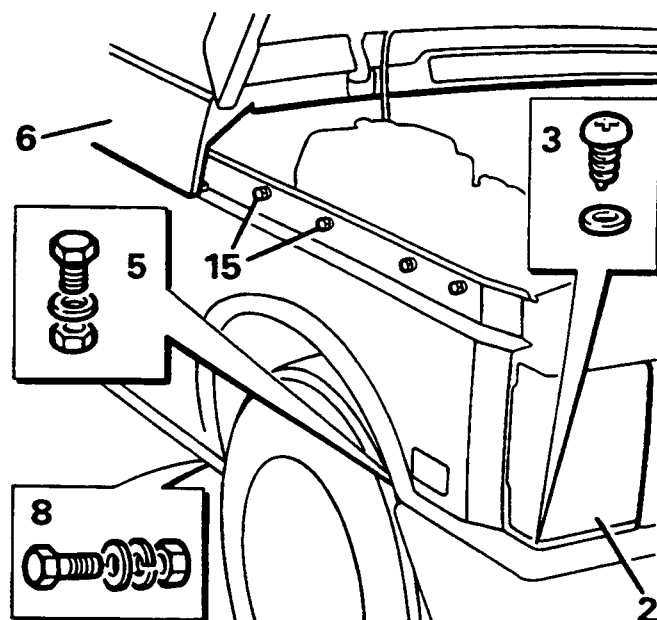

RR3596M

3. Remove screws, plain washers from bottom of side light recess.
4. Remove fixings securing bumper end cap. Remove moulding from bumper.
5. Remove bolt which secures spoiler to front wheel arch.
6. Release decker panel. *See Decker panel*
7. Remove five nuts, bolts, plain and spring washers securing wing to valance.
8. Remove two bolts, plain washers, securing sill finisher to bottom of wing.

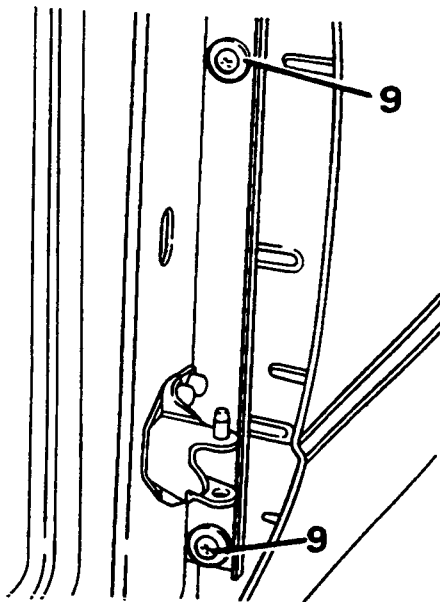

ASSISTED BONNET LIFT

Service repair no - 76.16.11.

Remove and refit

Remove

1. Remove bonnet. *See Bonnet*
2. Remove decker panel. *See Decker panel*
3. Place a tube over each hinge and lower to remove stop bracket. Slowly return hinges to upright position.

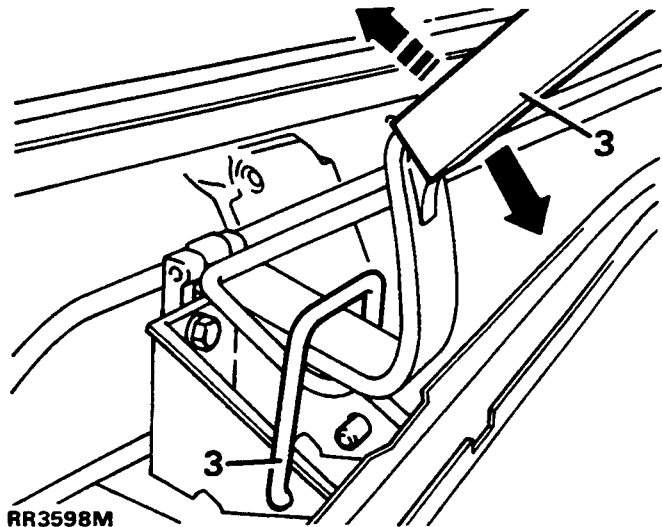

4. Release torsion bar from retaining clip.
5. Move torsion bar so it releases from hinge.
6. Release torsion bar from retaining bracket.

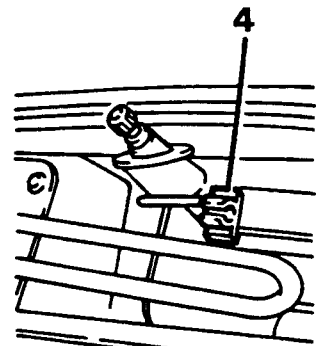
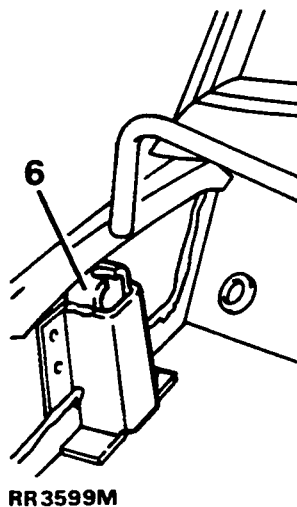

9. Remove two screws securing wing to 'A' post. Located near door hinges.

Refit

10. Apply suitable protection to wing inner. Apply sealant to mating faces.
11. Before tightening wing bolts ensure wing aligns with edge of front door.
12. Reverse remaining removal instructions.



7. Remove 2 bolts and plain washers securing hinge to mounting bracket.
8. Withdraw hinge.

Refit

9. Fit hinge and securely tighten 2 retaining bolts
10. Fit torsion bar ensure secure location into retaining clip and bracket.
11. Reverse removal procedure.

FUEL FILLER FLAP

Service repair no - 76.10.25.

From 1991 model year the filler flap is revised. Remove and refit instructions remains same.

Remove and refit

Remove

1. Open fuel filler flap.
2. Release 2 screws with plain washers.
3. Remove flap.

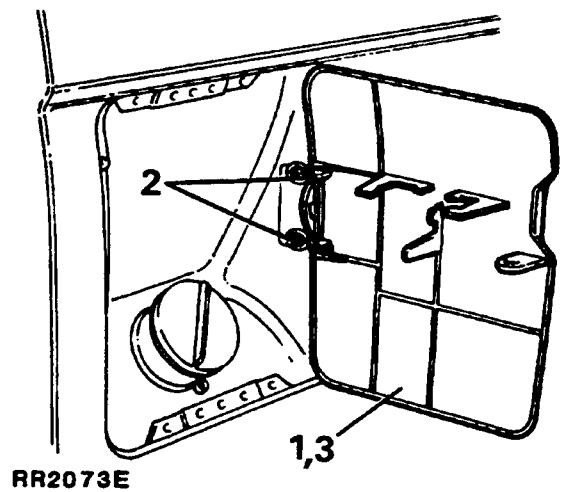

Refit

4. Fit flap, loosely fit screws.
5. Check outer profile of flap aligns with wing. Adjust hinge flap in or out of opening.
6. Tighten screws.

REAR CORNER PANEL AND WING

Service repair no - 76.10.20 / 76.10.27.



WARNING: On pre 1991 model year vehicles a fuel expansion tank is located between right wing and inner body side.

The wing must be removed before any repair requiring heat onto rear corner panel or wing.

Remove and refit

Remove

1. If applicable, remove 3 filler tube screws and fuel filler flap. See *Fuel Filler flap*

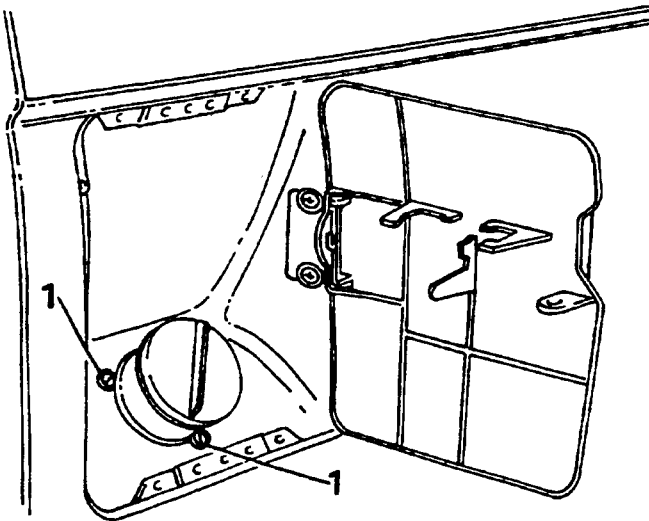

RR2130E

2. Remove load space cover and spare wheel.
3. Remove 2 nuts and washers securing bumper end cap to corner panel.
4. Remove bolt securing end cap to bumper.

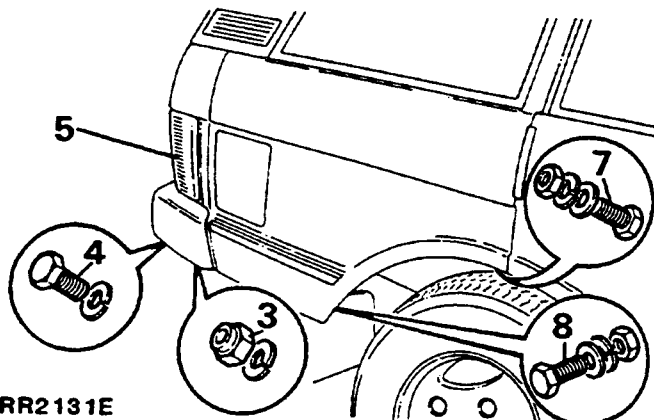

RR2131E

5. Remove rear lamp assembly. See *ELECTRICAL, Repair, Tail lamp assembly*
6. Drill out pop rivets securing corner panel to tailgate frame.
7. Remove 2 nuts and bolts securing wing to 'D' post, located beneath wheel arch.
8. Loosen nut and bolt retaining mud-flap bracket to wing.
9. Remove 5 screws securing wing to bodyside panel. To access screw adjacent to 'D' post, fold rear seat forward and remove seat locking mechanism housing.

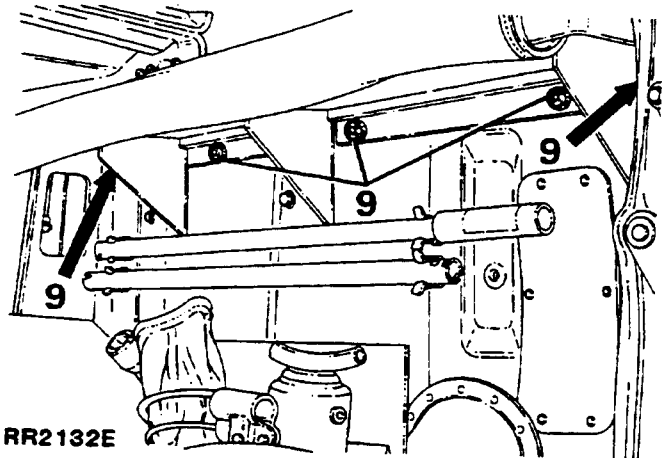

RR2132E

10. Remove rear wing with corner panel.
11. Remove 7 bolts, plain and spring washers securing wing to corner panel.

Refit

12. Assemble corner panel to rear wing with bolts. Align panels before tightening.
13. Coat underside of panels with body protection.
14. Fit assembly to vehicle. Align door shut face to wing edge and corner panel to tailgate, before tightening screws and fitting pop rivets.
15. Reverse remaining removal instructions.



REAR QUARTER PANEL-INTERIOR

Service repair no - 76.13.43.

Remove and refit

Remove



NOTE: Remove spare wheel when removing left rear quarter panel.

1. Remove cover and bolt from seat belt guide bracket.
2. Remove clip on cover from seat belt inertia reel. Remove bolt and place inertia reel to one side.
3. Remove clips securing trim panel to body side.
4. Ease trim panel from behind rubber moulding.
5. Remove panel.

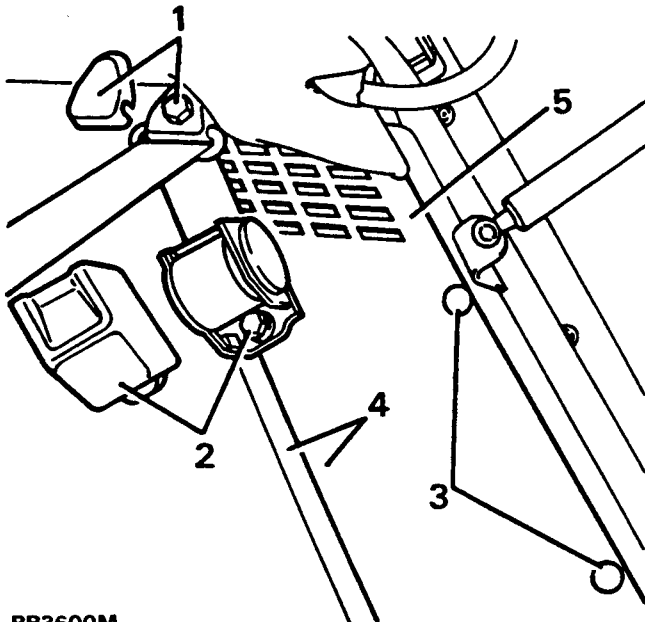

RR3600M

Refit

6. Ease top of trim panel under lip of rubber moulding.
7. Push panel up behind headlining until clip holes are visible.
8. Ease rubber moulding lip over remainder of trim panel.
9. Ensure electrical harness locates in channel behind trim panel. Fit 2 trim clips.
10. Fit seat belt guide bracket and inertia reel. Tighten to **20 Nm**.
11. Refit covers to guide bracket and inertia reel.

REAR QUARTER PANEL-EXTERIOR

Service repair no - 76.13.22.

Remove and refit

Remove

1. Remove spare wheel if removing left rear quarter panel.
2. Remove interior quarter panel. *See Rear Quarter panel-interior*
3. Remove 3 nuts with plain washers securing exterior quarter panel to bodyside.
4. Remove 4 screws securing quarter panel to tailgate opening.
5. Remove panel.

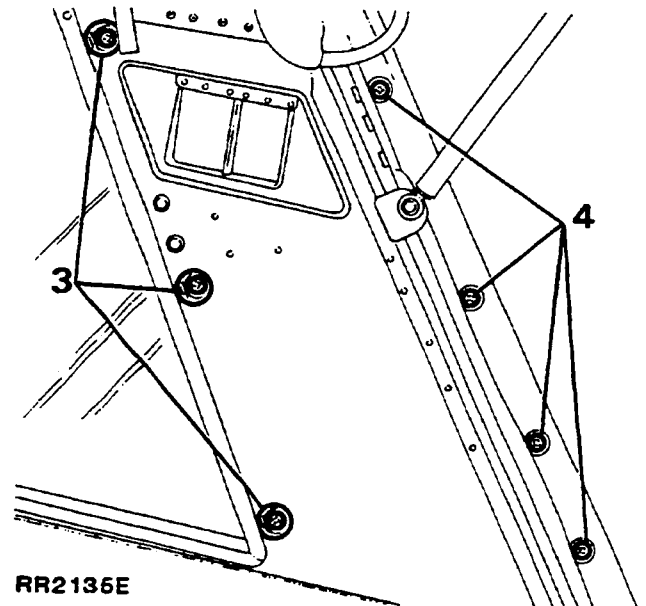

RR2135E

Refit

6. Reverse removal procedure.

TAILGATE UPPER

Service repair no - 76.28.29.

Remove and refit

Remove

1. Disconnect the battery negative lead.
2. Remove tailgate wiper arm.
3. Open tailgate and remove screws from electrical wiring shrouds.
4. Move shroud away from screen and headlining. Disconnect electrical wiring.



WARNING: DO NOT repair worn tailgate stays. Fit a replacement.

5. Pry stays off tailgate.
6. With assistance support tailgate, remove screws from hinge.

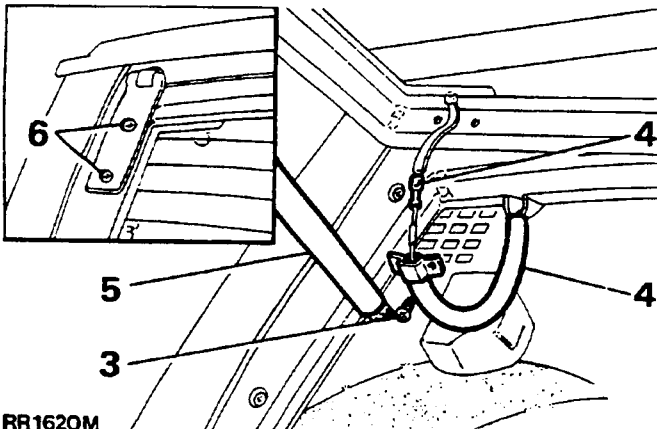

Refit

7. Reverse removal procedure.

TAILGATE UPPER LOCK

Remove and refit

Remove

1. Remove upper tailgate lock actuator unit. See *ELECTRICAL, Repair, Upper tailgate actuator unit*
2. Remove 2 screws securing release handle.
3. Move sealing rubber, remove screw to detach handle.

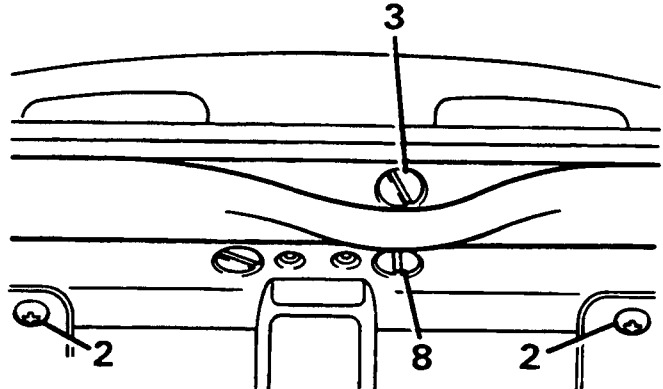

RR3601M

4. If required, remove key barrel by removing 2 screws at joint. Remove retaining plate and release spring.
5. Remove 8 screws securing operating rod covers either side of lock mechanism.
6. Remove 4 screws and 2 nuts securing lock catches to sides of tailgate.

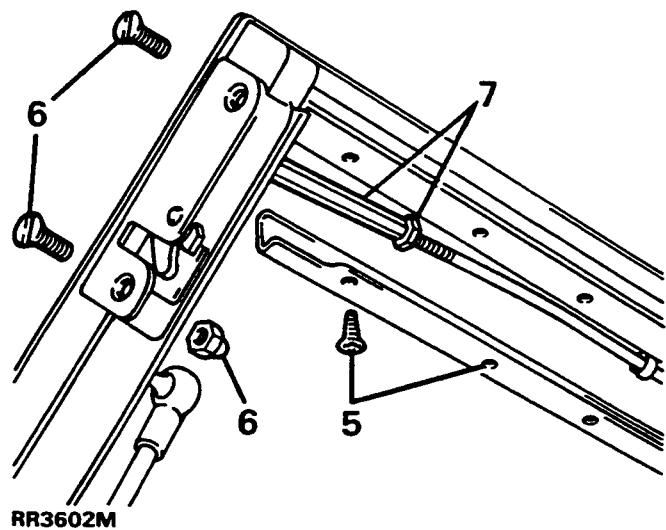

- 7. Release 2 locknuts on operating rods. Rotate connecting rod until side catches can be removed.
- 8. Remove 2 screws securing lock mechanism. Remove unit complete with operating rods.

Refit

- 9. Reverse removal procedure.
- 10. To adjust side catches release locknuts on operating rods. Rotate hexagonal link to shorten or extend length as necessary.

TAILGATE UPPER GLASS

Remove and refit

Remove

- 1. Tailgate upper glass and frame assembly are serviced as one unit.
- 2. Remove tailgate upper. *See Tailgate upper*
- 3. Remove high level stop lamp. *See ELECTRICAL, Repair, High level stop lamp*
- 4. Remove lock actuator unit. *See ELECTRICAL, Repair, Upper tail gate actuator unit*
- 5. Remove lock assembly. *See Tailgate upper lock.*

Refit

- 6. Reverse removal procedure.

TAILGATE LOWER STRIKER

Adjust

- 1. Adjustment is correct when tailgate profile aligns with rear body corner panels.
- 2. Open lower tailgate.
- 3. Add or remove spacing washers between striker and tailgate opening.
- 4. Move striker in appropriate direction and tighten.

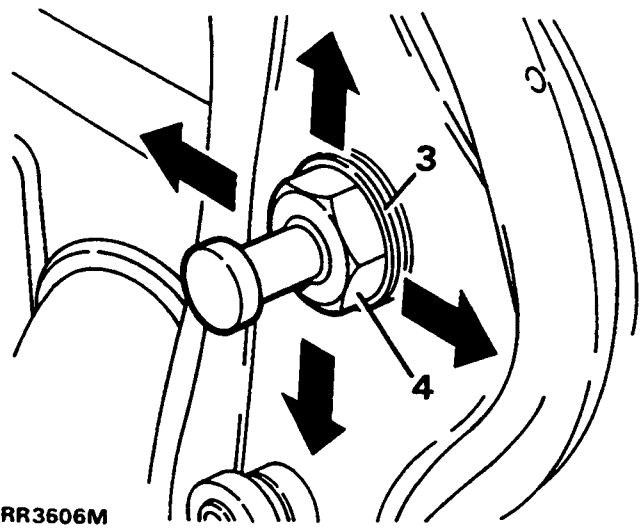

TAILGATE LOWER

Service repair no - 76.28.30.

Remove and refit**Remove**

1. Disconnect the battery negative lead.
2. Remove grommet and withdraw electrical leads from tailgate. Disconnect connectors.

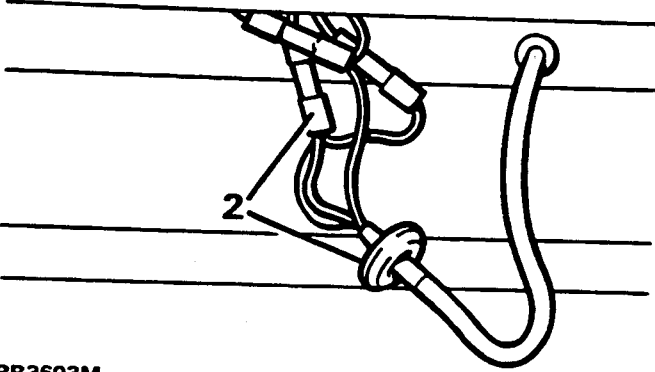

RR3603M

3. Remove tailgate trim panel.
4. Remove 4 screws securing seal around tailgate hinge.
5. Remove tailgate to hinge bolts.
6. With assistance disconnect check straps.
7. Withdraw tailgate.

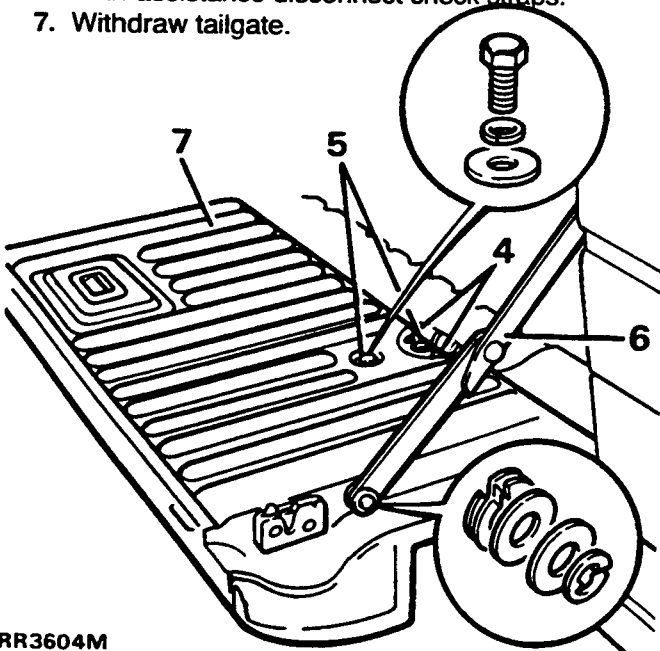

RR3604M

Refit

8. Reverse removal procedure. Ensure grommet is refitted onto tailgate.

TAILGATE LOWER RELEASE MECHANISM**Remove and refit****Remove**

1. Open lower tailgate.
2. Lever trim from handle surround.
3. Remove 4 clips, remove tailgate trim panel.
4. Remove screws securing lock cover plate.
5. Remove cover plate with release mechanism.
6. Remove 2 screws and detach handle release actuator lever.
7. Remove 2 nuts and detach handle release retaining bracket.
8. Withdraw handle release mechanism from cover plate.

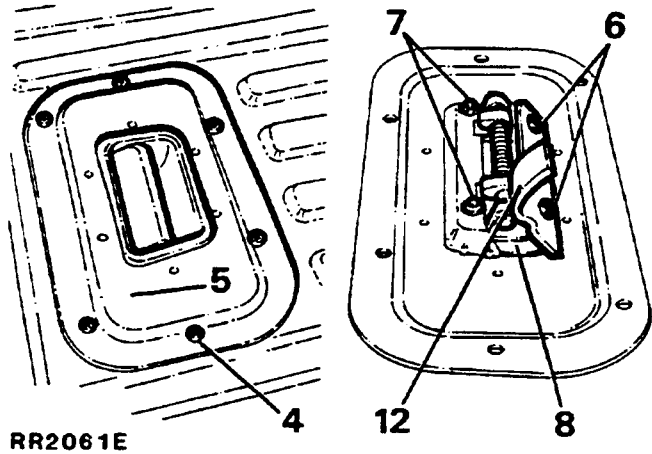

RR2061E

9. Release spring clips securing operating rods to tailgate release mechanism.

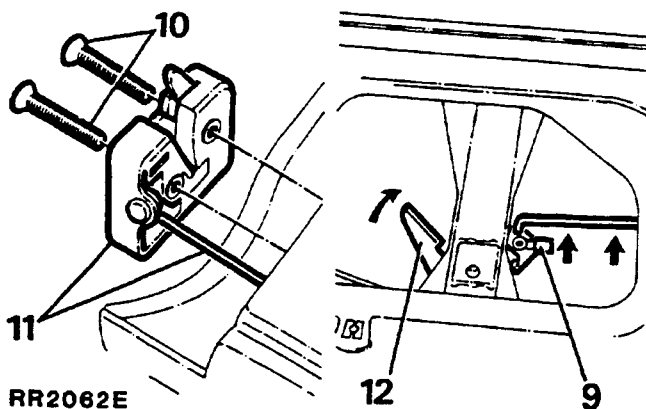

10. Remove screws securing 2 exterior locks on tailgate side.
11. Withdraw exterior locks with operating rods.

Refit

12. Reverse removal procedure. Grease handle release actuator lever and internal tailgate operating lever.

RADIATOR GRILLE

Service repair no - 76.55.06.

Remove and refit

Remove

1. Open and support bonnet.
2. Depress 4 retaining lugs and ease grille forward.
3. Lift grille to remove.

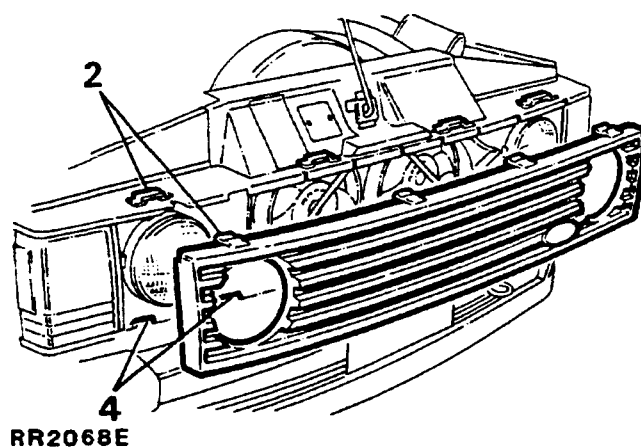

RR2068E

Refit

4. Locate lower lugs of grille into slots.
5. Ensure upper retaining lugs of grille locate behind bracket.

FRONT DOOR

Service repair no - 76.28.07.

Remove, refit and adjust

Remove

1. Disconnect the battery negative lead.
2. Open door to be removed.
3. Remove 2 clips securing trim panel to side of footwell.
4. Locate and disconnect door wiring plugs.

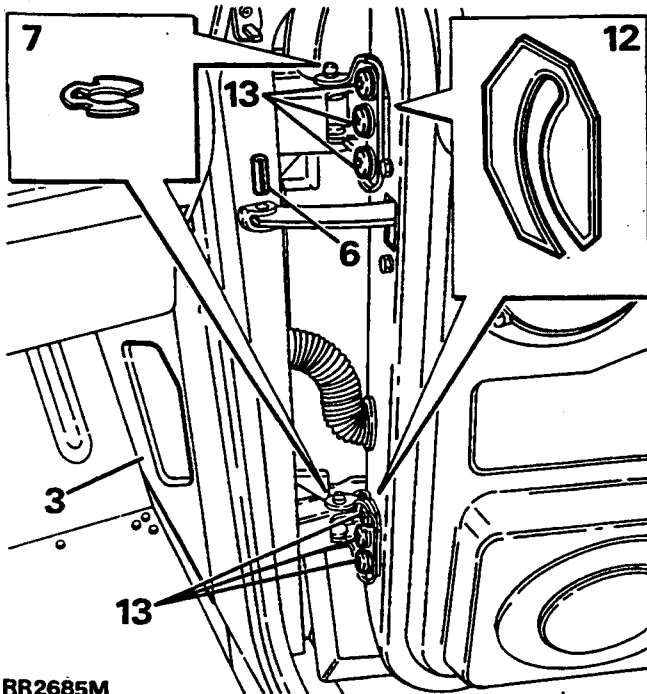

RR2685M

5. Disengage grommets either side of 'A' post. Feed wiring out.
6. Drive out roll pin from door check link.
7. Remove 'C' clips from hinge pins.



WARNING: Instruction 8 MUST BE carried out with assistance.

8. Lift opened door off hinge pins.

Refit

9. Reverse removal procedure. Renew clips if worn or distorted.
10. Open door, connect wiring plugs. Ensure they locate above trim panel.
11. Check operation of door and lock. If necessary, adjust door and striker plate.

Adjust

12. Adjust door by shims between hinge and door to move door forward or rearward in opening.
13. Loosen 6 screws securing hinges to door to adjust door up and down or in and out of opening. Tighten to **25 Nm**.
14. Adjust door lock striker by adding and subtracting spacing washers or moving in required direction.

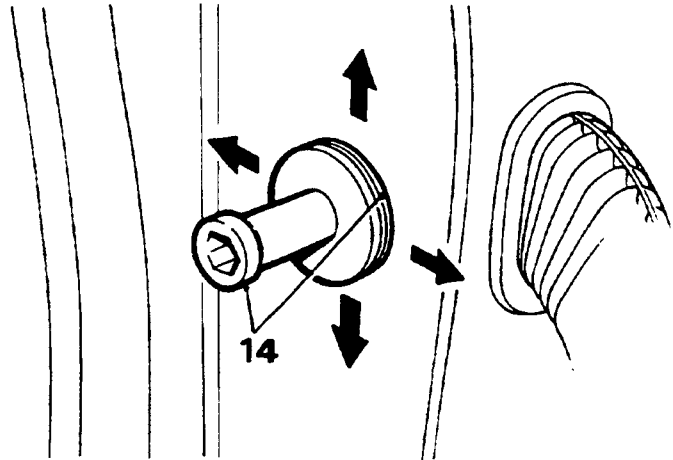

RR1588M

15. Note: If it is necessary to remove hinges from 'A' post. Refit in exactly same position using same thickness of shims.



FRONT DOOR GLASS AND REGULATOR

Service repair no - 76.31.01. - 76.31.45.

Remove and refit

Remove

1. Fully close window and secure with tape to prevent window from dropping.
2. Remove trim panel. *See Front door - Trim panel*
3. Remove vapor barrier.
4. Remove window lift motor. *See ELECTRICAL, Repair, Window lift motor - Front doors*

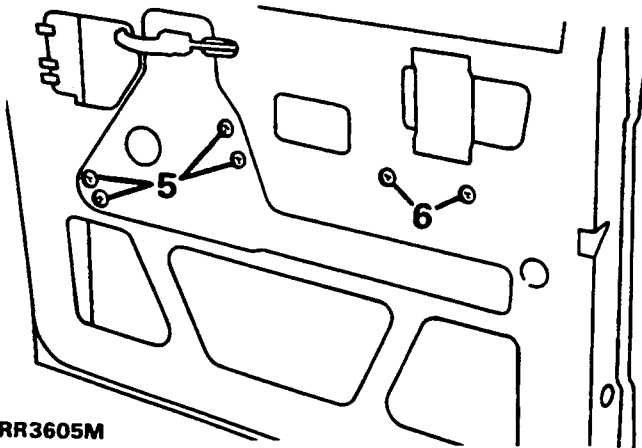

RR3605M

5. Remove 4 window regulator retaining bolts with shakeproof washers from door panel.
6. Remove 2 screws with shakeproof washers retaining lower window lift channel. Slide channel off stud.

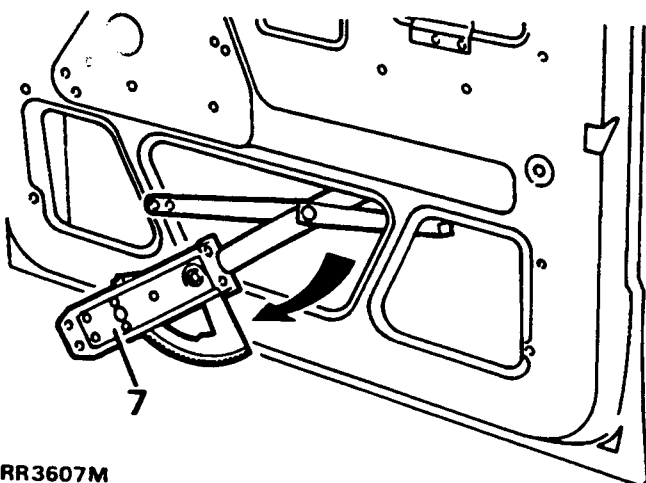

RR3607M

7. Disengage lifting arm stud from upper lifting channel. Remove window regulator through opening in door panel.
8. Remove exterior driving mirror. *See ELECTRICAL, Repair, Exterior driving mirrors*
9. Remove waist rail seal from top of door.

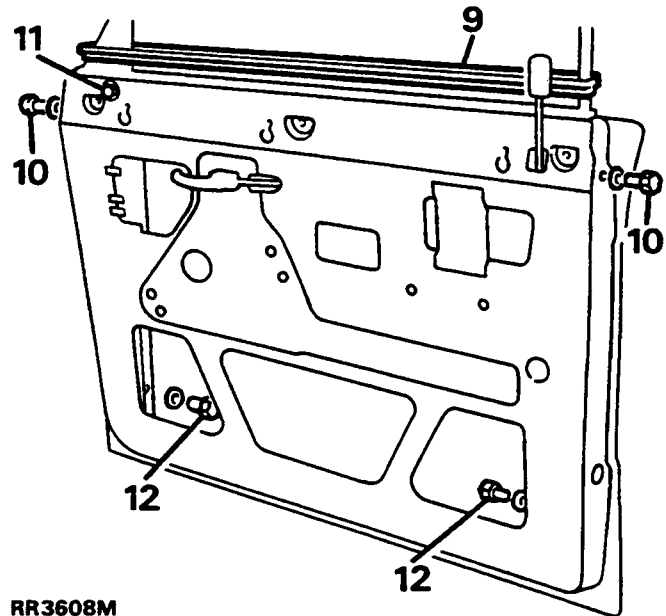

RR3608M

10. Remove bolt, shakeproof and plain washer from both end faces of door which secure door frame.
11. Remove bolt, spring and plain washer from recessed hole under mirror mounting plate.
12. Remove bolt spring and plain washer securing each lower side of door frame.
13. Remove glass and frame out of door panel.
14. Remove tape securing glass to frame.
15. Slide glass out of door frame.

Refit

16. Reverse removal procedure. When fitting door frame align to suit door opening. Then tighten door frame securing bolts.

FRONT DOOR - TRIM PANEL

Service repair no - 76.34.01.

Remove and refit

Remove

1. Disconnect the battery negative lead.
2. Remove screw securing handle surround.
3. Remove surround.

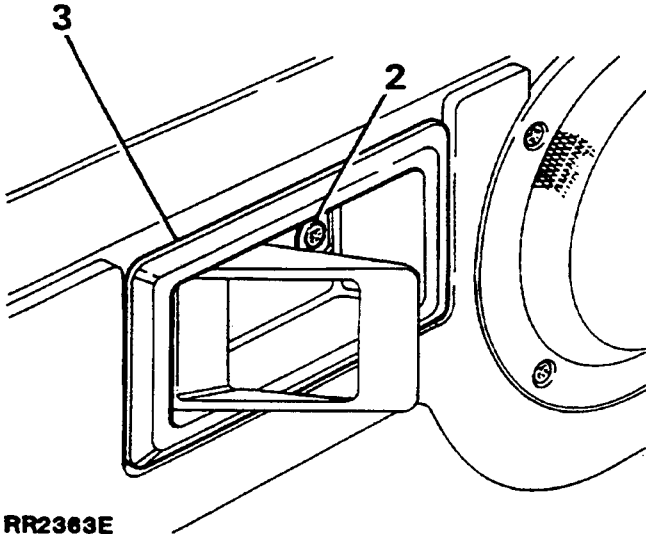

RR2363E

4. Pry sill button surround from trim panel.

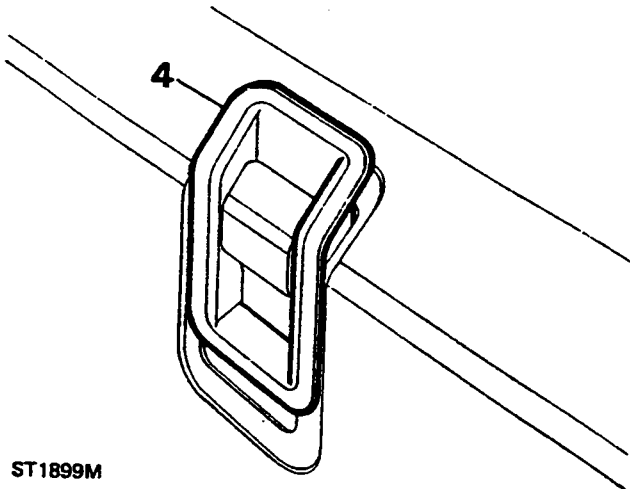

ST1899M

5. Remove buttons from bottom of door pull pocket.
6. Remove screws, withdraw pocket from trim panel.

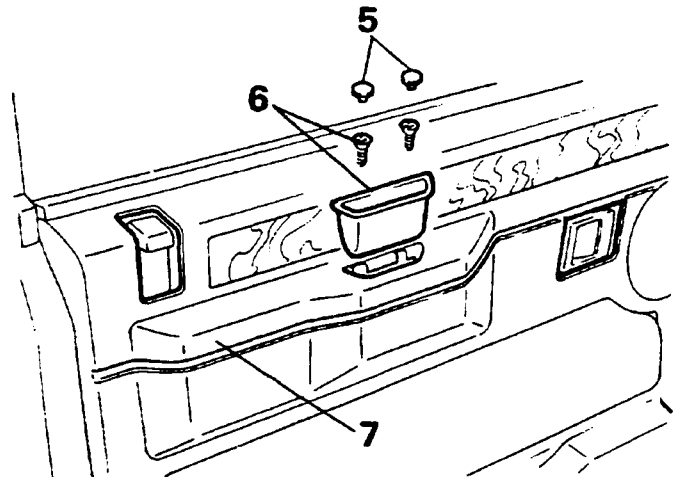

RR2364E

7. Pry trim panel from door.



NOTE: Support trim panel while speaker leads are disconnected.

8. Remove stowage bin by releasing screws behind trim panel.

Refit

9. Reverse removal procedure.



FRONT DOOR LOCK, OUTSIDE AND INSIDE DOOR RELEASE HANDLES

Service repair no - 76.37.12.

Remove and refit

Remove

1. Remove trim panel. *See Front door - trim panel*
2. Remove plastic vapor barrier sheet.
3. Remove window lift motor. *See ELECTRICAL, Repair, Window lift motor - Front Doors*
4. Remove door glass and regulator. *See Front door glass and regulator*
5. Remove door lock actuator. *See ELECTRICAL, Repair, Front door actuator unit*
6. Disconnect control rod from key operated lock. Release metal clip at bottom of rod.
7. Disconnect control rod from outside door release handle.
8. Disconnect rod between door release handle and door lock by releasing clip and pulling rod out of connecting block.

9. From inside door remove pin which secures quadrant to inner panel. Remove quadrant.
10. Remove screws securing sill button to door. Remove sill button from control rod.
11. Remove door lock by removing three screws as shown.
12. Withdraw lock through cut out below.

Continue for removal of outside release handle.

13. Remove nuts, shakeproof washers and retaining bracket.
14. Remove door release handle from outer panel.

Continue for removal of inside release handle.

15. Remove screws securing to door panel.
16. Withdraw handle with connecting rod attached.

Refit

17. Reverse removal procedure. 1 to 16.

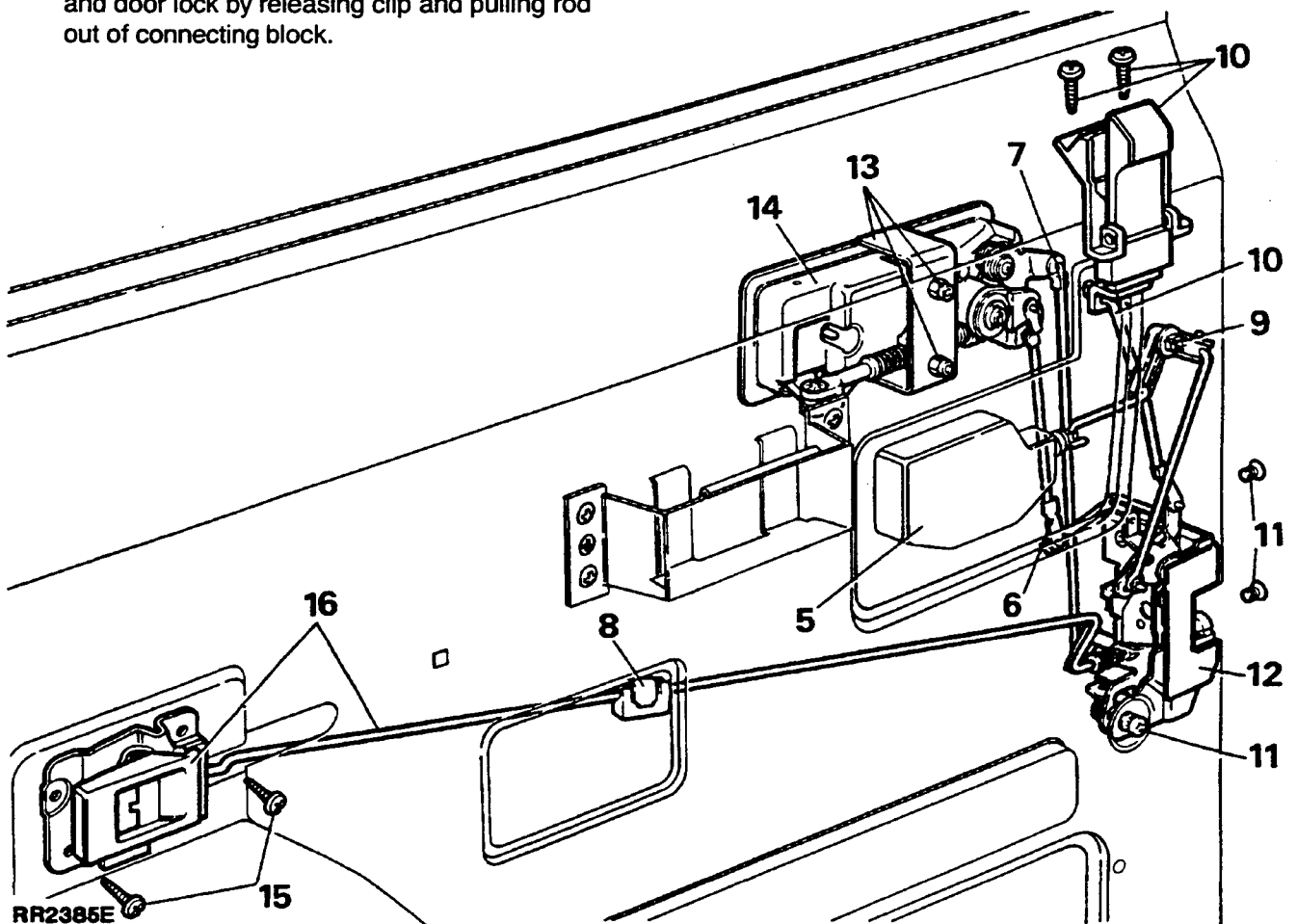

FRONT DOOR HEATED LOCK ASSEMBLY - 1991 MODEL YEAR

Remove and refit

Remove

1. Disconnect the battery negative lead.
2. Remove outside front door handle assembly.
See Front door lock outside and inside door release handles.

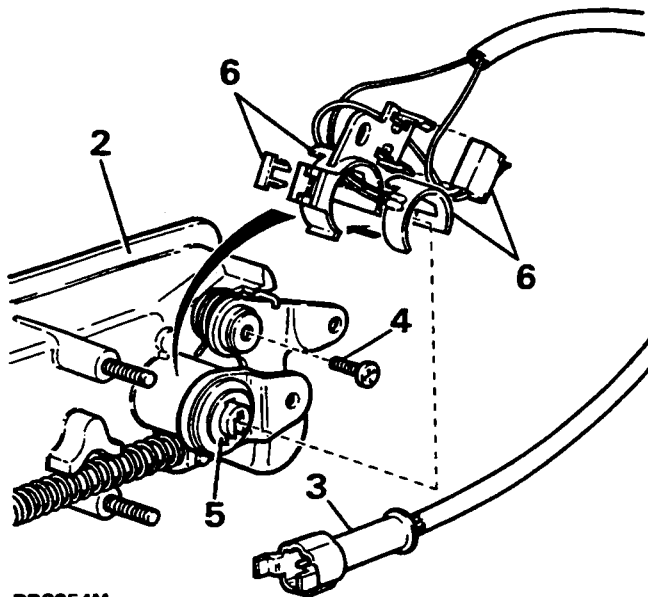

RR2954M

3. Disconnect heater electrical wiring at multiplug.
4. Remove heater retaining bracket screw.
5. Remove 'C' clip and colored cam link from end of barrel assembly.



CAUTION: Ensure loose barrel assembly remains in position, to avoid components falling apart.

6. Remove heater retaining bracket, complete with de-icing element, switch and wiring assembly.

Refit

7. Hold de-icing element in position and fit heater retaining bracket assembly.
8. Reverse removal procedure. 1 to 5.

FRONT DOOR LOCK AND HANDLE ASSEMBLY

Service repair no - 76.37.47.

Inside door release handle to lock

1. Ensure inside door release handle is in fitted position.
2. Adjust spring tensioned nut at door lock to shorten or extend rod as required, so door release occurs before maximum handle movement.

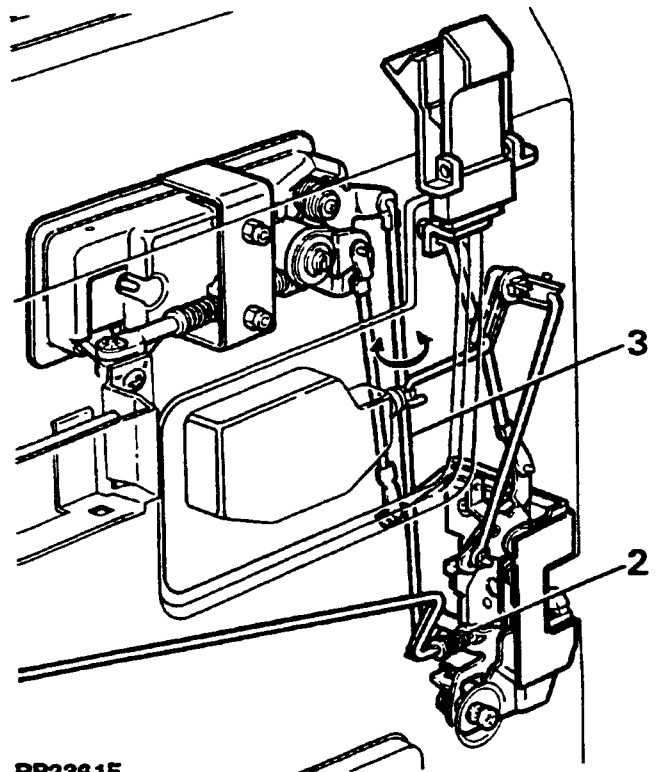

RR2361E

Outside door release handle to lock

3. Disconnect rod at outer door release handle by releasing plastic olive. Rotate rod to shorten or extend operating length as required, so door release occurs before maximum handle movement. Refit rod.



FRONT WHEEL ARCH LINER

Service repair no - 76.10.48.

Remove and refit

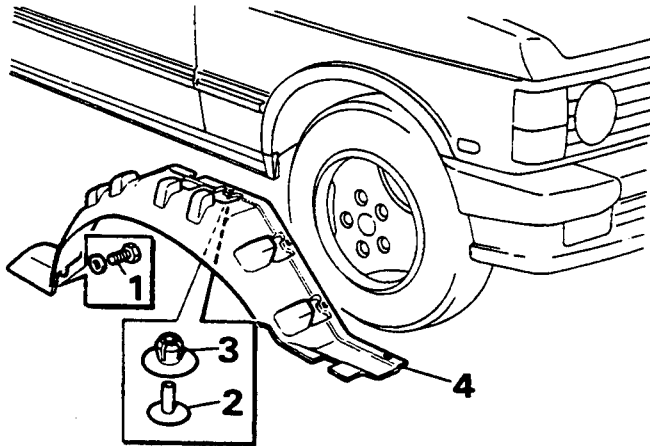

RR2711M

Remove

1. Remove bolt and washer securing rear lower edge of liner.
2. Pry out centre studs of eight plastic clips spaced around liner.
3. Pry out plastic clips.
4. Remove liner.

Refit

5. Reverse removal procedure. Renew clips as necessary.

SILL FINISHER

Remove and refit

Remove

1. Remove nut and washer from underneath front of sill finisher.
2. Tap out centre piece of ten Rocut fixing rivets.
3. Pry out Rocut rivets and remove sill finisher.

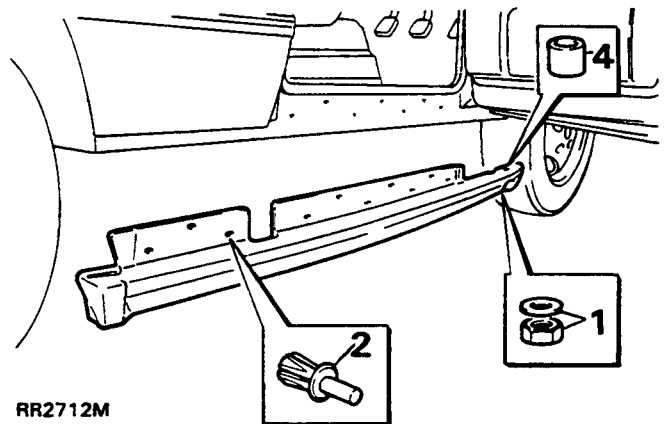

RR2712M

Refit

4. Reverse removal procedure. renewing Rocut rivets. Ensure metal tube insert is refitted into sill finisher where bolt goes through.

ENGINE UNDERTRAY

Service repair no - 76.10.50.

Remove and refit**Remove**

1. Disconnect the battery negative lead.
2. Remove three screws, securing undertray to spoiler.
3. Remove two screws, one each side, securing rear of undertray to chassis mounting brackets.
4. Remove undertray by flexing to clear rear mountings.
5. Removal of one or both rear mounting brackets may be necessary. For example when removing steering box. Remove nut and washer from chassis bolt.
6. Withdraw undertray mounting bracket.

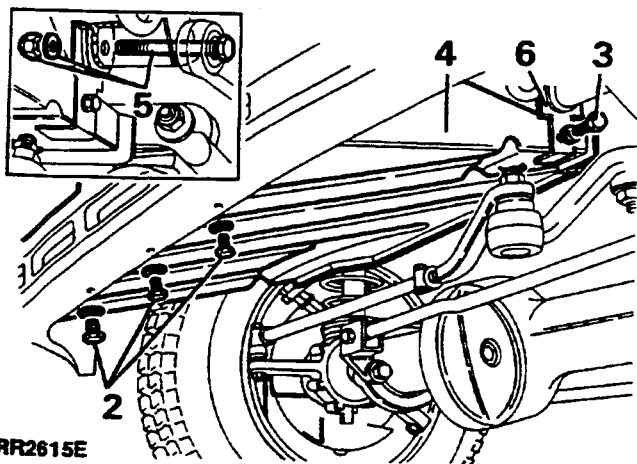
**Refit**

7. Reverse removal procedure.

REAR DOOR

Service repair no - 76.28.08.

Remove, refit and adjust**Remove**

1. Disconnect the battery negative lead.
2. Remove wiring grommet from 'B' post.
3. Withdraw door wiring plugs from 'B' post and disconnect.
4. Remove two bolts securing the check strap to 'B' post.
5. Remove 'C' clips from grooves in hinge pins.

**WARNING: Instruction 6. MUST BE carried out with assistance.**

6. Lift opened door off hinge pins.

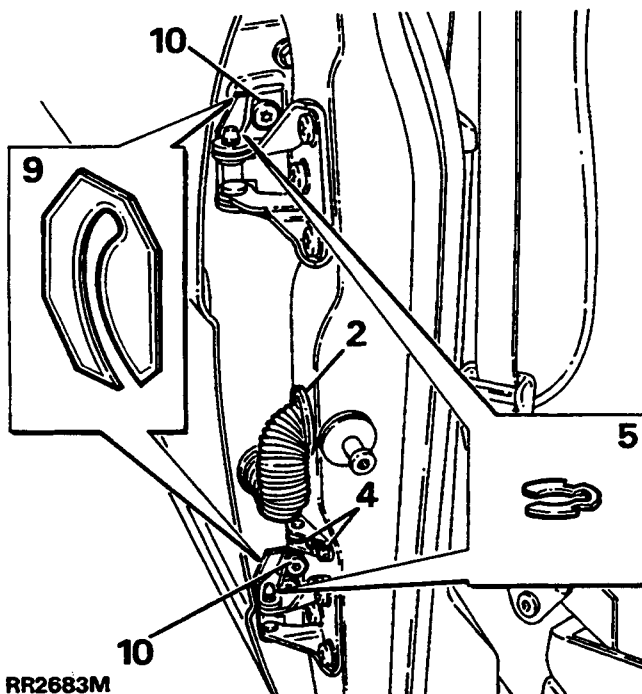
**Refit**

7. Reverse removal procedure. Renew 'C' clips if worn or distorted.



Adjust

8. Adjust door by means of shims between hinge and door to move door forward or rearward in the opening.
9. Loosen six screws securing hinges to door to adjust door up and down or in and out of opening. Retighten screws to **25 Nm**.
10. Adjustment to door striker is identical to front doors.
11. Note: If it is necessary to remove hinges from 'B' post they should be refitted in exact same position using same thickness of shims.

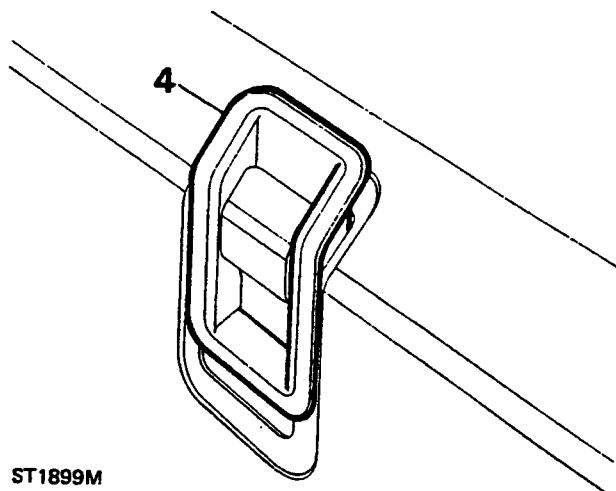

ST1899M

REAR DOOR - TRIM PANEL

Service repair no - 76.34.04/98

Remove and refit

Remove

1. Disconnect the battery negative lead.
2. Remove screw securing handle surround.
3. Remove surround.

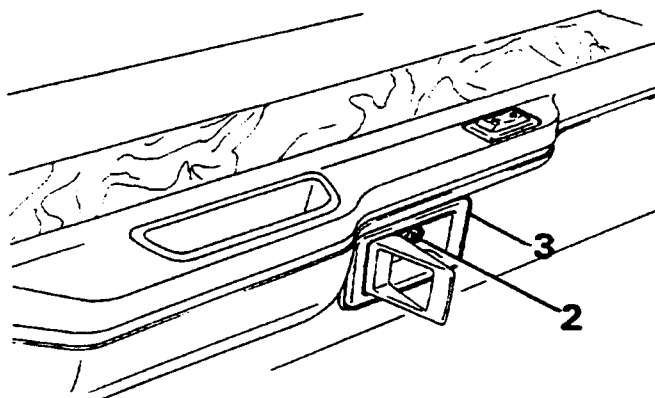

RR2476E

4. Pry door locking button surround from trim panel.

5. Remove two finisher buttons from door pull pocket to reveal securing screws.
6. Remove screws and withdraw pocket.
7. Pry trim panel away from door.
8. Disconnect electrical plug from window lift switch.
9. Remove window lift switch.

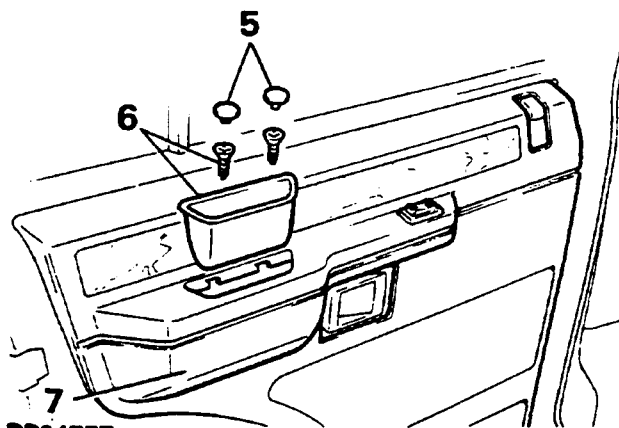

RR2477E

Refit

10. Reverse removal procedure.

REAR DOOR LOCK, OUTSIDE AND INSIDE DOOR RELEASE HANDLES

Service repair no - 76.37.13.

Remove and refit

Remove

1. Fully close window.
2. Disconnect the battery negative lead.
3. Remove trim panel. *See Rear door - trim panel.*
4. Remove plastic vapor barrier sheet.
5. Disconnect inside door release control rod from door lock.
6. Disconnect sill locking control rod from door lock by releasing metal clip.
7. Disconnect control rod from outside door release handle by pulling it out of plastic olive.
8. Remove door lock by removing two screws from door shut face and single screw with shakeproof washer on inside of door. Retrieve any spacing washers which may be fitted.
9. Remove lock through upper rear opening of panel.
10. Remove two nuts with shakeproof washers and retaining bracket securing outside door release handle.

11. Remove outside door release handle from outer door panel.
12. Remove two screws with plain washers securing inside door release handle to inner door panel.
13. Remove handle with connecting rod attached.
14. Remove two screws securing sill locking button to inner door panel and detach sill button from bellcrank.

Sill locking bellcranks

15. Press out plastic locking pins from inner door panel.
16. Release bellcranks from inner door panel and unhook respective connecting rods.
17. Withdraw bellcranks from inner door panel.



NOTE: When fitting bellcranks, locking pins are entered into square insert from outside and pressed in flush.

Refit

18. Reverse removal procedure. 1 to 17.

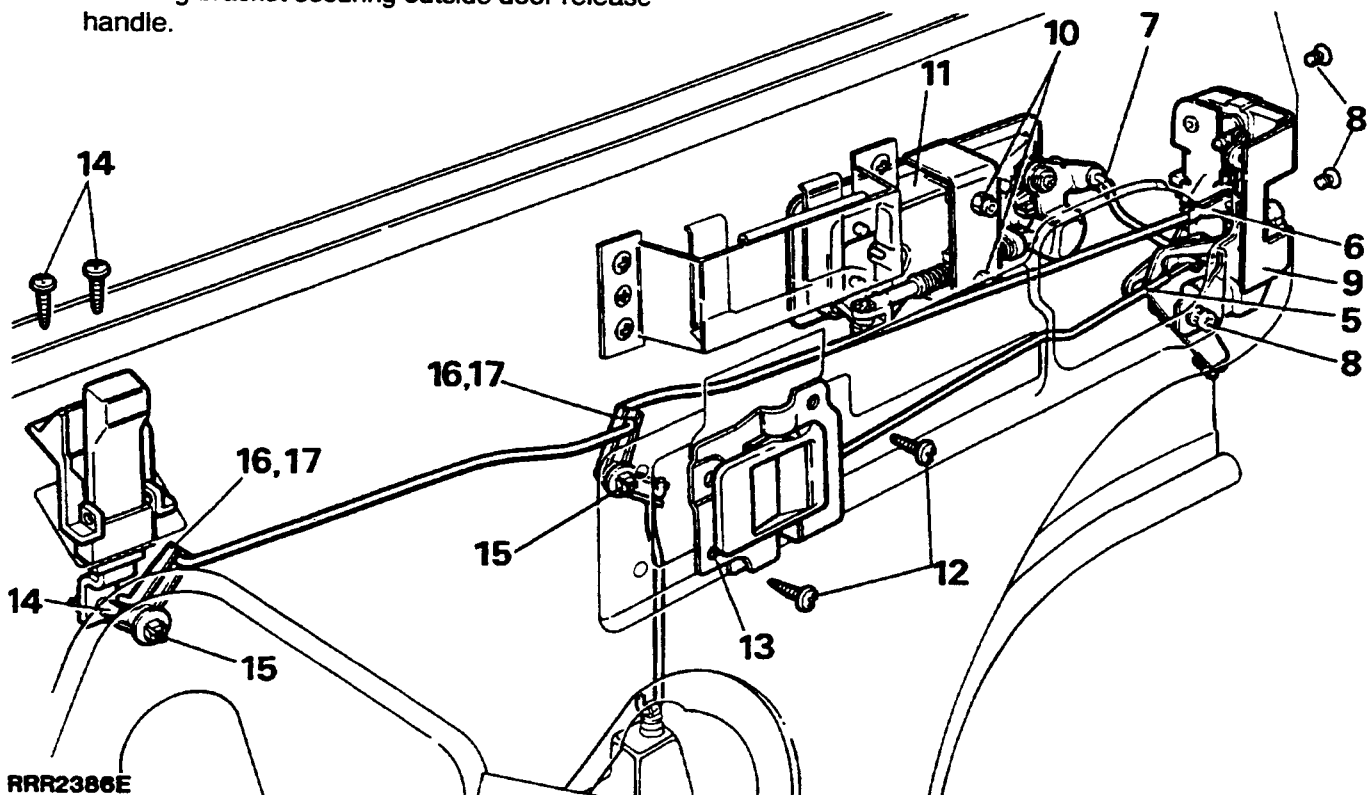



REAR DOOR LOCK AND HANDLE ASSEMBLY

Service repair no - 76.37.48.

Outside door release handle to lock

1. Disconnect connecting rod at rear of door outer release handle.
2. Rotate rod to adjust operating length as required, so that door release occurs before maximum handle movement.

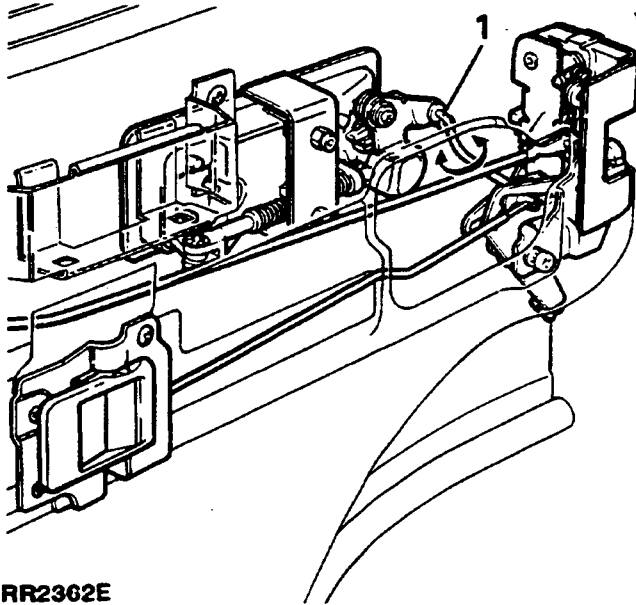

RR2362E

REAR DOOR GLASS AND REGULATOR

Service repair no - 76.31.02.

Service repair no - 76.31.46.

Remove and refit

Remove

1. Fully close window and secure with tape.
2. Disconnect the battery negative lead.
3. Remove trim panel. *See Rear door - trim panel*
4. Remove sill button.
5. Remove plastic vapour barrier.
6. Remove window lift motor. *See ELECTRICAL, Repair, Window lift motor - Rear Doors*
7. Remove four window regulator screws with shakeproof washers.

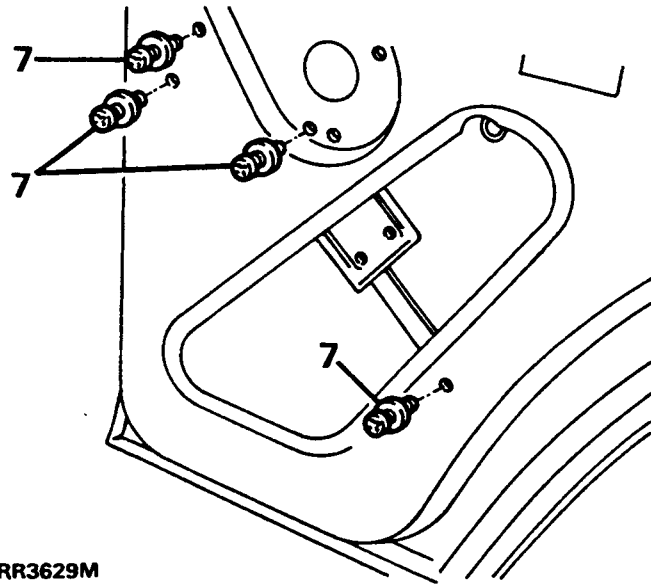

RR3629M

8. Disengage lifting arm stud from channel and remove window regulator.

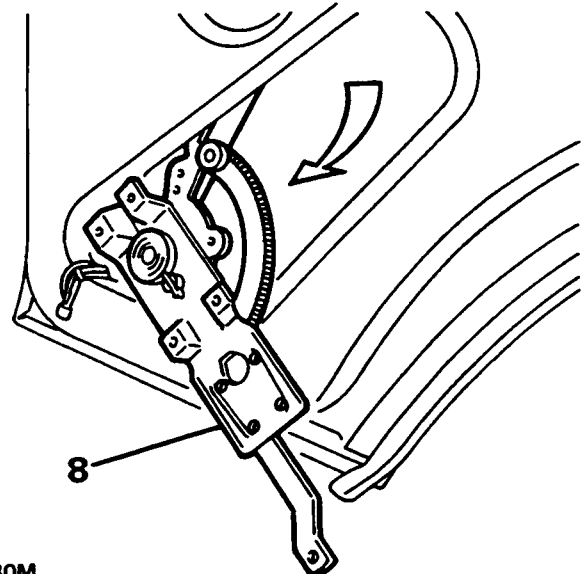

RR3630M

9. Remove waist rail seal from top of door panel.
10. Remove bolt, spring and plain washers which secures bottom of door frame.

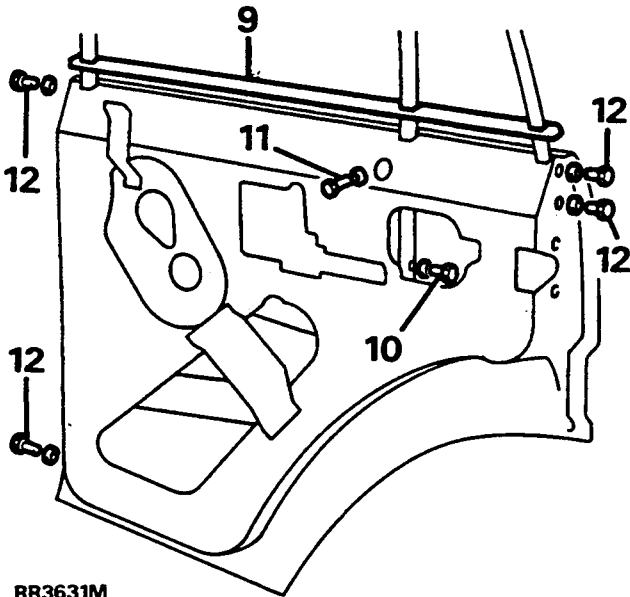

RR3631M

11. Remove bolt, spring and plain washer from door frame, as shown.
12. Remove two bolts, spring and plain washers from both door faces.
13. Remove door frame with glass in position.
14. Remove tape and slide glass out of door frame.

Refit

15. Reverse removal procedure. When fitting door frame align to suit door opening. Then tighten door frame securing bolts.

WINDSCREEN GLASS

Service repair no - 76.81.01.

Remove and refit**Remove**

1. Remove windscreen wiper arms. See *WIPERS AND WASHERS, Repair, Wiper arms - windscreen*
2. Remove expander strip from rubber moulding around glass.
3. Remove rubber moulding from windscreen opening.
4. Remove old sealant from around opening.
5. Clean windscreen opening and remove any broken glass.

Refit

CAUTION: To ensure bonding between windscreen and rubber **DO NOT** use petroleum based solvents or liquid soap to clean or aid assembly of windscreen to rubber.

6. Apply Sikaflex 207 cleaner primer to windscreen and rubber to remove any oil based film.
7. Apply Sikaflex 221 or 255 adhesive sealant to exterior channel of new rubber moulding. Ensure sealant is applied to bottom of channel.
8. Fit rubber moulding to windscreen opening.
9. Ensure edge of 'A' post interior trim panels are fitted under lip of rubber moulding.
10. Fit windscreen into bottom corner of rubber moulding channel.
11. Work glass into bottom of windscreen rubber using a wedged blunt lever. Working up and around seal, at same time pushing screen onto rubber. Ease lip of seal over windscreen glass.

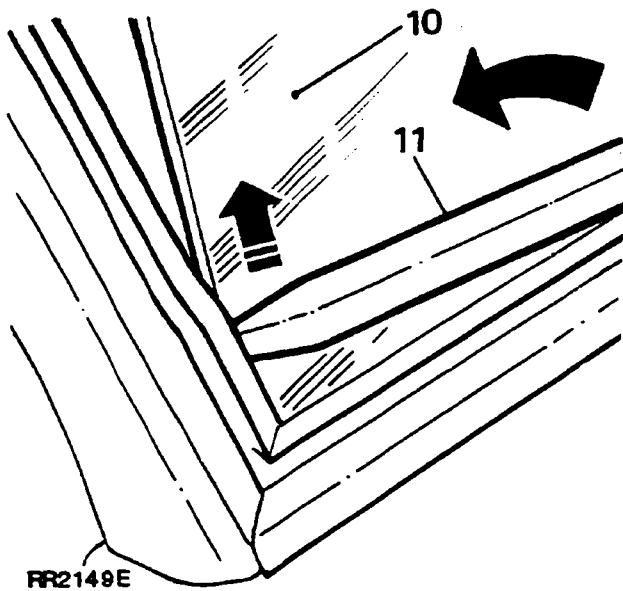

12. Apply Sikaflex 221 or 255 adhesive sealant between outer lip of moulding and exterior of windscreen. Ensure sealant is applied to bottom of channel.

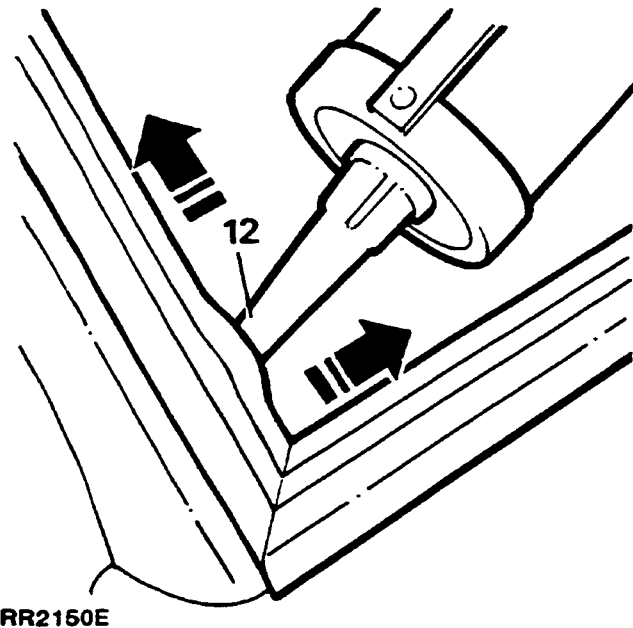

13. To aid assembly of expander strip apply a small amount of soap solution to receiving channel. Contain soap solution to channel only.
14. Fit expander strip to channel, do not overstretch.
15. Trim excess expander strip at 45° with a sharp knife.

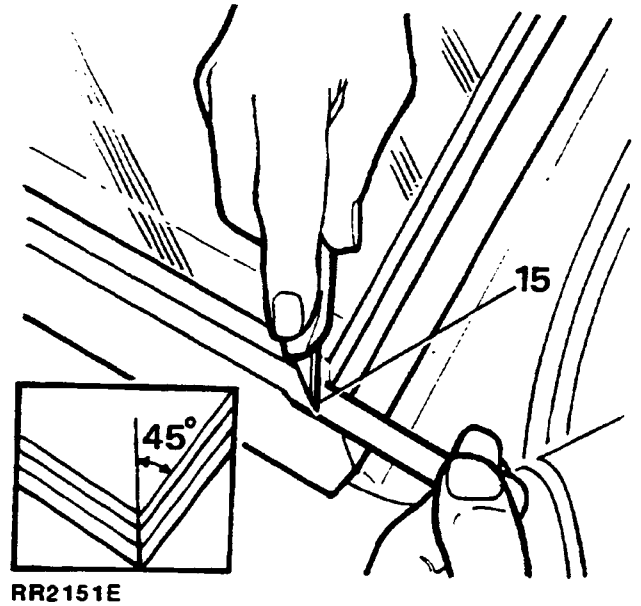

16. Remove surplus sealant from screen using Sikadur cleaner.
17. Ease bottom of moulding onto decker panel.
18. Ease bottom of moulding onto dashboard.
19. Refit wiper arms.
20. Reverse remaining removal instructions.

REAR QUARTER LIGHT GLASS

Service repair no - 76.81.25.

Remove and refit**Remove**

1. Remove and discard moulding from flange around opening.
2. Clean area where moulding contacts body.

Refit

3. Fit new moulding to glass.
4. Fit a draw cord around moulding retaining channel.
5. Coat flange around opening with liquid soap to aid assembly.
6. Hold glass and moulding to opening. Site draw cords inside vehicle.
7. With assistance push glass and moulding into opening. Pull draw cords enabling seal to ride over flange.
8. Ensure interior trim fits under moulding.
9. Ensure moulding is settled and contacts body.

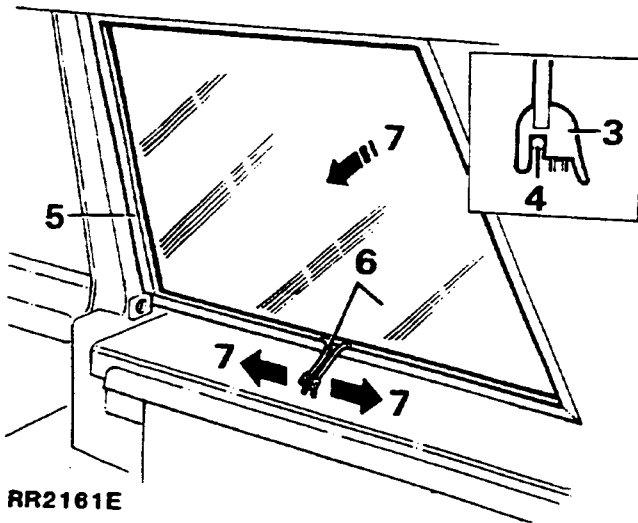



FRONT SEAT ELECTRICAL

Service repair no - 76.77.01.

Remove and refit

Remove

1. Remove screw securing seat side trim panel and remove panel.
2. Remove three screws from seat front trim panel. Remove screw from top of trim panel to seat base, located below seat base cushion. Remove panel.
3. Remove three fixings securing cushion side trim panel. Remove panel. Remove bolt securing seat belt.
4. Move seat to rearward position. If seat will not move *See ELECTRICAL, Repair, Electrical seat failure.*

5. Remove two screws at front of each slide channel.
6. Move seat to most forward position.
7. Remove four screws at rear of each slide channel.
8. Disconnect the battery negative lead.
9. Disconnect all electrical multiplugs to seat electrics.
10. Remove seat.

Refit

11. Reverse removal procedure. Arrange electrical leads so they can not become trapped by seat slide mechanism.

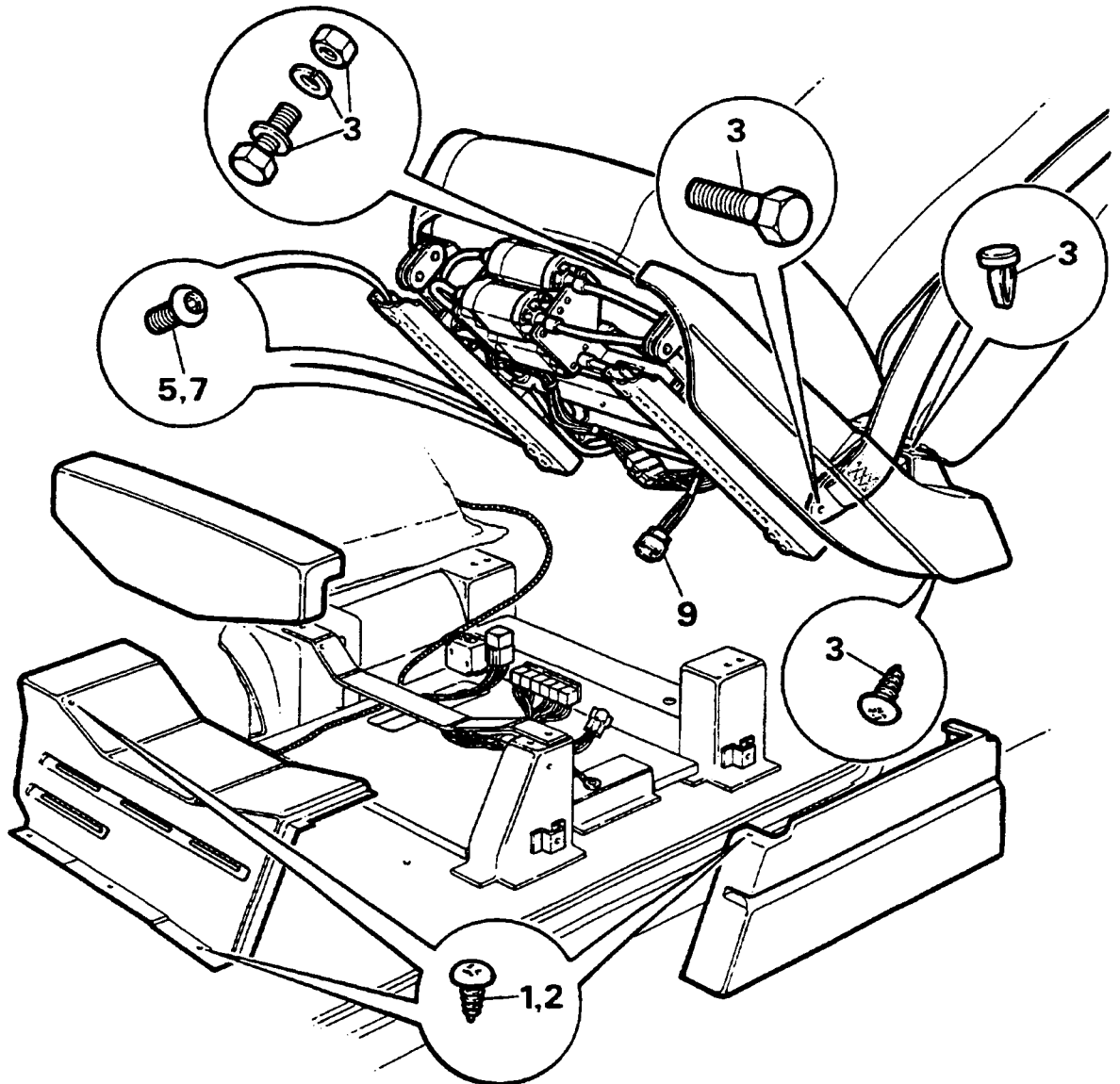

RR2152E

FRONT SEAT MANUAL

Service repair no - 76.70.01.

Remove and refit

Remove

1. Disconnect the battery negative lead.
2. Remove two screws securing side panel and remove panel.
3. Remove three screws from front trim panel. Remove screw from top of trim panel to seat base. Remove panel.

4. Remove bolt and washer securing seat belt.
5. Move seat to rearward position.
6. Remove two screws at front of each slide channel.
7. Move seat to most forward position.
8. Remove four screws at rear of each slide channel.
9. Remove seat, retaining spacers between slide channel and seat base.

Refit

10. Reverse removal procedure.

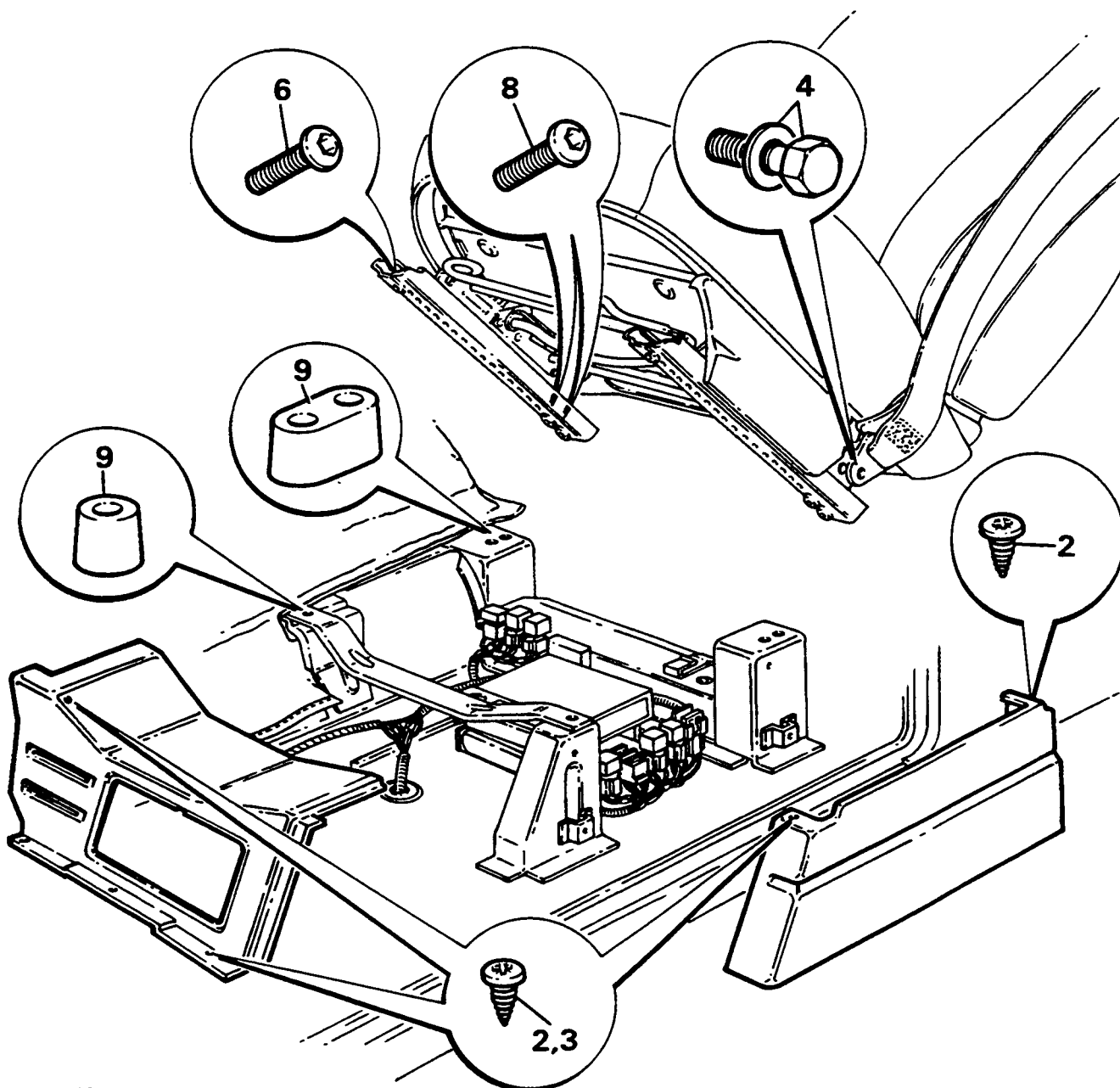

RR3554M



ASYMMETRIC SPLIT REAR SEAT

Service repair no - 76.70.38.

Remove and refit

Remove

1. Lift footwell carpet to access front hinge bolts.
2. Remove hinge bolts.
3. Fold seat fully forward.
4. Remove rear hinge bolts.

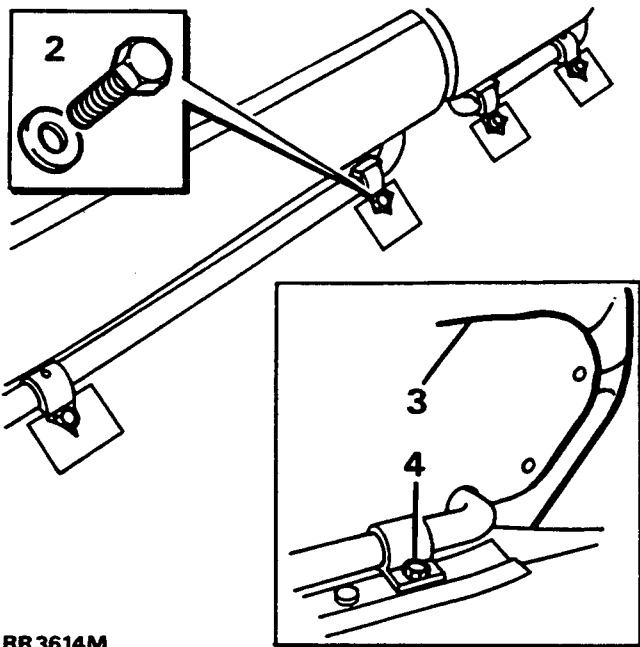

RR3614M

5. Remove seat from vehicle

Refit

6. Reverse the removal procedure. Ensure seat folds and latches smoothly.

ASYMMETRIC SPLIT REAR SEAT - LOCKING MECHANISM

Service repair no - 76.70.51.

Remove and refit

Remove

1. Depress release button and fold seat forward.
2. Unscrew and remove release button.
3. Remove two trim buttons securing trim cover.

4. Remove trim cover.
5. Remove three screws securing latch to tower. One screw is accessed through hole in tower.
6. Retrieve latch from opening rear of tower.
7. Remove operating rod by releasing plastic clip.

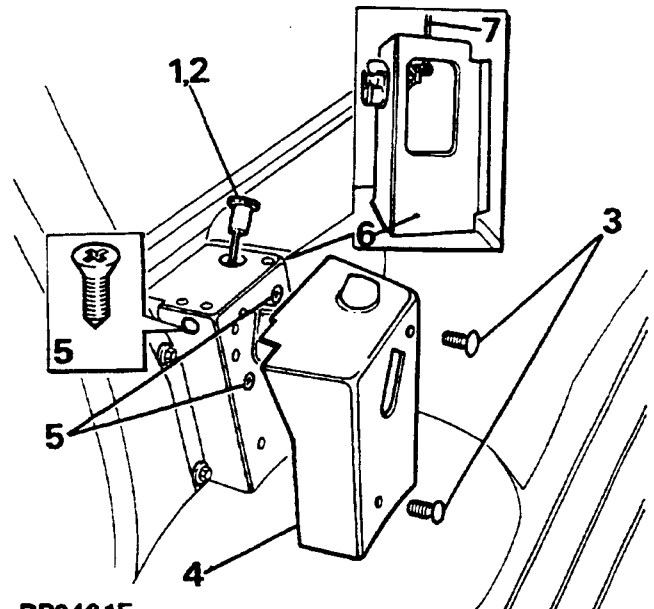

RR2461E

Refit

8. Reverse removal procedure. When release button is depressed there must be a gap from 5 to 8 mm between head of button and lip of trim cover.

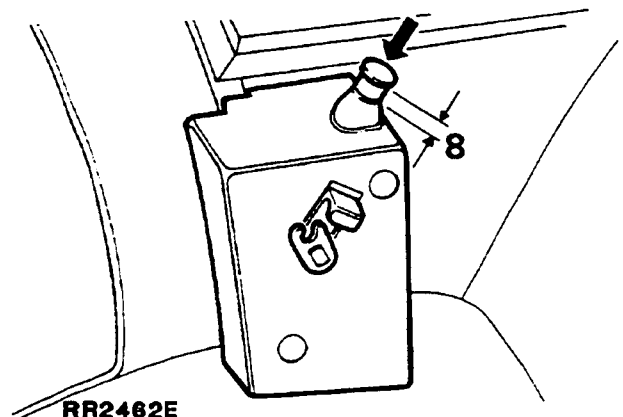

RR2462E

FRONT SEAT HEATED CUSHION AND SQUAB

Service repair no - 76.77.05. -76.77.14.

Remove heated cushion.

1. Remove front seat assembly. *See Front seat electrical*

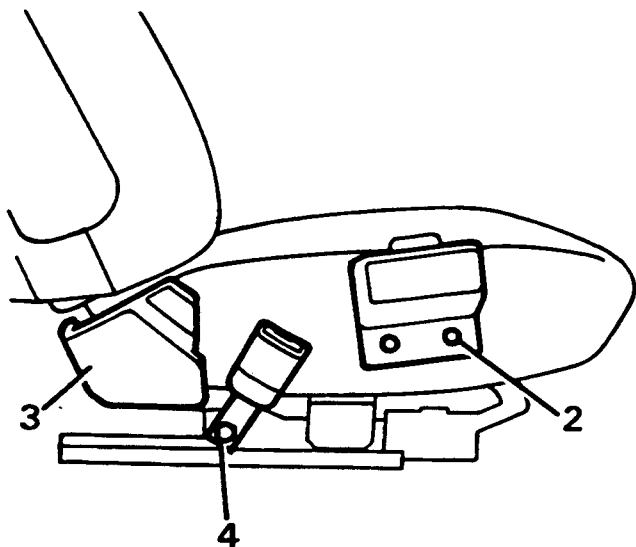

RR3645M

2. Remove two screws securing seat control adjustment unit.
3. Remove two screws securing corner trim.
4. Release seat belt buckle bracket.
5. Release trim from seat frame.

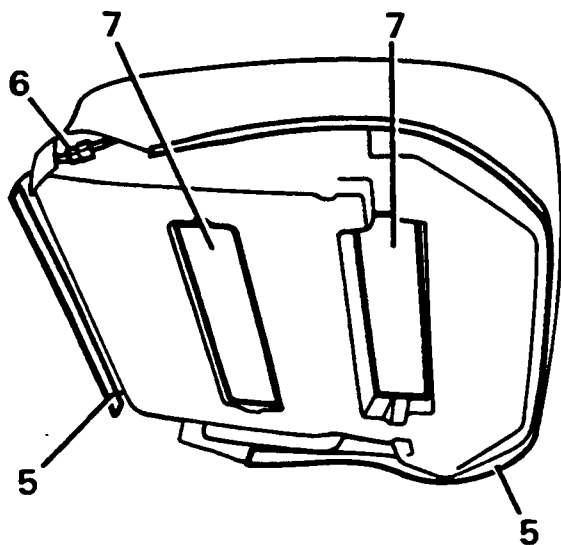

RR3646M

6. Disconnect heater wiring at multiplug to seat squab. Remove cushion and trim from seat frame.
7. Turn 90° two seat trim retention plates and push through slot in cushion foam.

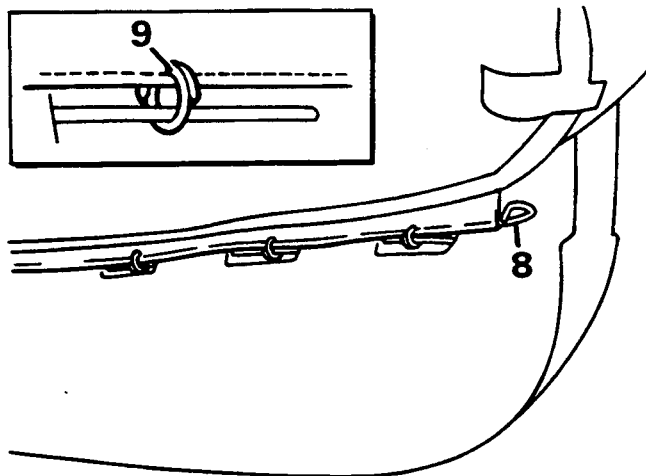

RR3647M

8. Fold seat trim over cushion to reveal stapled wire retention rods.
9. Pry open staples and release seat trim from seat cushion.

Continue for removal of heated squab.

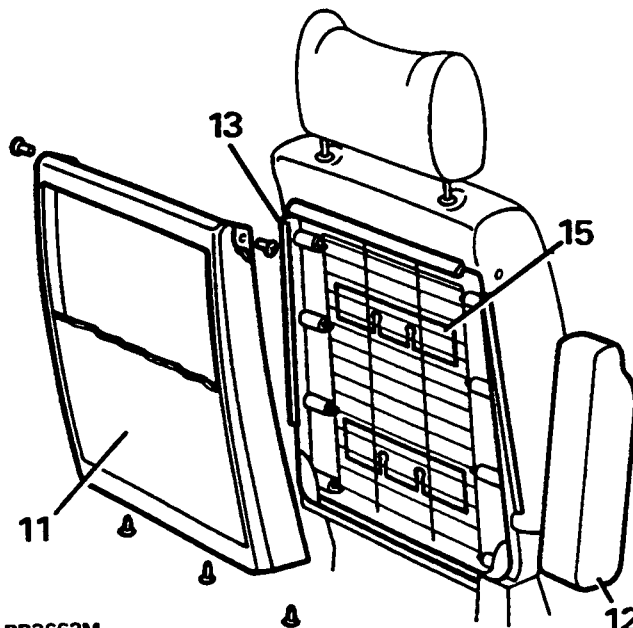

RR3662M



10. Remove headrest.
11. Remove squab panel rear. Three screws at base. Peel back trim to remove screw from each top corner.
12. Remove armrest assembly.
13. Release trim from edge of seat frame.
14. Remove squab foam with trim from seat frame.
15. Turn 90° two trim retention plates and push through slot in foam.
16. Fold trim over squab foam to reveal two wire retention rods.

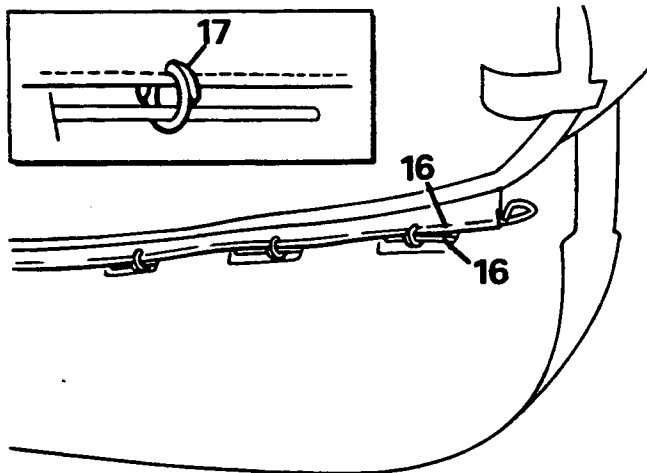

RR3663M

17. Pry open staples and release trim from squab cushion.

Refit

18. Reverse removal procedure.

SEAT BELTS

Introduction

Seat belt assemblies are factory fitted. If removal is necessary follow procedures in this section. All seat belt fixings **MUST** be tightened to correct torque values.

Seat belt assemblies **MUST** be replaced after they have been subjected to loading such as in a collision.

A lamp warning is incorporated to alert user. The warning lamp will illuminate for eight seconds when ignition is switched on regardless of seat belt usage.

On American specification vehicles a audible warning will sound with an high and low note from four to eight seconds unless driver seat belt is fitted.

A lap belt is provided for occupant of the centre rear seat.

FRONT SEAT BELT

Service repair no - 76.73.10.

Remove and refit

Remove

1. Move seat to access belt mountings.
2. Disconnect the battery negative lead.
3. Remove seat side trim panel. *See Front Seat Electrical See Front Seat Manual*

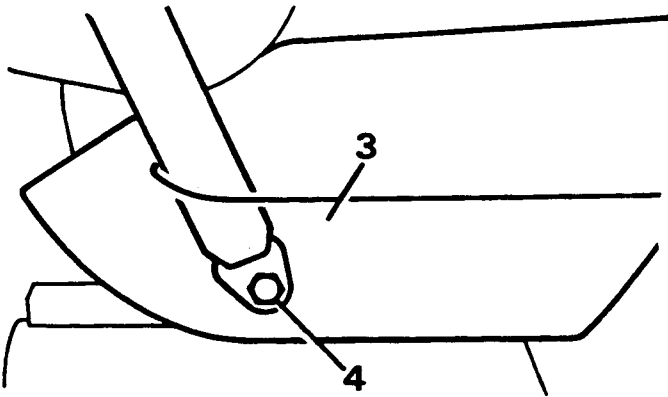

RR3611M

4. Remove bolt, plain washer and spacer from belt to seat base.
5. Remove moulding from adjustable seat belt mounting.
6. Remove nut and spacer securing seat belt to 'B' post.

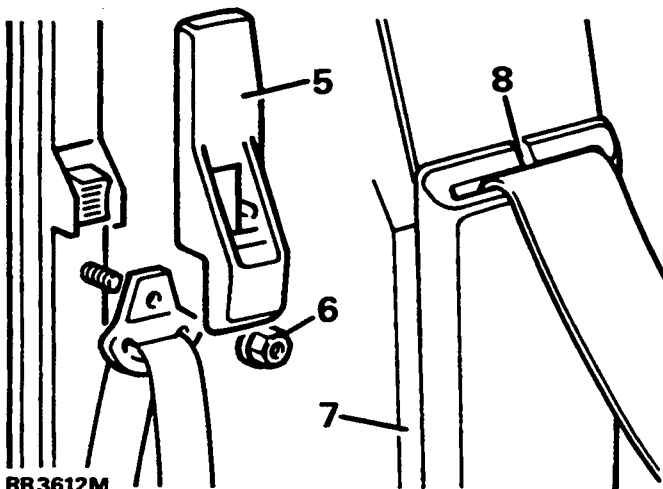

RR3612M

7. Pull door deal away to remove lower 'B' post trim.
8. Remove seat belt through slot in lower 'B' post trim.

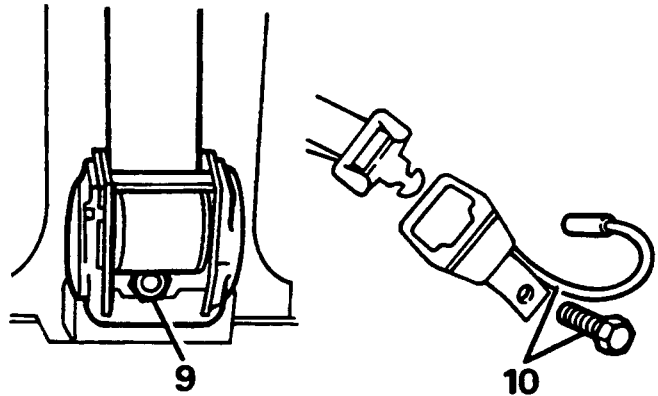

RR3613M

9. Remove bolt and spring washer from inertia reel assembly to 'B' post.
10. Disconnect electrical plug and remove bolt securing buckle to seat base.

Refit

11. Reverse removal procedure. Ensure belts are not twisted. Tighten bolts to **20 Nm**.



REAR SEAT BELT

Service repair no - 76.73.18.

Remove and refit

Remove

1. Remove plastic cover from upper guide bracket. Remove bolt, spacer, plain and wavy washer.
2. Unclip cover from inertia reel assembly. Remove bolt, spring washer. Place reel to one side.

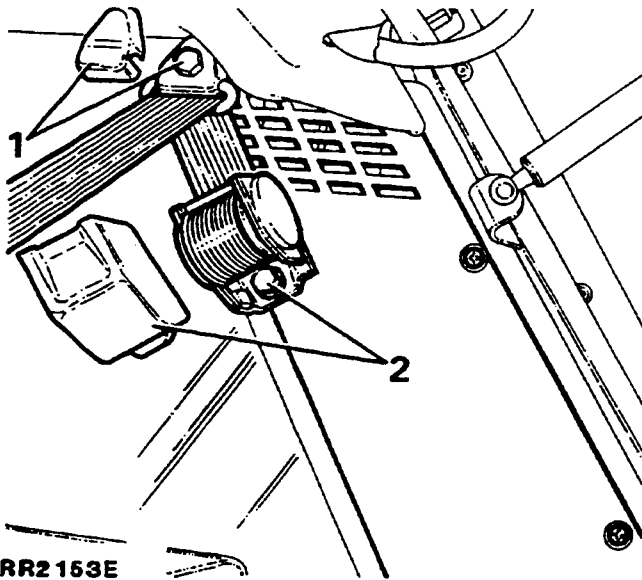

3. Remove plastic cover and bolt securing belt assembly to wheel arch.

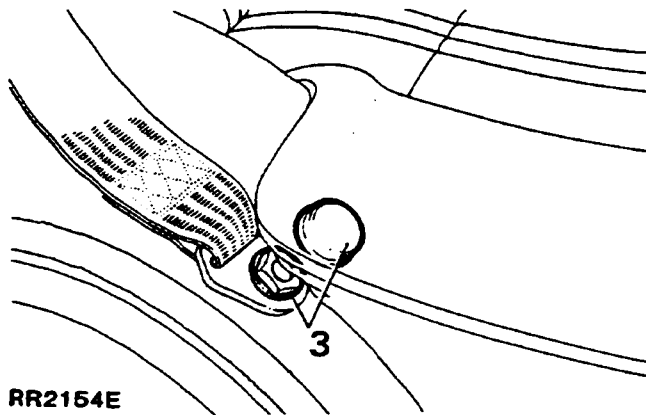

4. Remove belt assembly.

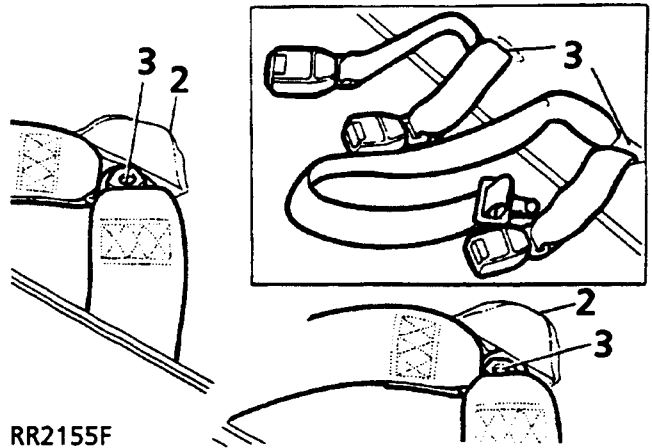

5. Remove bolt and plain washer securing belt bracket to load space floor.
6. Centre lap strap only: Remove bolts securing lap strap and buckle assembly and withdraw both components.

Refit

7. Reverse removal procedure. Ensure belts are not twisted. Tighten bolts to **20 Nm**.

GLOVE BOX AND FLOOR MOUNTED CONSOLE ASSEMBLY

Service repair no - 76.52.03.

Remove and refit

Remove

1. Disconnect the battery negative lead.
2. Remove screws securing glove box liner and withdraw liner.
3. Disconnect electrical leads to rear passenger cigar lighter.

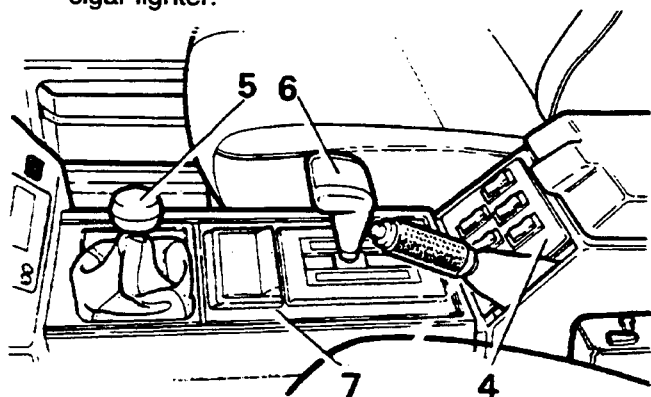

RR2170E

4. Remove switch panel. *See ELECTRICAL, Repair, Window lift switches*
5. Remove transfer gear knob.
6. Remove automatic gear selector knob. *See ELECTRICAL, Repair, Automatic gear selector-Panel illumination*
7. Remove illumination panel gear selector.
8. Remove two bolts and two screws securing console to gearbox tunnel.

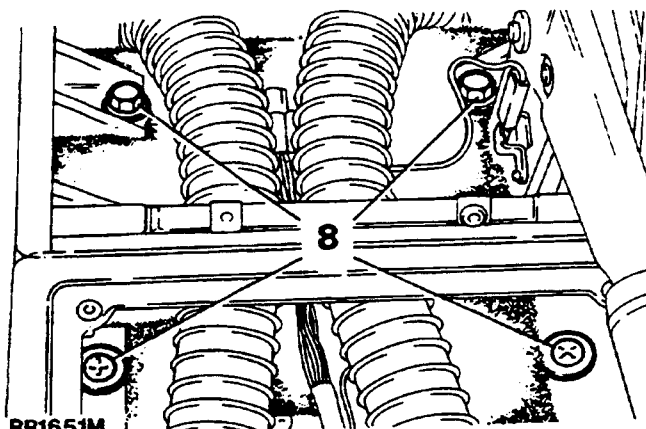

RR1651M

9. Move assembly rearwards to detach location tab at front of console from radio housing.
10. Move assembly over parking brake and gear levers. Remove from vehicle.

Refit

11. Reverse removal procedure. Ensure electrical plugs are fitted correctly and electrical wiring does not become trapped.



LOWER DASH PANEL

Remove and refit

Remove

1. Disconnect the battery negative lead.
2. Pry louvre from dash.
3. Remove two screws from base of panel.
4. Remove screw from side of panel.
5. Remove two screws from top of louvre opening.
6. Remove screw above rheostat switch.

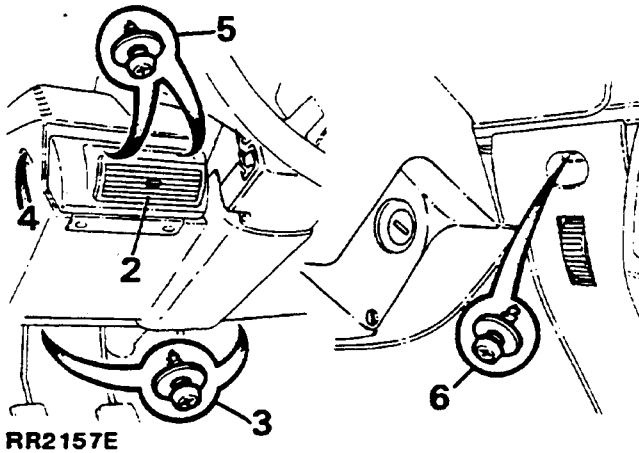

7. Lower dash panel and disconnect electrical plug from rheostat and detach bulb check unit from spring clip.
8. Remove panel from vehicle.

Refit

9. Reverse removal procedure.

RADIO HOUSING

Remove and refit

Remove

1. Disconnect the battery negative lead.
2. Remove console assembly. *See Glove box and floor mounted console assembly*
3. Remove radio from housing. See Manufacturers instructions for removal and installation.

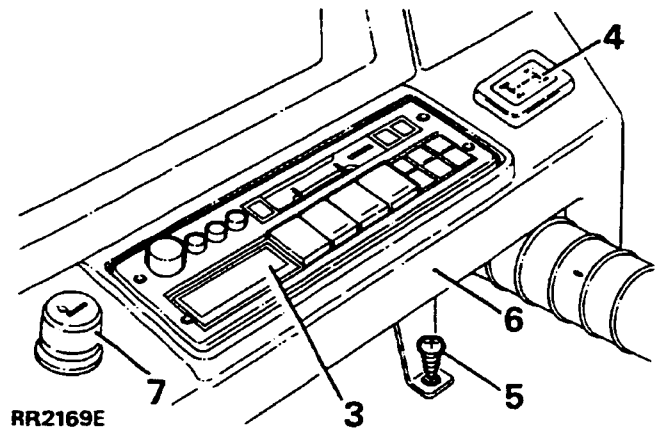

4. Where applicable remove switches and disconnect electrical leads.
5. Remove screw securing housing to tunnel.
6. Tilt front of housing upwards to access cigar lighter electrical leads.
7. Disconnect leads from cigar lighter and remove radio housing.

Refit

8. Reverse removal procedure.

CENTRE DASH PANEL**Remove and refit****Remove**

1. Disconnect the battery negative lead.
2. Remove lower dash panel. *See Lower dash panel*
3. Remove console assembly. *See Glove box and floor mounted console assembly*
4. Remove radio housing. *See Radio housing*
5. Remove fuse cover and remove three screws securing main and auxiliary fuse box.
6. Remove heater control knobs.
7. Remove screws securing heater graphics panel. Pull panel away from dash and remove bulbs from their locations.
8. Remove heater graphics panel.
9. Remove auxiliary switch panel.
10. Identify each multiplug to aid reassembly. Disconnect multiplugs from switches.

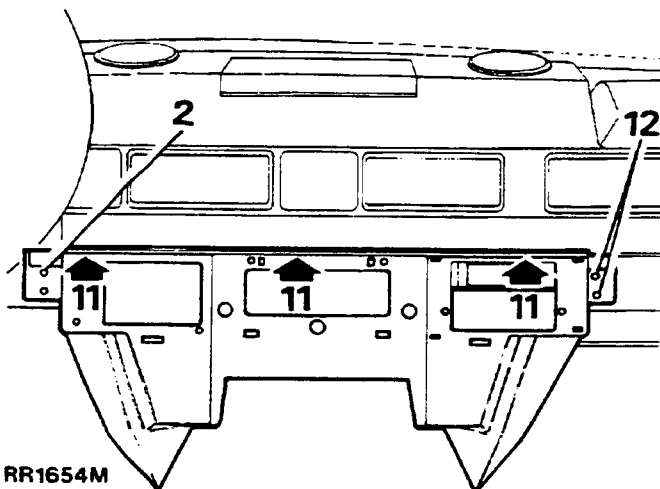

RR1654M

11. Remove three screws securing centre dash to louvre dash panel.
12. Remove two screws securing side of centre dash.
13. Remove centre dash panel.

Refit

14. Reverse removal procedure. Ensure all electrical multiplugs are fitted and secure.

LOUVRE DASH PANEL**Remove and refit****Remove**

1. Disconnect the battery negative lead.
2. Pry clock out of dash, disconnect electrical leads. Remove bulb and holder.
3. Remove screw securing end of dash panel.
4. Pry four louvres out then remove eight screws securing louvre dash panel to dash.
5. Pry out mirror control switch. Disconnect electrical multiplugs and remove screw.
6. Remove three screws securing bottom of the panel. Remove remaining three screws above blower motor trim panel.

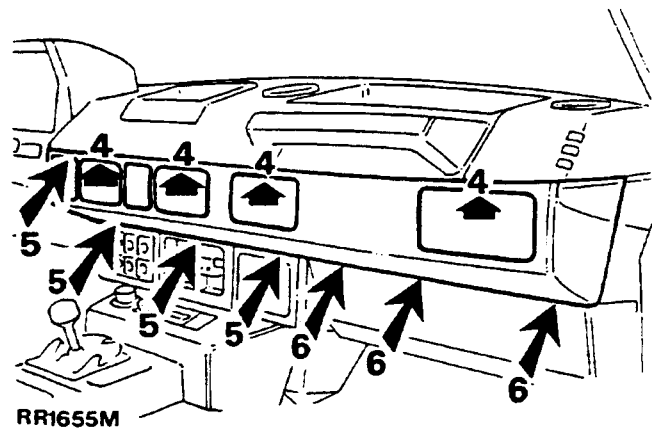

RR1655M

7. Remove louvre dash panel.

Refit

8. Reverse removal procedure.



DASHBOARD

Service repair no - 76.46.04.

Remove and refit

Remove

1. Disconnect the battery negative lead.
2. Remove the steering wheel. *See STEERING, Repair, Steering wheel*
3. Remove lower dash panel. *See Lower dash panel*
4. Remove instrument binnacle. *See ELECTRICAL, Repair, Instrument binnacle*
5. Remove glove box console assembly. *See Glove box and floor mounted console assembly*
6. Remove radio housing. *See Radio housing*
7. Remove centre dash panel. *See Centre dash panel*

8. Release evaporator case assembly if fitted. With hoses still attached lower assembly to footwell area. *See AIR CONDITIONING, Repair, Evaporator assembly*
9. Remove three nuts securing passenger grab handle.
10. Remove five nuts with washers securing map tray.
11. Disconnect side and centre air vent hoses.
12. Remove dashboard.

Refit



CAUTION: When refitting avoid trapping of electrical wiring.

13. Reverse removal procedure. Ensure dashboard locates on three brackets.
14. Ease sealing rubber over dashboard.

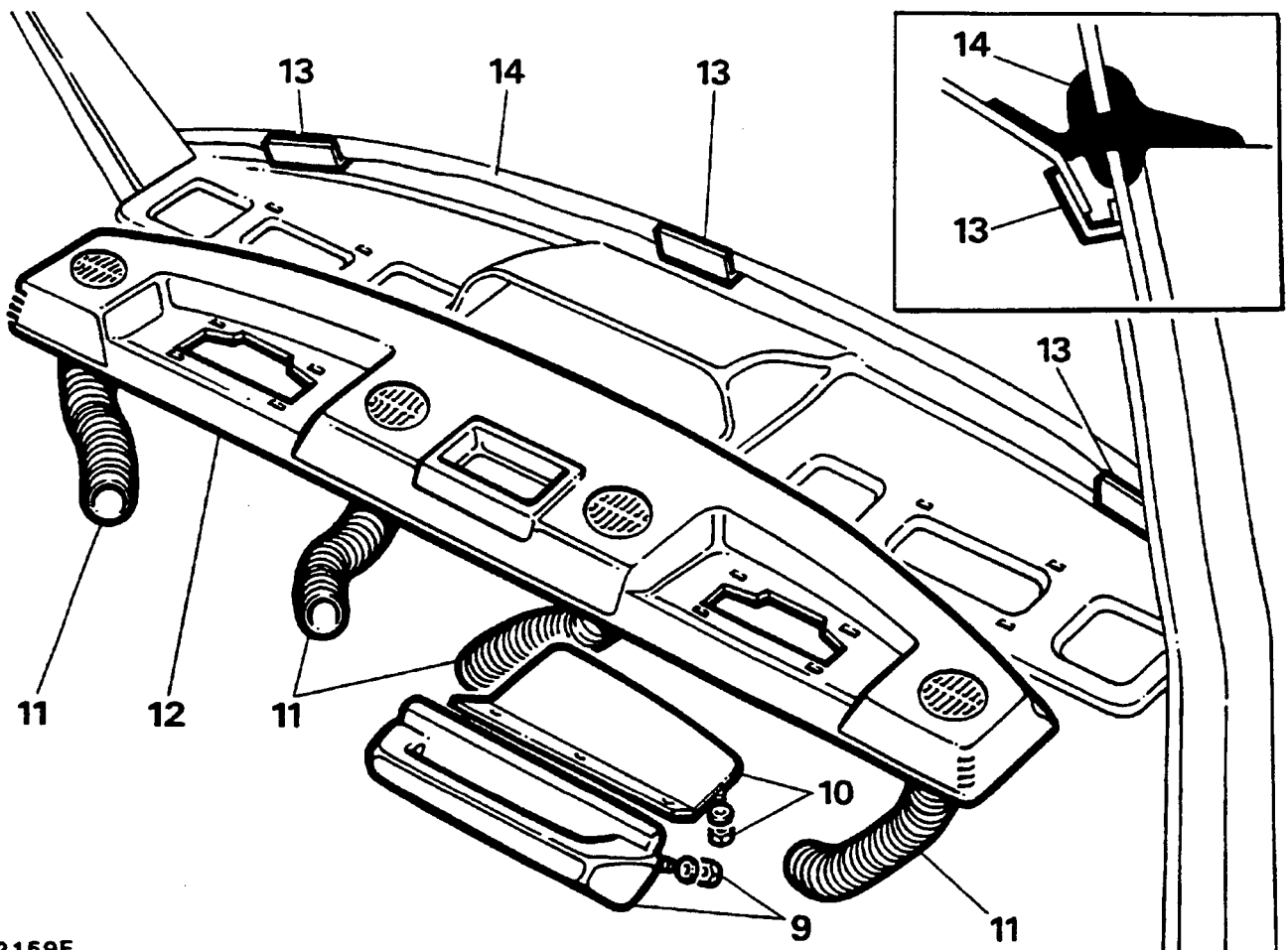

RR2159E

FRONT SPOILER

Service repair no - 76.10.46.

The spoiler will reduce the vehicle approach angle by approximately 10°. Where the vehicle is expected to perform on rough or hilly terrain, it is advisable to remove the spoiler to prevent any damage which may occur due to ground contact.

Remove and refit**Remove**

1. Disconnect electrical connections from auxiliary driving lamps.
2. Remove two screws with spring washers securing centre of spoiler.
3. Remove four nuts with spring washers located behind front bumper above driving lamp pockets.
4. Remove two bolts, nuts and washers securing outer edges of spoiler to front wings.
5. Remove spoiler.

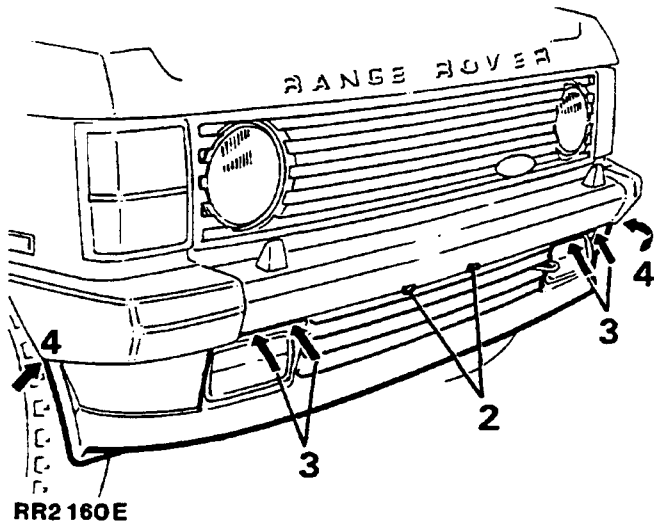
**Refit**

6. Reverse removal procedure.



METAL SUNROOF ASSEMBLY

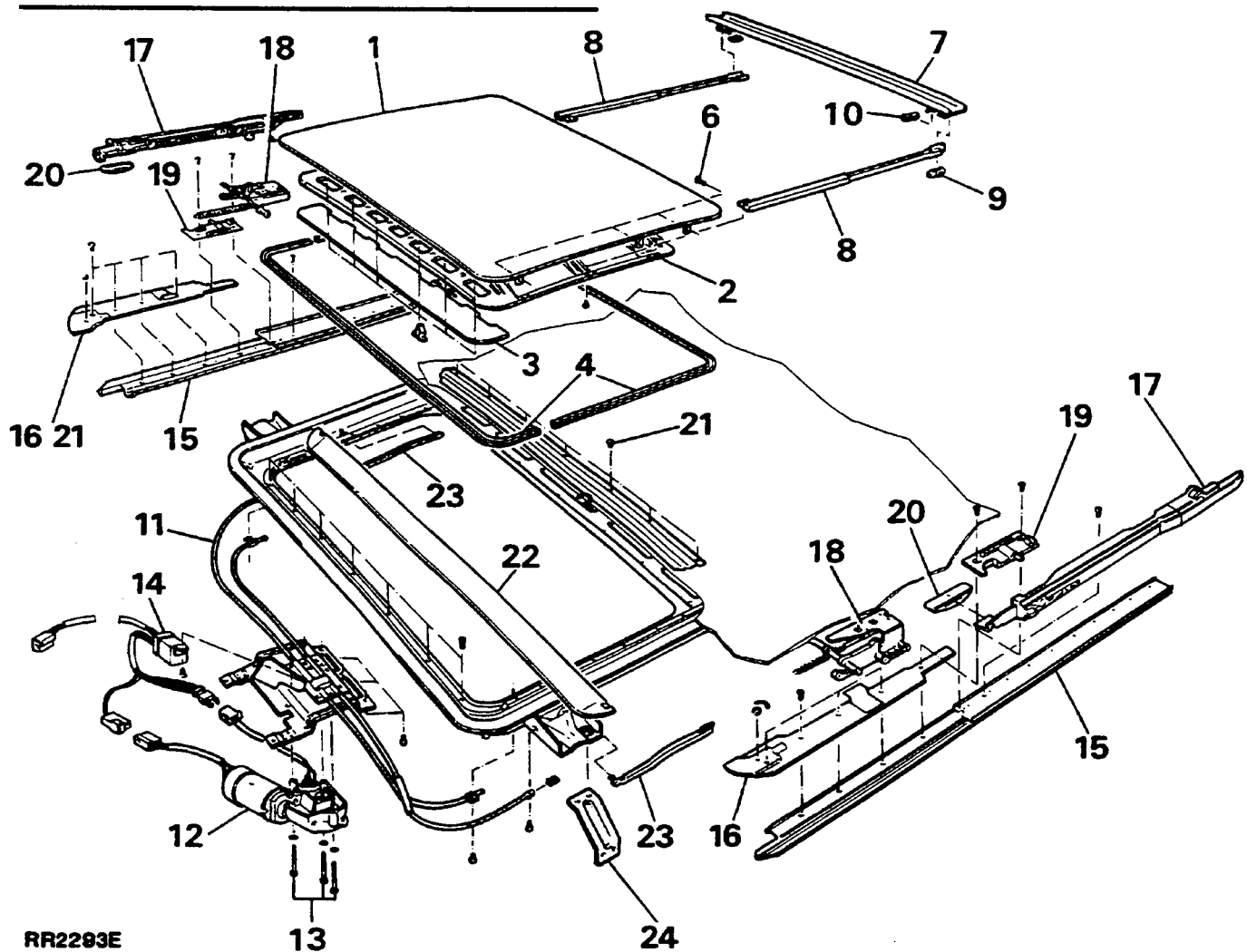

RR2293E

KEY

- | | |
|---|------------------------------------|
| 1. Roof panel | 13. Motor retaining screws |
| 2. Sunroof headliner | 14. Relay |
| 3. Insulation pad | 15. Lower guide rails |
| 4. Roof seals (front and rear) | 16. Front guide rails |
| 5. Sunroof headliner retaining clips (quantity - 6) | 17. Slide mechanism |
| 6. Roof panel retaining screws (quantity - 6) | 18. Rear guide |
| 7. Water channel | 19. Pivot bracket |
| 8. Water channel connectors | 20. Slide shoe |
| 9. Support bracket-water channel | 21. Rear edge trim finisher |
| 10. Slide shoe-water channel | 22. Wind deflector assembly |
| 11. Motor bracket/guide tube assembly | 23. Wind deflector operating arms |
| 12. Operating motor | 24. Support bracket (quantity - 6) |

OPERATION

Sunroof operation is a tilt and slide action controlled by a rocker switch adjacent to roof lamp, with ignition switched 'ON'.

1. Depress front of switch to lift rear edge of sunroof into 'Tilt' position.
2. Depress rear edge of switch to close roof.
3. Depress rear of switch to slide sunroof into 'Open' position.
4. Depress front of switch to slide sunroof into 'Close' position.



NOTE: The electric drive cuts out automatically in closed, tilt and open positions. If switch is operated in wrong direction in one of these positions, press switch once to reset and again to operate.

EMERGENCY OPERATION

If the sunroof fails to operate, check fuse. To close carry out following procedure.

1. Lower interior lamp mounting panel by releasing two turnbuckles.
2. Remove emergency handle from vehicle tool kit.
3. Engage handle in motor drive spindle and turn to close roof.

MAINTENANCE

At each service, water test drain tubes to ensure they are not blocked or kinked. Blow air up rear drain tubes which are clipped to rear mud flap supports. Blow down front drain tubes which run down 'A' post and out of engine bay.

Annually: Clean sunroof opening thoroughly.



NOTE: When vehicle is operated in extremely dusty conditions more frequent cleaning is recommended.

OPERATING MOTOR, MICRO-SWITCH AND RELAY**Remove and refit**

NOTE: The motor drive spindle retaining nut is set to correct torque value. If roof fails to operate check retaining nut torque.

Tighten to 5 Nm.

Remove

1. Ensure sunroof is closed. Disconnect the battery negative lead.
2. Remove interior lamp mounting panel to gain access to motor.
3. Disconnect two wiring connectors.
4. Remove three securing screws and withdraw motor.
5. Remove screw and withdraw relay.
6. Remove microswitch from motor by drilling out rivets, if required.

Refit

7. Secure new microswitch using nuts and bolts to replace rivets. Tighten nuts and apply a spot of paint to threads.
8. Ensure motor is in 'park' position, i.e. hole on driven gear aligned with drive spindle.
9. Reverse removal procedure.
10. Check operation of sunroof in all positions.



SUNROOF PANEL SEALS

Remove and refit

Remove

1. Position sunroof in tilt position and Disconnect the battery negative lead.
2. Unclip sunroof headliner from roof panel front and slide headliner back.
3. Remove three roof panel screws from each side and remove panel.
4. Remove both seals from roof panel.

Refit

5. Fit front seal to front edge of panel. Ensure there is an equal length of seal each side of centre point.
6. Butt rear seal against front seal fit tight around panel edge. Trim excess seal to produce a close joint with front seal.
7. Refit sunroof panel.

SUNROOF ASSEMBLY

Remove and refit

Including roof panel. Slide mechanism. Wind deflector. Motor mounting bracket. Guide tubes.

Remove

 **NOTE: Remove vehicle headlining ONLY if removing motor mounting bracket and guide tubes. See Headlining**

1. Partially open sunroof and unclip sunroof headliner from roof panel front. Slide sunroof headliner back.
2. Move sunroof to tilt position. Disconnect the battery negative lead.
3. Remove three roof panel screws from each side and remove panel.
4. Remove motor screws and withdraw motor.

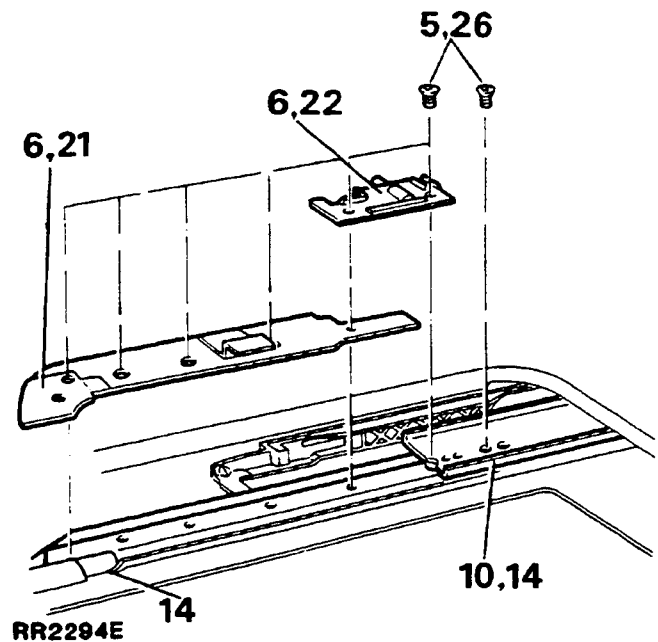

5. Remove guide rail screws, seven each side.
6. Remove pivot bracket and remove front guide rail .
7. Remove slide and tilt mechanism with flexible drive cable from both sides. Only disassemble if replacement parts are required.

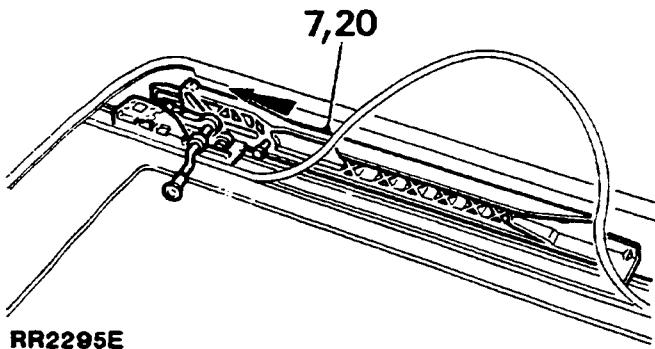

8. Unclip both wind deflector operating arms from rear mounting brackets. Remove arms from deflector, if required.

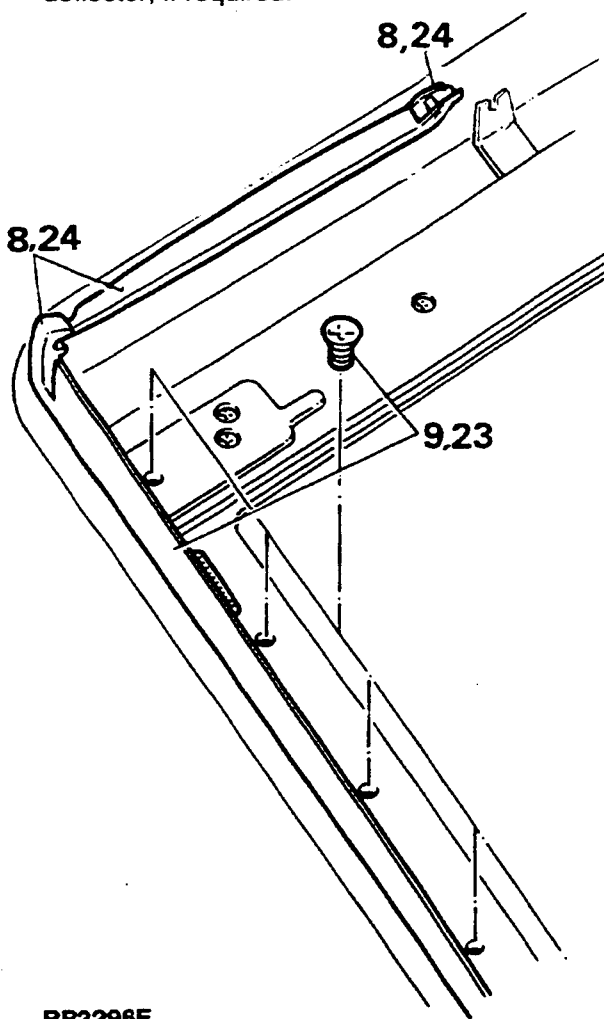

9. Remove seven screws, and withdraw wind deflector.
10. Remove lower guide rails and rear edge finisher, seven screws.
11. Remove screws from guide tubes, two each side. Remove five screws and withdraw motor mounting bracket.
12. Pull sunroof headliner assembly forward and remove.

Refit



NOTE: During assembly lightly lubricate all sliding parts using a silicon spray.

13. Position motor bracket and guide tube assembly. Fit and tighten securing screws.
14. Position right guide rail in rear retaining bracket. Push rearwards fully and locate leading edge under drive cable opening. Repeat operation for left hand guide rail.
15. Align fixing holes, and loosely fit screw in seventh hole from front.
16. Position finisher to rear edge of sun roof opening and secure using seven screws.
17. Position sunroof headliner assembly into outer guide runners, and push fully rearwards.
18. Lubricate drive cables. Ensure slide and tilt mechanism is fully assembled.
19. Push cable fully into right side guide tube. Loop remaining cable and enter rear end into right inner side runner.
20. Repeat operation 19. for left side. Push both assemblies rearwards to take up slack in cables, and push a further 75 mm to rear.
21. Position both front guide rails, aligning with four forward holes. Fit screws, do not tighten.
22. Position both pivot brackets, loosely fit screws.
23. Fit wind deflector and tighten fixings.
24. Position right operating arm in locating slot in deflector. Secure opposite end in frame bracket. Repeat for left side.
25. Pull right slide and tilt mechanism forward, align with pivot bracket and secure in position using setting key. Repeat operation for left side.
26. Tighten screws to guide rails, seven each side.
27. Fit and secure relay.
28. Ensure operating motor is in park position i.e. hole on driven gear aligned with drive spindle. Fit and secure to mounting bracket.

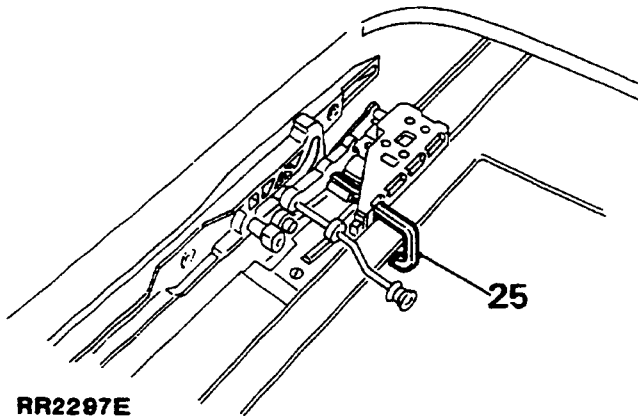

RR2297E

29. Remove setting keys. Temporarily connect operating switch and electrics.
30. Operate switch to 'tilt' position.
31. Position roof panel into roof opening with six screws, do not tighten.
32. Move roof to 'closed' position and adjust roof profile. The panel profile should be 0.5 mm low at forward edge, 1 mm high at rear edge.
33. Tighten roof panel screws.
34. Tilt sunroof, pull sunroof headliner forward and locate rear brackets in tilt mechanism. Align front six clips and push to secure.
35. Check operation of sunroof.

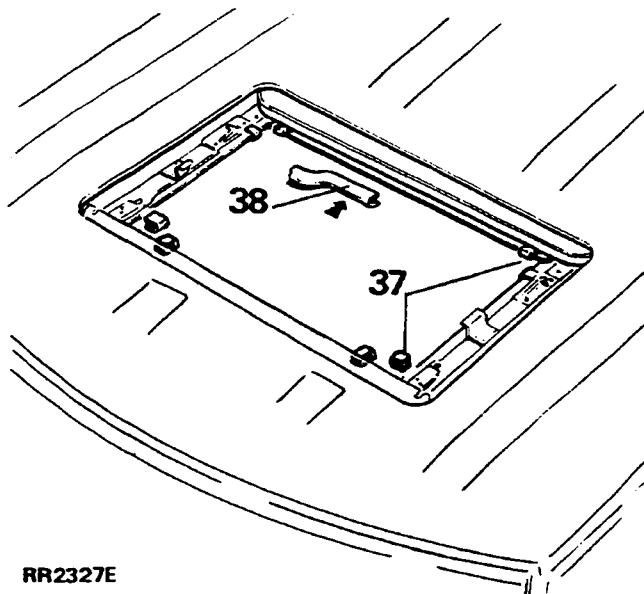

RR2327E

36. Refit vehicle headlining. *See Headlining*

SUNROOF HEADLINER ASSEMBLY

Remove, retrim and refit**Remove and retrim**

1. Remove sunroof headliner assembly. See *Sunroof Assembly*.
2. Remove trim covering from frame assembly. It is not necessary to remove three pads and insulation pad shown.
3. If required: remove water channel by unclipping connecting arms. Drill out rivets securing connecting arms to frame.

4. Secure connecting arms to frame using suitable rivets before retrimming frame.
5. Trim frame using a new headliner cover. Inset shows section through frame indicating where adhesive is applied. Dimension 'A' should be radially constant.

Refit

6. Refit sunroof headliner assembly and reassemble sunroof.

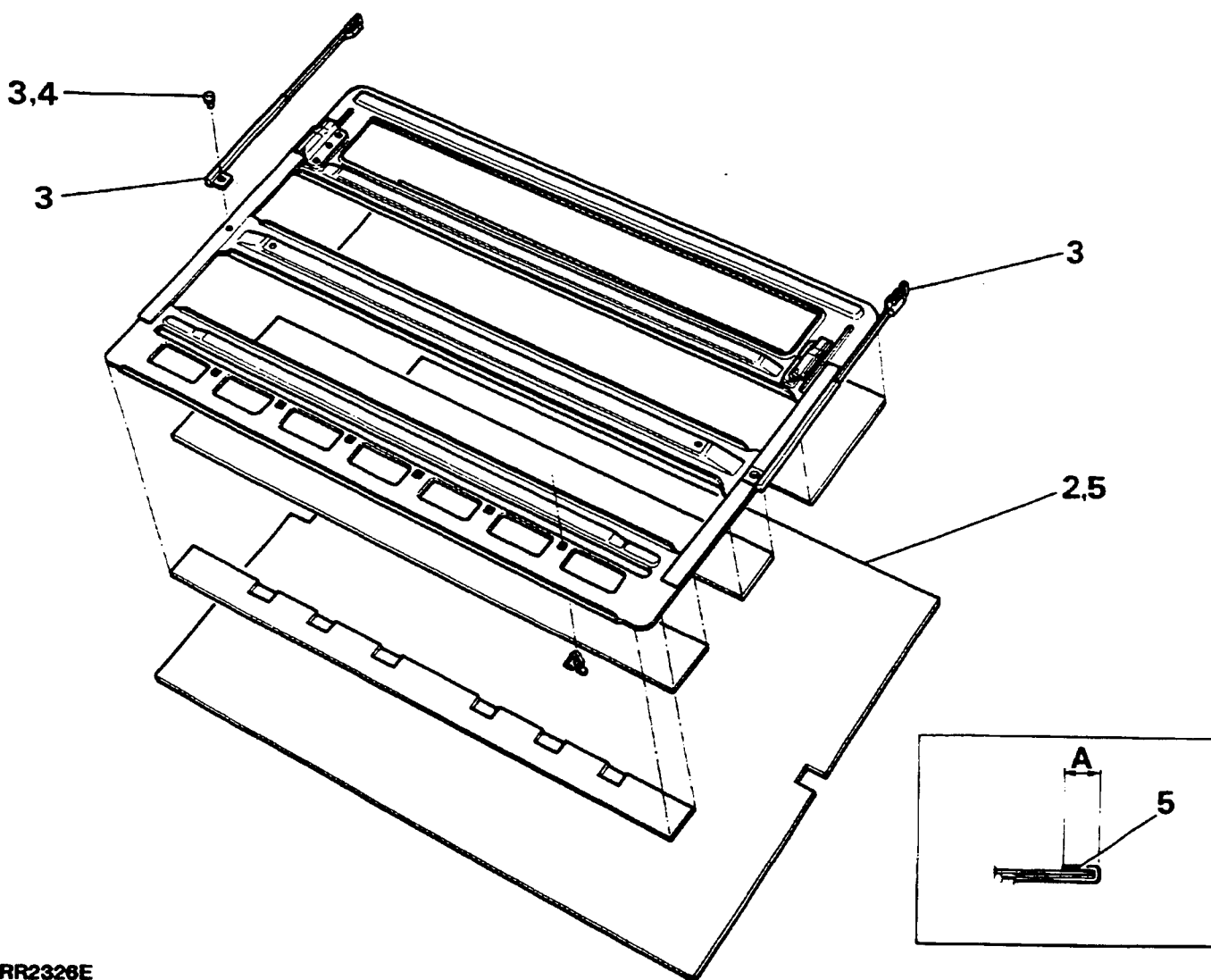

RR2326E



GLASS SUNROOF 1991 MODEL YEAR

Operation

The sunroof operates in a tilt and slide action controlled by a rocker switch near the interior lamp.

A drive motor and control unit is located behind the switch and interior lamp panel. The control units function is to stop the drive motor at the full tilt and slide positions.

Removal and refit of sunroof assemblies shown can be carried out without removing complete sunroof assembly.

GLASS PANEL ASSEMBLY

Service repair no - 76.82.64.

Remove, refit and adjust

Remove

1. Open sunroof to tilt position.
2. Remove mechanism covers. Slide rearwards to disengage from location and lift out.
3. Remove two screws from each side as shown.
4. Remove glass sunroof.

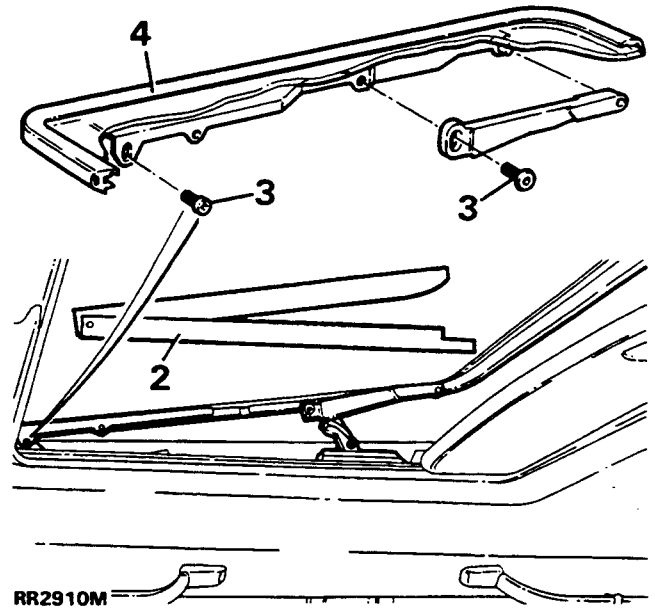

Refit and adjust

1. Fit glass sunroof.
2. Fit four screws but do not tighten.
3. Close sunroof
4. Check height of sunroof panel against roof aperture. The trimmed edge of glass sunroof to stand 1mm above roof aperture.
5. Adjust by moving sunroof panel up or down. Tighten screws.
6. Fit mechanism covers.
7. Check sunroof operates correctly.

WIND DEFLECTOR ASSEMBLY

Service repair no - 76. 82. 31.

Remove, refit and adjust**Remove**

1. Open sunroof.
2. Remove two screws accessed through slot in deflector.
3. Remove wind deflector.

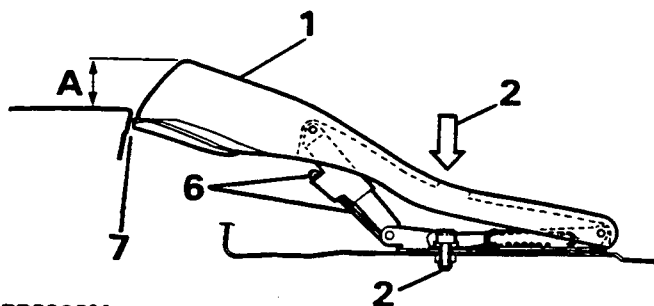

RR2909M

Refit

4. Fit wind deflector assembly
5. Fit two screws firmly but do not tighten.

Adjust

Adjustment and attachment of deflector is by same two screws.

6. Adjust wind deflector rearwards or forwards into position shown. At same time adjust height 'A' to 15-20 mm by moving slotted metal strip rearwards or forwards. Tighten two screws.
7. Ensure deflector does not catch front edge of roof aperture when operated.
8. Fully check that sunroof operates correctly.

MANUAL OPERATION

If sunroof fails to operate it can be opened or closed manually with key provided.

1. Remove two turnbuckles to access sunroof motor spindle located behind switch plate.
2. Engage key into motor spindle and turn to open or close sunroof panel.
3. After manual operation motor spindle **MUST BE TURNED BACK A QUARTER TURN TO ENGAGE ELECTRICAL DRIVE MOTOR.**

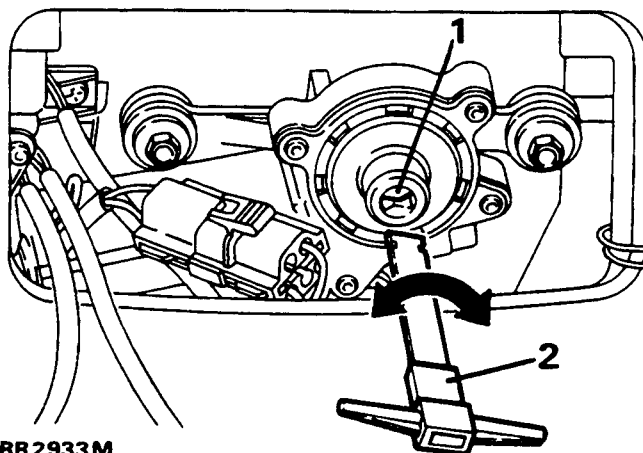

RR2933M



MOTOR DRIVE ASSEMBLY AND CONTROL UNIT

Service repair no - 76.82.72. -76.82.73.

Remove and refit



NOTE: The following servicing of sunroof assembly can be carried out without removing complete sunroof assembly.

Remove

1. Close sunroof. Disconnect the battery negative lead.
2. Release two turnbuckles to access motor drive assembly and control unit, located behind switchplate.
3. Remove switchplate and disconnect two multiplugs.
4. Release front of roof headlining to access motor drive assembly and control unit.
5. Disconnect two multiplugs from control unit to motor drive and to main harness.

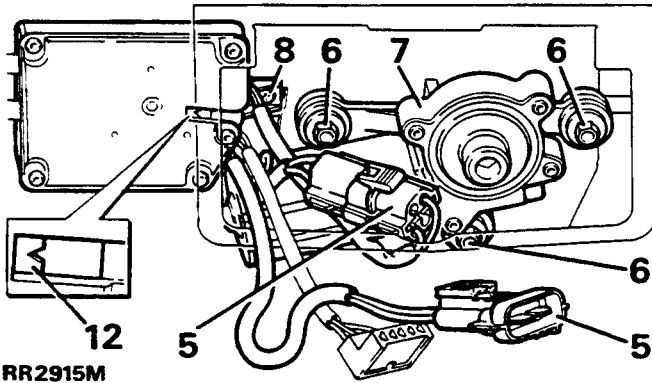

6. Remove three screws securing motor drive assembly.
7. Remove motor drive assembly.
8. To remove control unit undo screw. Lower then move control box inwards to release from mounting.
9. Inspect motor drive assembly and control unit for wear and damage, renew as necessary.

Refit

10. Refit motor drive assembly ensuring metal insert is fitted.



CAUTION: The motor drive assembly gear will not mesh correctly with drive cables if metal insert is NOT refitted.

11. Refit control unit.
12. Check timing of the control unit to sunroof:

A 'V' shaped notch should be visible through slot in control unit when sunroof is fully closed.

13. Reverse the removal instructions 2 to 5.
14. Check sunroof operates correctly.

GLASS SUNROOF COMPLETE ASSEMBLY

Service repair no - 76. 82.59.

Remove and refit

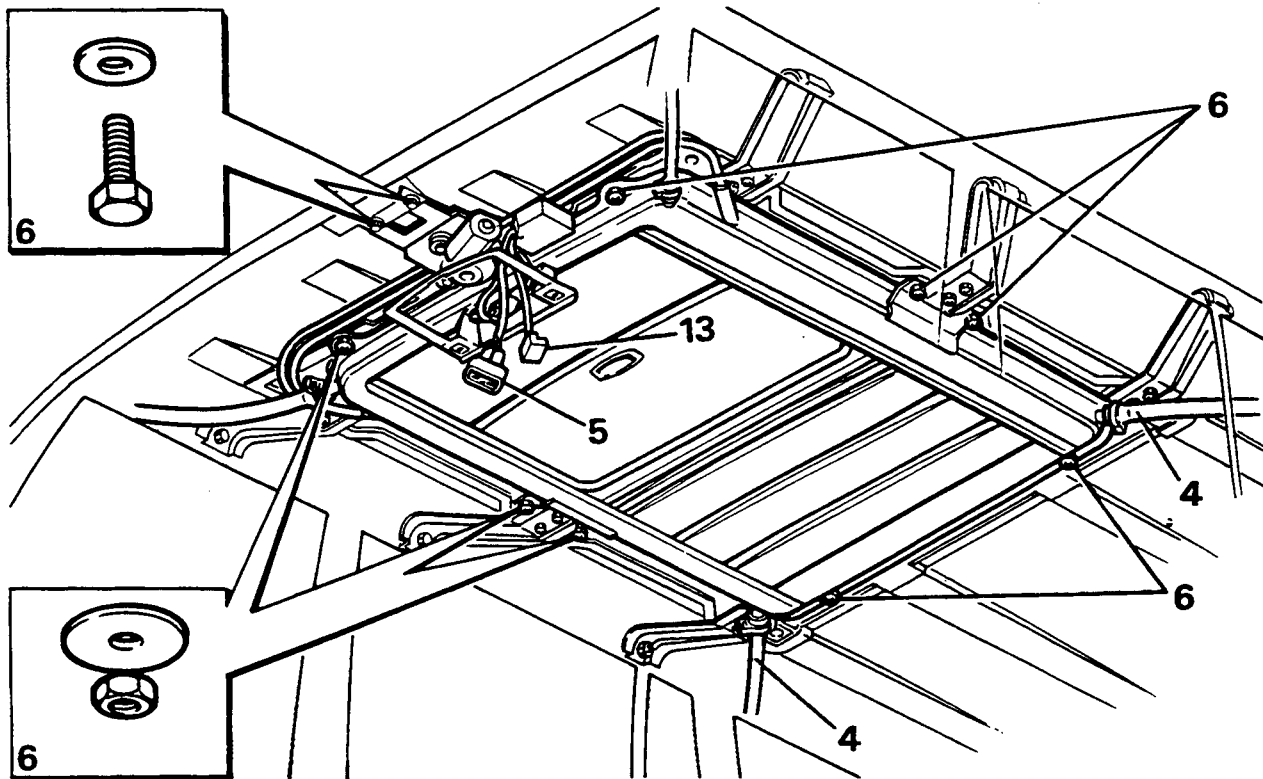

RR2914M

Remove

1. Open sunroof rearwards. Disconnect the battery negative lead.
2. Remove switchplate and disconnect two multiplugs from switch and courtesy light.
3. Remove headlining. *See Headlining*
4. Remove four clips and disconnect drain tubes.
5. Disconnect multiplug from control unit to main harness.
6. With assistance remove eight nuts and washers and two bolts. Lower sunroof assembly remove through rear of vehicle.

Refit

7. Manually close sunroof. *See Manual operation*
8. Lift complete sunroof assembly to roof panel.
9. Fit loosely eight retaining nuts and washers and two bolts.
10. Ensure closed sunroof fits equally positioned in roof panel aperture. Tighten retaining nuts and bolts, recheck fit.
11. Connect electrical multiplugs to main harness and sunroof switch.
12. Check sunroof operates correctly and leave in open position.
13. Disconnect sunroof switch
14. Fit drain tubes with retaining clips. Water test to ensure watertight seal.
15. Fit headlining and sunroof trim.
16. Reconnect electrical multiplugs to sunroof switch and interior light then fit switchplate.
17. Close sunroof and draw sunshade.



SLIDE AND GUIDE CHANNEL ASSEMBLIES OR SUNSHADE PANEL

Service repair no - 76. 82.71. -76.82.03.

Remove and refit

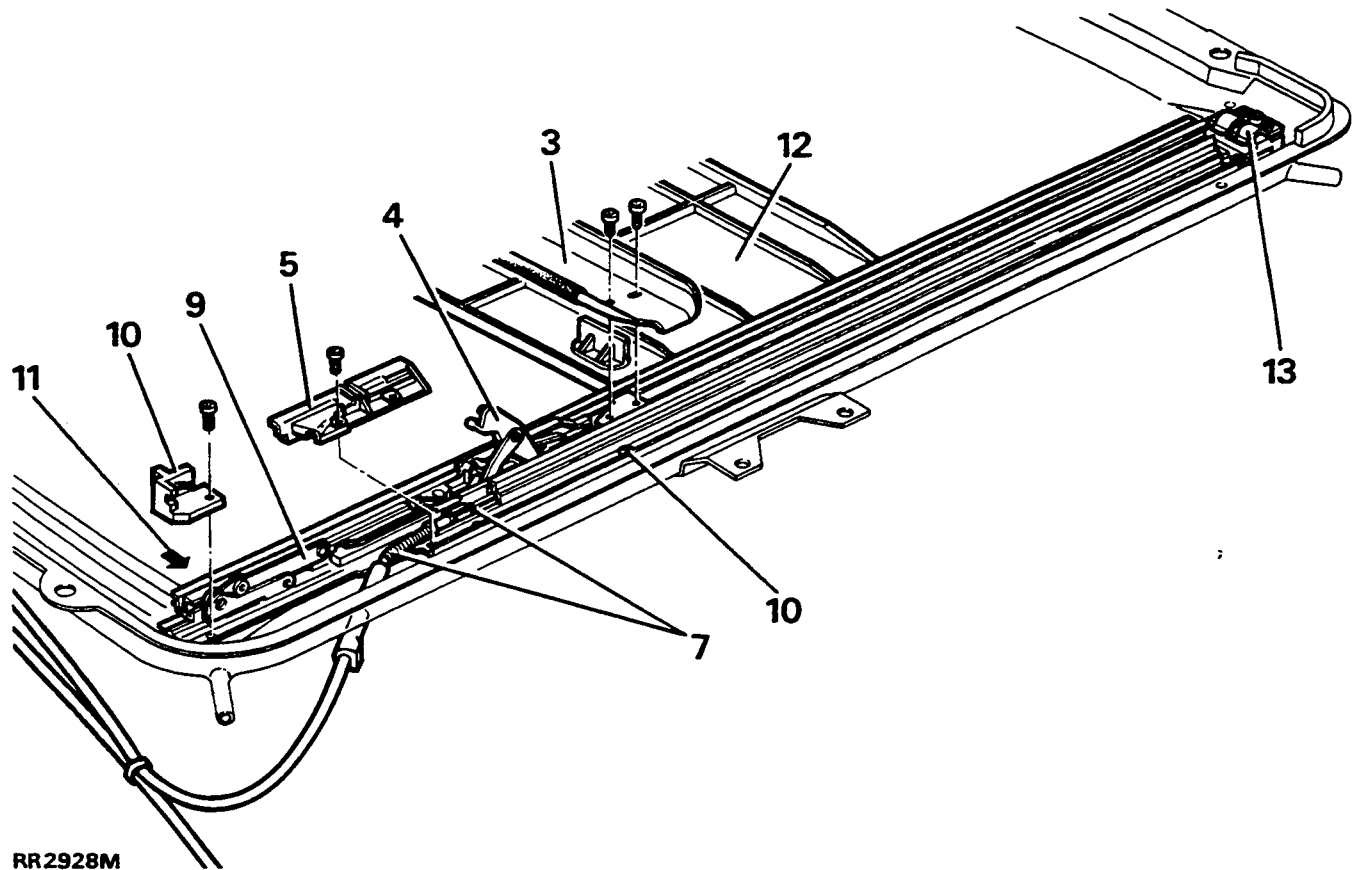

RR2928M



NOTE: The following can be carried out without removing complete sunroof assembly.

The sunshade panel is removed by releasing, either left or right slide and guide channel assembly, instructions 1. to 12.

Remove

1. Remove glass panel assembly. *See Glass panel assembly.*
2. Remove sunroof wind deflector assembly. *See Wind deflector assembly.*
3. Remove rear crossmember drain channel.
4. Move tilt slide rearwards until location cam is clear of locator block.
5. Remove locator block.

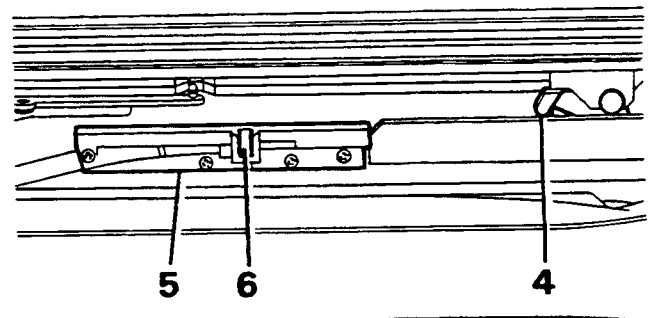

RR2929M

6. Move tilt slide forwards until location cam has reached position it normally locates into locator block. Manually adjust the cam outwards to allow tilt slide to pass and attain full tilt position.

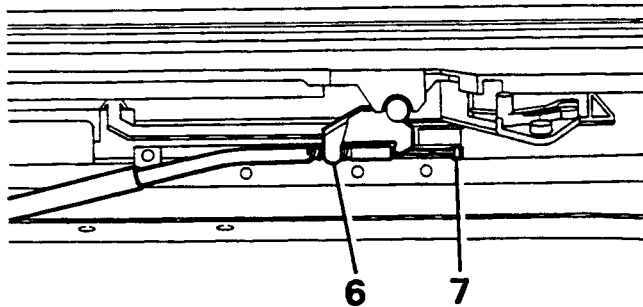

RR2930M

7. The drive cable end is now accessible. Disconnect drive cable from slide assembly.
8. Push tilt slide rearwards reversing instruction 6.
9. Push complete slide assembly rearwards approximately 2".
10. Remove front end stop and attaching screw from centre of guide channel.
11. Push guide channel assembly out sideways to release guide channel from roof panel.
12. Slide sunshade panel forward and lift out of runner to remove.

Continue for removal of slide and guide channel assembly.

13. Using a flashlight directed between roof panel and sunroof assembly. Observe for reassembly guide channel rear spring fixing point.
14. Pull guide channel forward to release from rear spring fixing point. Remove guide channel assembly

Refit

15. Reverse removal procedure.
16. Check sunroof operates correctly.

TIMING OF CONTROL UNIT TO SUNROOF OPERATION

The timing of control unit to sunroof operation will be disturbed:-

If sunroof position is altered when control unit is removed.

Or control unit is removed and control unit gear is moved.

1. To check timing of control unit to sunroof. A 'V' shaped notch should be visible through slot in control unit when sunroof is in fully closed position.

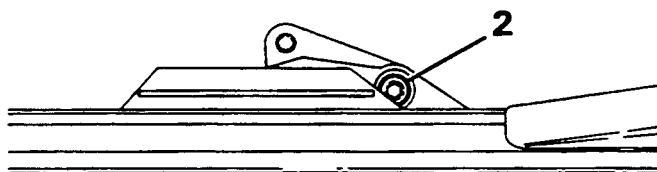
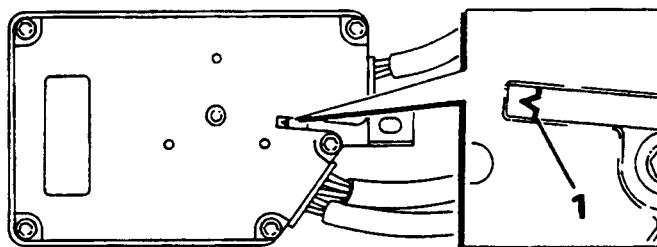

RR2927M

2. To check control unit timing when glass panel is removed. A 'V' shaped notch should be visible through slot in control unit when sunroof tilt mechanism rivet is at a tangent to angle on guide channel. Viewed from inside vehicle.



STEERING COLUMN SHROUD

Remove and refit

Unless removal of both sides of shroud is required, remove **ONLY** one side.

Remove

1. Disconnect the battery negative lead.
2. Remove lower dash panel.
3. Disconnect electrical multiplugs to master lighting switch or rear screen wash wipe switch.
4. Left hand shroud-remove three screws and remove shroud over indicator switch arm.
5. Right hand shroud-remove three screws and remove shroud over windscreen wipe switch arm.
6. Remove screw securing two halves of shroud together.

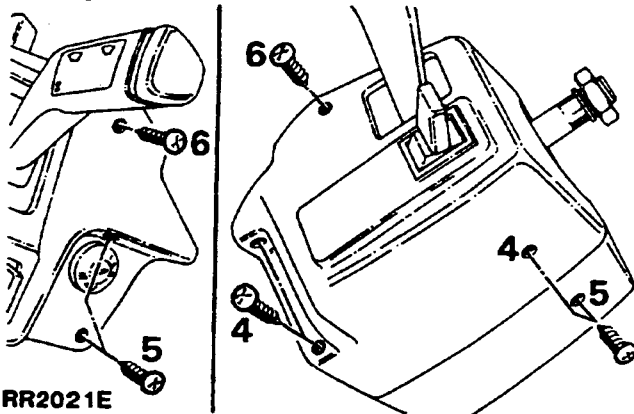

Refit

7. If both halves of shroud are removed ensure plate on steering column locates slot in shroud.
8. Reverse removal procedure.

CHASSIS AMERICA ONLY - 1990 ONWARDS

Alignment check - RR2718E

	Diagram reference	millimeters
AA	Wheelbase reference dimension	2540,00
BB	Centre line of front axle	
CC	Centre line of rear axle	
DD	Frame datum line	
EE	Side member datum line	
FF	Datum line	
1	264,525 ± 1,27
2	Frame datum to underside of cross-member	150,80
3	266,70 ± 2,54
4	237,74 ± 1,27
5	327,81 ± 2,54
6	979,94
7	2179,73 ± 2,54
8	291,74 ± 2,54
9	707,96 ± 2,54
10	1468,49 ± 2,54
11	1025,27 ± 2,54
12	338,84 ± 2,54
13A	222,25 ± 2,54
13B	252,984 ± 2,54
14	Reference dimension	824,92
15	To face of boss (both sides)	35,43 ± 2,54
16	838,2 ± 0,38
17	Check figure	630,94 ± 1,27
18	344,17 ± 1,27
19	485,77 ± 2,54
20	485,77 ± 2,54
21	828,68 ± 0,38
22	129,03 ± 2,54
23	2479,45 ± 0,25
24	1290,34 ± 0,38
25	1657,04 ± 0,38
26	2598,44 ± 0,38
27	79,09 ± 0,38
28	465,48 ± 2,54
29	1398,88 ± 0,38
30	368,30 ± 2,54
31	Reference dimension	317,50
32	Reference dimension	635,00

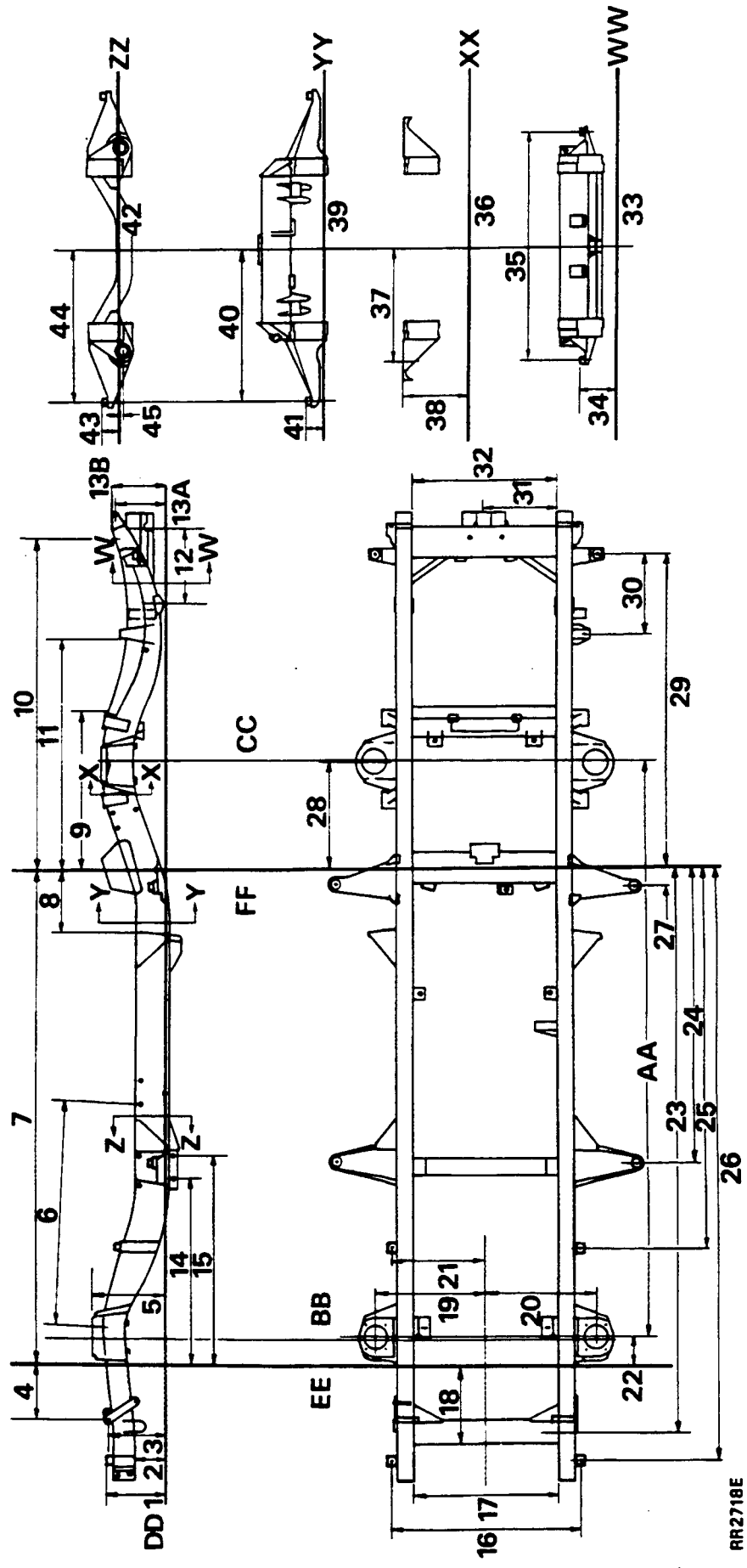

RR2718E

CHASSIS - RR2718E

	Diagram reference	millimeters
SECTION W - W		
33	Frame datum line DD	
34	155,91 ± 1,27
35	990,6 ± 0,38
SECTION X - X		
36	Frame datum line DD	
37	488,95 ± 2,54
38	295,27 ± 2,54
SECTION Y - Y		
39	Frame datum line DD	
40	660,40 ± 0,25
41	80,39 ± 1,27
SECTION Z - Z		
42	Frame datum line DD	
43	80,39 ± 1,27
44	660,40 ± 0,25
45	9,53 ± 2,54



CHASSIS NON AMERICAN - 1990 ONWARDS

Alignment check - RR2751M

	Diagram reference	millimeters
AA	Wheelbase reference dimension	2540,00
BB	Centre line of front axle	
CC	Centre line of rear axle	
DD	Frame datum line	
EE	Side member datum line	
FF	Datum line	
1	264,525 ± 1,27
2	Frame datum to underside of cross-member	150,80
3	266,70 ± 2,54
4	237,74 ± 1,27
5	327,81 ± 2,54
6	979,94
7	2179,73 ± 2,54
8	291,74 ± 2,54
9	707,96 ± 2,54
10	1468,49 ± 2,54
11	1025,27 ± 2,54
12	338,84 ± 2,54
13A	222,25 ± 2,54
13B	252,984 ± 2,54
14	Reference dimension	824,92
15	To face of boss (both sides)	935,43 ± 2,54
16	838,2 ± 0,38
17	Check figure	630,94 ± 1,27
18	344,17 ± 1,27
19	485,77 ± 2,54
20	485,77 ± 2,54
21	828,68 ± 0,38
22	129,03 ± 2,54
23	2479,45 ± 0,25
24	1290,34 ± 0,38
25	1657,04 ± 0,38
26	2598,44 ± 0,38
27	79,09 ± 0,38
28	465,48 ± 2,54
29	1398,88 ± 0,38
30	Reference dimension	635,00

CHASSIS - RR2751M

	Diagram reference	millimeters
SECTION W - W		
31	Frame datum line DD	
32	155,91 ± 1,27
33	990,6 ± 0,38
34	825,5 ± 2,54
SECTION X - X		
35	Frame datum line DD	
36	488,95 ± 2,54
37	295,27 ± 2,54
SECTION Y - Y		
38	Frame datum line DD	
39	660,40 ± 0,25
40	80,39 ± 1,27
SECTION Z - Z		
41	Frame datum line DD	
42	80,39 ± 1,27
43	660,40 ± 0,25
44	9,53 ± 2,54

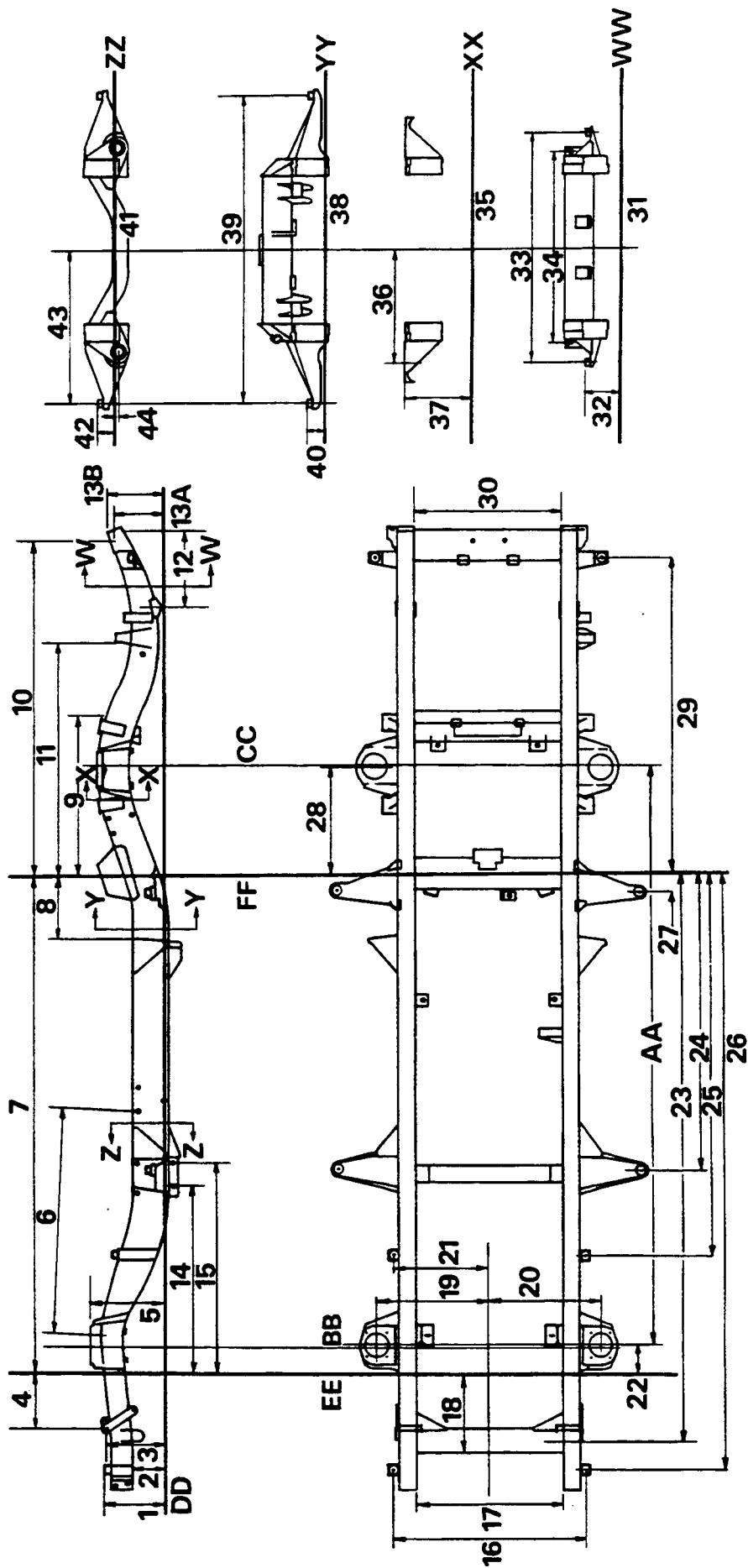

RR2751M

**CHASSIS - AMERICAN COUNTY LWB (108")
MODELS**

Alignment check - RR3919M

	Diagram reference	millimeters
AA	Wheelbase - Reference dimension	2743,20
BB	Centre line of front axle	
CC	Centre line of rear axle	
DD	Frame datum line	
EE	Sidemember datum holes	
FF	Datum line	
1	264,16 ± 1,27
2	Frame datum to underside of crossmember	150,80
3	266,70 ± 2,54
4	237,74 ± 1,00
5	337,34 ± 1,00
6	974,57 ± 1,00
7	2382,93 ± 2,54
8	1155,75 ± 1,00
9	707,96 ± 2,54
10	1468,49 ± 2,54
11	1025,27 ± 2,54
12	338,84 ± 2,54
13A	240,03 ± 2,54
13B	252,98 ± 2,54
14	Reference dimension	824,92
15	To face of boss (both sides)	935,43 ± 1,00
16	838,20 ± 0,50
17	Check figure	630,94 ± 1,27
18	344,17 ± 1,27
19	485,77 ± 2,54
20	485,77 ± 2,54
21	828,65 ± 0,50
22	129,03 ± 2,54
23	2682,65 ± 0,25
24	1493,54 ± 0,75
25	1860,24 ± 0,75
26	2801,64 ± 0,75
27	79,09 ± 0,75
28	390,88 ± 2,54
29	1398,88 ± 0,75
30	Reference dimension	317,50
31	Reference dimension	635,00

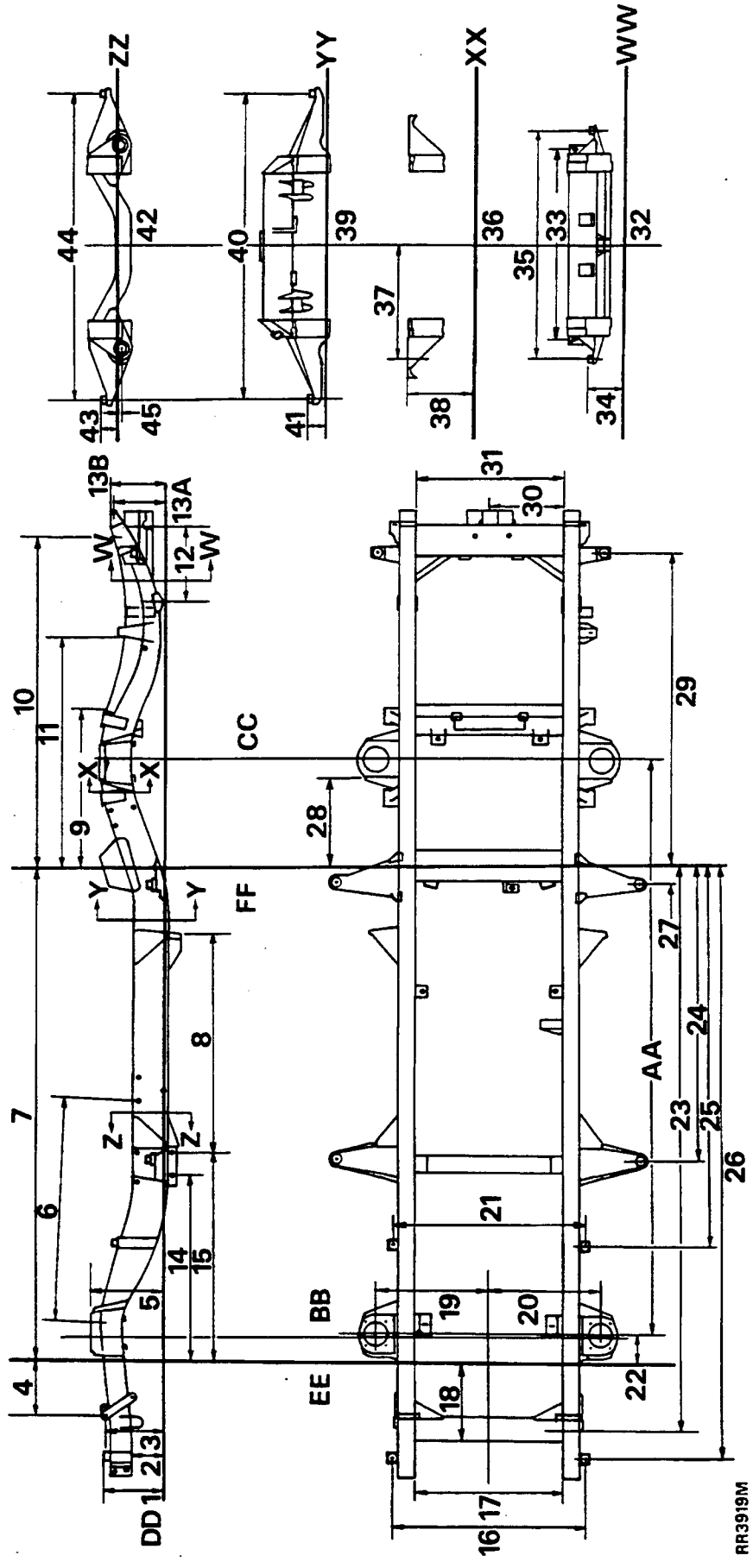

CHASSIS - RR3919M

	Diagram reference	millimeters
SECTION W - W		
32	Frame datum line DD	
33825,50 ± 2,54
34155,91 ± 1,27
35990,60 ± 0,50
SECTION X - X		
36	Frame datum line DD	
37488,95 ± 2,54
38309,83 ± 1,00
SECTION Y - Y		
39	Frame datum line DD	
401320,80 ± 0,50
4180,39 ± 1,27
SECTION Z - Z		
42	Frame datum line DD	
4380,39 ± 1,27
441320,8 ± 0,50
459,53 ± 2,54



CHASSIS - LSE (108") AIR SUSPENSION MODELS

Alignment check - RR3918M

	Diagram reference	millimeters
AA	Wheelbase - Reference dimension	2743,20
BB	Centre line of front axle	
CC	Centre line of rear axle	
DD	Frame datum line	
EE	Sidemember datum holes	
FF	Datum line	
1	264,16 ± 1,27
2	Frame datum to underside of crossmember	150,80
3	266,70 ± 2,54
4	237,74 ± 1,00
5	337,34 ± 1,00
6	974,57 ± 1,00
7	2382,93 ± 2,54
8	1155,75 ± 1,00
9	707,96 ± 2,54
10	1468,49 ± 2,54
11	1025,27 ± 2,54
12	338,84 ± 2,54
13A	222,25 ± 2,54
13B	240,03 ± 2,54
14	Reference dimension	824,92
15	To face of boss (both sides)	935,43 ± 1,00
16	838,20 ± 0,50
17	630,94 ± 1,27
18	344,17 ± 1,27
19	485,77 ± 2,54
20	485,77 ± 2,54
21	828,65 ± 0,50
22	129,03 ± 2,54
23	2682,65 ± 0,25
24	1493,54 ± 0,75
25	1860,24 ± 0,75
26	2801,64 ± 0,75
27	79,09 ± 0,75
28	390,88 ± 2,54
29	1398,88 ± 0,75
30	Reference dimension	635,00

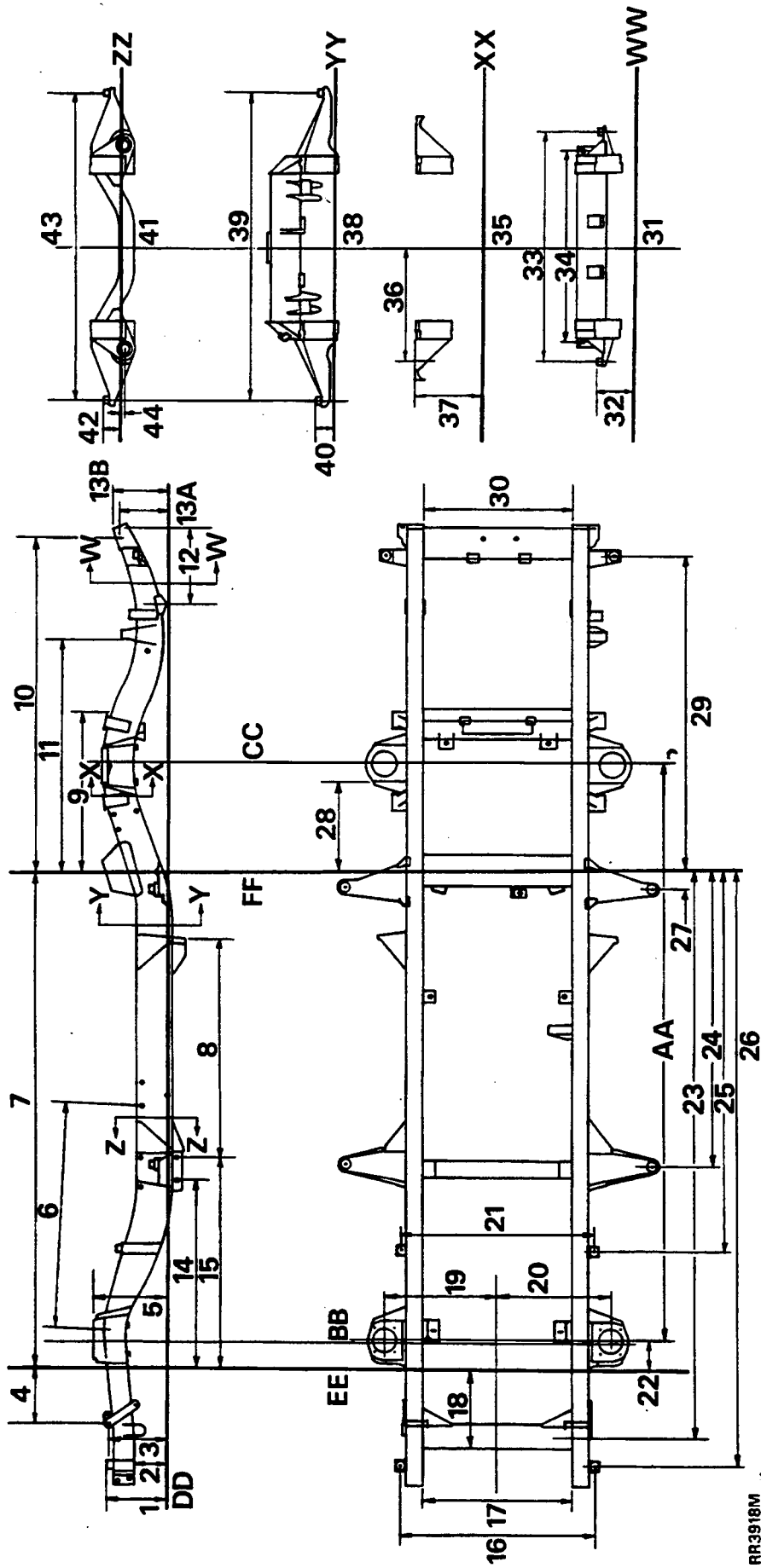

RR3918M



CHASSIS

	Diagram reference	millimeters
SECTION W - W		
31	Frame datum line DD	
32	155,91 ± 1,27
33	990,6 ± 0,50
34	825,5 ± 2,54
SECTION X - X		
35	Frame datum line DD	
36	488,95 ± 2,54
37	309,83 ± 1,00
SECTION Y - Y		
38	Frame datum line DD	
39	1320,8 ± 0,50
40	80,39 ± 1,27
SECTION Z - Z		
41	Frame datum line DD	
42	80,39 ± 1,27
43	660,4 ± 0,25
44	9,53 ± 2,54