

86 - ELECTRICAL

CONTENTS

Page

DESCRIPTION AND OPERATION

ELECTRICAL EQUIPMENT	1
ALTERNATOR - LUCAS A133/80	1
ANTI THEFT ALARM SYSTEM	2
ANTI-THEFT SYSTEM FUNCTION	2
ALARM COMPONENTS	2
BUILT IN TEST PROCEDURE	4
IN CAR ENTERTAINMENT (ICE)	5

FAULT DIAGNOSIS

ALTERNATOR TESTING	1
LUCAS CONSTANT ENERGY IGNITION SYSTEM	
35DLM8-PRELIMINARY CHECKS	2
MEMORY SEAT / MIRROR SYSTEM SERVICE CHECK	5
MEMORY SEAT / MIRROR SYSTEM - FAULT FINDING	6
MEMORY SEAT / MIRROR SYSTEM FAULT DIAGNOSIS	7
HEATED FRONT SCREEN - 1990	10
ELECTRIC SEAT ADJUSTMENT - 1990	11
CENTRAL DOOR LOCKING - 1990	12
ELECTRIC MIRRORS - 1990	13
ELECTRIC WINDOW LIFT - 1990	14
CIRCUIT DIAGRAM - 1990 MY - RIGHT HAND STEERING	16
Circuit diagram - 1990 MY - RIGHT HAND STEERING - illustrations	
RR2830M & RR2831M	17
CIRCUIT DIAGRAM - 1990 MY - LEFT HAND STEERING	20
CIRCUIT DIAGRAM - 1990 MY - LEFT HAND STEERING -	
ILLUSTRATIONS RR2828M & RR2829M	21
CIRCUIT DIAGRAM - 1990 MY - USA AND CANADA	24
CIRCUIT DIAGRAM - 1990 MY - USA AND CANADA - Illustrations	
RR2945E & RR2946E	25
CD PLAYER WITH POWER AMPLIFIERS - 1991	28
HEATED FRONT SCREEN - 1991	29
ELECTRIC SEAT ADJUSTMENT - 1991	30
DOOR LOCKS / FUEL FILLER FLAP - 1991	31
SUNROOF / AUTOMATIC GLARE CONTROL MIRROR - 1991	32
HEADLAMP LEVELLING - 1991	33
CIRCUIT DIAGRAM - 1991 MY - RIGHT HAND STEERING	34
CIRCUIT DIAGRAM - 1991 MY - RIGHT HAND STEERING - Illustrations	
RR2976M RR2977M	35



86 - ELECTRICAL

CONTENTS

	Page
CIRCUIT DIAGRAM - 1991 MY - LEFT HAND STEERING	38
CIRCUIT DIAGRAM - 1991 MY - LEFT HAND STEERING - Illustrations RR2978M & RR2979M	39
CIRCUIT DIAGRAM - 1991 MY - USA AND CANADA	42
Circuit diagram - 1991 MY - USA and CANADA Illustrations RR2970E & RR2971E	44
 ADJUSTMENT	
IGNITION TIMING	1
 REPAIR	
FUSE BOX - 1990 & 91 MY	1
LOCATION OF ELECTRICAL EQUIPMENT	3
RELAYS, DELAY UNITS, TIMER UNITS, DIODE PACK - 1990 / 91 - IDENTIFICATION	4
RELAYS, DELAY UNITS, TIMER UNITS, DIODE PACK - USA AND CANADA 1990 / 91 - IDENTIFICATION	7
BATTERY	10
ALTERNATOR	10
ALTERNATOR DRIVE BELTS	11
DISTRIBUTOR-LUCAS 35 DLM8	11
ELECTRONIC IGNITION	11
DISTRIBUTOR	11
IGNITION COIL	14
HEADLAMP ASSEMBLY / SEALED BEAM UNIT	14
HEADLAMP ASSEMBLY/BULB RELACEMENT	15
HEADLAMP ALIGNMENT	16
AUXILIARY DRIVING LAMP	16
SIDELIGHT AND FLASHER LAMP ASSEMBLY AND BULB	17
DIRECTION INDICATOR SIDE REPEATER LAMP BULB REPLACEMENT	18
TAIL LAMP ASSEMBLY	18
REFLECTORS/SIDE MARKER LAMP ASSEMBLY AND BULB	19
UNDER BONNET LAMP ASSEMBLY	19
HEATER/VENTILATION AND AIR CONDITIONING CONTROL PANEL	20
DOOR EDGE LAMPS / PUDDLE LAMPS	20
DOOR EDGE LAMPS/PUDDLE LAMPS	21
AUTOMATIC GEAR SELECTOR-PANEL ILLUMINATION	21
NUMBER PLATE LAMP ASSEMBLY AND BULB	22
INTERIOR ROOF LAMPS	23
INTERIOR ROOF LAMPS CIRCUIT DELAY	23

86 - ELECTRICAL

CONTENTS

	Page
STARTER MOTOR-LUCAS M78R	24
AUXILIARY SWITCH PANEL	24
AUXILIARY SWITCH PANEL WARNING LIGHT	25
AUXILIARY SWITCH PANEL ILLUMINATION	25
STEERING COLUMN CONTROLS	26
STEERING COLUMN SHROUD	26
MAIN LIGHTING SWITCH OR REAR SCREEN PROGRAMMED WASH WIPE SWITCH.....	27
WINDSCREEN PROGRAMMED WASH WIPE SWITCH OR HIGH AND LOW BEAM, DIRECTION INDICATORS AND HORN SWITCH	27
HAZARD WARNING SWITCH BULB REPLACEMENT	28
COLUMN SWITCH ILLUMINATION BULB REPLACEMENT	28
IGNITION STARTER SWITCH	29
DOOR PILLAR SWITCH.....	29
REAR TAILGATE SWITCH	30
UNDER BONNET ILLUMINATION SWITCH.....	30
CIGAR LIGHTER-RADIO HOUSING	31
 31
CIGAR LIGHTER - GLOVE BOX.....	32
REVERSE LIGHT SWITCH	32
START INHIBIT / REVERSE LIGHT SWITCH	33
OIL PRESSURE WARNING SWITCH.....	33
COOLANT TEMPERATURE TRANSMITTER.....	34
STOP LIGHT SWITCH	34
PARK BRAKE WARNING SWITCH	35
EXTERIOR DRIVING MIRRORS	35
CLOCK.....	37
WARNING LAMP CONTROL UNIT - USA	38
INSTRUMENT ILLUMINATION ELECTRONIC DIMMER / RHEOSTAT.....	39
WINDOW LIFT SWITCHES	39
WINDOW LIFT MOTOR - FRONT DOORS	40
WINDOW LIFT MOTOR - REAR DOORS.....	40
CENTRAL DOOR LOCKING	41
CENTRAL DOOR LOCK CONTROL UNIT	41
FRONT DOOR ACTUATOR UNIT	42
REAR DOOR ACTUATOR UNITS	42
UPPER TAILGATE ACTUATOR UNIT	43
FUEL FILLER FLAP ACTUATOR UNIT - PRE 1991 MODEL YEAR.....	43
FUEL TANK GAUGE UNIT - PRE 1991 MODEL YEAR	44
TRAILER SOCKET	45
AUDIBLE WARNING UNIT - USA	46
LOW OIL LEVEL SENSOR UNIT - USA	46
LOW OIL LEVEL WARNING LOGIC UNIT - USA	47
FRONT SEAT - MOTORS	47



86 - ELECTRICAL

CONTENTS

	Page
FRONT SEAT - SWITCH	48
RADIO ANTENNA AMPLIFIER	48
RELAYS	49
HEATED FRONT SCREEN	49
ALTERNATOR HEAT SHIELD	50
HIGH LEVEL STOP LAMP	50
INSTRUMENT BINNACLE	51
PANEL AND WARNING LIGHT BULBS	54
INSTRUMENT BINNACLE	54
GEAR SELECTOR-INTERLOCK	55
MAP LIGHT BULB RENEWAL	58
ELECTRICAL SEAT FAILURE	58
DRIVE CABLE - ELECTRIC SEAT	59
MEMORY SEAT - SWITCH	59
MEMORY SEAT SWITCH - CLEAN	60
EXTERIOR MIRROR SWITCHES - MEMORY TYPE	60
ECU - MEMORY SEAT	61
MEMORY SEAT - HARNESS LAYOUT	62
HANDSET INITIALISATION	63
HANDSET BATTERIES	63
ALARM ECU	63
ALARM HORN	64
SUBWOOFER BOX	64
ANTENNA AMPLIFIER	66
RADIO	66
 OVERHAUL	
ALTERNATOR - MAGNETTI MARELLI - TYPE A133/80	1
ALTERNATOR - A133/80	2
ALTERNATOR TESTING	3
TESTING-ALTERNATOR REMOVED	3
DISTRIBUTOR-LUCAS 35DLM8	5
DISTRIBUTOR CAP	5
ROTOR ARM	5
INSULATION COVER (FLASH SHIELD)	5
VACUUM UNIT	6
AMPLIFIER MODULE	6
PICK-UP AND BASE PLATE ASSEMBLY	6
LUBRICATION	7
STARTER MOTOR-LUCAS M78R	8
ALTERNATOR - 200 Tdi	11
ALTERNATOR DRIVE BELT TENSIONING - Tdi ENGINE	11

86 - ELECTRICAL

CONTENTS

	Page
STARTER MOTOR - Tdi ENGINE	12
STARTER MOTOR OVERHAUL - Tdi ENGINE	12
 SPECIFICATIONS, TORQUE	
TORQUE VALUES	1





ELECTRICAL EQUIPMENT

DESCRIPTION

The electrical system is Negative ground, and it is most important to ensure correct polarity of the electrical connections at all times. Any incorrect connections made when reconnecting cables may cause irreparable damage to the semi-conductor devices used in the alternator and regulator. Incorrect polarity would also seriously damage any transistorized equipment such as radio and tachometer etc.



WARNING: During battery removal or before carrying out any repairs or maintenance to electrical components always disconnect the battery negative lead if the positive lead is disconnected with the negative lead in place, accidental contact of the wrench to any grounded metal part could cause a severe spark, possibly resulting in personal injury. Upon installation of the battery the positive lead should be connected first.

ALTERNATOR - LUCAS A133/80

The alternator is a three phase, field sensed unit. The rotor and stator windings produce three phase alternating current, AC, which is rectified to direct current, DC. The electronic voltage regulator unit controls the alternator output voltage by high frequency switching of the rotor field circuit. Use only the correct Range Rover replacement fan belt. Occasionally check that the engine and alternator pulleys are accurately aligned.

It is essential that good electrical connections are maintained at all times. Of particular importance are those in the charging circuit (including those at the battery) which should be occasionally inspected to see that they are clean and tight. In this way any significant increase in circuit resistance can be prevented.

Do not disconnect battery cables while the engine is running or damage to the semi-conductor devices may occur. It is also inadvisable to break or make any connections in the alternator charging and control circuits while the engine is running.

The Model 15TR electronic voltage regulator employs micro-circuit techniques resulting in improved performance under difficult service conditions. The whole assembly is encapsulated in silicone rubber and housed in an aluminium heat sink, ensuring complete protection against the adverse effects of temperature, dust, and moisture etc.

The regulating voltage is set during manufacture to give the required regulating voltage range of 14.2 ± 0.2 volts, and no adjustment is necessary. The only maintenance needed is the occasional check on terminal connections and wiping with a clean dry cloth.

The alternator system provides for direct connection of a charge (ignition) indicator warning light, and eliminates the need for a field switching relay or warning light control unit. As the warning lamp is connected in the charging circuit, lamp failure will cause loss of charge. Lamp should be checked regularly and spare carried.

When using rapid charge equipment to re-charge the battery, the battery must be disconnected from the vehicle.



NOTE: For description and operation of 1992 model year electrical circuits see separate publication:- Electrical troubleshooting manual.

ANTI THEFT ALARM SYSTEM

For 1993 models a vehicle alarm system is available as original equipment. The main function of the system is to offer easy to use remote locking and unlocking of the vehicle without having to actively select the alarm function.

ANTI-THEFT SYSTEM FUNCTION

Perimetric protection

Using the key in the correct sequence will turn on and off perimetric protection only. When fully perimetrically armed, all doors, tailgate, and bonnet are protected against unauthorised access. If the door key is used in the normal manner the driver will be unaware of the door key sequence. The time taken to lock or unlock with the key must be less than 5 seconds. To prevent unauthorised tampering, the alarm will sound if the key is held in the unlocked position for longer than 5 seconds when armed. Cranking is disabled when perimetric protection is armed.



NOTE: When key is turned left or right the keyswitch input will be activated, in conjunction with the sill button switch when links are operated.

ALARM COMPONENTS

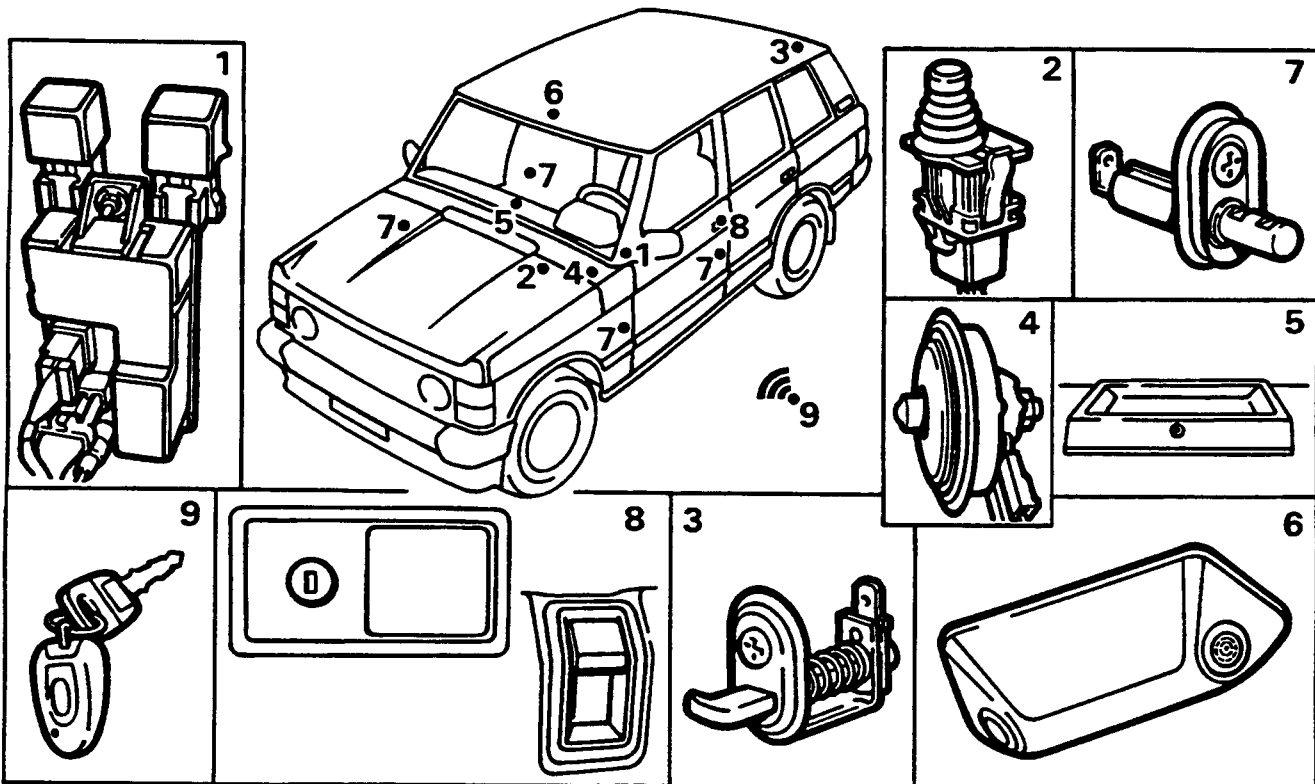

RR3911M

- | | |
|---|---------------------------------------|
| 1. Electronic control unit (ECU) and relays | 6. Ultrasonic unit |
| 2. Bonnet switch | 7. Door switches |
| 3. Tailgate switch | 8. Lock barrel, sill buttons |
| 4. Alarm horn | 9. Handset transmitter (two supplied) |
| 5. Light emitting diode (LED) | |



Volumetric protection

Using the handset transmitter will turn on and off volumetric protection. In volumetric mode the vehicle interior is protected using the ultrasonic sensor. Using the handset also arms and disarms the vehicle perimetrically. Cranking is disabled when volumetric and perimetric protection is armed.



NOTE: If armed volumetrically the vehicle CANNOT be disarmed using the key.

Alarm horn

When an intrusion is detected the alarm horn will sound intermittently (Switzerland and Denmark continuous horn sound) and the hazard lights flash (where territorial regulations allow) for 30 seconds. The alarm must be retriggered before alarm horn will sound again.

Vehicle status indication

Vehicle status is indicated by up to three devices: (a) alarm horn, (b) hazard lights, (c) dash board LED. When the vehicle arms in either mode the hazard lights will flash three times and the LED will flash rapidly for 10 seconds. LED will then flash at a slower rate while vehicle is armed. When the vehicle disarms, hazard lights will flash once and LED will extinguish. If LED remains lit, it indicates that the alarm has been triggered. Turning on ignition or arming the alarm will extinguish LED. The LED will give a long pulse flash to indicate the ultrasonic unit being activated.

Radio frequency system

The RF system uses four frequencies according to market. If the coaxial aerial is not fitted system performance will be impaired. Both ECU and handset have a colour coded label.

Frequency	Colour ECU/Handset	Territory
418.0 MHz	Pink/pink	UK, Ireland
224.5 MHz,	Yellow/yellow	France
433.92 MHz	Blue/blue	Europe, not France, Switzerland, Italy, Denmark
433.92 MHz	White/Blue	Switzerland, Denmark
315.0 MHz	Green/green	Rest of world, Italy, Australia
315.0 MHz	Orange/Green	Gulf, Japan

Central locking

Central locking is controlled by the alarm ECU and may be operated by the key, sill button(s) or handset. The system works on both front doors on four door vehicles or driver's door on two door vehicles.



NOTE: The central door locking system will shut down for a short period after more than 15 consecutive operations.

Inertia switch

An inertia switch is incorporated in the alarm system ECU. If ignition is on and the vehicle receives an impact sufficient to activate the inertia switch, the ECU will signal to unlock central locking actuators and flash hazard lights. Central locking will remain disabled for 30 seconds. To reset turn ignition off and then on after the 30 second period has elapsed.

Ultrasonic unit

The unit operates by emitting an air pressure carrier wave and receiving the wave back. Any disturbance within the vehicle which disturbs the wave will be detected, triggering the alarm.

When the volumetric sensor is activated it monitors movement within the vehicle for 15 seconds before detecting and responding to intrusions. If the sensor detects movement within the vehicle it delays arming until a 15 seconds quiet period has elapsed. If continuous movement is detected the alarm will not arm volumetrically.

Partially armed mode

If a door, tailgate or bonnet is left open when the system is armed, the LED will not light for 10 seconds indicating a mislock condition. Hazard lights will not flash. If an open door or tailgate is causing the mislock, the starter motor is disabled. The alarm will sound if ignition is turned to start position. If an open bonnet is causing the mislock the starter motor is disabled. The alarm will arm the volumetric part of the system. If the door tailgate or bonnet is subsequently closed, after a 5 second delay, the doors will unlock and immediately lock and the system will fully arm.

Handset transmitter

The handset LED will give one short flash when button is pressed momentarily.

If button is held down the LED will light again after 2 seconds for 2 seconds, and extinguish until button is released and repressed. The handset contains unique information distinguishing it from other transmitters. It also contains a set of 'random' rolling codes programmed into the ECU before leaving the factory. Each time the handset is pressed a different code is transmitted to the ECU.

If handset is operated more than four times outside the vehicle range (6 metres) or power supply is removed, it will be necessary to re-synchronise handset and the ECU by pressing the handset three times within range and within 5 seconds.



NOTE: If both handsets are lost or damaged when system is armed it will be necessary to fit a new ECU with two matching handsets.

Handset batteries

If handset LED flashes continuously when button is pressed, the batteries need replacing. The hazard lights will flash one 3 second pulse, instead of three times upon arming vehicle.

Power up mode

The alarm system always remembers the state it was left in when power was removed. If the alarm powers up in an armed state and is subsequently triggered it will give a warning that it will fully trigger unless disarmed. This warning consists of short horn pulses every two seconds for 15 seconds.

New born mode

When the ECU is first produced, it will be in its 'new born' mode. In this mode it will respond to any remote of the right frequency. This mode will be cancelled when the ECU has received ten valid handset signals without power interruption.

Engine cranking

It is only possible to crank the engine when ignition is ON and alarm disabled.

BUILT IN TEST PROCEDURE

The built in test procedure is accessed as follows:

1. Starting conditions: ignition off, doors unlocked, bonnet switch depressed.
2. Carry out instructions 3 to 7 within 8 seconds.
3. Release bonnet switch
4. Switch ignition ON.
5. Lock doors.
6. Switch ignition OFF.
7. Switch ignition ON.

If alarm is correctly accessed, horn will sound and LED will flash. The following checks can be made:

8. Open and close any door or tailgate - LED will light.
9. Depress bonnet switch - hazards will flash.
10. Check engine cranking is disabled. Do not turn off ignition.
11. Check ultrasonic by operating handset, LED will emit one 5 second flash, and will flash if interior is disturbed.



NOTE: If ECU is in new born mode any handset of the right frequency will work. If not an initialised handset is required see Handset Initialisation.

12. Turn OFF ignition or press handset to end test procedure. Horn will sound as before to indicate end of test mode.



IN CAR ENTERTAINMENT (ICE)

For 1993 model year three levels of factory fitted in car entertainment are available.

New features are as follows:

Side screen antenna, new head units, subwoofer assembly, new speakers and new CD autochanger.

The Mid/low line radio has the following features: Radio data system (RDS), electronic tuning, one touch memory, automatic programme control (APC), Dolby, subwoofer line output, CATS coded, manual tape deck.

High line radio is as above with the following exceptions:

Logic tape deck, blank skip/repeat, 5 channel line output, CD ready (this unit is fitted when the CD option is called for).

Subwoofer

The subwoofer unit is located in the right hand side of the luggage compartment. It amplifies frequencies between 20 and 150 Hz to give an enhanced bass sound.

Subwoofer amplifier

The amplifier is fitted on top of the subwoofer unit.

Speaker amplifier

A remote 4 x 20 amp speaker amplifier is part of high line ICE specification.

This is also fitted on top of the subwoofer.

Side screen antenna

The antenna is now printed into the rear side screen on four door models. For America and Japan the element is fitted in both rear side screens, known as diversity antenna system. Other markets have a single element in the right hand side screen only. Diversity reception means that if vehicle movement results in a loss of signal due to reflections from buildings (known as multipath distortion), the radio will switch to the antenna receiving the strongest signal. This results in less interference and better stereo performance.

Antenna amplifiers

New antenna amplifiers are located behind the headlining above the side screen antenna(s). Right hand side fitment is an FM + AM amplifier, left hand side, diversity, is an FM only amplifier.

Speakers

Trim level 1 - Two door vehicles have two front twin cone speakers Four door vehicles have two coaxial front speakers and two twin cone rear speakers.

Trim level 2 - Four coaxial speakers, two front, two rear and a subwoofer.

Trim level 3 - Four coaxial speakers, two front, two rear, two bass speakers and crossover unit front, a subwoofer and amplifier. Twin cone speakers have a mid range and tweeter cone driven by the same coil. Coaxial speakers have two cones and two coils. Where front doors have bass speakers a crossover unit is fitted which effectively splits the frequency between bass and coaxial.

CD autochanger

The CD autochanger is fitted underneath the subwoofer unit.



ALTERNATOR TESTING

Service repair no - 86.10.01

Charging system check

1. Check battery is in good condition, with an open circuit voltage of at least 12.6 V. Recharge or substitute battery to carry out test.
2. Check drive belt adjustment and condition, see **See SECTION 10, Maintenance, under bonnet maintenance**
3. Check battery connections are clean and tight.
4. Check alternator connections are clean and tight.
5. Ensure there is no drain on battery from, for example, interior, under bonnet or door edge lamps.

Alternator test

Following instructions refer to use of suitable test equipment using a carbon pile rheostat.

6. Connect test equipment referring to manufacturer's instructions.
7. Start engine and run at 3000 rev/min without accessory load.
8. Rotate carbon pile load control to achieve greatest output (amps) without allowing voltage to fall below 12.0 V. A reading in amps, of alternator output, minus 10% to allow for EFI and ignition loss, should be obtained.
9. Run engine at 3000 rev/min, switch selector to regulator test, read voltmeter. A reading of 13.6 to 14.4 V s should be obtained.
10. Switch selector to diode/stator test, switch on headlamps to load alternator. Raise engine speed to 3000 rev/min, read voltmeter, needle must be within 'OK' range.

TESTING IN POSITION

Charging circuit resistance test.

1. Connect a low range voltmeter between alternator terminal marked + and positive terminal of battery.

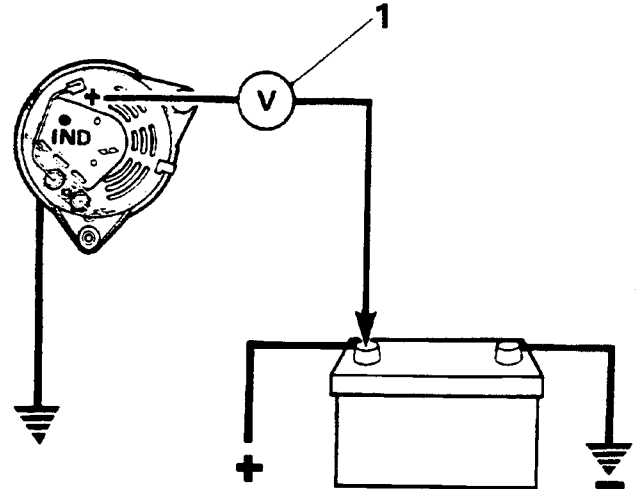

RR2317E

2. Switch on headlamps, start engine. Run engine at approximately 3000 rev/min. Note voltmeter reading.
3. Transfer voltmeter connections to frame of alternator and negative terminal of battery, and again note voltmeter reading.

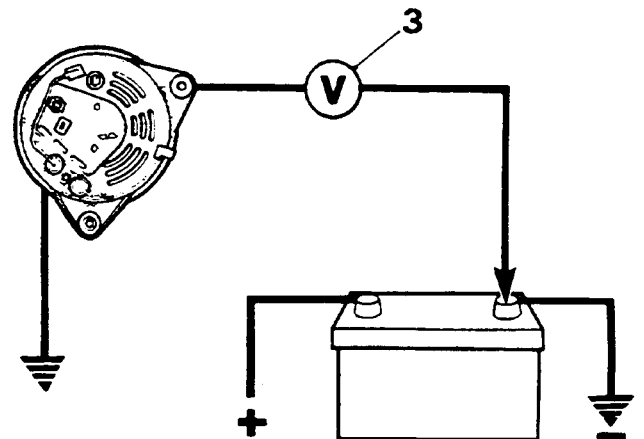

RR2318E

4. If reading exceeds 0.5 volt on positive side or 0.25 volt on negative side, there is a high resistance in charging circuit which must be traced and remedied.

LUCAS CONSTANT ENERGY IGNITION SYSTEM 35DLM8-PRELIMINARY CHECKS

Inspect battery cables and connections to ensure they are clean and tight. Check battery state of charge.

Inspect all L.T. connections, ensure they are clean and tight. Check H.T. leads are correctly positioned and not shorting to ground against any engine components. Wiring harness and individual cables should be firmly fastened to prevent chaffing.

Pick-up air gap

Check air gap between pick-up limb and retractor teeth is 0.20 - 0.35 mm, using a non-ferrous gauge.



NOTE: Air gap is set initially at factory and will only require adjusting if tampered with or when pick-up module is replaced.

TEST 1:

H.T. Sparking

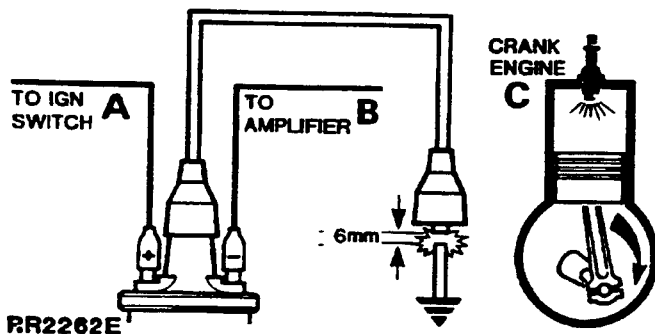

RR2262E

Remove coil/distributor H.T. lead from distributor cover and hold approximately 6mm (0.25 in) from engine block, using suitable insulated pliers. Switch ignition 'On' and operate starter.

Regular sparking indicates fault in H.T. distribution, plugs, timing or fuelling, proceed to Test 6. If no spark or weak spark occurs proceed to Test 2.

TEST 2:

L.T. Voltage

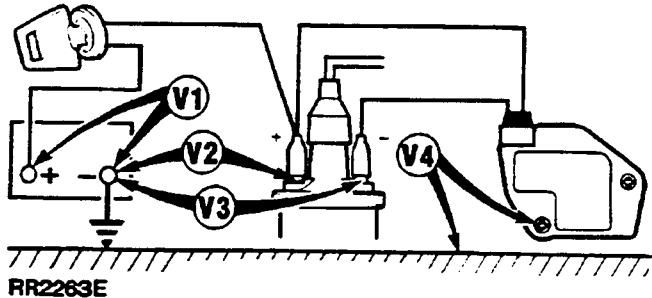

RR2263E

Switch ignition 'On' - engine stationary.

- Connect voltmeter to points in circuit indicated by V1 to V4 and make a note of voltage readings.
- Compare voltages obtained with specified values listed below:

Expected readings

- V1 More than 12 volts.
 V2 1 volt maximum below volts at V1.
 V3 1 volt maximum below volts at V1.
 V4 0 volt - 0.1 volt.
- If all readings are correct proceed to Test 3.
 - Check incorrect reading(s) with chart to identify area of possible faults, i.e. faults listed under heading SUSPECT and rectify.
 - If coil and amplifier is suspected, disconnect L.T. lead at coil, repeat V3. If voltage is still incorrect, fit new coil. If voltage is now correct, check L.T. lead, if satisfactory fit new amplifier.
 - If engine will not start proceed to Test 3.



1	2	3	4	SUSPECT
L	*	*	*	DISCHARGED BATTERY
*	L	L	*	IGN. SWITCH AND/OR WIRING
*	*	L	*	COIL OR AMPLIFIER
*	*	*	H	AMPLIFIER GROUND

Key

- * Expected Voltage
- H Voltage higher than expected
- L Voltage lower than expected

TEST 3:

Amplifier Switching

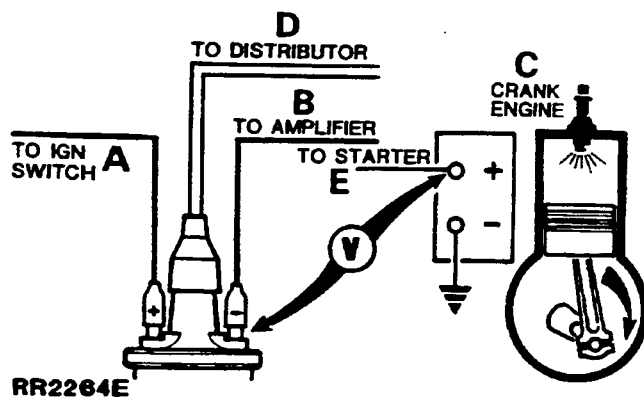

Connect voltmeter between battery positive (+ve) terminal and H.T. coil negative (-ve) terminal. Voltmeter should register 0 volts.

Switch ignition 'On', voltmeter should still register 0 volts.

Crank engine, voltmeter reading should increase when cranking, in which case proceed to Test 5.

If no increase in voltage during cranking proceed to Test 4.

TEST 4:

Pick-up Coil Resistance

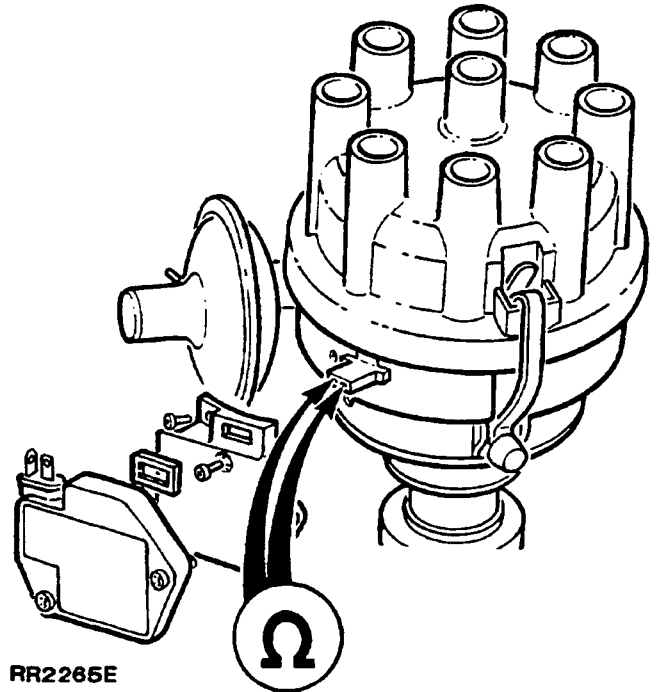

Remove amplifier.

Connect ohmmeter leads to two pick-up terminals in body of distributor.

The ohmmeter should register between 2k and 5k ohm if pick-up is satisfactory. If ohmmeter reading is correct, check all connections between pick-up and amplifier, if satisfactory, fit new amplifier. If engine still does not start carry out Test 5.

Change pick-up if ohmmeter reading is incorrect. If engine still does not start proceed to Test 5.

TEST 5:

Coil H.T. Sparking

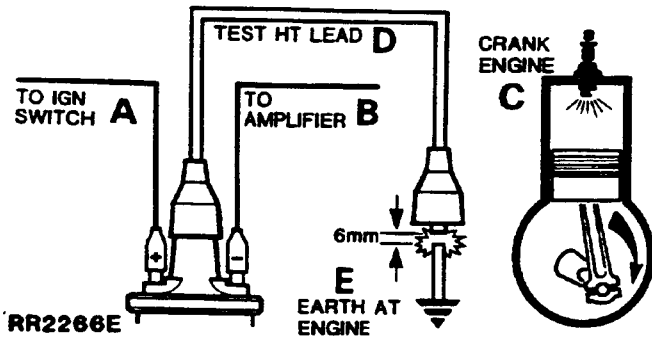

TEST 6:

Rotor Arm

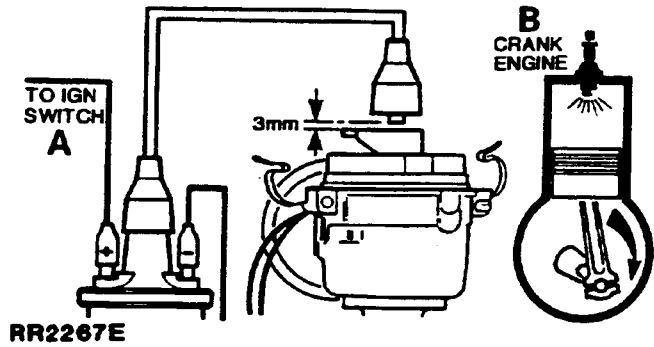

Remove existing coil/distributor H.T. lead and fit test H.T. lead to coil tower. Using suitable insulated pliers, hold free end about 6mm from engine block and crank engine. There should be good H.T. sparking.

If weak or no sparking, fit new coil, repeat test.

H.T. sparking good, repeat test with original H.T. lead. If sparking is good carry out Test 6.

If weak or no sparking, fit new H.T. lead, if engine will not start carry out Test 6.

Remove distributor cover. Disconnect coil H.T. lead from cover, using insulated pliers hold about 3mm (0.13 in) above rotor arm electrode and crank the engine.

There should be no H.T. sparking between rotor and H.T. lead. If satisfactory carry out Test 7.

If H.T. sparking occurs, an earth fault on rotor arm is indicated. Fit new rotor arm. If engine will not start carry out Test 7.

TEST 7:

Visual and H.T. Cable Checks

Examine:

- | | | |
|----|-----------------------------|---|
| 1. | Distributor Cover | Clean, dry, no tracking marks |
| 2. | Coil Top | Clean, dry, no tracking marks. |
| 3. | H.T. Cable Insulation | Must not be cracked, chafed or perished |
| 4. | H.T. Cable Continuity | Must not be open circuit |
| 5. | Sparking Plugs | Clean, dry, and set to correct gap |

Should be:

NOTE:

- | | | |
|----|----------------------------------|---|
| 1. | Reluctor | Must not foul pick-up or leads |
| 2. | Rotor and Insulation Cover | Must not be cracked or show signs of tracking marks |



MEMORY SEAT / MIRROR SYSTEM SERVICE CHECK

The correct operation of memory position store and recall must be checked to ensure correct and safe operation of memory system

Manual transmission vehicles

Memory position, store and recall is only possible when following conditions apply:

- Driver's door open OR ignition AUX or IGN, AND park brake applied, vehicle speed less than 6 kph.



CAUTION: It is potentially hazardous if memory store or recall is possible without park brake applied or with vehicle speed above 6 kph. The cause must be immediately investigated, See ETM, M5

1. If memory position recall/store is possible without park brake applied (vehicle stationary), it is essential to check following:
 - Park brake signal to ECU
 - ECU
2. If memory recall is possible when vehicle speed is over 6 kph, regardless of park brake position, it is essential to check following:
 - Speed signal to ECU
 - Park brake signal to ECU
 - ECU
3. Memory position store/recall function inoperative when park brake applied, check following:
 - Park brake signal to ECU
 - ECU

Automatic transmission vehicles:

Memory position, store and recall is only possible when following conditions apply:

Driver's door open OR ignition AUX or IGN, AND park brake applied, OR park/neutral engaged, vehicle speed less than 6 kph.



CAUTION: It is potentially hazardous if memory store or recall is possible without park brake or park/neutral applied or with vehicle speed above 6 kph. The cause must be immediately investigated, See ETM, M5

1. If memory position recall/store is possible without park brake applied (vehicle stationary), it is essential to check following:
 - Park brake signal to ECU
 - Park/neutral signal to ECU
 - ECU
2. If memory recall is possible with park brake applied or park/neutral engaged, and vehicle speed above 6 kph, it is essential to check following:
 - Park/neutral signal to ECU
 - Speed signal to ECU
 - ECU
3. If memory position store/recall function is NOT possible after applying park brake or engaging park/neutral, check following:
 - Park brake signal system continuity check
 - Park/neutral signal
 - ECU

MEMORY SEAT / MIRROR SYSTEM - FAULT FINDING



NOTE: The following chart lists care points referring to possible faults / remedies in the memory seat system.

SYMPTOMS	CAUSE	REMEDY
Seat or mirrors inoperative	Fuses blown, not inserted or drivers seat load relay	Reinsert or replace fuses under seat and courtesy light fuse, main fuse panel. Refit or fit new relay.
System only operative with door open	Passenger seat relay	Refit or replace
Mirrors and clock inoperative	Mirror/clock harness not connected to main harness	Connect mirror/clock harness behind mirror switch pack and dash
Mirror or mirrors inoperative	Pins backed out in 5-way Espa connector	Repair connector in mirror mounting
Mirrors inoperative	Non connection of 24-way Sumitomo connector	Connect 24-way to memory seat ECU under driver's seat
Mirrors operative but in wrong planes	Mirror switch assy in wrong position or elevation	Fit mirror switch in correct elevation
System partially functional	ECU link harness broken	Replace ECU
Seat inoperative	Non connection of 10-way Sumitomo connector	Reconnect, under driver's seat
Seat operating in different planes and travels to that demanded	Wrongly handed link harness fitted in seat	Fit correct link harness, between seat switch and ECU
Seat pulsing to position in more than one plane	Non connection of 6-way Sumitomo Connect	6-Way, under driver's seat
Seat pulsing to position	No connection at sensor/gear box (ECU input or output)	Make connection to sensor unit, at relevant gearbox

IMPORTANT: For correct wiring installation. See *Repair, Memory Seat - harness layout*

If fault has not been located. See *Memory seat / Mirror system fault diagnosis*



MEMORY SEAT / MIRROR SYSTEM FAULT DIAGNOSIS

Manual and memory seat / mirror system totally inoperative -

1. Seat system losing memory position - 7.

Memory recall function inoperative - 12.

Incorrect manual electric seat control operation - 17.

Incorrect manual mirror operation/movement - 28.

Service checks - 44.

Manual and memory seat / mirror system totally inoperative

1. Are 30 amp fuses and fuse B2 inserted correctly and intact?
Yes, go to 2.
No, replace fuse or reinsert, check system.
2. Is drivers seat load relay inserted correctly?
Yes, go to 3.
No, insert correctly, check system.
3. Does system operate after replacing drivers seat load relay?
Yes, check system.
No, go to 4.
4. Is fusible link inserted correctly and intact?
Yes, go to 6.
No, go to 5.
5. Upon replacing fusible link does system operate correctly?
Yes, check system.
No, go to 6.
6. See memory seat system continuity checks: 4, 5, 6, 7 8 and 9.

Seat system losing memory position

7. Does the seat system lose memory positions upon IGN/AUX being switched off and door closed?
Yes, go to 8.
No, check system.
8. Is 3A stand alone fuse inserted correctly and intact?
Yes, go to 9.
No, check 11.
9. Is fusible link intact?
Yes, go to 10.
No, go to 11.
10. See memory seat system continuity check 3.
11. Does system retain position 24 hours after replacing or reinserting fuse or fusible link?
Yes, check system
No, go to 10.

Memory recall function inoperative

12. Does system attempt to go through calibration sequence?
Yes, is recall function inoperative? Go to 7.
No, go to 13.
13. Does system attempt to go through calibration sequence after replacing original seat switch?
Yes, check system. Clean original switch, and recheck. **See Repair, Memory Seat Switch - Clean**
No, go to 14.
14. Are connectors / connections to seat switch via seat switch harness to ECU intact?
Yes, go to 16.
No, go to 15.
15. Does system attempt to go through calibration sequence after repairing connections to base of seat switch or reconnecting / replacing seat switch link harness, (between switch and ECU)?
Yes, check system.
No, go to 16.
16. See memory seat system continuity check.
Incorrect manual electric seat control operation

Incorrect manual electric seat control operation

17. Are 30 amp fuses intact and inserted correctly?
Yes, go to 18.
No, reinsert / replace fuses correctly, check system
18. Is fusible link intact and inserted correctly?
Yes, go to 20.
No, reinsert / replace fusible link correctly, check system.
19. Does seat operate or attempt to operate under calibrate sequence?
Yes, go to 20.
No, go to 13, then 21.
20. Does seat move under manual electric control in all demanded directions? (pulsing or not pulsing to demanded position)?
Yes, go to 22.
No, go to 21.
21. Does seat switch move seat under manual electric control in all demanded directions, after replacing seat switch?
Yes, check system
No, go to 14 or check seat motor operation.
22. Observe non movement of seat in plane/s where seat did not go through full movement or stop at mid positions under calibrate routine.
Go to 23
23. Does manual electric seat movement in this plane pulse to position demanded?
Yes, go to 24.
No, check motor operation.
24. Are connections between gearbox sensor unit and ECU secure (and electrically sound)?
Yes, go to 25.
No, go to 26.
25. Does manual movement in this plane pulse in demanded direction after replacing gearbox sensor unit?
Yes, check 27.
No, check system
26. Secure connections, re-check 22. and 23.
27. See memory seat system continuity check.

Incorrect manual mirror operation or movement

28. Are 3 amp fuses under driver's seat inserted correctly and intact?
Yes, go to 29.
No, replace or reinsert fuse, check system.
29. Do mirrors work correctly under calibrate sequence (both mirrors going through full movement and stopping near mid position)?
Yes, go to 30.
No, go to 33, 37, and 41.
30. Is mirror switch assembly mounted in correct elevation in dash?
Yes, go to 31
No, mount mirror correctly.
31. Does L.H. mirror work correctly under manual control without pulsing to position?
Yes/No, go to 32.
32. Does R.H. mirror work correctly under manual control without pulsing to position?
Yes/No, go to 33.
33. Is same fault common to both L.H. and R.H. mirrors?
Yes, go to 34.
No, go to 37.



34. Is connection made from manual mirror switches to main harness?
Yes, go to 35.
No, re-make connection and check system.
35. Do mirrors work correctly after replacing mirror joystick?
Yes, check system
No, go to 36.
36. See continuity checks.
37. Are connections to mirror faulty? (check for pin backout on 5 way ESPA connector)?
Yes, re-make connections and check system
No, go to 38.
38. Does mirror function correctly upon replacing mirror?
Yes, check system
No, go to 39.
39. Does mirror still exhibit same fault after replacing mirror changeover switch?
Yes, go to 41.
No, check system
40. See continuity checks
41. Does mirror movement still pulse in demanded direction under manual mirror electric control?
Yes, possible feed back from mirror missing, go to 40.
No, check system
42. Does mirror move, pulsing in opposite direction to that demanded under manual mirror electric control?
Yes, possible feedback short to vehicle ground, check 40, continuity to vehicle ground
No, check system
43. Are mirror or mirrors still inoperative?
Yes, go to 40.

Service checks

44. Do seats operate under manual control when driver's door is open?
Yes, check system fully, go to 47.
No, go to 45.
45. Is interior light on when driver's door is open?
Yes, check 30 amp fuses, then go to 46.
No, go to 48.
46. Does door switch have a tendency to stick in off position when opening door?
Yes, replace switch, check system
No, go to 48.
47. Do manual electric seats operate when door open, but NOT when either IGN or AUX are engaged and door closed?
Yes, check fuse and seat relays, go to 53.
No, check 48.
48. Are connections to door switch made, including fuse B2?
Yes, check 49.
No, make connections, check system.
49. Does door switch make a good electrical contact?
Yes, go to 53.
No, replace switch, check system.
50. Does memory position recall function operate when park brake or park / neutral is not engaged?
Yes, go to 53.
No, is system OK?
51. Does memory position recall function operate when either park brake or park / neutral engaged?
Yes, is system OK?
No, go to 53.
52. Does speed signal inhibit memory recall function?
Yes, is system OK?
No, go to 53.
53. See memory seat system continuity check.

HEATED FRONT SCREEN - 1990

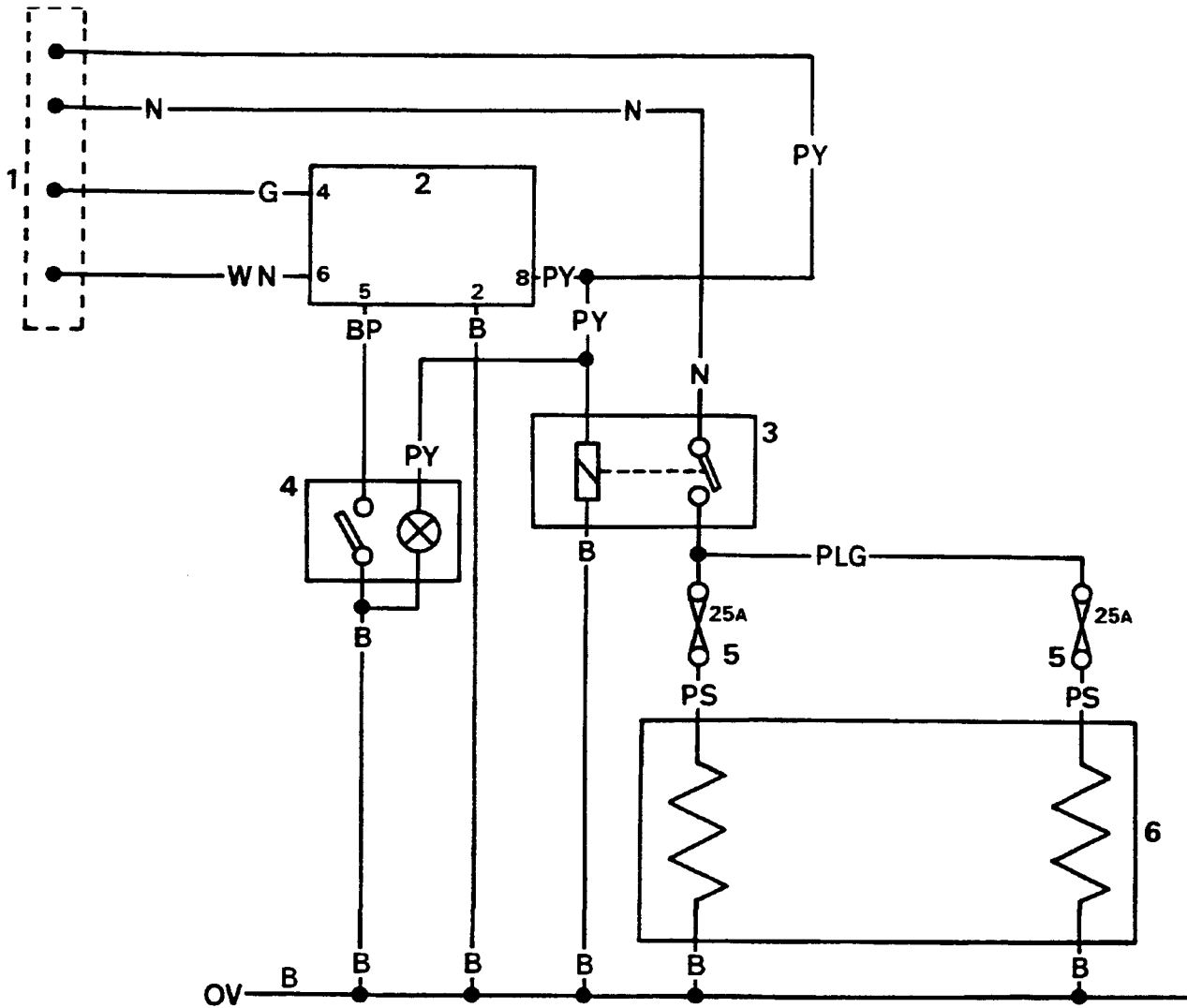

RR2593E

Circuit diagram - RR2593E

- | | |
|-------------------------------------|----------------------------|
| 1. Main harness connections | 2. Timer unit |
| Brown - live positive feed | 3. Load relay |
| Green - ignition positive feed | 4. Switch / warning light |
| Purple / yellow - EFI harness plug | 5. In line fuses - 25 Amp. |
| White / brown - oil pressure switch | 6. Heated front screen |
| Black - earth | |

Cable colour code

B Black	L Light	P Purple	U Blue
G Green	N Brown	R Red	W White
K Pink	O Orange	S Grey	Y Yellow

The last letter of a colour denotes the tracer colour.



ELECTRIC SEAT ADJUSTMENT - 1990

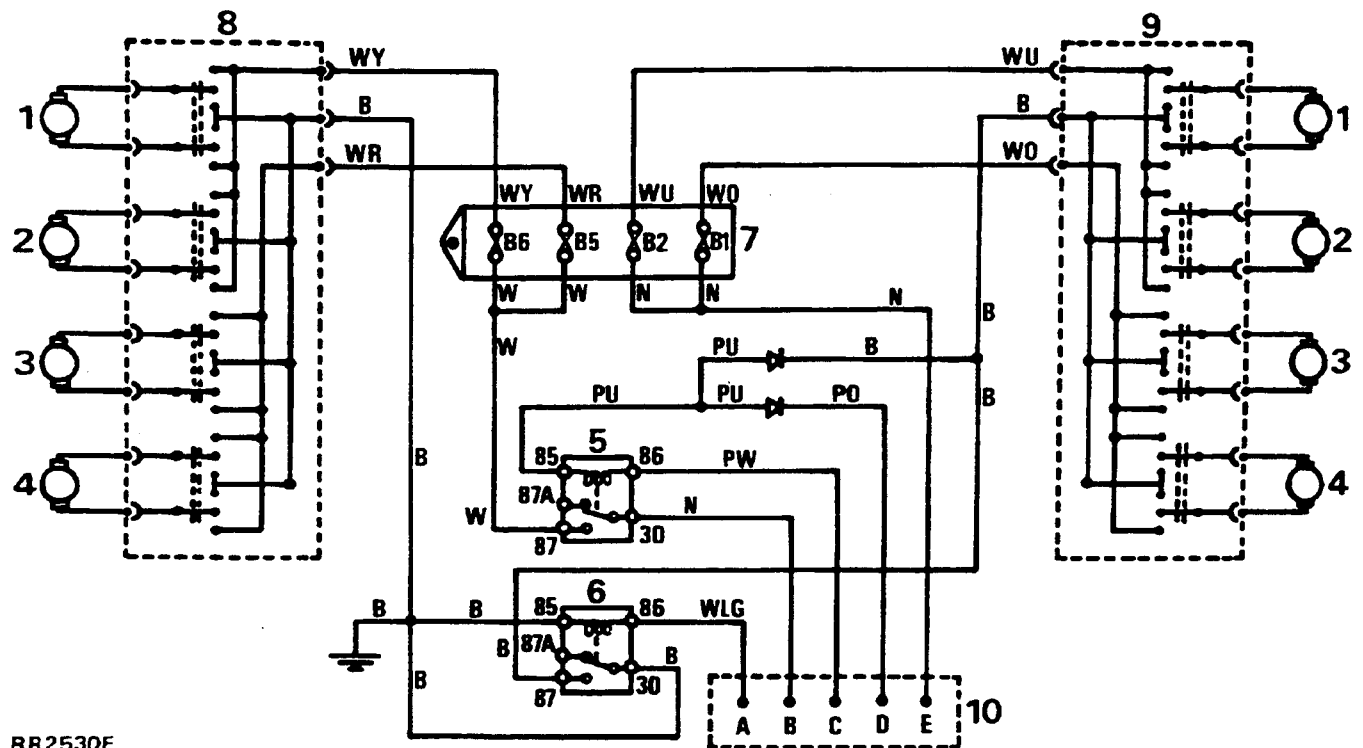

RR2530E

Circuit diagram - RR2530E

- | | |
|--|-----------------------------|
| 1. Seat recline motor | 8. Driver's seat control |
| 2. Seat height (rear) motor | 9. Passenger's seat control |
| 3. Seat base adjust motor | 10. Main cable connections: |
| 4. Seat height (front) motor | - A: Fused auxiliary feed |
| 5. Load relay-from driver's door courtesy switch | - B: Battery feed |
| 6. Load relay-fused auxiliary feed controlled | - C: Fused 12 volt |
| 7. Auxiliary fuse box (B) | - D: Courtesy switch earth |
| | - E: Battery feed |

Cable colour code

B	Black	L	Light	P	Purple	U	Blue
G	Green	N	Brown	R	Red	W	White
K	Pink	O	Orange	S	Grey	Y	Yellow

The last letter of a colour denotes the tracer colour.

CENTRAL DOOR LOCKING - 1990

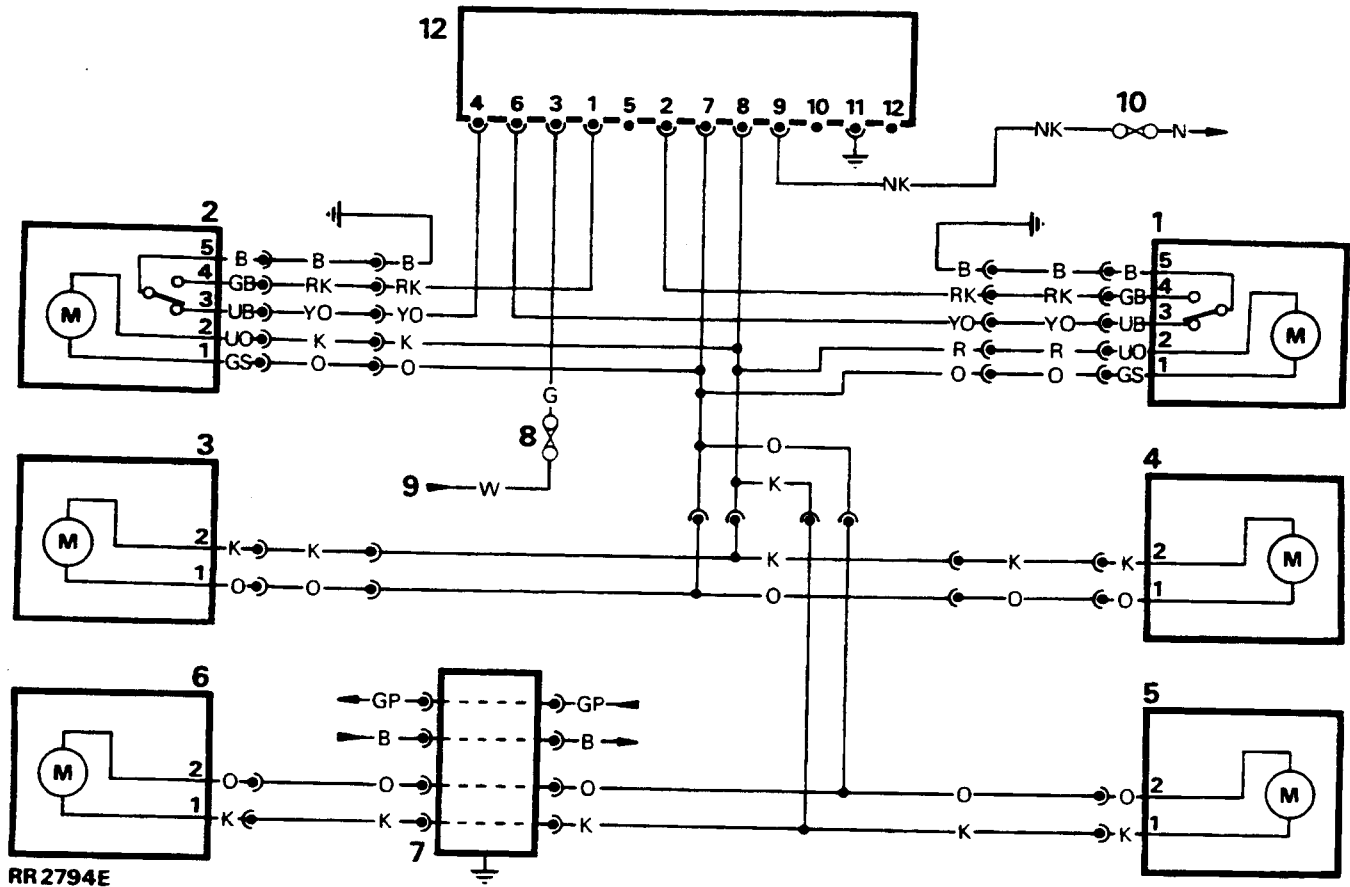

RR2794E

Circuit diagram - RR2794E

- | | |
|---|---------------------------------------|
| 1. Switch / lock unit right hand front door | 7. Suppressor |
| 2. Switch / lock unit left hand front door | 8. Fuse A5 |
| 3. Lock unit left hand rear door relay | 9. Feed from ignition load relay |
| 4. Lock unit right hand rear door relay | 10. Fuse C7 |
| 5. Fuel flap actuator | 11. Battery 12V + ve |
| 6. Lock unit tailgate | 12. Central door locking control unit |

Cable colour code

B Black	L Light	P Purple	U Blue
G Green	N Brown	R Red	W White
K Pink	O Orange	S Grey	Y Yellow

The last letter of a colour denotes the tracer colour.



ELECTRIC MIRRORS - 1990

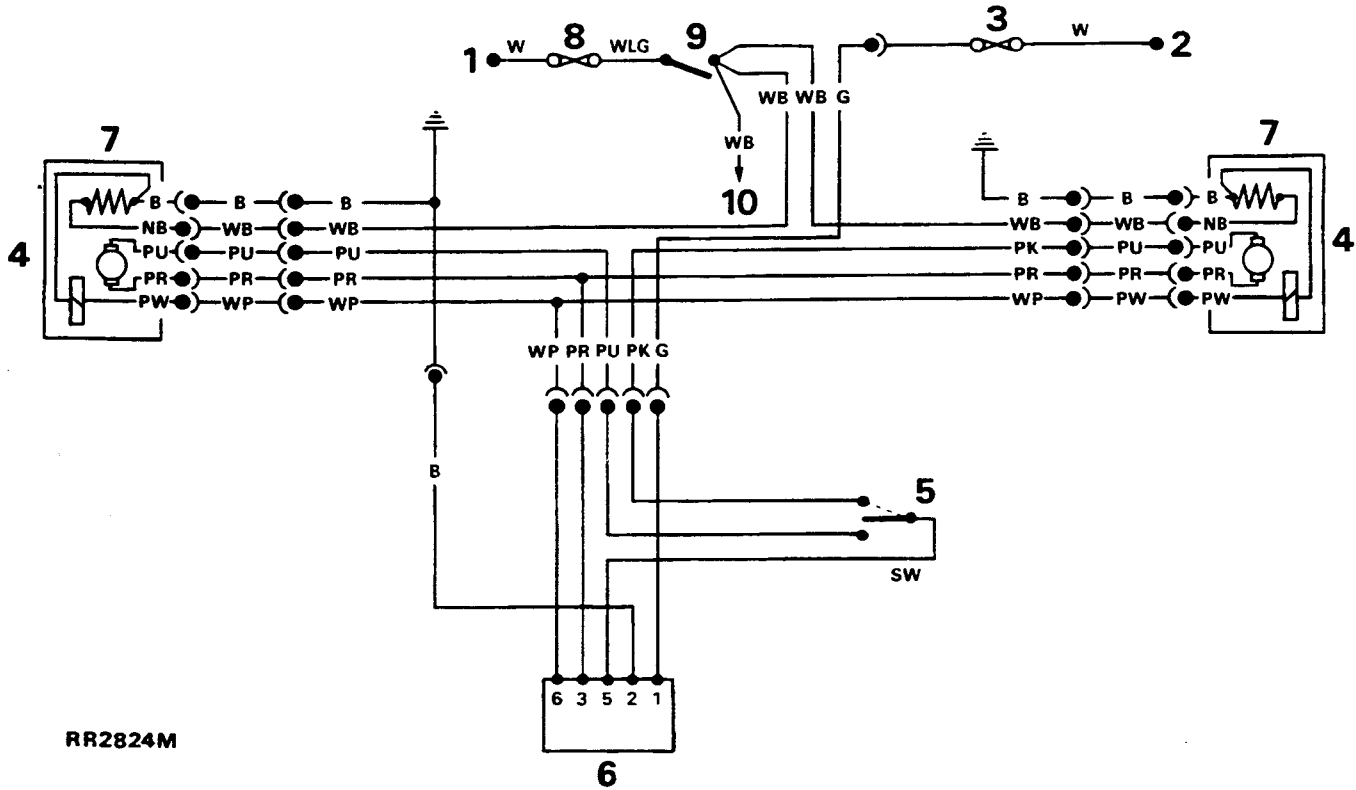

Circuit diagram - RR2824M

- | | |
|-----------------------------|--|
| 1. Ignition 12V. | 7. Mirror heating elements - active with heated rear screen. |
| 2. Ignition load relay. | 8. Fuse C3 - heating elements. |
| 3. Fuse C5 - mirror motors. | 9. Heated rear screen switch. |
| 4. Mirror motors. | 10. Feed to heated screen relay. |
| 5. Change over switch. | |
| 6. Mirror control switch. | |

Cable colour code

B Black	L Light	P Purple	U Blue
G Green	N Brown	R Red	W White
K Pink	O Orange	S Grey	Y Yellow

The last letter of a colour denotes the tracer colour.

ELECTRIC WINDOW LIFT - 1990

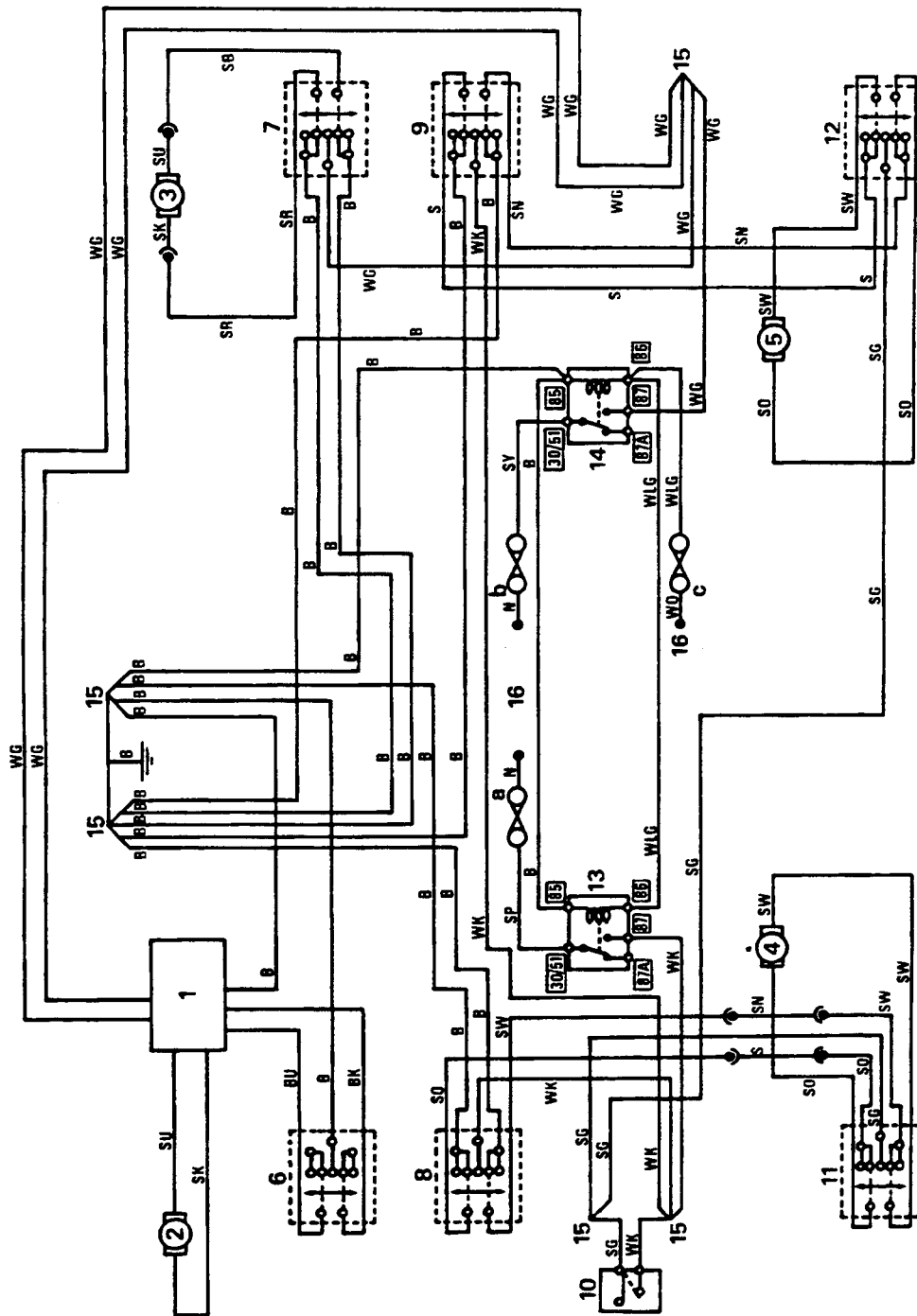

RR2531E



ELECTRIC WINDOW LIFT

Circuit diagram - RR2531E

- | | |
|---|--|
| 1. One touch control unit-drivers window | 11. Window lift switch in LH rear door |
| 2. Window lift motor-drivers window | 12. Window lift switch in RH rear door |
| 3. Window lift motor-front passengers side | 13. Relay-rear windows |
| 4. Window lift motor LH rear | 14. Relay-front windows |
| 5. Window lift motor RH rear | 15. Clinches |
| 6. Window lift switch drivers window | 16. Main cable fuses |
| 7. Window lift switch front passengers window | - a: Fuse C2 |
| 8. Window lift switch LH rear door | - b: Fuse C8 |
| 9. Window lift switch RH rear door | - c: Fuse B1 |
| 10. Isolator switch | |

Cable colour code

B Black	L Light	P Purple	U Blue
G Green	N Brown	R Red	W White
K Pink	O Orange	S Grey	Y Yellow

The last letter of a colour denotes the tracer colour.

CIRCUIT DIAGRAM - 1990 MY - RIGHT HAND STEERING - illustrations RR2830M & RR2831M

Numerical key

1.	Ignition load relay	59.	LH horn	122.	EFI Harness plug
2.	Battery	60.	Under bonnet illumination switch	123.	Fuel shut off solenoid (Diesel)
3.	Terminal post	61.	Under bonnet light	124.	Sun roof relay
4.	Starter solenoid	62.	Clock	124a.	Fuse B5
5.	Starter motor	63.	Fuse C7	125.	Radio fuse
6.	Starter relay	64.	Fuse C8	126.	Radio and four speakers
7.	Starter inhibit switch	65.	Pick-up point central locking/window lift		-LF-left hand front speaker
7a.	Resistor (manual)	66.	Fuse C1		-LR-left hand rear speaker
8.	Ignition switch	67.	Heated rear screen relay		-RF-right front speaker
9.	Tachometer	68.	Radio aerial amplifier		-RR-right hand rear speaker
10.	Voltage transformer (dim dip)	69.	Heated rear screen	127.	Sun roof pick up point
11.	Ignition warning lamp	70.	Heated rear screen warning lamp	128.	Auto transmission and transfer box oil temperature warning lamp
12.	Alternator	71.	Heated rear screen warning lamp	129.	Auto transmission oil temperature switch
13.	Fuse B1	72.	Voltage sensitive switch	129a.	Transfer box oil temperature switch
14.	Front wiper/wash switch	73.	Fuse A5	130.	Fuse C3
15.	Front wiper delay unit	74.	Hazard switch	131.	Rear wash wiper switch
16.	Front wiper motor	75.	Flasher unit	132.	Rear wiper delay unit
17.	Headlamp relay	76.	Direction indicator switch	133.	Rear wiper motor
18.	Front wash pump	77.	LH indicator warning lamp	134.	Rear screen wash pump
19.	Headlamp wash timer unit	77a.	RH indicator warning lamp	135.	Low screen wash fluid level warning lamp
20.	Headlamp wash pump	78.	LH rear indicator lamp	136.	Low screen wash switch
21.	Main lighting switch	79.	LH front indicator lamp	137.	Low coolant switch
22.	Fuse A3	80.	LH side repeater lamp	138.	Electronic speedo and instrument controls
23.	Fuse A7	81.	RH side repeater lamp	139.	Low coolant level warning lamp
24.	LH side lamp	82.	RH front indicator lamp	140.	Low fuel level warning lamp
25.	LH tail lamp	83.	RH rear indicator lamp	141.	Glow plug warning lamp (Diesel)
26.	LH number plate lamp	84.	Trailer warning lamp	142.	E.F.I. warning lamp
26a.	RH number plate lamp	85.	Fuse A6	143.	Glow plug timer unit
27.	High beam dip/flash switch	86.	Stop lamp switch	144.	Glow plugs (Diesel)
28.	Fuse B2	87.	Reverse lamp switch	145.	ABS warning lamp
29.	RH side lamp	88.	Front auxiliary lamp relay	146.	Handbrake/brake fluid level/pressure warning lamp
30.	RH tail lamp	89.	LH stop lamp	147.	Handbrake warning switch
31.	Rheostat	90.	RH stop lamp	148.	Brake fluid level warning switch
32.	Fuse A8	91.	LH reverse lamp	149.	Brake pad wear warning lamp
33.	Fuse A2	92.	RH reverse lamp	150.	Brake pad wear sensors
34.	Fuse A9	93.	LH front auxiliary lamp	151.	Brake check relay
35.	Fuse A1	94.	RH front auxiliary lamp	152.	Split charge relay (option)
36.	Rear fog switch	95.	Front auxiliary lamp switch	153.	Split charge terminal post (option)
37.	Fuse A4	96.	Fuse B4	154.	Heater/air conditioning connections
38.	Switch illumination (2 off)	97.	Dash cigar lighter	155.	Fuse C9
39.	Cigar lighter illumination (2 off)	98.	Glove box cigar lighter	156.	Coil negative (engine RPM input to ECU)
40.	Heater illumination (4 off)	99.	Front interior lamp	157.	Not used
41.	Clock illumination	100.	Rear interior lamp	158.	Ignition load relay (+)
42.	Auto gear selector illumination (2 off) - post April 1990 condition	101.	Interior lamp delay unit	159.	Battery feed (+)
42a.	Auto gear selector illumination (2 off) - pre April 1990 condition	102.	LH door edge lamp	160.	Ignition auxiliary (+)
43.	Instrument illumination (4 off)	103.	LH puddle lamp	161.	Ignition on (+)
43a.	Column switch illumination	104.	RH door edge lamp	162.	Earth (-)
44.	Rear fog warning lamp	105.	RH puddle lamp	163.	Heater/air con. load relay
45.	LH rear fog lamp	106.	Interior lamp switch	164.	Trailer pick up point
46.	RH rear fog lamp	107.	LH rear door switch	165.	Electric seats pick up point (option)
47.	LH dip beam	108.	RH rear door switch	166.	Fuse C2
48.	RH dip beam	109.	Tailgate switch	167.	Electric mirrors pick up point
49.	LH high beam	110.	LH front door switch	168.	Alarm pick up point
50.	RH high beam	111.	RH front door switch	169.	Fuse C5
51.	High beam warning lamp	112.	Heated washer jets (front screen)	170.	ABS pick up point
52.	Fuel gauge	113.	Thermostat heated jets	171.	Fuse B6
53.	Fuel gauge sender unit	114.	Oil pressure warning lamp	172.	Fuse B7
54.	Water temperature gauge	115.	Oil pressure switch	173.	Condenser fan relay
55.	Water temperature sender unit	116.	Fuse C4	174.	Fuse B8
56.	Fuse B3	117.	Heated front screen connections	175.	Fuse B9
57.	Horn switch	118.	Fuel pump (petrol models)	176.	Inertia switch
58.	RH horn	119.	Ignition coil	177.	Speed transducer
		120.	Capacitor		
		121.	Distributor		



Circuit diagram - 1990 MY - RIGHT HAND STEERING - illustrations RR2830M & RR2831M

Alphabetical key

170.	ABS pick up point	166.	Fuse C2	136.	Low screen wash switch
145.	ABS warning lamp	130.	Fuse C3	21.	Main lighting switch
168.	Alarm pick up point	116.	Fuse C4	115.	Oil pressure switch
12.	Alternator	169.	Fuse C5	114.	Oil pressure warning lamp
42.	Automatic gear selector illumination (2 off)	63.	Fuse C7	65.	Pick up point-central locking/window lift
129.	Automatic transmission oil temperature switch	64.	Fuse C8	68.	Radio aerial amplifier
128.	Automatic transmission/transfer box oil temperature warning lamp	155.	Fuse C9	126.	Radio and four speakers
2.	Battery	98.	Glove box cigar lighter	125.	Radio fuse
148.	Brake fluid level warning switch	144.	Glow plug (Diesel)	36.	Rear fog switch
150.	Brake pad wear sensors	143.	Glow plug timer unit (Diesel)	44.	Rear fog warning lamp
149.	Brake pad wear warning lamp	141.	Glow plug warning lamp (Diesel)	100.	Rear interior lamp
151.	Brake check relay	146.	Handbrake/brake fluid level/pressure warning lamp	134.	Rear screen wash pump
120.	Capacitor	147.	Handbrake warning switch	131.	Rear wash wipe switch
39.	Cigar lighter illumination (2 off)	74.	Hazard switch	132.	Rear wipe delay unit
62.	Clock	17.	Headlamp relay	133.	Rear wiper motor
41.	Clock illumination	20.	Headlamp wash pump	7a.	Resistor (manual)
156.	Coil negative, engine speed signal to ECU	19.	Headlamp wash timer unit	87.	Reverse lamp switch
43a.	Column switch illumination	117.	Heated front screen connections	48.	RH dip beam
173.	Condenser fan relay	69.	Heated rear screen	104.	RH door edge lamp
97.	Dash cigar lighter	67.	Heated rear screen relay	94.	RH front auxiliary lamp
76.	Direction indicator switch	70.	Heated rear screen switch	111.	RH front door switch
121.	Distributor	71.	Heated rear screen warning lamp	82.	RH front indicator lamp
167.	Electric mirrors pick up point (option)	112.	Heated washer jets	50.	RH high beam
165.	Electric seats pick up point (option)	40.	Heater illumination (4 off)	58.	RH horn
138.	Electronic speedo and instrument controls	154.	Heater/air con. connections	77a.	RH indicator warning lamp
122.	EFI Harness plug	163.	Heater/air con. load relay	26a.	RH number plate lamp
142.	EFI warning lamp	27.	High beam dip/flash switch	105.	RH puddle lamp
75.	Flasher unit	51.	High beam warning lamp	108.	RH rear door switch
88.	Front auxiliary lamp relay	57.	Horn switch	46.	RH rear fog lamp
95.	Front auxiliary lamp switch	119.	Ignition coil	83.	RH rear indicator lamp
99.	Front interior lamp	1.	Ignition load relay	92.	RH reverse lamp
18.	Front wash pump	8.	Ignition switch	29.	RH side lamp
15.	Front wipe delay unit	11.	Ignition warning lamp	81.	RH side repeater lamp
14.	Front wipe/wash switch	176.	Inertia switch	90.	RH stop lamp
16.	Front wiper motor	43.	Instrument illumination (4 off)	30.	RH tail lamp
52.	Fuel gauge	101.	Interior lamp delay unit	31.	Rheostat
53.	Fuel gauge sender unit	106.	Interior lamp switch	177.	Speed transducer
118.	Fuel pump (petrol models)	47.	LH dip beam	152.	Split charge relay (option)
123.	Fuel shut off solenoid (Diesel)	102.	LH door edge lamp	153.	Split charge terminal post (option)
35.	Fuse A1	93.	LH front auxiliary lamp	7.	Starter inhibit switch
33.	Fuse A2	110.	LH front door switch	5.	Starter motor
22.	Fuse A3	79.	LH front indicator lamp	6.	Starter relay
37.	Fuse A4	49.	LH high beam	4.	Starter solenoid
73.	Fuse A5	59.	LH horn	86.	Stop lamp switch
85.	Fuse A6	77.	LH indicator warning lamp	127.	Sunroof pick up point
23.	Fuse A7	25.	LH number plate lamp	124.	Sunroof relay
32.	Fuse A8	103.	LH puddle lamp	38.	Switch illumination (2 off)
34.	Fuse A9	107.	LH rear door switch	9.	Tachometer
13.	Fuse B1	45.	LH rear fog lamp	109.	Tailgate switch
28.	Fuse B2	78.	LH rear indicator lamp	3.	Terminal post
56.	Fuse B3	91.	LH reverse lamp	113.	Thermostat - heated washer jets
96.	Fuse B4	24.	LH side lamp	164.	Trailer pick up point
124a.	Fuse B5	80.	LH side repeater lamp	84.	Trailer warning lamp
171.	Fuse B6	89.	LH stop lamp	129a.	Transfer box oil temperature switch
172.	Fuse B7	25.	LH tail lamp	60.	Under bonnet illumination switch
174.	Fuse B8	139.	Low coolant level warning lamp	61.	Under bonnet light
175.	Fuse B9	137.	Low coolant switch	72.	Voltage sensitive switch
66.	Fuse C1	140.	Low fuel level warning lamp	10.	Voltage transformer (dim-dip)
		135.	Low screen wash fluid level warning lamp	54.	Water temperature gauge
				55.	Water temperature sender unit

Circuit diagram - 1990 MY - Right hand steering

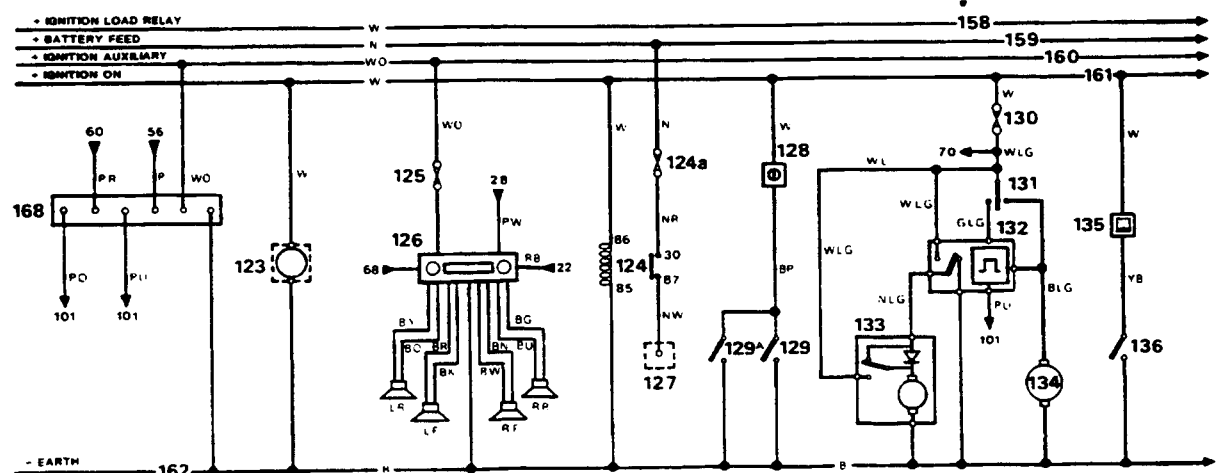
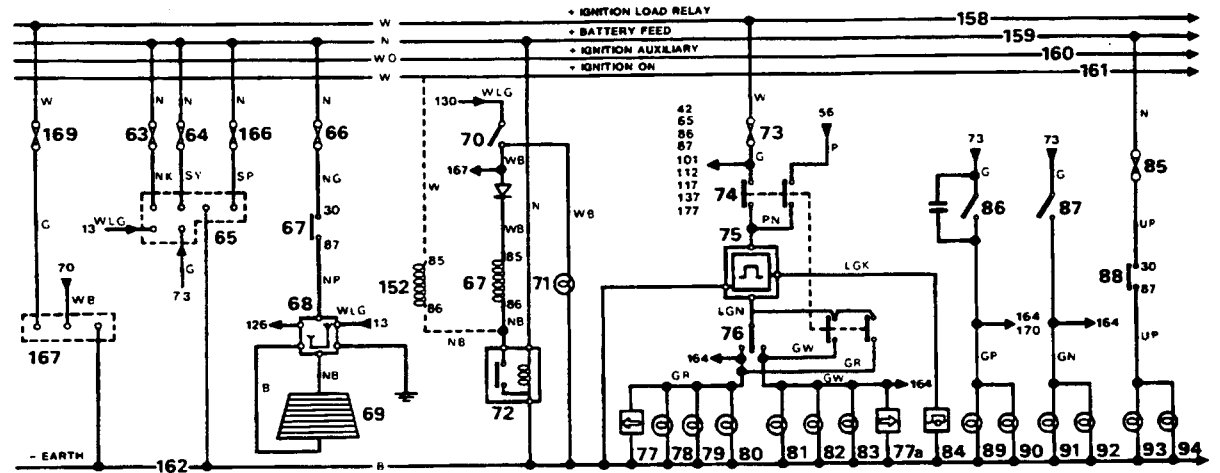
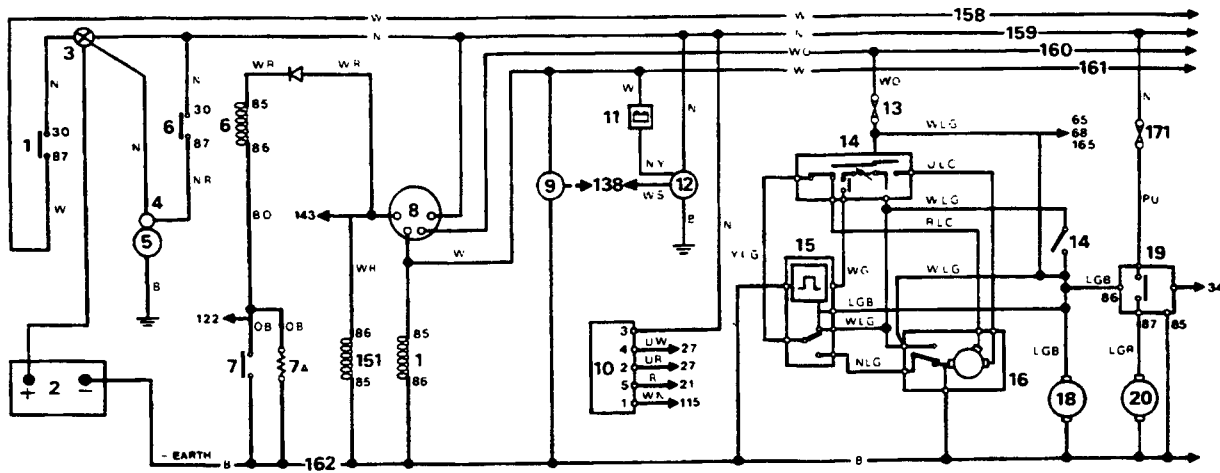

RR2830M



Illustrations RR2830M & RR2831M

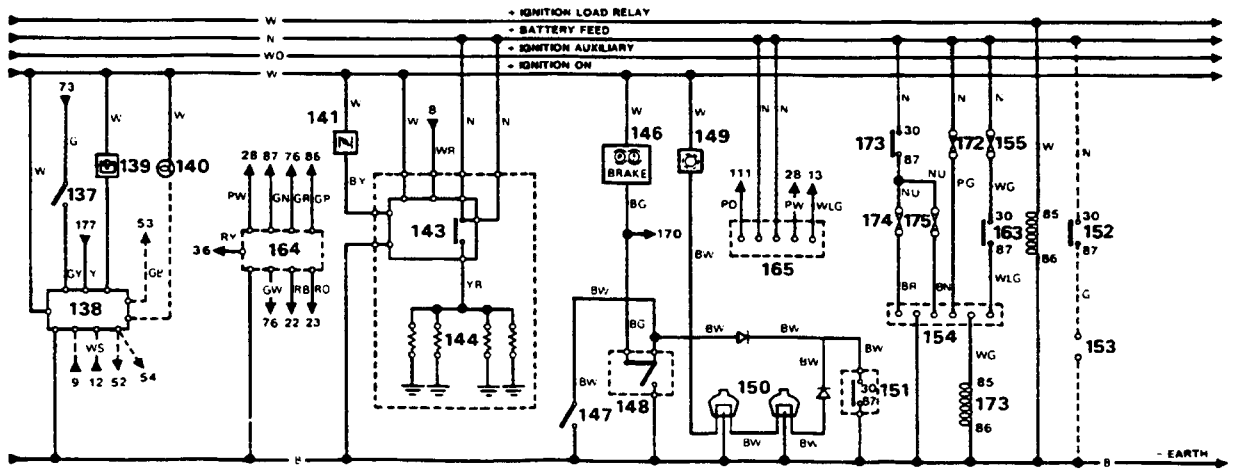
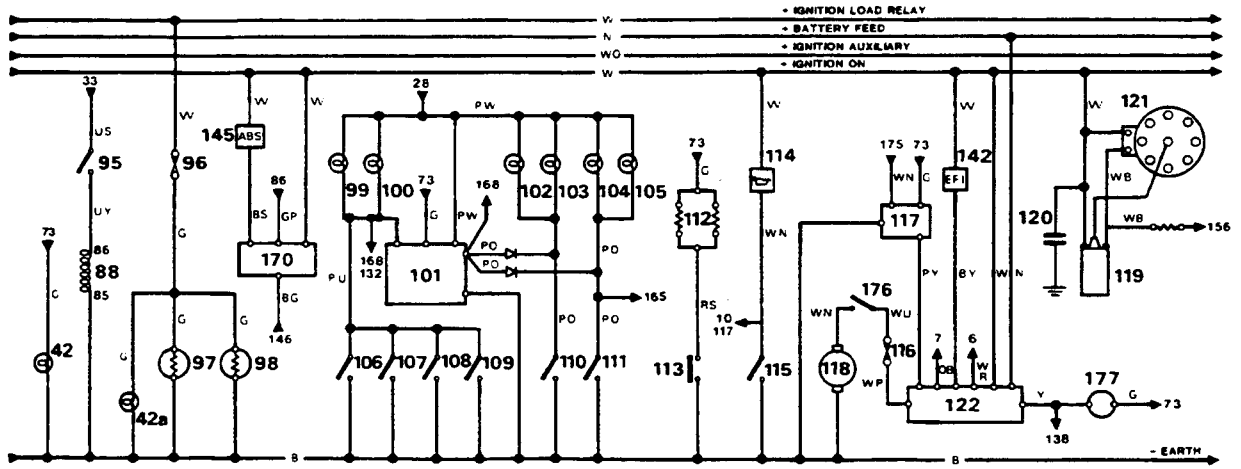
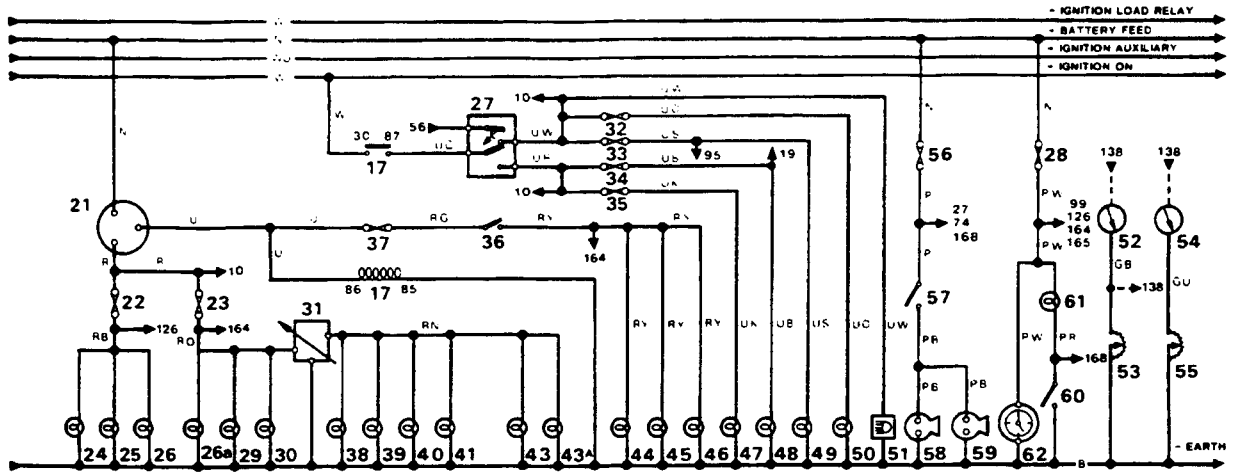

RR2831M

CIRCUIT DIAGRAM - 1990 MY - LEFT HAND STEERING - illustrations RR2828M & RR2829M

Numerical key

1.	Ignition load relay	60.	Clock	-LR-left hand rear speaker	
2.	Battery	61.	Fuse C7	-RF-right front speaker	
3.	Terminal post	62.	Fuse C2	-RR-right hand rear speaker	
4.	Starter solenoid	63.	Pick-up point central locking/window lift	125.	Sun roof relay
5.	Starter motor	64.	Heated rear screen relay	125a.	Fuse B5
6.	Starter relay	65.	Fuse C1	126.	Alarm pick up point
7.	Starter inhibit switch (auto)	66.	Radio aerial amplifier	127.	Overspeed warning (Saudi only)
7a.	Resistor (manual transmission)	67.	Heated rear screen	128.	Fuse B6
8.	Ignition switch	68.	Heated rear screen switch	129.	Fuse C5
9.	Tachometer	69.	Heated rear screen warning lamp	130.	Fuel shut off solenoid (Diesel)
10.	Ignition warning lamp	70.	Voltage sensitive switch	131.	Seat buckle switch (Saudi only)
11.	Alternator	71.	Fuse A5	132.	Overspeed monitor (Saudi only)
12.	Fuse B1	72.	Hazard switch	133.	Heated front screen pick up point (option)
13.	Front wipe/wash switch	73.	Flasher unit	134.	Sunroof pick up point (option)
14.	Front wipe delay unit	74.	Direction indicator switch	135.	Auto transmission/transfer box oil temperature warning lamp
15.	Front wiper motor	75.	LH indicator warning lamp	136.	Auto transmission oil temperature switch
16.	Headlamp relay	75a.	RH indicator warning lamp	136a.	Transfer box oil temperature switch
17.	Front wash pump	76.	LH rear indicator lamp	137.	Fuse C3
18.	Headlamp wash timer unit	77.	LH front indicator lamp	138.	Rear wash wipe switch
19.	Headlamp wash pump	78.	LH side repeater lamp	139.	Rear wipe delay unit
20.	Main lighting switch	79.	RH side repeater lamp	140.	Rear wiper motor
21.	Fuse A3	80.	RH front indicator lamp	141.	Rear screen wash pump
22.	Fuse A7	81.	RH rear indicator lamp	142.	Low screen wash fluid level warning lamp
23.	LH side lamp	82.	Trailer warning lamp	143.	Low screen wash switch
24.	LH tail lamp	83.	Fuse A6	144.	Low coolant switch
25.	LH number plate lamp	84.	Stop lamp switch	145.	Electronic speedo and instrument controls
25a.	RH number plate lamp	85.	Reverse lamp switch	146.	Low coolant level warning lamp
26.	High beam dip/flash switch	86.	Front auxiliary lamp relay (option)	147.	Low fuel level warning lamp
27.	RH side lamp	87.	LH stop lamp	148.	E.F.I. warning lamp
28.	RH tail lamp	88.	RH stop lamp	149.	Glow plug warning lamp (Diesel)
29.	Rheostat	89.	LH reverse lamp	150.	Glow plug timer unit(Diesel)
30.	Fuse A8	90.	RH reverse lamp	151.	Glow plugs (Diesel)
31.	Fuse A2	91.	LH front auxiliary lamp (option)	152.	ABS warning lamp
32.	Fuse A9	92.	RH front auxiliary lamp (option)	153.	Handbrake/brake fluid level/pressure warning lamp
33.	Fuse A1	93.	Front auxiliary lamp switch	153a.	Brake fluid level warning switch
34.	Rear fog switch	94.	Fuse B4	154.	Handbrake warning switch
35.	Fuse A4	95.	Dash cigar lighter	155.	Brake pad wear warning lamp
36.	Switch illumination (2 off)	96.	Glove box cigar lighter	156.	Brake pad wear sensors
36a.	Headlamp levelling switch illumination (Germany)	97.	Front interior lamp	157.	Brake check unit
37.	Cigar lighter illumination (2 off)	98.	Rear interior lamp	158.	Split charge relay (option)
38.	Heater illumination (4 off)	99.	Interior lamp delay unit	159.	Split charge terminal post (option)
39.	Clock illumination	100.	LH door edge lamp	160.	Heater/air conditioning connections
40.	Auto gear selector illumination (2 off) - post April 1990 condition	101.	LH puddle lamp	161.	Fuse C9
40a.	Auto gear selector illumination (2 off) - pre April 1990 condition	102.	RH door edge lamp	162.	Coil negative (engine RPM input to ECU)
41.	Instrument illumination (4 off)	103.	RH puddle lamp	163.	ignition load relay (+)
41a.	Column switch illumination	104.	Interior lamp switch	164.	Battery feed (+)
42.	Rear fog warning lamp	105.	LH rear door switch	165.	Ignition auxiliary (+)
43.	LH rear fog	106.	RH rear door switch	166.	Ignition on (+)
44.	RH rear fog	107.	Tailgate switch	167.	Earth (-)
45.	LH dip beam	108.	LH front door switch	168.	Warning lights supply common earth (-)
46.	RH dip beam	109.	RH front door switch	169.	Warning lights supply (+)
47.	LH high beam	110.	Heated washer jets (front screen)	170.	Electric seats pick up point
48.	RH high beam	111.	Thermostat-heated washer jets	171.	Fuse B3
49.	High beam warning lamp	112.	Oil pressure warning lamp	172.	Fuse B8
50.	Fuel gauge	113.	Oil pressure switch	173.	Fuse C8
51.	Fuel gauge sender unit	114.	Fuse C4	174.	Electric mirrors pick up point (option)
52.	Water temperature gauge	115.	Inertia switch	175.	Heater/air conditioning load relay
53.	Water temperature sender unit	116.	Fuel pump (petrol models)	176.	Cruise control pick up points (option)
54.	Fuse B2	117.	Ignition coil (petrol models)	177.	Fuse B9
55.	Horn switch	118.	Capacitor (petrol models)	178.	Condenser fan relay
56.	RH horn	119.	Distributor (petrol models)	179.	Fuse B7
57.	LH horn	120.	EFI Harness plug	180.	ABS pick up point
58.	Under bonnet illumination switch	121.	Speed transducer	181.	Headlamp levelling switch connection (German)
59.	Under bonnet light	122.	Trailer pick up point	182.	Headlamp levelling actuator (2) (German)
		123.	Radio fuse		
		124.	Radio and four speakers		
			-LF-left hand front speaker		



CIRCUIT DIAGRAM - 1990 MY - LEFT HAND STEERING - ILLUSTRATIONS RR2828M & RR2829M

Alphabetical key

- | | | |
|---|--|---|
| 180. ABS pick up point | 114. Fuse C4 | 143. Low screen wash switch |
| 152. ABS warning lamp | 129. Fuse C5 | 20. Main lighting switch |
| 126. Alarm pick up point | 61. Fuse C7 | 113. Oil pressure switch |
| 11. Alternator | 173. Fuse C8 | 112. Oil pressure warning lamp |
| 40. Automatic gear selector illumination (2 off) | 161. Fuse C9 | 132. Overspeed monitor (Saudi only) |
| 136. Automatic transmission oil temperature switch | 96. Glove box cigar lighter | 127. Overspeed warning (Saudi only) |
| 135. Automatic transmission/transfer box oil temperature warning lamp | 151. Glow plugs (Diesel) | 63. Pick up point-central locking/window lift |
| 2. Battery | 150. Glow plug timer unit (Diesel) | 66. Radio aerial amplifier |
| 153a. Brake fluid level warning switch | 149. Glow plug warning lamp (Diesel) | 124. Radio and four speakers |
| 157. Brake check unit | 153. Handbrake/brake fluid level/pressure warning lamp | 123. Radio fuse |
| 156. Brake pad wear sensors | 154. Handbrake warning switch | 34. Rear fog switch |
| 155. Brake pad wear warning lamp | 72. Hazard switch | 42. Rear fog warning lamp |
| 118. Capacitor (petrol models) | 182. Headlamp levelling actuator (2) (Germany) | 98. Rear interior lamp |
| 37. Cigar lighter illumination (2 off) | 181. Headlamp levelling switch connection (Germany) | 141. Rear screen wash pump |
| 60. Clock | 36a. Headlamp levelling switch illumination (Germany) | 138. Rear wash wipe switch |
| 39. Clock illumination | 16. Headlamp relay | 139. Rear wipe delay unit |
| 162. Coil negative, engine speed signal to ECU | 19. Headlamp wash pump | 140. Rear wiper motor |
| 41a. Column switch illumination | 18. Headlamp wash timer unit | 7a. Resistor (manual) |
| 178. Condenser fan relay | 133. Heated front screen pick up point (option) | 85. Reverse lamp switch |
| 176. Cruise control pick up point (option) | 67. Heated rear screen | 46. RH dip beam |
| 95. Dash cigar lighter | 64. Heated rear screen relay | 102. RH door edge lamp |
| 74. Direction indicator switch | 68. Heated rear screen switch | 92. RH front auxiliary lamp |
| 119. Distributor (petrol models) | 69. Heated rear screen warning lamp | 109. RH front door switch |
| 174. Electric mirrors pick up point (option) | 110. Heated washer jets | 80. RH front indicator lamp |
| 170. Electric seats pick up point (option) | 38. Heater illumination (4 off) | 48. RH high beam |
| 145. Electronic speedo and instrument controls | 160. Heater/air con. connections | 56. RH horn |
| 120. EFI harness plug | 175. Heater/air con. load relay | 75a. RH indicator warning lamp |
| 148. EFI warning lamp | 26. High beam dip/flash switch | 25a. RH number plate lamp |
| 73. Flasher unit | 49. High beam warning lamp | 103. RH puddle lamp |
| 86. Front auxiliary lamp relay (option) | 55. Horn switch | 106. RH rear door switch |
| 93. Front auxiliary lamp switch | 117. Ignition coil | 44. RH rear fog lamp |
| 97. Front interior lamp | 1. Ignition load relay | 81. RH rear indicator lamp |
| 17. Front wash pump | 8. Ignition switch | 90. RH reverse lamp |
| 14. Front wipe delay unit | 10. Ignition warning lamp | 27. RH side lamp |
| 13. Front wipe/wash switch | 115. Inertia switch | 79. RH side repeater lamp |
| 15. Front wiper motor | 41. Instrument illumination (4 off) | 88. RH stop lamp |
| 50. Fuel gauge | 99. Interior lamp delay unit | 28. RH tail lamp |
| 51. Fuel gauge sender unit | 104. Interior lamp switch | 29. Rheostat |
| 116. Fuel pump (petrol models) | 45. LH dip beam | 121. Speed transducer |
| 130. Fuel shut off solenoid (Diesel) | 100. LH door edge lamp | 158. Split charge relay (option) |
| 33. Fuse A1 | 91. LH front auxiliary lamp | 159. Split charge terminal post (option) |
| 31. Fuse A2 | 108. LH front door switch | 7. Starter inhibit switch |
| 21. Fuse A3 | 77. LH front indicator lamp | 5. Starter motor |
| 35. Fuse A4 | 47. LH high beam | 6. Starter relay |
| 71. Fuse A5 | 57. LH horn | 4. Starter solenoid |
| 83. Fuse A6 | 75. LH indicator warning lamp | 84. Stop lamp switch |
| 22. Fuse A7 | 25. LH number plate lamp | 134. Sunroof pick up point |
| 30. Fuse A8 | 101. LH puddle lamp | 125. Sunroof relay |
| 32. Fuse A9 | 105. LH rear door switch | 36. Switch illumination (2 off) |
| 12. Fuse B1 | 43. LH rear fog lamp | 9. Tachometer |
| 54. Fuse B2 | 76. LH rear indicator lamp | 107. Tailgate switch |
| 171. Fuse B3 | 89. LH reverse lamp | 3. Terminal post |
| 94. Fuse B4 | 23. LH side lamp | 111. Thermostat - heated washer jets |
| 125a. Fuse B5 | 78. LH side repeater lamp | 122. Trailer pick up point |
| 128. Fuse B6 | 87. LH stop lamp | 82. Trailer warning lamp |
| 179. Fuse B7 | 24. LH tail lamp | 136a. Transfer box oil temperature switch |
| 172. Fuse B8 | 146. Low coolant level warning lamp | 58. Under bonnet illumination switch |
| 177. Fuse B9 | 144. Low coolant switch | 59. Under bonnet light |
| 65. Fuse C1 | 147. Low fuel level warning lamp | 70. Voltage sensitive switch |
| 162. Fuse C2 | 142. Low screen wash fluid level warning lamp | 52. Water temperature gauge |
| 137. Fuse C3 | | 53. Water temperature sender unit |

Circuit diagram - 1990 MY - Left hand steering

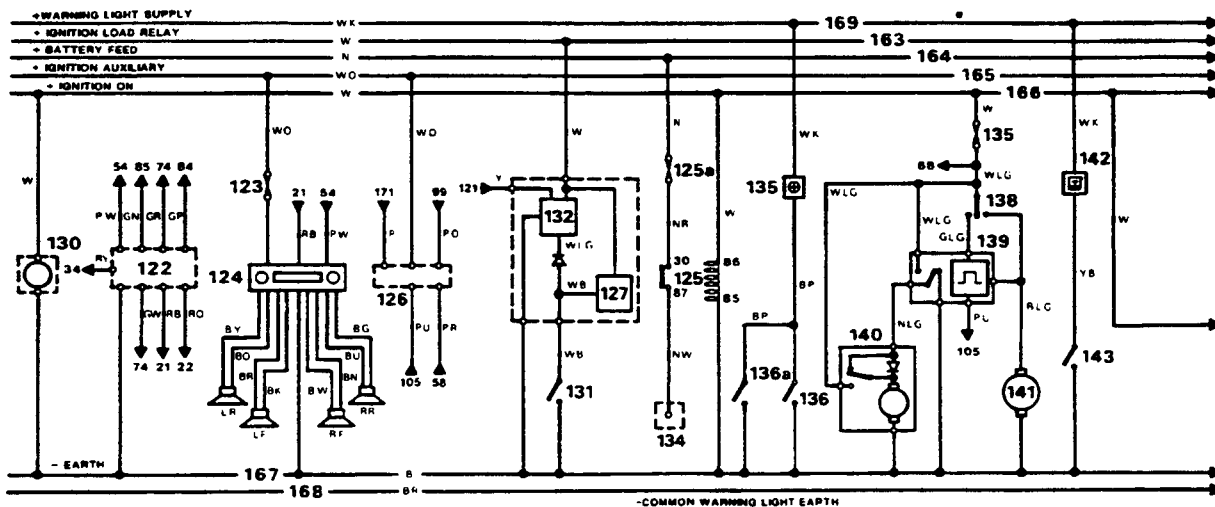
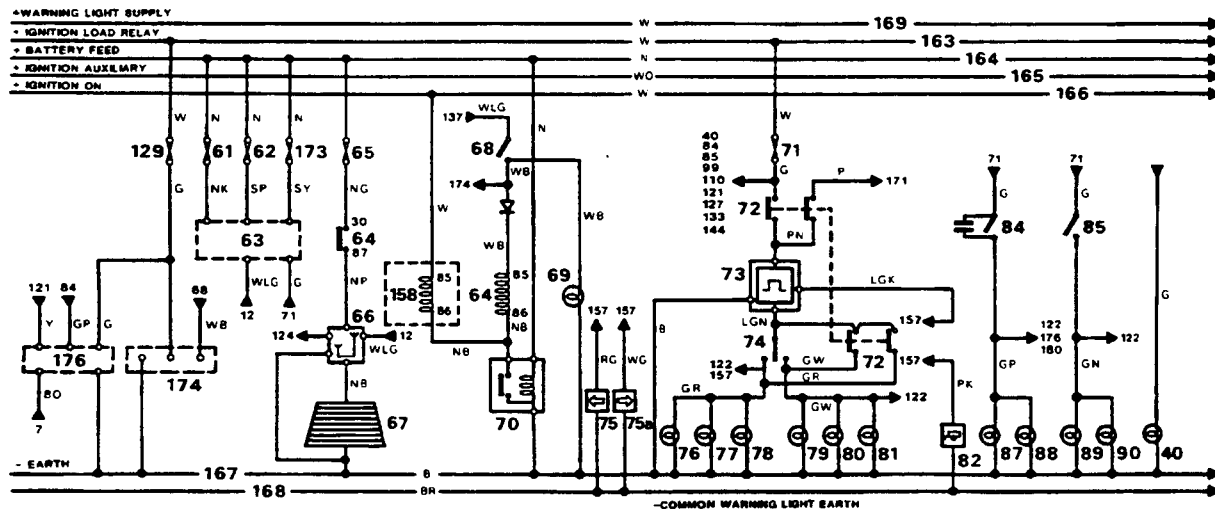
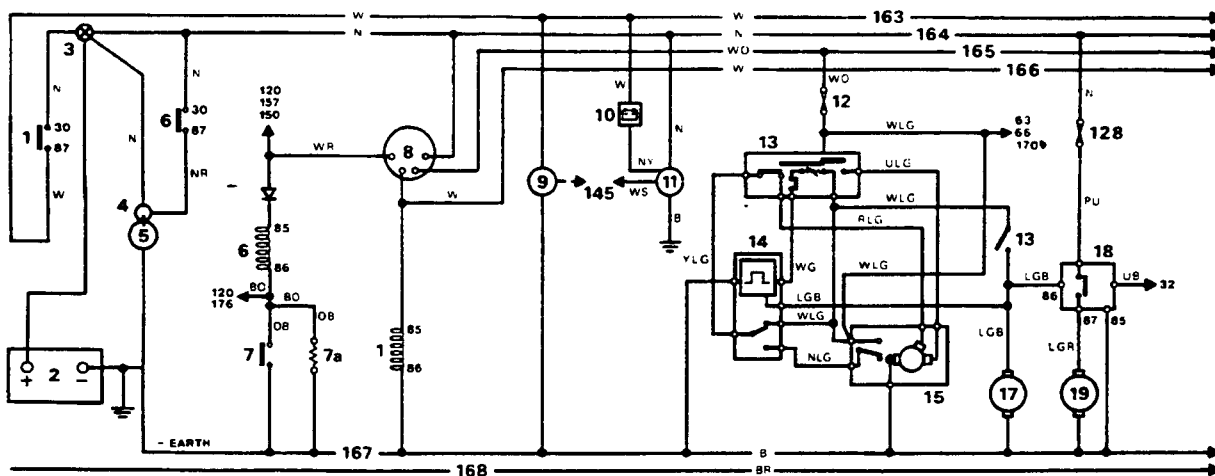

RR2828M

CIRCUIT DIAGRAM - 1990 MY - USA AND CANADA - Illustrations RR2945E & RR2946E

Numerical key

1.	Ignition load relay	61.	Fuse C7	123.	Radio fuse
2.	Battery	62.	Fuse C2	124.	Radio and six speakers
3.	Terminal post	63.	Pick-up point central locking/window lift	125.	Sun roof relay
4.	Starter solenoid	64.	Heated rear window relay	125a.	Fuse B5
5.	Starter motor	65.	Fuse C1	126.	Alarm pick up point
6.	Starter relay	66.	Radio aenal amplifier	127.	Seat belt warning lamp
7.	Starter inhibit switch	67.	Heated rear screen	128.	'Key-in switch'
8.	Ignition switch	68.	Heated rear screen switch	129.	Resistor
9.	Tachometer	69.	Heated rear screen warning lamp	130.	Audible warning unit
10.	Ignition warning lamp	70.	Voltage sensitive switch	131.	Seat buckle switch
11.	Alternator	71.	Fuse A5	132.	Transfer box neutral switch
12.	Fuse B1	72.	Hazard switch	133.	Heated front screen pick up point
13.	Front wipe/wash switch	73.	Flasher unit	134.	Sunroof connection point (option)
14.	Front wipe delay unit	74.	Direction indicator switch	135.	Auto transmission and transfer box oil temperature warning lamp
15.	Front wiper motor	75.	LH indicator warning lamp	136.	Auto transmission oil temperature switch
16.	Headlamp relay	75a.	RH indicator warning lamp	136a.	Transfer box oil temperature switch
17.	Front wash pump	76.	LH rear indicator lamp	137.	Fuse C3
18.	Headlamp wash timer unit	77.	LH front indicator lamp	138.	Rear wash wipe switch
19.	Headlamp wash pump	78.	Not used	139.	Rear wipe delay unit
20.	Main lighting switch	79.	Not used	140.	Rear wiper motor
21.	Fuse A3	80.	RH front indicator lamp	141.	Rear screen wash pump
22.	Fuse A7	81.	RH rear indicator lamp	142.	Low screen wash fluid level warning lamp
23.	LH side lamp	82.	Trailer warning lamp	143.	Low screen wash switch
24.	LH tail lamp	83.	Fuse A6	144.	Low coolant switch
25.	LH license plate lamp	84.	Stop lamp switch	145.	Electronic speedo and instrument controls
25a.	RH license plate lamp	85.	Reverse lamp switch	146.	Low coolant level warning lamp
26.	High beam dimmer/flash switch	86.	Front fog lamp relay	147.	Low fuel level warning lamp
27.	RH side lamp	87.	LH stop lamp	148.	E.F.I. warning lamp
28.	RH tail lamp	88.	RH stop lamp	149.	Low oil level logic unit
29.	Rheostat	89.	LH reverse lamp	150.	Low oil level probe
30.	Fuse A8	90.	RH reverse lamp	151.	Not used
31.	Fuse A2	91.	LH front fog lamp	152.	ABS warning lamp
32.	Fuse A9	92.	RH front fog lamp	153.	Parking brake/brake fluid loss warning lamp
33.	Fuse A1	93.	Front fog lamp switch	153a.	Brake fluid level warning switch
34.	Fuse B6	94.	Fuse B4	154.	Park brake warning switch
35.	Not used	95.	Dash cigar lighter	155.	Brake pad wear warning lamp
36.	Switch illumination (2 off)	96.	Glove box cigar lighter	156.	Brake pad wear sensors
37.	Cigar lighter illumination (2 off)	97.	Front interior lamp	157.	Warning lamp control unit
38.	Heater illumination (4 off)	98.	Rear interior lamp	158.	Check engine warning lamp
39.	Clock illumination	99.	Interior lamp delay unit	159.	Emission maintenance reminder unit
40.	Auto gear selector illumination (2 off)	100.	LH door edge lamp	160.	Heater/air conditioning connections
40a.	Auto gear selector illumination relay.	101.	LH puddle lamp	161.	Fuse C9
41.	Instrument illumination (4 off)	102.	RH door edge lamp	162.	Coil negative (engine RPM input to ECU)
42.	Column switch illumination	103.	RH puddle lamp	163.	Ignition load relay (+)
42.	Not used	104.	Interior lamp switch	164.	Battery feed (+)
43.	Not used	105.	LH rear door switch	165.	Ignition auxiliary (+)
44.	Fuse C5	106.	RH rear door switch	166.	Ignition on (+)
45.	LH low beam	107.	Tailgate switch	167.	Earth (-)
46.	RH low beam	108.	LH front door switch	168.	Warning lights supply common earth (-)
47.	LH high beam	109.	RH front door switch	169.	Warning lights supply (+)
48.	RH high beam	110.	Heated washer jets	170.	Electric seats pick up point
49.	High beam warning lamp	111.	Thermostat heated jets	171.	Fuse B3
50.	Fuel gauge	112.	Oil pressure/level warning lamp	172.	Fuse B8
51.	Fuel gauge sender unit	113.	Oil pressure switch	173.	Fuse C8
52.	Water temperature gauge	114.	Fuse C4	174.	Electric mirrors pick up point
53.	Water temperature sender unit	115.	Inertia switch	175.	Heater/air conditioning relay
54.	Fuse B2	116.	Fuel pump	176.	Cruise control connection points
55.	Horn switch	117.	Ignition coil	177.	Fuse B9
56.	RH horn	118.	Capacitor	178.	Condenser fan relay
57.	LH horn	119.	Distributor	179.	Fuse B7
58.	Under hood illumination switch	120.	EFI Harness plug	180.	ABS pick up point
59.	Under hood light	121.	Speed transducer		
60.	Clock	122.	Trailer pick up point		



CIRCUIT DIAGRAM - 1990 MY - USA AND CANADA - Illustrations RR2945E & RR2946E

Alphabetical key

180. ABS pick up point	65. Fuse C1	check
152. ABS warning lamp	62. Fuse C2	113. Oil pressure switch
126. Alarm pick up point	137. Fuse C3	112. Oil pressure/level warning lamp
11. Alternator	114. Fuse C4	154. Park brake warning switch
130. Audible warning unit	44. Fuse C5	153. Parking brake/brake fluid loss warning lamp
40. Auto gear selector illumination (2 off)	61. Fuse C7	63. Pick-up point central locking/window lift
40a. Auto gear selector illumination relay.	173. Fuse C8	102. RH door edge lamp
135. Auto transmission and transfer box oil temperature warning lamp	161. Fuse C9	109. RH front door switch
136. Auto transmission oil temperature switch	96. Glove box cigar lighter	92. RH front fog lamp
2. Battery	72. Hazard switch	80. RH front indicator lamp
164. Battery feed (+)	16. Headlamp relay	48. RH high beam
153a. Brake fluid loss warning switch	19. Headlamp wash pump	56. RH horn
155. Brake pad wear warning lamp	18. Headlamp wash timer unit	75a. RH indicator warning lamp
156. Brake pad wear sensors	133. Heated front screen pick up point	25a. RH license plate lamp
118. Capacitor	68. Heated rear screen switch	46. RH low beam
163. Check engine warning lamp	64. Heated rear window relay	103. RH puddle lamp
37. Cigar lighter illumination (2 off)	69. Heated rear screen warning lamp	106. RH rear door switch
60. Clock	67. Heated rear screen	81. RH rear indicator lamp
39. Clock illumination	110. Heated washer jets	90. RH reverse lamp
162. Coil negative (engine RPM input to ECU)	38. Heater illumination (4 off)	27. RH side lamp
42. Column switch illumination	175. Heater/air conditioning relay	88. RH stop lamp
178. Condense fan relay	160. Heater/air conditioning connections	28. RH tail lamp
176. Cruise control connection points	26. High beam dimmer/flash switch	66. Radio aerial amplifier
95. Dash cigar lighter	49. High beam warning lamp	124. Radio and six speakers
74. Direction indicator switch	55. Horn switch	123. Radio fuse
119. Distributor	165. Ignition auxiliary (+)	98. Rear interior lamp
148. E.F.I. warning lamp	117. Ignition coil	141. Rear screen wash pump
120. EFI Harness plug	1. Ignition load relay	138. Rear wash wipe switch
167. Earth (+)	163. Ignition load relay (+)	139. Rear wipe delay unit
174. Electric mirrors pick up point	166. Ignition on (+)	140. Rear wiper motor
170. Electric seats pick up point	8. Ignition switch	129. Resistor
145. Electronic speedo and instrument controls	10. Ignition warning lamp	85. Reverse lamp switch
159. Emission maintenance reminder	115. Inertia switch	29. Rheostat
73. Flasher unit	41. Instrument illumination (4 off)	127. Seat belt warning lamp
86. Front fog lamp relay	104. Interior lamp switch	131. Seat buckle switch
93. Front fog lamp switch	99. Interior lamp delay unit	121. Speed transducer
97. Front interior lamp	128. 'Key-in switch'	7. Starter inhibit switch
17. Front wash pump	100. LH door edge lamp	5. Starter motor
13. Front wipe/wash switch	108. LH front door switch	6. Starter relay
14. Front wipe delay unit	91. LH front fog lamp	4. Starter solenoid
15. Front wiper motor	77. LH front indicator lamp	84. Stop lamp switch
51. Fuel gauge sender unit	47. LH high beam	125. Sun roof relay
50. Fuel gauge	57. LH horn	134. Sunroof connection point (option)
116. Fuel pump	75. LH indicator warning lamp	36. Switch illumination (2 off)
33. Fuse A1	25. LH license plate lamp	9. Tachometer
31. Fuse A2	45. LH low beam	107. Tailgate switch
21. Fuse A3	101. LH puddle lamp	3. Terminal post
71. Fuse A5	105. LH rear door switch	111. Thermostat heated jets
83. Fuse A6	76. LH rear indicator lamp	122. Trailer pick up point
30. Fuse A8	89. LH reverse lamp	82. Trailer warning lamp
22. Fuse A7	23. LH side lamp	136a. Transfer box oil temperature switch
32. Fuse A9	87. LH stop lamp	132. Transfer box neutral switch
12. Fuse B1	24. LH tail lamp	58. Under hood illumination switch
54. Fuse B2	146. Low coolant level warning lamp	59. Under hood light
171. Fuse B3	144. Low coolant switch	70. Voltage sensitive switch
94. Fuse B4	147. Low fuel level warning lamp	157. Warning lamp control unit
125a. Fuse B5	150. Low oil level probe	168. Warning lights supply common earth (-)
34. Fuse B6	149. Low oil level logic unit	169. Warning lights supply (+)
179. Fuse B7	143. Low screen wash switch	53. Water temperature sender unit
172. Fuse B8	142. Low screen wash fluid level warning lamp	52. Water temperature gauge temperature warning lamp
177. Fuse B9	20. Main lighting switch	
	151. Not used - will illuminate on initial bulb	

Cable colour code

B Black	L Light	P Purple	U Blue
G Green	N Brown	R Red	W White
K Pink	O Orange	S Grey	Y Yellow

The last letter of a colour denotes the tracer colour.

Circuit diagram - 1990 MY - USA and CANADA

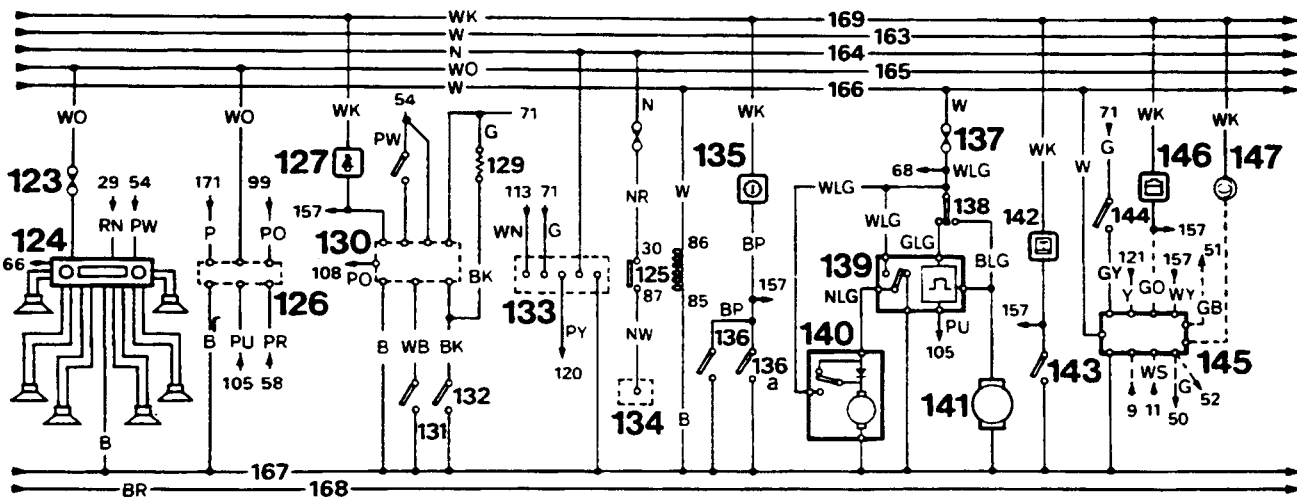
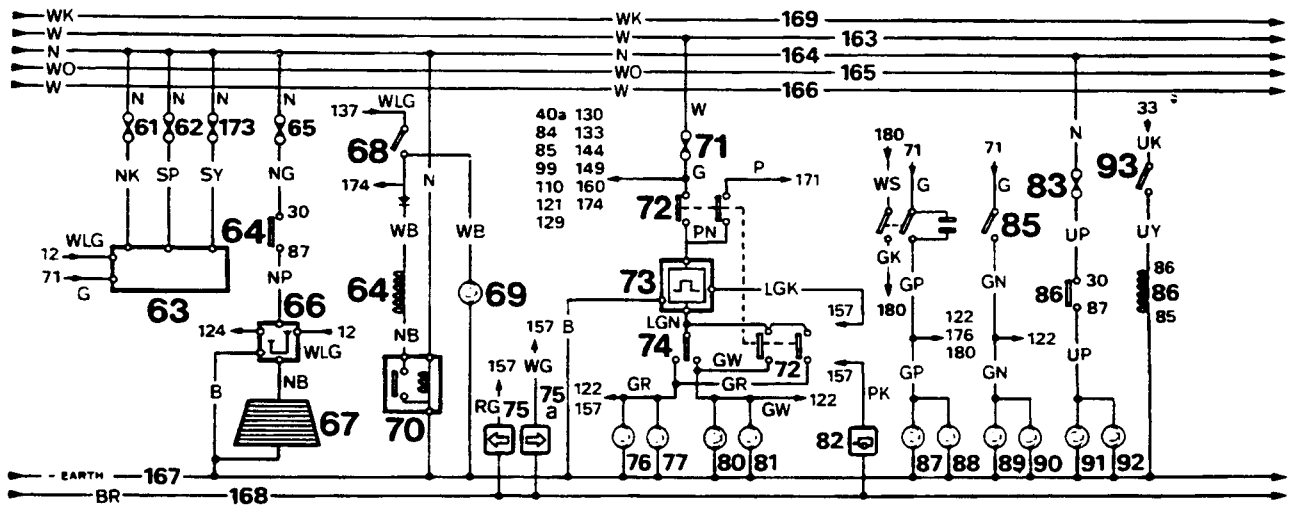
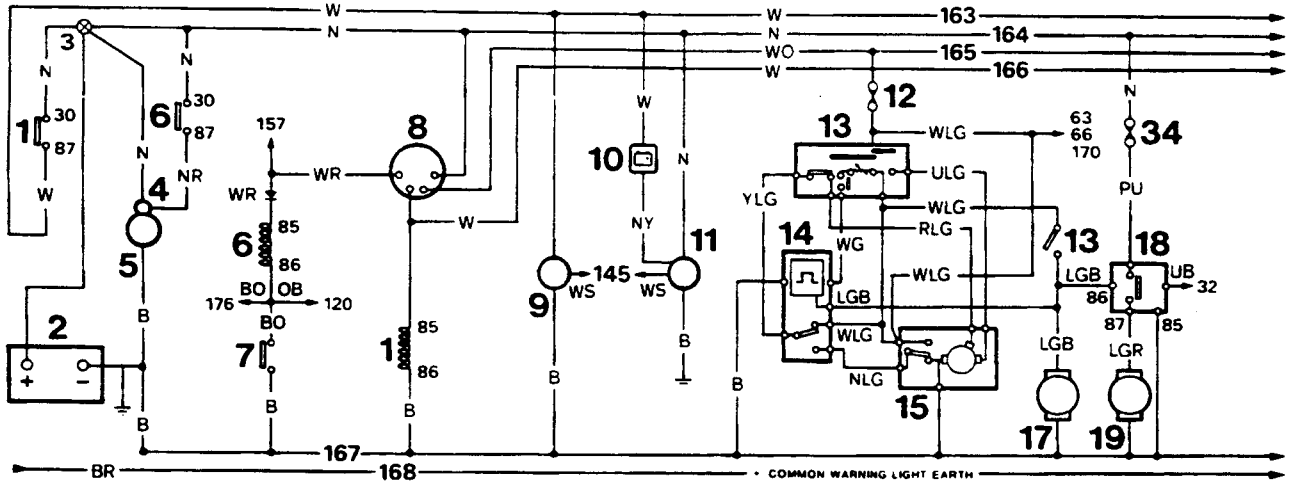

RR2945E - REVISED. SEPT. 90

CD PLAYER WITH POWER AMPLIFIERS - 1991

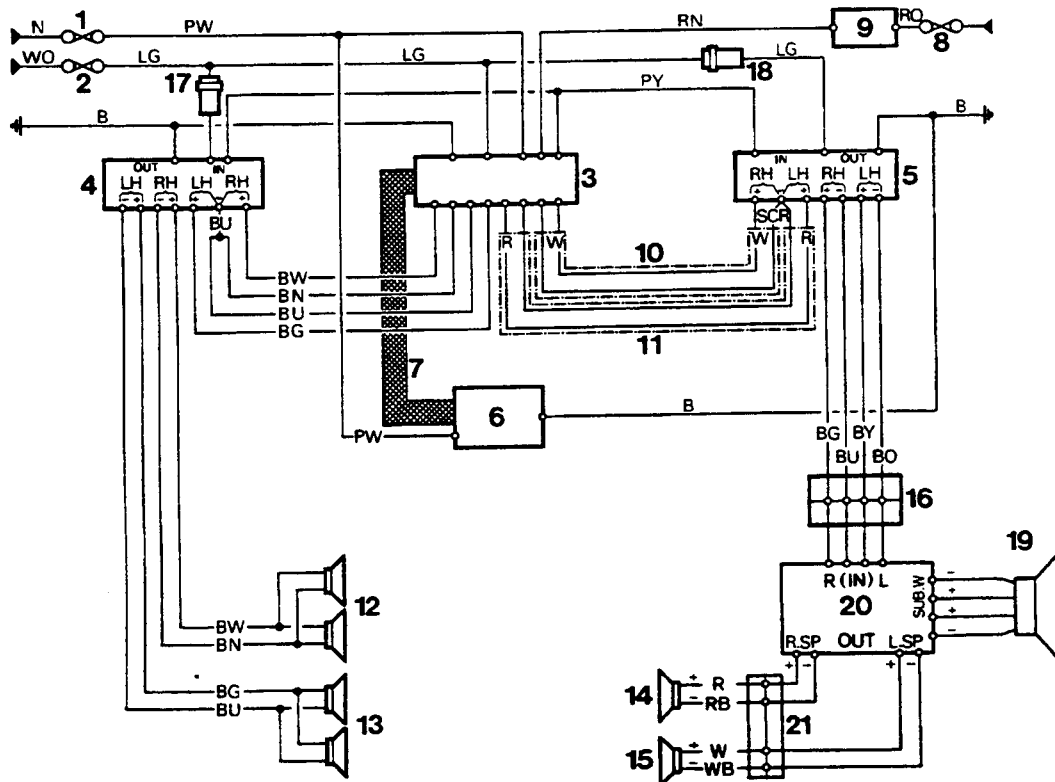

RR2993M

Circuit diagram - RR2993E

- | | |
|--|---|
| 1. Fuse B2 | 12. RH front door speaker |
| 2. Fuse B4 | 13. LH front door speaker |
| 3. Radio - head unit | 14. RH rear speaker |
| 4. Front power amplifier | 15. LH rear speaker |
| 5. Rear power amplifier | 16. In-line connector, cross-over unit IN |
| 6. CD auto changer | 17. 4 amp in-line fuse, front amplifier |
| 7. Data link cable | 18. 4 amp in-line fuse, rear amplifier |
| 8. Fuse A4 | 19. Sub-woofer |
| 9. Rheostat | 20. Cross-over assembly |
| 10. Screened cable, RH rear speaker signal | 21. In line connector cross-over unit OUT |
| 11. Screened cable, LH rear speaker signal | |



NOTE: SCR denotes screen

Cable colour code

B	Black	L	Light	P	Purple	U	Blue
G	Green	N	Brown	R	Red	W	White
K	Pink	O	Orange	S	Grey	Y	Yellow

The last letter of a colour denotes the tracer colour.



HEATED FRONT SCREEN - 1991

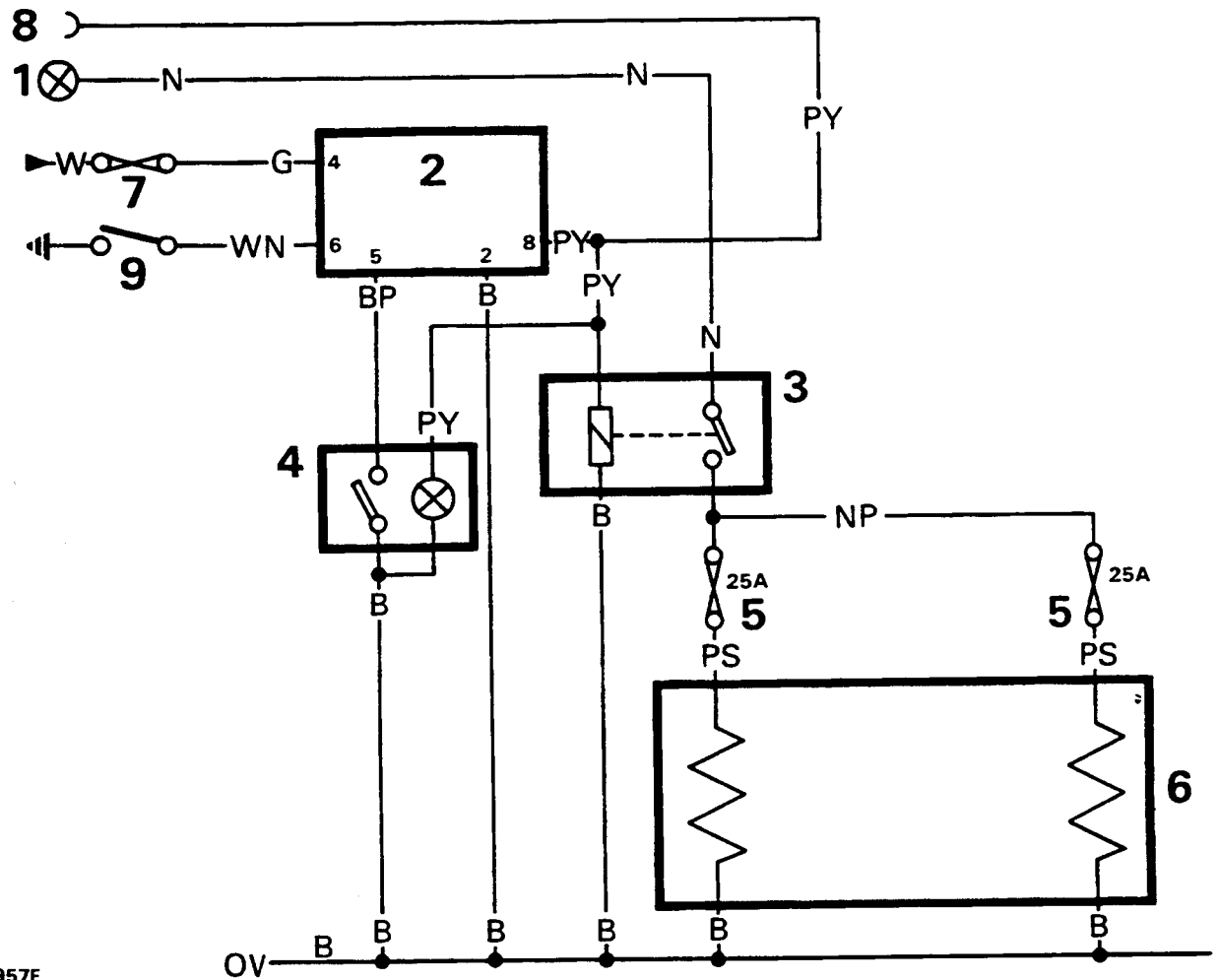

RR2957E

Circuit diagram - RR2957E

- | | |
|---------------------------|------------------------|
| 1. Terminal post | 7. Fuse A5 |
| 2. Timer unit | 8. EFI ECU pin 8 |
| 3. Load relay | 9. Oil pressure switch |
| 4. Switch/warning light | |
| 5. In line fuses - 25 Amp | |
| 6. Heated front screen | |

Cable colour code

B Black	L Light	P Purple	U Blue
G Green	N Brown	R Red	W White
K Pink	O Orange	S Grey	Y Yellow

The last letter of a colour denotes the tracer colour.

ELECTRIC SEAT ADJUSTMENT - 1991

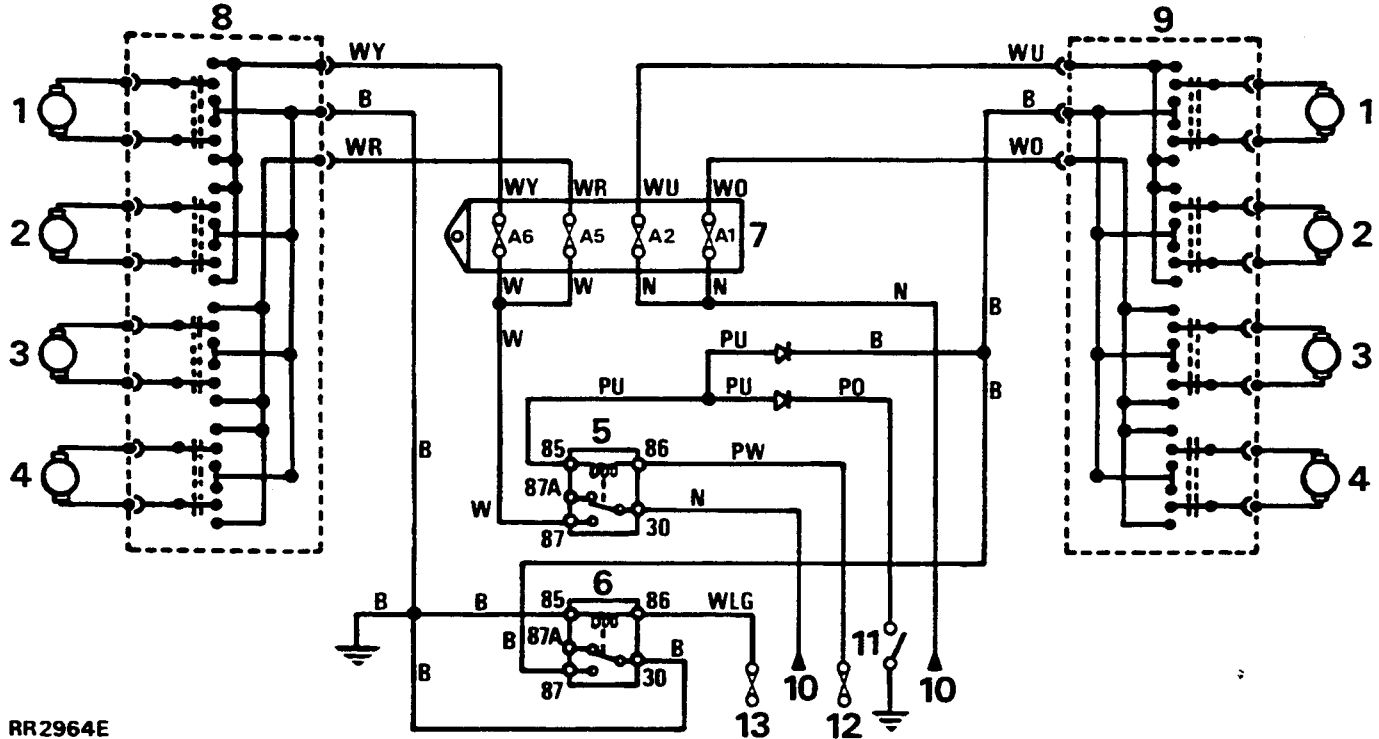

RR2964E

Circuit diagram - RR2530E

- | | |
|--|-----------------------------|
| 1. Seat recline motor | 8. Driver's seat control |
| 2. Seat height (rear) motor | 9. Passenger's seat control |
| 3. Seat base adjust motor | 10. Terminal post |
| 4. Seat height (front) motor | 11. Drivers door switch |
| 5. Load relay-from driver's door courtesy switch | 12. Fuse B2 |
| 6. Load relay-fused auxiliary feed controled | 13. Fuse B1 |
| 7. Auxiliary fuse box (B) | |

Cable colour code

B	Black	L	Light	P	Purple	U	Blue
G	Green	N	Brown	R	Red	W	White
K	Pink	O	Orange	S	Grey	Y	Yellow

The last letter of a colour denotes the tracer colour.



DOOR LOCKS / FUEL FILLER FLAP - 1991

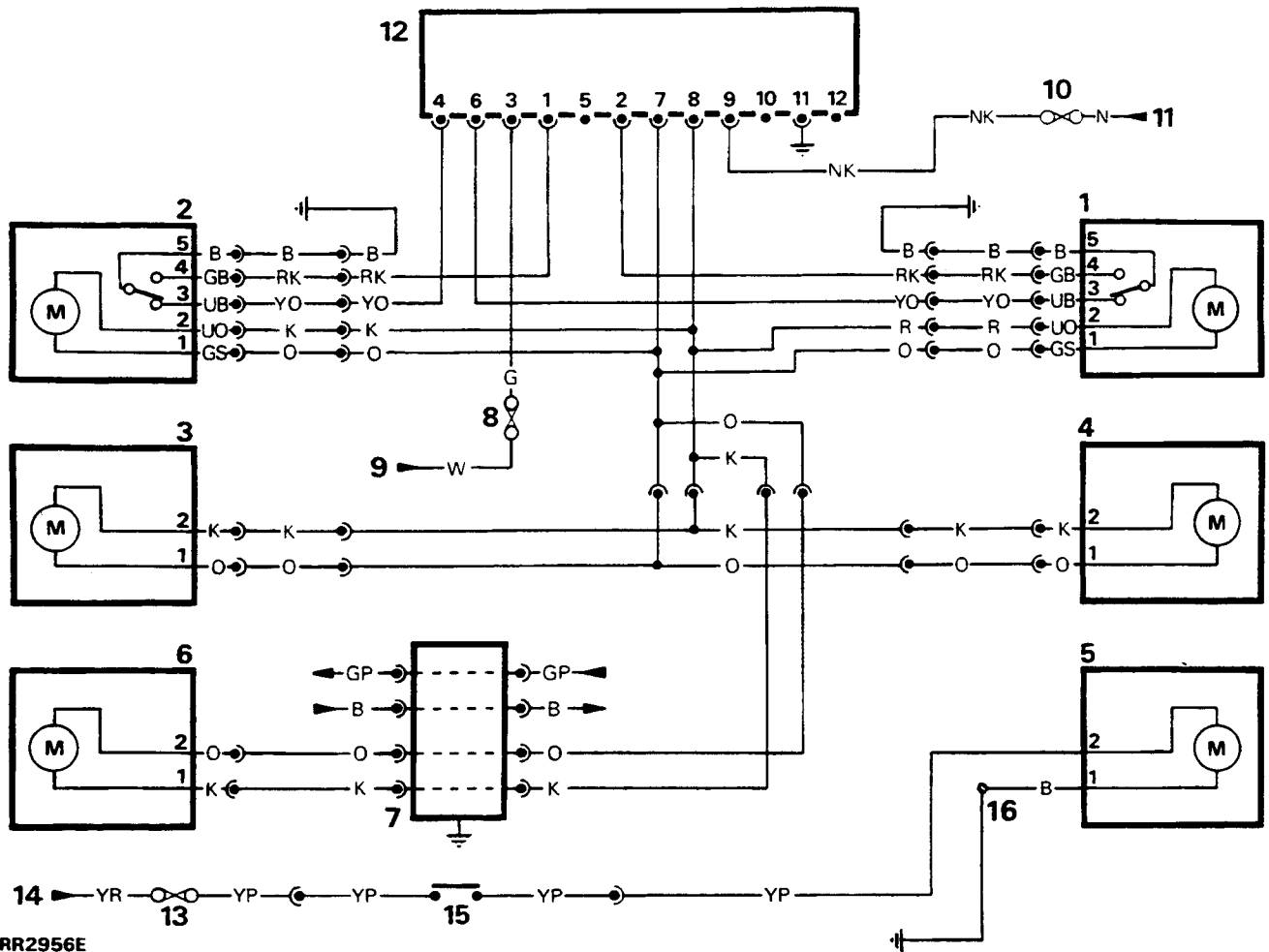

RR2956E

Circuit diagram - RR2956E

- | | |
|---|---|
| 1. Switch/lock unit right hand front door | 9. Feed from ignition load relay - pin 87 |
| 2. Switch/lock unit left hand front door | 10. Fuse C7 |
| 3. Lock unit left hand rear door relay | 11. Battery 12V +ve |
| 4. Lock unit right hand rear door | 12. Central door locking control unit |
| 5. Fuel flap actuator | 13. Fuse C6 |
| 6. Lock unit tailgate | 14. Feed from ignition load relay - pin 87A |
| 7. Suppressor | 15. Fuel flap release switch |
| 8. Fuse A5 | 16. Fuel tank filler pipe ground |

Cable colour code

B Black	L Light	P Purple	U Blue
G Green	N Brown	R Red	W White
K Pink	O Orange	S Grey	Y Yellow

The last letter of a colour denotes the tracer colour.

SUNROOF / AUTOMATIC GLARE CONTROL
MIRROR - 1991

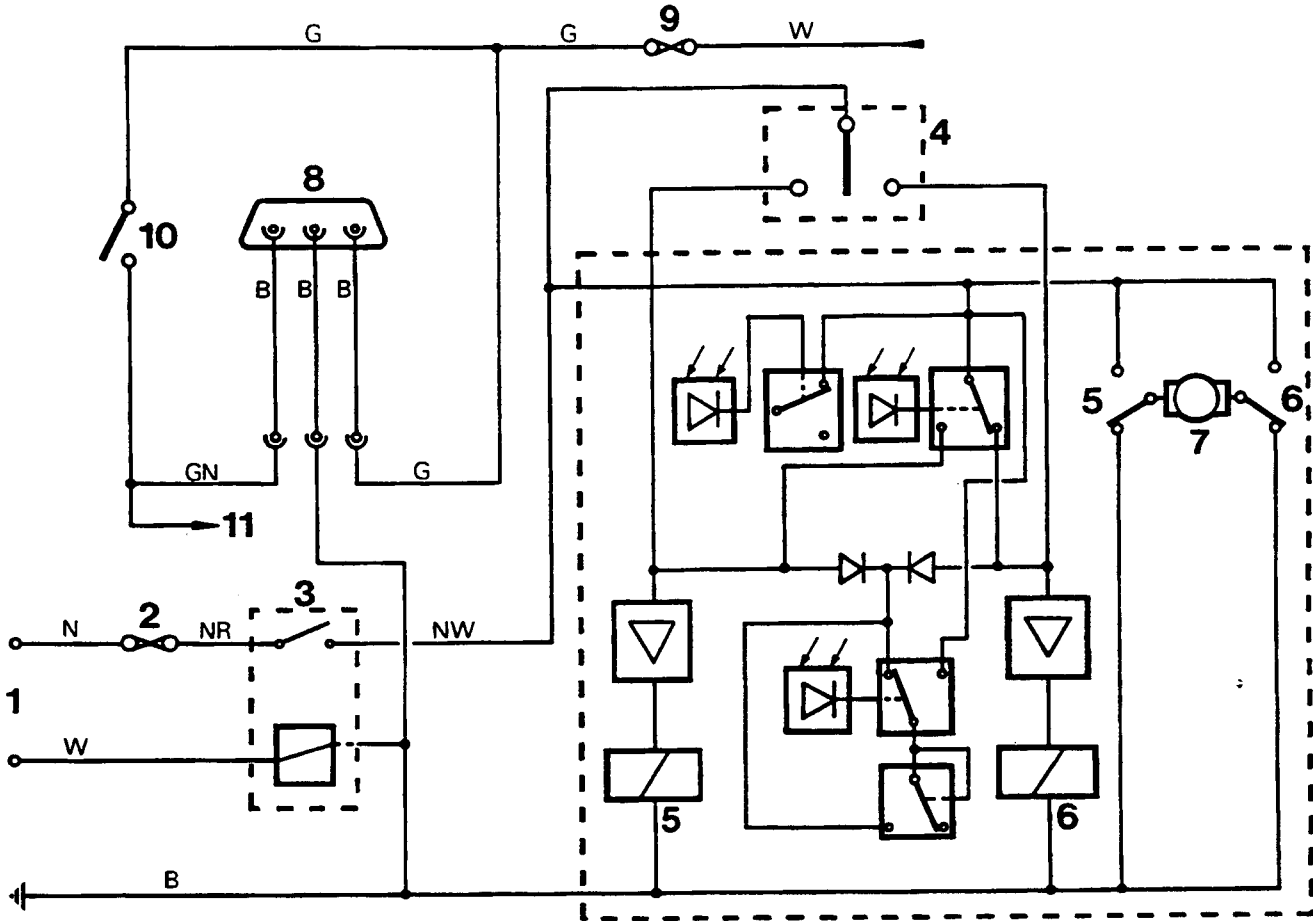

RR2958E

Circuit diagram - RR2958E

- | | |
|--|--|
| <p>1. Main harness connections
 Brown - live positive feed
 White - ignition positive feed
 Black - ground</p> <p>2. Fuse B5</p> <p>3. Auxiliary relay</p> <p>4. Operating switch</p> <p>5. Relay - tilt, open to closed
 - slide, closed to open</p> | <p>6. Relay - slide, open to closed
 - tilt, closed to open</p> <p>7. Drive motor</p> <p>8. Mirror connection</p> <p>9. Fuse A5</p> <p>10. Reverse lamps switch</p> <p>11. Reverse lamps</p> |
|--|--|

Cable colour code

B	Black	L	Light	P	Purple	U	Blue
G	Green	N	Brown	R	Red	W	White
K	Pink	O	Orange	S	Grey	Y	Yellow

The last letter of a colour denotes the tracer colour.

----- Denotes component enclosure



HEADLAMP LEVELLING - 1991

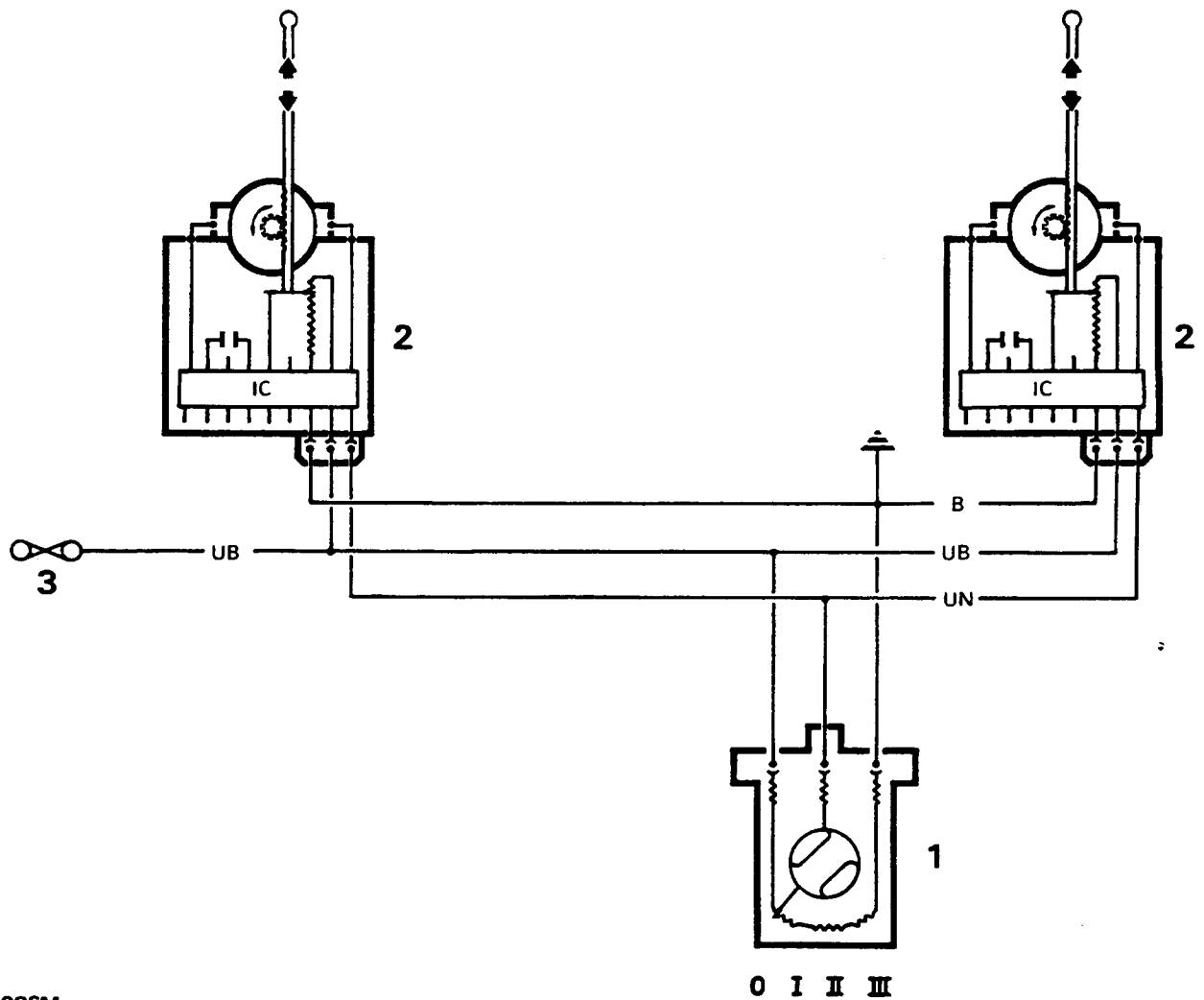

RR2986M

Circuit diagram - RR2986M

1. Headlamp levelling switch
2. Headlamp levelling actuator/motor
3. Fuse A9

Cable colour code

B Black	L Light	P Purple	U Blue
G Green	N Brown	R Red	W White
K Pink	O Orange	S Grey	Y Yellow

The last letter of a colour denotes the tracer colour.

CIRCUIT DIAGRAM - 1991 MY - RIGHT HAND STEERING - Illustrations RR2976M & RR2977M

Numerical key

- | | | | | | |
|------|------------------------------------|-------|-----------------------------------|-------|---|
| 1. | Ignition load relay | 63. | Fuse C7 | 126. | Radio and four speakers |
| 2. | Battery | 64. | Fuse C8 | | -LF-left hand front speaker |
| 3. | Terminal post | 65. | Window lift pick-up point | | -LR-left hand rear speaker |
| 4. | Starter solenoid | 66. | Fuse C1 | | -RF-right front speaker |
| 5. | Starter motor | 67. | Heated rear screen relay | | -RR-right hand rear speaker |
| 6. | Starter relay | 68. | Radio aerial amplifier | 127. | Sun roof pick up point |
| 7. | Starter inhibit switch | 69. | Heated rear screen | 128. | Auto transmission and transfer box oil temperature warning lamp |
| 7a. | Resistor (manual) | 70. | Heated rear screen switch | | |
| 8. | Ignition switch | 71. | Heated rear screen warning lamp | 129. | Auto transmission oil temperature switch |
| 9. | Tachometer | 72. | Voltage sensitive switch | 129a. | Transfer box oil temperature switch |
| 10. | Voltage transformer (dim dip) | 73. | Fuse A5 | 130. | Fuse C3 |
| 11. | Ignition warning lamp | 74. | Hazard switch | 131. | Rear wash wipe switch |
| 12. | Alternator | 75. | Flasher unit | 132. | Rear wipe delay unit |
| 13. | Fuse B1 | 76. | Direction indicator switch | 133. | Rear wiper motor |
| 14. | Front wipe/wash switch | 77. | LH indicator warning lamp | 134. | Rear screen wash pump |
| 15. | Front wipe delay unit | 77a. | RH indicator warning lamp | 135. | Low screen wash fluid level warning lamp |
| 16. | Front wiper motor | 78. | LH rear indicator lamp | 136. | Low screen wash switch |
| 17. | Headlamp relay | 79. | LH front indicator lamp | 137. | Low coolant switch |
| 18. | Front wash pump | 80. | LH side repeater lamp | 138. | Electronic speedo and instrument controls |
| 19. | Headlamp wash timer unit | 81. | RH side repeater lamp | 139. | Low coolant level warning lamp |
| 20. | Headlamp wash pump | 82. | RH front indicator lamp | 140. | Low fuel level warning lamp |
| 21. | Main lighting switch | 83. | RH rear indicator lamp | 141. | Glow plug warning lamp (Diesel) |
| 22. | Fuse A3 | 84. | Trailer warning lamp | 142. | E.F.I. warning lamp |
| 23. | Fuse A7 | 85. | Fuse A6 | 143. | Glow plug timer unit |
| 24. | LH side lamp | 86. | Stop lamp switch | 144. | Glow plugs (Diesel) |
| 25. | LH tail lamp | 87. | Reverse lamp switch | 145. | ABS warning lamp |
| 26. | LH number plate lamp | 88. | Front auxiliary lamp relay | 146. | Handbrake/brake fluid level/pressure warning lamp |
| 26a. | RH number plate lamp | 89. | LH stop lamp | | |
| 27. | High beam dip/flash switch | 90. | RH stop lamp | 147. | Handbrake warning switch |
| 28. | Fuse B2 | 91. | LH reverse lamp | 148. | Brake fluid level warning switch |
| 29. | RH side lamp | 92. | RH reverse lamp | 149. | Brake pad wear warning lamp |
| 30. | RH tail lamp | 93. | LH front auxiliary lamp | 150. | Brake pad wear sensors |
| 31. | Rheostat | 94. | RH front auxiliary lamp | 151. | Brake check relay (Australia only) |
| 32. | Fuse A8 | 95. | Front auxiliary lamp switch | 152. | Split charge relay (option) |
| 33. | Fuse A2 | 96. | Fuse B4 | 153. | Split charge terminal post (option) |
| 34. | Fuse A9 | 97. | Dash cigar lighter | 154. | Heater/air conditioning connections |
| 35. | Fuse A1 | 98. | Glove box cigar lighter | 155. | Fuse C9 |
| 36. | Rear fog switch | 99. | Front interior lamp | 156. | Coil negative (engine RPM input to ECU) |
| 37. | Fuse A4 | 100. | Rear interior lamp | 157. | Fuel filter flap (see door cable circuit diagram) |
| 38. | Switch illumination (2 off) | 101. | Interior lamp delay unit | 158. | Ignition load relay (+) |
| 39. | Cigar lighter illumination (2 off) | 102. | LH door edge lamp | 159. | Battery feed (+) |
| 40. | Heater illumination (4 off) | 103. | LH puddle lamp | 160. | Ignition auxiliary (+) |
| 41. | Clock illumination | 104. | RH door edge lamp | 161. | Ignition on (+) |
| 42. | Auto gear selector illumination | 105. | RH puddle lamp | 162. | Earth (-) |
| 43. | Instrument illumination (4 off) | 106. | Interior lamp switch | 163. | Heater/air con. load relay |
| 43a. | Column switch illumination | 107. | LH rear door switch | 164. | Trailer pick up point |
| 44. | Rear fog warning lamp | 108. | RH rear door switch | 165. | Electric seats pick up point (option) |
| 45. | LH rear fog lamp | 109. | Tailgate switch | 166. | Fuse C2 |
| 46. | RH rear fog lamp | 110. | LH front door switch | 167. | Electric mirrors |
| 47. | LH dip beam | 111. | RH front door switch | 168. | Alarm pick up point |
| 48. | RH dip beam | 112. | Heated washer jets (front screen) | 169. | Fuse C5 |
| 49. | LH high beam | 113. | Thermostat heated jets | 170. | ABS pick up point |
| 50. | RH high beam | 114. | Oil pressure warning lamp | 171. | Fuse B6 |
| 51. | High beam warning lamp | 115. | Oil pressure switch | 172. | Fuse B7 |
| 52. | Fuel gauge | 116. | Fuse C4 | 173. | Condenser fan relay |
| 53. | Fuel gauge sender unit | 117. | Heated front screen connections | 174. | Fuse B8 |
| 54. | Water temperature gauge | 118. | Fuel pump (petrol models) | 175. | Fuse B9 |
| 55. | Water temperature sender unit | 119. | Ignition coil | 176. | Inertia switch |
| 56. | Fuse B3 | 120. | Capacitor | 177. | Speed transducer |
| 57. | Horn switch | 121. | Distributor | 178. | Central locking |
| 58. | RH horn | 122. | EFI Harness plug | 179. | Fuse C6 |
| 59. | LH horn | 123. | Fuel shut off solenoid (Diesel) | 180. | Cruise control pick-up point (option) |
| 60. | Under bonnet illumination switch | 124. | Sun roof relay | | |
| 61. | Under bonnet light | 124a. | Fuse B5 | | |
| 62. | Clock | 125. | Radio fuse | | |



CIRCUIT DIAGRAM - 1991 MY - RIGHT HAND STEERING - Illustrations RR2976M & RR2977M

Alphabetical key

- | | | |
|---|--|---|
| 170. ABS pick up point | 66. Fuse C1 | 136. Low screen wash switch |
| 145. ABS warning lamp | 166. Fuse C2 | 21. Main lighting switch |
| 168. Alarm pick up point | 130. Fuse C3 | 115. Oil pressure switch |
| 12. Alternator | 116. Fuse C4 | 114. Oil pressure warning lamp |
| 42. Automatic gear selector illumination (2 off) | 169. Fuse C5 | 68. Radio aerial amplifier |
| 129. Automatic transmission oil temperature switch | 179. Fuse C6 | 126. Radio and four speakers |
| 128. Automatic transmission/transfer box oil temperature warning lamp | 63. Fuse C7 | 125. Radio fuse |
| 2. Battery | 64. Fuse C8 | 36. Rear fog switch |
| 148. Brake fluid level warning switch | 155. Fuse C9 | 44. Rear fog warning lamp |
| 150. Brake pad wear sensors | 98. Glove box cigar lighter | 100. Rear interior lamp |
| 149. Brake pad wear warning lamp | 144. Glow plugs (Diesel) | 134. Rear screen wash pump |
| 151. Brake check relay (Australia only) | 143. Glow plug timer unit (Diesel) | 131. Rear wash wipe switch |
| 120. Capacitor | 141. Glow plug warning lamp (Diesel) | 132. Rear wipe delay unit |
| 178. Central locking | 146. Handbrake/brake fluid level/pressure warning lamp | 133. Rear wiper motor |
| 39. Cigar lighter illumination (2 off) | 147. Handbrake warning switch | 7a. Resistor (manual) |
| 62. Clock | 74. Hazard switch | 87. Reverse lamp switch |
| 41. Clock illumination | 17. Headlamp relay | 48. RH dip beam |
| 156. Coil negative, engine speed signal to ECU | 20. Headlamp wash pump | 104. RH door edge lamp |
| 43a. Column switch illumination | 19. Headlamp wash timer unit | 94. RH front auxiliary lamp |
| 173. Condenser fan relay | 117. Heated front screen connections | 111. RH front door switch |
| 180. Cruise control pick-up point (option) | 69. Heated rear screen | 82. RH front indicator lamp |
| 97. Dash cigar lighter | 67. Heated rear screen relay | 50. RH high beam |
| 76. Direction indicator switch | 70. Heated rear screen switch | 58. RH horn |
| 121. Distributor | 71. Heated rear screen warning lamp | 77a. RH indicator warning lamp |
| 167. Electric mirrors | 112. Heated washer jets | 26a. RH number plate lamp |
| 165. Electric seats pick up point (option) | 40. Heater illumination (4 off) | 105. RH puddle lamp |
| 138. Electronic speedo and instrument controls | 154. Heater/air con. connections | 108. RH rear door switch |
| 122. EFI Harness plug | 163. Heater/air con. load relay | 46. RH rear fog lamp |
| 142. EFI warning lamp | 27. High beam dip/flash switch | 83. RH rear indicator lamp |
| 75. Flasher unit | 51. High beam warning lamp | 92. RH reverse lamp |
| 88. Front auxiliary lamp relay | 57. Horn switch | 29. RH side lamp |
| 95. Front auxiliary lamp switch | 119. Ignition coil | 81. RH side repeater lamp |
| 99. Front interior lamp | 1. Ignition load relay | 90. RH stop lamp |
| 18. Front wash pump | 8. Ignition switch | 30. RH tail lamp |
| 15. Front wipe delay unit | 11. Ignition warning lamp | 31. Rheostat |
| 14. Front wipe/wash switch | 176. Inertia switch | 177. Speed transducer |
| 16. Front wiper motor | 43. Instrument illumination (4 off) | 152. Split charge relay (option) |
| 52. Fuel gauge | 101. Interior lamp delay unit | 153. Split charge terminal post (option) |
| 53. Fuel gauge sender unit | 106. Interior lamp switch | 7. Starter inhibit switch |
| 118. Fuel pump (petrol models) | 47. LH dip beam | 5. Starter motor |
| 123. Fuel shut off solenoid (Diesel) | 102. LH door edge lamp | 6. Starter relay |
| 157. Fuel filler flap | 93. LH front auxiliary lamp | 4. Starter solenoid |
| 35. Fuse A1 | 110. LH front door switch | 86. Stop lamp switch |
| 33. Fuse A2 | 79. LH front indicator lamp | 127. Sunroof pick up point |
| 22. Fuse A3 | 49. LH high beam | 124. Sunroof relay |
| 37. Fuse A4 | 59. LH horn | 38. Switch illumination (2 off) |
| 73. Fuse A5 | 77. LH indicator warning lamp | 9. Tachometer |
| 85. Fuse A6 | 25. LH number plate lamp | 109. Tailgate switch |
| 23. Fuse A7 | 103. LH puddle lamp | 3. Terminal post |
| 32. Fuse A8 | 107. LH rear door switch | 113. Thermostat - heated washer jets |
| 34. Fuse A9 | 45. LH rear fog lamp | 164. Trailer pick up point |
| 13. Fuse B1 | 78. LH rear indicator lamp | 84. Trailer warning lamp |
| 28. Fuse B2 | 91. LH reverse lamp | 129a. Transfer box oil temperature switch |
| 56. Fuse B3 | 24. LH side lamp | 60. Under bonnet illumination switch |
| 96. Fuse B4 | 80. LH side repeater lamp | 61. Under bonnet light |
| 124a. Fuse B5 | 89. LH stop lamp | 72. Voltage sensitive switch |
| 171. Fuse B6 | 25. LH tail lamp | 10. Voltage transformer (dim-dip) |
| 172. Fuse B7 | 139. Low coolant level warning lamp | 54. Water temperature gauge |
| 174. Fuse B8 | 137. Low coolant switch | 55. Water temperature sender unit |
| 175. Fuse B9 | 140. Low fuel level warning lamp | 65. Window lift pick-up point |
| | 135. Low screen wash fluid level warning lamp | |

Circuit diagram - 1991 MY - Right hand steering

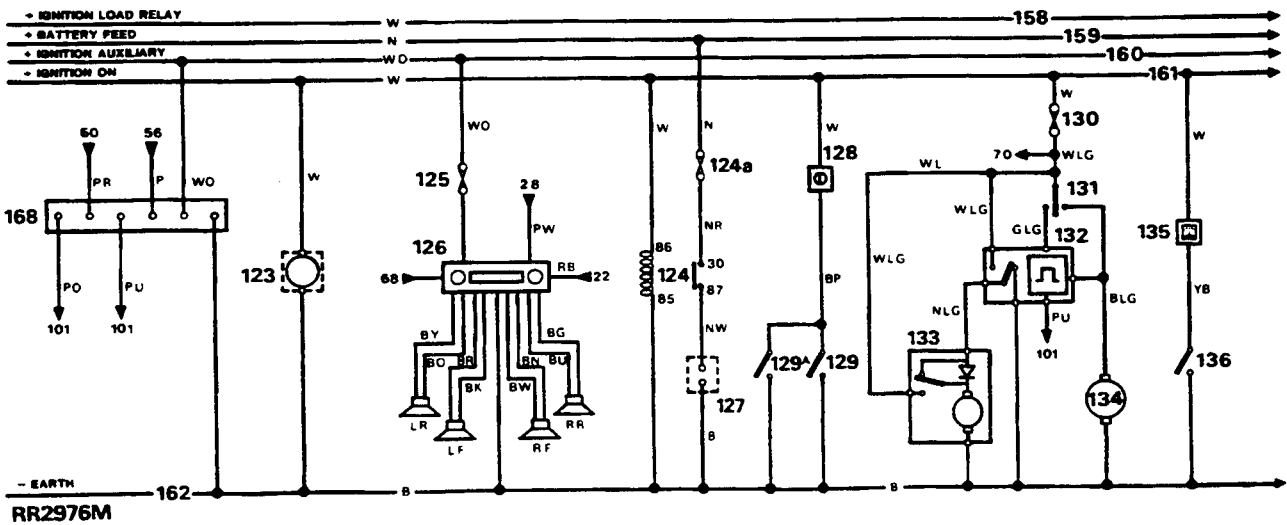
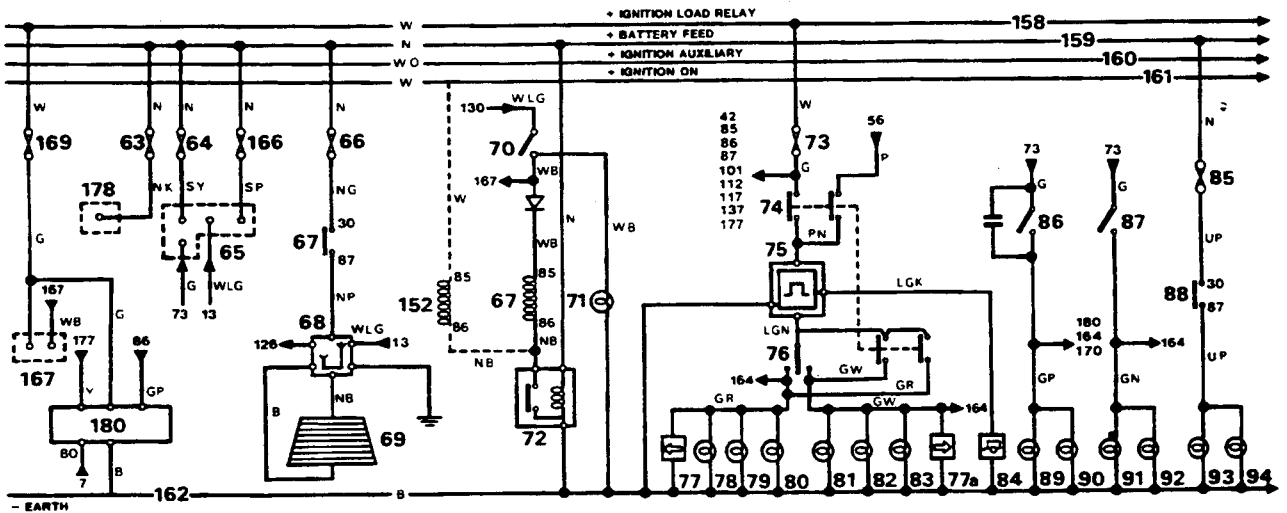
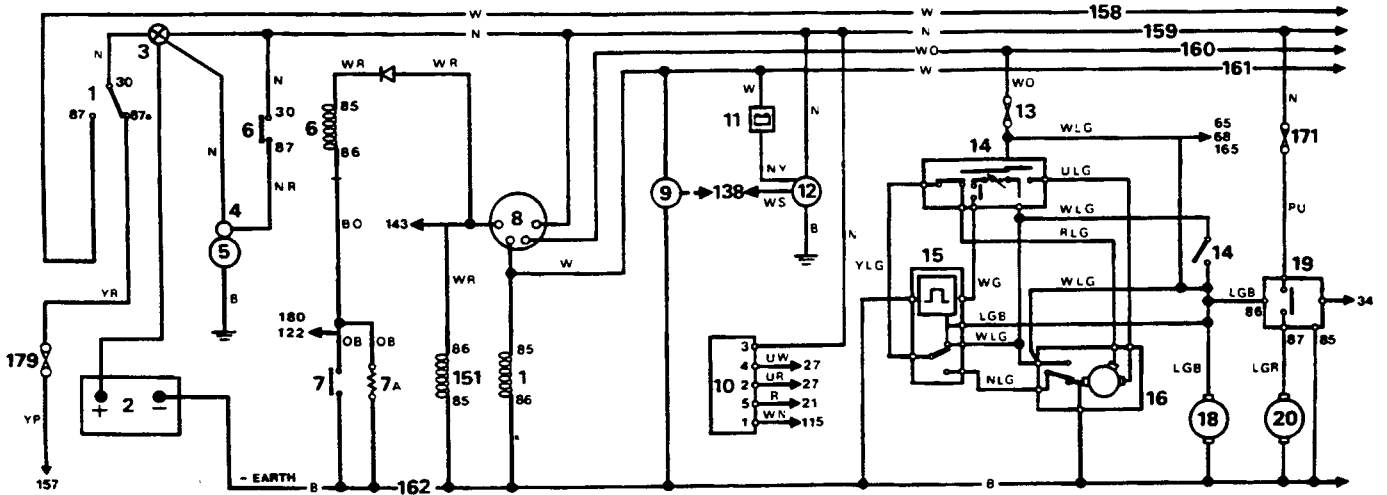

RR2976M

CIRCUIT DIAGRAM - 1991 MY - LEFT HAND STEERING - Illustrations RR2978M & RR2979M

Numerical key

- | | | | | | |
|------|--|------|---|-------|---|
| 1. | Ignition load relay | 63. | Pick-up point central locking/window lift | 125. | Sun roof relay |
| 2. | Battery | 64. | Heated rear screen relay | 125a. | Fuse B5 |
| 3. | Terminal post | 65. | Fuse C1 | 126. | Alarm pick up point |
| 4. | Starter solenoid | 66. | Radio aerial amplifier. | 127. | Overspeed warning (Saudi only) |
| 5. | Starter motor | 67. | Heated rear screen | 128. | Fuse B6 |
| 6. | Starter relay | 68. | Heated rear screen switch | 129. | Fuse C5 |
| 7. | Starter inhibit switch (auto) | 69. | Heated rear screen warning lamp | 130. | Fuel shut off solenoid (Diesel) |
| 7a. | Resistor (manual transmission) | 70. | Voltage sensitive switch | 131. | Seat buckle switch (Saudi only) |
| 8. | Ignition switch | 71. | Fuse A5 | 132. | Overspeed monitor (Saudi only) |
| 9. | Tachometer | 72. | Hazard switch | 133. | Heated front screen pick up point (option) |
| 10. | Ignition warning lamp | 73. | Flasher unit | 134. | Sunroof pick up point (option) |
| 11. | Alternator | 74. | Direction indicator switch | 135. | Auto transmission / transfer box oil temperature warning lamp |
| 12. | Fuse B1 | 75. | LH indicator warning lamp | 136. | Auto transmission oil temperature switch |
| 13. | Front wipe/wash switch | 75a. | RH indicator warning lamp | 136a. | Transfer box oil temperature switch |
| 14. | Front wipe delay unit | 76. | LH rear indicator lamp | 137. | Fuse C3 |
| 15. | Front wiper motor | 77. | LH front indicator lamp | 138. | Rear wash wipe switch |
| 16. | Headlamp relay | 78. | LH side repeater lamp | 139. | Rear wipe delay unit |
| 17. | Front wash pump | 79. | RH side repeater lamp | 140. | Rear wiper motor |
| 18. | Headlamp wash timer unit | 80. | RH front indicator lamp | 141. | Rear screen wash pump |
| 19. | Headlamp wash pump | 81. | RH rear indicator lamp | 142. | Low screen wash fluid level warning lamp |
| 20. | Main lighting switch | 82. | Trailer warning lamp | 143. | Low screen wash switch |
| 21. | Fuse A3 | 83. | Fuse A6 | 144. | Low coolant switch |
| 22. | Fuse A7 | 84. | Stop lamp switch | 145. | Electronic speedo and instrument controls |
| 23. | LH side lamp | 85. | Reverse lamp switch | 146. | Low coolant level warning lamp |
| 24. | LH tail lamp | 86. | Front auxiliary lamp relay (option) | 147. | Low fuel level warning lamp |
| 25. | LH number plate lamp | 87. | LH stop lamp | 148. | E.F.I. warning lamp |
| 25a. | RH number plate lamp | 88. | RH stop lamp | 149. | Glow plug warning lamp (Diesel) |
| 26. | High beam dip/flash switch | 89. | LH reverse lamp | 150. | Glow plug timer unit(Diesel) |
| 27. | RH side lamp | 90. | RH reverse lamp | 151. | Glow plugs (Diesel) |
| 28. | RH tail lamp | 91. | LH front auxiliary lamp (option) | 152. | ABS warning lamp |
| 29. | Rheostat | 92. | RH front auxiliary lamp (option) | 153. | Handbrake / brake fluid level / pressure warning lamp |
| 30. | Fuse A8 | 93. | Front auxiliary lamp switch | 153a. | Brake fluid level warning switch |
| 31. | Fuse A2 | 94. | Fuse B4 | 154. | Handbrake warning switch |
| 32. | Fuse A9 | 95. | Dash cigar lighter | 155. | Brake pad wear warning lamp |
| 33. | Fuse A1 | 96. | Glove box cigar lighter | 156. | Brake pad wear sensors |
| 34. | Rear fog switch | 97. | Front interior lamp | 157. | Fuse C6 |
| 35. | Fuse A4 | 98. | Rear interior lamp | 158. | Split charge relay (option) |
| 36. | Switch illumination (2 off) | 99. | Interior lamp delay unit | 159. | Split charge terminal post (option) |
| 36a. | Headlamp levelling switch illumination (Germany) | 100. | LH door edge lamp | 160. | Heater/air conditioning connections |
| 37. | Cigar lighter illumination (2 off) | 101. | LH puddle lamp | 161. | Fuse C9 |
| 38. | Heater illumination (4 off) | 102. | RH door edge lamp | 162. | Coil negative (engine RPM input to ECU) |
| 39. | Clock illumination | 103. | RH puddle lamp | 163. | Ignition load relay (+) |
| 40. | Auto gear selector illumination (2 off) | 104. | Interior lamp switch | 164. | Battery feed (+) |
| 41. | Instrument illumination (4 off) | 105. | LH rear door switch | 165. | Ignition auxiliary (+) |
| 41a. | Column switch illumination | 106. | RH rear door switch | 166. | Ignition on (+) |
| 42. | Rear fog warning lamp | 107. | Tailgate switch | 167. | Earth (-) |
| 43. | LH rear fog | 108. | LH front door switch | 168. | Fuel filler flap (see door locks circuit diagram) |
| 44. | RH rear fog | 109. | RH front door switch | 169. | Central locking |
| 45. | LH dip beam | 110. | Heated washer jets (front screen) | 170. | Electric seats pick up point |
| 46. | RH dip beam | 111. | Thermostat-heated washer jets | 171. | Fuse B3 |
| 47. | LH high beam | 112. | Oil pressure warning lamp | 172. | Fuse B8 |
| 48. | RH high beam | 113. | Oil pressure switch | 173. | Fuse C8 |
| 49. | High beam warning lamp | 114. | Fuse C4 | 174. | Electric mirrors |
| 50. | Fuel gauge | 115. | Inertia switch | 175. | Heater/air conditioning load relay |
| 51. | Fuel gauge sender unit | 116. | Fuel pump (petrol models) | 176. | Cruise control pick up points (option) |
| 52. | Water temperature gauge | 117. | Ignition coil (petrol models) | 177. | Fuse B9 |
| 53. | Water temperature sender unit | 118. | Capacitor (petrol models) | 178. | Condenser fan relay |
| 54. | Fuse B2 | 119. | Distributor (petrol models) | 179. | Fuse B7 |
| 55. | Horn switch | 120. | EFI Harness plug | 180. | ABS pick up point |
| 56. | RH horn | 121. | Speed transducer | 181. | Headlamp levelling switch connection (option) |
| 57. | LH horn | 122. | Trailer pick up point | 182. | Headlamp levelling actuator (2) (option) |
| 58. | Under bonnet illumination switch | 123. | Radio fuse | | |
| 59. | Under bonnet light | 124. | Radio and four speakers | | |
| 60. | Clock | | -LF-left hand front speaker | | |
| 61. | Fuse C7 | | -LR-left hand rear speaker | | |
| 62. | Fuse C2 | | -RF-right front speaker | | |
| | | | -RR-right hand rear speaker | | |



CIRCUIT DIAGRAM - 1991 MY - LEFT HAND STEERING - Illustrations RR2978M & RR2979M

Alphabetical key

180. ABS pick up point	137. Fuse C3	147. Low fuel level warning lamp
152. ABS warning lamp	114. Fuse C4	142. Low screen wash fluid level warning lamp
126. Alarm pick up point	129. Fuse C5	143. Low screen wash switch
11. Alternator	157. Fuse C6	20. Main lighting switch
40. Automatic gear selector illumination (2 off)	61. Fuse C7	113. Oil pressure switch
136. Automatic transmission oil temperature switch	173. Fuse C8	112. Oil pressure warning lamp
135. Automatic transmission/transfer box oil temperature warning lamp	161. Fuse C9	132. Overspeed monitor (Saudi only)
2. Battery	96. Glove box cigar lighter	127. Overspeed warning (Saudi only)
153a. Brake fluid level warning switch	151. Glow plugs (Diesel)	63. Pick up point-central locking/window lift
156. Brake pad wear sensors	150. Glow plug timer unit (Diesel)	66. Radio aerial amplifier
155. Brake pad wear warning lamp	149. Glow plug warning lamp (Diesel)	124. Radio and four speakers
118. Capacitor (petrol models)	153. Handbrake / brake fluid level / pressure warning lamp	123. Radio fuse
169. Central locking	154. Handbrake warning switch	34. Rear fog switch
37. Cigar lighter illumination (2 off)	72. Hazard switch	42. Rear fog warning lamp
60. Clock	182. Headlamp levelling actuator (2) (Germany)	98. Rear interior lamp
39. Clock illumination	181. Headlamp levelling switch connection (option)	141. Rear screen wash pump
162. Coil negative, engine speed signal to ECU	36a. Headlamp levelling switch illumination (option)	138. Rear wash wipe switch
41a. Column switch illumination	16. Headlamp relay	139. Rear wipe delay unit
178. Condenser fan relay	19. Headlamp wash pump	140. Rear wiper motor
176. Cruise control pick up point (option)	18. Headlamp wash timer unit	7a. Resistor (manual)
95. Dash cigar lighter	133. Heated front screen pick up point (option)	85. Reverse lamp switch
74. Direction indicator switch	67. Heated rear screen	46. RH dip beam
119. Distributor (petrol models)	64. Heated rear screen relay	102. RH door edge lamp
174. Electric mirrors	68. Heated rear screen switch	92. RH front auxiliary lamp
170. Electric seats pick up point (option)	69. Heated rear screen warning lamp	109. RH front door switch
145. Electronic speedo and instrument controls	110. Heated washer jets	80. RH front indicator lamp
120. EFI harness plug	38. Heater illumination (4 off)	48. RH high beam
148. EFI warning lamp	160. Heater/air con. connections	56. RH horn
73. Flasher unit	175. Heater/air con. load relay	75a. RH indicator warning lamp
86. Front auxiliary lamp relay (option)	26. High beam dip/flash switch	25a. RH number plate lamp
93. Front auxiliary lamp switch	49. High beam warning lamp	103. RH puddle lamp
97. Front interior lamp	55. Horn switch	106. RH rear door switch
17. Front wash pump	117. Ignition coil	44. RH rear fog lamp
14. Front wipe delay unit	1. Ignition load relay	81. RH rear indicator lamp
13. Front wipe/wash switch	8. Ignition switch	90. RH reverse lamp
15. Front wiper motor	10. Ignition warning lamp	27. RH side lamp
168. Fuel filler flap	115. Inertia switch	79. RH side repeater lamp
50. Fuel gauge	41. Instrument illumination (4 off)	88. RH stop lamp
51. Fuel gauge sender unit	99. Interior lamp delay unit	28. RH tail lamp
116. Fuel pump (petrol models)	104. Interior lamp switch	29. Rheostat
130. Fuel shut off solenoid (Diesel)	45. LH dip beam	121. Speed transducer
33. Fuse A1	100. LH door edge lamp	158. Split charge relay (option)
31. Fuse A2	91. LH front auxiliary lamp	159. Split charge terminal post (option)
21. Fuse A3	108. LH front door switch	7. Starter inhibit switch
35. Fuse A4	77. LH front indicator lamp	5. Starter motor
71. Fuse A5	47. LH high beam	6. Starter relay
83. Fuse A6	57. LH horn	4. Starter solenoid
22. Fuse A7	75. LH indicator warning lamp	84. Stop lamp switch
30. Fuse A8	25. LH number plate lamp	134. Sunroof pick up point
32. Fuse A9	101. LH puddle lamp	125. Sunroof relay
12. Fuse B1	105. LH rear door switch	36. Switch illumination (2 off)
54. Fuse B2	43. LH rear fog lamp	9. Tachometer
171. Fuse B3	76. LH rear indicator lamp	107. Tailgate switch
94. Fuse B4	89. LH reverse lamp	3. Terminal post
125a. Fuse B5	23. LH side lamp	111. Thermostat - heated washer jets
128. Fuse B6	78. LH side repeater lamp	122. Trailer pick up point
179. Fuse B7	87. LH stop lamp	82. Trailer warning lamp
172. Fuse B8	24. LH tail lamp	136a. Transfer box oil temperature switch
177. Fuse B9	146. Low coolant level warning lamp	58. Under bonnet illumination switch
65. Fuse C1	144. Low coolant switch	59. Under bonnet light
162. Fuse C2		70. Voltage sensitive switch
		52. Water temperature gauge
		53. Water temperature sender unit

Circuit diagram - 1991 MY - Left hand steering

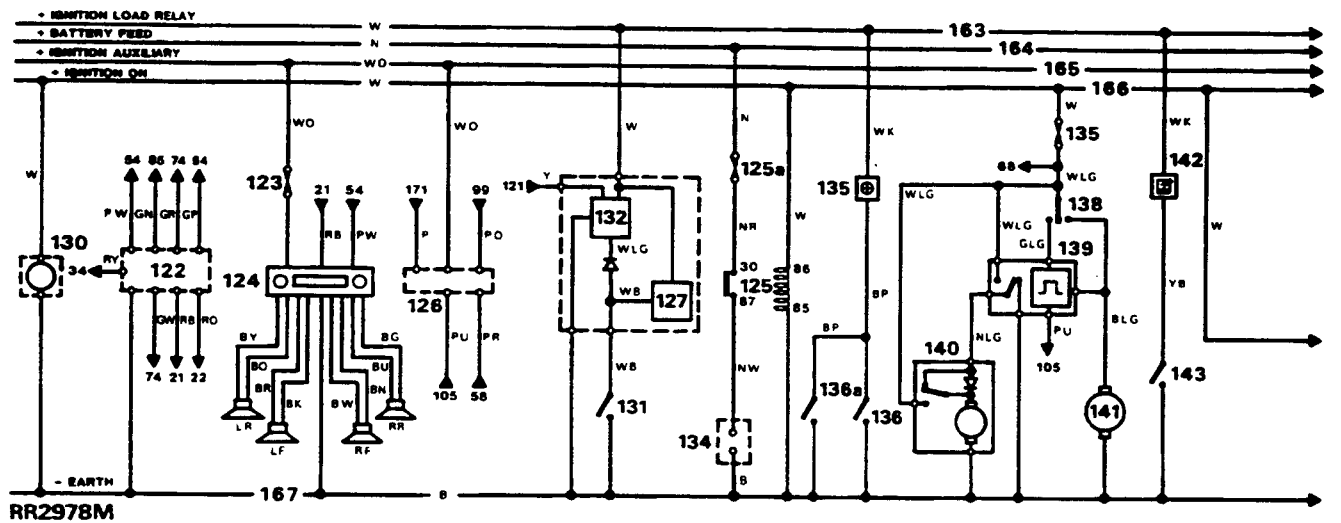
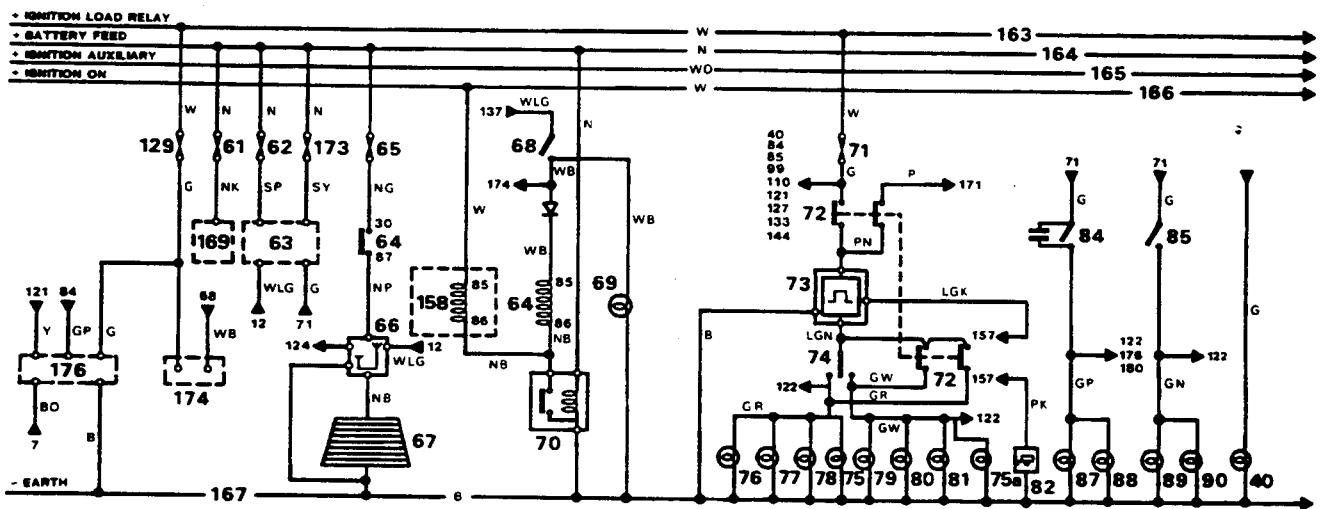
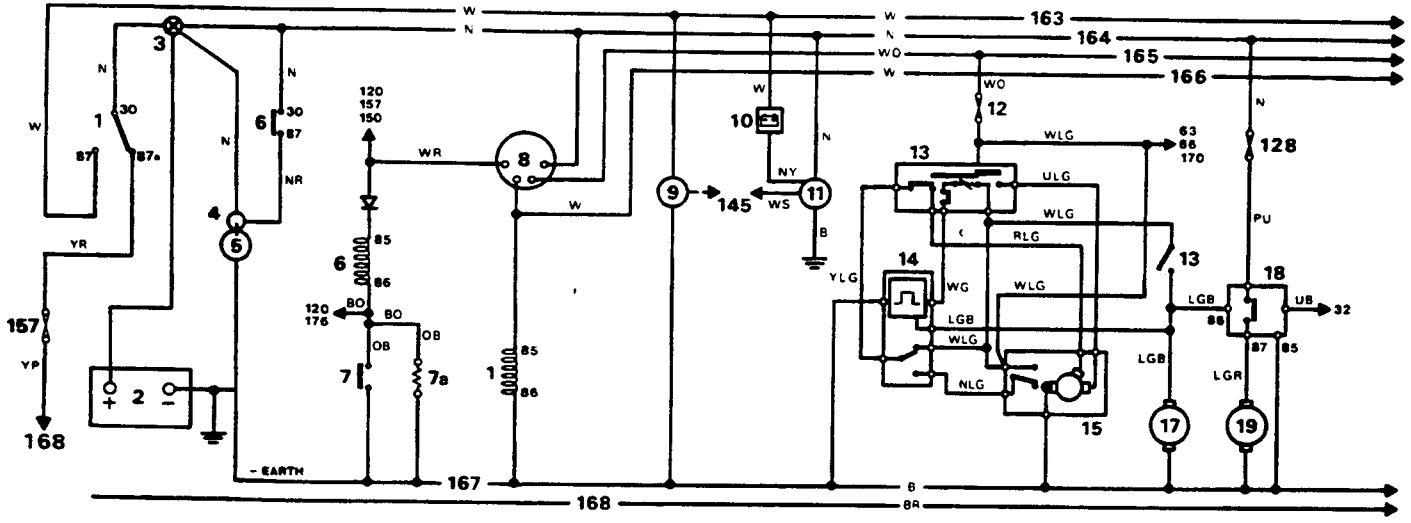

RR2978M



Illustrations RR2978M & RR2979M

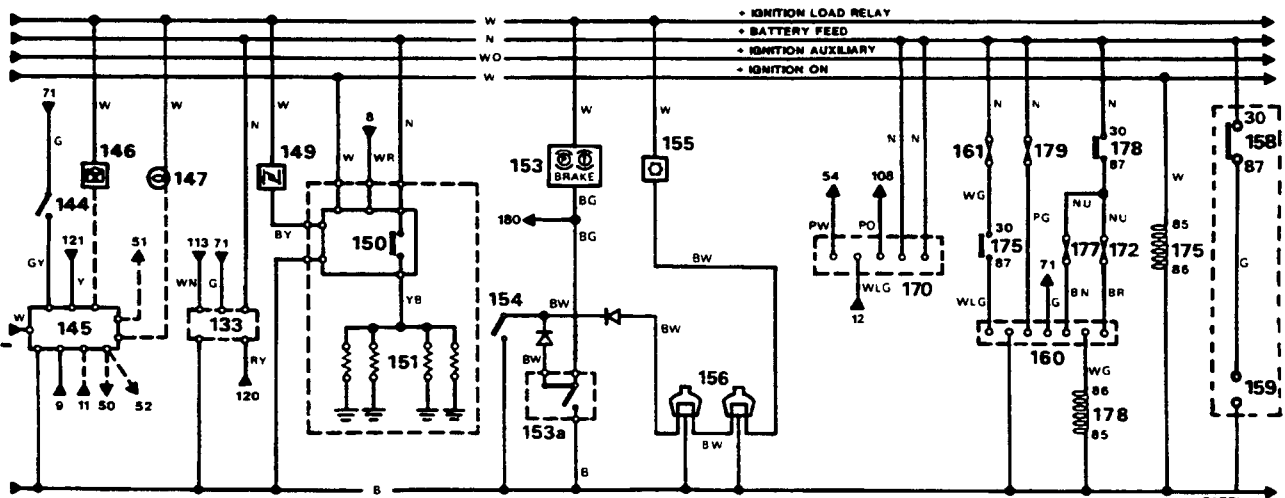
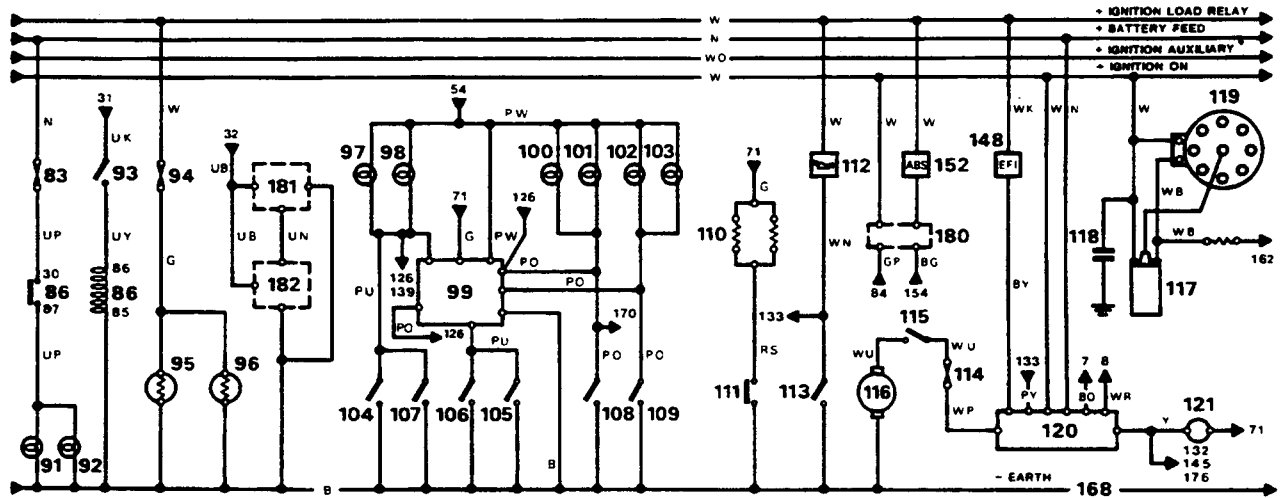
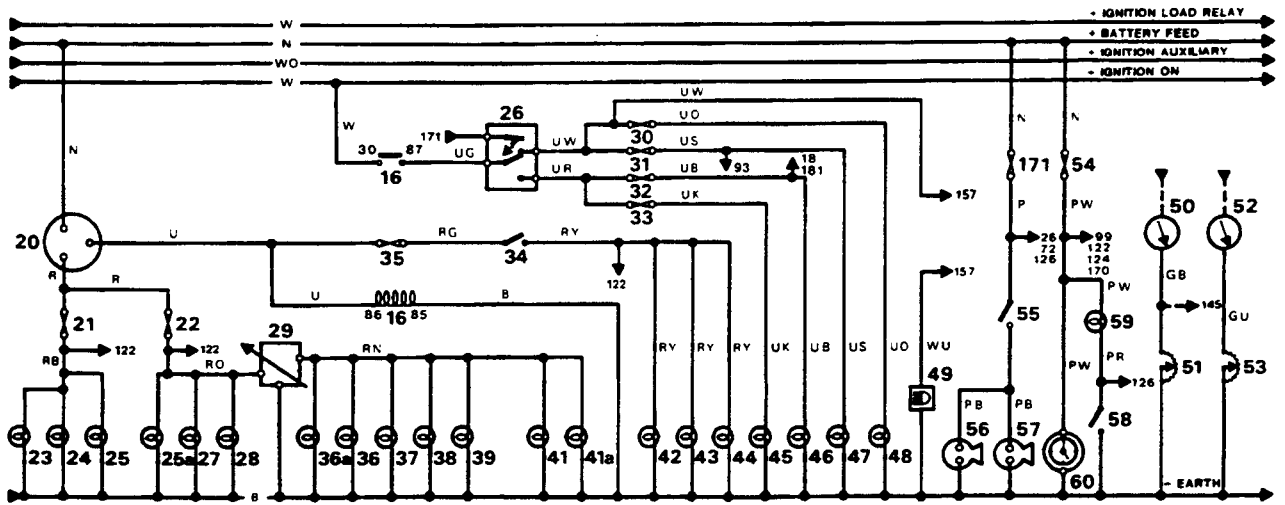

RR2979M

**CIRCUIT DIAGRAM - 1991 MY - USA AND CANADA
- Illustrations RR2970E & RR2971E**

Numerical key

- | | | | |
|------|---|------|---------------------------------|
| 1. | Ignition load relay | 50. | Fuel gauge |
| 2. | Battery | 51. | Fuel gauge sender unit |
| 3. | Terminal post | 52. | Water temperature gauge |
| 4. | Starter solenoid | 53. | Water temperature sender unit |
| 5. | Starter motor | 54. | Fuse B2 |
| 6. | Starter relay | 55. | Horn switch |
| 7. | Starter inhibit switch | 56. | RH horn |
| 8. | Ignition switch | 57. | LH horn |
| 9. | Tachometer | 58. | Under hood illumination switch |
| 10. | Ignition warning lamp | 59. | Under hood light |
| 11. | Alternator | 60. | Clock |
| 12. | Fuse B1 | 61. | Fuse C7 |
| 13. | Front wipe/wash switch | 62. | Fuse C2 |
| 14. | Front wipe delay unit | 63. | Central door locking unit |
| 15. | Front wiper motor | 64. | Heated rear window relay |
| 16. | Headlamp relay | 65. | Fuse C1 |
| 17. | Front wash pump | 66. | Radio aerial amplifier |
| 18. | Headlamp wash timer unit | 67. | Heated rear screen |
| 19. | Headlamp wash pump | 68. | Heated rear screen switch |
| 20. | Main lighting switch | 69. | Heated rear screen warning lamp |
| 21. | Fuse A3 | 70. | Voltage sensitive switch |
| 22. | Fuse A7 | 71. | Fuse A5 |
| 23. | LH side lamp | 72. | Hazard switch |
| 24. | LH tail lamp | 73. | Flasher unit |
| 25. | LH license plate lamp | 74. | Direction indicator switch |
| 25a. | RH license plate lamp | 75. | LH indicator warning lamp |
| 26. | High beam dimmer/flash switch | 75a. | RH indicator warning lamp |
| 27. | RH side lamp | 76. | LH rear indicator lamp |
| 28. | RH tail lamp | 77. | LH front indicator lamp |
| 29. | Rheostat | 78. | Not used |
| 30. | Fuse A8 | 79. | Not used |
| 31. | Fuse A2 | 80. | RH front indicator lamp |
| 32. | Fuse A9 | 81. | RH rear indicator lamp |
| 33. | Fuse A1 | 82. | Trailer warning lamp |
| 34. | Fuse B6 | 83. | Fuse A6 |
| 35. | Window lift connections | 84. | Stop lamp switch |
| 36. | Switch illumination (2 off) | 85. | Reverse lamp switch |
| 37. | Cigar lighter illumination (2 off) | 86. | Front fog lamp relay |
| 38. | Heater illumination (4 off) | 87. | LH stop lamp |
| 39. | Clock illumination | 88. | RH stop lamp |
| 40. | Auto gear selector illumination (2 off) | 89. | LH reverse lamp |
| 40a. | Auto gear selector illumination relay. | 90. | RH reverse lamp |
| 41. | Instrument illumination (4 off) | 91. | LH front fog lamp |
| 41a. | Column switch illumination | 92. | RH front fog lamp |
| 42. | Not used | 93. | Front fog lamp switch |
| 43. | Not used | 94. | Fuse B4 |
| 44. | Fuse B3 | 95. | Dash cigar lighter |
| 45. | LH low beam | 96. | Glove box cigar lighter |
| 46. | RH low beam | 97. | Front interior lamp |
| 47. | LH high beam | 98. | Rear interior lamp |
| 48. | RH high beam | 99. | Interior lamp delay unit |
| 49. | High beam warning lamp | | |



- | | | | |
|-------|---|-------|--|
| 100. | LH door edge lamp | 144. | Low coolant switch |
| 101. | LH puddle lamp | 145. | Electronic speedo and instrument controls |
| 102. | RH door edge lamp | 146. | Low coolant level warning lamp |
| 103. | RH puddle lamp | 147. | Low fuel level warning lamp |
| 104. | Interior lamp switch | 148. | Check engine warning lamp |
| 105. | LH rear door switch | 149. | Low oil level logic unit |
| 106. | RH rear door switch | 150. | Low oil level probe |
| 107. | Tailgate switch | 151. | Compressor clutch relay |
| 108. | LH front door switch | 152. | ABS warning lamp |
| 109. | RH front door switch | 153. | Parking brake/brake fluid loss warning lamp |
| 110. | Heated washer jets | 153a. | Brake fluid level warning switch |
| 111. | Thermostat heated jets | 154. | Park brake warning switch |
| 112. | Oil pressure/level warning lamp | 155. | Brake pad wear warning lamp |
| 113. | Oil pressure switch | 156. | Brake pad wear sensors |
| 114. | Fuse C4 | 157. | Warning lamp control unit |
| 115. | Inertia switch | 158. | Service engine warning lamp |
| 116. | Fuel pump | 159. | Emission maintenance reminder unit |
| 117. | Ignition coil | 160. | Diode pack (air con) |
| 118. | Capacitor | 161. | Fuse C9 |
| 119. | Distributor | 162. | Coil negative (engine RPM input to ECU) |
| 120. | EFI Harness plug | 163. | Ignition load relay (+) circuit |
| 121. | Speed transducer | 164. | Battery feed (+) circuit |
| 122. | Trailer pick up point | 165. | Ignition auxiliary (+) circuit |
| 123. | Fuse A4 | 166. | Ignition on (+) circuit |
| 124. | Radio and six speakers | 167. | Earth (-) circuit |
| 125. | Sun roof relay | 168. | Warning lights supply common earth (-) circuit |
| 125a. | Fuse B5 | 169. | Warning lights supply (+) circuit |
| 126. | Alarm pick up point | 170. | Fuse C6 |
| 127. | Seat belt warning lamp | 171. | Fuse C5 |
| 128. | 'Key-in switch' | 172. | Fuse B8 |
| 129. | Resistor | 173. | Fuse C8 |
| 130. | Audible warning unit | 174. | Fuel filler flap release |
| 131. | Seat buckle switch | 175. | Heater/air conditioning relay |
| 132. | Transfer box neutral switch | 176. | Cruise control connection points |
| 133. | Condenser fan motors | 177. | Fuse B9 |
| 134. | Sunroof connection point (option) | 178. | Condenser fan relay |
| 135. | Auto transmission and transfer box oil temperature warning lamp | 179. | Fuse B7 |
| 136. | Auto transmission oil temperature switch | 180. | ABS ECU |
| 136a. | Transfer box oil temperature switch | 181. | Front amplifier audio |
| 137. | Fuse C3 | 182. | Rear amplifier audio |
| 138. | Rear wash wipe switch | 183. | Electric seat relays |
| 139. | Rear wipe delay unit | 184. | Heated front screen timer unit |
| 140. | Rear wiper motor | 185. | Electric mirror elements |
| 141. | Rear screen wash pump | 186. | Glare control mirror |
| 142. | Low screen wash fluid level warning lamp | | |
| 143. | Low screen wash switch | | |

Cable colour code

B Black	L Light	P Purple	U Blue
G Green	N Brown	R Red	W White
K Pink	O Orange	S Grey	Y Yellow

The last letter of a colour denotes the tracer colour.



NOTE: The following items are now incorporated into the main harness assembly, ABS, air conditioning, CD player, cruise control, electric mirrors, door locks, heated front screen and window lift. These items are shown on the main circuit diagram as a box containing the relevant number, or indicated by an arrow and the item number. Refer to the appropriate circuit diagram for details of these items.

Circuit diagram - 1991 MY - USA and CANADA
Illustrations RR2970E & RR2971E

Alphabetical key

180.	ABS ECU	71.	Fuse A5
180.	ABS pick up point	83.	Fuse A6
152.	ABS warning lamp	22.	Fuse A7
126.	Alarm pick up point	30.	Fuse A8
11.	Alternator	32.	Fuse A9
130.	Audible warning unit	12.	Fuse B1
40.	Auto gear selector illumination (2 off)	54.	Fuse B2
40a.	Auto gear selector illumination relay.	44.	Fuse B3
135.	Auto transmission and transfer box oil temperature warning lamp	94.	Fuse B4
136.	Auto transmission oil temperature switch	125a.	Fuse B5
2.	Battery	34.	Fuse B6
164.	Battery feed (+)	179.	Fuse B7
153a.	Brake fluid loss warning switch	172.	Fuse B8
155.	Brake pad wear warning lamp	177.	Fuse B9
156.	Brake pad wear sensors	65.	Fuse C1
118.	Capacitor	62.	Fuse C2
63.	Central door locking unit	137.	Fuse C3
163.	Check engine warning lamp	114.	Fuse C4
37.	Cigar lighter illumination (2 off)	171.	Fuse C5
60.	Clock	170.	Fuse C6
39.	Clock illumination	61.	Fuse C7
162.	Coil negative (engine RPM input to ECU)	173.	Fuse C8
42.	Column switch illumination	161.	Fuse C9
151.	Compressor clutch relay	186.	Glare control mirror
133.	Condenser fan motors	96.	Glove box cigar lighter
178.	Condenser fan relay	72.	Hazard switch
176.	Cruise control connection points	16.	Headlamp relay
95.	Dash cigar lighter	19.	Headlamp wash pump
160.	Diode pack (air con)	18.	Headlamp wash timer unit
74.	Direction indicator switch	184.	Heated front screen timer unit
119.	Distributor	68.	Heated rear screen switch
148.	E.F.I. warning lamp	64.	Heated rear window relay
120.	EFI Harness plug	69.	Heated rear screen warning lamp
167.	Earth (+)	67.	Heated rear screen
185.	Electric mirror elements	110.	Heated washer jets
183.	Electric seat relays	38.	Heater illumination (4 off)
145.	Electronic speedo and instrument controls	175.	Heater/air conditioning relay
159.	Emission maintenance reminder	160.	Heater/air conditioning connections
73.	Flasher unit	26.	High beam dimmer/flash switch
181.	Front amplifier audio	49.	High beam warning lamp
86.	Front fog lamp relay	55.	Hom switch
93.	Front fog lamp switch	165.	Ignition auxiliary (+)
97.	Front interior lamp	117.	Ignition coil
17.	Front wash pump	1.	Ignition load relay
13.	Front wipe/wash switch	163.	Ignition load relay (+)
14.	Front wipe delay unit	166.	Ignition on (+)
15.	Front wiper motor	8.	Ignition switch
174.	Fuel filler flap release	10.	Ignition warning lamp
51.	Fuel gauge sender unit	115.	Inertia switch
50.	Fuel gauge	41.	Instrument illumination (4 off)
116.	Fuel pump	104.	Interior lamp switch
33.	Fuse A1	99.	Interior lamp delay unit
31.	Fuse A2		
21.	Fuse A3		
123.	Fuse A4		



- | | | | |
|------|--|-------|--|
| 128. | 'Key-in switch' | 27. | RH side lamp |
| 100. | LH door edge lamp | 88. | RH stop lamp |
| 108. | LH front door switch | 28. | RH tail lamp |
| 91. | LH front fog lamp | 66. | Radio aerial amplifier |
| 77. | LH front indicator lamp | 124. | Radio and six speakers |
| 47. | LH high beam | 123. | Radio fuse |
| 57. | LH horn | 182. | Rear amplifier audio |
| 75. | LH indicator warning lamp | 98. | Rear interior lamp |
| 25. | LH license plate lamp | 141. | Rear screen wash pump |
| 45. | LH low beam | 138. | Rear wash wipe switch |
| 101. | LH puddle lamp | 139. | Rear wipe delay unit |
| 105. | LH rear door switch | 140. | Rear wiper motor |
| 76. | LH rear indicator lamp | 129. | Resistor |
| 89. | LH reverse lamp | 85. | Reverse lamp switch |
| 23. | LH side lamp | 29. | Rheostat |
| 87. | LH stop lamp | 127. | Seat belt warning lamp |
| 24. | LH tail lamp | 131. | Seat buckle switch |
| 146. | Low coolant level warning lamp | 121. | Speed transducer |
| 144. | Low coolant switch | 7. | Starter inhibit switch |
| 147. | Low fuel level warning lamp | 5. | Starter motor |
| 150. | Low oil level probe | 6. | Starter relay |
| 149. | Low oil level logic unit | 4. | Starter solenoid |
| 143. | Low screen wash switch | 84. | Stop lamp switch |
| 142. | Low screen wash fluid level warning lamp | 125. | Sun roof relay |
| 20. | Main lighting switch | 134. | Sunroof connection point (option) |
| 151. | Not used - will illuminate on initial bulb check | 36. | Switch illumination (2 off) |
| 113. | Oil pressure switch | 9. | Tachometer |
| 112. | Oil pressure/level warning lamp | 107. | Tailgate switch |
| 154. | Park brake warning switch | 3. | Terminal post |
| 153. | Parking brake/brake fluid loss warning lamp | 111. | Thermostat heated jets |
| 182. | Rear amplifier audio | 122. | Trailer pick up point |
| 102. | RH door edge lamp | 82. | Trailer warning lamp |
| 109. | RH front door switch | 136a. | Transfer box oil temperature switch |
| 92. | RH front fog lamp | 132. | Transfer box neutral switch |
| 80. | RH front indicator lamp | 58. | Under hood illumination switch |
| 48. | RH high beam | 59. | Under hood light |
| 56. | RH horn | 70. | Voltage sensitive switch |
| 75a. | RH indicator warning lamp | 157. | Warning lamp control unit |
| 25a. | RH license plate lamp | 168. | Warning lights supply common earth (-) |
| 46. | RH low beam | 169. | Warning lights supply (+) |
| 103. | RH puddle lamp | 53. | Water temperature sender unit |
| 106. | RH rear door switch | 52. | Water temperature gauge temperature warning lamp |
| 81. | RH rear indicator lamp | 35. | Window lift connections |
| 90. | RH reverse lamp | | |



IGNITION TIMING

Service repair no - 86.35.15

Adjust

1. It is essential that following procedures are adhered to. Inaccurate timing can lead to serious engine damage and additionally create failure to comply with emission regulations. If timing is being checked in vehicle, air conditioning compressor must be disengaged.
2. On initial engine build, or if distributor has been disturbed for any reason, ignition timing must be set statically to 6° B.T.D.C.



NOTE: This approximate setting is made only to ensure that engine may be started.



CAUTION: On no account must engine be started before this operation is carried out.

Equipment required :-

**Calibrated Tachometer
Stroboscopic lamp**

3. Couple stroboscopic timing lamp and tachometer to engine following manufacturer's instructions.
4. Disconnect vacuum hose from distributor.
5. Start engine. With no load, and without exceeding 3,000 rev/min run engine until normal operating temperature is reached. (Thermostat open). Check that engine idles within tolerance specified in data section.
6. Idle speed for timing purposes must not exceed 800 rev/min.
7. With distributor clamping bolt loosened, turn distributor until timing flash coincides with timing pointer and correct timing mark on rim of torsional vibration damper.
8. Retighten distributor clamping bolt securely. Recheck timing, to ensure retightening has not disturbed distributor position.
9. Refit vacuum hose.
10. Disconnect stroboscopic timing lamp and tachometer from engine.



FUSE BOX - 1990 & 91 MY

A1 	A2 	A3 	A4 	A5 	A6 	A7 	A8 	A9
B1 	B2 	B3 	B4 	B5 	B6 	B7 	B8 	B9
C1 	C2 	C3 	C4 	C5 	C6 	C7 	C8 	C9

RR2984M

FUSE NUMBER	COLOUR CODE	RATING AMPS	IGN. KEY POSITION	FUNCTION
A1	Red	10	II	LH dipped beam
A2	Red	10	II	LH main beam, auxiliary lamp relay
A3	Tan	5	O	LH sidelamps, radio ill., trailer pickup
A4	Red	10	O	Rear fog guard (headlamp switch controlled) (Not USA)
A5	Yellow	20	II	Direction ind., resistor, heated jets, thermo., heated front screen timer, air con. low coolant, speed transducer, interior lamp delay, reverse lights, stop lights, dimming rear view mirror (1991)
A6	Red	10	II	Auxiliary driving lamps (from main beam)
A7	Tan	5	O	RH sidelamps, rheostat controlled instrument/switch illumination, trailer pick up
A8	Red	10	II	RH main beam
A9	Red	10	II	RH dipped beam, headlamp levelling (option)
B1	Yellow	20	I	Front wash/wipe, seat relays, window lift relays, antenna amplifier
B2	Yellow	20	O	Interior light, clock, underbonnet ill., elec. seat relays, radio, door lamps, heated door locks (1991)
B3	Yellow	20	O	Hazard switch, alarm, main beam/dip flash, horns
B4	Yellow	20	II	Cigar lighters
B5	Yellow	20	II	Sunroof motor
B6	Yellow	20	II	Headlamp wash
B7	Tan	5	II	Air conditioning compressor clutch
B8	Yellow	20	II	Air conditioning/radiator cooling fan
B9	Yellow	20	II	Air conditioning/radiator cooling fan
C1	Green	30	II	Heated rear screen (voltage switch controlled)
C2	Green	30	II	Window lifts - rear
C3	Red	10	II	Rear wash wipe motor, heated rear screen relay, mirror heaters
C4	Red	10	II	Fuel pump
C5	Red	10	II	Mirror motors, cruise control (option)
C6	Tan	5	O or I	Fuel filler flap (1991)
C7	Blue	15	O	Central locking
C8	Green	30	II	Window lifts - front
C9	Green	30	II	Heater/air conditioning motor

Key to RR2985M

1. Battery
2. Air conditioning compressor (option)
3. Horns
4. Oil pressure switch
5. Water temperature switch
6. Electronic distributor
7. Alternator
8. Starter motor
9. Coil
10. Headlamp wash timer unit
11. Heater
12. Relays/flasher units
13. Air con relays/diode unit (option)
14. Window lift motor (front RH door)
15. Door lock actuator (front RH door)
16. Electronic control unit (EFI)
17. Wiper motor - front screen
18. Relays/delay units
19. Park brake warning light switch
20. Window lift motor (front LH door)
21. Electronic control unit and relays (ABS) (option)
22. Seat adjustment fusebox (option)
23. Door lock actuator (front LH door)
24. Window lift motor (rear LH door)
25. Door lock actuator (rear LH door)
26. Seat adjustment relays - two (option)
27. Electrical in-tank fuel pump
28. Inertia switch
29. Tailgate lock actuator
30. Wiper motor - rear screen
31. Radio aerial amplifier
32. Fuel filler flap lock actuator
33. Window lift relays and one touch control unit
34. Door lock actuator (rear RH door)
35. Window lift motor (rear RH door)
36. EFI relays (two)
37. Condenser fan timer unit (option)
38. Cruise control relay (option)
39. Dimming mirror (option)
40. RH door lock heater
41. LH door lock heater



NOTE: Left hand drive vehicle shown. Items 10, 12, 13, 17 and 18 located symmetrically opposite on right hand drive vehicles.



LOCATION OF ELECTRICAL EQUIPMENT

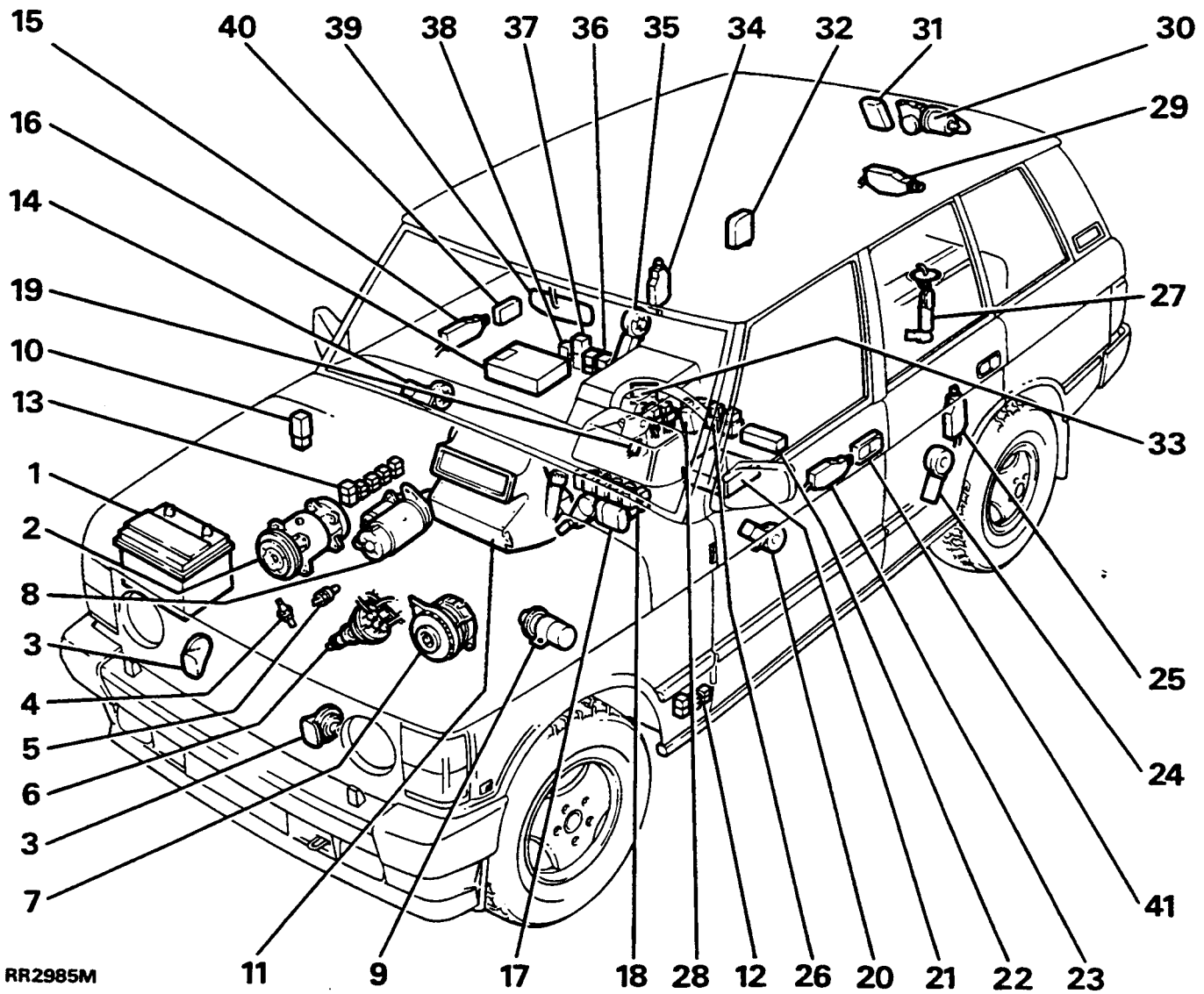

RR2985M

RELAYS, DELAY UNITS, TIMER UNITS, DIODE PACK - 1990 / 91 - IDENTIFICATION

Left hand drive vehicle shown, right hand drive symmetrically opposite.

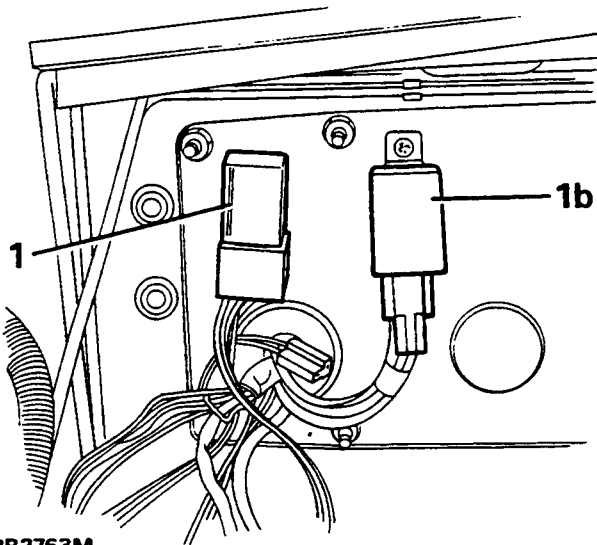

RR2763M

Closure panel viewed from the engine bay compartment, with protective cover removed.

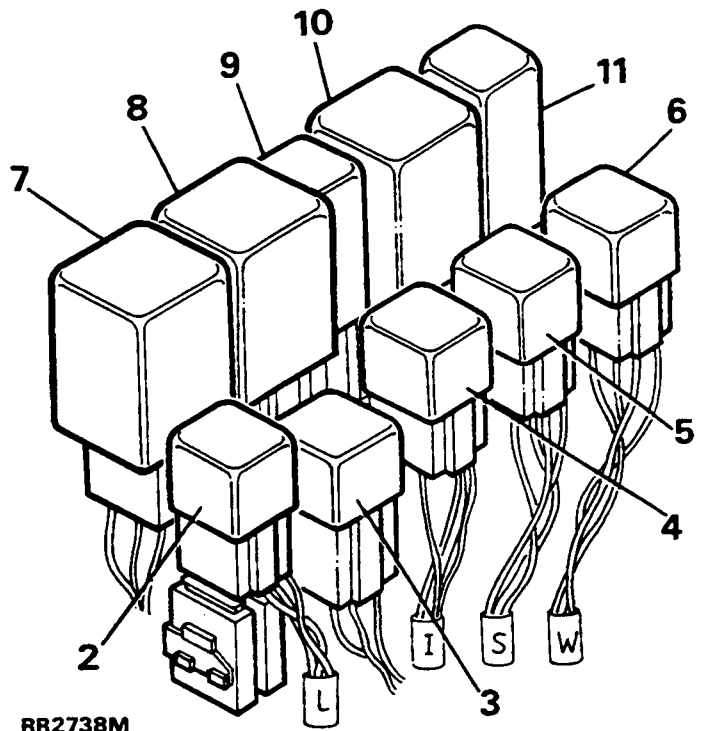

RR2738M

Steering column mounted relays viewed with the lower dash panel removed.

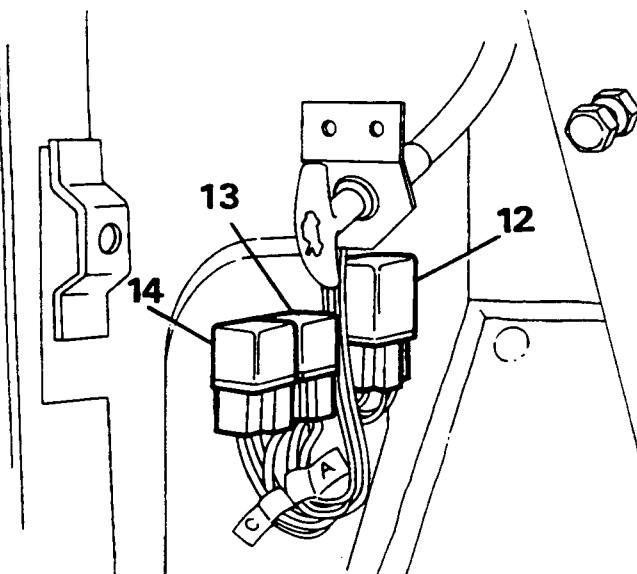

RR2739M

RR2379M shows relays mounted in left hand side of footwell, trim panel removed, left hand drive.

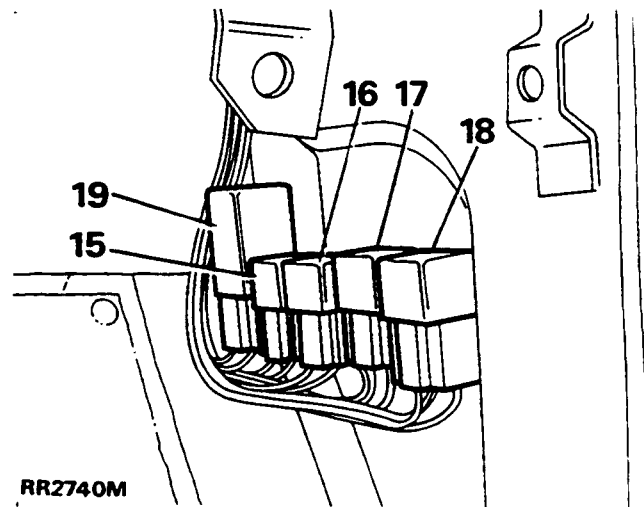

RR2740M

RR2740M shows relays mounted in right hand side of footwell, trim panel removed, left hand drive



	Relay/delay/timer/diode unit	Colour	Circuit Diagram Item Number	
			Right hand steer	Left hand steer
1.	Headlamp wash timer unit	Black	19.M	18.M
1b.	Glow plug timer unit (diesel)	Black	143.M	150.M
2.	Headlamp relay	Natural	17.M	16.M
3.	Heated front screen relay	Black	3.HF	3.HF
4.	Ignition load relay	Natural	1.M	1.M
5.	Starter solenoid relay	Natural	6.M	6.M
6.	Heated rear window relay	Natural	67.M	64.M
7.	Rear wiper delay	Blue	132.M	139.M
8.	Interior lamp delay/timer	Red	101.M	99.M
9.	Heated front screen timer unit	Grey	2.HF	2.HF
10.	Voltage sensitive switch	Yellow	72.M	70.M
11.	Front wiper delay	Red	15.M	14.M
12.	Flasher/hazard unit	Blue	75.M	73.M
13.	Auxiliary lamp relay	Natural	88.M	86.M
14.	Sunroof auxiliary relay	Natural	124.M	125.M
15.	Air con./heater relay	Natural	5.A	5.A
16.	Compressor clutch relay	Natural	11.A	11.A
17.	Heater/air con. load relay	Natural	163.M	175.M
18.	Condenser fan relay	Natural	9.A	9.A
19.	Air con. diode pack	Orange	1.A	1.A
20.	Seat adjustment relays - two	Natural	5.6.F	5.6.F
21.	Main EFI relay	Silver	22.E	22.E
22.	Fuel pump relay	Silver	21.E	21.E
23.	Cruise control relay	Natural	16.C	16.C
24.	Condenser fan timer unit	Green	33.E	33.E
25.	Rear window lift relay	Natural	13.W	13.W
26.	Front window lift relay	Natural	14.W	14.W
27.	Window lift one touch unit	Black	1.W	1.W
28.	Brake check relay (RH steering)	Natural	151.M	...

M Main circuit diagram
A Air conditioning circuit diagram
S Seat adjustment circuit diagram
HF Heated front screen circuit diagram

E EFI circuit diagram
SR Sunroof circuit diagram
W Window lift circuit diagram
C Cruise control circuit diagram

Relays cont'd

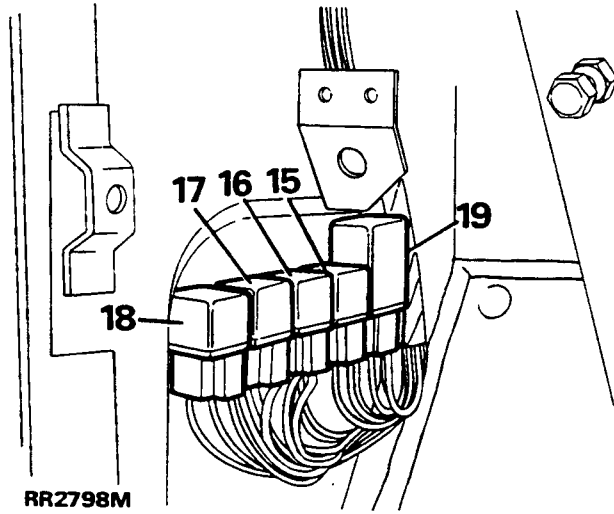

Seat adjustment relays (load control) located beneath the left hand front seat adjacent to fuse box (B).

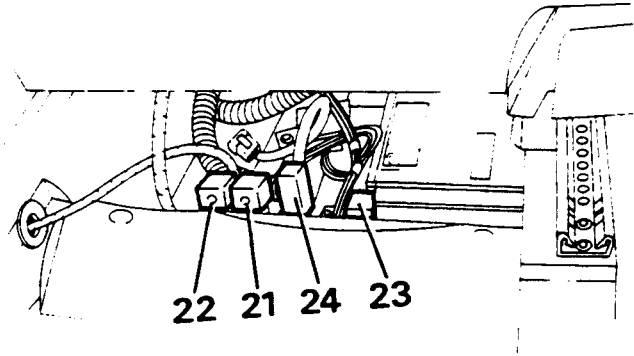

RR2765M

EFI (black terminal block) and fuel pump relays (blue terminal block) mounted beneath right hand front seat (21 and 22).

RR2798 shows relays mounted in left hand side of footwell, trim panel removed, right hand drive.

Condenser fan timer unit (24) mounted beneath right hand front seat.

Cruise control relay (23).

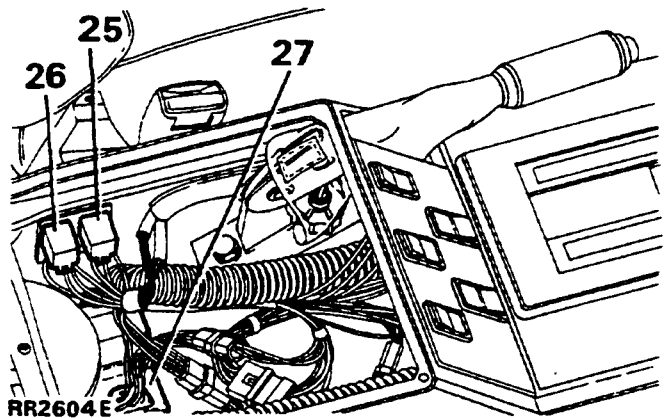
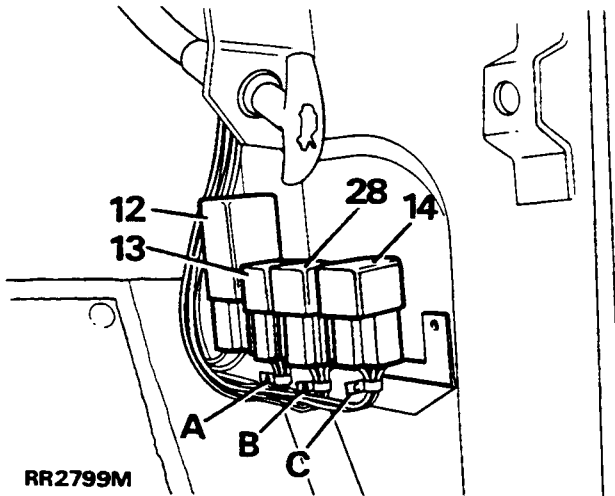

RR2799M

RR2604E

RR2799 shows relays mounted in right hand side of footwell, trim panel removed, right hand drive

Front (black terminal block) and rear (blue terminal block) window relays. One touch control unit (27) is located inside the glove box, accessible by removing glove box liner.

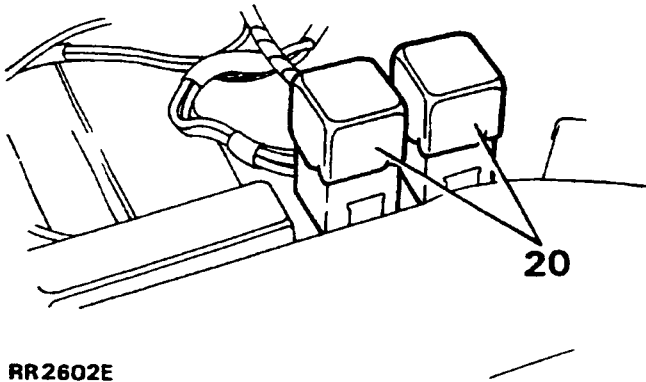

RR2602E



RELAYS, DELAY UNITS, TIMER UNITS, DIODE PACK - USA AND CANADA 1990 / 91 - IDENTIFICATION

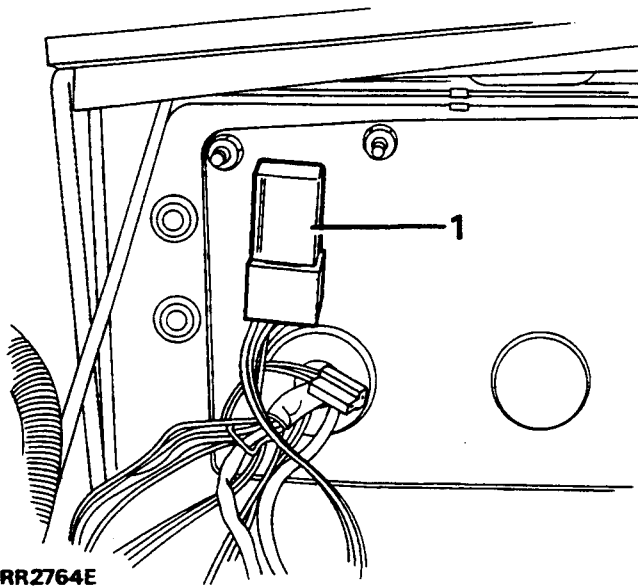

RR2764E

Closure panel viewed from the engine bay compartment, with protective cover removed.

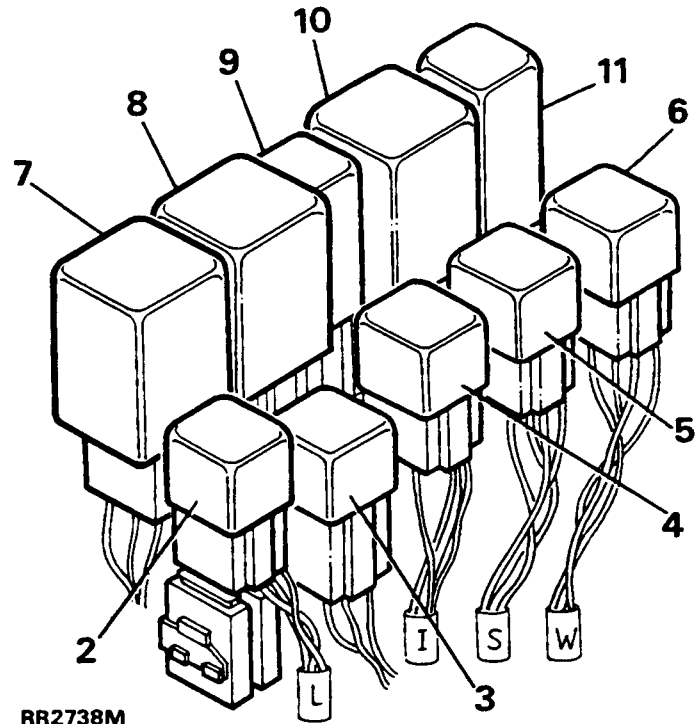

RR2738M

Steering column mounted relays viewed with the lower dash panel removed.

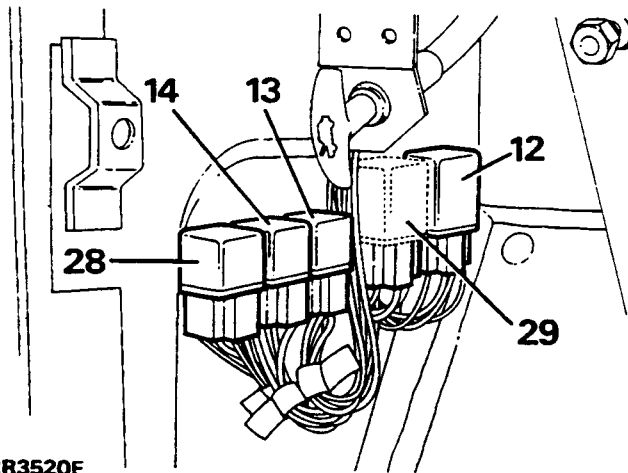

RR3520E

RR3520M shows relays mounted in left hand side of footwell, trim panel removed.

1990 vehicles have gear selector illumination (28) relay inside the glove box - see RR2906E

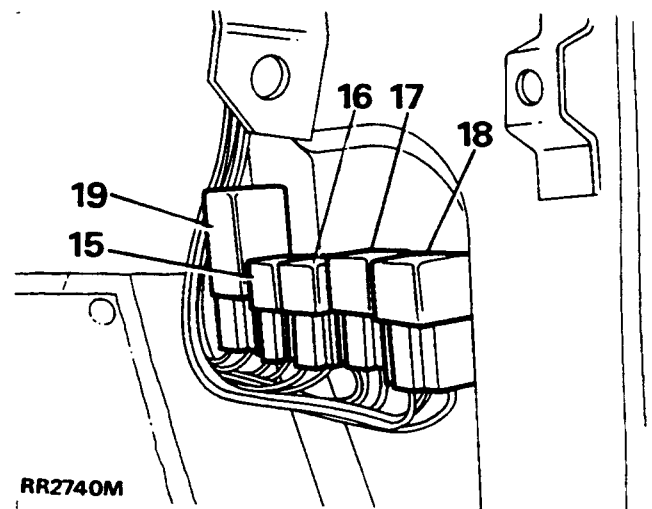

RR2740M

RR2740M shows relays mounted in right hand side of footwell, trim panel removed.

Relay/delay/timer/diode unit	Circuit diagram item number	Colour	
		Unit	Base
1. Headlamp wash timer unit	18. Main	Black	Black
2. Headlamp relay	16. Main	Yellow	Black
3. Heated front screen relay	3. Heated front screen	Black	Black
4. Ignition load relay	1. Main	Green	Black
5. Starter solenoid relay	6. Main	Yellow	Black
6. Heated rear window relay	64. Main	Yellow	Black
7. Rear wiper delay	139. Main	Blue	Black
8. Interior lamp delay/timer	99. Main	Yellow	Black
9. Heated front screen timer unit	2. Heated front screen	Grey	White
10. Voltage sensitive switch	70. Main	Yellow	Yellow
11. Front wiper delay	14. Main	Red	Black
12. Flasher/hazard unit	73. Main	Blue	Blue
13. Auxiliary lamp relay	86. Main	Yellow	Yellow
14. Sunroof auxiliary relay	3. Sunroof	Yellow	Yellow
15. Air con./heater relay	175. Main	Green	Yellow
16. Compressor clutch relay	11. Air conditioning	Yellow	Yellow
17. Heater/air con. load relay	5. Air conditioning	Yellow	Yellow
18. Condenser fan relay	9. Air conditioning	Yellow	Yellow
19. Air con. diode pack	1. Air conditioning	Orange	Red
20. Seat adjustment relays - two	5 & 6. Seat adjustment	Yellow	Yellow
21. Main EFI relay	22. EFI	Silver	Black
22. Fuel pump relay	21. EFI	Silver	Blue
23. Cruise control relay	16. Cruise control	Green	Black
24. Condenser fan timer unit	33. EFI	Green	Black
25. Rear window lift relay	13. Window lift	Yellow	Black
26. Front window lift relay	14. Window lift	Yellow	Blue
27. Window lift one touch unit	1. Window lift	Black	-
28. Gear selector illumination relay	40a Main	Green	Green
* 29. Daytime lights control (Canada)	-	Black	Black

* Control unit ONLY fitted when daytime running lights are required.

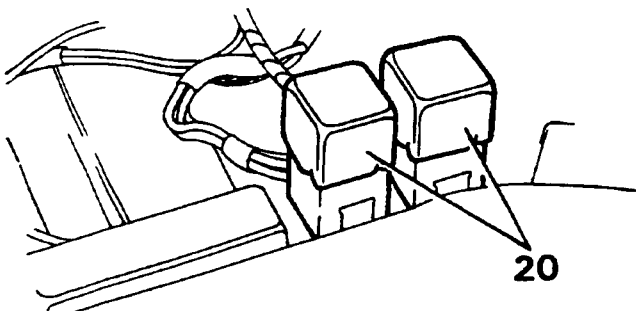

RR2602E

Seat adjustment relays (load control) located beneath the left hand front seat.

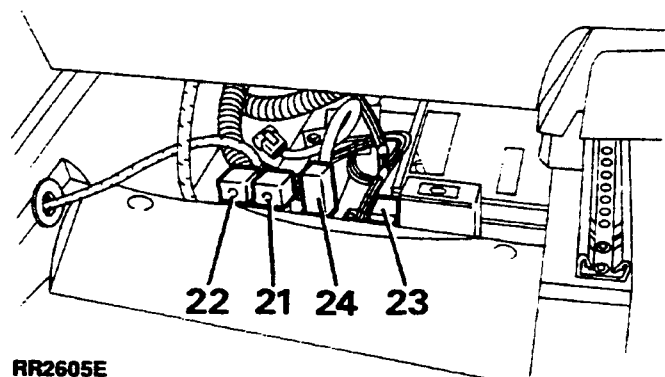

RR2605E

EFI (black terminal block) and fuel pump relays (blue terminal block) mounted beneath right hand front seat (21 and 22).

Condenser fan timer unit (24) mounted beneath right hand front seat.

Cruise control relay (23).

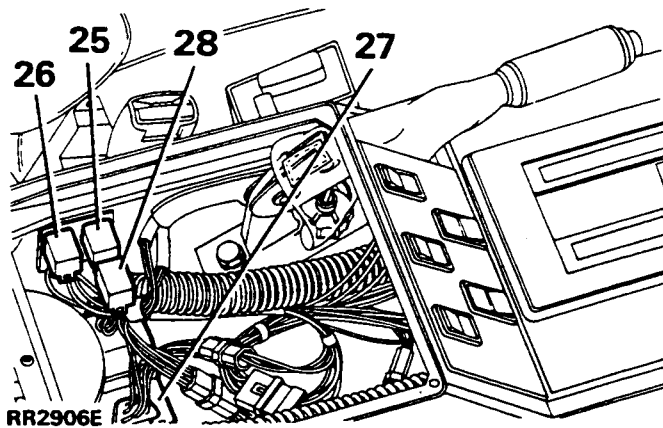

RR2906E shows relays located inside the glove box, accessible by removing the glove box liner. Front (black terminal block) and rear (blue terminal block) window relays (25 and 26) window lift one touch control unit (27).

Gear selector illumination relay (28) shown in 1990 position.

BATTERY

Service repair no - 86.15.01

Remove and refit**Remove**

WARNING: During battery removal or before carrying out any repairs or maintenance to electrical components always disconnect battery negative lead first. If positive lead is disconnected with negative lead in place, accidental contact of wrench to any grounded metal part could cause a severe spark, possibly resulting in personal injury. Upon installation of battery connect positive lead first.

1. Disconnect the battery negative lead. And positive lead.
2. Release four nuts securing battery bracket in position.
3. Remove bracket.
4. Remove battery.

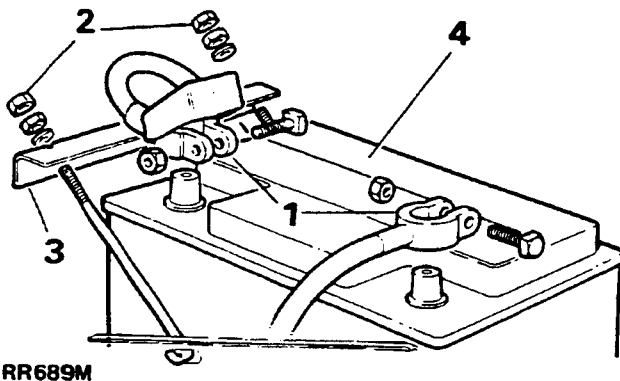
**Refit**

5. Reverse removal procedure.



NOTE: Coat battery clamps and terminals with petroleum jelly before refitting.

ALTERNATOR

Service repair no - 86.10.01

Remove and refit**Remove**

1. Disconnect the battery negative lead.
2. Disconnect leads from alternator.

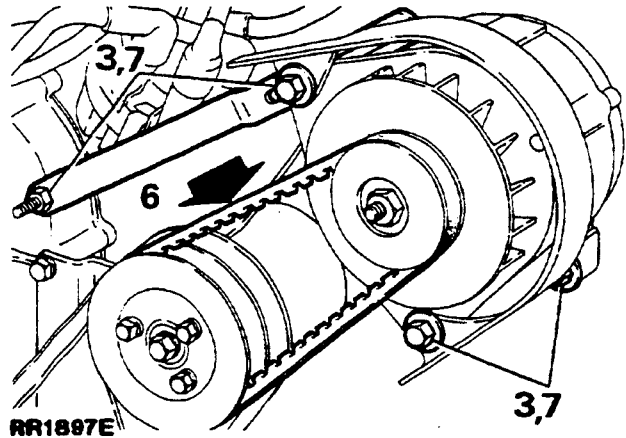

3. Loosen alternator pivot bolt.
4. Loosen adjusting bolt and adjusting strut pivot bolt.
5. Pivot alternator inwards, remove drive belt.
6. Remove mounting bolts and remove alternator.



NOTE: The radiator cowl has a hole to allow removal of alternator pivot bolt. Loosen cowl fixings and move cowl if hole is not sufficiently aligned to allow removal of bolt.

Refit

7. Fit alternator and mounting bolts.



NOTE: The fan guard is attached to the front mounting and adjustment bolts.



8. Fit drive belt, adjust tension. *See alternator drive belts*
9. Partially tighten alternator fixing to adjusting strut.
10. Partially tighten mounting bolt.
11. Partially tighten adjusting strut pivot bolt.
12. Finally tighten alternator fixings to correct torque, in following sequence:

Adjusting bolt 12 Nm.
 Alternator mounting bolt 25 Nm.
 Adjusting strut pivot bolt 25 Nm.

13. Connect wiring leads to alternator.
14. Reconnect battery.

ALTERNATOR DRIVE BELTS

For Alternator drive belts *See SECTION 10, Maintenance, Under Bonnet Maintenance*

DISTRIBUTOR-LUCAS 35 DLM8

Service parts

1. Cap
2. HT brush and spring
3. Rotor arm
4. Insulation cover
5. Pick-up module and base plate assembly
6. Vacuum unit
7. Amplifier module
8. 'O'-ring oil seal
9. Gasket

ELECTRONIC IGNITION

A Lucas 35DLM8 distributor is employed. This has a conventional vacuum advance unit and centrifugal automatic advance mechanism.

A pick-up module, in conjunction with a rotating timing retractor inside distributor body, generates timing signals. These are applied to an electronic ignition amplifier module mounted on side of distributor body.



NOTE: Pick-up air gap is factory set. Do not adjust gap unless pick-up is being changed or base plate has been moved.

Use a non-ferrous feeler gauge to set air gap.

DISTRIBUTOR

Service repair no - 86.35.20

Remove and refit

Remove

1. Disconnect the battery negative lead.
2. Disconnect vacuum hose.
3. Remove distributor cap.
4. Disconnect low tension lead from coil.
5. Mark distributor body and centre line of rotor arm.

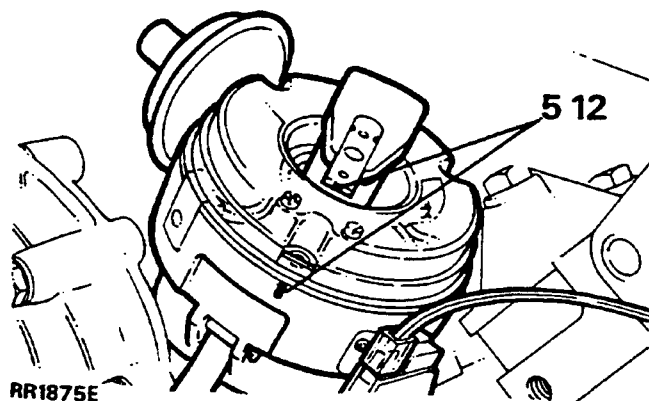

6. Add alignment marks to distributor and front cover.

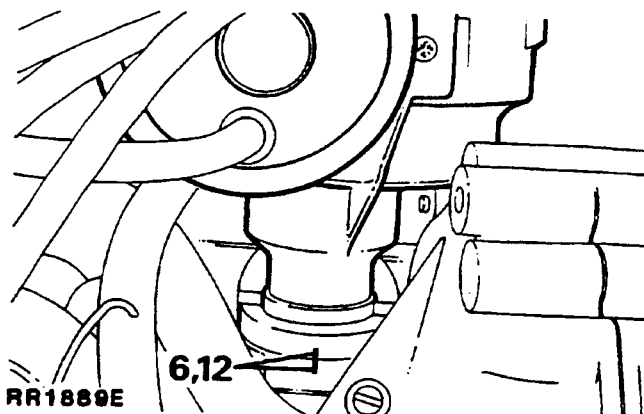

NOTE: Marking distributor enables refitting in exact original position, but if engine is turned while distributor is removed, complete ignition timing procedure must be followed.

7. Release distributor clamp and remove distributor.

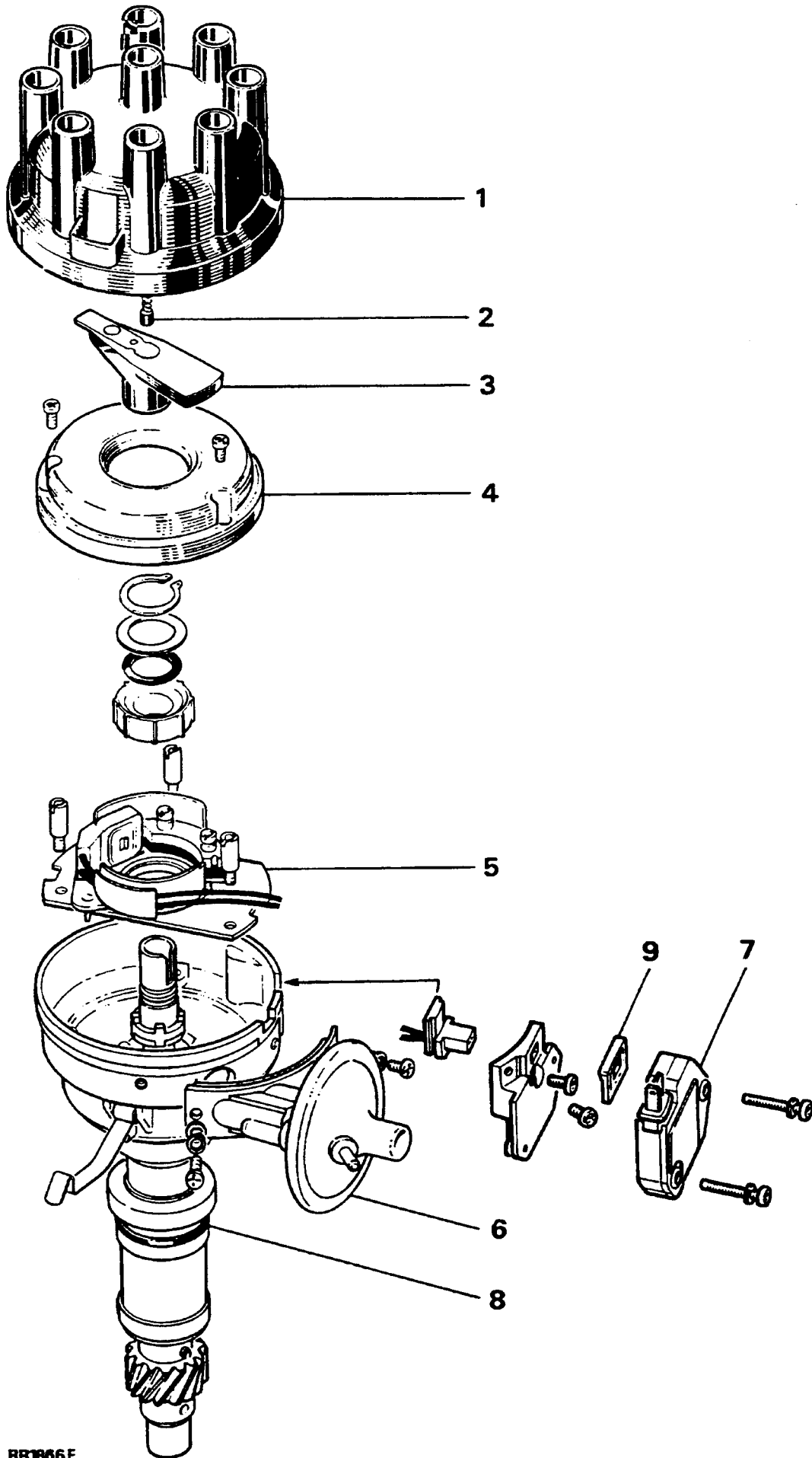

RR1866E



Refit



NOTE: If a new distributor is being fitted, mark body in same relative position as distributor removed.

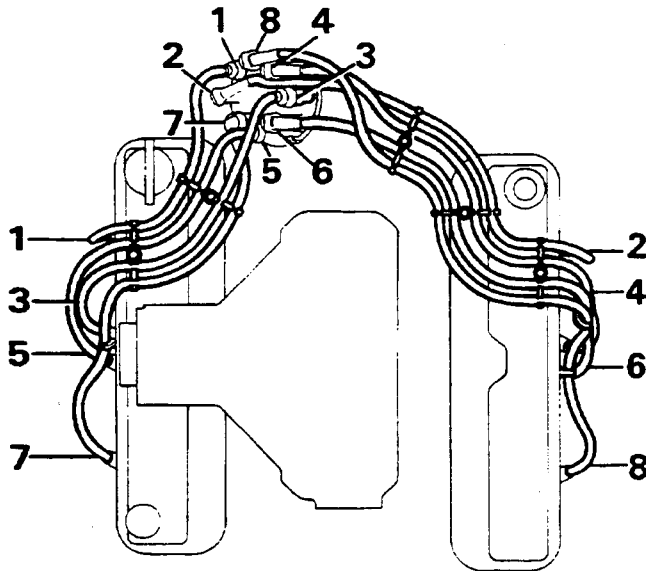

RR1876E

8. Leads for distributor cap should be connected as illustrated.
 Figures 1 to 8 inclusive indicate plug lead numbers.
 RH-Right hand side of engine, when viewed from rear.
 LH-Left hand side of engine, when viewed from rear.

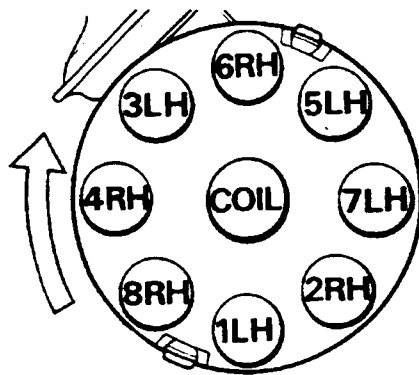

RR616M

9. If engine has not been turned while distributor has been removed, carry out instructions 10. to 17. Alternatively proceed to instruction 18.
10. Fit new 'O' ring seal to distributor housing.
11. Turn distributor drive until centre line of rotor arm is 30° anti-clockwise from mark made on top edge of distributor body.
12. Fit distributor in accordance with alignment markings.



NOTE: It may be necessary to align oil pump drive shaft to enable distributor drive shaft to engage in slot.

13. Fit clamp and bolt. Secure distributor in exact original position.
14. Connect vacuum hose to distributor and low tension lead to coil.
15. Fit distributor cap.
16. Reconnect battery.
17. Using suitable electronic equipment, set ignition timing. *See Adjustment, IGNITION TIMING*
18. If engine has been turned with distributor removed, carry out instructions 19. to 30.
19. Set engine-No. 1 piston to static ignition timing figure. *See ENGINE TUNING DATA, Information, Engine Tuning Data*
20. Turn distributor drive until rotor arm is approximately 30° anti-clockwise from number one sparking plug lead position on cap.
21. Fit distributor to engine.
22. Check that centre line of rotor arm is now in line with number one sparking plug lead on cap. Reposition distributor if necessary.
23. If distributor does not seat correctly in front cover, oil pump drive is not engaged. Engage by lightly pressing down distributor while turning engine.
24. Fit clamp and bolt, do not tighten.
25. Set ignition timing statically to 6° B.T.D.C.
26. Connect vacuum hose to distributor.
27. Fit low tension lead to coil.
28. Fit distributor cap.
29. Reconnect battery.
30. Using suitable electronic equipment set the ignition timing. *See Adjustment, IGNITION TIMING*

IGNITION COIL

Service repair no - 86.35.32

Remove and refit**Remove**

1. Disconnect the battery negative lead.
2. Disconnect High Tension and Low Tension electrical leads from ignition coil.

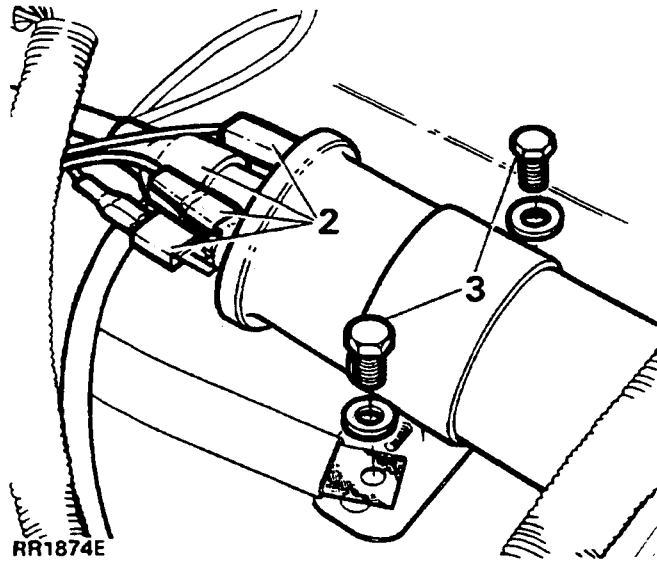

3. Remove two bolts securing coil, noting position of ground strap.
4. Remove coil.

Refit

5. Reverse removal procedure. Ensure that location for ground strap is free from paint and grease. Coat area around bolt with Petroleum Jelly.

HEADLAMP ASSEMBLY / SEALED BEAM UNIT

Service repair no - 86.40.02

Remove and refit**Remove**

1. Disconnect the battery negative lead.
2. Remove radiator grille. *See CHASSIS AND BODY, Repair, radiator grille*
3. Remove three screws and headlamp retaining rim.

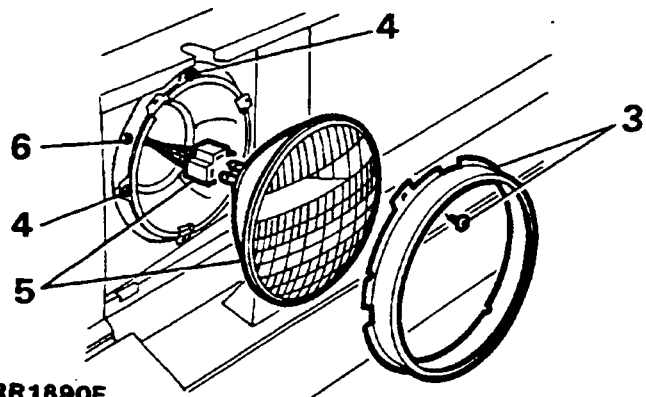

4. **DO NOT** disturb beam adjusting screws.
5. Withdraw sealed beam unit. Disconnect wiring plug from rear of unit.
6. Remove three securing screws, pry away grommet. Remove headlamp bowl.

Refit

7. Reverse removal procedure.



HEADLAMP ASSEMBLY/BULB RELACEMENT

Service repair no - 86.40.02

Remove and refit

Remove

1. Disconnect the battery negative lead.
2. Remove radiator grille. *See CHASSIS AND BODY, Repair, radiator grille*
3. Remove three screws and headlamp retaining rim.

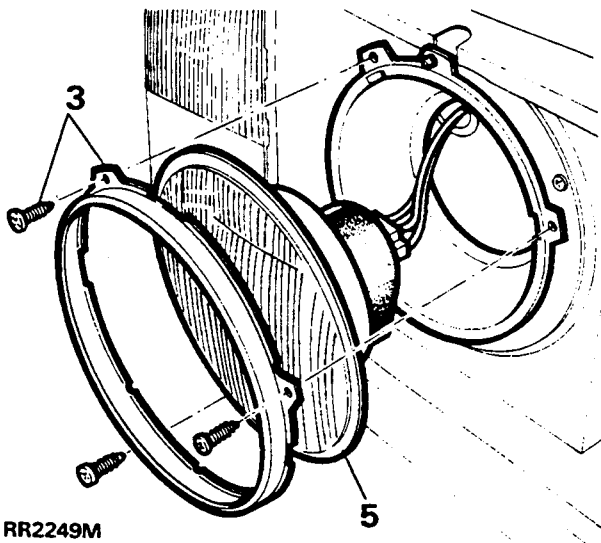

4. **DO NOT** disturb beam adjusting screws.
5. Withdraw headlamp unit. Disconnect wiring plug from rear of unit.
6. Remove rubber dust cover.

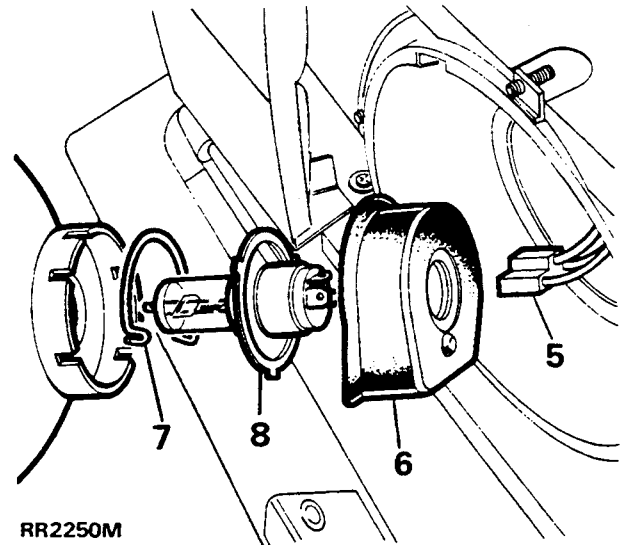

7. Release retaining clip, remove bulb
8. Remove three securing screws, pry away grommet. Remove headlamp bowl.

Refit

9. Reverse removal procedure. **DO NOT** touch quartz envelope of bulb. Gently clean using methylated spirits if contact does occur.

HEADLAMP ALIGNMENT

Service repair no - 86.40.17

Headlamp beam setting should only be carried out by qualified personnel using suitable beam setting equipment, for example the Lucas Beamtester.

RR3825M shows right hand drive beam pattern, left hand drive is symetrically opposite.

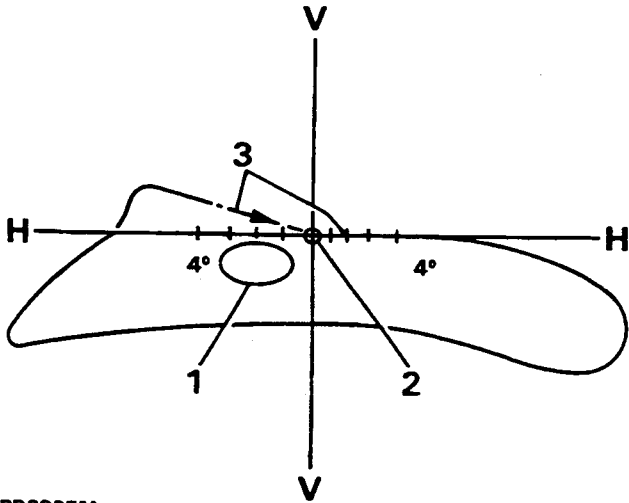

RR3825M

Guide to beam pattern:

1. Maximum intensity zone.
2. Beam aim kink point.
3. Aiming datum lines.

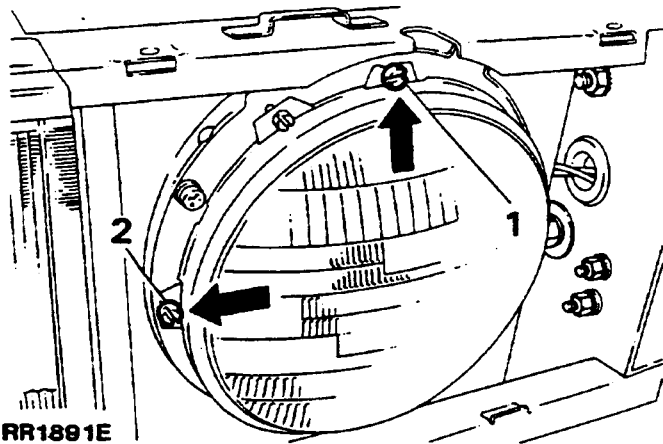

RR1891E

Adjust

1. Turn top adjusting screw anti-clockwise to lower beam, clockwise to raise beam.
2. Turn side adjusting screw anti-clockwise to move beam to left, clockwise to move beam to right.

AUXILIARY DRIVING LAMP

Service repair no - 86.40.96

Remove, refit and adjust**Bulb replacement**

1. Disconnect the battery negative lead.
2. Securing nut is located beneath front bumper, adjacent to front body fixing. Access to lamp is gained through front wheel arch.
3. Disconnect electrical plug.
4. Remove single nut and washer.

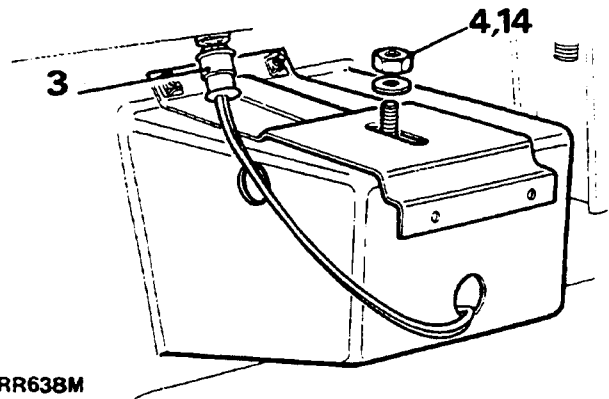

RR638M

5. From front of vehicle, manoeuvre lamp. Remove lamp from spoiler opening.
6. Remove two screws securing cover to rear of lamp.
7. Withdraw cover.
8. Disconnect lucar connector.
9. Release spring clip securing bulb to lamp unit.
10. Remove bulb.

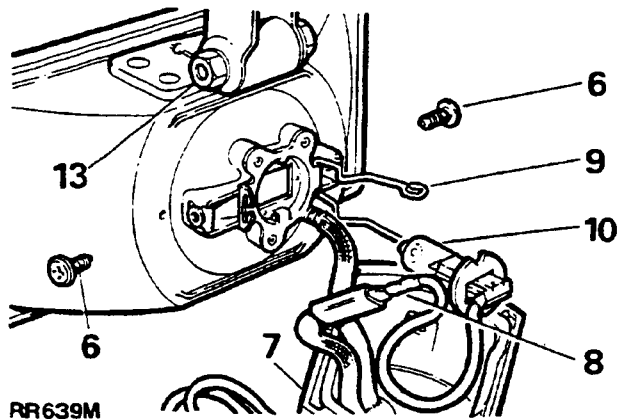

RR639M

Refit

11. Fit a new bulb. Ensure two notches on bulb body locate with registers on lamp unit.
12. Reverse removal procedure.

Adjust

Correct adjustment is beam horizontal (parallel to ground) and parallel to vehicle axis.

13. Loosen lamp adjusting bolt to lower or raise beam.
14. Loosen lamp securing bolt to move beam to left or right.
15. Tighten fixing bolts to **15 Nm**.

SIDELIGHT AND FLASHER LAMP ASSEMBLY AND BULB

Service repair no - 86.40.24

Remove and refit

Remove

1. Disconnect the battery negative lead.
2. Remove two screws and plain washers securing lamp assembly.
3. Lift assembly away sufficiently to gain access to rear of lamp.
4. Remove waterproof cover.
5. Depress two retaining clips and withdraw bulb holder.
6. Remove required bulb. Direction indicator bulb is located in upper section of bulb holder, side lamp bulb in lower.
7. Disconnect multi-plug. Remove complete assembly.

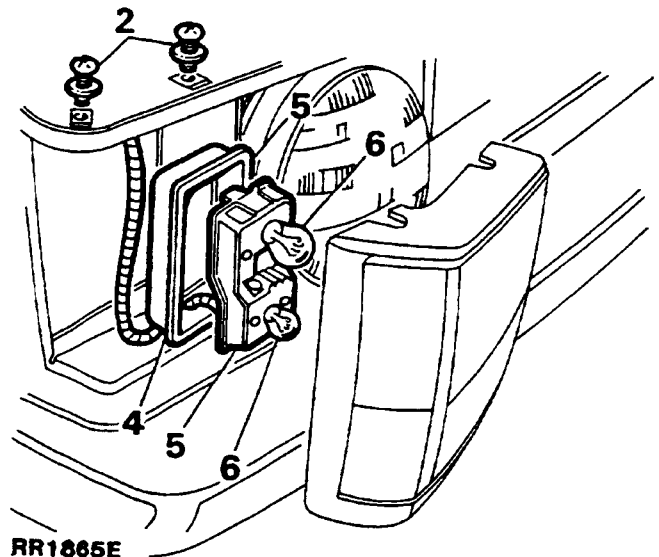

RR1885E

Refit

8. Reverse removal procedure. Ensure waterproof cover is correctly located.

DIRECTION INDICATOR SIDE REPEATER LAMP BULB REPLACEMENT

Service repair no - 86.40.65

Remove and refit

Remove

1. Disconnect the battery negative lead.
2. At back of lamp, twist bulb holder anti-clockwise to remove from lamp assembly.
3. Remove bulb.

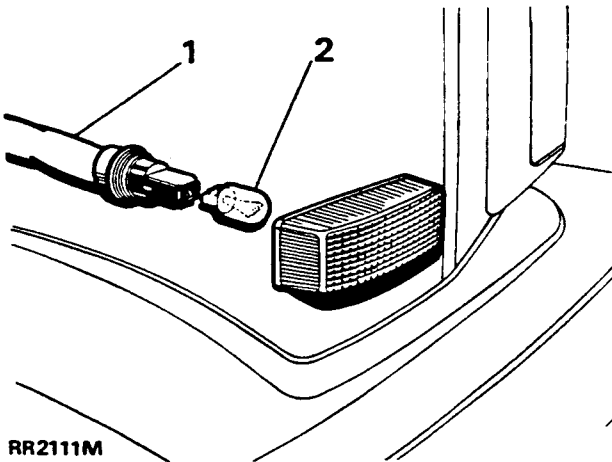

Refit

4. Reverse removal procedure. Correct bulb type is 5 watt wedge base.

TAIL LAMP ASSEMBLY

Service repair no - 86.40.74

Remove and refit

Remove

1. Disconnect the battery negative lead.
2. Remove four lens retaining screws.
3. Remove lens.
4. Remove sealing rubber, if required.



NOTE: To remove sealing rubber complete it is necessary to remove side marker lens.

5. Remove bulbs.
6. Remove four screws securing lamp unit to body.
7. Remove two through-screws from reflector side, which also secure lamp unit to body.
8. Ease lamp unit forward and disconnect leads at moulded connectors.

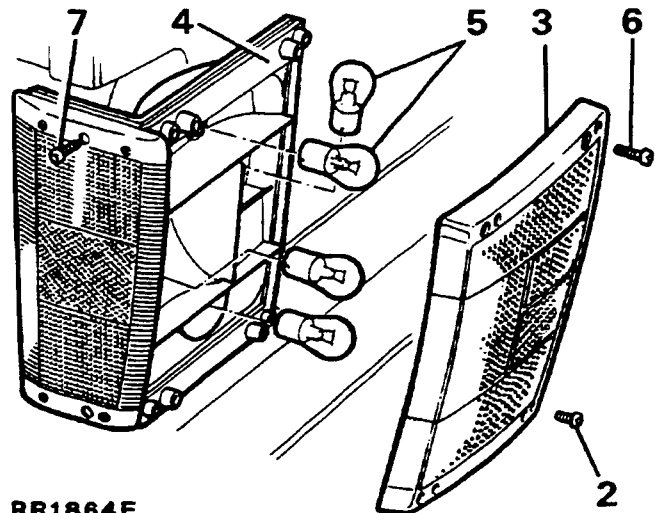

Refit

9. Reverse removal procedure.



REFLECTORS/SIDE MARKER LAMP ASSEMBLY AND BULB

Remove and refit

Remove

1. Remove four screws securing lens.
2. Remove lens.
3. Remove bulb.

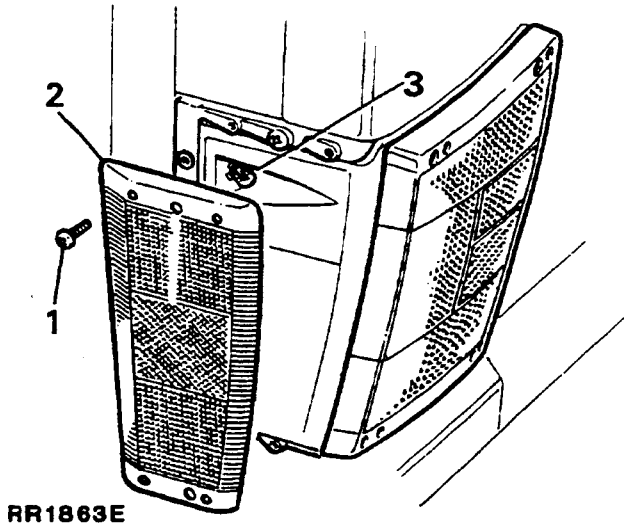

NOTE: To remove rubber seal completely it is necessary to remove tail light lens.

Refit

4. Reverse removal procedure.

UNDER BONNET LAMP ASSEMBLY

Remove and refit

Remove

1. Disconnect the battery negative lead.
2. Remove two securing screws.
3. Remove lamp glass.
4. Pull five-watt 'wedge' type bulb from bulb holder.

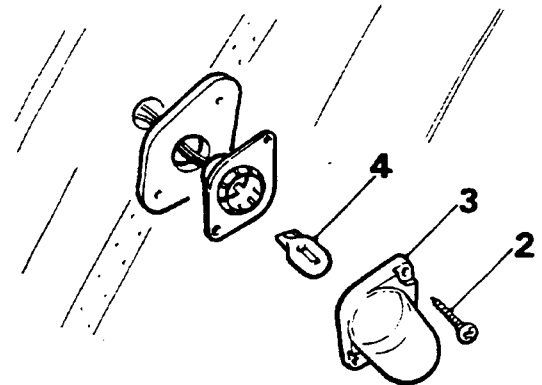

5. Disconnect electrical leads located below bonnet lamp switch attached to inner fender.
6. Pull rubber grommet off leads and pull lamp and leads up through hood stiffener channel.

Refit

7. Reverse removal procedure. 1 to 6.



NOTE: A piece of bent wire will be needed to pull electrical leads out of channel exit hole when fitting a new lamp assembly.

HEATER/VENTILATION AND AIR CONDITIONING CONTROL PANEL

Service repair no - 86.45.73

Bulb replacement

The heater/ventilation control panel is illuminated by four 12-volt 1.2 watt 'wedge' type (capless) bulbs.

1. Pull five finger tip knobs off control levers.
2. Remove two screws at top of panel.
3. Carefully ease panel away from centre console only as far as electrical leads will permit.
4. Pull appropriate bulb holder out of rear of panel.
5. Pull bulb from holder.
6. Fit a new bulb and push bulb holder firmly back into its location at rear of panel.

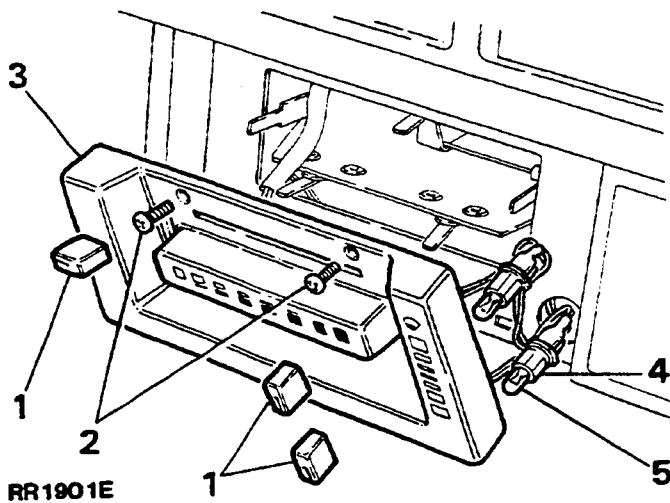

Refit

7. Ensuring that electrical leads do not become trapped between panel console and operating levers, refit panel.

DOOR EDGE LAMPS / PUDDLE LAMPS

Remove and refit

Incorporated into front door assemblies are door edge lamps and puddle lamps, located on door edge and bottom of door. The lamps are activated by courtesy light switches when either front door is opened and will immediately switch off when both doors are closed.

Remove

1. Ensure side door glass is fully closed.
2. Disconnect the battery negative lead.
3. Remove interior door handle and arm rest/door pull from door.
4. Carefully release interior door trim pad from inner door panel.
5. Peel back lower half of plastic vapour barrier.
6. Disconnect electrical connectors within door, accessible through lower centre and outer openings of inner door panel.
7. Release door edge lamp electrical leads from retaining clips.
8. Remove lens and pry lamps out of door and withdraw electrical leads.

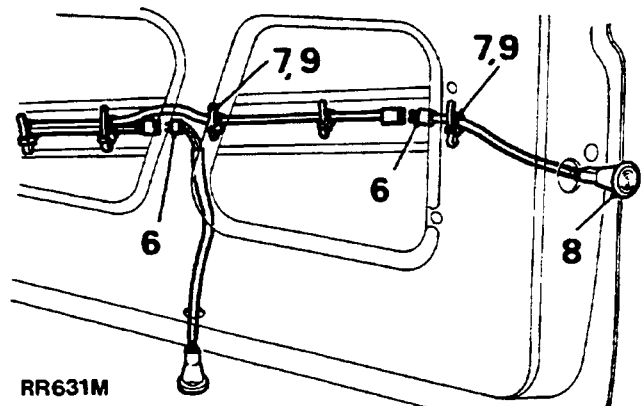

Refit

9. Reverse removal procedure.



NOTE: Ensure door lamp wiring harness is securely clipped to lower stiffener plate within door to prevent damage occurring to electrical leads when door glass is in its lowest position.



DOOR EDGE LAMPS/PUDDLE LAMPS

Bulb replacement

1. Disconnect the battery negative lead.
2. Carefully pry out lamp lens.
3. Withdraw lamp body from door **ONLY** as far as electrical leads will permit.
4. Pull bulb from holder.

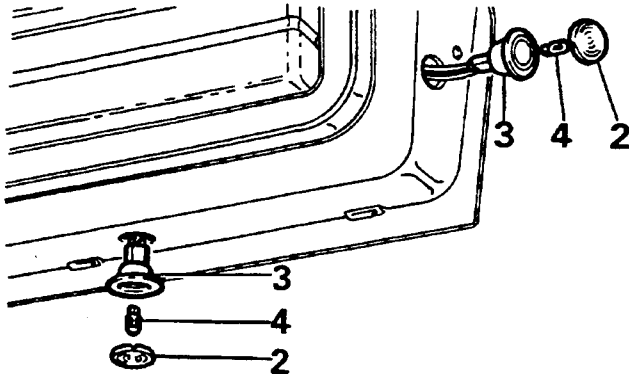

RR2120E

5. Fit new bulb, refit lamp lens. Correct bulb type is a 12-volt, 5-watt capless.
6. Push lamp into door.

AUTOMATIC GEAR SELECTOR-PANEL ILLUMINATION

Service repair no - 86.45.40

Bulb replacement

1. Disconnect the battery negative lead.
2. Unclip cover from top of gear selector knob.
3. Remove circlip retaining detent button.
4. Withdraw detent button.
5. Remove lower circlip above gear selector knob securing nut.
6. Remove securing nut.
7. Withdraw serrated washer.

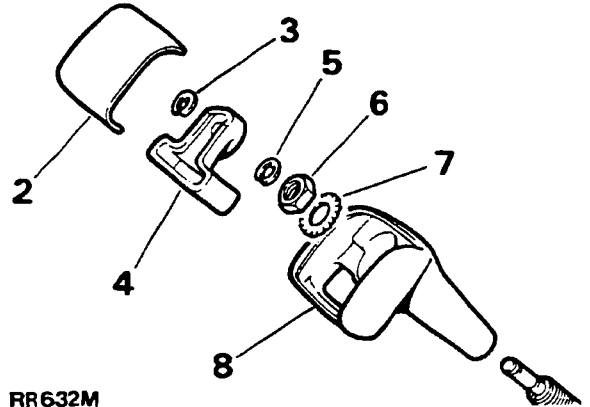

RR632M

8. Slide selector knob off shaft.
9. Pry inset panel out of floor mounted console. Remove complete with selector illumination panel and ash tray.
10. Two bulbs are located on reverse side of illumination panel.
11. Pull appropriate bulb holder from its location.
12. To facilitate removal of bulb holders, remove four screws securing illumination panel to outer surround panel.

NUMBER PLATE LAMP ASSEMBLY AND BULB

Service repair no - 86.40.86

Remove and refit**Remove**

1. Disconnect the battery negative lead.
2. Remove two self-tapping screws with washers.
3. Remove lamp assembly.
4. Disconnect bulb holder, remove bulb.



NOTE: Carefully pull electrical leads out of bottom of lower tailgate panel to reveal snap connectors.

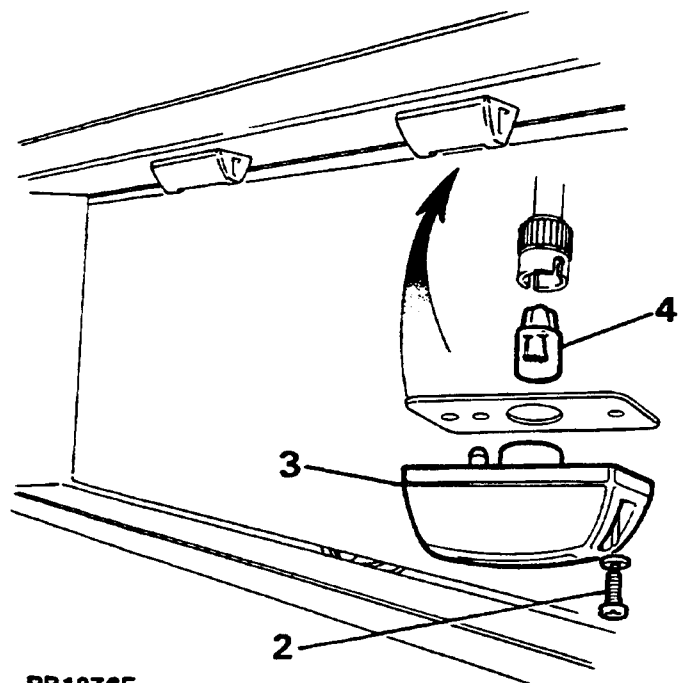

RR1976E

5. Disconnect electrical connections located at bottom of lower tailgate.
6. Remove bulb holder.
7. Carefully pull electrical leads up through inside of lower tailgate panels.

Refit

8. Reverse removal procedure. Correct bulb 'type' is 12-volt, 5 watt wedge base (capless).

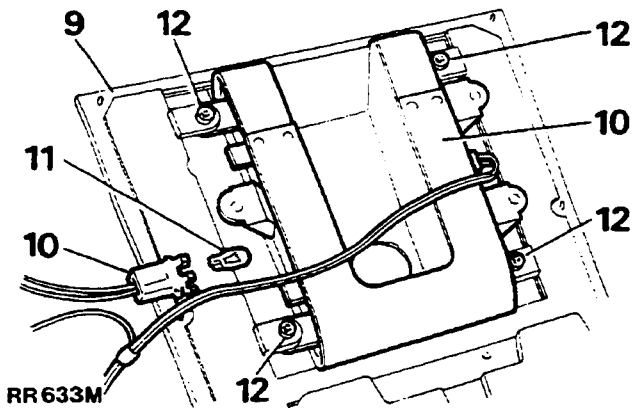

RR633M

13. Remove bulb from holder. Correct bulb type is a 24-volt, 5-watt 'wedge' base (capless).

Refit

14. Reverse removal procedure. Ensuring electrical leads beneath console do **NOT** become trapped between mating surfaces.
15. To prevent damage to gear selector knob on reassembly do **NOT** overtighten retaining nut.



INTERIOR ROOF LAMPS

Service repair no - 86.45.01

Remove and refit

Remove

Interior roof lamps are operated automatically via side door and tailgate courtesy switches or by an independent switch in auxiliary switch panel.

1. Disconnect the battery negative lead.
2. Remove lens from courtesy lamp by pressing upward and turning it counter-clockwise.
3. Withdraw bulb from spring clip holder.
4. Remove screws securing lamp base to roof panel.
5. Lower lamp to reveal cable snap connections.
6. Disconnect electrical connections.

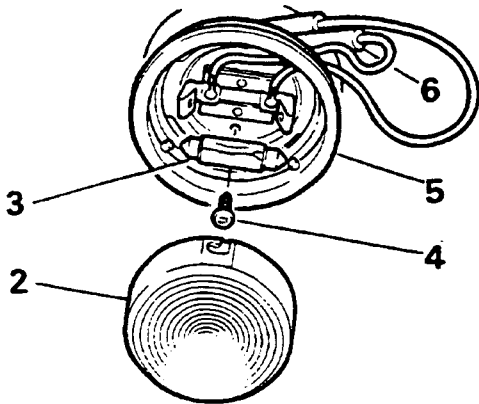

RR485M

Refit

7. Reverse removal procedure.

INTERIOR ROOF LAMPS CIRCUIT DELAY

Service repair no - 86.45.49

Remove and refit

Remove

The roof lamp circuit incorporates a delay function which is designed to allow lamps to remain on for 12 to 18 seconds after either front door is closed.



NOTE: Switching on ignition (with both doors closed) will immediately over-ride this feature, switching interior lamps off.

1. Disconnect the battery negative lead.
2. Remove six screws securing lower dash panel.
3. Lower dash panel to gain access to delay unit attached to steering column support bracket.
4. Remove delay unit from retaining bracket.
5. Pull multi-plug off delay unit.

Refit

6. Reverse removal procedure.

STARTER MOTOR-LUCAS M78R

Service repair no - 86.60.01

Remove and refit**Remove**

1. Place vehicle on a suitable hoist.
2. Disconnect the battery negative lead.
3. Disconnect leads from solenoid and starter motor. Remove exhaust heat shield.
4. Remove two bolts, starter motor to flywheel housing.
5. Remove starter motor.

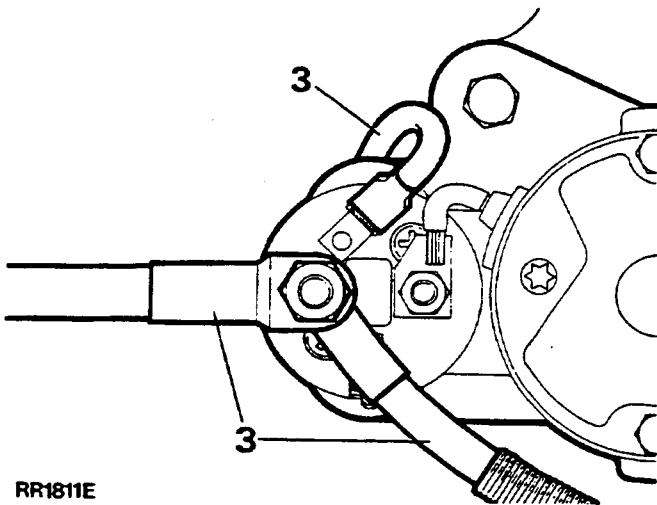
**Refit**

6. Reverse removal procedure.

AUXILIARY SWITCH PANEL**Remove and refit**

The auxiliary switch panel contains up to six switches depending on vehicle specification. Each switch incorporates integral symbols for identification. Unused switch openings are fitted with blank covers, which are removable, to facilitate fitting extra switches if required.

The symbols are illuminated by two bulbs which become operational when vehicle lights are on.

The heated rear screen switch is provided with an individual warning light, illuminated when the switch is operated.

Remove

1. Disconnect the battery negative lead.
2. Carefully pry auxiliary switch panel surround away from centre console.
3. Withdraw switch panel as far as electrical leads will permit.
4. Unclip multi-plugs at rear of switches by depressing retaining lugs.
5. Pull plugs from the switches.
6. Remove switch assembly complete.
7. Depress small retaining lugs on top and bottom of switch and push switch(es) through front of switch surround.

Refit

8. Reverse removal procedure.



NOTE: To aid identification and location of multi-plug to switch, a coloured plastic tab is attached to each body which corresponds with an appropriate coloured multi-plug. If removed, switches must be refitted in original positions.



AUXILIARY SWITCH PANEL WARNING LIGHT

Service repair no - 86.45.29

Bulb replacement

1. Disconnect the battery negative lead.
2. Carefully pry switch panel surround away from centre console.
3. Unclip multi-plug from rear of switch, disconnect plug.

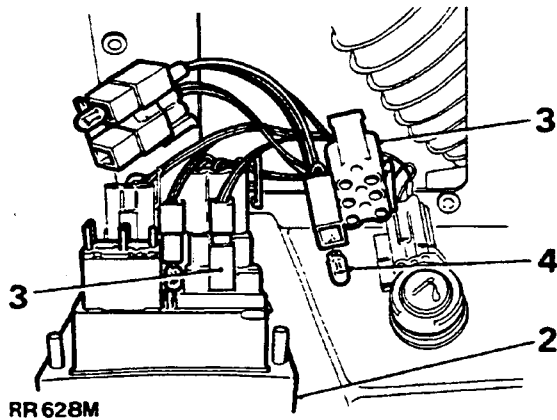

4. Warning light bulb is located in multi-plug. Remove by pulling bulb from its location.
5. Fit a new bulb and refit multi-plug.
6. Press auxiliary switch panel into centre console. Correct bulb type is an amber 12-volt 1.2-watt 'wedge' base (capless).

AUXILIARY SWITCH PANEL ILLUMINATION

Service repair no - 86.45.29

Bulb replacement

Auxiliary panel green illumination bulbs are located in interior lamp/heated rear screen multi-plugs. Each bulb is positioned in centre of four switches.

1. Disconnect the battery negative lead.
2. Carefully pry switch panel surround away from centre console to give access to multi-plugs at rear of switches.

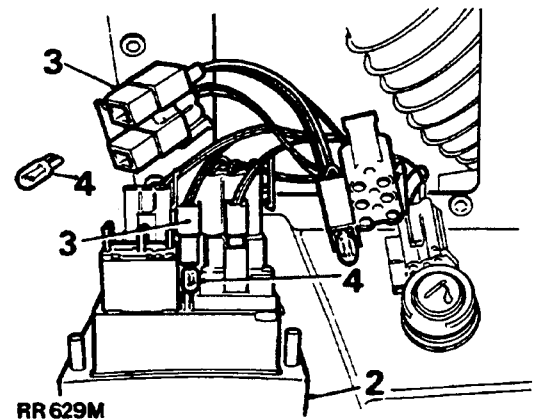

3. Unclip and pull multi-plugs from rear of appropriate switch.
4. Pull green illumination bulb from its location.
5. Fit new bulb, refit multi-plug.
6. Press auxiliary panel surround back in to centre console. Correct bulb type is a 12-volt 1.2-watt 'wedge' base (capless).

STEERING COLUMN CONTROLS

Steering column switch layout is as follows:

LEFT HAND CONTROLS

Lower switch-Main lighting switch.

Upper switch-High and low beam, direction indicators and horn.

RIGHT HAND CONTROLS

Lower switch - Rear screen programmed wash/wipe.

Upper switch - Windscreen programmed wash/wipe.

STEERING WHEEL

The following operations for steering column controls show steering wheel removed, this is for clarity only, and is not a necessary part of procedure. If steering wheel removal is required. *See STEERING, Repair, Steering wheel*

STEERING COLUMN SHROUD

Remove and refit

Certain operations within this section necessitate removal of steering column shroud. Unless removal of both sides of shroud is required, remove **ONLY** side necessary for access.

Remove

1. Disconnect the battery negative lead.
2. Remove lower dash panel. *See CHASSIS AND BODY, Repair, Lower dash panel*
3. Disconnect electrical connections to either master lighting switch or rear screen wash/wipe switch. (Disconnect both if removing complete shroud).
4. Left hand shroud - remove three securing screws and remove shroud over indicator/high beam switch.
5. Right hand shroud - remove three securing screws and remove shroud over windscreen wash/wipe switch.
6. To facilitate reassembly remove screw securing two halves of shroud together from one side only.

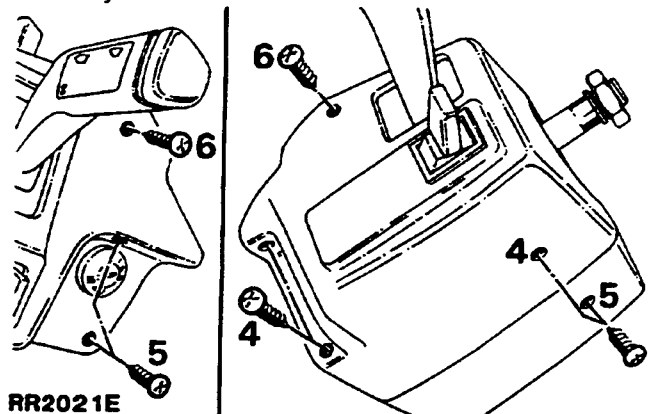

Refit

7. If both sides of shroud have been removed ensure that plate on steering column is correctly located in slot in shroud.
8. Reverse removal procedure.



MAIN LIGHTING SWITCH OR REAR SCREEN PROGRAMMED WASH WIPE SWITCH

Service repair no - 86.65.10/84.35.34

Remove and refit

Remove

1. Remove steering column shroud from required side.
2. Disconnect cables at snap connectors.
3. Push two spring clips locating switch inwards and remove switch from mounting.

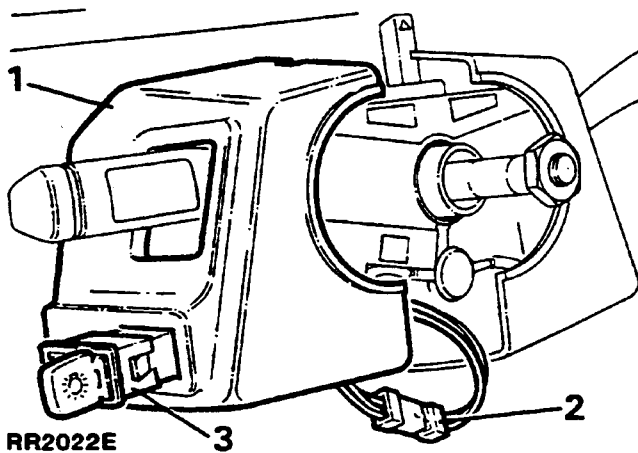

Refit

4. Reverse removal procedure.

WINDSCREEN PROGRAMMED WASH WIPE SWITCH OR HIGH AND LOW BEAM, DIRECTION INDICATORS AND HORN SWITCH

Service repair no - 84.15.34/86.65.55

Remove and refit

Remove

1. Remove steering column shroud from required side.
2. Release appropriate retaining clip and pull fibre optic guide from housing.

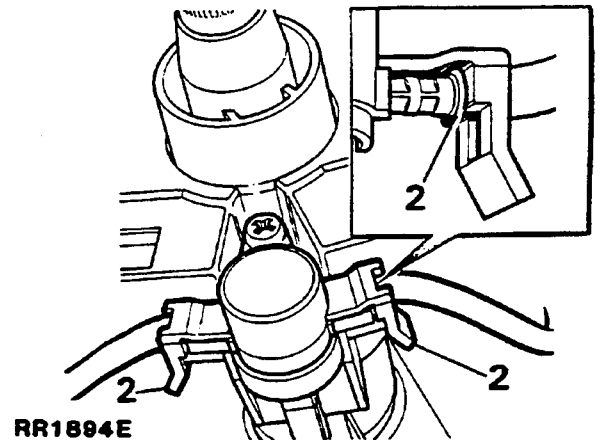

3. Depress retainers at top and bottom of switch and pull combined switch assembly away from steering column switch housing.

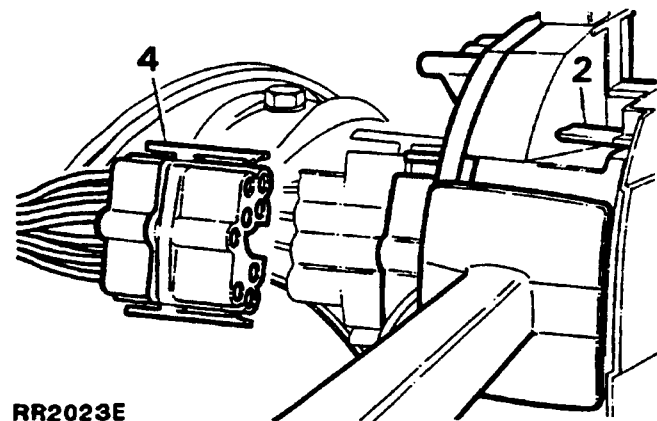

4. Lighting, indicator and horn switch: release two harness multi-plugs from back of switch and remove switch assembly.
Wiper and washer switch: release harness multi-plug from back of switch and remove switch assembly.

Refit

5. Reverse removal procedure.

HAZARD WARNING SWITCH BULB REPLACEMENT

Remove and refit

Remove

1. Disconnect the battery negative lead.
2. Pull hazard switch cover upwards, remove it to gain access to bulb.

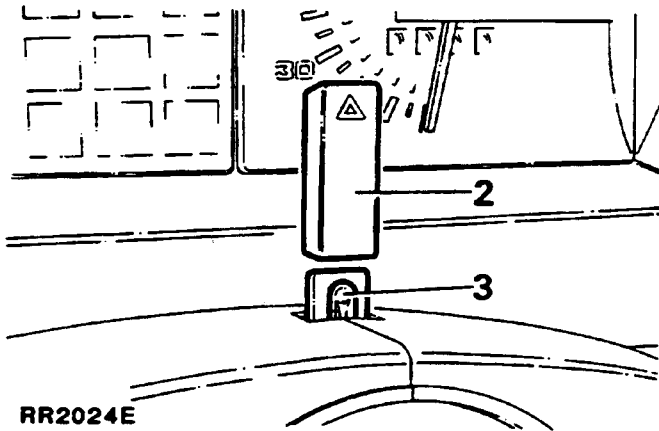

3. Remove bulb by pulling it upwards. A piece of rubber tubing or adhesive tape attached to bulb may facilitate removal and refitting.

Refit

4. Locate bulb in its holder and reverse instructions 1 to 3.
Correct bulb is a 12V, 1.2 watt 'wedge' base (capless).

COLUMN SWITCH ILLUMINATION BULB REPLACEMENT

Remove and refit

Remove

1. Disconnect the battery negative lead.
2. Remove left hand side steering column shroud.
3. Working behind column switch housing twist bulb holder through 90° to remove.
4. Remove bulb.

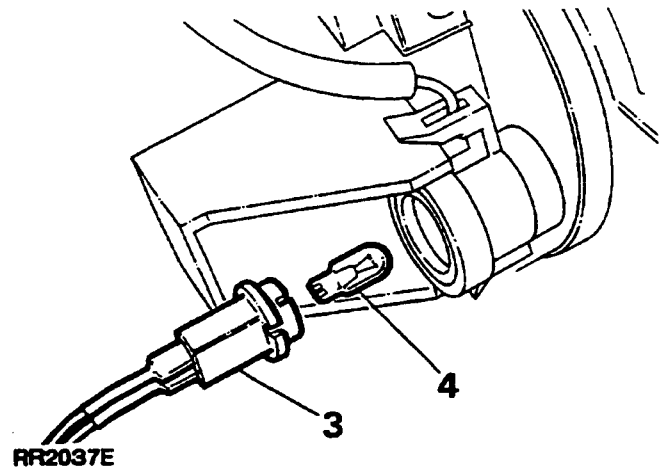

Refit

5. Reverse removal procedure. Correct bulb type is a 12-volt, 1.2-watt 'wedge' base (capless).



IGNITION STARTER SWITCH

Service repair no - 86.65.02

Remove and refit

Remove

1. Disconnect the battery negative lead.
2. Remove lower dash panel.
3. Remove steering column shroud, left hand side.
4. Disconnect ignition switch cable at multi-plug.
5. Remove rubber cover protecting switch.

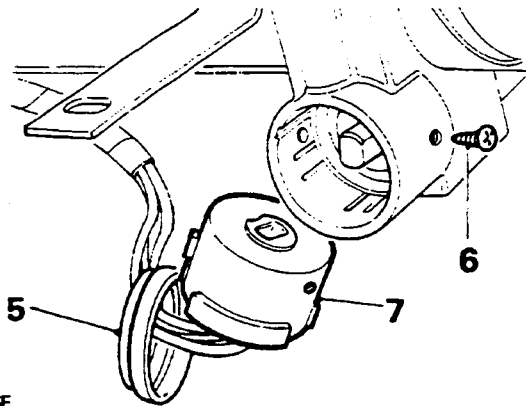

RR1966E

6. Remove single screw securing ignition/starter switch to housing.
7. Remove switch.

Refit

8. Reverse removal procedure.

DOOR PILLAR SWITCH

Service repair no - 86.65.15

Remove and refit

Remove

1. Disconnect the battery negative lead.
2. Remove screw securing switch to door pillar.
3. Remove switch.
4. Disconnect electrical lead from connector blade.

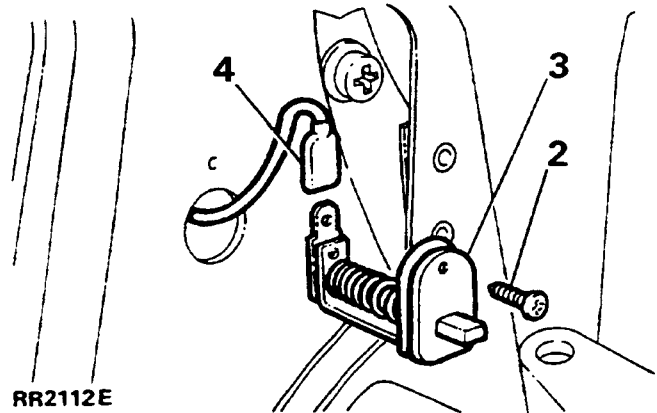

RR2112E

Refit

5. Reverse removal procedure.

REAR TAILGATE SWITCH**Remove and refit****Remove**

1. Disconnect the battery negative lead.
2. Remove single screw securing switch to tailgate opening.
3. Withdraw switch.
4. Disconnect electrical lead.

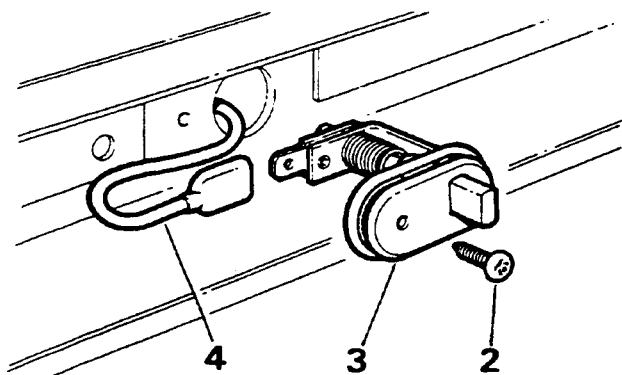

RR 498M

Refit

5. Reverse removal procedure.

UNDER BONNET ILLUMINATION SWITCH**Remove and refit****Remove**

1. Disconnect the battery negative lead.
2. Remove single screw securing switch to decker panel.
3. Withdraw switch.
4. Disconnect electrical lead.

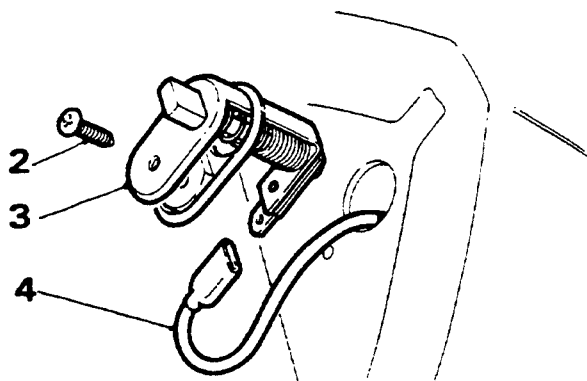

RR499M

Refit

5. Reverse removal procedure.



CIGAR LIGHTER-RADIO HOUSING

Service repair no - 86.65.60

Remove and refit

Remove

1. Disconnect the battery negative lead.
2. Remove transfer gear lever knob.
3. Remove main gear lever knob. *See Automatic gear selector-panel illumination*
4. Remove glove box liner. Release park brake cable from lever. Pry inset panel out of floor mounted console. Pull two illumination bulbs from selector panel.
5. Release glove box from four fixings.
6. Raise front of glove box and console assembly, ease away from radio housing.

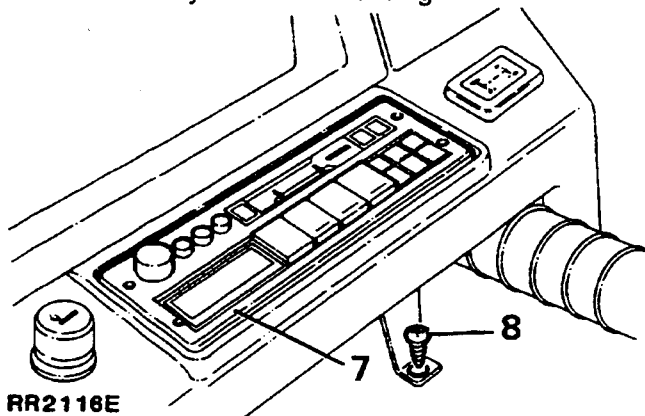

RR2116E

7. Remove radio, referring to Manufacturer's instructions.
8. Remove single screw securing housing to top of gearbox tunnel.
9. Pull housing away from lower dash panel.
10. Disconnect electrical leads at rear of cigar lighter.
11. Remove push in switch from lighter outer body.
12. Depress outer plastic surround where denoted by arrows and push outer body through surround.
13. Manoeuvre plastic surround, remove from radio housing.

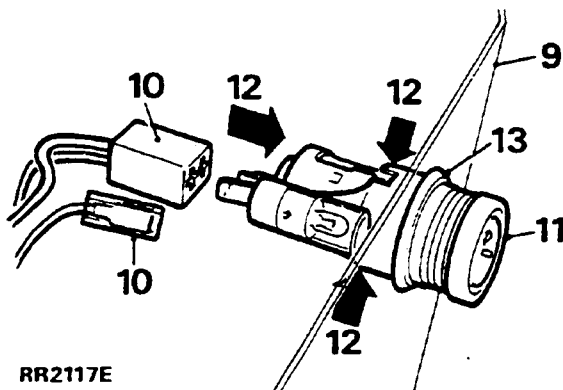

RR2117E

Refit

14. Reverse removal procedure.

CIGAR LIGHTER ILLUMINATION - BULB REPLACEMENT

Service repair no - 86.45.55

15. Remove bulb holder from plastic surround.
16. Pull bulb from holder. Correct bulb type is a 12V 1.2-watt wedge base (capless).

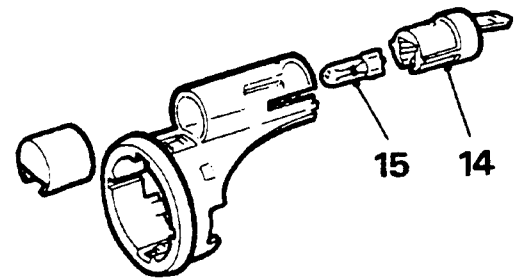

RR2118E

Refit

17. Reverse removal procedure.

CIGAR LIGHTER - GLOVE BOX

Service repair no - 86.65.61

Rear cigar lighter is located in bottom of glove box, access to rear of lighter is gained by removing glove box liner.

Follow instructions 10 to 16 of **CIGAR LIGHTER-radio housing** to remove lighter from glove box. See **CIGAR LIGHTER-radio housing**

REVERSE LIGHT SWITCH

Service repair no - 37.27.01

Remove and refit

Manual gearbox

Remove

Reverse light switch is located at rear of selector housing, accesible from beneath vehicle.

1. Place vehicle on suitable ramp.
2. Disconnect the battery negative lead.
3. Disconnect electrical leads.
4. Release lock-nut.
5. Remove switch.

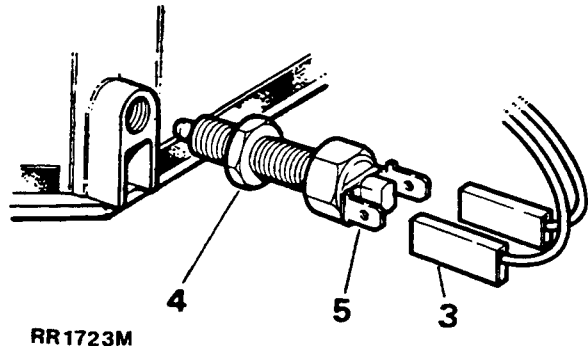

Refit



NOTE: Reverse light switch requires re-setting on reassembly.

6. Select reverse gear.
7. Connect 12 volt supply and test lamp across switch terminals.
8. Screw switch into housing until test lamp is illuminated. Screw switch in a further half turn, tighten locknut.
9. Connect electrical lead.
10. Reconnect battery.



START INHIBIT / REVERSE LIGHT SWITCH

Service repair no - 44.15.19

Remove and refit

Automatic gearbox

Remove

Reverse light switch is an integral part of start inhibitor switch. It is located on left hand side of gearbox, accessible from beneath vehicle.

1. Place vehicle on suitable ramp.
2. Disconnect the battery negative lead.
3. Disconnect multi-plug.
4. Release clamp bolt, remove clamp.
5. Remove switch.

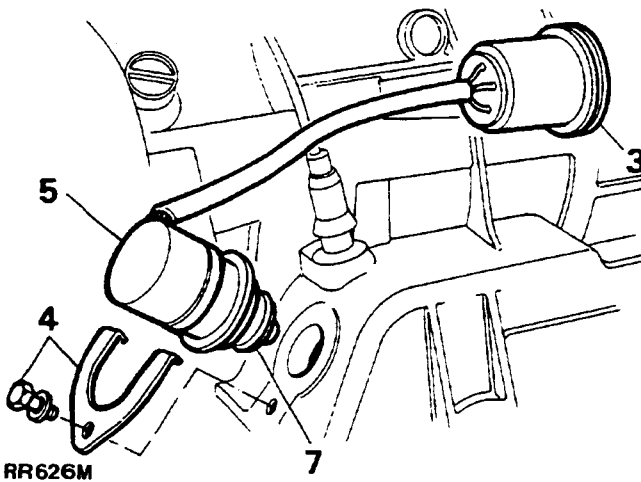

Refit

6. Fit a NEW 'O' ring to switch.
7. Reverse removal procedure.

OIL PRESSURE WARNING SWITCH

Service repair no - 86.65.30

Remove and refit

Remove

1. Disconnect the battery negative lead.
2. Disconnect electrical lead.
3. Unscrew switch unit.
4. Remove switch and sealing washer.

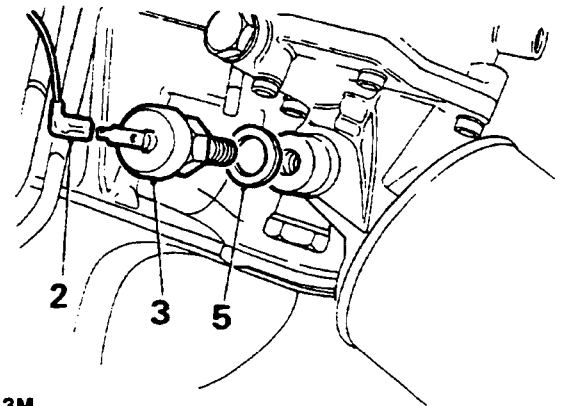

Refit

5. Reverse removal procedure. Using a NEW sealing washer.

COOLANT TEMPERATURE TRANSMITTER

Service repair no - 26.10.02

Remove and refit**Remove**

1. Disconnect the battery negative lead.
2. Disconnect electrical lead.
3. Remove transmitter from inlet manifold.

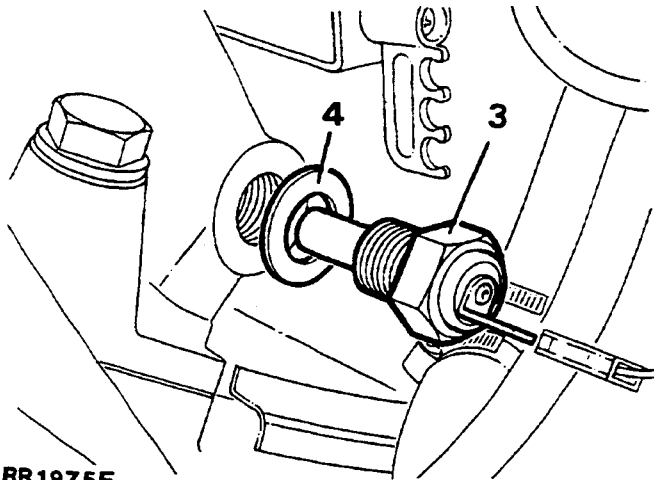

RR1975E

Refit

4. Reverse removal procedure. Using a **NEW** sealing washer.

STOP LIGHT SWITCH

Service repair no - 86.65.51

Remove and refit**Remove**

1. Disconnect the battery negative lead.
2. Remove lower dash panel. *See CHASSIS AND BODY, Repair, lower dash panel*
3. Depress foot brake.
4. Remove rubber protector from switch, if fitted.
5. Remove hexagon nut.
6. Withdraw switch.
7. Disconnect electrical leads.

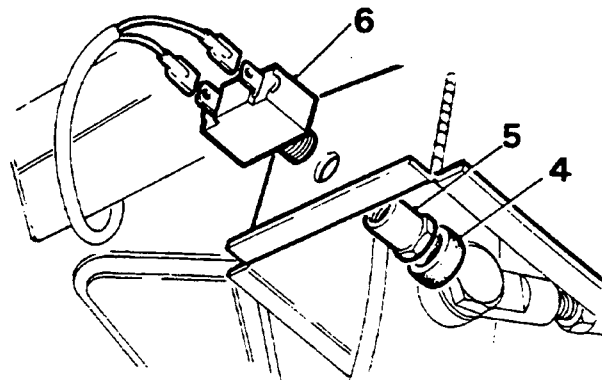

RR509M

Refit

8. Reverse removal procedure.



PARK BRAKE WARNING SWITCH

Service repair no - 86.65.45

Remove and refit

Remove

1. Disconnect the battery negative lead.
2. Apply park brake.
3. Remove four screws.
4. Remove glove box liner.
5. Carefully pull hose away from side of park brake mounting bracket.
6. Remove two screws.
7. Manoeuvre switch around front of mounting bracket. Disconnect electrical lead.
8. Remove switch.

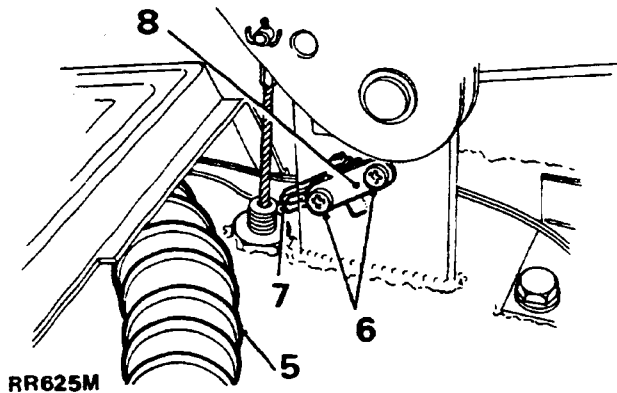

Refit

9. Reverse removal procedure.

EXTERIOR DRIVING MIRRORS

1. Mirror housing is hinged vertically. It should be set in one of two fixed angle positions provided to suit left or right side location.
2. For safety and convenience, mirror housing is designed to fold completely forwards or rearwards against vehicle body.

Adjust

3. Adjustment is controlled by an electric motor inside mirror housing. This is operated by two controls fitted in dash panel. To adjust, select left or right hand mirror. Move head of finger tip control to left, right, up or down as required.
4. Mirror also incorporates a demist facility, activated by operation of rear window demist switch.

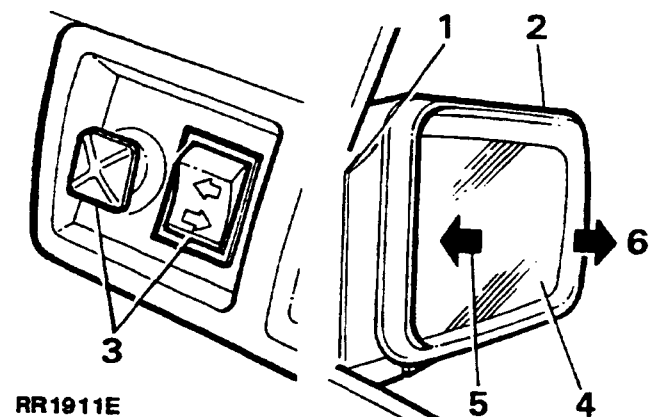

Replacing mirror glass

5. Press inner (wider) end of glass to full extent inwards.
6. Insert fingers under outer (narrower) end of glass. Pull outwards until glass is released from four retaining clips.
7. Disconnect two leads from back of glass.
8. To replace glass, locate inner (wider) end in mirror housing.

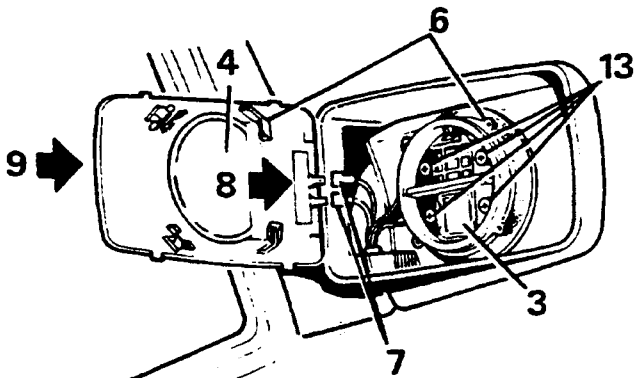

RR2038E

9. Carefully press outer (narrower) end of glass inwards until it locates on four retaining clips.
10. Adjust mirror as required.

ELECTRIC MOTORS

Remove and refit

Remove

11. Disconnect the battery negative lead.
12. Remove mirror glass, as described in items 5 to 7.
13. Remove four self-tapping screws securing motor assembly to mirror body.
14. Manoeuvre motor assembly to reveal electrical connections on rear of motor.
15. Pull leads from rear of motor assembly.

Refit

16. Reverse removal procedure. 11 to 15, ensuring that electrical leads are correctly refitted.

CONTROL SWITCHES

Service repair no - 86.65.75

Remove and refit

Remove

17. Disconnect the battery negative lead.
18. Remove switch retaining panel from fascia.
19. Withdraw panel to access electrical leads.

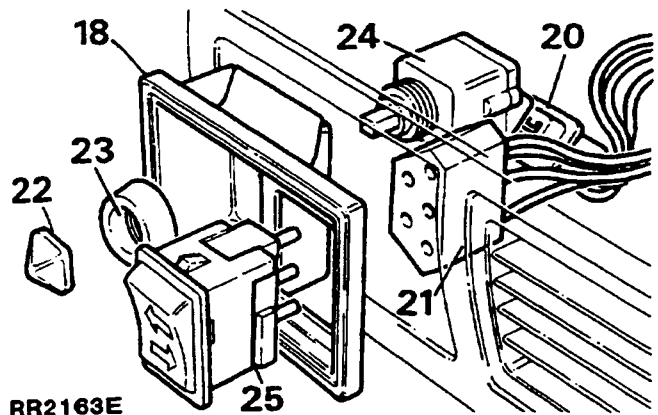

RR2163E

20. Pull multi-plug from rear of fingertip switch.
21. Disconnect multi-plug at rear of selector switch. Remove panel.
22. Carefully pry off fingertip button from switch.
23. Unscrew black plastic retaining collar securing switch.
24. Remove switch from panel. Note position of locating hole in panel retaining clip.
25. Depress two spring clips securing selector switch, push it through panel.

Refit

26. Reverse removal procedure. 17 to 25.

**COMPLETE ASSEMBLY**

Service repair no - 76.11.10

Remove and refit**Remove**

27. Disconnect the battery negative lead.
28. Pry off interior finisher plate.
29. Disconnect two electrical plugs.
30. Support exterior mirror assembly, remove three securing screws, plain and spring washers.
31. Pull inner mounting plate from inner door frame complete with two retaining clips.
32. Detach mirror assembly from outer door frame.
33. Remove sealing rubber.

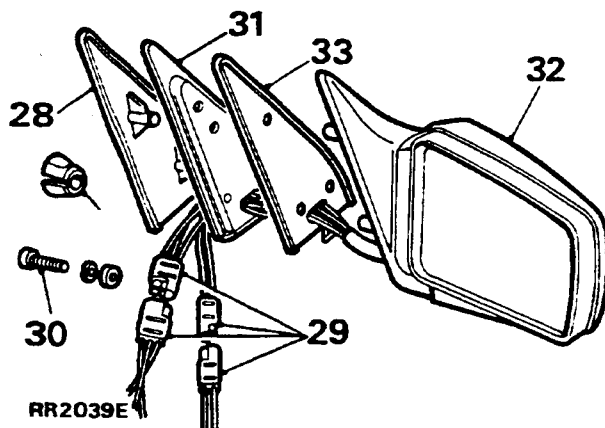
**Refit**

34. Reverse removal procedure. 27 to 33.



CAUTION: To prevent damage to electrical wiring do not push leads down inside door casing.

CLOCK

Service repair no - 88.15.07

Remove and refit**Remove**

1. Disconnect the battery negative lead.
2. Carefully pry clock out of dash panel.

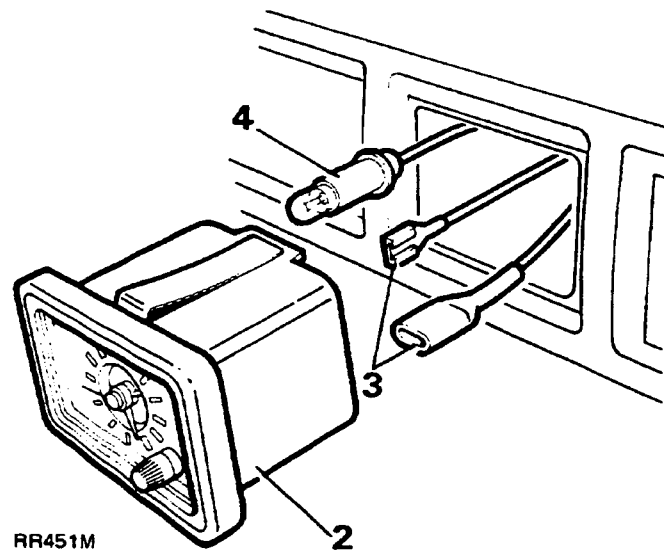

3. Disconnect electrical leads.
4. Remove bulb holder and bulb. Correct bulb is a 2-watt bayonet type.

Refit

5. Reverse removal procedure.

WARNING LAMP CONTROL UNIT - USA

Service repair no - 86.55.45

Remove and refit**Introduction**

The fifteen warning light symbols in binnacle will all be illuminated when ignition key is turned to position II as an initial check to ensure that all bulbs are operational. All bulbs, except for Brake Failure / Parking Brake, ABS (if fitted), Engine Oil Pressure' and 'Ignition On' symbols will extinguish automatically after 12 + 4 seconds.

If engine is cranked during bulb check, check will terminate in 0,75 + 0,25 seconds.

'Engine Oil Pressure' and 'Ignition On' symbols will remain on when engine is cranked extinguished when engine is running.

ABS symbol will extinguish when vehicle reaches 8 kph (5 mph).

The 'Brake Failure/Transmission Parking Brake' symbol will extinguish when parking brake lever is released.



NOTE: Should ignition key be turned directly to engine crank position, bulb check procedure will be overridden.

Remove

1. Disconnect the battery negative lead.
2. Remove six screws from lower dash panel.
3. Lower dash panel, disconnect multi-plug from rheostat switch.
4. Pull warning lamp control unit from spring clip on underside of dash panel, disconnect three multi-plugs from unit.
5. Remove warning lamp control unit.

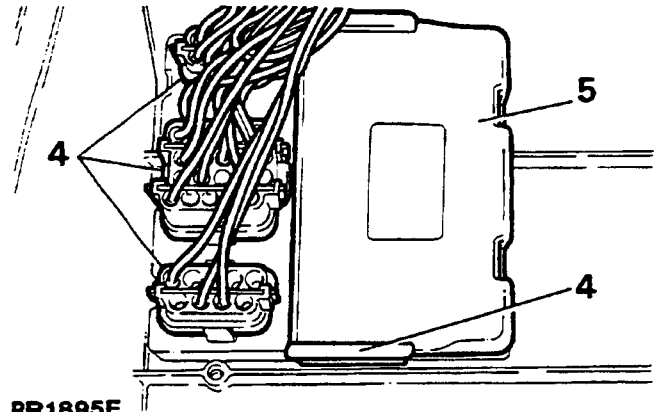

.RR1895E

Refit

6. Reverse removal procedure. Ensure multi-plugs and unit are securely located.



INSTRUMENT ILLUMINATION ELECTRONIC DIMMER / RHEOSTAT

Service repair no - 86.65.07

Remove and refit

Electronic dimming control switch is located on lower dash panel adjacent to steering column. Rotate control upwards to fully illuminate instruments and downwards to reduce intensity. Dimmer control unit also controls clock, heater and cigar lighter illumination.

Remove

1. Disconnect the battery negative lead.
2. Remove lower dash panel. *See CHASSIS AND BODY, Repair, lower dash panel*
3. Disconnect dimmer control multi-plug.
4. Remove two screws securing dimmer control switch.

Refit

5. Reverse removal procedure. 1 to 4.

WINDOW LIFT SWITCHES

Service repair no - 86.25.16

Remove and refit

Remove

1. Disconnect the battery negative lead.
2. Pry window lift switch surround from glove box.
3. Disconnect multi-plug at rear of switch(es).
4. Apply pressure to rear of switch, push it through surround.

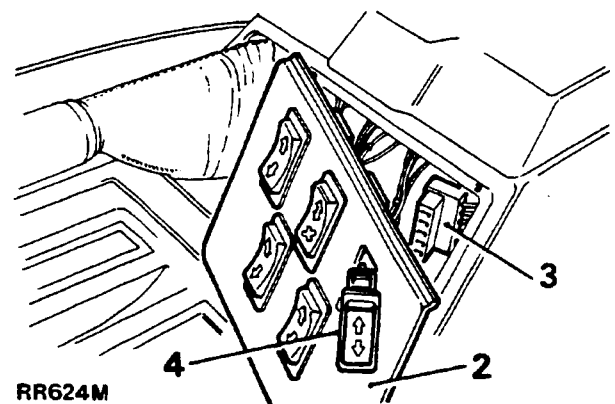

Refit

5. Reverse removal procedure.

WINDOW LIFT MOTOR - FRONT DOORS

Service repair no - 86.25.04

Remove and refit**Remove**

1. Ensure that side door glass is fully closed, secure with adhesive tape.
2. Remove front door trim panel. *See CHASSIS AND BODY, Repair, front door - trim panel*
3. Peel back front top corner of plastic vapour barrier to reveal window lift motor.
4. Release window lift motor wiring harness from three retaining clips to allow harness to be pulled out of opening at front of inner door panel.
5. Disconnect window lift motor multi-plug from main door harness.

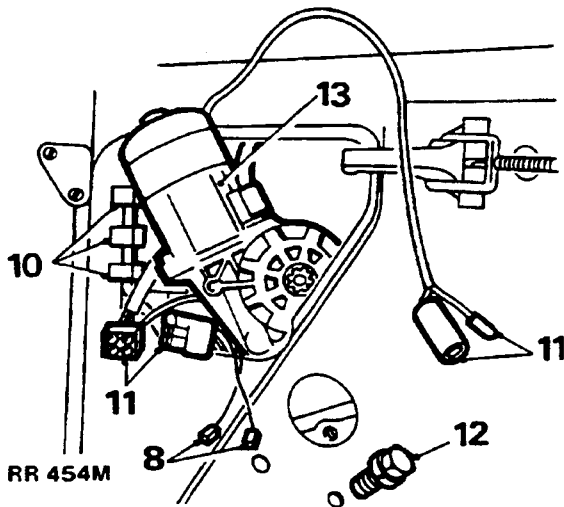

6. Support motor, remove three securing bolts.
7. Remove motor through top front opening of door.

Refit

8. Reverse removal procedure. 1 to 7.



NOTE: Ensure that drive gear is engaged and correctly aligned with window lift linkage before fitting securing bolts.

WINDOW LIFT MOTOR - REAR DOORS

Service repair no - 86.25.09

Remove and refit**Remove**

1. Ensure that side door glass is fully closed, secure with adhesive tape.
2. Remove rear door trim panel. *See CHASSIS AND BODY, Repair, rear door - trim panel*
3. Carefully detach bottom half of vapour barrier to reveal window lift motor.
4. Release motor wiring harness from retaining clips.
5. Disconnect lift motor harness snap connections from main door harness.
6. Support motor, release three securing bolts.
7. Remove lift motor from lower opening in inner door panel.

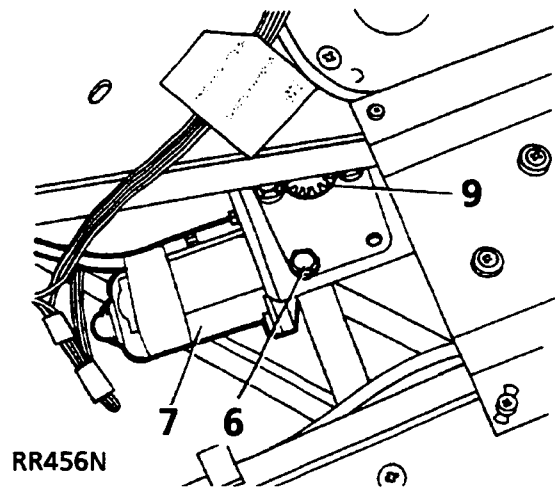
**Refit**

8. Reverse removal procedure. 1 to 7.
9. Ensure lift motor drive gear is engaged and correctly aligned with window lift linkage before fitting securing bolts.



CENTRAL DOOR LOCKING

The central door locking system on four door models is activated from both driver and front passenger doors. A switch/lock actuator is fitted in both front doors. The system is controlled by an electronic unit situated on steering column support bracket.

Locking or unlocking front doors from outside by key operation, or from inside by sill knob automatically locks or unlocks all four doors, upper tailgate and, vehicles up to 1991 model year fuel filler flap.

Vehicles from 1991 model year: Fuel filler flap is released by pressing button on steering column shroud.

Front and rear passenger doors can be independently locked or unlocked from inside vehicle by sill knob operation but can be overridden by further operation of driver's door locking control.

On rear doors only, a child safety lock is provided which can be mechanically pre-set to render interior door handles inoperative.

Failure of an actuator will not affect locking of remaining three doors, tailgate or fuel filler flap. A door with inoperative actuator can still be locked or unlocked manually, but not fuel filler flap.



NOTE: Actuator units contain non-serviceable parts. If a fault occurs, fit a new unit.

CENTRAL DOOR LOCK CONTROL UNIT

Remove and refit

Remove

1. Disconnect the battery negative lead.
2. Remove the lower fascia panel.
3. Disconnect the harness multi-plug.
4. Remove the securing screws.
5. Remove the control unit.

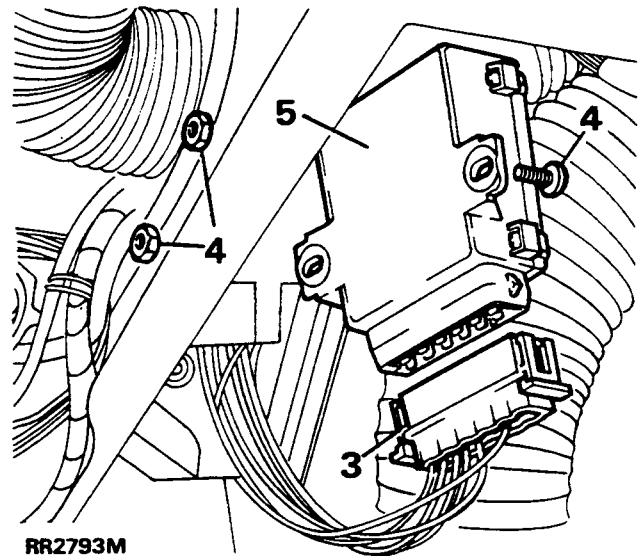

Refit

6. Reverse removal procedure.

FRONT DOOR ACTUATOR UNIT

Service repair no - 86.26.08

Remove and refit

Remove

1. Ensure window is in its fully closed position.
2. Remove front door trim panel. *See CHASSIS AND BODY, Repair, front door - trim panel*
3. Peel back plastic vapour barrier to expose actuator unit.
4. Remove four screws and plain washers securing lock actuator mounting plate to inner door panel.
5. Release cable tie, at trailing edge of door, retaining electrical cable.
6. Manoeuvre actuator assembly from actuator link.

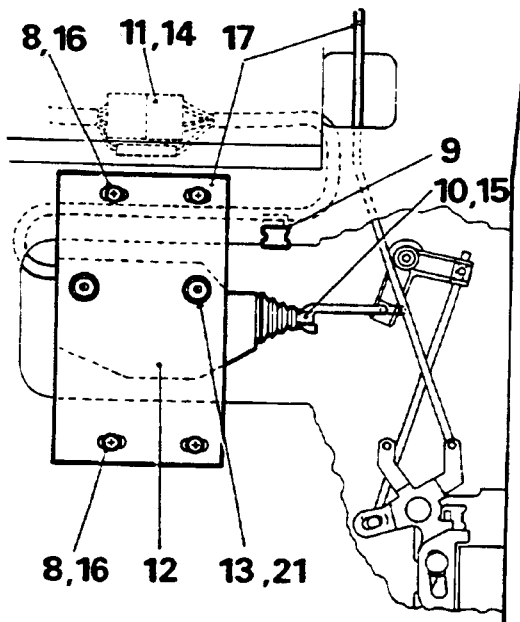

RR369M

7. Withdraw actuator assembly, disconnect multi-plug.
8. Remove actuator assembly.
9. Remove actuator unit by loosening two screws securing it to mounting plate.

Refit

10. Fit actuator unit to mounting plate.
11. Connect multi-plug.
12. Manoeuvre actuator assembly to engage actuator link.
13. Loosely fit actuator mounting plate to inner door panel with four screws. Set mounting plate in centre of slotted holes.
14. Ensure that manual operation of sill locking control is not restricted by operation of actuator operating rod and vice versa. Reset mounting plate as necessary.
15. Reconnect vehicle battery.
16. Check that electrical operation of door lock occurs when sill locking control is moved through half of total movement. Reset mounting plate if necessary, tighten four screws.



NOTE: Above adjustment ensures that full tolerance on switching operation is utilised.

REAR DOOR ACTUATOR UNITS

Service repair no - 86.26.09

Remove and refit

Instructions as for front doors with following exceptions:

17. Electrical cable and plug is retained and is accessible through large opening in door.
18. Instruction 16 does not apply to rear actuator units which are not fitted with switches.



NOTE: Actuator may be detached from mounting plate to facilitate removal of lock actuator from connector rod.



UPPER TAILGATE ACTUATOR UNIT

Service repair no - 86.26.10

Remove and refit

Remove

1. Remove two screws and trim covering to gain access to actuator.
2. Disconnect electrical connection.
3. Remove two actuator retaining screws.
4. Manoeuvre actuator assembly link from actuator link.
5. Withdraw tailgate actuator unit.

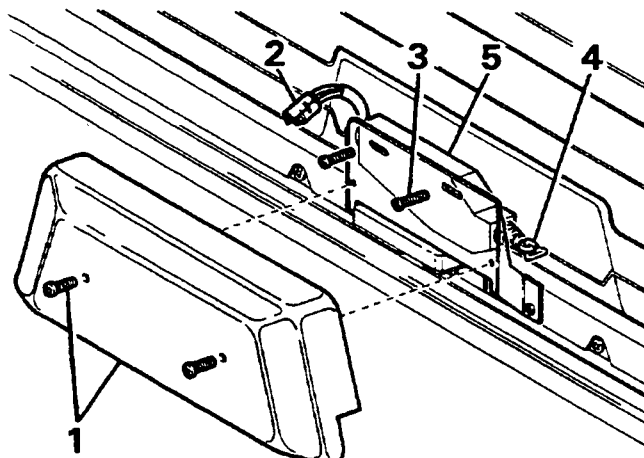

RR2570E

Refit

6. Reverse removal procedure.
7. Check operation of central locking system.

FUEL FILLER FLAP ACTUATOR UNIT - PRE 1991 MODEL YEAR

Service repair no - 86.26.16

Remove and refit

Remove

1. Remove six screws to withdraw closure panel, situated in tool stowage area.
2. Ensure that actuator is in unlocked position and fuel filler flap is open.
3. Release two screws and manoeuvre actuator unit clear of its mounting.

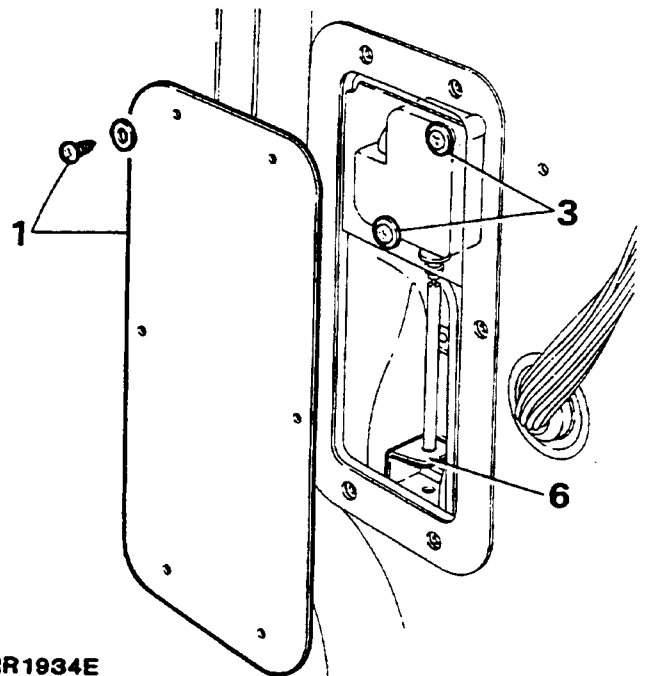

RR1934E

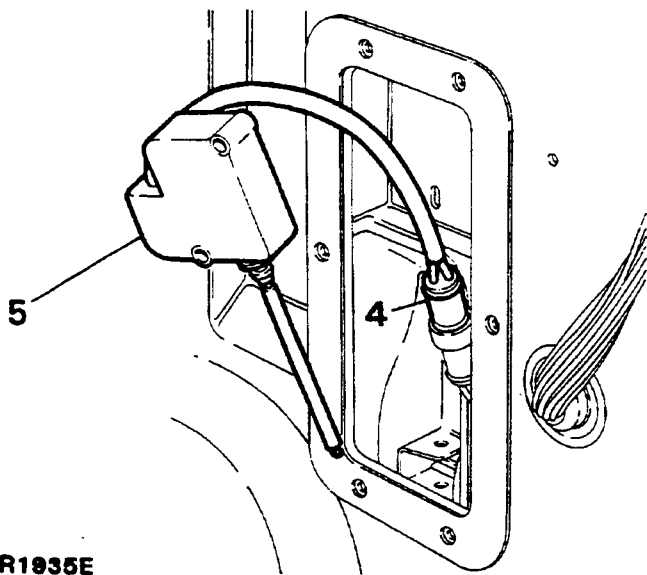

RR1935E

4. Disconnect wiring plug.
5. Withdraw actuator.

Refit

6. Reverse removal procedure. Actuator mounting holes in body are elongated. Adjust position of actuator to ensure that rod will pass through guide brackets without fouling.
7. Check operation of central locking system.

FUEL TANK GAUGE UNIT - PRE 1991 MODEL YEAR

Service repair no - 88.25.32

Remove and refit**Remove**

Service tool-RO 600964 Locking wrench.

1. Disconnect the battery negative lead.
2. Remove fuel tank. *See FUEL SYSTEM, Repair, fuel tank - pre 1991*
3. Release tank unit locking ring, using service tool RO 600964.
4. Remove gauge unit and sealing washer.

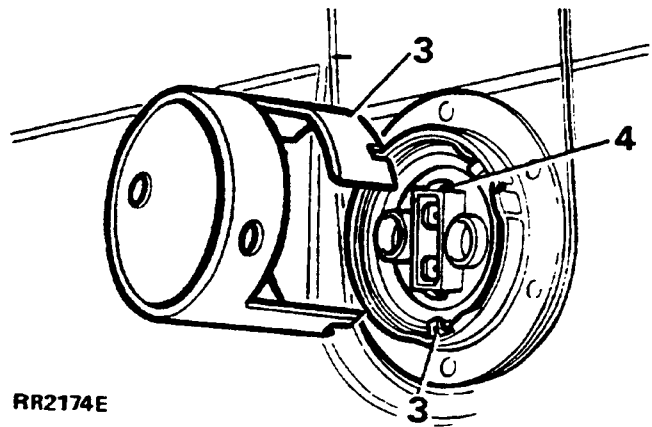

RR2174E

Refit

5. Coat mating faces with Bostik 772 adhesive. Fit a NEW sealing washer. Locate gauge unit ensuring that notch in gauge unit locates with register in tank.
6. Retighten locking ring.
7. Refit fuel tank.



TRAILER SOCKET

Incorporated in vehicle electrical harness is a facility for fitting a seven pin trailer lighting socket.

Pick-up point is located behind right hand tail lamp cluster assembly.

Pick-up point consists of a seven pin pre-wired plug, a separate auxiliary fused line feed and reverse light lead.



CAUTION: Fitting trailer socket and associated wiring **MUST** be carried out by a qualified vehicle electrician.

1. Disconnect the battery negative lead.
2. Remove tail lamp. *See tail lamp assembly*
3. Remove protective cap from trailer pick-up point plug.



NOTE: Cable colours in this plug correspond to main circuit diagram. Red / yellow is unused.

4. Feed seven core cable Part No. PRC4143 (fitted with a pre-wired plug to one end-suitable for connection to pick-up point) down between inner and outer body panels through rear light opening.

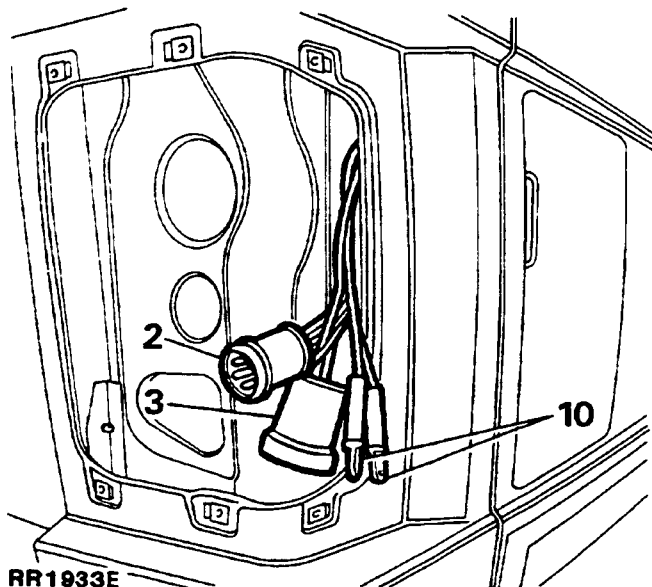

RR1933E

5. Feed cable alongside existing rear lighting harness.
6. Pull cable through opening between chassis side member and fuel tank.
7. Fit two retaining clips to cable and secure it to rear end cross member.
8. Connect electrical leads to vehicle trailer socket. (Refer to current trailer wiring regulations).
9. Secure trailer socket to tow bar.
10. Two extra leads in rear light opening provide a line feed and reverse light feed.

Electrical lead identification

Single leads - item 10, RR1933E.

Pink - Fused auxiliary line feed.

Green/Brown - Reverse light feed.

Pre-wired cable and plug - Part No. PRC4143

Yellow - Left indicator.

Green - Right indicator.

Red/Yellow - Unused.

White - Ground.

Brown - Right-hand tail lights.

Black - Left-hand tail lights.

Red - Stop lamps.

11. Refit tail lamp.

12. Reconnect battery.

AUDIBLE WARNING UNIT - USA

Service repair no - 86.55.13

Remove and refit

Audible warning unit will sound with varying notes to warn driver of following conditions:

- (a) Intermittent high and low notes for a period of 4 to 8 seconds:
 - key in ignition position 'II' AND driver's seat belt unfastened.
- (b) Interrupted low note:
 - driver's door open with key in switch but not in ignition position.
- (c) Constant high note:
 - ignition switched on with transfer gearbox lever in neutral.

Remove

1. Disconnect the battery negative lead.
2. Remove steering column shroud. *See steering column shroud*
3. Remove lower dash panel. *See CHASSIS AND BODY, Repair, lower dash panel*
4. Disconnect multi-plug.
5. Remove two securing screws, remove audible warning unit.

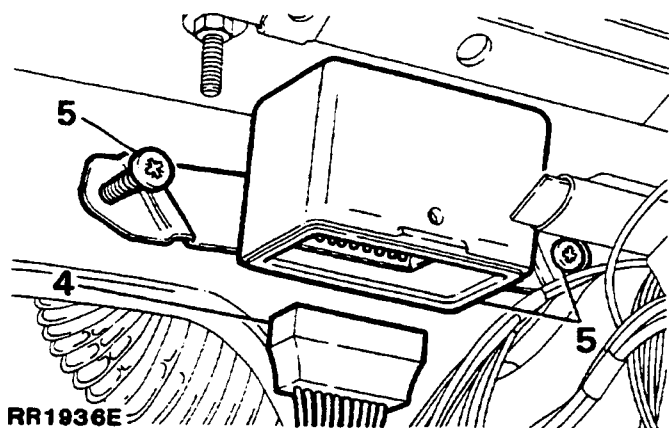
**Refit**

6. Reverse removal procedure.

LOW OIL LEVEL SENSOR UNIT - USA

Service repair no - 12.60.54

Remove and refit

The low oil level sensor unit is fitted into right hand side of engine sump.

Remove

NOTE: Ensure oil level is below sensor before removal.

1. Disconnect the battery negative lead.
2. Disconnect wiring connector.

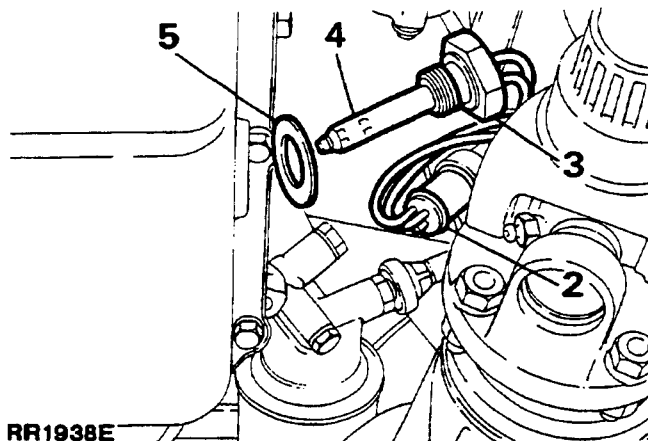

3. Remove securing nut.
4. Remove sensor unit.

Refit

5. Fit new sealing washer.
6. Reverse removal procedure.
7. Top up engine oil level. Run engine and check for leaks around sensor unit.



LOW OIL LEVEL WARNING LOGIC UNIT - USA

Service repair no - 86.55.64

Remove and refit

When ignition is switched 'ON' warning lamp in binnacle will flash for 10 to 20 seconds if low oil level is detected. Warning will not be repeated until ignition is again switched 'ON'.

If ignition is switched 'ON' within 15 to 30 seconds of preceding sequence, warning lamp will not operate.

Remove

1. Disconnect the battery negative lead.
2. Remove lower dash panel. *See CHASSIS AND BODY, Repair, lower dash panel*
3. Disconnect wiring at multi-plug.
4. Remove securing screws, remove logic control unit.

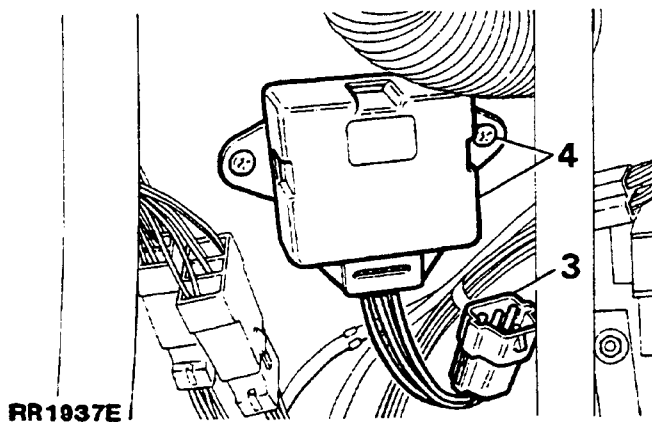

RR1937E

Refit

5. Reverse removal procedure.

FRONT SEAT - MOTORS

Service repair no - 86.75.06

Remove and refit

Remove

Four electric motors, mounted beneath each front seat, control fore and aft movement, cushion height front and rear, and angle of recline. Adjustment is possible with either front door open, or with ignition switched ON.

1. Position seat to give access to motors.
2. Disconnect the battery negative lead.
3. Remove seat base trim.
4. Remove two securing screws from each side of required motor.

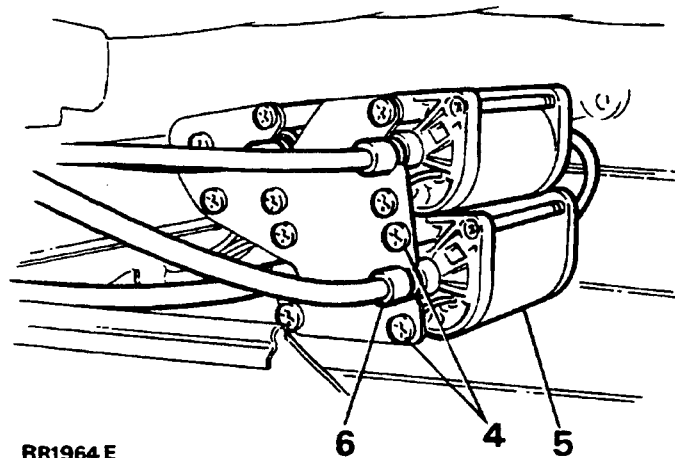

RR1964 E

5. Remove motor from mounting.
6. Disconnect drive cables by unscrewing ferrule.
7. Disconnect wires from multi-plug, remove motor.

Refit

8. Reverse removal procedure.
9. Check seat adjustment for correct operation.

FRONT SEAT - SWITCH

Service repair no - 86.75.03

Remove and refit**Remove**

1. Disconnect the battery negative lead.
2. Pry two finger tip controls from switch housing.
3. Remove switch housing cover by lightly depressing sides of cover to disengage clips. Remove diaphragm fitted to later models.
4. Remove two crosshead screws and washers. Lift switch assembly to gain access to two multi-plugs.
5. Disconnect multiplugs, remove switch assembly.

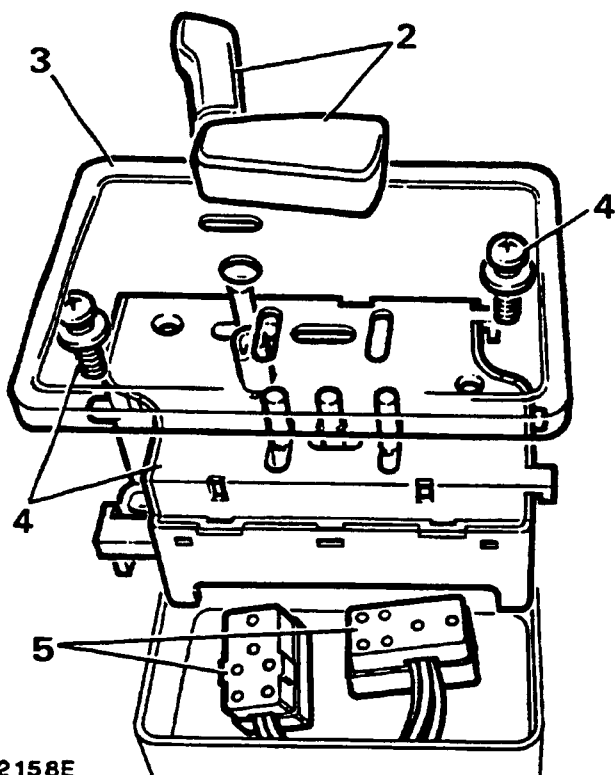

RR2158E

Refit

6. Reverse removal procedure. 1 to 5.



NOTE: If switch housing removal is required it is necessary to remove seat to gain access to two securing screws. See *CHASSIS AND BODY, Repair, front seat electrical.*

RADIO ANTENNA AMPLIFIER

Service repair no - 86.50.29

Remove and refit**Remove**

1. Disconnect the battery negative lead.
2. Lower or remove headlining. See *CHASSIS AND BODY, Repair, Headlining*
3. Remove electrical leads and radio antenna lead.
4. Remove two screws, remove amplifier unit.

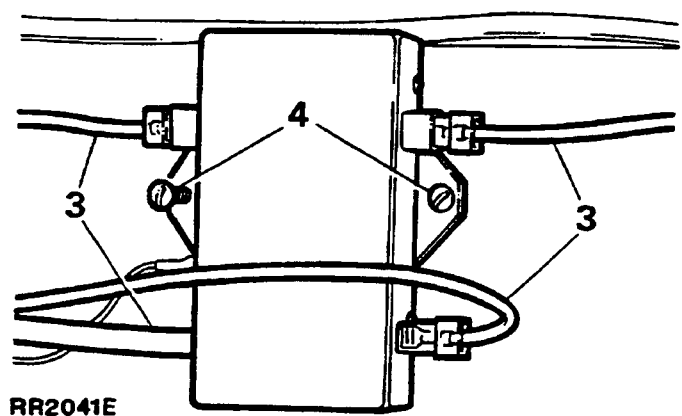

RR2041E

Refit

5. Reverse removal procedure.



RELAYS

To identify individual relays. *See Relays, delay units, timer units, diode pack - 1990 / 91 - identification See Relays, delay units, timer units, diode pack - USA and Canada 1990 / 91 - identification*

For relays 1992 onwards *See ETM, Z5*

Mounted on engine compartment closure panel.

Remove and refit

Remove

1. Disconnect the battery negative lead.
2. Remove relay protective cover.
3. Pull appropriate relay off its base.

Refit

4. Reverse removal procedure.

Mounted on steering column support bracket

Remove and refit

Remove

1. Remove lower fascia panel. *See CHASSIS AND BODY, Repair, lower dash panel*
2. Locate appropriate relay on mounting bracket, remove relay from base.

Refit

3. Reverse removal procedure.

Floor mounted beneath front seats

Remove and refit

Remove

1. Position seat to gain access to relay.
2. Disconnect the battery negative lead.
3. Remove relay from base.

Refit

4. Reverse removal procedure.
5. Heated front screen

HEATED FRONT SCREEN

Heated front screen will operate when switch is operated, with engine running. Timer unit will provide a preset time cycle of 7 1/2 minutes \pm 20%.

To identify timer unit. *See Relays, delay units, timer units, diode pack - 1990 / 91 - identification See Relays, delay units, timer units, diode pack - USA and Canada 1990 / 91 - identification.*

Switching OFF ignition, or further operation of heated front screen switch during cycle will switch off screen and cancel, reset and switch off timer unit.

Fuses

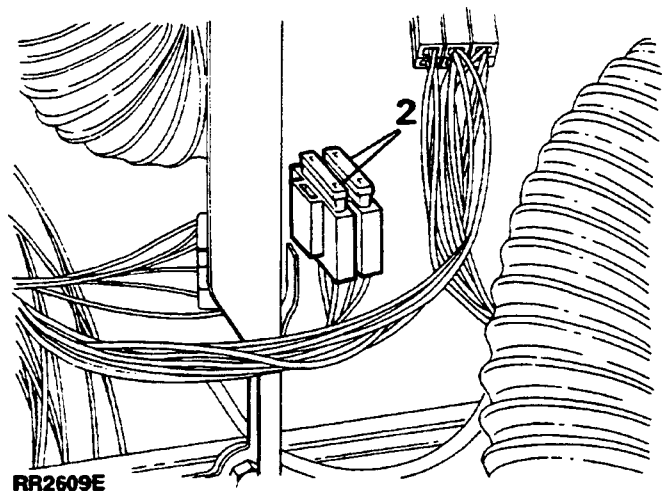

Heated front screen (2) has two 25 amp white, blade type fuses mounted adjacent to the bank of steering column mounted relays.

ALTERNATOR HEAT SHIELD**Remove and refit****Remove**

1. Disconnect the battery negative lead.
2. Remove fixing screw to rocker cover.
3. Remove nut from alternator rear mounting bolt.
Remove heat shield.

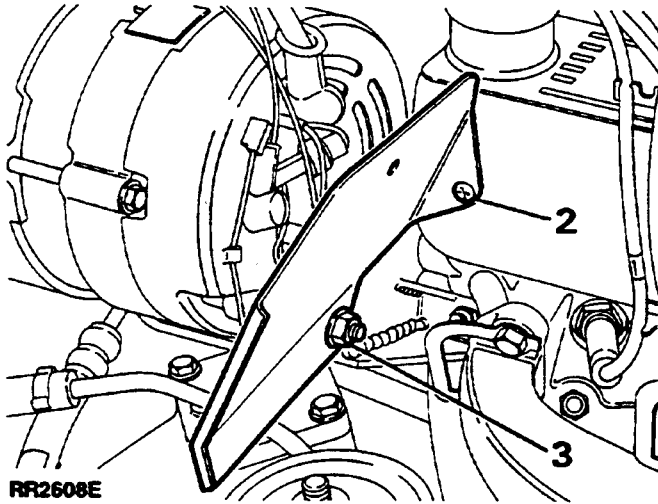
**Refit**

4. Reverse removal procedure. Check and adjust drive belt tension if required. *See Alternator drive belts*

HIGH LEVEL STOP LAMP

Service repair no - 86.41.35

Includes bulb renewal

Service repair no - 86.41.34

Remove and refit**Remove**

1. Disconnect the battery negative lead.

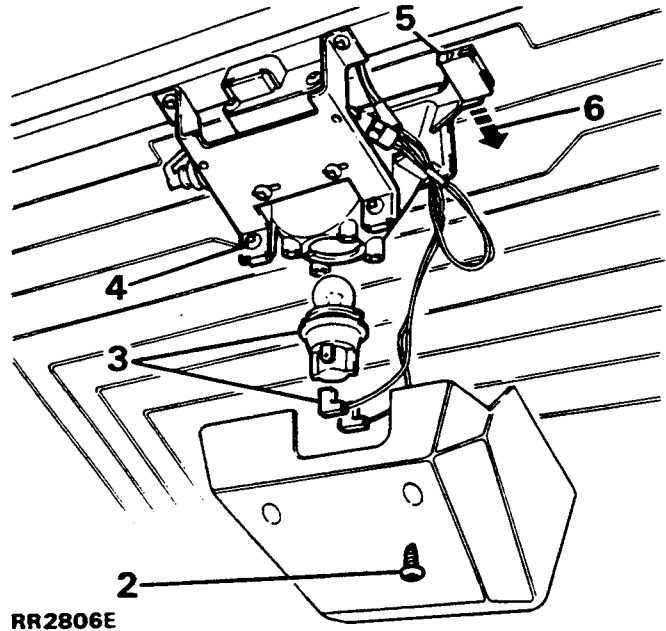

2. Remove two cover retaining screws. Remove cover.
3. Disconnect electrical leads to bulb holder. Remove bulbholder and bulb by twisting anti-clockwise.
4. Remove two screws, mounting plate to stop lamp.
5. Observe position of stop lamp on rear screen. Carefully release tabs on stop lamp from rear screen mountings.
6. Remove stop lamp.

Refit

7. Renew bulb if necessary, correct bulb is a 12V, 21 watt, bayonet type.
8. Reverse removal procedure.



INSTRUMENT BINNACLE

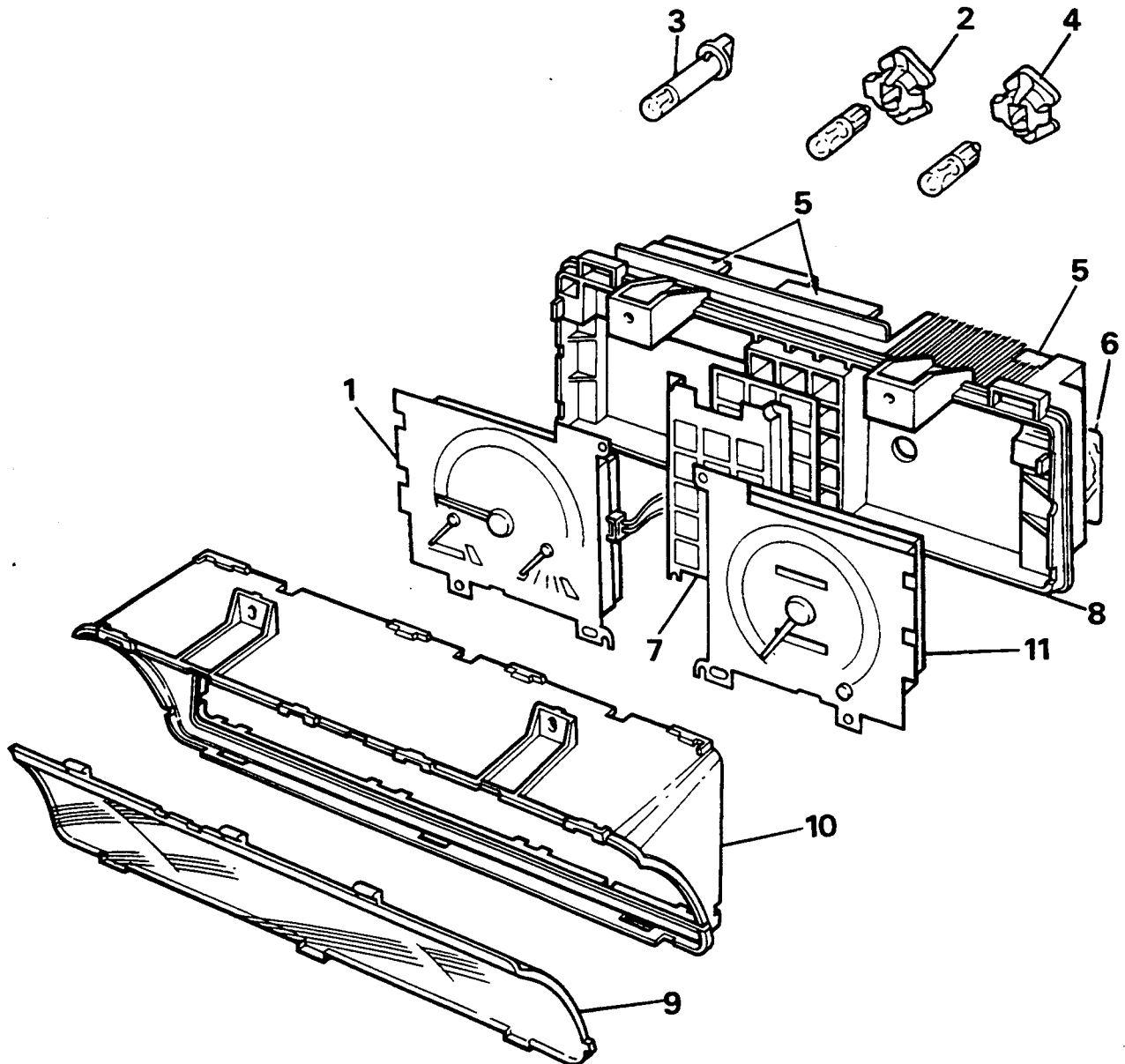

RR2732M

A revised instrument pack was fitted to 1990 model year vehicles. An electronic speedometer is fitted, deleting the requirement for a speedometer cable between speed transducer and speedometer. The instruments are restyled to improve the clarity of graphics.

Instrument pack - RR2732M

- | | |
|---|-----------------------------|
| 1. Tachometer, fuel and temperature gauge. | 6. Printed circuit. |
| 2. Ignition warning bulb (with separate blue holder unit) | 7. Warning light panel. |
| 3. Panel illumination bulb and holder. | 8. Instrument case (front). |
| 4. Warning lights bulb and holder. | 9. Curved lens. |
| 5. Printed circuit input tags (for harness connection). | 10. Binnacle housing. |
| | 11. Speedometer. |

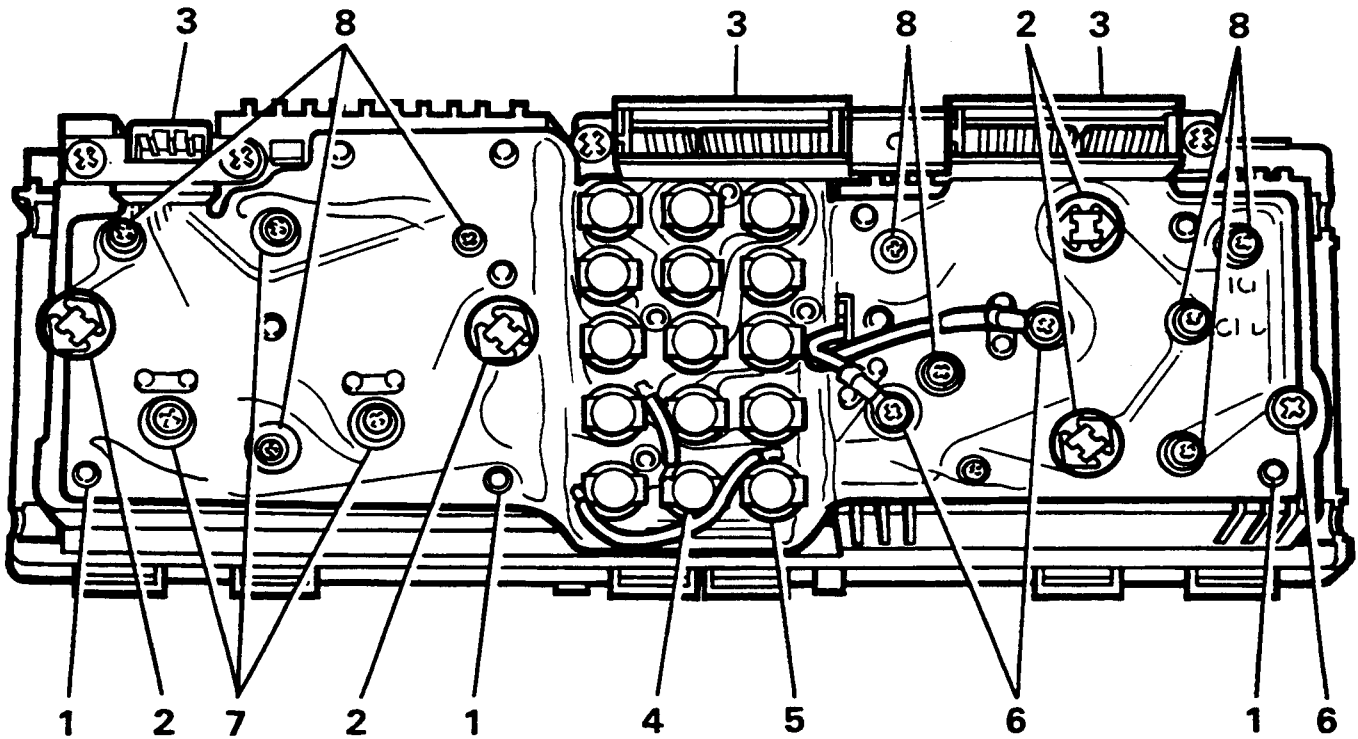

RR2733M

Instrument case back - RR2733M

- | | |
|--|---|
| <ul style="list-style-type: none"> 1. Printed circuit locating pegs. 2. Panel illumination bulbs - 4. 3. Harness connectors. 4. Warning light bulbs. 5. No charge warning light bulb (blue holder). | <ul style="list-style-type: none"> 6. Tachometer/fuel/temperature gauge securing screws - 3. 7. Speedometer securing screws - 3. 8. Printed circuit securing screws 8. |
|--|---|

Printed circuit harness connections - RR2762

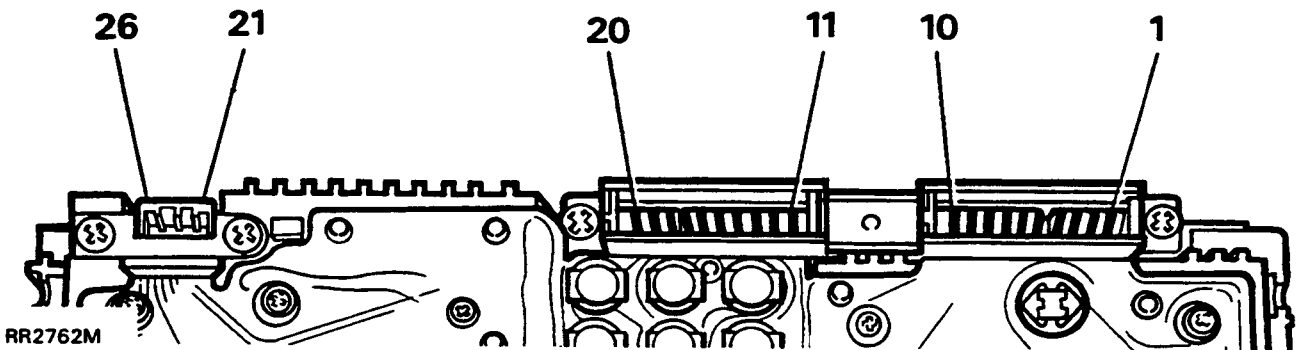

RR2762M

Connection sequence looking towards BACK of instrument case.



CIRCUIT SERVED

Numbers refer to pin number on instrument pack circuit diagram RR2735M and illustration RR2762M

Coolant temperature	1
Low coolant input	2
Ignition switch 12V+	3
Ignition warning light	4
Oil pressure warning light	5
Fuel tank unit	6
Transmission oil temperature.....	7
Cold start warning (diesel)	8
12V+ ignition	9
Tachometer signal	10
Brake fail/handbrake warning light.....	11
Brake pad wear warning light.....	12
Low wash fluid	13
Direction indicator - left	14
Zero volts from dimmer	15
Main beam warning light	16
Trailer warning light.....	17
Direction indicator - right.....	18
EFI warning light	19
ABS warning light.....	20
Seat belt warning light.....	21
Low coolant check	22
Speed signal	23
Photo transistor	24
Panel illumination bulbs (4).....	25
Earth -ve	26

Instrument pack

Key

- A. Speedometer
- B. Tachometer
- C. Temperature gauge
- D. Fuel gauge
- E. Low fuel warning unit
- F. Low fuel warning light
- G. Low coolant warning light
- H. Low coolant warning unit

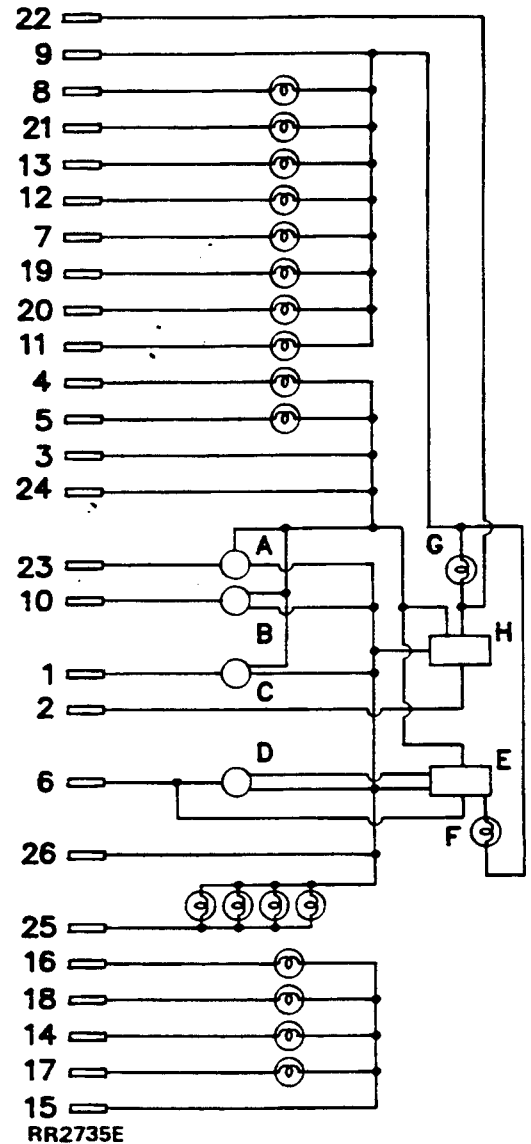

PANEL AND WARNING LIGHT BULBS

Service repair no - 86.45.31 panel

Service repair no - 86.45.61 warning light

Remove and refit**Remove**

1. Disconnect the battery negative lead.
2. Unclip cowl from back of instrument binnacle.
3. Rotate appropriate bulb holder anti-clockwise to remove.



NOTE: 'No Charge/Ignition On' warning light, identified by BLUE bulb holder, is a 2 watt capless type.

4. Fit new bulb. Rotate bulb holder clockwise to lock in position. Correct bulb type is: warning lights, 1.4 watt capless type, panel illumination, 3 watt capless type.
5. Refit cowl.
6. Refit battery negative lead.



NOTE: Difficulty may be experienced in changing bulbs due to limited space. Instrument binnacle fixings may be removed to enable binnacle to be raised as far as connections permit. See 'Instrument Binnacle - remove and refit' below for details of binnacle mounting bracket fixing.

INSTRUMENT BINNACLE

Service repair no - 88.20.13

Remove and refit**Remove**

1. Disconnect the battery negative lead.
2. Remove lower fascia by releasing six retaining screws.
3. Remove four nuts, spring and plain washers securing instrument.
4. Remove binnacle cowl.
5. Disconnect two multi-plugs and single plug.
6. Remove instrument binnacle.

Refit

7. Reverse removal procedure. 1 to 6.

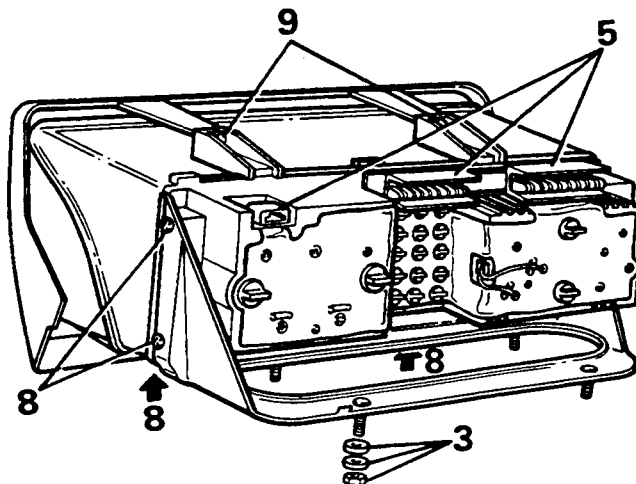

RR2731M

Removing instrument pack

8. Remove binnacle mounting bracket.
9. Remove two screws, remove bezel.
10. Detach curved lens from binnacle housing by depressing four tabs and easing top of lens out, then depressing three tabs and easing lower edge of lens out.
11. Remove instrument case from binnacle housing by releasing upper and lower locating tabs.

Refitting Instrument Pack to Binnacle

12. Reverse removal procedure. 9 to 11.



TACHOMETER, FUEL AND TEMPERATURE GAUGE UNIT

Service repair no - 88.25.17



NOTE: Tachometer, fuel and temperature gauges are replaced as a unit.

13. Remove two panel illumination bulb holders.
14. Remove three larger screws retaining tachometer, fuel and temperature gauges. Note position of black and white leads secured by two screws.
15. Remove unit from instrument case.

Refit

16. Reverse removal procedure. Items 13 to 15.

SPEEDOMETER

Service repair no - 88.30.01

17. Remove two panel illumination bulb holders.
18. Remove three screws securing speedometer.
19. Remove speedometer from instrument case.

Refit

20. Reverse removal procedure. Items 16 to 18.

PRINTED CIRCUIT

Service repair no - 88.20.19

21. Remove Speedometer and Tachometer units as described above. Remove all warning light bulbs. Note position of no charge warning light, blue bulb holder.
22. Remove two harness connectors, retained by four screws release printed circuit tags and input plug.
23. Remove eight screws and plain washers, securing printed circuit.
24. Carefully remove printed circuit from locating pegs.

Refit

25. Reverse removal procedure. Items 21 to 24.

GEAR SELECTOR-INTERLOCK

Interlock solenoid

Remove and refit

Remove

1. Disconnect the battery negative lead.
2. Remove gear selector head and illumination panel. *See Automatic gear selector-panel illumination*
3. Disconnect electrical multiplug.

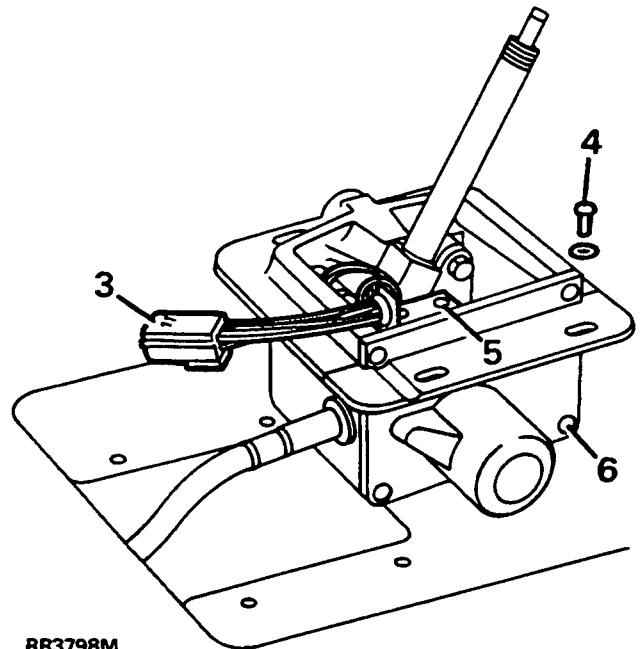

RR3798M

4. Remove screws and lift gear selector mechanism above housing.
5. Remove screws from microswitch support bracket.
6. Remove screws and separate side cover from housing.
7. Disconnect wiring solenoid to multiplug.
8. Remove circlip and retainer plate.
9. Remove clip and centre sleeve.
10. Refit clip into groove on spindle and lever against it to remove solenoid from housing.

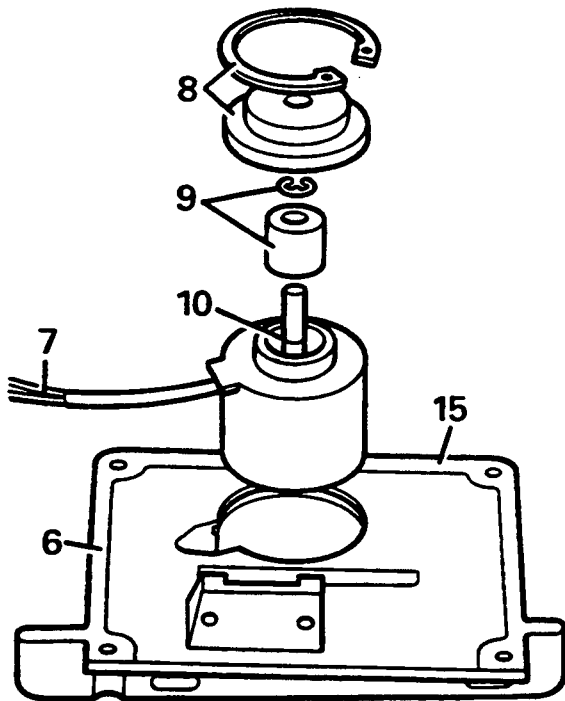

RR3800M

Refit

11. Fit solenoid with wiring positioned into side cover recess.
12. Fit sleeve and new clip.
13. Fit retaining plate and circlip.
14. Connect wiring to multiplug.
15. Apply sealant and fit side cover to housing. Use Silcoset 152 sealant or equivalent.
16. Grease all moving parts of gear selector mechanism. Use Rocol E1A or equivalent grease.
17. Reverse instructions 1 to 5.

Interlock microswitch onto castellated plate.**Remove and refit****Remove**

1. Disconnect the battery negative lead.
2. Remove gear selector head and illumination panel. *See Automatic gear selector-panel illumination*
3. Disconnect electrical multiplug.

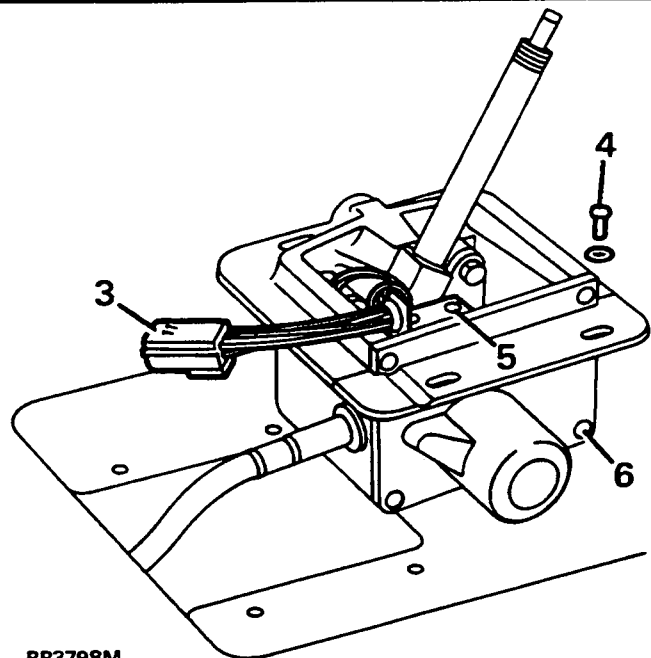

RR3798M

4. Remove screws and lift gear selector mechanism above housing.
5. Remove screws from microswitch support bracket.
6. Remove screws and separate side cover from housing.
7. Disconnect wiring microswitch to multiplug.

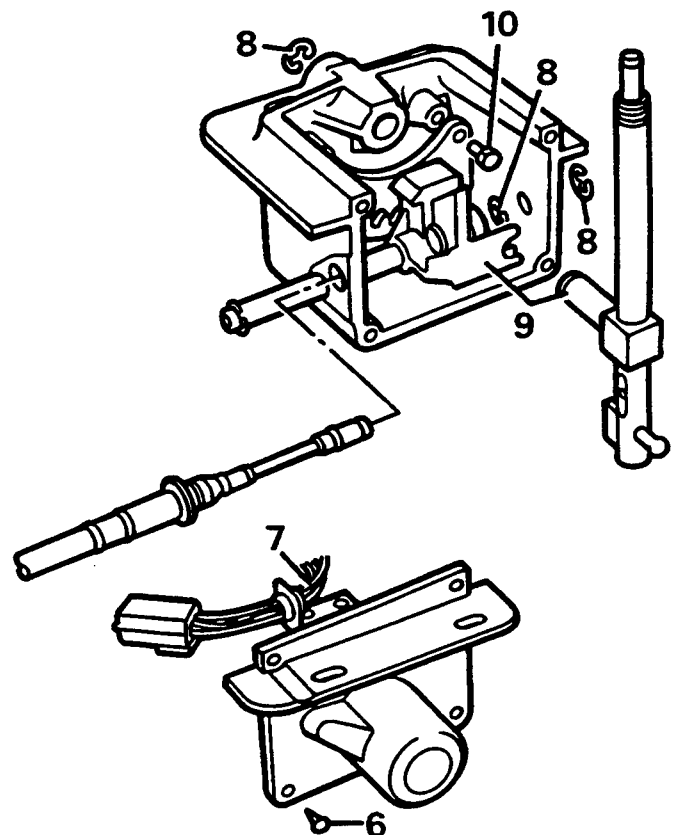

RR3797M

8. Remove 3 clips as shown.
9. Slide trunnion forward and remove gear selector arm.

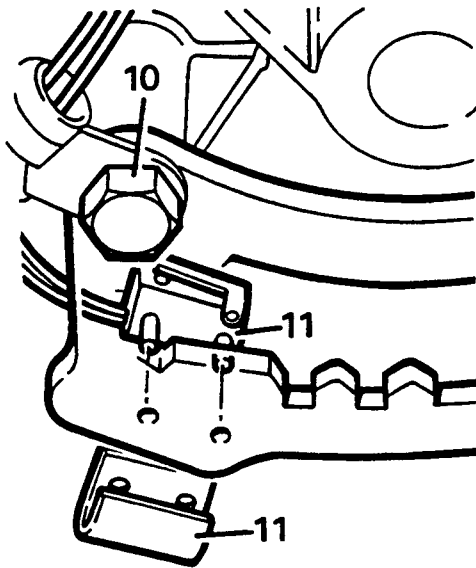

RR3799M

10. Remove bolts securing coxcomb.
11. Remove microswitch retaining clip and microswitch.

Refit

12. Reverse removal procedure, correctly positioning microswitch.
13. Apply Loctite 242E to castellated plate bolts and Tighten to **9 Nm**.
14. Grease all moving parts of gear selector mechanism. Use Rocol E1A or equivalent grease.
15. Apply Silcoset 152 sealant or equivalent and fit side cover to housing.

Interlock microswitch onto side cover

Remove and refit

Remove

1. Disconnect the battery negative lead.
2. Remove gear selector head and illumination panel. *See Automatic gear selector-panel illumination*

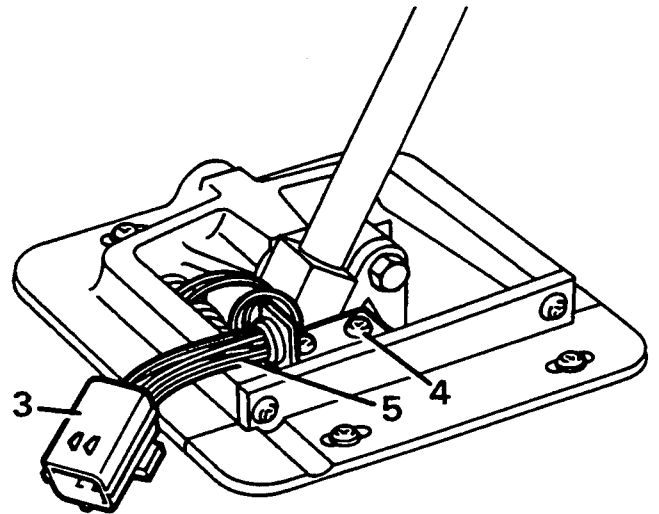

RR3801M

3. Disconnect electrical multiplug.
4. Remove screws from microswitch support bracket.
5. Disconnect wiring microswitch to multiplug.

Refit

6. Reverse removal procedure, correctly positioning microswitch.
7. Grease all moving parts of gear selector mechanism. Use Rocol E1A or equivalent grease.

MAP LIGHT BULB RENEWAL**Remove and refit****Remove**

1. Disconnect the battery negative lead.

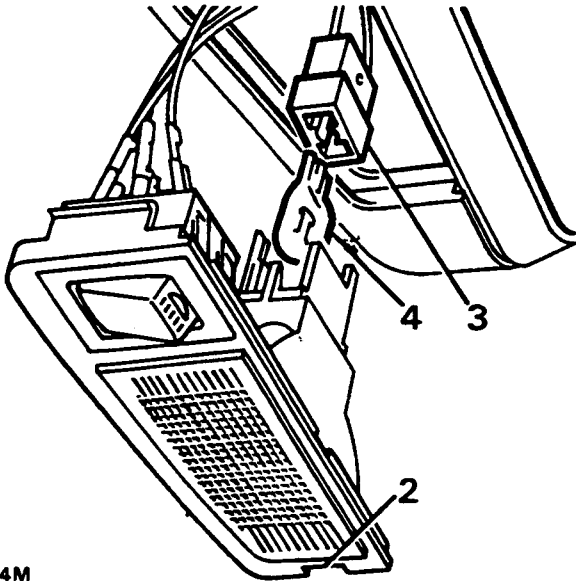

RR3644M

2. Pry slot to open cover.
3. Remove bulbholder.
4. Remove bulb from holder.
5. Replace bulb with 12v 5w capless.

Refit

6. Reverse removal procedure.

ELECTRICAL SEAT FAILURE

NOTE: Carry out following procedure if seat failure occurs with seat obscuring fixing bolts.

1. Check 30A fuses and courtesy lamp fuse B2.
2. Disconnect 9 way connector between seat ECU and motors (memory seat). Power motor from a separate battery source.
3. If partial failure occurs in forward and reverse travel only, change drive cable as required to move seat to desired position.
4. If 2. and 3. is not possible, move seat by driving cables manually.



DRIVE CABLE - ELECTRIC SEAT

Remove and refit

Remove

1. Remove seat. *See CHASSIS AND BODY, Repair, Front Seat Electrical*
2. Cut cable tie, remove drive cable securing clips.
3. Remove drive cable from gearbox.
4. Remove drive cable from motor by unscrewing ferrule.
5. Cut cable ties from drive cable. Note position for reassembly.
6. Remove drive cable. If cable has failed, 'twist' may have occurred in seat. To rectify this, use a small screwdriver to turn gearbox of failed cable until twist is removed.

Refit

7. Reverse removal procedure. Ensuring new cable ties are fitted in original positions.
8. Operate seats to full extent of travel. To ensure that 'twist' has been removed, check that both gearboxes stop simultaneously.

MEMORY SEAT - SWITCH

Remove and refit

Remove

1. Disconnect the battery negative lead.
2. Pry finger tip controls from top of switch housing.

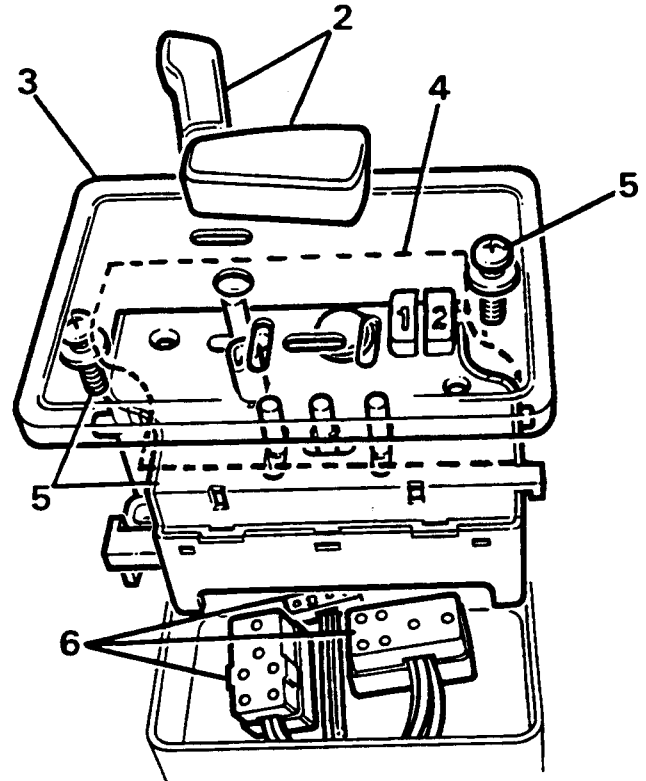

RR3762M

3. Remove switch housing cover by lightly depressing sides of switch housing to disengage clips.
4. Remove sealing diaphragm.
5. Remove switch securing screws, lift switch to gain access to multiplugs.
6. Disconnect multiplugs and remove switch.

Refit

7. Reverse removal procedure. Fitting a new sealing diaphragm.

MEMORY SEAT SWITCH - CLEAN

NOTE: If a seat switch problem is diagnosed, the cause may be liquid spillage or ingress of foreign matter. The switch may be cleaned using the following procedure.

1. Remove seat switch. *See Memory Seat - Switch*
2. Discard sealing membrane.
3. Clean affected area of switch using a slightly damp clean cloth.
4. If contamination still exists, clean switch using a clean cloth slightly dampened with methylated spirits.
5. Allow switch to dry completely.
6. Refit switch using a new membrane.
7. Check seat switch for satisfactory operation.

EXTERIOR MIRROR SWITCHES - MEMORY TYPE**Remove and refit****Remove**

1. Disconnect the battery negative lead.
2. Remove air vent adjacent to switches.
3. Carefully pry button from mirror adjustment switch.

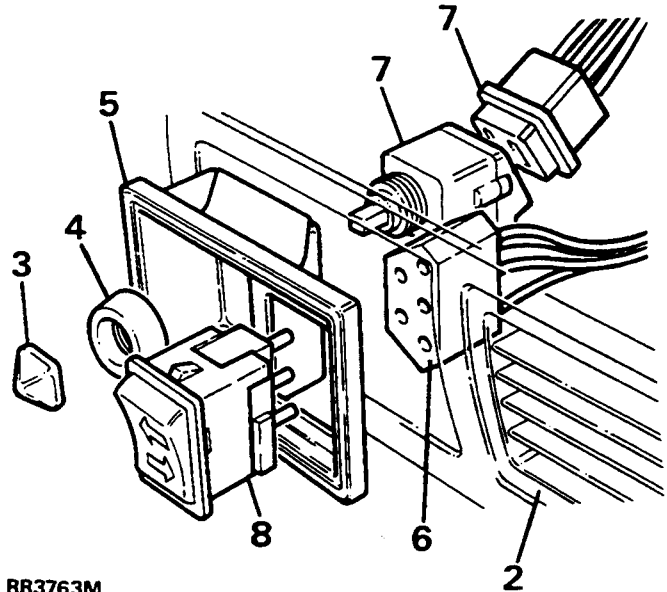

RR3763M

4. Unscrew locking ring from switch.
5. Withdraw switch retaining panel, noting position of adjustment switch in panel retaining clip.
6. Disconnect multiplug at rear of changeover switch, remove panel.
7. Disconnect multiplug to remove mirror adjustment switch.
8. Depress two spring clips and remove change over switch.

Refit

9. Reverse removal procedure. 1 to 8.



NOTE: The mirror adjustment switch is located on the multiplug connector in the 12 o'clock position. (On non memory mirrors this connector is in the 9 o'clock position).



ECU - MEMORY SEAT

Remove and refit**Remove**

1. Remove driver's seat. *See CHASSIS AND BODY, Repair, Front seat Electrical*
2. Disconnect connector from seat.

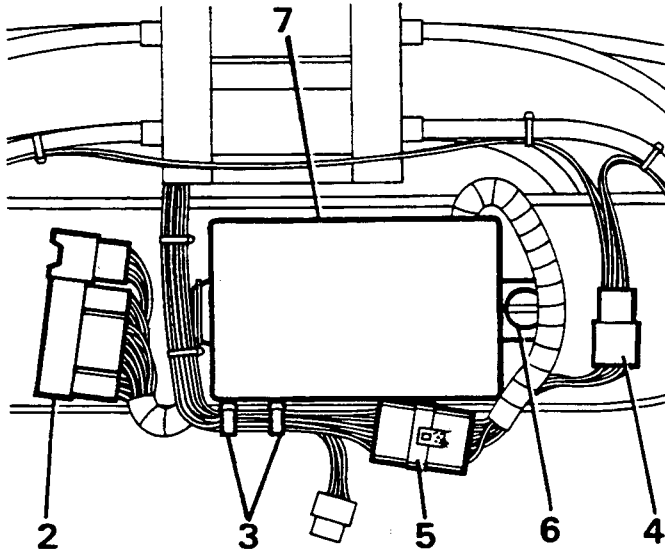

RR3761M

3. Remove cable ties.
4. Disconnect sensor and seat switch multiplug, remove from seat.
5. Disconnect seat motor multiplug.
6. Turn ECU retaining turnbuckle half a turn.
7. Remove ECU.

Refit

8. Reverse removal procedure. Ensuring cable retaining clips are correctly located. *See Memory Seat - harness layout*
9. Initialise system. *See Fault diagnosis, Memory Seat / Mirror System Service Check*

MEMORY SEAT - HARNESS LAYOUT



WARNING: To prevent damage to wiring under driver's seat and subsequent failure, the wiring must be installed as shown in

RR3748M

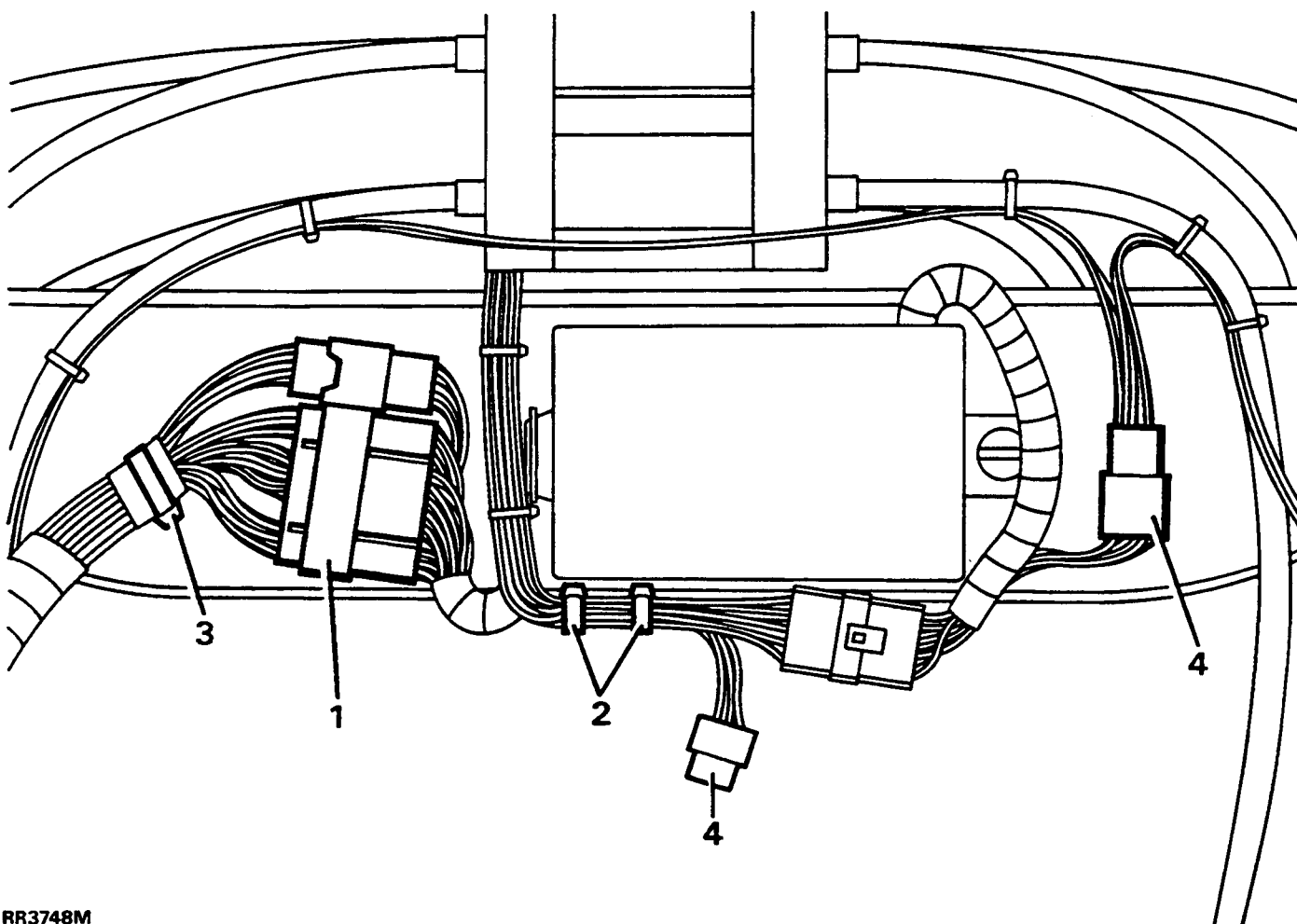

RR3748M

1. ECU link harness connector has retaining clip to seat base.
2. Link harness has two cable ties to seat motor harness, one of which is secured to seat base.
3. Main harness has P-clip securing it to seat base.
4. Sensor connector to link harness has retaining clip to seat base.



HANDSET INITIALISATION



NOTE: New handsets are supplied in pairs. If a new handset is required, it will require initialisation to the ECU using the following procedure:

1. Starting conditions: ignition off, doors unlocked, bonnet switch depressed.
2. Carry out instructions 3. to 9. within 8 seconds.
3. Switch ignition ON.
4. Switch ignition OFF.
5. Lock doors.
6. Unlock doors.
7. Release bonnet switch.
8. Switch ignition ON.
9. Switch ignition OFF.

If alarm is correctly accessed, horn will sound and LED will light. It is now possible to programme two handsets of correct frequency to vehicle alarm ECU. This must be carried out within two minutes.

10. Press and hold down button on first handset until dash LED flashes.
11. Repeat instruction 10. for second handset.
12. The LED will extinguish if both handsets have been initialised correctly.

HANDSET BATTERIES

Replace

1. Gently prise handset apart using a coin or small flat bladed screwdriver.
2. Hold the board in one hand, cup other hand, clap hands together to jar batteries from clip.
3. Leave batteries out, operate handset by pressing button for 10 seconds to allow integrated circuit to reset itself.



CAUTION: Handle new batteries as little as possible. Hands should be clean, dry and free from grease.

4. Fit new batteries in clip, positive side uppermost.
5. Clip handset case together.

ALARM ECU

Service repair no - 86.77.01

Remove and refit

Remove

1. Remove lower dash panel, *See CHASSIS AND BODY, Repair, lower dash panel*
2. Remove multiplugs and aerial lead from ECU.

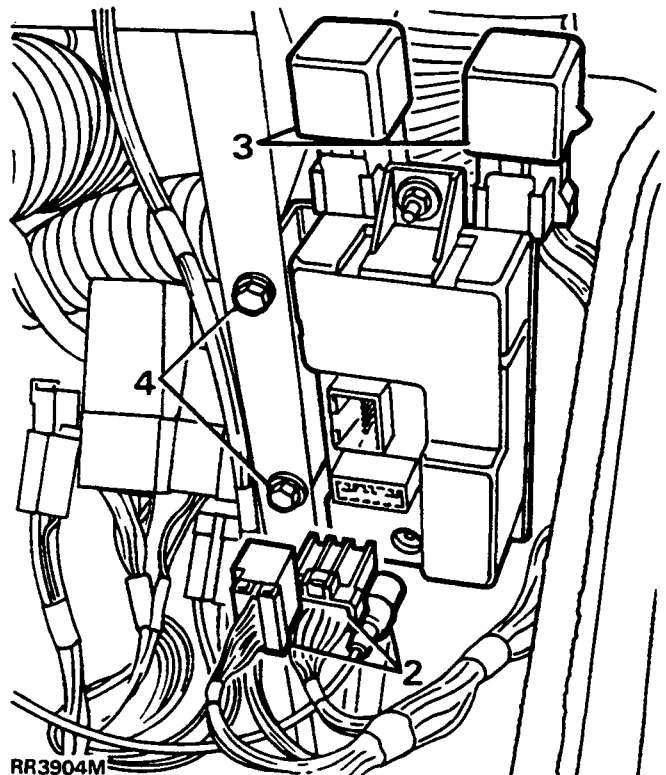

3. Remove relays and bases from bracket.
4. Remove ECU bracket fixings.
5. Remove ECU with bracket.

Refit

6. Reverse removal procedure. Ensure aerial and multiplugs are fitted securely to ensure alarm functions correctly.

ALARM HORN**Remove and refit****Remove**

1. Remove decker panel, *See CHASSIS AND BODY, Repair, decker panel*

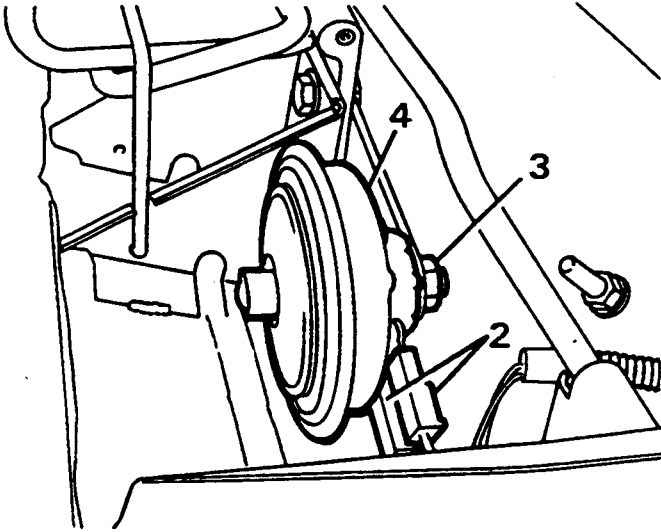

RR3905M

2. Disconnect two Lucar connectors.
3. Remove single nut securing horn.
4. Remove horn.

Refit

5. Reverse removal procedure.

SUBWOOFER BOX**Remove and refit****Remove**

1. Disconnect the battery negative lead.
2. Disconnect electrical leads.
3. Remove four bolts from upper fixing.
4. Remove four bolts from lower fixing.
5. Remove subwoofer box from vehicle.
6. Remove ten screws securing two halves of subwoofer.
7. Remove top half of unit.
8. Remove subwoofer speaker.

Refit

9. Reverse removal procedure.

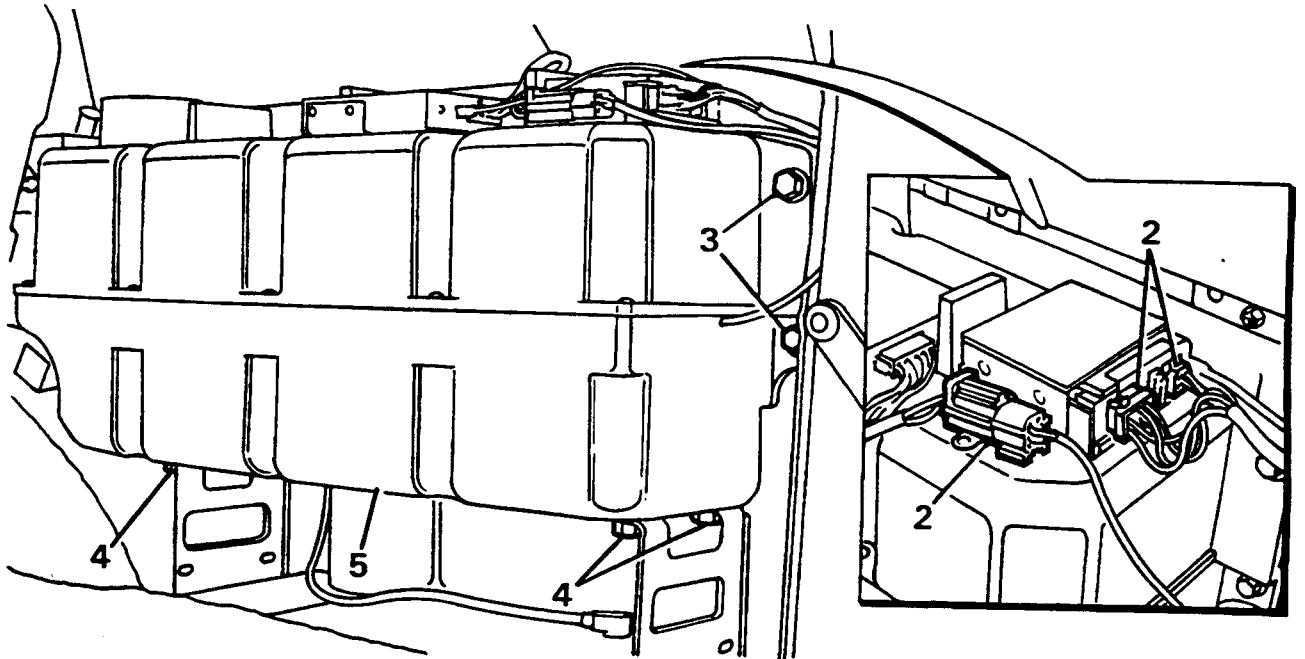

RR3906M

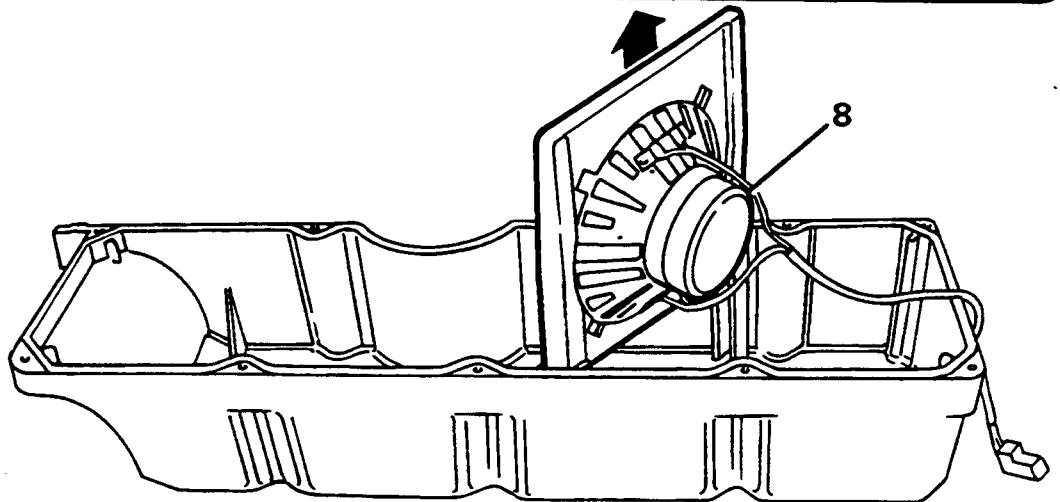
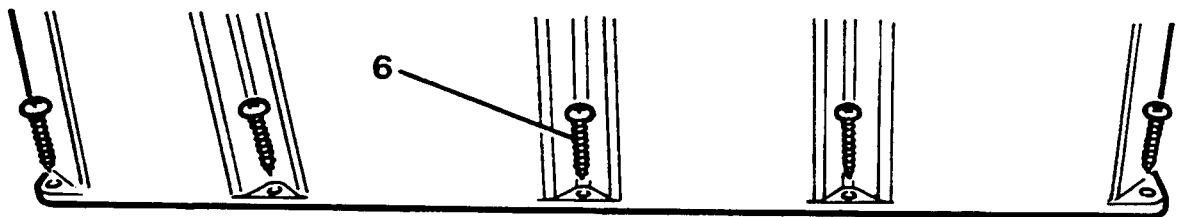

RR3907M

ANTENNA AMPLIFIER**Remove and refit****Remove**

1. Remove headlining sufficiently to gain access to signal amplifier. *See CHASSIS AND BODY, Repair, headlining*
2. Remove 'RF in' lead from antenna.

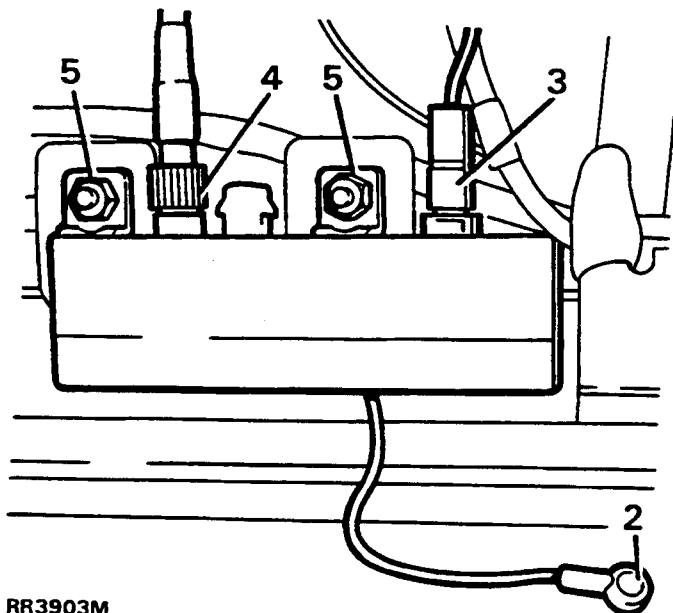

RR3903M

3. Remove '+ VE' lead from amplifier.
4. Unscrew 'RF out' lead, disconnect.
5. Remove two securing nuts.
6. Remove amplifier.

Refit

7. Reverse removal procedure. To ensure 'RF out' lead is correctly located, hold centre lead down in position while tightening knurled nut.

RADIO**Remove and refit****Remove**

1. Disconnect the battery negative lead.
2. Remove access covers from radio.

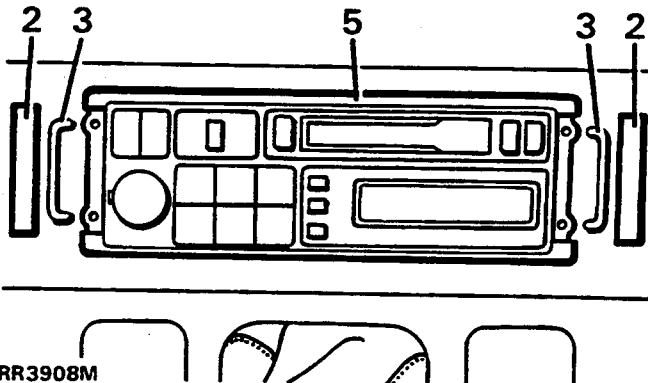

RR3908M

3. Insert suitable radio removal tools e.g. SMD 4091 into access holes.
4. Press removal tools to release radio.
5. Remove radio, disconnect aerial and multiplugs from rear of radio.

Refit

6. Reverse radio code.
7. Reactivate radio code.



ALTERNATOR - MAGNETTI MARELLI - TYPE A133/80

Service repair no - 86.10.08

Overhaul

Including Test (Bench)



NOTE: Alternator charging circuit ignition warning light is connected in series with alternator field circuit. Bulb failure would prevent alternator charging, except at very high engine speeds. Therefore, bulb **MUST** be checked before suspecting alternator failure.

Precautions

Battery polarity is **NEGATIVE GROUND**, which must be maintained at all times.

No separate control unit is fitted; instead a voltage regulator of micro-circuit construction is incorporated on slip ring end bracket, inside alternator cover.

Battery voltage is applied to alternator output cable even when ignition is switched off, battery must be disconnected before commencing any work on alternator. Disconnect battery when repairing body structure using electric welding equipment.

Sequence of connections

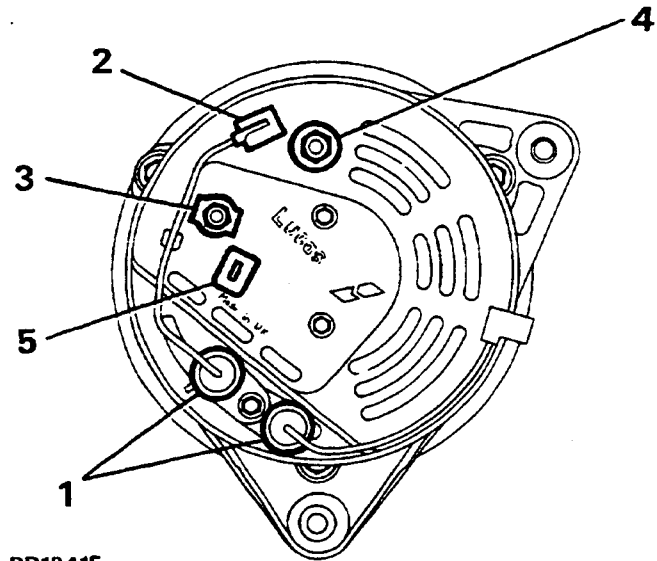

RR1841E

1. Suppression capacitors (two)
2. Positive suppression terminal
3. IND terminal
4. + output terminal
5. Sensing terminal

ALTERNATOR - MAGNETTI MARELLI - TYPE A133/80 - RR2260E

- | | |
|--------------------------|---------------------------|
| 1. Cover | 8. Slip rings |
| 2. Regulator | 9. Slip ring end bracket |
| 3. Rectifier | 10. Stator |
| 4. Drive end bracket | 11. Brush box |
| 5. Bearing assembly | 12. Brushes |
| 6. Rotor | 13. Through bolts (three) |
| 7. Slip ring end bearing | 14. Suppressors |

ALTERNATOR - A133/80

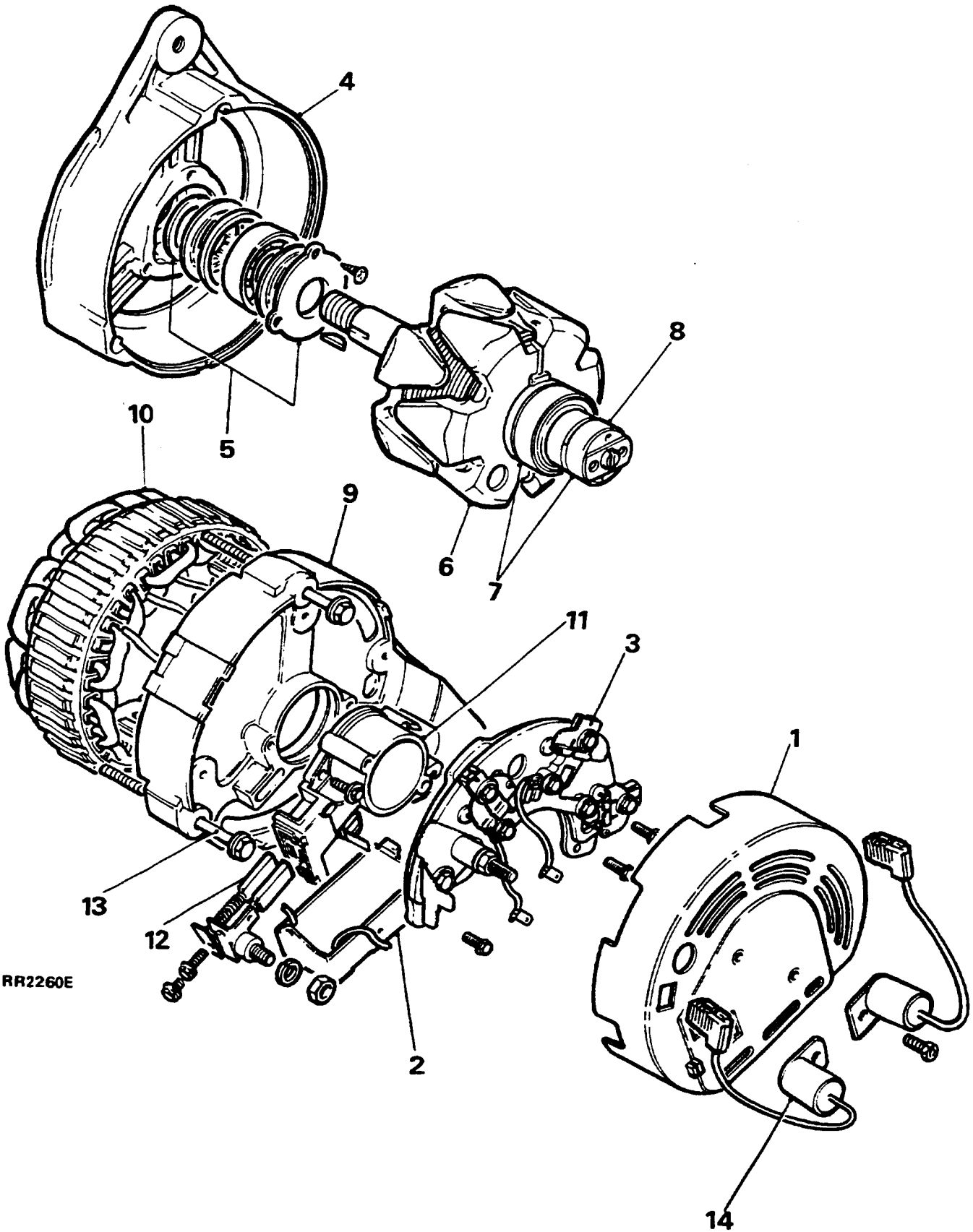

RR2260E



ALTERNATOR TESTING

Service repair no - 86.10.01

Charging system check

1. Check battery is in good condition, with an open circuit voltage of at least 12.6 V. Recharge or substitute battery to carry out test.
2. Check drive belt adjustment and condition, *See SECTION 10, Maintenance, Under Bonnet Maintenance*
3. Check battery connections are clean and tight.
4. Check alternator connections are clean and tight.
5. Ensure there is no drain on battery from, for example, interior, under bonnet or door edge lamps.

Alternator test

Following instructions refer to use of suitable test equipment using a carbon pile rheostat.

6. Connect test equipment referring to manufacturer's instructions.
7. Start engine and run at 3000 rev/min without accessory load.
8. Rotate carbon pile load control to achieve greatest output (amps) without allowing voltage to fall below 12.0 V. A reading in amps, of alternator output, minus 10% to allow for EFl and Ignition loss, should be obtained.
9. Run engine at 3000 rev/min, switch selector to regulator test, read voltmeter. A reading of 13.6 to 14.4 V should be obtained.
10. Switch selector to diode/stator test, switch on headlamps to load alternator. Raise engine speed to 3000 rev/min, read voltmeter, needle must be within 'OK' range.

TESTING-ALTERNATOR REMOVED

11. Withdraw connectors from alternator.
12. Remove alternator. *See Repair, alternator*
13. Disconnect suppressor and remove alternator cover.

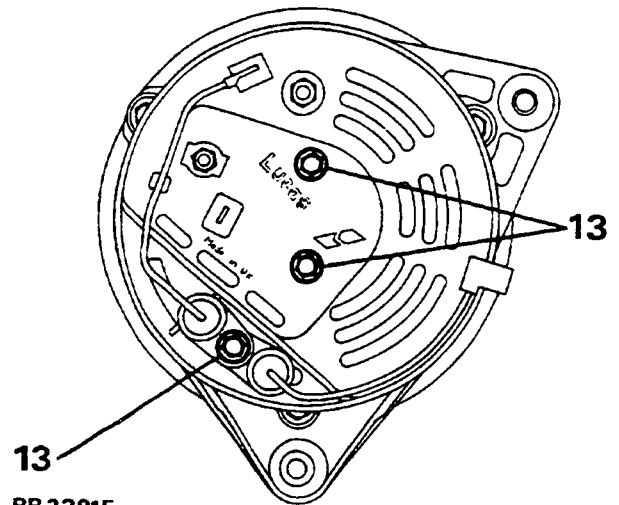

RR 2291E

14. Disconnect lead and remove rectifier assembly.
15. Note arrangement of brush box connections. Remove screws securing regulator to brush box and withdraw.
16. Remove screw retaining outer brush box in position and withdraw both brushes.
17. Check brushes for wear by measuring length of brush protruding beyond brush box moulding. Fit new brushes if length is 10mm or less.
18. Check brushes move freely in holders. If sticking, clean with a mineral spirit moistened cloth or polish sides of brush with fine file.
19. Check brush spring pressure using push-type spring gauge. Gauge should register 136 to 279g when brush is pulled back until face is flush with housing. Fit new brush assembly if reading is outside these limits.
20. Remove two screws securing brush box to slip ring end bracket and lift off brush box assembly.
21. Securely clamp alternator in a vice. Release stator winding cable ends from rectifier by applying a hot soldering iron to terminal tags of the rectifier. Pry out cable ends when solder melts.

22. Remove two remaining screws securing rectifier assembly to slip ring end bracket and lift off rectifier assembly. Further dismantling of rectifier is not required.
23. Check diodes. Connect test equipment as shown and test each diode in turn, note whether lamp lights, then reverse test lead connections. The lamp should light in one direction only. Renew rectifier assembly if a faulty diode is diagnosed.

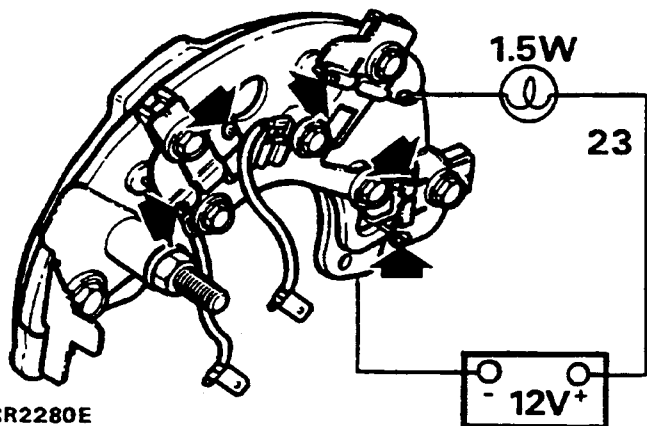

RR2280E

24. Remove slip ring end bracket bolts, remove bracket.
25. Connect a 12 volt battery and a 36 watt test lamp to two stator connections. Repeat test replacing one of two stator connections with the third. If test lamp fails to light in either test, fit a new stator.

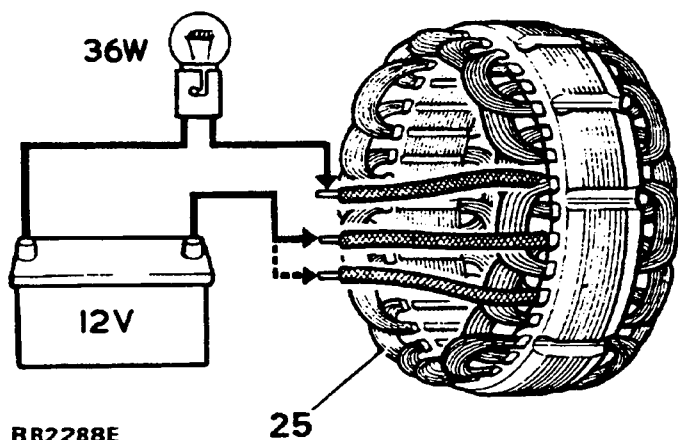

RR2288E

26. Using a 110 volt a.c. supply and a 15 watt test lamp, test for insulation between any one of three stator connections and stator laminations. If test lamp lights, fit a new stator.

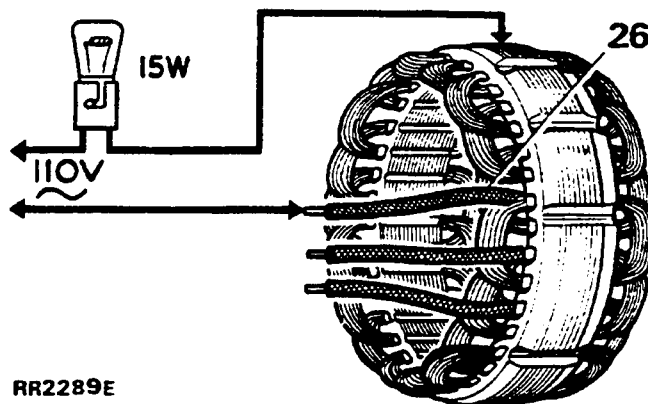

RR2289E

27. Clean surfaces of slip rings using a solvent moistened cloth.
28. Inspect slip ring surfaces for signs of burning, remove burn marks using very fine sandpaper. On no account should emery cloth or similar abrasives be used, or any attempt made to machine the slip rings.
29. Note position of stator output leads in relation to alternator fixing lugs, and lift stator from drive end bracket.
30. Connect ohmmeter to slip rings. A reading of 2.6 ohms should be obtained.

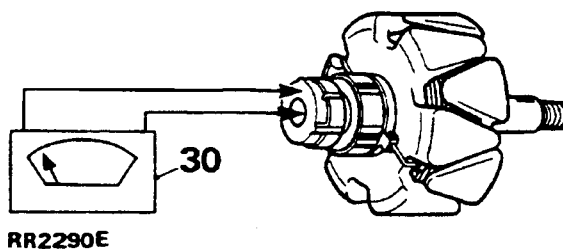

RR2290E

31. Using a 110 volt a.c. supply and a 15 watt test lamp, test for insulation between one slip ring and one rotor pole. Fit a new rotor if test lamp lights.



32. To separate drive end bracket and rotor, remove shaft nut, washers, woodruff key and spacers from shaft.
33. Remove bearing retaining plate by removing three screws. Using a press, drive rotor shaft from drive end bearing.
34. If necessary, to remove slip rings or slip ring end bearing on rotor shaft, unsolder outer slip ring connection and gently pry slip ring off shaft, repeat procedure for inner slip ring connection. Using a suitable extraction tool, withdraw slip ring bearing from shaft.

Reassemble

35. Reverse dismantling procedure, noting following points.
 - (a) Use Shell Alvania 'RA' to lubricate bearings.
 - (b) When refitting slip ring end bearing, ensure it is fitted with open side facing rotor.
 - (c) Use Fry's H.T.3 solder on slip ring field connections.
 - (d) When refitting rotor to drive end bracket, support inner track of bearing. Do not use drive end bracket to support bearing when fitting rotor.
 - (e) Tighten through bolts evenly to **5 Nm**.
 - (f) Fit brushes into housings before fitting brush moulding.
 - (g) Tighten shaft nut to **40 Nm**.
 - (h) Refit regulator pack to brush moulding.
36. Reconnect leads between regulator, brush box and rectifier.
37. Refit alternator.

DISTRIBUTOR-LUCAS 35DLM8

Overhaul

DISTRIBUTOR CAP

Service repair no - 86.35.10

1. Unclip and remove cap
2. Fit a new cap if faulty.
3. Clean cap and HT brush with a lint free cloth.

ROTOR ARM

Service repair no - 86.35.16

4. Pull rotor arm from shaft.
5. Fit a new rotor arm if faulty.

INSULATION COVER (FLASH SHIELD)

Service repair no - 86.35.40

6. Remove cover secured by three screws.
7. Fit a new cover if faulty.

VACUUM UNIT

Service repair no - 86.35.21

8. Remove two screws from vacuum unit securing bracket. Disengage vacuum unit connecting rod from pick-up base plate connecting peg. Withdraw vacuum unit from distributor body.

AMPLIFIER MODULE

Service repair no - 86.35.30

9. Remove two screws and withdraw module.
10. Remove gasket.
11. Remove two screws and cast heatsink.



WARNING: Amplifier module is a sealed unit containing Beryllia. This substance is extremely dangerous if handled. DO NOT attempt to open or crush module.

PICK-UP AND BASE PLATE ASSEMBLY

Service repair no - 86.35.42

12. Use circlip pliers to remove circlip retaining reluctor on rotor shaft.
13. Remove flat washer, and 'O' ring recessed in top of reluctor.
14. Gently withdraw reluctor from shaft, taking care not to damage teeth.



NOTE: Coupling ring fitted beneath reluctor.

15. Remove three support pillars and cable grommet. Lift out pick-up and base plate assembly.



NOTE: Do not disturb two barrel nuts securing pick-up module, otherwise air gap will need re-adjustment.

16. Fit a new pick-up and base plate assembly if module is known to be faulty, otherwise check pick-up winding resistance (2k-5k ohm).

Reassemble

17. This is mainly a reversal of dismantling procedure, noting following points:



LUBRICATION

Apply clean engine oil:

- a. A spot into rotor spindle before fitting rotor arm.

Apply Omnilube 2 (or equivalent) grease.

- b. Auto advance mechanism.
- c. Pick-up plate centre bearing.
- d. Pre tilt spring and its rubbing area (pick-up and base plate assembly).
- e. Vacuum unit connecting peg (pick-up and base plate assembly).
- f. Connecting peg hole in vacuum unit connecting rod.

Fitting pick-up and base plate assembly

18. Pick-up leads must be prevented from fouling rotating reluctor. Both leads should be located in plastic guide as illustrated. Check during re-assembly.

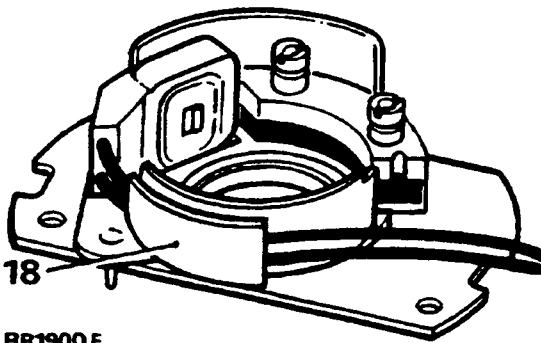

Fitting reluctor

19. Slide reluctor as far as it will go on rotor shaft, rotate reluctor until it engages with coupling ring beneath pick-up base plate. Distributor shaft, coupling ring and reluctor are 'keyed' and rotate together. Fit 'O' ring, flat washer and retaining circlip.

Pick-up air gap adjustment

20. Air gap between pick-up limb and reluctor teeth must be set within specified limits, using a non-ferrous feeler gauge.

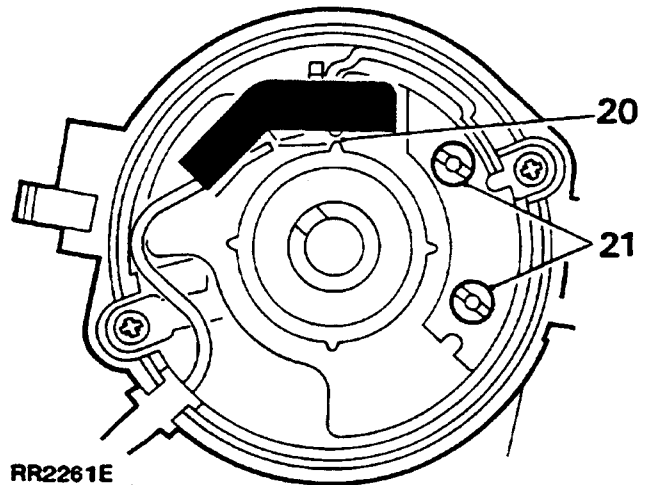

21. If adjustment is necessary, slacken two barrel nuts to set the air gap. See **ENGINE TUNING DATA, Information, Engine Tuning Data**

 **NOTE:** When original pick-up and base plate assembly has been refitted, air gap should be checked, and adjusted if necessary.

When fitting a new assembly air gap will require adjusting to within specified limits.

Amplifier module

22. Before fitting module, apply MS4 Silicone grease or equivalent heat-conducting compound to amplifier module backplate, seating face on distributor body and both faces of heatsink casting.

STARTER MOTOR-LUCAS M78R

Overhaul**Dismantling**

1. Remove starter motor.
2. Remove braid between starter and solenoid terminal.
3. Remove two solenoid fixings.
4. Withdraw solenoid body.
5. Lift and remove solenoid plunger.
6. Remove two nuts and two screws from commutator end bracket.
7. Remove commutator end bracket.
8. Remove grommet from yoke.
9. Lift brushbox assembly clear of armature.
10. Remove brush springs.
11. Unclip and remove ground brushes.
12. Remove insulating plate.
13. Withdraw brushes and bus bar.
14. Remove armature from yoke.
15. Remove yoke.
16. Remove intermediate bracket.
17. Loosen and remove through bolts from drive end bracket.
18. Remove sun and planet gears.
19. Push out drive shaft sprocket assembly from drive end bracket.
20. Carefully tap thrust collar from over jump ring back towards drive.
21. Pry snap ring from locating groove.
22. Remove drive assembly from drive shaft.

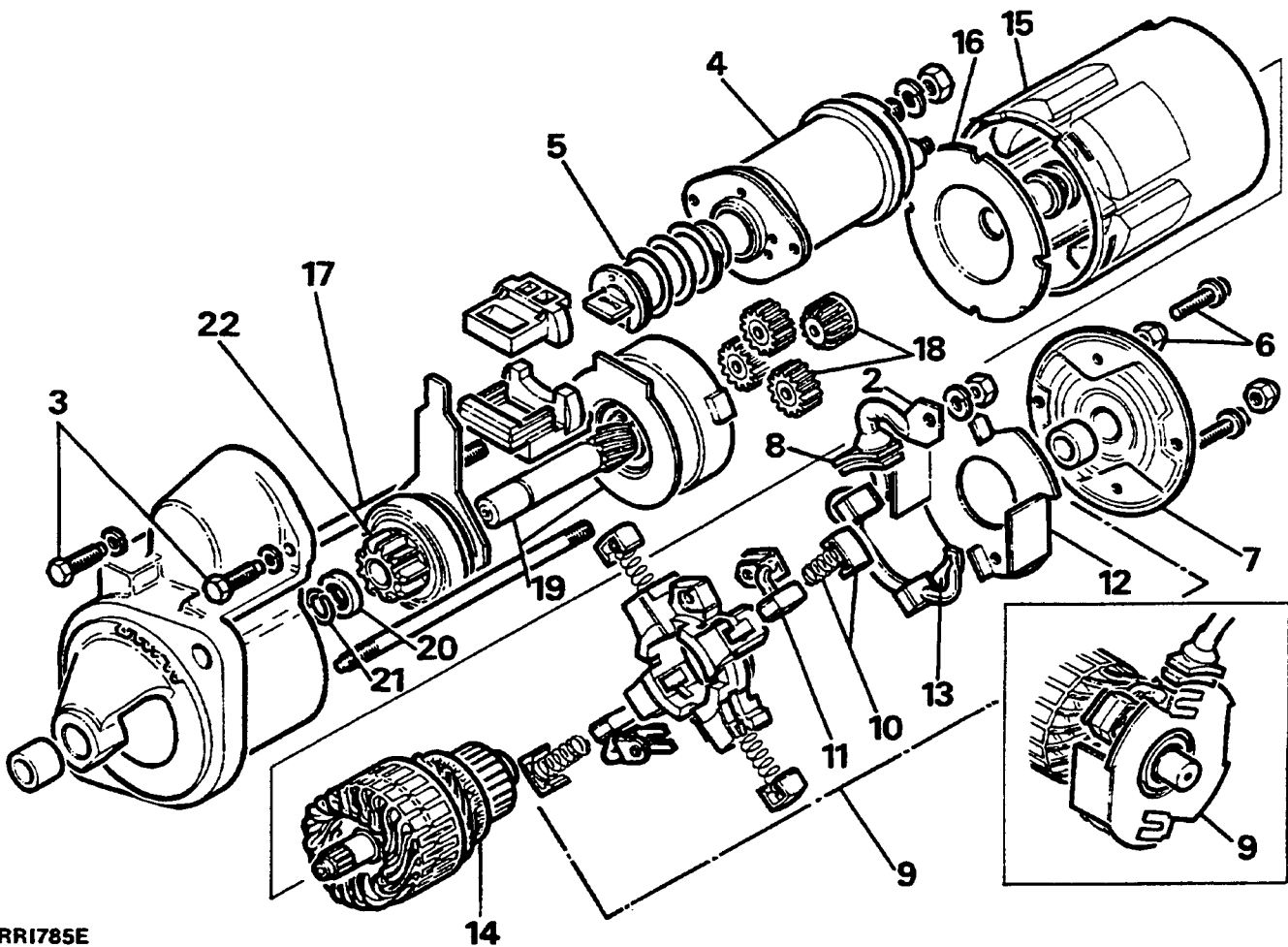

RR1785E

14



Inspecting

Solenoid

23. Check continuity and resistance value of windings by connecting an ohmmeter as shown.

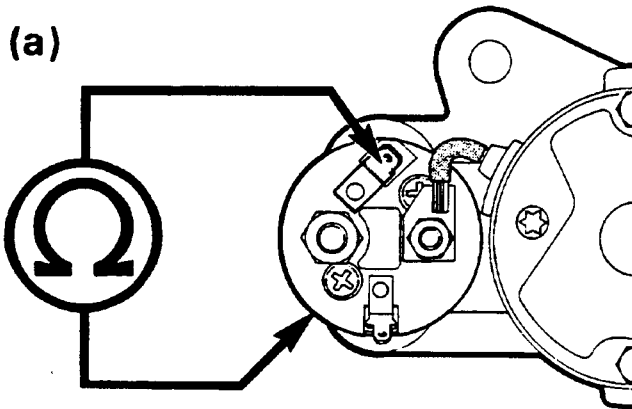

- (a) Resistance value should be: 1.074 ± 0.035 ohms

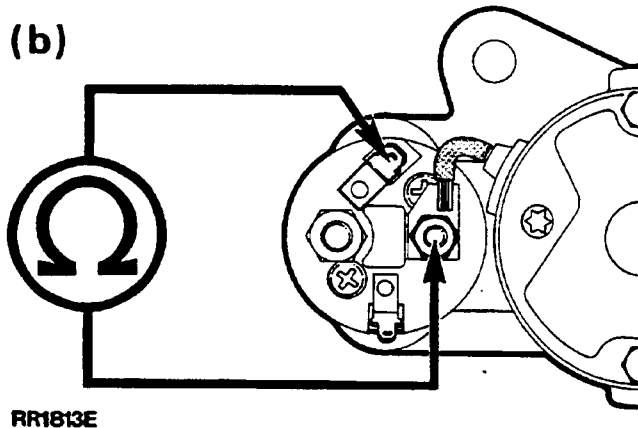

- (b) Resistance value should be: 0.298 ± 0.015 ohms

Incorrect results: replace solenoid.

Correct results: proceed to 24.

24. Check contacts by connecting an ohmmeter as shown. Solenoid plunger removed, ohmmeter should read infinity.

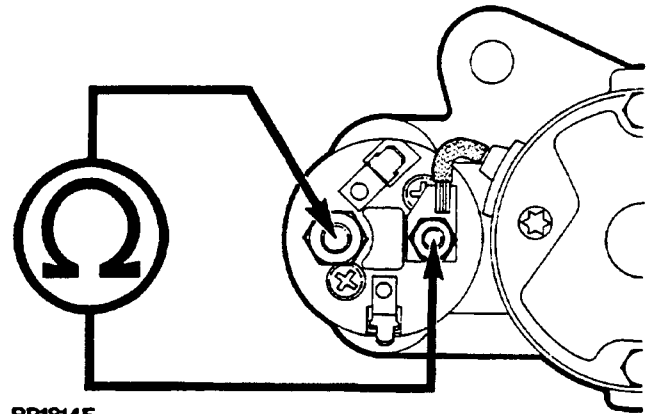

Solenoid plunger operated by hand, ohmmeter should read zero. Incorrect results: replace solenoid. Correct results: proceed to 25.

25. Check operation of spring for freedom of movement.

Brush gear

26. Check brush springs and ensure brushes move freely in holders. Clean brushes with a solvent moistened cloth, if required.

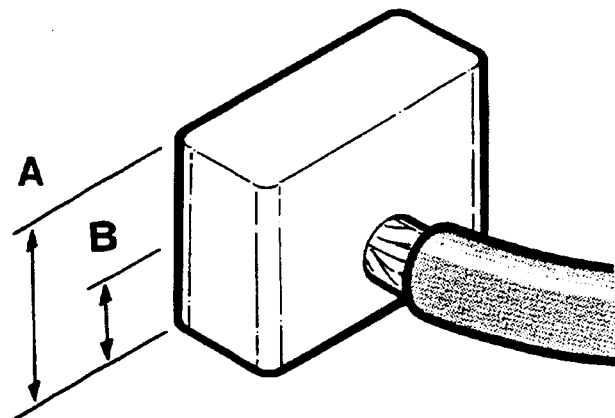

Brush length new, Dimension A is 9 mm.
Minimum brush length, Dimension B is 3.5 mm.

Armature

27. Check armature insulation. The method illustrated uses a 110V, 15W test lamp. Connect tester between any one commutator segment and shaft. If lamp illuminates armature is faulty, and a replacement component is required.

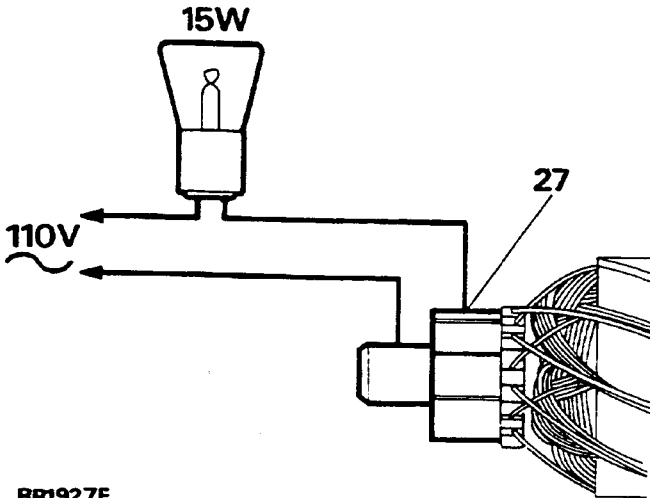

RR1927E

28. If necessary, the commutator may be machined, providing a finished surface can be obtained without reducing diameter below 28.8 mm. Otherwise a new commutator must be fitted. Finish surface with fine emery cloth. Do not undercut insulation slots.

Drive assembly

29. Test roller clutch. Pinion should rotate in one direction only, independent of clutch body. Replace unit if unsatisfactory, or if teeth are damaged or worn.

Bearings

30. Fit new bearing bushes if there is evidence of armature fouling magnets or if there is perceptible side play between shaft and bush.
31. Drive end/intermediate end bracket: press out bush using a suitable press and mandrel.
32. Press new bush in, ensuring that on drive end bracket, bush is flush with casting.
33. Commutator end bracket: thread a 9/16" Whitworth or suitable similar tap firmly into bush. Extract bush with tap using a power press in reverse.



NOTE: Soak new bushes in engine oil for thirty minutes before fitting.

Reassemble

34. Reverse instructions 1 to 22. Smear teeth and operating collar of roller clutch with Shell Retinax 'A' grease. Smear pivot lever of drive assembly with Mobil 22 grease. Smear drive shaft sun and planet gears with Rocol BRB1200 grease.
35. Tighten fixings to correct torque: Starter motor through bolts - **6.2 Nm**. Solenoid screws - **6.1 Nm**.



ALTERNATOR - 200 Tdi

Remove

1. Disconnect the battery negative lead.
2. Disconnect the electrical leads from the alternator.
3. Slacken the alternator securing bolts, pivot the alternator inwards and remove the drive belt.
4. Remove the adjustment bolt from under the alternator.
5. Remove the nut from the pivot bolt and detach the heat shield.
6. Support the alternator, withdraw the pivot bolt and detach the alternator from the engine.

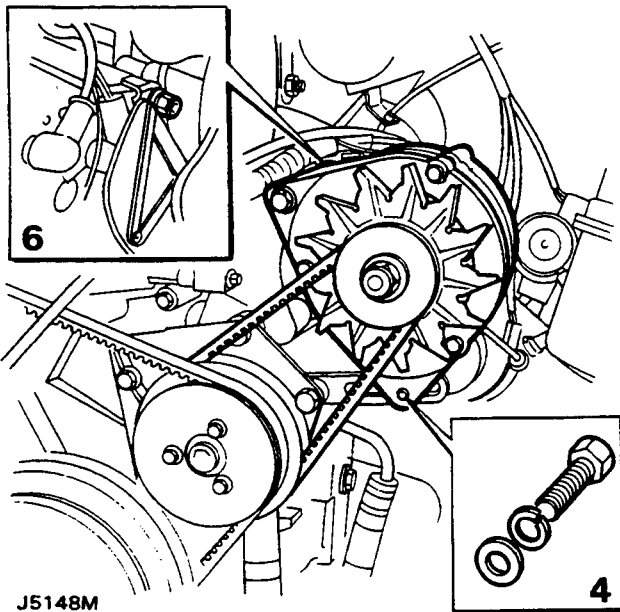

J5148M

Refit

7. Position the alternator on the engine and insert the pivot bolt.
8. Fit the heat shield and secure with the nut. Do not fully tighten the nut at this stage.
9. Fit the adjustment bolt and the drive belt.
10. Adjust the belt tension and tighten the adjustment and pivot bolts.
11. Connect the electrical leads to the alternator.
12. Reconnect the battery negative lead.

ALTERNATOR DRIVE BELT TENSIONING - Tdi ENGINE

Adjust tension

1. Slacken the alternator pivot and adjustment bolts.
2. Adjust the alternator to give the correct belt tension.

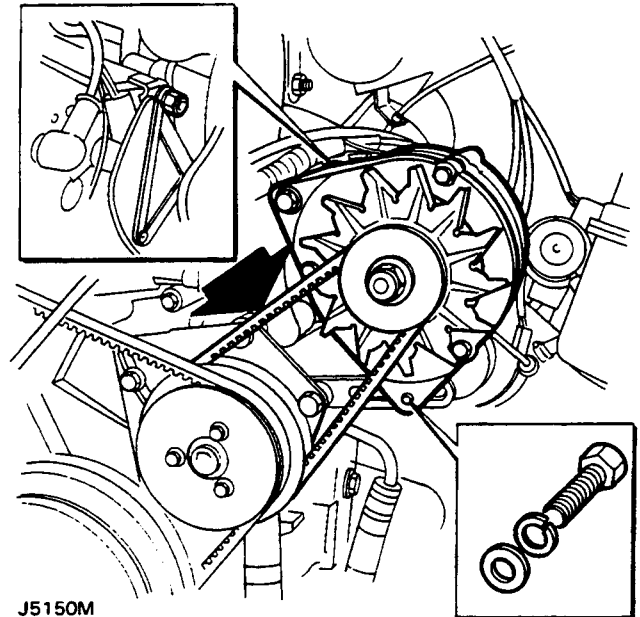

J5150M

3. Tight the adjustment and pivot bolts.



NOTE: If a new drive belt has been fitted, run the engine at fast idle speed for 3 to 5 minutes; then check the tension.

STARTER MOTOR - Tdi ENGINE**Remove and refit****Remove**

1. Disconnect the battery negative lead.
2. Remove the securing bolts and detach the starter motor heat shield.
3. Disconnect electrical leads from the solenoid and detach the plastic tie.
4. Disconnect the earth leads from the starter motor.
5. Remove the securing nuts and bolts and detach the starter motor complete with heat shield mounting bracket.

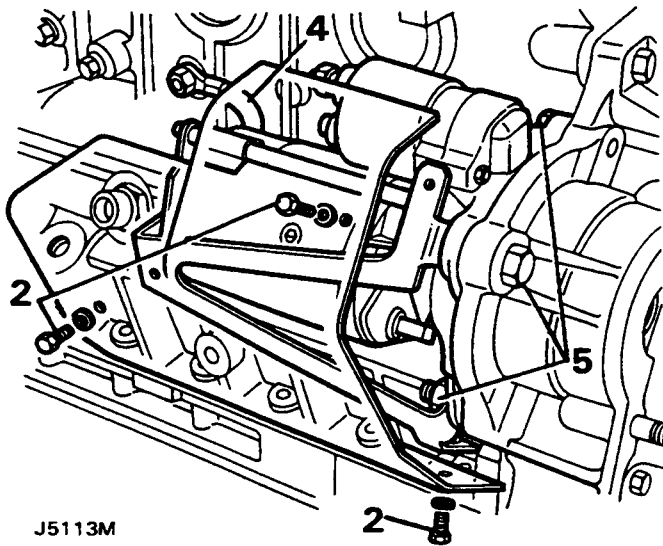
**Refit**

6. Refit the starter motor to the engine in reverse order to removal.

STARTER MOTOR OVERHAUL - Tdi ENGINE**Dismantling**

1. Remove the starter motor from the engine.
2. Disconnect the field winding lead from the solenoid.
3. Remove the two securing nuts and washers and withdraw the solenoid and spring, leaving the plunger in place.
4. Remove the two outer nuts from the through studs and withdraw the terminal strap.
5. Remove the inner nuts from the two through studs.
6. Remove the two nuts securing the brush plate assembly to the cover and detach the cover.
7. Withdraw the yoke complete with the brush plate assembly, noting the position of the yoke location plate in the reduction gear housing.
8. Remove the socket head screw and withdraw the armature and the reduction gear housing from the drive end bracket.
9. Remove the clutch drive and pinion assembly and detach the solenoid plunger from the lever.
10. Withdraw the brushes from their boxes.

Inspection and test

11. Clean and examine all parts for condition. Check bearings, bushes and the pinion drive assembly for wear. Examine the reduction drive pinion and drive gear internal teeth. Check that the field coil and armature brushes are satisfactory for continued use.

ARMATURE

12. Using very fine glass paper, clean the commutator and wipe the surface with a petrol moistened cloth. Do not undercut the insulation slots.
13. Check the armature insulation by connecting a 100V AC 15 watt test lamp between each segment in turn and the armature shaft. The lamp should not light.

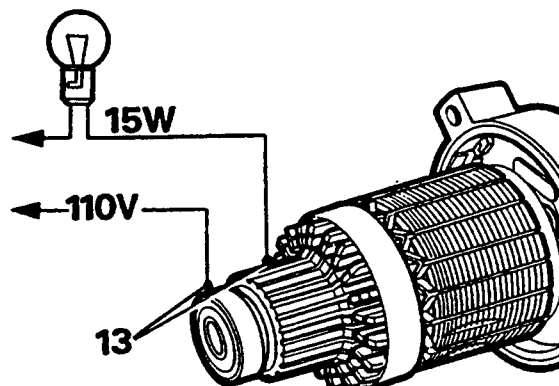

ST1846M



FIELD COIL INSULATION

14. Connect a 110V AC 15 watt test lamp between the disconnected end of the winding and a clean unpainted part of the yoke, ensuring that the brushes or leads do not touch the yoke during the test.
15. The lamp should not light; if it does light fit a new field coil assembly.

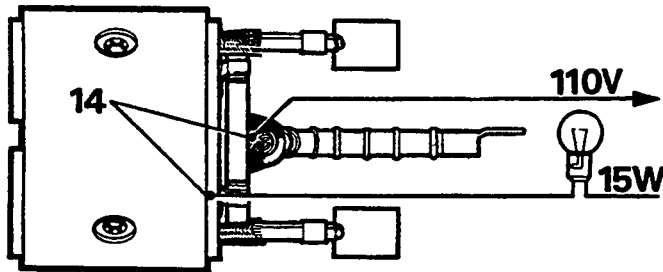

ST1847M

FIELD COIL CONTINUITY

16. Connect a 12V battery operated 60 watt test lamp between each brush in turn and a link lead.
17. The lamp should not light; if it does light, fit a new field coil assembly.

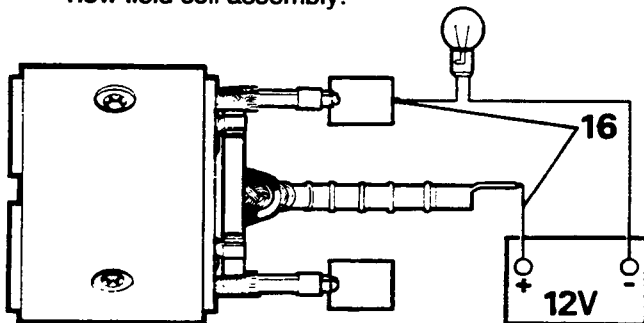

J5203M

SOLENOID

18. Connect a 12 V battery operated 60 watt test lamp across the solenoid main terminals. The lamp should not light: if it does light, fit a new solenoid assembly.
19. Leave the test lamp connected and, using the same 12V battery supply, energise the solenoid by connecting the 12V supply between the small solenoid operating Lucar terminal blade and a good earth point on the solenoid body.

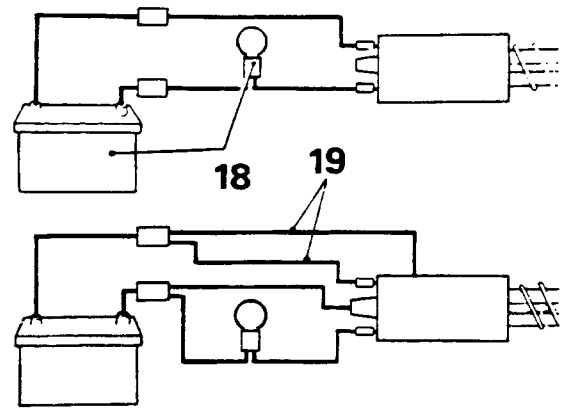

J5204M

20. The solenoid should be heard to operate and the test lamp should light with full brilliance, otherwise fit a new solenoid, assembly.

REASSEMBLY

21. If removed fit the round rubber pad to the drive end bracket.
22. Fit the lever to the clutch drive and pinion assembly, locate the solenoid plunger in the end of the lever and fit the assembly to the drive-end bracket, ensuring that the two washers are in position on the shaft.
23. Position the fibre washer on the shaft inside the reduction gear.

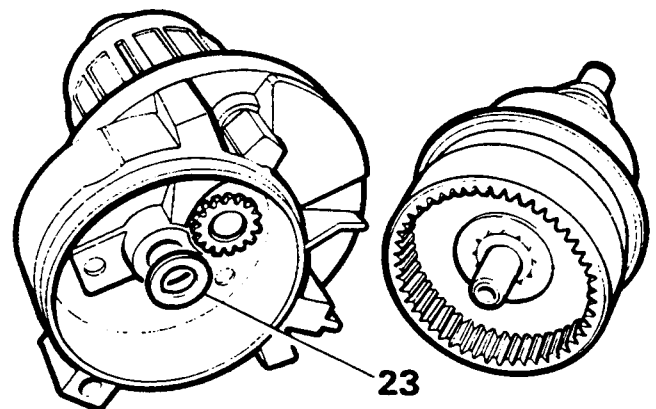

J5205M

24. Position the rubber pad, plain side towards the drive-end bracket, fit the 'O' ring seal and assemble the reduction gear housing to the drive-end bracket and secure with the socket head bolt.
25. Place the yoke location plate in position in the reduction gear housing, ensuring that it is fitted in the slot noted during dismantling, and fit the yoke and brush plate to the armature.

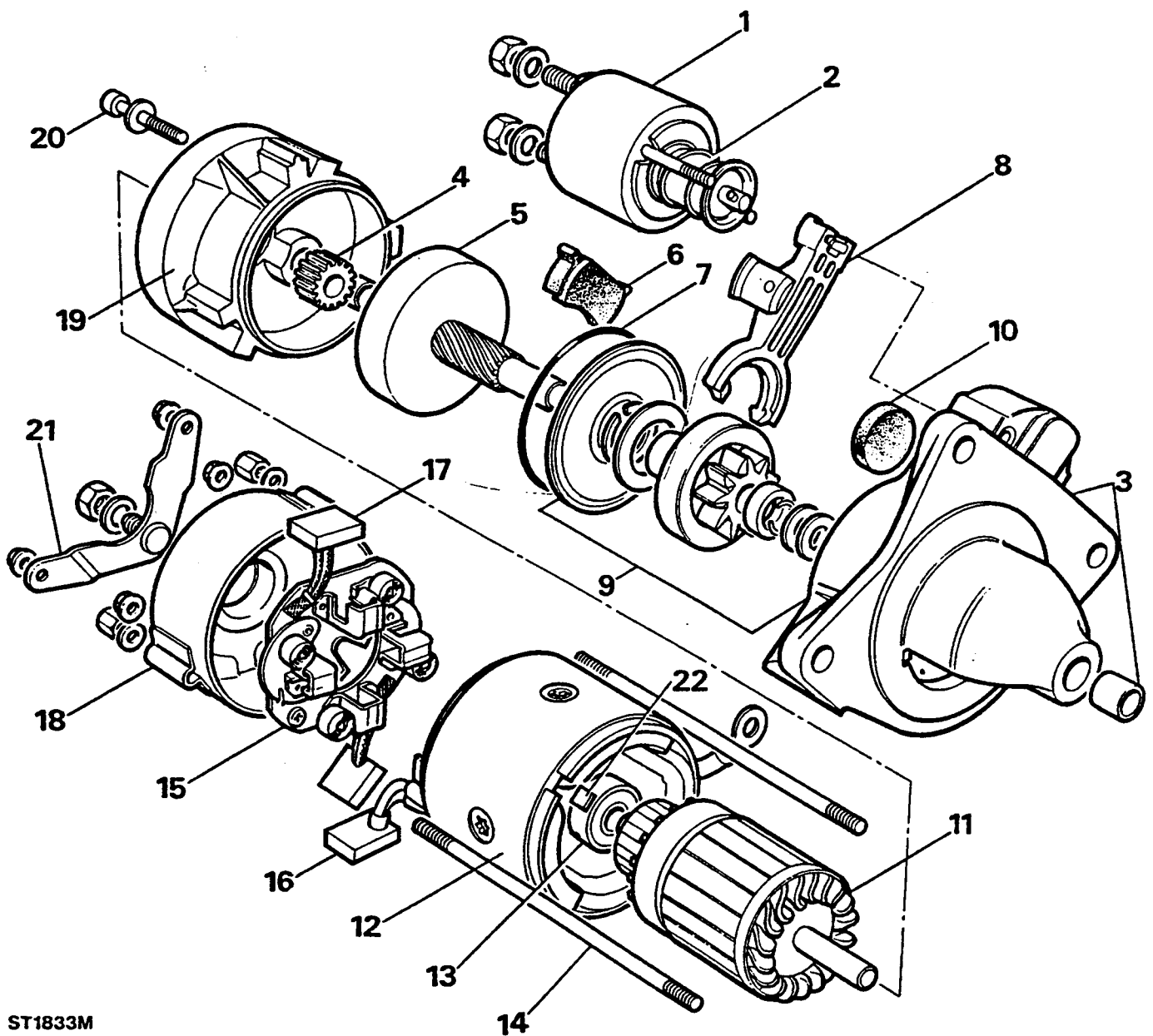

ST1833M

STARTER MOTOR

- | | |
|-------------------------------------|----------------------------|
| 1. Solenoid | 12. Yoke |
| 2. Solenoid plunger and spring | 13. Roller bearing |
| 3. Drive end bracket and bush | 14. Through-studs |
| 4. Reduction gear pinion | 15. Brush plate |
| 5. Reduction gear | 16. Field coil brushes |
| 6. Rubber pad | 17. Armature brushes |
| 7. 'O'ring seal | 18. Brush plate cover |
| 8. Lever | 19. Reduction gear housing |
| 9. Clutch drive and pinion assembly | 20. Socket headed screw |
| 10. Rubber pad | 21. Terminal strap |
| 11. Armature | 22. Yoke location key |



26. Insert the brushes into their boxes and release the retaining springs, ensuring that the brushes rest correctly on the commutator.
27. If removed refit the through studs to the drive end bracket.
28. Fit the brush plate cover and secure to the brush plate with the two nuts.
29. Secure the assembly with the through studs nuts.
30. Fit the terminal strap to the through studs and secure with the two nuts.
31. Fit the coil spring to the solenoid plunger, assemble the solenoid to the drive-end bracket and secure with the two nuts.
32. Check that the starter motor turns freely without tight spots.



TORQUE VALUES



NOTE: Torque wrenches should be regularly checked for accuracy to ensure that all fixings are tightened to the correct torque.

	Nm
Alternator mounting bracket to cylinder head	34
Alternator to mounting bracket	24
Alternator to adjusting link	24
Alternator shaft nut	35
Alternator through bolts	5
Alternator rectifier bolts.....	3.5
Amplifier module screws.....	1.2
Amplifier heat sink screws	1.2
Auxiliary driving lamp mounting bolts	15
Distributor clampbolt	20
Distributor pick-up bearing plate support pillars	1.2
Distributor pick-up barrel nuts.....	1.2
Distributor vacuum unit.....	2
Spark plug	20
Starter motor to engine bolts	45
Starter motor through bolts	6.2
Solenoid fixing screws	6.1
Solenoid battery terminal nut.....	4
Solenoid statter terminal nut.....	3.2
Reverse light switch.....	25
Wiper motor yoke retaining bolts	1.5

Torque values below cover all screws and bolts used, unless specified otherwise.

METRIC	Nm
M5	6
M6	9
M8	25
M10	45
M12	90
M14	105
M16	180
UNC / UNF	
1/4	9
5/16	24
3/8	39
7/16	78
1/2	90
5/8	136



Land Rover

Lode Lane, Solihull, England B92 8NW.

Telephone: 0121- 722 2424 Fax: 0121- 742 1927 Telex: 338641 Lan Rov G.

LHAWMENA02

© 1997 Rover Group Limited

Published by Rover Technical Communication