

86 - ELECTRICAL

CONTENTS

Page

REPAIR

ALTERNATOR	1
ALTERNATOR DRIVE BELT TENSIONING	1
STARTER MOTOR	2

OVERHAUL

STARTER MOTOR OVERHAUL	1
------------------------------	---





ALTERNATOR

Remove

1. Disconnect the battery negative lead.
2. Disconnect the electrical leads from the alternator.
3. Slacken the alternator securing bolts, pivot the alternator inwards and remove the drive belt.
4. Remove the adjustment bolt from under the alternator.
5. Remove the nut from the pivot bolt and detach the heat shield.
6. Support the alternator, withdraw the pivot bolt and detach the alternator from the engine.

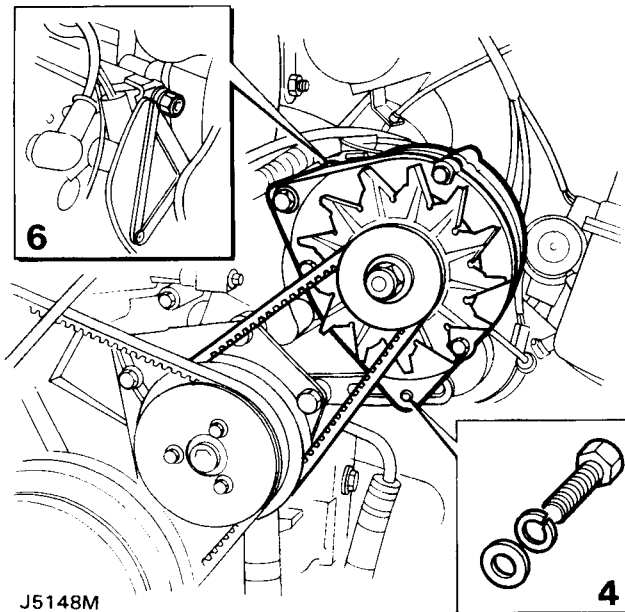

ALTERNATOR DRIVE BELT TENSIONING

Adjust tension

1. Slacken the alternator pivot and adjustment bolts.
2. Adjust the alternator to give the correct belt tension. **See SECTION 10, Maintenance .**

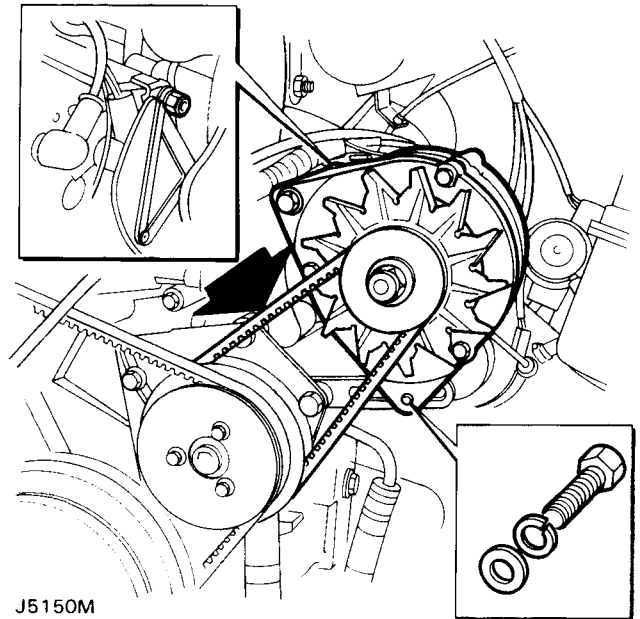

3. Tight the adjustment and pivot bolts.



NOTE: If a new drive belt has been fitted, run the engine at fast idle speed for 3 to 5 minutes; then check the tension.

Refit

7. Position the alternator on the engine and insert the pivot bolt.
8. Fit the heat shield and secure with the nut. Do not fully tighten the nut at this stage.
9. Fit the adjustment bolt and the drive belt.
10. Adjust the belt tension and tighten the adjustment and pivot bolts.
11. Connect the electrical leads to the alternator.
12. Reconnect the battery negative lead.

STARTER MOTOR

Remove

1. Disconnect the battery negative lead.
2. Remove the securing bolts and detach the starter motor heat shield.
3. Disconnect electrical leads from the solenoid and detach the plastic tie.
4. Disconnect the earth leads from the starter motor.
5. Remove the securing nuts and bolts and detach the starter motor complete with heat shield mounting bracket.

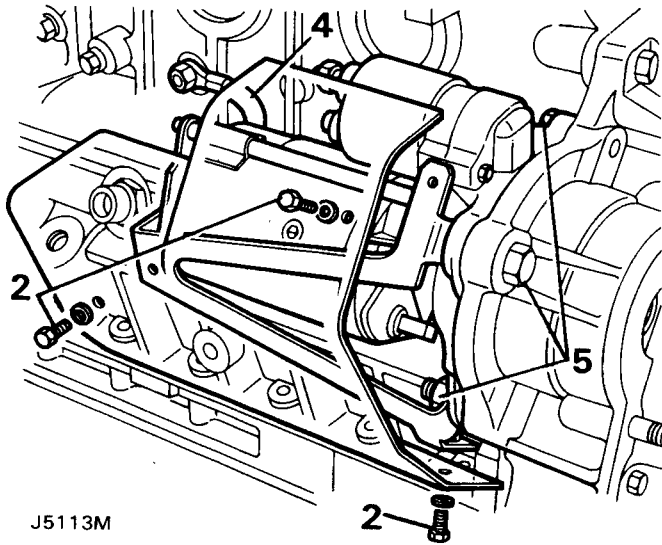
**Refit**

6. Refit the starter motor to the engine in reverse order to removal.



STARTER MOTOR OVERHAUL

Dismantling

1. Remove the starter motor from the engine.
2. Disconnect the field winding lead from the solenoid.
3. Remove the two securing nuts and washers and withdraw the solenoid and spring, leaving the plunger in place.
4. Remove the two outer nuts from the through studs and withdraw the terminal strap.
5. Remove the inner nuts from the two through studs.
6. Remove the two nuts securing the brush plate assembly to the cover and detach the cover.
7. Withdraw the yoke complete with the brush plate assembly, noting the position of the yoke location plate in the reduction gear housing.
8. Remove the socket head screw and withdraw the armature and the reduction gear housing from the drive end bracket.
9. Remove the clutch drive and pinion assembly and detach the solenoid plunger from the lever.
10. Withdraw the brushes from their boxes.

Inspection and test

11. Clean and examine all parts for condition. Check bearings, bushes and the pinion drive assembly for wear. Examine the reduction drive pinion and drive gear internal teeth. Check that the field coil and armature brushes are satisfactory for continued use.

ARMATURE

12. Using very fine glass paper, clean the commutator and wipe the surface with a petrol moistened cloth. Do not undercut the insulation slots.
13. Check the armature insulation by connecting a 100V AC 15 watt test lamp between each segment in turn and the armature shaft. The lamp should not light.

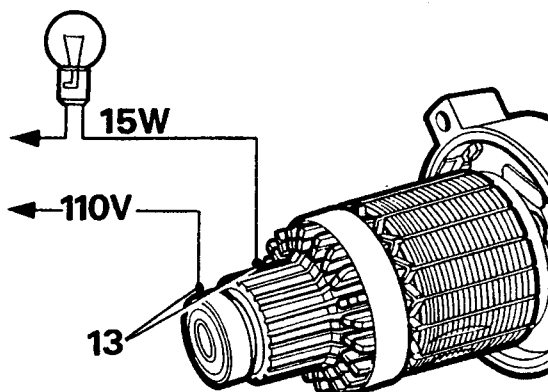

ST1846M

FIELD COIL INSULATION

14. Connect a 110V AC 15 watt test lamp between the disconnected end of the winding and a clean unpainted part of the yoke, ensuring that the brushes or leads do not touch the yoke during the test.
15. The lamp should not light; if it does light fit a new field coil assembly.

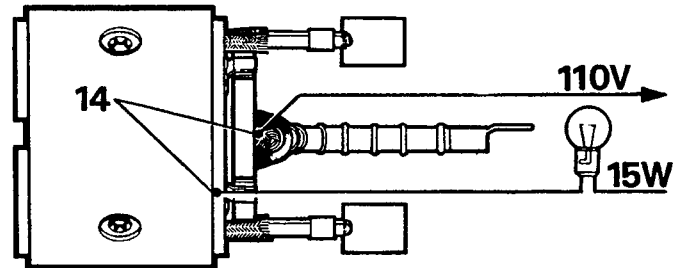

ST1847M

FIELD COIL CONTINUITY

16. Connect a 12V battery operated 60 watt test lamp between each brush in turn and a link lead.
17. The lamp should not light; if it does light, fit a new field coil assembly.

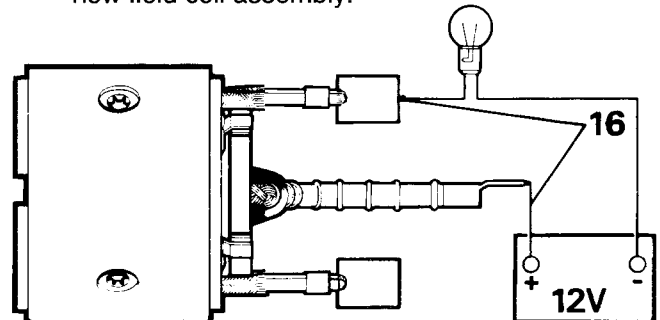

J5203M

SOLENOID

18. Connect a 12 V battery operated 60 watt test lamp across the solenoid main terminals. The lamp should not light: if it does light, fit a new solenoid assembly.
19. Leave the test lamp connected and, using the same 12V battery supply, energise the solenoid by connecting the 12V supply between the small solenoid operating Lucar terminal blade and a good earth point on the solenoid body.

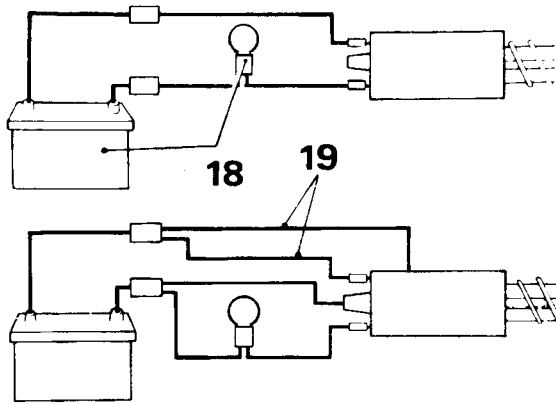

J5204M

20. The solenoid should be heard to operate and the test lamp should light with full brilliance, otherwise fit a new solenoid, assembly.

REASSEMBLY

21. If removed fit the round rubber pad to the drive end bracket.
22. Fit the lever to the clutch drive and pinion assembly, locate the solenoid plunger in the end of the lever and fit the assembly to the drive-end bracket, ensuring that the two washers are in position on the shaft.
23. Position the fibre washer on the shaft inside the reduction gear.

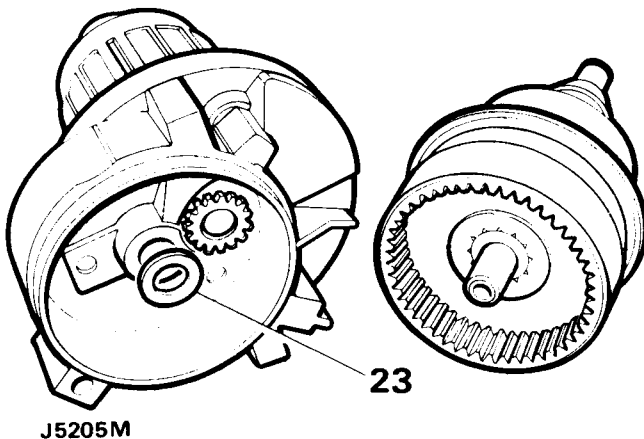

J5205M

24. Position the rubber pad, plain side towards the drive-end bracket, fit the 'O' ring seal and assemble the reduction gear housing to the drive-end bracket and secure with the socket head bolt.
25. Place the yoke location plate in position in the reduction gear housing, ensuring that it is fitted in the slot noted during dismantling, and fit the yoke and brush plate to the armature.

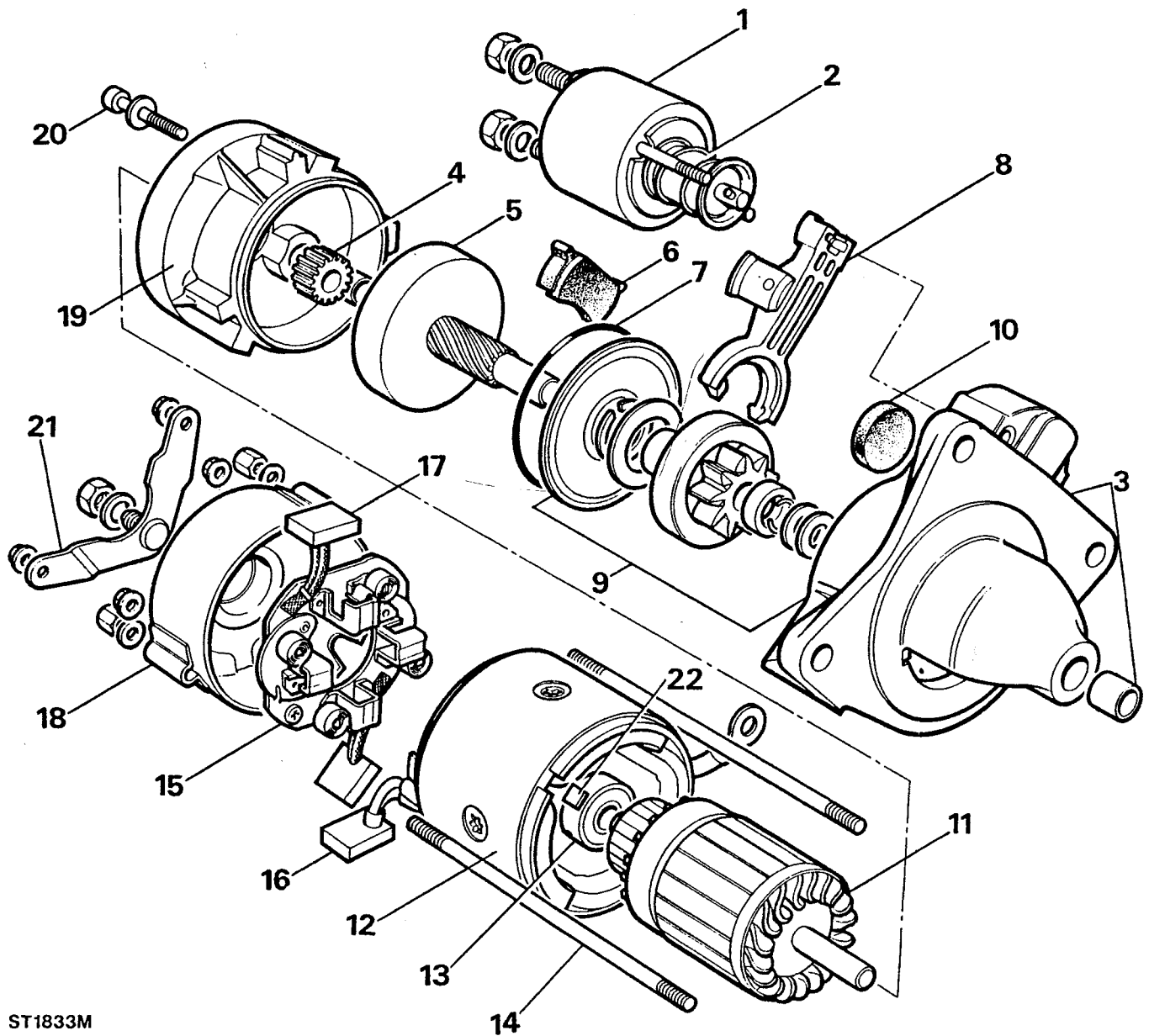

ST1833M

STARTER MOTOR

- | | |
|-------------------------------------|----------------------------|
| 1. Solenoid | 12. Yoke |
| 2. Solenoid plunger and spring | 13. Roller bearing |
| 3. Drive end bracket and bush | 14. Through-studs |
| 4. Reduction gear pinion | 15. Brush plate |
| 5. Reduction gear | 16. Field coil brushes |
| 6. Rubber pad | 17. Armature brushes |
| 7. 'O'ring seal | 18. Brush plate cover |
| 8. Lever | 19. Reduction gear housing |
| 9. Clutch drive and pinion assembly | 20. Socket headed screw |
| 10. Rubber pad | 21. Terminal strap |
| 11. Armature | 22. Yoke location key |

26. Insert the brushes into their boxes and release the retaining springs, ensuring that the brushes rest correctly on the commutator.
27. If removed refit the through studs to the drive end bracket.
28. Fit the brush plate cover and secure to the brush plate with the two nuts.
29. Secure the assembly with the through studs nuts.
30. Fit the terminal strap to the through studs and secure with the two nuts.
31. Fit the coil spring to the solenoid plunger, assemble the solenoid to the drive-end bracket and secure with the two nuts.
32. Check that the starter motor turns freely without tight spots.