

12 - ENGINE

CONTENTS

Page

Tdi

REPAIR

DRIVE BELT INFORMATION	1
DRIVE BELT RENEW	2
COMPRESSOR DRIVE BELT	2
ENGINE	3
CRANKSHAFT PULLEY	6
FRONT COVER PLATE	7
CAMSHAFT DRIVE BELT AND GEARS	8
FRONT COVER/TIMING GEAR HOUSING GASKET	12
OIL SUMP	13
OIL PICK-UP STRAINER	13
FLYWHEEL	14
CRANKSHAFT REAR OIL SEAL	15
CRANKSHAFT BEARING BUSH	16
FLYWHEEL HOUSING	17
OIL FILTER	18
OIL TEMPERATURE CONTROL VALVE	19
OIL FILTER HEAD GASKET	19
CYLINDER HEAD GASKET	20
VACUUM PUMP	23
GENERATOR	23

SPECIFICATIONS, TORQUE

TORQUE VALUES	1
---------------------	---





DRIVE BELT INFORMATION

A single 'serpentine drive belt' drives all the ancillaries bar the air conditioning compressor, which has a separate drive belt. It is essential that the belts are fitted exactly as shown. It should also be noted that the water pump/viscous fan is driven in a clockwise direction.

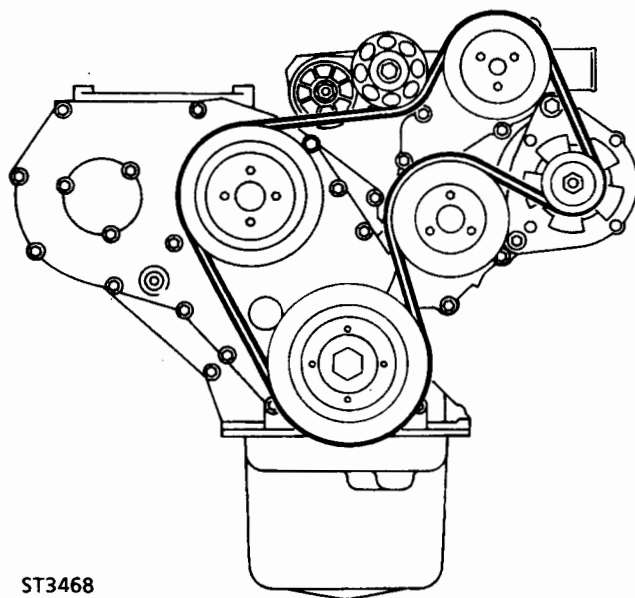

ST3468

A drive belt tensioner automatically tensions the drive belt, eliminating the need for tensioning individual drive belts. Turning the tensioner pulley in a clockwise direction will release drive belt tension.

Under normal highway use the belt must be changed at 160,000 kilometres, 96,000 miles or eight years whichever occurs first.

The drive belt must be examined at every service and replaced if necessary.

Off road driving

Regular examination of the drive belt is essential if the vehicle is used off road. The vehicle driver should be requested to identify the type of mileage the vehicle has covered.

After every off road session the owner should inspect the belt for cuts and possible damage caused by stones. If belt has jumped, reposition belt correctly. A new belt must be fitted at the next service or before, dependant on the type of damage sustained.

Fan cowl

To ensure easy access to the drive belt the top portion of the fan cowl is detachable.

Check condition

Check condition of drive belt. Renew a belt that shows signs of wear, splitting or oil contamination.

DRIVE BELT RENEW

Service repair no - 86.10.03



NOTE: If cast lines on tensioner arm and tensioner spring case are aligned, a new drive belt must be fitted.

Remove

1. Remove fan cowl upper.
2. Apply ring spanner to tensioner pulley retaining bolt.
3. Turn spanner to release pulley tension from belt.
4. Detach belt from pulley.
5. Release tensioner.
6. Complete removal of belt. Mark direction on belt if refitting.

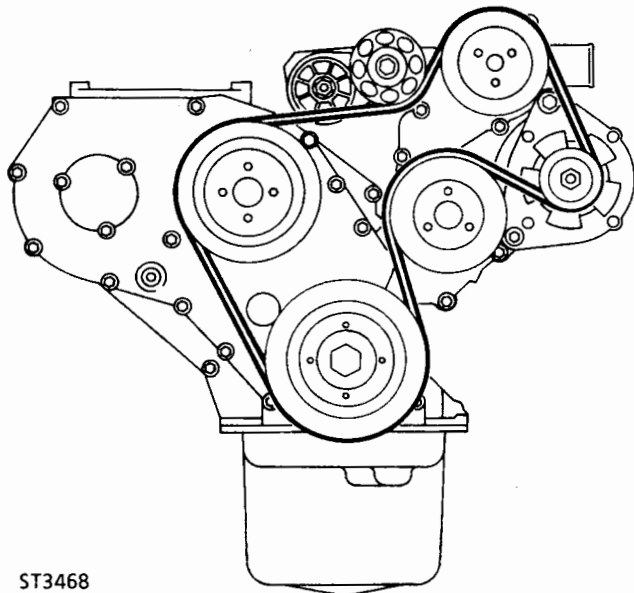

Refit

7. Reverse removal procedure.

COMPRESSOR DRIVE BELT

Service repair no - 86.10.02

Remove

1. Remove auxiliary drive belt. *See Drive Belt Renew*
2. Remove compressor shield.
3. Loosen tensioner retaining bolts.
4. Remove compressor drive belt. Mark direction on belt if refitting.

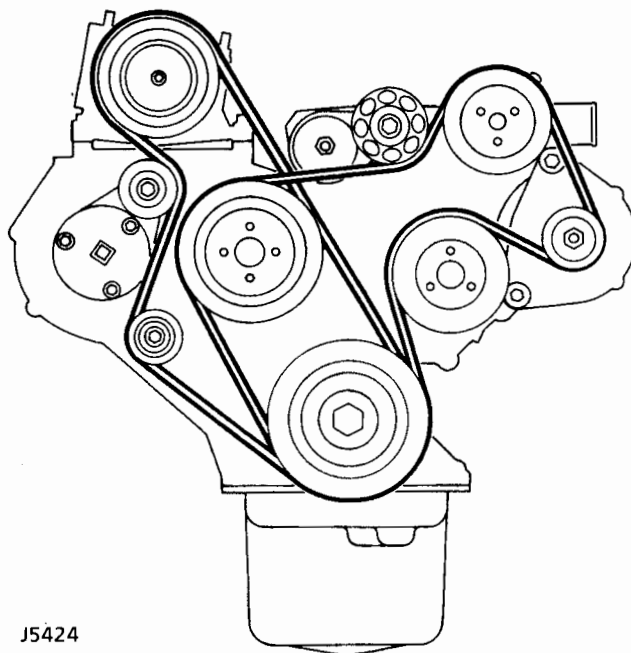

Refit

5. Fit compressor drive belt.
6. Fit torque meter to centre of tensioner and apply and hold a torque of **35 Nm**. Tighten 3 tensioner retaining bolts.
7. Rotate crankshaft 2 full turns.
8. Reapply and hold a torque of **35 Nm** to tensioner, then fully loosen and retighten 3 tensioner retaining screws to **25 Nm**.



ENGINE

Service repair no - 12.41.01

Remove



CAUTION: Seal all exposed pipe ends against ingress of dirt after disconnection.

1. Park vehicle on level ground and apply park brake.
2. Disconnect battery negative lead.
3. Remove bonnet [hood]. *See CHASSIS AND BODY, Repair, Bonnet [Hood]*
4. If air conditioning is fitted, remove RH footwell side trim panel and disconnect harness multiplug from relay.

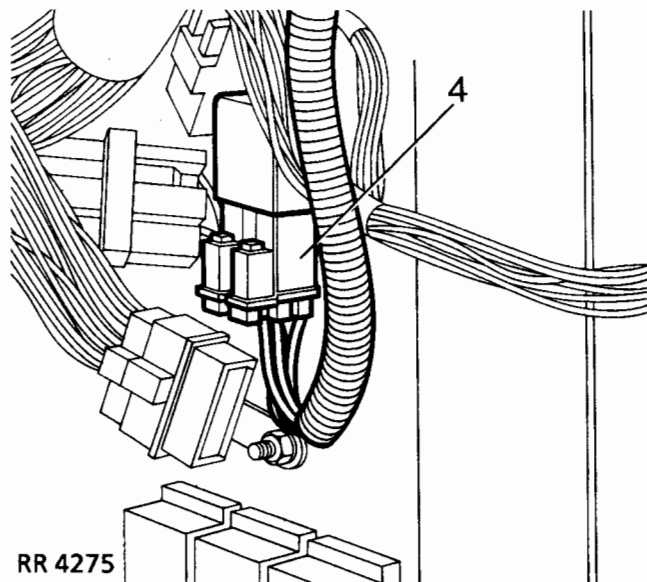

RR 4275

5. Disconnect the two engine harness multiplugs on LH side of footwell.

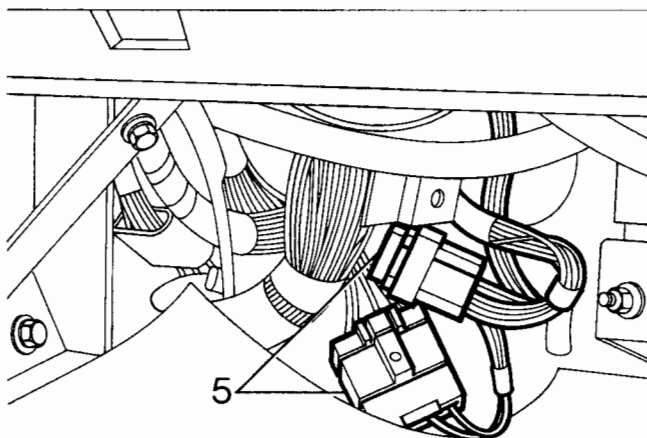

RR 4276

6. Remove engine harness grommet from bulkhead and move harness into engine bay.
7. Release battery positive lead from retaining clip at base of suspension turret.
8. Remove Radiator Assembly *See COOLING SYSTEM, Repair, Radiator*
9. Discharge air conditioning system. *See AIR CONDITIONING, Adjustment, Refrigerant Recovery Recycling Recharging*
Remove retaining bolts and disconnect both pipe adaptors from rear of compressor.
10. Remove rocker cover insulation.
11. Disconnect cyclone hose from air cleaner hose.
12. Remove air cleaner hose from turbocharger.
13. Remove feed pipe/hose from turbocharger and intercooler.
14. Disconnect heater hoses from cylinder head and heater rails.
15. Remove bolt securing transmission breather pipe clip to cylinder head; move breather pipes aside.
16. Disconnect inlet and outlet hoses from power steering pump.
17. Disconnect bypass hose from thermostat housing.
18. Release bypass hose from retaining clips on front timing cover.
19. Remove split pin securing inner throttle cable to injector pump.
20. Depress tags on outer cable adjusting nut, remove cable from mounting bracket, and move aside.
21. If automatic transmission is fitted, release kickdown cable from injector pump and mounting bracket.

22. Disconnect feed pipe and spill return pipe from injector pump.
23. Disconnect both pipes from fuel lift pump.
24. Disconnect servo hose from vacuum pump.
25. Remove three retaining nuts and disconnect exhaust down pipe.
26. Remove oil cooler pipes from oil filter adaptor.
27. If automatic transmission is fitted, disconnect feed and return pipes at gearbox oil cooler. Remove retaining bracket from LH side of cylinder block and release both oil cooler pipes.
28. Support gearbox.
29. Disconnect ground strap from starter motor.
30. On vehicles with automatic transmission, remove fixings and detach drive plate housing access panel and gasket.
31. Working through drive plate housing aperture mark the torque converter and drive plate to facilitate reassembly.
32. Remove the four converter to flexible drive securing bolts, rotating crankshaft to gain access to each individual bolt.
33. Fit engine lifting bracket to the two RH rear cylinder head fixing bolts.
34. Using suitable hoist, fit lifting chains to engine.
35. Remove four bolts, from both sides, securing front engine mounting brackets to cylinder block.
36. Remove two bolts, from both sides, securing front engine mounting bracket to bell housing.

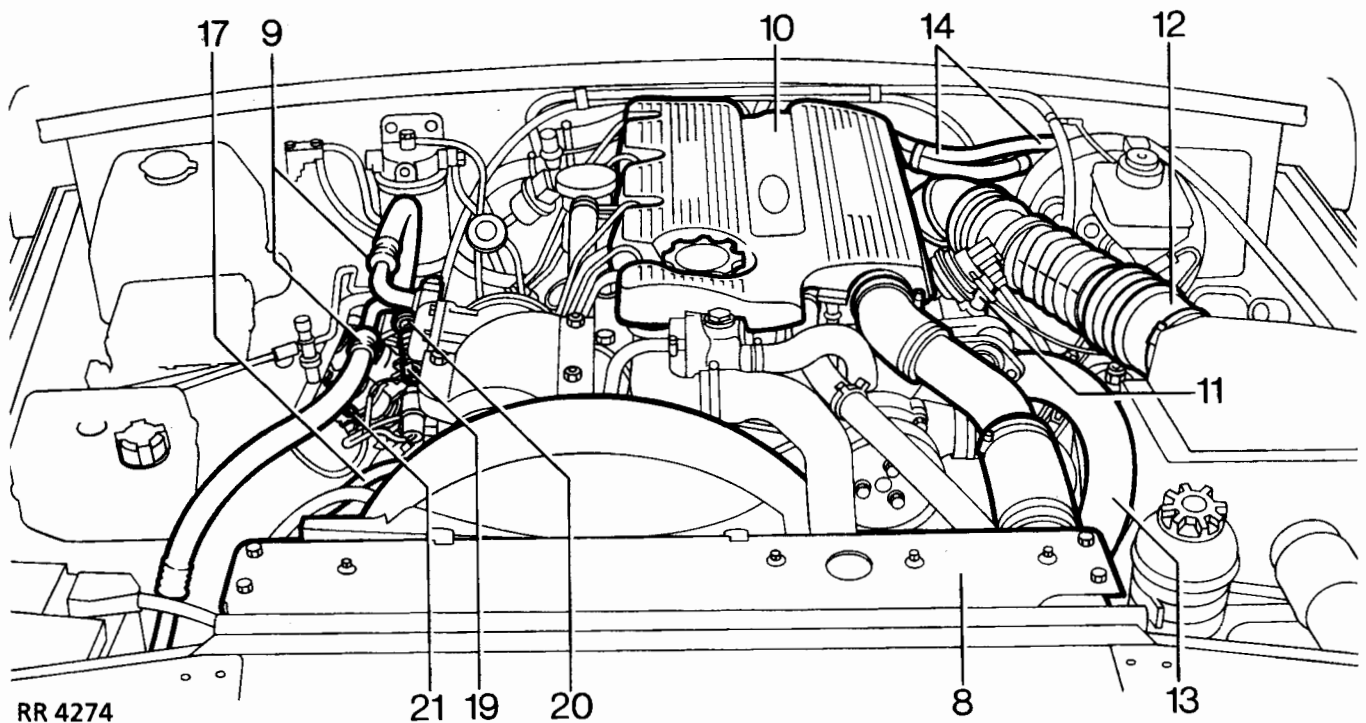

RR 4274

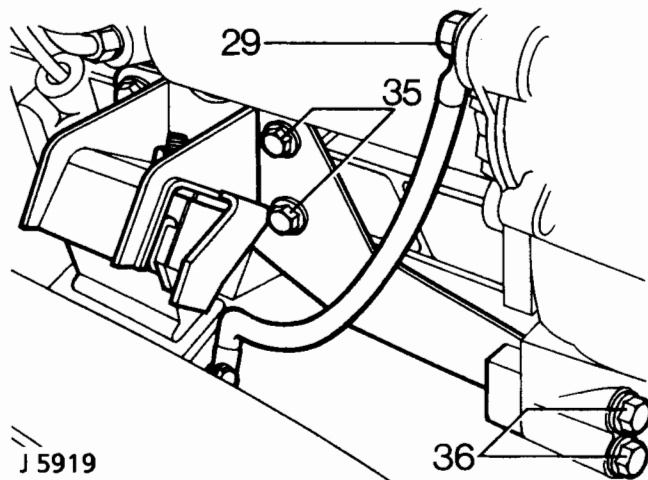

J 5919

37. Remove nuts and plain washers securing front engine mountings to chassis, and lift both engine mounting bracket assemblies from vehicle.
38. Remove engine to bell housing fixings. Leave starter motor attached.
39. Raise engine to separate from transmission.
40. Check all connections to engine have been disconnected.
41. Remove engine.

Refit

42. Apply Hylomar to mating faces of bell housing. Lubricate splines of gearbox primary pinion with Rocol MV 3.
If automatic transmission, coat the four drive plate to torque converter bolts with Loctite 290. Tighten to **39 Nm**.
43. Lower engine and locate with transmission.
If manual transmission locate primary pinion into clutch and engage bell housing dowels. Fit engine to bell housing fixings. Tighten to **40 Nm**.
If automatic transmission fixings. Tighten to **46 Nm**.
44. Raise engine, refit front engine mounting brackets to cylinder block and bell housing.
45. Remove gearbox support and lower engine.
46. Tighten front engine mountings to chassis fixings. Tighten to **45 Nm**.
47. Reverse removal procedure. 1 to 37.

CRANKSHAFT PULLEY

Service repair no - 12.21.01

Remove

1. Disconnect battery negative lead.
2. Drain coolant.
3. Remove top hose from radiator.
4. Remove intercooler to induction manifold hose.
5. Remove viscous fan and coupling. *See COOLING SYSTEM, Repair, Viscous Coupling, Fan Blades, Pulley and Fan Cowl*
6. Remove fan cowl.
7. Remove drive belt. *See Drive Belt Renew*
8. Fit crankshaft pulley retainer LRT-12-080 and secure with four bolts.
9. Remove crankshaft pulley retaining bolt using socket and suitable long bar.

Refit

12. Refit in reverse order, lightly greasing pulley spigot. Tighten to **80 Nm + 90°**.

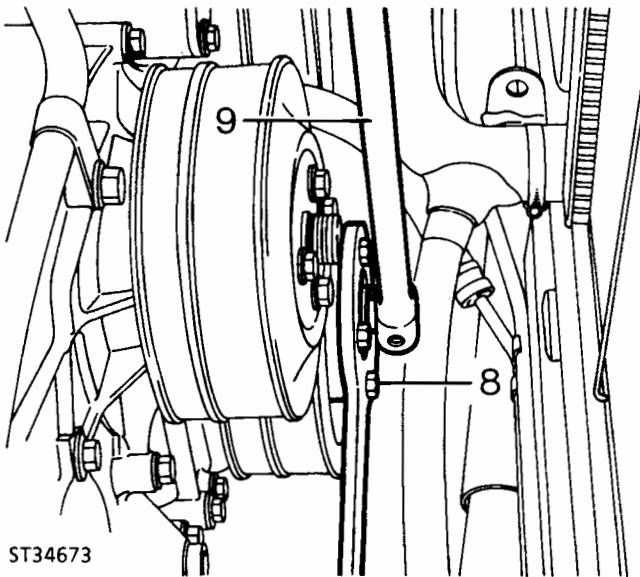

ST34673

10. Remove pulley retainer.
11. Remove pulley, if necessary using extractor LRT-12-049 with thrust pad from LRT-12-031.



FRONT COVER PLATE

Service repair no - 12.65.01

Remove

1. Disconnect battery negative lead.
2. Drain coolant.
3. Remove top hose from radiator.
4. Remove inter-cooler to induction manifold hose.
5. Remove viscous coupling and fan. **See COOLING SYSTEM, Repair, Viscous Coupling, Fan Blades, Pulley and Fan Cowl**
6. Remove fan cowl.
7. Remove drive belt. **See Drive Belt Renew**
8. Remove crankshaft pulley. **See Crankshaft Pulley**
9. Remove 14 bolts securing front cover plate, noting top two bolts also retain thermostat hose clips.
10. Remove cover plate complete with gasket.
11. Remove small gasket from centre bolt boss.

Seal replacement

12. Remove worn seal from cover and clean recess.
13. Support cover and fit new seal, open side fitted into recess, using special tool LRT-12-077.

LRT-12-077

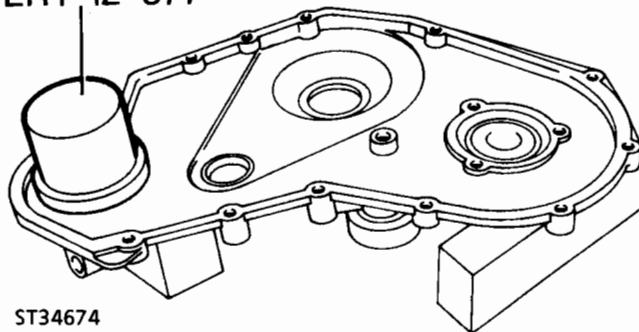

ST34674

Refit

14. Refit in reverse order to removal using new gaskets, fitting the securing bolts as shown in illustration ST3475. Tighten to **25 Nm**.

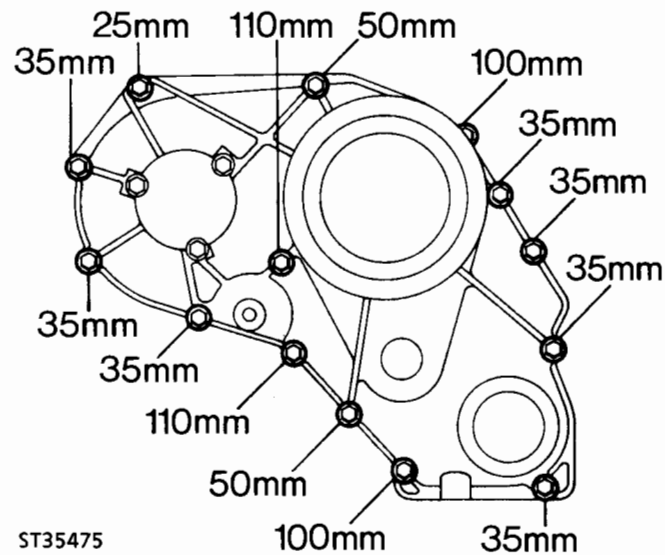

ST35475

CAMSHAFT DRIVE BELT AND GEARS

Service repair no - 12.65.18

TIMING BELT

Remove

1. Remove front cover plate. *See Front Cover Plate*
2. Position engine at TDC on No. 1 cylinder.
3. If manual gearbox: Remove blanking plug from flywheel housing and insert timing tool LRT-12-044. If EDC - timing tool LRT-12-085 must be used.
If automatic gearbox: Sited to the rear of the engine sump on engine backplate is a blanking plate. Remove 2 blanking plate bolts and insert timing tool LRT-12-044 into the larger bolt hole.

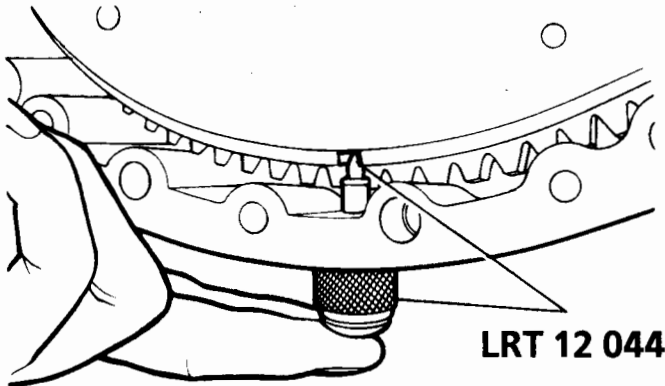

ST3531

4. Engage timing tool pin with slot in flywheel.
5. Check correct alignment of timing mark on camshaft gear and that crankshaft key aligns with cast arrow on housing.

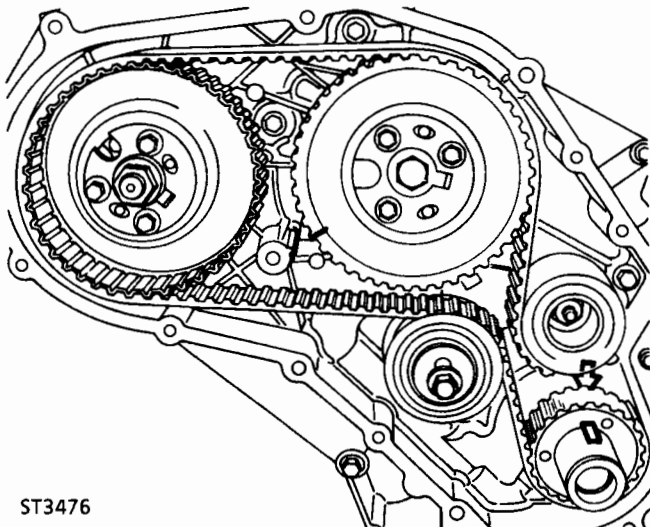

ST3476

6. Insert pin from special tool LRT-12-045 in injection pump gear and through into pump flange.



NOTE: If the camshaft gear is to be removed during these operations its retaining bolt should be slacked before the timing belt is removed.

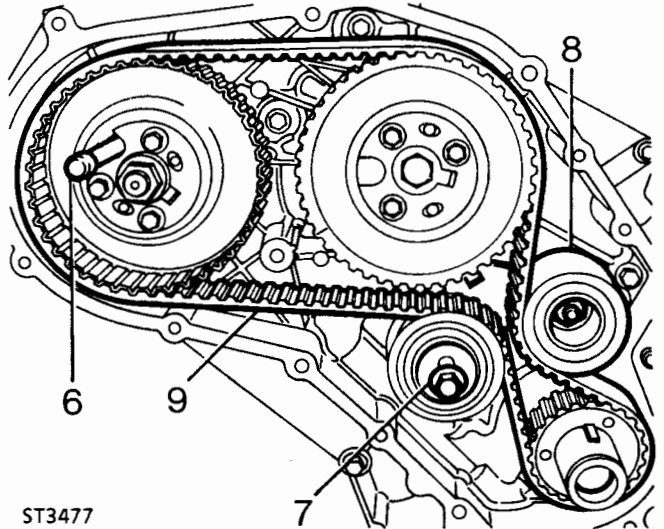

ST3477

7. Slacken belt tensioner bolt.
8. Remove idler pulley.
9. Remove timing belt.



NOTE: During use, a belt develops a wear pattern relative to its running direction, if the original belt is to be re-used it must be refitted so that it rotates in the original direction.



CAUTION: Belts must be stored on edge on a clean surface and in such a manner that bends are not less than 50 mm radius. Do not bend belts at an acute angle or radius of less than 50 mm, otherwise premature failure could result.

10. Mark belt direction of rotation, using soft chalk, to ensure correct refitment.



Belt tensioner



NOTE: The belt tensioner need only be removed if it is being replaced or for access purposes to remove front cover.

11. Remove securing bolt and withdraw tensioner complete with spacer.

Crankshaft gear/front cover oil seal

12. If the crankshaft gear cannot be removed by hand, use special tool LRT-12-078 with main body and thrust button from special tool LRT-12-031 as illustrated ST3478M. Withdraw gear complete with 'O' ring seal.

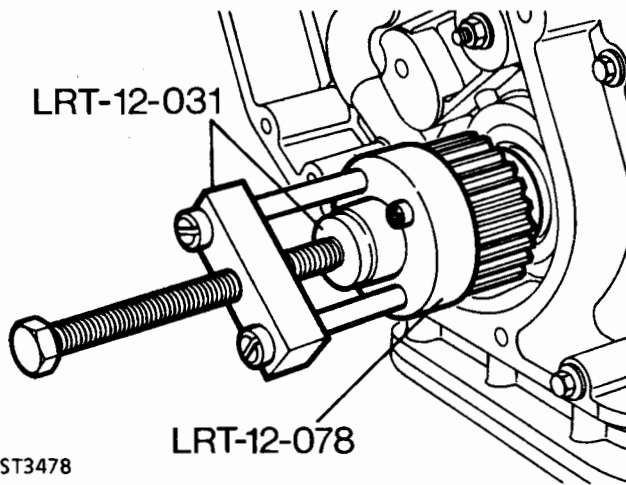

13. If necessary prise out oil seal from front cover.
14. Lubricate a new crankshaft oil seal with clean engine oil.
15. With lip side leading, drive-in seal squarely using special tool LRT-12-079.

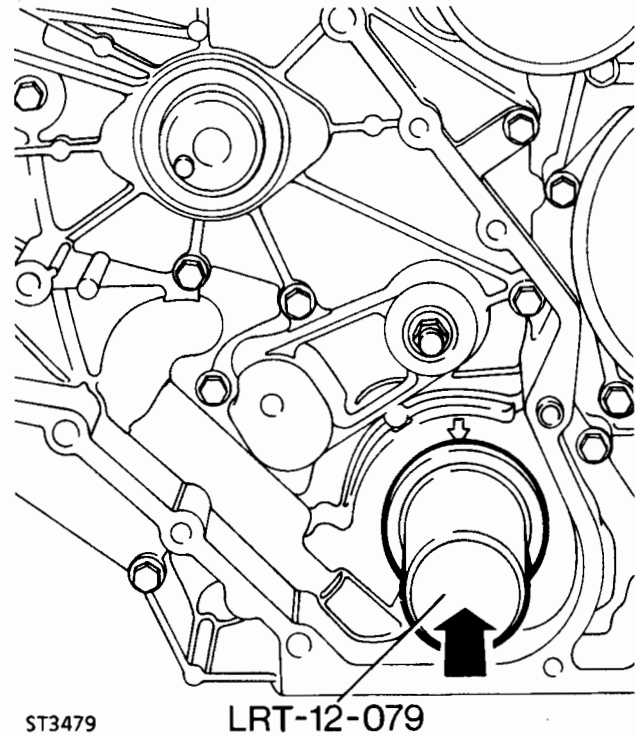

16. Lubricate new 'O' ring seal with petroleum jelly and slide onto shaft, taking care not to damage seal on the woodruff keys.
17. Fit crankshaft gear, tap fully home ensuring 'O' ring seal is properly seated.

CAMSHAFT GEAR/FRONT COVER OIL SEAL Service repair no - 12.13.05

18. Remove centre bolt from camshaft gear and withdraw gear.
19. Remove existing oil seal from front cover using special tool LRT-12-038.
20. Lubricate a new camshaft oil seal with clean engine oil.

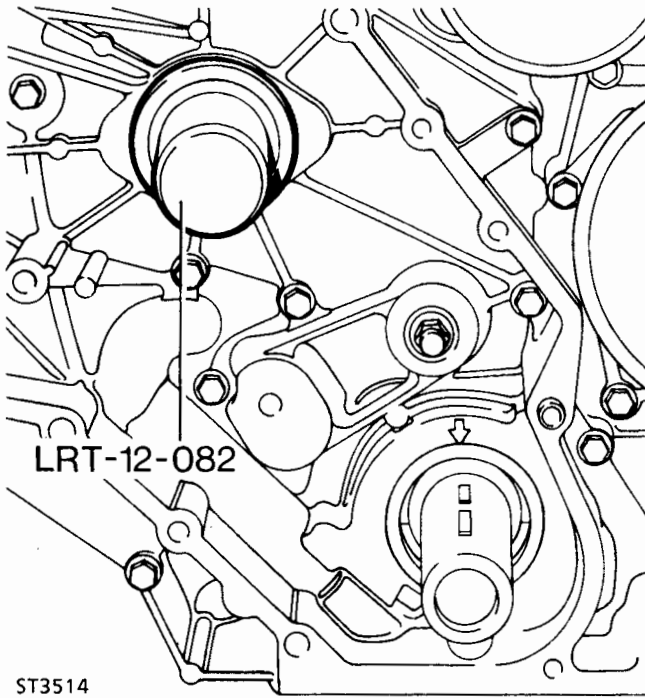

21. With lip side leading, drive-in seal squarely using special tool LRT-12-082.
22. Refit gear.

FUEL INJECTION PUMP GEAR

Service repair no - 19.30.06

Remove

23. Slacken the three bolts on front of gear.



CAUTION: It is important to ensure that when the injection pump is locked no attempt must be made to rotate it. Take care not to allow the crankshaft to be turned.

24. Remove special tool pin from gear.
25. Remove three bolts and withdraw plate and gear.

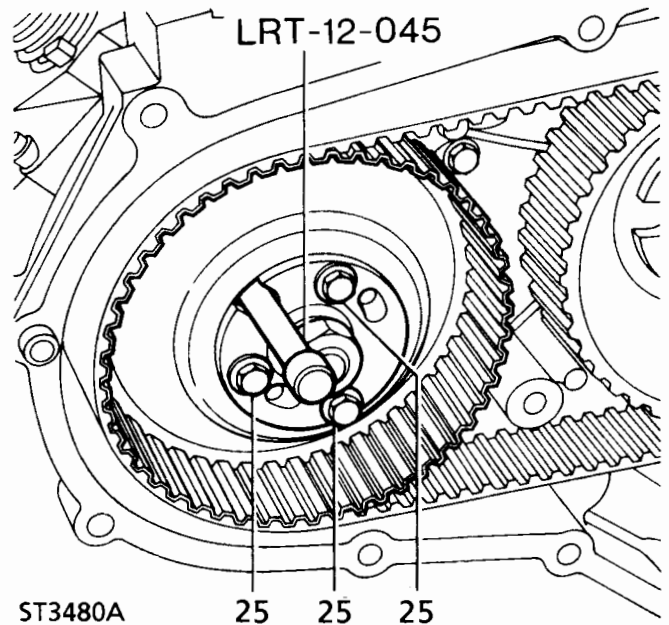

Refit

26. Fit gear and plate and secure with three bolts.
27. Insert pin from special tool LRT-12-045 in injection pump gear and through into pump flange.



Timing belt fitting and tensioning



NOTE: It is important that belt tensioning is carried out carefully and accurately. The following procedure involves tensioning the belt twice to ensure that it is equally tensioned between each gear. New and original belts are tensioned to different figures.

28. Ensure timing marks are correctly aligned, pin from special tool LRT-12-045 is correctly inserted in injection pump gear and timing tool LRT-12-044 (LRT-12-085 if EDC) is fitted to flywheel housing with pin located in flywheel slot. Or if automatic: Timing tool LRT-12-044 is fitted to engine backplate and pin located in ring gear.
29. Fit belt observing rotational marks made during removal. Feed belt over gears keeping it tight on drive side.
30. Fit idler pulley.
31. Slacken injection pump gear retaining bolts.
32. Adjust belt to correctly sit in gears.

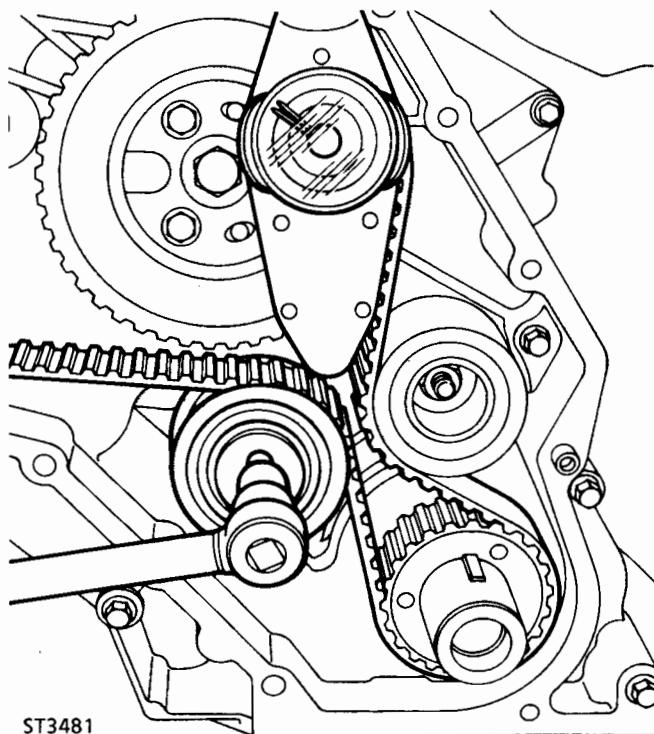

ST3481

33. Slacken belt tensioner securing bolt to finger tight.
34. Insert 13 mm square drive extension bar in tensioner plate.



NOTE: Belt tensioning should be carried out using a dial type torque meter having a range not exceeding 60 Nm. The torque meter should be used in the almost vertical position.

35. Apply a tension of **14 to 16 Nm** for a new belt or **11 to 13 Nm** for an original belt. When tension is correct tighten clamp bolt.
36. Tighten injection pump gear bolts.
37. Remove pin from injection pump gear.
38. Disengage timing pin from timing slot in flywheel or ring gear.
39. Rotate crankshaft one and three quarter turns in a clockwise direction; then continue rotation until timing pin in timing tool can be engaged with slot in flywheel or ring gear.
40. Disengage timing pin.
41. Insert pin from special tool LRT-12-045 in injection pump gear and through into pump flange.
42. Slacken injection pump gear retaining bolts.
43. Slacken tensioner and retension belt.
44. Tighten injection pump gear retaining bolts.
45. Remove pin from injection pump gear.
46. Remove timing tool and refit plug.
47. Fit front cover plate using new gaskets. **See Front Cover Plate**

FRONT COVER/TIMING GEAR HOUSING GASKET

Service repair no - 12.65.10

Remove

1. Remove timing belt and gears. *See Camshaft Drive Belt and Gears*
2. Remove fuel injection pump. *See FUEL SYSTEM, Repair, Fuel Injection Pump and Timing*
3. Remove engine oil sump. *See Oil Sump*
4. Remove oil pick up strainer. *See Oil Pick-Up Strainer*
5. Remove bolts securing timing gear housing to block.
6. Withdraw timing gear housing complete with gasket.
7. Clean all gasket material from mating faces.

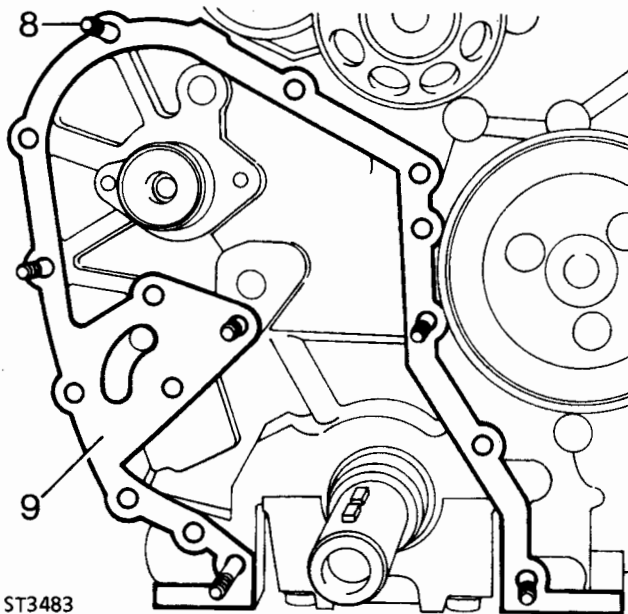

10. Align flats on oil pump with flats on crankshaft.
11. Fit front cover to block taking care not to damage oil seal.
12. Secure with bolts of correct length in locations where slave studs are not fitted (ST3482).
13. Remove slave studs and fit correct length bolts.
14. Tighten to 25 Nm.

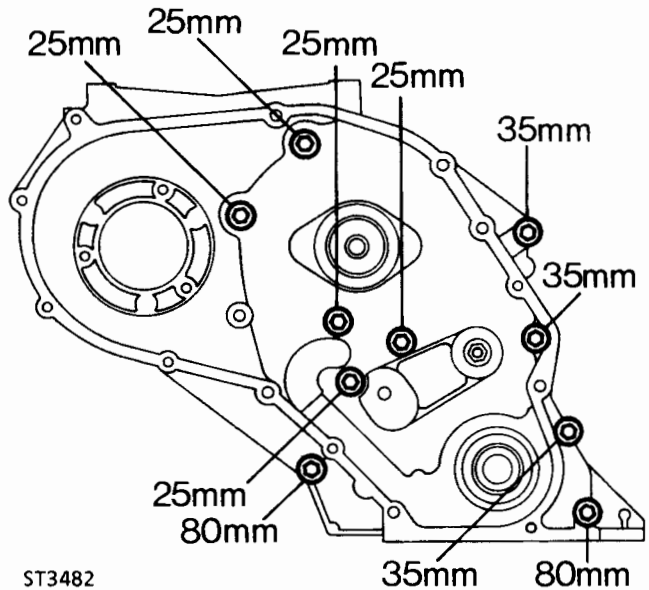

15. Fit oil pick-up strainer. *See Oil Pick-Up Strainer*
16. Fit oil sump. *See Oil Sump*
17. Refit fuel injection pump. *See FUEL SYSTEM, Repair, Fuel Injection Pump and Timing*

Refit

8. Fit slave guide studs to locate gasket.
9. Fit new gasket, over slave studs, to cylinder block.



OIL SUMP

Service repair no - 12.60.44

Remove

1. Disconnect battery negative lead.
2. Drain engine oil.
3. Slacken sump securing bolts and, using a sharp knife, break sealant around sump flange.
4. Remove bolts and withdraw sump.

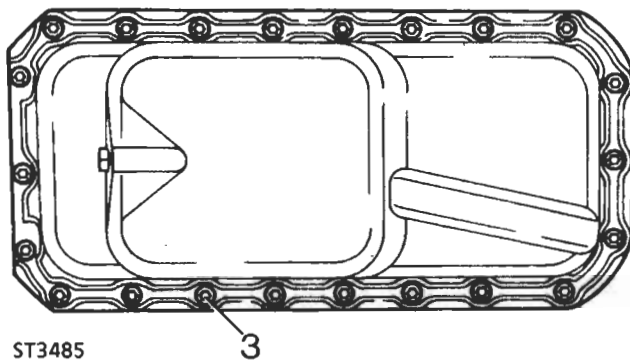

Refit

5. Clean mating faces of sump, timing gear housing and cylinder block.
6. Apply a 2,0 mm bead of 'Hylosil RTV102' to the sump flange, ensuring bead is applied inboard of the bolt holes.
7. Secure sump to block with bolts. Tighten to **25 Nm**.
8. Refill engine oil. *See LUBRICANTS, FLUIDS AND CAPACITIES, Information, Recommended Lubricants and Fluids*
9. Reconnect battery negative lead.

OIL PICK-UP STRAINER

Service repair no - 12.60.20

Remove

1. Disconnect battery negative lead.
2. Drain engine oil.
3. Remove engine oil sump. *See Oil Sump*
4. Remove bolts securing pipe support bracket.
5. Remove bolts from pipe flanges.
6. Withdraw pick-up strainer assembly.

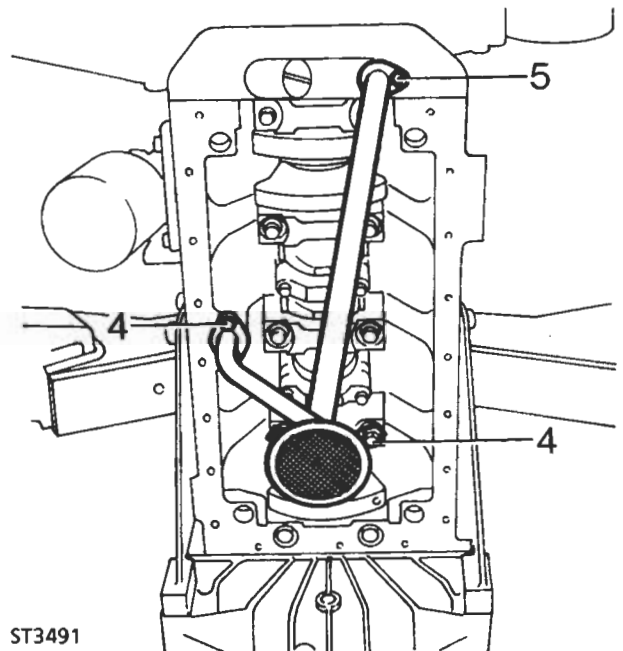

Refit

7. Refit pick-up strainer assembly, fitting a new 'O' ring seal at oil pump connection.
8. Apply Loctite 242E to the two screws at the bearing cap. Tighten to **9 Nm**.
9. Fit bolts to pipe flanges. Tighten to **25 Nm**.
10. Refit engine oil sump. *See Oil Sump*
11. Reconnect battery negative lead.

FLYWHEEL

Service repair no - 12.53.07

Remove

1. Disconnect battery negative lead.
2. Remove gearbox. *See MANUAL GEARBOX, Repair, R380 Manual Gearbox*
3. Remove clutch. *See CLUTCH, Repair, Clutch Assembly*
4. Fit two long 8mm bolts into the clutch bolt holes, diametrically opposite, to use as handles when lifting the flywheel off the crankshaft.
5. Remove fan cowl
6. Fit crankshaft pulley retainer LRT-12-080 and secure with four bolts, to restrain crankshaft while removing flywheel retaining bolts.
7. Remove the bolts and lift off flywheel.

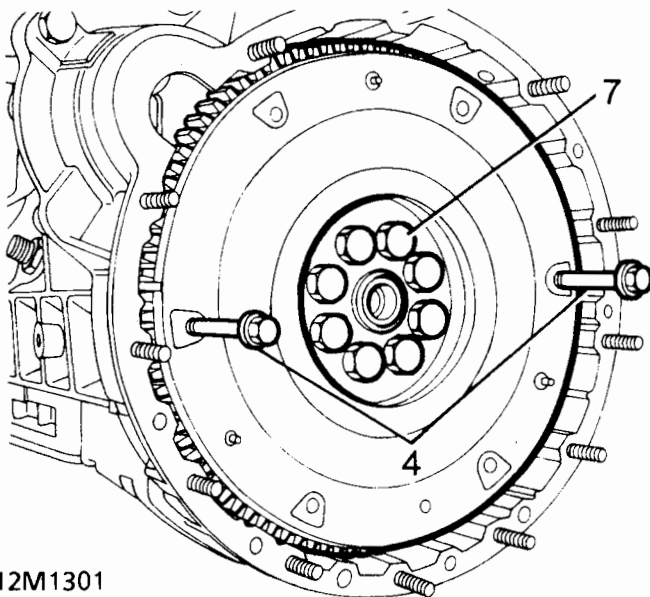

Refit

8. Locate the flywheel on the crankshaft and secure with new patched retaining bolts, progressively tighten to **147 Nm**.

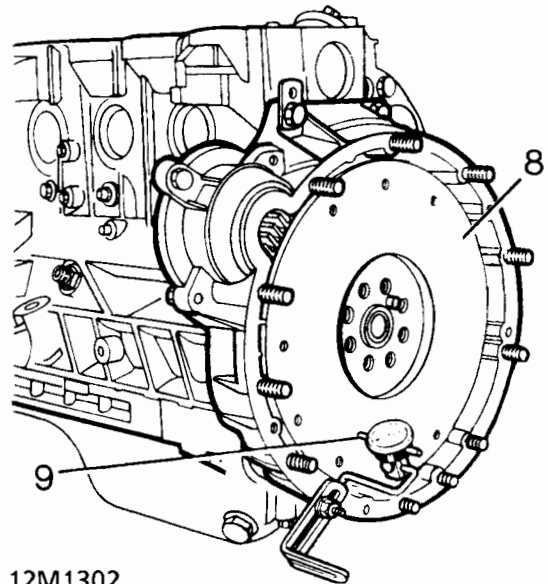

9. Check the flywheel for possible run-out by mounting a dial test indicator with the stylus in a loaded condition resting on the flywheel face at a radius of 114mm from the centre.
10. Turn the flywheel and check that run-out does not exceed 0,05 to 0,07mm. Should run-out be excessive, remove the flywheel and check again for irregularities on the crankshaft and flywheel mating faces and the dowel.
11. Reverse removal procedure. 1 to 6.



NOTE: To prevent excessive flywheel run-out, ensure that the mating faces of the flywheel and crankshaft are clean.



CRANKSHAFT REAR OIL SEAL

Service repair no - 12.21.20

Remove



NOTE: The crankshaft rear oil seal is retained in its own housing, if the seal requires replacing the housing and seal assembly (1) must be renewed complete with the housing seal (3). Housing and seal assemblies are supplied with their own former/seal guide (2) already fitted. This former must not be removed before fitting the assembly to the engine. If a seal and housing assembly is received without a former/guide fitted it must be returned to the supplier. Used formers/guides must be discarded immediately after use, under no circumstances should they be reused on other assemblies.

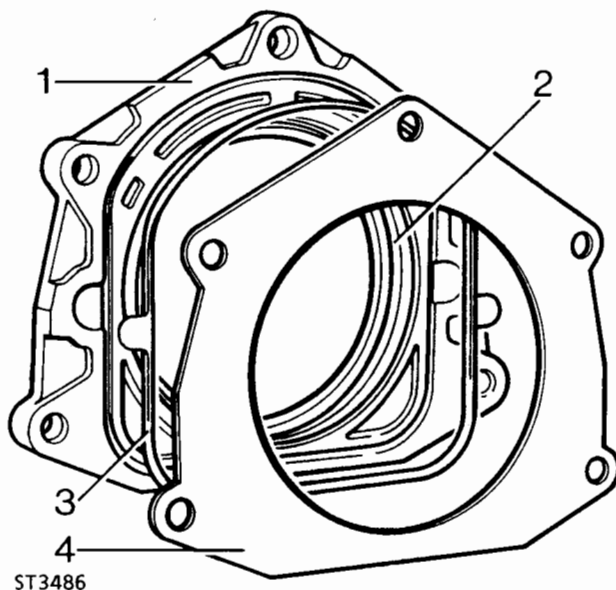

1. Disconnect battery negative lead.
2. Remove gearbox. *See MANUAL GEARBOX, Repair, R380 Manual Gearbox*

3. Remove clutch. *See CLUTCH, Repair, Clutch Assembly*
4. Remove flywheel. *See Flywheel*
5. Remove five bolts and withdraw seal housing and seal assembly complete with gasket.

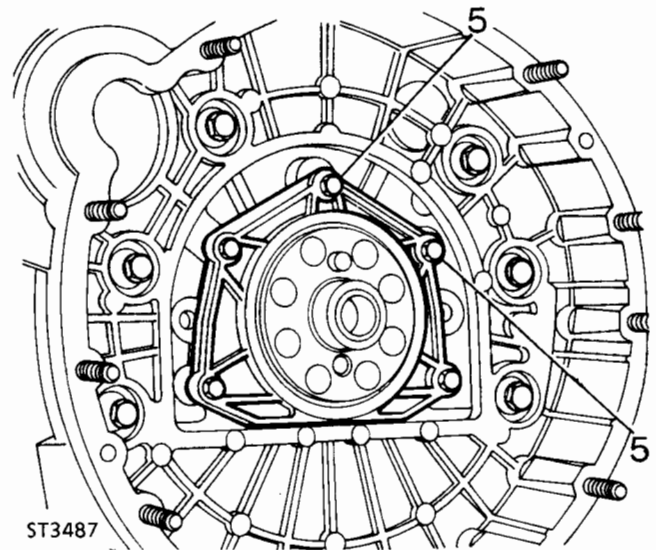

Refit

6. Insert slave studs to seal housing mounting face.
7. Position new seal housing gasket over slave studs and crankshaft flange onto cylinder block.

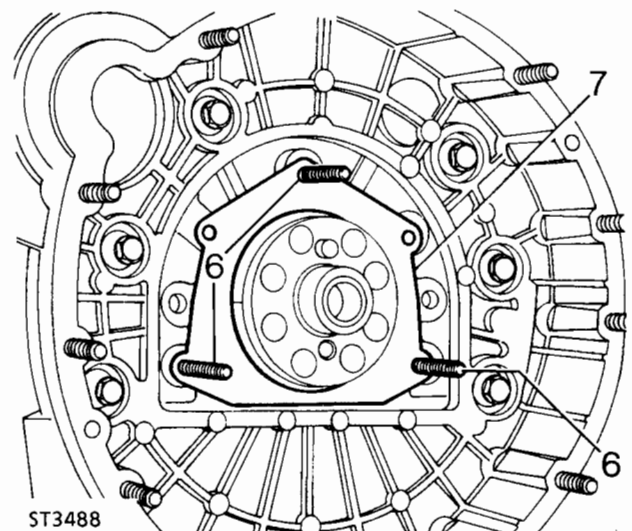

8. Ensure housing seal is correctly seated in its groove in new housing and seal assembly.
9. Fit new assembly, with former/guide in-situ, over crankshaft flange, this action will eject former/guide.
10. Secure assembly to cylinder block with five bolts tightened to correct torque, removing slave studs individually and inserting bolts.
11. Refit flywheel. *See Flywheel*
12. Refit clutch. *See CLUTCH, Repair, Clutch Assembly*
13. Refit gearbox. *See MANUAL GEARBOX, Repair, R380 Manual Gearbox*
14. Reconnect battery negative lead.

CRANKSHAFT BEARING BUSH

Service repair no - 12.21.45

1. Disconnect battery negative lead.
2. Remove gearbox. *See MANUAL GEARBOX, Repair, R380 Manual Gearbox*
3. Remove clutch. *See CLUTCH, Repair, Clutch Assembly*

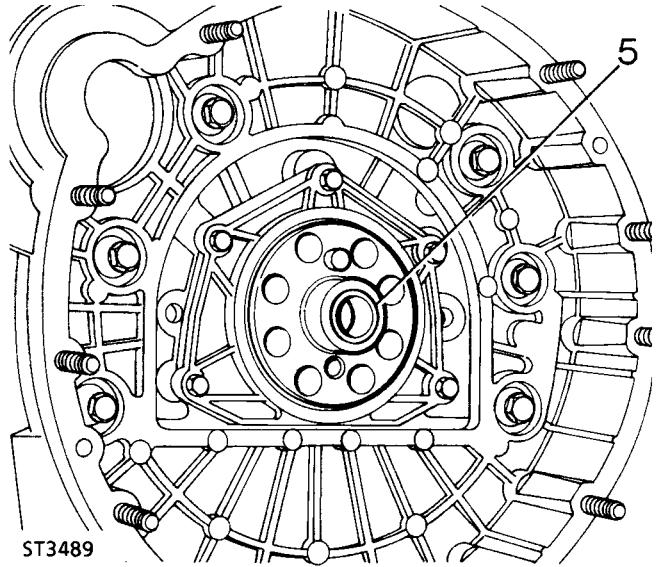

4. Remove flywheel. *See Flywheel*
5. Remove bearing bush.



NOTE: The bearing bush can be removed by using one of the following methods.

Method 1.

Obtain a short length of steel rod of a diameter having a good slide fit in the bore of the bush. Pack the bore with grease and insert the steel rod into the end of the bore, give a sharp blow with a hammer and the grease should drive out the bush. It is recommended that the bush and rod be covered by a suitable cloth or rag to prevent grease from splashing.



Method 2.

Thread the bore of the existing bush and using a suitable bolt extract the bush. Thoroughly clean bush location ensuring all swarf is removed.

Fitting

6. Fit new bush using a suitable shouldered drift, inserting bush flush with end of crankshaft.
7. Refit flywheel. *See Flywheel*
8. Refit clutch. *See CLUTCH, Repair, Clutch Assembly*
9. Refit gearbox. *See MANUAL GEARBOX, Repair, R380 Manual Gearbox*
10. Reconnect battery negative lead.

FLYWHEEL HOUSING

Service repair no - 12.53.01

Remove

1. Disconnect battery negative lead.
2. Remove gearbox. *See MANUAL GEARBOX, Repair, R380 Manual Gearbox*
3. Remove clutch. *See CLUTCH, Repair, Clutch Assembly*
4. Remove flywheel. *See Flywheel*
5. Remove starter motor.
6. Remove two bolts from top of flywheel housing.
7. Remove four bolts from bottom of flywheel housing.
8. Remove six inner bolts and lift off flywheel housing.

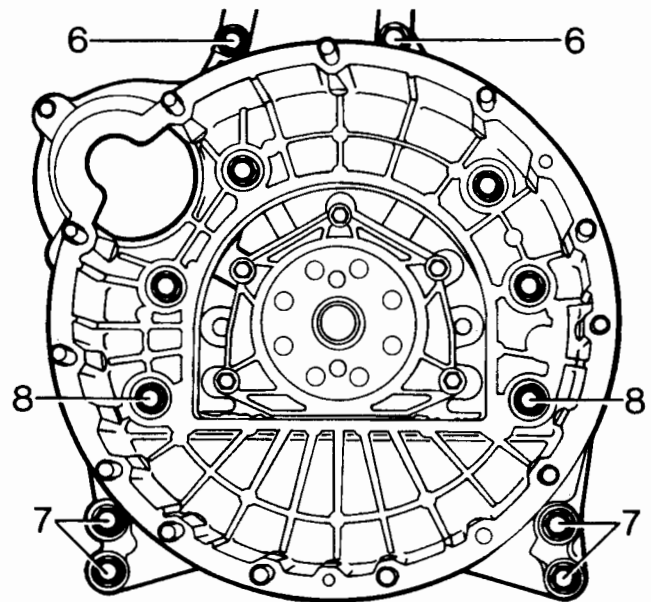

ST3490

Refit

9. Clean rear face of housing and mating face on block, ensuring all old sealant is removed.

10. Apply sealant to flywheel housing mating face on cylinder block (Fig. J5944).

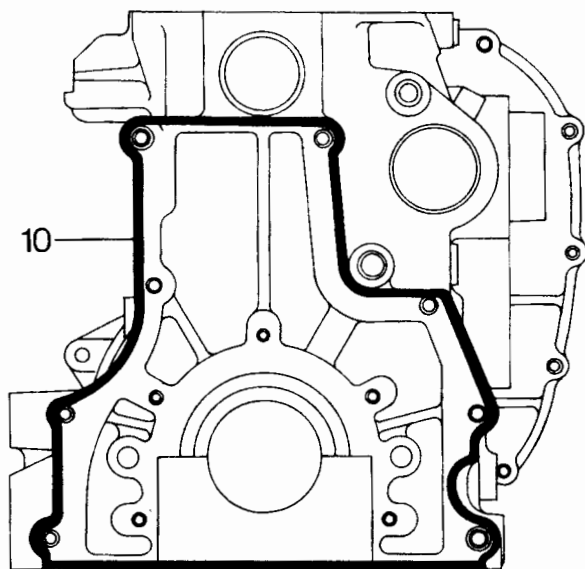

J5944

11. Fit housing to cylinder block and secure with bolts as removed. Tighten to **45 Nm**.
12. Remove surplus sealant from block.
13. Refit starter motor.
14. Refit flywheel. **See Flywheel**
15. Refit clutch. **See CLUTCH, Repair, Clutch Assembly**
16. Refit gearbox. **See MANUAL GEARBOX, Repair, R380 Manual Gearbox**
17. Reconnect battery negative lead.

OIL FILTER

Service repair no - 12.60.01

Remove

1. Place drain tray under filter.
2. Unscrew filter anti-clockwise, using a strap or spanner.

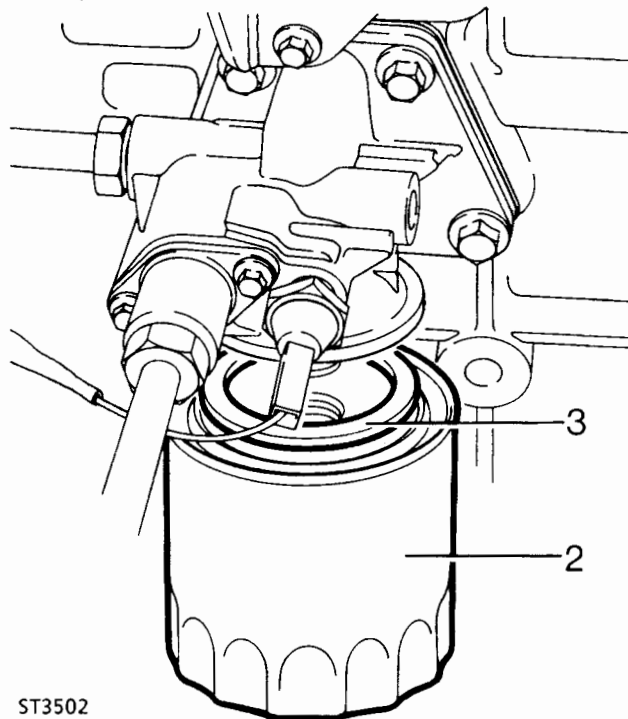

ST3502

Refit

3. Smear clean engine oil on seal of new filter.
4. Screw on filter until sealing ring touches machined face, then tighten a further half turn by hand only. Do not over tighten.



OIL TEMPERATURE CONTROL VALVE

Service repair no - 12.60.69

Remove

1. Disconnect oil cooler pipes.
2. Remove two bolts and carefully withdraw thermostat extension housing (1) complete with O ring seal (2), thermostat (3), two washers (4) and spring (5).

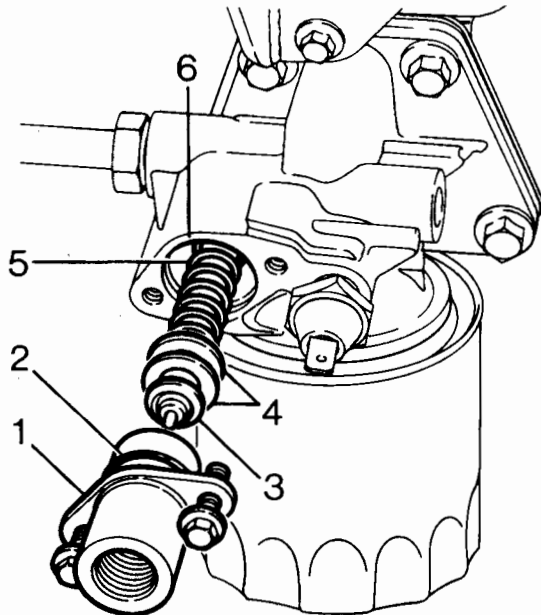

ST3504

3. Clean adaptor housing.
4. Inspect all parts and renew as necessary.

Refit

5. Fit thermostat to extension housing ensuring pin locates in hole.
6. Fit two washers and spring to thermostat.
7. Fit a new 'O' ring to extension housing.
8. Insert spring into adaptor and secure extension housing to adaptor with bolts. Tighten to **9 Nm**.

OIL FILTER HEAD GASKET

Service repair no - 12.60.03

Renew

1. Disconnect oil cooler pipes.
2. Disconnect pressure switch lead.
3. Remove securing bolts and withdraw head complete with gasket.
4. Clean mating faces.

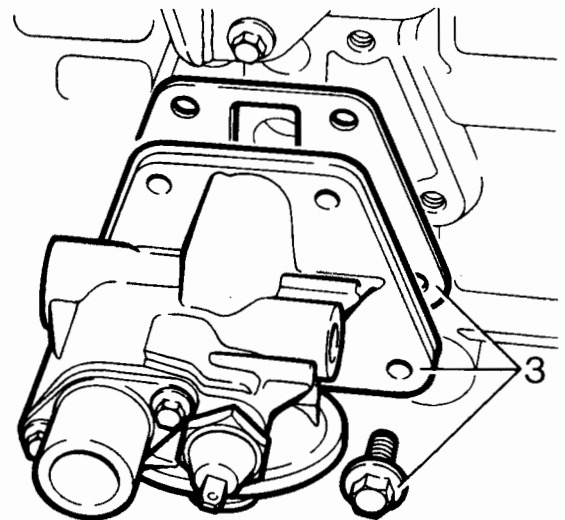

ST3503

5. Refit head with new gasket.
6. Secure with bolts Tighten to **45 Nm**.
7. Refit pipes and reconnect pressure switch.

CYLINDER HEAD GASKET

Service repair no - 12.29.02

Remove

1. Disconnect battery negative lead.
2. Remove bonnet [Hood]. *See CHASSIS AND BODY, Repair, Bonnet [Hood]*
3. Drain coolant.
4. Remove air cleaner assembly. *See FUEL SYSTEM, Repair, Air Cleaner*
5. Detach crankcase ventilation valve and side breather hose from rocker cover and move to one side.
6. Remove injection pipes.

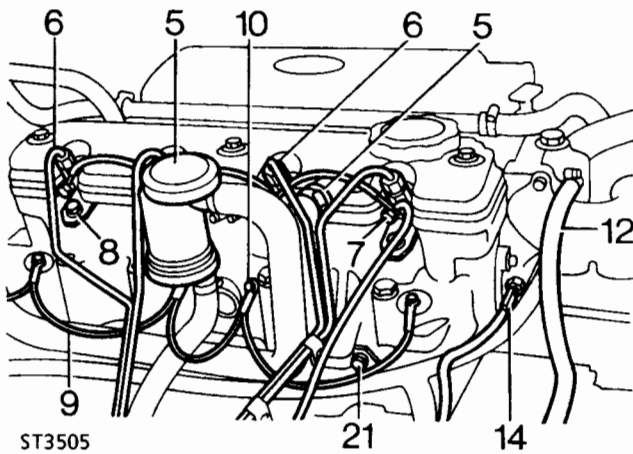

7. Disconnect spill rail from fuel injectors.
8. Remove fuel injectors and sealing washers. Identify each injector to the location from which it is removed. *See FUEL SYSTEM, Repair, Injectors*
9. Remove inter-connecting harness from glow plugs.
10. Remove glow plugs. *See FUEL SYSTEM, Repair, Glow Plugs*

11. Remove top hose, radiator to thermostat.
12. Disconnect by-pass hose from thermostat.
13. Disconnect hose, thermostat to water pump.
14. Disconnect water temperature sensor lead.

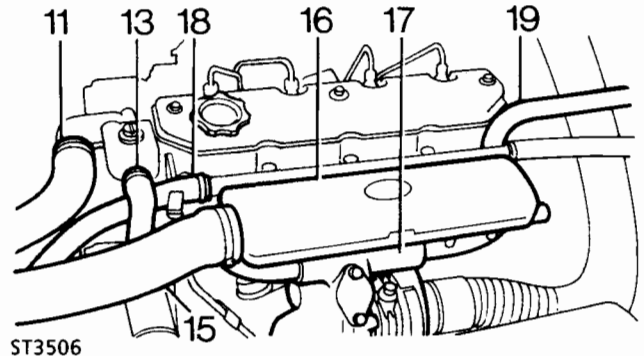

15. Remove hose inter-cooler to induction manifold.
16. Remove induction manifold. *See MANIFOLD AND EXHAUST SYSTEM, Repair, Exhaust Manifold - Tdi*
17. Remove exhaust manifold and turbocharger assembly. *See MANIFOLD AND EXHAUST SYSTEM, Repair, Exhaust Manifold - Tdi*
18. Disconnect heater hose from water pump and move heater rail aside.
19. Disconnect heater hose from rear of cylinder head.
20. Remove bolt securing air cleaner mounting bracket to support strut.
21. Remove bolt securing harness bracket to cylinder head.
22. Remove rear lifting bracket, this will also release clips securing transmission and engine breather pipes and multiplug. Note loose spacer under clip securing engine breather pipe and multiplug.



23. Remove rocker cover.

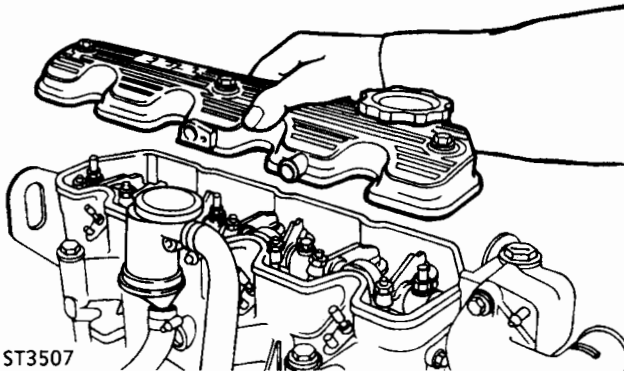

24. Remove nuts and bolts and withdraw rocker shaft assembly.

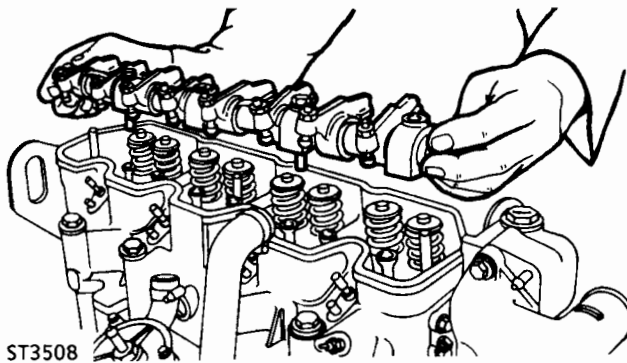

25. Remove push rods, store as an identified set to allow refitment to same location.

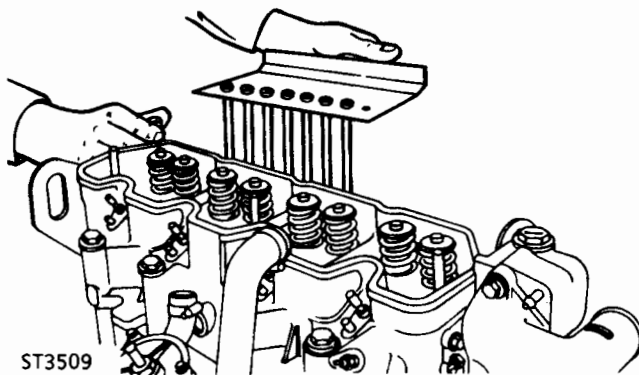

26. Remove valve stem caps.
27. Evenly slacken, then remove, bolts retaining cylinder head to block. Two of the bolts also secure the air cleaner mounting bracket.
28. Lift off cylinder head and remove gasket.

Refit

29. Ensure face of cylinder block is thoroughly clean.
30. Select new gasket of correct thickness.



CAUTION: Three thicknesses of gasket are available, different thicknesses are identified by the number of small holes punched in the right hand side of the gasket. One hole identifies the thinnest gasket and three holes the thickest. When renewing gaskets the gasket being fitted must be of the same thickness as the one removed. Therefore if the removed gasket had two holes punched in the side the replacement gasket must also have two holes punched in the side.

31. Place gasket on cylinder block with identification holes positioned towards rear on right hand side and side marked TOP uppermost.

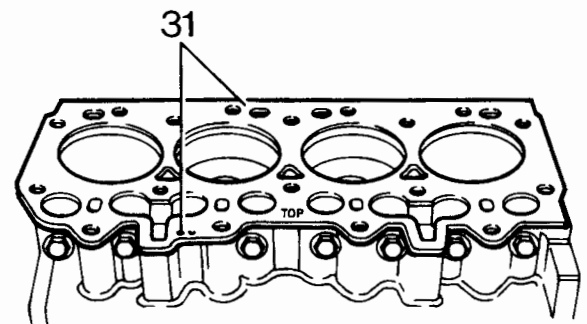

ST3510

32. Clean mating face of cylinder head.
33. Lower cylinder head onto block ensuring correct location with dowels.



NOTE: Cylinder head retaining bolts can be used up to a maximum of five times.

34. Lubricate threads of bolts with light oil and fit to positions illustrated.

Bolt sizes:

M10 x 117mm locations 3, 5, 12, and 13.

M12 x 140mm locations 1, 2, 7, 8, 9, 10, 15, 16, 17, and 18.

M12 x 100mm locations 4, 6, 11, 14.

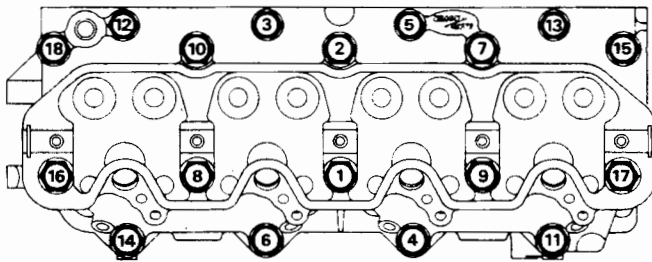

ST2619 M

35. Tighten bolts so that underside of heads just make contact with cylinder head.
36. Following the sequence illustrated tighten all bolts to **40 Nm**.
37. Attach degree disc special tool LRT-12-007 to a power bar.
38. Make a suitable pointer from welding rod and attach to a bolt screwed into a rocker shaft securing bolt hole.

LRT 12 007

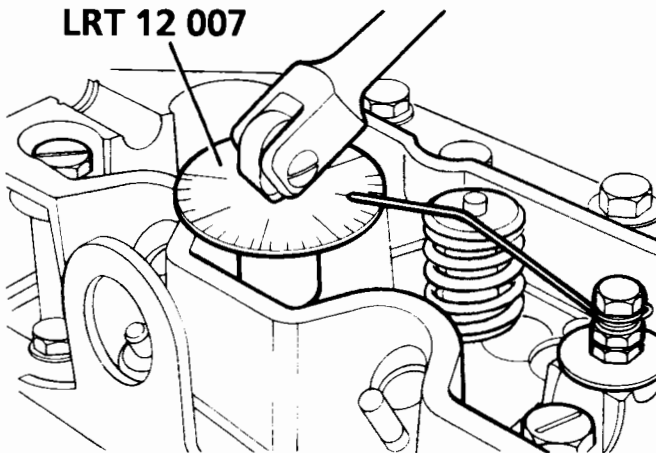

ST3515

39. Tighten all bolts through 60° strictly in sequence illustrated.
40. Repeat 60° tightening procedure, again strictly in sequence illustrated.
41. Tighten the ten longer bolts (M12 x 140mm) a further 20° , again following the sequence illustrated.



NOTE: Repositioning of the pointer will be necessary to reach all bolts, the pointer can be fitted to the rocker shaft securing studs using two nuts.



CAUTION: The double tightening procedure must be carried out, on no account should the total angles of tightening be performed in one operation, otherwise damage to the cylinder head may occur.

42. Fit valve stem caps.
43. Fit push rods to locations from which they were removed.
44. Fit rocker shaft assembly evenly tightening securing nuts and bolts to correct torque.
45. Fit rocker cover ensuring oil seal is satisfactory for continued use.



NOTE: Rocker cover seals can be re-used up to a maximum of five times.

46. Secure rocker cover with special seal washers and nuts tightened to correct torque.
47. Refit remainder of items by reversing operations 1 to 22 tightening securing bolts to correct torque where applicable.



VACUUM PUMP

Service repair no - 70.50.19

Remove



NOTE: To ease pump removal set engine to T.D.C. on No.1 cylinder.

1. Disconnect battery negative lead.
2. Detach servo hose from vacuum pump.

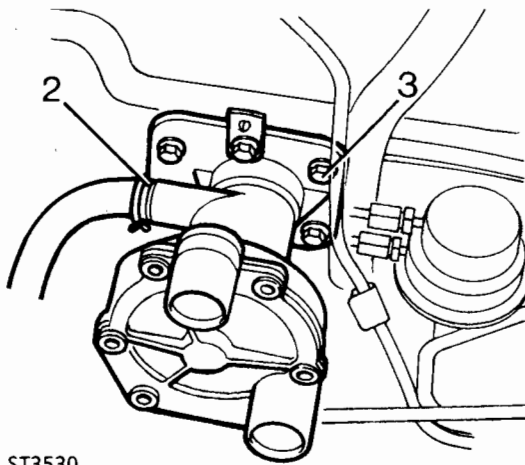

ST3530

3. Remove six bolts securing vacuum pump.
4. Detach pump complete with harness bracket. Note location of bracket for refitting.

Refit

5. Clean mating faces of pump and block.
6. Loosely assemble pump to block with a new gasket and with harness bracket located under head of bolt noted during removal.
7. Evenly tighten bolts, to depress pump plunger, finally tightening to **25 Nm**.
8. Connect vacuum hose and secure with clip.
9. Reconnect battery negative lead.

GENERATOR

Service repair no - 86.10.02

Remove

1. Disconnect battery negative lead.
2. Remove drive belt. **See Drive Belt Renew**
3. Disconnect electrical leads from rear of generator.
4. Remove securing bolt from bottom of generator.
5. Remove long through bolt from top fixing and withdraw generator.

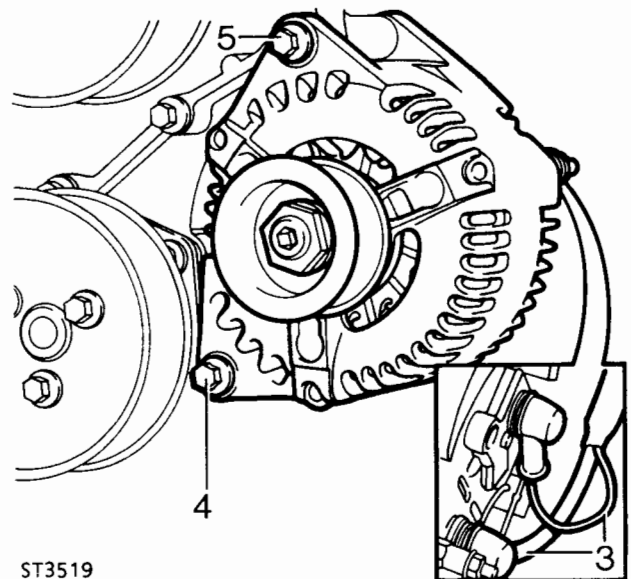

ST3519

Refit

6. Reverse removal procedure.



TORQUE VALUES



NOTE: Torque wrenches should be regularly checked for accuracy to ensure that all fixings are tightened to the correct torque.

	Nm
Engine block	
Bearing cap	133
Blanking plug, oil gallery, rear	37
Oil squirt jet assembly	17
Drain plug, cylinder block	25
Oil squirt jet, vacuum pump cam	7
Connecting rod to cap	59
Oil pick up assembly to bearing cap	9
Oil pick up assembly to front cover	25
Camshaft thrust plate	9
Oil drain pipe to block (internal)	25
Oil drain pipe to block (external)	25
Sump to cylinder block and front cover	25
Drain plug, oil sump	35
Tappet guide	14
Breather side cover assembly	25
Baffle plate to breather side cover	4
Vacuum pump	25
Fuel lift pump	25
Flywheel housing	45
Flywheel housing clutch cover stud	10
Plug, flywheel housing	12
Rear oil seal assembly	25
Oil filter adaptor	45
Waxstat adaptor to oil filter adaptor	9
Oil pressure switch	17
Oil filter, spin on	13
Oil cooler unions to filter adaptor	45
Oil level tube	25
Engine mounting foot to cylinder block	85
Engine mounting foot to flywheel housing	45
Engine mounting foot rubber to mounting foot (bolt and nut)	85
Flywheel to crankshaft	146
Clutch cover plate to flywheel	34
Flex drive plate to crankshaft (auto)	146
Flex drive plate to ring gear (auto)	25
Flex drive plate to torque converter (auto)	45

Cylinder head

Cylinder head to cylinder block	See repair section
Stub pipe heater feed	22
Water temperature sensor	14
Blanking plug cylinder head	14
Engine lifting brackets	25
Electrical harness clip bracket	25
Exhaust manifold stud	10
Exhaust manifold nut	45
Inlet manifold stud	8
Inlet manifold nut and bolt	25
Air temperature sensor, inlet manifold	14
Blanking plug, inlet manifold	14
Heatshield to inlet manifold	6
Glow plug	20
Glow plug terminal nut	2
Injector clamp (stud)	8
Injector clamp (nut)	25
Thermostat housing	25
Water outlet elbow to thermostat housing	25
Water temperature switch, thermostat housing	11
Plug thermostat housing	6
Rocker shaft pedestal bolt	5 + 50 °
Rocker cover (stud)	8
Rocker cover (fixing nut)	10
Breather cyclone to rocker cover	9
Tappet adjusting nut	16
Front cover to cylinder block	25
Front cover plate to front cover	25
Static idler - timing belt (stud)	10
Static idler - timing belt (nut)	45
Tensioner (timing belt)	45
Camshaft hub bolt	80
Timing pulley to camshaft hub	25
Fuel injection pump (stud)	8
Fuel injection pump (nut)	25
Abutment bracket to injection pump	25
Support bracket injection pump to cylinder block	25
Fuel injection pump access plate to front cover plate	25
Timing pulley to injection pump hub	25
TV Damper pulley bolt to crankshaft	80 + 90 °
Fan pulley to hub	25
Fan and viscous coupling to hub	45
Auto tensioner, auxiliary drive (stud)	14
Auto tensioner, auxiliary drive (nut)	45
Auxiliary mounting bracket to cylinder block (stud)	8
Auxiliary mounting bracket to cylinder block (bolt and nut)	25
Water pump to block and mounting plate	25
Water pump pulley to hub	25



Turbo charger oil drain adaptor to block	42
Oil drain pipe to turbocharger	25
Turbocharger oil drain pipe to adaptor	38
Turbocharger oil feed pipe adaptor to block	25
Turbocharger oil feed pipe to adaptor	25
Oil feed pipe to turbocharger	19
Turbocharger to cylinder head (stud)	10
Turbocharger to cylinder head (nut)	45
Turbocharger to blanking plate	25
Turbocharger to EGR valve	25
EGR delivery tube to valve	25
EGR delivery tube to mixing tube	25
Fuel lift pump to filter (union)	15
Fuel filter from lift pump (banjo bolt)	33
Fuel filter to fuel injection pump (banjo bolt)	33
Fuel injection pump from fuel filter (banjo bolt)	25
Injector pipes to injectors and fuel injection pump	29
Spill rail to injectors (banjo bolt)	10
Spill rail to injection pump (banjo bolt)	25
Boost pipe injection pump (banjo bolt)	10
Plug, rear of injection pump	29
PAS pump to mounting plate	25
PAS pump mounting plate to auxiliaries mounting bracket	25
PAS pump pulley to hub	25
Generator to auxiliaries mounting bracket	25
Starter motor (bolt and nut)	45
Tachometer electrical connection	4
Air conditioning compressor	
Compressor mounting bracket to front cover	45
Compressor to mounting bracket (stud)	8
Compressor to mounting bracket (nut)	25
Belt tensioner pulley to tensioner arm	45
Belt tensioner assembly to front cover plate	25
Idler pulley to front cover plate	45
Compressor belt guard (nut)	25
Sensors to water outlet elbow (air/con)	25
Blanking plug, water outlet elbow (air/con)	25
Generator mounting bracket to front cover	45
Generator to mounting bracket	85
Generator pulley to hub	95
Generator belt guard	25

METRIC	Nm
M5	6
M6	9
M8	25
M10	45
M12	90
M14	105
M16	180

UNC / UNF	Nm
1/4	9
5/16	24
3/8	39
7/16	78
1/2	90
5/8	136



NOTE: Torque values above are for all screws and bolts used except for those specified.

12 - ENGINE

CONTENTS

Page

V8

DESCRIPTION AND OPERATION

DESCRIPTION	1
-------------------	---

FAULT DIAGNOSIS

ENGINE OIL PRESSURE TEST	1
CYLINDER COMPRESSION - TEST	1
ENGINE NOISES	2
ENGINE STARTING PROBLEMS	3
ENGINE RUNNING PROBLEMS	3

REPAIR

DRIVE BELT	1
DRIVE BELT RENEW	1
DRIVE BELT - CHECK TENSION	2
DRIVE BELT TENSIONER	3
CYLINDER HEAD GASKETS - RENEW	4
CYLINDER HEADS - RENEW	5
ROCKER COVER - RIGHT HAND - RENEW	5
ROCKER COVER - LEFT HAND - RENEW	6
ROCKER SHAFT RENEW	7
HYDRAULIC TAPPETS RENEW	7
CRANKSHAFT PULLEY ASSEMBLY	8
FRONT COVER OIL SEAL - RENEW	8
FRONT COVER GASKET	9
TIMING CHAIN AND CHAINWHEELS	10
FLYWHEEL	10
FLEXIBLE DRIVE PLATE AND RING GEAR	11
CRANKSHAFT REAR OIL SEAL	11
ENGINE	12
OIL SUMP	15

SPECIFICATIONS, TORQUE

TORQUE VALUES	1
---------------------	---

SERVICE TOOLS

ENGINE	1
--------------	---





DESCRIPTION

The V8i engine has cast aluminium cylinder heads and cylinder block. The two banks of steel cylinder liners which are pressed down to stops in the block, are set at 90° to one another. The three ringed aluminium pistons transmit the power through the connecting rods to a cast iron five bearing crankshaft, which drives the centrally located camshaft via a duplex type chain.

The electronic ignition distributor is driven by a gear off the front of the camshaft and the lubrication oil pump is driven by a gear off the front of the crankshaft. The overhead inlet and exhaust valves are operated by rocker shafts, pushrods and self adjusting hydraulic tappets.

Multipoint fuel injection ensures that engine performance, economy and exhaust emissions are automatically correct for the demands of highway and off road operation.

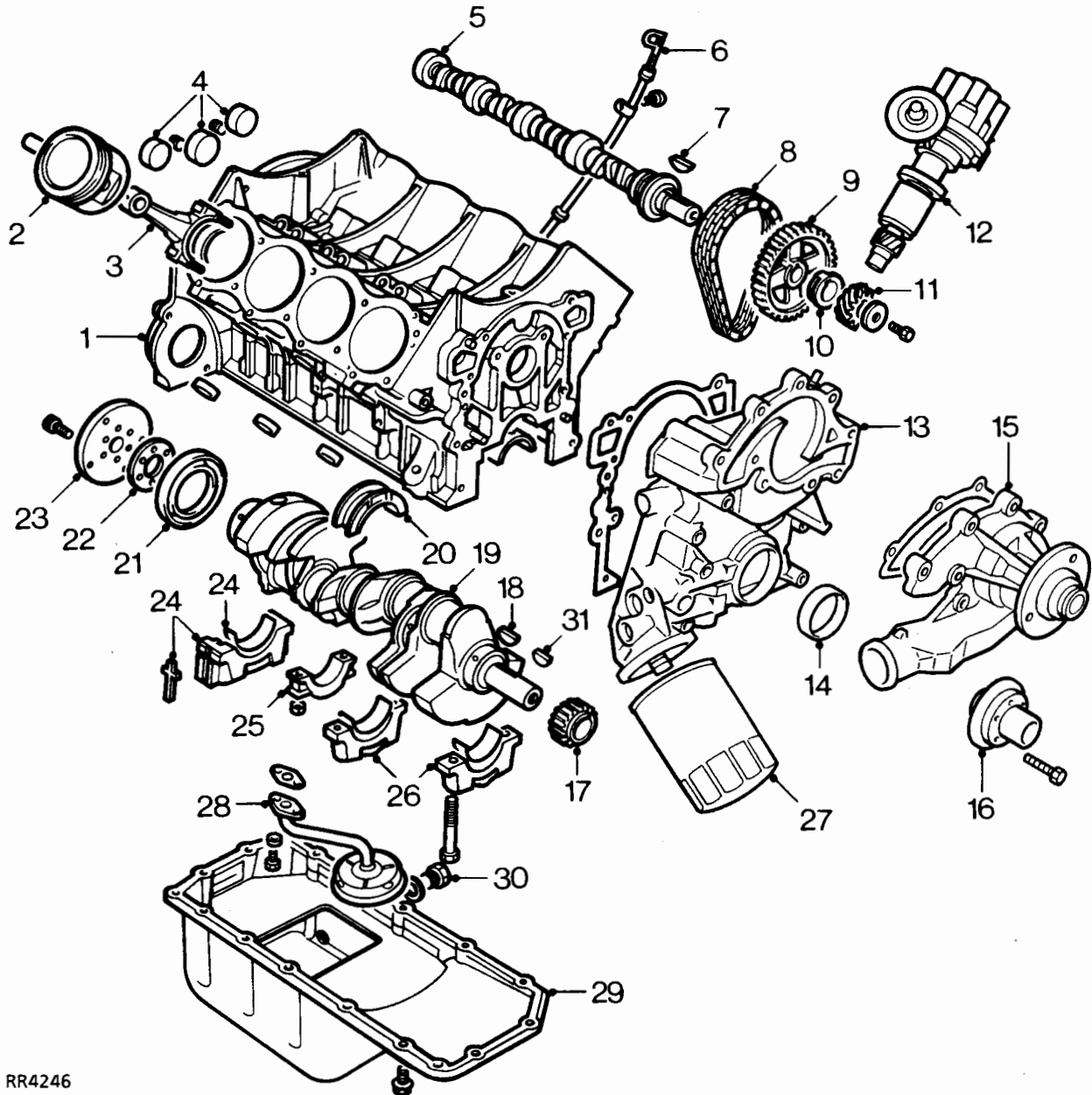

RR4246

- | | |
|---------------------------------|---|
| 1. Cylinder block | 17. Crankshaft sprocket |
| 2. Pistons and gudgeon pins (8) | 18. Crankshaft sprocket key |
| 3. Connecting rods (8) | 19. Crankshaft |
| 4. Core plugs | 20. Centre main bearing shells (2) |
| 5. Camshaft | 21. Crankshaft rear oil seal |
| 6. Dipstick | 22. Spacer |
| 7. Camshaft key | 23. Adaptor plate |
| 8. Timing chain | 24. Rear main bearing cap, shell and side seals |
| 9. Camshaft sprocket | 25. Connecting rod caps |
| 10. Distance piece | 26. Main bearing caps and shell bearings |
| 11. Distributor drive gear | 27. Oil filter |
| 12. Distributor | 28. Oil pump suction pipe/strainer |
| 13. Front cover | 29. Oil sump |
| 14. Front cover oil seal | 30. Oil sump drain plug |
| 15. Coolant pump | 31. Oil pump drive key |
| 16. Crankshaft damper / pulley | |

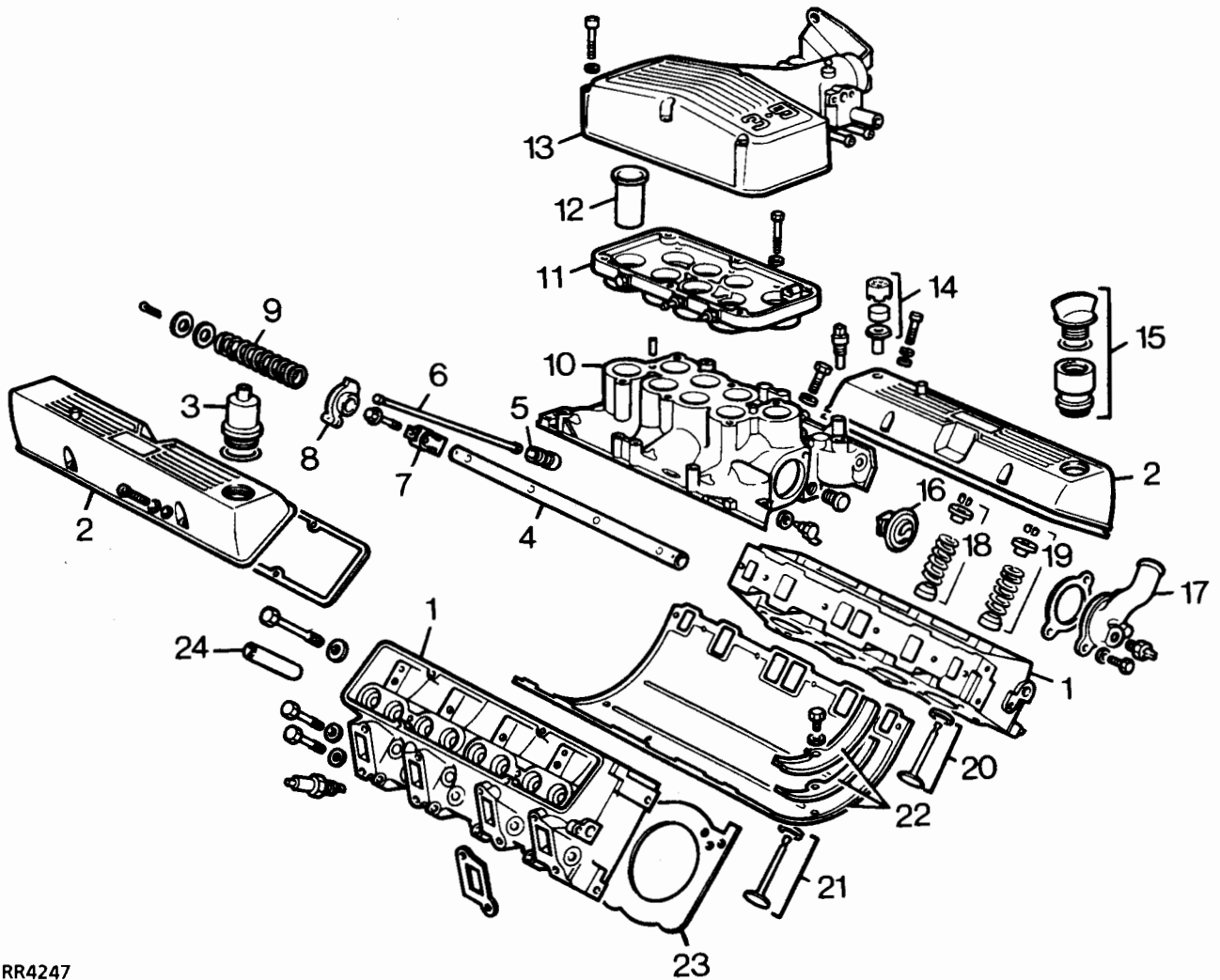

RR4247

- | | |
|---------------------------------------|---|
| 1. Cylinder heads (2) | 13. Plenum chamber upper |
| 2. Rocker covers (2) | 14. PCV air intake filter |
| 3. PCV filter | 15. Oil filler |
| 4. Rocker shafts (2) | 16. Thermostat |
| 5. Hydraulic tappets (8) | 17. Thermostat cover |
| 6. Pushrods (8) | 18. Inlet valve seal, spring, cap and collets (8) |
| 7. Rocker brackets (8) | 19. Exhaust valve seal, spring, cap and collets (8) |
| 8. Rocker arms (4) left and (4) right | 20. Inlet valve and seat (8) |
| 9. Rocker shaft springs (6) | 21. Exhaust valve and seat (8) |
| 10. Inlet manifold | 22. Inlet manifold gasket and seals |
| 11. Plenum chamber lower | 23. Cylinder head gaskets (2) |
| 12. Ram pipes (8) | 24. Valve guides (16) |

Lubrication system

The V8i full flow lubrication system uses a gear type oil pump which is driven from the front of the crankshaft. The oil pump gears are housed in the front cover and the pressure relief valve, warning light switch and filter are also fitted to the front cover.

Oil drawn through the centrally located steel gauze strainer in the sump, is pumped under pressure through oil cooler located in the lower half of the main coolant radiator. The cooled oil then passes through the filter, before being distributed from the main gallery via drillings, to the various components in the engine.

Lubrication to the thrust side of the cylinders is by oil grooves machined in each connecting rod big end joint face, which are timed to align with holes in the big end journals on the power and exhaust strokes.

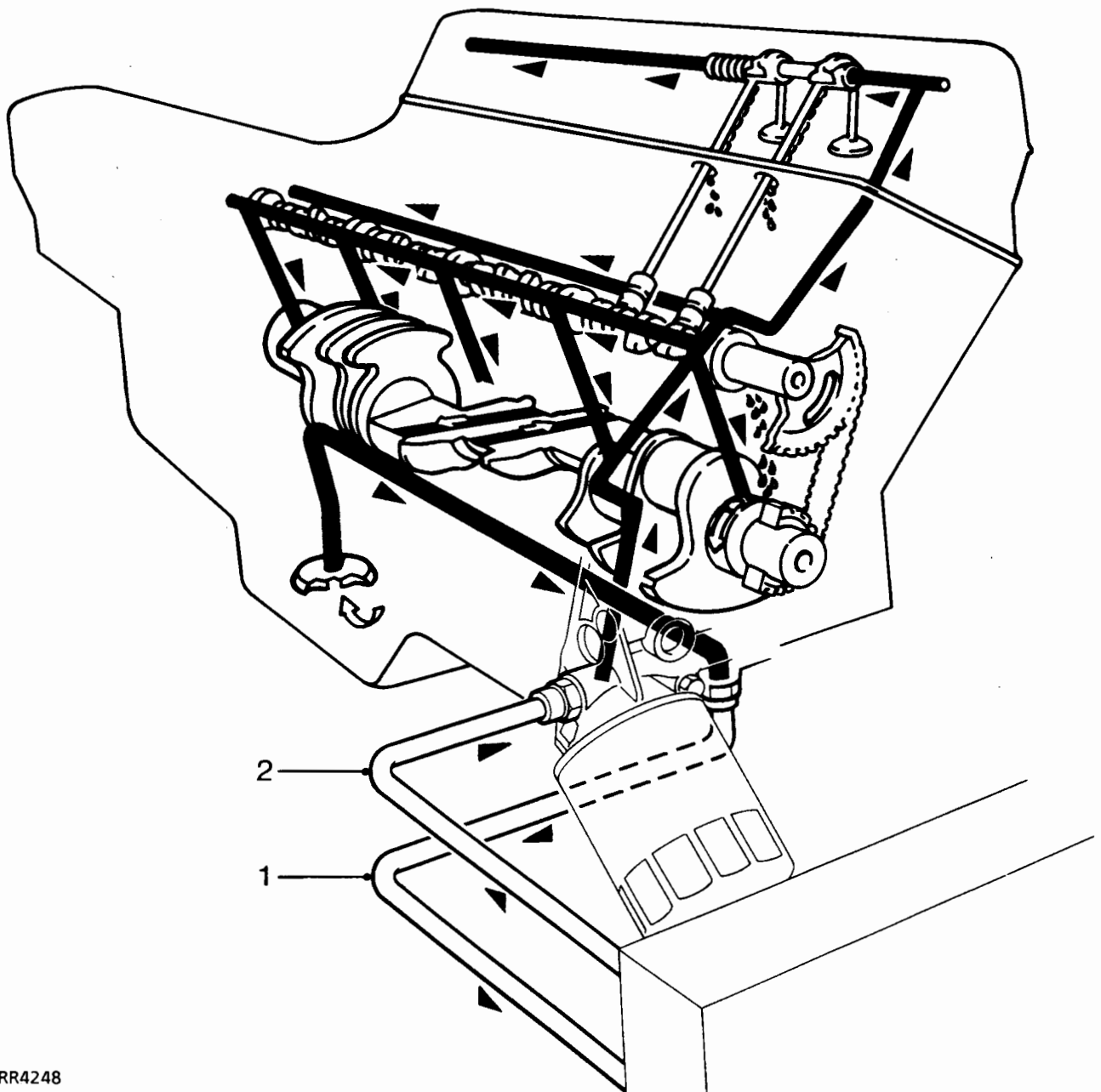

Lubrication system

1. Oil to cooler
2. Oil from cooler



Distributor and timing chain lubrication

The distributor and timing chain are lubricated from the camshaft front bearing. The feed to the timing chain is channelled along the camshaft sprocket, key and spacer where it sprays onto the chain.

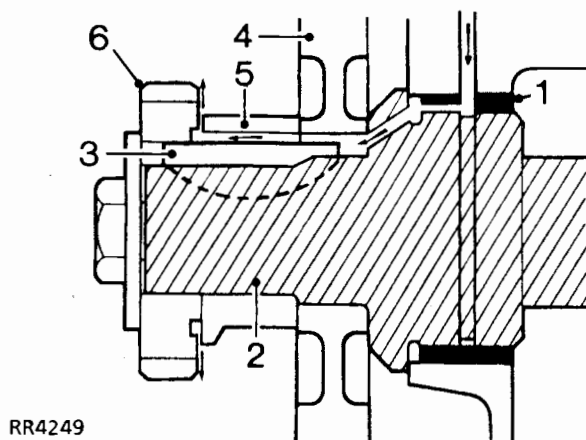

RR4249

1. Bearing
2. Camshaft
3. Key
4. Camshaft timing chain sprocket
5. Spacer
6. Distributor drive gear

Hydraulic tappets

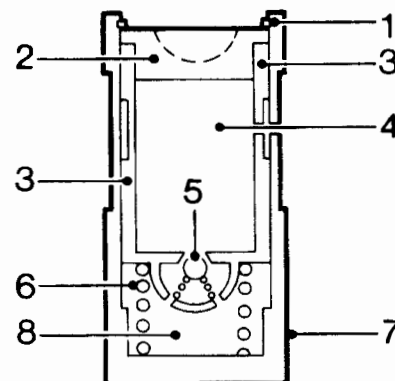

RR4250

1. Clip
2. Pushrod seat
3. Inner sleeve
4. Upper chamber
5. Non-return ball valve
6. Spring
7. Outer sleeve
8. Lower chamber - high pressure

The purpose of the hydraulic tappet is to provide maintenance free and quiet operation of the inlet and exhaust valves. It achieves its designed purpose by utilizing engine oil pressure to eliminate the mechanical clearance between the rockers and the valve stems.

During normal operation, engine oil pressure present in the upper chamber 4, passes through the non-return ball valve 5 and into the lower (high pressure) chamber 8.

When the cam begins to lift the outer sleeve 7, the resistance of the cylinder valve spring felt through the pushrod seat 2, causes the inner sleeve 3, to move downwards inside the outer. This slight downward movement of the inner sleeve closes the ball valve 5 and increases the hydraulic pressure in the high pressure chamber, sufficient to ensure that the push rod opens the valve fully.

As the tappet assembly moves off the peak of the cam the ball valve 5 opens to equalize the pressure in both chambers which ensures that the valve fully closes when the tappet is on the back of the cam.



ENGINE OIL PRESSURE TEST

Service tools:

LRT-12-052: Pressure test equipment



WARNING: Use suitable exhaust extraction equipment, if test is being carried out in workshop.



WARNING: If vehicle has been running, engine oil will be hot, care must be taken when fitting equipment to prevent personal injury due to scalding.

Test

1. Check lubricant is to correct level.
2. Place vehicle on a ramp [hoist].
3. Disconnect battery negative lead. Remove oil pressure switch.
4. Fit the test gauge.
5. Reconnect battery negative lead.
6. Start and run engine to normal operating temperature.
7. At a steady engine speed of 2500 rev/min - engine oil pressure reading should be - 2.75 bar (40 lbf/in²).
8. If the pressure is low - Remove and overhaul oil pump

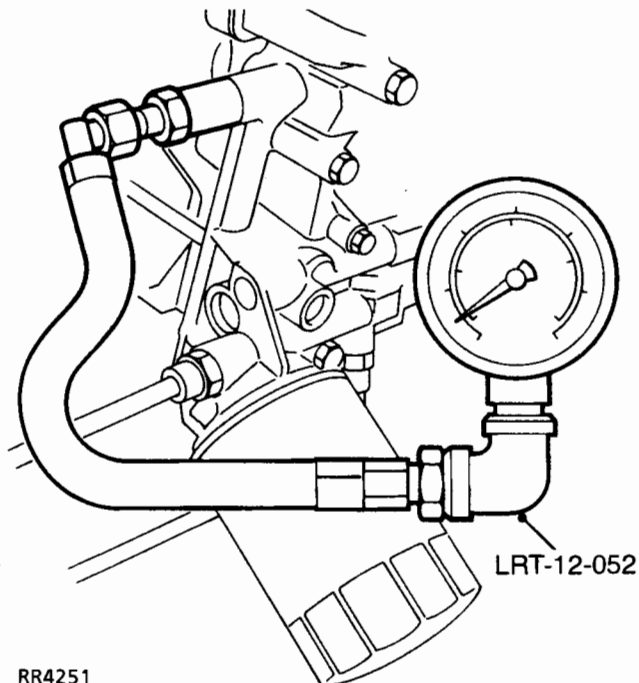

RR4251

CYLINDER COMPRESSION - TEST

Equipment:

Compression pressure gauge

Test

1. Start and run engine until normal engine operating temperature is achieved (thermostat open).
2. Remove all spark plugs.
3. Disconnect both coil negative (WB) leads
4. Insert compression gauge, crank engine until reading stabilises.
5. Expected readings, throttle fully open, battery fully charged:
 - 8.31:1 = 10.2-10.9 bar, 150-160lbf/in²
 - 9.35:1 = 11.5-12.2 bar, 170-180lbf/in²

ENGINE NOISES

Excessive or obtrusive noise from the engine compartment originates from three main sources:

- A. The exhaust system, which makes an unmistakable and easy to diagnose noise.
- B. External components emit the greatest variety of noises, but are also easy to diagnose by simply removing the drive belt.
- C. Engine internal mechanical noises which can vary in volume and pitch and may be a combination of, tapping - knocking or rumbling, are the most difficult to diagnose. The following is therefore a guide to diagnosis of engine internal mechanical noises only.

Engine internal mechanical noises.

Single or multiple, light tapping noise, particularly when engine is cold. *See Description and operation, Description*

1. Is engine oil level correct?
NO - Top up to correct level. *See LUBRICANTS, FLUIDS AND CAPACITIES, Information, Recommended Lubricants and Fluids*
YES - Continue.
2. Is the lubricating pressure correct?
NO - *See Engine Oil Pressure Test*
YES - Suspect valve operating mechanism.
3. To confirm diagnosis, remove the rocker covers and with the engine idling, insert a feeler gauge of 0,015mm between each rocker and valve stem. A faulty valve operating mechanism will emit a different noise when the feeler gauge is inserted. *See Repair, Rocker Shaft Renew*

Heavy knocking noise (particularly on load and when engine is hot). *See Description and operation, Description*

1. Is engine oil level correct?
NO - Top up to correct level. *See LUBRICANTS, FLUIDS AND CAPACITIES, Information, Recommended Lubricants and Fluids*
YES - Continue.
2. Is the lubricating pressure correct?
NO - *See Engine Oil Pressure Test*
YES - Drain engine oil and filter, and examine for metallic contamination.
3. Is the oil contaminated with metal particles?
YES - Suspect faulty big end bearings. To confirm diagnosis, short out the ignition to each spark plug in turn. The noise will disappear or be reduced when the cylinder with the faulty big end is shorted out.
4. If noise is not conclusively diagnosed, check the security of the flywheel and crankshaft front pulley. Temporarily release the drive belt to reduce general noise level and use a stethoscope to locate source of noise.

Heavy rumbling noise (particularly during hard acceleration). *See Description and operation, Description*

1. Is engine oil level correct?
NO - Top up to correct level. *See LUBRICANTS, FLUIDS AND CAPACITIES, Information, Recommended Lubricants and Fluids*
YES - Continue.
2. Is the lubricating pressure correct?
NO - *See Engine Oil Pressure Test*
YES - Drain engine oil and filter, and examine for metallic contamination.
3. Is the oil contaminated with metal particles?
YES - Suspect faulty main bearings. If noise is not conclusively diagnosed, check the security of the flywheel and crankshaft front pulley. Temporarily release the drive belt to reduce general noise level and use a stethoscope to locate source of noise.



ENGINE STARTING PROBLEMS

Engine fails to crank in park or neutral (Automatic Transmission)

1. Is battery in good state of charge?
NO - *See INTRODUCTION, Information, Jump Starting*
YES - Continue.
2. Is automatic transmission inhibitor switch faulty or gear selection linkage incorrectly adjusted?
YES - *See AUTOMATIC GEARBOX, Repair, Inhibitor Switch*,
NO - *See Electrical Trouble Shooting Manual*.
If problem is not diagnosed repeat tests, starting at 1.

Engine fails to crank (Manual Transmission)

1. Is battery in good state of charge?
NO - *See INTRODUCTION, Information, Jump Starting*
YES - *See Electrical Trouble Shooting Manual*.
If problem is not diagnosed repeat tests, starting at 1.

Engine cranks but fails to start

1. Is the cranking speed fast enough (120 rpm)?
NO - *See INTRODUCTION, Information, Jump Starting*
If necessary also. *See Electrical Trouble Shooting Manual*.
YES - Continue.
2. Is there combustion in any cylinder?
NO - *See ELECTRICAL, Fault diagnosis, Lucas Constant Energy Ignition System - V8i See Electrical Trouble Shooting Manual*.
YES - Continue.
3. Are the fuel supply, tank, pump, ventilation and emission control systems in correct working order or the fuel contaminated?
NO - *See FUEL SYSTEM, Repair, Fuel Filter See FUEL SYSTEM, Repair, Fuel Tank See FUEL SYSTEM, Repair, Fuel pump and Sender Unit See EMISSION CONTROL, Description and operation, Emission control*
If problem is not diagnosed repeat tests, starting at 2.

ENGINE RUNNING PROBLEMS

Engine runs at high speed but will not idle (stops) Engine idle speed erratic Engine starts but stops immediately

Engine stalls Engine misfires/hesitation

1. Multiport fuel injection. *See Electrical Trouble Shooting Manual. See ELECTRICAL, Fault diagnosis, Lucas Constant Energy Ignition System - V8i*
Check brake vacuum connections. *See BRAKES, Description and operation, Brake Servo Unit*
Check heater/ventilation unit vacuum connections. *See HEATING AND VENTILATION, Description and operation, Heating and Ventilation Unit*
If problem is not diagnosed continue.
2. Are HT leads correctly routed and clipped?
NO - *See ELECTRICAL, Repair, Distributor - V8i*
YES - Continue.
3. Is fuel supply, tank, pump, ventilation and emission control systems in correct working order or the fuel contaminated?
NO - *See FUEL SYSTEM, Repair, Fuel Filter See FUEL SYSTEM, Repair, Fuel Tank See FUEL SYSTEM, Repair, Fuel Pump and Sender Unit See EMISSION CONTROL, Description and operation, Emission Control*
If problem is not diagnosed repeat tests, starting at 1.

Engine lacks power/poor performance

1. Is throttle travel restricted or cable incorrectly adjusted?
YES - Check thickness of carpets. *See FUEL SYSTEM, Repair, Throttle Cable See FUEL SYSTEM, Repair, Accelerator Pedal*
NO - Continue.
2. Are the Ignition and Multiport Fuel Injection systems in order?
NO - *See Electrical Trouble Shooting Manual.A1 See ELECTRICAL, Fault diagnosis, Lucas Constant Energy Ignition System - V8i See ELECTRICAL, Repair, Distributor - V8i*
YES - Continue.

3. Are fuel supply, tank, pump, ventilation and emission control systems in correct working order or the fuel contaminated?
NO - **See FUEL SYSTEM, Repair, Fuel Filter See FUEL SYSTEM, Repair, Fuel Tank See FUEL SYSTEM, Repair, Fuel Pump and Sender Unit**
YES - Suspect valves held open by hydraulic tappets due to high oil pressure. **See Engine Oil Pressure Test**
4. Is oil pressure high?
YES - Remove oil filter and cooler adaptor and check pressure relief valve strainer gauze for blockage and that the relief valve is not stuck closed. **See Description and operation, Description**
NO - Carry out cylinder compression tests to determine condition of head gaskets and valves. **See Cylinder Compression - Test**
5. Are cylinder compressions satisfactory?
NO - **See Repair, Cylinder Heads - Renew**
YES - Check brake vacuum connections. **See BRAKES, Description and operation, Brake Servo Unit**

Check heater/ventilation unit vacuum connections. **See HEATING AND VENTILATION, Description and operation, Heating and Ventilation Unit**

If problem is not diagnosed: Continue.

6. Are the brakes binding?
YES - Investigate cause of binding.
NO - Continue.
7. Automatic Transmission only. Is the Torque Converter and Transmission operating correctly?
Carry out Road test, Static tests and Stall tests to determine condition of Automatic transmission.

If problem is not diagnosed: repeat tests starting at 1.

Engine backfires into exhaust system

1. Are there any leaking joints/connections or holes in the exhaust system?
YES - **See MANIFOLD AND EXHAUST SYSTEM, Repair, Exhaust System Complete**
NO - Continue.
2. Is distributor fitted correctly, HT leads in correct firing order and routed correctly?
NO - **See ELECTRICAL, Repair, Distributor - V8i**
YES - Continue.
3. Is air fuel ratio correct?
NO - Check multiport fuel injection. **See Electrical Trouble Shooting Manual.**
Check brake vacuum connections. **See BRAKES, Description and operation, Brake Servo Unit**
Check heater/ventilation unit vacuum connections. **See HEATING AND VENTILATION, Description and operation, Heating and Ventilation Unit**
Check the crank case and fuel tank ventilation system. **See EMISSION CONTROL, Description and operation, Emission Control**
YES - Continue.
4. Are cylinder compressions satisfactory?
NO - Carry out compression test to check for leaking gaskets valves etc. **See Cylinder Compression - Test**
See Repair, Cylinder Heads - Renew

If problem is not diagnosed: repeat tests starting at 1.



Engine backfires into inlet system

1. Is the Distributor, HT connections and routing correct?
NO - **See ELECTRICAL, Repair, Distributor - V8i**
YES - Continue.

2. Is air fuel ratio correct?
NO - Check multipoint fuel injection. **See Electrical Trouble Shooting Manual.**
Check brake vacuum connections. **See BRAKES, Description and operation, Brake Servo Unit**
Check heater/ventilation unit vacuum connections. **See HEATING AND VENTILATION, Description and operation, Heating and Ventilation Unit**
Check the crank case and fuel tank ventilation system. **See EMISSION CONTROL, Description and operation, Emission Control**
YES - Continue.

3. Are cylinder compressions satisfactory?
NO - Carry out compression test to check for leaking gaskets valves etc. **See Cylinder Compression - Test**
For repair **See Repair, Cylinder Heads - Renew**

If problem is not diagnosed: repeat tests starting at 1.



DRIVE BELT

A single 'serpentine drive belt' is introduced for 1995 model year. This belt drives the water pump and all the ancillaries. It is essential that the belt is fitted exactly as shown in illustrations RR3956 and RR3957. It should also be noted that the water pump/viscous fan is driven in a counter clockwise direction.

A drive belt tensioner automatically tensions the drive belt, eliminating the need for tensioning individual drive belts. Turning the tensioner pulley in a clockwise direction will release drive belt tension.

Under normal highway use the belt must be changed at 120,000 kilometres, 75,000 miles or five years whichever occurs first.

The drive belt must be examined at every service and replaced if necessary.

Off road driving

Regular examination of the drive belt is essential if the vehicle is used off road. The vehicle driver should be requested to identify the type of mileage the vehicle has covered.

After every off road session the owner should inspect the belt for cuts and possible damage caused by stones. If belt has jumped, reposition belt correctly. A new belt must be fitted at the next service or before, dependant on the type of damage sustained.

Fan cowl

To ensure easy access to the drive belt the top portion of the fan cowl is detachable.

Check condition

Check condition of drive belt. Renew a belt that shows signs of wear, splitting or oil contamination.

DRIVE BELT RENEW

Service repair no - 86.10.03

Air conditioning

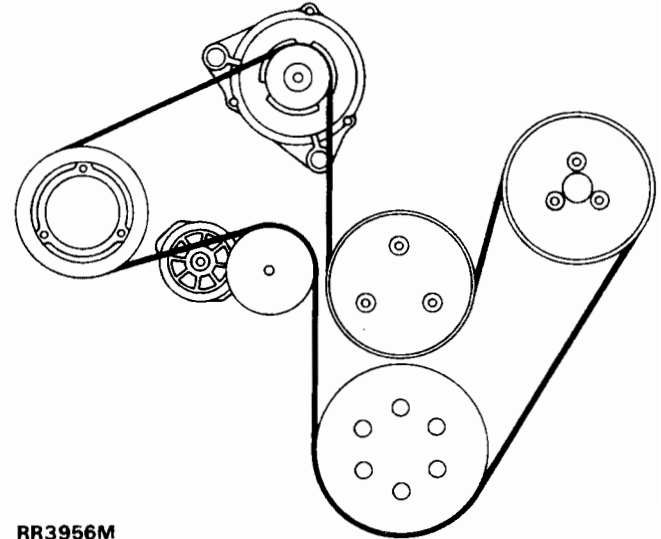

RR3956M

Non air conditioning

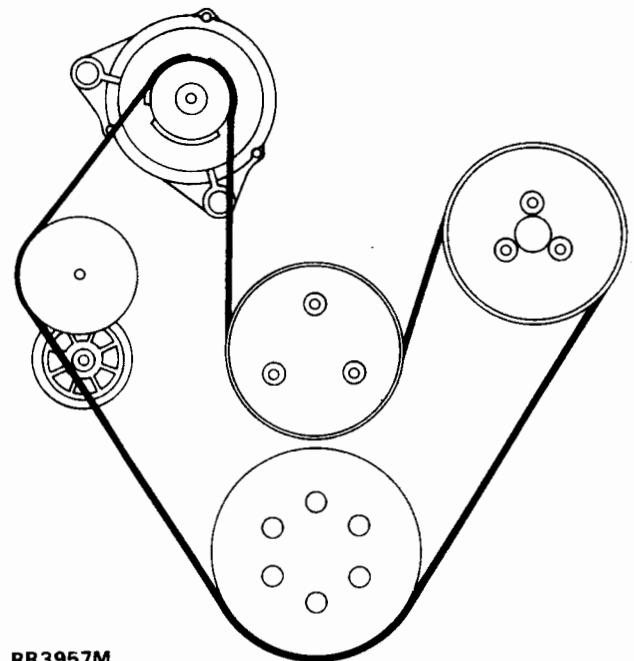

RR3957M

Remove

1. Remove fan cowl upper.
2. Release drive belt tension by turning tensioner clockwise.

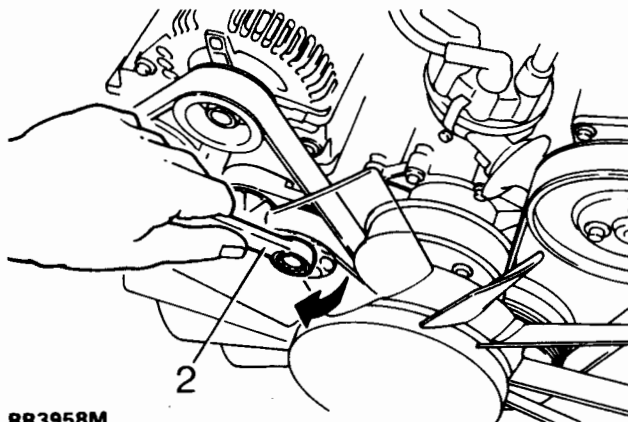

RR3958M

3. With tension released, remove belt from generator pulley.
4. Release tensioner pulley.
5. Remove drive belt. Mark direction of rotation on belt if refitting

Refit

6. Clean drive belt pulley grooves and ensure grooves are not damaged.
7. Position belt correctly around all pulleys except generator. Illustrations RR3956 and RR3957 show correct drive belt run.
8. Turn drive belt tensioner clockwise.
9. Locate drive belt on generator pulley.
10. Ensure drive belt is squarely located on pulleys with all grooves engaged.
11. Release tensioner to tension drive belt.
12. Fit upper fan cowl section.

DRIVE BELT - CHECK TENSION

As the drive belt is automatically tensioned, no tension check or adjustment should be necessary. If the drive belt is believed to be slack carry out the following checks:

1. Visually check drive belt tension.
2. Watch movement of tensioner with engine running, 5 mm 'bounce' is normal. If tensioner movement is 12 mm or more, fit a new tensioner. **See Drive Belt Tensioner**
3. Inspect tensioner. Is the tensioner arm and spring case in contact? If so fit a new tensioner.
4. Using a recognised drive belt tensioning gauge, check belt tension several times, running engine between checks. The checks should be made at the same point on the belt, away from the tensioner.

Drive belt tension, with used tensioner and used drive belt should be more than:-

270N. Non air conditioning or
295N with air conditioning.



DRIVE BELT TENSIONER

Service repair no - 86.10.09

Remove

1. Remove drive belt from tensioner. *See Drive Belt Renew*
2. Loosen tensioner centre bolt.
3. Remove bolt and tensioner.

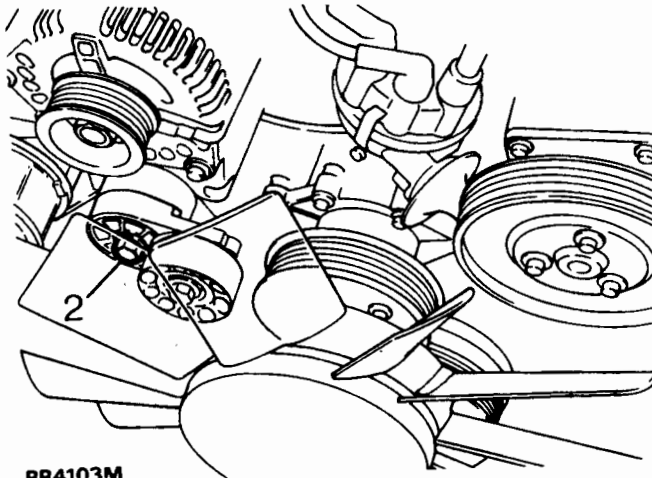

Refit

4. Reverse removal procedure.

CYLINDER HEAD GASKETS - RENEW

Service repair no - 12.29.01

1. Drain cooling system. *See COOLING SYSTEM, Adjustment, Coolant*
2. Remove inlet manifold. *See FUEL SYSTEM, Repair, Intake Manifold*
3. Remove generator.
4. If fitted, remove compressor. *See AIR CONDITIONING, Repair, Compressor*
5. Remove rocker shafts. *See Rocker Shaft Renew*
6. Remove push rods.
7. Remove both exhaust manifolds. *See MANIFOLD AND EXHAUST SYSTEM, Repair, Exhaust Manifold - V8i*
8. Remove air cleaner assembly. *See FUEL SYSTEM, Repair, Air Cleaner*
9. Remove air flow sensor. *See FUEL SYSTEM, Repair, Air Flow Sensor*
10. Remove ground leads from rear of left hand cylinder head
11. Right hand cylinder head - remove breather pipe from lifting bracket.
12. Loosen cylinder head bolts, reversing tightening sequence.
13. Remove cylinder heads.
14. Remove cylinder head gaskets.
15. Clean exhaust mating faces.
16. Clean head and block faces.
17. Fit new cylinder head gaskets, word TOP uppermost. DO NOT use sealant.
18. Oil cylinder bores.
19. Clean threads of head bolts and lightly oil.
20. Locate cylinder heads on block.
21. Locate cylinder head bolts in position illustrated.
96 mm long bolts - 2, 4, 6, 7, 8, 9, 10
66 mm long bolts - 1, 3, 5



NOTE: There are no bolts fitted in the four lower holes in each cylinder head.

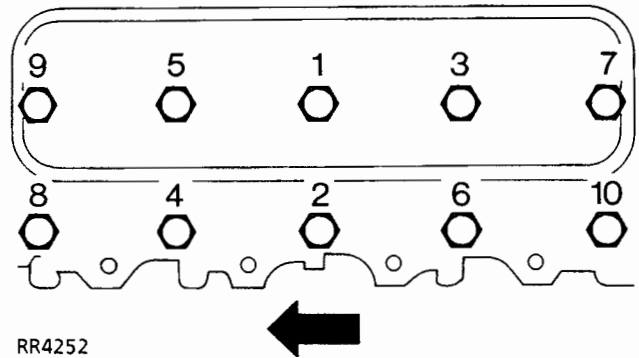

RR4252



NOTE: Left hand cylinder head illustrated, arrow points to front of vehicle.

22. Tighten bolts progressively in sequence, shown to **20 Nm** then a further $180^\circ \pm 5^\circ$
23. Reverse removal procedure. 1 to 11.



CYLINDER HEADS - RENEW

Service repair no - 12.29.15

1. Remove cylinder heads and gaskets. See **Cylinder Head Gaskets - Renew**
2. Remove spark plugs.
3. Using spring compressor LRT-12-034, remove seals, valves, collets, springs and caps.



CAUTION: Keep components in fitted order

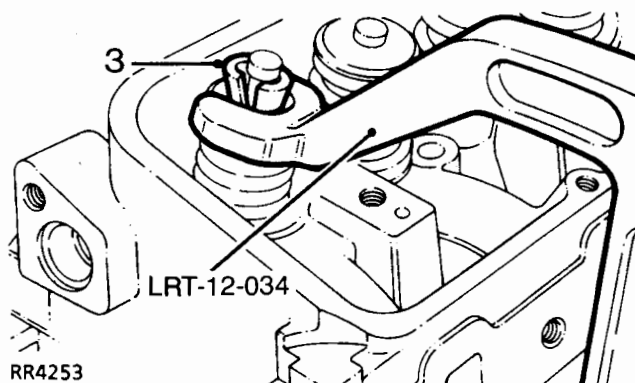

4. From left hand cylinder head, remove earth lead studs.
5. Remove three bolts securing power steering pump mounting bracket to cylinder head.
6. Remove four bolts securing generator mounting bracket to cylinder head.
7. Right hand cylinder head, remove rear lifting bracket.
8. Fit lifting bracket to new right hand cylinder head.
9. Fit mounting brackets and earth lead studs to new cylinder head. Tighten bolts to **30 Nm**.
10. Re grind valves- refer to engine overhaul publication
11. Lubricate valve stems, fit valves, springs, and caps. Fit new inlet and exhaust valve stem seals.
12. Using spring compressor LRT-12-034, compress springs, fit collets. Tap valve to check correct collet seating.
13. Fit spark plugs.
14. Fit cylinder heads with new gaskets. See **Cylinder Head Gaskets - Renew**

ROCKER COVER - RIGHT HAND - RENEW

Service repair no - 12.29.41

1. Disconnect battery negative lead.
2. Disconnect purge pipe from charcoal canister at plenum.
3. Remove breather pipe from rocker cover.
4. Remove coolant pipes from inlet manifold.
5. Remove spark plug leads from plugs and retaining clips.
6. Remove four rocker cover bolts. Moving fuel pipes aside, remove rocker cover.
7. Discard rocker cover gasket.
8. Remove plug lead retaining clips from rocker cover, fit to new rocker cover.
9. Clean and dry rocker cover and cylinder head mating faces, using Bostik cleaner 6001.



NOTE: Gasket fits one way round only. It must be fitted accurately, first time. Subsequent movement will destroy bonding.

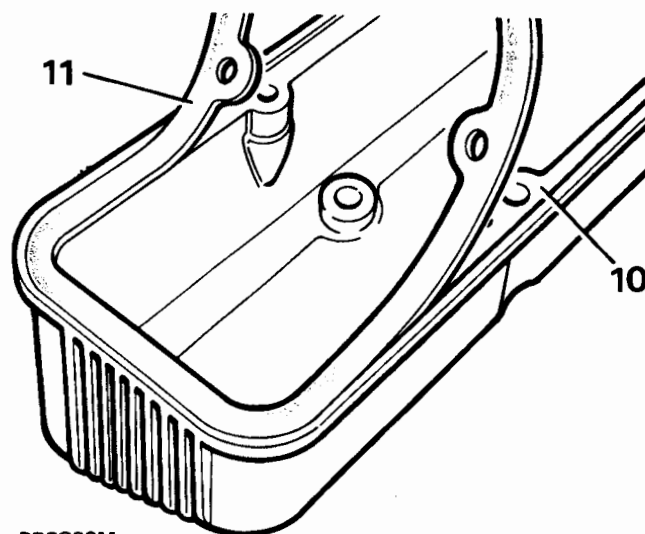

10. Apply Bostik 1775 impact adhesive to rocker cover seal face and gasket, using a brush to ensure an even film. Allow adhesive to become touch dry.

11. Place one end of gasket into cover recess with edge firmly against recess wall, holding remainder of gasket clear. Work around cover, pressing gasket into place ensuring edge firmly contacts recess wall.
12. Allow cover to stand for thirty minutes before fitting.
13. Fit rocker cover to cylinder head with four screws, short screws inboard, tighten to **9 Nm**.
14. Position fuel pipes.
15. Fit breather pipe to rocker cover, tighten clip.
16. Fit coolant pipes to inlet manifold, tighten bolts.
17. Fit spark plug leads to plugs and retaining clips.
18. Connect purge pipe from charcoal canister at plenum, tighten clip.

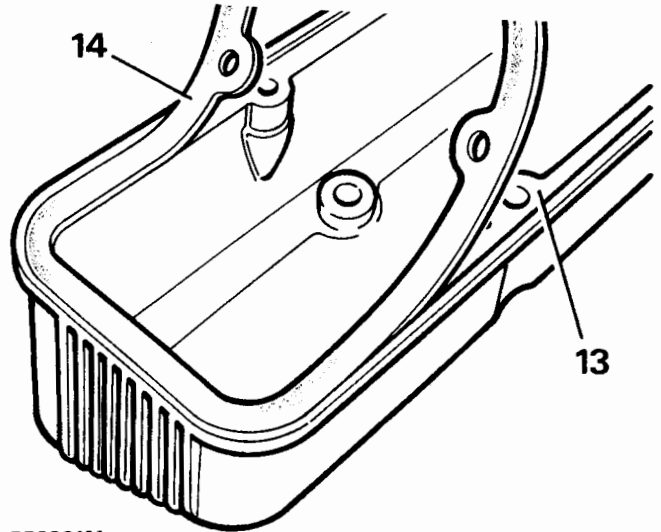

RR3821M

ROCKER COVER - LEFT HAND - RENEW

Service repair no - 12.29.40

1. Remove air flow sensor. **See FUEL SYSTEM, Repair, Air Flow Sensor**
2. Remove plenum chamber. **See FUEL SYSTEM, Repair, Plenum Chamber**
3. Remove dipstick.
4. Remove spark plug leads from plugs and retaining clips.
5. Disconnect HT lead from coil.
6. Remove generator heat shield securing nut from rocker cover.
7. Remove air flow meter harness clip.
8. Remove bolt securing dipstick tube clip.
9. Remove four rocker cover bolts, remove rocker cover.
10. Discard gasket
11. Remove plug lead retaining clips from rocker cover, fit to new rocker cover.
12. Clean and dry rocker cover and cylinder head mating faces, using Bostik cleaner 6001.

13. Apply Bostik 1775 impact adhesive to rocker cover seal face and gasket, using a brush to ensure an even film. Allow adhesive to become touch dry, approximately fifteen minutes.
14. Place one end of gasket into cover recess with edge firmly against recess wall, holding remainder of gasket clear. Work around cover, pressing gasket into place ensuring edge firmly contacts recess wall.
15. Allow cover to stand for thirty minutes before fitting.
16. Fit rocker cover to cylinder head with four screws, short screws inboard. Tighten to **9 Nm**.
17. Position dipstick tube clip. Fit and tighten bolts.
18. Fit and tighten air flow meter harness clip.
19. Fit generator heat shield to rocker cover.
20. Connect HT lead to coil.
21. Connect spark plug leads to plugs and retaining clips.
22. Fit dipstick.
23. Fit plenum chamber.
24. Fit air flow meter.



NOTE: Gasket fits one way round only. It must be fitted accurately, first time. Subsequent movement will destroy

bonding.



ROCKER SHAFT RENEW

Service repair no - 12.29.29

1. Remove rocker covers as required. See *Rocker Cover - Right Hand - Renew* or. See *Rocker Cover - Left Hand - Renew*
2. Loosen four rocker shaft fixings.

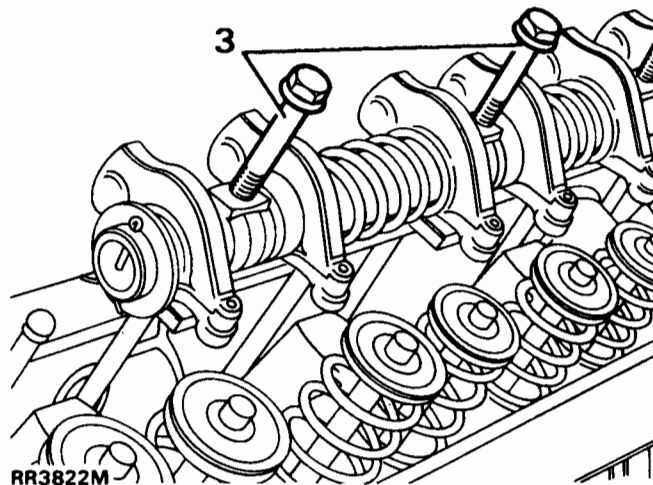

3. Remove rocker shaft assembly.



NOTE: Each rocker shaft is notched at **ONE** end. Notch must be uppermost and towards front of engine on right hand side, towards rear on left hand side.

4. Clean rocker pedestal locations on cylinder head.
5. Fit rocker shaft assembly, locating push rods to rockers.
6. Tighten rocker shaft fixings to **38 Nm**.
7. Fit rocker covers.

HYDRAULIC TAPPETS RENEW

Service repair no - 12.29.57

1. Remove rocker shafts. See *Rocker Shaft Renew*
2. Remove intake manifold. See *FUEL SYSTEM, Repair, Intake Manifold*
3. Remove push rods, retain in removal sequence.

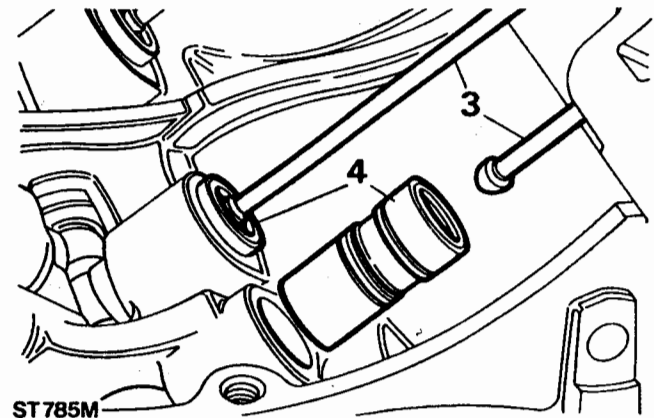

4. Remove hydraulic tappets
5. Fit tappets, push rods and rocker assemblies. See *V8 Engine Overhaul Manual*.
6. Fit inlet manifold.
7. Reverse removal procedure.

CRANKSHAFT PULLEY ASSEMBLY

Service repair no - 12.21.01

1. Remove viscous coupling. *See COOLING SYSTEM, Repair, Viscous Coupling, Fan Blades, Pulley and Fan Cowl*
2. Remove drive belt. *See Drive Belt*
3. Raise vehicle on ramp [hoist].
4. Remove bell housing bottom cover.
5. Remove engine undertray.
6. With assistance to stop flywheel rotation, remove crankshaft pulley assembly retaining bolt.
7. Remove crankshaft pulley assembly.
8. If required: Place assembly in vice and remove pulley.
9. Fit pulley to torsional vibration damper.
10. Lubricate seal face of assembly.
11. Fit pulley assembly.
12. With assistance to stop flywheel rotation, fit retaining bolt. Tighten to **280 Nm**.
13. Reverse removal procedure. 1 to 5.

FRONT COVER OIL SEAL - RENEW

Service repair no - 12.21.14

1. Remove crankshaft pulley. *See Crankshaft Pulley Assembly. Do not remove pulleys.*
2. Remove eight screws and remove mud excluder.
3. Fit button of 18G1328 to crankshaft, fit extractor to seal.
4. Turn centre bolt of extractor to remove seal.
5. Remove seal from extractor.
6. Clean seal seating.
7. Lubricate outside diameter of seal.
8. Locate seal in front cover.
9. Fit adaptor 18G1291/5 to 18G1291/4.
10. Fit tool to seal.
11. Fit and tighten centre bolt to crankshaft, tighten centre locknut to seat seal.
12. Slacken locknut and remove tool.
13. Lubricate seal lip.
14. Fit mud excluder and tighten screws.
15. Fit crankshaft pulley assembly.



FRONT COVER GASKET

Service repair no - 12.65.04

1. Remove crankshaft pulley. *See Crankshaft Pulley Assembly. Do not remove pulleys*
2. Remove water pump pulley.
3. Release distributor cap clips.
4. Release plug leads from plugs and clips.
5. Place cap and leads to one side.
6. Turn engine until No. 1 piston is at T.D.C.
7. Check position of rotor arm.
8. Remove fixings securing power steering pump bracket to water pump bracket.
9. Remove power steering pump bracket from water pump.
10. Remove clips securing wiring to generator tensioner.
11. Disconnect distributor feed wire.
12. Pivot power steering pump away from front cover, tighten pivot to retain in position.
13. Disconnect vacuum pipe from distributor.
14. Remove water pump bottom hose.
15. Disconnect oil pressure switch.
16. Disconnect heater hose at water pump.
17. Remove generator tensioner from water pump, move tensioner aside.
18. Mark distributor position to front cover.
19. Remove distributor clamp, remove distributor. *See ELECTRICAL, Repair, Distributor - V8i*
20. Remove fixings sump to front cover.
21. Loosen four adjacent sump fixings.
22. Remove generator support strut from front cover, move strut aside.
23. Loosen remaining front cover fixings and remove front cover.
24. Remove front cover gasket.

Refit

25. Clean timing cover, clean block face.
26. Lightly grease gasket faces.
27. Fit new gasket to block face.
28. Apply hylosil to sump gasket.
29. Clean threads of cover fixing bolts, apply Loctite 372 to threads.
30. Fit timing cover, fit fixing bolts. Tighten to **28 Nm**.
31. Fit generator support strut to front cover.
32. Tighten sump to timing cover fixings to **10 Nm**.
33. Tighten sump fixings to **10 Nm**.
34. Lubricate distributor O ring.
35. Fit distributor in position marked.
36. Align oil pump drive, if distributor does not seat correctly.
37. Fit distributor clamp. Tighten to **20 Nm**.
38. Locate generator tensioner on water pump bracket.
39. Connect heater hose, tighten clip.
40. Connect oil pressure switch.
41. Connect bottom hose, tighten clip.
42. Connect vacuum pipe to distributor.
43. Loosen power steering pump pivot, lower pump.
44. Connect distributor feed wire.
45. Connect wire ties to generator tensioner.
46. Fit power steering pump bracket to water pump. Tighten to **28 Nm**.
47. Fit power steering pump to bracket.
48. Position distributor cap. Fit plug leads to plugs and clips.
49. Clip distributor cap in position.
50. Fit water pump pulley. Tighten to **10 Nm**.
51. Fit crankshaft pulley. *See Crankshaft Pulley Assembly*
52. Tension drive belts correctly.
53. Check ignition timing.
54. Refill cooling system.

TIMING CHAIN AND CHAINWHEELS

Service repair no - 12.65.12

Remove

1. Remove front cover. *See Front Cover Gasket*
2. Remove retaining bolt and washer, remove distributor drive gear and spacer.
3. Ensure number one piston is at TDC.
4. Remove chainwheels and chain as an assembly. *See V8 Engine Overhaul Manual.*

Refit

5. Clean chainwheels and chain.
6. Fit chainwheels to chain, aligning timing marks.
7. Ensure camshaft key is fitted parallel to shaft axis to ensure adequate lubrication to distributor drive gear.
8. Engage chainwheel assembly on camshaft and crankshaft keys, ensure chain wheels are fully located.
9. Check alignment of timing marks with straight edge.
10. Fit spacer with flange to front,
11. Fit distributor drive gear with groove towards spacer.
12. Fit retaining bolt and washer. Tighten to **58 Nm**.
13. Fit front cover. *See Front Cover Gasket*

FLYWHEEL

Service repair no - 12.53.07

Remove

1. Remove gearbox and clutch. *See CLUTCH, Repair, Clutch Assembly*
2. Loosen starter motor bolts.

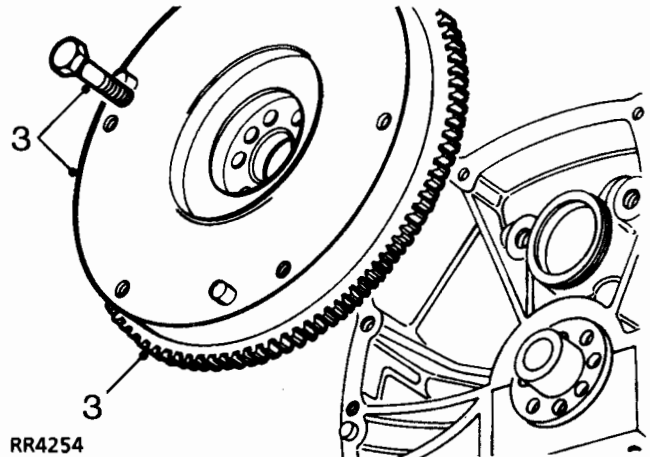

3. Lock flywheel, remove flywheel bolts and flywheel.

Refit

4. Clean components for reassembly.
5. Fit flywheel.
6. Clean threads, apply Loctite 270 to threads.
7. Lock flywheel, fit flywheel bolts. Tighten to **80 Nm**.



FLEXIBLE DRIVE PLATE AND RING GEAR

Service repair no - 12.53.13

Remove

1. Remove transmission. *See AUTOMATIC GEARBOX, Repair, ZF Auto with Borg Warner Transfer Gearbox.*
2. Remove flexible drive plate and ring gear assembly. *See V8 Engine Overhaul Manual.*

Refit

3. Clean all components for reassembly.
4. Fit ring gear and flexible drive plate assembly. *See V8 Engine Overhaul Manual.*
5. Fit transmission.

CRANKSHAFT REAR OIL SEAL

Service repair no - 12.21.20

1. Automatic transmission, remove drive plate. *See Flexible Drive Plate and Ring Gear*
OR manual transmission, remove flywheel. *See Flywheel*
2. Remove sump. *See Oil Sump*
3. Remove rear main bearing cap.
4. Remove cross seals from cap.
5. Remove crankshaft rear oil seal.
6. Clean main bearing cap and oil seal area of block.
7. Fit new cross seals to bearing cap.
8. Apply Hylomar SQ32M to block as illustrated.

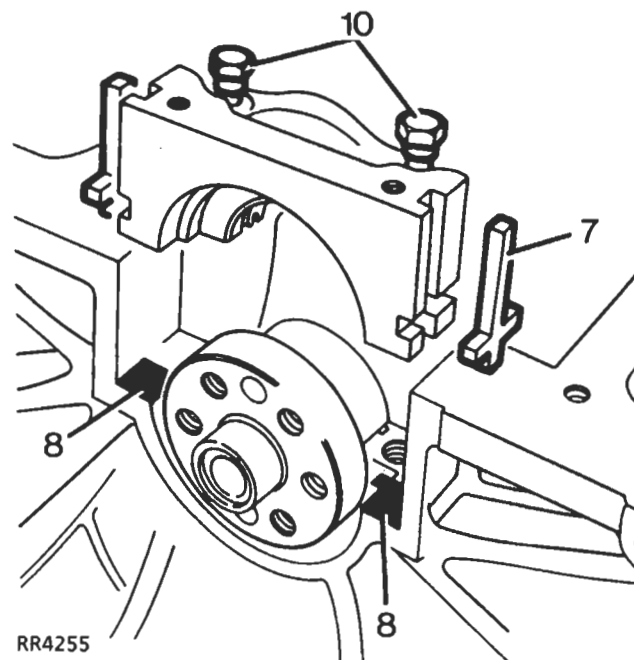

9. Lubricate bearing shell and cross seals using clean engine oil.
10. Fit bearing cap, do not tighten bolts.
11. Ensure cap is fully home and seated squarely on the block.

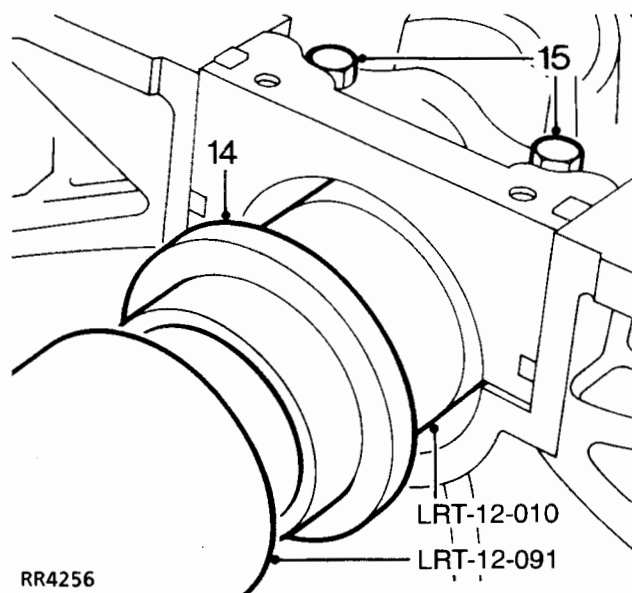

12. Ensure service tools LRT-12-010 and LRT-12-091 are scrupulously clean. Coat seal guide and oil seal journal with clean engine oil.



CAUTION: Do not handle oilseal lip, check it is not damaged. Ensure outside diameter remains clean and dry.

13. Position oil seal guide LRT-12-010 on crankshaft flange.



NOTE: Lubricant coating must cover seal guide outer surface completely to ensure that oil seal lip is not turned back during assembly. Position oil seal, lipped side towards engine, on seal guide. Seal outside diameter **MUST** be clean and dry.

14. Fit oil seal using tool LRT-12-091. Remove seal guide.
 15. Tighten rear main bearing cap to **90 Nm**.
 16. Fit sump.
 17. Fit flywheel or flexible drive plate and ring gear.

ENGINE

Service repair no - 12.41.01

Remove

1. Park vehicle on level ground and apply park brake.
2. De-pressurise fuel system. *See FUEL SYSTEM, Repair, Depressurising Fuel System*
3. Remove bonnet (hood). *See CHASSIS AND BODY, Repair, Bonnet (Hood)*
4. Remove battery. *See ELECTRICAL, Repair, Battery.*
5. Remove radiator/oil coolers. *See COOLING SYSTEM, Repair, Radiator/Oil Coolers*
6. Place an absorbent cloth around fuel feed hose at fuel rail and release compression nut. Remove feed hose from rail, seal end of pipes with masking tape to prevent ingress of dirt.
7. Release fuel return hose clamp and remove hose from pressure regulator, seal both openings with masking tape to prevent ingress of dirt.
8. Remove vacuum hose from rear of regulator.
9. Manual vehicles: Disconnect throttle cable from bracket. Automatic vehicles: Detach throttle bracket from plenum chamber and lay assembly to one side. *See FUEL SYSTEM, Repair, Plenum Chamber DO NOT DISTURB KICK DOWN CABLE SETTING.*
10. Remove ram housing. *See FUEL SYSTEM, Repair, Ram Housing*
11. Remove air flow sensor. *See FUEL SYSTEM, Repair, Air Flow Sensor*
12. Remove air cleaner assembly. *See FUEL SYSTEM, Repair, Air Cleaner*
13. Remove Generator. *See ELECTRICAL, Repair, Generator*
14. Release air conditioning compressor from its mounting and lay to one side. **DO NOT** discharge air conditioning system. *See AIR CONDITIONING, Repair, Compressor*



NOTE: Release bolts securing compressor mounting bracket to engine and remove bracket to enable temporary lifting eye ETC 5964 to be fitted. Secure lifting eye to mounting bracket fixing points with suitable bolts of equivalent size, pitch and thread. Leave lifting eye attached until engine is reinstalled in vehicle.

15. Place drain tray underneath vehicle.
16. Disconnect hose from reservoir to power steering pump. Secure hose end above level of fluid reservoir to avoid unnecessary loss of fluid.
17. Disconnect power steering pump to power steering box hose. Seal hose and pump openings with masking tape to prevent ingress of dirt. Wipe away any fluid spillage from chassis or steering box.
18. Disconnect fuel temperature and coolant temperature sensor multi-plugs.
19. Disconnect leads from coil.
20. Identify each injector multi-plug for re-assembly and disconnect plugs from injectors.
21. Manoeuvre harness from behind fuel rails and place to one side clear of engine assembly.
22. Remove two clamps securing gearbox oil cooler pipes to engine block.
23. Remove engine mounting fixings on both sides of cylinder block.
24. Fit lifting chains to engine lifting eyes as shown in illustration RR1780E.

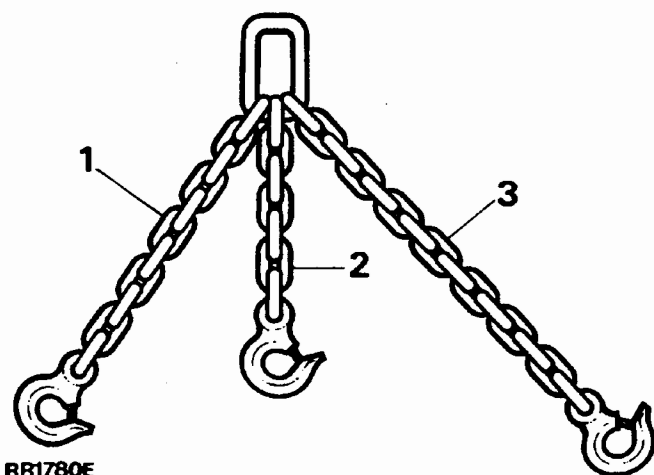

1. L/H Front chain 356mm total overall length.
2. R/H Front chain 330mm total overall length.
3. R/H Rear chain 457mm total overall length.



NOTE: All chain dimensions are measured from end of lifting hook to end of last link in chain.

25. Fit chain lifting eye to a suitable engine hoist. Raise hoist high enough to enable engine mountings to be removed, and withdraw rubber mountings.
26. Lower hoist until engine rests securely on engine mounting brackets. Remove lifting chains and hoist.
27. Disconnect two heater hoses located on top of right hand rocker cover.
28. Remove ground strap from rear of left hand cylinder head. DO NOT remove from retaining clip.
29. Remove all electrical harnesses from retaining clips at rear of engine.
30. Remove transmission breather pipes from retaining clip on rear lifting eye.
31. Remove top two bolts securing bell housing to cylinder block.
32. Raise front of vehicle, lower vehicle on to axle stands.
33. Remove bell housing bottom cover. Remove gasket from bell housing face.
34. Remove nuts securing exhaust downpipes to manifolds, remove heat shield from right hand side downpipe.
35. Remove electrical leads from starter motor solenoid. Disconnect multi-plug from oil level sensor on side of sump, if fitted.



NOTE: Instructions 37, 38 and 39 refer to automatic vehicles only.

36. With assistance rotate engine at crankshaft pulley until two access holes in drive plate/ring gear assembly are visible.
37. Remove two bolts visible through access holes. Mark one access hole and one bolt hole to ensure unit is reassembled in its original position.
38. Rotate crankshaft 180° until two remaining access holes are visible, remove two bolts.

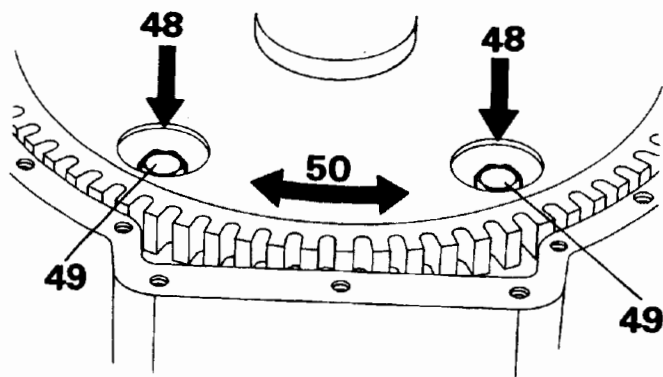

RR1808E

39. Remove remaining bell housing to cylinder block bolts.
 40. Remove starter motor ground strap from chassis.
 41. Remove stands and lower vehicle.
 42. Position hydraulic trolley jack under bell housing to support gearbox when engine and gearbox are separated.
 43. Fit lifting chains to engine. Carefully raise hoist a little, ease engine and gearbox apart, steady engine on hoist.
 44. Ensure no components remain that will prevent engine being removed.
 45. Slowly raise engine clear of engine compartment. Move engine away from vehicle and place on a suitable engine stand.
- Refit**
46. Fit lifting chains to engine. Raise engine using hoist.
 47. Lower engine into engine compartment. Ensure all components are clear of engine assembly.
 48. Automatic vehicles: With assistance, manoeuvre engine until bottom two engine and bellhousing bolt holes align. Ensure that two cylinder block dowels locate in bell housing.
Manual vehicles: Lower engine into position. Locate primary pinion into clutch. Engage bell housing dowels.
 49. Fit two bolts and partially tighten.
 50. Remove jack and lower hoist until engine rests securely on engine mounting brackets.
 51. Fit top two bell housing securing bolts. Tighten to **40 Nm**.
 52. Fit remaining bell housing to cylinder block bolts. Tighten to **40 Nm**.
 53. Automatic vehicles: With assistance, rotate crankshaft pulley, line up marked holes in drive plate and torque converter. Fit two bolts. Tighten to **40 Nm**.
 54. Rotate crankshaft 180° and fit remaining two bolts tighten to correct torque, **40 Nm**.
 55. Fit new gasket and refit bottom cover, tighten bolts to **9 Nm**.
 56. Fit new exhaust flange gaskets, fit exhaust to manifold.
 57. Refit all harnesses, ground straps breather pipes and hoses at rear of engine.
 58. Raise engine and refit engine mounting rubbers, tighten nuts to **20 Nm**.
 59. Remove temporary lifting eye ETC 5964 and reverse instructions 1 to 23, ensuring that all electrical plugs and harnesses are fitted in correct locations.



OIL SUMP

Service repair no - 12.60.44

Remove

1. Drain engine oil **See SECTION 10, Maintenance, Under Vehicle Maintenance**
2. Fit drain plug. Tighten to **40 Nm**.
3. If fitted, disconnect low oil level sensor multiplug.

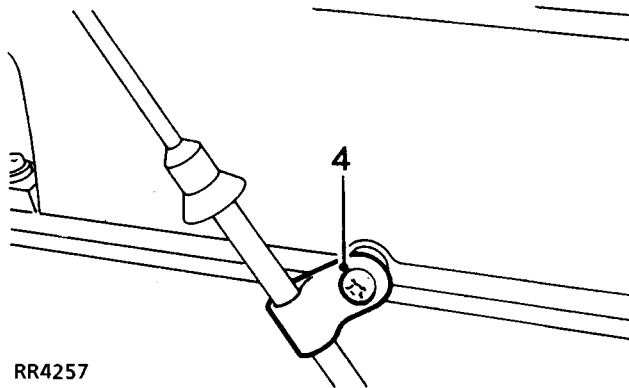

4. Remove bolt securing dipstick tube to rocker cover.
5. Working from the centre outwards, progressively loosen and remove 17 bolts securing sump. Remove sump.
6. Remove all traces of sealant from mating surfaces of sump, cylinder block and front cover, using a suitable solvent or plastic scraper.
7. Degrease mating surfaces of sump, cylinder block and front cover.

Refit

8. Apply RTV Hylosil White sealant to mating surface of sump.
9. Position sump, tighten bolts finger tight.

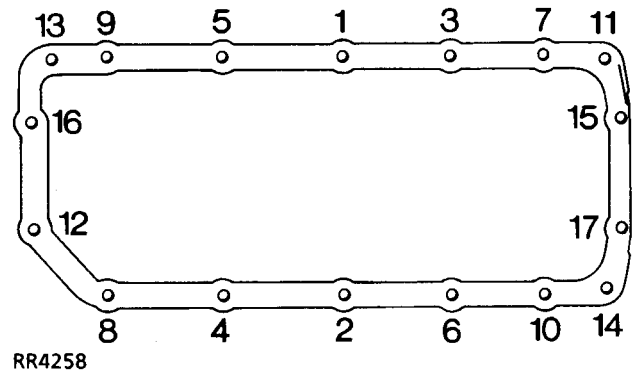

10. Tighten bolts progressively in sequence shown. Tighten to **18 Nm**.
11. Fit bolt securing dipstick tube to rocker cover.
12. If fitted, connect low oil level sensor multiplug.



TORQUE VALUES



NOTE: Torque wrenches should be regularly checked for accuracy to ensure that all fixings are tightened to the correct torque.

	Nm
Engine	
Adaptor plate to crankshaft	84
Generator and power steering mounting bracket to cylinder head	30
Cylinder head:	
Stage 1:	20
Stage 2: - Further 180° ± 5°	
Drive plate to converter	39
Engine mountings to engine and chassis	55
Engine mounting rubbers to brackets	30
Flexible drive plate to crankshaft adaptor plate	41**
Flywheel to crankshaft bolts	78**
Lifting eye to cylinder heads	39
Main bearing cap rear bolts	92*
Oil sump drain plug	40
Oil sump to cylinder block	18
Rocker cover to cylinder head	9
Rocker shaft bracket to cylinder head	38
Spark plug	21
Starter motor attachment	44

* These bolts must have threads coated in lubricant EXP16A before assembly.

** These bolts must have threads coated in sealant Loctite 270

METRIC	Nm
M5	6
M6	9
M8	25
M10	45
M12	90
M14	105
M16	180

UNC / UNF	
1/4	9
5/16	24
3/8	39
7/16	78
1/2	90
5/8	136



NOTE: Torque values above are for all screws and bolts used except for those specified.



ENGINE

LRT-12-034 Spring compressor
MS1519A

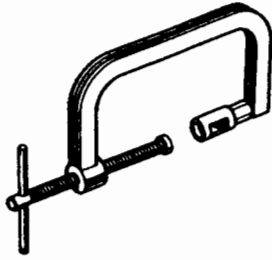

MS1519A

LRT-12-010 Crankshaft rear seal guide
RO1014

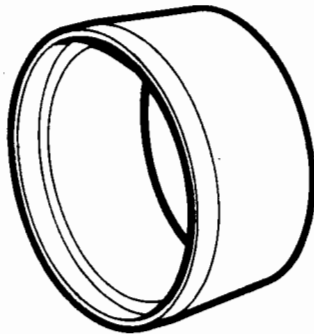

RO1014

LRT-12-052 Oil pressure test kit

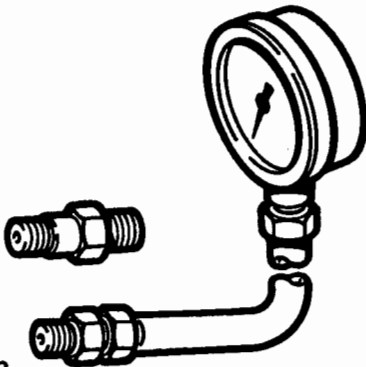

LRT12052