

74 - WHEELS AND TYRES

CONTENTS

Page

DESCRIPTION AND OPERATION

TYPES OF WHEEL RIMS AND TYRES 1

FAULT DIAGNOSIS

TYRE WEAR CHART 1

FAULT - SYMPTOMS 2

REPAIR

GENERAL INFORMATION 1

TYRE INSPECTION 1

WHEELS INSPECTION 2

VALVES INSPECTION 2

TYRE PRESSURES 2

WHEEL BALANCING 3

TYRE FITTING 5

WHEELS 6

WHEEL STUD 7





TYPES OF WHEEL RIMS AND TYRES

Description

Dependent on specification, the vehicle is equipped with alloy or pressed steel wheel rims, both using tubeless radial ply tyres.

Tyre codes

The writing, codes and numbers moulded into the tyre wall vary between tyre manufacturers, however most tyres are marked with the information shown in the illustrated example.

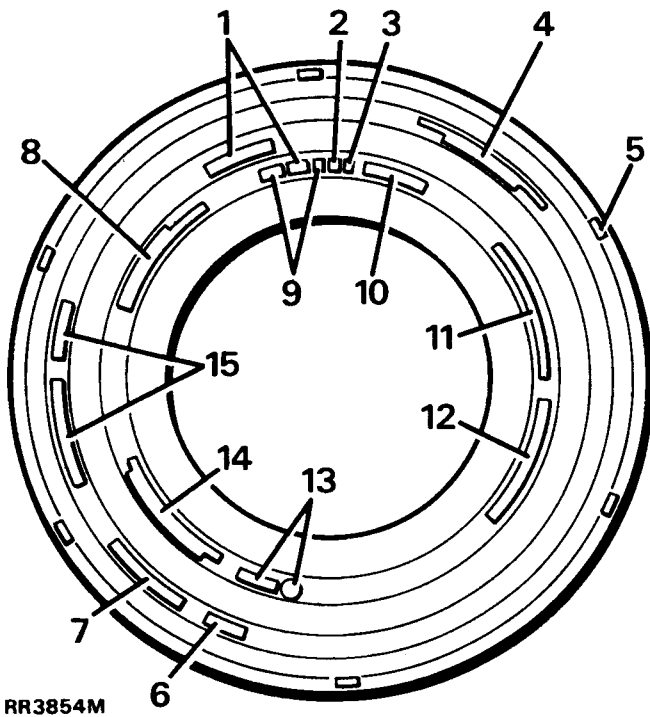



1. Type of tyre construction - **Radial Ply**
2. Load index - **104**
3. Speed symbol - **S or T**
4. USA Tyre quality grading - **Tread wear 160 Traction A temperature B**
5. Tread wear indicators moulded into tread pattern are located at intervals around the tyre and marked by a code - **E66 103S6**
6. Tyres with 'Mud Snow' type tread pattern are marked - **M&S**
7. Tyre reinforcing mark - **Reinforced**
8. USA Load and pressure specification - **(900Kg(1984LBS) at 340KA (50PSI) MACS PRESS**
9. Tyre size - **205 16 or 235/70 R16**
10. Type of tyre - **TUBELESS**
11. Country of manufacture - **MADE IN GREAT BRITAIN**
12. USA Compliance symbol and identification - **DOT AB7C DOFF 267**
13. European type approval identification - **E11 01234**
14. Tyre construction - **SIDE WALL 2 PLYS RAYON. TREAD 2 RAYON 2 STEEL**
15. Manufacturer's brand name/type - **TRACTION PLUS mzx M**



NOTE: The illustration is an example of the type of markings moulded into tyres and is for guidance only. For specific tyre specifications. See **GENERAL SPECIFICATION DATA, Information, Wheels and Tyres**

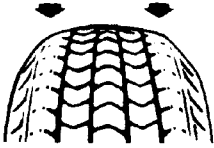
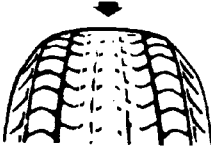
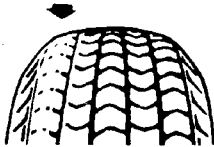

TYRE WEAR CHART

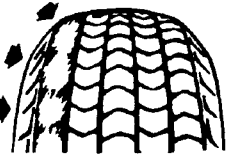
FAULT	CAUSE	REMEDY
<p>Rapid wear at shoulders</p> 	<p>Tyres under-inflated Worn suspension components i.e. ball joints, panhard rod bushes, steering damper</p> <p>Excessive cornering speeds</p>	<p>Inflate to correct pressure Replace worn components</p>
<p>Rapid wear at centre of tread</p> 	<p>Tyres over-inflated</p>	<p>Inflate to correct pressure</p>
<p>Wear at one shoulder</p> 	<p>Track out of adjustment Bent panhard rod</p>	<p>Adjust track to correct figure Check and replace worn or damaged components</p>
<p>Bald spots or tyre cupping</p> 	<p>Wheel out of balance Excessive radial runout Shock absorber worn Excessive braking</p>	<p>Balance wheel and tyre assembly Check runout and replace tyre if necessary Replace shock</p>
<p>Tyre scalloped</p>  <p>RR2136E</p>	<p>Track out of adjustment Worn suspension components Excessive cornering speeds</p>	<p>Adjust toe to correct figure Replace as necessary</p>



CAUTION: This diagnosis chart is for general guidance only and does not necessarily include every cause of abnormal tyre wear.

FAULT - SYMPTOMS

Vibration through steering wheel

1. Check tyre pressures. *See Repair, Tyre Pressures*
2. Check condition of tyres. *See Tyre Wear Chart*
3. Check front wheel alignment. *See STEERING, Adjustment, Front Wheel Alignment*
4. Check wheel balance. *See Repair, Wheel Balancing*

△ NOTE: In the event that any apparent vibration is not eliminated at this stage. *See PROPELLER SHAFTS, Fault diagnosis, Vibration Harshness*

△ NOTE: In the event that any apparent vibration is not eliminated at this stage, go to steering Fault Diagnosis, Fault - Symptom (Steering vibration, road wheel shimmy/wobble). *See STEERING, Fault diagnosis, Steering Faults*



NOTE: Radial ply tyres have a flexible sidewall, which produces a sidewall bulge making the tyre appear under-inflated. This is a normal condition for radial ply tyres. Do not attempt to reduce this bulge by over-inflating the tyre.

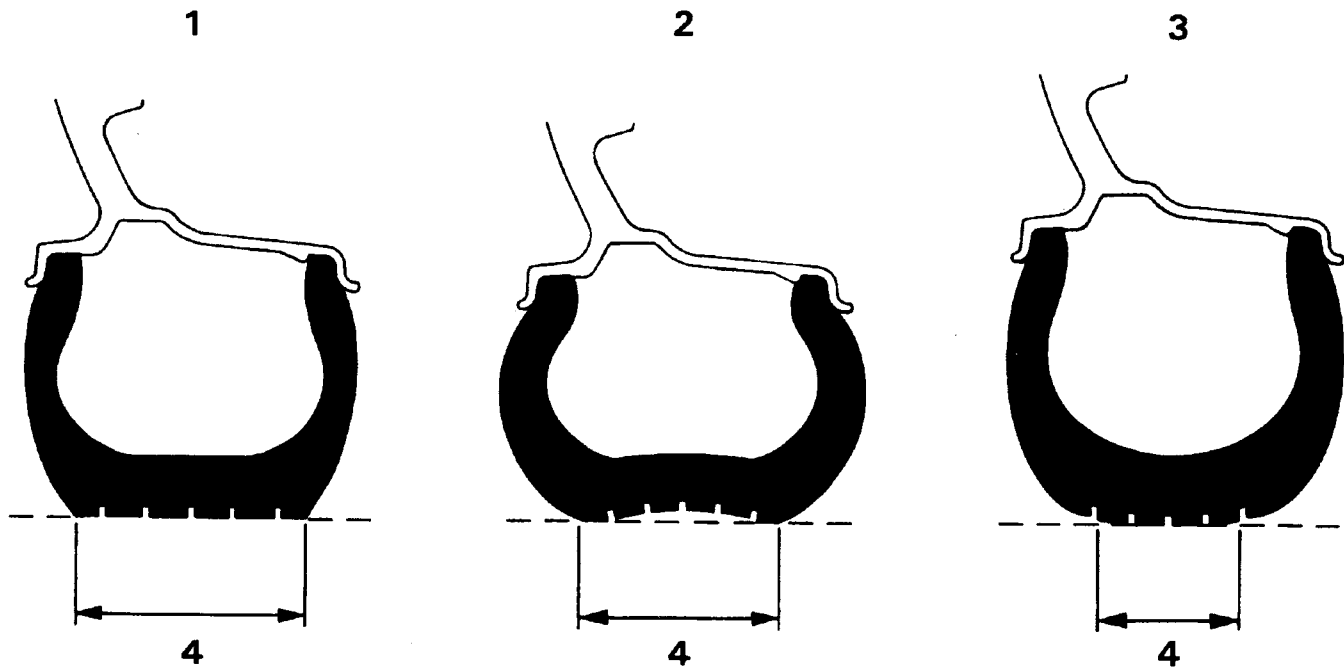

RR2133E

1. Correct inflation.
2. Under-inflation.
3. Over-inflation.
4. Tread contact with road.



GENERAL INFORMATION



WARNING: This is a multi- purpose vehicle with wheels and tyres designed for both on and off road usage. Only use wheels and tyres specified for use on the vehicle.

The vehicle is equipped with tubeless 'S', 'T' or 'H' rated radial ply tyres as standard equipment. The tyres are of European metric size and must not be confused with the "P" size metric tyres available in North America.

Vehicle wheel sets, including spare wheel, must be fitted with the same make and type of tyre to the correct specification and tread pattern. Under no circumstances must cross-ply or bias-belted tyres be used.

For tyre specification and pressures. See **GENERAL SPECIFICATION DATA, Information, Wheels and Tyres**

Alloy Wheels

Tubeless tyres are mounted on 7.0 inch wide by 16 inch diameter cast aluminium alloy wheels. The surface has a paint finish covered with a clear polyurethane lacquer. Care must be taken when handling the wheel to avoid scratching or chipping the finish.

The alloy wheel rim is of the asymmetric hump type incorporating a safety hump to improve location of the tyre bead in its seat. If difficulty is experienced in fitting tyres to this type of rim. See Tyre Fitting



WARNING: Do not fit an inner tube to an alloy wheel.

Steel wheels

Tubeless tyres are mounted on 7.0 inch wide by 16 inch diameter steel wheels.

TYRE INSPECTION

Inspect tyres at weekly intervals to obtain maximum tyre life and performance and to ensure compliance with legal requirements. Check for signs of incorrect inflation and uneven wear, which may indicate a need for balancing or front wheel alignment. See **Fault diagnosis, Tyre Wear Chart** if the tyres have abnormal or uneven wear patterns.

Check tyres at least weekly for cuts, abrasions, bulges and for objects embedded in the tread. More frequent inspections are recommended when the vehicle is regularly used in off road conditions.

To assist tyre inspection, tread wear indicators are moulded into the bottom of the tread grooves, as shown in the illustration below.

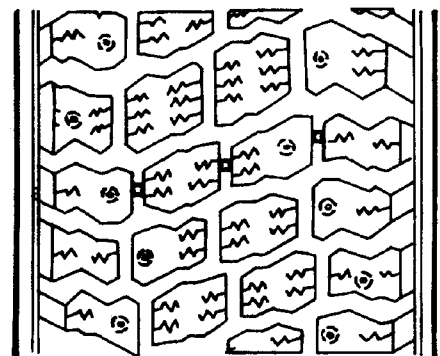

RR2145E

When the tread has worn to a remaining depth of 1.6 mm the indicators appear as bars which connect the tread pattern across the width of the tread as shown in the illustration below.

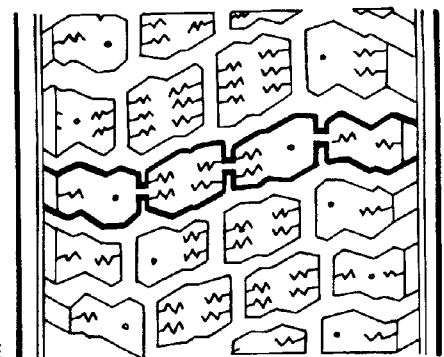

RR2146E

When the indicators appear in two or more adjacent grooves, at three locations around the tyre, a new tyre must be fitted.



NOTE: Do not attempt to interchange tyres, e.g. from front to rear, as tyre wear produces characteristic patterns depending on their position. If tyre position is changed after wear has occurred, the performance of the tyre will be adversely affected.



NOTE: Territorial vehicle regulations governing tyre wear MUST be adhered to.

WHEELS INSPECTION

Regularly check the condition of the wheels. Replace any wheel that is bent, cracked, dented or has excessive runout.

VALVES INSPECTION

Check condition of inflation valve. Replace any valve that is worn, cracked, loose, or leaking air.

TYRE PRESSURES

Maximum tyre life and performance will be obtained only if tyres are maintained at the correct pressures.

Tyre pressures must be checked at least once a month and at least once a week, preferably daily, if the vehicle is used off road.

The tyre inflation pressure is calculated to give the vehicle satisfactory ride and steering characteristics without compromising tyre tread life. For recommended tyre pressures in all conditions. **See GENERAL SPECIFICATION DATA, Information, Wheels and Tyres**

American vehicles - A label attached to the inside edge of the driver's door also provides tyre pressure information.

Always check tyre inflation pressures using an accurate gauge and inflate tyres to the recommended pressures only.

Check and adjust tyre pressures **ONLY** when the tyres are cold, vehicle parked for three hours or more, or driven for less than 3.2 km (2 miles) at speeds below 64 km/h (40 mph). Do not reduce inflation pressures if the tyres are hot or the vehicle has been driven for more than 3.2 km (2 miles) at speeds over 64 km/h (40 mph), as pressures can increase by 0.41 bars (6 p.s.i.) over cold inflation pressures.

Check **ALL** tyre pressures including the spare. Refit the valve caps as they form a positive seal and keep dust out of the valve.



WHEEL BALANCING



CAUTION: It is essential that all wheel balancing is carried out off the vehicle. The use of on the vehicle balancing could cause component damage or personal injury and **MUST NOT** be attempted.



NOTE: Before attempting to balance a wheel and tyre assembly clean all mud and dirt deposits from both inside and outside rims and remove existing balance weights.

Remove stones from the tyre tread in order to avoid operator injury during dynamic balancing and to obtain the correct balance.

Inspect tyres for damage and correct tyre pressures and balance according to the equipment manufacturer's instructions.

Alloy wheels

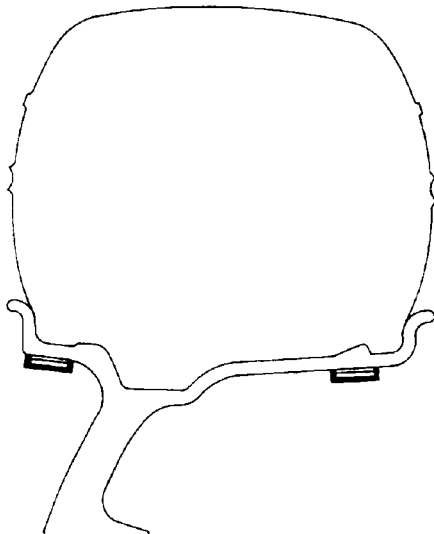

RR2138E

Clean area of wheel rim and attach adhesive balance weights in position shown. Cut through rear face of weight strip to detach required weights.

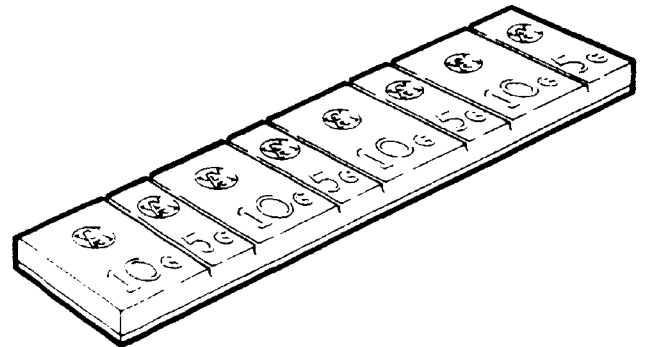

RR2137E



CAUTION: Use only correct adhesive balance weights to avoid damage to aluminium wheel rim. **DO NOT** attempt to use a steel wheel weight on an aluminium wheel.

Steel wheels

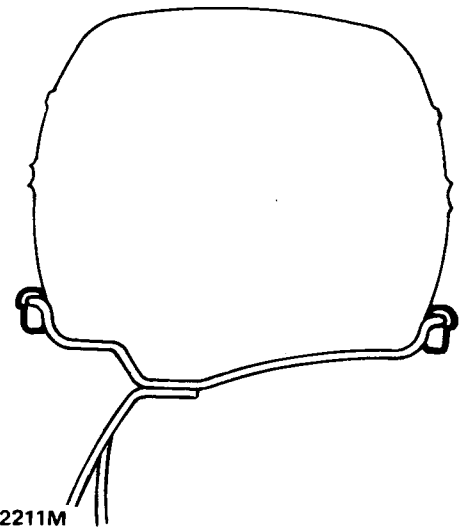

RR2211M

Clean area of wheel rim and attach balance weights in position shown.

Static balance

Wheel tramp

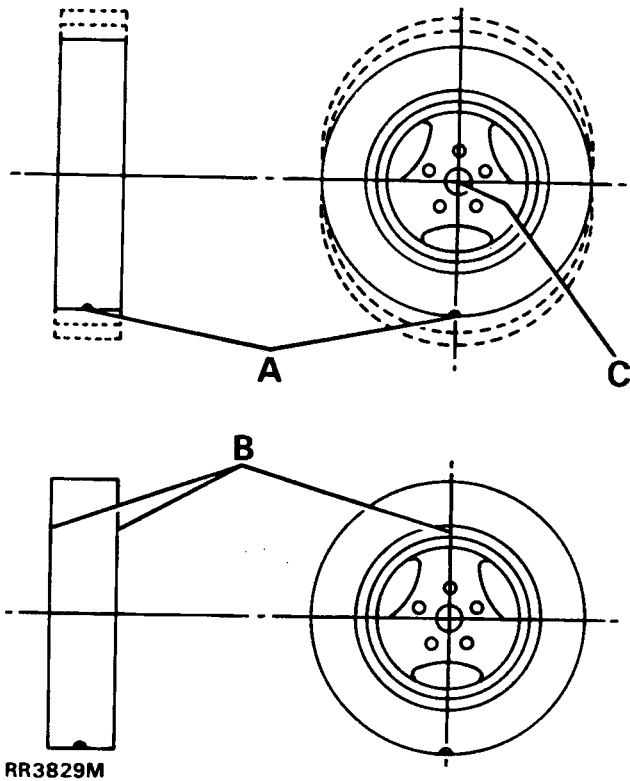

- A. Heavy spot.
- B. Add balance weights here.
- C. Centre line of spindle.

Static balance is the equal distribution of weight around the wheel. A statically unbalanced wheel will cause a bouncing action called wheel tramp. This condition will eventually cause uneven tyre wear.

Dynamic balance

Wheel shimmy

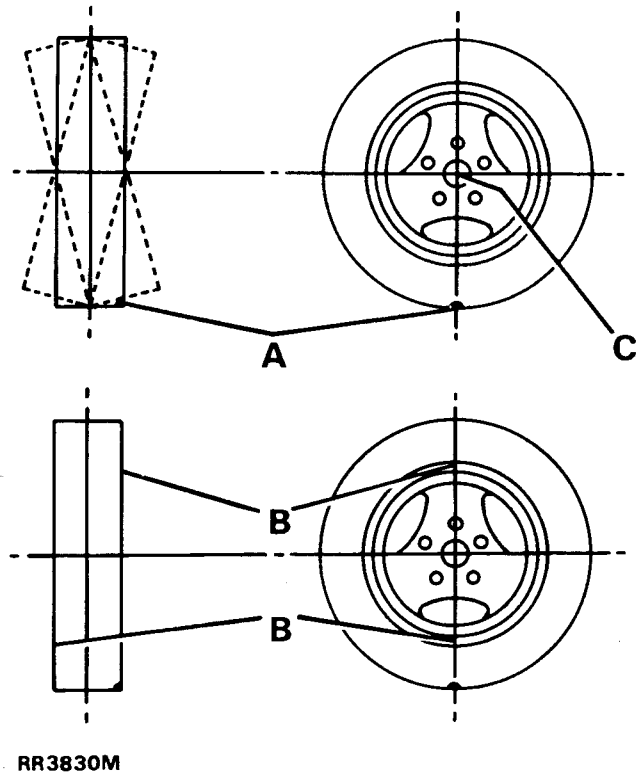

- A. Heavy spot.
- B. Add balance weights here.
- C. Centre line of spindle.

Dynamic balance is the equal distribution of weight on each side of the centre line so that when the wheel spins there is no tendency for side to side movement. A dynamically unbalanced wheel will cause wheel shimmy.



Off vehicle balancing

Balance wheel assembly referring to equipment manufacturer's instructions.

It is essential that the wheel is located by the centre hole **NOT** the stud holes. To ensure positive wheel location the diameter of the locating collar on the machine shaft must be 112.80 to 112.85 mm (4.441 to 4.443 in). This diameter will ensure that the collar fits correctly within the centre hole of the wheel.

Where possible always use the vehicle wheel retaining nuts to locate the wheel on the balancer, to avoid damaging the wheel. If this is not possible, the locating nuts must be of a similar pattern to the original wheel nuts. The use of conical type wheel nuts for this purpose may damage the aluminium alloy.

Cleaning

Wash the aluminium wheels using a suitable wash and wax concentrate correctly diluted and rinse with cold clear water. **DO NOT** use abrasives or aluminium wheel cleaners containing acid, as they will destroy the lacquer finish.

Tyre changing

Use only tyre changing equipment to mount or demount tyres, following the equipment manufacturer's instructions. **DO NOT** use hand tools or tyre levers, as they may damage tyre beads or the aluminium wheel rim.

Puncture repair

Remove punctured tyre from wheel and repair using a combination service plug and vulcanising patch. Always follow manufacturer's instructions when using a puncture repair kit.

Only punctures in tread area are repairable, **DO NOT** attempt to repair punctures in tyre shoulders or sidewalls.

Do not attempt to repair a tyre that has sustained the following: bulges or blisters, ply separation, broken or cracked beads, wear indicators visible and punctures larger than 6 mm diameter.



CAUTION: Do not use tyre sealants that are injected through valve stem to repair punctured tyres, they may produce wheel corrosion and tyre imbalance.

Aluminium wheel rim bead seats should be cleaned using a non-abrasive cleaner to remove the mounting lubricants and old rubber. Before mounting or demounting a tyre, bead area should be well lubricated with a suitable tyre lubricant.

TYRE FITTING

Alloy wheels

1. Install a new valve assembly.
2. Ensure wheel and tyre is adequately lubricated.
3. Mount tyre in normal manner. Inflate tyre and at same time apply hand pressure to area around valve to aid seating over valve first.



NOTE: Stop inflation immediately if tyre seats opposite valve, as this will result in valve being blocked by tyre beading, making further inflation impossible, and carry out following procedure.

4. Deflate tyre, unseat and rotate it around the rim until valve is in line with that part of tyre which seated initially. This part of beading having seated over hump previously will automatically seat first when tyre is re-inflated.
5. Inflate tyre to seat beads correctly, finally inflate to correct pressure.

WHEELS

Remove



WARNING: The parking brake acts on transmission, not rear wheels, and may not hold vehicle when jacking unless following procedure is used. If one front wheel and one rear wheel is raised no vehicle holding or braking effect is possible. Wheels **MUST** be chocked in all circumstances.

Apply parking brake, select 'P' or a gear in main gearbox and engage low gear in transfer box.

1. Loosen five wheel nuts.
2. Using a suitable trolley jack raise vehicle and place on axle stands. **See INTRODUCTION, Information, Jacking**
3. Remove wheel nuts and carefully withdraw wheel over studs.

Refit

4. Ensure that retaining studs and nuts are clean.
5. Alloy wheels: Lightly coat wheel mounting spigot face with a suitable anti-seize compound to minimise possibility of adhesion between wheel and spigot face.
6. Refit wheel taking care not to damage stud threads. (Do not apply oil)
7. Fit wheel nuts and turn by hand for at least three full threads before using any form of wheel wrench.
8. Tighten nuts as much as possible using a suitable wrench.

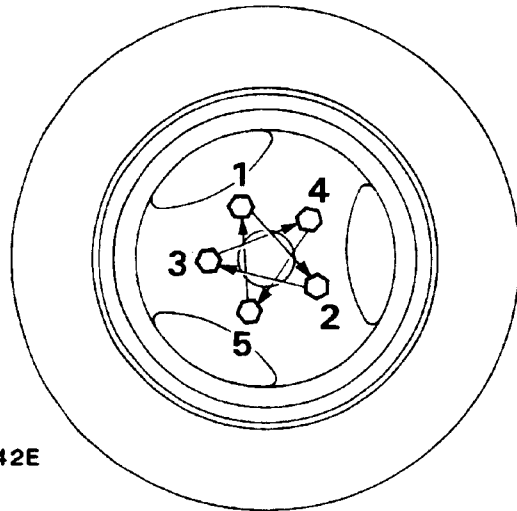

RR2 142E

9. Lower vehicle and finally tighten nuts to correct torque sequence shown. Alloy wheels and steel wheels: **130Nm**.



WHEEL STUD

Remove

1. Remove wheel. *See Wheels*
2. Drive stud out of driveshaft flange.

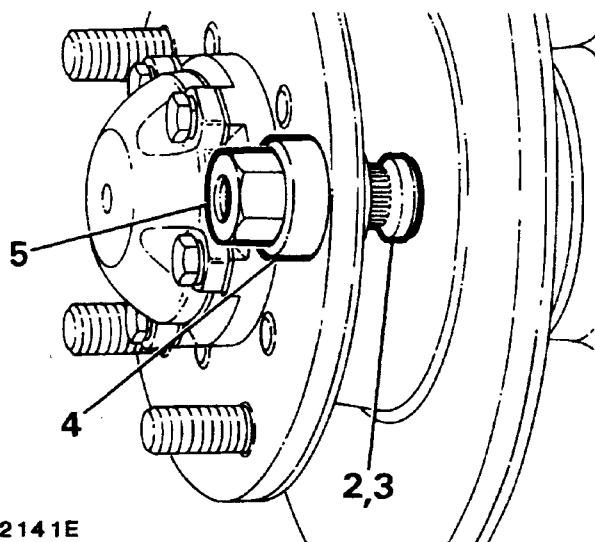

RR214 1E

Refit

3. Position stud in flange.
4. Install a suitable spacer over stud.
5. Using a M16 x 1.5P nut, a slave wheel nut is suitable, pull stud into flange until shoulder of stud abuts flange.
6. Refit wheel.