

86 - ELECTRICAL

CONTENTS

Page

DESCRIPTION AND OPERATION

ELECTRICAL EQUIPMENT	1
A.C. GENERATOR - A127/100.....	1
ANTI THEFT ALARM SYSTEM	2
ANTI-THEFT SYSTEM FUNCTION	2
ALARM COMPONENTS	3
BUILT IN TEST PROCEDURE	5

FAULT DIAGNOSIS

LUCAS CONSTANT ENERGY IGNITION SYSTEM - V8i	1
---	---

ADJUSTMENT

IGNITION TIMING	1
-----------------------	---

REPAIR

BATTERY	1
A.C. GENERATOR - V8i ENGINE	1
A.C. GENERATOR DRIVE BELT	2
DISTRIBUTOR-LUCAS 35 DLM8	2
ELECTRONIC IGNITION - V8i	4
DISTRIBUTOR - V8i	4
IGNITION COIL	6
BULB REPLACEMENT	6
HEADLAMP ASSEMBLY / SEALED BEAM UNIT	6
HEADLAMP ASSEMBLY/BULB REPLACEMENT	7
HEADLAMP ALIGNMENT	8
AUXILIARY DRIVING LAMP	8
SIDELIGHT AND FLASHER LAMP ASSEMBLY AND BULB	9
DIRECTION INDICATOR/SIDE REPEATER LAMP BULB REPLACEMENT	10
TAIL LAMP ASSEMBLY	10
REFLECTORS/SIDE MARKER LAMP ASSEMBLY AND BULB	11
UNDER BONNET LAMP ASSEMBLY	11
HEATER/VENTILATION AND AIR CONDITIONING CONTROL PANEL BULB	12
HEATER/VENTILATION AND AIR CONDITIONING CONTROL PANEL SWITCHES AND BULBS	12
DOOR EDGE LAMPS / PUDDLE LAMPS	13
DOOR EDGE LAMPS/PUDDLE LAMPS BULB	13



86 - ELECTRICAL

CONTENTS

	Page
AUTOMATIC GEAR SELECTOR-PANEL BULB	14
NUMBER/LICENSE PLATE LAMP ASSEMBLY AND BULB	14
INTERIOR ROOF LAMP	15
STARTER MOTOR - V8i ENGINE	15
AUXILIARY SWITCHES AND BULBS	16
AIR SUSPENSION SWITCHES AND BULBS	17
HEADLAMP/FLASHER SWITCH AND WINDSCREEN WASH/WIPE SWITCH	18
HAZARD WARNING SWITCH AND BULB	18
IGNITION/STARTER SWITCH - BULB REPLACEMENT	19
DOOR PILLAR SWITCH	19
IGNITION/STARTER SWITCH	20
REAR TAILGATE SWITCH	20
UNDER BONNET/HOOD ILLUMINATION SWITCH	21
CIGAR LIGHTER AND BULB	21
REVERSE LIGHT SWITCH	22
START INHIBIT / REVERSE LIGHT SWITCH	22
OIL PRESSURE WARNING SWITCH - V8i	23
PARK BRAKE WARNING SWITCH	23
EXTERIOR DRIVING MIRRORS MOTOR	24
CONTROL SWITCHES	24
INSTRUMENT ILLUMINATION ELECTRONIC DIMMER / RHEOSTAT	25
WINDOW LIFT/HEATED SEAT CUSHION SWITCHES AND BULBS	25
WINDOW LIFT MOTOR - FRONT DOORS	26
WINDOW LIFT MOTOR - REAR DOORS	26
CENTRAL DOOR LOCKING	27
HANDSET INITIALISATION	27
FRONT DOOR ACTUATOR UNIT	27
REAR DOOR ACTUATOR UNITS	28
UPPER TAILGATE ACTUATOR UNIT	28
FUEL FILLER FLAP ACTUATOR UNIT	29
TRAILER SOCKET	30
FRONT SEAT - MOTORS	31
FRONT SEAT - SWITCHES	31
MAP LIGHT BULB RENEWAL	32
ELECTRICAL SEAT FAILURE	32
DRIVE CABLE - ELECTRIC SEAT	32
MEMORY SEAT - SWITCH	33
MEMORY SEAT SWITCH - CLEAN	33
ECU - MEMORY SEAT	34
RADIO ANTENNA AMPLIFIER	34
MEMORY SEAT - HARNESS LAYOUT	35
A.C. GENERATOR HEAT SHIELD	36
HIGH LEVEL STOP LAMP	36
ALARM HORN	37
GEAR SELECTOR-INTERLOCK	37
SUBWOOFER BOX	40

86 - ELECTRICAL

CONTENTS

	Page
HEATED FRONT SCREEN	41
RADIO	42
COOLANT TEMPERATURE TRANSMITTER - V8i	42
CLOCK AND BULB	43
INSTRUMENT PANEL FINISHER	43
INSTRUMENT BINNACLE	44
INSTRUMENT ILLUMINATION AND WARNING LIGHT BULBS	45
MAIN PRINTED CIRCUIT	46
CIRCUIT BOARD	47
INSTRUMENT BINNACLE COMPONENTS	48
PRINTED CIRCUIT AND WARNING LIGHTS	49
INSTRUMENT COWL AND ILLUMINATION BOARD	50
SPEEDOMETER	51
TACHOMETER	51
COOLANT TEMPERATURE AND FUEL GAUGES	52
SPEEDOMETER TRANSDUCER	52
ALARM ECU	53
 OVERHAUL	
DISTRIBUTOR-LUCAS 35DLM8	1
DISTRIBUTOR CAP	1
ROTOR ARM	1
INSULATION COVER (FLASH SHIELD)	1
VACUUM UNIT	1
AMPLIFIER MODULE	1
PICK-UP AND BASE PLATE ASSEMBLY	1
LUBRICATION	2
 SPECIFICATIONS, TORQUE	
TORQUE VALUES	1





ELECTRICAL EQUIPMENT

DESCRIPTION

The electrical system is Negative ground, and it is most important to ensure correct polarity of the electrical connections at all times. Any incorrect connections made when reconnecting cables may cause irreparable damage to the semi-conductor devices used in the A.C. generator and regulator. Incorrect polarity would also seriously damage any transistorized equipment such as the radio.



WARNING: During battery removal or before carrying out any repairs or maintenance to electrical components always disconnect the battery negative lead first. If the positive lead is disconnected with the negative lead in place, accidental contact of tools to any earthed metal part could cause a severe spark, possibly resulting in personal injury. Upon installation of the battery the positive lead should be connected first.

A.C. GENERATOR - A127/100

The A.C. generator is a three phase, field sensed unit. The rotor and stator windings produce three phase alternating current, AC, which is rectified to direct current, DC. The electronic voltage regulator unit controls the A.C. generator output voltage by high frequency switching of the rotor field circuit.

It is essential that good electrical connections are maintained at all times. Of particular importance are those in the charging circuit (including those at the battery) which should be occasionally inspected to see that they are clean and tight. In this way any significant increase in circuit resistance can be prevented.

Do not disconnect battery cables while the engine is running or damage to the semi-conductor devices may occur. It is also inadvisable to break or make any connections in the charging and control circuits while the engine is running.

The electronic voltage regulator employs micro-circuit techniques resulting in improved performance under difficult service conditions. The whole assembly is encapsulated in silicone rubber and housed in an aluminium heat sink, ensuring complete protection against the adverse effects of temperature, dust, and moisture etc.

The regulating voltage is set during manufacture to give the required regulating voltage range of 14.2 ± 0.2 volts, and no adjustment is necessary. The only maintenance needed is the occasional check on terminal connections and wiping with a clean dry cloth.

The system provides for direct connection of a charge (ignition) indicator warning light, and eliminates the need for a field switching relay or warning light control unit. As the warning lamp is connected in the charging circuit, lamp failure will cause loss of charge. Lamp should be checked regularly and spare carried.

When using rapid charge equipment to re-charge the battery, the battery must be disconnected from the vehicle.



NOTE: For description and operation of electrical circuits see separate publication:- Electrical Troubleshooting Manual.

ANTI THEFT ALARM SYSTEM

A vehicle alarm system is available as original equipment. The main function of the system is to offer easy to use remote locking and unlocking of the vehicle without having to actively select the alarm function.

ANTI-THEFT SYSTEM FUNCTION

Perimetric protection

Using the key in the correct sequence will turn on and off perimetric protection only. When fully perimetrically armed, all doors, tailgate, and bonnet [hood] are protected against unauthorised access. If the door key is used in the normal manner the driver will be unaware of the door key sequence. The time taken to lock or unlock with the key must be less than 5 seconds. To prevent unauthorised tampering, the alarm will sound if the key is held in the unlocked position for longer than 5 seconds when armed. Cranking is disabled when perimetric protection is armed.



NOTE: When key is turned left or right the keyswitch input will be activated, in conjunction with the sill button switch when links are operated.



ALARM COMPONENTS

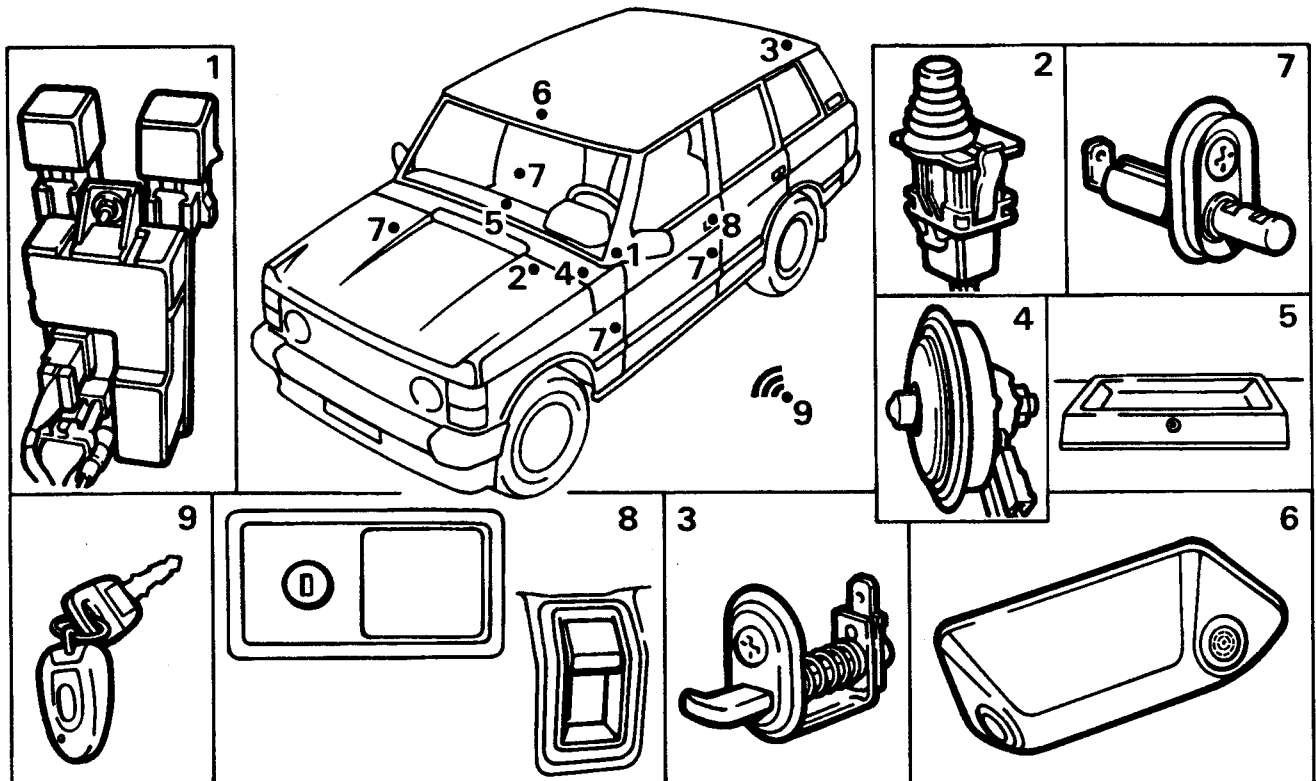

RR3911M

- | | |
|---|---------------------------------------|
| 1. Electronic control unit (ECU) and relays | 6. Ultrasonic unit |
| 2. Bonnet [hood] switch | 7. Door switches |
| 3. Tailgate switch | 8. Lock barrel, sill buttons |
| 4. Alarm horn | 9. Handset transmitter (two supplied) |
| 5. Light emitting diode (LED) | |

Volumetric protection

Using the handset transmitter will turn on and off volumetric protection. In volumetric mode the vehicle interior is protected using the ultrasonic sensor. Using the handset also arms and disarms the vehicle perimetrically. Cranking is disabled when volumetric and perimetric protection is armed.



NOTE: If armed volumetrically the vehicle CANNOT be disarmed using the key.

Alarm horn

When an intrusion is detected the alarm horn will sound intermittently (Switzerland and Denmark continuous horn sound) and the hazard lights flash (where territorial regulations allow) for 30 seconds. The alarm must be retriggered before alarm horn will sound again.

Vehicle status indication

Vehicle status is indicated by up to three devices: (a) alarm horn, (b) hazard lights, (c) dash board LED. When the vehicle arms in either mode the hazard lights will flash three times and the LED will flash rapidly for 10 seconds. LED will then flash at a slower rate while vehicle is armed. When the vehicle disarms, hazard lights will flash once and LED will extinguish. If LED remains lit, it indicates that the alarm has been triggered. Turning on ignition or arming the alarm will extinguish LED. The LED will give a long pulse flash to indicate the ultrasonic unit being activated.

Radio frequency system

The RF system uses four frequencies according to market. If the coaxial aerial is not fitted system performance will be impaired. Both ECU and handset have a colour coded label.

Frequency	Colour ECU/Handset	Territory
418.0 MHz	Pink/Pink	UK, Ireland
224.5 MHz,	Yellow/Yellow	France
433.92 MHz	Blue/Purple	Germany
433.92 MHz	Blue/Blue	Europe, not France, Switzerland, Italy, Denmark, Germany
433.92 MHz	White/Blue	Switzerland, Denmark
315.0 MHz	Green/Green	Rest of world, Italy, Australia
315.0 MHz	Orange/Green	Gulf, Japan

Central locking

Central locking is controlled by the alarm ECU and may be operated by the key, sill button(s) or handset. The system works on both front doors on four door vehicles or driver's door on two door vehicles.



NOTE: The central door locking system will shut down for a short period after more than 15 consecutive operations.

Inertia switch

An inertia switch is incorporated in the alarm system ECU. If ignition is on and the vehicle receives an impact sufficient to activate the inertia switch, the ECU will signal to unlock central locking actuators and flash hazard lights. Central locking will remain disabled for 30 seconds. To reset turn ignition off and then on after the 30 second period has elapsed.

Ultrasonic unit

The unit operates by emitting an air pressure carrier wave and receiving the wave back. Any disturbance within the vehicle which disturbs the wave will be detected, triggering the alarm.

When the volumetric sensor is activated it monitors movement within the vehicle for 15 seconds before detecting and responding to intrusions. If the sensor detects movement within the vehicle it delays arming until a 15 seconds quiet period has elapsed. If continuous movement is detected the alarm will not arm volumetrically.



Partially armed mode

If a door, tailgate or bonnet [hood] is left open when the system is armed, the LED will not light for 10 seconds indicating a mislock condition. Hazard lights will not flash. If an open door or tailgate is causing the mislock, the starter motor is disabled. The alarm will sound if ignition is turned to start position. If an open bonnet [hood] is causing the mislock the starter motor is disabled. The alarm will arm the volumetric part of the system. If the door tailgate or bonnet [hood] is subsequently closed, after a 5 second delay, the doors will unlock and immediately lock and the system will fully arm.

Handset transmitter

The handset LED will give one short flash when button is pressed momentarily.

If button is held down the LED will light again after 2 seconds for 2 seconds, and extinguish until button is released and repressed. The handset contains unique information distinguishing it from other transmitters. It also contains a set of 'random' rolling codes programmed into the ECU before leaving the factory. Each time the handset is pressed a different code is transmitted to the ECU.

If handset is operated more than four times outside the vehicle range (6 metres) or power supply is removed, it will be necessary to re-synchronise handset and the ECU by pressing the handset three times within range and within 5 seconds.



NOTE: If both handsets are lost or damaged when system is armed it will be necessary to fit a new ECU with two matching handsets.

Handset batteries

If handset LED flashes continuously when button is pressed, the batteries need replacing. The hazard lights will flash one 3 second pulse, instead of three times upon arming vehicle.

Power up mode

The alarm system always remembers the state it was left in when power was removed. If the alarm powers up in an armed state and is subsequently triggered it will give a warning that it will fully trigger unless disarmed. This warning consists of short horn pulses every two seconds for 15 seconds.

New born mode

When the ECU is first produced, it will be in its 'new born' mode. In this mode it will respond to any remote of the right frequency. This mode will be cancelled when the ECU has received ten valid handset signals without power interruption.

Engine cranking

It is only possible to crank the engine when ignition is ON and alarm disabled.

BUILT IN TEST PROCEDURE

The built in test procedure is accessed as follows:

1. Starting conditions: ignition off, doors unlocked, bonnet [hood] switch depressed.
2. Carry out instructions 3 to 7 within 8 seconds.
3. Release bonnet [hood] switch
4. Switch ignition ON.
5. Lock doors.
6. Switch ignition OFF.
7. Switch ignition ON.

If alarm is correctly accessed, horn will sound and LED will flash. The following checks can be made:

8. Open and close any door or tailgate - LED will light.
9. Depress bonnet [hood] switch - hazards will flash.
10. Check engine cranking is disabled. Do not turn off ignition.
11. Check ultrasonic by operating handset, LED will emit one 5 second flash, and will flash if interior is disturbed.



NOTE: If ECU is in new born mode any handset of the right frequency will work. If not an initialised handset is required see Handset Initialisation.

12. Turn OFF ignition or press handset to end test procedure. Horn will sound as before to indicate end of test mode.



LUCAS CONSTANT ENERGY IGNITION SYSTEM - V8i

Preliminary Checks

Inspect battery cables and connections to ensure they are clean and tight. Check electrical condition of battery.

Inspect all L.T. connections, ensure they are clean and tight. Check H.T. leads are correctly positioned and not shorting to ground against any engine components. Wiring harness and individual cables should be firmly fastened to prevent chaffing.

Pick-up air gap

Check air gap between pick-up limb and reductor teeth is 0.20 - 0.35 mm, using a non-ferrous gauge.



NOTE: Air gap is set initially at factory and will only require adjusting if tampered with or when pick-up module is replaced.

TEST 1:

H.T. Sparking

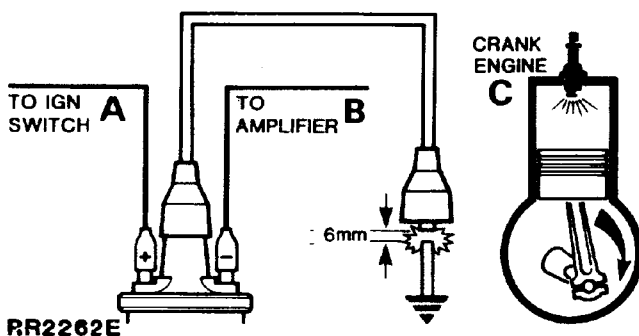

Remove coil/distributor H.T. lead from distributor cover and hold approximately 6mm from engine block, using suitable insulated pliers. Switch ignition 'On' and operate starter.

Regular sparking indicates fault in H.T. distribution, plugs, timing or fuelling, proceed to Test 6. If no spark or weak spark occurs proceed to Test 2.

TEST 2:

L.T. Voltage

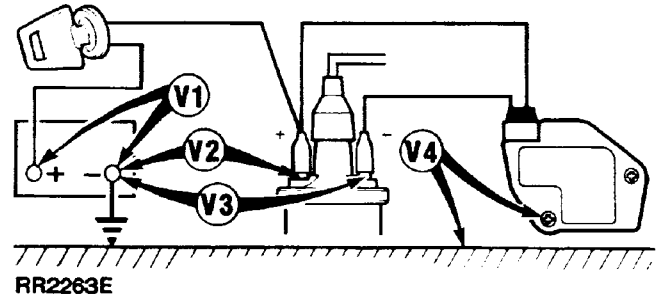

Switch ignition 'On' - engine stationary.

- Connect voltmeter to points in circuit indicated by V1 to V4 and make a note of voltage readings.
- Compare voltages obtained with specified values listed below:

Expected readings

- | | |
|----|-----------------------------------|
| V1 | More than 12 volts. |
| V2 | 1 volt maximum below volts at V1. |
| V3 | 1 volt maximum below volts at V1. |
| V4 | 0 volt - 0.1 volt. |
- If all readings are correct proceed to Test 3.
 - Check incorrect reading(s) with chart to identify area of possible faults, i.e. faults listed under heading SUSPECT and rectify.
 - If coil and amplifier is suspected, disconnect L.T. lead at coil, repeat V3. If voltage is still incorrect, fit new coil. If voltage is now correct, check L.T. lead, if satisfactory fit new amplifier.
 - If engine will not start proceed to Test 3.

1	2	3	4	SUSPECT
L	*	*	*	DISCHARGED BATTERY
*	L	L	*	IGN. SWITCH AND/OR WIRING
*	*	L	*	COIL OR AMPLIFIER
*	*	*	H	AMPLIFIER GROUND

Key

- * Expected Voltage
- H Voltage higher than expected
- L Voltage lower than expected

TEST 3:

Amplifier Switching

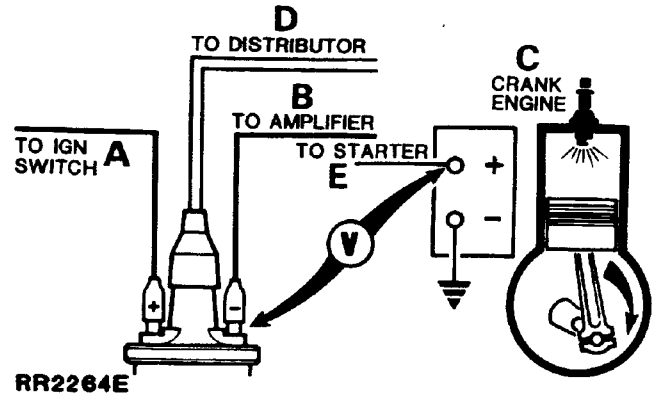

Connect voltmeter between battery positive (+ve) terminal and H.T. coil negative (-ve) terminal. Voltmeter should register 0 volts.

Switch ignition 'On', voltmeter should still register 0 volts.

Crank engine, voltmeter reading should increase when cranking, in which case proceed to Test 5.

If no increase in voltage during cranking proceed to Test 4.

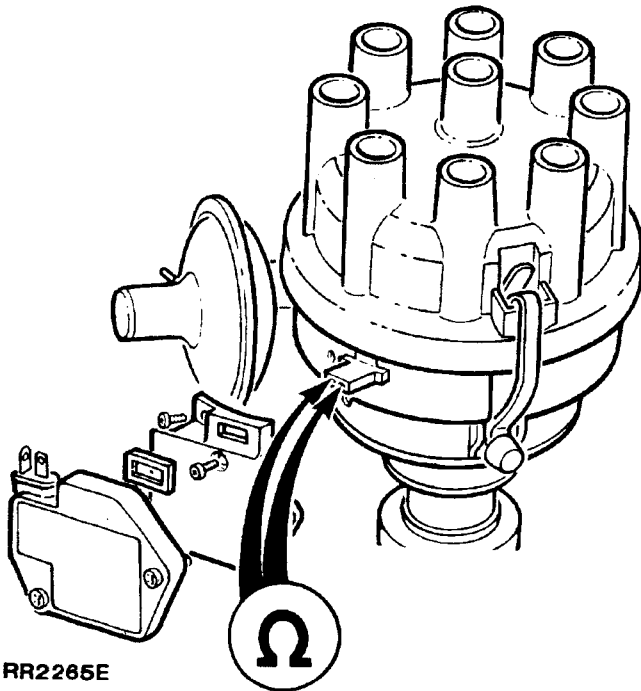
**TEST 4:****Pick-up Coil Resistance**

RR2265E

Remove amplifier.

Connect ohmmeter leads to two pick-up terminals in body of distributor.

The ohmmeter should register between 2k and 5k ohm if pick-up is satisfactory. If ohmmeter reading is correct, check all connections between pick-up and amplifier, if satisfactory, fit new amplifier. If engine still does not start carry out Test 5.

Change pick-up if ohmmeter reading is incorrect. If engine still does not start proceed to Test 5.

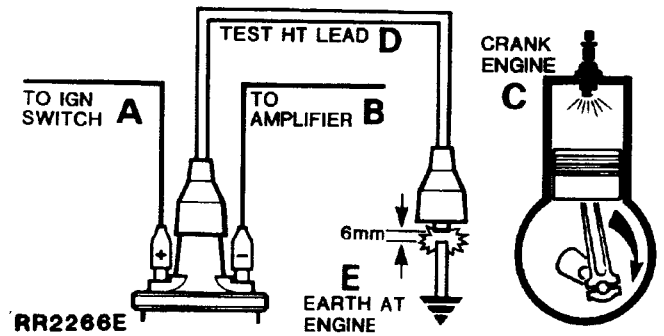
TEST 5:**Coil H.T. Sparking**

Remove existing coil/distributor H.T. lead and fit test H.T. lead to coil tower. Using suitable insulated pliers, hold free end about 6mm from engine block and crank engine. There should be good H.T. sparking.

If weak or no sparking, fit new coil, repeat test.

H.T. sparking good, repeat test with original H.T. lead. If sparking is good carry out Test 6.

If weak or no sparking, fit new H.T. lead, if engine will not start carry out Test 6.

TEST 6:

Rotor Arm

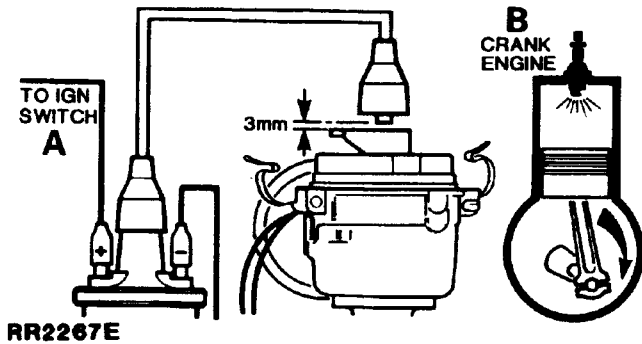

Remove distributor cover. Disconnect coil H.T. lead from cover, using insulated pliers hold about 3mm (0.13 in) above rotor arm electrode and crank the engine.

There should be no H.T. sparking between rotor and H.T. lead. If satisfactory carry out Test 7.

If H.T. sparking occurs, an earth fault on rotor arm is indicated. Fit new rotor arm. If engine will not start carry out Test 7.

TEST 7:

Visual and H.T. Cable Checks

Examine:

Should be:

- | | |
|--------------------------------|---|
| 1. Distributor Cover | Clean, dry, no tracking marks |
| 2. Coil Top | Clean, dry, no tracking marks. |
| 3. H.T. Cable Insulation | Must not be cracked, chafed or perished |
| 4. H.T. Cable Continuity | Must not be open circuit |
| 5. Sparking Plugs | Clean, dry, and set to correct gap |

NOTE:

- | | |
|-------------------------------------|---|
| 1. Reluctor | Must not foul pick-up or leads |
| 2. Rotor and Insulation Cover | Must not be cracked or show signs of tracking marks |



IGNITION TIMING

Service repair no - 86.35.15

Adjust

1. It is essential that following procedures are adhered to. Inaccurate timing can lead to serious engine damage and additionally create failure to comply with emission regulations. If timing is being checked in vehicle, air conditioning compressor must be disengaged.
2. On initial engine build, or if distributor has been disturbed for any reason, ignition timing must be set statically to the figure given:

If engine is 3.9 V8. **See ENGINE TUNING DATA, Information, ENGINE - 3.9 V8**

If engine is 4.2 V8. **See ENGINE TUNING DATA, Information, ENGINE - 4.2 V8**



NOTE: This approximate setting is made only to ensure that engine may be started.



CAUTION: On no account must engine be started before this operation is carried out.

Equipment required :-

**Calibrated Tachometer
Stroboscopic lamp**

3. Couple stroboscopic timing lamp and tachometer to engine following manufacturer's instructions.
4. Disconnect vacuum hose from distributor.
5. Start engine. With no load, and without exceeding 3,000 rev/min run engine until normal operating temperature is reached. (Thermostat open). Check that engine idles within tolerance.

If engine is 3.9 V8 check tolerance in. **See ENGINE TUNING DATA, Information, Engine - 3.9 V8**

If engine is 4.2 V8 check tolerance in. **See ENGINE TUNING DATA, Information, Engine - 4.2 V8**

6. Idle speed for timing purposes must not exceed 800 rev/min.
7. Run engine at idle speed and check timing using stroboscope light on timing marker and pointer.



WARNING: Keep hands and equipment away from drive belt.

8. If timing is not as specified, switch off engine. Loosen distributor clamp bolt and turn distributor to advance or retard ignition as necessary. Tighten clamp bolt, start engine and recheck timing.



WARNING: Personal injury may result if an attempt is made to adjust distributor whilst engine is running.

9. Upon completion, switch off engine and tighten distributor clamping bolt securely. Recheck timing, to ensure retightening has not disturbed distributor position.
10. Refit vacuum hose.
11. Disconnect stroboscopic timing lamp and tachometer from engine.



BATTERY

Service repair no - 86.15.01

Remove



WARNING: During battery removal always disconnect battery negative lead first. If positive lead is disconnected with negative lead in place, accidental contact of wrench to any grounded metal part could cause a severe spark, possibly resulting in personal injury. Upon installation of battery connect positive lead first.

1. Disconnect battery negative lead. Then disconnect the positive lead.
2. Release four nuts securing battery bracket.
3. Remove bracket.
4. Remove battery.

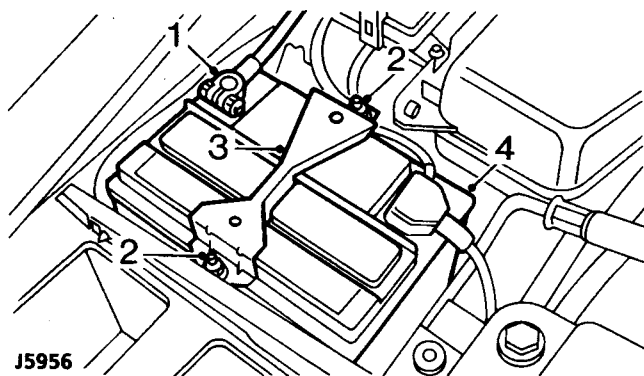

Refit

5. Reverse removal procedure.



NOTE: Coat battery clamps and terminals with petroleum jelly before refitting.

A.C. GENERATOR - V8i ENGINE

Service repair no - 86.10.01

Remove

1. Disconnect battery negative lead.

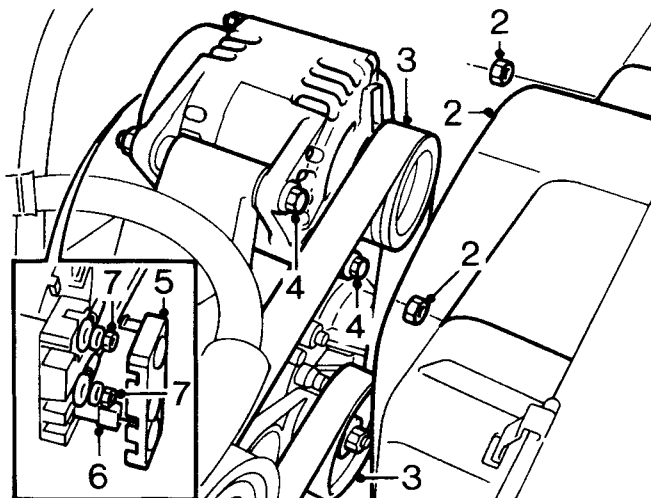

RR4107

2. Remove 2 nuts securing cooling fan cowl centre section, remove centre section.
3. Move drive belt tensioner pulley away from drive belt, release drive belt from A.C. generator pulley.
4. Remove 2 nuts and bolts securing alternator to mounting bracket.
5. Position A.C. generator to obtain access to rear cover, remove cover.
6. Disconnect ignition feed Lucar from A.C. generator.
7. Remove 2 nuts securing terminals to A.C. generator, release terminals from studs; remove alternator.

Refit

8. Reverse removal procedure. Tighten A.C. generator securing nuts to 24 Nm.

A.C. GENERATOR DRIVE BELT

For A.C. Generator drive belt. See *ENGINE, Repair, Drive Belt*

DISTRIBUTOR-LUCAS 35 DLM8

Service parts

1. Cap
2. HT brush and spring
3. Rotor arm
4. Insulation cover
5. Pick-up module and base plate assembly
6. Vacuum unit
7. Amplifier module
8. 'O'-ring oil seal
9. Gasket

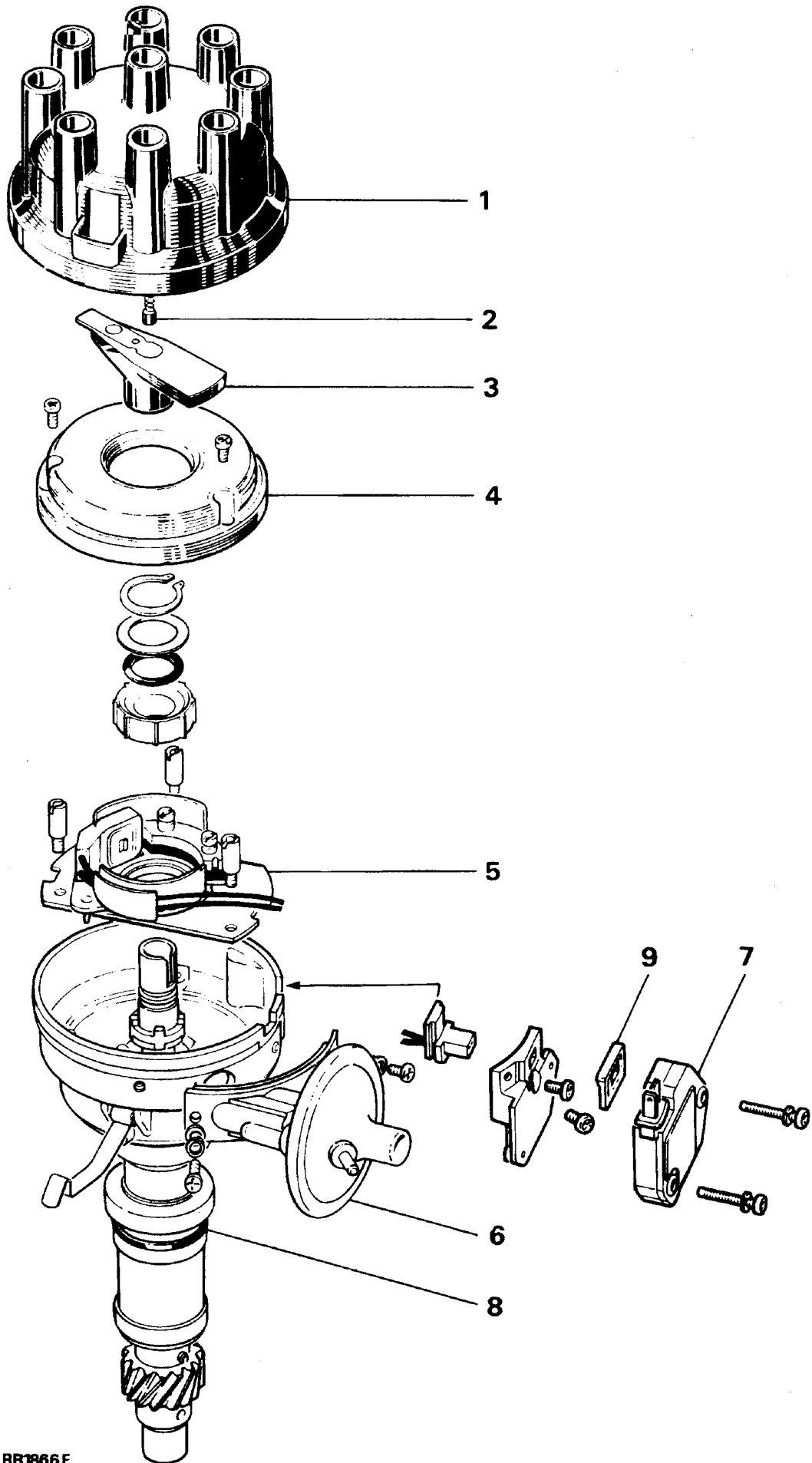

RR1866E

ELECTRONIC IGNITION - V8i

A Lucas 35DLM8 distributor is employed. This has a conventional vacuum advance unit and centrifugal automatic advance mechanism.

A pick-up module, in conjunction with a rotating timing retractor inside distributor body, generates timing signals. These are applied to an electronic ignition amplifier module mounted on side of distributor body.



NOTE: Pick-up air gap is factory set. Do not adjust gap unless pick-up is being changed or base plate has been moved. Use a non-ferrous feeler gauge to set air gap.

DISTRIBUTOR - V8i

Service repair no - 86.35.20

Remove

1. Disconnect battery negative lead.
2. Disconnect vacuum hose.
3. Remove distributor cap.

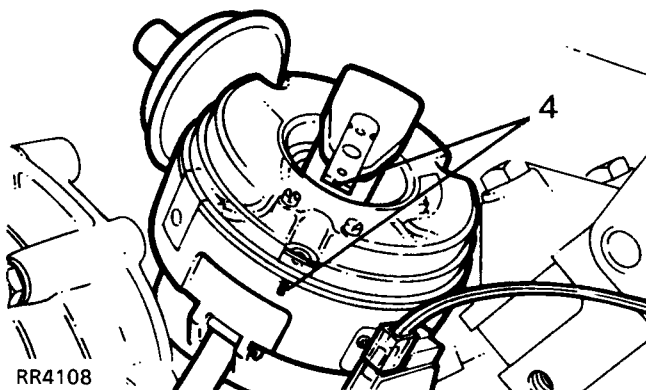

RR4108

4. Mark distributor body and centre line of rotor arm.

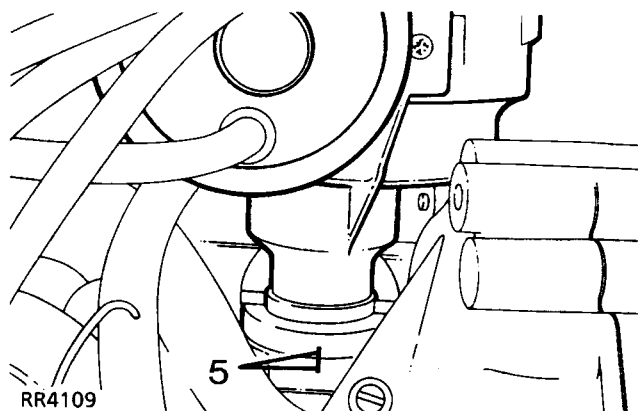

RR4109

5. Add alignment marks to distributor and front cover.



NOTE: Marking distributor enables refitting in exact original position, but if engine is turned while distributor is removed, complete ignition timing procedure must be followed.

6. Release distributor clamp.
7. Raise distributor, disconnect multiplug from amplifier unit.



Refit



NOTE: If a new distributor is being fitted, mark body in same relative position as distributor removed.

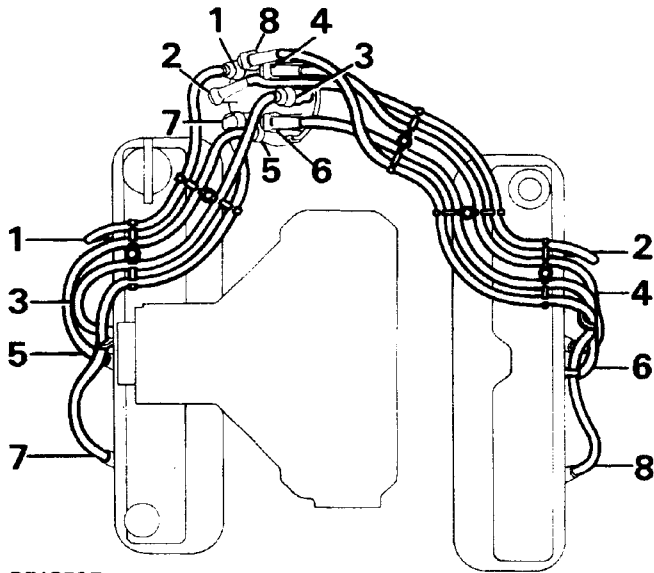

RR1876E

8. Leads for distributor cap should be connected as illustrated.
 Figures 1 to 8 inclusive indicate plug lead numbers.
 RH-Right hand side of engine, when viewed from rear.
 LH-Left hand side of engine, when viewed from rear.

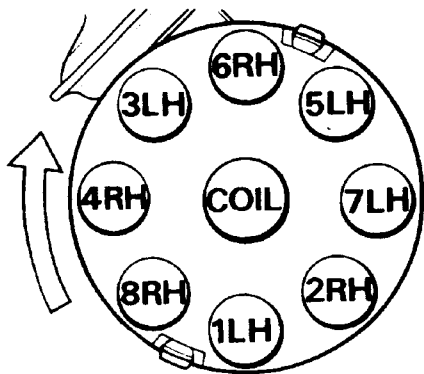

RR616M

9. If engine has not been turned while distributor has been removed, carry out instructions 10. to 17. Alternatively proceed to instruction 18.
 10. Fit new 'O' ring seal to distributor housing.

11. Turn distributor drive until centre line of rotor arm is 30° anti-clockwise from mark made on top edge of distributor body.
 12. Position distributor to engine, connect multiplug to amplifier; fit distributor in accordance with alignment markings.



NOTE: It may be necessary to align oil pump drive shaft to enable distributor drive shaft to engage in slot.

13. Fit clamp and bolt. Secure distributor in exact original position.
 14. Connect vacuum hose to distributor and low tension lead to coil.
 15. Fit distributor cap.
 16. Reconnect battery.
 17. Using suitable electronic equipment, set ignition timing. *See Adjustment, Ignition Timing*
 18. If engine has been turned with distributor removed, carry out instructions 19. to 29.
 19. Set engine-No. 1 piston to static ignition timing figure.

If engine is 3.9 V8i. *See ENGINE TUNING DATA, Information, ENGINE 3.9 V8i.*

If engine is 4.2 V8i. *See ENGINE TUNING DATA, Information, ENGINE 4.2 V8i.*

20. Turn distributor drive until rotor arm is approximately 30° anti-clockwise from number one sparking plug lead position on cap.
 21. Fit distributor to engine.
 22. Check that centre line of rotor arm is now in line with number one sparking plug lead on cap. Reposition distributor if necessary.
 23. If distributor does not seat correctly in front cover, oil pump drive is not engaged. Engage by lightly pressing down distributor while turning engine.
 24. Fit clamp and bolt, do not tighten.
 25. Set ignition timing statically.

If engine is 3.9 V8i. *See ENGINE TUNING DATA, Information, ENGINE 3.9 V8i.*

If engine is 4.2 V8i. *See ENGINE TUNING DATA, Information, ENGINE 4.2 V8i.*

26. Connect vacuum hose to distributor.
 27. Fit distributor cap.
 28. Reconnect battery negative lead.
 29. Using suitable electronic equipment set the ignition timing. *See Adjustment, Ignition Timing*

IGNITION COIL

Service repair no - 86.35.32

Remove

1. Disconnect battery negative lead.

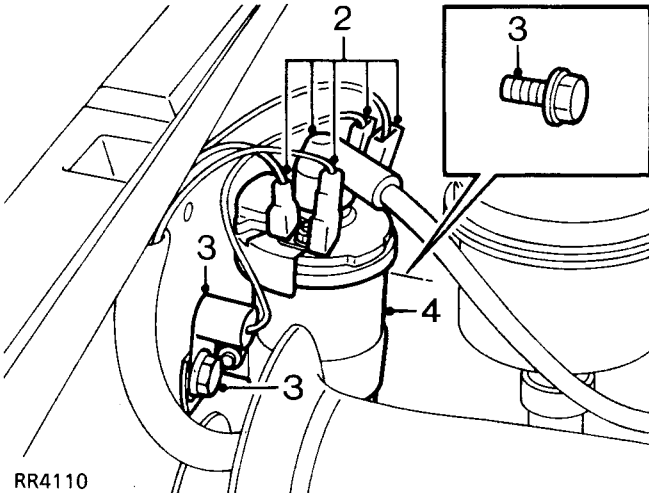

RR4110

2. Noting their fitted positions, disconnect electrical leads from ignition coil.
3. Remove two bolts securing ignition coil clamp, recover suppressor.
4. Remove coil.

Refit

5. Reverse removal procedure.

BULB REPLACEMENT

For bulb type and rating refer to rating shown on the bulb or bulb replacement list. **See GENERAL SPECIFICATION DATA, Information, Bulbs**

HEADLAMP ASSEMBLY / SEALED BEAM UNIT

Service repair no - 86.40.02

Remove

1. Disconnect battery negative lead.
2. Remove radiator grille. **See CHASSIS AND BODY, Repair, Radiator Grille**
3. Remove three screws and headlamp retaining rim.

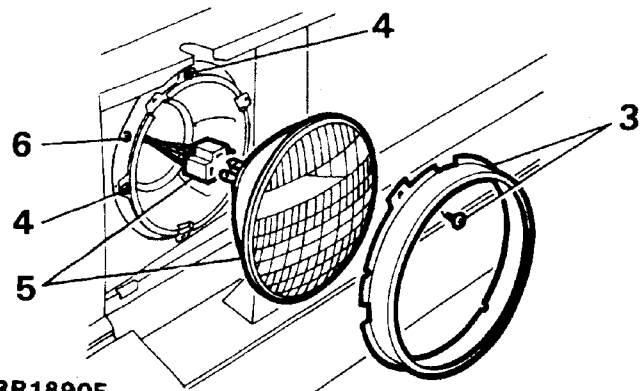

RR1890E

4. **DO NOT** disturb beam adjusting screws.
5. Withdraw sealed beam unit. Disconnect wiring plug from rear of unit.
6. Remove three securing screws, pry away grommet. Remove headlamp bowl.

Refit

7. Reverse removal procedure.



HEADLAMP ASSEMBLY/BULB REPLACEMENT

Service repair no - 86.40.02

Remove

1. Disconnect battery negative lead.
2. Remove radiator grille. *See CHASSIS AND BODY, Repair, Radiator Grille*
3. Remove three screws and headlamp retaining rim.

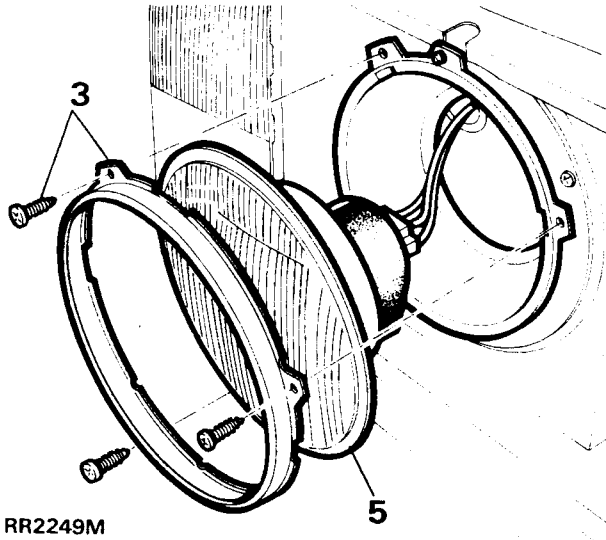

RR2249M

4. **DO NOT** disturb beam adjusting screws.
5. Withdraw headlamp unit. Disconnect wiring plug from rear of unit.
6. Remove rubber dust cover.

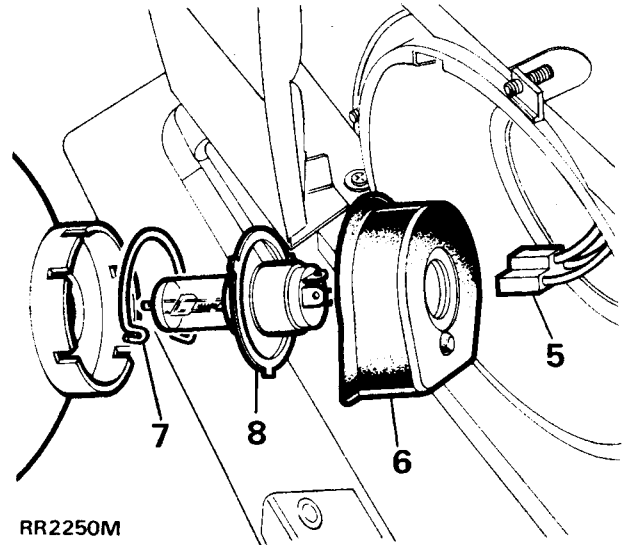

RR2250M

7. Release retaining clip, remove bulb
8. Remove three securing screws, pry away grommet. Remove headlamp bowl.

Refit

9. Reverse removal procedure.
DO NOT touch quartz envelope of bulb. Gently clean using methylated spirits if contact does occur.

HEADLAMP ALIGNMENT

Service repair no - 86.40.17

Headlamp beam setting should only be carried out by qualified personnel using suitable beam setting equipment, for example the Lucas Beamtester.

RR3825M shows right hand drive beam pattern, left hand drive is symetrically opposite.

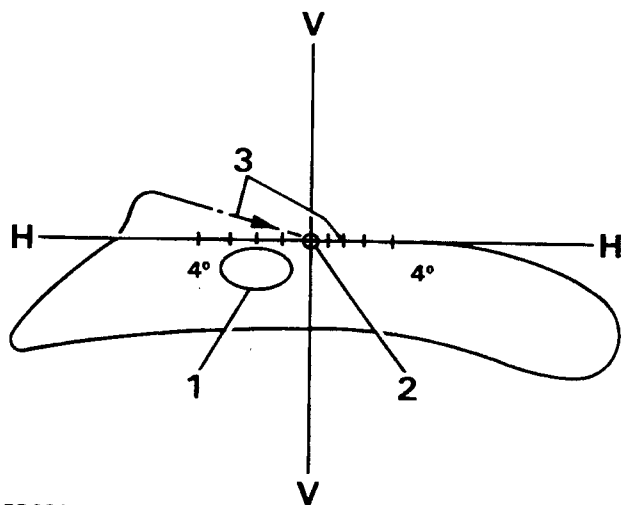

RR3825M

Guide to beam pattern:

1. Maximum intensity zone.
2. Beam aim kink point.
3. Aiming datum lines.

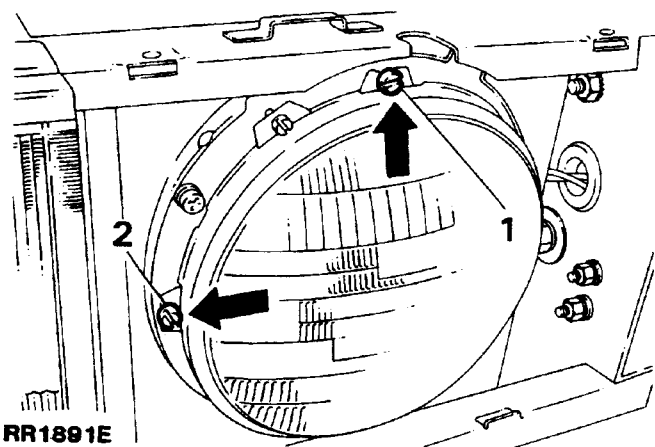

RR1891E

Adjust

1. Turn top adjusting screw anti-clockwise to lower beam, clockwise to raise beam.
2. Turn side adjusting screw anti-clockwise to move beam to left, clockwise to move beam to right.

AUXILIARY DRIVING LAMP

Service repair no - 86.40.96

Bulb replacement

1. Disconnect battery negative lead.
2. Securing nut is located beneath front bumper, adjacent to front body fixing. Access to lamp is gained through front wheel arch.
3. Disconnect electrical plug.
4. Remove single nut and washer.

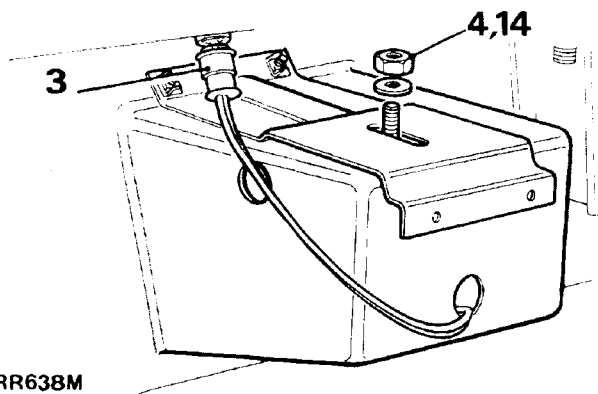

RR638M

5. From front of vehicle, manoeuvre lamp. Remove lamp from spoiler opening.
6. Remove two screws securing cover to rear of lamp.
7. Withdraw cover.
8. Disconnect lucar connector.
9. Release spring clip securing bulb to lamp unit.
10. Remove bulb.

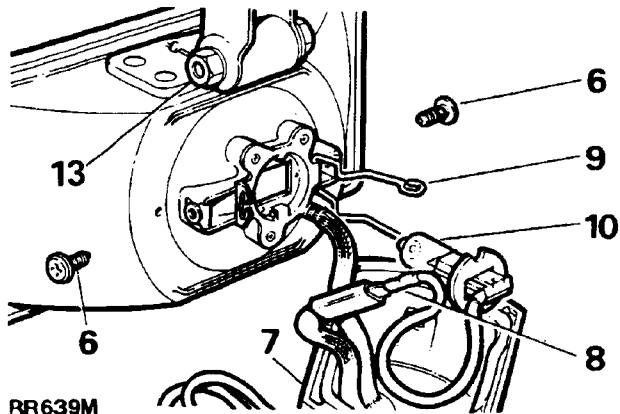

RR639M

Refit

11. Fit a new bulb. Ensure two notches on bulb body locate with registers on lamp unit.
12. Reverse removal procedure.

Adjust

Correct adjustment is beam horizontal (parallel to ground) and parallel to vehicle axis.

13. Loosen lamp adjusting bolt to lower or raise beam.
14. Loosen lamp securing bolt to move beam to left or right.
15. Tighten fixing bolts to **15 Nm**.

SIDELIGHT AND FLASHER LAMP ASSEMBLY AND BULB

Service repair no - 86.40.24

Remove

1. Disconnect battery negative lead.
2. Remove two screws and plain washers securing lamp assembly.
3. Lift assembly away sufficiently to gain access to rear of lamp.
4. Remove waterproof cover.
5. Depress two retaining clips and withdraw bulb holder.
6. Remove required bulb. Direction indicator bulb is located in upper section of bulb holder, side lamp bulb in lower.
7. Disconnect multi-plug. Remove complete assembly.

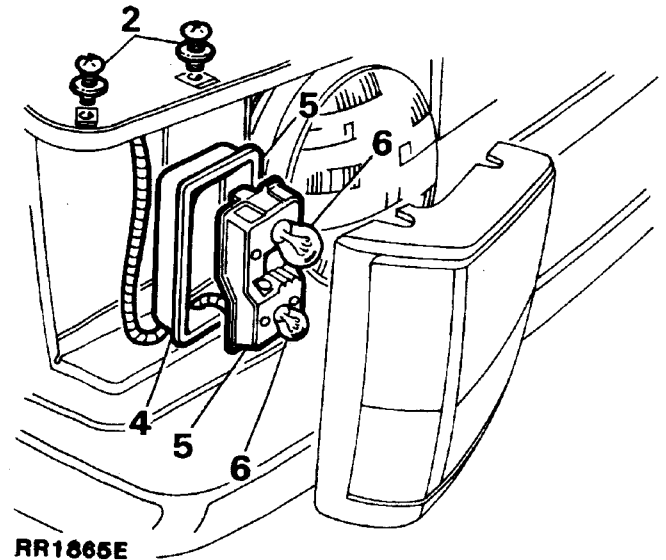

RR1865E

Refit

8. Reverse removal procedure. Ensure waterproof cover is correctly located.

DIRECTION INDICATOR/SIDE REPEATER LAMP BULB REPLACEMENT

Service repair no - 86.40.65

Remove

1. Disconnect battery negative lead.
2. Release clips securing wheel arch liner.

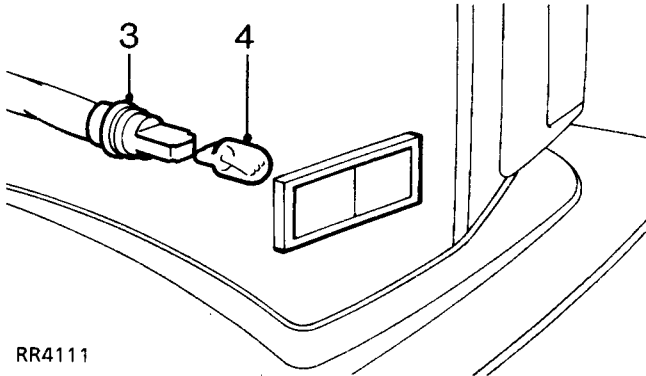

RR4111

3. At back of lamp, twist bulb holder anti-clockwise to remove from lamp assembly.
4. Remove bulb.

Refit

5. Reverse removal procedure.

TAIL LAMP ASSEMBLY

Service repair no - 86.40.74

Remove

1. Disconnect battery negative lead.
2. Remove four lens retaining screws.
3. Remove lens.
4. Remove sealing rubber, if required.



NOTE: To remove sealing rubber complete it is necessary to remove side marker lens.

5. Remove bulbs.
6. Remove four screws securing lamp unit to body.
7. Remove two through-screws from reflector side, which also secure lamp unit to body.
8. Ease lamp unit forward and disconnect leads at moulded connectors.

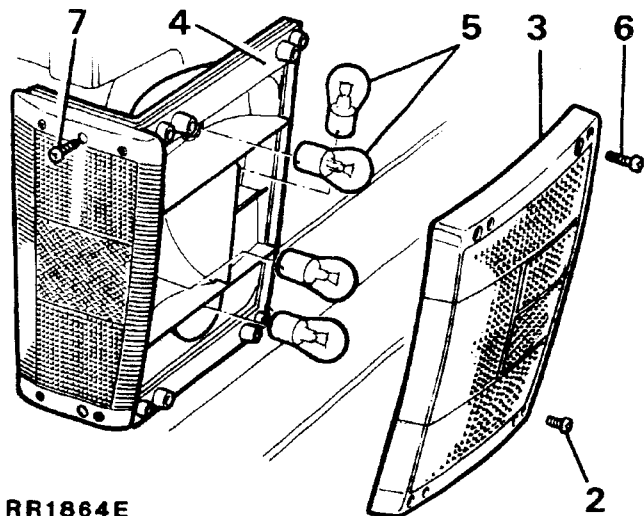

RR1864E

Refit

9. Reverse removal procedure.



REFLECTORS/SIDE MARKER LAMP ASSEMBLY AND BULB

Service repair no - 86.40.67

Remove

1. Remove four screws securing lens.
2. Remove lens.
3. Remove bulb.

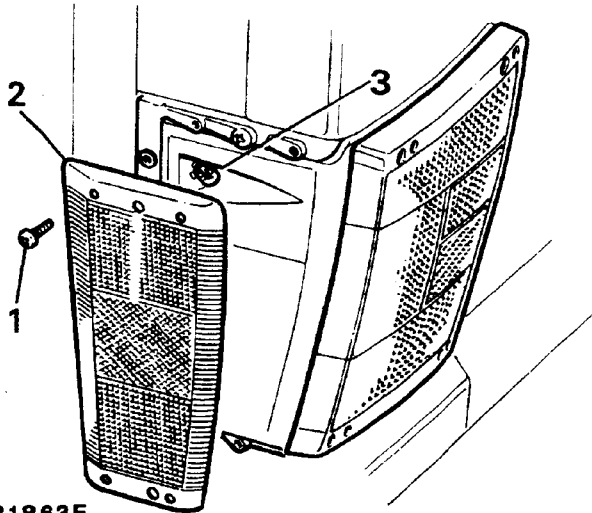

RR1863E



NOTE: To remove rubber seal completely it is necessary to remove tail light lens.

Refit

4. Reverse removal procedure.

UNDER BONNET LAMP ASSEMBLY

Service repair no - 86.45.24

Remove

1. Disconnect battery negative lead.
2. Remove two securing screws.
3. Remove lamp glass.
4. Pull 'wedge' type bulb from bulb holder.

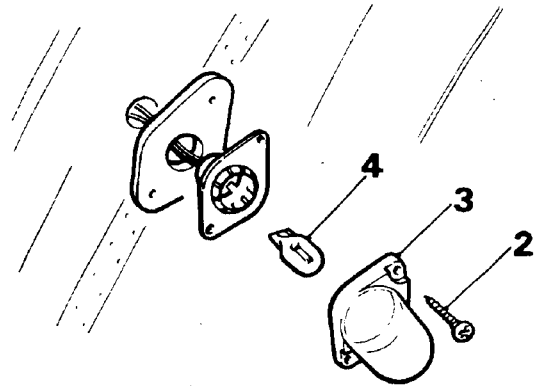

RR483M

5. Disconnect electrical leads located below bonnet lamp switch attached to inner fender.
6. Pull rubber grommet off leads and pull lamp and leads up through hood stiffener channel.

Refit

7. Reverse removal procedure. 1 to 6.



NOTE: A piece of bent wire will be needed to pull electrical leads out of channel exit hole when fitting a new lamp assembly.

HEATER/VENTILATION AND AIR CONDITIONING CONTROL PANEL BULB

Service repair no - 86.45.73

Remove

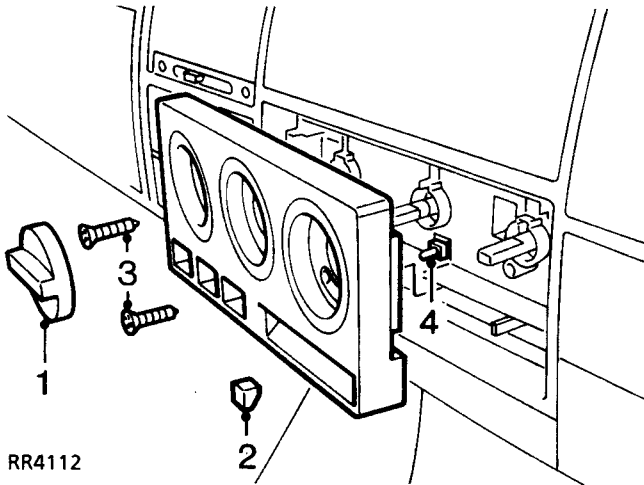

RR4112

1. Carefully pull 3 rotary knobs off switches.
2. Prise blower speed control knob off lever.
3. Remove 2 screws securing panel, ease panel away from fascia.
4. Pull bulb from holder.
5. Insert new bulb in holder.

Refit

6. Reverse removal procedure.

HEATER/VENTILATION AND AIR CONDITIONING CONTROL PANEL SWITCHES AND BULBS

Service repair no - 82.20.49 - Air conditioning switch

Service repair no - 86.10.27 - Recirculation switch

1. Remove centre dash panel. *See CHASSIS AND BODY, Repair, Dash Panel Central Louvre Panel*

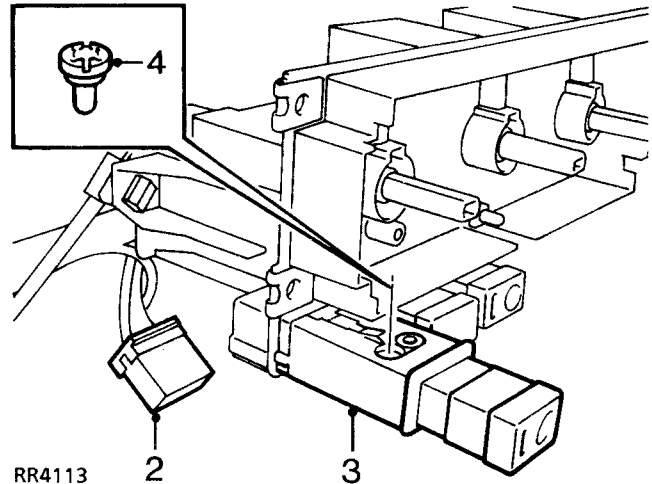

RR4113

2. Disconnect multiplug from appropriate switch.
3. Depress retaining lugs, withdraw switch from panel.

Bulb replacement

4. Rotate bulb holder, withdraw holder and bulb.

Refit

5. Reverse removal procedure.



DOOR EDGE LAMPS / PUDDLE LAMPS

Service repair no - 86.40.38

Incorporated into front door assemblies are door edge lamps and puddle lamps, located on door edge and bottom of door. The lamps are activated by courtesy light switches when either front door is opened and will immediately switch off when both doors are closed.

Remove

1. Ensure side door glass is fully closed.
2. Disconnect battery negative lead.
3. Remove interior door handle and arm rest/door pull from door.
4. Carefully release interior door trim pad from inner door panel.
5. Peel back lower half of plastic vapour barrier.
6. Disconnect electrical connectors within door, accessible through lower centre and outer openings of inner door panel.
7. Release door edge lamp electrical leads from retaining clips.
8. Remove lens and pry lamps out of door and withdraw electrical leads.

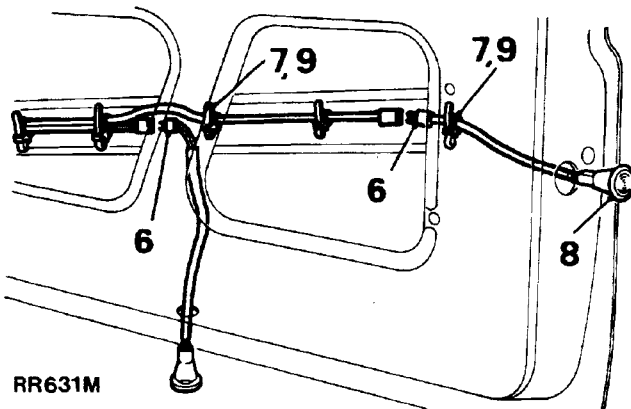

Refit

9. Reverse removal procedure.



NOTE: Ensure door lamp wiring harness is securely clipped to lower stiffener plate within door to prevent damage occurring to electrical leads when door glass is in its lowest position.

DOOR EDGE LAMPS/PUDDLE LAMPS BULB

Service repair no - 86.40.47

1. Disconnect battery negative lead.

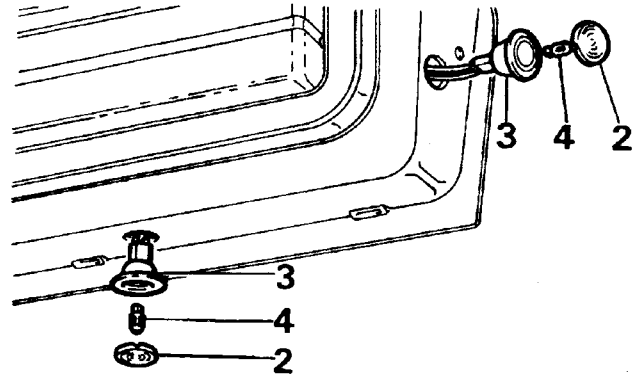

2. Carefully pry out lamp lens.
3. Withdraw lamp body from door **ONLY** as far as electrical leads will permit.
4. Pull bulb from holder.

Refit

5. Fit new bulb, refit lamp lens.
6. Push lamp into door.

AUTOMATIC GEAR SELECTOR-PANEL BULB

Service repair no - 86.45.40

1. Disconnect battery negative lead.

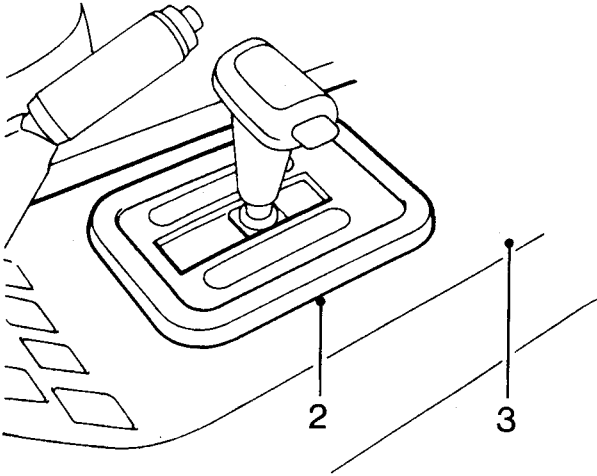

RR4115

2. Carefully prise quadrant finisher out of surround.
3. Carefully prise rear of surround away from centre console.

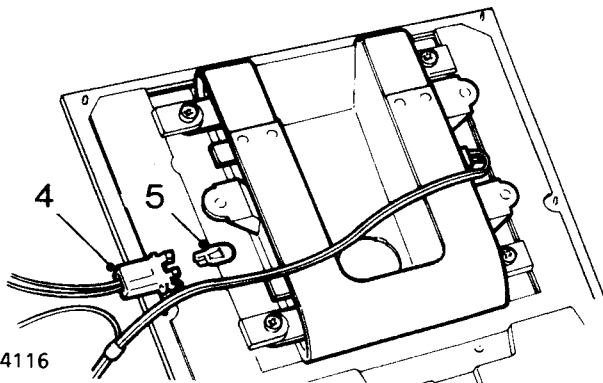

RR4116

4. Pull appropriate bulb holder from fitted position.
5. Remove bulb from holder.

Refit

6. Reverse removal procedure.

NUMBER/LICENSE PLATE LAMP ASSEMBLY AND BULB

Service repair no - 86.40.86

Remove

1. Disconnect battery negative lead.
2. Remove two self-tapping screws with washers.
3. Remove lamp assembly.
4. Disconnect bulb holder, remove bulb.



NOTE: Carefully pull electrical leads out of bottom of lower tailgate panel to reveal snap connectors.

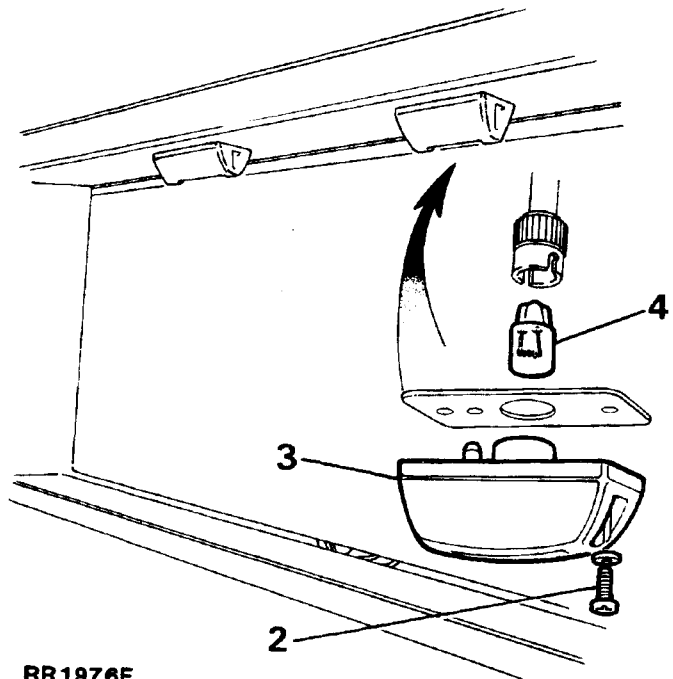

RR1976E

5. Disconnect electrical connections located at bottom of lower tailgate.
6. Remove bulb holder.
7. Carefully pull electrical leads up through inside of lower tailgate panels.

Refit

8. Reverse removal procedure.



INTERIOR ROOF LAMP

Service repair no - 86.45.01

Remove

Interior roof lamps are operated automatically via side door and tailgate courtesy switches or by an independent switch in auxiliary switch panel.

1. Disconnect battery negative lead.
2. Remove lens from courtesy lamp by pressing upward and turning it counter-clockwise.
3. Withdraw bulb from spring clip holder.
4. Remove screws securing lamp base to roof panel.
5. Lower lamp to reveal cable snap connections.
6. Disconnect electrical connections.

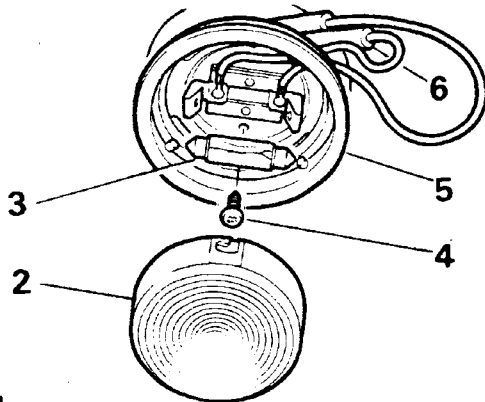

RR485M

Refit

7. Reverse removal procedure.

STARTER MOTOR - V8i ENGINE

Service repair no - 86.60.01

Remove

1. Place vehicle on a suitable ramp [hoist].
2. Disconnect battery negative lead.
3. Disconnect leads from solenoid and starter motor. Remove exhaust heat shield.
4. Remove two bolts, starter motor to flywheel housing.
5. Remove starter motor.

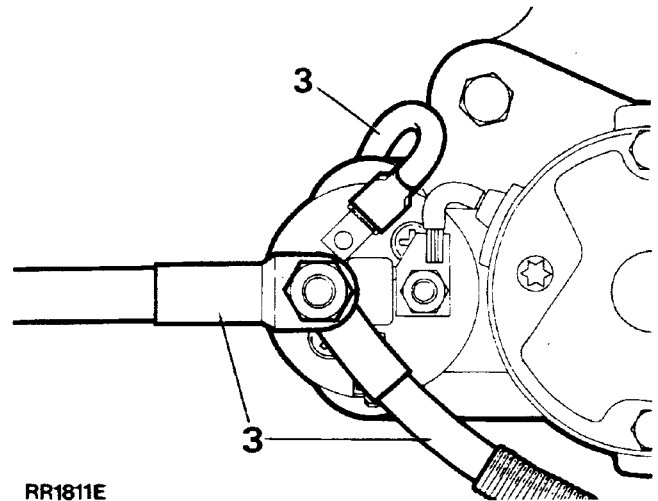

RR1811E

Refit

6. Reverse removal procedure.

AUXILIARY SWITCHES AND BULBS

Service repair no - 86.45.49 - Switches

Service repair no - 86.45.29 - Bulbs

The auxiliary switch panel contains up to six switches depending on vehicle specification. Each switch incorporates integral symbols for identification. Unused switch openings are fitted with blank covers, which are removable, to facilitate fitting extra switches if required.

The symbols are illuminated by two bulbs which become operational when vehicle lights are on.

Switch replacement

Remove

1. Disconnect battery negative lead.
2. Remove air suspension switch panel. *See Air Suspension Switches and Bulbs*

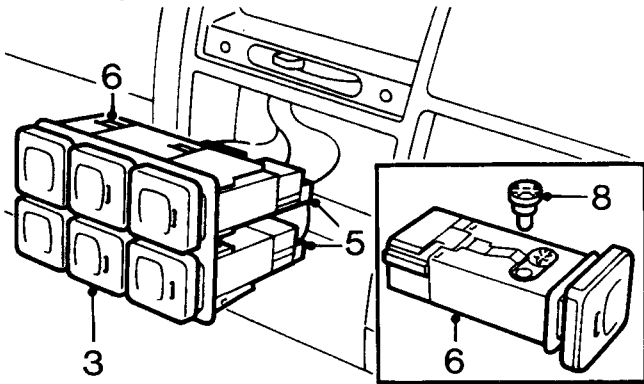

RR4117

3. Carefully prise auxiliary switch panel out of fascia.
4. Withdraw switch panel as far as electrical leads will permit.
5. Noting their fitted position, disconnect multiplug(s) from the switch(es).
6. Depress small retaining lugs on top and bottom of switch and push switch(es) through front of switch surround.

Bulb replacement

7. Identify bulb to be replaced and remove appropriate switch.
8. Rotate bulb holder 90 deg. and withdraw it from switch; discard bulb holder and bulb.

Refit

9. Reverse removal procedure.



AIR SUSPENSION SWITCHES AND BULBS

Service repair no - 86.65.88 - Switches

Service repair no - 86.45.29 - Bulbs

Switch replacement

Remove

1. Disconnect battery negative lead.

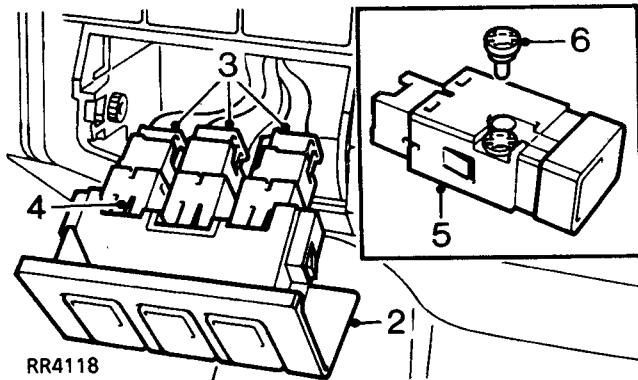

2. Carefully release lower edge of panel from surround, withdraw panel.
3. Noting their fitted positions, disconnect multiplugs from switches.
4. Depress retaining lugs on switches, remove switches from panel.

Bulb replacement

5. Identify bulb to be replaced and remove appropriate switch.
6. Rotate bulb holder 90 deg. and withdraw it from switch.

Refit

7. Reverse removal procedure.

HEADLAMP/FLASHER SWITCH AND WINDSCREEN WASH/WIPE SWITCH

Service repair no - 84.15.34 - Wash wipe switch
Service repair no - 86.65.41 - Headlamp/flasher switch



NOTE: The following procedure applies to either switch.

Remove

1. Remove steering column shroud. *See STEERING, Repair, Steering Column Shroud*
2. Position steering wheel for access.

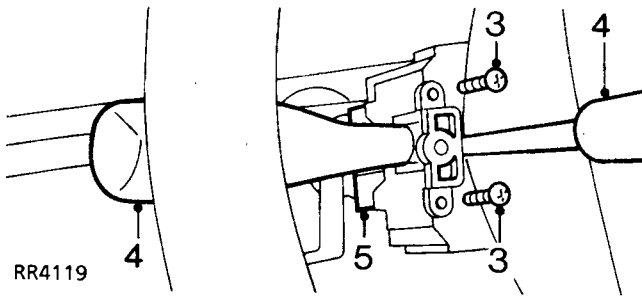

RR4119

3. Remove 2 screws securing switch.
4. Insert a suitable, flat bladed tool between switch and casing, depress raised 'pip', release switch from casing.
5. Disconnect switch multiplugs.

Refit

6. Connect switch multiplugs.
7. Position switch to casing ensuring 'pip' is engaged.
8. Reverse removal procedure. 1 and 3.

HAZARD WARNING SWITCH AND BULB

Service repair no - 86.65.50 - Switch
Service repair no - 86.45.29 - Bulb

Switch replacement

Remove

1. Disconnect battery negative lead.
2. Remove ashtray.

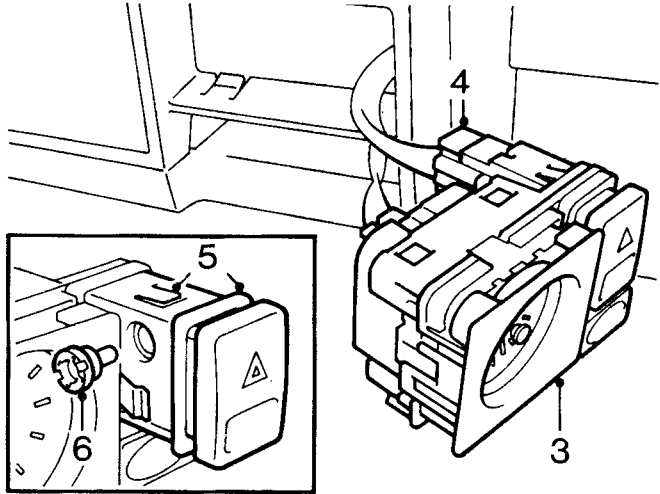

RR4120

3. Carefully release panel from fascia.
4. Disconnect multiplug from switch.
5. Depress retaining lugs, remove switch from panel.

Bulb replacement

6. Rotate bulb holder 90 deg. and withdraw it from switch, discard bulb holder and bulb.

Refit

7. Reverse removal procedure.



IGNITION/STARTER SWITCH - BULB REPLACEMENT

Service repair no - 86.45.29

Remove

1. Remove steering column shroud. *See STEERING, Repair, Steering Column Lock Assembly*

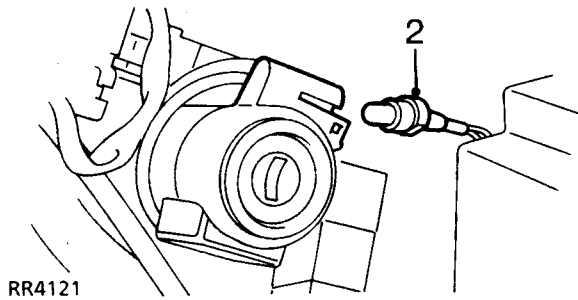

RR4121

2. Withdraw bulb holder, remove bulb.

Refit

3. Reverse removal procedure.

DOOR PILLAR SWITCH

Service repair no - 86.65.15

Remove

1. Disconnect battery negative lead.
2. Remove screw securing switch to door pillar.
3. Remove switch.
4. Disconnect electrical lead from connector blade.

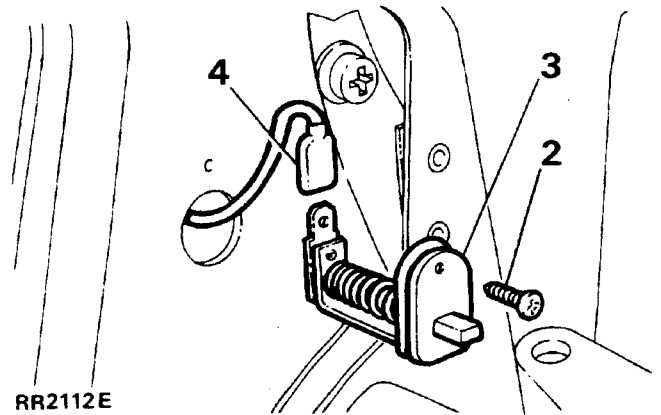

RR2112E

Refit

5. Reverse removal procedure.

IGNITION/STARTER SWITCH

Service repair no - 86.65.02

Remove

1. Remove steering column lock. **See STEERING, Repair, Steering Column Lock Assembly**

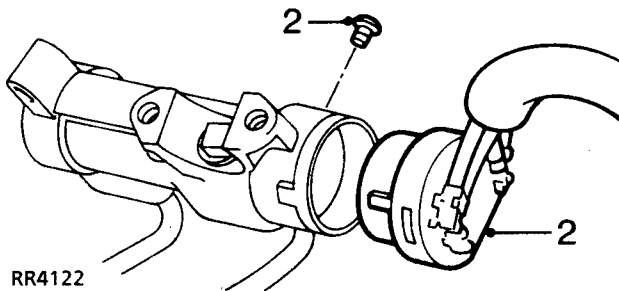

2. Remove screw securing ignition/starter switch, remove switch from lock barrel.

Refit

3. Position switch to lock barrel ensuring peg is inserted in switch, fit and tighten screw.
4. Fit steering column lock. **See STEERING, Repair, Steering Column Lock Assembly**

REAR TAILGATE SWITCH

Service repair no - 86.65.22

Remove

1. Disconnect battery negative lead.
2. Remove single screw securing switch to tailgate opening.
3. Withdraw switch.
4. Disconnect electrical lead.

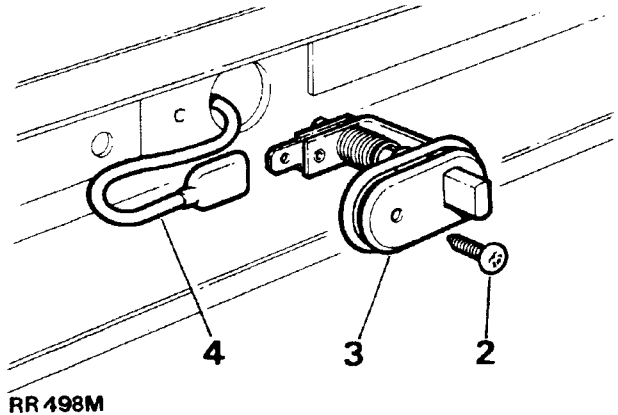
**Refit**

5. Reverse removal procedure.



UNDER BONNET/HOOD ILLUMINATION SWITCH

Service repair no - 86.65.23

Remove

1. Disconnect battery negative lead.
2. Remove single screw securing switch to decker panel.
3. Withdraw switch.
4. Disconnect electrical lead.

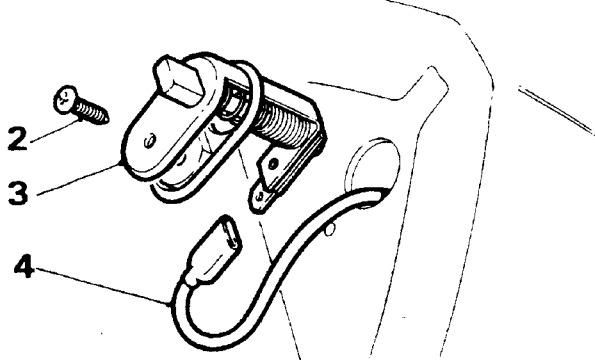

RR499M

Refit

5. Reverse removal procedure.

CIGAR LIGHTER AND BULB

Service repair no - 86.65.60 - Cigar lighter

Service repair no - 86.45.55 - Bulb

Cigar lighter

Remove

1. Remove centre console. *See CHASSIS AND BODY, Repair, Centre Console*

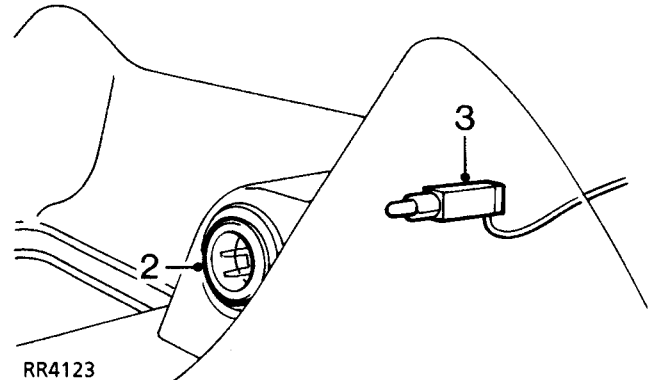

RR4123

2. Depress lugs securing cigar lighter, withdraw lighter from centre console.

Bulb replacement

3. Remove bulb from holder.

Refit

4. Reverse removal procedure.

REVERSE LIGHT SWITCH

Service repair no - 37.27.01

Manual gearbox

Remove

Reverse light switch is located at rear of selector housing, accessible from beneath vehicle.

1. Place vehicle on suitable ramp.
2. Disconnect battery negative lead.
3. Disconnect electrical leads.
4. Release lock-nut.
5. Remove switch.

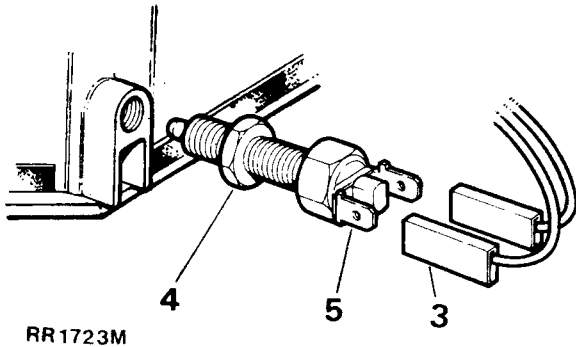

Refit



NOTE: Reverse light switch requires re-setting on reassembly.

6. Select reverse gear.
7. Connect 12 volt supply and test lamp across switch terminals.
8. Screw switch into housing until test lamp is illuminated. Screw switch in a further half turn, tighten locknut.
9. Connect electrical leads.
10. Reconnect battery negative lead.

START INHIBIT / REVERSE LIGHT SWITCH

Service repair no - 44.15.19

Automatic gearbox

Remove

Reverse light switch is an integral part of start inhibitor switch. It is located on left hand side of gearbox, accessible from beneath vehicle.

1. Place vehicle on suitable ramp.
2. Disconnect battery negative lead.
3. Disconnect multi-plug.
4. Release clamp bolt, remove clamp.
5. Remove switch.

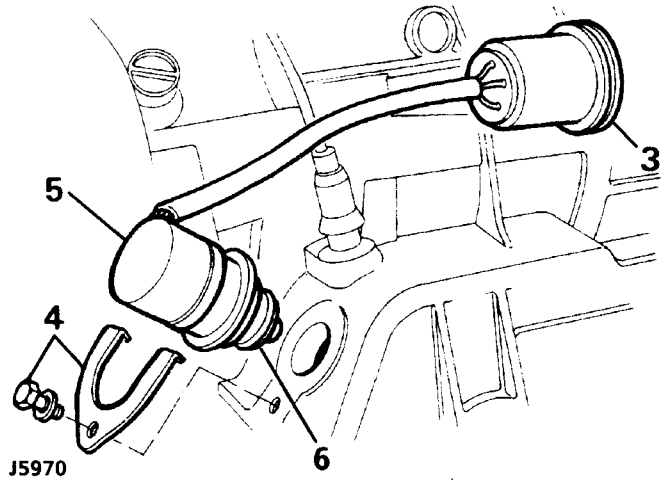

Refit

6. Fit a new 'O' ring to switch.
7. Reverse removal procedure.



OIL PRESSURE WARNING SWITCH - V8i

Service repair no - 86.65.30

Remove

1. Disconnect battery negative lead.
2. Disconnect electrical lead.
3. Unscrew switch unit.
4. Remove switch and sealing washer.

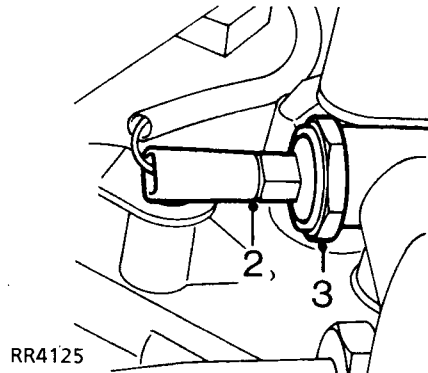

Refit

5. Reverse removal procedure. Using a NEW sealing washer.

PARK BRAKE WARNING SWITCH

Service repair no - 86.65.45

Remove

1. Remove centre console. *See CHASSIS AND BODY, Repair, Centre Console*
2. Apply park brake.
3. Reposition hose at side of bracket to gain access to switch.

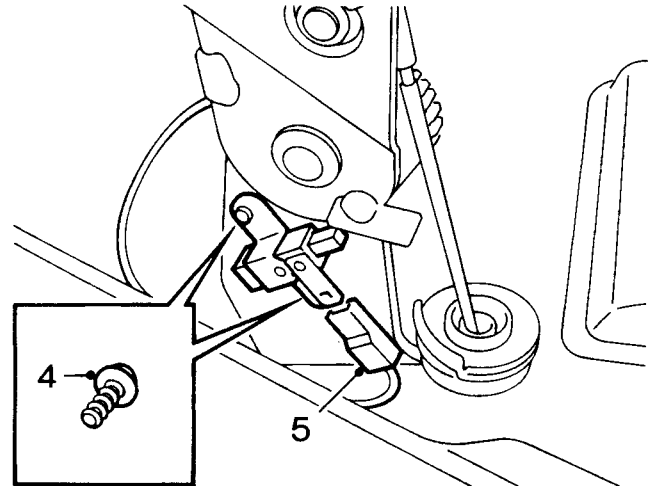

RR4126

4. Remove screw securing switch.
5. Withdraw switch, disconnect Lucar, remove switch.

Refit

6. Reverse removal procedure.

EXTERIOR DRIVING MIRRORS MOTOR**Remove**

1. Disconnect battery negative lead.
2. Remove mirror glass.

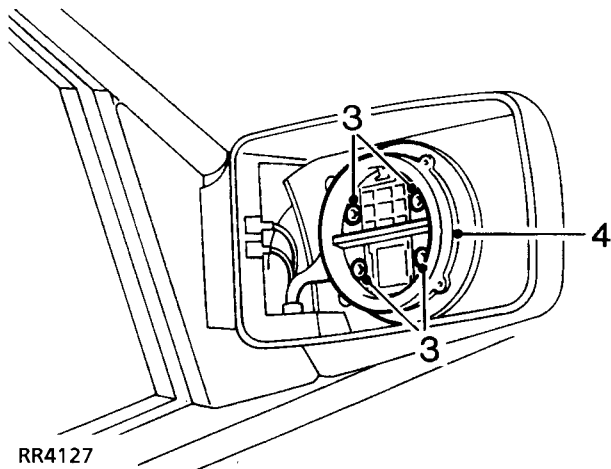

3. Remove 4 screws securing motor.
4. Position motor to obtain access to electrical connections.
5. Disconnect harness from motor, remove motor.

Refit

6. Position motor, connect harness.
7. Fit and tighten securing screws.
8. Fit mirror glass.
9. Reconnect battery negative lead.

CONTROL SWITCHES

Service repair no - 86.65.75 - Switches

Service repair no - 86.45.29 - Bulbs



NOTE: The following operation covers the exterior driving mirror, rear screen wash, rear screen wipe and petrol filler flap switches and bulbs.

Switch replacement**Remove**

1. Disconnect battery negative lead.
2. Release turnbuckles, lower driver's access panel.

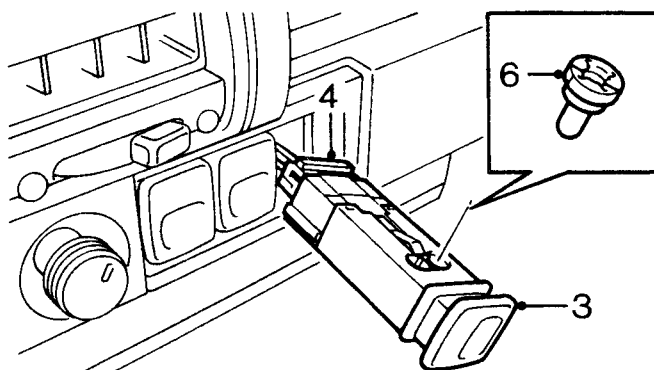

RR4128

3. Depress lugs retaining appropriate switch, press switch from panel.
4. Disconnect multiplug from switch, remove switch.

Bulb replacement

5. Identify bulb to be replaced and remove appropriate switch.
6. Rotate bulb holder 90 deg. and withdraw it from switch; discard bulb holder and bulb.

Refit

7. Reverse removal procedure.



INSTRUMENT ILLUMINATION ELECTRONIC DIMMER / RHEOSTAT

Service repair no - 86.65.07

Electronic dimming control switch is located in instrument panel finisher. Rotate control to vary intensity of illumination.

Remove

1. Disconnect battery negative lead.
2. Remove instrument panel finisher. See *Instrument Panel Finisher*

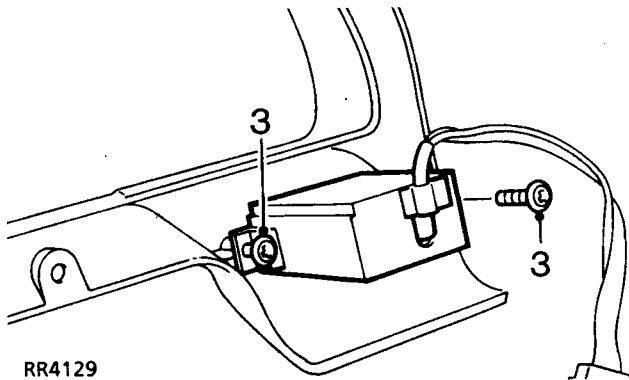

RR4129

3. Remove 2 screws securing rheostat, remove rheostat.

Refit

4. Reverse removal procedure.

WINDOW LIFT/HEATED SEAT CUSHION SWITCHES AND BULBS

Service repair no - 86.25.16 - Switches

Service repair no - 86.45.29 - Bulb

Switch replacement

Remove

1. Disconnect battery negative lead.

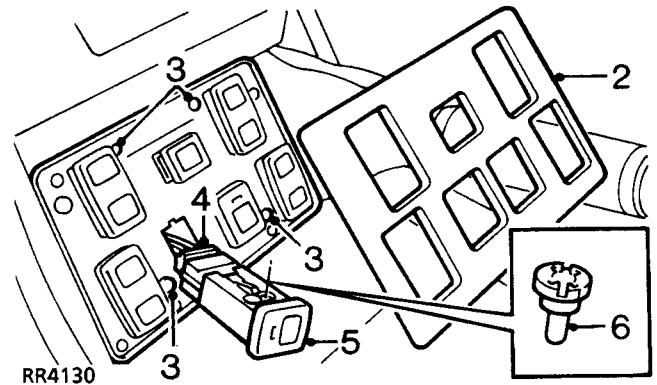

RR4130

2. Carefully release rear of surround from centre console.
3. Remove screws, pry window lift switch surround from glove box.
4. Disconnect multi-plug(s) at rear of switch(es).
5. Apply pressure to rear of switch, push it through surround.

Bulb replacement

6. Identify bulb to be replaced and remove appropriate switch.
7. Rotate bulb holder 90° and withdraw it from switch; discard bulb and holder.

Refit

8. Reverse removal procedure.

WINDOW LIFT MOTOR - FRONT DOORS

Service repair no - 86.25.04

Remove

1. Ensure that side door glass is fully closed, secure with adhesive tape.
2. Remove front door trim panel. *See CHASSIS AND BODY, Repair, Front Door Trim Panel*
3. Peel back front top corner of plastic vapour barrier to reveal window lift motor.
4. Release window lift motor wiring harness from three retaining clips to allow harness to be pulled out of opening at front of inner door panel.
5. Disconnect window lift motor multi-plug from main door harness.

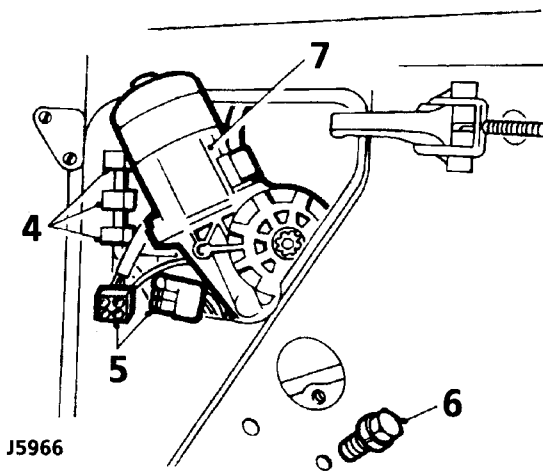

6. Support motor, remove three securing bolts.
7. Remove motor through top front opening of door.

Refit

8. Reverse removal procedure. 1 to 7.



NOTE: Ensure that drive gear is engaged and correctly aligned with window lift linkage before fitting securing bolts.

WINDOW LIFT MOTOR - REAR DOORS

Service repair no - 86.25.09

Remove

1. Ensure that side door glass is fully closed, secure with adhesive tape.
2. Remove rear door trim panel. *See CHASSIS AND BODY, Repair, Rear Door Trim Panel*
3. Carefully detach bottom half of vapour barrier to reveal window lift motor.
4. Release motor wiring harness from retaining clips.
5. Disconnect lift motor harness snap connections from main door harness.
6. Support motor, release three securing bolts.
7. Remove lift motor from lower opening in inner door panel.

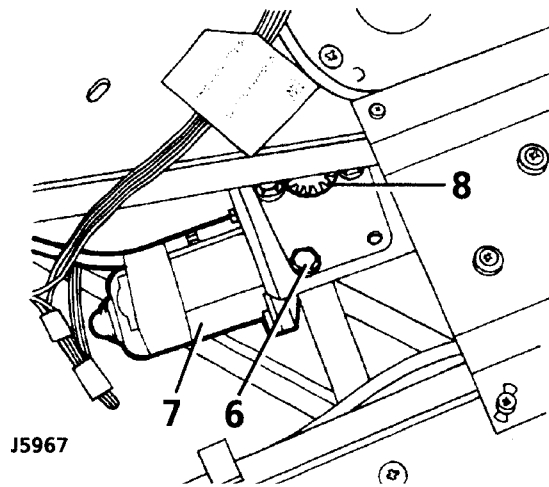

Refit

8. Reverse removal procedure. 1 to 7.



NOTE: Ensure that drive gear is engaged and correctly aligned with window lift linkage before fitting securing bolts.



CENTRAL DOOR LOCKING

The central door locking system on four door models is activated from both driver and front passenger doors. A switch/lock actuator is fitted in both front doors.

Front and rear passenger doors can be independently locked or unlocked from inside vehicle but can be overridden by further operation of driver's door locking control.

On rear doors only, a child safety lock is provided which can be mechanically pre-set to render interior door handles inoperative.

Failure of an actuator will not affect locking of remaining three doors, tailgate or fuel filler flap. A door with inoperative actuator can still be locked or unlocked manually, but not fuel filler flap.



NOTE: Actuator units contain non-serviceable parts. If a fault occurs, fit a new unit.

HANDSET INITIALISATION



NOTE: New handsets are supplied in pairs. If a new handset is required, it will require initialisation to the ECU using the following procedure:

1. Starting conditions: ignition off, doors unlocked, bonnet switch depressed.
2. Carry out instructions 3 to 9. within 8 seconds.
3. Switch ignition ON.
4. Switch ignition OFF.
5. Lock doors.
6. Unlock doors.
7. Release bonnet switch.
8. Switch ignition ON.
9. Switch ignition OFF.

If alarm is correctly accessed, horn will sound and LED will light. It is now possible to programme two handsets of correct frequency to vehicle alarm ECU. This must be carried out within two minutes.

10. Press and hold down button on first handset until dash LED flashes.
11. Repeat instruction 10 for second handset.
12. The LED will extinguish if both handsets have been initialised correctly.

FRONT DOOR ACTUATOR UNIT

Service repair no - 86.26.08

Remove

1. Ensure window is in its fully closed position.
2. Remove front door trim panel. *See CHASSIS AND BODY, Repair, Front Door Trim Panel*
3. Peel back plastic vapour barrier to expose actuator unit.
4. Remove four screws and plain washers securing lock actuator mounting plate to inner door panel.
5. Release cable tie, at trailing edge of door, retaining electrical cable.
6. Manoeuvre actuator assembly from actuator link.

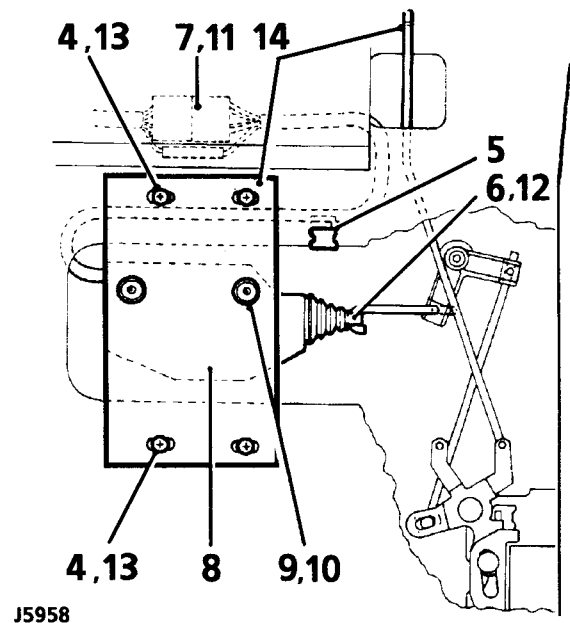

7. Withdraw actuator assembly, disconnect multi-plug.
8. Remove actuator assembly.
9. Remove actuator unit by loosening two screws securing it to mounting plate.

Refit

10. Fit actuator unit to mounting plate.
11. Connect multi-plug.
12. Manoeuvre actuator assembly to engage actuator link.
13. Loosely fit actuator mounting plate to inner door panel with four screws. Set mounting plate in centre of slotted holes.
14. Ensure that manual operation of sill locking control is not restricted by operation of actuator operating rod and vice versa. Reset mounting plate as necessary.
15. Reconnect vehicle battery.
16. Check that electrical operation of door lock occurs when sill locking control is moved through half of total movement. Reset mounting plate if necessary, tighten four screws.



NOTE: Above adjustment ensures that full tolerance on switching operation is utilised.

REAR DOOR ACTUATOR UNITS

Service repair no - 86.26.09

Instructions as for front doors with following exceptions:

1. Electrical cable and plug is retained and is accessible through large opening in door.
2. Instruction 16 does not apply to rear actuator units which are not fitted with switches.



NOTE: Actuator may be detached from mounting plate to facilitate removal of lock actuator from connector rod.

UPPER TAILGATE ACTUATOR UNIT

Service repair no - 86.26.10

Remove

1. Remove two screws and trim covering to gain access to actuator.
2. Disconnect electrical connection.
3. Remove two actuator retaining screws.
4. Manoeuvre actuator assembly link from actuator link.
5. Withdraw tailgate actuator unit.

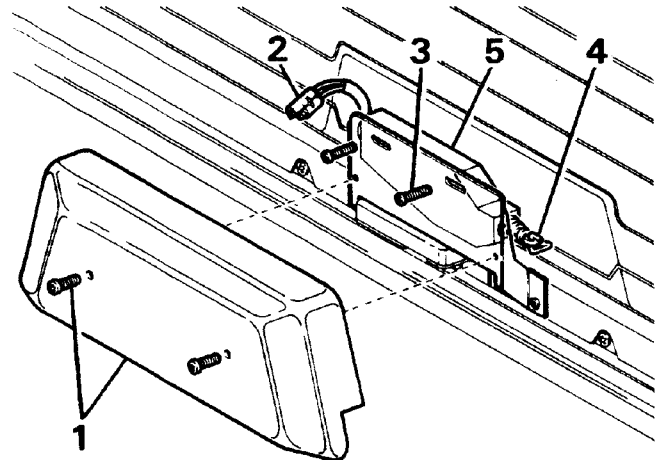

RR2570E

Refit

6. Reverse removal procedure.
7. Check operation of central locking system.



FUEL FILLER FLAP ACTUATOR UNIT

Service repair no - 86.26.16

Remove

1. Remove sub-woofer assembly. See *Sub-Woofer Box*

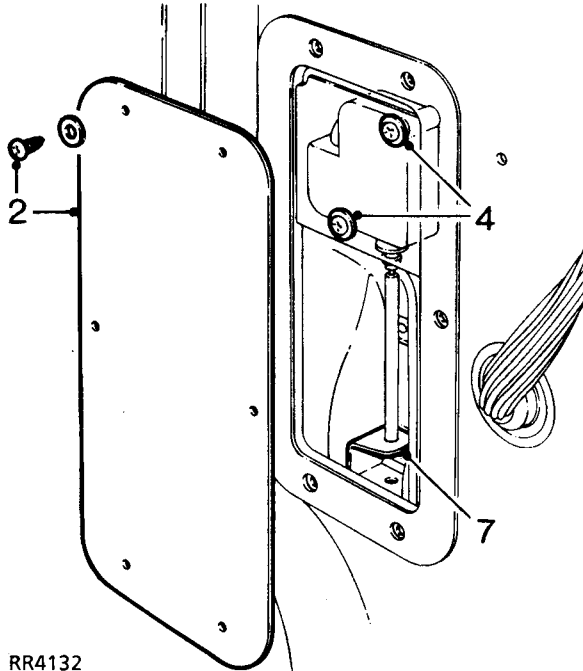

RR4132

2. Remove six screws to withdraw closure panel, situated in tool stowage area.
3. Ensure that actuator is in unlocked position and fuel filler flap is open.
4. Release two screws and manoeuvre actuator unit clear of its mounting.

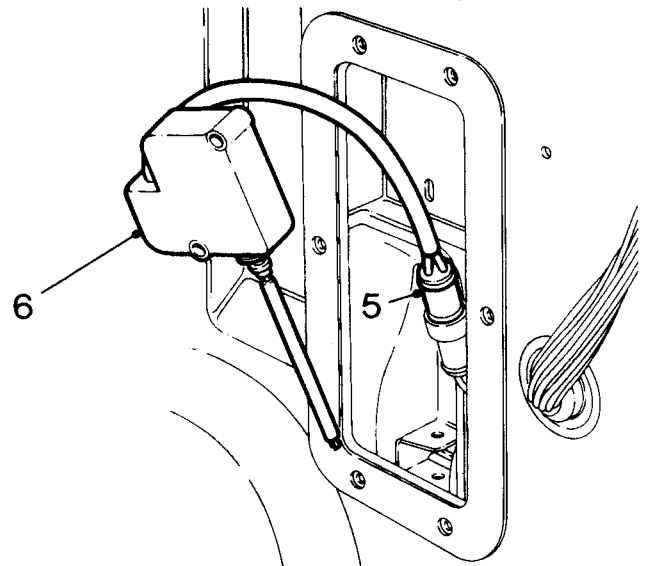

RR4133

5. Disconnect wiring plug.
6. Withdraw actuator.

Refit

7. Reverse removal procedure. Actuator mounting holes in body are elongated. Adjust position of actuator to ensure that rod will pass through guide brackets without fouling.

TRAILER SOCKET

Incorporated in vehicle electrical harness is a facility for fitting a seven pin trailer lighting socket.

Pick-up point is located behind right hand tail lamp cluster assembly.

Pick-up point consists of a seven pin pre-wired plug, a separate auxiliary fused line feed and reverse light lead.



CAUTION: Fitting trailer socket and associated wiring MUST be carried out by a qualified vehicle electrician.

1. Disconnect battery negative lead.
2. Remove tail lamp. *See Tail Lamp Assembly*
3. Remove protective cap from trailer pick-up point plug.



NOTE: Cable colours in this plug correspond to main circuit diagram. Red / yellow is unused.

4. Feed seven core cable Part No. PRC4143 (fitted with a pre-wired plug to one end-suitable for connection to pick-up point) down between inner and outer body panels through rear light opening.

5. Feed cable alongside existing rear lighting harness.
6. Pull cable through opening between chassis side member and fuel tank.
7. Fit two retaining clips to cable and secure it to rear end cross member.
8. Connect electrical leads to vehicle trailer socket. (Refer to current trailer wiring regulations).
9. Secure trailer socket to tow bar.
10. Two extra leads in rear light opening provide a line feed and reverse light feed.
11. Refit tail lamp.
12. Reconnect battery.

Electrical lead identification

Single leads - item 10 in illustration J5963.

Pink Fused auxiliary line feed.
Green/Brown Reverse light feed.

Pre-wired cable and plug - Part No. PRC4143

Yellow Left indicator.
Green Right indicator.
Red/Yellow Unused.
White Ground.
Brown Right-hand tail lights.
Black Left-hand tail lights.
Red Stop lamps.

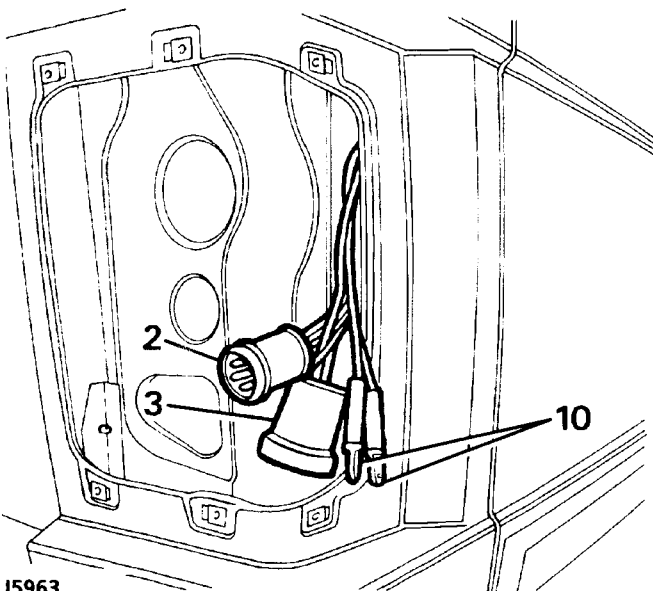

J5963



FRONT SEAT - MOTORS

Service repair no - 86.75.06

Remove

Four electric motors, mounted beneath each front seat, control fore and aft movement, cushion height front and rear, and angle of recline. Adjustment is possible with either front door open, or with ignition switched **ON**.

1. Position seat to give access to motors.
2. Disconnect battery negative lead.
3. Remove seat base trim.
4. Remove two securing screws from each side of required motor.

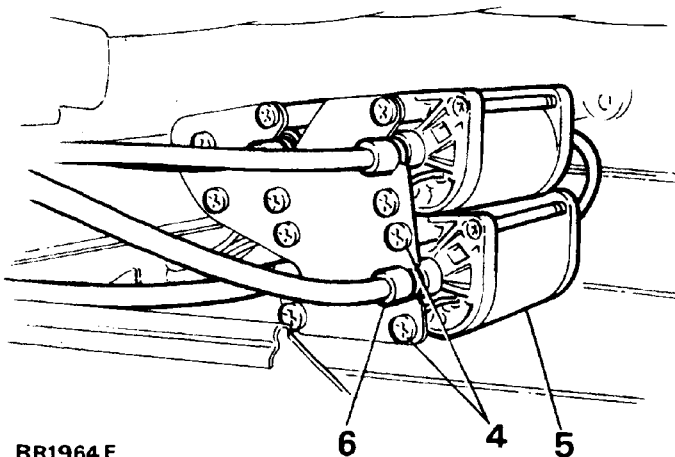

RR1964 E

5. Remove motor from mounting.
6. Disconnect drive cables by unscrewing ferrule.
7. Disconnect wires from multi-plug, remove motor.

Refit

8. Reverse removal procedure.
9. Check seat adjustment for correct operation.

FRONT SEAT - SWITCHES

Service repair no - 86.75.03

Remove

1. Disconnect battery negative lead.
2. Pry two finger tip controls from switch housing.
3. Removing switch housing cover by lightly depressing sides of cover to disengage clips, remove diaphragm.
4. Remove two crosshead screws and washers. Lift switch assembly to gain access to two multi-plugs.
5. Disconnect multiplugs, remove switch assembly.

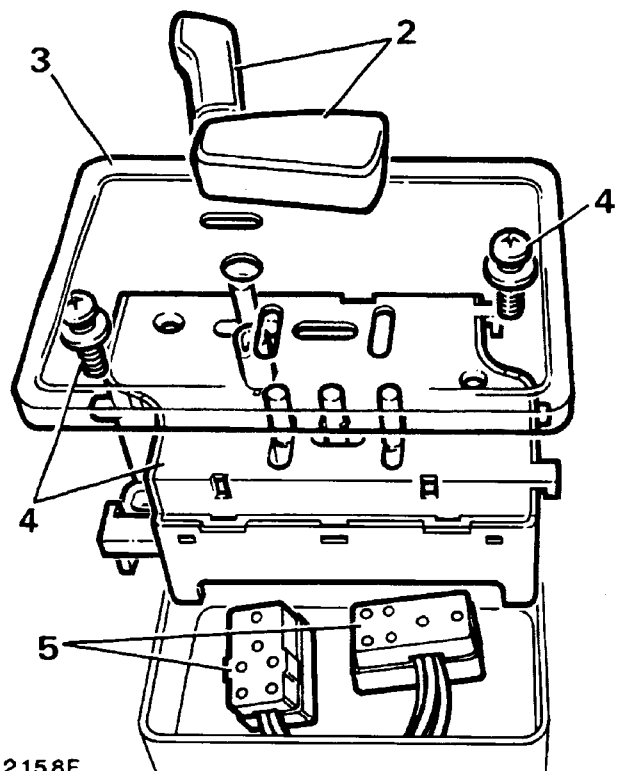

RR2158E

Refit

6. Reverse removal procedure.



NOTE: If switch housing removal is required it is necessary to remove seat to gain access to two securing screws. See *CHASSIS AND BODY, Repair, Front Seat Electrical*

MAP LIGHT BULB RENEWAL

Service repair no - 86.45.09

Remove

1. Disconnect battery negative lead.

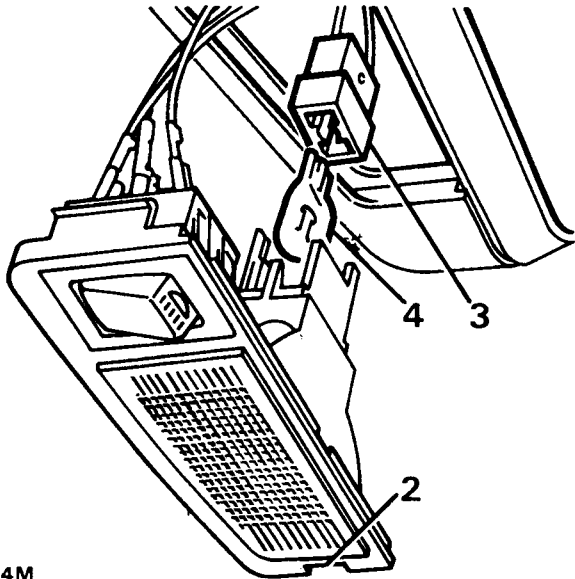

RR3644M

2. Pry slot to open cover.
3. Remove bulbholder.
4. Remove bulb from holder.
5. Replace bulb.

Refit

6. Reverse removal procedure.

ELECTRICAL SEAT FAILURE



NOTE: Carry out following procedure if seat failure occurs with seat obscuring fixing bolts.

1. Check 30A fuses and courtesy lamp fuse B2.
2. Disconnect 9 way connector between seat ECU and motors (memory seat). Power motor from a separate battery source.
3. If partial failure occurs in forward and reverse travel only, change drive cable as required to move seat to desired position.
4. If 2. and 3. not possible, move seat by driving cables manually.

DRIVE CABLE - ELECTRIC SEAT

Remove

1. Remove seat. *See CHASSIS AND BODY, Repair, Front Seat Electrical*
2. Cut cable tie, remove drive cable securing clips.
3. Remove drive cable from gearbox.
4. Remove drive cable from motor by unscrewing ferrule.
5. Cut cable ties from drive cable. Note position for reassembly.
6. Remove drive cable. If cable has failed, 'twist' may have occurred in seat. To rectify this, use a small screwdriver to turn gearbox of failed cable until twist is removed.

Refit

7. Reverse removal procedure. Ensuring new cable ties are fitted in original positions.
8. Operate seats to full extent of travel. To ensure that 'twist' has been removed, check that both gearboxes stop simultaneously.



MEMORY SEAT - SWITCH

Service repair no - 86.75.03

Remove

1. Disconnect battery negative lead.
2. Pry finger tip controls from top of switch housing.

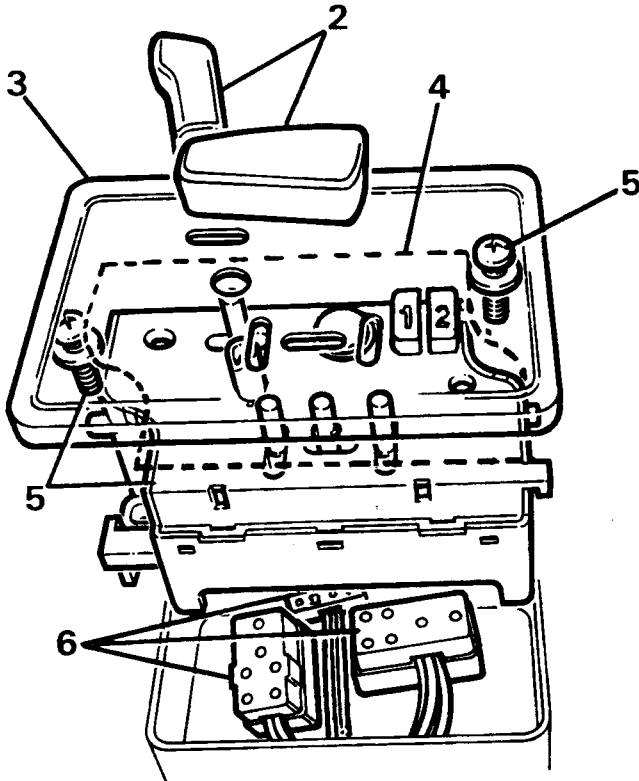

RR3762M

3. Remove switch housing cover by lightly depressing sides of switch housing to disengage clips.
4. Remove sealing membrane.
5. Remove switch securing screws, lift switch to gain access to multiplugs.
6. Disconnect multiplugs and remove switch.

Refit

7. Reverse removal procedure. Renew sealing membrane.

MEMORY SEAT SWITCH - CLEAN



NOTE: If a seat switch problem is diagnosed, the cause may be liquid spillage or ingress of foreign matter. The switch may be cleaned using the following procedure.

1. Remove seat switch. *See Memory Seat - Switch*
2. Discard sealing membrane.
3. Clean affected area of switch using a slightly damp clean cloth.
4. If contamination still exists, clean switch using a clean cloth slightly dampened with methylated spirits.
5. Allow switch to dry completely.
6. Refit switch using a new membrane.
7. Check seat switch for satisfactory operation.

ECU - MEMORY SEAT**Remove**

1. Remove driver's seat. *See CHASSIS AND BODY, Repair, Front Seat Electrical*
2. Disconnect connector from seat.

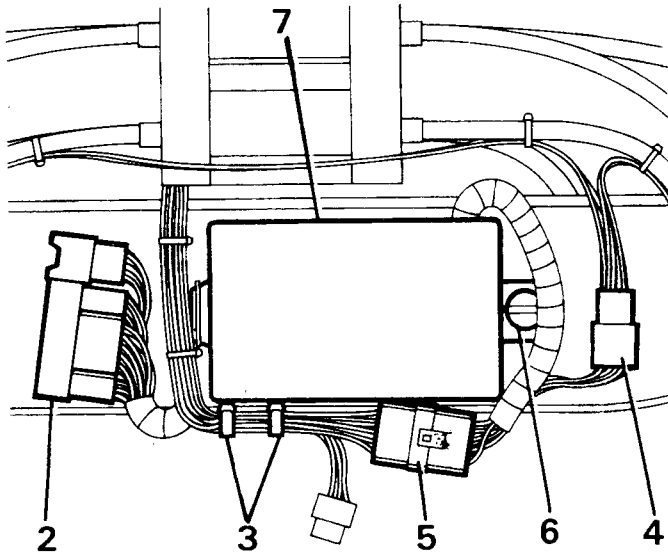

RR3761M

3. Remove cable ties.
4. Disconnect sensor and seat switch multiplug, remove from seat.
5. Disconnect seat motor multiplug.
6. Turn ECU retaining turnbuckle half a turn.
7. Remove ECU.

Refit

8. Reverse removal procedure. Ensuring cable retaining clips are correctly located. *See Memory Seat - Harness Layout*
9. Initialise system.

RADIO ANTENNA AMPLIFIER

Service repair no - 86.50.29

Remove

1. Disconnect battery negative lead.
2. Lower or remove headlining. *See CHASSIS AND BODY, Repair, Headlining*
3. Remove electrical leads and radio antenna lead.
4. Remove two screws, remove amplifier unit.

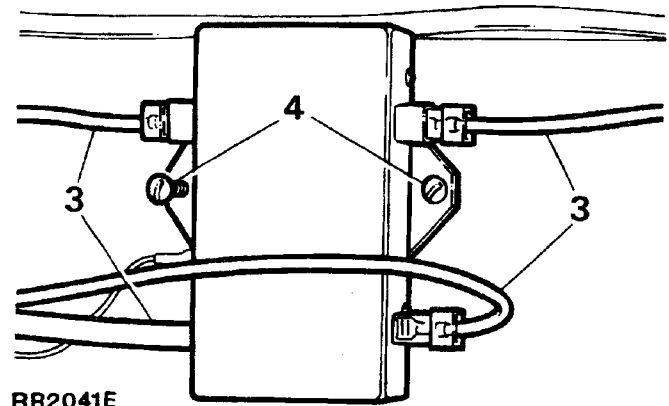

RR2041E

Refit

5. Reverse removal procedure.

**MEMORY SEAT - HARNESS LAYOUT**

WARNING: To prevent damage to wiring under driver's seat and subsequent failure, the wiring must be installed as shown in

RR3748M

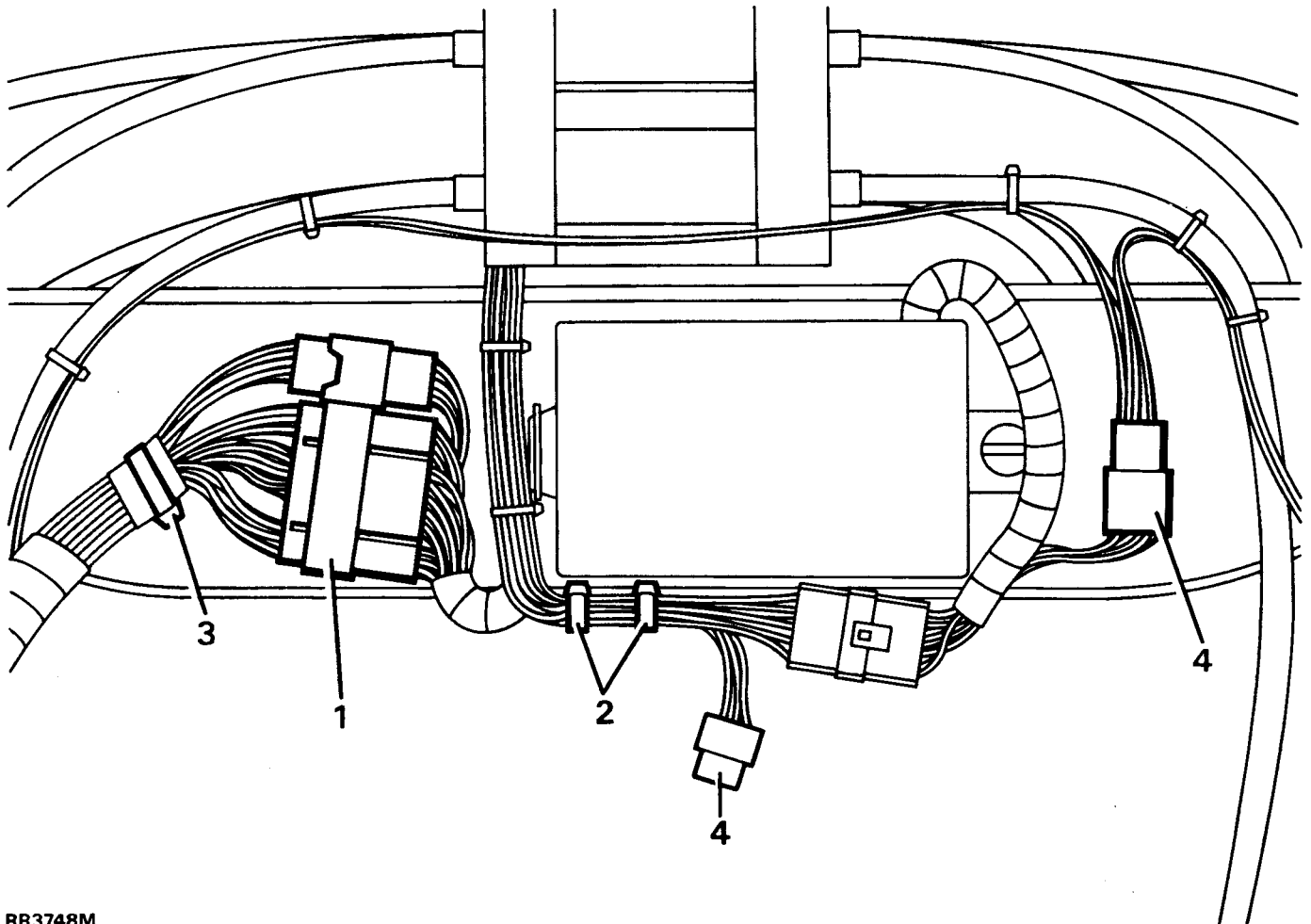

RR3748M

1. ECU link harness connector has retaining clip to seat base.
2. Link harness has two cable ties to seat motor harness, one of which is secured to seat base.
3. Main harness has P-clip securing it to seat base.
4. Sensor connector to link harness has retaining clip to seat base.

A.C. GENERATOR HEAT SHIELD**Remove**

1. Disconnect battery negative lead.
2. Remove fixing screw.
3. Remove nut from A.C. generator rear mounting bolt, remove heat shield.

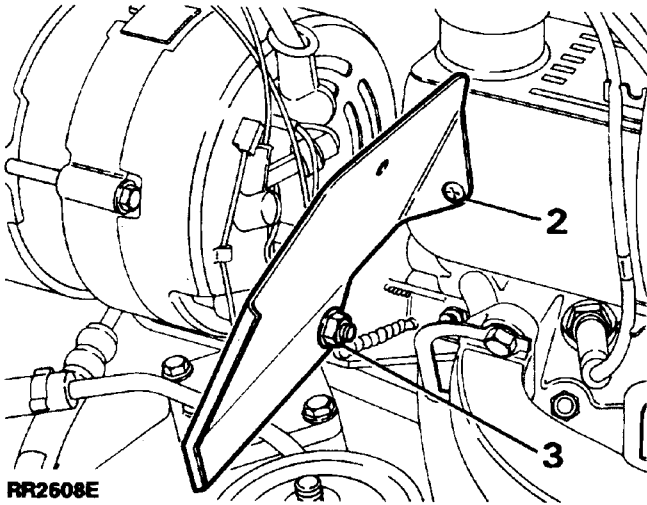
**Refit**

4. Reverse removal procedure.

HIGH LEVEL STOP LAMP

Service repair no - 86.41.35

Includes bulb renewal

Service repair no - 86.41.34

Remove

1. Disconnect battery negative lead.

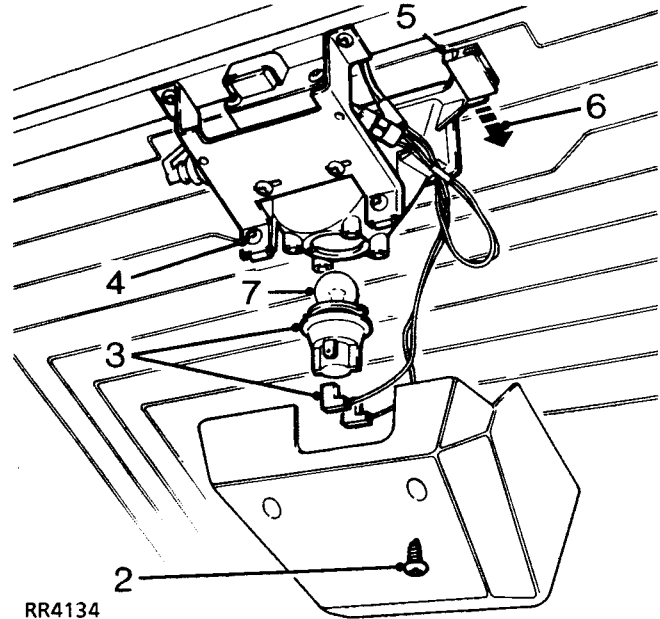

2. Remove two cover retaining screws. Remove cover.
3. Disconnect electrical leads to bulb holder. Remove bulbholder and bulb by twisting anti-clockwise.
4. Remove two screws, mounting plate to stop lamp.
5. Observe position of stop lamp on rear screen. Carefully release tabs on stop lamp from rear screen mountings.
6. Remove stop lamp.
7. Renew bulb if necessary.

Refit

8. Reverse removal procedure.



ALARM HORN

Service repair no - 86.77.10

Remove

1. Remove decker panel. *See CHASSIS AND BODY, Repair, Decker Panel*

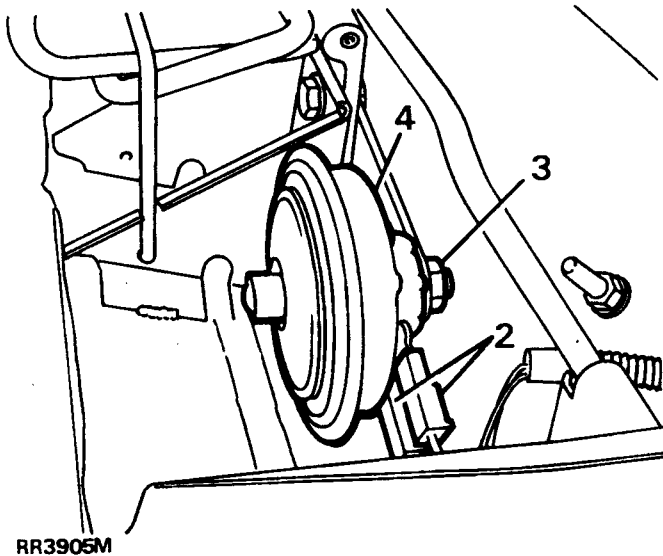

2. Disconnect two Lucar connectors.
3. Remove single nut securing horn.
4. Remove horn.

Refit

5. Reverse removal procedure.

GEAR SELECTOR-INTERLOCK

Interlock solenoid

Remove

1. Disconnect battery negative lead.
2. Remove gear selector head and illumination panel. *See CHASSIS AND BODY, Repair, Centre Console*

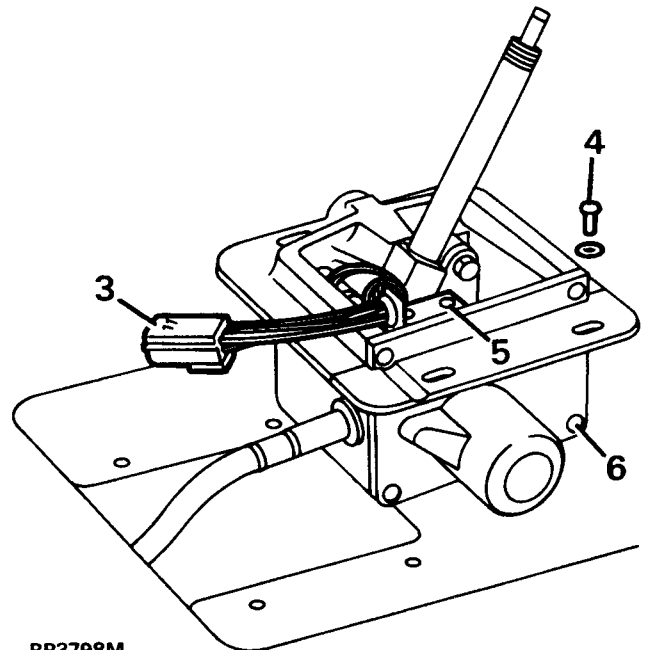

3. Disconnect electrical multiplug.
4. Remove screws and lift gear selector mechanism above housing.
5. Remove screws from microswitch support bracket.
6. Remove screws and separate side cover from housing.
7. Disconnect wiring solenoid to multiplug.
8. Remove circlip and retainer plate.
9. Remove clip and centre sleeve.
10. Refit clip into groove on spindle and lever against it to remove solenoid from housing.

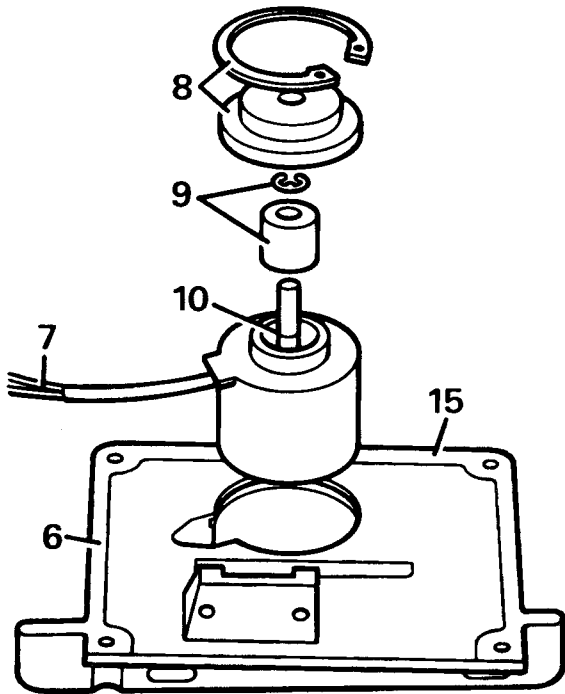

RR3800M

Refit

11. Fit solenoid with wiring positioned into side cover recess.
12. Fit sleeve and new clip.
13. Fit retaining plate and circlip.
14. Connect wiring to multiplug.
15. Apply sealant and fit side cover to housing. Use Silcoset 152 sealant or equivalent.
16. Grease all moving parts of gear selector mechanism. Use Rocol E1A or equivalent grease.
17. Reverse instructions 1 to 5.

Interlock microswitch onto castellated plate.**Remove**

1. Disconnect battery negative lead.
2. Remove gear selector head and illumination panel. *See CHASSIS AND BODY, Repair, Centre Console.*
3. Disconnect electrical multiplug.

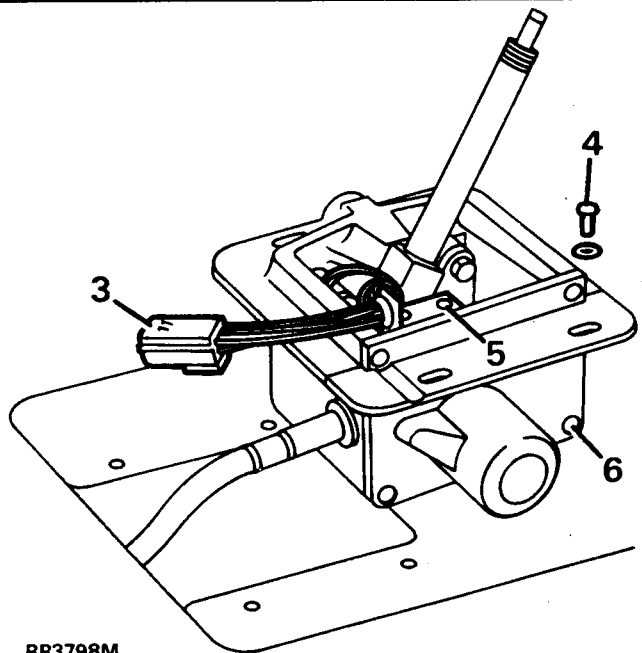

RR3798M

4. Remove screws and lift gear selector mechanism above housing.
5. Remove screws from microswitch support bracket.
6. Remove screws and separate side cover from housing.
7. Disconnect wiring microswitch to multiplug.

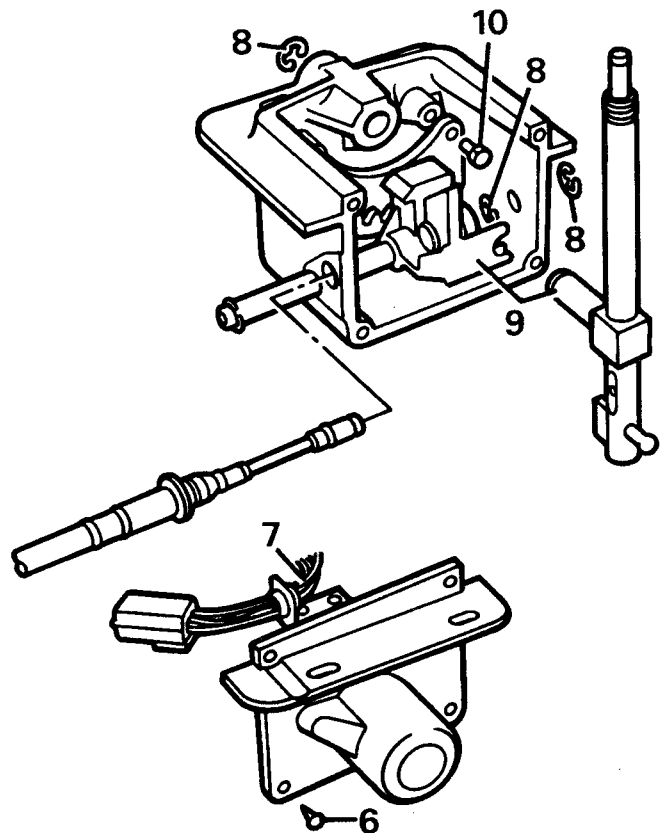

RR3797M

8. Remove 3 clips as shown.
9. Slide trunnion forward and remove gear selector arm.

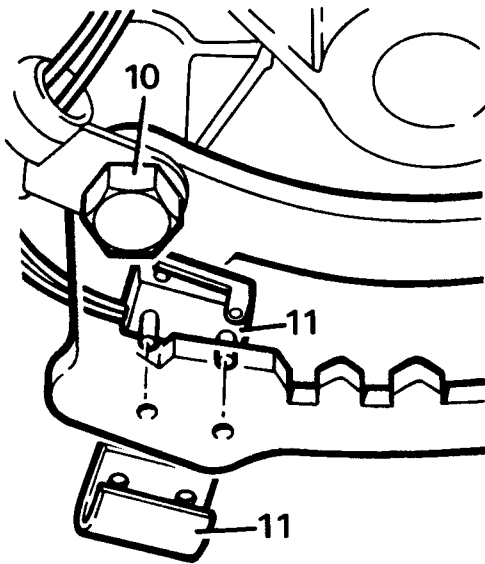

RR3799M

10. Remove bolts securing coxcomb.
11. Remove microswitch retaining clip and microswitch.

Refit

12. Reverse removal procedure. correctly positioning microswitch.
13. Apply Loctite 242E to castellated plate bolts and tighten to **9Nm**.
14. Grease all moving parts of gear selector mechanism. Use Rocol E1A or equivalent grease.
15. Apply Silcoset 152 sealant or equivalent and fit side cover to housing.

Interlock microswitch onto side cover**Remove**

1. Disconnect battery negative lead.
2. Remove gear selector head and illumination panel. *See Automatic Gear Selector-Panel Bulb*

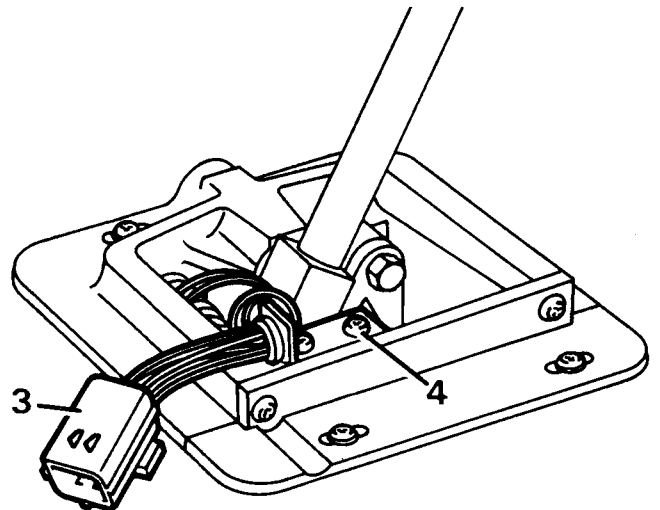

J5957

3. Disconnect electrical multiplug.
4. Remove screws from microswitch support bracket.
5. Disconnect wiring microswitch to multiplug.

Refit

6. Reverse removal procedure. Correctly positioning microswitch.
7. Grease all moving parts of gear selector mechanism. Use Rocol E1A or equivalent grease.

SUBWOOFER BOX

Service repair no - 86.50.51

Remove

1. Disconnect battery negative lead.
2. Remove rear parcel shelf RH support panel.

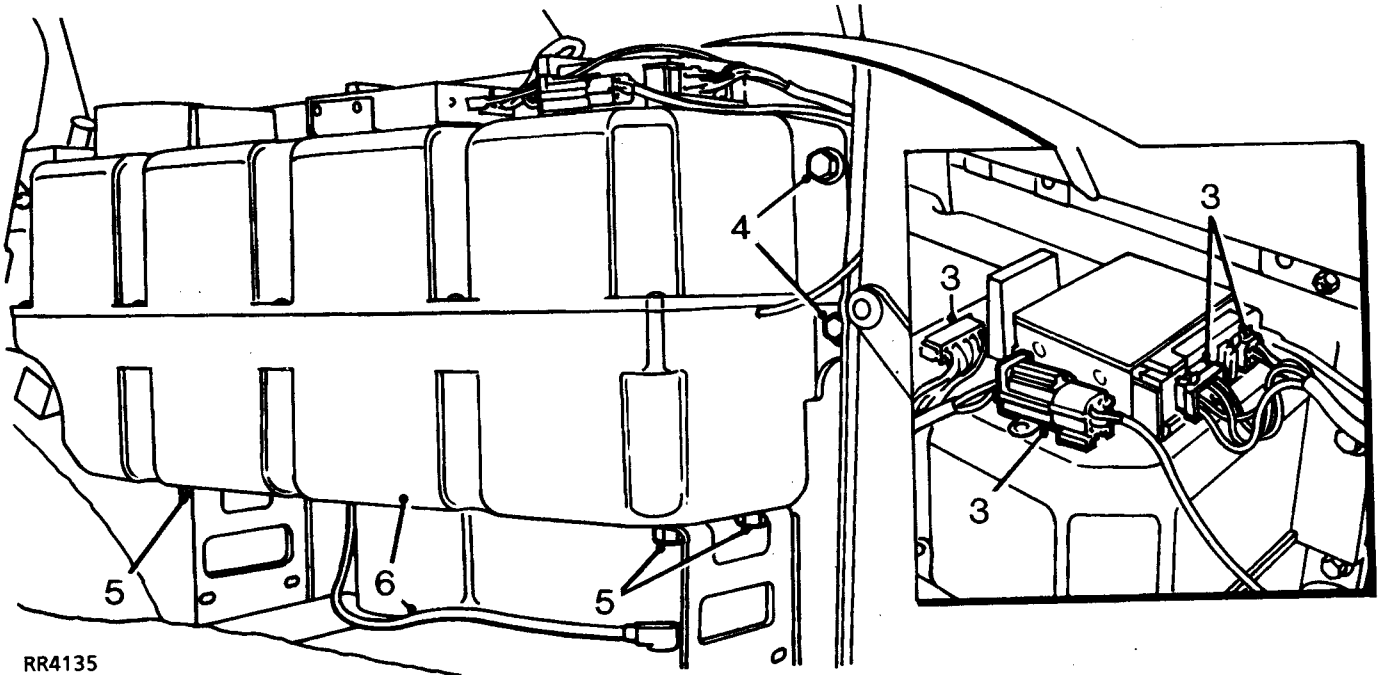

RR4135

3. Disconnect multiplugs.
4. Remove 3 bolts securing side of subwoofer box to body.
5. Remove 4 bolts securing bottom of subwoofer box to body.
6. Withdraw subwoofer box, disconnect speaker lead.

**NOTE:**

Do not carry out further dismantling if component is removed for access only.

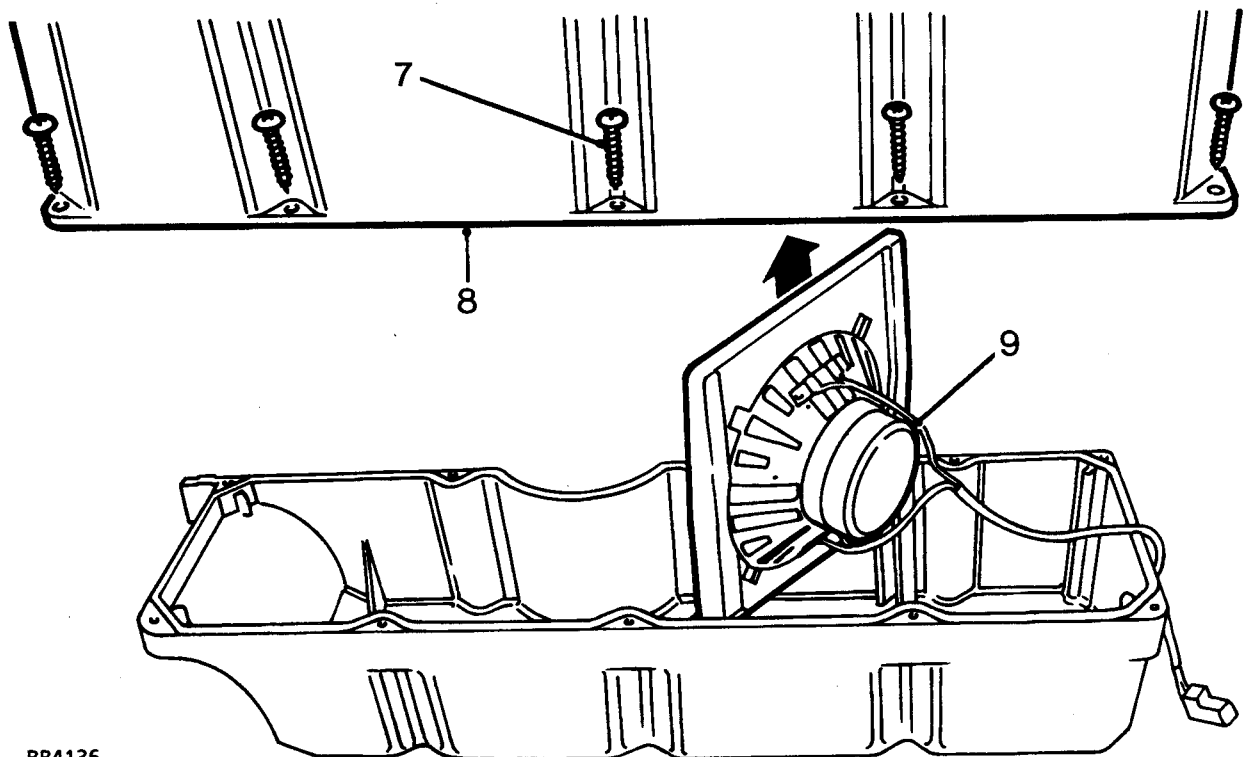

RR4136

7. Remove 10 screws securing both halves of subwoofer box.
8. Remove top half of box.
9. Remove speaker.

Refit

10. Reverse removal procedure.

HEATED FRONT SCREEN

Heated front screen will operate when switch is operated, with engine running. Timer unit will provide a preset time cycle of 7 1/2 minutes \pm 20%.

To identify timer unit.

Switching OFF ignition, or further operation of heated front screen switch during cycle will switch off screen and cancel, reset and switch off timer unit.

RADIO

Service repair no - 86.50.03

Remove

1. Disconnect battery negative lead.

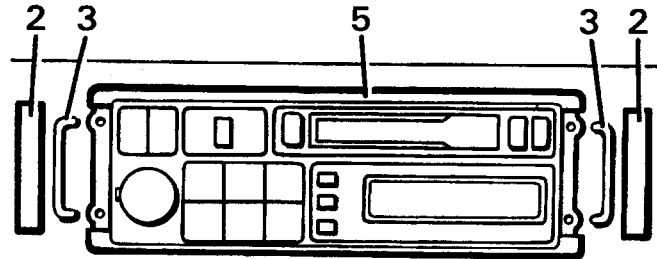

2. Remove access covers from radio.
3. Insert suitable radio removal tools e.g. SMD 4091 into access holes.
4. Press removal tools to release radio.
5. Remove radio, disconnect radio aerial, CD aerial and multiplugs from rear of radio.

Refit

6. Reverse removal procedure.
7. Reactivate radio code.

COOLANT TEMPERATURE TRANSMITTER - V8i

Service repair no - 26.10.02

Remove

1. Disconnect battery negative lead.

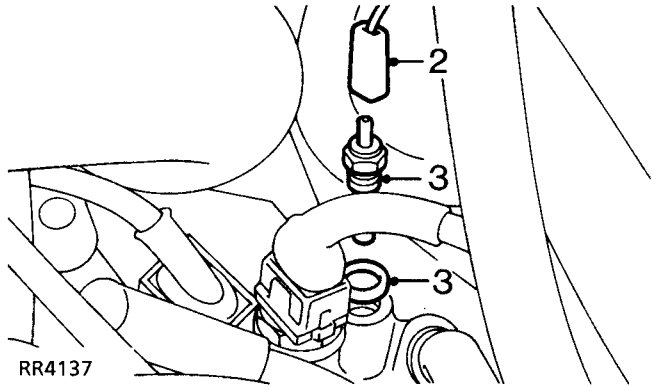

RR4137

2. Disconnect lead from transmitter.
3. Remove transmitter, discard sealing washer if fitted.

Refit

4. Coat threads of replacement transmitter with Loctite 572.
5. Fit a new sealing washer to transmitter.
6. Fit transmitter, connect lead.
7. Top-up cooling system.



CLOCK AND BULB

Service repair no - 88.15.07 - Clock
Service repair no - 86.45.29 - Bulb

Clock

Remove

1. Remove hazard switch. *See Hazard Warning Switch and Bulb*

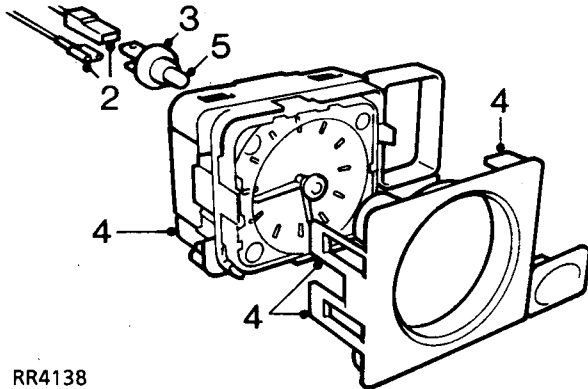

RR4138

2. Disconnect electrical leads from clock.
3. Release bulb holder from clock.
4. Release 3 retaining lugs, remove clock from surround.

Bulb replacement

5. Withdraw bulb from holder.

Refit

6. Reverse removal procedure.
7. Set clock to correct time.

INSTRUMENT PANEL FINISHER

Service repair no - 88.20.03

Remove

1. Position steering wheel for access.

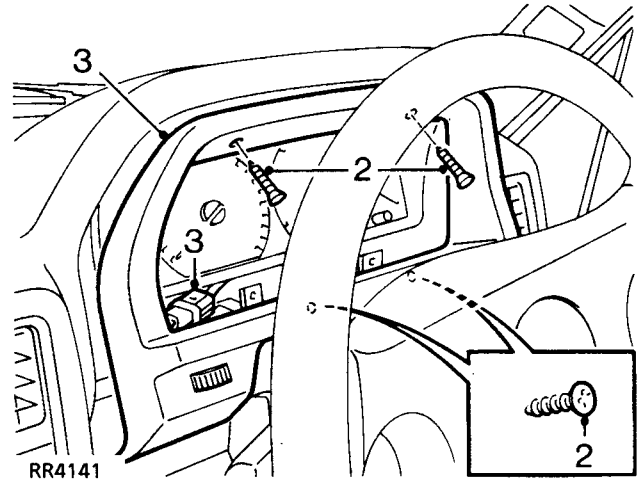

RR4141

2. Remove 4 screws securing finisher.
3. Withdraw finisher, disconnect rheostat multiplug.

Refit

4. Reverse removal procedure.

INSTRUMENT BINNACLE

Service repair no - 88.20.13

Remove

1. Remove instrument panel finisher. See *Instrument Panel Finisher*

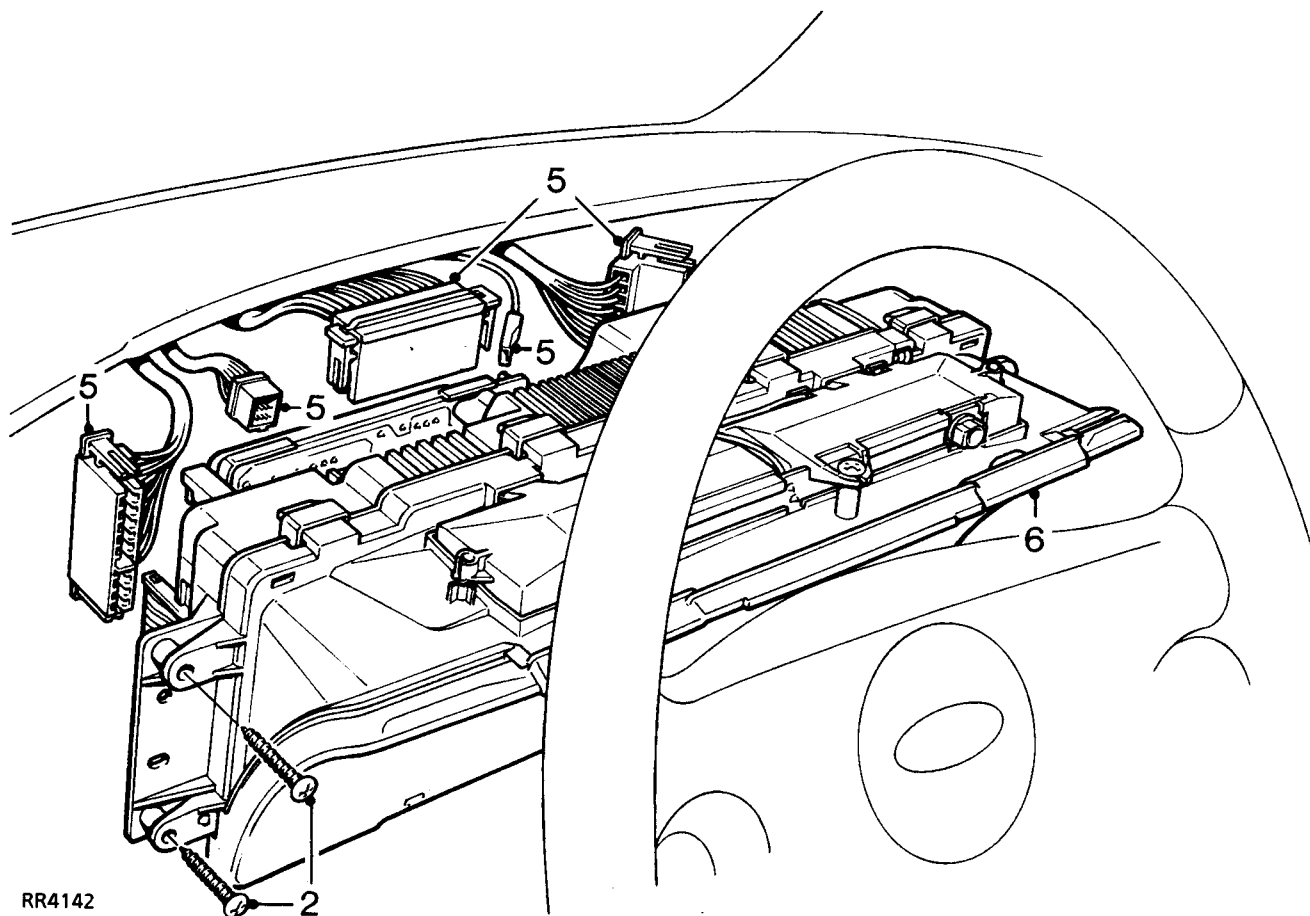

2. Remove 4 screws securing binnacle to fascia.
3. Carefully ease 2 lower panel finisher brackets downwards.
4. Withdraw binnacle to gain access to multiplugs.
5. Noting their fitted positions, disconnect multiplugs.
6. Remove binnacle.

Refit

7. Reverse removal procedure.



INSTRUMENT ILLUMINATION AND WARNING LIGHT BULBS

Service repair no - 86.45.48 - Instrument

Service repair no - 86.45.61 - Warning light

Remove

1. Remove binnacle. *See Instrument Binnacle*
2. Identify bulb to be replaced.



NOTE: If faulty bulb is not accessible, remove screws securing circuit board and carefully ease circuit board aside.

3. Rotate bulb holder anti-clockwise, withdraw bulb holder and remove bulb.

Refit

4. Fit new bulb to holder.



CAUTION: Ensure bulb of correct wattage and type is fitted.

5. Reverse removal procedure.

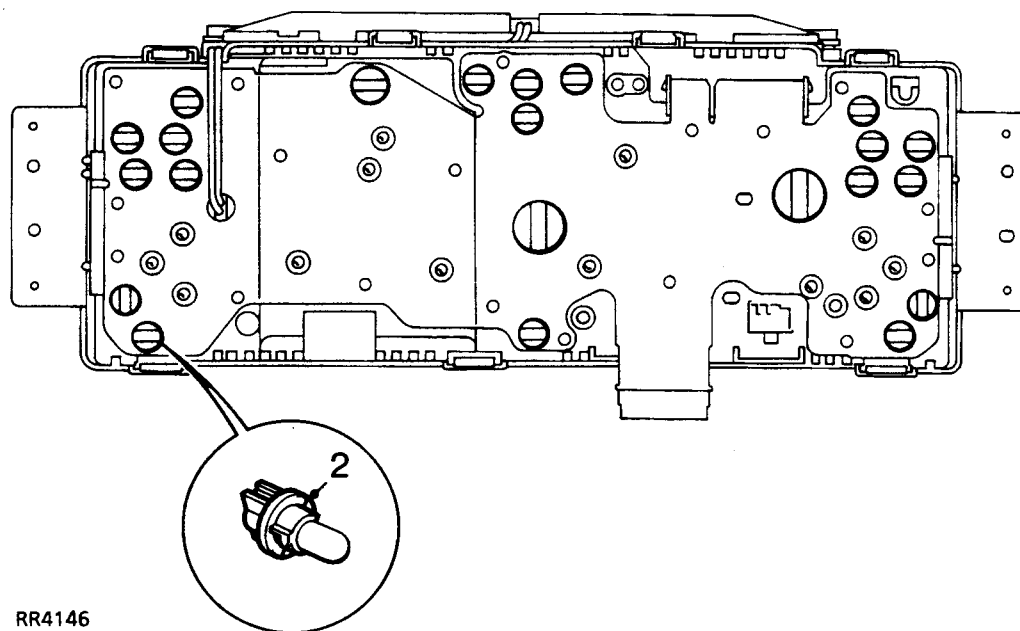

RR4146

MAIN PRINTED CIRCUIT

Service repair no - 88.20.19

Remove

1. Remove instrument cowl. *See Instrument Cowl and Illumination Board*
2. Remove circuit board. *See Circuit Board*

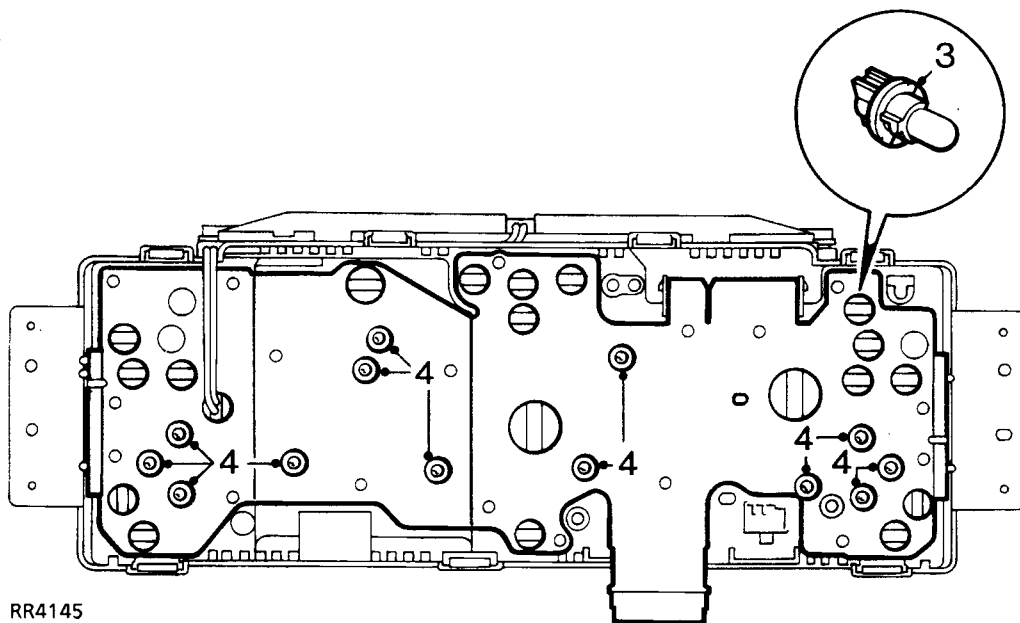

3. Remove illumination and warning lamp bulbs.
4. Remove 13 screws securing main printed circuit, remove circuit.

Refit

5. Position main printed circuit to binnacle.
6. Ensure screw holes in instruments are aligned with holes in binnacle, fit and tighten screws.
7. Reverse removal procedure. 1 and 2.



CIRCUIT BOARD

Service repair no - 88.20.25

Remove

1. Remove binnacle. *See Instrument Binnacle*

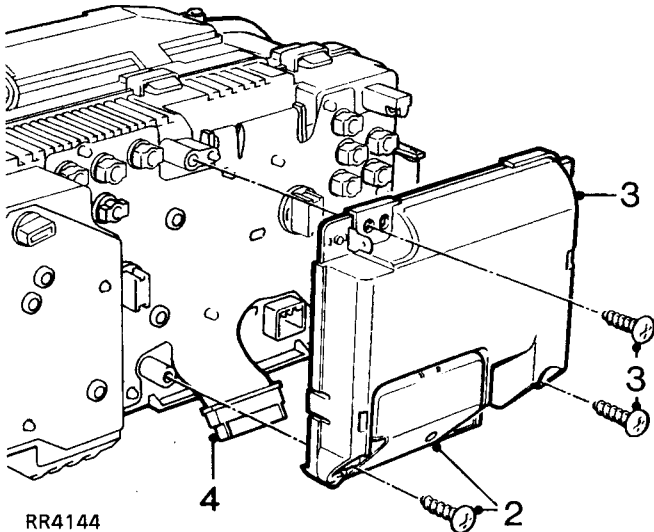

2. Remove screw, release lower cover from circuit board.
3. Remove 2 screws securing circuit board to binnacle, release board.
4. Disconnect multiplug.

Refit

5. Reverse removal procedure.

INSTRUMENT BINNACLE COMPONENTS

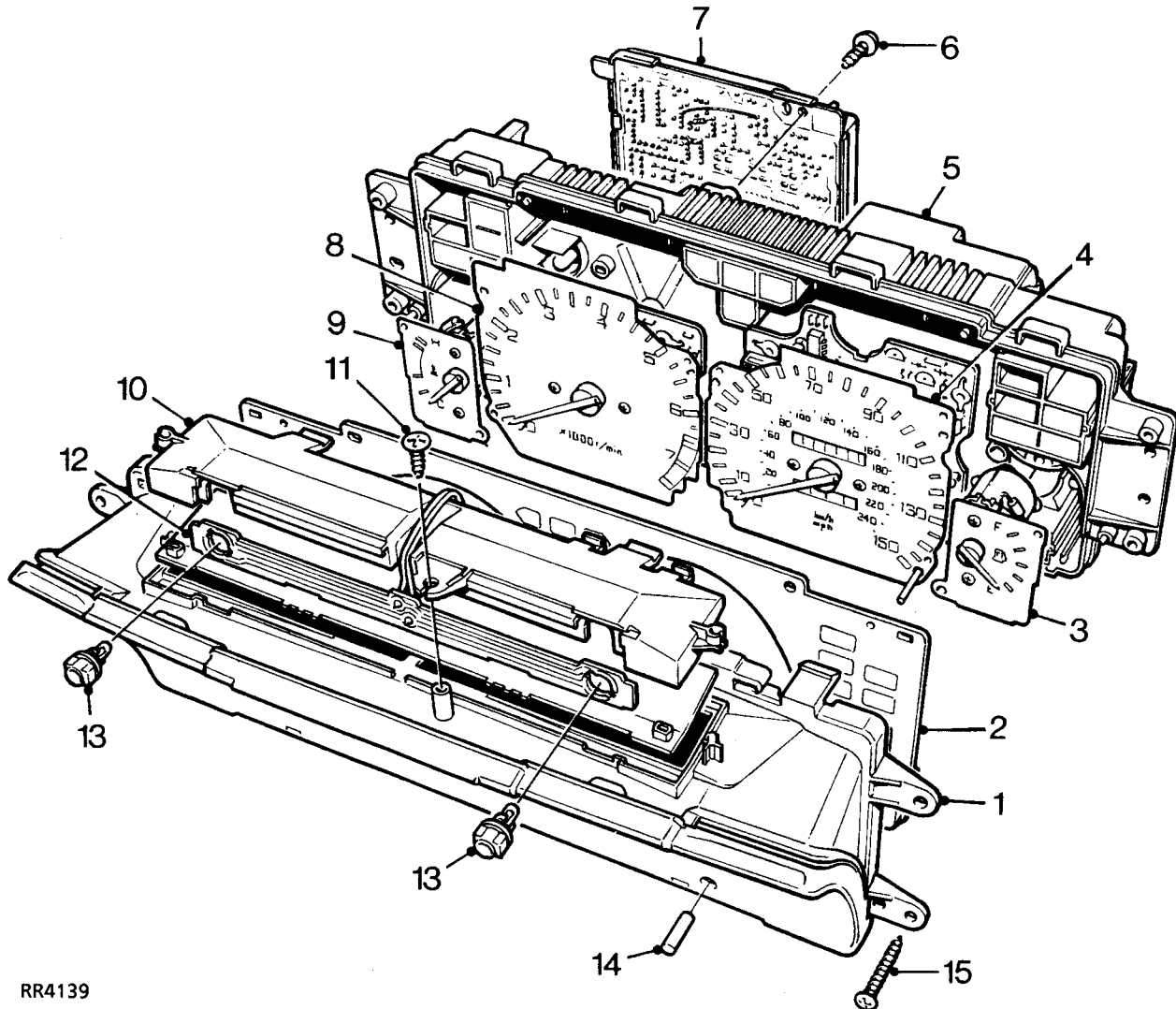

RR4139

- | | |
|-----------------------------------|--|
| 1. Instrument cowl | 8. Tachometer |
| 2. Face plate | 9. Temperature gauge |
| 3. Fuel gauge | 10. Illumination board |
| 4. Speedometer | 11. Screw securing illumination board |
| 5. Instrument binnacle | 12. Circuit board - instrument illumination |
| 6. Screw - securing circuit board | 13. Instrument illumination bulb holder and bulb |
| 7. Circuit board | 14. Speedometer trip reset button sleeve |
| | 15. Screw - cowl and binnacle |



PRINTED CIRCUIT AND WARNING LIGHTS

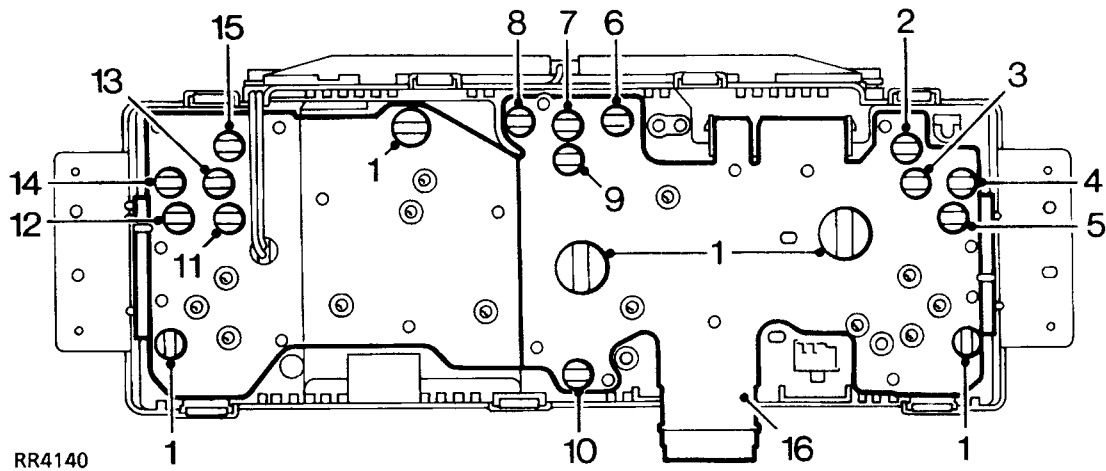

- | | |
|---|--|
| 1. Panel illumination bulbs | 9. Direction indicator warning lamp bulb |
| 2. Transmission oil temperature warning lamp bulb | 10. Air suspension warning lamp bulb |
| 3. Hazard warning lamp bulb | 11. Ignition/no charge warning lamp bulb |
| 4. Check engine warning lamp bulb | 12. Seat belt warning lamp bulb |
| 5. Handbrake/brake fluid warning lamp bulb | 13. Not used |
| 6. ABS warning lamp bulb | 14. Traction control warning lamp bulb |
| 7. Headlamp main beam warning lamp bulb | 15. Diesel heater plug warning lamp bulb (if fitted) |
| 8. Trailer direction warning lamp bulb | 16. Main printed circuit |

INSTRUMENT COWL AND ILLUMINATION BOARD

Service repair no - 88.20.06 - Instrument cowl

Service repair no - 88.20.22 - Illumination board

Remove

1. Remove binnacle. *See Instrument Binnacle*

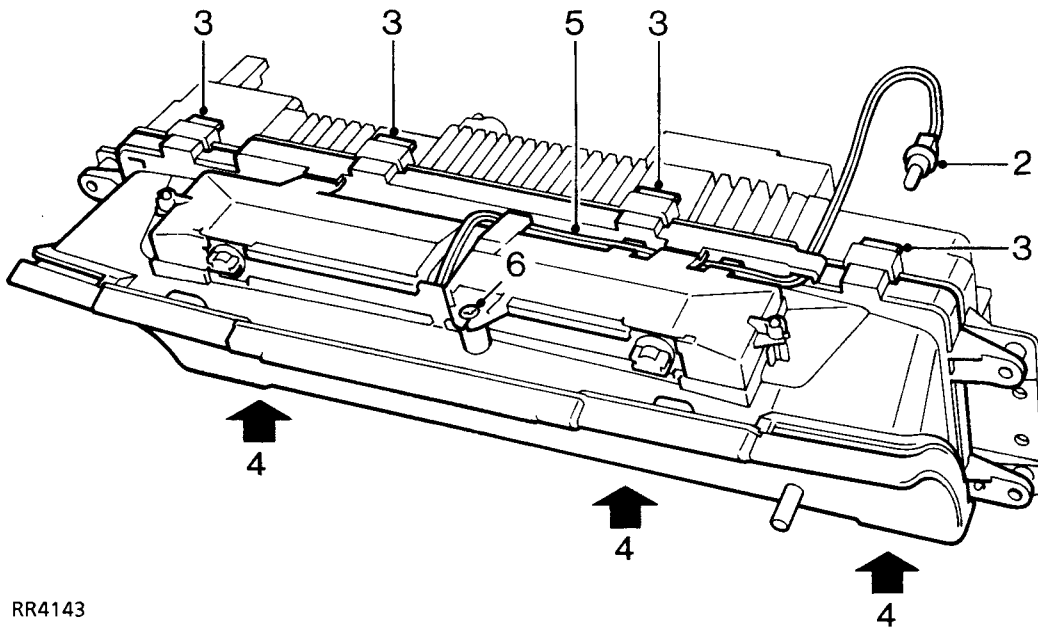
Instrument cowl

RR4143

2. Remove bulb holder from binnacle.
3. Release 4 clips securing top of cowl to binnacle.
4. Release 3 clips securing bottom of cowl to binnacle, remove cowl.

Illumination board

5. Release bulb holder wires from clip.
6. Remove screw securing illumination board to cowl, remove board.

Refit**Illumination board**

7. Position illumination board to cowl, fit and tighten screw.
8. Secure bulb holder wires in clip.

Instrument cowl

9. Ensure instrument face plate is correctly positioned.
10. Position cowl to binnacle ensuring speedometer trip passes through hole in cowl.
11. Secure cowl retaining clips.
12. Fit bulb holder in binnacle.
13. Fit binnacle. *See Instrument Binnacle*



SPEEDOMETER

Service repair no - 88.30.01

Remove

1. Remove instrument cowl. *See Instrument Cowl and Illumination Board*

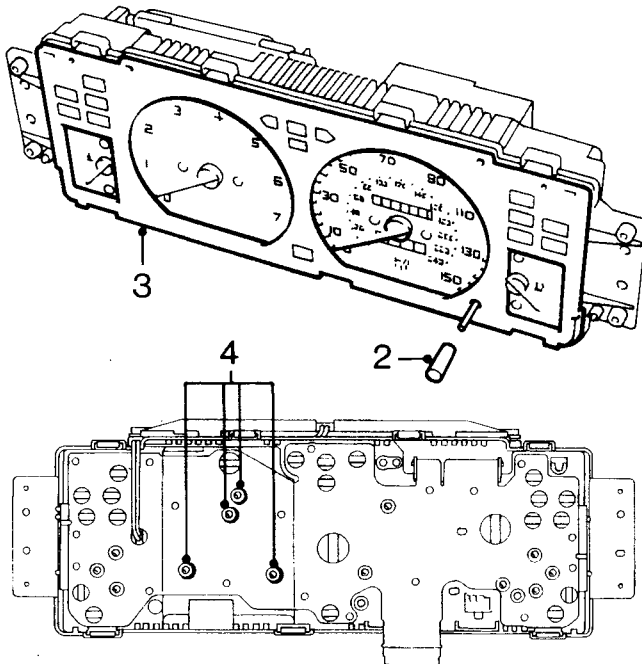

RR4131

2. Remove speedometer trip reset button sleeve.
3. Remove instrument face plate.
4. Remove 4 screws securing speedometer, remove speedometer.

Refit

5. Reverse removal procedure.

TACHOMETER

Service repair no - 88.30.21

Remove

1. Remove circuit board. *See Circuit Board*
2. Remove instrument cowl. *See Instrument Cowl and Illumination Board*

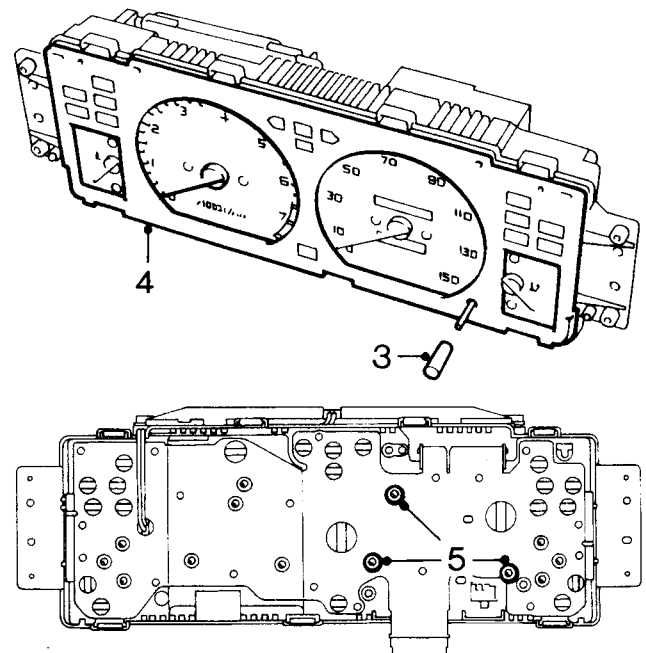

RR4124

3. Remove speedometer trip reset button sleeve.
4. Remove instrument face plate.
5. Remove 3 screws securing tachometer to binnacle, remove tachometer.

Refit

6. Reverse removal procedure.

COOLANT TEMPERATURE AND FUEL GAUGES

Service repair no - 88.25.14 - Coolant temperature gauge

Service repair no - 88.25.26 - Fuel gauge

Remove

1. Remove instrument cowl. *See Instrument Cowl and Illumination Board*

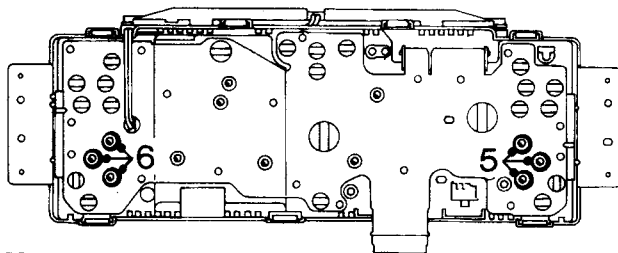
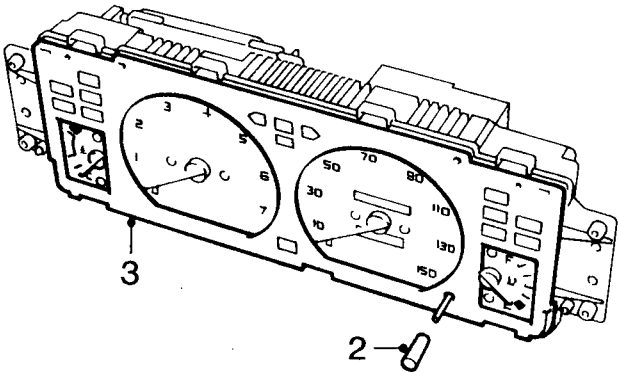

RR4147

2. Remove speedometer trip reset button sleeve.
3. Remove instrument face plate.

Coolant temperature gauge

4. Remove circuit board. *See Circuit Board*
5. Remove 3 screws securing coolant temperature gauge to binnacle, remove gauge.

Fuel gauge

6. Remove 3 screws securing fuel gauge to binnacle, remove gauge.

Refit

7. Reverse removal procedure.

SPEEDOMETER TRANSDUCER

Service repair no - 88.30.14

Remove

1. Position vehicle on ramp and chock wheels.
2. Raise ramp.

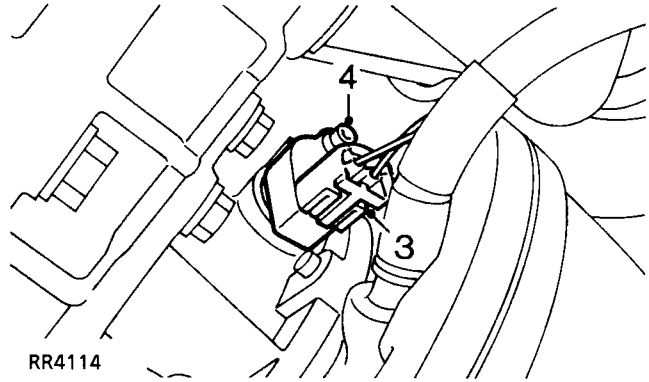

RR4114

3. Disconnect multiplug from transducer.
4. Remove bolt securing transducer, remove transducer.

Refit

5. Reverse removal procedure.



ALARM ECU

Service repair no - 86.77.01

Remove

1. Remove lower dash panel. *See CHASSIS AND BODY, Repair, lower dash panel.*
2. Remove multiplugs and aerial lead from ECU.

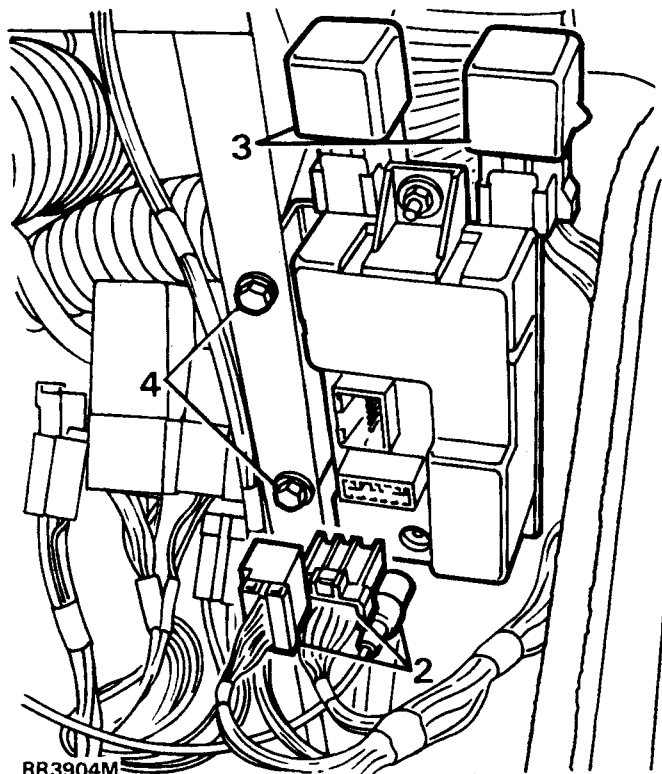

3. Remove relays and bases from bracket.
4. Remove ECU bracket fixings.
5. Remove ECU with bracket.

Refit

6. Reverse removal procedure. Aerial and multiplugs must be fitted securely to ensure alarm functions correctly.



DISTRIBUTOR-LUCAS 35DLM8

Overhaul

DISTRIBUTOR CAP

Service repair no - 86.35.10

1. Unclip and remove cap
2. Fit a new cap if faulty.
3. Clean cap and HT brush with a lint free cloth.

ROTOR ARM

Service repair no - 86.35.16

1. Pull rotor arm from shaft.
2. Fit a new rotor arm if faulty.

INSULATION COVER (FLASH SHIELD)

Service repair no - 86.35.40

1. Remove cover secured by three screws.
2. Fit a new cover if faulty.

VACUUM UNIT

Service repair no - 86.35.21

1. Remove two screws from vacuum unit securing bracket. Disengage vacuum unit connecting rod from pick-up base plate connecting peg. Withdraw vacuum unit from distributor body.

AMPLIFIER MODULE

Service repair no - 86.35.30

1. Remove two screws and withdraw module.
2. Remove gasket.
3. Remove two screws and cast heatsink.



WARNING: Amplifier module is a sealed unit containing Beryllia. This substance is extremely dangerous if handled. DO NOT attempt to open or crush module.

PICK-UP AND BASE PLATE ASSEMBLY

Service repair no - 86.35.42

1. Use circlip pliers to remove circlip retaining reluctor on rotor shaft.
2. Remove flat washer, and 'O' ring recessed in top of reluctor.
3. Gently withdraw reluctor from shaft, taking care not to damage teeth.



NOTE: Coupling ring fitted beneath reluctor.

4. Remove three support pillars and cable grommet. Lift out pick-up and base plate assembly.



NOTE: Do not disturb two barrel nuts securing pick-up module, otherwise air gap will need re-adjustment.

5. Fit a new pick-up and base plate assembly if module is known to be faulty, otherwise check pick-up winding resistance (2k-5k ohm).

Reassemble

6. This is mainly a reversal of dismantling procedure, noting following points:

LUBRICATION

Apply clean engine oil:

- a. A spot into rotor spindle before fitting rotor arm.

Apply Omnilube 2 (or equivalent) grease.

- b. Auto advance mechanism.
- c. Pick-up plate centre bearing.
- d. Pre tilt spring and its rubbing area (pick-up and base plate assembly).
- e. Vacuum unit connecting peg (pick-up and base plate assembly).
- f. Connecting peg hole in vacuum unit connecting rod.

Fitting pick-up and base plate assembly

1. Pick-up leads must be prevented from fouling rotating reluctor. Both leads should be located in plastic guide as illustrated. Check during re-assembly.

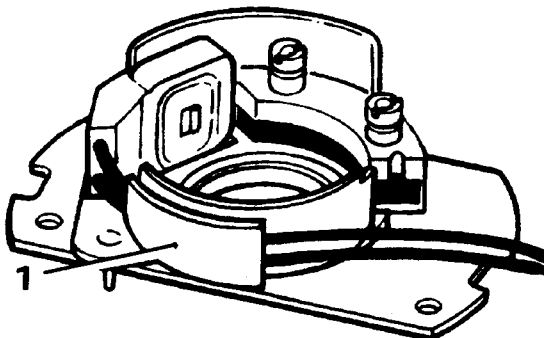

J5971

Fitting reluctor

2. Slide reluctor as far as it will go on rotor shaft, rotate reluctor until it engages with coupling ring beneath pick-up base plate. Distributor shaft, coupling ring and reluctor are 'keyed' and rotate together. Fit 'O' ring, flat washer and retaining circlip.

Pick-up air gap adjustment

1. Air gap between pick-up limb and reluctor teeth must be set within specified limits, using a non-ferrous feeler gauge.

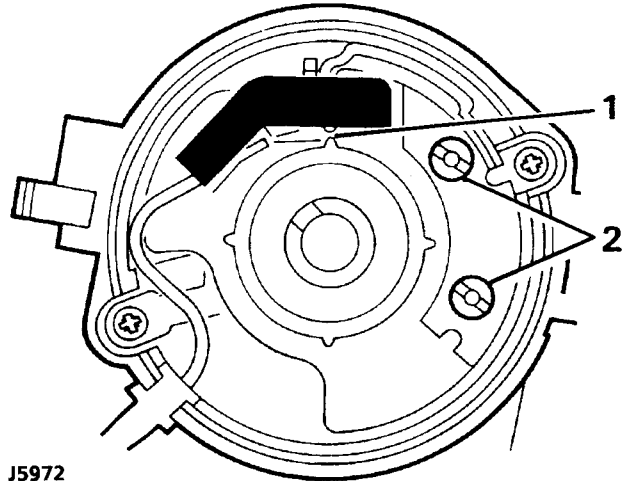

J5972

2. If adjustment is necessary, slacken two barrel nuts to set the air gap. **See ENGINE TUNING DATA, Information, Engine - 3.9 V8i**

 **NOTE:** When original pick-up and base plate assembly has been refitted, air gap should be checked, and adjusted if necessary.

When fitting a new assembly air gap will require adjusting to within specified limits.

Amplifier module

1. Before fitting module, apply MS4 Silicone grease or equivalent heat-conducting compound to amplifier module backplate, seating face on distributor body and both faces of heatsink casting.



TORQUE VALUES



NOTE: Torque wrenches should be regularly checked for accuracy to ensure that all fixings are tightened to the correct torque.

	Nm
A.C. generator to mounting bracket	24
A.C. generator module screws	1.2
Amplifier heat sink screws	1.2
Auxiliary driving lamp mounting bolts	15
Distributor clampbolt	20
Distributor pick-up bearing plate support pillars	1.2
Distributor pick-up barrel nuts	1.2
Distributor vacuum unit	2
Starter motor to engine bolts - V8i engine	45
Reverse light switch	25
Wiper motor yoke retaining bolts	1.5

Torque values below cover all screws and bolts used, unless specified otherwise.

METRIC	Nm
M5	6
M6	9
M8	25
M10	45
M12	90
M14	105
M16	180

UNC / UNF	
1/4	9
5/16	24
3/8	39
7/16	78
1/2	90
5/8	136



BY APPOINTMENT
TO HM THE QUEEN
MANUFACTURERS OF ROVER CARS,
LAND ROVERS AND RANGE ROVERS
ROVER GROUP LTD. BIRMINGHAM



BY APPOINTMENT
TO HRH THE DUKE OF EDINBURGH
MANUFACTURERS OF
LAND ROVERS AND RANGE ROVERS
ROVER GROUP LTD. BIRMINGHAM



BY APPOINTMENT
TO HM QUEEN ELIZABETH THE QUEEN MOTHER
MANUFACTURERS OF LAND ROVERS
ROVER GROUP LTD. BIRMINGHAM



BY APPOINTMENT
TO HRH THE PRINCE OF WALES
MANUFACTURERS OF
LAND ROVERS AND RANGE ROVERS
ROVER GROUP LTD. BIRMINGHAM



Land Rover, Lode Lane, Solihull, England B92 8NW. Telephone: 0121-722 2424.
Fax: 0121-742 1927. Telex: 338641 Lan Rov G.
A Division of the Rover Group Ltd.

LRL 0030ENG