

RANGE ROVER CLASSIC



Workshop Manual



Workshop manual

RANGE ROVER

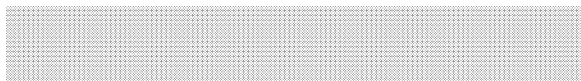















This manual covers vehicles from
1995 model year

01	INTRODUCTION
04	GENERAL SPECIFICATION DATA
05	ENGINE TUNING DATA
07	GENERAL FITTING REMINDERS
09	LUBRICANTS, FLUIDS AND CAPACITIES
10	MAINTENANCE
12	ENGINE Tdi
12	ENGINE 3.9 V8
17	EMISSION CONTROL
19	FUEL SYSTEM Tdi
19	FUEL SYSTEM MFI
19	CRUISE CONTROL
26	COOLING SYSTEM Tdi
26	COOLING SYSTEM V8
30	MANIFOLD AND EXHAUST SYSTEM
33	CLUTCH
37	MANUAL GEARBOX
41	TRANSFER GEARBOX
44	AUTOMATIC GEARBOX
47	PROPELLER SHAFTS
51	REAR AXLE AND FINAL DRIVE
54	FRONT AXLE AND FINAL DRIVE
57	STEERING
60	FRONT SUSPENSION
64	REAR SUSPENSION
68	AIR SUSPENSION
70	BRAKES NON ABS
70	BRAKES ABS
70	BRAKES ELECTRONIC TRACTION CONTROL
74	WHEELS AND TYRES
76	SUPPLEMENTARY RESTRAINT SYSTEM
76	CHASSIS AND BODY
80	HEATING AND VENTILATION
82	AIR CONDITIONING
84	WIPERS AND WASHERS
86	ELECTRICAL

Published by Rover Technical Communication

© Rover Group Limited 1995
Publication Part No. LRL0030ENG



	01 04 05 06 07 09
	10
	12
	17 19
	26
	30
	33
	37 41 44
	47 51 54
	57
	60 64 68 74
	70
	76
	80 82
	84 86



INTRODUCTION

This workshop manual covers vehicles from 1995 model year onwards. Amendments and additional pages will be issued to ensure that the manual covers latest models. Amendments and additions will be identified by the addition of a dated footer at the bottom of the page.

This Workshop Manual is designed to assist skilled technicians in the efficient repair and maintenance of Land Rover vehicles.

Individuals who undertake their own repairs should have some skill and training, and limit repairs to components which could not affect the safety of the vehicle or its passengers. Any repairs required to safety critical items such as steering, brakes, suspension or supplementary restraint system should be carried out by a Land Rover Dealer. Repairs to such items should NEVER be attempted by untrained individuals.

WARNINGS, CAUTIONS and NOTES are given throughout this Manual in the following form:



WARNING: Procedures which must be followed precisely to avoid the possibility of personal injury.



CAUTION: This calls attention to procedures which must be followed to avoid damage to components.



NOTE: This calls attention to methods which make a job easier or gives helpful information.

DIMENSIONS

The dimensions quoted are to design engineering specification. Alternative unit equivalents, shown in brackets following the dimensions, have been converted from the original specification.

REFERENCES

References to the left or right hand side in the manual are made when viewing the vehicle from the rear. With the engine and gearbox assembly removed, the water pump end of the engine is referred to as the front.

To reduce repetition, some operations covered in this Manual do not include reference to testing the vehicle after repair.

It is essential that work is inspected and tested after completion and if necessary a road test of the vehicle is carried out particularly where safety related items are concerned.

REPAIRS AND REPLACEMENTS

When replacement parts are required it is essential that Land Rover parts are used. Attention is particularly drawn to the following points concerning repairs and the fitting of replacement parts and accessories: Safety features embodied in the vehicle may be impaired if other than Land Rover parts are fitted. In certain territories, legislation prohibits the fitting of parts not to the vehicle manufacturer's specification. Torque spanner values given in the Workshop Manual must be strictly adhered to. Locking devices, where specified, must be fitted. If the efficiency of a locking device is impaired during removal it must be replaced with a new one. Certain fasteners must not be re-used. These fasteners are specified in the Workshop Manual.

POISONOUS SUBSTANCES

Many liquids and other substances used are poisonous and therefore must not be consumed. It is also advisable to keep all substances away from open wounds. These substances among others include anti-freeze, brake fluid, fuel, windscreen washer additives, air conditioning refrigerant, lubricants and various adhesives.

FUEL HANDLING PRECAUTIONS

The following information provides basic precautions which must be observed if fuel is to be handled safely. It also outlines the other areas of risk which must not be ignored.

This information is issued for basic guidance only, and in any case of doubt, appropriate enquiries should be made of your local Fire Officer or Fire Department.

Fuel vapour is highly flammable and in confined spaces is also very explosive and toxic.

When fuel evaporates it produces 150 times its own volume in vapour, which when diluted with air becomes a readily ignitable mixture. The vapour is heavier than air and will always fall to the lowest level. It can readily be distributed throughout a workshop by air current, consequently, even a small spillage of fuel is very dangerous.

Always have a fire extinguisher containing **FOAM CO² GAS**, or **POWDER** close at hand when handling fuel, or when dismantling fuel systems and in areas where fuel containers are stored.



WARNING: It is imperative that the battery is not disconnected during fuel system repairs as arcing at the battery terminal could ignite fuel vapour in the atmosphere. Always disconnect the vehicle battery BEFORE carrying out work on the fuel system.

Whenever fuel is being handled, transferred or stored, or when fuel systems are being dismantled all forms of ignition must be extinguished or removed, any leadlamps used must be flame proof and kept clear of spillage.

No one should be permitted to repair components associated with fuel without first having had fuel system training.

Hot fuel handling precautions



WARNING: Before commencing any operation requiring fuel to be drained from the fuel tank, the following procedure must be adhered to:

1. Allow sufficient time for the fuel to cool, thus avoiding contact with hot fuels.
2. Vent the system by removing the fuel filler cap in a well ventilated area. Refit the filler cap until the commencement of fuel drainage.

Fuel transfer



WARNING: Fuel must not be extracted or drained from any vehicle while it is standing over a pit.

The transfer of fuel from the vehicle fuel tank must be carried out in a well ventilated area. An approved transfer tank must be used according to the transfer tank manufacturer's instructions and local regulations, including attention to grounding of tanks.

Fuel tank removal

A **FUEL VAPOUR** warning label must be attached to the fuel tank upon removal from the vehicle.

Fuel tank repair

Under no circumstances should a repair to any tank be attempted.



SYNTHETIC RUBBER

Many 'O' ring seals, flexible pipes and other similar items which appear to be natural rubber are made of synthetic materials called Fluoroelastomers. Under normal operating conditions this material is safe, and does not present a health hazard. However, if the material is damaged by fire or excessive heat, it can break down and produce highly corrosive Hydrofluoric acid which can cause serious burns on contact with skin. Should the material be in a burnt or overheated condition handle only with seamless industrial gloves. Decontaminate and dispose of the gloves immediately after use.

If skin contact does occur, remove any contaminated clothing immediately and obtain medical assistance without delay. In the meantime, wash the affected area with copious amounts of cold water or limewater for fifteen to sixty minutes.

RECOMMENDED SEALANTS

A number of branded products are recommended in this manual for use during maintenance and repair work.

These items include:

HYLOMAR GASKET AND JOINTING COMPOUND
and
HYLOSIL RTV SILICON COMPOUND.

They should be available locally from garage equipment suppliers. If there is any problem obtaining supplies, contact the following company for advice and the address of the nearest supplier.

MARSTON LUBRICANTS LTD.

Hylo House,
Cale Lane,
New Springs,
Wigan WN2 1JR

Tel 01942 824242

USED ENGINE OIL



WARNING: Prolonged and repeated contact with engine or motor oil will result in the removal of natural fats from the skin, leading to dryness, irritation and dermatitis.

Used engine oil contains potentially harmful contaminants which may cause skin cancer. Adequate means of skin protection and washing facilities should be provided.

Handling precautions

1. Avoid prolonged and repeated contact with oils, particularly used engine oils.
2. Wear protective clothing, including impervious gloves where applicable.
3. Do not put oily rags in pockets.
4. Avoid contaminating clothes, particularly underwear, with oil.
5. Overalls must be cleaned regularly. Discard unwashable clothing and oil impregnated footwear.
6. First aid treatment must be obtained immediately for open cuts and wounds.
7. Use barrier creams, before each work period, to help the removal of oil from the skin.
8. Wash with soap and water to ensure all oil is removed (skin cleansers and nail brushes will help). Preparations containing lanolin replace the natural skin oils which have been removed.
9. Do not use gasoline, kerosene, diesel fuel, petrol, thinners or solvents for washing the skin.
10. If skin disorders develop, obtain medical advice.
11. Where practicable, degrease components prior to handling.
12. Where there is a risk of eye contact, eye protection should be worn, for example, goggles or face shields; in addition an eye wash facility should be provided.

Disposing of used oils

Environmental protection precaution

It is illegal to pour used oil onto the ground, down sewers or drains, or into waterways.

Dispose of used oil through authorised waste disposal contractors. If in doubt contact your Local Authority for advice on disposal facilities.

ACCESSORIES AND CONVERSIONS

DO NOT FIT unapproved accessories or conversions, as they could affect the safety of the vehicle. Land Rover will not accept liability for death, personal injury, or damage to property which may occur as a direct result of the fitting of non-approved conversions to the vehicle.

WHEELS AND TYRES



WARNING: DO NOT replace the road wheels with any type other than genuine Land Rover wheels which are designed for multi-purpose on and off road use and have very important relationships with the proper operation of the suspension system and vehicle handling. Replacement tyres must be of the make and sizes recommended for the vehicle, and all tyres must be the same make, ply rating and tread pattern.

STEAM CLEANING

To prevent consequential rusting, any steam cleaning within the engine bay **MUST** be followed by careful re-waxing of the metallic components affected. Particular attention must be given to the steering column, engine water pipes, hose clips and ignition coil clamp.

SPECIFICATION

The specification details and instructions set out in this Manual apply only to a range of vehicles and not to any one. For the specification of a particular vehicle purchasers should consult their Dealer. The Manufacturer reserve the right to vary their specifications with or without notice, and at such times and in such manner as they think fit. Major as well as minor changes may be involved in accordance with the Manufacturer's policy of constant product improvement.

Whilst every effort is made to ensure the accuracy of the particulars contained in this Manual, neither the Manufacturer or Dealer, by whom this Manual is supplied, shall in any circumstances be held liable for any inaccuracy or the consequences thereof.

SPECIAL SERVICE TOOLS

The use of approved special service tools is important. They are essential if service operations are to be carried out efficiently, and safely. Where special tools are specified, **only these tools should be used to avoid the possibility of personal injury or damage to the components.** Also the amount of time which they save can be considerable.

Every special tool is designed with the close co-operation of Land Rover, and no tool is put into production which has not been tested and approved by us. New tools are only introduced where an operation cannot be satisfactorily carried out using existing tools or standard equipment. The user is therefore assured that the tool is necessary and that it will perform accurately, efficiently and safely.

Special tools bulletins will be issued periodically giving details of new tools as they are introduced.

All orders and enquiries from the United Kingdom should be sent direct to V. L. Churchill. Overseas orders should be placed with the local V. L. Churchill distributor, where one exists. Countries where there is no distributor may order direct from:
V. L. Churchill Limited,
PO Box 3,
Daventry, Northants,
England, NN11 4NF.

The tools recommended in this Workshop Manual are listed in a multi-language illustrated catalogue, obtainable from:
Messers. V. L. Churchill at the above address, or from:
Land Rover Merchandising Service,
PO Box 534,
Erdington,
Birmingham, B24 0Q5,

COPYRIGHT

© Land Rover 1995

All rights reserved. No part of this publication may be produced, stored in a retrieval system or transmitted in any form, electronic, mechanical, recording or other means without prior written permission of Land Rover.



JACKING

The following instructions must be carried out before raising the vehicle off the ground.

1. Use a solid level ground surface.
2. Apply parking brake.
3. Select 'P' or 1st gear in main gearbox.
4. Select Low range in transfer gearbox.



CAUTION: To avoid damage occurring to the under body components of the vehicle the following jacking procedures must be adhered to.

DO NOT POSITION JACKS OR AXLE STANDS UNDER THE FOLLOWING COMPONENTS.

- Body structure
- Bumpers
- Fuel lines
- Brake lines
- Front radius arms
- Panhard rod
- Steering linkage
- Rear Trailing links
- Fuel tank
- Engine sump
- Gearbox bell housing

Jack or support vehicle by axles only.

Vehicle jack

The jack provided with the vehicle is only intended to be used in an emergency, for changing a tyre. Do **NOT** use the jack for any other purpose. Refer to Owner's Manual for vehicle jack location points and procedure. Never work under a vehicle supported by the vehicle jack.

Hydraulic jack

A hydraulic jack with a minimum 1500 kg, 3,300 lbs load capacity must be used.



CAUTION: Do not commence work on the underside of the vehicle until suitable axle stands have been positioned under the axle.

Raise the front of the vehicle

1. Position cup of hydraulic arm under differential casing.



NOTE: The differential casing is not central to the axle. Care should be taken when raising the front road wheels off the ground as the rear axle has less sway stiffness.

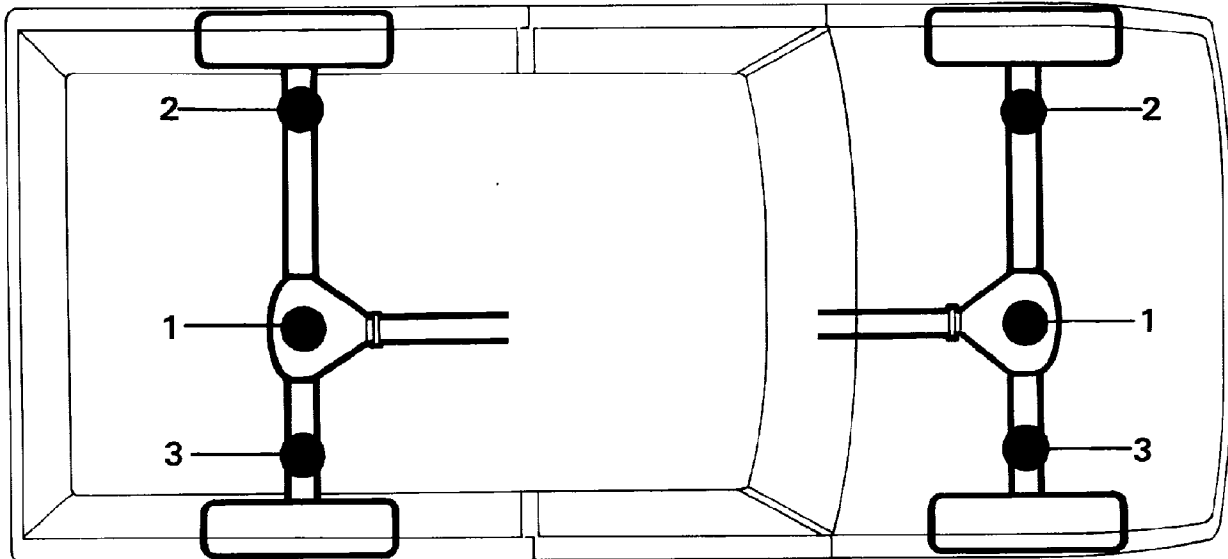

RR1839E

2. Raise front road wheels to enable an axle stand to be installed under left hand axle tube.
3. Position an axle stand under right hand axle tube, carefully lower jack until axle sits securely on both axle stands, remove trolley jack.
4. Before commencing work on underside of vehicle re-check security of vehicle on stands.
5. Reverse procedure when removing vehicle from stands.

Raise rear of vehicle

1. Position cup of hydraulic arm under differential casing.
2. Raise vehicle to enable axle stands to be installed under left and right hand axle tubes.
3. Lower jack until axle sits securely on axle stands, remove trolley jack.
4. Before commencing work on underside of vehicle re-check security of vehicle on stands.
5. Reverse procedure when removing vehicle from stands.

HYDRAULIC VEHICLE RAMP (FOUR POST)

Use only a 'drive on' type ramp which supports vehicle by its own road wheels. If a 'wheel-free' condition is required, use a 'drive on' ramp incorporating a 'wheel-free' system that supports under axle casings. Alternatively, place vehicle on a firm, flat floor and support on axle stands.

TWO POST VEHICLE RAMPS

The manufacturer of LAND ROVER VEHICLES DOES NOT recommend using 'Two Post' ramps that employ four adjustable support arms. These are NOT considered safe for Land Rover vehicles. If vehicle is installed on a Two Post ramp responsibility for safety of vehicle and personnel performing service operations is in the hands of the Service Provider.

DYNAMOMETER TESTING - NON ANTI-LOCK BRAKE VEHICLES

Viscous coupling

The front and rear axles cannot be driven independently due to the viscous coupling. This eliminates the need for differential lock by progressively locking the centre differential automatically if slip occurs at any wheel.



WARNING: DO NOT attempt to drive individual wheels with vehicle supported on floor jacks or stands.

Four wheel dynamometers

Provided that front and rear dynamometer rollers are rotating at identical speeds and that normal workshop safety standards are applied, there is no speed restriction during testing except any that may apply to the tyres.

Two wheel dynamometers

IMPORTANT: Use a four wheel dynamometer for brake testing if possible.

If brake testing on a single axle rig is necessary it must be carried out with propeller shaft to rear axle removed, AND neutral selected in BOTH main gearbox and transfer gearbox. When checking brakes, run engine at idle speed to maintain servo vacuum. If checking engine performance, the transfer box must be in high range and propeller shaft to stationary axle must be removed.

DYNAMOMETER TESTING - VEHICLES WITH ANTI-LOCK BRAKES (ABS)



WARNING: Do not attempt to test ABS function on a dynamometer

Four wheel dynamometers



NOTE: Before testing a vehicle on a four wheel dynamometer disconnect the valve relay. See *Electrical Trouble Shooting Manual*.

The ABS function will not work, the ABS warning light will illuminate. Normal braking will be available.

Provided that front and rear rollers are rotating at identical speeds and that normal workshop safety standards are applied, there is no speed restriction during testing except any that may apply to the tyres.

Two wheel dynamometers

IMPORTANT: Use a four wheel dynamometer for brake testing if possible.



NOTE: ABS will not function on a two wheel dynamometer. The ABS light will illuminate during testing. Normal braking will be available.

If brake testing on a single rig is necessary it must be carried out with propeller shaft to the rear axle removed, AND neutral selected in BOTH main and transfer boxes.

If checking engine performance, the transfer box must be in high range and drive shaft to stationary axle removed.

TOWING



CAUTION: The vehicle has permanent four-wheel drive. The following towing instructions must be adhered to:

Towing the vehicle on all four wheels with driver operating steering and brakes.

1. Turn ignition key turn to position '1' to release steering lock.
2. Select neutral in main gearbox and transfer gearbox.

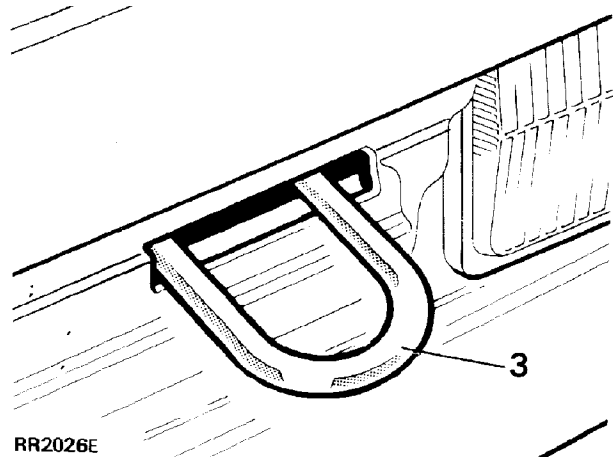

RR2026E

3. Secure tow rope, chain or cable to towing eye.
4. Release the parking brake.



CAUTION: The brake servo and power assisted steering system will not be functional without the engine running. Greater pedal pressure will be required to apply the brakes, the steering system will require greater effort to turn the front road wheels. The vehicle tow connection should be used only in normal road conditions, 'snatch' recovery should be avoided.

Suspended tow by breakdown vehicle



CAUTION: To prevent vehicle damage, front or rear propeller shaft **MUST BE** removed, dependent upon which axle is being trailed.

1. Mark propeller shaft drive flanges at transfer gearbox and axles with identification lines to enable the propeller shaft to be refitted in its original position.
2. Remove the propeller shaft fixings, remove the shaft from the vehicle.
3. If the front axle is to be trailed turn ignition key to position '1' to release steering lock.



CAUTION: The steering wheel and/or linkage must be secured in a straight ahead position. **DO NOT** use the steering lock mechanism for this purpose.

TRANSPORTING THE VEHICLE BY TRAILER

Lashing eyes are provided on front and rear of the chassis side members, to facilitate the securing of the vehicle to a trailer or other means of transportation.



CAUTION: Underbody components must not be used as lashing points.

Install vehicle on trailer and apply park brake. Select neutral in main gearbox. Selecting 'N' will prevent damage to parking pawl of the automatic gearbox.

FRONT OF CHASSIS

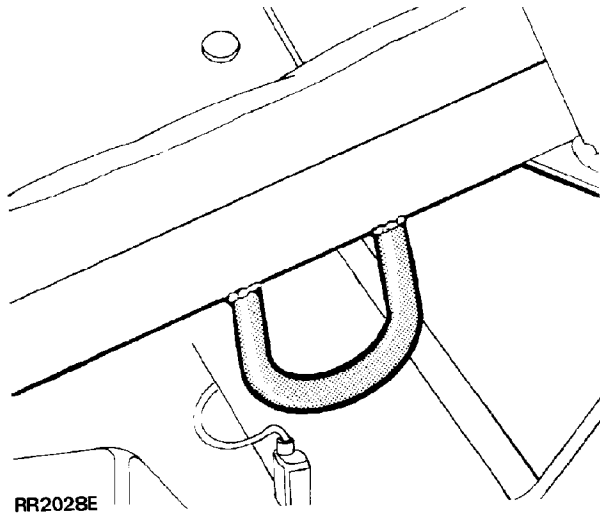

REAR OF CHASSIS

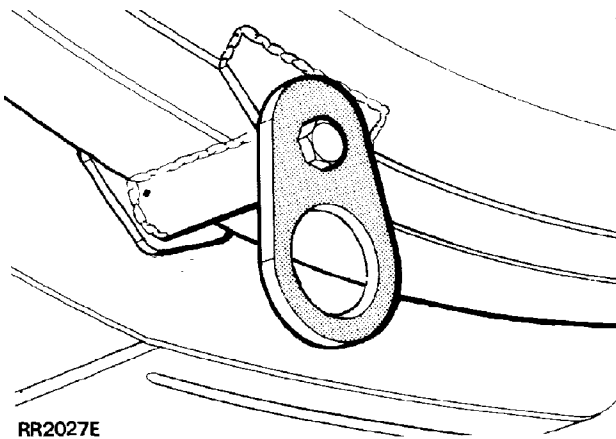

JUMP STARTING



WARNING: Hydrogen and oxygen gases are produced during normal battery operation. This gas mixture can explode if flames, sparks or lighted tobacco are brought near battery. When charging or using a battery in an enclosed space, always provide ventilation and shield your eyes.

Keep out of reach of children. Batteries contain sulphuric acid. Avoid contact with skin, eyes, or clothing. Also, shield eyes when working near battery to protect against possible splashing of acid solution. In case of acid contact with skin, eyes, or clothing, flush immediately with water for a minimum of fifteen minutes. If acid is swallowed, drink large quantities of milk or water, followed by milk of magnesia, a beaten egg, or vegetable oil. SEEK MEDICAL AID IMMEDIATELY.

To Jump Start - Negative Ground Battery



WARNING: To avoid any possibility of injury use particular care when connecting a booster battery to a discharged battery.

1. Position vehicles so that jump leads will reach, ensuring that vehicles **DO NOT TOUCH**, alternatively a fully charged slave battery may be positioned on floor adjacent to vehicle.
2. Ensuring that ignition and all electrical accessories are switched off, that parking brake is applied and neutral is selected on a manual gearbox, with an automatic gearbox select neutral (N) or park (P) and then connect the jump leads as follows;
 - A. Connect one end of first jumper cable to positive (+) terminal of booster battery.
 - B. Connect other end of first jumper cable to positive (+) terminal of discharged battery.
 - C. Connect one end of second jumper cable to negative terminal of booster battery.

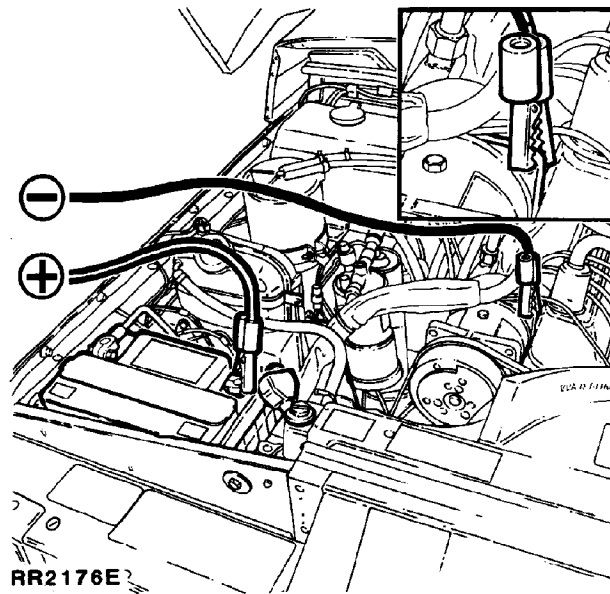

- D. Connect other end of second jumper cable to a good earth point on the engine, **NOT TO NEGATIVE TERMINAL OF DISCHARGED BATTERY**. Keep jumper lead away from moving parts, pulleys, drive belts and fan blade assembly.

WARNING: Making final cable connection could cause an electrical arc which if made near battery could cause an explosion.

3. If booster battery is installed in another vehicle, start engine and allow to idle.
4. Start engine of vehicle with discharged battery, following starting procedure in Owners' Manual.

CAUTION: If vehicle fails to start within a maximum time of 12 seconds, switch ignition off and investigate cause. Failing to follow this instruction could result in irreparable damage to catalyts.

5. Remove negative (-) jumper cable from the engine and then terminal of booster battery.
6. Remove positive (+) jumper cable from positive terminals of booster battery and discharged battery.

ABBREVIATIONS AND SYMBOLS USED IN THIS MANUAL

Across flats (bolt size)	AF	Low tension	l.t.
After bottom dead centre	ABDC	Maximum	max.
After top dead centre	ATDC	Metre	m
Alternating current	a.c.	Millilitre	ml
Ampere	amp	Millimetre	mm
Ampere hour	amp hr	Miles per gallon	mpg
Before bottom dead centre	BBDC	Miles per hour	mph
Before top dead centre	BTDC	Minute (angle)	'
Bottom dead centre	BDC	Minus (of tolerance)	-
Brake horse power	bhp	Negative (electrical)	-
British Standards	BS	Newton metres (torque)	Nm
Carbon monoxide	CO	Number	No.
Centimetre	cm	Ohms	ohm
Centigrade (Celsius)	C	Ounces (force)	ozf
Cubic centimetre	cm ³	Ounces (mass)	oz
Cubic inch	in ³	Ounce inch (torque)	ozf.in.
Degree (angle)	deg or °	Outside diameter	O.D.
Degree (temperature)	deg or °	Part number	Part No.
Diameter	dia.	Percentage	%
Direct current	d.c.	Pints	pt
Electronic Control Unit	ECU	Pints (US)	US pt
Electronic Fuel Injection	EFI	Plus (tolerance)	+
Fahrenheit	F	Positive (electrical)	+
Feet	ft	Pound (force)	lbf
Feet per minute	ft/min	Pounds inch (torque)	in.lbf.
Fifth	5th	Pound (mass)	lb
First	1st	Pounds per square inch	P.S.I.
Fluid ounce	fl oz	Ratio	:
Foot pounds (torque)	lbf ft	Reference	ref.
Fourth	4th	Revolution per minute	rev/min
Gramme (force)	gf	Right-hand	RH
Gramme (mass)	g	Second (angle)	"
Gallons	gal	Second (numerical order)	2nd
Gallons (US)	US gal	Specific gravity	sp.gr.
High tension (electrical)	H.T.	Square centimetres	cm ²
Internal diameter	I.D.	Square inches	in ²
Inches of mercury	in. Hg	Standard wire gauge	s.w.g.
Inches	in	Synchroniser/Synchromesh	synchro.
Kilogramme (force)	kgf	Third	3rd
Kilogramme (mass.)	kg	Top dead centre	TDC
Kilogramme centimetre (torque)	kgf.cm	United Kingdom	UK
Kilogramme per square millimetre	kgf/mm ²	Vehicle Identification Number	VIN
Kilogramme per square centimetre	kgf/cm ²	Volts	V
Kilogramme metres (torque)	kgf.m	Watts	W
Kilometres	km		
Kilometres per hour	km/h		
Kilovolts	kV		
Left-hand	LH		
Left-hand steering	LHStg		
Left-hand thread	LHThd		
Litres	litre		

SCREW THREADS

American Standard Taper Pipe	NPTF
British Standard Pipe	BSP
Unified Coarse	UNC
Unified Fine	UNF



CROSS REFERENCE OF EMISSION SYSTEM TERMINOLOGY

NEW TERM	(ACRONYM)	OLD TERM	(ACRONYM)
Accelerator pedal	(AP)	Throttle pedal	(-)
Air cleaner	(ACL)	Air cleaner	(-)
Air conditioning	(AC)	Air conditioning	(AC)
Battery positive voltage	(B+)	Battery plus, bat +, bat feed	(B+)
Closed loop	(CL)	Closed loop	(-)
Closed throttle position	(CTP)	Closed throttle, idle position	(-)
Canister purge valve	(CANPV)	Charcoal canister purge valve	(-)
Data link connector	(DLC)	Serial link	(-)
Diagnostic trouble code	(DTC)	Fault code	(-)
Distributor ignition	(DI)	Electronic ignition	(-)
Engine control module	(ECM)	Electronic control unit	(ECU)
Engine coolant level	(ECL)	Coolant level	(-)
Engine coolant temperature	(ECT)	Coolant temperature	(temp)
Engine coolant temperature sensor	(ECTS)	Coolant temperature thermistor	(-)
Engine speed	(RPM)	Engine speed	(rev/min)
Evaporative emission system	(EVAP)	Evaporative loss system	(ELC)
Engine fuel temperature sensor	(EFTS)	Fuel temperature thermistor	(-)
4th gear, 3rd gear etc.	(4GR, 3GR)	Fourth gear, 3rd gear	(-)
Fuel pump	(FP)	Fuel pump	(-)
Fan control module	(FCM)	Condenser fan timer	(-)
Generator	(GEN)	Alternator	(-)
Ground	(GND)	Ground, earth	(B-)
Heated oxygen sensor	(H02S)	Lambda (O2) sensor	(-)
Idle air control	(IAC)	Idle speed control	(ISC)
Idle air control valve	(IACV)	Stepper motor	(-)
Ignition control module	(ICM)	Ignition module	(-)
Inertia fuel shutoff	(IFS)	Inertia switch	(-)
Inertia fuel shutoff switch	(IFSS)	Inertia switch	(-)
Intake air temperature	(IAT)	Intake temperature/ambient temperature	(-)
Malfunction indicator lamp	(MIL)	EFI warning lamp	(-)
Manifold vacuum zone	(MVZ)	Manifold depression, vacuum	(-)
Mass air flow sensor	(MAFS)	Air flow meter	(-)
Multiport fuel injection	(MFI)	Electronic fuel injection	(EFI)
On board diagnostic	(OBD)	Fault code display unit	(-)
Open loop	(OL)	Open loop	(-)
Park/neutral position	(PNP)	Park or neutral	(-)
Park/neutral position switch	(PNPS)	Start inhibit switch	(-)
Programmable read only memory	(PROM)	Chip, PROM	(PROM)
Relay module	(RM)	Relay	(-)
Service reminder indicator	(SRI)	Check engine light	(-)
Solid state relay module	(SSRM)	Control unit	(-)
Three way catalytic converter	(TWC)	Catalyst, catalytic converter	(CAT)
Throttle body	(TB)	Throttle housing	(-)
Throttle position sensor	(TPS)	Throttle potentiometer	(-)
Torque converter clutch	(TCC)	Direct drive clutch	(DDC)
Transmission range	(TR)	Transmission gear	(-)
Transmission range selector	(TRS)	Shift lever, shifter	(-)
Vehicle speed sensor	(VSS)	Road speed transducer	(-)
Wide open throttle	(WOT)	Full throttle, wide open throttle	(WOT)

VEHICLE IDENTIFICATION NUMBER (VIN)

The Vehicle Identification Number and the recommended maximum vehicle weights are stamped on a plate located under the bonnet [hood] riveted to the front of the engine compartment.

Vehicle Identification Number Plate (UK, Australia, R.O.W., Europe)

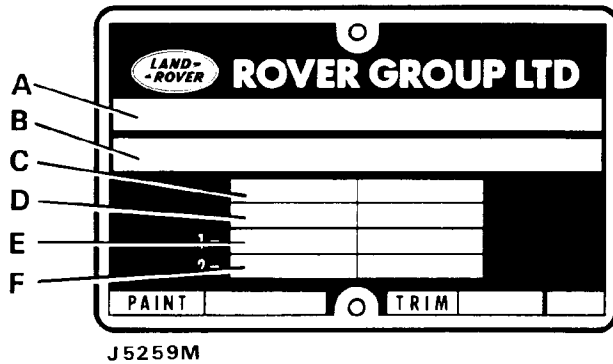

- A. Build date (Australia). Type approval
- B. VIN (17 digits)
- C. Maximum permitted laden weight for vehicle
- D. Maximum vehicle and trailer weight
- E. Maximum road weight-front axle
- F. Maximum road weight-rear axle

The number is also stamped on the right side of the chassis forward of the spring mounting turret.

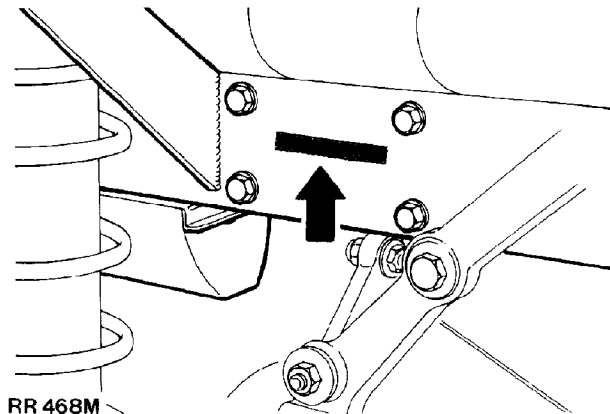

RR 468M

Vehicle Identification Number Plate (Saudi Arabia)

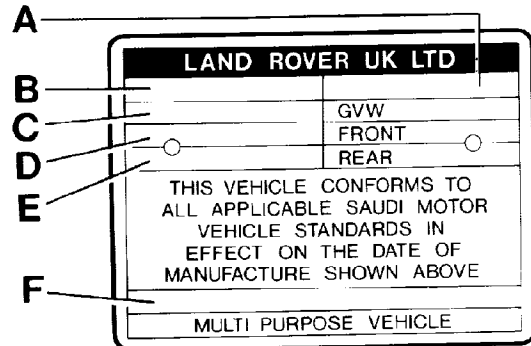

RR466M

- A. Year of manufacture
- B. Month of manufacture
- C. Maximum vehicle weight
- D. Maximum road weight-front axle
- E. Maximum road weight-rear axle
- F. VIN (17 digits)

The vehicle identification number identifies the manufacturer, model range, wheel base, body type, engine, steering, transmission, model year and place of manufacture. The following example shows the coding process.

- SAL** World manufacturer identifier
- LH** Range Rover or
- LJ** Discovery
- G** Class 100 inch
- B** 2 door
- F** 300 Tdi or
- V** V8i Petrol
- 8** 5 speed LHD or
- 7** 5 speed RHD
- M** 1995 MY
- A** Solihull site



European vehicle identification number (VIN)

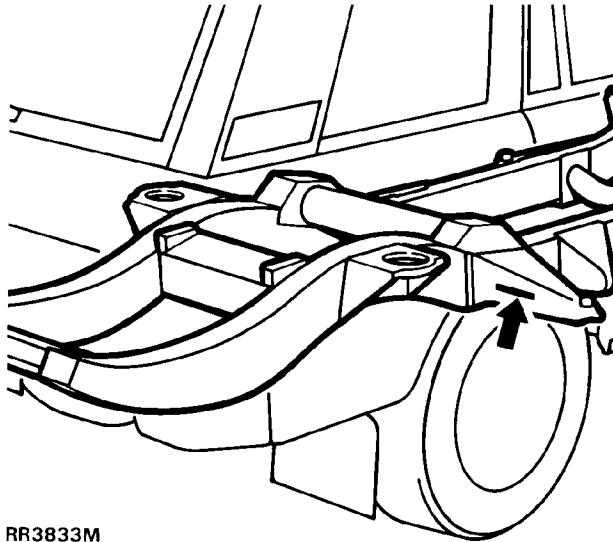

RR3833M

Stamped on the right hand side chassis forward of rear wheel.

Federal (USA) vehicle identification number

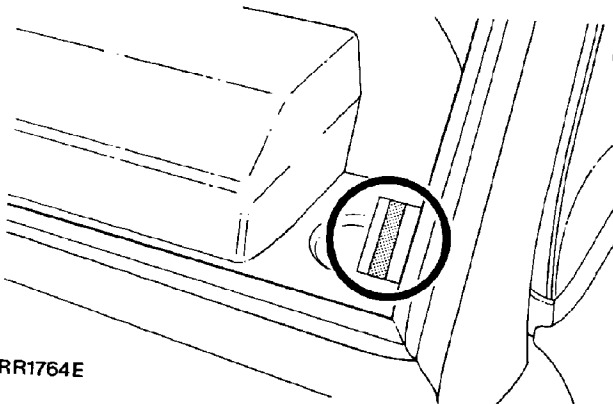

RR1764E

Stamped on a plate rivetted to the upper left hand 'A' - post, visible through the front screen of the vehicle.

Vehicle identification number (VIN)

An adhesive label containing the Vehicle Identification Number, date of manufacture and gross axle weight ratings is fixed to the lock face of the front left hand door. The information includes wheel and tyre sizes and tyre pressures at gross axle weight ratings.

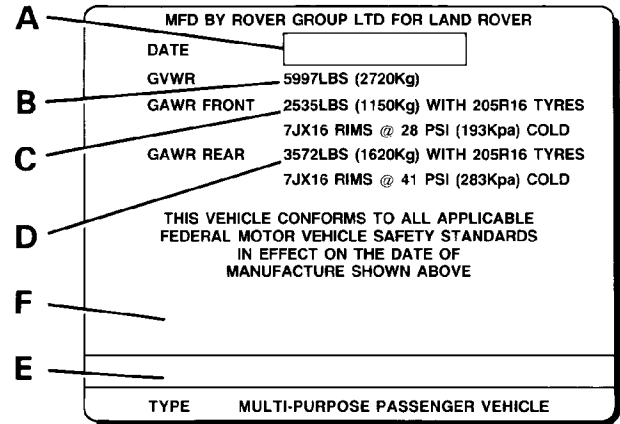

RR2944E

Key to vehicle identification label

- A. Month and year of manufacture
- B. Gross vehicle weight rating
- C. Gross axle weight rating for front axle
- D. Gross axle weight rating for rear axle
- E. Vehicle identification number (17 digits)
- F. Vehicle identification number - bar code

LOCATION OF IDENTIFICATION NUMBERS

Engine serial number - V8i engine

Stamped on a cast pad on the cylinder block, between numbers 3 and 5 cylinders.

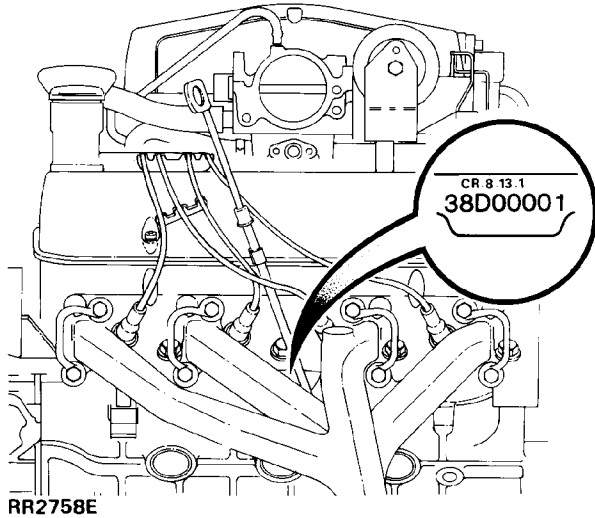

Engines are identified by the prefix:

3.9 Litre:

- 35D. - 9.35:1 compression, manual transmission
- 36D. - 9.35:1 compression, automatic transmission
- 37D. - 8.13:1 compression, manual transmission
- 38D. - 8.13:1 compression, automatic transmission

4.2 Litre:

- 40D. - 8.94:1 compression, automatic transmission

Engine serial number - Diesel engine

Stamped on the RH side of cylinder block above the camshaft front cover plate.

Main gearbox R380

Stamped on a cast pad on the bottom right hand side of the gearbox.

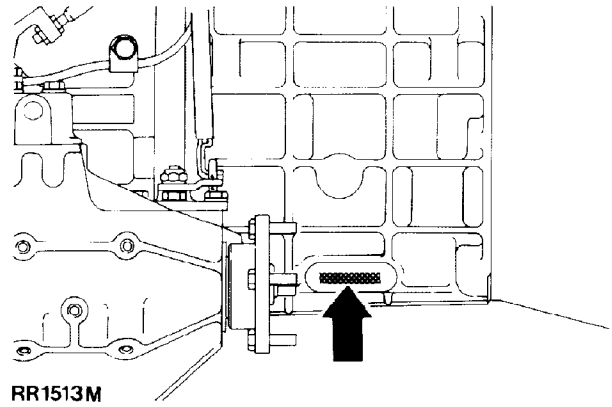

Automatic gearbox

Stamped on a plate riveted to the bottom left hand side of the gearbox casing.

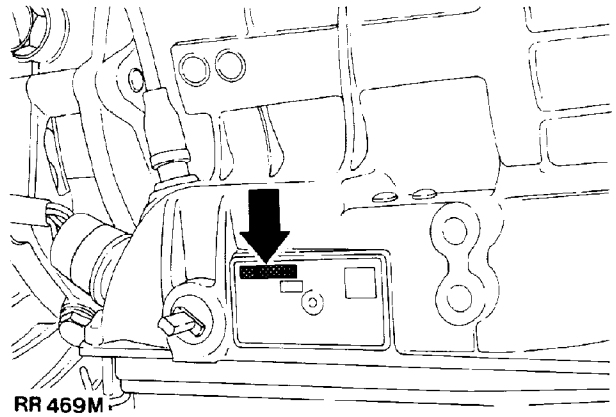

Transfer gearbox-Borg Warner

Stamped on a plate attached to the gearbox casing, between filler/level and drain plug.

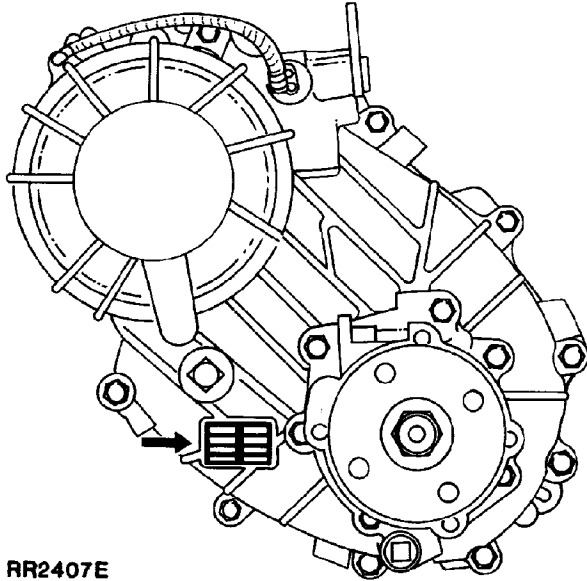
**Front and rear axle**

Stamped on the top of the left hand axle tubes.

FAULT DIAGNOSTIC EQUIPMENT

TESTBOOK

Today's Land Rover Vehicles are equipped with a large amount of electronics to provide the best performance of the vehicles systems. Diagnostic equipment named TESTBOOK is available to expand the diagnostic abilities of the dealer workshop. This repair manual is produced with Testbook in mind. Features of Testbook include: - Fully upgradable support for the technician. Structured diagnostics to accommodate all skill levels. Touch screen operation. Direct print out of screen information and test results.

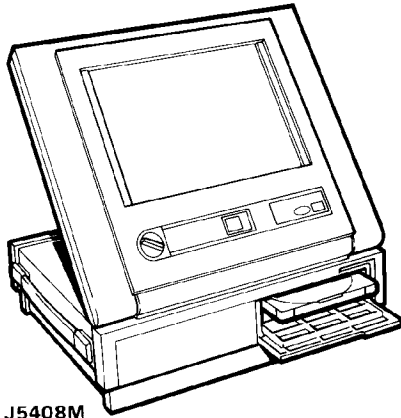

J5408M

ELECTRICAL TROUBLESHOOTING MANUAL

The Electrical Troubleshooting Manual is a separate publication that is intended for use by trained Land Rover technicians as an aid to diagnosing electrical concerns.

It provides circuit diagrams, system diagnosis flow charts, electrical component location tables, electrical component location views, and circuit operation details.

READING THIS MANUAL

This manual is divided into sections shown on the contents page, alongside a range of icons, familiar to service technicians.

Relevant information is contained within each of these sections. These are further divided into the following sub-sections which appear at the foot of each page:

Description and operation.
Fault diagnosis.
Adjustment.
Repair.
Overhaul.
Specifications, Torque.
Service tools.

To avoid repeating information through the sections, where part of the repair operation impacts on another section, a cross reference is given to direct the reader to where the information is sited.

For example:

The maintenance section states the need to renew V8i drive belt. A cross reference sites this information in:
- Section: V8i Engine
- Sub-section: Repairs
- Heading: Drive belt renew

Sections that contain derivatives such as engines are further separated into within that section.

American terminology

A few words used in this manual differ to words used in America. Where this occurs the American word is placed inside brackets. For example: bonnet [hood], wing [fender], ramp [hoist].



ENGINE - V8

Type	3.9 litre V8
Number of cylinders	Eight, two banks of four
Bore	94.00 mm
Stroke	71.12 mm
Capacity	3950 cm ³
Valve operation	Overhead by push-rod
Compression ratio	8.13:1 or 9.35:1
Valve operation	Overhead by push-rod
Maximum power:	
- 8.13:1	127kW at 4550 rev/min
- 9.35:1	134kW at 4750 rev/min

Type	4.2 litre V8
Number of cylinders	Eight, two banks of four
Bore	94.00 mm
Stroke	77.00 mm
Capacity	4275 cm ³
Valve operation	Overhead by push-rod
Compression ratio	8.94:1
Valve operation	Overhead by push-rod
Maximum power	149kW at 4850 rev/min

Crankshaft

Main journal diameter	58.409-58.422 mm
Minimum regrind diameter	57.393-57.406 mm
Crankpin journal diameter	50.800-50.812 mm
Minimum regrind diameter	49.784-49.797 mm
Crankshaft end thrust	Taken on thrust washers of centre main bearing
Crankshaft end float	0.10-0.20 mm

Main bearings

Number and type	5, Vandervell shells
Material	Lead-indium
Diametrical clearance	0.010-0.048 mm
Undersize bearing shells	0.254 mm, 0.508 mm

Connecting rods

Type	Horizontally split big-end, plain small-end
Length between centres	143.81-143.71 mm

Big-end bearings

Type and material	Vandervell VP lead-indium
Diametrical clearance	0.015-0.055 mm
End-float crankpin	0.15-0.36mm
Undersize bearing shells	0.254 mm, 0.508 mm

Piston pins

Length	72.67-72.79 mm
Diameter	22.215-22.220 mm
Fit-in connecting rod	Press fit
Clearance in piston	0.002-0.007 mm

Pistons

Clearance in bore, measured at bottom
of skirt at right angles to piston pin 0.018-0.041 mm

Piston rings

Number of compression rings 2
 Number of control rings 1
 No 1 compression ring Molybdenum barrel faced
 No 2 compression ring Tapered and marked 'T' or 'TOP'
 Width of compression rings 1.478-1.49 mm
 Compression ring gap 0.40-0.65 mm
 Oil control ring type Hepworth and Grandage
 Oil control ring width 3.0 mm
 Oil control ring rail gap 0.38-1.40 mm

Camshaft

Location Central
 Bearings Tin-aluminium
 Number of bearings 5
 Drive Chain 9.52 mm pitch x 54 pitches.

Tappets Hydraulic self-adjusting

Valves

Length: Inlet 116.59-117.35 mm
 Exhaust 116.59-117.35 mm
 Seat angle: Inlet 45°- 45 1/2°
 Exhaust 45°- 45 1/2°
 Head diameter: Inlet 39.75-40.00 mm
 Exhaust 34.226-34.480 mm
 Stem diameter: Inlet 8.664-8.679 mm
 Exhaust 8.651-8.666 mm
 Stem to guide clearance: Inlet 0.025-0.066 mm
 Exhaust 0.038-0.078 mm
 Valve lift (Inlet and Exhaust) 9.49 mm
 Valve spring length fitted 40.4 mm at pressure of 29.5 kg

Lubrication

System type Wet sump, pressure fed
 Oil pump type Eccentric rotor
 Oil pressure 2.75 bar (40 lbf/in²) at 2500 rev/min with engine at
 running temperature
 Oil filter-internal Wire screen, pump intake filter in sump
 Oil filter-external Full flow, self-contained cartridge



ENGINE - 300Tdi

Type	Direct injection, turbocharged, intercooled
Number of cylinders	4
Bore	90,47 mm
Stroke	97,00 mm
Capacity	2495 cm ³
Compression ratio	19.5:1 ± 0.5:1
Valve operation	O.H.V. pushrod operated
Turbo charger	Garrett T25

Crankshaft

Main bearing journal diameter	63,475 - 63,487 mm
Regrind dimensions	63,2333 - 63,246 mm
	Use 0.010 in U/S bearings
Crankpin journal diameter	58,725 - 58,744 mm
Regrind dimensions	58,4708 - 58,48985 mm
	Use 0.010 in U/S bearings
Crankshaft end thrust	Taken on thrust washers at centre main bearing
Crankshaft end float	0,05 - 0,15 mm

Main bearings

Number and type	5 halved shells with oil grooves
Diametrical clearance	0,0792 - 0,0307 mm

Connecting rods

Length between centres	175,38 - 175,43 mm
Diametrical clearance (big-end bearings)	0,025 - 0,075 mm
End float on crankpin	0,15 - 0,356 mm

Pistons

Type	Aluminium alloy, combustion chamber in crown
Skirt diametrical clearance (at right angle to gudgeon pin)	0,025 - 0,05 mm
Maximum height above combustion face	0,8 mm

Gudgeon pins

Type	Floating
Fit in piston	Hand push fit
Diameter	30,1564 - 30,1625 mm
Clearance in connecting rod	0,0025 - 0,0163 mm

Piston rings

Type:

- Top Barrel edge, chrome plated
- Second Taper faced
- Oil control Expander and rails

Gap in bore:

- Top 0,40 - 0,60 mm
- Second 0,30 - 0,50 mm
- Oil control 0,3 - 0,6 mm

Clearance in piston grooves:

- Top 0,167 - 0,232 mm
- Second 0,05 - 0,08 mm
- Oil control 0,05 - 0,08 mm

Camshaft

- Drive 30 mm (1.2 in) wide dry toothed belt
- Location Right hand side (thrust side)
- End float 0,1 - 0,2 mm
- Number of bearings 4
- Material Steel shell, white metal lined

Valves

Tappet clearance:

- Inlet and exhaust 0,20 mm

Seat angle:

- Inlet 30°
- Exhaust 45°

Head diameter:

- Inlet 39,75 - 39,05 mm
- Exhaust 36,35 - 36,65 mm

Stem diameter:

- Inlet 7,960 - 7,975 mm
- Exhaust 7,940 - 7,960 mm

Valve lift:

- Inlet 9,67 mm
- Exhaust 9,97 mm

Cam lift:

- Inlet 6,81 mm
- Exhaust 7,06 mm

Valve head stand down:

- Inlet 0,81 - 1,09 mm
- Exhaust 0,86 - 1,14 mm

Valve springs

- Type Single coil
- Length, free 46,28 mm
- Length, under 21 kg (46 lb) load 40,30 mm

**Lubrication**

System	Wet sump, pressure fed
Pressure, engine warm at normal operating speeds	1.7-3.8 bar (25 - 55 lbf/in ²)
Oil pump:	
- Type	Double gear 10 teeth, sintered iron gears
- Drive	Splined shaft from camshaft skew gear
- End float of both gears	0,026 - 0,135 mm
- Radial clearance of gears	0,025 - 0,075 mm
- Backlash of gears	0,1 - 0,2 mm
Oil pressure relief valve	Non-adjustable
Relief valve spring:	
- Full length	51.6 mm
- Compressed length at 7.71 kg load	31.0 mm
Oil filter	Screw-on disposable canister
Engine oil cooler	Combined with coolant radiator and intercooler

FUEL SYSTEM - V8 Engine

Fuel system type	Lucas 14CUX hot wire system electronically controlled
Fuel pump-make/type	High pressure electrical, immersed in the fuel tank
Fuel pump delivery pressure	2.4-2.6 bar (34-37 lbf/in ²)
Fuel filter	Bosch in-line filter 'canister' type

Airflow Sensor

Make and type	Lucas 'Hot Wire' 5AM
---------------------	----------------------

Injectors

Make and type	Lucas 8NJ
---------------------	-----------

Electronic Control Unit

Make and type	Lucas 14CUX
---------------------	-------------

Fuel pressure regulator

Make and type	Lucas 8RV
---------------------	-----------

Fuel temperature sensor

Make and type	Lucas 6TT
---------------------	-----------

Coolant temperature sensor

Make and type	Lucas 3TT
---------------------	-----------

Bypass Air valve (Stepper motor)

Make and type	Lucas 2ACM
---------------------	------------

Throttle potentiometer

Make and type	Lucas 215SA
---------------------	-------------

Lambda sensor - catalyst vehicles

Make and type	Lucas 3LS
---------------------	-----------

FUEL SYSTEM - 300Tdi Engine

Injection pump type	Bosch rotary VE4/11F. See ENGINE TUNING DATA, Information, Engine - 300Tdi
Injectors	See ENGINE TUNING DATA, Information, Engine - 300Tdi
Heater plugs	See ENGINE TUNING DATA, Information, Engine - 300Tdi
Fuel lift pump type	Mechanical with hand primer
Fuel lift pump pressure	0.4 - 0.55 bar (6 - lbf/in ²) at 1800 rpm
Fuel filter	Paper element in disposable canister
Air cleaner	Paper element type
Turbocharger	Garrett T25. See ENGINE TUNING DATA, Information, Engine - 300Tdi



COOLING SYSTEM - V8 ENGINE

Type	Pressurized system with cross- flow radiator and remote header tank, thermostat control, pump and fan assisted
Type of pump	Centrifugal
Thermostat	88°C
Expansion tank cap pressure (system pressure)	1.0 bar (15 lbf/in ²)

COOLING SYSTEM - 300Tdi ENGINE

System type	Pressurised, spill return, thermostatically controlled water and anti freeze mixture. Pump assisted thermo syphon. Coolant radiator combined with oil cooler and turbo intercooler.
Cooling fan	11 blade axial flow 433 mm diameter. 1.29:1 drive ratio. Viscous coupling.
Pump type	Centrifugal, impeller, belt driven.
Thermostat opening	88°C
Expansion tank cap pressure (system pressure)	1.0 bar (15 lbf/in ²)

TRANSMISSION

Clutch

Make and type - V8 engine	Borg and Beck, diaphragm spring
Clutch plate diameter	266.5mm
Make and type - Diesel engine	Valeo, diaphragm spring
Clutch plate diameter	235mm

Transfer gearbox

Borg Warner	Two speed reduction on main gearbox output, front and rear drive permanently engaged via a centre differential controlled by a Viscous unit giving a 50/50 nominal front and rear torque split.
-------------------	---

Transfer gearbox ratios

High	1.206:1
Low	3.244:1

Manual gearbox

Type R380	5 speed, single helical constant mesh with synchromesh on all forward gears
-----------------	---

Manual gearbox ratios:

5th	0.731:1
4th	1.000:1
3rd	1.397:1
2nd	2.132:1
1st	3.321:1
Reverse	3.429:1
Diesel models low first gear	3.692:1

Overall ratio (final drive):

	High transfer	Low transfer
5th	3.119:1	8.39:1
4th	4.267:1	11.476:1
3rd	5.959:1	16.027:1
2nd	9.095:1	24.462:1
1st	14.172:1	38.115
Reverse	14.629:1	39.346:1
Diesel models low 1st gear	15.750:1	42.362

Automatic gearbox

Model	ZF4HP22
Type	Four speed and reverse epicyclic gears with fluid torque converter and lock up.

Automatic gearbox ratios

4th	0.728:1
3rd	1.000:1
2nd	1.480:1
1st	2.480:1
Reverse	2.086:1

Overall ratio (final drive):

	High transfer	Low transfer
4th	3.11:1	8.36:1
3rd	4.27:1	11.48:1
2nd	6.32:1	17.00:1
1st	10.59:1	28.50:1
Reverse	8.91:1	23.96:1

**SHIFT SPEED SPECIFICATION - AUTOMATIC
ZF4HP22 GEARBOX**

OPERATION	SELECTOR POSITION	VEHICLE SPEED APPROX		ENGINE SPEED APPROX (RPM)
KICKDOWN				
		MPH	KPH	
KD4 - 3	D	84 - 92	136 - 150	
KD3 - 2	3(D)	57 - 62	91 - 99	
KD2 - 1	2(D,3)	27 - 34	44 - 56	
KD3 - 4	D	N/A	N/A	
KD2 - 3	D(3)	60 - 63	96 - 104	4750 - 5200
KD1 - 2	D(3,2)	34 - 40	56 - 64	4600 - 5250
FULL THROTTLE				
FT4 - 3	D	61 - 67	98 - 108	
FT3 - 2	3(D)	40 - 46	64 - 73	
FT3 - 4	D	74 - 80	119 - 129	3980 - 4330
FT2 - 3	D(3)	55 - 60	88 - 96	4350 - 4800
T1 - 2	D(3,2)	29 - 34	48 - 56	3950 - 465
PART THROTTLE				
PT4 - 3	D	47 - 54	75 - 86	
PT3 - 2	D(3)	29 - 37	48 - 59	
PT2 - 1	D(3,2)	10 - 12	16 - 19	
LIGHT THROTTLE				
LT3 - 4	D	26 - 30	43 - 49	1430 - 1650
LT2 - 3	D(3)	18 - 22	29 - 35	1420 - 1820
LT1 - 2	D(3,2)	9 - 10	14 - 16	1180 - 1220
ZERO THROTTLE				
ZT4 - 3	D	19 - 25	31 - 41	
ZT3 - 2	D(3)	12 - 15	19 - 24	
ZT2 - 1	D(3,2)	6 - 7	10 - 11	
TORQUE CONVERTER				
Lock up (IN)	D	51 - 54	81 - 86	1875 - 2000
Unlock (OUT)	D	49 - 52	78 - 83	1825 - 1930
<p>Note: The speeds given in the above chart are approximate and only intended as a guide. Maximum shift changes should take place within these tolerance parameters.</p>				

Propeller shafts

Type	Tubular 51mm diameter
Front	Tubular 51mm diameter
Front - Catalyst vehicles	Solid bar 28.6mm diameter
Rear	Tubular 51mm diameter
Universal joints	Open type Hooks O3EHD

Rear axle

Type	Spiral bevel, fully floating shafts
Ratio	3.54:1

Front axle

Type	Spiral bevel, enclosed constant velocity joints, fully floating shafts
Ratio	3.54:1

STEERING**Power steering box**

Make/type	Adwest Varamatic - worm and roller box
Ratio	Variable: straight ahead 19.3:1 on lock 17.2:1
Steering wheel turns, lock-to-lock	3.375

Steering pump

Make/type:	
V8 engine	ZF 'UNICORN'
Diesel engine	Hobourn-Eaton series 500
Operating pressure - straight ahead position - at idle	7 bar (100 p.s.i.) maximum
Full lock (left or right) at idle	28 bar (400 p.s.i.) minimum
Full lock (left or right) 1000 rev/min	70-77 bar (1000-1100 p.s.i.)

Steering geometry

Steering wheel diameter	406.4mm
Toe-out measurement	0 to 2mm toe out
Toe-out included angle	0° to 0°16'
Camber angle	0°C

Castor angle 3°

Swivel pin inclination static 7°

Check with vehicle in static unladen condition, that is, vehicle with water, oil and five gallons of fuel. Rock the vehicle up and down at the front to allow it to take up a position



SUSPENSION

Type:	
- Coil spring suspension	Coil springs controlled by telescopic dampers front and rear.
- Air suspension	Air springs controlled by an ECU providing variable rate springs and 5 height settings.
Front	Lateral location of axle by Panhard rod, and longitudinal location by two radius arms.
Rear	Lateral location of axle by a centrally positioned 'A' frame bolted at the apex to a ball joint mounting. Coil spring suspension: A levelling unit is positioned between the ball joint and upper cross member. Longitudinal location of axle by two tubular trailing links.

SHOCK ABSORBERS

Type	Telescopic, double-acting non-adjustable
Bore diameter	35.47mm

ROAD SPRING DATA**V8i**

LEFT HAND DRIVE	Part No.	Colour Code
Left hand front	NRC4306	Blue/White
Right hand front	572315	Blue
Left hand rear	ANR 3519	Brown/Red
Right hand rear	ANR 3520	Brown/Yellow
Heavy duty rear	NRC 4304	Red/White

RIGHT HAND DRIVE

Left hand front	572315	Blue
Right hand front	572315	Blue
Left hand rear	ANR 3520	Brown/Yellow
Right hand rear	ANR 3520	Brown/Yellow
Heavy duty rear	NRC 4304	Red/White

Tdi Diesel

LEFT HAND DRIVE	Part No.	Colour Code
Left hand front	NTC 8476	White/Blue/Pink
Right hand front	NRC 8477	Green/Blue/Yellow
Left hand rear	ANR 3519	Brown/Red
Right hand rear	ANR 3520	Brown/Yellow
Heavy duty rear	NRC 4304	Red/White

RIGHT HAND DRIVE

Left hand front	NRC 8477	Green/Blue/Yellow
Right hand front	NRC 8477	
Left hand rear	ANR 3520	Brown/Yellow
Right hand rear	ANR 3520	
Heavy duty rear	NRC 4304	Red/White



BRAKES

Front service brake

Type Outboard discs with four piston calipers
Operation Hydraulic, servo assisted self-adjusting
Pad material Ferodo 3440 non asbestos

Rear service brake

Type Outboard discs with two piston calipers
Operation Hydraulic, servo assisted, self-adjusting
Pad material Ferodo 3440 non asbestos

Parking brake

Type Mechanical-cable operated drum brake on the rear
of the transfer gearbox output shaft
Lining material Non asbestos

Servo/master cylinder

Manufacturer Lucas Girling
Servo type LSC 115
Master cylinder type AS/AS

Anti-lock brake system

Manufacturer/type Wabco LRC M15 - 4 channel, 4 wheel sensed
integrated anti-lock brake system.

WHEELS AND TYRES

Type and size	Alloy 7.00J X 16
Tyre size	205R16 (tubeless)
Type and size	Steel 6.00JK X 16
Tyre size	205R16 (tubed)



NOTE: Petrol vehicles must be fitted with 'S' or 'T' rated tyres.

AIR CONDITIONING

System	CFC free expansion valve system (Nippon Denso)
Compressor	Nippon Denso 10PA17 Fixed displacement swash plate

WIPER MOTORS

Tailgate wiper motor

Make/type	IMOS (non-serviceable)
Running current, wet screen at 20°C ambient	1.0 to 2.8 amps
Wiper speed, wet screen at 20°C ambient	37 to 43 cycles per minute

Windscreen wiper motor

Make/type	Lucas 28W 2-speed
Running current (Link disconnected)	1.5 amps at 39 to 45 rev/min (normal speed)
Rotary link speed	60 to 73 rev/min (high speed)



ELECTRICAL

System 12 volt, negative ground

Battery

Make/type - basic Land Rover Parts and Equipment/Chloride maintenance free 9-plate-210/85/90

Make/type - heavy duty Land Rover Parts and Equipment/Chloride maintenance free 14-plate-380/120/90

Generator

Manufacturer Magnetti Marelli

Type A133 - 100A

Polarity Negative ground

Brush length

New 20 mm

Worn, minimum free protrusion

from brush box 10 mm

Brush spring pressure flush with brush box face 136 to 279 g

Rectifier pack output rectification 6 diodes (3 positive side and 3 ground side)

Field winding supply rectification 3 diodes

Stator windings 3 phase-delta connected

Field winding rotor poles 12

Maximum speed 16,000 rev/min

Winding resistance at 20°C 2.6 ohms

Control Field voltage sensed regulation

Regulator-type 15 TR

voltage 13.6 to 14.4 volts

Nominal output

Condition Hot

Generator speed 6000 rev/min

Control voltage 14 volt

Amp 100 amp

Fuses

Type Autofuse (blade type)
blow ratings to suit individual circuits

Horns

Make/type Klamix (Mixo) TR99

Starter motor

V8 Engine

Make/type Lucas M78R pre-engaged

Minimum brush length 3.5 mm

Minimum commutator diameter 28.8 mm

Diesel Engine

Make and type Bosch 0.001.362.092

REPLACEMENT BULBS

REPLACEMENT BULBS	TYPE		
Exterior lights			
Headlamps	12V	60/55W	(Halogen)
Auxiliary driving lamps	12V	55W H3	(Halogen)
Sidelamps	12V	5W	bayonet
Tail lamps	12V	5/21W	bayonet
Reverse lamps	12V	21W	bayonet
Stop lamps	12V	21W	bayonet
Direction indicator lamps	12V	21W	bayonet
Rear side marker lamps	12V	4W	bayonet
Number plate lamps	12V	5W	capless
Interior lights			
Interior roof lamps	12V	10W	'Festoon'
Door shut face/puddle lamps	12V	5W	capless
Instrument panel lamps and warning lamps	14V	1.2W	bulb/holder unit
Ignition warning lamp (Instrument panel)	14V	2W	capless
SRS warning lamp (Instrument panel)	14V	1.4W	capless
Clock illumination	12V	2W	bayonet
Cigar lighter illumination	12V	1.2W	capless
Auxiliary switch illumination	12V	0.2W	capless
Auxiliary switch warning lamp	12V	0.2W	capless
Hazard warning switch illumination	14V	0.2W	capless
Automatic selector graphics illumination	12V	5W	capless
Heater/air conditioning graphics illumination	12V	1.2W	capless



CAUTION: The fitting of new bulbs with wattages in excess of those specified will result in damage to vehicle wiring and switches.



VEHICLE WEIGHTS AND PAYLOAD

When loading a vehicle to its maximum (Gross Vehicle Weight), consideration must be taken of the vehicle kerb weight and the distribution of the payload to ensure that axle loadings do not exceed the permitted maximum values. It is the customer's responsibility to limit the vehicle's payload in an appropriate manner such that neither maximum axle loads nor Gross Vehicle Weight are exceeded.

Basic models		Front Axle kg	Rear Axle kg	Total kg
Manual	V8 engine	EEC Kerb weight	990	2070
		Gross Vehicle Weight*	1100	2510
V8 engine SE		EEC Kerb weight	1055	2150
		Gross Vehicle Weight*	1100	2510
V8 engine LSE (long wheelbase models)		EEC Kerb weight	1090	2185
		Gross Vehicle Weight*	1200	2620
Diesel engine	Tdi	EEC Kerb weight	1040	2110
		Gross Vehicle Weight*	1200	2620
Tdi SE		EEC Kerb weight	1105	2110
		Gross Vehicle Weight*	1200	2620



NOTE: EEC KERB WEIGHT is the minimum vehicle specification, plus full fuel tank and 75 kg driver. **GROSS VEHICLE WEIGHT** is the maximum all-up weight of the vehicle including driver, passengers, and equipment. This figure is liable to vary according to legal requirements in certain countries.

Maximum roof rack load (including weight of rack) 75 kg must be included in total vehicle weight.

VEHICLE DIMENSIONS

Overall length	4.48m
- Long wheelbase vehicles	4.68m
Overall width	1.82m
Overall height	1.80m
Wheelbase	2.54m
- Long wheelbase vehicles	2.74m
Track: front and rear	1.49m
Ground clearance: under differential	190mm
Turning circle	11.89m
- Long wheelbase vehicles	13.64m
Loading height	749mm
Maximum cargo height	1.028m
Rear opening height	0.87m
Usable luggage capacity, rear seat folded	2.00m ³
Usable luggage capacity, rear seat in use	1.03m ³

TYRE PRESSURES

Pressures: Check with tyres cold	Normal on and off-road use. All speeds and loads		Off-road 'emergency' soft use maximum speed of 40 kph (25 mph)	
	Front	Rear (*)	Front	Rear
bar	1.9	2.4 (2.6)	1.2	1.8
lbf/in ²	28	35 (38)	17	25
kgf/cm ²	2.0	2.5 (2.7)	1.2	1.8

(*) Long wheelbase vehicles (2.74m, 108")

The pressure of tyres must be increased by 0.3 bar (3 lbf in² 0.2 kgf/cm²). For use with sustained driving speeds above 160 km/hr (100 miles/hour) or with heavy axle loads.

Normal operating pressures should be restored as soon as reasonable road conditions or hard ground is reached. After any usage off the road, tyres and wheels should be inspected for damage particularly if high cruising speeds are subsequently to be used.

Towing: When the vehicle is used for towing, the reduced rear tyre pressures for extra ride comfort are not applicable.



WARNING: Vehicles fitted with tubeless alloy road wheels as original equipment, note that these wheels DO NOT accept inner tubes and tubed tyres MUST NOT be fitted.



ENGINE - 3.9 V8

Type	3.9 Litre V8
Firing order	1-8-4-3-6-5-7-2
Cylinder Numbers	
Left bank	1-3-5-7
Right bank	2-4-6-8
No 1 Cylinder location	Pulley end of left bank
Timing marks	On crankshaft vibration damper
Spark plugs	
Make/type(8.13:1 Compression)	Champion RN11YCC
Gap	0.84-0.96mm (0.033-0.038 in)
Make/type(9.35:1 Compression)	Champion RN11YCC
Gap	0.84-0.96mm (0.033-0.038 in)
Coil	
Make/type	Bosch 0-221-122-392, (ETC 6574)
Compression ratio	8.13:1 or 9.35:1
Fuel injection system	Lucas 14 CUX Hot-wire air flow sensor system electronically controlled

Valve Timing	Inlet	Exhaust
Opens	32°BTDC	70°BBDC
Closes	73°ABDC	35°ATDC
Duration	285°	285°
Valve peak	104°ATDC	114°BTDC

Idle speed - controlled by EFi system

- all loads off in neutral	665 to 735 rev/min
- auto gearbox in gear, air con operating	650 ± 28 rev/min
- auto gearbox in gear, air con off	600 ± 28 rev/min
- manual gearbox	700 ± 28 rev/min
- manual gearbox, air con operating	750 ± 28 rev/min

Base idle speed 525 ± 25 rev/min -
See FUEL SYSTEM, Fault diagnosis, Base Idle Speed Setting

Ignition Timing - dynamic at 800 rev/min max, vacuum disconnected

8.13:1 compression, non catalyst	2°BTDC ± 1°
9.35:1 compression, non catalyst	4°BTDC ± 1°
9.35:1 compression, catalyst	5°BTDC ± 1°

Exhaust gas

CO content at idle

0.5 to 1.0% max.

Distributor

Make/type	Lucas 35DLM8 electronic
Rotation	Clockwise
Air gap	0.20-0.35mm

Part number

	Lucas	Rover
8.13:1, non catalyst	42584A	ERR 4753
9.35:1, non catalyst	42552A	ERR 4754
9.35:1, catalyst	42583A	ERR 4755

Centrifugal Advance

Decelerating check-vacuum hose disconnected
Distributor rpm decelerating speeds

8.13:1 non catalyst

2000	Distributor advance	5°30' to 8°30'
1400		6°18' to 8°30'
800		2° to 4°

9.35:1 non catalyst

2200	Distributor advance	7° to 10°
1400		7°48' to 10°
650		1° to 3°

9.35:1 catalyst

2200	Distributor advance	5°30' to 8°30'
1400		6°18' to 8°30'
800		2° to 4°

Fuel

8.13:1, non catalyst	91 RON minimum unleaded
9.35:1, non catalyst	95 RON minimum unleaded
9.35:1, catalyst	95 RON minimum unleaded
USA-Premium unleaded (PUG)	CLC or AKI 90 octane minimum 95 RON minimum

Australian market variations

Fuel	91 RON minimum unleaded
Compression ratio	8.13:1
Spark plug	Champion RN11YCC
Spark plug gap	0.84-0.96mm (0.033-0.038 in)
Ignition Timing at 800 rev/min max (vacuum pipe disconnected)	2° BTDC ± 1°
Exhaust gas idle CO	1% max (hot)



ENGINE - 4.2 V8

Type	4.2 Litre V8
Firing order	1-8-4-3-6-5-7-2
Cylinder Numbers	
Left bank	1-3-5-7
Right bank	2-4-6-8
No 1 Cylinder location	Pulley end of left bank
Timing marks	On crankshaft vibration damper
Spark plugs	
Make/type	Champion RN11YCC
Gap	0.84-0.96mm (0.033-0.038 in)
Coil	
Make/type	Bosch 0-221-122-392, (ETC 6574)
Compression ratio	8.94:1
Fuel injection system	Lucas 14 CUX Hot-wire air flow sensor system electronically controlled

Valve Timing	Inlet	Exhaust
Opens	28°BTDC	72°BBDC
Closes	64°ABDC	20°ATDC
Duration	272°	272°
Valve peak	108°ATDC	116°BTDC

Idle speed - controlled by EFi system

- all loads off in neutral	665 to 735 rev/min
-auto gearbox in gear, air con operating	650 ± 28 rev/min
-auto gearbox in gear, air con off	600 ± 28 rev/min
-manual gearbox	700 ± 28 rev/min
-manual gearbox, air con operating	750 ± 28 rev/min

Base idle speed 525 ± 25 rev/min -.
See FUEL SYSTEM, Fault diagnosis, Base Idle Speed Setting

Ignition Timing

Dynamic, vacuum disconnected 8°BTDC ± 1°at 800 rev/min max

Exhaust gas

CO content at idle 0.5 to 1.0% max.

Distributor

Make/type Lucas 35DLM8 electronic
Rotation Clockwise
Air gap 0.20-0.35mm
Lucas 42510A
Rover Part number ERR 0744

Centrifugal Advance

Decelerating check-vacuum hose disconnected

Distributor rpm decelerating speeds
2200 7° to 10°
1400 7°48' to 10°
800 1° to 3°

Fuel

UK, Europe and Rest of World 95 RON minimum unleaded
USA - Premium unleaded (PUG) CLC or AKI 90 octane minimum
95 RON minimum



ENGINE - 300Tdi

ENGINE

Type 2.5 Litre Turbo diesel with intercooler
Firing order 1-3-4-2
Injection timing 1,54 mm lift at T.D.C.
 - with electronic EGR 1,40 mm lift at T.D.C.

Timing marks:

Valve timing - manual Slot for pin in flywheel and TDC mark on front pulley
 Valve timing - automatic Slot for pin in ring gear, access through rear engine plate. TDC mark on front pulley

Injection timing Dial gauge inserted into pump
Tappet clearances - inlet and exhaust 0,20 mm cold

Valve timing:

	Inlet	Exhaust
- Opens	16°B.T.D.C.	51°BBDC
- Closes	42°ABDC	13°ATDC
- Peak	103°ATDC	109°BTDC
- Lift	9,67 mm	9.97 mm

Maximum governed speeds:

- Full load (speed cut-off starts) 4000 rev/min
 - No load (flight speed) 4600 + 40 - 120 rev/min
 - Idle speed 720 ± 20 rev/min
 - Die-down time 4 seconds

INJECTION PUMP**Make/type:**

- Standard Bosch rotary R509 type with boost control and two speed mechanical governor with auto advance and solenoid electrical shut-off. Tamper proof sealing on flight speed and fuel adjustment screws. Constant volume delivery valves.
 - with Electronic EGR Bosch rotary R509/1 type with boost control and two speed mechanical governor with auto advance and solenoid electrical shut-off. Tamper proof sealing on flight speed and fuel adjustment screws. Constant volume delivery valves. GST start up excess fuel control. Throttle position sensor for EGR.

Direction of rotation Clockwise, viewed from drive end
Advance box (two stage) 7°advance with 3°start retard

Back leakage rate 150-100 Atmospheres:

- New nozzle 7 seconds
 - Original nozzle 5 seconds

INJECTORS**Make/type**

- Standard and Electronic EGR	Bosch KBAL 90 P37
Nozzle type	DSL A 145P366
Opening pressure (working pressure)	Initial pressure 200 atmospheres
Secondary 280 atmospheres	
- EDC feedback injector 1 in each engine	Bosch KBAL 90 P38
Nozzle type	DSL A 145P365
Opening pressure (working pressure)	Initial pressure 200 atmospheres
Secondary 300 atmospheres	
- EDC standard injector 3 in each engine	Bosch KBAL 90 P36
Nozzle type	DSL A 145P365
Opening pressure (working pressure)	Initial pressure 200 atmospheres
Secondary 300 atmospheres	

GLOW PLUGS

Make/type	Probe type, No.0100226129A Beru 12 volts
Time to reach operating temperature of 850°C	8 seconds

TURBOCHARGER

Make/type	Allied signal
Maximum boost pressure	0.8-1.0 bar (12-15lbf/in ²) measured at wastegate actuator 'T' piece



GENERAL FITTING REMINDERS

WORKSHOP SAFETY IS YOUR RESPONSIBILITY!

The suggestions, cautions and warnings in the section are intended to serve as reminders for trained and experienced mechanics. This manual is not a course in automotive mechanics or workshop safety.

Shop equipment, shop environment, and the use and disposal of solvents, fluids, and chemicals are subject to government regulations which are intended to provide a level of safety. It is your responsibility to know and comply with such regulations.

PRECAUTIONS AGAINST DAMAGE

1. Always fit covers to protect wings before commencing work in engine compartment.
2. Cover seats and carpets, wear clean overalls and wash hands or wear gloves before working inside vehicle.
3. Avoid spilling hydraulic fluid or battery acid on paint work. Wash off with water immediately if this occurs. Use Polythene sheets to protect carpets and seats.
4. Always use a recommended Service Tool, or a satisfactory equivalent, where specified.
5. Protect temporarily exposed screw threads by replacing nuts or fitting plastic caps.

SAFETY PRECAUTIONS

1. Whenever possible use a ramp or pit when working beneath vehicle, in preference to jacking. Chock wheels as well as applying parking brake.



WARNING: Do not use a pit when removing fuel system components.

2. Never rely on a jack alone to support vehicle. Use axle stands carefully placed at jacking points to provide rigid support.
3. Ensure that a suitable form of fire extinguisher is conveniently located.
4. Check that any lifting equipment used has adequate capacity and is fully serviceable.
5. Disconnect negative (grounded) terminal of vehicle battery.



WARNING: Do not disconnect any pipes in air conditioning refrigeration system, unless trained and instructed to do so. A refrigerant is used which can cause blindness if allowed to contact eyes.

6. Ensure that adequate ventilation is provided when volatile degreasing agents are being used.
7. Do not apply heat in an attempt to free stiff nuts or fittings; as well as causing damage to protective coatings, there is a risk of damage to electronic equipment and brake linings from stray heat.

PREPARATION

1. Before removing a component, clean it and its surrounding areas as thoroughly as possible.
2. Blank off any openings exposed by component removal, using greaseproof paper and masking tape.
3. Immediately seal fuel, oil or hydraulic lines when separated, using plastic caps or plugs, to prevent loss of fluid and entry of dirt.
4. Close open ends of oilways, exposed by component removal, with tapered hardwood plugs or readily visible plastic plugs.
5. Immediately a component is removed, place it in a suitable container; use a separate container for each component and its associated parts.
6. Before dismantling a component, clean it thoroughly with a recommended cleaning agent; check that agent is suitable for all materials of component.
7. Clean bench and provide marking materials, labels, containers and locking wire before dismantling a component.

INSPECTION-GENERAL

1. Never inspect a component for wear or dimensional check unless it is absolutely clean; a slight smear of grease can conceal an incipient failure.
2. When a component is to be checked dimensionally against figures quoted for it, use correct equipment (surface plates, micrometers, dial gauges, etc.) in serviceable condition. Makeshift checking equipment can be dangerous.
3. Reject a component if its dimensions are outside limits quoted, or if damage is apparent. A part may, however, be refitted if its critical dimension is exactly limit size, and is otherwise satisfactory.
4. Use 'Plastigauge' 12 Type PG-1 for checking bearing surface clearances. Directions for its use, and a scale giving bearing clearances in 0,0025 mm steps are provided with it.

DISMANTLING

1. Observe scrupulous cleanliness when dismantling components, particularly when brake, fuel or hydraulic system parts are being worked on. A particle of dirt or a cloth fragment could cause a dangerous malfunction if trapped in these systems.
2. Blow out all tapped holes, crevices, oilways and fluid passages with an air line. Ensure that any O-rings used for sealing are correctly replaced or renewed, if disturbed.
3. Use marking ink to identify mating parts, to ensure correct reassembly. If a centre punch or scribe is used they may initiate cracks or distortion of components.
4. Wire together mating parts where necessary to prevent accidental interchange (e.g. roller bearing components).
5. Wire labels on to all parts which are to be renewed, and to parts requiring further inspection before being passed for reassembly; place these parts in separate containers from those containing parts for rebuild.
6. Do not discard a part due for renewal until after comparing it with a new part, to ensure that its correct replacement has been obtained.

BALL AND ROLLER BEARINGS



CAUTION: Never refit a ball or roller bearing without first ensuring that it is in a fully serviceable condition.

1. Remove all traces of lubricant from bearing under inspection by washing in a suitable degreaser; maintain absolute cleanliness throughout operations.
2. Inspect visually for markings of any form on rolling elements, raceways, outer surface of outer rings or inner surface of inner rings. Reject any bearings found to be marked, since any marking in these areas indicates onset of wear.
3. Holding inner race between finger and thumb of one hand, spin outer race and check that it revolves absolutely smoothly. Repeat, holding outer race and spinning inner race.
4. Rotate outer ring gently with a reciprocating motion, while holding inner ring; feel for any check or obstruction to rotation, and reject bearing if action is not perfectly smooth.
5. Lubricate bearing generously with lubricant appropriate to installation.
6. Inspect shaft and bearing housing for discoloration or other marking suggesting that movement has taken place between bearing and seatings. (This is particularly to be expected if related markings were found in operation 2).
7. Ensure that shaft and housing are clean and free from burrs before fitting bearing.

8. If one bearing assembly of a pair shows an imperfection it is generally advisable to replace both with new bearings; an exception could be made if the faulty bearing had covered a low mileage, and it could be established that damage was confined to it only.
9. When fitting bearing to shaft, apply force only to inner ring of bearing, and only to outer ring when fitting into housing. (Refer to ST1042M).

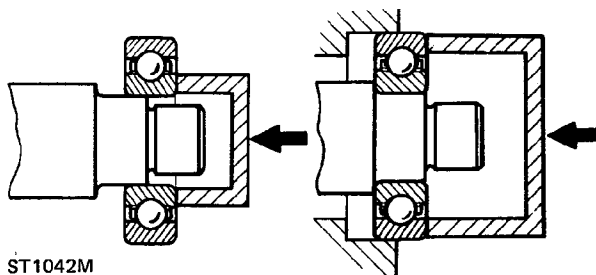

ST1042M

10. In the case of grease lubricated bearings (e.g. hub bearings) fill space between bearing and outer seal with recommended grade of grease before fitting seal.
11. Always mark components of separable bearings (e.g. taper roller bearings) in dismantling, to ensure correct reassembly. Never fit new rollers in a used outer ring, always fit a complete new bearing assembly.

OIL SEALS



NOTE: Ensure that the seal running track is free from pits, scores, corrosion and general damage prior to fitting replacement seal.

1. Always fit new oil seals when rebuilding an assembly.
2. Carefully examine seal before fitting to ensure that it is clean and undamaged.
3. Coat the sealing lips with clean grease; pack dust excluder seals with grease, and heavily grease duplex seals in cavity between sealing lips.
4. Ensure that seal spring, if provided, is correctly fitted.
5. Place lip of seal towards fluid to be sealed and slide into position on shaft, using fitting sleeve when possible to protect sealing lip from damage by sharp corners, threads or splines. If fitting sleeve is not available, use plastic tube or tape to prevent damage to sealing lip.

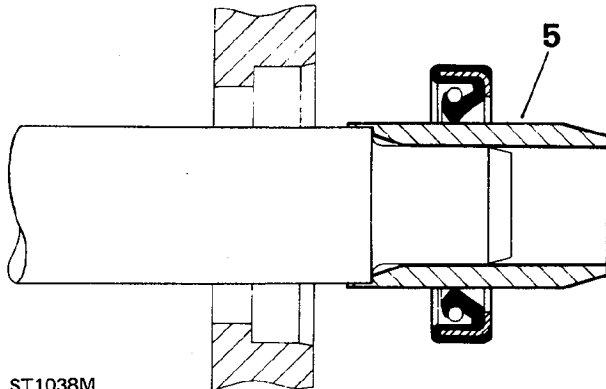

6. Grease outside diameter of seal, place square to housing recess and press into position, using great care and if possible a 'bell piece' to ensure that seal is not tilted. (In some cases it may be preferable to fit seal to housing before fitting to shaft). Never let weight of unsupported shaft rest in seal.

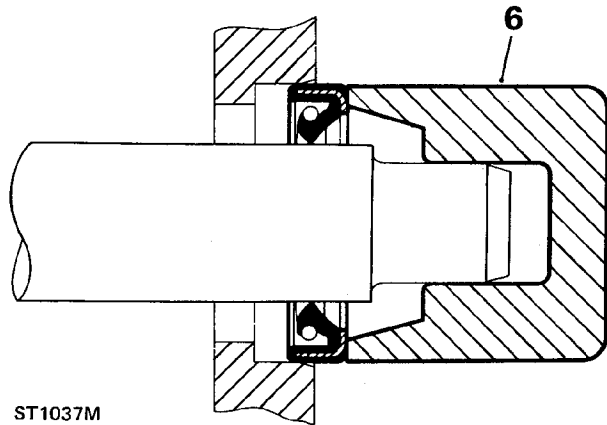

7. If correct service tool is not available, use a suitable drift approximately 0.4mm (0.015 in) smaller than outside diameter of seal. Use a hammer **VERY GENTLY** on drift if a press is not suitable.
8. Press or drift seal in to depth of housing if housing is shouldered, or flush with face of housing where no shoulder is provided. Ensure that the seal does not enter the housing in a tilted position.



NOTE: Most cases of failure or leakage of oil seals are due to careless fitting, and resulting damage to both seals and sealing surfaces. Care in fitting is essential if good results are to be obtained. **NEVER** use a seal which has been improperly stored or handled, such as hung on a hook or nail.



JOINTS AND JOINT FACES

1. Always use correct gaskets where they are specified.
2. Use jointing compound only when recommended. Otherwise fit joints dry.
3. When jointing compound is used, apply in a thin uniform film to metal surfaces; take great care to prevent it from entering oilways, pipes or blind tapped holes.
4. Remove all traces of old jointing materials prior to reassembly. Do not use a tool which could damage joint faces.
5. Inspect joint faces for scratches or burrs and remove with a fine file or oil stone; do not allow removed material or dirt to enter tapped holes or enclosed parts.
6. Blow out any pipes, channels or crevices with compressed air, fit new 'O' rings or seals displaced by air blast.

FLEXIBLE HYDRAULIC PIPES, HOSES

1. Before removing any brake or power steering hose, clean end fittings and area surrounding them as thoroughly as possible.
2. Obtain appropriate plugs or caps before detaching hose end fittings, so that ports can be immediately covered to exclude dirt.
3. Clean hose externally and blow through with airline. Examine carefully for cracks, separation of plies, security of end fittings and external damage. Reject any hose found faulty.
4. When refitting hose, ensure that no unnecessary bends are introduced, and that hose is not twisted before or during tightening of union nuts.
5. Containers for hydraulic fluid must be kept absolutely clean.
6. Do not store brake fluid in an unsealed container. It will absorb water, and fluid in this condition would be dangerous to use due to a lowering of its boiling point.
7. Do not allow brake fluid to be contaminated with mineral oil, or use a container which has previously contained mineral oil.
8. Do not re-use brake fluid bled from system.
9. Always use clean brake fluid to clean hydraulic components.
10. Fit a cap to seal a hydraulic union and a plug to its socket after removal to prevent ingress of dirt.
11. Absolute cleanliness must be observed with hydraulic components at all times.
12. After any work on hydraulic systems, inspect carefully for leaks underneath the vehicle while a second operator applies maximum pressure to the brakes (engine running) and operates the steering.

FUEL SYSTEM HOSES



CAUTION: All fuel hoses are made up of two laminations, an armoured rubber outer sleeve and an inner viton core. If any of the fuel system hoses have been disconnected, it is imperative that the internal bore is inspected to ensure that the viton lining has not become separated from the armoured outer sleeve. A new hose must be fitted if separation is evident.

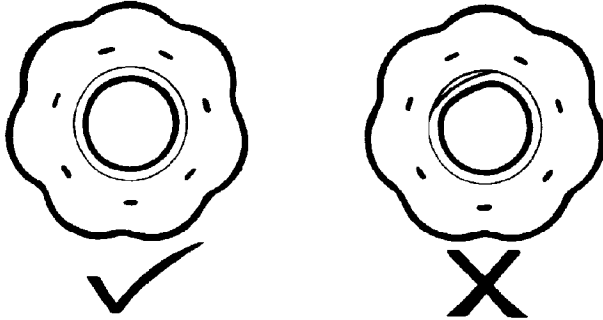

RR2302M

METRIC BOLT IDENTIFICATION

1. An ISO metric bolt or screw, made of steel and larger than 6 mm in diameter can be identified by either of the symbols ISO M or M embossed or indented on top of the head.
2. In addition to marks to identify the manufacture, the head is also marked with symbols to indicate the strength grade, e.g. 8.8, 12.9 or 14.9, where the first figure gives the minimum tensile strength of the bolt material in tens of kgf/mm².
3. Zinc plated ISO metric bolts and nuts are chromate passivated, a gold-bronze colour.

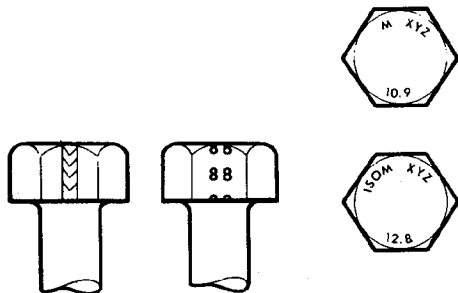

ST1035M

METRIC NUT IDENTIFICATION

1. A nut with an ISO metric thread is marked on one face or on one of the flats of the hexagon with the strength grade symbol 8, 12 or 14. Some nuts with a strength 4, 5 or 6 are also marked and some have the metric symbol M on the flat opposite the strength grade marking.
2. A clock face system is used as an alternative method of indicating the strength grade. The external chamfers or a face of the nut is marked in a position relative to the appropriate hour mark on a clock face to indicate the strength grade.
3. A dot is used to locate the 12 o'clock position and a dash to indicate the strength grade. If the grade is above 12, two dots identify the 12 o'clock position.

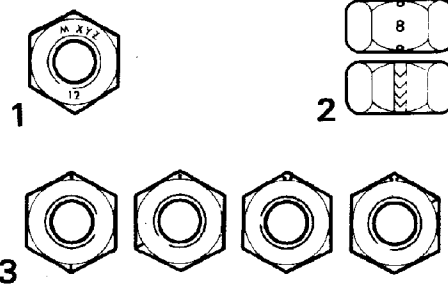

ST1036M

KEYS AND KEYWAYS

1. Remove burrs from edges of keyways with a fine file and clean thoroughly before attempting to refit key.
2. Clean and inspect key closely; keys are suitable for refitting only if indistinguishable from new, as any indentation may indicate the onset of wear.

TAB WASHERS

1. Fit new washers in all places where they are used. Always fit a new tab washer.
2. Ensure that the new tab washer is of the same design as that replaced.

SPLIT PINS

1. Fit new split pins throughout when replacing any unit.
2. Always fit split pins where cotter pins were originally used. Do not substitute spring washers: there is always a good reason for the use of a split pin.
3. All split pins should be fitted as shown unless otherwise stated.

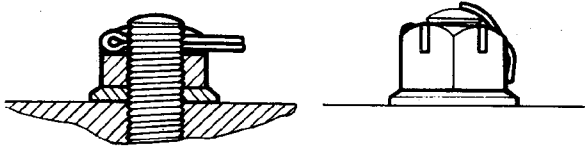

ST1030M

SCREW THREADS

1. Both UNF and Metric threads to ISO standards are used. See below for thread identification.
2. Damaged threads must always be discarded. Cleaning up threads with a die or tap impairs the strength and closeness of fit of the threads and is not recommended.
3. Always ensure that replacement bolts are at least equal in strength to those replaced.
4. Do not allow oil, grease or jointing compound to enter blind threaded holes. The hydraulic action on screwing in the bolt or stud could split the housing.
5. Always tighten a nut or bolt to the recommended torque value. Damaged or corroded threads can affect the torque reading.
6. To check or re-tighten a bolt or screw to a specified torque value first loosen a quarter of a turn, then re-tighten to the correct value.
7. Oil thread lightly before tightening to ensure a free running thread, except in the case of threads treated with sealant/lubricant, and self-locking nuts.

NUTS

1. When tightening a slotted or castellated nut never loosen it back to insert split pin or locking wire except in those recommended cases where this forms part of an adjustment. If difficulty is experienced, alternative washers or nuts should be selected, or washer thickness reduced.
2. Where self-locking nuts have been removed it is advisable to replace them with new ones of the same type.



NOTE: Where bearing pre-load is involved nuts should be tightened in accordance with special instructions.

LOCKING WIRE

1. Fit new locking wire of the correct type for all assemblies incorporating it.
2. Arrange wire so that its tension tends to tighten the bolt heads, or nuts, to which it is fitted.

UNIFIED THREAD IDENTIFICATION

1. **Bolts**
A circular recess is stamped in the upper surface of the bolt head.
2. **Nuts**
A continuous line of circles is indented on one of the flats of the hexagon, parallel to the axis of the nut.
3. **Studs, Brake Rods, etc.**
The component is reduced to the core diameter for a short length at its extremity.

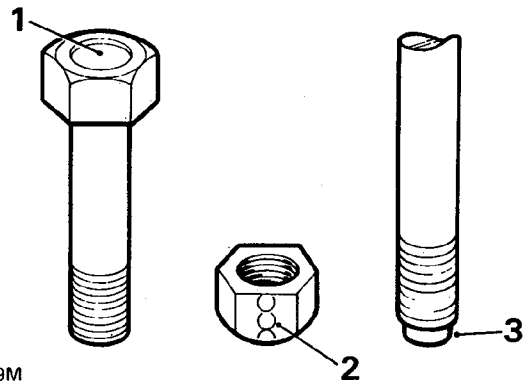

ST1039M



**RECOMMENDED LUBRICANTS AND FLUIDS -
USA VEHICLES**

COMPONENT	SPECIFICATION	VISCOSITY	AMBIENT TEMPERATURE °C									
			-30	-20	-10	0	10	20	30	40	50	
Engine V8i	Use oils to API service level SG or SH or RES.22.OL.G4 or CCMC-G4	5W/20)	██████████									
		5W/30) 5W/40)	████████████████████									
		10W/30	██████████									
		10W/40) 10W/50)	████████████████████									
		15W/40) 15W/50)	████████████████████									
		20W/40) 20W/50)	████████████████████									
Automatic gearbox	ATF Dexron IID		████████████████████									
Final drive units Swivel pin housings	API or GL5 MIL - L - 2105 or MIL - L - 2105B, C or D	90 EP	██████████									
		80W EP	████████████████████									
Power steering	ATF Dexron IID		████████████████████									
Borg Warner transfer gearbox	ATF Dexron IID		████████████████████									
Brake reservoir	Brake fluid must have a minimum boiling point of 260°C (500°F) and comply with FMVSS/116/DOT 4		████████████████████									
Lubrication nipples (hubs, ball joints, etc.)	NLGI-2 multipurpose lithium based grease		████████████████████									

See table on page 3 for remaining vehicle components



Propeller shaft Front and Rear Lubrication nipples (hubs, ball joints etc.) Seat slides Door lock striker	NLGI - 2 Multi-purpose Lithium based GREASE
Brake and clutch reservoirs	Brake fluids having a minimum boiling point of 260°C (500 °F) and complying with FMVSS 116 DOT4
Engine cooling system	Use an ethylene glycol based anti-freeze (containing no methanol) with non-phosphate corrosion inhibitors suitable for use in aluminium engines to ensure the protection of the cooling system against frost and corrosion in all seasons.
Battery lugs, Earthing surfaces where paint has been removed	Petroleum jelly. NOTE: Do not use Silicone Grease
Air Conditioning System Refrigerant	Refrigerant R134a CAUTION: DO NOT use any other type of refrigerant.
Compressor Oil	Nippon denso ND-OIL8 UNIPART R134a ND-OIL8
ABS Sensor bush-rear	Silicone grease: Staborags NBU - Wabco 830 502,0634 Wacker chemie 704 - Wabco 830 502,0164 Kluber GL301

LUBRICATION PRACTICE

Use a high quality oil of the correct viscosity range and service classification in the engine during maintenance and when topping up. The use of oil not to the correct specification can lead to high oil and fuel consumption and ultimately to damaged components.

Oil to the correct specification contains additives which disperse the corrosive acids formed by combustion and prevent the formation of sludge which can block the oilways. Additional oil additives should not be used. Always adhere to the recommended servicing intervals.



WARNING: Many liquids and other substances used in motor vehicles are poisonous. They must not be consumed and must be kept away from open wounds. These substances, among others, include anti-freeze windscreen washer additives, lubricants and various adhesives.

CAPACITIES

The following capacity figures are approximate and provided as a guide only. Refer to Section 10 for correct checking procedure for oil levels.

Capacities (approx.)*	Litres	Imp Unit	US unit
Engine sump and filter from dry			
- petrol	6.6	11.60 pints	14.0 pints
- diesel - Tdi	7.0	12.30 pints	14.8 pints
Manual gearbox - R380	2.7	4.70 pints	5.7 pints
Automatic gearbox	9.1	16.00 pints	20 pints
Transfer gearbox from dry	1.7	3.00 pints	3.6 pints
Front axle from dry	1.7	3.00 pints	3.6 pints
Front axle swivel pin housing (each)	0.35	0.60 pints	0.7 pints
Rear axle from dry	1.7	3.00 pints	3.6 pints
Power steering box and reservoir	2.9	5.00 pints	6.0 pints
Cooling system	11.4	20.00 pints	24 pints
Fuel tank	89	19.5 gallons	23 gallons



NOTE: * All levels must be checked by dipstick or level plugs as applicable.

When draining oil from the ZF automatic gearbox, oil will remain in the torque converter, refill to high level on dipstick only.

ANTI-FREEZE

ENGINE TYPE	MIXTURE STRENGTH	PERCENTAGE CONCENTRATION	PROTECTION LOWER TEMPERATURE LIMIT
V8 Engine Diesel Engine	One part anti-freeze One part water	50%	
Complete protection Vehicle may be driven away immediately from cold			- 33°F - 36°C
Safe limit protection Coolant in mushy state. Engine may be started and driven away after warm-up period			- 41°C - 42°F
Lower protection Prevents frost damage to cylinder head, block and radiator. Thaw out before starting engine			- 47°C - 53°F



CAUTION: Anti-freeze content must never be allowed to fall below 25% otherwise damage to the engine is liable to occur. Also, anti-freeze content should not exceed 60% as this will greatly reduce the cooling effect of the coolant.



FUEL REQUIREMENTS

Catalyst vehicles

Vehicles equipped with catalytic converter are designed to use **ONLY** unleaded fuel. Unleaded fuel must be used for the emission control system to operate properly. Its use will also reduce spark plug fouling, exhaust system corrosion and engine oil deterioration.

Using fuel that contains lead will result in damage to the emission control system and could result in loss of warranty coverage. The effectiveness of the catalysts in the catalytic converters will be seriously impaired if leaded fuel is used. The vehicle is equipped with an electronic fuel injection system, which includes two oxygen sensors. Leaded fuel will damage the sensors, and will deteriorate the emission control system.

Regulations require that pumps delivering unleaded fuel be labelled **UNLEADED**. Only these pumps have nozzles which fit the filler neck of the vehicle fuel tank.

RECOMMENDED FUEL

Petrol engines

- with catalytic converter unleaded only, 95 RON (USA 90 CLC or AKI)
- non catalytic, 9.35:1 compression ratio leaded 97 RON/unleaded 95 RON
- non catalytic, 8.13:1 compression ratio leaded 90 RON/unleaded 95 RON
- Australia minimum 91 RON unleaded

Diesel engines

- 300Tdi Diesel fuel oil, distillate, diesel fuel, automotive gas or Derv to British standard 2869, (1983) class A1 or A2.

Using fuel with an octane rating lower than stated above could seriously impair vehicle performance.



CAUTION: Do not use oxygenated fuels such as blends of methanol/gasoline or ethanol/gasoline (e.g. 'Gasohol'). Take care not to spill fuel during refuelling.



SERVICE SCHEDULE

This section gives information on the range of service procedures.

Where required, instructions are given for carrying out each service procedure, or a cross reference is given, where the procedure can be found in this manual.

Service Schedule sheets are published separately to reflect the maintenance needs and intervals for each vehicle variant and model year. Procedures given in this manual must be used in conjunction with the service schedule sheets.

The Service Schedule sheets are available in pads from:

Land Rover Merchandising
PO Box 534
Erdington
Birmingham B24 0QS.
England.

VEHICLE INTERIOR

CHECK SEATS & BELTS

Check condition and security of seats, seat belt mountings, seat belts, buckles and operation of inertia seat belts. Lubricate seat tilt pivots.

CHECK OPERATION OF FOOT BRAKE AND CLUTCH

If pedal feels 'spongy' bleed system. ***See BRAKES, Repair, Brake System Bleed (ABS)*** or ***See BRAKES, Repair, Brake System Bleed (non ABS)*** or ***See CLUTCH, Repair, Bleed Hydraulic System***
Check all hoses and pipes for security, fractures and leaks. Fit new hoses and pipes as necessary.

CHECK OPERATION OF LAMPS

Check operation of all lamps, horns and warning indicators.

CHECK OPERATION OF WIPERS

Check operation of front/rear screen wipers and washers and condition of wiper blades.

CHECK AIR BAG MODULE COVERS

Check visually for signs of damage.

RENEW AIR BAG MODULE

Every ten years

CHECK SECURITY AND OPERATION OF PARK BRAKE

Parking brake adjust

1. Select a gear or 'P' in main gearbox.
2. Chock road wheels.
3. Release parkbrake lever.
4. Remove switch panel from centre console.

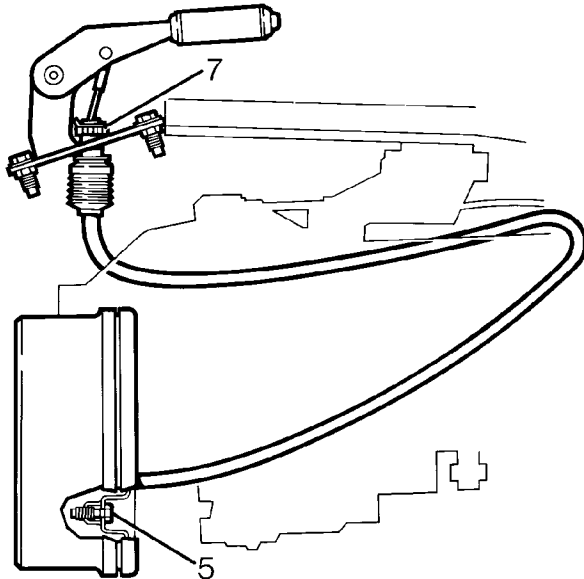

J5960

5. Underneath vehicle, rotate brake adjuster clockwise until brake shoes are fully expanded against drum.
6. Back off adjuster until drum is free to rotate.
7. Rotate adjustment thumbwheel below parkbrake lever until parking brake is fully operational on third notch of ratchet.

NOTE: Cable adjustment must **ONLY** be used for initial setting and to compensate for cable stretch. It **MUST NOT** be used to take up brake shoe wear, which **MUST** be adjusted at brake drum.

8. Operate parking brake to settle shoes. Recheck parkbrake is fully operational on third notch of ratchet. Readjust if necessary.
9. Refit switch panel.



VEHICLE EXTERIOR

CHECK/ADJUST HEADLAMP ALIGNMENT

Check/adjust headlamp and auxiliary alignment.

CHECK HEADLAMP LEVELLING SYSTEM

Check system for correct operation.

CHECK FRONT WHEEL ALIGNMENT

Use recognised wheel alignment equipment to perform this check and adjustment. **See STEERING, Adjustment, Front Wheel Alignment**

REMOVE WHEELS, CHECK TYRES

Check tyres (including spare) for compliance with manufacturers' specification.

Check visually for cuts, lumps, bulges, uneven tread wear and tread depth. Check road wheels for damage.

Check/adjust tyre pressures.

INSPECT BRAKE PADS FOR WEAR, CALIPERS FOR LEAKS AND CONDITION

Check thickness of brake pads, fit new pads if minimum thickness is less than 3,0mm. Check brake pads for oil contamination. If new brake pads required. **See BRAKES, Repair, Front Brake Pads** or **See BRAKES, Repair, Rear Brake Pads**



WARNING: When renewing brake pads, it is essential that only genuine components with correct grade of lining are used.

Always fit new pads as complete axle sets, NEVER individually or as a single wheel set. Serious consequences could result from out of balance braking due to mixing of linings.

Refit road wheels

Fit road wheels in original hub position. Secure in position with wheel nuts, do not fully tighten wheel nuts at this stage, lower vehicle and finally tighten wheel nuts to correct torque.

Alloy wheels: **130 Nm.**

Steel wheels: **130 Nm.**

CHECK SECURITY OF SPARE WHEEL

CHECK OPERATION OF DOORS, BONNET [HOOD] AND TAILGATE LOCKS

LUBRICATE ALL HINGES, DOOR CHECK MECHANISMS, BONNET [HOOD] CATCHES AND FUEL FILLER FLAP

UNDER BONNET [HOOD] MAINTENANCE**CHECK COOLING/HEATER SYSTEMS**

Check cooling/heater systems for leaks and hoses for security and condition.

Cooling system hoses should be changed at first signs of deterioration.

CHECK BRAKE SERVO HOSE FOR SECURITY AND CONDITION**CHECK FUEL EVAPORATIVE LOSS CONTROL SYSTEM FOR LEAKS - V8****CHECK FUEL FILLER CAP SEAL FOR LEAKS****CHECK CONDITION OF HEATER PLUG WIRING FOR FRAYING, CHAFING AND DETERIORATION - Tdi****CHECK IGNITION WIRING**

Check ignition wiring and high tension leads for fraying, chafing and deterioration.

CLEAN DISTRIBUTOR CAP - V8

The electronic ignition employs a Lucas 35DLM8 distributor.

Internal operating parts of distributor are pre-set at factory and do not normally require resetting. Adjustments should only be made if unit is known to be faulty or damaged. Distributor maintenance consists of following items.

1. Clean outer surfaces of distributor cap to remove dirt, grease etc.
2. Unclip cap, check cap for cracks.
3. Wipe inside cap with lint free cloth.
4. Check rotor arm, cap and flash shield tracking.

DO NOT DISTURB clear plastic insulating cover (flash shield) which protects magnetic pick-up module.

LUBRICATE DISTRIBUTOR ROTOR SPINDLE - V8

Apply a spot of clean engine oil into rotor spindle after rotor arm has been removed.

CLEAN/ADJUST SPARK PLUGS - V8**RENEW SPARK PLUGS - V8**



Clean, adjust and renew

1. Take great care when fitting spark plugs not to cross-thread plug, otherwise costly damage to cylinder head will result.
2. Clean or replace spark plugs as applicable.
3. It is essential that correct type of spark plugs are fitted.
4. Incorrect grade of plugs may lead to piston overheating and engine failure.

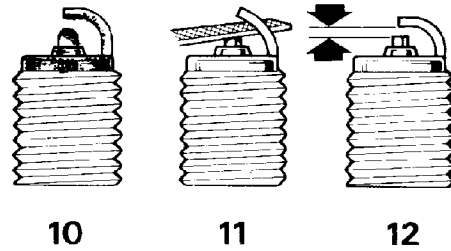

RR740M

Remove

5. Disconnect battery negative lead. Remove H.T. leads from spark plugs.
6. Remove plugs and washers.

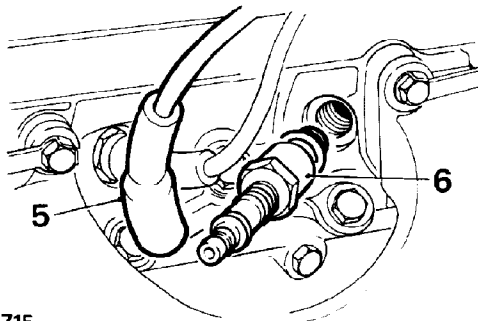

RR2171E

13. Test plugs in accordance with plug cleaning machine manufacturers' recommendations.
14. Satisfactory plugs can be refitted.
15. When pushing leads onto plugs, ensure that shrouds are firmly seated.

Fitting H.T. leads

16. Ensure replacement H.T. leads are correctly refitted as illustrated. Failure to observe this instruction may result in cross-firing between two closely fitted leads which are consecutive in firing order.

Clean spark plugs

7. Fit plug into 14 mm adaptor of approved spark plug cleaning equipment. Wobble plug in adaptor with circular motion for three or four seconds only with abrasive blast in operation. Important: Excessive abrasive blasting will lead to severe erosion of insulator nose. Continue to wobble plug in adaptor with air only, blasting plug for a minimum of 30 seconds: this will remove abrasive grit from plug cavity.
8. Wire-brush plug threads; open gap slightly, and vigorously file electrode sparking surfaces using a point file. This operation is important to ensure correct plug operation by squaring electrode sparking surfaces.
9. Set electrode gap to recommended clearance.
10. Shows dirty plug.
11. Filing plug electrodes.
12. Clean plug, set to correct gap.

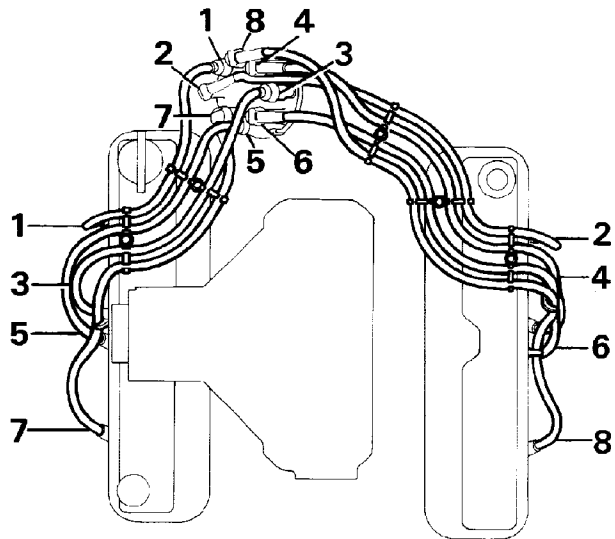

RR1876E

CHECK/ADJUST VALVE CLEARANCES. - Tdi

Valve adjustment. *See GENERAL SPECIFICATION DATA, Information, Engine - 300Tdi*

RENEW FUEL FILTER ELEMENT - Tdi

Drain off water and sediment



CAUTION: It is essential that any water and sediment in fuel filter is drained off, as water in fuel can result in damage to injection pump.

1. Hold a small receptacle beneath drain cock. Unscrew the drain cock half a turn.
2. Drain off water and sediment.
3. Tighten the drain cock immediately fuel starts to flow from drain cock.



NOTE: Any delay in tightening drain cock when fuel starts to flow could possibly mean bleeding fuel system.

Renew fuel filter element

1. Clean area around filter, place a container beneath.
2. Unscrew filter, a quantity of fuel will be released, and discard filter.

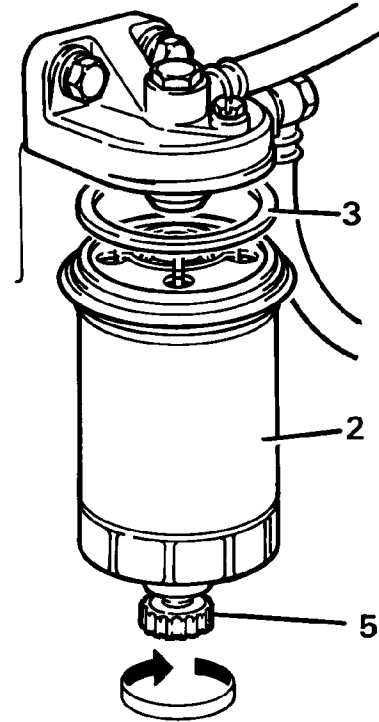

3. Wet seal of new filter with fuel.
4. Screw new filter into position.
5. Ensure that drain cock is secure.

CHECK POSITIVE CRANKCASE VENTILATION (PCV) SYSTEM FOR LEAKS AND HOSES FOR SECURITY AND CONDITION - V8

RENEW AIR CLEANER ELEMENT - V8 CATALYST - Tdi - V8 NON CATALYST

To renew air cleaner element
See FUEL SYSTEM, Repair, Air Cleaner



CLEAN ENGINE BREATHER FILTER - V8

1. Release hose clamp and pull hose off canister.
2. Unscrew canister and remove it from rocker cover.
3. Remove large 'O' ring from threaded end of canister.
4. Visually inspect condition of wire screen within canister, if in poor condition fit new assembly, if in acceptable condition clean screen as follows:
5. Immerse canister in small amount of solvent and allow solvent to dissolve and loosen any debris.
6. Remove canister from solvent and dry in still air.

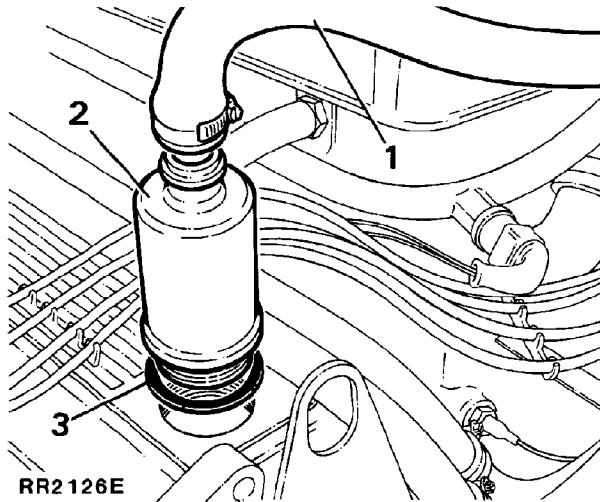

RR2126E

WARNING: Do not use compressed air line to remove remaining solvent or debris in canister, this could cause fire or personal injury.

Refitting breather/filter

1. Fit new rubber 'O' ring.
2. Screw canister into rocker cover, hand tight only.
3. Refit hose, tighten clamp securely.

CLEAN PLENUM CHAMBER VENTILATION PASSAGEWAY - V8

Cleaning plenum chamber ventilation passageway can be carried out without removing plenum chamber from ram housing.



CAUTION: Care must be taken to prevent debris from passageway passing beyond throttle butterfly disc.



WARNING: Safety glasses must be worn when performing this operation. Ensure that debris is not blown into atmosphere which could be harmful to other persons closeby.

1. Disconnect battery negative lead.
2. Release hose clamp and remove hose from plenum chamber inlet.
3. Remove crankcase ventilation hose from side of plenum chamber.
4. Insert a piece of lint free cloth down throttle butterfly bore to prevent debris passing throttle butterfly.
5. Place a cloth over tube protruding from side of plenum from which ventilation hose was removed to prevent debris from passageway being blown into atmosphere.

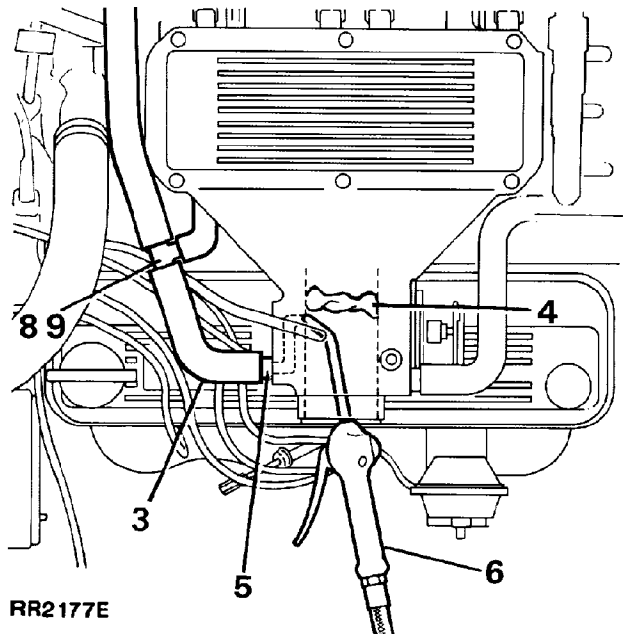

RR2177E

6. Use a compressed air line with a slim bent nozzle to enable passageway to be cleaned out from within throttle butterfly bore.
7. Any remaining matter can be dislodged using soft bent wire or pipe cleaner. Finally blow out passageway again to remove remaining debris.
8. Remove small 'T' piece between crankcase ventilation hoses and check it is free from blockages, clean as necessary.
9. Refit 'T' piece and hoses, tighten hose clamps securely.

CHECK CONDITION OF DRIVE BELT - V8 - Tdi

RENEW - V8 - Tdi

Renew V8 drive belt. *See ENGINE, Repair, Drive Belt - Renew*

Renew Tdi drive belt. *See ENGINE, Repair, Drive Belt - Renew*

RENEW CHARCOAL CANISTER - V8

Charcoal canister

Remove

1. Disconnect battery negative lead.
2. Pry out purge valve.
3. Disconnect pipe.
4. Loosen bolt.
5. Remove charcoal canister.

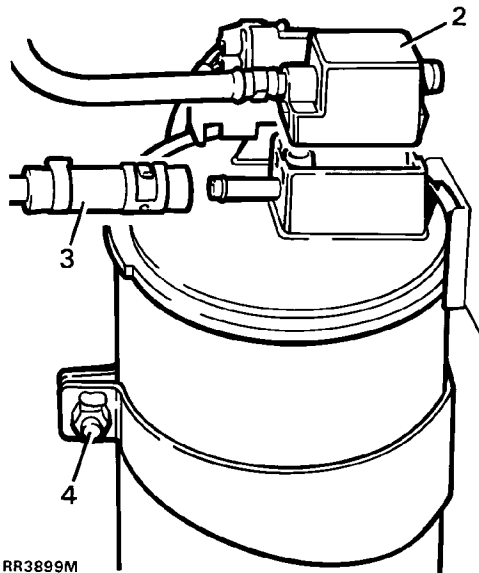

Refit

6. Reverse removal procedure.



CHECK THROTTLE AND AUTOMATIC TRANSMISSION CABLE OPERATION

CHECK/TOP UP AUTOMATIC TRANSMISSION FLUID LEVEL



NOTE: Transmission fluid level is checked when fluid is cold with engine idling in neutral.

1. Ensure vehicle is on level ground.
 2. Check fluid level registers between MAX and MIN marking on dipstick.
-

CHECK SECURITY OF JACK, BRACE AND CHOCKS

CHECK ENGINE EMISSION CONTROL SYSTEM V8

CHECK OPERATION OF ELECTRONIC CONTROL UNIT/SYSTEMS - V8

CHECK/TOP UP COOLING SYSTEM

1. To prevent corrosion of aluminium alloy engine parts it is imperative that cooling system is filled with a solution of water and phosphate free anti-freeze, winter or summer. Never fill or top up with plain water.



WARNING: Do not remove filler cap when engine is hot because cooling system is pressurised and personal scalding could result.

2. When removing filler cap, turn cap slowly anti-clockwise, pause and allow all pressure to escape.
3. Continue to turn until cap is removed.
4. When engine is cold expansion tank coolant should be level with top of indicator post, visible inside tank through filler hole.
5. If necessary, top up cooling system with premixed coolant. Use soft water whenever possible, if local water supply is hard, rainwater should be used.

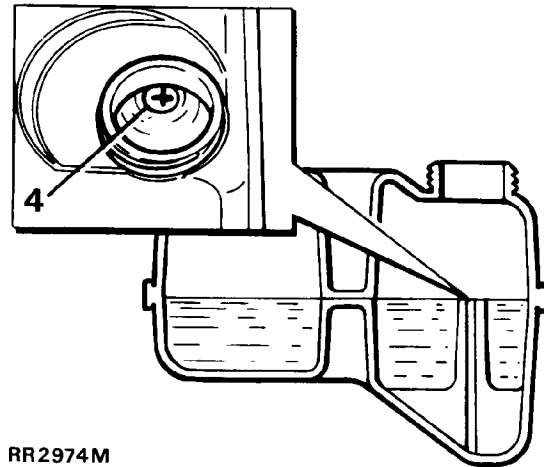

RR2974M

6. When replacing filler cap it is important that it is tightened down fully. Failure to tighten filler cap properly may result in water loss, with possible damage to engine.

The cooling system should be drained and flushed at 2 year intervals or at onset of second winter. Refer to Coolant Requirements. **See COOLING SYSTEM, Adjustment, Coolant Requirements**

**CHECK/TOP UP POWER STEERING FLUID
RESERVOIR**

1. Remove fluid reservoir cap. Check that fluid is up to high mark on dipstick.
-

**CHECK/ TOP UP CLUTCH AND BRAKE FLUID
RESERVOIRS**

CAUTION: Brake fluid can damage paintwork. If spillage occurs, wash affected area **IMMEDIATELY** with a large quantity of water.

CHECK/TOP UP WASHER RESERVOIR

Top up washer reservoir to within 25 mm of filler neck. Use a screen washer solvent/anti-freeze solution to assist removing mud, flies and road film and protect against freezing.

**LUBRICATE ACCELERATOR CONTROL
LINKAGES AND PEDAL PIVOT**

CHECK/ADJUST IGNITION TIMING - V8

Check ignition timing.

If 3.9. See **ENGINE TUNING DATA, Information, Engine - 3.9 V8**

If 4.2. See **ENGINE TUNING DATA, Information, Engine - 4.2 V8**



CHECK/ADJUST ENGINE IDLE SPEED - Tdi

For idle speed. **See ENGINE TUNING DATA, Information, Engine - 300Tdi**

CHECK/ADJUST STEERING BOX

Check steering box for fluid leaks.

Check that there is no backlash in steering box in straight ahead position. Adjust steering box if necessary. **See STEERING, Adjustment, Power Steering Box**

CLEAN BATTERY CONNECTIONS

Remove battery terminals, clean and coat with petroleum jelly.

A low maintenance battery is installed in vehicle. Dependent upon climate conditions electrolyte levels should be checked as follows:

Temperate climates, every three years.
Hot climates, every year.

RENEW CAMSHAFT DRIVE BELT - Tdi

Renew camshaft drive belt. **See ENGINE, Repair, Camshaft Drive Belt and Gears**

The engine timing gears are driven by a flexible rubber belt which must be renewed at intervals determined by the severity of operating conditions. In reasonable, temperate climate operation, renew the belt every 120,000 km (72,000 miles) or every six years whichever occurs earlier.

In adverse operating conditions such as work in dusty atmospheres, high ambient temperatures and desert and tropical zones, renew the belt every 60,000 km (36,000 miles) or every three years whichever occurs earlier.



CAUTION: If the drive belt is not renewed at the correct interval, it could fail, resulting in serious damage.

EXTERNALLY CHECK INTERCOOLER FOR OBSTRUCTION - Tdi

Clear any trapped dirt or flies from veins of intercooler

CLEAN INTERCOOLER ELEMENT - Tdi**Remove**

1. Remove intercooler element.
2. Flush intercooler with ICI 'GENKLENE' or 'D-SOLVE' propriety cleaner, following the manufacturer's instructions.
3. Dry the intercooler completely ensuring that no liquid remains in the element.

Refit

4. Refit intercooler element.
-

CHECK TURBO CHARGER BOOST PRESSURE - Tdi

For boost pressure. **See ENGINE TUNING DATA, Information, Turbocharger**

1. Disconnect, from turbocharger, hose to actuator. Insert into a suitable "T" piece.
2. Connect a short length of suitable hose to turbocharger and connect other end to "T" piece.
3. Connect a further length of hose to third leg of the "T" piece and other end to a pressure gauge capable of reading in excess of 61 cm Hg. The pressure gauge hose must be capable of reaching passenger compartment so that gauge may be observed.
4. To check maximum boost pressure, drive vehicle normally but in such a manner that full throttle can be maintained whilst climbing a hill with engine speed held steady between 2,500 and 3,000 rev/min.

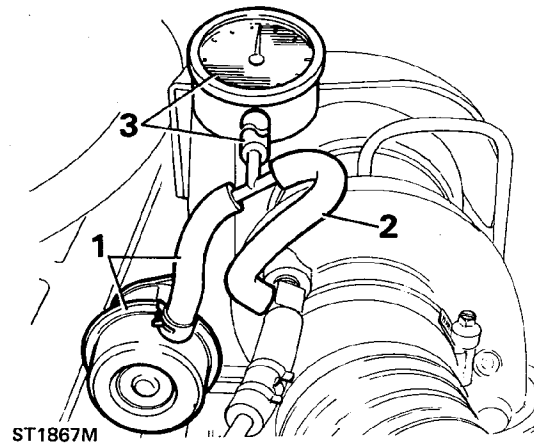



UNDER VEHICLE MAINTENANCE

Vehicles operating under severe conditions of dust, sand, mud and water should have oils changed and lubrication carried out at more frequent intervals than is recommended in maintenance schedules.

RENEW ENGINE OIL AND FILTER - Tdi



CAUTION: Serious damage to the turbocharger will result if engine is run above idling speed before oil pressure is restored.

RENEW ENGINE OIL AND FILTER - V8



CAUTION: To prevent an airlock occurring after removing filter, fill new filter with oil and fit immediately after removing old filter. If airlock does occur fill oil pump with petroleum jelly.

CHECK/TOP UP MANUAL GEARBOX OIL - V8

1. Place vehicle on ramp or level ground.
2. Remove oil filler level plug. If necessary, inject new oil into the gearbox until it runs out of filler hole. Fit plug. Tighten to **30 Nm**.

RENEW MANUAL GEARBOX OIL

RENEW AUTOMATIC GEARBOX FLUID AND OIL SCREEN

1. Place vehicle on either ramp or level ground. Place suitable container to drain gearbox fluid. Disconnect battery negative lead.
2. Remove gearbox dipstick, located at rear of right hand rocker cover, to aid oil drainage. Release plug from bottom of sump and allow fluid to drain completely.
3. Refit plug using a new sealing washer. Tighten to **10 Nm**.

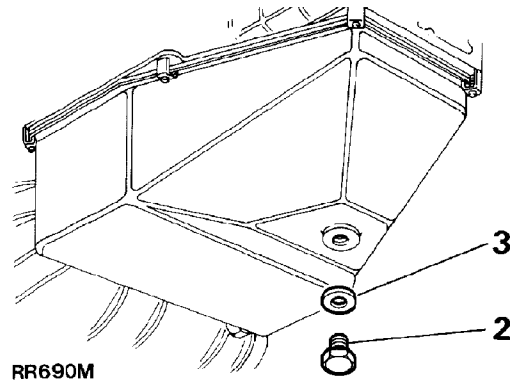

Refill ZF Automatic Gearbox and Check Fluid Level.



NOTE: The fluid level must be checked when fluid is cold and engine idling in park gear.

4. Ensure vehicle is on level ground.
5. Refill or top-up with correct quantity and grade of fluid. **See LUBRICANTS, FLUIDS AND CAPACITIES, Information, Recommended Lubricants and Fluids**

- Reconnect battery negative lead. Start and run engine, apply footbrake, select Position 1, revert to park position, release footbrake. Check fluid level, this must be between two markings on dipstick.

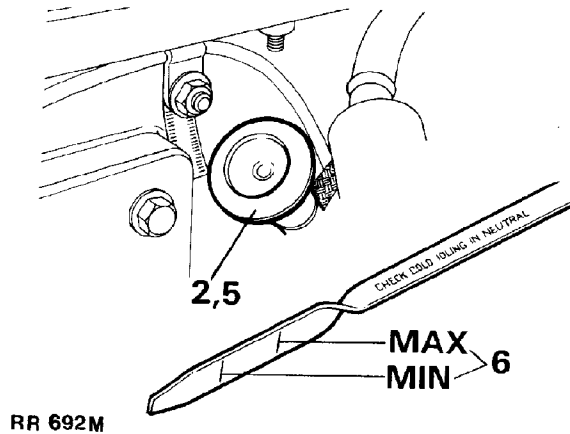

Oil screen replacement ZF automatic gearbox.
See *AUTOMATIC GEARBOX, Repair, Oil screen*

RENEW TRANSFER GEARBOX OIL

- Before renewing oil ensure that vehicle is level, either on a ramp or on ground.
- Disconnect battery negative lead.
- Clean immediate area around filler/level and drain plugs.



WARNING: When draining gearbox care should be taken to ensure that oil is not hot as personal scalding could result.

- Place a container under gearbox to drain oil into.
- Remove filler/level plug to vent gearbox and assist draining.
- Remove drain plug and allow oil to drain.

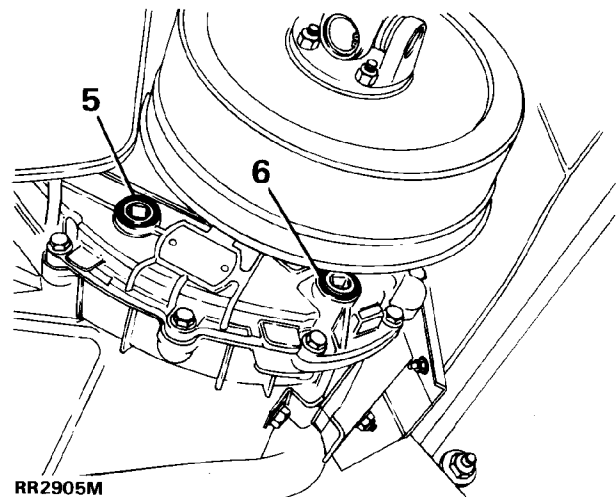

- Thoroughly clean drain plug threads prior to applying fresh 'Hylomar' sealant. Fit plug Tighten to **25 Nm**.
- Fill gearbox with correct quantity and grade of oil until oil seeps from filler level hole. Wipe away any surplus oil.
- Thoroughly clean filler/level plug threads prior to applying fresh 'Hylomar' sealant. Fit plug Tighten to **25 Nm**.
- Reconnect battery negative lead.



CHECK/TOP UP TRANSFER GEARBOX OIL

1. Before topping up oil ensure that vehicle is level, either on a ramp or on ground.
2. Disconnect battery negative lead.
3. Clean immediate area around filler/level plug.
4. Remove plug and fill gearbox with recommended grade of oil, until oil starts to seep from filler/level hole.
5. Clean any previously applied sealant from filler/level plug.
6. Apply Hylomar sealant to threads of plug and refit plug. Tighten to **25 Nm**.

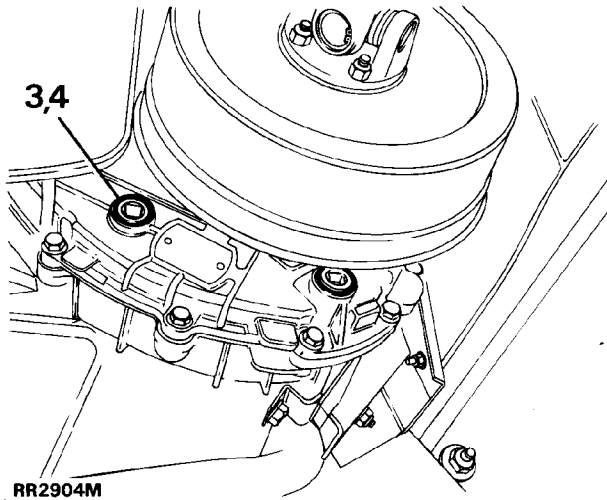

7. Wipe away any surplus oil.
8. Reconnect battery negative lead.

RENEW FRONT AND REAR AXLE OIL

1. Vehicle must be level. Place container under axle to be drained.
2. Using a 13mm square drive wrench, remove drain and filler/level plugs from axle. Allow oil to drain completely. Clean and refit drain plug.
3. Inject new oil of recommended make and grade until it reaches level hole. Clean and refit filler/level plug and wipe away surplus oil.

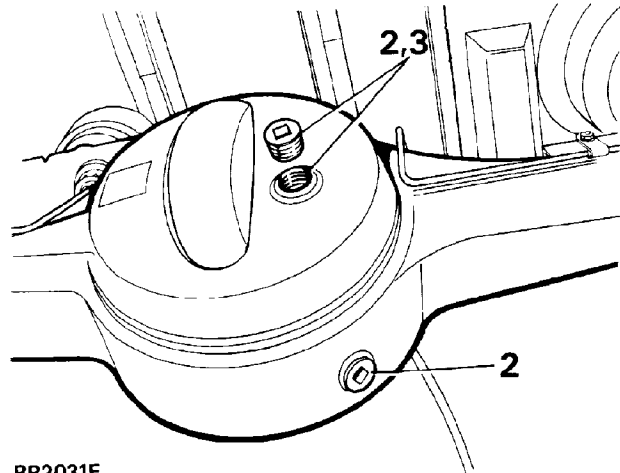

CHECK/TOP UP FRONT AND REAR AXLE OIL

1. Vehicle must be level.
2. Using a 13mm square drive wrench, remove filler/level plug from axle.
3. If necessary inject new oil of recommended make and grade until it reaches level hole. Clean and refit filler/level plug and wipe away surplus oil.

RENEW SWIVEL PIN HOUSING OIL

1. Vehicle must be level. Place container under swivel to be drained.
2. Remove drain and level plugs, allow oil to drain completely, clean and refit drain plug.
3. Remove filler plug and inject recommended make and grade of oil it reaches level hole.
4. Clean and refit level and filler plugs, wipe away any surplus oil.

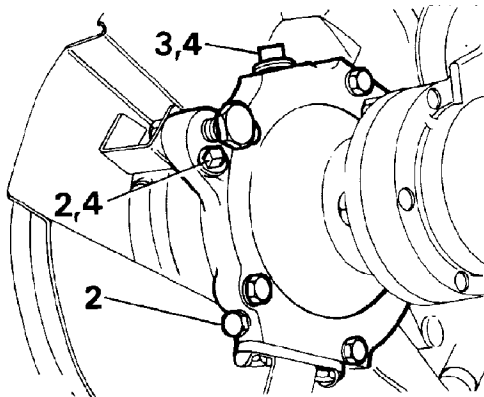

RR2032E

LUBRICATE PROPELLER SHAFT SLIDING, AND UNIVERSAL JOINTS

1. Clean all grease nipples on front and rear propeller shafts.
2. Using a low pressure hand grease gun, apply recommended grease, to grease nipples at front and rear propeller shaft universal and sliding joints.



NOTE: The rear propeller shaft flexible coupling is not fitted with a grease nipple.

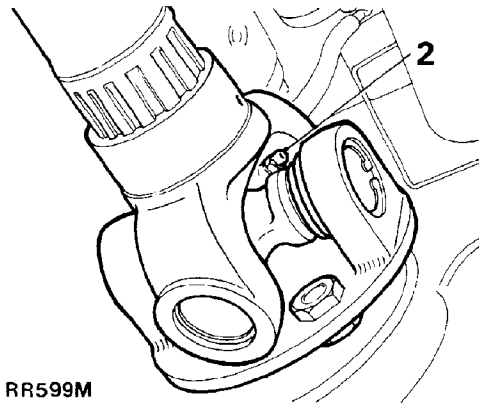

RR599M

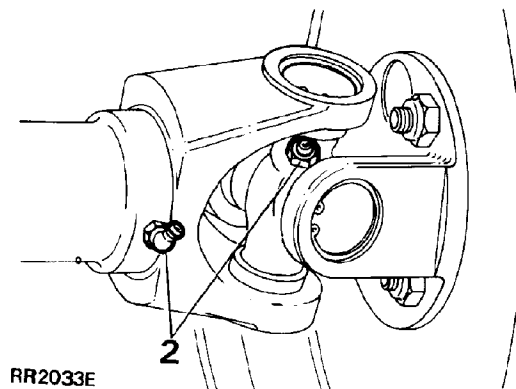

RR2033E



LUBRICATE PARKBRAKE MECHANICAL LINKAGE

CHECK VISUALLY BRAKE, FUEL, CLUTCH PIPES/UNIONS FOR CHAFING LEAKS AND CORROSION

CHECK EXHAUST SYSTEM FOR LEAKS, SECURITY AND DAMAGE

CHECK FOR FLUID LEAKS FROM POWER STEERING AND SUSPENSION SYSTEMS, HYDRAULIC PIPES AND UNIONS FOR CHAFING AND CORROSION

CHECK/TIGHTEN STEERING UNIT AND STEERING ROD BALL JOINT FIXINGS, CHECK CONDITION OF OF BALL JOINTS AND DUST COVERS

Ball joints are lubricated for their normal life during manufacture and require no further lubrication. This applies ONLY if rubber boot has not been dislodged or damaged. Joints should be checked at specified mileage intervals but more frequently if vehicle is used under arduous conditions.

1. Check for wear in joints by moving ball joint up and down vigorously. If free movement is apparent fit a new joint assembly.
-

CHECK TIGHTNESS OF PROPELLER SHAFT COUPLING BOLTS

Tighten propellor shaft nuts to **47Nm**.

ENSURE FRONT AND REAR AXLE BREATHERS ARE FREE FROM OBSTRUCTION

CHECK/TIGHTEN FRONT AND REAR AXLE SUSPENSION LINK FIXINGS, CHECK CONDITION OF MOUNTING RUBBERS

CLEAN FUEL SEDIMENTER - Tdi

Fuel sedimenter

The sedimenter is attached to left-hand side of chassis frame near fuel tank. It increases the working life of the fuel filter by removing larger droplets of water and larger particles of foreign matter from fuel.

Drain off water

1. Loosen drain plug, allow water to run out. Tighten plug immediately pure diesel fuel starts to flow.

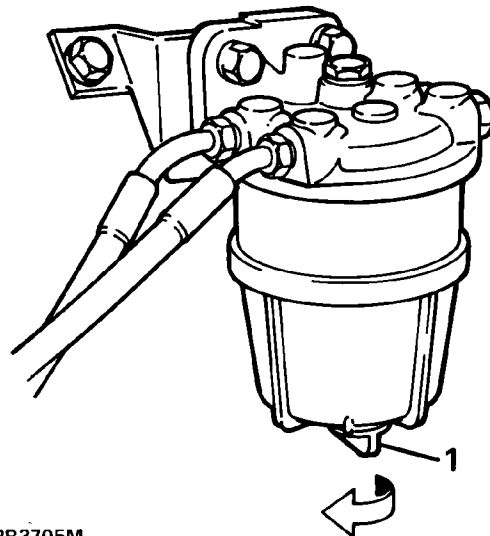

RR3705M

Clean element

1. Disconnect fuel inlet pipe from sedimenter and raise pipe above level of fuel tank. Support in this position to prevent fuel draining from tank.
2. Support sedimenter bowl, loosen bolt on top of unit and remove bowl.
3. Remove sedimenter element, clean all parts in kerosene.

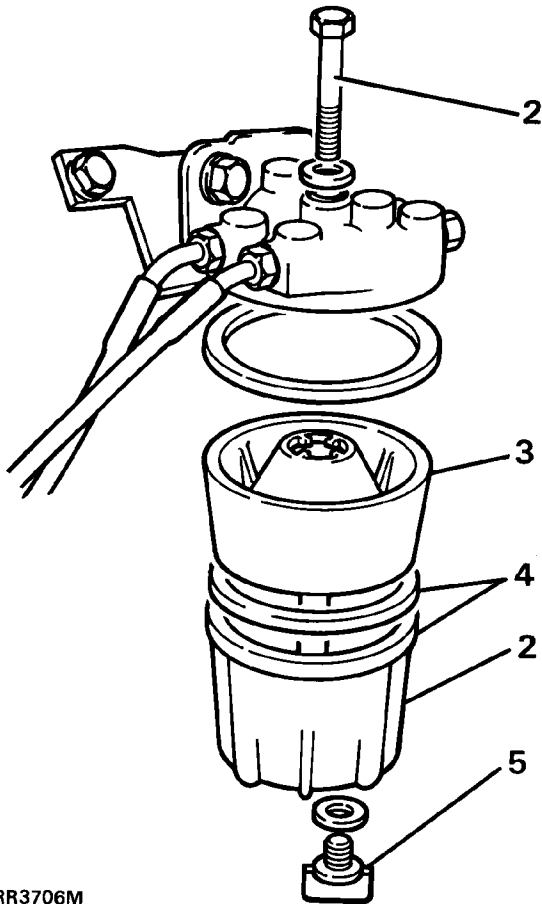

RR3706M

4. Fit new seals, reassemble sedimenter.
5. Loosen drain plug, when pure diesel fuel runs out, tighten plug.
6. Start engine and check sedimenter for leaks.

CHECK FOR OIL LEAKS FROM ENGINE AND TRANSMISSION

DRAIN FLYWHEEL HOUSING IF DRAIN PLUG IS FITTED FOR WADING

CHECK/TIGHTEN FUEL TANK FIXINGS



RENEW FUEL FILTER - V8



WARNING: Ensure that fuel handling precautions given in Section 01 - Introduction regarding fuel handling are strictly adhered to when carrying out following instructions. See *INTRODUCTION, Information, Fuel Handling Precautions*



WARNING: The spilling of fuel is unavoidable during this operation. Ensure that all necessary precautions are taken to prevent fire and explosion.

1. Depressurise fuel system. See *FUEL SYSTEM, Repair, Depressurising Fuel system*
2. The fuel line filter is located on right hand chassis side member forward of fuel tank filler neck. Access to filter is gained through right hand rear wheel arch.
3. Thoroughly clean area around hose connections to prevent ingress of foreign matter into fuel system.

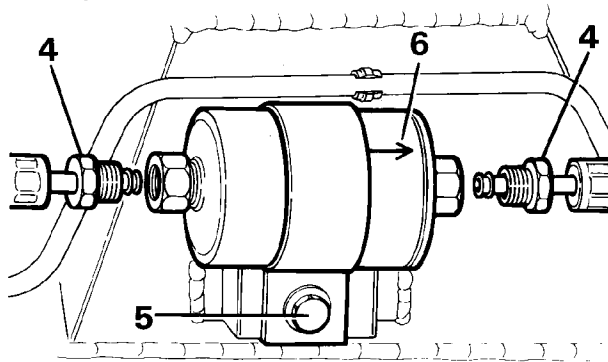

RR2966E

4. Loosen two fuel unions and remove hoses from filter canister.
5. Release securing bolt and bracket, remove filter from chassis side member.
6. Fit a new filter observing direction of flow arrow on canister.
7. Fit inlet and outlet hoses. Tighten to **30 Nm**.
8. Refit fuel pump relay.
9. Reconnect battery negative lead.
10. Recode radio.
11. Start engine and inspect hose connections for fuel leaks.

ABS VEHICLES - CHECK ROAD WHEEL SPEED SENSOR ELECTRICAL HARNESS FOR DAMAGE

RENEW OXYGEN SENSORS

See *EMISSION CONTROL, Repair, Lambda (Oxygen) Sensor*

RENEW CATALYTIC CONVERTERS

See *MANIFOLD AND EXHAUST SYSTEM, Repair, Exhaust System Complete*

CARRY OUT ROAD OR ROLLER TEST

WARNING: The front and rear axles cannot be driven independently due to the viscous coupling. Before brake testing a single axle, remove the propeller shaft to the rear axle, AND select neutral in BOTH main gearbox and transfer gearbox. Run the engine at idle speed to maintain servo vacuum.

For details of dynamometer testing *See INTRODUCTION, Information, Dynamometer Testing - Non Anti-Lock Brake Vehicles See INTRODUCTION, Information, Dynamometer Testing - Vehicles with Anti-Lock Brakes (ABS)*

Check following items:

1. Inhibitor switch only operates in P and N.
2. Engine for excessive noise.
3. Clutch for slip, judder or spin.
4. Automatic gear selection/shift speeds.
5. Gear selection/noise - high/low range.
6. Steering for abnormal noise/effort.
7. Steering for free play.
8. All instruments, gauges and warning indicators.
9. Heater and air conditioning systems.
10. Heated rear screen.
11. Shock absorbers - ride irregularities.
12. Foot brake, on emergency stop, pulling to one side, binding, pedal effort.
13. Parkbrake efficiency.
14. Seat reclining and latching.
15. Fully extend seat belt, check operation of retraction and latching. Inertia belts lock when snatched or vehicle on slope.
16. Road wheel balance.
17. Transmission for vibrations.
18. Body noises, squeaks and rattles.
19. Excessive exhaust smoke.
20. Engine idle speed.
21. Endorse service record.
22. Report any unusual features of vehicle condition and additional work required.

RESET EMISSION MAINTENANCE REMINDER - USA

The emission maintenance reminder is designed to activate at 52,500 and 105,000 miles respectively and will illuminate a 'Service Engine' red warning light in instrument binnacle.

The emission maintenance reminder must be reset after required maintenance has been carried out and a new tamperproof label fitted by a Land Rover of North America dealer.

Reset

1. The control unit is located rear of RH front seat.
2. Identify control unit and remove from plug.
3. Remove tamperproof label to reveal access hole for resetting.
4. Place a thin metallic probe into access hole and momentarily electrically short between reset pins inside unit.



RECOMMENDED SERVICE ITEMS

Refer to Service Schedule sheets for intervals.

Clean sunroof drain tubes, clean and lubricate guide rails and slides.

Renew the hydraulic brake fluid. **See BRAKES, Repair, Brake System Bleed**

Renew all hydraulic brake fluid, seals, brake servo filter and flexible hoses.

All working services of the master cylinder and caliper cylinders should be examined and renewed where necessary.

ABS vehicles only - renew hydraulic brake fluid and flexible hoses examine the working surfaces of the caliper cylinders and renew the seals or cylinders where necessary.

Air cleaner - When the vehicle is used in dusty or field conditions or deep wading, frequent attention to the air cleaner may be required.

ABS vehicles used extensively in arduous off-road conditions - check the rear wheel road speed sensor for abrasive wear.



DRIVE BELT INFORMATION

A single 'serpentine drive belt' drives all the ancillaries bar the air conditioning compressor, which has a separate drive belt. It is essential that the belts are fitted exactly as shown. It should also be noted that the water pump/viscous fan is driven in a clockwise direction.

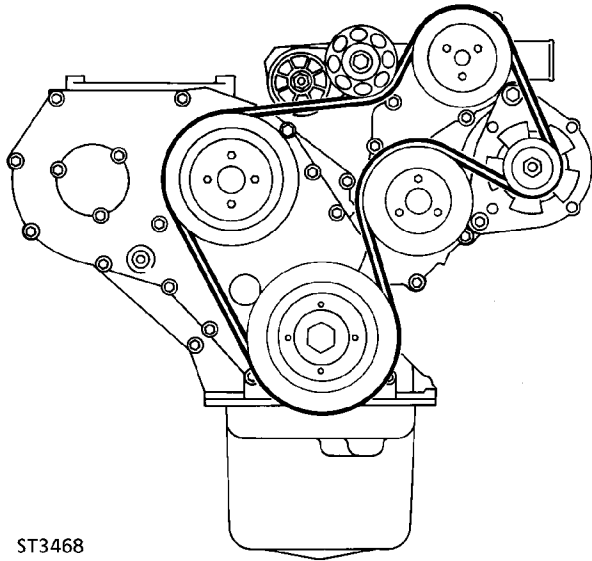

ST3468

A drive belt tensioner automatically tensions the drive belt, eliminating the need for tensioning individual drive belts. Turning the tensioner pulley in a clockwise direction will release drive belt tension.

Under normal highway use the belt must be changed at 160,000 kilometres, 96,000 miles or eight years whichever occurs first.

The drive belt must be examined at every service and replaced if necessary.

Off road driving

Regular examination of the drive belt is essential if the vehicle is used off road. The vehicle driver should be requested to identify the type of mileage the vehicle has covered.

After every off road session the owner should inspect the belt for cuts and possible damage caused by stones. If belt has jumped, reposition belt correctly. A new belt must be fitted at the next service or before, dependant on the type of damage sustained.

Fan cowl

To ensure easy access to the drive belt the top portion of the fan cowl is detachable.

Check condition

Check condition of drive belt. Renew a belt that shows signs of wear, splitting or oil contamination.

DRIVE BELT RENEW

Service repair no - 86.10.03



NOTE: If cast lines on tensioner arm and tensioner spring case are aligned, a new drive belt must be fitted.

Remove

1. Remove fan cowl upper.
2. Apply ring spanner to tensioner pulley retaining bolt.
3. Turn spanner to release pulley tension from belt.
4. Detach belt from pulley.
5. Release tensioner.
6. Complete removal of belt. Mark direction on belt if refitting.

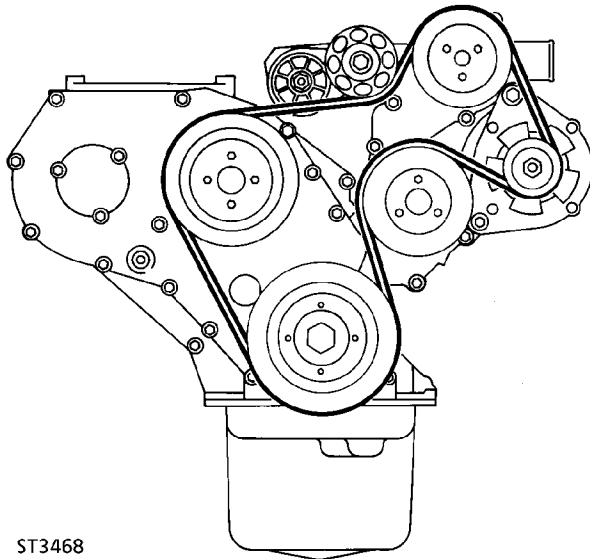

ST3468

Refit

7. Reverse removal procedure.

COMPRESSOR DRIVE BELT

Service repair no - 86.10.02

Remove

1. Remove auxiliary drive belt. *See Drive Belt Renew*
2. Remove compressor shield.
3. Loosen tensioner retaining bolts.
4. Remove compressor drive belt. Mark direction on belt if refitting.

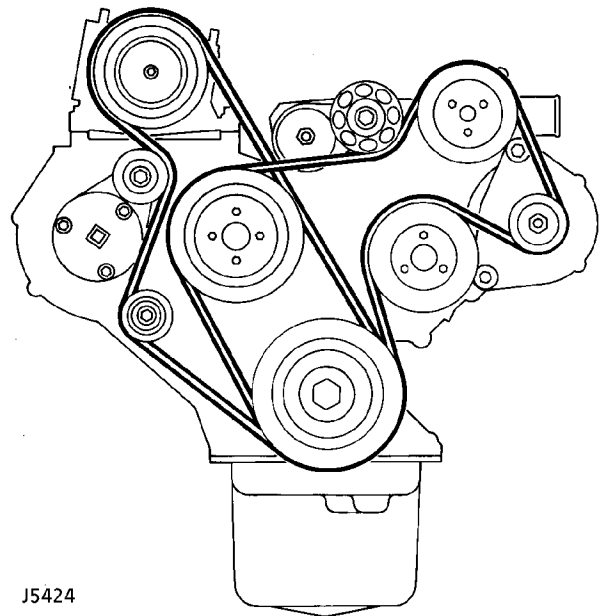

J5424

Refit

5. Fit compressor drive belt.
6. Fit torque meter to centre of tensioner and apply and hold a torque of **35 Nm**. Tighten 3 tensioner retaining bolts.
7. Rotate crankshaft 2 full turns.
8. Reapply and hold a torque of **35 Nm** to tensioner, then fully loosen and retighten 3 tensioner retaining screws to **25 Nm**.



ENGINE

Service repair no - 12.41.01

Remove



CAUTION: Seal all exposed pipe ends against ingress of dirt after disconnection.

1. Park vehicle on level ground and apply park brake.
2. Disconnect battery negative lead.
3. Remove bonnet [hood]. **See CHASSIS AND BODY, Repair, Bonnet [Hood]**
4. If air conditioning is fitted, remove RH footwell side trim panel and disconnect harness multiplug from relay.

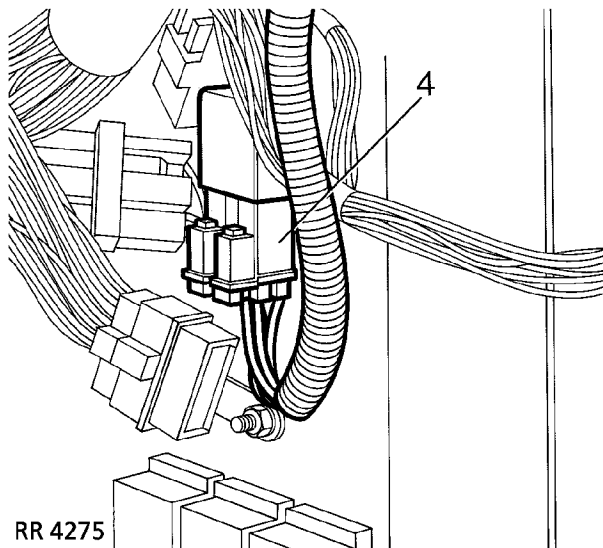

5. Disconnect the two engine harness multiplugs on LH side of footwell.

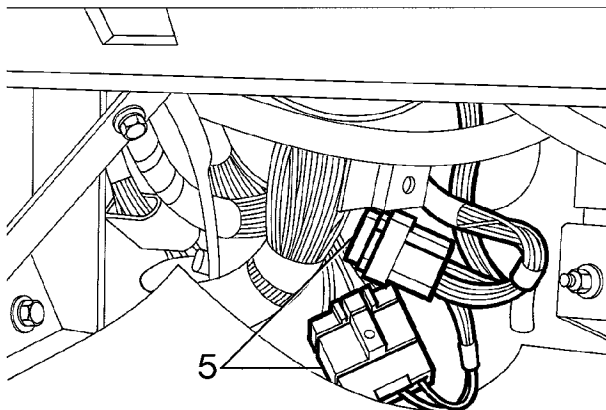

RR 4276

6. Remove engine harness grommet from bulkhead and move harness into engine bay.
7. Release battery positive lead from retaining clip at base of suspension turret.
8. Remove Radiator Assembly **See COOLING SYSTEM, Repair, Radiator**
9. Discharge air conditioning system. **See AIR CONDITIONING, Adjustment, Refrigerant Recovery Recycling Recharging**
Remove retaining bolts and disconnect both pipe adaptors from rear of compressor.
10. Remove rocker cover insulation.
11. Disconnect cyclone hose from air cleaner hose.
12. Remove air cleaner hose from turbocharger.
13. Remove feed pipe/hose from turbocharger and intercooler.
14. Disconnect heater hoses from cylinder head and heater rails.
15. Remove bolt securing transmission breather pipe clip to cylinder head; move breather pipes aside.
16. Disconnect inlet and outlet hoses from power steering pump.
17. Disconnect bypass hose from thermostat housing.
18. Release bypass hose from retaining clips on front timing cover.
19. Remove split pin securing inner throttle cable to injector pump.
20. Depress tags on outer cable adjusting nut, remove cable from mounting bracket, and move aside.
21. If automatic transmission is fitted, release kickdown cable from injector pump and mounting bracket.

12 ENGINE

22. Disconnect feed pipe and spill return pipe from injector pump.
23. Disconnect both pipes from fuel lift pump.
24. Disconnect servo hose from vacuum pump.
25. Remove three retaining nuts and disconnect exhaust down pipe.
26. Remove oil cooler pipes from oil filter adaptor.
27. If automatic transmission is fitted, disconnect feed and return pipes at gearbox oil cooler. Remove retaining bracket from LH side of cylinder block and release both oil cooler pipes.
28. Support gearbox.
29. Disconnect ground strap from starter motor.
30. On vehicles with automatic transmission, remove fixings and detach drive plate housing access panel and gasket.
31. Working through drive plate housing aperture mark the torque converter and drive plate to facilitate reassembly.
32. Remove the four converter to flexible drive securing bolts, rotating crankshaft to gain access to each individual bolt.
33. Fit engine lifting bracket to the two RH rear cylinder head fixing bolts.
34. Using suitable hoist, fit lifting chains to engine.
35. Remove four bolts, from both sides, securing front engine mounting brackets to cylinder block.
36. Remove two bolts, from both sides, securing front engine mounting bracket to bell housing.

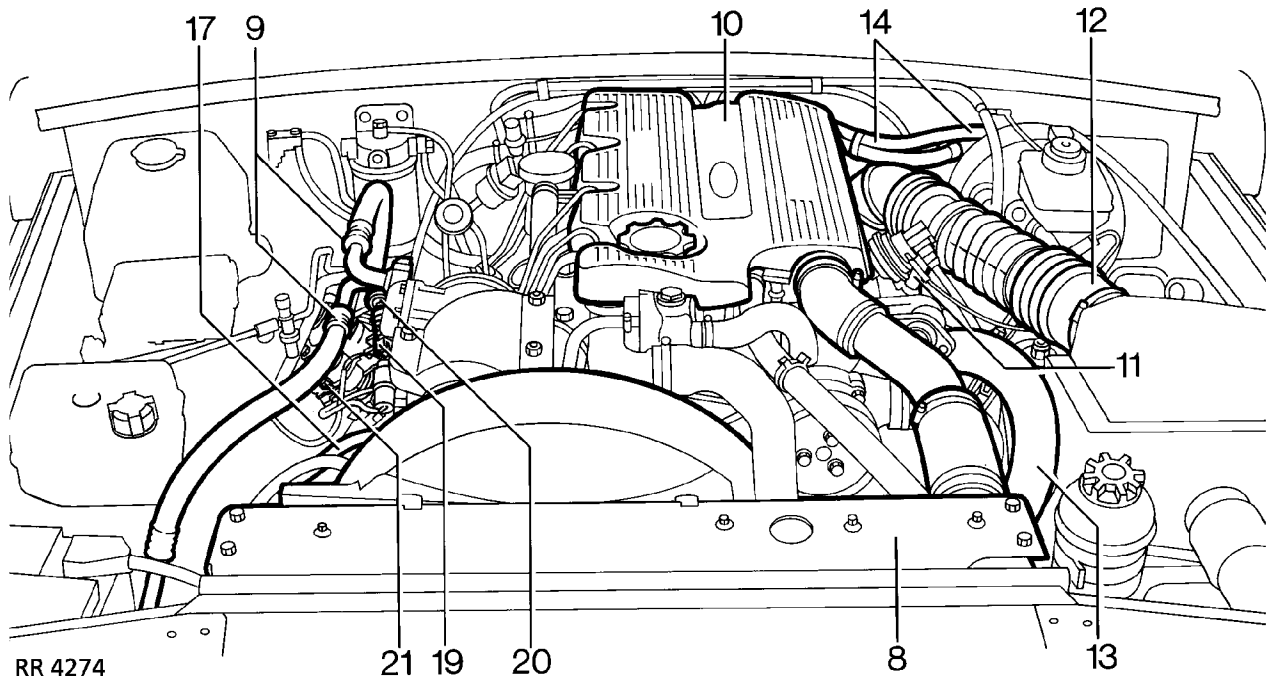

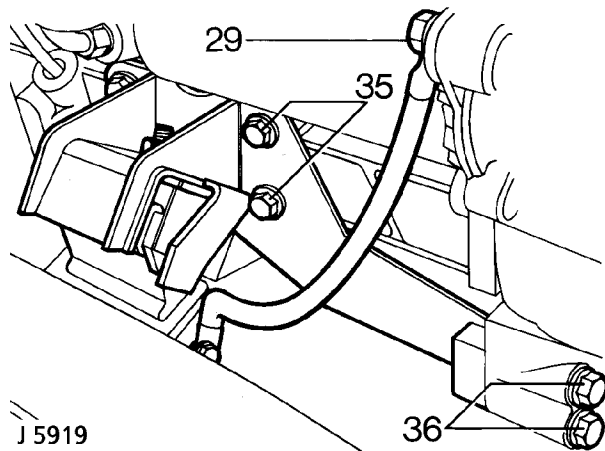

37. Remove nuts and plain washers securing front engine mountings to chassis, and lift both engine mounting bracket assemblies from vehicle.
38. Remove engine to bell housing fixings. Leave starter motor attached.
39. Raise engine to separate from transmission.
40. Check all connections to engine have been disconnected.
41. Remove engine.

Refit

42. Apply Hylomar to mating faces of bell housing. Lubricate splines of gearbox primary pinion with Rocol MV 3. If automatic transmission, coat the four drive plate to torque converter bolts with Loctite 290. Tighten to **39 Nm**.
43. Lower engine and locate with transmission. If manual transmission locate primary pinion into clutch and engage bell housing dowels. Fit engine to bell housing fixings. Tighten to **40 Nm**. If automatic transmission fixings. Tighten to **46 Nm**.
44. Raise engine, refit front engine mounting brackets to cylinder block and bell housing.
45. Remove gearbox support and lower engine.
46. Tighten front engine mountings to chassis fixings. Tighten to **45 Nm**.
47. Reverse removal procedure. 1 to 37.

CRANKSHAFT PULLEY

Service repair no - 12.21.01

Remove

1. Disconnect battery negative lead.
2. Drain coolant.
3. Remove top hose from radiator.
4. Remove intercooler to induction manifold hose.
5. Remove viscous fan and coupling. **See COOLING SYSTEM, Repair, Viscous Coupling, Fan Blades, Pulley and Fan Cowl**
6. Remove fan cowl.
7. Remove drive belt. **See Drive Belt Renew**
8. Fit crankshaft pulley retainer LRT-12-080 and secure with four bolts.
9. Remove crankshaft pulley retaining bolt using socket and suitable long bar.

Refit

12. Refit in reverse order, lightly greasing pulley spigot. Tighten to **80 Nm + 90°**.

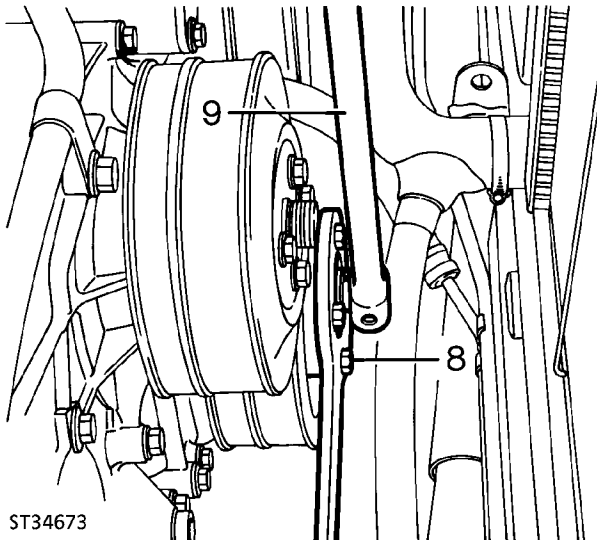

ST34673

10. Remove pulley retainer.
11. Remove pulley, if necessary using extractor LRT-12-049 with thrust pad from LRT-12-031.



FRONT COVER PLATE

Service repair no - 12.65.01

Remove

1. Disconnect battery negative lead.
2. Drain coolant.
3. Remove top hose from radiator.
4. Remove inter-cooler to induction manifold hose.
5. Remove viscous coupling and fan. *See COOLING SYSTEM, Repair, Viscous Coupling, Fan Blades, Pulley and Fan Cowl*
6. Remove fan cowl.
7. Remove drive belt. *See Drive Belt Renew*
8. Remove crankshaft pulley. *See Crankshaft Pulley*
9. Remove 14 bolts securing front cover plate, noting top two bolts also retain thermostat hose clips.
10. Remove cover plate complete with gasket.
11. Remove small gasket from centre bolt boss.

Seal replacement

12. Remove worn seal from cover and clean recess.
13. Support cover and fit new seal, open side fitted into recess, using special tool LRT-12-077.

LRT-12-077

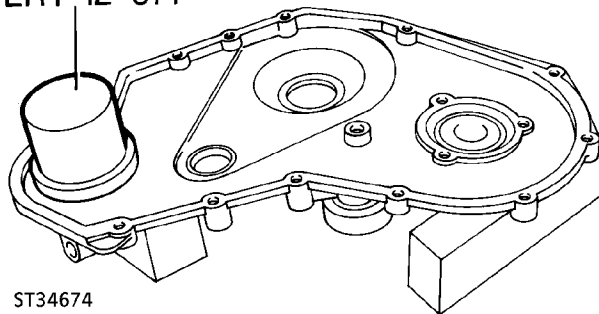

ST34674

Refit

14. Refit in reverse order to removal using new gaskets, fitting the securing bolts as shown in illustration ST3475. Tighten to **25 Nm**.

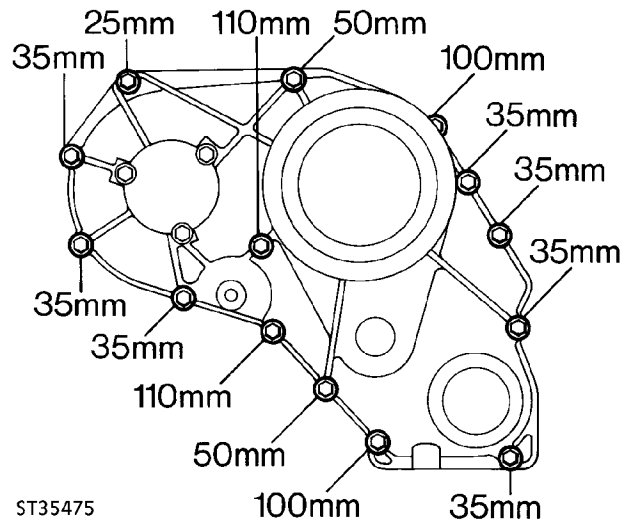

ST35475

CAMSHAFT DRIVE BELT AND GEARS

Service repair no - 12.65.18

TIMING BELT

Remove

1. Remove front cover plate. *See Front Cover Plate*
2. Position engine at TDC on No. 1 cylinder.
3. If manual gearbox: Remove blanking plug from flywheel housing and insert timing tool LRT-12-044. If EDC - timing tool LRT-12-085 must be used.
If automatic gearbox: Sited to the rear of the engine sump on engine backplate is a blanking plate. Remove 2 blanking plate bolts and insert timing tool LRT-12-044 into the larger bolt hole.

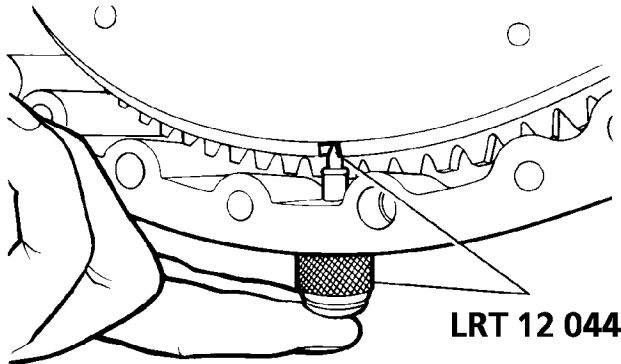

4. Engage timing tool pin with slot in flywheel.
5. Check correct alignment of timing mark on camshaft gear and that crankshaft key aligns with cast arrow on housing.

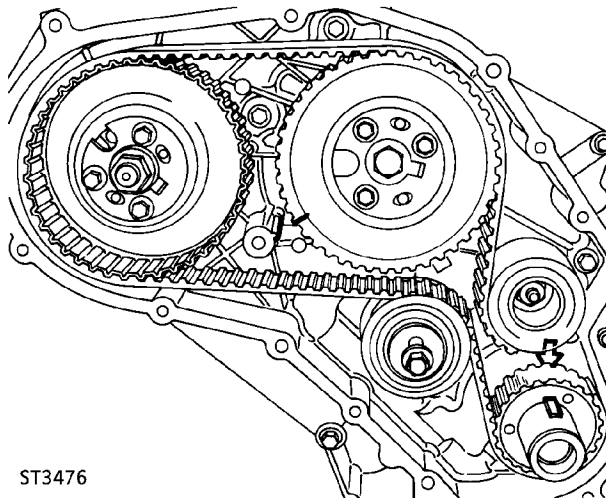

6. Insert pin from special tool LRT-12-045 in injection pump gear and through into pump flange.



NOTE: If the camshaft gear is to be removed during these operations its retaining bolt should be slackened before the timing belt is removed.

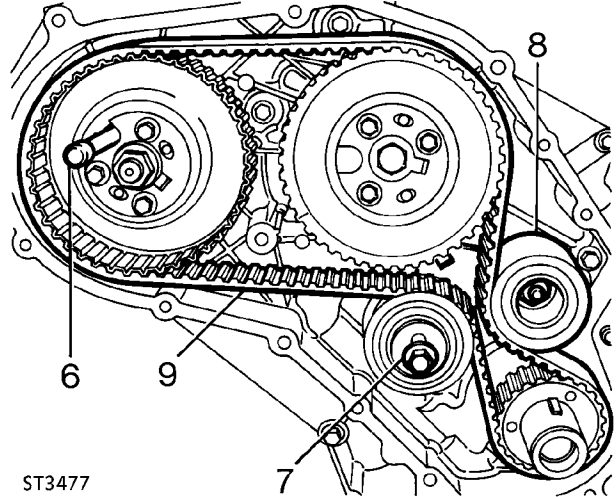

7. Slacken belt tensioner bolt.
8. Remove idler pulley.
9. Remove timing belt.



NOTE: During use, a belt develops a wear pattern relative to its running direction, if the original belt is to be re-used it must be refitted so that it rotates in the original direction.



CAUTION: Belts must be stored on edge on a clean surface and in such a manner that bends are not less than 50 mm radius. Do not bend belts at an acute angle or radius of less than 50 mm, otherwise premature failure could result.

10. Mark belt direction of rotation, using soft chalk, to ensure correct refitment.



Belt tensioner



NOTE: The belt tensioner need only be removed if it is being replaced or for access purposes to remove front cover.

11. Remove securing bolt and withdraw tensioner complete with spacer.

Crankshaft gear/front cover oil seal

12. If the crankshaft gear cannot be removed by hand, use special tool LRT-12-078 with main body and thrust button from special tool LRT-12-031 as illustrated ST3478M. Withdraw gear complete with 'O' ring seal.

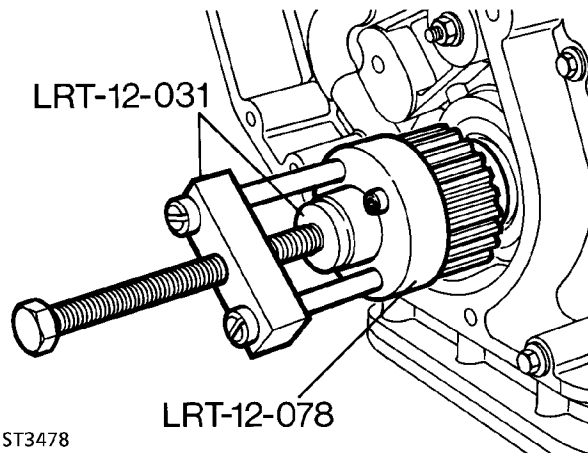

13. If necessary prise out oil seal from front cover.
14. Lubricate a new crankshaft oil seal with clean engine oil.
15. With lip side leading, drive-in seal squarely using special tool LRT-12-079.

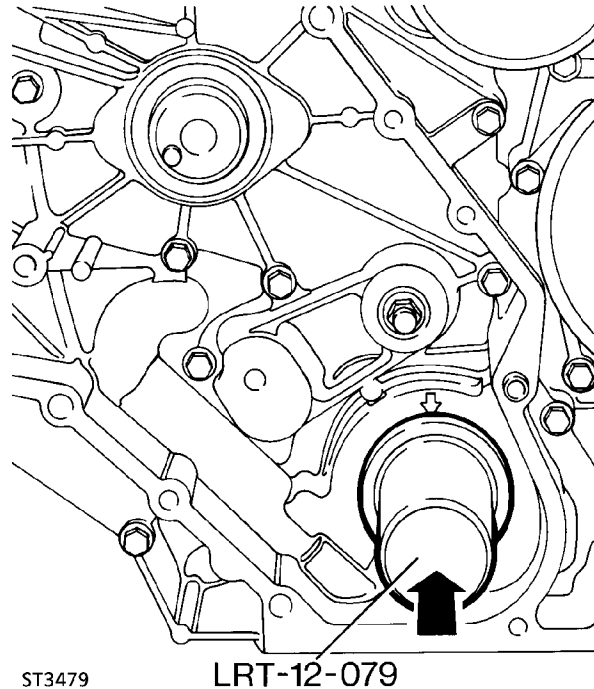

16. Lubricate new 'O' ring seal with petroleum jelly and slide onto shaft, taking care not to damage seal on the woodruff keys.
17. Fit crankshaft gear, tap fully home ensuring 'O' ring seal is properly seated.

CAMSHAFT GEAR/FRONT COVER OIL SEAL

Service repair no - 12.13.05

18. Remove centre bolt from camshaft gear and withdraw gear.
19. Remove existing oil seal from front cover using special tool LRT-12-038.
20. Lubricate a new camshaft oil seal with clean engine oil.

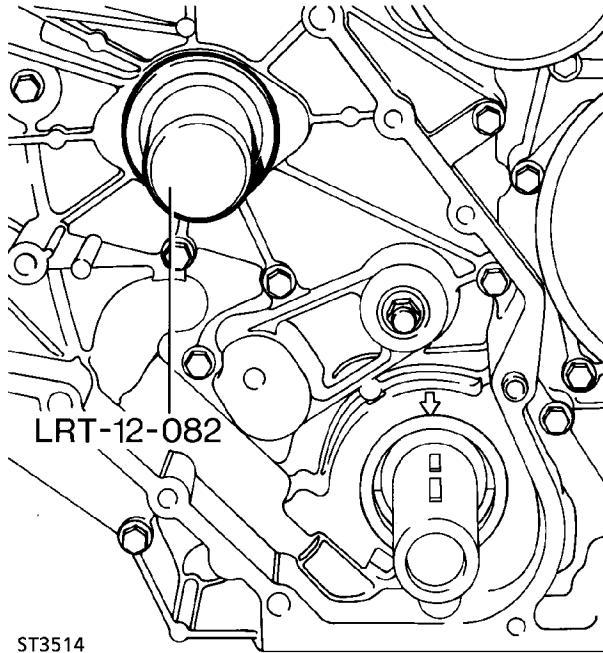

21. With lip side leading, drive-in seal squarely using special tool LRT-12-082.
22. Refit gear.

FUEL INJECTION PUMP GEAR

Service repair no - 19.30.06

Remove

23. Slacken the three bolts on front of gear.



CAUTION: It is important to ensure that when the injection pump is locked no attempt must be made to rotate it. Take care not to allow the crankshaft to be turned.

24. Remove special tool pin from gear.
25. Remove three bolts and withdraw plate and gear.

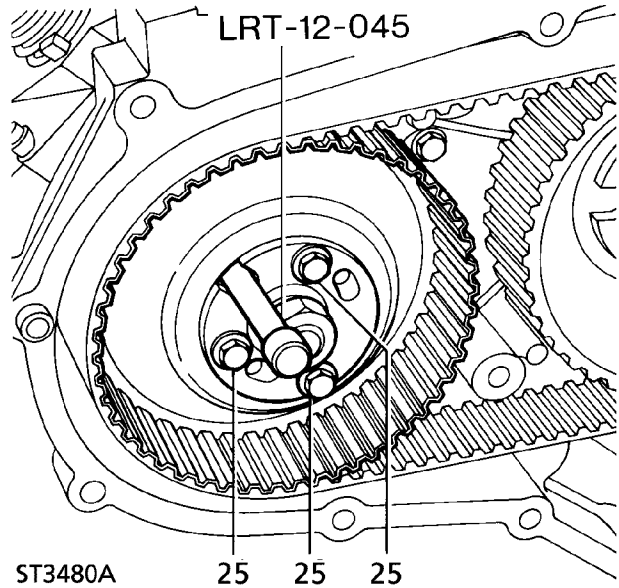

Refit

26. Fit gear and plate and secure with three bolts.
27. Insert pin from special tool LRT-12-045 in injection pump gear and through into pump flange.



Timing belt fitting and tensioning



NOTE: It is important that belt tensioning is carried out carefully and accurately. The following procedure involves tensioning the belt twice to ensure that it is equally tensioned between each gear. New and original belts are tensioned to different figures.

28. Ensure timing marks are correctly aligned, pin from special tool LRT-12-045 is correctly inserted in injection pump gear and timing tool LRT-12-044 (LRT-12-085 if EDC) is fitted to flywheel housing with pin located in flywheel slot. Or if automatic: Timing tool LRT-12-044 is fitted to engine backplate and pin located in ring gear.
29. Fit belt observing rotational marks made during removal. Feed belt over gears keeping it tight on drive side.
30. Fit idler pulley.
31. Slacken injection pump gear retaining bolts.
32. Adjust belt to correctly sit in gears.

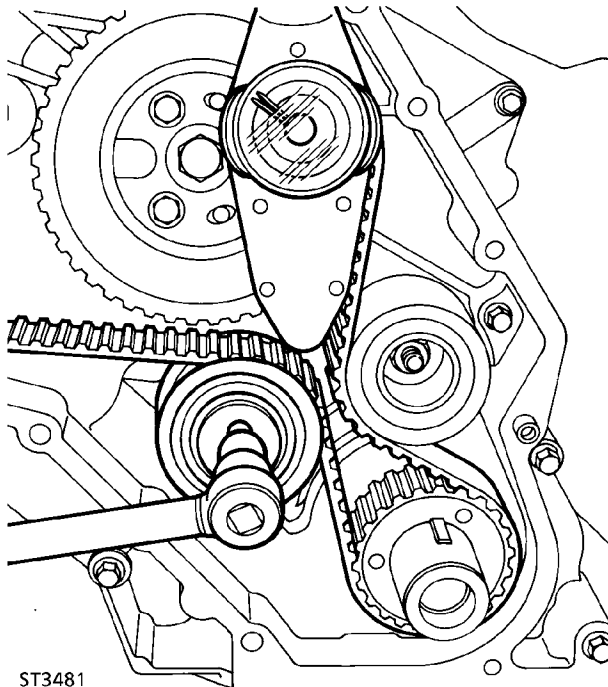

ST3481

33. Slacken belt tensioner securing bolt to finger tight.
34. Insert 13 mm square drive extension bar in tensioner plate.



NOTE: Belt tensioning should be carried out using a dial type torque meter having a range not exceeding **60 Nm**. The torque meter should be used in the almost vertical position.

35. Apply a tension of **14 to 16 Nm** for a new belt or **11 to 13 Nm** for an original belt. When tension is correct tighten clamp bolt.
36. Tighten injection pump gear bolts.
37. Remove pin from injection pump gear.
38. Disengage timing pin from timing slot in flywheel or ring gear.
39. Rotate crankshaft one and three quarter turns in a clockwise direction; then continue rotation until timing pin in timing tool can be engaged with slot in flywheel or ring gear.
40. Disengage timing pin.
41. Insert pin from special tool LRT-12-045 in injection pump gear and through into pump flange.
42. Slacken injection pump gear retaining bolts.
43. Slacken tensioner and retension belt.
44. Tighten injection pump gear retaining bolts.
45. Remove pin from injection pump gear.
46. Remove timing tool and refit plug.
47. Fit front cover plate using new gaskets. **See Front Cover Plate**

FRONT COVER/TIMING GEAR HOUSING GASKET

Service repair no - 12.65.10

Remove

1. Remove timing belt and gears. *See Camshaft Drive Belt and Gears*
2. Remove fuel injection pump. *See FUEL SYSTEM, Repair, Fuel Injection Pump and Timing*
3. Remove engine oil sump. *See Oil Sump*
4. Remove oil pick up strainer. *See Oil Pick-Up Strainer*
5. Remove bolts securing timing gear housing to block.
6. Withdraw timing gear housing complete with gasket.
7. Clean all gasket material from mating faces.

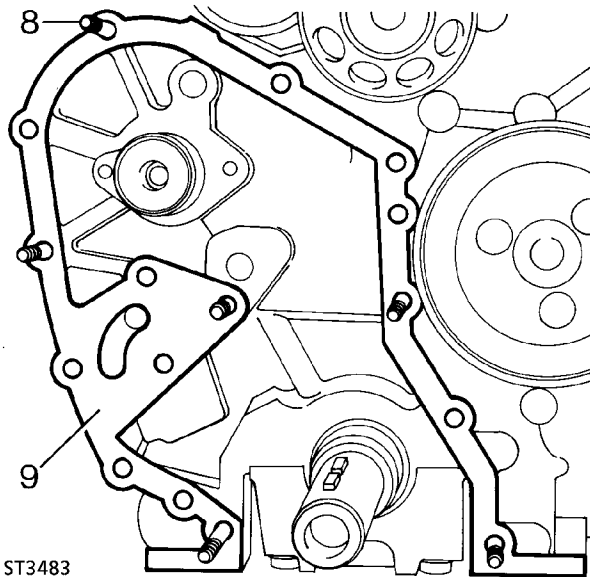

Refit

8. Fit slave guide studs to locate gasket.
9. Fit new gasket, over slave studs, to cylinder block.

10. Align flats on oil pump with flats on crankshaft.
11. Fit front cover to block taking care not to damage oil seal.
12. Secure with bolts of correct length in locations where slave studs are not fitted (ST3482).
13. Remove slave studs and fit correct length bolts.
14. Tighten to **25 Nm**.

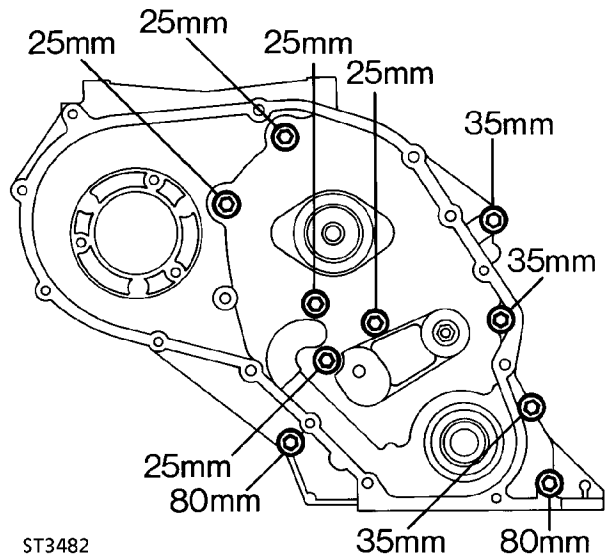

15. Fit oil pick-up strainer. *See Oil Pick-Up Strainer*
16. Fit oil sump. *See Oil Sump*
17. Refit fuel injection pump. *See FUEL SYSTEM, Repair, Fuel Injection Pump and Timing*



OIL SUMP

Service repair no - 12.60.44

Remove

1. Disconnect battery negative lead.
2. Drain engine oil.
3. Slacken sump securing bolts and, using a sharp knife, break sealant around sump flange.
4. Remove bolts and withdraw sump.

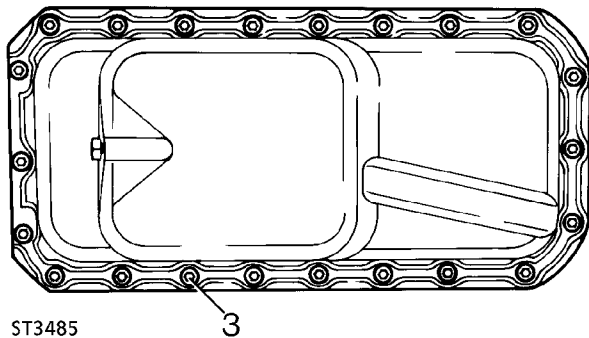

Refit

5. Clean mating faces of sump, timing gear housing and cylinder block.
6. Apply a 2,0 mm bead of 'Hylosil RTV102' to the sump flange, ensuring bead is applied inboard of the bolt holes.
7. Secure sump to block with bolts. Tighten to **25 Nm**.
8. Refill engine oil. **See LUBRICANTS, FLUIDS AND CAPACITIES, Information, Recommended Lubricants and Fluids**
9. Reconnect battery negative lead.

OIL PICK-UP STRAINER

Service repair no - 12.60.20

Remove

1. Disconnect battery negative lead.
2. Drain engine oil.
3. Remove engine oil sump. **See Oil Sump**
4. Remove bolts securing pipe support bracket.
5. Remove bolts from pipe flanges.
6. Withdraw pick-up strainer assembly.

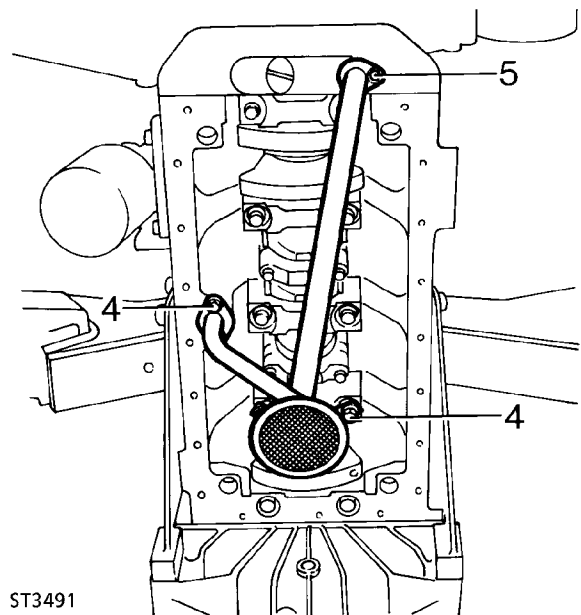

Refit

7. Refit pick-up strainer assembly, fitting a new 'O' ring seal at oil pump connection.
8. Apply Loctite 242E to the two screws at the bearing cap. Tighten to **9 Nm**.
9. Fit bolts to pipe flanges. Tighten to **25 Nm**.
10. Refit engine oil sump. **See Oil Sump**
11. Reconnect battery negative lead.

FLYWHEEL

Service repair no - 12.53.07

Remove

1. Disconnect battery negative lead.
2. Remove gearbox. *See MANUAL GEARBOX, Repair, R380 Manual Gearbox*
3. Remove clutch. *See CLUTCH, Repair, Clutch Assembly*
4. Fit two long 8mm bolts into the clutch bolt holes, diametrically opposite, to use as handles when lifting the flywheel off the crankshaft.
5. Remove fan cowl
6. Fit crankshaft pulley retainer LRT-12-080 and secure with four bolts, to restrain crankshaft while removing flywheel retaining bolts.
7. Remove the bolts and lift off flywheel.

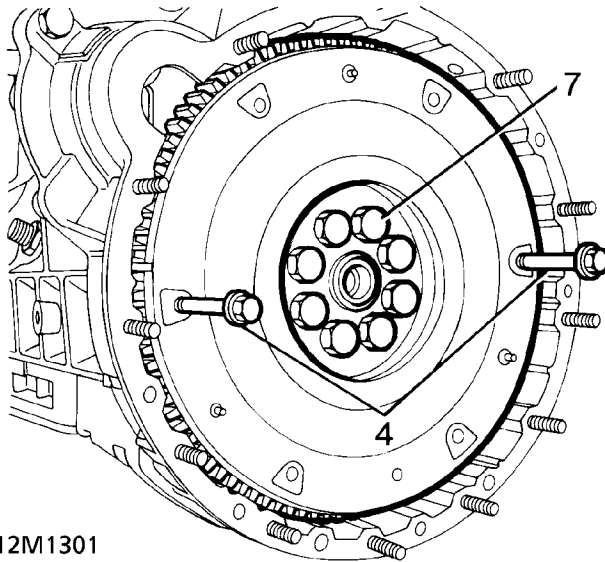

12M1301



NOTE: To prevent excessive flywheel run-out, ensure that the mating faces of the flywheel and crankshaft are clean.

Refit

8. Locate the flywheel on the crankshaft and secure with new patched retaining bolts, progressively tighten to **147 Nm**.

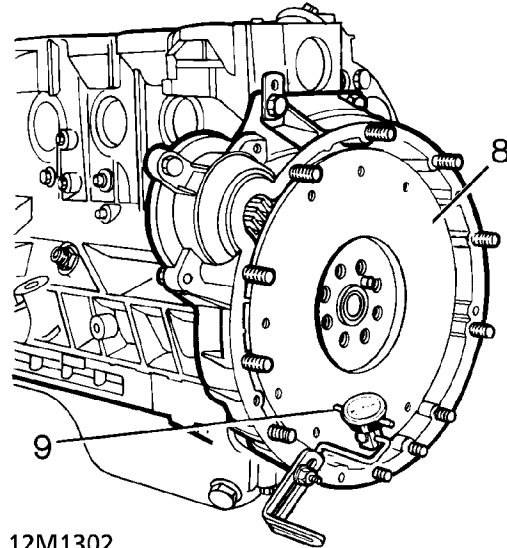

12M1302

9. Check the flywheel for possible run-out by mounting a dial test indicator with the stylus in a loaded condition resting on the flywheel face at a radius of 114mm from the centre.
10. Turn the flywheel and check that run-out does not exceed 0,05 to 0,07mm. Should run-out be excessive, remove the flywheel and check again for irregularities on the crankshaft and flywheel mating faces and the dowel.
11. Reverse removal procedure. 1 to 6.



CRANKSHAFT REAR OIL SEAL

Service repair no - 12.21.20

Remove

 **NOTE:** The crankshaft rear oil seal is retained in its own housing, if the seal requires replacing the housing and seal assembly (1) must be renewed complete with the housing seal (3). Housing and seal assemblies are supplied with their own former/seal guide (2) already fitted. This former must not be removed before fitting the assembly to the engine. If a seal and housing assembly is received without a former/guide fitted it must be returned to the supplier. Used formers/guides must be discarded immediately after use, under no circumstances should they be reused on other assemblies.

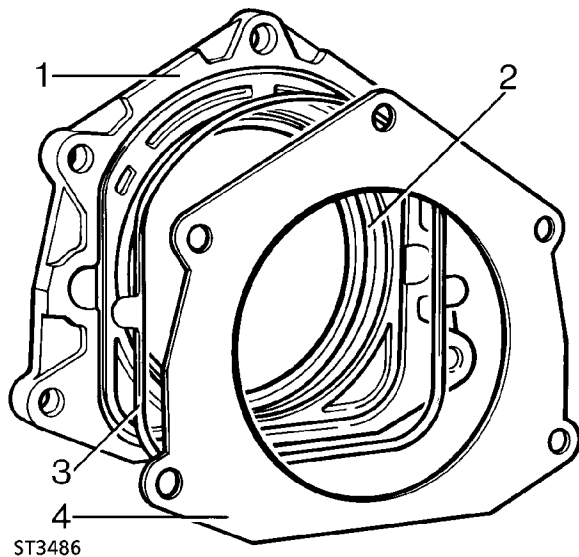

1. Disconnect battery negative lead.
2. Remove gearbox. *See MANUAL GEARBOX, Repair, R380 Manual Gearbox*

3. Remove clutch. *See CLUTCH, Repair, Clutch Assembly*
4. Remove flywheel. *See Flywheel*
5. Remove five bolts and withdraw seal housing and seal assembly complete with gasket.

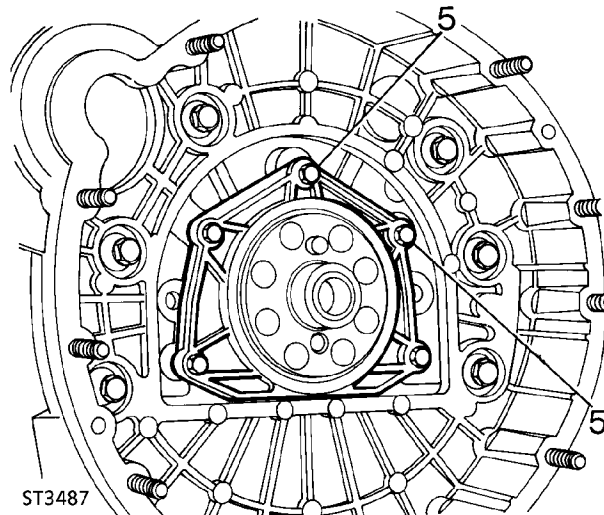

Refit

6. Insert slave studs to seal housing mounting face.
7. Position new seal housing gasket over slave studs and crankshaft flange onto cylinder block.

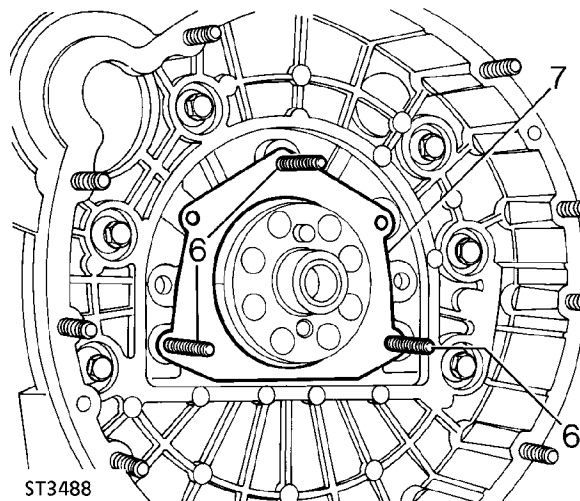

8. Ensure housing seal is correctly seated in its groove in new housing and seal assembly.
9. Fit new assembly, with former/guide in-situ, over crankshaft flange, this action will eject former/guide.
10. Secure assembly to cylinder block with five bolts tightened to correct torque, removing slave studs individually and inserting bolts.
11. Refit flywheel. *See Flywheel*
12. Refit clutch. *See CLUTCH, Repair, Clutch Assembly*
13. Refit gearbox. *See MANUAL GEARBOX, Repair, R380 Manual Gearbox*
14. Reconnect battery negative lead.

CRANKSHAFT BEARING BUSH

Service repair no - 12.21.45

1. Disconnect battery negative lead.
2. Remove gearbox. *See MANUAL GEARBOX, Repair, R380 Manual Gearbox*
3. Remove clutch. *See CLUTCH, Repair, Clutch Assembly*

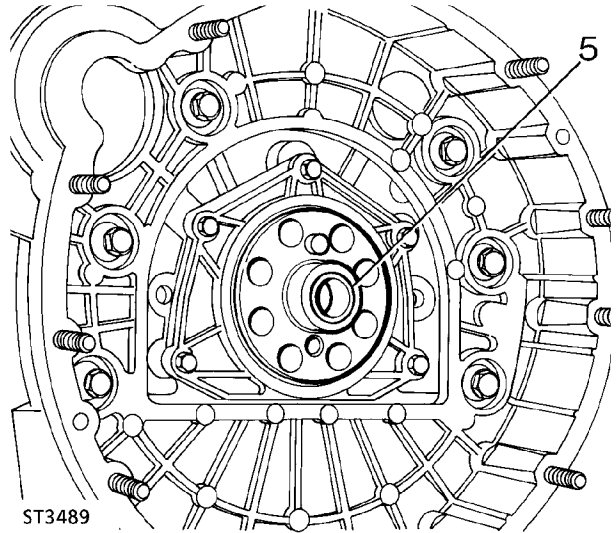

4. Remove flywheel. *See Flywheel*
5. Remove bearing bush.



NOTE: The bearing bush can be removed by using one of the following methods.

Method 1.

Obtain a short length of steel rod of a diameter having a good slide fit in the bore of the bush. Pack the bore with grease and insert the steel rod into the end of the bore, give a sharp blow with a hammer and the grease should drive out the bush. It is recommended that the bush and rod be covered by a suitable cloth or rag to prevent grease from splashing.



Method 2.

Thread the bore of the existing bush and using a suitable bolt extract the bush. Thoroughly clean bush location ensuring all swarf is removed.

Fitting

6. Fit new bush using a suitable shouldered drift, inserting bush flush with end of crankshaft.
7. Refit flywheel. *See Flywheel*
8. Refit clutch. *See CLUTCH, Repair, Clutch Assembly*
9. Refit gearbox. *See MANUAL GEARBOX, Repair, R380 Manual Gearbox*
10. Reconnect battery negative lead.

FLYWHEEL HOUSING

Service repair no - 12.53.01

Remove

1. Disconnect battery negative lead.
2. Remove gearbox. *See MANUAL GEARBOX, Repair, R380 Manual Gearbox*
3. Remove clutch. *See CLUTCH, Repair, Clutch Assembly*
4. Remove flywheel. *See Flywheel*
5. Remove starter motor.
6. Remove two bolts from top of flywheel housing.
7. Remove four bolts from bottom of flywheel housing.
8. Remove six inner bolts and lift off flywheel housing.

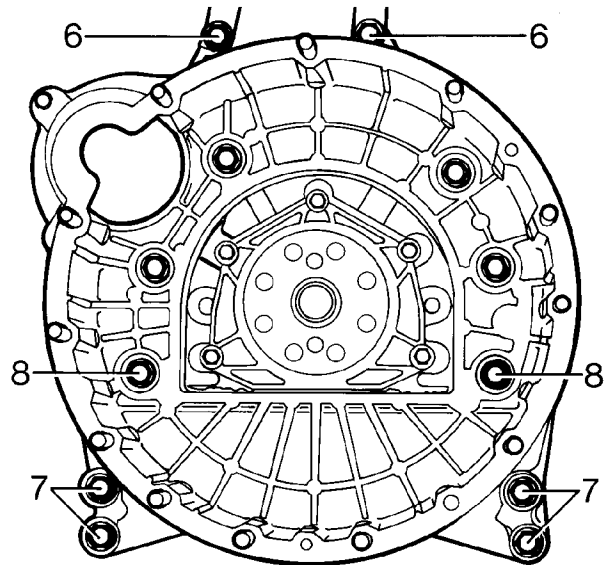

ST3490

Refit

9. Clean rear face of housing and mating face on block, ensuring all old sealant is removed.

10. Apply sealant to flywheel housing mating face on cylinder block (Fig. J5944).

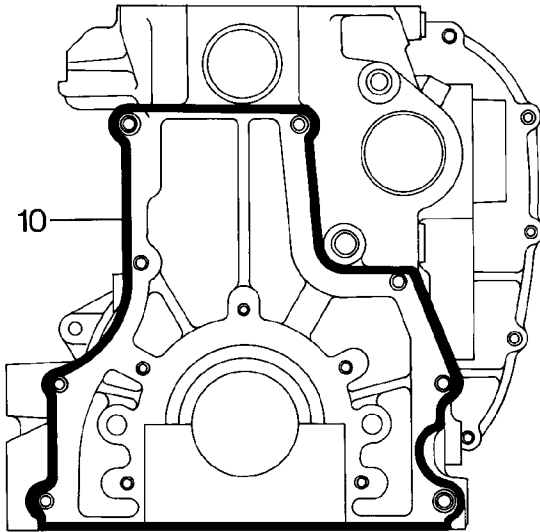

J5944

11. Fit housing to cylinder block and secure with bolts as removed. Tighten to **45 Nm**.
12. Remove surplus sealant from block.
13. Refit starter motor.
14. Refit flywheel. *See Flywheel*
15. Refit clutch. *See CLUTCH, Repair, Clutch Assembly*
16. Refit gearbox. *See MANUAL GEARBOX, Repair, R380 Manual Gearbox*
17. Reconnect battery negative lead.

OIL FILTER

Service repair no - 12.60.01

Remove

1. Place drain tray under filter.
2. Unscrew filter anti-clockwise, using a strap or spanner.

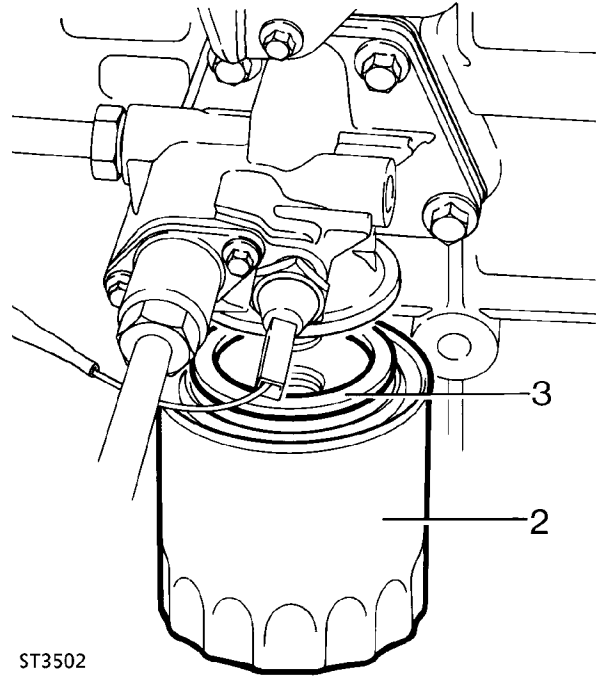

ST3502

Refit

3. Smear clean engine oil on seal of new filter.
4. Screw on filter until sealing ring touches machined face, then tighten a further half turn by hand only. Do not over tighten.



OIL TEMPERATURE CONTROL VALVE

Service repair no - 12.60.69

Remove

1. Disconnect oil cooler pipes.
2. Remove two bolts and carefully withdraw thermostat extension housing (1) complete with O ring seal (2), thermostat (3), two washers (4) and spring (5).

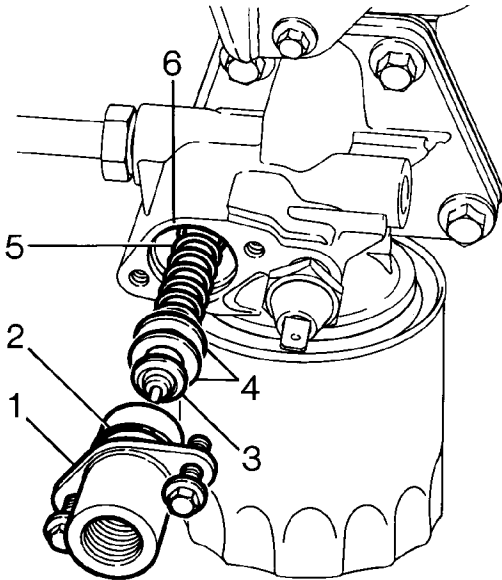

ST3504

3. Clean adaptor housing.
4. Inspect all parts and renew as necessary.

Refit

5. Fit thermostat to extension housing ensuring pin locates in hole.
6. Fit two washers and spring to thermostat.
7. Fit a new 'O' ring to extension housing.
8. Insert spring into adaptor and secure extension housing to adaptor with bolts. Tighten to **9 Nm**.

OIL FILTER HEAD GASKET

Service repair no - 12.60.03

Renew

1. Disconnect oil cooler pipes.
2. Disconnect pressure switch lead.
3. Remove securing bolts and withdraw head complete with gasket.
4. Clean mating faces.

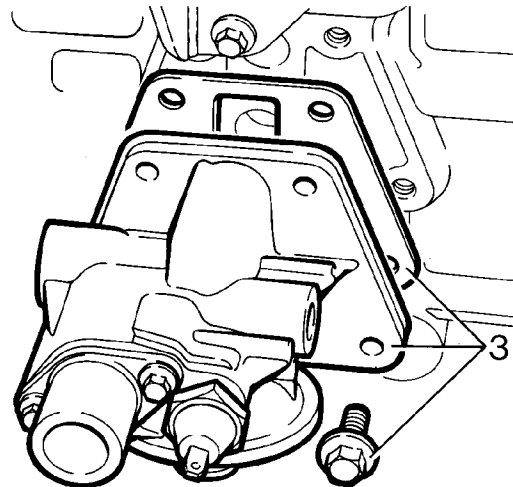

ST3503

5. Refit head with new gasket.
6. Secure with bolts. Tighten to **45 Nm**.
7. Refit pipes and reconnect pressure switch.

CYLINDER HEAD GASKET

Service repair no - 12.29.02

Remove

1. Disconnect battery negative lead.
2. Remove bonnet [Hood]. **See CHASSIS AND BODY, Repair, Bonnet [Hood]**
3. Drain coolant.
4. Remove air cleaner assembly. **See FUEL SYSTEM, Repair, Air Cleaner**
5. Detach crankcase ventilation valve and side breather hose from rocker cover and move to one side.
6. Remove injection pipes.

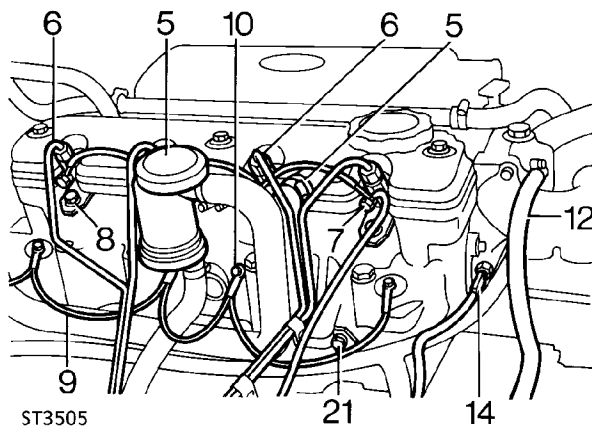

7. Disconnect spill rail from fuel injectors.
8. Remove fuel injectors and sealing washers. Identify each injector to the location from which it is removed. **See FUEL SYSTEM, Repair, Injectors**
9. Remove inter-connecting harness from glow plugs.
10. Remove glow plugs. **See FUEL SYSTEM, Repair, Glow Plugs**

11. Remove top hose, radiator to thermostat.
12. Disconnect by-pass hose from thermostat.
13. Disconnect hose, thermostat to water pump.
14. Disconnect water temperature sensor lead.

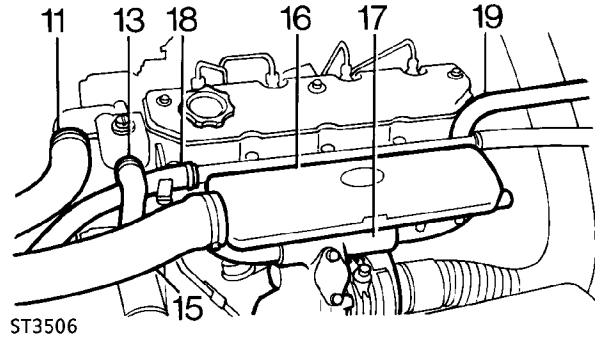

15. Remove hose inter-cooler to induction manifold.
16. Remove induction manifold. **See MANIFOLD AND EXHAUST SYSTEM, Repair, Exhaust Manifold - Tdi**
17. Remove exhaust manifold and turbocharger assembly. **See MANIFOLD AND EXHAUST SYSTEM, Repair, Exhaust Manifold - Tdi**
18. Disconnect heater hose from water pump and move heater rail aside.
19. Disconnect heater hose from rear of cylinder head.
20. Remove bolt securing air cleaner mounting bracket to support strut.
21. Remove bolt securing harness bracket to cylinder head.
22. Remove rear lifting bracket, this will also release clips securing transmission and engine breather pipes and multiplug. Note loose spacer under clip securing engine breather pipe and multiplug.



23. Remove rocker cover.

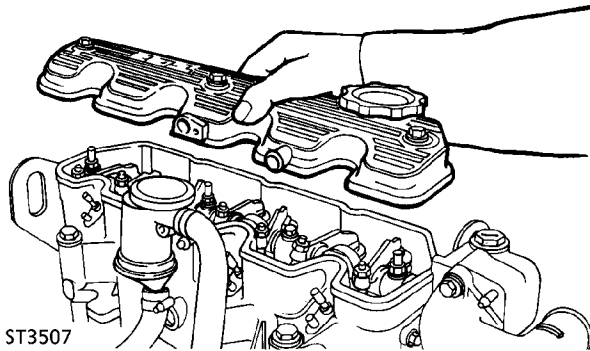

24. Remove nuts and bolts and withdraw rocker shaft assembly.

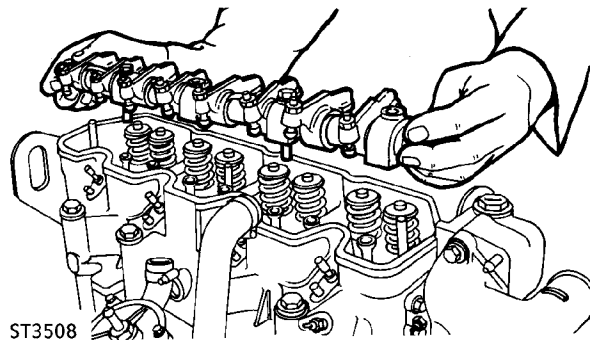

25. Remove push rods, store as an identified set to allow refitment to same location.

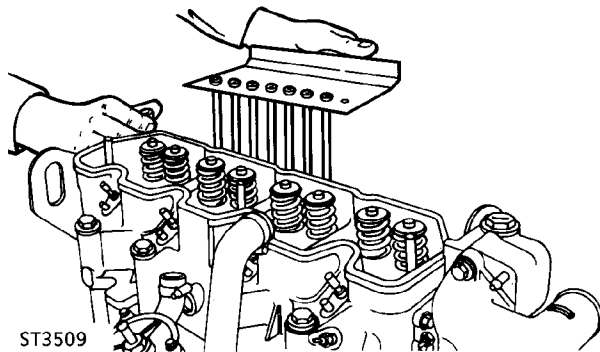

26. Remove valve stem caps.
27. Evenly slacken, then remove, bolts retaining cylinder head to block. Two of the bolts also secure the air cleaner mounting bracket.
28. Lift off cylinder head and remove gasket.

Refit

29. Ensure face of cylinder block is thoroughly clean.
30. Select new gasket of correct thickness.



CAUTION: Three thicknesses of gasket are available, different thicknesses are identified by the number of small holes punched in the right hand side of the gasket. One hole identifies the thinnest gasket and three holes the thickest. When renewing gaskets the gasket being fitted must be of the same thickness as the one removed. Therefore if the removed gasket had two holes punched in the side the replacement gasket must also have two holes punched in the side.

31. Place gasket on cylinder block with identification holes positioned towards rear on right hand side and side marked TOP uppermost.

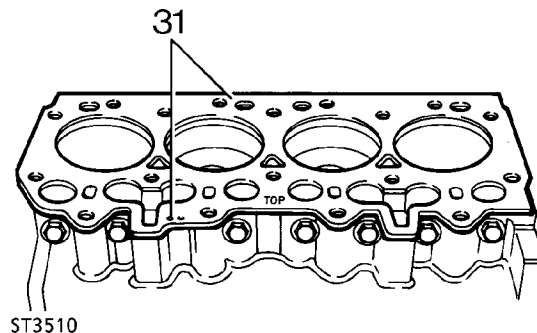

32. Clean mating face of cylinder head.
33. Lower cylinder head onto block ensuring correct location with dowels.



NOTE: Cylinder head retaining bolts can be used up to a maximum of five times.

34. Lubricate threads of bolts with light oil and fit to positions illustrated.

Bolt sizes:

M10 x 117mm locations 3, 5, 12, and 13.

M12 x 140mm locations 1, 2, 7, 8, 9, 10, 15, 16, 17, and 18.

M12 x 100mm locations 4, 6, 11, 14.

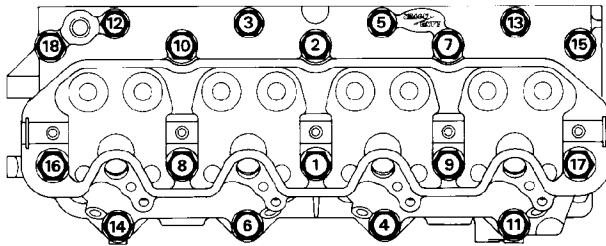

ST2619M

35. Tighten bolts so that underside of heads just make contact with cylinder head.
36. Following the sequence illustrated tighten all bolts to **40 Nm**.
37. Attach degree disc special tool LRT-12-007 to a power bar.
38. Make a suitable pointer from welding rod and attach to a bolt screwed into a rocker shaft securing bolt hole.

LRT 12 007

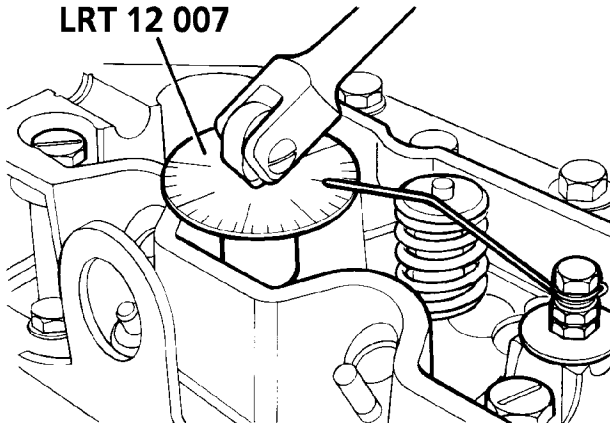

ST3515

39. Tighten all bolts through 60° strictly in sequence illustrated.
40. Repeat 60° tightening procedure, again strictly in sequence illustrated.
41. Tighten the ten longer bolts (M12 x 140mm) a further 20°, again following the sequence illustrated.



NOTE: Repositioning of the pointer will be necessary to reach all bolts, the pointer can be fitted to the rocker shaft securing studs using two nuts.



CAUTION: The double tightening procedure must be carried out, on no account should the total angles of tightening be performed in one operation, otherwise damage to the cylinder head may occur.

42. Fit valve stem caps.
43. Fit push rods to locations from which they were removed.
44. Fit rocker shaft assembly evenly tightening securing nuts and bolts to correct torque.
45. Fit rocker cover ensuring oil seal is satisfactory for continued use.



NOTE: Rocker cover seals can be re-used up to a maximum of five times.

46. Secure rocker cover with special seal washers and nuts tightened to correct torque.
47. Refit remainder of items by reversing operations 1 to 22 tightening securing bolts to correct torque where applicable.



VACUUM PUMP

Service repair no - 70.50.19

Remove



NOTE: To ease pump removal set engine to T.D.C. on No.1 cylinder.

1. Disconnect battery negative lead.
2. Detach servo hose from vacuum pump.

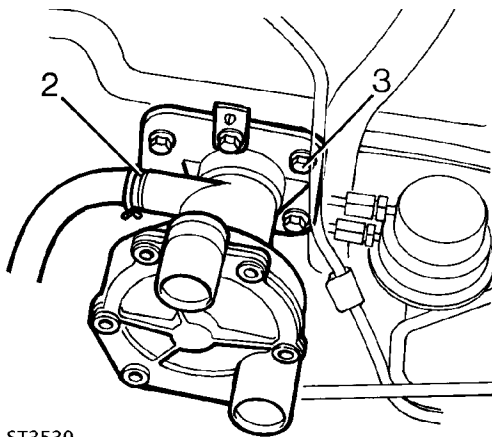

ST3530

3. Remove six bolts securing vacuum pump.
4. Detach pump complete with harness bracket. Note location of bracket for refitting.

Refit

5. Clean mating faces of pump and block.
6. Loosely assemble pump to block with a new gasket and with harness bracket located under head of bolt noted during removal.
7. Evenly tighten bolts, to depress pump plunger, finally tightening to **25 Nm**.
8. Connect vacuum hose and secure with clip.
9. Reconnect battery negative lead.

GENERATOR

Service repair no - 86.10.02

Remove

1. Disconnect battery negative lead.
2. Remove drive belt. **See Drive Belt Renew**
3. Disconnect electrical leads from rear of generator.
4. Remove securing bolt from bottom of generator.
5. Remove long through bolt from top fixing and withdraw generator.

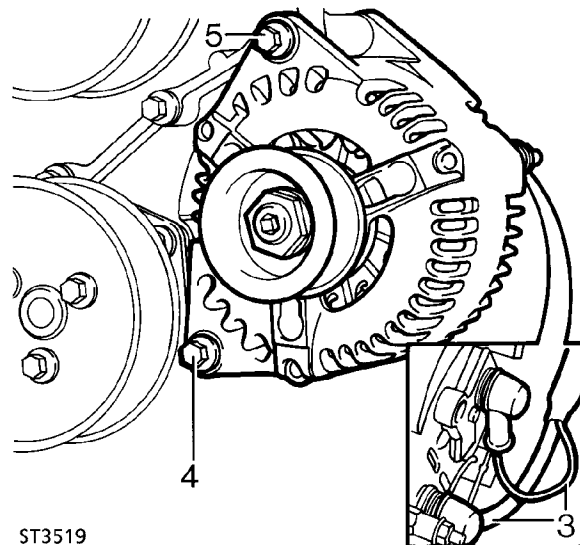

ST3519

Refit

6. Reverse removal procedure.



TORQUE VALUES



NOTE: Torque wrenches should be regularly checked for accuracy to ensure that all fixings are tightened to the correct torque.

	Nm
Engine block	
Bearing cap	133
Blanking plug, oil gallery, rear	37
Oil squirt jet assembly	17
Drain plug, cylinder block	25
Oil squirt jet, vacuum pump cam	7
Connecting rod to cap	59
Oil pick up assembly to bearing cap	9
Oil pick up assembly to front cover	25
Camshaft thrust plate	9
Oil drain pipe to block (internal)	25
Oil drain pipe to block (external)	25
Sump to cylinder block and front cover	25
Drain plug, oil sump	35
Tappet guide	14
Breather side cover assembly	25
Baffle plate to breather side cover	4
Vacuum pump	25
Fuel lift pump	25
Flywheel housing	45
Flywheel housing clutch cover stud	10
Plug, flywheel housing	12
Rear oil seal assembly	25
Oil filter adaptor	45
Waxstat adaptor to oil filter adaptor	9
Oil pressure switch	17
Oil filter, spin on	13
Oil cooler unions to filter adaptor	45
Oil level tube	25
Engine mounting foot to cylinder block	85
Engine mounting foot to flywheel housing	45
Engine mounting foot rubber to mounting foot (bolt and nut)	85
Flywheel to crankshaft	146
Clutch cover plate to flywheel	34
Flex drive plate to crankshaft (auto)	146
Flex drive plate to ring gear (auto)	25
Flex drive plate to torque converter (auto)	45

Cylinder head

Cylinder head to cylinder block	See repair section
Stub pipe heater feed	22
Water temperature sensor	14
Blanking plug cylinder head	14
Engine lifting brackets	25
Electrical harness clip bracket	25
Exhaust manifold stud	10
Exhaust manifold nut	45
Inlet manifold stud	8
Inlet manifold nut and bolt	25
Air temperature sensor, inlet manifold	14
Blanking plug, inlet manifold	14
Heatshield to inlet manifold	6
Glow plug	20
Glow plug terminal nut	2
Injector clamp (stud)	8
Injector clamp (nut)	25
Thermostat housing	25
Water outlet elbow to thermostat housing	25
Water temperature switch, thermostat housing	11
Plug thermostat housing	6
Rocker shaft pedestal bolt	5 + 50°
Rocker cover (stud)	8
Rocker cover (fixing nut)	10
Breather cyclone to rocker cover	9
Tappet adjusting nut	16
Front cover to cylinder block	25
Front cover plate to front cover	25
Static idler - timing belt (stud)	10
Static idler - timing belt (nut)	45
Tensioner (timing belt)	45
Camshaft hub bolt	80
Timing pulley to camshaft hub	25
Fuel injection pump (stud)	8
Fuel injection pump (nut)	25
Abutment bracket to injection pump	25
Support bracket injection pump to cylinder block	25
Fuel injection pump access plate to front cover plate	25
Timing pulley to injection pump hub	25
TV Damper pulley bolt to crankshaft	80 + 90°
Fan pulley to hub	25
Fan and viscous coupling to hub	45
Auto tensioner, auxiliary drive (stud)	14
Auto tensioner, auxiliary drive (nut)	45
Auxiliary mounting bracket to cylinder block (stud)	8
Auxiliary mounting bracket to cylinder block (bolt and nut)	25
Water pump to block and mounting plate	25
Water pump pulley to hub	25



Turbo charger oil drain adaptor to block	42
Oil drain pipe to turbocharger	25
Turbocharger oil drain pipe to adaptor	38
Turbocharger oil feed pipe adaptor to block	25
Turbocharger oil feed pipe to adaptor	25
Oil feed pipe to turbocharger	19
Turbocharger to cylinder head (stud)	10
Turbocharger to cylinder head (nut)	45
Turbocharger to blanking plate	25
Turbocharger to EGR valve	25
EGR delivery tube to valve	25
EGR delivery tube to mixing tube	25
Fuel lift pump to filter (union)	15
Fuel filter from lift pump (banjo bolt)	33
Fuel filter to fuel injection pump (banjo bolt)	33
Fuel injection pump from fuel filter (banjo bolt)	25
Injector pipes to injectors and fuel injection pump	29
Spill rail to injectors (banjo bolt)	10
Spill rail to injection pump (banjo bolt)	25
Boost pipe injection pump (banjo bolt)	10
Plug, rear of injection pump	29
PAS pump to mounting plate	25
PAS pump mounting plate to auxiliaries mounting bracket	25
PAS pump pulley to hub	25
Generator to auxiliaries mounting bracket	25
Starter motor (bolt and nut)	45
Tachometer electrical connection	4
Air conditioning compressor	
Compressor mounting bracket to front cover	45
Compressor to mounting bracket (stud)	8
Compressor to mounting bracket (nut)	25
Belt tensioner pulley to tensioner arm	45
Belt tensioner assembly to front cover plate	25
Idler pulley to front cover plate	45
Compressor belt guard (nut)	25
Sensors to water outlet elbow (air/con)	25
Blanking plug, water outlet elbow (air/con)	25
Generator mounting bracket to front cover	45
Generator to mounting bracket	85
Generator pulley to hub	95
Generator belt guard	25

METRIC	Nm
M5	6
M6	9
M8	25
M10	45
M12	90
M14	105
M16	180

UNC / UNF	
1/4	9
5/16	24
3/8	39
7/16	78
1/2	90
5/8	136



NOTE: Torque values above are for all screws and bolts used except for those specified.



DESCRIPTION

The V8i engine has cast aluminium cylinder heads and cylinder block. The two banks of steel cylinder liners which are pressed down to stops in the block, are set at 90° to one another. The three ringed aluminium pistons transmit the power through the connecting rods to a cast iron five bearing crankshaft, which drives the centrally located camshaft via a duplex type chain.

The electronic ignition distributor is driven by a gear off the front of the camshaft and the lubrication oil pump is driven by a gear off the front of the crankshaft. The overhead inlet and exhaust valves are operated by rocker shafts, pushrods and self adjusting hydraulic tappets.

Multipoint fuel injection ensures that engine performance, economy and exhaust emissions are automatically correct for the demands of highway and off road operation.

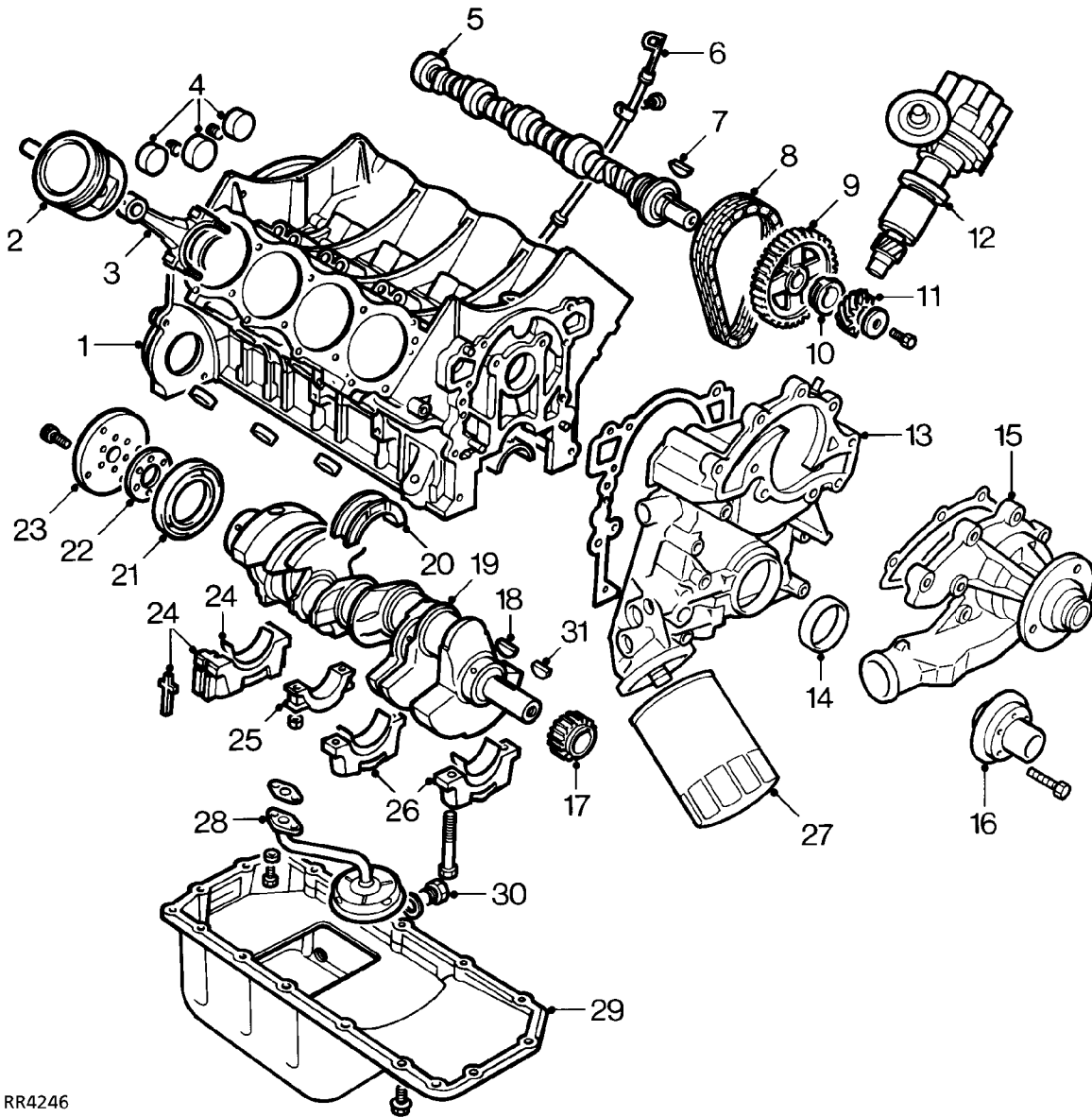

RR4246

- | | |
|---------------------------------|---|
| 1. Cylinder block | 17. Crankshaft sprocket |
| 2. Pistons and gudgeon pins (8) | 18. Crankshaft sprocket key |
| 3. Connecting rods (8) | 19. Crankshaft |
| 4. Core plugs | 20. Centre main bearing shells (2) |
| 5. Camshaft | 21. Crankshaft rear oil seal |
| 6. Dipstick | 22. Spacer |
| 7. Camshaft key | 23. Adaptor plate |
| 8. Timing chain | 24. Rear main bearing cap, shell and side seals |
| 9. Camshaft sprocket | 25. Connecting rod caps |
| 10. Distance piece | 26. Main bearing caps and shell bearings |
| 11. Distributor drive gear | 27. Oil filter |
| 12. Distributor | 28. Oil pump suction pipe/strainer |
| 13. Front cover | 29. Oil sump |
| 14. Front cover oil seal | 30. Oil sump drain plug |
| 15. Coolant pump | 31. Oil pump drive key |
| 16. Crankshaft damper / pulley | |

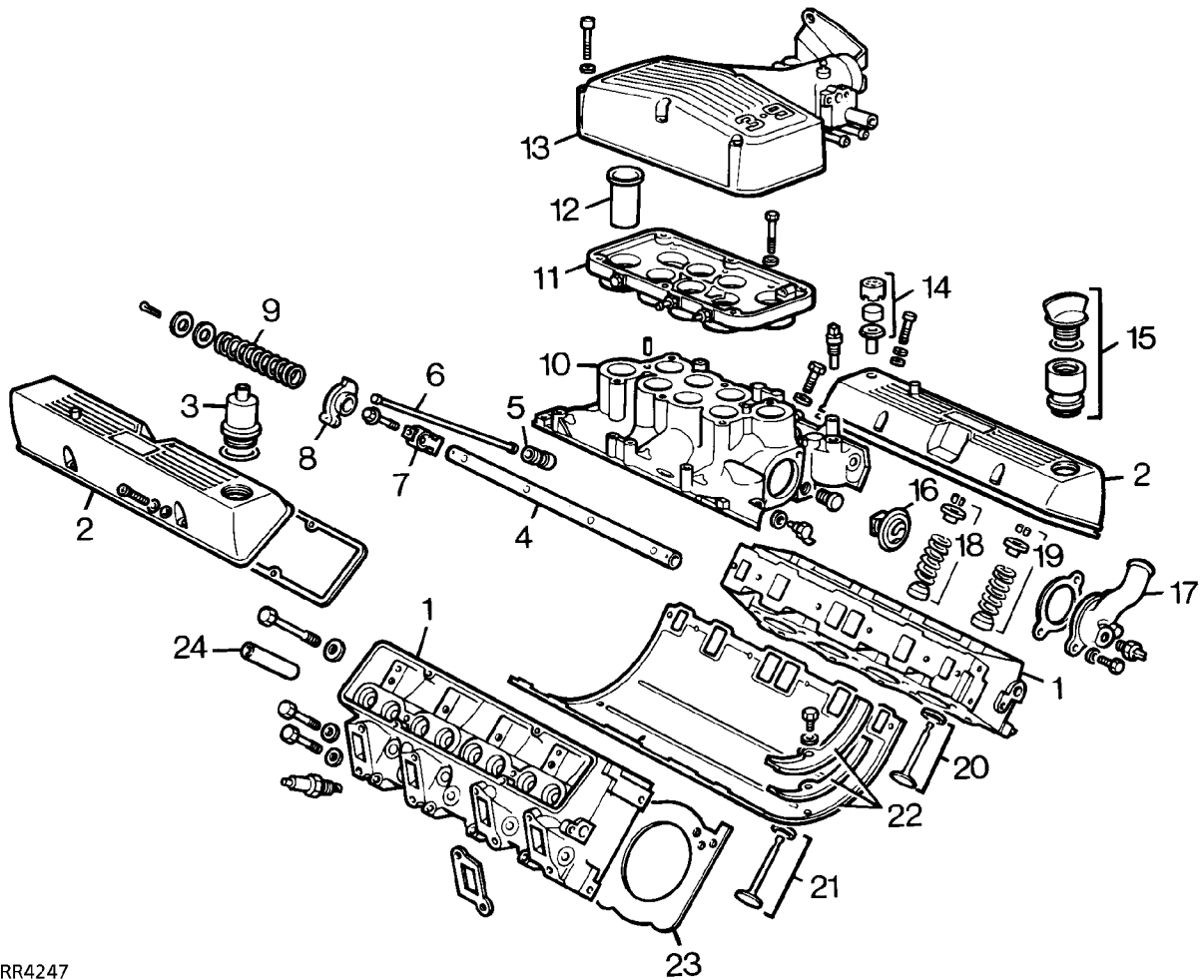

RR4247

- | | |
|---------------------------------------|---|
| 1. Cylinder heads (2) | 13. Plenum chamber upper |
| 2. Rocker covers (2) | 14. PCV air intake filter |
| 3. PCV filter | 15. Oil filler |
| 4. Rocker shafts (2) | 16. Thermostat |
| 5. Hydraulic tappets (8) | 17. Thermostat cover |
| 6. Pushrods (8) | 18. Inlet valve seal, spring, cap and collets (8) |
| 7. Rocker brackets (8) | 19. Exhaust valve seal, spring, cap and collets (8) |
| 8. Rocker arms (4) left and (4) right | 20. Inlet valve and seat (8) |
| 9. Rocker shaft springs (6) | 21. Exhaust valve and seat (8) |
| 10. Inlet manifold | 22. Inlet manifold gasket and seals |
| 11. Plenum chamber lower | 23. Cylinder head gaskets (2) |
| 12. Ram pipes (8) | 24. Valve guides (16) |

Lubrication system

The V8i full flow lubrication system uses a gear type oil pump which is driven from the front of the crankshaft. The oil pump gears are housed in the front cover and the pressure relief valve, warning light switch and filter are also fitted to the front cover.

Oil drawn through the centrally located steel gauze strainer in the sump, is pumped under pressure through oil cooler located in the lower half of the main coolant radiator. The cooled oil then passes through the filter, before being distributed from the main gallery via drillings, to the various components in the engine.

Lubrication to the thrust side of the cylinders is by oil grooves machined in each connecting rod big end joint face, which are timed to align with holes in the big end journals on the power and exhaust strokes.

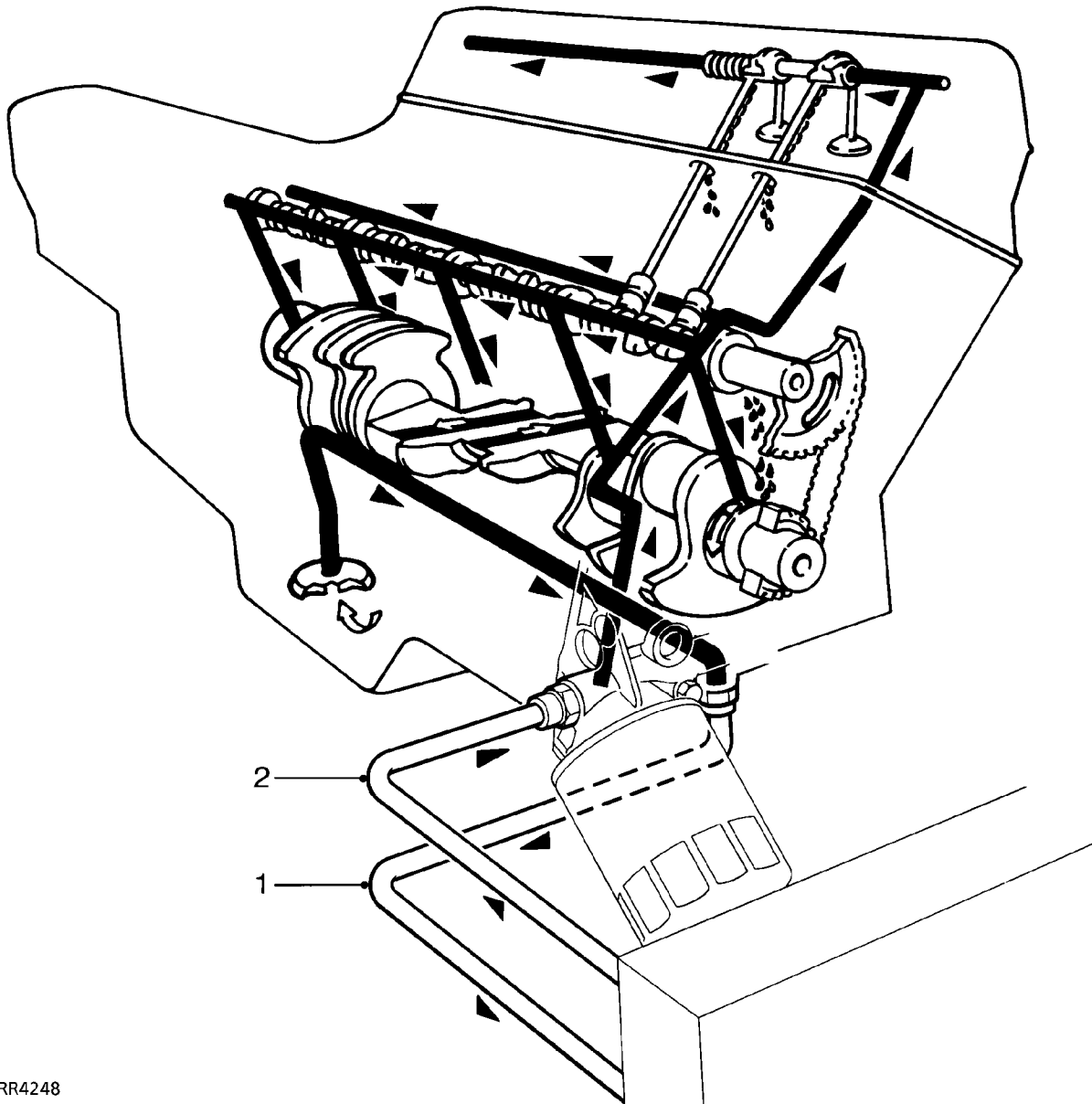

RR4248

Lubrication system

1. Oil to cooler
2. Oil from cooler



Distributor and timing chain lubrication

The distributor and timing chain are lubricated from the camshaft front bearing. The feed to the timing chain is channelled along the camshaft sprocket, key and spacer where it sprays onto the chain.

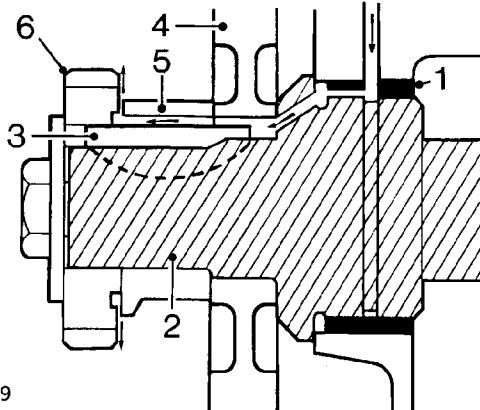

RR4249

1. Bearing
2. Camshaft
3. Key
4. Camshaft timing chain sprocket
5. Spacer
6. Distributor drive gear

Hydraulic tappets

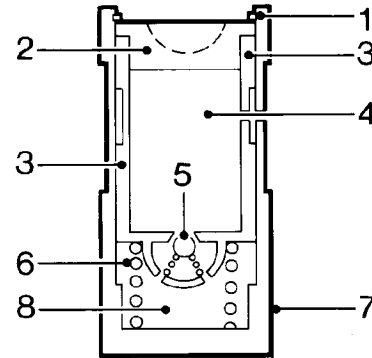

RR4250

1. Clip
2. Pushrod seat
3. Inner sleeve
4. Upper chamber
5. Non-return ball valve
6. Spring
7. Outer sleeve
8. Lower chamber - high pressure

The purpose of the hydraulic tappet is to provide maintenance free and quiet operation of the inlet and exhaust valves. It achieves its designed purpose by utilizing engine oil pressure to eliminate the mechanical clearance between the rockers and the valve stems.

During normal operation, engine oil pressure present in the upper chamber 4, passes through the non-return ball valve 5 and into the lower (high pressure) chamber 8.

When the cam begins to lift the outer sleeve 7, the resistance of the cylinder valve spring felt through the pushrod seat 2, causes the inner sleeve 3, to move downwards inside the outer. This slight downward movement of the inner sleeve closes the ball valve 5 and increases the hydraulic pressure in the high pressure chamber, sufficient to ensure that the push rod opens the valve fully.

As the tappet assembly moves off the peak of the cam the ball valve 5 opens to equalize the pressure in both chambers which ensures that the valve fully closes when the tappet is on the back of the cam.



ENGINE OIL PRESSURE TEST

Service tools:

LRT-12-052: Pressure test equipment



WARNING: Use suitable exhaust extraction equipment, if test is being carried out in workshop.



WARNING: If vehicle has been running, engine oil will be hot, care must be taken when fitting equipment to prevent personal injury due to scalding.

Test

1. Check lubricant is to correct level.
2. Place vehicle on a ramp [hoist].
3. Disconnect battery negative lead. Remove oil pressure switch.
4. Fit the test gauge.
5. Reconnect battery negative lead.
6. Start and run engine to normal operating temperature.
7. At a steady engine speed of 2500 rev/min - engine oil pressure reading should be - 2.75 bar (40 lbf/in²).
8. If the pressure is low - Remove and overhaul oil pump

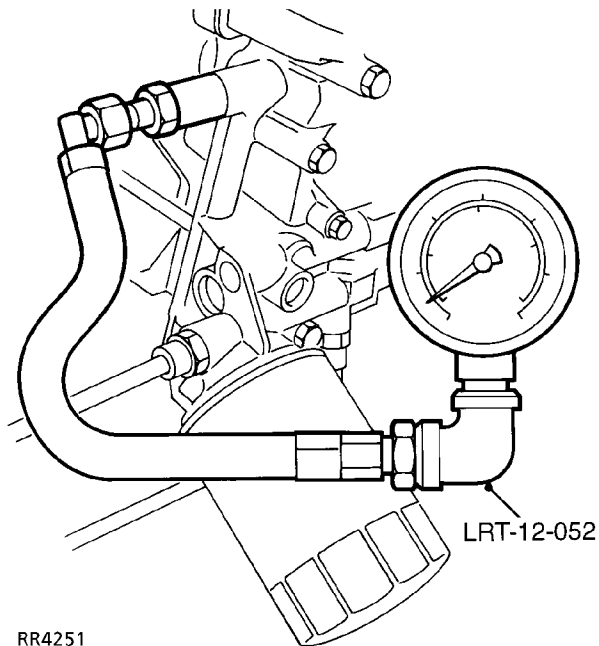

RR4251

CYLINDER COMPRESSION - TEST

Equipment:

Compression pressure gauge

Test

1. Start and run engine until normal engine operating temperature is achieved (thermostat open).
2. Remove all spark plugs.
3. Disconnect both coil negative (WB) leads
4. Insert compression gauge, crank engine until reading stabilises.
5. Expected readings, throttle fully open, battery fully charged:
 - 8.31:1 = 10.2-10.9 bar, 150-160lbf/in²
 - 9.35:1 = 11.5-12.2 bar, 170-180lbf/in²

ENGINE NOISES

Excessive or obtrusive noise from the engine compartment originates from three main sources:

- A. The exhaust system, which makes an unmistakable and easy to diagnose noise.
- B. External components emit the greatest variety of noises, but are also easy to diagnose by simply removing the drive belt.
- C. Engine internal mechanical noises which can vary in volume and pitch and may be a combination of, tapping - knocking or rumbling, are the most difficult to diagnose. The following is therefore a guide to diagnosis of engine internal mechanical noises only.

Engine internal mechanical noises.

Single or multiple, light tapping noise, particularly when engine is cold. See Description and operation, Description

- 1. Is engine oil level correct?
NO - Top up to correct level. **See LUBRICANTS, FLUIDS AND CAPACITIES, Information, Recommended Lubricants and Fluids**
YES - Continue.
- 2. Is the lubricating pressure correct?
NO - **See Engine Oil Pressure Test**
YES - Suspect valve operating mechanism.
- 3. To confirm diagnosis, remove the rocker covers and with the engine idling, insert a feeler gauge of 0,015mm between each rocker and valve stem. A faulty valve operating mechanism will emit a different noise when the feeler gauge is inserted. **See Repair, Rocker Shaft Renew**

Heavy knocking noise (particularly on load and when engine is hot). See Description and operation, Description

- 1. Is engine oil level correct?
NO - Top up to correct level. **See LUBRICANTS, FLUIDS AND CAPACITIES, Information, Recommended Lubricants and Fluids**
YES - Continue.
- 2. Is the lubricating pressure correct?
NO - **See Engine Oil Pressure Test**
YES - Drain engine oil and filter, and examine for metallic contamination.
- 3. Is the oil contaminated with metal particles?
YES - Suspect faulty big end bearings. To confirm diagnosis, short out the ignition to each spark plug in turn. The noise will disappear or be reduced when the cylinder with the faulty big end is shorted out.
- 4. If noise is not conclusively diagnosed, check the security of the flywheel and crankshaft front pulley. Temporarily release the drive belt to reduce general noise level and use a stethoscope to locate source of noise.

Heavy rumbling noise (particularly during hard acceleration). See Description and operation, Description

- 1. Is engine oil level correct?
NO - Top up to correct level. **See LUBRICANTS, FLUIDS AND CAPACITIES, Information, Recommended Lubricants and Fluids**
YES - Continue.
- 2. Is the lubricating pressure correct?
NO - **See Engine Oil Pressure Test**
YES - Drain engine oil and filter, and examine for metallic contamination.
- 3. Is the oil contaminated with metal particles?
YES - Suspect faulty main bearings. If noise is not conclusively diagnosed, check the security of the flywheel and crankshaft front pulley. Temporarily release the drive belt to reduce general noise level and use a stethoscope to locate source of noise.



ENGINE STARTING PROBLEMS

Engine fails to crank in park or neutral (Automatic Transmission)

1. Is battery in good state of charge?
NO - **See INTRODUCTION, Information, Jump Starting**
YES - Continue.
2. Is automatic transmission inhibitor switch faulty or gear selection linkage incorrectly adjusted?
YES - **See AUTOMATIC GEARBOX, Repair, Inhibitor Switch**,
NO - **See Electrical Trouble Shooting Manual**.
If problem is not diagnosed repeat tests, starting at 1.

Engine fails to crank (Manual Transmission)

1. Is battery in good state of charge?
NO - **See INTRODUCTION, Information, Jump Starting**
YES - **See Electrical Trouble Shooting Manual**.
If problem is not diagnosed repeat tests, starting at 1.

Engine cranks but fails to start

1. Is the cranking speed fast enough (120 rpm)?
NO - **See INTRODUCTION, Information, Jump Starting**
If necessary also. **See Electrical Trouble Shooting Manual**.
YES - Continue.
2. Is there combustion in any cylinder?
NO - **See ELECTRICAL, Fault diagnosis, Lucas Constant Energy Ignition System - V8i See Electrical Trouble Shooting Manual**.
YES - Continue.
3. Are the fuel supply, tank, pump, ventilation and emission control systems in correct working order or the fuel contaminated?
NO - **See FUEL SYSTEM, Repair, Fuel Filter See FUEL SYSTEM, Repair, Fuel Tank See FUEL SYSTEM, Repair, Fuel pump and Sender Unit See EMISSION CONTROL, Description and operation, Emission control**
If problem is not diagnosed repeat tests, starting at 2.

ENGINE RUNNING PROBLEMS

Engine runs at high speed but will not idle (stops) Engine idle speed erratic Engine starts but stops immediately

Engine stalls Engine misfires/hesitation

1. Multiport fuel injection. **See Electrical Trouble Shooting Manual. See ELECTRICAL, Fault diagnosis, Lucas Constant Energy Ignition System - V8i**
Check brake vacuum connections. **See BRAKES, Description and operation, Brake Servo Unit**
Check heater/ventilation unit vacuum connections. **See HEATING AND VENTILATION, Description and operation, Heating and Ventilation Unit**
If problem is not diagnosed continue.
2. Are HT leads correctly routed and clipped?
NO - **See ELECTRICAL, Repair, Distributor - V8i**
YES - Continue.
3. Is fuel supply, tank, pump, ventilation and emission control systems in correct working order or the fuel contaminated?
NO - **See FUEL SYSTEM, Repair, Fuel Filter See FUEL SYSTEM, Repair, Fuel Tank See FUEL SYSTEM, Repair, Fuel Pump and Sender Unit See EMISSION CONTROL, Description and operation, Emission Control**
If problem is not diagnosed repeat tests, starting at 1.

Engine lacks power/poor performance

1. Is throttle travel restricted or cable incorrectly adjusted?
YES - Check thickness of carpets. **See FUEL SYSTEM, Repair, Throttle Cable See FUEL SYSTEM, Repair, Accelerator Pedal**
NO - Continue.
2. Are the Ignition and Multiport Fuel Injection systems in order?
NO - **See Electrical Trouble Shooting Manual.A1 See ELECTRICAL, Fault diagnosis, Lucas Constant Energy Ignition System - V8i See ELECTRICAL, Repair, Distributor - V8i**
YES - Continue.

3. Are fuel supply, tank, pump, ventilation and emission control systems in correct working order or the fuel contaminated?
NO - **See FUEL SYSTEM, Repair, Fuel Filter** **See FUEL SYSTEM, Repair, Fuel Tank** **See FUEL SYSTEM, Repair, Fuel Pump and Sender Unit**
YES - Suspect valves held open by hydraulic tappets due to high oil pressure. **See Engine Oil Pressure Test**
4. Is oil pressure high?
YES - Remove oil filter and cooler adaptor and check pressure relief valve strainer gauze for blockage and that the relief valve is not stuck closed. **See Description and operation, Description**
NO - Carry out cylinder compression tests to determine condition of head gaskets and valves. **See Cylinder Compression - Test**
5. Are cylinder compressions satisfactory?
NO - **See Repair, Cylinder Heads - Renew**
YES - Check brake vacuum connections. **See BRAKES, Description and operation, Brake Servo Unit**

Check heater/ventilation unit vacuum connections. **See HEATING AND VENTILATION, Description and operation, Heating and Ventilation Unit**

If problem is not diagnosed: Continue.

6. Are the brakes binding?
YES - Investigate cause of binding.
NO - Continue.
7. Automatic Transmission only. Is the Torque Converter and Transmission operating correctly?
Carry out Road test, Static tests and Stall tests to determine condition of Automatic transmission.

If problem is not diagnosed: repeat tests starting at 1.

Engine backfires into exhaust system

1. Are there any leaking joints/connections or holes in the exhaust system?
YES - **See MANIFOLD AND EXHAUST SYSTEM, Repair, Exhaust System Complete**
NO - Continue.
2. Is distributor fitted correctly, HT leads in correct firing order and routed correctly?
NO - **See ELECTRICAL, Repair, Distributor - V8i**
YES - Continue.
3. Is air fuel ratio correct?
NO - Check multiport fuel injection. **See Electrical Trouble Shooting Manual.** Check brake vacuum connections. **See BRAKES, Description and operation, Brake Servo Unit**
Check heater/ventilation unit vacuum connections. **See HEATING AND VENTILATION, Description and operation, Heating and Ventilation Unit**
Check the crank case and fuel tank ventilation system. **See EMISSION CONTROL, Description and operation, Emission Control**
YES - Continue.
4. Are cylinder compressions satisfactory?
NO - Carry out compression test to check for leaking gaskets valves etc. **See Cylinder Compression - Test** **See Repair, Cylinder Heads - Renew**

If problem is not diagnosed: repeat tests starting at 1.



Engine backfires into inlet system

1. Is the Distributor, HT connections and routing correct?
NO - **See *ELECTRICAL, Repair, Distributor - V8i***
YES - Continue.

2. Is air fuel ratio correct?
NO - Check multipoint fuel injection. **See *Electrical Trouble Shooting Manual***.
Check brake vacuum connections. **See *BRAKES, Description and operation, Brake Servo Unit***
Check heater/ventilation unit vacuum connections. **See *HEATING AND VENTILATION, Description and operation, Heating and Ventilation Unit***
Check the crank case and fuel tank ventilation system. **See *EMISSION CONTROL, Description and operation, Emission Control***
YES - Continue.

3. Are cylinder compressions satisfactory?
NO - Carry out compression test to check for leaking gaskets valves etc. **See *Cylinder Compression - Test***
For repair **See *Repair, Cylinder Heads - Renew***

If problem is not diagnosed: repeat tests starting at 1.



DRIVE BELT

A single 'serpentine drive belt' is introduced for 1995 model year. This belt drives the water pump and all the ancillaries. It is essential that the belt is fitted exactly as shown in illustrations RR3956 and RR3957. It should also be noted that the water pump/viscous fan is driven in a counter clockwise direction.

A drive belt tensioner automatically tensions the drive belt, eliminating the need for tensioning individual drive belts. Turning the tensioner pulley in a clockwise direction will release drive belt tension.

Under normal highway use the belt must be changed at 120,000 kilometres, 75,000 miles or five years whichever occurs first.

The drive belt must be examined at every service and replaced if necessary.

Off road driving

Regular examination of the drive belt is essential if the vehicle is used off road. The vehicle driver should be requested to identify the type of mileage the vehicle has covered.

After every off road session the owner should inspect the belt for cuts and possible damage caused by stones. If belt has jumped, reposition belt correctly. A new belt must be fitted at the next service or before, dependant on the type of damage sustained.

Fan cowl

To ensure easy access to the drive belt the top portion of the fan cowl is detachable.

Check condition

Check condition of drive belt. Renew a belt that shows signs of wear, splitting or oil contamination.

DRIVE BELT RENEW

Service repair no - 86.10.03

Air conditioning

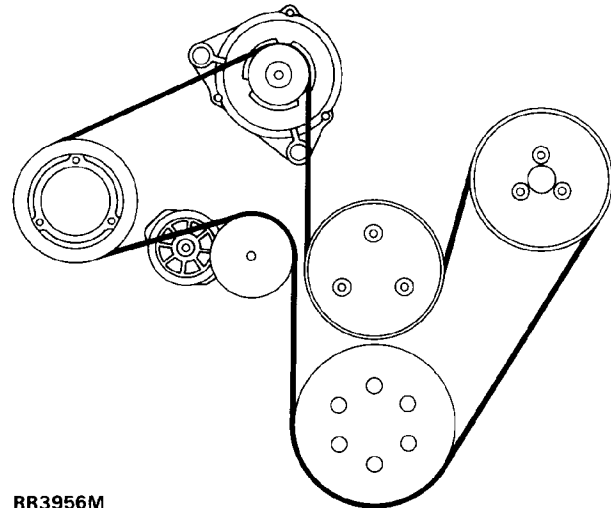

RR3956M

Non air conditioning

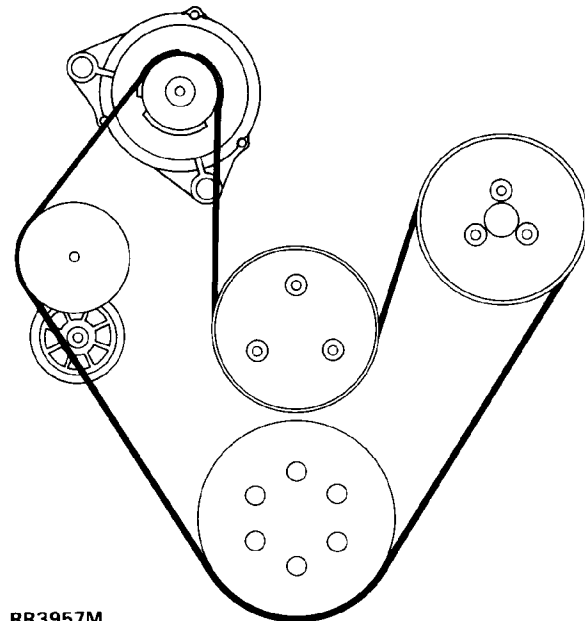

RR3957M

Remove

1. Remove fan cowl upper.
2. Release drive belt tension by turning tensioner clockwise.

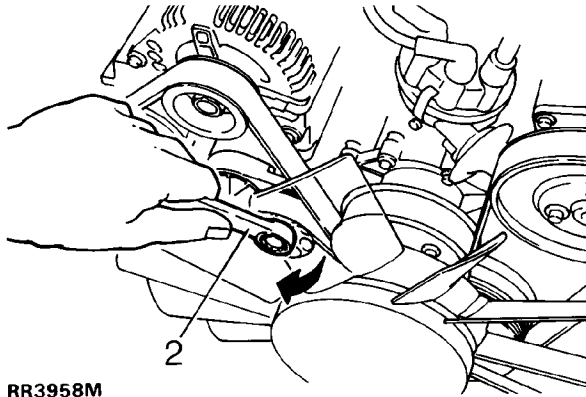

RR3958M

3. With tension released, remove belt from generator pulley.
4. Release tensioner pulley.
5. Remove drive belt. Mark direction of rotation on belt if refitting

Refit

6. Clean drive belt pulley grooves and ensure grooves are not damaged.
7. Position belt correctly around all pulleys except generator. Illustrations RR3956 and RR3957 show correct drive belt run.
8. Turn drive belt tensioner clockwise.
9. Locate drive belt on generator pulley.
10. Ensure drive belt is squarely located on pulleys with all grooves engaged.
11. Release tensioner to tension drive belt.
12. Fit upper fan cowl section.

DRIVE BELT - CHECK TENSION

As the drive belt is automatically tensioned, no tension check or adjustment should be necessary. If the drive belt is believed to be slack carry out the following checks:

1. Visually check drive belt tension.
2. Watch movement of tensioner with engine running, 5 mm 'bounce' is normal. If tensioner movement is 12 mm or more, fit a new tensioner.
See Drive Belt Tensioner
3. Inspect tensioner. Is the tensioner arm and spring case in contact? If so fit a new tensioner.
4. Using a recognised drive belt tensioning gauge, check belt tension several times, running engine between checks. The checks should be made at the same point on the belt, away from the tensioner.

Drive belt tension, with used tensioner and used drive belt should be more than:-

- 270N. Non air conditioning or
- 295N with air conditioning.



DRIVE BELT TENSIONER

Service repair no - 86.10.09

Remove

1. Remove drive belt from tensioner. *See Drive Belt Renew*
2. Loosen tensioner centre bolt.
3. Remove bolt and tensioner.

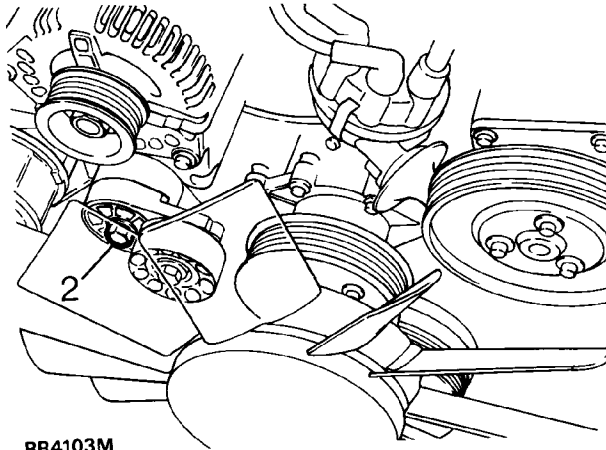

RR4103M

Refit

4. Reverse removal procedure.

CYLINDER HEAD GASKETS - RENEW

Service repair no - 12.29.01

1. Drain cooling system. *See COOLING SYSTEM, Adjustment, Coolant*
2. Remove inlet manifold. *See FUEL SYSTEM, Repair, Intake Manifold*
3. Remove generator.
4. If fitted, remove compressor. *See AIR CONDITIONING, Repair, Compressor*
5. Remove rocker shafts. *See Rocker Shaft Renew*
6. Remove push rods.
7. Remove both exhaust manifolds. *See MANIFOLD AND EXHAUST SYSTEM, Repair, Exhaust Manifold - V8i*
8. Remove air cleaner assembly. *See FUEL SYSTEM, Repair, Air Cleaner Assembly*
9. Remove air flow sensor. *See FUEL SYSTEM, Repair, Air Flow Sensor*
10. Remove ground leads from rear of left hand cylinder head
11. Right hand cylinder head - remove breather pipe from lifting bracket.
12. Loosen cylinder head bolts, reversing tightening sequence.
13. Remove cylinder heads.
14. Remove cylinder head gaskets.
15. Clean exhaust mating faces.
16. Clean head and block faces.
17. Fit new cylinder head gaskets, word TOP uppermost. DO NOT use sealant.
18. Oil cylinder bores.
19. Clean threads of head bolts and lightly oil.
20. Locate cylinder heads on block.
21. Locate cylinder head bolts in position illustrated.
96 mm long bolts - 2, 4, 6, 7, 8, 9, 10
66 mm long bolts - 1, 3, 5



NOTE: There are no bolts fitted in the four lower holes in each cylinder head.

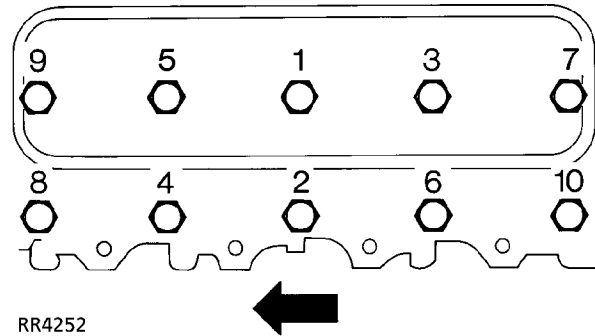

NOTE: Left hand cylinder head illustrated, arrow points to front of vehicle.

22. Tighten bolts progressively in sequence, shown to **20 Nm** then a further 180° ± 5°
23. Reverse removal procedure. 1 to 11.



CYLINDER HEADS - RENEW

Service repair no - 12.29.15

1. Remove cylinder heads and gaskets. **See *Cylinder Head Gaskets - Renew***
2. Remove spark plugs.
3. Using spring compressor LRT-12-034, remove seals, valves, collets, springs and caps.



CAUTION: Keep components in fitted order

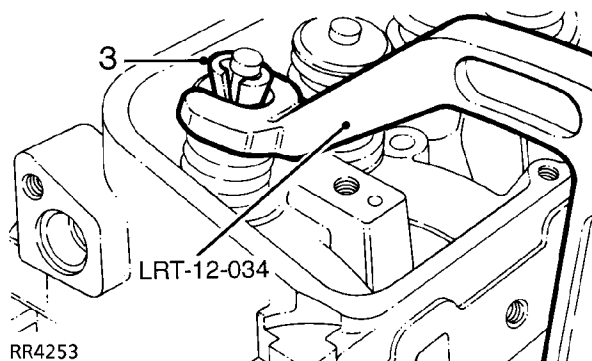

4. From left hand cylinder head, remove earth lead studs.
5. Remove three bolts securing power steering pump mounting bracket to cylinder head.
6. Remove four bolts securing generator mounting bracket to cylinder head.
7. Right hand cylinder head, remove rear lifting bracket.
8. Fit lifting bracket to new right hand cylinder head.
9. Fit mounting brackets and earth lead studs to new cylinder head. Tighten bolts to **30 Nm**.
10. Regrind valves- refer to engine overhaul publication
11. Lubricate valve stems, fit valves, springs, and caps. Fit new inlet and exhaust valve stem seals.
12. Using spring compressor LRT-12-034, compress springs, fit collets. Tap valve to check correct collet seating.
13. Fit spark plugs.
14. Fit cylinder heads with new gaskets. **See *Cylinder Head Gaskets - Renew***

ROCKER COVER - RIGHT HAND - RENEW

Service repair no - 12.29.41

1. Disconnect battery negative lead.
2. Disconnect purge pipe from charcoal canister at plenum.
3. Remove breather pipe from rocker cover.
4. Remove coolant pipes from inlet manifold.
5. Remove spark plug leads from plugs and retaining clips.
6. Remove four rocker cover bolts. Moving fuel pipes aside, remove rocker cover.
7. Discard rocker cover gasket.
8. Remove plug lead retaining clips from rocker cover, fit to new rocker cover.
9. Clean and dry rocker cover and cylinder head mating faces, using Bostik cleaner 6001.



NOTE: Gasket fits one way round only. It must be fitted accurately, first time. Subsequent movement will destroy bonding.

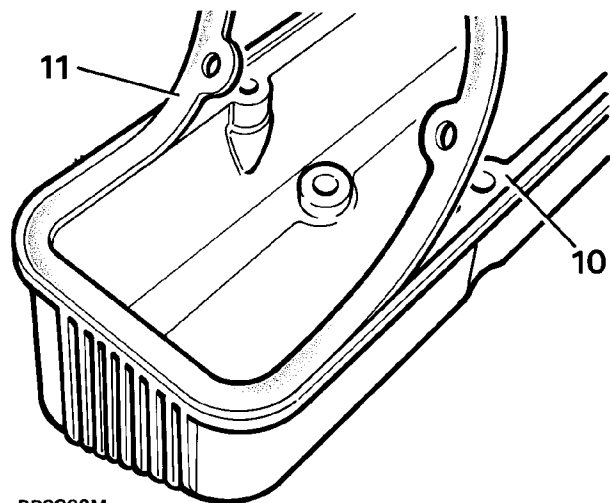

10. Apply Bostik 1775 impact adhesive to rocker cover seal face and gasket, using a brush to ensure an even film. Allow adhesive to become touch dry.

11. Place one end of gasket into cover recess with edge firmly against recess wall, holding remainder of gasket clear. Work around cover, pressing gasket into place ensuring edge firmly contacts recess wall.
12. Allow cover to stand for thirty minutes before fitting.
13. Fit rocker cover to cylinder head with four screws, short screws inboard, tighten to **9 Nm**.
14. Position fuel pipes.
15. Fit breather pipe to rocker cover, tighten clip.
16. Fit coolant pipes to inlet manifold, tighten bolts.
17. Fit spark plug leads to plugs and retaining clips.
18. Connect purge pipe from charcoal canister at plenum, tighten clip.

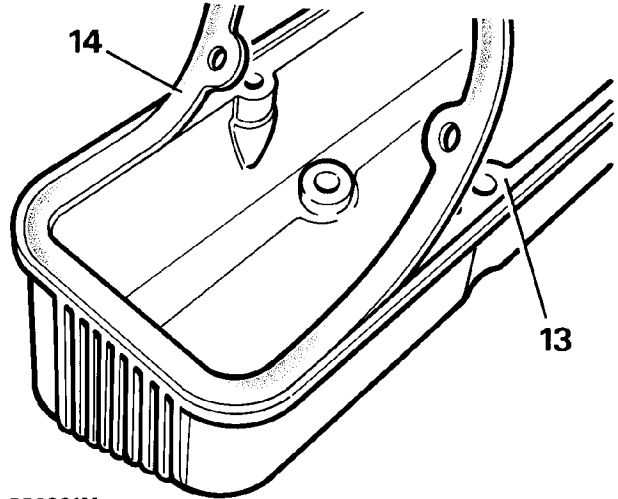

RR3821M

ROCKER COVER - LEFT HAND - RENEW

Service repair no - 12.29.40

1. Remove air flow sensor. *See FUEL SYSTEM, Repair, Air Flow Sensor*
2. Remove plenum chamber. *See FUEL SYSTEM, Repair, Plenum Chamber*
3. Remove dipstick.
4. Remove spark plug leads from plugs and retaining clips.
5. Disconnect HT lead from coil.
6. Remove generator heat shield securing nut from rocker cover.
7. Remove air flow meter harness clip.
8. Remove bolt securing dipstick tube clip.
9. Remove four rocker cover bolts, remove rocker cover.
10. Discard gasket
11. Remove plug lead retaining clips from rocker cover, fit to new rocker cover.
12. Clean and dry rocker cover and cylinder head mating faces, using Bostik cleaner 6001.



NOTE: Gasket fits one way round only. It must be fitted accurately, first time. Subsequent movement will destroy bonding.

13. Apply Bostik 1775 impact adhesive to rocker cover seal face and gasket, using a brush to ensure an even film. Allow adhesive to become touch dry, approximately fifteen minutes.
14. Place one end of gasket into cover recess with edge firmly against recess wall, holding remainder of gasket clear. Work around cover, pressing gasket into place ensuring edge firmly contacts recess wall.
15. Allow cover to stand for thirty minutes before fitting.
16. Fit rocker cover to cylinder head with four screws, short screws inboard. Tighten to **9 Nm**.
17. Position dipstick tube clip. Fit and tighten bolts.
18. Fit and tighten air flow meter harness clip.
19. Fit generator heat shield to rocker cover.
20. Connect HT lead to coil.
21. Connect spark plug leads to plugs and retaining clips.
22. Fit dipstick.
23. Fit plenum chamber.
24. Fit air flow meter.



ROCKER SHAFT RENEW

Service repair no - 12.29.29

1. Remove rocker covers as required. *See **Rocker Cover - Right Hand - Renew** or **Rocker Cover - Left Hand - Renew***
2. Loosen four rocker shaft fixings.

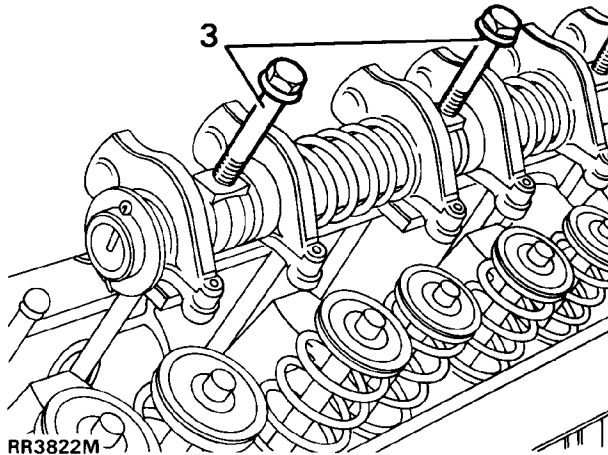

3. Remove rocker shaft assembly.



NOTE: Each rocker shaft is notched at **ONE** end. Notch must be uppermost and towards front of engine on right hand side, towards rear on left hand side.

4. Clean rocker pedestal locations on cylinder head.
5. Fit rocker shaft assembly, locating push rods to rockers.
6. Tighten rocker shaft fixings to **38 Nm**.
7. Fit rocker covers.

HYDRAULIC TAPPETS RENEW

Service repair no - 12.29.57

1. Remove rocker shafts. *See **Rocker Shaft Renew***
2. Remove intake manifold. *See **FUEL SYSTEM, Repair, Intake Manifold***
3. Remove push rods, retain in removal sequence.

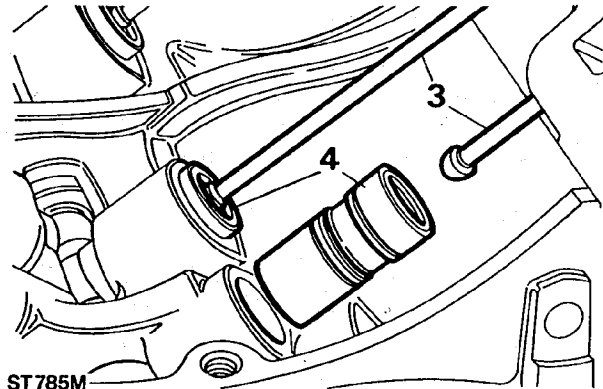

4. Remove hydraulic tappets
5. Fit tappets, push rods and rocker assemblies. *See **V8i Overhaul Manual**.*
6. Fit inlet manifold.
7. Reverse removal procedure.

CRANKSHAFT PULLEY ASSEMBLY

Service repair no - 12.21.01

1. Remove viscous coupling. *See COOLING SYSTEM, Repair, Viscous Coupling, Fan Blades, Pulley and Fan Cowl*
2. Remove drive belt. *See Drive Belt*
3. Raise vehicle on ramp [hoist].
4. Remove bell housing bottom cover.
5. Remove engine undertray.
6. With assistance to stop flywheel rotation, remove crankshaft pulley assembly retaining bolt.
7. Remove crankshaft pulley assembly.
8. If required: Place assembly in vice and remove pulley.
9. Fit pulley to torsional vibration damper.
10. Lubricate seal face of assembly.
11. Fit pulley assembly.
12. With assistance to stop flywheel rotation, fit retaining bolt. Tighten to **280 Nm**.
13. Reverse removal procedure. 1 to 5.

FRONT COVER OIL SEAL - RENEW

Service repair no - 12.21.14

1. Remove crankshaft pulley. *See Crankshaft Pulley Assembly* Do not remove pulleys.
2. Remove eight screws and remove mud excluder.
3. Fit button of 18G1328 to crankshaft, fit extractor to seal.
4. Turn centre bolt of extractor to remove seal.
5. Remove seal from extractor.
6. Clean seal seating.
7. Lubricate outside diameter of seal.
8. Locate seal in front cover.
9. Fit adaptor 18G1291/5 to 18G1291/4.
10. Fit tool to seal.
11. Fit and tighten centre bolt to crankshaft, tighten centre locknut to seat seal.
12. Slacken locknut and remove tool.
13. Lubricate seal lip.
14. Fit mud excluder and tighten screws.
15. Fit crankshaft pulley assembly.



FRONT COVER GASKET

Service repair no - 12.65.04

1. Remove crankshaft pulley. **See Crankshaft Pulley Assembly** Do not remove pulleys
2. Remove water pump pulley.
3. Release distributor cap clips.
4. Release plug leads from plugs and clips.
5. Place cap and leads to one side.
6. Turn engine until No. 1 piston is at T.D.C.
7. Check position of rotor arm.
8. Remove fixings securing power steering pump bracket to water pump bracket.
9. Remove power steering pump bracket from water pump.
10. Remove clips securing wiring to generator tensioner.
11. Disconnect distributor feed wire.
12. Pivot power steering pump away from front cover, tighten pivot to retain in position.
13. Disconnect vacuum pipe from distributor.
14. Remove water pump bottom hose.
15. Disconnect oil pressure switch.
16. Disconnect heater hose at water pump.
17. Remove generator tensioner from water pump, move tensioner aside.
18. Mark distributor position to front cover.
19. Remove distributor clamp, remove distributor. **See ELECTRICAL, Repair, Distributor - V8i**
20. Remove fixings sump to front cover.
21. Loosen four adjacent sump fixings.
22. Remove generator support strut from front cover, move strut aside.
23. Loosen remaining front cover fixings and remove front cover.
24. Remove front cover gasket.

Refit

25. Clean timing cover, clean block face.
26. Lightly grease gasket faces.
27. Fit new gasket to block face.
28. Apply hylosil to sump gasket.
29. Clean threads of cover fixing bolts, apply Loctite 372 to threads.
30. Fit timing cover, fit fixing bolts. Tighten to **28 Nm.**
31. Fit generator support strut to front cover.
32. Tighten sump to timing cover fixings to **10 Nm.**
33. Tighten sump fixings to **10 Nm.**
34. Lubricate distributor O ring.
35. Fit distributor in position marked.
36. Align oil pump drive, if distributor does not seat correctly.
37. Fit distributor clamp. Tighten to **20 Nm.**
38. Locate generator tensioner on water pump bracket.
39. Connect heater hose, tighten clip.
40. Connect oil pressure switch.
41. Connect bottom hose, tighten clip.
42. Connect vacuum pipe to distributor.
43. Loosen power steering pump pivot, lower pump.
44. Connect distributor feed wire.
45. Connect wire ties to generator tensioner.
46. Fit power steering pump bracket to water pump. Tighten to **28 Nm.**
47. Fit power steering pump to bracket.
48. Position distributor cap. Fit plug leads to plugs and clips.
49. Clip distributor cap in position.
50. Fit water pump pulley. Tighten to **10 Nm.**
51. Fit crankshaft pulley. **See Crankshaft Pulley Assembly**
52. Tension drive belts correctly.
53. Check ignition timing.
54. Refill cooling system.

TIMING CHAIN AND CHAINWHEELS

Service repair no - 12.65.12

Remove

1. Remove front cover. **See Front Cover Gasket**
2. Remove retaining bolt and washer, remove distributor drive gear and spacer.
3. Ensure number one piston is at TDC.
4. Remove chainwheels and chain as an assembly. **See V8i Overhaul Manual.**

Refit

5. Clean chainwheels and chain.
6. Fit chainwheels to chain, aligning timing marks.
7. Ensure camshaft key is fitted parallel to shaft axis to ensure adequate lubrication to distributor drive gear.
8. Engage chainwheel assembly on camshaft and crankshaft keys, ensure chain wheels are fully located.
9. Check alignment of timing marks with straight edge.
10. Fit spacer with flange to front,
11. Fit distributor drive gear with groove towards spacer.
12. Fit retaining bolt and washer. Tighten to **58 Nm**.
13. Fit front cover. **See Front Cover Gasket**

FLYWHEEL

Service repair no - 12.53.07

Remove

1. Remove gearbox and clutch. **See CLUTCH, Repair, Clutch Assembly**
2. Loosen starter motor bolts.

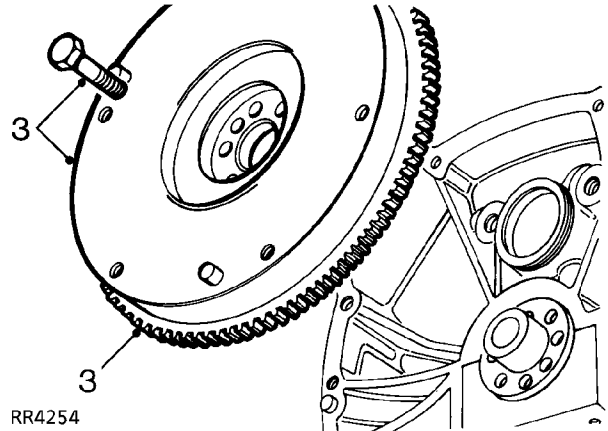

3. Lock flywheel, remove flywheel bolts and flywheel.

Refit

4. Clean components for reassembly.
5. Fit flywheel.
6. Clean threads, apply Loctite 270 to threads.
7. Lock flywheel, fit flywheel bolts. Tighten to **80 Nm**.



FLEXIBLE DRIVE PLATE AND RING GEAR

Service repair no - 12.53.13

Remove

1. Remove transmission. *See AUTOMATIC GEARBOX, Repair, ZF Auto with Borg Warner Transfer Gearbox*
2. Remove flexible drive plate and ring gear assembly. *See V8i Overhaul Manual.*

Refit

3. Clean all components for reassembly.
4. Fit ring gear and flexible drive plate assembly. *See V8i Overhaul Manual.*
5. Fit transmission.

CRANKSHAFT REAR OIL SEAL

Service repair no - 12.21.20

1. Automatic transmission, remove drive plate. *See Flexible Drive Plate and Ring Gear*
OR manual transmission, remove flywheel. *See Flywheel*
2. Remove sump. *See Oil Sump*
3. Remove rear main bearing cap.
4. Remove cross seals from cap.
5. Remove crankshaft rear oil seal.
6. Clean main bearing cap and oil seal area of block.
7. Fit new cross seals to bearing cap.
8. Apply Hylomar SQ32M to block as illustrated.

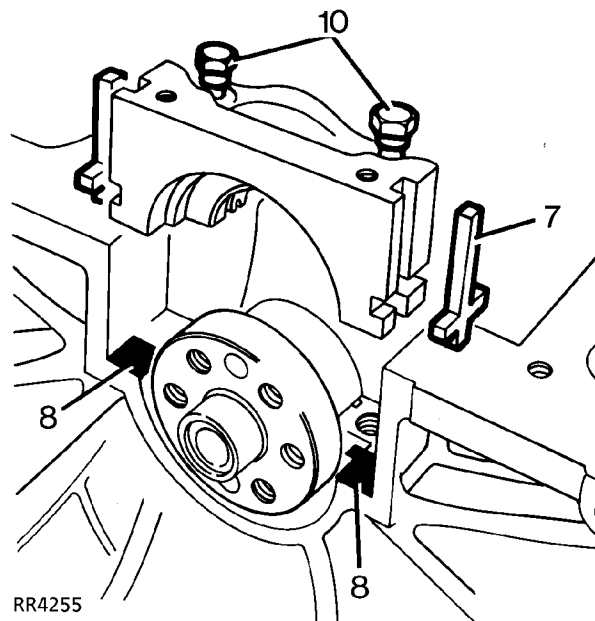

9. Lubricate bearing shell and cross seals using clean engine oil.
10. Fit bearing cap, do not tighten bolts.
11. Ensure cap is fully home and seated squarely on the block.

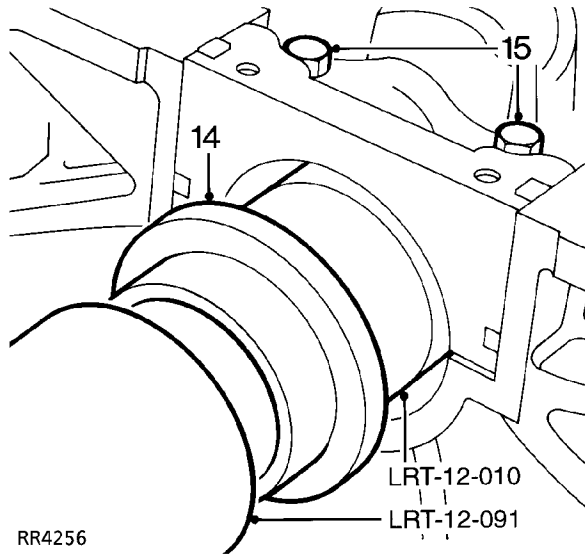

12. Ensure service tools LRT-12-010 and LRT-12-091 are scrupulously clean. Coat seal guide and oil seal journal with clean engine oil.



CAUTION: Do not handle oilseal lip, check it is not damaged. Ensure outside diameter remains clean and dry.

13. Position oil seal guide LRT-12-010 on crankshaft flange.



NOTE: Lubricant coating must cover seal guide outer surface completely to ensure that oil seal lip is not turned back during assembly. Position oil seal, lipped side towards engine, on seal guide. Seal outside diameter MUST be clean and dry.

14. Fit oil seal using tool LRT-12-091. Remove seal guide.
15. Tighten rear main bearing cap to **90 Nm**.
16. Fit sump.
17. Fit flywheel or flexible drive plate and ring gear.

ENGINE

Service repair no - 12.41.01

Remove

1. Park vehicle on level ground and apply park brake.
2. De-pressurise fuel system. **See FUEL SYSTEM, Repair, Depressurising Fuel System**
3. Remove bonnet [hood]. **See CHASSIS AND BODY, Repair, Bonnet [Hood]**
4. Remove battery. **See ELECTRICAL, Repair, Battery**
5. Remove radiator/oil coolers. **See COOLING SYSTEM, Repair, Radiator/Oil Coolers**
6. Place an absorbent cloth around fuel feed hose at fuel rail and release compression nut. Remove feed hose from rail, seal end of pipes with masking tape to prevent ingress of dirt.
7. Release fuel return hose clamp and remove hose from pressure regulator, seal both openings with masking tape to prevent ingress of dirt.
8. Remove vacuum hose from rear of regulator.
9. Manual vehicles: Disconnect throttle cable from bracket. Automatic vehicles: Detach throttle bracket from plenum chamber and lay assembly to one side. **See FUEL SYSTEM, Repair, Plenum Chamber DO NOT DISTURB KICK DOWN CABLE SETTING.**
10. Remove ram housing. **See FUEL SYSTEM, Repair, Ram Housing**
11. Remove air flow sensor. **See FUEL SYSTEM, Repair, Air Flow Sensor**
12. Remove air cleaner assembly. **See FUEL SYSTEM, Repair, Air Cleaner Assembly**
13. Remove Generator. **See ELECTRICAL, Repair, Generator**
14. Release air conditioning compressor from its mounting and lay to one side. DO NOT discharge air conditioning system. **See AIR CONDITIONING, Repair, Compressor**



NOTE: Release bolts securing compressor mounting bracket to engine and remove bracket to enable temporary lifting eye ETC 5964 to be fitted. Secure lifting eye to mounting bracket fixing points with suitable bolts of equivalent size, pitch and thread. Leave lifting eye attached until engine is reinstalled in vehicle.

15. Place drain tray underneath vehicle.
16. Disconnect hose from reservoir to power steering pump. Secure hose end above level of fluid reservoir to avoid unnecessary loss of fluid.
17. Disconnect power steering pump to power steering box hose. Seal hose and pump openings with masking tape to prevent ingress of dirt. Wipe away any fluid spillage from chassis or steering box.
18. Disconnect fuel temperature and coolant temperature sensor multi-plugs.
19. Disconnect leads from coil.
20. Identify each injector multi-plug for re-assembly and disconnect plugs from injectors.
21. Manoeuvre harness from behind fuel rails and place to one side clear of engine assembly.
22. Remove two clamps securing gearbox oil cooler pipes to engine block.
23. Remove engine mounting fixings on both sides of cylinder block.
24. Fit lifting chains to engine lifting eyes as shown in illustration RR1780E.

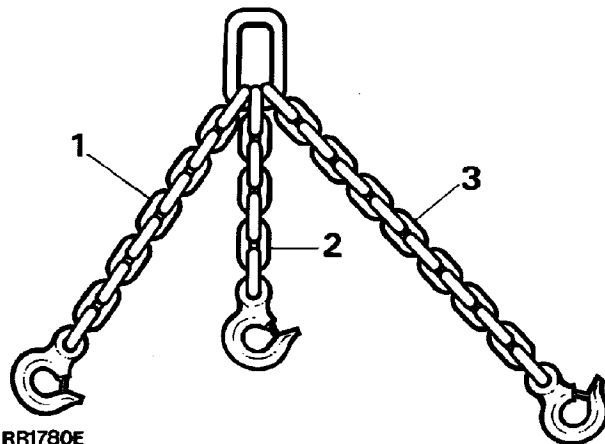

RR1780E

1. L/H Front chain 356mm total overall length.
2. R/H Front chain 330mm total overall length.
3. R/H Rear chain 457mm total overall length.



NOTE: All chain dimensions are measured from end of lifting hook to end of last link in chain.

25. Fit chain lifting eye to a suitable engine hoist. Raise hoist high enough to enable engine mountings to be removed, and withdraw rubber mountings.
26. Lower hoist until engine rests securely on engine mounting brackets. Remove lifting chains and hoist.
27. Disconnect two heater hoses located on top of right hand rocker cover.
28. Remove ground strap from rear of left hand cylinder head. DO NOT remove from retaining clip.
29. Remove all electrical harnesses from retaining clips at rear of engine.
30. Remove transmission breather pipes from retaining clip on rear lifting eye.
31. Remove top two bolts securing bell housing to cylinder block.
32. Raise front of vehicle, lower vehicle on to axle stands.
33. Remove bell housing bottom cover. Remove gasket from bell housing face.
34. Remove nuts securing exhaust downpipes to manifolds, remove heat shield from right hand side downpipe.
35. Remove electrical leads from starter motor solenoid. Disconnect multi-plug from oil level sensor on side of sump, if fitted.



NOTE: Instructions 37, 38 and 39 refer to automatic vehicles only.

36. With assistance rotate engine at crankshaft pulley until two access holes in drive plate/ring gear assembly are visible.
37. Remove two bolts visible through access holes. Mark one access hole and one bolt hole to ensure unit is reassembled in its original position.
38. Rotate crankshaft 180° until two remaining access holes are visible, remove two bolts.

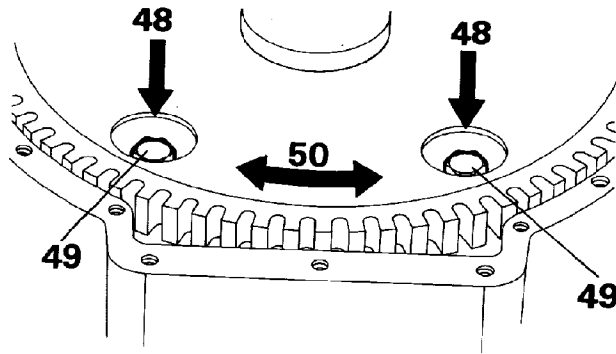

RR1808E

39. Remove remaining bell housing to cylinder block bolts.
40. Remove starter motor ground strap from chassis.
41. Remove stands and lower vehicle.
42. Position hydraulic trolley jack under bell housing to support gearbox when engine and gearbox are separated.
43. Fit lifting chains to engine. Carefully raise hoist a little, ease engine and gearbox apart, steady engine on hoist.
44. Ensure no components remain that will prevent engine being removed.
45. Slowly raise engine clear of engine compartment. Move engine away from vehicle and place on a suitable engine stand.

Refit

46. Fit lifting chains to engine. Raise engine using hoist.
47. Lower engine into engine compartment. Ensure all components are clear of engine assembly.
48. Automatic vehicles: With assistance, manoeuvre engine until bottom two engine and bellhousing bolt holes align. Ensure that two cylinder block dowels locate in bell housing.
Manual vehicles: Lower engine into position. Locate primary pinion into clutch. Engage bell housing dowels.
49. Fit two bolts and partially tighten.
50. Remove jack and lower hoist until engine rests securely on engine mounting brackets.
51. Fit top two bell housing securing bolts. Tighten to **40 Nm**.
52. Fit remaining bell housing to cylinder block bolts. Tighten to **40 Nm**.
53. Automatic vehicles: With assistance, rotate crankshaft pulley, line up marked holes in drive plate and torque converter. Fit two bolts. Tighten to **40 Nm**.
54. Rotate crankshaft 180° and fit remaining two bolts tighten to correct torque, **40 Nm**.
55. Fit new gasket and refit bottom cover, tighten bolts to **9 Nm**.
56. Fit new exhaust flange gaskets, fit exhaust to manifold.
57. Refit all harnesses, ground straps breather pipes and hoses at rear of engine.
58. Raise engine and refit engine mounting rubbers, tighten nuts to **20 Nm**.
59. Remove temporary lifting eye ETC 5964 and reverse instructions 1 to 23, ensuring that all electrical plugs and harnesses are fitted in correct locations.



OIL SUMP

Service repair no - 12.60.44

Remove

1. Drain engine oil **See SECTION 10, Maintenance, Under Vehicle Maintenance**
2. Fit drain plug. Tighten to **40 Nm**.
3. If fitted, disconnect low oil level sensor multiplug.

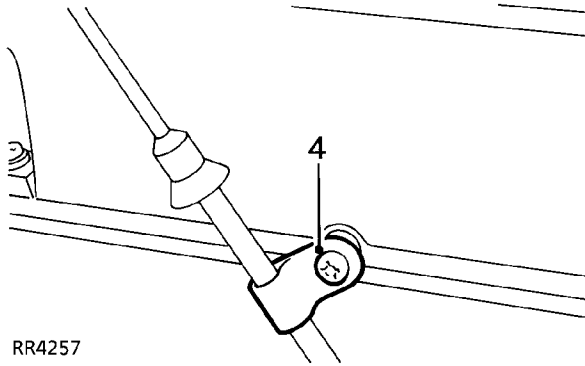

4. Remove bolt securing dipstick tube to rocker cover.
5. Working from the centre outwards, progressively loosen and remove 17 bolts securing sump. Remove sump.
6. Remove all traces of sealant from mating surfaces of sump, cylinder block and front cover, using a suitable solvent or plastic scraper.
7. Degrease mating surfaces of sump, cylinder block and front cover.

Refit

8. Apply RTV Hylosil White sealant to mating surface of sump.
9. Position sump, tighten bolts finger tight.

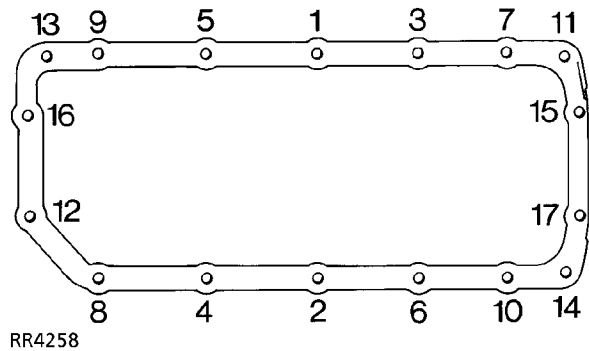

10. Tighten bolts progressively in sequence shown. Tighten to **18 Nm**.
11. Fit bolt securing dipstick tube to rocker cover.
12. If fitted, connect low oil level sensor multiplug.



TORQUE VALUES



NOTE: Torque wrenches should be regularly checked for accuracy to ensure that all fixings are tightened to the correct torque.

	Nm
Engine	
Adaptor plate to crankshaft	84
Generator and power steering mounting bracket to cylinder head	30
Cylinder head:	
Stage 1:	20
Stage 2: - Further 180° ± 5°	
Drive plate to converter	39
Engine mountings to engine and chassis	55
Engine mounting rubbers to brackets	30
Flexible drive plate to crankshaft adaptor plate	41**
Flywheel to crankshaft bolts	78**
Lifting eye to cylinder heads	39
Main bearing cap rear bolts	92*
Oil sump drain plug	40
Oil sump to cylinder block	18
Rocker cover to cylinder head	9
Rocker shaft bracket to cylinder head	38
Spark plug	21
Starter motor attachment	44

* These bolts must have threads coated in lubricant EXP16A before assembly.

** These bolts must have threads coated in sealant Loctite 270

METRIC	Nm
M5	6
M6	9
M8	25
M10	45
M12	90
M14	105
M16	180

UNC / UNF	
1/4	9
5/16	24
3/8	39
7/16	78
1/2	90
5/8	136



NOTE: Torque values above are for all screws and bolts used except for those specified.



ENGINE

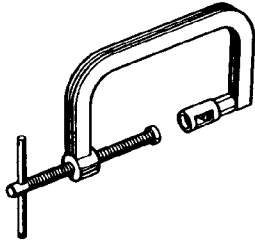

MS1519A

LRT-12-034 Spring compressor
MS1519A

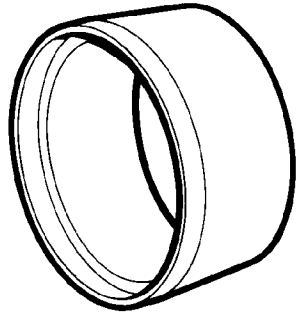

RO1014

LRT-12-010 Crankshaft rear seal guide
RO1014

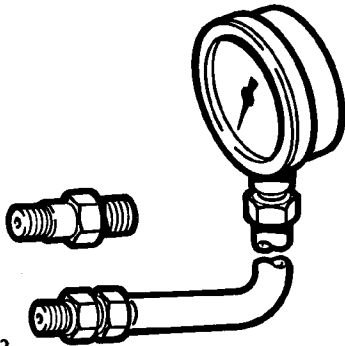

LRT12052

LRT-12-052 Oil pressure test kit



EMISSION CONTROL

Three systems are used to control the vehicle atmospheric emissions these are:

- Engine crankcase fume emissions.
- Fuel tank Evaporative emissions
- Engine exhaust gas emissions.

Crankcase ventilation system

The crankcase ventilation system which is an integral part of the air supply to the engine combustion chambers, is often overlooked when diagnosing problems associated with engine performance. A blocked ventilation pipe or filter or excessive air leak into the inlet system through a damaged pipe or leaking gasket can effect the mixture, performance and economy of the engine.

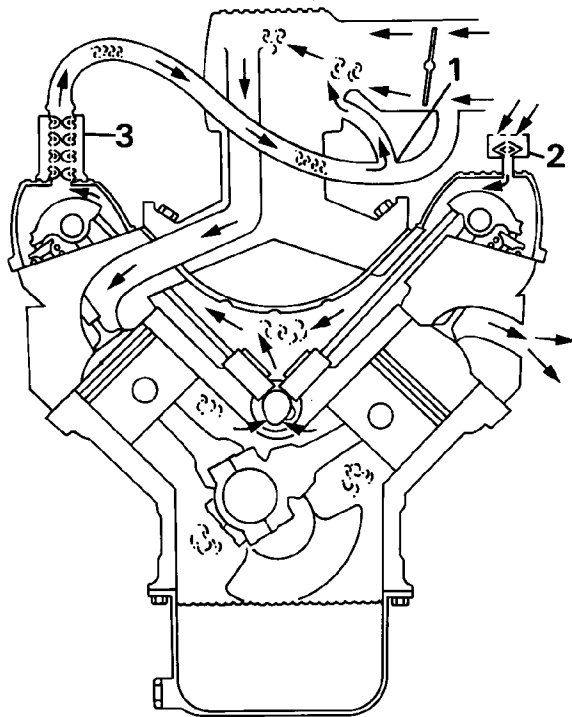

RR3534M

1. Three way connector
2. Air filter
3. Oil separator

The purpose of the crankcase ventilation system is to ensure that any noxious gas generated in the engine crankcase is rendered harmless by burning in the combustion chambers as follows:

Oil laden noxious gas in the engine crankcase is drawn through an oil separator 3 located on the right cylinder head rocker cover, where the oil is separated and returned to the sump. The gas flows through a restrictor in the three way connection 1 and into the inlet plenum chamber where it is drawn into the combustion chambers and burned. The volume of fresh air which is drawn from the atmospheric side of the throttle butterfly to mix with the gas, depends on the position of the throttle and the engine speed.

The air filter 2 fitted to the left cylinder head rocker cover, must be maintained in clean condition to ensure sufficient air enters the crankcase under varying throttle openings and manifold depression, to prevent excessive crankcase pressure or depression developing.

Exhaust emission control.

The multiport fuel injection system provides accurately metered quantities of fuel to the combustion chambers to ensure the most efficient air to fuel ratio under all conditions of operation. A further improvement to combustion is made by measuring the oxygen content of the exhaust gases to enable the quantity of fuel injected to be varied, according to conditions, to correct any unsatisfactory composition of the exhaust.

The main components of the exhaust emission system are two Catalytic converters which are an integral part of the front exhaust pipe assembly. The Catalytic converters are included in the system to reduce the emission, to atmosphere, of carbon monoxide, oxides of nitrogen, and hydrocarbons. The active constituents of the converters are platinum and rhodium. The correct functioning of the converters is dependent upon close control of the oxygen concentration in the exhaust gas entering the catalyst. The oxygen content of the exhaust gas is signalled to the Engine Control Module (ECM) by oxygen sensors (Lambda sensors) located in the exhaust front pipes between the manifold and converter. The ECM can then make an appropriate adjustment to the fuel supply to correct the composition of the exhaust.



CAUTION: Unleaded fuel only must be used on vehicles fitted with catalytic converters. As a reminder, a label to indicate this is adhered to the inside of the fuel filler flap. Furthermore the filler neck is designed to accommodate only unleaded fuel pump nozzles.



EXHAUST SYSTEM

1. Manifold to front pipe connection.
2. Lambda sensor.
3. Front silencer support bracket.
4. Front pipe to silencer joint.
5. Silencer rear support bracket.
6. Rear silencer support bracket.

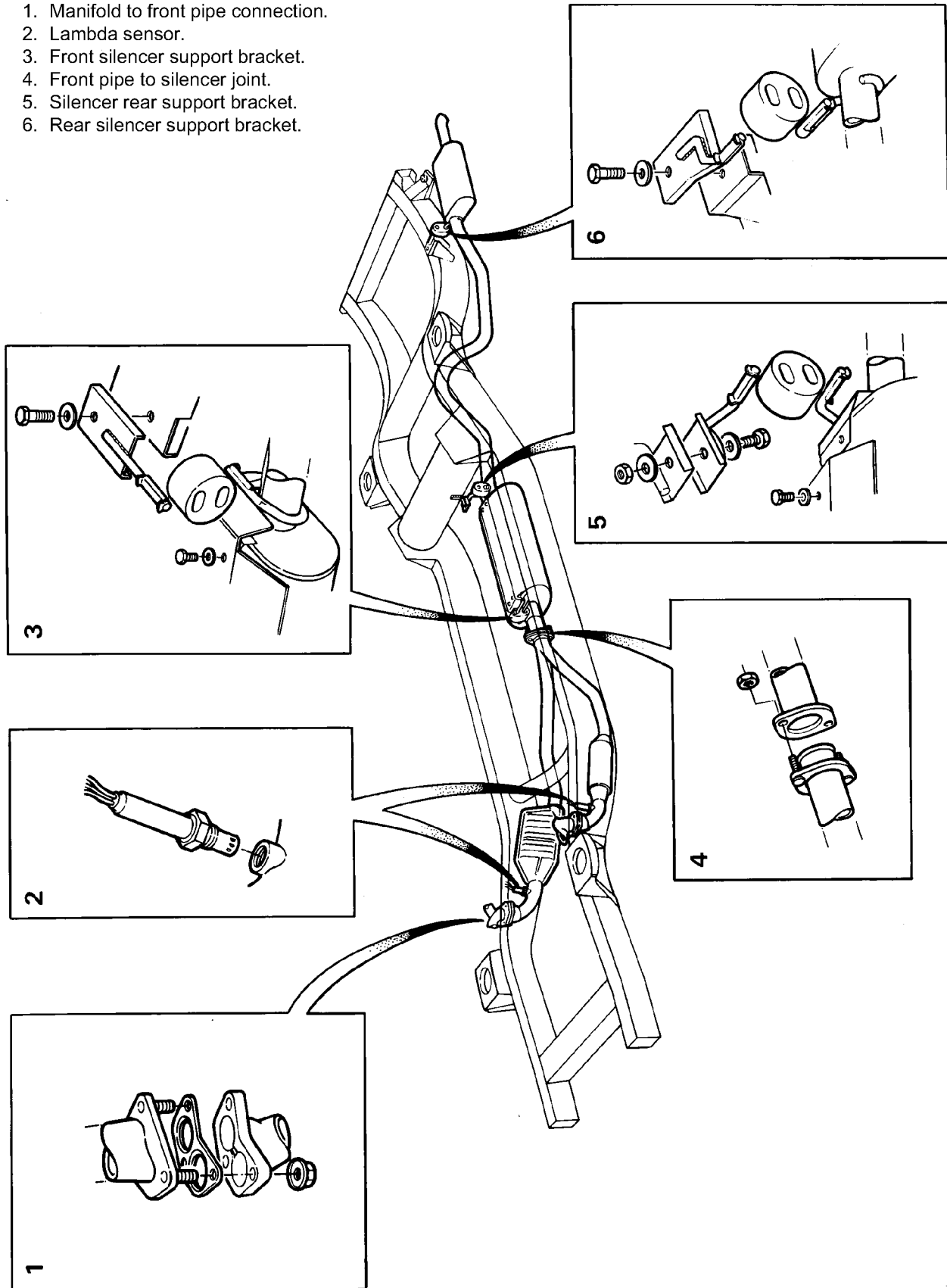

ST2787M

Evaporative emission control system.

The system is designed to prevent harmful fuel vapour from escaping to the atmosphere. The system consists of a vapour separator tank, connected to the fuel tank and located between the body inner and outer panels on the right hand side of the vehicle near the rear wheel arch. An adsorbtion canister, containing activated charcoal, is positioned in the engine compartment attached to the front right valance. The two components are connected by a pipe running the length of the chassis.

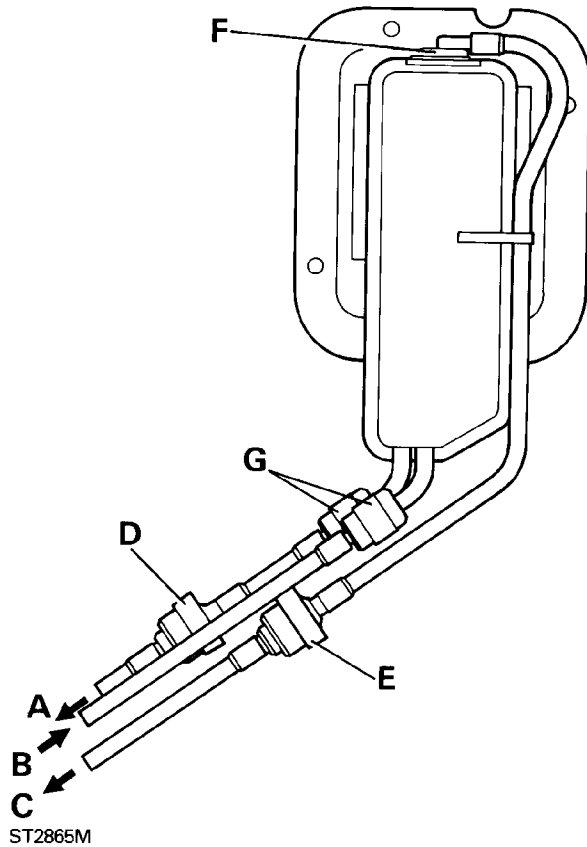

- A Pressure relief to atmosphere.
- B From fuel tank to separator.
- C To adsorbtion canister.
- D Pressure relief valve.
- E Pressure relief valve.
- F Shut-off valve.
- G "Speed Fit" connectors.

A pressure relief valve is fitted in the hose which is open to atmosphere. This valve acts as a safety valve should a build-up of pressure occur in the system, for example if a hose became blocked or kinked. The volume of vapour emitted, in such an instance, would be acceptable.

A pressure relief valve is also fitted in the hose connected to the adsorbtion canister and releases vapor to the canister when the pressure in the separator reaches between 5 and 7 Kpa.

In the top of the separator a shut-off valve is incorporated in the vapor exit port to prevent the possible presence of any liquid fuel being transmitted to the adsorbtion canister should the vehicle roll over.

The adsorbtion canister, which is connected by a hose to the plenum chamber, absorbs and stores the fuel vapour from the fuel tank while the engine is not running. When the engine is started, the vapour is purged from the canister by air drawn through an orifice in the base of the canister and by the influence of vacuum at the top. The vapour drawn into the plenum chamber through a solenoid operated purge valve is finally burnt in the combustion chambers.

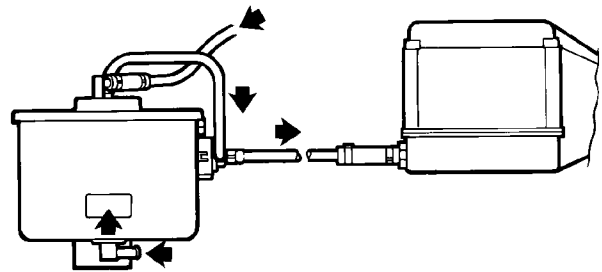

The purge valve, which is attached to the adsorbtion canister support bracket, is controlled by the Engine Control Module ECM which determines the most emission acceptable time at which purging should take place. This will normally be at engine speeds above idle and when the vehicle is in motion. A signal from the ECM to the purge valve operates the solenoid and opens the valve to purge the canister of fuel vapour.

**EVAPORATIVE CONTROL SYSTEM**

1. Adsorption canister and purge valve.
2. Location of vapour separator and pipes.
3. Fuel tank.

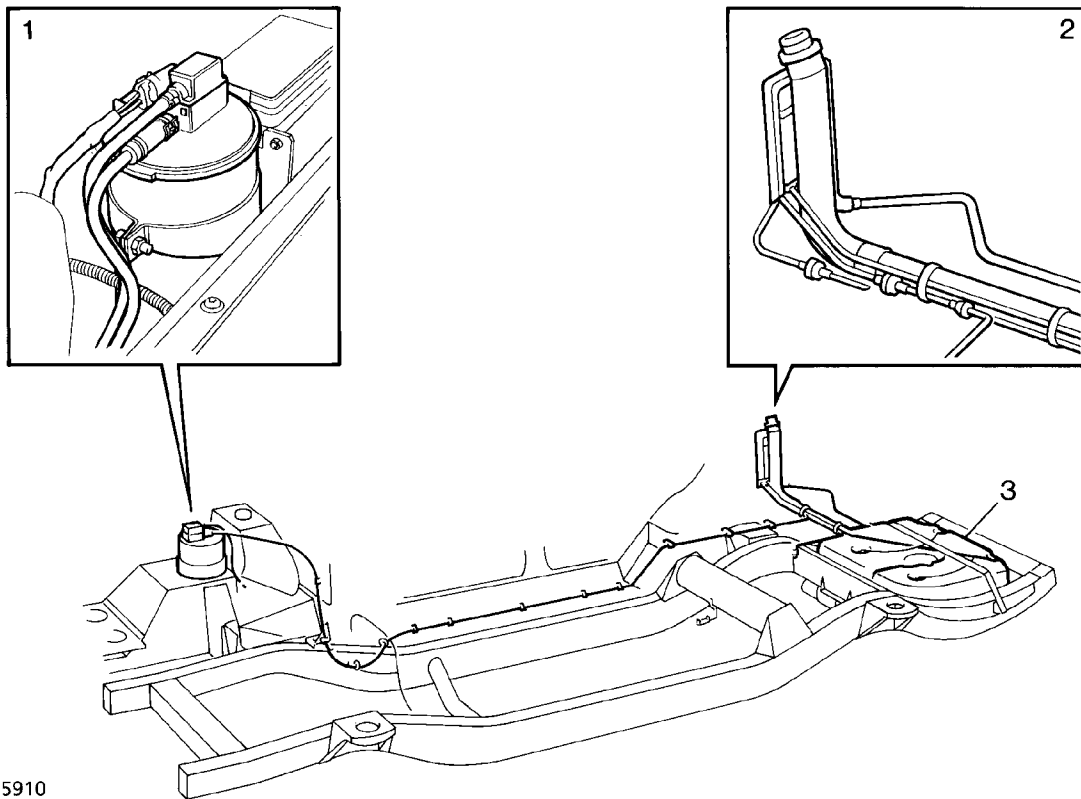



TESTING EVAPORATIVE EMISSION CONTROL

The following pressure test procedure is intended to provide a method for ensuring that the system does not leak excessively and will effectively control evaporative emissions.

Equipment required.

Nitrogen cylinder (compressed air may be used to pressure the system when there has NEVER been fuel present in the fuel or evaporative control systems).

Water manometer (0 - 30" H₂O or more).

Pipework and a "T" piece.

Method.

1. Ensure that there is at least two gallons of fuel in the petrol tank unless there has never been any fuel in the system.
2. Disconnect, at the adsorption canister, the pipe to the vapour separator.
3. Connect this pipe to the nitrogen cylinder and the water manometer using the "T" piece.
4. Pressurize the system to between 26.5 and 27.5 inches of water, allow the reading to stabilize, then turn off the nitrogen supply.
5. Measure the pressure drop within a period of 2 minutes 30 seconds. If the drop is greater than 2.5 inches of water the system has failed the test. Note that a fully sealed system will show a slight increase in pressure.
6. Should the system fail the test, maintain the pressure in the system and apply a soap solution round all the joints and connections until bubbles appear to reveal the source of the leak.
7. Repeat the test and if successful, dismantle the test equipment and reconnect the pipe to the adsorption canister.



POSITIVE CRANKCASE VENTILATION AIR INTAKE FILTER

Service repair no - 17.10.02

The PCV air intake filter is located at the rear of the left hand rocker cover, beneath the throttle linkage bracket.

Remove

1. Pry the filter outer cover upwards to release it from its mounting.
2. Remove the sponge filter from the cover and discard the sponge.

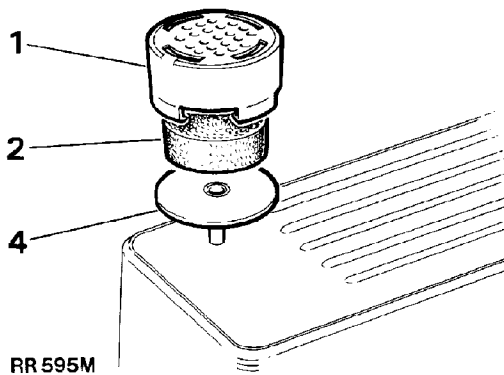

Refit

3. Insert a new filter into the filter cover.
4. Press the filter onto its mounting until it clips firmly into position.

POSITIVE CRANKCASE VENTILATION BREATHER FILTER

Service repair no - 17.10.03

Remove

1. Release the hose clamp and pull the hose off the canister.
2. Unscrew the canister and remove it from the rocker cover.
3. Remove the large rubber 'O' ring and inspect for deterioration.

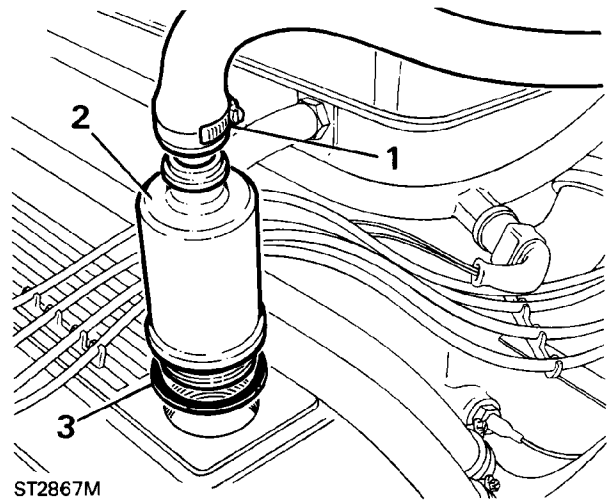

4. Visually inspect the condition of the wire screen within the canister, if in poor condition, replace the whole assembly, if the filter unit is in an acceptable condition, clean as follows.
5. Immerse the canister in a small amount of solvent (mineral spirits) and allow time for the solvent to dissolve or loosen any debris.
6. Remove the canister from the solvent bath and allow to dry in still air.

WARNING: Do not use a compressed air line to dry, clean or remove any remaining particles of debris within the canister as this could cause fire or personal injury.

Refit

7. If the original canister is being refitted, fit a new 'O' ring.
8. Screw the canister into the rocker cover securely - hand tight only.
9. Refit the hose and tighten the hose clamp securely.

LAMBDA (OXYGEN) SENSOR

Service repair no - 19.26.16

The removal of the sensors from the exhaust system must only be carried out when the engine is cold.

Remove

1. Disconnect battery negative lead.
2. Disconnect the electrical plugs from the sensors.
3. Unscrew and remove the sensors from the two exhaust downpipes.

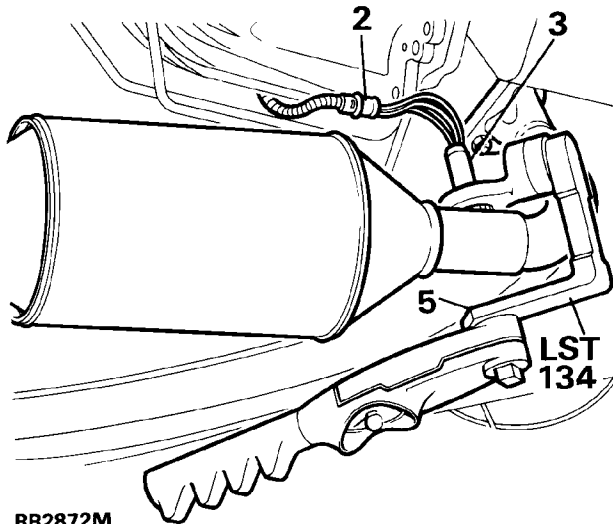

RR2872M

Refit

4. Coat the threads of the sensors with anti-seize compound.



CAUTION: To ensure that the efficiency of the sensor is not impaired, DO NOT allow anti-seize compound to come into contact with the sensor nose.

5. Screw in the sensor and tighten to the correct torque using special tool LST134.
6. Connect the electrical plugs and battery lead.

PURGE CONTROL VALVE

Service repair no - 17.15.39

Remove

1. Disconnect battery negative lead.

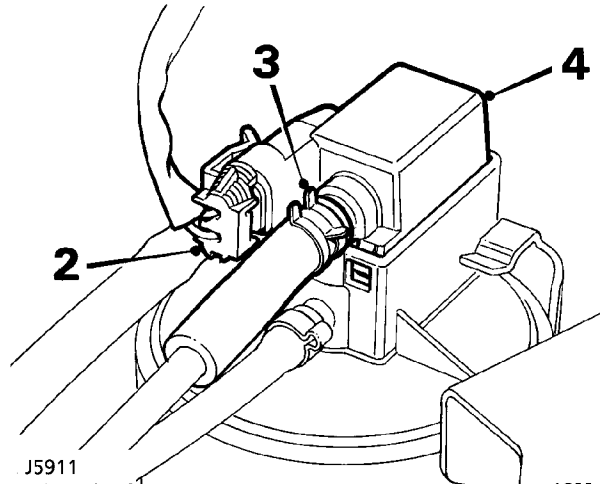

2. Disconnect multiplug from purge control valve.
3. Release clip and disconnect hose from valve.
4. Release valve from charcoal canister.
5. Remove valve.

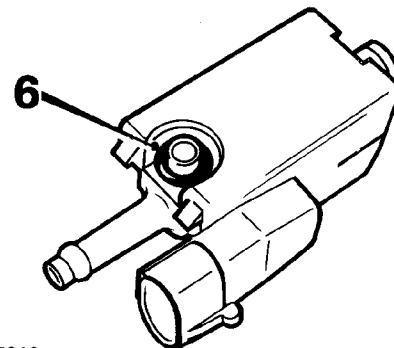

6. Discard 'O' ring.

Refit

7. Clean valve and valve location.
8. Fit new 'O' ring to purge valve.
9. Position and secure valve to charcoal canister.
10. Connect hose to purge valve and secure with clip.
11. Connect multiplug to valve.
12. Reconnect battery negative lead.



CHARCOAL CANISTER

Service repair no - 17.15.13

Remove

1. Disconnect battery negative lead.
2. Pry out purge valve.
3. Disconnect pipe.

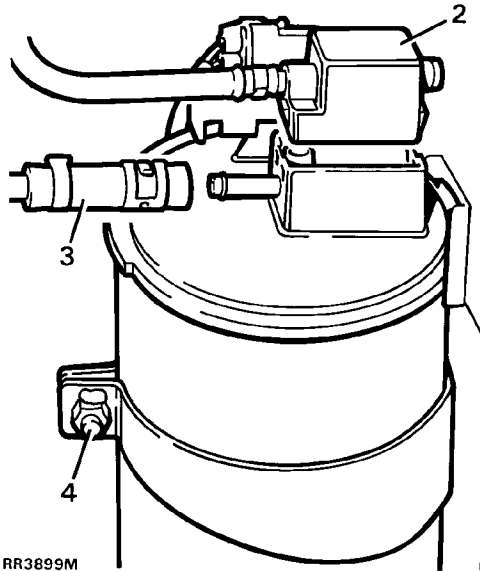

4. Loosen bolt.
5. Remove charcoal canister.

Refit

6. Reverse removal procedure.



DESCRIPTION

Air intake

The air cleaner is positioned to the right of the engine and connected by hoses to a cold air intake duct and the turbocharger inlet. A crankcase breather hose is fitted between the air cleaner and the separator.

A single stage turbocharger, fitted between the exhaust manifold and exhaust pipe, is connected by hoses to the air cleaner and to an intercooler mounted on the right of the radiator. The intercooler is connected by a hose to the inlet manifold.

Fuel system

A 89 litre fuel tank is mounted at the rear of the vehicle beneath the load space floor. The tank is vented by a 2 way valve in the filler cap.

A mechanical lift pump, driven by the camshaft, is mounted on the side of the engine.

A fuel filter, fitted with a replaceable element and incorporating a water separator, is positioned on the LH side of the bulkhead.

A Bosch Type injection pump, incorporating a cold start advance unit and a high idle setting is mounted on the LH side of the engine and is directly driven by gears from the crankshaft. The pump meters and distributes fuel to 4 pintle type injectors located in pre-combustion chambers in the cylinder heads.

A return line passes excess fuel from the injection pump and injectors back to the fuel tank.

Glow plugs

Four glow plugs are located in the cylinder head, directly below each injector.

Exhaust gas recirculation (EGR)

Exhaust gas recirculation is controlled by the EGR control unit mounted in the passenger compartment on the RH 'A' post behind the fascia and receives the following inputs:

- a. Engine temperature from coolant temperature transmitter in No. 4 cylinder head;
- b. Throttle position from the potentiometer on the injection pump;
- c. Engine speed from the tachometer.
- d. EGR valve lift position.

When all correct signals are received, the EGR solenoid allows vacuum to open the EGR valve and recirculate a portion of the exhaust gas.

FUEL SYSTEM LAYOUT

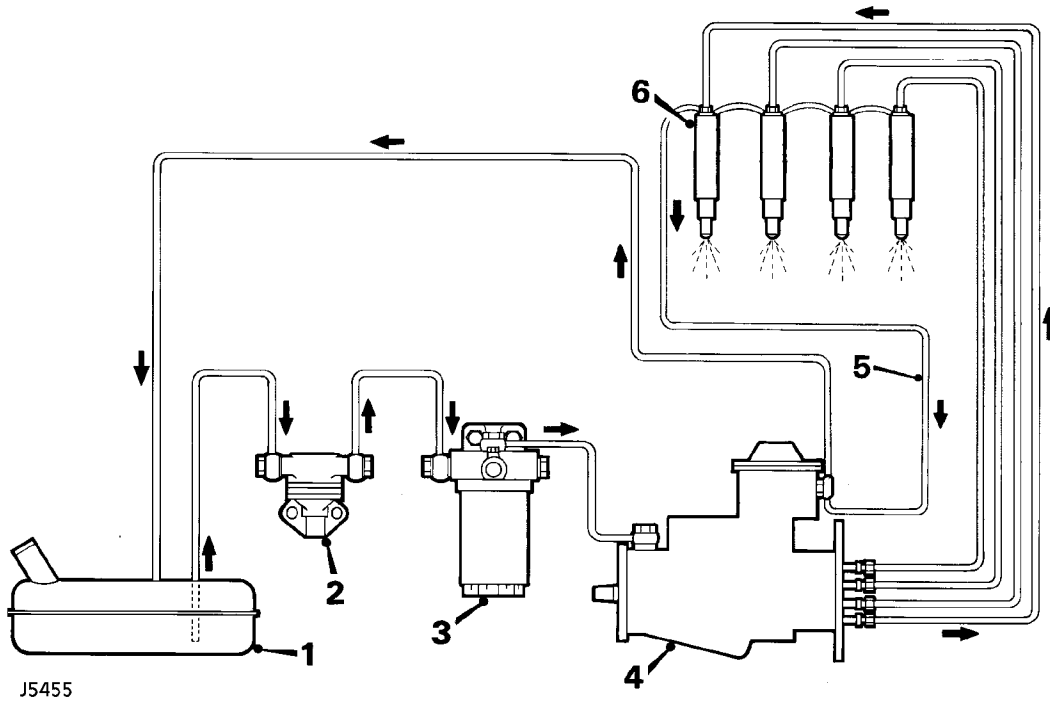

1. Fuel tank
2. Fuel lift pump
3. Fuel filter
4. Fuel injection pump
5. Spill return line
6. Fuel injectors

FUEL SYSTEM COMPONENT LOCATION

1. Fuel filter bleed screw
2. Fuel filter
3. Turbocharger
4. Wastegate
5. Air cleaner
6. Fuel injector
7. Glow plug
8. Glow plug controller
9. EGR valve and valve lift potentiometer
10. Coolant temperature transmitter - EGR and instruments
11. Fuel injection pump
12. EGR throttle potentiometer
13. Fuel lift pump
14. Intercooler
15. EGR Control unit

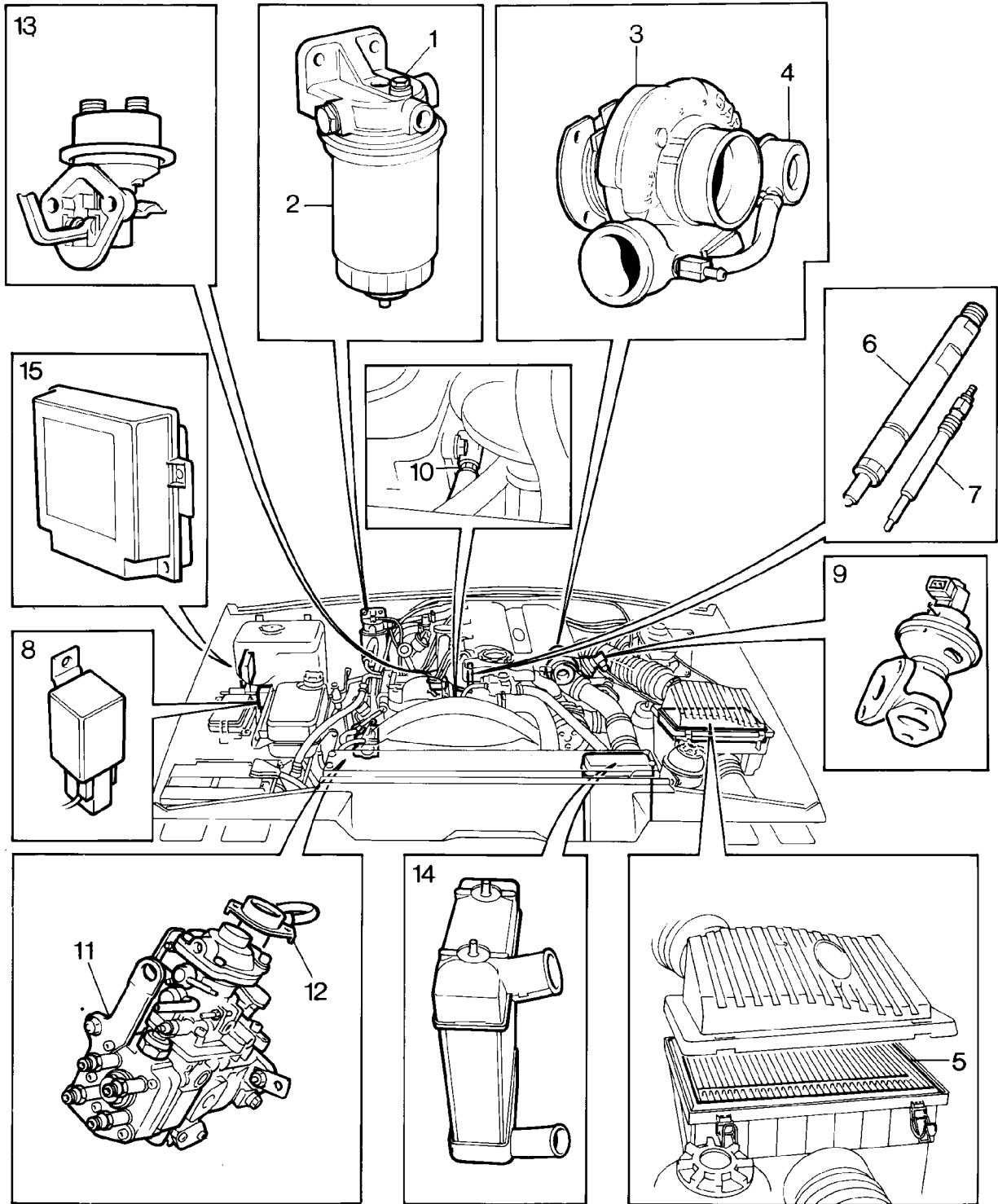

J5456

OPERATION

Diesel engines operate by compression ignition. The rapid compression of air in the cylinder during the compression cycle heats the injected fuel, causing it to self ignite. During cold starting, automatically controlled glow plugs assist in raising the temperature of the compressed air to ignition point.

A cold start advance unit advances the injection timing to further assist starting. Idle quality is improved by the high idle setting.

The engine is supplied with pre-compressed air by a single stage turbocharger.

Exhaust gases passing over a turbine cause it to rotate, driving a compressor mounted on the turbine shaft. Air drawn from the cold air intake passes, via the air cleaner, to the turbocharger where it is compressed. The compressed air passes to the cylinders via an intercooler, which reduces the temperature of the compressed air, increasing its density.

Fuel is drawn from the tank by a mechanical lift pump and passes to the injection pump via a filter. In addition to removing particle contamination from the fuel, the filter incorporates a water separator, which removes and stores both bound and unbound water.

The injection pump meters a precisely timed, exact quantity of fuel to the injectors in response to throttle variations, injection timing varying with engine speed. Any excess fuel delivered to the injection pump is not injected, passing back to the tank via the fuel return line.

Fuel is injected in a finely atomised form into a pre-combustion chamber in the cylinder head where it ignites. The burning fuel expands rapidly into the main combustion chamber, creating extreme turbulence which mixes the burning fuel thoroughly with the compressed air, providing complete combustion.

Cold Starting is assisted by glow plugs, a cold start advance unit and a high idle setting.

Glow plugs

Glow plug operation is controlled by a timer unit, start relay and resistor. When the ignition is turned on the timer unit is energised, the glow plugs start to operate and a warning light on the dashboard illuminates, remaining illuminated until the glow plugs are automatically switched off.

The length of time the glow plugs will operate is dependent on under bonnet temperature, which is monitored by a sensor located in the timer unit.

Starting the engine results in the power supply to the glow plugs passing through the resistor, which reduces their operating temperature. The glow plugs are cut out either by the temperature sensor in the timer, or by a microswitch on the injection pump which operates when the throttle is depressed.

Cold start advance

The cold start advance unit is connected to the engine cooling system via hoses. It contains a temperature sensitive element which is retracted when cold and pulls the advance lever, via cable, towards the rear of the pump against spring pressure. As coolant temperature rises, the cold start element expands releasing tension on the cable and allowing spring pressure to move the advance lever forwards.



Exhaust Gas Recirculation (EGR)

Operation of the EGR system is dependent on the following:

- a. Engine temperature - must be between 20 °C and 100 °C approx.
- b. Engine speed - must be between 630 and 2850 rev/min.
- c. Engine load - calculated by throttle potentiometer position.
- d. EGR valve lift position.
- e. Duration of engine idling.

Under varying engine speed and load conditions the control unit sends a signal to open the vacuum modulator which allows a vacuum to be applied above the EGR valve diaphragm, the vacuum supply being taken from a 'T' connector in the brake servo hose. This process is controlled by an engine speed/load map stored in the EGR control unit memory.

Engine speed is measured by monitoring the waveform present on one phase of the generator. Throttle position is measured via a potentiometer mounted on the fuel injection pump throttle lever. Closed loop control is achieved by allowing the control unit to continually monitor EGR valve lift via a potentiometer mounted on the valve; this valve lift is compared with the actual valve lift required on the control unit map and adjusted if necessary.

With coolant temperature between 20 °C and 100 °C; the engine having just returned to idle, EGR will shut off after 25-30 seconds idling.



THROTTLE CABLE

Adjust

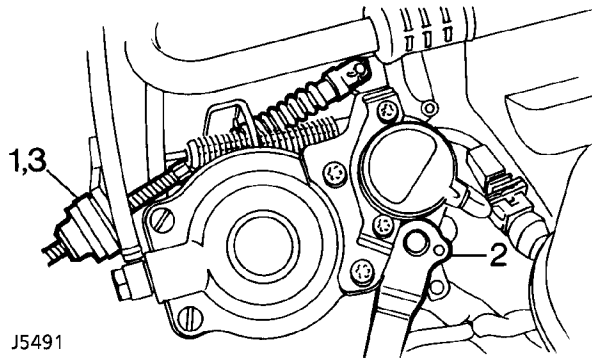

1. Loosen throttle cable adjustment ferrule.
2. Hold throttle lever in fully closed position.
3. Adjust outer cable, by rotating ferrule, to give 1.57 mm (0.062 in) of free play in the inner cable.
4. Check that throttle opens fully when the throttle is depressed.

EGR THROTTLE POSITION SENSOR

Check

1. Run engine until normal operating temperature is reached.

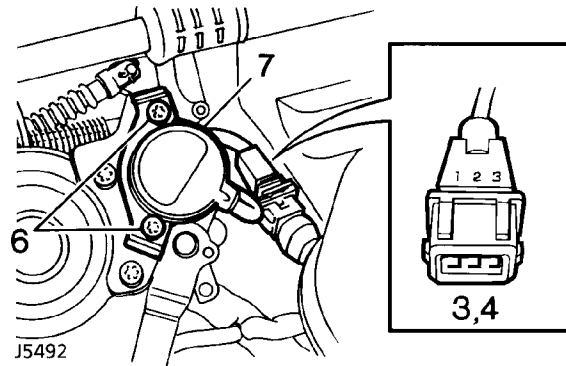

2. Switch off engine and disconnect throttle position sensor multiplug.
3. Connect an Ohmmeter across pins 1 and 3 of multiplug. Ohmmeter should read between 1K and 1.05K ohms.
4. Connect an Ohmmeter across pins 1 and 2 of multiplug. Ohmmeter should read between 850 and 900 ohms.
5. If the readings are correct, EGR position sensor is OK - reconnect multiplug.
6. Loosen 2 Torx screws securing position sensor.
7. Rotate position sensor to achieve correct Ohmmeter readings, then tighten Torx screws.
8. Re-check Ohmmeter readings, then reconnect multiplug.

LOW AND HIGH IDLE SPEED

Adjust

The high idle speed (cold start idle) is automatically set by the setting of the low idle speed and can not be adjusted individually.

1. Check and adjust throttle cable.
2. Start engine and run it until normal operating temperature is reached.
3. Using a suitable tachometer, check the engine idle speed. **See ENGINE TUNING DATA, Information, Engine - 300Tdi**

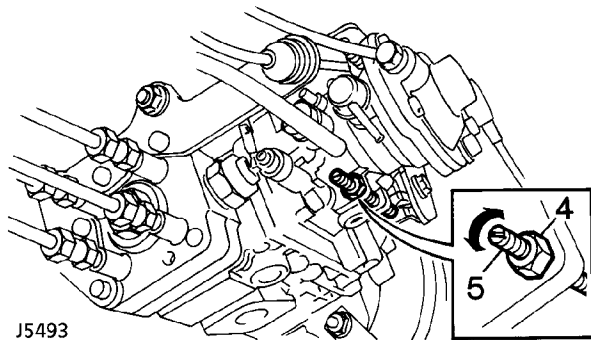

J5493

4. If adjustment is necessary, loosen the locknut on the injector pump.
5. Turn the adjustment screw either clockwise to increase the engine speed or anti-clockwise to decrease the speed. Run the engine at an increased speed for a few seconds then check the idle speed again.
6. When the correct speed has been achieved, hold the adjuster screw steady while tightening the locknut.



NOTE: The low idle speed control is the only permitted adjustment in service. Any additional adjustments required must be entrusted to authorised Bosch agents.

CHECK TURBOCHARGER BOOST PRESSURE

For boost pressure. **See ENGINE TUNING DATA, Information, Turbocharger**

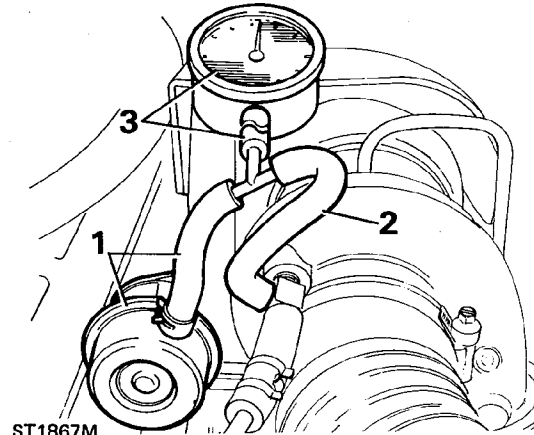

ST1867M

1. Disconnect, from turbocharger, hose to actuator. Insert into a suitable "T" piece.
2. Connect a short length of suitable hose to turbocharger and connect other end to "T" piece.
3. Connect a further length of hose to third leg of the "T" piece and other end to a pressure gauge capable of reading in excess of 61 cm Hg. The pressure gauge hose must be capable of reaching passenger compartment so that gauge may be observed.
4. To check maximum boost pressure, drive vehicle normally but in such a manner that full throttle can be maintained whilst climbing a hill with engine speed held steady between 2,500 and 3,000 rev/min.



TANK SENDER UNIT

Service repair no - 88.25.32



WARNING: Ensure that the **WARNINGS** and **FUEL HANDLING PRECAUTIONS** given in Section 01 are adhered to before carrying out the following operations.

Special tool - LST131

Remove

1. Disconnect battery negative lead.
2. Remove the rear carpet retainer.
3. Ease the carpet from under the lower trim panels at the rear of the fold down seats.
4. Raise the carpet to expose the sound insulation.
5. Fold back the sound insulation to reveal the access panel.
6. Remove the securing screws and detach the access panel from the floor.
7. Disconnect the multi-plug from sender unit.

8. Disconnect the fuel pipes from the sender unit.
9. Using special tool LST131 remove the locking ring and withdraw the sender unit from the fuel tank.

Refit

10. Fit the sender unit to the fuel tank and secure with the locking ring. Tighten to **45 to 50 Nm**.
11. Connect the fuel pipes to the sender unit.
12. Connect multi-plug to sender unit.
13. Inspect the access panel seal to ensure that it is satisfactory for further use, renew as necessary.
14. Fit the access panel to the aperture in the floor and secure with the screws.
15. Reverse removal procedure. 1 to 5. Refit the sound insulation and carpet.

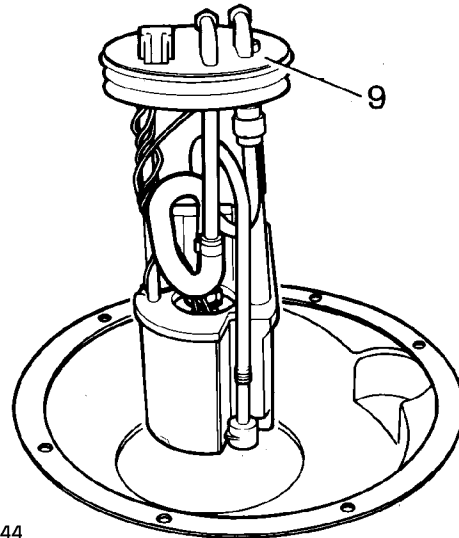

J5444

THROTTLE CABLE

Service repair no - 19.20.06

Remove

1. Disconnect battery negative lead.

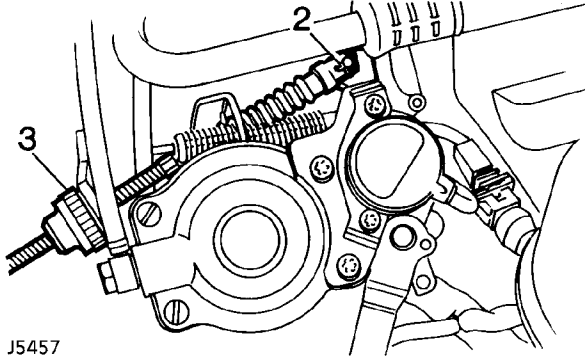

2. Remove pin and clevis pin securing throttle cable to throttle lever.
3. Pull ferrule from abutment bracket and withdraw throttle cable.
4. Release throttle cable from clip on bulkhead.

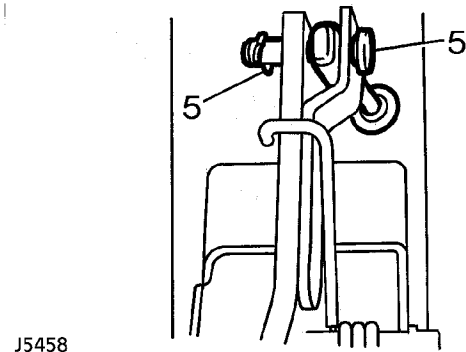

5. Remove pin and clevis pin securing throttle cable to throttle lever.
6. Release grommet from bulkhead.
7. Withdraw throttle cable from engine compartment.

Refit

8. Reverse removal procedure. Use new pins to secure clevis pins.
9. Adjust throttle cable. **See Adjustment, Throttle Cable Adjustment**

INTAKE HOSE TURBOCHARGER

Service repair no - 19.42.11

Remove

1. Disconnect battery negative lead.

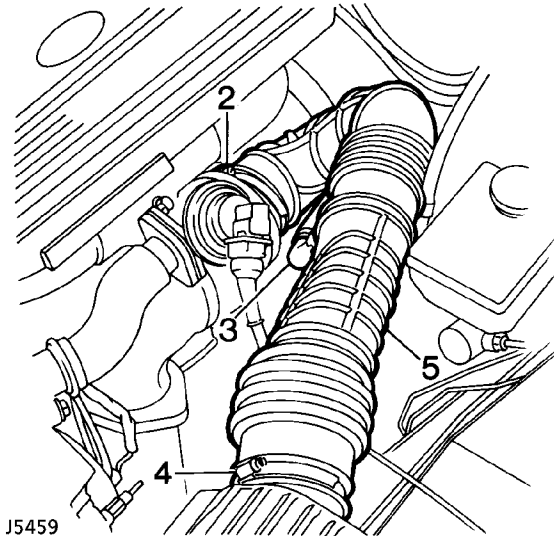

2. Loosen clip and disconnect intake hose from turbocharger.
3. Loosen clip and disconnect breather hose from intake hose.
4. Remove clip and disconnect hose from air cleaner, discard clip.
5. Remove intake hose

Refit

6. Reverse removal procedure. Use a new clip to secure intake hose to air cleaner.



TURBOCHARGER OIL FEED PIPE

Service repair no - 19.42.14

Remove

1. Disconnect battery negative lead.
2. Remove exhaust front pipe. *See MANIFOLD AND EXHAUST SYSTEM, Repair, Manifold and Exhaust System - Tdi*

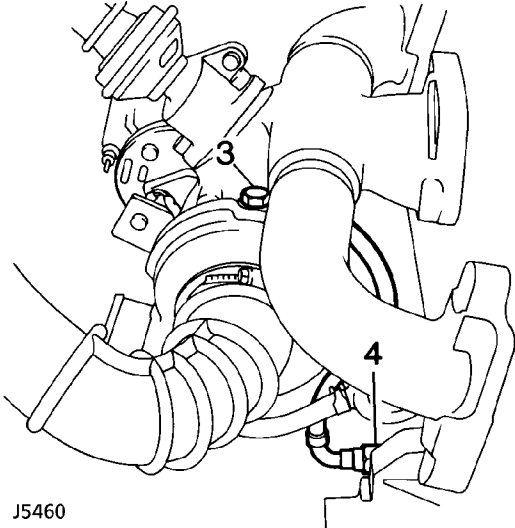

J5460

3. Remove banjo bolt securing oil feed pipe to turbocharger, discard 2 sealing washers.
4. Unscrew union, disconnect oil feed pipe from cylinder block.



CAUTION: Plug the connections.

5. Move oil feed pipe from behind turbocharger and remove.

Refit

6. Reverse removal procedure. use new sealing washers.
7. Tighten banjo bolt to **20 Nm**.
8. Check/top-up engine oil level.

TURBOCHARGER OIL DRAIN PIPE

Service repair no - 19.42.12

Remove

1. Disconnect battery negative lead.
2. Remove exhaust front pipe. *See MANIFOLD AND EXHAUST SYSTEM, Repair, Manifold and Exhaust System - Tdi*

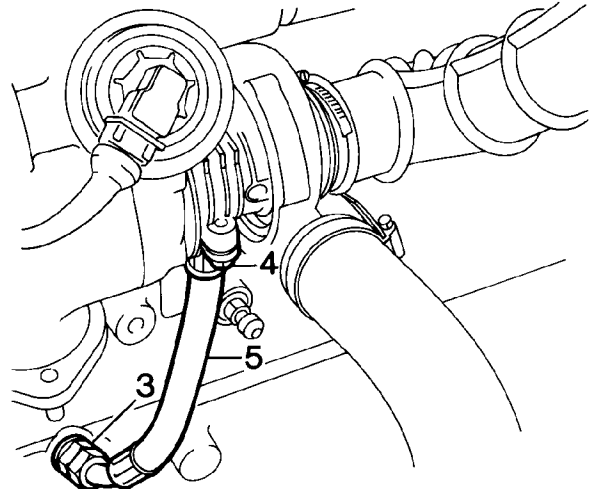

J5461

3. Unscrew union and disconnect oil drain pipe from cylinder lock.
4. Remove 2 bolts securing oil drain pipe to turbocharger.
5. Remove oil drain pipe, remove and discard gasket.



CAUTION: Plug the connection.

Refit

6. Ensure mating surfaces of oil pipe, turbocharger and engine block are clean.
7. Reverse removal procedure. Use a new gasket.
8. Tighten oil drain pipe to turbocharger bolts to **25 Nm**.
9. Check/top-up engine oil level.

TURBOCHARGER ACTUATOR

Service repair no - 19.42.31

Remove

1. Remove exhaust manifold and turbocharger.
See MANIFOLD AND EXHAUST SYSTEM, Repair, Exhaust Manifold - Tdi

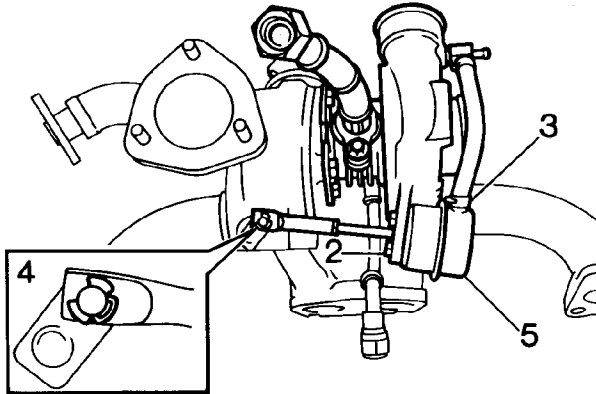

J5488

2. Remove 2 nuts securing the actuator to the turbocharger bracket.
3. Release clip and disconnect hose from actuator.
4. Remove and discard clip securing control lever to wastegate spindle.
5. Remove turbocharger actuator.

Refit

6. Fit the replacement actuator and secure with nuts.
7. Push the control lever as far as possible towards the actuator and apply pressure to keep the lever in this position.
8. Pressurise the actuator to 57 - 62 cm Hg and hold this pressure.

CAUTION: Use only the threaded end of the lever to make adjustments. Forcing the complete lever in or out will change the calibration with the possibility of damaging engine boost.

9. Screw the lever in either direction until the eye on the end will locate easily over the wastegate spindle and secure with a new clip.
10. Release the pressure and tighten the locknut.
11. Refit exhaust manifold and turbocharger. *See MANIFOLD AND EXHAUST SYSTEM, Repair, Exhaust Manifold - Tdi*

TURBOCHARGER AND GASKET

Service repair no - Turbocharger - 19.42.01

Service repair no - Gasket - 19.42.25

Remove

1. Disconnect battery negative lead.
2. Remove air cleaner assembly. *See Air Cleaner Assembly*
3. Remove exhaust manifold assembly. *See MANIFOLD AND EXHAUST SYSTEM, Repair, Exhaust Manifold - Tdi*

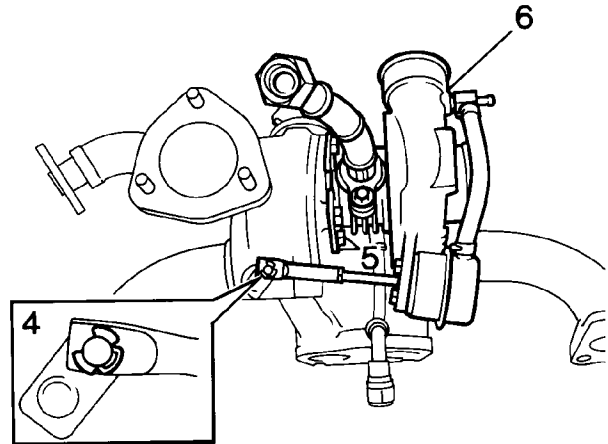

J5469

4. Remove and discard clip securing control lever to wastegate spindle.
5. Remove 4 bolts and 2 clamp plates securing turbocharger to exhaust manifold.
6. Remove turbocharger and discard gaskets.

Refit

7. Clean mating faces of turbocharger and exhaust manifold.
8. Reverse removal procedure. Use new clip to secure control lever to wastegate spindle. Tighten to **45 Nm**.
9. Check/top-up engine oil level.



FUEL LIFT PUMP

Service repair no - 19.45.09

Remove

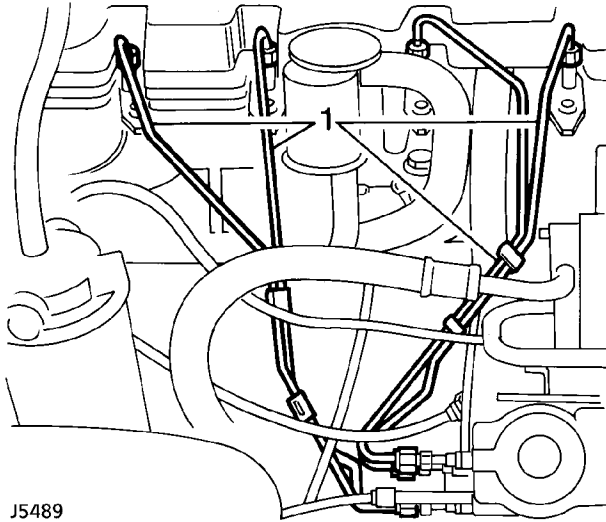

J5489

1. Loosen unions securing fuel injection pipes to injectors and injector pump. Remove injection pipes.
2. Plug the connections to prevent the ingress of foreign material.

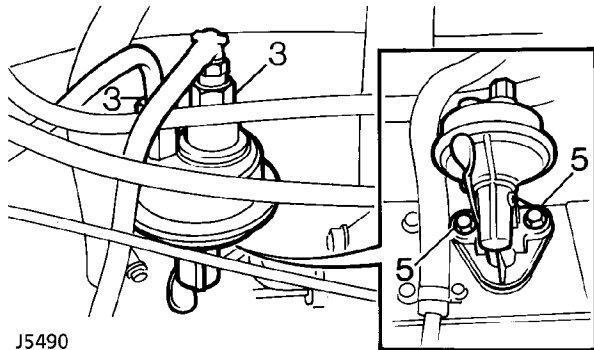

J5490

3. Loosen unions and disconnect fuel supply and feed hoses from fuel lift pump.
4. Plug the connections to prevent the ingress of foreign material.
5. Remove 2 bolts securing lift pump to engine block.
6. Remove fuel lift pump and discard gasket.

Refit

7. Clean mating faces of fuel lift pump and engine block.
8. Using a new gasket, fit fuel pump, ensure correct location of lever with camshaft. Fit securing bolts. Tighten to **25 Nm**.
9. Connect fuel hoses to pump and secure unions. Tighten to **33 Nm**.
10. Fit injector pipes to injectors and injection pump, and secure unions. Tighten to **28 Nm**.

FUEL FILTER ELEMENT

Service repair no - 19.25.07

Remove

1. Disconnect battery negative lead.
2. Clean area around filter head.
3. Place a suitable container beneath filter bowl to collect any spillage.

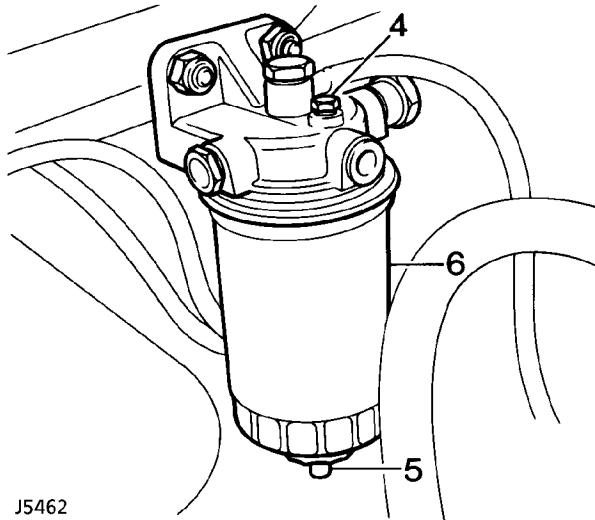

J5462

4. Loosen bleed screw.
5. Loosen drain tap, allow fuel to drain into container.
6. Unscrew filter element, discard element.

Refit

7. Clean seal and seating in filter head.
8. Lubricate filter element seal with fuel.
9. Position filter element to filter head and hand tighten.
10. Reconnect battery negative lead.
11. Crank engine until fuel is drawn through the system and starts.

INTERCOOLER

Service repair no - 19.42.15

Remove

1. Disconnect battery negative lead.

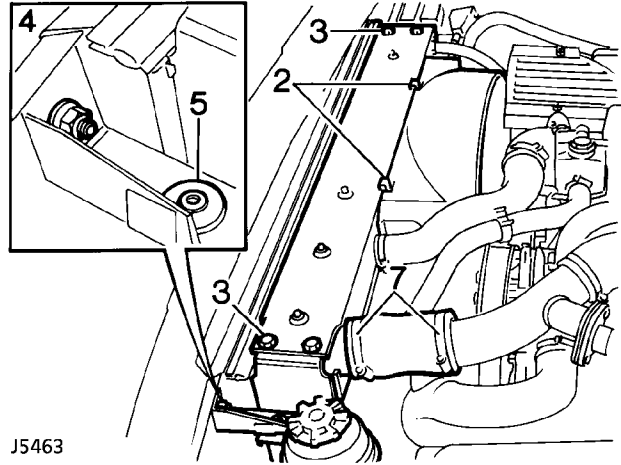

J5463

2. Release 2 clips securing fan cowl to radiator top cover.
3. Remove 4 bolts securing radiator top cover, remove top cover.
4. Remove nut, bolt and washers securing intercooler side cover bracket to bonnet [hood] platform.
5. Release bracket from side cover lug, position bracket and power steering reservoir aside.
6. Position side cover away from intercooler.
7. Loosen 2 clips and disconnect top hose from intercooler.
8. Loosen 2 clips and disconnect bottom hose from intercooler.

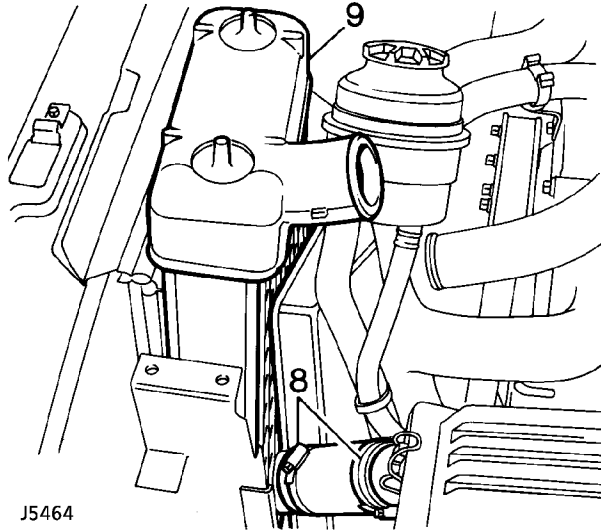

J5464

9. Move intercooler upwards and clear of fan cowl.

Refit

10. Ensure locating lug grommets are fitted and in good condition.
11. Ensure foam pad is in good condition and attached to intercooler.
12. Move intercooler into position.
13. Reverse removal procedure.

GLOW PLUGS

Service repair no - 19.60.31

Remove

1. Disconnect battery negative lead.

No.1 glow plug - air conditioning models

2. Release drive belt from compressor pulley. **See ENGINE, Repair, Drive Belt Renew**

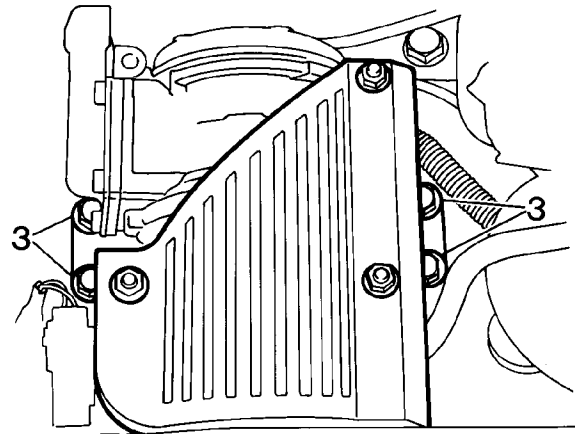

J5465

3. Remove 4 bolts securing compressor to front cover, move compressor aside.

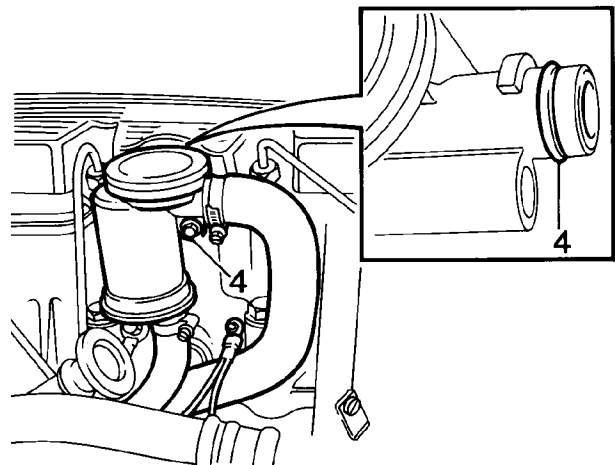

J5466

No.3 glow plug

4. Remove bolt securing Hummel valve, withdraw valve, remove and discard 'O' ring.

All glow plugs

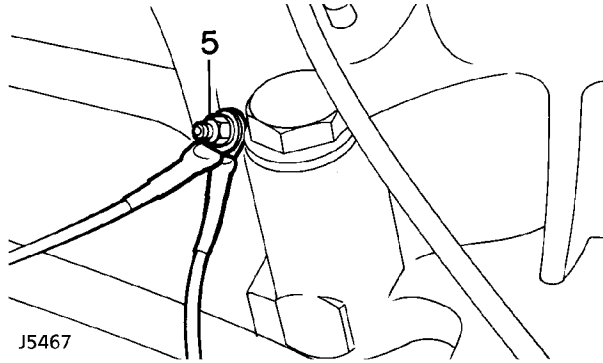

5. Remove terminal nut from glow plug, disconnect wire from glow plug terminal.
6. Remove glow plug.

Refit

7. Clean glow plug and seating.
8. Coat threads of glow plug with suitable anti-seize compound operational to a temperature of 1000°C.
9. Fit glow plug. Tighten to **23 Nm**.
10. Connect wire to glow plug terminal and secure with nut.



NOTE: Feed wire must be connected to No. 4 glow plug terminal.

11. *No. 3 glow plug:* Lubricate new 'O' ring with engine oil and fit to Hummel valve. Fit valve and secure with bolt. Tighten to **15 Nm**.

No. 1 glow plug - air conditioning models

12. Position compressor to front cover, fit bolts. Tighten to **25 Nm**.
13. Fit drive belt to compressor pulley and adjust tension. **See ENGINE, Repair, Drive Belt Renew**

All models

14. Reconnect battery negative lead.

EGR VALVE

Service repair no - 19.45.01

Remove

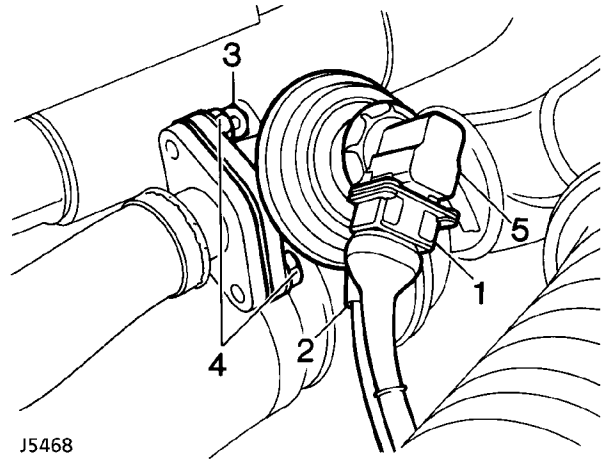

1. Disconnect multiplug from EGR valve.
2. Disconnect vacuum pipe from EGR valve.
3. Remove 2 Allen screws securing EGR valve to exhaust manifold.
4. Remove 2 bolts securing hose to EGR valve.
5. Remove EGR valve and discard gaskets.

Refit

6. Clean mating faces of EGR valve and exhaust manifold.
7. Reverse removal procedure. Tighten bolts to **25 Nm**.



GLOW PLUG CONTROL UNIT

Service repair no - 19.60.33

Remove

1. Disconnect battery negative lead.

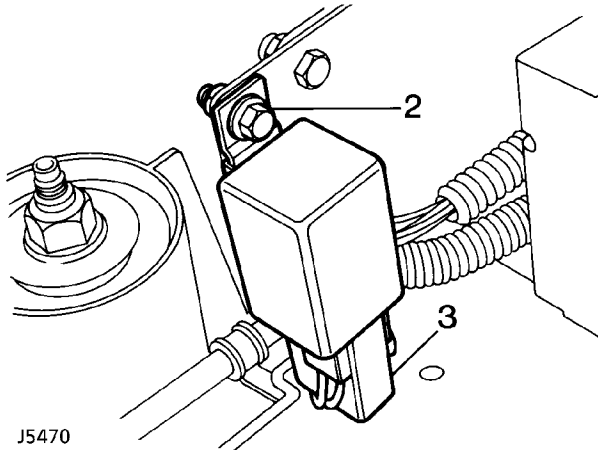

J5470

2. Remove nut and bolt securing control unit to mounting bracket.
3. Disconnect multiplug and remove control unit.

Refit

4. Reverse removal procedure.

EGR CONTROL UNIT

Service repair no - 19.45.06

Remove

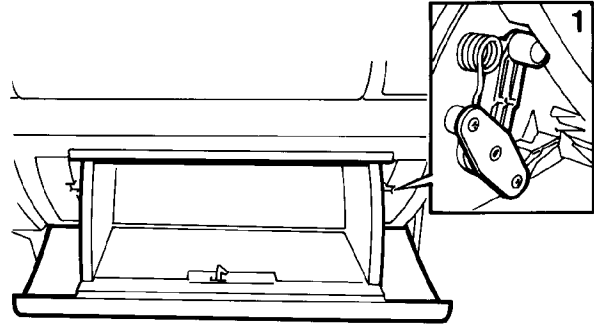

J5471

1. Release 2 glovebox stays from fascia and pivot glovebox fully downwards.

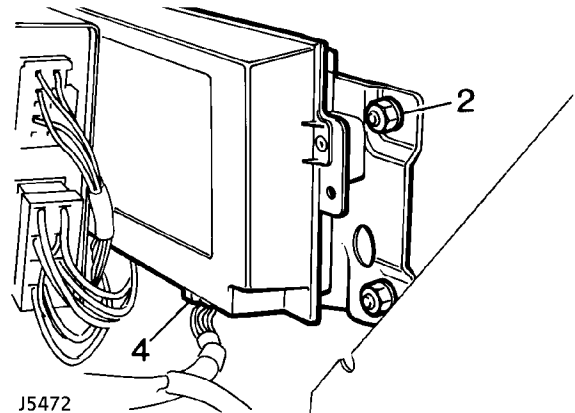

J5472

2. Remove 2 plastic nuts securing control unit to body.
3. Release control unit from fixings.
4. Disconnect multiplug and remove control unit.

Refit

5. Reverse removal procedure.

EGR THROTTLE POSITION SENSOR

Service repair no - 19.30.14

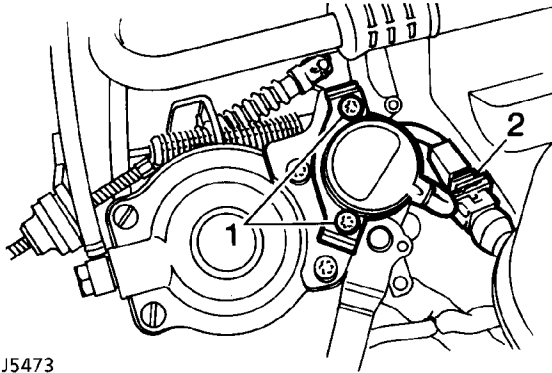
Remove

J5473

1. Remove 2 screws securing throttle position sensor mounting plate to injection pump.
2. Disconnect throttle position sensor multiplug from harness.
3. Remove throttle position sensor assembly.

Refit

4. Locate throttle position sensor assembly on injection pump and fit and tighten screws.
5. Connect multiplug.
6. Adjust throttle position sensor. *See Adjustment, EGR Throttle Position sensor*

INJECTORS

Service repair no - 19.60.10

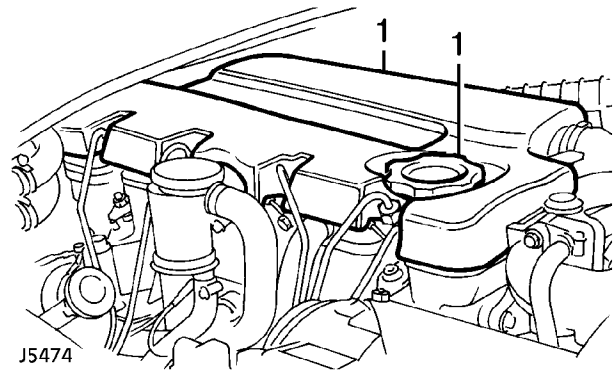
Remove

J5474

1. Remove oil filler cap and remove sound deadening pad from top of engine.
2. Remove high pressure pipe from relevant injector and injection pump.
3. Disconnect spill return hose(s) from injector.
4. Plug pipes and injector connections to prevent the ingress of dirt and foreign matter.
5. Remove nut securing injector clamp plate to cylinder head.
6. Remove injector.

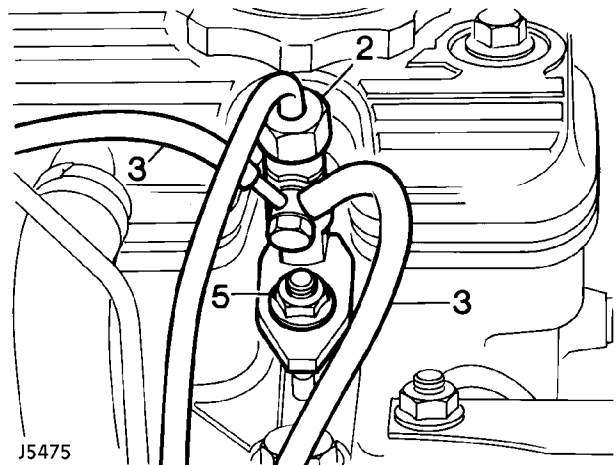

J5475

Refit

7. Reverse removal procedure. Renew copper washer on injector. Tighten injector clamp plate nut to **25 Nm**.



FUEL INJECTION PUMP AND TIMING

Service repair no - 19.30.07



NOTE: The following text refers to a Tdi vehicle with a manual gearbox without electronic diesel control. Where reference is made to the timing tool substitute the following information for automatic and EDC variants.

If manual gearbox: Timing tool LRT-12-044 fits into the base of the flywheel housing

If manual gearbox with EDC: Timing tool LRT-12-085 must be used and also fits into the base of the flywheel housing.

If automatic gearbox: Timing tool LRT-12-044 fits into the larger bolt hole of coverplate on engine backplate, sited near to the rear of sump. Pin locates in ring gear.

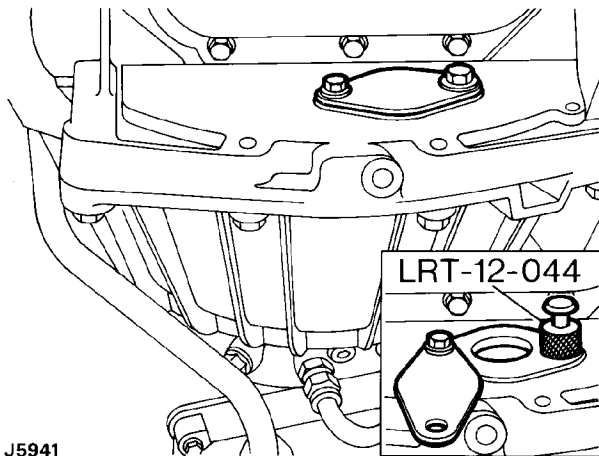

J5941

Remove

1. Disconnect battery negative lead.
2. Remove injection pipes, pump to injector.
3. Remove oil filler cap from rocker cover.
4. Viewing valve mechanism through filler aperture, turn crankshaft clockwise until No. 1 cylinder is just before TDC.
5. Refit oil filler cap.
6. Remove blanking plug from flywheel housing.
7. Fit timing tool LRT-12-044 to flywheel housing, do not engage centre pin.

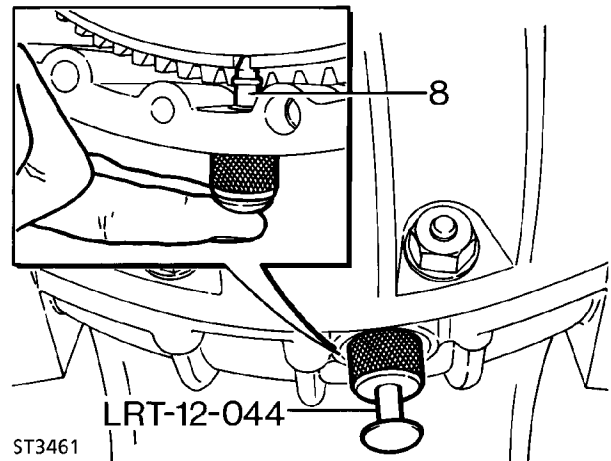

8. Continue rotating crankshaft clockwise until centre pin engages with timing slot in flywheel.
9. Remove injection pump access plate, complete with gasket, from front cover plate.
10. Fit pin from LRT-12-045 to injection pump gear.

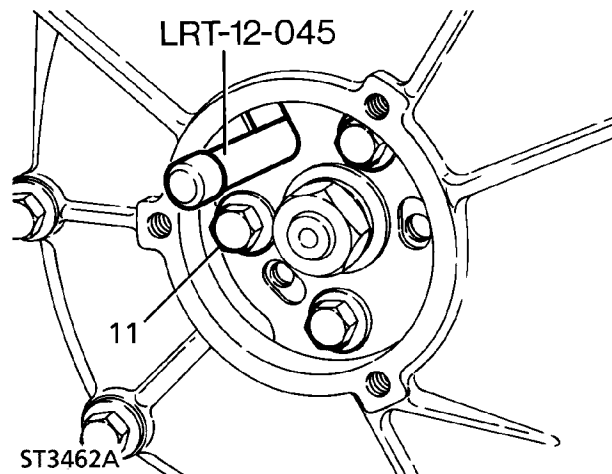

11. Remove drive gear to pump hub fixing bolts and plate.
12. Remove pin from pump gear.

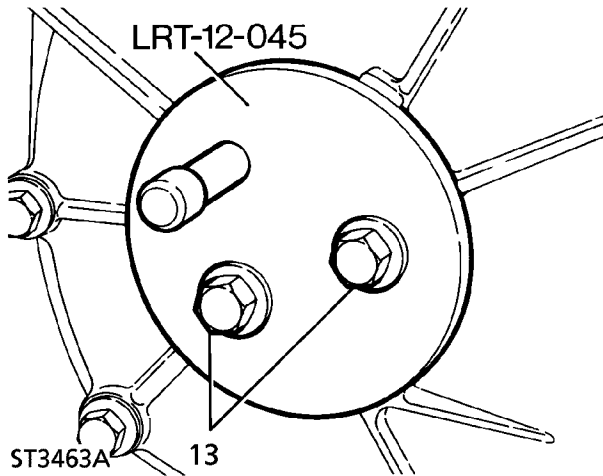

13. Fit gear retaining tool LRT-12-045 with an 8 mm washer, 1.5 to 2 mm thick, under each bolt head in addition to the existing washer.
14. Remove throttle cable and hand throttle cable if fitted.

15. Disconnect stop control solenoid connector.
16. Remove banjo bolts securing spill return, main fuel and boost signal pipes, refit banjo bolts after disconnecting pipes.

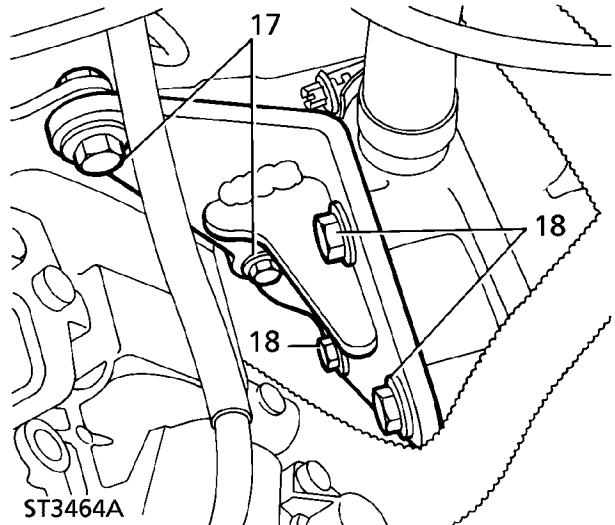

17. Remove pump mounting bracket bolts 2 off.
18. Loosen pump support bracket bolts to block, sufficient for bracket to just move.
19. Remove pump securing nuts at flange and withdraw pump and gasket.
20. Fit blanks to pipe connections.



Refit

21. Remove blanks from pump.

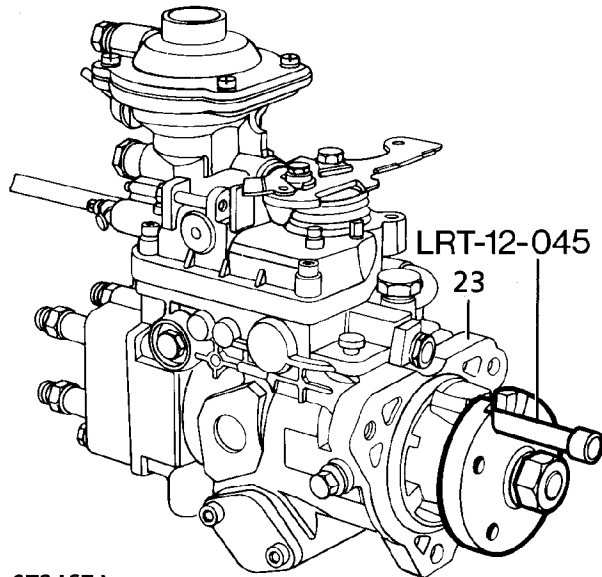

ST3467A

22. Remove special tool pin from pump.
23. Clean mating faces of pump and front cover.
24. Fit pump to cover with a new gasket and secure with nuts. Tighten to **25 Nm**.
25. Attach pump to bracket and finger tighten nuts and bolts
26. First tighten bolts securing bracket to block and then bolts securing pump to bracket.
27. Connect spill return, main fuel pipes. Tighten to **25 Nm**.
28. Connect boost signal pipe and secure with banjo bolts. Tighten to **10 Nm**.
29. Connect stop control solenoid lead.
30. Connect throttle cable and where applicable hand throttle cable.
31. Remove special tool LRT-12-045.
32. Fit gear lock plate.
33. Fit pin from special tool LRT-12-045.
34. Secure gear with bolts.
35. Remove special tool pin.
36. Turn crankshaft two complete revolutions, check timing pin from LRT-12-045 can be fully and easily inserted into the pump. At the same time check flywheel timing pin LST-12-044 can also be inserted in the flywheel slot.
37. If, with the flywheel timing pin located, the timing pin cannot be inserted cleanly into the injection pump, carry out the following:
- Ensure flywheel timing pin is disengaged from slot in flywheel.
 - Turn the crankshaft the small amount necessary to enable the timing pin to be inserted into the pump.
 - Loosen the three pump gear retaining bolts.
 - Turn the crankshaft to T.D.C..
 - Check that the timing pin is an easy fit in the pump and that the flywheel timing pin locates.
 - Tighten the pump gear retaining bolts to the correct torque.
 - Remove the timing pin from the pump and the timing tool from the flywheel housing.
38. Using antisieze compound, fit the blanking plug to flywheel housing. Tighten to **12 Nm**.
39. Fit access plate with gasket to front cover plate. Tighten to **25 Nm**.
40. Refit injector pipes. Tighten to **29 Nm**.

VEHICLE SPEED SENSOR

Service repair no - 18.30.22

Remove



NOTE: The following procedure is carried out with the ramp still raised.

1. Disconnect battery negative lead.

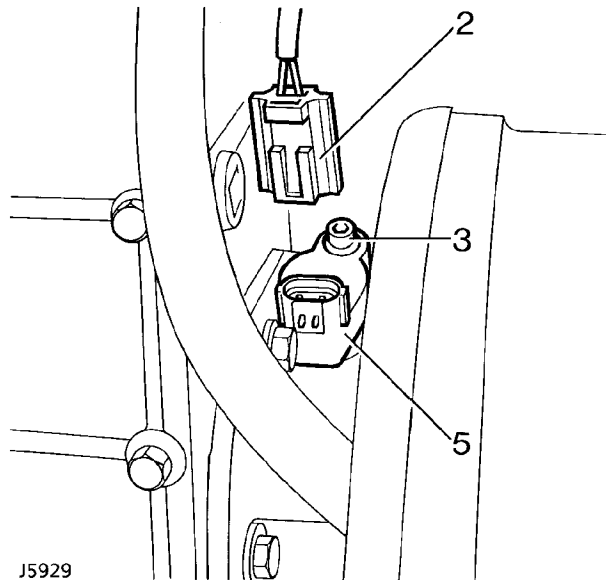

2. Disconnect sensor multi-plug.
3. Remove sensor retaining screw.
4. Remove sensor retaining plate.
5. Remove sensor from transfer box.

Refit

6. Reverse removal procedure.

COOLANT TEMPERATURE SENSOR

Service repair no - 18.30.68

Remove

1. Disconnect battery negative lead.

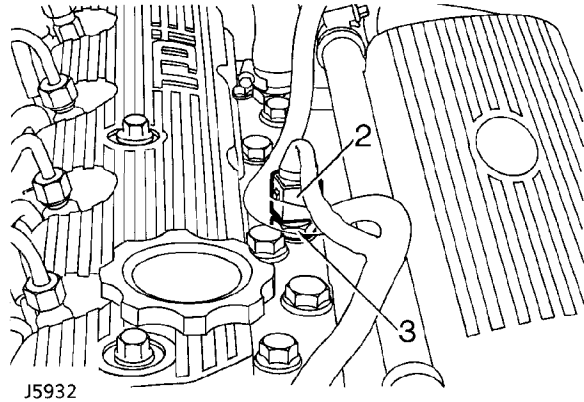

2. Disconnect sensor multi-plug.
3. Remove sensor.
4. Clean off water spillage from sensor area.

Refit

5. Fit a new copper washer.
6. Fit sensor and tighten securely.
7. Refill cooling system.
8. Run engine, check for water leaks around sensor.



DESCRIPTION

Hot Wire Multiport Fuel Injection

The 'Hot Wire' Multiport fuel injection system derives its name from the mass air flow sensor which uses one cold wire and one electrically heated wire to measure the volume of air entering the engine.

The function of the system is to supply the exact amount of fuel directly into the intake manifold according to the prevailing engine operating conditions.

To monitor these conditions, various sensors are fitted to the engine to measure engine parameters. Data from the sensors is received by the Engine control module (ECM), the ECM will then determine the exact amount of fuel required at any condition.

The ECM having received data from the sensors produces pulses, the length of which will determine the simultaneous open time of each bank of injectors in turn, which will govern the amount of fuel injected.

Engine control module - ECM

The Multiport fuel injection system is controlled by the 14 CUX Engine Control Module comprising of a microprocessor with integrated circuits and components mounted on printed circuit boards. The ECM is connected to the main harness by a 40 pin plug.

Injectors

The eight fuel injectors are fitted between the pressurized fuel rail and inlet manifold. Each injector comprises a solenoid operated needle valve with a movable plunger rigidly attached to the nozzle valve. When the solenoid is energized the plunger is attracted off its seat and allows pressurized fuel into the intake manifold.

Engine coolant temperature sensor

The engine coolant temperature sensor is located in the front of the thermostat housing. The sensor provides engine coolant information to the ECM. The ECM increases the injector opening time when cold to provide improved driveability, and reduces the opening time as the engine reaches normal operating temperature.

Engine fuel temperature sensor

The engine fuel temperature sensor is located in the rail on the RH side of the ram housing. The sensor sends fuel temperature data to the ECM, the ECM on receiving the data will adjust the injector open time accordingly to produce good hot starting in high ambient temperatures.

Idle air control valve

The idle air control valve is screwed into a housing attached to the rear of the plenum chamber, between the plenum chamber and bulkhead. The idle air control valve has two windings which enable the motor to be energised in both directions thus opening or closing the air valve as required by the ECM. The idle air control valve will open and allow extra air into the plenum chamber to maintain engine idle speed when the engine is under increased (Electrical and Mechanical) loads. The idle air control valve will control engine idle speed when the vehicle is stationary.

Heated oxygen sensors (O₂ sensors) - Catalyst vehicles

The two heated oxygen sensors are located forward of the catalysts mounted in the exhaust downpipes. The sensors monitor the oxygen content of the exhaust gases and provide feedback information of the air/fuel ratio to the ECM. Each sensor is heated by an electrical element to improve its response time when the ignition is switched on.

Fuel pressure regulator

The fuel pressure regulator is mounted in the fuel rail at the rear of the plenum chamber. The regulator is a mechanical device controlled by plenum chamber vacuum, it ensures that fuel rail pressure is maintained at a constant pressure difference of 2.5 bar above that of the manifold.

When pressure exceeds the regulator setting excess fuel is returned to the fuel tank.

Fuel pump

The electric fuel pump is located in the fuel tank, and is a self priming 'wet' pump, the motor is immersed in the fuel within the tank.

Air flow sensor

The hot-wire air flow sensor is mounted on a bracket attached to the left hand valance, rigidly connected to the air cleaner and by hose to the plenum chamber inlet neck.

The air flow sensor consists of a cast alloy body through which air flows. A proportion of this air flows through a bypass in which two wire elements are situated: one is a sensing wire and the other is a compensating wire. Under the control of an electronic module which is mounted on the air flow sensor body, a small current is passed through the sensing wire to produce a heating effect. The compensating wire is also connected to the module but is not heated, but reacts to the temperature of the air taken in, as engine intake air passes over the wires a cooling effect takes place.

The electronic module monitors the reaction of the wires in proportion to the air stream and provides output signals in proportion to the air mass flow rate which are compatible with the requirements of the ECM.

Throttle position sensor

The throttle position sensor is mounted on the side of the plenum chamber inlet neck and is directly coupled to the throttle butterfly shaft.

The throttle position sensor is a resistive device supplied with a voltage from the ECM. Movement of the accelerator pedal causes the throttle valve to open, thus rotating the wiper arm within the throttle position sensor which in turn varies the resistance in proportion to the valve position. The ECM lengthens the injector open time when it detects a change in output voltage (rising) from the throttle position sensor.

In addition the ECM will weaken the mixture when it detects the throttle position sensor output voltage is decreasing under deceleration and will shorten the length of time the injectors are open.

When the throttle is fully open, the ECM will detect the corresponding throttle position sensor voltage and will apply full load enrichment. This is a fixed percentage and is independent of temperature. Full load enrichment is also achieved by adjusting the length of the injector open time.

When the throttle is closed, overrun fuel cut off or idle speed control may be facilitated dependant on other inputs to the ECM.

The throttle position sensor is 'self adaptive', which means that adjustment is not possible. It also means the throttle position sensor setting is not lost, for example, when throttle stop wear occurs.



CAUTION: Do not attempt to adjust throttle position sensor.



Tune select resistor -

To suit individual market requirements a tune select resistor is connected across pins 5 and 27 of the ECM.

It is located adjacent to the ECM, and strapped to the MFI cable assembly. The value of the resistor is dependent on the market application:

Red wire, 180 ohms, Australia, Rest of world.

Green wire, 470 Ohms, UK and Europe - non catalyst.

Yellow wire 910 Ohms, Saudi non catalyst.

White wire, 3K9 Ohms, European catalyst

Condenser fans

It should be noted that under high coolant temperatures, when the engine is switched off, the condenser fans will be activated and will run for approximately ten minutes.

Vehicle speed sensor

The vehicle speed sensor is located on the side of the Transfer box adjacent to the parking brake. The sensor provides road speed data to the ECM. The ECM in turn detects vehicle movement from the road speed input and ensures that idle air control mode is disengaged. Should the vehicle speed sensor fail in service the ECM idle air control would become erratic.

The sensor also provides road speed data to the electric speedometer and cruise control ECU.

Inertia fuel shutoff switch

The inertia fuel shutoff switch is a mechanically operated switch, located on the bulkhead adjacent to the washer reservoir under bonnet [hood]. The switch is normally closed and is in line with the fuel pump. In the event of a sudden impact the switch opens, and disconnects the electrical feed to the fuel pump. The switch is reset by pressing down the button.



WARNING: Check the integrity of the fuel system before the inertia switch is reset.

Relay modules

The two multiport fuel injection relay are located in the RH footwell area behind the 'A' post panel. The main relay module is energized via the ECM when the ignition is switched on and supplies current to the multiport fuel injection system. The fuel pump relay module is energized by the ECM which in turn operates the fuel pump to pressurize the fuel system.

ENGINE MOUNTED COMPONENTS

1. By-pass air valve (stepper motor).
2. Fuel pressure regulator.
3. Air flow meter.
4. Throttle position sensor.
5. Fuel temperature sensor.
6. Coolant temperature sensor.
7. Fuel injector.

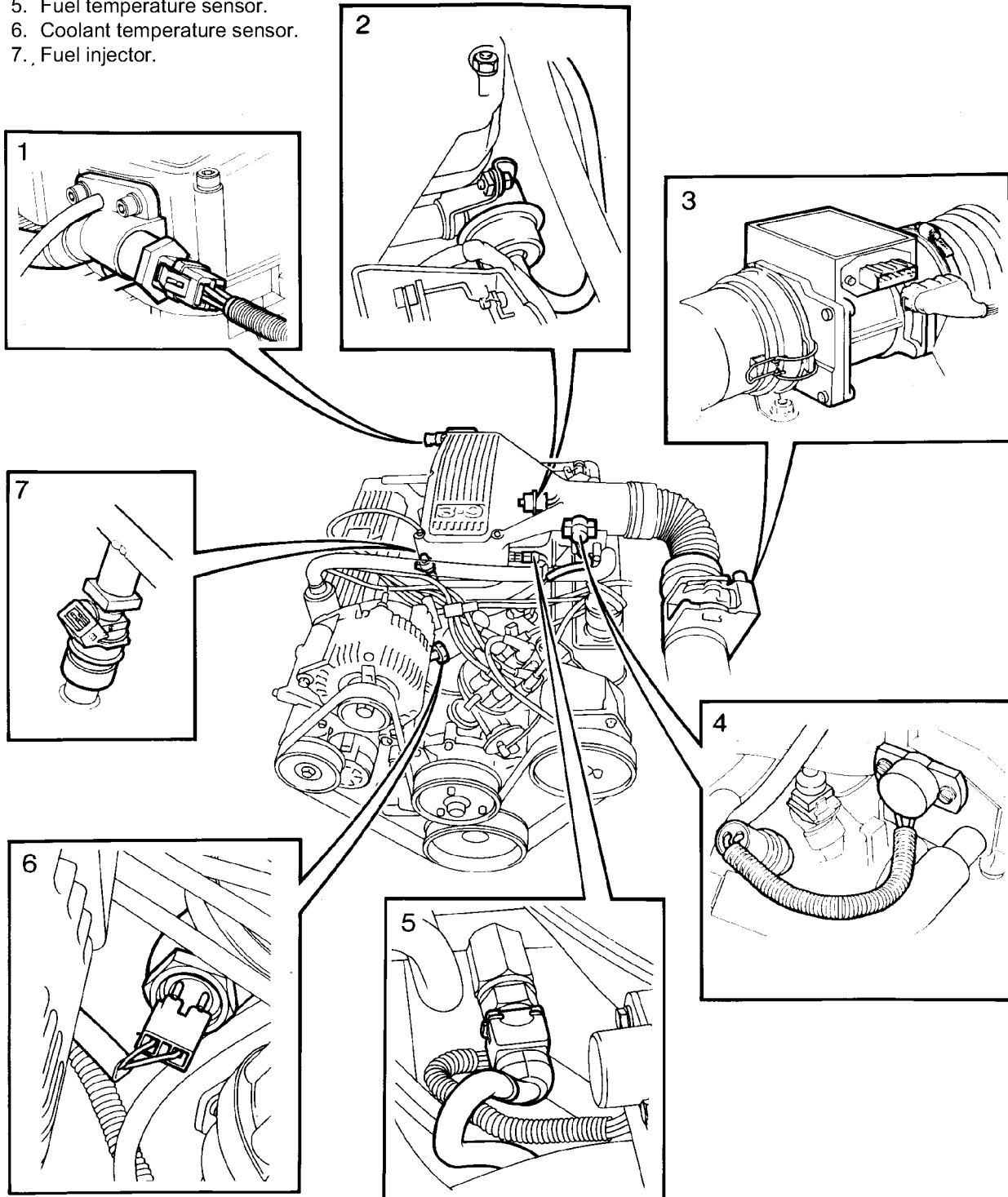

J5425



CHASSIS MOUNTED COMPONENTS

1. Fuel filter.
2. Fuel pump (in fuel tank).

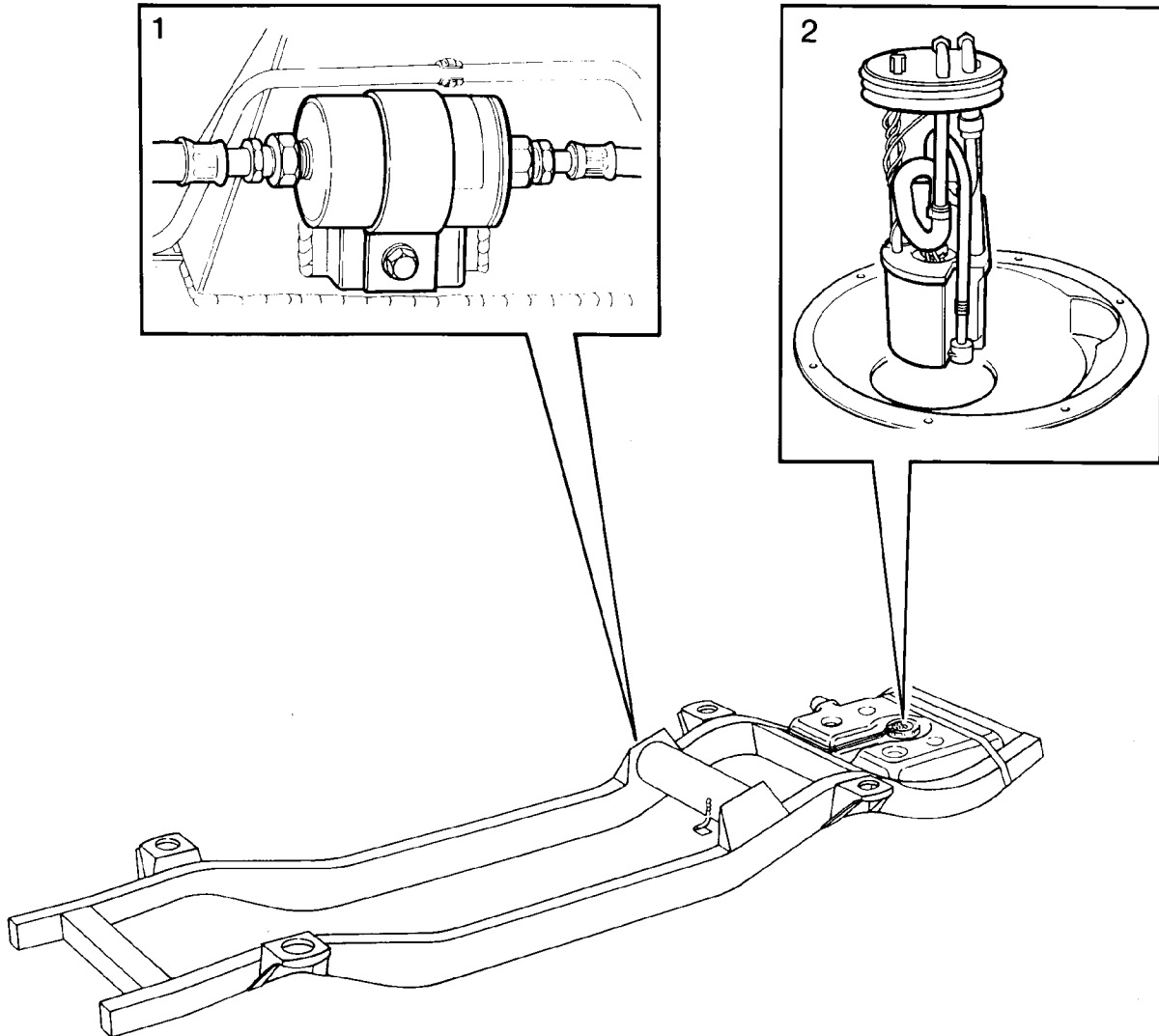

J5426

BODY MOUNTED COMPONENTS

1. Engine control module (ECM).
2. Main relay and fuel pump relay.
3. Inertia switch.
4. Ignition coil.
5. Charcoal canister.
6. Purge control valve.

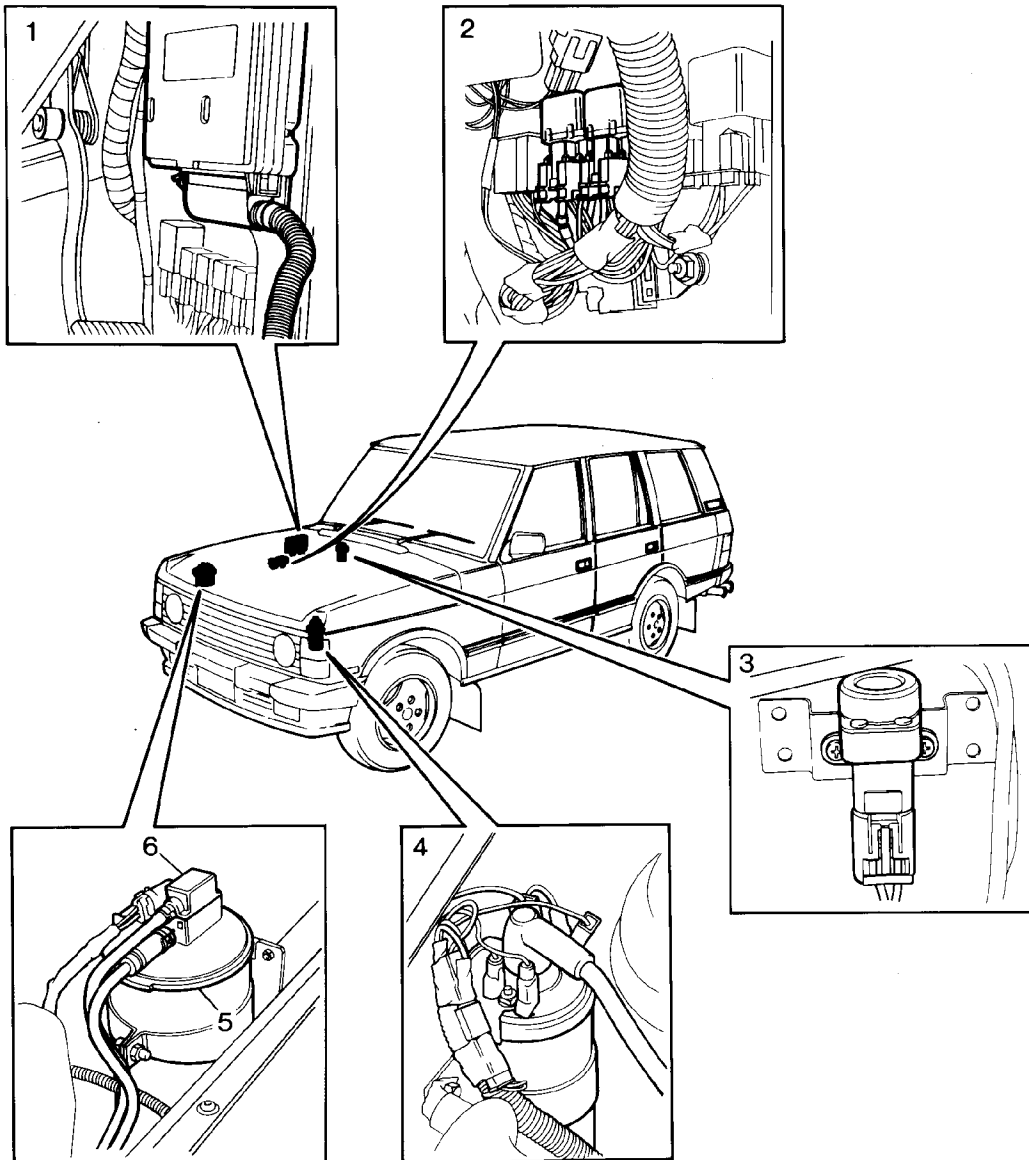

RR4266



MICRO PROCESSOR POWER CHECK (Instrument binnacle - Service use only)

As part of the engine starting procedure, this symbol will illuminate momentarily.

FUEL INJECTION SYSTEM



CAUTION: The fuel system incorporates fine metering components that would be affected by any dirt in the system; therefore it is essential that working conditions are scrupulously clean. If it is necessary to disconnect any part of the fuel injection system, the system **MUST** be depressurized. All openings left open after the removal of any component from the fuel system, **MUST** be sealed off to prevent ingress of dirt.

ENGINE SETTING PROCEDURE

If a major overhaul has been undertaken of the fuel injection/engine system, the following check and adjustments must be carried out before attempting to start the engine.

1. Spark plug gaps. *See ENGINE TUNING DATA, Information, Engine 3.9 V8i or See ENGINE TUNING DATA, Information, Engine 4.2 V8i*
2. Ignition timing. *See ELECTRICAL, Adjustment, Ignition Timing*



CAUTION: Catalyst vehicle - if the engine is misfiring, it should be immediately shut down and the cause rectified. Failure to do so will result in irreparable damage to the catalyts.



NOTE: If the previous checks and adjustments are satisfactory but the engine will not start, the ignition and fuel injection electrical circuits must be checked using the appropriate recommended equipment.



ENGINE TUNING

Circuit fault diagnosis may be carried out on all V8i vehicles, using Testbook. Testbook will guide the operator by visual prompts through a series of diagnostic checks.

Before commencing any fault diagnosis, the following preliminary checks must be carried out.

Preliminary checks



CAUTION: Catalyst exhaust: If engine is misfiring or fails to start within 12 seconds the cause must be rectified. Failure to do so will result in irreparable damage to the catalysts. After rectification the engine must be run at 1500 rev/min (no load) for 3 minutes to purge any accumulation of fuel in the system.

1. Check that the inertia fuel shut off switch is not tripped.
2. Check fuse in main fuse panel.
3. Check for ample fuel in tank.
4. Check air inlet system for possible leaks into the intake manifold.
5. Check HT cables for correct firing order and routing.
6. Check ignition timing.

Only when the above checks have been carried out, should circuit diagnosis begin. **See *Electrical Trouble Shooting Manual*.**

INJECTOR TESTS



NOTE: Before removing any of the injectors, remove and examine the spark plugs, check for consistent colouration of plugs. A leaking injector will result in the appropriate spark plug being 'sooted up'.

The following test may only be carried out using suitable injector test equipment.

Leak Test

Leak test with the injectors closed but pressurise to 2.54 Kgf/cm². No injector should leak more than 2 drops of fuel per minute.

Fuel Delivery Test

Fuel delivery test with the injector open and pressurised as above, fuel delivery from each injector should be 160-175cc per minute using white spirit, or 180-195cc per minute using petrol at 20°C ± 2°C.

BASE IDLE SPEED SETTING



NOTE: Base idle speed is set at factory. It should not require further adjustment unless plenum chamber is changed. The adjustment screw is sealed with a plug to prevent unauthorised alteration. Check ignition timing before attempting following procedure, since this will affect idle speed.

Equipment required

Two blanking hoses. these are manufactured using a new air by-pass valve hose - Part No.ETC7874. Cut two equal pieces 90mm long from hose and seal one end of each, using 13mm diameter bar. Use a suitable clamp to ensure an air tight seal.

Checking procedure

1. Drive vehicle at least two miles until engine and transmission are hot. Switch off engine.
2. Check all electrical loads are OFF, including air conditioning.
3. Remove air by-pass valve hose.

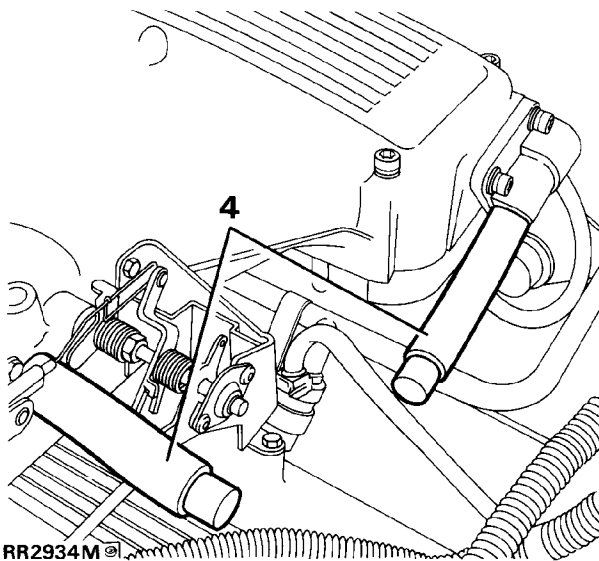

4. Fit blanking hoses to both plenum chamber and air by-pass valve. Ensure hoses are securely fitted to prevent air leaks. Note throttle cable and cruise control actuator have been omitted from illustration.

5. Start engine and check idle speed is within limits. **See ENGINE TUNING DATA, Information, Basic Idle Speed**

Adjusting base idle speed

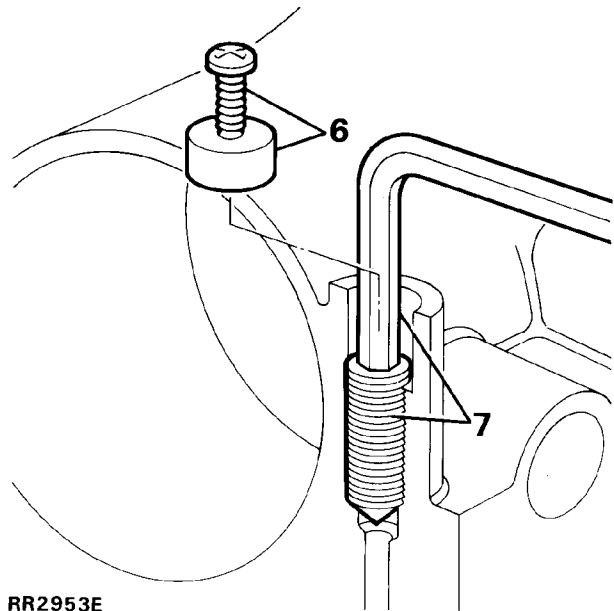

6. Drill tamper proof plug and insert a self tapping screw to enable plug to be extracted.
7. Start engine, adjust idle screw clockwise to decrease or counter-clockwise to increase idle speed.
8. Stop engine, remove blanking hoses. Reconnect hose to plenum.
9. Fit new tamper proof plug.



FUEL PRESSURE CHECK

In order to check the fuel pressure it is necessary to first depressurise the fuel system as follows:



WARNING: Under normal operating conditions the multiport fuel injection system is pressurised by a high pressure fuel pump, operating at up to 2.3 to 2.5 bar. When engine is stationary pressure is maintained within system. To prevent pressurised fuel escaping and to avoid personal injury it is necessary to depressurise multiport fuel injection system before any service operations are carried out.

If vehicle has not been run there will be a small amount of residual pressure in fuel line. The depressurising procedure must still be carried out before disconnecting any component within the fuel system.

The spilling of fuel is unavoidable during this operation. Ensure that all necessary precautions are taken to prevent fire and explosion.

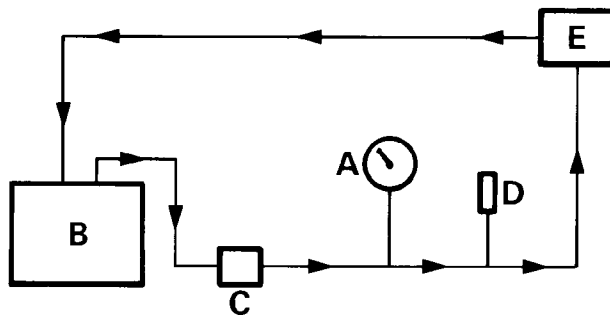

RR3834M

- A Pressure gauge 18G1500
- B Fuel tank and pump
- C Fuel filter
- D Fuel injectors x 8
- E Regulator

1. Remove fuel pump relay module. *See Repair, Multiport Fuel Injection Relay Modules*
2. Start and run engine.
3. When sufficient fuel has been used to cause fuel line pressure to drop, injectors will become inoperative, resulting in engine stall. Switch off ignition.
4. Disconnect battery negative lead. .



NOTE: Fuel at low pressure will remain in system. To remove low pressure fuel, place absorbent cloth around fuel pipe at the filter during disconnection.

5. Connect the pressure gauge on the outlet from the filter, located on the chassis under the right rear wheel arch.
6. Reconnect the battery and turn the ignition to position II while observing the pressure gauge. Results
Expected reading 2,39-2,672 kgf/cm²
Pressure drop-max 0.7 kgf/cm² in one minute.
If pressure is low check that filter is not blocked and pump is operating satisfactorily. Then recheck pressure. If pressure is still low renew regulator. *See Repair, Fuel Pressure Regulator*



AIR CLEANER ASSEMBLY

Service repair no - 19.10.01

Remove

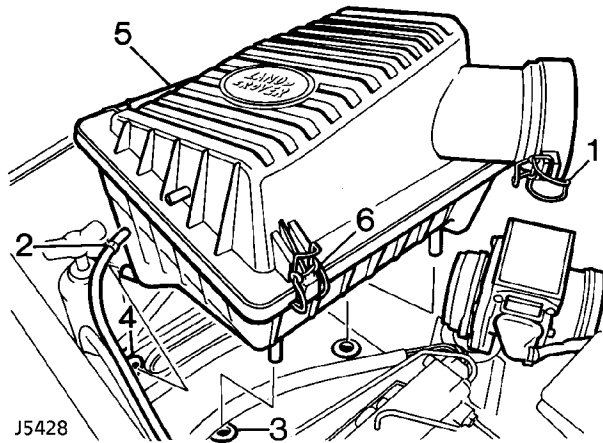

J5428

1. Release 2 clips securing air cleaner to air flow sensor.
2. Release clip and disconnect hose from air cleaner.
3. Release 2 rubber mountings securing bottom of air cleaner to body.
4. Slide air cleaner backwards and release from mounting bracket.
5. Remove air cleaner assembly. **Do not carry out further dismantling if component is removed for access only.**
6. Release 4 clips securing top of air cleaner and remove.
7. Withdraw air cleaner element and discard.

Refit

8. Fit new air cleaner element and secure in position.
9. Reverse removal procedure.

AIR CLEANER ELEMENT

Service repair no - 19.10.08

Remove

1. Release four clips retaining air cleaner cover.
2. Release two clips to air flow meter.
3. Remove air cleaner cover, retain air flow meter 'O'ring.
4. Remove element.

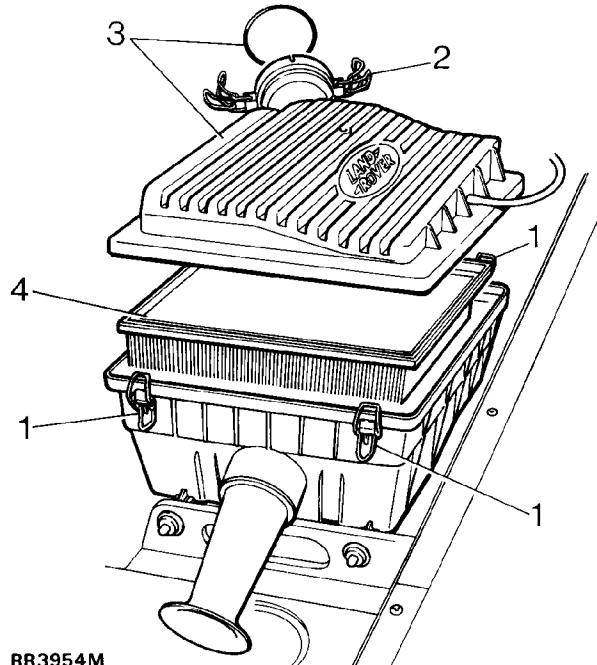

RR3954M

Refit

5. Fit new element.
6. Fit O ring.
7. Position air cleaner cover, secure two clips to air flow meter.
8. Secure four air cleaner cover clips.

AIR FLOW SENSOR

Service repair no - 19.22.25

Remove



NOTE: The air flow sensor is not a serviceable item. In event of failure or damage the complete unit must be replaced.

1. Disconnect battery negative lead.
2. Release intake hose clamp, disconnect from sensor.
3. Disconnect multi-plug.
4. Release two clips securing air cleaner to air flow sensor. Remove sensor from engine compartment.

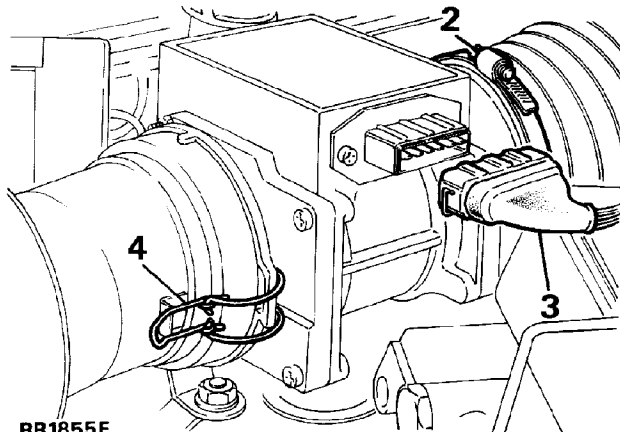

Refit

5. Reverse removal procedure. Ensure multi-plug is firmly reconnected, and hose clamp at the rear of sensor is securely tightened, to prevent unmetered air entering engine.

THROTTLE POSITION SENSOR

Service repair no - 19.22.49

Remove

1. Disconnect battery negative lead.
2. Disconnect multi-plug from harness.
3. Remove two screws securing sensor to plenum chamber and carefully pull sensor off throttle shaft.

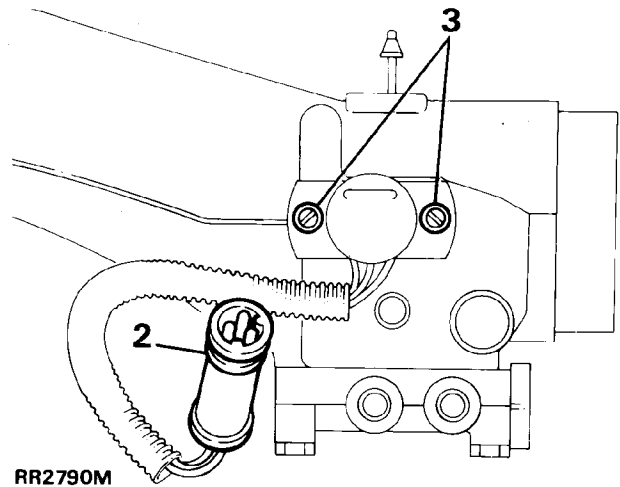

4. Remove old gasket.

Refit

5. Fit new gasket.
6. Align sensor and shaft flats, slide sensor on to throttle shaft. Secure sensor to plenum chamber.



CAUTION: DO NOT operate throttle mechanism while throttle position sensor is loosely fitted, damage may be caused to throttle position sensor wiper track.



IDLE AIR CONTROL VALVE

Service repair no - 19.22.54

Remove

1. Disconnect battery negative lead.
2. Disconnect multi-plug.
3. Unscrew valve from rear plenum chamber.
4. Remove washer.

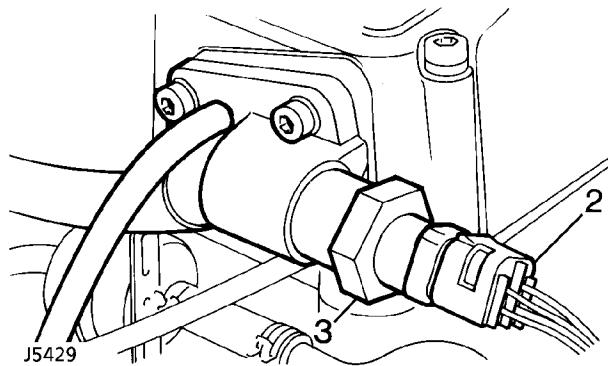

Refit

5. Fit **NEW** sealing washer.



NOTE: If same idle air control valve is being refitted clean sealing compounds from threads. Apply Loctite 241 to threads of valve before reassembly.

6. Tighten valve to **20 Nm**.
7. Reverse removal procedure.

VEHICLE SPEED SENSOR

Service repair no - 88.30.14

The vehicle speed sensor is located in the LH side of the transfer box.

Remove

1. Place vehicle on lift, apply parking brake.
2. Disconnect battery negative lead.
3. Raise lift, disconnect multiplug from vehicle speed sensor.
4. Remove screw securing sensor to transfer box.
5. Remove vehicle speed sensor

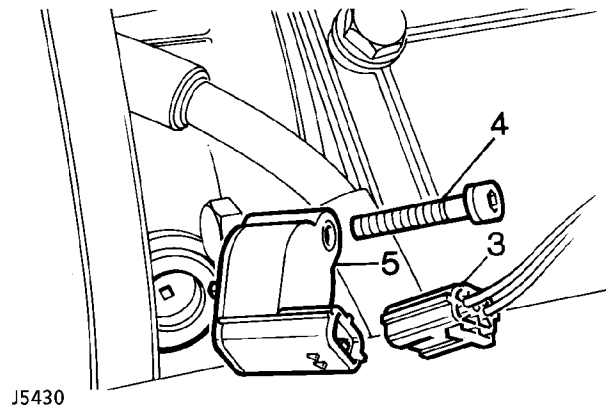

Refit

6. Reverse removal procedure.

MULTIPORT FUEL INJECTION RELAYS

Service repair no - 19.22.08

The two Multiport fuel injection relays are located in the RH footwell area behind the 'A' post trim panel. The fuel injection relays can be identified as follows:

A. Fuel pump relay - Blue base

B. Main relay - Black base

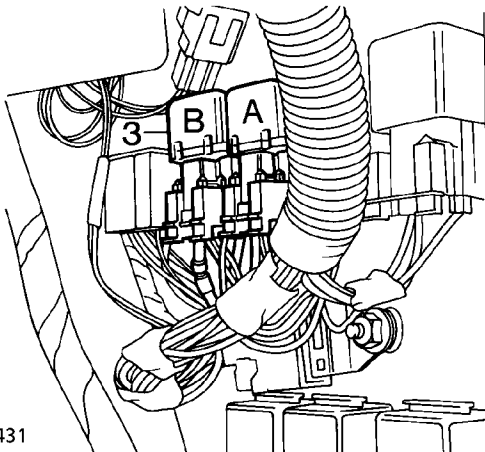

Remove

1. Release front door seal from 'A' post.
2. Remove lower 'A' post trim panel.
3. Pull relay from base.

Refit

4. Reverse removal procedure.

ENGINE CONTROL MODULE (ECM)-14 CUX

Service repair no - 19.22.34



NOTE: The ECM is not serviceable, in event of unit failure it must be replaced.

Remove

1. Remove the fascia right-hand closing panel.
2. Remove the right-hand footwell side panel trim.
3. Disconnect battery negative lead.
4. Release ECM plug retaining clip.
5. Manoeuvre the front of the plug (in the direction of the bold arrow) and detach the other end of the plug from the retaining peg.
6. Release the two screws securing the ECM to the right-hand footwell side panel.
7. Withdraw the ECM from the clip.

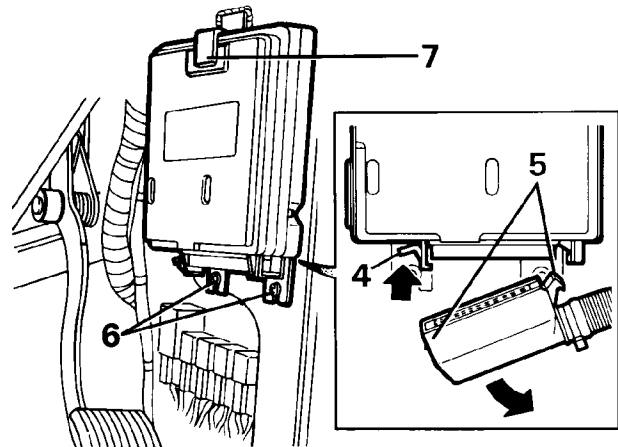

Refit

8. Refit the ECM securely in the clip and fit the two screws.
9. Reconnect the ECM harness plug. Ensure that the plug is pushed firmly into its location and that the retaining clip secures the plug in position.
10. Reverse removal procedure.



INERTIA FUEL SHUTOFF SWITCH

Service repair no - 18.30.35

The inertia fuel shutoff switch is located on the bulkhead next to the washer reservoir under bonnet [hood].

Remove

1. Disconnect battery negative lead.
2. Disconnect multiplug from inertia switch.
3. Remove 2 screws securing inertia switch to mounting bracket.
4. Remove inertia switch.

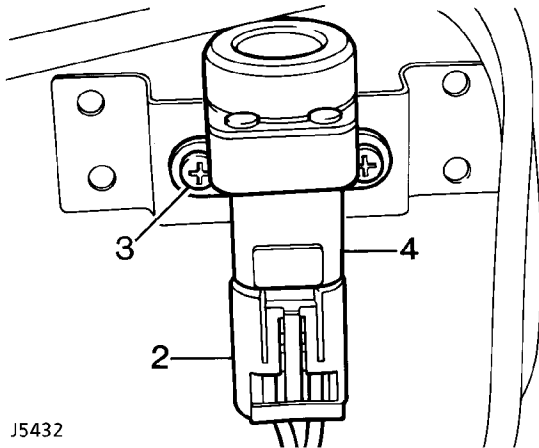

Refit

5. Position inertia switch to mounting bracket and secure with screws.
6. Connect multiplug to inertia switch.
7. Reconnect battery negative lead.

ENGINE FUEL TEMPERATURE SENSOR

Service repair no - 19.22.08

Remove



NOTE: Fuel leakage will not occur when sensor is removed from fuel rail, therefore it is not necessary to depressurise the fuel system.

1. Disconnect battery negative lead.
2. Disconnect multi-plug from sensor.
3. Release sensor from fuel feed rail.

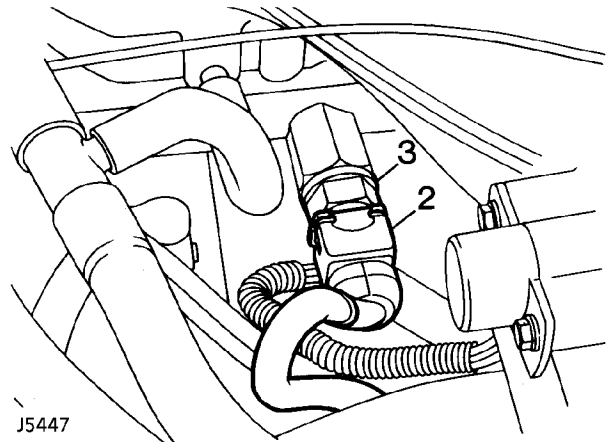

Refit

4. Reverse removal procedure. Ensure sensor is tightened securely in fuel rail.

ENGINE COOLANT TEMPERATURE SENSOR

Service repair no - 19.22.18

Remove

1. Position drain tray to collect coolant spillage.
2. Disconnect multiplug from coolant sensor.
3. Remove sensor from thermostat housing.
4. Remove and discard copper washer.

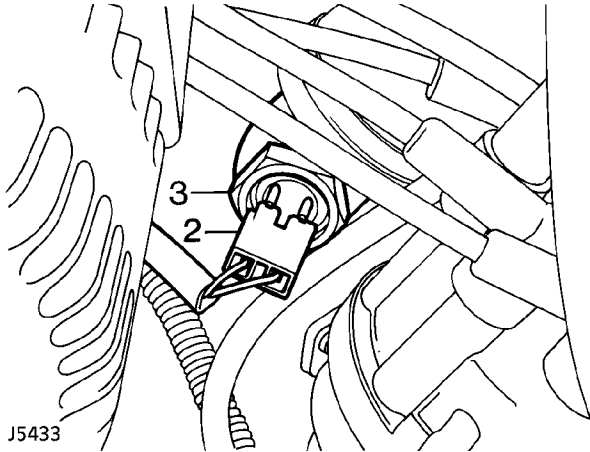
**Refit**

5. Fit a new copper washer.
6. Fit sensor and tighten securely.
7. Top-up cooling system.
8. Run engine, check for water leaks around sensor.

DEPRESSURISING FUEL SYSTEM

WARNING: Under normal operating conditions the Multiport fuel injection system is pressurised by a high pressure fuel pump, operating at up to 2.3 to 2.5 bar. When engine is stationary pressure is maintained within system. To prevent pressurised fuel escaping and to avoid personal injury it is necessary to depressurise multiport fuel injection system before any service operations are carried out.

If vehicle has not been run there will be a small amount of residual pressure in fuel line. The depressurising procedure must still be carried out before disconnecting any component within the fuel system.

The spilling of fuel is unavoidable during this operation. Ensure that all necessary precautions are taken to prevent fire and explosion.

1. Remove fuel pump relay module. *See Multiport Fuel Injection Relays*
2. Start and run engine.
3. When sufficient fuel has been used to cause fuel line pressure to drop, injectors will become inoperative, resulting in engine stall. Switch off ignition.
4. Disconnect battery negative lead.



NOTE: Fuel at low pressure will remain in system. To remove low pressure fuel, place absorbent cloth around fuel feed hose at fuel rail.

5. Disconnect either:
 - a) Nut and olive at fuel rail
 - OR
 - b) Hose at inlet end of fuel filter.

Refit

6. Refit fuel feed hose.
7. Refit fuel pump relay module, reconnect battery.
8. Crank engine (engine will fire in approximately 6 to 8 seconds).



FUEL PRESSURE REGULATOR

Service repair no - 19.45.06

Remove

1. Depressurise fuel system. *See Depressurising Fuel System*
2. Disconnect battery negative lead.
3. Remove plenum chamber. *See Plenum Chamber*
4. Release clip and disconnect fuel return hose from regulator.
5. Disconnect vacuum hose from regulator.
6. Remove 2 bolts securing pressure regulator to fuel rail.
7. Release regulator from fuel rail and withdraw.
8. Remove and discard 'O' ring.

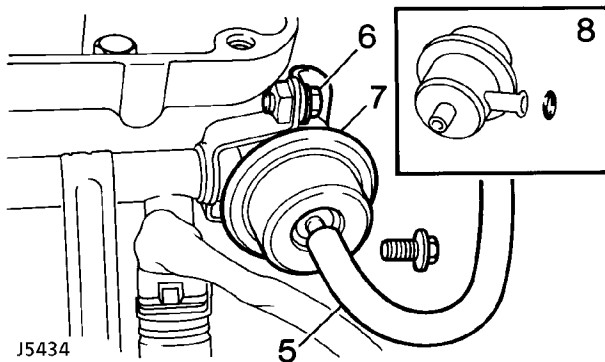

Refit

9. Lightly coat 'O' ring with silicon grease 300 and fit to regulator.
10. Reverse removal procedure.
11. Reconnect battery and pressurise fuel system. Check there are no fuel leaks around regulator connections.

FUEL RAIL-INJECTORS R/H AND L/H

Service repair no - 19.60.04 - Rail

Service repair no - 19.60.01 - Injectors

Remove

1. Depressurise fuel system. *See Depressurising Fuel System*
2. Disconnect battery negative lead.
3. Remove plenum chamber. *See Plenum Chamber*
4. Remove ram housing. *See Ram Housing*



NOTE: Place cloth over ram tube openings to prevent ingress of dirt.

5. Loosen clip and disconnect fuel return hose from regulator.
6. Loosen union and disconnect fuel supply hose from fuel rail.
7. Disconnect multi-plug from fuel temperature sensor.
8. Disconnect multi-plugs from injectors.
9. Remove four bolts securing fuel rail support brackets to intake manifold. Lay injector harnesses to one side.

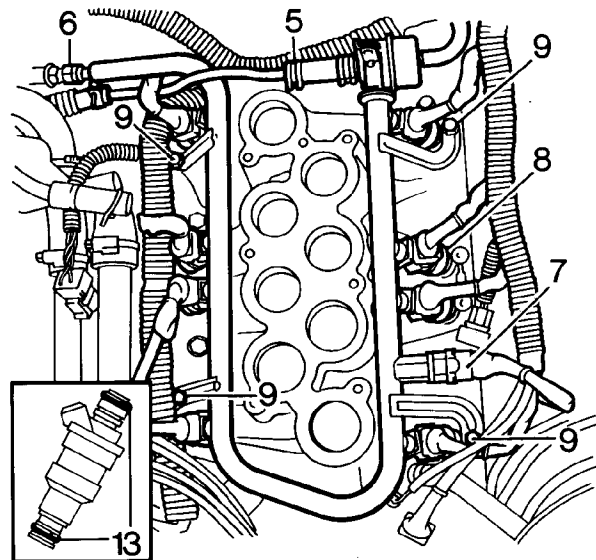

J5435

10. Remove fuel rail and injectors.
11. Remove injector retaining clips, ease injectors from rail. Remove and discard 'O' rings from injectors.
12. Remove fuel pressure regulator if required.

Refit

13. Fit **NEW** 'O' rings, to injectors. Lightly coat 'O' rings with silicon grease 300. Insert injectors into fuel rail, multi-plug connections facing outwards.
14. Refit retaining clips.



CAUTION: Care must be taken when refitting the fuel rail and injectors to intake manifold to prevent damage to 'O' rings.

15. Fit a **NEW** 'O' ring to pressure regulator lightly coat 'O' ring with silicon grease 300 and secure regulator to the fuel rail.
16. Fit fuel rail and heater pipe assemblies to intake manifold. Secure rail and pipes in position with five bolts.
17. Reverse removal procedure. 2 to 7.
18. Pressurise fuel system and check for fuel leaks around injectors and pressure regulator.

PLENUM CHAMBER

Service repair no - 19.22.46

Includes throttle levers and throttle disc

Remove

1. Disconnect battery negative lead.
2. Disconnect electrical multi-plug from bypass air valve.
3. Disconnect vacuum hose adjacent to bypass air valve.
4. Mark an identification line on throttle cable outer to assist re-assembly.
5. Remove clevis pin from throttle cable.
6. Pry adjustment thumb wheel from throttle bracket. Lay cable aside.
7. Remove retaining clip and clevis pin from kick down cable (automatic vehicles).
8. Apply adhesive tape behind rear adjustment nut on kick down cable to prevent nut moving.
9. Remove front lock nut. Remove cable and lay aside.
10. Remove cruise control vacuum hose.

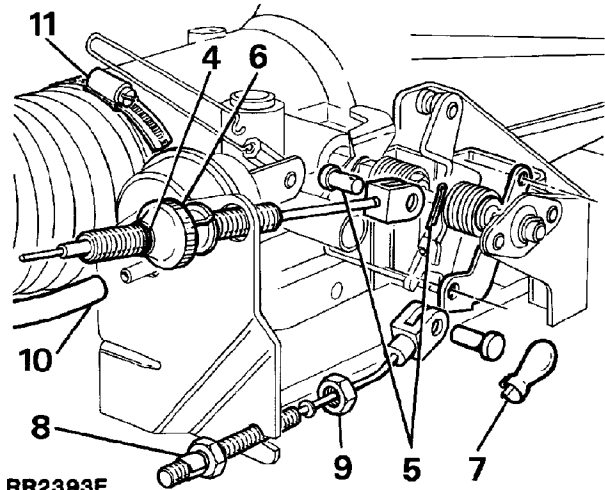

11. Remove intake hose from neck of plenum chamber.
12. Disconnect throttle position sensor multi-plug.
13. Remove PCV breather hose.
14. Disconnect two coolant hoses and plug each hose to prevent excessive loss of coolant. Identify each hose for re-assembly.

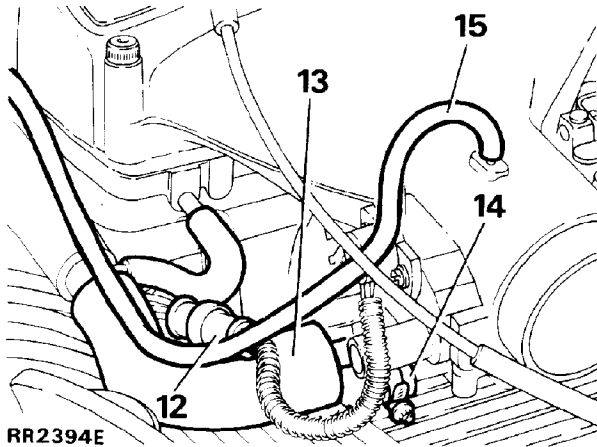

RR2394E

15. Remove distributor vacuum hose.
16. Release two screws and remove throttle position sensor.
17. Remove six screws securing plenum chamber. Remove plenum chamber.
18. Remove air idle air control valve hose.

Throttle lever assembly - remove

19. If fitted - unclip cruise control actuator link. Hold throttle fully open, release link from countershaft assembly. Carefully return lever assembly to close throttle.
20. Release tension on inboard throttle spring.
21. Bend back lock washer tabs.
22. Hold throttle stop lever in closed position, release nut from throttle shaft.
23. Release tension on outboard throttle spring.
24. Remove overtravel spring.

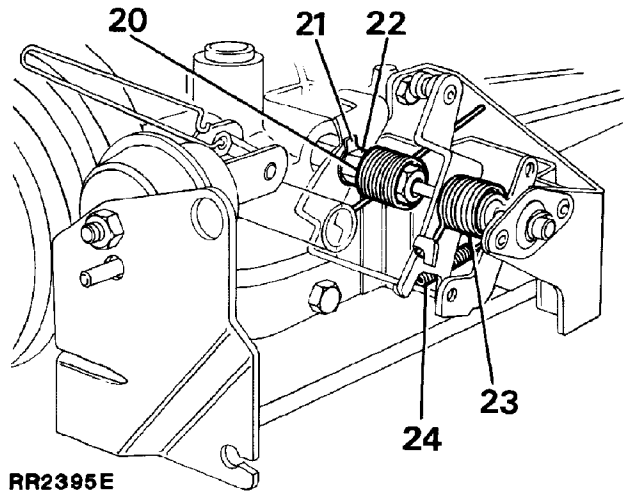

RR2395E

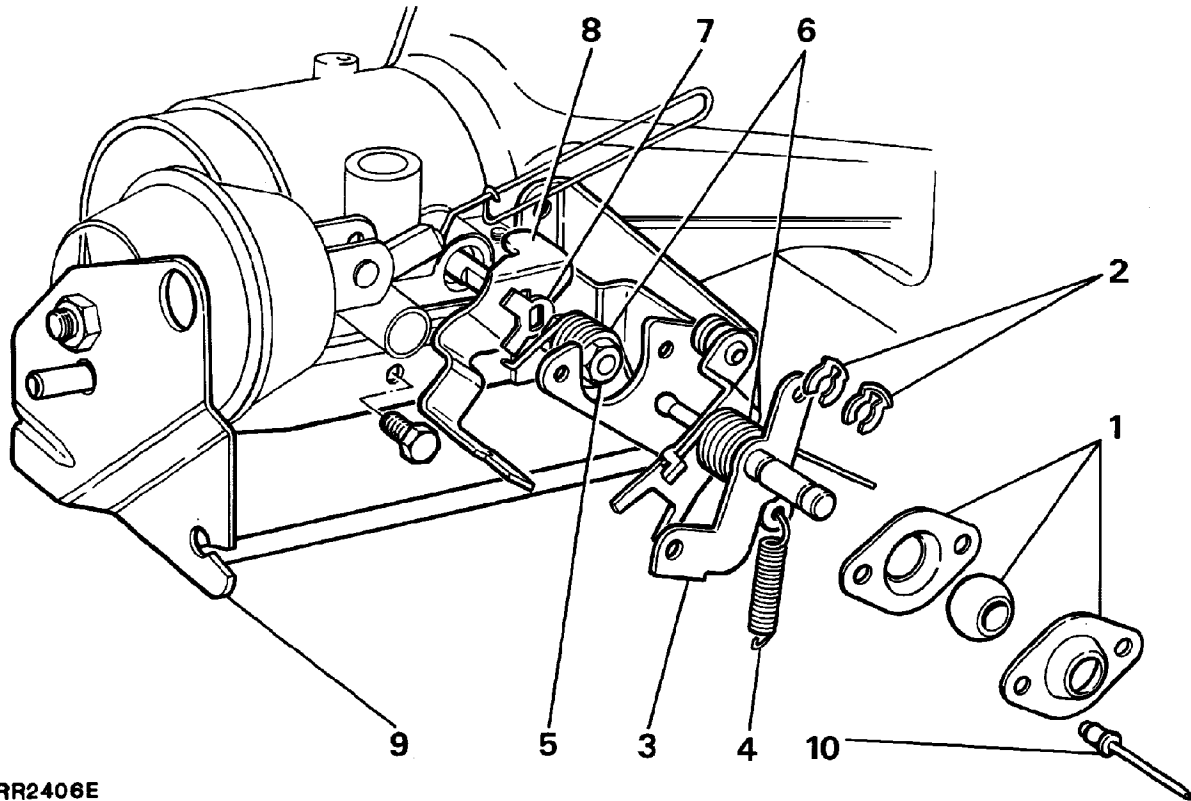

RR2406E

KEY

1. Spherical bush/housing
2. Retaining clips (2)
3. Countershaft assembly
4. Overtravel spring
5. Throttle shaft nut
6. Throttle return spring (2)
7. Tab washer
8. Throttle stop lever
9. Throttle bracket assembly
10. Pop rivets (2)



25. Remove three bolts securing throttle bracket to plenum chamber, withdraw bracket assembly.
26. Remove tab washer and throttle stop lever from throttle shaft.

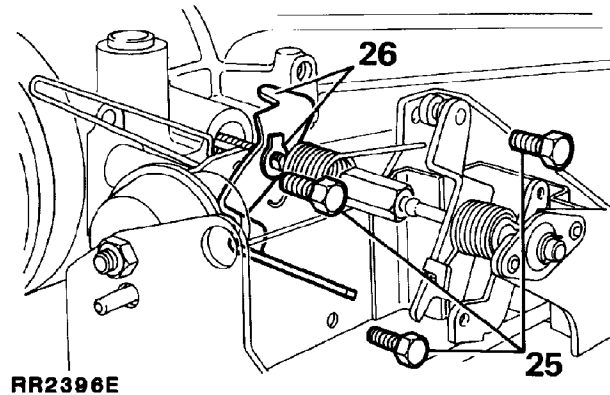

RR2396E

31. Grease new bush with Admax L3 or Energrease LS3. Assemble bush into housing. Assemble to throttle bracket using two 4.7 mm (3/16 in) diameter domed head rivets.
32. Examine bearing surface of countershaft assembly. If worn fit new assembly, otherwise wind throttle return spring off levers.

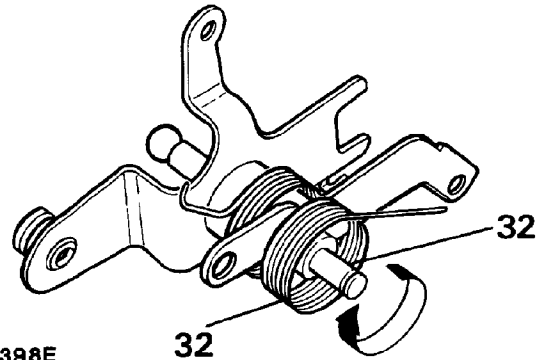

RR2398E

Throttle lever assembly - inspect and overhaul

27. Remove two retaining clips from spherical bush.
28. Remove the countershaft assembly.
29. If spherical bush worn, drill out two securing rivets (4,7 mm, (3/16 in) diameter drill).
30. Split assembly, discard worn bush.

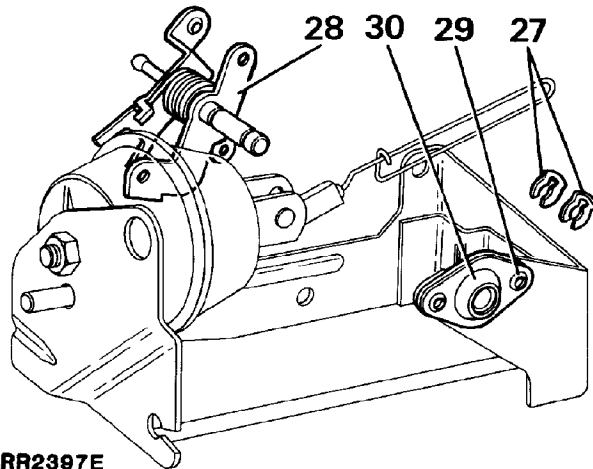

RR2397E

33. Wind new spring onto countershaft assembly, small hooked end of spring is wound on first.

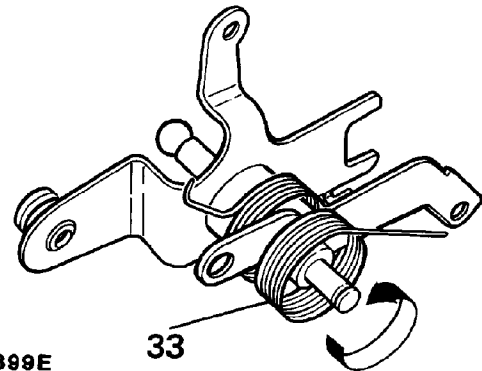

RR2399E

34. Grease shaft with Admax L3 or Energrease LS3, fit countershaft assembly to spherical bearing, secure with two clips.
35. Examine throttle stop lever for wear, fit a new lever if necessary.

Throttle disc - inspect and overhaul

36. Examine throttle shaft for excessive wear between bushes in plenum chamber and shaft. A small amount of clearance is permissible. If excessive wear is evident fit new shaft and bushes as follows.
37. Remove two split screws securing throttle disc and withdraw disc.



CAUTION: Take care not to damage shaft.

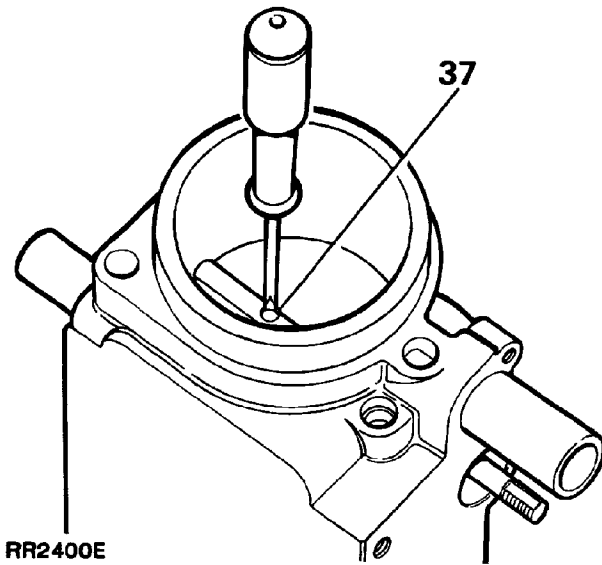

38. Remove shaft and air seal from plenum chamber.

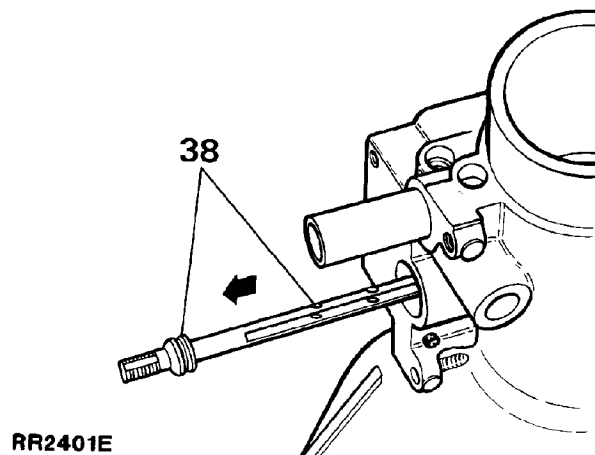

39. Using suitable drift, drive out bushes.



CAUTION: Take care not to damage plenum chamber bores

40. Press in new bushes until flush with throttle disc bore.



CAUTION: Ensure that bushes do not protrude into bore, as they will interfere with movement of throttle disc.

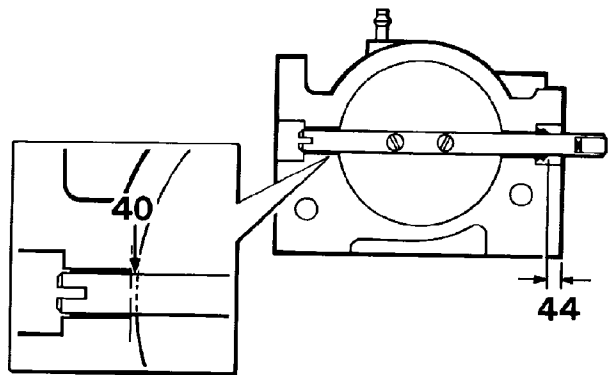

41. Fit throttle shaft and disc, secure with two split screws. Do not fully tighten screws.
42. Rotate throttle shaft 360° once or twice to centralise disc in bore. Tighten split screws.
43. Rotate shaft. Use screw driver to spread split.

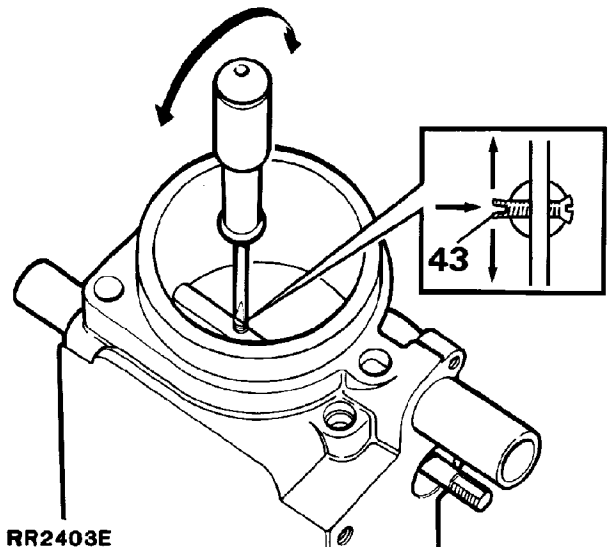





44. Grease new air seal with Admax L3 or Energrease LS3. Push seal down shaft, into counterbore until seal is 6.0 mm (0.236 in) below face of plenum.

Throttle levers and bracket - assemble

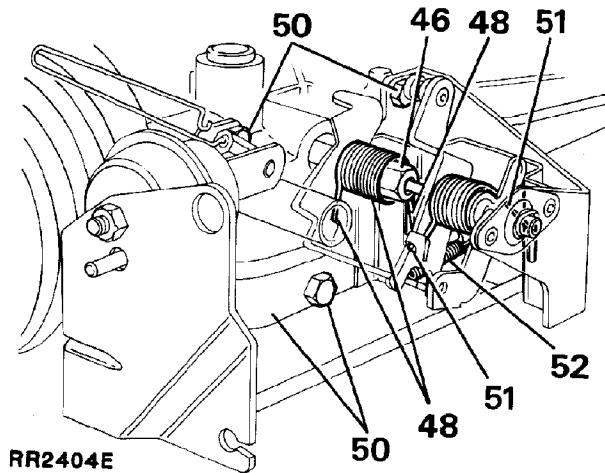
45. Fit stop lever to throttle shaft, a new tab washer and secure with throttle shaft nut.
46. Holding stop lever on stop, tighten throttle shaft nut securely, bend over tabs to lock nut in position.
47. Fit inboard throttle return spring noting that small hooked end of spring is nearest plenum.
48. Locate hooked end of inboard spring on stop lever. Wind up straight end one full turn and locate in appropriate slot.
49. Fit countershaft to interconnecting nut of throttle valve shaft.
50. Secure throttle bracket assembly to plenum. Secure with three retaining bolts.
51. Ensure hooked end of outboard spring is retained by lever, wind spring up one full turn and locate free end in appropriate slot.
52. Fit overtravel spring.
Lightly grease throttle return and overtravel springs with Admax L3 or Energrease LS3.



 **NOTE:** If new throttle levers have been fitted, minimum throttle setting of disc must be checked to ensure it is 90° to bore.

53. Using a depth vernier or depth micrometer, check dimension from mouth of bore to top and bottom of valve disc. Dimension must be within 0.5 mm (0.019 in) total indicator reading across diameter of disc.
54. If dimension is out of limits, adjust small set screw below stop lever.

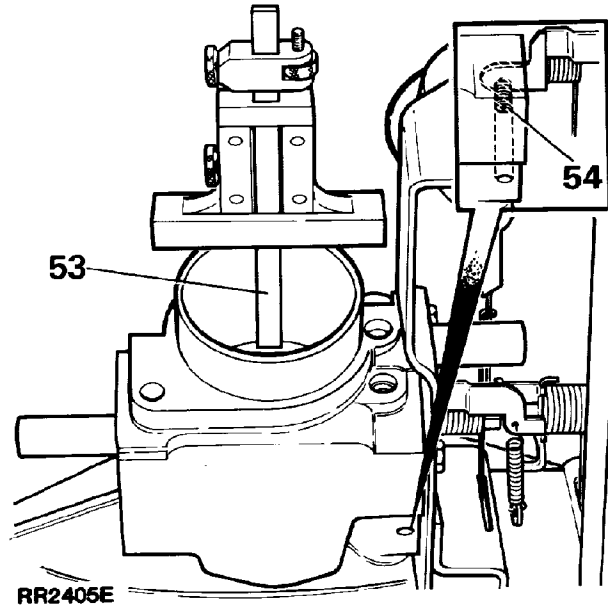

Refit

55. Reconnect and adjust cruise control actuator link. **See Actuator Link Setting**
56. Clean joint faces of plenum and ram housing. Apply 'Hylomar' sealant, refit plenum chamber. Tighten bolts to **26 Nm**.
57. Reverse removal procedure.

RAM HOUSING

Service repair no - 19.70.04

Remove

1. Disconnect battery negative lead.
2. Remove plenum chamber. *See Plenum Chamber*
3. Release hoses from ram housing.
4. Remove six through bolts (with plain washers) securing ram housing to intake manifold.

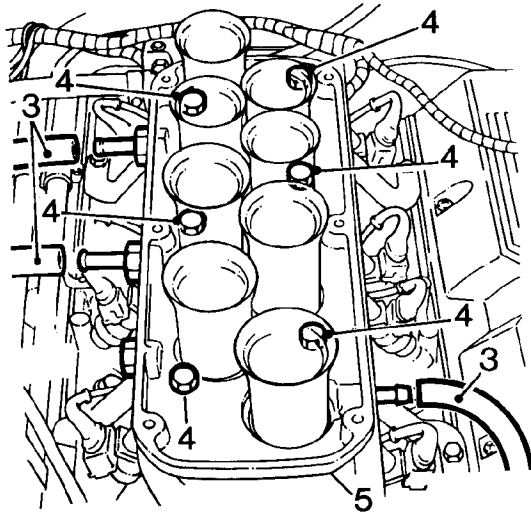

J5436

5. Remove ram housing from intake manifold.
6. Place a protective cover over inlet bores to prevent ingress of dirt.

Refit

7. Clean all mating faces.
8. Apply 'Hylomar' sealant to intake manifold face.
9. Fit ram housing. Tighten bolts, working from two centre bolts, diagonally towards outer four bolts.
10. Tighten to **26 Nm**.

INTAKE MANIFOLD

Service repair no - 30.15.08

Remove

1. Depressurise fuel system. *See Depressurising Fuel System*
2. Disconnect battery negative lead.
3. Drain cooling system. *See COOLING SYSTEM, Repair, Radiator*
4. Remove plenum chamber. *See Plenum chamber*
5. Remove ram housing. *See Ram Housing*



CAUTION: Place a protective cover over intake manifold openings to prevent the ingress of dirt.

6. Disconnect the fuel temperature sensor and injector multiplugs.
7. Remove fuel pressure regulator. *See Fuel Pressure Regulator*

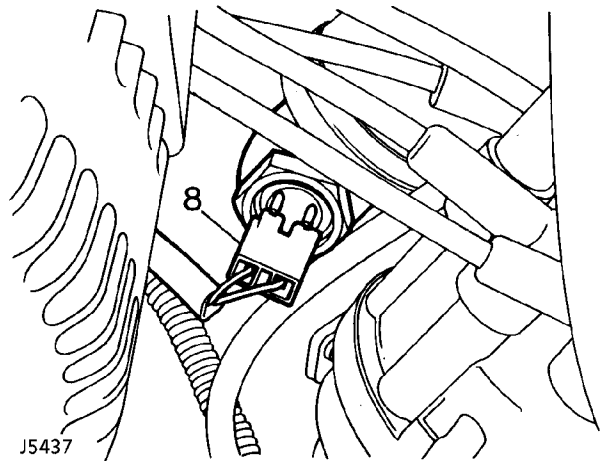

J5437

8. Disconnect multiplug from coolant temperature sensor.
9. Disconnect instrument pack temperature thermistor.
10. Disconnect coolant sensor multiplug.



11. Loosen clip and disconnect top hose from thermostat housing.
12. Disconnect multiplug from distributor amplifier module.

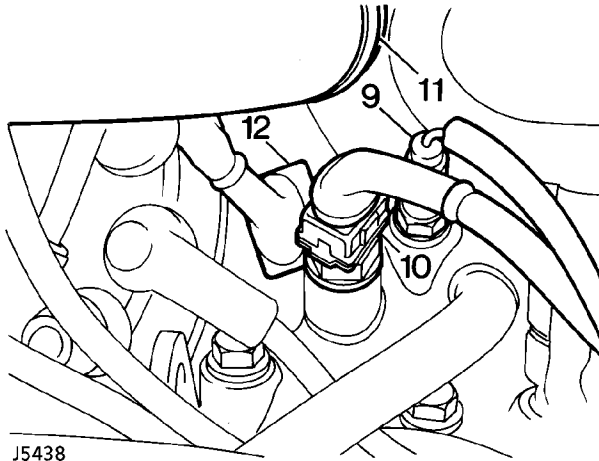

J5438

13. Loosen clip and disconnect hose from heater valve.
14. Remove injector harnesses from behind fuel rail and lay to one side.
15. Loosen union and disconnect fuel return hose from fuel rail.



NOTE: The intake manifold can be removed from the cylinder block without removing the fuel rail and injectors.

16. Using the sequence shown, remove 12 bolts securing the intake manifold to cylinder block.

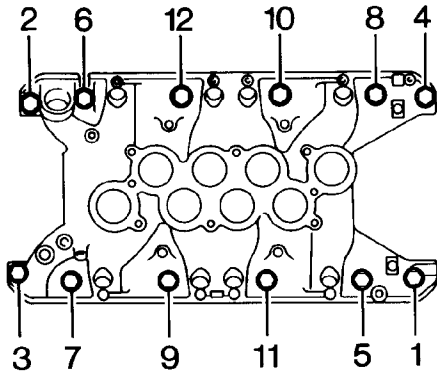

J5439

17. Remove the intake manifold.
18. Noting their fitted position, remove bolts and clamps securing intake manifold gasket to cylinder block.
19. Remove and discard gasket.
20. Remove and discard gasket seals.

Do not carry out further dismantling if component is removed for access only.

21. Remove 5 nuts securing fuel rail support brackets to intake manifold.
22. Remove fuel rail and injectors.
23. Remove 2 bolts securing thermostat housing to intake manifold.
24. Remove thermostat housing.
25. Remove bolt securing coolant pipe to intake manifold. Loosen union and remove coolant pipe. Remove and discard 'O' ring.
26. Fit new 'O' ring to coolant pipe. Position coolant pipe to intake manifold. Fit bolt securing coolant pipe support bracket to intake manifold and tighten pipe union.
27. Clean mating faces of thermostat housing and intake manifold.
28. Fit thermostat housing to intake manifold using a new gasket, fit and tighten bolts.
29. Position fuel rail to intake manifold, fit and tighten retaining bolts.

Refit

1. Clean mating faces of cylinder heads, cylinder block and intake manifold.
2. Locate NEW seals in position with ends engaged in notches formed between the cylinder heads and block.
3. Apply RTV sealant between ends of seals, cylinder head and block.
4. Fit intake manifold gasket with the word 'FRONT' to the front and open bolts hole to the front RH side.
5. Fit gasket clamps and tighten bolts finger tight.

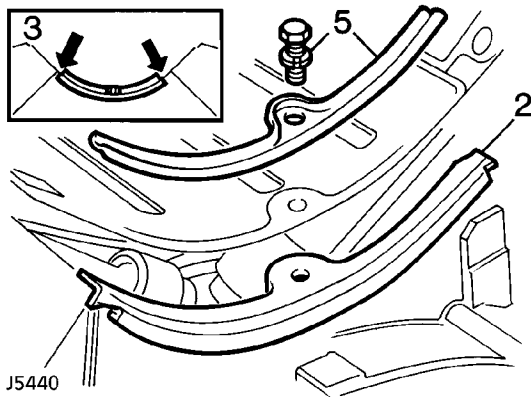

6. Locate intake manifold onto cylinder heads, clean threads of manifold securing bolts.
7. Allow 10 minutes for RTV sealant to cure.
8. Fit manifold bolts finger tight. Working in the sequence shown tighten the bolts to **38 Nm**.

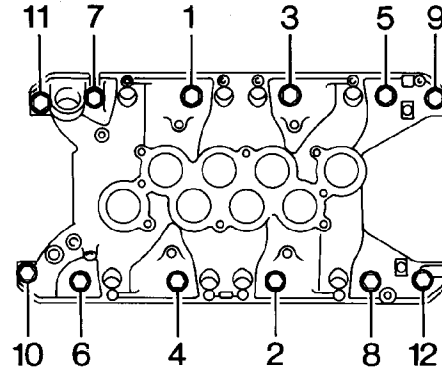

9. Tighten the gasket clamp bolts to **18 Nm**.
10. Reverse removal procedure.
11. Fill cooling system. **See COOLING SYSTEM, Repair, Radiator**
12. Start engine check for water and fuel leaks.



FUEL FILTER

Service repair no - 19.25.02

Remove



WARNING: Spilling of fuel is unavoidable during this operation. Ensure all necessary precautions are taken to prevent fire and explosion.



WARNING: Ensure fuel handling precautions given in Section 01 - Introduction are strictly adhered to when carrying out following instructions.

1. Depressurise fuel system. *See Depressurising Fuel System*
2. Access to filter is gained through right hand rear wheel arch.
3. Clean area around hose connections to prevent ingress of foreign matter into fuel system. Clamp inlet and outlet hoses to prevent fuel spillage when disconnecting hoses.
4. Loosen two fuel line unions and remove hoses. Plug ends of hoses to prevent ingress of dirt.
5. Release securing bolt and bracket and remove filter from chassis side member.

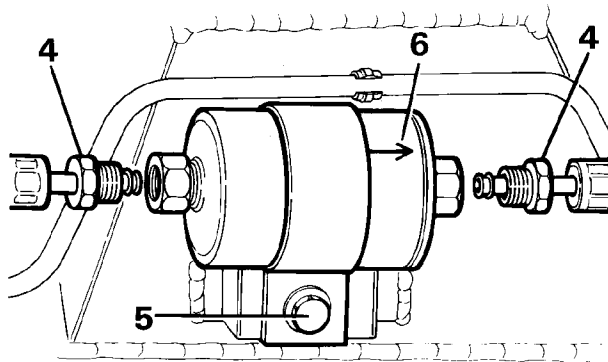

RR2966E

Refit

6. Fit a new filter observing direction of flow arrows stamped on canister.
7. Tighten securing nut and bolt.
8. Fit inlet and outlet hoses. Tighten to **30Nm**.
9. Refit fuel pump relay module, reconnect battery.
10. Start engine and inspect for fuel leaks around hose connections.

FUEL PIPES

Service repair no - 19.40.92



WARNING: Depressurise fuel system. See *Depressurise Fuel System* before disconnecting any fuel pipes ensure that all necessary precautions are taken against fuel spillage



WARNING: Ensure fuel handling precautions given in Section 01 - introduction are strictly adhered to when carrying out following instructions.

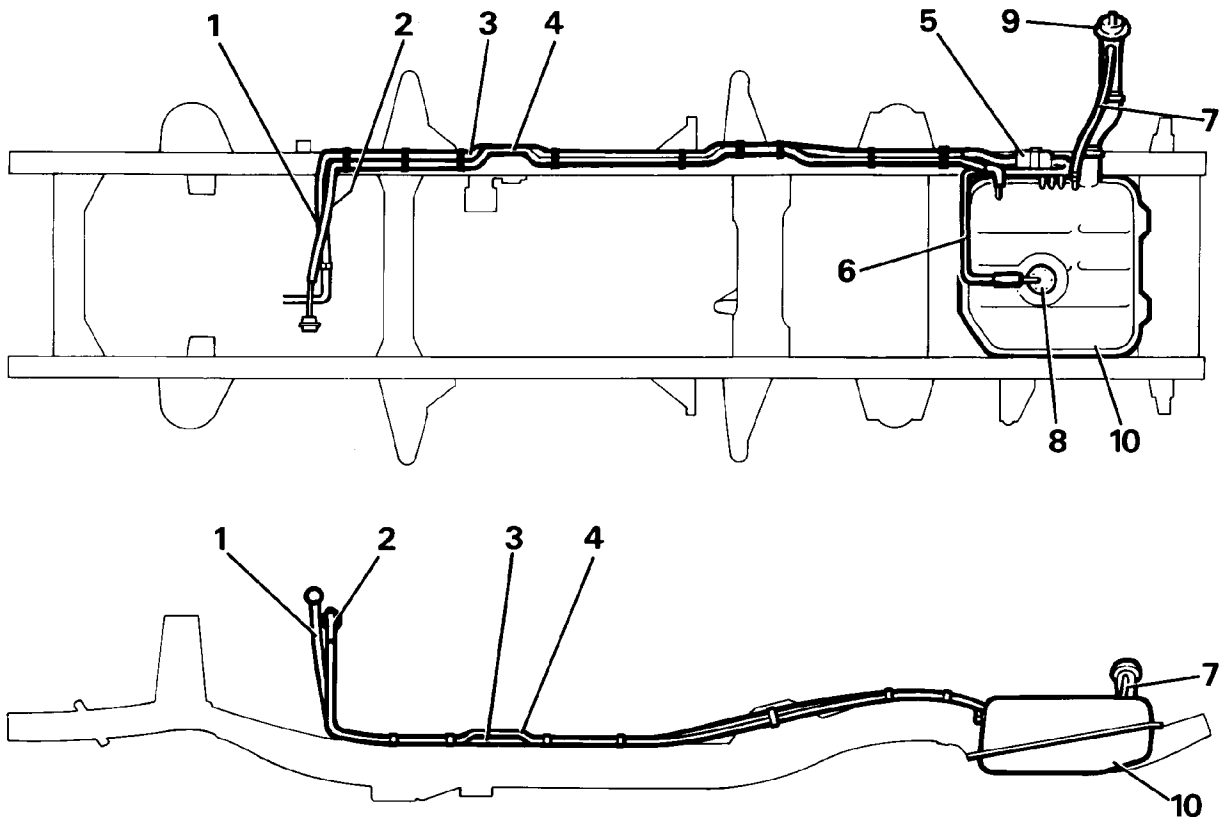

J5442

KEY

- | | |
|-----------------------------------|------------------------------------|
| 1. Fuel feed hose to fuel rail. | 6. Rigid fuel feed pipe to filter. |
| 2. Fuel return hose to fuel tank. | 7. Breather hose. |
| 3. Rigid fuel feed pipe. | 8. In-tank fuel pump. |
| 4. Rigid fuel return pipe. | 9. Fuel filler neck. |
| 5. Fuel filter. | 10. Fuel tank. |



THROTTLE CABLE

Service repair no - 19.20.06

Remove

1. Remove clevis pin securing cable to lever.
2. Carefully pry throttle cable adjustment nut out of mounting bracket.
3. Remove cable from mounting bracket.

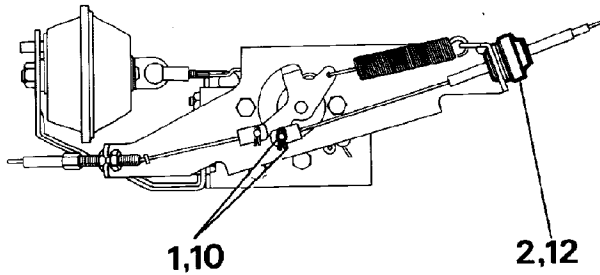

RR1954E

4. Release outer cable from retaining clips in engine compartment.
5. Remove lower dash panel.
6. Disconnect cable from accelerator pedal and release cable locknut.
7. Feed cable through bulkhead grommet into engine compartment.

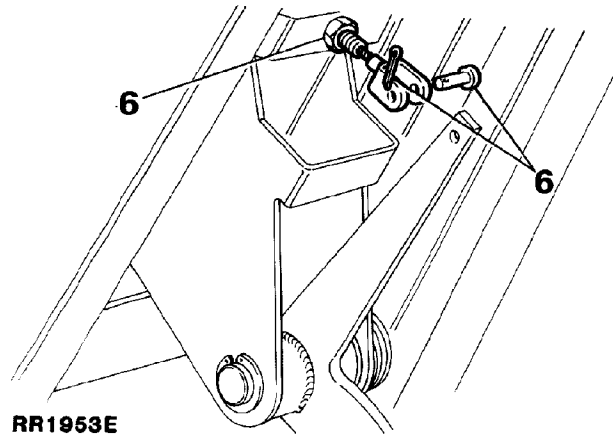

RR1953E

Refit

8. Feed new cable from engine compartment through bulkhead grommet.
9. Connect cable to accelerator pedal.
10. Connect cable to throttle linkage, using a new cotter pin.
11. Clip outer cable adjustment nut into mounting bracket.
12. Adjust outer cable to give 1.57 mm free play in inner cable. Check throttle operation.

ACCELERATOR PEDAL

Service repair no - 18.30.35

Remove

1. Remove lower dash panel.
2. Remove clevis pin securing throttle cable to accelerator pedal.
3. Release tension from pedal return spring.
4. Remove circlip from pedal pivot pin.
5. Withdraw pivot pin.



NOTE: It may be necessary to lower steering column to gain access to pivot pin circlip.

6. Remove accelerator pedal.

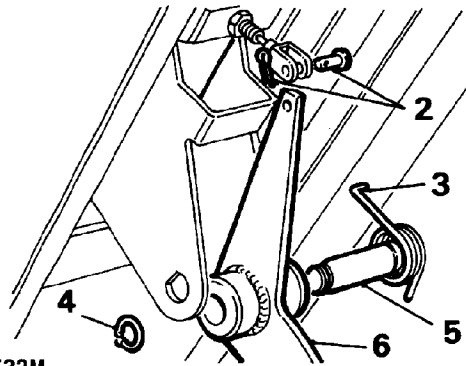

RR 732M

Refit

7. Lightly grease pivot and clevis pins.
8. Fit clevis pin using a **NEW** cotter pin.
9. Reverse removal procedure.

FUEL PUMP AND SENDER UNIT

Service repair no - 19.45.03

A plastic fuel tank with a combined fuel pump/sender unit is fitted. The fuel pump/sender unit is accessed through a panel in the load space floor.

Fuel pump/sender unit



WARNING: Ensure that fuel handling precautions given in Section 01 - Introduction are strictly adhered to when carrying out following instructions.



CAUTION: Before disconnecting any part of fuel system, it is imperative that all dust, dirt and debris is removed from around components to prevent ingress of foreign matter into fuel system.

Service Tools:

LRT-19-001 wrench - pump retaining ring
LRT-19-002 'Speedfit' disconnecter

Remove

1. Depressurise fuel system. *See Depressurising Fuel System*
2. Disconnect battery negative lead.
3. Syphon at least 9 litres (2 gallons) of fuel from fuel tank into a suitable container that can be sealed.
4. Remove carpet from loadspace floor and tailgate.
5. Fold back loadspace sound insulation to reveal access panel.

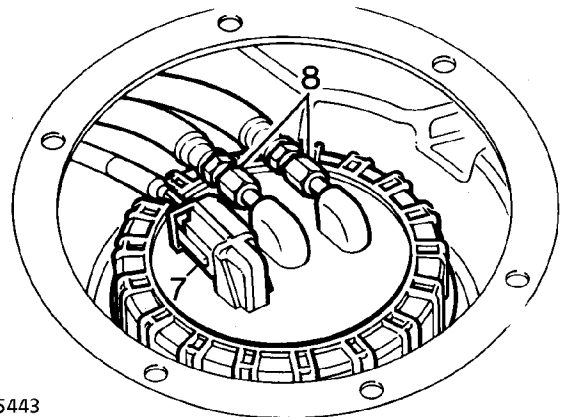

J5443



6. Remove access panel from floor.
7. Disconnect multi-plug from fuel sender unit.
8. Disconnect two fuel line unions from fuel pump.
9. Using service tool no. LRT-19-001, remove pump unit retaining ring. Withdraw unit from fuel tank.



WARNING: A quantity of fuel will be retained in body of unit, care must be taken to prevent fuel spillage when unit is removed.

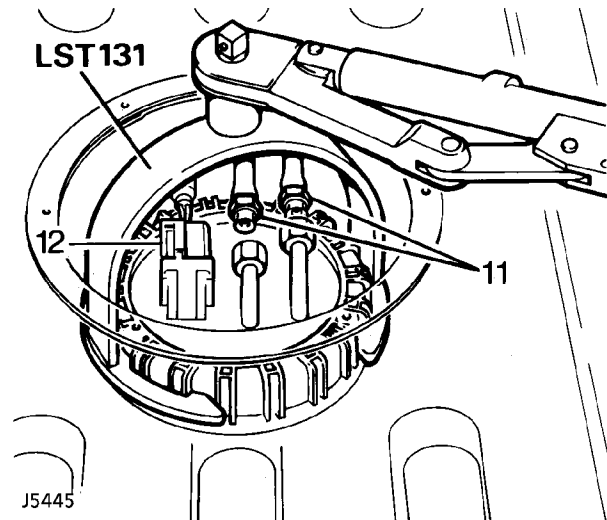
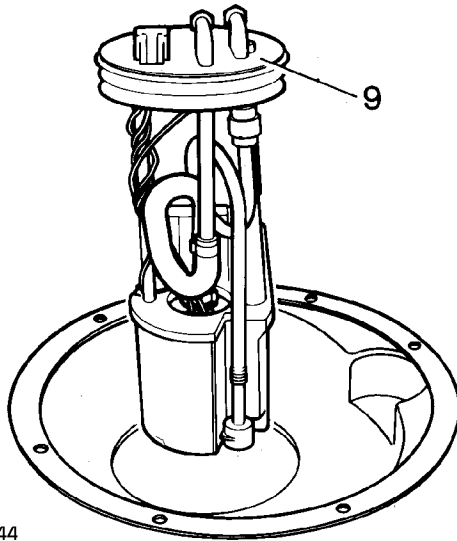

Refit

10. Insert fuel pump into tank. Fit retaining ring. Tighten to **48 Nm**.
11. Connect fuel lines to pump.
12. Connect multi-plug to sender unit.
13. After assembly, check all fuel pipes, sealing rings and hose connections are secure.
14. Run engine to check for fuel leaks.
15. Inspect access panel seal, fit a new seal if necessary.
16. Fit access panel and tighten screws.
17. Reverse removal procedure. 4 - 5. Fit insulation and carpet.

FUEL TANK

Service repair no - 19.55.01



WARNING: Ensure that fuel handling precautions given in Section 01 - introduction are strictly adhered to when carrying out following instructions.



CAUTION: Before disconnecting any part of fuel system, it is imperative that all dust, dirt and debris is removed from around components to prevent ingress of foreign matter into fuel system.

Remove

1. Depressurise fuel system. Disconnect battery negative lead.
2. Syphon fuel tank into a suitable container that can be sealed afterwards.
ENSURE TANK IS DRAINED COMPLETELY. (refer to Warning concerning fuel vapour and spillage at start of procedure).
3. Remove carpet loadspace floor and tailgate.
4. Fold back sound insulation to reveal access panel.

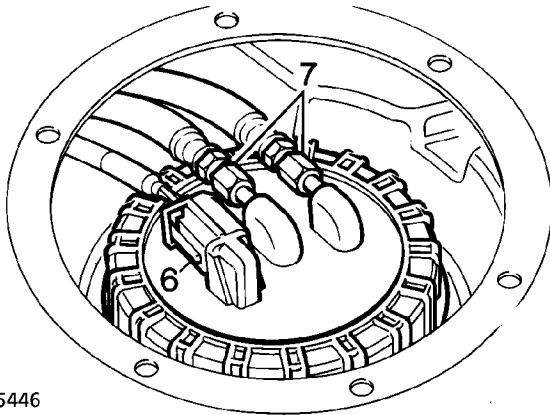

J5446

5. Remove access panel.
6. Disconnect electrical multi-plug.
7. Disconnect two fuel line unions from fuel pump.
8. Working underneath vehicle mark location of anti-roll [sway] bar straps.
9. Remove rear anti-roll [sway] bar straps, and allow bar to swing down clear of tank.

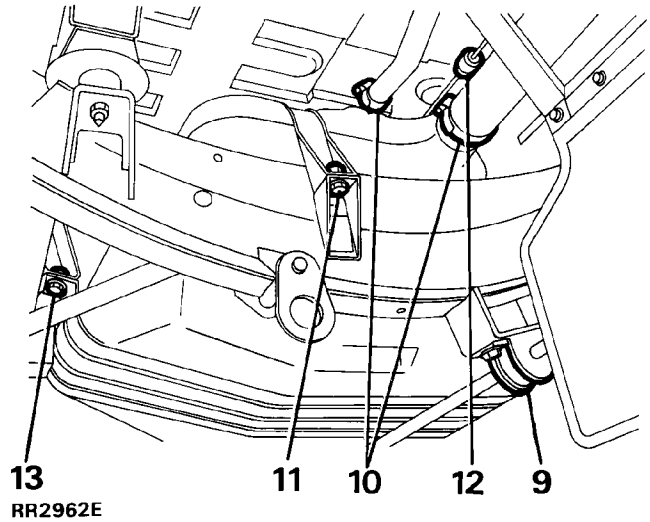

RR2962E

10. Remove tank filler and vent hoses at fuel tank.
11. Remove nut and bolt securing right hand side fuel tank strap.
12. Disconnect evaporative control pipe at green end of 'speedfit' connector.

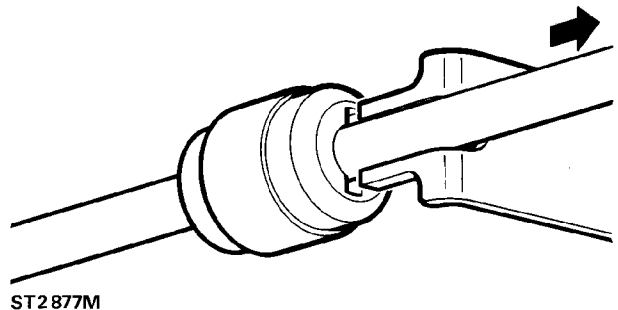

ST2877M



NOTE: To disconnect 'speedfit' connector, insert forked end of LRT-19-002 into slots of connector see illustration. Press down on collet and simultaneously pull pipe from connector.

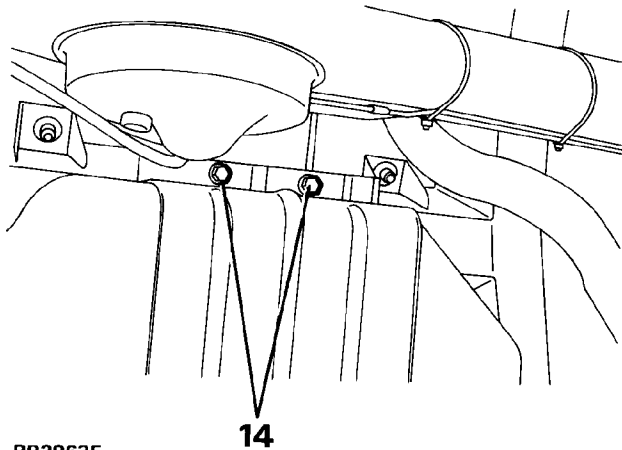

RR2963E

13. Remove back two bolts and nut plates securing fuel tank cradle.
14. Remove front nuts, bolts and washers. Remove fuel tank cradle.
15. With assistance, tilt right hand side of tank upwards and manoeuvre tank through chassis to remove.

Refit

16. Reverse removal procedure. Ensuring sealing ring, fuel pipe and hose connections are secure.
17. Run engine, check all connections for fuel leaks.

FUEL FILLER FLAP RELEASE BUTTON

Service repair no - 19.55.23

On closing, filler flap will be locked automatically. Note that release button will only work with ignition switched to OFF or AUX.

Remove

1. Disconnect the battery negative lead.
2. Carefully pry release button from mirror switch panel.

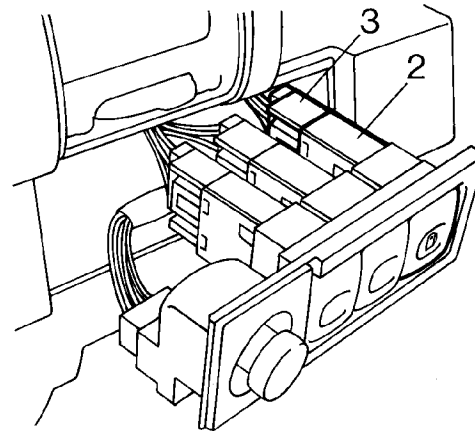

RR4270

3. Remove release button from shroud and disconnect tow wiring connectors. Ensure wires protrude through panel for reassembly.

Refit

4. Reverse removal procedure.

FUEL FILLER FLAP RELEASE ACTUATOR**Service repair no - 19.55.17****Remove**

1. Release fuel filler flap. Disconnect the battery negative lead.
2. Remove eight screws, with draw closure panel, in right hand side of load space.
3. Release two screws and manoeuvre actuator clear of its mounting.
4. Disconnect wiring plug.
5. Withdraw actuator.

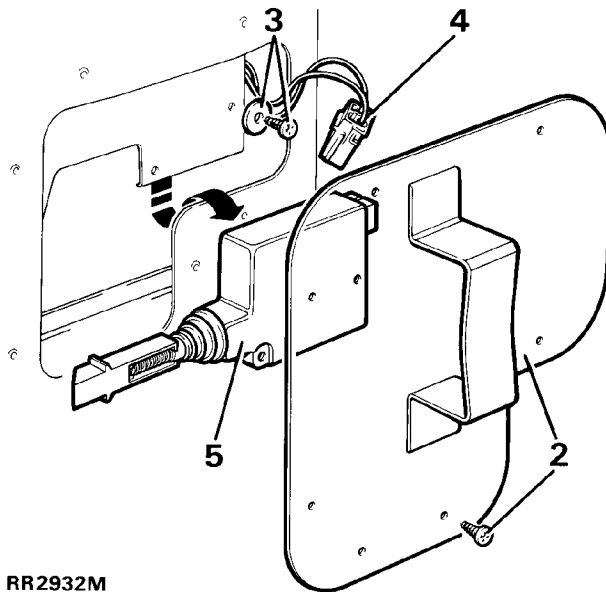

RR2932M

Refit

6. Reverse removal procedure.



TORQUE VALUES



NOTE: Torque wrenches should be regularly checked for accuracy to ensure that all fixings are tightened to the correct torque.

	Nm
Air-Bypass valve (stepper motor)	20
All flexible hose securing clamps	1,3
Fuel feed pipe - hose to fuel rail	22
Fuel filter	31

EVAPORATIVE LOSS CONTROL SYSTEM

All flexible hose securing clamps	1,7
---	-----

METRIC

	Nm
M5	6
M6	9
M8	25
M10	45
M12	90
M14	105
M16	180

UNC / UNF

1/4	9
5/16	24
3/8	39
7/16	78
1/2	90
5/8	136



NOTE: Torque values above are for all screws and bolts used except for those specified.



FUEL SYSTEM

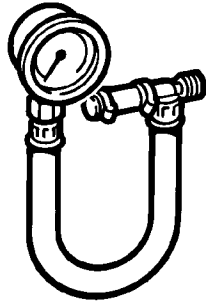

LRT-19-004 Test equipment fuel pressure
18G 500

18G1500

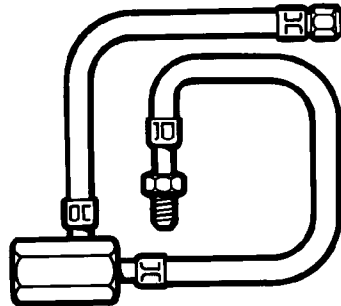

LRT-19-003 MFI pressure test adaptor
LST 143

LST143

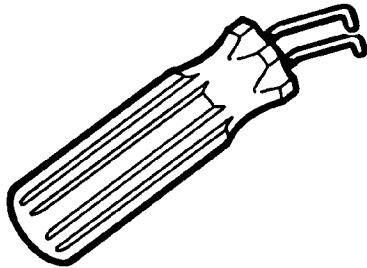

LRT-19-002 Connector splitter
LST 144

LST144

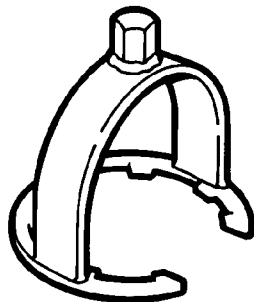

LRT-19-001 Fuel pump remover
LST 131

LST131



CRUISE CONTROL SYSTEM-HELLA GR66

Description

The cruise control system consists of electro-mechanical devices, and comprises of the following components.

ELECTRONIC CONTROL UNIT (ECU)

The engine control module is located behind the lower dash panel. The microprocessor based ECU evaluates the signals provided by the driver controls, brake pedal switch, clutch pedal switch on manual models, and the vehicle speed sensor. The ECU activates the vacuum pump as required. The ECU also has a memory function for set speed storage.

Driver operated switches

The main cruise control switch is located in the auxiliary switch panel and activates the cruise control system. The steering wheel switches provide 'set/accelerate' and 'resume/decelerate' features. These switches provide the interface between driver and cruise control system.

Brake pedal switch

The brake pedal switch is located under the lower dash attached to the brake pedal mounting bracket. The switch provides for fast disengagement of the cruise control system and rapid return of the throttle levers to the idle position when the brake pedal is applied.

Clutch pedal switch

The clutch pedal switch is located under the lower dash attached to the clutch pedal mounting bracket. The switch provides for fast disengagement of the cruise control system and rapid return of the throttle levers to the idle position when the clutch pedal is applied.

Vehicle speed sensor

The vehicle speed sensor is located on the side of the transfer box adjacent to park brake. The sensor provides road speed data to the ECU. The cruise control system cannot be engaged until the road speed exceeds 45 km/h, (28 mph) the system will automatically disengage at a road speed of 42 km/h (26 mph).

Vacuum pump

The vacuum pump is located in the engine compartment, attached to the left hand valance. The vacuum pump is energised when the main cruise control switch is operated, and is actuated by the steering wheel and brake pedal switches. The pump provides a vacuum source to the cruise control actuator at the throttle levers. A control valve in the pump provides for steady increase of road speed or purge of the system when the brake pedal is applied.

Actuator

The actuator is located in the engine compartment and is bolted to the throttle lever bracketry. The actuator provides the servo mechanism link between the cruise control system and throttle linkage and is operated by vacuum from the vacuum pump.

Neutral lockout relay module-cruise control - Automatic vehicles

The relay module is located in the right hand side footwell, accessible by removing the trim panel.

The function of the relay module is to disengage the cruise control system if neutral, or park, is selected in the main gearbox, when the system is engaged.

Engine speed trip ECU - Manual vehicles

This unit is located in the right hand side footwell, accessible by removing the trim panel.

The function of the unit is to disengage cruise control if engine speed exceeds 5000 rev/min.



ROAD TEST



CAUTION: Do not engage cruise control when vehicle is being used in low transfer gear or reverse.



WARNING: The use of cruise control is not recommended on winding, snow covered or slippery roads or in heavy traffic conditions where a constant speed cannot be maintained.

1. Start engine, depress main control switch to actuate cruise control system. Accelerate to approximately 50 km/h, (30 mph), operate 'set/acc' switch, immediately release switch, remove foot from accelerator pedal. Vehicle should maintain speed at which 'set/acc' switch was operated.
2. Operate 'set/acc' switch and hold at that position, vehicle should accelerate smoothly until switch is released. Vehicle should now maintain new speed at which 'set/acc' switch was released.
3. Momentarily touch and release 'set/acc' switch, vehicle speed should increase 1.6 km/h (1 mph) for each touch. Note that five touches will increase speed 8 km/h (5 mph).
4. Apply 'res/decel' switch while vehicle is in cruise control mode, cruise control should disengage. Slow to approximately 55 km/h, (35 mph) operate 'res/decel' switch, immediately release switch and remove foot from accelerator, vehicle should smoothly accelerate to previously set speed. Increase speed using accelerator pedal, release pedal, vehicle should return to previously set speed.
5. Operate brake pedal, cruise control system should immediately disengage returning vehicle to driver control at accelerator pedal. Operate 'res/decel' switch, vehicle should accelerate to previously set speed without driver operation of accelerator pedal.
6. Operate 'res/decel' switch and allow vehicle to decelerate to below 42 km/h, (26 mph). Operate 'res/decel' switch, cruise control system should remain disengaged.
7. Operate 'set/acc' switch below 40 km/h, (28 mph), cruise control system should remain disengaged. Accelerate, using accelerator pedal to above 45 km/h, (28 mph), operate 'res/decel' switch, and remove foot from accelerator pedal, vehicle should smoothly adjust to previously memorised speed.
8. **Automatic vehicles** - select neutral, system should disengage. **Manual vehicles** - depress clutch, system should disengage.
9. Cruise at 80 km/h (50 mph), declutch, select neutral, remove foot from clutch. Operate 'res/decel' switch. Engine should rev to 5000 rev/min, cruise control disengages, engine returns to idle.
10. Engage forward gear. Operate 'res/decel' switch. Remove foot from accelerator. Speed should accelerate to previous set speed.
11. Depress main control switch in control system should immediately disengage and erase previously set speed from ECU memory. **See *Electrical Trouble Shooting Manual*.**



BRAKE AND CLUTCH PEDAL SWITCHES/VENT VALVES

Service repair no - 19.75.34 - Clutch Switch
 Service repair no - 19.75.35 - Brake Switch

Remove

1. Remove lower dash panel.

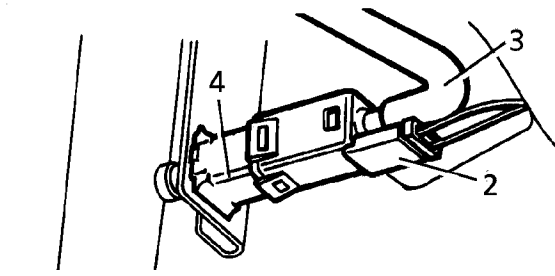

19M7021A

2. Disconnect electrical multi-plug from pedal switch.
3. Pull vent hose from switch.
4. Release switch/vent valve from bracket.

Refit

5. Reverse removal procedure.



NOTE: The switch/vent valve is factory set and does not require adjustment in service.

MAIN CONTROL SWITCH

Service repair no - 19.75.30

Switch Replacement

Remove

1. Disconnect battery negative lead.

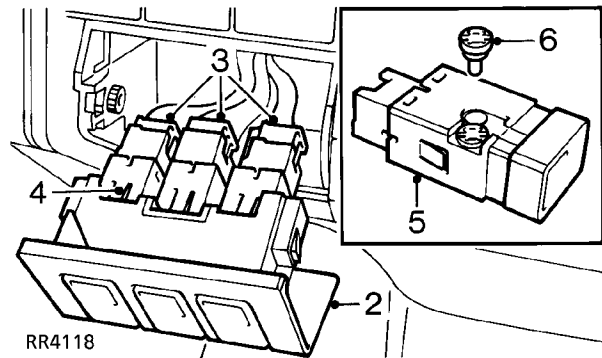

RR4118

2. Carefully release lower edge of panel from surround, withdraw panel.
3. Noting their fitted positions, disconnect multiplugs from switches.
4. Depress retaining lugs on switches, remove switches from panel.

Bulb replacement

5. Identify bulb to be replaced and remove appropriate switch.
6. Rotate bulb holder 90 deg. and withdraw it from switch.

Refit

7. Reverse removal procedure.

CRUISE CONTROL SWITCH

Service repair no - 19.75.36

Remove

1. Disconnect battery negative lead.
2. **Models fitted with airbags:** Remove driver's airbag module. *See SUPPLEMENTARY RESTRAINT SYSTEM, Repair, Driver's Airbag Module*

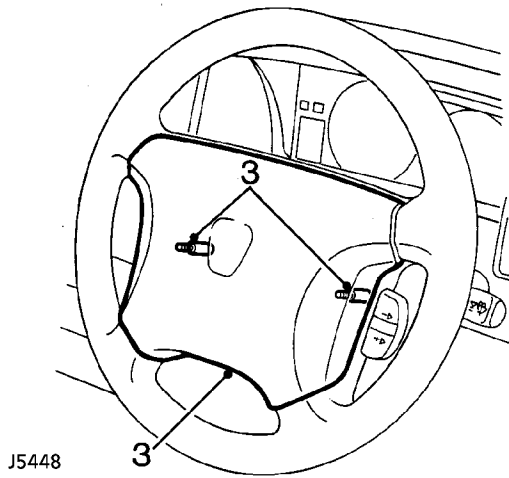

3. **Models without airbags:** Turn steering wheel through 90°. Remove 2 Torx screws securing pad to steering wheel and remove steering wheel pad.
4. Disconnect cruise control switch multiplug from main harness.

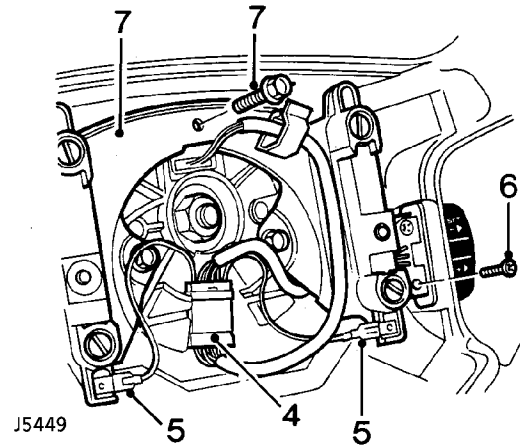

5. Disconnect 2 Lucars from horn contacts.
6. Remove 2 screws securing cruise control switch to steering wheel.
7. Remove 3 bolts securing mounting bracket to steering wheel and remove mounting bracket.
8. Remove cruise control switch from steering wheel.

Refit

9. Reverse removal procedure. Ensuring wiring harness is routed correctly.
10. **Models fitted with airbags:** Refit driver's airbag module and follow all safety precautions. *See SUPPLEMENTARY RESTRAINT SYSTEM, Repair, Driver's Airbag Module*



ROTARY COUPLER

Service repair no - 19.75.54

The rotary coupler is located behind the steering wheel. Access is gained by removing the steering wheel and steering column shroud.



NOTE: On vehicles fitted with airbags. See SUPPLEMENTARY RESTRAINT SYSTEM, Repair, Rotary Coupler

Remove

1. Disconnect battery negative lead.
2. Remove steering wheel. *See STEERING, Repair, Steering Wheel*
3. Release 2 turnbuckles securing lower dash closing panel and lower.
4. Remove 3 screws securing lower half of shroud to steering column.

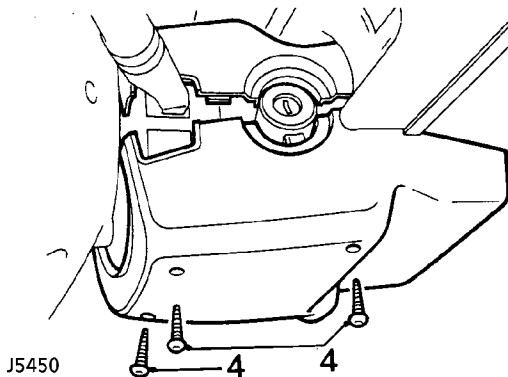

5. Disconnect rotary coupler multiplug from steering column harness.



NOTE: If rotary coupler is to be re-used a piece of adhesive tape should be placed around the moulding in position A to prevent rotation. Failure to do this may result in damage to the wires inside the coupler.

6. Release clips securing rotary coupler to column stalk assembly.
7. Remove rotary coupler from column stalk assembly.

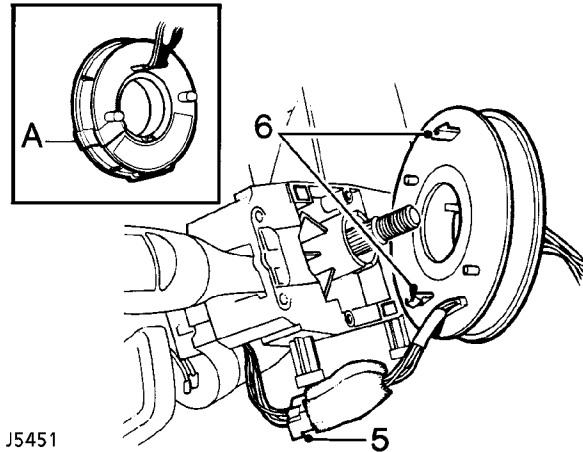

CAUTION: Ensure front wheels are in the straight ahead position before removal and refitting. Store in a plastic bag. DO NOT rotate mechanism whilst removed.

Refit

8. Reverse removal procedure. Ensuring that the column harnesses are not trapped by the column shroud.



NOTE: If original rotary coupler is to be fitted and there is evidence of tampering, it is imperative that the coupler is centralised. See SUPPLEMENTARY RESTRAINT SYSTEM, Repair, Rotary Coupler Centralise



NOTE: If a new rotary coupler is to be fitted and the sealing tape is broken it MUST NOT be used. Ensure rotary coupler lugs are correctly engaged in the rear of the steering wheel.

ACTUATOR

Service repair no - 19.75.12



NOTE: The actuator is non serviceable, fit a new unit if failure or damage occurs.

Remove

1. Disconnect battery negative lead.
2. Disconnect vacuum hose from actuator.
3. Remove nut securing actuator to throttle bracket.
4. Remove actuator, and manoeuvre actuator operating link off throttle lever.
5. Withdraw actuator.

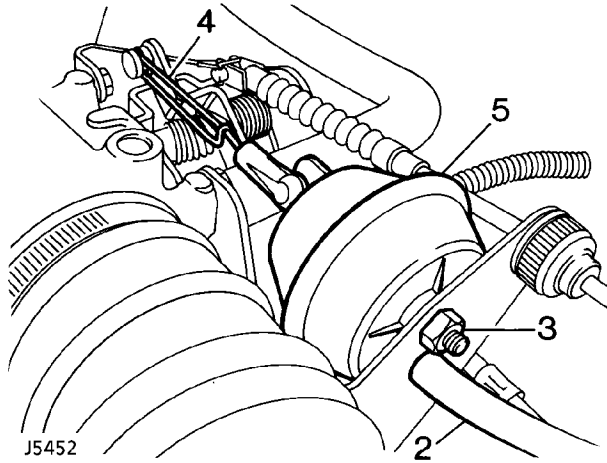

Refit

6. Inspect rubber diaphragm. Fit a new actuator assembly if diaphragm is damaged.
7. Reverse removal procedure. Fitting the hook uppermost.

ACTUATOR LINK-SETTING

Service repair no - 19.75.21



NOTE: Setting procedure is carried out at minimum throttle condition only.

1. Ensure ignition is switched 'OFF'.
2. Check clearance between inside edge of actuator link and recessed diameter of throttle lever. Clearance should be 0.2 to 2.0 mm.

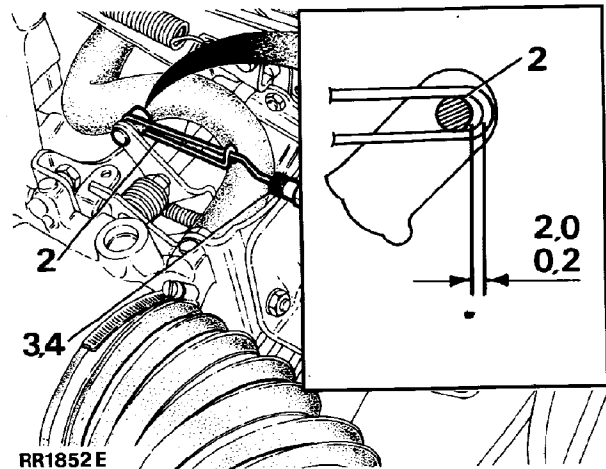



Link - adjust

3. Remove link from actuator.
4. Rotate socket joint adjuster as necessary.
5. Refit link to actuator and recheck clearance between link and lever.
6. With throttle fully open, check a gap of at least 3mm exists between side of link ("A" in illustration) and side of small spring ("B" in illustration). Realign link by bending to achieve correct gap. Recheck clearance at closed throttle/open throttle. Check link slides smoothly in groove of throttle lever.

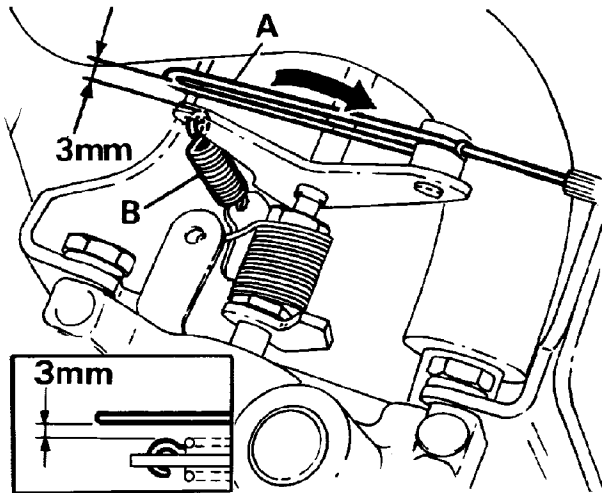

RR2316E

VACUUM PUMP

Service repair no - 19.75.06



NOTE: The vacuum pump is non serviceable, fit a new unit if failure or damage occurs.

Remove

1. Remove air cleaner. **See Air Cleaner Assembly**
2. From under the LH front wing [fender]: Press 3 rubber mountings through panel and release vacuum pump.
3. From inside engine compartment: Withdraw out of panel aperture.
4. Disconnect multiplug from vacuum pump.
5. Release vacuum pump rubber mountings from body.
6. Disconnect vacuum feed hose and remove vacuum pump.

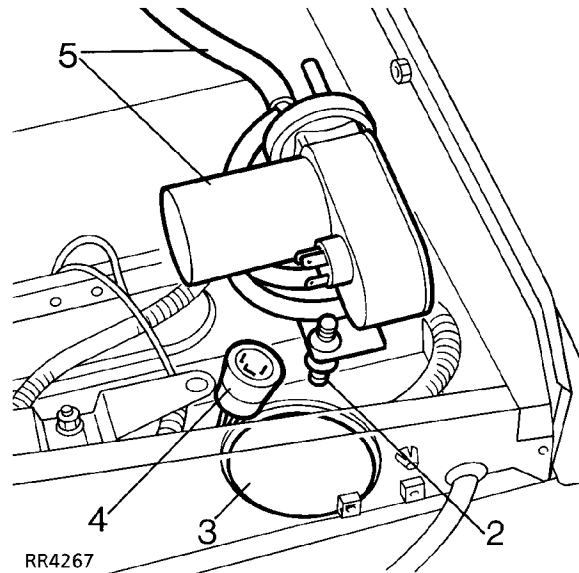

RR4267

Refit

7. Reverse removal procedure. Ensuring all hose and electrical connections are secure.

CRUISE CONTROL ECU

Service repair no - 19.75.49

Remove

1. Remove lower dash panel.

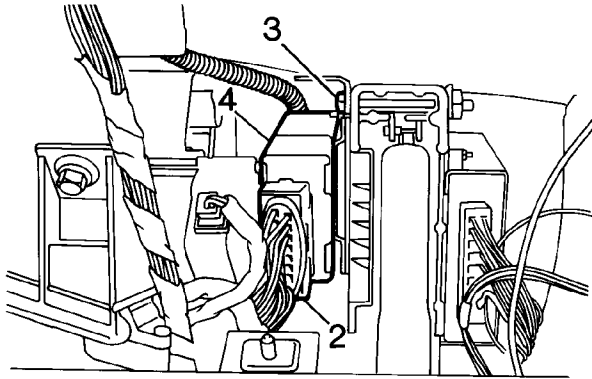

J5454

2. Disconnect ECU multi-plug.
3. Remove ECU fixing.
4. Remove ECU.
5. Reverse removal procedure. Ensuring that electrical multi-plug is securely reconnected.

SPEED TRIP ECU - MANUAL



NOTE: The neutral lock out relay module/speed trip ECU is mounted in the right hand side footwell. To identify components. See *Electrical Trouble Shooting Manual*.



ENGINE COOLING

Description

The Tdi engine uses a pressurized cooling system and cross flow radiator which is supplied from a separate header tank. The radiator assembly is in three sections. The largest section is for engine coolant and the other two sections which are cast in aluminium, are the engine oil cooler and the turbo charger intercooler.

A belt driven viscous fan and centrifugal water pump is located in the front of the cylinder block. Hot coolant is supplied to the heater through hoses. Two small diameter air purge hoses connect the top of the radiator and cylinder head water gallery, to the header tank.

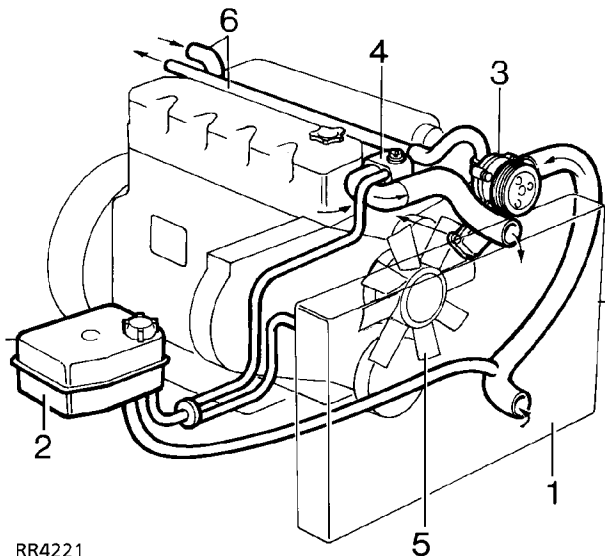

RR4221

Coolant circulation (engine cold)

1. Cross flow radiator
2. Header tank
3. Viscous fan and water pump
4. Heater hoses
5. By pass hose and engine thermostat
6. Air purge hoses

COOLANT CIRCULATION

Operation

When the engine is started from cold the thermostat prevents any coolant circulation through the radiator by closing off the top hose. During the engine warm up period, the water pump, pumps coolant towards the rear of the cylinder block around each of the cylinders. Coolant as it is heated rises through ports in the cylinder block and head gasket, into the cylinder head. The coolant flows forwards to the thermostat, by-pass port and radiator top hose connection.

Start from cold (thermostat closed)

While the thermostat is closed, coolant circulates around the cylinder block and cylinder head via the by-pass.

Engine warm (thermostat open)

When the engine reaches normal running temperature the thermostat closes off the by-pass and opens the flow to the top of the radiator.

VISCOUS FAN

Description

The viscous drive unit for the engine cooling fan, provides a means of controlling the speed of the fan relative to the running temperature of the engine. The viscous unit is a type of fluid coupling, which drives the fan blades through the medium of a special 'silicone fluid' injected into the unit during manufacture.

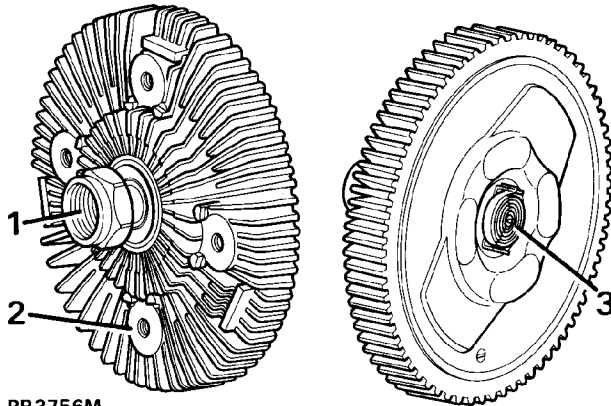

RR3756M

1. Drive in from water pump spindle
2. Drive out to fan blades
3. Bi-metal

Operation

The viscous unit consists of two principal components: An inner member 1 which is secured to water pump spindle and is driven by the fan belt. An outer member 2 which has the fan blades attached, houses the working parts and is driven through the medium of the viscous fluid.

The inner and outer members have interlocking annular grooves machined in each, with a small running clearance 3 to allow the silicone fluid to circulate through the valve plate 4.

The unit also contains a valve 5 which is controlled by an external bi-metal thermostat 6.

Starting engine from cold

During the time the engine is at rest the silicone fluid drains down, half filling chambers A and B. Thus when the engine is first started sufficient fluid is present in chamber A to provide a positive drive between the members, as is evident by the initial noise of the fan. However within a very short period of time, after starting the engine, the fan speed and noise will decline indicating that the fluid is being centrifuged into chamber B (as seen in RR3757M) causing the drive to slip.

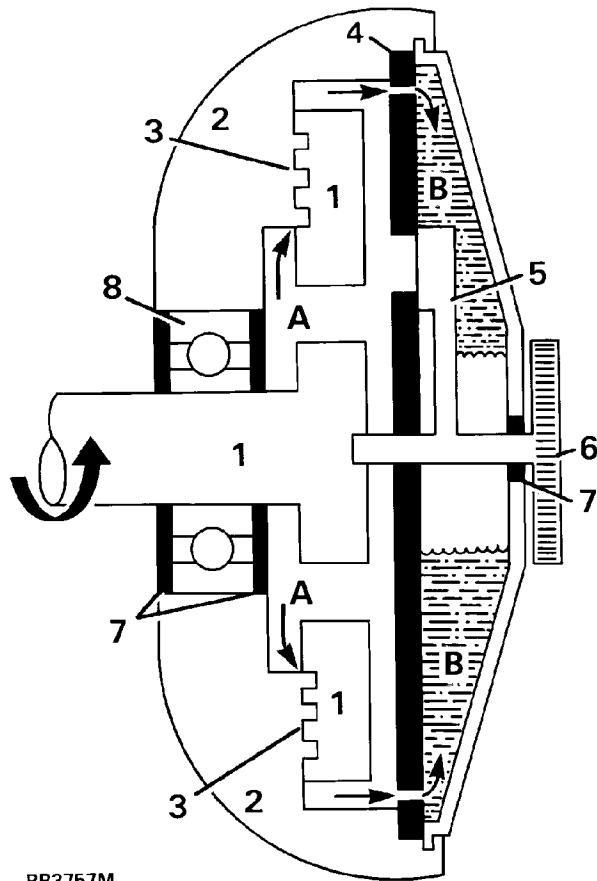

RR3757M

Viscous unit slipping (Engine at normal running temperature)

1. Inner member (drive in fast)
 2. Outer member (drive out slow)
 3. Running clearance
 4. Valve plate
 5. Valve (closed)
 6. Bi-metal
 7. Fluid seals
 8. Ball race
- A** Fluid chamber
B Fluid chamber

If the engine speed is increased the degree of slip will also increase to limit the maximum fan speed.

Hot conditions

When operating in high ambient temperatures or when stationary in traffic, the bi-metal thermostat will operate and open the valve port between chambers A and B.

Opening the valve (as shown in RR3758M) allows the fluid to circulate between the two members, causing the unit to couple, thus increasing the fan speed and cooling effect.

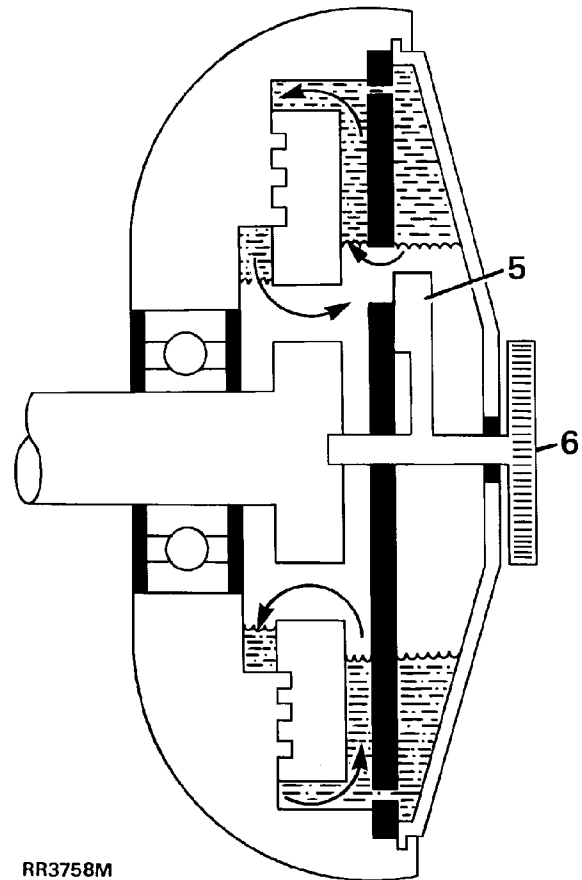

RR3758M

Viscous unit coupled (Hot running conditions)

Bi-metal expanded, valve (open)



ENGINE OVERHEATING

Before conducting any cooling system diagnosis: **See Description and operation, Engine Cooling**

1. Is coolant level correct?
NO - Allow engine to cool, top up level to expansion tank seam.
YES - Continue.
2. Is drive belt tension correct?
NO - **See ENGINE, Repair, Compressor Drive Belt**
YES - Continue.
3. Is coolant in radiator frozen?
YES - Slowly thaw and drain system. **See Adjustment, Coolant**
NO - Continue.
4. Is air flow through radiator restricted or blocked?
YES - Apply air pressure from engine side of radiator to clear obstruction.
NO - Continue.
5. Are there any external leaks, from water pump, engine gaskets, fast idle thermostat or the heater unit?
YES - Investigate and rectify. **See Adjustment, Coolant**
NO - Continue.
6. Are fan blades fitted correct way round, concave side towards engine?
NO - Rectify.
YES - Continue
7. Is viscous unit operating correctly? **See Description and operation, Viscous Fan**
NO - Renew. **See Repair, Viscous Coupling, Fan Blades, Pulley and Fan Cowl**
YES - Carry out a pressure test on radiator cap and system. Check thermostat type, operation and correct fitting. **See Repair, Thermostat**
If pressure test leads you to suspect coolant leakage across gaskets, go to check 10, otherwise: Continue.

8. Are the air conditioning fans operating correctly?
See Electrical Trouble Shooting Manual.
NO - Rectify.
YES - Continue.
9. Is temperature sender and gauge giving accurate readings?
NO - Substitute parts and compare readings.
YES - Continue.
10. Carry out cylinder pressure test to determine if pressure is leaking into cooling system causing over pressurising and loss of coolant.

If problem is not diagnosed, check the coolant system for engine oil contamination and engine lubrication system for coolant contamination.

If only the coolant system is contaminated suspect a cylinder head gasket.

If both systems are contaminated, suspect the radiator.

If only the lubrication system is contaminated with coolant, suspect leakage past cylinder liner seals or cylinder head gasket.

ENGINE RUNS COLD

Before conducting any cooling system diagnosis: **See Description and operation, Engine Cooling**

1. Check operation of viscous unit. **See Description and operation, Viscous Fan**
Is viscous unit operating correctly?
NO - **See Repair, Viscous Coupling, Fan Blades, Pulley and Fan Cowl**
YES - Continue.
2. Is thermostat correct type and operating? **See Repair, Thermostat**
If problem is not diagnosed: Continue.
3. Are the air conditioning fans operating continuously?
YES - **See Electrical Troubleshooting Manual**
NO - Continue.
4. Is temperature sender and gauge giving accurate readings? Substitute parts and compare readings. If problem is not diagnosed repeat tests, starting at 1.



COOLANT

Service repair no - 26.10.01

Draining



WARNING: Do not remove any caps or plugs when the engine is hot. The cooling system is pressurised and personal scalding could result.

1. Remove expansion tank filler cap.
2. Disconnect bottom hose from radiator and allow coolant to drain into a container. Ensure container is clean if reusing coolant.



NOTE: When expansion tank has emptied, remove thermostat housing plug to assist drainage. Similarly when coolant level is below top of radiator, remove radiator plug.

3. Reconnect hose after draining and tighten hose clamp.

Refit



CAUTION: In order to expel ALL air from the cooling system, follow the procedures carefully.



NOTE: Refill procedure is slow but can be accelerated by squeezing hoses to assist removal of air from the system.

4. Add correct mix of coolant into expansion tank until radiator is full (as seen through plug hole on top of radiator). **See LUBRICANTS, FLUIDS AND CAPACITIES, Information, Anti-Freeze**



CAUTION: Take care to avoid excess coolant spillage from radiator.

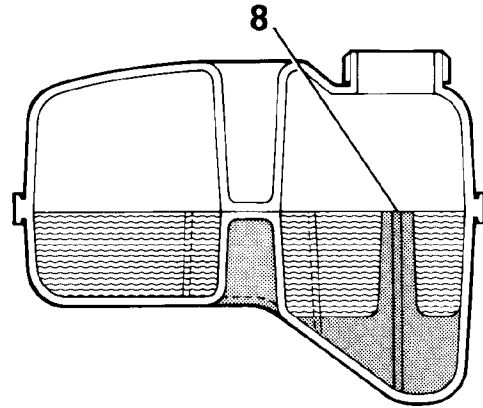

RR2897A

5. Fit radiator plug.
6. Continue adding coolant into expansion tank until coolant appears in thermostat housing.



CAUTION: Take care to avoid excess coolant spillage from thermostat housing.

7. Fit thermostat housing plug.
8. Check coolant in expansion tank is level with indicator post. Add more coolant if necessary.
9. Start engine and run for 5 minutes.
10. Allow engine to cool, check coolant level in expansion tank; top up to level indicator post if necessary.
11. Fit expansion tank filler cap.



VISCOUS COUPLING, FAN BLADES, PULLEY AND FAN COWL

Service repair no - 26.25.03/05

Viscous coupling	- Remove 1 to 3
Fan blades	- Remove 1 to 4
Fan cowl	- Remove 1 to 3
Fan pulley	- Remove 1 to 6

Remove



WARNING: Disconnect battery negative terminal to prevent engine being started before removing or adjusting drive belt.

1. Slacken nut securing viscous coupling/fan blade assembly to pulley.



NOTE: Nut securing viscous unit to pulley has a left hand thread. Release by turning clockwise when viewed from front of viscous unit.

2. Drop viscous unit and fan assembly into bottom of cowl
3. Remove two fixings clips from top of cowl and lift cowl complete with viscous unit and fan out of lower mountings.
4. Remove fan blades from viscous coupling if necessary.
5. Remove serpentine drive belt and, if fitted, air conditioning compressor belt.
6. Remove pulley fixings, remove pulley.



NOTE: The serpentine belt is removed by using a hexagonal socket and tommy bar on the auto-tensioning pulley nut. Whilst tensioning the device the belt can be removed.

7. Reverse removal procedure. Ensure fan blades are fitted correctly. Fan is marked 'front' and should be fitted with word 'front' closest to radiator. Tighten to **30 Nm**.
8. Refit drive belt. **See ENGINE, Repair, Drive Belt**

THERMOSTAT

Service repair no - 26.45.01

Remove

1. Partially drain cooling system, until coolant level is below thermostat housing.
2. Disconnect hose from thermostat housing.
3. Disconnect electrical connections to water temperature switch.

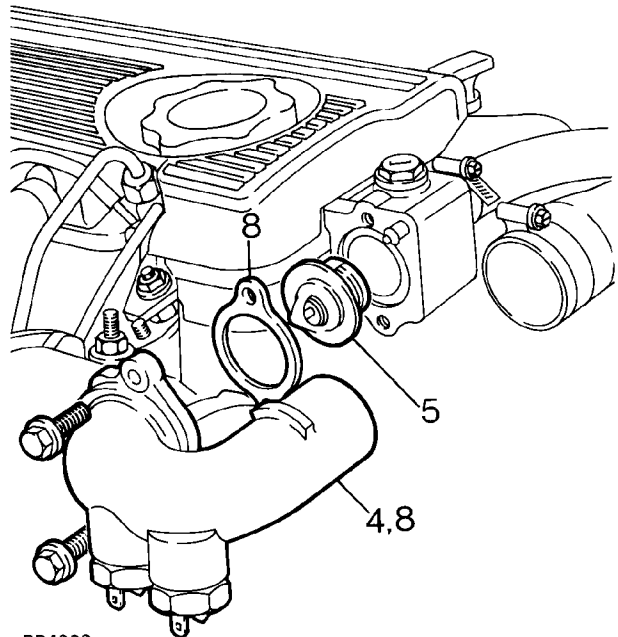

RR4223

4. Remove outlet elbow.
5. Withdraw thermostat.

Test

6. Note rating of thermostat is 88°C. Place thermostat in a container half full of water. Heat water, observe temperature at which thermostat begins to open. Thermostat is satisfactory if its open between 85°C and 89°C.

Refit

7. Insert thermostat with jiggle pin/vent hole upper most (12 o'clock position).
8. Fit the outlet elbow and new joint washer. Tighten to **28 Nm**.
9. Reverse removal procedure. 1 to 3.
10. Check for coolant leaks around all connections and joint faces.

WATER PUMP

Service repair no - 26.50.01

Remove

WARNING: Disconnect battery negative terminal to prevent engine being started before removing drive belts.

1. Drain engine cooling system. *See Adjustment, Coolant*
2. Remove top hose radiator to thermostat.
3. Remove top hose intercooler to induction manifold.
4. Slacken water pump and power steering pump pulley retaining bolts.
5. Remove drive belt.
6. Remove centre nut from belt tensioner.
7. Manoeuvre pulley upwards and withdraw tensioner from retaining stud.
8. Disconnect hose thermostat to bottom hose, release hose from clip on water pump and move aside.
9. Remove water pump pulley.
10. Remove power steering pump pulley.

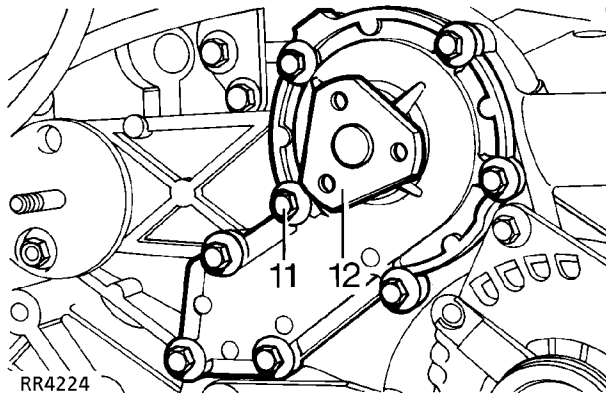

11. Remove 8 bolts securing water pump, noting location of 3 through bolts.
12. Withdraw pump and gasket, clean all gasket material from mating surfaces.

Refit

13. Refit water pump in reverse order to removal using new gasket.

RADIATOR

Service repair no - 26.40.01

Remove

1. Drain cooling system. *See Adjustment, Coolant*
2. Disconnect radiator top hose.
3. Remove fan blade assembly.
4. Remove cowl.
5. Disconnect engine oil cooler connections and turbo intercooler connections from radiator ends.



NOTE: Oil spillage will occur when connections are loosened. Blank off exposed oil connections.

6. Disconnect expansion tank bleed hose from radiator.
7. Remove radiator securing brackets from each side.
8. Remove radiator unit by lifting from its location. Check condition of rubber mounting pads.

Refit

9. Check radiator sealing strips are securely located.
10. Transfer oil cooler adaptors if fitting new radiator.
11. Reverse removal procedure. Tighten oil cooler connections to **30 Nm**, before fitting fan blades and cowl.
12. Check all connections for leaks.



ENGINE COOLING

Description

The V8i engine uses a pressurised cooling system and cross flow radiator which is supplied from a separate header tank. The coolant radiator also incorporates a section at the left hand end for cooling the transmission oil and a section at the other end for cooling the engine oil.

The belt driven viscous fan and centrifugal water pump is located in the engine front cover with ports for circulation of coolant to both banks of cylinders and cylinder heads. Coolant returns to the top of the radiator via ports in the inlet manifold where the thermostat is mounted horizontally.

Coolant also circulates through the vehicle heating system and is used to heat air entering the inlet manifold plenum chamber.

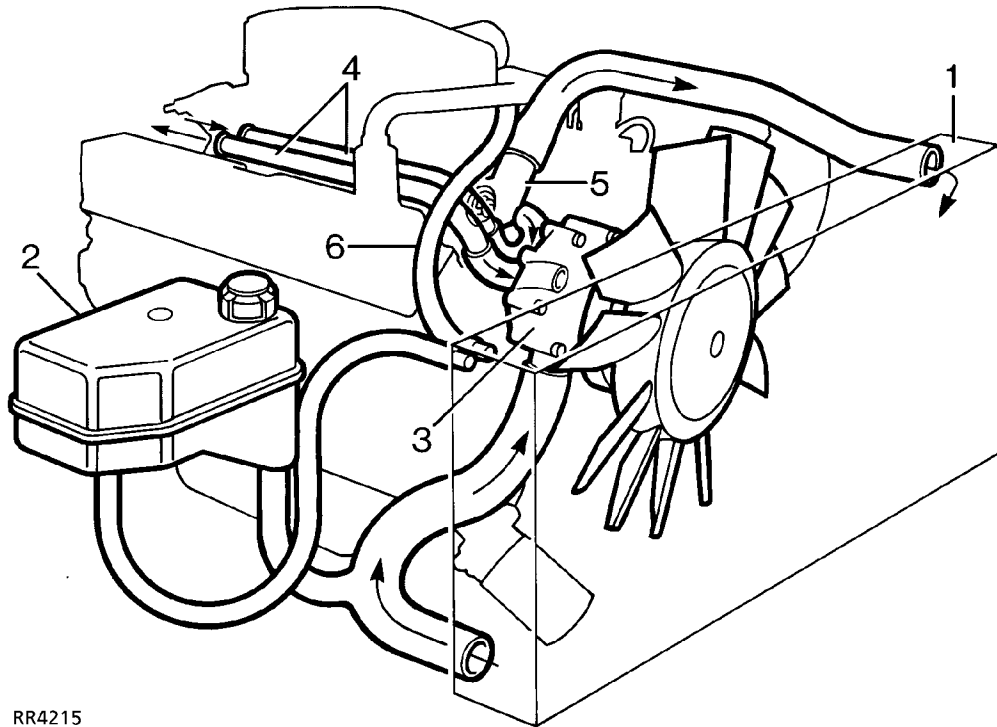

RR4215

Coolant circulation (engine hot)

1. Cross flow radiator
2. Header tank
3. Viscous fan and water pump
4. Heater pipes
5. Plenum chamber connection
6. Thermostat

COOLANT CIRCULATION

Operation

When the engine is started from cold the thermostat prevents any coolant circulation through the radiator by closing off the top hose. During the engine warm up period, the water pump, pumps coolant around the cylinders to the rear of the cylinder block along the main galleries in both cylinder banks. At the rear of the cylinder block the coolant rises through a large port in each cylinder head/block joint face, and then flows forward to connect with ports at the front of the inlet manifold. From the manifold the coolant is carried by an external pipe to the heater unit and from the heater through another external pipe to the pump inlet.

The coolant circulation through the cylinder block and heads, does not change when normal running temperature is reached and the thermostat opens. But with the thermostat open, coolant flows through the top hose to the radiator where it is cooled and drawn back into the pump via the bottom hose.

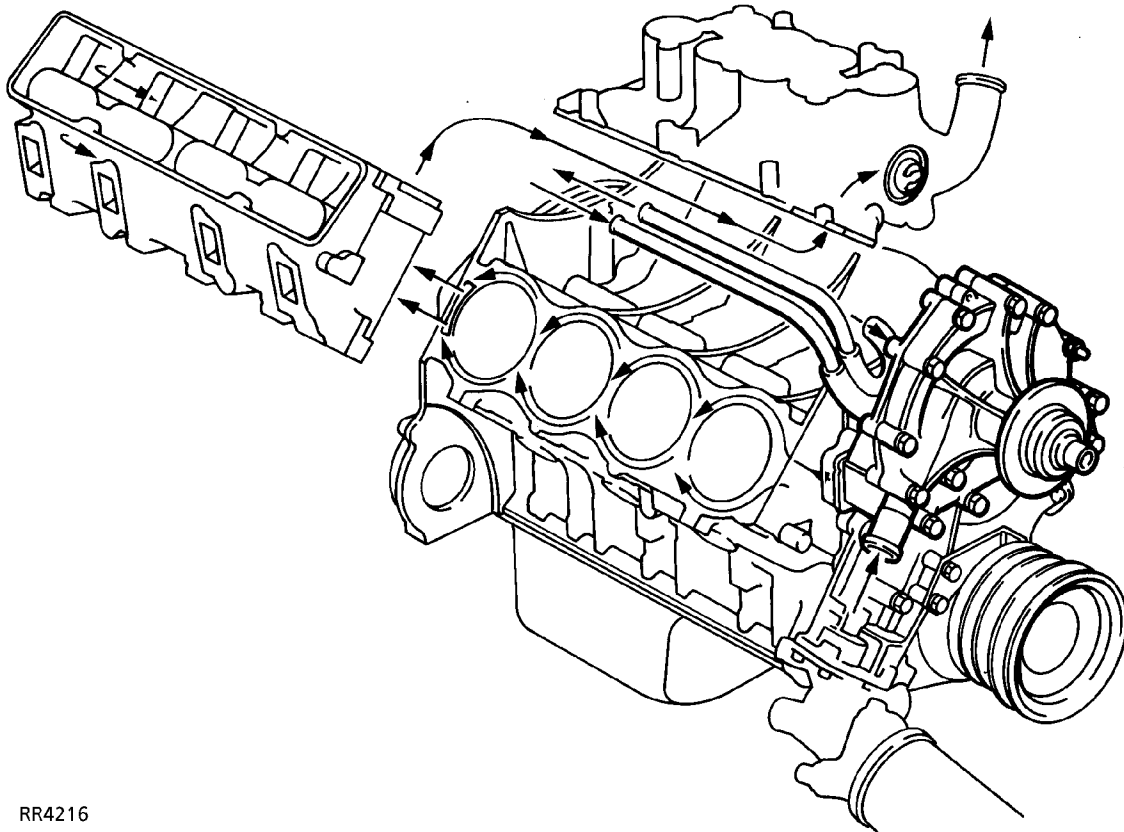

RR4216



Plenum chamber heating

Air entering the plenum chamber is heated by a flow of coolant from the inlet manifold which returns through a long hose, to the top right corner of the radiator.

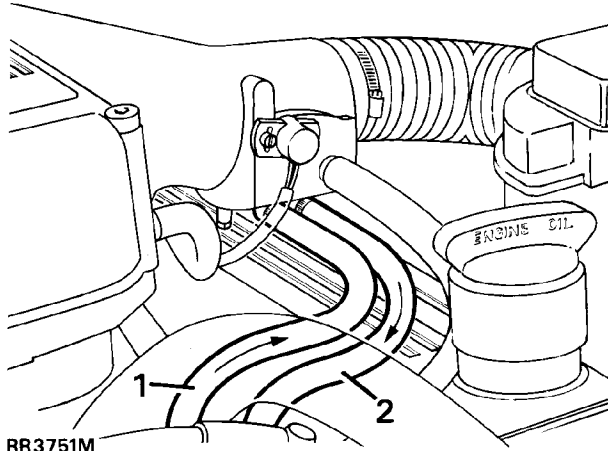

RR3751M

1. Hot water supply
2. Cold return to radiator

VISCOUS FAN

Description

The viscous drive unit for the engine cooling fan, provides a means of controlling the speed of the fan relative to the running temperature of the engine. The viscous unit is a type of fluid coupling, which drives the fan blades through the medium of a special 'silicone fluid' injected into the unit during manufacture.

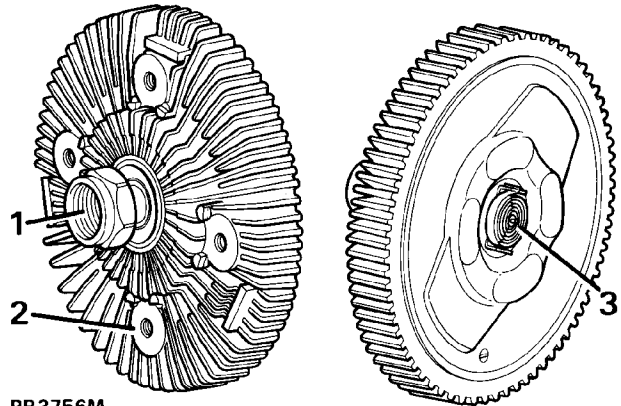

RR3756M

1. Drive in from water pump spindle
2. Drive out to fan blades
3. Bi-metal

Operation

The viscous unit consists of two principal components:
 An inner member 1 which is secured to water pump spindle and is driven by the fan belt.
 An outer member 2 which has the fan blades attached, houses the working parts and is driven through the medium of the viscous fluid.

The inner and outer members have interlocking annular grooves machined in each, with a small running clearance 3 to allow the silicone fluid to circulate through the valve plate 4.

The unit also contains a valve 5 which is controlled by an external bi-metal thermostat 6.

Starting engine from cold

During the time the engine is at rest the silicone fluid drains down, half filling chambers A and B. Thus when the engine is first started sufficient fluid is present in chamber A to provide a positive drive between the members, as is evident by the initial noise of the fan. However within a very short period of time, after starting the engine, the fan speed and noise will decline indicating that the fluid is being centrifuged into chamber B (as seen in RR3757M) causing the drive to slip.

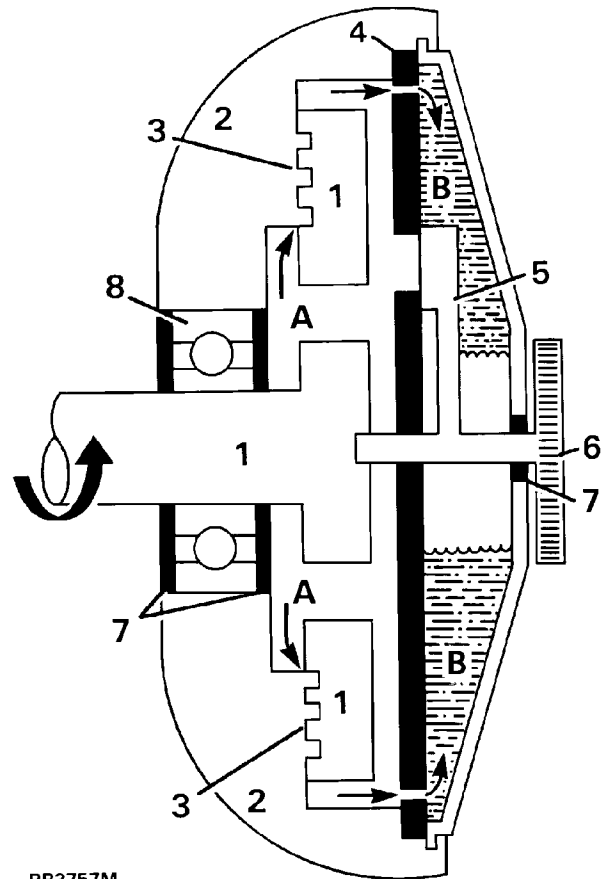

RR3757M

Viscous unit slipping (Engine at normal running temperature)

1. Inner member (drive in fast)
2. Outer member (drive out slow)
3. Running clearance
4. Valve plate
5. Valve (closed)
6. Bi-metal
7. Fluid seals
8. Ball race
- A. Fluid chamber
- B. Fluid chamber

If the engine speed is increased the degree of slip will also increase to limit the maximum fan speed.



Hot conditions

When operating in high ambient temperatures or when stationary in traffic, the bi-metal thermostat will operate and open the valve port between chambers A and B.

Opening the valve (as shown in RR3758M) allows the fluid to circulate between the two members, causing the unit to couple, thus increasing the fan speed and cooling effect.

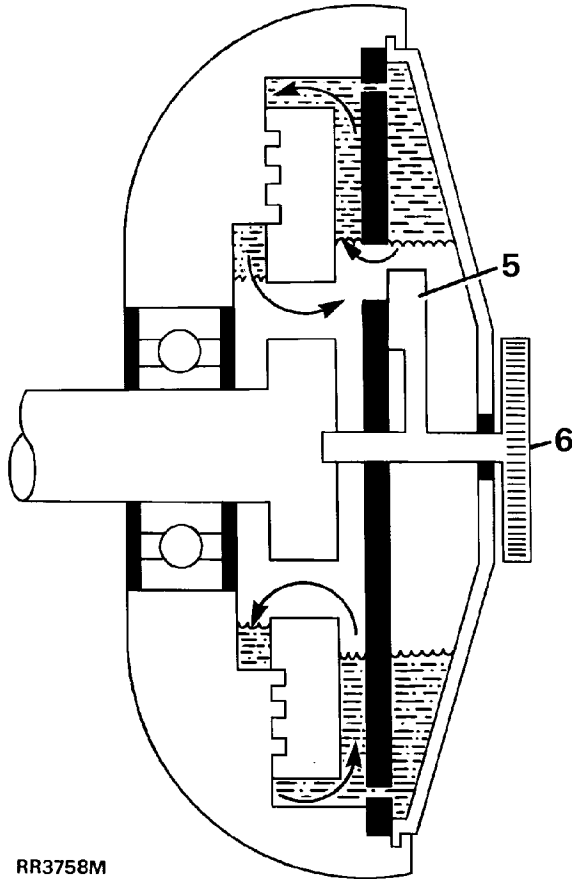

Viscous unit coupled (Hot running conditions)

Bi-metal expanded, valve (open)



ENGINE OVERHEATING

Before conducting any cooling system diagnosis: **See Description and operation, Engine Cooling**

1. Is coolant level correct?
NO - Allow engine to cool, top up level to expansion tank seam.
YES - Continue.
2. Is drive belt tension correct?
NO - **See ENGINE, Repair, Drive Belt - Check Tension**
YES - Continue.
3. Is ignition timing correct?
NO - **See ELECTRICAL, Adjustment, Ignition Timing**
YES - Continue.
4. Is coolant in radiator frozen?
YES - Slowly thaw and drain system. **See Adjustment, Coolant Requirements**
NO - Continue.
5. Is air flow through radiator restricted or blocked?
YES - Apply air pressure from engine side of radiator to clear obstruction.
NO - Continue.
6. Are there any external leaks, from water pump, engine gaskets or the heater unit?
YES - Investigate and rectify. **See Adjustment, Coolant Requirements**
NO - Continue.
7. Are fan blades fitted correct way round, concave side towards engine?
NO - Rectify.
YES - Continue.
8. Is viscous unit operating correctly? **See Description and operation, Viscous Fan**
NO - Renew. **See Repair, Viscous Coupling, Fan Blades, Pulley and Fan Cowl**
YES - Carry out a pressure test on radiator cap and system. Check thermostat type, operation and correct fitting **See Repair, Thermostat**
If pressure test leads you to suspect coolant leakage across gaskets, go to check 11, otherwise: Continue.
9. Are the air conditioning fans operating correctly? **See Electrical Trouble Shooting Manual.K5**
NO - Rectify.
YES - Continue.
10. Is temperature sender and gauge giving accurate readings?
NO - Substitute parts and compare readings.
YES - Continue.
11. Carry out cylinder pressure test to determine if pressure is leaking into cooling system causing over pressurising and loss of coolant.

If problem is not diagnosed, check the coolant system for engine oil contamination and engine lubrication system for coolant contamination.

If the coolant only, or both systems are contaminated, suspect cylinder head gaskets or radiator.

If only the lubrication system is contaminated with coolant, suspect inlet manifold or front cover gaskets.

ENGINE RUNS COLD

Before conducting any cooling system diagnosis: **See Description and operation, Engine cooling**

1. Check operation of viscous unit. **See Description and operation, Viscous Fan**
Is viscous unit operating correctly?
NO - **See Repair, Viscous coupling, fan blades, pulley and fan cowl**
YES - Continue.
2. Is thermostat correct type and operating? **See Repair, Thermostat**
If problem is not diagnosed: Continue.
3. Are the air conditioning fans operating continuously?
YES - **See Electrical Troubleshooting Manual**
NO - Continue.
4. Is temperature sender and gauge giving accurate readings? Substitute parts and compare readings. If problem is not diagnosed repeat tests, starting at 1.



COOLANT REQUIREMENTS

Frost precautions and engine protection.

Cooling system **MUST ALWAYS** be filled and topped-up with solution of water and anti-freeze, winter and summer. **NEVER** use water alone, this may corrode aluminium alloy.



CAUTION: Do not use salt water otherwise corrosion will occur. In certain territories where only available natural water supply has some salt content use only rain or distilled water.

Recommended solutions

Anti-freeze: Universal anti-freeze or permanent type ethylene base, without methanol, containing a suitable inhibitor for aluminium engines and engine parts.

Use one part of anti-freeze to one part of water.

Anti-freeze can remain in the cooling system and will provide adequate protection for two years provided that specific gravity of coolant is checked before onset of second winter and topped-up with new anti-freeze as required.

Vehicles leaving factory have cooling system filled with 50% solution of anti-freeze and water. This gives protection against frost down to minus 36°C (minus 33°F). Vehicles so filled are identified by a label affixed to radiator.



NOTE: Should ambient temperatures be below that stated above refer to **Anti-Freeze Data in Recommended Lubricants, Fluids and Capacities in Section 09. Instructions in chart must be strictly adhered to before driving vehicle.**

After the second winter the system should be drained and thoroughly flushed. Before adding new anti-freeze examine all joints and replace defective hoses to make sure that the system is leakproof.

See the 'Recommended Lubricants Fluids and Capacities' for protection quantities. **See LUBRICANTS, FLUIDS AND CAPACITIES, Information, Recommended Lubricants and Fluids**

COOLANT

Service repair no - 26.10.01

Draining



WARNING: Do not remove expansion tank filler cap when engine is hot. The cooling system is pressurised and personal scalding could result.

See coolant requirements before refilling system.

1. Remove expansion tank filler cap by slowly turning it anti-clockwise, pause to allow pressure to escape. Continue turning it in same direction and remove.

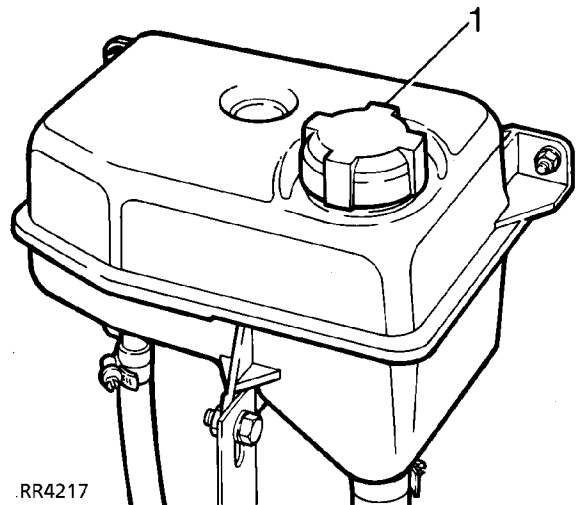

RR4217

2. Remove radiator filler plug and 'O' ring to assist drainage.

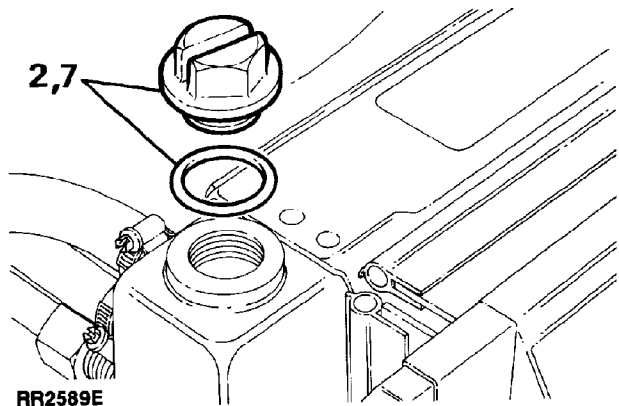

RR2589E

3. Disconnect bottom hose from radiator. Drain coolant into a clean container. Reconnect bottom hose, re-tighten hose clamp.

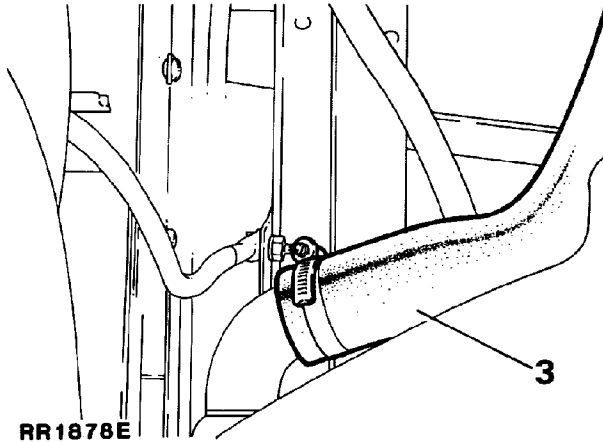

5. Pour correct solution of water and anti-freeze into expansion tank until radiator is full.
6. Start engine, run it until normal operating temperature is attained, topping up as necessary.
7. Refit radiator filler plug and 'O' ring, with new 'O' ring if required. Tighten to **6 Nm**.
8. Fit expansion tank filler cap.
9. Allow engine to cool, check coolant level. Finally top up expansion tank until level reaches seam of expansion tank.



NOTE: It is not possible to drain all coolant retained in heater system. It is not desirable to flush through system, after draining.

4. Remove engine drain plugs, one each side of cylinder block, beneath exhaust manifolds. Drain coolant, refit and tighten plugs.

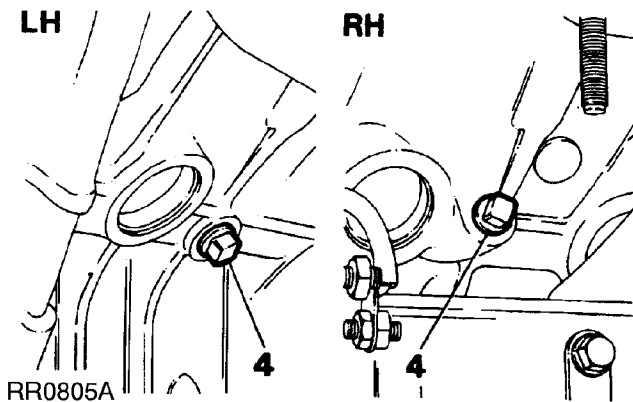



EXPANSION TANK

Service repair no - 26.15.01

Remove



WARNING: Do not remove expansion tank filler cap when engine is hot. The cooling system is pressurised and personal scalding could result.

1. Remove expansion tank filler cap by first turning it slowly anti-clockwise, pause to allow pressure to escape. Continue turning in same direction and lift off.
2. Disconnect two hoses from bottom of expansion tank, allowing coolant to drain into a suitable container.
3. Remove three fixing bolts, remove expansion tank.

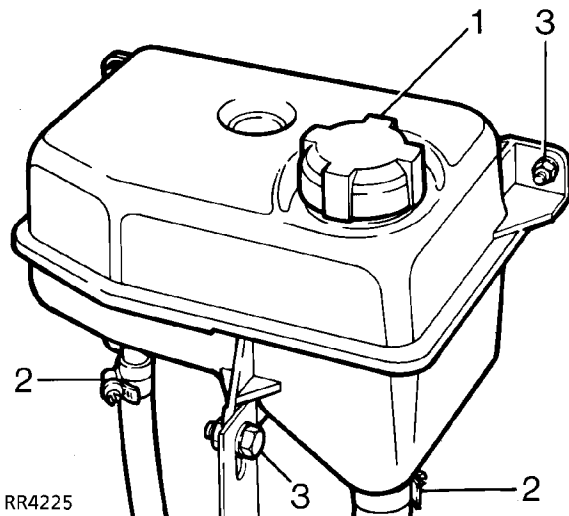

Refit

4. Reverse removal procedure.
5. Replenish cooling system.
6. Check for leaks around all hose connections.

VISCOUS COUPLING, FAN BLADES, PULLEY AND FAN COWL

Service repair no - 26.25.03/05

Viscous coupling - remove 1 to 3

Fan blades - remove 1 to 3

Fan cowl - remove 1 to 2

Fan pulley - remove 1 to 5

Remove



WARNING: Disconnect battery negative terminal to prevent engine being started before removing or adjusting drive belts.

1. Loosen nut securing viscous coupling/fan blade assembly to water pump, and place into bottom of fan cowl.



NOTE: Nut securing viscous unit to water pump has a right hand thread. Release by turning anti-clockwise when viewed from front of viscous unit.

2. Remove two fan cowl clips, lift cowl out of lower mountings complete with fan blade assembly.

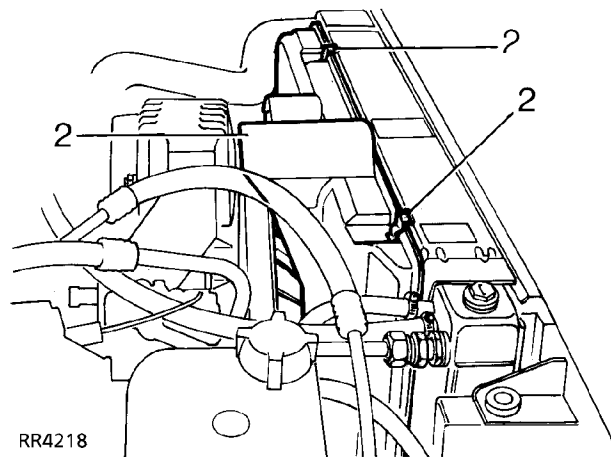

3. Remove fan blades from viscous coupling, if necessary.
4. Remove serpentine drive belt.
5. Remove pulley fixings, remove pulley.

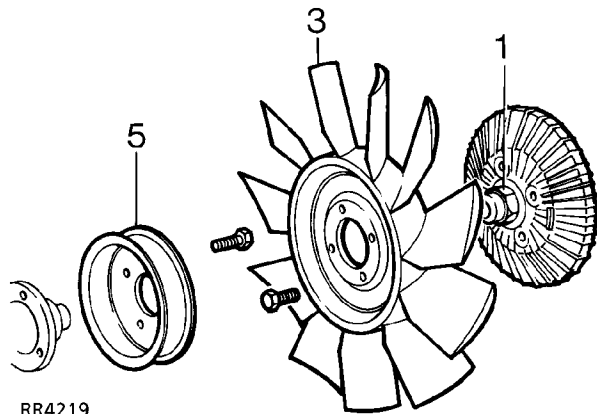

RR4219

Refit

- Reverse removal procedure. Ensuring fan blades are fitted correctly. Fan is marked **FRONT** and should be fitted with word **FRONT** closest to radiator. Tighten to **35 Nm**.

THERMOSTAT

Service repair no - 26.45.01

Remove

- Partially drain cooling system, until coolant level is below thermostat housing.
- Disconnect hose from thermostat housing.
- Disconnect electrical connections to water temperature switch.

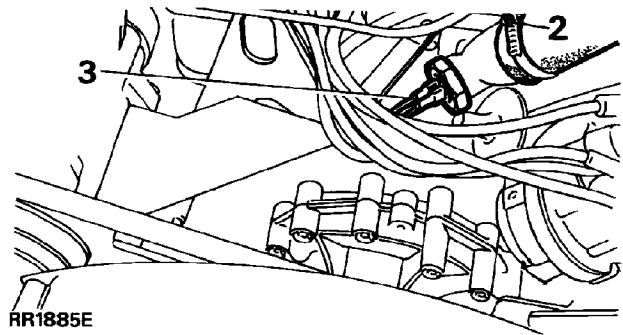

RR1885E

- Remove outlet elbow.
- Withdraw thermostat.

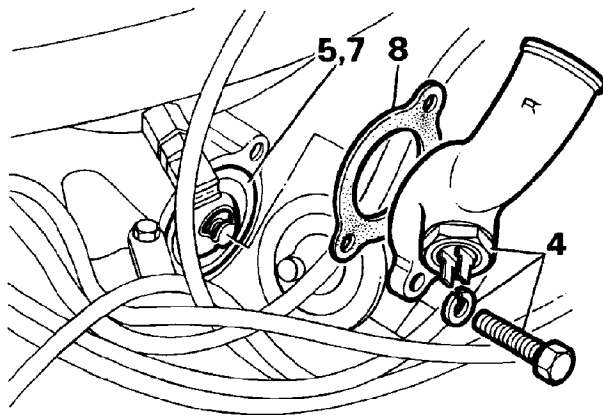

RR1792E

Test

6. Note rating of thermostat is 88°C. Place thermostat in a container half full of water. Heat water, observe temperature at which thermostat opens. Thermostat is satisfactory if it opens between 85°C and 89°C.

Refit

7. Insert thermostat with jiggle pin/vent hole uppermost (12 o'clock position).
8. Fit the outlet elbow and new joint washer. Tighten to **28 Nm**.
9. Reverse removal procedure. 1 to 3.
10. Check for coolant leaks around all connections and joint faces.

WATER PUMP

Service repair no - 26.50.01

Remove



WARNING: Disconnect battery negative terminal to prevent engine being started before removing or adjusting drive belts.

1. Drain engine cooling system. *See Adjustment, Coolant*
2. Remove fan blades and pulley. *See Viscous Coupling, Fan Blades, Pulley and Fan Cowl*
3. Disconnect inlet hose from water pump.
4. Remove water pump bolts.
5. Remove water pump and joint washer.

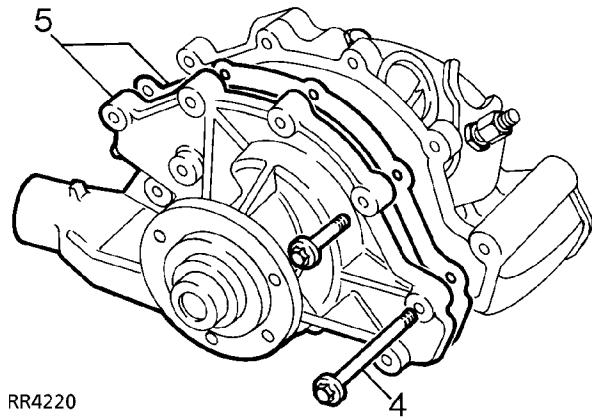

RR4220

Refit

6. Lightly grease new joint washer, position on timing cover.
7. Clean threads of all long bolts and coat with Loctite 572 thread lubricant-sealant.
8. Locate water pump in position. Tighten remaining water pump housing bolts evenly to **28 Nm**.
9. Reverse removal procedure. 1 to 3.
10. Check for coolant leaks around all hose connections and joint faces.

RADIATOR

Service repair no - 26.40.01

Remove

1. Drain cooling system.
2. Remove fan blade assembly.
3. Remove fan cowl.
4. Disconnect radiator top hoses.
5. Disconnect four transmission and engine oil cooler connections to radiator end tanks. Note oil spillage will occur when connections are loosened. Blank off exposed oil connections.
6. Disconnect transmission oil temperature sensor.

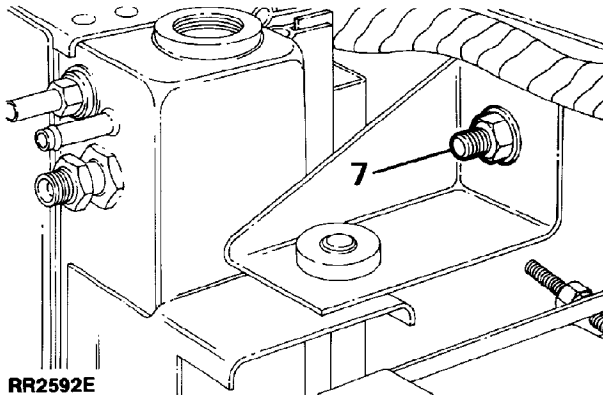

7. Remove radiator securing brackets from each side.
8. Remove radiator unit by lifting from its location. Check condition of rubber mounting pads.

Refit

9. Check radiator sealing strips are securely located.
10. Transfer oil cooler adaptors if fitting new radiator.
11. Reverse removal procedure. Ensure that oil cooler connections are tightened to **30 Nm** before fitting fan blades and cowl.
12. Clean coolant/oil spillage from vehicle.
13. Check all connections for coolant/oil leaks.

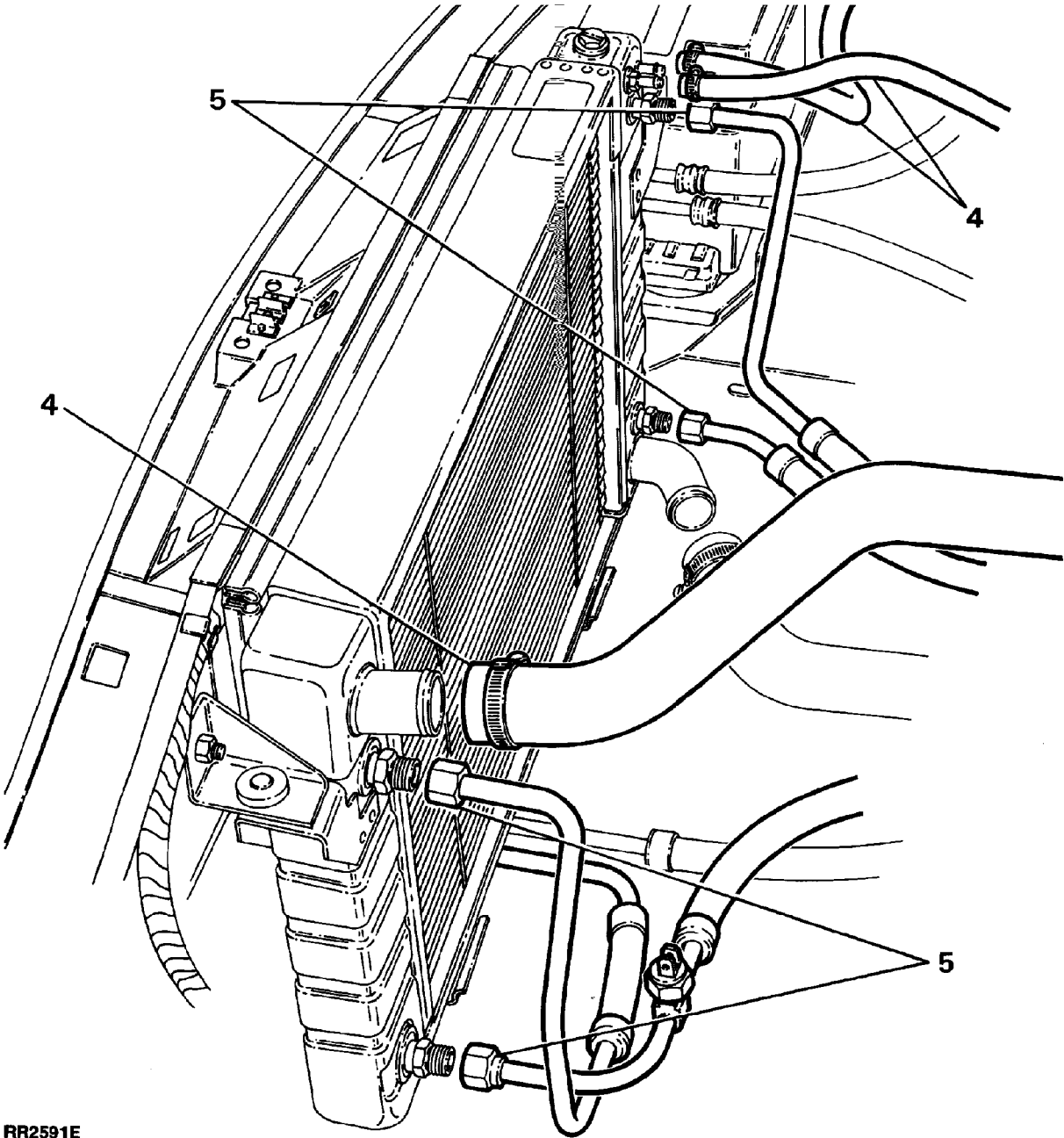

RR2591E



TORQUE VALUES



NOTE: Torque wrenches should be regularly checked for accuracy to ensure that all fixings are tightened to the correct torque.

	Nm
Oil cooler pipes	30
Radiator filler plug (plastic)	6



CATALYTIC CONVERTERS - V8i

Description

Catalytic converters which form part of the engine emission control system, are designed to 'clean' the exhaust gases, by closely controlling the fuel air ratio delivered to the engine and converting the residual exhaust compounds into products more acceptable to the environment.

The front section of the exhaust system to each cylinder bank contain the ceramic elements of the catalytic converters. The oxygen sensors which transmit information to the fuel ECU for control of the mixture, are located in the exhaust down pipes.

The Hydrocarbons (HC), Nitrogen oxides (NO_x) and Carbon monoxide (CO) emitted by the engine react with the catalytic element and exhaust temperature to convert the toxic gas, into Nitrogen (N), Carbon dioxide (CO₂) and water vapour.

Should the engine be supplied with a rich mixture causing high CO in the exhaust gas, the ceramic element will become coated and the useful life of the catalyst reduced. If the mixture is too weak, excess oxygen in the exhaust gas will cause the catalysts to burn out.

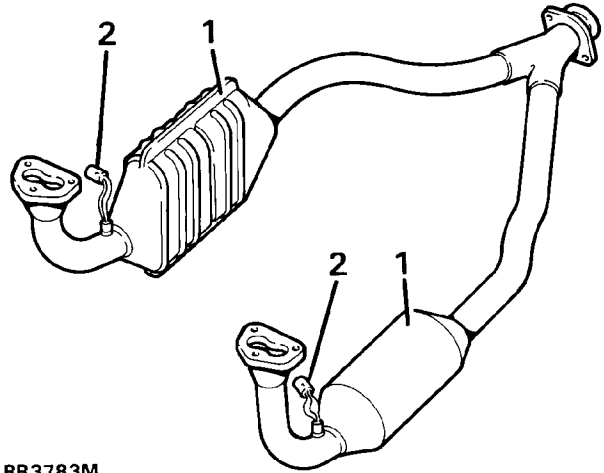

RR3783M

1. Catalysts
2. Lambda oxygen sensors



EXHAUST SYSTEM COMPLETE

Service repair no - 30.11.01

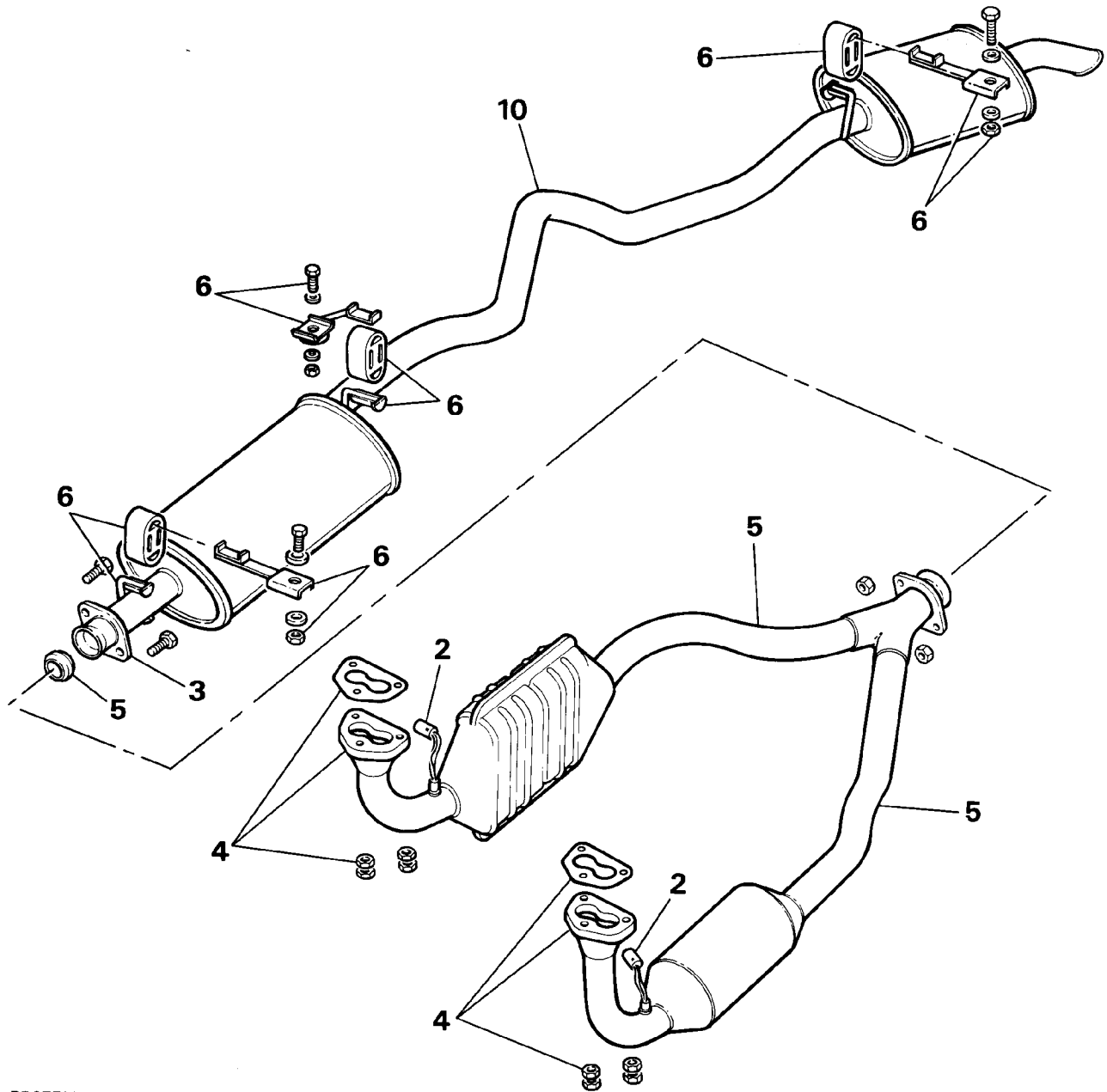

RR2777M

To improve sealing and accuracy of assembly, a two piece exhaust system is fitted.



NOTE: Ensure no exhaust leaks are evident in either a new or old exhaust system, as this will affect vehicle performance.



WARNING: To prevent personal injury occurring from a hot exhaust system, **DO NOT** attempt to disconnect any components until exhaust system has cooled down.

Remove**Catalysts - remove and refit 1 to 5**

1. Raise vehicle on a ramp [hoist].
2. **Catalyst vehicles only:** Disconnect two lambda sensor wiring connectors.
3. Remove two bolts securing rear exhaust assembly to front exhaust assembly.
4. Remove nuts and release front downpipes from manifolds. Discard gaskets.
5. Lower front exhaust assembly with catalysts (if fitted), retain olive.



NOTE: Assistance is required for removing and refitting rear exhaust assembly.

6. Remove bolts securing three hanger brackets to chassis. Lower exhaust assembly onto rear axle. Detach rubbers from hanging brackets.
7. Place extended axle stands underneath chassis, in front of chassis mounted rear towing brackets.
8. Lower ramp[hoist] until vehicle weight is supported securely on stands.
9. Lower ramp [hoist] until rear shock absorbers are ALMOST fully extended.
10. Move rear exhaust to a diagonal position, centre silencer to right of vehicle.
11. Facing rear of vehicle, twist assembly anti-clockwise clear of rear axle.
12. Remove rear exhaust assembly from vehicle.

Refit

13. Position rear exhaust assembly over rear axle in a diagonal position, as for removing.
14. Twist assembly clockwise until it is in mounting position.
15. Reverse removal procedure. 1. to 9. using new manifold gaskets and applying exhaust sealer to system joint.
16. Examine system for leaks, ensuring that system does not foul underbody components. Rectify if necessary.

EXHAUST MANIFOLD - V8i

Service repair no - Left hand - 30.15.10

Service repair no - Right hand - 30.15.11

Remove

1. Disconnect front exhaust pipe(s) from manifold(s).
2. Tap back bolt locking tabs and remove eight bolts, lock tabs and washers.
3. Remove manifold(s) and old gaskets.

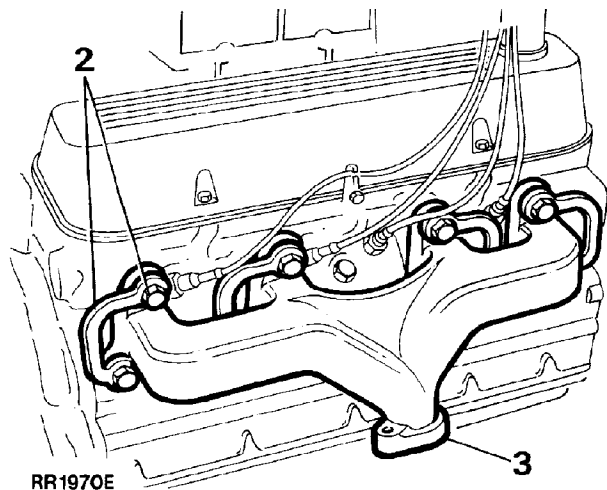
**Refit**

4. Ensure that mating surfaces of cylinder head and exhaust manifold are clean and smooth.
5. Coat threads of each bolt with anti-seize compound.
6. Place manifold and new gaskets in position on cylinder head and fit securing bolts, new lockplates and plain washers. Plain washers are fitted between manifold and lockplates.
7. Evenly tighten manifold bolts to **20Nm** bend over lockplate tabs.
8. Reconnect front exhaust pipe, using new exhaust flange gaskets.



MANIFOLD AND EXHAUST SYSTEM - Tdi

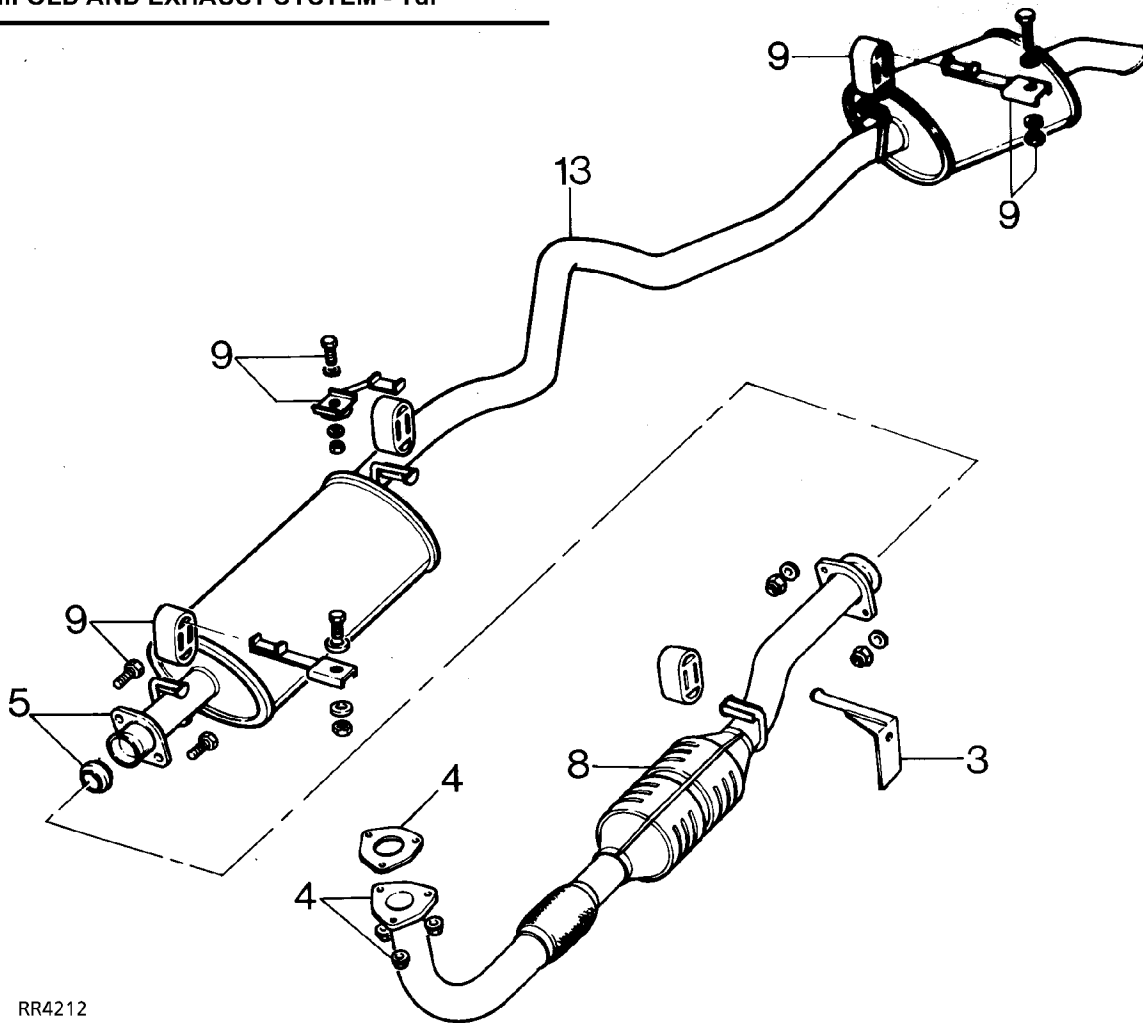

RR4212

Remove

1. Raise vehicle on a ramp [hoist].
2. Remove anti-roll[sway] bar bolts to chassis and allow to swing down clear of axle. **See REAR SUSPENSION, Repair, Anti-roll[Sway] Bar Assembly Rear**
3. Remove exhaust support bracket behind catalyst.
4. Disconnect exhaust at manifold.
5. Disconnect flange between rear and front exhaust.
6. Fit axle stands in suitable place on chassis.
7. Allow hoist to lower until front suspension is fully extended.
8. Manoeuvre front exhaust section from underneath vehicle.
9. Remove bolts securing three hanger brackets to chassis. Lower rear exhaust assembly onto rear axle. Detach rubbers from hanging brackets.
10. Place extended axle stands underneath chassis in front of chassis mounted rear towing brackets.

11. Lower hoist until vehicle weight is supported securely on stands.
12. Lower hoist until rear suspension is almost fully extended.
13. Move rear exhaust to a diagonal position, centre silencer to right of vehicle.
14. Facing rear of vehicle, twist assembly anti-clockwise clear of rear axle.
15. Remove rear exhaust assembly from vehicle.

Refit

16. Position rear exhaust assembly over rear axle in a diagonal position, as for removing.
17. Twist assembly clockwise until it is in mounting position.
18. Reverse removal procedure instructions 1 to 15 using a new manifold gasket and applying exhaust sealer to system joints.
19. Examine system for leaks, ensuring that system does not foul under body components. Rectify if necessary.

EXHAUST MANIFOLD - Tdi

Service repair no - 30.15.10

Remove

1. Disconnect battery negative lead.
2. Remove heat shield from rear of air intake manifold.
3. Release dip stick tube from cylinder block.
4. Disconnect the intake hose from the manifold.

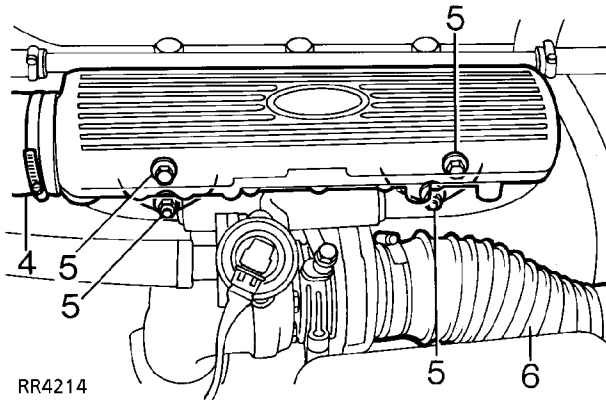

RR4214

5. Remove the two bolts and two nuts securing the intake manifold to the cylinder head and withdraw the inlet manifold.
6. Remove air filter inlet pipe to turbo unit.
7. Remove intercooler pipe from turbo to intercooler.
8. Disconnect the EGR pipe from the inlet manifold hose.
9. Remove the three fixings at the exhaust pipe flange.
10. Release the turbo charger oil pipes from the cylinder block.
11. Remove the turbo boost pipes.

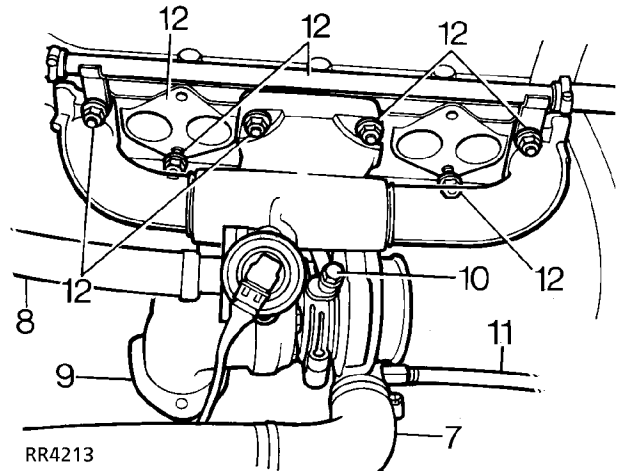

RR4213

12. Remove seven bolts securing the exhaust manifold, release the heater rail and remove the manifold gasket, complete with turbo unit.
13. Remove four bolts and disconnect diaphragm rod from manifold, and remove turbo charger if necessary.

Refit

14. Reverse removal procedure. 1 to 12. Use a new manifold and exhaust flange gaskets.
15. Reconnect battery negative lead. Start engine and check for leaks.



TORQUE VALUES



NOTE: Torque wrenches should be regularly checked for accuracy to ensure that all fixings are tightened to the correct torque.

	Nm
MANIFOLDS AND EXHAUSTS - Mpi	
Inlet manifold nuts and bolts	25
Fuel pipe to fuel rail	10
Exhaust manifold nuts	45
Exhaust frontpipe to manifold	10
Exhaust downpipe to silencer box	30
Manifold chamber gasket	10



DESCRIPTION

The clutch unit fitted with the manual transmission, comprises a single dry plate friction disc and diaphragm spring clutch unit, secured to the engine flywheel.

OPERATION

The unit is operated hydraulically by the clutch master cylinder 12 and a slave cylinder 13 attached to the transmission bell housing.

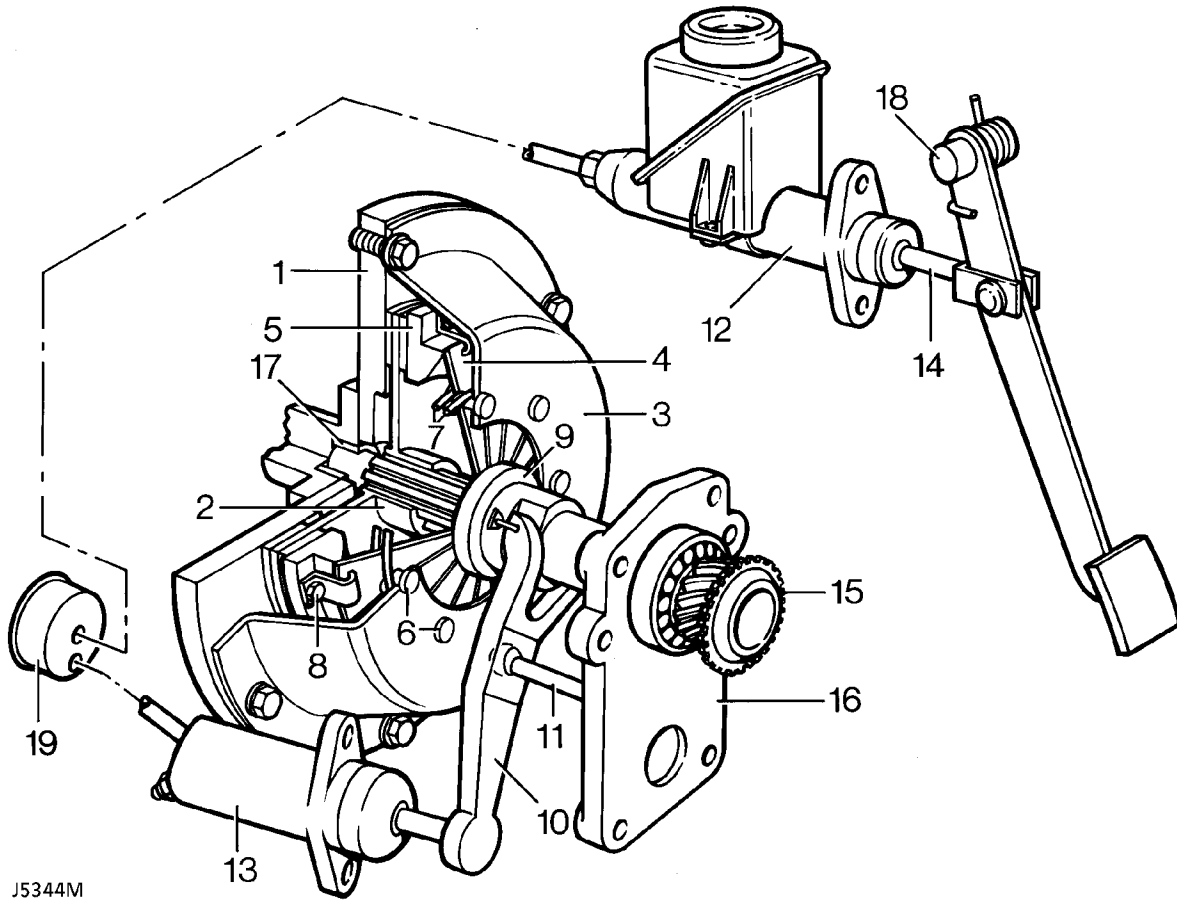

J5344M

- | | |
|--|--|
| 1. Crankshaft and flywheel | 11. Release lever pivot post |
| 2. Friction plate | 12. Master cylinder |
| 3. Clutch cover | 13. Slave cylinder |
| 4. Diaphragm spring | 14. Master cylinder pedal pushrod |
| 5. Pressure plate | 15. Primary shaft and taper bearing (in gearbox) |
| 6. Fulcrum posts (9) for diaphragm spring | 16. Gearbox front cover |
| 7. Bearing rings (2) for diaphragm spring | 17. Primary shaft flywheel bush |
| 8. Retraction links and bolts (3) for pressure plate | 18. Pedal pivot and return spring |
| 9. Release bearing | 19. Hydraulic damper (Diesel only) |
| 10. Release lever | |

33 CLUTCH

When the clutch pedal is depressed, hydraulic fluid transmits the movement via the slave cylinder, release lever 10, bearing 9, to the inner fingers of the diaphragm spring 4.

The diaphragm spring 4 pivots on the bearing rings 7 and fulcrum posts 6 causing the pressure plate 5 to release the clamping force on the friction plate and linings 2.

As the the clamping force is removed from the friction plate 2, the plate slides on the splines of the primary shaft 15 and takes up a neutral position between the flywheel 1 and the pressure plate 5 , thus breaking the drive between the engine and the gearbox.



NOTE: Diesel engined vehicles have an hydraulic damper 19 fitted into the system. The damper contains a steel diaphragm which absorbs slight hydraulic pulses caused by cyclic variations of the diesel engine crankshaft at low rpm.

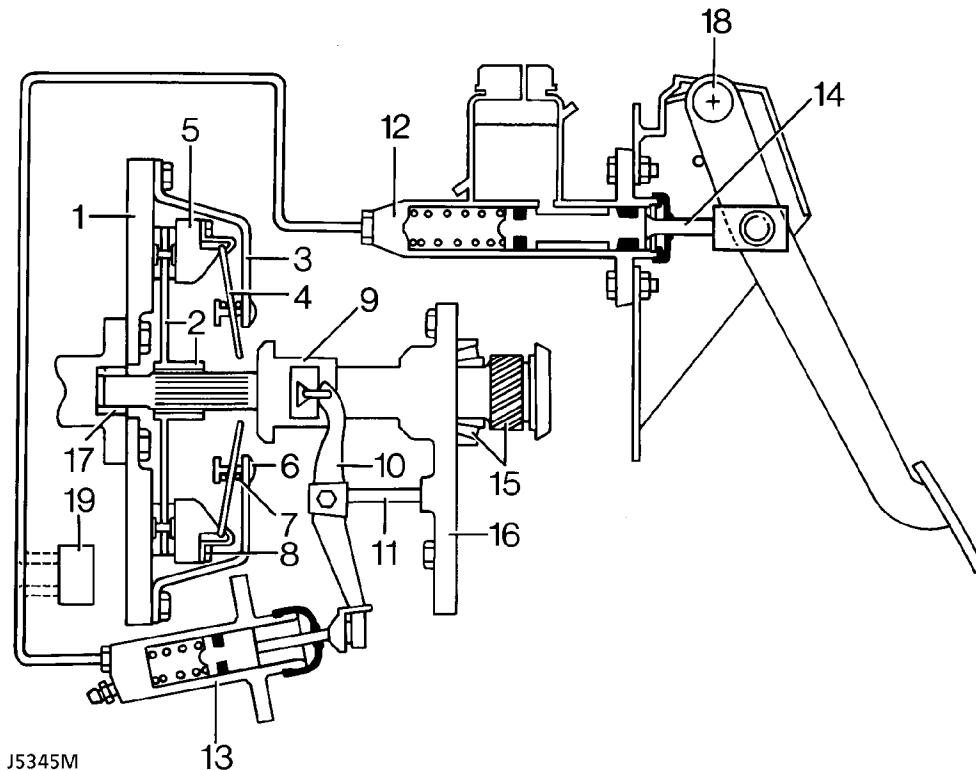

J5345M



CLUTCH ASSEMBLY CONDITIONS

For the clutch to operate correctly as described and illustrated in the "Description and Operation", it is important the following conditions are satisfied:-

- A. The primary shaft 15 must be free in the crankshaft spigot bush 17.
- B. The friction plate 2 must be able to slide easily on the splines on the primary shaft 15, to a position where it does not contact either the flywheel or the pressure plate.
- C. The friction plate must not be distorted or the linings contaminated with oil, which may cause it to stick or continue to run in contact with the flywheel or pressure plate.

A number of faults can develop in the operation of the clutch for a variety of reasons and although most faults are due to normal wear at high mileage, problems can also occur if the unit has been renewed by an unskilled operator.

Recognising and diagnosing a particular clutch fault is therefore of paramount importance in ensuring, that the problem is rectified at the first attempt.

Problems which develop in the clutch are as follows:-

- A. Clutch spin/drag
- B. Clutch slip
- C. Clutch judder/fierce

CLUTCH SPIN - DRAG

Symptoms

Clutch spin is that, with engine running and clutch pedal depressed, the gears cannot be immediately engaged without making a grinding noise. This indicates the clutch is not making a clean break.

However, if the clutch pedal is held depressed for several seconds the friction plate will eventually break free from the engine and the gear will engage silently.

Clutch spin as it becomes more severe develops into clutch drag, making the silent engagement of a gear impossible, regardless of how long the pedal is held depressed.

CLUTCH SLIP

Symptoms

Clutch slip is most evident climbing a hill or when the vehicle is moving off from stationary with a heavy load. As the clutch is released slip occurs between the engine and the transmission, allowing the engine speed to increase without a corresponding increase in vehicle speed.

Clutch slip can develop to the stage where no power is transmitted through the clutch as the pedal is released.

CLUTCH JUDDER - FIERCE

Symptoms

Clutch judder or fierce engagement, like slip, is most likely to occur when the vehicle is moving off from stationary. As the clutch pedal is released the vehicle will move rapidly or in a series of jerks, which can not be controlled even by careful operation of the clutch by the driver.

It should be noted that a vehicle may display all the symptoms or any combination of the symptoms described, depending on the driving conditions vehicle load and operating temperatures.

FAULT/SYMPTOM CHART

Symptoms			Fault	Item
Slip	Spin/Drag	Judder/Fierce		
*	*	*	Worn or oil on clutch linings	2
*	*	*	Mechanical damage	4 5 6 7 8
	*	*	Distorted clutch plate	2
	*		Failed or air in hydraulic system	12 13
	*	*	Primary shaft tight fit in crankshaft bush	15 17
	*		Clutch splines sticking	2 15
		*	Weak clutch plate springs or insecure/worn engine/gearbox mountings	6
		*	Insecure/worn propeller shafts	
		*	Insecure/worn suspension components/rubber bushes	

For items referred to in this chart. *See Description and operation, Description*

CLUTCH NOISE - MECHANICAL FAULTS

Noise from clutch or gearbox in neutral, which disappears when clutch is depressed.

Suspect gearbox input/primary shaft bearings.

See MANUAL GEARBOX, Fault diagnosis, Manual Gearbox

- Noise from gearbox in neutral, which disappears when clutch is depressed

Noise from clutch or gearbox in neutral, which changes tone or becomes worse when the clutch is depressed.

Suspect worn release bearing.

Knocking/rattling from clutch or gearbox in neutral, which is reduced or disappears when the clutch is depressed.

Suspect worn/weak release lever retainer or clutch unit.

Noise from clutch or gearbox in neutral, which disappears when clutch is depressed.

Suspect gearbox fault.

See MANUAL GEARBOX, Fault diagnosis, Manual Gearbox

- Noise from gearbox in neutral, which disappears when clutch is depressed.

HYDRAULIC FAULTS

Unable to dis-engage clutch, little or no pedal resistance.

1. Check condition, specification and level of fluid.
2. Check pipes and cylinders for leaks.
3. Check that air vent in reservoir lid is clear.
Suspect faulty master cylinder if no fluid leaks present. *See Repair, Master Cylinder*

Spongy pedal operation

1. Check condition, specification and level of fluid.
2. Check that air vent in reservoir lid is clear.
Suspect air in fluid.
See Repair, Bleed Hydraulic System

Clutch is difficult to dis-engage and/or does not immediately re-engage when pedal is released.

1. Check condition, specification and level of fluid.
2. Check that air vent in reservoir lid is clear.
Suspect pedal pivot, master cylinder or slave cylinder seizure. *See Repair, Master Cylinder*



CLUTCH ASSEMBLY

Service repair no - 33.10.01

Clutch pressure plate

Renew pressure plate if diaphragm spring fingers are worn or if pressure plate shows signs of wear, cracks or burning.

Clutch driven plate

Renew driven plate if centre hub splines are worn or if lining is contaminated, burned or unevenly worn.

Service tools:

Clutch centralising tool

LRT-12-001 - V8

LRT-12-040 - Tdi

Remove

1. Remove gearbox. **See MANUAL GEARBOX, Repair, R380 Manual Gearbox**
2. Mark position of clutch cover to flywheel for reassembly.
3. Remove clutch cover securing bolts, working evenly and diagonally.
4. Do not disturb three bolts in clutch cover.
5. Remove clutch assembly.
6. Withdraw clutch driven plate.

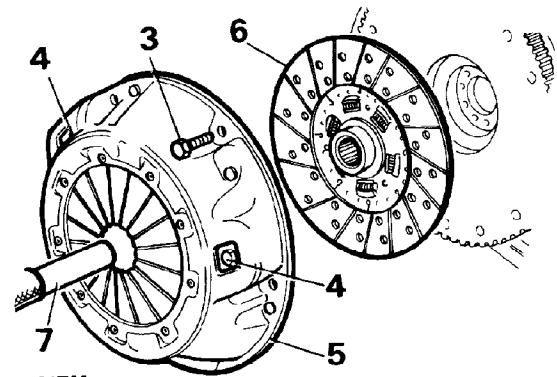

RR817M

Refit



NOTE: To prevent clutch plate sticking, lubricate splines using Rocol MV 3 or Rocol MTS 1000 grease.

7. Renew/refit clutch driver plate and clutch assembly using centralising tool, where applicable, align assembly marks.
8. Secure clutch assembly cover fixings evenly, working in a diagonal sequence. Tighten to **28 Nm**.
9. Fit gearbox to engine.

BLEED HYDRAULIC SYSTEM

Service repair no - 33.15.01

Procedure



NOTE: During bleed procedure, keep fluid reservoir topped up to avoid introducing air to system. For hydraulic fluid recommendations. See **LUBRICANTS, FLUIDS AND CAPACITIES, Information, Recommended Lubricants and Fluids**

1. Attach suitable tubing to slave cylinder bleed screw.
2. Place free end of tube in a glass jar containing clutch fluid.
3. Loosen bleed screw.

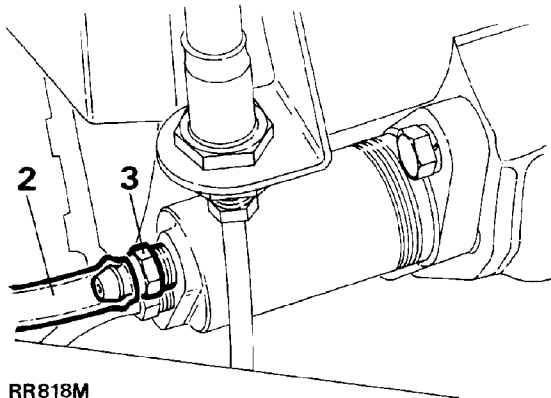

4. Pump clutch pedal, pausing at end of each stroke, until fluid from tubing is free of air. Keeping free end of tube below surface of fluid.
5. Hold clutch pedal down, tighten bleed screw.
6. Top up fluid reservoir.

MASTER CYLINDER

Service repair no - 33.20.01/03



NOTE: All flexible and pipe connections and joints should be tightened to **15 Nm**.

Remove

1. Evacuate hydraulic fluid from system.
2. Disconnect fluid pipe at master cylinder. Plug master cylinder fluid port and seal end of hydraulic pipe to prevent ingress of foreign matter.
3. Lower fascia fuse box panel.
4. Remove master cylinder fixings.
5. Remove retaining washer and clevis pin from push rod and clutch pedal.
6. Remove master cylinder.

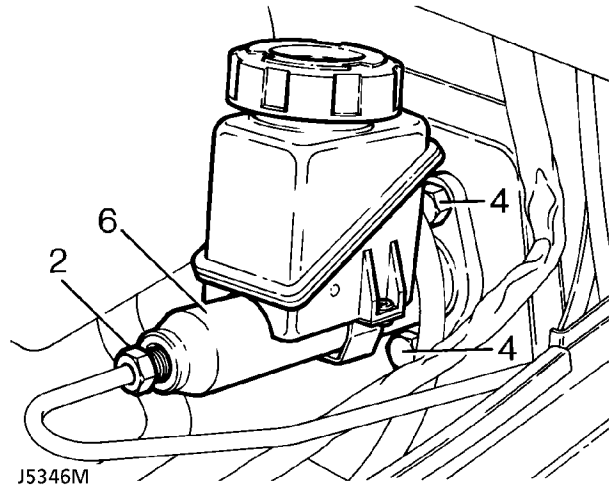



Refit

7. Fit the master cylinder and fixings.
8. Fit push-rod to pedal and retain with clevis pin and washer.
9. Raise fascia fuse box panel.

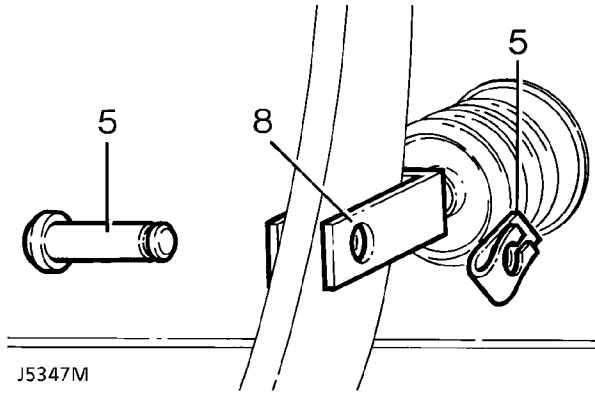

J5347M

10. Fit fluid pipe to master cylinder.
11. Bleed system. *See Bleed Hydraulic System*

RELEASE BEARING ASSEMBLY

Service repair no - 33.10.07

Remove

1. Remove gearbox. *See MANUAL GEARBOX, Repair, R380 Manual Gearbox*
2. Remove clutch slave cylinder. *See Slave Cylinder*
3. Withdraw retainer staple.

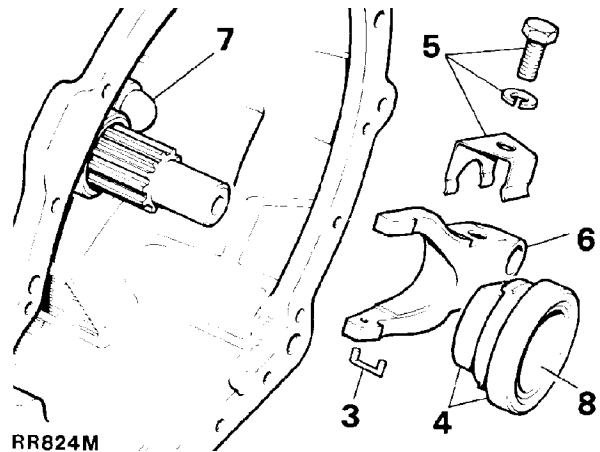

RR824M

4. Withdraw bearing and sleeve. If required, press bearing off sleeve. Fit replacement bearing with domed face outwards from sleeve.
5. Remove spring clip and fixings.
6. Withdraw release lever assembly.

Refit

7. Smear pivot with grease and fit release lever and retain with spring clip and bolt.
8. Smear release bearing sleeve inner diameter with molybdenum disulphide base grease.
9. Reverse removal procedure. 1 to 4.

SLAVE CYLINDER

Service repair no - 33.35.01



NOTE: All flexible and pipe connections and joints should be tightened to **15 Nm**.

Remove

1. Evacuate clutch system fluid at slave cylinder bleed valve.
2. Disconnect fluid pipe.
3. Remove two securing bolts and withdraw slave cylinder and backing plate.
4. If dust cover is not withdrawn with slave cylinder, withdraw it from bell housing.

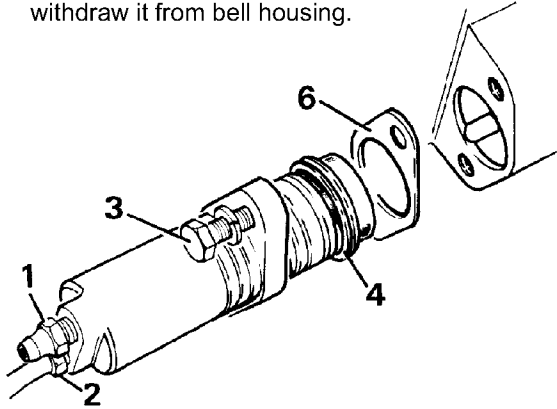

RR628M

Refit

5. Withdraw dust cover and backing plate from slave cylinder.
6. Coat both sides of backing plate with Hylomar P232M waterproof jointing compound.
7. Locate backing plate and dust cover in position on slave cylinder.
8. Fit slave cylinder, engaging push-rod through centre of dust cover and with bleed screw uppermost.

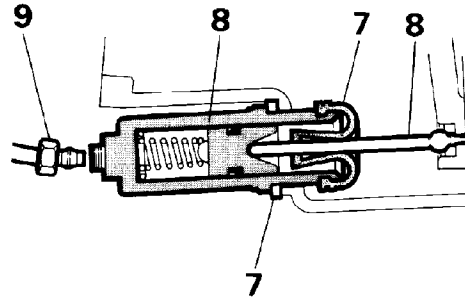

RR829M

9. Reconnect fluid pipe.
10. Replenish and bleed clutch hydraulic system.
11. Check for fluid leaks with pedal depressed and also with system at rest.



RENEWING HYDRAULIC DAMPER - Tdi

Service repair no - 33.15.05



NOTE: All flexible and pipe connections and joints should be tightened to *15 Nm*.

Remove

1. Remove the pipe between the slave cylinder and damper.
2. Disconnect the hydraulic hose from the damper.
3. Remove the two bolts securing the damper to the bracket and remove the damper.

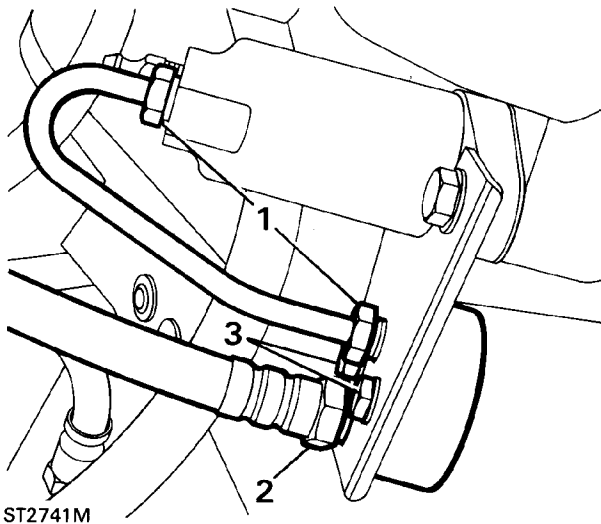
**Refit**

4. Fit the damper to the bracket and tighten the two bolts.
5. Connect the flexible hose to the damper.
6. Fit the pipe to the slave cylinder and to the damper and tighten the unions.
7. Bleed the hydraulic system.



MASTER CYLINDER

Service repair no - 30.20.07

1. Remove master cylinder. *See Repair, Master Cylinder*

Disassemble

2. Pull back and remove rubber sealing boot from pushrod.
3. Depress push-rod and extract circlip.
4. Withdraw push-rod assembly.
5. Withdraw piston assembly.
6. Withdraw retainer and spring.

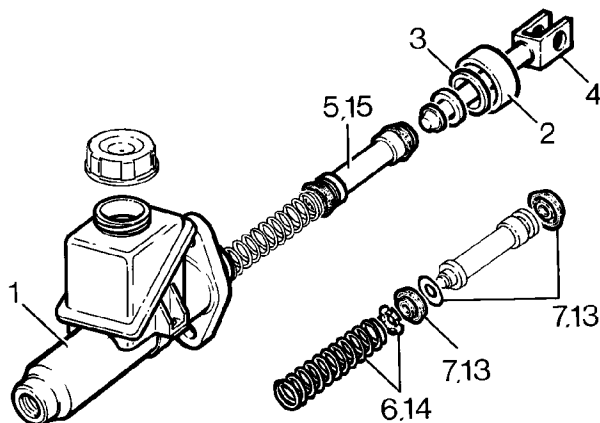

J5348M

7. Remove two piston seals and piston washer.

Inspecting

8. Clean all components thoroughly using new hydraulic fluid. Dry, using a lint-free cloth.
9. Examine cylinder bore and piston, ensure they are smooth to touch with no corrosion, score marks or ridges. If in doubt, fit new components.
10. Fit new seals and rubber boot. These items are all included in master cylinder overhaul kit.
11. Ensure that feed and by-pass ports are not obstructed.

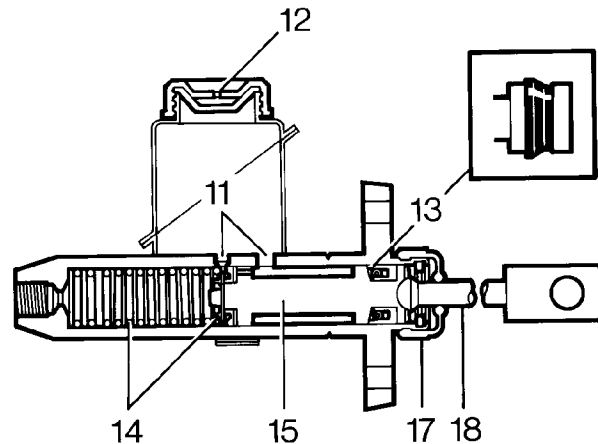

J5349M

12. Ensure reservoir cap vent is clear.

Assemble



NOTE: Cleanliness is essential, ensure hands are free of grease or dirt. Lubricate cylinder bore and rubber seals with new hydraulic fluid before assembly.

13. Fit a new piston washer and thinner of two piston seals, lip last, over piston nose, up against drilled piston head. Fit thicker seal into piston groove with lip facing towards seal at opposite end.
14. Insert spring and retainer into master cylinder bore.
15. Insert piston and seal assembly, ensuring that seal lips do not bend back.
16. Reverse 3 and 4, correctly locating circlip.
17. Stretch new rubber boot over push-rod, pack with rubber grease. Fit securely into locating groove.
18. Operate push-rod several times to ensure free movement of internal components.
19. Fit master cylinder.

SLAVE CYLINDER

Service repair no - 33.35.07

Overhaul

1. Remove slave cylinder. **See Repair, Slave Cylinder**

Disassemble

2. Withdraw rubber boot.
3. Withdraw push-rod.
4. Remove circlip.
5. Extract piston and seal assembly, applying low pressure air to fluid inlet if necessary.
6. Withdraw spring.
7. Remove bleed valve.

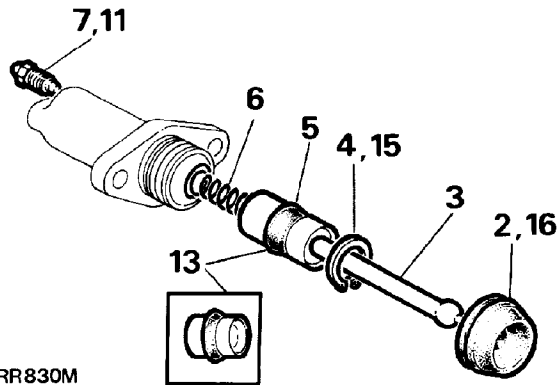

Inspecting

8. Clean all components thoroughly using new hydraulic fluid, and dry using lint-free cloth.
9. Examine cylinder bore and piston which must be free from corrosion, scores and ridges.
10. Replace seal and rubber boot using appropriate repair kit.

Assemble



NOTE: Cleanliness is essential, ensure hands are free of grease or dirt.

11. Fit bleed valve. Do not overtighten.
12. Lubricate seals, piston and bore using new hydraulic fluid.
13. Fit seal into piston groove, lip of seal towards fluid inlet end of cylinder.
14. Enter piston assembly, spring first, into cylinder bore. Ensure that seal lip does not fold back.
15. Secure with circlip.
16. Fill rubber boot with rubber grease.
17. Reverse removal procedure. 1 to 3.



TORQUE VALUES



NOTE: Torque wrenches should be regularly checked for accuracy to ensure that all fixings are tightened to the correct torque.

	Nm
Clutch pipes	
Master cylinder union	15
Pipe joint	15
Pipe to damper	15
Pipe out of damper	15
Pipe to jump hose	15
Jump hose to pipe	15
Pipe to slave cylinder	15



MANUAL TRANSMISSION

Description

The 77mm all synchromesh five speed manual gearbox unit, is married to a Borg Warner two speed chain drive transfer gearbox.

All the gears including reverse run on needle roller bearings and the main, layshaft and primary shafts are supported by tapered roller bearings.

The whole of the geartrain is lubricated through drillings in the shafts, supplied by a low pressure pump driven from the rear of the layshaft. The gear change has a single rail selector and spool type interlock. The main and transfer gearboxes ventilate through nylon pipes, which terminate high up in the engine compartment to prevent water entry when the vehicle is operating in adverse conditions.

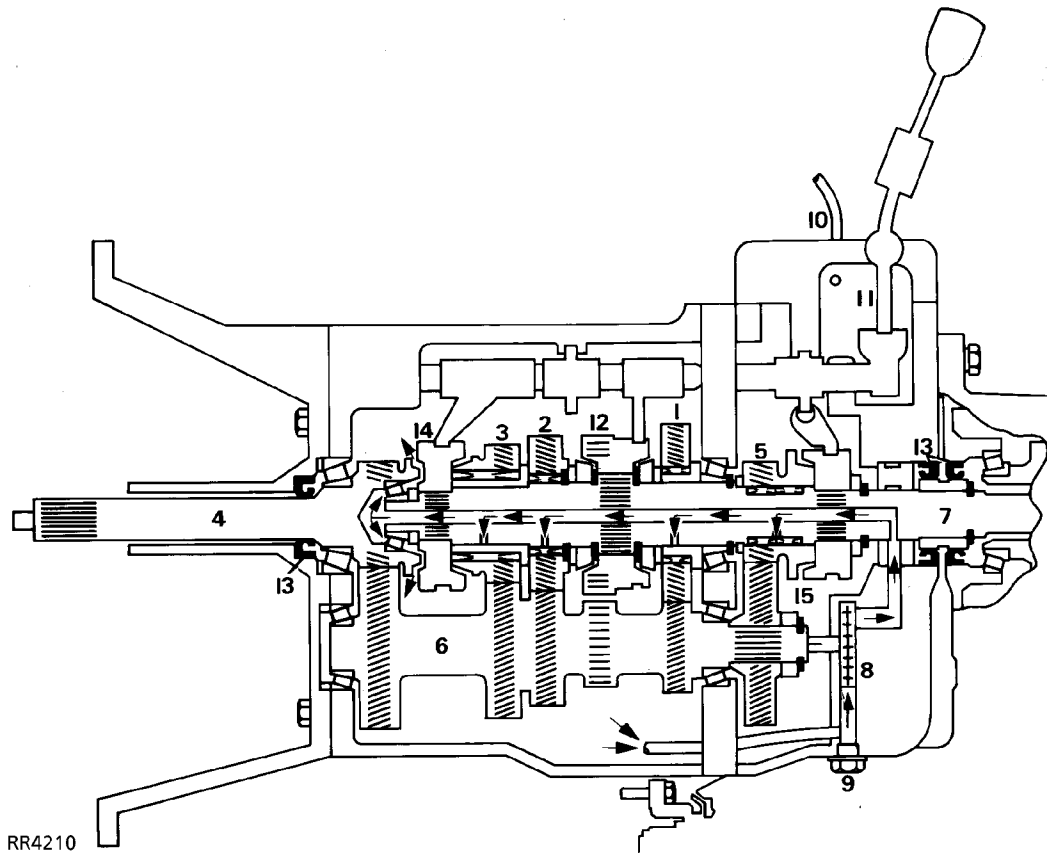

- | | |
|------------------------|----------------------------|
| 1. Mainshaft 1st gear | 9. Drain plug |
| 2. Mainshaft 2nd gear | 10. Ventilation pipe |
| 3. Mainshaft 3rd gear | 11. Single rail gear shift |
| 4. Primary input shaft | 12. 1st/2nd synchromesh |
| 5. Mainshaft 5th gear | 13. Oil seals |
| 6. Layshaft | 14. 3rd/4th synchromesh |
| 7. Mainshaft | 15. 5th gear synchromesh |
| 8. Lubrication pump | |



MANUAL GEARBOX

Symptom - Gear jumps out of engagement (any forward gear)

1. Check condition and security of transmission and engine mountings.
2. Check in situ, gear lever and selector adjustments.
3. In situ, remove gearshift and check selector rail yoke security.
Also check selector detent spring tension and both spool retainers.
Suspect internal fault
See remove and overhaul manual.
4. Check action/operation of main selector rail and forks.
5. Check condition of synchromesh and gear dog teeth.
6. Check main and layshaft end floats bearings and adjustments.
7. Check condition of all gearbox components, ensure clearances and adjustments are correct on reassembly.

Symptom - Reverse gear only jumps out of engagement

1. Check condition and security of transmission and engine mountings.
2. Check in situ, gear lever and selector adjustments.
3. In situ, remove gearshift and check selector rail yoke security.
Also check selector detent spring tension and both spool retainers.
Suspect internal fault
See remove and overhaul manual.
4. Check action/operation of main selector rail and reverse lever.
5. Check condition of reverse gear, angled bearings and shaft.
6. Check condition of all gearbox components, ensure clearances and adjustments are correct on reassembly.

Symptom - Excessive force required to engage or change gear, vehicle stationary or moving.

1. Check lubricant specification and level, if low do not top up at this stage.
2. In situ, lubricate gear mechanism, and check selector adjustments.
3. In situ, remove gearshift and check selector rail is free and that the yoke is secure. Also check selector detent spring tension and both spool retainers.
4. Drain lubricant and check for contamination or metal particles.
Suspect worn synchromesh unit or baulk rings on affected gears. See remove and overhaul manual.

Symptom - Noisy gear engagement, vehicle stationary. See *CLUTCH, Fault diagnosis, Clutch Noise - Mechanical Faults*

Symptom - Noisy gear selection, vehicle moving.

1. Confirm that clutch operation is satisfactory.
2. Establish which gear/gears is causing noise.
3. Check lubricant specification and level, if low do not top up at this stage.
4. Drain lubricant and check for contamination or metal particles.
Suspect worn synchromesh. See remove and overhaul manual.
5. Check condition of synchromesh unit, springs and cones for distortion and wear. Also check dog teeth for damage and cone mating surface on gear for signs of overheating.
6. Check condition of all gearbox components, ensure clearances and adjustments are correct on reassembly.

Symptom - Noise from gearbox in neutral, which changes tone or becomes worse when clutch is depressed. See *CLUTCH, Fault diagnosis, Clutch Noise - Mechanical Faults*

Symptom - Noise from gearbox in neutral, which disappears when clutch is depressed.

1. Check lubricant specification and level, if low do not top up at this stage.
2. Drain lubricant and check for contamination or metal particles.
Suspect worn bearings on layshaft, primary shaft or front of main shaft. See remove and overhaul manual.

Symptom - Noise from gearbox in one or more gears when being driven.

1. Check lubricant specification and level, if low do not top up at this stage.
2. Drain lubricant and check for contamination or metal particles.
Suspect worn roller bearings on particular mainshaft gears. See remove and overhaul manual.



R380 GEARBOX

Service repair no - 37.20.02

Remove

1. Site vehicle on ramp and chock wheels.
2. Disconnect battery negative lead.
3. Remove fan blade assembly.



NOTE: The nut securing viscous unit has left hand thread.

4. Disconnect airflow meter to plenum chamber hose. (V8i only)
5. Remove two gear lever knobs.

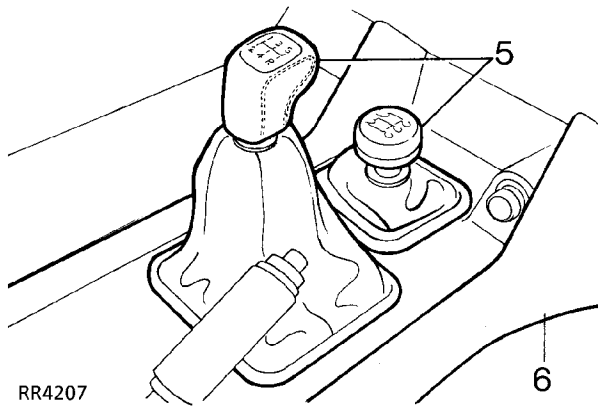

6. Remove floor mounted console assembly. **See CHASSIS AND BODY, Repair, Centre Console**
7. Remove padding from top of transmission tunnel.
8. Loosen pinch bolt and remove upper gear lever.
9. Remove screws and detach high low lever and main gear lever retaining plates.

Underneath vehicle

10. Drain oil from transfer gearbox, main gearbox and extension housing.
11. Refit plugs.

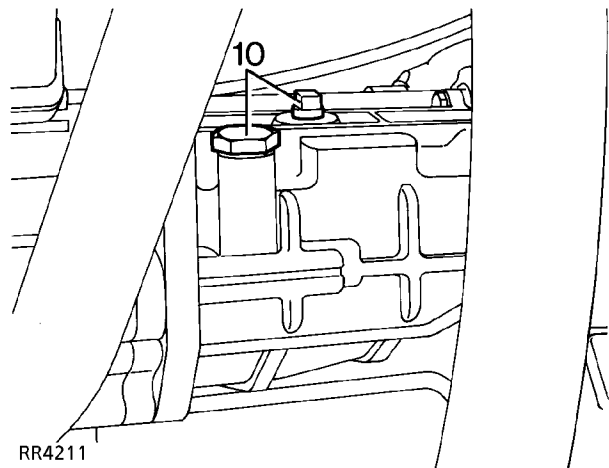
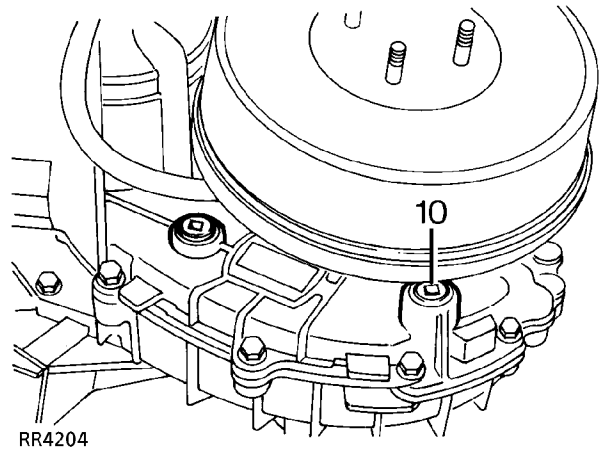

12. Disconnect heated oxygen sensor and remove front section of exhausts. (V8i only)
13. Remove chassis cross member secured by eight nuts and bolts. (V8i only)

14. Mark each drive flange for reassembly and disconnect front and rear propeller shafts from transfer box. Tie the shafts to one side.
15. Disconnect multiplug from speed transducer.
16. Release breather pipe and electrical cables from 'P' clip on right hand side of gearbox.
17. Remove two bolts and withdraw clutch slave cylinder from bell housing.
18. Remove transmission brake drum. Remove four bolts securing back plate to transfer box, and tie assembly aside complete with handbrake cable.
24. Secure fixture to transfer box mounting points.
25. Remove hoist from rear of transfer box.
26. Lower transmission until top of transfer gearbox clears rear floor.
27. Position hoist under engine to support weight.
28. Remove bolts from bell housing.
29. Ensuring all fixings are released, withdraw transmission.

Remove transmission assembly

19. Position a suitable transmission hoist on rear output housing to support weight of assembly.
20. Remove fixings and withdraw transfer gearbox mountings.

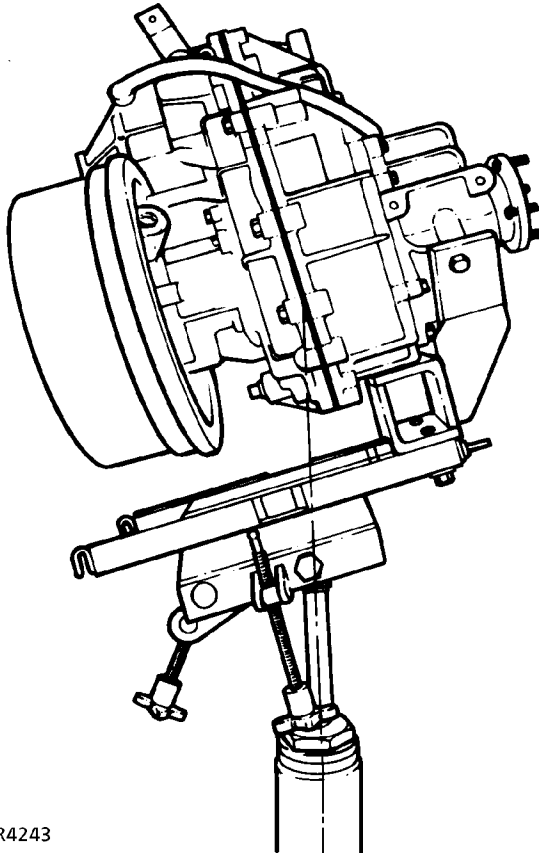

RR4243

21. Remove Chassis Cross member (Tdi only)
22. Remove front exhaust section. (Tdi only)
23. Fit adaptor plate to transmission hoist. Raise hoist and position under transfer box. **See TRANSFER GEARBOX, Service tools, Adapter Plate Transfer Box**

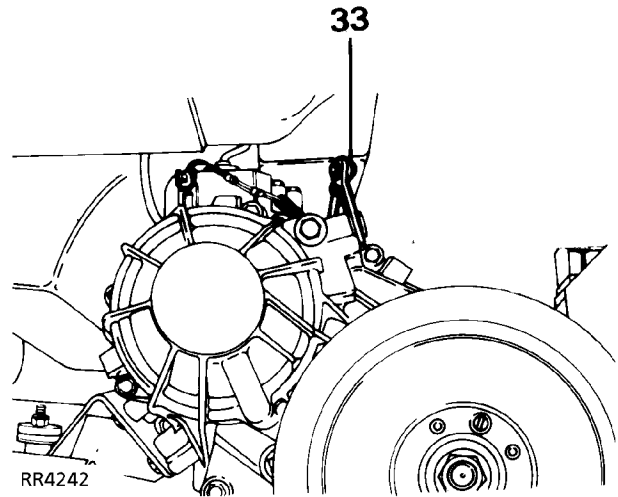

Separating transfer box from gearbox

30. Remove transmission assembly from hoist and cradle.
31. Place sling round transfer box and attach to hoist.
32. Detach high low link from transfer gearbox selector lever and remove breather pipe.
33. Remove bolts and two nuts retaining transfer box to extension housing and separate.



Assembling transfer box to main gearbox

34. Stand gearbox bell housing face on two pieces of wood.
35. Lower transfer gearbox onto main gearbox.
Secure with bolts and two nuts tighten to **40Nm**
36. Refit breather pipe and selector link.

Transfer gearbox high/low link adjustment

37. Ensure transfer gearbox is in neutral position.
38. Set transfer gearbox lever in a vertical position.
Rotate fork end of rod until holes align with hole in selector lever.
39. Fit clevis pin and retaining clip. Select high and low transfer to ensure full engagement is obtained. Repeat adjustment procedure if full engagement is not evident.

Refit

40. Fit cradle to transmission hoist and transmission to cradle. Apply Hylomar on bell housing mating face with engine.
41. Select any gear in main and transfer gearbox to facilitate entry of the input shaft. Ensure that the clutch centre plate is in alignment.
42. Position and raise hoist to line up with engine, feed handbrake cable through aperture in tunnel, ensure that any pipes or electrical leads do not become trapped.
43. Fit transmission assembly to engine and tighten bolts to **40Nm**
44. Reverse removal procedure noting following points.
45. Tighten all fixings to the correct torque. **See Specifications, torque, Torque Values**
46. Fill both main and transfer gearboxes with recommended oil up to level of filler hole. Apply Hylomar sealant to threads and fit level plugs.
See LUBRICANTS, FLUIDS AND CAPACITIES, Information, Recommended Lubricants and Fluids



TORQUE VALUES



NOTE: Torque wrenches should be regularly checked for accuracy to ensure that all fixings are tightened to the correct torque.

	Nm
Bottom cover to clutch housing	8
Extension case to gearcase	25
Slave cylinder to bell housing	25
Bell housing to gearbox	70
Oil drain plug	50
Breather	15
Oil level plug	30
Gear change housing to extension case	25
Cover to gear change housing	10
Bell housing to cylinder block	40



NOTE: Torque values below apply to all screws and bolts used unless otherwise specified.

METRIC	Nm
M5	6
M6	9
M8	25
M10	45
M12	90
M14	105
M16	180
UNC / UNF	
1/4	9
5/16	24
3/8	39
7/16	78
1/2	90
5/8	136



DESCRIPTION

The Borg Warner transfer gearbox incorporates a single epicyclic gear set which is driven by the main gearbox output shaft to provide high, neutral or low gear ratios.

With high or low gear selected, power is transmitted by a Morse Chain to the front and rear output shafts via a differential and a limited slip viscous unit.

The gear lever allows neutral, high or low to be selected. A differential lock is not necessary as this function is automatically performed by the viscous coupling unit.

Lubrication is by a low pressure plunger type oil pump, driven by the epicyclic gear set. Oil is delivered to the gears and bearings via oilways in the components.

The viscous coupling though partly immersed in lubricating oil, is a self contained and sealed unit.

Illustration RR3548M showing the component parts of the transfer box, is a useful cross reference when studying the following power flow diagrams.

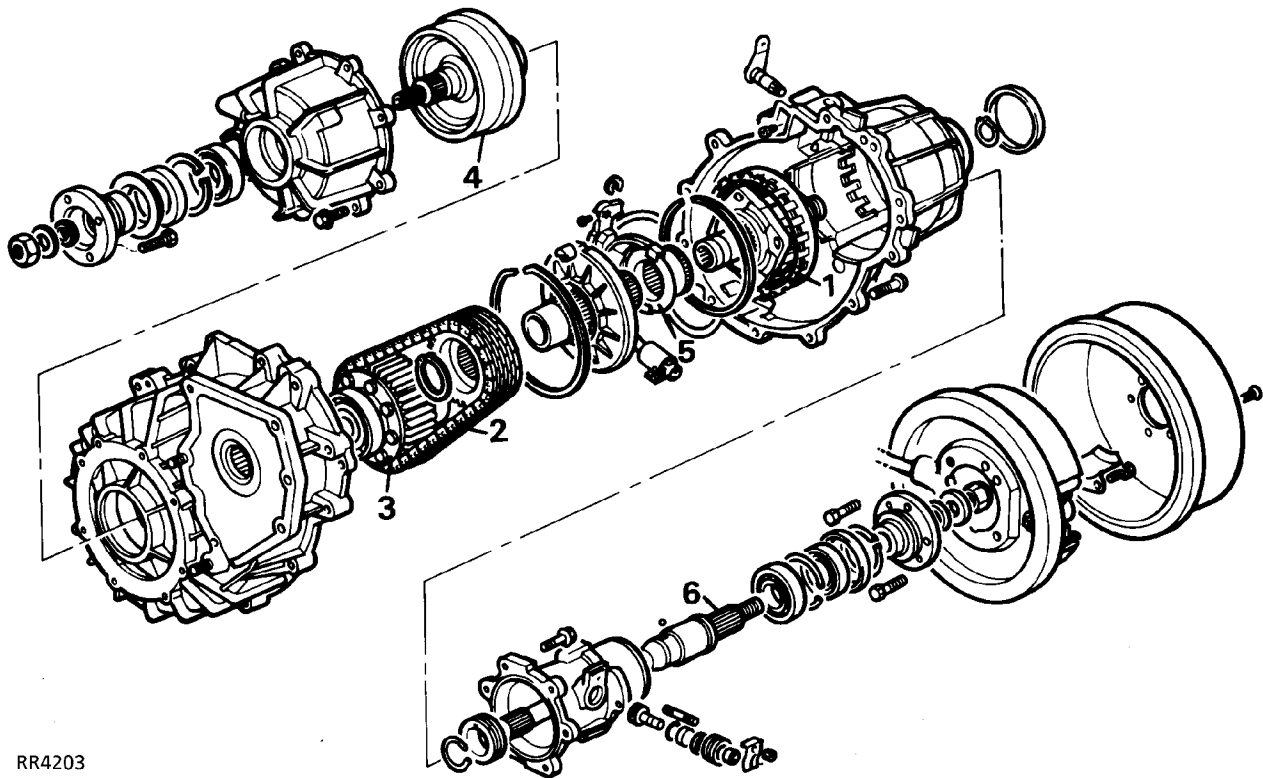

RR4203

1. Epicyclic gear set
2. Morse chain
3. Differential
4. Viscous unit/front output shaft
5. High, neutral, low selection sleeve
6. Rear output shaft

41 TRANSFER GEARBOX

Power flow - operation

Broken lines in the following illustration indicate gear or sliding splined connections.

High ratio

Moving the gear lever to the high position seen in RR3551M causes the sleeve 3 to engage directly with the sun gear 2, allowing the power to by-pass the planetary gear set 5 and provide a direct drive to the drive sprocket 7, and Morse chain 8 to the differential and output shafts.

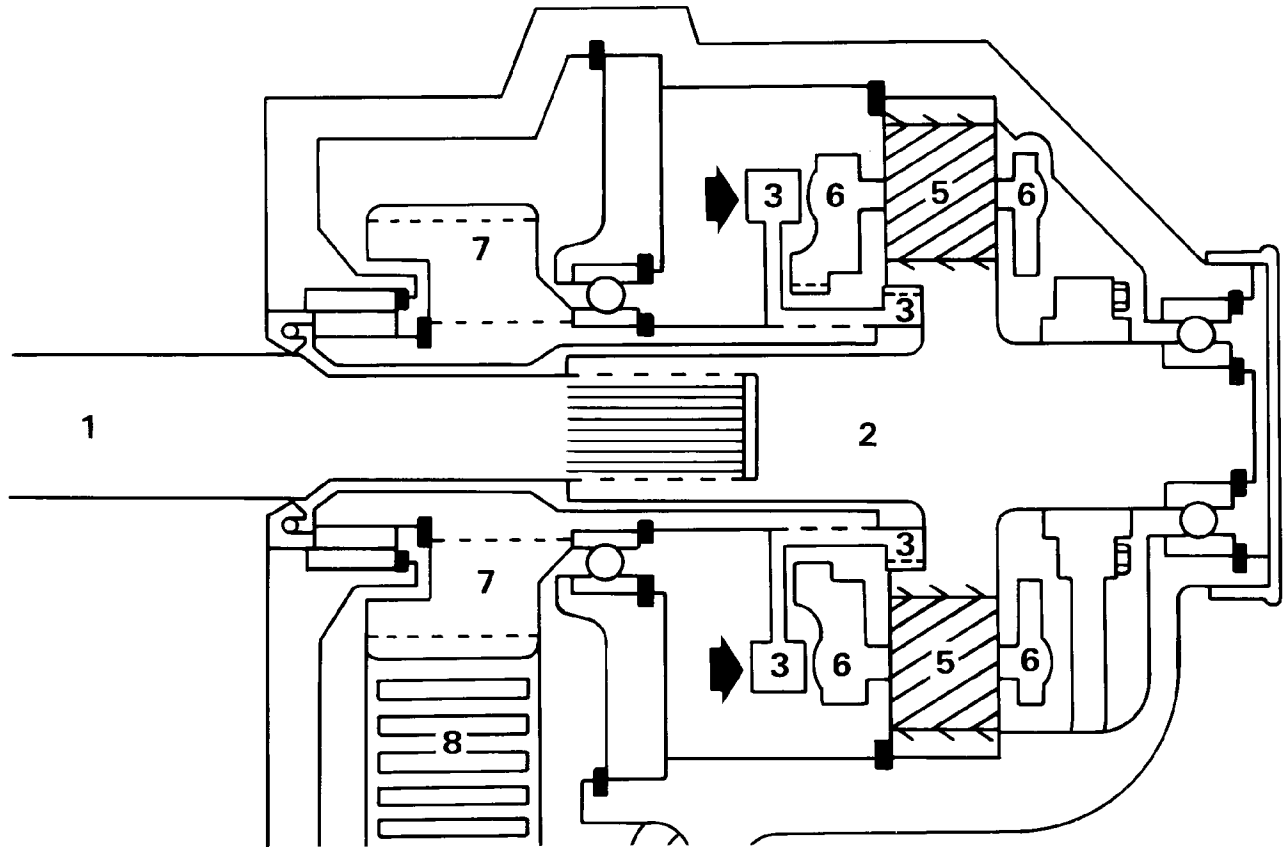

RR3551M



Low ratio

In low gear the selector sleeve 3 connects with the planet carrier 6 and planet gears 5 to provide low ratio.

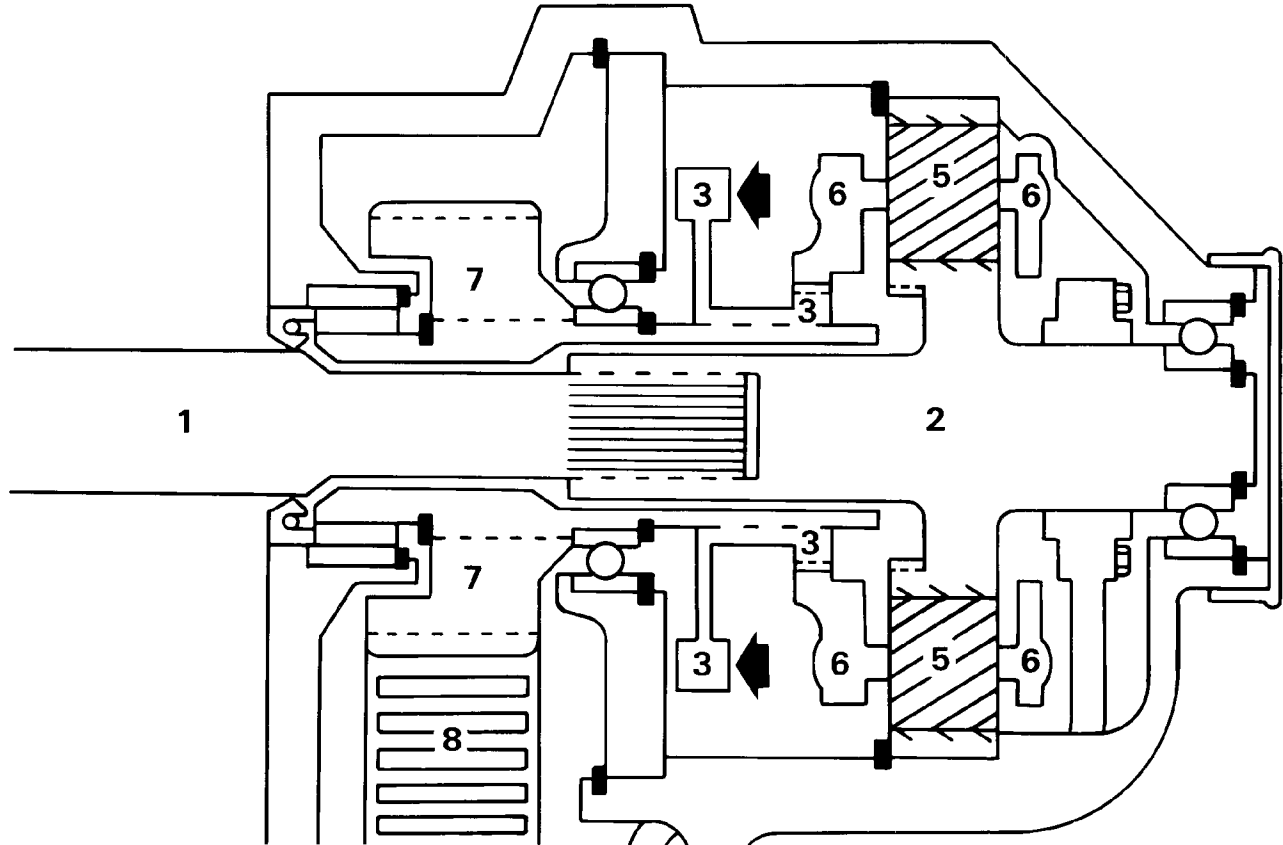

RR3550M

Differential and viscous coupling

The Morse chain 8 drives a conventional type differential 9. The front and rear output shafts 10 and 11 are splined to the differential output pinions. The front output shaft 10 forms the outer member of the viscous coupling, while the inner member plates are splined to the rear output shaft 11.

Its only function is to limit the maximum difference in speed between the two shafts, with the effect of automatically locking the differential.

The maximum difference in speed permitted by the viscous coupling must however be sufficient to allow the vehicle to be driven on a dry road surface, in a circle on full lock, without inducing 'wind up' or causing damage to the transmission.

The viscous coupling has alternate plates splined to the inner and outer members.

One set of plates is splined to 10, the outer member/front shaft and the other plates are splined the rear output shaft 11. The coupling is filled with a special silicone jelly which allows sufficient slip to occur in normal driving conditions but, which increase the drag between the plates as the speed difference and temperature rises, thus eliminating the need for a manual differential lock.

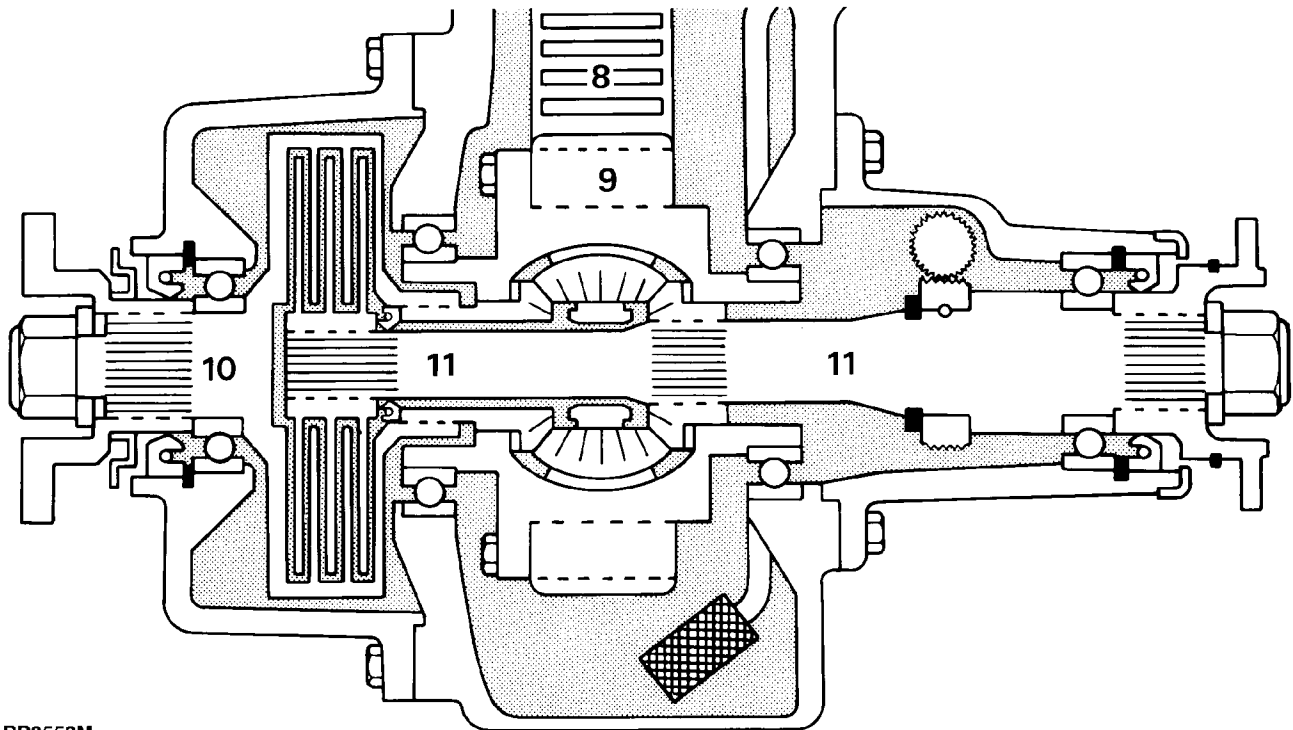

RR3553M



BORG WARNER - SYMPTOMS

Oil leaks

1. Check that nylon ventilation pipes are not blocked or damaged.
2. Check lubrication level and specification in both boxes and recheck leaks.
3. Location area of leak.

A - Transfer box front output flange oil seal.

B - Transfer box rear output flange oil seal.

C - Oil leaking from vent hole between main and transfer boxes.
The oil may be leaking from the main or transfer box oil seals. Renew the faulty seal.

D - Oil leaking from engine flywheel housing.
The oil may be leaking from the gearbox front seal, torque converter seal or the engine crankshaft rear seal. Renew the faulty seal.

Loss of drive - no abnormal noise from box.

1. Check that the main transmission unit is satisfactory and confirm that loss of drive is in the transfer box.
2. Check by 'feel' the operation of the High/Low transfer gear selection. Suspect failed viscous unit.

Knocking or rattling noise in high and low ratio.

1. Check lubricant specification and level, if low do not top up at this stage.
2. Drain lubricant and check for contamination or metal particles.
Suspect drive chain has stretched.

Abnormal noise in operation.

1. Check lubricant specification and level, if low do not top up at this stage.
2. Drain lubricant and check for contamination or metal particles.
Suspect oil pump failure, mechanical wear or damage.

Transmission wind up

'Transmission wind up' is a build up of tension in the transmission which will only occur if either the differential or viscous unit is partially or completely seized.

Vibration - harshness

1. Check operation of differential and viscous units.
Ensure that neither is partially seized.



NOTE: If both are satisfactory, but the vibration - harshness is still present, the alignment of the propeller shafts and balance of the road wheels should be checked.

For balancing of road wheels. **See WHEELS AND TYRES, Repair, Wheel Balancing**

For propeller shaft alignment. **See PROPELLER SHAFTS, Description and operation, Propeller Shaft Alignment**



REAR OUTPUT SHAFT OIL SEAL

Service tool: 18G1422

1. Disconnect rear propeller shaft from output drive flange and tie shaft to one side.
2. Apply parkbrake and release drive flange nut.
3. Release parkbrake and remove brake drum secured with two screws.
4. Remove output shaft nut, steel washer, rubber seal and withdraw flange.
5. Tap dust cover from housing and remove oil seal.
6. Lubricate and fit new seal using service tool 18G1422. Fit so spring side of seal abutting circlip.
7. Fit dust cover.
8. If necessary release circlip from drive flange to allow new bolts to be installed.
9. Examine flange, if surface is corroded or a groove worn by previous seal discard flange.
10. Lubricate running surface and fit flange. Do not tighten nut.
11. Fit brake drum and secure with two screws. Apply parkbrake and tighten drive flange nut to **224 Nm**
12. Fit propeller shaft. Tighten to **46Nm**

FRONT OUTPUT SHAFT OIL SEAL

Service tool: 18G1422

1. Disconnect front propeller shaft from flange.
2. Apply parkbrake and release drive flange nut.
3. Remove output shaft nut, steel washer, rubber seal and withdraw flange.
4. Prise out oil seal.
5. Lubricate and fit new seal using service tool 18G1422. Fit spring side of seal abutting circlip.
6. Examine flange if surface is corroded or worn by previous seal discard flange.
7. Lubricate seal running surface of flange.
8. Fit flange. Tighten to **224 Nm**
9. Refit propeller shaft. Tighten to **46Nm**

BORG WARNER TRANSFER GEARBOX

Service repair no - 41.20.25

Remove

1. Site vehicle on ramp and chock wheels.
2. Disconnect battery negative lead.
3. Remove fan blade assembly.



NOTE: The nut securing viscous unit has left hand thread.

4. Disconnect airflow meter to plenum chamber hose. (V8i only)
5. Remove two gear lever knobs. If Automatic type remove gear selector. **See ELECTRICAL, Repair, Automatic Gear Selector-Panel Bulb**
6. Remove floor mounted console assembly. **See CHASSIS AND BODY, Repair, Centre Console**
7. Remove padding from top of transmission tunnel.
8. Loosen pinch bolt and remove upper gear lever.
9. Remove screws and detach high low lever and main gearlever retaining plates.

Underneath vehicle

10. Drain oil from transfer gearbox.
11. Refit plug.

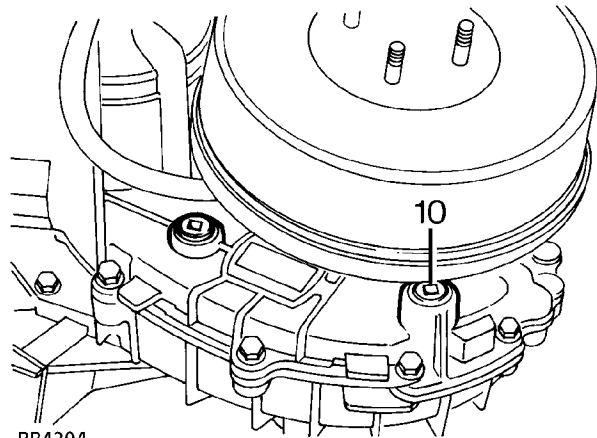

12. Disconnect Lambda sensor. (V8i only)
13. Remove front exhaust sections. (V8i only)
14. Remove chassis cross member secured by eight nuts and bolts. (V8i only)
15. Mark each drive flange for reassembly and disconnect front and rear propeller shafts from transfer box. Tie the shafts to one side.
16. Disconnect the speed transducer multiplug.
17. Remove transmission brake drum. Remove four bolts securing back plate to transfer box and tie assembly aside complete with handbrake cable.
18. Remove two bolts and withdraw clutch slave cylinder from bell housing. (Manual only)



Remove transmission assembly

19. Position a suitable transmission hoist on rear output housing to support weight of assembly.
20. Remove fixings and withdraw transfer gearbox mountings.

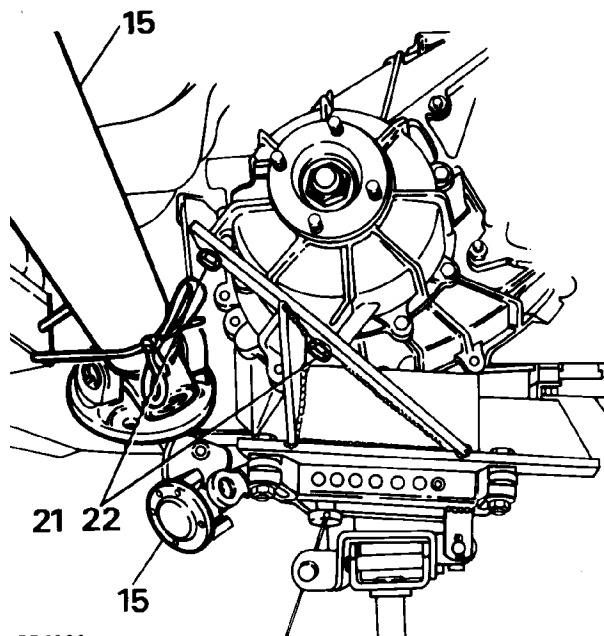

RR4208

21. Fit adaptor plate to transmission hoist. Raise hoist and position under transfer box. **See Service tools, Adapter Plate Transfer Box**



NOTE: Centralise adaptor plate on hoist platform so split line of gearbox is aligned with centre of ram.

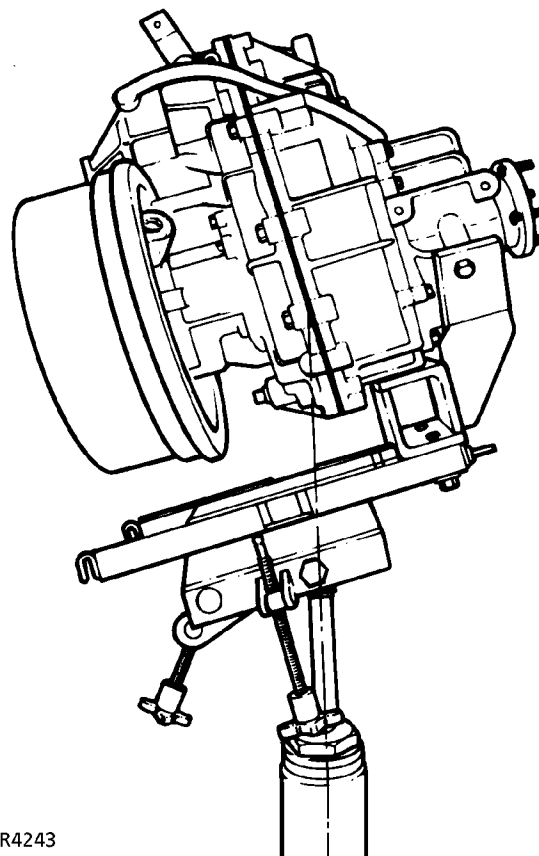

RR4243

22. Secure fixture to transfer box mounting points.
23. Remove hoist from rear of transfer box.
24. Remove chassis cross member. (Tdi only)
25. Remove front exhaust section. (Tdi only)
26. Lower transmission until top of transfer gearbox clears rear floor.
27. Remove breather pipe from top of gearbox.

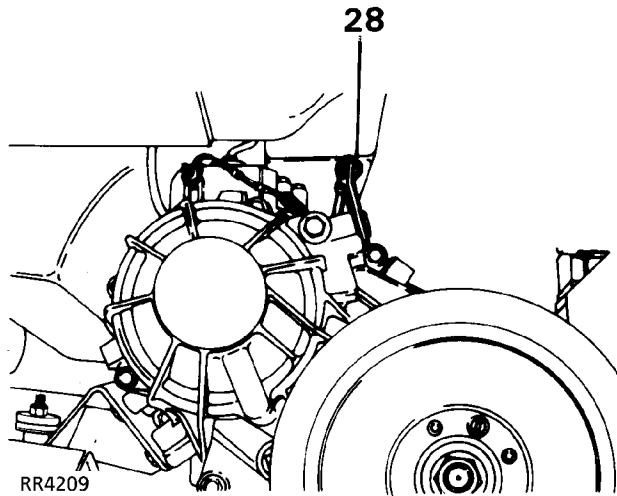

RR4209

28. Remove high/low rod from gearbox selector lever.
29. Support main gearbox with hoist and detach transfer gearbox.
30. Remove upper and lower bolts and two nuts securing transfer box to main gearbox.
31. Move transfer gearbox rearwards to detach it.

Refit Transfer Gearbox

1. Clean joint faces of transfer gearbox and main gearbox.
2. Lubricate oil seal in joint face of transfer gearbox.
3. Fit gearbox to adaptor plate on hoist. Raise hoist until input shaft enters transfer gearbox.



CAUTION: Ensure input shaft splines do not damage oil seal in transfer gearbox.

4. Fit transfer gearbox to main gearbox with nuts onto two studs. Fit remaining bolts.

Transfer gearbox high/low link adjustment

5. Select neutral gear position.
6. Set transfer gearbox lever in a vertical position. Rotate clevis on end of rod until hole aligns with hole in selector lever.
7. Fit clevis pin and retaining clip. Select high and low transfer to prove operation.

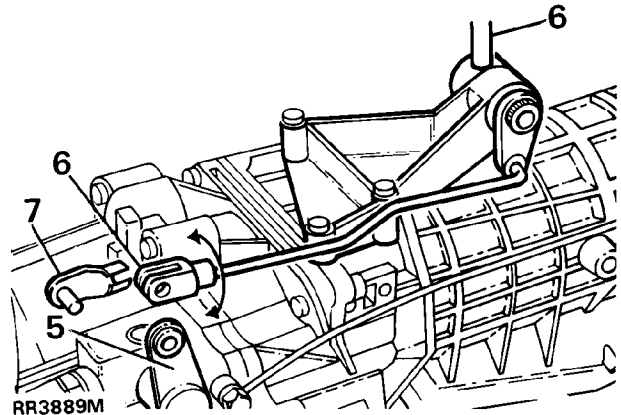

RR3889M

8. Reverse removal instructions, noting following points.
9. Fit mounting bracket to gearbox. Tighten to **102 Nm**
10. Fit three fixings which secure right hand mounting bracket to chassis. Tighten to **45 Nm**
11. Fit propeller shafts. Tighten to **46Nm**
12. Refill transfer gearbox with oil. See maintenance schedule - check / top up transfer gearbox oil. **See LUBRICANTS, FLUIDS AND CAPACITIES, Information, Recommended Lubricants and Fluids**
13. Check operation of parkbrake and adjust if necessary. **See SECTION 10, Maintenance, Vehicle Interior**



**BORG WARNER GEARBOX ILLUSTRATED
ASSEMBLIES**

Service repair no - 41.20.28

- 1. Front output housing assembly
- 2. Viscous unit

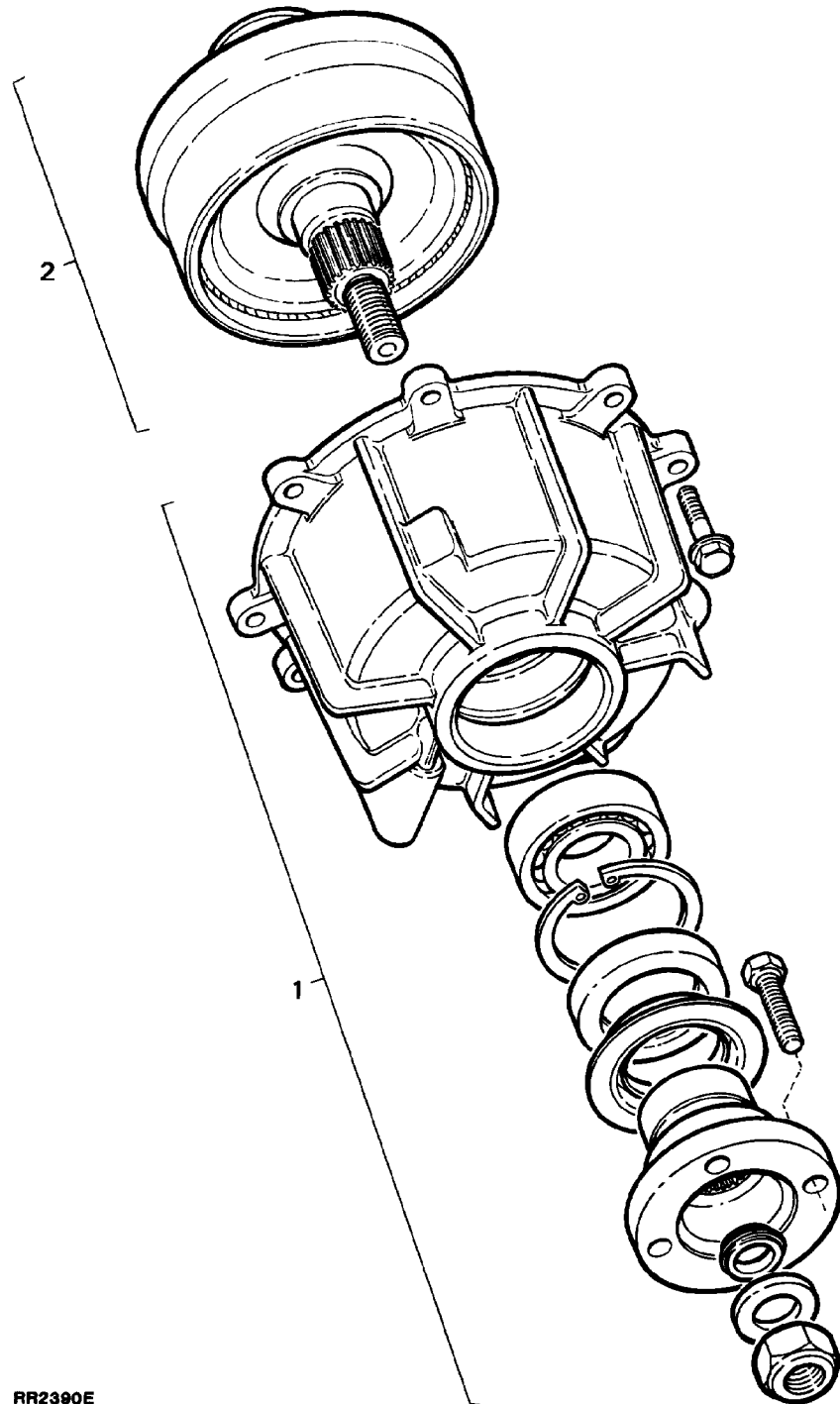

RR2390E

41 TRANSFER GEARBOX

1. Rear output housing and output shaft assembly
2. Transmission brake drum assembly
3. Speedometer drive pinion assembly

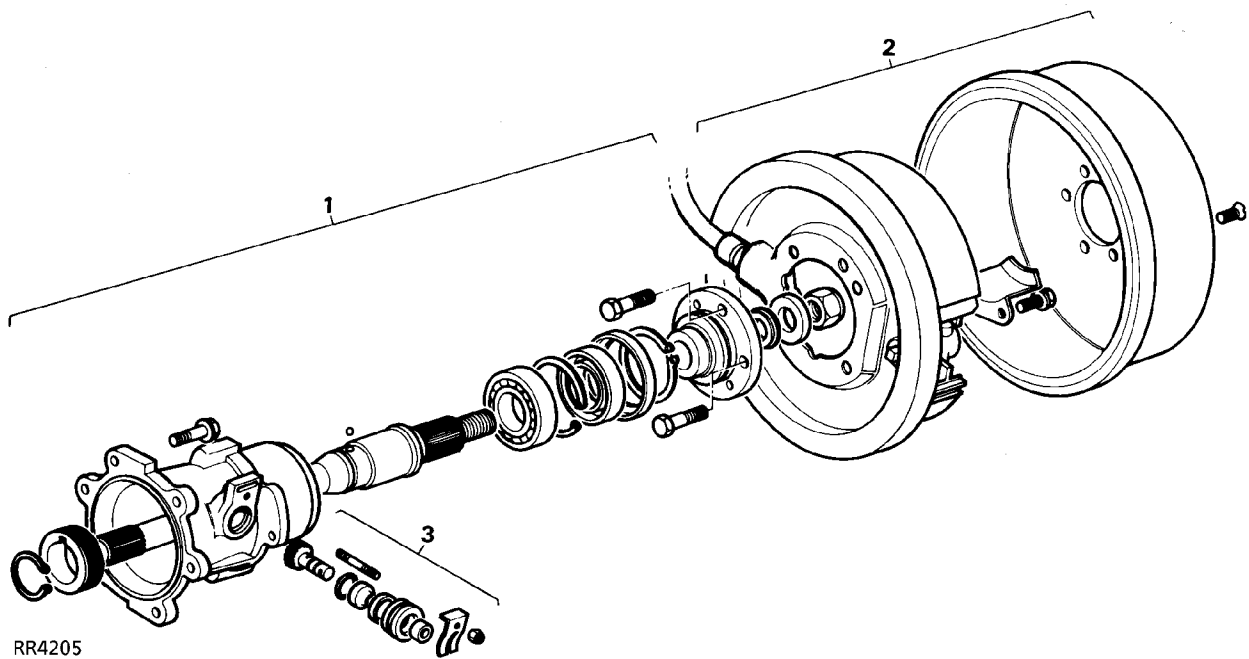

RR4205



1. Front cover - main casing
2. Transfer sprocket, centre differential assembly, driven sprocket and chain
3. Bearing carrier and transfer shaft
4. Selector fork and lever assembly
5. Selector sleeve
6. Oil pickup pipe and filter
7. Planetary set (epicyclic unit)
8. Rear cover - main case
9. End cap

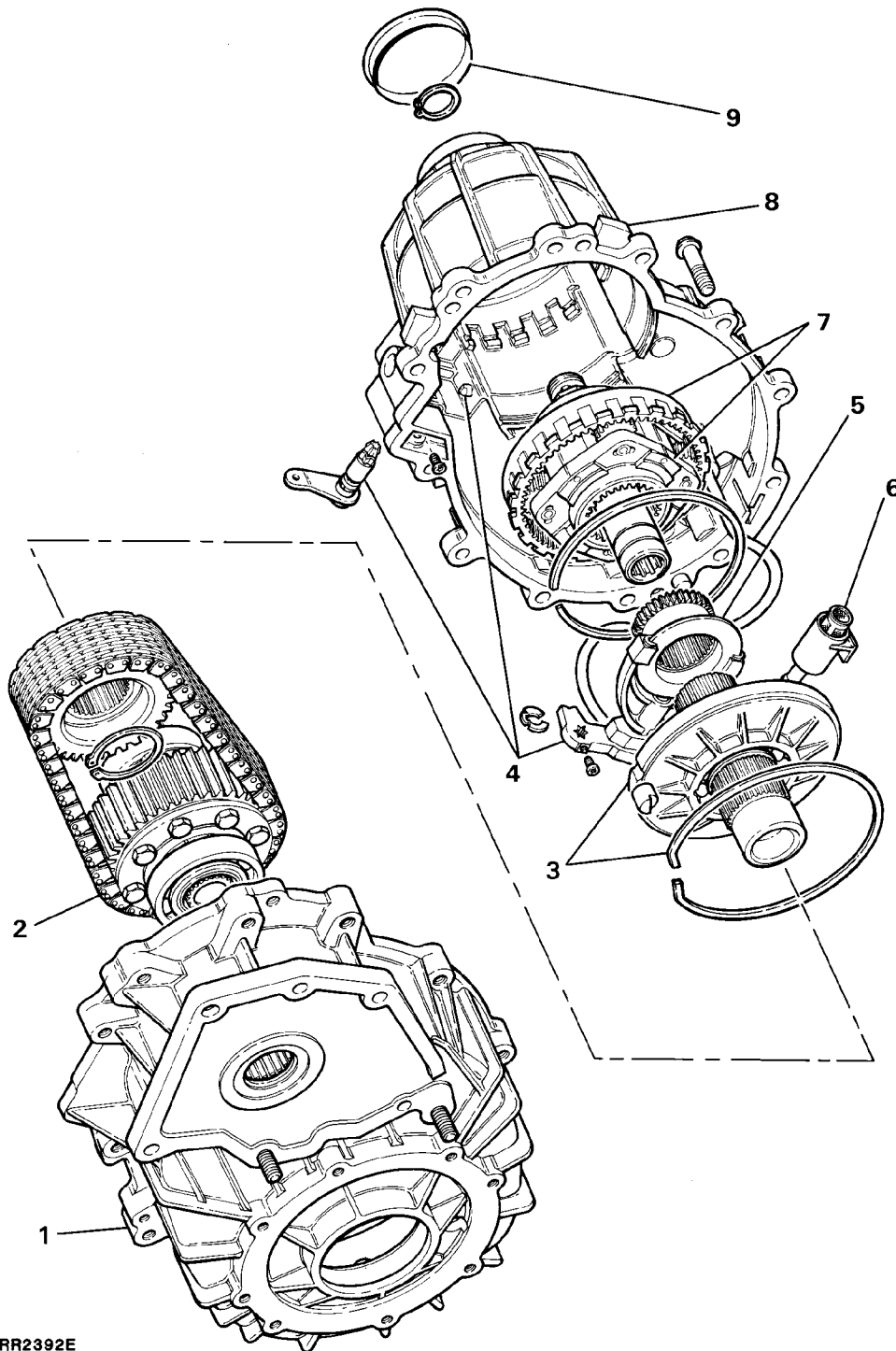

RR2392E

BORG WARNER TRANSFER GEARBOX

DISMANTLING, OVERHAUL AND REASSEMBLY

Service Tools. See *Service tools, Adapter Plate Transfer Box*

- 18G1422 - Oil seal replacer
- 18G1205 - Adjustable flange holding wrench
- 18G134 - Bearing and oil seal replacer
- LST550 - 6 - Input shaft oil seal replacer

 **NOTE:** Before commencing the overhaul procedure thoroughly clean the exterior of the transfer gearbox. If the gearbox oil has not previously been drained, drain the oil into a suitable container.

DISMANTLING

 **NOTE:** Before commencing the dismantling procedure remove the brake drum assembly.

Rear output housing

1. Remove the six bolts and withdraw the rear output housing complete with output shaft.

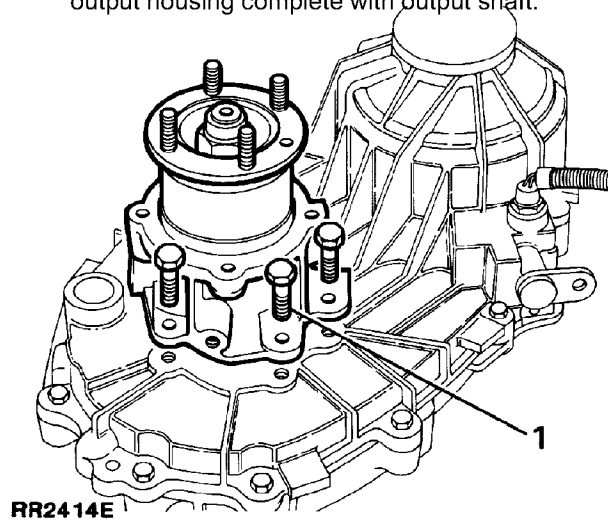

Front output housing

 **NOTE:** Invert the gearbox. Level up the assembly by placing wooden blocks under the transfer gearbox to main gearbox joint face.

2. Remove the eight bolts and withdraw the front output housing complete with viscous unit.

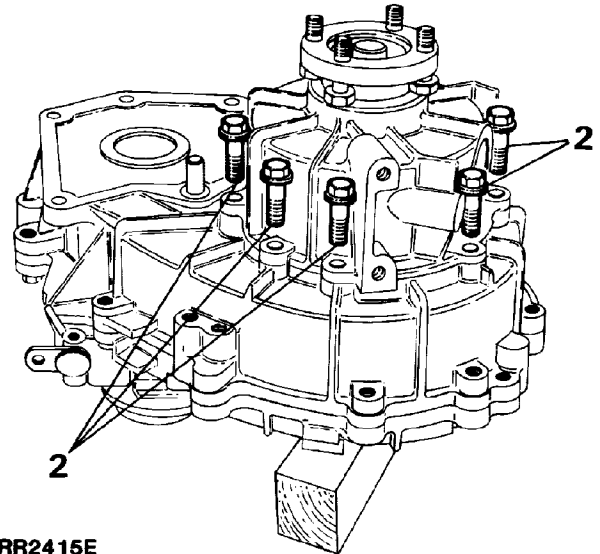

Front cover - main casing

3. Remove the eleven bolts securing the front and rear cover (main case) together.

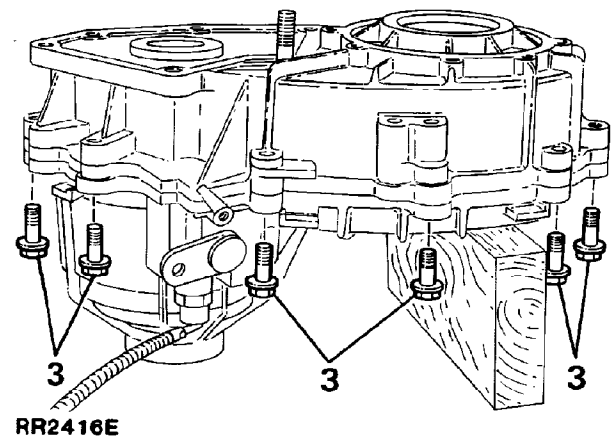



4. Clean any previous sealant from the threads of the bolts.
5. Using two levers between the cast lugs on the outer edges of the casing, to assist in separating the gearbox, carefully prise the front cover from the rear cover.



CAUTION: Do not lever between the mating faces.

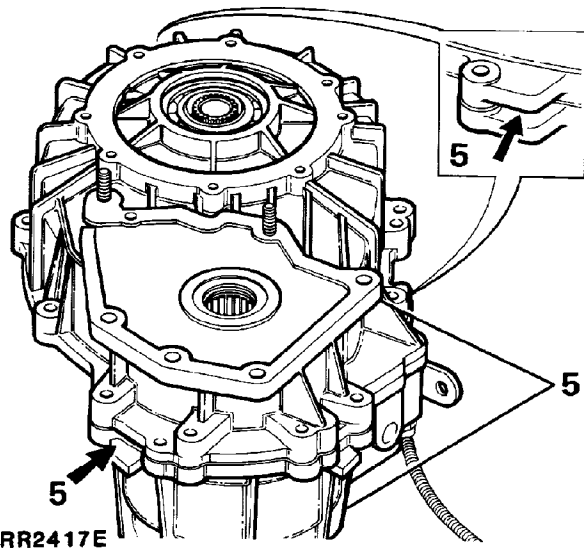

8. Remove the transfer sprocket from the chain.
9. Remove the differential assembly from the chain.

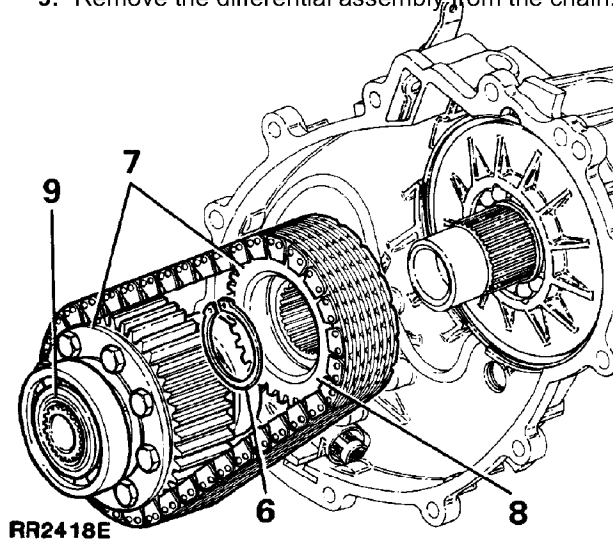

Bearing carrier and transfer shaft

10. Insert a screw driver between the anti - rotation dowel and snap ring gently prise the snap ring out of the groove.
11. Withdraw the carrier complete with transfer shaft.
12. Withdraw the anti - rotation dowel.

Transfer sprocket, centre differential, assembly and chain



NOTE: Before dismantling, mark one chain link and corresponding tooth on the transfer sprocket with an identification line. This is to ensure that the balance of the unit is maintained when reassembled with original components and that the chain is fitted the correct way up.

6. Remove the circlip retaining the transfer sprocket to the transfer shaft.
7. Place two thin pieces of wood on the joint face to prevent damage and using two levers behind the differential assembly carefully lever the differential bearing from its bore while simultaneously easing the transfer sprocket off the transfer shaft to maintain alignment during removal.

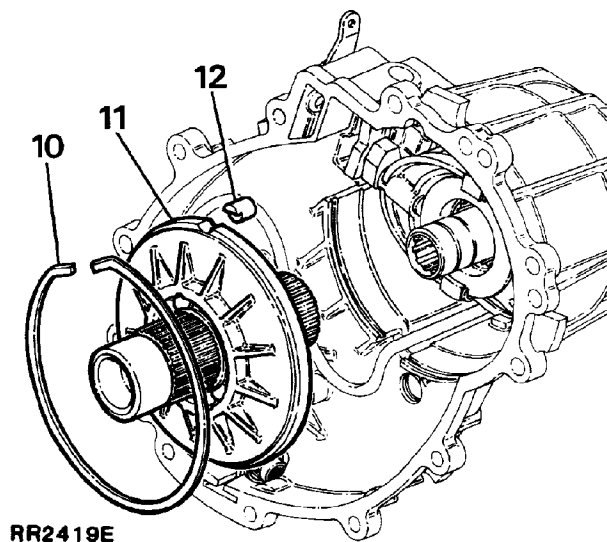

41 TRANSFER GEARBOX

Selector fork assembly

13. Using Torx bit 25 remove the screw securing the selector arm to the selector lever shaft.
14. Remove the retaining clip securing the selector fork arm to the selector lever shaft.
15. Using Torx bit 25 remove the screw retaining the selector lever.
16. Remove the selector lever shaft from the case and fork assembly.
17. Withdraw the selector fork assembly and selector sleeve.

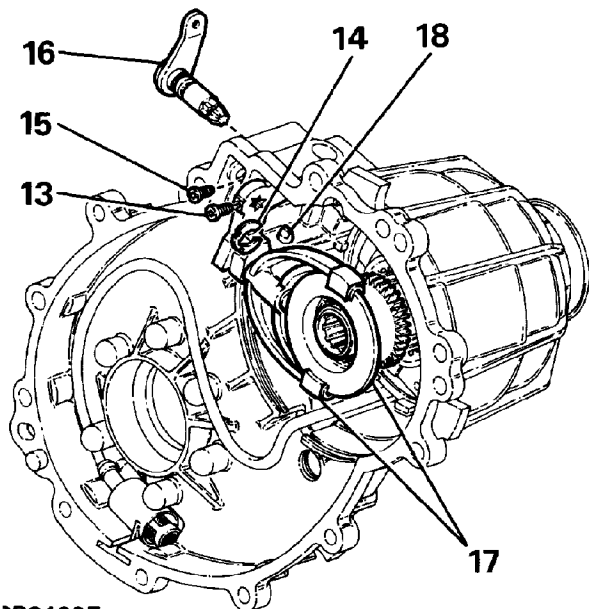

RR2420E

18. Retrieve the selector plunger and spring from the rear cover.

Planetary set (Epicyclic unit)

19. Turn the case over and prise the end cap off the planetary set housing.
20. Remove the circlip retaining the sun gear shaft.

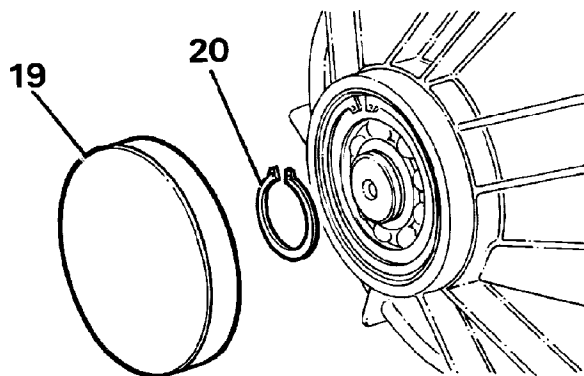

RR2421E

21. Turn the casing over and remove the large snap ring retaining the planetary set.
22. Withdraw the annulus and planetary assembly from the planetary set housing, complete with oil pump, feed pipe and filter.

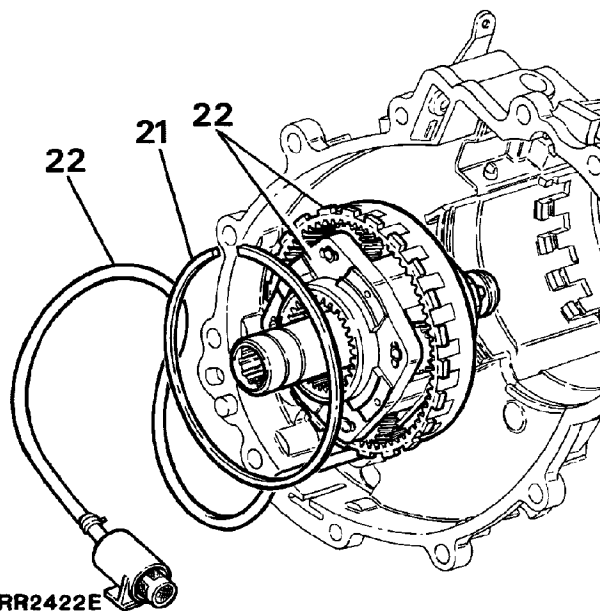

RR2422E



DISMANTLE, INSPECTION AND OVERHAUL

Rear cover main case - Dismantle and inspection

1. Remove the circlip retaining the bearing in the rear cover.
2. Drive or press the bearing from the cover and discard the bearing.

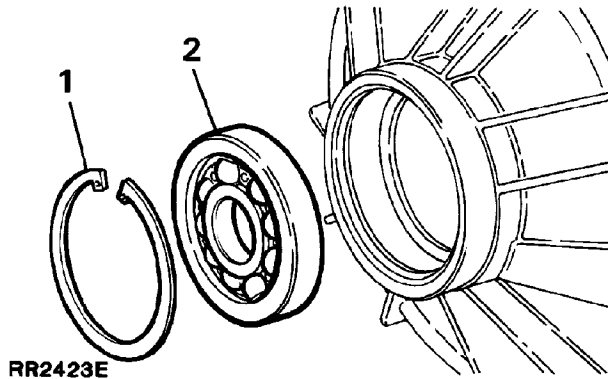

3. Remove any previous sealant evident on the rear cover joint faces.
4. Using a suitable solvent thoroughly clean the cover.
5. Examine the cover for damage, cracks and porosity, renew if necessary.
6. Check the selector lever shaft bore, for ovality and wear. If worn renew the cover.

Rear cover main case - Assemble

7. Drive or press a new bearing into the cover and secure in position with the circlip.
8. Place the cover aside until the gearbox is ready to be assembled.

Front cover main case - Dismantle and inspection

9. Prise the input shaft oil seal from the front cover and discard the oil seal.

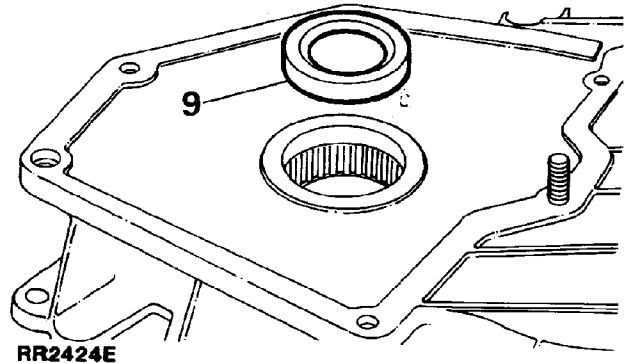

10. Remove the snap ring retaining the needle roller bearing, withdraw the bearing and discard.

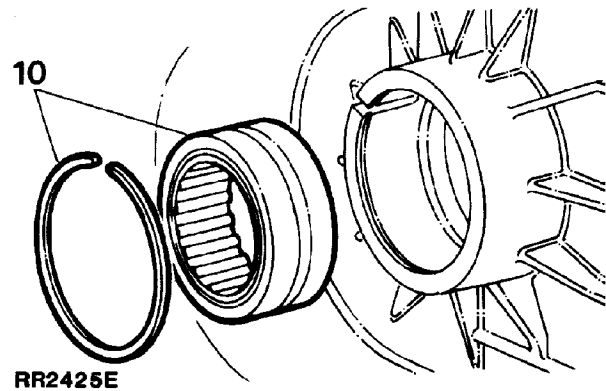

11. Remove any previous sealant from the joint faces of the front cover.
12. Thoroughly clean the cover using a suitable solvent.
13. Examine the cover for damage, cracks and porosity, renew if necessary.
14. Check the inside edges of the case for witness marks which may indicate a chain that has stretched.

Front cover main case - Assemble

15. Lubricate a new oil seal. Using service tool LST 550 - 6 in conjunction with bearing and oil seal replacer 18G134 fit the seal, open side of the seal leading, until the face of the seal is 1 mm (0.039 in) below the surface of the boss.

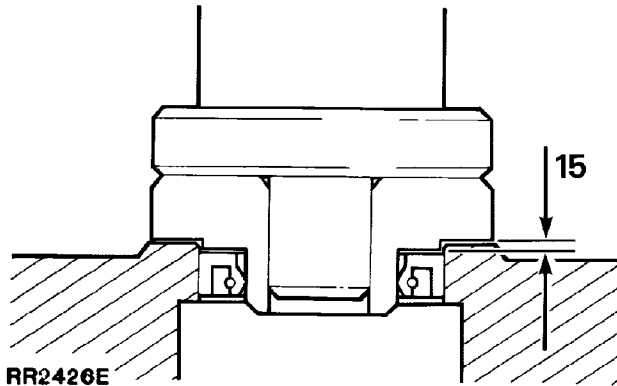

16. Lubricate a new needle roller bearing and drive or press the bearing into its recess until contact is made with the shoulder at the bottom of the bore.
17. Fit the snap ring to retain the bearing.
18. Place the cover aside until the gearbox is ready to be assembled.

Planetary set (Epicyclic unit) and oil pump - Dismantle and inspection

 **NOTE:** The Epicyclic unit and oil pump are serviced as a complete assembly, if after inspection either of the units is found to be worn a complete new assembly must be fitted.

1. Remove the annulus from the planetary set.

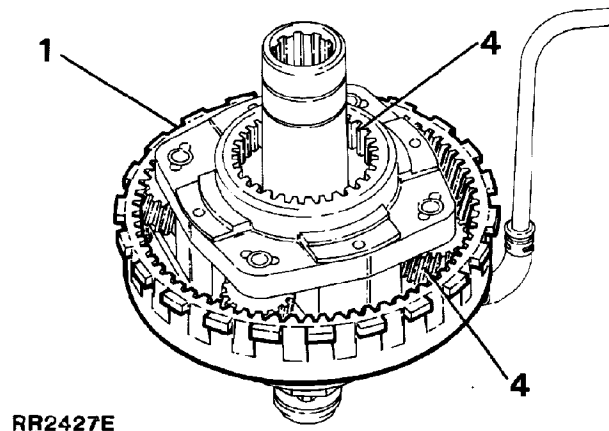

2. Thoroughly clean all components using a suitable solvent.
3. Examine the helical teeth of the annulus for wear or damage. If damage is evident it will be necessary to renew both the annulus and planetary set.
4. Examine the planetary gears and high/low gear teeth for wear or damage. If damaged renew both the annulus and planetary set.
5. Check the end float of the four planet gears, between the end of the gear and planetary set carrier. End float of each planet gear should not exceed 0.83 mm (0.033 in) if any one of the planet gears is out of limits renew the planetary set assembly.

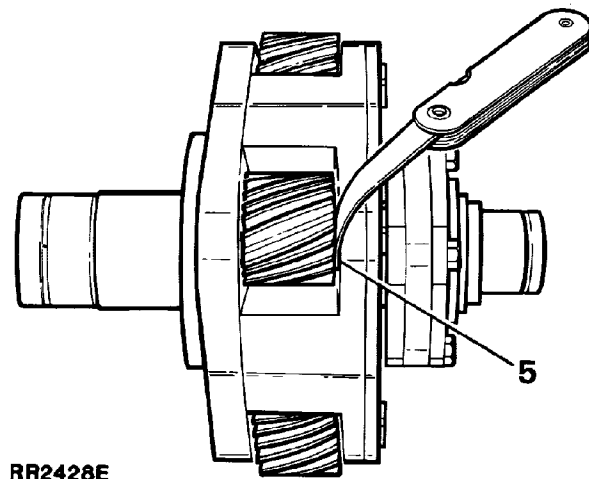



6. Check the end float of the sun gear to the planetary set carrier by supporting the body of the assembly on the top of a vice. Using a dial test indicator attached to a magnetic base, position the base on top of the assembly and zero the indicator on the end of the sun gear shaft, lift the shaft and check the end float. End float should not exceed 0.83 mm (0.033 in). Fit a new planetary set assembly if out of limits.

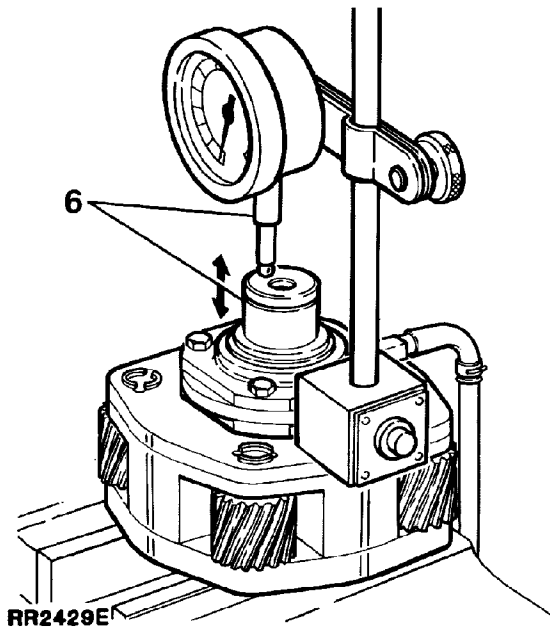

RR2429E



NOTE: If the previous inspection instructions prove the assembly to be in an acceptable condition carry out the following examination of the oil pump.

Oil pump and filter - Dismantle and inspection

7. To aid re-assembly mark an identification line on the edges of the oil pump plates. Remove the four bolts securing the pump front and rear plates, separate the pump by removing the plungers, spring and bearing plate.



NOTE: The front plate of the oil pump is stamped 'TOP', the centre bearing plate is stamped 'REAR' and the rear plate is stamped 'TOP REAR'. The fixing holes of the plates and body are also offset to ensure correct re-assembly of the pump.

8. Depress the retaining clips, remove the oil pick-up pipe and rubber connection tubes. Examine the tubes and pipe for damage or fractures, renew as necessary.

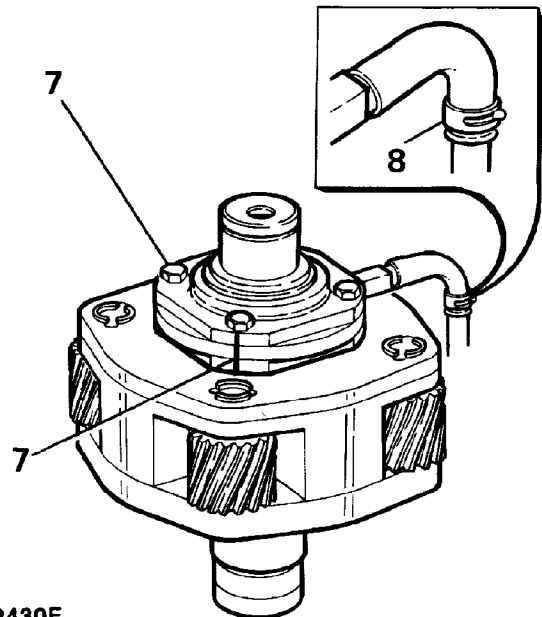

RR2430E

9. Clean the pump components and check for damage and wear, ie: blueing of the pump plungers, scoring of the centre bearing plate, if any wear is evident a new planetary set must be fitted, as the pump is part of the complete assembly.
10. Thoroughly clean the oil pick-up filter, examine the filter screen for damage and blockage, renew or clean the filter as necessary.

Oil pump and filter - Assemble

11. Clean the sealant from the oil pump securing screws.
12. Prior to assembly lubricate the pump components with clean oil.
13. Fit the plate stamped 'TOP' to the sun gear shaft with the word 'TOP' facing the planetary assembly.
14. Fit the plungers and spring noting that the flats on the plungers must be uppermost to enable the 'TOP REAR' plate to be fitted.
15. Compress the plungers and fit the middle bearing plate with the word 'REAR' uppermost. Align the offset fixing holes and also noting the previously marked identification line.
16. Fit the top rear plate with the words 'TOP REAR' uppermost.
17. Apply Loctite 242 to the threads of the four screws and fit the screws, tighten to the specified torque.

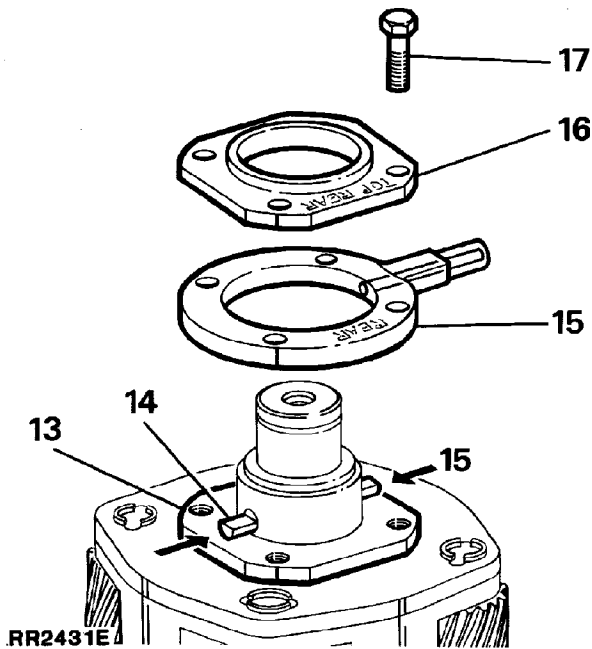

18. Fit the rubber connection tube and oil pick - up pipe to the oil pump, fit the retaining clip. Note that the clip securing the tube to the pick - up pipe is positioned in front of the flare on the pipe.

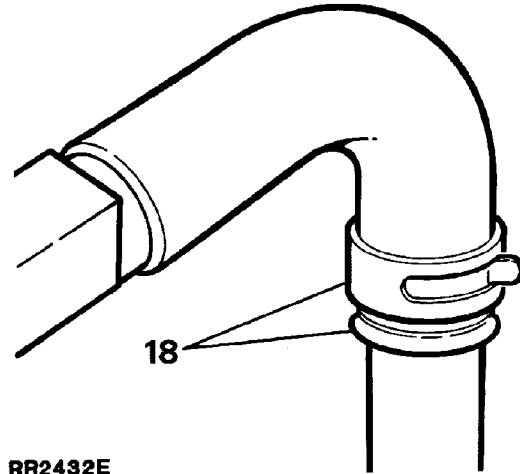

19. Fit the rubber connection tube to the filter end of the pipe, fit the clip ensuring that the tube is clamped by the clip in front of the flare on the pipe.
20. Push the filter into the tube. The radial position of the filter to pipe at this stage is unimportant.

Planetary set and annulus - assemble

21. Lubricate the planetary set and annulus with clean oil.
22. Position the annulus around the planetary set, fit the assembly to the rear cover locating the oil pump inlet port in the groove at the bottom of the planetary set housing, the sun gear shaft in the bearing and the lugs on the outer edge of the annulus in the anti - rotation lugs. It may be necessary to tap the sun gear shaft into the bearing to enable the large ring gear snap ring to be fitted.

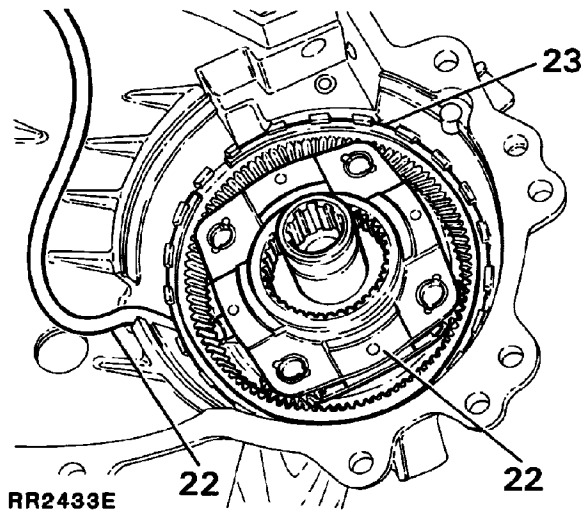



23. Fit the snap ring with the stepped ends adjacent to the selector shaft bore.
24. Turn the rear cover over and fit the circlip to retain the sun gear shaft.
25. Remove any previous sealant from the end cap. Apply Dow Corning 732 silicon sealant or a suitable equivalent to the outside diameter of the rear cover, evenly tap the cap into position.

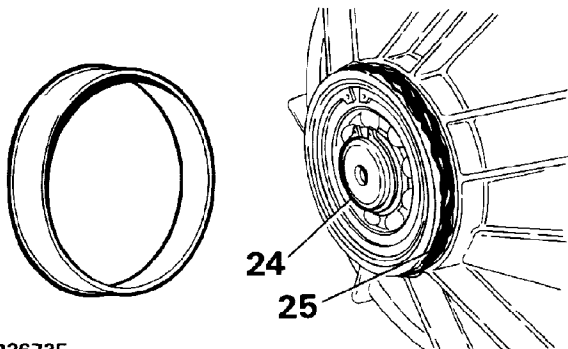

RR2673E

26. If necessary re - position the filter on the oil pick - up pipe until the lug on the filter can be pushed into the slot in the rear cover.

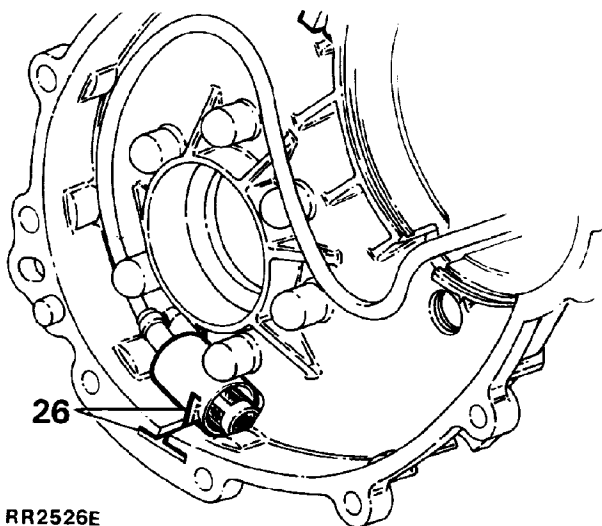

RR2526E

Selector fork

- Dismantle and inspection

1. Remove the retaining clip and separate the fork from the arm.
2. Detach the two nylon slippers from the selector fork feet and discard.
3. Thoroughly clean all components.
4. Examine the fork, arm and pivot pin for wear. Renew as necessary.
5. Remove the 'O' ring and discard. Examine the shaft and lever for wear and damage, renew as necessary.
6. Examine the selector sleeve teeth and internal splines for damage and wear. Renew as necessary.

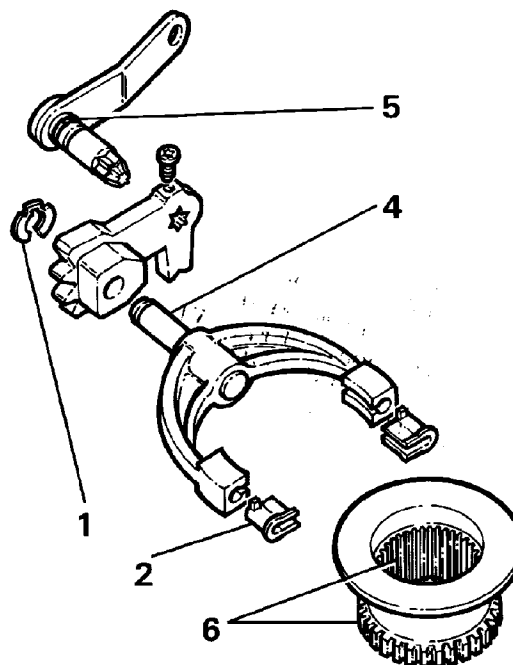

RR2434E

Selector fork - Assemble

7. Fit new nylon slippers to the fork.
8. Assemble the fork to the selector arm and secure in position using a new retaining clip.
9. Lightly lubricate and fit the spring and selector plunger.

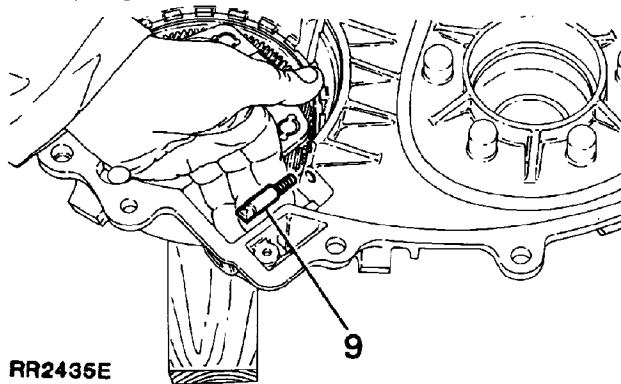

RR2435E

10. While compressing the plunger and spring, fit the selector fork, operating arm assembly and selector sleeve simultaneously.
11. Select neutral gear position at the operating arm.
12. Fit a new 'O' ring to the selector lever shaft. Lubricate the 'O' ring and fit the lever assembly to the rear cover, noting that when fully assembled the lever should lie parallel with the joint face of the rear cover.
13. Fit a new retaining clip to secure the selector fork operating arm to the selector lever shaft.

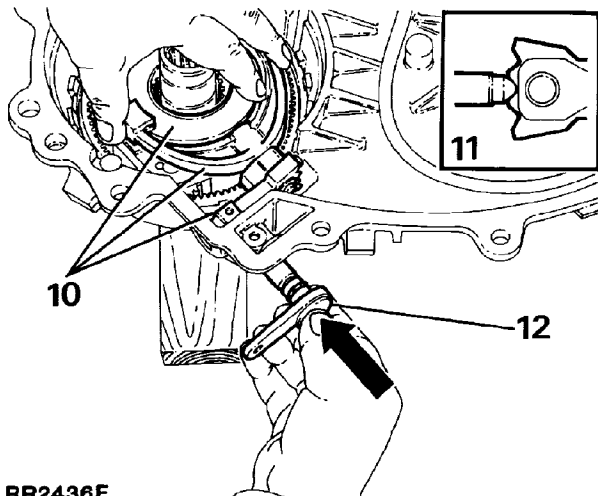

RR2436E

14. Remove any previous sealant from the Torx screw. Align the selector lever shaft groove to the retaining screw hole, apply a small amount of Loctite 242 to the screw threads and using Torx bit 25 fit and tighten the screw to the specified torque. Ensure that the screw locates in the groove of the shaft.
15. Clean any previous sealant from the Torx screw. Apply a small amount of Loctite 242 to the threads of the screw and fit to the selector fork operating arm, tighten using Torx bit 25 to the specified torque.

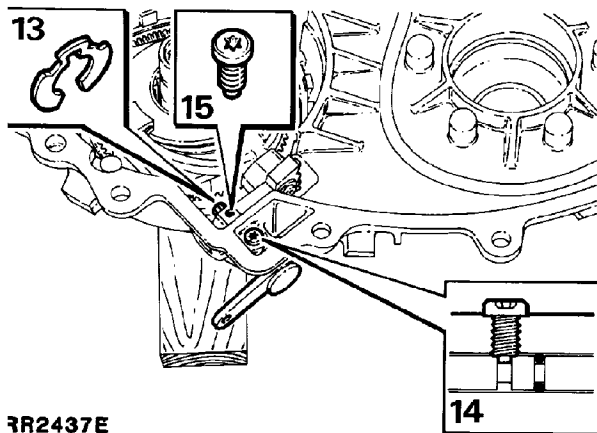

RR2437E

Bearing carrier

- Dismantle, inspection and assemble

1. Remove the circlip and drive or press the transfer shaft from the bearing.
2. Remove the circlip retaining the bearing in the carrier.
3. Drive or press the bearing from the carrier and discard the bearing.
4. Clean and examine the carrier for cracks and general condition. Renew as necessary.
5. Press or drive a new bearing into the carrier and secure with the circlip.

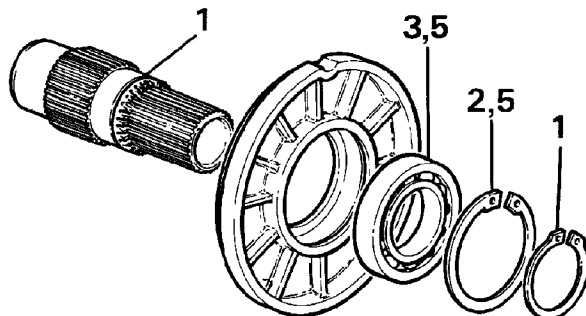

RR2438E



Transfer shaft

- Inspection and assemble

1. Clean the transfer shaft.
2. Visually examine the external splines for damage and wear, if worn fit a new component.
3. Check the phospher bronze bush for wear by measuring the internal diameter of the bush with internal calipers and a micrometer or with an internal micrometer. The bush diameter must not exceed 38.515 mm (1.516 in) fit a new transfer shaft if the bush has worn above the figure given.

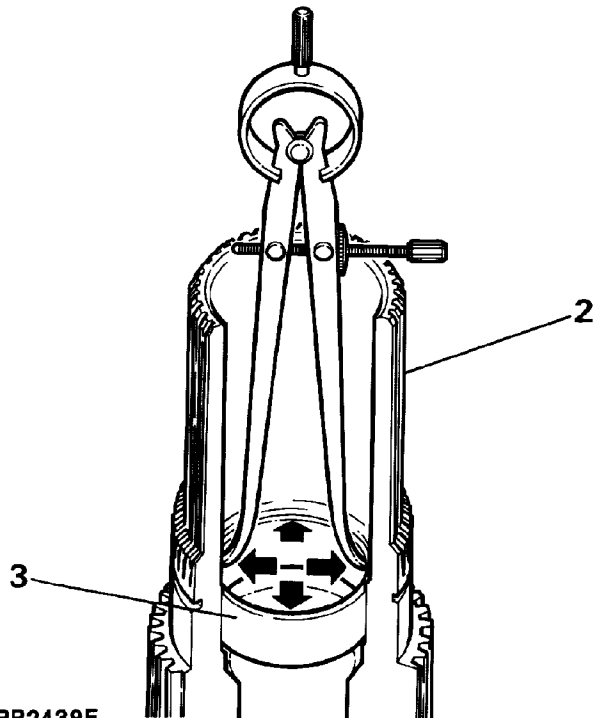

RR2439E

4. Drive or press the transfer shaft into the bearing in the carrier. Secure the shaft with the circlip.
5. Fit the carrier to the rear cover, fit the anti-rotation dowel and secure the assembly with the snap ring, noting that the open ends of the snap ring must be positioned by the cast relief in the bearing carrier upper face.

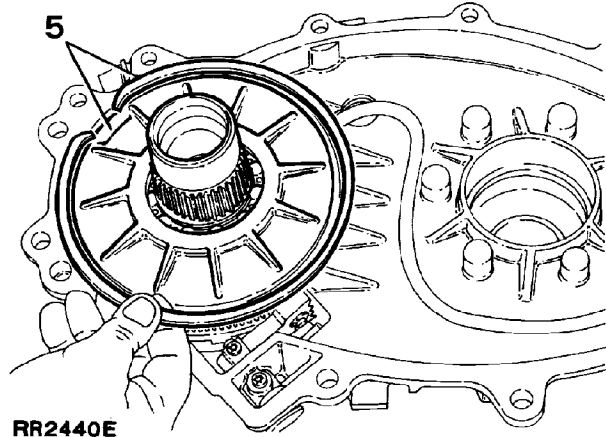

RR2440E

Transfer sprocket - Inspection

1. Examine the sprocket teeth and splines for wear and damage, if either are evident discard the sprocket, otherwise clean and place to one side.

Chain - Inspection



NOTE: A stretched chain can be identified by either excessive noise when the gearbox is operational or by witness marks on the inside edges of the case. If either is evident, renew the chain.

1. Using a suitable solvent thoroughly clean the chain.
2. Check the chain links for wear and damage, if necessary renew the chain.
3. Place the chain to one side.

Centre differential and sprocket - Dismantle and inspection

1. Place the differential unit in a vice fitted with soft jaws. If the original components are to be refitted mark an identification line on the sprocket and differential unit.
2. Remove the bolts securing the sprocket to the differential.
3. Lift the differential assembly from the sprocket.

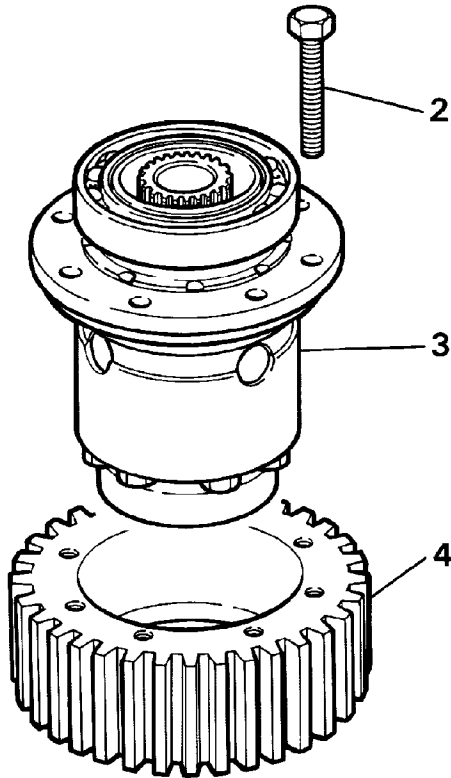

RR2441E

4. Examine the sprocket teeth for wear and damage, if either are evident renew the sprocket. Place the sprocket aside until the differential is ready to be assembled.

Centre differential - Dismantle and inspection

1. Using a two legged puller, ease the bearings from the differential assembly and discard the bearings.

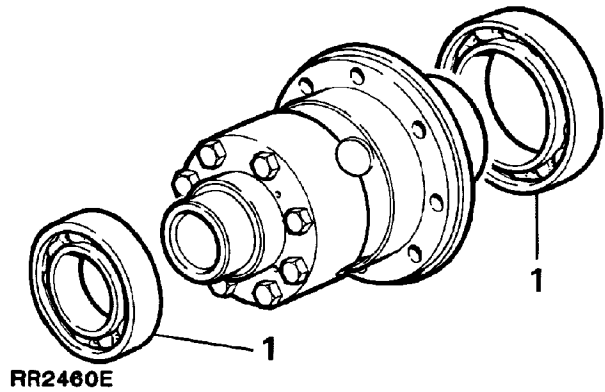

RR2460E

2. Secure the front half of the differential unit in a vice fitted with soft jaws, remove the eight retaining bolts securing the front and rear halves of the assembly together, lift off the rear part of the differential unit. Note the identification marks on the exterior of the differential unit.

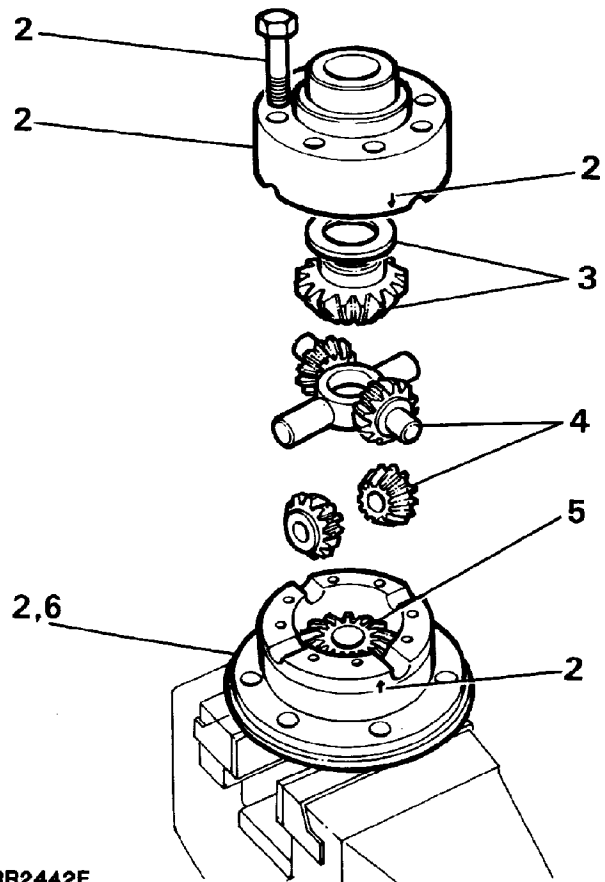

RR2442E



3. Remove the rear upper bevel gear and thrust washer.
4. Remove the pinion gears and dished washers along with the cross shaft.
5. Remove the front lower bevel gear and thrust washer from the front half of the differential unit.
6. Remove the front half of the differential unit from the vice and clean all components. Examine for wear or damage, renew if necessary.

Differential pinions - rolling resistance

7. Using soft jaws secure the front half of the differential unit in the vice.
8. Fit the front bevel gear without the thrust washer. Lightly lubricate and fit the cross shaft, pinion gears and new dished washers.
9. Fit the rear bevel gear together with the thinnest thrust washer to the rear half of the differential. Assemble both halves of the differential noting the identification marks. Fit the bolts and tighten to the specified torque.

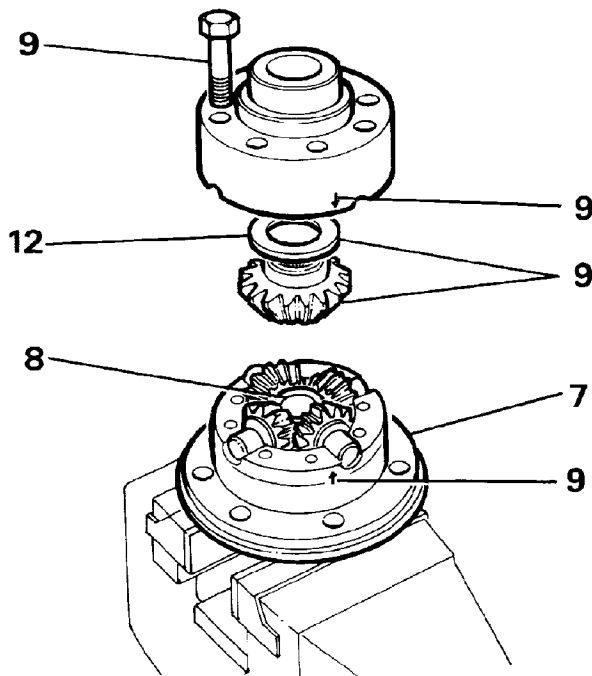

RR2443E

10. Invert the differential unit in the vice, fit the front output housing to the differential, locating the viscous unit splines on the front bevel gear. Fit the drive flange to the viscous unit and place the brake drum on top of the drive flange, secure with the nut. Check that the gears are free to rotate.
11. Tie a length of string around the brake drum, attach a spring balance to the free end and carefully tension the string until a load to turn is achieved. Alternatively use a torque wrench applied to the drive flange nut. Rotate the brake drum slowly by hand to overcome the initial load when using either method.

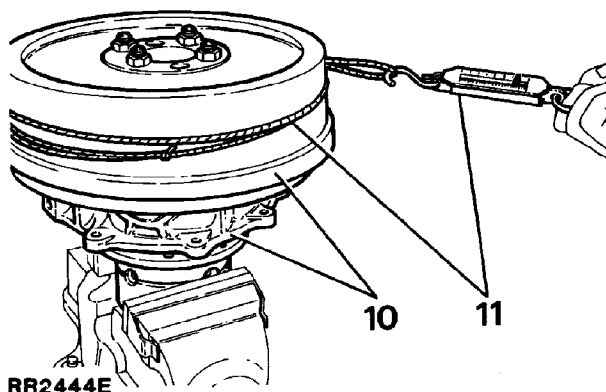

RR2444E

NOTE: Gears that have been run will rotate smoothly and will require a torque of 0.56 Nm (5 in lb), equivalent force using a spring balance 0.45 kg (1 lb). New gears will rotate with a notchy feel and will require a torque of not more than 2.26 Nm (20 in lb), equivalent force using a spring balance 7.72 Kg (3.8 lb). Keep all components lubricated when carrying out these adjustments.

12. Change the thrust washer for a thicker one if the torque reading is too low and re - check the torque. Five thrust washers are available in 0.10mm steps ranging from 1.05 to 1.45mm.
13. Dismantle the unit when the rear bevel gear thrust washer has been selected.
14. Remove and retain the rear bevel gear and thrust washer combination.

15. Repeat the procedure to obtain the correct thrust washer for the front bevel gear, it is not necessary to fit the rear bevel gear when checking the front bevel gear rolling resistance.
16. When the thrust washer has been selected for the front bevel gear, again dismantle the differential unit and retain the thrust washer and front bevel gear combination.

Centre differential - Assemble

17. Fit the thrust washer and front bevel gear into the front half of the differential unit.
18. Fit the pinion gears with dished washers to the cross shaft and fit the assembly to the differential unit.
19. Fit the thrust washer and rear bevel gear to the rear half of the differential unit.
20. Align both halves of the differential noting the identification marks. Secure both halves together with the eight bolts. Tighten the bolts to the specified torque.

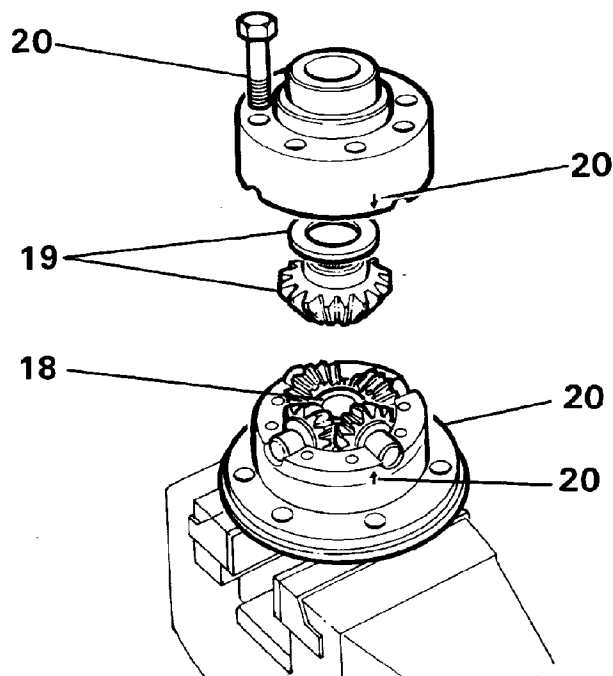

RR2445E

21. Check the overall torque required to turn the differential, this should be approximately equal to both bevel gears added together.
22. Drive or press new bearings onto the differential, noting that the smaller of the two bearings is fitted to the rear half of the differential.

Centre differential sprocket - Assemble

1. Fit the sprocket to the differential noting that the face of the sprocket with the relieved threads must contact the flange of the differential housing. Observe the previously marked identification lines if the original components are being refitted.
2. Fit new bolts and tighten evenly to the specified torque.

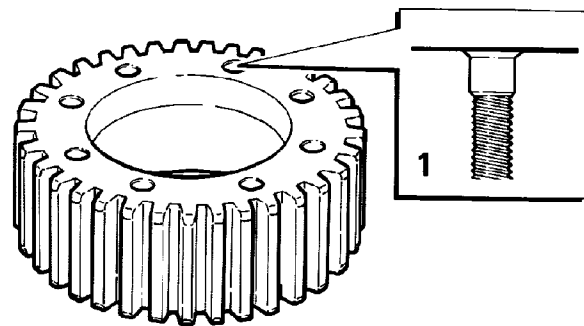

RR2446E

Transfer sprocket, centre differential assembly and chain - Assemble

1. Place the differential assembly and transfer sprocket inside the chain. If the original components are being refitted observe the identification marks previously applied to the chain and transfer sprocket. Fit the complete assembly simultaneously.
2. Carefully tap the differential bearing into its bore while easing the transfer sprocket onto the transfer shaft.

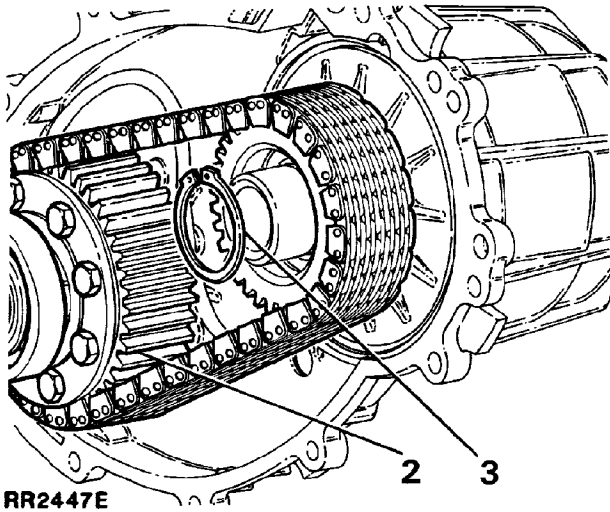

RR2447E

3. Ensuring that the transfer sprocket is fully down, secure the sprocket to the transfer shaft with the circlip.

Front and rear cover - main casing - Assemble

1. Ensuring that the joint faces of the front and rear covers are clean, apply a bead of Dow Corning 732 or a suitable equivalent silicone sealant to the joint face of the rear cover and evenly spread the sealant over the face. Do not over apply the sealant.

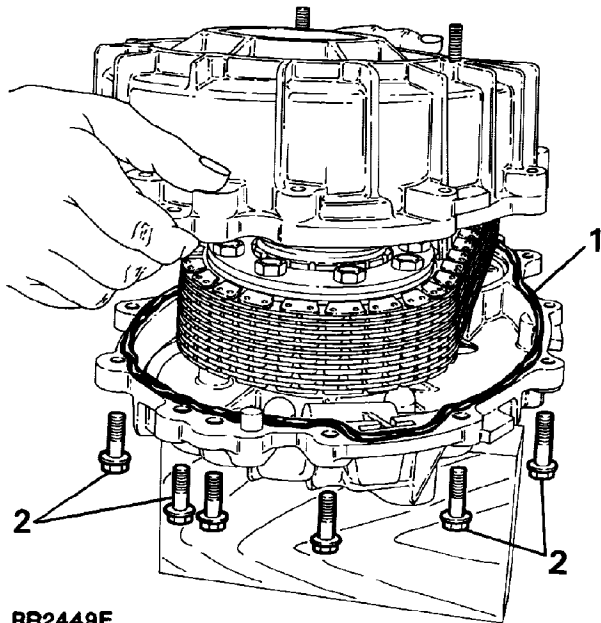

RR2449E

2. Fit the front cover, secure with the eleven bolts, tightening evenly to the specified torque. Do not wipe away the surplus sealant which is forced out of the joint.

**Rear output housing
- Dismantle and inspection**

Service tools:

18G1422 - Oil seal replacer

18G1205 - Adjustable flange holding wrench

1. Support the rear output housing by the output shaft in a vice fitted with soft jaws.
2. Using service tool 18G1205 to restrain the drive flange, release and remove the nyloc nut and plain washer securing the drive flange to the output shaft, withdraw the rubber seal. Discard the nut and seal.

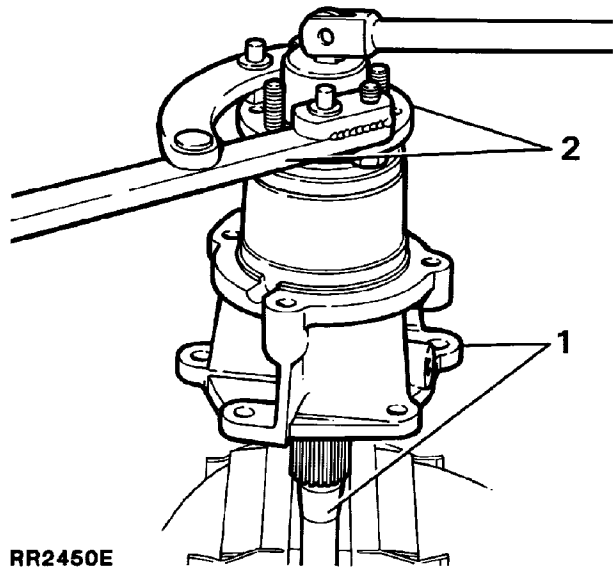

RR2450E

3. Remove the drive flange from the output shaft. Examine the flange for damage or wear particularly the seal running surface, if the surface is corroded or a groove has been worn by the previous seal discard the flange.
4. Prise the speedometer sleeve and driven gear from the housing. Examine the gear teeth for wear, if worn discard the gear.
5. Prise the oil seal from the sleeve and remove the 'O' ring, discard both the seal and 'O' ring.

41 TRANSFER GEARBOX

6. Clean the sleeve and place to one side.
7. Drive or press the output shaft from the housing.

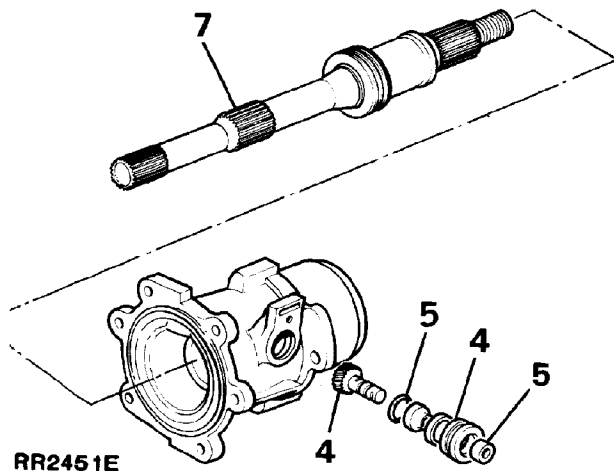

8. Clean and examine the splines and speedometer drive gear for wear or damage. The output shaft can be further dismantled if either the speedometer drive gear or output shaft is worn: remove the circlip and slide the gear from the shaft, retrieve the ball bearing from the indent in the shaft. Discard the worn component.

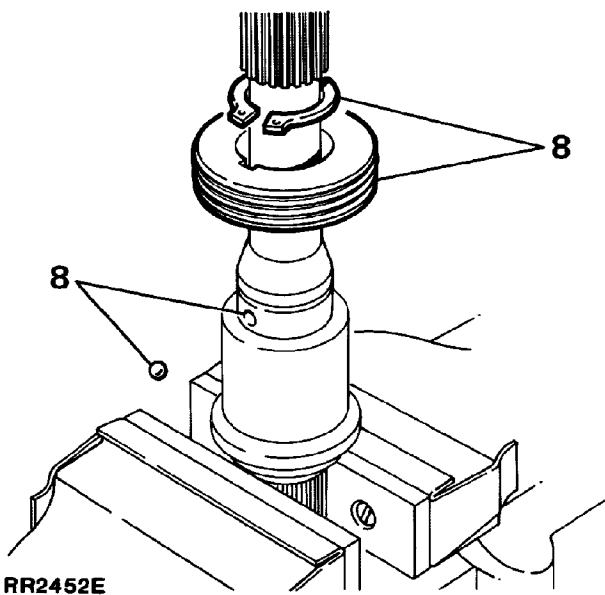

Viscous unit - rolling resistance Bench check



NOTE: Testing should be carried out in an ambient of 20 °C.

9. Secure the output shaft in a vice fitted with soft jaws, gripping the shaft on the drive flange splines.
10. With the viscous unit still installed in the front output housing place the assembly on the rear output shaft spline.
11. Apply a clockwise torque of **27 Nm** to output flange nut. If no resistance to turn is felt, unit requires replacing.
12. If resistance to turn is felt, apply a clockwise torque of **20Nm**, to output flange nut for 1 minute, this should result in a rotation of approximately 25° - 30°. If no rotation or a greater force is required, unit requires replacing.

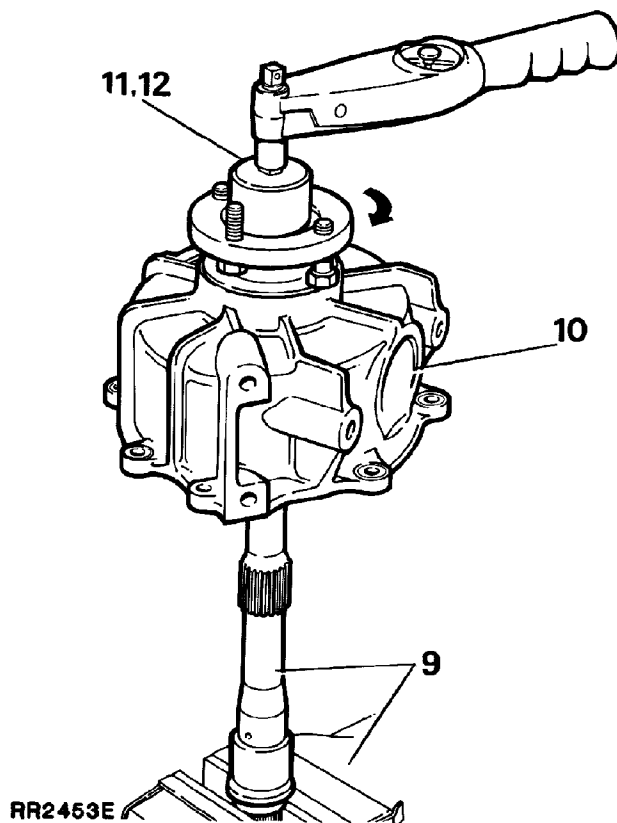

NOTE: While the output shaft is removed from the rear output housing, the shaft can be utilised for checking the rolling resistance of the viscous unit as follows.



Rear output housing (continued)

13. Lever off the dust shield.
14. Prise the oil seal from the housing and discard the seal.
15. Remove the circlip retaining the bearing.
16. Drive or press the bearing from the housing. Discard the bearing.
17. Remove any previous sealant from the housing joint face.

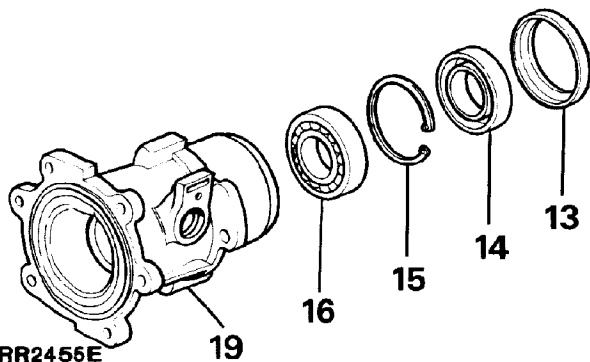

18. Thoroughly clean all components with a suitable solvent.
19. Examine the housing for damage and wear. Renew as necessary.

Rear output housing - Assemble

20. Drive or press a new bearing into the housing until the bearing contacts the shoulder.
21. Fit the circlip.
22. Lubricate a new oil seal. Using oil seal replacer 18G1422 fit the seal, lip side leading until it contacts the circlip.
23. Fit the dust shield.
24. Place the ball bearing in the indent on the output shaft, fit the speedometer drive gear to the shaft, secure together with the circlip.
25. Press or drive the output shaft into the housing until the shoulder of the shaft contacts the bearing.
26. Lubricate the oil seal bearing surface of the drive flange and fit the flange followed by a new rubber seal. Fit the steel washer and secure the flange to the shaft using a new nut. Tighten to the specified torque.
27. Lubricate a new speedometer sleeve oil seal, press the seal into the top of the sleeve.

28. Fit a new 'O' ring to the outside of the sleeve, push the driven gear spindle into the sleeve.
29. Lubricate the 'O' ring and push the sleeve and gear assembly into the housing. It may be necessary to rotate the output shaft to ensure that the driven gear engages with the drive gear on the shaft.
30. Apply Dow Corning 732 or a suitable equivalent silicone sealant to the rear output housing joint face on the main casing. Evenly spread the sealant on the face to ensure a good seal.
31. Fit the housing to the main casing and secure with the six bolts tightened to the specified torque.

**Front output housing
- Dismantle and Inspection**

Service tools:
 18G1422 - Oil seal replacer.
 18G1205 - Adjustable flange holding wrench

1. Support the viscous unit and front output housing in a vice fitted with soft jaws gripping on the two flats of the viscous unit.
2. Using service tool 18G1205 to restrain the drive flange, release and remove the nyloc nut and plain washer securing the drive flange to the output shaft, withdraw the rubber seal. Discard the nut and seal.
3. Remove the drive flange from the viscous unit. Examine the flange for damage or wear particularly the seal running surface, if the surface is corroded or a groove has been worn by the previous seal discard the flange.

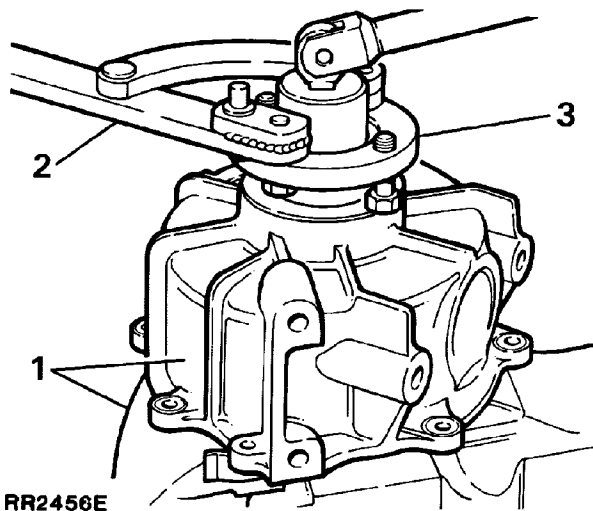

41 TRANSFER GEARBOX

4. If necessary the oil catcher can be carefully pressed from the drive flange, if either a new oil catcher or bolts are being fitted.

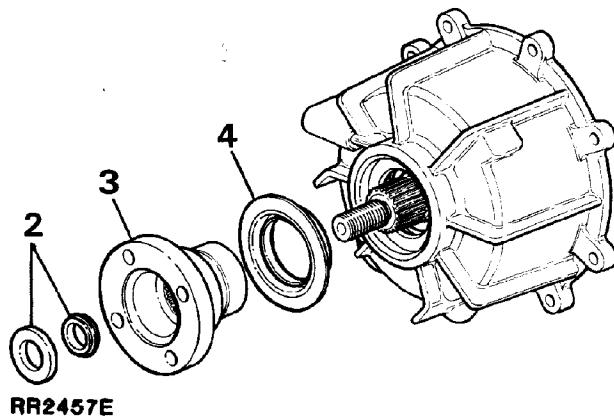

5. Carefully tap the viscous unit out of the housing. If the original unit is being refitted wipe clean with a clean cloth.

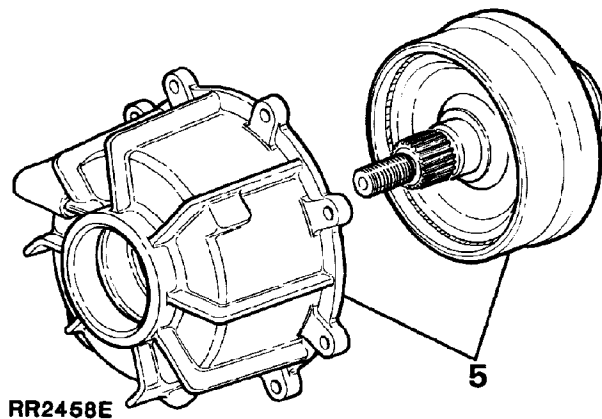

NOTE: The viscous unit is a sealed assembly and cannot be further dismantled, a new unit should be fitted if the unit is damaged or if the torque to turn is out of limits.

6. Prise the oil seal out from the front output housing and discard.
7. Remove the circlip retaining the bearing.
8. Drive or press the bearing from the housing and discard.

9. Clean the housing with a suitable solvent.
10. Remove any previous sealant from the joint face of the housing.

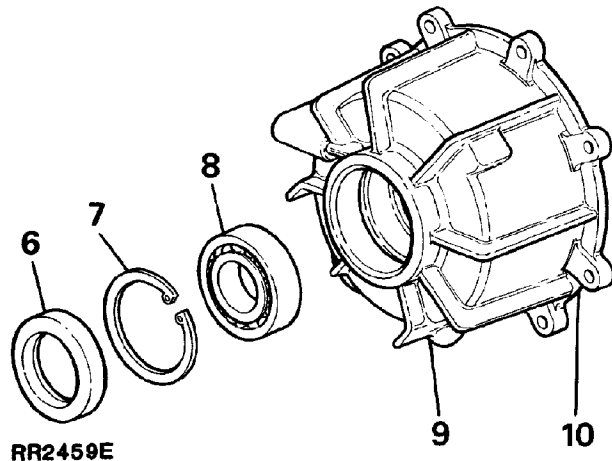

11. Examine the housing for damage and wear, renew the housing if necessary.

Front output housing - Assemble

12. Drive or press a new bearing into the housing
13. Fit the circlip to retain the bearing.
14. Lubricate a new oil seal. Using oil seal replacing tool 18G1422 fit the seal, lip side of the seal leading until it contacts the circlip.
15. Carefully tap the original or new viscous unit into the housing until contact is made with the face of the bearing.
16. Lubricate the lips of the seal and fit the flange followed by a new rubber seal; fit the steel washer and secure the flange with a new nut. Tighten to the specified torque.
17. Apply Dow Corning 732 or a suitable equivalent silicone sealant to the output housing joint face of the main casing. Evenly spread the sealant on the face to ensure a good seal.
18. Fit the housing to the main casing and secure in position with the eight bolts tightened evenly to the specified torque.
19. Refit the gearbox to the vehicle.



TORQUE VALUES



NOTE: Torque wrenches should be regularly checked for accuracy to ensure that all fixings are tightened to the correct torque.

	Nm
Brake drum back plate to rear output housing	73
Brake drum to drive flange	25
Centre differential (front to rear)	60
Drive flanges to transfer gearbox	224
Driven gear to centre differential	50
Front cover to rear cover - main case	40
Front output housing to main case	33
Gearbox mounting brackets to chassis	45
Mounting bracket to gearbox	102
Neutral warning switch	47
Oil drain plug	25
Oil filler/level plug	25
Oil pump fixings	7
Propeller shafts to drive flanges	46
Rear output housing to main case	40
Selector lever shaft	8
Selector fork operating arm	8

Torque values below are for all screws and bolts used except for those that are specified otherwise.

METRIC	Nm
M5	6
M6	9
M8	25
M10	45
M12	90
M14	105
M16	180

UNC / UNF	
1/4	9
5/16	24
3/8	39
7/16	78
1/2	90
5/8	136

LRT-41-010 Oil seal replacer.
LST.550-6

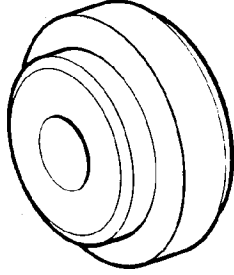

LST5506



DESCRIPTION

The automatic transmission is specially tailored version of the ZF4 HP22, used by many manufacturers of high performance vehicles.

A three element torque converter delivers the power to a four speed epicyclic transmission. First, second and third gears are reduction ratios but fourth is an overdrive gear for high speed cruising. A direct drive clutch, integral with the torque converter operates to engage fourth gear.

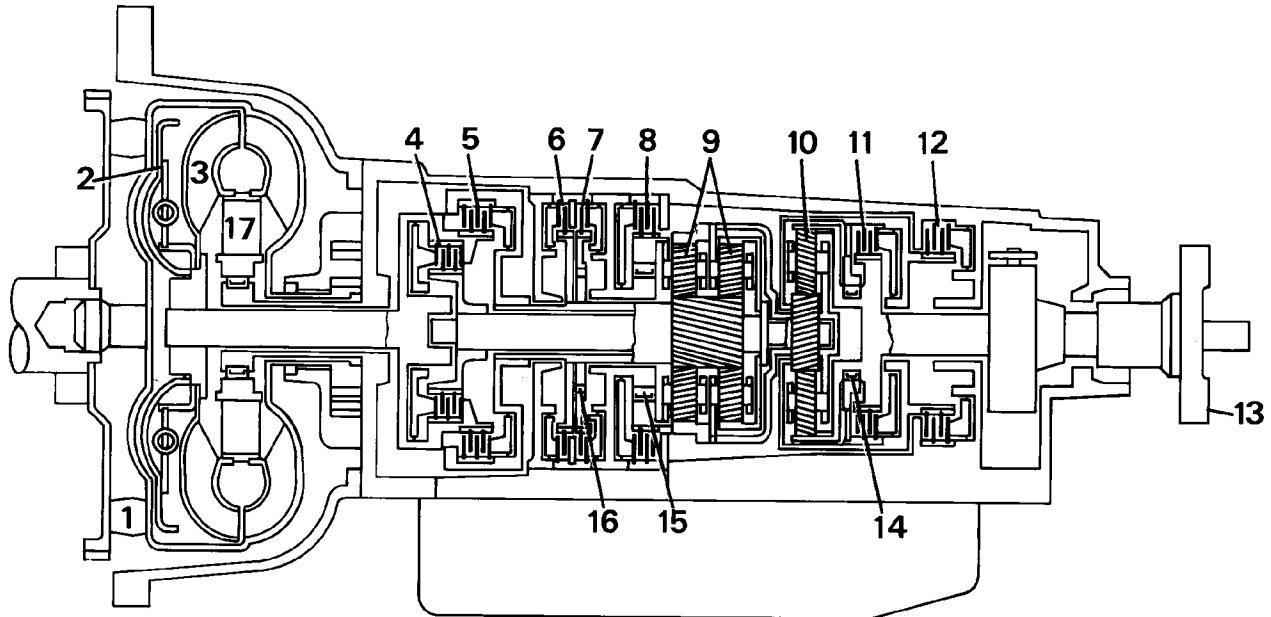

RR3560A

The gear selector has seven positions as follows:

- P = Park provides a mechanical lock on the output shaft.
- R = Reverse gear.
- N = Neutral.
- D = Provides a 1st gear start and automatic shifts 1-2-3-4-3-2-1.
- 3 = Provides a 1st gear start and automatic shifts 1-2-3-2-1.
- 2 = Provides a 1st gear start and automatic shifts 1-2-1 or 3-2-1.
- 1 = Provides a 1st gear start with no up shifts, or 3-2-1.

All automatic shifts are automatically controlled by the valve block and an hydraulic governor driven by the output shaft.

Power flow

1st gear D selected

With D selected 1st gear engaged, clutches 4 and 11 are operative. The front planet gear carrier of gear set 9 is locked against the housing through freewheel 15 when the engine is pulling but freewheels when the vehicle is coasting. Epicyclic gear set 10 rotates as a solid unit with the front planet gear carrier. In selector position 1 with 1st gear engaged, clutch 8 operates to prevent the loss of drive on the overrun through freewheel 15, to provide engine braking.

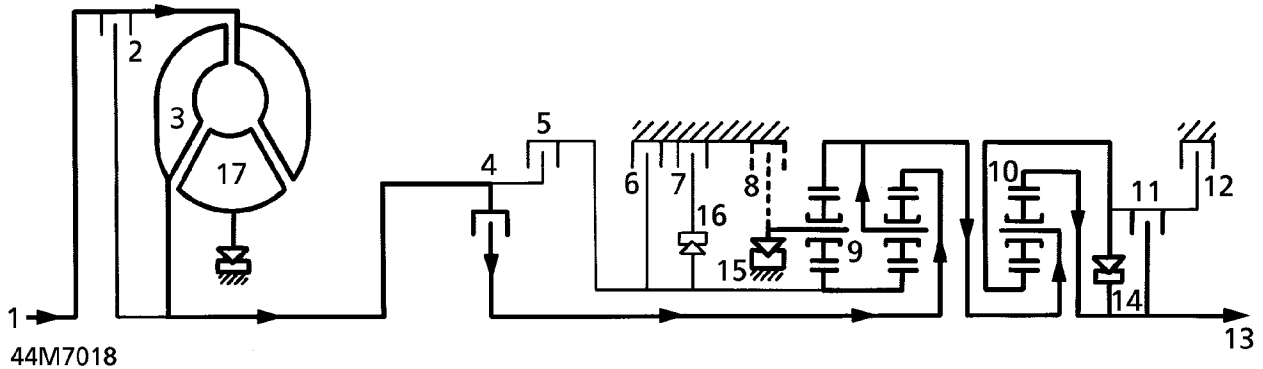

2nd gear D selected

Clutches 4, 6, 7 and 11 are engaged. Freewheel 15 overruns, the hollow shaft with the sun wheel of epicyclic gear set 9 is locked. Epicyclic gear set 10 also rotates as a solid unit.

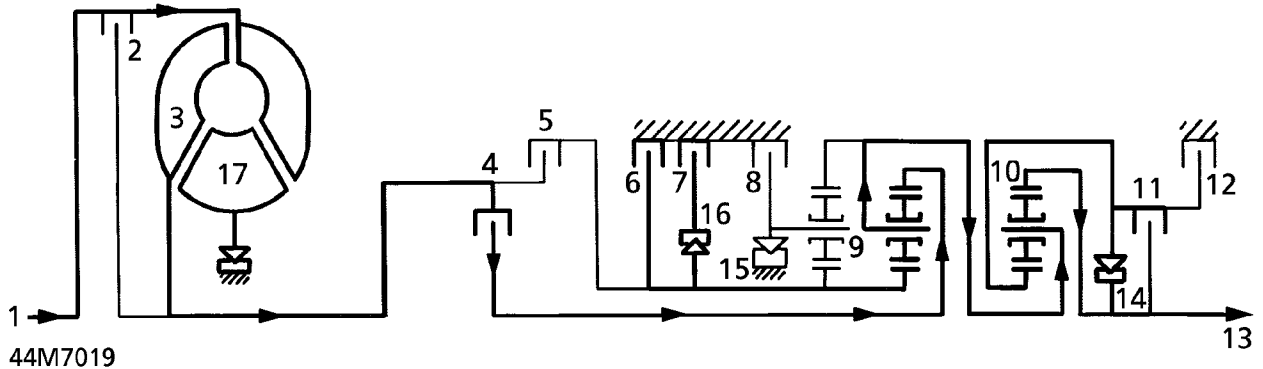



3rd gear D selected

Clutches 4, 5, 7 and 11 are engaged. Freewheel 15 and 16 are overrun. Epicyclic gear set 9 and 10 rotate as a solid unit at a ratio of 1:1.

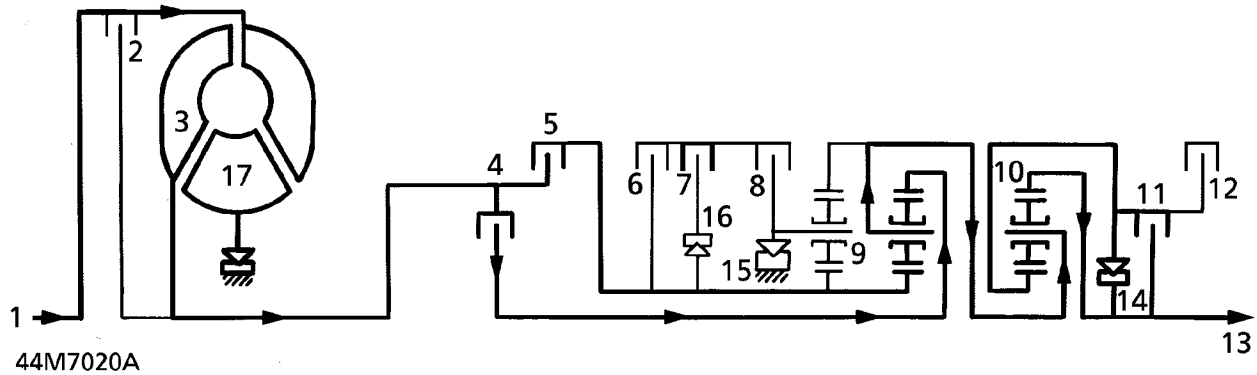

4th gear D selected

Clutches 4, 5, 7 and 12 are engaged. Freewheel 14, 15 and 16 are overrun. Epicyclic gear set 9 rotates as a solid unit. The hollow shaft with the sun wheel of epicyclic gear set 10 is locked.

Above a predetermined road speed, clutch 2 locks the gearbox power input direct to the engine, by-passing the torque converter.

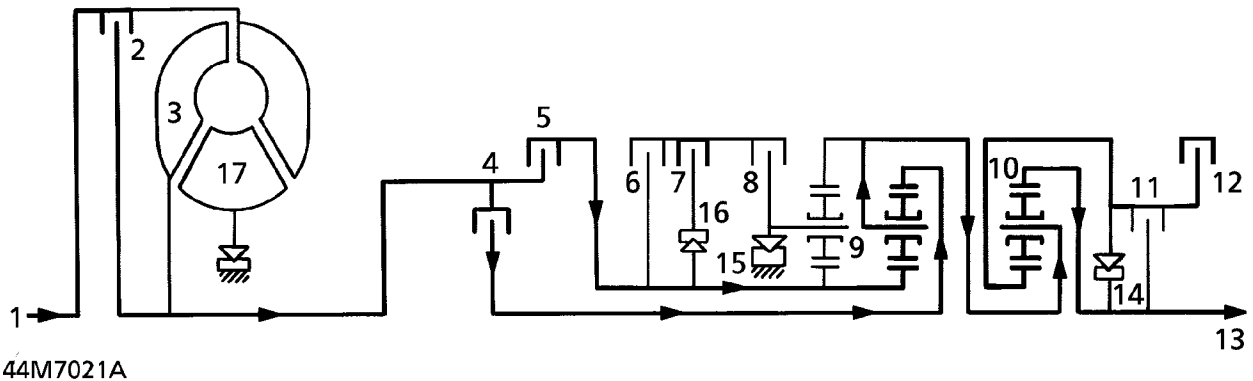

Reverse gear

Clutches 5, 8 and 11 are engaged. Since the front planet gear carrier of epicyclic gear set 9 is locked, the direction of output-shaft rotation is reversed. Epicyclic gear set 10 also rotates as a solid block.

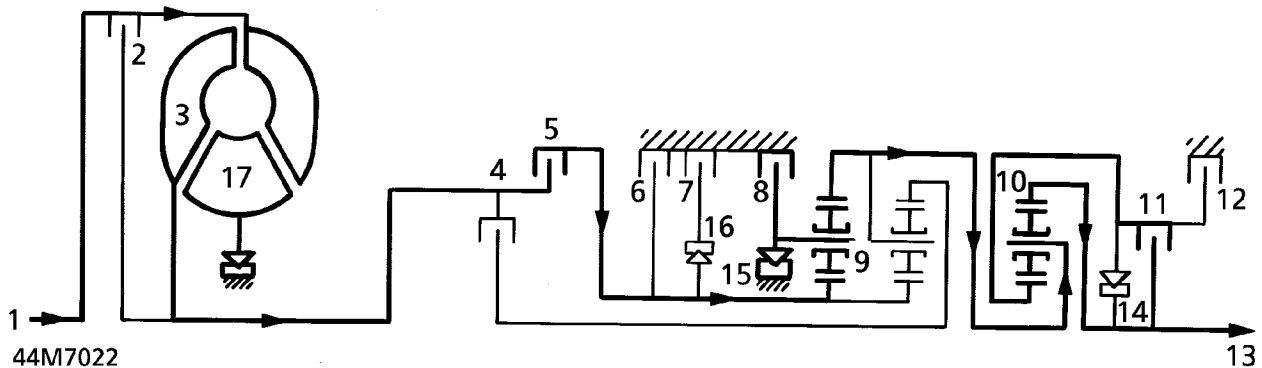



ZF AUTOMATIC GEARBOX

Before referring to fault symptoms, carry out initial static checks first:

INITIAL STATIC CHECKS

Check start positions	'P' & 'N' only
Reverse lights	'R' only
Gear engagements	N-D,N-3,N-2,N-1,N-R
Full throttle	Engine switched off, check full travel at engine and at pedal.
Oil level	'N' selected, engine running at normal running temperature.

Pressure test

2000 rev/min	10 \pm 0.3 bar, 150 \pm 5 lbf/in ²
Idle pressure	6.9 \pm 0.3 bar, 100 \pm 5 lbf/in ² at 665 to 735 rev/min.

To fit pressure gauge

Service tools: See *Service tools, Automatic Gearbox*

0 to 20 bar, 0 to 300 lbf/in² Pressure gauge.
Flexible hose adaptor.

1. Site vehicle on a ramp [hoist].
2. From under gearbox, remove socket head plug (located 10cm from oil pipe) Fit hose adaptor LST502-1.
3. Fit hose to adaptor.
4. Fit gauge 18G502A to hose and route into vehicle, ensuring hose is clear of rotating parts and exhaust pipes.

Remove pressure gauge

6. Reverse removal procedure.

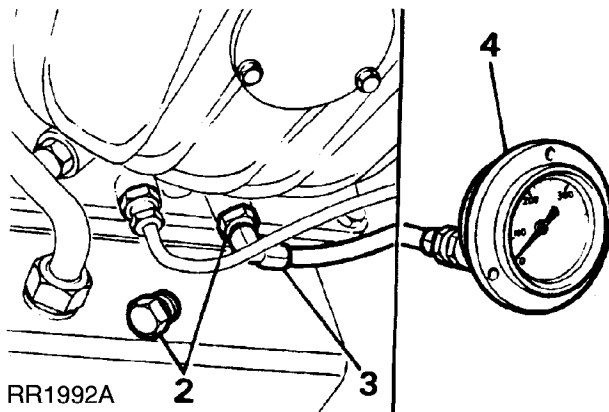

5. Carry out road test. See *Road Test Procedure*

ROAD TEST PROCEDURE

Follow the procedure given commencing each test, from a standing start, on a level road, in good weather conditions.

ROADTEST 1 = CHECKS 1-2-3-4-5-6-7-8

D SELECTED KICKDOWN START FROM REST

CHECK 1

Check for clutch squeal and slip. Check pressure is 10 bar, 150lb/in²

CHECK 2

Check 1st to 2nd upshift speed and quality. Pressure should fall to 8.2 bar, 120 lb/in².

CHECK 3

Check 2nd-3rd upshift speed and quality. Pressure should fall to 6.8 bar, 100 lb/in²

CHECK 4

Release throttle to allow simultaneous engagement 4th + DDC. Check shift quality and engine rpm drop of approximately 500 rpm.

CHECK 5

To proceed to Check 5 release throttle and check drop out speed of direct drive clutch to 4th.

CHECK 6

Check down shift speed and quality 4th to 3rd.



NOTE: This shift is usually very smooth and difficult to detect.

CHECK 7

Check downshift speed and quality 3rd to 2nd.

CHECK 8

Check downshift speed and quality 2nd to 1st. Also difficult to detect.

END OF ROADTEST 1

ROADTEST 2 CHECKS = 9-10-11

D SELECTED FROM REST

FULL THROTTLE START

CHECK 9

Check 1st-2nd upshift speed and quality.

CHECK 10

Check 2nd 3rd upshift speed and quality.

CHECK 11

Check 3rd 4th and direct drive clutch upshift speed and quality.



NOTE: 4th and the direct drive clutch engage simultaneously.

END OF ROADTEST 2



ROADTEST 3 = CHECKS
12-13-14-15-16-17-18-19-20-21-22-23

D SELECTED FROM REST

LIGHT THROTTLE START

CHECK 12

Check 1st 2nd upshift speed and quality.

CHECK 13

Check 2nd 3rd upshift speed and quality.

CHECK 14

Check 3rd 4th upshift speed and quality.



NOTE: This shift is usually very difficult to detect but can be confirmed by a 200 rpm drop in engine speed.

CHECK 15

Check speed and quality of shift into direct drive clutch, confirmed by 300 rpm drop in engine speed.



NOTE: An intermediate throttle position engagement of 4th and the direct drive clutch, which is indicated by a fall of 500rpm in engine speed.

CHECK 16

At approximately 88 kph (55 mph) depress throttle to kickdown - gearbox should change down to 2nd - release throttle to re-engage 4th direct drive clutch continue to accelerate gently.

CHECK 17

At approximately 128 kph (80 mph) depress throttle to kickdown - gearbox should change down to 3rd - release throttle to re-engage 4th direct drive clutch and continue to accelerate gently.

CHECK 18

At approximately 138 kph (85 mph) select 3rd, gearbox should change immediately down to 3rd. Release throttle.

CHECK 19

De-accelerate to approximately 47 kph (30 mph) depress throttle to kickdown - gearbox should downshift to 1st gear, continue accelerating at full throttle until 3rd gear is attained. To do this you will have repeated check 2 of Test 1.

CHECK 20

At 128 kph (80 mph) select 2nd no downshift should occur. Release throttle.

CHECK 21

At 104 kph (65 mph) an automatic downshift into 2nd gear should occur. Continue to de-accelerate.

CHECK 22

At 88 kph (55 mph) select 1st. No downshift should occur. Continue to de-accelerate.

CHECK 23

With 1 selected 2nd gear engaged continue to de-accelerate and at 45 kph (28 mph) the box should automatically downshift to 1st gear after which no upshifts will occur in this selector position.

END OF ROADTEST

AUTOMATIC GEARBOX ASSEMBLY ILLUSTRATED

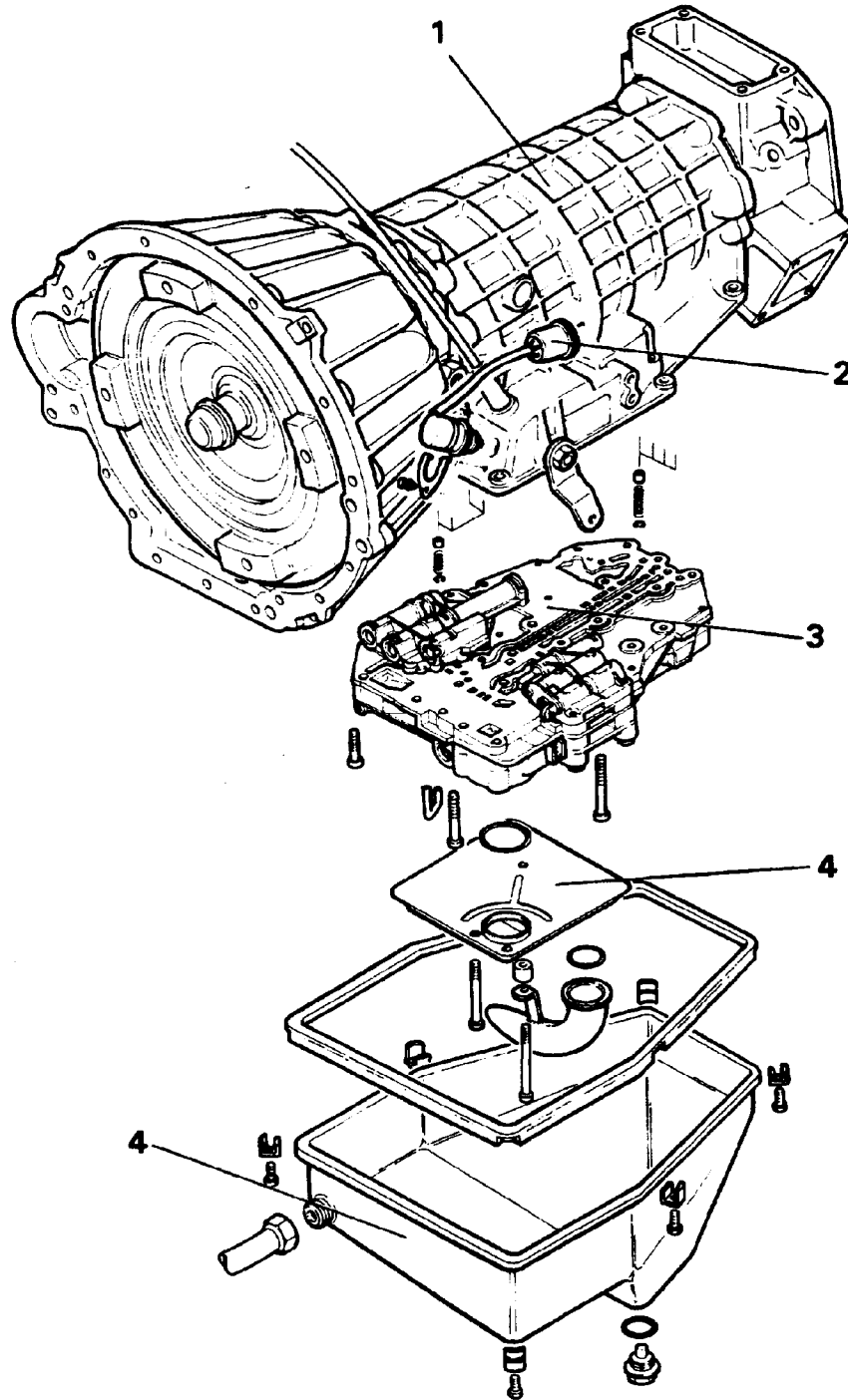

RR0524A

1. Gearbox assembly
2. Inhibitor switch assembly
3. Control unit assembly
4. Filter and sump assembly



1. Torque converter housing assembly
2. Gearbox pump and casing assembly
3. Governor and adaptor housing assembly

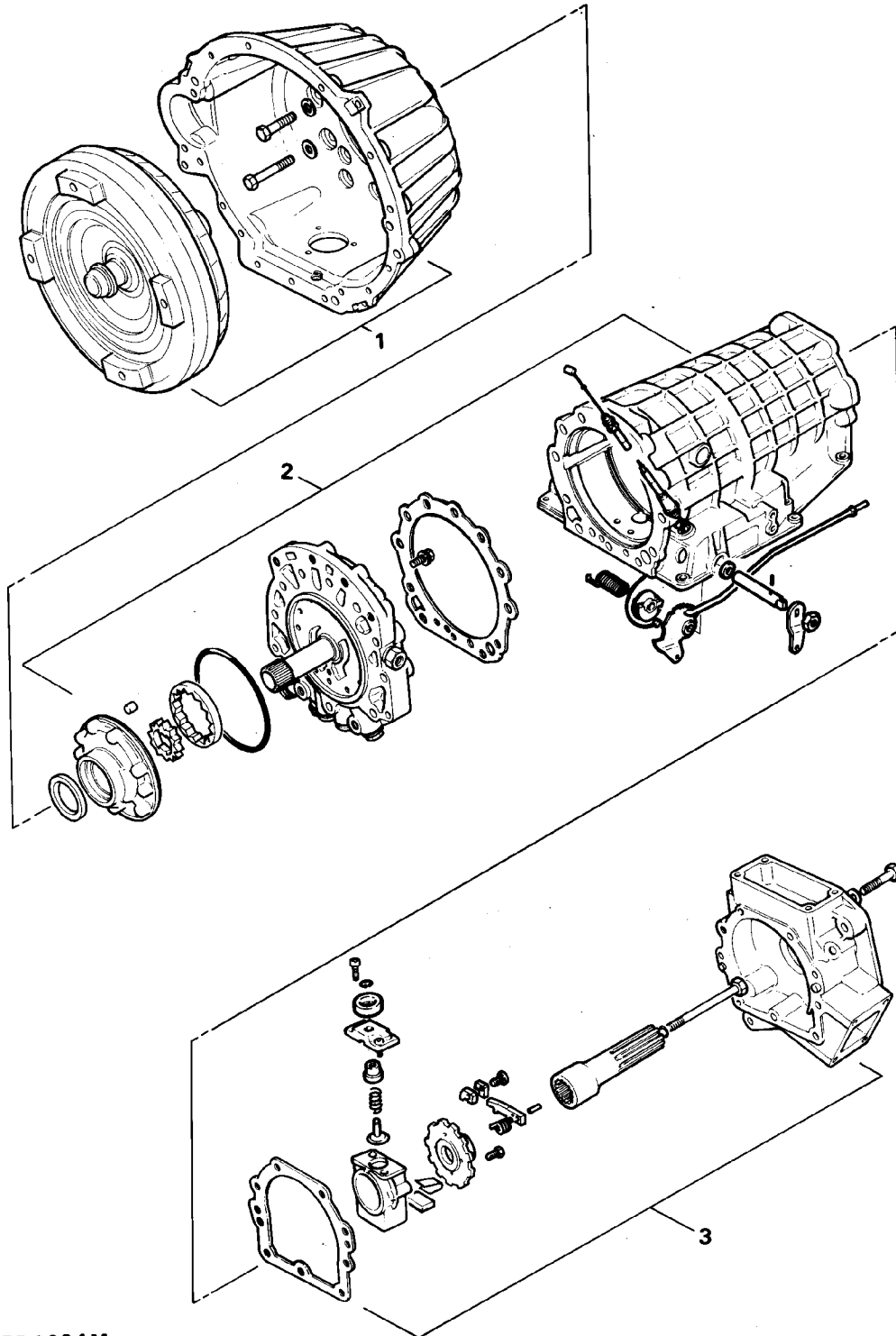

RR 3894M

- 1. A Clutch assembly
- 2. B Clutch assembly

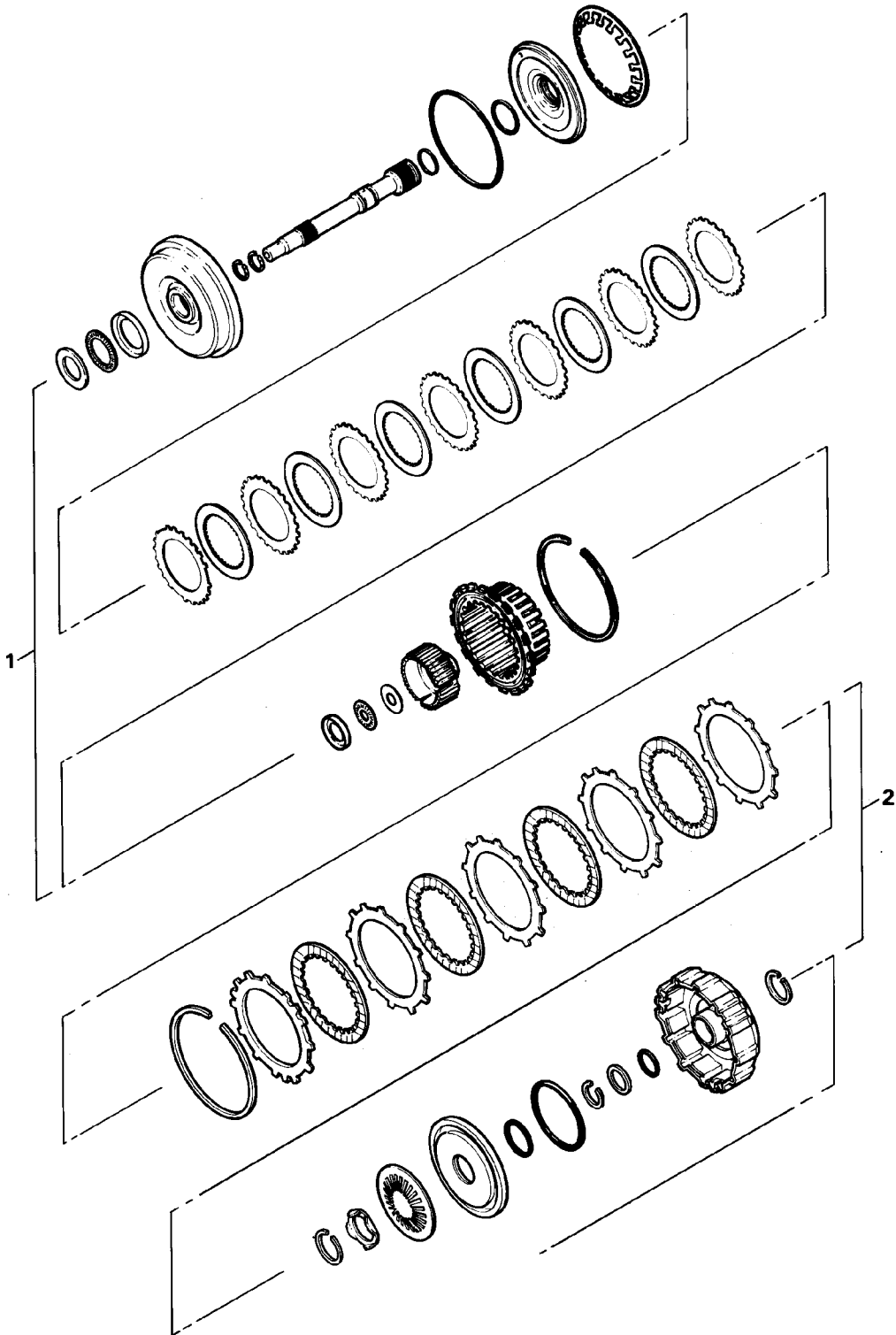

RR3895M



1. C, C' and D Clutch assembly

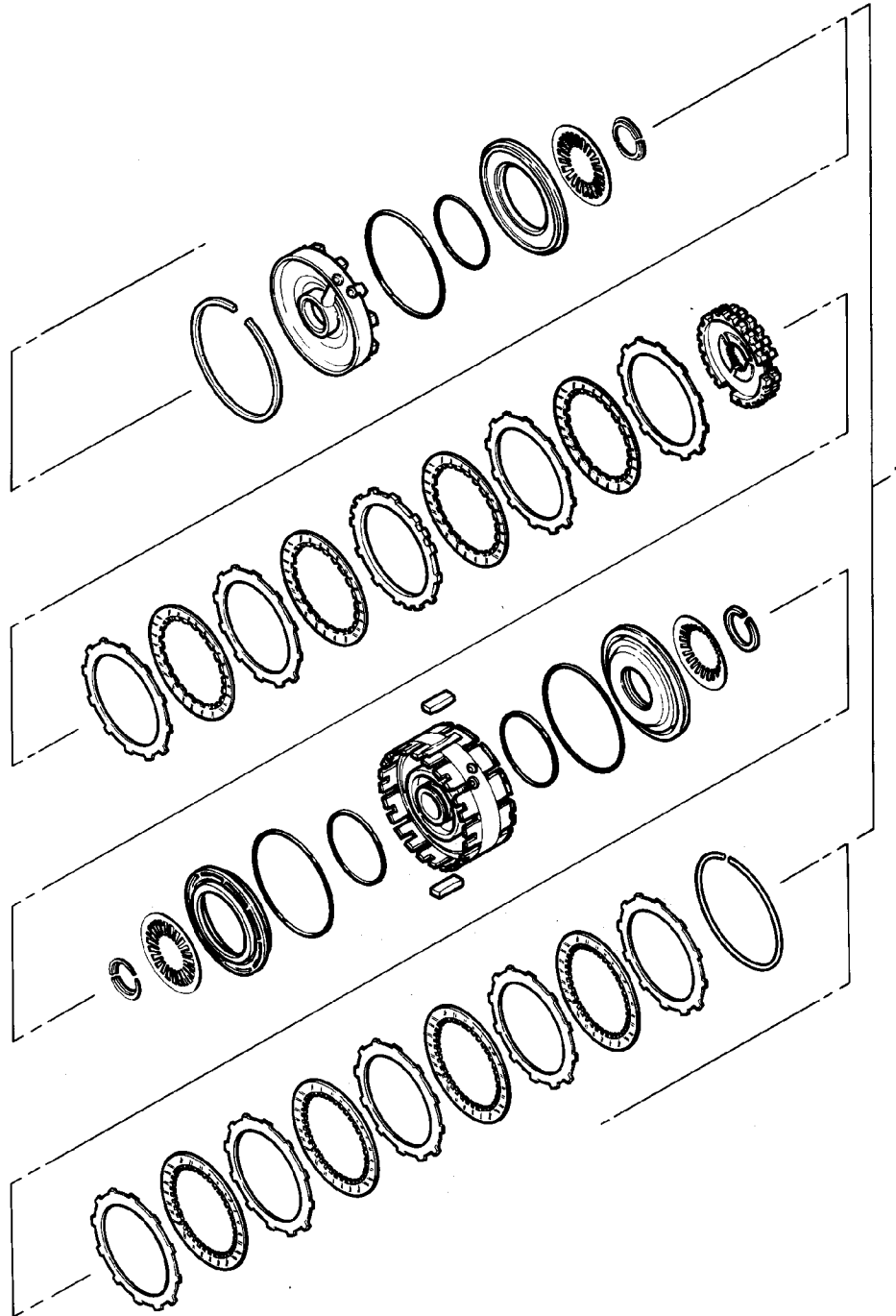

RR3896M

1. Freewheel and fourth gear assembly

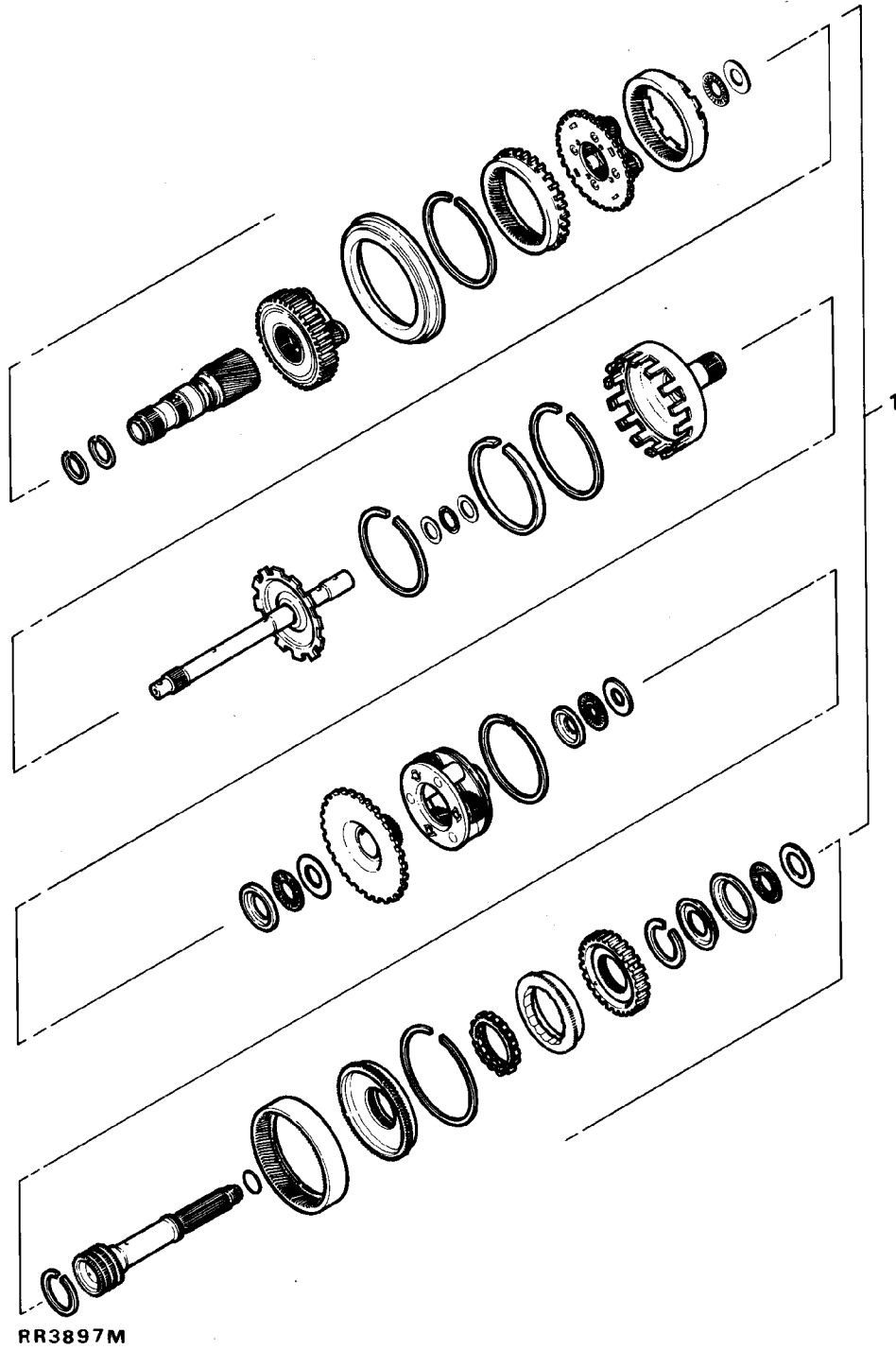



1. E and F Clutch assembly

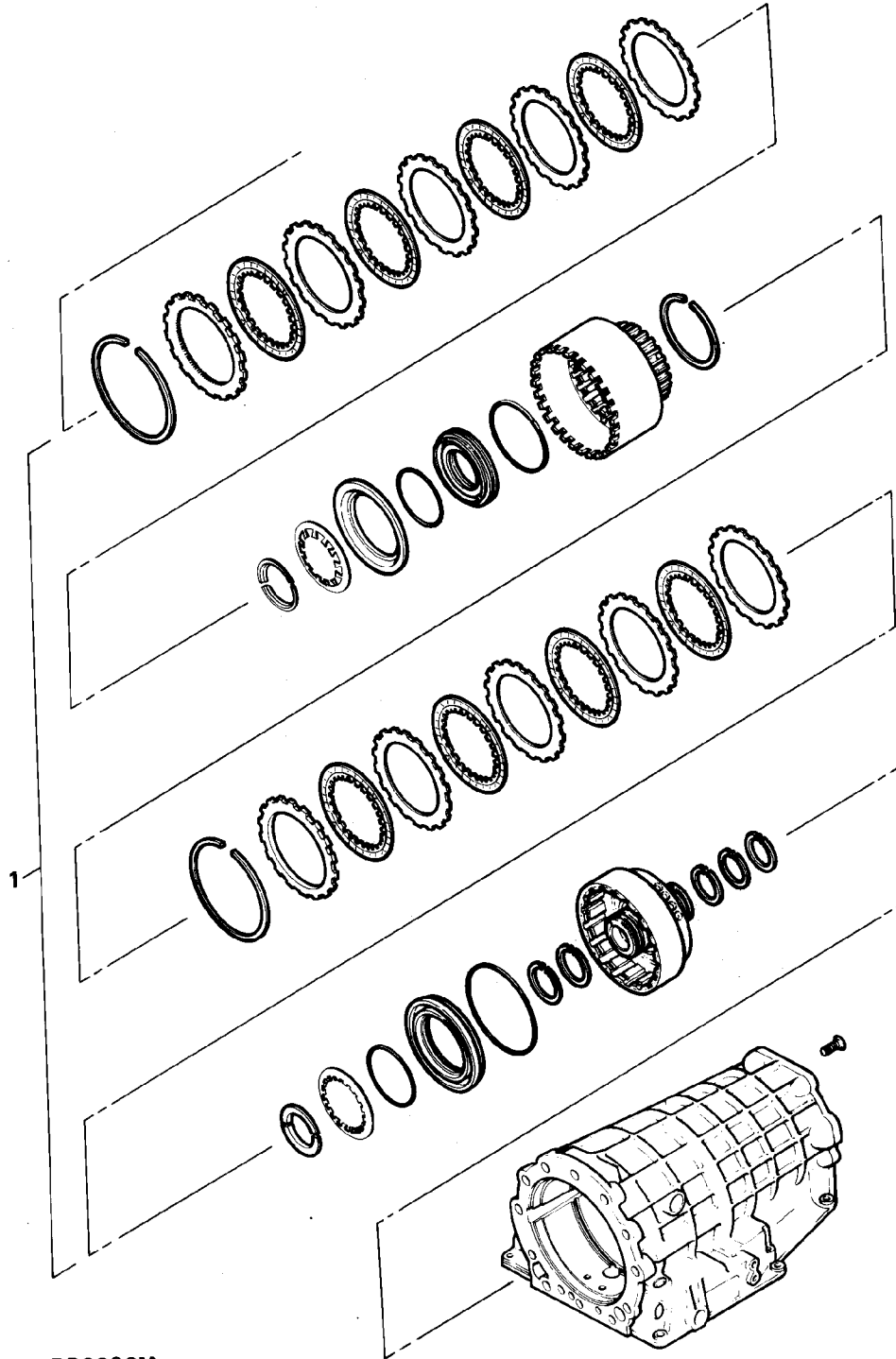

RR3898M

FAULT SYMPTOMS

SYMPTOM 1 - Intermittent drive and high pitched noise

FAULT - Low fluid level or restricted filter

SYMPTOM 2 - No drive in reverse

Select 'D'

œ No drive

FAULT - Continue with Symptom 3

œ Drives forward

FAULT - Reverse gear interlock valve seized

Select '1'

œ No engine braking

FAULT - Clutch brake 3

SYMPTOM 3 - No drive from rest with 'D' selected

Select '1'

œ Vehicle drives

FAULT - No 2 freewheel

œ No drive

Carry out main line pressure check

œ Normal pressure

FAULT - Clutch A

œ No pressure

FAULT - Blocked filter or pump failure

œ Low pressure

FAULT - Restricted filter or sticking primary regulator

SYMPTOM 4 - Slip in all forward gears

Carry out main line pressure check

œ No pressure

FAULT - Blocked filter or pump failure

œ Low pressure

FAULT - Restricted filter or sticking primary regulator

œ Normal pressure

FAULT - Clutch 'A'

SYMPTOM 5 - Harsh engagement 'N' to 'D'

Check engine idle speed

Carry out main line pressure check

œ High pressure

FAULT - Primary regulator stuck

œ Normal pressure

FAULT - Clutch 'A' or damper for clutch 'A'

SYMPTOM 6 - Fierce shift or flare 1st to 2nd shift

Check engine idle speed

Carry out mainline pressure check

œ High pressure

FAULT - Continue with symptom 5

œ Normal pressure

FAULT - Modulator valve or dampers for clutch brake CB1 and/or clutch brake CB2

FAULT - Clutch brake CB1 and/or clutch brake CB2

SYMPTOM 7 - Fierce shift or flare 2nd to 3rd

Carry out mainline pressure check

œ High pressure

FAULT - Continue with symptom 5

œ Normal pressure

FAULT - Modulator valve or clutch 'B' damper

FAULT - Clutch 'B'

SYMPTOM 8 - No 3rd gear

FAULT - 2-3 shift valve

FAULT - Clutch 'B'

SYMPTOM 9 - No 4th gear 'D' selected

FAULT - 4th to 3rd downshift valve stuck or

3rd to 4th upshift valve stuck

FAULT - Clutch brake 4



SYMPTOM 10 - None or harsh engagement of direct drive clutch



NOTE: The direct drive clutch will only engage if 4th gear is engaged at 40 to 45 mph (65 to 70 km/h).

Carry out road test pressure check with gauge connected to torque converter.

- œ Normal pressure
 FAULT - Failed direct drive clutch
- œ Pressures correct but remains high
 FAULTS POSSIBLE -
 Direct drive clutch and torque converter control valve stuck
 Hysteresis valve stuck
 Direct drive clutch control valve stuck

SYMPTOM 11 - Direct drive clutch shift point incorrect or at low speed



NOTE: Direct drive clutch engagement at low speed will cause vibration in the torque converter

Carry out mainline and torque converter pressure check

- œ Normal pressure
 FAULT - Governor valve sticking
- œ Low or incorrect pressure
 FAULTS POSSIBLE -
 Direct drive clutch and torque converter control valve sticking.
 Hysteresis valve stuck.
 Direct drive clutch control valve stuck.

SYMPTOM 12 - Drives in 'D' but immediately upshifts to 3rd

FAULT - 2nd to 3rd shift valve stuck.

SYMPTOM 13 - With 'D' selected vehicle starts in 2nd

FAULTS POSSIBLE -
1st and 2nd shift valve stuck.
Governor sleeve sticking.

SYMPTOM 14 - With 'D' selected vehicle starts in 3rd

FAULTS POSSIBLE -
1st to 2nd and 2nd to 3rd shift valves stuck.
Governor sleeve sticking.

SYMPTOM 15 - No kickdown 4th to 3rd

FAULT - 4th to 3rd kickdown valve stuck.

SYMPTOM 16 - Upshifts/downshifts and kickdown shifts at incorrect road speeds

Check throttle kickdown cable adjustment
Carry out main line pressure check

- œ Normal pressure
 FAULT - Governor valve sticking
- œ Incorrect pressure
 FAULTS POSSIBLE -
 Incorrect throttle valve adjustment
 Primary regulator sticking

SYMPTOM 17 - No upshifts at light throttle

FAULTS POSSIBLE
Governor valve sticking
Shift valves sticking

SYMPTOM 18 - No engine braking '3' selected 3rd gear

FAULT - Clutch 'C'

SYMPTOM 19 - Delayed or no downshift occurs when making a manual selection from '3' to '2'

FAULTS POSSIBLE -
2nd and 3rd upshift valve sticking.
Governor valve sticking.
'2' Position interlock valve sticking.

SYMPTOM 20 - At speeds below 28 mph (45 km/h) when making a manual selection from '2' to '1', downshift is delayed or does not occur

FAULTS POSSIBLE -
Governor sticking.
1st to 2nd shift valve sticking.
'1' Position interlock valve sticking.

SYMPTOM 21 - '1' Selected 1st gear no engine braking

FAULT - Clutch brake 3

SYMPTOM 22 - '2' Selected 2nd gear no engine braking

FAULT - Clutch brake 1

SYMPTOM 23 - Vehicle drives forward in 'N'

FAULT - Clutch 'A' stuck



ZF AUTO WITH BORG WARNER TRANSFER GEARBOX

Remove

Underbonnet



WARNING: When using transmissions jack, follow equipment manufacturers instructions to ensure safe and effective use of equipment.

1. Place vehicle on ramp [hoist]. Check road wheels.
2. Disconnect battery negative lead.
3. Remove fan blade assembly. Note assembly has left hand thread.
4. Remove air intake hose from plenum chamber (V8i only).
5. Disconnect kickdown cable from throttle linkage.
6. Release gearbox breather pipes from the rear of the engine.
7. Remove gearbox dip stick.

Inside Vehicle

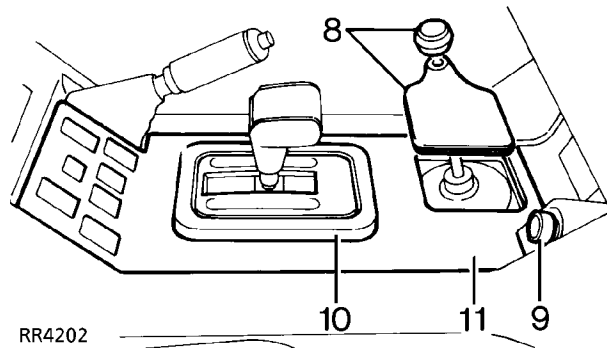

RR4202

8. Select low range, unscrew and remove transfer gearbox knob.
9. Remove cigar lighter.
10. Remove surround from gear selector panel.
11. Prise out wood veneer panel from centre console, and disconnect multiplugs from switches.

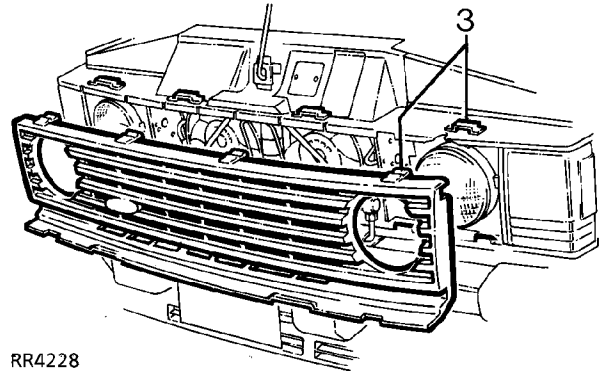

RR4228

12. Remove the five fixings securing the centre console to the floor, and two clips at the front.
13. Disconnect multiplugs from window lift switch panel.
14. Disconnect multiplug to selector graphics panel and remove inset panel.
15. Disconnect electrical leads to cigar lighter.
16. Remove sound deadening trim from top of gearbox tunnel.
17. Remove retaining plate from transfer gearbox lever.

Under Vehicle

18. Raise ramp [hoist].

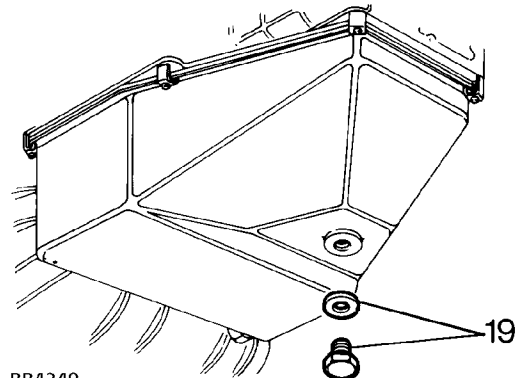

RR4240

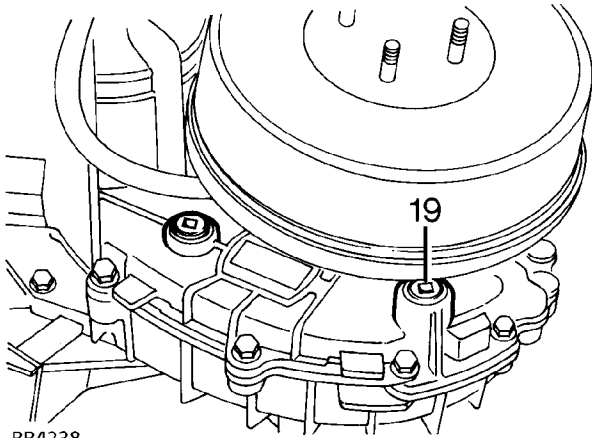

19. Drain oil from main and transfer gearbox. Refit plugs.
20. Disconnect multiplugs to oxygen sensors and remove front exhaust sections. (V8i only)
21. Remove chassis cross member secured by eight nuts and bolts. (V8i only)
22. Release two clamps securing gearbox oil cooler pipes.
23. Place a suitable container below gearbox, disconnect oil cooler return pipes from gearbox. Plug open ends of pipe.
24. Remove dipstick tube from gearbox sump.
25. Mark propeller shaft and transfer gearbox flanges for reassembly. Disconnect propeller shafts at output flanges. Tie shafts to one side.
26. Disconnect multiplug from speed transducer.
27. Disconnect main gearbox selector cable and rod from left side of gearbox. Lay cable aside.
28. Disconnect inhibitor switch.
29. Remove transmission brake drum, remove four bolts securing back plate to transfer box and tie assembly aside complete with handbrake.

Remove Transmission Assembly

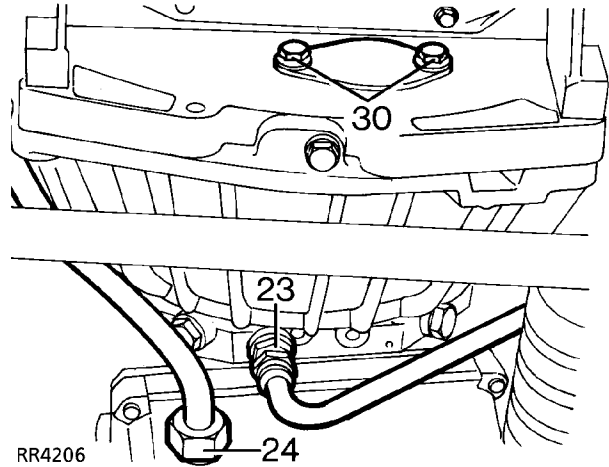

30. Remove two bolts and remove cover plate from bottom of gearbox bell housing.
31. Rotate engine using crankshaft pulley until the access holes in the drive plate are visible.
32. Remove the bolts securing drive plate to torque converter. Mark one access hole and one bolt with an identification line for accurate reassembly.
33. Rotate crankshaft to remove all bolts.
34. Position transmission jack on rear output housing to support weight of transmission assembly.
35. Remove bolts and withdraw transfer gearbox and main gearbox mountings.
36. Remove bolts securing the chassis cross member, and using a suitable method of spreading the chassis remove the chassis cross member. (Tdi only)
37. Fit adaptor plate (See service tools) to transmission hoist, raise and position hoist under transfer gearbox mounting points.
38. Secure adaptor plate to gearbox using gearbox mounting bolts.



39. Remove transmission jack from transmission assembly.
40. Remove front exhaust pipe. (Tdi only)
41. Carefully lower transmission until top of transfer gearbox clears rear passenger footwell.
42. Position transmission jack under engine to support weight while bell housing bolts are removed.
43. Remove bell housing bolts, note that one bolt secures gearbox dip stick tube.
44. Withdraw transmission assembly from engine, ensuring torque converter is removed with gearbox.

Refit

45. Refitting gearbox is reverse of removal instructions, noting following points.
46. Coat drive plate to torque converter bolts with Loctite 270.
47. Tighten all bolts to specified torque. **See Specifications, torque, Torque Values**
48. Fit new exhaust gaskets to torque.
49. Refill gearbox with correct grade and quantity of oil **See LUBRICANTS, FLUIDS AND CAPACITIES, Information, Recommended fluid and lubricants**

INHIBITOR SWITCH

Service repair no - 44.15.19

Remove

1. Site vehicle on ramp. Disconnect battery negative lead.

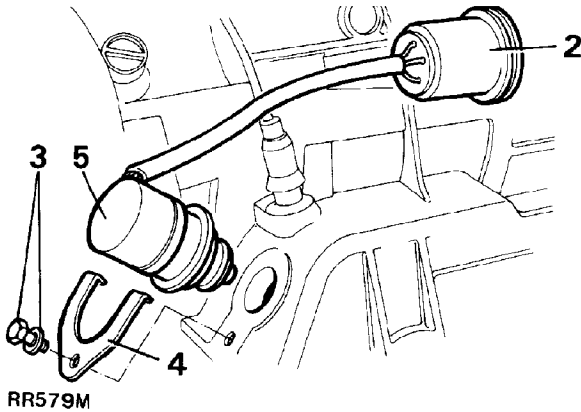

2. Disconnect inhibitor lead.
3. Remove bolt and spring washer.
4. Remove retaining plate.
5. Remove inhibitor switch.

Refit

6. Fit new 'O' ring seal to inhibitor switch.
7. Fit switch and secure with retaining plate, spring washer and bolt.
8. Connect inhibitor lead.
9. Reconnect battery negative lead.

SELECTOR SHAFT OIL SEAL

Service repair no - 44.15.34

1. Site vehicle on ramp. Disconnect battery negative lead.
2. Remove gear change lever.

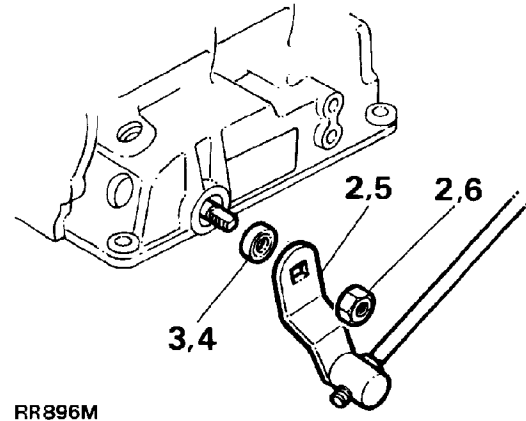

3. Remove oil seal.
4. Coat new oil seal with light grease. Fit seal using selector shaft oil seal replacer LST114.
5. Refit gearchange lever.
6. Fit nut. Tighten to **25 Nm**.



OIL SUMP GASKET

Service repair no - 44.24.05

1. Site vehicle on ramp. Disconnect battery negative lead.
2. Drain gearbox oil. Remove oil level tube.
3. Remove six retaining plates and bolts.
4. Remove sump, discard gasket.
5. Inspect sump for damage. Replace if necessary.

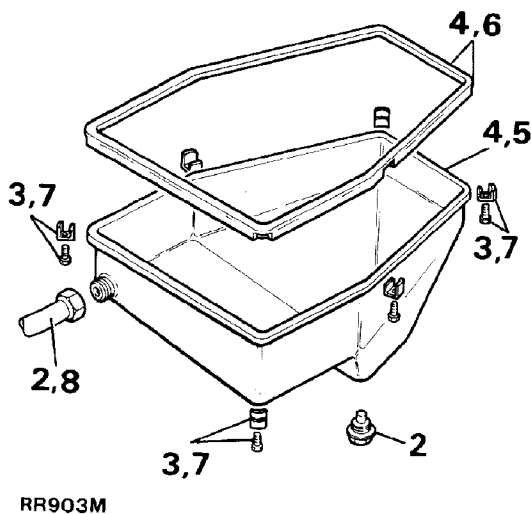

6. Fit new gasket to sump.
7. Refit sump. Fit six retaining plates tighten screws to **10Nm**.
8. Reconnect oil filler level tube. Tighten to **70Nm**. Fit sump plug with new seal. Tighten to **10Nm**.
9. Reconnect battery negative lead.
10. Add correct oil through filler/level tube. **See LUBRICANTS, FLUIDS AND CAPACITIES, Information, Recommended Lubricants and Fluids**
11. Ensure vehicle is on level ground with park brake applied. Check oil level with engine at idle, neutral selected after selecting each gear.



NOTE: If leak persists after fitting existing oil pan - fit new oil pan.

KICKDOWN CABLE LEAK

Service repair no - 44.15.01

Remove

1. Site vehicle on ramp. Disconnect battery negative lead.
2. Disconnect kickdown cable from engine.
3. Drain gearbox oil. Remove front exhaust assembly and chassis cross member.
4. Remove oil level tube.
5. Remove six retaining plates and bolts.
6. Remove sump, discard gasket.

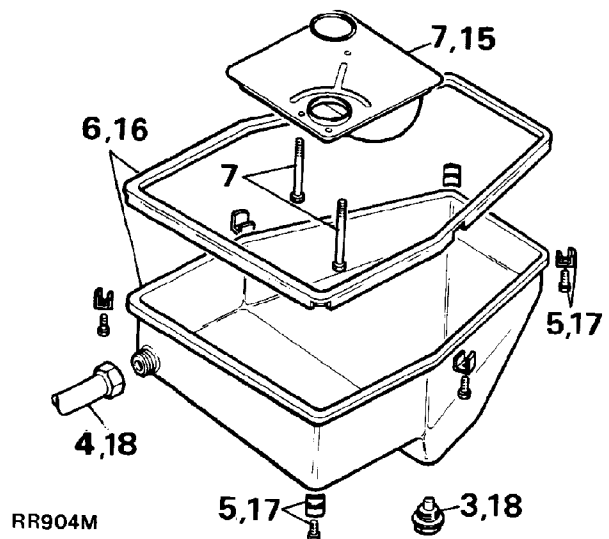

7. Loosen three bolts, remove oil screen.
8. Loosen thirteen remaining bolts, remove control unit.
9. Locate selector cam, remove nipple, holding kickdown cable from seat.

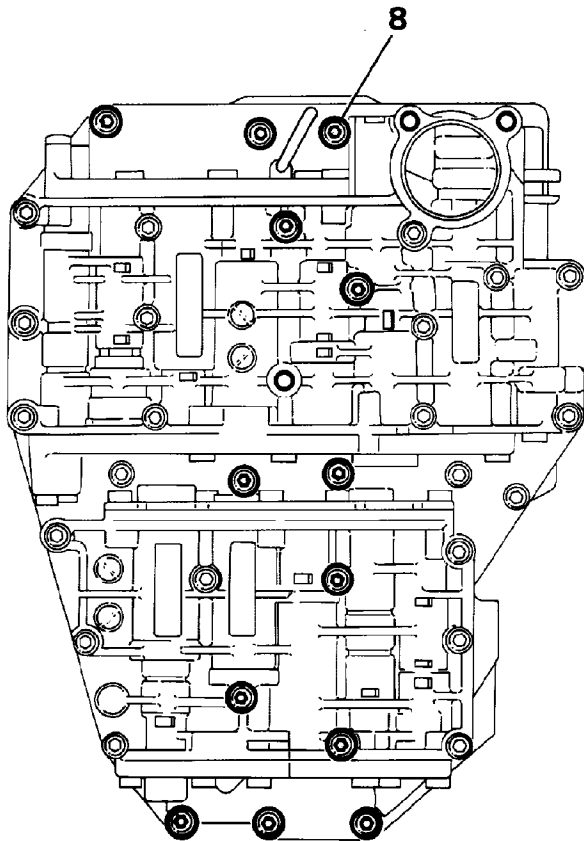

RR905M

10. Using kickdown cable remover LST112, remove cable and its housing from casing and discard.

Refit

11. Fit new cable and new 'O' ring into casing.

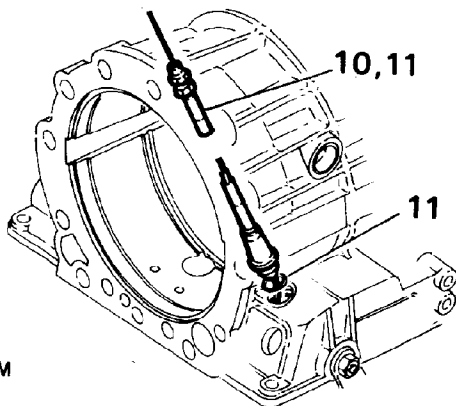

RR906M

12. Spring load cam by turning once before fitting. Fit nipple into cam seat.

13. Fit control unit after cleaning face with a lint free rag. Ensure selector shaft locates into gear shift fork. Fit thirteen bolts loosely.
14. Place selector linkage setting gauge LST109 in position, gently press control unit in direction shown. Tighten all thirteen bolts to **8Nm**.

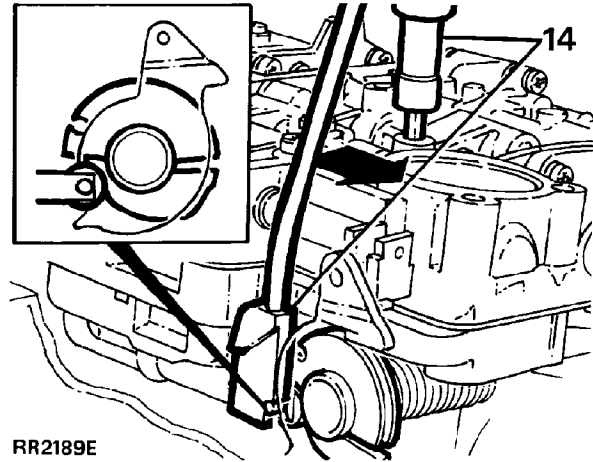

RR2189E

15. Remove setting gauge. Fit oil screen, tighten fixings to **8Nm**.
16. Refit sump with new gasket.
17. Refit six retaining plates tighten screws to **8Nm**.
18. Reconnect oil filler tube. Tighten to **70Nm**. Fit sump plug with new seal. Tighten to **10Nm**.
19. Fit chassis cross member
20. Fit front exhaust assembly
21. Reconnect battery negative lead.
22. Add correct quantity and grade oil to gearbox. **See LUBRICANTS, FLUIDS AND CAPACITIES, Information, Recommended Lubricants and Fluids**
23. Connect kickdown cable to engine.

Adjust

24. Adjust cable sheath to achieve a crimp gap of 0.25 to 1.25 mm.
25. Hold cable sheath while tightening locknuts.
26. Ensuring vehicle is on level ground with park brake applied. Check oil level with engine at idle with neutral selected, after selecting each gear.



EXTENSION HOUSING

Service repair no - 44.20.18

1. Remove transfer box. *See TRANSFER GEARBOX, Repair, Borg Warner Transfer Gearbox*
2. Remove transfer gear selector.
3. Loosen nine bolts holding extension housing.
4. Remove extension housing, discard gasket.
5. Place extension housing on bench, remove oil seal.
6. Ensure that all surfaces are clean and case is free from damage.
7. If fitting new case, fit two dowels to case.
8. Fit a new gasket and oil seal using rear oil seal replacer LST108.

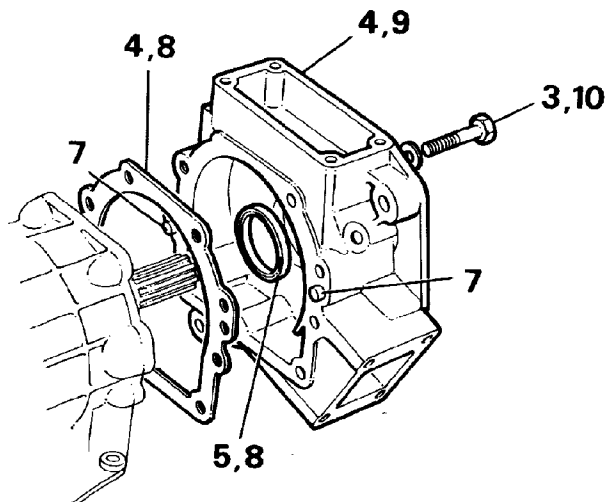

RR908M

9. Fit extension case to gearbox, ensure oil seal is not damaged by extension shaft.
10. Fit and tighten nine bolts to **23 Nm**.
11. Refit transfer gear selector.
12. Tighten three bolts to **25 Nm**.
13. Refit transfer box.

OIL SCREEN

Service repair no - 44.24.07

1. Site vehicle on ramp. Disconnect battery negative lead.
2. Drain gearbox oil.
3. Discard sump plug seal.
4. Remove level tube from sump.
5. Remove six retaining plates and bolts.
6. Remove sump, discard gasket.
7. Loosen three screws from oil screen.
8. Remove oil screen, discard 'O' rings.
9. Separate oil screen from suction tube, discard 'O' ring and oil screen.
10. Fit two new 'O' rings to oil screen.
11. Fit suction tube to oil screen.
12. Fit oil screen to control unit, tighten three bolts to **8 Nm**.

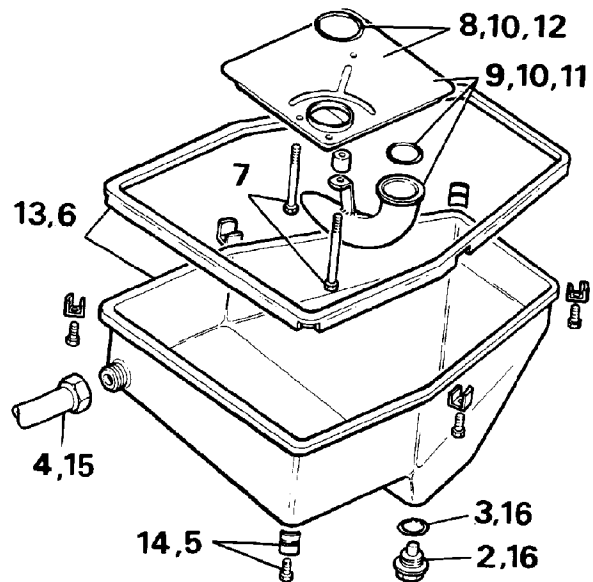

RR691M

13. Refit sump using a new gasket.
14. Secure using six retaining plates and bolts. Tighten to **8Nm**.
15. Reconnect oil level/filler tube. Tighten to **70 Nm**.
16. Fit sump plug using a new seal. Tighten to **10 Nm**.
17. Connect battery lead.
18. Add correct oil to gearbox. **See LUBRICANTS, FLUIDS AND CAPACITIES, Information, Recommended Lubricants and Fluids**
19. Ensuring vehicle is on level ground with park brake applied, check oil level with engine at idle, neutral selected, after selecting each gear.

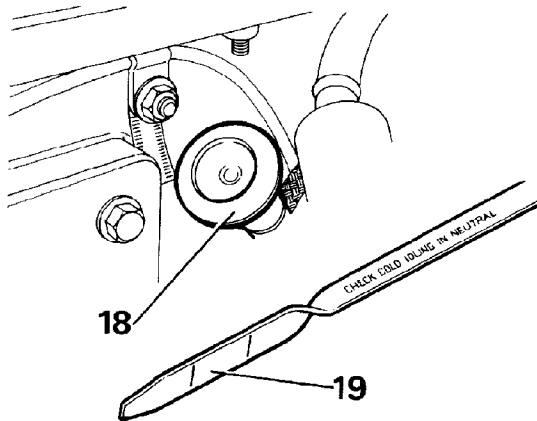

RR 922 M

CONTROL UNIT

1. Site vehicle on ramp. Disconnect battery negative lead.
2. Drain gearbox oil into a container.
3. Discard sump plug seal.
4. Remove oil level tube from sump.

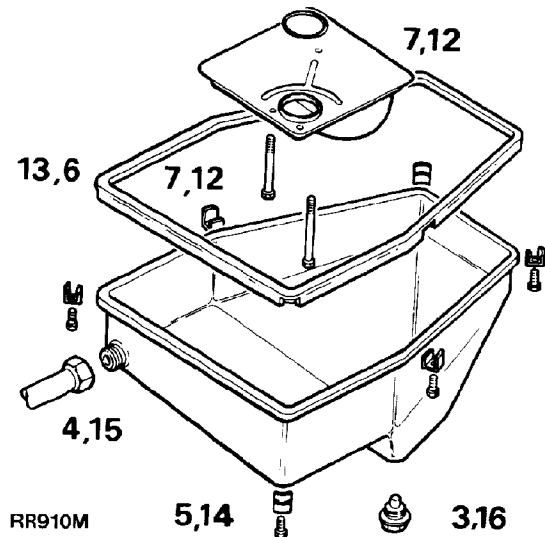

5. Remove six retaining plates and bolts.
6. Remove sump, discard gasket.
7. Loosen three bolts and remove oil screen.
8. Loosen remaining thirteen bolts retaining control unit.

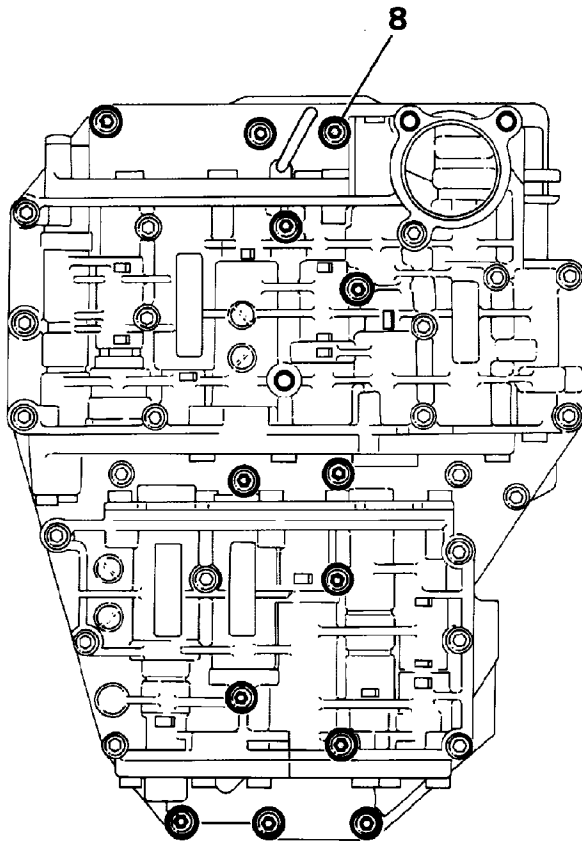

RR905M

9. Clean surfaces using a lint-free rag. Ensure no damage has occurred to mounting face of case.
10. Fit control unit ensuring selector shaft locates into gear shift fork. Loosely fit thirteen bolts.

11. Place selector linkage setting gauge LST109 in position, gently press control unit against tool. Tighten to **8Nm**.

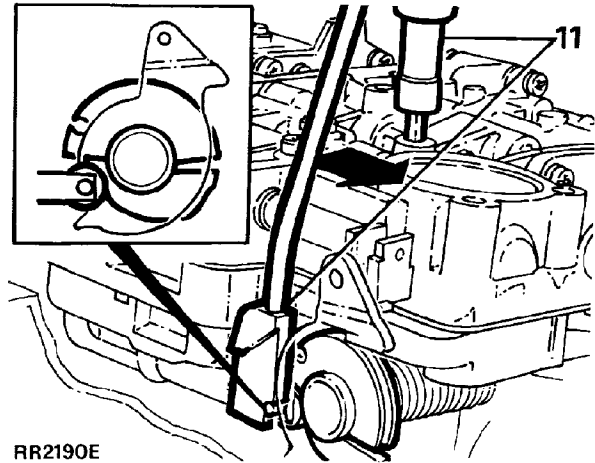

RR2190E

12. Remove setting gauge. Fit oil screen. Tighten to **8Nm**.
13. Refit sump using a new gasket.
14. Secure with six retaining plates and bolts. Tighten to **8 Nm**.
15. Reconnect oil level tube. Tighten to **70 Nm**.
16. Fit sump plug with new seal. Tighten to **10 Nm**.
17. Reconnect battery negative lead.
18. Add correct quantity and grade of oil to gearbox. **See LUBRICANTS, FLUIDS AND CAPACITIES, Information, Recommended Lubricants and Fluids**
19. Ensure vehicle is on level ground with park brake applied. Check oil level with engine at idle, neutral selected, after selecting each gear.

OIL INLET SEALING RINGS

Service repair no - 44.20.13

1. Site vehicle on ramp. Disconnect battery negative lead.
2. Drain gearbox oil into a container.

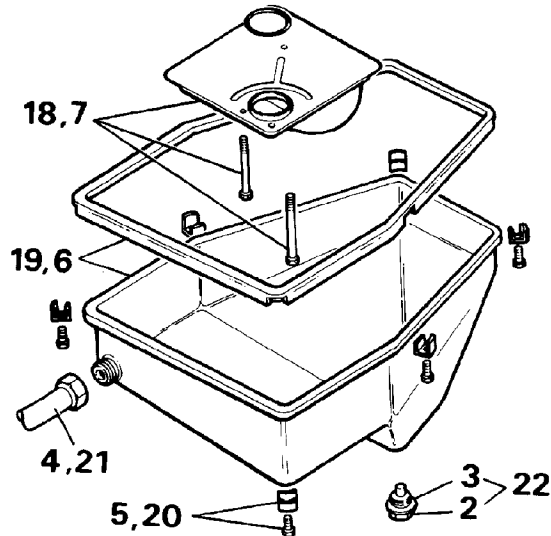

RR913M

3. Discard sump plug seal.
4. Remove oil level tube from sump.
5. Remove six retaining plates and bolts.
6. Remove sump, discard gasket.
7. Loosen three bolts and remove oil screen.
8. Loosen remaining thirteen bolts retaining control unit.
9. Clean surfaces using a lint-free rag. Ensure no damage has occurred to mounting face of case.
10. Remove eight circlips and springs from gearbox.
11. Using LST 113 remove eight oil seals.
12. Clean orifices, check for damage.



NOTE: If damage has occurred replace box. See *ZF Auto with Borg Warner Transfer Gearbox*

13. Using LST 113 fit new seals.
14. Fit eight compression springs, four short ones at front and four long ones at rear.

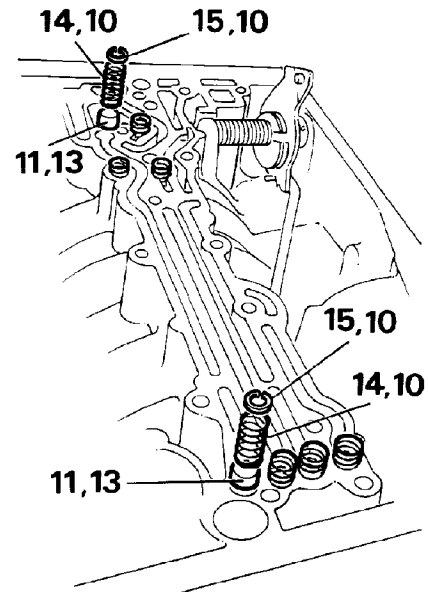

RR580M

15. Fit eight circlips to retain compression springs.
16. Fit control unit locating selector shaft into gear shift fork. Fit thirteen bolts loosely.
17. Place setting gauge LST 109 in position. Press control unit against tool, tighten thirteen bolts to **8Nm**.

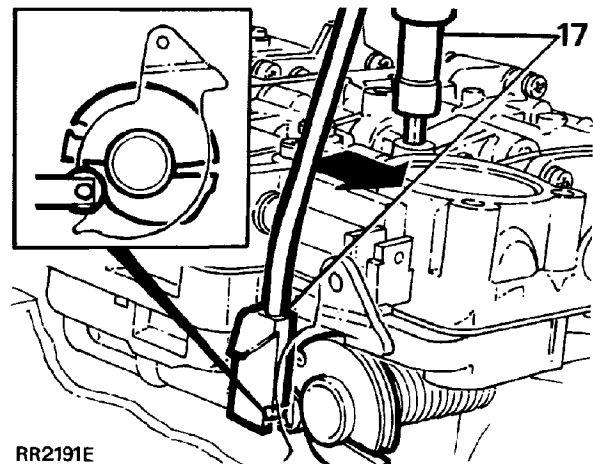

RR2191E



18. Remove setting gauge. Fit oil screen, tighten fixings to **8 Nm**.
19. Refit oil pan with new gasket.
20. Secure with six retaining plates and bolt. Tighten to **8 Nm**.
21. Reconnect oil level tube. Tighten to **70 Nm**.
22. Fit sump plug with new seal. Tighten to **10 Nm**.
23. Reconnect battery negative lead.
24. Add correct quantity and grade of oil to gearbox.
See LUBRICANTS, FLUIDS AND CAPACITIES, Information, Recommended Lubricants and Fluids
25. Ensure vehicle is on level ground with park brake applied. Check oil level with engine at idle, neutral selected, after selecting each gear.

MANUAL VALVE OPERATING MECHANISM

Service repair no - 44.40.01

1. Site vehicle on ramp. Disconnect battery negative lead.
2. Drain gearbox oil into a container. Discard sump plug seal.
3. Remove oil level tube from sump.
4. Remove six retaining plates and bolts.
5. Remove sump, discard gasket.
6. Loosen three bolts and remove oil screen.
7. Loosen remaining thirteen bolts retaining control unit.

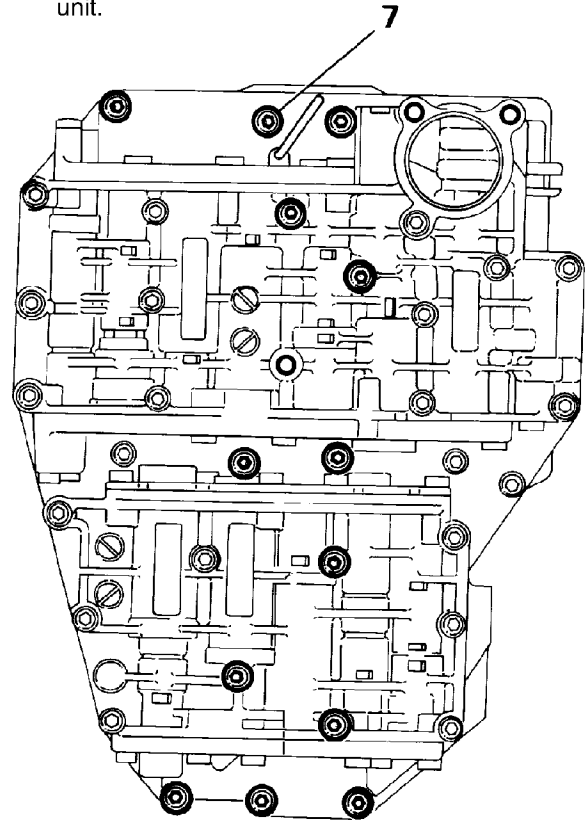

RR914M

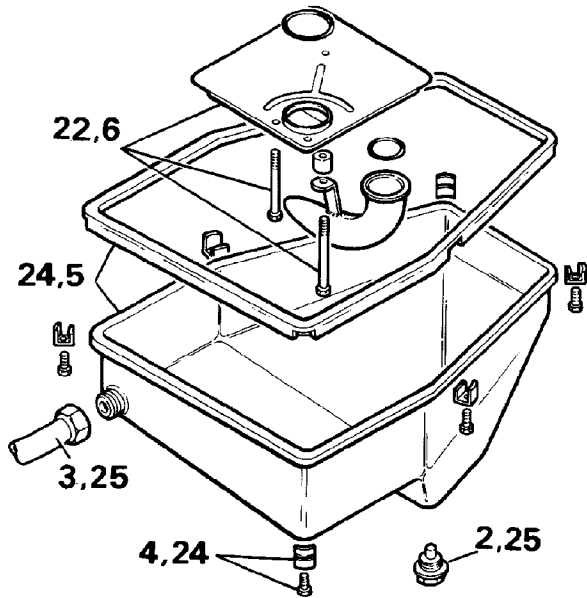

RR582M

8. Locate selector cam, remove kickdown cable nipple from its seat.
9. Remove gear change lever.
10. Drift out roll pin from selector shaft, discard pin.
11. Remove selector shaft from box, note position of detent plate for reassembly.
12. Remove connecting rod with detent plate, accelerator cam, and spring. Remove and discard oil seal.
13. Check all parts for wear or damage, replace as necessary.

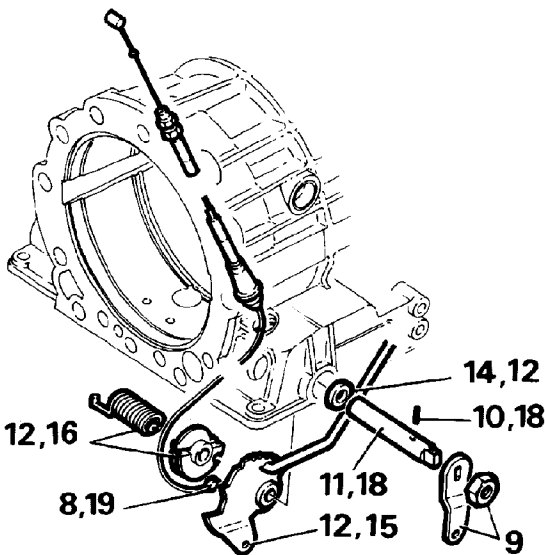

RR581M

14. Using LST114, fit oil seal use petroleum jelly to aid assembly.
15. Fit connecting rod to detent plate, locate in box by pushing selector shaft through from outside of casing.
16. Fit accelerator cam with spring.
17. Fit assembly into box and secure by pushing selector shaft through.
18. Align hole in selector shaft with hole in detent plate. Secure with a new roll pin.
19. Spring load cam by turning once. Fit kickdown cable nipple into cam seat.
20. Fit control unit ensuring selector shaft locates into gear shift fork. Fit thirteen bolts loosely.
21. Position setting gauge LST 109. Press control unit against tool. Tighten thirteen bolts to **8 Nm**.

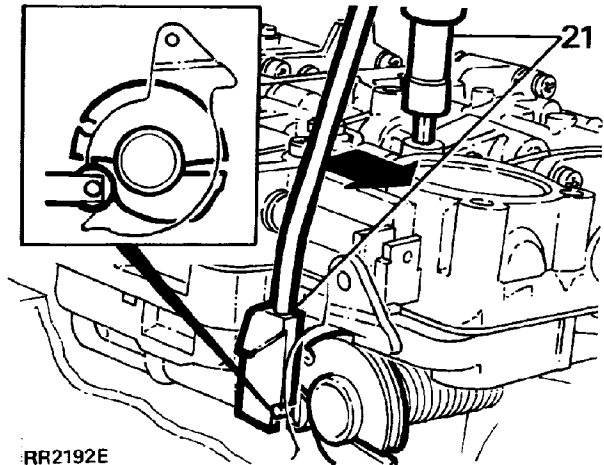

RR2192E

22. Remove setting gauge, fit oil screen, tighten fixings to **8 Nm**.
23. Refit oil pan with new gasket.
24. Secure with six retaining plates and bolt. Tighten to **8 Nm**.
25. Reconnect oil level tube. Tighten to **70 Nm**.
26. Fit sump plug with new seal. Tighten to **10 Nm**.
27. Reconnect battery negative lead.
28. Add correct quantity and grade of oil to gearbox. **See LUBRICANTS, FLUIDS AND CAPACITIES, Information, Recommended Lubricants and Fluids**
29. Ensure vehicle is on level ground with park brake applied. Check oil level with engine at idle, neutral selected, after selecting each gear.



GOVERNOR HOUSING

Service repair no - 44.22.01

Remove

1. Remove transfer box. *See TRANSFER GEARBOX, Repair, Borg Warner Transfer Gearbox*
2. Remove transfer gear selector housing.
3. Loosen nine bolts holding extension housing.
4. Remove extension housing ensuring that seal is not damaged, discard gasket.
5. Remove extension shaft and retaining bolt with 'O' ring. If Tdi vehicle, remove spacer.
6. Remove governor assembly with parking wheel.
7. Remove two screws holding governor housing.
8. Remove governor housing complete and discard.
9. Inspect governor hub and parking wheel for damage.

Refit

10. Fit new governor housing complete to governor hub and parking wheel. Tighten to **10 Nm**.
11. Push governor assembly with parking wheel onto output shaft until fully seated.



NOTE: Apply petroleum jelly to 'O' ring. Ensure seal rings are snapped together and seated.

12. Fit extension shaft, with spacer if Tdi, apply Loctite 270 to retaining bolt. Using a new 'O' ring. Tighten to **42 Nm**.
13. Fit new gasket to rear of gearbox. Fit extension housing, avoid damage to seal.
14. Tighten nine extension housing nine bolts to **23 Nm**.
15. Fit transfer gear selector housing.
16. Tighten three bolts to **25Nm**.
17. Refit transfer box.

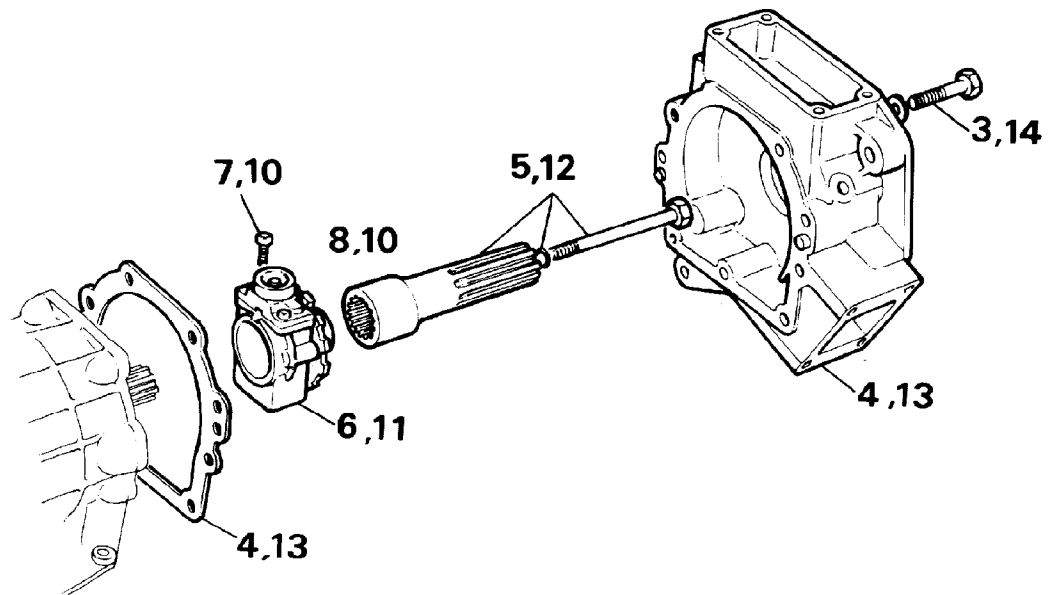

RR586M

GOVERNOR HUB

Service repair no - 44.22.04

Remove

1. Remove transfer box. *See TRANSFER GEARBOX, Repair, Borg Warner Transfer Gearbox*
2. Remove transfer gear selector housing.
3. Loosen nine bolts holding extension housing.
4. Remove extension housing ensuring that seal is not damaged, discard gasket.
5. Remove extension shaft and retaining bolt with 'O' ring.
6. Remove governor assembly with parking wheel.
7. Remove two screws holding governor housing.
8. Remove two bolts, remove parking wheel. Discard governor hub.
9. Remove security clip and counter-weight.
10. Remove 'O' ring from output shaft and discard.
11. Remove three seal rings from 'F' clutch housing shaft.
12. Inspect all parts for damage or wear, replace if necessary.

Refit

13. Fit counterweight and security clip into new governor hub.

14. Secure governor housing to governor hub. Tighten to **10Nm**.
15. Fit parking wheel to governor hub. Tighten to **10 Nm**.
16. Fit three new seal rings onto F clutch housing shaft, fit 'O' ring onto output shaft.



NOTE: To aid fitting of 'O' ring apply petroleum jelly.

17. Push governor assembly and parking wheel onto output shaft until seated.



NOTE: Apply petroleum jelly to 'O' ring. Ensure seal rings are snapped together and seated.

18. Fit new gasket to rear of gearbox. Fit extension housing, avoid damaging seal.
19. Fit extension shaft, apply Loctite 270 to retaining bolt. Using a new 'O' ring. Tighten to **42 Nm**.
20. Tighten nine extension housing nine bolts to **23 Nm**.
21. Fit transfer gear selector housing, tighten three bolts to **25 Nm**.
22. Refit transfer box.

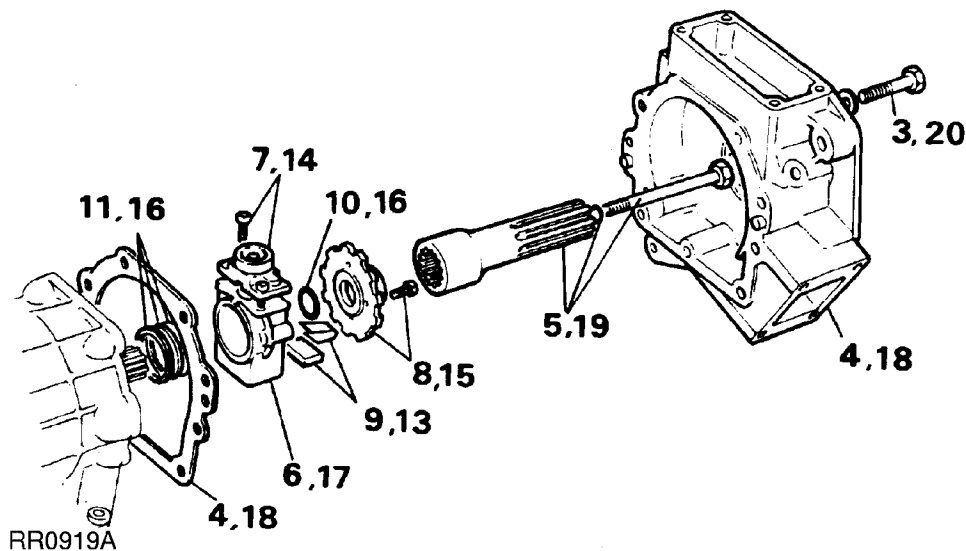



PARKING PAWL MECHANISM

Service repair no - 44.28.07

Remove

1. Remove transfer box. *See TRANSFER GEARBOX, Repair, Borg Warner Transfer Gearbox*
2. Remove transfer gear selector housing.
3. Loosen nine bolts holding extension housing.
4. Remove extension housing ensuring that seal is not damaged, discard gasket.
5. Remove extension shaft and retaining bolt with 'O' ring. If Tdi vehicle, remove spacer.
6. Remove governor assembly with parking wheel.

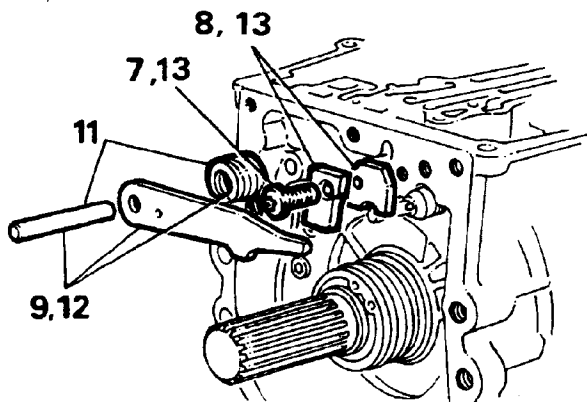

RR0584A

7. Remove guide plate bolt.
8. Remove plate and guide plate from gearbox case.
9. Remove pin, pawl and spring.



CAUTION: When removing assembly. Avoid damaging parts which could weaken spring tension.

10. Inspect all parts for wear or damage. Replace if necessary.

Refit

11. Fit pin and leg spring, locate spring correctly.
12. Fit pawl to pin. Locate spring leg into hole in pawl to create tension in spring.
13. Fit plate and guide plate. Tighten to **10 Nm**.
14. Push governor assembly with parking wheel onto output shaft until seated.



NOTE: Apply petroleum jelly to 'O' ring. Ensure seal rings are snapped together and seated.

15. Fit new gasket to rear of gearbox. Fit extension housing, taking care not to damage seal or assembly.
16. Fit extension shaft with spacer if Tdi and retaining bolt with new 'O' ring.
17. Fit extension housing, tighten nine bolts to **23Nm**.
18. Fit transfer gear selector housing, tighten three bolts to **25 Nm**.
19. Refit transfer box.

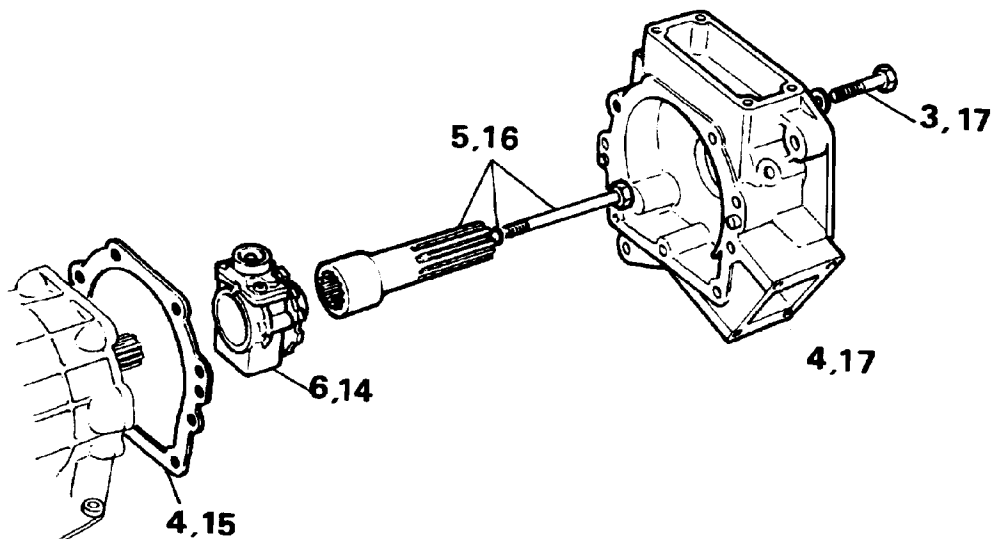

RR0920A

REPLACING TORQUE CONVERTER

1. Remove gearbox and transfer box assembly. **See ZF Auto with Borg Warner Transfer Gearbox**
2. Place gearbox on bench. Remove torque converter using torque converter handles 18G1501, taking care not to damage torque converter/oil pump housing oil seal.
3. Fit new torque converter using torque converter handles 18G1501. Check dimension from converter fixing boss to converter housing face is 50 mm. This shows converter is correctly seated in housing.
4. Refit gearbox and transfer box assembly. **See ZF Auto with Borg Warner Transfer Gearbox**

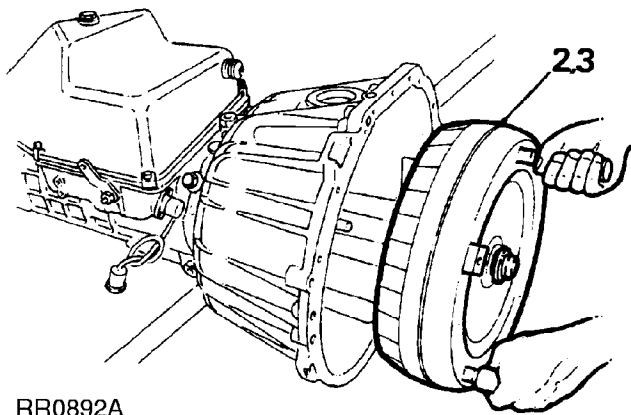

RR0892A

ELIMINATING LEAKS ON PUMP HOUSING

1. Remove gearbox and transfer box assembly. **See ZF Auto with Borg Warner Transfer Gearbox**
2. Place gearbox on bench. Remove torque converter using torque converter handles 18G1501, taking care not to damage torque converter/oil pump housing oil seal.

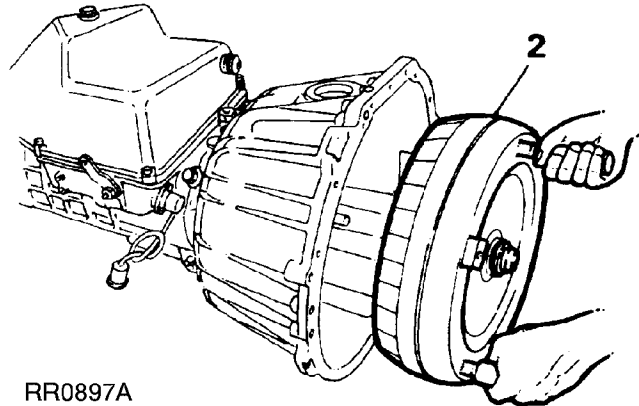

RR0897A

3. Remove twelve hexagonal bolts (inner ring pattern).

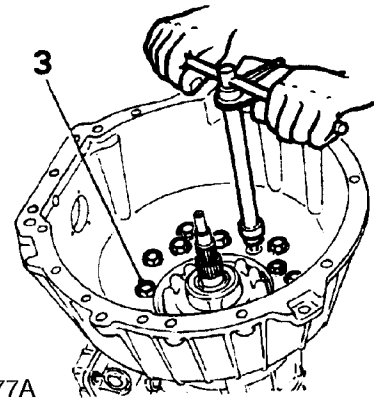

RR0577A

4. Remove bell housing and pump assembly, discard gasket.
5. Remove eight hexagonal bolts on rear of pump.



6. Screw in two bolts, diagonally opposite each other. Tap lightly using a soft headed mallet to remove pump assembly from intermediate plate.

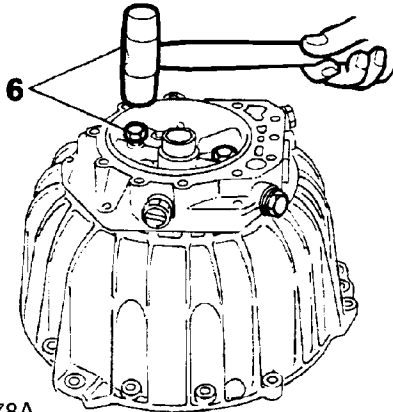

RR0578A

7. Remove shaft sealing ring and 'O' ring from pump housing and discard.
8. Using oil seal replacer LST108 fit shaft seal ring into pump housing.
9. Fit 'O' ring onto circumference of pump housing.
10. Align dowel with hole in intermediate plate and press pump housing home.

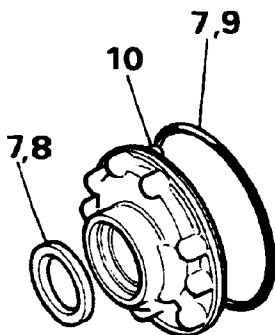

RR0878A

11. Fit pump housing to intermediate plate, tighten eight bolts to **10 Nm**.
12. Place bell housing and intermediate plate assembly on bench, front face up. Using oil pump rotation sleeve LST111, check that pump gears rotate freely.
13. Before fitting intermediate plate and bell housing assembly, check that thrust washer and axial cage are seated on A clutch housing.
14. Place gasket and disc washer onto bell housing and intermediate plate assembly using Petroleum Jelly.
15. Fit bell housing and intermediate plate assembly to gearcase. Tighten twelve bolts to **46 Nm**.
16. Place end float gauge LST111 onto pump housing and check that axial play is between 0.2-0.4 mm. Replace existing washer, situated at rear of intermediate plate, with a suitable washer to give required end float.
17. Refit torque converter into housing using torque converter handles 18G1501, checking that dimension from converter fixing bolt boss to converter housing face is 50 mm. This shows converter is properly seated in housing.
18. Refit gearbox/transfer box assembly. *See ZF Auto with Borg Warner Transfer Gearbox*

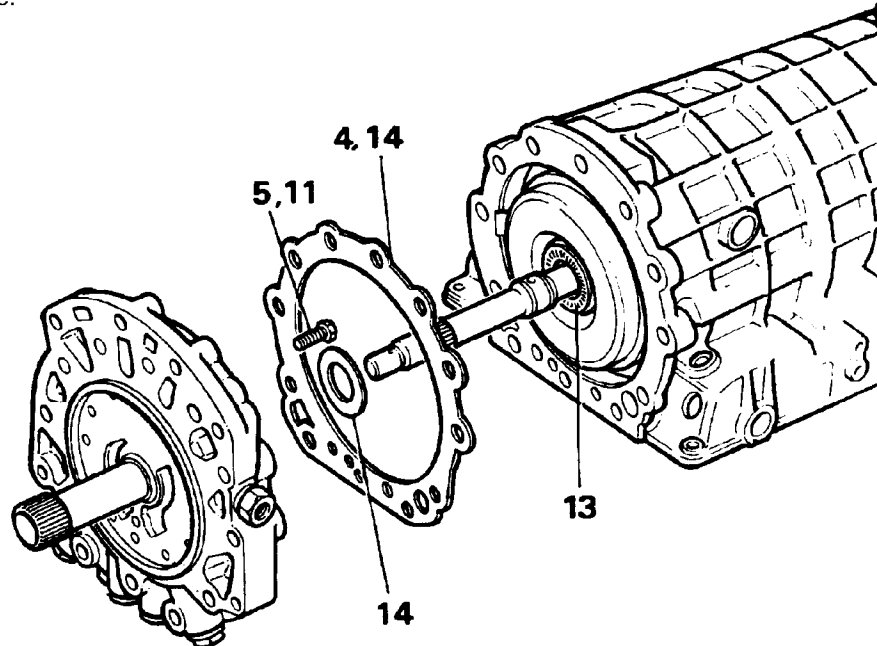

ELIMINATING LEAKS BETWEEN GEARBOX HOUSING AND INTERMEDIATE PLATE

1. Remove gearbox and transfer box assembly. **See ZF Auto with Borg Warner Transfer Gearbox**
2. Place gearbox on bench. Remove torque converter using torque converter handles 18G1501, taking care not to damage torque converter/oil pump housing oil seal.

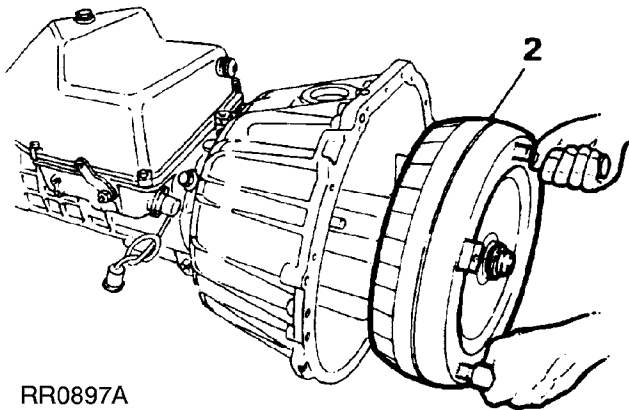

RR0897A

3. Remove twelve hexagonal bolts (inner ring pattern).
4. Remove bell housing/intermediate plate assembly from gearbox case and discard gasket.
5. Place new gasket onto intermediate plate using Petroleum Jelly.

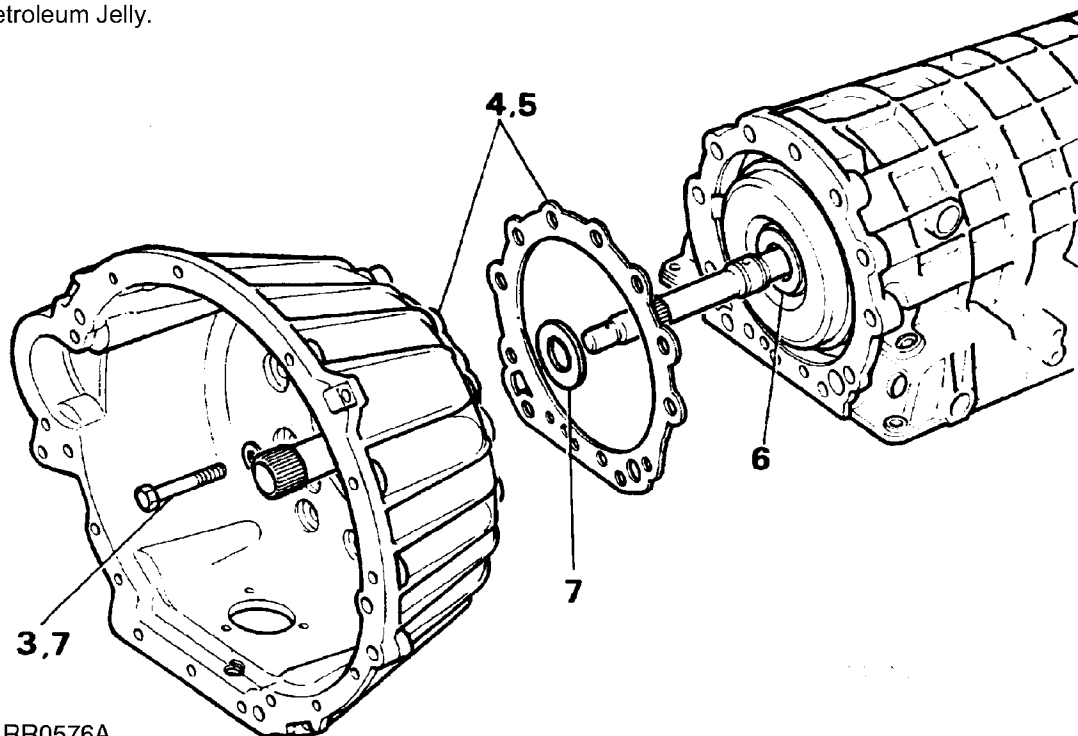

RR0576A

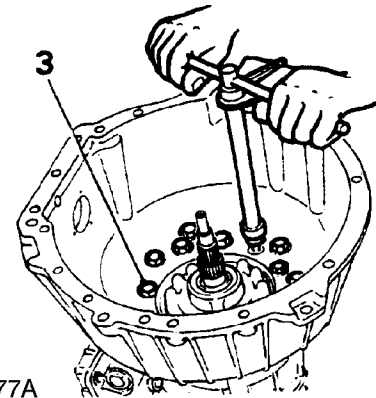

RR0577A

6. Before fitting bell housing assembly check that thrust washer and axial cage are seated on A clutch housing.
7. Fit bell housing assembly with disc washer to gearcase. Tighten twelve bolts to **46Nm**.
8. Place end-float gauge LST111 onto pump housing and check that axial play is between 0.2-0.4 mm. Replace existing washer, situated at rear of intermediate plate, with a suitable washer to give required end-float.
9. Refit torque converter using torque converter handles 18G1501. Checking that dimension from converter fixing boss to converter housing case is 50mm. This dimension shows converter is properly seated.
10. Refit gearbox/transfer box assembly. **See ZF Auto with Borg Warner Transfer Gearbox**



REPLACING BELLHOUSING

Service repair no - 44.17.01

1. Remove gearbox and transfer box assembly.
See ZF Auto with Borg Warner Transfer Gearbox
2. Place gearbox on bench. Remove torque converter using torque converter handles 18G1501, taking care not to damage torque converter/oil pump housing oil seal.

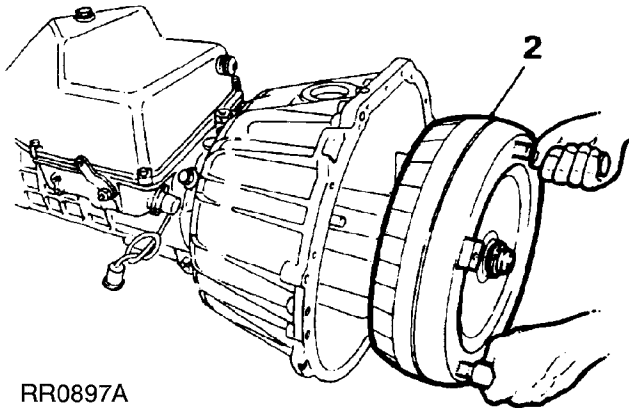

RR0897A

3. Remove eighteen hexagonal bolts.
4. Remove bell housing.
5. Fit new bell housing.
6. Secure bell housing, tighten eighteen bolts to **46 Nm**.

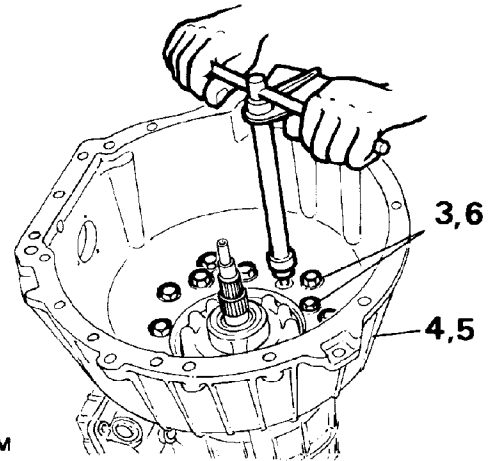

RR899M

7. Refit torque converter using torque converter handles 18G1501. Check that dimension from converter fixing boss to converter housing face is 50 mm. This dimension shows converter is properly seated in housing.
8. Refit gearbox/transfer assembly. *See ZF Auto with Borg Warner Transfer Gearbox*

REPLACING PUMP

Service repair no - 44.32.01

1. Remove gearbox and transfer box assembly.
See ZF Auto with Borg Warner Transfer Gearbox
2. Place gearbox on bench. Remove torque converter using torque converter handles 18G1501, taking care not to damage torque converter/oil pump housing oil seal.

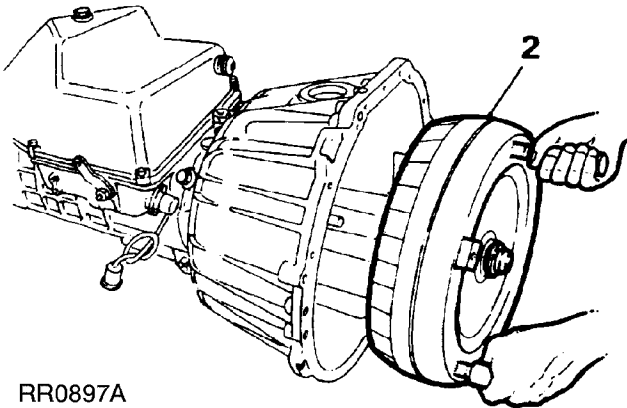

RR0897A

3. Remove twelve bolts (inner ring pattern).

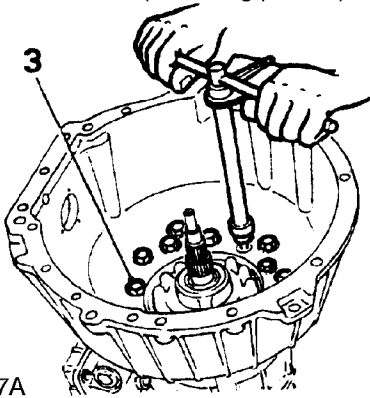

RR0577A

4. Remove bell housing and pump assembly from gearbox case, discard gasket.
5. Remove eight bolts on rear of pump.
6. Screw in two bolts, diagonally opposite each other, tap lightly using a soft headed mallet to free pump assembly from intermediate plate.

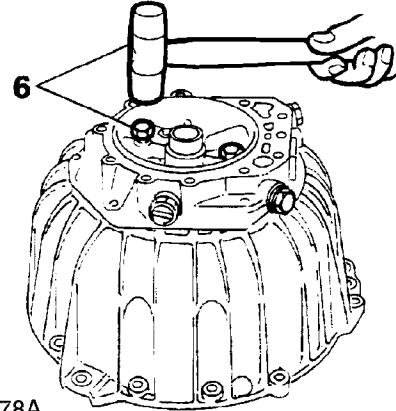

RR0578A

7. Fit new pump assembly, aligning dowel with hole in intermediate plate, press pump housing home.
8. Secure pump housing to intermediate plate using eight hexagonal bolts and. Tighten to **10 Nm**.
9. Place bell housing and intermediate plate assembly on bench, front face up. Using oil pump rotation sleeve LST111, check that pump gears rotate freely.
10. Before replacing intermediate plate/bell housing assembly check that thrust washer and axial cage are seated on A clutch housing.
11. Place new gasket and disc washer onto bell housing and intermediate plate assembly using a Petroleum Jelly.
12. Fit bell housing and intermediate plate assembly, tighten twelve bolts to **46 Nm**.

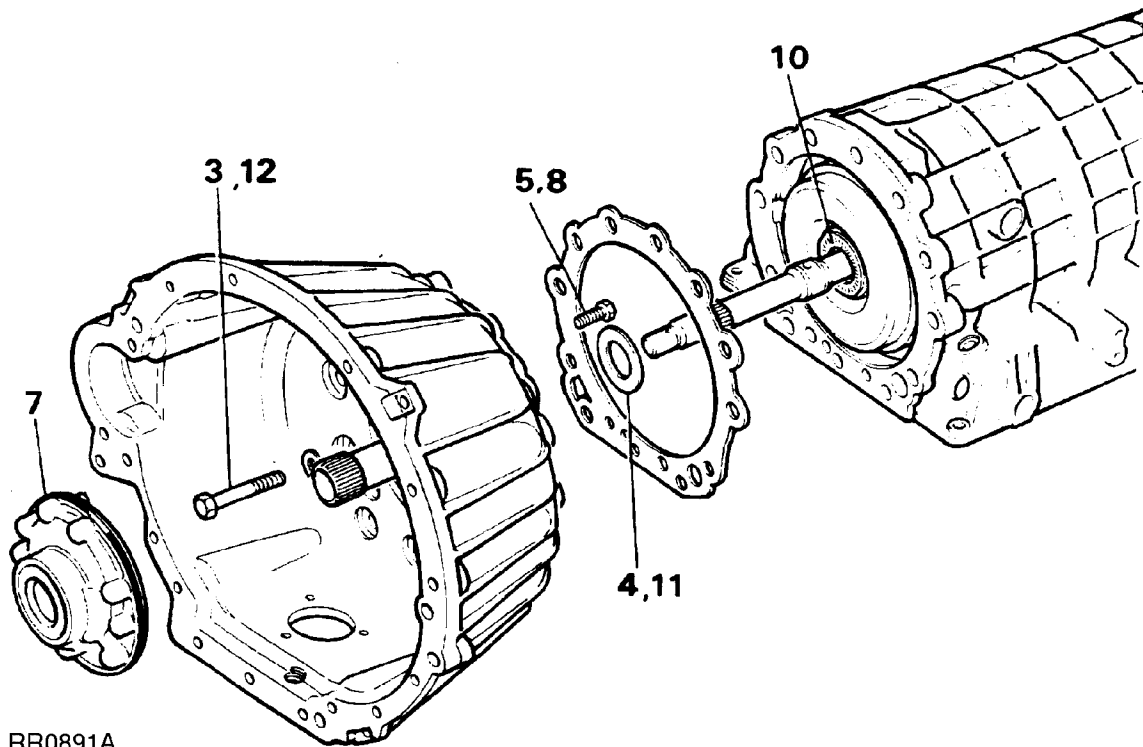

RR0891A

13. Place end-float gauge LST111 onto pump housing and check that axial play is between 0.2-0.4 mm. Replace existing washer, situated at rear of intermediate plate, with suitable washer to give required end-float.



NOTE: If damage is apparent to bolts they should be replaced.

14. Refit torque converter into housing using torque converter handles 18G1501. Check dimension converter fixing boss to converter housing face is 50 mm. This shows converter is properly seated in housing.
15. Refit gearbox/transfer box assembly. **See ZF Auto with Borg Warner Transfer Gearbox**

REPLACING INTERMEDIATE PLATE

Service repair no - 44.20.11

1. Remove gearbox and transfer box assembly.
See ZF Auto with Borg Warner Transfer Gearbox
2. Place gearbox on bench. Remove torque converter using torque converter handles 18G1501.

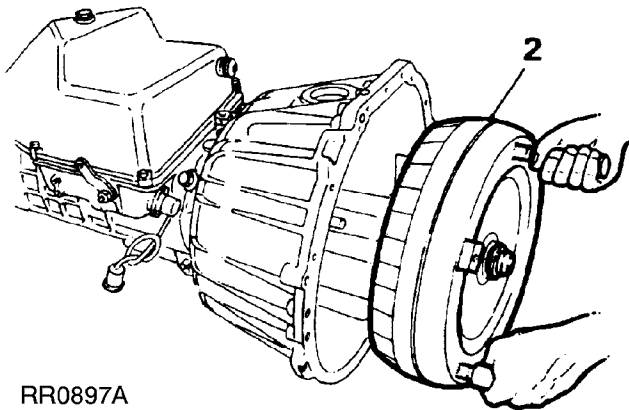

RR0897A

3. Remove twelve bolts (inner ring pattern).

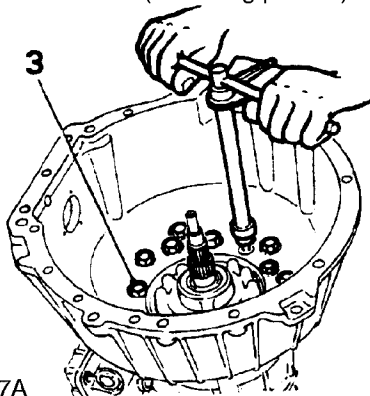

RR0577A

4. Remove bell housing and pump assembly from gearbox case, discard gasket.
5. Remove eight bolts from rear of pump.
6. Screw in two bolts, diagonally opposite each other, tap pump to free pump assembly from intermediate plate.

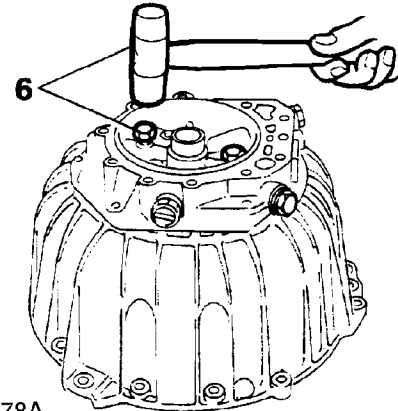

RR0578A

7. Remove 'O' ring from pump housing and discard.
8. Place bell housing and intermediate plate assembly on bench.

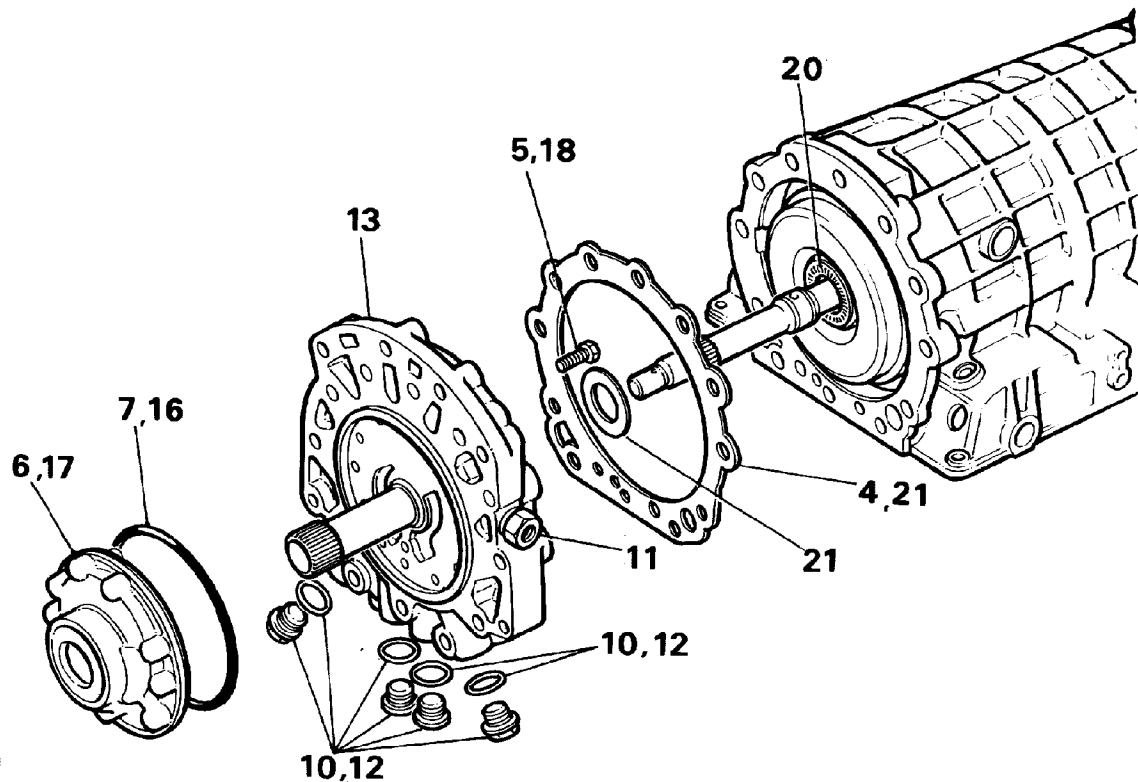

RR876M

9. Remove six bolts and remove bell housing from intermediate plate assembly.
10. Remove four screw plugs and seal rings from intermediate plate, discard seal rings.
11. Remove oil cooler pipe adaptors, fit them into new intermediate plate.
12. Fit plugs and new seal rings into new intermediate plate.
13. Fit intermediate plate assembly onto bell housing.
14. Secure with six hexagonal bolts (outer ring pattern). Tighten to **46 Nm**.
15. Place intermediate plate and bell housing assembly on bench, front face up.
16. Fit 'O' ring onto circumference of pump housing.
17. Align dowel with hole in intermediate plate, press pump housing home.
18. Secure pump housing to intermediate plate, tighten eight bolts to **10Nm**.
19. Place bell housing and intermediate plate assembly on bench. Using oil pump rotation sleeve LST111, check that pump gears rotate freely.
20. Before replacing intermediate plate and bell housing assembly check that thrust washer and axial cage are seated on 'A' clutch housing.
21. Place gasket and disc washer onto bell housing and intermediate plate assembly using Petroleum Jelly.
22. Fit bell housing and intermediate plate assembly onto gearcase, tighten twelve bolts to **46 Nm**.
23. Place end-float gauge LST111 on pump housing and check that axial play is between 0,2-0,4 mm. Renew existing washer, at rear of intermediate plate, to give required end-float.
24. Refit torque converter into housing using torque converter handles 18G1501. Check dimension from converter fixing boss to converter housing face is 50 mm. This shows converter is properly seated in housing.
25. Refit gearbox/transfer box assembly. **See ZF Auto with Borg Warner Transfer Gearbox**



TORQUE VALUES



NOTE: Torque wrenches should be regularly checked for accuracy to ensure that all fixings are tightened to the correct torque.

	Nm
Coupling shaft to mainshaft	42*
Filler tube to sump	68
Gear change lever to gearbox	25
Cooler pipe adaptor to gearbox	42
Securing screws - clutch F	10
Securing screw - parking pawl	10
Securing screws - pump	10
Intermediate plate plugs (M20)	50
Intermediate plate plugs (M14)	40
Bell housing mounting bolts	46
Governor mounting screws	10
Extension housing bolts	23
Control unit mounting bolts	8
Sump plug	10
Mounting screws for sump	8
Drive plate to converter	39*
Gearbox to engine	42
Strut (threaded end)	42
Bottom cover to converter housing	9
Cover - converter housing	9
Drive plates to crankshaft adaptor	40*
Adaptor to crankshaft	84



NOTE: * These bolts must have threads coated with Loctite 270 prior to assembly.

Torque values below are for all screws and bolts used except for those that are specified otherwise.

METRIC	Nm
M5	6
M6	9
M8	25
M10	45
M12	90
M14	105
M16	180
UNC / UNF	
1/4	9
5/16	24
3/8	39
7/16	78
1/2	90
5/8	136

ZF GEARBOX DATA

Axial end float 0.2 to 0.4 mm.

From torque converter boss to torque converter housing face 50 mm

Freewheel cage assembly to ring gear; minimum clearance 0.1 mm

Output shaft above cylinder F assembly; dimension 10.00 mm

A cylinder protrusion above gearbox front face not more than 8.5 mm



AUTOMATIC GEARBOX HOLDING FIXTURE



NOTE: This fixture enables ZF gearbox to be held securely during bench sited repairs. It can be manufactured to details given, or purchased under service tool number LST 118.

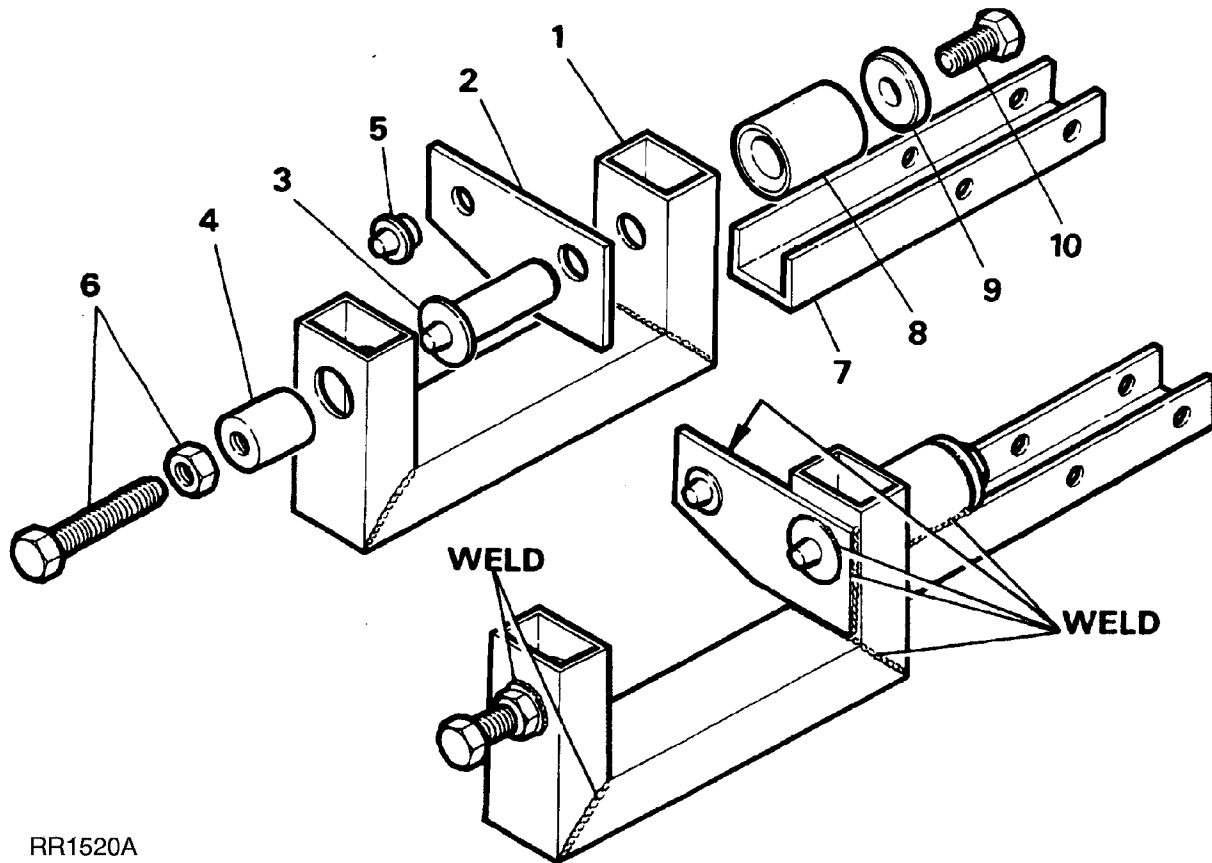

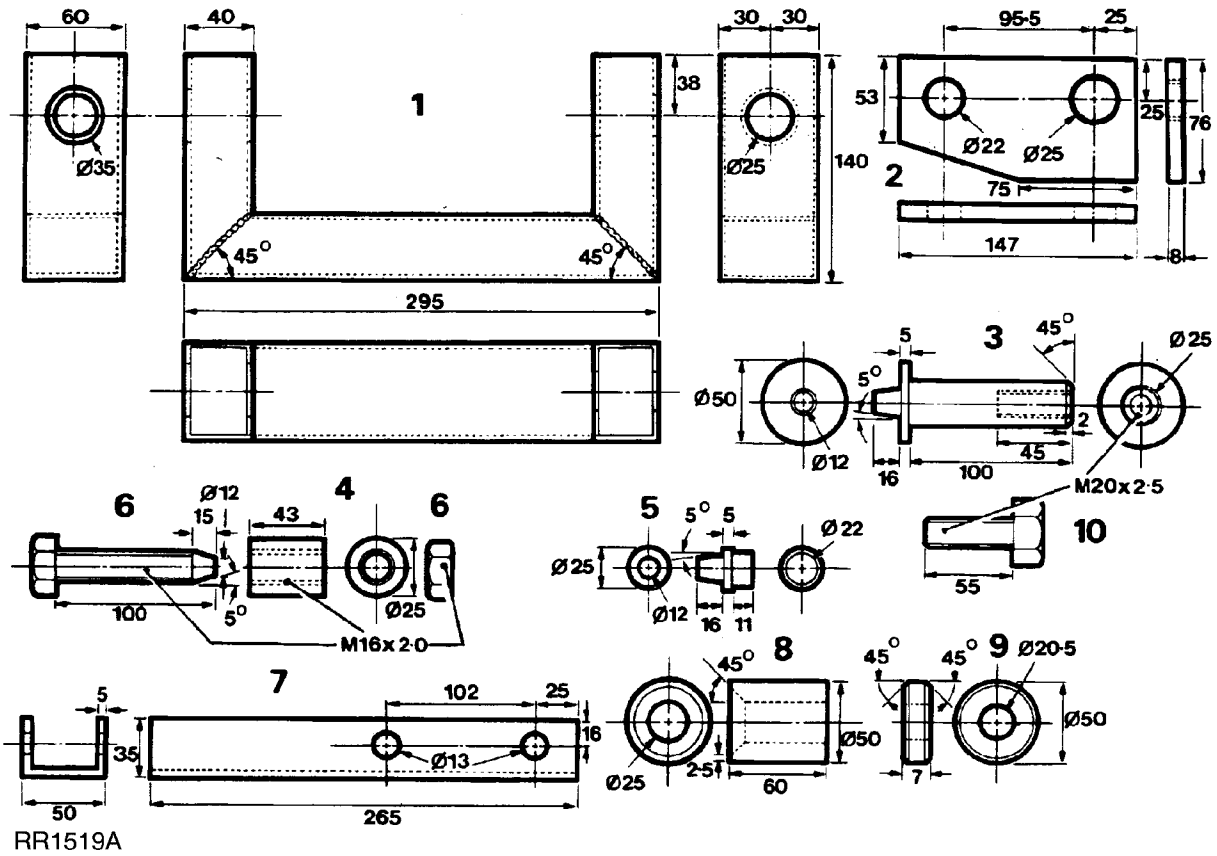



AUTOMATIC GEARBOX AND BORG WARNER TRANSFER GEARBOX

Adaptor plate

To remove transmission assembly from vehicle it is necessary to manufacture an adaptor plate to use with transmission hoist.

NOTE: Four holes (A) to be countersunk on underside to suit hoist.

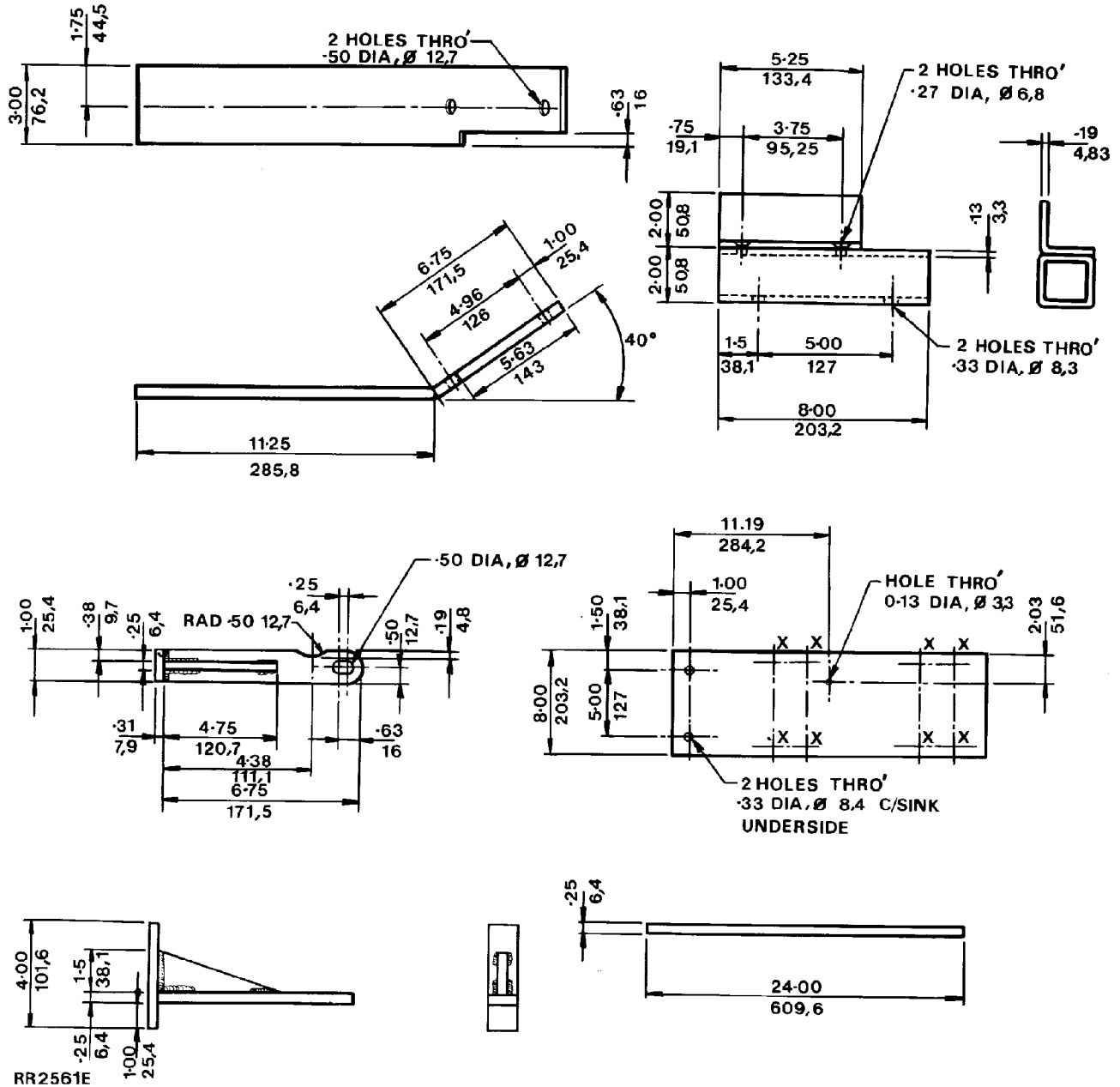

44 AUTOMATIC GEARBOX

- A: Centre of the lifting hoist
- X: Drill fixing holes to suit hoist table

Material: Mild Steel plate BS 1449, 14SWG

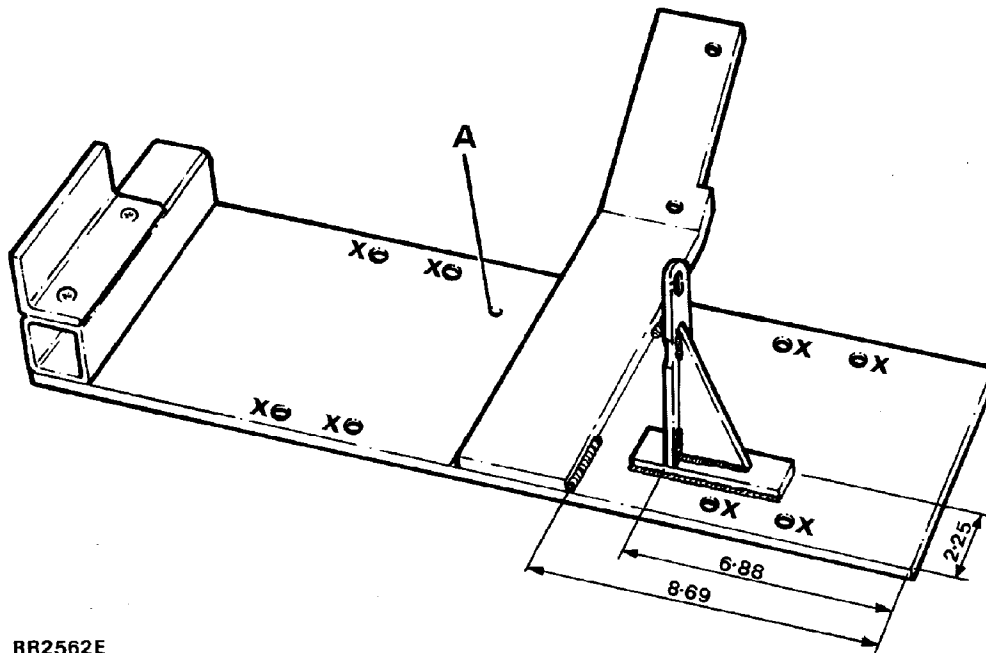

RR2562E



AUTOMATIC GEARBOX

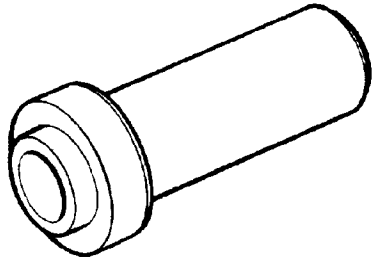

LST108

LRT-44-001 Front and rear oil seal replacer.
LST 108

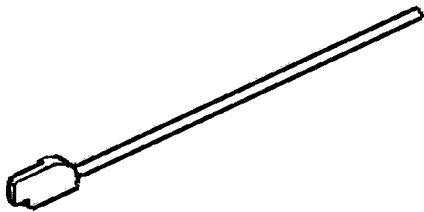

LST109

LRT-44-002 Selector linkage setting gauge.
LST 109

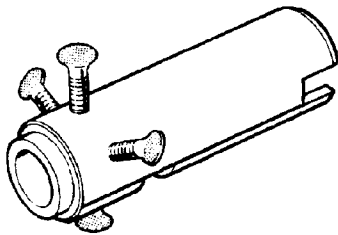

LST111

LRT-44-003 Oil pump rotation sleeve and end float
gauge.
LST 111

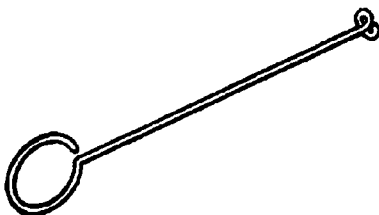

LST112

LRT-44-004 Kickdown cable remover.
LST 112

44 AUTOMATIC GEARBOX

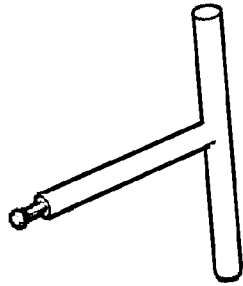

LRT-44-005 Control unit oil seal remover/replacer.
LST 113

LST113

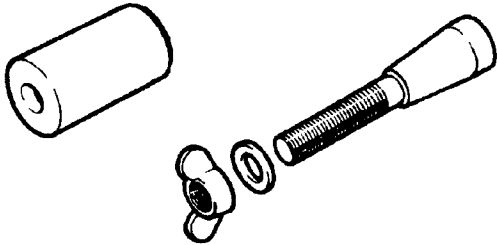

LRT-44-006 Selector shaft oil seal replacer.
LST 114

LST114

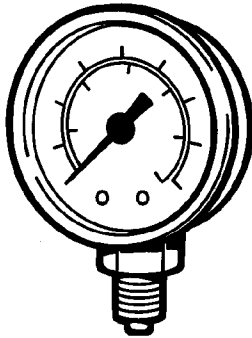

LRT-44-007 Line pressure test gauge.
18G.502A

18G502A

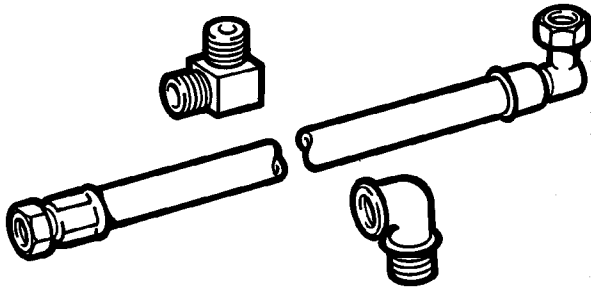

LRT-44-008 Hose and adaptor.
18G.502K

18G502K



LRT-44-009 Adaptor pressure take off.
LST 502-1

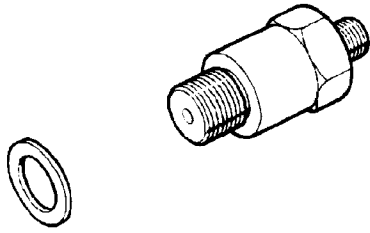

LST502-1

LRT-44-010 Converter lifting handles.
18G.1501

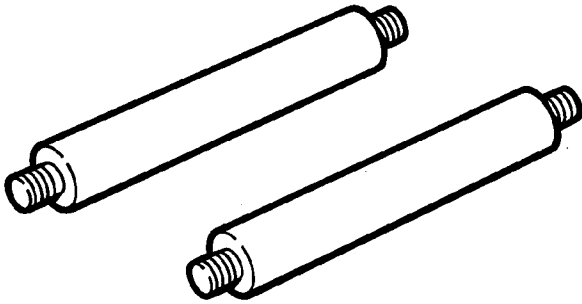

18G1501



PROPELLER SHAFT ALIGNMENT

Description

The front and rear propeller shafts have non-constant velocity 'Hooks' type universal joints, with needle roller bearings. The bearing cups are pre-packed with lubricant on assembly and a grease nipple is fitted for servicing as specified, in maintenance section.

Both shafts have Rilsan coated sliding splines to accommodate the variation in distance between the axles and transmission. The splines are pre-packed with lubricant and sealed.

The rear shaft is fitted with a conventional joint at gearbox end and the sliding joint sealed with a rubber gaiter. An SGF rubber coupling is fitted at the differential end of the shaft.

The front shaft which is shorter than the rear is 'Phased', with the joints at each end, A and B mis-aligned as shown in RR4199.

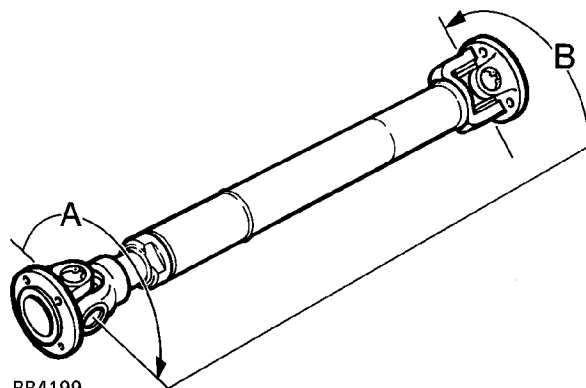

RR4199

The phasing is necessary on the front shaft only to allow for greater variation in angular changes.

Catalyst vehicles

The front shaft is 'phased' as above but is of solid bar construction.

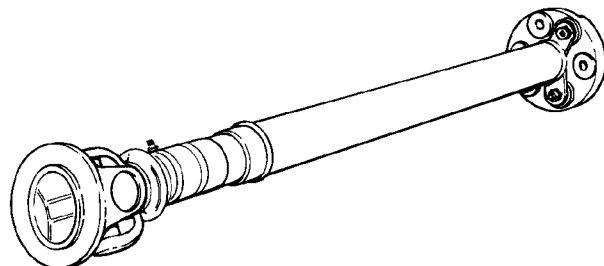

J5976

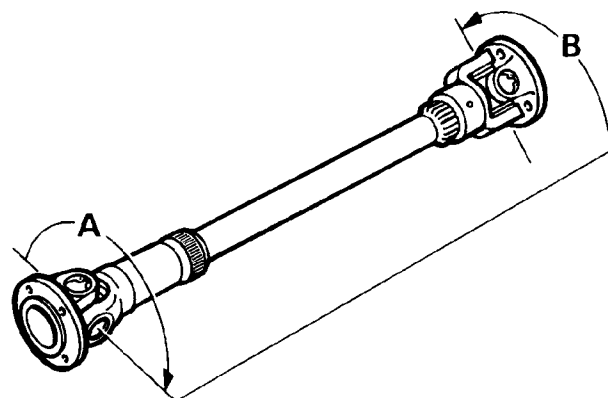

RR3643A



VIBRATION HARSHNESS

1. Check that the propeller shaft universal joints and sliding splines are not siezed or worn and that the shafts are correctly aligned.



NOTE: In the event that both shafts are satisfactory, but the vibration/harshness is still present, the transfer box and balance of the road wheels should be checked.

For transfer box faults. **See TRANSFER GEARBOX, Fault diagnosis, Borg Warner Symptoms**

For balance of road wheels. **See WHEELS AND TYRES, Repair, Wheel Balancing**



FRONT PROPELLER SHAFT

Service repair no - 47.15.02 - Front

Remove

1. Place vehicle over pit or on a ramp [hoist].
2. Remove nuts from each end of propeller shaft. Remove shaft.
3. Scribe alignment marks on flanges at both ends of propeller shaft to ensure correct refitting.

Service repair no - 47.15.11

Overhaul

4. Thoroughly examine universal joint for signs of damage or wear. Replace if necessary.
5. Clean universal joint bearing cups and circlips.

CAUTION: To ensure correct assembly and reduce possibility of imbalance. Before removing propeller shaft joint. Mark position of spider pin lubricator relative to journal yoke ears.

6. Remove circlips, and grease nipple.

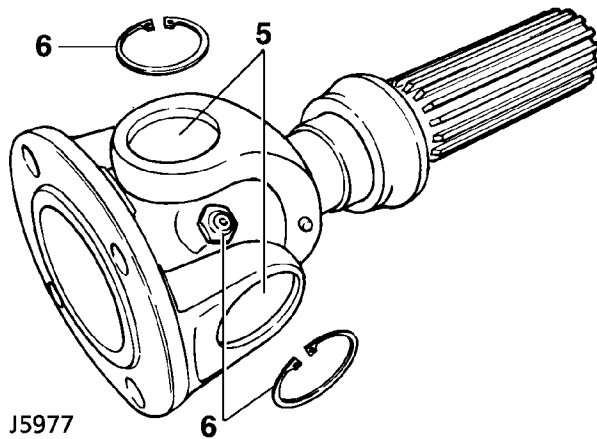

J5977

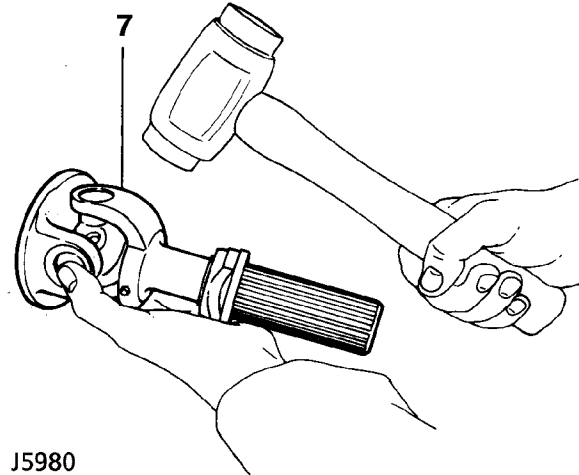

J5980

7. Tap yokes to eject bearing cups.
8. Remove bearing cups and spider.
9. Repeat instructions 4 to 7 for opposite end of propeller shaft if necessary.
10. Clean yokes and bearing cup locations.

Assemble

11. Remove bearing cups from new spider.
12. Check all needle rollers are present and positioned in bearing cups.
13. Ensure bearing cups are one-third full of lubricant. **See LUBRICANTS, FLUIDS AND CAPACITIES, Information, Recommended Lubricants and Fluids**
14. Enter new spider with seals into yokes of sliding member flange.
15. Partially insert one bearing cup into flange yoke and enter spider trunnion into bearing cup.
16. Insert opposite bearing cup into flange yoke.
17. Press both cups into place.

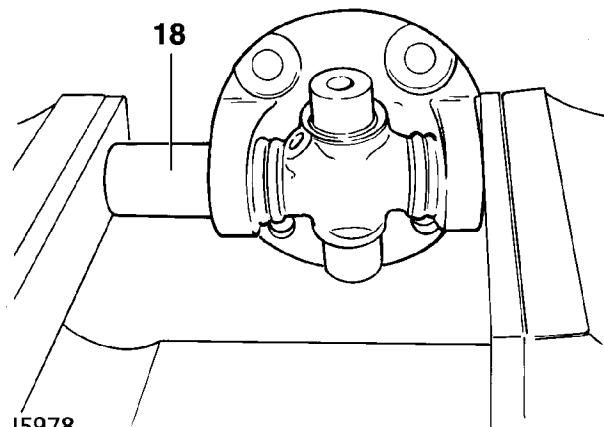

J5978

47 PROPELLER SHAFTS

18. Press each cup into its respective yoke up to lower land of circlip grooves. Damage may be caused to cups and seals if cups pass this point.
19. Fit circlips and check no end float exists.
20. Engage spider in yokes of sliding member. Fit bearing cups and circlips as described in instructions 14 to 19.

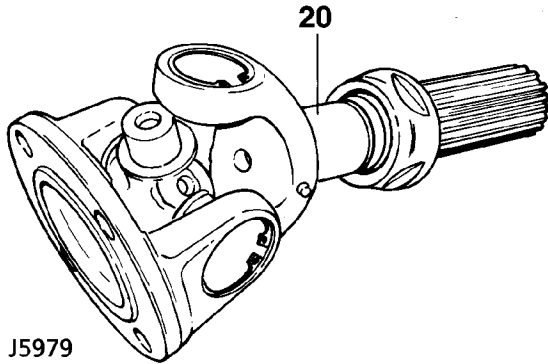

21. Fit grease nipples to spider and sliding member.
22. Apply instructions 14 to 19 to opposite end of propeller shaft.
23. Fit grease nipple and lubricate.

Refit

24. Fit propeller shafts to vehicle and tighten nuts to **47Nm**
Refit FRONT propeller shaft so sliding joint end of shaft is fitted to transfer gearbox.



SPIDER ASSEMBLY COMPONENTS

1. Circlip
2. Bearing cup
3. Nylatron washer
4. Needle rollers (27 per cup)
5. Seal retainer and seal

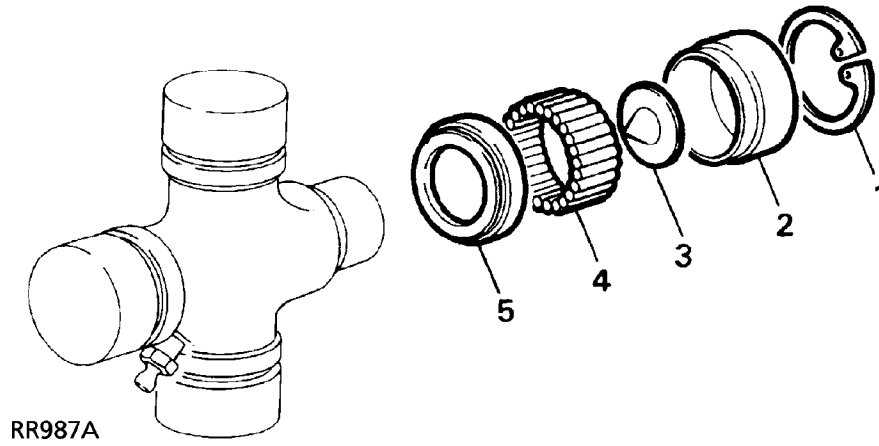

REAR PROPELLER SHAFT

Service repair no - 47.15.03



NOTE: SGF rubber coupling should be left attached to propeller shaft. Only remove coupling from propeller shaft if replacement is required.

Remove

1. Scribe alignment marks on flanges at both ends of propeller shaft to ensure correct refitting.
2. Remove three nuts and bolts securing flexible coupling to axle flange.
3. Remove nuts securing propeller shaft flange to transfer gearbox.
4. Raise propeller shaft at gearbox end detach coupling from spigot at differential and withdraw shaft.



NOTE: For replacement of spigot (pinion flange centralising peg). See **REAR AXLE AND FINAL DRIVE, Overhaul, Axle Differential Assembly**

Overhaul

Service repair no - 47.15.12



NOTE: Refer to front propeller shaft overhaul procedure for gearbox end of shaft. The SGF rubber coupling is a non-serviceable item.

Refit

5. Locate flexible coupling over spigot, align scribed marks and secure at transfer gearbox. Tighten to **47 Nm**.
6. Secure flexible coupling to axle flange with three nuts and bolts and Tighten to **78 Nm**.

FLEXIBLE COUPLING



NOTE: Flexible coupling should only be removed if a new coupling is to be fitted.

Remove

1. Remove rear propeller shaft. See **Rear Propeller Shaft**
2. Remove nuts and bolts securing flexible coupling to propeller shaft.

Refit

3. Reverse removal procedure. Fit nuts and bolts. Tighten to **78 Nm**.



DESCRIPTION

The welded steel rear axle casing houses a separate spiral bevel type differential unit, which is off set to the right of the vehicle centre line. The differential unit drives the rear wheels via the axle shafts and fully floating hubs which are mounted on tapered roller bearings.

Lubrication

The differential is lubricated with oil and the hub bearings with grease. The hub bearings are fitted

with inner and outer seals. The outer seals prevent the differential oil mixing with the hub grease and the inner seals prevent dirt ingress into the hub.

Ventilation

Ventilation of the hub bearings is through the outer oil seals and the differential ventilation pipe, which terminates at a high level.

The wheel hubs on axles with ABS brakes share the same construction to non ABS axles except for the addition of a sensor ring 11 on the brake disc 10.

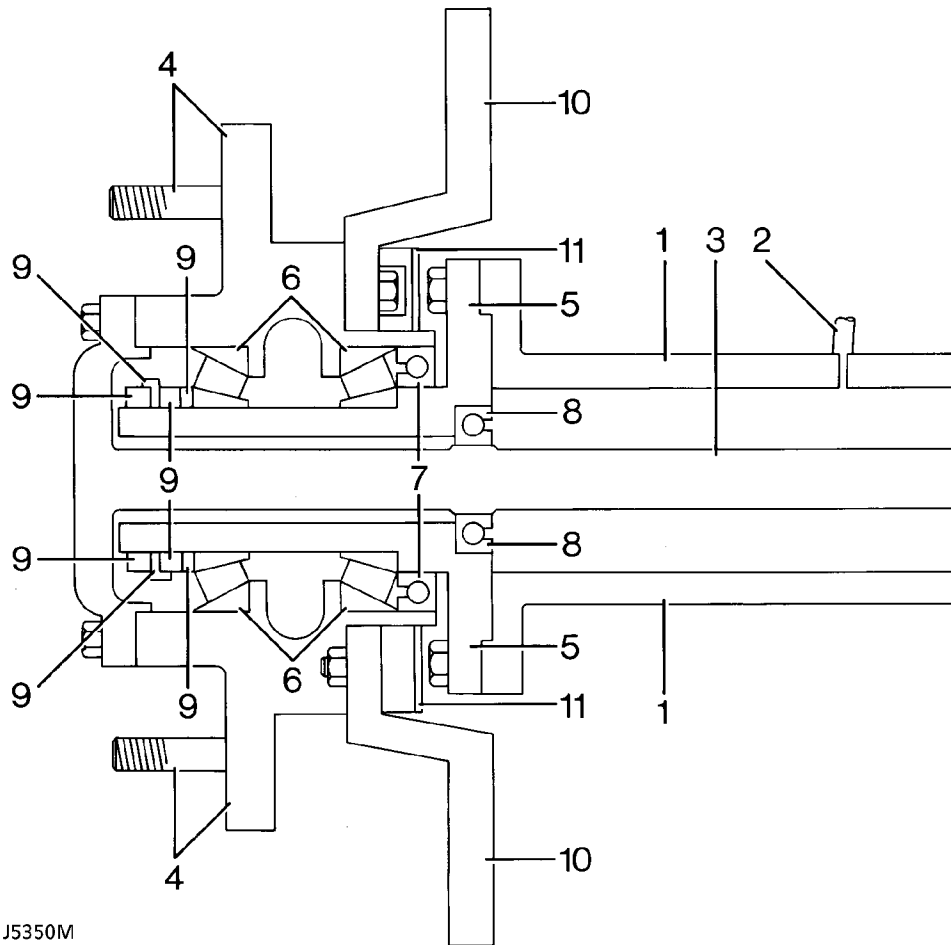

Rear axle hub

- | | |
|----------------------------|---|
| 1. Axle casing | 7. Inner hub seal |
| 2. Ventilation pipe | 8. Outer hub/axle shaft seal |
| 3. Axle shaft | 9. Hub lock plate, thrust washer and nuts (2) |
| 4. Wheel studs and hub | 10. Brake disc |
| 5. Wheel bearing stub axle | 11. Sensor ring, ABS |
| 6. Wheel bearings (2) | |



FAULT DIAGNOSIS

Complaint - Oil leaks

An external leak of lubrication from the hub seals can be caused by a faulty internal seal. For example, if the internal seals which separate the differential from the hubs are faulty and the vehicle is operating or parked on an embankment. Oil from the differential may flood one hub causing a leak and leave the differential lacking lubrication.

When a seal is found to be leaking check the axle ventilation system, as a blockage can cause internal pressure to force oil past the seals.

See 'Description and Operation' for illustrations of oil seal locations.

When investigating hub seal leaks check the grease for dilution with oil. Check also the differential level and oil for metal particles and the condition of internal seals.

If the vehicle is driven in deep water with defective oil seals, water may contaminate the lubricants and raise the differential level giving a false impression that the housing has been overfilled with oil.

Do not assume that a high oil level in the differential is due to over filling or, that a low level is because of an external leak.



REAR AXLE

Service repair no - 51.25.01

Remove



WARNING: Remove and refit of axle requires a further two persons to steady the axle when lowering or repositioning axle.

axle.

1. Drain brake system.
2. Support chassis rear.
3. Remove road wheels.
4. Support axle weight with hydraulic jack.
5. Disconnect ABS wiring harness multi-plug at jump hose bracket, if applicable.
6. Disconnect shock absorbers.
7. Disconnect flexible brake hose at connection under floor.
8. Disconnect lower links at axle.
9. Mark differential and propeller shaft flanges with identification marks for assembly. Remove four nuts and bolts. Lower propeller shaft and tie to one side.

10. Disconnect pivot bracket ball joint at axle bracket.
11. Release bolts and remove coil spring retaining plates.
12. Lower axle and remove road springs.
13. Disconnect anti-roll[sway] bar links to axle. **See REAR SUSPENSION, Repair, Anti-Roll[Sway] Bar Ball Joint Links**
14. Remove axle assembly.

Refit

15. Position axle and fit lower links. Tighten to **176 Nm**
16. Reverse removal procedure.
17. Tighten pivot bracket ball joint to axle to **176 Nm**.
18. Tighten propeller shaft to differential drive flange to **47 Nm**
19. Bleed brake system. **See BRAKES, Repair, Brake System Bleed**

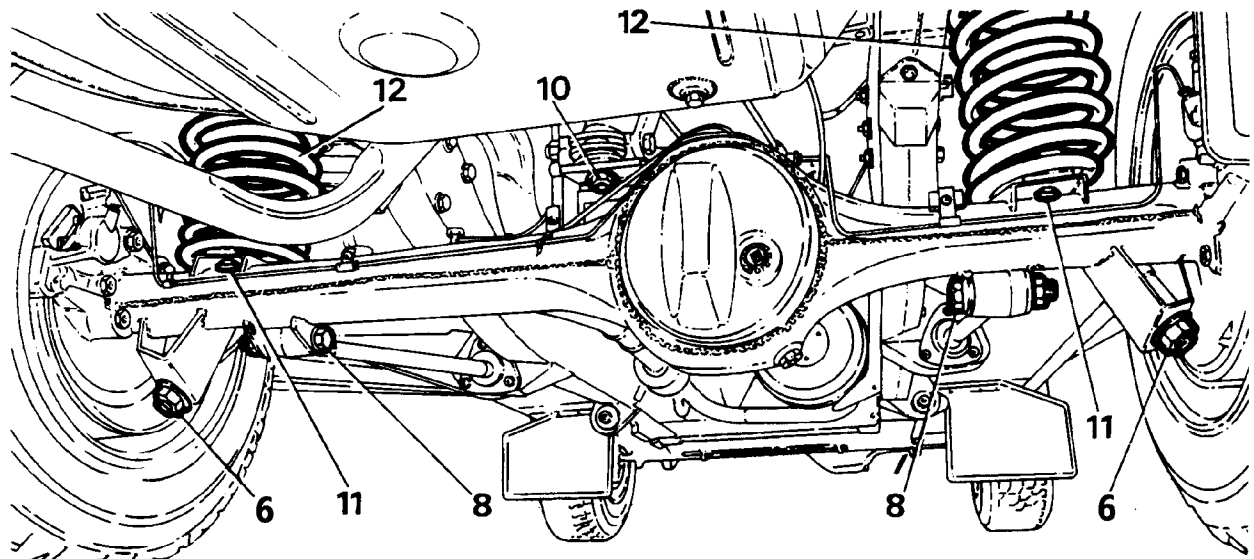

RR2004F

REAR BRAKE DISC NON ABS

Service repair no - 70.10.11.

Remove

1. Remove rear hub assembly. *See Rear Hub Assembly*
2. Remove disc bolts.
3. Remove disc from rear hub.

Refit

4. Fit disc to rear hub.
5. Fit disc bolts. Tighten to **73 Nm**.
6. Check total disc run out, this must not exceed 0,15 mm. If necessary reposition disc.

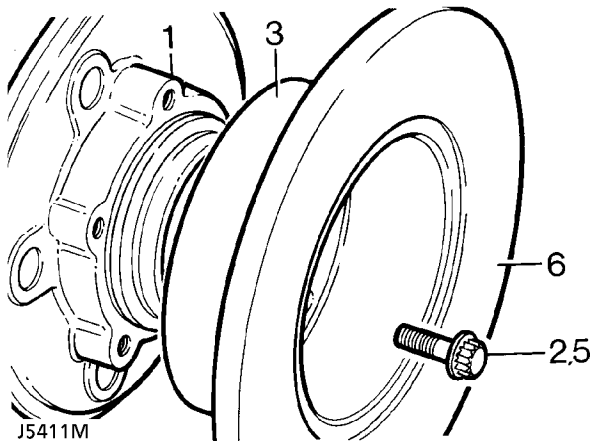

7. Fit rear hub assembly. *See Rear Hub Assembly*

Disc reclamation

8. Check disc thickness. This dimension may be reduced to minimum thickness of 12 mm. Machine equal amounts off each face.

REAR BRAKE DISCS ABS

Service repair no - 70.11.11.

Remove

1. Remove rear hub assembly. *See Rear Hub Assembly*
2. Remove five nyloc nuts.
3. Remove sensor ring.
4. Remove five hub to disc retaining bolts.
5. Remove disc from hub.

Refit

6. Fit disc onto hub.
7. Apply loctite 270 and fit hub to disc retaining bolts. Tighten to **73 Nm**.
8. Using new nyloc nuts fit sensor ring.

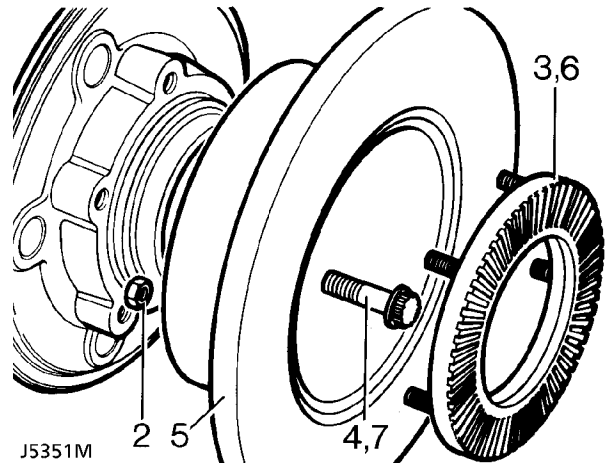

9. Check total disc run out, this must not exceed 0,15 mm. If necessary reposition disc.
10. Fit hub assembly. *See Rear Hub Assembly*

Disc reclamation

11. Check disc thickness. This dimension may be reduced to a minimum thickness of 12 mm. Machine equal amounts off each face.



REAR HUB ASSEMBLY

Service repair no - 64.15.01

Remove

1. Place rear axle onto axle stands and remove road wheel.
2. Release brake hose clips and remove brake caliper bolts. Secure to one side.



WARNING: Take care not to kink brake hose.

3. Remove five bolts and withdraw axle shaft.
4. Remove joint washer.
5. Bend back lock washer tabs.
6. Remove locknut and lock washer.
7. Remove hub adjusting nut.
8. Remove spacing washer.
9. Remove hub and brake disc assembly complete with bearings.

REAR HUB COMPONENTS

1. Sensor ring retaining nut ABS.
2. Axle shaft.
3. Axle shaft joint washer.
4. Axle shaft retaining bolt (five off).
5. Lock nut.
6. Lock washer.
7. Hub adjusting nut.
8. Spacing washer.
9. Outer bearing.
10. Hub.
11. Inner bearing.
12. Grease seal.
13. Brake disc.
14. Disc retaining bolt (five off).
15. Sensor ring ABS.

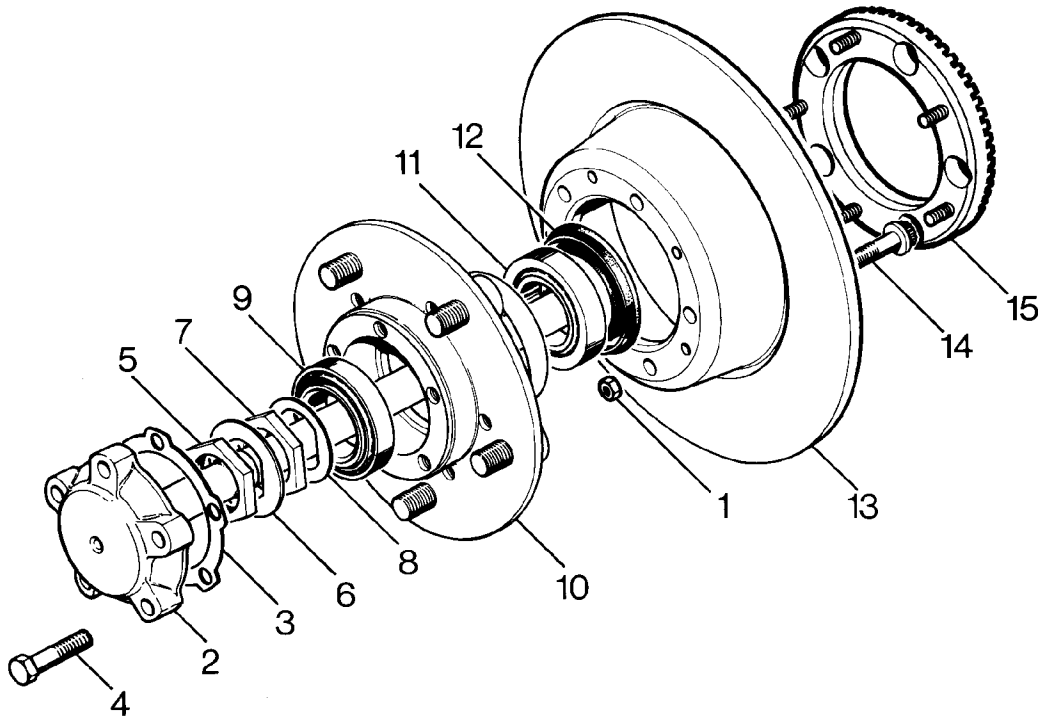

J5352M

Refit

10. Clean stub axle. Retract ABS sensor slightly from sensor sleeve, if applicable
11. Fit hub assembly to stub axle.
12. Fit spacing washer.
13. Fit hub adjusting nut. Tighten to **61 Nm**. Back off adjusting nut 90°. Tighten to **4 Nm**. This will give the required hub end float of 0,010mm
14. Fit a new lock washer.
15. Fit locknut. Tighten to **61 Nm**.
16. Tab over lock washer to secure adjusting nut and locknut.
17. Using a new joint washer fit axle shaft to hub, secure with five bolts. Tighten to **65 Nm**.
18. Fit brake caliper. Tighten to **82 Nm**. Secure brake pipes to axle casing.
19. If applicable, set ABS brakes sensor. Push sensor in until it touches sensor ring then rotate hub to set sensor.
20. Fit road wheel, remove axle stands and final tighten road wheel nuts to **126 Nm**.
21. Operate footbrake to locate brake pads before driving vehicle.

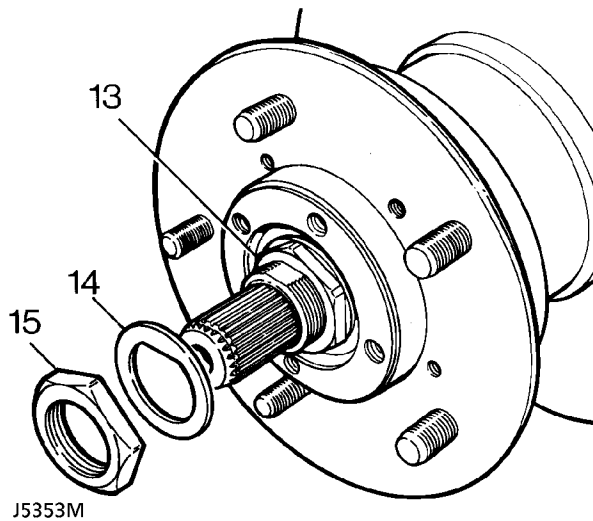



AXLE DIFFERENTIAL ASSEMBLY

Service repair no - 51.15.07.

DISMANTLE



NOTE: Mark differential components so their original positions relative to other components is maintained. Bearing caps must not be interchanged.

1. Remove axle shafts then differential assembly from axle.
2. Remove roll pin securing bearing nut locking fingers to bearing caps. Remove locking fingers.
3. Loosen bearing cap bolts and mark caps for assembly.
4. Using service tool LRT-54-508, remove bearing adjusting nuts.
5. Remove bearing cap bolts and bearing caps.
6. Remove crown wheel differential unit and bearings.

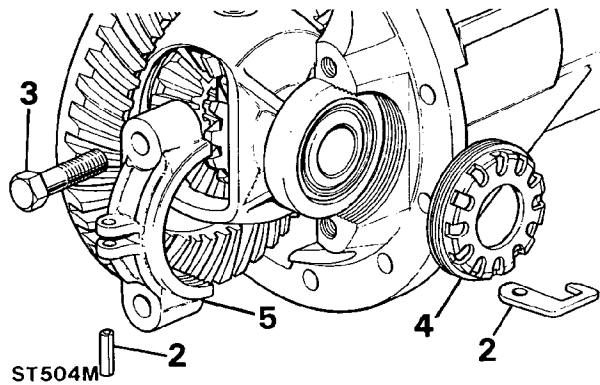

Remove pinion FRONT AXLE DIFFERENTIAL ONLY

7. Remove pinion flange nut using service tool LRT-51-003 to restrain flange.
8. Remove washer and pinion drive flange.

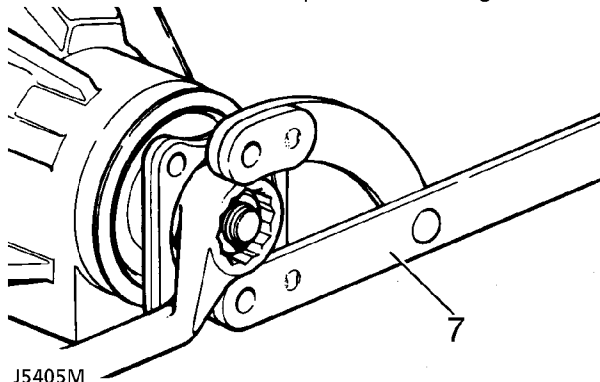

9. Remove pinion complete with bearing and outer bearing shims.
10. Remove pinion flange oil seal, spacer and bearing.

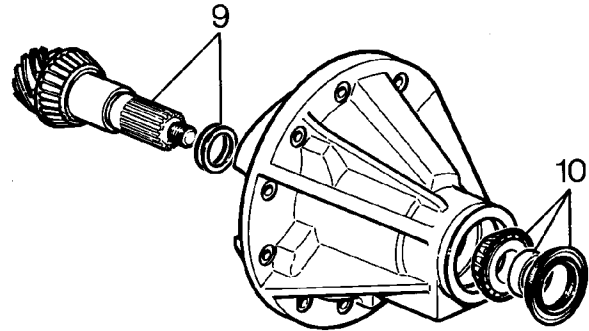

Remove pinion REAR AXLE DIFFERENTIAL ONLY

7. Remove pinion flange centralising peg using service tool LRT 51-008.
8. Remove pinion flange nut using service tool LRT-51-003 to restrain flange.
9. Remove pinion complete with bearing and outer bearing shims.
10. Remove pinion flange oil seal, spacer and bearing.

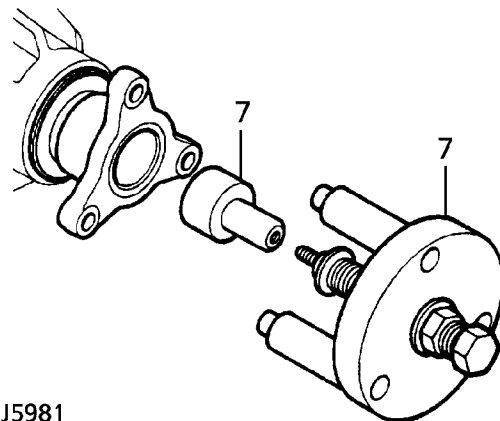

11. Using service tool LRT-54-505, remove pinion head bearing track and shim and drive out outer bearing of differential housing.

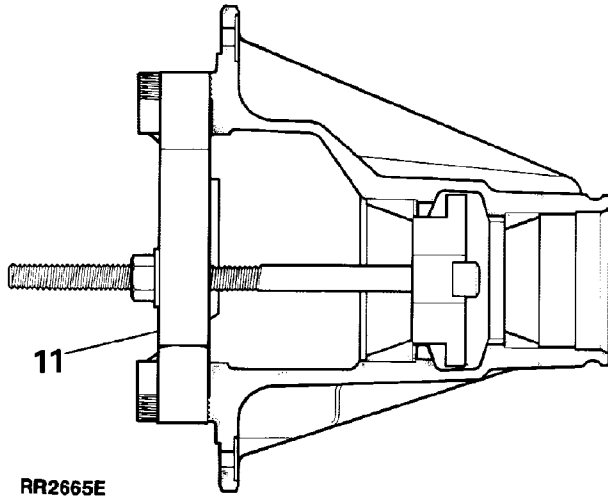

RR2665E

12. Remove pinion head bearing with service tool LRT-99-002.

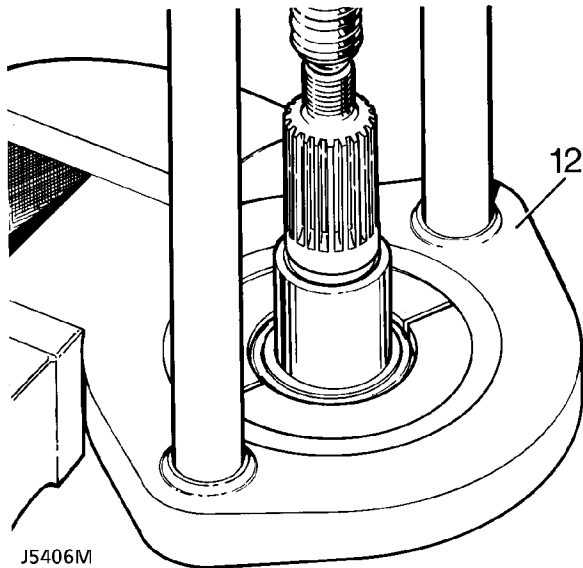

J5406M

13. Remove bolts and washers securing crown wheel to differential flange. Remove crown wheel.
14. Remove differential carrier bearings.
15. Remove circlips and extract differential cross shaft.
16. Withdraw differential gears and pinions.
17. Clean all components.

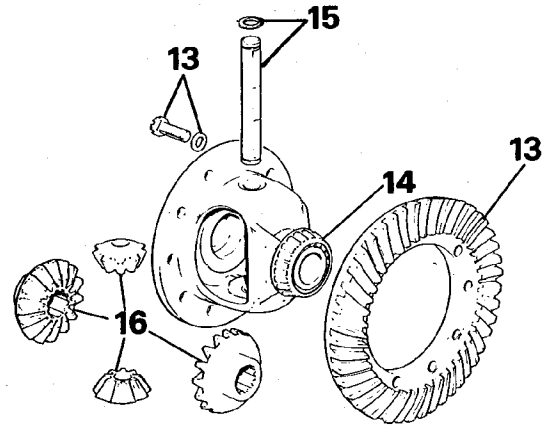

ST509M

INSPECTION

18. Check all bearings for wear and pitting.
19. Check all gears for wear, scuffing, pitting and damaged teeth.
20. Supplied as matched sets are: crown wheel and pinion, pinion housing and bearing caps.

ASSEMBLE

Differential gears

21. Fit differential gears to differential housing.
22. Fit differential cross shaft and circlips.

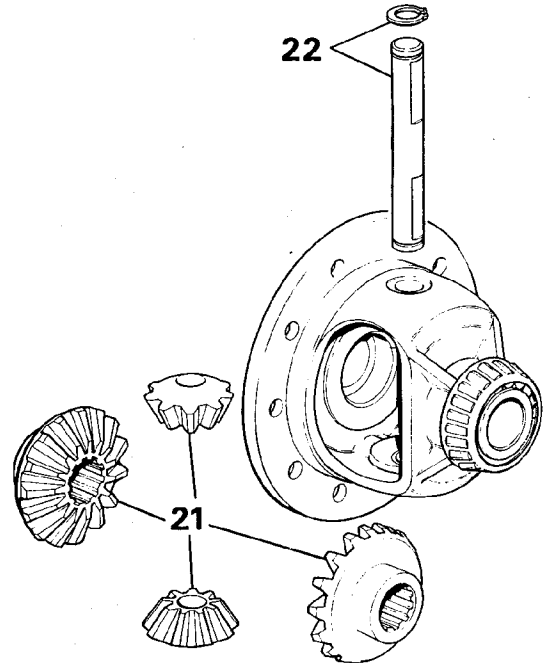

ST510M



- 23. Check gear for freedom of rotation and backlash. Nominal backlash should be present. Excess backlash necessitates replacement of gears or differential housing.
- 24. Check serial number marked on pinion end face matches that on crown wheel.
- 25. Clean and fit crown wheel.
- 26. Fit carrier bearings and assemble tracks to bearings.

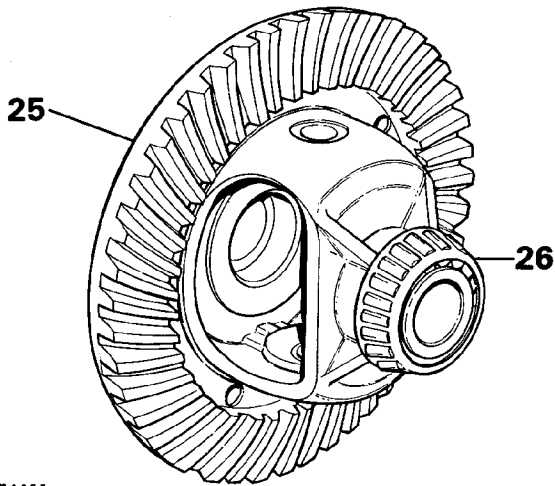

ST511M

- 30. Tighten bearing cap bolts to **90 Nm**.
- 31. Check crown wheel for run-out. This should not exceed 0,10 mm. If exceeded examine crown wheel and mounting flange for burrs, grit, etc. Refit and recheck. A buckled or damaged differential housing flange is corrected by replacing differential gear housing.
- 32. After checking run out remove differential housing from pinion housing.
- 33. Remove crown wheel bolts and refit using Loctite 'Studlock'. Tighten to **58 Nm**.

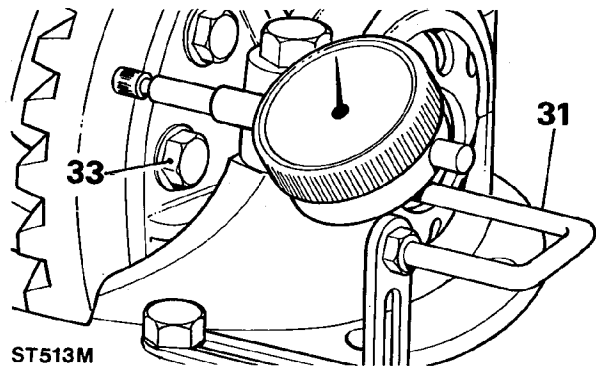

ST513M

- 27. Place differential housing with crown wheel and bearings in pinion housing.
- 28. Fit bearing caps and bolts. Do not tighten bolts.
- 29. Fit bearing adjusting nuts and adjust to obtain zero end float.

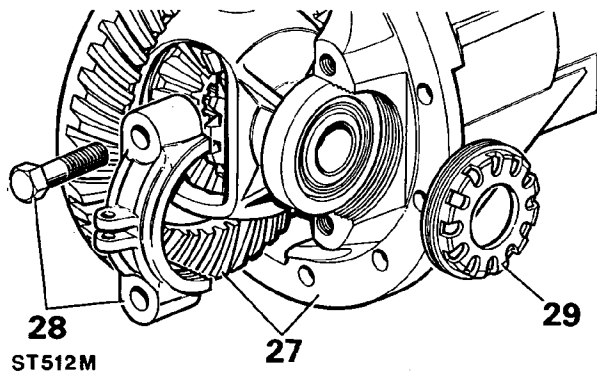

ST512M

- 34. Fit pinion head bearing track and original shim to pinion housing. Use service tools LRT-54-505 and LRT-54-506. If fitting a new shim use minimum 1.27 mm thickness.

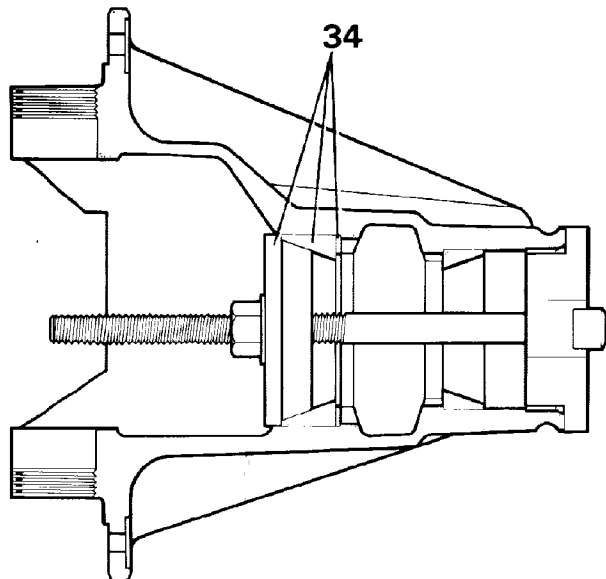

RR2666E

35. Fit pinion outer bearing track to pinion housing. Use service tools LRT-54-505 and LRT-54-507.

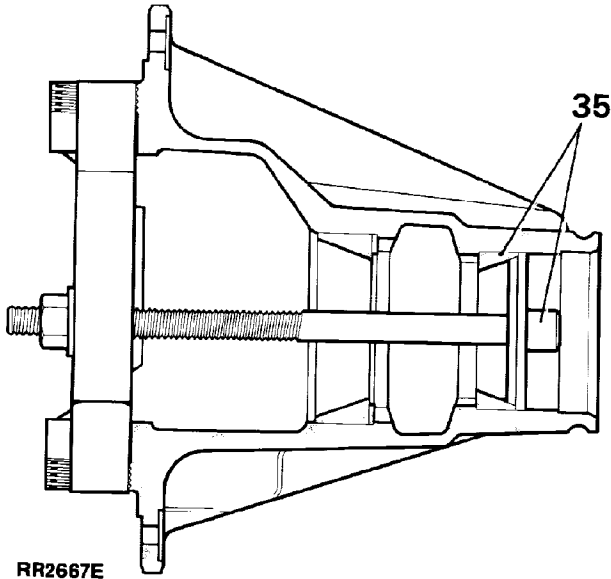

36. Fit pinion head bearing to pinion. Use service tool LRT-54-502.

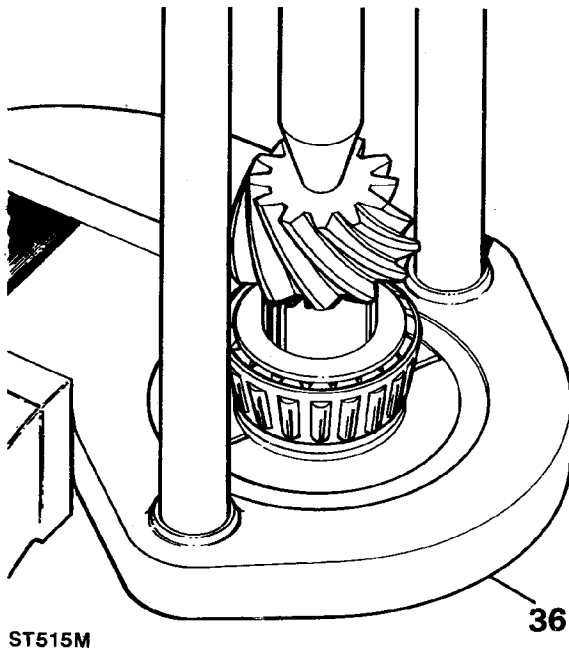

37. Fit pinion into its location without shims for bearing pre-load.
38. Fit outer bearing, and spacer (front axle differential only).
39. Fit driving flange, washer and nut.

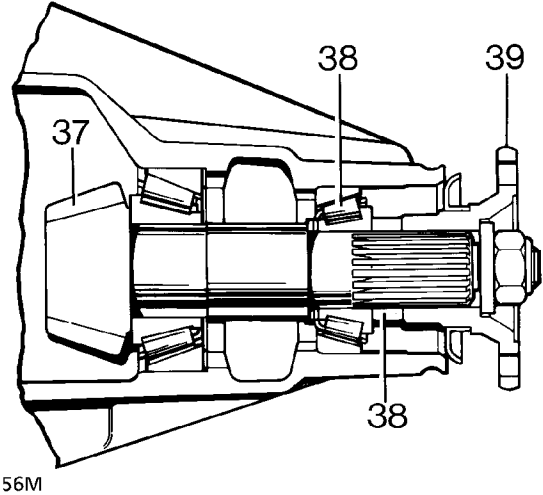

40. Do not fit oil seal at this stage.
41. Tighten pinion flange nut until force required to rotate pinion is **3 Nm** if new bearings are fitted. This will pre-load bearings to check pinion height dimension.

NOTE: If using original bearings, pre-load figure is 1.5 Nm.

Drive pinion markings

NOTE: Markings on end face adjacent to serial number are of no relevance to servicing.

42. Figures marked on end face opposite to serial number show in thousandths of an inch, deviation from nominal, required to set pinion. Pinions marked plus (+) must be set below nominal. Pinions marked minus (-) must be set above nominal. Unmarked pinions must be set at nominal.

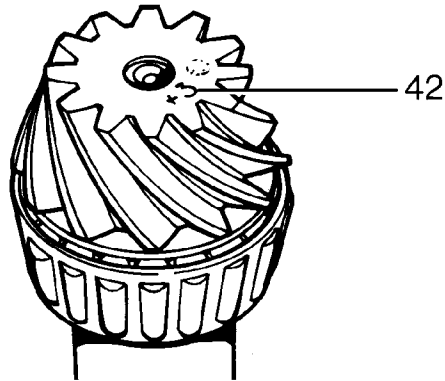

J5357M

- 43. Nominal setting dimension is represented by setting gauge block LRT-54-503. Referenced from pinion end face to bottom radius of differential bearing bore.

Drive pinion adjustment

- 44. Ensure pinion end face is free of burrs around etched markings.
- 45. Remove keep disc from magnetized base of dial gauge tool.
- 46. Place dial gauge and setting block on surface plate. Zero dial gauge trace pin on setting block.



NOTE: Setting block has three height settings heights.

Use 39.50mm setting mark for this differential.

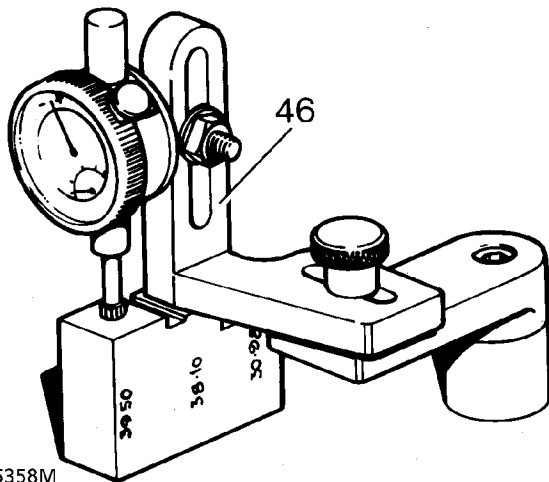

J5358M

Pinion height shims

PART No.	INCH	MM
FTC3853	.061	1.548
FTC3854	.060	1.523
FTC3855	.059	1.498
FTC3856	.058	1.473
FTC3857	.057	1.448
FTC3858	.056	1.423
FTC3859	.055	1.398
FTC3860	.054	1.373
FTC3861	.053	1.348
FTC3862	.052	1.323
FTC3863	.051	1.298
FTC3864	.050	1.273
FTC3865	.049	1.248
FTC3866	.048	1.223
FTC3867	.047	1.198
FTC3868	.046	1.173

- 47. Position dial gauge centrally on pinion end face, register on lowest point on one differential bearing bore. Note dial gauge measurement from zeroed setting.

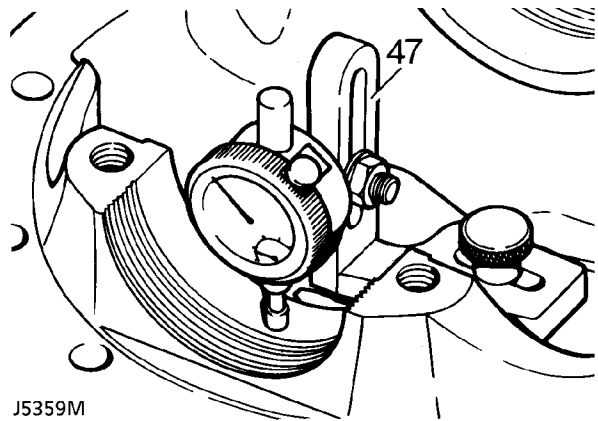

J5359M

48. Repeat on other bearing bore. Add readings then halve sum to obtain mean reading. Note whether trace pin has moved up or down from zero.
- Where trace pin moves down, reading is equal to thickness of shims to remove, to bring pinion to nominal.
 - Where trace pin moves up, reading is equal to thickness of shims to add, to bring pinion to nominal.
49. Before adjusting shim thickness: check pinion face marking. If a plus (+) figure, subtract in thousandths of an inch from shim thickness figure.
50. If pinion has a minus (-) figure, add amount to shim thickness figure.
Adjust shim thickness under pinion head bearing track as necessary.

INCH	=	MM
.001	=	.025
.002	=	.05
.003	=	.075
.004	=	.10
.005	=	.125
.006	=	.15
.007	=	.175
.008	=	.20
.009	=	.225
.010	=	.25



NOTE: Where dial indicator is metric conversion must be made to inches when measuring and selecting shims.

51. Recheck pinion height setting. If setting is correct, mean reading of dial gauge will agree with figure marked on pinion end face.
For example, with end face marking of +3, dial gauge reading should indicate pinion is +0.003 in.

Bearing pre-load adjustment

- Remove the pinion flange, pinion, outer bearing and spacer.
- Slide new shim, of same thickness as original (bearing pre-load) into position on pinion shaft. If fitting a new shim use thickest shim 2.155 mm.
- Fit pinion to pinion housing and fit outer bearing and spacer (front differential only).
- Fit driving flange, washer and nut.
- Do not fit oil seal at this stage.

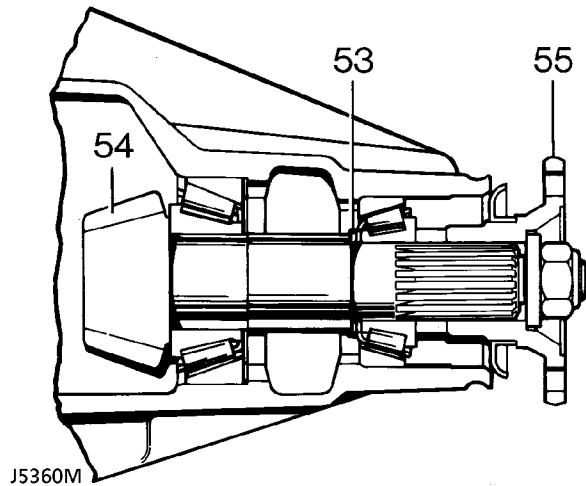

- Tighten pinion flange nut to **130 Nm**. Force to rotate pinion shaft is 3Nm using new bearings. Change shim as necessary to obtain reading. Thicker shim will reduce pre-load. Thinner shim will increase pre-load.



NOTE: If using original bedded in bearings, pre-load figure is 1.5 Nm.

- Remove pinion flange.



PINION PRELOAD SHIMS

PART No.	INCH	MM
FTC3869	.085	2.155
FTC3870	.084	2.130
FTC3871	.083	2.105
FTC3872	.082	2.080
FTC3873	.081	2.055
FTC3874	.080	2.030
FTC3875	.079	2.005
FTC3876	.078	1.980
FTC3877	.077	1.955
FTC3878	.076	1.930
FTC3879	.075	1.905
FTC3880	.074	1.880
FTC3881	.073	1.855
FTC3882	.072	1.830
FTC3883	.071	1.805
FTC3884	.070	1.780
FTC3885	.069	1.755
FTC3886	.068	1.730
FTC3887	.067	1.705
FTC3888	.066	1.680
FTC3889	.065	1.655
FTC3890	.064	1.630
FTC3891	.063	1.605
FTC3892	.062	1.580
FTC3893	.061	1.555
FTC3894	.060	1.530
FTC3895	.059	1.505
FTC3896	.058	1.480

Fit pinion drive flange - front axle differential

- 60. Lubricate seal lips with axle oil.
- 61. Fit spacer and pinion drive flange to differential.
- 62. Secure flange with washer and nylon nut. Tighten to **130 Nm**.

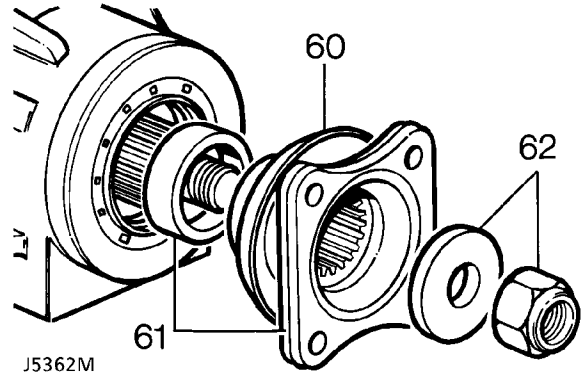

Fit pinion drive flange - rear axle differential

- 60. Lubricate seal lips with axle oil.
- 61. Fit pinion drive flange to differential and secure with washer and nylon nut. Tighten to **130 Nm**.
- 62. Coat centralizing peg with Loctite 601 or 638 and fit over pinion retaining nut in drive flange.

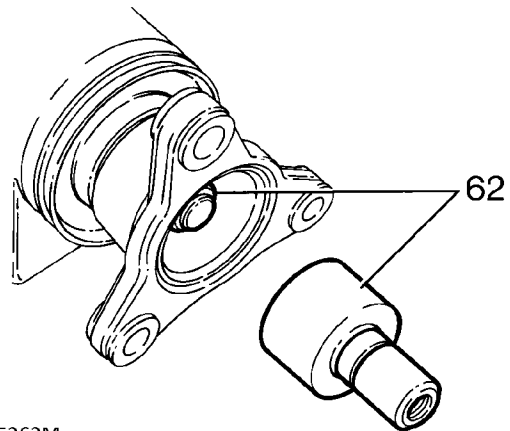

Fitting Pinion Oil Seal

- 59. Coat outer diameter of seal with grease. Fit seal lip side leading flush with end face of housing using tool LRT-51-001.

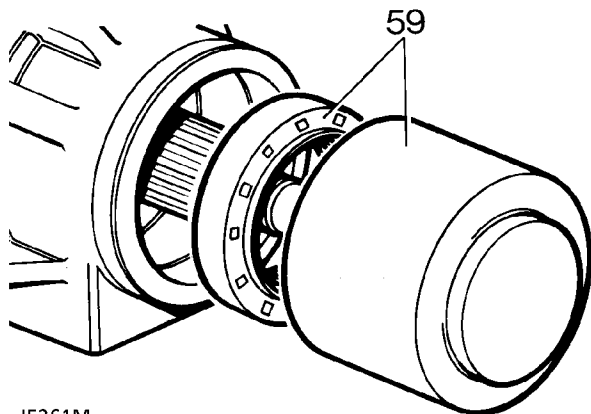

CROWN WHEEL/PINION BACKLASH ADJUSTMENT

63. Place differential housing in pinion housing.
64. Fit bearing caps and partly tighten bolts.

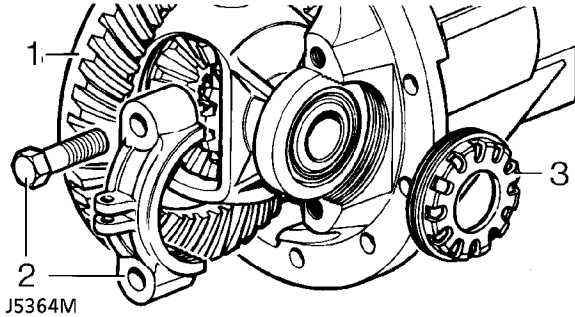

68. Tighten left nut until it contacts bearing. Continue turning until a backlash of 0,10 to 0,17 mm is met. **DO NOT** loosen right nut otherwise bearing preload will be affected.
69. Fit locking fingers and roll pins. Align locking finger with a slot.
70. Evenly tighten bearing cap bolts to **90 Nm**.

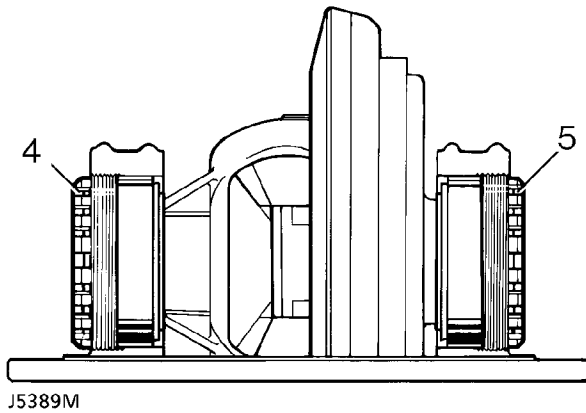
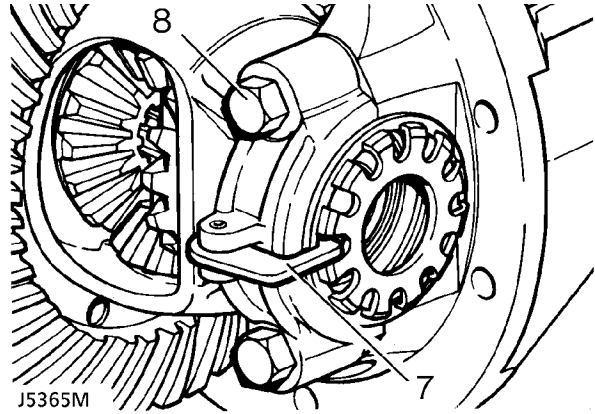

71. Recheck crown wheel/pinion backlash.
72. Lubricate bearings and gears.

65. Fit bearing adjusting nuts.
66. Mesh crown wheel to pinion. Using service tool LRT-54-508 loosen left bearing adjuster nut.
67. Tighten right nut until crown wheel/pinion backlash is just removed.



REAR HUB ASSEMBLY

Service repair no - 61.15.13.

Overhaul

1. Remove rear hub assembly. *See Repair, Rear Hub Assembly*
2. Remove outer bearing.
3. Remove five nyloc nuts and withdraw ABS sensor ring, if applicable.
4. Mark, for reassembly, position of hub to brake disc.

5. Remove five bolts and separate hub from brake disc.



WARNING: A maximum of two road wheel retaining studs can be renewed. Should more studs be unserviceable fit new hub with studs.

6. Remove grease seal and inner bearing from hub.
7. Remove inner and outer bearing tracks.

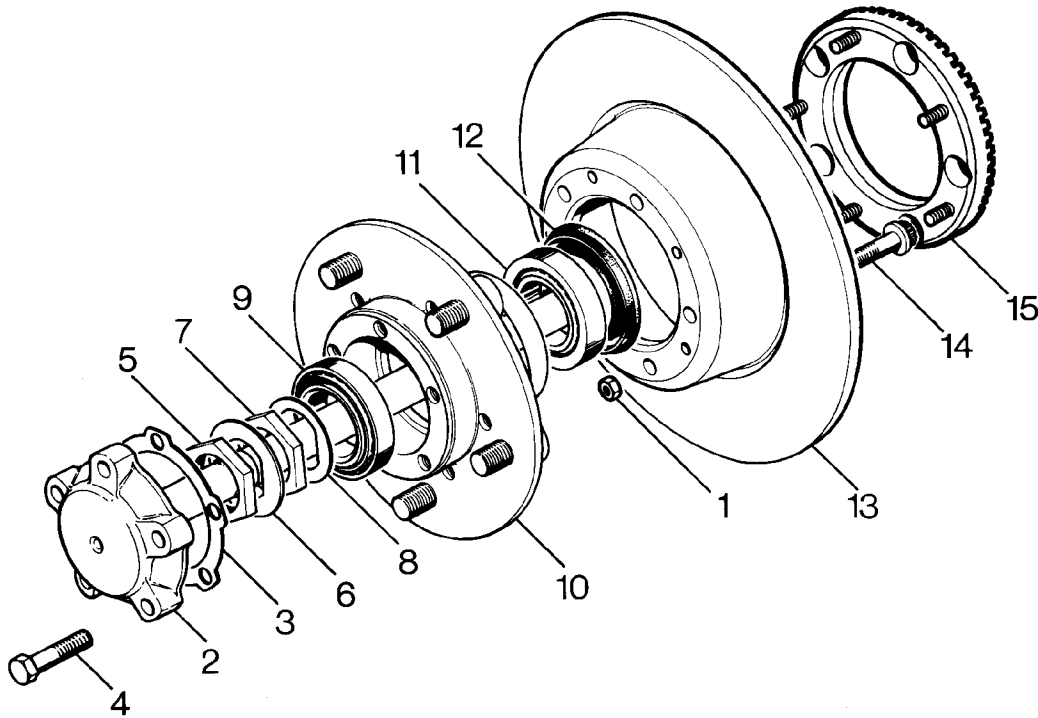

J5352M

REAR HUB COMPONENTS

- | | |
|--|---|
| <ol style="list-style-type: none"> 1. Sensor ring retaining nut ABS. 2. Axle shaft. 3. Axle shaft joint washer. 4. Axle shaft retaining bolt (five off). 5. Lock nut. 6. Lock washer. 7. Hub adjusting nut. 8. Spacing washer. | <ol style="list-style-type: none"> 9. Outer bearing. 10. Hub. 11. Inner bearing. 12. Grease seal. 13. Brake disc. 14. Disc retaining bolt (five off). 15. Sensor ring ABS. |
|--|---|

Refit

8. Clean hub and fit inner and outer bearing tracks.

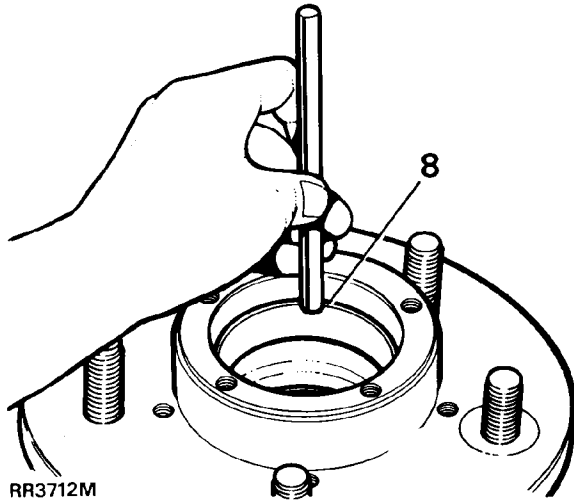

9. Pack hub inner bearing with grease and fit to hub.
10. With lip side leading fit a new seal flush with rear face of hub. Using service tool LRT-54-003 seal replacer and drift. Apply grease between seal lips.

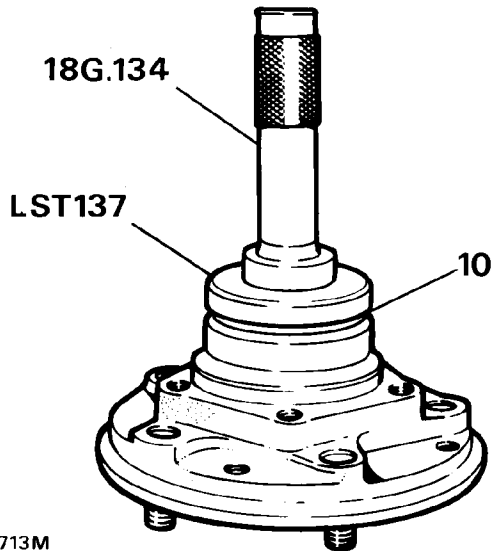

11. Assemble brake disc to the hub, line up reassembly marks. Applying Loctite 270, fit and tighten retaining bolts to **73 Nm**.
12. If necessary, where applicable, renew sensor ring studs applying Loctite 270 to threads. Fit sensor ring using new nyloc nuts. Tighten to **9 Nm**. Ensuring it is correctly fitted to avoid tooth run out.
13. Pack hub outer bearing with grease and fit to hub.
14. Fit rear hub assembly. **See Repair, Rear Hub Assembly**



REAR STUB AXLE

Service repair no - 64.15.22.

STUB AXLE COMPONENTS

1. Rear axle shaft.
2. Stub axle to axle casing bolt.
3. Mudshield.
4. Stub axle.
5. Stub axle joint washer.
6. Axle case.
7. Sensor ABS.

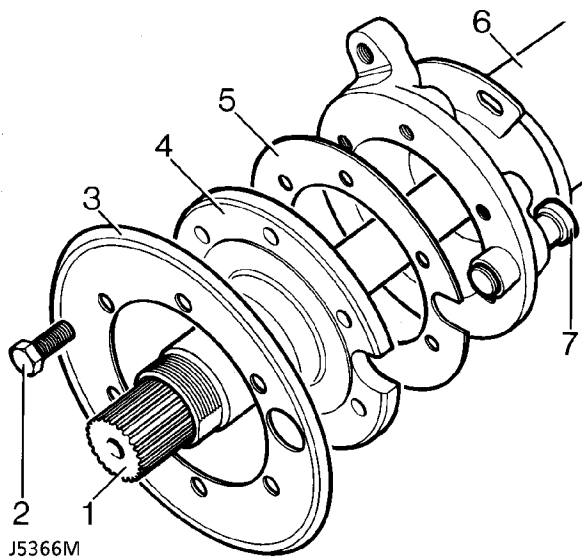

Overhaul

1. Remove hub assembly. *See Repair, Rear Hub Assembly*
2. Remove six bolts from stub axle to axle casing.
3. Remove mudshield.
4. Remove stub axle and joint washer.
5. Remove rear axle shaft from axle casing.

Renew rear stub axle oil seal

6. Remove and discard oil seal. Lubricate seal and lip with EP90 oil. Using special tool LST 138 fit new oil seal lipside trailing so that seal is flush with rear face of stub axle.

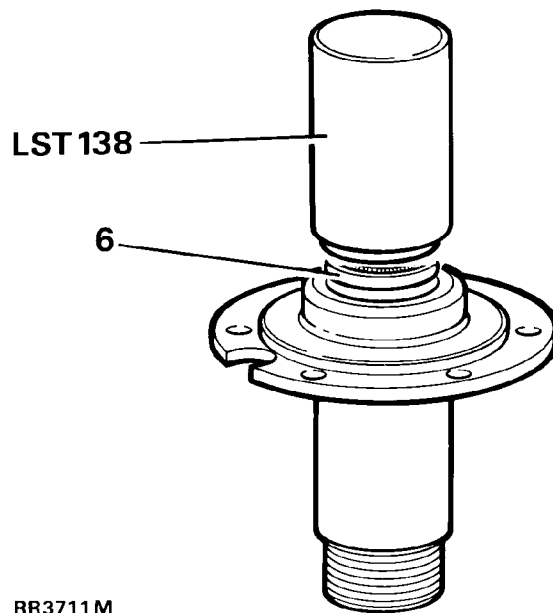

Refit

7. Fit new joint washer, stub axle and mudshield with bolts. Tighten to **65 Nm**.
8. Fit rear axle shaft avoid damaging stub axle seal.
9. Refit rear hub assembly. *See Repair, Rear Hub Assembly*



AXLE DIFFERENTIAL DATA

Pinion bearing pre-load:	
(new bearings)	3 Nm
(bearings bedded in)	1,5 Nm
Crown wheel run-out	0,10 mm
Crown wheel/pinion backlash	0,10 to 0,17 mm

REAR HUB

Rear hub end float	0,010 mm
--------------------------	----------

TORQUE VALUES



NOTE: Torque wrenches should be regularly checked for accuracy to ensure that all fixings are tightened to the correct torque.

	Nm
REAR AXLE	
Pinion housing to axle case	41
Crown wheel to differential case	58
Differential bearing cap to pinion housing	90
Differential drive flange to drive shaft	47
Bevel pinion nut	129
Lower link to axle	176
Pivot bracket ball joint to axle	176
REAR HUB ABS VEHICLES	
Hub driving member to hub	65 *
Brake disc to hub	73 *
Stub axle rear to axle case	65
Brake caliper to axle case	82
Disc shield to axle case	11
Sensor ring to brake disc ABS	9

* Apply loctite 270 prior to assembly.

Torque values below cover all screws and bolts used, unless specified otherwise.

METRIC	Nm
M5	6
M6	9
M8	25
M10	45
M12	90
M14	105
M16	180

UNC / UNF	Nm
1/4	9
5/16	24
3/8	39
7/16	78
1/2	90
5/8	136



AXLE DIFFERENTIAL

LRT-51-003 Flange holder tool
18G1205

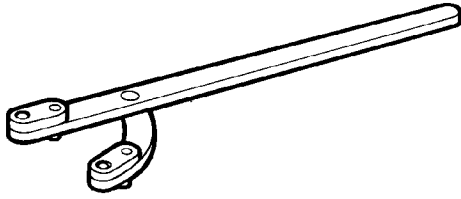

18G1205

LRT-54-504 Universal setting block
18G1914

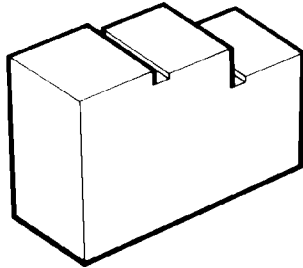

18G1914

LRT-54-502 Pinion head bearing remover/replacer
18G476

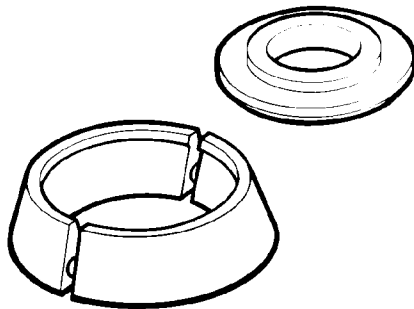

18G476

LRT-99-002 Press
MS47

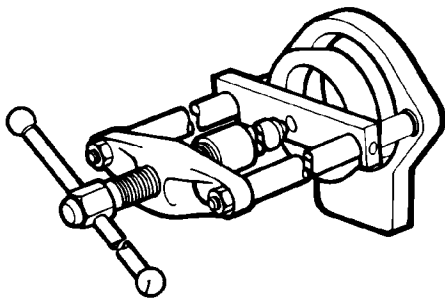

MS47

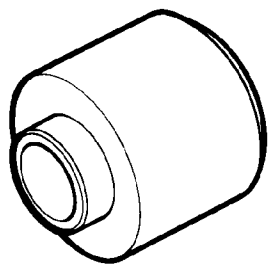

LRT-51-001 Oil seal replacer
LST106

LST106

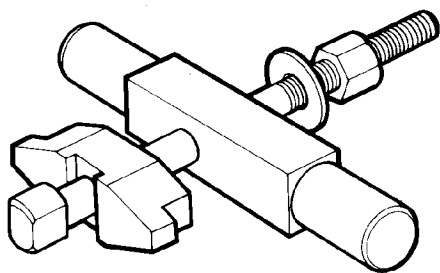

LRT-54-505 Extractor for pinion bearing races
RO262757A

262757A

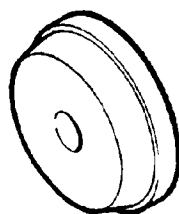

LRT-54-506 Replacer adapter pinion head bearing
cup
RO2627571

2627571

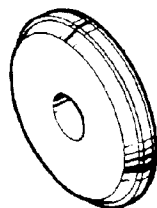

LRT-54-507 Adaptor pinion tail bearing cup
replacer
RO2627572

2627572

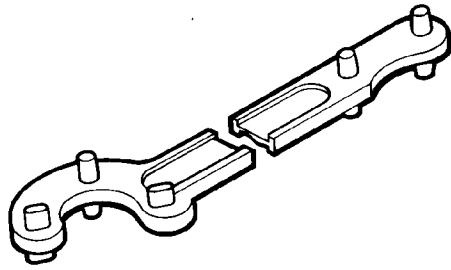

RO530105

LRT-54-508 Wrench flange and carrier
RO530105 bearing nuts

REAR HUB

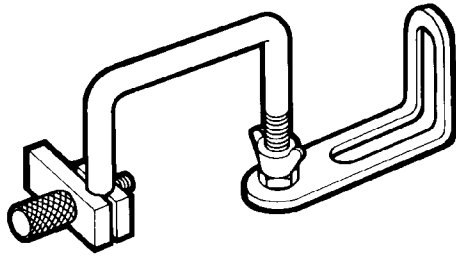

RO530106

LRT-99-503 Bracket for dial gauge and indicator
RO530106

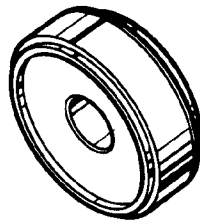

LST 5505

LRT-54-001 Oil seal replacer non ABS
LST550-5

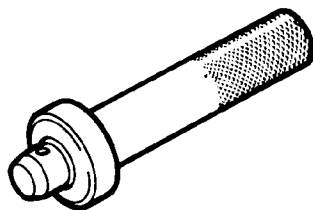

18G134

LRT-99-003 Drift
18G134

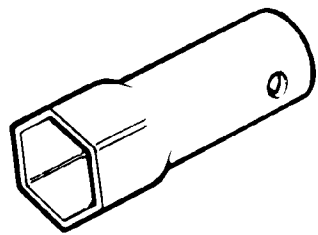
**606435A**

LRT-54-002 Hub nut wrench
RO606435A

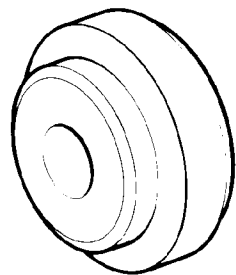
**LST137**

LRT-54-003 Hub oil seal replacer ABS
LST137

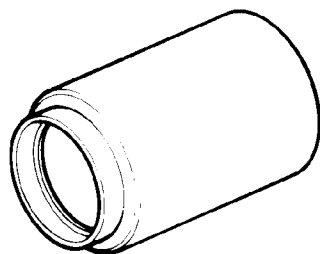
**LST138**

LRT-54-004 Oil seal replacer ABS
LST138



DESCRIPTION

The welded steel front axle casing houses a separate spiral bevel type differential unit, which is off set to the right of the vehicle centre line. The differential unit drives the front wheels via the axle shafts and constant velocity joints which are totally enclosed in the spherical and swivel housings.

The front axles fitted with ABS brakes or non ABS brakes are of the same construction except for different top swivel pins in the swivel housing and a sensor on the constant velocity joint.

Front axle - ABS

The front wheels are pivoted on taper roller bearings 19 at the bottom of the swivel housing and a 'Rialco bush' 25 at the top. The top swivel pin also houses the ABS pickup (electrical connection) as shown in the main illustration, J5367.

Front axle - non ABS

The front wheels are pivoted on taper roller bearings at the top (see insert) and bottom of the swivel housing. The wheel hubs on all axles are supported by two taper bearings and driven by drive flanges which are splined to the one piece, stub shaft/constant velocity joint.

Lubrication

The differential, swivel pin housing and wheel hubs are individually lubricated and separated by oil seals 7 and 8 to prevent oil transfer across the axle when the vehicle is traversing steep inclines. The wheel bearings are lubricated with grease and the swivel housing and differential with oil.

Ventilation

Ventilation of the differential is through a plastic pipe 2 which terminates at a high level in the vehicle on both ABS and non ABS axles. The swivel housings ventilate through axle shaft oil seals 8 into the differential and the hub bearings vent via the oil seals into swivel housing.

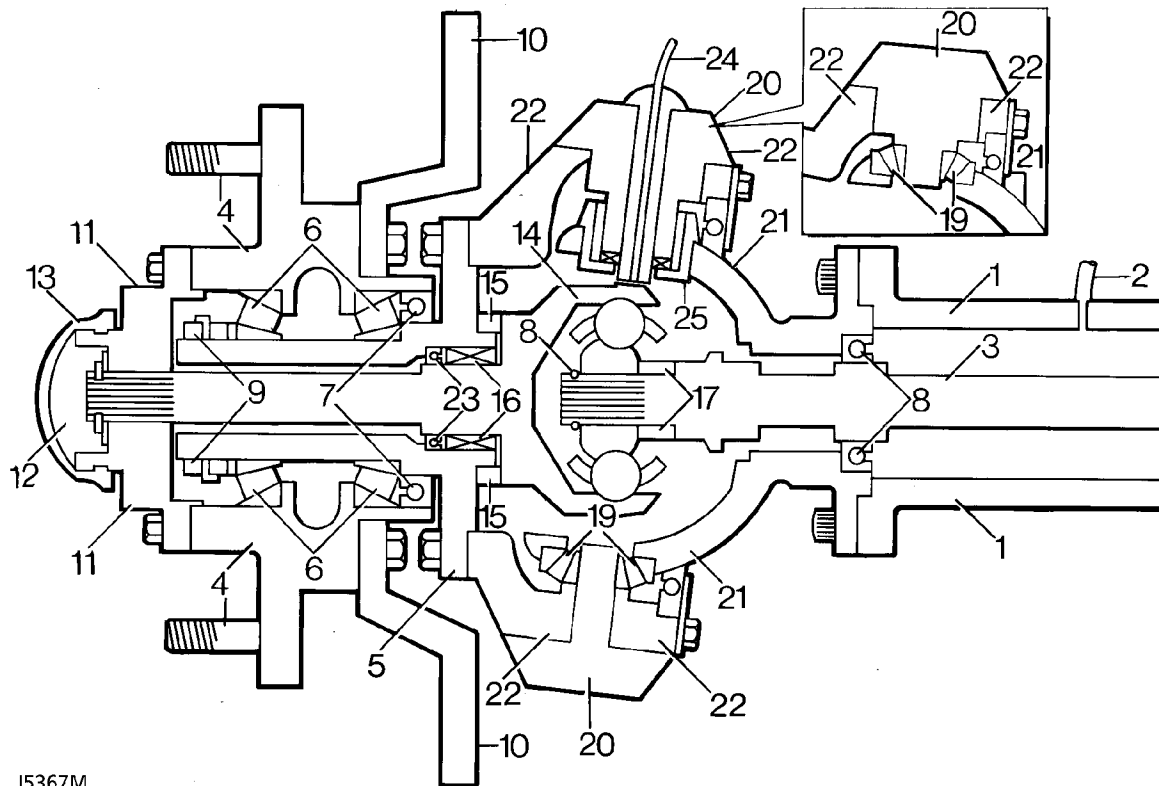

J5367M

Front axle

- | | |
|---|--|
| 1. Axle casing | 14. Constant velocity joint/shaft |
| 2. Ventilation pipe | 15. Thrust collar for CV joint |
| 3. Axle shaft | 16. Roller bearing |
| 4. Wheel studs and hub | 17. Spacer |
| 5. Stub axle | 18. Circlip |
| 6. Wheel bearings (2) | 19. Bottom swivel taper bearing |
| 7. Inner and outer hub seals | 20. Top and bottom swivel pins |
| 8. Axle shaft seal | 21. Spherical housing, seal and retainer |
| 9. Hub lock plate, thrust washer and nuts (2) | 22. Swivel housing |
| 10. Brake disc | 23. Constant velocity shaft seal |
| 11. Drive flange | 24. ABS pickup (electrical connection) |
| 12. Shim washer and circlip | 25. 'Rialco' bush ABS |
| 13. Dust cap | |



FAULT DIAGNOSIS

Complaint - Oil leaks

An external leak of lubrication can be caused by a faulty internal seal. For example, if the seals which separate the differential from the swivel housings are faulty and the vehicle is operating or parked on an embankment, oil may leak across the axle leaving one swivel with a high level and the other swivel and differential lacking lubrication.

See 'Description and Operation' for illustrations of oil seal locations.

When investigating leaks or checking oil levels, it is essential that all the lubrication is drained from any housing with a high level and that the other levels are checked.

Swivel oil should be checked for signs of grease leaking from the hub bearings and the hub grease should not contain oil.

Check that the axle ventilation system is clear, as a blockage can cause internal pressure to force oil past the seals.

If the vehicle is driven in deep water with defective oil seals, water may contaminate the lubricants and when checked, give a false impression that the housing has been overfilled with oil.

Do not assume that a high oil level is due to over filling or, that a low level is because of an external leak.



FRONT AXLE ASSEMBLY

Service repair no - 54.15.01

Remove

⚠ WARNING: Remove and refit of axle requires a further two persons to steady axle when lowering or repositioning axle.

1. Support chassis front.
2. Remove road wheels.
3. Support axle weight with hydraulic jack.
4. Remove radius arms to chassis frame nuts.

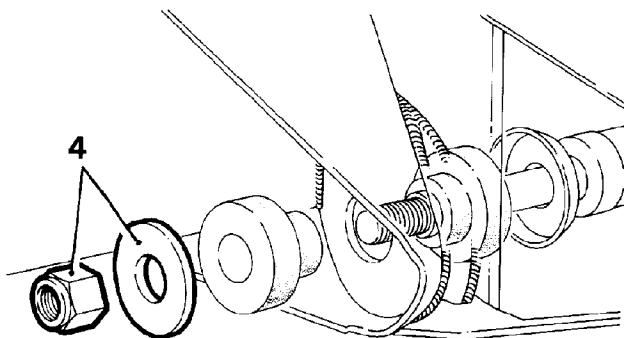

RR983M

5. Disconnect steering damper from track rod. Using an extractor remove track rod links from swivel pin arms.
6. Remove four nuts and bolts securing radius arms to axle bracket.
7. Remove radius arms.
8. Remove bolts securing brake hose brackets. Refit bolts to prevent oil leakage.
9. Remove ABS sensor, if applicable.
10. Remove bolts from brake calipers and tie to one side.
11. Remove nuts and washers securing shock absorbers to axle.
12. Disconnect drag link from swivel pin housing arm.

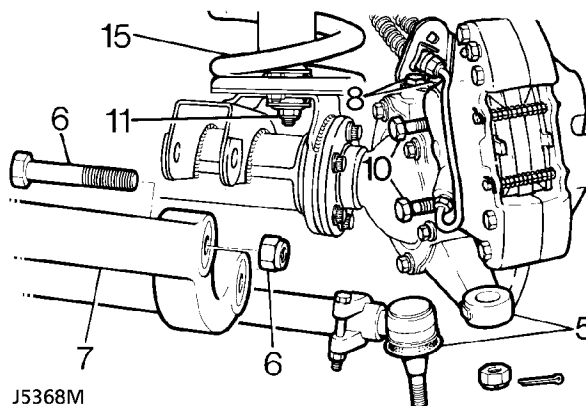

J5368M

13. Remove two nuts and bolts securing panhard rod to axle bracket. Lift rod clear of axle.
14. Mark for reassembly drive shaft flanges. Remove four nuts and bolts, tie propeller shaft to one side.
15. Lower axle assembly and remove road springs.
16. Disconnect anti-roll[sway] bar link. **See FRONT SUSPENSION, Repair, Anti-Roll[Sway] Bar Ball Joint Links**
17. Remove axle assembly.

Refit

18. Position axle under vehicle, supporting left side of axle.
19. Reverse removal procedure.
20. Tighten propeller shaft bolts to **47 Nm**.
21. Tighten panhard rod to axle bracket to **88 Nm**.
22. Tighten drag link to hub arm to **40 Nm**.
23. Tighten upper swivel pin bolts. **See Specifications, torque, Torque Values**
24. Tighten radius arms to axle bolts to **197 Nm**.
25. Tighten radius arms to chassis side member nuts to **197 Nm**.
26. Tighten track rod end to **40 Nm**. **Fit new split [cotter] pin.**

FRONT BRAKE DISCS

Service repair no - 70.10.10.

Remove

1. Remove front hub assembly. *See Front Hub Assembly*
2. Remove five hub to disc bolts.
3. Tap disc to separate from hub.

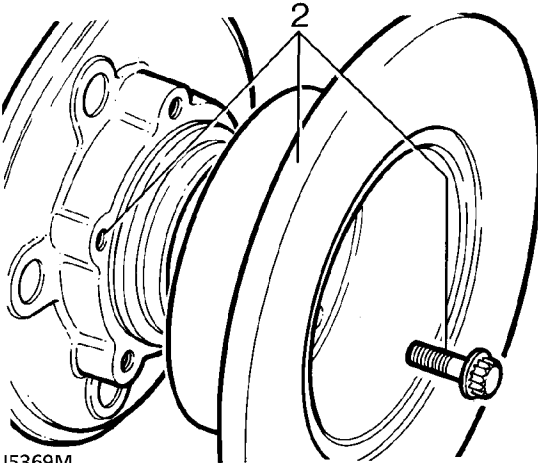

J5369M

Refit

4. Locate disc to hub.
5. Apply Loctite 270 to disc bolts. Tighten to **73 Nm**.
6. Check total disc runout with a dial indicator, this must not exceed 0,15 mm. If necessary reposition disc.
7. Fit hub assembly. *See Front Hub Assembly*

Disc reclamation

8. Check disc thickness. This dimension may be reduced to minimum thickness of 12 mm. Machine equal amount off each face.



FRONT HUB ASSEMBLY

Service repair no - 60.25.01.

Remove

1. Loosen front wheel nuts, jack up vehicle and lower onto axle stands and remove road wheel.
2. Release brake hose clips and remove brake caliper. Secure to one side.
3. Lever off dust cap.
4. Remove circlip and drive shaft shim from driveshaft.
5. Remove five bolts and withdraw driving member and joint washer.
6. Bend back lock washer tabs.
7. Remove locknut and lock washer.
8. Remove hub adjusting nut.
9. Remove spacing washer.
10. Remove hub and brake disc assembly complete with bearings.

HUB COMPONENTS

1. Dust cap.
2. Drive shaft circlip.
3. Drive shaft shim.
4. Drive member.
5. Drive member joint washer.
6. Drive member retaining bolt.
7. Lock nut.
8. Lock washer.
9. Hub adjusting nut.
10. Spacing washer.
11. Outer bearing.
12. Hub.
13. Inner bearing.
14. Grease seal.
15. Brake disc
16. Disc retaining bolt.

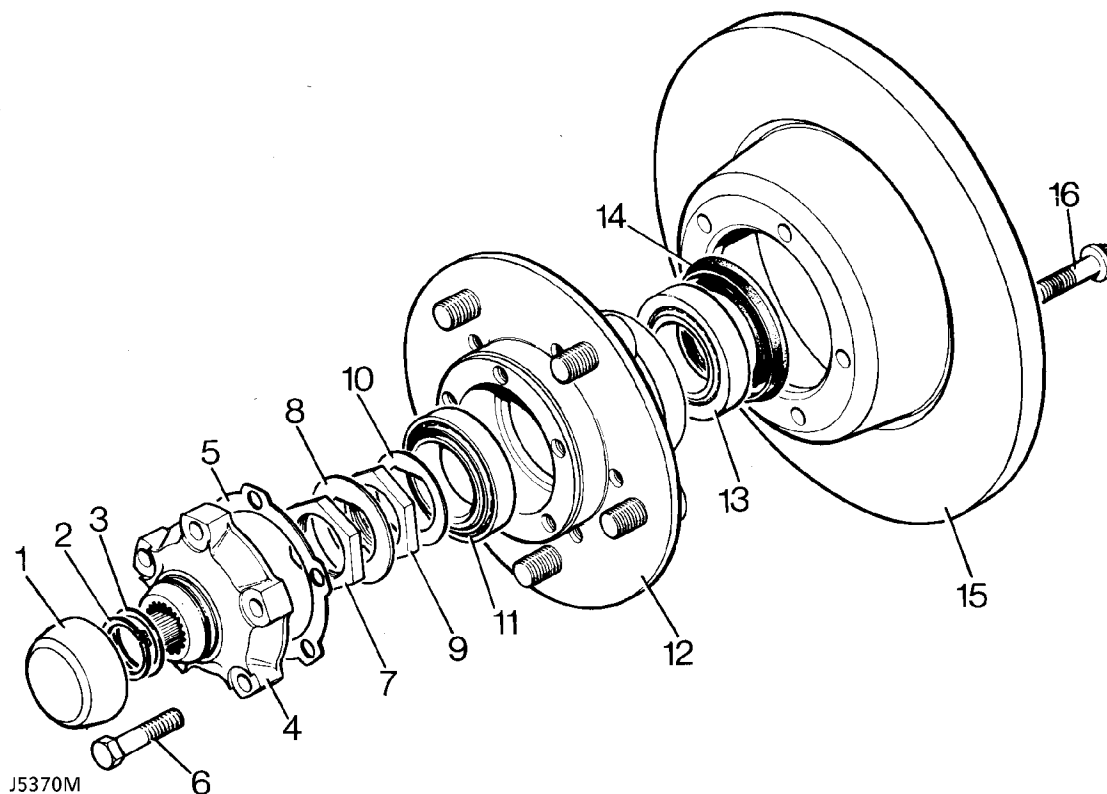

Refit

11. Clean stub axle and drive shaft and fit hub assembly to axle.
12. Fit spacing washer.
13. Fit hub adjusting nut. Tighten to **61 Nm**.
14. Back off adjusting nut 90°. Tighten to **4 Nm**.
This will give the required hub end float of 0,010mm
15. Fit a new lock washer.

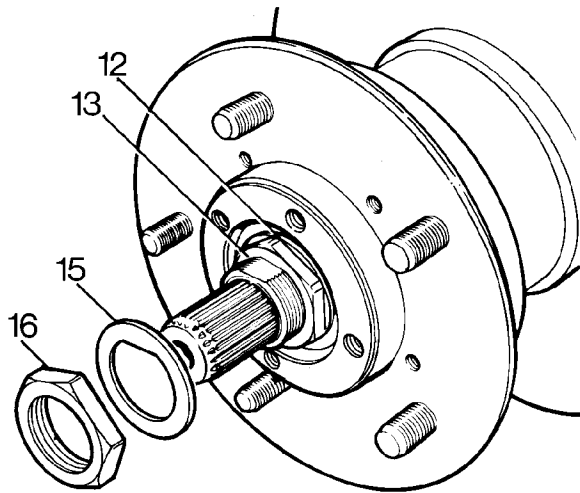

J5371M

16. Fit locknut. Tighten to **61 Nm**.
17. Tab over lock washer to secure adjusting nut and locknut.
18. Fit a new joint washer to driving member and fit member to hub and secure with five bolts. Tighten to **65 Nm**.

19. Fit original drive shaft shim and secure with a circlip.
20. To check drive shaft end play mount a dial gauge using bracket LRT-99-503 and rest pin in a loaded condition on end of drive shaft.
21. Fit a suitable bolt to threaded end of drive shaft. Move drive shaft in and out noting dial gauge reading. End play should be between **0,08 to 0,25 mm**.

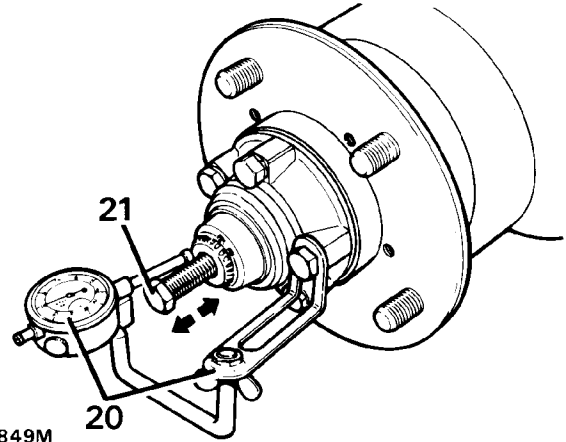

RR3849M

22. If end play requires adjustment, remove circlip, measure shim thickness and fit an appropriate shim to give required end-play.
23. Remove bolt from drive shaft, fit circlip and dust cap.
24. Fit brake caliper. Tighten to **82 Nm**.
25. Bleed brake system. **See BRAKES, Repair, Brake System Bleed**
26. Fit road wheel, remove axle stands and tighten road wheel nuts to **126 Nm**.
27. Operate footbrake to locate brake pads before taking vehicle on road.



FRONT DIFFERENTIAL

Service repair no - 54.10.07.

Overhaul

The front and rear differentials are the same. When overhauling front differential. **See REAR AXLE AND FINAL DRIVE, Overhaul, Axle Differential Assembly**

5. Drift out grease seal and inner bearing from hub and discard seal.
6. Drift out inner and outer bearing tracks.
7. Clean hub and drift in inner and outer bearing tracks.

FRONT HUB

Service repair no - 60.26.14.

Overhaul

1. Remove front hub assembly. **See Repair, Front Hub Assembly.**
2. Remove outer bearing.
3. Mark, for reassembly, relationship between hub and brake disc, if original hub is to be refitted.
4. Remove five bolts and separate hub from brake disc.

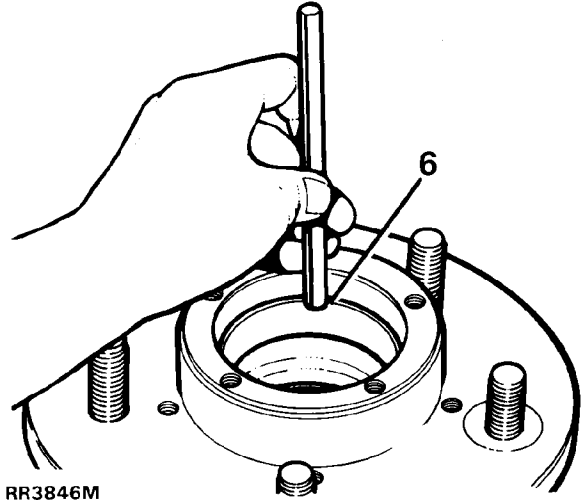

8. Pack hub inner bearing with recommended grease and fit to hub.

HUB COMPONENTS

- | | |
|---------------------------------|--------------------------|
| 1. Dust cap. | 8. Lock washer. |
| 2. Drive shaft circlip. | 9. Hub adjusting nut. |
| 3. Drive shaft shim. | 10. Spacing washer. |
| 4. Drive member. | 11. Outer bearing. |
| 5. Drive member joint washer. | 12. Hub. |
| 6. Drive member retaining bolt. | 13. Inner bearing. |
| 7. Lock nut. | 14. Grease seal. |
| | 15. Brake disc. |
| | 16. Disc retaining bolt. |

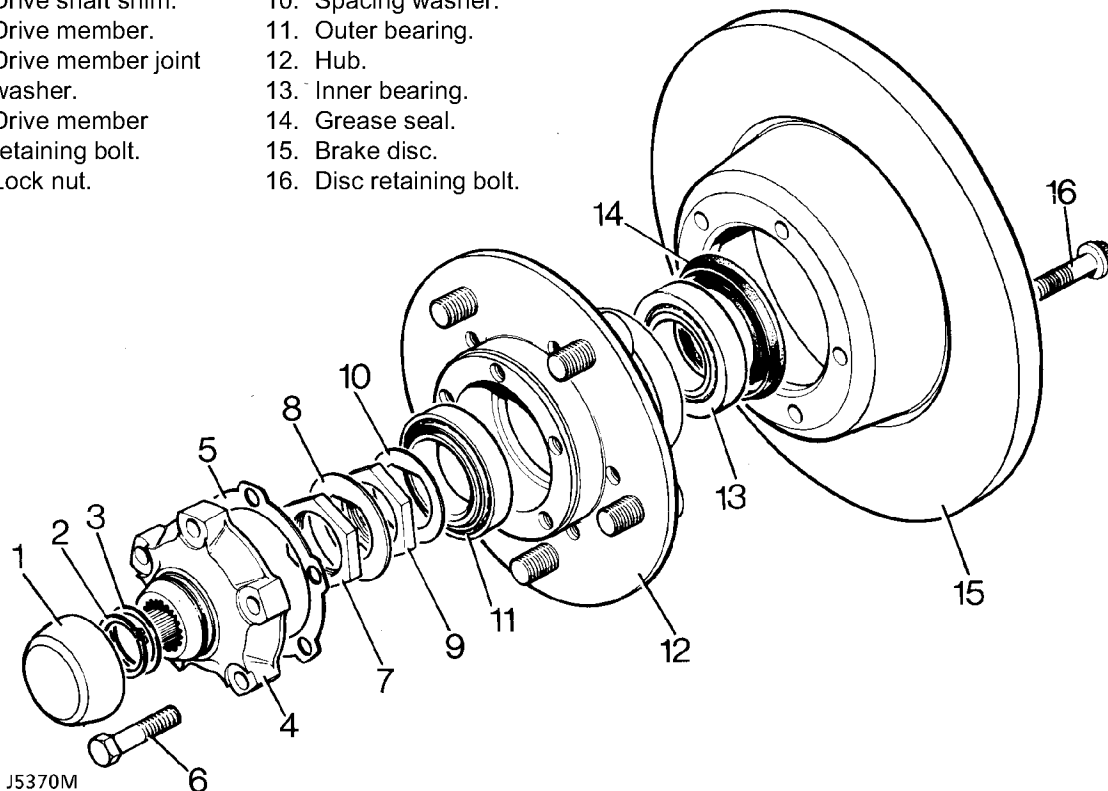

J5370M

9. With lip side leading fit new seal to hub using special tool LST 137 seal replacer and drift 18G 134. Drive in seal flush with rear face of hub. Apply grease between seal lips.
10. Fit brake disc to hub, lining up to marks made during dismantling. applying Loctite 270, fit five retaining bolts. Tighten to **73 Nm**.

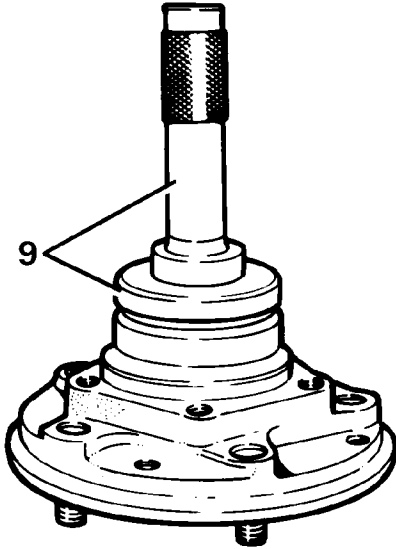

RR3845M

11. Grease and fit outer bearing to hub.
12. Fit front hub assembly. **See Repair, Front Hub Assembly**



FRONT STUB AXLE, CONSTANT VELOCITY JOINT AND SWIVEL PIN HOUSING NON ABS

Service repair no - 60.15.43.

Remove stub axle, axle shaft and constant velocity joint.

1. Remove front hub assembly. *See Repair, Front Hub Assembly*
2. Drain swivel pin housing and refit plug.
3. Remove six bolts retaining stub axle to swivel housing.
4. Remove mud shield.
5. Remove stub axle and joint washer.

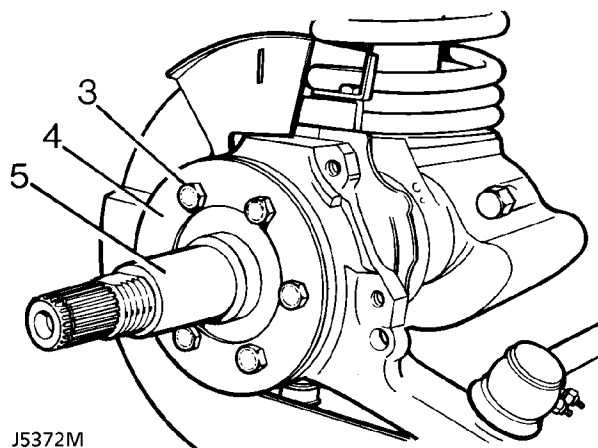

6. Pull out axle shaft and constant velocity joint from axle casing.

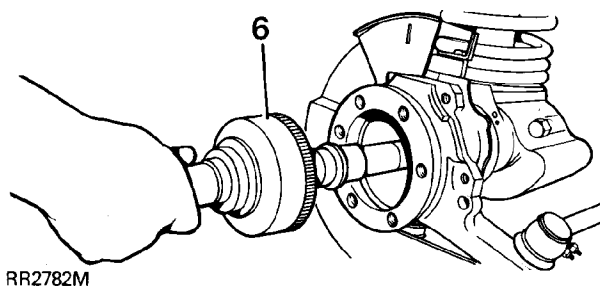

Remove constant velocity joint from axle shaft

7. Hold axle shaft firmly in a soft jawed vice.
8. Using a soft mallet drive constant velocity joint from shaft.
9. Remove circlip and collar from axle shaft.

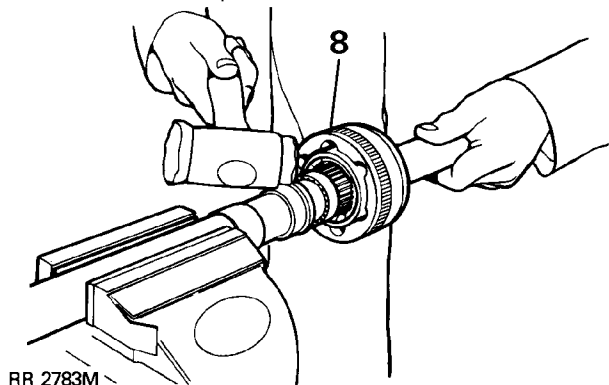

Constant velocity joint

10. Mark positions of constant velocity joint, inner and outer race and cage for reassembly.
11. Swivel cage and inner race to remove balls.

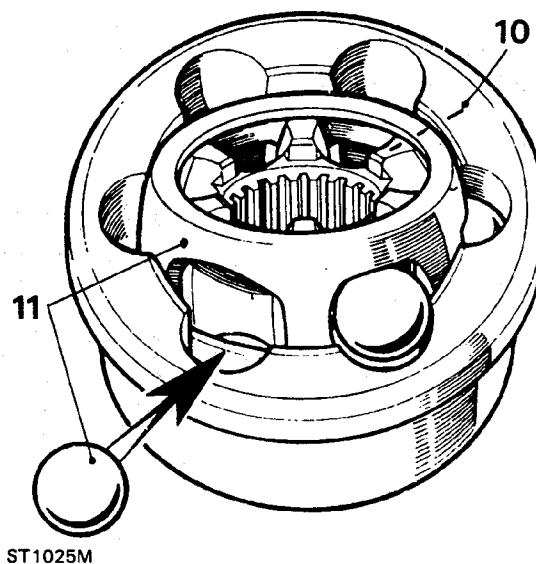

12. Examine all components in particular inner and outer track, cage balls and bearing surfaces for damage and excessive wear.
13. Maximum acceptable end-float on assembled joint 0,64mm. Renew if worn or damaged. Lubricate with a recommended oil during assembly.

Fit constant velocity joint to axle

14. Fit collar and a new circlip.
15. Engage constant velocity joint on axle shaft splines and using a soft mallet, drive joint in fully.

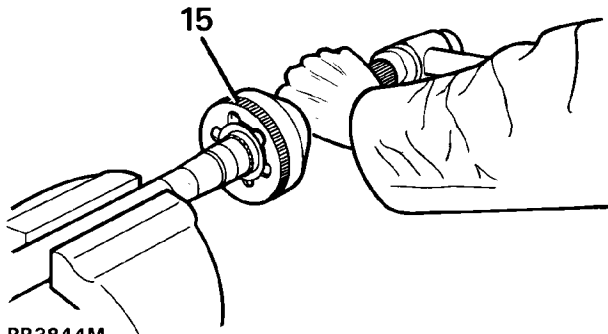

Renew stub axle, thrust ring, oil seal and bearing

16. Drill and chisel off thrust ring taking care to avoid damaging stub axle.
17. Remove bearing and oil seal using special tool LRT-37-004 and slide hammer LRT-99-004. Ensure lip of tool locates behind bearing to drive it out.
18. Repeat instruction for removal of oil seal.

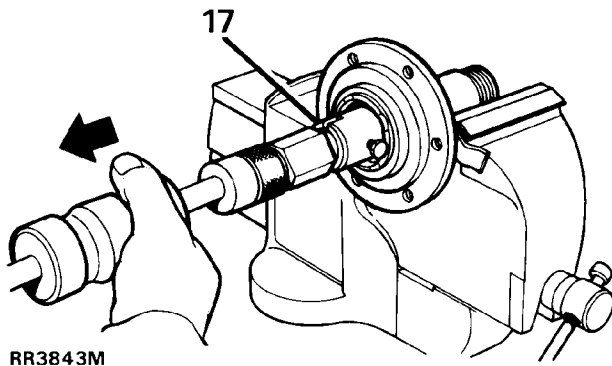

19. Lubricate seal and lip with EP90 oil and with cavity side leading press in a new oil seal using special tool LRT-54-004.

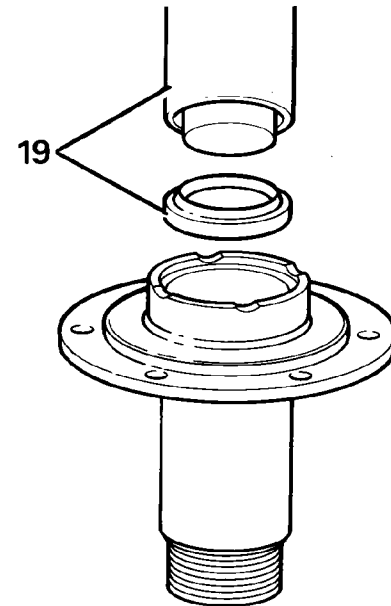

20. Using special tool LRT-54-005, fit bearing with its part number visible when fitted, and flush with end face of stub axle.
21. Press fit a new thrust ring onto stub axle.

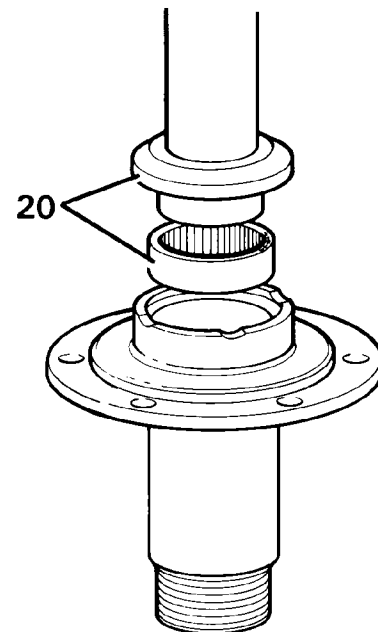



Swivel pin housing

22. Remove bolts securing oil seal retaining plate and joint washer. Release assembly from swivel pin housing.



NOTE: Removal of oil seal and retaining plate is achieved when swivel bearing housing is removed.

23. Remove two bolts, retaining lower swivel pin to housing.
24. Remove brake disc shield bracket.
25. Tap lug to remove lower swivel pin and joint washer.
26. Remove two bolts retaining brake hose bracket and top swivel pin.
27. Remove bracket, top swivel pin and shims.
28. Remove swivel pin housing while retrieving lower and upper bearings.

Swivel bearing housing

29. Remove lower bearing track from swivel bearing housing.



NOTE: Use upper bearing opening to gain access to lower bearing track.

30. Remove seven bolts retaining swivel bearing housing to axle case.
31. Remove inner oil seal from back of housing.
32. Remove top bearing track from swivel bearing housing.



NOTE: Use lower bearing opening to gain access to upper bearing track.

33. If worn, pitted or damaged, renew housing.
34. Fit upper and lower bearing tracks into swivel bearing housing.



CAUTION: Ensure bearing tracks are fitted square or damage could occur.

35. With seal lips trailing, fit swivel housing inner oil seal into rear of housing. Grease seal lips.

Fit swivel pin housing

36. Coat swivel bearing housing to axle casing bolts with Loctite 270 or equivalent.
37. Coat both sides of joint washer with a sealing compound. Position swivel bearing housing to axle mating face.
38. Place retaining plate, joint washer and oil seal over axle flange ready for assembly.
39. Fit swivel bearing housing to axle flange with seven bolts. Tighten to **73 Nm**.
40. Grease and fit upper and lower swivel pin taper roller bearings.
41. Position swivel pin housing over swivel bearing housing.
42. Coat joint washer both sides with sealing compound and position on lower swivel pin.
43. Loosely fit brake shield bracket plus lower swivel pin with lug outboard to swivel pin housing.
44. Loosely fit top swivel pin plus existing shims and brake hose bracket to swivel pin housing.
45. Apply Loctite 270 or equivalent to lower swivel pin bolts. Tighten to **78 Nm** bend over lock tabs.
46. Tighten top swivel pin bolts to **78 Nm**.

Swivel assembly components

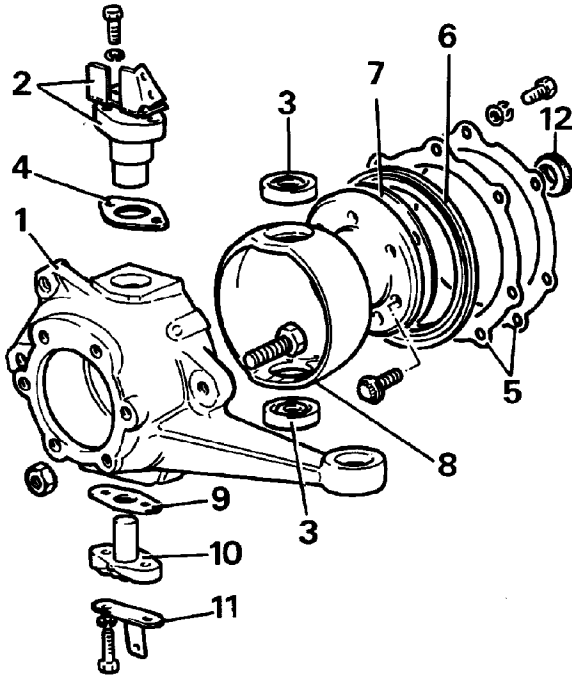

RR980M

1. Swivel pin housing
2. Top swivel pin and brake hose bracket
3. Upper and lower swivel pin bearings
4. Shim
5. Retaining plate and washer
6. Oil seal
7. Joint washer
8. Swivel bearing housing
9. Joint washer
10. Lower swivel pin
11. Mudshield bracket
12. Swivel housing inner oil seal

Check and adjust preload on bearings



NOTE: Swivel housing oil seal and axle should not be fitted.

47. Attach a spring balance to ball joint bore and pull balance to determine effort required to turn swivel pin housing. Resistance, once initial inertia has been overcome, should be **1.16 to 1.46 kg**. Adjust by removing or adding shims to top swivel pin.

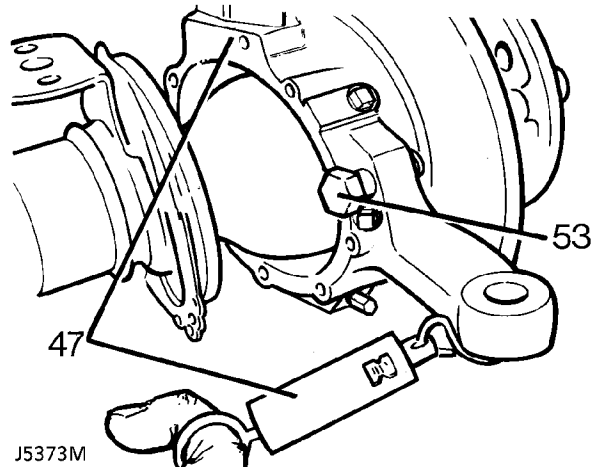

J5373M

48. When setting is correct remove top swivel bolts, apply Loctite 270 or equivalent. Refit to **78 Nm**, and bend over lock tabs.
49. Apply recommended grease between lips of swivel oil seal.
50. Fit oil seal, joint washer and retaining plate with seven bolts and spring washers to **11 Nm**.
51. Fit tie rod and drag link and secure with new cotter pins. Tighten to **40 Nm**.
52. Fit brake disc shield.
53. Loosely fit lock stop bolt and nut.
54. Apply a recommended grease between lips of swivel housing oil seal.
55. Secure oil seal with retaining plate and securing bolts. Tighten to **11 Nm**.
56. Fit track-rod and drag link and secure with new cotter pins.
57. Loosely fit lock stop bolt for later adjustment.
58. Fit brake disc shield.



Fit driveshaft and stub axle

59. Insert axle shaft, and when differential splines are engaged, push assembly in fully.



CAUTION: Take care not to damage axle shaft oil seals.

60. Place a new joint washer in position on swivel pin housing to stub axle mating face. Coat threads of stub axle bolts with Loctite 270.
61. Fit stub axle with flat at 12 o'clock position.



CAUTION: Ensure that constant velocity joint bearing journal is butted against thrust ring on stub axle. Before stub axle is secured.

62. Place mud shield in position and secure stub axle to swivel pin housing with six bolts and tighten evenly to **65 Nm**.
63. Fit brake jump hoses to brake jump hose bracket.
64. Fit front hub complete assembly. **See Repair, Front Hub Assembly**
65. Check swivel pin housing oil drain plug is fitted.
66. Fill swivel assembly to correct level, with new oil. **See SECTION 10, Maintenance, Under Vehicle Maintenance**
67. Set steering lock stop bolts to provide a clearance of 20mm. **See STEERING, Adjustment, Steering Lock Stops**

FRONT STUB AXLE, CONSTANT VELOCITY JOINT AND SWIVEL PIN HOUSING ABS

Service repair no - 60.15.43.

Remove stub axle, axle shaft and constant velocity joint.

1. Remove front hub assembly. **See Repair, Front Hub Assembly**
2. Drain swivel pin housing and refit plug.
3. Remove six bolts retaining stub axle to swivel housing.
4. Remove mud shield.
5. Remove stub axle and joint washer.

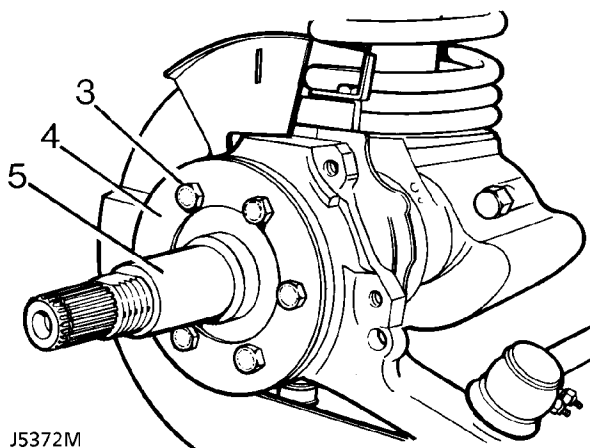

6. Pull out axle shaft and constant velocity joint from axle casing.

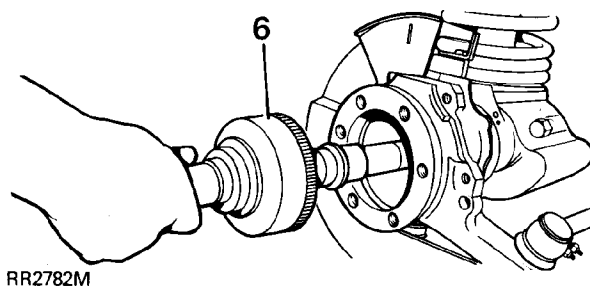

Remove constant velocity joint from axle shaft

7. Hold axle shaft firmly in a soft jawed vice.
8. Using a soft mallet drive constant velocity joint from shaft.
9. Remove circlip and collar from axle shaft.

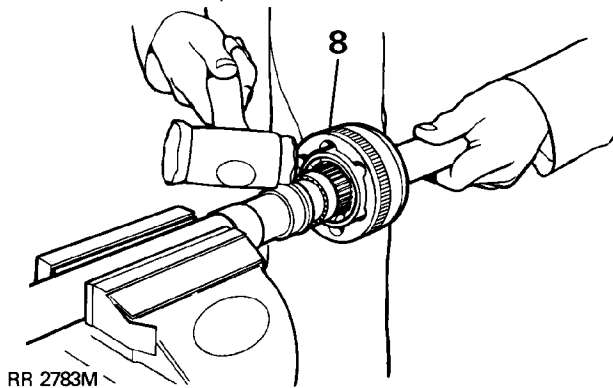

RR 2783M

Constant velocity joint

10. Mark positions of constant velocity joint, inner and outer race and cage for reassembly.
11. Swivel cage and inner race to remove balls.

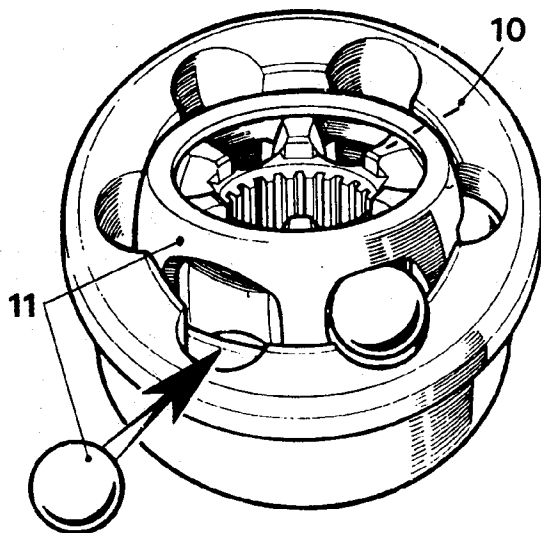

ST1025M

12. Examine all components in particular inner and outer track, cage balls and bearing surfaces for damage and excessive wear.
13. Maximum acceptable end-float on assembled joint 0,64mm. Renew if worn or damaged. Lubricate with a recommended oil during assembly.

Fit constant velocity joint to axle

14. Fit collar and a new circlip.
15. Engage constant velocity joint on axle shaft splines and using a soft mallet, drive joint in fully.

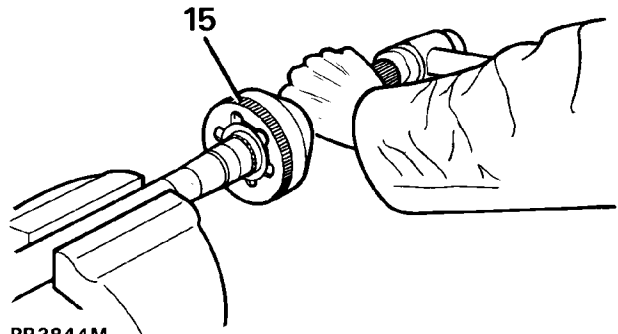

RR3844M

Renew stub axle, thrust ring, oil seal and bearing

16. Drill and chisel off thrust ring taking care to avoid damaging stub axle.
17. Remove bearing and oil seal using special tool LRT-37-004 and slide hammer LRT-99-004. Ensure lip of tool locates behind bearing to drive it out.
18. Repeat instruction for removal of oil seal.

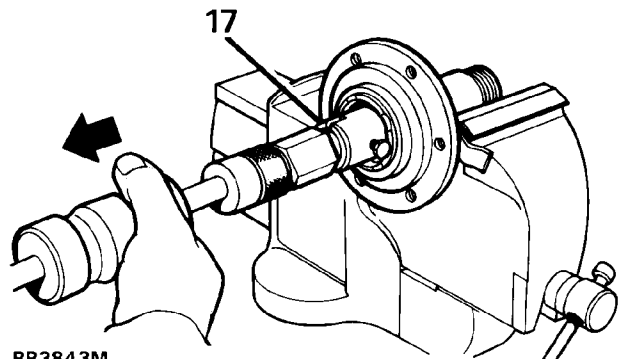

RR3843M



19. Lubricate seal and lip with EP90 oil and with cavity side leading press in a new oil seal using special tool LRT-54-004.

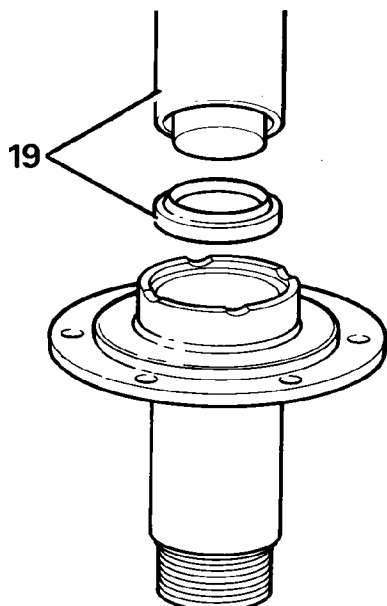

RR3840M

20. Using special tool LRT-54-005, fit bearing with its part number visible when fitted, and flush with end face of stub axle.
21. Press fit a new thrust ring onto stub axle.

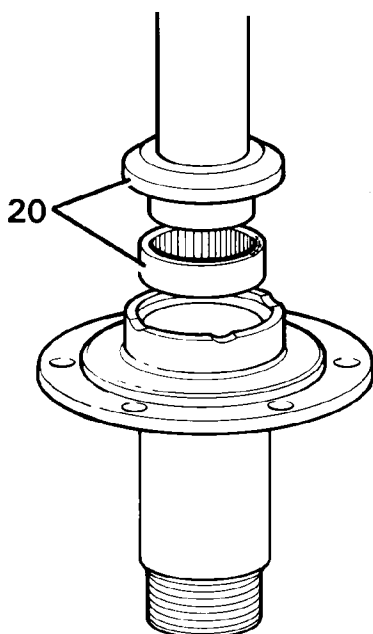

RR3839M

Swivel pin housing assembly

22. Remove brake disc shield bracket.
23. Disconnect track-rod end ball joint from housing.
24. Disconnect drag-link ball joint.
25. Disconnect jump hoses from brake jump hose bracket.
26. Remove ABS brake sensor.
27. Remove six bolts securing oil seal and retaining plate to swivel pin housing. Prise seal from swivel pin housing.



NOTE: Oil seal and retaining plate cannot be removed until swivel pin bearing housing is removed.

28. Remove two screws securing brake damper/shield bracket, and lower swivel pin to housing.
29. Withdraw lower swivel pin and joint washer by tapping protruding lug.
30. Remove top swivel pin retaining bolts complete with brake jump hose bracket.
31. Remove top swivel pin and shims.
32. Remove swivel pin housing while retrieving lower taper bearing.

Swivel pin bearing housing

33. Remove seven bolts securing swivel pin bearing housing to axle case.
34. Remove and discard oil seal and joint washer.
35. Remove lower swivel pin bearing track.
36. Remove top swivel pin bush housing assembly. Discard two thrust washers and bearing.
37. If worn, pitted or damaged, renew swivel pin bearing housing.
38. Fit a new lower swivel pin bearing track.
39. Fit a new bush and bush housing. Ensure relieved lip of bush housing faces towards rear, as shown.

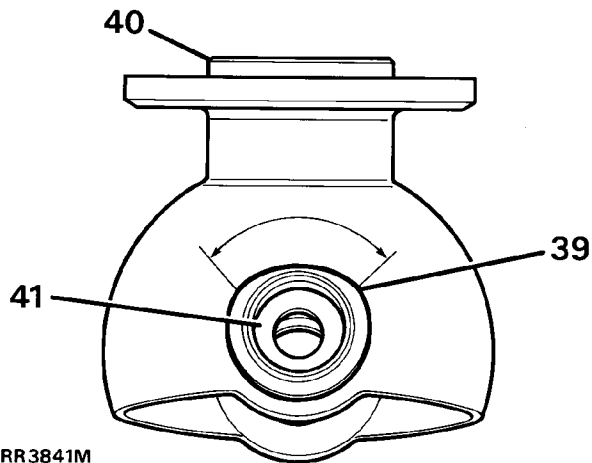

RR3841M

40. With seal lips trailing press axle shaft oil seal flush into rear of housing. Grease lips.
41. Fit new thrust washers and bearing into top swivel pin bush.
42. Hang swivel pin bearing housing oil seal and retainer plate over back of housing. Ensure they are in correct assembly order.
43. Fit a new joint washer and secure swivel pin bearing housing to axle. Starting with top fixing dowel bolt. Tighten to **72Nm**.

Fit swivel pin housing

44. Grease and fit lower swivel pin bearing to bearing housing.
45. Place swivel pin housing in position over swivel pin bearing housing.
46. Using a new joint washer, fit lower swivel pin with lip outboard. Do not secure with screws at this stage.
47. Fit a new sensor bush and new oil seal, lip side leading to top swivel pin.
48. Lubricate with a recommended oil and fit top swivel pin with existing shims.
49. Coat threads of top swivel pin bolts with Loctite 542. Fit bolts and jump hose bracket (do not tighten).

50. Coat threads of lower swivel pin screws with Loctite 270 and fit, together with damper and shield bracket. Tighten to **25 Nm**.
51. Tighten top swivel pin and brake jump hose bracket securing bolts to **65 Nm**.

Check and adjust preload on bearings

52. The preload on bearings to be **0,25 to 0,30 mm**, **without** swivel housing oil seal and axle fitted, and reading from centre of swivel pin. The torque required to turn swivel assembly from lock to lock to be **2.0 to 2.8 Nm**. Adjust by removing or adding shims as necessary.
53. To take a reading use special tool LRT-57-024 torque test adaptor, with a torque wrench and extension as shown.

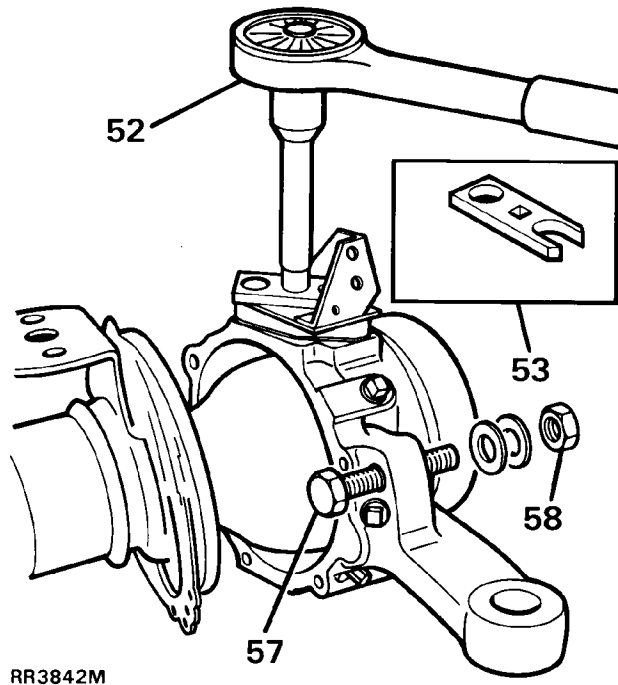

RR3842M

54. Apply a recommended grease between lips of swivel housing oil seal.
55. Secure oil seal with retaining plate and securing bolts. Tighten to **11Nm**.
56. Fit track-rod and drag link and secure with new cotter pins.
57. Loosely fit lock stop bolt for later adjustment.
58. Fit brake disc shield.



Fit driveshaft and stub axle

69. Insert axle shaft, and when differential splines are engaged, push assembly in fully.



CAUTION: Take care not to damage axle shaft oil seals.

60. Place a new joint washer in position on swivel pin housing to stub axle mating face. Coat threads of stub axle bolts with Loctite 270.
61. Fit stub axle with flat at 12 o'clock position.



CAUTION: Ensure that constant velocity joint bearing journal is butted against thrust ring on stub axle. Before stub axle is secured.

62. Place mud shield in position and secure stub axle to swivel pin housing with six bolts and tighten evenly to **65 Nm**.
63. Fit brake jump hoses to brake jump hose bracket.
64. Fit front hub complete assembly. **See Repair, Front Hub Assembly**
65. Check swivel pin housing oil drain plug is fitted.
66. Fill swivel assembly to correct level, with new oil. **See SECTION 10, Maintenance, Under Vehicle Maintenance**
67. Set steering lock stop bolts to provide a clearance of 20mm. **See STEERING, Adjustment, Steering Lock Stops**
68. Fit ABS brake sensor. **See BRAKES, Repair, Sensors - Front**

FRONT HUB AND SWIVEL COMPONENTS

- | | |
|---|---|
| 1. Brake caliper. | 15. Joint washer. |
| 2. Mud shield. | 16. Lower swivel pin. |
| 3. Stub axle. | 17. Damper and shield bracket. |
| 4. Joint washer. | 18. Thrust washer, ABS. |
| 5. Oil seal. | 19. Bush and housing, ABS. |
| 6. Bearing. | 20. Swivel pin bearing housing. |
| 7. Brake disc shield. | 21. Lower swivel pin bearing (and upper bearing non ABS). |
| 8. Constant velocity joint. | 22. Oil seal. |
| 9. Circlip. | 23. Oil seal retaining plate. |
| 10. Bush. | 24. Joint washer. |
| 11. Inner driveshaft. | 25. Oil seal, ABS. |
| 12. Top swivel pin and jump hose bracket. | 26. Sensor bush, ABS. |
| 13. Shim. | 27. Thrust bearing, ABS. |
| 14. Swivel pin housing. | |

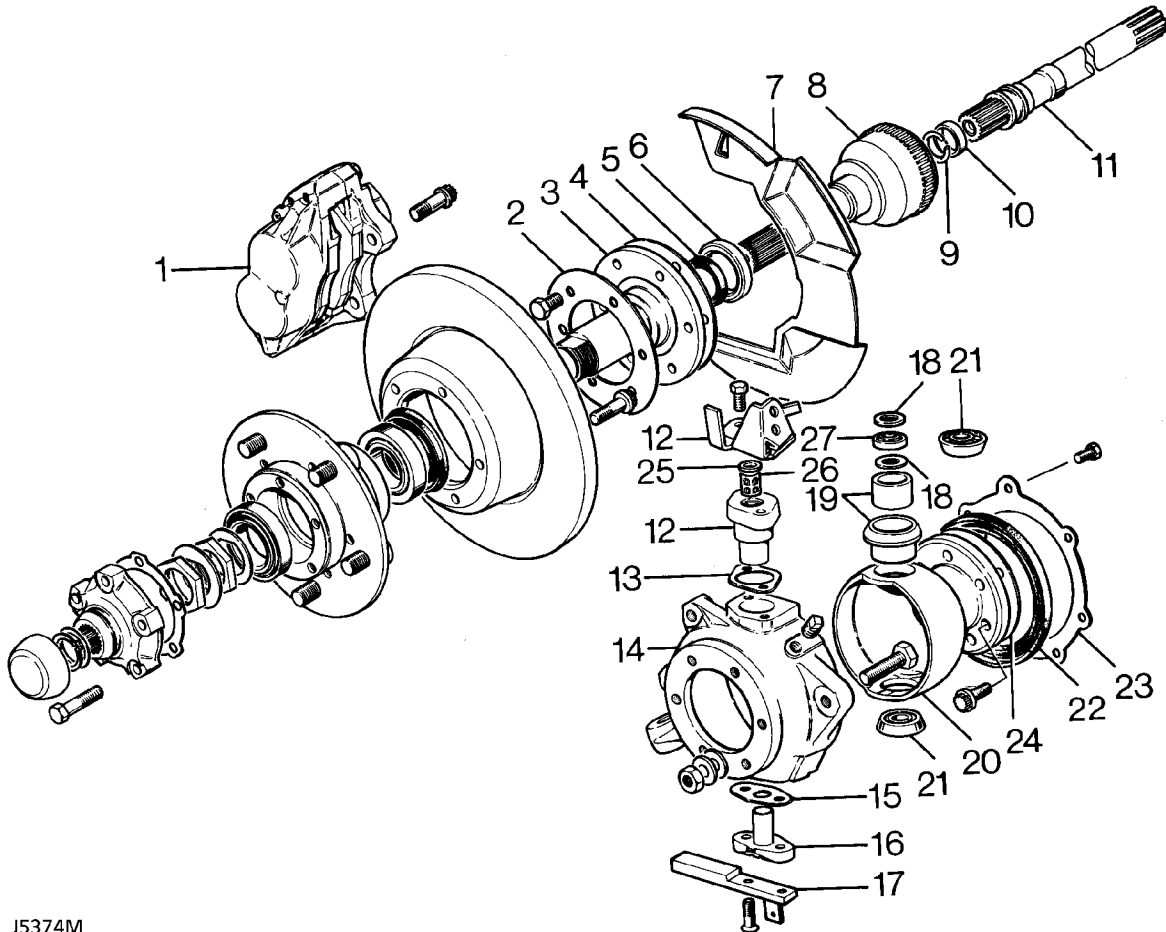

J5374M



TORQUE VALUES



NOTE: Torque wrenches should be regularly checked for accuracy to ensure that all fixings are tightened to the correct torque.

	Nm
FRONT AXLE	
Hub driving member to hub	65*
Brake disc to hub	73
Stub axle to swivel pin housing	65*
Brake caliper to swivel pin housing	82
Upper swivel pin to swivel pin housing	78*
Upper swivel pin to swivel pin housing ABS	65
Lower swivel pin to swivel pin housing	78*
Lower swivel pin to swivel pin housing ABS	25*
Oil seal retainer to swivel pin housing	11
Swivel bearing housing to axle case	73*
Pinion housing to axle case	41
Crown wheel to differential housing	58
Differential bearing cap to pinion housing	90
Differential drive flange to drive shaft	47
Mudshield to bracket lower swivel pin	11
Disc shield to bracket lower ABS	9
Bevel pinion nut	130
Draglink to hub arm	40
Panhard rod to axle bracket	88
Radius arm to axle	190
Radius arm to chassis side member	190



NOTE: * These bolts to be coated with Loctite 270 prior to assembly.

Torque values below cover all screws and bolts used, unless specified otherwise.

METRIC	Nm
M5	6
M6	9
M8	25
M10	45
M12	90
M14	105
M16	180
UNC / UNF	
1/4	9
5/16	24
3/8	39
7/16	78
1/2	90
5/8	136

FRONT HUB AND SWIVEL DATA

Front hub

Front hub end float	0,010 mm
Drive shaft end play	0,08 to 0,25 mm

Swivel pin bearing preload

ABS vehicles - Torque to turn	2. to 3. Nm
Non ABS vehicles - Resistance to turn	1,16 to 1,46Kg



FRONT HUB

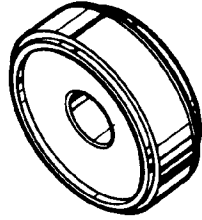

LST 5505

LRT-54-001 Oil seal replacer non ABS
LST550-5

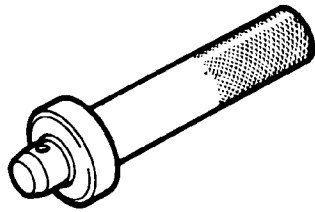

18G134

LRT-99-003 Drift
18G134

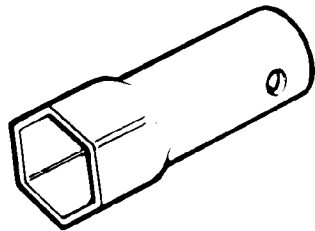

606435A

LRT-54-002 Hub nut wrench
RO606435A

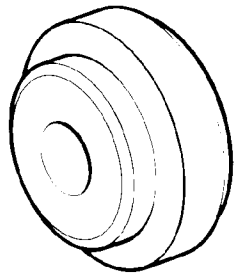

LST137

LRT-54-003 Hub oil seal replacer ABS
LST137

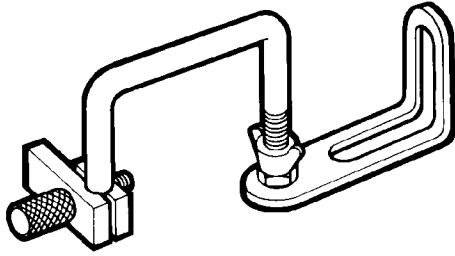

RO530106

LRT-99-503 Dial gauge bracket
RO530106

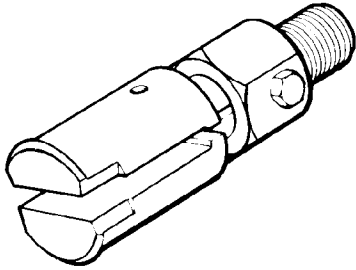

8G284AAH

LRT-37-004 Extractor ABS
18G284AAH

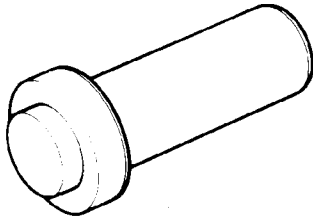

LST132

LRT-54-005 Bearing installer ABS
LST132

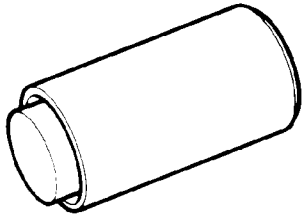

LST133

LRT-54-004 Seal installer ABS
LST133

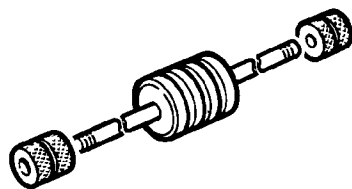

LRT-99-004 Impulse extractor
MS284

MS284

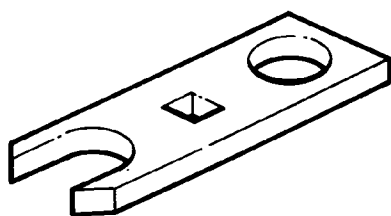

LRT-570-024 Torque test adaptor ABS
LST141

LST141



DESCRIPTION

The power assisted steering system incorporates a compression joint in the lower shaft, designed to collapse on impact and for certain countries, an air bag located in the centre of the steering wheel.

The mis-alignment of the upper steering column with the steering box and the inclusion of two universal joints and a compression joint in the lower shaft, is also designed to prevent frontal impact moving the column toward the driver.

The steering box is located behind the first cross member of the chassis and is connected to the road wheels by the drag link and track rod. An hydraulic damper absorbs shocks in the steering, caused by road wheel deflections when operating on rough terrain.

Power steering system

The power steering system comprises a hydraulic pump which is belt driven from the engine and supplied with fluid from a reservoir that also acts as a cooler.

The steering box houses a self neutralizing rotary valve which is part of the worm/valve assy and a hydraulic piston/rack to assist the mechanical operation.

The rotary valve which is operated by movement of the steering wheel, directs fluid pressure to the appropriate side of the hydraulic piston/rack to provide assistance.

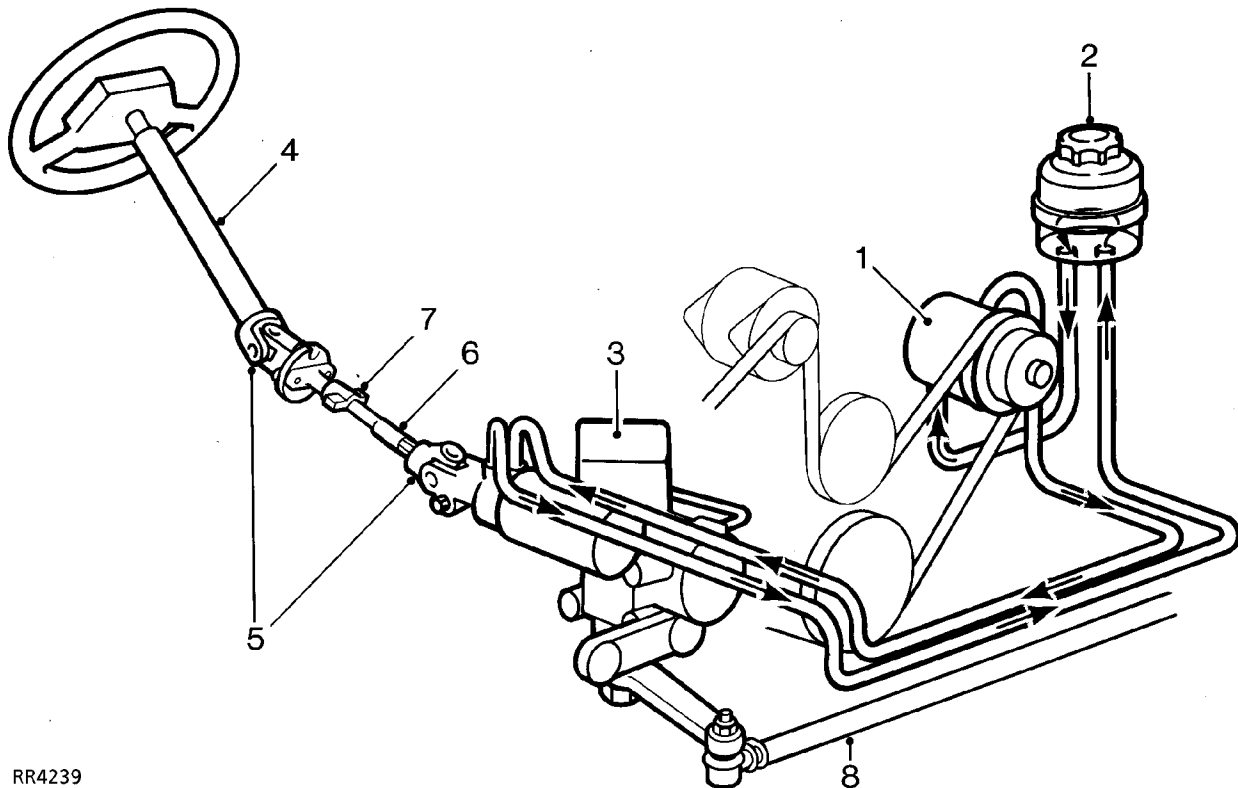

RR4239

Power steering system

1. Hydraulic pump
2. Fluid reservoir
3. Steering box
4. Upper column
5. Universal joints
6. Lower shaft
7. Compression joint
8. Drag link

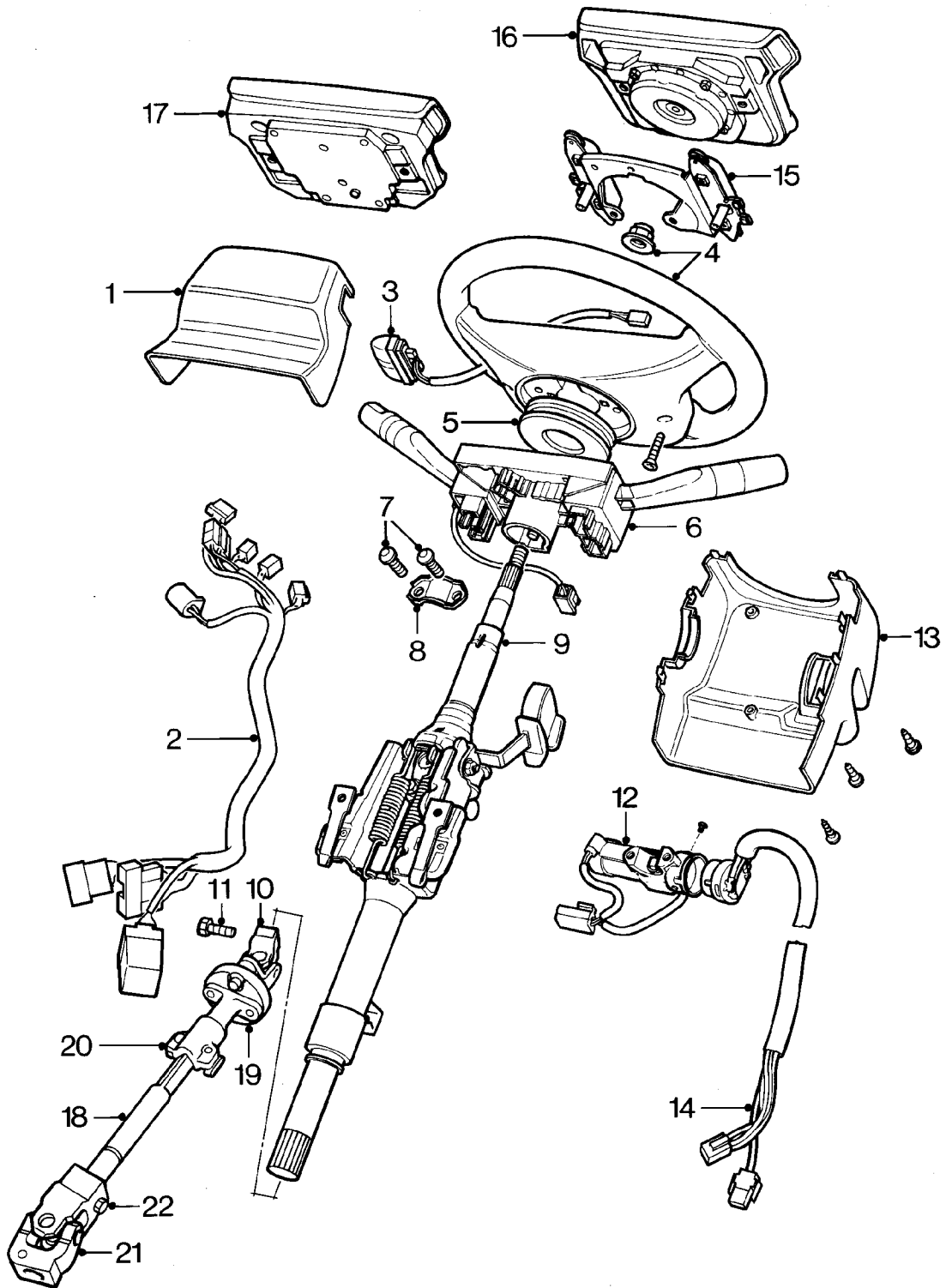

J5950

**Steering column components**

1. Upper shroud
2. Column harness
3. Cruise control switch (if fitted)
4. Steering wheel and nut
5. Rotary coupler
6. Column switch
7. Shear bolts
8. Switch saddle
9. Upper steering column
10. Universal joint
11. Universal joint bolt
12. Steering column lock assembly
13. Lower shroud
14. Column lock/ignition
15. Air bag mounting bracket (if fitted)
16. Air bag module
17. Steering pad (non-airbag)
18. Lower shaft
19. Rubber coupling
20. Compression joint
21. Universal joint
22. Universal joint bolt

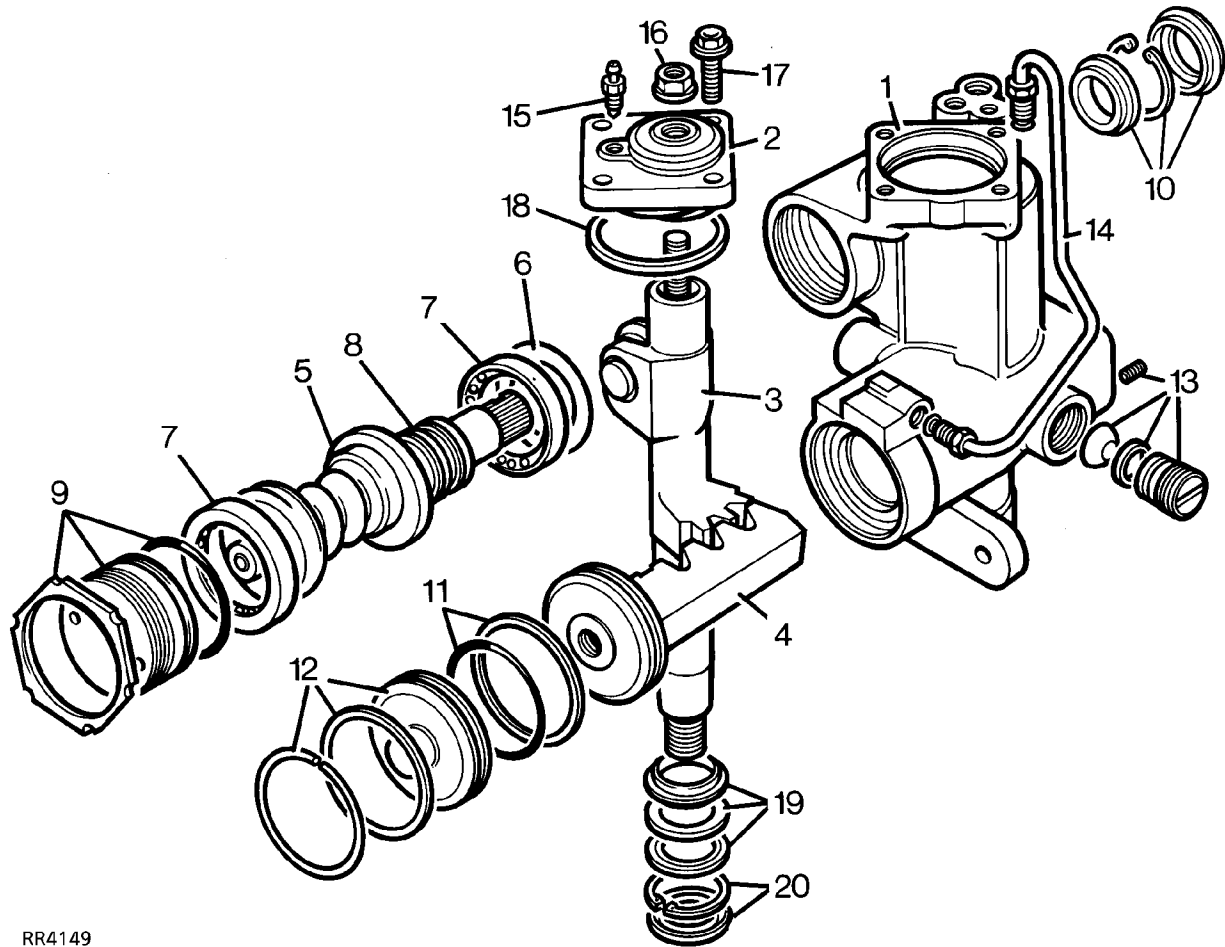

RR4149

Power steering box components

- | | |
|---|--|
| 1. Housing complete with sector shaft bearings | 11. 'Teflon' and rubber seal for piston |
| 2. Cover plate complete with bearing | 12. End cover seal and snap ring |
| 3. Sector shaft | 13. Adjustment components for piston/rack |
| 4. Hydraulic piston/rack | 14. Hydraulic pipe |
| 5. Worm/valve and torsion bar assembly | 15. Bleed screw |
| 6. Shims for centralizing worm/valve | 16. Sector shaft adjustment lock nut with seal |
| 7. Ball race (2) | 17. Cover plate bolts (4) |
| 8. 'Teflon' seals for valve sleeve (3) | 18. Cover plate seal |
| 9. Bearing adjuster, locknut and seal | 19. Seal, washer and backup seal |
| 10. Worm shaft pressure seal, circlip and dirt excluder | 20. Circlip and dust cover |



Rotary valve operation

The rotary valve assembly seen in RR3620M comprises the worm (1), the valve sleeve (2), the input shaft (4) and the torsion bar (5).

The valve sleeve is retained inside the worm by the trim screw (3), and incorporates valve ports in its inner bore. The input shaft is attached to the steering wheel via the steering shaft and steering column and incorporates valve ports in its outer diameter to align with those in the sleeve. The torsion bar which is secured to the worm and input shaft with pins (6) at each end (later models use one pin at input shaft end), holds the valve ports in neutral alignment when there is no demand for assistance.

No demand for assistance (Valve at neutral)

When there is no demand for assistance as seen in RR3620M, the torsion bar holds the input shaft and sleeve valve ports in neutral relationship to one another, allowing equal pump pressure A to both sides of the piston/rack (9). Any excess fluid flow from the pump returns to the reservoir via B.

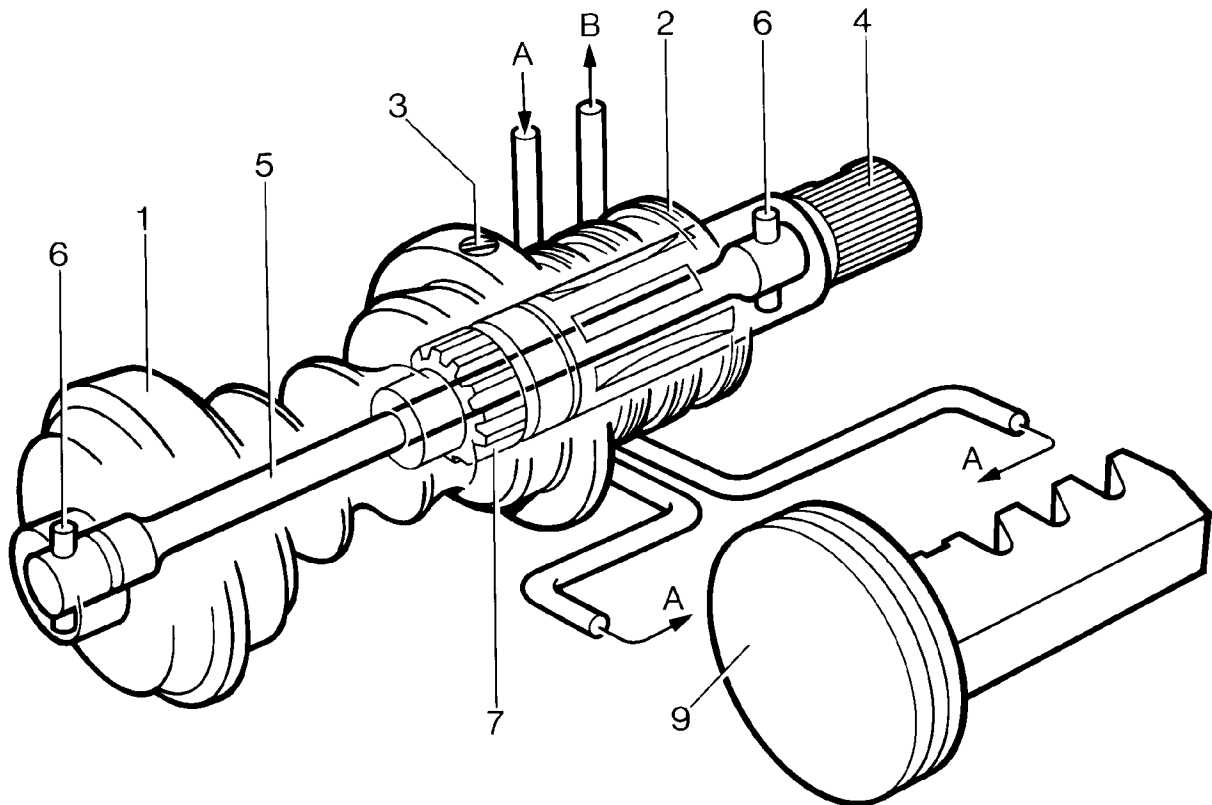

RR3620M

Rotary valve at neutral

Demand for assistance (Valve misaligned)

When the steering wheel and input shaft is turned, steering resistance transmitted to the worm causes the torsion bar to be twisted and the valve ports to be misaligned for a right or left turn. The misalignment of the valve ports directs all fluid pressure A to one side of the piston and allows displaced fluid B on the other side.

When demanding maximum assistance, any excessive fluid output from the pump due to high pump speed, will circulate through the regulator valve located in the pump unit, causing the temperature of the fluid and the pump to rise rapidly.

To avoid excessive fluid temperatures which could damage the oil seals, the steering must not be held on full lock for more than 30 seconds in one minute.

Only when the steering wheel and the demand for assistance is released, will the torsion bar return the valve to neutral, allowing the fluid to circulate through the reservoir where it is cooled.

In the unlikely event of mechanical failure of the torsion bar, a coarse splined connection (7) between the input shaft and worm, ensures steering control is maintained sufficient to allow the vehicle to be recovered.

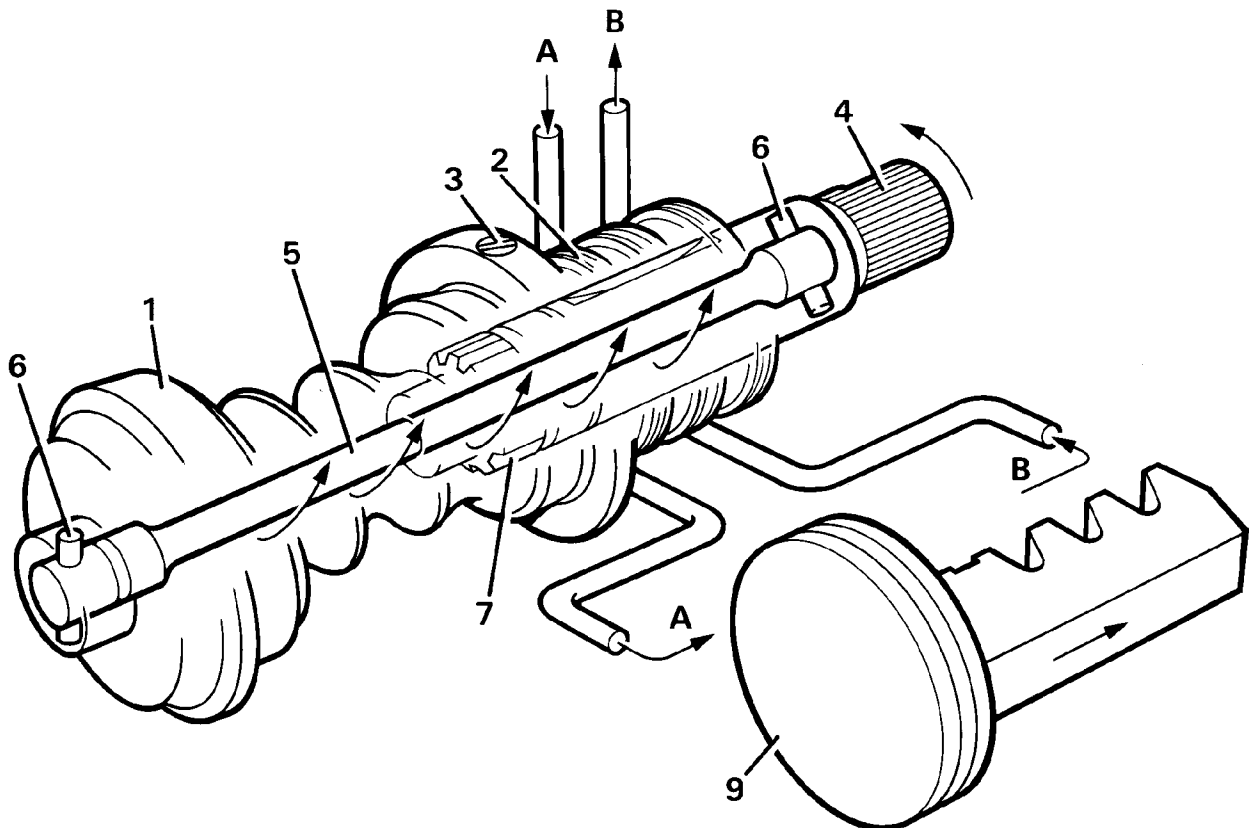

RR3621M

Rotary valve misaligned



Pump and regulator valve operation

The pump which is belt driven from the engine is an eccentric roller type and also houses the pressure regulator and flow control valve. The pressure is controlled by a spring loaded ball valve 3 which is housed inside the flow control valve piston 4.

No demand for assistance High flow through box - Low pressure

With no demand for assistance as illustrated in RR3568M the rotary valve in the steering box acts as a pressure relief valve, allowing fluid A to flow freely through the steering box and back to the reservoir and pump inlet B.

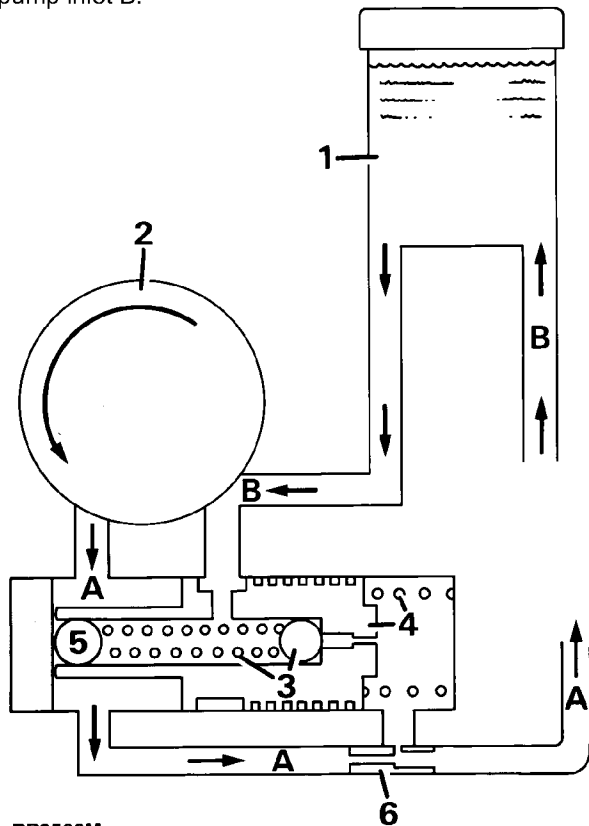

RR3568M

No demand for assistance

1. Reservoir
2. Pump
3. Pressure control ball valve and spring
4. Flow control valve and spring
5. Press fit plug (ball bearing)
6. Restrictor

The ball plug item 5 is pressed into the valve 4 during manufacture and determines the opening pressure of pressure relief valve 3.

No flow, through box - High pressure

When the steering is turned, the rotary valve effectively stops all fluid flow through the steering box, thus causing an increase in pressure A. This increase in pressure is felt in the flow control valve spring chamber where, at a pre-determined pressure the relief valve 3 will open and allow the pressure to escape. The fall in pressure in the flow control spring chamber, allows the flow control valve to move to the right, which in turn allows pump output A to escape directly into the pump inlet B, as seen in RR3569M.

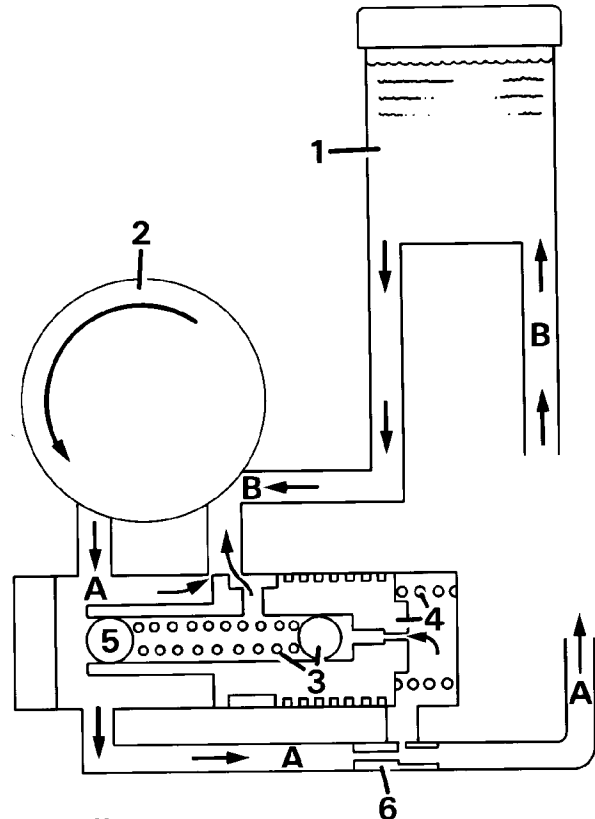

RR3569M

Assistance demanded

As soon as the steering wheel is released after making a turn, the system reverts to the condition seen in RR3568M and the road wheels are returned to the straight ahead position by the mechanical steering geometry.

In the event of any hydraulic failure steering control though heavy, will be maintained through the mechanical components in the steering box.



INSUFFICIENT POWER ASSISTANCE

1. Is fluid level correct?
YES - go to 3.
NO - Fill/bleed system
2. Is problem a leak?
YES - Diagnose. **See Power Steering Fluid Leaks**
NO - continue
3. Is drive belt tension correct?
YES - go to 5.
NO - retension. **See ENGINE, Repair, Drive Belt**
4. Is problem resolved?
YES - end
NO - continue
5. Carry out pressure test at idle and 1000 rev/min.
See Power Steering System - Test
6. Is correct pressure achieved?
YES - steering box defective
Not at any speed go to 9.
Not at idle go to 7.
7. Is idle speed correct?
YES - Go to 8.
NO - Correct idle speed -
If 3.9 **See ENGINE TUNING DATA, Information, Engine 3.9 - V8i**
If 4.2 **See ENGINE TUNING DATA, Information, Engine - 4.2 V8i**
If Tdi **See ENGINE TUNING DATA, Information, Engine - 300 Tdi**
8. Is problem resolved?
YES - end
NO - go to 9.
9. Bypass steering box using adaptor tap LRT-57-001
10. Is correct pressure obtained?
YES - defective steering box
NO - defective steering pump



CAUTION: Do not hold steering wheel on full lock for more than 30 seconds in any one minute to avoid overheating fluid and possibly damaging seals.



NOTE: 1. Excessive pressure in the system is almost always caused by a faulty relief valve in the PAS pump.



NOTE: 2. Insufficient pressure in the system is usually caused by low fluid level or PAS pump drive belt slip, or one of the following: PAS system leaks, faulty PAS pump relief valve, fault in steering box valve and worm assembly, leak at piston in steering box, worn components in PAS pump or box.

POWER STEERING SYSTEM - TEST



NOTE: If steering lacks power assistance. Check pressure of hydraulic pump before fitting new components. Use fault diagnosis chart to assist in tracing faults.

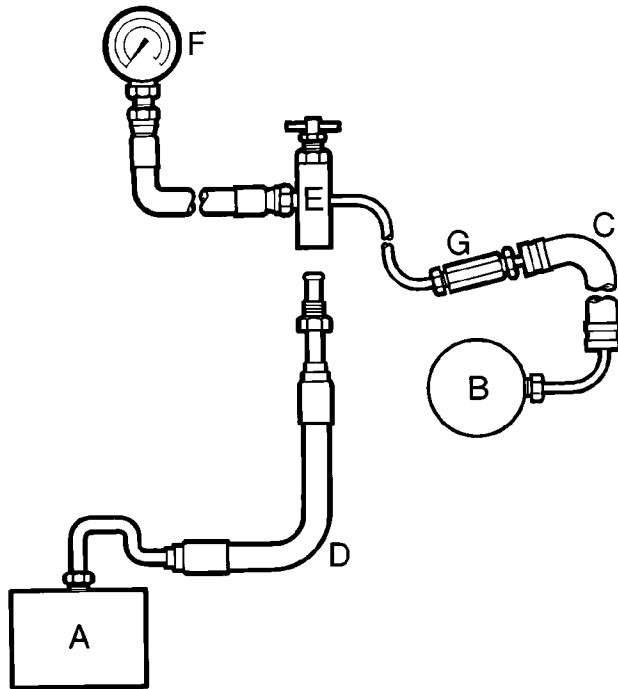

RR3959M

- A. Steering box.
- B. Steering pump.
- C. Existing hose, steering box to pump.
- D. Hose LRT-57-030.
- E. Test adaptor LRT-57-001.
- F. Pressure gauge LRT-57-005.
- G. Thread adaptor LRT-57-004.
- H. Thread adaptor LRT-57-022.

Procedure

1. A hydraulic pressure gauge and test adaptor is used to test power steering system. This gauge is able to measure 140 kgf/cm². The maximum power steering system pressure is 77 kgf/cm².
2. Some fault conditions of hydraulic pump may obtain pressures up to 105 kgf/cm². Pressure on gauge is same pressure being exerted upon steering wheel. When testing, turn steering wheel gradually while reading pressure gauge.
3. Check and maintain maximum fluid level of reservoir.
4. Examine power steering units and connections for leaks. All leaks must be rectified before attempting to test the system.
5. Check steering pump drive belt tension. **See ENGINE, Repair, Drive Belt**
6. Assemble test equipment and fit to vehicle, as shown in RR3959M.
7. Open tap of adaptor.
8. Bleed system, take care not to overload pressure gauge.
9. With system in good condition, pressures should be:

- (A) Steering wheel held on full lock and engine running at 1,000 rev/min, 70 to 77 kgf/cm².
- (B) Steering wheel held on full lock and engine idling, 28 kgf/cm².

Checks should be carried out on both full lock positions.



CAUTION: Do not maintain this pressure for more than 30 seconds in any one minute to avoid overheating fluid and possibly damaging seals.

10. Release steering wheel and with engine idling. Pressure should read below 7 kgf/cm².
11. If pressures differ to those given a fault exists.
12. To determine if fault is steering box or pump. Close adaptor tap for a maximum five seconds.
13. If gauge does not register specified pressure, pump is faulty.
14. Fit a new pump, bleed system and repeat test. If low pressure or a substantial imbalance exists, fault is in steering box valve and worm assembly.



STEERING DAMPER

The power steering system, as well as reducing the effort required to manoeuvre the vehicle when parking, also helps to dampen any deflections of the road wheels, being transmitted back to the steering wheel.

When operating the vehicle off road, the road wheels are often deflected by ruts and boulders causing the steering wheel to turn left and right. This phenomenon is known as 'steering kickback'. To subdue the effects of 'steering kickback', a hydraulic damper is fitted in the steering linkage between the track rod and the differential casing. The damper, which offers the same resistance in extension and compression, is sealed for life.

Steering damper check

Check the condition operation of the hydraulic steering damper as follows:

Check procedure

1. Inspect damper for casing damage or leaks.
2. Clamp one end of the damper horizontally in a vice using soft jaws. Compress and extend the unit by hand. Resistance should be equal in both directions.
3. If it is felt that the unit is outside acceptable limits, fit a new steering damper

STEERING FAULTS

Symptom:-

Excessive kickback through steering wheel - when driven on rough terrain.

1. Is the steering damper in good working order?
See Steering Damper
NO - Renew unit. **See Repair, Steering Damper**
YES - Continue.
2. Is there any looseness or free play in the steering ball joints and linkage?
YES - **See Steering Linkage Inspect**
NO - Continue.
3. Is there any looseness or worn bushes in front suspension?
YES - **See FRONT SUSPENSION, Repair, Radius Arm**



NOTE: When replacing suspension bushes ALL bushes and fixings must be replaced.

- NO - Continue.
4. Is the steering exceptionally light/sensitive when driven on good road surface?
YES - See fault symptom - **Steering excessively light/sensitive and freeplay at steering wheel.**
NO - Suspect axle swivel resistance.
5. Check the resistance of the axle swivels. **See FRONT AXLE AND FINAL DRIVE, Overhaul, Front Stub Axle, Constant Velocity Joint and Swivel Pin Housing Non ABS See FRONT AXLE AND FINAL DRIVE, Overhaul, Front Stub Axle, Constant Velocity Joint and Swivel Pin Housing ABS**

Symptom:-

Fluid leaks from steering box seals.



CAUTION: The steering wheel must not be held on full lock for more than 30 seconds in one minute, as this may overheat the fluid and cause damage to the oil seals.

1. Check fluid level. **See Repair, Power Steering Fluid Reservoir**
Check fluid pressure. **See Power Steering System - Test**
2. Is pressure high?
YES - Renew pump. **See Repair, Power steering Pump**
If oil seal leaks persist after renewing the pump. **See Overhaul, Power Steering Box**
NO - **See Overhaul, Power Steering Box**

Symptom:-

Insufficient power assistance - castor return action normal.

1. Are tyres correct type and pressure?
NO - **See GENERAL SPECIFICATION DATA, Information, Wheels and Tyres**
YES - Continue.
2. Is fluid level correct?
NO - Check fluid level **See Repair, Power Steering Fluid Reservoir**
YES - Check system for air locks. **See Repair, Power Steering System - Bleed**
3. Is pressure correct?
NO - Check fluid pressure. **See Power Steering System - Test**
If pressure is not correct after bleeding the system, renew pump. **See Repair, Power Steering Pump**
YES - **See Overhaul, Power Steering Box**

Symptom:-

Steering heavy - stiff, poor castor return action.

1. Are tyres correct type and pressure?
NO - **See GENERAL SPECIFICATION DATA, Information, Wheels and Tyres**
YES - Check universal joints for seizure and correct alignment. **See Repair, Lower Steering Shaft and Universal Joints**
Check power steering box adjustments. **See Overhaul, Power Steering Box**
2. Is the power assistance satisfactory?
NO - See fault symptom **Insufficient assistance, (castor return action normal)**.
YES - Disconnect drag link from drop arm and check steering column and box for stiffness. **See Repair, Drag Link and Drag Link Ends**
3. Is the steering stiff with the drag link disconnected?
NO - Check steering ball joints for seizure and axle swivels lubrication and resistance. **See Repair, Drag Link and Drag Link Ends See FRONT AXLE AND FINAL DRIVE, Overhaul, Front Stub Axle, Constant Velocity Joint and Swivel Pin Housing Non ABS See FRONT AXLE AND FINAL DRIVE, Overhaul, Front Stub Axle, Constant Velocity Joint and Swivel Pin Housing ABS**
YES - Disconnect the lower steering shaft and check the column and box for stiffness. **See Repair, Lower Steering Shaft and Universal Joints**
4. Is the steering column stiff to turn when disconnected from the box?
NO - Remove and overhaul box. **See Overhaul, Power Steering Box**
YES - Adjust steering column. **See Stiff Steering Checklist**

**Symptom :-**

Steering excessively light/sensitive. Excessive freeplay at steering wheel.

1. Are steering box adjustments correct?
NO - **See Adjustment, Power Steering Box**



WARNING: Adjustments of steering box should not be required while in warranty period. If box is within warranty, it must be returned to manufacturer. No attempt must be made to introduce backlash.

- YES - Suspect worn panhard rod or radius arm bushes Check condition of ball joints and the lower steering column shaft universal joints for wear. **See Repair, Lower Steering Shaft and Universal Joints**

Symptom :-

Steering vibration, road wheel shimmy - wobble.

Vibration through the steering linkage powerful enough to induce high frequency oscillation of the steering wheel, is generally caused by out of balance road wheels. However there are a number of other possible causes of this symptom which if severe, may be described as shimmy or wobble. Regardless of the terminology used by the owner/driver to describe the symptoms, the following diagnostic checks should be carried out in the order presented.

1. Check the tyres and balance of the road wheels. **See GENERAL SPECIFICATION DATA, Information, Wheels and Tyres See WHEELS AND TYRES, Fault diagnosis, Fault - Symptoms See WHEELS AND TYRES, Repair, Wheel Balancing**
2. Check the steering hydraulic damper function. **See Steering Damper**
3. Check steering column universal joints for wear and correct alignment. **See Repair, Lower Steering Shaft and Universal Joints**

4. Check steering linkage ball joints for wear, correct alignment and security, including steering box and tie rod. **See Steering Linkage Inspect**
5. Check all front suspension rubbers for wear. Check all fixing torques, including radius arm bushes, panhard rod and anti-roll [sway] bar. **See FRONT SUSPENSION, Repair, Panhard Rod See FRONT SUSPENSION, Repair, Radius Arm See FRONT SUSPENSION, Repair, Anti-Roll[Sway] Bar Assembly See FRONT SUSPENSION, Repair, Front Shock Absorber**
6. Fit new radius arm bushes using NTC 6860. Fit harmonic damper if vehicle has air suspension. Fit new nuts, bolts and washers.
7. **Coil spring vehicles only** - If problem persists fit damper kit STC 241 (2 off front) and STC 1474 (2 off rear). Road test vehicle.
8. Check the power steering box adjustments and operation. **See Overhaul, Power Steering Box**
9. Check the hub bearing end floats and determine the condition of the hub bearings. As applicable. **See FRONT AXLE AND FINAL DRIVE, Repair, Front Hub Assembly ABS or See FRONT AXLE AND FINAL DRIVE, Repair, Front Hub Assembly non ABS**
10. Check the resistance and condition of the swivels. **See FRONT AXLE AND FINAL DRIVE, Description and operation, Description**
If problem is not diagnosed: Repeat checks starting at 1.
11. Carry out a full steering geometry check. **See INTRODUCTION, Information, Steering**

STEERING STABILITY AND VEER UNDER BRAKING

Possible cause:

Incorrectly set, swivel pin bearing preload. There are three different settings for these bearings dependant on model year and if fitted with ABS brakes.

Remedy.

1. Establish model year of vehicle.
2. If fitted with or without antilock brakes.
3. Follow instructions to overhaul front stub axle, constant velocity joint and swivel pin non ABS, or with ABS as appropriate.
See FRONT AXLE AND FINAL DRIVE, Overhaul, Front Stub Axle, Constant Velocity Joint and Swivel Pin Housing Non ABS See FRONT AXLE AND FINAL DRIVE, Overhaul, Front Stub Axle, Constant Velocity Joint and Swivel Pin Housing ABS

1. GENERAL STEERING

1. Carry out visual and safety checks. **See Visual and Safety Checks**
2. Road test vehicle. **See Road Test Procedure**
3. Is problem resolved?
YES - end
NO - continue
4. Is problem stiff steering?
YES - **See Stiff Steering Checklist**
NO - Go to 6.
5. Is problem resolved?
YES - end
NO - go to 8.
6. Is problem steering niggle ?
YES - Replace radius arm bushes, arm and axle. **See FRONT SUSPENSION, Repair, Radius Arm**
NO - go to 8.
7. Is problem resolved?
YES - end
NO - continue.
8. Centralise steering box. **See Adjustment, Centralise Steering Box**
9. Is problem resolved?
YES - end
NO - continue.
10. Check, adjust if necessary, steering geometry.
11. Is problem resolved?
YES - end
NO - continue.
12. Categorise the remaining problems into one or more of the following descriptions:
See 2. Steering Veer
See 3. Veer Under Braking
See 4. Directional Stability



2. STEERING VEER

From 1. GENERAL STEERING:

1. Vehicle veers, not under braking, swap front tyres side to side.
2. Is problem resolved?
YES - end
NO - continue.
3. Does vehicle now veer in other direction?
YES - fit new tyres
NO - continue.
4. Recentralise steering box. **See Adjustment, Centralise Steering Box**
5. Is problem resolved?
YES - end
NO - contact local technical office.

3. VEER UNDER BRAKING

From 1. GENERAL STEERING:

1. Vehicle veers under braking, bleed brake system.
2. Is problem resolved?
YES - end
NO - continue.
3. Check brake pads for glazing, and discs, axles etc for contamination.
4. Is problem resolved?
YES - end
NO - continue.
5. Check brake lines and hoses for deterioration. Replace as necessary.
6. Is problem resolved?
YES - end
NO - continue.
7. Contact local technical office.

4. DIRECTIONAL STABILITY

From 1. GENERAL STEERING:

1. Is directional stability concern when vehicle is towing?
YES - Check towing/vehicle loading parameters in Owner's Handbook.
NO - go to 3.
2. Is problem resolved?
YES - end
NO - continue.
3. Check condition of rear trailing link/chassis bushes.
4. Is problem resolved?
YES - end
NO - continue.
5. Check condition of front and rear shock absorbers. If in doubt change units in pairs, side to side.
6. Is problem resolved?
YES - end
NO - continue.
7. Check steering damper. **See Steering Damper**
8. Is problem resolved?
YES - end
NO - continue.
9. Check wheel balance
10. Is problem resolved?
YES - end
NO - contact local technical office.

POWER STEERING FLUID LEAKS

1. Is fluid level correct?
YES - go to 3.
NO - Refill or drain to correct level. Bleed system, check for leaks. **See Repair, Power Steering System - Bleed**
2. Is problem resolved?
YES - end
NO - continue.
3. Are hoses or joints leaking? Check on full lock with engine at 2000 rev/min.
YES - loosen and retorque joints.
NO - go to 6.
4. Does leak remain?
YES - change PAS pipe.
NO - end.
5. Does leak remain?
YES - suspect seal in component. Check and replace as necessary.
NO - end.
6. Is oil escaping from filler cap?
YES - bleed system. **See Repair, Power Steering System - Bleed**
NO - go to 8.
7. Is oil still escaping from filler cap?
YES - go back to 1.
NO - end.
8. Is oil leaking from PAS pump?
YES - go to 10.
NO - continue.
9. Is oil leaking from PAS box?
YES - go to 10.
NO - end.
10. Clean unit, add tracer dye to system. Retest
11. Is oil still leaking?
YES - establish leak point. Repair or replace unit as necessary.
NO - end.



POWER STEERING SYSTEM - EXCESSIVE NOISE

1. Is fluid level correct?
YES - go to 3.
NO - Refill or drain to correct level. Bleed system, check for leaks. **See Repair, Power Steering System - Bleed**
2. Is problem resolved?
YES - end
NO - continue.
3. Is pressure hose from pump to box touching body in a hard foul condition?
YES - reroute hose away from body.
NO - go to 5.
4. Does noise remain?
YES - continue.
NO - end.
5. Is noise a whistle or hiss on full lock?
YES - noise is not a fault unless excessive. Compare with other vehicles
NO - go to 8.
6. Is noise excessive?
YES - continue.
NO - end.
7. Change steering box and/or pump.
8. Is noise a squeal on full lock?
YES - check/reset drive belt tension. **See ENGINE, Repair, Drive Belt**
NO - go to 10.
9. Does squeal remain?
YES - drive belt contaminated, change belt.
NO - end.
10. Is noise a continuous moan?
YES - bleed PAS system. **See Repair, Power Steering System - Bleed**
NO - go to 13.
11. Does moan remain?
YES - do figure 8 manoeuvres.
NO - end.
12. Does moan remain?
YES - continue
NO - end.
13. Is noise an intermittent "grunt"?
YES - **See Power Steering System - Grunt**
NO - continue.
14. Is it a clunking noise?
YES - reset drive belt tension. **See ENGINE, Repair, Drive Belt**
NO - contact local technical office.
15. Does noise remain?
YES - Suspect suspension or drive train.
NO - end.

POWER STEERING SYSTEM - GRUNT

Steering box grunts intermittently when turning from lock to lock:

1. Is fluid level correct?
YES - go to 3.
NO - refill or drain to correct level. Bleed system, check for leaks. **See Repair, Power Steering System - Bleed**
2. Does grunt remain?
YES - continue
NO - end.
3. Is correct low pressure hose ANR 3152, steering box to reservoir fitted?
YES - go to 5.
NO - Fit correct hose.
4. Does grunt remain?
YES - continue
NO - end.
5. Purge box by doing figure 8 manoeuvres e.g. on car park, followed by 10 minutes normal road use.
6. Does grunt remain?
YES - Contact local technical office
NO - end.

VISUAL AND SAFETY CHECKS



WARNING: Before taking vehicle out on the public highway for road test, it is important that the following basic visual checks are carried out to ensure that the vehicle complies with legal requirements.

Tyres and wheel rims

1. Check and adjust tyre pressures. **See GENERAL SPECIFICATION DATA, Information, Tyre Pressures**
Note that this information refers to standard tyres fitted as original equipment.
2. Check condition of tyres. Inspect for signs of uneven wear, damage and feathering. Check tread depth.
3. Ensure that the tyre make, type and general condition are common across each axle.
4. Check wheel rims for signs of damage and excessive run out.
5. Carry out road test. **See Road Test Procedure**

ROAD TEST PROCEDURE

General steering/handling problems can usually be classified into one of the categories listed and ARE GENERALLY RELATED TO THE AGE, CONDITION AND USE OF THE VEHICLE.



WARNING: Ensure that all road tests are conducted by suitably qualified drivers in a safe and legal manner, and where local traffic conditions allow.

1. Carry out visual and safety checks. **See Visual and Safety Checks**

Confirm general nature of complaint with customer, simulating where possible the conditions under which the problem occurs. Carry out following road test procedure to establish the problem.

2. Steering load assessment - drive at 16 km/h (10 mph). Put 90° turn input into steering wheel, check self centering. The self centering should be equal on each lock BUT not necessarily return to exactly straight ahead without assistance from the driver.
3. Steering assessment - drive at 64 km/h (40 mph) on a straight FLAT road (no camber), check for steering veer. The vehicle should follow a straight path with NO tendency to follow a curved path. If vehicle veers towards the kerb, vehicle may be 'camber sensitive'. A small amount of veer in direction of camber is acceptable.
4. Directional stability assessment - drive at 112 km/h (70 mph) or maximum legal speed on a straight flat road. Carry out a normal lane change. Vehicle should quickly settle into a new straight path.
5. Braking assessment (medium effort) - drive at 96 km/h (60 mph) on a straight flat road. Apply steady medium braking effort, noting any tendency to veer. Carry out brake test three times, if a veer is consistently noted carry out a braking efficiency test on a rolling road.
6. Braking assessment (full effort) - drive at 96 km/h (60 mph) on a straight flat road. Apply full braking effort, noting any tendency to veer. Carry out brake test three times, if a veer is consistently noted carry out a braking efficiency test on a rolling road.

If the symptom described by the customer is stiff steering or steering niggles, carry out stiff steering procedure. **See Stiff Steering Checklist**

If not proceed with basic checks and adjustments. **See Visual Check and Basic Adjustments**



STIFF STEERING CHECKLIST



NOTE: Having completed visual checks and steering assessment and confirmed that vehicle steering load is incorrect carry out the following procedure in order shown.

Steering wheel 'torque to turn' loads

1. Raise vehicle so both front wheels free.
2. With engine off, centralise steering wheel, and remove air bag, if fitted or steering wheel pad. Using torque wrench on column nut, check torque required to turn the steering wheel one turn in each direction.
3. Record readings obtained in each direction. Compare figures obtained with the specified figures:

Without ABS **4.40 Nm**.

With ABS **4.65 Nm**.



NOTE: If figures are in excess of those specified carry out steering box tie bar reset below. If figures are as specified. See *Visual Check and Basic Adjustments*

Steering box tie bar reset

1. Loosen the three tie bar fixings one complete turn.
2. Drive vehicle carefully a short distance (within the dealership) applying full lock in both directions in order to settle steering components. Drive vehicle over speed bumps and include harsh braking if possible.



WARNING: Do not drive on public highway.

3. Near end of 2. ensure vehicle is driven in a straight line on level ground and halted.
4. Tighten panhard rod mounting arm nut, **110 Nm**.
5. Tighten the two fixings tie bar to steering box, **81 Nm**.
6. Recheck steering wheel torque to turn. If torque reading is still greater than specified, carry out steering shaft universal joint lubrication.

Lower steering shaft universal joint lubrication

1. Check lower steering shaft is correctly phased. See *Repair, Lower Steering Shaft and Universal Joints*
2. Lubricate universal joints with an anti-seizure type penetrating spray. Work the joints to ensure full penetration of the spray by driving vehicle and steering from lock to lock.
3. If steering stiffness still persists carry out swivel pin preload setting.

Swivel pin preload setting

The swivel pin preload setting must be checked and set following the workshop manual procedure.

1. NON ABS vehicles. See *FRONT AXLE AND FINAL DRIVE, Overhaul, Front Stub Axle, Constant Velocity Joint and Swivel Pin Housing Non ABS*
Note that a pull load of 1.16 - 1.46 kg is required after the axle shaft and swivel housing seal have been removed.
2. ABS vehicles. See *FRONT AXLE AND FINAL DRIVE, Overhaul, Front Stub Axle, Constant Velocity Joint and Swivel Pin Housing ABS*
Note that a torque to turn of 2.0 - 2.8 Nm is required after the axle shaft and swivel housing seal have been removed.
3. If steering stiffness still persists carry out steering column alignment.

Steering column alignment

1. Place vehicle on level ground. Measure the angle of lower steering shaft using a Pernumeter placed on the shaft between the universal joints. The angle should measure a minimum of 12°.
2. If necessary, realign the shaft. Release the five fixings securing the steering column. Position column as required. Tighten the fixings evenly, **27 Nm**.
3. Loosen the three screws securing lower steering column shroud to upper shroud ensure lower shroud is clipped to upper shroud. Reposition shroud, tighten screws.
4. Recheck steering column angle.

Steering box adjustment

1. Check steering box adjustment. **See Adjustment, Power Steering Box**

Steering damper check

1. Check condition of steering damper **See Steering Damper**

VISUAL CHECK AND BASIC ADJUSTMENTS

NOTE: It is important that the following instructions are carried out in the sequence shown and the results recorded.

1. Road springs - check that road springs are correctly seated and are to correct specification for vehicle. For spring specification. **See GENERAL SPECIFICATION DATA, Information, Road Springs Data**
2. Ride height - measure trim height from wheel centre to wheelarch eyebrow. Record results on data sheet.
3. Check/top up power steering fluid **See Repair, Power Steering Fluid Reservoir**
4. Check tension and condition of drive belt. **See ENGINE, Repair, Drive Belt**
5. Track rod/drag link - check condition of track rod, drag link and ball joints. **See Repair, Drag Link and Drag Link Ends**
If either component is damaged, check operation of steering damper and steering box for smoothness. Replace all damaged or worn components that impair the operation of the steering system.
6. Suspension bushes - examine all steering and suspension bushes for signs of wear and deterioration. Also check all fixings for torque relaxation. Tighten to correct torque value. **See FRONT SUSPENSION, Specifications, torque, Torque Values**
7. Oil leaks - check front and rear axle hubs for leak and repair as necessary.
8. Brake system - check brake system for leaks, pipe condition, pad wear/contamination, disc wear/condition and ABS sensors for correct fitting.
9. Hub end float - check movement in the hubs by rocking the wheels.
10. Check front wheel alignment. Vehicles displaying a tendency to veer more than considered allowable, it is permissible to set the front track to parallel.
11. Having completed all the above checks and adjustments, road test vehicle. **See Road Test Procedure**
Attempting to reproduce the symptoms established earlier. If symptoms still exist refer to relevant Diagnostic Chart.



STEERING LINKAGE INSPECT



NOTE: When inspecting steering linkages and ball joints for wear the following items must be checked.

Steering ball joints

1. Check ball joint rubber boots for security, signs of cracking or deterioration.
2. Check ball joint assemblies for seizure i.e. no movement on ball joint and associated assemblies.
3. Check for excessive wear. This will be evident as extreme movement on track rod and steering linkages. Renew parts as necessary. **See Repair, Track Rod and Linkage See Repair, Drag Link and Drag Link Ends**

Steering linkages

4. Check all linkages for wear, deterioration and damage. Renew parts as necessary. **See Repair, Track Rod and Linkage See Repair, Drag Link and Drag Link Ends**



POWER STEERING BOX

Service repair no - 57.10.13



WARNING: Adjustments of steering box should not be required while in warranty period. If box is stiff or tight and within warranty, it must be returned to manufacturer. No attempt must be made to introduce backlash.

1. Apply park brake, select 'P' in automatic transmission and chock wheels. Support chassis front on axle stands.
2. Remove engine undertray.
3. Disconnect drag link from steering drop arm.
4. Check torque to turn. *See Fault diagnosis, Stiff Steering Checklist*
5. Centralise steering box. *See Centralise Steering Box*



NOTE: Only check for no backlash when steering box is in central position.



NOTE: If steering wheel is not straight, it should be repositioned. *See Repair, Steering Wheel*

The adjustment of the steering box ensures any preload or end float present on centre is removed.

6. The adjustment is obtained by rocking the drop arm about centre whilst an assistant slowly tightens the steering box adjuster screw.

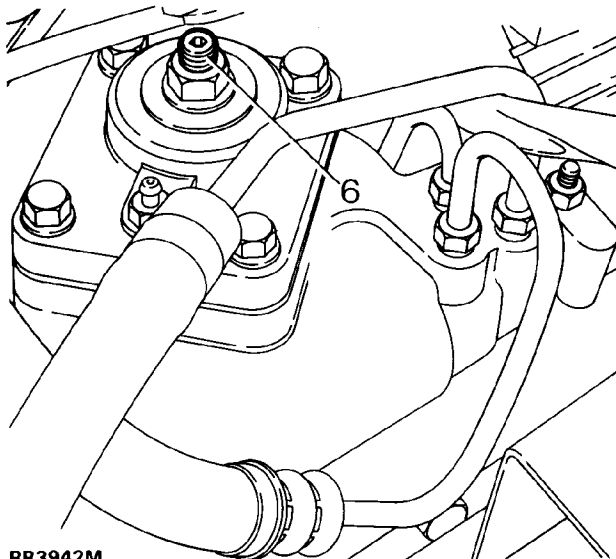

RR3942M

7. Tighten the locknut when all backlash has been removed.
8. Repeat the check for backlash. If backlash exists loosen locknut and repeat adjustment procedure.
9. Turn steering wheel lock to lock and check no tightness exists.
10. Ensure front wheels are aligned and in straight ahead position. *See Front Wheel Alignment*
11. Adjust drag link 924 mm between ball joint centres.
12. Connect drag link. Tighten to **40 Nm**.
13. Lower vehicle to ground level and remove chocks.
14. Road test vehicle. *See Fault diagnosis, Road Test Procedure*



NOTE: If steering wheel is not in straight ahead position when vehicle is travelling in a straight line, drag link length is incorrect and is pushing drop arm away from central position.

Drag link adjust

15. Right hand drive vehicles - if steering wheel is to right, drag link is too long. If steering wheel is to left drag link is too short.
Left hand drive vehicles - if steering wheel is to right, drag link is too short. If steering wheel is to left drag link is too long.
16. Adjust drag link until steering wheel points straight ahead when vehicle is travelling in a straight line.

CENTRALISE STEERING BOX

1. To centralise the box, insert a suitable peg (hole size 8.06 mm) into the rear of the drop arm and into the steering box casing to enable rapid and accurate setting on centre.

STEERING LOCK STOPS

Service repair no - 57.65.03

Check

1. Measure clearance between tyre wall and radius arm at full lock. This must be 20 mm.

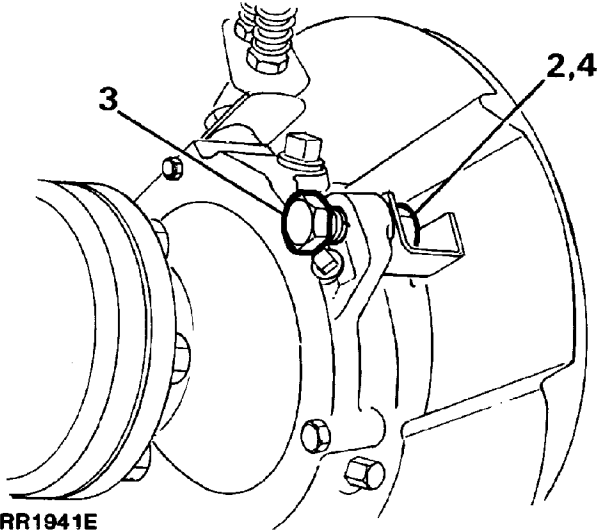
**Adjust**

2. Loosen stop bolt locknut.
3. Turn stop bolt as required.
4. Tighten locknut.
5. Check clearance between tyre wall and radius arm on each lock.



NOTE: Alternatively lock stop adjustment may be carried out using following procedure.

Check

1. Measure stop bolt protrusion as shown in RR1697M. This must be 40.5 mm.

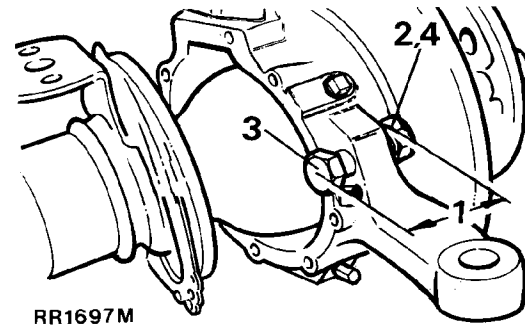
**Adjust**

2. Loosen stop bolt locknut.
3. Turn stop bolt as required.
4. Tighten locknut.
5. Check wheel position at full lock.



FRONT WHEEL ALIGNMENT

Service repair no - 57.65.01

Checking Toe-out dimensions



NOTE: No Adjustment is provided for castor, camber or swivel pin inclinations.

1. Set vehicle on level ground with road wheels positioned straight ahead.
2. Push vehicle back and forwards to settle linkage.
3. Measure toe-out at horizontal centre-line of wheels.
4. Check tightness of clamp bolt fixings. Tighten to **14 Nm**.

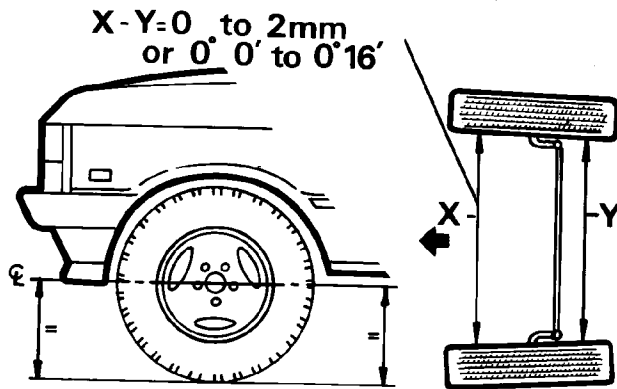

RR2172E

**X-Y=0 to 2mm
or 0° 0' to 0° 16'**

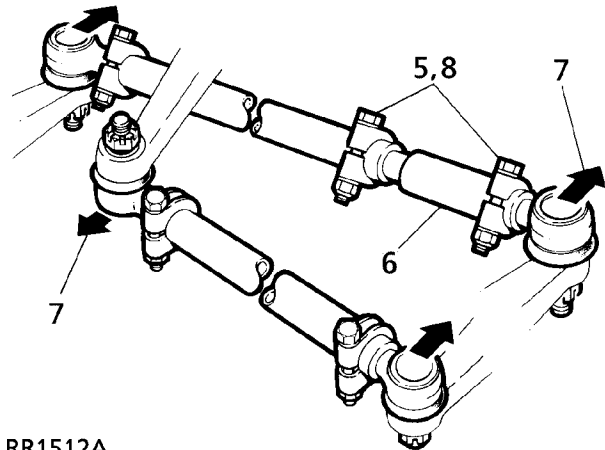

RR1512A

Adjust

5. Loosen adjuster sleeve clamp.
6. Rotate adjuster to lengthen or shorten track rod.
7. Check toe-out setting as instructions 1 to 4. When toe-out is correct, tap steering linkage ball joint, in directions of arrows shown, to maximum of their travel. This ensures full unrestricted working travel.
8. Tighten clamp bolts to **14 Nm**.

POWER STEERING PUMP DRIVE BELT

Service repair no - 57.20.01

Adjust



NOTE: For details of drive belt adjust procedure See ENGINE, Repair, Drive Belt



POWER STEERING FLUID PIPES

Service repair no - 57.15.21



CAUTION: If any joints are disconnected, it is essential that open pipe and ports are plugged to prevent ingress of dirt.

The following procedures must be followed when refitting fluid pipes:

Power steering pump

1. Remove plugs, place clamp on feed hose.

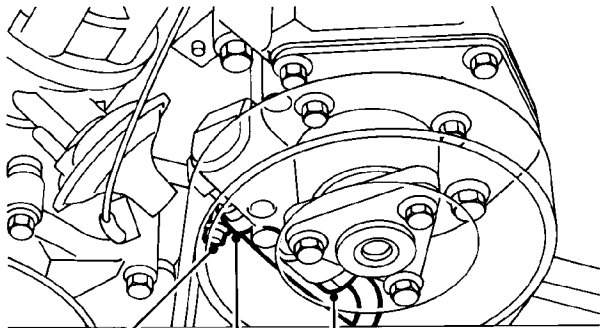

RR4150

V8i Steering pump illustrated

2. Push hose onto pump.
3. Hold clamp in position, Tighten to **3 Nm**.
4. Fit high pressure union into pump.
5. Hold pipe in correct position. Tighten to **20 Nm**.

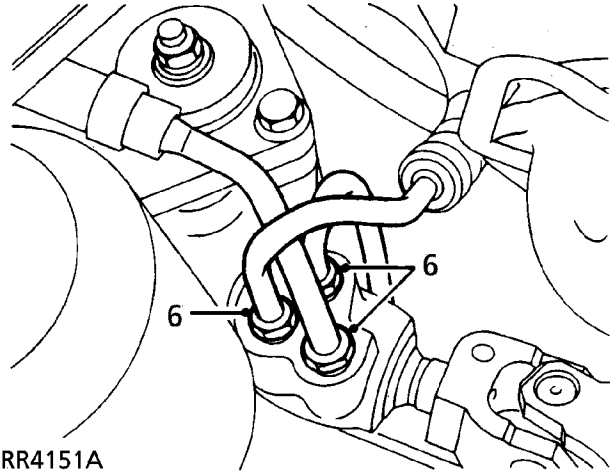

RR4151A

6. Remove plugs and refit pipes to steering box, leave fingertight.
7. Tighten to torque: 16mm thread **20 Nm**.
14mm thread **15 Nm**.

Power steering reservoir

1. Remove plugs and refit pipes and clamps.

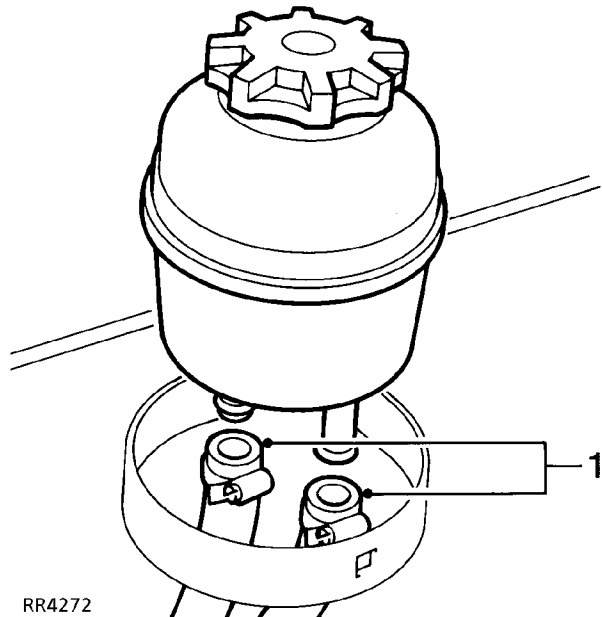

RR4272

2. Tighten clamps to **3 Nm**.

POWER STEERING BOX

Service repair no - 57.10.01

General precautions

1. Whenever any part of system, is removed or disconnected, utmost cleanliness must be observed.
2. Disconnected ports and hoses must be plugged to prevent ingress of dirt. If metal sediment is found in system, establish cause rectify and flush system.
3. Do not start engine until reservoir is full as pump will be damaged.
4. Metric pipe fittings are used with 'O' ring pipe ends on fittings to steering box.
5. Follow normal 'O' ring replacement procedure whenever pipes are disconnected.
6. Ensure compatible metric components when fitting replacement pipes.



CAUTION: Before removing any parts of steering linkage, it is imperative that road wheels are positioned straight ahead.

Then steering wheel removed to prevent rotary coupler being wound up or damaged.



CAUTION: After refitting steering linkage parts follow correct procedure to ensure that road wheels, steering box and steering wheel are correctly positioned relative to each other when in straight ahead condition. If steering wheel requires repositioning, ensure that drive pegs on rotary coupler are correctly positioned before steering wheel is replaced.

This ensures drive pegs locate in their holes in rear of steering wheel.

After final alignment connect rotary coupler multiplug, tighten steering wheel securing nut and fit air bag - if fitted or steering wheel trim pad.



NOTE: When drag link is disconnected from steering box, travel available at steering wheel to each full lock is not equal.

Remove

1. Site vehicle on level surface.
2. Open bonnet[hood].
3. Remove filler cap from power steering fluid reservoir.
4. Clean steering box.
5. Disconnect feed and return pipes from steering box.

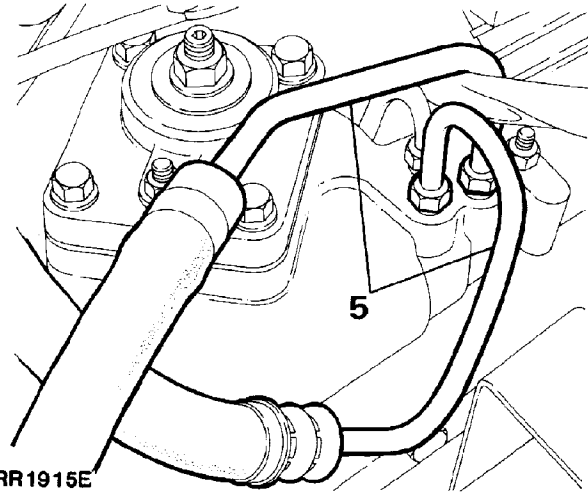

6. Plug open pipes and steering box ports to prevent ingress of dirt.
7. Support chassis front on axle stands. Or raise vehicle on a hoist.



WARNING: Ensure wheels are chocked, parking brake is applied, and low range selected.



8. Remove undertray

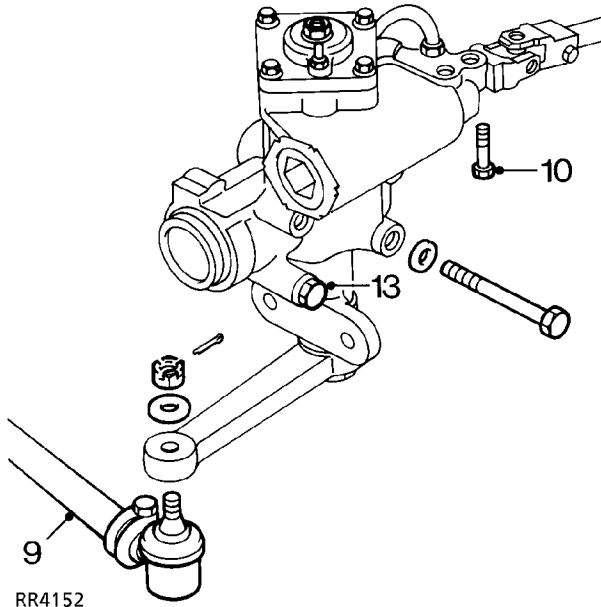

RR4152

- 9. Disconnect drag link from drop arm using a suitable extractor.
- 10. Remove pinch bolt securing lower shaft universal joint to power steering box.

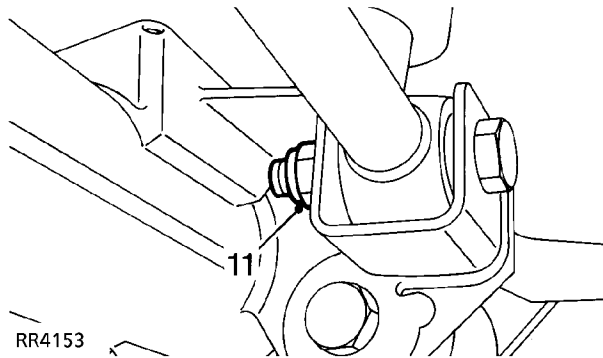

RR4153

- 11. Loosen but do not remove nut securing tie bar to mounting.

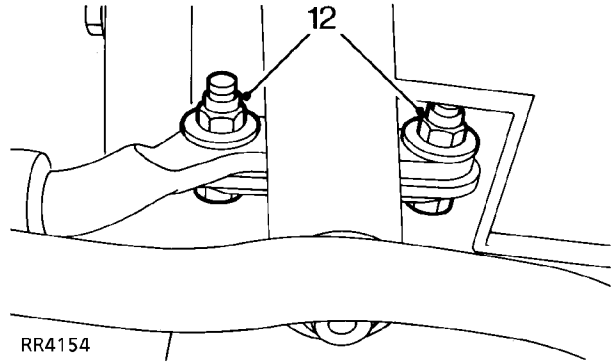

RR4154

- 12. Remove bolts securing tie bar, move tie bar aside.

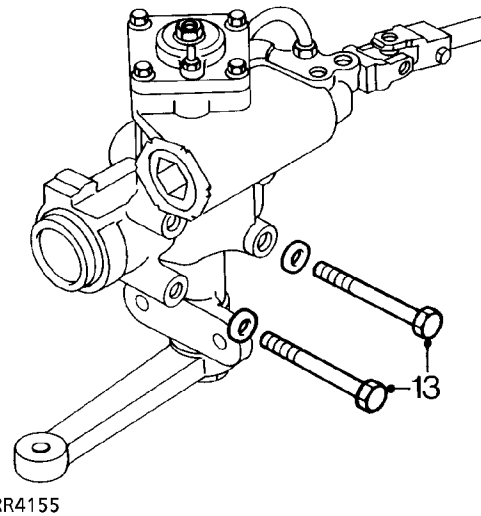

RR4155

- 13. Remove bolts securing power steering box to chassis side member.
- 14. Withdraw power steering box.

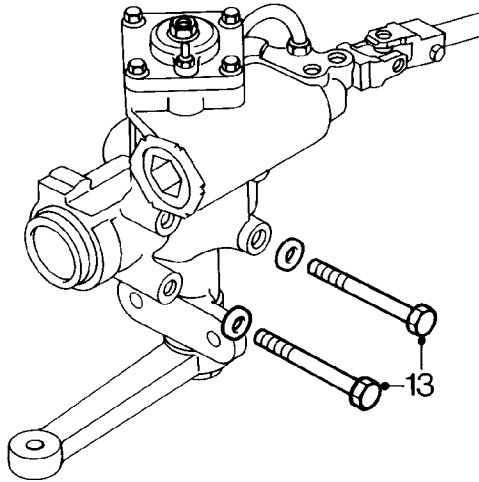

RR4155



CAUTION: Do not maintain this pressure for more than 30 seconds in any one minute, to avoid oil overheating and possible seal damage.

26. Test drive vehicle: using both full lock directions, to settle steering components. If possible, drive vehicle over speed bumps and include harsh braking.



WARNING: Do not test drive vehicle on public highway.

27. Drive vehicle in a straight line on level ground and stop.
28. Tighten tie bar to mounting nut to **110 Nm**.
29. Tighten bolts securing tie bar to **81 Nm**.
30. Ensure steering wheel is correctly aligned when wheels are positioned straight ahead.
31. If necessary reposition steering wheel. **See Steering Wheel**
32. Road test vehicle.

Refit

15. Position steering box to chassis side member, ensuring locating peg is engaged. Tighten bolts to **81 Nm**.
16. Fit pinch bolt and nut securing universal joint to power steering box. Tighten to **25 Nm**.
17. Position tie bar, tighten bolts and nut to **81 Nm, starting with tie bar to mounting nut, then loosen nut and bolts by one complete turn**.
18. Check steering box, adjust if necessary. **See Adjustment, Power Steering Box**
19. Refit drag link to drop arm tighten nut to **40 Nm**.
20. Fit undertray.
21. Lower vehicle to ground.
22. Remove plugs and refit pipes to steering box. Tighten 16mm thread to **20 Nm**.
14mm thread to **15 Nm**.
23. Remove filler cap. Fill reservoir to oil level mark on dipstick. Use recommended fluid. **See LUBRICANTS, FLUIDS AND CAPACITIES, Information, Recommended Lubricants and Fluids** and bleed power steering system. **See Power Steering System - Bleed**
24. Recheck fluid level and replace cap.
25. With engine running, test steering system for leaks by holding steering in both full lock directions.



POWER STEERING SYSTEM - BLEED

Service repair no - 57.15.02

1. Ensure fluid in reservoir reaches dipstick maximum.
2. Run engine to normal operating temperature.
3. Recheck and correct reservoir fluid level.



NOTE: During instructions 4 to 6, maintain maximum fluid level in reservoir. Do not increase engine speed or move steering wheel.

4. With engine at idle speed, loosen bleed screw. When fluid seeps past bleed screw retighten screw.

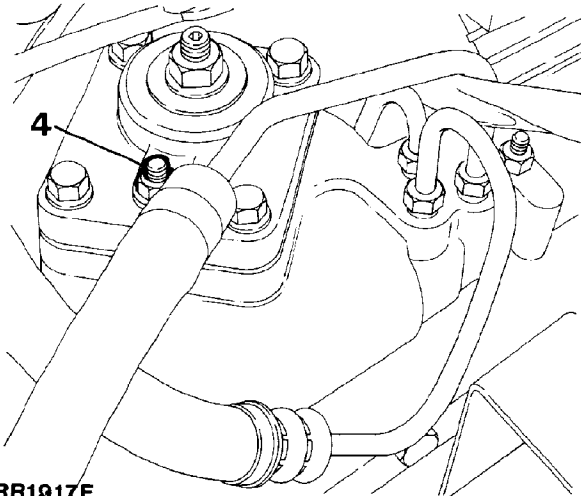

5. Check fluid level.
6. Clean away fluid around bleed screw.
7. Check hose connections, pump and steering box for fluid leaks by holding steering on full lock in both directions.



CAUTION: Do not maintain this pressure for more than 30 seconds in any one minute to avoid overheating fluid and possibly damaging seals.

8. Carry out road test.

POWER STEERING FLUID RESERVOIR

Service repair no - 57.15.08

Remove

1. Remove undertray.
2. Position drain tin beneath reservoir.

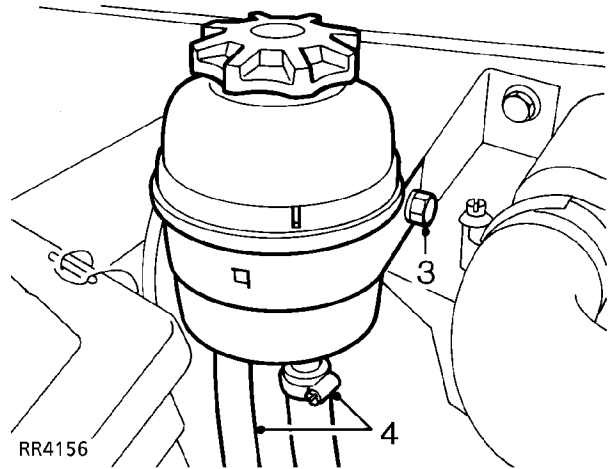

3. Loosen mounting bracket clamp bolt, raise reservoir to gain access to pipe clamps.
4. Loosen clamps, disconnect feed and return hoses from reservoir, allow fluid to drain.



CAUTION: Plug the connections.

5. Remove reservoir.



CAUTION: Discard fluid drained from system. Do not allow fluid to contact paintwork, if spilled, remove fluid and clean area with warm water.

Refit

6. Position reservoir, connect feed and return hoses and tighten clamps to **3 Nm**.
7. Fit reservoir in clamp, tighten clamp bolt.
8. Fill reservoir to 'MAX' mark on dipstick with power steering fluid. **See LUBRICANTS, FLUIDS AND CAPACITIES, Information, Recommended Lubricants and Fluids**
9. Fit undertray.
10. Bleed power steering system. **See Power Steering System - Bleed**

POWER STEERING PUMP DRIVE BELT

Service repair no - 57.20.02



NOTE: For details of drive belt remove and refit. **See ENGINE, Repair, Drive Belt**

POWER STEERING PUMP - V8i

Service repair no - 57.20.14



NOTE: The power steering pump is not serviceable. Fit new pump if worn or damaged.

Remove

1. Disconnect battery negative lead.
2. Remove drive belt from steering pump. **See ENGINE, Repair, Drive Belt**
3. Remove undertray.
4. Remove fan blades and viscous coupling. **See COOLING SYSTEM, Repair, Viscous Coupling, Fan Blades, Pulley and Fan Cowl**
5. Position drain tin beneath steering pump.

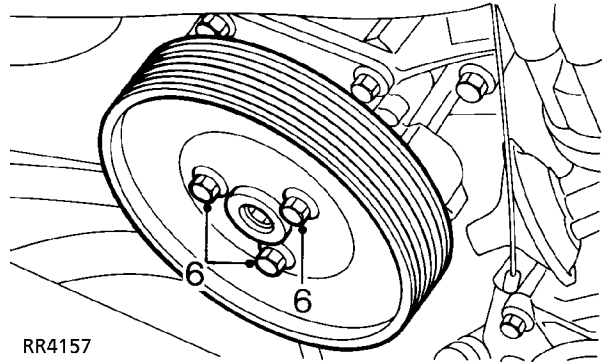

6. Using a 9 mm Allen key to restrain steering pump pulley, remove 3 bolts securing pulley to pump; remove pulley.

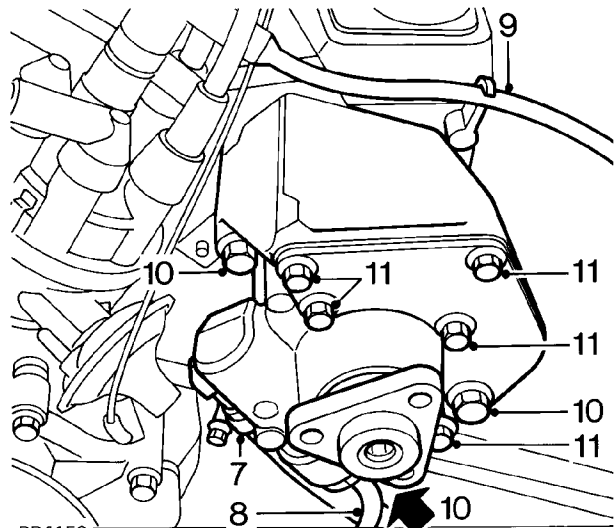



7. Loosen clamp securing reservoir hose to steering pump; disconnect hose.
8. Disconnect high pressure pipe from steering pump.



CAUTION: Plug the connections.

9. Release ht lead from clip
10. Remove 3 bolts securing steering pump. Remove pump and recover engine lifting bracket.



NOTE: Do not carry out further dismantling if component is removed for access only.

11. Remove 5 bolts securing front mounting plate.
12. Fit front mounting plate to replacement steering pump. Tighten bolts to **9 Nm**.

Refit

13. Position steering pump and engine lifting plate, fit bolts. Tighten to **35 Nm**. Secure ht lead in clip.
14. Connect high pressure pipe to steering pump, tighten union to **20 Nm**.
15. Connect reservoir hose to steering pump. Tighten clamp to **3 Nm**.
16. Position pulley to pump, coat threads of bolts with Loctite 242.
17. Restrain pulley using a 9 mm Allen key, fit bolts. Tighten to **10 Nm**.
18. Fit drive belt. **See ENGINE, Repair, Drive Belt**
19. Fit fan blades and viscous coupling. **See COOLING SYSTEM, Repair, Viscous Coupling, Fan Blades, Pulley and Fan Cowl**
20. Fit undertray.
21. Reconnect battery negative lead.
22. Bleed power steering system. **See Power Steering System - Bleed**

POWER STEERING PUMP - Tdi

Service repair no - 57.20.14

Remove

1. Remove fan blades and viscous coupling. **See COOLING SYSTEM, Repair, Viscous Coupling, Fan Blades, Pulley and Fan Cowl**

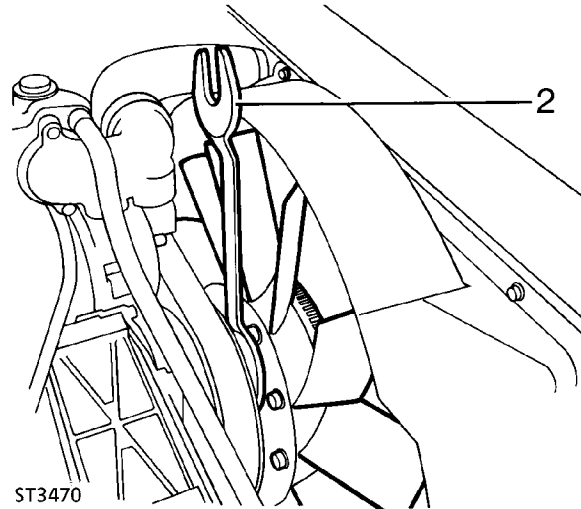

2. Restrain steering pump pulley, loosen but do not remove 3 bolts securing pulley.
3. Remove drive belt. **See ENGINE, Repair, Drive Belt**
4. Remove 3 bolts securing steering pump pulley, remove pulley.
5. Remove undertray.
6. Position drain tin beneath steering pump.

7. Loosen clamp securing reservoir hose to steering pump, disconnect hose.
8. Disconnect high pressure pipe from steering pump.



CAUTION: Plug the connections.

9. Remove 4 bolts securing steering pump to mounting bracket, remove pump.



NOTE: Do not carry out further dismantling if component is removed for access only.

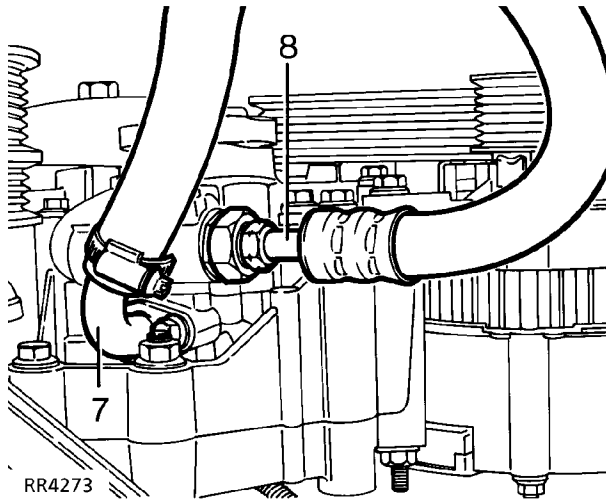

10. Remove 3 bolts securing mounting plate to pump, remove plate.
11. Fit mounting plate to replacement steering pump. Tighten bolts to **9 Nm**.

Refit

12. Position steering pump, fit 3 bolts. Tighten to **35 Nm**.
13. Connect high pressure pipe to steering pump. Tighten to **20 Nm**.
14. Connect reservoir hose to steering pump. Tighten clamp to **3 Nm**.
15. Position pulley to steering pump, coat threads of bolts with Loctite 242; fit but do not fully tighten 3 bolts.
16. Fit drive belt. **See ENGINE, Repair, Drive Belt.**
17. Restrain steering pump pulley, tighten bolts to **10 Nm**.
18. Fit fan blades and viscous coupling. **See COOLING SYSTEM, Repair, Viscous Coupling, Fan Blades, Pulley and Fan Cowl.**
19. Fit undertray.
20. Bleed power steering system. **See Power Steering System - Bleed.**



LOWER STEERING SHAFT AND UNIVERSAL JOINTS

Service repair no - 57.40.25



CAUTION: Before removing any parts of steering linkage, it is imperative that road wheels are positioned straight ahead.

Then steering wheel removed to prevent rotary coupler being wound up or damaged.



CAUTION: After refitting steering linkage parts follow correct procedure to ensure that road wheels, steering box and steering wheel are correctly positioned relative to each other when in straight ahead condition. If steering wheel requires repositioning, ensure that drive pegs on rotary coupler are correctly positioned before steering wheel is replaced.

This ensures drive pegs locate in their holes in rear of steering wheel.

After final alignment connect rotary coupler, tighten steering wheel securing nut and fit air bag module - if fitted or steering wheel trim pad.

Remove

1. Ensure road wheels are straight ahead.
2. Remove pinch bolt securing top universal joint to steering column.
3. Remove 2 pinch bolts securing lower universal joint.
4. Move lower shaft up to release lower universal joint from steering box splines. Remove lower shaft.
5. Remove universal joint from lower shaft.



NOTE: Do not dismantle upper coupling joint. Steering shaft, rubber coupling and top universal joint is only available as an assembly.

6. Inspect lower universal joint for wear and excessive play, renew if necessary.
7. Inspect top universal joint and rubber coupling, renew lower shaft as an assembly if necessary.
8. Inspect universal joints for stiffness, lubricate if necessary.



NOTE: Prior to fitting a replacement steering shaft check the following:

9. Release stud fasteners securing heat shield (if fitted).

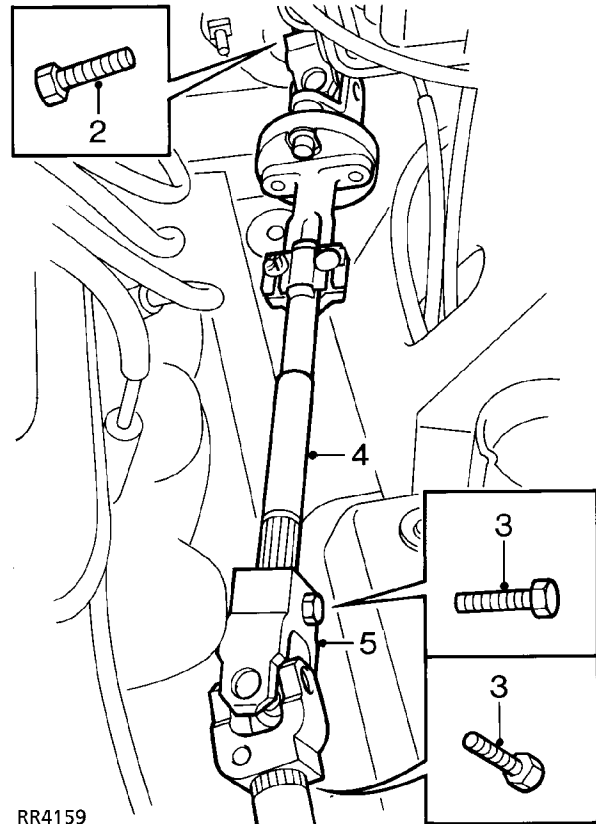

10. Check that indicator clip coloured red is fully inserted under head of compression joint bolt.



WARNING: If clip is displaced, no attempt must be made to drive clip into engagement, a new shaft assembly must be fitted.

11. Secure heat shield stud fasteners (if fitted).

Refit



NOTE: Fit universal joints so pinch bolt holes line up with flat on shaft.

12. Position lower universal joint on shaft.
13. Position shaft assembly onto steering column. Move assembly up spline to enable lower universal joint to fit onto steering box splines.
14. Align bolt holes with grooves in splines. Fit pinch bolts. Tighten to **25 Nm**.

STEERING COLUMN SHROUD

Service repair no - 57.40.29

Remove

1. Disconnect battery negative lead.

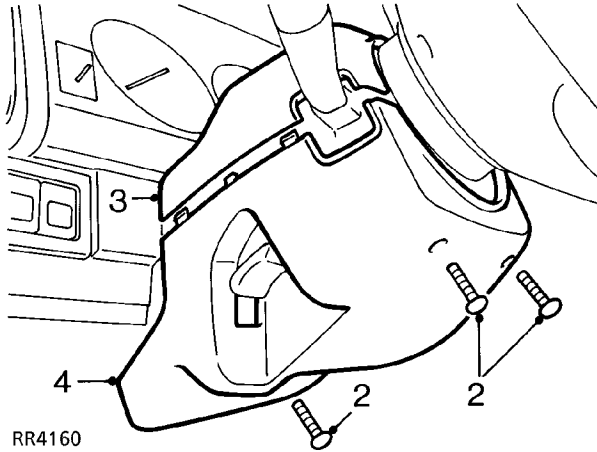

2. Remove 3 screws securing shroud.
3. Carefully release upper shroud from lower.
4. Manoeuvre lower shroud clear of steering column.

Refit

5. Position upper and lower shrouds to steering column ensuring plastic tags on lower shroud are correctly located. Clip both halves of shroud together.
6. Fit and tighten 3 screws.

STEERING WHEEL

Service repair no - 57.60.01



CAUTION: Prior to commencing work on vehicles fitted with an air bag, See **SUPPLEMENTARY RESTRAINT SYSTEM, Description and operation,**



CAUTION: Before removing any parts of steering linkage, it is imperative that road wheels are positioned straight ahead. Then remove steering wheel to prevent rotary coupler being wound up or damaged.



CAUTION: After refitting steering linkage parts follow correct procedure to ensure that road wheels, steering box and steering wheel are correctly positioned relative to each other when in straight ahead condition. If steering wheel requires repositioning, ensure that drive pegs on rotary coupler are correctly positioned before steering wheel is replaced.

This ensures drive pegs locate in their holes in rear of steering wheel.

After final alignment connect rotary coupler multiplug, tighten steering wheel securing nut and fit air bag - if fitted or steering wheel trim pad.



Remove

1. Disconnect battery negative lead.
2. Position road wheels straight ahead so steering wheel can be correctly re-assembled.
3. **Airbag fitted:** Remove air bag. *See SUPPLEMENTARY RESTRAINT SYSTEM, Repair, Driver's Airbag Module*
4. Remove trim pad from steering wheel, disconnect Lucars from horn button.

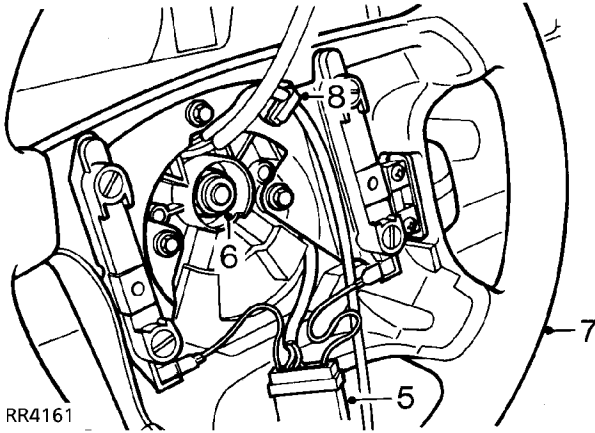

5. Disconnect rotary coupler multiplug.
6. Loosen but do not remove retaining nut.
7. Release steering wheel from taper, remove retaining nut and washer.
8. Release harness from retaining clip.
9. Withdraw steering wheel whilst at the same time feeding harness through wheel hub.



CAUTION: Prevent rotation of rotary coupler once steering wheel is removed. Secure in position with adhesive tape.



NOTE: Do not carry out further dismantling if component is removed for access only.

Refit

10. Recheck road wheels are positioned straight ahead.
11. Position steering wheel to column, feed harness through wheel hub.
12. Remove adhesive tape securing rotary coupler.
13. Locate rotary coupler drive pegs and indicator switch self-cancel pegs in steering wheel hub, push wheel fully onto taper.
14. Fit steering wheel nut. Tighten to **50 Nm**.
15. Connect rotary coupler multiplug.
16. Non airbag module: Fit horn push assembly, connect Lucars to horn button, secure harness in clip.
17. Fit airbag module - if fitted. *See SUPPLEMENTARY RESTRAINT SYSTEM, Repair, Driver's Airbag Module*
18. Reconnect battery negative lead.

UPPER STEERING COLUMN

Service repair no - 57.40.01



NOTE: Steering column assembly is not a serviceable component.



CAUTION: Before removing any parts of steering linkage, it is imperative that road wheels are positioned straight ahead. then steering wheel removed to prevent rotary coupler being wound up or damaged.



CAUTION: After refitting steering linkage parts follow correct procedure to ensure that road wheels, steering box and steering wheel are correctly positioned relative to each other when in straight ahead condition. if steering wheel requires repositioning, ensure that drive pegs on rotary coupler are correctly positioned before steering wheel is replaced.

This ensures drive pegs locate in their holes in rear of steering wheel.

After final alignment, connect rotary coupler multiplug, tighten steering wheel securing nut and fit airbag - if fitted or steering wheel trim pad and horn push assembly.

Remove

1. Remove steering wheel. *See Steering Wheel*



CAUTION: Prevent rotation of rotary coupler once steering wheel is removed. Secure in position with adhesive tape.

2. Remove driver's access panel.
3. Remove steering column shroud. *See Steering Column Shroud*
4. Remove rotary coupler. *See SUPPLEMENTARY RESTRAINT SYSTEM, Repair, Rotary Coupler*

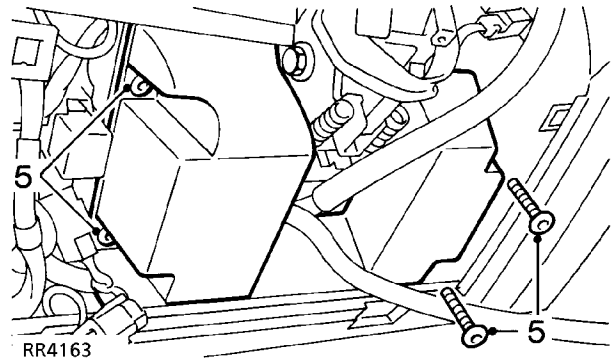

5. If fitted - remove 4 screws securing knee bolster, remove knee bolster.

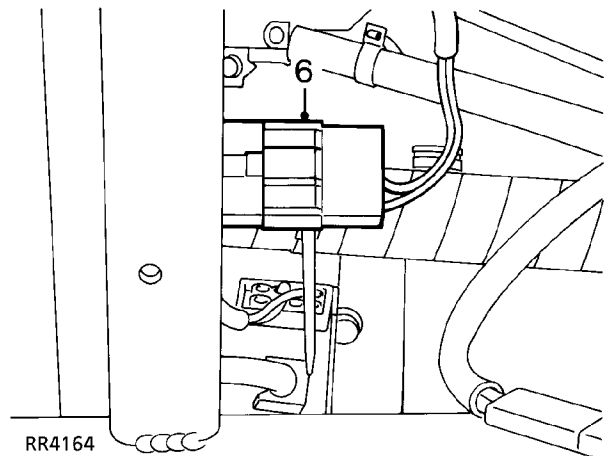

6. Disconnect column switch multiplug.

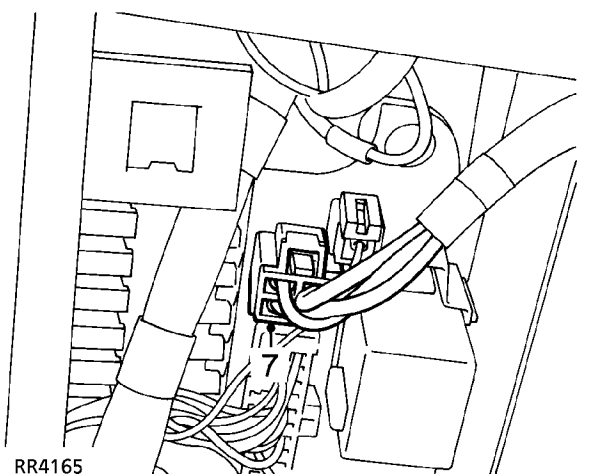

7. Disconnect ignition switch multiplug from fuse box.

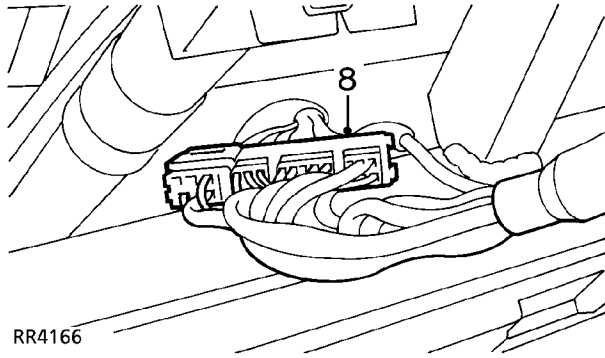

RR4166

8. Disconnect ignition switch main feed multiplug.

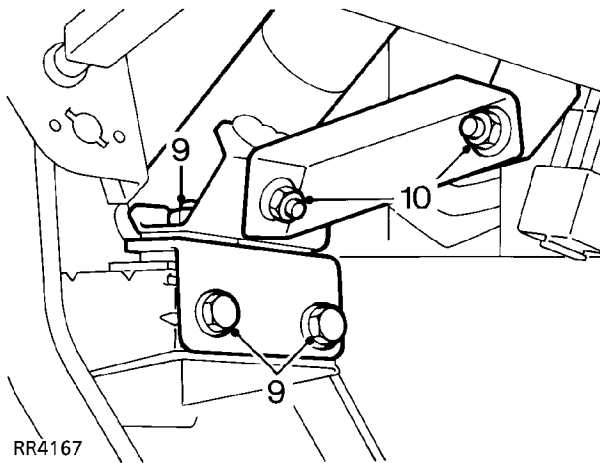

RR4167

- 9. Remove 4 nuts securing upper column to lower mounting.
- 10. Remove 2 nuts securing lower mounting steady bracket, remove bracket.
- 11. Remove pinch bolt securing upper column to universal joint.

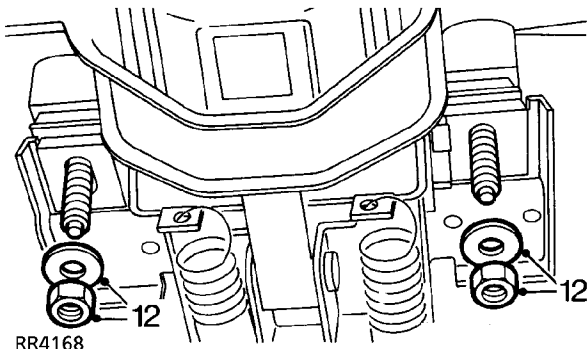

RR4168

12. Remove 2 nuts and washes securing upper column to upper mounting bracket.

13. Carefully manoeuvre upper column out of footwell, recover rubber boot.



NOTE: Do not carry out further dismantling if upper column is removed for access only.

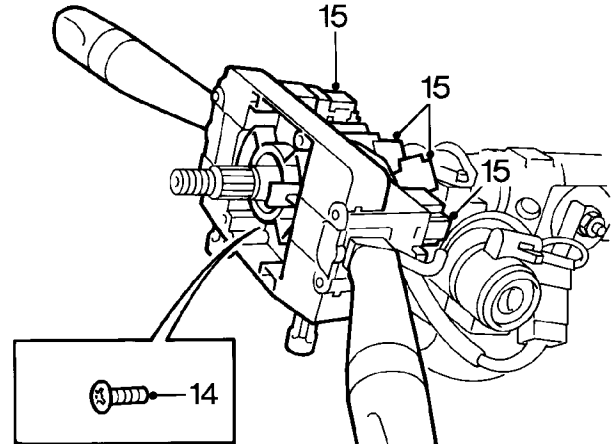

RR4169

- 14. Loosen but, do not remove screw securing column switch assembly, withdraw assembly to gain access to multiplugs.
- 15. Disconnect column switch multiplugs, remove column switch assembly.

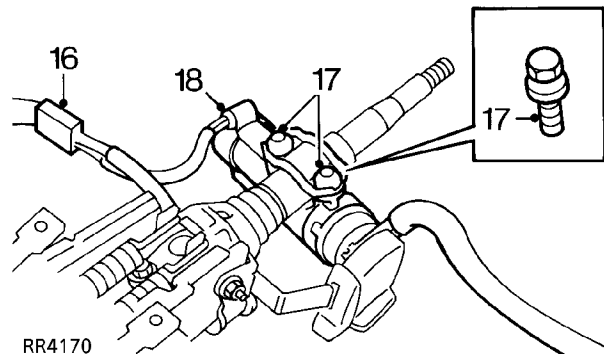

RR4170

- 16. Disconnect ignition switch multiplug.
- 17. Remove shear bolts securing steering column lock, remove lock and saddle; discard shear bolts.
- 18. Withdraw bulb holder from column lock shroud.
- 19. Transfer components to new upper column, connect multiplug.



NOTE: Do not shear column lock bolts at this stage.

Refit

20. Manoeuvre upper column to position in footwell, ensure splines in column and universal joint are correctly engaged and rubber boot is fitted.
21. Fit but do not tighten universal joint pinch bolt.
22. Position upper column to upper mounting, fit washers and nuts, do not tighten nuts.
23. Fit but do not tighten nuts and bolts securing upper column to lower mounting.
24. Fit lower mounting steady bracket, fit but do not tighten nuts and bolts.
25. Ensure upper column is aligned to mountings.
26. Tighten all nuts and bolts to **22 Nm**.
27. Tighten universal joint pinch bolt to **25 Nm**.
28. Connect column switch multiplug.
29. Connect ignition switch multiplugs.
30. Fit rotary coupler. **See SUPPLEMENTARY RESTRAINT SYSTEM, Repair, Rotary Coupler**
31. Fit steering wheel. **See Steering Wheel**
32. Reconnect battery negative lead.
33. Check steering column lock for correct operation, tighten shear bolts until heads shear off.
34. If fitted - position knee bolster, fit and tighten screws.
35. Fit steering column shroud. **See Steering Column Shroud**
36. Fit driver's access panel.



STEERING COLUMN LOCK ASSEMBLY

Service repair no - 57.40.31

Remove



CAUTION: Before removing any parts of steering linkage, it is imperative that road wheels are positioned straight ahead.

Then steering wheel removed to prevent rotary coupler being wound up or damaged.



CAUTION: After refitting steering linkage parts follow correct procedure to ensure that road wheels, steering box and steering wheel are correctly positioned relative to each other when in straight ahead condition. If steering wheel requires repositioning, ensure that drive pegs on rotary coupler are correctly positioned before steering wheel is replaced.

This ensures drive pegs locate in their holes in rear of steering wheel.

After final alignment connect rotary coupler multiplug, tighten steering wheel securing nut and fit airbag module - if fitted.

1. Disconnect battery negative lead.
2. Remove steering column shroud. **See Steering Column Shroud**
3. Release turnbuckles, lower driver's access panel.
4. If fitted, remove 4 screws securing knee pad, remove bolster.

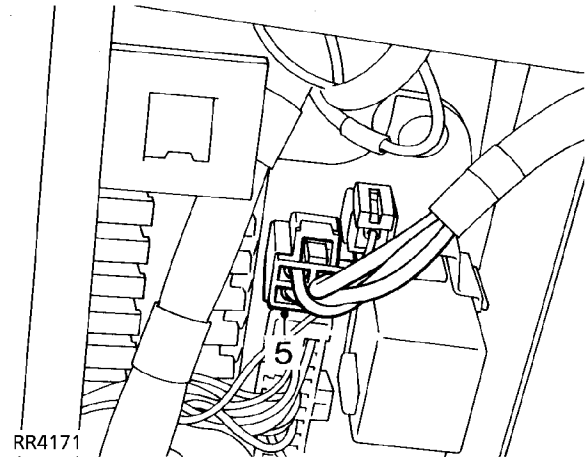

RR4171

5. Disconnect ignition switch multiplug from fuse box.

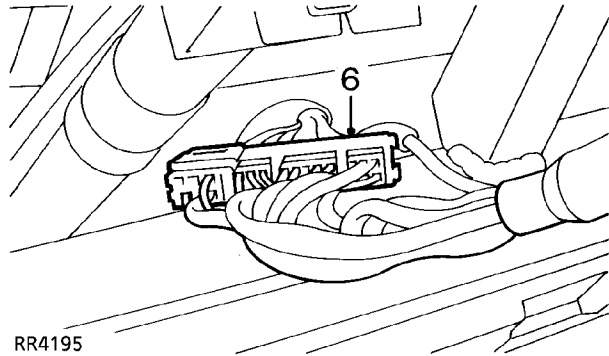

RR4195

6. Disconnect ignition switch main feed multiplug.

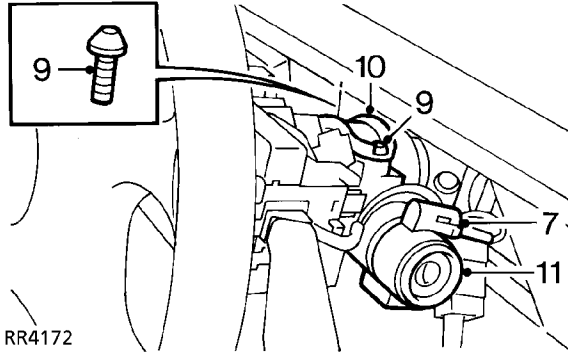

RR4172

7. Remove bulb holder from steering column lock shroud.
8. Tap head of shear bolts anti-clockwise to release them.
9. Remove and discard shear bolts.
10. Detach saddle.
11. Remove steering column lock assembly.

Refit

12. Position steering lock saddle on column, locating spigot in hole provided.
13. Place lower lock assembly into column.
14. Fit but do not fully tighten new shear bolts.
15. Connect multiplugs.
16. Insert bulb holder into steering column lock shroud.
17. Reconnect battery negative lead.
18. Check steering column lock for correct operation, tighten shear bolts until heads shear off.
19. Fit steering column shroud. **See Steering Column Shroud**
20. If fitted - fit knee bolster, fit and tighten screws.
21. Raise driver's access panel, secure turnbuckles.

DROP ARM

Service repair no - 57.50.14

Remove

1. Place vehicle on a hoist, or support front axle on axle stands.

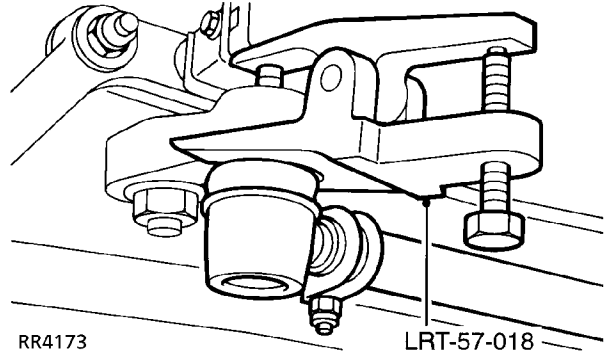

RR4173

LRT-57-018

2. Disconnect drag link ball joint from drop arm, using extractor LRT-57-018.



3. Bend back tabs on locking washer and remove drop arm using extractor LRT-57-012. Loosen drop arm securing nut, but do not remove before using extractor.
4. Remove nut, discard locking washer.

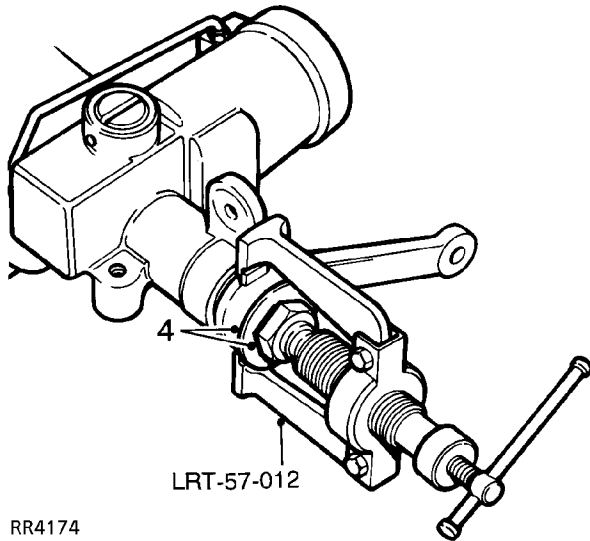

Refit

5. Centralise steering box. **See Adjustment, Centralise Steering Box**
6. Fit drop arm, align master splines.
7. Fit a new tab washer and drop arm fixing nut. Tighten to **176 Nm**, bend over tab.
8. Fit drag link. Tighten ball joint nut **40 Nm**.

STEERING DAMPER

Service repair no - 57.55.21

Remove

1. Site vehicle on a ramp [hoist].
2. Remove fixings at differential case bracket.
3. Remove fixings at track rod bracket.
4. Remove steering damper.

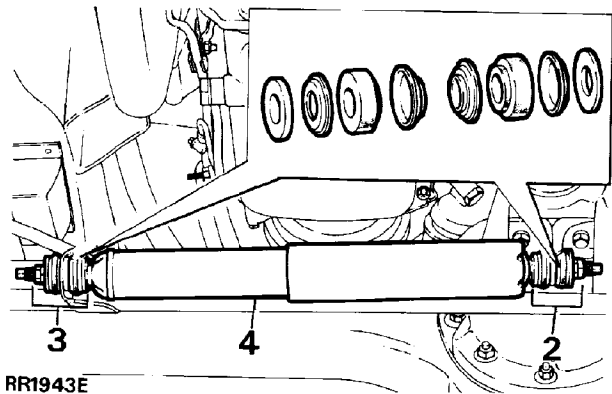

Refit

5. Reverse removal procedure. 1 to 4.

TRACK ROD AND LINKAGE

Service repair no - 57.55.09

Remove track rod

1. Site vehicle on a ramp [hoist].

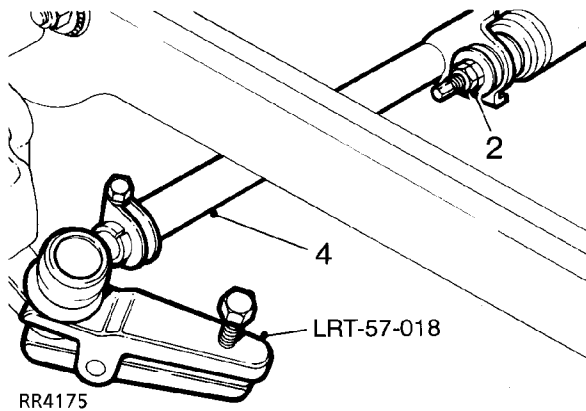

2. Disconnect steering damper at track rod.
3. Disconnect track rod at ball joints, using extractor LRT-57-018.
4. Remove track rod.

Remove linkage

5. Loosen clamp bolts.
6. Unscrew ball joints.
7. Unscrew track rod adjuster. (left hand thread).

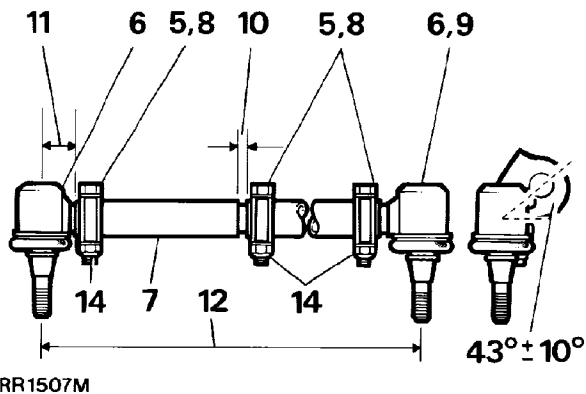

Refit linkage

8. Fit replacement parts. Loosely fit clamp pinch bolts.
9. Screw in ball joint to full extent of threads.
10. Set adjuster to track rod distance to 9mm as shown.
11. Set adjuster end ball joint distance to 28.5mm as shown.
12. Track rod effective length of 1230.0mm is subject to adjustment during wheel alignment check.

Refit track rod



CAUTION: Fit a new track rod if existing is damaged or bent. No attempt should be made to repair it.

13. Fit track rod and tighten ball joint nuts to **40 Nm**.
14. Check front wheel alignment. **See Adjustment, Front Wheel Alignment**
15. Connect steering damper to track rod.
16. Remove vehicle from hoist, or axle stands.



DRAG LINK AND DRAG LINK ENDS

Service repair no - 57.55.17

Remove drag link

1. Check front wheel alignment. **See Adjustment, Front Wheel Alignment**
2. Ensure wheels are positioned straight ahead during following procedure.
3. Place vehicle on a hoist, or support front axle on axle stands.
4. Remove right front road wheel.

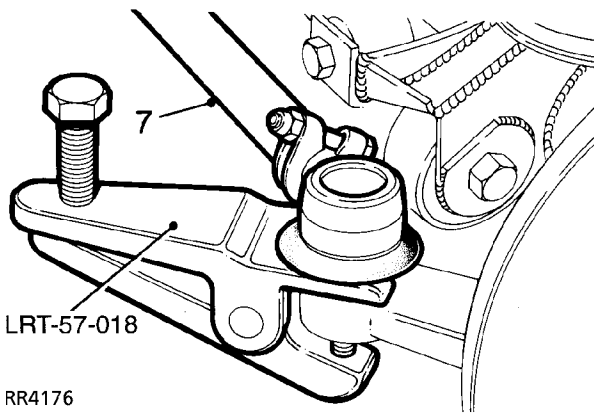

5. Disconnect drag link ball joint at swivel housing arm, using extractor LRT-57-018.
6. Disconnect drag link ball joint at drop arm using LRT-57-018.
7. Remove drag link.

Remove drag link ends

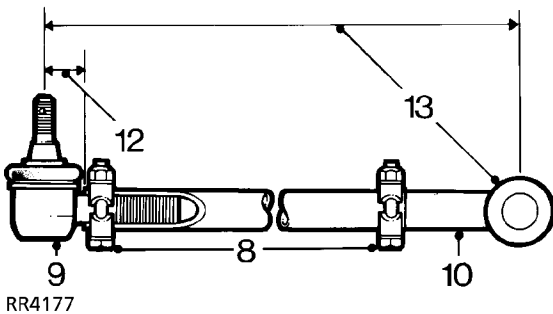

8. Loosen clamp bolts.
9. Unscrew ball joints.
10. Clean internal threads in drag link.

Refit drag link ends

11. Fit replacement ends. Loosely fit clamp bolts.
12. Set ball joints to drag link distance to 28.5mm as shown.
13. Adjust ball pin centres to nominal length of 924.0mm. this length is adjusted during refit.
14. Centralise steering box. **See Adjustment, Centralise Steering Box**
15. Align steering wheel, if necessary. **See Steering Wheel**

Refit drag link



CAUTION: Fit new drag link if existing drag link is damaged or bent. No attempt should be made to repair it.

16. Fit drag link. Tighten ball-joint nuts to **40 Nm**.
17. Check steering lock stops. **See Adjustment, Steering Lock Stops**
18. Ensure full steering travel is obtained between lock stops. Adjust drag link length to suit.
19. Tap ball joints in direction shown, so both pins are in same angular plane.
20. Tighten clamp bolts to **14 Nm**.

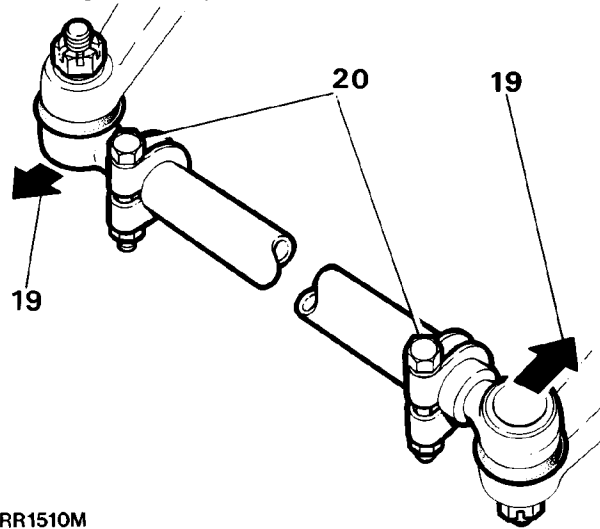

21. Reverse removal procedure. 3 and 4.
22. Road test vehicle.
23. If driving straight ahead and steering wheel is offset by 0° to ± 5° in either direction. Remedy by adjusting drag link length.



WARNING: To correct steering wheel deviations greater than ± 5°. Remove and reposition steering wheel. See Steering Wheel.



POWER STEERING BOX

Service repair no - 57.10.07

Overhaul



NOTE: Overhaul of steering box should not be carried out during the warranty period.



WARNING: Wear safety glasses while removing and refitting circlips and retaining ring.



CAUTION: Absolute cleanliness is essential when overhauling power steering box.

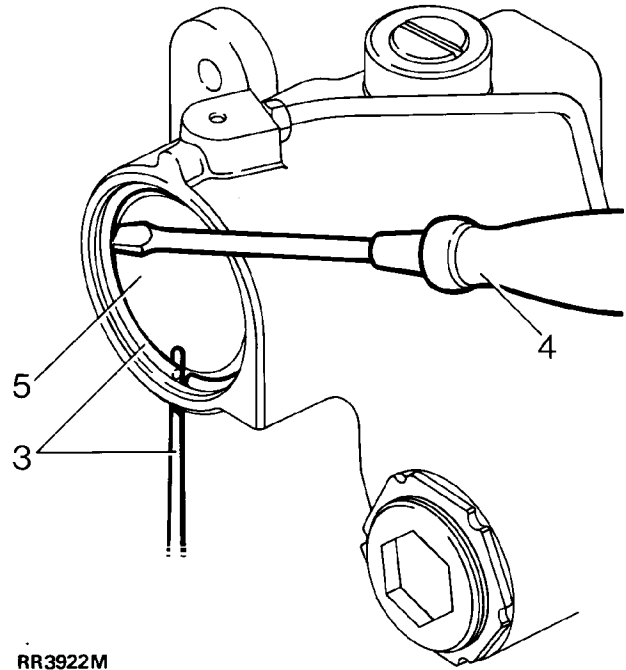
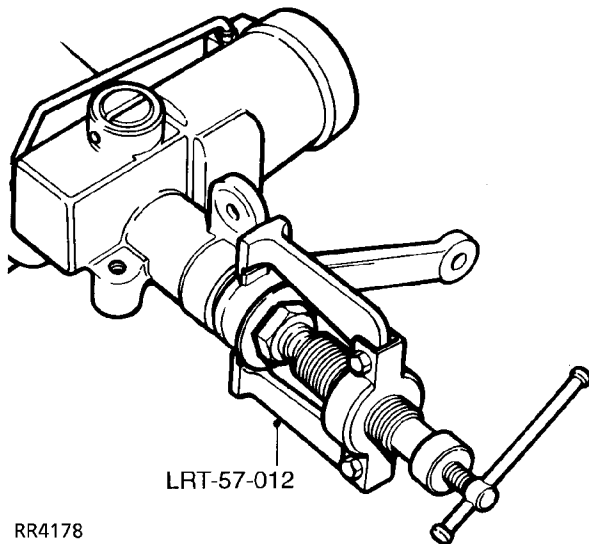

5. Turn input shaft (left lock on left hand drive, right lock on right hand drive) until piston pushes out cover. Turn input shaft fully in opposite direction, applying pressure to piston.
6. Remove set screw retaining rack pad adjuster.
7. Remove rack adjuster and pad.
8. Remove sector shaft adjuster locknut.
9. Remove four bolts from sector shaft cover.
10. Screw in sector shaft adjuster until cover is removed.



NOTE: Sealant is applied to hexagon socket to 'tamperproof' sector shaft adjuster

11. Slide out sector shaft.

1. Remove steering box from vehicle. **See Repair, Power Steering Box**
Remove drop arm using extractor LRT-57-012. Loosen drop arm securing nut, but do not remove before using extractor. Remove dirt excluder from output shaft.
2. Drain oil, remove blanking plugs and bleed screw. Hold steering box over suitable container, turn input shaft from lock to lock, until oil is drained. Refit bleed screw.
3. Rotate retainer ring until one end is 12 mm from extractor hole. Using a drift through hole in cylinder, lift retaining ring from groove in cylinder bore.
4. Remove retainer ring, using a screwdriver.

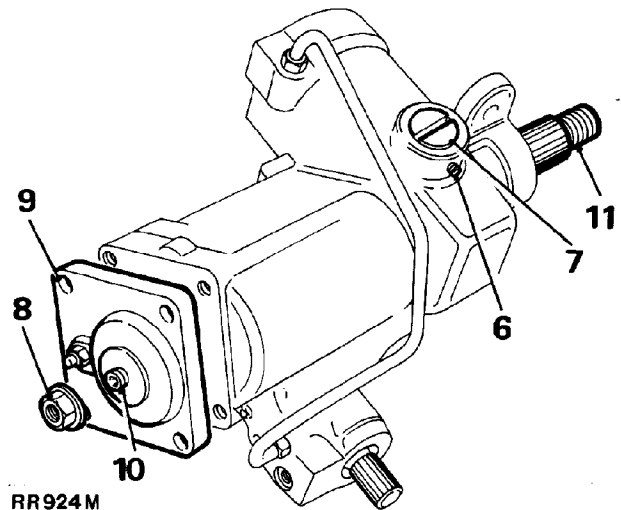

12. Remove piston, a bolt screwed into piston will assist removal.
13. Remove input shaft dirt excluder.

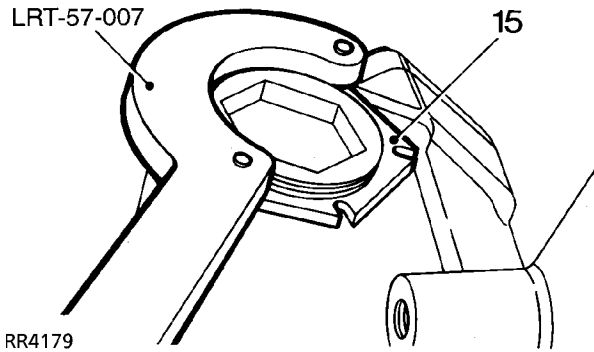

14. Remove worm adjuster locknut using 'C' wrench LRT-57-007.
15. Remove worm adjuster using wrench LRT-57-006.
16. Tap splined end of shaft to free bearing.
17. Remove bearing cup and caged ball bearing assembly.
18. Remove valve and worm assembly.
19. Remove inner bearing cage, cup and shim washers. Retain shims for reassembly.

NOTE: Should difficulty be experienced warm casing and bearing assembly. Cool bearing cup using a mandrel and tap steering box on a bench.

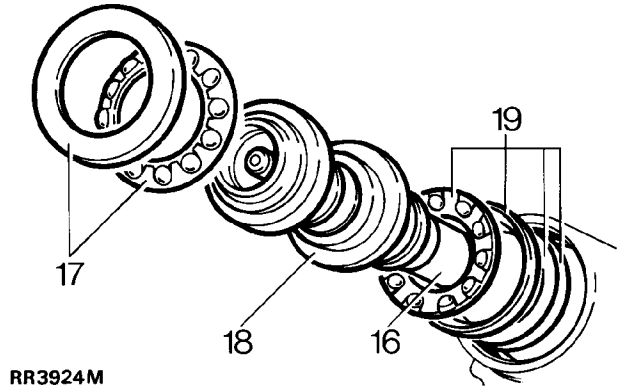

Steering box seals

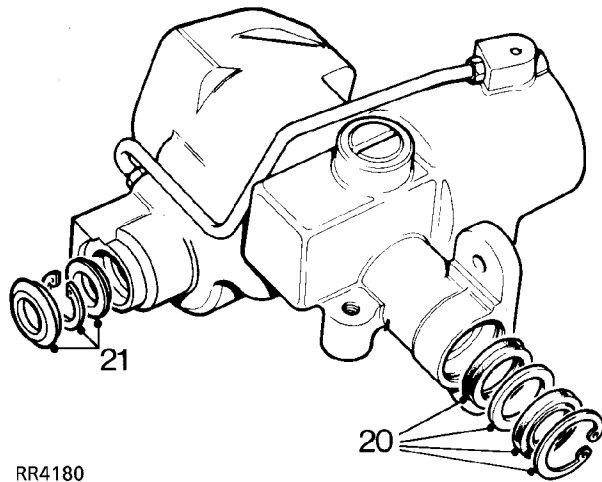

20. Remove circlip and seal from sector shaft housing bore.



CAUTION: Do not remove sector shaft bearings from casing. Replacement parts are not available. If sector shaft bearings are worn fit a new steering box.

21. Remove dirt excluder, circlip and seal from input shaft housing bore.



CAUTION: The use of a seal puller is recommended to prevent damage to casing, and possible oil leaks.

INSPECTING

Piston

22. Discard all rubber seals and provide replacements.



NOTE: A rubber seal is fitted behind plastic ring on rack piston. Discard seal and plastic ring.

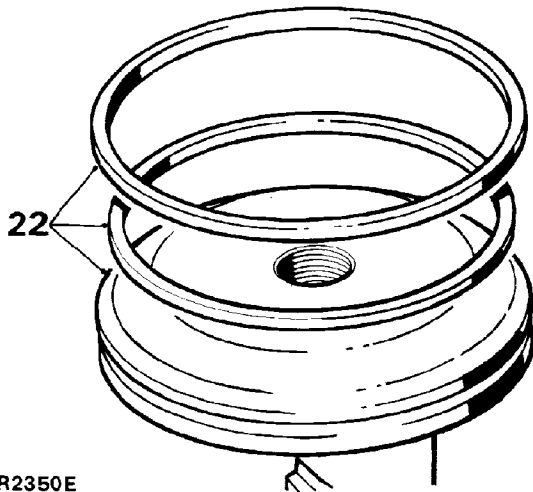

RR2350E

Steering box casing

23. Examine piston bore for scoring and wear.
24. Examine feed tube.
25. Fit a new feed tube if damaged. Tighten to **22 Nm**.

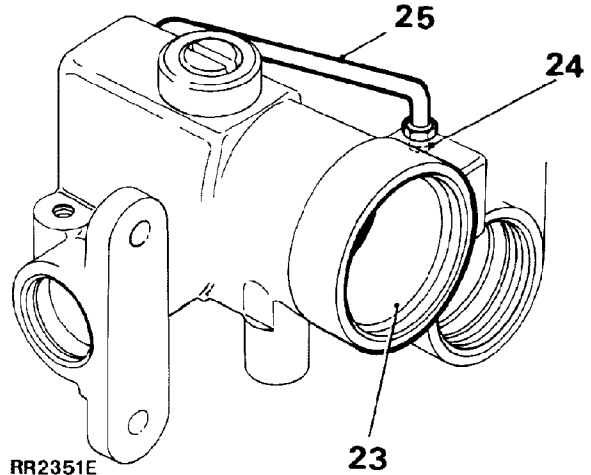

RR2351E

Sector shaft assembly

26. Check there is no side play on roller.
27. If side play on roller exists fit a new sector shaft.
28. Check condition of adjuster screw threads. Check adjuster end float. Fit new adjuster if end float exceeds 0.15 mm.
29. Examine bearing areas on shaft for excessive wear.
30. Examine gear teeth for uneven or excessive wear.

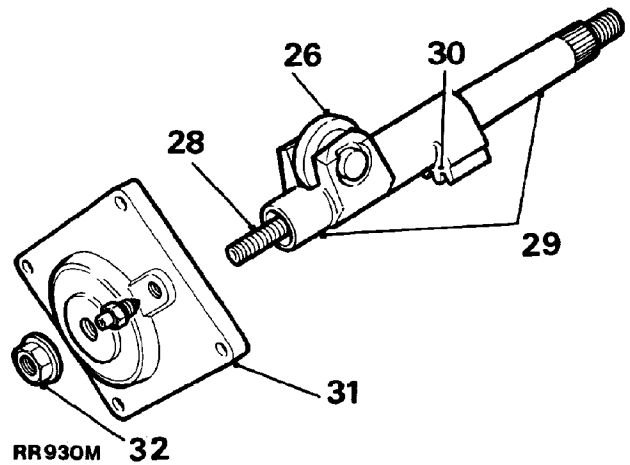

RR930M 32

Sector shaft cover assembly

31. Inspect cover and bearing. If worn or damaged, replacement parts are not available, fit a new steering box.

Sector shaft adjuster locknut

32. The locknut is also a fluid seal. Fit new nut at overhaul.

Valve and worm assembly

33. Examine bearing areas for wear. The areas must be smooth and not indented.
34. Examine worm track which must be smooth and not indented.

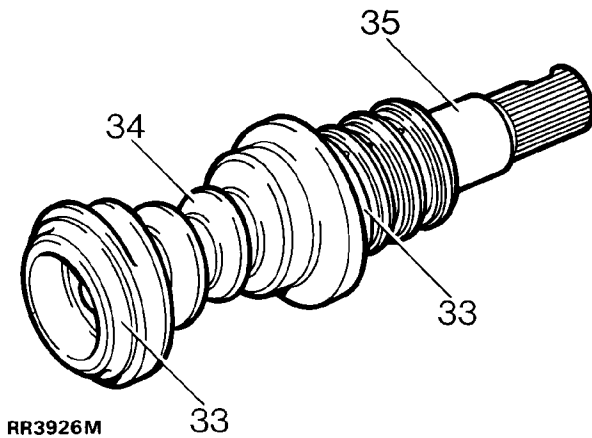

35. Check for wear on torsion bar assembly pin. No free movement should exist between input shaft and torsion bar or between torsion bar and worm.



NOTE: Any sign of wear makes it essential to fit new valve and worm assembly.

36. Examine valve rings for cuts, scratches and grooves. The valve rings should be free to rotate in grooves.

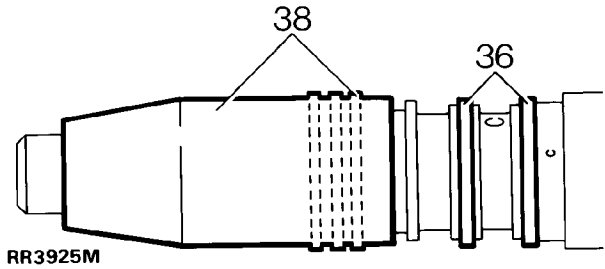

37. If required, replace all three rings, using ring expander LRT-57-019. The expander will not pass over rings already fitted. Remove rings to allow access without damaging seal grooves.
38. Warm rings and expander tool to aid assembly. Fit rings to expander, slide expander over valve and worm assembly. In turn fit rings to their grooves. Remove expander, slide valve and worm assembly into ring compressor LRT-57-020 and allow to cool.

Ball bearing and cage assemblies

39. Examine ball races and cups for wear and general condition.
40. If ball cage has worn against bearing cup, fit replacements.
41. Bearing balls must be retained by cage.
42. Bearing and cage repair is carried out by complete replacement of assembly.

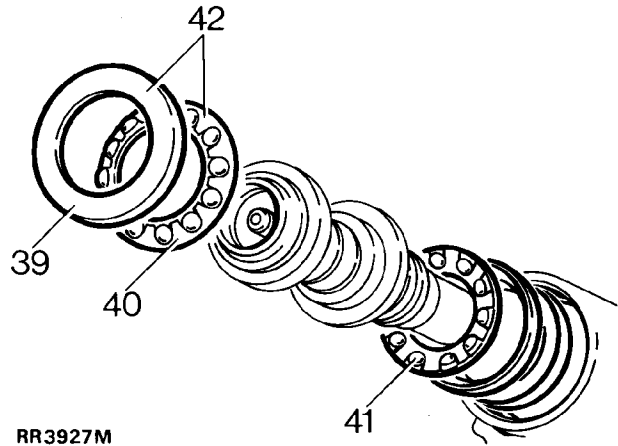



Rack thrust pad and adjuster

43. Examine thrust pad for scores.
44. Examine adjuster for wear in pad seat.
45. Fit new sealing ring to rack adjuster.

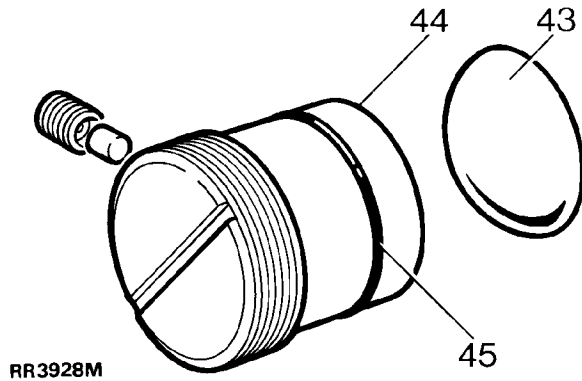

Rack and piston

46. Examine for excessive wear on rack teeth.
47. Ensure thrust pad bearing surface is free from scores and wear.
48. Ensure piston outer diameters are free from burrs and damage.

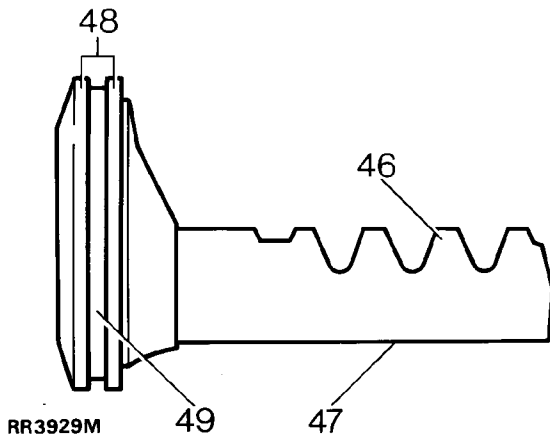

49. Examine seal and ring groove for scores and damage.
50. Fit new ring to piston. Warm nylon seal and fit to piston.
51. Slide piston assembly into cylinder with rack tube outwards.

Reassemble



NOTE: When fitting replacement oil seals lubricate with recommended fluid and ensure absolute cleanliness.

Sector shaft oil seal

52. Fit oil seal, lip side first.
53. Fit extrusion washer.
54. Fit dust seal, lipped side last.
55. Fit circlip.

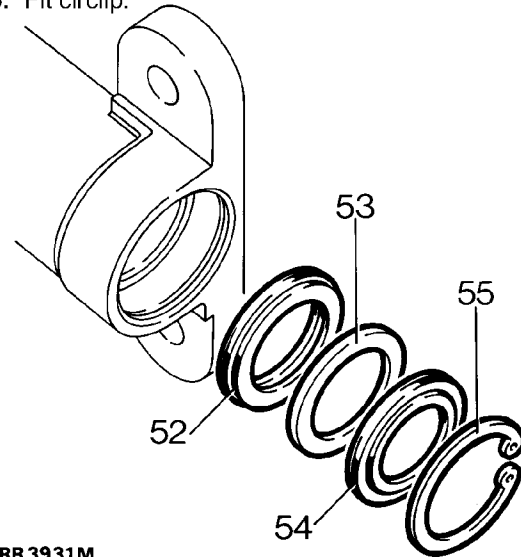

Fitting valve and worm assembly

56. Refit original shims and inner bearing cup. Use Petroleum Jelly to aid assembly.



NOTE: If original shims are not used, fit shims of 0.76 mm thickness.

57. Fit inner cage and bearings assembly.
58. Fit valve and worm assembly.
59. Fit outer cage and bearings assembly.
60. Fit outer bearing cup.

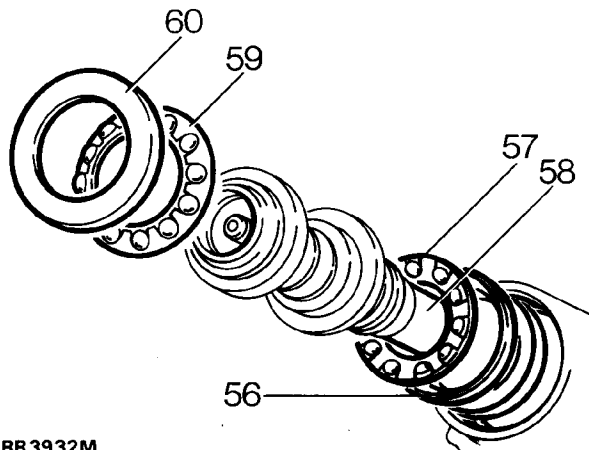

RR3932M

61. Fit new worm adjuster sealing ring.

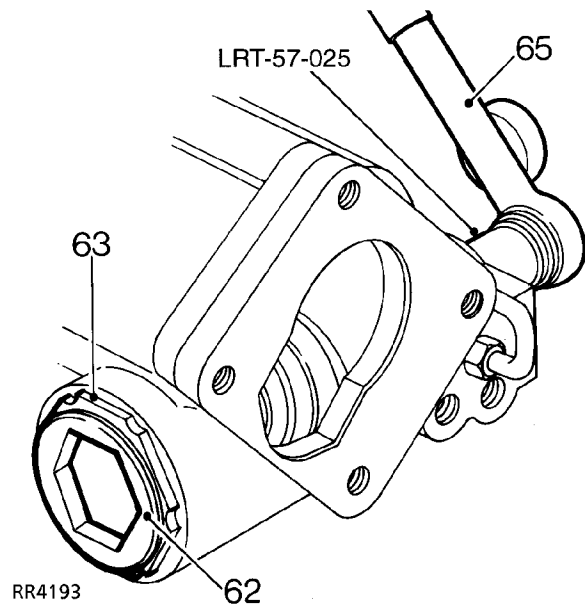

62. Loosely screw adjuster into casing.
 63. Fit locknut, do not tighten.
 64. Turn in worm adjuster until end float is almost eliminated. Ensure bearing cages are seated correctly.
 65. Measure maximum rolling torque of valve and worm assembly, using a torque wrench and spline socket LRT-57-025.
 66. Turn in worm adjuster while rotating shaft to increase figure measured in instruction 65. to 0.56 Nm.
 67. Back off worm adjuster 1/4 turn. Turn in worm adjuster to increase reading at 65. by 0.21 - 0.34 Nm with locknut tight, **100 Nm**. Use worm adjusting wrench LRT-57-006 and locknut wrench LRT-57-028.

Fitting rack and piston

68. Screw slave bolt into piston to aid assembly.
 69. Fit piston and rack so piston is 70 mm from outer end of bore.

Fitting sector shaft

70. Fit sector shaft using seal saver LRT-57-021. Align roller with cut out in casing - see RR3934M. Push in sector shaft while rotating input shaft to allow sector roller to engage worm.

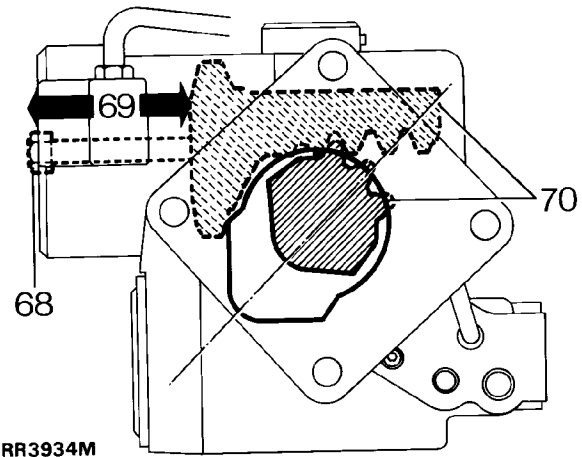

RR3934M

Fitting rack adjuster

71. Fit rack adjuster and thrust pad to engage rack. Back off half turn on adjuster.
 72. Loosely fit new nylon pad and adjuster set screw assembly.

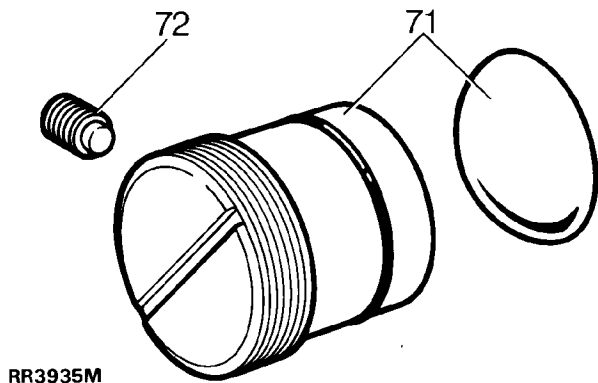

RR3935M



Fitting sector shaft cover

73. Fit new sealing ring to cover.
74. Align cover with casing.
75. Screw cover assembly fully on to sector shaft adjuster screw.
76. If necessary back off sector shaft adjuster screw. Tap cover in place to allow cover to joint fully with casing.

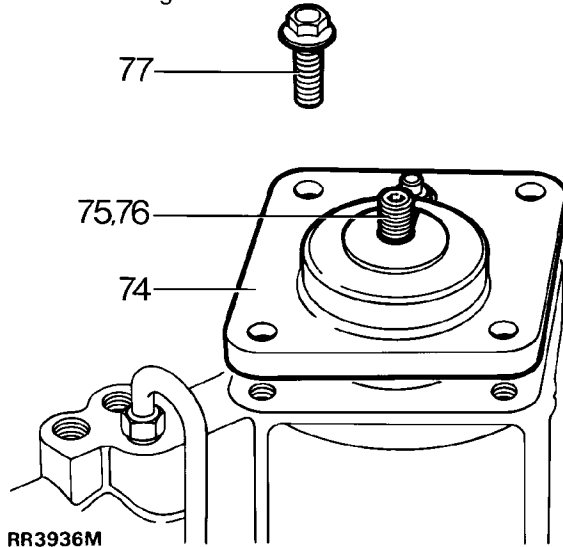

NOTE: Before tightening fixings, rotate input shaft to ensure sector shaft roller is free to move in valve worm. If initial resistance is left, turn adjuster screw approximately two turns in a clockwise direction.

77. Fit cover bolts. Tighten to **75 Nm**.

Fitting cylinder cover

78. Fit new square section seal to cover.
79. Remove slave bolt fitted at instruction 68. Press cover into cylinder just to clear retainer ring groove.
80. Fit retaining ring to groove with one end of ring positioned 12 mm from extractor hole.

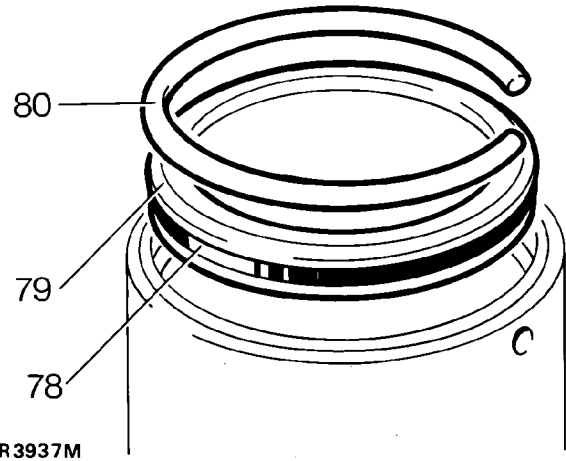

Adjusting sector shaft



NOTE: Refit drop arm and tighten nut sufficiently to ensure that no backlash exists between drop arm and sector shaft.

81. To set worm on centre, rotate input shaft to full inner-lock (full right lock for a left hand drive vehicle, full left lock for a right hand drive vehicle). Rotate input shaft back towards centre two full turns.
82. The box is now on centre and can be adjusted.

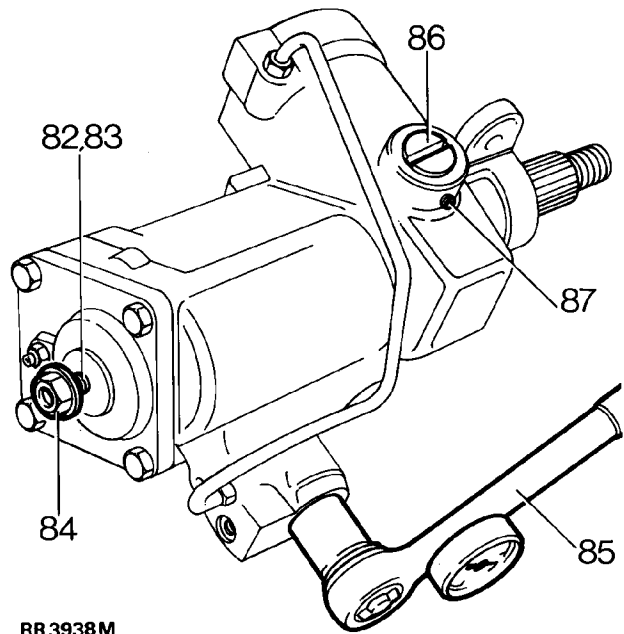

83. Hold input shaft and rock drop arm to establish backlash is present. Continue rocking and slowly turn sector shaft adjusting screw clockwise. Continue rotating adjuster screw until backlash has almost been eliminated.
84. Refit locknut and tighten.



NOTE: It is important steering box is centralised before any adjustments are made.

85. Check maximum rolling torque one and a quarter turns either side of centre position, using a torque wrench and spline socket LRT-57-025. Rotate adjuster screw to obtain across centre torque of 0.34 Nm plus torque figure at one and a quarter turns. Tighten adjuster locknut to **60 Nm**.

Adjusting rack adjuster.

86. Turn in rack adjuster to increase figure measured in instruction 85. by 0.23 - 0.34 Nm. **The final figure may be less, but must not exceed 1.35 Nm.**
87. Lock rack adjuster in position with grub screw. Tighten to **5 Nm**.

Torque peak check

With input shaft rotated from lock to lock, rolling torque figures should be greatest across centre position and equally disposed about centre position.

The condition depends on value of shimming fitted between valve and worm assembly inner bearing cup and casing. The original shim washer value will give correct torque peak position unless major components have been replaced.

Procedure

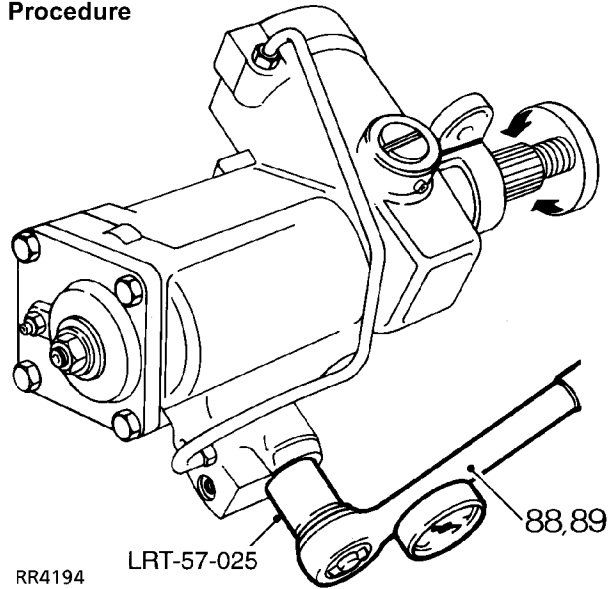

88. With input coupling shaft toward the operator, turn shaft fully counter-clockwise.
89. Check torque figures obtained from lock to lock using torque wrench and spline socket LRT-57-025.
90. Check also for equal engagement either side of centre.

Adjustments

91. Note where greatest figures are recorded relative to steering position. If greatest figures are not recorded across centre of travel (steering straight-ahead), adjust as follows:

If torque peak occurs **before** centre position, **add** to shim washer value; if torque peak occurs **after** centre position, **subtract** from shim washer value, **refer to fitting valve and worm assembly** .

Shim washers are available as follows:
0.03mm, 0.07mm, 0.12mm and 0.24mm.



NOTE: Adjustment of 0.07mm to shim value will move torque peak area by 1/4 turn on the shaft.



CAUTION: When reshimming valve and worm, extreme caution must be exercised to prevent seal damage during reassembly.



Input shaft oil seal

92. Fit seal, lip side first, into housing. Use seal saver LRT-57-016 and seal installer LRT-57-026. Note that seal is fitted to a depth of 4.75 - 5.00 mm from face of box.
93. Secure seal with circlip.
94. Smear inner lip of dirt excluder with PTFE grease. Fit dirt excluder using LRT-57-027. When fitted correctly outer shoulder of excluder is 4.00 - 4.50 mm from face of box, dimension X in RR3941M.

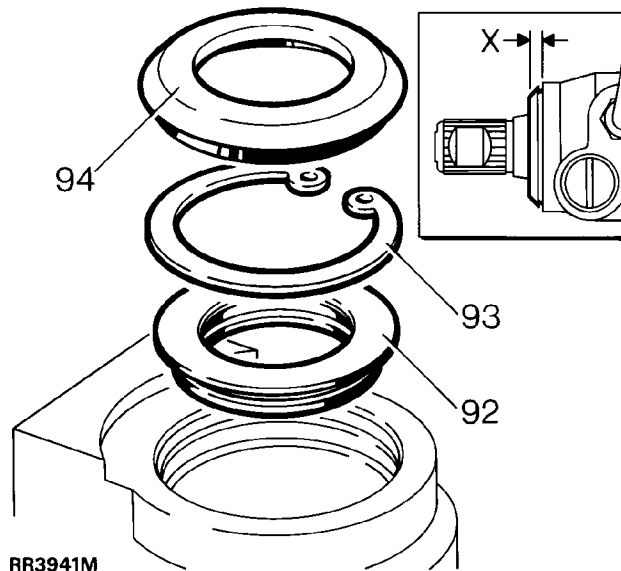

RR3941M

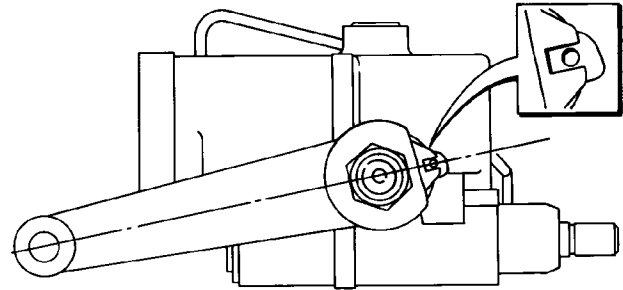

RR3940M

97. Fit steering box. *See Repair, Power Steering Box*

95. Remove drop arm. Smear inner lip of dirt excluder with PTFE grease and refit, ensuring outer lip is flush with casing.
96. With input shaft on centre, line up centralising holes in drop arm and steering box see inset in RR3940M. Fit drop arm to steering box using a new tab washer. Tighten to **176 Nm**, bend over tab.



STEERING PUMP

Make/type - V8i	ZF 'Unicorn'
Make/type - Tdi	Hobourn Eaton 500 series
Operating pressure - straight ahead position - at idle	7 bar, 100 lbf/in ² maximum
Full lock (left or right) at idle	28 bar, 400 lbf/in ² minimum
Full lock (left or right) 1000 rev/min	70-77 bar, 1000-1100 lbf/in ²

TORQUE VALUES



NOTE: Torque wrenches should be regularly checked for accuracy to ensure that all fixings are tightened to the correct torque.

	Nm
Ball joint nuts	40
Clamp bolt nuts	14
Steering column bracket nuts	22
Steering wheel nut	50
Tie bar to mounting nut	110
Universal joint pinch bolt	25
PAS box	
Adjuster locknut	60
Drop arm nut	176
Sector shaft cover to steering box	75
Steering box to chassis	81
Steering box fluid pipes 14mm thread	15
Steering box fluid pipes 16mm thread	20
Tie bar	81
PAS pump	
High pressure fluid pipe	20
Power steering pump mounting	35
Pulley bolts, power steering pump	10
Hose clamp	3
Front mounting plate bolts	9
PAS reservoir	
Hose clamp	3

* Torque values below are for all screws and bolts used except for those that are specified otherwise.

METRIC	Nm
M5	6
M6	9
M8	25
M10	45
M12	90
M14	105
M16	180
 UNC / UNF	
1/4	9
5/16	24
3/8	39
7/16	78
1/2	90
5/8	136



POWER STEERING BOX

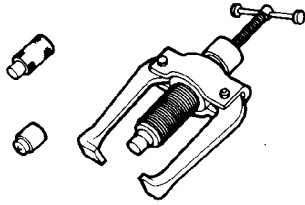

LRT-57-012 Drop arm extractor

MS252A

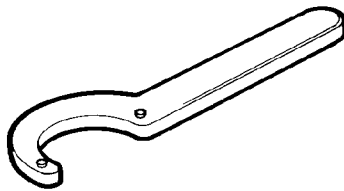

LRT-57-007 'C' Wrench

LST120

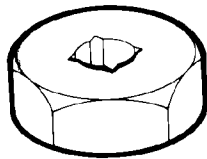

LRT-57-006 Worm adjusting wrench

LST119

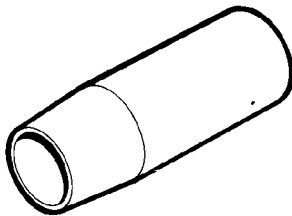

LRT-57-019 Ring expander

RO606602

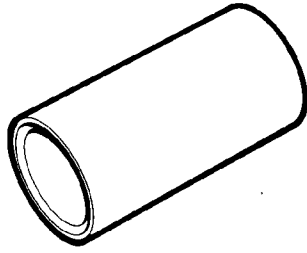

RO606603

LRT-57-020

Ring compressor

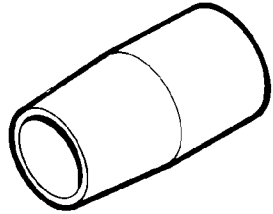

RO606604

LRT-57-021

Seal saver, sector shaft

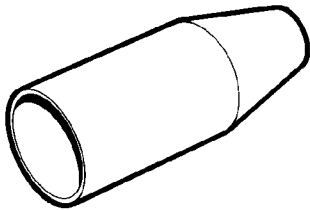

RO1015

LRT-57-016

Seal saver, valve and worm

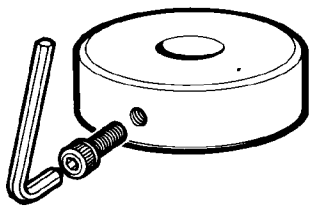

RO1016

LRT-57-017

Torque setting tool

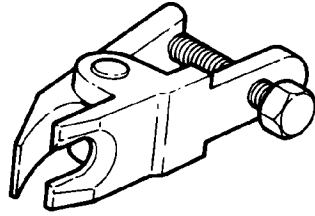

18G1036A

LRT-57-018

Ball joint remover

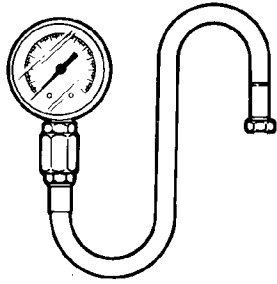

HY23

LRT-57-005

Pressure gauge

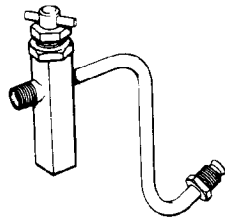

JD102

LRT-57-001

Test adaptor

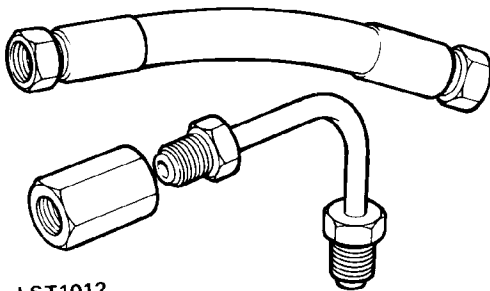

LST1012

LRT-57-022

Pressure test adaptors

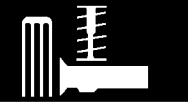

INTRODUCTION

Suspension design is a major factor in determining the comfort, safety and performance of any vehicle, but is particularly significant to 4 wheel drive cross country vehicles. The ideal suspension must allow maximum wheel travel and axle articulation, and provide good ground clearance without loss of traction or directional stability.

A well designed beam axle layout can embrace all of these qualities and also has the inherent advantage (over independent systems) of no variation in wheel track or camber angle.

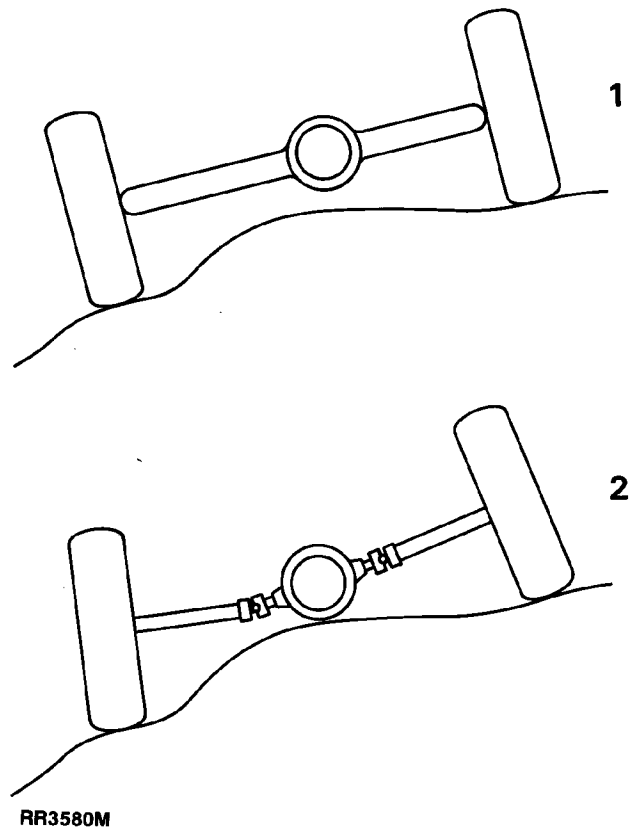

Suspension comparison

1. Beam axle system
2. Independent system

AXLE LOCATION

The front axle is controlled longitudinally by two forged steel radius arms and transversely by a panhard rod.

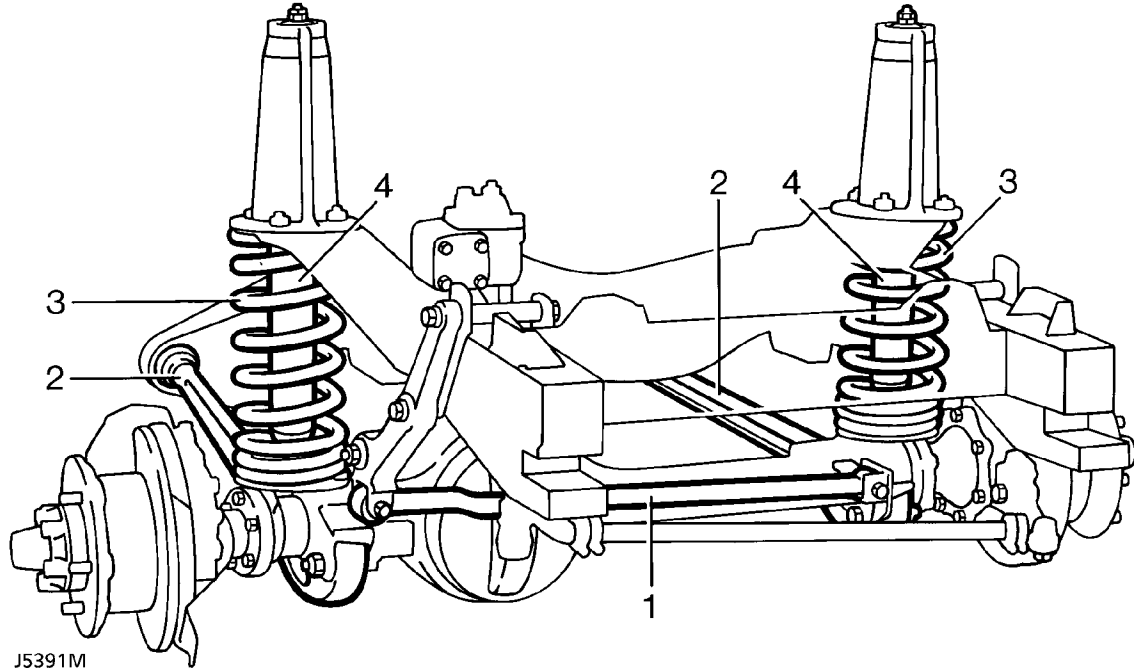
**Front axle suspension**

1. Panhard rod - transverse location
2. Radius arms - fore aft location
3. Coil springs
4. Shock absorbers

Long travel coil springs and hydraulic shock absorbers, provide the springing for each wheel.



SELF LOCKING NUTS



WARNING: Where self locking nuts are removed, they must be replaced with new nuts of same specification.

PANHARD ROD

Service repair no - 60.10.07

Remove



WARNING: Air suspension vehicles: Depressurise system before commencing work. See *AIR SUSPENSION, Adjustment, Depressurise System*

1. Remove fixings at mounting arm.
2. Remove fixings at axle bracket.
3. Remove Panhard rod.
4. Press out flexible bushes. Ensure the steel tubing locates on the outer edge of the bush and not on the rubber inner.

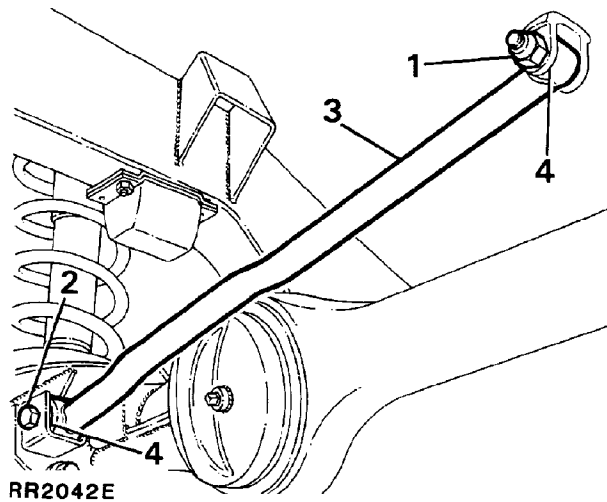

Refit

5. Fit replacement bushes.



CAUTION: Apply pressure to outer edge of bush, and not rubber inner.

6. Reverse removal procedure. 1 to 4. Tighten fixings to **88Nm**



NOTE: Air suspension vehicles: Repressurise system

RADIUS ARM

Service repair no - 60.10.16

Remove



WARNING: Air suspension vehicles: Depressurise system before commencing work. See *AIR SUSPENSION, Adjustment, Depressurise System*

1. Loosen road wheel retaining nuts.
2. Raise front of vehicle. Support chassis on stands and remove wheel.
3. Support front axle weight with jack.

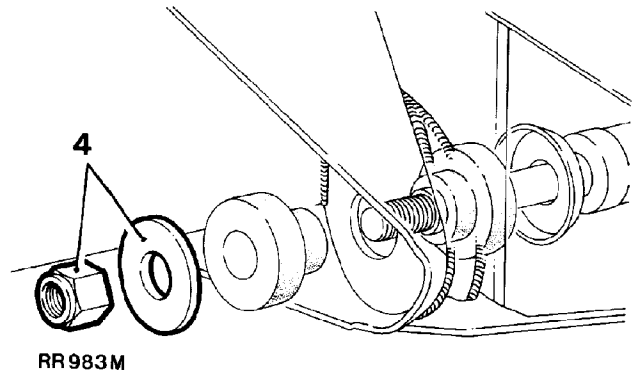

4. Remove radius arm to chassis side member fixings.

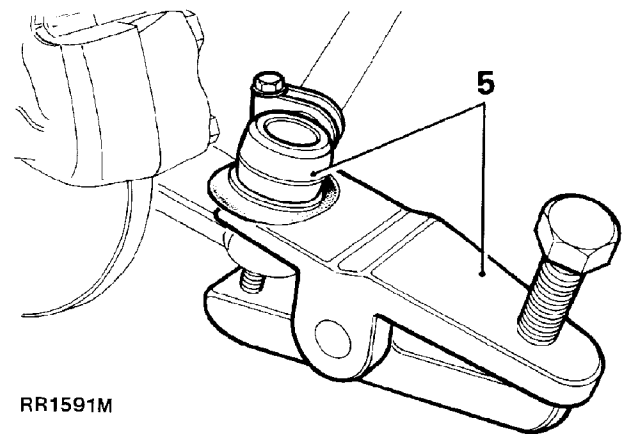

5. Disconnect track rod at ball joint.

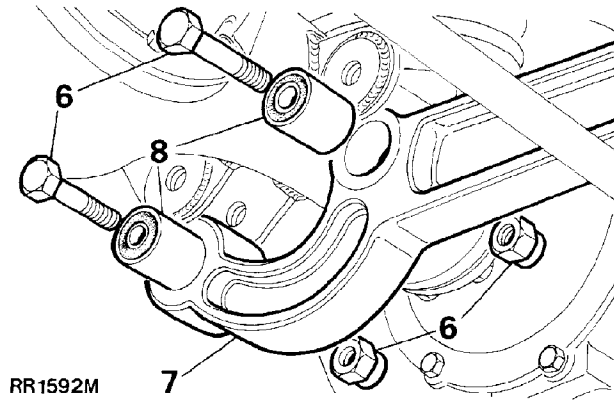

RR1592M

6. Remove fixings, radius arm to axle.
7. Lower radius arm front end to clear axle and remove from vehicle.
8. Press out flexible bushes.

Refit

9. Press in replacement bushes.



CAUTION: When pressing in new bushes press on outer edge of bush and not rubber inner.

10. Reverse removal procedure. 1 to 7. Tighten fixings to following torques:
Radius arm to chassis **175Nm**.
Radius arm to axle **200Nm**.



NOTE: Air suspension vehicles:
Repressurise system

FRONT SHOCK ABSORBER

Service repair no - 60.30.02



NOTE: Air suspension vehicles: See **AIR SUSPENSION, Repair, Front Damper**

Remove

1. Loosen road wheel retaining nuts.
2. Support chassis on stands and remove road wheel.
3. Support axle weight with jack.

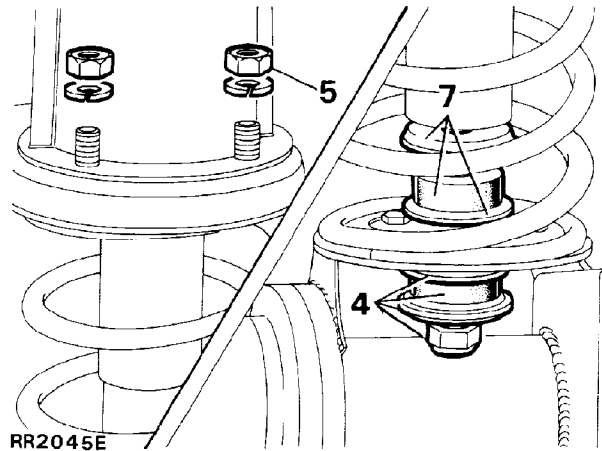

RR2045E

4. Remove shock absorber lower fixing and withdraw cupwasher, rubber bush and seating washer.
5. Remove four shock absorber bracket fixings.

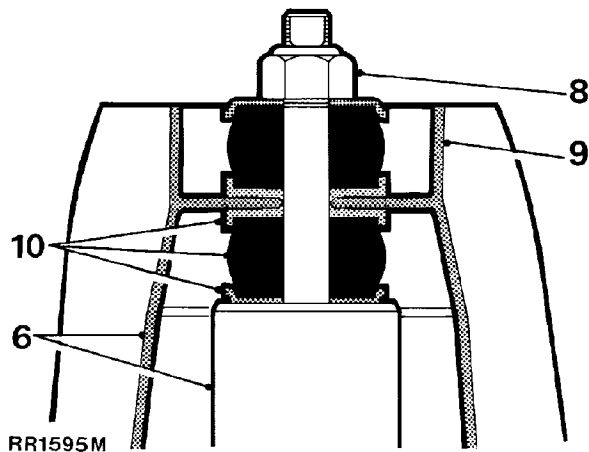

6. Withdraw shock absorber and bracket complete.
7. Withdraw lower seating washer, rubber bush and cupwasher.
8. Remove fixings, shock absorber to mounting bracket.
9. Withdraw mounting bracket.
10. Lift off top seating washer, rubber bush and cupwasher.

Refit

11. Reverse removal procedure. 1 to 10.

FRONT ROAD SPRING

Service repair no - 60.20.11

Remove

1. Remove front shock absorber. *See Front Shock Absorber*



CAUTION: Avoid over stretching brake hoses. If necessary loosen hose connector locknuts to allow hoses to follow axle.

2. Lower axle sufficient to free road spring.
3. Withdraw road spring.
4. Withdraw shock absorber bracket securing ring.

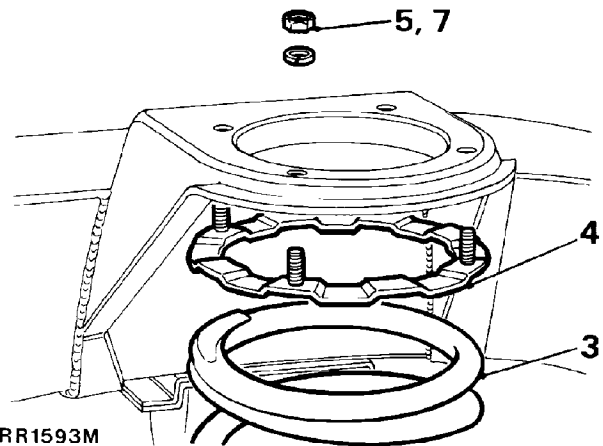

Refit

5. Fit shock absorber bracket retaining ring. Retain in position with a nut.
6. Reverse removal procedure. 2 and 3.
7. Remove nut retaining securing ring.
8. Fit front shock absorber.

BUMP STOP

Service repair no - 60.30.10

Remove

1. Remove fixings.
2. Remove bump stop.

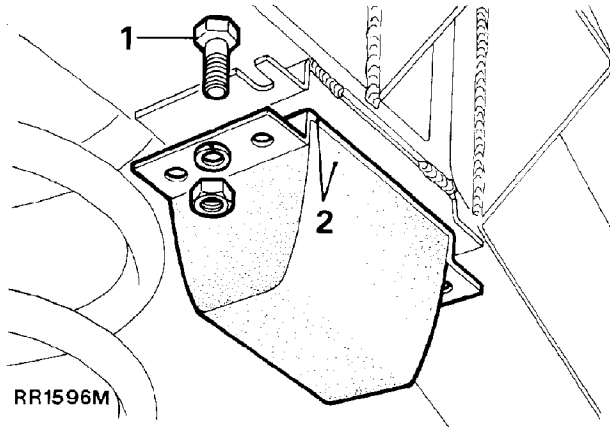
**Refit**

3. Position bolts in slots in chassis brackets.
4. Fit bump stop, secure with washers and nuts.

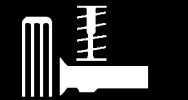

ANTI-ROLL [SWAY] BAR FRONT

Service repair no - 60.10.01

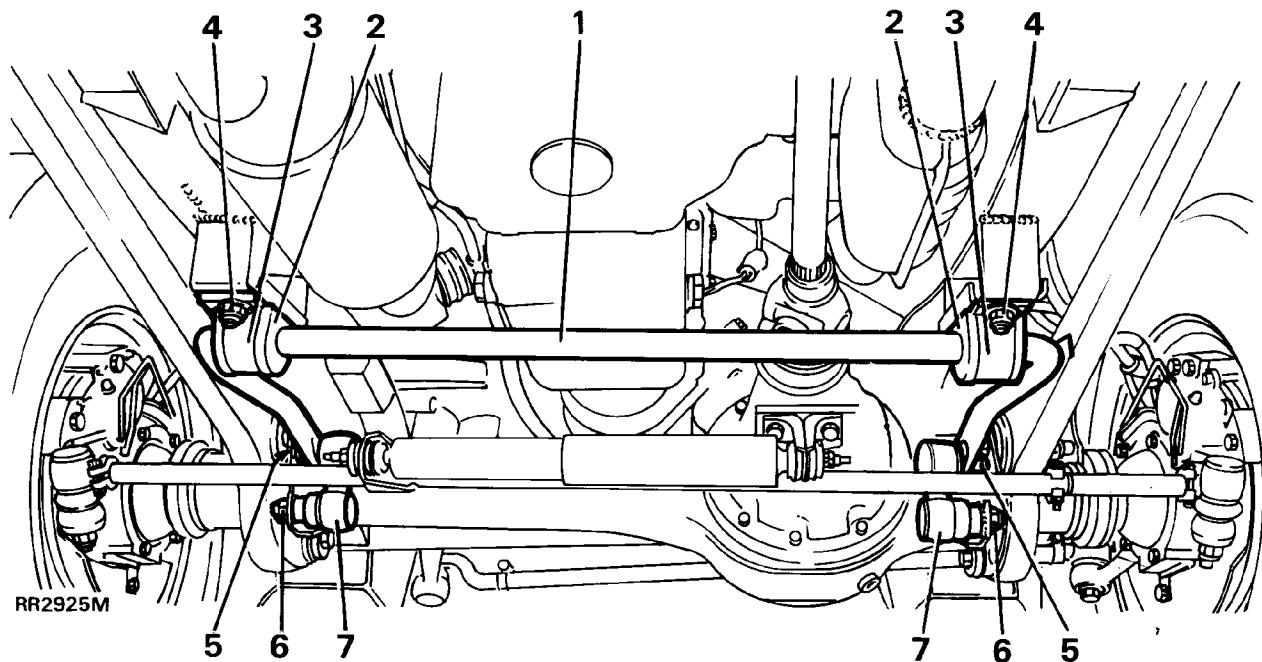

KEY

- | | |
|------------------------|-----------------------------------|
| 1. Anti-roll[sway] bar | 5. Nut and washer |
| 2. Rubber bush | 6. Castellated nut and cotter pin |
| 3. Strap | 7. Ball joint link arm |
| 4. Nut, bolt, washer | |

Remove

1. Mark for reassembly position of rubber bushes on anti- roll[sway] bar.
2. Remove four nuts, bolts and washers securing two bush straps.
3. Remove nuts, bolts, washers and rubber bushes from ball joint links and remove anti-roll[sway] bar.

Refit

4. Position bushes on anti-roll[sway] bar.
LH side, joint in bush to the rear.
RH side, joint in bush to the front.



CAUTION: The bush bore is tapered and must be fitted as indicated.

5. Fit anti-roll[sway] bar with two straps. To ensure correct fit angled sides of bar should point down as shown. Loosely fit the bolts, washers and Nyloc nuts.
6. Fit bolt, washers and rubber bushes. Using new nuts fit anti-roll[sway] bar to ball joint links. Tighten to **68Nm**.
7. Tighten nuts securing straps to **30Nm**

ANTI-ROLL[SWAY] BAR BALL JOINT LINKS

Service repair no - 60.10.04

Remove

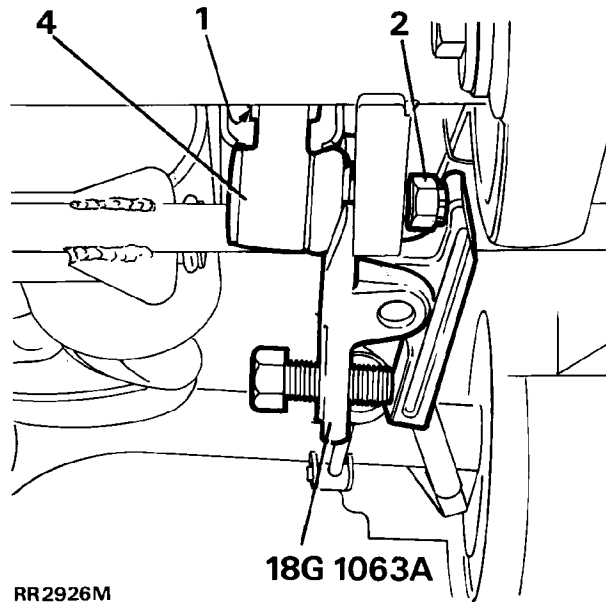

1. Remove two nuts, bolts, washers and rubber bushes from ball joint links.
2. Remove cotter pin and loosen castellated nut a few turns.
3. Release ball joint using special tool 18G 1063A as shown.
4. Remove castellated nut and ball joint link.

Refit

5. Fit ball joint link and castellated nut. Ensure ball joint link arm points up. Tighten to **40Nm** and fit new cotter pin.
6. Align anti-roll[sway] bar to ball joint links.
7. Fit bolts, washers and rubber bushes using new self locking nuts secure anti-roll[sway] bar to ball joint links. Tighten to **68Nm**.

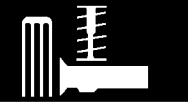

TORQUE VALUES



NOTE: Torque wrenches should be regularly checked for accuracy to ensure that all fixings are tightened to the correct torque.

	Nm
Anti-roll bar front	
- Strap nyloc nuts	30
- Ball link self lock nut	68
- Castellated nut	40
Drag link to axle	40
Securing ring for mounting turret	14
Radius arm to chassis	175
Panhard rod mounting arm to chassis	88
Panhard rod to axle	88
Panhard rod to mounting bracket	88
Tie bar to Panhard rod	110
Radius arm to axle (front only)	200

Torque values below are for all screws and bolts used except for those that are specified otherwise.

METRIC	Nm
M5	6
M6	9
M8	25
M10	45
M12	90
M14	105
M16	180

UNC / UNF	
1/4	9
5/16	24
3/8	39
7/16	78
1/2	90
5/8	136



AXLE LOCATION

Longitudinal location of the rear axle is by 2 long, rubber trailing links which allow maximum vertical movement of the wheels. Lateral movement of the axle is prevented by a centrally mounted 'A' frame. This frame assembly consists of 'I' section steel secured at the apex by a ball joint which is mounted on top of the axle to the left of the differential housing. The open end of the 'A' frame is bolted to the underside of the chassis cross-member. This permits vertical movement of the axle while articulation takes place around the ball joint, with the resultant controlled ride over rough terrain.

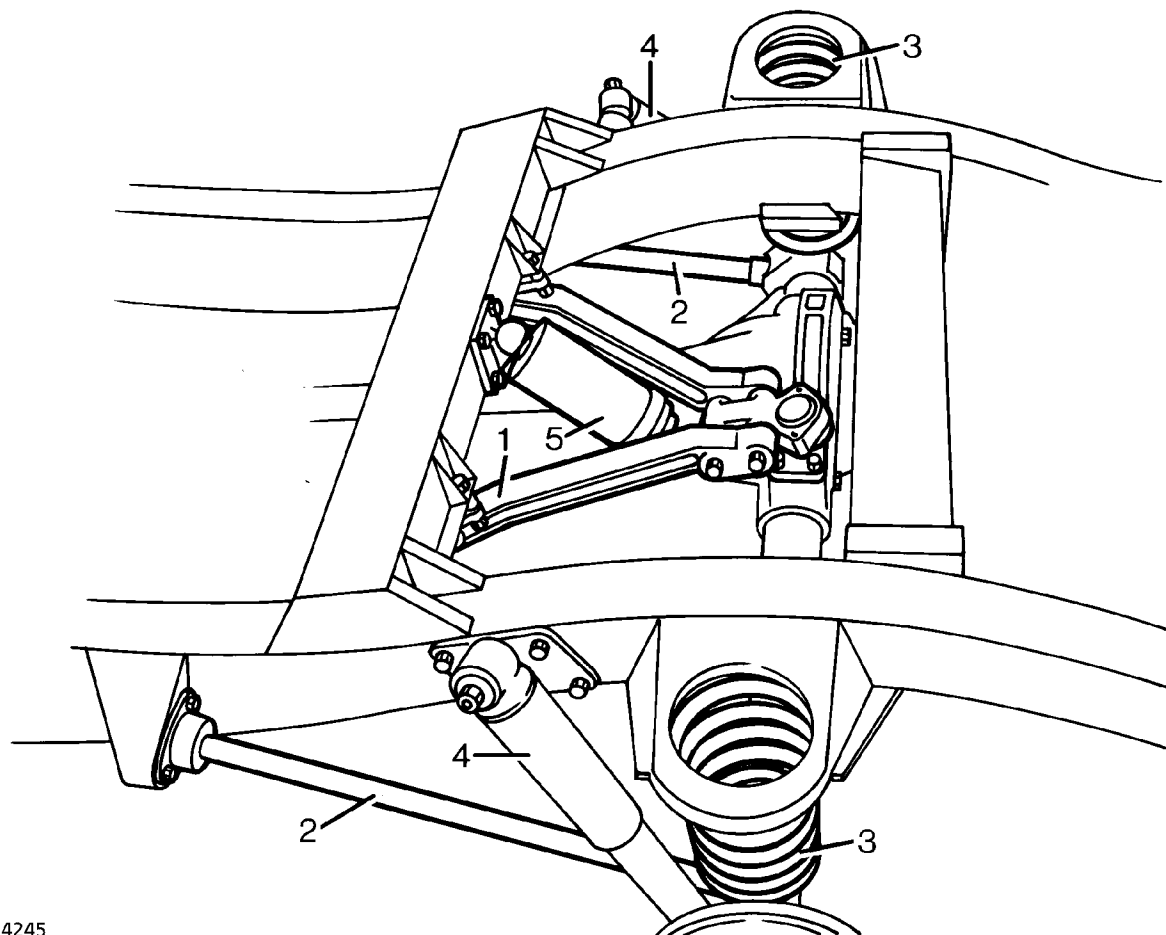

RR4245

Rear axle suspension

- 1. "A" frame upper link assembly - transverse location
- 2. Trailing links - longitudinal location
- 3. Coil springs
- 4. Shock absorbers
- 5. Self levelling unit

Long travel coil springs and hydraulic shock absorbers, provide the springing for each wheel. On the rear only, a self levelling unit is mounted in conjunction with the "A" frame to provide automatic self levelling of the vehicle, when heavily loaded or towing a trailer.

SELF LEVELLING UNIT**DESCRIPTION**

The levelling unit fitted to the rear axle is a self contained and sealed for life hydropneumatic device, which resembles a large telescopic damper. The unit utilizes the energy produced by the relative movement of the axle to the vehicle, when the vehicle is in motion, to maintain the vehicle at nominally level height. The unit will compensate for additional loads placed on the vehicle up to the recommended maximum. Excess load beyond the design limits of the unit will prevent it levelling the vehicle but, will not impede its capabilities as a damper.

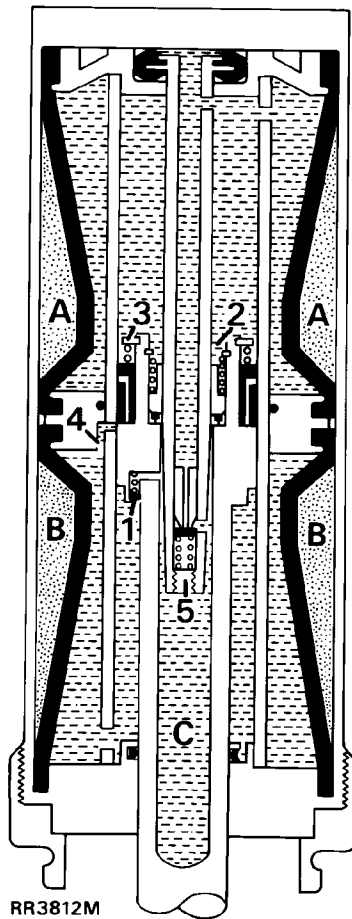
**OPERATION****Levelling the suspension (Pumping up)**

The unit, contains hydraulic fluid and an inert gas, pressurised to approximately 65 bar during manufacture. The gas which provides the springing medium, is contained in two chambers **A** and **B** and is separated from the fluid by rubber sleeves. The movement of the axle and pumping action of the piston shaft when the vehicle is in motion, causes fluid to be transferred from the lower chamber to the upper chamber via internal valves **1** and **2** and high pressure chamber **C**. As the fluid is transferred to the upper section of the unit, pressure is applied to the gas in chamber **A** which provides the springing. At the same time the piston shaft is forced outwards increasing the operating length of the levelling unit.

Level position (Fluid circulates)

When the optimum level position is reached, as illustrated in RR3812M, fluid pumped from the lower section to the upper section as previously explained, circulates via valve **3** and port **4** back to the lower section.

Full bump/over load

If the vehicle suspension encounters a large 'bump' in the road or is over loaded the unit provides a damping effect only, as valves **5** and **1** are forced open allowing the pressure to escape from the upper to the lower chamber.

Full rebound

If the vehicle suspension encounters a large 'hole' in the road, the unit extends causing port **4** to allow free flow of fluid between the upper and lower chambers and the pressures to equalise.



SELF LEVELLING UNIT

Functional check

Before carrying out checks, verify vehicle is used within specified maximum loading capability.

1. Check levelling unit for excessive oil leakage, if so, change unit. Slight oil seepage is permissible.
2. Remove excessive mud deposits from underneath vehicle and any heavy items from vehicle that are not original equipment.
3. Measure clearance between rear axle bump pad and bump stop rubber at front outer corner on both sides. Average clearance should be in excess of 67mm. If less, remove rear springs and check their free length against Road Spring Data. **See GENERAL SPECIFICATION DATA, Information, Road Spring Data**
4. Replace any spring whose free length is more than 20mm shorter than figure given. If after replacing a spring the average bump clearance is still less than 67mm, replace levelling unit.
5. With rear seat upright, load 450 kg into rear of vehicle, distributing the load evenly. Check bump stop clearance, with driving seat occupied.
6. Drive vehicle for 5km (3 miles) over undulating roads or graded tracks. Stop vehicle without disturbing loading. With driving seat occupied, check bump stop clearance again.
7. If change in clearance is less than 20mm levelling unit must be replaced. **See Repair, Levelling Unit**

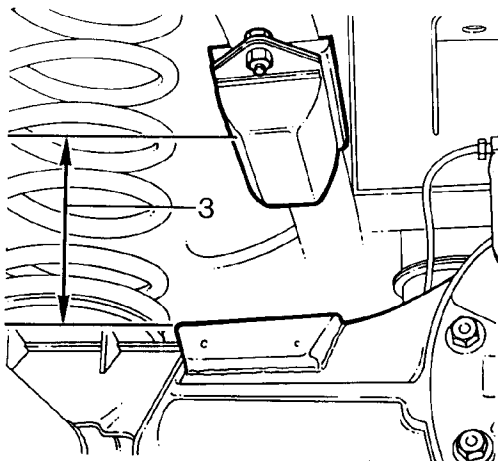

RR 590

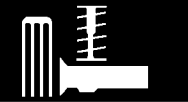

REAR ROAD SPRING

Service repair no - 64.20.01

Remove

1. Loosen rear road wheel retaining nuts.
2. Support chassis on stands and remove wheels.

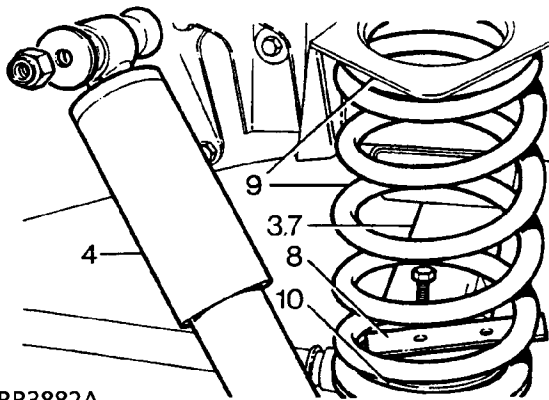

RR3882A

3. Support rear axle weight with jack.
4. Disconnect shock absorbers at one end.
5. Position coil spring compressor correctly on road spring.
6. Compress spring evenly to facilitate removal.
7. Lower axle to free road spring from upper seat.



CAUTION: Avoid lowering axle further than rear brake flexible hose will allow.

8. Remove spring retainer plate.
9. Withdraw road spring and spring isolator.
10. Lift off spring.

Refit

11. Reverse removal procedure.

REAR SHOCK ABSORBER

Service repair no - 64.30.02

Remove



NOTE: Air suspension vehicles: See AIR SUSPENSION, Repair, Rear Damper

1. Loosen road wheel retaining nuts.
2. Support chassis on stands. Remove road wheel and support rear axle weight with jack.

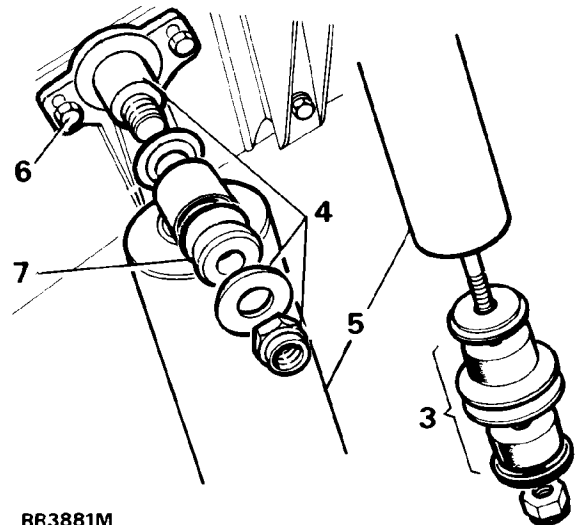

RR3881M

3. Remove fixings and withdraw shock absorber from axle bracket.
4. Remove upper fixings.
5. Withdraw shock absorber.
6. If required remove mounting bracket.
7. If required remove mounting rubbers.

Refit

8. Reverse removal procedure.

LEVELLING UNIT

Service repair no - 64.30.09

Remove



WARNING: The levelling unit contains pressurised gas and must not be dismantled or casing screws removed.

Repair is by replacement of complete unit only.

1. Support chassis rear on stands.
2. Support axle weight with jack.
3. Disconnect suspension upper links at pivot bracket.

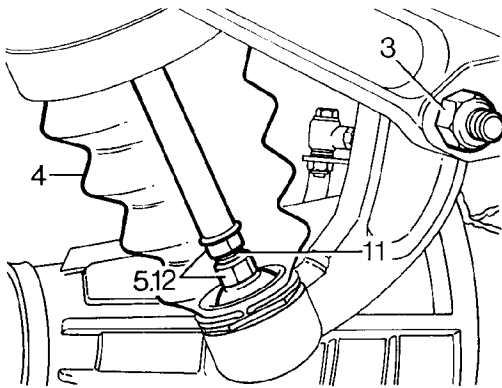

RR 1602

4. Lift up lower boot.
5. Unscrew lower ball joint at levelling unit push rod.
6. Remove top bracket fixings at cross member.
7. Withdraw levelling unit and top bracket complete.
8. Lift up upper boot.
9. Unscrew upper ball joint at levelling unit.
10. Withdraw upper and lower boots and retaining spring.

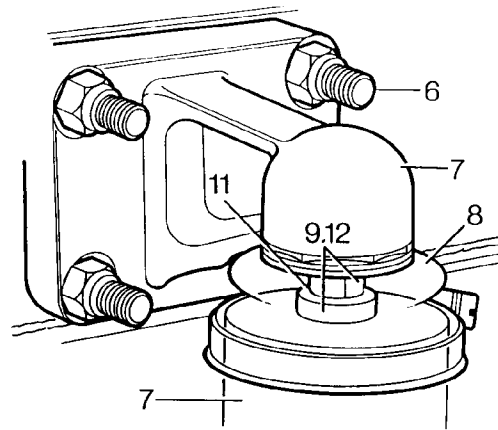

RR 1603

Refit

11. Coat ball pin threads with 'Loctite' grade CVX or equivalent sealant.
12. Reverse removal procedure. 1 to 10. Fit all items in position, then tighten to correct torque. **See Specifications, torque, Torque Values**

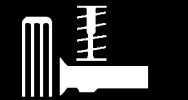

LEVELLING UNIT BALL JOINTS

Service repair no - 64.30.10

Remove

1. Remove levelling unit. *See Levelling Unit*

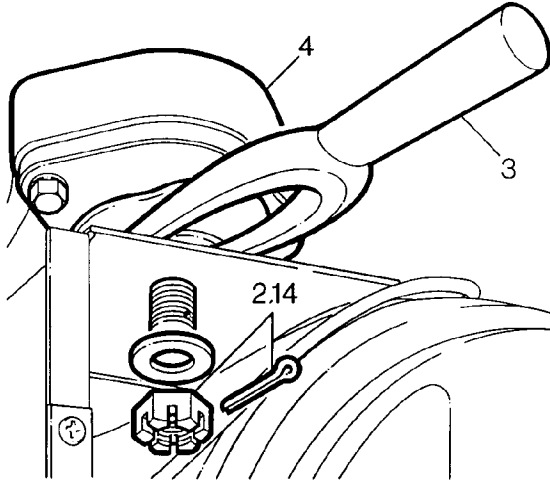

RR 1604

2. Remove cotter pin and nut at rear axle bracket.
3. Extract ball pin from axle bracket using extractor RO1006.
4. Withdraw pivot bracket with ball joints.
5. Unscrew ball joint assembly.
6. Remove ball joint assembly from axle bracket.

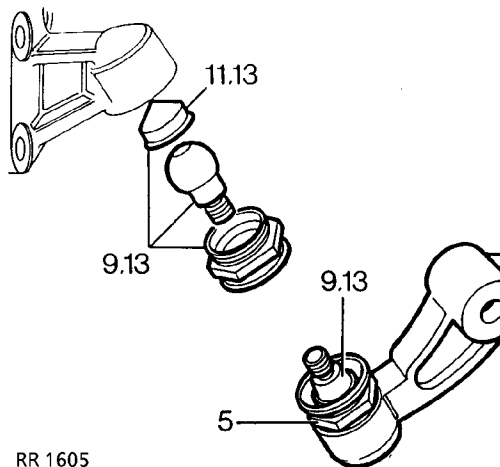

RR 1605

7. Replacement ball joints are supplied complete, less fixings, and greased.
8. Axle bracket ball joint must not be dismantled.
9. Levelling unit ball joint may be dismantled and cleaned.
10. Pack ball joint with Dextagrease GP or equivalent grease.
11. Ensure that ball is square in housing before refitting.

Refit

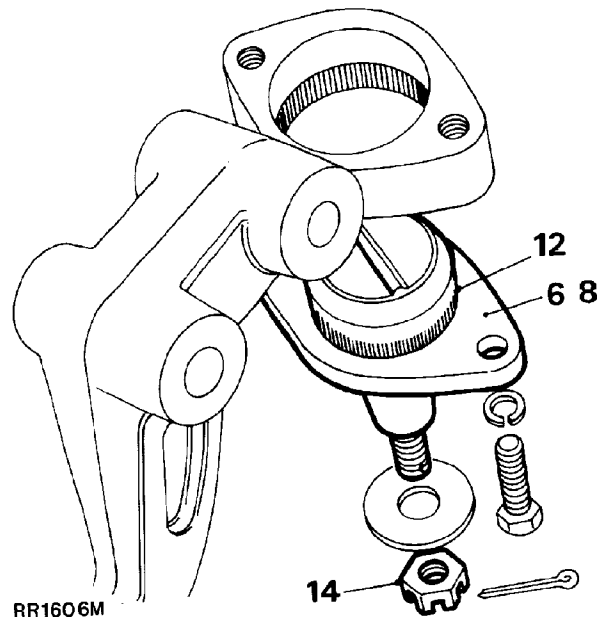

RR1606M

12. Press knurled ball joint into pivot bracket.
13. Screw levelling unit ball joints into mounting brackets. Ball joints should screw in easily and fully. Tighten to correct torque. *See Specifications, torque, Torque Values*
14. Fit pivot bracket complete with ball joints to rear axle. Tighten to **175Nm**.
15. Fit levelling unit.

BUMP STOP

Service repair no - 64.30.15

Remove

1. Remove fixings.
2. Remove bump stop.

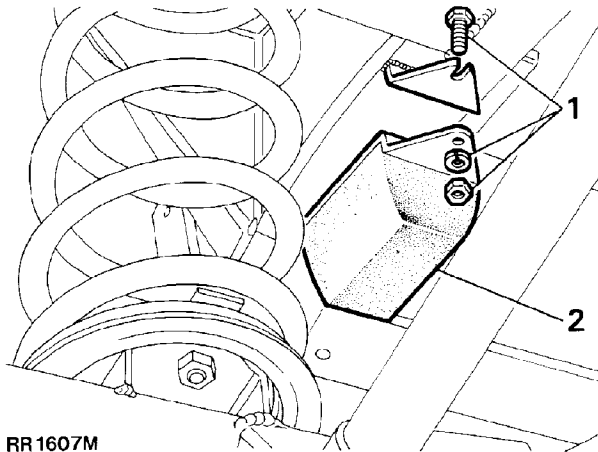

RR1607M

Refit

3. Position bolts in slots in bracket.
4. Fit bump stop secure with washer and nuts.

SUSPENSION LINK UPPER

Service repair no - 64.35.44

Remove

1. Support rear of chassis on stands, allow axle to hang freely.

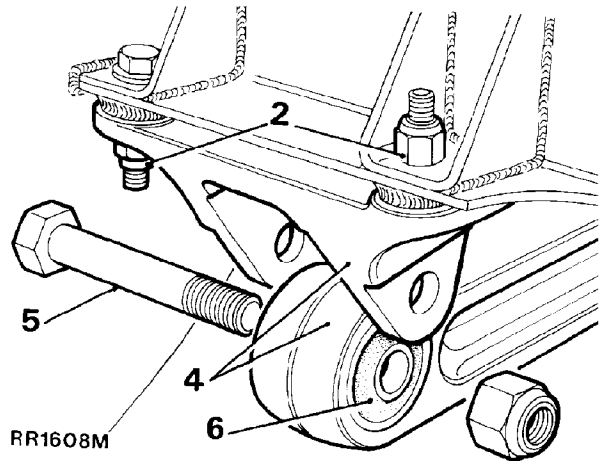

RR1608M

2. Remove fixings, upper link bracket to frame.
3. Remove fixings, upper links to pivot bracket.
4. Remove upper link complete with frame bracket.
5. Remove bolt.
6. Separate link from bracket.

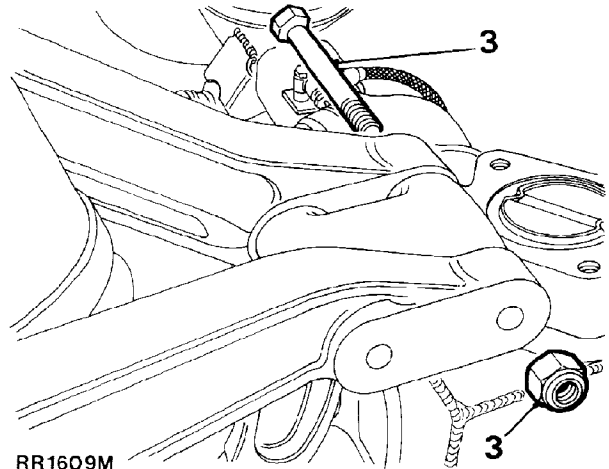

RR1609M



Renew bush

7. Press out rubber bushes.
8. Fit bush centrally in housing.



CAUTION: Apply pressure to outer edge of bush, and not rubber inner.

Refit

9. Reverse removal procedure. 1 to 6. Do not fully tighten fixings until all components are in position.
10. Tighten fixings to correct torque. **See Specifications, torque, Torque Values**

SUSPENSION LINK LOWER

Service repair no - 64.35.02



WARNING: Air suspension vehicles: Depressurise system before commencing work. *See AIR SUSPENSION, Adjustment, Depressurise System*

Remove

1. Site vehicle on a ramp [hoist].
2. Alternatively, support vehicle on stands under rear axle.

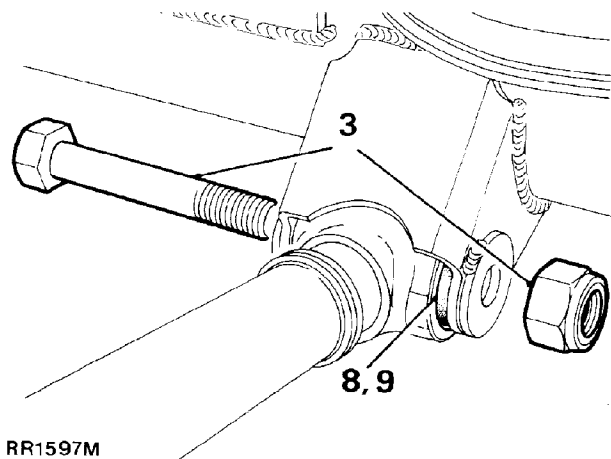

3. Remove rear fixings.

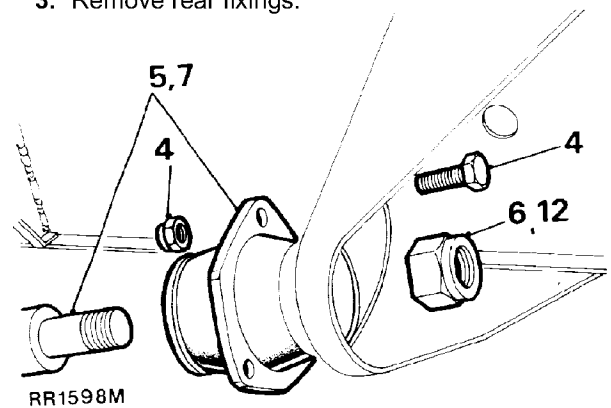

4. Remove mounting bracket fixings at side member bracket.
5. Remove lower link complete.
6. Remove locknut.
7. Remove mounting bracket from lower link.

Renew bush

8. Press out rubber bushes.
9. Fit bush centrally in housing.



CAUTION: Apply pressure to outer edge of bush, and not rubber inner.

Refit

10. Reverse removal procedure. 6 and 7. Do not tighten locknut.
11. Reverse removal procedure. 3 to 5.
12. Lower vehicle, allow axle to take up static laden position. Tighten to **175Nm**



NOTE: Air suspension vehicles:
Repressurise system



ANTI-ROLL BAR REAR

Service repair no - 64.35.08

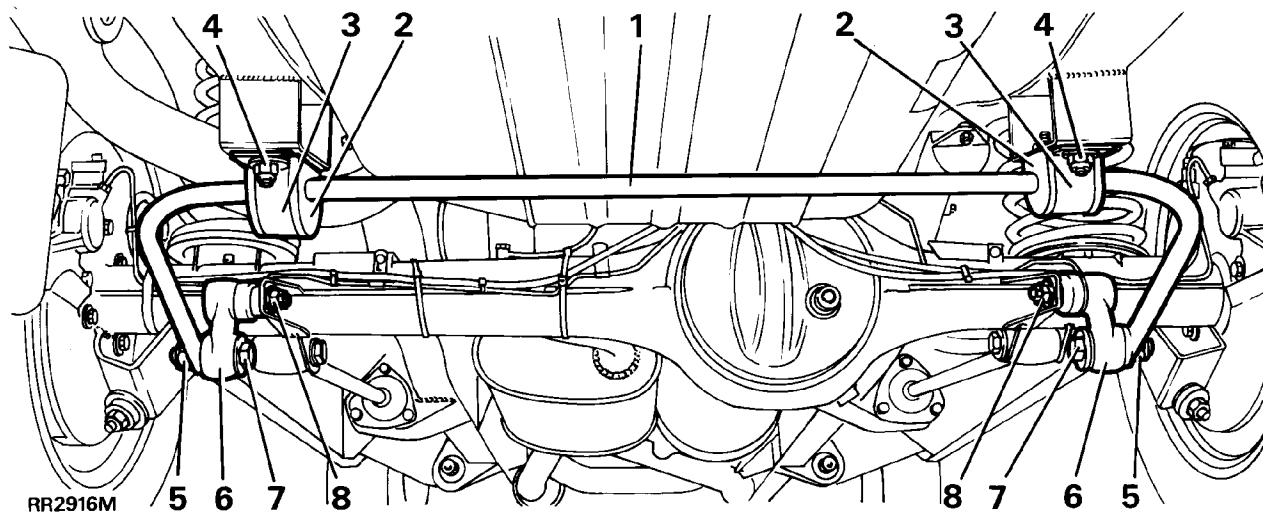

KEY

- | | |
|------------------------|-----------------------------------|
| 1. Anti-roll[sway] bar | 5. Nut and washer |
| 2. Rubber bush | 6. Ball joint link arm |
| 3. Strap | 7. Bolt and washer |
| 4. Nut, bolt, washer | 8. Castellated nut and cotter pin |

Remove

1. Note for reassembly, position of rubber bushes on anti-roll[sway] bar.
2. Remove four nuts, bolts and washers securing two bush straps.
3. Remove nuts, bolts, washers and rubber bushes from the ball joint links and remove anti-roll[sway] bar.

Refit

4. Position rubber bushes on anti-roll[sway] bar. Fit joint in bush towards axle.
5. Fit anti-roll[sway] bar with two straps. Ensure ball joint link arms point down as shown. Loosely fit, bolts, washers and new Nyloc nuts.
6. Fit bolt, washers and rubber bushes. Fit anti-roll[sway] bar to ball joint links. Tighten to **68Nm**
7. Tighten nuts securing straps to **30Nm**.

ANTI-ROLL BAR BALL JOINT LINKS

Service repair no - 64.35.24

Remove

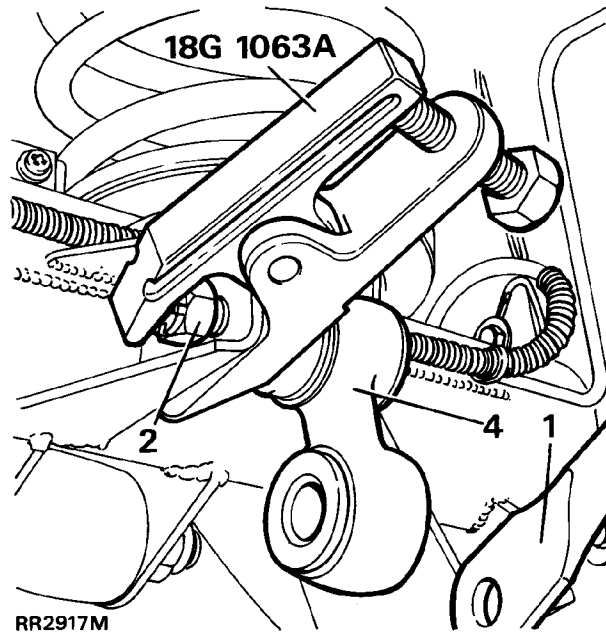

1. Remove two nuts, bolts, washers and rubber bushes from ball joint links and lower anti-roll[sway] bar to clear links.
2. Remove cotter pin and loosen castellated nut a few turns.
3. Release ball joint using special tool 18G 1063A as shown.
4. Remove castellated nut and ball joint link.

Refit

5. Fit ball joint link arm and castellated nut. Point ball joint link arm down as shown. Tighten to **40Nm** and fit new cotter pin.
6. Align anti-roll[sway] bar to ball joint links.
7. Fit bolts, washers and rubber bushes using new self locking nuts secure anti-roll[sway] bar to ball joint links. Tighten to **68Nm**.



TORQUE VALUES



NOTE: Torque wrenches should be regularly checked for accuracy to ensure that all fixings are tightened to the correct torque.

	Nm
Anti-roll bar rear	
- Strap nyloc nuts	30
- Ball link self lock nut	68
- Castellated nut	40
Ball joint - levelling unit to rear axle	176
Top link to levelling unit	115
Top link to mounting bracket	176
Upper joint to levelling unit	34
Lower joint to levelling unit	34
Bottom link to axle	176
Bottom link to chassis	176
Top link bracket to rear cross member	47
Levelling unit to cross member	47
Shock absorber to axle	37

Torque values below are for all screws and bolts used except for those that are specified otherwise.

METRIC	Nm
M5	6
M6	9
M8	25
M10	45
M12	90
M14	105
M16	180

UNC / UNF	
1/4	9
5/16	24
3/8	39
7/16	78
1/2	90
5/8	136

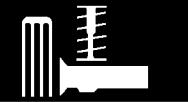

ELECTRONIC AIR SUSPENSION - (EAS)

Description

The electronic air suspension is a versatile microprocessor controlled system that exploits the advantages of air suspension. It provides a variable spring rate which achieves near constant ride frequency for all load conditions, giving:

- Improved ride quality.
- Continuity of ride quality, laden or unladen.
- Constant ride height.
- Improved headlamp levelling.

The function of the system is to provide five height modes, each of which is automatically maintained at the given height by the system logic with the minimum of driver involvement. Vehicle height is sensed by four rotary potentiometer type height sensors. Vehicle height information from each potentiometer signals the ECU to adjust each air spring by switching the solenoid valves to hold, add or release air. The system provides five height settings and automatic self levelling as follows:

Standard - standard ride height measured from centre of wheelarch eyebrow to floor = 790mm \pm 7mm.

Low profile: 20 mm below standard.

Access: 60 mm below standard.

High profile: 40 mm above standard.

Extended profile: 20 to 30 mm above high profile.

Self levelling

The system provides self levelling under varying vehicle loads. The vehicle will self level to the lowest corner height level for 20 seconds after switching off engine, exiting vehicle and closing doors.

Standard

Vehicle ride height is the same as with conventional suspension, but is maintained under all load conditions. This also provides improved headlamp levelling.

Low profile

This position gives improved handling and fuel consumption at high speed. When the vehicle speed exceeds 80 kph (50 mph) for more than 30 seconds, with INHIBIT switch off, the vehicle will enter the low profile position. The vehicle will return to standard height when vehicle speed drops below 56 kph (35 mph) for more than 30 seconds, unless vehicle stops, in which case it returns to standard when driven away. The LOWER lamp is illuminated in this condition.

Access

This position makes passenger boarding and luggage loading easier. With the vehicle stationary, park brake on (manual), 'P' selected (automatic), footbrake off, doors closed and INHIBIT switch off, pressing the LOWER switch will select the ACCESS position. It is possible to select access for 15 seconds after switching engine off. The LOWER lamp flashes until access position is reached, when it remain constantly illuminated



NOTE: Opening a door will freeze vehicle position.

From access the vehicle will return to standard ride height if:

- the RAISE switch is pressed,
- or the INHIBIT switched is on,
- or park brake is released,
- or the is vehicle driven off.

High profile

This position is used to improve approach and departure angles and when wading. Pressing the RAISE switch will select this position provided the road speed is below 56 kph (35 mph) with INHIBIT off. The vehicle will return to standard position when road speed exceeds 56 kph (35 mph) or LOWER switch is pressed. The RAISE lamp is illuminated in this condition.



NOTE: When raising ride height, rear of vehicle will raise by 70% of movement first followed by 70% of front. Rear will raise remaining 30% before front. Lowering will be achieved by lowering front of vehicle first. This will ensure that, with headlamps illuminated, there is no inconvenience from headlamp dazzle to other road users. BUT, lowering to access position will be achieved by the fastest possible means, by opening all air valves at the same time.

Extended profile

This position is achieved when vehicle is off road in standard or high profile and the chassis is grounded leaving wheels unsupported. Initial ECU reaction is to

deflate (lower) affected springs. After a timed period ECU detects no height change, therefore it reinflates springs in an attempt to regain traction. The RAISE lamp will flash in this mode. After ten minutes system will return to high profile, unless LOWER switch is pressed.

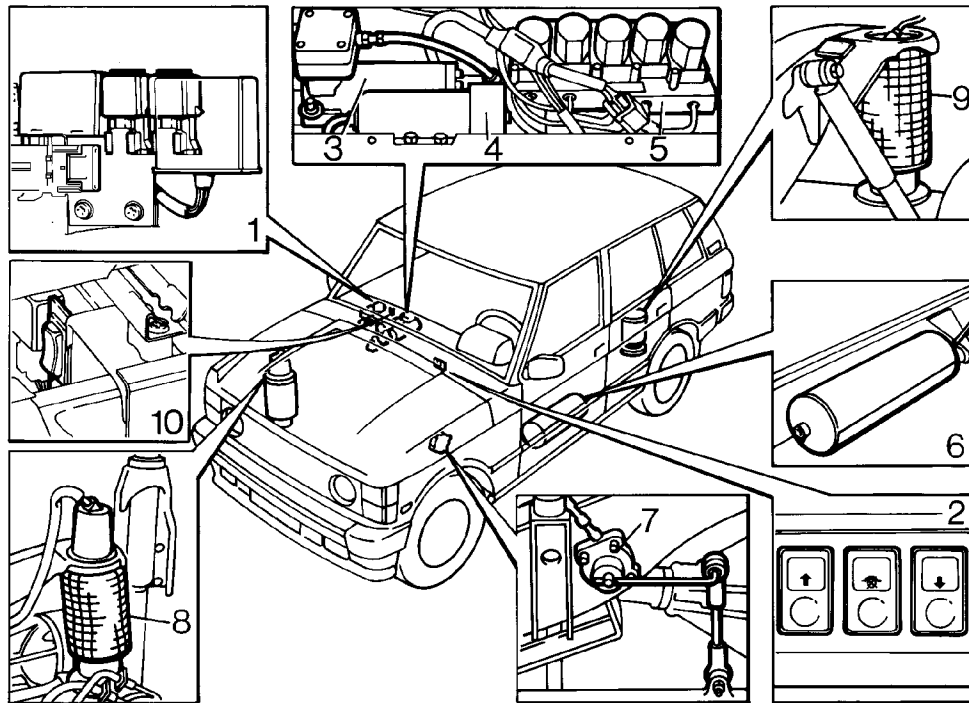
LOCATION OF COMPONENTS

RR4091

- | | |
|--|-------------------------|
| 1. Electronic control unit (ECU) and relays. | 6. Reservoir |
| 2. Control switches | 7. Height sensors (4) |
| 3. Compressor | 8. Front air spring (2) |
| 4. Air drier | 9. Rear air spring (2) |
| 5. Valve block | 10. Disable switch |

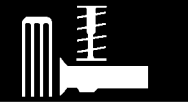

DESCRIPTION OF COMPONENTS

Electrical control unit - ECU

The ECU is located underneath the right hand front seat, on top of the fuel ECU. It maintains the requested vehicle ride height by adjusting the volume of air in each air spring. It is connected to the cable assembly by a 35 way connector. To ensure safe operation the ECU has extensive on board diagnostic and safety features. The ECU is non-serviceable, in case of failure it must be replaced.

Relays, fuses

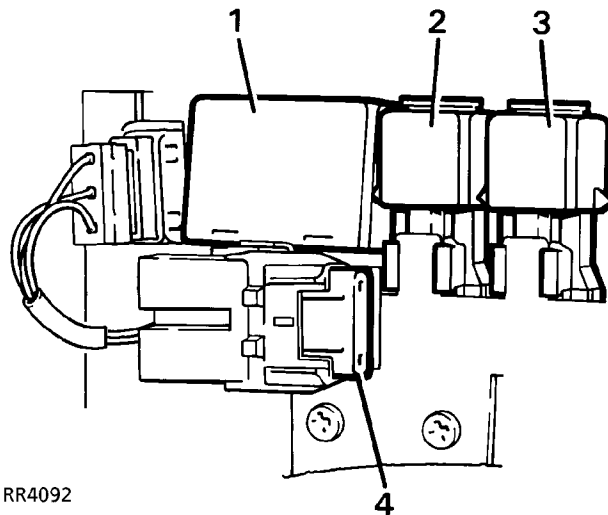

Power supply for the system consists of the following components:

1. Delayed power turn off relay. This remains powered up for 20 seconds after exiting vehicle to allow self levelling.
2. Compressor relay, 4 pin.
3. Warning light relay, 5 pin.
4. 30 amp 'maxifuse' for compressor power.
15 amp fuse in dash fusebox for ECU pin 1.

Disable switch

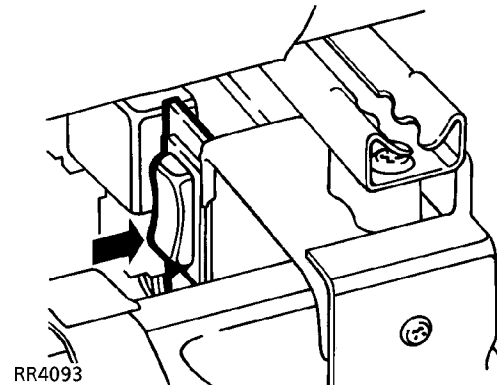

The disable switch is mounted on the RH runner under the rear of the RH front seat. The switch has no markings, in the DISABLE position the bottom of the switch is pushed in. It is used to disable the system when the vehicle is being delivered, or when working on the system after depressurising. The switch disables the system at speeds below 56 kph (35 mph).

Height sensors

Four potentiometer type height sensors signal vehicle height information to the ECU. The potentiometers are mounted on the chassis and activated by links to the front radius arms and rear trailing links. In case of height sensor failure the assembly must be replaced.

Control switches

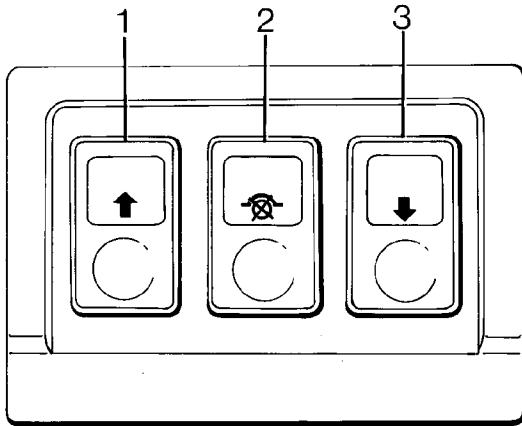

RR4094

Mounted on the lower dash, three control switches are arranged thus:

1 - Raise - momentary touch switch.

2 - Inhibit - self latching switch, when switched on the vehicle will remain at standard ride height. This position is used when the automatic height adjustment is not required i.e. when towing. Self levelling will continue to function.

3 - Lower - momentary touch switch.

The switches incorporate a warning lamp. When engine is started all three warning lamps will illuminate for three seconds as part of bulb check. The switches are illuminated when the vehicle lights are on.

The following components are contained in the AIR SUPPLY UNIT mounted on the RH side of the chassis:

AIR COMPRESSOR
AIR DRIER
VALVE BLOCK

Air compressor

The air compressor provides system pressure. A thermal switch is incorporated which switches off the compressor relay ground at 130°C. The compressor has an air intake silencer mounted behind rear mud flap. The air intake filter is located adjacent to the fuel filler flap. The filter is renewed every 40,000 kms/24,000 miles/24 months. (30,000 miles USA).

Air drier

The air drier is connected into the air line between compressor and reservoir. It removes moisture from pressurised air entering the system. When air is exhausted from the system it passes through the drier in the opposite direction. The air drier is regenerative in that air absorbs moisture in the drier and expels it to the atmosphere.

The air drier unit is non-serviceable, designed to last the life of the vehicle. However if water is found in the system when reservoir drain plug is removed, the air drier must be changed.



CAUTION: If the air drier is removed from the vehicle the ports must be plugged to prevent moisture ingress.

Valve block

The valve block controls the direction of air flow. Air flow to and from the air springs is controlled by six solenoid operated valves, one for each air spring, one inlet and one exhaust. A diaphragm valve operated by the solenoid outlet valve ensures that all exhausted air passes through the air drier. In response to signals by the ECU, the valves allow high pressure air to flow in or out of the air springs according to the need to increase or decrease pressure. The valve block is non-serviceable, in case of failure it must be replaced.

Non-return valves

The valve block contains three non-return valves. NRV1 retains compressor air pressure by preventing flow back to the compressor. NRV2 prevents loss of pressure in the system if reservoir pressure drops. It also ensures correct flow through the inlet valve. NRV3 ensures correct flow through the exhaust valve.

Reservoir

The 10 litre reservoir is mounted on the left hand side of the chassis. One connection acts as inlet and outlet to the rest of the system. It stores compressed air between set pressure levels. The reservoir drain plug requires removing every 40,000 kms/24,000 miles/24 months. (30,000 miles USA) to check for moisture in the system. **See Adjustment, Air Reservoir - Drain**



Pressure switch

Mounted on the reservoir is a pressure switch which senses air pressure and signals the ECU to operate the compressor when required. The compressor will operate when pressure falls to between 7.2 and 8.0 bar. It will cut out at a rising pressure of between 9.5 and 10.5 bar.

Air springs

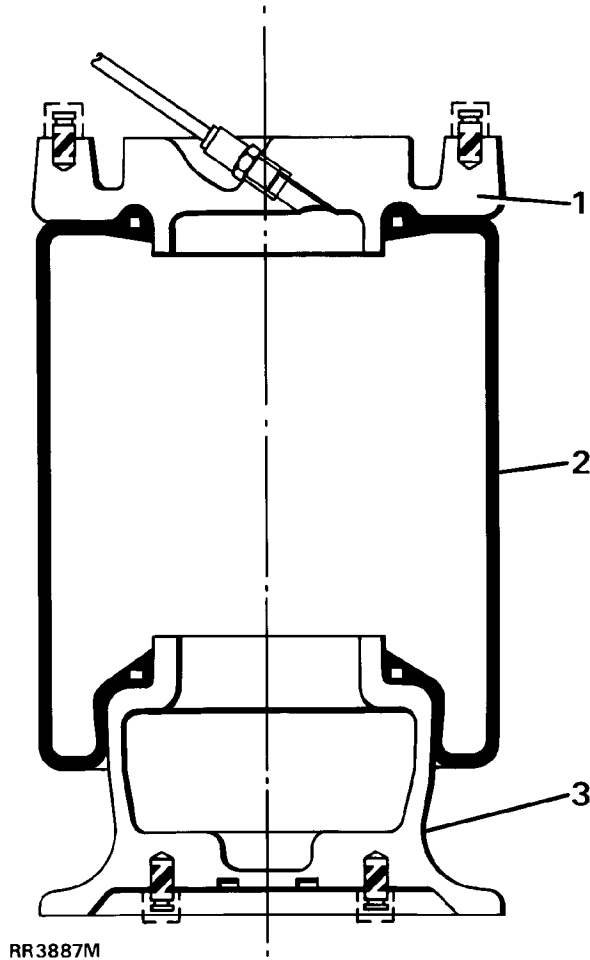

Air springs components

1. Top plate
2. Rolling rubber diaphragm
3. Piston

The air springs are mounted in the same position as conventional coil springs.

Front and rear air springs are of similar construction, but are not interchangeable.

The diaphragm is NOT repairable, if failure occurs the complete unit must be replaced.

PNEUMATIC SYSTEM DIAGRAM

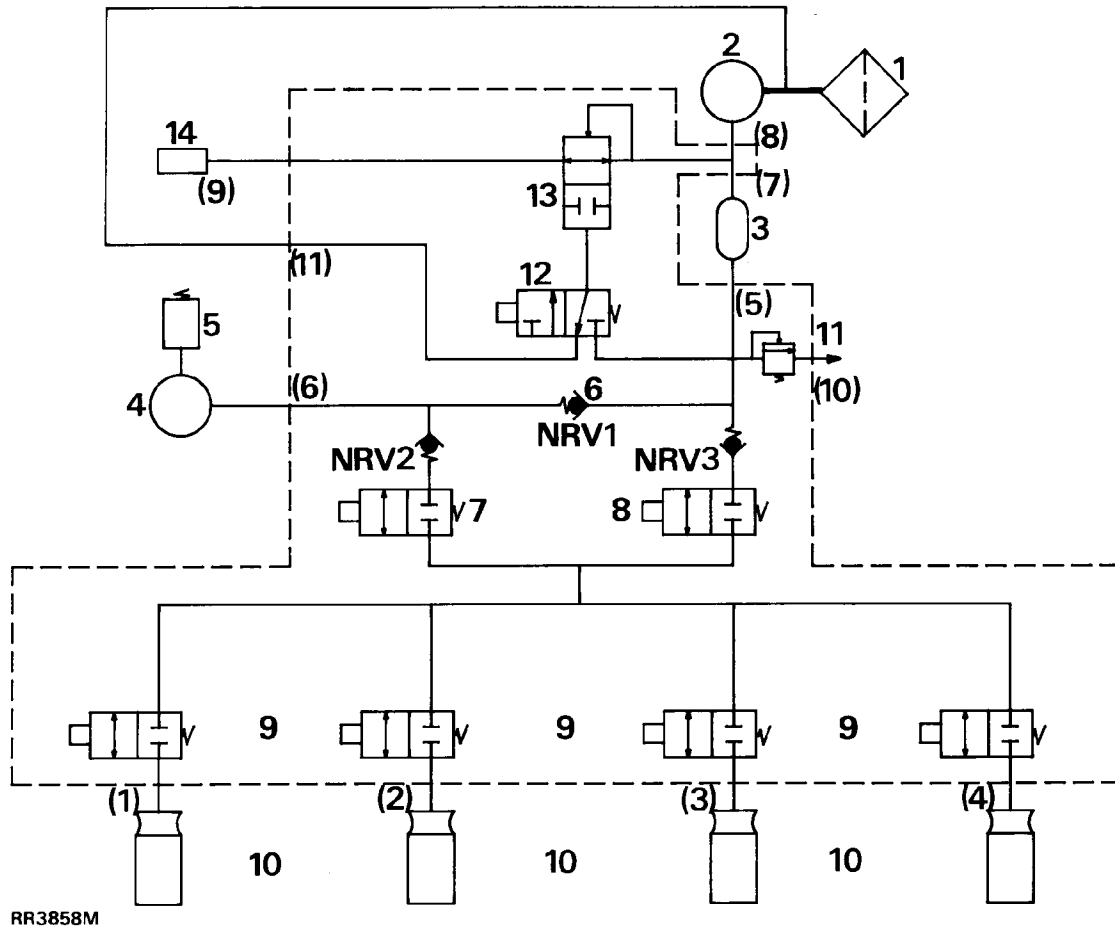

Key to RR3858M

1. Inlet filter
2. Compressor
3. Air drier
4. Reservoir
5. Pressure switch

Valve block comprises items 6. to 12.

6. One way valves NRV1, 2 and 3.
7. Inlet solenoid valve
8. Exhaust solenoid valve
9. Air spring solenoid valves
10. Air springs
11. Pressure relief valve
12. Solenoid diaphragm valve
13. System air operated diaphragm valve
14. Silencer

Valve block port numbers (1) TO (11)

- (1) Air spring - rear left
- (2) Air spring - rear right
- (3) Air spring - front left
- (4) Air spring - front right
- (5) Dryer outlet
- (6) Reservoir in/out
- (7) Dryer inlet
- (8) Compressor inlet
- (9) Outlet
- (10) Pressure relief valve vent
- (11) Diaphragm outlet (to compressor inlet)

----- denotes valve block



AIR PIPE COLOUR CODES

The following pipes have a coloured band to aid assembly:

Component	Colour
Rear left spring	RED
Rear right spring	BLUE
Front left spring	YELLOW
Front right spring	GREEN
Reservoir	BROWN
Exhaust	VIOLET

SYSTEM OPERATION

- see RR3858M

Air is drawn through the inlet filter 1. to the compressor 2., where it is compressed to 10.0 ± 0.5 bar.

Compressor operation activates the diaphragm solenoid valve 12. to prevent air going straight to atmosphere.

Compressed air passes to the air drier 3. Moisture is removed as air flows through the drier desiccant. The desiccant in the drier becomes wet.

Dried air passes to the valve block, through NRV1 to the reservoir 4.

The three non-return valves 6. ensure correct air flow. They also prevent loss of spring pressure if total loss of reservoir pressure occurs.

A pressure switch 5. maintains system pressure between set limits by switching the compressor on and off via an ECU controlled relay.

For air to be admitted to any spring or springs, inlet valve 7. and the relevant air spring solenoid valve or valves 9. must be energised.

For air to be exhausted from any spring, the exhaust valve 8. and the relevant air spring solenoid valve or valves must be energised.

The diaphragm solenoid valve ensures that air exhausted to atmosphere passes through the drier. This action purges moisture from the desiccant and regenerates the air drier.

Air is finally exhausted through the system air operated diaphragm valve 13. and to atmosphere through a silencer 14. at the chassis rear cross-member.

ECU INPUTS

The air suspension system is controlled by the ECU, which operates dependent on driver selected inputs plus those listed below. In each mode the ECU maintains the requested ride height by adjusting the volume of air in one or more of the air springs.

Battery - 12 volt supply from ignition load relay.

Engine - from A.C. generator phase tap, signals engine speed to ECU. Note that engine must be running for all height changes, except access and self-levelling when parked. The compressor will be disabled if engine speed falls below 500 rev/min. This is to prevent the compressor drawing current from the battery when the A.C. generator is not charging.

Height sensors - four potentiometer height sensors provide suspension height signals to the ECU.

Road speed - the vehicle speed sensor provides information enabling height changes to occur at correct road speed. Input speed signal to ECU is from a buffer unit located in the driver's side footwell.

Interior light delay unit - signals ECU if any door, not tailgate, is opened, which immediately suspends all height changes.

Parkbrake switch, manual vehicles - the Parkbrake must be ON to enter ACCESS.

Gearbox inhibit switch, automatic vehicles - the transmission must be in park to enter ACCESS, Parkbrake on or off.

Footbrake switch (brake light) - when footbrake is applied, and for one second after release, all height levelling is suspended below 1.6 kph (1 mph) and above 8 kph (5 mph). The purpose of this is to prevent the system reacting to suspension movement caused by weight transfer during braking and to prevent suspension wind up during height change. Note that this inhibit function is removed after sixty seconds e.g. if footbrake is held on for this time.

Delayed turn off relay - remains energised after switching engine off and exiting vehicle, enables self levelling to occur for 20 seconds. If vehicle is stationary, the ECU will energise the relay every six hours to allow self levelling to occur if necessary.

Reservoir pressure switch - when the ECU detects an output from the pressure switch indicating low pressure, the ECU will operate the compressor relay until the pressure switch indicates normal pressure.

Diagnostic plug ground - note that the two halves of the diagnostic plug are normally connected. When disconnected the system will not operate. It will remain frozen at its current height until reconnected.

Disable switch - In the disable position the switch sends a door open signal to the ECU. This freezes the system in position at speeds below 56 kph (35 mph).



SYSTEM FUNCTION

The following table indicates conditions required for various air suspension modes.



NOTE: That the engine must be running unless indicated, and that **ACCESS** may be selected for 15 seconds after switching engine off.

Function	Condition	Warning lamp on
1. Automatic functions - Inhibit switch OFF.		
High profile to standard	Over 56kph (35mph)	No
Standard to low profile	Over 80kph (50 mph) for 30 secs	Lower
Low profile to standard	Below 56kph (35 mph) for 30 secs (but above 1.6 kph (1 mph))	No
Access to standard	Park brake off or drive away	No
2. Driver select functions - Inhibit switch OFF.		
Standard to high profile	Raise switch below 56kph (35 mph)	Raise
High profile to standard	Lower switch below 56kph (35 mph)	No
Standard to access	Lower switch)Stationary/)park brake on	Lower
Low profile to access (where vehicle has not returned to standard)	Lower switch)- manual/)transmission P)- automatic/	Lower
High to Access	Press lower switch twice)doors shut	Lower
Access to standard	Raise switch	Lower
Access to high	Press raise switch twice	Raise
3. Inhibit switch ON		
High profile to standard	Below 56kph (35 mph)	Inhibit
Low profile to standard		Inhibit
Access to standard	Stationary/park brake on	Inhibit
4. Self levelling		
Vehicle levelling for 20 secs, and every 6 hrs	Stationary/engine off/ exit vehicle	No

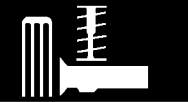

DIAGNOSTICS AND FAULT RECOVERY

The ECU incorporates Fault Recovery Strategies to minimise the effect of a system failure. A serial data link is provided to allow diagnostic information to be retrieved using TestBook. This is also used to set height sensor datum when required.

Note that the serial link connector is coloured black for identification purposes. Any faults stored in the ECU memory, from the previous or current running period will cause the ECU to flash the RAISE and LOWER lamps for 30 secs. followed by continuous illumination. If the ECU registers a system fault, it will store the fault in the memory. The fault recovery programme will operate the system depending on the nature of the fault as follows:

Speed sensor fault - the ECU will place the system in standard height and activate inhibit.

Height sensor fault - the ECU will place the system in standard height and activate inhibit. Note that if more than one height sensor fails, the ECU will deflate the air springs to the bump stops.



WARNING: If any two failure occur the system deflates and lowers vehicle to its bump stops, it is possible to drive the vehicle provided that great caution is exercised. The vehicle ride will be extremely uncomfortable and only low speeds will be possible. It is essential that the vehicle fault is rectified as soon as possible.

Pressure switch fault - the ECU will register pressure switch failure if it detects that the compressor has worked for a programmed time with normal air spring operation possible. The ECU will periodically operate the compressor as air is required. The vehicle will be inhibited to standard.

Compressor fault - the ECU will register compressor failure if it detects that the compressor has worked for a programmed time with normal air spring operation not possible. The ECU will attempt to place the system in standard ride height, or a safe lowered position (which could be system deflated). The system will be inhibited from further ride height changes.

Air leaks - during normal operation the ECU correlates the operating time of the compressor with air usage. If compressor use is greater than programmed, the ECU will register an air leak and attempt to place the system in standard ride height, or a safe lowered position (which could be system deflated). The system will be inhibited from further ride height changes.

Valve block fault - the control of each air spring is monitored to determine that every valve is working correctly.

1. If the ECU detects an air valve stuck open it will attempt to adjust the vehicle to standard height or a safe lowered position (which could be system deflated). The system will be inhibited from further ride height changes.
2. If an air valve is stuck closed above standard height the ECU will deflate the other three air springs.
3. If an air valve is stuck closed, at or below standard height, the ECU will attempt to adjust the other springs to the same height and activate inhibit.

AIR SUSPENSION CIRCUIT DIAGRAM

See Electrical Trouble Shooting Manual.

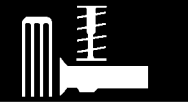

DEPRESSURISE SYSTEM

Service repair no - 60.50.38

Service tool:
TestBook

Depressurise

WARNING: Air suspension is pressurised up to 10 bar. Dirt or grease must not enter the system. Wear hand, ear and eye safety standard protection when servicing system.

1. Connect TestBook and follow instructions to depressurise complete system.

CAUTION: Depressurising system will lower body on to bump stops.

2. Ensure system is completely depressurised: Check that all air springs are deflated, and vehicle has dropped evenly on to the bump stops. If a spring, or springs, remains inflated possibly due to a stuck solenoid valve, it will be necessary to disconnect the pressurised pipe at that air spring.

WARNING: Wear hand, ear and eye safety standard protection. For extra protection wrap a clean cloth around pipe to be disconnected. Note that vehicle will lower to bump stop when pipe is disconnected.

3. Disconnect air pipe. *See Repair, Disconnect/Connect Air Pipe*

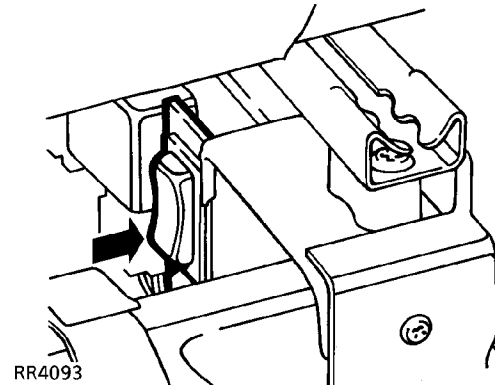

4. Disable system using switch under rear of RH front seat.

Repressurise

1. Switch disable switch OFF.
2. Run engine to repressurise system.

SYSTEM CALIBRATION - HEIGHT SENSOR DATUM

Equipment required:

TestBook



NOTE: This procedure must be carried out when a new ECU or height sensor has been fitted.

Calibration will also be required if any part affecting damper relationship to body is changed i.e. damper mounts, axles, chassis unit and body panels. The vehicle can be calibrated laden or unladen, but Gross Vehicle Weight must not be exceeded. Tyres must all be the same size and at the correct pressures.

IMPORTANT: The floor used for calibration must be level and smooth in all directions to enable procedure to be carried out successfully.

AIR RESERVOIR - DRAIN

Service repair no - 60.50.24

Drain the reservoir every 40,000 Kms (24,000 miles) - USA 30,000 miles.

1. Depressurise system. *See Depressurise System*
2. Clean area around reservoir drain plug.
3. Partially open drain plug, allow residual air to escape.

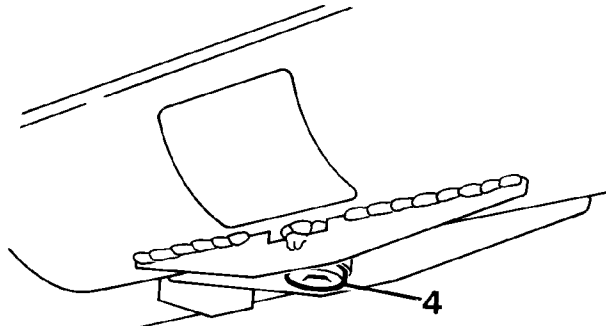

RR3865M

4. Remove drain plug, NO water should be present. If water is present, air drier unit must be changed. *See Repair, Air Drier*
5. Fit drain plug, checking sealing washer. Tighten to **70 Nm**.
6. Repressurise system.

AIR SPRINGS/HEIGHT SENSORS - INSPECT

Visually check air springs for cuts, abrasions and stone damage to alloy end plates. Check security of retention clips. Check height sensors for damage to housing, operating links and cable assembly.

AIR HARNESS INSPECT

Check air harness (pipes) for damage and security over its full length around vehicle.

LEAK TEST PROCEDURE

Service repair no - 60.50.35

If an air leak is suspected the use of a proprietary leak detection spray is recommended. This procedure should also be used where pneumatic components have been disturbed.

The spray used must have a corrosion inhibitor, and must not cause damage to paintwork, plastics, metals and plastic pipes.

Recommended leak detection spray is GOTEC LDS. This is available under part number STC1090.

1. Ensure system is fully pressurised.
2. Clean around area of suspected leak.
3. Using manufacturer's instructions, spray around all component joints and air springs, working systematically until source of leak is found.
4. If a component eg: air spring, air drier is leaking, rectify by fitting a new component.
5. If an air pipe connection is leaking cut 5 mm off end of pipe. Fit new collet. *See Repair, Air Pipe Connection Collet and 'O' Rings*
6. Reinflate system, carry out leak test.

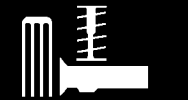

SUSPENSION COMPONENTS



CAUTION: It is essential to note that repairs to other suspension and transmission components are affected by air suspension.

The air suspension must be DEPRESSURISED before attempting to remove the following components:

Front panhard rod Radius arms Front axle

Rear top and bottom links Rear axle



WARNING: Before inflation, the air spring must be restricted by suspension and the dampers fitted. Unrestricted movement of a pressurised air spring will result in failure of the assembly, causing component and possible personal injury.

OPERATING SWITCHES AND BULBS

Service repair no - 60.50.17/18/19



NOTE: Each switch contains a warning light bulb and an illumination bulb.

Remove

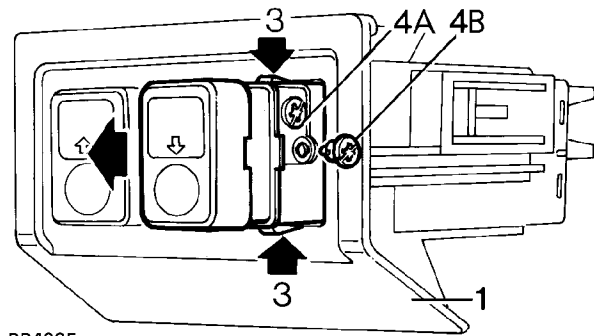

RR4095

1. Release switch panel from its fitted position.
2. Disconnect multiplug from switch.
3. Depress locating tags of switch to remove switch from panel.
4. Remove bulb by turning counter-clockwise:
 - A Warning
 - B Illumination

Refit

5. Fit new bulb and turn clockwise until fully located.
6. Reverse removal procedure.

DISCONNECT/CONNECT AIR PIPE**Remove**

WARNING: Air suspension is pressurised up to 10 bar. Dirt or grease must not enter the system. Wear hand, ear and eye safety standard protection when servicing system.

1. Depressurise complete system. *See Adjustment, Depressurise System*



CAUTION: Air pipes may be damaged if not disconnected correctly, resulting in possible leaks.

2. Clean air pipe connection with stiff brush and soapy water. Peel back rubber boot.

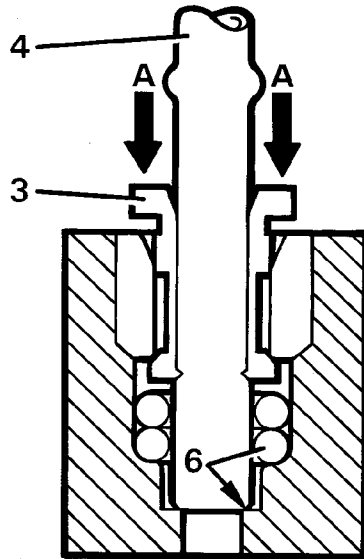

RR3592M

3. Apply equal downward pressure on collet flange at 'A' as shown.
4. Pull air pipe firmly out through centre of collet.
5. Inspect disconnected end of air pipe for damage and scores. Rectify as necessary.



NOTE: Air pipe may be trimmed if sufficient straight pipe remains. Ensure pipe end is cut square, without distortion or frays to obtain air tight seal. Use service tool LRT-60-002. Lightly chamfer pipe using a pencil sharpener after cutting. **DO NOT CUT PIPES MORE THAN TWICE.**

Refit

6. Push pipe firmly through two 'O' rings until it contacts base of housing as shown. Gently pull pipe to ensure connection. The collet will retain some movement while depressurised. Refit rubber boot.
7. Pressurise system. *See Adjustment, Depressurise System*
8. Leak test connection. *See Adjustment, Leak Test Procedure*

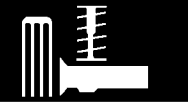

AIR PIPE CONNECTION COLLET AND 'O' RINGS

Remove



WARNING: Air suspension is pressurised up to 10 bar. Dirt or grease must not enter the system. Wear hand, ear and eye safety standard protection when servicing system.

1. Clean area with stiff brush and soapy water.
2. Depressurise system. *See Adjustment, Depressurise System*

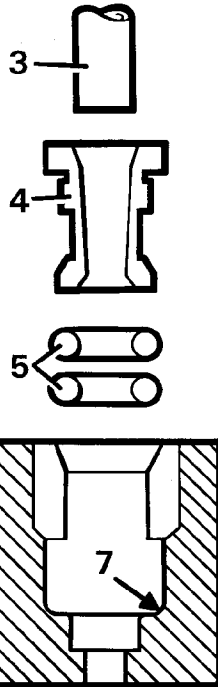

RR3593M

3. Disconnect air pipe. *See Disconnect/Connect Air Pipe*
4. Remove collet.
5. Carefully pry out two 'O' rings, using a smooth plastic hook, eg: a crochet hook.



CAUTION: Avoid scratching inside wall of housing, creating possible leak path.

Refit

6. Lightly grease new 'O' rings.
7. Fit 'O' rings into recess. Use a crochet hook to avoid damage to 'O' rings and housing.
8. Locate collet legs into housing, push fully home.
9. Inspect end of air pipe for damage and scores rectify by trimming.



NOTE: Air pipe may be trimmed if sufficient straight pipe remains. Ensure pipe end is cut square, without distortion or frays to obtain air tight seal. Use service tool LRT-60-002. Lightly chamfer pipe using a pencil sharpener after cutting. **DO NOT CUT PIPES MORE THAN TWICE.**

10. Connect air pipe. *See Disconnect/Connect Air Pipe*
11. Pressurise system. *See Adjustment, Depressurise System*
12. Leak test connection. *See Adjustment, Leak Test Procedure*

FRONT DAMPER

Service repair no - 60.30.02

Remove



WARNING: Air suspension is pressurised up to 10 bar. Dirt or grease must not enter the system. Wear hand, ear and eye safety standard protection when servicing system.



WARNING: Unrestricted movement of a pressurised air spring will result in failure of assembly, causing component damage and possible personal injury. It is possible to remove damper assembly without depressurising air springs, providing distance between axle and chassis is held as if damper assembly were still fitted. This is achieved by supporting vehicle on stands with a jack under the axle.

1. Disconnect battery negative lead.
2. Remove wheel. *See WHEELS AND TYRES, Repair, Wheels*
3. Support chassis on axle stands.
4. Support front axle with jack.



CAUTION: Do not lower axle when damper is removed, this may result in damage to air springs.

5. Remove top and bottom damper fixings.

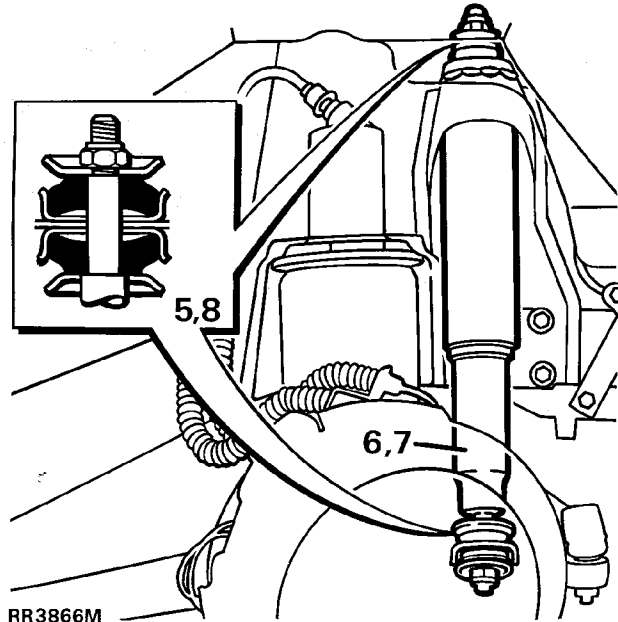

6. Remove damper.

Refit

7. Fit damper.
8. Fit top and bottom fixings, ensuring mounting rubbers are fitted as shown.
9. Tighten fixings to **38Nm**.
10. Reverse removal procedure. 1 to 4.



REAR DAMPER

Service repair no - 64.31.02

Remove



WARNING: Air suspension is pressurised up to 10 bar. Dirt or grease must not enter the system. Wear hand, ear and eye safety standard protection when servicing system.



WARNING: Unrestricted movement of pressurised air spring will result in failure of assembly, causing component damage and possible personal injury. It is possible to remove damper assembly without depressurising air springs, providing distance between axle and chassis is held as if damper assembly were still fitted. This is achieved by supporting vehicle on stands with a jack under the axle.

1. Disconnect battery negative lead.
2. Remove wheel. *See WHEELS AND TYRES, Repair, Wheels*
3. Support chassis on stands.
4. Support axle with jack.



CAUTION: Do not lower axle when damper is removed, this may result in damage to air springs.

5. Remove damper top and bottom fixings.

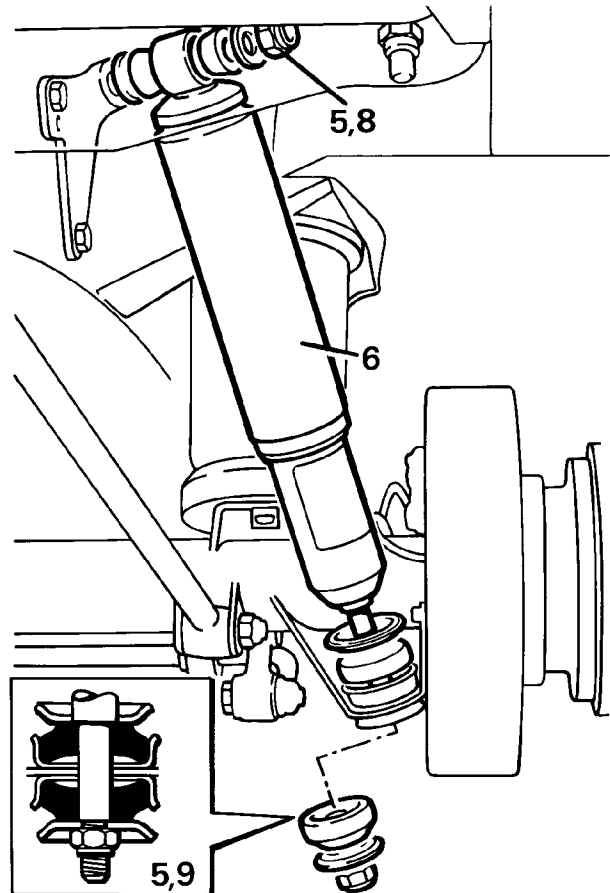

RR3867M

6. Remove damper.

Refit

7. Fit damper.
8. Fit top fixings. Tighten to **82Nm**.
9. Fit bottom fixings, ensure mounting rubbers are fitted as shown. Tighten to **38Nm**.
10. Reverse removal procedure. 1 to 4.

FRONT AIR SPRING

Service repair no - 60.21.01

Remove

WARNING: Air suspension is pressurised up to 10 bar. Dirt or grease must not enter the system. Wear hand, ear and eye safety standard protection when servicing system.



WARNING: The air spring must be restricted by suspension loading, with dampers fitted before inflation. Failure to observe this warning could cause air spring failure, resulting in component damage or personal injury. **DO NOT ATTEMPT TO DISMANTLE AIR SPRING**

1. Depressurise system. *See Adjustment, Depressurise System*
2. Disconnect battery negative lead.
3. Remove wheel, *See WHEELS AND TYRES, Repair, Wheels*
4. Support chassis on axle stands.
5. Support front axle with jack.
6. Peel back rubber boot. Disconnect air pipe from air spring. *See Disconnect/Connect Air Pipe*

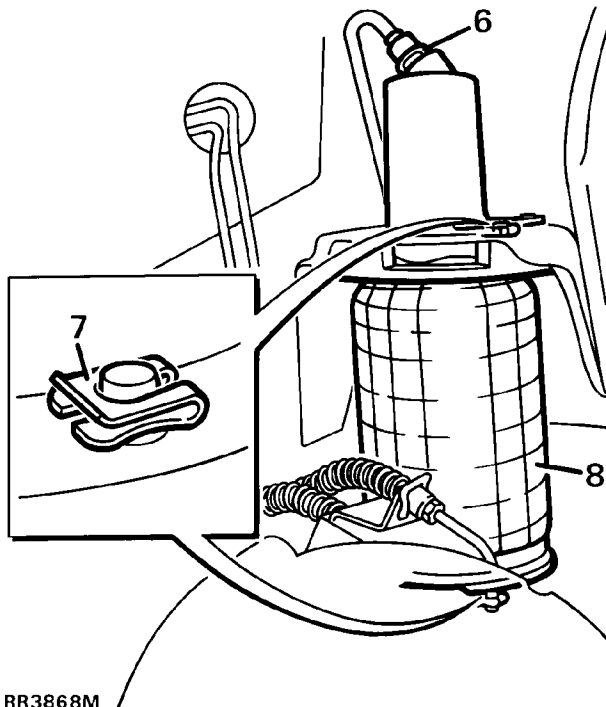

RR3868M

7. Remove four retaining clips from upper and lower fixing.
8. Remove air spring assembly.

Refit

9. Locate air spring assembly onto lower fixing, ensure air pipe connection points rearwards.
10. Connect air pipe to air spring assembly. *See Disconnect/Connect Air Pipe*
11. Raise axle to locate air spring assembly into upper fixing, if required.
12. Fit new retaining clips to fixing points.
13. Reverse removal instructions 1 to 6.
14. Leak test air spring and around connections. *See Adjustment, Leak Test Procedure*

REAR AIR SPRING ASSEMBLY

Service repair no - 64.21.01

Remove

WARNING: Air suspension is pressurised up to 10 bar. Dirt or grease must not enter the system. Wear hand, ear and eye safety standard protection when servicing system.



WARNING: The air spring must be restricted by suspension loading, with dampers fitted before inflation. Failure to observe this warning could cause air spring failure, resulting in component damage or personal injury. **DO NOT ATTEMPT TO DISMANTLE AIR SPRING**

1. Depressurise system. *See Adjustment, Depressurise System*
2. Disconnect battery negative lead.
3. Remove wheel, *See WHEELS AND TYRES, Repair, Wheels*
4. Support chassis on axle stands.
5. Support axle with jack.

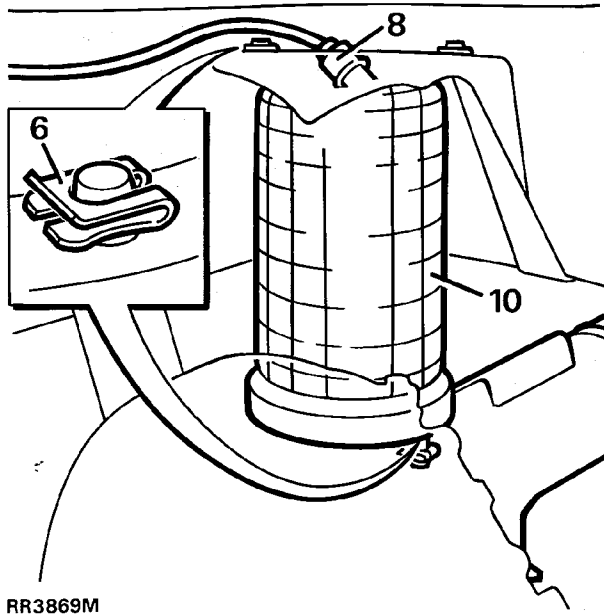

RR3869M

6. Remove four retaining clips from upper and lower fixing.
7. Lower axle for access to air pipe connection at top of air spring.
8. Clean connection with a stiff brush and soapy water. Peel back rubber boot.
9. Disconnect air pipe. **See Disconnect/Connect Air Pipe**, seal all ends.
10. Remove air spring assembly.

Refit

11. Locate air spring assembly onto lower fixing. Ensure air pipe connection points towards rear.
12. Connect air pipe to air spring assembly, fitting rubber boot. **See Disconnect/Connect Air Pipe**
13. Raise axle to locate air spring assembly into upper fixing, if required.
14. Fit four new retaining clips to fixing points.
15. Reverse removal instructions 1 to 5.
16. Leak test air spring and connector. **See Adjustment, Leak Test Procedure**

BUMP STOP

Service repair no - 60.30.10



CAUTION: Air suspension system uses 'progressive' bump stops, which must not be interchanged with those used on coil spring suspension.

Remove

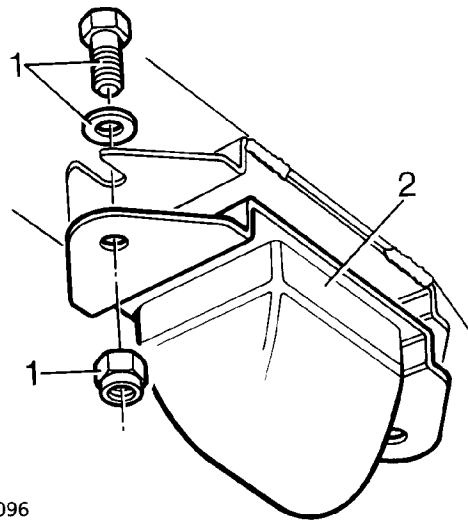

RR4096

1. Remove 2 locknuts and bolts with flat washers.
2. Remove bump stop assembly.

Refit

3. Position fixing bolts and flat washers in chassis bracket.
4. Fit bump stop.
5. Tighten fixings.

HEIGHT SENSOR

Service repair no - 60.36.01 - Front

Service repair no - 64.36.01 - Rear

Remove

1. Disconnect battery negative lead.
2. Remove wheel.
3. Disconnect height sensor multiplug.

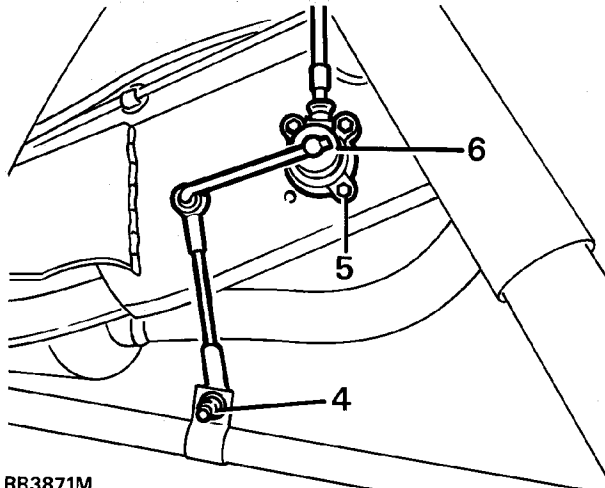

RR3871M

4. Remove height sensor lower link fixing.



CAUTION: Back height sensors have longer lower link than the front sensors.

5. Remove height sensor fixings.
6. Remove height sensor.

Refit

7. Reverse removal instructions.
8. Recalibrate system. *See Adjustment, System Calibration - Height Sensor Datum*
9. Attain standard ride height.

PRESSURE RELIEF VALVE

Service repair no - 60.50.31



WARNING: Air suspension is pressurised up to 10 bar. Dirt or grease must not enter the system. Wear hand, ear and eye safety standard protection when servicing system.

Remove

1. Remove valve block. *See Valve Block*
2. Clean around pressure relief valve with a stiff brush and soapy water.

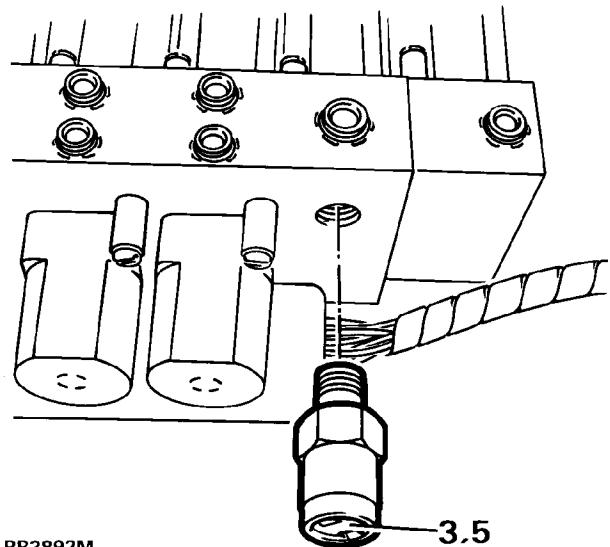

RR3892M

3. Remove pressure relief valve.

Refit

4. Coat threads of pressure relief valve with Loctite 572.
5. Fit valve. Tighten to **12 Nm**.
6. Reverse removal procedure.

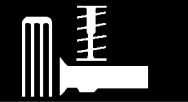

COMPRESSOR INLET FILTER

Service repair no - 60.50.12

Change the inlet filter every 40,000 Kms (24,000 miles) - USA 30,000 miles.



NOTE: Compressor inlet filter is situated adjacent to the fuel filler flap. Access is gained by removing the closure plate situated in the right hand side of load space.

Remove

1. Remove sub woofer, (if fitted). *See ELECTRICAL, Repair, Subwoofer Box*

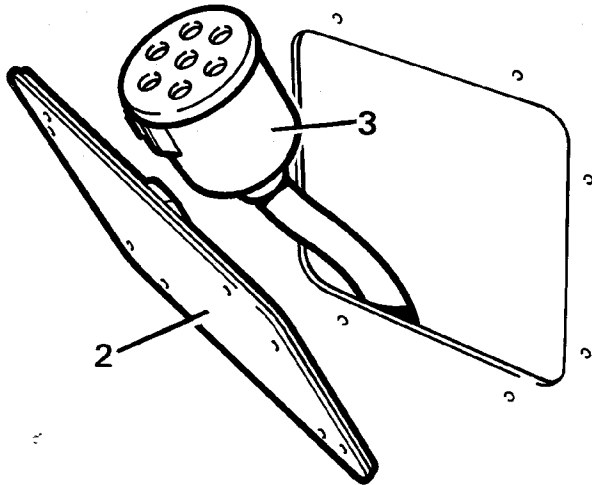

RR3891M

2. Remove eight screws. Remove closure panel.
3. Remove inlet filter from mounting bracket.
4. Remove filter from pipe.

Refit

5. Fit new filter.
6. Reverse removal procedure.

AIR SUPPLY UNIT

Service repair no - 60.50.23

Mounted on the chassis this unit contains the compressor, air drier and valve block. The unit must be removed before removing these components.



WARNING: System is pressurised up to 10 bar. Dirt or grease must not enter the system. Wear hand, ear and eye safety standard protection when servicing system.

Remove

1. Depressurise system. *See Adjustment, Depressurise System*
2. Disconnect battery negative lead.

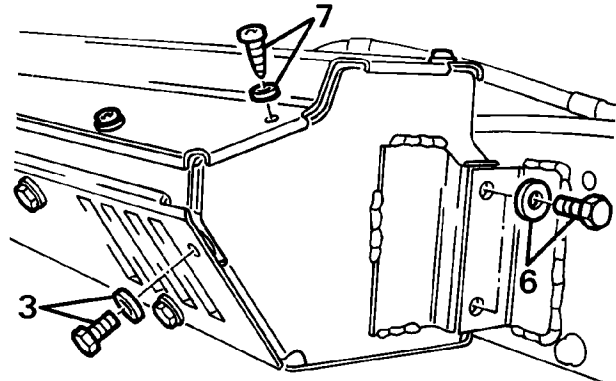

RR3872M

3. Remove air supply unit side cover plate.
4. Disconnect multiplug.
5. Disconnect compressor inlet pipe, seal all exposed ends.
6. Support air supply unit. Remove four mounting bolts.



CAUTION: DO NOT allow unit to hang on pipes or electrical leads.

7. Remove air supply assembly top cover plate.

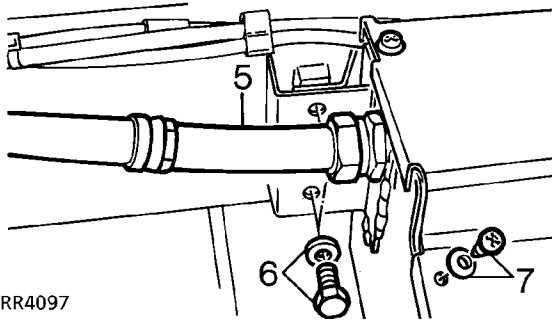

RR4097

8. Clean all components. Identify air pipe connections.
9. Disconnect air pipe connections. **See *Disconnect/Connect Air Pipe***
Seal all exposed ends Disconnect remaining multiplug.
10. Remove air pipes and wiring harness from assembly.
11. Remove air supply unit from vehicle.

Refit

12. Reverse removal procedure. Tighten mounting bolts to **24Nm**.
13. Leak test all disturbed connections. **See *Adjustment, Leak Test Procedure***

AIR DRIER

Service repair no - 60.50.09

Remove



WARNING: Air suspension is pressurised up to 10 bar. Dirt or grease must not enter the system. Wear hand, ear and eye safety standard protection when servicing system.

1. Remove air supply unit. **See *Air Supply Unit***
2. Disconnect two air pipes from air drier. **See *Disconnect/Connect Air Pipe***

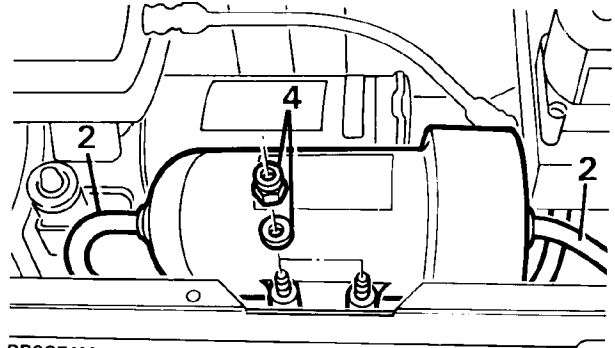

RR3874M

3. Seal drier connections to prevent moisture intake.
4. Remove fixings.
5. Remove drier.

Refit

6. Inspect air pipes. If damaged fit new pipes. DO NOT ATTEMPT TO TRIM DRIER PIPES.
7. Reverse removal procedure. Tighten nuts to **12Nm**.
8. Leak test connections. **See *Adjustment, Leak Test Procedure***



AIR COMPRESSOR

Service repair no - 60.50.10

Remove



WARNING: The air compressor assembly becomes hot when running. Avoid personal contact or allow to cool.

1. Remove air supply unit. *See Air Supply Unit*
2. Remove compressor outlet pipe, seal all exposed ends.

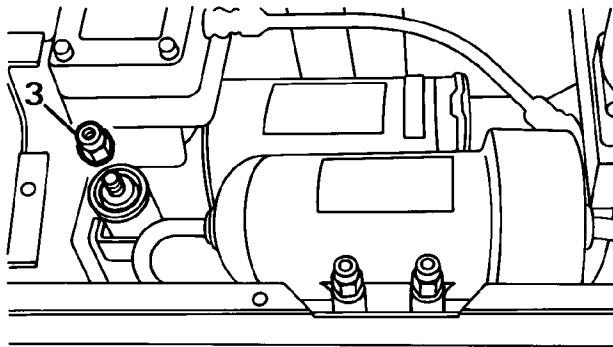

RR 3875M

3. Remove four fixing nuts.
4. Remove compressor assembly.

Refit

5. Inspect compressor mountings, replace if necessary.
6. Reverse removal procedure. Tighten nuts to **7Nm**.
7. Check operation of compressor.
8. Leak test connections. *See Adjustment, Leak Test Procedure*

VALVE BLOCK

Service repair no - 60.50.11

Remove



WARNING: Air suspension is pressurised up to 10 bar. Dirt or grease must not enter the system. Wear hand, ear and eye safety standard protection when servicing system.

1. Remove air supply assembly. *See Air Supply Unit*
2. Disconnect air pipes from valve block, seal all pipe ends *See Disconnect/Connect Air Pipe*



CAUTION: Air pipes must be refitted correctly to avoid component damage.

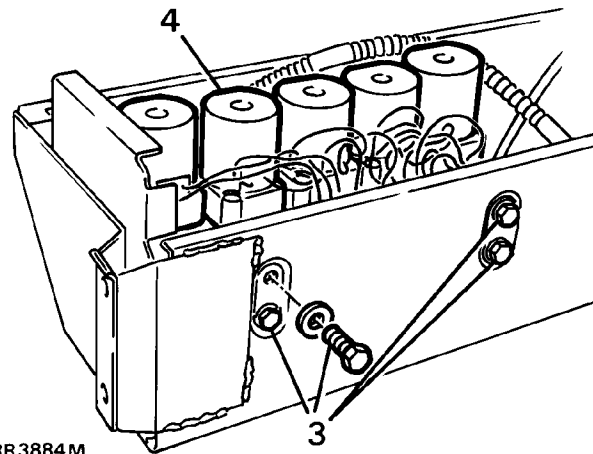

RR3884M

3. Remove four fixing bolts.
4. Remove valve block assembly.

Refit

5. Reverse removal procedure.
6. Leak test connections. *See Adjustment, Leak Test Procedure*

RESERVOIR PRESSURE SWITCH

Service repair no - 60.50.07

Remove

WARNING: Air suspension is pressurised up to 10 bar. Dirt or grease must not enter the system. Wear hand, ear and eye safety standard protection when servicing system.

1. Depressurise system. *See Adjustment, Depressurise System*
2. Disconnect battery negative lead.
3. Clean around pressure switch with stiff brush and soapy water.

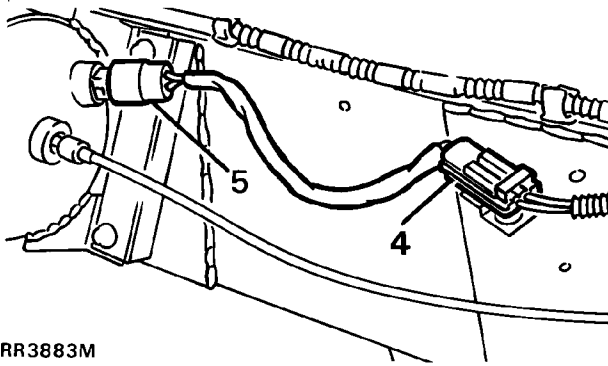

RR3883M

4. Disconnect pressure switch multiplug.
5. Unscrew and remove pressure switch.



CAUTION: Protect opening from ingress of dirt.

Refit

6. Apply Loctite 572 to thread of pressure switch.
7. Fit pressure switch. Tighten to **23 Nm**.
8. Connect multiplug and battery.
9. Start engine to re-pressurise system.
10. Attain standard ride height.
11. Leak test pressure switch. *See Adjustment, Leak Test Procedure*

AIR RESERVOIR

Service repair no - 60.50.03

Remove

WARNING: Air suspension is pressurised up to 10 bar. Dirt or grease must not enter the system. Wear hand, ear and eye safety standard protection when servicing system.

1. Depressurise reservoir. *See Adjustment, Depressurise System*
2. Clean around air pipe connection and drain plug with stiff brush and soapy water.
3. Open drain plug to release any residual pressure.

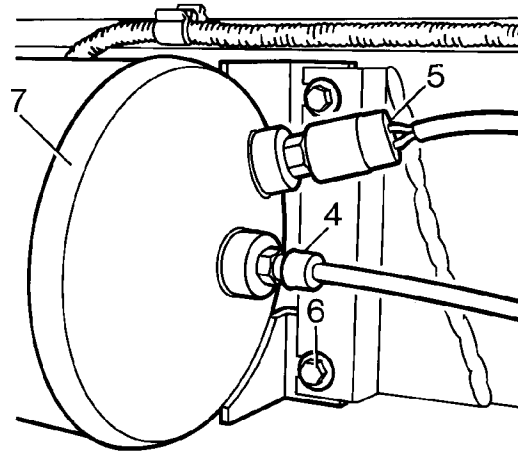

RR4098

4. Disconnect air pipe. *See Disconnect/Connect Air Pipe*
5. Disconnect pressure switch multiplug.
6. Release four fixing bolts.
7. Remove reservoir.

Refit

8. Fit reservoir. Tighten bolts to **24Nm**.
9. Connect air pipe, fitting rubber boot. *See Disconnect/Connect Air Pipe*
10. Connect pressure switch multiplug.
11. Tighten drain plug to **70 Nm**.
12. Start engine to repressurise system.
13. Leak test reservoir. *See Adjustment, Leak Test Procedure*

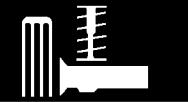

ELECTRONIC CONTROL UNIT

Service repair no - 60.50.04

Remove

1. Remove front trim from right hand front seat base.
2. Adjust seat rearward and upward.
3. Disconnect battery negative lead.

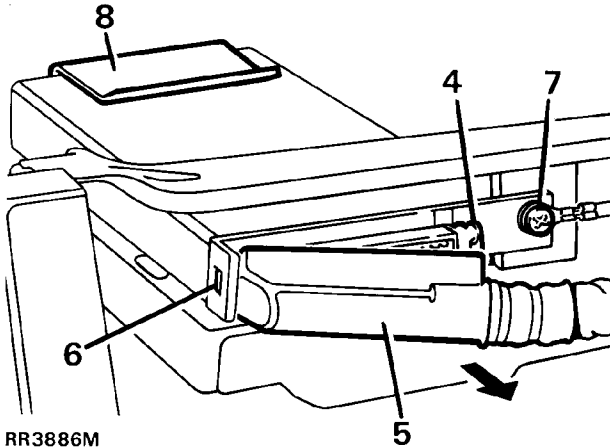

4. Release retaining clip from upper ECU plug.
5. Move plug in direction of arrow.
6. Detach hooked end of plug from retaining post.
7. Remove retaining screw.
8. Remove ECU from retaining clip.

Refit

9. Fit ECU into retaining clip.
10. Fit retaining screw.
11. Connect ECU harness plug. Ensure plug retaining clip engages.
12. If fitting a new ECU, recalibrate height settings.
See Adjustment, System Calibration - Height Sensor Datum

AIR HARNESS

Service repair no - 60.50.21

Remove



CAUTION: Thoroughly clean around all connections before disconnecting air pipes. Seal all exposed components against ingress of dirt and moisture.

1. Place vehicle on a wheel free lift.
2. Remove wheels.
3. Remove air supply unit. **See Air Supply Unit**
4. Disconnect air pipe from front left air spring.
5. Release front left chassis cable ties and clips.
6. Disconnect air pipe from reservoir.
7. Release back left chassis cable ties and clips, leave clips in chassis.
8. Disconnect air pipe from back left air spring.
9. Release three rear chassis cable ties.
10. Disconnect air pipe from back right air spring.
11. Release back right chassis cable ties and clips.
12. Disconnect air pipe from front right air spring.
13. Release front right chassis cable ties and clips.
14. Remove air harness from vehicle.

Refit

15. Layout air harness, identifying routing and connections.
16. Route air harness around chassis.
17. Remove sealing plugs, reconnect left front air spring.
18. Secure left front chassis ties and clips.
19. Working around chassis.



RECOMMENDED EQUIPMENT

TestBook

- Pressure test equipment LRT-60-001
- Pipe cutter LRT-60-002
- Leak detection spray STC 1090
- 35 way 'pin out' box STC 644



BRAKE SERVO UNIT

Description

The power assistance for the brake system is provided by a twin diaphragm suspended vacuum servo.

A 'Suspended Vacuum' servo is one where, with the engine running vacuum is present both sides of the diaphragm or diaphragms when the brakes are fully released or partially applied. The principal of having vacuum both sides of the diaphragm has two main advantages. First, it ensures instantaneous servo response to the brake being applied or released and second, it provides very accurate control of the position of the diaphragm and therefore, the degree of partial brake application.

At full pedal depression, vacuum is present in front of the diaphragm with atmospheric pressure on the rear.

Operation

Brakes released

With the brakes released depression is present both sides of the diaphragms, in chambers 1,2,3 and 4. The chambers communicate by ports A, B, D via the valve C which is shown fully released in RR3640M.

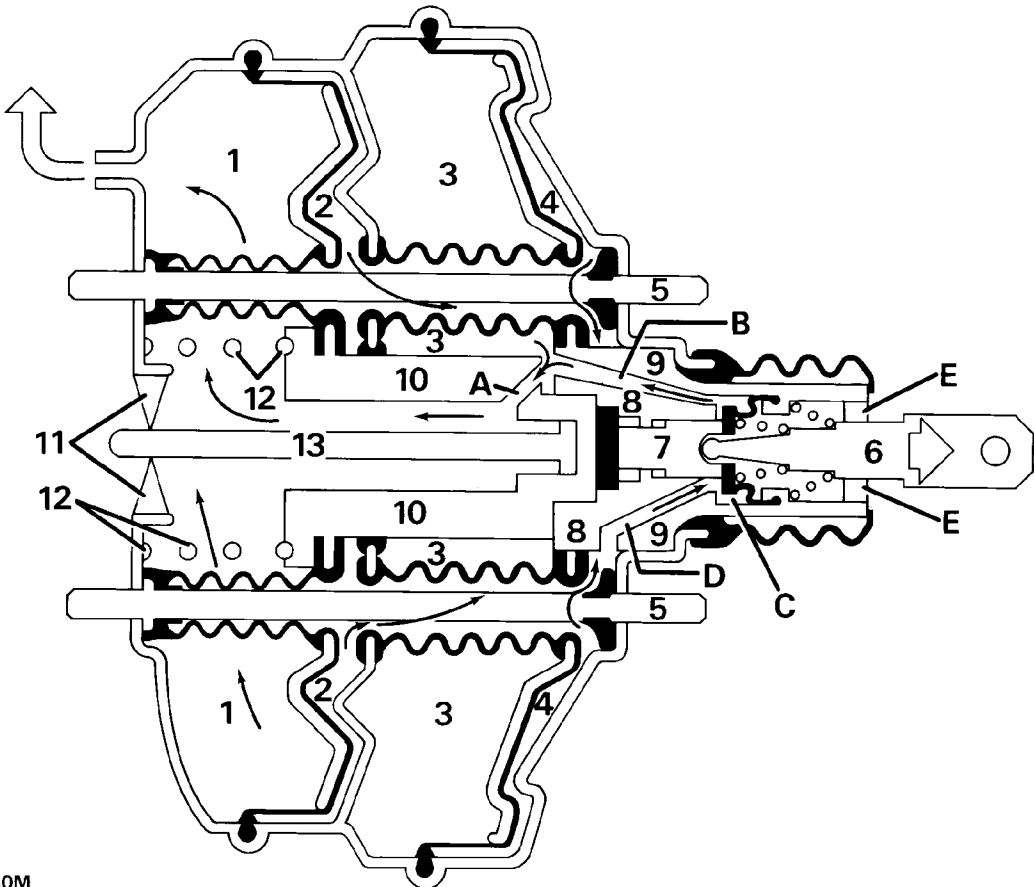

RR3640M

Brakes applied

When the brake pedal is depressed the pedal pushrod operates valve C situated in the plastic diaphragm hub 9 and 10. Initial depression of the the brake pedal, push rod 6 and plunger 7 compress a rubber pad 8. This slight movement causes valve C to close port D sealing off the vacuum to chambers 2/4 and allows atmospheric pressure to enter the chambers through the air filter E.

With depression in chambers 1/3 and air pressure in chambers 2/4 the servo hub will apply the brakes via the master cylinder push rod 13.

Atmospheric pressure over the large area of the diaphragms multiplies the force applied to the master cylinder piston, to provide the power assistance. If the brake pedal is only partially depressed, the servo hub, diaphragms and master cylinder push rod will stop moving, when valve C comes to rest on the plunger 7. At this point the valve will balance the pressure in all the chambers, to the applied effort at the pedal and provide proportional braking.

It is only when the brakes are fully applied that the valve does not balance the pressures in all the chambers, but ensures that maximum available depression is in chambers 1/3 and full atmospheric pressure enters chambers 2/4.

When the brake pedal is released, the pressure in all chambers is equalised and the servo is returned to the rest position by spring 12.

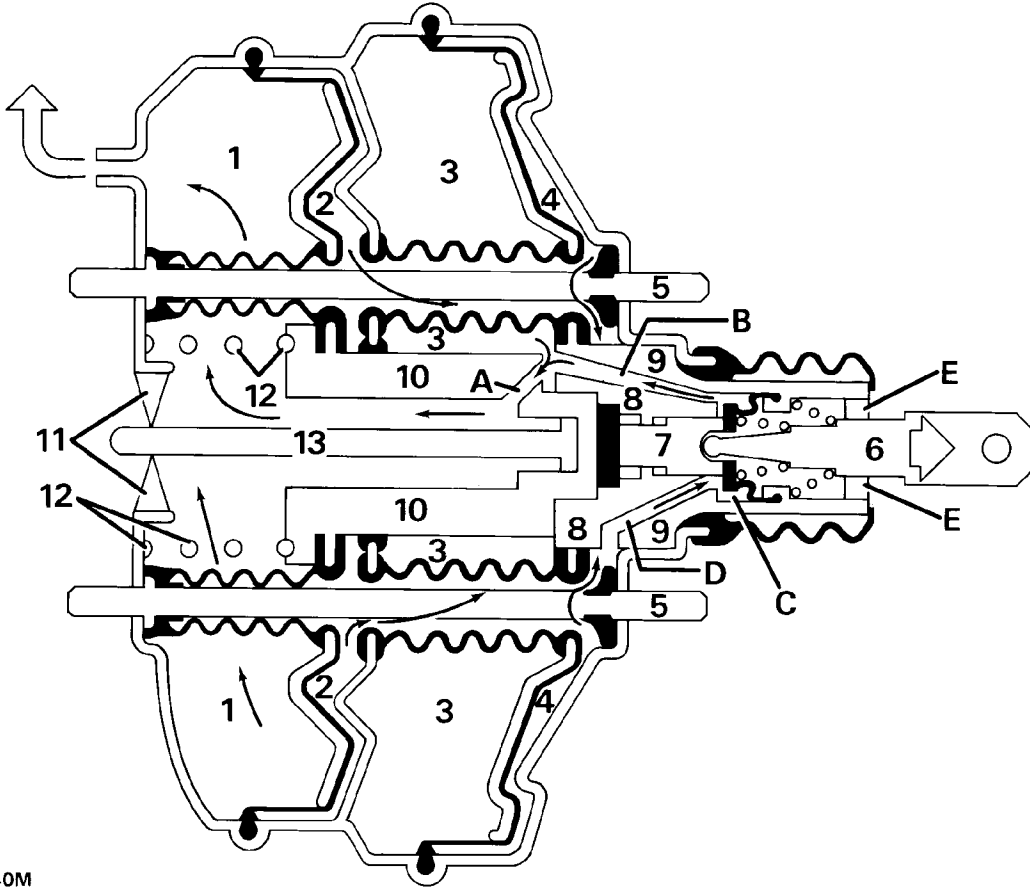

RR3640M



Petrol engine vacuum system

The vacuum necessary to operate the brake servo on petrol engine vehicles is provided by the engine inlet manifold. During normal operation of the brakes only a small volume of air is drawn from the servo and into the inlet manifold or plenum chamber. However any excessive air leaks due to damage in the brake servo system or manifold hose connection, will effect the mixture strength and ECM fuelling calculations on engines equipped with an MFI system. **See FUEL SYSTEM, Description and operation, Hot Wire Multiport Fuel Injection**

Diesel engine vacuum system

As the diesel engine inlet system does not produce depression sufficient to operate the brake servo, it is necessary to install an engine driven vacuum pump.

During normal operation of the brakes only a small volume of air is drawn from the servo by the vacuum pump. However as the pump exhausts air into the engine crankcase atmosphere, an air leak due to damage in the brake servo system or pump hose connection, may cause excessive crankcase pressure.

BRAKE SYSTEM

Description

The servo assisted hydraulic braking system is the dual line type, incorporating primary and secondary hydraulic circuits, see illustration RR2225M.



NOTE: References made to primary or secondary do not imply main service brakes or emergency brakes but denote hydraulic line identification.

The brake pedal is connected to a vacuum assisted mechanical servo which in turn operates a tandem master cylinder. The front disc brake calipers each house four pistons, the upper pistons are fed by the primary hydraulic circuit, the lower pistons by the secondary hydraulic circuit. The rear disc brake calipers each house two pistons, these are fed by the secondary hydraulic circuit via a pressure reducing valve.

A brake fluid level switch is incorporated into the reservoir cap assembly, the switch will immediately illuminate a warning light in the instrument binnacle indicating low fluid or sudden fluid loss.

The brake fluid reservoir is divided, the section closest to the servo feeds the primary circuit and the section furthest from the servo feeds the secondary circuit. Under normal operating conditions both the primary and secondary circuits operate simultaneously on brake pedal application. In the event of a failure in the primary circuit the secondary circuit will still function and operate front and rear calipers. Alternatively, if the secondary circuit fails the primary circuit will still function and operate the lower pistons in the front calipers, allowances should be made and vehicle speed adjusted accordingly to allow for the lack of full braking efficiency.

If the servo should fail, both hydraulic circuits will still function but would require greater pedal effort due to the lack of vacuum assistance.

The hand operated parking brake acts on a brake drum at the rear of the transfer gearbox and is completely independent of the hydraulic circuits.

Brake pad wear sensors are incorporated in the front and rear RH side inboard brake pads. The sensors will illuminate a brake pad wear warning light in the instrument binnacle, when pads require renewal.



CAUTION: Thoroughly clean all brake calipers, pipes and fittings before commencing work on any part of the brake system. Failure to do so could cause foreign matter to enter the system and cause damage to seals and pistons which will seriously impair the efficiency of the brake system.

To ensure the brake system efficiency is not impaired the following warnings must be adhered to :-

DO NOT use any petroleum (gasoline) based cleaning fluids or any proprietary fluids containing petroleum (gasoline) Use only the correct brake fluid.

USE ONLY the correct brake fluid if assembly fluid is required.



WARNING: Some components on the vehicle such as gaskets and friction surfaces (brake linings, clutch discs, or automatic transmission brake bands), may contain asbestos. Inhaling asbestos dust is dangerous to your health and the following essential precautions must be observed:

- **Work out of doors or in a well ventilated area. Wear a protective mask.**
- **Dust found on vehicle or produced during work on vehicle should be removed by vacuuming or by using a well dampened cloth and not by blowing.**
- **Dust waste should be dampened, placed in a sealed container and marked to ensure safe disposal.**
- **If any cutting, drilling etc, is attempted on materials containing asbestos the item should be dampened and only hand tools or low speed power tools used.**

DO NOT use brake fluid previously bled from the system.

DO NOT use old or stored brake fluid.

ENSURE that only new fluid is used and that it is taken from a sealed container.

DO NOT flush the brake system with any fluid other than the recommended brake fluid.

The brake system should be drained and flushed at the recommended service intervals.



PRIMARY HYDRAULIC
CIRCUIT

SECONDARY HYDRAULIC
CIRCUIT

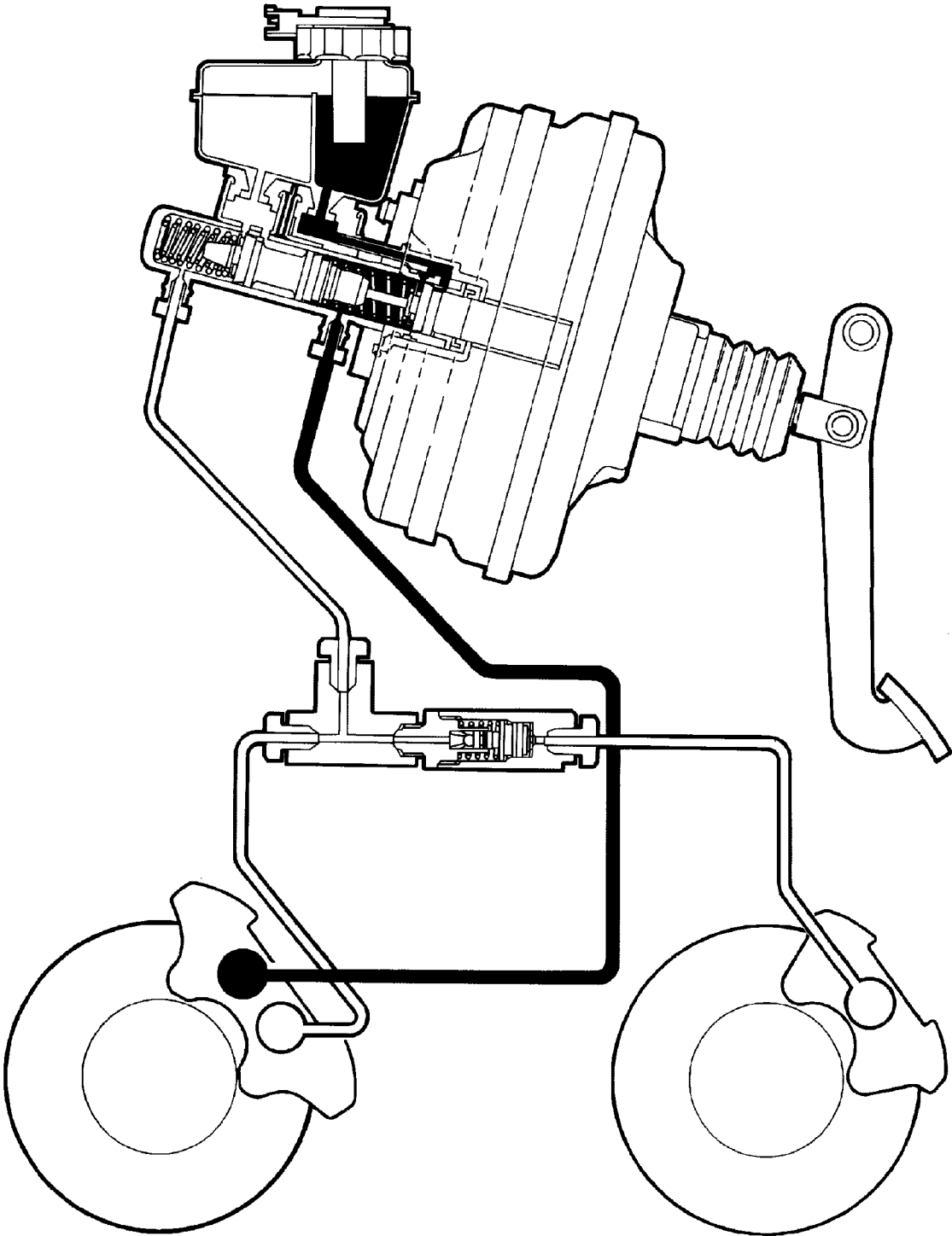

RR225M

BRAKE PIPE LAYOUT

Left hand drive

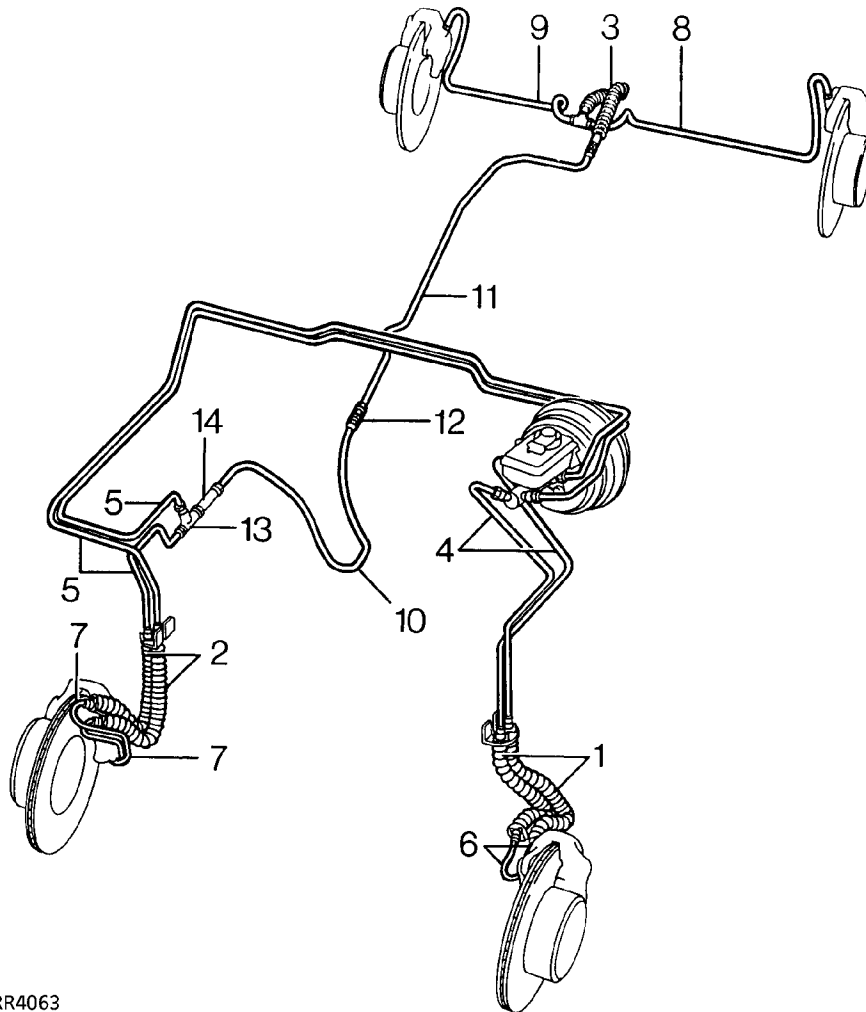

RR4063

HOSES

1. Front LH flexible hoses.
2. Front RH flexible hoses.
3. Intermediate flexible hose.



BRAKE PIPE LAYOUT

Right hand drive

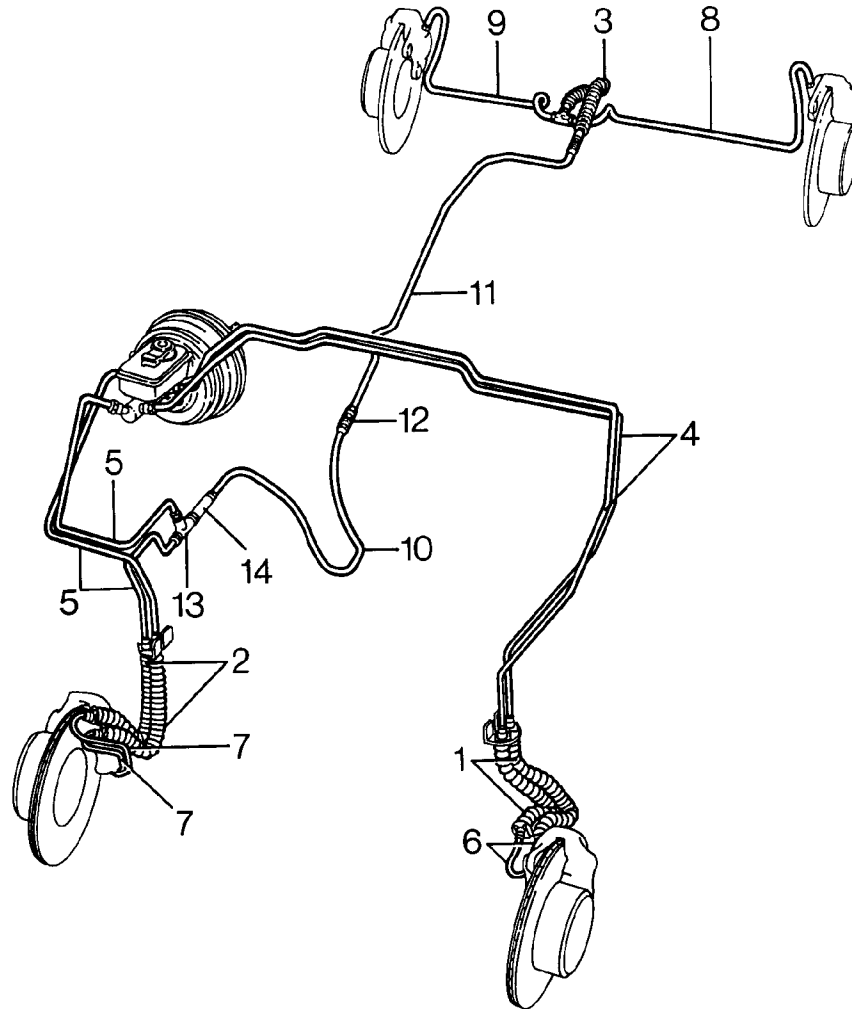

RR4064

PIPES

- | | |
|-------------------------------------|--------------------------------|
| 4. Feed to front LH hose connector. | 9. Feed to rear RH caliper. |
| 5. Feed to front RH hose connector. | 10. Feed to two way connector. |
| 6. Feed to front LH caliper. | 11. Feed to intermediate hose. |
| 7. Feed to front RH caliper. | 12. Two way connector. |
| 8. Feed to rear LH caliper. | 13. Three way connector. |
| | 14. Pressure reducing valve. |



BRAKE SYSTEM BLEED (NON ABS)

Service repair no - 70.25.02

Also. *See Brake System Bleed (ABS)*

The hydraulic system comprises two completely independent circuits. The rear calipers and lower pistons in the front calipers form the secondary circuit, while upper pistons in the front calipers form the primary circuit. The following procedure covers bleeding complete system, but it is permissible to bleed one circuit only if disconnection is limited to that circuit.

Bleeding will be assisted if engine is run or a vacuum supply is connected to servo.



WARNING: If engine is running during brake bleeding process ensure that neutral or park is selected in main gearbox and that park brake is applied.

When bleeding any part of secondary circuit, almost full brake pedal travel is available. When bleeding primary circuit only, brake pedal travel will be restricted to approximately half.



NOTE: When bleeding system commence with caliper furthest from master cylinder. Finally tighten bleed screws to 10 Nm.

Bleeding

1. Fill fluid reservoir with correct grade of fluid. *See LUBRICANTS, FLUIDS AND CAPACITIES, Information, Recommended Lubricants and Fluids*



NOTE: Maintain correct fluid level throughout procedure of bleeding.

2. Connect bleed hose to bleed screw on rear caliper furthest from master cylinder.
3. Submerge free end of bleed hose in a container of clean brake fluid.
4. Loosen bleed screw 1/2-3/4 of a turn.
5. Operate brake pedal fully and allow to return.

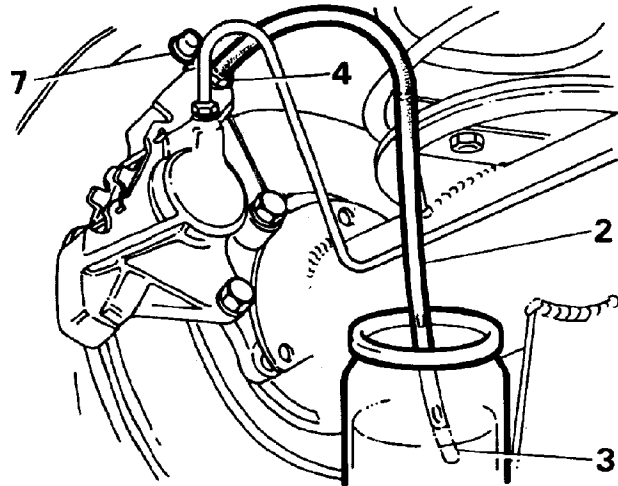

RR1946E



NOTE: Allow at least five seconds to elapse with foot right off pedal to ensure pistons fully return before operating pedal again.

6. Repeat 5 until fluid clear of air bubbles appears in container. Keeping pedal fully depressed, tighten bleed screw.
7. Remove bleed hose, replace dust cap on bleed screw.
8. Repeat 1 to 7 for other rear caliper.
9. Remove front wheel furthest from master cylinder

10. Connect a bleed hose to primary bleed screw on front caliper.
11. Connect a bleed hose to secondary bleed screw on same side of caliper as primary screw.

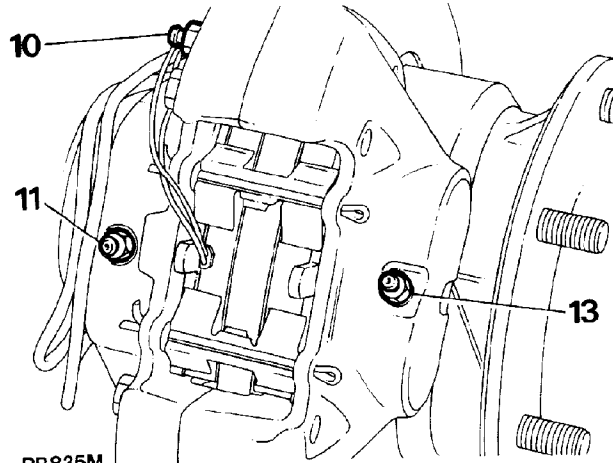

12. Repeat 3 to 7 for front caliper, bleeding two screws simultaneously.
13. Connect a bleed hose to other screw on front caliper furthest from master cylinder.
14. Repeat 3 to 7 for second secondary screw on front caliper.
15. Refit front wheel.
16. Repeat 9 to 15 for front caliper nearest master cylinder.

MASTER CYLINDER

- Lucas Girling - Type 25.4mm AS/AS

Service repair no - 70.30.08 - Remove
Service repair no - 70.30.09 - Repair

Remove

1. Disconnect battery negative lead.
2. Place a suitable container under master cylinder to catch brake fluid from cylinder when brake pipes are disconnected.

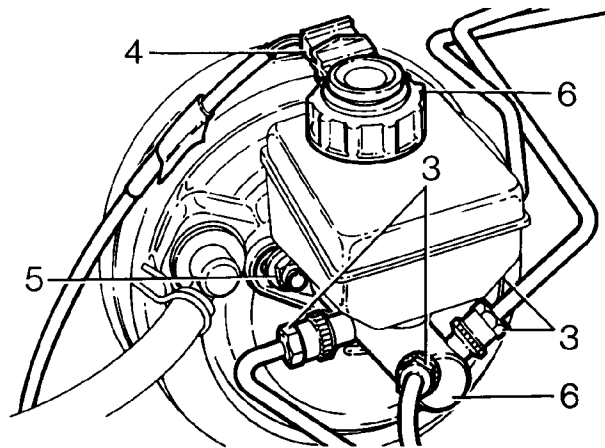

RR4065

3. Thoroughly clean immediate area around all outlet ports. Remove each brake pipe, sealing each pipe and outlet port with suitable plugs to prevent ingress of foreign matter.
4. Disconnect electrical plug from low fluid switch on reservoir cap.
5. Remove two nuts securing master cylinder to servo unit remove also spring and plain washers.
6. Detach master cylinder from servo, remove reservoir cap and drain brake fluid into a suitable container.



WARNING: Do not use brake fluid previously drained or bled from system. Carefully dispose of unwanted fluid, if stored in a sealed container, ensure that container is marked USED BRAKE FLUID.



Repair



WARNING: Use only unused brake fluid to clean any part of brake system. **DO NOT** use petrol, kerosene or other mineral based fluids.

7. Thoroughly clean master cylinder and inspect outer surfaces for damage and condition, renew complete assembly if necessary.
8. Using two soft jaws, clamp master cylinder flange in a suitable vice. Remove water ingress 'O' ring seal from master cylinder to servo flange and discard.

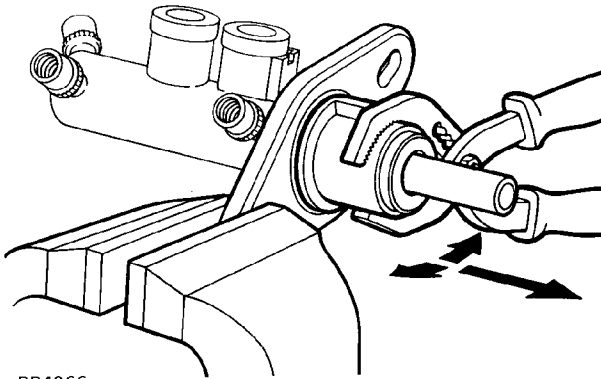

RR4066

9. Grip outside of transfer housing with a suitable pair of pliers, carefully pull, working pliers in a backwards and forwards rocking motion to ease housing off master cylinder. Discard housing and vacuum seal.

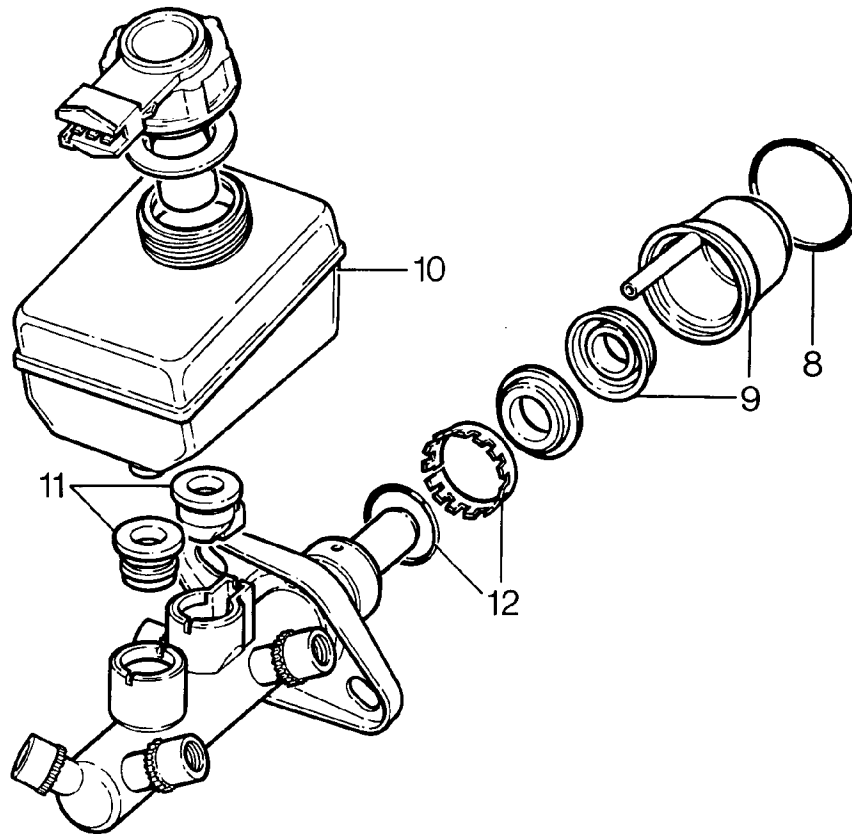

RR4067

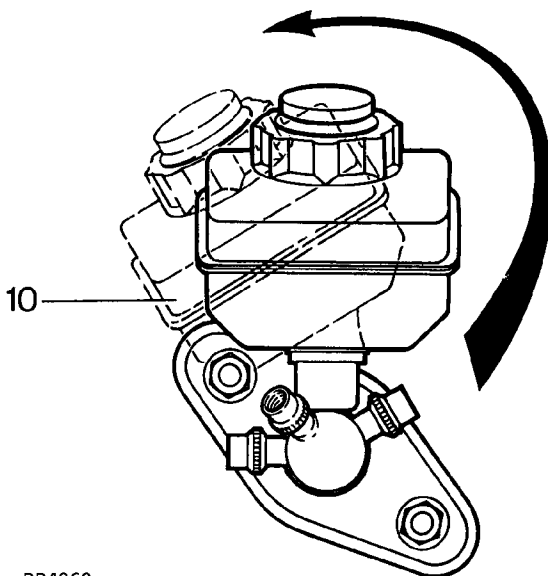

RR4068

10. Ease reservoir out of master cylinder taking care to ensure that two outlet ports on bottom of reservoir do not become damaged during this process.
11. Withdraw two reservoir seals from master cylinder inlet ports. Note for reassembly these seals are different. Discard seals.
12. Remove retaining ring and 'O' ring seal from machined outer surface of master cylinder. Discard both seal and retaining ring.



13. Remove guide ring, which supports primary plunger assembly, from mouth of master cylinder. Place to one side for reassembly, note this component is not part of service kit.
14. Pull primary plunger assembly out of master cylinder.



NOTE: The primary plunger assembly cannot be broken down any further and is serviced as a complete unit. Discard assembly.

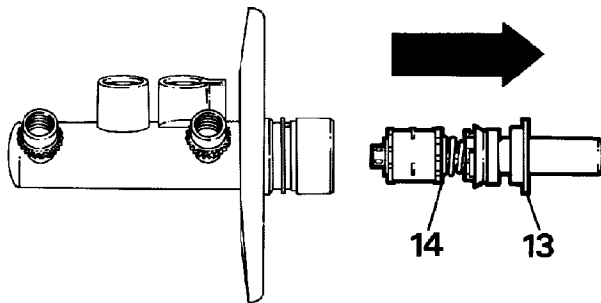

RR2238M

15. The secondary plunger assembly will remain at bottom of master cylinder bore. Remove, tapping assembly on a piece of wood until plunger appears at cylinder mouth, carefully pull plunger out of master cylinder.

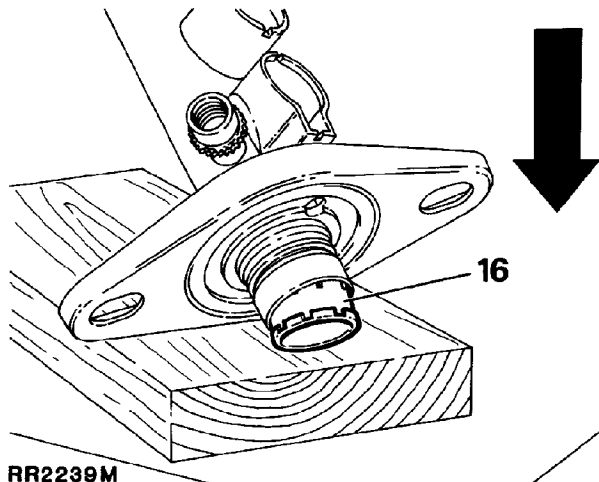

RR2239M

16. If swirl tube was not expelled at same time as secondary plunger, repeat above operation to remove it from bottom of master cylinder bore and discard.

17. Clean all parts with unused brake fluid. Place cleaned parts onto a clean sheet of paper. Inspect cylinder bore and plungers for signs of corrosion, ridges and score marks. Provided working surfaces are in perfect condition, new seals from a Girling Service repair kit may be used.

Renewing secondary plunger seals

18. Remove following components from secondary plunger and discard:



NOTE: A small screwdriver with end rounded off and polished is required to remove 'L' seal. DO NOT damage secondary plunger.

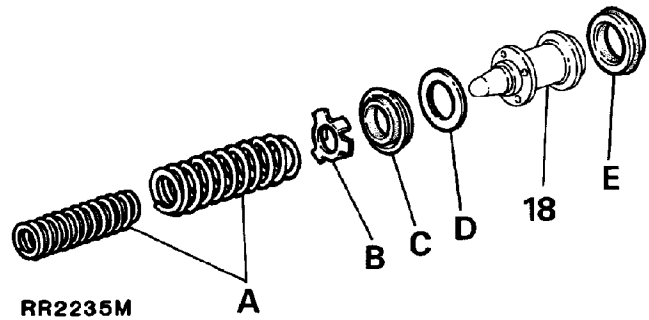

RR2235M

- (A) Springs
- (B) Seal retainer
- (C) Recuperating seal (primary cup)
- (D) Washer
- (E) 'L' seal

MASTER CYLINDER ASSEMBLY

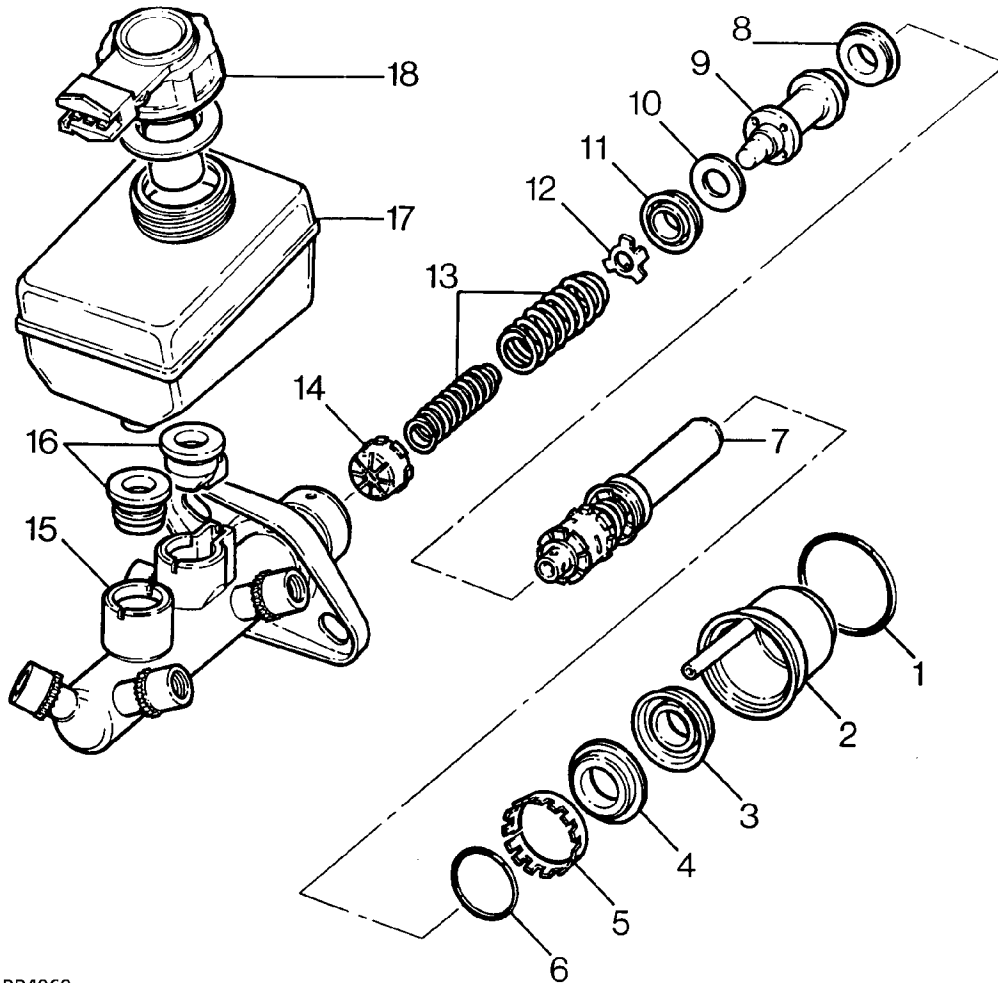

RR4069

Key to master cylinder

- | | | |
|-----------------------|-------------------------------------|------------------------------------|
| 1. Water ingress seal | 7. Primary plunger assembly | 13. Springs (2 off) |
| 2. Transfer housing | 8. 'L' seal | 14. Swirl tube |
| 3. Vacuum seal | 9. Secondary plunger | 15. Master cylinder body |
| 4. Guide ring | 10. Washer | 16. Reservoir seals |
| 5. Retaining ring | 11. Recuperating seal (primary cup) | 17. Reservoir |
| 6. 'O' ring seal | 12. Seal retainer | 18. Low fluid level switch and cap |



NOTE: Thoroughly check that no debris is lodged in fluid passageways and drillings. If debris is found, carefully remove, re-clean cylinder and re-check.



19. Coat new seals in unused brake fluid. Fit 'L' seal to plunger.
20. Fit washer followed by recuperating seal. Fit seal retainer and springs, ensure springs are correctly seated.

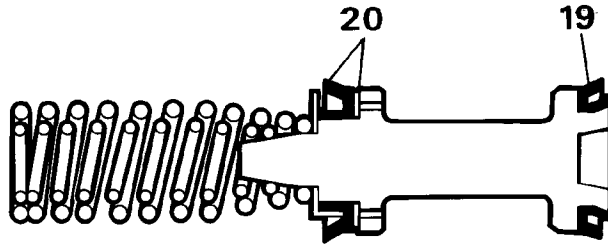

RR2236M

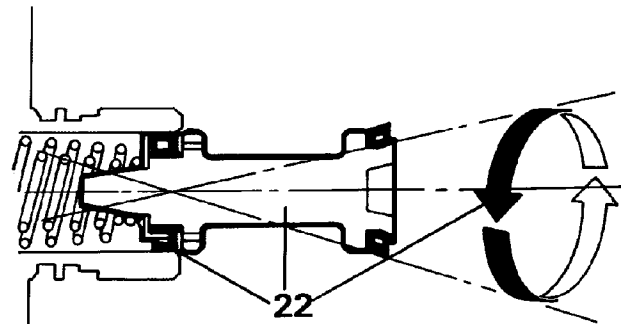

RR2240M

ASSEMBLING MASTER CYLINDER



CAUTION: It is important that following instructions are carried out precisely, otherwise damage could be caused to new seals when inserting plungers into cylinder bore. Generous amounts of new brake fluid should be used to lubricate parts during assembly. Never use old fluid or any other form of cleaning and lubricating material. Cleanliness throughout is essential.

21. Fit new swirl tube to bottom of cylinder bore.
22. Lubricate secondary plunger and cylinder bore. Offer plunger assembly to cylinder until recuperation seal is resting centrally in mouth of bore. Gently introduce plunger with a circular rocking motion, as illustrated. Ensuring that seal does not become trapped, ease seal into bore and slowly push plunger down bore in one continuous movement.

23. Fit new primary plunger assembly using same method as for secondary plunger.
24. Fit original guide ring to support primary plunger.
25. Coat a new 'O' ring with brake fluid and fit to its respective groove on outer location surface of master cylinder.



NOTE: DO NOT ROLL 'O' ring down outer location surface of master cylinder. It should be slightly stretched and eased down cylinder and into its groove. DO NOT OVER STRETCH SEAL.

26. Fit new retaining ring on outer surface of master cylinder ensuring that serrations of ring are facing mounting flange.
27. Fit two new reservoir seals in respective ports.
28. Fit a new vacuum seal to either primary plunger or to bottom of transfer housing bore, open face of seal towards primary plunger.
29. Lubricate vacuum seal with brake fluid. Fit transfer housing to master cylinder, push housing fully up to cylinder mounting flange, DO NOT ADJUST TRANSFER HOUSING AFTER FITTING.
30. Lubricate new water ingress seal with brake fluid, Slightly stretch seal and ease down housing until it is in position between housing and flange.
31. Roll reservoir into top of master cylinder, reversing procedure described in instruction 10.

Refit

32. Fit master cylinder to servo. Secure in position with two nuts, plain and spring washers. Tighten to **26 Nm**.
33. Fit brake pipes to master cylinder. Tighten to **10Nm**.
34. Top-up master cylinder with correct grade of brake fluid. **See LUBRICANTS, FLUIDS AND CAPACITIES, Information, Recommended Lubricants and Fluids**
35. Bleed system. **See Brake System Bleed (Non ABS)**



WARNING: Do not use brake fluid previously drained or bled from system. Carefully dispose of unwanted fluid, if stored in a sealed container, ensure that container is marked USED BRAKE FLUID.

36. Fit cap, reconnect electrical lead to fluid level switch. Reconnect battery negative lead.

SERVO ASSEMBLY

Service repair no - 70.50.01

Remove



NOTE: Other than replacing filter, non-return valve and grommet, the servo is not a serviceable component, in event of failure or damage fit a new unit.

1. Disconnect battery negative lead.
2. Disconnect electrical plug to low fluid level switch.
3. Thoroughly clean immediate area around all master cylinder outlet ports. Remove each brake pipe, sealing each pipe and outlet port with suitable plugs to prevent ingress of foreign matter.
4. Disconnect vacuum supply hose to servo.
5. Remove lower dash panel to gain access to servo push rod.

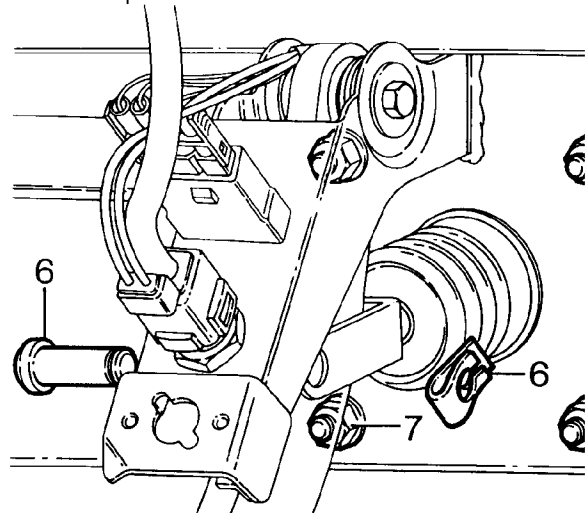

RR4070

6. Remove clevis pin securing servo push rod to brake pedal.
7. Remove 2 nuts and plain washers securing servo.



8. Remove servo and master cylinder assembly.
9. Drain brake fluid into a suitable container. (If master cylinder is kept horizontal it is not necessary to drain fluid).



WARNING: Do not use brake fluid previously drained or bled from system. Carefully dispose of unwanted fluid, if stored in a sealed container, ensure that container is marked USED BRAKE FLUID.

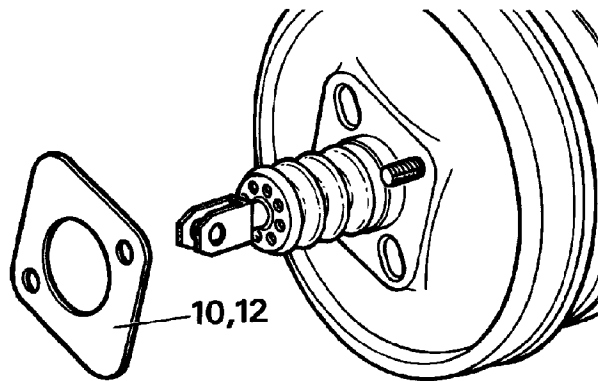

RR2233M

10. Detach spacer from pedal box mounting face of servo.



NOTE: Retain spacer reassembly. The spacer ensures stringent pedal to servo operating dimensions are maintained.

11. Remove master cylinder from existing servo and refit to new servo, if fitting new unit.

Refit

12. Fit spacer to servo.
13. Fit servo to pedal box.
14. Lightly grease brake pedal around area servo push rod pivots.
15. Fit push rod to brake pedal. Fit clevis pin and clip. Use lower hole.
16. Secure servo with two nuts and plain washers. Tighten nuts to **24 Nm**.
17. Refit lower dash panel.
18. Fit master cylinder to servo, refit nuts, plain and spring washers. Tighten nuts to **26 Nm**.
19. Remove all sealing plugs. Refit brake pipes to respective ports. Tighten brake pipes to **10 Nm**.
20. Refit vacuum supply hose.
21. Fill master cylinder to correct level using correct grade of brake fluid. **See LUBRICANTS, FLUIDS AND CAPACITIES, Information, Recommended Lubricants and Fluids**
22. Bleed brake system. **See Brake System Bleed (non ABS)**

FRONT BRAKE PADS

Service repair no - 70.40.02

Service tool:
LRT-70-500 - Piston clamp

Remove

Brake pad identification

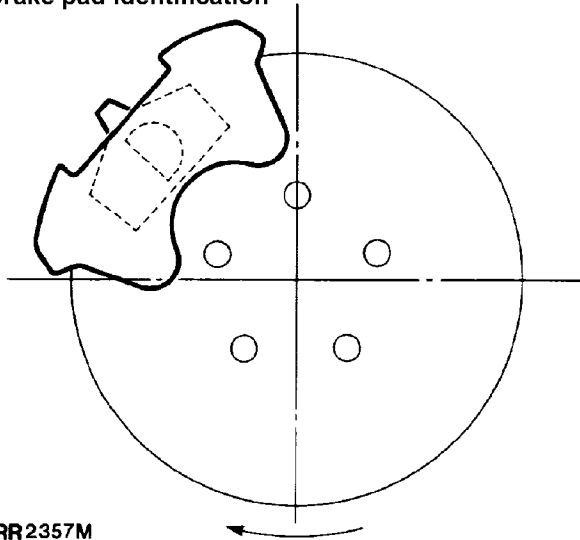

Direction of rotation

From side of vehicle, looking through disc and caliper at inboard pad, 'D' shaped material on rear of inboard pad should face direction of forward rotation of road wheel with curved part of 'D' always at trailing end of caliper.

Brake pad wear sensed on RH calipers.

1. Remove front road wheels. *See WHEELS AND TYRES, Repair, Wheels*
2. Disconnect battery negative lead.

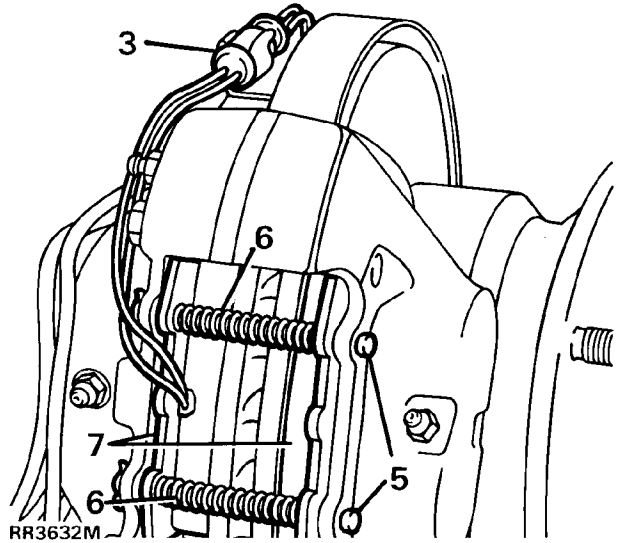

3. Disconnect pad wear sensor plug (front right hand side only).
4. Clean exterior of calipers.
5. Remove split pins from retaining pins.
6. Remove pad retaining pins and anti-rattle springs.
7. Remove brake pads.
8. Clean exposed parts of pistons, using new brake fluid.

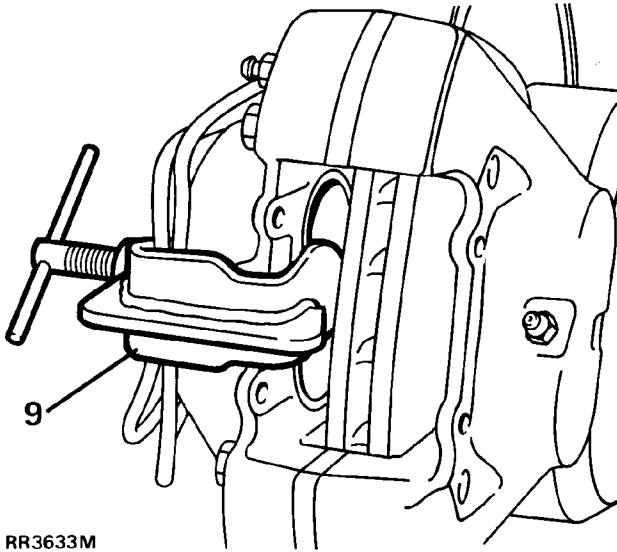

RR3633M

9. Using piston clamp LRT-70-500 press each piston back into its bore. Ensure that displaced brake fluid does not overflow from reservoir.
10. Coat faces of pistons with brake fluid, keeping it away from lining material.

Refit

11. Insert brake pads, ensuring pad with wear indicator is fitted to inboard side RH caliper.
12. Fit pad retaining pins and anti-rattle springs. Secure with new split pins. Reconnect pad sensor wear plug.
13. Apply service brake pedal several times to locate pads.
14. Check fluid reservoir. Top up if necessary, using correct grade of fluid. **See LUBRICANTS, FLUIDS AND CAPACITIES, Information, Recommended Lubricants and Fluids**

REAR BRAKE PADS

Service repair no - 70.40.03

Service tool:
LRT-70-500 - Piston clamp

Remove

1. Remove rear road wheels. **See WHEELS AND TYRES, Repair, Wheels**
2. Disconnect battery negative lead.
3. Disconnect pad wear sensor plug (rear RH side only).
4. Clean exterior of calipers.

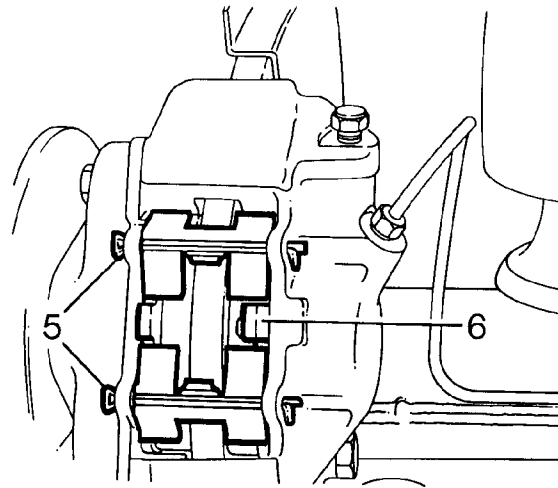

RR4073

5. Remove pad retaining pins and springs.
6. Remove brake pads.
7. Clean exposed parts of pistons, using new brake fluid.
8. Using piston clamp LRT-70-500 press each piston back into its bore. Ensure that displaced brake fluid does not overflow from reservoir.
9. Coat faces of pistons with brake fluid, keeping it away from lining material.

Refit

10. Insert brake pads, ensuring pad with wear indicator is fitted to inboard, RH side caliper.
11. Position pad retaining springs, fit new pins and spread ends. Reconnect pad sensor wear plug.
12. Apply service brake pedal several times to locate pads.
13. Check fluid reservoir, top up if necessary, using correct grade of fluid. ***See LUBRICANTS, FLUIDS AND CAPACITIES, Information, Recommended Lubricants and Fluids***



FRONT BRAKE CALIPER ASSEMBLY

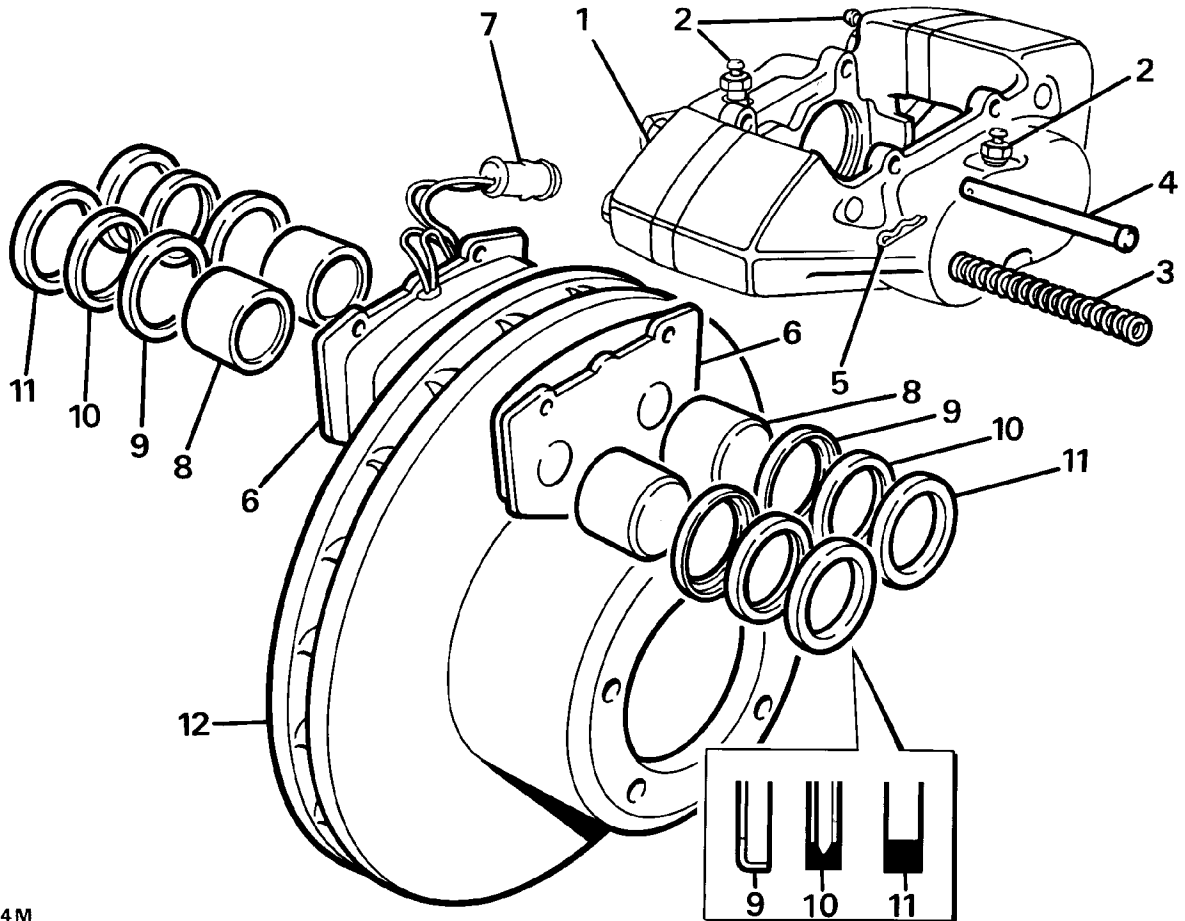

RR3634 M

Key to caliper

- | | |
|------------------------|----------------------------|
| 1. Caliper | 7. Pad wear indicator plug |
| 2. Bleedscrews | 8. Piston |
| 3. Anti-rattle springs | 9. Wiper seal retainer |
| 4. Pad retaining pins | 10. Wiper seal |
| 5. Split pins | 11. Fluid seal |
| 6. Friction pads | 12. Brake disc |

FRONT BRAKE CALIPERS

Service repair no - 70.55.03

Service repair no - 70.55.16

Service tool:

LRT-70-500 - Piston clamp



NOTE: Pad wear warning indicators are incorporated into front and rear RH inboard pads.

Remove caliper

1. Loosen front wheel retaining nuts, raise front of vehicle, lower onto axle stands, remove wheels.

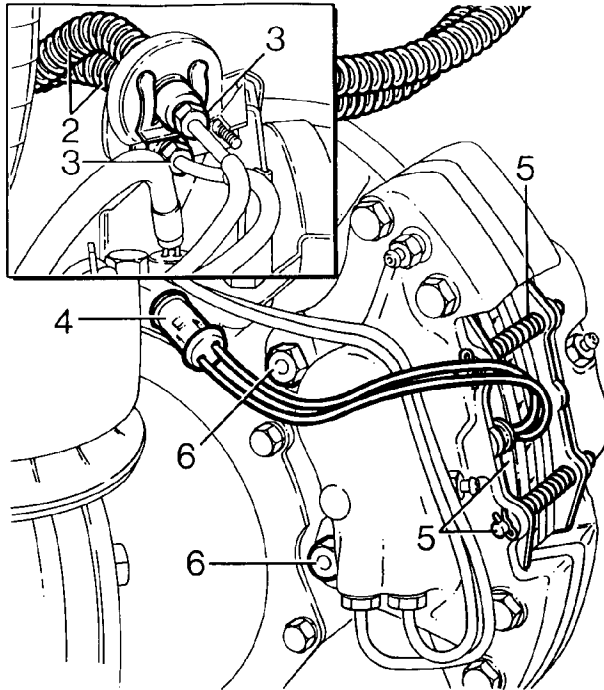

RR4074

2. Expose flexible brake hoses by moving coiled protective covering. Using a recognised hose clamp, clamp both hoses to prevent loss of brake fluid.
3. Disconnect rigid brake pipes from flexible hoses, seal exposed ends to prevent ingress of dirt. (If necessary rigid brake pipes to caliper can be disconnected when caliper is removed).

4. Disconnect pad wear warning indicator (front RH side only).
5. Remove split pins, retaining pins and springs, withdraw pads. If refitting pads, identify them for assembly to original locations.
6. Loosen bolts and remove caliper.

DISMANTLE AND REPAIR



CAUTION: Do not separate caliper halves. Overhaul both calipers.

7. Clean outer surfaces of caliper using aerosol brake cleaner.

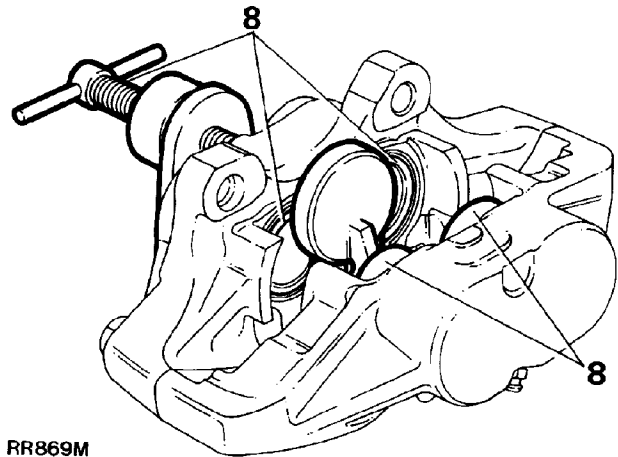

RR869M

8. Using special tool LRT-70-500, clamp pistons in inboard half of caliper. Gently, keeping fingers clear, and with **CAUTION**, apply air pressure to fluid inlet port to expel pistons. It is unlikely that pistons will expel at same time, regulate rate with a suitable piece of wood between appropriate piston and caliper.
9. Finally remove pistons, identifying them with their respective bores.
10. Remove wiper seal retainer by inserting a blunt screwdriver between retainer and seal. Pry retainer carefully from mouth of bore.
11. Taking care not to damage seal grooves, extract wiper seal and fluid seal.
12. Clean bores, pistons and seal grooves using clean brake fluid only. If caliper or pistons are corroded, or their condition is not perfect, new parts must be fitted.



Assemble outboard pistons

13. Coat new fluid seal with brake fluid. Ease seal into groove in bore using only fingers, ensuring it is properly seated. Fluid seal and groove are not same in section, so when seal is seated it feels raised to touch at edge furthest away from mouth of bore.
14. Coat appropriate piston with brake fluid. Insert it squarely into bore by hand only. Do not tilt piston during insertion, leave approximately 8mm projecting from bore.
15. Coat new wiper seal with brake fluid and fit to new seal retainer. Slide assembly, seal first, over protruding piston and into bore recess. Use piston clamp to press home seal retainer and piston.

Mounting inboard pistons

16. Clamp outboard pistons and carry out same procedure for removing and fitting outboard pistons and seals, instructions 8 to 15.

Fit calipers and pads

17. Fit caliper, tighten bolts progressively to, **82 Nm**.
18. Connect brake flexible hoses to caliper. Tighten to **10 Nm**.
19. Remove hose clamps.
20. Lightly coat back and edges of pads with brake fluid, avoid friction material.
21. Insert pads. Fit pins and springs, secure using new split pins.



NOTE: Ensure friction pad with wear indicator is fitted to inboard side of front RH caliper. New pads must be fitted to each caliper.

22. Reconnect pad wear indicator plug.
23. Bleed brake system. **See Brake System Bleed (non ABS)**
24. Press brake pedal firmly several times to locate friction pads.
25. Fit road wheels, remove axle stands. Finally tighten road wheel nuts.
26. Road test vehicle. Note that new friction pads require 'bedding-in', this may take several hundred miles before brakes are at maximum efficiency.

REAR BRAKE CALIPERS

Service repair no - 70.55.06

Service repair no - 70.55.17

Service tool:

LRT-50-700 - Piston clamp

Remove caliper

1. Loosen rear road wheel nuts. Jack up vehicle, lower onto axle stands, remove wheels.
2. Using a recognised hose clamp, clamp flexible brake hose above rear axle.

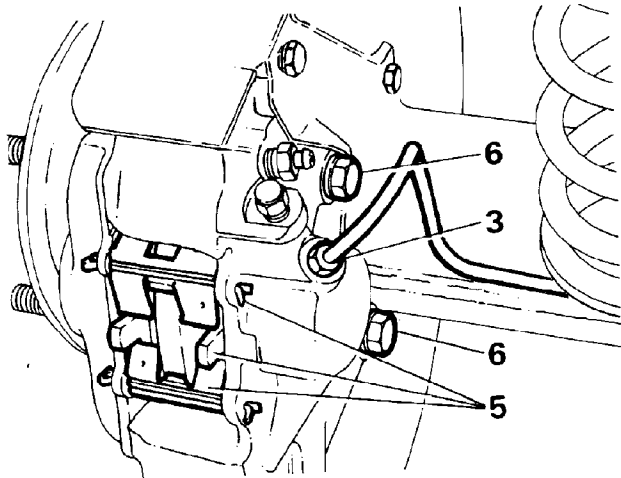

RR2007E

3. Remove brake pipe(s) from rear brake caliper(s). Seal pipe ends to prevent ingress of dirt.
4. Rear RH caliper only, disconnect pad wear indicator.
5. Remove retaining pins and springs and withdraw pads. If same pads are to be refitted, identify them for assembly in original positions.
6. Remove two bolts, withdraw caliper from axle.

DISMANTLE AND REPAIR



CAUTION: Do not separate caliper halves. Overhaul both calipers

7. Clean outer surfaces of caliper with aerosol brake cleaner.
8. **WITH CAUTION** expel pistons from their bores by applying air pressure to fluid inlet port. It is unlikely both pistons will expel at same time, regulate rate with a suitable piece of wood inserted between two pistons.

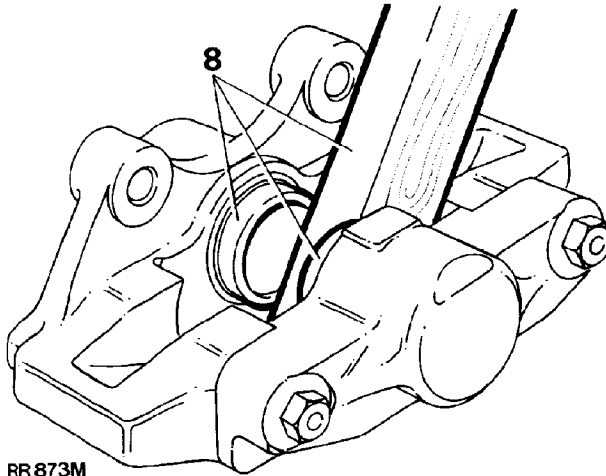

RR873M

9. Finally, remove pistons keeping them identified with their respective bores.
10. Remove wiper seal retainer by inserting a blunt screwdriver between retainer and seal and pry retainer carefully from mouth of bore.
11. Taking care not to damage seal grooves, extract wiper seal and fluid seal.
12. Clean bores, pistons and particularly seal grooves using clean brake fluid only. If caliper or pistons are corroded or their condition is not perfect new parts must be fitted. Assemble outboard pistons.
13. Coat a new fluid seal using brake fluid. Ease seal into groove in bore using only fingers and ensure that it is properly seated. The fluid seal and groove are not same in section so that when seal is seated it feels raised to touch at edge furthest away from mouth of bore.
14. Coat appropriate piston with brake fluid. Insert it squarely into bore by hand only. Do not tilt piston during insertion and leave approximately 8mm projecting from bore.
15. Coat a new wiper seal with brake fluid and fit to new seal retainer. Slide assembly, seal first, over protruding piston into bore recess.

16. Using special tool LRT-70-500 - piston clamp, press home seal retainer and piston.

Mounting inboard piston

17. Carry out same procedure as for removing and fitting outboard piston and seals, instructions 8 to 16.

Fit calipers and pads to vehicle

18. Fit caliper to axle, tighten two bolts progressively to **82Nm**.
19. Connect brake pipe to caliper. Tighten to **12Nm**. Remove clamp from flexible brake hose.
20. Lightly coat back and edges of pads using brake fluid, avoid friction material.
21. Insert pads and retaining springs, secure in position with new retaining pins and spread ends. Note correct position of retaining springs.

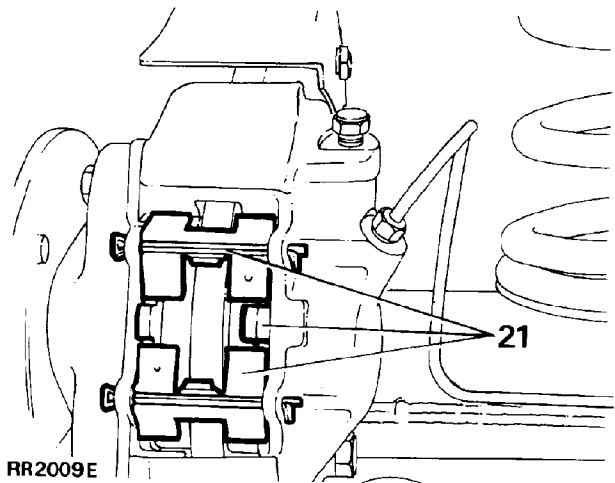

RR2009E



NOTE: Ensure pad with wear indicator is fitted to inboard side of rear RH brake caliper. New brake pads must be fitted to each caliper.

22. Reconnect pad wear indicator electrical plug.
23. Bleed secondary brake system at rear calipers, starting at caliper furthest away from master cylinder.
24. Press brake pedal firmly several times to locate pads.
25. Fit road wheels, remove axle stands and finally tighten road wheel nuts,
26. Road test vehicle. Note new brake pads require 'bedding-in', for several hundred miles before brakes are at maximum efficiency.



PARKING BRAKE LEVER

Service repair no - 70.45.01

Remove

1. Disconnect battery negative lead.
2. Chock road wheels and release parking brake.
3. Remove centre console assembly. **See CHASSIS AND BODY, Repair, Centre Console**

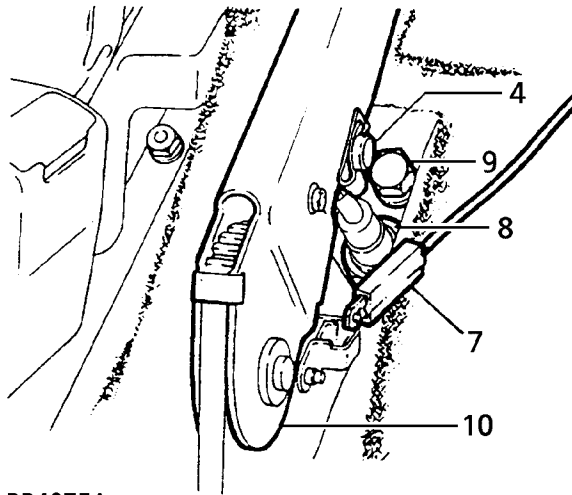

RR4075A

4. Remove spring clip and clevis pin.
5. Disconnect parking brake cable from lever.
6. Raise parking brake lever fully.
7. Disconnect electrical lead from parking brake warning switch.
8. Release parking brake cable outer retaining nut.
9. Remove 2 bolts securing parking brake mounting bracket.
10. Remove parking brake lever assembly from parking brake outer cable.

Refit

11. Position parking brake lever over parking brake cable and secure in position.
12. Secure parking brake outer cable to mounting plate, tighten nut securely.
13. Reverse removal procedure. Ensure electrical wiring does not become trapped between mating faces.
14. Check parking brake adjustment. **See SECTION 10, Maintenance, Vehicle Interior**

STOP LIGHT SWITCH - NON ABS

Service repair no - 86.65.51

Remove

1. Disconnect battery negative lead.
2. Remove lower dash panel.
3. Depress foot brake.
4. Remove rubber protector from switch, if fitted.
5. Remove hexagon nut.
6. Withdraw switch.
7. Disconnect electrical leads.

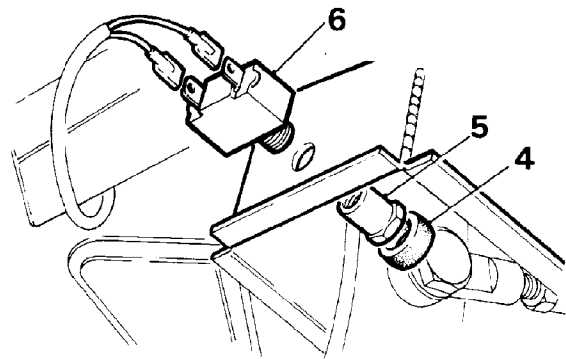

RR509M

Adjust

8. With switch still in position and multiplug disconnected, connect an ohmmeter across switch terminals.
9. Screw switch in until open circuit exists across terminals with pedal released and continuity exists as soon as pedal is depressed.
10. Tighten locknut.



CAUTION: Ensure switch does not prevent brake pedal returning fully.

Refit

11. Reverse removal procedure.

REAR BRAKE CALIPER ASSEMBLY

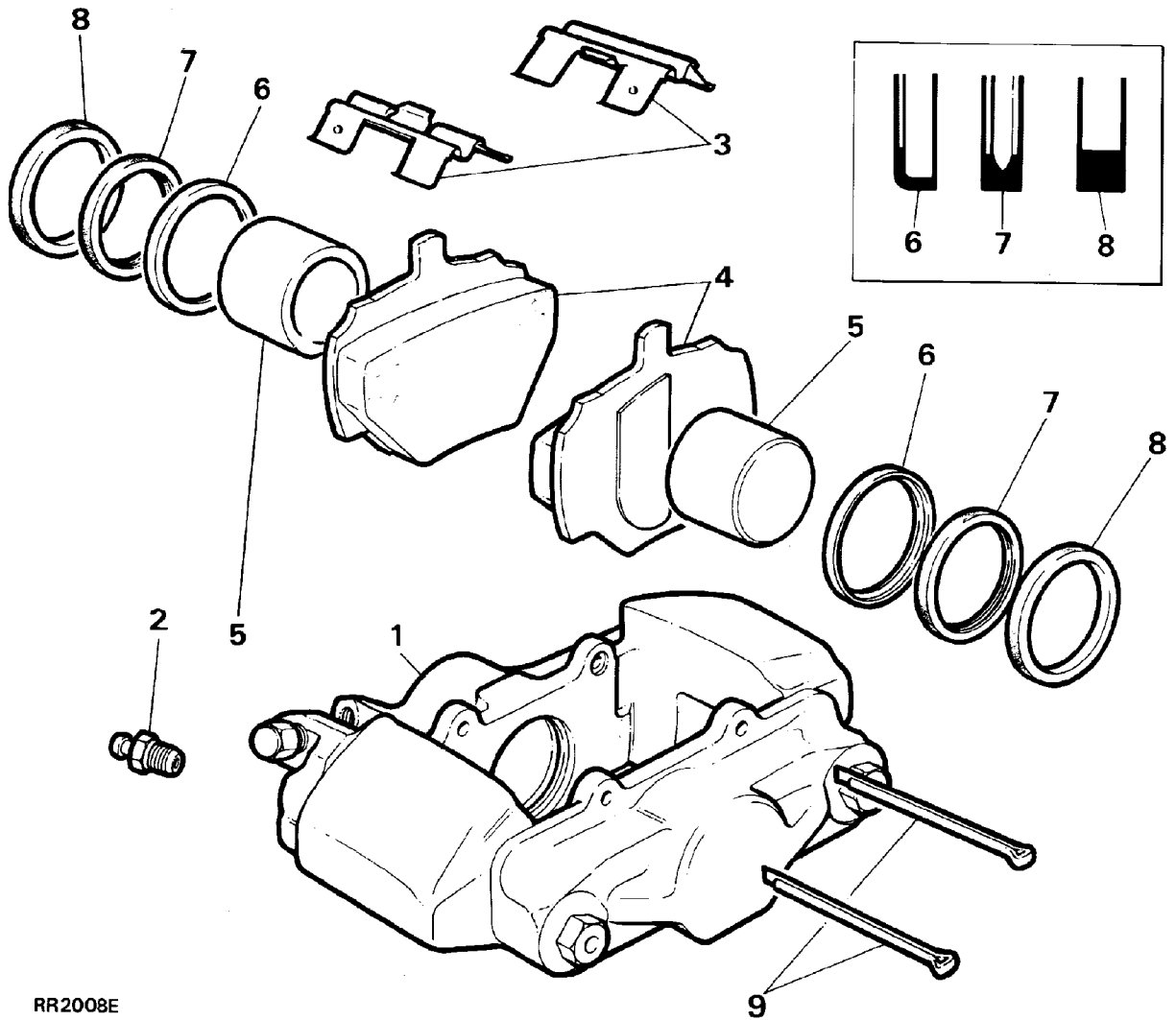

RR2008E

LH Rear Caliper illustrated

Key to caliper

- | | |
|--------------------------|------------------------|
| 1. Caliper | 6. Wiper seal retainer |
| 2. Bleed screw | 7. Wiper seal |
| 3. Pad retaining springs | 8. Fluid seal |
| 4. Brake pads | 9. Retaining pins |
| 5. Piston | |



ANTI-LOCK BRAKE SYSTEM - ABS

CLAYTON DEWANDRE - WABCO POWER ASSISTED HYDRAULIC BRAKE SYSTEM WITH INTEGRATED ANTI-LOCK BRAKE SYSTEM - ABS

Introduction

The purpose of ABS is to prevent vehicle wheels locking during brake application, thus maintaining vehicle steerability and stability. This allows vehicle to be steered whilst brakes are applied, even under emergency conditions, and to avoid obstacles where there is sufficient space to redirect the vehicle.



WARNING: ABS is an aid to retaining steering control and stability while braking.

- **ABS cannot defy the natural laws of physics acting on the vehicle.**
- **ABS will not prevent accidents resulting from excessive cornering speeds, following another vehicle too closely or aquaplaning, i.e. where a layer of water prevents adequate contact between tyre and road surface.**
- **The additional control provided by ABS must never be exploited in a dangerous or reckless manner which could jeopardise the safety of driver or other road users.**

SYSTEM DESCRIPTION

The brake system is hydraulically power assisted with an integrated, electronically controlled four channel anti-lock brake system (ABS).

The use of a power assisted brake system means that, during brake application, additional hydraulic energy is provided by a hydraulic power unit.

This hydraulic power unit consists of an electrically driven pump and an accumulator which stores hydraulic energy in readiness for brake application. A pressure switch controls the hydraulic pump to maintain fluid pressure in accumulator.

The hydraulic system comprises two completely independent circuits. The rear calipers and upper pistons of front calipers form POWER CIRCUIT. The lower pistons in front calipers form COMBINED POWER/HYDROSTATIC CIRCUIT.



CAUTION: Thoroughly clean all brake components, calipers, pipes and fittings before commencing work on brake system. Failure to do so could cause foreign matter to enter system and damage seals and pistons, which will seriously impair brake system efficiency.

WARNING:

DO NOT use brake fluid previously bled from system.

DO NOT use old or stored brake fluid.

ENSURE that only new fluid is used and that it is taken from a clean sealed container.

DO NOT flush brake system with any fluid other than recommended brake fluid.

Brake system must be drained and flushed at recommended service intervals.

Fluid pressures of 180 bar (2600 lbf/in²) are produced by hydraulic pump. It is essential that procedure for depressurising system is carried out where instructed.

HYDRAULIC COMPONENTS

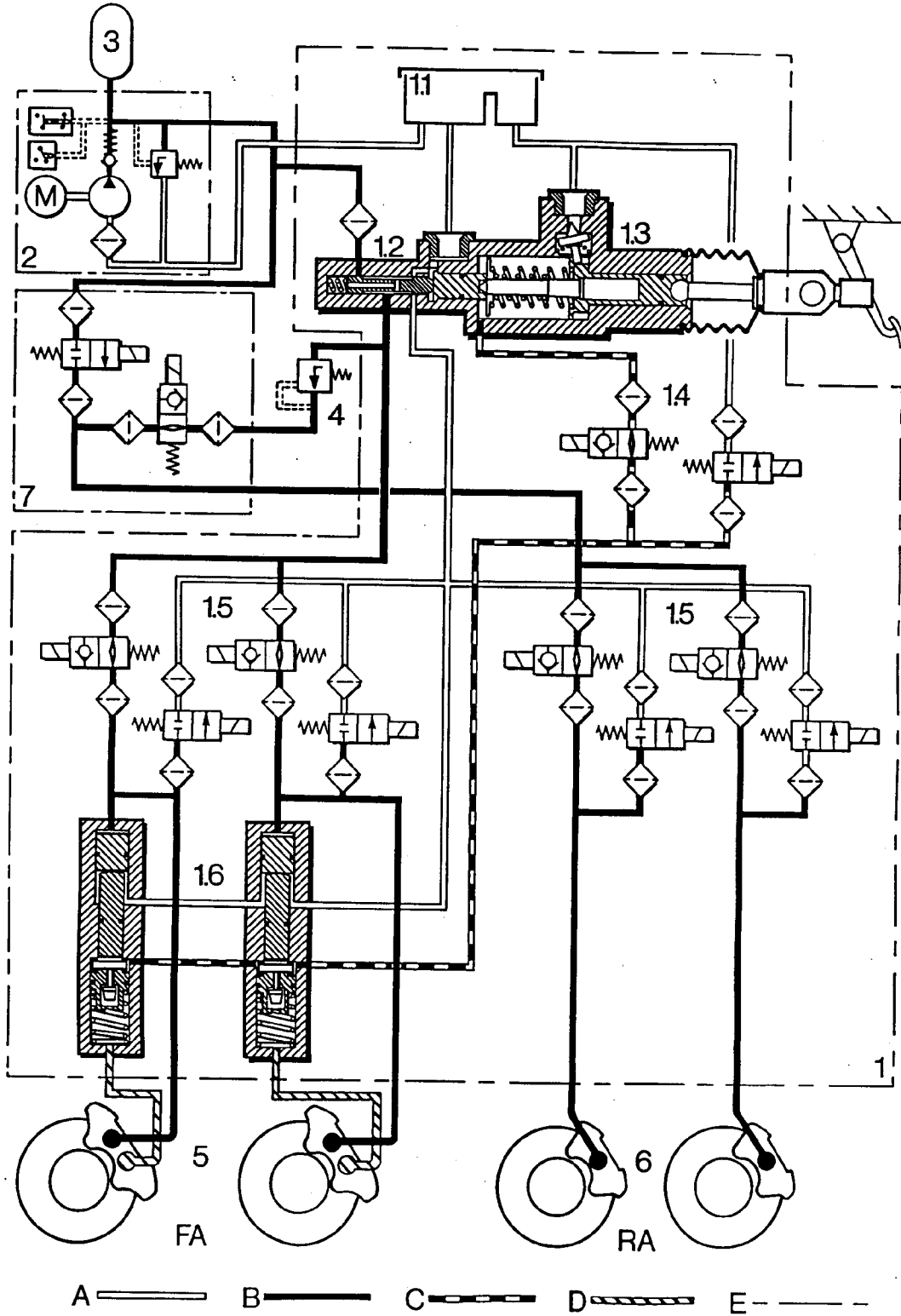

RR4076



Hydraulic circuit - RR4076

Key to diagram

- A Fluid feed/return
- B Power circuit
- C Hydrostatic (master cylinder) circuit
- D Combined hydrostatic/power circuit
- E Component enclosure

Hydraulic components

Hydraulic booster unit (1)

Mounted in same position as conventional master cylinder/servo unit, booster unit contains following components:

Fluid reservoir, power valve, master cylinder, isolating valve, ABS solenoid control valves, servo cylinders.



NOTE: Hydraulic booster unit is not a serviceable item, if internal failure occurs a new unit must be fitted. The fluid reservoir and its seals may be changed in the event of damage. Extreme care must be taken when changing reservoir seals to avoid ingress of debris.

Fluid reservoir (1.1)

Mounted on top of booster unit, the plastic reservoir is subdivided internally to provide separate capacity for brake fluid used in the hydrostatic and power circuits. A central tube incorporates a filter and low fluid warning level switch.

Power valve (1.2)

The power valve is an extension of master cylinder, it controls fluid pressure in power circuit in direct proportion to pressure in master cylinder. Power valve is of spool valve design.

Master cylinder (1.3)

Operation of master cylinder displaces a volume of brake fluid into servo cylinders and increases fluid pressure. Piston movement inside master cylinder will also activate power valve. A tilt valve is incorporated to supply fluid to master cylinder from the reservoir connection.

Isolating valve (1.4)

Isolating valve consists of two solenoid valves controlling fluid inlet and outlet. Their function is to disconnect master cylinder from servo cylinder and to connect servo cylinder to reservoir return during ABS function.

ABS solenoid control valves - 8 off (1.5)

Each pair, comprising inlet and outlet solenoid valves, controls ABS braking to each wheel. In response to signals from ECU, the valves decrease, hold or increase brake pressure according to need to retain wheel rotation and obtain optimum braking. The solenoid valves are designed to respond rapidly to ECU signals.

Servo cylinders - 2 off (1.6)

Servo cylinders have four functions:

1. To provide combined energy from both hydrostatic and power circuit to brake calipers.
2. To provide 'brake feel' at brake pedal.
3. To provide hydrostatic (master cylinder) braking through servo cylinder to calipers in event of no power circuit pressure to servo cylinder.
4. To provide braking from both power circuit and from hydrostatic fluid remaining in servo cylinder, in event of no hydrostatic circuit pressure from master cylinder.

Hydraulic power unit (2)

Hydraulic power unit comprises an electrically driven pump and a pressure switch. Pressure switch incorporates three electro-mechanical switches: one for pump, another, at a different pressure setting, to illuminate pressure warning light. The latter switch plus third switch inform ECU of low pressure and that ABS function should cease whilst pressure remains low.

The pump also incorporates a non-return valve, a low pressure inlet filter, and a pressure relief valve to protect the system.

Accumulator (3)

Diaphragm accumulator is precharged with nitrogen at up to 80 bar (1160 psi), its function is to store hydraulic energy.

Pressure conscious reducing valve (PCRIV) (4)

PCRIV valve is located between power valve and ABS solenoid valves for rear axle. Its function is to limit brake pressure to rear axle.

Brake calipers - front - (5) rear - (6)

NOTE: To identify separate hydraulic circuits, they are referred to as HYDROSTATIC and POWER circuits.

Power circuit - Consists of rear calipers and upper pistons in the front calipers, supplied by direct hydraulic power from power valve.

Hydrostatic circuit - Lower pistons in the front calipers form this circuit, supplied with hydraulic energy from servo cylinders comprising a combination of master cylinder pressure and direct hydraulic power.

Electronic traction control valve block (7)

Refer to **BRAKES - Electronic Traction Control, repair, ETC Valve Block**



LOCATION OF COMPONENTS

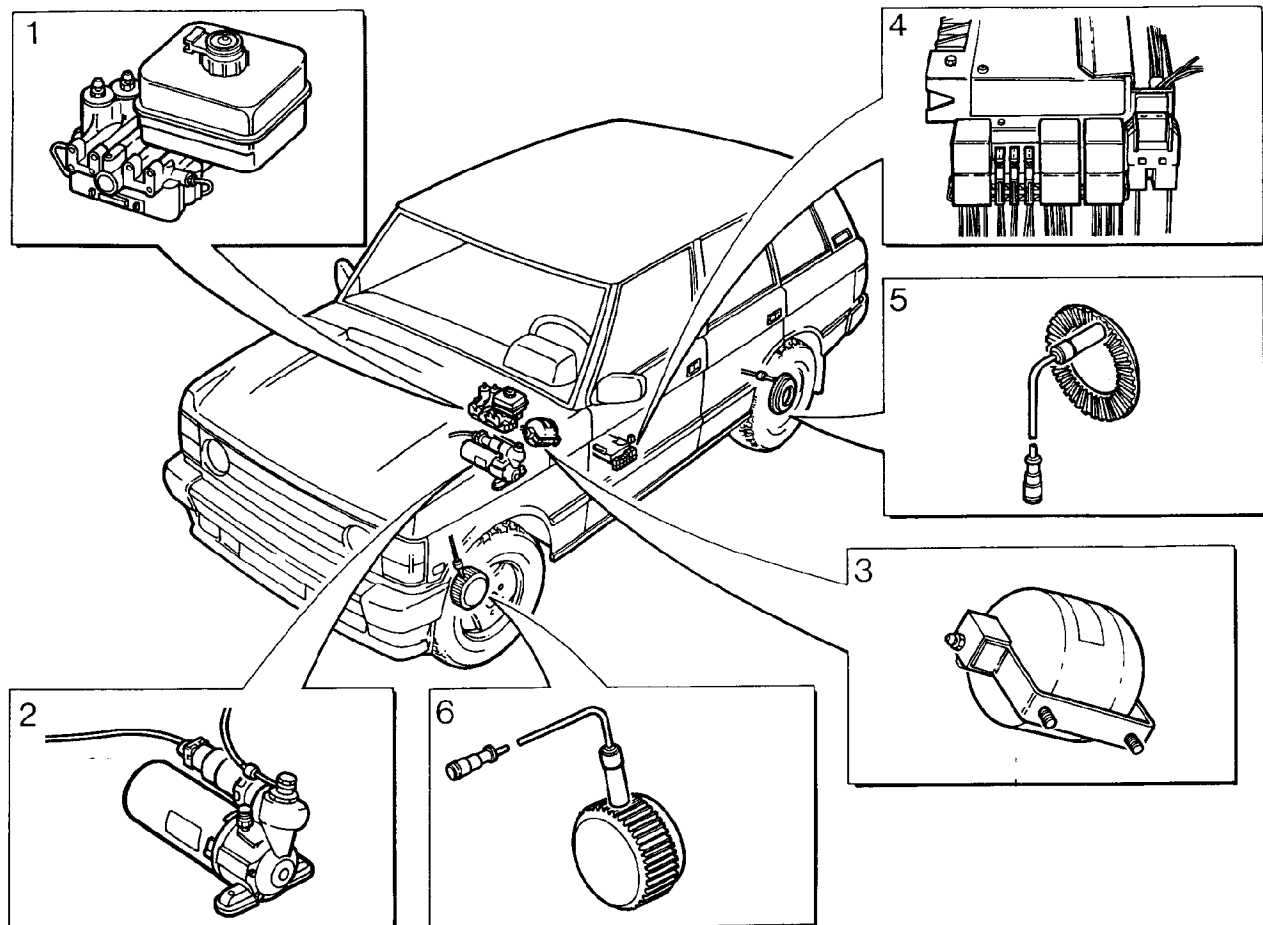

RR4077

Key to diagram (RR4077)

- | | |
|--|--|
| <ul style="list-style-type: none"> 1. Hydraulic booster unit. 2. Power unit - hydraulic pump. 3. Accumulator. | <ul style="list-style-type: none"> 4. Electronic control unit (ECU), relays and fuses. 5. Rear sensors/exciter rings. 6. Front sensors/exciter rings. |
|--|--|

Electronic control unit - ECU

ABS operation is controlled by ECU located under left hand front seat, and earthed to centre tunnel.

ECU is connected to ABS harness by a 35 way connector.

The ECU is a non-serviceable item, it must be replaced if failure occurs.

Sensors, exciter rings - 4 off

A sensor is mounted at each wheel, sensing a 60 tooth exciter ring. When vehicle is in motion inductive sensors send signals to ECU. Front exciter ring is fitted to outside diameter of constant velocity joint in each front hub. Rear exciter ring is bolted to rear of each brake disc bell.

BRAKE PIPE LAYOUT - LEFT HAND DRIVE

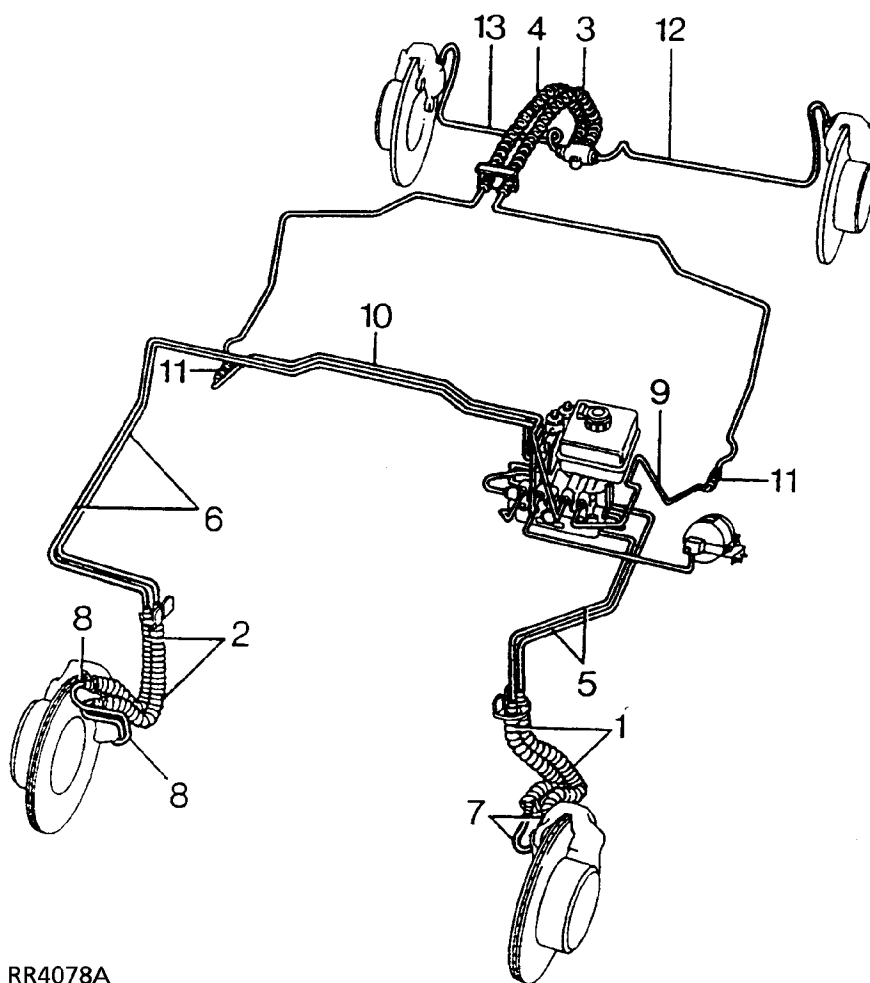

RR4078A

HOSES

- | | |
|-------------------------------------|---------------------------------|
| 1. Front left hand flexible hoses. | 3. Left hand intermediate hose |
| 2. Front right hand flexible hoses. | 4. Right hand intermediate hose |



BRAKE PIPE LAYOUT - RIGHT HAND DRIVE

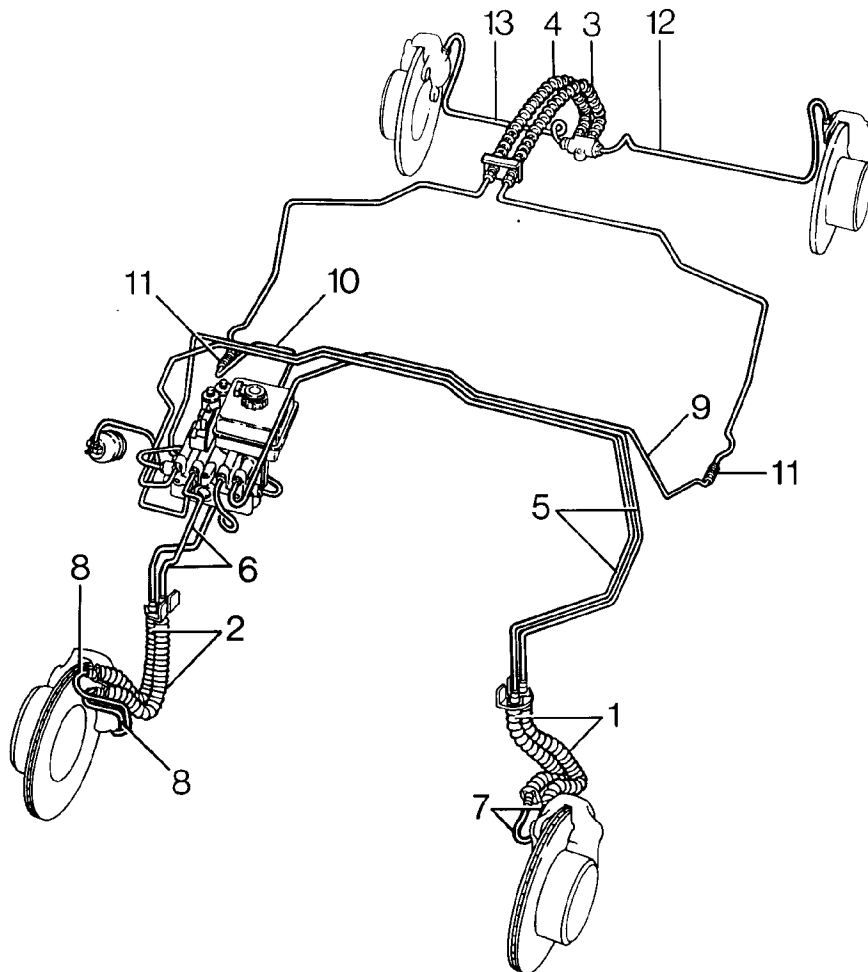

RR4079

PIPES

- | | |
|---|---|
| 5. Feed to front left hand hose connector. | 10. Feed to right hand intermediate hose. |
| 6. Feed to front right hand hose connector. | 11. Two way connector. |
| 7. Feed to front left hand caliper. | 12. Feed to rear left hand caliper. |
| 8. Feed to front right hand caliper. | 13. Feed to rear right hand caliper. |
| 9. Feed to left hand intermediate hose. | |

WARNING LIGHTS

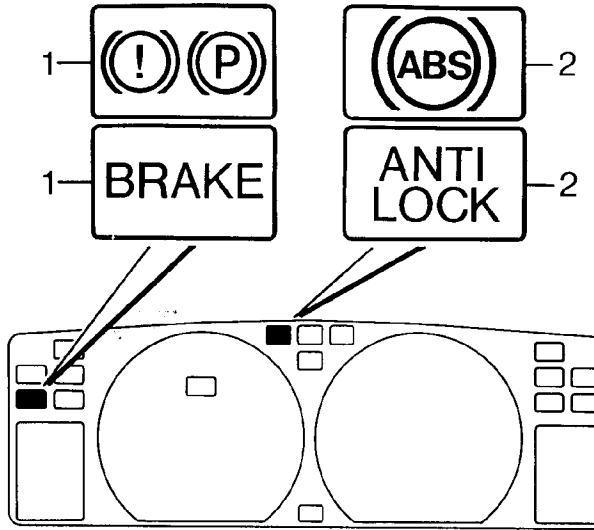

RR4080

Brake fluid pressure/level and parking brake warning light (RED) - 1 BRAKE - USA vehicles (RED) - 1

The warning light situated in instrument binnacle indicates insufficient pressure in system and/or low fluid level. Warning light will illuminate when ignition is switched ON as part of initial bulb check, and when parking brake is applied.

If pressure in hydraulic system is lower than cut-in pressure for warning light, light will illuminate. When light is on hydraulic pump will run. Note, if light remains illuminated after bulb check and releasing park brake, DO NOT drive vehicle until light extinguishes.



WARNING: If light illuminates while vehicle is in motion, investigate fault immediately. Braking will be available after loss of pressure, but greater force will be required at pedal to slow vehicle.

ABS warning light - (AMBER) - 2 ANTI LOCK - USA vehicles (RED) - 2



WARNING: Power assisted braking is not available if ignition is switched off. An increase in effort at brake pedal will be required to apply brakes.

The ABS warning light situated in instrument binnacle indicates a failure in ABS system. Warning light will illuminate when ignition is switched ON, it will extinguish when vehicle speed exceeds 7 km/h (5 mph). This indicates that system self monitoring check was successful and the system is performing correctly.

If light remains on or subsequently illuminates with ignition ON a fault in ABS system is indicated. The self monitoring procedure is repeated frequently while ignition is ON. If a fault is detected during self monitoring, light will illuminate indicating that one or more wheels are not under ABS control.

The ABS warning light will also indicate whether or not the ABS ECU has recorded any faults which have not been repaired. After the ignition is switched on and the ECU has completed its self check no faults are recorded the ABS warning light will switch off for half a second. This will occur before driving above 7 kph (5 mph).

This enables a vehicle tester to check ABS without driving the vehicle.



WARNING: Reduced ABS control is possible with ABS warning light illuminated depending on severity and type of fault. If both ABS and brake failure warning lights are illuminated, loss of system pressure or hydraulic pump failure is indicated. IT IS ESSENTIAL THAT FAULT IS IMMEDIATELY INVESTIGATED.

ABS warning light

If no faults have been recorded, the ABS warning light will switch off for half a second after ignition is switched on and the ECU has completed its self checks. This will occur during the time that the light is on between switching on and driving above 7 kph (5 mph).

This enables a vehicle tester to check ABS without driving the vehicle.



DRIVING VEHICLE



WARNING: On surfaces which are soft and deep, for example deep powdery snow, sand or gravel, braking distance may be greater than with non ABS braking. In these conditions wheel lock and the build up of snow or gravel under wheels may be an aid to shorter stopping distance. However it is still an advantage to maintain the stability and manoeuvrability available with ABS control.

1. Switch on ignition, system will automatically carry out self test function. This will be felt as a slight movement in brake pedal and a short, rapid series of clicks indicating that solenoid valves have been checked.
2. Observe warning lights, check parking brake/fluid pressure/level warning light extinguishes after initial bulb check or when parking brake is released, indicating that power assistance is available. Note time taken to pressurise system is approximately 20 seconds.
3. Start vehicle and drive away, at 7 km/h (5 mph) the ABS warning light must be extinguished - see **Warning Lights**.
4. In road conditions where surface friction is sufficient to slow or stop the vehicle without wheel lock, ABS does not operate.
5. In an emergency braking situation, if one or more wheels begin to slow rapidly in relation to vehicle speed, ABS will detect wheel locking tendency and will regulate brake pressure to maintain wheel rotation.
6. ABS operation will be felt as a vibration through pedal, at same time solenoid cycling will be heard.



NOTE: Constant pressure on foot pedal whilst ABS is operating is more effective than cadence braking. Do not pump brake pedal, this may reduce ABS efficiency and increase stopping distance.

7. Downward travel of pedal will also feel hard at point at which ABS operates. Little further pedal travel is possible at this point, BUT, force on the pedal can be varied to influence braking force while ABS retains control.

BRAKE APPLICATION WITH PARTIAL FAILURE



WARNING: If a fault develops in brake system it is essential that fault is investigated immediately.



NOTE: If, during braking, a drastically reduced resistance is detected at pedal and braking effectiveness is very much reduced, failure of the non-powered (master cylinder) portion of system is indicated. When this occurs **DO NOT PUMP BRAKE PEDAL**. Push the pedal through free movement to obtain braking effort. It is essential that brake pedal travel is not obstructed by items such as extra footwell mats.

1. When power assistance is not available, ABS braking is not operative. Both warning lights are illuminated. Braking effort is available from master cylinder only. This results in longer pedal travel and greater pedal effort required to decelerate vehicle.



WARNING: Foot pressure on pedal, using master cylinder only, will not achieve same degree of braking as is available from power assistance.

2. If master cylinder fails, i.e. there is insufficient fluid in master cylinder to create pressure, braking to all four wheels is retained and ABS remains operative. The red warning light will be illuminated if cause of master cylinder failure is a fluid leak and level in master cylinder is low enough to actuate fluid level switch.



WARNING: Longer pedal travel is required, but power assisted braking is available at reduced efficiency.

3. If brake failure occurs due to a fractured brake pipe between a servo unit and a wheel, there may be no pressure in master cylinder. The fluid warning light will illuminate when level in master cylinder is low enough to actuate fluid level switch. Master cylinder and power valve will operate as for master cylinder failure, BUT, fluid from power circuit will push all moving parts in servo cylinder associated with failure to limit of travel. No pressurised fluid passes to those brake pistons served by servo cylinder, but all other pistons in front and rear calipers will be supplied with direct pressure from power valve. Pistons served by other servo cylinder retain braking as fluid from master cylinder is retained in servo cylinder not associated with the leakage.



WARNING: Brake pedal travel will be greater and extra pedal effort will be required, accompanied by the vehicle pulling to one side.



ACCUMULATOR PRECHARGE

Check

The diaphragm type accumulator is precharged with nitrogen at 80 bar, its function is to store hydraulic energy. Over a period of several years a normal loss of precharge will occur. This procedure will indicate extent to which precharge pressure has fallen.



NOTE: A new accumulator at 20°C has a nominal pressure of 80 bar + 2. Minimum acceptable pressure is 50 bar.

Equipment - LRT-70-001 ABS pressure test equipment

1. Depressurise brake system. *See Repair, Depressurise System*

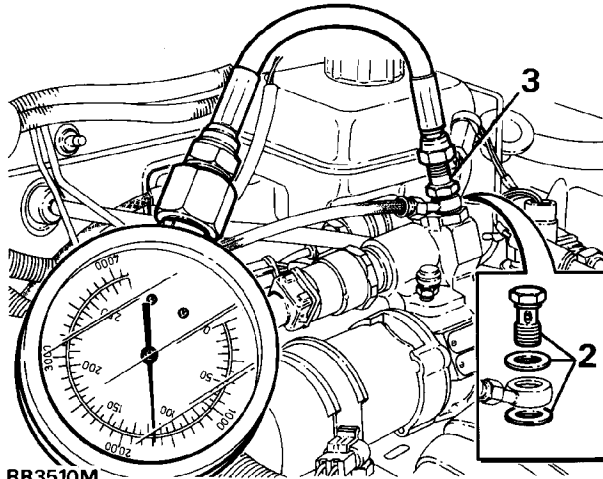

RR3510M

2. Remove banjo bolt securing high pressure hose, use a second spanner on large hexagon to prevent it being slackened.
3. Fit pressure gauge adapter, using sealing washers. Connect pressure gauge.
4. Switch ignition on and observe pressure gauge.

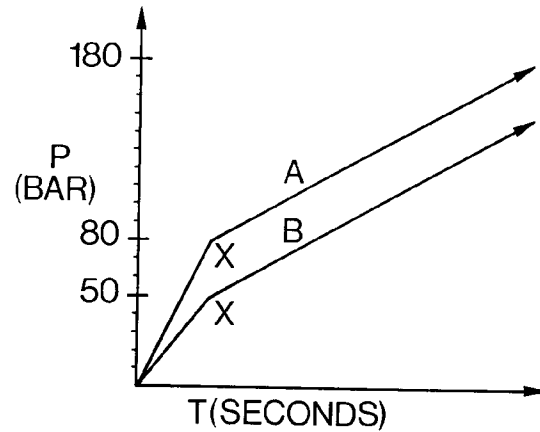

RR4081

5. There should be a rapid rise in pressure to accumulator precharge, point X, of 80 bar, then a slowing down in rate of increase as pressure rises to system pressure, 180 bar, see graph **A**
6. Accumulator has lost precharge if point X occurs below 80 bar, see graph **B**
7. Fit new accumulator if point X occurs below 50 bar.
8. Depressurise system, remove pressure gauge and adapter.
9. Fit banjo bolt securing high pressure hose, use NEW sealing washers. Tighten to **15 Nm**.
10. Bleed pump.
11. Check/top up fluid level.

ABS FAULT DIAGNOSIS

If a fault has occurred, or has been identified by ECU self diagnostic function and ABS warning light is illuminated, system and components must be checked to locate and rectify fault using Testbook diagnostics.



NOTE: If warning lamp has indicated a fault in system, and no fault code has been stored in memory, cause of fault is:

- a) Failure in electrical supply
- b) Loss of hydraulic pressure
- c) Faulty pressure switch
- d) Bad ECU ground
- e) Faulty warning light relay
- f) System not fully charged before driving away
- g) ECU not connected

Before commencing fault diagnosis procedure the following items must be checked:

1. Inspect all exposed cables for damage or abrasion.
2. Check ground on ABS system.
3. Battery - state of charge.
4. Fluid level in reservoir.
5. All ABS fuses and electrical connections.
6. Check hub end-float.

Refer to the **Electrical Troubleshooting Manual - D1**.

Fault rectification

1. Complete harness must be replaced if faults are found in wiring harness.
2. DO NOT use unspecified cables or connectors, as this could jeopardise safe function of ABS.
3. DO NOT attempt to open sealed 35 way connector to ECU.

FAULT DIAGNOSIS PROCEDURE



NOTE: If ABS warning light illuminates due to large sensor air gap, fault will be retained by the ECU memory. Where wheel sensors have been pushed fully home prior to test, blink code will indicate a fault that has been rectified.



NOTE: After any steering adjustment, bearing replacement/adjustment, brake disc replacement: Check hub end-float and sensor clearance.



ABS FAULT AND REMEDY CHART

SYMPTOM	POSSIBLE CAUSE	CHECK	REMEDY
ABS warning light on	ABS electrical fault High sensor air gaps	Check ABS electrical circuit to identify fault	Change component if necessary Push in sensors
Both warning lights ON. Pedal travel and pedal force increased	No booster pressure (fluid loss) No booster pressure (pump not operating) Pump faulty	Check reservoir fluid level and inspect system for leaks Check electrical supply to pump	Rectify as necessary and refill reservoir Rectify electrical supply if necessary Change hydraulic pump
Both warning lights ON (no additional symptoms)	Malfunction of pressure switch	Disconnect pressure switch a) If light remains illuminated vehicle wiring faulty b) If lights extinguish pump defective	a) Test wiring, change harness if necessary b) Change pump
Brake fluid warning light ON	Fluid loss Reservoir fluid level switch malfunction Pressure switch malfunction	Check reservoir fluid level and inspect system for leaks Check fluid level switch Check switch with pressure gauge a) If wiring faulty b) If switch faulty	Rectify leakage, refill reservoir Change reservoir cap/switch a) Replace harness b) Change hydraulic pump
Brake fluid warning light ON. Pedal travel increased, foot pressure normal	Fluid loss from hydrostatic circuit	Check reservoir level and inspect system for leaks	Rectify leakage and refill reservoir Rebleed as necessary

SYMPTOM	POSSIBLE CAUSE	CHECK	REMEDY
Brake fluid warning light OFF. Pedal travel increased, foot pressure normal	Insufficient bleeding Master cylinder malfunction		Rebleed master cylinder circuit Change booster and bleed system
Hydraulic pump runs constantly	Fluid loss Pump non-return valve faulty	Check reservoir level and inspect system for leaks	Rectify leakage as necessary, refill reservoir Change hydraulic pump
Hydraulic pump runs constantly with warning lights OFF. Pedal travel normal.	Malfunction of pressure switch Relay switch malfunction	Disconnect pressure switch a) If pump stops b) If pump continues running	a) Change hydraulic pump b) Change relay or cable
Pedal can be moved downwards under constant pressure	Seal leaking in master cylinder Seal leaking in servo unit	Inspect system for leaks	Change booster unit Change booster unit



GENERAL SERVICE INFORMATION



NOTE: ABS components ARE NOT serviceable. Replace components found to be faulty.

Brake fluid precautions



WARNING: Do not allow brake fluid to come into contact with eyes or skin.



CAUTION: Brake fluid can damage paintwork, if spilled wash off immediately with plenty of clean water.



CAUTION: Use only correct brake fluid. If an assembly fluid is required use **ONLY** brake fluid. Do **NOT** use mineral oil, i.e. engine oil etc.

FLUID LEVEL CHECK / TOP UP

1. Park vehicle on level ground.
2. Turn ignition ON, to activate hydraulic pump. If pump does not activate depress brake pedal several times until pump operates.
3. When pump stops, check level is between 'MIN' and 'MAX' marks.
4. If level is below 'MIN' mark top up fluid level to 'MAX' mark on reservoir, using correct fluid. **See LUBRICANTS, FLUIDS AND CAPACITIES, Information, Recommended Lubricants and Fluids**



WARNING: Clean reservoir body and filler cap before removing cap. Use only fluid from a sealed container.

DO NOT OVER FILL RESERVOIR

DEPRESSURISE SYSTEM



WARNING: Before bleeding the system or working on any component in the brake system the following procedure **MUST** be carried out to depressurise the accumulator.

1. Switch off ignition.
2. Operate the brake pedal 30 times. Pedal travel will increase slightly and reduced resistance will be felt as pressure decreases.
3. Wait for 60 seconds, press the brake pedal four more times. This procedure will ensure that all pressure is evacuated from the system.

BRAKE SYSTEM BLEED (ABS)

Service repair no - 70.25.02

Equipment: Bleed tube and a clean bottle containing a small amount of clean liquid.



CAUTION: Clean all bleed screws, filler cap and connections thoroughly using clean brake fluid only. **DO NOT USE MINERAL OIL I.E. ENGINE OIL ETC. MAINTAIN CLEANLINESS THROUGHOUT.**



NOTE: Do not allow reservoir fluid level to fall below 'MIN' level during bleeding. Regularly check level and keep topped up to 'MAX' level.



WARNING: Do not use previously used brake fluid. Ensure only new fluid is used, taken from a clean sealed container. Carefully dispose of unwanted fluid in a sealed container, marked **USED BRAKE FLUID.**

1. Switch off ignition and depressurise system. Ensure ignition remains OFF until instruction 7.

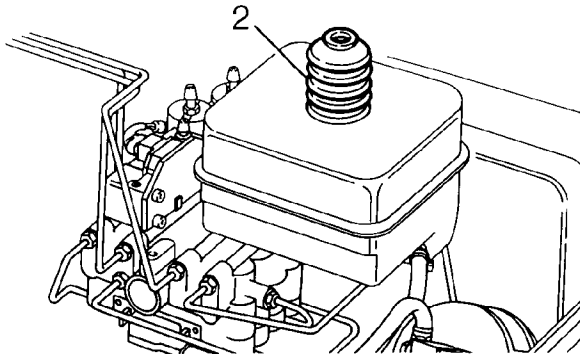

RR4082

2. Fill fluid reservoir with specified fluid to 'MAX' level.



NOTE: Time consumed in filling booster may be reduced by fitting a rubber bellows unit to filler neck, using hand pressure to pressurise the reservoir. A spare bellows unit from booster push rod is suitable for this purpose. Ensure bellows unit is perfectly clean to avoid foreign matter entering system. Raising rear of vehicle will assist fill procedure.

3. Depress brake pedal slowly and progressively five times, using full pedal stroke. Release pedal for five to ten seconds, air bubbles will rise into reservoir.
4. Repeat instruction 3. until some resistance is felt. If no resistance is felt check clevis pin is connected to correct (UPPER) hole in brake pedal
5. Bleed four front caliper lower (hydrostatic) bleed screws in the conventional manner. In the order: outer bleed screw driver's side, opposite caliper outer bleed screw, inner bleed screw, inner bleed screw driver's side. Depress brake pedal slowly and progressively, locking bleed screw at bottom of each stroke.

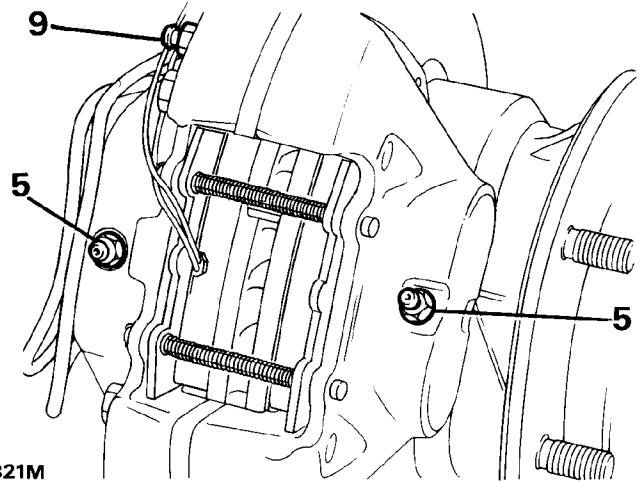

RR2821M

6. Bleed hydraulic pump - open bleed screw on pump and allow fluid to flow until clear of air bubbles. Do not use bleed bottle, use a clean absorbant cloth to prevent fluid spillage.



7. Bleed accumulator - open bleed screw. If vehicle has ETC, accumulator bleed screw is on top of ETC valve block. Switch on ignition, run pump for 3-4 secs, switch off and repeat procedure until fluid is clear of air bubbles. Switch off ignition. Close bleed screw.
8. Bleed two hydraulic booster bleed screws. Open one bleed screw, depress brake pedal, switch on ignition, run pump until fluid is clear of air bubbles. Close booster bleed screw, switch off ignition, release pedal. Repeat for other bleed screw.
12. Close caliper bleed screw before releasing pedal, repeat for remaining three hydrostatic bleed screws.
13. Check/top up reservoir fluid level. **See Fluid Level Check / Top Up**
14. Dry all connections, fully pressurise system, check for leaks. If two full brake applications switch on pump, from fully charged, rebleed system.

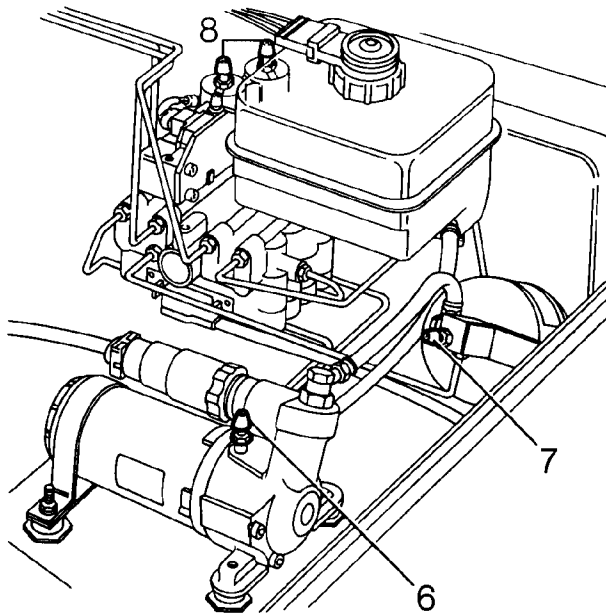

RR4083

9. Bleed power circuit at four calipers in turn. Depress pedal, open bleed screw, (upper bleed screw on front calipers). Switch on ignition, run pump for 3-4 secs, switch off and repeat procedure until fluid is clear of air bubbles. Switch off ignition, close caliper bleed screw, release pedal.
10. Bleed master cylinder - switch ignition on. System pressure will increase until pump cuts out. If pump does not cut out after running for 45 secs, check system for leaks.
11. Bleed hydrostatic circuit calipers - open one front lower caliper bleed screw. Actuate brake pedal several times, using only lower two thirds of pedal travel, until fluid is clear of air bubbles. Stop actuation if fluid warning light comes on and allow pressure to build up.

HYDRAULIC BOOSTER UNIT

Service repair no - 70.65.20

Remove



CAUTION: Do not allow booster unit to be dropped or rested on its front face. Damage to plastic tangs of multiplug could occur, requiring fitting a new booster unit

1. Disconnect battery negative lead. Depressurise system. **See *Depressurising System***
2. Thoroughly clean area around booster unit outlet ports and electrical connector.

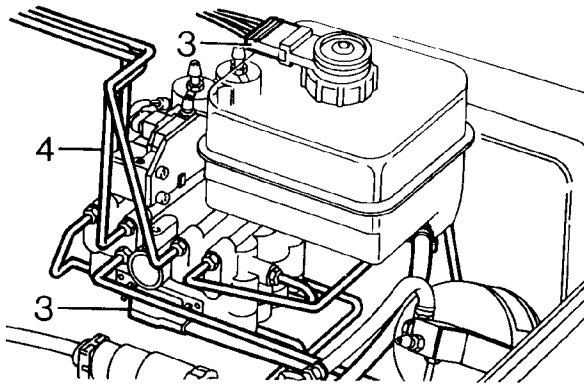

RR4084

3. Disconnect electrical multiplug and connector from low fluid switch. Remove booster earth strap.
4. Remove brake pipes and hydraulic pipes to accumulator and hydraulic power unit.



NOTE: Each outlet port is numbered, each brake pipe is marked with corresponding number for reassembly. Immediately seal each pipe and outlet port to prevent ingress of foreign matter.

5. Inside vehicle: Remove lower dash panel and knee bolster, where fitted.

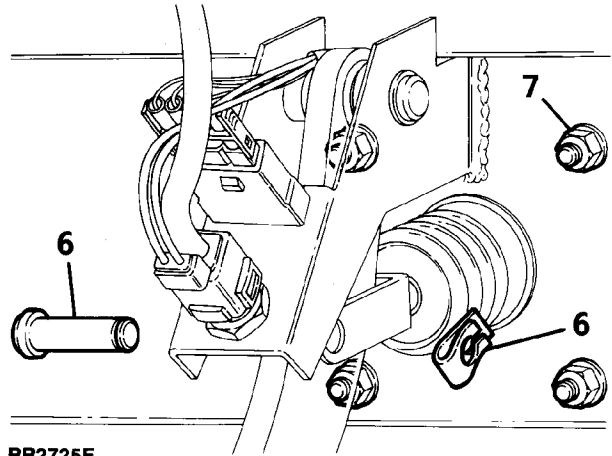

RR2725E

6. Release spring clip and clevis pin from brake pedal.
7. Remove 4 nuts securing booster unit.
8. Remove booster unit.

Refit



NOTE: New booster units are supplied in a sealed pack marked with a 'use by' date. **DO NOT** fit a booster if date has elapsed, or if pack is not sealed. **DO NOT** open sealed pack until ready to fit unit.

9. Reverse removal procedure. Ensuring correct fitting of pipes. Tighten booster fixings to **25 Nm** and pipes to **15 Nm**.
10. Fit clevis pin into UPPER of two holes in brake pedal.
11. Adjust brake light switch: pull red (later vehicles, white) sleeve and black plunger fully forward. Pull brake pedal back fully to reset switch.
12. Bleed brake system. **See *Brake System Bleed (ABS)***



RESERVOIR (INCLUDE SEALS)

Service repair no - 70.65.22

Remove

1. Disconnect battery negative lead.
2. Depressurise system. *See Depressurise System*
3. Disconnect low fluid warning plug.
4. Remove reservoir cap. Remove hose from pump, plugging exposed apertures.
5. Remove securing bolt, adjacent to low pressure hose.
6. Ease reservoir from booster unit.

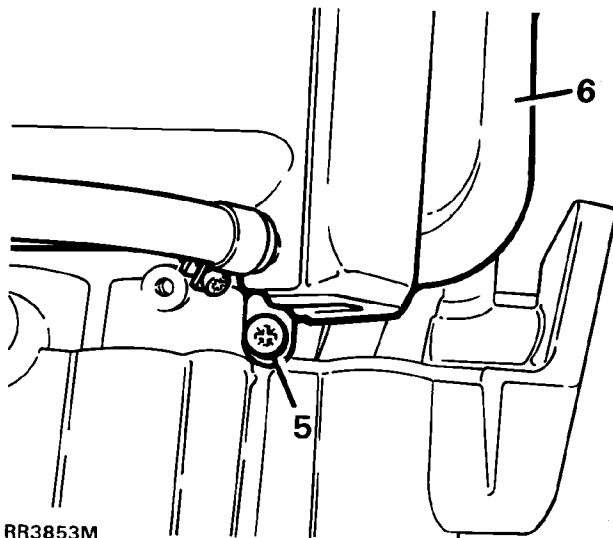

7. Remove two seals from top of booster unit. Avoid damage to seals which could result in rubber particles entering system. Plug booster unit apertures

Refit

8. Lubricate and fit new seals. Refit reservoir. Tighten securing bolt to **10 Nm**.
9. Bleed pump. Check/top up fluid level.

HYDRAULIC POWER UNIT

Service repair no - 70.65.20

Remove

1. Disconnect battery negative lead.
2. Depressurise system. *See Depressurise System*
3. Disconnect braided hose to accumulator.
4. Disconnect low pressure hose to reservoir, clamp hose to prevent fluid loss and ingress of debris.

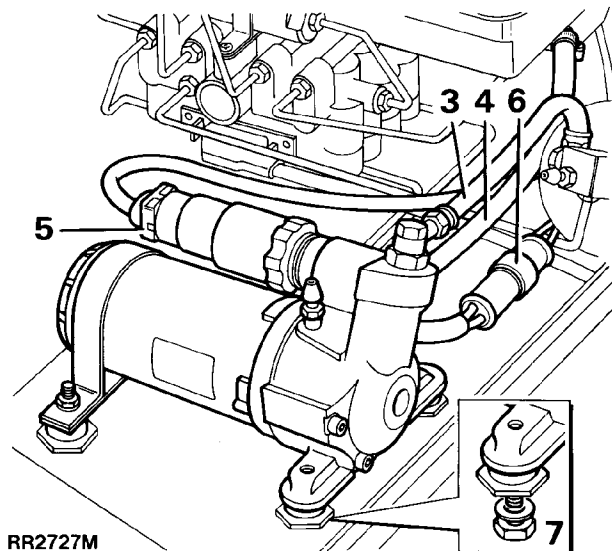

5. Disconnect pressure switch plug.
6. Disconnect power unit connector.
7. Working below unit remove four nuts and plain washers.
8. Remove hydraulic power unit complete with mountings. Note position of earth strap, if fitted, when removing mountings.

Refit

9. Reverse removal procedure. Fit new sealing washers on high pressure hose.
10. Bleed system. *See Brake System Bleed (ABS)*

ACCUMULATOR

Service repair no - 70.65.21



WARNING: The accumulator is precharged with nitrogen at up to 80 bar. Handle with extreme caution. **DO NOT** puncture or burn if disposal is necessary.

Remove, refit and disposal

1. Disconnect battery negative lead.
2. Depressurise system. **See Depressurise System**

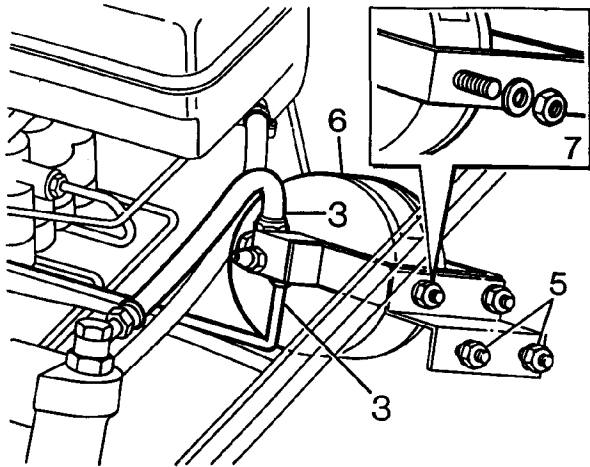

RR4086

3. Remove fluid inlet and outlet pipes from accumulator.
4. On driver's side of vehicle, release rear of front wheel arch inner liner.
5. From inside wheel arch, remove two nuts and plain washers securing accumulator bracket to wing valance
6. Remove accumulator assembly. **Do not carry out further dismantling if component is removed for access only.**
7. Remove nuts and plain washers and remove bracket from accumulator.

Refit

8. Reverse removal procedure. Fit new sealing washers on high pressure hose.
9. Bleed brakes. **See Brake System Bleed (ABS)**

Disposal



WARNING: It is essential that safety goggles and gloves are worn when carrying out this procedure.

1. Secure accumulator firmly using a suitable vice.
2. Drill 5mm diameter hole in accumulator, opposite hole fluid ports, to depressurise nitrogen chamber.
3. Dispose of accumulator in normal way.



ELECTRONIC CONTROL UNIT - ECU

Service repair no - 70.65.01

Remove

1. Remove front and side trim from left hand front seat.
2. Adjust seat to its most rearward position and raise seat cushion height to allow access to ECU.
3. Disconnect battery negative lead.
4. Release ECU plug retaining clip.
5. Manoeuvre plug in direction of arrow and detach hooked end of plug from retaining post.
6. Remove two screws securing ECU to mounting bracket.
7. Remove ECU from retaining clip.

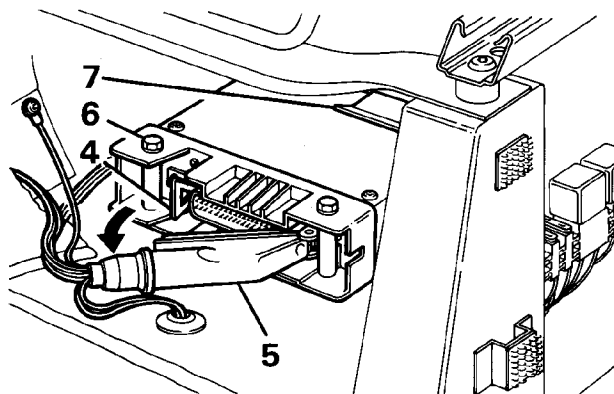

RR2726M

Refit

8. Refit ECU securely in retaining bracket, fit and tighten two screws.
9. Reconnect ECU harness plug. Ensure plug is firmly located and that retaining clip secures plug.
10. Reverse removal procedure.

SENSORS - FRONT

Service repair no - 70.65.32



CAUTION: If a sensor is removed for any reason, a **NEW sensor bush and seal must be fitted.**

Remove

1. Disconnect battery negative lead.
2. Disconnect required sensor electrical connection, located on inner wing panel adjacent to decker panel.
3. Remove sensor lead and pad wear harness plug from clips.

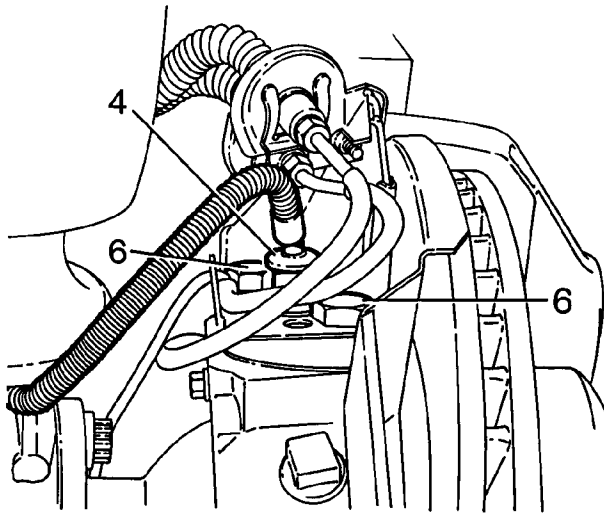

RR4087

4. Clean area surrounding sensor to prevent ingress of dirt. Using a suitable lever pry sensor from mounting bush.
5. Release harness cable ties, remove sensor lead from vehicle.
6. Remove top swivel retaining bolts complete with brake jump hose and sensor seal. Remove sensor bush.

Refit

7. Insert new sensor bush and seal.
8. Refit brake jump hose bracket, coat bolts with Loctite 270.
9. Lightly coat new sensor using EP 90 oil. Push sensor through bush until it contacts exciter ring. Rotate wheel, turning steering from lock to lock to set sensor air gap.
10. Secure sensor lead in original position.
11. Reconnect sensor electrical connection.
12. Clear error code. **See Fault diagnosis, Fault Diagnosis Procedure**
13. Drive vehicle to ensure ABS warning light is extinguished.



SENSORS - REAR

Service repair no - 70.65.31



CAUTION: If a sensor is removed for any reason, a **NEW** sensor bush must be fitted.

Remove

1. Disconnect battery negative lead.
2. Disconnect sensor electrical connections, located above rear axle.
3. Remove sensor from its locating clip.

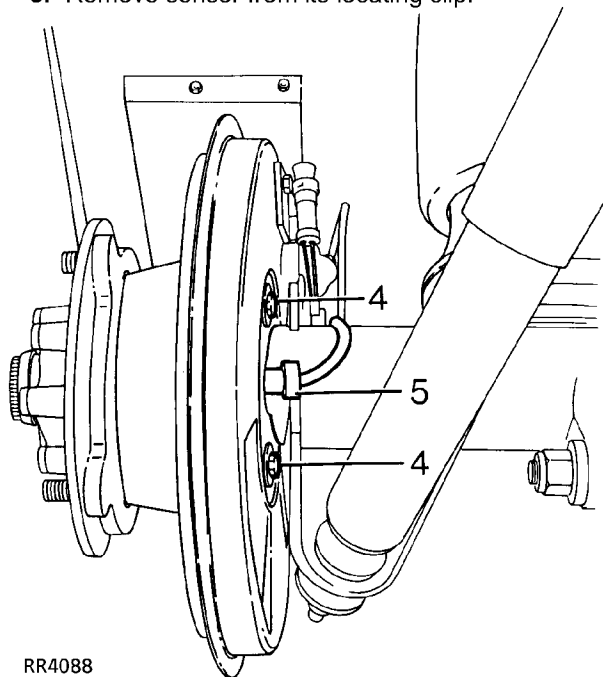

RR4088

4. Remove bolts securing mudshield.
5. Using a suitable lever, pry sensor from mounting bush.
6. Release harness cable ties, remove sensor lead from vehicle.



NOTE: The two rear sensor leads are integral with pad wear harness. In case of sensor failure complete harness must be changed.

7. Remove sensor bush.

Refit

8. Fit new sensor bush.
9. Lightly grease new sensor using silicone grease. **See LUBRICANTS, FLUIDS AND CAPACITIES, Information, Recommended Lubricants and Fluids**
10. Push sensor through bush until it touches exciter ring. Sensor will be 'knocked back' to correct position when vehicle is driven.
11. Secure harness in position.
12. Reconnect sensor electrical connection.
13. Clear error code. **See Fault diagnosis, Fault Diagnosis Procedure**
Drive vehicle to ensure ABS warning light is extinguished.

STOP LIGHT SWITCH

Service repair no - 86.65.51

Remove

1. Turn ignition off and disconnect battery negative lead.
2. Remove lower fascia panel.
3. Disconnect multi-plug to switch.

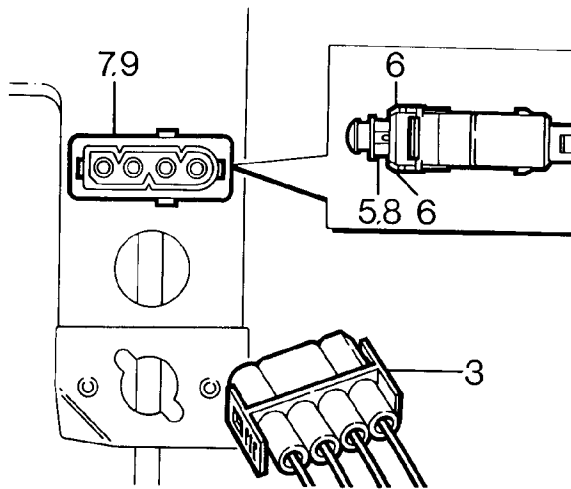

RR4089

4. Depressurise system. *See Depressurise System*
5. Depress brake pedal, pull WHITE sleeve and BLACK plunger of switch FULLY forward.
6. Release switch retaining clips.



NOTE: If clips are difficult to release, check WHITE sleeve is FULLY forward.

7. Remove switch.

Refit

8. Pull WHITE sleeve AND BLACK plunger of switch fully forward.
9. Depress brake pedal, fit switch. Ensure retaining clips are FULLY located.
10. Hold switch firmly in place, pull brake pedal back fully to set switch.
11. Turn ignition on. Wait for ABS pump to shut off.
12. Check switch adjustment by slowly depressing brake pedal and checking that the switch clicks at least once before booster hisses.
13. If incorrect, adjust switch by depressing brake pedal and pushing black plug in one detent at a time.
14. Check that stop lamps go off when pedal is released. If not, depress pedal and pull black plunger out one detent at a time.

EXCITER RINGS

See REAR AXLE AND FINAL DRIVE, Repair, Rear Hub Assembly or See FRONT AXLE AND FINAL DRIVE, Overhaul, Front Stub Axle, Constant Velocity Joint and Swivel Pin housing ABS



ABS BRAKES SERVICE TOOLS

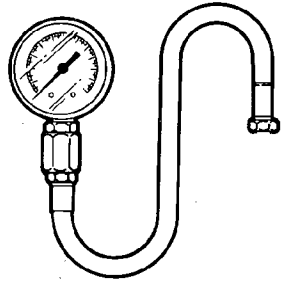

LST140

LRT-70-001
LST 140

ABS pressure test adaptor



ELECTRONIC TRACTION CONTROL - ETC

WABCO, manufacturer of the ABS brake system have developed a differential braking system, ETC, available as an extension to ABS. The system operates on the rear axle only, to prevent loss of traction where one wheel has more grip than the other.

The system works by applying the brake to a spinning rear wheel. This transfers torque to the wheel with the grip. The brake supplies the torque resistance which the wheel cannot.

An example of when the system would operate is where one side of the vehicle is on ice and the other side on tarmac. ETC will control the spinning rear wheel.

If both wheels spin the system does not operate, as braking one wheel will not aid traction.

The system switches itself out at 50 kph (30 mph) since a vehicle travelling above this speed will not need ETC.

System operation is smooth and continuous and will not affect the comfort of the vehicle.

ETC is inhibited when the brakes are applied.

COMPONENTS

As ETC is an extension of the ABS unit it is only available on ABS equipped vehicles.

ECU - the system uses an extended ABS ECU. The same ECU is used on both ETC and non ETC vehicles. If ETC valve block is not connected electrically the ECU assumes the vehicle does not have ETC.

Two solenoid valves - similar to ABS control valves, incorporated in a valve block fitted to the ABS booster. In case of failure the valve block may be removed from the booster unit and a new unit fitted.

Brake pipes - three additional brake pipes to the ETC valve block are required.

ETC Warning light - situated in the instrument binnacle, the warning light works in three different ways:

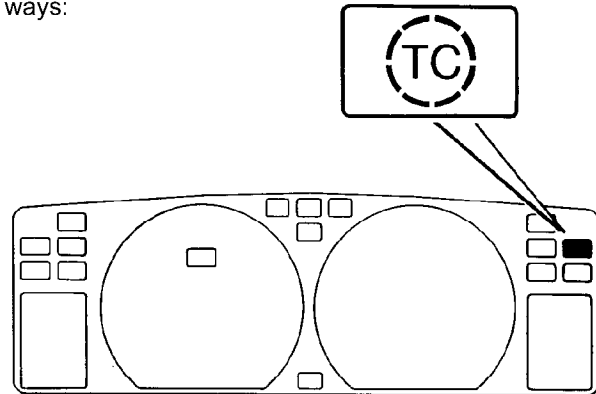

RR4090

ETC active - The light will illuminate for a minimum of two seconds or as long as the system is active. In practice this time will rarely exceed ten seconds. This warns the driver that traction is becoming limited.

Protection mode - In the unlikely event that the system remains active continuously for more than sixty seconds, the system shuts down to protect brakes and solenoid valves from overheating. The warning light will flash at half second intervals for a minimum of ten seconds while ETC is shut down. If ETC is shut down, but NOT required by conditions, the light will not flash.

ETC fault - If a fault occurs which disables ETC, the warning light is constantly illuminated, (even when there is no wheel spin,) until ignition is switched off.

Bulb check - The light will illuminate for three seconds when ignition is switched on and ABS/ETC self checks completed.

USA vehicles - the warning light will NOT be illuminated as part of warning light bulb check.

ETC HYDRAULIC COMPONENTS

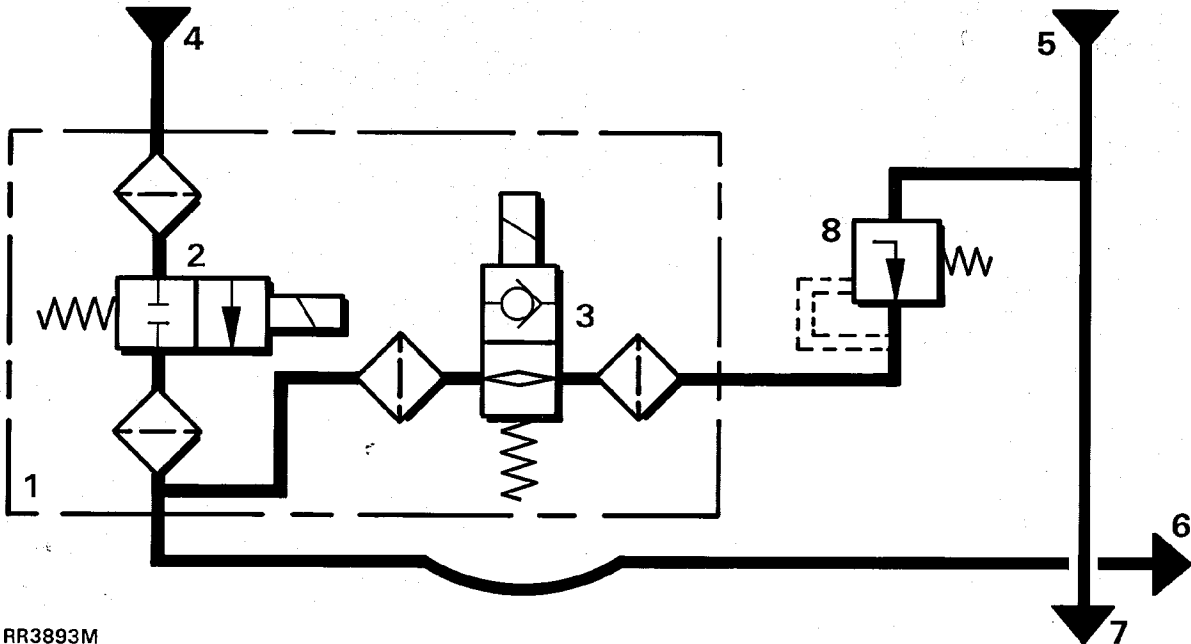

RR3893M

For full details of ABS components. *See Hydraulic Components*

1. ETC valve block
2. Power circuit solenoid valve - normally closed
3. Master cylinder isolating solenoid valve - normally open
4. From accumulator
5. From master cylinder power valve
6. Power circuit to rear brakes
7. Power circuit to front brakes
8. PCRV valve

ETC OPERATION

When the wheelspeed sensors detect a rear wheel is spinning at above vehicle speed, solenoid valve 3. closes, isolating the master cylinder from the rear brakes. Solenoid valve 2. is pulsed open, allowing accumulator pressure to the rear brakes. The rear brake ABS valves operate to apply or release the brake at the spinning wheel as required.

FAULT DIAGNOSIS

Diagnosis is by TestBook or Wabco Diagnostic Controller - STC 2 with software card, for both ETC and non ETC vehicles. See also Range Rover Electrical Trouble Shooting Manual.



ETC VALVE BLOCK

Service repair no - 70.65.61

Remove

1. Disconnect battery negative lead.
2. Depressurise brake system. **See *Depressurise System***
3. Remove three hydraulic pipes from ETC valve block.

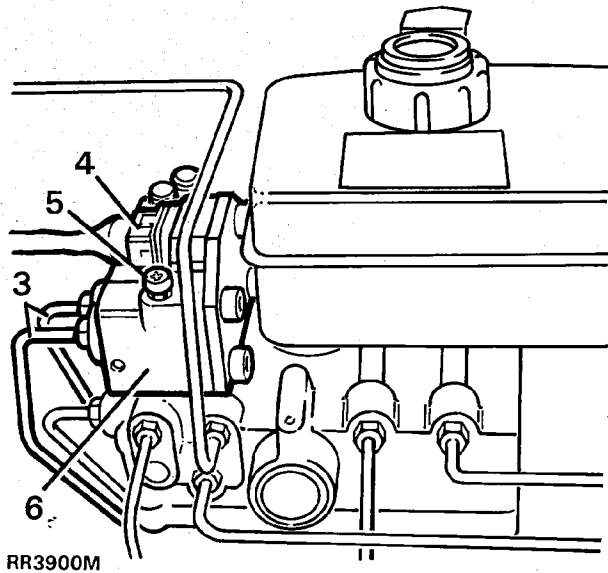

4. Disconnect ETC multiplug.
5. Remove two valve block securing bolts.
6. Remove ETC valve block.

Refit

7. Reverse removal procedure.
8. Bleed brakes. **See *Brake System Bleed (ABS)***



NOTE: Bleed screw on ETC valve block is used when bleeding accumulator.



TYPES OF WHEEL RIMS AND TYRES

Description

Dependent on specification, the vehicle is equipped with alloy or pressed steel wheel rims, both using tubeless radial ply tyres.

Tyre codes

The writing, codes and numbers moulded into the tyre wall vary between tyre manufacturers, however most tyres are marked with the information shown in the illustrated example.

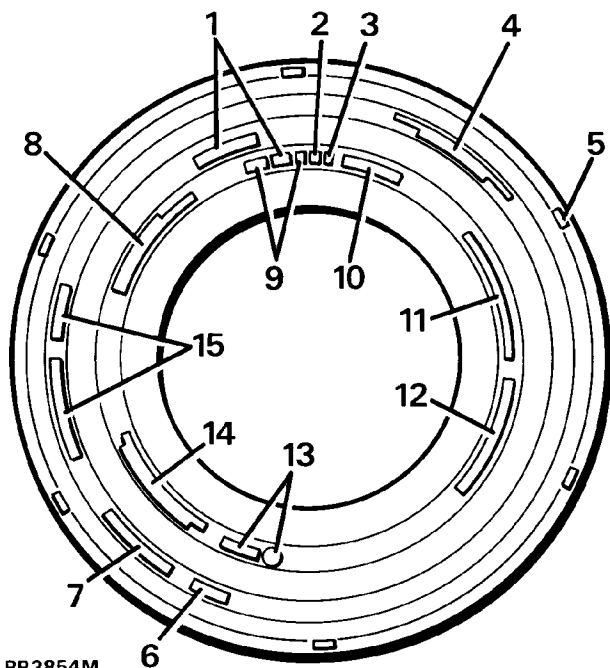



1. Type of tyre construction - **Radial Ply**
2. Load index - **104**
3. Speed symbol - **S or T**
4. USA Tyre quality grading - **Tread wear 160 Traction A temperature B**
5. Tread wear indicators moulded into tread pattern are located at intervals around the tyre and marked by a code - **E66 103S6**
6. Tyres with 'Mud Snow' type tread pattern are marked - **M&S**
7. Tyre reinforcing mark - **Reinforced**
8. USA Load and pressure specification - **(900Kg(1984LBS) at 340KA (50PSI) MACS PRESS**
9. Tyre size - **205 16 ot 235/70 R16**
10. Type of tyre - **TUBELESS**
11. Country of manufacture - **MADE IN GREAT BRITAIN**
12. USA Compliance symbol and identification - **DOT AB7C DOFF 267**
13. European type approval identification - **E11 01234**
14. Tyre construction - **SIDE WALL 2 PLYS RAYON. TREAD 2 RAYON 2 STEEL**
15. Manufacturer's brand name/type - **TRACTION PLUS mzx M**

 **NOTE:** The illustration is an example of the type of markings moulded into tyres and is for guidance only. For specific tyre specifications. See **GENERAL SPECIFICATION DATA, Information, Wheels and Tyres**

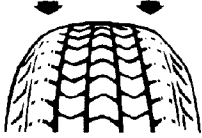
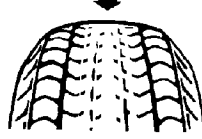
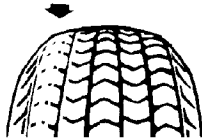

TYRE WEAR CHART

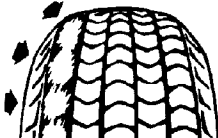
FAULT	CAUSE	REMEDY
<p>Rapid wear at shoulders</p> 	<p>Tyres under-inflated Worn suspension components i.e. ball joints, panhard rod bushes, steering damper</p> <p>Excessive cornering speeds</p>	<p>Inflate to correct pressure Replace worn components</p>
<p>Rapid wear at centre of tread</p> 	<p>Tyres over-inflated</p>	<p>Inflate to correct pressure</p>
<p>Wear at one shoulder</p> 	<p>Track out of adjustment Bent panhard rod</p>	<p>Adjust track to correct figure Check and replace worn or damaged components</p>
<p>Bald spots or tyre cupping</p> 	<p>Wheel out of balance Excessive radial runout Shock absorber worn Excessive braking</p>	<p>Balance wheel and tyre assembly Check runout and replace tyre if necessary Replace shock</p>
<p>Tyre scalloped</p>  <p>RR2138E</p>	<p>Track out of adjustment Worn suspension components Excessive cornering speeds</p>	<p>Adjust toe to correct figure Replace as necessary</p>



CAUTION: This diagnosis chart is for general guidance only and does not necessarily include every cause of abnormal tyre wear.

FAULT - SYMPTOMS**Vibration through steering wheel**

1. Check tyre pressures. *See Repair, Tyre Pressures*
2. Check condition of tyres. *See Tyre Wear Chart*
3. Check front wheel alignment. *See STEERING, Adjustment, Front Wheel Alignment*
4. Check wheel balance. *See Repair, Wheel Balancing*



NOTE: In the event that any apparent vibration is not eliminated at this stage. *See PROPELLER SHAFTS, Fault diagnosis, Vibration Harshness*



NOTE: In the event that any apparent vibration is not eliminated at this stage, go to steering Fault Diagnosis, Fault - Symptom (Steering vibration, road wheel shimmy/wobble). *See STEERING, Fault diagnosis, Steering Faults*



NOTE: Radial ply tyres have a flexible sidewall, which produces a sidewall bulge making the tyre appear under-inflated. This is a normal condition for radial ply tyres. Do not attempt to reduce this bulge by over-inflating the tyre.

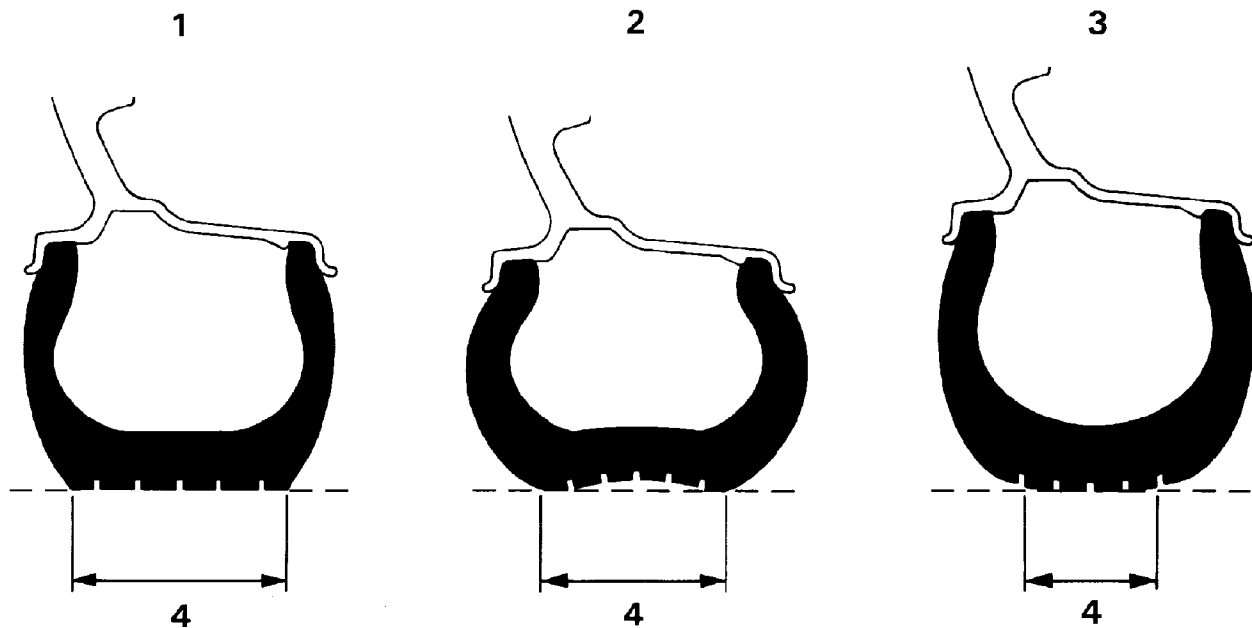

RR2133E

1. Correct inflation.
2. Under-inflation.
3. Over-inflation.
4. Tread contact with road.

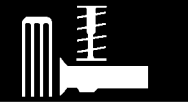

GENERAL INFORMATION



WARNING: This is a multi- purpose vehicle with wheels and tyres designed for both on and off road usage. Only use wheels and tyres specified for use on the vehicle.

The vehicle is equipped with tubeless 'S', 'T' or 'H' rated radial ply tyres as standard equipment. The tyres are of European metric size and must not be confused with the "P" size metric tyres available in North America.

Vehicle wheel sets, including spare wheel, must be fitted with the same make and type of tyre to the correct specification and tread pattern. Under no circumstances must cross-ply or bias-belted tyres be used.

For tyre specification and pressures. **See GENERAL SPECIFICATION DATA, Information, Wheels and Tyres**

Alloy Wheels

Tubeless tyres are mounted on 7.0 inch wide by 16 inch diameter cast aluminium alloy wheels. The surface has a paint finish covered with a clear polyurethane lacquer. Care must be taken when handling the wheel to avoid scratching or chipping the finish.

The alloy wheel rim is of the asymmetric hump type incorporating a safety hump to improve location of the tyre bead in its seat. If difficulty is experienced in fitting tyres to this type of rim. See Tyre Fitting



WARNING: Do not fit an inner tube to an alloy wheel.

Steel wheels

Tubeless tyres are mounted on 7.0 inch wide by 16 inch diameter steel wheels.

TYRE INSPECTION

Inspect tyres at weekly intervals to obtain maximum tyre life and performance and to ensure compliance with legal requirements. Check for signs of incorrect inflation and uneven wear, which may indicate a need for balancing or front wheel alignment. **See Fault diagnosis, Tyre Wear Chart** if the tyres have abnormal or uneven wear patterns.

Check tyres at least weekly for cuts, abrasions, bulges and for objects embedded in the tread. More frequent inspections are recommended when the vehicle is regularly used in off road conditions.

To assist tyre inspection, tread wear indicators are moulded into the bottom of the tread grooves, as shown in the illustration below.

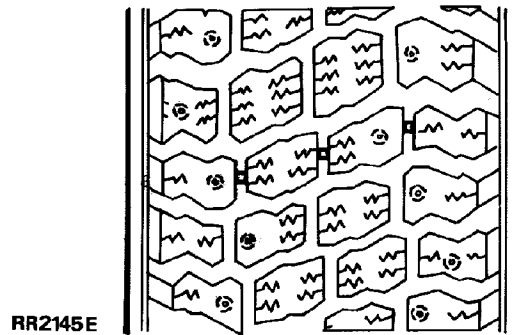

When the tread has worn to a remaining depth of 1.6 mm the indicators appear at the surface as bars which connect the tread pattern across the width of the tread as shown in the illustration below.

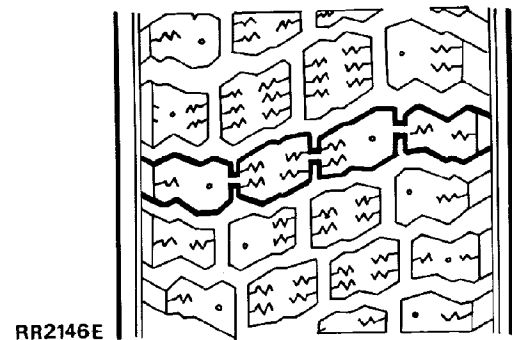

When the indicators appear in two or more adjacent grooves, at three locations around the tyre, a new tyre must be fitted.



NOTE: Do not attempt to interchange tyres, e.g. from front to rear, as tyre wear produces characteristic patterns depending on their position. If tyre position is changed after wear has occurred, the performance of the tyre will be adversely affected.



NOTE: Territorial vehicle regulations governing tyre wear MUST be adhered to.

WHEELS INSPECTION

Regularly check the condition of the wheels. Replace any wheel that is bent, cracked, dented or has excessive runout.

VALVES INSPECTION

Check condition of inflation valve. Replace any valve that is worn, cracked, loose, or leaking air.

TYRE PRESSURES

Maximum tyre life and performance will be obtained only if tyres are maintained at the correct pressures.

Tyre pressures must be checked at least once a month and at least once a week, preferably daily, if the vehicle is used off road.

The tyre inflation pressure is calculated to give the vehicle satisfactory ride and steering characteristics without compromising tyre tread life. For recommended tyre pressures in all conditions. **See GENERAL SPECIFICATION DATA, Information, Wheels and Tyres**

American vehicles - A label attached to the inside edge of the driver's door also provides tyre pressure information.

Always check tyre inflation pressures using an accurate gauge and inflate tyres to the recommended pressures only.

Check and adjust tyre pressures **ONLY** when the tyres are cold, vehicle parked for three hours or more, or driven for less than 3.2 km (2 miles) at speeds below 64 km/h (40 mph). Do not reduce inflation pressures if the tyres are hot or the vehicle has been driven for more than 3.2 km (2 miles) at speeds over 64 km/h (40 mph), as pressures can increase by 0.41 bars (6 p.s.i.) over cold inflation pressures.

Check **ALL** tyre pressures including the spare. Refit the valve caps as they form a positive seal and keep dust out of the valve.

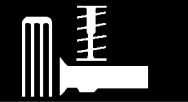

WHEEL BALANCING



CAUTION: It is essential that all wheel balancing is carried out off the vehicle. The use of on the vehicle balancing could cause component damage or personal injury and **MUST NOT** be attempted.



NOTE: Before attempting to balance a wheel and tyre assembly clean all mud and dirt deposits from both inside and outside rims and remove existing balance weights.

Remove stones from the tyre tread in order to avoid operator injury during dynamic balancing and to obtain the correct balance.

Inspect tyres for damage and correct tyre pressures and balance according to the equipment manufacturer's instructions.

Alloy wheels

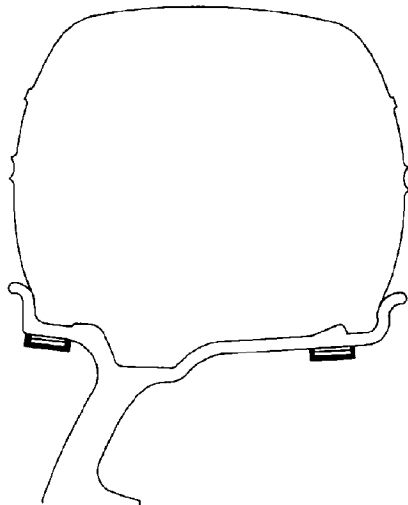

RR2138E

Clean area of wheel rim and attach adhesive balance weights in position shown. Cut through rear face of weight strip to detach required weights.

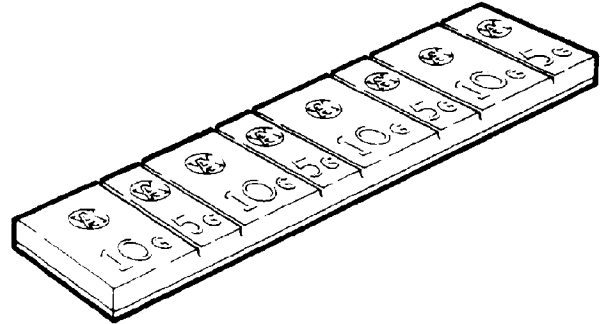

RR2137E



CAUTION: Use only correct adhesive balance weights to avoid damage to aluminium wheel rim. **DO NOT** attempt to use a steel wheel weight on an aluminium wheel.

Steel wheels

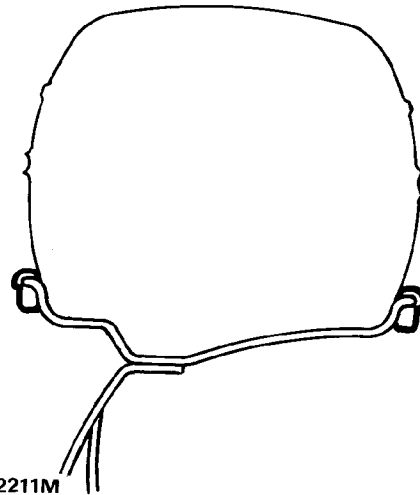

RR2211M

Clean area of wheel rim and attach balance weights in position shown.

Static balance

Wheel tramp

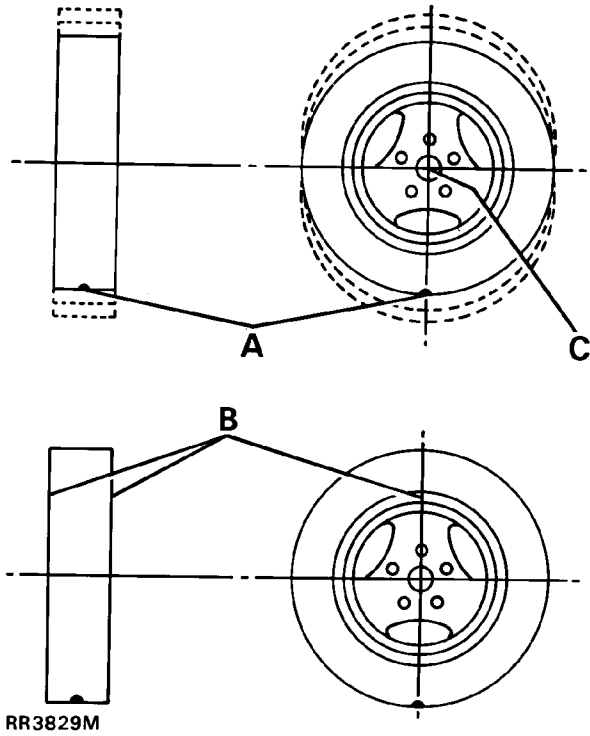

- A. Heavy spot.
- B. Add balance weights here.
- C. Centre line of spindle.

Static balance is the equal distribution of weight around the wheel. A statically unbalanced wheel will cause a bouncing action called wheel tramp. This condition will eventually cause uneven tyre wear.

Dynamic balance

Wheel shimmy

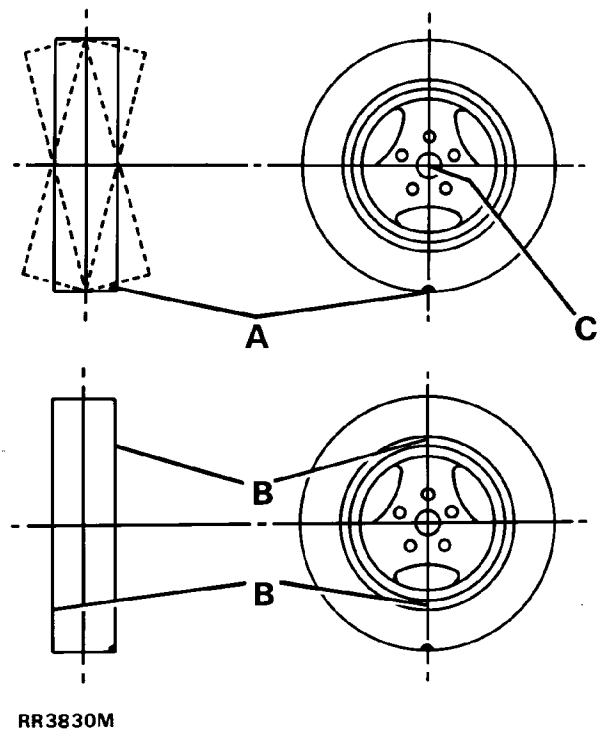

- A. Heavy spot.
- B. Add balance weights here.
- C. Centre line of spindle.

Dynamic balance is the equal distribution of weight on each side of the centre line so that when the wheel spins there is no tendency for side to side movement. A dynamically unbalanced wheel will cause wheel shimmy.



Off vehicle balancing

Balance wheel assembly referring to equipment manufacturer's instructions.

It is essential that the wheel is located by the centre hole **NOT** the stud holes. To ensure positive wheel location the diameter of the locating collar on the machine shaft must be 112.80 to 112.85 mm (4.441 to 4.443 in). This diameter will ensure that the collar fits correctly within the centre hole of the wheel.

Where possible always use the vehicle wheel retaining nuts to locate the wheel on the balancer, to avoid damaging the wheel. If this is not possible, the locating nuts must be of a similar pattern to the original wheel nuts. The use of conical type wheel nuts for this purpose may damage the aluminium alloy.

Cleaning

Wash the aluminium wheels using a suitable wash and wax concentrate correctly diluted and rinse with cold clear water. **DO NOT** use abrasives or aluminium wheel cleaners containing acid, as they will destroy the lacquer finish.

Tyre changing

Use only tyre changing equipment to mount or demount tyres, following the equipment manufacturer's instructions. **DO NOT** use hand tools or tyre levers, as they may damage tyre beads or the aluminium wheel rim.

Puncture repair

Remove punctured tyre from wheel and repair using a combination service plug and vulcanising patch. Always follow manufacturer's instructions when using a puncture repair kit.

Only punctures in tread area are repairable, **DO NOT** attempt to repair punctures in tyre shoulders or sidewalls.

Do not attempt to repair a tyre that has sustained the following: bulges or blisters, ply separation, broken or cracked beads, wear indicators visible and punctures larger than 6 mm diameter.



CAUTION: Do not use tyre sealants that are injected through valve stem to repair punctured tyres, they may produce wheel corrosion and tyre imbalance.

Aluminium wheel rim bead seats should be cleaned using a non-abrasive cleaner to remove the mounting lubricants and old rubber. Before mounting or demounting a tyre, bead area should be well lubricated with a suitable tyre lubricant.

TYRE FITTING

Alloy wheels

1. Install a new valve assembly.
2. Ensure wheel and tyre is adequately lubricated.
3. Mount tyre in normal manner. Inflate tyre and at same time apply hand pressure to area around valve to aid seating over valve first.



NOTE: Stop inflation immediately if tyre seats opposite valve, as this will result in valve being blocked by tyre beading, making further inflation impossible, and carry out following procedure.

4. Deflate tyre, unseat and rotate it around the rim until valve is in line with that part of tyre which seated initially. This part of beading having seated over hump previously will automatically seat first when tyre is re-inflated.
5. Inflate tyre to seat beads correctly, finally inflate to correct pressure.

WHEELS

Remove

WARNING: The parking brake acts on transmission, not rear wheels, and may not hold vehicle when jacking unless following procedure is used. If one front wheel and one rear wheel is raised no vehicle holding or braking effect is possible. Wheels **MUST** be chocked in all circumstances.

Apply parking brake, select 'P' or a gear in main gearbox and engage low gear in transfer box.

1. Loosen five wheel nuts.
2. Using a suitable trolley jack raise vehicle and place on axle stands. *See INTRODUCTION, Information, Jacking*
3. Remove wheel nuts and carefully withdraw wheel over studs.

Refit

4. Ensure that retaining studs and nuts are clean.
5. Alloy wheels: Lightly coat wheel mounting spigot face with a suitable anti-seize compound to minimise possibility of adhesion between wheel and spigot face.
6. Refit wheel taking care not to damage stud threads. (Do not apply oil)
7. Fit wheel nuts and turn by hand for at least three full threads before using any form of wheel wrench.
8. Tighten nuts as much as possible using a suitable wrench.

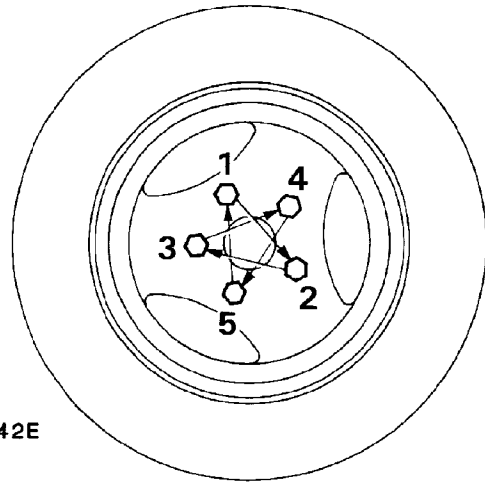
**RR2142E**

9. Lower vehicle and finally tighten nuts to correct torque sequence shown. Alloy wheels and steel wheels: **130Nm**.



WHEEL STUD

Remove

1. Remove wheel. *See Wheels*
2. Drive stud out of driveshaft flange.

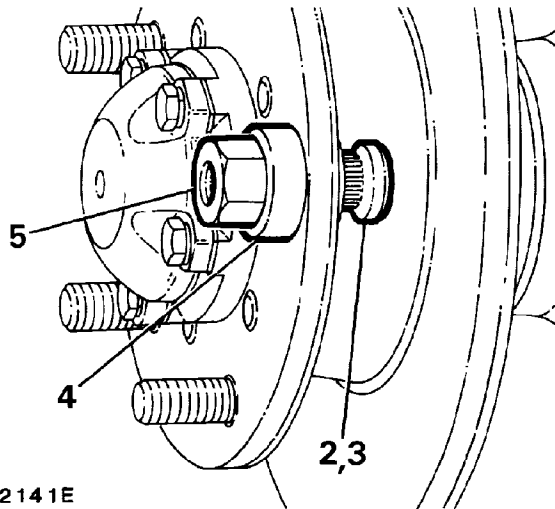

RR2141E

Refit

3. Position stud in flange.
4. Install a suitable spacer over stud.
5. Using a M16 x 1.5P nut, a slave wheel nut is suitable, pull stud into flange until shoulder of stud abuts flange.
6. Refit wheel.



SYSTEM COMPONENTS

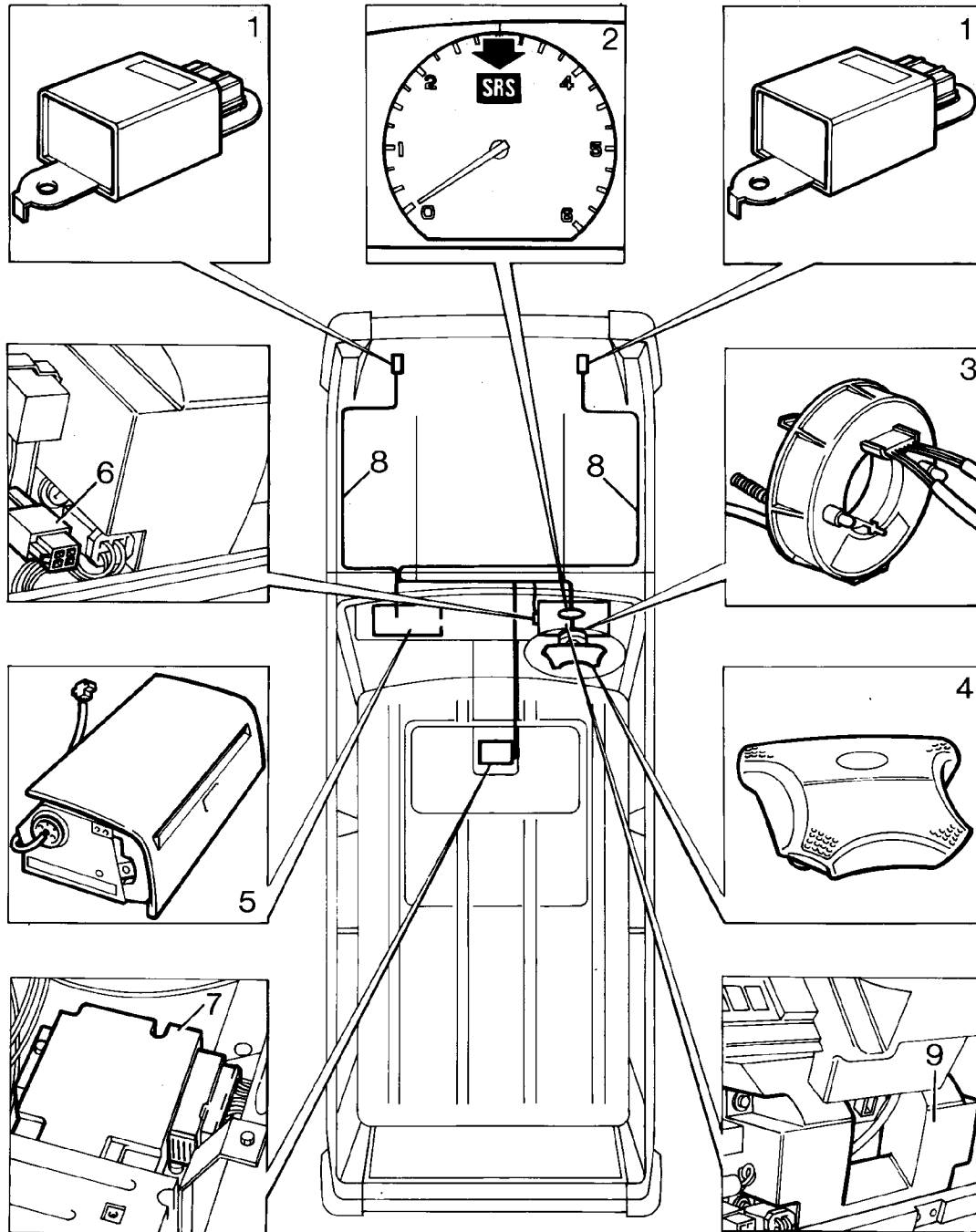

RR4231

- | | |
|-------------------------------|-----------------------------------|
| 1. Airbag crash sensors | 6. Airbag diagnostic socket |
| 2. SRS warning light (airbag) | 7. Airbag diagnostic control unit |
| 3. Rotary coupler | 8. Airbag harness |
| 4. Driver's airbag module | 9. Knee bolsters (where fitted) |
| 5. Passenger's airbag module | |

OPERATION

The airbag supplementary restraint system (SRS) is a safety device which, when used in conjunction with the seat belt, is designed to protect the driver and front passenger by operating when the vehicle receives a frontal impact (in the area indicated) exceeding a certain set speed.

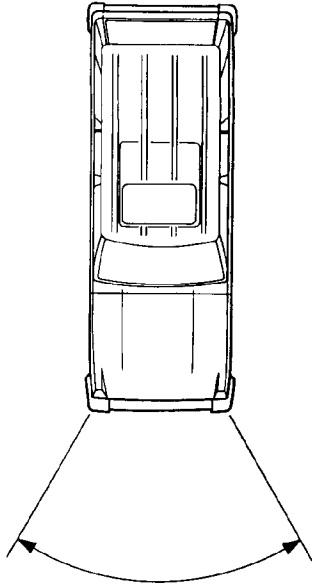

RR4232

In the event of a frontal impact, when the airbag diagnostic control unit and one of the airbag crash sensors senses the impact, the diagnostic control unit fires igniters. This in turn ignites tablets of sodium azide which generate a large amount of Nitrogen gas leading to airbag inflation in approximately 30 milli-seconds.

When fully deployed the airbag offers additional protection to the front seat occupant. As an occupant moves into the airbag it immediately discharges the gas to provide progressive occupant deceleration and reduce risk of injuries. The whole process is completed in approximately 0.3 seconds.



WARNING: All the airbag system components, including the wiring harness, MUST be renewed after the airbags have deployed.

SRS warning light (airbag)

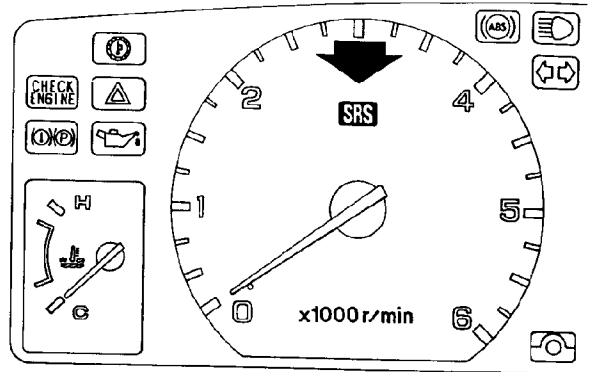

RR4233

The warning light in the instrument pack illuminates after the electrical circuits are switched on whilst a system check is carried out. After about 8 seconds the warning light will go out. The system checks airbag diagnostic control unit, airbag crash sensors, airbag harness, driver and passenger modules.

In the event of a fault in the system the warning light will illuminate and begin modulating. The airbag diagnostic control unit logs the fault which can only be accessed using TestBook.



GENERAL PRECAUTIONS

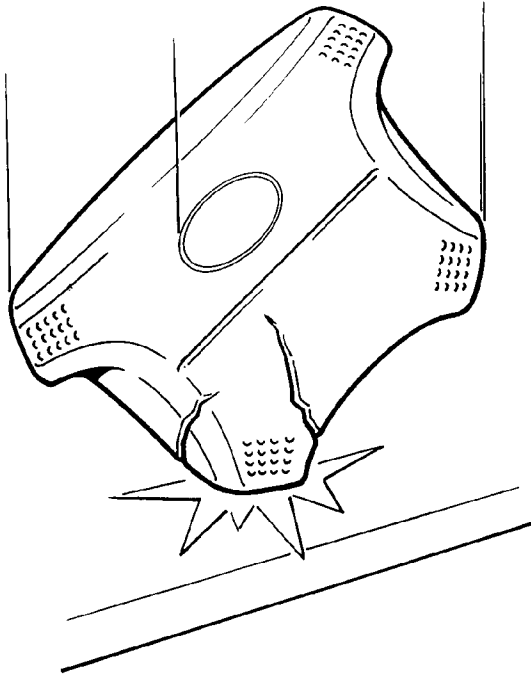

RR4234

1. Carefully inspect any airbag part before installing. Do not install any part that shows signs of being dropped or improperly handled, such as dents, cracks or deformation.

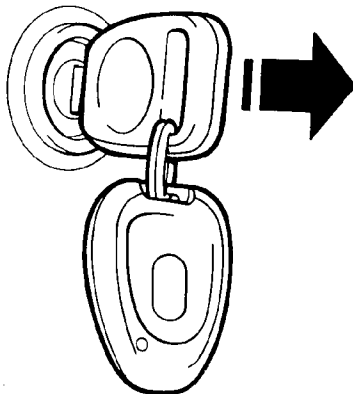

RR4235

2. Always remove the key from the starter switch before beginning work.

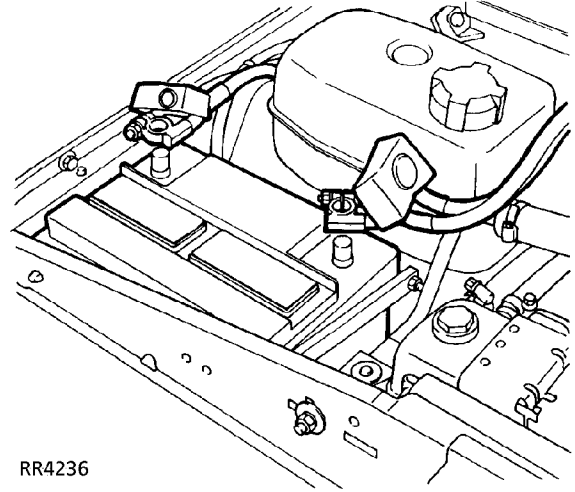

RR4236

3. Always disconnect both the negative '-' cable and positive '+' cable at the battery before removal of driver or passenger airbag modules. Disconnect the negative cable first.



CAUTION: The airbag system has sufficient stored energy to deploy airbags for up to 20 minutes

4. To continue work immediately, disconnect the driver's airbag and passenger's airbag (where fitted).
5. Do not try to dismantle the airbag module. There are NO separately serviceable parts. Once an airbag has been deployed, it cannot be repaired or reused.
6. Do not install used airbag parts from another vehicle. When repairing, use only new airbag parts.

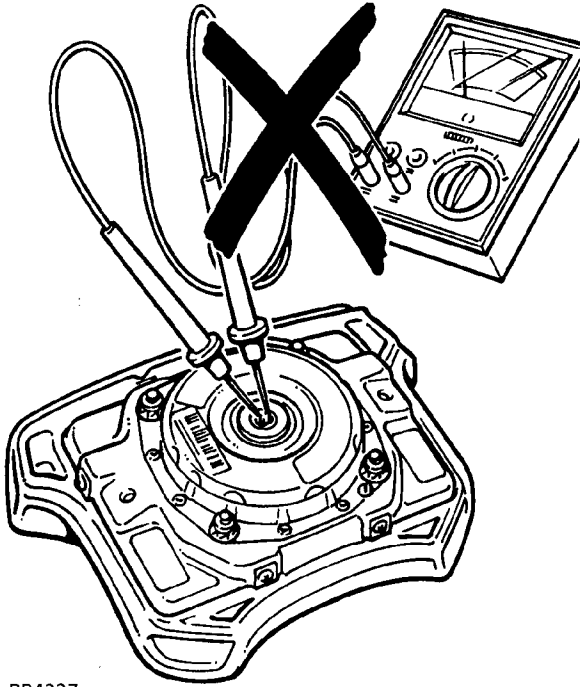

RR4237

7. Do not use electrical test equipment on the airbag harness or connectors. Tampering with or disconnecting the harness could result in accidental firing of the airbag or make the system inoperative, which may result in serious injury.
8. **An airbag system fault can only be diagnosed using TestBook.**
9. The airbag module contains Sodium Azide which is poisonous and extremely flammable. Contact with water, acid or heavy metals may produce harmful or explosive compounds. Do not dismantle, incinerate or bring into contact with electricity.

VEHICLE RECOVERY

Towing - airbag not deployed

Normal towing procedures are unlikely to cause an airbag to deploy. However, as a precaution switch the ignition off and then disconnect both battery leads. Disconnect the negative '-' lead first.

Towing - airbag deployed

Once the driver's airbag has been deployed the vehicle must have a front suspended tow. However, as a precaution switch the ignition off and then disconnect both battery leads. Disconnect the negative '-' lead first.



AIRBAG STORAGE

Temporary storage

For temporary storage of the airbag module during service, observe the following precautions:

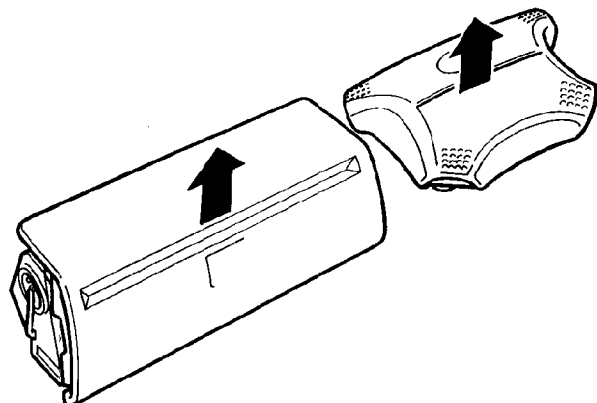

RR4017

Store the airbag module with the pad surface up.

Place the airbag module in designated storage area. If no designated storage area is available, the module may be stored in the boot of the vehicle from which it was removed. Always lock the boot when module is stored in it and inform workshop supervisor.



WARNING: If the airbag is improperly stored face down, accidental deployment could propel the unit with enough force to cause serious injury.

Store the removed airbag module on a secure flat surface away from heat, oil, grease, detergent or water.



CAUTION: Improper handling or storage can internally damage the airbag module, making it inoperative. If you suspect the airbag module has been damaged, install a new unit.

Overnight storage

Airbag modules are classed as an explosive article and as such they must be stored in a secure steel cabinet which has been approved by the local authority.



CRASH SENSOR INSPECTION

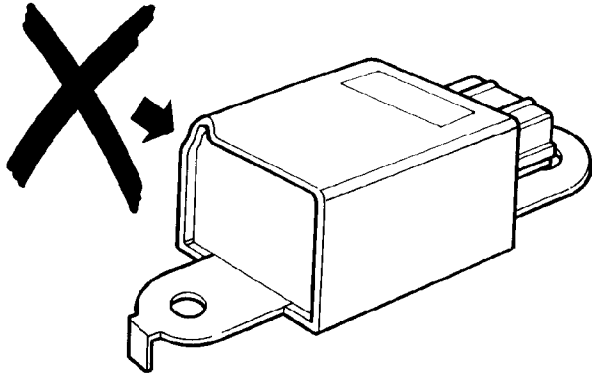

RR4018

1. After any degree of front body damage, inspect both front crash sensors. Replace a sensor if there are any signs of dents, cracks or deformation.

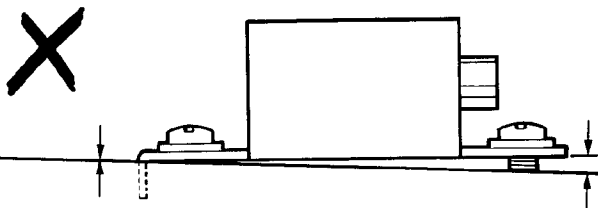
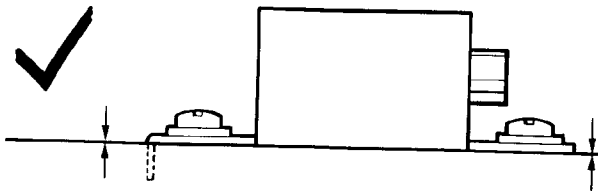

RR4019

2. Ensure the sensors are installed correctly. There must be no gap between the sensor and body of the vehicle. Use the fixing screws supplied with the sensor and tighten to the correct torque. Tighten front sensor fixing before rear sensor fixing.



CAUTION: Take extra care when painting or doing body work in the vicinity of the sensors. Avoid direct exposure of the sensors or harness to heat guns, welding or spraying equipment.

AIRBAG HARNESS

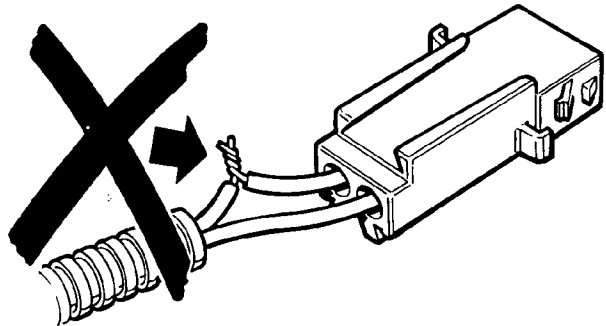

RR4020

1. Never attempt to modify, splice or repair the airbag harness. Never install electronic equipment such as; a mobile telephone, two-way radio or in-car entertainment system in such a way that it interferes electrically with the airbag harness.



NOTE: The airbag harness can be identified by a special yellow outer protective covering.

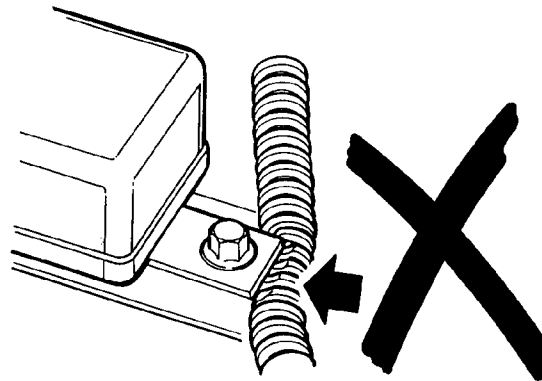

RR4021

2. Make sure the airbag harness is installed correctly and not pinched or trapped.

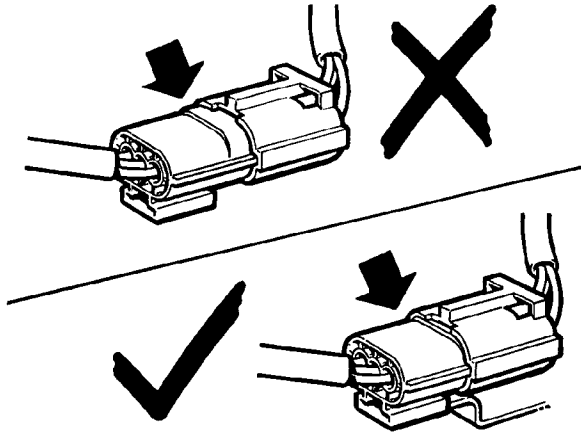

RR4022

3. Ensure all airbag harness connectors are mated correctly and securely fastened. Do not leave the connectors hanging loose.

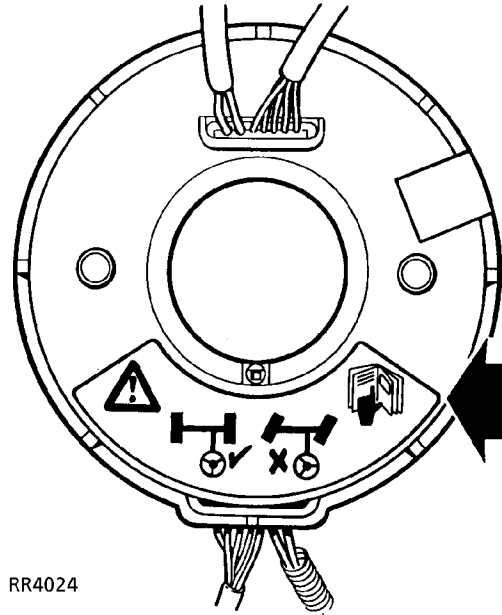

RR4024

2. Rotary coupler



CAUTION: Ensure wheels are straight ahead before removal and installation.

WARNING LABELS

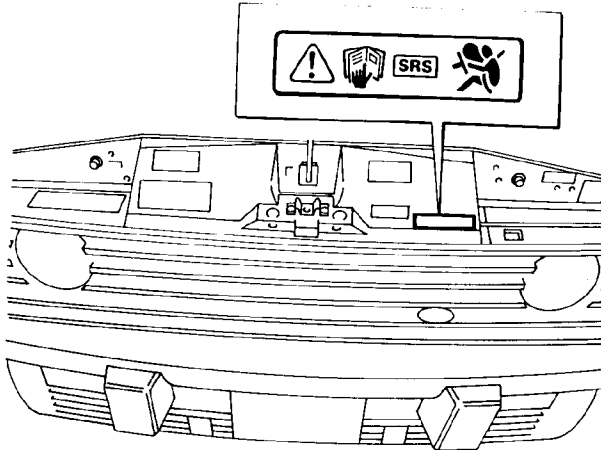

RR4023

1. Bonnet locking platform

Refer to the Owner's Handbook for information on the airbag system.

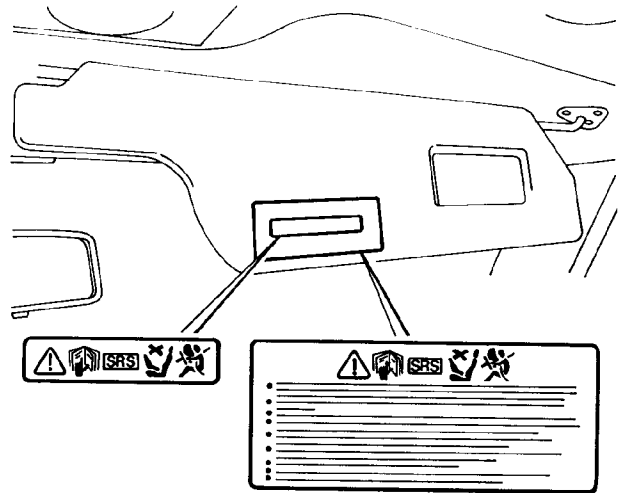

RR4025

3. Driver's sun visor

Refer to the Owner's Handbook for information on the airbag system.

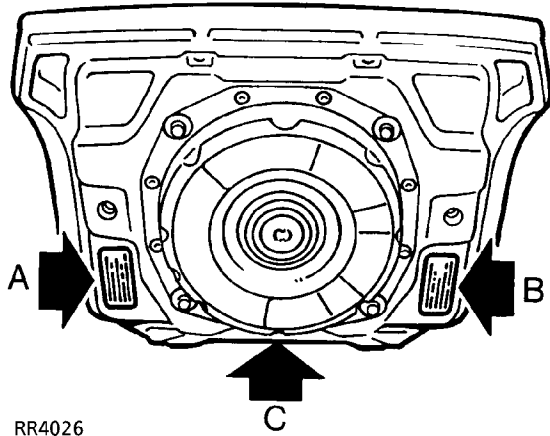

4. Airbag modules

A - If defective, replace and dispose of the entire unit as directed in the instructions. Under no circumstances should a diagnosis be performed using electrically powered test equipment or probing devices.

B - Tampering or mishandling can result in personal injury. For special handling instruction refer to the Workshop manual. This airbag module cannot be repaired. Use diagnostic instructions to determine if the unit is defective.

C - ROVER Bar code - The code number must be recorded if the airbag module is to be replaced.

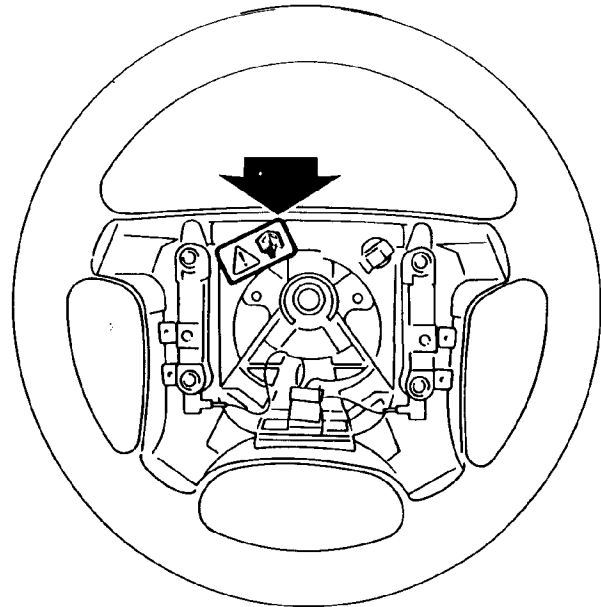

5. Steering wheel
Refer to the Owner's Handbook for information on the airbag system.



SYSTEM PRECAUTIONS



CAUTION: Before and during any removal operations within the SRS section, note routing and position of all harnesses to aid correct refitting and to avoid accidentally trapping cables.



CAUTION: During refitting of any item within the SRS section, always ensure connectors are fully engaged and latched before proceeding to the next stage of the operation.

DRIVER'S AIRBAG MODULE

Service repair no - 76.74.01



WARNING: All the airbag system components, including the wiring harness, **MUST** be renewed after the airbags have deployed.

Remove

1. Turn steering wheel 90° from horizontal.
2. Switch off ignition.
3. Disconnect battery negative '-' and then the positive '+' lead.



CAUTION: Always disconnect both leads.

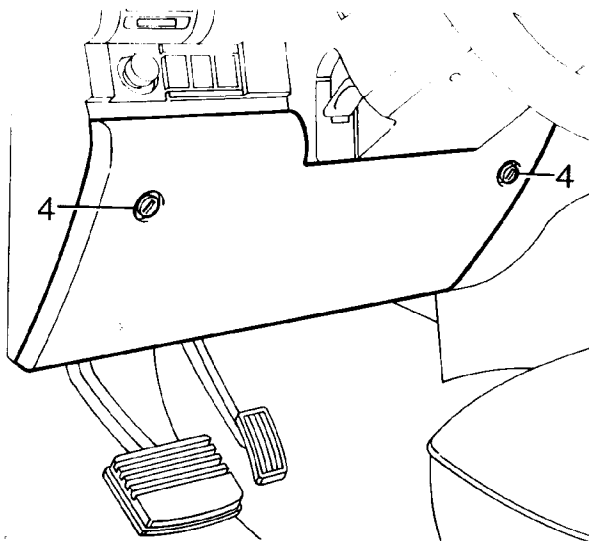

RR4029

4. Release 2 turnbuckles and remove dash lower panel.

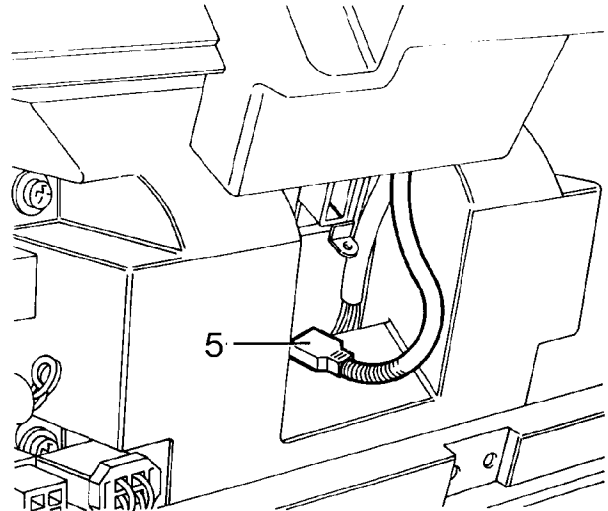

RR4030

5. Disconnect airbag harness connector from yellow airbag column harness.

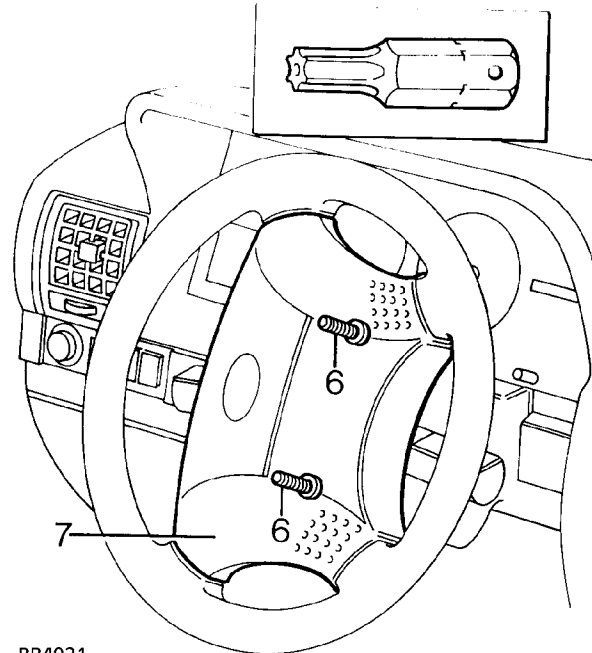

RR4031

6. Use special socket, unscrew 2 tamper-proof Resistorx screws securing airbag module to steering wheel.
7. Release airbag module from steering wheel.



CAUTION: Do not allow the airbag module to hang by the airbag harness.

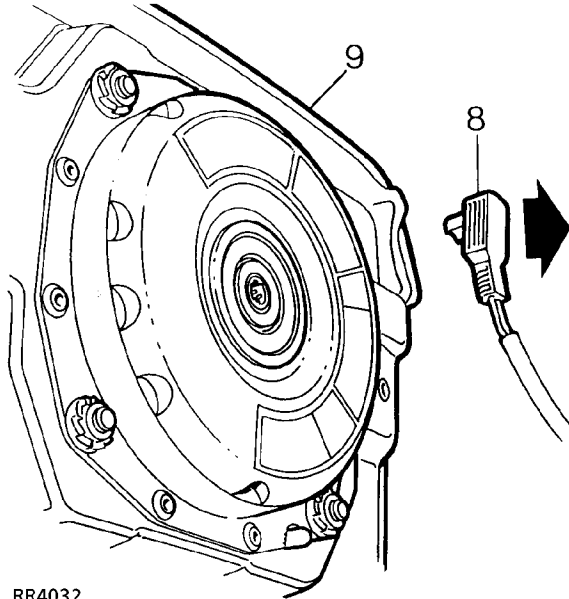

RR4032

8. Disconnect harness connector from airbag module.
9. Remove airbag module.



CAUTION: Store the airbag module in accordance with the storage procedures outlined in Description and Operation.



NOTE: If airbag module is to be replaced the serial numbers must be recorded in the vehicle service record.

Refit

10. Reverse removal procedure.
11. Connect harness connector to airbag module with harness downwards (as shown at 8).
12. Position airbag module on steering wheel and engage retained screws. Use special socket to tighten screws to **8Nm**.



CAUTION: Take care not to cross thread screws.

13. Check Supplementary Restraint System using **Testbook**.

STEERING WHEEL

Service repair no - 57.60.01

Remove

1. Remove driver's airbag module. *See Driver's Airbag Module*
2. Position steering wheel so the road wheels are in the straight ahead position.

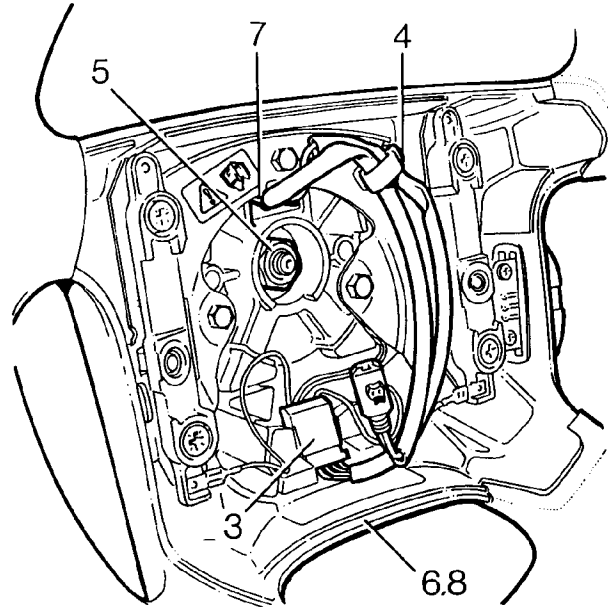

RR4033

3. Disconnect cruise control switch connector (where fitted) from rotary coupler harness.
4. Release harnesses from clip on steering wheel.
5. Remove steering wheel nut.
6. Release steering wheel from column.
7. Feed harnesses through hole in steering wheel.
8. Remove steering wheel.



CAUTION: Prevent rotation of rotary coupler once steering wheel is removed. Secure in position with adhesive tape.

Refit

9. Reverse removal procedure.



CAUTION: Ensure road wheels are straight ahead before fitting steering wheel.

10. Fit steering wheel ensuring the rotary coupler lugs are correctly engaged.
11. Fit steering wheel nut. Tighten to **50Nm**.
12. Refit driver's airbag module. *See Driver's Airbag Module*



ROTARY COUPLER

Service repair no - 19.75.54



CAUTION: Ensure wheels are straight ahead before removal and refitting. Store in plastic bag. **DO NOT** rotate mechanism whilst removing.

Remove

1. Remove driver's airbag module. *See Driver's Airbag Module*
2. Remove steering wheel. *See Steering Wheel*
3. Release lever and lower steering column.

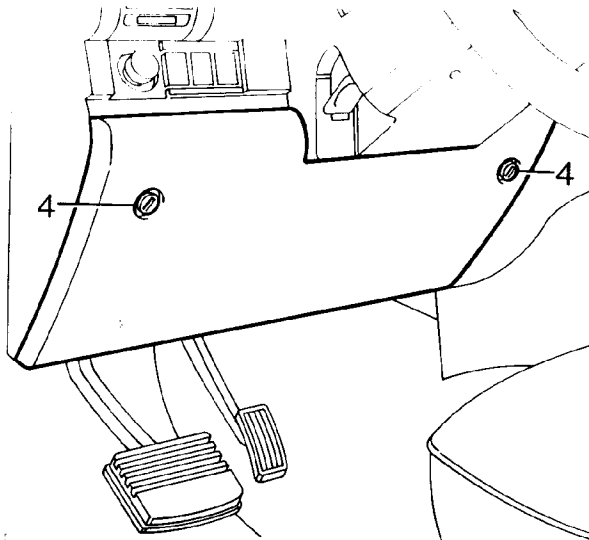

RR4029

4. Release 2 turnbuckles and remove lower dash panel.

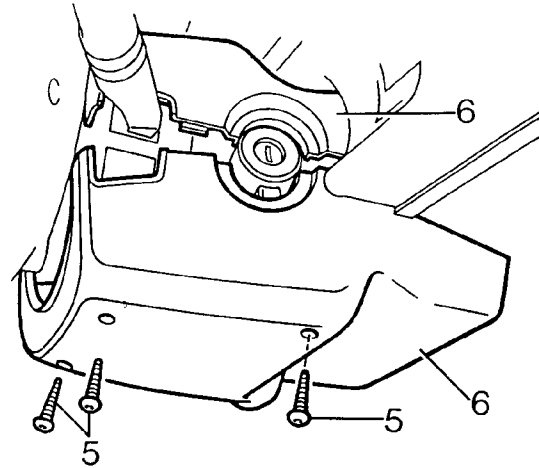

RR4034

5. Remove 3 screws securing lower half of nacelle to steering column.
6. Separate the 2 halves of the nacelle and remove from steering column.

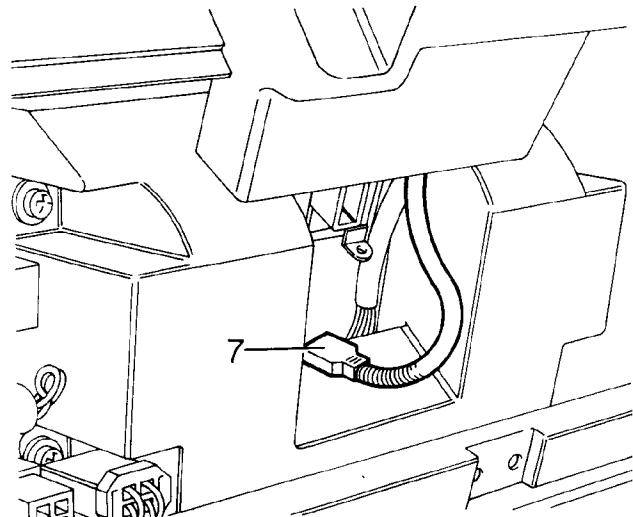

RR4035

7. Release airbag harness connector from bracket and disconnect.

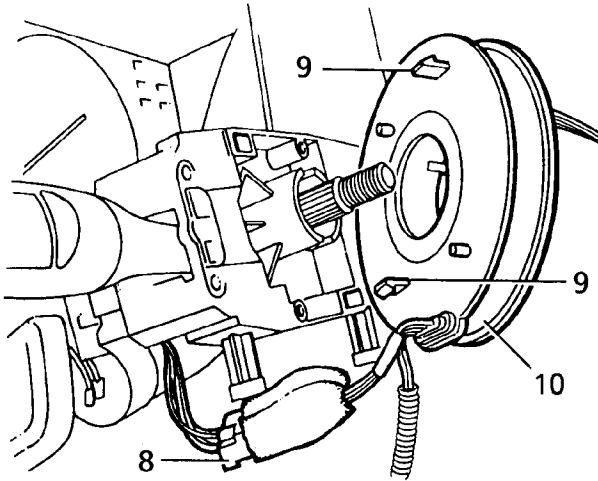

RR4036A

8. Disconnect rotary coupler connector from steering column harness.
9. Release 2 clips securing rotary coupler to column switch assembly.
10. Remove rotary coupler from column switch assembly.

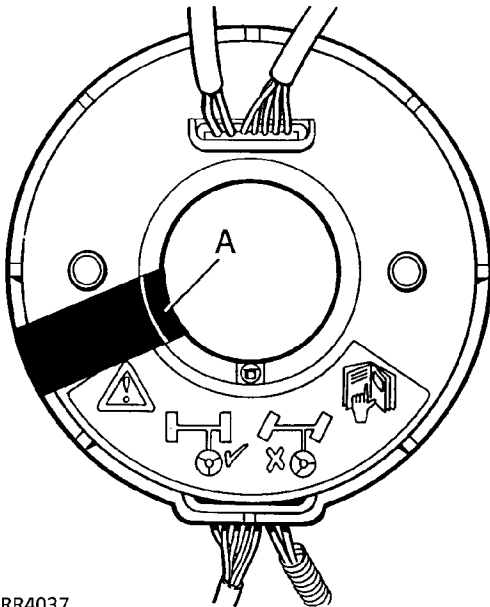

RR4037

11. If rotary coupler is being re-used, place a piece of adhesive tape around moulding in position **A** to prevent rotation.

Refit

12. Reverse removal procedure.



CAUTION: Ensure indicator cancellation pegs correctly engage into back of steering wheel.

13. Align direction indicator cancellation bush. If original rotary coupler is being fitted remove adhesive tape and then fit rotary coupler to column switch assembly.



NOTE: If original rotary coupler is to be fitted and there is evidence of tampering, it is imperative that the coupler is centralised. *See Rotary Coupler centralise*

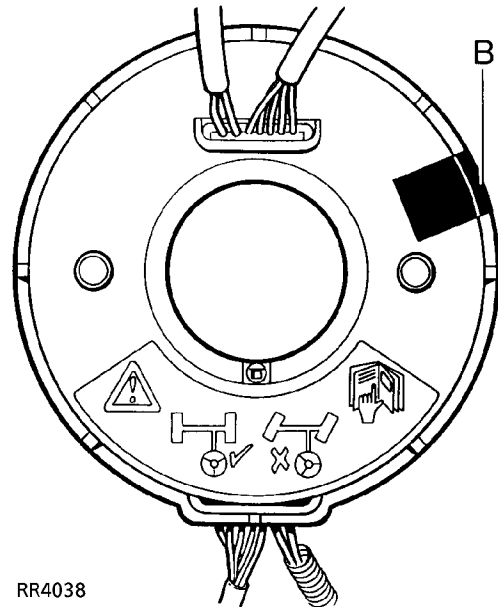

RR4038

14. If a new rotary coupler is being fitted and the sealing tape at position **B** is broken it **MUST NOT** be used.
15. Refit steering wheel. *See Steering Wheel*
16. Turn steering wheel to both LH and RH lock 5 times. If adverse noises can be heard, check alignment of indicator cancellation pegs.
17. Refit driver's airbag module. *See Driver's Airbag Module*



ROTARY COUPLER CENTRALISE

Fitting a rotary coupler which has not been centralised could result in tape breakage. If the tape is broken, a new rotary coupler must be fitted.

Providing the removal procedure has been correctly followed this operation should not be necessary. If however there is evidence of tampering, it is imperative that the coupler is centralised.

CAUTION: Ensure wheels are positioned straight ahead before fitting the rotary coupler.

1. Correctly fit rotary coupler to column switch assembly but do not fit steering wheel or make any electrical connections. **See Rotary Coupler**
2. Depress rotary coupler locking peg and without using undue force, rotate coupler anti-clockwise as far as inner tape will allow. Releasing peg will lock coupler in its current position.

NOTE: Do not apply excessive force when limit is reached as this may result in tape breakage. If no limit can be found, tape has already broken and rotary coupler must be replaced.

3. Having turned rotary coupler fully anti-clockwise to limit position, proceed to turn coupler 2.5 turns clockwise to obtain central position. (Coupler will normally rotate a full five turns from anti-clockwise limit to clockwise limit).
4. Make necessary electrical connections and refit steering wheel. **See Steering Wheel**
5. Refit driver's airbag module. **See Driver's Airbag Module**

COLUMN SWITCH ASSEMBLY

Service repair no - Indicator/lighting - 86.65.55
Service repair no - Wash/wipe - 84.15.34

Remove

1. Remove steering wheel. **See Steering Wheel**

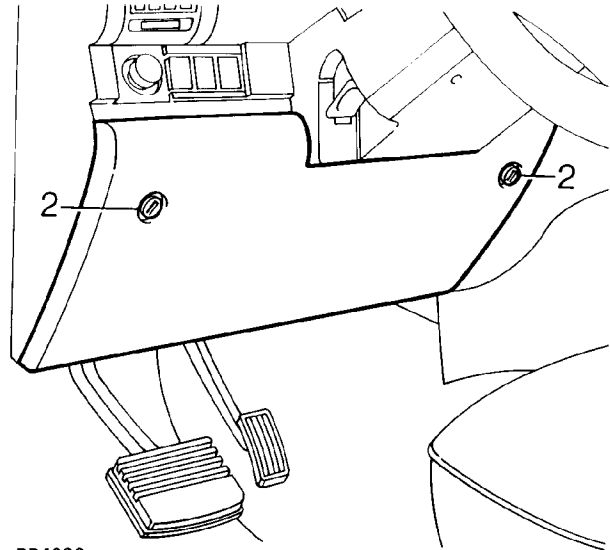

RR4039

2. Release 2 turnbuckles and remove lower dash panel.

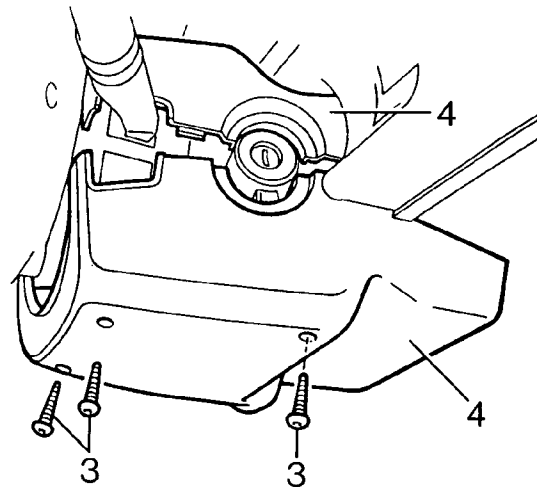

RR4040

3. Remove 3 screws securing lower half of nacelle to steering column.
4. Separate the halves of the nacelle and remove from steering column.

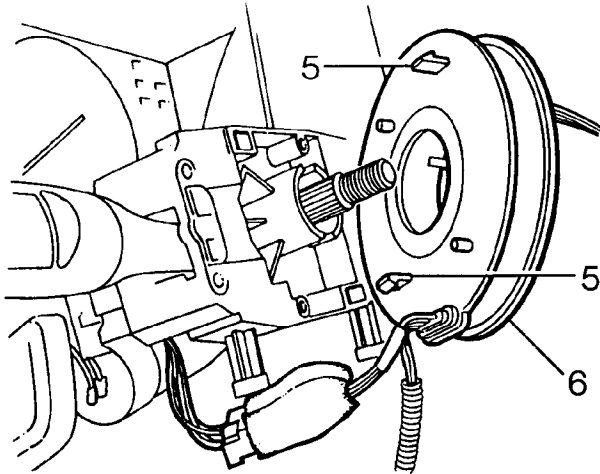

RR4041

5. Release 2 clips securing rotary coupler to column switch assembly.
6. Release rotary coupler.



CAUTION: Do not allow rotary coupler to hang on its harness.

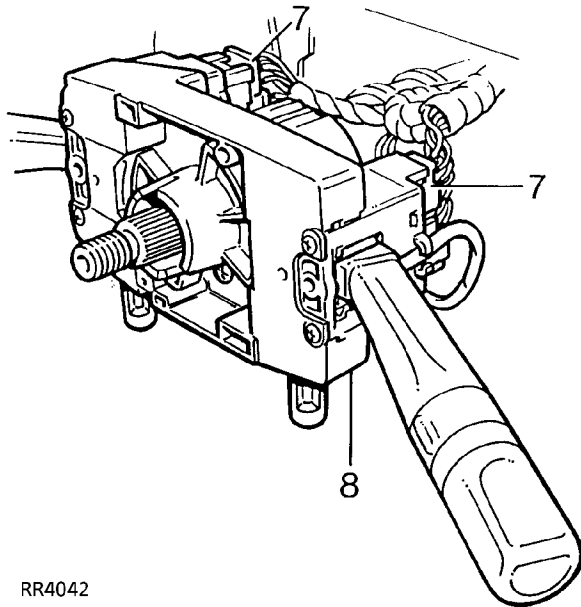

RR4042

7. Disconnect 4 connectors from column switch assembly.
8. Remove column switch assembly from steering column.

Refit

9. Reverse removal procedure.

PASSENGER'S AIRBAG MODULE

Service repair no - 76.74.02



WARNING: All the airbag system components, including the wiring harness, **MUST** be renewed after the airbags have deployed.

Remove

1. Switch off ignition.
2. Disconnect battery negative lead and then positive lead.

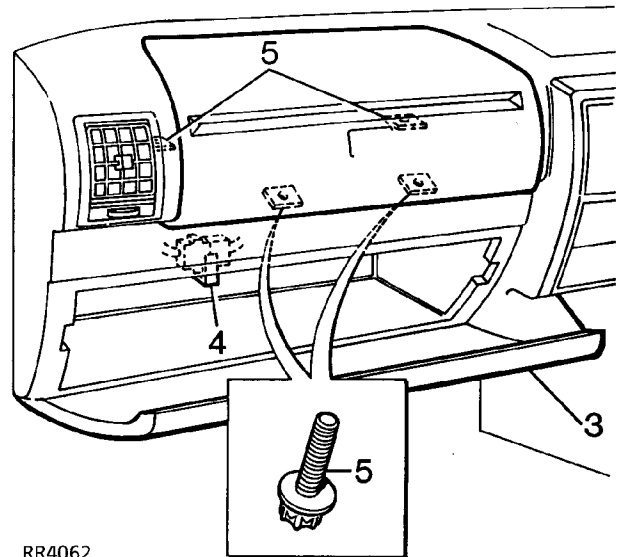

RR4062

3. Open glovebox and disconnect harness connector from airbag module.
4. Use special socket and long extension, remove 2 torx head screws securing front of airbag module to fascia panel.
5. Use special socket, remove 2 torx head screws securing rear of airbag module to fascia panel.

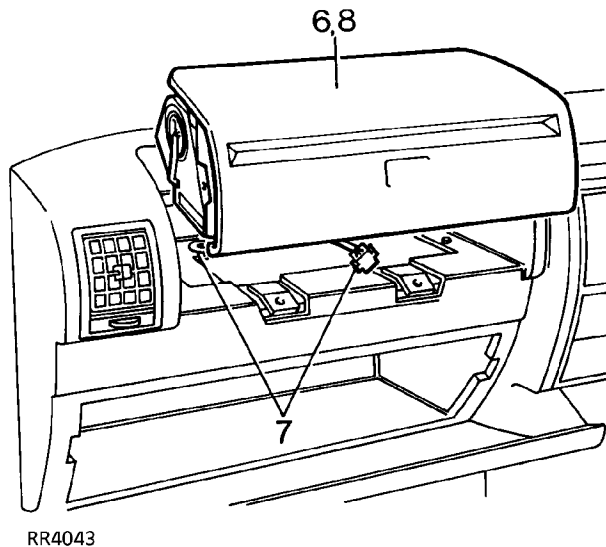

RR4043

- Release airbag module from fascia panel.



CAUTION: Do not allow the airbag module to hang by the airbag harness.

- Carefully and without pulling on connector remove airbag module.



CAUTION: Store the airbag module in accordance with the storage procedures outlined in Description and Operation.



NOTE: If airbag module is to be replaced the serial number must be recorded in the vehicle service record.

Refit

- Reverse removal procedure.
- Tighten airbag module securing screws to **8 Nm**.



CAUTION: Take care not to cross thread screws.

- Check Supplementary Restraint System using **Testbook**.

CRASH SENSOR

Service repair no - 76.74.04

Remove

- Disconnect battery negative lead.
- LH sensor only:**Slacken power steering reservoir clamp and lift reservoir to provide access.
Diesel model only:Remove jack and mounting bracket.

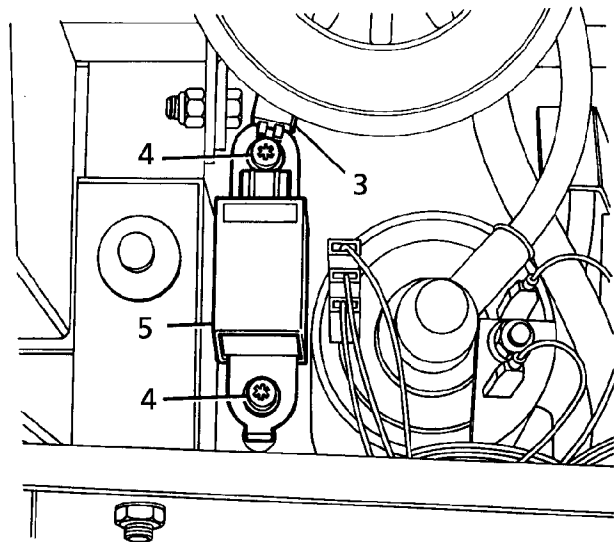

RR4044A

- Disconnect multiplug from sensor



CAUTION: Ensure airbag harness connector seal and anti-backout **DO NOT** come adrift when disconnecting sensor.

- Use special socket, remove 2 screws securing crash sensor to body.
- Remove crash sensor.

Refit

- Reverse removal procedure.
- Tighten crash sensor securing screws to **10Nm**. Ensure multiplug is fully engaged on sensor and retained by its latch.
- Check Supplementary Restraint System using **Testbook**.

AIRBAG DIAGNOSTIC CONTROL UNIT

Service repair no - 76.73.72

Remove

1. Disconnect battery negative lead.
2. Remove centre console assembly. *See CHASSIS AND BODY, Repair, Centre Console*

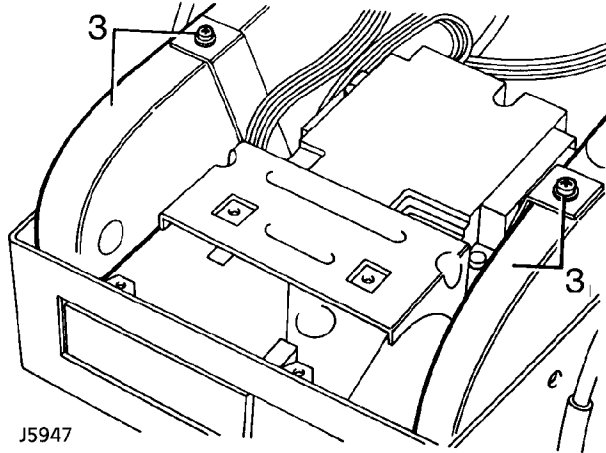

3. Remove 4 screws and release the 2 rear passenger air ducts from their fitted position and remove centre console mounting bracket.

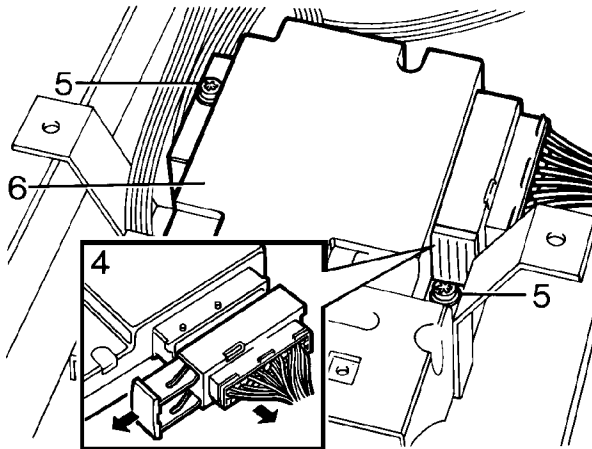

4. Use flat ended screwdriver and release YELLOW retainer, pull retainer 30mm from multiplug and disconnect airbag harness multiplug from airbag control unit.
5. Use special socket, remove 2 screws securing airbag control unit to body bracket.
6. Remove airbag diagnostic control unit.

Refit

7. Reverse removal procedure.
8. Tighten control unit securing screws to **10Nm**.
9. Check Supplementary Restraint System using **Testbook**.



SRS WARNING LIGHT BULBS

Service repair no - 76.73.74

Remove

1. Remove instrument binnacle. See *ELECTRICAL, Repair, Instrument Binnacle*

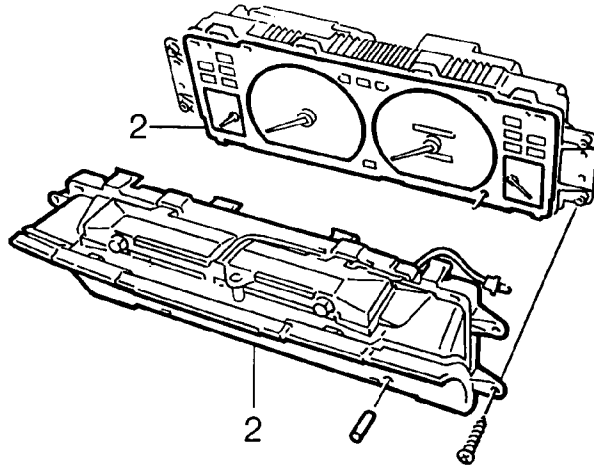

RR4047

2. Remove window and face plate from instrument panel.

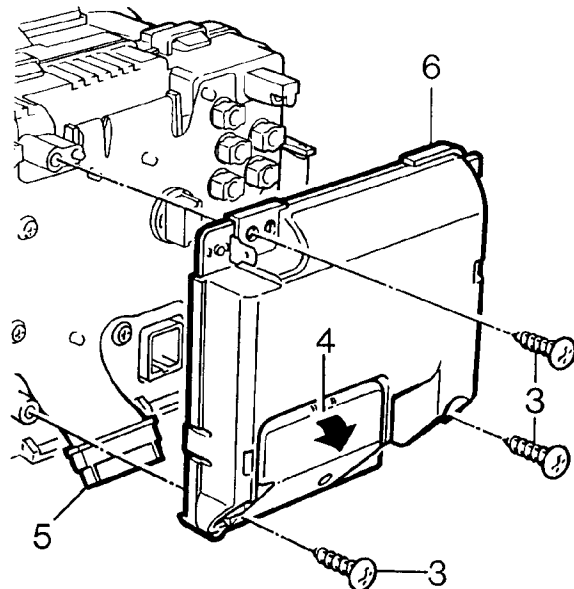

RR4048

3. Remove 3 screws securing ECU to instrument panel.
4. Release and remove small cover from ECU.
5. Disconnect multiplug from ECU.

6. Remove ECU

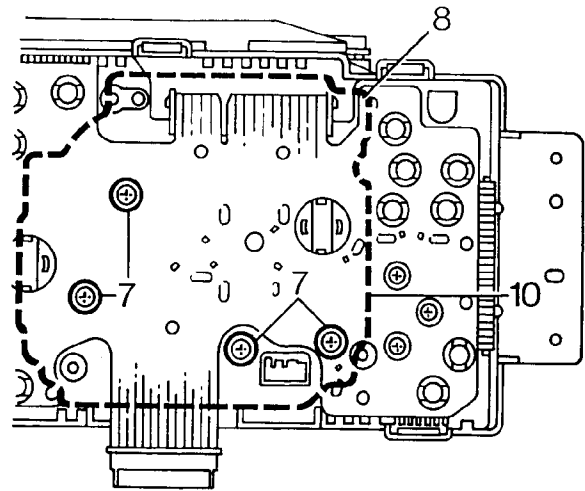

RR4049

7. Remove 4 screws securing tachometer.
8. Remove tachometer.

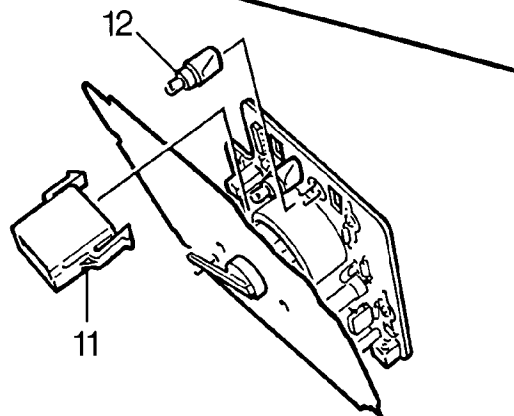
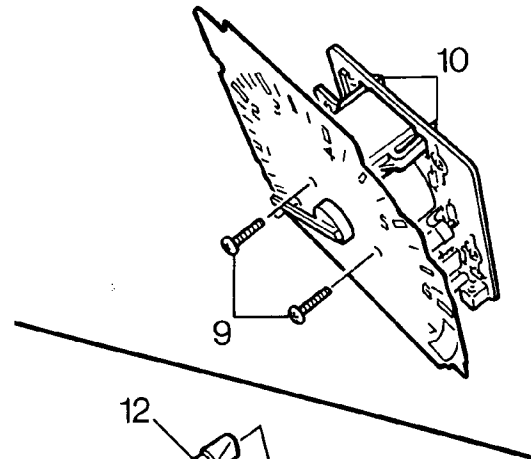

RR4050

9. Carefully remove 2 screws securing face plate to tachometer.
10. Release warning light housing from tachometer circuit board.
11. Carefully (to avoid damage to tachometer needle and spindle), tilt and remove warning light housing.
12. Remove 2 warning light bulbs

Refit

13. Reverse removal procedure.
14. Fit new warning light bulbs
15. Carefully fit warning light housing, ensuring that locating pegs engage correctly and that retaining clips lock housing into position.
16. Ensure that tachometer needle is on the correct side of its stop.
17. Fit instrument panel. *See ELECTRICAL, Repair, Instrument Binnacle*

AIRBAG HARNESS

Service repair no - 76.70.63

Remove

1. Remove driver's airbag. *See Driver's Airbag module*
2. Remove passenger's airbag. *See Passenger's Airbag Module*
3. Remove fascia panel assembly. *See CHASSIS AND BODY, Repair, Dash Panel Assembly*
4. Remove heater blower unit. *See HEATING AND VENTILATION, Repair, Blower Motor Unit - Heater and Air Conditioning*
5. Remove heater and cooler unit. *See AIR CONDITIONING, Repair, Heater and Cooler Unit*

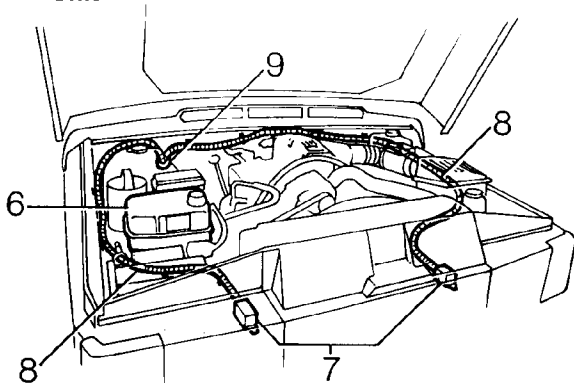

RR4051

6. Remove 3 screws securing expansion tank and position expansion tank aside.
7. Disconnect multiplug from each crash sensor.
8. Release airbag harness from clips and ties along the bulkhead and each valance.
9. Displace airbag harness grommet to inside of bulkhead and feed harness through bulkhead.

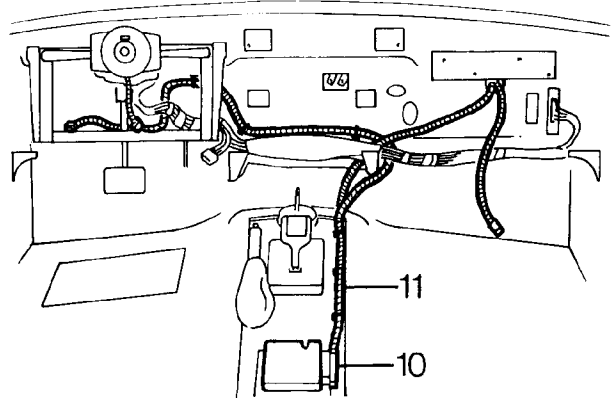

RR4052

10. Disconnect multiplug from airbag control unit.
11. Release airbag harness from under carpet.

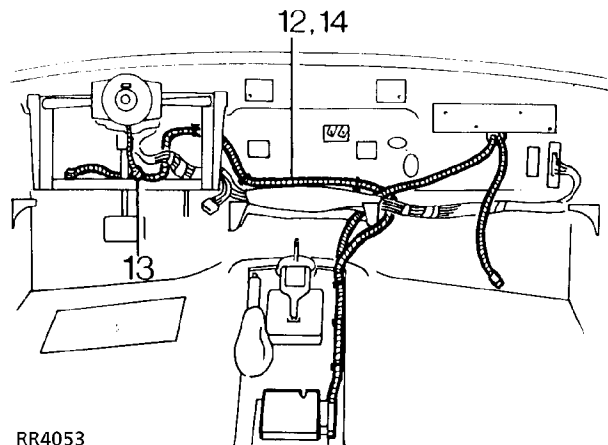

RR4053

12. Release ties securing harness along toeboard.
13. Disconnect steering wheel airbag multiplug.
14. Release airbag harness from driver's side and remove.

Refit

15. Reverse removal procedure.



CAUTION: Ensure harness is correctly routed in harness protector and that all securing clips and ties are correctly engaged and harness is undamaged. Ensure all connections are fully engaged and retained by their latches.



AIRBAG MANUAL DEPLOYMENT

Service repair no - 76.73.00 - Fitted to vehicle
 Service repair no - 76.73.00 - Removed from vehicle



CAUTION: Deployment in the vehicle will damage the steering wheel; if the vehicle is not being scrapped deploy the module away from the vehicle in accordance with the separate procedure.

If a vehicle is to be scrapped and contains an undeployed airbag module, the module must be manually deployed. This operation should only be carried out using the following recommended manual deployment procedure.

Before deployment is started the deployment tool self test procedure should be carried out.

Deployment tool SMD 4082/1 self test procedure

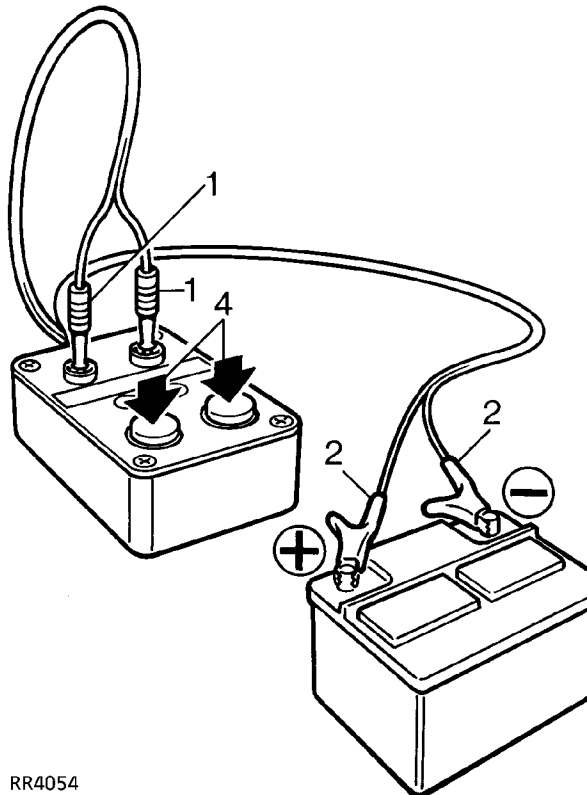

RR4054

1. Insert BLUE and YELLOW connectors of tool lead into corresponding sockets on face of tool.
2. Connect crocodile clips of second tool lead to battery, RED to positive and BLACK to negative.
3. RED "READY" light should illuminate.
4. Press and hold both operating buttons.

5. GREEN "DEFECTIVE" light should illuminate.
6. Release both operating buttons.
7. RED "READY" light should illuminate.
8. Disconnect tool from battery.
9. Disconnect blue and yellow connectors from tool face sockets.
10. Self test now complete.

Deployment with module fitted to vehicle

These guidelines are written to aid authorised personnel to carry out the safe disposal of the airbag module when fitted to the vehicle.



WARNING: Only use the LAND ROVER approved deployment equipment. Deploy airbag module in a well ventilated designated area. Ensure airbag module is not damaged or ruptured before deploying.

1. Carry out deployment tool self test.

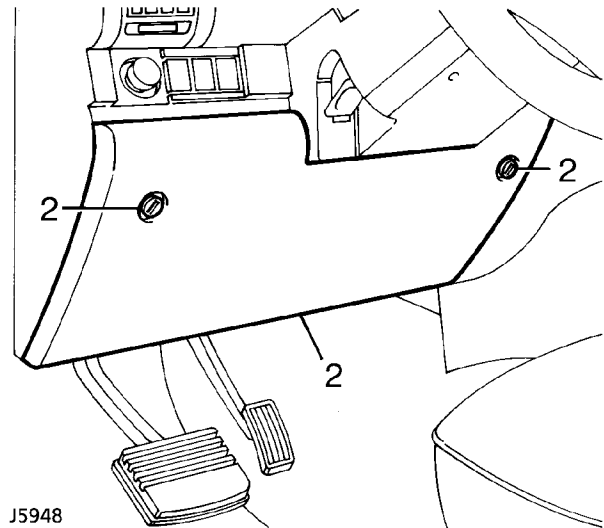

2. Release 2 turnbuckles securing lower panel to dash, remove lower panel.

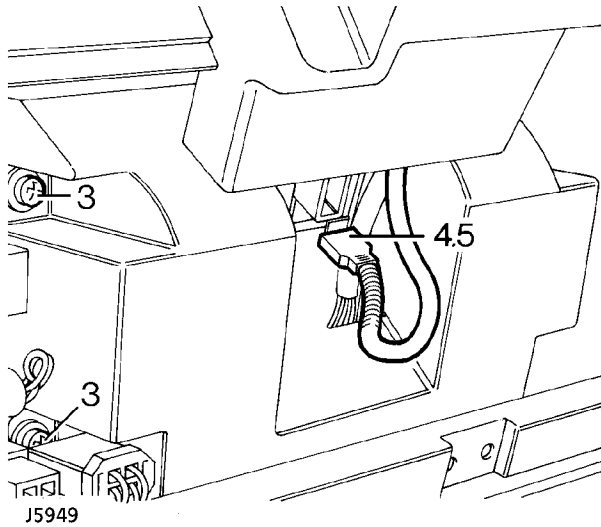

3. Knee bolster (where fitted); Remove 4 screws and withdraw kneebolster.
4. Release airbag harness to column harness connector from bracket.
5. Disconnect airbag harness connector from column harness.

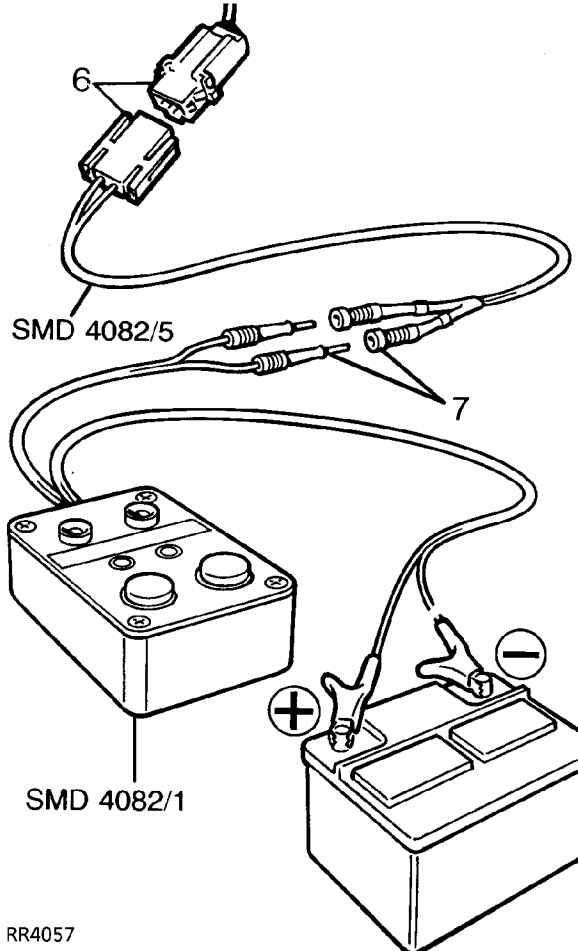

WARNING: Ensure tool is not connected to battery.

6. Connect flylead **SMD 4082/5** to column harness connector.
7. Connect flylead **SMD 4082/5** to tool **SMD 4082/1**.



WARNING: Ensure airbag module is secure within steering wheel.

8. Connect tool **SMD 4082/1** to battery.



WARNING: Ensure all personnel are standing at least 15 metres away from vehicle.

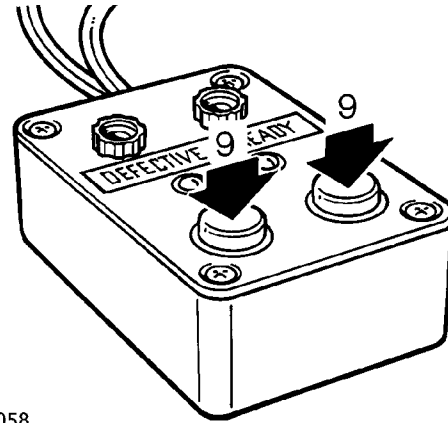

9. Press both operating buttons to deploy airbag module.
10. **DO NOT** return to airbag module for 30 minutes.
11. Using gloves and face mask, remove airbag module from steering wheel, place airbag module in plastic bag and seal bag.
12. Transport deployed airbag module to designated area for incineration.



NOTE: **DO NOT** transport airbag module in the vehicle passenger compartment.

13. Scrap all remaining parts of airbag system. **DO NOT** re-use or salvage any parts of the airbag system including steering wheel.



Deployment with module removed from vehicle.

Driver's Airbag Module

These guidelines are written to aid authorised personnel to carry out the safe disposal of airbag modules when removed from the vehicle.

WARNING: Only use the LAND ROVER approved deployment equipment. Deploy airbag modules in a well ventilated designated area. Ensure airbag module is not damaged or ruptured before deploying.

1. Carry out deployment tool self test.
2. Remove airbag module from steering wheel.
See Driver's Airbag Module

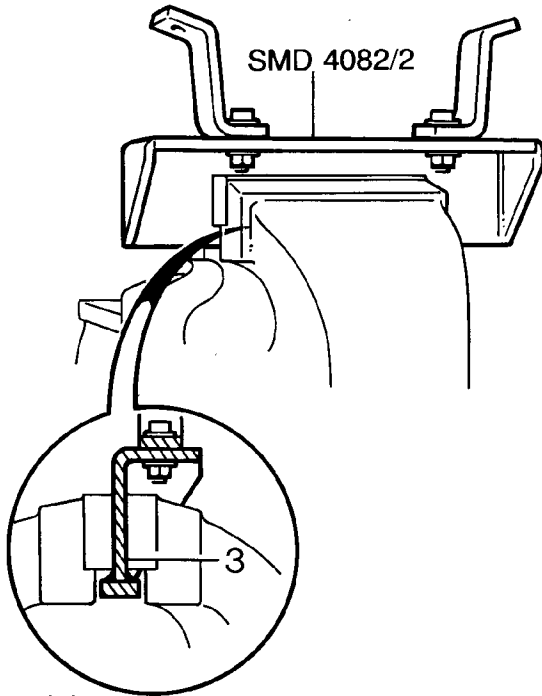
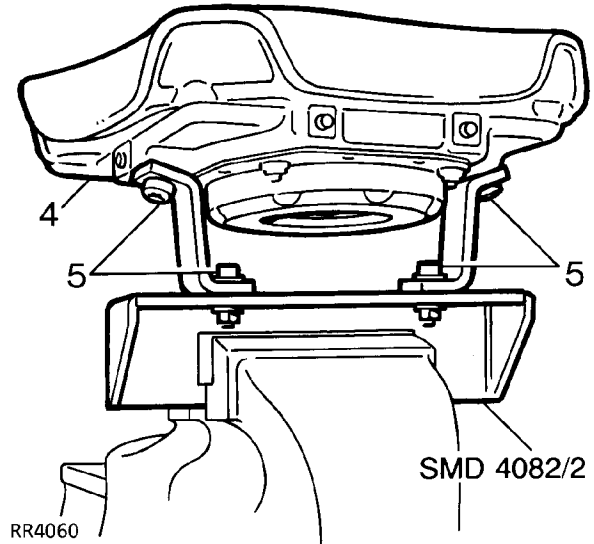

WARNING: Ensure tool SMD 4082/1 is not connected to battery.

4. Secure airbag module to tool **SMD 4082/2**. Ensure module is correctly secured using both fixings.
5. Ensure airbag module mounting brackets are secure.

3. Position tool **SMD 4082/2** in vice, ensuring that vice jaws grip tool above bottom flange to prevent possibility of tool being forced upwards from vice. Tighten vice.

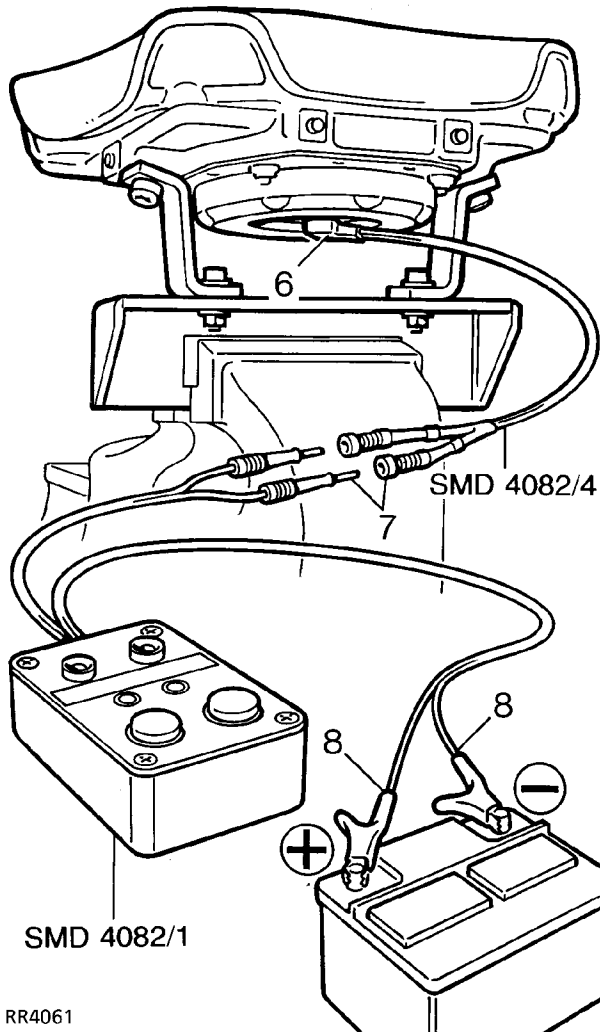

6. Connect flylead **SMD 4082/4** to airbag module.
7. Connect flylead **SMD 4082/4** to tool **SMD 4082/1**.



WARNING: Do not lean over module whilst connecting.

8. Connect tool **SMD 4082/1** to battery.



WARNING: Ensure all personnel are standing at least 15 metres away from module.

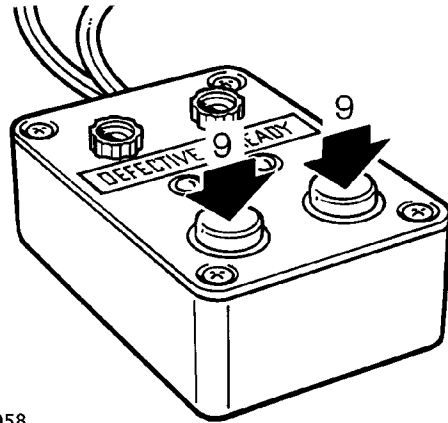

RR4058

9. Press both operating buttons to deploy airbag module.
10. **DO NOT** return to airbag module for 30 minutes.
11. Using gloves and face mask, remove airbag module from tool, place airbag module in plastic bag and seal bag.
12. Wipe down tool with damp cloth.
13. Transport deployed airbag module to designated area for incineration.



NOTE: **DO NOT** transport airbag module in the vehicle passenger compartment. **DO NOT** re-use or salvage any parts of the airbag system including steering wheel or steering column.



Passenger's Airbag Module

1. Carry out deployment tool self test.
2. Remove airbag module from fascia. See *Passenger's airbag module*

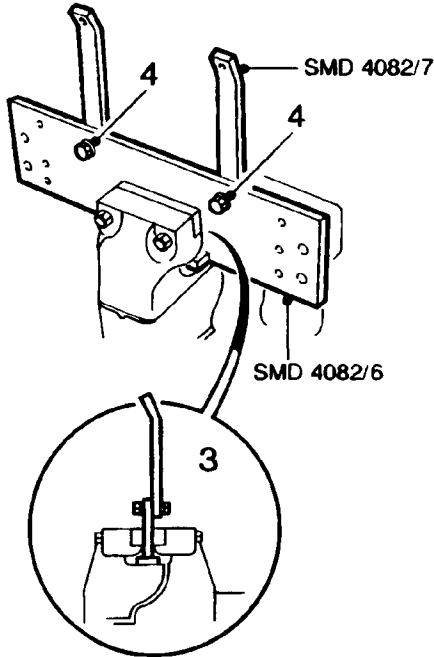

76M1255

3. Position tool **SMD 4082/6** in vice, ensuring that vice jaws grip tool above bottom flange to prevent possibility of tool being forced upwards from vice. Tighten vice.
4. Position brackets **SMD 4082/7** to tool; lightly tighten bolts.

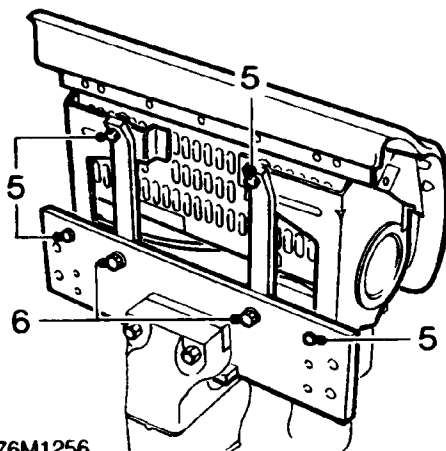

76M1256

5. Position airbag module to tool **SMD 4082/6**. Ensure module is correctly secured using all fixings.
6. Ensure airbag module mounting brackets are secure.

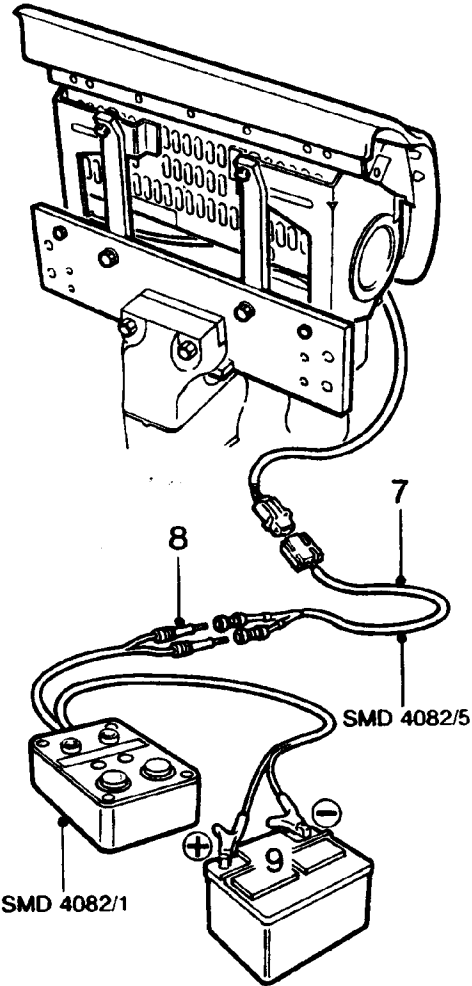

76M1257

WARNING: Ensure tool **SMD 4082/1** is not connected to battery.

7. Connect flylead **SMD 4082/5** to airbag module.
8. Connect flylead **SMD 4082/5** to tool **SMD 4082/1**

WARNING: Do not lean over module whilst connecting.

9. Connect tool **SMD 4082/1** to battery.

WARNING: Ensure all personnel are standing at least 15 metres away from module.

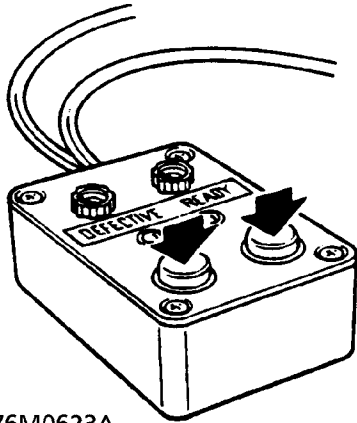

76M0623A

10. Press both operating buttons to deploy airbag module.
11. **DO NOT** return to airbag module for 30 minutes.
12. Using gloves and face mask, remove airbag module from tool, place airbag module in plastic bag and seal bag.
13. Wipe down tool with damp cloth.
14. Transport deployed airbag module to designated area for incineration.



NOTE: DO NOT transport airbag module in the vehicle passenger compartment. **DO NOT** re-use or salvage any parts of the airbag system.



TORQUE VALUES



NOTE: Torque wrenches should be regularly checked for accuracy to ensure that all fixings are tightened to the correct torque.

	Nm
Airbag module screws	8
Steering wheel nut	50
Crash sensor screws	10
Control unit.....	10



BODY CONSTRUCTION

Description

The Range Rover body consists of a steel frame to which alloy outer panels are attached. The decker panel, front wings, side door outer panels, body side outer panels and roof are made from a special light magnesium aluminium alloy.

The manufacture of body panels from aluminium has two distinct advantages, the first of which is an improved resistance to corrosion, the second being it reduces the gross vehicle weight.

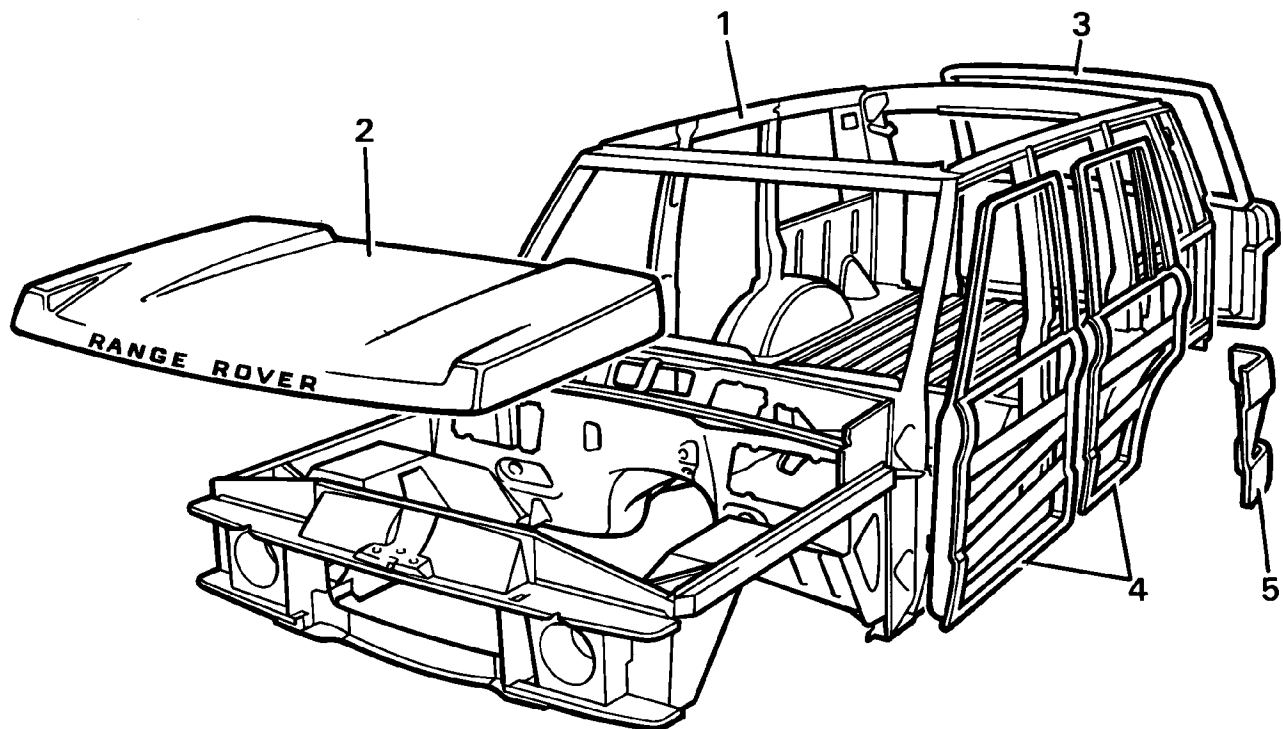

RR3577M

Steel components

1. Body shell
2. Bonnet
3. Tailgate
4. Door frames
5. Quarter panel

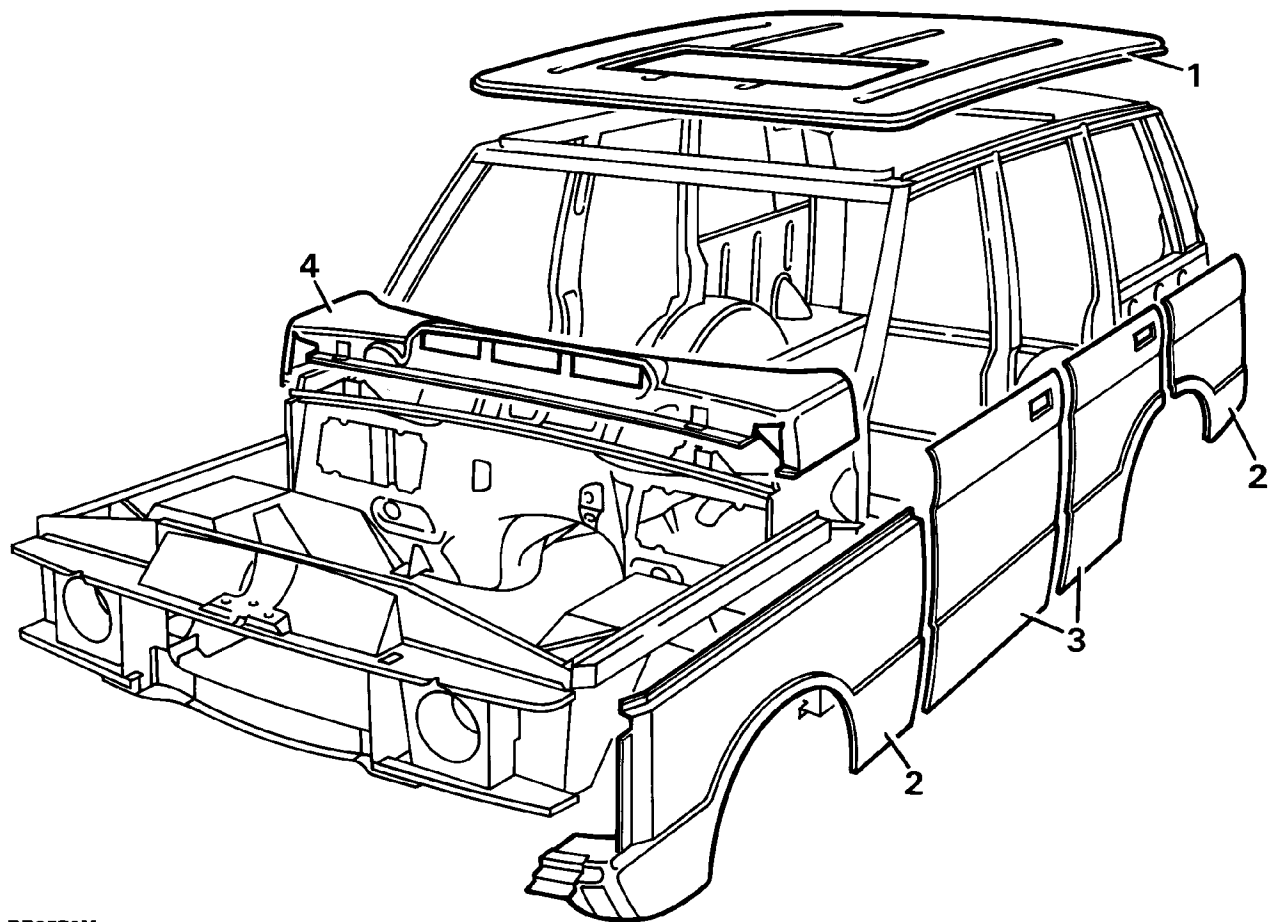

RR3578M

Aluminium alloy components

1. Roof
2. Wings
3. Door panels
4. Decker panel



PAINT CODES - 1995

The following information should be used when ordering paint for 1995 model year vehicles.

COLOUR	TYPE	LRC	INTERIOR	DECALS
VOGUE				
CONISTON	SOLID	570	b,S	MID SILVER
ARLES BLUE	SOLID	424	dg,DG	MID SILVER
ALPINE WHITE	SOLID	456	b,dg,S,AG,DG	DARK GRANITE
PEMBROKE GREY	SOLID	476	dg,AG,DG	MID SILVER
PORTOFINO RED	SOLID	390	b,dg,S,AG,DG	MID SILVER
100"				
BELUGA BLACK	SOLID COB	416	S,AG	MID SILVER
ARDENNES GREEN	MICATALLIC	413	b,dg,S,DG	MID SILVER
ROMAN BRONZE	METALLIC	479	b,dg,S,DG	DARK GRANITE
ASPEN	METALLIC	458	dg,DG	DARK GRANITE
PLYMOUTH BLUE	MICATALLIC	434	b,dg,S,AG,DG	MID SILVER
AEGEAN BLUE	MICATALLIC	490	b,dg,S,AG,DG	MID SILVER
AVALON	MICATALLIC	575	dg,DG	MID SILVER
MONTPELIER	MICATALLIC	536	b,dg,S,DG	MID SILVER
VOGUE SE				
ALPINE WHITE	SOLID	456	S,DG	DARK GRANITE
BELUGA BLACK	SOLID COB	416	S,DG	MID SILVER
ARDENNES GREEN	MICATALLIC	413	S,AG	MID SILVER
ASPEN	METALLIC	458	S,DG	DARK GRANITE
PLYMOUTH BLUE	MICATALLIC	434	S,DG	MID SILVER
AVALON	MICATALLIC	575	DG	MID SILVER
NIAGARA	MICATALLIC	536	DG	MID SILVER
LSE 108"				
ALPINE WHITE	SOLID	456	S,AG,DG	DARK GRANITE
BELUGA BLACK	SOLID COB	416	S,AG,DG	MID SILVER
ARDENNES GREEN	MICATALLIC	413	S,AG,DG	MID SILVER
MOSSWOOD	MICATALLIC	987	S,AG,DG	MID SILVER
PLYMOUTH BLUE	MICATALLIC	434	S,AG,DG	MID SILVER
AVALON	MICATALLIC	575	S,AG,DG	MID SILVER
NIAGARA	MICATALLIC	574	S,AG,DG	MID SILVER
KEY TO COLOURS:				
INTERIOR: Velour: b - BROGUE, dg - DARK GRANITE Leather: S - SORREL, AG - ASH GREY, DG - DARK GRANITE				



BODY REPAIRS, GENERAL INFORMATION

Aluminium panels can be effectively repaired using the 'Argon Arc' process of welding, because the aforementioned is a specialist operation it is necessary that only a skilled operator or specialist body shop undertake such repairs.

Under certain conditions it may not be practical to repair an exterior damaged panel, if this is the case, then panels can be easily removed and replaced with new ones.

Panel beating



WARNING: Before applying heat to any panel ensure that the panel is clean and free from underseal and that the area to be worked on is well clear of any combustible materials. Ensure that all precautions are taken against fire.

1. Aluminium alloy panels can be beaten out after accidental damage in the same way as sheet steel. Hammering causes metal to work harden, and requires annealing to prevent the possibility of cracking. To anneal, apply spread of heat to the area, until the heated metal will char a piece of soft wood when touched on it. Followed by slow air cooling.

Welding



WARNING: The battery ground lead MUST be disconnected before commencing welding.



WARNING: Before applying heat to any panel ensure that the panel is clean and free from underseal and that the area to be worked on is well clear of any combustible materials. Ensure that all precautions are taken against fire.

1. Clean off all grease and paint, dry thoroughly and then clean the edges to be welded, and an area at least half an inch on either side of the weld, with a stiff wire scratch brush or wire wool. Cleanliness is essential. Also clean the welding rod or strip with steel wool.
2. It is strongly recommended that a few welds are made on scrap metal before the actual repair is undertaken if the operator is not already experienced in welding aluminium and its alloys.
3. Use only 5 per cent magnesium aluminium welding rod (5 Mg/A).

Welding tears and patching

1. If a tear extends to the edge of a panel, start the weld from the end away from the edge and also at this point drill a small hole to prevent the crack spreading, then work towards the edge.
2. When welding a long tear, or making a long welded joint, tack the edges to be welded at intervals of 50 to 100mm. After this, weld continuously along the joint, increasing the speed of the weld as the material heats up.
3. When patching, cut the patch to the correct shape for the hole to be filled, but of such sizes as to leave a gap 0.80mm between it and the panel, and then weld as described above. Never apply an 'overlay' patch.

Spot welding

1. Spot welding is mainly used in the manufacture of the Range-Rover inner steel body frame and exterior magnesium-aluminium alloy panels, and is a process which can be carried out satisfactorily by the use of the proper apparatus in a specialist body shop. Aluminium and its alloys are very good conductors of heat and electricity, and thus it is most important to maintain the right conditions for successful spot welding. The correct current density must be maintained, and so must the 'dwell' of the electrodes. Special spot welding machines have been developed, but they are expensive, and though the actual work can be carried out by comparatively unskilled labour, supervision and machine maintenance must be in the hands of properly qualified persons.

Riveting

1. Where both sides of the metal are accessible and it is possible to use an anvil or 'dolly' solid aluminium rivets may be used, with a suitable punch or 'pop' to ensure clean rounded head on the work. For riveting blind holes, 'pop-rivets' must be used. These are inserted and closed by special 'Lazy-Tong' 'pop-rivet' pliers.

PAINTWORK

General Information

Before undertaking any paintwork process on the exterior body of Range Rover, firstly ascertain which is the best method of repair either by panel repair or replacement.

The initial preparation of a panel is very important to ensure that when finished it is of a standard that meets and matches existing bodywork. Panels must be thoroughly degreased with Berger Preclean 802.0516 or a suitable equivalent, any unsound paint to be stripped using Berger Double strength Meltic 301.8051. Always refer to the paint manufacturers instructions.

Paintwork processes should be performed by a specialist bodyshop where paint spraying can be undertaken in a controlled environment whereby temperatures are kept constant and the atmosphere dust free.

The flow chart on the following page gives a guide to preparing and painting a panel. Wherever possible refer to the Berger Vehicle Refinishes Product Data and Application Sheets for further information.



SUBSTRATE	ALUMINIUM PANELS	
	PANEL REPAIR	REPLACEMENT PANEL
PREPARATION	Wet for using P60 Grade paper or dry sand using P240 grit discs.	Wet flat using P60 Grade paper or dry sand using P240 grit discs. Care must be taken to avoid cutting through to bare aluminium.
BODY FILLING	If filling is required, thoroughly abrade bare aluminium area to be filled and apply Standox Polyester	If filling is required, fill small indentations with Standox Polyester stopper 430-5029.
ETCHING	<p style="text-align: right;">This process is not required if the original electrocoat primer is in sound condition.</p> <p style="text-align: center;">IF NOT</p> <p>Etch the bare aluminium and filler with auto-speed self etch primer 414-1171, mixed 1:1 with activator 801-7995. Apply one coat and allow to dry for approximately 20 minutes. Recoat within 1 hour.</p>	
PRIMING	To obtain maximum adhesion and excellent build, apply Standox 2K 4:1 full primer 405-0381. Coats of 30-40 microns can be wet flatted with P60 grade paper after 45 minutes at 20°C.	
COLOUR COATING	Apply either Standox 2K Standocryl or Standox Metallic Basislack to the colour required. Hardeners and thinners will vary depending upon system employed, conditions available, temperature and size of vehicle etc. Refer to paint manufacturer's Technical Information Sheet for correct selection.	

BODY

Introduction:

The information which follows is concerned solely with the 'Monocoque' assembly of the inner body shell on Range Rover models.

Body repairs often require the removal of mechanical and electrical units and associated wiring. Where necessary, reference should be made to the relevant section of the Repair Manual for removal and refitting instructions.

The inner body shell is of 'Monocoque' construction and to gain access to the repair area, it may be necessary to remove exterior body panels, all exterior body panels are bolted to the inner body shell to facilitate easier panel removal and replacement or repair.

It is expected that a repairer will select the best and most economic repair method possible, making use of the facilities available. The instructions given are intended to assist a skilled body repairer by expanding approved procedures for panel replacement with the objective of restoring the car to a safe running condition and effecting a repair which is visually acceptable.



WARNING: After collision damage has been repaired and the airbags(s) has not deployed, the SRS integrity must be confirmed using TestBook.

WELDING

The following charts and illustrations show the locations and types of weld for securing the body side assembly, tailgate frame assembly and the front valance and wheel arch assembly. Before undertaking any spot weld joints to the inner body, it is advisable to make a test joint using offcuts of the damaged components, and to use this test piece to perform a weld integrity test.

Spot welding is satisfactory if the joints do not pull apart. If the weld pulls a hole or tears the metal the weld is satisfactory. It is defective if the weld joint pulls apart or if there are signs of burning, porosity or cracking evident.

PREPARATION

Thoroughly clean all areas to be welded, remove any sealants and corrosion protectives from around original panels. Align and clamp all new panels in position and check relationship to one another.



INNER BODY SHELL ASSEMBLY

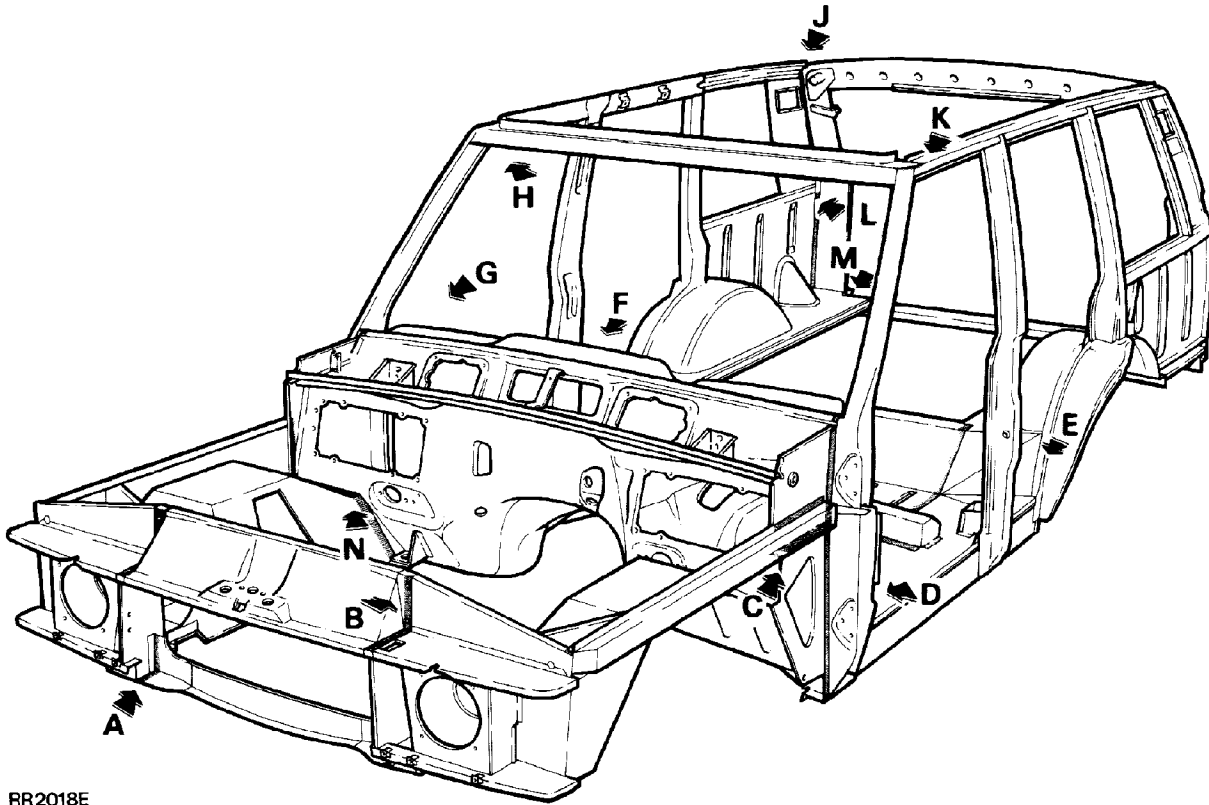

RR2018E

LOCATION	FACTORY JOINT (minimum number of spot welds quoted)
A. Front cross member to valance and wheel arch assembly	6 spot welds, 20mm pitch
B. Bonnet[hood] locking platform to valance and wheel arch assembly	10 spot welds, 25mm pitch
C. Valance and wheel arch assembly to dash and tunnel assembly	16 spot welds, 25mm pitch
D. Body side complete to dash and tunnel assembly	10 spot welds, 65mm pitch

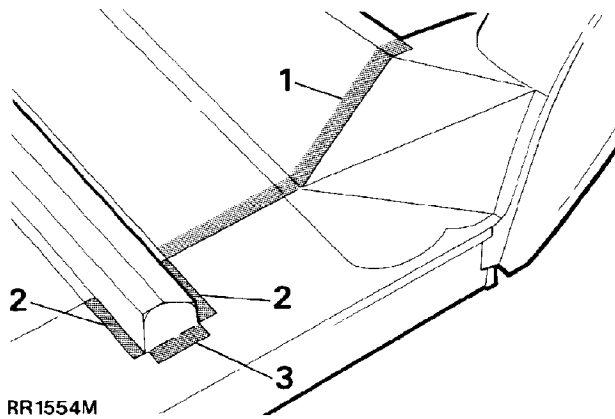

LOCATION E

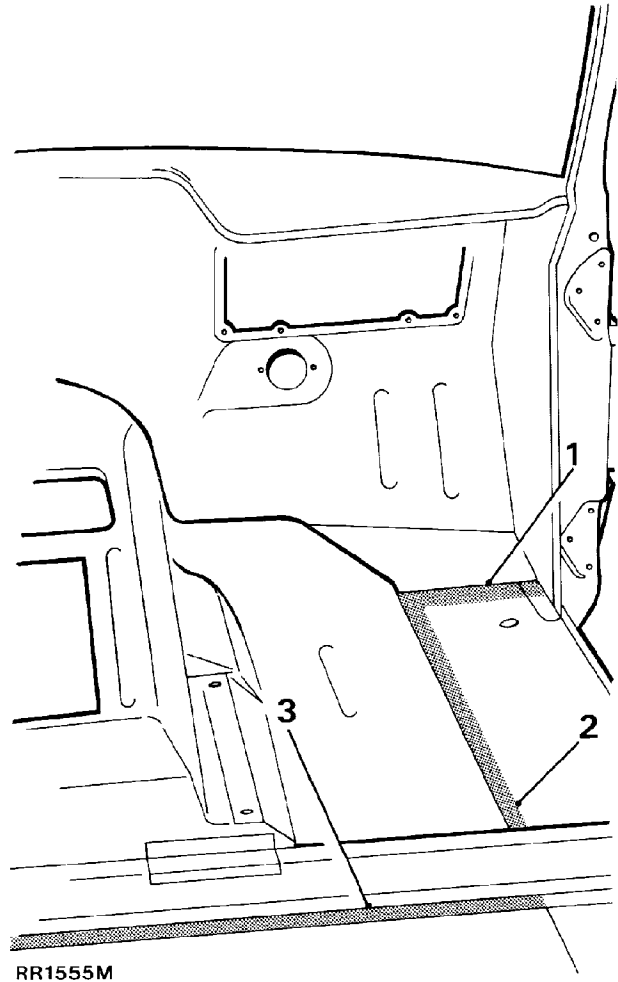

LOCATION F

LOCATION	
<p>E. 1. Body side complete to heelboard panel assembly. 2. Body side complete to dash and tunnel assembly complete. 3. Body side complete to dash and tunnel assembly complete.</p>	<p>14 spot welds, 35mm pitch 10 spot welds, 25mm pitch 3 spot welds, 30mm pitch</p>
<p>F. 1. Body side complete to dash and tunnel assembly complete 2. Body side complete to dash and tunnel assembly complete 3. Body side complete to dash and tunnel assembly complete</p>	<p>7 spot welds, 30mm pitch 18 spot welds, 40mm pitch 30 spot welds, 34mm pitch</p>

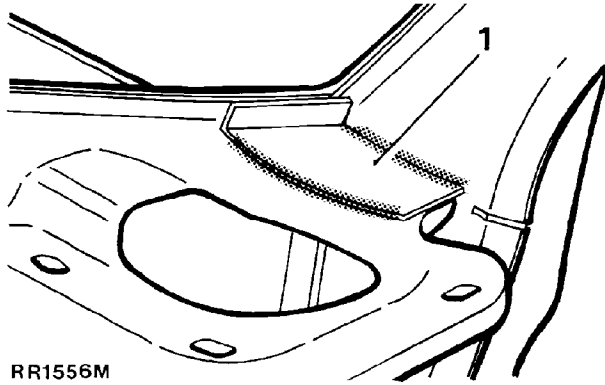

RR1556M

LOCATION G

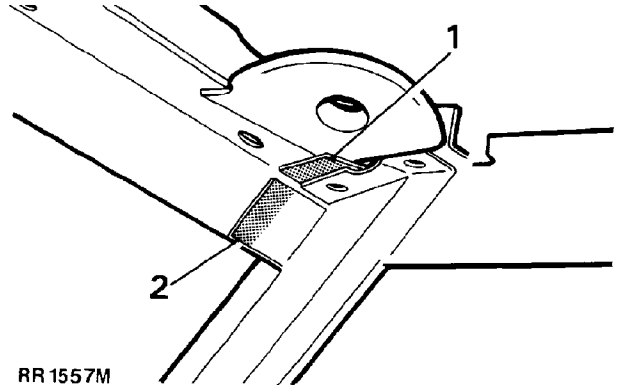

RR1557M

LOCATION H

LOCATION	FACTORY JOINT (minimum weld requirement quoted)
G. 1. Reinforcement plate to dash and tunnel assembly and body side assembly complete.	CO ² weld, 2 places 75mm long each weld.
H. 1. Body side complete to roof header panel assembly (internal joint) 2. Body side complete to roof header panel assembly (internal joint)	3 spot welds, 15mm pitch 3 spot welds, 15mm pitch

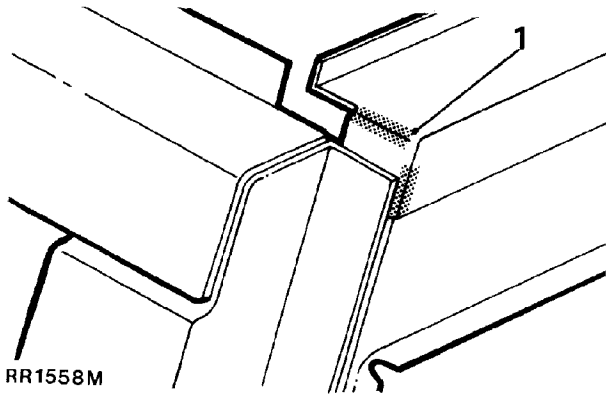

LOCATION J

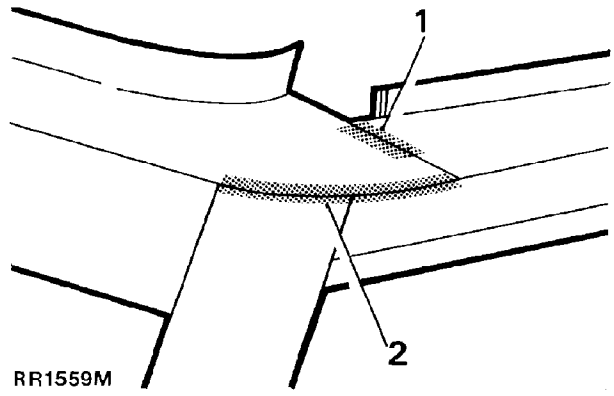

LOCATION K

LOCATION	FACTORY JOINT (minimum weld requirement quoted)
<p>J. 1. Body side complete to rear tailgate frame assembly</p>	<p>CO² weld, one run 40mm long</p>
<p>K. 1. Body side complete to roof header panel assembly (external joint) 2. Body side complete to roof header panel assembly (external joint)</p>	<p>CO² weld, one run 20mm long CO² weld, one run 100mm long</p>

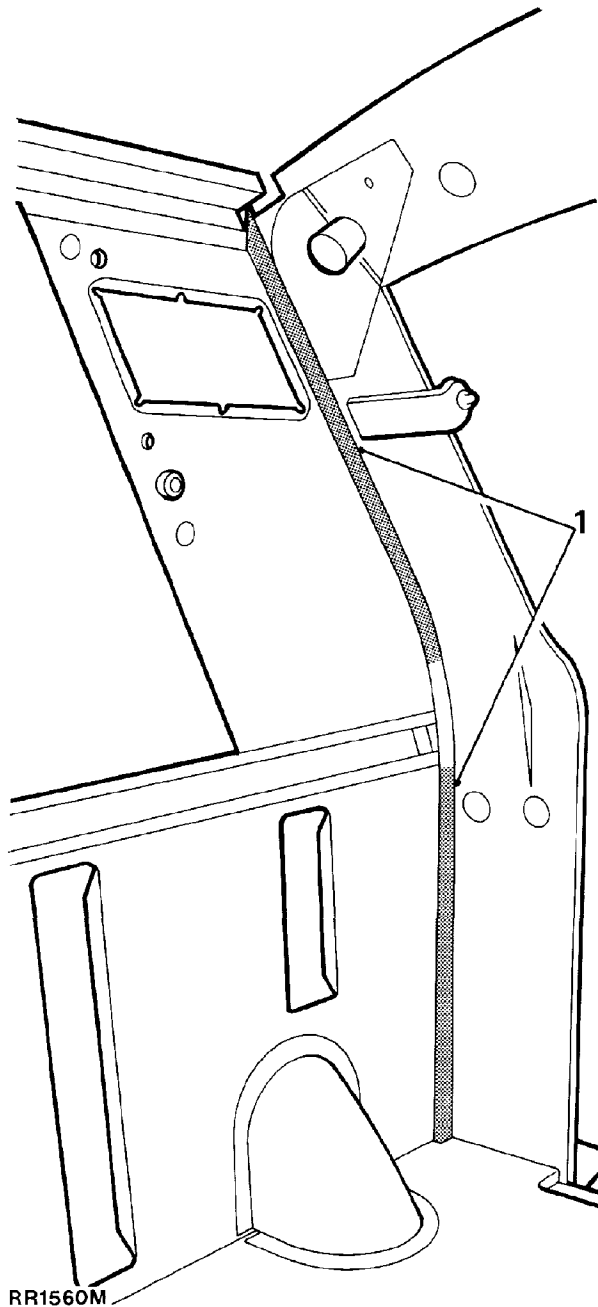

LOCATION L

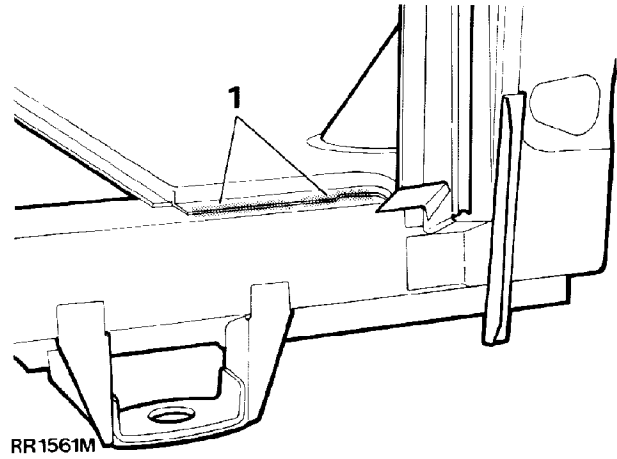

LOCATION M

LOCATION	FACTORY JOINT (minimum weld requirement quoted)
L. 1. Body side complete to rear tailgate side member	32 spot welds, 30mm pitch
M. 1. Body side complete to rear tailgate bottom cross member	CO ² weld, 2 runs 40mm long

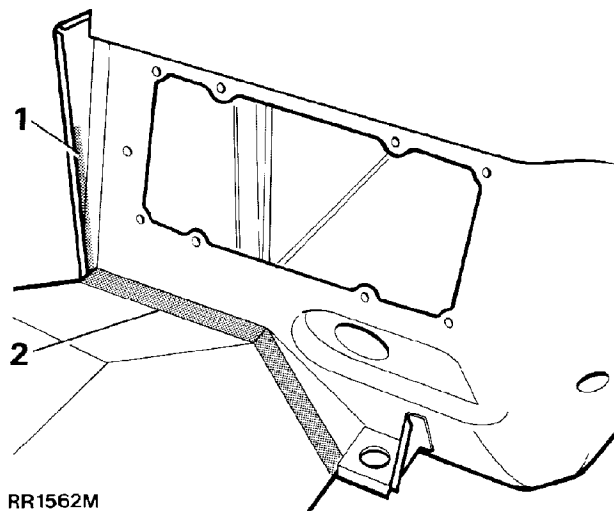

LOCATION N

LOCATION	FACTORY JOINT (minimum number of spot welds quoted)
N. 1. Valance and wheel arch assembly to dash and tunnel assembly 2. Valance and wheel arch assembly to dash and tunnel assembly.	4 spot welds, 45mm pitch 15 spot welds, 25mm pitch



HEADLINING

Service repair no - 76.64.01

Remove

1. Remove spare wheel.
2. Remove rear seat belt upper guide brackets and inertia reel assemblies.
3. Fold rear seat backrest forward. Recline front seats.
4. Disconnect battery negative lead.
5. Remove two roof lamp assemblies. Remove interior lamp mounting panel if sunroof is fitted.
6. Remove rear view mirror.
7. Remove two sun visors and centre retaining bracket.
8. Remove passenger grab handles.
Sunroof vehicles: Remove edge trim and clips from roof opening.
9. With assistance support front of headlining. Remove two plastic retaining clips above rear door.
10. Remove two plastic retaining clips securing rear end of headlining near upper tailgate hinges.
11. Pull headlining forward to clear rear quarter trim. Lower headlining, disconnect electrical leads from speakers.
12. Remove headlining through tailgate.



CAUTION: To assist removal tilt headlining at an angle. **DO NOT** flex headlining as damage may occur.

Refit

13. Reverse removal procedure.
Sunroof vehicles: Secure headlining around roof opening with edging finisher.

ROOF PANEL

Service repair no - 76.10.13

Remove

1. Remove headlining. *See Headlining*
2. Remove blanking plugs from rail above door frames to access screws.
3. Remove the screws washers from around inner edge of roof panel.

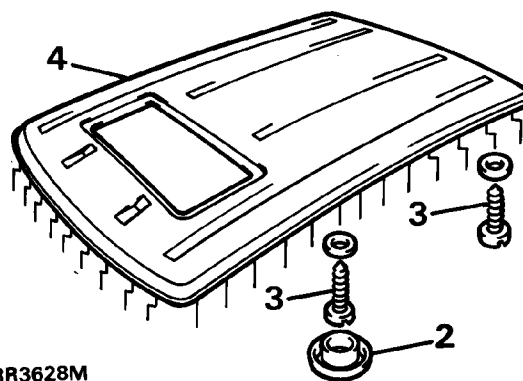

4. With assistance lift roof panel from body. Remove sealant from roof and body mating faces.

Refit

5. Apply sealant to roof and body mating faces.
6. Reverse removal procedure.

BONNET

Service repair no - 76.16.01

Remove

1. Disconnect battery negative lead.

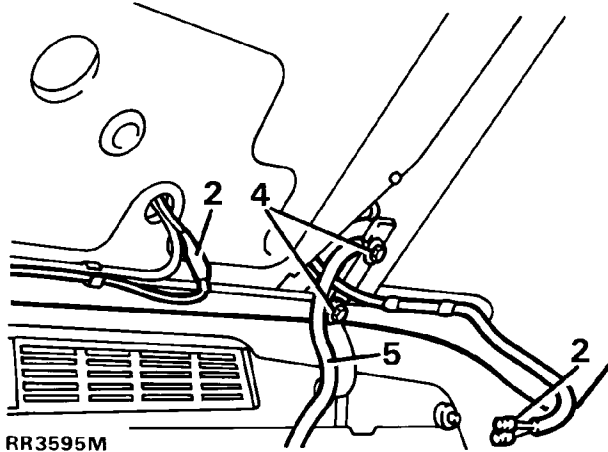

2. Disconnect electrical leads to under bonnet[hood] lamp and heated washer jets.
3. Disconnect windscreen washer tube at 'T' joint.
4. With assistance release four bolts securing bonnet[hood] to hinges. Note ground strap located onto left hinge for reassembly. Lift bonnet[hood] clear of vehicle.

Refit

5. Fit bonnet[hood] ensure ground strap is refitted. Before final tightening of bolts align bonnet[hood] with decker[cowl] panel, wing[fender] and front grille.
6. Reverse removal procedure.

DECKER PANEL

Service repair no - 76.10.35

Remove

1. Disconnect battery negative lead.
2. Remove bonnet[hood]. *See Bonnet*

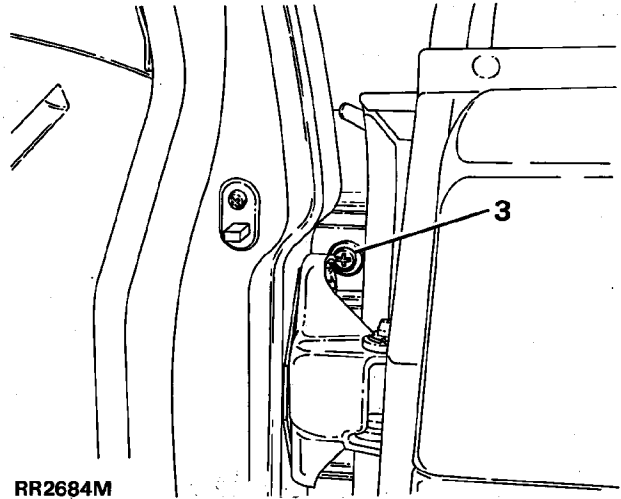

3. Remove wiper arms and two nuts securing wheel boxes to decker[cowl] panel. Remove two exterior sealing rubbers.
4. Remove nine screws securing front of decker[cowl] panel.

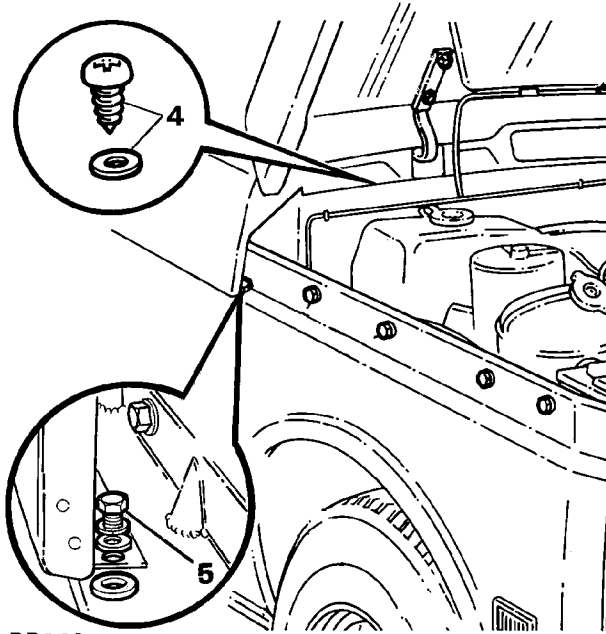

RR2686M

5. Remove four bolts, spring and plain washers retaining decker[cowl] panel to wing[fender]s.
6. With assistance place a tube over each hinge and lower to enable decker[cowl] panel to be removed. Slowly return hinges to upright position.



WARNING: Gradually let hinges return to upright position to prevent possibility of personal injury or damage.

Refit

7. Reverse removal procedure.
8. Using a soft blunt implement ease windscreen rubber onto top of decker[cowl] panel.

FRONT WING

Service repair no - 76.10.24

Remove

1. Remove wheel arch liner. *See Front Wheel Arch Liner*
2. Remove side light and flash lamp assembly. *See ELECTRICAL, Repair, Side Light and Flash Lamp Assembly and bulb*

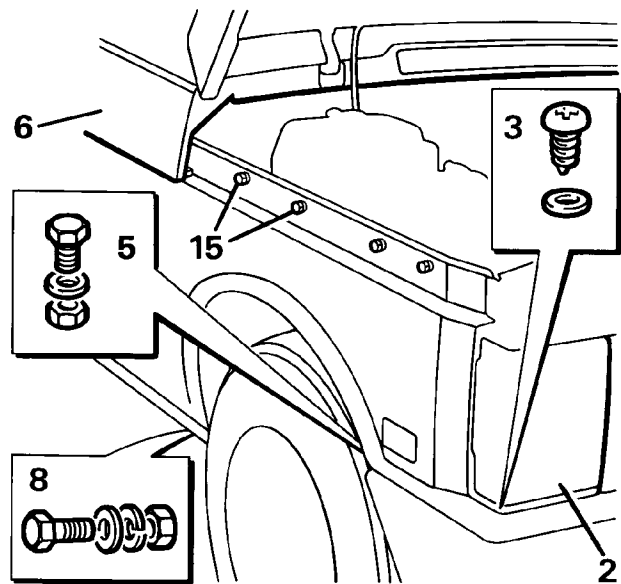

RR3596M

3. Remove screws, plain washers from bottom of side light recess.
4. Remove fixings securing bumper end cap. Remove moulding from bumper.
5. Remove bolt which secures spoiler to front wheel arch.
6. Release decker[cowl] panel. *See Decker Panel*
7. Remove five nuts, bolts, plain and spring washers securing wing[fender] to valance.
8. Remove two bolts, plain washers, securing sill finisher to bottom of wing[fender].

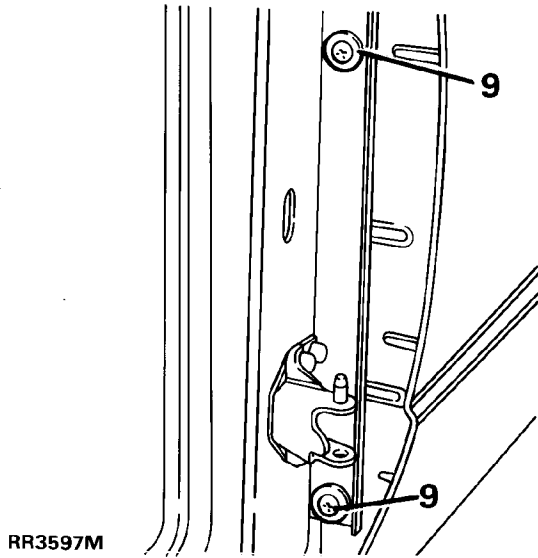

9. Remove two screws securing wing[fender] to 'A' post. Located near door hinges.

Refit

10. Apply suitable protection to wing[fender] inner. Apply sealant to mating faces.
11. Before tightening wing[fender] bolts ensure wing[fender] aligns with edge of front door.
12. Reverse removal procedure.

ASSISTED BONNET LIFT

Service repair no - 76.16.11

Remove

1. Remove bonnet[hood]. *See Bonnet*
2. Remove decker[cowl] panel. *See Decker Panel*

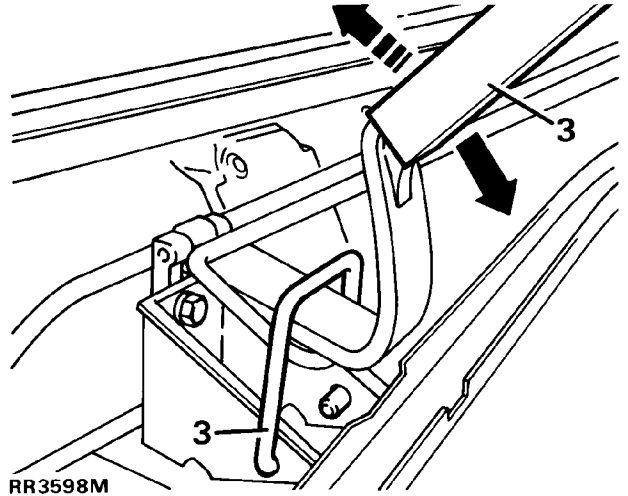

3. Place a tube over each hinge and lower to remove stop bracket. Slowly return hinges to upright position.

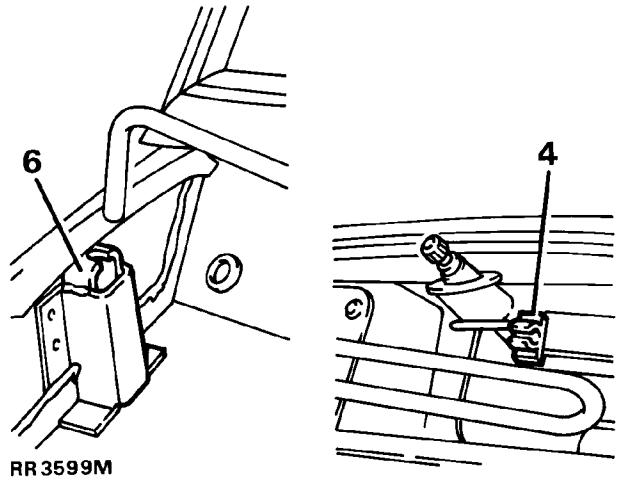

4. Release torsion bar from retaining clip.
5. Move torsion bar so it releases from hinge.
6. Release torsion bar from retaining bracket.



7. Remove 2 bolts and plain washers securing hinge to mounting bracket.
8. Withdraw hinge.

Refit

9. Fit hinge and securely tighten 2 retaining bolts
10. Fit torsion bar, ensure secure location into retaining clip and bracket.
11. Reverse removal procedure.

FUEL FILLER FLAP

Service repair no - 76.10.25

Remove

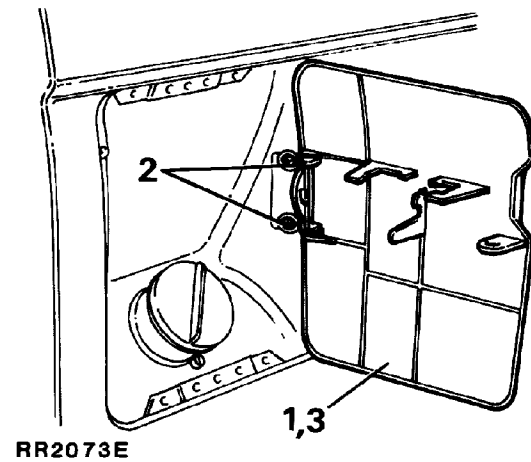

1. Open fuel filler flap.
2. Release 2 screws with plain washers.
3. Remove flap.

Refit

4. Fit flap, loosely fit screws.
5. Check outer profile of flap aligns with wing[fender]. Adjust hinge flap in or out of opening.
6. Tighten screws.

REAR CORNER PANEL AND WING

Service repair no - 76.10.20 / 76.10.27

Remove

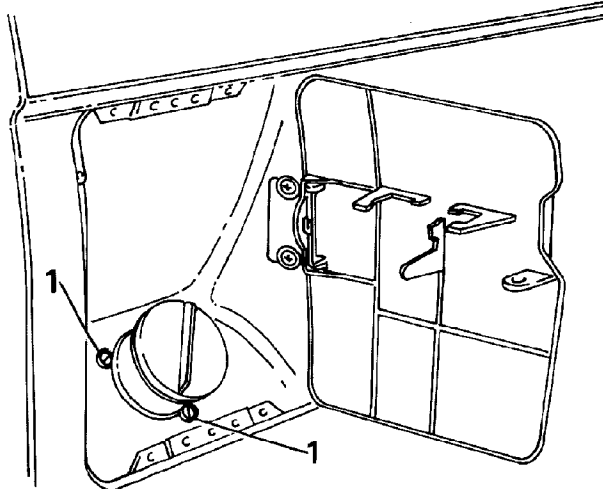

RR2130E

1. If applicable, remove 3 filler tube screws and fuel filler flap. **See Fuel Filler Flap**
2. Remove load space cover and spare wheel.

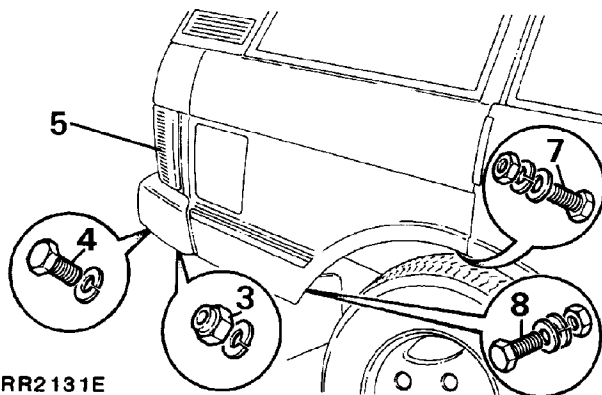

RR2131E

3. Remove 2 nuts and washers securing bumper end cap to corner panel.
4. Remove bolt securing end cap to bumper.

5. Remove rear lamp assembly. **See ELECTRICAL, Repair, Tail Lamp Assembly**
6. Drill out pop rivets securing corner panel to tailgate frame.
7. Remove 2 nuts and bolts securing wing[fender] to 'D' post, located beneath wheel arch.
8. Loosen nut and bolt retaining mud-flap bracket to wing[fender].

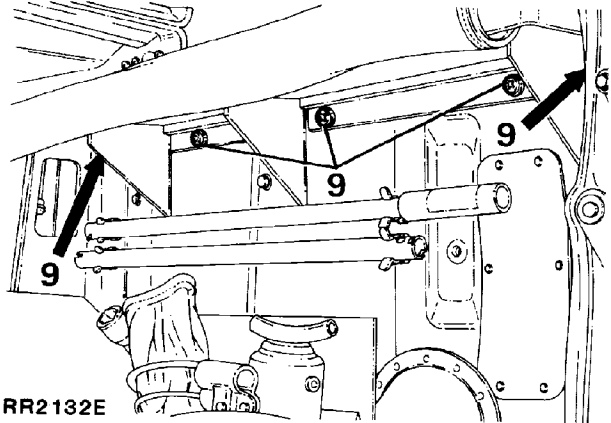

RR2132E

9. Remove 5 screws securing wing[fender] to bodyside panel. To access screw adjacent to 'D' post, fold rear seat forward and remove seat locking mechanism housing.
10. Remove rear wing[fender] with corner panel.
11. Remove 7 bolts, plain and spring washers securing wing[fender] to corner panel.

Refit

12. Assemble corner panel to rear wing[fender] with bolts. Align panels before tightening.
13. Coat underside of panels with body protection.
14. Fit assembly to vehicle. Align door shut face to wing[fender] edge and corner panel to tailgate, before tightening screws and fitting pop rivets.
15. Reverse removal procedure.



REAR QUARTER PANEL-INTERIOR

Service repair no - 76.13.43

Remove



NOTE: Remove spare wheel when removing left rear quarter panel.

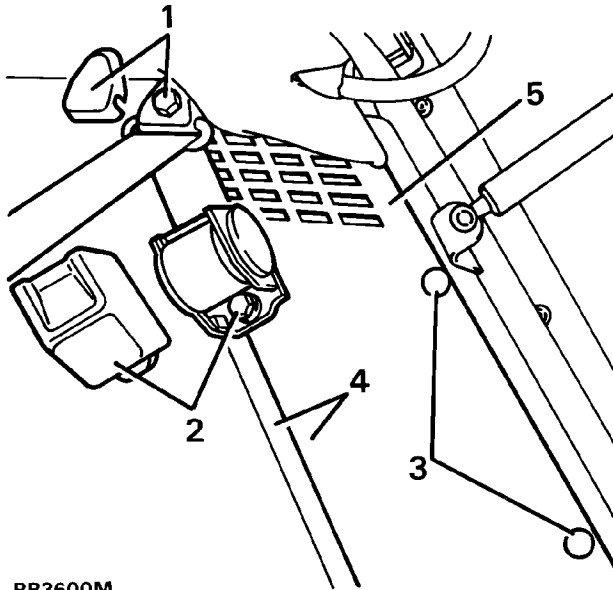

RR3600M

1. Remove cover and bolt from seat belt guide bracket.
2. Remove clip on cover from seat belt inertia reel. Remove bolt and place inertia reel to one side.
3. Remove clips securing trim panel to body side.
4. Ease trim panel from behind rubber moulding.
5. Remove panel.

Refit

6. Ease top of trim panel under lip of rubber moulding.
7. Push panel up behind headlining until clip holes are visible.
8. Ease rubber moulding lip over remainder of trim panel.
9. Ensure electrical harness locates in channel behind trim panel. Fit 2 trim clips.
10. Fit seat belt guide bracket and inertia reel. Tighten bolts to **20Nm**.
11. Refit covers to guide bracket and inertia reel.

REAR QUARTER PANEL-EXTERIOR

Service repair no - 76.13.22

Remove

1. Remove spare wheel if removing left rear quarter panel.
2. Remove interior quarter panel. *See Rear Quarter Panel-Interior*

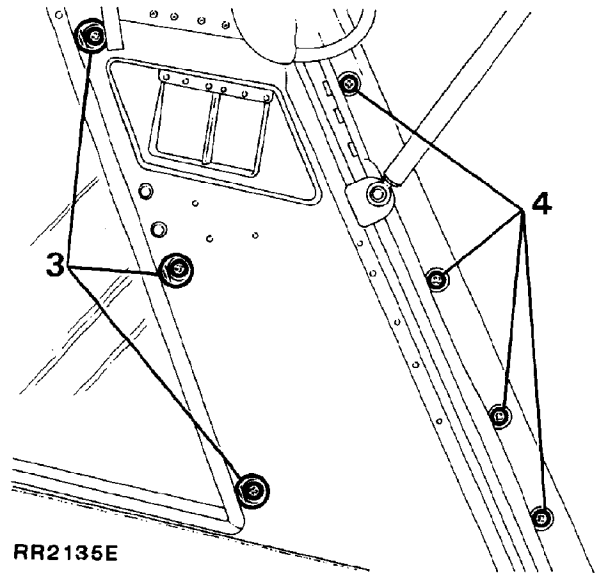

RR2135E

3. Remove 3 nuts with plain washers securing exterior quarter panel to bodyside.
4. Remove 4 screws securing quarter panel to tailgate opening.
5. Remove panel.

Refit

6. Reverse removal procedure.

TAILGATE UPPER

Service repair no - 76.28.29

Remove

1. Disconnect battery negative lead.
2. Remove tailgate wiper arm.

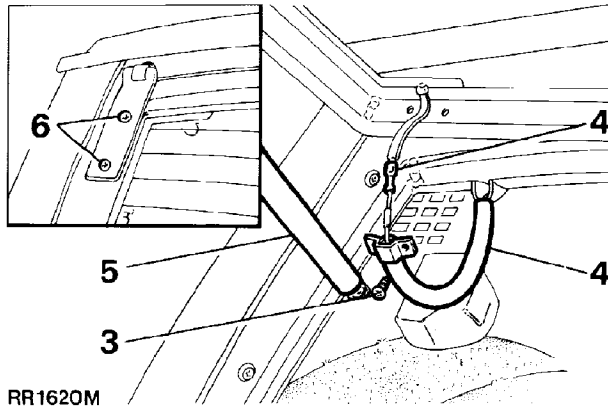

RR1620M

3. Open tailgate and remove screws from electrical wiring shrouds.
4. Move shroud away from screen and headlining. Disconnect electrical wiring.



WARNING: DO NOT repair worn tailgate stays. Fit a replacement.

5. Pry stays off tailgate.
6. With assistance support tailgate, remove screws from hinge.

Refit

7. Reverse removal procedure.

TAILGATE UPPER LOCK**Remove**

1. Remove upper tailgate lock actuator unit. See *ELECTRICAL, Repair, Upper Tailgate Actuator Unit*

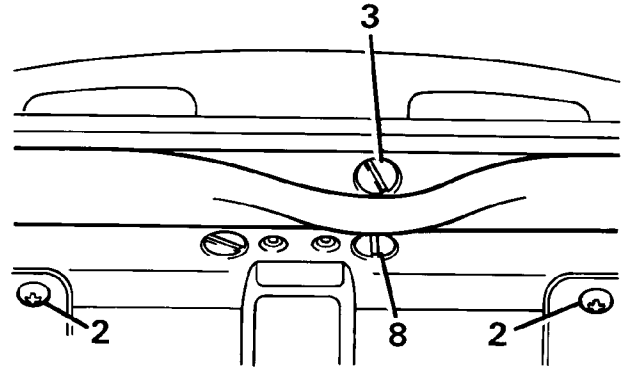

RR3601M

2. Remove 2 screws securing release handle.
3. Move sealing rubber, remove screw to detach handle.
4. If required, remove key barrel by removing 2 screws at joint. Remove retaining plate and release spring.
5. Remove 8 screws securing operating rod covers either side of lock mechanism.
6. Remove 4 screws and 2 nuts securing lock catches to sides of tailgate.

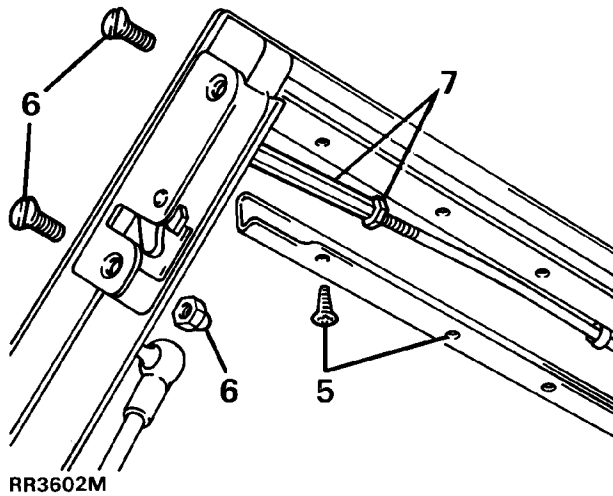

7. Release 2 locknuts on operating rods. Rotate connecting rod until side catches can be removed.
8. Remove 2 screws securing lock mechanism. Remove unit complete with operating rods.

Refit

9. Reverse removal procedure.
10. To adjust side catches release locknuts on operating rods. Rotate hexagonal link to shorten or extend length as necessary.

TAILGATE LOWER STRIKER

Adjust

1. Adjustment is correct when tailgate profile aligns with rear body corner panels.
2. Open lower tailgate.
3. Add or remove spacing washers between striker and tailgate opening.
4. Move striker in appropriate direction and tighten.

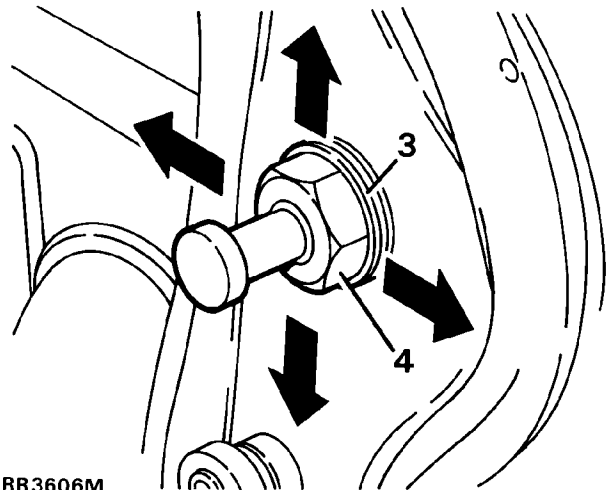

TAILGATE UPPER GLASS

Remove

1. Tailgate upper glass and frame assembly are serviced as one unit.
2. Remove tailgate upper. *See Tailgate Upper*
3. Remove high level stop lamp. *See ELECTRICAL, Repair, High Level Stop Lamp*
4. Remove lock actuator unit. *See ELECTRICAL, Repair, Upper Tailgate Actuator Unit*
5. Remove lock assembly. *See Tailgate Upper Lock*

Refit

6. Reverse removal procedure.

TAILGATE LOWER

Service repair no - 76.28.30

Remove

1. Disconnect battery negative lead.

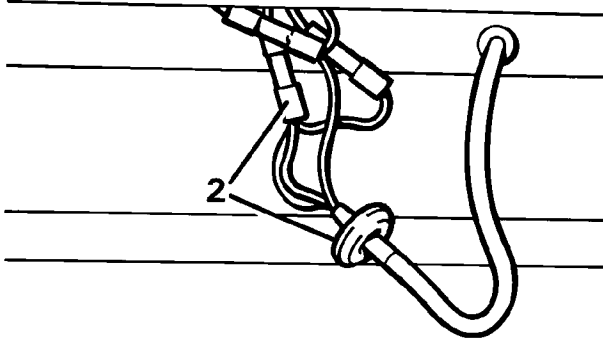

RR3603M

2. Remove grommet and withdraw electrical leads from tailgate. Disconnect connectors.
3. Remove tailgate trim panel.

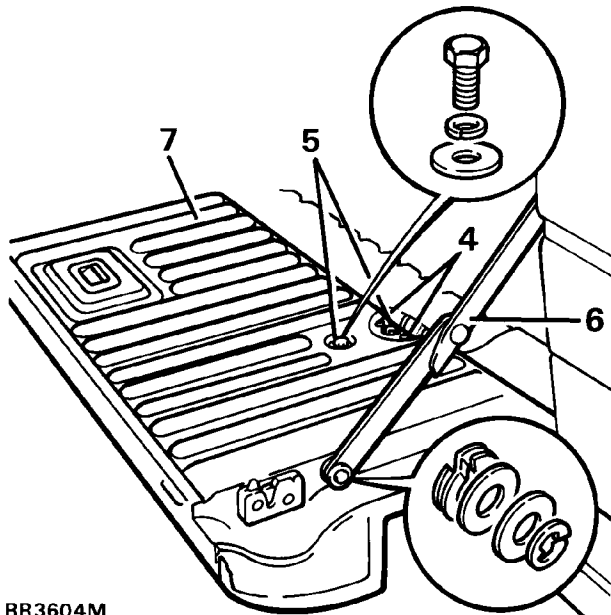

RR3604M

4. Remove 4 screws securing seal around tailgate hinge.
5. Remove tailgate to hinge bolts.
6. With assistance disconnect check straps.
7. Withdraw tailgate.

Refit

8. Reverse removal procedure. Ensure grommet is refitted onto tailgate.

TAILGATE LOWER RELEASE MECHANISM**Remove**

1. Open lower tailgate.
2. Lever trim from handle surround.
3. Remove 4 clips, remove tailgate trim panel.

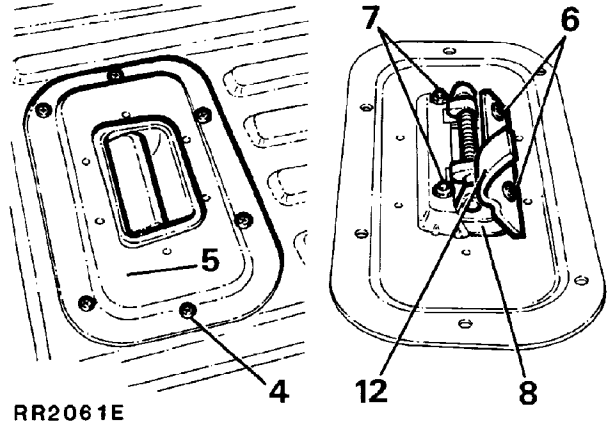

RR2061E

4. Remove screws securing lock cover plate.
5. Remove cover plate with release mechanism.
6. Remove 2 screws and detach handle release actuator lever.
7. Remove 2 nuts and detach handle release retaining bracket.
8. Withdraw handle release mechanism from cover plate.
9. Release spring clips securing operating rods to tailgate release mechanism.

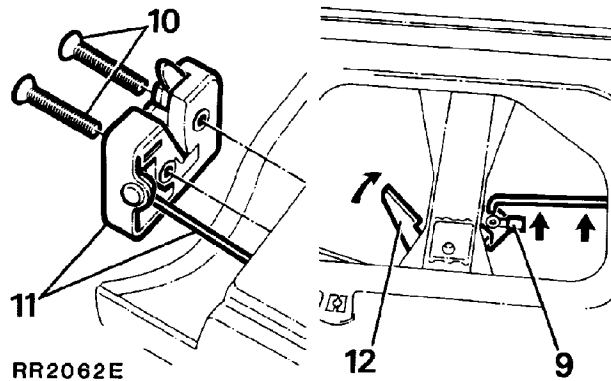

RR2062E

10. Remove screws securing 2 exterior locks on tailgate side.
11. Withdraw exterior locks with operating rods.

Refit

12. Reverse removal procedure. Grease handle release actuator lever and internal tailgate operating lever.

RADIATOR GRILLE

Service repair no - 76.55.06

Remove

1. Open and support bonnet[hood].
2. Depress 4 retaining lugs and ease grille forward.
3. Lift grille to remove.

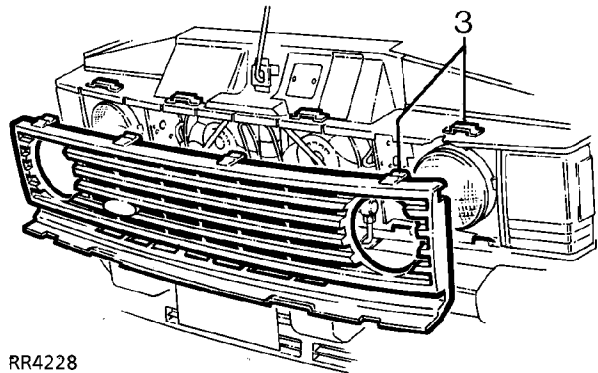

RR4228

Refit

4. Locate lower lugs of grille into slots.
5. Ensure upper retaining lugs of grille locate behind bracket.

FRONT DOOR

Service repair no - 76.28.07

Remove

1. Disconnect battery negative lead.
2. Open door to be removed.

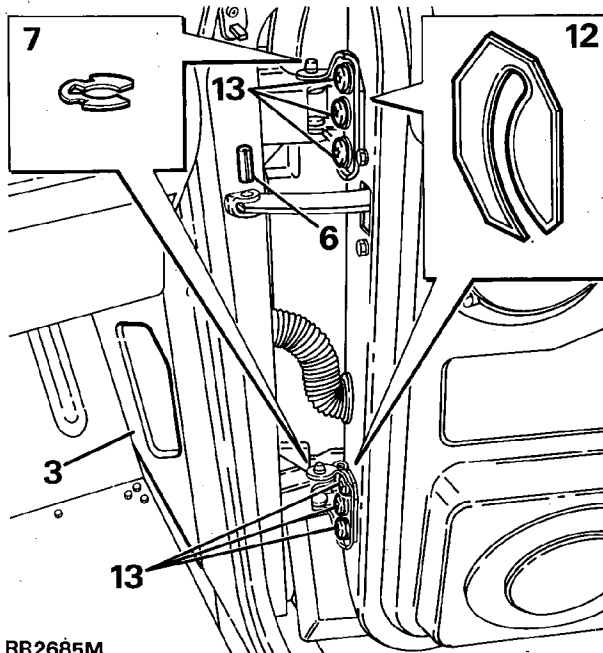

RR2685M

3. Remove 2 clips securing trim panel to side of footwell.
4. Locate and disconnect door wiring plugs.
5. Disengage grommets either side of 'A' post. Feed wiring out.
6. Drive out roll pin from door check link.
7. Remove 'C' clips from hinge pins.



WARNING: Instruction 8 **MUST BE** carried out with assistance.

8. Lift opened door off hinge pins.

Refit

9. Reverse removal procedure. Renew clips if worn or distorted.
10. Open door, connect wiring plugs. Ensure they locate above trim panel.
11. Check operation of door and lock. If necessary, adjust door and striker plate.

Adjust

12. Adjust door by shims between hinge and door to move door forward or rearward in opening.
13. Loosen 6 screws securing hinges to door to adjust door up and down or in and out of opening. Tighten to **25Nm**.

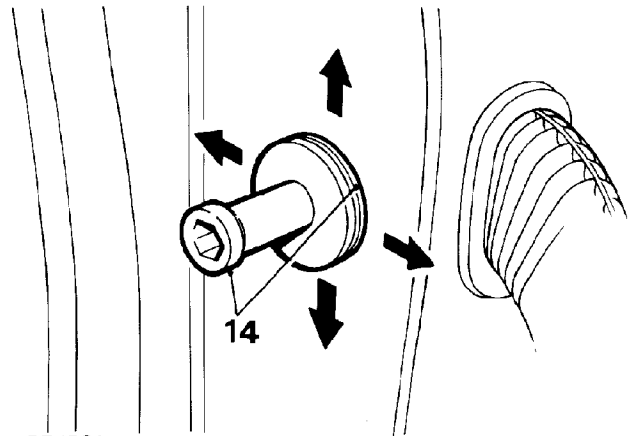

RR1588M

14. Adjust door lock striker by adding and subtracting spacing washers or moving in required direction.
15. Note: If it is necessary to remove hinges from 'A' post. Refit in exactly same position using same thickness of shims.



FRONT DOOR GLASS AND REGULATOR

Service repair no - 76.31.01 / 76.31.45

Remove

1. Fully close window and secure with tape to prevent window from dropping.
2. Remove trim panel. *See Front Door Trim Panel*
3. Remove vapour barrier.
4. Remove window lift motor. *See ELECTRICAL, Repair, Window Lift Motor - Front Doors*

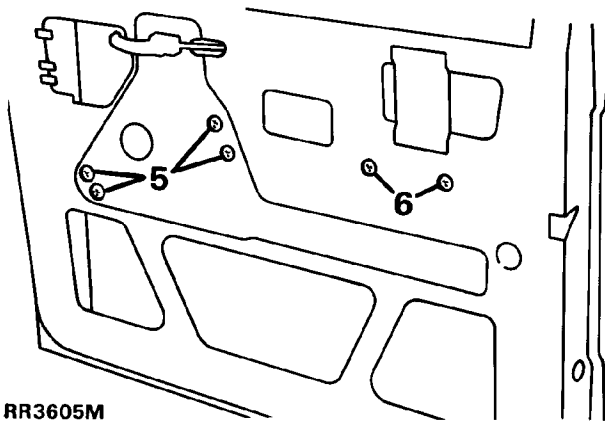

RR3605M

5. Remove 4 window regulator retaining bolts with shakeproof washers from door panel.
6. Remove 2 screws with shakeproof washers retaining lower window lift channel. Slide channel off stud.

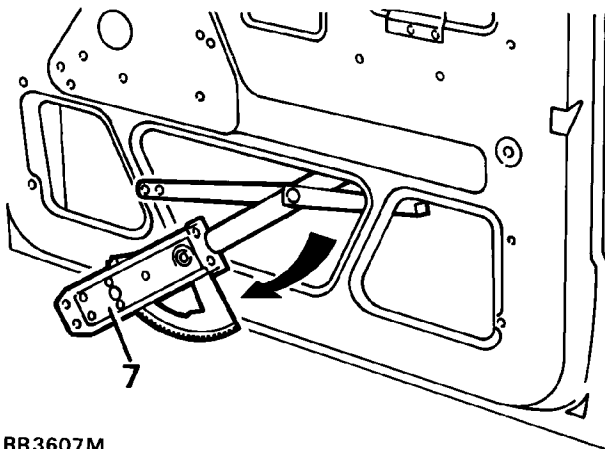

RR3607M

7. Disengage lifting arm stud from upper lifting channel. Remove window regulator through opening in door panel.
8. Remove exterior driving mirror.

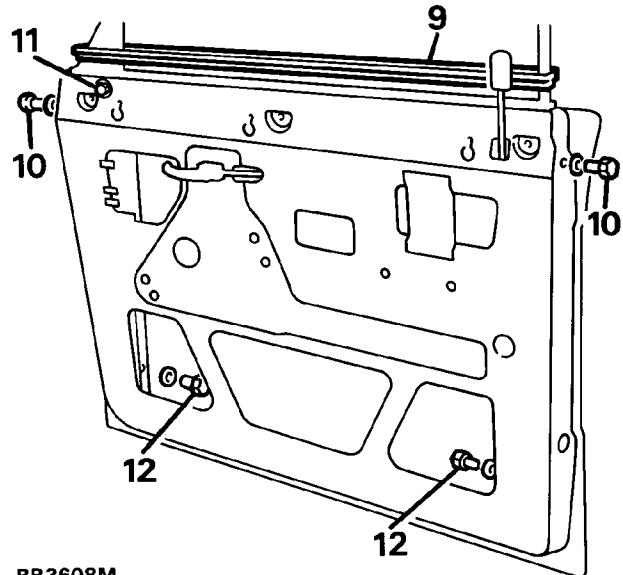

RR3608M

9. Remove waist rail seal from top of door.
10. Remove bolt, shakeproof and plain washer from both end faces of door which secure door frame.
11. Remove bolt, spring and plain washer from recessed hole under mirror mounting plate.
12. Remove bolt spring and plain washer securing each lower side of door frame.
13. Remove glass and frame out of door panel.
14. Remove tape securing glass to frame.
15. Slide glass out of door frame.

Refit

16. Reverse removal procedure. When fitting door frame align to suit door opening. Then tighten door frame securing bolts.

FRONT DOOR TRIM PANEL

Service repair no - 76.34.01

Remove

1. Disconnect battery negative lead.

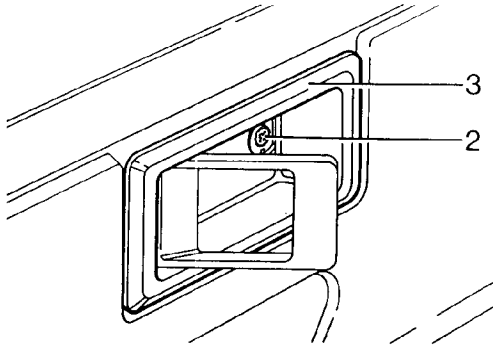

RR 4100

2. Remove screw securing handle surround.
3. Remove surround.

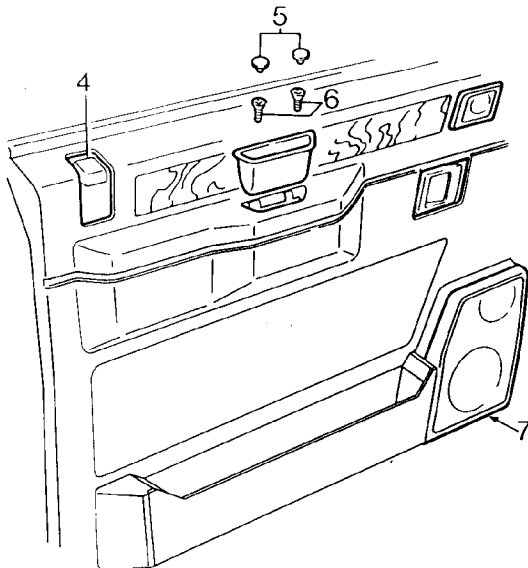

RR 4101

4. Pry sill button surround from trim panel.
5. Remove buttons from bottom of door pull pocket.
6. Remove screws, withdraw pocket from trim panel.
7. Use trim stud release fork, start at front bottom corner and release 14 trim studs from door panel.



NOTE: Support trim panel while speaker leads are disconnected.

8. Disconnect 2 multiplugs from speakers. **Do not carry out further dismantling if component is removed for access only.**
9. Remove 2 nuts securing speaker grille, depress 3 clips and remove speaker.
10. Remove 4 plates retaining speaker harness and release harness connector block.
11. Depress 2 clips retaining tweeter speaker, disconnect 2 Lucars and remove tweeter.
12. Disconnect 2 Lucars from top speaker and multiplug from bottom speaker.
13. Remove 4 nuts securing each speaker and remove 2 speakers from panel.
14. Remove trim panel pocket secured by 6 screws.
15. Remove 14 trim clips from trim panel.
16. Transfer components removed to new trim panel.



NOTE: Renew trim clips as necessary.

Refit

17. Reverse removal procedure.



FRONT DOOR LOCK, OUTSIDE AND INSIDE DOOR RELEASE HANDLES

Service repair no - 76.37.12

Remove

1. Remove trim panel. *See Front Door Trim Panel*
2. Remove plastic vapour barrier sheet.
3. Remove window lift motor. *See ELECTRICAL, Repair, Window Lift Motor - Front Door*
4. Remove door glass and regulator. *See Front Door Glass and Regulator*
5. Remove door lock actuator. *See ELECTRICAL, Repair, Front Door Actuator Unit*
6. Disconnect control rod from key operated lock. Release metal clip at bottom of rod.
7. Disconnect control rod from outside door release handle.
8. Disconnect rod between door release handle and door lock by releasing clip and pulling rod out of connecting block.
9. From inside door remove pin which secures quadrant to inner panel. Remove quadrant.

10. Remove screws securing sill button to door. Remove sill button from control rod.
11. Remove door lock by removing three screws as shown.
12. Withdraw lock through cut out below.

Continue for removal of outside release handle.

13. Remove nuts, shakeproof washers and retaining bracket.
14. Remove door release handle from outer panel.

Continue for removal of inside release handle.

15. Remove screws securing handle to door panel.
16. Withdraw handle with connecting rod attached.

Refit

17. Reverse removal procedure. 1 to 16.

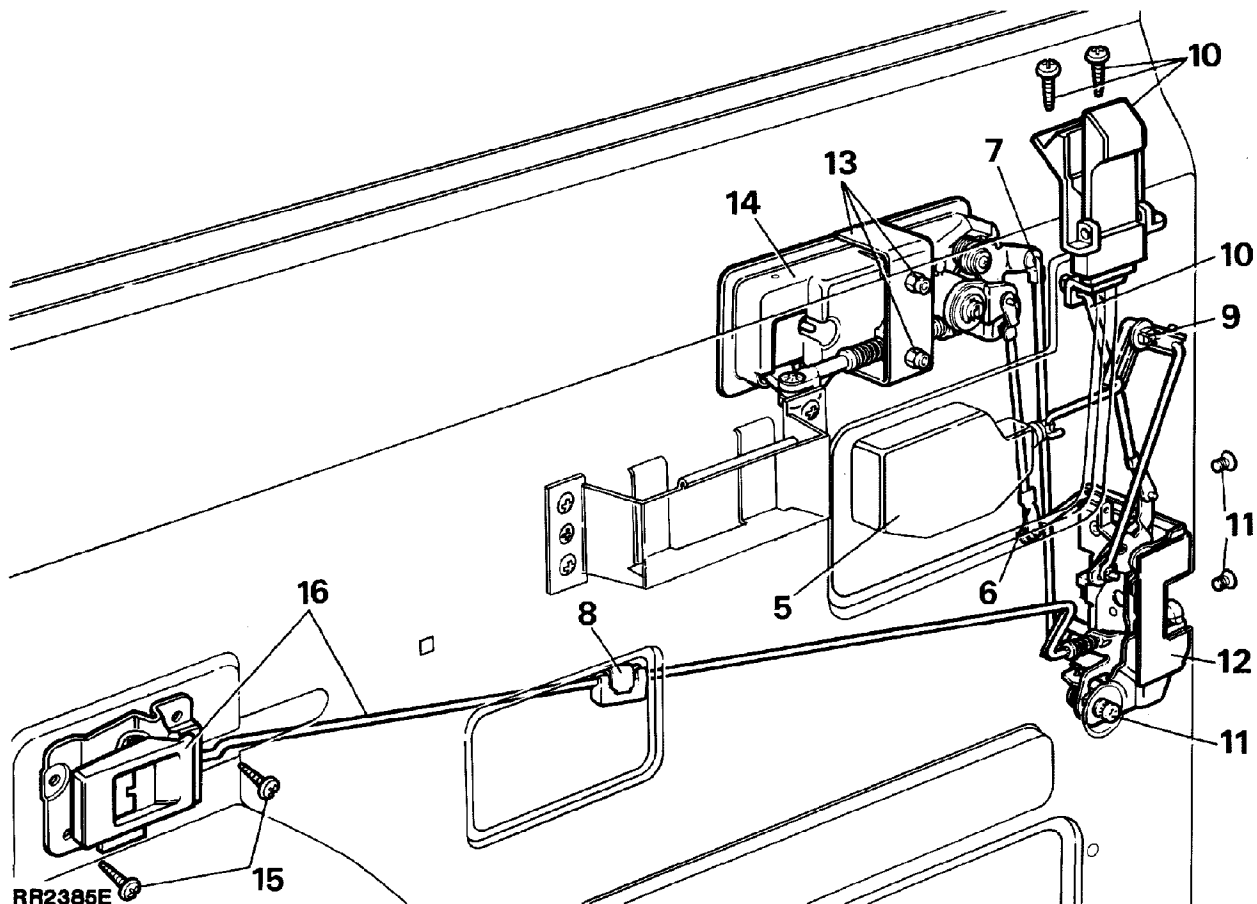

FRONT DOOR HEATED LOCK ASSEMBLY**Remove**

1. Disconnect battery negative lead.
2. Remove outside front door handle assembly.
See Front Door Lock, Outside and Inside Door Release Handles

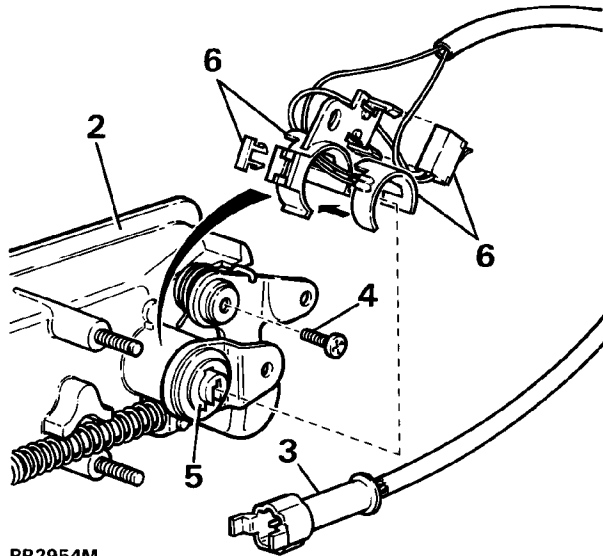

RR2954M

3. Disconnect heaters electrical wiring at multiplug.
4. Remove heater retaining bracket screw.
5. Remove 'C' clip and coloured cam link from end of barrel assembly.



CAUTION: Ensure loose barrel assembly remains in position, to avoid components falling apart.

6. Remove heater retaining bracket, complete with de-icing element, switch and wiring assembly.

Refit

7. Hold de-icing element in position and fit heater retaining bracket assembly.
8. Reverse removal procedure. 1 to 5.

ADJUSTMENT - FRONT DOOR LOCK AND HANDLE ASSEMBLY

Service repair no - 76.37.47

Inside door release handle to lock

1. Ensure inside door release handle is in fitted position.
2. Adjust spring tensioned nut at door lock to shorten or extend rod as required, so door release occurs before maximum handle movement.

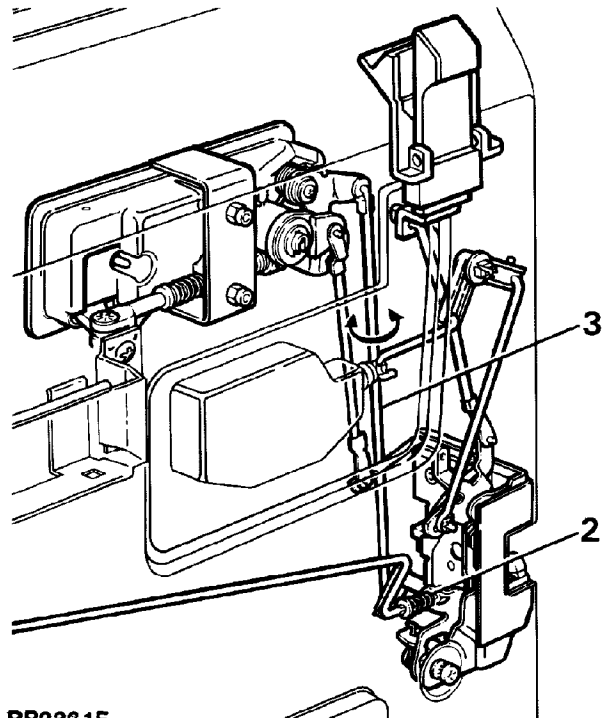

RR2361E

Outside door release handle to lock

3. Disconnect rod at outer door release handle by releasing plastic olive. Rotate rod to shorten or extend operating length as required, so door release occurs before maximum handle movement. Refit rod.



FRONT WHEEL ARCH LINER

Service repair no - 76.10.48

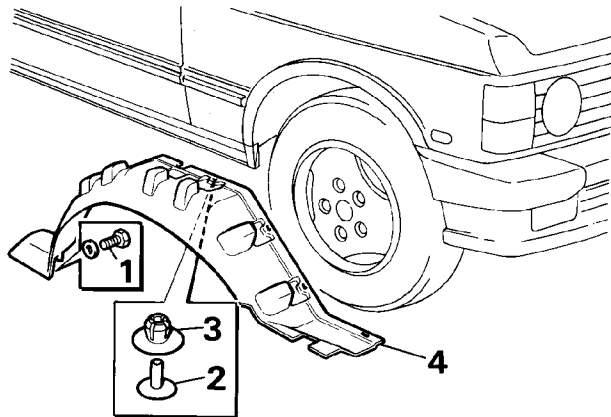

RR2711M

Remove

1. Remove bolt and washer securing rear lower edge of liner.
2. Pry out centre studs of eight plastic clips spaced around liner.
3. Pry out plastic clips.
4. Remove liner.

Refit

5. Reverse removal procedure. Renew clips as necessary.

SILL FINISHER

Remove

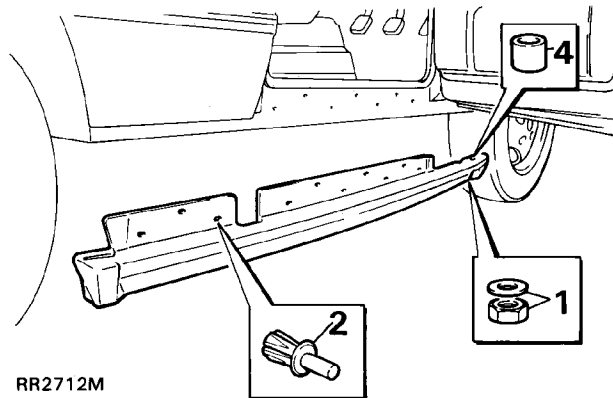

RR2712M

1. Remove nut and washer from underneath front of sill finisher.
2. Tap out centre piece of ten Rocut fixing rivets.
3. Pry out Rocut rivets and remove sill finisher.

Refit

4. Reverse removal procedure. Renewing Rocut rivets. Ensure metal tube insert is refitted into sill finisher where bolt goes through.

REAR DOOR

Service repair no - 76.28.06

Remove

1. Disconnect battery negative lead.

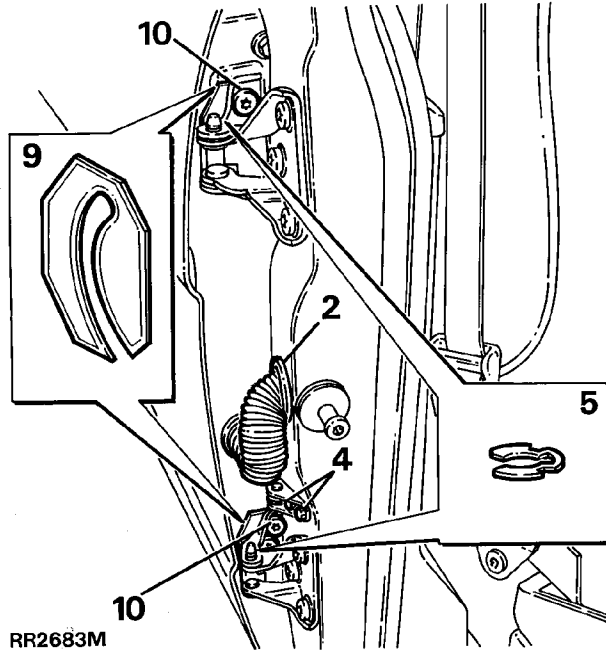

2. Remove wiring grommet from 'B' post.
3. Withdraw door wiring plugs from 'B' post and disconnect.
4. Remove two bolts securing the check strap to 'B' post.
5. Remove 'C' clips from grooves in hinge pins.



WARNING: Instruction 6. MUST BE carried out with assistance.

6. Lift opened door off hinge pins.

Refit

7. Reverse removal procedure. Renew 'C' clips if worn or distorted.

Adjust

8. Adjust door by means of shims between hinge and door to move door forward or rearward in the opening.
9. Loosen six screws securing hinges to door to adjust door up and down or in and out of opening. Retighten screws to **25Nm**.
10. Adjustment to door striker is identical to front doors.
11. Note: If it is necessary to remove hinges from 'B' post they should be refitted in exact same position using same thickness of shims.



REAR DOOR - TRIM PANEL

Service repair no - 76.34.04/98

Remove

1. Disconnect battery negative lead.

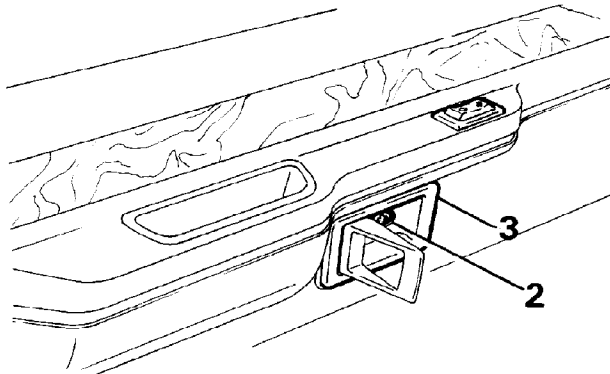

RR2476E

2. Remove screw securing handle surround.
3. Remove surround.
4. Pry door locking button surround from trim panel.

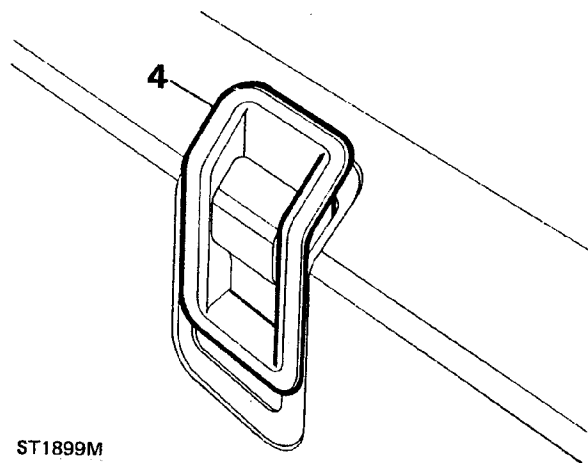

ST1899M

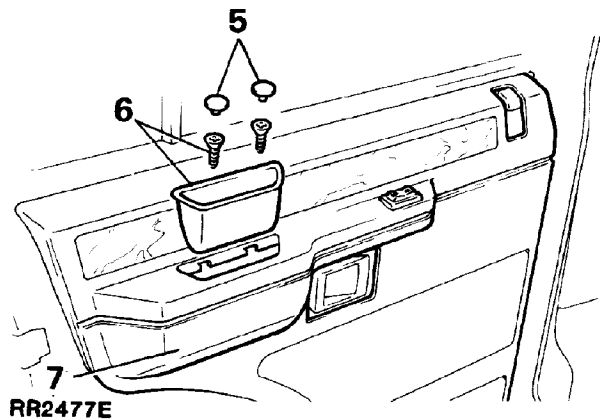

RR2477E

5. Remove two finisher buttons from door pull pocket to reveal securing screws.
6. Remove screws and withdraw pocket.
7. Pry trim panel away from door.
8. Disconnect electrical plug from window lift switch.
9. Remove window lift switch.

Refit

10. Reverse removal procedure.

REAR DOOR LOCK, OUTSIDE AND INSIDE DOOR RELEASE HANDLES

Service repair no - 76.37.13

Remove

1. Fully close window.
2. Disconnect battery negative lead.
3. Remove trim panel. *See Rear Door - Trim Panel*
4. Remove plastic vapour barrier sheet.
5. Disconnect inside door release control rod from door lock.
6. Disconnect sill locking control rod from door lock by releasing metal clip.
7. Disconnect control rod from outside door release handle by pulling it out of plastic olive.
8. Remove door lock by removing two screws from door shut face and single screw with shakeproof washer on inside of door. Retrieve any spacing washers which may be fitted.
9. Remove lock through upper rear opening of panel.
10. Remove two nuts with shakeproof washers and retaining bracket securing outside door release handle.

11. Remove outside door release handle from outer door panel.
12. Remove two screws with plain washers securing inside door release handle to inner door panel.
13. Remove handle with connecting rod attached.
14. Remove two screws securing sill locking button to inner door panel and detach sill button from bellcrank.

Sill locking bellcranks

15. Press out plastic locking pins from inner door panel.
16. Release bellcranks from inner door panel and unhook respective connecting rods.
17. Withdraw bellcranks from inner door panel.



NOTE: When fitting bellcranks, locking pins are entered into square insert from outside and pressed in flush.

Refit

18. Reverse removal procedure. 1 to 17.

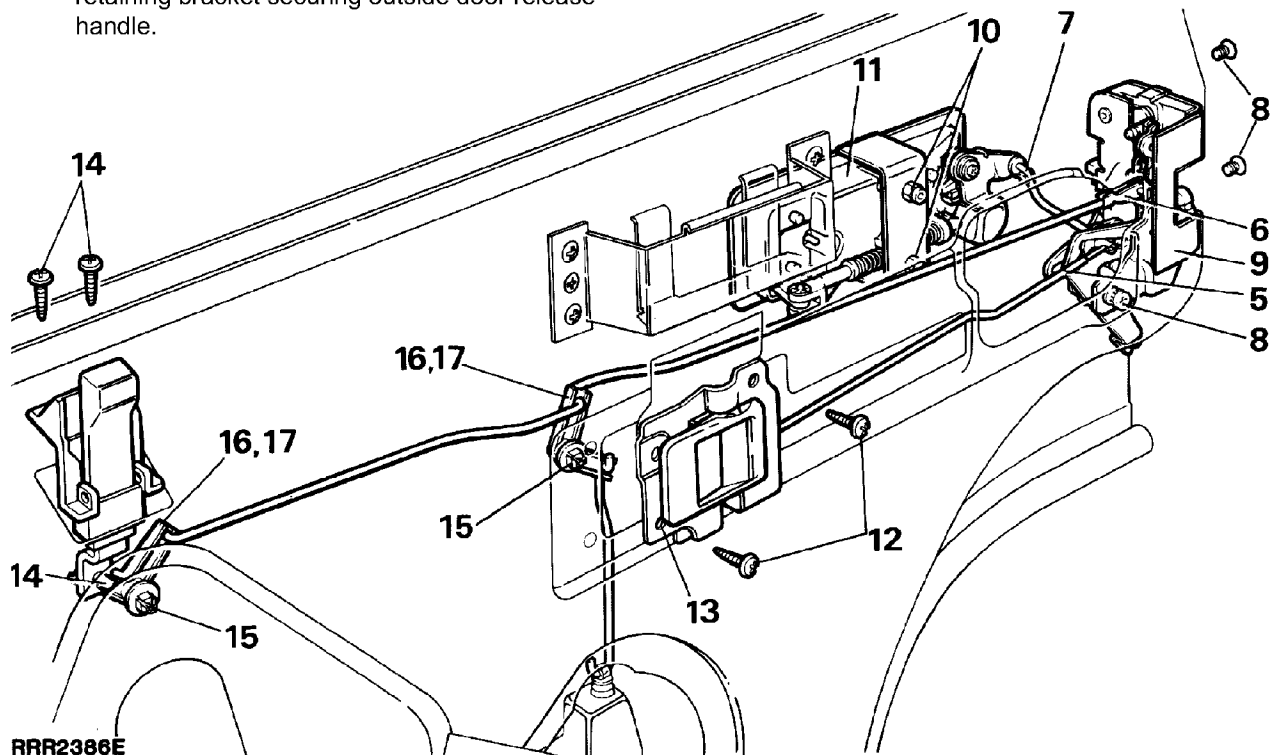



REAR DOOR LOCK AND HANDLE ASSEMBLY

Service repair no - 76.37.48

Outside door release handle to lock

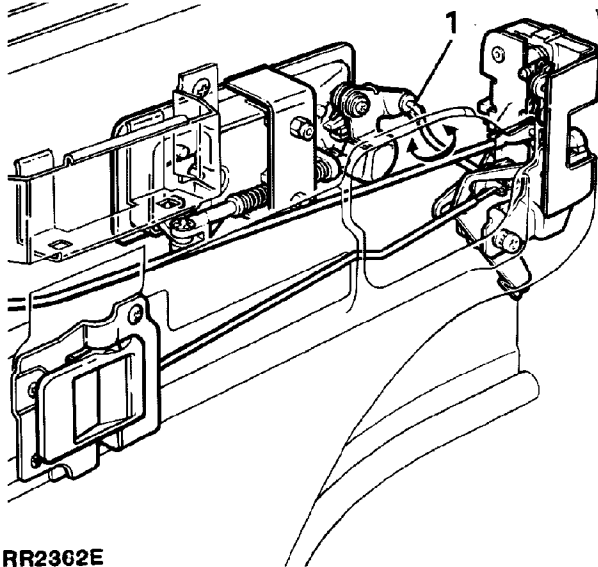

RR2362E

1. Disconnect connecting rod at rear of door outer release handle.
2. Rotate rod to adjust operating length as required, so that door release occurs before maximum handle movement.

REAR DOOR GLASS AND REGULATOR

Service repair no - 76.31.02 / 76.31.46

Remove

1. Fully close window and secure with tape.
2. Disconnect battery negative lead.
3. Remove trim panel. *See Rear Door - Trim Panel*
4. Remove sill button.
5. Remove plastic vapour barrier.
6. Remove window lift motor. *See ELECTRICAL, Repair, Window Lift Motor - Rear Doors*

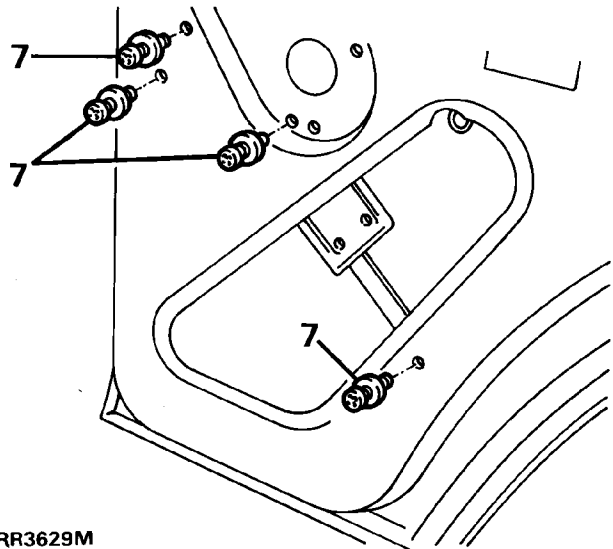

RR3629M

7. Remove four window regulator screws with shakeproof washers.
8. Disengage lifting arm stud from channel and remove window regulator.

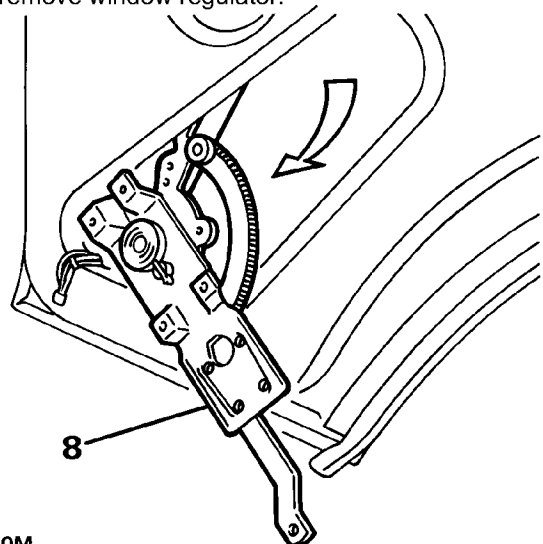

RR3630M

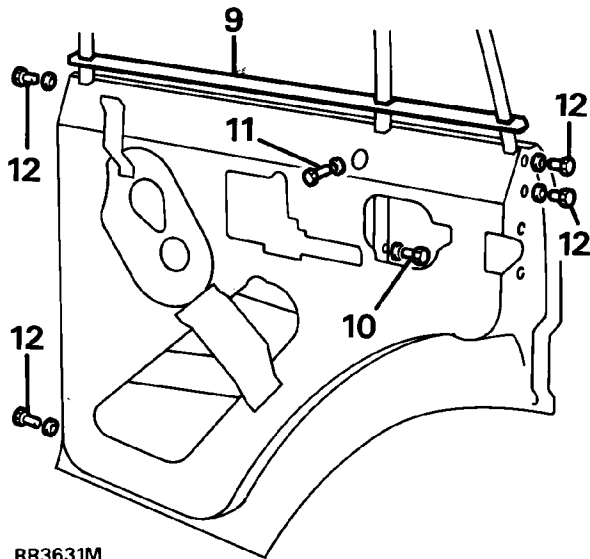

RR3631M

9. Remove waist rail seal from top of door panel.
10. Remove bolt, spring and plain washers which secures bottom of door frame.
11. Remove bolt, spring and plain washer from door frame, as shown.
12. Remove two bolts, spring and plain washers from both door faces.
13. Remove door frame with glass in position.
14. Remove tape and slide glass out of door frame.

Refit

15. Reverse removal procedure. When fitting door frame align to suit door opening. Then tighten door frame securing bolts.

REAR QUARTER LIGHT GLASS

Service repair no - 76.81.25

Remove

1. Remove and discard moulding from flange around opening.
2. Clean area where moulding contacts body.

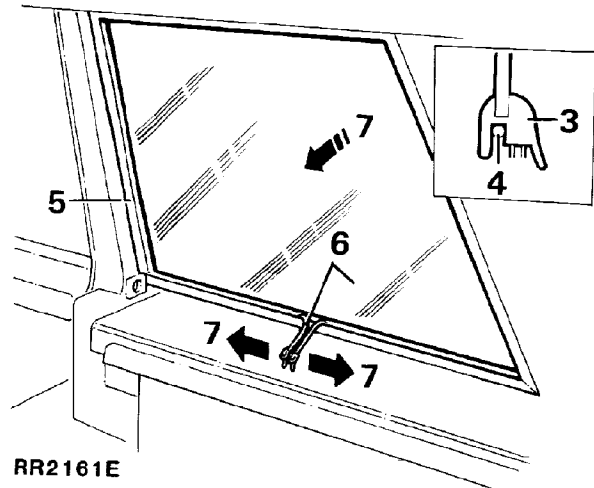

RR2161E

Refit

3. Fit new moulding to glass.
4. Fit a draw cord around moulding retaining channel.
5. Coat flange around opening with liquid soap to aid assembly.
6. Hold glass and moulding to opening. Site draw cords inside vehicle.
7. With assistance push glass and moulding into opening. Pull draw cords enabling seal to ride over flange.
8. Ensure interior trim fits under moulding.
9. Ensure moulding is settled and contacts body.



FRONT SEAT ELECTRICAL

Service repair no - 76.77.01

Remove

1. Remove screw securing seat side trim panel and remove panel.
2. Remove three screws from seat front trim panel. Remove screw from top of trim panel to seat base, located below seat base cushion. Remove panel.
3. Remove three fixings securing cushion side trim panel. Remove panel. Remove bolt securing seat belt.
4. Move seat to rearward position. If seat will not move. **See ELECTRICAL, Repair, Electrical Seat Failure**

5. Remove two screws at front of each slide channel.
6. Move seat to most forward position.
7. Remove four screws at rear of each slide channel.
8. Disconnect battery negative lead.
9. Disconnect all electrical multiplugs to seat electrics.
10. Remove seat.

Refit

11. Reverse removal procedure. Arrange electrical leads so they can not become trapped by seat slide mechanism.

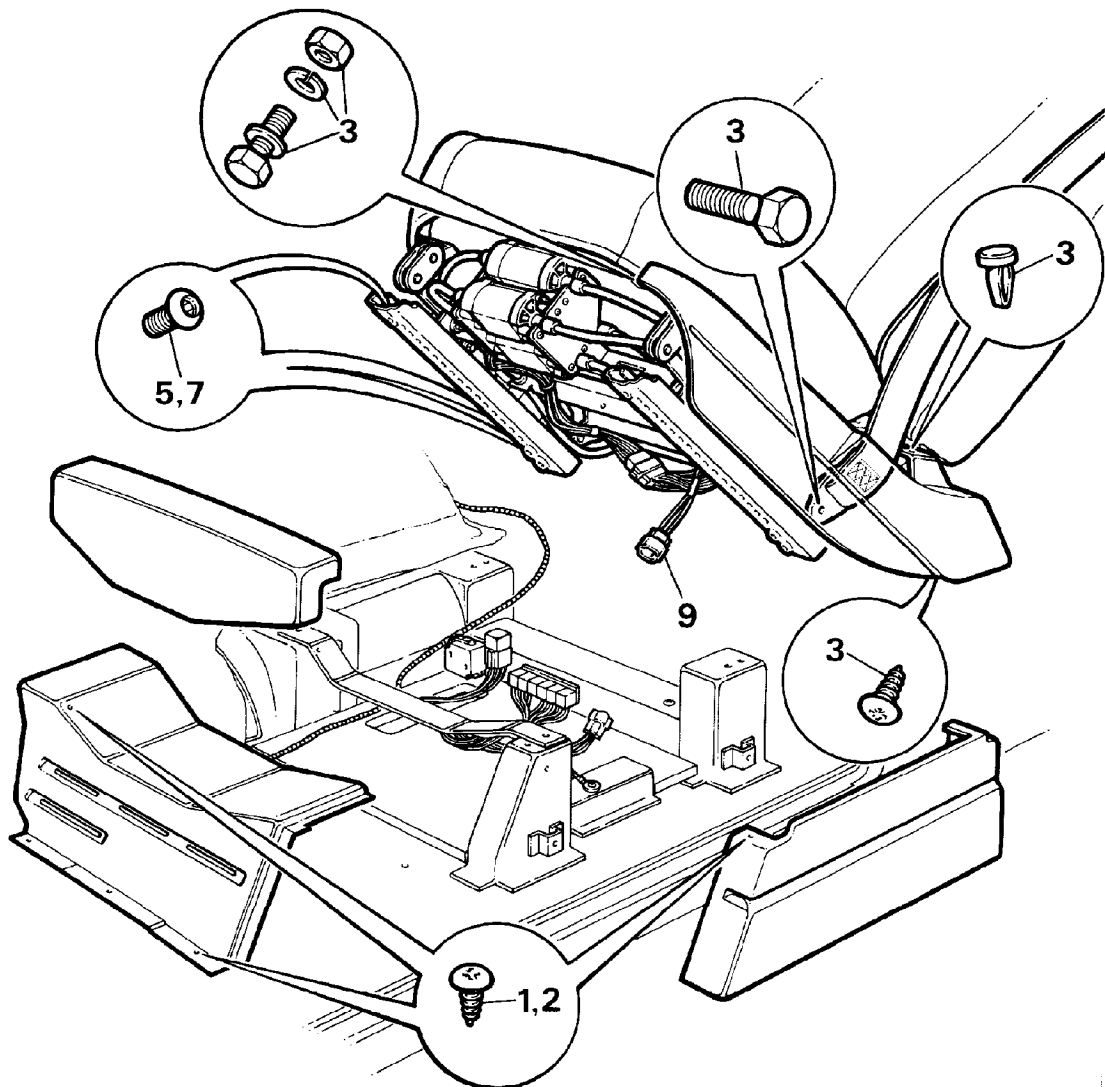

RR2152E

FRONT SEAT MANUAL

Service repair no - 76.70.01

Remove

1. Disconnect battery negative lead.
2. Remove two screws securing side panel and remove panel.
3. Remove three screws from front trim panel. Remove screw from top of trim panel to seat base. Remove panel.

4. Remove bolt and washer securing seat belt.
5. Move seat to rearward position.
6. Remove two screws at front of each slide channel.
7. Move seat to most forward position.
8. Remove four screws at rear of each slide channel.
9. Remove seat, retaining spacers between slide channel and seat base.

Refit

10. Reverse removal procedure.

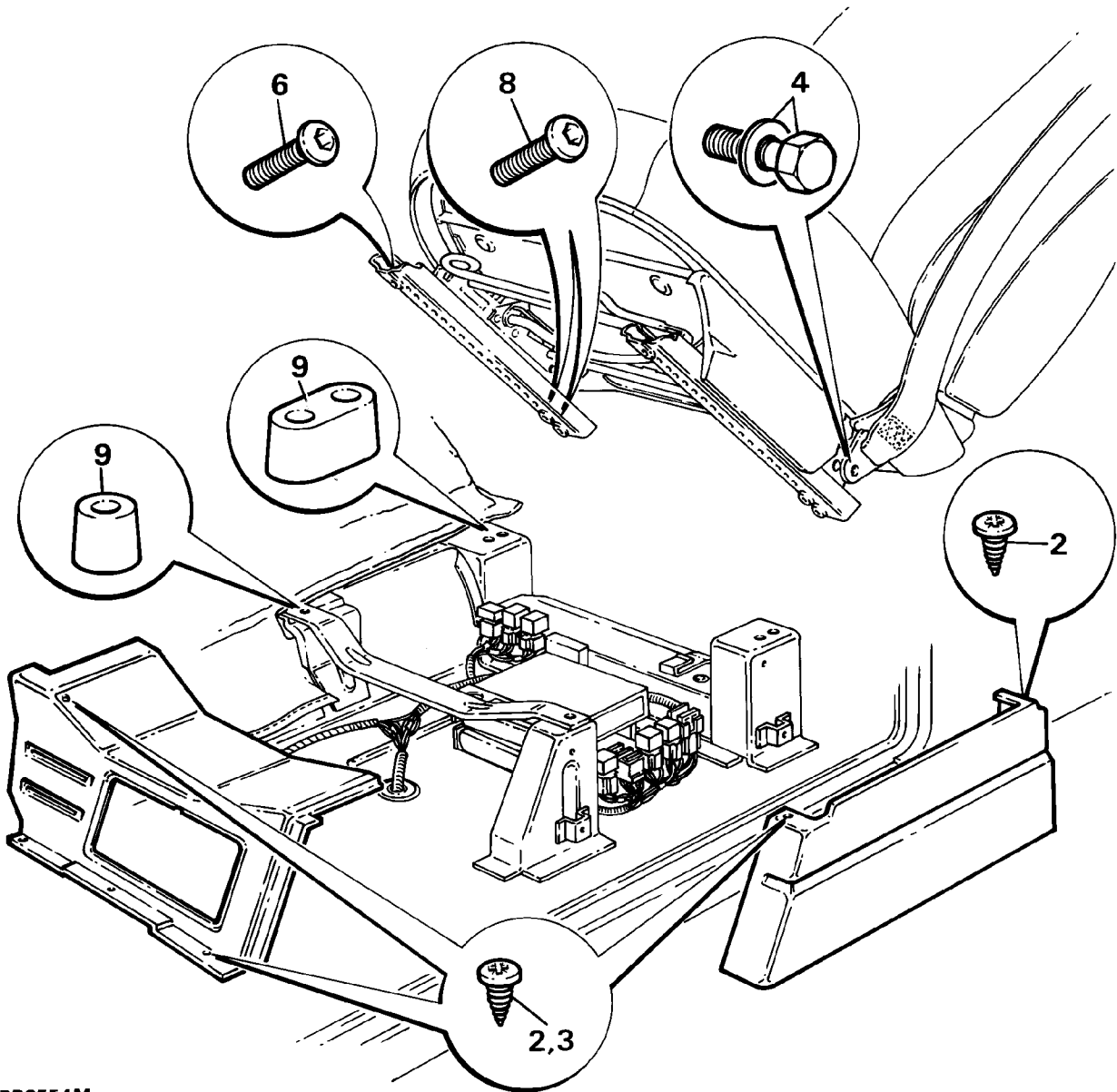

RR3554M



ASYMMETRIC SPLIT REAR SEAT

Service repair no - 76.70.38

Remove

1. Lift footwell carpet to access front hinge bolts.

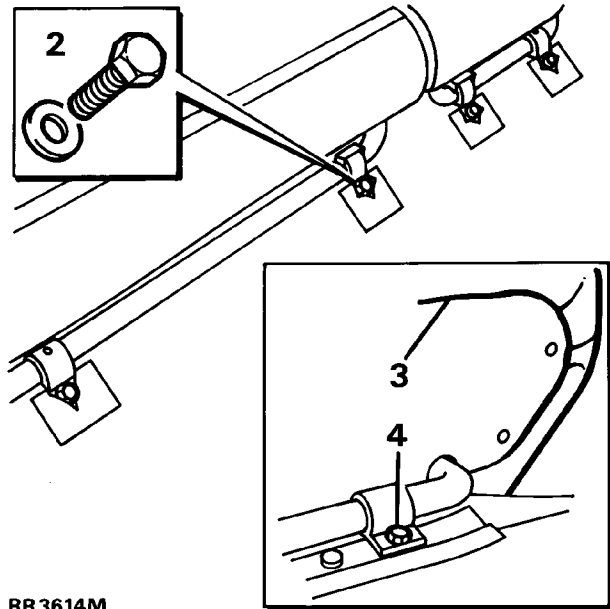

RR3614M

2. Remove hinge bolts.
3. Fold seat fully forward.
4. Remove rear hinge bolts.
5. Remove seat from vehicle.

Refit

6. Reverse removal procedure. Ensure seat folds and latches smoothly.

ASYMMETRIC SPLIT REAR SEAT - LOCKING MECHANISM

Service repair no - 76.70.51

Remove

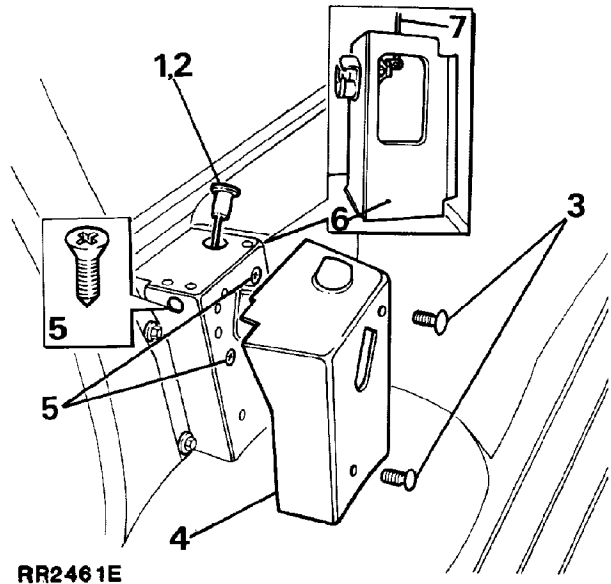

RR2461E

1. Depress release button and fold seat forward.
2. Unscrew and remove release button.
3. Remove two trim buttons securing trim cover.
4. Remove trim cover.
5. Remove three screws securing latch to tower. One screw is accessed through hole in tower.
6. Retrieve latch from opening rear of tower.
7. Remove operating rod by releasing plastic clip.

Refit

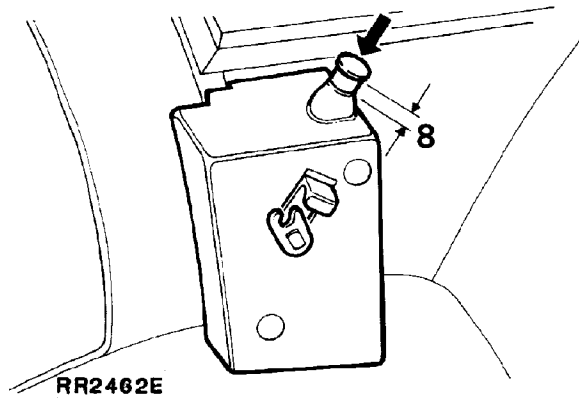

8. Reverse removal procedure. When release button is depressed there must be a gap from 5 to 8 mm between head of button and lip of trim cover.

FRONT SEAT HEATED CUSHION AND SQUAB

Service repair no - 76.77.05 / 76.77.14

Remove heated cushion.

1. Remove front seat assembly. *See Front Seat Electrical*

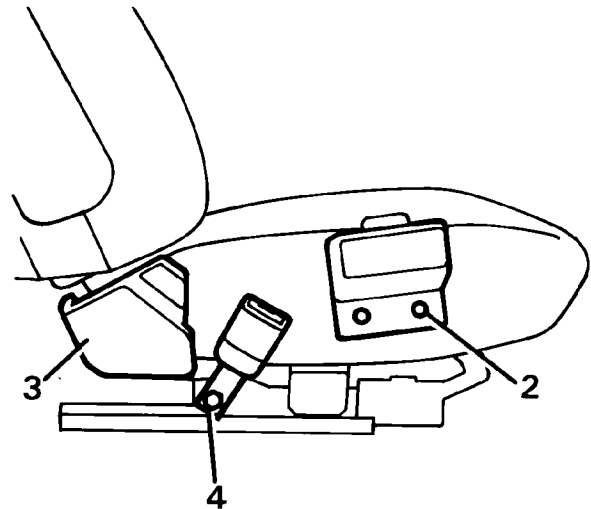

2. Remove two screws securing seat control adjustment unit.
 3. Remove two screws securing corner trim.
 4. Release seat belt buckle bracket.
 5. Release trim from seat frame.

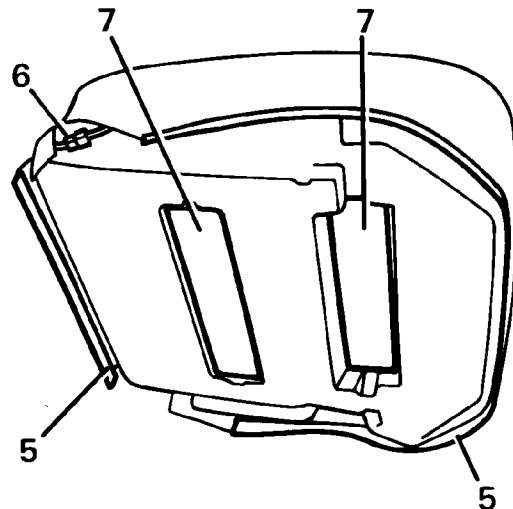



6. Disconnect heater wiring at multiplug to seat squab. Remove cushion and trim from seat frame.
7. Turn 90° two seat trim retention plates and push through slot in cushion foam.

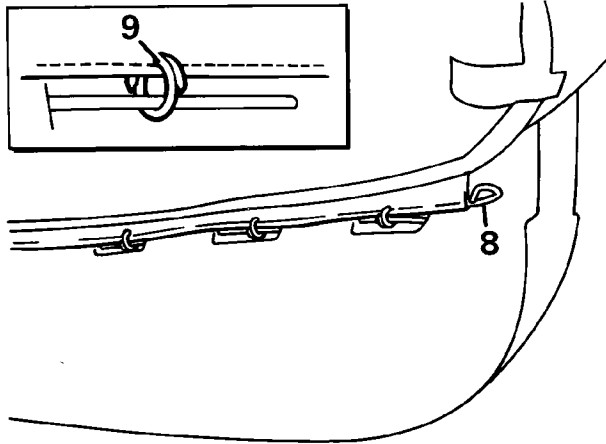

RR3647M

8. Fold seat trim over cushion to reveal stapled wire retention rods.
9. Pry open staples and release seat trim from seat cushion.

Continue for removal of heated squab.

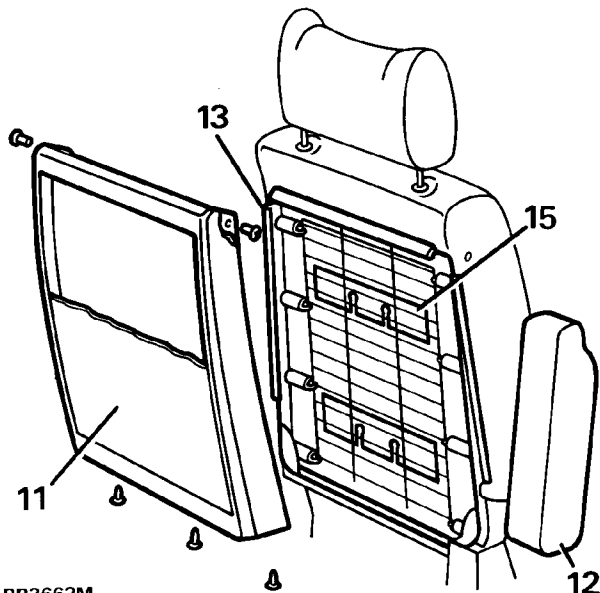

RR3662M

10. Remove headrest.
11. Remove squab panel rear. Three screws at base. Peel back trim to remove screw from each top corner.
12. Remove armrest assembly.
13. Release trim from edge of seat frame.
14. Remove squab foam with trim from seat frame.
15. Turn 90° two trim retention plates and push through slot in foam.

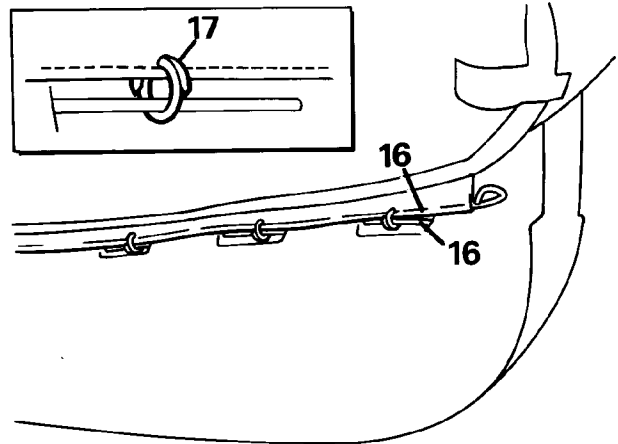

RR3663M

16. Fold trim over squab foam to reveal two wire retention rods.
17. Pry open staples and release trim from squab cushion.

Refit

18. Reverse removal procedure.

SEAT BELTS**Introduction**

Seat belt assemblies are factory fitted. If removal is necessary follow procedures in this section. All seat belt fixings **MUST** be tightened to correct torque values.

Seat belt assemblies **MUST** be replaced after they have been subjected to loading such as in a collision.

A lamp warning is incorporated to alert user. The warning lamp will illuminate for eight seconds when ignition is switched on regardless of seat belt usage.

On American specification vehicles a audible warning will sound with an high and low note from four to eight seconds unless driver seat belt is fitted.

A lap belt is provided for occupant of the centre rear seat.

FRONT SEAT BELT

Service repair no - 76.73.10

Remove

1. Move seat to access belt mountings.
2. Disconnect battery negative lead.
3. Remove seat side trim panel. *See Front seat*

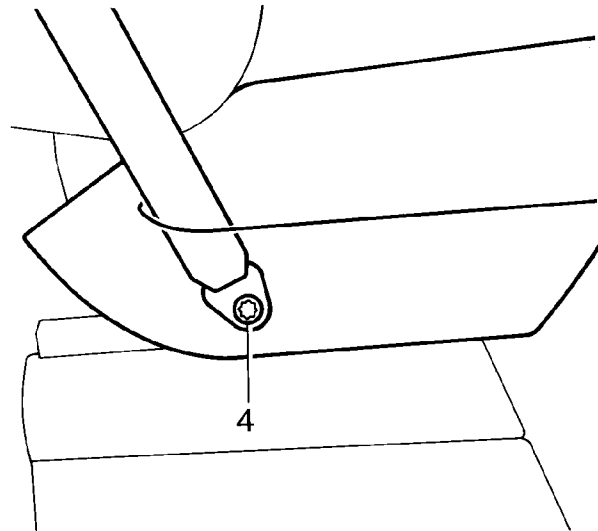

RR4196

4. Remove bolt, plain washer and spacer from belt to seat base.
5. Remove moulding from adjustable seat belt mounting.
6. Remove nut and spacer securing seat belt to 'B' post.

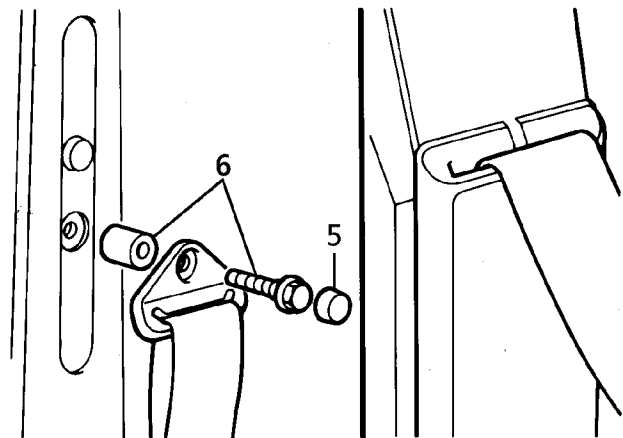

RR3612A



7. Pull door seal away to remove lower 'B' post trim.
8. Remove seat belt through slot in lower 'B' post trim.

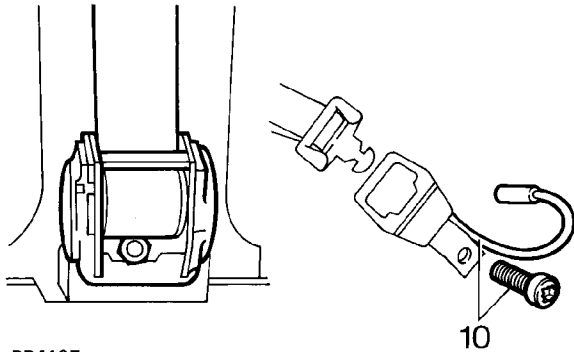

RR4197

9. Remove bolt and spring washer from inertia reel assembly to 'B' post.
10. Disconnect electrical plug and remove bolt securing buckle to seat base.

Refit

11. Reverse removal procedure. Ensure belts are not twisted. Tighten bolts to **25Nm**.

REAR SEAT BELT

Service repair no - 76.73.18

Remove

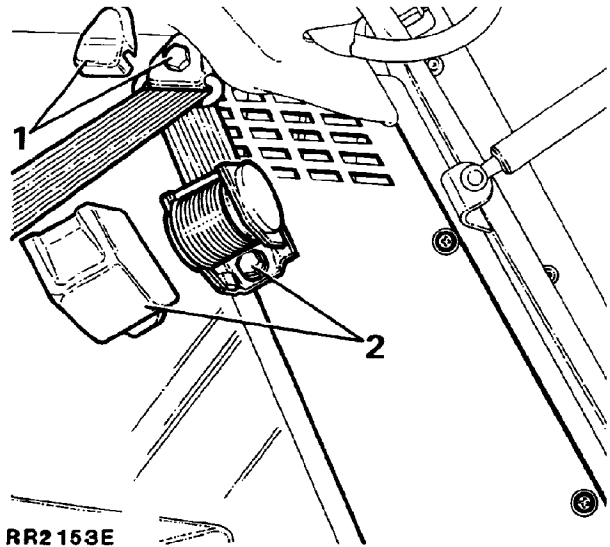

RR2 153E

1. Remove plastic cover from upper guide bracket. Remove bolt, spacer, plain and wavy washer.
2. Unclip cover from inertia reel assembly. Remove bolt, spring washer. Place reel to one side.

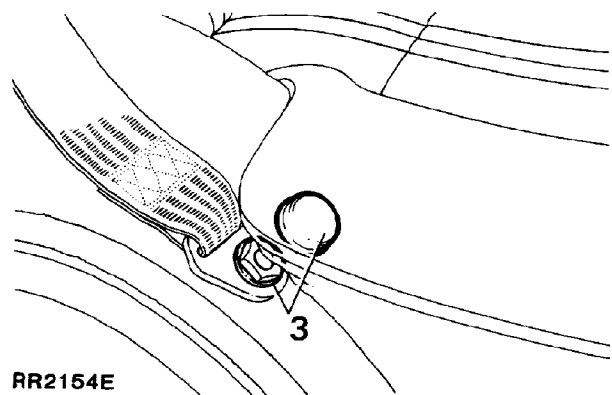

RR2154E

3. Remove plastic cover and bolt securing belt assembly to wheel arch.
4. Remove belt assembly.

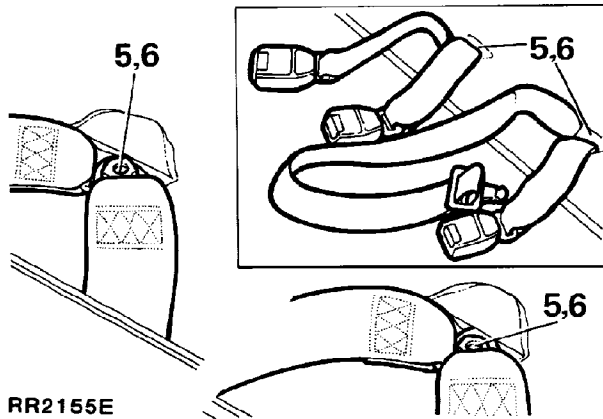

RR2155E

5. Remove bolt and plain washer securing belt bracket to load space floor.
6. Centre lap strap only: Remove bolts securing lap strap and buckle assembly and withdraw both components.

Refit

7. Reverse removal procedure. Ensure belts are not twisted. Tighten bolts to **25Nm**.

CENTRE CONSOLE

Service repair no - 76.52.00

Service repair no - 76.25.09 Veneer panel

Service repair no - 76.25.25 Switch panel

Remove

1. Disconnect battery negative lead.

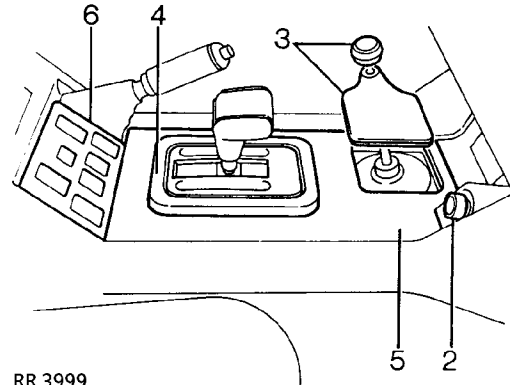

RR 3999

2. Remove cigar lighter.
3. Release gaiter and unscrew transfer gear lever knob.
4. Lift at front and remove finisher from automatic gear selector housing.
5. Lift at front and remove veneer panel.
6. Remove switch panel veneer.

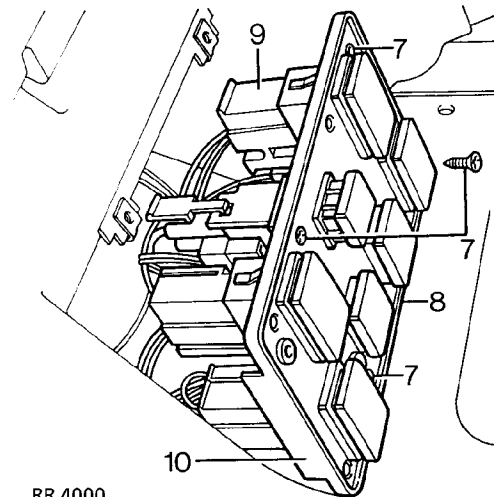

RR 4000

7. Remove 4 screws securing switch panel.
8. Withdraw switch panel from console.
9. Disconnect multiplugs from 9 switches.
10. Remove switch panel assembly.

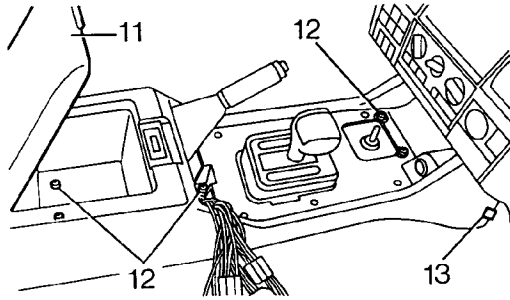

RR 4001

11. Open glovebox lid.
12. Remove 5 screws securing console.
13. Release 2 clips, securing front of console to bracket.
14. Release handbrake gaiter from console.
15. Remove spring clip (from RH side) and clevis pin securing cable to handbrake lever.
16. Lift handbrake lever and manoeuvre console slightly away from tunnel.
17. Disconnect Lucar connectors from cigar lighter.
18. Lift console assembly over handbrake and gear levers and remove from vehicle.

Refit

19. Reverse removal procedure. Ensure electrical plugs are fitted correctly and wiring is not trapped.
20. Lubricate handbrake clevis pin.

DRINKS TRAY

Service repair no - 76.46.41

Remove

1. Disconnect battery negative lead.
2. Remove ash tray.
3. Release air suspension switch panel from dash and position below aperture. **See *ELECTRICAL, Repair, Air Suspension Switches and Bulbs***

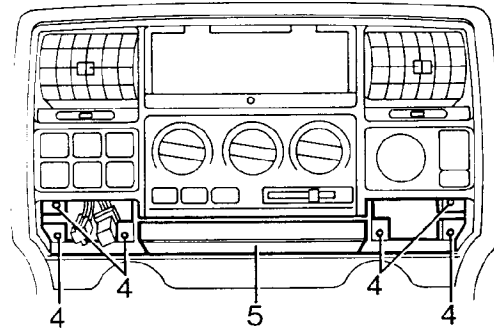

RR 4003

4. Remove 6 screws securing drinks tray to dash.
5. Remove drinks tray assembly.

Refit

6. Reverse removal procedure.

DASH PANEL CENTRAL LOUVRE PANEL

Service repair no - 76.46.42

Remove

1. Disconnect battery negative lead.
2. Remove radio from mounting frame. *See ELECTRICAL, Repair, Radio*
3. Remove clock assembly.
4. Remove drinks tray. *See Drinks Tray*
5. Remove heater control unit. *See HEATING AND VENTILATION, Repair, Heater Control Unit*
6. Remove centre console assembly. *See Centre Console*

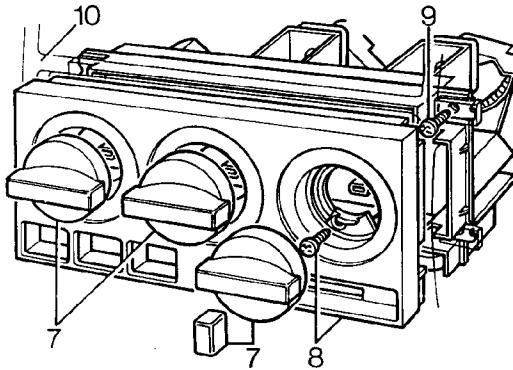

RR 4004

7. Remove 3 heater control knobs and blower switch knob.
8. Undo 2 screws and remove heater graphic display panel.
9. Remove 4 screws securing heater control unit to panel.
10. Push heater control unit through panel.

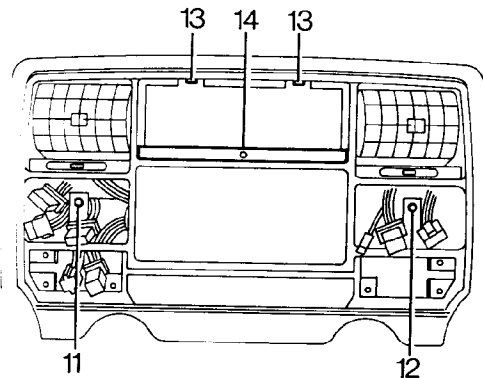

RR 4005

11. Inside auxiliary switch panel aperture, remove 2 screws securing panel.
12. Inside clock aperture, remove 2 screws securing panel.
13. Slacken 2 screws securing upper panel.
14. Manoeuvre LED light panel from panel, disconnect bulb holder and remove light panel.

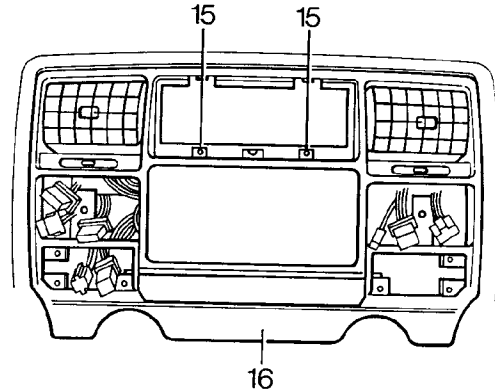

RR 4006

15. Remove 2 screws securing louvre panel.
16. Remove louvre panel from dash panel.

Refit**CAUTION: When refitting avoid trapping of electrical wiring.**

17. Reverse removal procedure. Place louvre panel in position, ensure wiring looms are free and multiplugs and connectors are through their apertures
18. Check function of all switches and controls.



DASH PANEL ASSEMBLY

Service repair no - 76.46.23

Remove

1. Move front seats to rearmost position.
2. Disconnect battery negative lead.
3. Disconnect air bag multiplugs under dash panel.



CAUTION: When air bags are fitted, reference must be made to the Airbag Supplementary Restraint System section.

4. Remove passenger's side glove box.
5. Remove driver's side access panel.
6. Remove centre console assembly. *See Centre Console*
7. Remove airbag from steering wheel. *See SUPPLEMENTARY RESTRAINT SYSTEM, Repair, Driver's Airbag Module*
8. Remove airbag from panel panel. *See SUPPLEMENTARY RESTRAINT SYSTEM, Repair, Passenger's Airbag Module*
9. Release clamp and lower steering column.
10. Remove steering wheel. *See STEERING, Repair, Steering Wheel*
11. Remove column switch assembly. *See SUPPLEMENTARY RESTRAINT SYSTEM, Repair, Column Switch Assembly*
12. Remove instrument housing. *See ELECTRICAL, Repair, Instrument Binnacle*
13. Remove radio. *See ELECTRICAL, Repair, Radio*
14. Remove exterior mirrors switch panel. *See ELECTRICAL, Repair, Auxiliary Switches and Bulbs*
15. Remove air suspension switch panel. *See AIR SUSPENSION, Repair, Operating Switches and Bulbs*
16. Remove switch panel. *See ELECTRICAL, Repair, Switch Panel*
17. Remove clock panel assembly. *See ELECTRICAL, Repair, Clock*
18. Undo 4 screws and remove RH front door tread plate.
19. Position RH footwell carpet aside.
20. Undo 4 screws and remove front finisher from RH seat.
21. Remove screw securing air suspension ECU bracket.
22. Release multiplug from bracket and disconnect multiplug.
23. Cut tie securing air suspension switch harness to tunnel.
24. Position switch harness aside and lay carpet in footwell.
25. Undo screw securing mounting bracket and position passenger's side relay assembly aside.
26. Set heater controls fully clockwise.
27. Note position of levers, disconnect heater control cables from levers and outer cable from retaining clips.

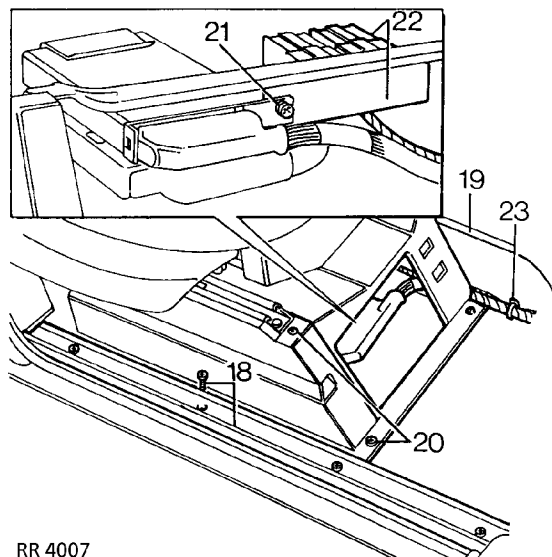

RR 4007

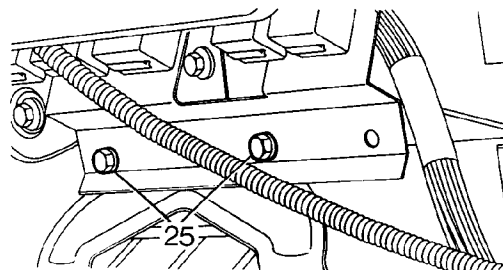

RR 4008

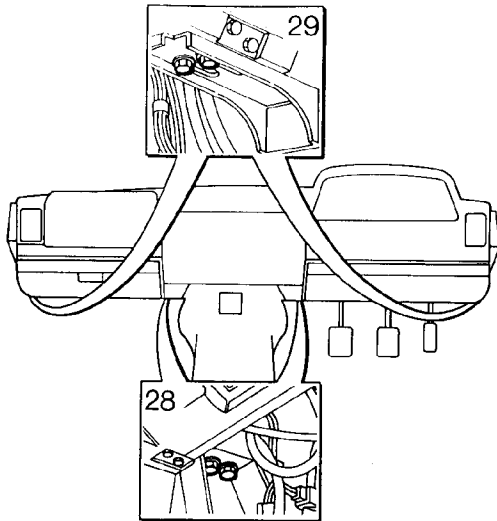

RR 4009

28. Remove 4 bolts securing dash panel to centre lower mounting brackets.
29. Remove 4 bolts securing dash panel to side lower mounting brackets.

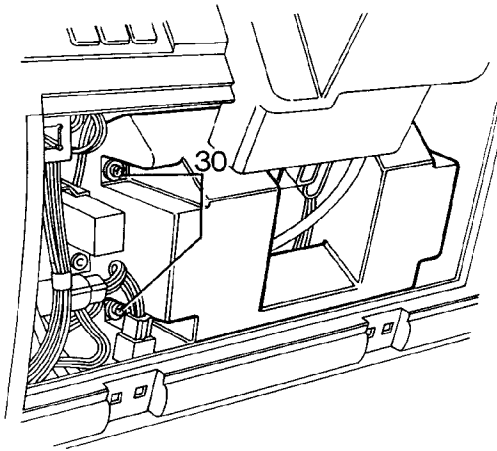

RR 4010

30. Undo 4 screws and remove 2 driver's knee bolster pads from below steering column.

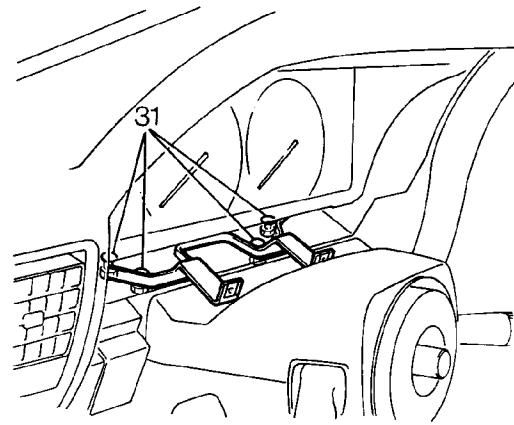

RR 4011

31. Remove 4 nuts securing instrument mounting bracket to dash panel.

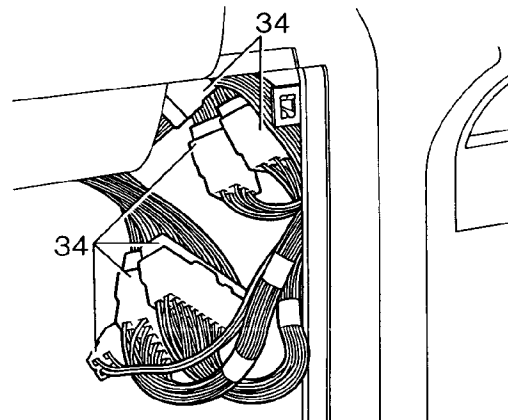

RR 4012

32. With assistance: Manoeuvre dash panel partially rearward.
33. Driver's side: Disconnect 6 multiplugs connecting dash harness to main harness.
34. Disconnect 3 multiplugs connecting dash harness to fusebox.
35. With assistance: Lift dash panel rearward to clear fixings and remove from vehicle.



Refit



CAUTION: When refitting avoid trapping of electrical wiring.

36. Reverse removal procedure.
37. With assistance: Position dash panel and connect dash harness multiplugs to fusebox and main harness.
38. Reverse removal procedure. Ensure dash panel upper bracket studs are located before the 4 lower brackets.
39. Reverse removal procedure. Disconnect glovebox switch Lucars to ease fitting of relay bracket.

FRONT SPOILER

Service repair no - 76.10.46

The spoiler will reduce the vehicle approach angle by approximately 10°. Where the vehicle is expected to perform on rough or hilly terrain, it is advisable to remove the spoiler assembly to prevent possible damage from ground contact.

Remove

1. Raise and support front of vehicle on safety stands.
2. Remove engine undertray.

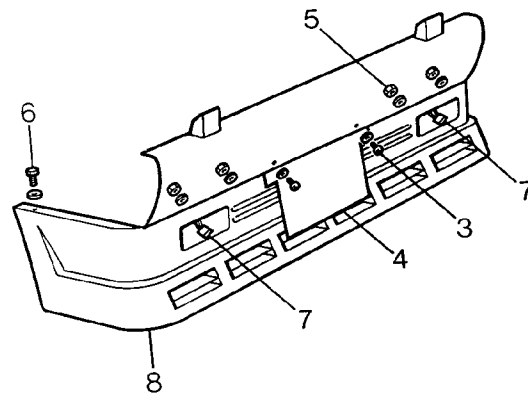

RR 4013

3. Remove two screws with spring washers securing centre of front spoiler and number plate.
4. Remove number plate.
5. Remove four nuts with spring washers located behind front bumper above auxiliary lamps.
6. Remove two bolts, nuts and washers securing outer edges of spoiler to front wing[fender]s.
7. Release auxiliary lamp multiplugs from clips and disconnect the multiplugs.
8. Remove front spoiler assembly. **Do not carry out further dismantling if component is removed for access only.**
9. Remove nut retaining each auxiliary lamp.
10. Remove 2 auxiliary lamps.
11. Transfer components removed to new spoiler.

Refit

12. Reverse removal procedure.

FRONT BUMPER

Service repair no - 76.22.08

Service repair no - 76.22.41 - End cap

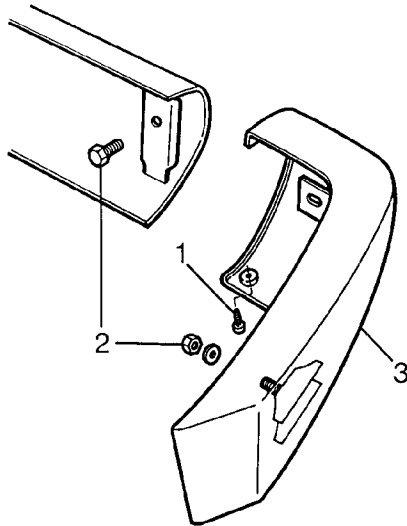
Remove

RR 4014

End cap - each

1. Remove screw securing bottom of end cap.
2. From inside, remove 2 nuts and bolts securing top of end cap.
3. Remove end cap.

Front bumper

4. Raise and support front of vehicle on safety stands.
5. Remove radiator grille. *See Radiator Grille*
6. Remove engine undertray.

7. Remove front spoiler assembly. *See Front Spoiler*

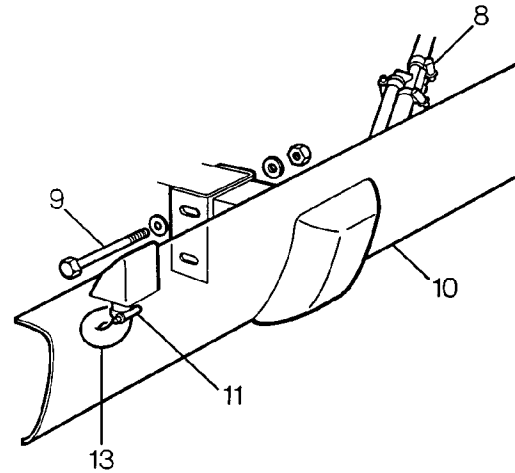

RR 4015

8. Release 2 clips and disconnect headlamp washer pipes from 'T' piece. Plug pipe ends.
9. Remove 4 bolts securing bumper to chassis frame.
10. Remove bumper assembly. ***Do not carry out further dismantling if component is removed for access only.***
11. Release 2 clips and disconnect pipes from headlamp washers.
12. Remove pipe and valve assembly.
13. Remove nut and washer and remove each washer jet.
14. Transfer components removed to new bumper.

Refit

15. Reverse removal procedure.



METAL SUNROOF ASSEMBLY

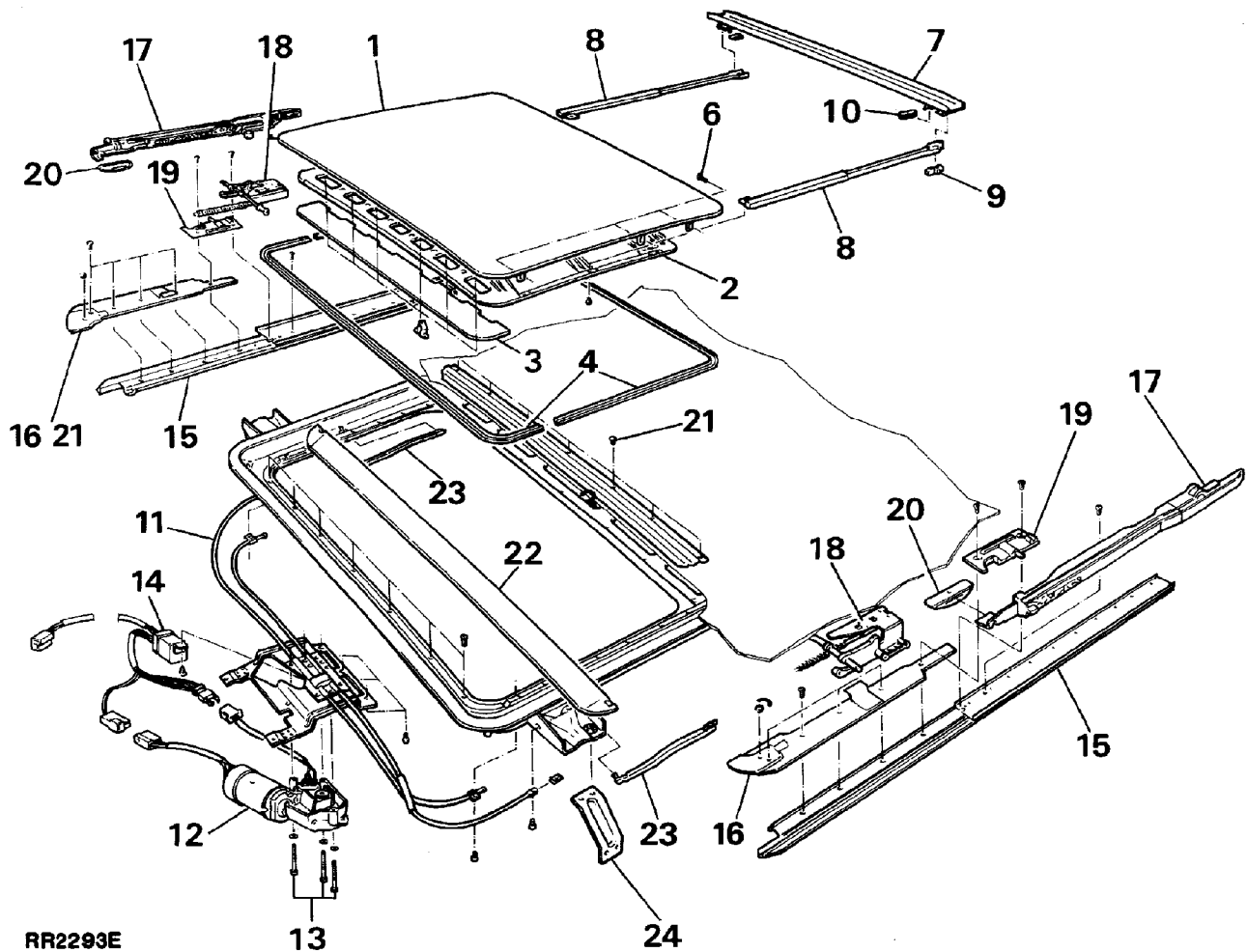

RR2293E

KEY

- | | |
|---|------------------------------------|
| 1. Roof panel | 13. Motor retaining screws |
| 2. Sunroof headliner | 14. Relay |
| 3. Insulation pad | 15. Lower guide rails |
| 4. Roof seals (front and rear) | 16. Front guide rails |
| 5. Sunroof headliner retaining clips (quantity - 6) | 17. Slide mechanism |
| 6. Roof panel retaining screws (quantity - 6) | 18. Rear guide |
| 7. Water channel | 19. Pivot bracket |
| 8. Water channel connectors | 20. Slide shoe |
| 9. Support bracket-water channel | 21. Rear edge trim finisher |
| 10. Slide shoe-water channel | 22. Wind deflector assembly |
| 11. Motor bracket/guide tube assembly | 23. Wind deflector operating arms |
| 12. Operating motor | 24. Support bracket (quantity - 6) |

OPERATION

Sunroof operation is a tilt and slide action controlled by a rocker switch adjacent to roof lamp, with ignition switched 'ON'.

1. Depress front of switch to lift rear edge of sunroof into 'Tilt' position.
2. Depress rear edge of switch to close roof.
3. Depress rear of switch to slide sunroof into 'Open' position.
4. Depress front of switch to slide sunroof into 'Close' position.



NOTE: The electric drive cuts out automatically in closed, tilt and open positions. If switch is operated in wrong direction in one of these positions, press switch once to reset and again to operate.

EMERGENCY OPERATION

If the sunroof fails to operate, check fuse. To close, carry out following procedure:

1. Lower interior lamp mounting panel by releasing two turnbuckles.
2. Remove emergency handle from vehicle tool kit.
3. Engage handle in motor drive spindle and turn to close roof.

MAINTENANCE

At each service water test drain tubes to ensure they are not blocked or kinked. Blow air up rear drain tubes which are clipped to rear mud flap supports. Blow down front drain tubes which run down 'A' post and out of engine bay.

Annually: Clean sunroof opening thoroughly.



NOTE: When vehicle is operated in extremely dusty conditions more frequent cleaning is recommended.

OPERATING MOTOR, MICRO-SWITCH AND RELAY

NOTE: The motor drive spindle retaining nut is set to correct torque value. If roof fails to operate check retaining nut torque.

Tighten to 5Nm.

Remove

1. Ensure sunroof is closed. Disconnect battery negative lead.
2. Remove interior lamp mounting panel to gain access to motor.
3. Disconnect two wiring connectors.
4. Remove three securing screws and withdraw motor.
5. Remove screw and withdraw relay.
6. Remove microswitch from motor by drilling out rivets, if required.

Refit

7. Secure new microswitch using nuts and bolts to replace rivets. Tighten nuts and apply a spot of paint to threads.
8. Ensure motor is in 'park' position, ie. hole on driven gear aligned with drive spindle.
9. Reverse removal procedure.
10. Check operation of sunroof in all positions.



SUNROOF PANEL SEALS

Service repair no - 76.82.55

Remove

1. Position sunroof in tilt position and Disconnect battery negative lead.
2. Unclip sunroof headliner from roof panel front and slide headliner back.
3. Remove three roof panel screws from each side and remove panel.
4. Remove both seals from roof panel.

Refit

5. Fit front seal to front edge of panel. Ensure there is an equal length of seal each side of centre point.
6. Butt rear seal against front seal fit tight around panel edge. Trim excess seal to produce a close joint with front seal.
7. Refit sunroof panel.

SUNROOF ASSEMBLY

Service repair no - 76.82.71

Including roof panel. Slide mechanism. Wind deflector. Motor mounting bracket. Guide tubes.

Remove



NOTE: Remove vehicle headlining ONLY if removing motor mounting bracket and guide tubes. See Headlining

1. Partially open sunroof and unclip sunroof headliner from roof panel front. Slide sunroof headliner back.
2. Move sunroof to tilt position. Disconnect battery negative lead.
3. Remove three roof panel screws from each side and remove panel.
4. Remove motor screws and withdraw motor.

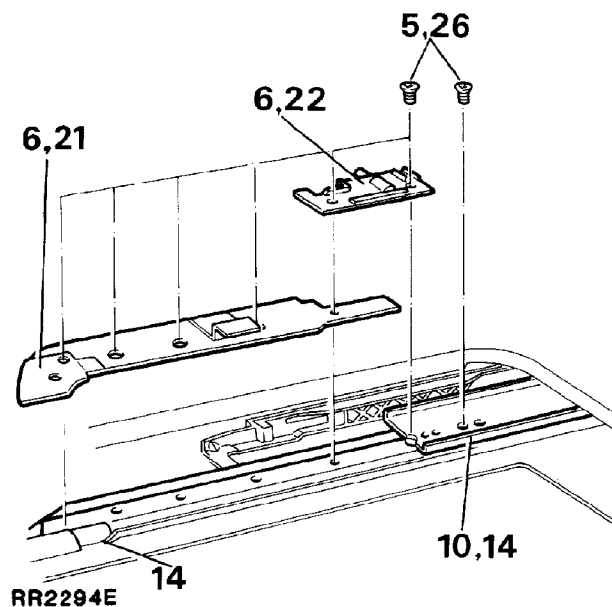

5. Remove guide rail screws, seven each side.
6. Remove pivot bracket and remove front guide rail.
7. Remove slide and tilt mechanism with flexible drive cable from both sides. Only disassemble if replacement parts are required.

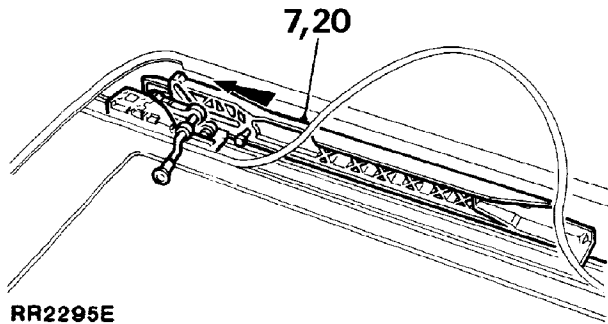

RR2295E

8. Unclip both wind deflector operating arms from rear mounting brackets. Remove arms from deflector, if required.

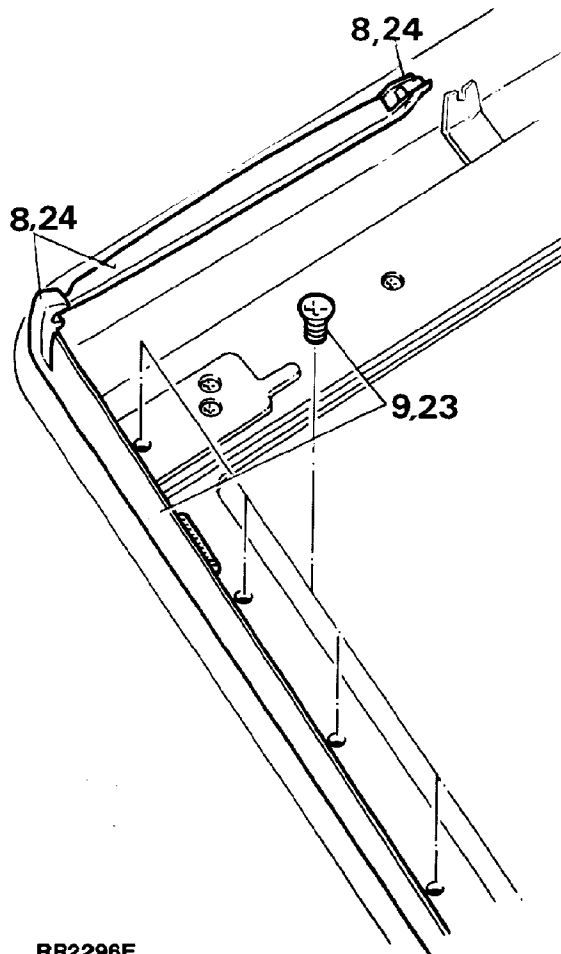

RR2296E

9. Remove seven screws, and withdraw wind deflector.
10. Remove lower guide rails and rear edge finisher, seven screws.
11. Remove screws from guide tubes, two each side. Remove five screws and withdraw motor mounting bracket.
12. Pull sunroof headliner assembly forward and remove.

Refit



NOTE: During assembly lightly lubricate all sliding parts using a silicon spray.

13. Position motor bracket and guide tube assembly. Fit and tighten securing screws.
14. Position right guide rail in rear retaining bracket. Push rearwards fully and locate leading edge under drive cable opening. Repeat operation for left hand guide rail.
15. Align fixing holes, and loosely fit screw in seventh hole from front.
16. Position finisher to rear edge of sun roof opening and secure using seven screws.
17. Position sunroof headliner assembly into outer guide runners, and push fully rearwards.
18. Lubricate drive cables. Ensure slide and tilt mechanism is fully assembled.
19. Push cable fully into right side guide tube. Loop remaining cable and enter rear end into right inner side runner.
20. Repeat operation 19. for left side. Push both assemblies rearwards to take up slack in cables, and push a further 75 mm to rear.
21. Position both front guide rails, aligning with four forward holes. Fit screws, do not tighten.
22. Position both pivot brackets, loosely fit screws.
23. Fit wind deflector and tighten fixings.
24. Position right operating arm in locating slot in deflector. Secure opposite end in frame bracket. Repeat for left side.
25. Pull right slide and tilt mechanism forward, align with pivot bracket and secure in position using setting key. Repeat operation for left side.
26. Tighten screws to guide rails, seven each side.
27. Fit and secure relay.
28. Ensure operating motor is in park position ie. hole on driven gear aligned with drive spindle. Fit and secure to mounting bracket.

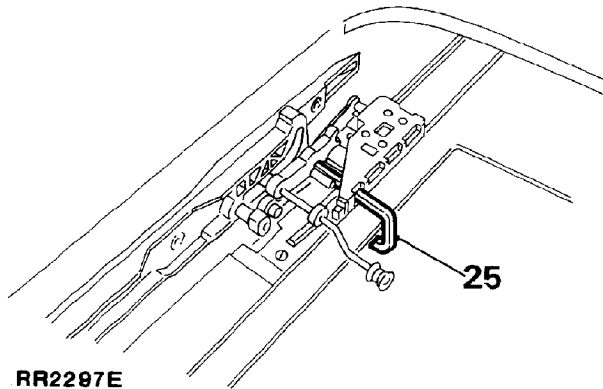

RR2297E

29. Remove setting keys. Temporarily connect operating switch and electrics.
30. Operate switch to 'tilt' position.
31. Position roof panel into roof opening with six screws, do not tighten.
32. Move roof to 'closed' position and adjust roof profile. The panel profile should be 0.5 mm low at forward edge, 1 mm high at rear edge.
33. Tighten roof panel screws.
34. Tilt sunroof, pull sunroof headliner forward and locate rear brackets in tilt mechanism. Align front six clips and push to secure.
35. Check operation of sunroof.

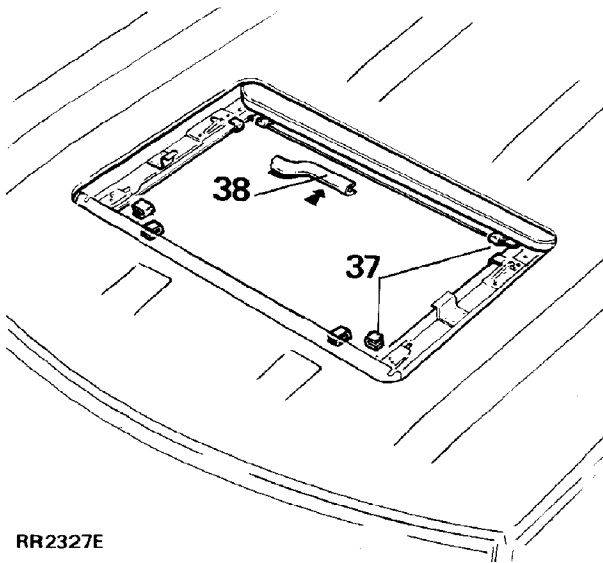

RR2327E

36. Refit vehicle headlining. *See Headlining*

SUNROOF HEADLINER ASSEMBLY

Service repair no - 76.82.03

Remove, retrim and refit**Remove and retrim**

1. Remove sunroof headliner assembly. *See Sunroof Assembly*
2. Remove trim covering from frame assembly. It is not necessary to remove three pads and insulation pad shown.
3. If required: remove water channel by unclipping connecting arms. Drill out rivets securing connecting arms to frame.

4. Secure connecting arms to frame using suitable rivets before retrimming frame.
5. Trim frame using a new headliner cover. Inset shows section through frame indicating where adhesive is applied. Dimension 'A' should be radially constant.

Refit

6. Refit sunroof headliner assembly and reassemble sunroof.

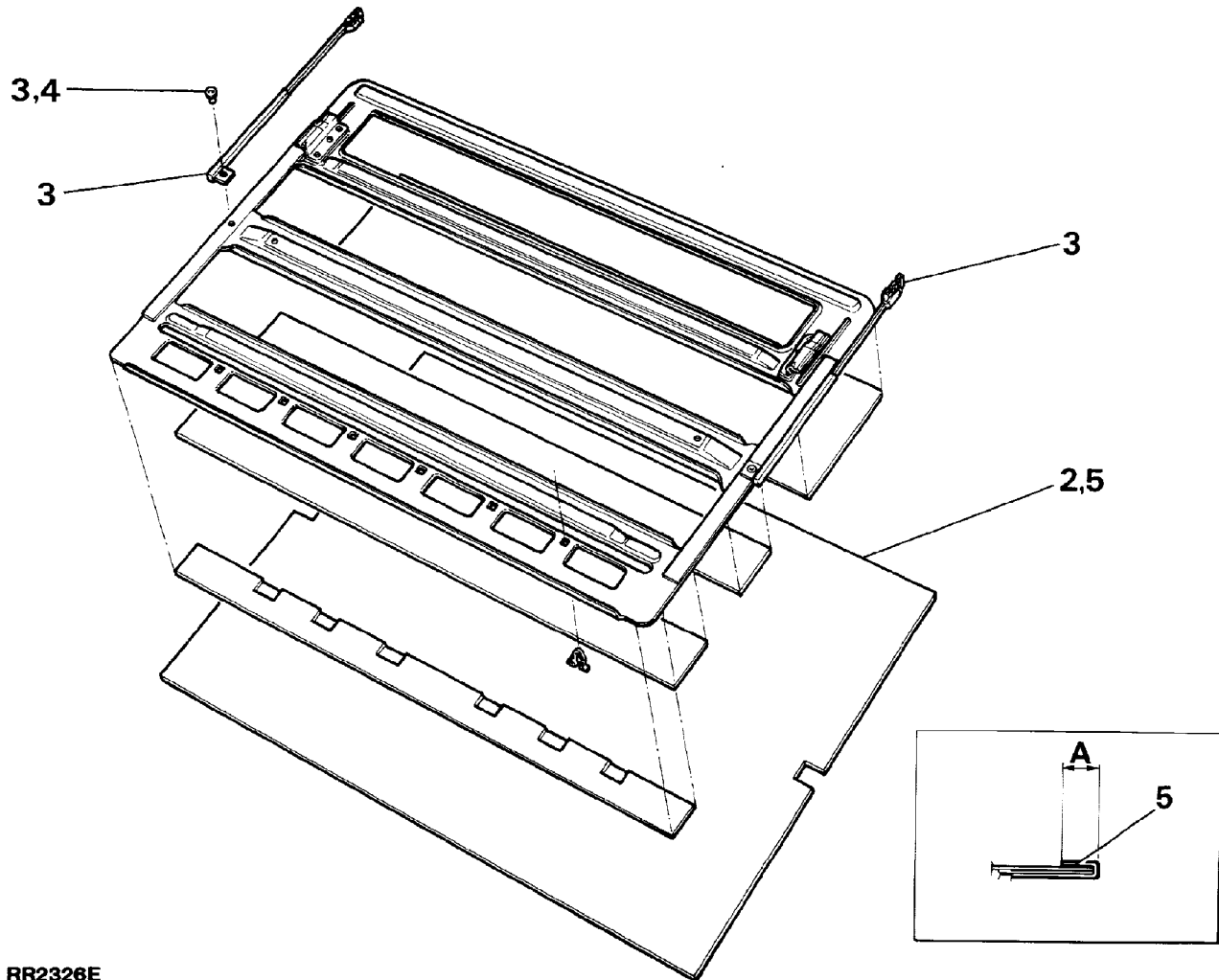

RR2326E



GLASS SUNROOF

Operation

The sunroof operates in a tilt and slide action controlled by a rocker switch near the interior lamp.

A drive motor and control unit is located behind the switch and interior lamp panel. The control units function is to stop the drive motor at the full tilt and slide positions.

Removal and refit of sunroof assemblies shown can be carried out without removing complete sunroof assembly.

GLASS PANEL ASSEMBLY

Service repair no - 76.82.64

Remove

1. Open sunroof to tilt position.

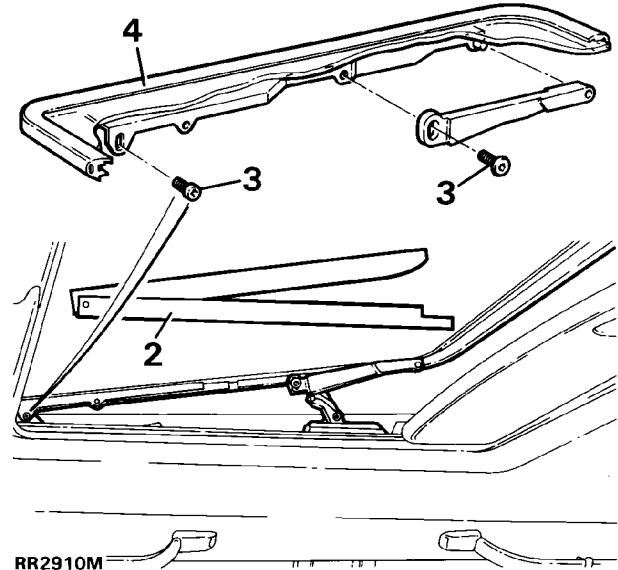

Refit and Adjust

1. Remove mechanism covers. Slide rearwards to disengage from location and lift out.
2. Remove two screws from each side as shown.
3. Remove glass sunroof.
4. Fit glass sunroof.
5. Fit four screws but do not tighten.
6. Close sunroof.
7. Check height of sunroof panel against roof aperture. The trimmed edge of glass sunroof to stand **1mm** above roof aperture.
8. Adjust by moving sunroof panel up or down. Tighten screws.
9. Fit mechanism covers.
10. Check sunroof operates correctly.

WIND DEFLECTOR ASSEMBLY

Service repair no - 76.82.31

Remove

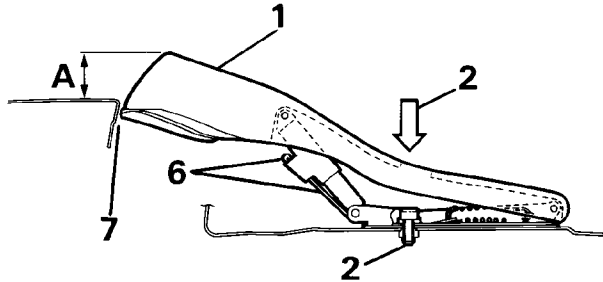

RR2909M

1. Open sunroof.
2. Remove two screws accessed through slot in deflector.
3. Remove wind deflector.

Refit

4. Fit wind deflector assembly.
5. Fit two screws firmly but do not tighten.

Adjust

Adjustment and attachment of deflector is by same two screws.

6. Adjust wind deflector rearwards or forwards into position shown. At same time adjust height 'A' to **15-20 mm** by moving slotted metal strip rearwards or forwards. Tighten two screws.
7. Ensure deflector does not catch front edge of roof aperture when operated.
8. Fully check that sunroof operates correctly.

MANUAL OPERATION

If sunroof fails to operate it can be opened or closed manually with key provided.

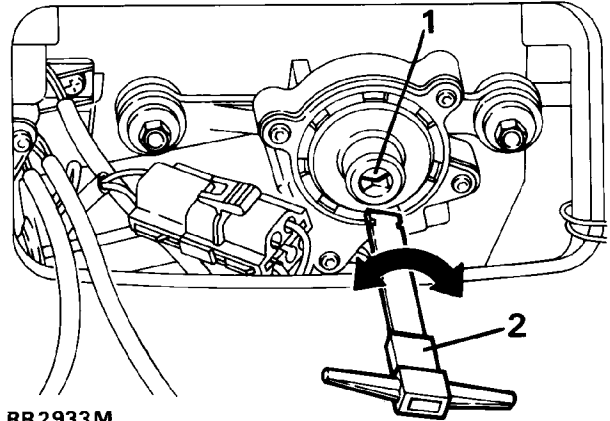

RR2933M

1. Remove two turnbuckles to access sunroof motor spindle located behind switch plate.
2. Engage key into motor spindle and turn to open or close sunroof panel.
3. After manual operation motor spindle **MUST BE TURNED BACK A QUARTER TURN TO ENGAGE ELECTRICAL DRIVE MOTOR.**



MOTOR DRIVE ASSEMBLY AND CONTROL UNIT

Service repair no - 76.82.72 / 76.82.73



NOTE: The following servicing of sunroof assembly can be carried out without removing complete sunroof assembly.

Remove

1. Close sunroof and disconnect battery negative lead.
2. Release two turnbuckles to access motor drive assembly and control unit, located behind switchplate.
3. Remove switchplate and disconnect two multiplugs.
4. Release front of roof headlining to access motor drive assembly and control unit.
5. Disconnect two multiplugs from control unit to motor drive and to main harness.

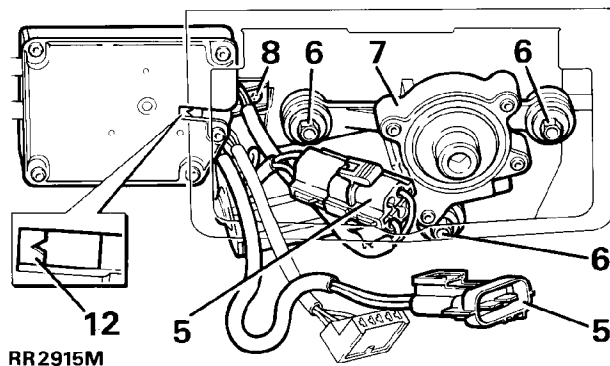

6. Remove three screws securing motor drive assembly.
7. Remove motor drive assembly.
8. To remove control unit undo screw. Lower then move control box inwards to release from mounting.
9. Inspect motor drive assembly and control unit for wear and damage, renew as necessary.

Refit

10. Refit motor drive assembly ensuring metal insert is fitted.



CAUTION: The motor drive assembly gear will not mesh correctly with drive cables if metal insert is NOT refitted.

11. Refit control unit.
12. Check timing of the control unit to sunroof:

A 'V' shaped notch should be visible through slot in control unit when sunroof is fully closed.

13. Reverse removal procedure. 2 to 5.
14. Check sunroof operates correctly.

GLASS SUNROOF COMPLETE ASSEMBLY

Service repair no - 76.82.59

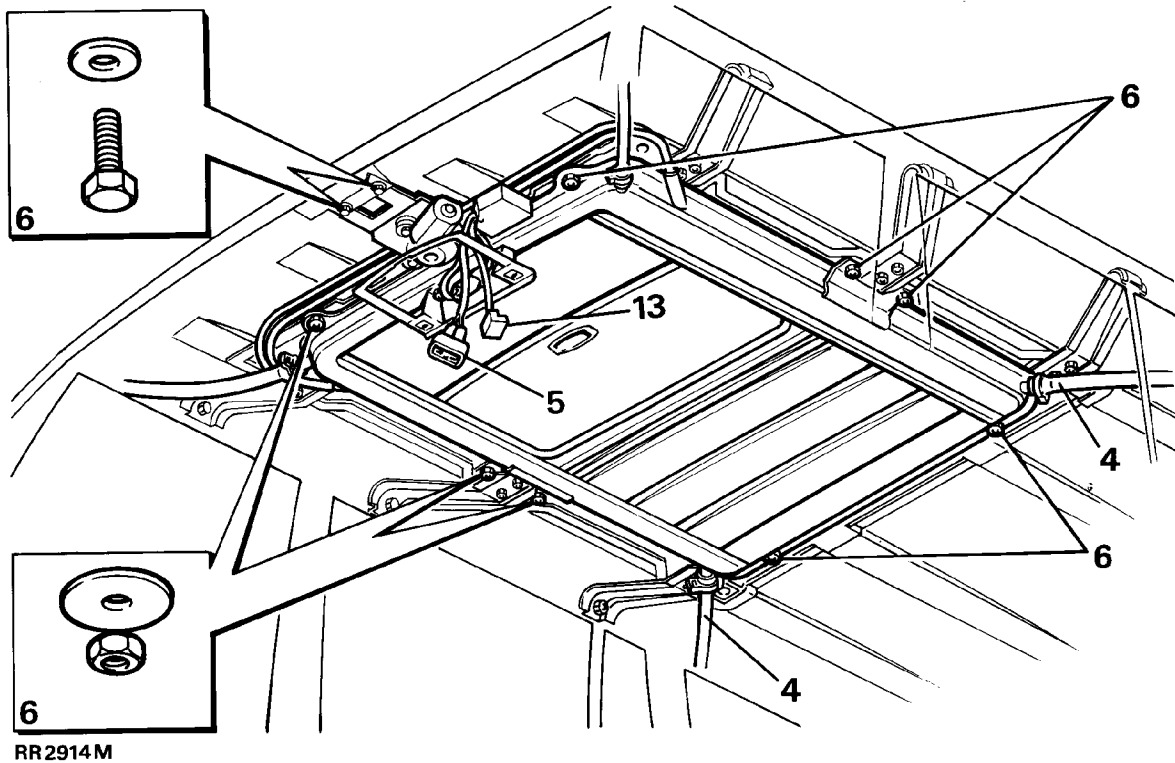

Remove

1. Open sunroof rearwards. Disconnect battery negative lead.
2. Remove switchplate and disconnect two multiplugs from switch and courtesy light.
3. Remove headlining. **See Headlining**
4. Remove four clips and disconnect drain tubes.
5. Disconnect multiplug from control unit to main harness.
6. With assistance remove eight nuts and washers and two bolts. Lower sunroof assembly remove through rear of vehicle.

Refit

7. Manually close sunroof. **See Manual Operation**
8. Lift complete sunroof assembly to roof panel.
9. Fit loosely eight retaining nuts and washers and two bolts.
10. Ensure closed sunroof fits equally positioned in roof panel aperture. Tighten retaining nuts and bolts, recheck fit.
11. Connect electrical multiplugs to main harness and sunroof switch.
12. Check sunroof operates correctly and leave in open position.
13. Disconnect sunroof switch
14. Fit drain tubes with retaining clips. Water test to ensure watertight seal.
15. Fit headlining and sunroof trim.
16. Reconnect electrical multiplugs to sunroof switch and interior light then fit switchplate.
17. Close sunroof and draw sunshade.



SLIDE AND GUIDE CHANNEL ASSEMBLIES OR SUNSHADE PANEL

Service repair no - 76.82.71 / 76.82.03

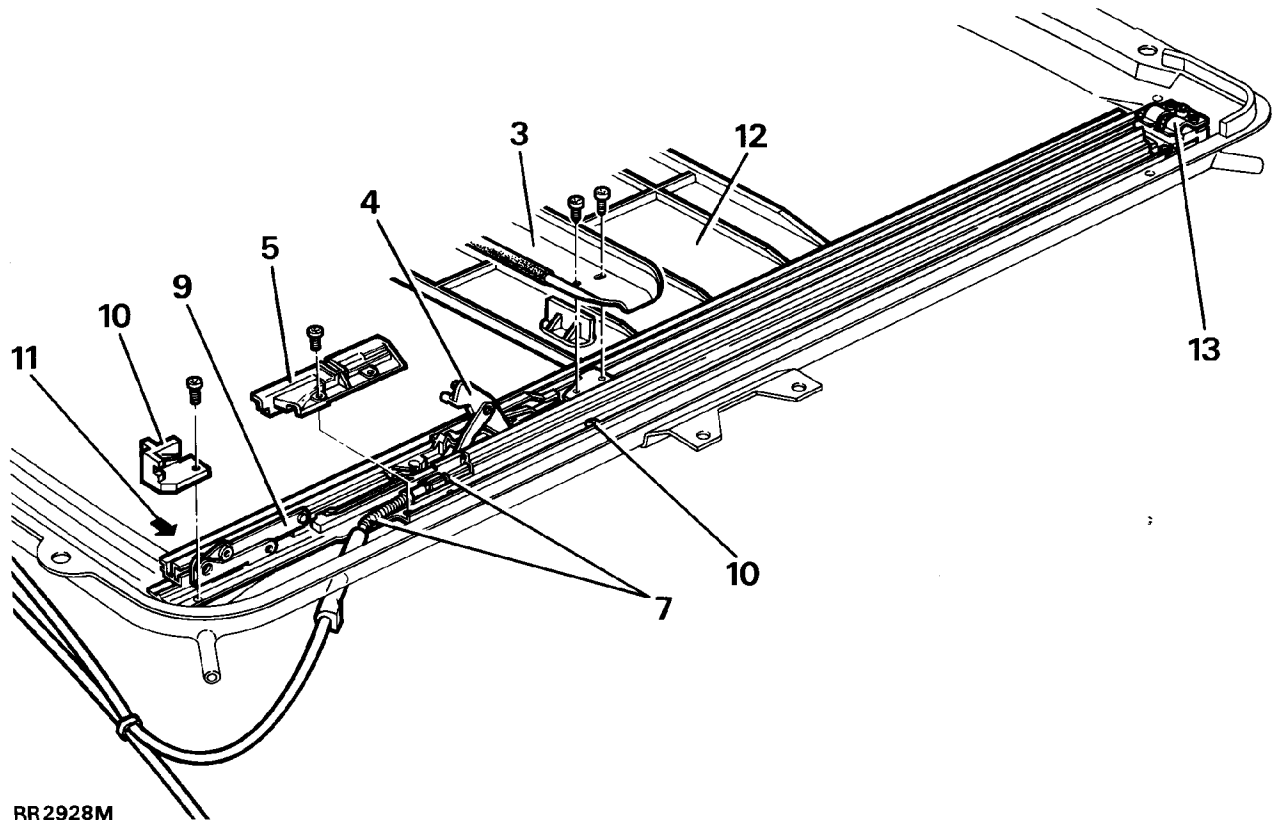

RR2928M



NOTE: The following can be carried out without removing complete sunroof assembly.

The sunshade panel is removed by releasing, either left or right side and guide channel assembly, instructions 1. to 12.

Remove

1. Remove glass panel assembly. *See Glass Panel Assembly*
2. Remove sunroof wind deflector assembly. *See Wind Deflector Assembly*
3. Remove rear cross member drain channel.
4. Move tilt slide rearwards until location cam is clear of locator block.
5. Remove locator block.

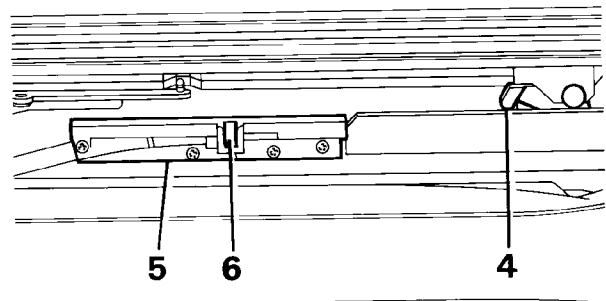

RR2929M

6. Move tilt slide forwards until location cam has reached position it normally locates into locator block. Manually adjust the cam outwards to allow tilt slide to pass and attain full tilt position.

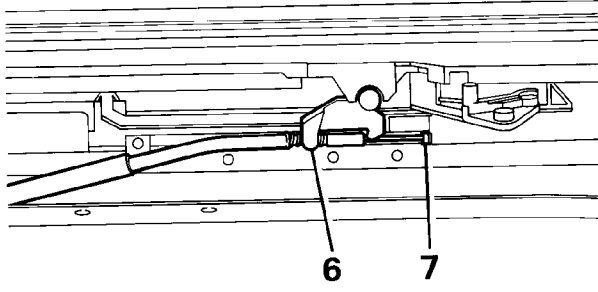
**RR2930M**

7. The drive cable end is now accessible. Disconnect drive cable from slide assembly.
8. Push tilt slide rearwards reversing instruction 6.
9. Push complete slide assembly rearwards approximately 2".
10. Remove front end stop and attaching screw from centre of guide channel.
11. Push guide channel assembly out sideways to release guide channel from roof panel.
12. Slide sunshade panel forward and lift out of runner to remove.

Continue for removal of slide and guide channel assembly.

13. Using a flashlight directed between roof panel and sunroof assembly. Observe for reassembly guide channel rear spring fixing point.
14. Pull guide channel forward to release from rear spring fixing point. Remove guide channel assembly.

Refit

15. Reverse removal procedure.
16. Check sunroof operates correctly.

TIMING OF CONTROL UNIT TO SUNROOF OPERATION

The timing of control unit to sunroof operation will be disturbed:-

If sunroof position is altered when control unit is removed.

Or control unit is removed and control unit gear is moved.

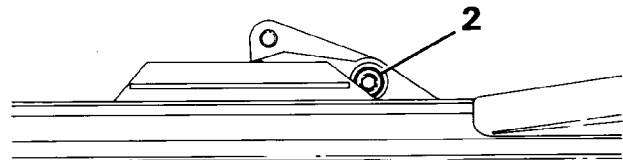
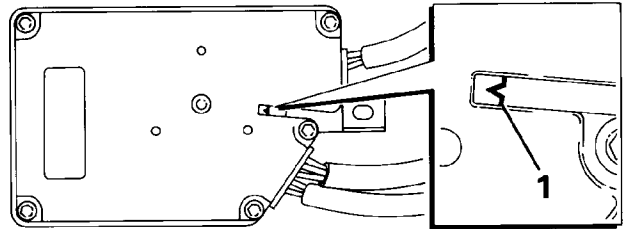
**RR2927M**

1. To check timing of control unit to sunroof. A 'V' shaped notch should be visible through slot in control unit when sunroof is in fully closed position.
2. To check control unit timing when glass panel is removed. A 'V' shaped notch should be visible through slot in control unit when sunroof tilt mechanism rivet is at a tangent to angle on guide channel. Viewed from inside vehicle.



This page is intentionally left blank

CHASSIS AMERICA ONLY - 1990 ONWARDS

Alignment check - RR2718E

	Diagram reference	millimetres
AA	Wheelbase reference dimension	2540,00
BB	Centre line of front axle	
CC	Centre line of rear axle	
DD	Frame datum line	
EE	Side member datum line	
FF	Datum line	
1	264,525 ± 1,27
2	Frame datum to underside of cross-member	150,80
3	266,70 ± 2,54
4	237,74 ± 1,27
5	327,81 ± 2,54
6	979,94
7	2179,73 ± 2,54
8	291,74 ± 2,54
9	707,96 ± 2,54
10	1468,49 ± 2,54
11	1025,27 ± 2,54
12	338,84 ± 2,54
13A	222,25 ± 2,54
13B	252,984 ± 2,54
14	Reference dimension	824,92
15	To face of boss (both sides)	935,43 ± 2,54
16	838,2 ± 0,38
17	Check figure	630,94 ± 1,27
18	344,17 ± 1,27
19	485,77 ± 2,54
20	485,77 ± 2,54
21	828,68 ± 0,38
22	129,03 ± 2,54
23	2479,45 ± 0,25
24	1290,34 ± 0,38
25	1657,04 ± 0,38
26	2598,44 ± 0,38
27	79,09 ± 0,38
28	465,48 ± 2,54
29	1398,88 ± 0,38
30	368,30 ± 2,54
31	Reference dimension	317,50
32	Reference dimension	635,00

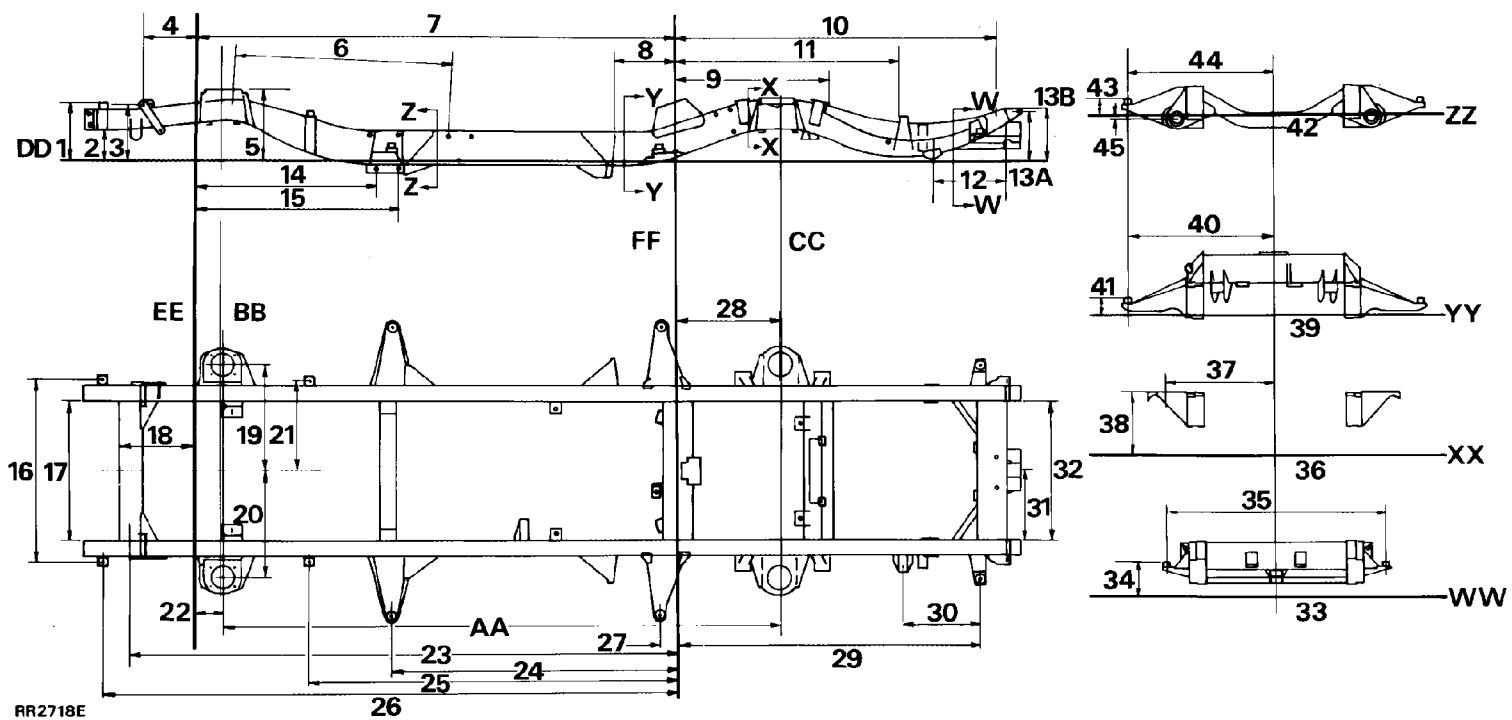

CHASSIS

	Diagram reference	millimetres
SECTION W - W		
31	Frame datum line DD	
32	155,91 ± 1,27
33	990,6 ± 0,50
34	825,5 ± 2,54
SECTION X - X		
35	Frame datum line DD	
36	488,95 ± 2,54
37	309,83 ± 1,00
SECTION Y - Y		
38	Frame datum line DD	
39	1320,8 ± 0,50
40	80,39 ± 1,27
SECTION Z - Z		
41	Frame datum line DD	
42	80,39 ± 1,27
43	660,4 ± 0,25
44	9,53 ± 2,54



CHASSIS NON AMERICAN - 1990 ONWARDS

Alignment check - RR2751M

	Diagram reference	millimetres
AA	Wheelbase reference dimension	2540,00
BB	Centre line of front axle	
CC	Centre line of rear axle	
DD	Frame datum line	
EE	Side member datum line	
FF	Datum line	
1	264,525 ± 1,27
2	Frame datum to underside of cross-member	150,80
3	266,70 ± 2,54
4	237,74 ± 1,27
5	327,81 ± 2,54
6	979,94
7	2179,73 ± 2,54
8	291,74 ± 2,54
9	707,96 ± 2,54
10	1468,49 ± 2,54
11	1025,27 ± 2,54
12	338,84 ± 2,54
13A	222,25 ± 2,54
13B	252,984 ± 2,54
14	Reference dimension	824,92
15	To face of boss (both sides)	935,43 ± 2,54
16	838,2 ± 0,38
17	Check figure	630,94 ± 1,27
18	344,17 ± 1,27
19	485,77 ± 2,54
20	485,77 ± 2,54
21	828,68 ± 0,38
22	129,03 ± 2,54
23	2479,45 ± 0,25
24	1290,34 ± 0,38
25	1657,04 ± 0,38
26	2598,44 ± 0,38
27	79,09 ± 0,38
28	465,48 ± 2,54
29	1398,88 ± 0,38
30	Reference dimension	635,00

CHASSIS - RR2751M

	Diagram reference	millimetres
SECTION W - W		
31	Frame datum line DD	
32	155,91 ± 1,27
33	990,6 ± 0,38
34	825,5 ± 2,54
SECTION X - X		
35	Frame datum line DD	
36	488,95 ± 2,54
37	295,27 ± 2,54
SECTION Y - Y		
38	Frame datum line DD	
39	660,40 ± 0,25
40	80,39 ± 1,27
SECTION Z - Z		
41	Frame datum line DD	
42	80,39 ± 1,27
43	660,40 ± 0,25
44	9,53 ± 2,54

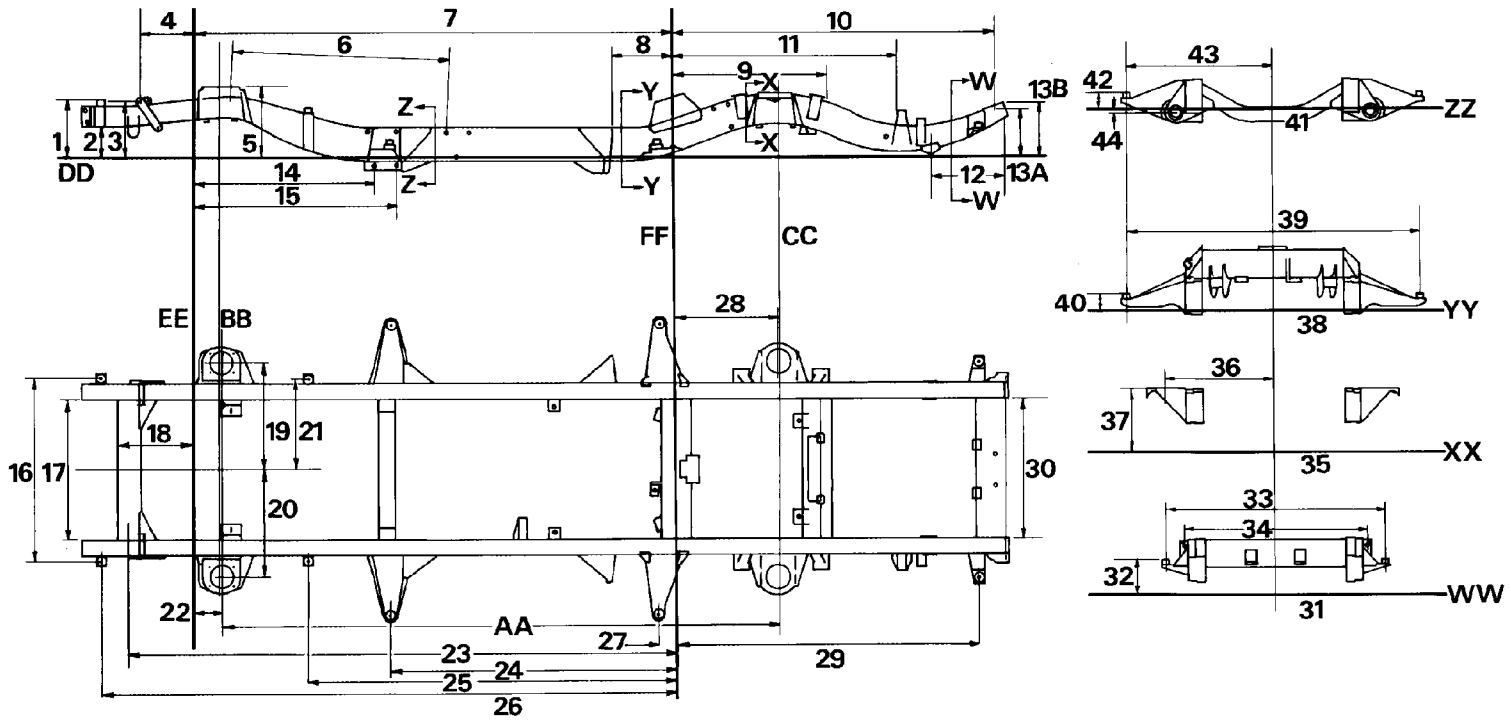

RR2751M



**CHASSIS - AMERICAN COUNTY LWB (108")
MODELS**

Alignment check - RR3919M

	Diagram reference	millimetres
AA	Wheelbase - Reference dimension	2743,20
BB	Centre line of front axle	
CC	Centre line of rear axle	
DD	Frame datum line	
EE	Sidemember datum holes	
FF	Datum line	
1	264,16 ± 1,27
2	Frame datum to underside of crossmember	150,80
3	266,70 ± 2,54
4	237,74 ± 1,00
5	337,34 ± 1,00
6	974,57 ± 1,00
7	2382,93 ± 2,54
8	1155,75 ± 1,00
9	707,96 ± 2,54
10	1468,49 ± 2,54
11	1025,27 ± 2,54
12	338,84 ± 2,54
13A	240,03 ± 2,54
13B	252,98 ± 2,54
14	Reference dimension	824,92
15	To face of boss (both sides)	935,43 ± 1,00
16	838,20 ± 0,50
17	Check figure	630,94 ± 1,27
18	344,17 ± 1,27
19	485,77 ± 2,54
20	485,77 ± 2,54
21	828,65 ± 0,50
22	129,03 ± 2,54
23	2682,65 ± 0,25
24	1493,54 ± 0,75
25	1860,24 ± 0,75
26	2801,64 ± 0,75
27	79,09 ± 0,75
28	390,88 ± 2,54
29	1398,88 ± 0,75
30	Reference dimension	317,50
31	Reference dimension	635,00

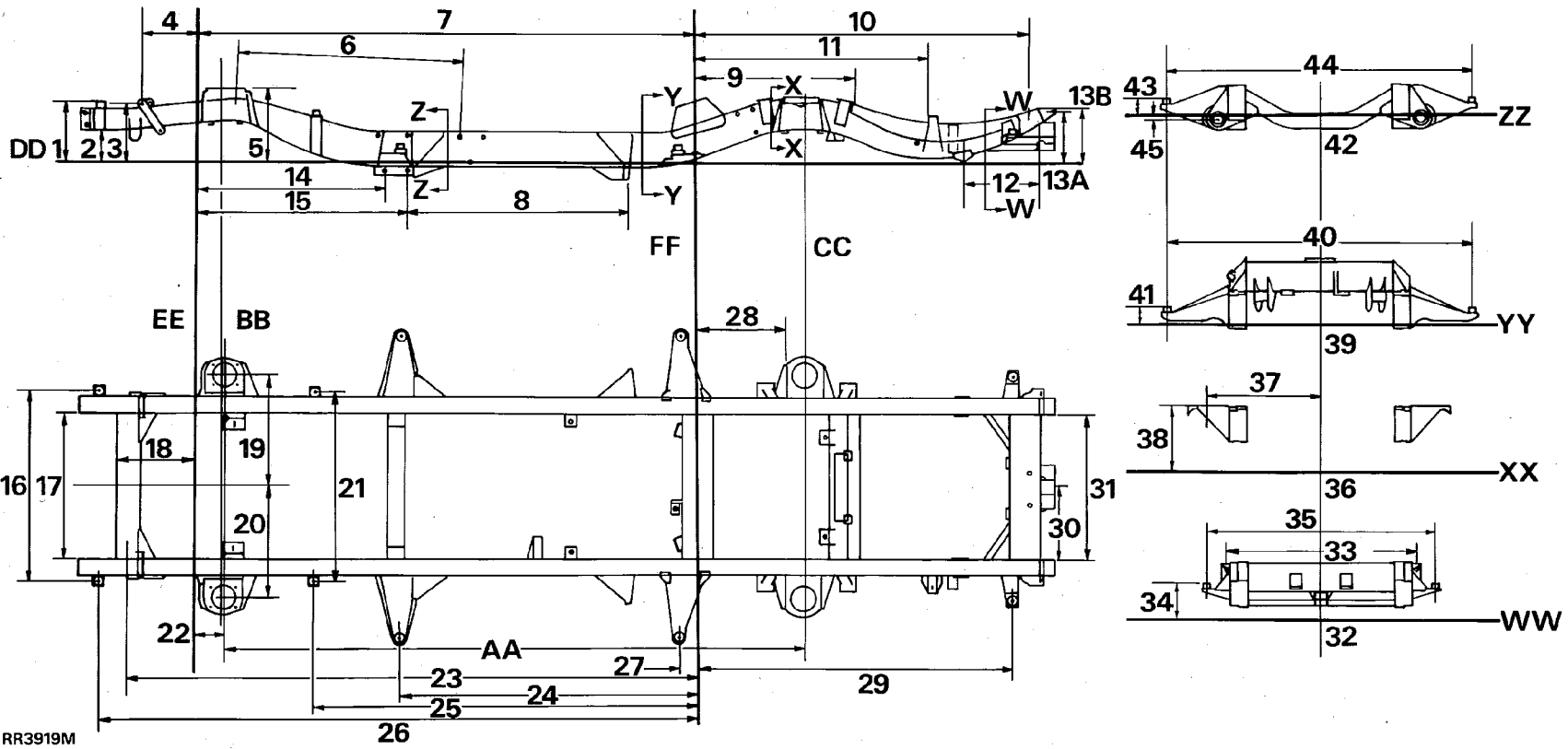

RR3919M

CHASSIS AND BODY



CHASSIS - RR3919M

	Diagram reference	millimetres
SECTION W - W		
32	Frame datum line DD	
33	825,50 ± 2,54
34	155,91 ± 1,27
35	990,60 ± 0,50
SECTION X - X		
36	Frame datum line DD	
37	488,95 ± 2,54
38	309,83 ± 1,00
SECTION Y - Y		
39	Frame datum line DD	
40	1320,80 ± 0,50
41	80,39 ± 1,27
SECTION Z - Z		
42	Frame datum line DD	
43	80,39 ± 1,27
44	1320,8 ± 0,50
45	9,53 ± 2,54



CHASSIS - LSE (108") AIR SUSPENSION MODELS

Alignment check - RR3918M

Diagram reference	millimetres
AA Wheelbase - Reference dimension	2743,20
BB Centre line of front axle	
CC Centre line of rear axle	
DD Frame datum line	
EE Sidemember datum holes	
FF Datum line	
1	264,16 ± 1,27
2 Frame datum to underside of crossmember	150,80
3	266,70 ± 2,54
4	237,74 ± 1,00
5	337,34 ± 1,00
6	974,57 ± 1,00
7	2382,93 ± 2,54
8	1155,75 ± 1,00
9	707,96 ± 2,54
10	1468,49 ± 2,54
11	1025,27 ± 2,54
12	338,84 ± 2,54
13A	222,25 ± 2,54
13B	240,03 ± 2,54
14 Reference dimension	824,92
15 To face of boss (both sides)	935,43 ± 1,00
16	838,20 ± 0,50
17	630,94 ± 1,27
18	344,17 ± 1,27
19	485,77 ± 2,54
20	485,77 ± 2,54
21	828,65 ± 0,50
22	129,03 ± 2,54
23	2682,65 ± 0,25
24	1493,54 ± 0,75
25	1860,24 ± 0,75
26	2801,64 ± 0,75
27	79,09 ± 0,75
28	390,88 ± 2,54
29	1398,88 ± 0,75
30 Reference dimension	635,00

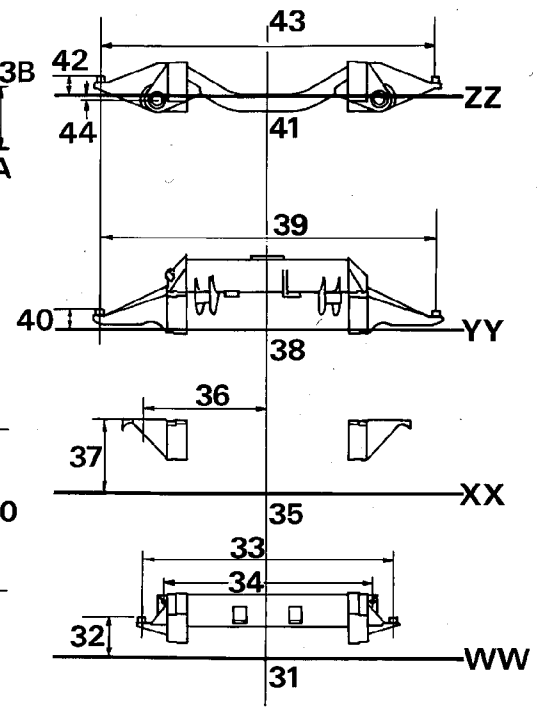
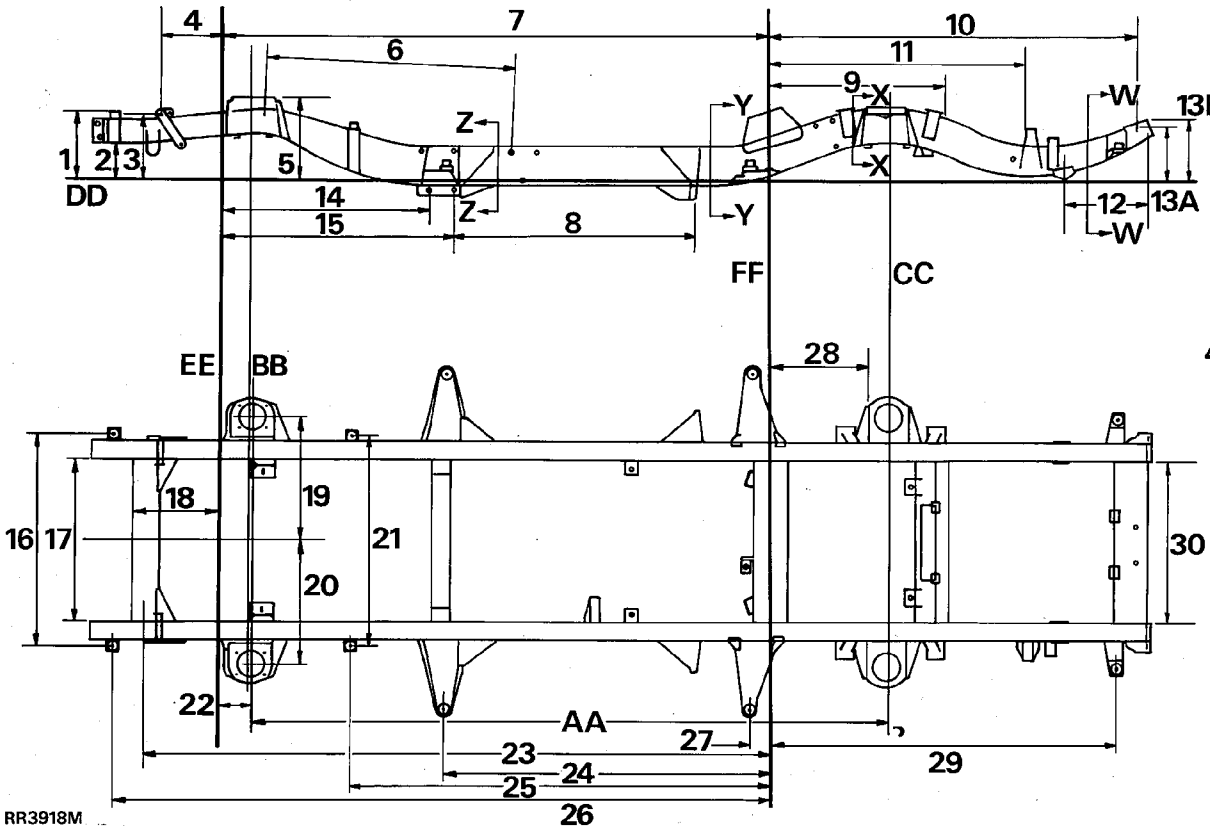



CHASSIS

	Diagram reference	millimetres
SECTION W - W		
31	Frame datum line DD	
32	155,91 ± 1,27
33	990,6 ± 0,50
34	825,5 ± 2,54
SECTION X - X		
35	Frame datum line DD	
36	488,95 ± 2,54
37	309,83 ± 1,00
SECTION Y - Y		
38	Frame datum line DD	
39	1320,8 ± 0,50
40	80,39 ± 1,27
SECTION Z - Z		
41	Frame datum line DD	
42	80,39 ± 1,27
43	660,4 ± 0,25
44	9,53 ± 2,54

WINDSCREEN GLASS

Service repair no - 76.81.01

Information

The following equipment is required:

Cutting wire and handles
 Windscreen repair kit **See WIPERS AND WASHERS, Repair, Wiper arms - windscreen**
 Sealant applicator gun
 Suction cup lifters

The following materials are included in the windscreen repair kit:

Glass cleaning solvent - 'Betawipe' Glass activator (yellow cap)
 Cotton buds.
 Glass primer - 'Betaprime'(green cap)
 Body primer - 'Betaprime' paint/plastic primer (red cap)
 Betaseal Adhesive sealant

**NOTE: The adhesive sealant cures in 6 to 8 hours****CAUTION: Once existing sealant is cut, the exposed surfaces oxidises in approximately 90 minutes. The refit procedure must be completed within this time span to prevent the sealant oxidising, to effect a satisfactory joint.****CAUTION: If the windscreen aperture body flange shows signs of corrosion it must be treated with anti corrosion primer and repainted. Newly painted areas must then be left for 8 hours or more before applying adhesive sealant.****NOTE: The multiplugs for heated windscreen are located under the decker[cowl] panel, release decker[cowl] panel to gain access.****Remove**

1. Remove windscreen wiper arms. **See WIPERS AND WASHERS, Repair, Wiper Arms - Windscreen.**
2. Remove rear view mirror and stickers from glass.
3. Remove 'A' post finishers.
4. Fit protective cover over dash panel and apply masking tape to protect 'A' posts.

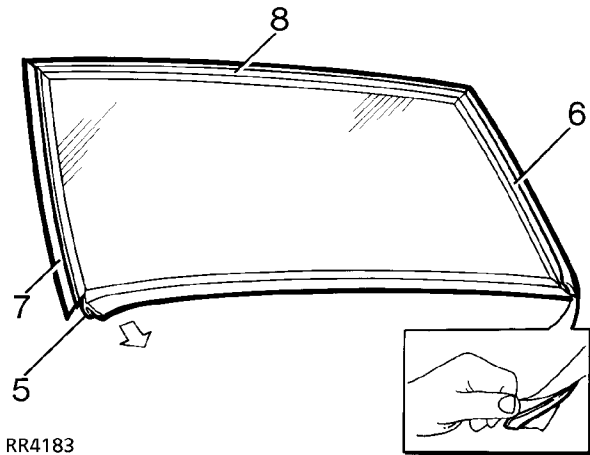

RR4183

5. Ease one end of bottom finisher away from glass, pull to disengage finisher flange and remove.
6. Lift lip of LH 'A' post finisher and release sealing strip along its length, pull to disengage finisher flange from glass and remove.



7. Remove RH 'A' post finisher.
8. Remove header finisher.
9. Apply masking tape to protect paint finish around glass.

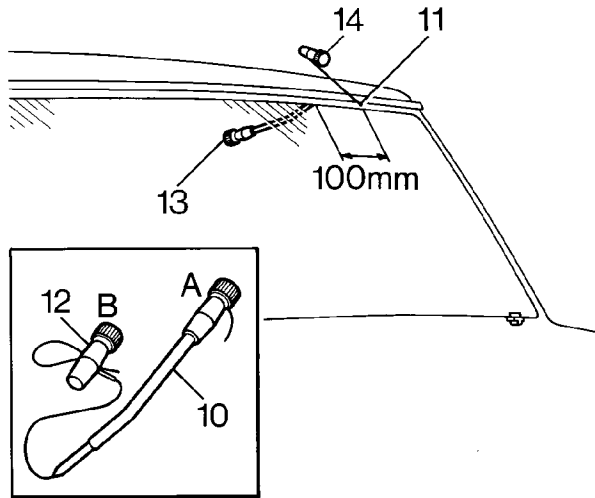

RR4184

10. Prepare cutting wire in handle 'A'. Bend end of wire to handle and tape over end.
11. Force cutting wire through sealer from inside and 100mm from a top corner. Use a needle if necessary to make a pilot hole.
12. Attach handle 'B'. Allow 200mm of wire between handles, tape over end of wire.
13. **With an assistant on the inside:** Wedge the tube of the handle 'A' between glass and body flange 100mm ahead of hole in sealer.
14. **From the outside:** Carefully cut sealer from flange using a straight pull away from the glass. Continue in 100mm steps around the glass, use a sawing action at the corners.



CAUTION: Along the bottom edge, great care must be taken to cut up to the 2 supports, positions indicated on the obscuration band (See item 18).

15. Remove handle 'B', withdraw the cutting wire and insert it through the sealer between the supports. Refit handle 'B'.

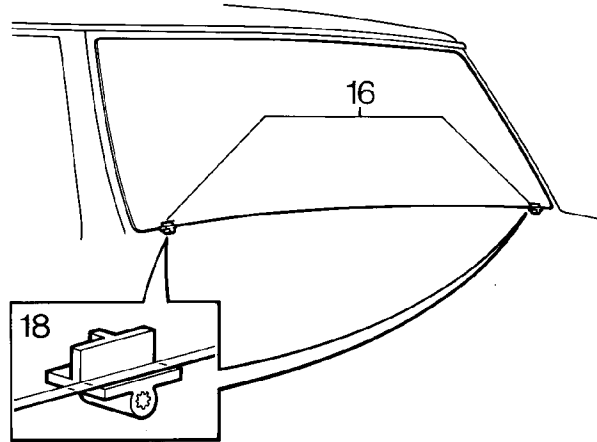

RR4185

16. Cut through sealer between the supports. If heated front screen: Cut through the 2 wires each side of the supports. Tape cut wires and panels to prevent damage to bodywork when screen is removed.
17. Attach suction cups to glass and lift glass from body flange, cut sealer free around supports as necessary.



WARNING: If glass has splintered: Protect eyes and operate demister blower at maximum speed to remove any glass from ducts. Use a vacuum cleaner to remove glass particles from inside the vehicle.

Refit

18. Check condition of supports, renew if necessary. Locating studs must be at right angle to flange.



NOTE: The supports were fitted to early vehicles and now replaced with nylon sheaths.

19. Carefully cut back old sealant around body flange to obtain a smooth surface 2mm thick. **DO NOT cut down to flange.**
20. **If refitting original glass:** It must be free from chips or cracks. Cut back old sealant around glass to obtain a smooth surface 2mm thick. **DO NOT cut down to glass surface.**



CAUTION: Lay glass on felt covered supports, do not stand on edge. Any chipping of glass edge may develop into cracks.

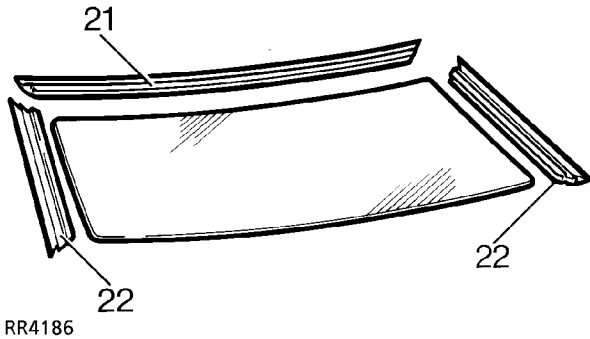

21. Align header finisher on top edge of glass, push flange fully onto glass and use a wooden block and mallet to ensure fit.
22. Carefully align each side finisher on edge of glass, push flange fully onto glass and use a wooden block and mallet to ensure fit.

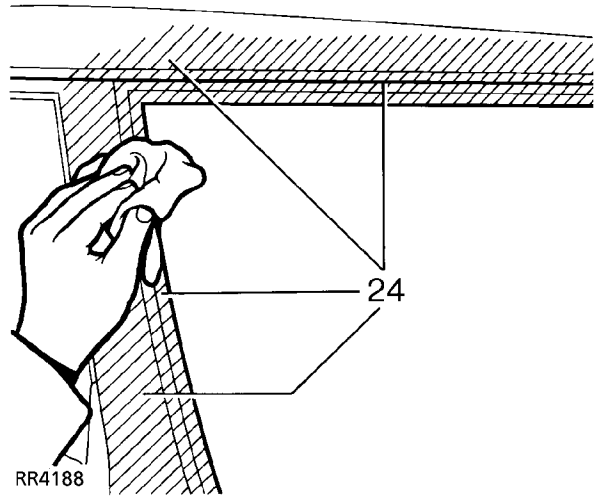

24. Ensure body flanges and surfaces covered by the finishers are clean

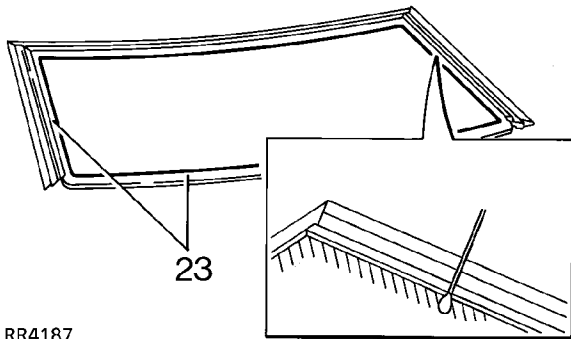

23. Using a cotton bud, apply glass cleaning solvent (yellow cap) to inside face of glass, 20mm strip around inside of finishers and 30mm wide along bottom edge. Immediately wipe off solvent with a clean cloth.



CAUTION: Do not touch cleaned or primed surfaces with fingers.

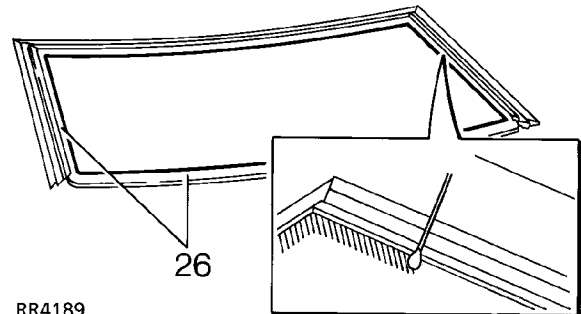

25. Shake the primer container for at least 30 seconds.
26. Using a cotton bud, apply Glass Primer (green cap) to inside face of glass, 20mm strip around inside of finishers and 30mm wide along bottom edge. This must be touch dry before applying adhesive.



27. Remove protective coverings and tape.

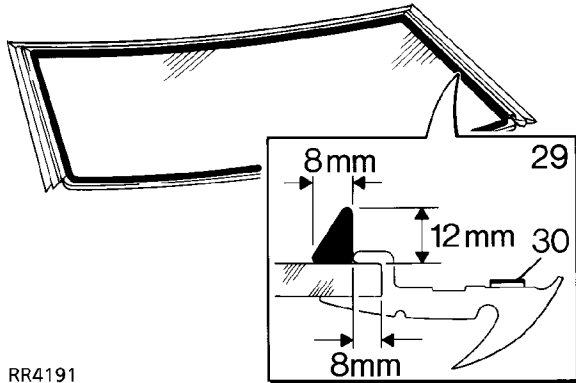

RR4191

28. Pierce top and pre-cut nozzle to sealer cartridge, remove lid and shake out crystals and install cartridge in applicator gun.
29. Apply a continuous bead of adhesive sealant around the glass as shown. Vertical edge of sealer to abutt finishers and to be 8mm from bottom edge of glass.
30. Remove protective covering (RED) from side finisher sealing strip.

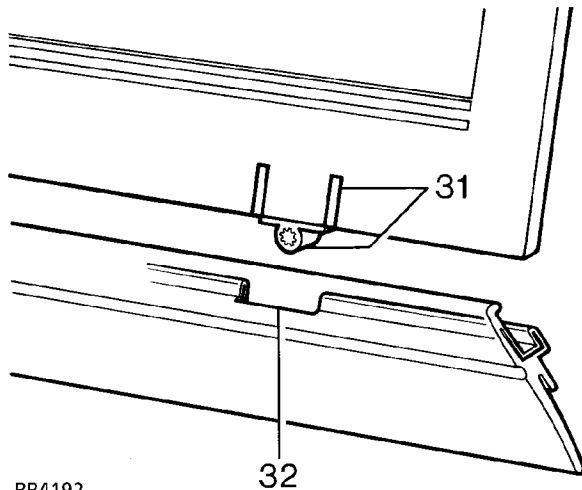

RR4192

31. **With assistance:** Attach suction cups to glass and lift into position, carefully align the indicators on the obscuration band with the supports. Lower screen onto body flange, check alignment and firmly press to seat glass in the aperture.



NOTE: The finisher on later vehicles will not have cutouts, or supports fitted, as shown.

32. Align cut outs with the supports and push finisher fully onto the glass. Use a wooden block to ensure fit.
33. Refit 'A' post finishers and interior mirror.
34. Refit wiper arms.



HEATING AND VENTILATION UNIT

The heating and ventilation and blower units are standard on all models. Air conditioning system is an optional module, which when fitted provides fully integrated climate control for the vehicle interior.

The heating and ventilation unit controls the air distribution and heating to the vehicle interior. The blower unit controls the volume of air supplied, while the air conditioning module (when fitted) provides refrigerated and dehumidified air.

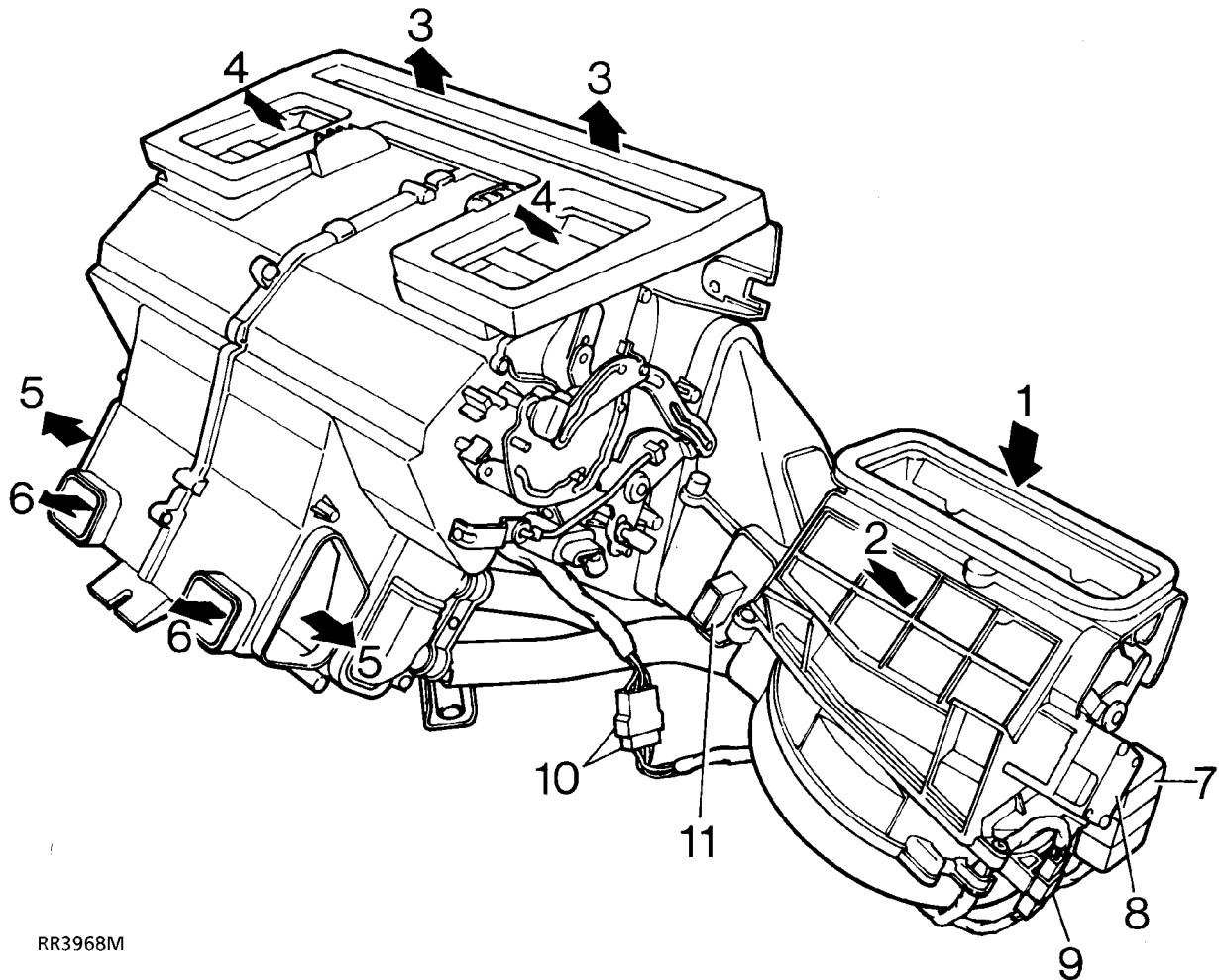

RR3968M

- | | |
|----------------------------------|--|
| 1. Fresh air inlet | 7. Fresh/recirculation air flap servo |
| 2. Recirculation air inlet | 8. Blower motor relay |
| 3. Air outlets screen de-mist | 9. Multiplug connector to main harness |
| 4. Air outlet face level vents | 10. Multiplug connector, blower to heater unit |
| 5. Air outlets front footwells | 11. Resistor unit - blower speed. |
| 6. Air outlets to rear footwells | |

Through-flow ventilation

Through-flow ventilation is achieved by means of one-way air extraction vents incorporated in both rear quarter body panels. The vents open and close automatically dependent upon the heating and ventilation unit control settings and the volume of air entering the vehicle.

Heating and ventilation unit, controls

The Heating and Ventilation Unit is centrally located and concealed by the dash assembly. When air conditioning is fitted, an evaporator is mounted in the heater unit forward of the heater matrix.

The dash mounted central controls are used to operate both systems. A single switch controls the air conditioning unit when fitted.

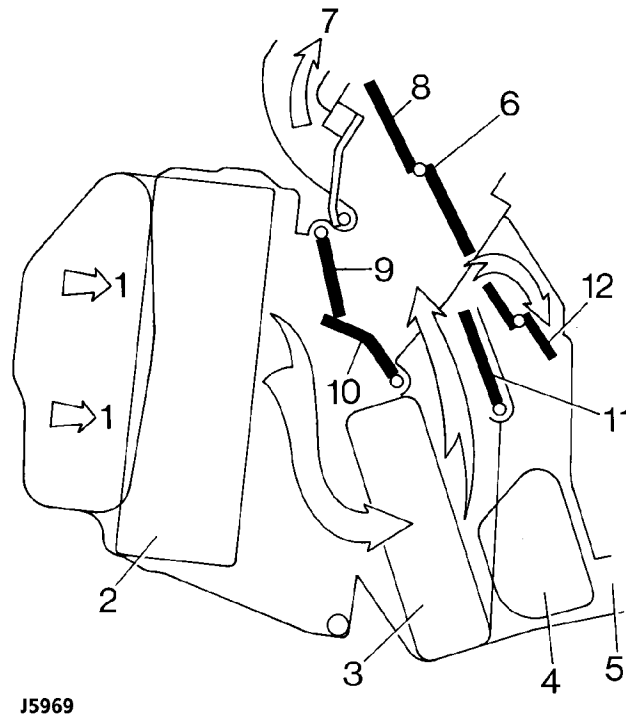

Controls set for maximum heat to footwells and face level vents

Heating and ventilation flaps and air flow key

- | | |
|---|------------------------------------|
| 1. Fresh or recirculated air from blower unit | 7. Air outlets screen de-mist |
| 2. Evaporator matrix - air conditioning (when fitted) | 8. Control flap - face level vents |
| 3. Heater matrix | 9. Control flap - demist vents |
| 4. Air outlet front footwells | 10. Control flap - air direction |
| 5. Air outlet to rear footwells | 11. Control flap - air temperature |
| 6. Air outlet face level vents | 12. Control flap - air direction |

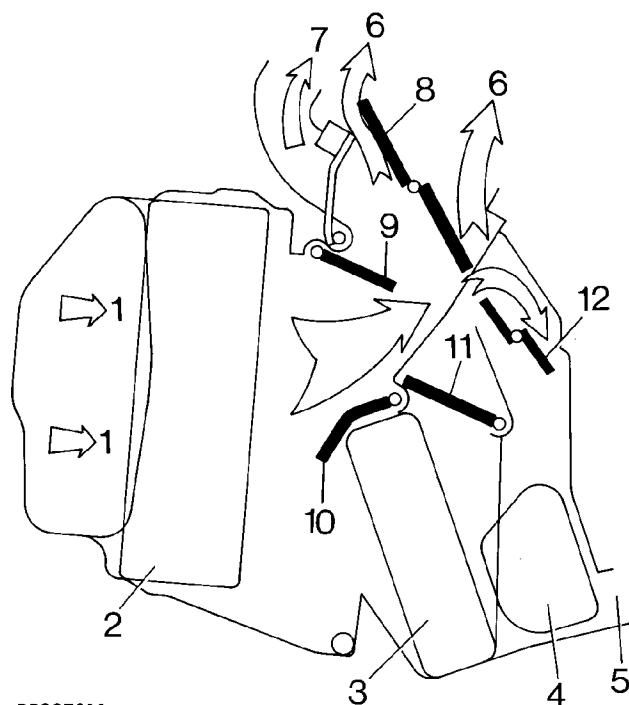

RR3970M

Controls set for unheated air to footwells and face level vents

Heater and ventilation operation

The heating and ventilation system contains a heater matrix, which is connected to the engine cooling system, and a 4 speed fan for air distribution. Engine coolant is circulated through the heater matrix continuously, except when the temperature controls are set to COLD.

Recirculated air

When the recirculation switch is pressed, an electrical servo operates and fully closes the fresh air intake flap.

Fresh air

When the recirculation switch is returned to the OFF position, the electrical servo returns and fully opens the fresh air intake flap.

Heated air

Temperature output is controlled by the temperature controls which move the air direction and temperature flaps independently to increase or decrease the volume of air flow through the heater matrix.

V8 Engine: When both controls are in the cold position, the coolant valve is turned off.

Face level vent flap

Control at face level, flap fully open. All other vents closed.

Control at face and foot level, flaps half open.

Unless an air conditioning unit is fitted, only fresh or re-circulated air is available from the face level vents.

Demist vent flap

Control at demist, flap fully open. All other vents closed.

Control at demist and foot level, flaps half open.

Air direction flap

Flap moves across mixing chamber to direct the air flow away from the heater matrix.

Air temperature flap

Control at HOT, flaps fully closed. All air flow passes through heater matrix. As control is moved towards COLD the flaps progressively open directing air flow away from the heater matrix.

Control at COLD, flaps fully open.

V8 Engine: When both controls are at COLD, 2 micro-switches are closed and operate a vacuum valve which closes the coolant valve.

Air conditioning

When an air conditioning unit is fitted, the mechanical operation of the heater controls remains unaltered. However the air conditioning evaporator is positioned in front of the mixing chamber through which all air flow passes.



HEATER OUTPUT

Symptom:-**Heater emits cold air.**

1. Engine running: Check coolant valve opens as a temperature control is moved from COLD.
2. Check for engine running cold. **See COOLING SYSTEM, Fault diagnosis, Engine Runs Cold**
3. Check heater pipes and hoses for blockage or restriction.
4. Check heater matrix for blockage or restriction, flush system.

Heater emits warm air.

5. **Engine running:** Check coolant valve closes when both temperature controls are moved to COLD.



HEATER BLOWER SWITCH AND ILLUMINATION BULB

Service repair no - 80.10.22 - Switch

Service repair no - 86.48.73 - Bulb

Remove

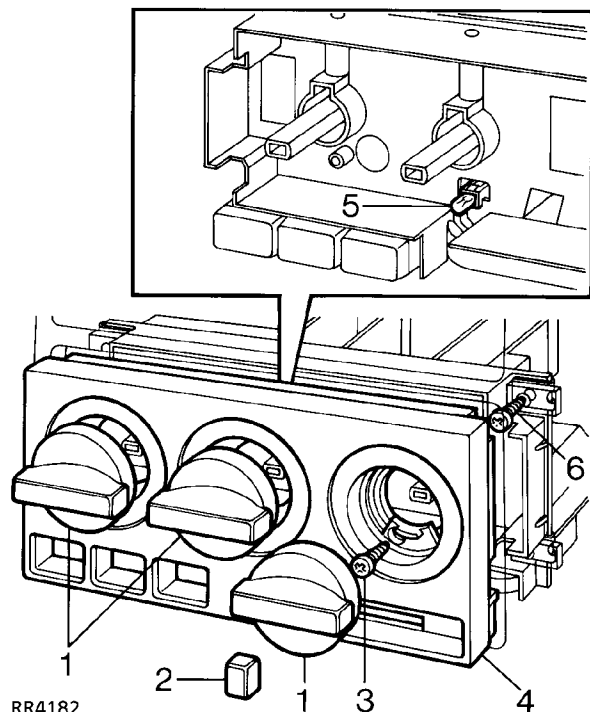

RR4182

1. Pull 3 knobs from rotary controls.
2. Pull knob from blower switch.
3. Remove 2 screws retaining graphics panel.
4. Remove graphics plate.
5. Remove capless bulb.
6. Remove 4 screws retaining switch.
7. Remove switch panel. Use plastic tube to assist removal.

Blower switch

8. Pull blower switch from rear of panel.
9. Disconnect multiplug and remove blower switch.

Refit

10. Reverse removal procedure.

HEATER CONTROL UNIT

Service repair no - 80.10.42.

Remove

1. Disconnect battery negative lead.

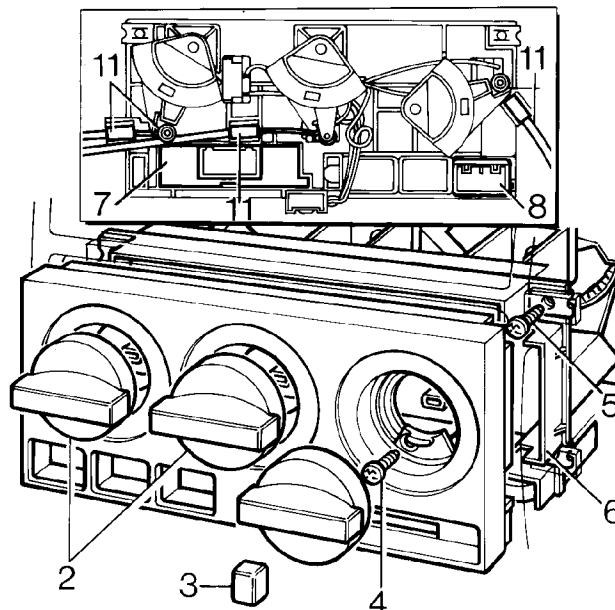

RR3971M

2. Pull 3 knobs from rotary controls.
3. Pull knob from blower switch.
4. Remove 2 retaining screws and remove graphics panel.
5. Remove 4 screws retaining switch.
6. Remove switch panel.
7. Release fascia centre louvre vent panel from its fitted position to gain access to rear of panel.
See CHASSIS AND BODY, Repair, Dash Panel Central Louvre Panel

8. Disconnect 4 multiplugs and position harness aside.



NOTE: *Do not carry out further dismantling if component is removed for access only.*

9. **Fan speed switch:** remove fan speed switch slide and push out fan speed switch.
 10. Pull out light bulb disconnect terminals and remove fan speed light strip.
 11. Unclip 3 heater control cables from control unit.
 12. **Microswitch:** Unclip 3 micro switches.
 13. Cut cable tie and release wiring harness from control unit.
 14. Remove heater control unit.

Refit

15. Reverse removal procedure. Check the satisfactory function of the controls before fitting louvre vent panel.

CONTROL CABLES

Service repair no - 80.10.06 - Air flow

Service repair no - 80.10.25 - Temperature control RH

Service repair no - 80.10.26 - Temperature control LH

Remove

1. Release fascia centre louvre vent panel from its fitted position to gain access to rear of panel.
See CHASSIS AND BODY, Repair, Dash Panel Central Louvre Panel
2. Open glove box, manoeuvre side springs through cut-outs and lower lid.

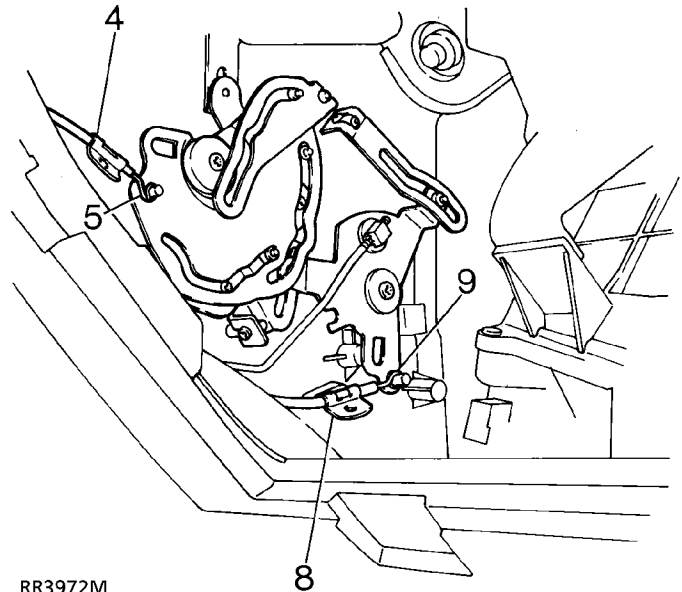

RR3972M



Air direction

3. Set control fully clockwise
4. Release outer cable from 2 clips on unit.
5. Release cable from stud on flap lever.
6. Remove control cable from control lever.

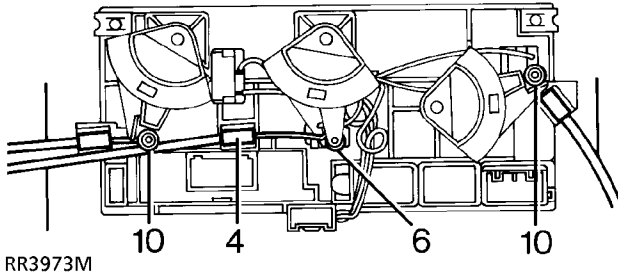

RR3973M

Temperature

7. Set RH control fully clockwise, LH control fully anti-clockwise
8. Release outer cable from 2 clips on unit.
9. Release cable from stud on flap lever.
10. Remove control cable from control lever.

Refit

11. Reverse removal procedure. Check the satisfactory function of the controls before fitting louvre vent panel.

RESISTOR UNIT

Service repair no - 80.20.17

Remove

1. Open glove box, manoeuvre side springs through cut-outs and lower lid.

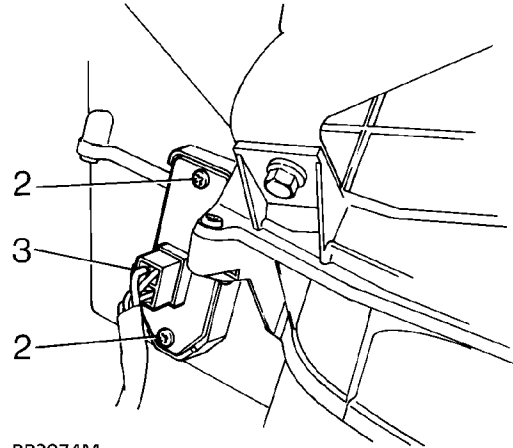

RR3974M

2. Remove 2 screws securing resistor unit to trunking.
3. Disconnect multiplug and remove resistor unit.

Refit

4. Reverse removal procedure.

WATER VALVE

Service repair no - 80.10.16

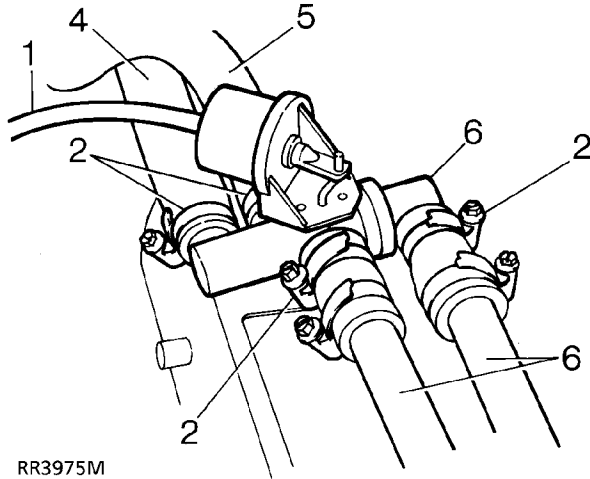
Remove

RR3975M

1. Disconnect vacuum pipe from water valve.
2. Slacken 4 clips securing hoses to water valve.
3. Use a thin blade to break seal between hoses and nozzles
4. Disconnect heater inlet hose from valve.



NOTE: A quantity of coolant will be released.

5. Disconnect heater outlet hose from valve.
6. Lever valve from coolant pipe hoses.

Refit

7. Reverse removal procedure. Lightly lubricate water valve nozzles with petroleum jelly.
8. Reverse removal procedure. Top-up engine coolant

VACUUM SWITCH - WATER VALVE

Service repair no - 80.10.36

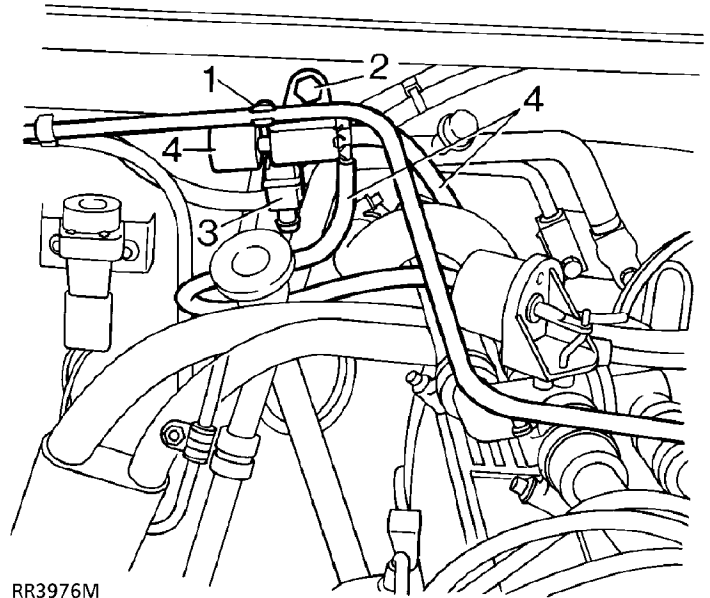
Remove

RR3976M

1. Release emission pipe from retaining clip.
2. Remove bolt securing switch to bulkhead.
3. Disconnect multiplug from switch.
4. Disconnect 2 vacuum pipes and remove vacuum switch.

Refit

5. Reverse removal procedure.



RECIRCULATION SWITCH

Service repair no - 80.10.27

Remove

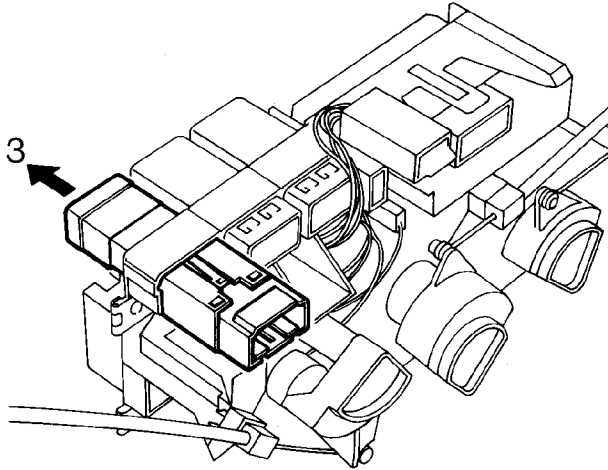

RR3977M

1. Release fascia centre louvre vent panel from its fitted position to gain access to rear of panel.
See CHASSIS AND BODY, Repair, Dash Panel Central Louvre Panel
2. Disconnect multiplug from switch
3. From the rear, push switch out of panel.

Refit

4. Reverse removal procedure.

RECIRCULATION FLAP SOLENOID

Service repair no - 80.10.43

Remove

1. Open glove box, manoeuvre side springs through cut-outs and lower lid.

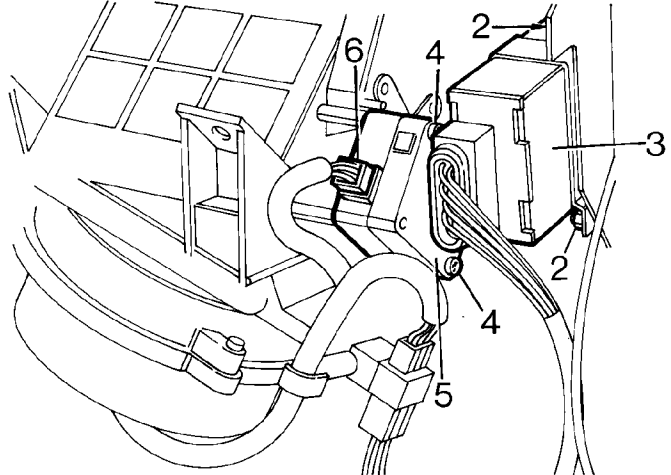

RR3978M

2. Remove 2 locknuts securing cruise control ECU to bracket.
3. Position cruise control ECU aside.
4. Remove 2 screws securing recirculation solenoid to casing.
5. Release solenoid from lever.
6. Disconnect multiplug and remove solenoid.

Refit

7. Reverse removal procedure.

BLOWER MOTOR UNIT - HEATER AND AIR CONDITIONING

Service repair no - 80.20.17
 Service repair no - 82.25.54.

Remove

1. Move seats to rear most position.
2. Disconnect battery negative lead.
3. Remove fascia panel assembly. **See CHASSIS AND BODY, Repair, Dash Panel Assembly**

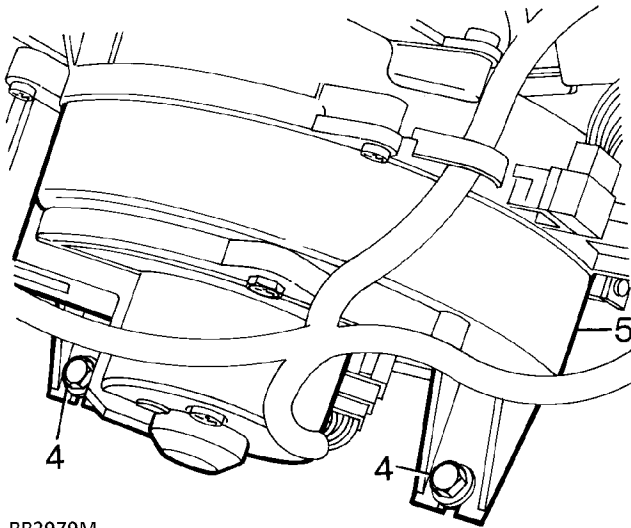

RR3979M

4. Remove 2 nuts securing lower brackets to toeboard.
5. Manoeuvre blower unit from heater unit and remove.

Refit

6. Reverse removal procedure. Ensure seal between blower and heater unit is tight.

BLOWER MOTOR

Service repair no - 80.20.17
 Service repair no - 82.25.33.

Remove

1. Remove blower motor unit. **See Blower Motor Unit - Heater and Air Conditioning**

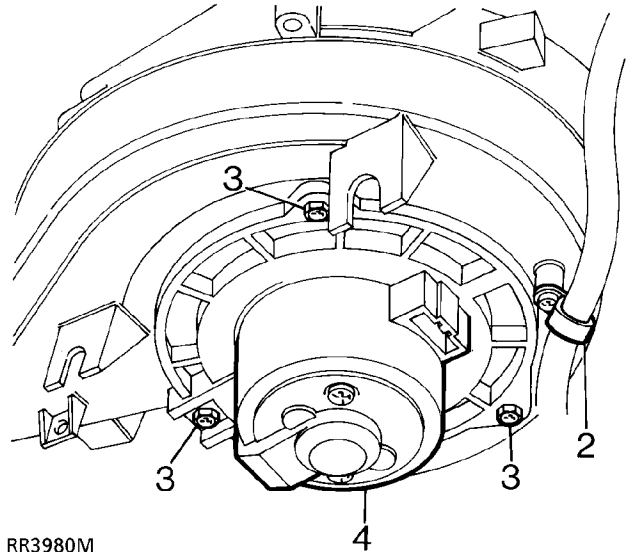

RR3980M

2. Release wiring harness retaining clip.
3. Remove 3 screws securing casing.
4. Remove blower motor assembly.

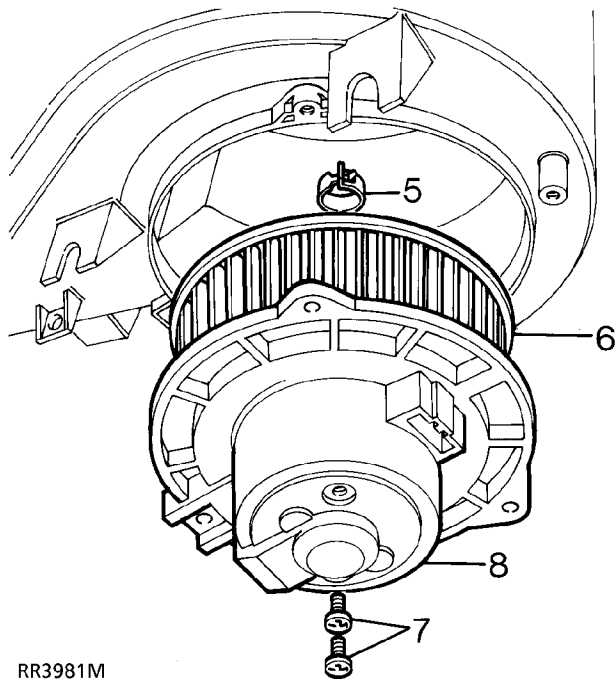

RR3981M

5. Remove fan retaining clip.
6. Remove fan.
7. Remove 2 screws securing motor to casing.
8. Remove blower motor.

Refit

9. Reverse removal procedure.

HEATER MATRIX

Service repair no - 80.20.29

Remove

1. Remove heater unit. *See AIR CONDITIONING, Repair, Heater and Cooler Unit*
2. Remove evaporator. *See AIR CONDITIONING, Repair, Evaporator and Expansion Valve*

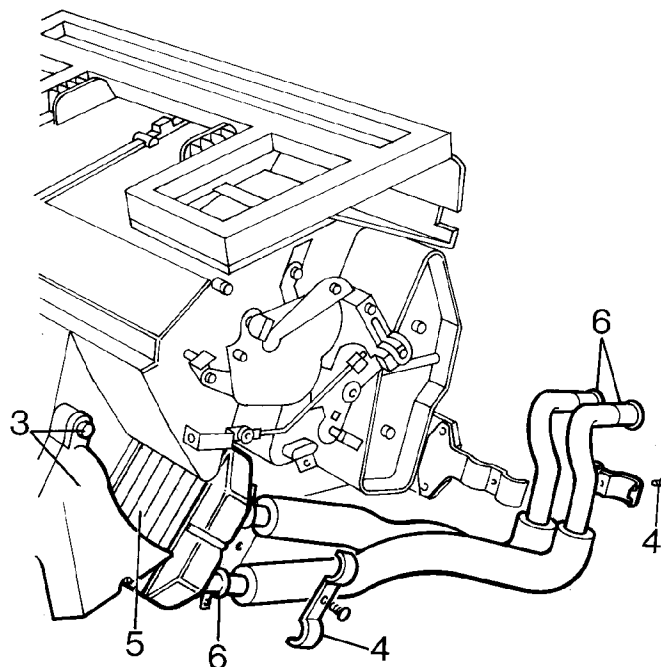

RR3982M

3. Remove 2 screws and remove RH side footwell outlet.
4. Remove heater pipe clips.
5. Slide heater matrix from casing.
6. Release 2 clips and remove 2 heater pipes from matrix.

Refit

7. Reverse removal procedure.



TORQUE VALUES



NOTE: Torque wrenches should be regularly checked for accuracy to ensure that all fixings are tightened to the correct torque.

	Nm
METRIC	
M5	6
M6	9
M8	25
M10	45
M12	90
M14	105
M16	180
 UNC / UNF	
1/4	9
5/16	24
3/8	39
7/16	78
1/2	90
5/8	136

Torque values above apply to all screws and bolts used unless otherwise specified.



AIR CONDITIONING SYSTEM COMPONENTS

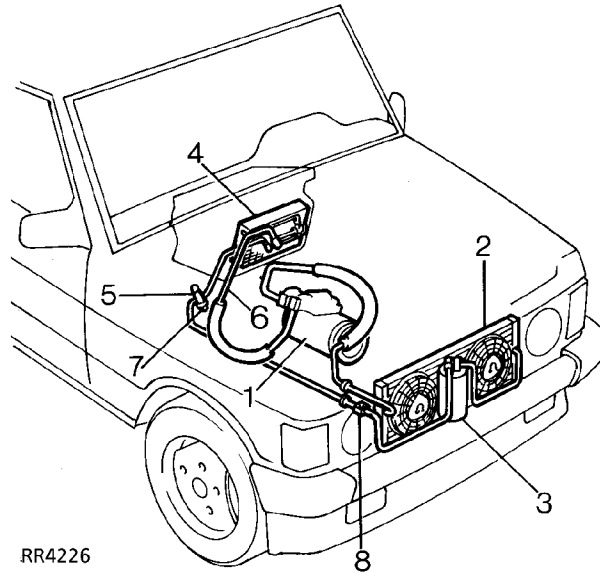

RR4226

- 1. Compressor
- 2. Condenser
- 3. Receiver/drier
- 4. Evaporator

- 5. High pressure servicing connection
- 6. Low pressure servicing connection
- 7. Dual pressure switch
- 8. Sight glass

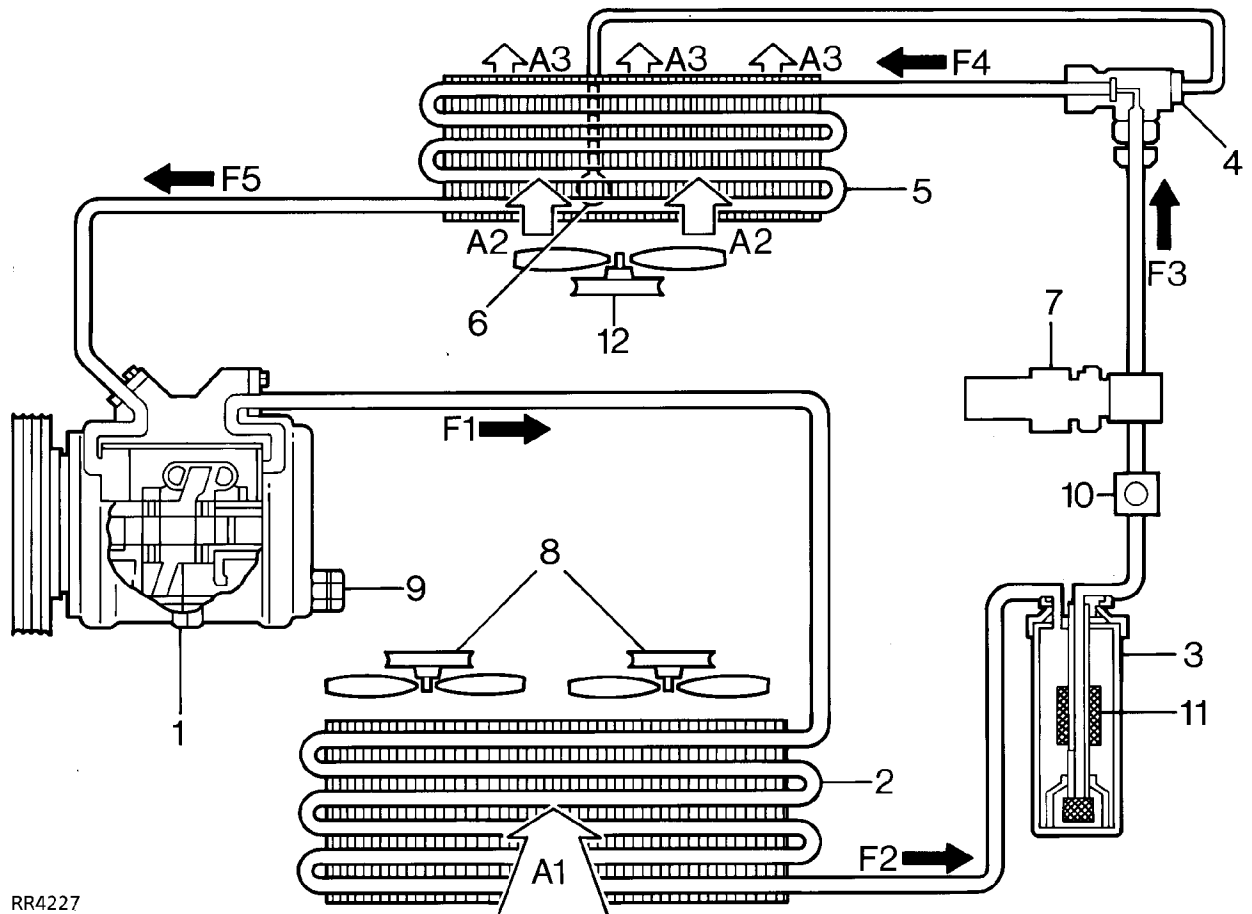
SCHEMATIC LAYOUT OF THE AIR CONDITIONING SYSTEM

RR4227

- | | |
|--|---|
| 1. Compressor | A1 Ambient air flow through condenser |
| 2. Condenser | A2 Ambient air flow through fan and evaporator |
| 3. Receiver/drier | A3 Cooled air flow to vehicle interior |
| 4. Thermostatic expansion valve | F1 High pressure high temperature refrigerant vapour |
| 5. Evaporator | F2 High pressure slightly subcooled refrigerant liquid |
| 6. Capillary tube | F3 High pressure slightly subcooled refrigerant liquid with moisture, vapour bubbles and foreign matter removed |
| 7. Dual pressure switch | F4 Low pressure low temperature mixed liquid and vapour |
| 8. Cooling fans to maintain air flow | F5 Low pressure slightly superheated refrigerant vapour |
| 9. Compressor high pressure relief valve | |
| 10. Sight glass - refrigerant | |
| 11. Drying agent - receiver/drier | |
| 12. Blower motor | |



AIR CONDITIONING SYSTEM OPERATION

The air conditioning system provides the means of supplying cooled and dehumidified, fresh or recirculated air to the interior of the vehicle. The cooling effect is obtained by blowing air through the matrix of an evaporator unit and when required, mixing that air with heated air by means of the heater distribution and blend unit, to provide the conditions required inside the vehicle. The volume of conditioned air being supplied is controlled by a variable speed blower.

A sealed system, charged with Refrigerant R134a, together with a blower unit, blend unit and control system combine to achieve the cooled air condition.

For air conditioning air distribution system. **See HEATING AND VENTILATION, Description and operation, Heating and Ventilation Unit**

The air conditioning system comprises five major units:

1. An engine-mounted compressor.
2. A condenser mounted in front of the radiator.
3. A receiver/drier unit located in front of the condenser.
4. Thermostatic expansion valve mounted above the evaporator.
5. An evaporator unit mounted in front of the heater matrix.

These units are interconnected by hoses and pipes carrying Refrigerant R134a, the evaporator is linked into the vehicle ventilation system.

Refrigeration cycle

1. Compressor

The compressor (1), belt driven from the crankshaft pulley, pressurises and circulates the refrigerant through the system. Mounted on the compressor, an electro-mechanical clutch maintains the correct temperature and pressure by engaging or disengaging to support the system's requirements. The clutch action is normally controlled by a thermostat located at the evaporator (5). The compressor is of the swashplate type having fixed displacement.

Should the temperature at the evaporator (5) fall low enough for ice to begin to form on the fins, the thermostat disengages the clutch and also isolates the cooling fans relays. When the temperature at the evaporator (5) rises to the control temperature, the clutch is re-engaged.

Should the system pressure become excessive or drop sufficiently to cause damage to the compressor (1) a dual pressure switch (7), located in the high pressure line, signals the relay unit to disengage the clutch. The compressor also has an emergency high pressure relief valve (9) fitted.

The cooling fans are controlled by engine temperature when the air conditioning is not switched on.

2. Condenser

From the compressor, hot high pressure vaporised refrigerant (F1) passes to the condenser (2), which is mounted in front of the engine coolant radiator. Ram air(A1) passing through the condenser (2), supplemented by 2 cooling fans (8) mounted in front of the condenser, cools the refrigerant vapour sufficiently to form a high pressure slightly subcooled liquid (F2).

3. Receiver/drier

This liquid then passes to a receiver/drier (3) which fulfils two functions. It acts as a reservoir and moisture extractor (11).

A sight glass (10), in the high pressure line, provides a method of determining the state of the refrigerant without breaking into the system.

4. Expansion valve

From the receiver/drier (3) the moisture free high pressure liquid refrigerant (F3) passes through a thermostatic expansion valve (4). A severe pressure drop occurs across the valve and as the refrigerant enters the evaporator space at a temperature of approximately -5°C it boils and vaporises.

5. Evaporator

As this change of state occurs, a large amount of latent heat is absorbed. The evaporator is therefore cooled and as a result heat is extracted from the air flowing across the evaporator. The air flow is controlled by the ventilation fan which can be operated at anyone of four speeds.

To prevent liquid passing through to the compressor, a capillary tube (6), attached to the outlet pipe of the evaporator (5) and connected to the thermostatic expansion valve (4), controls the amount that the valve opens and closes in relation to the temperature of the low pressure high temperature refrigerant vapour (F4) at the outlet. The atomised refrigerant then passes through the evaporator (5). Fan blown air (A2) passes through the matrix (A3) of the evaporator and is cooled by absorption due to the low temperature refrigerant passing through the evaporator.

A thermostat is fitted in the airflow out of the evaporator to sense the temperature of the exterior fins. Should ice begin to form, due to a too cold condition, it will signal to disengage the electro-mechanical clutch on the compressor (1).

From the evaporator, low pressure slightly superheated refrigerant (F5) passes to the compressor to complete the cycle.

AIR CONDITIONING CONTROL SYSTEM

The air conditioning control system comprises relays, thermostat, pressure switches, and a control panel. Inputs from outside the air conditioning system comprise temperature information from the engine cooling system. Together these controls, in conjunction with the cooling fans, compressor clutch, blower and heater distribution and blend unit enable minimal input to maintain the required environment inside the vehicle.

When air conditioning is not selected, air is supplied by ram effect or blower to the areas selected by the controls. The air mix flap on the blend unit controls the temperature of the air being supplied. No cooled air is available.

Selecting air conditioning provides the added facility of cooled air available to be mixed as before. When required a fully cold condition can be selected by turning the temperature controls to cold, which automatically closes the heated coolant access to the heater matrix. Mixtures of cooled, fresh, and hot air can be selected to give required interior environmental conditions by selection at the control panel.

Dual pressure switch

This switch, located in the high pressure line between the receiver drier and the expansion valve, monitors refrigerant pressure and by means of the relay module controls the following system functions:

1. Refrigerant pressure drops below 2.0 bar, 29 lbf/in² (due to possible leakage), the compressor's electro-mechanical clutch is dis-engaged.
When pressure rises above 2.0 bar, 29 lbf/in² the compressor's clutch is re-engaged.
2. Refrigerant pressure rises above 32 bar, 455 lbf/in² (due to possible blockage), even with cooling fan operation, the compressor's electro-mechanical clutch is dis-engaged.
When the pressure drops below 26 bar, 375 lbf/in² the compressor clutch is re-engaged.

**Condenser cooling fans**

The condenser cooling fans operate automatically whenever the air conditioning system is switched on.

Fan timer unit

The thermostatically controlled timer will continue to operate the cooling fans after the air conditioning or ignition is switched off. When the system temperature is excessive, the fans will operate for 10 minutes to reduce condenser and underbonnet temperature.

Blower control

The blower can be operated at any one of four speeds by sliding the blower switch to the required position. When the blower is switched off the air conditioning system will not operate.

The fresh air/recirculation flaps can move between two positions. One position covers the outside air inlet, leaving open an inlet from the inside of the vehicle clear, when recirculated air is required. In the other position they will cover the inlet from the inside of the vehicle leaving open the outside air inlet, when fresh air is required.

Heater distribution and blend unit control

Blower unit air flow, having passed through the evaporator passes into the heater blend unit to be heated, if required. It is then directed into the vehicle interior in accordance with the flap positions designated by the air distribution control. Heater flaps control the amount of air flowing through the heater matrix. These flaps are controlled individually by the driver's and passenger's temperature controls.

When the temperature control is in the cold position, a micro switch actuates a vacuum control to close the coolant valve on the engine. As the temperature control is moved away from cold, the coolant valve is opened allowing heated engine coolant to flow through the heater matrix. The temperature of the heated air flow into the vehicle interior is controlled by the blend flaps.

The distribution control moves the flaps which control the direction of the air flow into the interior of the vehicle.



**AIR CONDITIONING - ELECTRICAL -
MECHANICAL FAULTS**

FAULT	CAUSE	REMEDY
<p>A. BLOWER MOTOR INOPERATIVE OR SLOW RUNNING</p>	<ol style="list-style-type: none"> 1. Incorrect voltage. 2. Open or defective fuse or relay. 3. Loose wire connection including ground. 4. Switch open or defective. 5. Tight, worn, or burnt motor bearings. 6. Open rotor windings. 7. Worn motor brushes. 8. Shaft binding-blade misaligned. 9. Defective resistors 	<ol style="list-style-type: none"> 1. Check voltage. 2. Check and replace as necessary. 3. Check system wires; tighten all connections. 4. Replace switch. 5. Replace motor. 6. Replace motor. 7. Replace motor. 8. Check alignment. Repair or replace as necessary. 9. Rectify or replace.
<p>B. COMPRESSOR CLUTCH INOPERATIVE</p>	<ol style="list-style-type: none"> 1. Incorrect voltage. 2. Open or defective fuse or relay. 3. Defective thermostat control or pressure switch. 4. Shorted or open field coil. 5. Bearing seized (clutch will not disengage). 6. Refrigeration circuit problem causing heavy load and excessive drive torque. 	<ol style="list-style-type: none"> 1. Check voltage. 2. Check and replace as necessary. 3. Replace thermostat or pressure switch. 4. Replace coil. 5. Replace clutch pulley assembly. 6. Check and rectify.
<p>C. COMPRESSOR CLUTCH NOISY</p>	<ol style="list-style-type: none"> 1. Incorrect alignment. 2. Loose belt. 3. Compressor not mounted securely. 4. Bearing in clutch-pulley assembly not pressed in. 5. Low voltage to clutch. 6. Clutch will not spin freely. 7. Oil on clutch face. 8. Slipping clutch. 9. Overloaded or locked compressor. 10. Icing. 	<ol style="list-style-type: none"> 1. Check alignment; repair as necessary. 2. Adjust to proper tension. 3. Repair as necessary. 4. Remove clutch and replace clutch pulley assembly. 5. Check connections and voltage. 6. Refer to B5 above. 7. Check compressor seals for leaks. 8. Refer to C5 above. Then check air gap. 9. Repair or replace compressor. 10. Check for suction line frosting. Replace expansion valve if necessary. Replace receiver/drier if necessary.
<p>D. CONDENSER VIBRATION</p>	<ol style="list-style-type: none"> 1. Motor and/or blades improperly mounted. 2. Foreign matter build-up on blades. 3. Excessive wear of motor bearings. 	<ol style="list-style-type: none"> 1. Check mountings, adjust as necessary. 2. Clean blades with a suitable non-inflammable cleaner. 3. Replace motor.

REFRIGERATION SYSTEM FAULTS

For any refrigeration system to function properly all components must be in good working order. The unit cooling cycle and the relationship between air discharge temperature and ambient temperature and the pressures at the compressor can help to determine proper operation of the system.

The length of any cooling cycle is determined by such factors as ambient temperature and humidity, thermostat setting, compressor speed and air leakage into the cooled area, etc. With these factors constant, any sudden increase in the length of the cooling cycle would be indicative of abnormal operation of the air conditioner.

The low and high side pressures at the compressor will vary with changing ambient temperature, humidity, in-car temperature and altitude.

The following items should be checked before operating the system:

1. Compressor drive belt tension.
2. Compressor magnetic clutch operation.
3. Condenser fan operation.
4. Condenser fins, dirt will cause poor cooling and higher operating temperatures.

The following conditions should be checked after operating the system for several minutes:

1. All high pressure lines and components should be hot to the touch.
2. All low pressure lines should be cool to the touch.
3. Inlet and outlet temperatures at the receiver/drier should be at the same temperature (warm). Any very noticeable temperature difference indicates a blocked receiver/drier.
4. Heavy frost on the inlet to the expansion valve may indicate a defective valve or moisture in the system.
5. Evaporation air temperature will vary with ambient temperature and humidity. As humidity increases the outlet temperature will be higher.



FAULT	CAUSE	REMEDY
<p>A. HIGH HEAD PRESSURE</p>	<ol style="list-style-type: none"> 1. Overcharge of refrigerant. 2. Air in system. 3. Condenser air passage clogged with dirt or other foreign matter. 4. Condenser fan motor defective. 5. Incorrect voltage to fan motor. 	<ol style="list-style-type: none"> 1. Discharge, evacuate and charge system. 2. Discharge system, fit new drier, evacuate and charge system. 3. Clean condenser of debris. 4. Replace motor. 5. Check voltage.
<p>B. LOW HEAD PRESSURE</p>	<ol style="list-style-type: none"> 1. Undercharge of refrigerant; evident by bubbles in sight glass while system is operating 2. Split compressor gasket or leaking valves. 3. Defective compressor. 	<ol style="list-style-type: none"> 1. Evacuate and charge system. Check for leakage. 2. Replace gasket and/or reed valve. Fit new drier, evacuate and charge system. 3. Repair or replace compressor.
<p>C. HIGH SUCTION PRESSURE</p>	<ol style="list-style-type: none"> 1. Loose drive belt 2. Refrigerant flooding through evaporator into suction line; evident by ice on suction line and suction service valve. 3. Expansion valve stuck open. 4. Leaking compressor valves, valve gaskets and/or service valves. 5. Receiver/drier blocked; evident by temperature difference between input and output lines. 	<ol style="list-style-type: none"> 1. Check belt tension. 2. Check thermobulb. Bulb should be securely clamped to clean horizontal section of copper suction pipe. 3. Replace expansion valve. 4. Replace valves and/or gaskets. Fit new drier evacuate and charge system. 5. Fit new drier, evacuate and charge system.
<p>D. LOW SUCTION</p>	<ol style="list-style-type: none"> 1. Expansion valve thermobulb not operating. 2. Expansion valve sticking closed. 3. Moisture freezing in expansion valve orifice. Valve outlet tube will frost while inlet hose tube will have little or no frost. System operates periodically. 4. Dust, paper scraps, or other debris restricting evaporator blower grille 5. Defective evaporator blower motor, wiring, or blower switch. 	<ol style="list-style-type: none"> 1. Warm thermobulb with hand. Suction should rise rapidly to 1.4 bar 20 lb/in² or more. If not replace expansion valve. 2. Check inlet side screen. Clean if clogged. Refer to C-2 and C-3. 3. Fit new drier, evacuate and charge system. 4. Clean grilles as required. 5. Refer to Fault Diagnosis Chart for blower motor.

FAULT	CAUSE	REMEDY
E. NOISY EXPANSION VALVE (steady hissing)	1. Low refrigerant charge; evident by bubbles in sight glass.	1. Leak test. Repair or replace components as required.
F. INSUFFICIENT COOLING	1. Expansion valve not operating properly. 2. Low refrigerant charge-evident by bubbles in sight glass. 3. Compressor not pumping.	1. Refer to C-2, C-3, D-1 and E. 2. Refer to B-1 and E. 3. Refer to B-2 and B-3
G. COMPRESSOR BELT SLIPPING	1. Belt tension. 2. Excessive head pressure. 3. Incorrect alignment of pulleys or worn belt not riding properly. 4. Nicked or broken pulley. 5. Seized compressor.	1. Adjust belt tension. 2. Refer to A-1 through A-4 and C-6. 3. Repair as needed. 4. Replace as needed. 5. Replace compressor.
H. ENGINE NOISE AND/OR VIBRATION	1. Loose or missing mounting bolts. 2. Broken mounting bracket. 3. Loose flywheel or clutch retaining bolt. 4. Rough idler pulley bearing. 5. Bent, loose, or improperly mounted engine drive pulley. 6. Defective compressor bearing. 7. Insecure mountings of accessories; generator, power steering, air filter, etc. 8. Excessive head pressure. 9. Incorrect compressor oil level.	1. Repair as necessary. 2. Replace bracket. 3. Repair as necessary. 4. Replace bearing. 5. Repair as necessary. 6. Replace bearing. 7. Repair as necessary. 8. Refer to A-1, A-2, A-3 A-4 and C-6. 9. Refer to compressor Oil Level Check.

HEATER AND AIR CONDITIONING - CIRCUIT DIAGRAMS

1. For details of heating and air conditioning electrics. **See *Electrical Trouble Shooting Manual*.**



GENERAL PRECAUTIONS

The refrigerant used in the air conditioning system is HFC (Hydrofluorocarbon) R134a.



WARNING: R134a is a hazardous liquid and when handled incorrectly can cause serious injury. Suitable protective clothing must be worn when carrying out servicing operations on the air conditioning system.



WARNING: R134a is odourless and colourless. Do not handle or discharge in an enclosed area, or in any area where the vapour or liquid can come in contact with naked flame or hot metal. R134a is not flammable but can form a highly toxic gas.



WARNING: Do not smoke or weld in areas where R134a is in use. Inhalation of concentrations of the vapour can cause dizziness, disorientation, uncoordination, narcosis, nausea or vomiting.



WARNING: Do not allow fluids other than R134a or compressor lubricant to enter the air conditioning system. Spontaneous combustion may occur.



WARNING: R134a splashed on any part of the body will cause immediate freezing of that area. Also refrigerant cylinders and replenishment trolleys when discharging will freeze skin to them if contact is made.



WARNING: The refrigerant used in an air conditioning system must be reclaimed in accordance with the recommendations given with a Refrigerant Recovery Recycling Recharging Station.



NOTE: Suitable protective clothing comprises: Wrap around safety glasses or helmet, heatproof gloves, rubber apron or waterproof overalls and rubber boots.

REMEDIAL ACTIONS

1. If liquid R134a strikes the eye, do not rub it. Gently run large quantities of eyewash over the eye to raise the temperature. If eyewash is not available cool, clean water may be used. Cover eye with clean pad and seek immediate medical attention.
2. If liquid R134a is splashed on the skin run large quantities of water over the area as soon as possible to raise the temperature. Carry out the same actions if skin comes into contact with discharging cylinders. Wrap affected parts in blankets or similar material and seek immediate medical attention.
3. If suspected of being overcome by inhalation of R134a vapour seek fresh air. If unconscious remove to fresh air. Apply artificial respiration and/or oxygen and seek immediate medical attention.



NOTE: Due to its low evaporating temperature of -30°C, R134a should be handled with care.



WARNING: Do not allow a refrigerant container to be heated by a direct flame or to be placed near any heating appliance. A refrigerant container must not be heated above 50°C.



WARNING: Do not leave a container of refrigerant without its cap fitted. Do not transport a container of refrigerant that is unrestrained, especially in the boot of a car.

SERVICING PRECAUTIONS

Care must be taken when handling refrigeration system components. Units must not be lifted by their hoses, pipes or capillary lines. Hoses and lines must not be subjected to any twist or stress. Ensure that hoses are positioned in their correct run before fully tightening the couplings, and ensure that all clips and supports are used. Torque wrenches of the correct type must be used when tightening refrigerant connections to the stated value. An additional spanner must be used to hold the union to prevent twisting of the pipe.

Before connecting any hose or pipe ensure that refrigerant oil is applied to the seat of the new 'O' ring but not to the threads.

Check the oil trap for the amount of oil lost.

All protective plugs on components must be left in place until immediately prior to connection.

The receiver/drier contains desiccant which absorbs moisture. It must be positively sealed at all times.



CAUTION: Whenever the refrigerant system is opened, the receiver/drier must be renewed immediately before evacuating and recharging the system.

Use alcohol and a clean cloth to clean dirty connections.

Ensure that all new parts fitted are marked for use with **R134a**.

Refrigerant oil

Use the approved refrigerant lubricating oil:

Nippon Denso ND-OIL 8

Unipart R134a ND-OIL8



CAUTION: Do not use any other type of refrigerant oil.

Refrigerant oil easily absorbs water and must not be stored for long periods. Do not pour unused oil back into the container.

When renewing system components, add the following quantities of refrigerant oil:

Condenser	40 ml
Evaporator	80 ml
Pipe or hose	20 ml
Receiver/drier	20 ml

Total quantity of refrigerant oil in system = **180 ml = 6.3 Fl oz**

A new compressor is sealed and pressurised with Nitrogen gas, slowly release the sealing cap, gas pressure should be heard to release as the seal is broken.



NOTE: A new compressor should always have its sealing caps in place and must not be removed until immediately prior to fitting.

Fitting a new compressor

A new compressor is supplied with an oil fill (X) of: 180 ml

A calculated quantity of oil must be drained from a new compressor before fitting.

To calculate the quantity of oil to be drained:

1. Remove sealing plugs from the OLD compressor
2. Invert compressor and gravity drain oil into measuring cylinder. Rotating the compressor clutch plate will assist complete draining.
3. Note the quantity of oil drained (Y).
4. Calculate the quantity (Q) of oil to be drained from the NEW compressor using the following formula:

$$X - (Y + 20 \text{ ml}) = Q$$

Rapid refrigerant discharge

When the air conditioning system is involved in accident damage and the circuit is punctured, the refrigerant is discharged rapidly. The rapid discharge of refrigerant will also result in the loss of most of the oil from the system. The compressor must be removed and all the remaining oil in the compressor drained and refilled as follows:

1. Gravity drain all the oil, assist by rotating the clutch plate (not the pulley).
2. Refill the compressor with the following amount of new refrigerant oil:

130 ml

3. Plug the inlet and outlet ports.



SERVICING EQUIPMENT

The following equipment is required for full servicing of the air conditioning system.

- Recovery, recycling and charging station
- Leak detector
- Thermometer +20°C to -60°C
- Safety goggles and gloves

REFRIGERANT RECOVERY RECYCLING RECHARGING



WARNING: The air conditioning system is charged with a high pressure, potentially toxic refrigerant. Repairs or servicing must only be carried out by an operator familiar with both the vehicle system and the charging and testing equipment.

All operations must be carried out in a well-ventilated area away from open flame and heat sources.

Always wear safety goggles and gloves when opening refrigerant connections.



WARNING: Wear eye and hand safety protection. Open connections slowly in case liquid or pressure is present. Allow to bleed off slowly.



CAUTION: Overcharging air conditioning system will cause excessive head pressure.

An air conditioning portable Refrigerant Recovery Recycling Recharging Station for use with R134a refrigerant incorporates all the features necessary to recover refrigerant R134a from the air conditioning system, to filter and remove moisture, to evacuate and recharge with the reclaimed refrigerant. The unit can also be used for performance testing and air conditioning system analysis. The operator must adhere to the equipment manufacturer's instructions.

Recovery and recycling

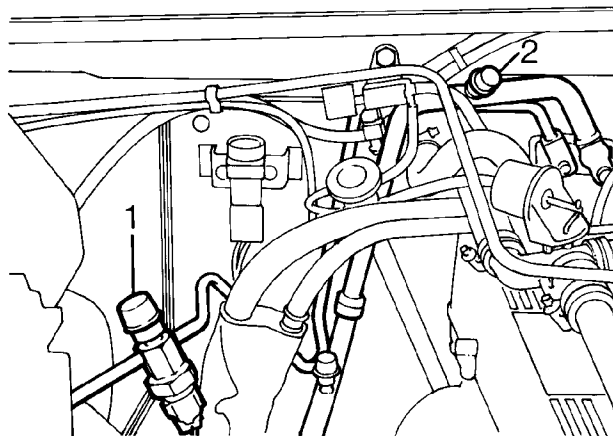

RR3963M

- 1. High pressure servicing connection
- 2. Low pressure servicing connection

1. Connect a Refrigerant Station to the high and low pressure servicing connections.
2. Operate the refrigerant recovery system according to the manufacturer's instructions.
3. Measure the amount of oil discharged from the system. Add an equal amount of new refrigerant oil to compressor before evacuation sequence.



WARNING: Refrigerant must always be recycled before reuse, to ensure that the purity of the refrigerant is high enough for safe use in the air conditioning system. Recycling should always be carried out with equipment which is design certified by Underwriter Laboratory Inc. for compliance with SAE-J1991. Other equipment may not recycle refrigerant to the required level of purity.

A R134a Refrigerant Recovery Recycling Recharging Station must not be used with any other type of refrigerant.

Refrigerant R134a from domestic and commercial sources must not be used in motor vehicle air conditioning systems.

Evacuation and recharging

1. Add refrigerant oil to compressor if necessary.
2. Renew the receiver/drier.



CAUTION: When a major repair has been carried out, a leak test should be carried out using inert gas.

3. Connect a Refrigerant Station to the high and low pressure servicing connections.



CAUTION: Whenever the refrigerant system is opened, the receiver/drier must be renewed immediately before evacuating and recharging the system.

4. Operate the refrigerant evacuation system according to the manufacturer's instructions.



NOTE: If the vacuum reading is below 700mmHg after 15 minutes, suspect a leak in the system. Partially recharge the system and check for leaks using an electronic leak tester. Check suction lines first, then run the compressor for 5 minutes and then check the high pressure lines.



CAUTION: The system must be Evacuated immediately before recharging commences. Delay between Evacuation and Recharging is not permitted.

5. Operate the refrigerant recharging system according to the manufacturer's instructions.

Refrigerant to charge system is 0.90kg

6. If the full charge has not been accepted by the system, start the engine and run it at 1500 rev/min for a minimum of 2 minutes. Switch on the air conditioning system, open the car windows, set the temperature control to cold and switch the blower to maximum speed.
7. Consult Refrigerant Station Manual for correct procedure to complete the charge.
8. Carry out the air conditioning system performance test.

LEAK TEST SYSTEM

The following instructions refer to an electronic type Refrigerant Leak Detector for use with R134a, which are the safest and most sensitive.



CAUTION: When a major repair has been carried out, a leak test should be carried out using an inert gas (see below).

1. Place the vehicle in a well ventilated area but free from draughts, as leakage from the system could be dissipated without detection.
2. Follow the instructions issued by the manufacturer of the particular leak detector being used.
3. Commence searching for leaks by passing the detector probe around all joints and components, refrigerant gas is heavier than air.
4. Insert the probe into an air outlet of the evaporator or into the evaporator drain tube. Switch the air conditioning blower on and off at intervals of ten seconds. Any leaking refrigerant will be gathered in by the blower and detected.
5. Insert the probe between the magnetic clutch and compressor to check the shaft seal for leaks.
6. Check all service valve connections, valve plate, head and base plate joints and back seal plate.
7. Check the condenser for leaks at the pipe unions.
8. If any leaks are found, the system must be discharged before rectification.
9. Rectify any leaks and recheck for leaks during evacuation prior to charging.

Leak test using inert gas

Use Nitrogen or Helium gas.

1. Connect gas line to recharging station.
2. Pressurise system to 3 bar.
3. Carry out leak test as above.



AIR CONDITIONING SYSTEM - PERFORMANCE TEST



WARNING: R134a is hazardous, refer to the GENERAL PRECAUTIONS given at the beginning of this section.

Carry out this test with bonnet and doors or windows open, air conditioning switched on, temperature control set to cold and blower at maximum speed. Set the air supply control to supply fresh air.

1. Close low pressure valve on refrigerant station.
2. Close high pressure valve on refrigerant station.
3. Connect a Refrigerant Station to the high and low pressure servicing connections.

4. Insert dry bulb thermometer into cold air outlet and position dry and wet bulb thermometer close to outside air inlet.
Do not spill water from the wet thermometer (psychrometer).
5. Start engine and run it at 1500 rev/min for 10 minutes with air conditioning switched on.
6. Check that sight glass is free of bubbles.
7. Read both pressure gauges and thermometers. Check readings against table below with humidity between 60% and 80%. If readings are incorrect. **See Fault diagnosis, Refrigeration System Faults**
8. Switch off air conditioning, stop engine, disconnect test equipment.

Performance range

Intake temperature	Outlet temperature	Low pressure	High pressure
20 - 24°C	4 - 10°C	18 - 28 lbf/in ² 1.2 - 1.9 bar	213 - 299 lbf/in ² 14.7 - 20.6 bar
25 - 29°C	9 - 19°C	27 - 37 lbf/in ² 1.9 - 2.6 bar	256 - 341 lbf/in ² 17.6 - 23.5 bar
30 - 35°C	20 - 27°C	33 - 47 lbf/in ² 2.3 - 3.2 bar	299 - 384 lbf/in ² 20.6 - 26.5 bar

Table 1

Ambient Temperature		Compound Gauge Readings		High Pressure Gauge Readings	
°C	°F	bar	lbf/in ²	bar	lbf/in ²
16	60	1,03-1,4	15-20	6,9-10,3	100-150
26,7	80	1,4-1,72	20-25	9,6-13,1	140-190
38	100	1,72-2,1	25-30	12,4-15,5	180-225
43,5	110	2,1-2,4	30-35	14,8-17,2	215-250

SYSTEM TEST

1. Place the vehicle in a ventilated, shaded area free from excessive draught, with the doors and windows open.
2. Check that the surface of the condenser is not restricted with dirt, leaves, flies, etc. Do not neglect to check the surface between the condenser and the radiator. Clean as necessary.
3. Switch on the ignition and the air conditioner air flow control. Check that the blower is operating efficiently at low, medium and high speeds. Switch off the blower and the ignition.
4. Check that the evaporator condensate drain tubes are open and clear.
5. Check the tension of the compressor driving belt, and adjust if necessary.
6. Inspect all connections for the presence of refrigerant oil. If oil is evident, check for leaks, and repair as necessary.



NOTE: The compressor oil is soluble in Refrigerant R134a and is deposited when the refrigerant evaporates from a leak.

7. Start the engine.
8. Set the temperature controls to cold and switch the air conditioner blower control on and off several times, checking that the magnetic clutch on the compressor engages and releases each time.

9. With the temperature control at maximum cooling and the blower control at high speed, warm up the engine and fast idle at 1000 rev/min. Check the sight glass for bubbles or foam. The sight glass should be generally clear after five minutes running, occasional bubbles being acceptable. Continuous bubbles may appear in a serviceable system on a cool day, or if there is insufficient air flow over the condenser at a high ambient temperature.
10. Repeat at 1800 rev/min.
11. Gradually increase the engine speed to the high range, and check the sight glass at intervals.
12. Check for frosting on the service valves.
13. Check the high pressure hoses and connections by hand for varying temperature. Low temperature indicates a restriction or blockage at that point.
14. Switch off the air conditioning blower and stop the engine.
15. If the air conditioning equipment is still not satisfactory, carry out a pressure test as previously described in this section.

COMPRESSOR DRIVE BELT

Service repair no - 82.10.01

See ENGINE, Repair, Drive Belt -Tdi

See ENGINE, Repair, Compressor Drive Belt - V8i



PRECAUTIONS IN HANDLING REFRIGERANT LINES



WARNING: Wear eye and hand protection when disconnecting components containing refrigerant. Plug all exposed connections immediately.

1. When disconnecting any hose or pipe connection the system must be discharged of all pressure. Proceed cautiously, regardless of gauge readings. Open connections slowly, keeping hands and face well clear, so that no injury occurs if there is liquid in the line. If pressure is noticed, allow it to bleed off slowly.
2. Lines, flexible end connections and components must be capped immediately they are opened to prevent the entrance of moisture and dirt.
3. Any dirt or grease on fittings must be wiped off with a clean alcohol dampened cloth. Do not use chlorinated solvents such as trichloroethylene. If dirt, grease or moisture cannot be removed from inside the hoses, they must be replaced with new hoses.
4. All replacement components and flexible end connections must be sealed, and only opened immediately prior to making the connection.
5. Ensure the components are at room temperature before uncapping, to prevent condensation of moisture from the air that enters.
6. Components must not remain uncapped for longer than fifteen minutes. In the event of delay, the caps must be fitted.
7. Receiver/driers must never be left uncapped as they contain Silica Gel crystals which will absorb moisture from the atmosphere. A receiver/ drier left uncapped must not be used, fit a new unit.
8. The compressor shaft must not be rotated until the system is entirely assembled and contains a charge of refrigerant.
9. A new compressor contains an initial charge of refrigerant oil. The compressor also contains a holding charge of gas when received which should be retained by leaving the seals in place until the pipes are re-connected.
10. The receiver/drier should be the last component connected to the system to ensure optimum dehydration and maximum moisture protection of the system.
11. All precautions must be taken to prevent damage to fittings and connections. Slight damage could cause a leak with the high pressures used in the system.
12. Always use two wrenches of the correct size, one on each fitting when releasing and tightening refrigeration unions.
13. Joints and 'O' rings should be coated with refrigeration oil to aid correct seating. Fittings which are not lubricated with refrigerant oil are almost certain to leak.
14. All lines must be free of kinks. The efficiency of the system is reduced by a single kink or restriction.
15. Flexible hoses should not be bent to a radius less than 90mm.
16. Flexible hoses should not be within 100mm of the exhaust manifold.
17. Completed assemblies must be checked for refrigeration lines touching metal panels. Any direct contact of lines and panels transmits noise and must be eliminated.

PERIODIC MAINTENANCE

Routine servicing, apart from visual checks, is not necessary. The visual inspections are as follows:

Condenser

With a water hose or air line, clean the fins of the condenser to remove flies, leaves, etc. Check the pipe connections for signs of oil leakage.

Compressor

Check pipe connections for signs of oil leakage. Check flexible hoses for swelling. Examine the compressor belt for tightness and condition.

Sight glass and Receiver/Drier

Examine the sight glass for bubbles with the system operating. Check connections for leakage.

Evaporator

Examine the refrigeration connections at the unit. If the system should develop a fault, or if erratic operation is noticed. **See *Fault diagnosis, Refrigeration System Faults***

RECEIVER DRIER

Service repair no - 82.17.01

Remove



CAUTION: If receiver/drier is to be refitted, the ports must be blanked off immediately on disconnection. Exposed life of unit is only 15 minutes.

1. Disconnect battery negative lead.
2. Recover refrigerant from system. **See *Adjustment, Refrigerant Recovery Recycling Recharging***



WARNING: Wear eye and hand protection when disconnecting components containing refrigerant. Plug all exposed connections immediately.

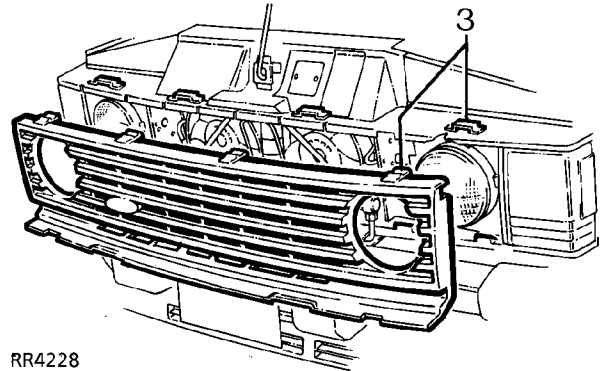

RR4228

3. Release 4 clips from brackets on bonnet locking platform and remove radiator grille.

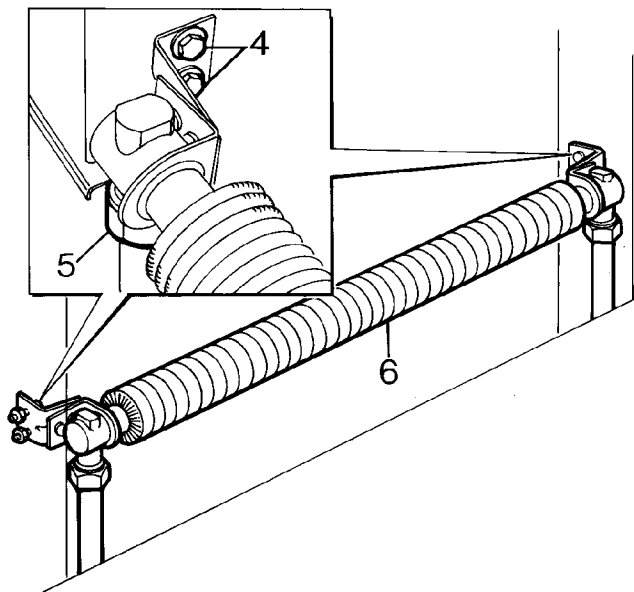

RR3964M

Automatic gearbox

4. Remove 4 bolts securing transmission oil cooler to body.
5. Disconnect 2 pipe unions from oil cooler. Use a second spanner to support hose adapter.
6. Remove transmission oil cooler. Seal connections.

All models

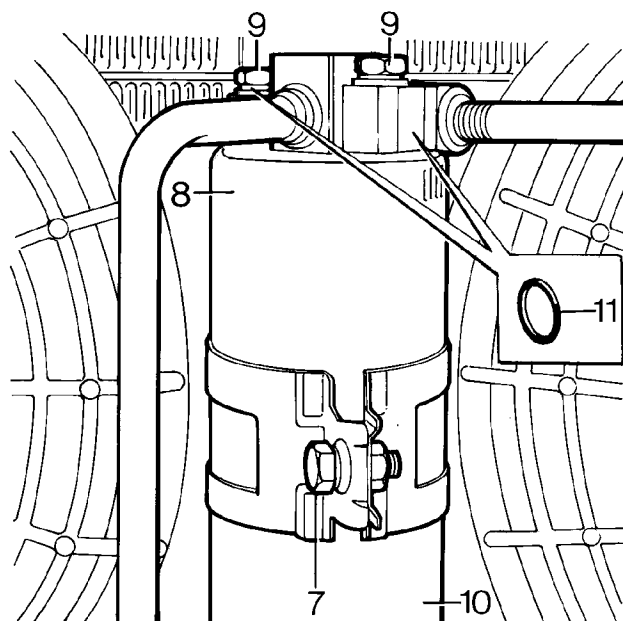

RR3965M

7. Remove bolt securing receiver/drier clamp.



WARNING: Wear eye and hand protection when disconnecting components containing refrigerant. Plug all exposed connections immediately.

8. Move receiver/drier just sufficiently to gain access to pipe flange bolts without distorting the pipes.
9. Remove bolt securing each pipe flange to receiver/drier.
10. Disengage pipe flanges and withdraw receiver/drier from mounting bracket.
11. Remove 'O' ring from each pipe flange.

Refit

12. Fit new 'O' ring to each pipe flange, lubricate with refrigerant oil.
13. Position receiver/drier in mounting bracket with inlet and outlet connections correctly aligned.
14. Engage pipe flanges, fit bolts in turn and tighten.
15. Fit clamp bolt.

Automatic gearbox

16. Refit transmission oil cooler. Use a second spanner to support pipe unions.
17. Check gearbox fluid level, top-up if necessary.

All models

18. Evacuate and recharge air conditioning system. **See Adjustment, Refrigerant Recovery Recycling Recharging**
19. Perform a leak test on disturbed joints.
20. Carry out a functional check.

AIR CONDITIONING SWITCH

Service repair no - 82.20.29

Remove

1. Remove fascia centre louvre vent panel. **See CHASSIS AND BODY, Repair, Dash Panel Central Louvre Panel**

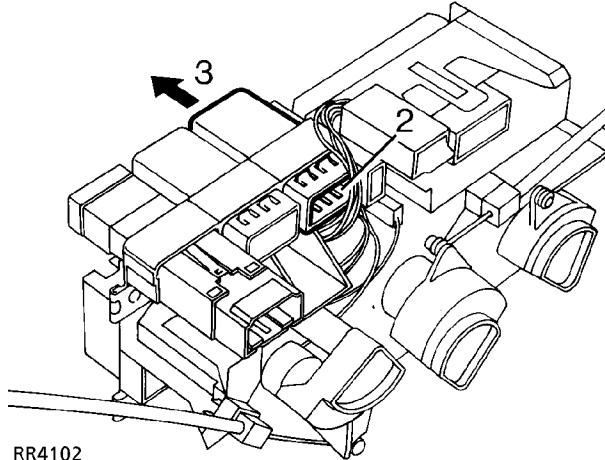

RR4102

2. Disconnect multiplug from switch
3. From the rear, push switch out of panel.

Refit

4. Reverse removal procedure.

DUAL PRESSURE SWITCH

Service repair no - 82.20.20

Remove

1. Disconnect battery negative lead.
2. Recover refrigerant from system. **See Adjustment, Refrigerant Recovery Recycling Recharging**

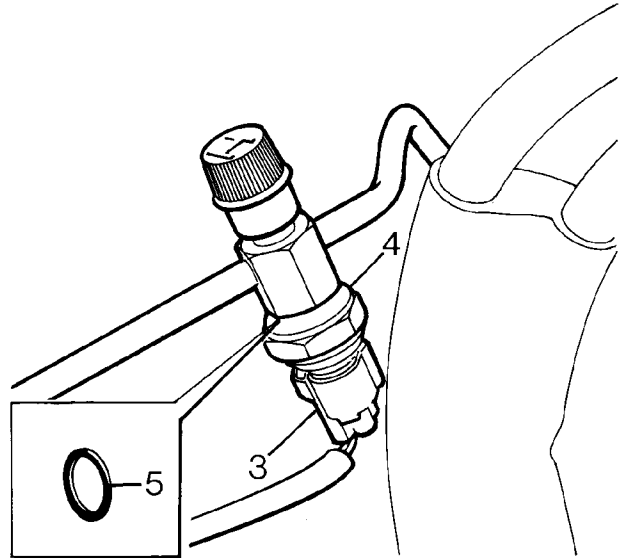

RR3966M

3. Disconnect multiplug from switch.
4. Unscrew switch from adapter. Use a second spanner to support adapter.



WARNING: Wear eye and hand protection when disconnecting components containing refrigerant. Plug all exposed connections immediately.

5. Remove 'O' ring from switch.

Refit

6. Reverse removal procedure. Lubricate new 'O' ring with refrigerant oil and fit to switch.
7. Screw switch into adapter and tighten to **11 Nm**.
8. Evacuate and recharge air conditioning system. **See Adjustment, Refrigerant Recovery Recycling Recharging**



COMPRESSOR

Service repair no - 82.10.20

Remove

1. Disconnect battery negative lead.
2. Recover refrigerant from air conditioning system. **See Adjustment, Refrigerant Recovery Recycling Recharging**
3. Remove screws retaining centre panel to fan cowl
4. Remove centre panel.

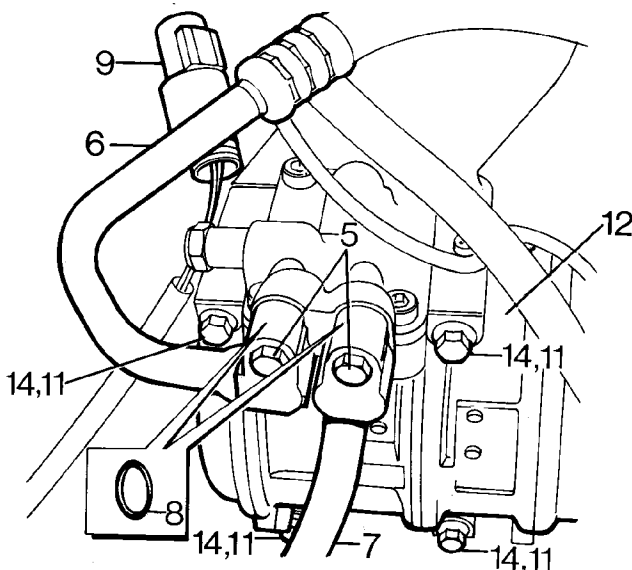

RR3967M

6. Disconnect high pressure hose from compressor.
7. Disconnect low pressure hose from compressor.
8. Remove 'O' ring from each flange.
9. Disconnect electrical lead from compressor clutch.
10. Release drive belt from compressor pulley. **See ENGINE, Repair, Drive Belt**
11. Remove 4 bolts securing compressor to mounting bracket.
12. Remove compressor from mounting bracket.

Refit

13. New compressor to be fitted: Drain oil from new compressor outlet port. Drain and measure oil from old compressor. Measure new oil equal to amount drained from old compressor, add 30 ml extra to this amount and refill new compressor through outlet port.
14. Locate compressor in mounting bracket, fit bolts. Tighten to **25 Nm**.
15. Connect electrical lead to compressor clutch.
16. Fit new 'O' rings to high and low pressure hose flanges, lubricate with refrigerant oil.
17. Engage hose flanges, fit bolts. Tighten to **10 Nm**.
18. Fit compressor drive belt. **See ENGINE, Repair, Drive Belt**
19. Fit centre panel to fan cowl.
20. Evacuate and recharge air conditioning system. **See Adjustment, Refrigerant Recovery Recycling Recharging**
21. Perform a leak test on disturbed joints.
22. Carry out a functional check.

V8i Engine Illustrated

5. Remove 2 bolts securing hose flanges to compressor.



WARNING: Wear eye and hand protection when disconnecting components containing refrigerant. Plug all exposed connections immediately.

CONDENSER

Service repair no - 82.15.07

Remove

1. Disconnect battery negative lead.



WARNING: Wear eye and hand protection when disconnecting components containing refrigerant. Plug all exposed connections immediately.

2. Recover refrigerant from system. *See Adjustment, Refrigerant Recovery Recycling Recharging*
3. Remove front grille panel.
4. Remove battery. *See ELECTRICAL, Repair, Battery*
5. Remove radiator and oil coolers assembly. *See COOLING SYSTEM, Repair, Radiator/Oil Coolers*

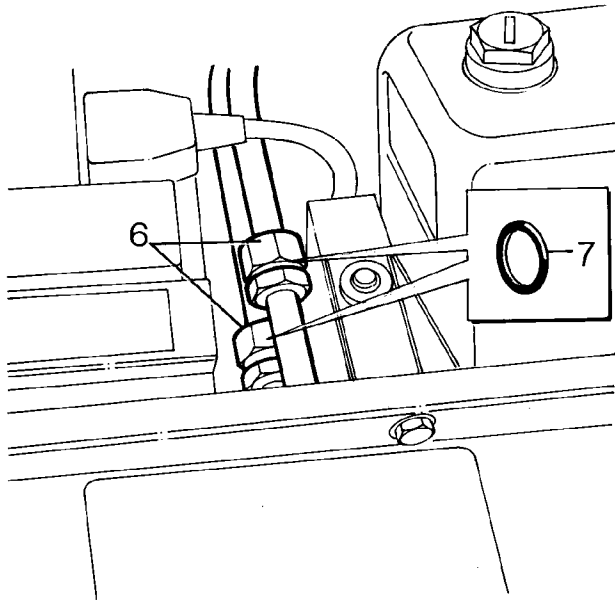

RR3988M

6. Disconnect high and low pressure pipes at condenser unions.
7. Discard 'O' ring seal from each union.

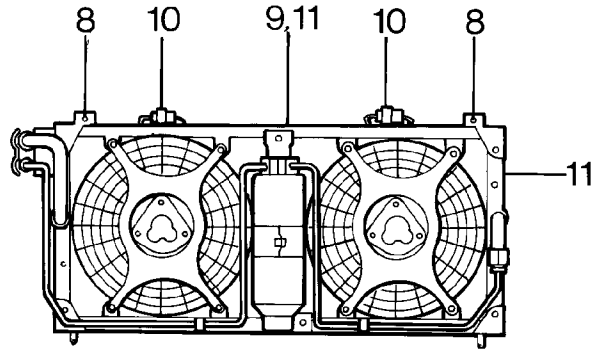

RR3989M

8. Remove 2 bolts securing condenser to body.
9. Pull condenser into radiator area.
10. Disconnect multiplug from each fan lead.
11. Remove condenser assembly. **Do not carry out further dismantling if component is removed for access only.** Blank off inlet and outlet ports.

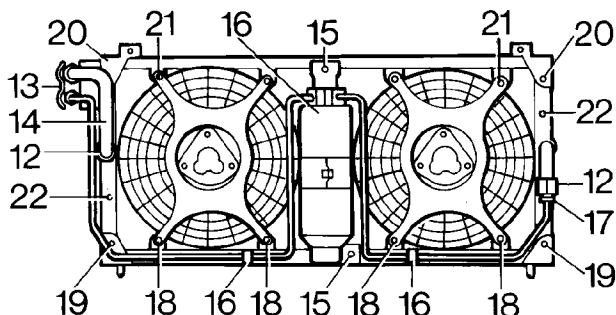

RR3990M

12. Disconnect receiver/drier pipes at condenser unions.
13. Remove retaining bracket from side pipe.
14. Remove LH pipe from condenser and discard 'O' ring.
15. Remove 2 screws securing receiver/drier bracket.
16. Release pipes from lower clips and remove receiver/drier assembly.
17. Remove 'O' ring from RH pipe.
18. Remove 2 screws securing lower end of each fan motor.
19. Remove 2 bolts and remove condenser lower mounting bracket.
20. Remove 2 bolts and securing condenser upper mounting bracket.
21. Remove upper mounting bracket and fan motor assembly.
22. Remove 2 screws securing each side mounting bracket and remove the brackets.
23. Transfer parts removed to new condenser.
24. Add 40 ml of refrigerant oil to new compressor to compensate for oil loss.

Refit

25. Reverse removal procedure. 3 to 11.
26. Evacuate and recharge air conditioning system.
See Adjustment, Refrigerant Recovery Recycling Recharging
27. Carry out leak test on disturbed joints. **See Adjustment, Leak Test System**
28. Check air conditioning operation by carrying out a System Test. **See Adjustment, System Test**

CONDENSER FANS AND MOTORS

Service repair no - 82.15.01 - Motor
Service repair no - 82.15.03 - Fan

Remove

1. Remove condenser assembly. **See Condenser**

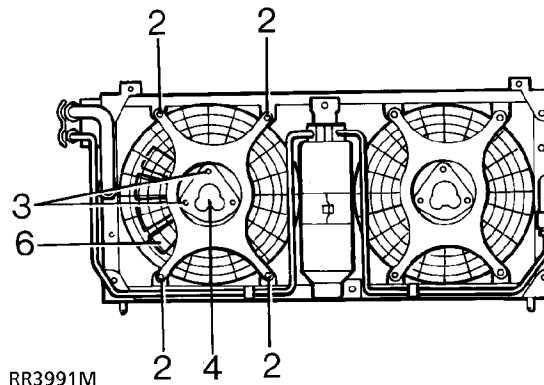

RR3991M

2. Remove 4 bolts securing fan cowl to condenser.
3. Remove 3 bolts securing fan motor to cowl.
4. Remove fan motor assembly.
5. Remove 3 screws securing fan blades to motor.
6. Remove fan blades.

Refit

7. Reverse removal procedure. Ensuring that wiring is clipped and no fouling of fan blade can occur.

HEATER AND COOLER UNIT

Service repair no - 86.25.21



WARNING: All work involving the service and maintenance of air conditioning requires special equipment, knowledge, experience and a full awareness and adherence to safety precautions.

Remove

1. Disconnect battery negative lead.
2. Drain engine coolant. *See COOLING SYSTEM, Adjustment, Coolant*
3. Recover refrigerant from air conditioning system. *See Adjustment, Refrigerant Recovery Recycling Recharging*
4. Remove fascia panel assembly. *See CHASSIS AND BODY, Repair, Dash Panel Assembly*

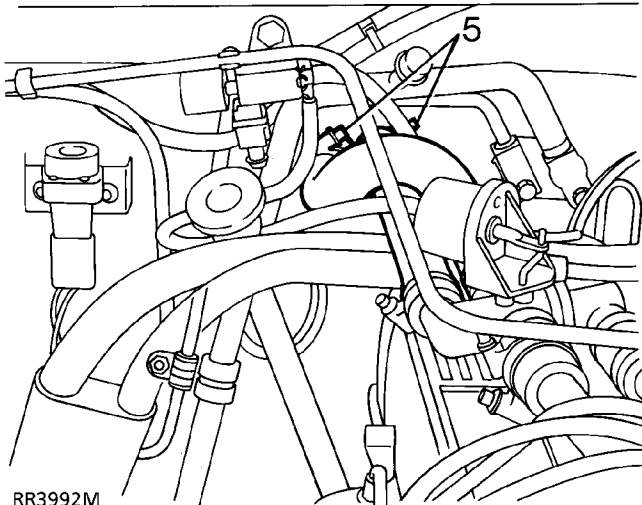

5. Release clips and disconnect coolant hoses from heater pipes.

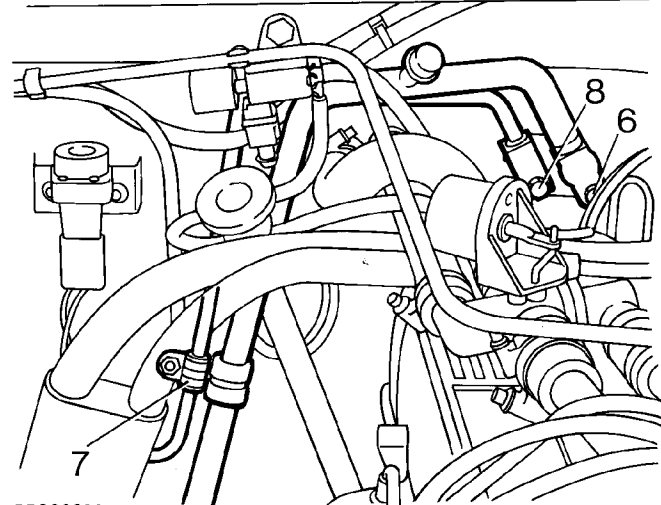

6. Remove securing bolt and disconnect low pressure pipe from evaporator.



WARNING: Wear eye and hand protection when disconnecting components containing refrigerant. Plug all exposed connections immediately.

7. Release 'P' clip retaining high and low pressure pipes.
8. Remove securing bolt and disconnect high pressure pipe from evaporator.
9. Discard 'O' ring seals.



EVAPORATOR AND EXPANSION VALVE

Service repair no - 86.25.20 - Evaporator
 Service repair no - 86.25.01 - Expansion valve

Remove



WARNING: Wear eye and hand protection when disconnecting components containing refrigerant. Plug all exposed connections immediately.

1. Remove heater and cooler unit. *See Heater and Cooler Unit*

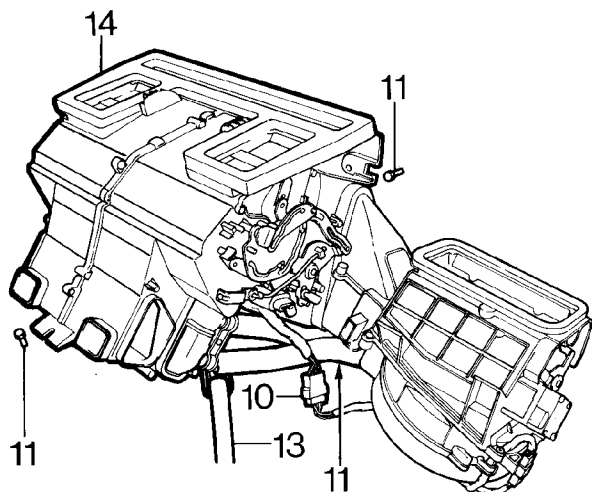

RR3994M

10. Disconnect multiplug connecting heater to blower unit, remove 3 screws and remove blower unit.
11. Remove 5 screws securing casing to bulkhead and tunnel.
12. Remove 2 securing bolts and remove centre console front mounting bracket.
13. Disconnect 2 drain tubes..
14. Ease heater and cooler unit from its location and remove from vehicle.

Refit

15. Ease heater and cooler unit into position.
16. Fit retaining bolts finger tight. Tighten in sequence, centre and top bolts and then the bottom bolt.
17. Reverse removal procedure.
18. Use new 'O' rings and lubricate with refrigerant oil.
19. Evacuate and recharge system. *See Adjustment, Refrigerant Recovery Recycling Recharging*
20. Leak test any disturbed joints. *See Adjustment, Leak Test System*
21. Perform a functional check.

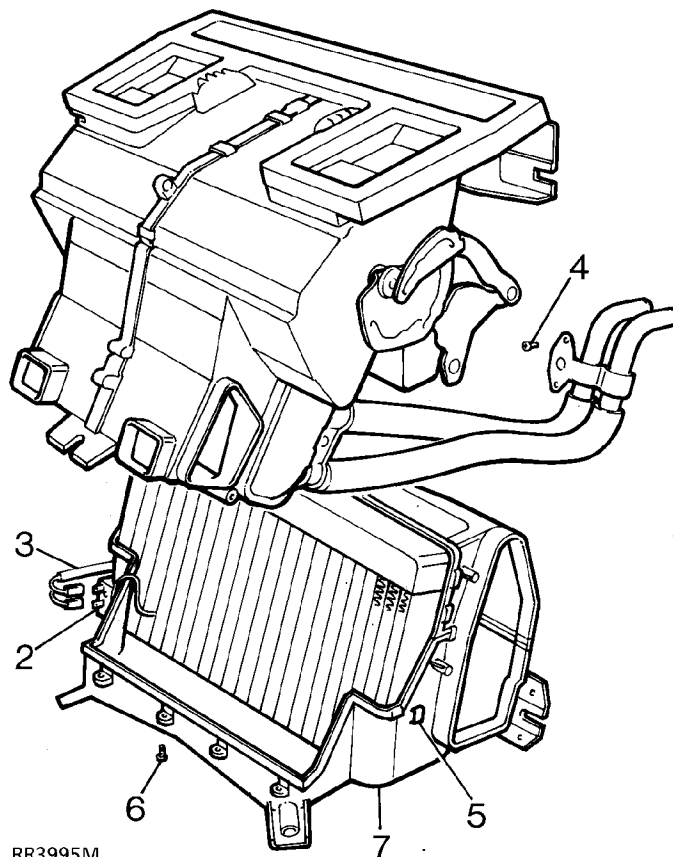

RR3995M

2. Disconnect 2 Lucar connectors from thermostat.
3. Position wiring aside.
4. Remove 2 screws securing heater pipe bracket and position pipes aside.
5. Remove 10 clips retaining upper and lower casings.
6. Remove 5 screws retaining upper casing.
7. Remove lower casing and evaporator.

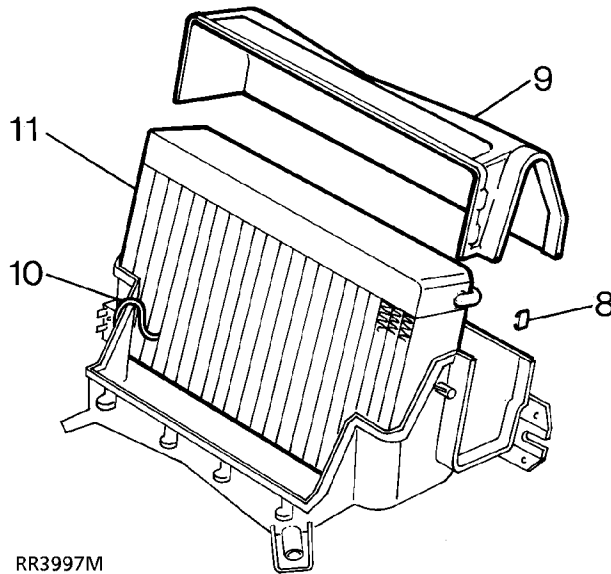

8. Remove 4 clips securing evaporator top cover.
9. Remove evaporator top cover.
10. Remove thermostat sensor from evaporator matrix.
11. Remove evaporator assembly from lower casing.
12. Remove bulkhead seal from case.

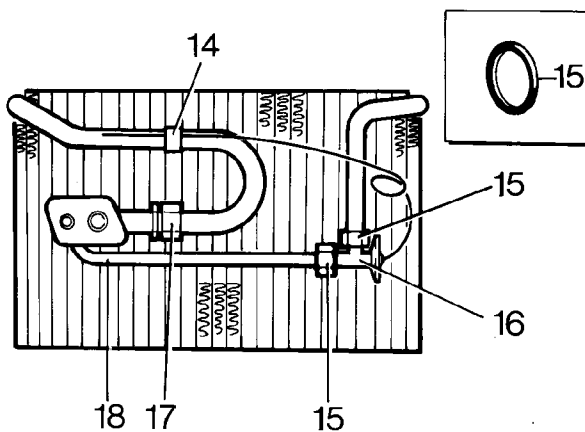

Expansion valve

13. Remove insulation from evaporator and expansion valve connections.
14. Remove expansion valve sensor retaining clip.
15. Unscrew 2 pipe unions. Discard 'O' ring seals.



CAUTION: Use a second wrench to support pipe adapters and plug connections.

16. Remove expansion valve.
17. Unscrew pipe union. Discard 'O' ring seal.
18. Remove evaporator pipe.

Refit

19. Reverse removal procedure. Use new 'O' rings, insulation and bulkhead seal.



NOTE: Use refrigerant oil on all 'O' rings and mating surfaces. Tighten connection. See Specifications, torque, Torque Values

20. Wrap all exposed metal at hose connections with prestite tape.
21. Evacuate and recharge system. *See Adjustment, Refrigerant Recovery Recycling Recharging*
22. Leak test any disturbed joints. *See Adjustment, Leak Test System*
23. Perform a functional check.
24. Disconnect service unit.



THERMOSTAT

Service repair no - 86.25.50

Remove

1. Remove heater and cooler unit. *See Heater and Cooler Unit*
2. Remove lower cover and evaporator. *See Evaporator and Expansion Valve*
3. Remove 5 clips and screw securing evaporator top cover.
4. Remove evaporator top cover.

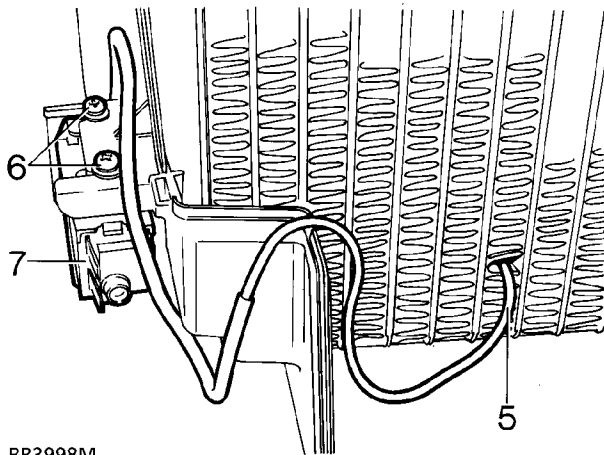

RR3998M

5. Remove thermostat sensor from evaporator matrix.
6. Remove 2 screws securing sensor unit.
7. Remove thermostat and insulation.

Refit

8. Reverse removal procedure.



CAUTION: The thermostat insulation must be installed in the ORIGINAL POSITION in the evaporator.



TORQUE VALUES



NOTE: Torque wrenches should be regularly checked for accuracy to ensure that all fixings are tightened to the correct torque.

	Nm
AIR CONDITIONING	
Compressor flange bolts	10
Receiver drier union bolts	6
Dual pressure switch	11
Pressure pipe union nuts - M16	14
Discharge pipe union nuts - M22	22
Suction pipe union nuts - M24	33

AIR CONDITIONING CHARGE DATA

Total oil in system	180ml - 6.3 Fl oz
Total refrigerant in system	0.90kg - 32 Fl oz



WIPER MOTOR CHECKING



NOTE: These instructions apply to Windscreen and Tailgate wiper motors.

If unsatisfactory operation of wiping equipment is experienced, a systematic check to determine fault should be carried out:

1. Check blades for signs of excessive friction. This reduces wiping speed of motor and cause increased current draw which may damage armature. Check by substitution.
2. Check windscreen wiper motor light running current and speed with motor coupling link disconnected from wiper shaft transmission linkage.

Check tailgate glass wiper motor with wiper connected and glass wet. Connect an ammeter in series with motor supply. Measure current consumption when motor is switched on. Check operating speed by timing speed of rotation of motor coupling link. The results should compare with figures given in 'General Specification Data'.



NOTE: If vehicle wiring connections are disconnected and an alternative supply source is applied it is essential that correct polarity is observed. Failure to observe this will cause motor to rotate in reverse direction, which may result in limit switch contacts being damaged.

3. If motor does not run satisfactorily or takes higher than normal current, a fault exists and must be remedied.
4. If current consumption and speed of motor are satisfactory. A check should be carried out for proper functioning of transmission linkage and wiper arm shafts.



NOTE: Service parts are not available for windscreen and tailgate wiper motors with exception of windscreen wiper rotary connecting link.



WASHER RESERVOIR

Service repair no - 84.10.03.

Remove

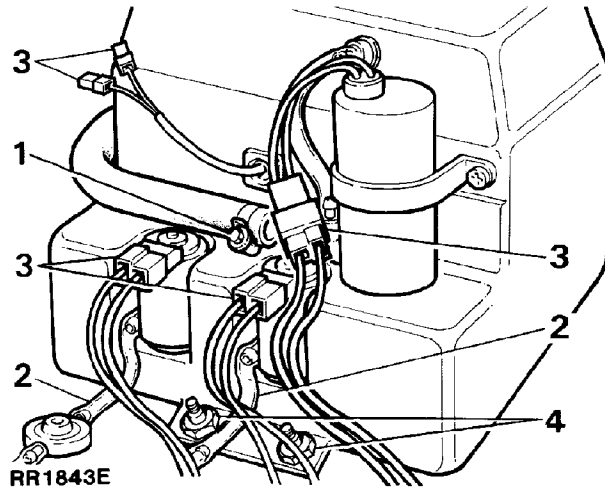

1. Loosen hose clamp and remove power wash hose.
2. Disconnect tubing from washer pumps.
3. Disconnect electrical leads from pumps and low level warning unit.
4. Remove 3 bolts and withdraw reservoir.

Refit

5. Reverse removal procedure.

POWER WASH PUMP

Service repair no - 84.20.21.

Remove

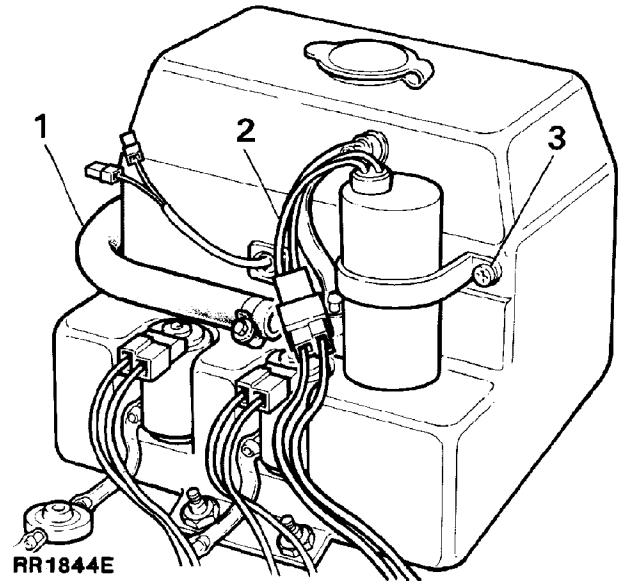

1. Disconnect hose from power wash pump.
2. Disconnect electrical leads from pump.
3. Remove two screws and withdraw power wash pump.

Refit

4. Reverse removal procedure.

WASHER PUMP - WINDSCREEN OR TAILGATE

Service repair no - 84.10. 21.

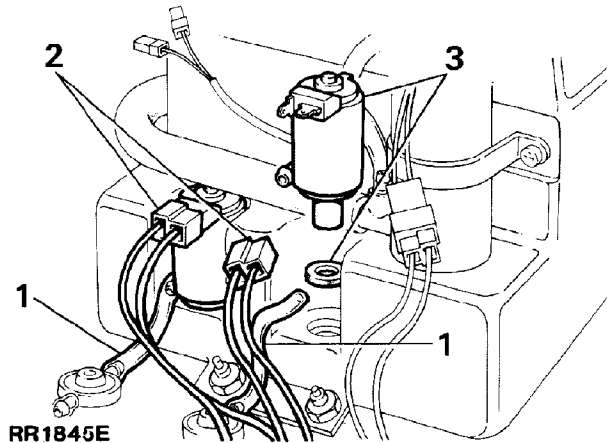
Remove

RR1845E

1. Disconnect washer tubing from pump.
2. Disconnect electrical leads from pump.
3. Pull top of pump away from its location in reservoir and remove pump. Note position of sealing gasket in reservoir.

Refit

4. Reverse removal procedure.

HEATED WINDSCREEN WASHER JETS

Service repair no - 84.10. 09.

Remove

NOTE: The thermostat will close at 4°C æ 3°C and re-open at 10°C æ 3°C.

1. Disconnect battery negative lead.

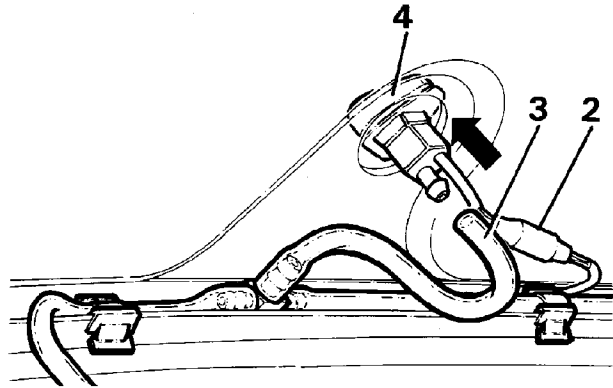

RR2549M

2. Disconnect electrical connection at plug.
3. Withdraw washer tube from jet.
4. Push jet upwards to remove from its mounting.
5. Remove washer jet mounting from bonnet[hood], if necessary.

Refit

6. Reverse removal procedure.



HEATED WINDSCREEN WASHER JETS THERMOSTAT

Service repair no - 84.10.12.

The thermostat is located on right headlamp mounting panel.

Remove

1. Disconnect battery negative lead.
2. Remove radiator grill. *See CHASSIS AND BODY, Repair, Radiator Grille*

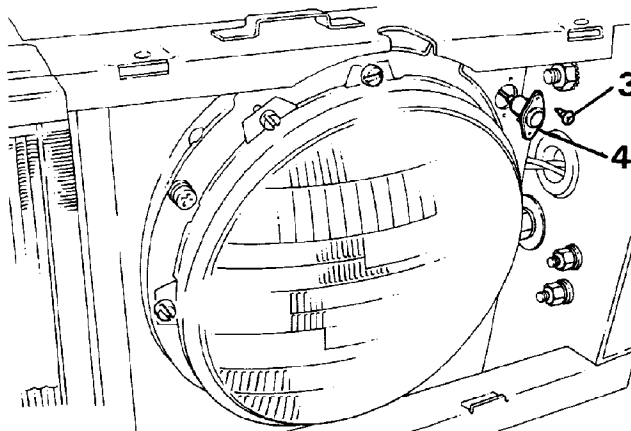

RR2550M

3. Remove two screws securing thermostat to right hand headlamp mounting panel.
4. Withdraw thermostat, disconnecting electrical connector.

Refit

5. Reverse removal procedure.

WINDSCREEN WASHER TUBES

Service repair no - 84.10.15.

Remove

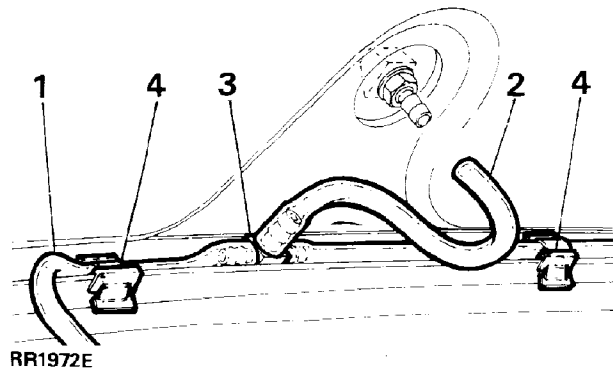

RR1972E

1. Disconnect tubing from reservoir pump.
2. Disconnect tubing from washer jets.
3. Disconnect tubing from three-way tee piece.
4. Release tubing from edge clips.

Refit

5. Reverse removal procedure.

WIPER ARMS - WINDSCREEN

Service repair no - 85.15.01

Remove

1. Hold back small spring clip which retains wiper arm on shaft boss using a suitable tool.
2. Gently pry off wiper arm from shaft boss.

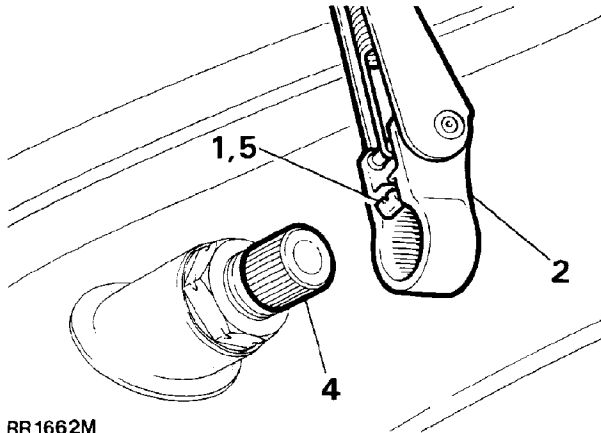
**Refit**

3. Allow motor to move to 'park' position.
4. Push arm on to boss, locating it on splines so that wiper blades are clear of screen rail.
5. Ensure that spring retaining clip is located in retaining groove on shaft boss.
6. Operate wiper on a wet screen to ensure blades do not over travel.

WIPER ARM - TAILGATE

Service repair no - 84.35.01.

Remove

1. Lift wiper arm end cap to access wiper motor shaft.
2. Remove wiper arm securing nut.

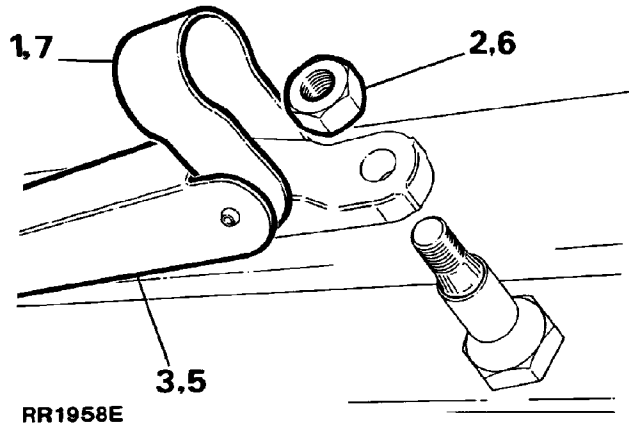

3. Withdraw wiper arm from shaft.

Refit

4. Allow motor to move to 'park' position.
5. Fit wiper arm to shaft, locating it on the splines so that wiper blade is clear of screen surround.
6. Fit and tighten securing nut.
7. Push end cap back into position.
8. Check correct operation of wiper.



WIPER BLADES - WINDSCREEN AND TAILGATE

Service repair no - 84.15.05.

Remove

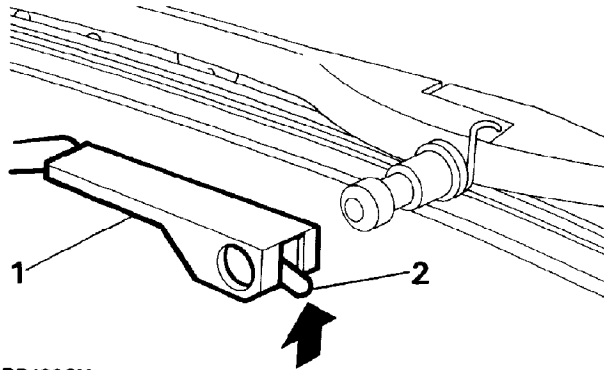

RR1663M

1. Pull wiper arm away from glass.
2. Lift spring clip and withdraw blade from arm.

Refit

3. Reverse removal procedure.

WINDSCREEN WIPER MOTOR, LINKAGE AND WHEEL BOXES

Service repair no - 84.15.12.

Remove

1. Disconnect battery negative lead. Remove wiper arms.

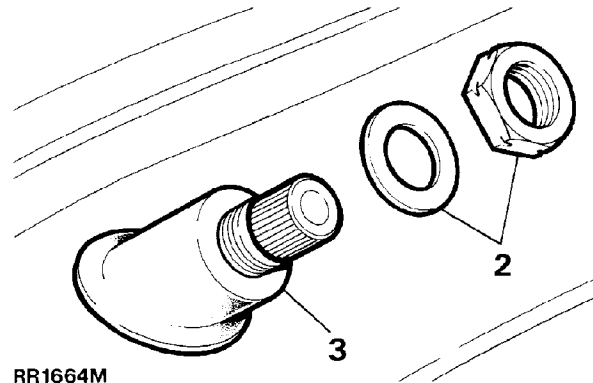

RR1664M

2. Remove locknuts from wheel boxes.
3. Remove grommet from wheel boxes.
4. Remove bonnet[hood]. **See CHASSIS AND BODY, Repair, Bonnet**
5. Remove front decker[cowl] panel. **See CHASSIS AND BODY, Repair, Decker Panel**

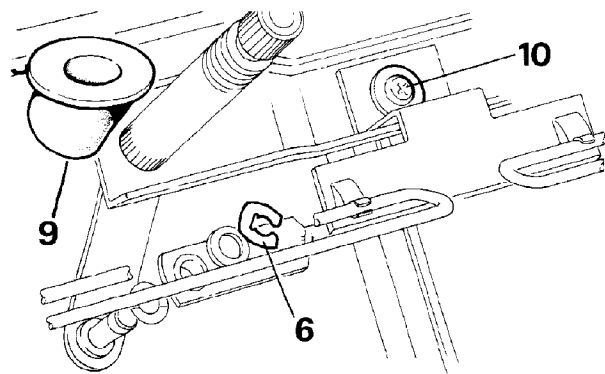

RR1955E

6. Remove spring clips securing primary links to wheelbox shaft links.
7. Remove spring clips securing primary links to motor crank.
8. Remove primary links.
9. Remove lower grommet from wheelboxes.
10. Remove screw securing bonnet[hood] torsion bar bracket. Unclip bracket from torsion bar.

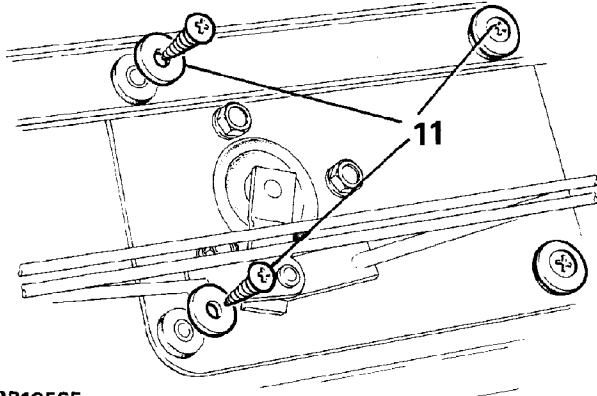

RR1956E

11. Remove remaining screws securing motor and linkage assembly to bulkhead.
12. Ease unit from mounting location and disconnect electrical leads at plug and socket.
13. Withdraw unit.

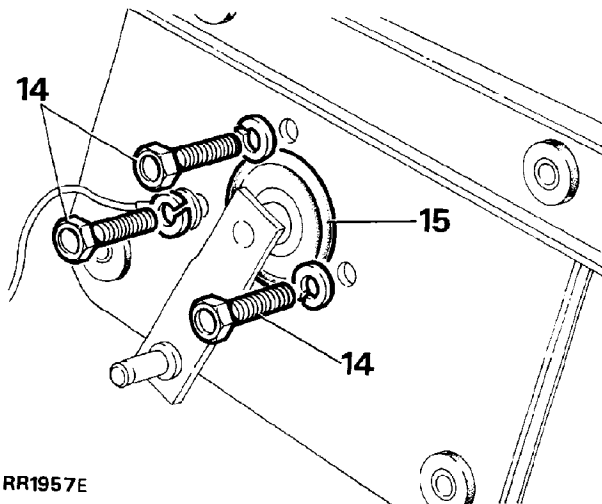

RR1957E

14. Remove three bolts securing motor to mounting plate.
15. Separate motor from mounting plate by pulling motor crank through grommet.

Refit

16. Reverse removal procedure.
17. Ensure primary links are mounted with bushes on inside, towards wiper motor. The shorter primary link is mounted on driver side.
18. Replace front decker[cowl] panel.
19. Replace bonnet.
20. Replace wiper arms.



TAILGATE GLASS WIPER MOTOR

Service repair no - 84.35.12.

Remove

1. Disconnect battery negative lead.
2. Lower headlining rear section to access wiper motor assembly.
3. Remove wiper arm and blade.

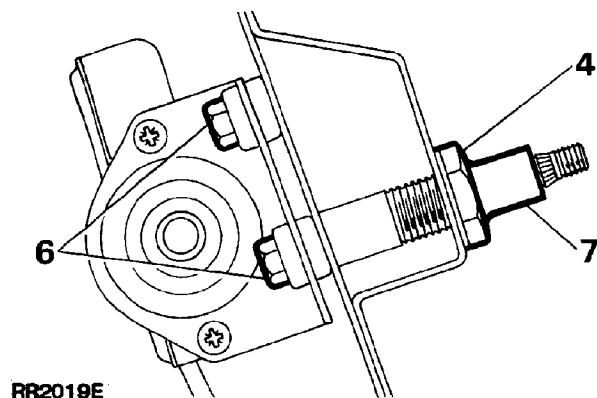

RR2019E

4. Loosen nut securing wiper motor to body. **DO NOT** remove at this stage.

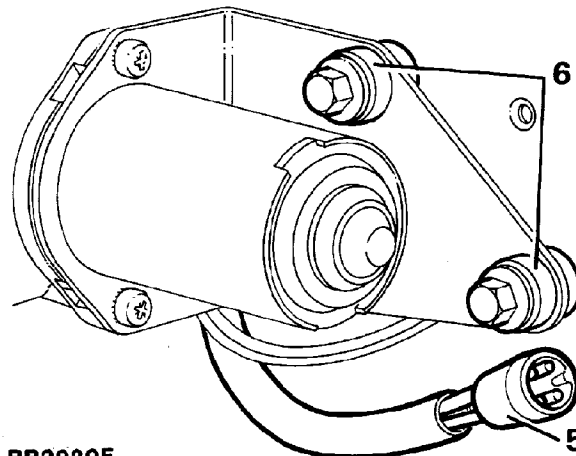

RR2020E

5. Disconnect electrical leads at multi-plug.
6. Remove two bolts securing wiper motor to inner body.
7. Support wiper motor remove nut loosened at instruction 4, complete with protective cover, washer and seal. Simultaneously withdraw wiper motor.

Refit

8. Reverse removal procedure. Ensuring that spacer is correctly positioned before fitting motor.

TAILGATE GLASS WASHER JET

Service repair no - 84.30.09

Remove

1. Lower or remove headlining rear section to gain access to jet securing nut and washer tube connection.

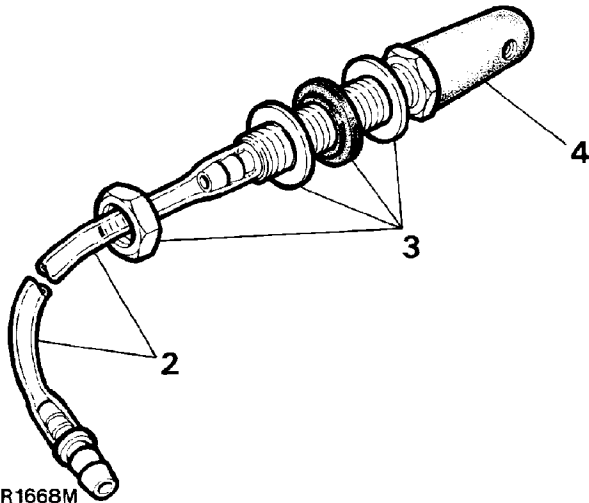

RR1668M

2. Disconnect washer tube. Remove grommet. Drain away water in tube to avoid damaging trim.
3. Hold base of jet and remove nut and washer.
4. Withdraw washer jet from outside vehicle.

Refit

5. Reverse removal procedure.

HEADLAMP POWER WASH JET

Service repair no - 84.20.08.

Remove

1. Raise and support front of vehicle.
2. Remove engine undertray.
3. Remove front spoiler. *See CHASSIS AND BODY, Repair, Front Spoiler*

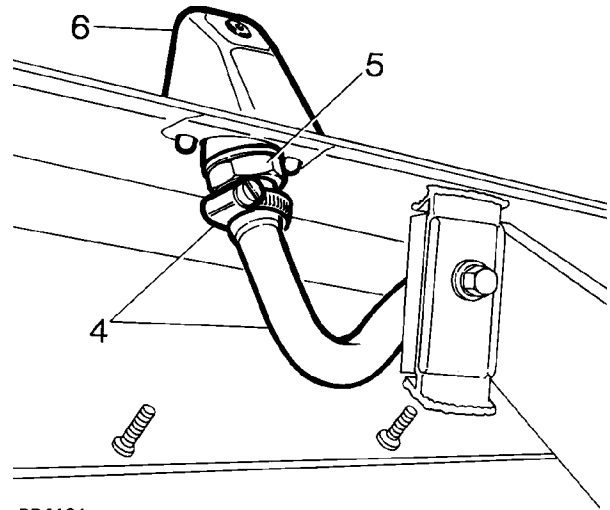

RR4181

4. Disconnect hose from power wash jet.
5. Remove nut securing jet to bumper.
6. Remove power wash jet.

Refit

7. Reverse removal procedure.



POWER WASH HOSE

Service repair no - 84.20.14

Remove

1. Disconnect hoses from jets and washer pump.
2. Release clamps locating hose.
3. Remove power wash hose.

Refit

4. Reverse removal procedure. Locating hose in its original position.



ELECTRICAL EQUIPMENT

DESCRIPTION

The electrical system is Negative ground, and it is most important to ensure correct polarity of the electrical connections at all times. Any incorrect connections made when reconnecting cables may cause irreparable damage to the semi-conductor devices used in the A.C. generator and regulator. Incorrect polarity would also seriously damage any transistorized equipment such as the radio.



WARNING: During battery removal or before carrying out any repairs or maintenance to electrical components always disconnect the battery negative lead first. If the positive lead is disconnected with the negative lead in place, accidental contact of tools to any earthed metal part could cause a severe spark, possibly resulting in personal injury. Upon installation of the battery the positive lead should be connected first.

A.C. GENERATOR - A127/100

The A.C. generator is a three phase, field sensed unit. The rotor and stator windings produce three phase alternating current, AC, which is rectified to direct current, DC. The electronic voltage regulator unit controls the A.C. generator output voltage by high frequency switching of the rotor field circuit.

It is essential that good electrical connections are maintained at all times. Of particular importance are those in the charging circuit (including those at the battery) which should be occasionally inspected to see that they are clean and tight. In this way any significant increase in circuit resistance can be prevented.

Do not disconnect battery cables while the engine is running or damage to the semi-conductor devices may occur. It is also inadvisable to break or make any connections in the charging and control circuits while the engine is running.

The electronic voltage regulator employs micro-circuit techniques resulting in improved performance under difficult service conditions. The whole assembly is encapsulated in silicone rubber and housed in an aluminium heat sink, ensuring complete protection against the adverse effects of temperature, dust, and moisture etc.

The regulating voltage is set during manufacture to give the required regulating voltage range of 14.2 ± 0.2 volts, and no adjustment is necessary. The only maintenance needed is the occasional check on terminal connections and wiping with a clean dry cloth.

The system provides for direct connection of a charge (ignition) indicator warning light, and eliminates the need for a field switching relay or warning light control unit. As the warning lamp is connected in the charging circuit, lamp failure will cause loss of charge. Lamp should be checked regularly and spare carried.

When using rapid charge equipment to re-charge the battery, the battery must be disconnected from the vehicle.



NOTE: For description and operation of electrical circuits see separate publication:- Electrical Troubleshooting Manual.

ANTI THEFT ALARM SYSTEM

A vehicle alarm system is available as original equipment. The main function of the system is to offer easy to use remote locking and unlocking of the vehicle without having to actively select the alarm function.

ANTI-THEFT SYSTEM FUNCTION

Perimetric protection

Using the key in the correct sequence will turn on and off perimetric protection only. When fully perimetrically armed, all doors, tailgate, and bonnet [hood] are protected against unauthorised access. If the door key is used in the normal manner the driver will be unaware of the door key sequence. The time taken to lock or unlock with the key must be less than 5 seconds. To prevent unauthorised tampering, the alarm will sound if the key is held in the unlocked position for longer than 5 seconds when armed. Cranking is disabled when perimetric protection is armed.



NOTE: When key is turned left or right the keyswitch input will be activated, in conjunction with the sill button switch when links are operated.



ALARM COMPONENTS

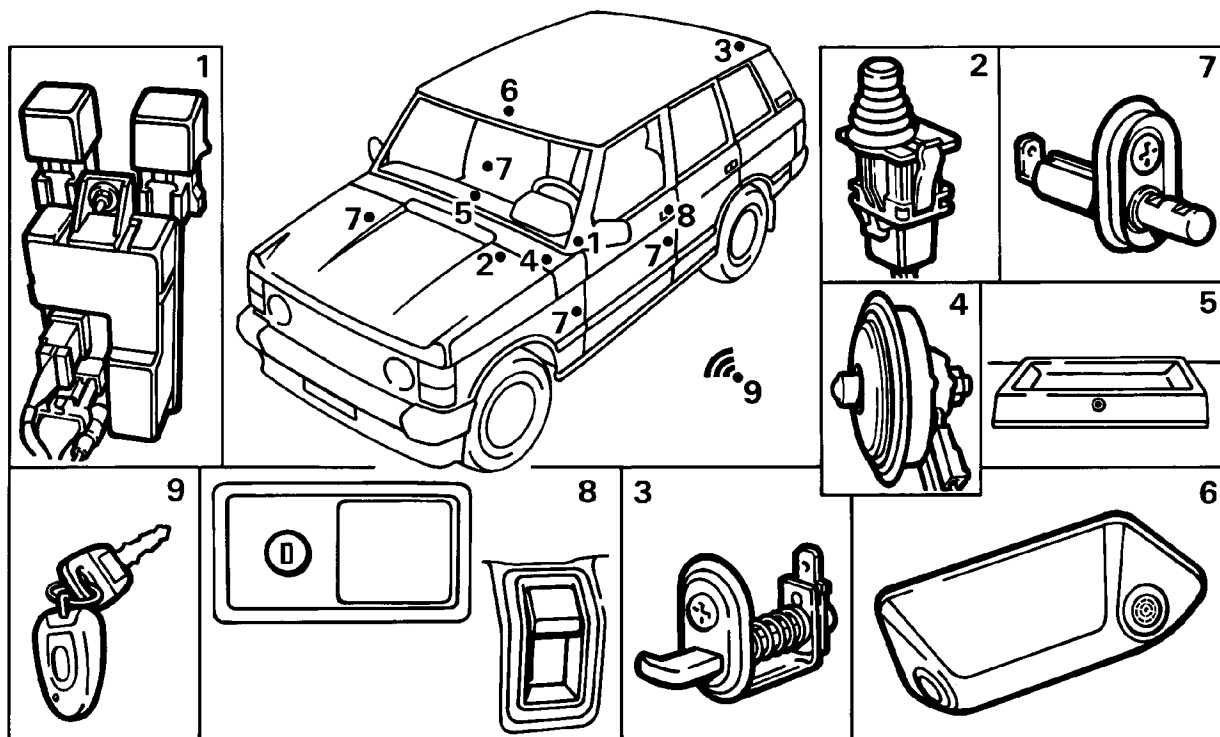

RR3911M

- | | |
|---|---------------------------------------|
| 1. Electronic control unit (ECU) and relays | 6. Ultrasonic unit |
| 2. Bonnet [hood] switch | 7. Door switches |
| 3. Tailgate switch | 8. Lock barrel, sill buttons |
| 4. Alarm horn | 9. Handset transmitter (two supplied) |
| 5. Light emitting diode (LED) | |

Volumetric protection

Using the handset transmitter will turn on and off volumetric protection. In volumetric mode the vehicle interior is protected using the ultrasonic sensor. Using the handset also arms and disarms the vehicle perimetrically. Cranking is disabled when volumetric and perimetric protection is armed.



NOTE: If armed volumetrically the vehicle CANNOT be disarmed using the key.

Alarm horn

When an intrusion is detected the alarm horn will sound intermittently (Switzerland and Denmark continuous horn sound) and the hazard lights flash (where territorial regulations allow) for 30 seconds. The alarm must be retrIGGERED before alarm horn will sound again.

Vehicle status indication

Vehicle status is indicated by up to three devices: (a) alarm horn, (b) hazard lights, (c) dash board LED. When the vehicle arms in either mode the hazard lights will flash three times and the LED will flash rapidly for 10 seconds. LED will then flash at a slower rate while vehicle is armed. When the vehicle disarms, hazard lights will flash once and LED will extinguish. If LED remains lit, it indicates that the alarm has been triggered. Turning on ignition or arming the alarm will extinguish LED. The LED will give a long pulse flash to indicate the ultrasonic unit being activated.

Radio frequency system

The RF system uses four frequencies according to market. If the coaxial aerial is not fitted system performance will be impaired. Both ECU and handset have a colour coded label.

Frequency	Colour ECU/Handset	Territory
418.0 MHz	Pink/Pink	UK, Ireland
224.5 MHz,	Yellow/Yellow	France
433.92 MHz	Blue/Purple	Germany
433.92 MHz	Blue/Blue	Europe, not France, Switzerland, Italy, Denmark, Germany
433.92 MHz	White/Blue	Switzerland, Denmark
315.0 MHz	Green/Green	Rest of world, Italy, Australia
315.0 MHz	Orange/Green	Gulf, Japan

Central locking

Central locking is controlled by the alarm ECU and may be operated by the key, sill button(s) or handset. The system works on both front doors on four door vehicles or driver's door on two door vehicles.



NOTE: The central door locking system will shut down for a short period after more than 15 consecutive operations.

Inertia switch

An inertia switch is incorporated in the alarm system ECU. If ignition is on and the vehicle receives an impact sufficient to activate the inertia switch, the ECU will signal to unlock central locking actuators and flash hazard lights. Central locking will remain disabled for 30 seconds. To reset turn ignition off and then on after the 30 second period has elapsed.

Ultrasonic unit

The unit operates by emitting an air pressure carrier wave and receiving the wave back. Any disturbance within the vehicle which disturbs the wave will be detected, triggering the alarm.

When the volumetric sensor is activated it monitors movement within the vehicle for 15 seconds before detecting and responding to intrusions. If the sensor detects movement within the vehicle it delays arming until a 15 seconds quiet period has elapsed. If continuous movement is detected the alarm will not arm volumetrically.



Partially armed mode

If a door, tailgate or bonnet [hood] is left open when the system is armed, the LED will not light for 10 seconds indicating a mislock condition. Hazard lights will not flash. If an open door or tailgate is causing the mislock, the starter motor is disabled. The alarm will sound if ignition is turned to start position. If an open bonnet [hood] is causing the mislock the starter motor is disabled. The alarm will arm the volumetric part of the system. If the door tailgate or bonnet [hood] is subsequently closed, after a 5 second delay, the doors will unlock and immediately lock and the system will fully arm.

Handset transmitter

The handset LED will give one short flash when button is pressed momentarily. If button is held down the LED will light again after 2 seconds for 2 seconds, and extinguish until button is released and repressed. The handset contains unique information distinguishing it from other transmitters. It also contains a set of 'random' rolling codes programmed into the ECU before leaving the factory. Each time the handset is pressed a different code is transmitted to the ECU. If handset is operated more than four times outside the vehicle range (6 metres) or power supply is removed, it will be necessary to re-synchronise handset and the ECU by pressing the handset three times within range and within 5 seconds.



NOTE: If both handsets are lost or damaged when system is armed it will be necessary to fit a new ECU with two matching handsets.

Handset batteries

If handset LED flashes continuously when button is pressed, the batteries need replacing. The hazard lights will flash one 3 second pulse, instead of three times upon arming vehicle.

Power up mode

The alarm system always remembers the state it was left in when power was removed. If the alarm powers up in an armed state and is subsequently triggered it will give a warning that it will fully trigger unless disarmed. This warning consists of short horn pulses every two seconds for 15 seconds.

New born mode

When the ECU is first produced, it will be in its 'new born' mode. In this mode it will respond to any remote of the right frequency. This mode will be cancelled when the ECU has received ten valid handset signals without power interruption.

Engine cranking

It is only possible to crank the engine when ignition is ON and alarm disabled.

BUILT IN TEST PROCEDURE

The built in test procedure is accessed as follows:

1. Starting conditions: ignition off, doors unlocked, bonnet [hood] switch depressed.
2. Carry out instructions 3 to 7 within 8 seconds.
3. Release bonnet [hood] switch
4. Switch ignition ON.
5. Lock doors.
6. Switch ignition OFF.
7. Switch ignition ON.

If alarm is correctly accessed, horn will sound and LED will flash. The following checks can be made:

8. Open and close any door or tailgate - LED will light.
9. Depress bonnet [hood] switch - hazards will flash.
10. Check engine cranking is disabled. Do not turn off ignition.
11. Check ultrasonic by operating handset, LED will emit one 5 second flash, and will flash if interior is disturbed.



NOTE: If ECU is in new born mode any handset of the right frequency will work. If not an initialised handset is required see Handset Initialisation.

12. Turn OFF ignition or press handset to end test procedure. Horn will sound as before to indicate end of test mode.



LUCAS CONSTANT ENERGY IGNITION SYSTEM - V8i

Preliminary Checks

Inspect battery cables and connections to ensure they are clean and tight. Check electrical condition of battery.

Inspect all L.T. connections, ensure they are clean and tight. Check H.T. leads are correctly positioned and not shorting to ground against any engine components. Wiring harness and individual cables should be firmly fastened to prevent chaffing.

Pick-up air gap

Check air gap between pick-up limb and reluctor teeth is 0.20 - 0.35 mm, using a non-ferrous gauge.



NOTE: Air gap is set initially at factory and will only require adjusting if tampered with or when pick-up module is replaced.

TEST 1:

H.T. Sparking

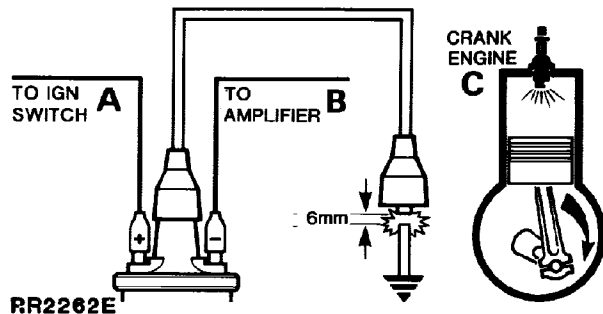

Remove coil/distributor H.T. lead from distributor cover and hold approximately 6mm from engine block, using suitable insulated pliers. Switch ignition 'On' and operate starter.

Regular sparking indicates fault in H.T. distribution, plugs, timing or fuelling, proceed to Test 6. If no spark or weak spark occurs proceed to Test 2.

TEST 2:

L.T. Voltage

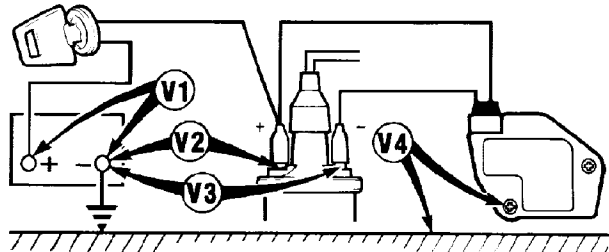

RR2263E

Switch ignition 'On' - engine stationary.

- Connect voltmeter to points in circuit indicated by V1 to V4 and make a note of voltage readings.
- Compare voltages obtained with specified values listed below:

Expected readings

- V1 More than 12 volts.
 - V2 1 volt maximum below volts at V1.
 - V3 1 volt maximum below volts at V1.
 - V4 0 volt - 0.1 volt.
- If all readings are correct proceed to Test 3.
 - Check incorrect reading(s) with chart to identify area of possible faults, i.e. faults listed under heading SUSPECT and rectify.
 - If coil and amplifier is suspected, disconnect L.T. lead at coil, repeat V3. If voltage is still incorrect, fit new coil. If voltage is now correct, check L.T. lead, if satisfactory fit new amplifier.
 - If engine will not start proceed to Test 3.

1	2	3	4	SUSPECT
L	*	*	*	DISCHARGED BATTERY
*	L	L	*	IGN. SWITCH AND/OR WIRING
*	*	L	*	COIL OR AMPLIFIER
*	*	*	H	AMPLIFIER GROUND

Key

- * Expected Voltage
- H Voltage higher than expected
- L Voltage lower than expected

TEST 3:

Amplifier Switching

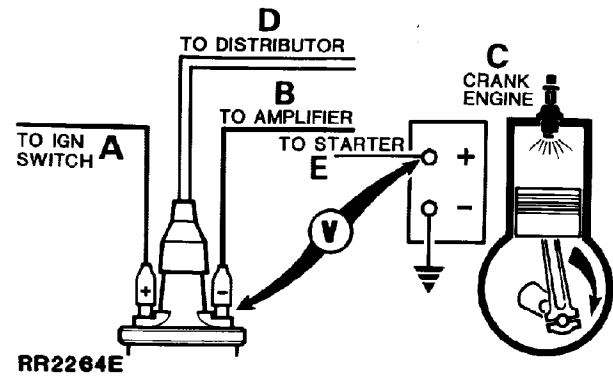

Connect voltmeter between battery positive (+ve) terminal and H.T. coil negative (-ve) terminal. Voltmeter should register 0 volts.

Switch ignition 'On', voltmeter should still register 0 volts.

Crank engine, voltmeter reading should increase when cranking, in which case proceed to Test 5.

If no increase in voltage during cranking proceed to Test 4.

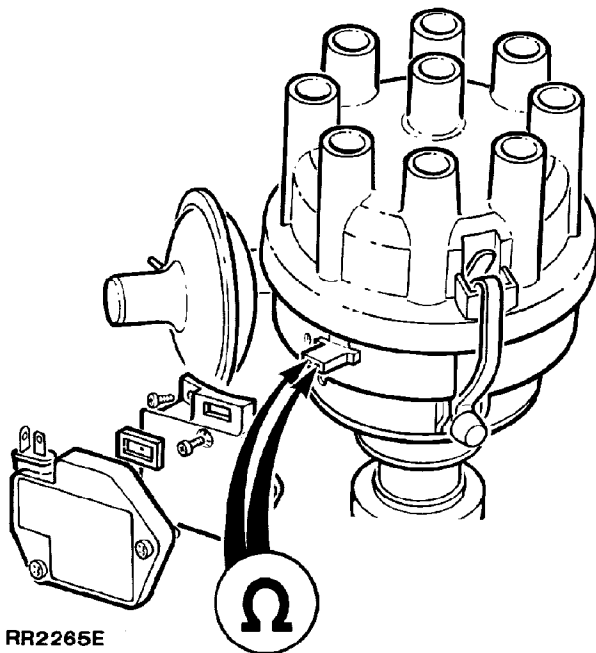
**TEST 4:****Pick-up Coil Resistance**

Remove amplifier.

Connect ohmmeter leads to two pick-up terminals in body of distributor.

The ohmmeter should register between 2k and 5k ohm if pick-up is satisfactory. If ohmmeter reading is correct, check all connections between pick-up and amplifier, if satisfactory, fit new amplifier. If engine still does not start carry out Test 5.

Change pick-up if ohmmeter reading is incorrect. If engine still does not start proceed to Test 5.

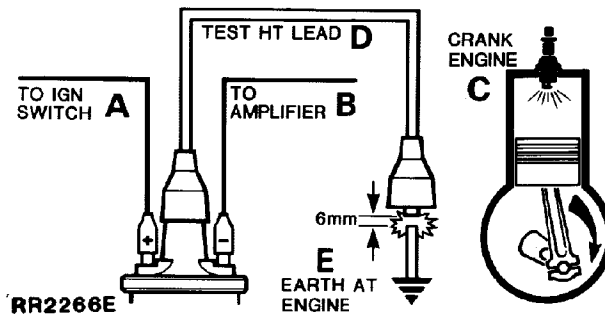
TEST 5:**Coil H.T. Sparking**

Remove existing coil/distributor H.T. lead and fit test H.T. lead to coil tower. Using suitable insulated pliers, hold free end about 6mm from engine block and crank engine. There should be good H.T. sparking.

If weak or no sparking, fit new coil, repeat test.

H.T. sparking good, repeat test with original H.T. lead. If sparking is good carry out Test 6.

If weak or no sparking, fit new H.T. lead, if engine will not start carry out Test 6.

TEST 6:

Rotor Arm

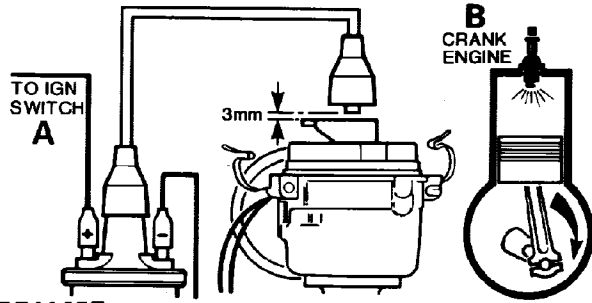

RR2267E

Remove distributor cover. Disconnect coil H.T. lead from cover, using insulated pliers hold about 3mm (0.13 in) above rotor arm electrode and crank the engine.

There should be no H.T. sparking between rotor and H.T. lead. If satisfactory carry out Test 7.

If H.T. sparking occurs, an earth fault on rotor arm is indicated. Fit new rotor arm. If engine will not start carry out Test 7.

TEST 7:

Visual and H.T. Cable Checks

Examine:

Should be:

- | | |
|--------------------------------|---|
| 1. Distributor Cover | Clean, dry, no tracking marks |
| 2. Coil Top | Clean, dry, no tracking marks. |
| 3. H.T. Cable Insulation..... | Must not be cracked, chafed or perished |
| 4. H.T. Cable Continuity | Must not be open circuit |
| 5. Sparking Plugs | Clean, dry, and set to correct gap |

NOTE:

- | | |
|-------------------------------------|---|
| 1. Reluctor | Must not foul pick-up or leads |
| 2. Rotor and Insulation Cover | Must not be cracked or show signs of tracking marks |



IGNITION TIMING

Service repair no - 86.35.15

Adjust

1. It is essential that following procedures are adhered to. Inaccurate timing can lead to serious engine damage and additionally create failure to comply with emission regulations. If timing is being checked in vehicle, air conditioning compressor must be disengaged.
2. On initial engine build, or if distributor has been disturbed for any reason, ignition timing must be set statically to the figure given:

If engine is 3.9 V8. **See ENGINE TUNING DATA, Information, ENGINE - 3.9 V8**

If engine is 4.2 V8. **See ENGINE TUNING DATA, Information, ENGINE - 4.2 V8**



NOTE: This approximate setting is made only to ensure that engine may be started.



CAUTION: On no account must engine be started before this operation is carried out.

Equipment required :-

**Calibrated Tachometer
Stroboscopic lamp**

3. Couple stroboscopic timing lamp and tachometer to engine following manufacturer's instructions.
4. Disconnect vacuum hose from distributor.
5. Start engine. With no load, and without exceeding 3,000 rev/min run engine until normal operating temperature is reached. (Thermostat open). Check that engine idles within tolerance.

If engine is 3.9 V8 check tolerance in. **See ENGINE TUNING DATA, Information, Engine - 3.9 V8**

If engine is 4.2 V8 check tolerance in. **See ENGINE TUNING DATA, Information, Engine - 4.2 V8**

6. Idle speed for timing purposes must not exceed 800 rev/min.
7. Run engine at idle speed and check timing using stroboscope light on timing marker and pointer.



WARNING: Keep hands and equipment away from drive belt.

8. If timing is not as specified, switch off engine. Loosen distributor clamp bolt and turn distributor to advance or retard ignition as necessary. Tighten clamp bolt, start engine and recheck timing.



WARNING: Personal injury may result if an attempt is made to adjust distributor whilst engine is running.

9. Upon completion, switch off engine and tighten distributor clamping bolt securely. Recheck timing, to ensure retightening has not disturbed distributor position.
10. Refit vacuum hose.
11. Disconnect stroboscopic timing lamp and tachometer from engine.



BATTERY

Service repair no - 86.15.01

Remove



WARNING: During battery removal always disconnect battery negative lead first. If positive lead is disconnected with negative lead in place, accidental contact of wrench to any grounded metal part could cause a severe spark, possibly resulting in personal injury. Upon installation of battery connect positive lead first.

1. Disconnect battery negative lead. Then disconnect the positive lead.
2. Release four nuts securing battery bracket.
3. Remove bracket.
4. Remove battery.

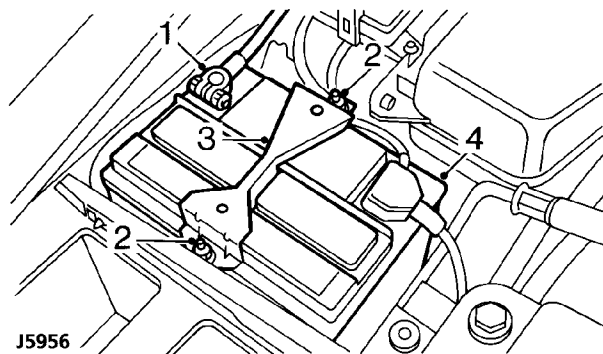

Refit

5. Reverse removal procedure.



NOTE: Coat battery clamps and terminals with petroleum jelly before refitting.

A.C. GENERATOR - V8i ENGINE

Service repair no - 86.10.01

Remove

1. Disconnect battery negative lead.

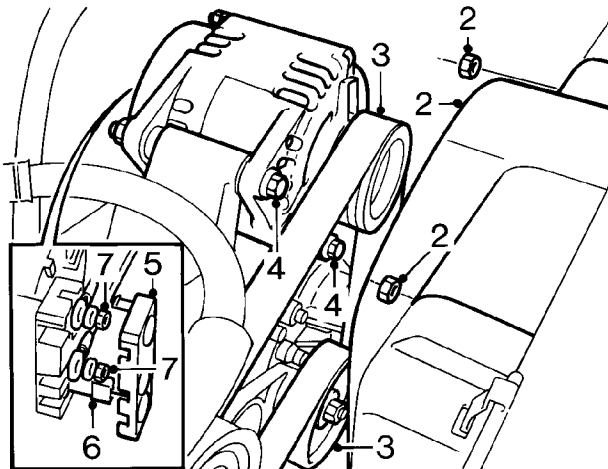

RR4107

2. Remove 2 nuts securing cooling fan cowl centre section, remove centre section.
3. Move drive belt tensioner pulley away from drive belt, release drive belt from A.C. generator pulley.
4. Remove 2 nuts and bolts securing alternator to mounting bracket.
5. Position A.C. generator to obtain access to rear cover, remove cover.
6. Disconnect ignition feed Lucar from A.C. generator.
7. Remove 2 nuts securing terminals to A.C. generator, release terminals from studs; remove alternator.

Refit

8. Reverse removal procedure. Tighten A.C. generator securing nuts to **24 Nm**.

A.C. GENERATOR DRIVE BELT

For A.C. Generator drive belt. *See ENGINE, Repair, Drive Belt*

DISTRIBUTOR-LUCAS 35 DLM8

Service parts

1. Cap
2. HT brush and spring
3. Rotor arm
4. Insulation cover
5. Pick-up module and base plate assembly
6. Vacuum unit
7. Amplifier module
8. 'O'-ring oil seal
9. Gasket

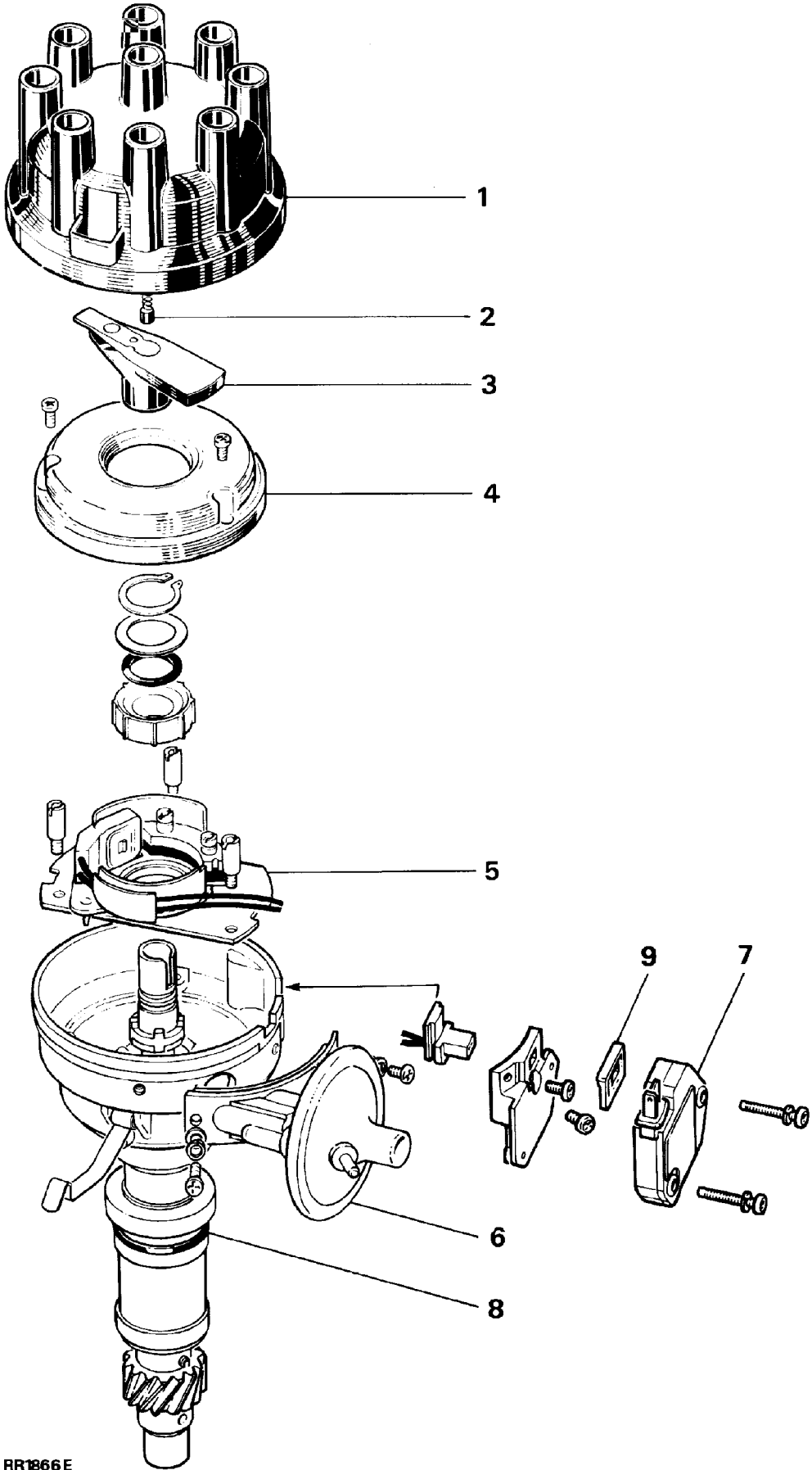

RR1866E

ELECTRONIC IGNITION - V8i

A Lucas 35DLM8 distributor is employed. This has a conventional vacuum advance unit and centrifugal automatic advance mechanism.

A pick-up module, in conjunction with a rotating timing reluctor inside distributor body, generates timing signals. These are applied to an electronic ignition amplifier module mounted on side of distributor body.



NOTE: Pick-up air gap is factory set. Do not adjust gap unless pick-up is being changed or base plate has been moved. Use a non-ferrous feeler gauge to set air gap.

DISTRIBUTOR - V8i

Service repair no - 86.35.20

Remove

1. Disconnect battery negative lead.
2. Disconnect vacuum hose.
3. Remove distributor cap.

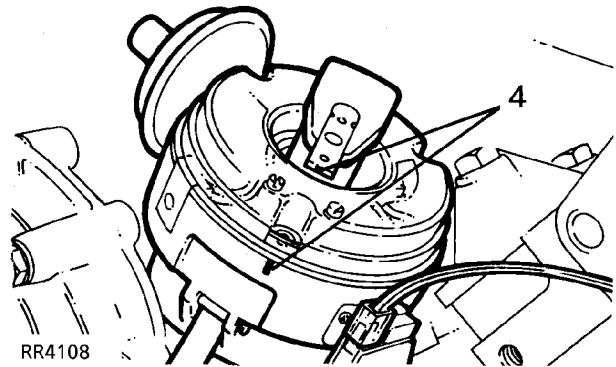

4. Mark distributor body and centre line of rotor arm.

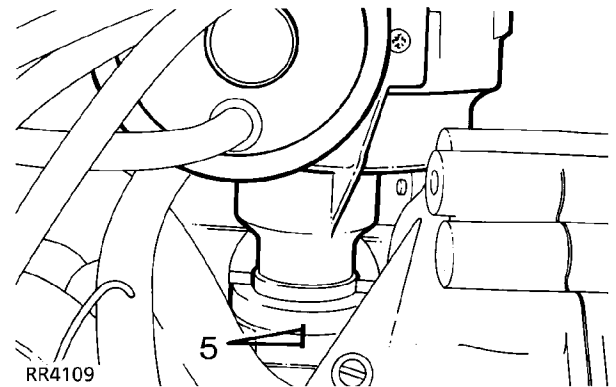

5. Add alignment marks to distributor and front cover.



NOTE: Marking distributor enables refitting in exact original position, but if engine is turned while distributor is removed, complete ignition timing procedure must be followed.

6. Release distributor clamp.
7. Raise distributor, disconnect multiplug from amplifier unit.



Refit



NOTE: If a new distributor is being fitted, mark body in same relative position as distributor removed.

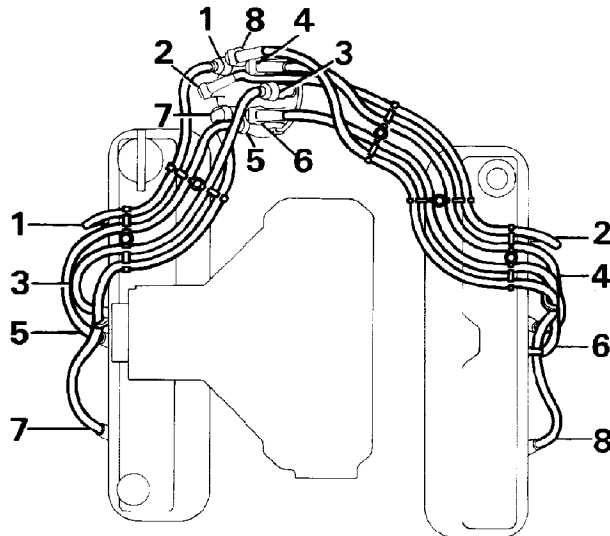

RR1876E

8. Leads for distributor cap should be connected as illustrated. Figures 1 to 8 inclusive indicate plug lead numbers. RH-Right hand side of engine, when viewed from rear. LH-Left hand side of engine, when viewed from rear.

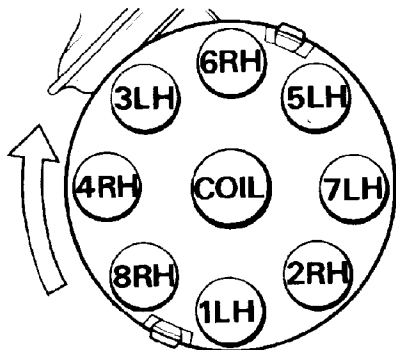

RR616M

9. If engine has not been turned while distributor has been removed, carry out instructions 10. to 17. Alternatively proceed to instruction 18.
10. Fit new 'O' ring seal to distributor housing.

11. Turn distributor drive until centre line of rotor arm is 30° anti-clockwise from mark made on top edge of distributor body.
12. Position distributor to engine, connect multiplug to amplifier; fit distributor in accordance with alignment markings.



NOTE: It may be necessary to align oil pump drive shaft to enable distributor drive shaft to engage in slot.

13. Fit clamp and bolt. Secure distributor in exact original position.
14. Connect vacuum hose to distributor and low tension lead to coil.
15. Fit distributor cap.
16. Reconnect battery.
17. Using suitable electronic equipment, set ignition timing. **See Adjustment, Ignition Timing**
18. If engine has been turned with distributor removed, carry out instructions 19. to 29.
19. Set engine-No. 1 piston to static ignition timing figure.

If engine is 3.9 V8i. **See ENGINE TUNING DATA, Information, ENGINE 3.9 V8i.**

If engine is 4.2 V8i. **See ENGINE TUNING DATA, Information, ENGINE 4.2 V8i.**

20. Turn distributor drive until rotor arm is approximately 30° anti-clockwise from number one sparking plug lead position on cap.
21. Fit distributor to engine.
22. Check that centre line of rotor arm is now in line with number one sparking plug lead on cap. Reposition distributor if necessary.
23. If distributor does not seat correctly in front cover, oil pump drive is not engaged. Engage by lightly pressing down distributor while turning engine.
24. Fit clamp and bolt, do not tighten.
25. Set ignition timing statically.

If engine is 3.9 V8i. **See ENGINE TUNING DATA, Information, ENGINE 3.9 V8i.**

If engine is 4.2 V8i. **See ENGINE TUNING DATA, Information, ENGINE 4.2 V8i.**

26. Connect vacuum hose to distributor.
27. Fit distributor cap.
28. Reconnect battery negative lead.
29. Using suitable electronic equipment set the ignition timing. **See Adjustment, Ignition Timing**

IGNITION COIL

Service repair no - 86.35.32

Remove

1. Disconnect battery negative lead.

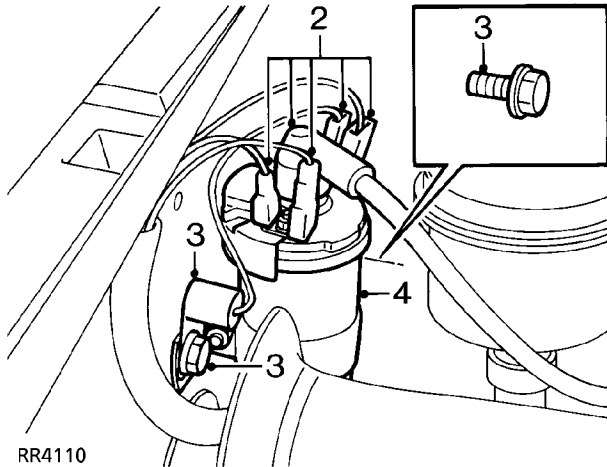

2. Noting their fitted positions, disconnect electrical leads from ignition coil.
3. Remove two bolts securing ignition coil clamp, recover suppressor.
4. Remove coil.

Refit

5. Reverse removal procedure.

BULB REPLACEMENT

For bulb type and rating refer to rating shown on the bulb or bulb replacement list. **See GENERAL SPECIFICATION DATA, Information, Bulbs**

HEADLAMP ASSEMBLY / SEALED BEAM UNIT

Service repair no - 86.40.02

Remove

1. Disconnect battery negative lead.
2. Remove radiator grille. **See CHASSIS AND BODY, Repair, Radiator Grille**
3. Remove three screws and headlamp retaining rim.

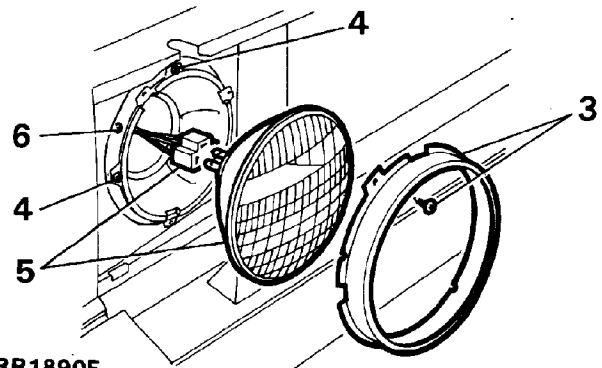

4. **DO NOT** disturb beam adjusting screws.
5. Withdraw sealed beam unit. Disconnect wiring plug from rear of unit.
6. Remove three securing screws, pry away grommet. Remove headlamp bowl.

Refit

7. Reverse removal procedure.



HEADLAMP ASSEMBLY/BULB REPLACEMENT

Service repair no - 86.40.02

Remove

1. Disconnect battery negative lead.
2. Remove radiator grille. *See CHASSIS AND BODY, Repair, Radiator Grille*
3. Remove three screws and headlamp retaining rim.

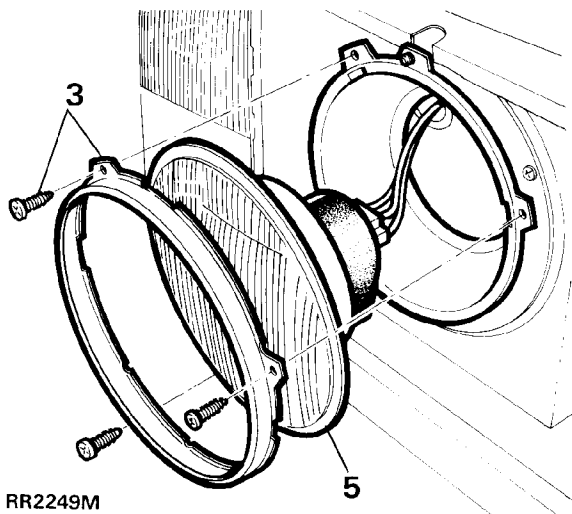

4. **DO NOT** disturb beam adjusting screws.
5. Withdraw headlamp unit. Disconnect wiring plug from rear of unit.
6. Remove rubber dust cover.

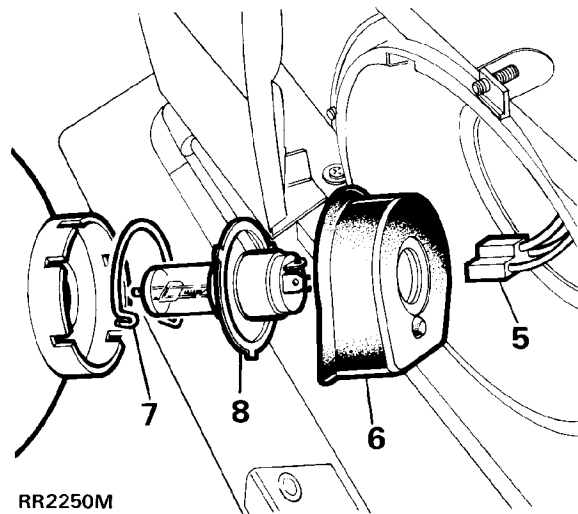

7. Release retaining clip, remove bulb
8. Remove three securing screws, pry away grommet. Remove headlamp bowl.

Refit

9. Reverse removal procedure.
DO NOT touch quartz envelope of bulb. Gently clean using methylated spirits if contact does occur.

HEADLAMP ALIGNMENT

Service repair no - 86.40.17

Headlamp beam setting should only be carried out by qualified personnel using suitable beam setting equipment, for example the Lucas Beamtester.

RR3825M shows right hand drive beam pattern, left hand drive is symmetrically opposite.

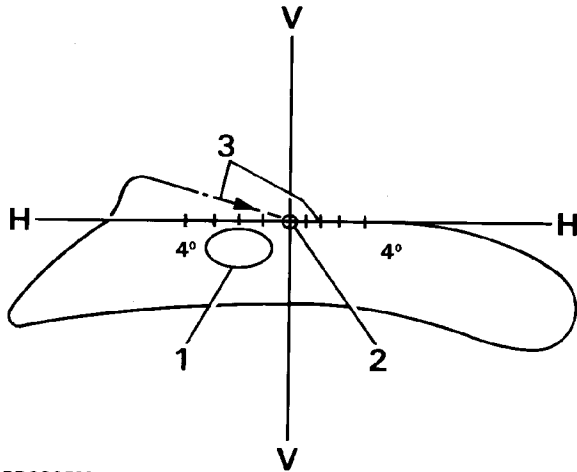

RR3825M

Guide to beam pattern:

1. Maximum intensity zone.
2. Beam aim kink point.
3. Aiming datum lines.

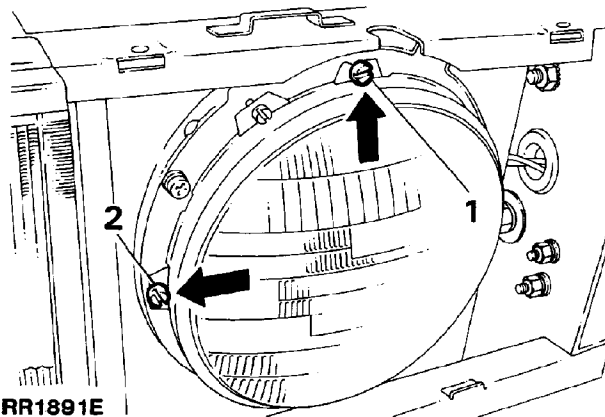

RR1891E

Adjust

1. Turn top adjusting screw anti-clockwise to lower beam, clockwise to raise beam.
2. Turn side adjusting screw anti-clockwise to move beam to left, clockwise to move beam to right.

AUXILIARY DRIVING LAMP

Service repair no - 86.40.96

Bulb replacement

1. Disconnect battery negative lead.
2. Securing nut is located beneath front bumper, adjacent to front body fixing. Access to lamp is gained through front wheel arch.
3. Disconnect electrical plug.
4. Remove single nut and washer.

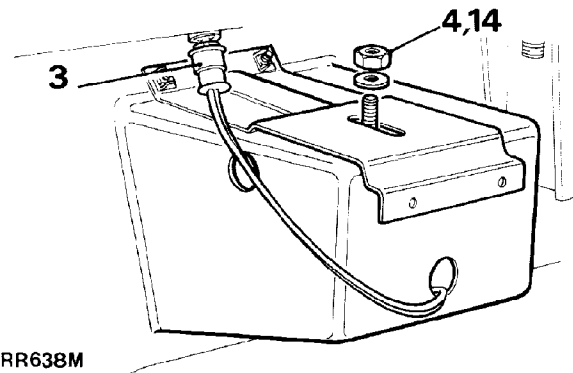

RR638M

5. From front of vehicle, manoeuvre lamp. Remove lamp from spoiler opening.
6. Remove two screws securing cover to rear of lamp.
7. Withdraw cover.
8. Disconnect lucar connector.
9. Release spring clip securing bulb to lamp unit.
10. Remove bulb.

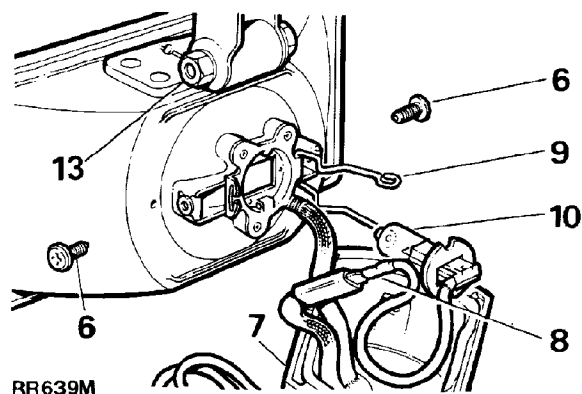

Refit

11. Fit a new bulb. Ensure two notches on bulb body locate with registers on lamp unit.
12. Reverse removal procedure.

Adjust

Correct adjustment is beam horizontal (parallel to ground) and parallel to vehicle axis.

13. Loosen lamp adjusting bolt to lower or raise beam.
14. Loosen lamp securing bolt to move beam to left or right.
15. Tighten fixing bolts to **15 Nm**.

SIDELIGHT AND FLASHER LAMP ASSEMBLY AND BULB

Service repair no - 86.40.24

Remove

1. Disconnect battery negative lead.
2. Remove two screws and plain washers securing lamp assembly.
3. Lift assembly away sufficiently to gain access to rear of lamp.
4. Remove waterproof cover.
5. Depress two retaining clips and withdraw bulb holder.
6. Remove required bulb. Direction indicator bulb is located in upper section of bulb holder, side lamp bulb in lower.
7. Disconnect multi-plug. Remove complete assembly.

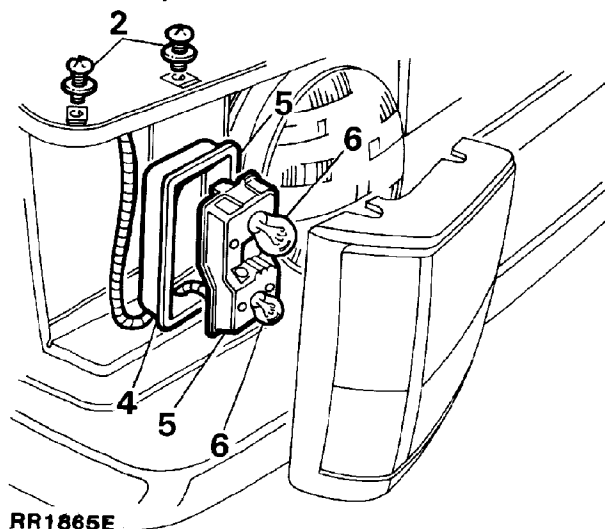

Refit

8. Reverse removal procedure. Ensure waterproof cover is correctly located.

DIRECTION INDICATOR/SIDE REPEATER LAMP BULB REPLACEMENT

Service repair no - 86.40.65

Remove

1. Disconnect battery negative lead.
2. Release clips securing wheel arch liner.

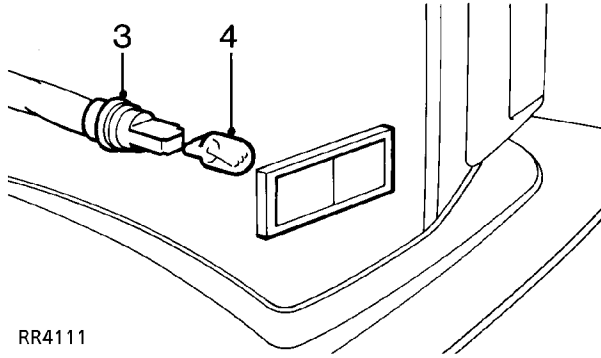

RR4111

3. At back of lamp, twist bulb holder anti-clockwise to remove from lamp assembly.
4. Remove bulb.

Refit

5. Reverse removal procedure.

TAIL LAMP ASSEMBLY

Service repair no - 86.40.74

Remove

1. Disconnect battery negative lead.
2. Remove four lens retaining screws.
3. Remove lens.
4. Remove sealing rubber, if required.



NOTE: To remove sealing rubber complete it is necessary to remove side marker lens.

5. Remove bulbs.
6. Remove four screws securing lamp unit to body.
7. Remove two through-screws from reflector side, which also secure lamp unit to body.
8. Ease lamp unit forward and disconnect leads at moulded connectors.

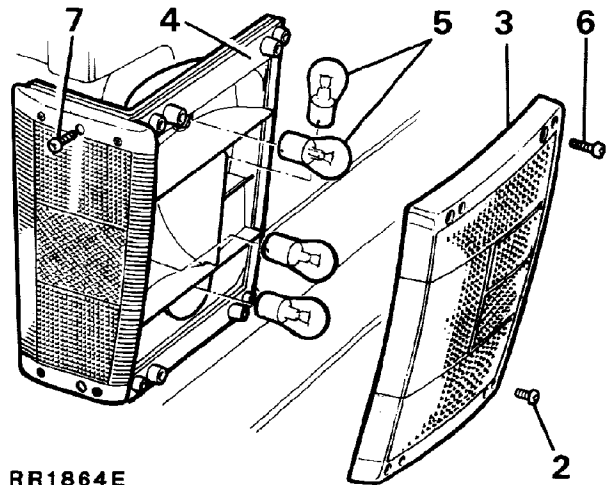

RR1864E

Refit

9. Reverse removal procedure.



REFLECTORS/SIDE MARKER LAMP ASSEMBLY AND BULB

Service repair no - 86.40.67

Remove

1. Remove four screws securing lens.
2. Remove lens.
3. Remove bulb.

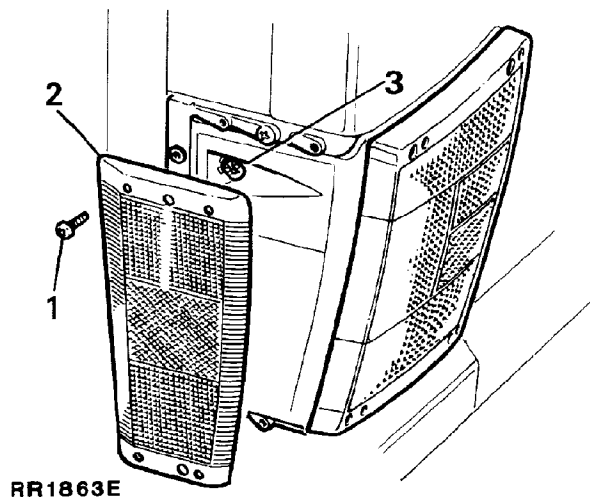

NOTE: To remove rubber seal completely it is necessary to remove tail light lens.

Refit

4. Reverse removal procedure.

UNDER BONNET LAMP ASSEMBLY

Service repair no - 86.45.24

Remove

1. Disconnect battery negative lead.
2. Remove two securing screws.
3. Remove lamp glass.
4. Pull 'wedge' type bulb from bulb holder.

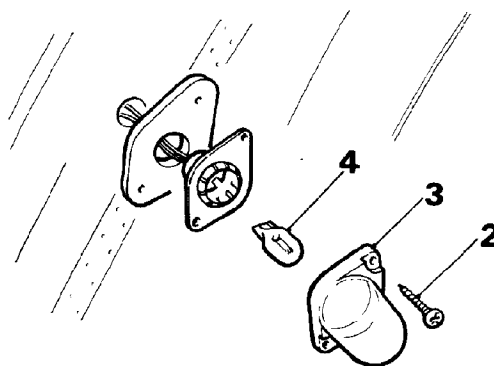

5. Disconnect electrical leads located below bonnet lamp switch attached to inner fender.
6. Pull rubber grommet off leads and pull lamp and leads up through hood stiffener channel.

Refit

7. Reverse removal procedure. 1 to 6.



NOTE: A piece of bent wire will be needed to pull electrical leads out of channel exit hole when fitting a new lamp assembly.

HEATER/VENTILATION AND AIR CONDITIONING CONTROL PANEL BULB

Service repair no - 86.45.73

Remove

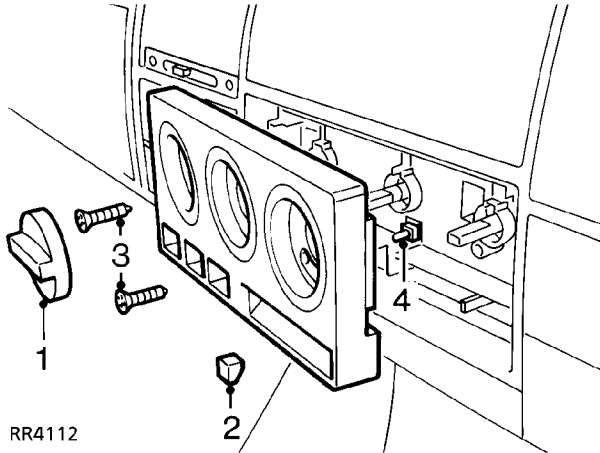

RR4112

1. Carefully pull 3 rotary knobs off switches.
2. Prise blower speed control knob off lever.
3. Remove 2 screws securing panel, ease panel away from fascia.
4. Pull bulb from holder.
5. Insert new bulb in holder.

Refit

6. Reverse removal procedure.

HEATER/VENTILATION AND AIR CONDITIONING CONTROL PANEL SWITCHES AND BULBS

Service repair no - 82.20.49 - Air conditioning switch

Service repair no - 86.10.27 - Recirculation switch

1. Remove centre dash panel. *See CHASSIS AND BODY, Repair, Dash Panel Central Louvre Panel*

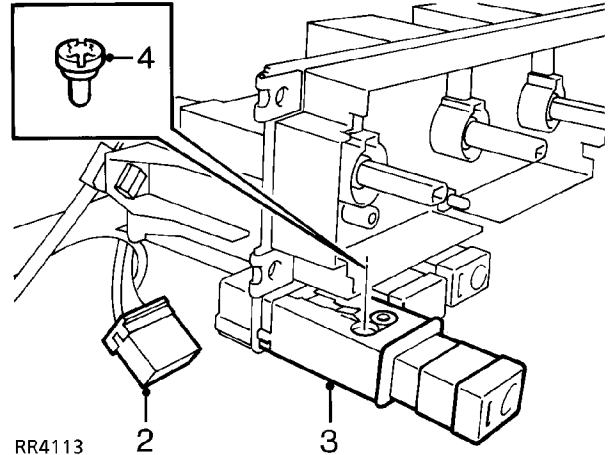

RR4113

2. Disconnect multiplug from appropriate switch.
3. Depress retaining lugs, withdraw switch from panel.

Bulb replacement

4. Rotate bulb holder, withdraw holder and bulb.

Refit

5. Reverse removal procedure.



DOOR EDGE LAMPS / PUDDLE LAMPS

Service repair no - 86.40.38

Incorporated into front door assemblies are door edge lamps and puddle lamps, located on door edge and bottom of door. The lamps are activated by courtesy light switches when either front door is opened and will immediately switch off when both doors are closed.

Remove

1. Ensure side door glass is fully closed.
2. Disconnect battery negative lead.
3. Remove interior door handle and arm rest/door pull from door.
4. Carefully release interior door trim pad from inner door panel.
5. Peel back lower half of plastic vapour barrier.
6. Disconnect electrical connectors within door, accessible through lower centre and outer openings of inner door panel.
7. Release door edge lamp electrical leads from retaining clips.
8. Remove lens and pry lamps out of door and withdraw electrical leads.

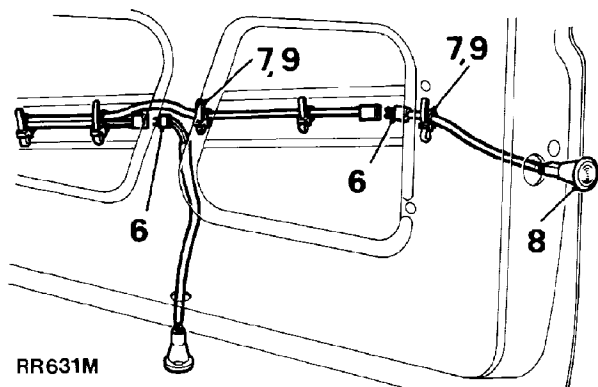

Refit

9. Reverse removal procedure.



NOTE: Ensure door lamp wiring harness is securely clipped to lower stiffener plate within door to prevent damage occurring to electrical leads when door glass is in its lowest position.

DOOR EDGE LAMPS/PUDDLE LAMPS BULB

Service repair no - 86.40.47

1. Disconnect battery negative lead.

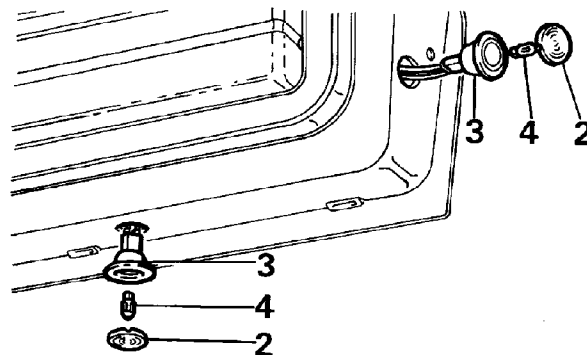

2. Carefully pry out lamp lens.
3. Withdraw lamp body from door **ONLY** as far as electrical leads will permit.
4. Pull bulb from holder.

Refit

5. Fit new bulb, refit lamp lens.
6. Push lamp into door.

AUTOMATIC GEAR SELECTOR-PANEL BULB

Service repair no - 86.45.40

1. Disconnect battery negative lead.

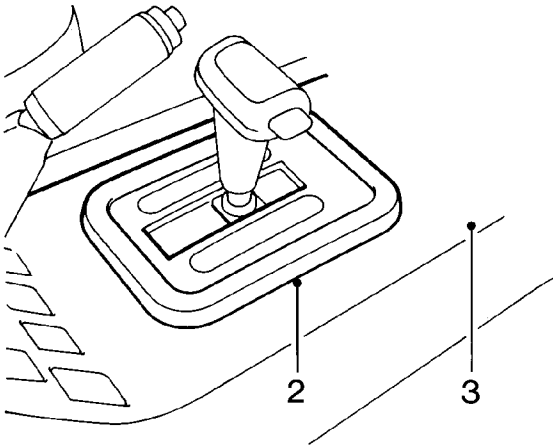

RR4115

2. Carefully prise quadrant finisher out of surround.
3. Carefully prise rear of surround away from centre console.

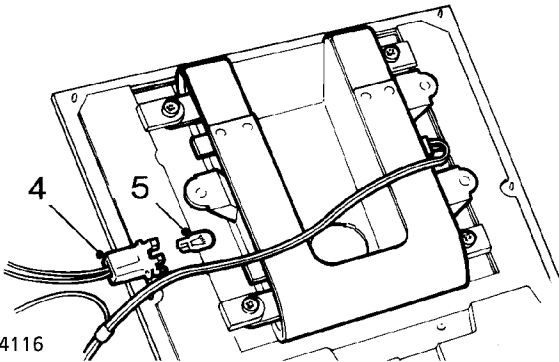

RR4116

4. Pull appropriate bulb holder from fitted position.
5. Remove bulb from holder.

Refit

6. Reverse removal procedure.

NUMBER/LICENSE PLATE LAMP ASSEMBLY AND BULB

Service repair no - 86.40.86

Remove

1. Disconnect battery negative lead.
2. Remove two self-tapping screws with washers.
3. Remove lamp assembly.
4. Disconnect bulb holder, remove bulb.



NOTE: Carefully pull electrical leads out of bottom of lower tailgate panel to reveal snap connectors.

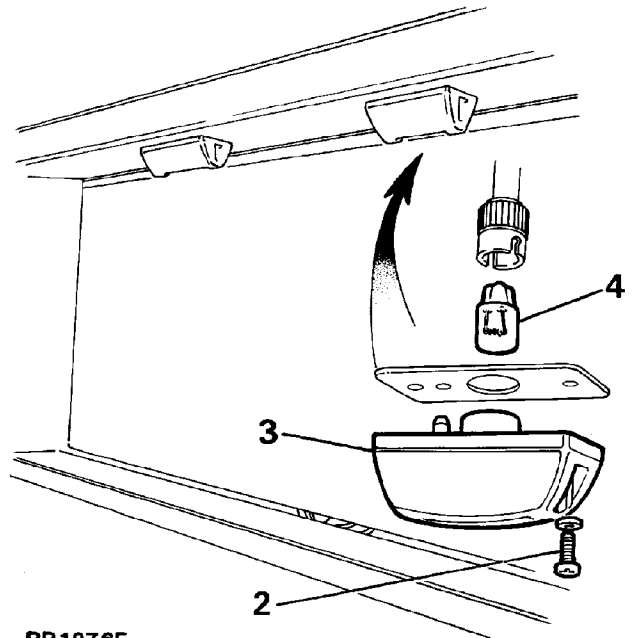

RR1976E

5. Disconnect electrical connections located at bottom of lower tailgate.
6. Remove bulb holder.
7. Carefully pull electrical leads up through inside of lower tailgate panels.

Refit

8. Reverse removal procedure.



INTERIOR ROOF LAMP

Service repair no - 86.45.01

Remove

Interior roof lamps are operated automatically via side door and tailgate courtesy switches or by an independent switch in auxiliary switch panel.

1. Disconnect battery negative lead.
2. Remove lens from courtesy lamp by pressing upward and turning it counter-clockwise.
3. Withdraw bulb from spring clip holder.
4. Remove screws securing lamp base to roof panel.
5. Lower lamp to reveal cable snap connections.
6. Disconnect electrical connections.

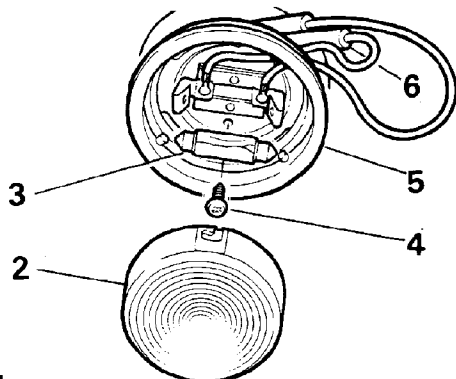

RR485M

Refit

7. Reverse removal procedure.

STARTER MOTOR - V8i ENGINE

Service repair no - 86.60.01

Remove

1. Place vehicle on a suitable ramp [hoist].
2. Disconnect battery negative lead.
3. Disconnect leads from solenoid and starter motor. Remove exhaust heat shield.
4. Remove two bolts, starter motor to flywheel housing.
5. Remove starter motor.

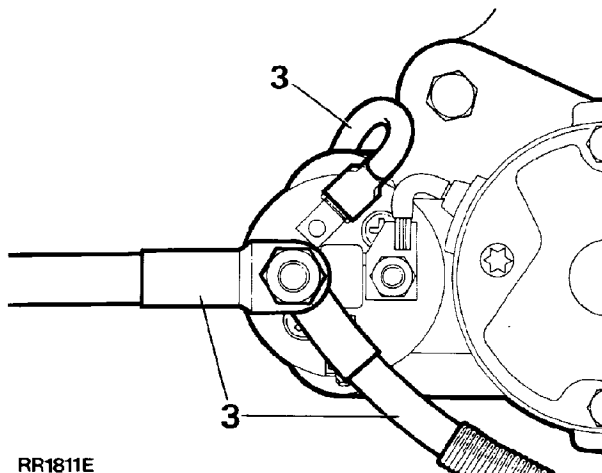

RR1811E

Refit

6. Reverse removal procedure.

AUXILIARY SWITCHES AND BULBS

Service repair no - 86.45.49 - Switches

Service repair no - 86.45.29 - Bulbs

The auxiliary switch panel contains up to six switches depending on vehicle specification. Each switch incorporates integral symbols for identification. Unused switch openings are fitted with blank covers, which are removable, to facilitate fitting extra switches if required.

The symbols are illuminated by two bulbs which become operational when vehicle lights are on.

Switch replacement

Remove

1. Disconnect battery negative lead.
2. Remove air suspension switch panel. *See Air Suspension Switches and Bulbs*

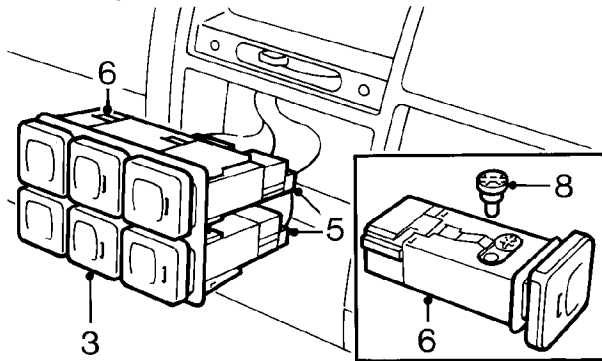

RR4117

3. Carefully prise auxiliary switch panel out of fascia.
4. Withdraw switch panel as far as electrical leads will permit.
5. Noting their fitted position, disconnect multiplug(s) from the switch(es).
6. Depress small retaining lugs on top and bottom of switch and push switch(es) through front of switch surround.

Bulb replacement

7. Identify bulb to be replaced and remove appropriate switch.
8. Rotate bulb holder 90 deg. and withdraw it from switch; discard bulb holder and bulb.

Refit

9. Reverse removal procedure.



AIR SUSPENSION SWITCHES AND BULBS

Service repair no - 86.65.88 - Switches

Service repair no - 86.45.29 - Bulbs

Switch replacement

Remove

1. Disconnect battery negative lead.

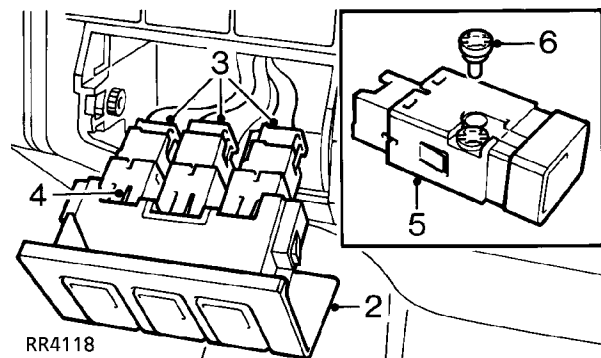

2. Carefully release lower edge of panel from surround, withdraw panel.
3. Noting their fitted positions, disconnect multiplugs from switches.
4. Depress retaining lugs on switches, remove switches from panel.

Bulb replacement

5. Identify bulb to be replaced and remove appropriate switch.
6. Rotate bulb holder 90 deg. and withdraw it from switch.

Refit

7. Reverse removal procedure.

HEADLAMP/FLASHER SWITCH AND WINDSCREEN WASH/WIPE SWITCH

Service repair no - 84.15.34 - Wash wipe switch
Service repair no - 86.65.41 - Headlamp/flasher switch



NOTE: The following procedure applies to either switch.

Remove

1. Remove steering column shroud. **See STEERING, Repair, Steering Column Shroud**
2. Position steering wheel for access.

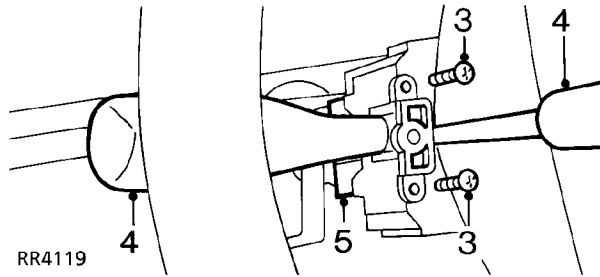

RR4119

3. Remove 2 screws securing switch.
4. Insert a suitable, flat bladed tool between switch and casing, depress raised 'pip', release switch from casing.
5. Disconnect switch multiplugs.

Refit

6. Connect switch multiplugs.
7. Position switch to casing ensuring 'pip' is engaged.
8. Reverse removal procedure. 1 and 3.

HAZARD WARNING SWITCH AND BULB

Service repair no - 86.65.50 - Switch
Service repair no - 86.45.29 - Bulb

Switch replacement

Remove

1. Disconnect battery negative lead.
2. Remove ashtray.

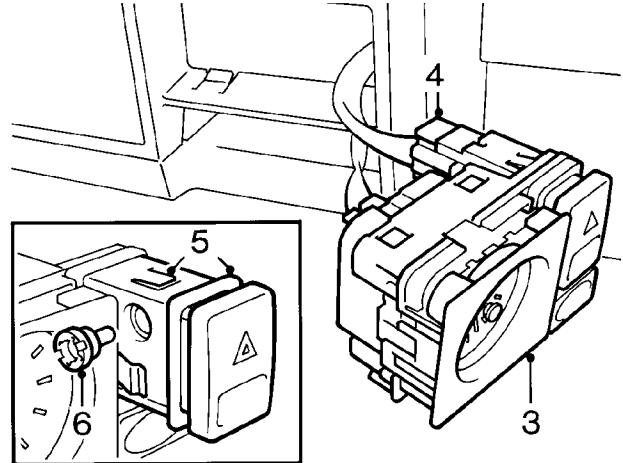

RR4120

3. Carefully release panel from fascia.
4. Disconnect multiplug from switch.
5. Depress retaining lugs, remove switch from panel.

Bulb replacement

6. Rotate bulb holder 90 deg. and withdraw it from switch, discard bulb holder and bulb.

Refit

7. Reverse removal procedure.



IGNITION/STARTER SWITCH - BULB REPLACEMENT

Service repair no - 86.45.29

Remove

1. Remove steering column shroud. *See STEERING, Repair, Steering Column Lock Assembly*

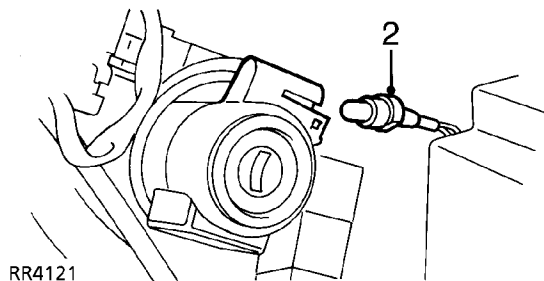

2. Withdraw bulb holder, remove bulb.

Refit

3. Reverse removal procedure.

DOOR PILLAR SWITCH

Service repair no - 86.65.15

Remove

1. Disconnect battery negative lead.
2. Remove screw securing switch to door pillar.
3. Remove switch.
4. Disconnect electrical lead from connector blade.

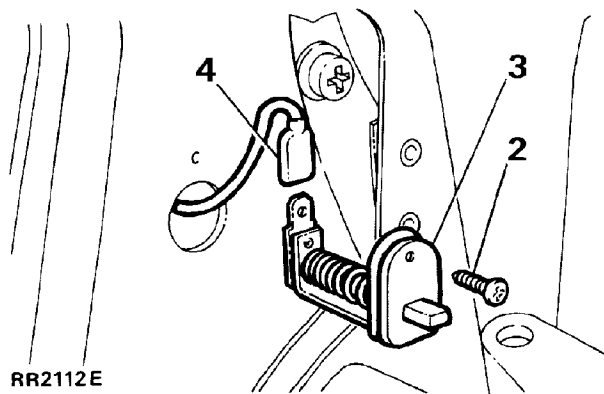

Refit

5. Reverse removal procedure.

IGNITION/STARTER SWITCH

Service repair no - 86.65.02

Remove

1. Remove steering column lock. **See STEERING, Repair, Steering Column Lock Assembly**

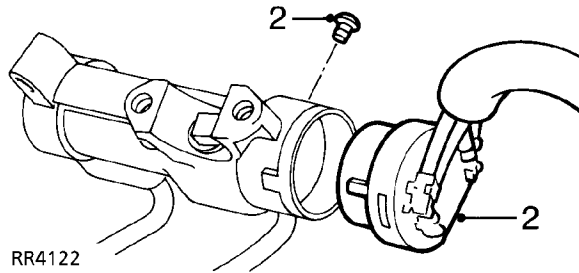

2. Remove screw securing ignition/starter switch, remove switch from lock barrel.

Refit

3. Position switch to lock barrel ensuring peg is inserted in switch, fit and tighten screw.
4. Fit steering column lock. **See STEERING, Repair, Steering Column Lock Assembly**

REAR TAILGATE SWITCH

Service repair no - 86.65.22

Remove

1. Disconnect battery negative lead.
2. Remove single screw securing switch to tailgate opening.
3. Withdraw switch.
4. Disconnect electrical lead.

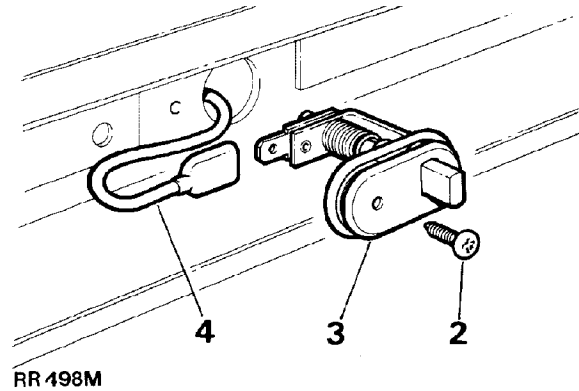
**Refit**

5. Reverse removal procedure.



UNDER BONNET/HOOD ILLUMINATION SWITCH

Service repair no - 86.65.23

Remove

1. Disconnect battery negative lead.
2. Remove single screw securing switch to decker panel.
3. Withdraw switch.
4. Disconnect electrical lead.

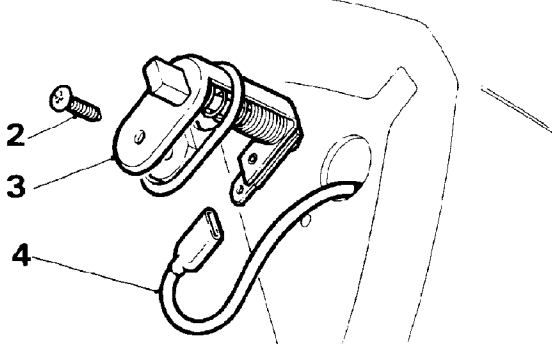

RR499M

Refit

5. Reverse removal procedure.

CIGAR LIGHTER AND BULB

Service repair no - 86.65.60 - Cigar lighter

Service repair no - 86.45.55 - Bulb

Cigar lighter

Remove

1. Remove centre console. *See CHASSIS AND BODY, Repair, Centre Console*

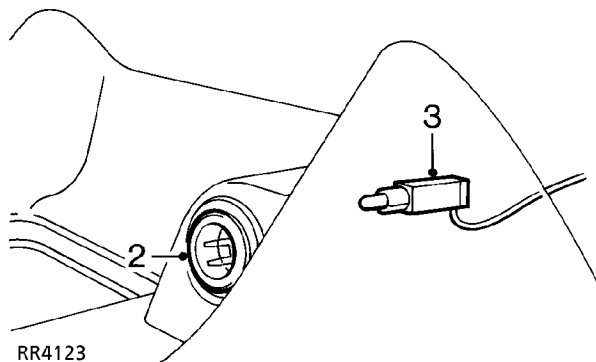

RR4123

2. Depress lugs securing cigar lighter, withdraw lighter from centre console.

Bulb replacement

3. Remove bulb from holder.

Refit

4. Reverse removal procedure.

REVERSE LIGHT SWITCH

Service repair no - 37.27.01

Manual gearbox**Remove**

Reverse light switch is located at rear of selector housing, accessible from beneath vehicle.

1. Place vehicle on suitable ramp.
2. Disconnect battery negative lead.
3. Disconnect electrical leads.
4. Release lock-nut.
5. Remove switch.

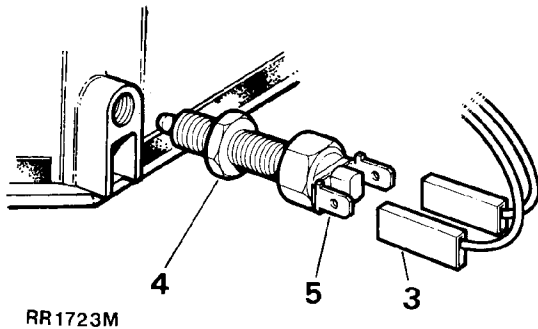
**Refit**

NOTE: Reverse light switch requires re-setting on reassembly.

6. Select reverse gear.
7. Connect 12 volt supply and test lamp across switch terminals.
8. Screw switch into housing until test lamp is illuminated. Screw switch in a further half turn, tighten locknut.
9. Connect electrical leads.
10. Reconnect battery negative lead.

START INHIBIT / REVERSE LIGHT SWITCH

Service repair no - 44.15.19

Automatic gearbox**Remove**

Reverse light switch is an integral part of start inhibitor switch. It is located on left hand side of gearbox, accessible from beneath vehicle.

1. Place vehicle on suitable ramp.
2. Disconnect battery negative lead.
3. Disconnect multi-plug.
4. Release clamp bolt, remove clamp.
5. Remove switch.

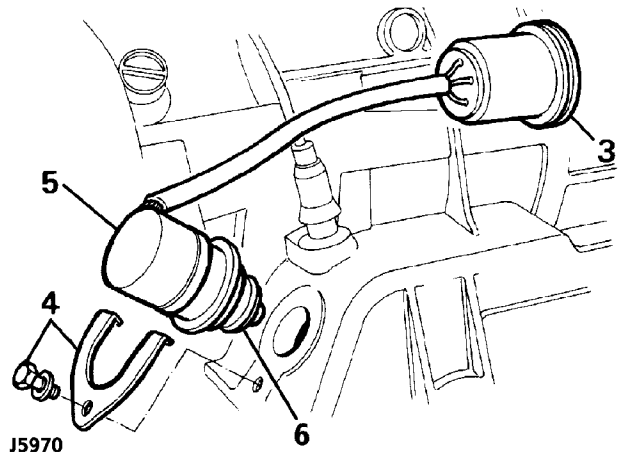
**Refit**

6. Fit a new 'O' ring to switch.
7. Reverse removal procedure.



OIL PRESSURE WARNING SWITCH - V8i

Service repair no - 86.65.30

Remove

1. Disconnect battery negative lead.
2. Disconnect electrical lead.
3. Unscrew switch unit.
4. Remove switch and sealing washer.

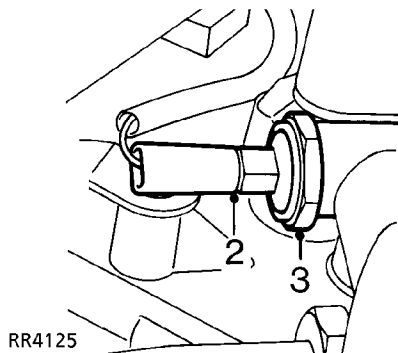

Refit

5. Reverse removal procedure. Using a NEW sealing washer.

PARK BRAKE WARNING SWITCH

Service repair no - 86.65.45

Remove

1. Remove centre console. *See CHASSIS AND BODY, Repair, Centre Console*
2. Apply park brake.
3. Reposition hose at side of bracket to gain access to switch.

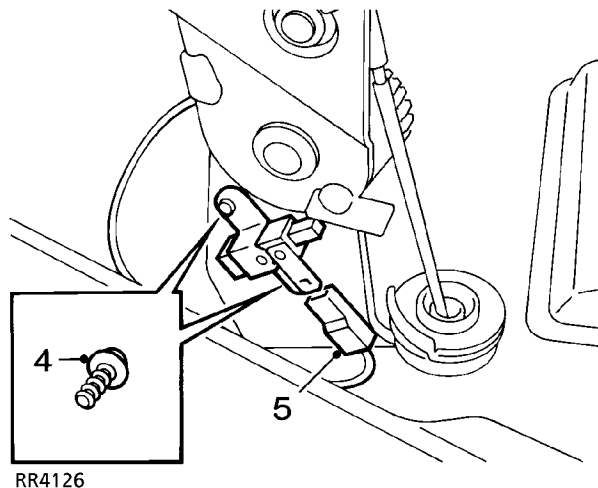

4. Remove screw securing switch.
5. Withdraw switch, disconnect Lucar, remove switch.

Refit

6. Reverse removal procedure.

EXTERIOR DRIVING MIRRORS MOTOR**Remove**

1. Disconnect battery negative lead.
2. Remove mirror glass. *See CHASSIS AND BODY, Repair, Exterior Driving mirror*

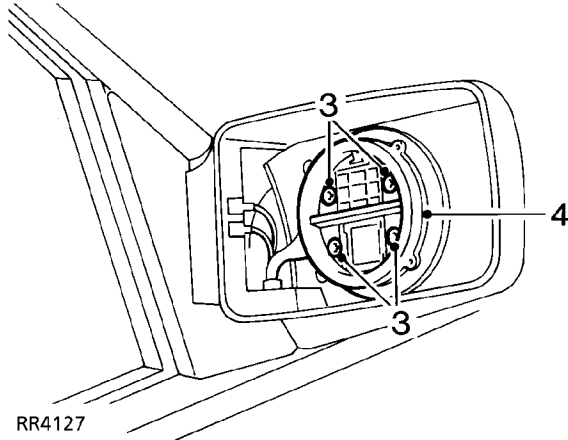

3. Remove 4 screws securing motor.
4. Position motor to obtain access to electrical connections.
5. Disconnect harness from motor, remove motor.

Refit

6. Position motor, connect harness.
7. Fit and tighten securing screws.
8. Fit mirror glass. *See CHASSIS AND BODY, Repair, Exterior driving mirror*
9. Reconnect battery negative lead.

CONTROL SWITCHES

Service repair no - 86.65.75 - Switches

Service repair no - 86.45.29 - Bulbs



NOTE: The following operation covers the exterior driving mirror, rear screen wash, rear screen wipe and petrol filler flap switches and bulbs.

Switch replacement**Remove**

1. Disconnect battery negative lead.
2. Release turnbuckles, lower driver's access panel.

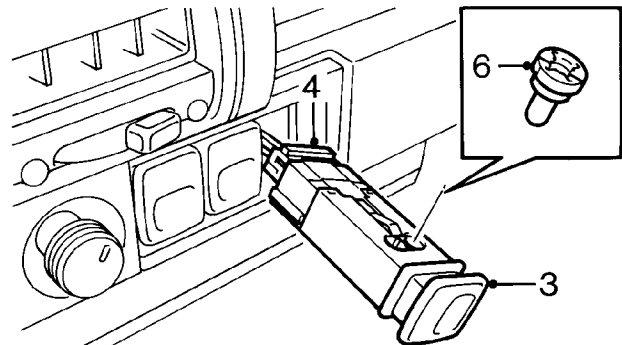

RR4128

3. Depress lugs retaining appropriate switch, press switch from panel.
4. Disconnect multiplug from switch, remove switch.

Bulb replacement

5. Identify bulb to be replaced and remove appropriate switch.
6. Rotate bulb holder 90 deg. and withdraw it from switch; discard bulb holder and bulb.

Refit

7. Reverse removal procedure.



INSTRUMENT ILLUMINATION ELECTRONIC DIMMER / RHEOSTAT

Service repair no - 86.65.07

Electronic dimming control switch is located in instrument panel finisher. Rotate control to vary intensity of illumination.

Remove

1. Disconnect battery negative lead.
2. Remove instrument panel finisher. *See Instrument Panel Finisher*

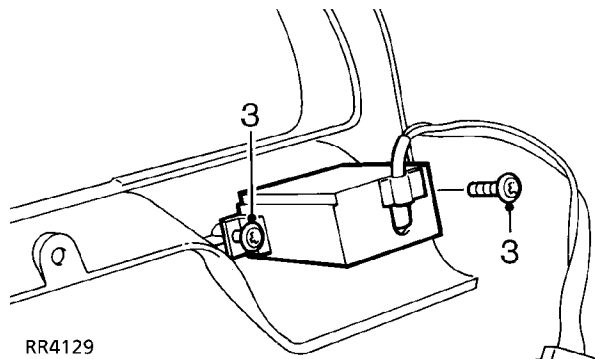

RR4129

3. Remove 2 screws securing rheostat, remove rheostat.

Refit

4. Reverse removal procedure.

WINDOW LIFT/HEATED SEAT CUSHION SWITCHES AND BULBS

Service repair no - 86.25.16 - Switches

Service repair no - 86.45.29 - Bulb

Switch replacement

Remove

1. Disconnect battery negative lead.

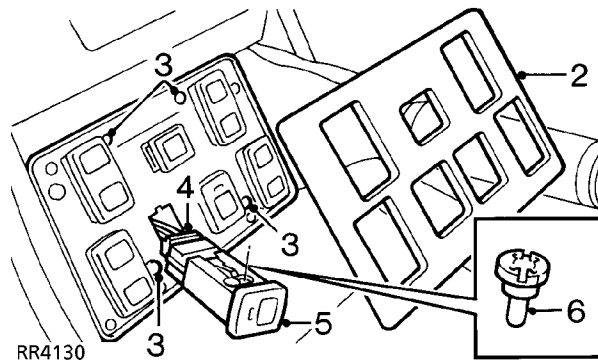

RR4130

2. Carefully release rear of surround from centre console.
3. Remove screws, pry window lift switch surround from glove box.
4. Disconnect multi-plug(s) at rear of switch(es).
5. Apply pressure to rear of switch, push it through surround.

Bulb replacement

6. Identify bulb to be replaced and remove appropriate switch.
7. Rotate bulb holder 90° and withdraw it from switch; discard bulb and holder.

Refit

8. Reverse removal procedure.

WINDOW LIFT MOTOR - FRONT DOORS

Service repair no - 86.25.04

Remove

1. Ensure that side door glass is fully closed, secure with adhesive tape.
2. Remove front door trim panel. **See CHASSIS AND BODY, Repair, Front Door Trim Panel**
3. Peel back front top corner of plastic vapour barrier to reveal window lift motor.
4. Release window lift motor wiring harness from three retaining clips to allow harness to be pulled out of opening at front of inner door panel.
5. Disconnect window lift motor multi-plug from main door harness.

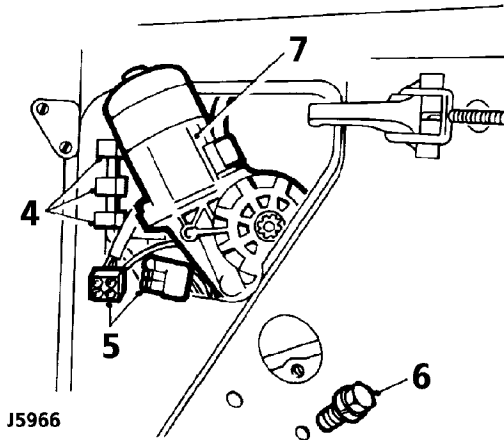

6. Support motor, remove three securing bolts.
7. Remove motor through top front opening of door.

Refit

8. Reverse removal procedure. 1 to 7.



NOTE: Ensure that drive gear is engaged and correctly aligned with window lift linkage before fitting securing bolts.

WINDOW LIFT MOTOR - REAR DOORS

Service repair no - 86.25.09

Remove

1. Ensure that side door glass is fully closed, secure with adhesive tape.
2. Remove rear door trim panel. **See CHASSIS AND BODY, Repair, Rear Door Trim Panel**
3. Carefully detach bottom half of vapour barrier to reveal window lift motor.
4. Release motor wiring harness from retaining clips.
5. Disconnect lift motor harness snap connections from main door harness.
6. Support motor, release three securing bolts.
7. Remove lift motor from lower opening in inner door panel.

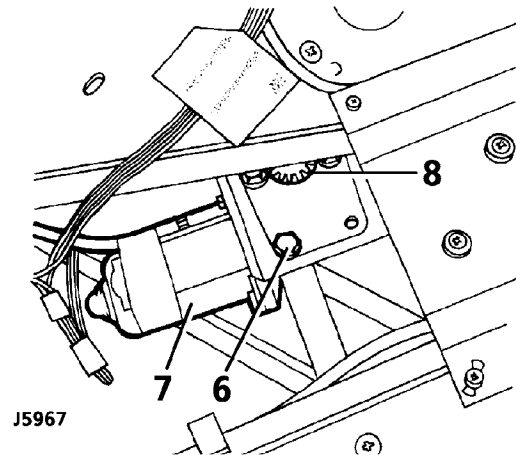
**Refit**

8. Reverse removal procedure. 1 to 7.



NOTE: Ensure that drive gear is engaged and correctly aligned with window lift linkage before fitting securing bolts.



CENTRAL DOOR LOCKING

The central door locking system on four door models is activated from both driver and front passenger doors. A switch/lock actuator is fitted in both front doors.

Front and rear passenger doors can be independently locked or unlocked from inside vehicle but can be overridden by further operation of driver's door locking control.

On rear doors only, a child safety lock is provided which can be mechanically pre-set to render interior door handles inoperative.

Failure of an actuator will not affect locking of remaining three doors, tailgate or fuel filler flap. A door with inoperative actuator can still be locked or unlocked manually, but not fuel filler flap.



NOTE: Actuator units contain non-serviceable parts. If a fault occurs, fit a new unit.

HANDSET INITIALISATION



NOTE: New handsets are supplied in pairs. If a new handset is required, it will require initialisation to the ECU using the following procedure:

1. Starting conditions: ignition off, doors unlocked, bonnet switch depressed.
2. Carry out instructions 3 to 9. within 8 seconds.
3. Switch ignition ON.
4. Switch ignition OFF.
5. Lock doors.
6. Unlock doors.
7. Release bonnet switch.
8. Switch ignition ON.
9. Switch ignition OFF.

If alarm is correctly accessed, horn will sound and LED will light. It is now possible to programme two handsets of correct frequency to vehicle alarm ECU. This must be carried out within two minutes.

10. Press and hold down button on first handset until dash LED flashes.
11. Repeat instruction 10 for second handset.
12. The LED will extinguish if both handsets have been initialised correctly.

FRONT DOOR ACTUATOR UNIT

Service repair no - 86.26.08

Remove

1. Ensure window is in its fully closed position.
2. Remove front door trim panel. **See CHASSIS AND BODY, Repair, Front Door Trim Panel**
3. Peel back plastic vapour barrier to expose actuator unit.
4. Remove four screws and plain washers securing lock actuator mounting plate to inner door panel.
5. Release cable tie, at trailing edge of door, retaining electrical cable.
6. Manoeuvre actuator assembly from actuator link.

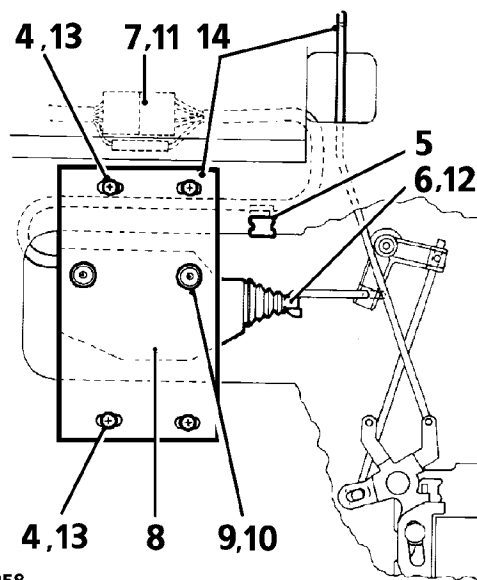

7. Withdraw actuator assembly, disconnect multi-plug.
8. Remove actuator assembly.
9. Remove actuator unit by loosening two screws securing it to mounting plate.

Refit

10. Fit actuator unit to mounting plate.
11. Connect multi-plug.
12. Manoeuvre actuator assembly to engage actuator link.
13. Loosely fit actuator mounting plate to inner door panel with four screws. Set mounting plate in centre of slotted holes.
14. Ensure that manual operation of sill locking control is not restricted by operation of actuator operating rod and vice versa. Reset mounting plate as necessary.
15. Reconnect vehicle battery.
16. Check that electrical operation of door lock occurs when sill locking control is moved through half of total movement. Reset mounting plate if necessary, tighten four screws.



NOTE: Above adjustment ensures that full tolerance on switching operation is utilised.

REAR DOOR ACTUATOR UNITS

Service repair no - 86.26.09

Instructions as for front doors with following exceptions:

1. Electrical cable and plug is retained and is accessible through large opening in door.
2. Instruction 16 does not apply to rear actuator units which are not fitted with switches.



NOTE: Actuator may be detached from mounting plate to facilitate removal of lock actuator from connector rod.

UPPER TAILGATE ACTUATOR UNIT

Service repair no - 86.26.10

Remove

1. Remove two screws and trim covering to gain access to actuator.
2. Disconnect electrical connection.
3. Remove two actuator retaining screws.
4. Manoeuvre actuator assembly link from actuator link.
5. Withdraw tailgate actuator unit.

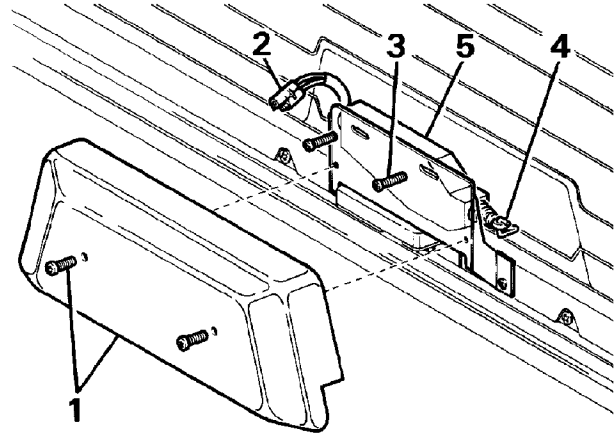

RR2570E

Refit

6. Reverse removal procedure.
7. Check operation of central locking system.



FUEL FILLER FLAP ACTUATOR UNIT

Service repair no - 86.26.16

Remove

1. Remove sub-woofer assembly. See *Sub-Woofer Box*

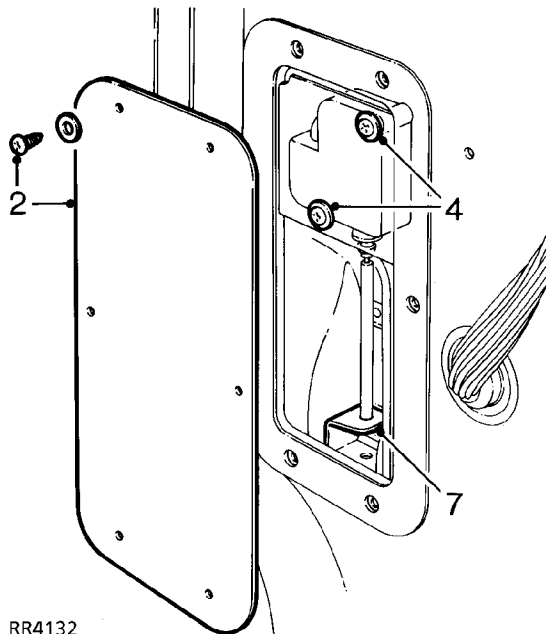

RR4132

2. Remove six screws to withdraw closure panel, situated in tool storage area.
3. Ensure that actuator is in unlocked position and fuel filler flap is open.
4. Release two screws and manoeuvre actuator unit clear of its mounting.

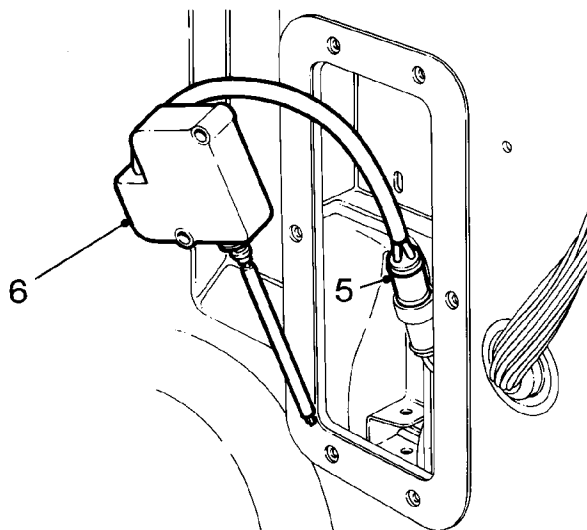

RR4133

5. Disconnect wiring plug.
6. Withdraw actuator.

Refit

7. Reverse removal procedure. Actuator mounting holes in body are elongated. Adjust position of actuator to ensure that rod will pass through guide brackets without fouling.

TRAILER SOCKET

Incorporated in vehicle electrical harness is a facility for fitting a seven pin trailer lighting socket.

Pick-up point is located behind right hand tail lamp cluster assembly.

Pick-up point consists of a seven pin pre-wired plug, a separate auxiliary fused line feed and reverse light lead.



CAUTION: Fitting trailer socket and associated wiring MUST be carried out by a qualified vehicle electrician.

1. Disconnect battery negative lead.
2. Remove tail lamp. *See Tail Lamp Assembly*
3. Remove protective cap from trailer pick-up point plug.



NOTE: Cable colours in this plug correspond to main circuit diagram. Red / yellow is unused.

4. Feed seven core cable Part No. PRC4143 (fitted with a pre-wired plug to one end-suitable for connection to pick-up point) down between inner and outer body panels through rear light opening.

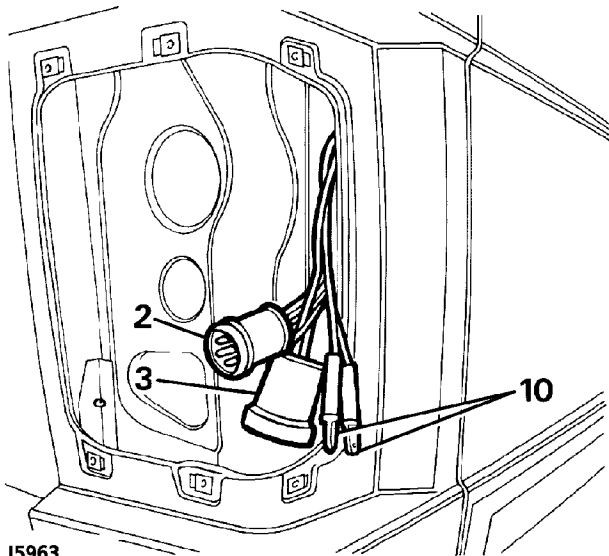

J5963

5. Feed cable alongside existing rear lighting harness.
6. Pull cable through opening between chassis side member and fuel tank.
7. Fit two retaining clips to cable and secure it to rear end cross member.
8. Connect electrical leads to vehicle trailer socket. (Refer to current trailer wiring regulations).
9. Secure trailer socket to tow bar.
10. Two extra leads in rear light opening provide a line feed and reverse light feed.
11. Refit tail lamp.
12. Reconnect battery.

Electrical lead identification

Single leads - item 10 in illustration J5963.

Pink Fused auxiliary line feed.
Green/Brown Reverse light feed.

Pre-wired cable and plug - Part No. PRC4143

Yellow Left indicator.
Green Right indicator.
Red/Yellow Unused.
White Ground.
Brown Right-hand tail lights.
Black Left-hand tail lights.
Red Stop lamps.



FRONT SEAT - MOTORS

Service repair no - 86.75.06

Remove

Four electric motors, mounted beneath each front seat, control fore and aft movement, cushion height front and rear, and angle of recline. Adjustment is possible with either front door open, or with ignition switched **ON**.

1. Position seat to give access to motors.
2. Disconnect battery negative lead.
3. Remove seat base trim.
4. Remove two securing screws from each side of required motor.

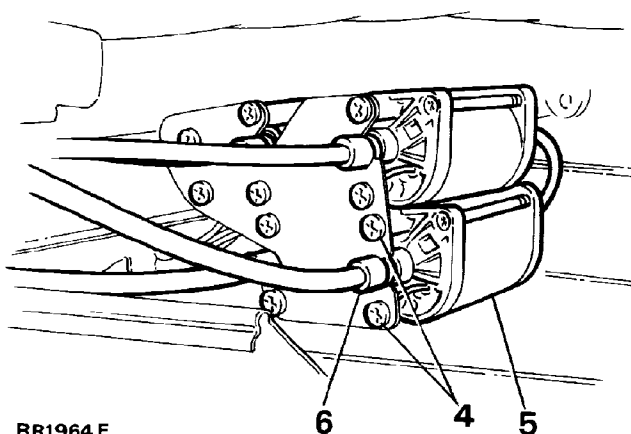

RR1964 E

5. Remove motor from mounting.
6. Disconnect drive cables by unscrewing ferrule.
7. Disconnect wires from multi-plug, remove motor.

Refit

8. Reverse removal procedure.
9. Check seat adjustment for correct operation.

FRONT SEAT - SWITCHES

Service repair no - 86.75.03

Remove

1. Disconnect battery negative lead.
2. Pry two finger tip controls from switch housing.
3. Removing switch housing cover by lightly depressing sides of cover to disengage clips, remove diaphragm.
4. Remove two crosshead screws and washers. Lift switch assembly to gain access to two multi-plugs.
5. Disconnect multiplugs, remove switch assembly.

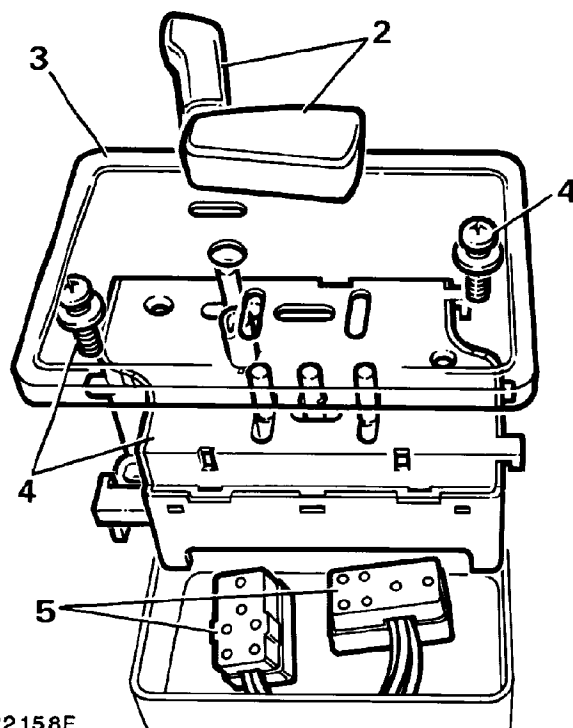

RR2158E

Refit

6. Reverse removal procedure.



NOTE: If switch housing removal is required it is necessary to remove seat to gain access to two securing screws. See *CHASSIS AND BODY, Repair, Front Seat Electrical*

MAP LIGHT BULB RENEWAL

Service repair no - 86.45.09

Remove

1. Disconnect battery negative lead.

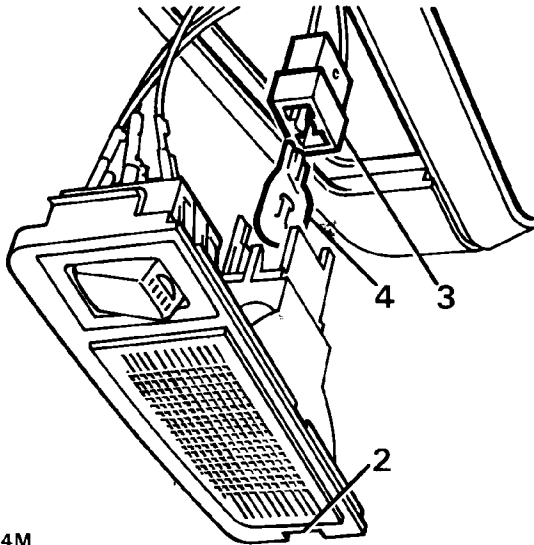

RR3644M

2. Pry slot to open cover.
3. Remove bulbholder.
4. Remove bulb from holder.
5. Replace bulb.

Refit

6. Reverse removal procedure.

ELECTRICAL SEAT FAILURE

NOTE: Carry out following procedure if seat failure occurs with seat obscuring fixing bolts.

1. Check 30A fuses and courtesy lamp fuse B2.
2. Disconnect 9 way connector between seat ECU and motors (memory seat). Power motor from a separate battery source.
3. If partial failure occurs in forward and reverse travel only, change drive cable as required to move seat to desired position.
4. If 2. and 3. not possible, move seat by driving cables manually.

DRIVE CABLE - ELECTRIC SEAT**Remove**

1. Remove seat. **See CHASSIS AND BODY, Repair, Front Seat Electrical**
2. Cut cable tie, remove drive cable securing clips.
3. Remove drive cable from gearbox.
4. Remove drive cable from motor by unscrewing ferrule.
5. Cut cable ties from drive cable. Note position for reassembly.
6. Remove drive cable. If cable has failed, 'twist' may have occurred in seat. To rectify this, use a small screwdriver to turn gearbox of failed cable until twist is removed.

Refit

7. Reverse removal procedure. Ensuring new cable ties are fitted in original positions.
8. Operate seats to full extent of travel. To ensure that 'twist' has been removed, check that both gearboxes stop simultaneously.



MEMORY SEAT - SWITCH

Service repair no - 86.75.03

Remove

1. Disconnect battery negative lead.
2. Pry finger tip controls from top of switch housing.

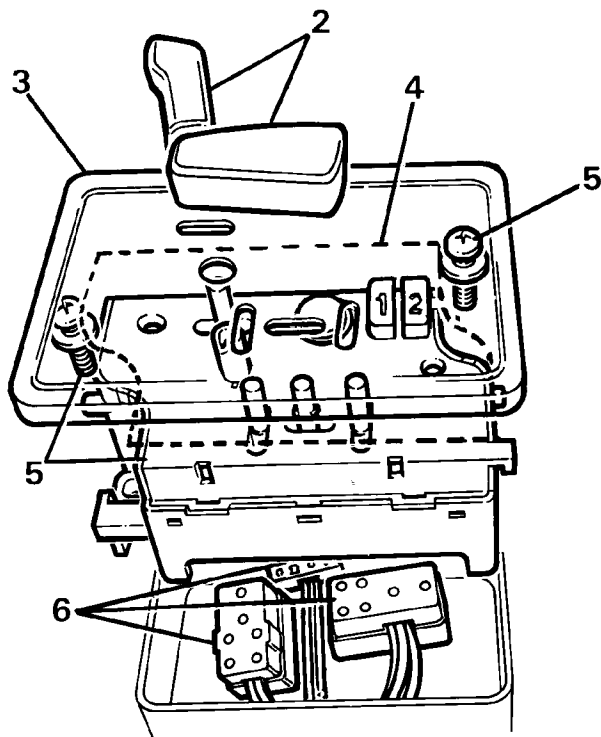

RR3762M

3. Remove switch housing cover by lightly depressing sides of switch housing to disengage clips.
4. Remove sealing membrane.
5. Remove switch securing screws, lift switch to gain access to multiplugs.
6. Disconnect multiplugs and remove switch.

Refit

7. Reverse removal procedure. Renew sealing membrane.

MEMORY SEAT SWITCH - CLEAN



NOTE: If a seat switch problem is diagnosed, the cause may be liquid spillage or ingress of foreign matter. The switch may be cleaned using the following procedure.

1. Remove seat switch. *See Memory Seat - Switch*
2. Discard sealing membrane.
3. Clean affected area of switch using a slightly damp clean cloth.
4. If contamination still exists, clean switch using a clean cloth slightly dampened with methylated spirits.
5. Allow switch to dry completely.
6. Refit switch using a new membrane.
7. Check seat switch for satisfactory operation.

ECU - MEMORY SEAT**Remove**

1. Remove driver's seat. *See CHASSIS AND BODY, Repair, Front Seat Electrical*
2. Disconnect connector from seat.

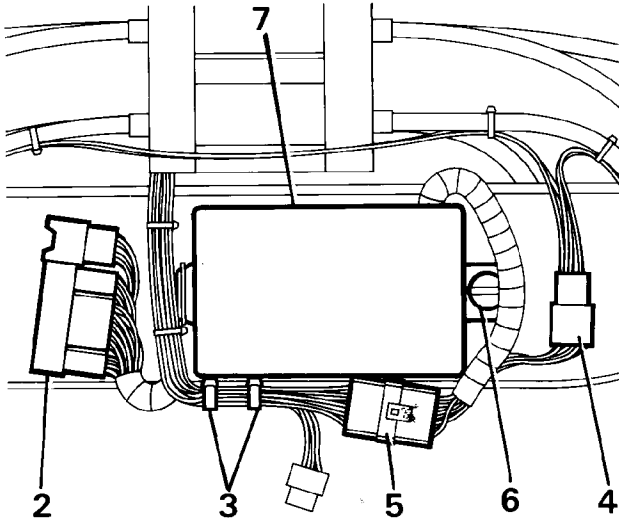

RR3761M

3. Remove cable ties.
4. Disconnect sensor and seat switch multiplug, remove from seat.
5. Disconnect seat motor multiplug.
6. Turn ECU retaining turnbuckle half a turn.
7. Remove ECU.

Refit

8. Reverse removal procedure. Ensuring cable retaining clips are correctly located. *See Memory Seat - Harness Layout*
9. Initialise system.

RADIO ANTENNA AMPLIFIER

Service repair no - 86.50.29

Remove

1. Disconnect battery negative lead.
2. Lower or remove headlining. *See CHASSIS AND BODY, Repair, Headlining*
3. Remove electrical leads and radio antenna lead.
4. Remove two screws, remove amplifier unit.

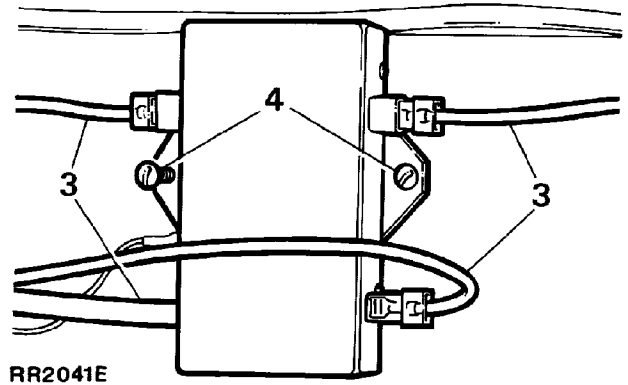

RR2041E

Refit

5. Reverse removal procedure.



MEMORY SEAT - HARNESS LAYOUT



WARNING: To prevent damage to wiring under driver's seat and subsequent failure, the wiring must be installed as shown in RR3748M

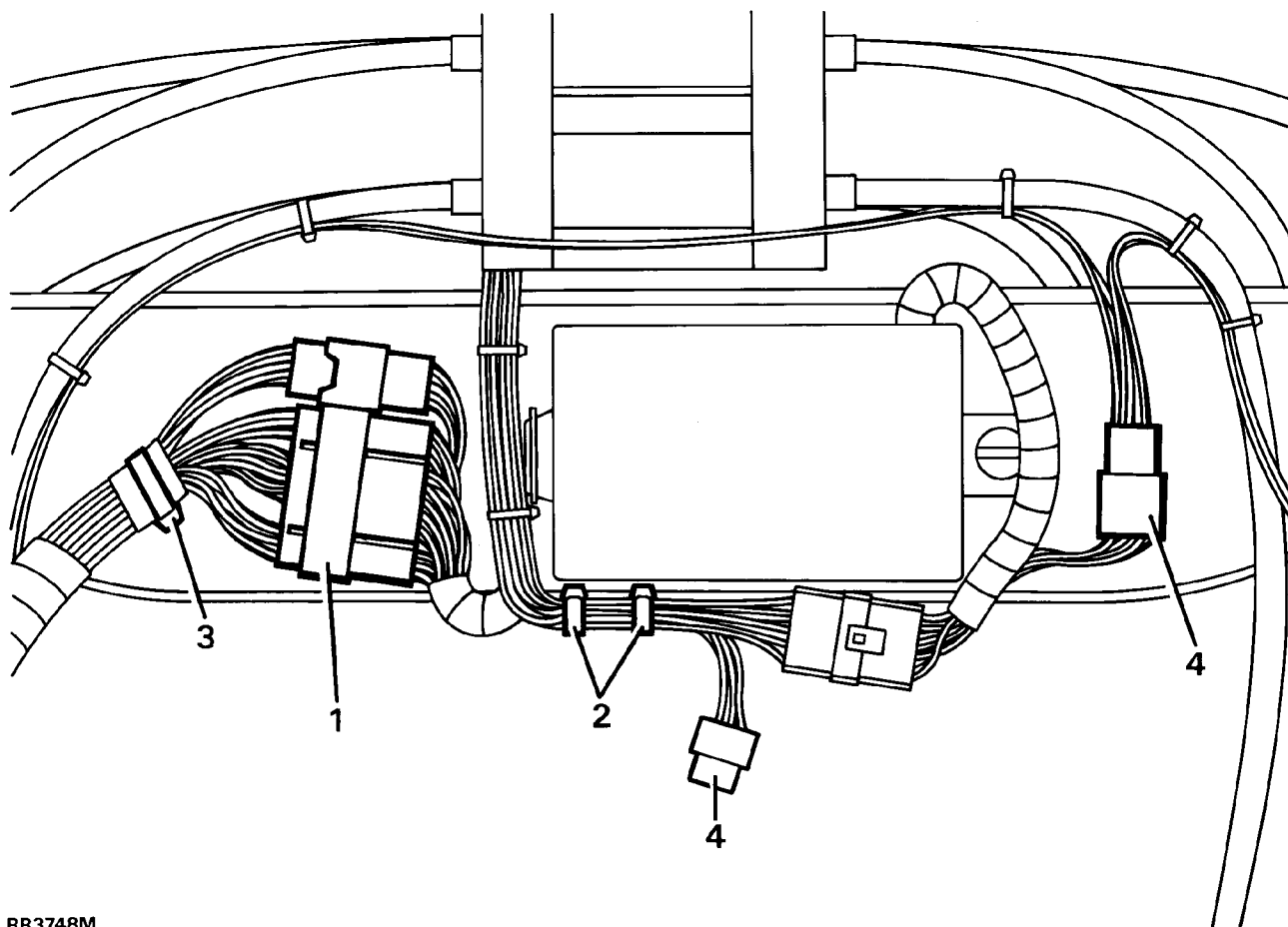

RR3748M

1. ECU link harness connector has retaining clip to seat base.
2. Link harness has two cable ties to seat motor harness, one of which is secured to seat base.
3. Main harness has P-clip securing it to seat base.
4. Sensor connector to link harness has retaining clip to seat base.

A.C. GENERATOR HEAT SHIELD**Remove**

1. Disconnect battery negative lead.
2. Remove fixing screw.
3. Remove nut from A.C. generator rear mounting bolt, remove heat shield.

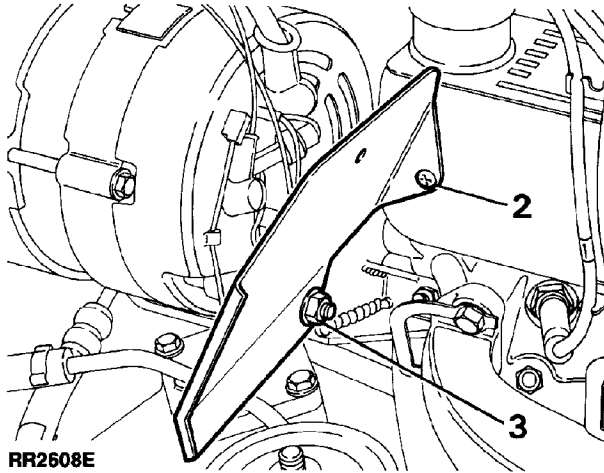
**Refit**

4. Reverse removal procedure.

HIGH LEVEL STOP LAMP

Service repair no - 86.41.35

Includes bulb renewal

Service repair no - 86.41.34

Remove

1. Disconnect battery negative lead.

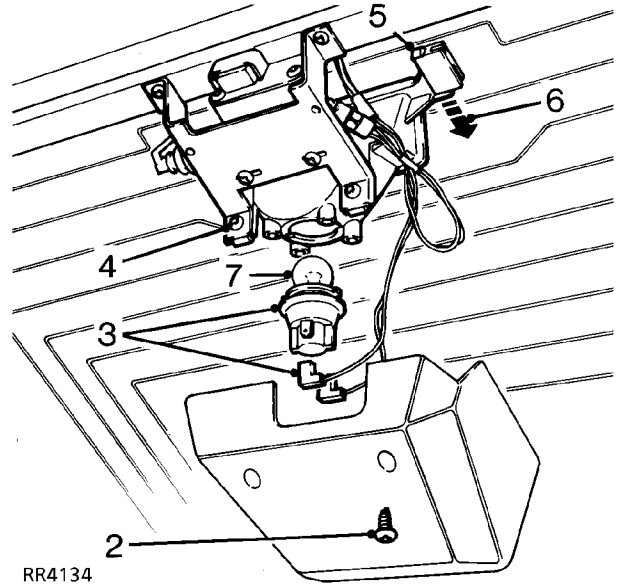

2. Remove two cover retaining screws. Remove cover.
3. Disconnect electrical leads to bulb holder. Remove bulbholder and bulb by twisting anti-clockwise.
4. Remove two screws, mounting plate to stop lamp.
5. Observe position of stop lamp on rear screen. Carefully release tabs on stop lamp from rear screen mountings.
6. Remove stop lamp.
7. Renew bulb if necessary.

Refit

8. Reverse removal procedure.



ALARM HORN

Service repair no - 86.77.10

Remove

1. Remove decker panel. *See CHASSIS AND BODY, Repair, Decker Panel*

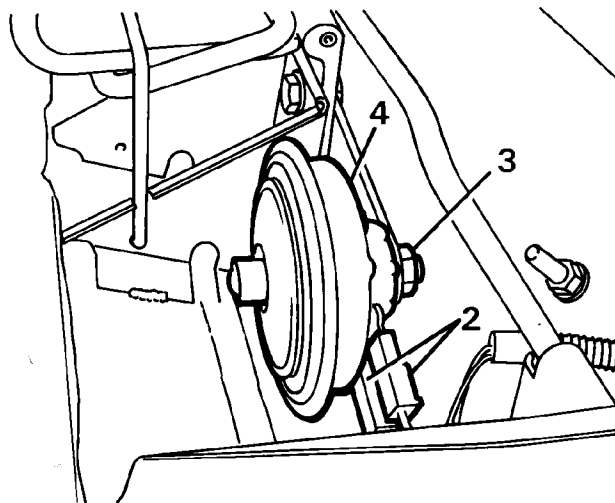

RR3905M

2. Disconnect two Lucar connectors.
3. Remove single nut securing horn.
4. Remove horn.

Refit

5. Reverse removal procedure.

GEAR SELECTOR-INTERLOCK

Interlock solenoid

Remove

1. Disconnect battery negative lead.
2. Remove gear selector head and illumination panel. *See CHASSIS AND BODY, Repair, Centre Console*

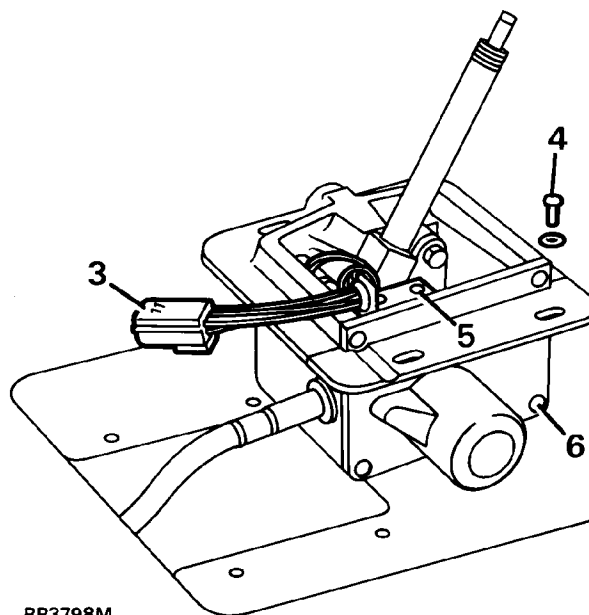

RR3798M

3. Disconnect electrical multiplug.
4. Remove screws and lift gear selector mechanism above housing.
5. Remove screws from microswitch support bracket.
6. Remove screws and separate side cover from housing.
7. Disconnect wiring solenoid to multiplug.
8. Remove circlip and retainer plate.
9. Remove clip and centre sleeve.
10. Refit clip into groove on spindle and lever against it to remove solenoid from housing.

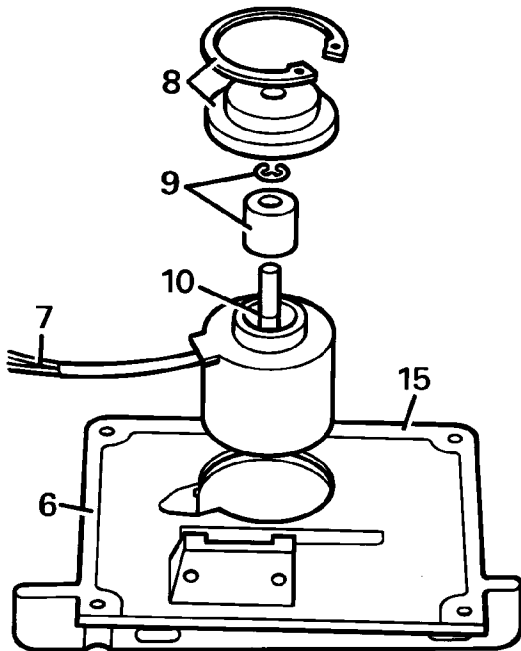

RR3800M

Refit

11. Fit solenoid with wiring positioned into side cover recess.
12. Fit sleeve and new clip.
13. Fit retaining plate and circlip.
14. Connect wiring to multiplug.
15. Apply sealant and fit side cover to housing. Use Silcoset 152 sealant or equivalent.
16. Grease all moving parts of gear selector mechanism. Use Rocol E1A or equivalent grease.
17. Reverse instructions 1 to 5.

Interlock microswitch onto castellated plate.**Remove**

1. Disconnect battery negative lead.
2. Remove gear selector head and illumination panel. *See CHASSIS AND BODY, Repair, Centre Console*
3. Disconnect electrical multiplug.

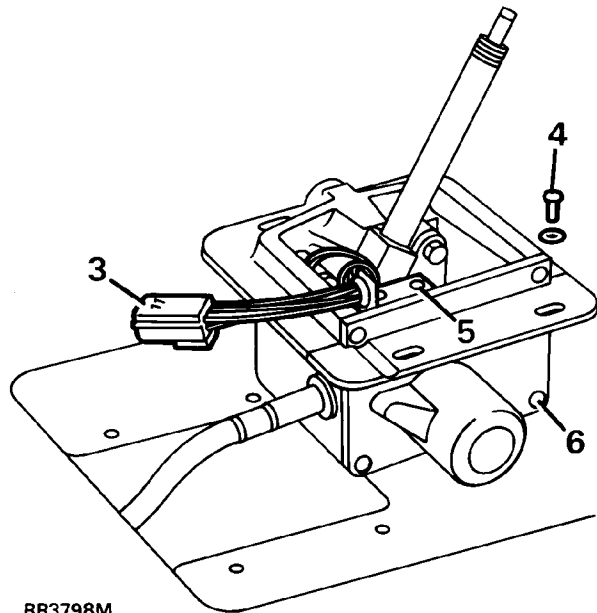

RR3798M

4. Remove screws and lift gear selector mechanism above housing.
5. Remove screws from microswitch support bracket.
6. Remove screws and separate side cover from housing.
7. Disconnect wiring microswitch to multiplug.

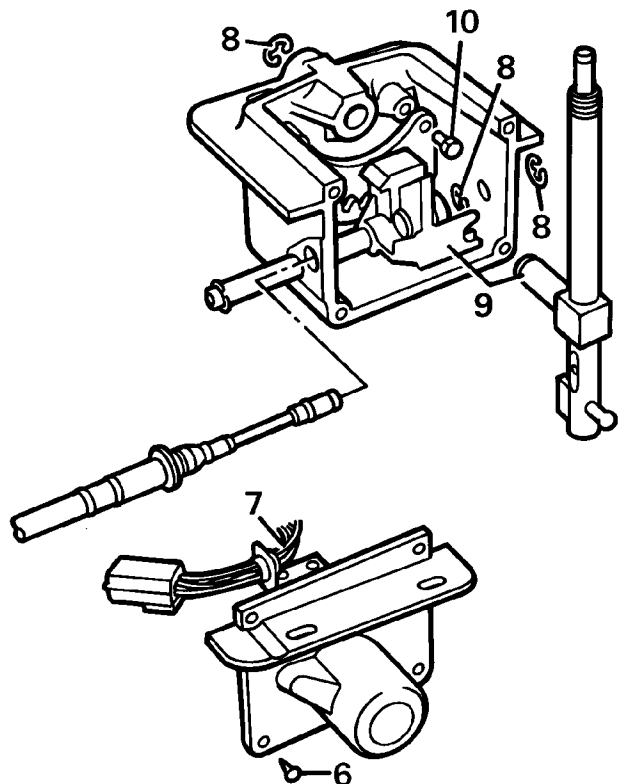

RR3797M

8. Remove 3 clips as shown.
9. Slide trunnion forward and remove gear selector arm.

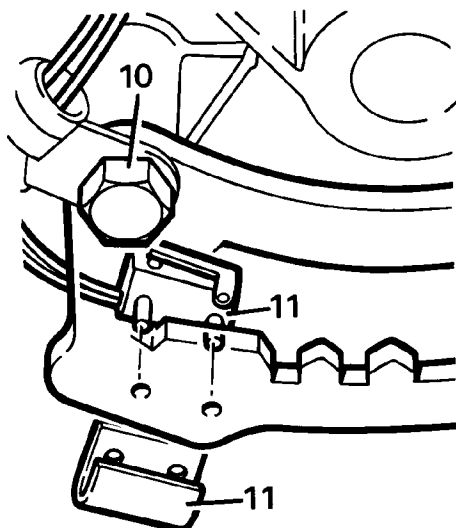

RR3799M

10. Remove bolts securing coxcomb.
11. Remove microswitch retaining clip and microswitch.

Refit

12. Reverse removal procedure, correctly positioning microswitch.
13. Apply Loctite 242E to castellated plate bolts and tighten to **9Nm**.
14. Grease all moving parts of gear selector mechanism. Use Rocol E1A or equivalent grease.
15. Apply Silcoset 152 sealant or equivalent and fit side cover to housing.

Interlock microswitch onto side cover

Remove

1. Disconnect battery negative lead.
2. Remove gear selector head and illumination panel. **See Automatic Gear Selector-Panel Bulb**

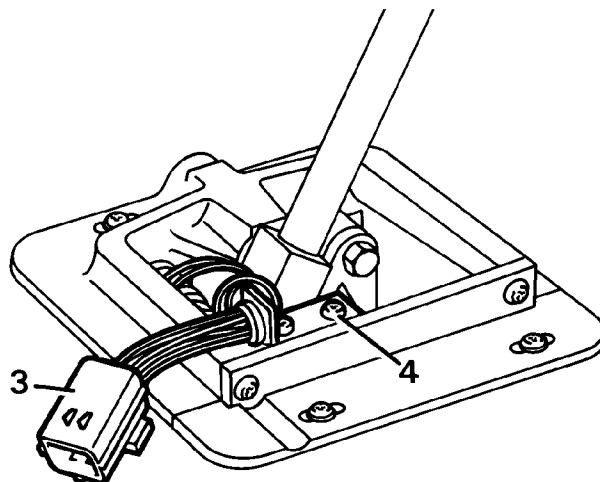

J5957

3. Disconnect electrical multiplug.
4. Remove screws from microswitch support bracket.
5. Disconnect wiring microswitch to multiplug.

Refit

6. Reverse removal procedure. Correctly positioning microswitch.
7. Grease all moving parts of gear selector mechanism. Use Rocol E1A or equivalent grease.

SUBWOOFER BOX

Service repair no - 86.50.51

Remove

1. Disconnect battery negative lead.
2. Remove rear parcel shelf RH support panel.

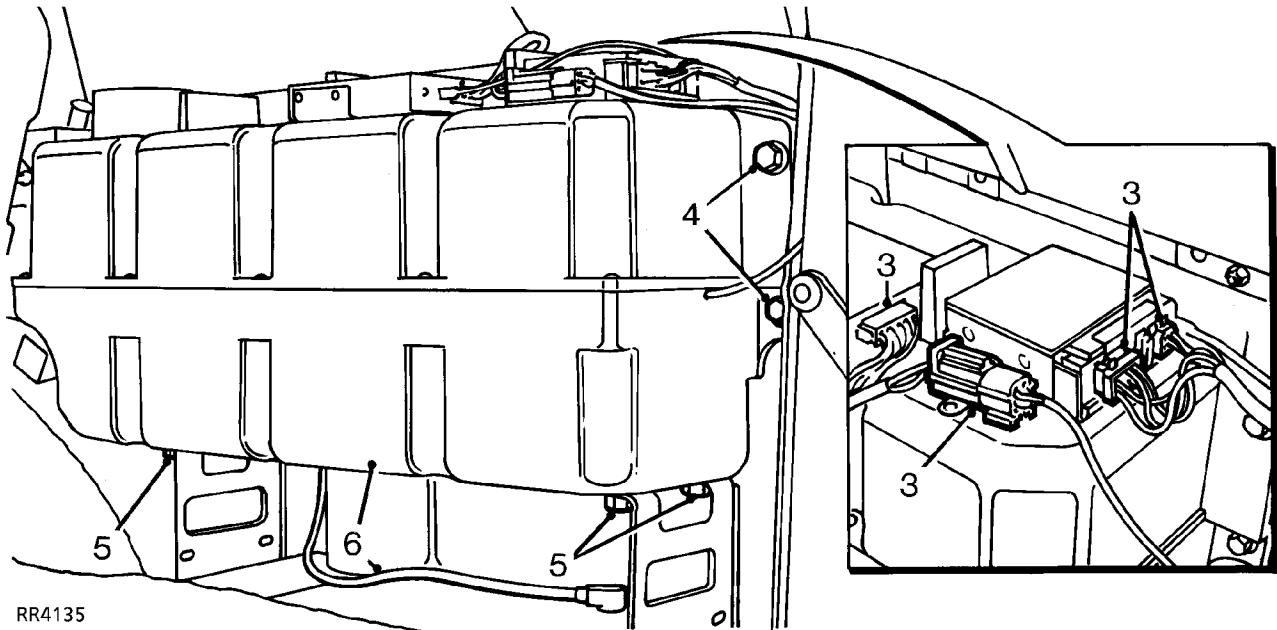

3. Disconnect multiplugs.
4. Remove 3 bolts securing side of subwoofer box to body.
5. Remove 4 bolts securing bottom of subwoofer box to body.
6. Withdraw subwoofer box, disconnect speaker lead.



NOTE: Do not carry out further dismantling if component is removed for access only.

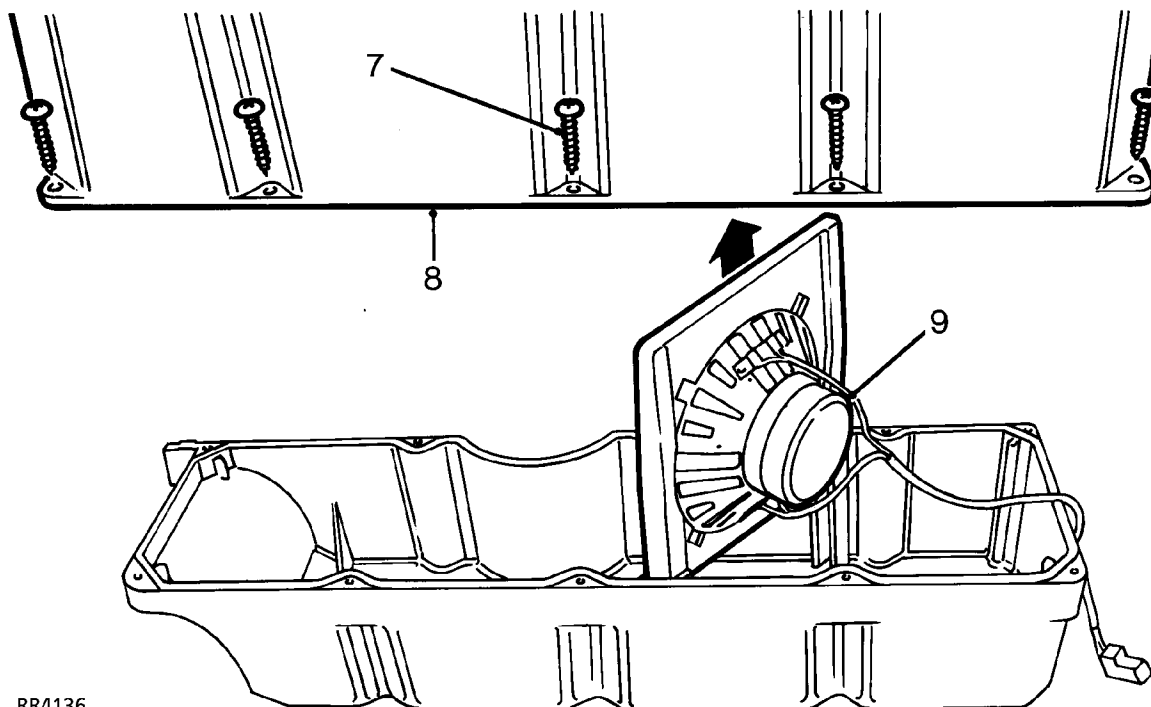

RR4136

7. Remove 10 screws securing both halves of subwoofer box.
8. Remove top half of box.
9. Remove speaker. **See CHASSIS AND BODY, Repair, Parcel Shelf**

Refit

10. Reverse removal procedure.

HEATED FRONT SCREEN

Heated front screen will operate when switch is operated, with engine running. Timer unit will provide a preset time cycle of 7 1/2 minutes \pm 20%.

To identify timer unit.

Switching OFF ignition, or further operation of heated front screen switch during cycle will switch off screen and cancel, reset and switch off timer unit.

RADIO

Service repair no - 86.50.03

Remove

1. Disconnect battery negative lead.

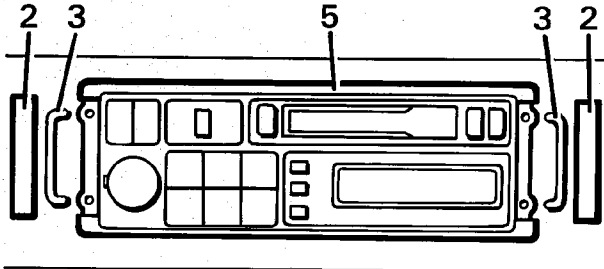

RR3908M

2. Remove access covers from radio.
3. Insert suitable radio removal tools e.g. SMD 4091 into access holes.
4. Press removal tools to release radio.
5. Remove radio, disconnect radio aerial, CD aerial and multiplugs from rear of radio.

Refit

6. Reverse removal procedure.
7. Reactivate radio code.

COOLANT TEMPERATURE TRANSMITTER - V8i

Service repair no - 26.10.02

Remove

1. Disconnect battery negative lead.

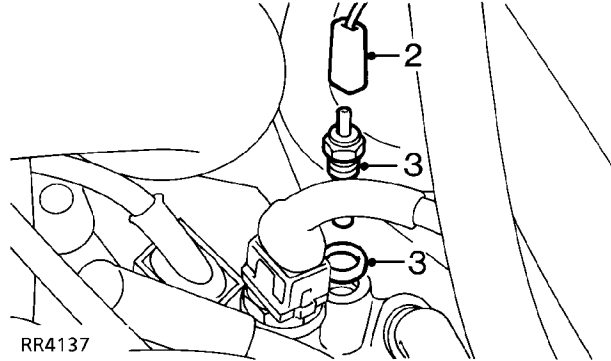

RR4137

2. Disconnect lead from transmitter.
3. Remove transmitter, discard sealing washer if fitted.

Refit

4. Coat threads of replacement transmitter with Loctite 572.
5. Fit a new sealing washer to transmitter.
6. Fit transmitter, connect lead.
7. Top-up cooling system.



CLOCK AND BULB

Service repair no - 88.15.07 - Clock

Service repair no - 86.45.29 - Bulb

Clock

Remove

1. Remove hazard switch. *See Hazard Warning Switch and Bulb*

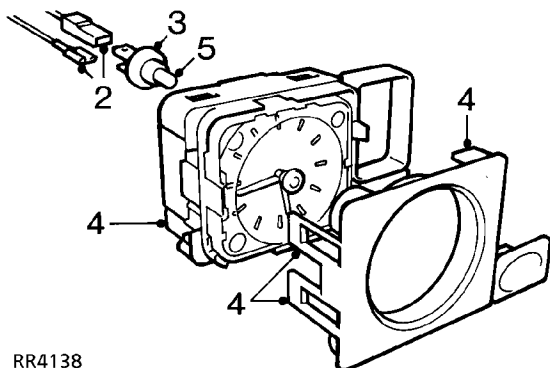

RR4138

2. Disconnect electrical leads from clock.
3. Release bulb holder from clock.
4. Release 3 retaining lugs, remove clock from surround.

Bulb replacement

5. Withdraw bulb from holder.

Refit

6. Reverse removal procedure.
7. Set clock to correct time.

INSTRUMENT PANEL FINISHER

Service repair no - 88.20.03

Remove

1. Position steering wheel for access.

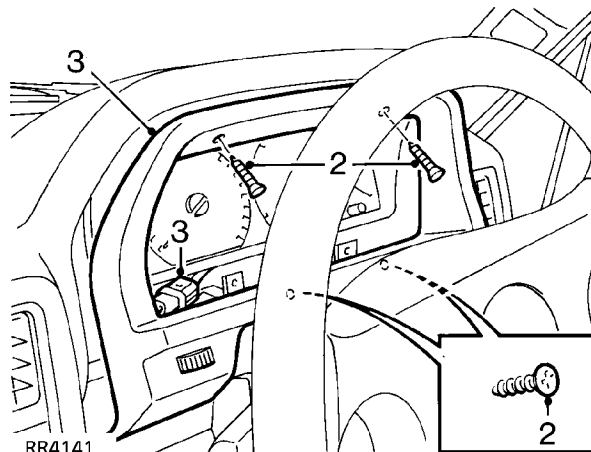

RR4141

2. Remove 4 screws securing finisher.
3. Withdraw finisher, disconnect rheostat multiplug.

Refit

4. Reverse removal procedure.

INSTRUMENT BINNACLE

Service repair no - 88.20.13

Remove

1. Remove instrument panel finisher. *See Instrument Panel Finisher*

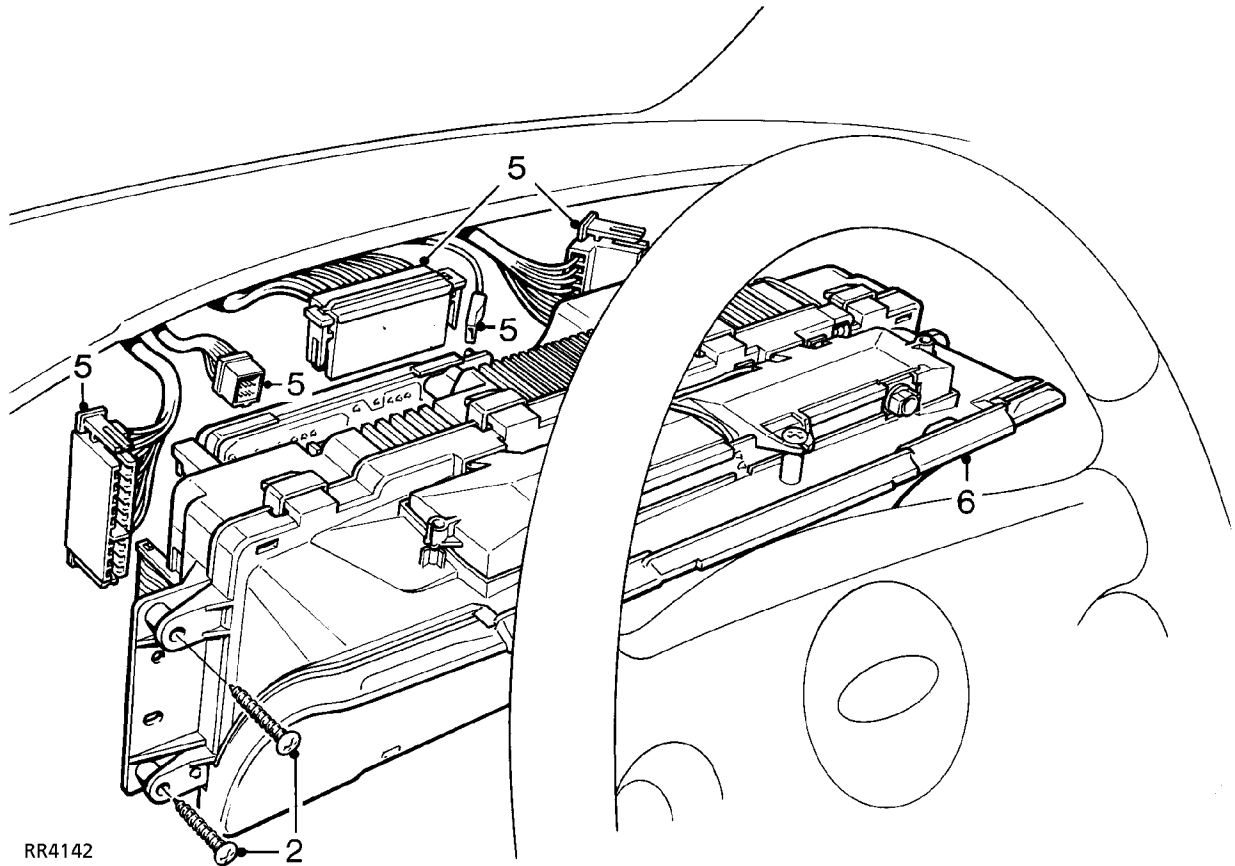

RR4142

2. Remove 4 screws securing binnacle to fascia.
3. Carefully ease 2 lower panel finisher brackets downwards.
4. Withdraw binnacle to gain access to multiplugs.
5. Noting their fitted positions, disconnect multiplugs.
6. Remove binnacle.

Refit

7. Reverse removal procedure.



INSTRUMENT ILLUMINATION AND WARNING LIGHT BULBS

Service repair no - 86.45.48 - Instrument

Service repair no - 86.45.61 - Warning light

Remove

1. Remove binnacle. *See Instrument Binnacle*
2. Identify bulb to be replaced.



NOTE: If faulty bulb is not accessible, remove screws securing circuit board and carefully ease circuit board aside.

3. Rotate bulb holder anti-clockwise, withdraw bulb holder and remove bulb.

Refit

4. Fit new bulb to holder.



CAUTION: Ensure bulb of correct wattage and type is fitted.

5. Reverse removal procedure.

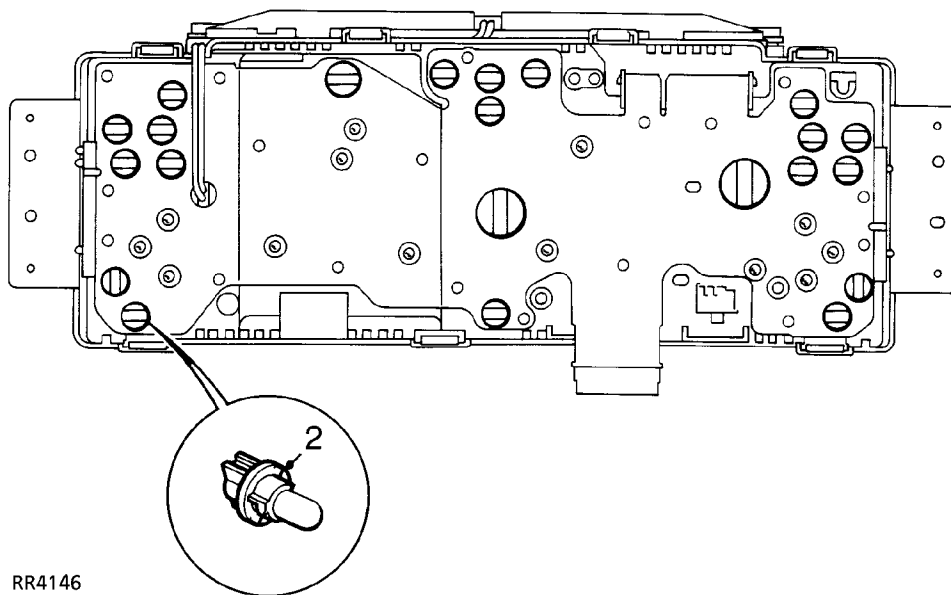

RR4146

MAIN PRINTED CIRCUIT

Service repair no - 88.20.19

Remove

1. Remove instrument cowl. *See Instrument Cowl and Illumination Board*
2. Remove circuit board. *See Circuit Board*

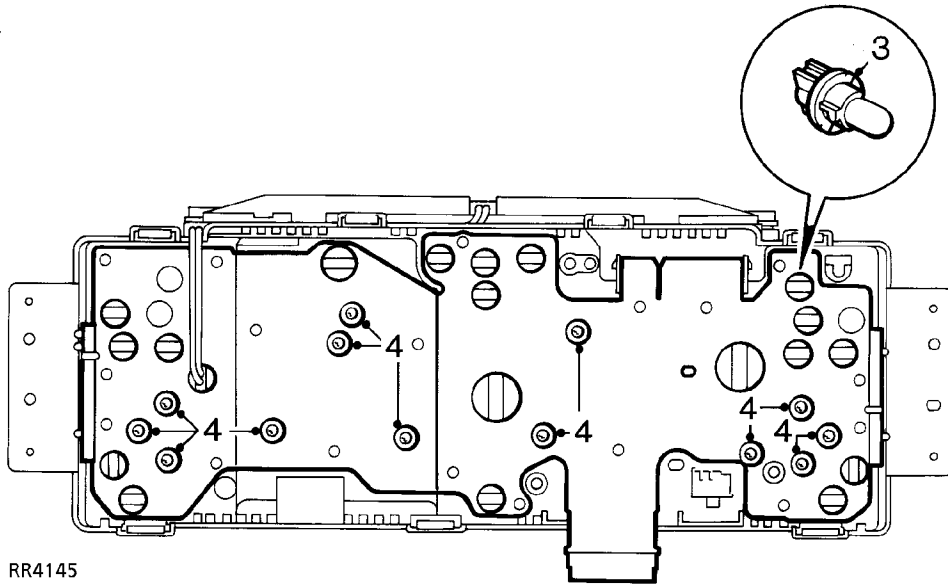

RR4145

3. Remove illumination and warning lamp bulbs.
4. Remove 13 screws securing main printed circuit, remove circuit.

Refit

5. Position main printed circuit to binnacle.
6. Ensure screw holes in instruments are aligned with holes in binnacle, fit and tighten screws.
7. Reverse removal procedure. 1 and 2.



CIRCUIT BOARD

Service repair no - 88.20.25

Remove

1. Remove binnacle. *See Instrument Binnacle*

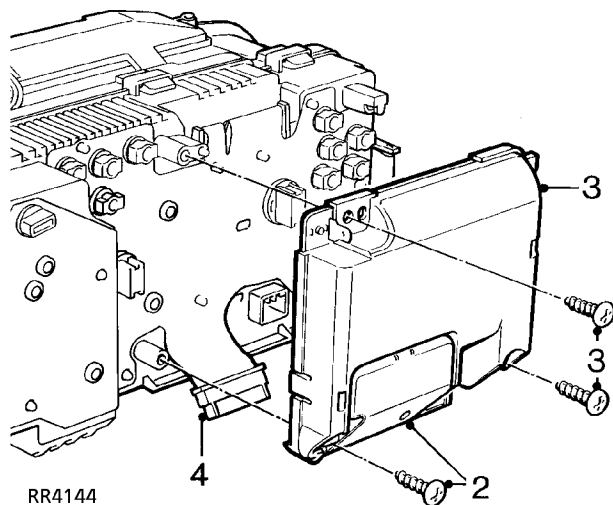

2. Remove screw, release lower cover from circuit board.
3. Remove 2 screws securing circuit board to binnacle, release board.
4. Disconnect multiplug.

Refit

5. Reverse removal procedure.

INSTRUMENT BINNACLE COMPONENTS

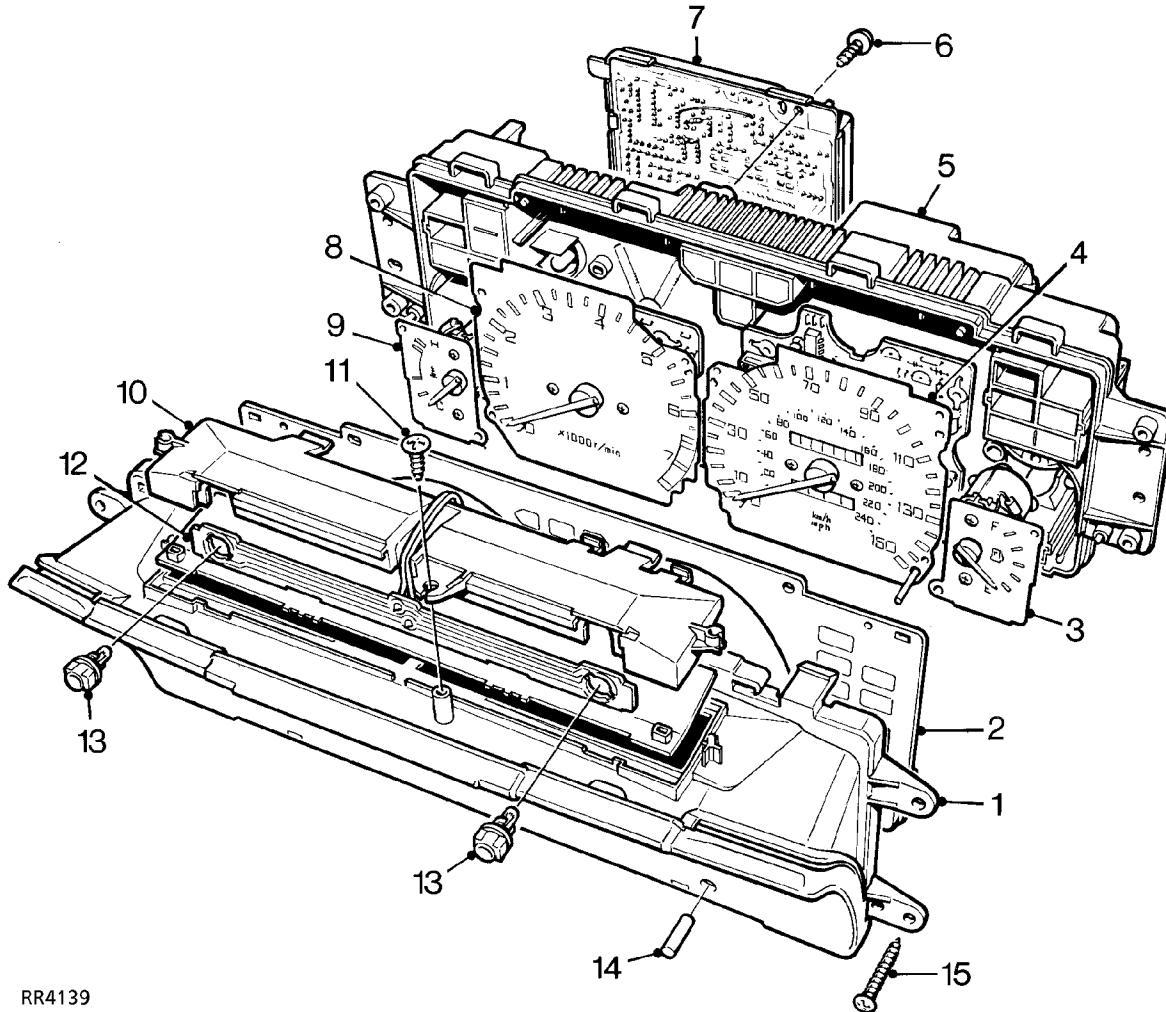

RR4139

- | | |
|-----------------------------------|--|
| 1. Instrument cowl | 8. Tachometer |
| 2. Face plate | 9. Temperature gauge |
| 3. Fuel gauge | 10. Illumination board |
| 4. Speedometer | 11. Screw securing illumination board |
| 5. Instrument binnacle | 12. Circuit board - instrument illumination |
| 6. Screw - securing circuit board | 13. Instrument illumination bulb holder and bulb |
| 7. Circuit board | 14. Speedometer trip reset button sleeve |
| | 15. Screw - cowl and binnacle |



PRINTED CIRCUIT AND WARNING LIGHTS

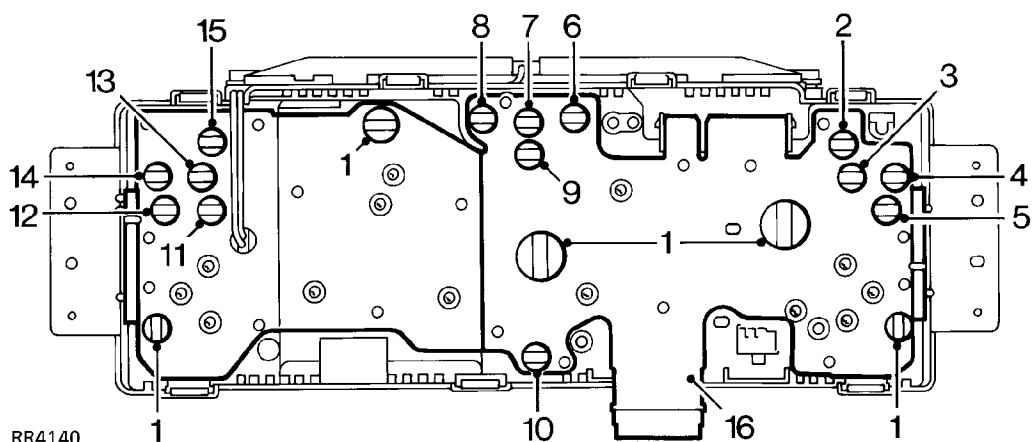

- | | |
|---|--|
| 1. Panel illumination bulbs | 9. Direction indicator warning lamp bulb |
| 2. Transmission oil temperature warning lamp bulb | 10. Air suspension warning lamp bulb |
| 3. Hazard warning lamp bulb | 11. Ignition/no charge warning lamp bulb |
| 4. Check engine warning lamp bulb | 12. Seat belt warning lamp bulb |
| 5. Handbrake/brake fluid warning lamp bulb | 13. Not used |
| 6. ABS warning lamp bulb | 14. Traction control warning lamp bulb |
| 7. Headlamp main beam warning lamp bulb | 15. Diesel heater plug warning lamp bulb (if fitted) |
| 8. Trailer direction warning lamp bulb | 16. Main printed circuit |

INSTRUMENT COWL AND ILLUMINATION BOARD

Service repair no - 88.20.06 - Instrument cowl

Service repair no - 88.20.22 - Illumination board

Remove

1. Remove binnacle. *See Instrument Binnacle*

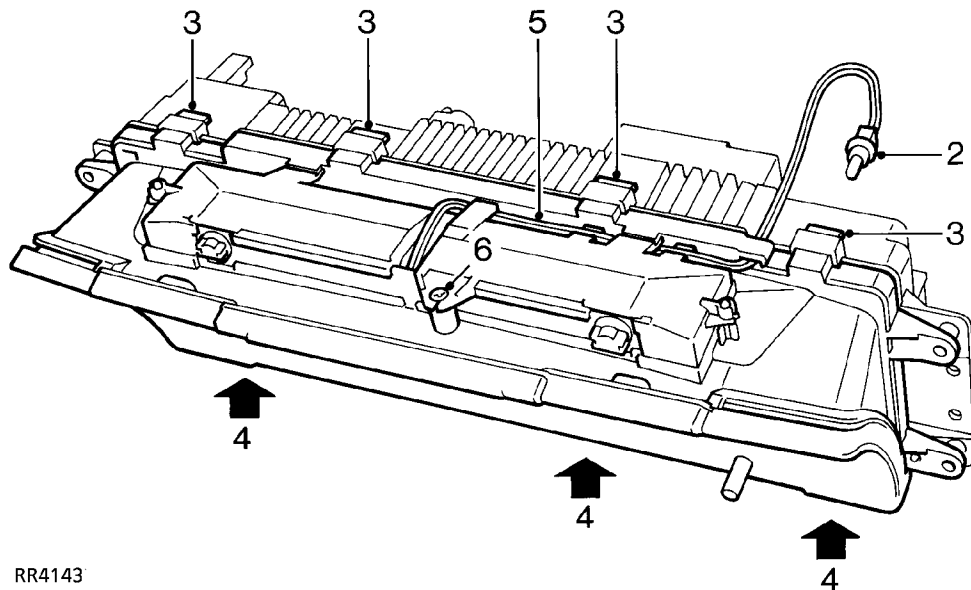
Instrument cowl

RR4143

2. Remove bulb holder from binnacle.
3. Release 4 clips securing top of cowl to binnacle.
4. Release 3 clips securing bottom of cowl to binnacle, remove cowl.

Illumination board

5. Release bulb holder wires from clip.
6. Remove screw securing illumination board to cowl, remove board.

Refit**Illumination board**

7. Position illumination board to cowl, fit and tighten screw.
8. Secure bulb holder wires in clip.

Instrument cowl

9. Ensure instrument face plate is correctly positioned.
10. Position cowl to binnacle ensuring speedometer trip passes through hole in cowl.
11. Secure cowl retaining clips.
12. Fit bulb holder in binnacle.
13. Fit binnacle. *See Instrument Binnacle*



SPEEDOMETER

Service repair no - 88.30.01

Remove

1. Remove instrument cowl. *See Instrument Cowl and Illumination Board*

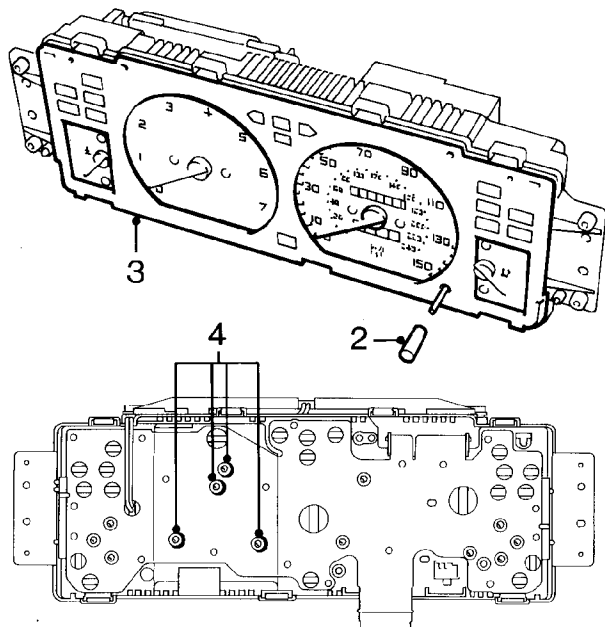

RR4131

2. Remove speedometer trip reset button sleeve.
3. Remove instrument face plate.
4. Remove 4 screws securing speedometer, remove speedometer.

Refit

5. Reverse removal procedure.

TACHOMETER

Service repair no - 88.30.21

Remove

1. Remove circuit board. *See Circuit Board*
2. Remove instrument cowl. *See Instrument Cowl and Illumination Board*

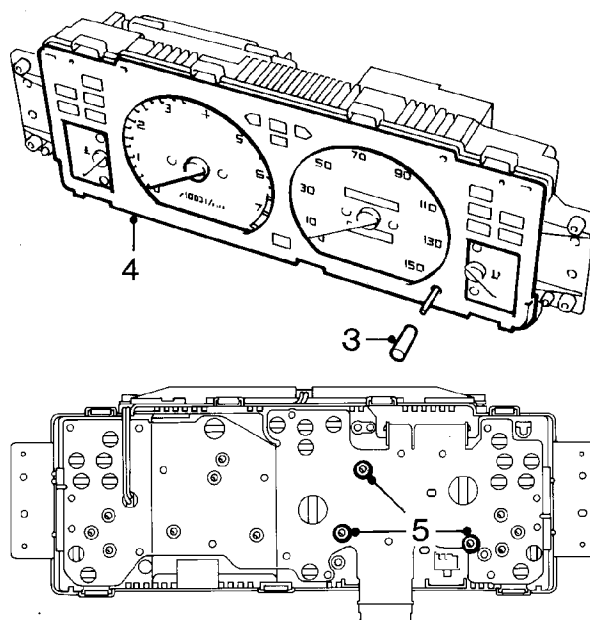

RR4124

3. Remove speedometer trip reset button sleeve.
4. Remove instrument face plate.
5. Remove 3 screws securing tachometer to binnacle, remove tachometer.

Refit

6. Reverse removal procedure.

COOLANT TEMPERATURE AND FUEL GAUGES

Service repair no - 88.25.14 - Coolant temperature gauge
Service repair no - 88.25.26 - Fuel gauge

Remove

1. Remove instrument cowl. *See Instrument Cowl and Illumination Board*

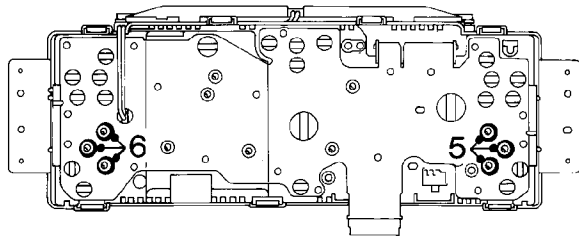
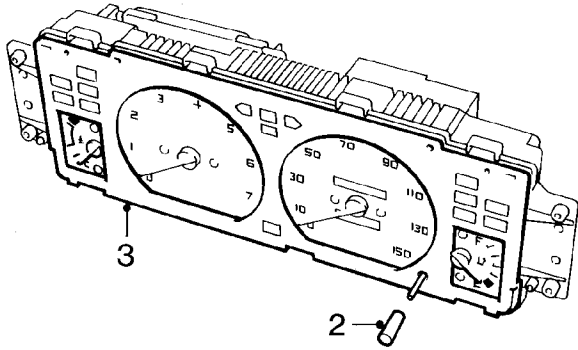

RR4147

2. Remove speedometer trip reset button sleeve.
3. Remove instrument face plate.

Coolant temperature gauge

4. Remove circuit board. *See Circuit Board*
5. Remove 3 screws securing coolant temperature gauge to binnacle, remove gauge.

Fuel gauge

6. Remove 3 screws securing fuel gauge to binnacle, remove gauge.

Refit

7. Reverse removal procedure.

SPEEDOMETER TRANSDUCER

Service repair no - 88.30.14

Remove

1. Position vehicle on ramp and chock wheels.
2. Raise ramp.

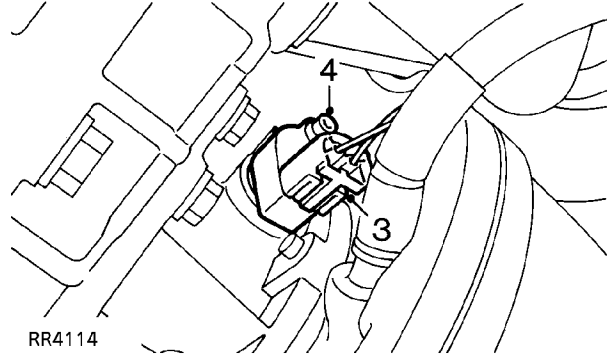

RR4114

3. Disconnect multiplug from transducer.
4. Remove bolt securing transducer, remove transducer.

Refit

5. Reverse removal procedure.



ALARM ECU

Service repair no - 86.77.01

Remove

1. Remove lower dash panel, *See CHASSIS AND BODY, Repair, lower dash panel*
2. Remove multiplugs and aerial lead from ECU.

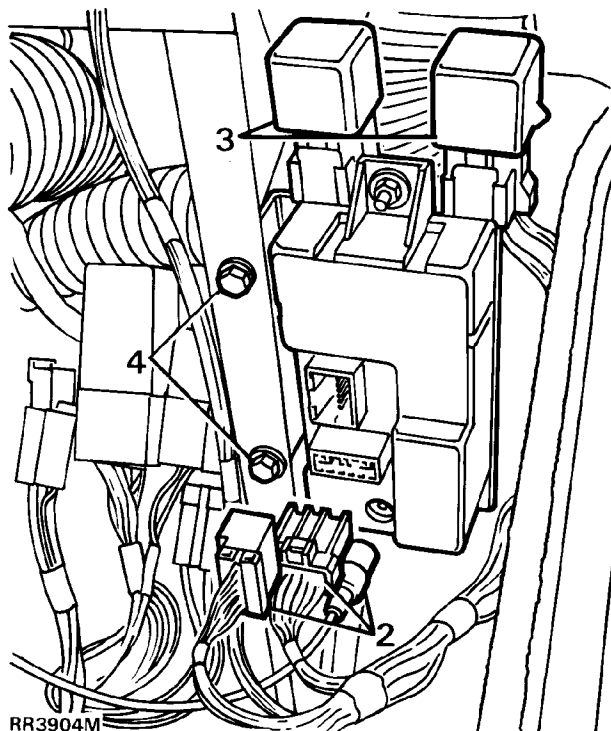

3. Remove relays and bases from bracket.
4. Remove ECU bracket fixings.
5. Remove ECU with bracket.

Refit

6. Reverse removal procedure. Aerial and multiplugs must be fitted securely to ensure alarm functions correctly.



DISTRIBUTOR-LUCAS 35DLM8

Overhaul

DISTRIBUTOR CAP

Service repair no - 86.35.10

1. Unclip and remove cap
2. Fit a new cap if faulty.
3. Clean cap and HT brush with a lint free cloth.

ROTOR ARM

Service repair no - 86.35.16

1. Pull rotor arm from shaft.
2. Fit a new rotor arm if faulty.

INSULATION COVER (FLASH SHIELD)

Service repair no - 86.35.40

1. Remove cover secured by three screws.
2. Fit a new cover if faulty.

VACUUM UNIT

Service repair no - 86.35.21

1. Remove two screws from vacuum unit securing bracket. Disengage vacuum unit connecting rod from pick-up base plate connecting peg. Withdraw vacuum unit from distributor body.

AMPLIFIER MODULE

Service repair no - 86.35.30

1. Remove two screws and withdraw module.
2. Remove gasket.
3. Remove two screws and cast heatsink.



WARNING: Amplifier module is a sealed unit containing Beryllia. This substance is extremely dangerous if handled. DO NOT attempt to open or crush module.

PICK-UP AND BASE PLATE ASSEMBLY

Service repair no - 86.35.42

1. Use circlip pliers to remove circlip retaining reductor on rotor shaft.
2. Remove flat washer, and 'O' ring recessed in top of reductor.
3. Gently withdraw reductor from shaft, taking care not to damage teeth.



NOTE: Coupling ring fitted beneath reductor.

4. Remove three support pillars and cable grommet. Lift out pick-up and base plate assembly.



NOTE: Do not disturb two barrel nuts securing pick-up module, otherwise air gap will need re-adjustment.

5. Fit a new pick-up and base plate assembly if module is known to be faulty, otherwise check pick-up winding resistance (2k-5k ohm).

Reassemble

6. This is mainly a reversal of dismantling procedure, noting following points:

LUBRICATION

Apply clean engine oil:

- a. A spot into rotor spindle before fitting rotor arm.

Apply Omnilube 2 (or equivalent) grease.

- b. Auto advance mechanism.
- c. Pick-up plate centre bearing.
- d. Pre tilt spring and its rubbing area (pick-up and base plate assembly).
- e. Vacuum unit connecting peg (pick-up and base plate assembly).
- f. Connecting peg hole in vacuum unit connecting rod.

Fitting pick-up and base plate assembly

1. Pick-up leads must be prevented from fouling rotating reluctor. Both leads should be located in plastic guide as illustrated. Check during re-assembly.

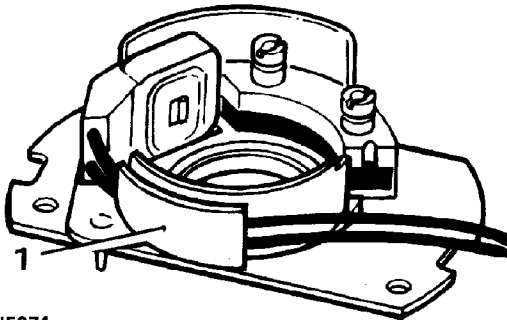

J5971

Fitting reluctor

2. Slide reluctor as far as it will go on rotor shaft, rotate reluctor until it engages with coupling ring beneath pick-up base plate. Distributor shaft, coupling ring and reluctor are 'keyed' and rotate together. Fit 'O' ring, flat washer and retaining circlip.

Pick-up air gap adjustment

1. Air gap between pick-up limb and reluctor teeth must be set within specified limits, using a non-ferrous feeler gauge.

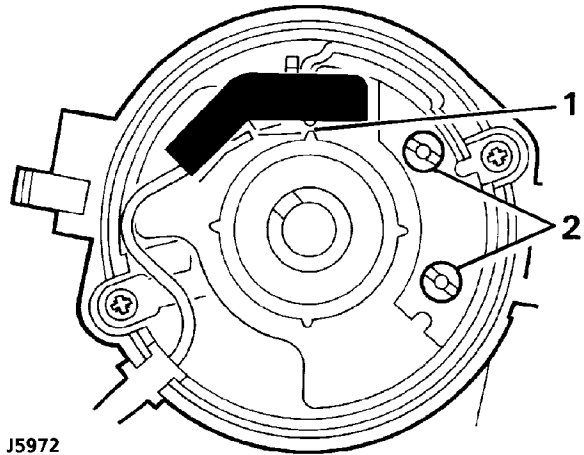

J5972

2. If adjustment is necessary, slacken two barrel nuts to set the air gap. **See ENGINE TUNING DATA, Information, Engine - 3.9 V8i**

 **NOTE:** When original pick-up and base plate assembly has been refitted, air gap should be checked, and adjusted if necessary.

When fitting a new assembly air gap will require adjusting to within specified limits.

Amplifier module

1. Before fitting module, apply MS4 Silicone grease or equivalent heat-conducting compound to amplifier module backplate, seating face on distributor body and both faces of heatsink casting.



TORQUE VALUES



NOTE: Torque wrenches should be regularly checked for accuracy to ensure that all fixings are tightened to the correct torque.

	Nm
A.C. generator to mounting bracket	24
A.C. generator module screws	1.2
Amplifier heat sink screws	1.2
Auxiliary driving lamp mounting bolts	15
Distributor clampbolt	20
Distributor pick-up bearing plate support pillars	1.2
Distributor pick-up barrel nuts	1.2
Distributor vacuum unit	2
Starter motor to engine bolts - V8i engine	45
Reverse light switch	25
Wiper motor yoke retaining bolts	1.5

Torque values below cover all screws and bolts used, unless specified otherwise.

METRIC	Nm
M5	6
M6	9
M8	25
M10	45
M12	90
M14	105
M16	180

UNC / UNF	
1/4	9
5/16	24
3/8	39
7/16	78
1/2	90
5/8	136