

TECHNICAL BULLETIN



MODEL/DERIVATIVE:
Discovery II

Bulletin N°: 0046
CDS. ref: L8750bu
Issue: 1
Date: 16.01.02

AFFECTED RANGE:
All vehicles fitted with an Alpine radio

PROBLEM:
RADIO SECURING CLIPS - BREAKING WHEN RADIO IS REMOVED

CAUSE:
Incorrect tools have been used, or the correct tools have been used incorrectly.

ACTION:
Read and understand fully the following procedure before removing the radio.

1. Insert radio removal keys, horizontally (shown in illustration 1), into the slots located at the top of the radio. Refer to tool information for part number detail.
2. Push the radio removal keys forwards horizontally, until a click is heard. This indicates that the radio removal keys are locked in position on the radio securing clips.
NOTE: If no force is felt between a radio removal key and the radio securing clip, then remove the key, and re-insert correctly.
3. Using the radio removal keys pull unit horizontally rearwards and remove from fascia.
NOTE: Only pull on the radio removal keys. Do not pull on the radio.
4. Remove the radio removal keys by pushing the radio securing clip down and pulling the radio removal keys out.

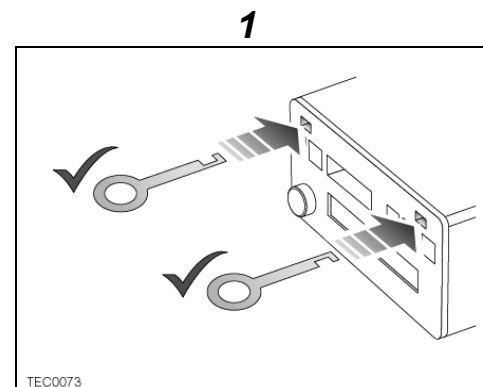

Correct fitment of radio removal keys illustrated

Tool Information

Land Rover approved radio removal keys can be obtained from Cartool (UK) Ltd, part number LRT-86-006 – radio removal key.

PARTS INFORMATION:

Not applicable

WARRANTY CLAIMS:

Not applicable