

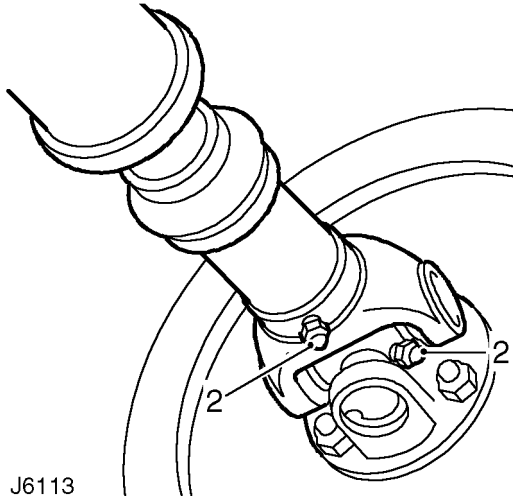

LUBRICATE PROPELLER SHAFT UNIVERSAL AND SLIDING JOINTS

1. Clean all grease nipples on front and rear propeller shafts.



J6113

2. Using a low pressure hand grease gun, apply recommended grease *See LUBRICANTS, FLUIDS AND CAPACITIES, Information, Recommended lubricants and fluids* to grease nipples at front and rear propeller shaft universal and sliding joints.

VISUALLY CHECK BRAKE, FUEL, CLUTCH HOSES/PIPES/UNIONS FOR CHAFING, LEAKS AND CORROSION

CHECK EXHAUST SYSTEM FOR LEAKS, SECURITY AND DAMAGE

RENEW CATALYTIC CONVERTERS *See MANIFOLD AND EXHAUST SYSTEM, Repair, manifolds and exhaust system*

CHECK FOR FLUID LEAKS FROM POWER STEERING AND SUSPENSION SYSTEMS, HYDRAULIC PIPES AND UNIONS FOR CHAFING AND CORROSION

CHECK/TIGHTEN STEERING UNIT AND STEERING ROD BALL JOINT FIXINGS, CHECK CONDITION OF BALL JOINTS AND DUST COVERS

Ball joints are lubricated for life during manufacture and require no further lubrication unless the rubber boot has been dislodged or damaged. All joints should be checked at specified service intervals, but more frequently if vehicle is used under arduous conditions.

1. Check for wear in joints by moving ball joint up and down vigorously. If free movement is apparent, fit a new joint assembly. *See STEERING, Repair, Drop arm ball* *See STEERING, Repair, Track rod and* *See STEERING, Repair, Drag link and drag link ends*

CHECK/TIGHTEN FRONT AND REAR AXLE SUSPENSION LINK FIXINGS, CHECK CONDITION OF MOUNTING RUBBERS

DRAIN AND CLEAN FUEL SEDIMENTER, IF FITTED

The fuel sedimenter is located on a chassis side member on the RH side of vehicle near rear wheel. It increases the working life of the fuel filter by removing larger droplets of water and other matter from fuel.



NOTE: On 110/130 models with a twin tank fuel system, two sedimenters may be fitted, one on each side of the vehicle chassis.

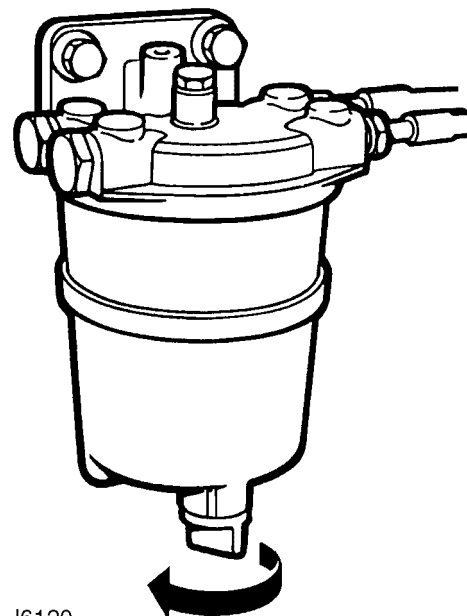

J6120

1. Slacken drain plug and allow any water to drain off.