

# 'T' SERIES

up to engine number 135750



## Overhaul Manual

**T-serie motor revisiehandboek  
T/m motor-nummer 135750**

**Moteur de serie T manuel de révision  
Jusqu' au numéro de moteur 135750**

**T motor überholungsanleitung  
Bis Motornummer 135750**

**Motore serie T manuale di revisione  
Fino al No. motore 135750**

**Motor serie T manual de revisión  
Até ao motor número 135750**

**Motor da série T manual de revisão  
Hasta el motor número 135750**





# Technical Information Review

While every attempt is made to ensure that the technical information we supply is as accurate and up to date as possible, from time to time, errors do occur. There may also be instances where the style or content of our publications do not meet your exact needs.

We would value your assistance in helping us to improve the quality of our publications and invite you to submit details of any technical errors, or improvements you would like to see, in the space below.

Publication part number and edition .....

Publication title .....

Section and/or pages affected .....

**Technical information errors:**

---



---



---



---



---



---



---



---

**Other improvements/changes you would like us to consider:**

---



---



---



---



---



---



---



---

Service manager's signature .....

Date .....

*Please return to:*

Technical Communication, Rover Group After Sales, PO BOX 29,  
Cowley, Oxford, OX4 5NL

Dealer Stamp

# 'T' SERIES ENGINE

## OVERHAUL MANUAL

---

This Overhaul Manual is applicable to engines up to engine number:- 135750

This engine is fitted to the following model up to 1996 Model Year:

Discovery MPi

Publication Part No. LRL 0110 ENG  
Published by Rover Technical Communication  
© 1997 Rover Group Limited





---

## INTRODUCTION

---

### How to use this manual

To assist in the use of this manual the section title is given at the top and the relevant sub-section is given at the bottom of each page.

This manual contains procedures for overhaul of the 'T' Series engine on the bench with the gearbox, clutch and coolant pump housing removed. For all other information regarding General Information, Adjustments, Removal of oil seals, engine units and ancillary equipment, consult the Repair Manual for the model concerned.

This manual is divided into 3 sections,

- Description and Operation,
- Overhaul and
- Data, Torque & Tools.

To assist filing of revised information each sub-section is numbered from page 1.

Individual items are to be overhauled in the sequence in which they appear in this manual. Items numbered in the illustrations are referred to in the text.

Overhaul operations include reference to Service Tool numbers and the associated illustration depicts the tool. Where usage is not obvious the tool is shown in use. Operations also include reference to wear limits, relevant data, torque figures, and specialist information and useful assembly details.

WARNINGS, CAUTIONS and Notes have the following meanings:



**WARNING:** Procedures which must be followed precisely to avoid the possibility of injury.



**CAUTION:** Calls attention to procedures which must be followed to avoid damage to components.



**NOTE:** Gives helpful information.

### References

With the engine and gearbox assembly removed, the crankshaft pulley end of the engine is referred to as the front.

Operations covered in this manual do not include reference to testing the vehicle after repair. It is essential that work is inspected and tested after completion and if necessary a road test of the vehicle is carried out particularly where safety related items are concerned.

### Dimensions

The dimensions quoted are to design engineering specification with Service limits where applicable.

# INTRODUCTION

---

---

## REPAIRS AND REPLACEMENTS

---

When replacement parts are required it is essential that only Land Rover recommended parts are used.

Attention is particularly drawn to the following points concerning repairs and the fitting of replacement parts and accessories.

Safety features and corrosion prevention treatments embodied in the car may be impaired if other than Land Rover recommended parts are fitted. In certain territories, legislation prohibits the fitting of parts not to the manufacturer's specification.

Torque wrench setting figures given in this Manual must be used. Locking devices, where specified, must be fitted. If the efficiency of a locking device is impaired during removal it must be renewed.

The Terms of the vehicle Warranty may be invalidated by the fitting of other than Land Rover recommended parts. All Land Rover recommended parts have the full backing of the vehicle Warranty.

Land Rover Dealers are obliged to supply only Land Rover recommended parts.

---

## SPECIFICATION

---

Land Rover are constantly seeking to improve the specification, design and production of their vehicles and alterations take place accordingly. While every effort has been made to ensure the accuracy of this Manual, it should not be regarded as an infallible guide to current specifications of any particular component or vehicle.

This Manual does not constitute an offer for sale of any particular component or vehicle. Land Rover Dealers are not agents of the Company and have no authority to bind the manufacturer by any expressed or implied undertaking or representation.



**This page is intentionally left blank**

# ENGINE

---

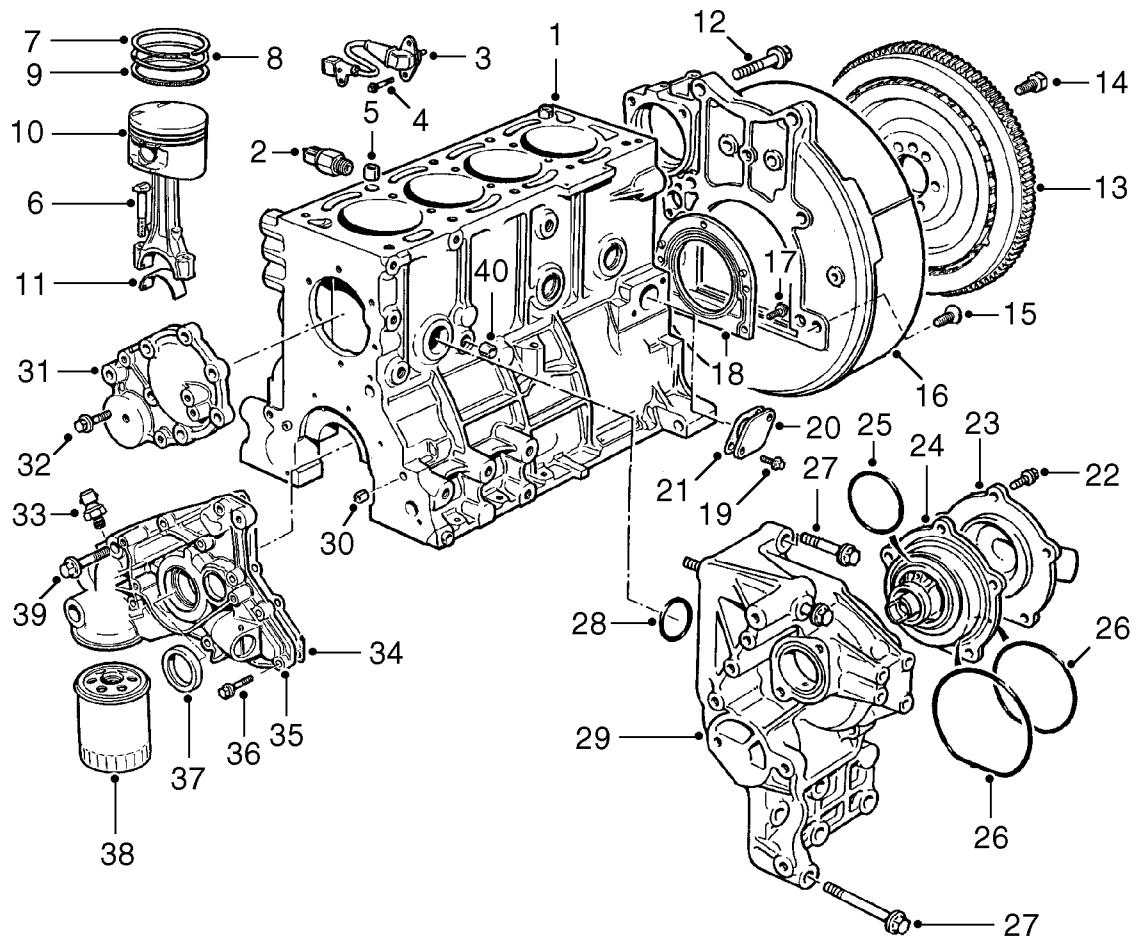

12M3748



---

**CYLINDER BLOCK COMPONENTS**

---

1. Cylinder block
2. Knock sensor
3. Crankshaft sensor
4. Bolt - crankshaft sensor
5. Locating dowel - cylinder head
6. Bolt - connecting rod
7. Piston ring - top compression
8. Piston ring - 2nd compression
9. Piston ring - oil control
10. Piston and connecting rod assembly
11. Big-end bearing shell - upper
12. Bolt - gearbox adaptor plate
13. Flywheel
14. Bolt - flywheel
15. Torx screw - gearbox adaptor plate
16. Gearbox adaptor plate
17. Bolt - crankshaft rear oil seal housing
18. Crankshaft rear oil seal and housing
19. Bolt - blanking plate
20. Blanking plate
21. Gasket
22. Bolt - coolant pump cover
23. Coolant pump cover
24. Impeller and housing
25. 'O' ring
26. Sealing rings
27. Bolts - coolant pump body and mounting
28. 'O' ring
29. Coolant pump body and mounting
30. Locating dowel - oil pump
31. Belt tensioner mounting plate
32. Bolt - belt tensioner mounting plate
33. Oil pressure switch
34. Gasket - oil pump
35. Oil pump
36. Bolt - M6 - oil pump
37. Crankshaft front oil seal
38. Oil filter element
39. Bolt - M10 - oil pump
40. Locating dowel - coolant pump body and mounting



# ENGINE

---

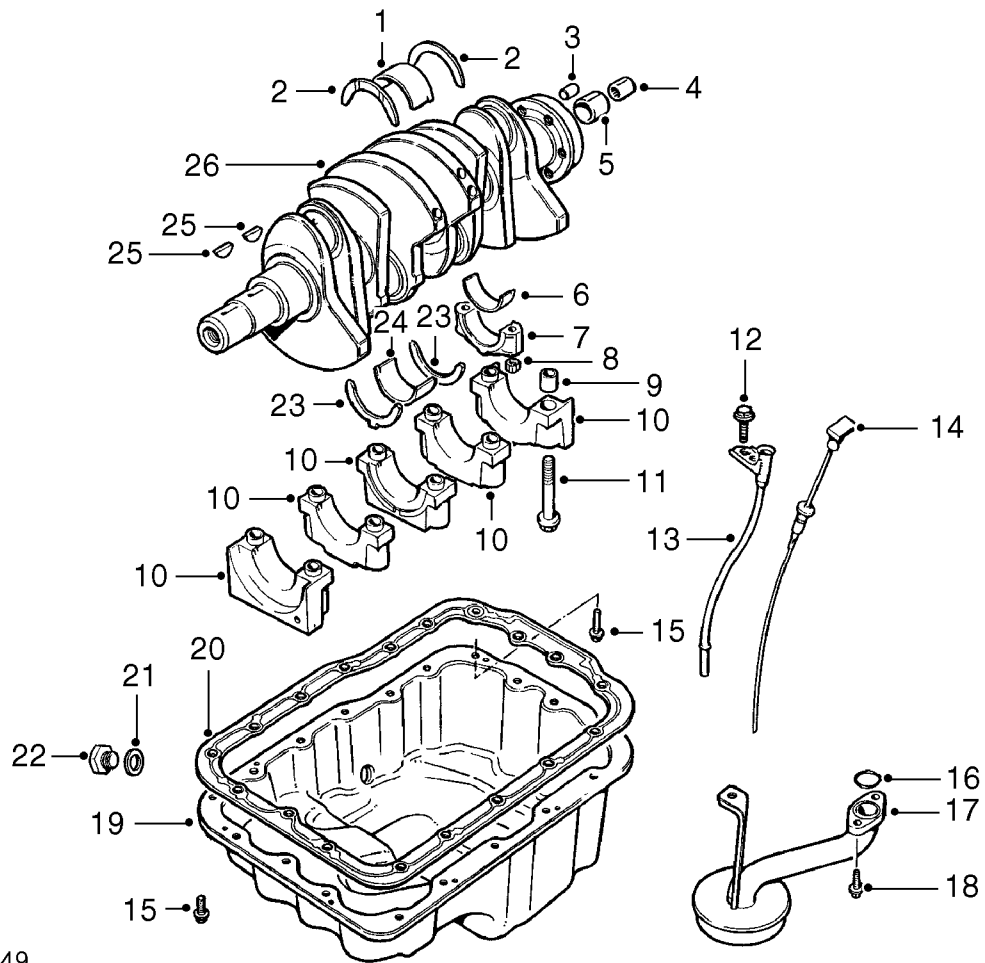

12M3749



---

**CRANKSHAFT AND SUMP**

---

1. Main bearing shell - upper
2. Thrust washer halves - upper
3. Locating dowel - flywheel
4. Crankshaft spigot bearing
5. Crankshaft spigot bush
6. Big-end bearing shell - lower
7. Big-end bearing cap
8. Nut - connecting rod bolt
9. Locating dowel - main bearing cap
10. Main bearing caps
11. Bolt - main bearing caps
12. Bolt - dipstick tube
13. Dipstick tube
14. Dipstick
15. Bolt - sump
16. 'O' ring
17. Oil pick-up pipe and strainer
18. Bolt - oil pick-up pipe
19. Sump
20. Gasket - sump
21. Sealing washer
22. Sump drain plug
23. Thrust washer halves - lower
24. Main bearing shell - lower
25. Woodruff keys
26. Crankshaft

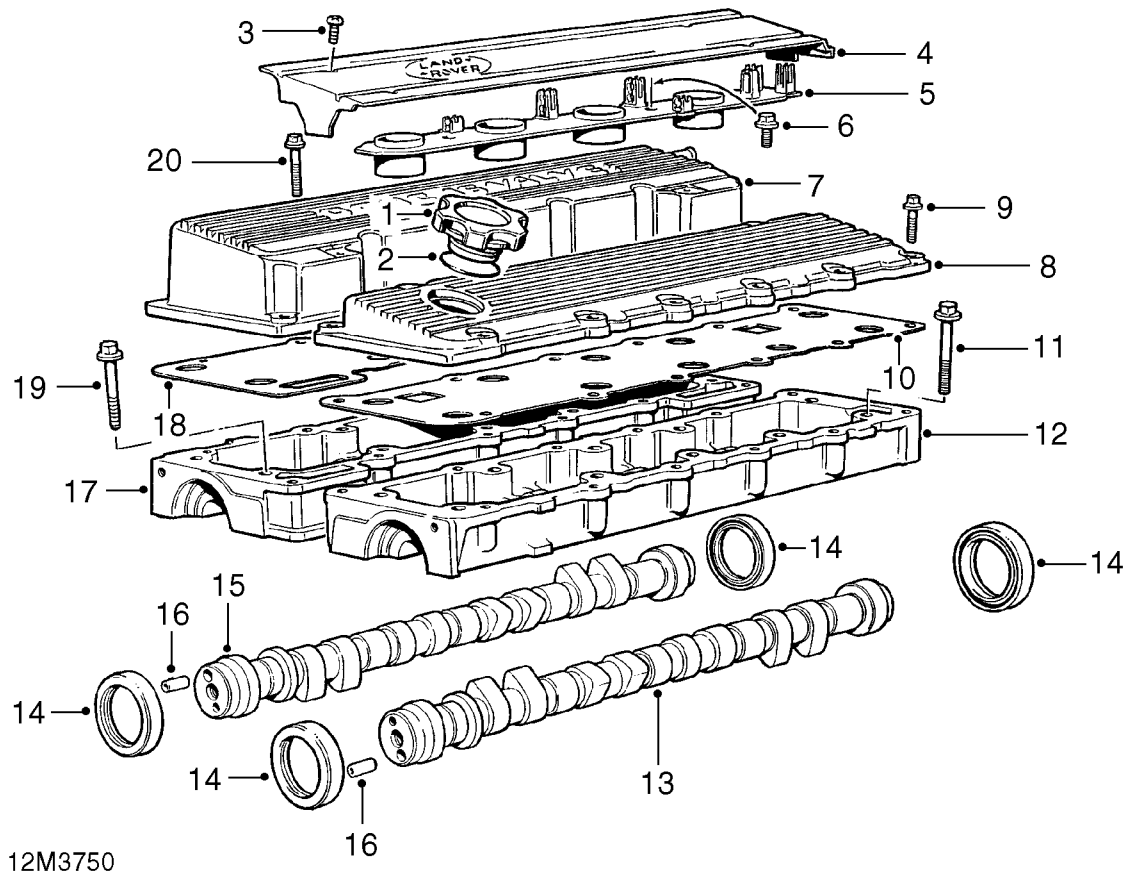



---

**CAMSHAFTS AND COVERS**

---

1. Engine oil filler cap
2. Seal - oil filler cap
3. Screw - spark plug cover
4. Spark plug cover
5. HT lead plate
6. Screw - HT lead plate
7. Inlet camshaft cover
8. Exhaust camshaft cover
9. Bolt - exhaust camshaft cover
10. Exhaust camshaft cover gasket/baffle plate
11. Bolt - exhaust camshaft carrier
12. Exhaust camshaft carrier
13. Exhaust camshaft
14. Camshaft oil seals
15. Inlet camshaft
16. Drive pins
17. Inlet camshaft carrier
18. Inlet camshaft cover gasket/baffle plate
19. Bolt - inlet camshaft carrier
20. Bolt - inlet camshaft cover

# ENGINE

---

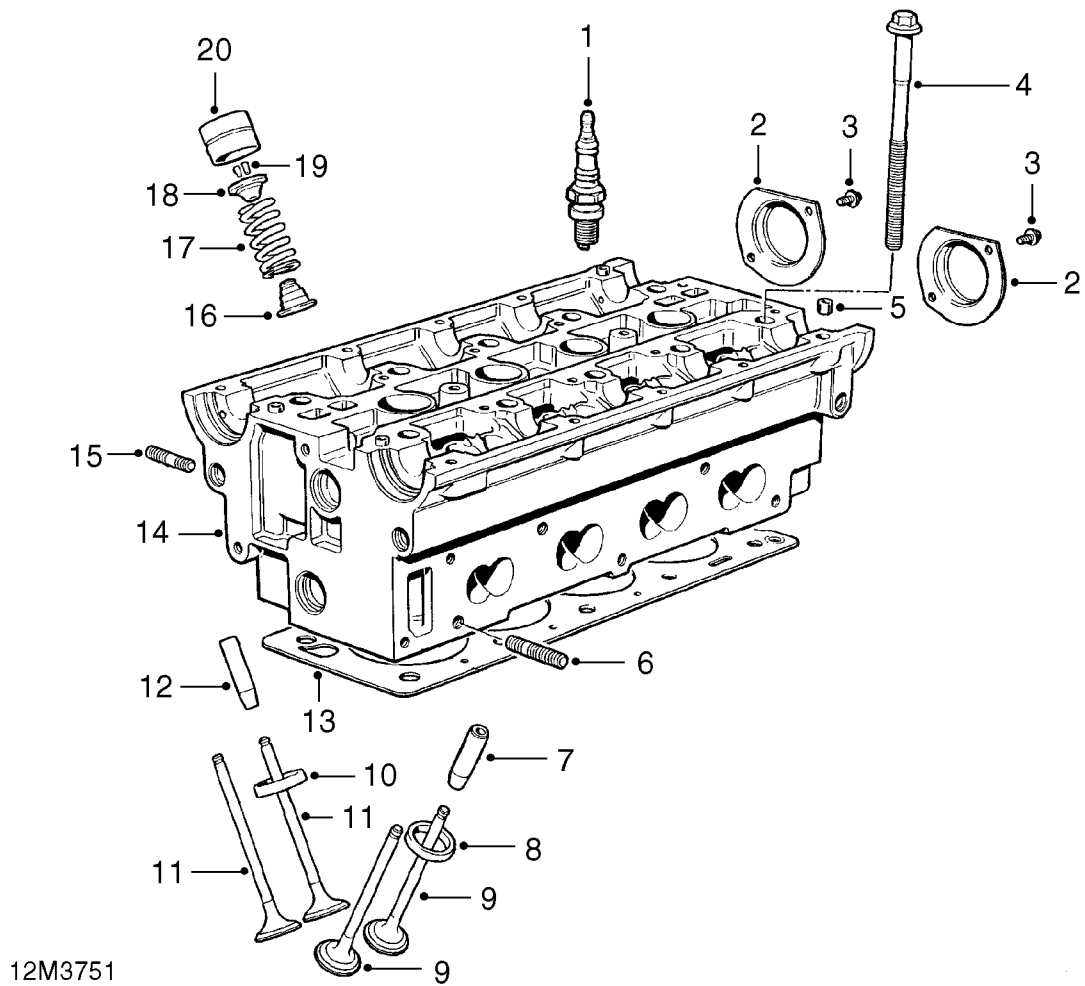



---

**CYLINDER HEAD COMPONENTS**

---

1. Spark plug
2. Blanking plates
3. Bolt - blanking plates
4. Bolt - cylinder head
5. Locating dowel - camshaft carrier
6. Stud - exhaust manifold
7. Guide - exhaust valve
8. Insert - exhaust valve seat
9. Exhaust valves
10. Insert - inlet valve seat
11. Inlet valves
12. Guide - inlet valve
13. Cylinder head gasket
14. Cylinder head
15. Stud - inlet manifold
16. Valve stem oil seal
17. Valve spring
18. Valve spring cap
19. Collets
20. Tappet

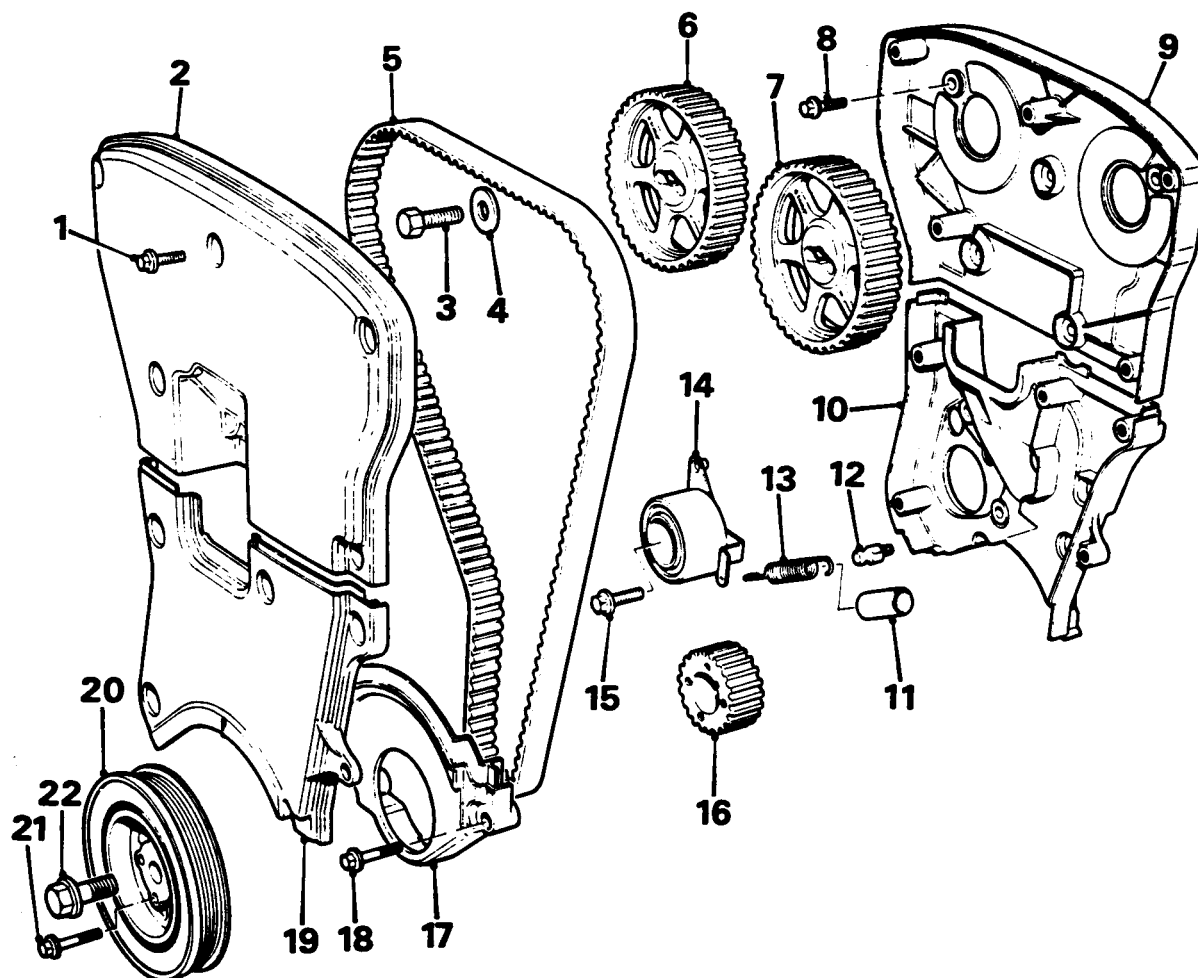

12M 0326

## TIMING BELT COMPONENTS

- |  |  |
|--|--|
| 1. Bolt - timing belt upper cover      | 12. Anchorage bolt                     |
| 2. Timing belt upper cover             | 13. Tensioner spring                   |
| 3. Bolt - camshaft timing gear         | 14. Tensioner pulley                   |
| 4. Plain washer                        | 15. Tensioner clamp bolt               |
| 5. Timing belt                         | 16. Crankshaft timing gear             |
| 6. Inlet camshaft timing gear          | 17. Timing belt lower cover            |
| 7. Exhaust camshaft timing gear        | 18. Bolt - timing belt lower cover     |
| 8. Bolt - upper timing cover backplate | 19. Timing belt centre cover           |
| 9. Upper timing cover backplate        | 20. Crankshaft pulley                  |
| 10. Lower timing cover backplate       | 21. Crankshaft pulley/timing gear bolt |
| 11. Tensioner spring sleeve            | 22. Crankshaft pulley bolt             |

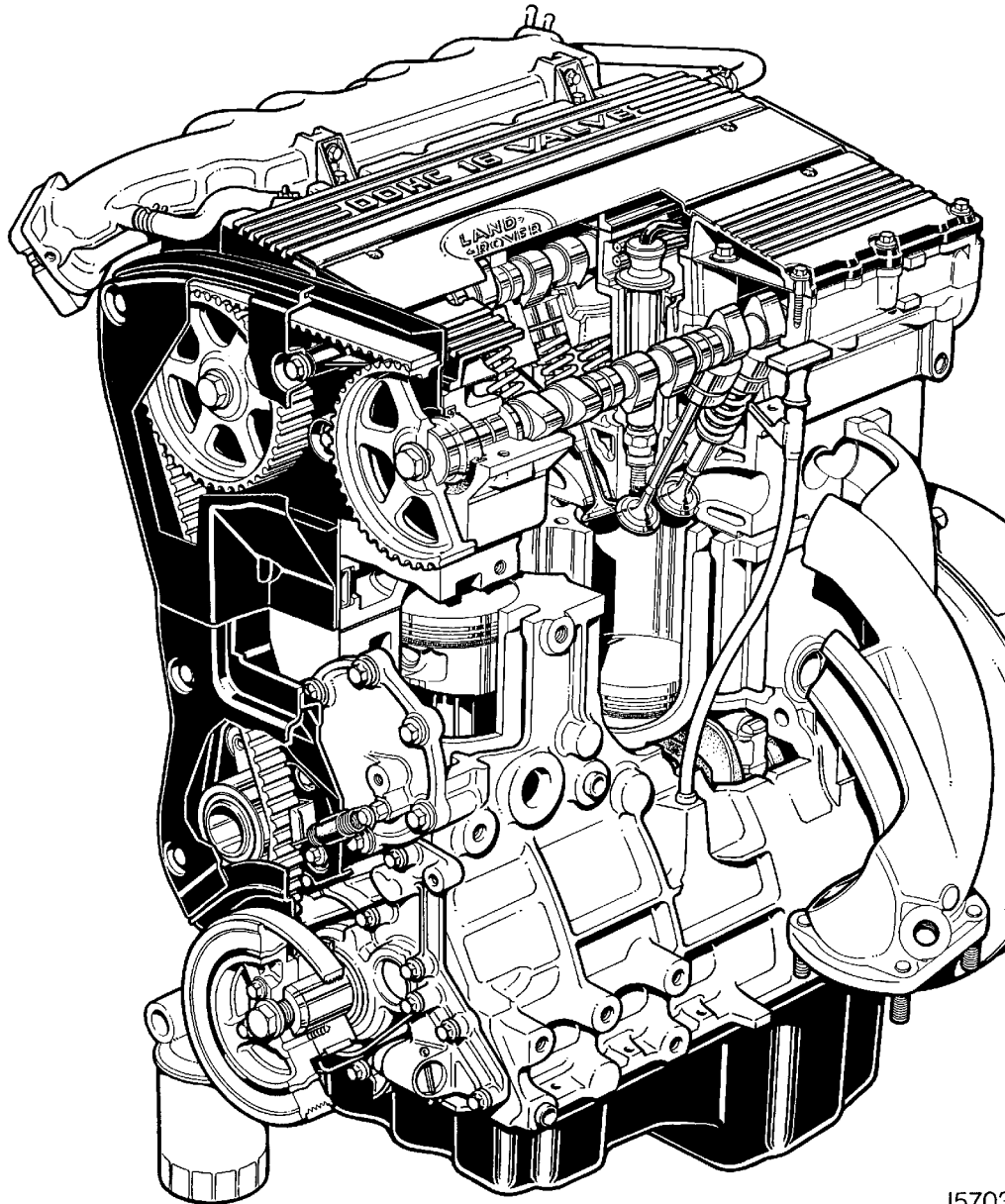

J5703

## OPERATION

The 'T' Series engine is a four cylinder, water cooled unit comprising a cast iron cylinder block, aluminium alloy cylinder head and twin aluminium alloy camshaft carriers.

The cylinder block incorporates direct bored, siamesed cylinder bores which provide good structural rigidity. The crankshaft is carried in five main bearings, end-float being controlled by thrust washers positioned each side of the centre main bearing. The main bearing caps are located to the cylinder block by dowels; the bearing shells fitted to Numbers 1, 3 and 5 bearings are fully grooved whilst those fitted to Numbers 2 and 4 bearings are plain.

The cylinder head carries twin camshafts operating four valves per cylinder via hydraulic tappets. Exhaust valves fitted to later engines are of the 'carbon break' type. A machined profile on the valve stem removes any build-up of carbon in the combustion chamber end of the valve guide thereby preventing valves from sticking. These valves may be fitted to all early engines. Both camshafts are driven by the timing belt and run directly in journals line bored in the cylinder head and camshaft carriers. The plastic camshaft covers are bolted to the camshaft carriers.



## ENGINE

---

The aluminium alloy, tin coated pistons have two compression and an oil control ring and are secured to the connecting rods by semi-floating gudgeon pins which are an interference fit in the small-end bush. Gudgeon pins are offset towards the thrust side of the pistons to reduce frictional drag.

Plain, big-end bearing shells are fitted to each connecting rod.

The internally toothed timing belt is driven from a gear which is keyed to the crankshaft, belt tension being controlled by a semi-automatic tensioner.

The trochoidal type oil pump is mounted on the front of the engine and carries the crankshaft front oil seal. Drive to the pump is via a Woodruff key inserted in the crankshaft.

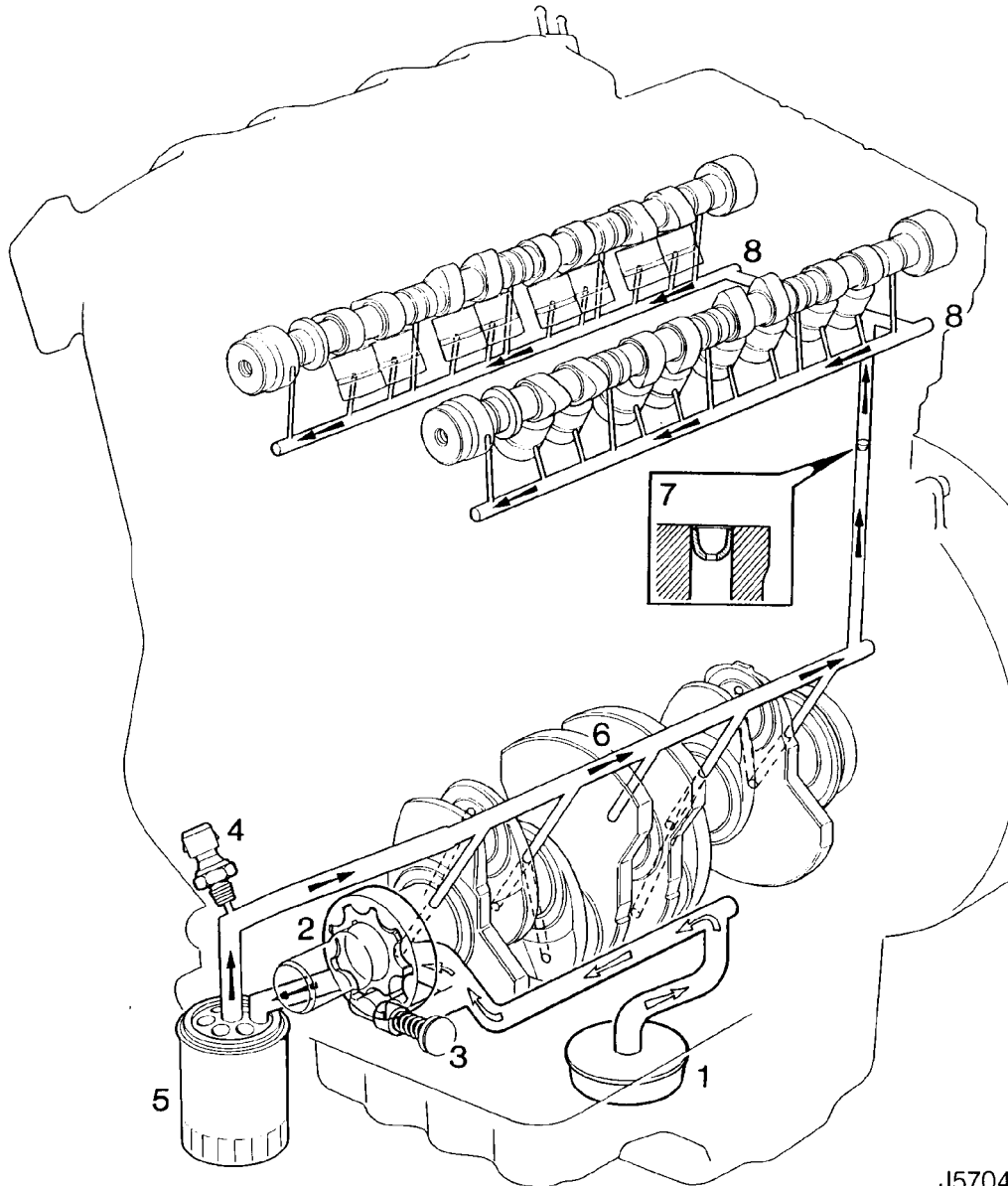

J5704

## Lubrication

Oil is drawn from the pressed steel sump through a strainer (1) and into the oil pump (2); excess pressure being relieved by a pressure relief valve (3) integral with the pump. The low oil pressure sensor (4) is screwed into the adaptor and registers the oil pressure in the main oil gallery on the outflow side of the filter. Pressurised oil passes through the full flow oil filter (5) to internal drillings in the crankshaft where it is directed to each main bearing and to the big-end bearings via Numbers 1, 3 and 5 main bearings (6). An internal drilling in the cylinder block directs oil, via a restrictor - if fitted (7) to the cylinder head where it passes through further internal drillings to the hydraulic tappets and camshaft journals (8).

Gudgeon pin and small-end bush lubrication is by splash from the big-end bearings.

## Crankcase ventilation

With the exception of two hoses connected from the inlet camshaft cover to the inlet manifold and throttle housing, all crankcase ventilation is via internal voids in the cylinder head and block. The inlet camshaft cover carries a wire gauze flame trap located over the breather pipe connections.



## CAMSHAFT TIMING BELT AND TENSIONER

### Camshaft timing belt - remove

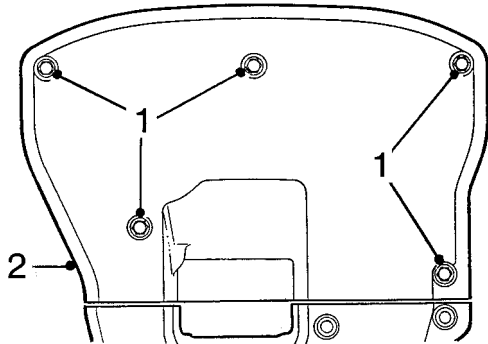

J5705

1. Remove 5 bolts securing timing belt upper cover.
2. Remove timing cover.

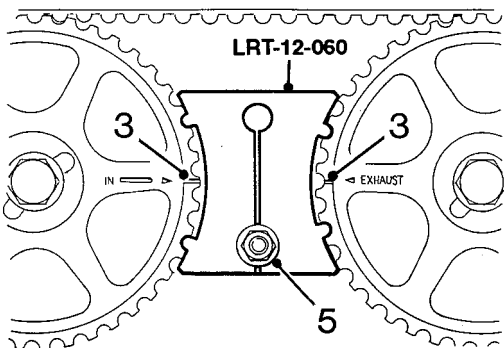

J5706

3. Using a socket and extension bar on crankshaft pulley bolt, rotate crankshaft until timing marks are in position shown - 90° BTDC



**CAUTION:** Do not use camshaft gears or retaining bolts to rotate engine.

4. Position camshaft locking tool **LRT-12-060** to camshaft gears.
5. Tighten nut on tool **LRT-12-060** to retain tool.

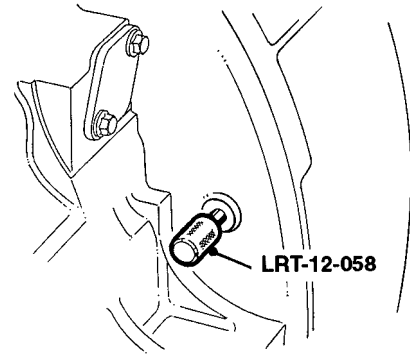

J5707

6. Insert timing pin **LRT-12-058** through hole in gearbox adaptor plate and into hole in flywheel.

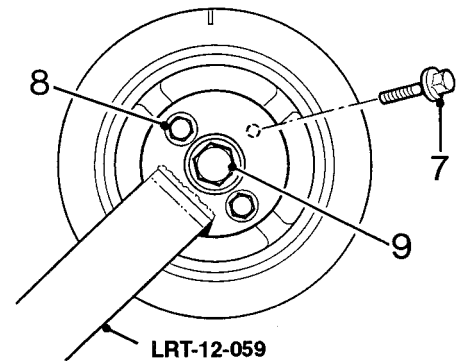

J5708

7. Remove 4 bolts securing crankshaft pulley to crankshaft timing gear.
8. Position tool **LRT-12-059** to crankshaft pulley, fit and tighten 2 bolts to retain tool.
9. Restrain crankshaft pulley using tool **LRT-12-059** and remove crankshaft pulley bolt.
10. Remove bolts retaining tool **LRT-12-059**, remove tool and crankshaft pulley.

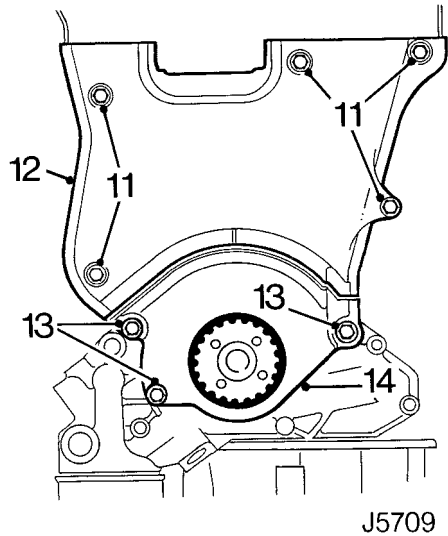

J5709

11. Remove 5 bolts securing timing belt centre cover.
12. Remove centre cover.
13. Remove 3 bolts securing timing belt lower cover.
14. Remove lower cover.

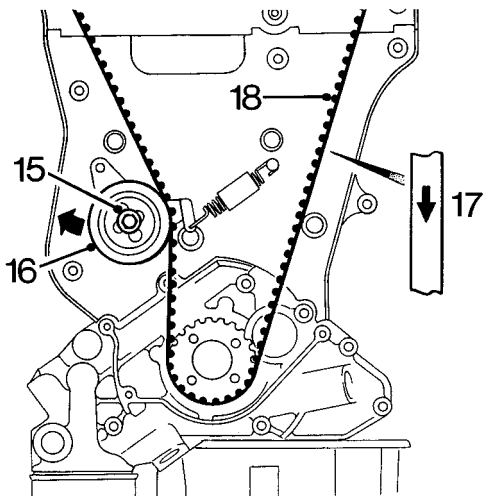

J5710

15. Slacken but do not remove timing belt tensioner clamp bolt.
16. Move timing belt tensioner pulley away from timing belt; tighten clamp bolt sufficiently to prevent tensioner pulley moving.
17. If timing belt is to be refitted, mark direction of rotation of belt using chalk or crayon.
18. Using fingers only, ease timing belt off gears.



**CAUTION:** Do not rotate crankshaft or camshafts with timing belt removed and cylinder head fitted.

## Timing belt tensioner - remove

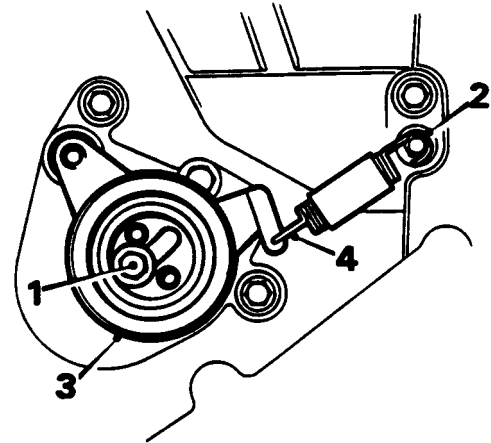

12M 0239

1. Slacken but do not remove timing belt tensioner clamp bolt, allow tensioner to operate.
2. Unhook tensioner spring from anchorage bolt.
3. Remove tensioner clamp bolt, remove tensioner.
4. Release tensioner spring from tensioner.



### Camshaft timing belt and tensioner - inspection

1. Inspect timing belt for signs of splits at base of teeth, fraying, oil contamination or uneven wear. Renew timing belt if it fails inspection or has been used for more than 48,000 miles, 80,000 km.



**CAUTION: If timing belt is contaminated with oil, cause of oil contamination must be rectified. Timing belts must be stored and handled with care. Always store a belt on its edge with a bend radius greater than 30 mm. Do not use a timing belt which has been twisted or bent double as this can fracture the reinforcing fibres. Do not use a belt that has been contaminated with oil.**

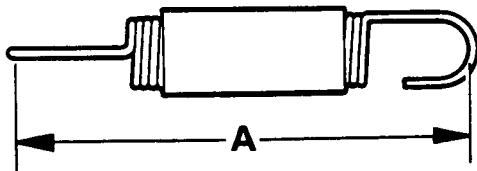

12M 0240

### Timing belt tensioner - refit

1. Attach tensioner spring to timing belt tensioner arm.
2. Position timing belt tensioner to cylinder block, fit but do not tighten clamp bolt.
3. Connect tensioner spring to anchorage bolt.
4. Move timing belt tensioner to minimum tension position, tighten clamp bolt.

2. Check free length of tensioner spring:  
Tensioner spring free length  $A = 57.5$  to  $58.5$  mm.
3. Renew tensioner spring if free length is greater than specified.
4. Clean timing gears, timing belt tensioner pulley, timing belt covers and backplate.
5. Check timing belt covers for damage, renew as necessary.
6. Clean crankshaft pulley.

## Timing belt - refit and adjust

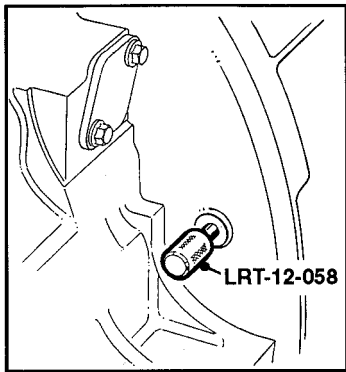
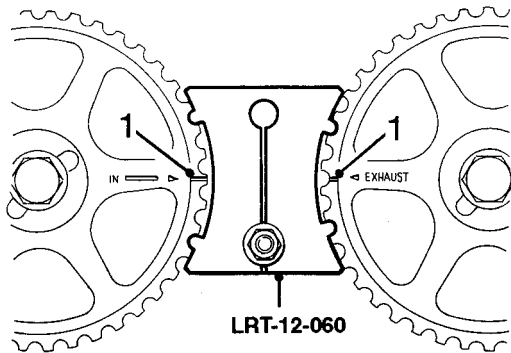

J5713

1. Ensure timing marks on camshaft gears are correctly aligned and camshaft locking tool **LRT-12-060** is fitted.
2. Ensure timing pin **LRT-12-058** is inserted in hole in flywheel.
3. Ensure timing belt tensioner is at minimum tension position and clamp bolt is tightened sufficiently to prevent tensioner operating.
4. Fit timing belt to crankshaft timing gear keeping belt taut between crankshaft timing gear and exhaust camshaft gear.



**CAUTION:** If original timing belt is to be refitted, ensure direction of rotation mark is facing correct way.

5. Slacken timing belt tensioner clamp bolt just sufficiently to allow tensioner to operate and tension timing belt.



**CAUTION:** Do not tighten clamp bolt at this stage.

6. Fit timing belt lower cover, fit securing bolts and tighten to 6 Nm.

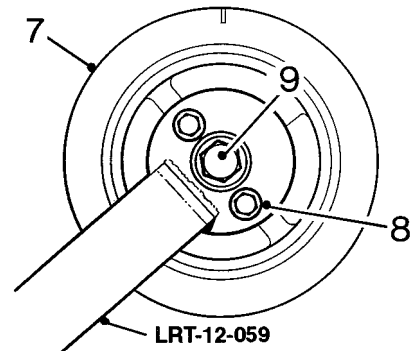

J5714

7. Position crankshaft pulley on crankshaft, align bolt holes with timing gear.
8. Position tool **LRT-12-059** to crankshaft pulley, fit and tighten 2 bolts to retain tool.
9. Fit crankshaft pulley bolt and using tool **LRT-12-059** to restrain crankshaft, tighten bolt to 85 Nm.
10. Slacken nut retaining camshaft locking tool **LRT-12-060**; remove tool.
11. Remove timing pin **LRT-12-058**.
12. Using tool **LRT-12-059**, rotate crankshaft 2 complete turns - viewed from front of engine.
13. Tighten timing belt tensioner clamp bolt to 30 Nm.
14. Remove bolts retaining tool **LRT-12-059**, remove tool.
15. Fit crankshaft to timing gear bolts and tighten to 8 Nm.
16. Fit timing belt centre cover, fit securing bolts and tighten to 6 Nm.
17. Fit timing belt upper cover, fit securing bolts and tighten to 6 Nm.





---

**CYLINDER HEAD**

---

**Inlet manifold - remove**

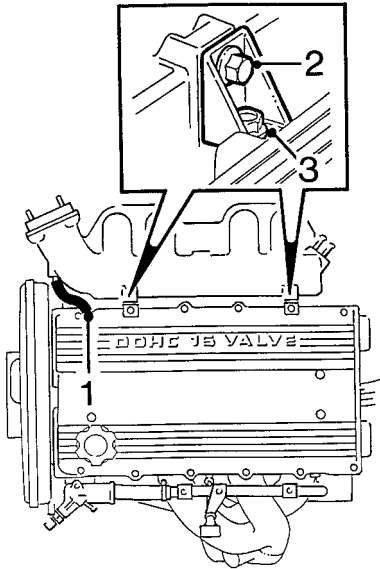
---



J5715

1. Disconnect breather pipe from inlet camshaft cover.
2. Remove 2 bolts securing inlet manifold to support brackets.
3. Remove bolt securing each support bracket to camshaft cover; remove brackets.

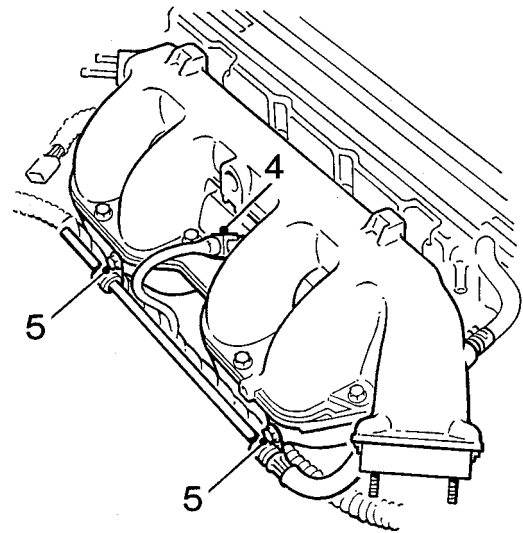

J5716

4. Disconnect multiplug from fuel temperature sensor.
5. Remove 2 bolts securing engine harness and fuel pipe clips to inlet manifold

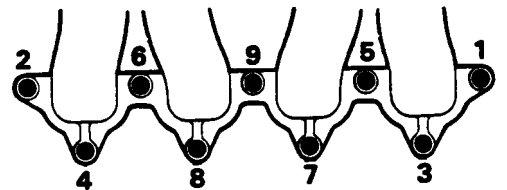

12M 0273

6. Remove 7 bolts and 2 nuts securing inlet manifold to cylinder head in sequence shown, remove manifold, discard gasket.

# ENGINE

## Exhaust manifold - remove

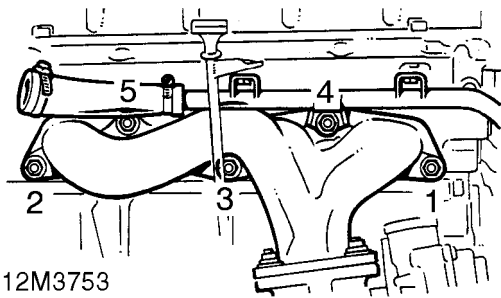

1. Remove 3 bolts and 2 nuts securing exhaust manifold to cylinder head in sequence shown, release coolant rail bracket from manifold stud; remove exhaust manifold and discard gasket.

## Cylinder head - remove

1. Remove camshaft timing belt.
2. Suitably identify each timing gear to its appropriate camshaft.

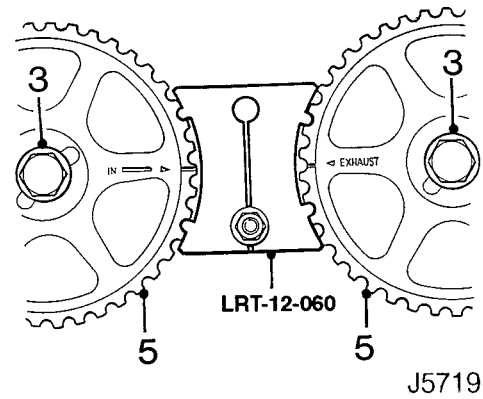

3. Remove bolt and washer securing each timing gear.
4. Remove tool LRT-12-060.

**CAUTION:** Do not rotate crankshaft or camshafts with timing belt removed and cylinder head fitted.

5. Remove camshaft timing gears.

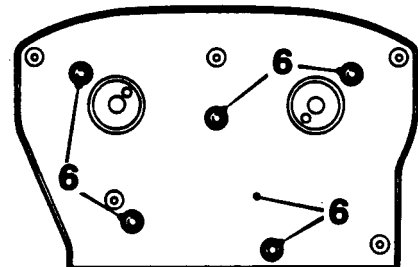

6. Remove 5 bolts securing upper timing cover backplate, remove backplate.



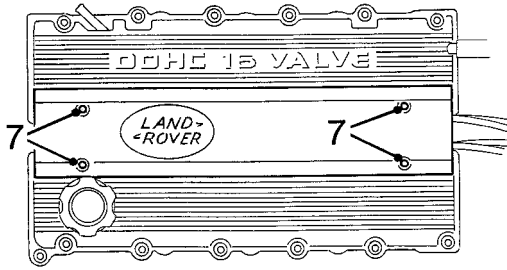

J5721

7. Remove 4 screws securing spark plug cover; remove cover.

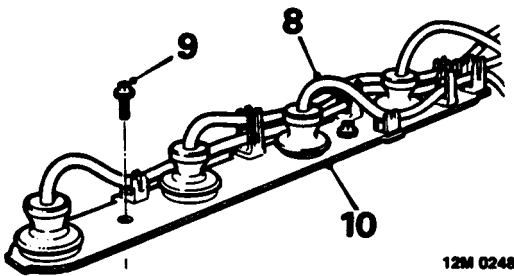

12M 0248

8. Disconnect HT leads from spark plugs.
9. Remove 2 screws securing HT lead plate.
10. Remove HT lead plate.
11. Remove 4 spark plugs.

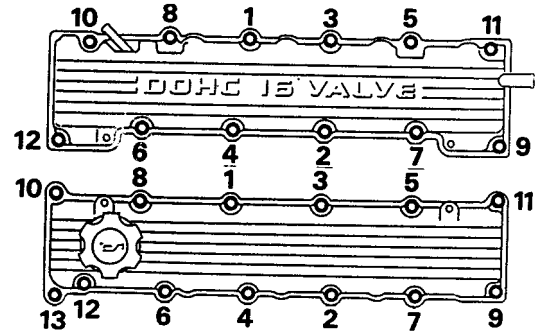

12M 0250

12. Using sequence shown, slacken then remove 12 bolts securing inlet camshaft cover and 13 bolts securing exhaust camshaft cover. Recover inlet manifold support brackets.
13. Remove camshaft covers, discard gaskets.

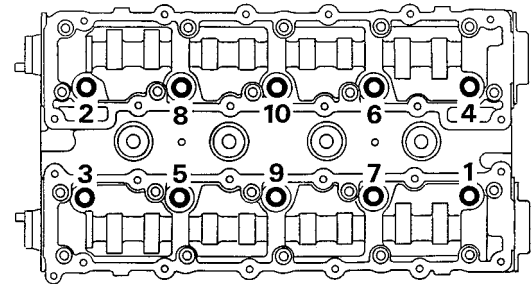

J5725

14. Using sequence shown, progressively slacken then remove 10 bolts securing cylinder head.
15. Remove cylinder head, discard gasket.

**CAUTION:** Support cylinder head on wooden blocks to prevent damaging valves. Take great care not to damage gasket face of head.

# ENGINE

## Camshafts end float - check

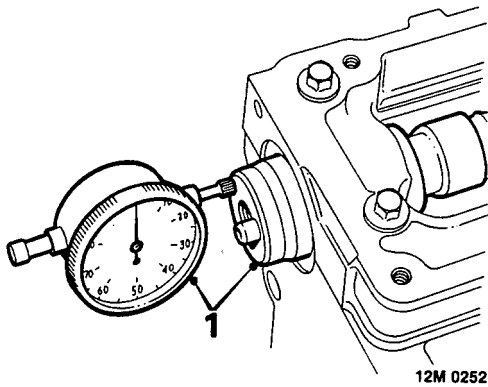

1. Check end-float of each camshaft using a DTI gauge.  
Camshaft end-float = 0.06 to 0.25 mm

If end-float exceeds limits given, repeat check with a new camshaft, if end-float is still excessive, a new cylinder head and camshaft assembly must be fitted.

## Camshafts - remove

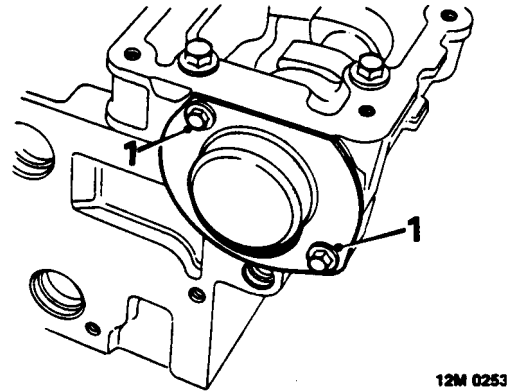

1. Remove 2 bolts securing blanking plates to camshaft carrier and cylinder head; remove plates.

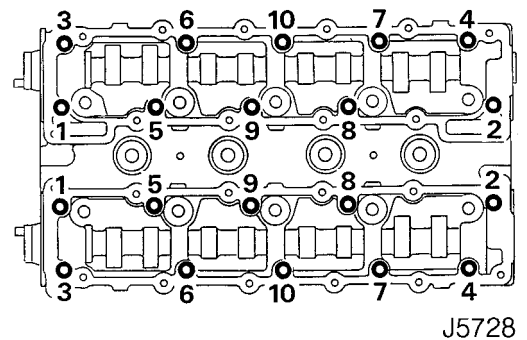

2. Using sequence shown, progressively slacken then remove 10 bolts securing each camshaft carrier to cylinder head; remove carriers.



**NOTE: Dowel located.**

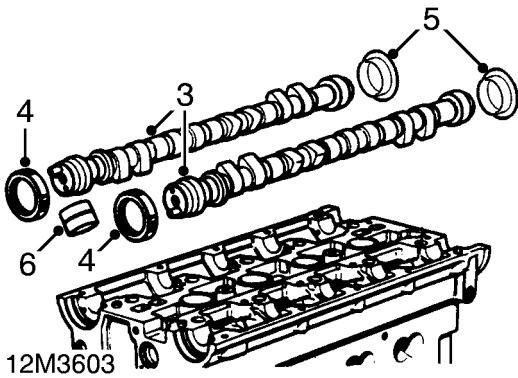

3. Remove inlet and exhaust camshafts.



**CAUTION:** Suitably identify each camshaft to its fitted position, do not interchange camshafts.

4. Remove and discard 2 oil seals from each camshaft.
5. Using a stick magnet, remove 16 tappets.



**CAUTION:** Store tappets in their fitted order and invert to prevent oil loss.

### Camshafts - inspection



**NOTE:** Carry out camshaft inspection after removal of valves and springs.

1. Clean camshafts and bearing journals in camshaft carriers and cylinder head.
2. Inspect cams and camshaft bearing journals, replace camshaft(s) if scoring, pitting or excessive wear is evident.
3. Inspect bearing journals in cylinder head and camshaft carriers, replace components if scoring, pitting or excessive wear is evident.
4. Remove all traces of oil from bearing journals in cylinder head, camshaft carriers and camshafts.
5. Position camshafts on cylinder head.
6. Position a piece of Plastigage across each camshaft bearing journal.
7. Fit camshaft carriers, fit securing bolts and working from the centre outwards, progressively tighten bolts to 25 Nm. Do not rotate camshafts.
8. Remove camshaft carrier securing bolts, remove carriers.

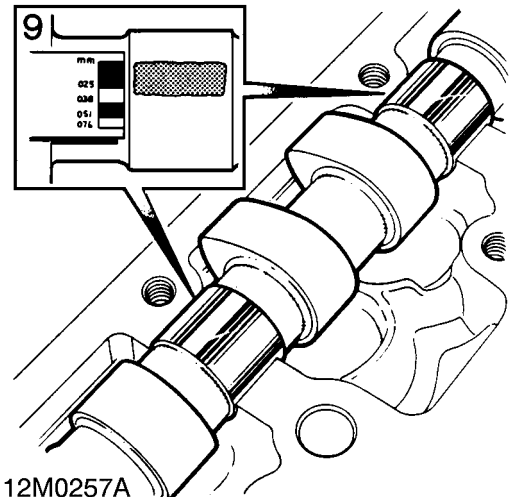

9. Measure widest portion of Plastigage on each bearing journal and from dimensions obtained, calculate camshaft bearing clearance.  
Camshaft bearing clearance = 0.060 to 0.094 mm  
Service limit = 0.15 mm

10. If bearing clearance is excessive, fit new camshaft(s) and repeat check; if excessive clearances still exist, renew cylinder head and camshaft carriers.
11. Remove all traces of Plastigage using an oily rag.

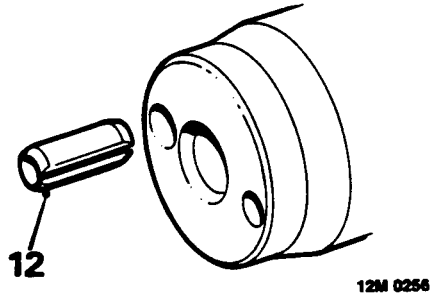

12. Transfer drive pins from old camshafts to new with split fitted towards centre of camshaft.

## Valves and springs - remove

1. Using a hollow drift, tap each valve spring cap to free collets.
2. Position cylinder head on its exhaust manifold face.

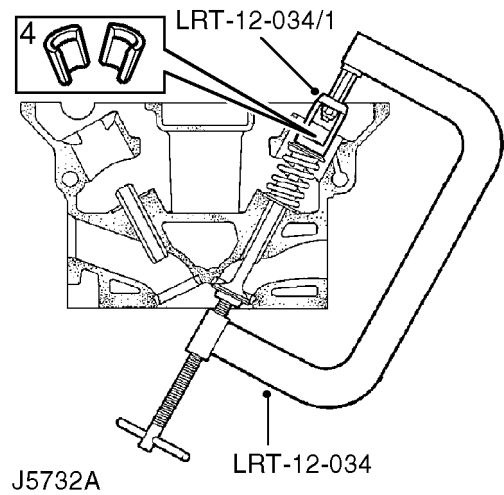

3. Using tool **LRT-12-034** and adaptor **LRT-12-034/1**, compress inlet valve spring.
4. Remove 2 collets using a magnet.

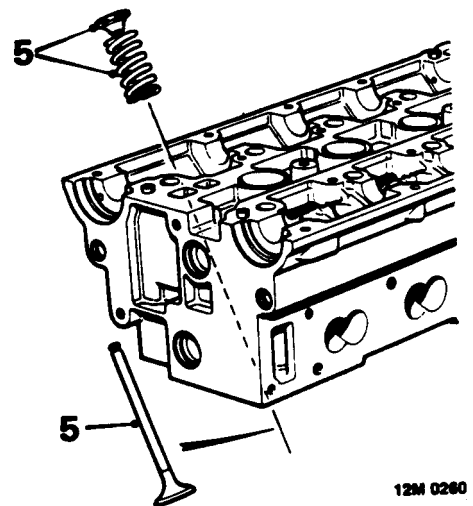

5. Release tool **LRT-12-034** and remove valve, valve spring cap and valve spring.

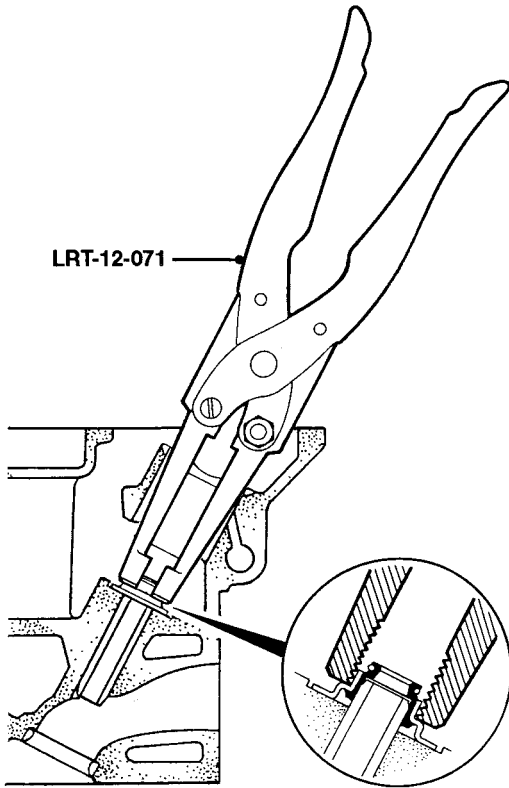

J5734

6. Using tool **LRT-12-071**, remove and discard valve stem oil seal.
7. Repeat above operations for remaining inlet valves.



**CAUTION: Keep valves, springs, caps and collets in fitted order.**

8. Position cylinder head on its inlet manifold face.
9. Remove exhaust valves and valve stem oil seals using the above procedures.

### Cylinder head - inspection

1. Clean all traces of gasket material from cylinder head using suitable gasket removal spray and a plastic scraper. Remove sealant using suitable solvent.



**CAUTION: Take great care not to damage gasket face of head. If locating dowels have been removed with cylinder head, they must be refitted in cylinder block.**

2. Thoroughly clean cylinder head, blow out oilways and coolant passages.
3. Ensure camshaft carrier locating dowels are fitted.
4. Check cylinder head for damage, cracks or burning.
5. Check condition of 10 core plugs, renew any plug showing signs of cracks, corrosion or weeping, seal new plugs using Loctite 601.

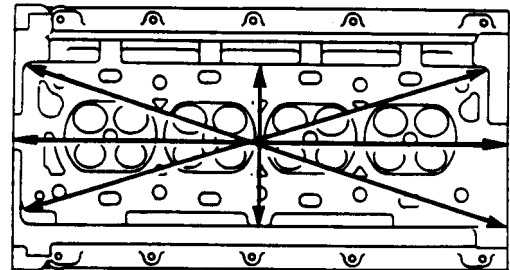

12M 0262

6. Check cylinder head face for warping.  
Longitudinal warp = 0.1 mm max.  
Transverse warp = 0.1 mm max.  
Diagonal warp = 0.1 mm max.



**CAUTION: If warping exceeds the figures given, a new cylinder head must be fitted. Cylinder heads must not be refaced.**

7. Check cylinder head height measured from face of head to camshaft carrier face.  
Cylinder head height = 135.0 to 135.1 mm

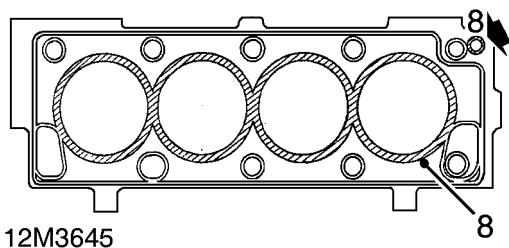

8. Check gasket face of cylinder head for scratches or indentations paying particular attention to the shaded areas in the above illustration.

## Cylinder head gasket selection

---

1. If scratches or indentations exist, fit cylinder head gasket coated with black sealant.



**NOTE: This gasket was fitted as standard to all engines up to engine no. 128817. It will be necessary to fit the oil restrictor in the cylinder block.**

2. If no scratches or indentations exist, fit cylinder head gasket which is of multi-layer steel construction.



**NOTE: This gasket is fitted as standard to all engines from engine no. 128817 and may be fitted to all engines prior to this number provided the above conditions are met. It will be necessary to remove the oil restrictor - if fitted from the cylinder block.**



### Oil restrictor - fitting

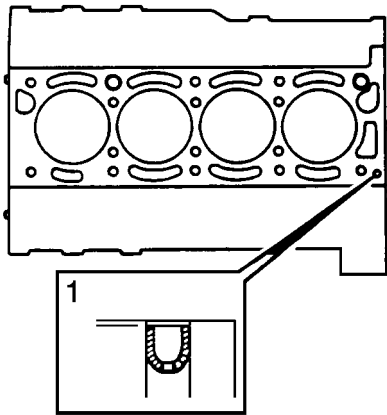

12M3605A

1. Insert oil restrictor in oil passage in cylinder block ensuring that top of restrictor is positioned below gasket face of block.

### Valve springs - inspection

1. Check condition of valve springs:  
Free length = 46.25 mm  
Fitted length = 37.0 mm  
Load - valve closed =  $255 \pm 12$  N  
Load - valve open =  $560 \pm 22.5$  N



**CAUTION:** Valve springs must be replaced as a complete set.

## Valves and guides - inspection

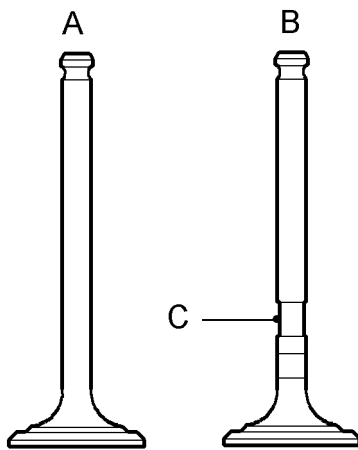

12M3669



**NOTE:** Two types of exhaust valve may be fitted, standard valves A in illustration or carbon break valves, B. Carbon break valves may be identified by the machined profile C on the valve stem. To prevent exhaust valves sticking, carbon break valves together with the later type valve guides - see following illustration should always be fitted whenever standard valves or early type guides are to be replaced.

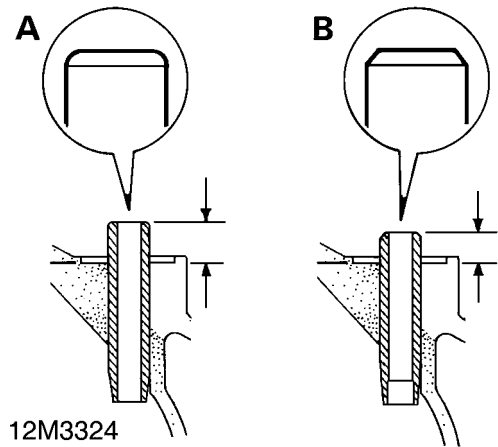

**NOTE:** Exhaust valve guides illustrated



**NOTE:** Two types of valve guide may be fitted and before removing guides, reference should be made to the above illustration to identify the type of guide. The early type of guide, A in illustration has a radiussed top and a fitted height of 12.0 mm. The later type, B in illustration, has a flat, chamfered top and a fitted height of 10.3 mm. Additionally, exhaust valve guides are counterbored at the exhaust valve end of the guide. Replacement valve guides will all be of the later type and these, together with carbon break exhaust valves should be fitted in engine sets to cylinder heads whenever the early type of guide and standard exhaust valves are to be replaced.



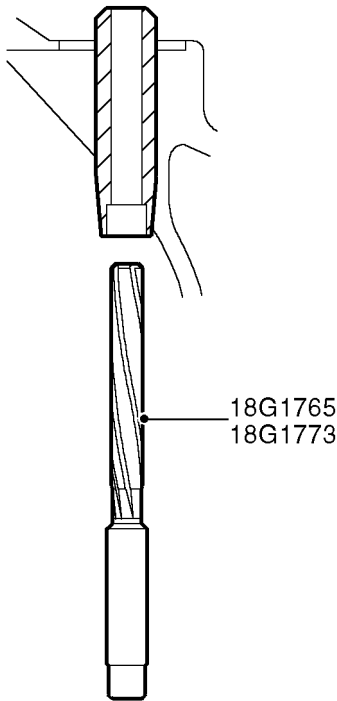

12M3755

**NOTE: Later type exhaust valve guide illustrated**

1. *Early type exhaust valve guides fitted:* Remove carbon deposits from exhaust valve guides using Rover tool **18G 1773**.
2. *Later type exhaust valve guides fitted:* Remove carbon deposits from exhaust valve guides using Rover tool **18G 1773** and from valve guide counterbores using Rover tool **18G 1765**.

**NOTE: Tools must be inserted into guide from combustion face side of cylinder head.**

3. Remove carbon from valves, inlet valve guides and valve seat inserts. Ensure all traces of carbon are removed on completion.

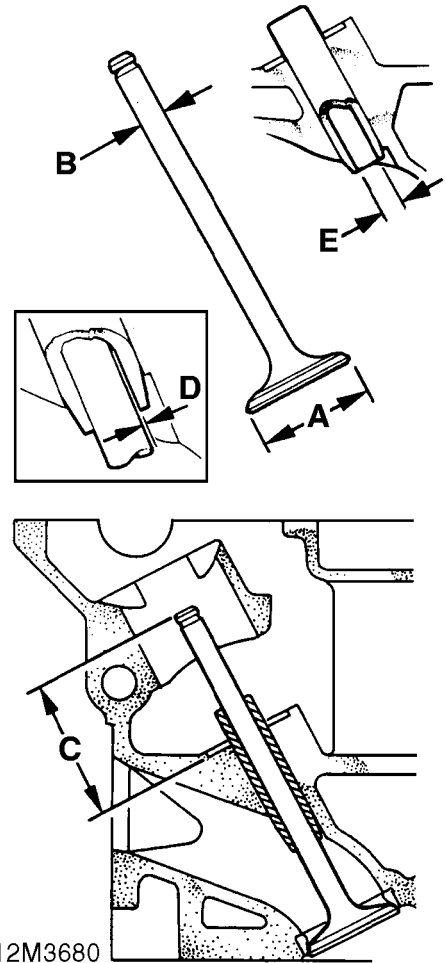

12M3680

**NOTE: Later type exhaust valve guide illustrated**

4. Remove carbon from valves, inlet valve guides and valve seat inserts. Remove all loose particles of carbon on completion.
5. Check existing valve stem and head diameters.
6. Check valve stem to guide clearance using new valves.
7. Renew valves and guides as necessary.

**Valve head diameter A:**

Inlet = 31.7 to 31.95 mm

Exhaust = 29.2 to 29.43 mm

**Valve stem diameter B:**

Inlet = 7.09 to 7.10 mm

Exhaust = 7.07 to 7.09 mm

8. Check installed height of each valve.

**Valve installed height C:**

Inlet and exhaust = 43.4 mm max.



**NOTE: If valve installed height exceeds dimension given, valve/valve seat insert must be replaced.**

9. **Valve stem to guide clearance D:**

Inlet = 0.04 to 0.06 mm

Service limit = 0.09 mm

Exhaust = 0.06 to 0.07 mm

Service limit = 0.10 mm

10. **Valve guide internal diameter E:**

Inlet and exhaust = 7.137 to 7.162 mm

## Valve guides - renew

1. Heat cylinder head evenly to 100° C.



**WARNING: Wear protective gloves when handling cylinder head.**

2. Place cylinder head face downwards and using a piloted mandrel, press valve guide towards combustion face side for a distance of 2.0 mm.
3. Invert cylinder head and remove all traces of carbon from periphery of valve guide.
4. Re-heat cylinder head to 100° C.
5. Using a piloted mandrel, press valve guide out from the combustion face side of the cylinder head.



**NOTE: The tapered portion of the valve guide is either plain or has 1, 2 or 3 grooves machined around the circumference. Additionally, later type exhaust valve guides are counterbored at the combustion face end of the guide. When replacing guides it is essential to ensure that a plain guide is replaced with a guide having 2 grooves and a guide having 1 groove is replaced with a guide having 3 grooves.**

6. Re-heat cylinder head to 100° C.

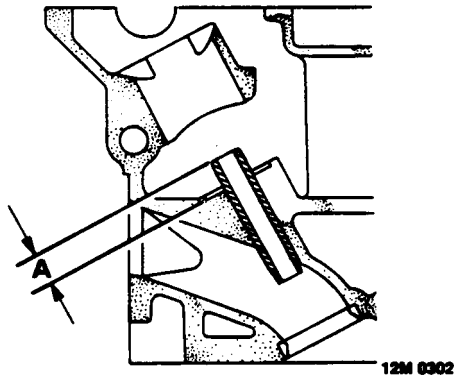

### Valve seat inserts - inspection

1. Check valve seat inserts for pitting and burning, replace as necessary.



**CAUTION:** Where valve installed height exceeds dimension given, seat inserts must be replaced.

Valve guide renewal must be carried out before renewal of valve seat inserts.



**NOTE:** Inlet valve guide illustrated.

7. Using a piloted mandrel, press valve guide into cylinder head from the combustion face side until top of guide is 10.3 mm **A** from valve spring seat face.



**CAUTION:** Ensure when fitting later type exhaust valve guides that counterbore is towards combustion face side of cylinder head.

8. Allow cylinder head to air cool.

# ENGINE

---

## Valve seat inserts - renew

---

1. Remove valve seat inserts.



**CAUTION: Take care not to damage cylinder head counterbore when removing seat inserts.**

2. Heat cylinder head to 100° C, fit new valve seat inserts.



**CAUTION: Ensure insert is kept square to counterbore.**

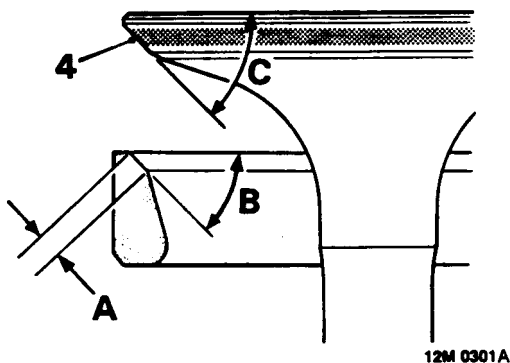

3. Cut valve seats using tools LRT-12-501, LRT-12-518 and LRT-12-504.

**Valve seat:**

Width **A** = 1.5 to 2.0 mm

Angle **B** = 45°

Valve face angle **C**

Inlet and exhaust = 45° to 45°15'

4. Lap all valves to their seats.

## Valves - lapping-in

---

1. Lap each valve to its seat using fine grinding paste.
2. Apply Prussian Blue to valve seat, insert valve and press it into position several times without rotating. Remove valve and check for even and central seating. Seating position shown by Prussian Blue should be in centre of valve face.
3. Check valve installed height if valve seats have been re-cut or new valves or valve seat inserts fitted.
4. Ensure all traces of grinding paste are removed on completion.



### Valves and camshafts - assembling

1. Lubricate valve guides, valve stems, springs, caps, spring seats and new valve stem oil seals with engine oil.
2. Insert each inlet valve in its respective guide and fit valve stem oil seals.  
Early type guides - fit **GREEN** coloured seals  
Later type guides - fit **BLACK** coloured seals.

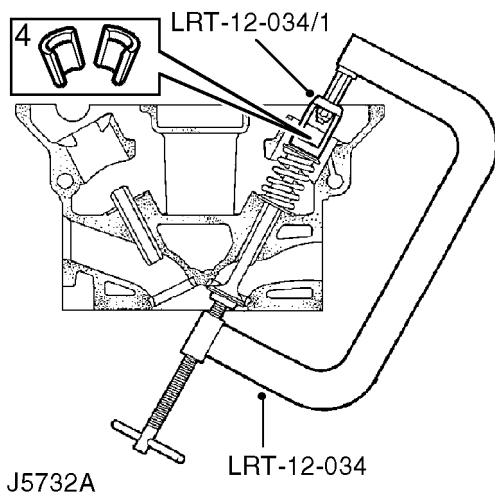

3. Fit valve springs and caps, use tool **LRT-12-034** and adaptor **LRT-12-034/1** to compress valve springs.
4. Fit 2 collets.
5. Using a wooden dowel and mallet, lightly tap each valve stem two or three times to seat valve cap and collets.
6. Fit exhaust valves using above procedures.

7. Support each end of cylinder head on blocks of wood.
8. Lubricate outside diameter of tappets, fit each tappet to its original bore.
9. Lubricate camshaft journals.

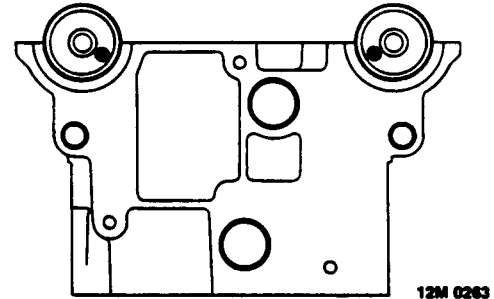

10. Fit camshafts and rotate to position drive pins as follows:  
Inlet pin at 4 o'clock.  
Exhaust pin at 8 o'clock.

# ENGINE

## Camshaft carriers and oil seals - assembling

- Using an M8 x 1.25 tap, remove all traces of sealant from camshaft cover bolt holes; clean sealant from camshaft carriers using suitable solvent.

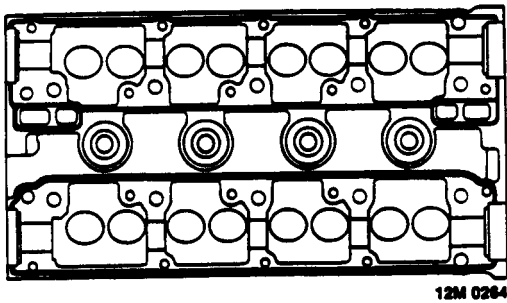

- Apply a thin, continuous bead of sealant from kit, Part Number GUG 705548GM to cylinder head as shown.
- Spread sealant to an even film using a brush or roller.



**CAUTION:** Ensure grooves adjacent to each bearing journal are clear of sealant.

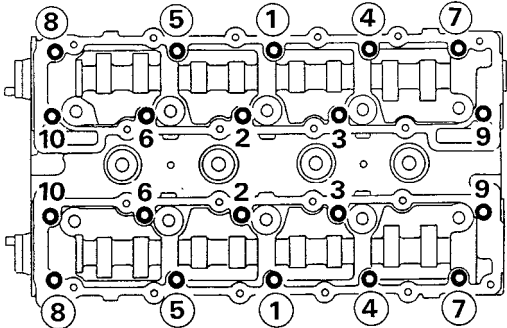

J5743

- Fit camshaft carriers, fit new Patchlock bolts - circled in illustration and plain bolts in all other positions.
- Working in sequence shown, progressively tighten bolts to 25 Nm.

- Lubricate new camshaft front and rear oil seals with engine oil.

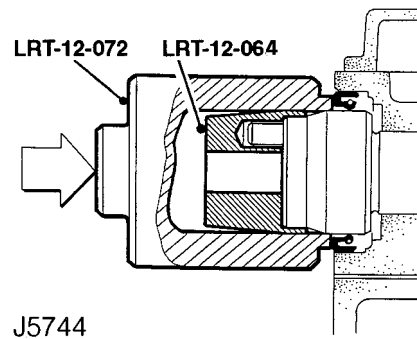

**NOTE:** Remove any burrs from lip of tool LRT-12-072.

- Fit front oil seals using tools LRT-12-072 and LRT-12-064 .

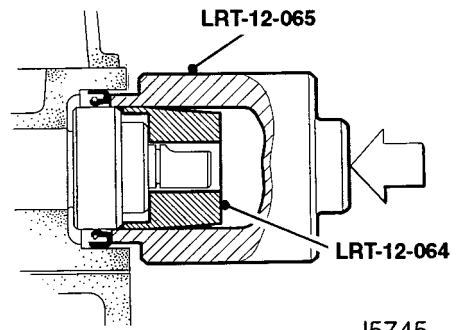

**CAUTION:** Remove any burrs from lip of tool LRT-12-065.

- Fit rear oil seals using tools LRT-12-064 and LRT-12-065 .
- Fit blanking plates to camshaft carriers, fit bolts and tighten to 8 Nm.



## Cylinder head - refit

1. Clean cylinder head bolt threads, replace any bolt showing signs of wasting or corrosion.
2. Screw each cylinder head bolt by hand into bolt holes in cylinder block.
3. Clean any tight threads using an M11 x 1.5 tap.
4. Thoroughly clean bolt holes ensuring all traces of oil and dirt are removed

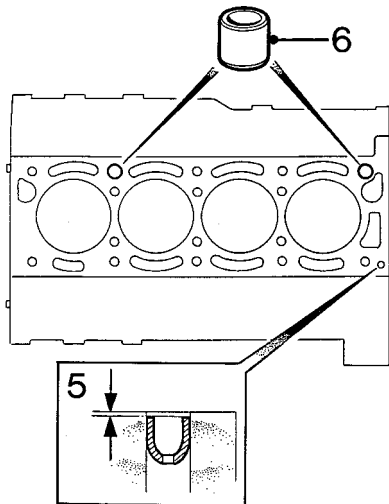

J5746

5. Check that oil restrictor if it is to be fitted is clear and fitted below face of cylinder block:-  
*See cylinder head gasket selection.*
6. Ensure 2 nylon locating dowels are fitted in cylinder block.
7. Remove all traces of oil from cylinder block and cylinder head; position new, dry gasket on locating dowels.

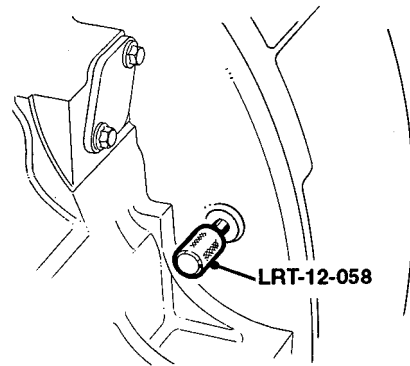

J5747

8. Ensure timing pin **LRT-12-058** is inserted in hole in flywheel.



**NOTE:** If flywheel is not fitted, rotate crankshaft until pistons are half-way up cylinder bores.

9. Fit cylinder head ensuring it is located on dowels.
10. Apply a light film of oil to bolt threads and underside of heads.

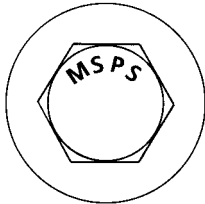
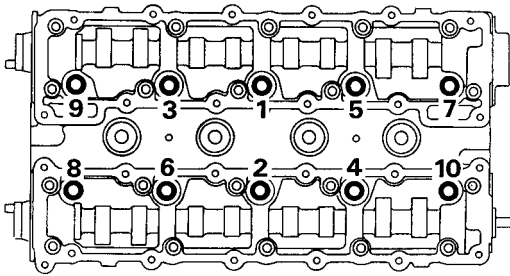

**A**

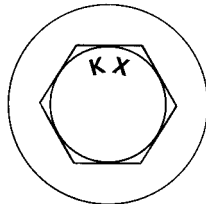

**B**

12M 0269 A

11. Fit 10 cylinder head bolts and tighten in sequence shown to **A** or **B** torque figures depending on type of bolt fitted.

**A:**

Stage 1 - 45 Nm

Stage 2 - 80 Nm

Stage 3 - Further 90°

**B:**

Stage 1 - 45 Nm

Stage 2 - 70 Nm

Stage 3 - Further 90°

For stage 3 use angular torque gauge and 150 mm extension. Fit pointer on an adjacent bolt, adjust pointer length and align zero on disc with pointer.

12. Fit spark plugs and tighten to 26 Nm.
13. Fit HT lead plate, tighten 2 screws.
14. Connect HT leads to spark plugs.
15. Fit spark plug cover, fit and tighten screws.

## Camshaft covers and timing gears - refit

1. Clean camshaft covers ensuring gauze filter panels and breather pipes are unobstructed.
2. Clean timing gears.
3. Fit new, dry gasket to each camshaft carrier.
4. Fit camshaft covers, position inlet manifold support brackets to inlet camshaft cover.

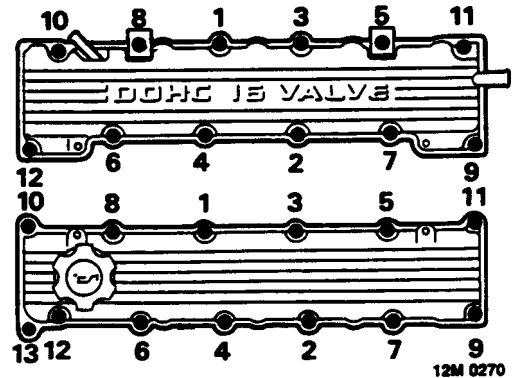

5. Fit bolts to camshaft covers; tighten bolts working in sequence shown to 8 Nm.
6. Fit timing cover upper backplate, fit securing bolts and tighten to 6 Nm.
7. Fit timing gears.



**NOTE:** Ensure each gear is fitted to its respective camshaft.



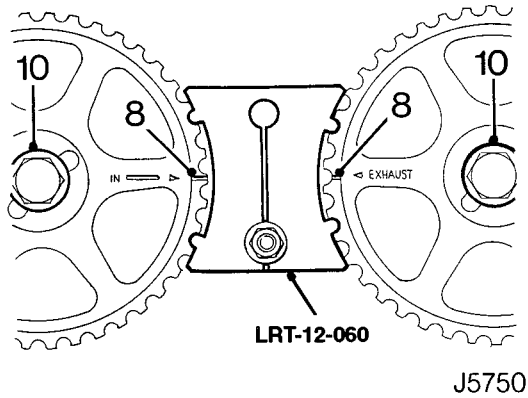

8. Check that timing marks on gears are aligned.
9. Position camshaft locking tool **LRT-12-060** to timing gears; tighten nut to retain tool.
10. Fit bolt and washer to retain each camshaft gear, tighten bolts to 65 Nm.
11. Fit timing belt and adjust tension.

### Inlet manifold - refit

1. Clean mating surface of inlet manifold.
2. Position new gasket on studs, fit inlet manifold.

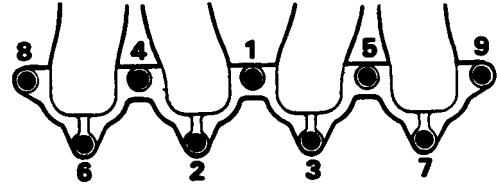

12M 0242

3. Fit 7 bolts and 2 nuts and working in sequence shown, tighten to 25 Nm.
4. Fit 2 support bracket bolts and tighten to 8 Nm.
5. Connect breather pipe.
6. Connect multiplug to fuel temperature sensor.
7. Position engine harness and fuel pipe clips to inlet manifold, fit bolts and tighten to 10 Nm.

# ENGINE

## Exhaust manifold - refit

1. Clean mating surface of exhaust manifold.
2. Position new gasket on studs, fit exhaust manifold.



**CAUTION: Metal face of gasket must face towards manifold.**

3. Position coolant rail bracket to exhaust manifold stud.

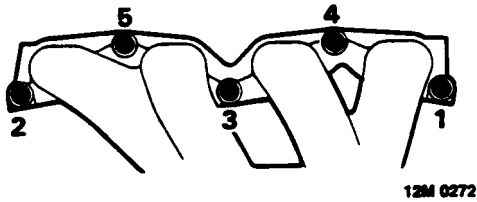

4. Fit 3 bolts and 2 nuts and working in sequence shown, tighten to 45 Nm.

## OIL PUMP AND OIL PRESSURE RELIEF VALVE

### Oil pump - remove

1. Remove camshaft timing belt.

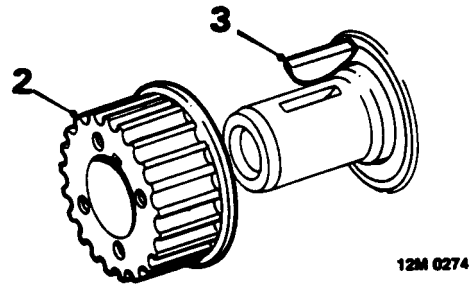

2. Slide crankshaft timing gear off crankshaft.
3. Remove Woodruff key from crankshaft.

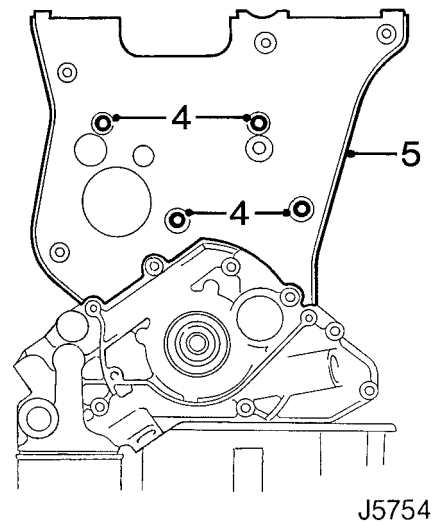

4. Remove 4 bolts securing timing belt lower cover backplate.
5. Remove lower cover backplate.

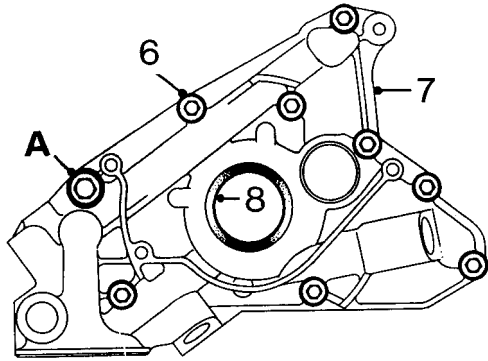

J5755

6. Noting fitted position of M10 x 20 bolt **A**, remove 9 bolts securing oil pump to cylinder block.
7. Slide oil pump off crankshaft, discard gasket.
8. Carefully prise crankshaft front oil seal out of oil pump body; discard oil seal.

### Oil pump - inspection



**NOTE:** The oil pump is serviced as an assembly. The following checks can be carried out to determine serviceability.

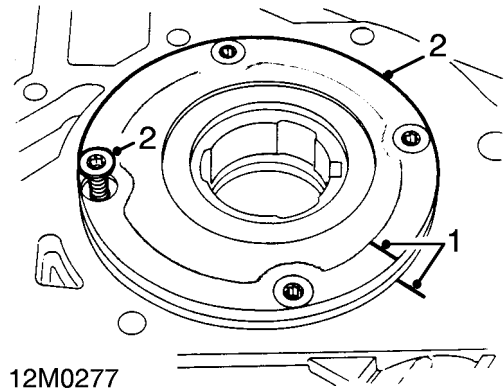

12M0277

1. Make suitable alignment marks between oil pump body and cover plate.
2. Remove 4 Torx screws securing cover plate, remove plate.

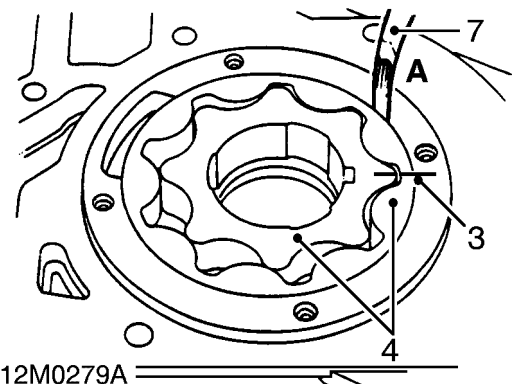

12M0279A

3. Using a felt tipped pen, make suitable alignment marks between inner and outer rotors and oil pump body.
4. Remove inner and outer rotors.
5. Check rotors and oil pump body for signs of wear and scoring.
6. Fit rotors ensuring that reference marks are aligned and chamfered side of outer rotor carrying a square identification mark is facing away from backplate side of pump body.
7. Check outer rotor to body clearance:  
Clearance **A** = 0.05 to 0.10 mm

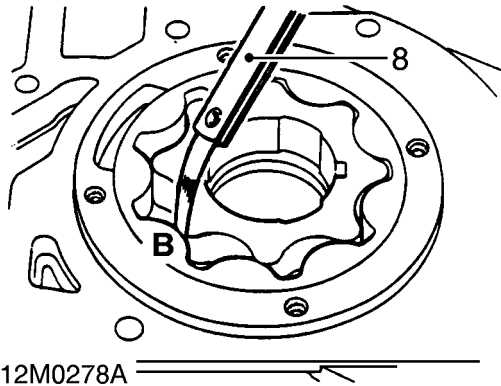

12M0278A

8. Check inner rotor lobe tip clearance:  
Clearance **B** = 0.025 to 0.12 mm

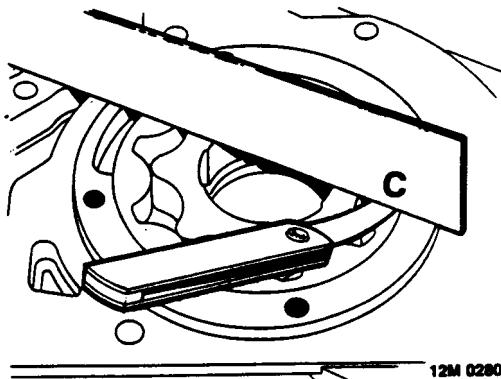

12M 0280

9. Check outer rotor end float:  
End float **C** = 0.03 to 0.08 mm  
Renew oil pump assembly if clearances are excessive or scoring of components is evident.

## Oil pressure relief valve

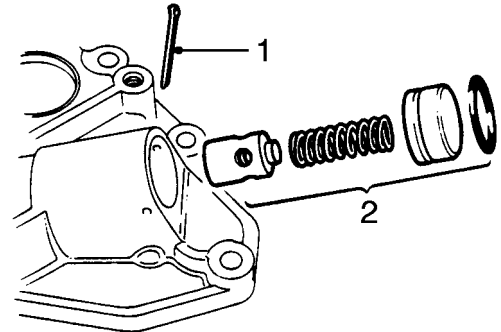

12M0281A

1. Remove and discard split pin securing relief valve cap.
2. Remove relief valve cap, spring and plunger, discard relief valve cap 'O' ring.
3. Check that plunger is not scored and slides freely in bore.
4. Check that bore is free from corrosion.



**NOTE:** Light corrosion may be removed using grade 600 emery cloth soaked in engine oil.

5. Check free length of spring:  
Spring free length = 38.9 mm

Renew relief valve as an assembly if scoring of plunger is evident or free length of spring is less than specified.



## Oil pump - assembling

1. Clean relief valve components and ensure bore in oil pump body is clean.
2. Using suitable solvent, gasket removal spray and plastic scraper, remove all traces of sealant and gasket from oil pump and cover plate.
3. Remove all traces of Loctite from Torx screws and tapped holes in oil pump body; ensure holes are clean and dry.

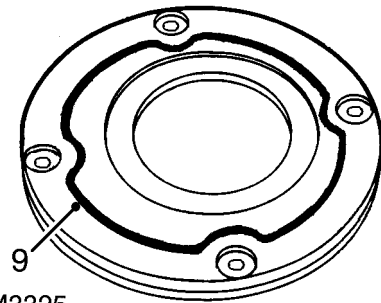

12M3325



**CAUTION: Do not use a tap.**

### Oil pressure relief valve

4. Smear a new 'O' ring with engine oil and fit to relief valve cap.
5. Lubricate spring, plunger and bore in oil pump body with engine oil.
6. Fit plunger, spring and relief valve cap; secure assembly with a new split pin.

9. Apply a 1 mm bead of Loctite 573 to cover plate as shown.
10. Apply Loctite 222 to threads of Torx screws.
11. Fit cover plate ensuring reference marks are correctly aligned.
12. Fit Torx screws and tighten in diagonal sequence to 6 Nm.
13. Check that pump rotates freely.

### Oil pump

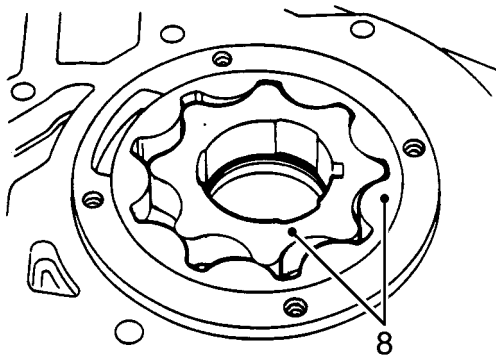

12M0282A

7. Lubricate rotors with engine oil.
8. Fit rotors ensuring that reference marks are aligned and chamfered side of outer rotor carrying a square identification mark is facing away from backplate side of pump body.

# ENGINE

## Oil pump - refit

1. Using gasket removal spray and plastic scraper, remove all traces of gasket from cylinder block.
2. Using suitable solvent, remove sealant from front main bearing cap,
3. Ensure 2 oil pump locating dowels are in position.
4. Remove all traces of Loctite from threads of oil pump securing bolts and bolt holes. Ensure bolt holes are clean and dry.
5. Clean timing belt lower cover backplate.
6. Position a new gasket to oil pump body.

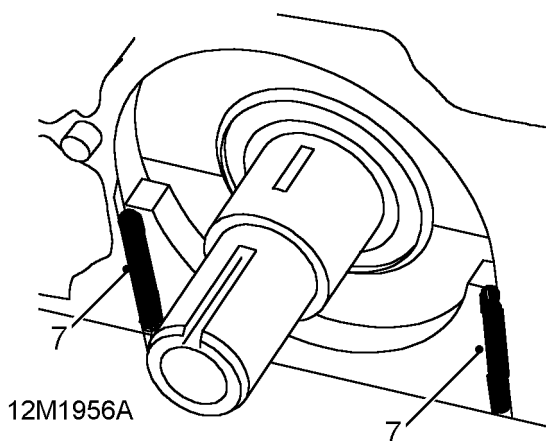

7. Apply a 1.0 mm bead of sealant from kit, Part Number GUG 705548GM to vertical joint of front main bearing cap.

 **NOTE: Main bearing caps fitted to later engines have a groove machined along either side of sump mating face, do not fill the side grooves with sealant until sump is fitted.**

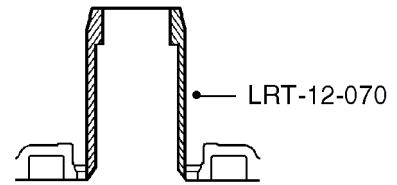

12M3740

8. Insert oil seal protector sleeve **LRT-12-070** into oil pump inner rotor; this will assist in locating oil pump inner rotor on Woodruff key.
9. Align Woodruff key slot in oil pump inner rotor with crankshaft Woodruff key.

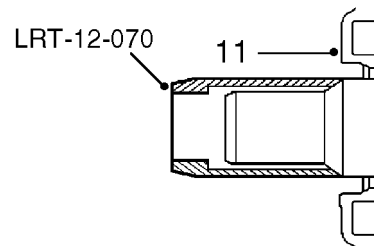

12M3741

10. Slide oil pump over crankshaft ensuring Woodruff key is located in keyway in inner rotor.
11. Locate oil pump on dowels; oil seal protector sleeve **LRT-12-070** will be displaced as pump is fitted.
12. Apply Loctite 222 to threads of oil pump securing bolts.

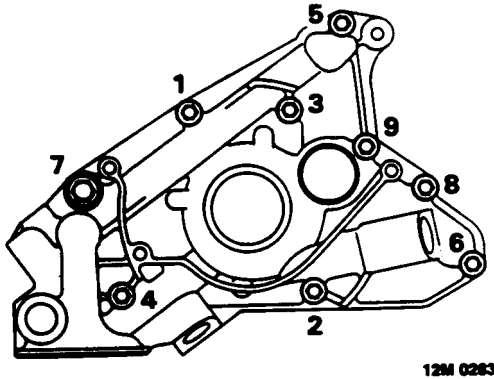

12M 0283

13. Fit securing bolts ensuring that M10 x 20 bolt is fitted at position 7, tighten bolts in sequence shown to:  
M6 bolts - 8 Nm  
M10 bolt - 45 Nm.

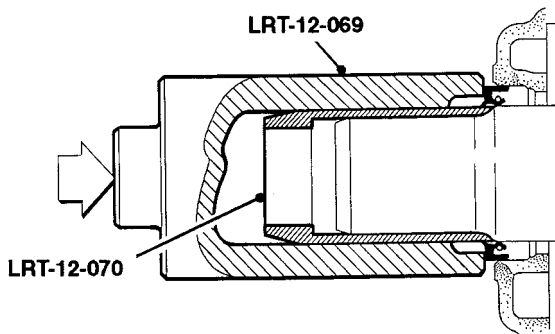

J5763

14. Slide oil seal protector sleeve **LRT-12-070** on to crankshaft.  
15. Fit new oil seal using tool **LRT-12-069**.  
16. Remove oil seal protector sleeve **LRT-12-070**.  
17. Position timing belt lower cover backplate to cylinder block.  
18. Fit and tighten bolts to 6 Nm.  
19. Fit Woodruff key to crankshaft.  
20. Slide crankshaft timing gear on to crankshaft.  
21. Fit camshaft timing belt.

## PISTONS, RINGS AND CYLINDER BLOCK

### Pistons and connecting rods - remove

1. Remove cylinder head.
2. Remove sump.
3. Remove big-end bearings.
4. Remove carbon ridge from top of each cylinder bore.
5. Suitably identify each piston to its respective cylinder bore.
6. Push pistons to top of cylinder bores; withdraw each piston and connecting rod assembly.



**CAUTION: Ensure connecting rod big-end bosses do not contact cylinder bores.**

# ENGINE

## Piston rings - remove

1. Using a suitable expander remove and discard piston rings.
2. Using squared off end of an old piston ring, remove carbon from piston ring grooves.

## Piston rings - inspection

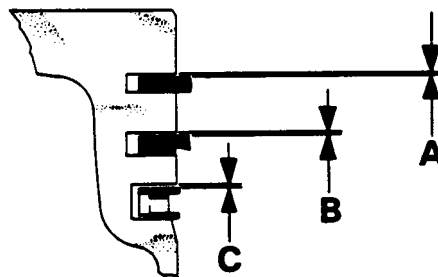

12M 0306

1. Check new ring to groove clearance:  
Top compression **A** = 0.06 to 0.09 mm  
2nd compression **B** = 0.05 to 0.07 mm  
Oil control **C** = 0.03 to 0.05 mm

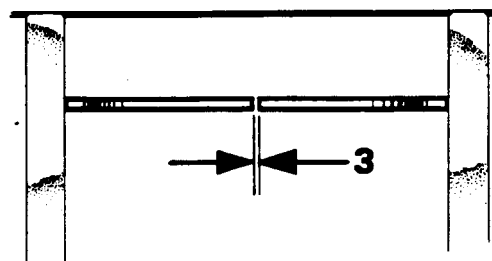

12M 0307

2. Insert new piston rings in turn 20 mm from top of cylinder bore.
3. Check new ring gap:  
Top compression = 0.25 to 0.35 mm  
Second compression = 0.3 to 0.5 mm  
Oil control rails = 0.38 to 1.14 mm



**CAUTION:** Ensure that on completion of checking, piston rings are identified with the cylinder in which they were checked.





## Pistons - inspection

1. Clean carbon from pistons.
2. Check pistons for distortion and cracks.
3. Using fingers only, check that each big-end bearing cap nut runs freely on the threads of its respective connecting rod bolt; if threads show signs of binding, bolt and nut must be replaced.



**CAUTION: Arrow on bolt head must face away from connecting rod. Retain nuts with their respective bolts.**

4. From markings on piston crown, determine which grade of piston is fitted - **A** or **B**.
5. Measure piston diameter at 90° to gudgeon pin axis and 10 mm from bottom of skirt.  
Grade A = 84.409 to 84.422 mm  
Grade B = 84.423 to 84.436 mm

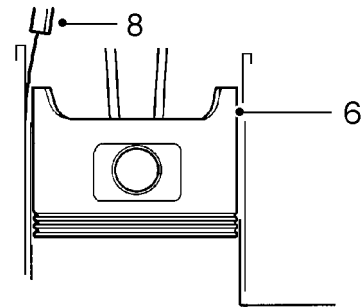

12M3742

6. Starting with number 1 piston, invert piston and connecting rod and with arrow on piston crown pointing towards REAR of cylinder block, insert piston into top of cylinder bore.
7. Position piston with bottom of skirt 50 mm from top of cylinder bore.
8. Using feeler gauges, measure and record clearance between piston skirt and left hand side of cylinder bore 60 mm from top of bore (viewed from front of cylinder block).  
Grade A or B piston clearance in cylinder bore = 0.04 mm - maximum



**NOTE: Oversize pistons are not available. Pistons and connecting rods are only supplied as an assembly.**

9. Repeat above procedures for remaining pistons.

# ENGINE

## Cylinder block - inspection

1. Clean carbon deposits from cylinder bores.
2. Check cylinder bores for scoring.

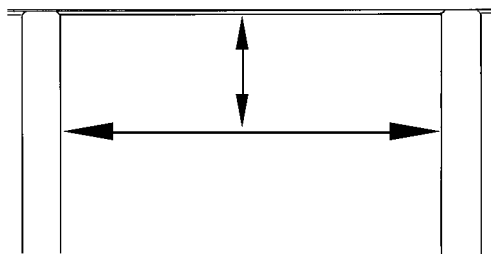

12M2114

3. Check cylinder bores for wear, measure and record diameter of each bore, 60 mm from top of cylinder bore.

Bore diameter:

Grade A = 84.442 to 84.455 mm

Grade B = 84.456 to 84.469 mm



**CAUTION: Measurements must be taken from side to side and front to rear of bore. No honing or glaze busting of cylinder bores is permissible.**



**NOTE: Cylinder bore grade is stamped on a machined lug at the rear, RH side of cylinder block. Grade A cylinder bores may be machined to grade B dimensions and grade B pistons fitted.**

4. Check core plugs for condition, replace as necessary.
5. Check that all bolt holes are clean and dry.
6. Check that oil and water passages are clear.
7. Remove all traces of gasket material from cylinder block using suitable gasket removal spray and a plastic scraper.

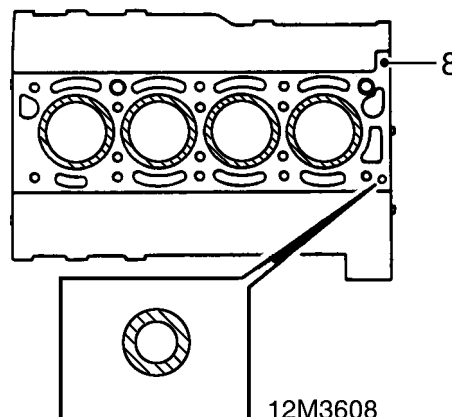

8. Check cylinder block gasket face for scratches or indentations paying particular attention to areas around top of cylinder bores and oil feed hole.
9. Check that oil restrictor - if fitted is clear, remove or fit restrictor depending on type of cylinder head gasket to be fitted:- See cylinder head gasket selection.



### Pistons - assembling

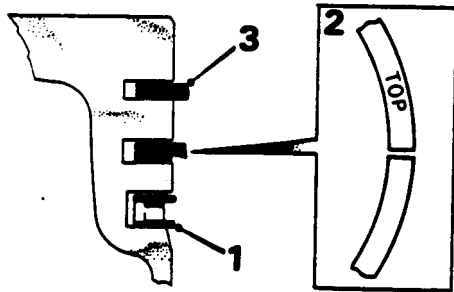

12M 0308

1. Using a suitable expander fit oil control spring rails and expander.
2. Using a suitable expander fit 2nd compression ring with 'TOP' towards top of piston.
3. Using a suitable expander fit top compression ring either way up.

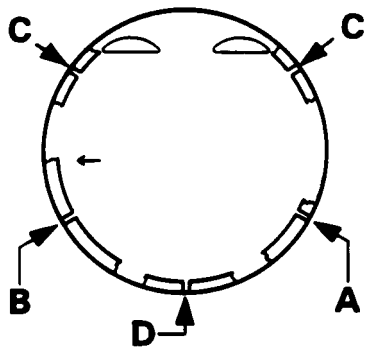

12M 0309

4. Position ring gaps as follows:  
 Compression ring gaps **A** and **B** at 120° to each other and away from the inlet valve cut out side of the piston.  
 Oil control rail gaps **C** at 120° to each other.  
 Oil control expander gap **D** at 120° to oil control rail gaps.

### Pistons and connecting rods - refit

1. Fit big-end bearing shell to connecting rod.
2. Lubricate big-end bearing shell, piston rings and gudgeon pin with engine oil.
3. Lubricate cylinder bores and crankshaft big-end journals with engine oil.

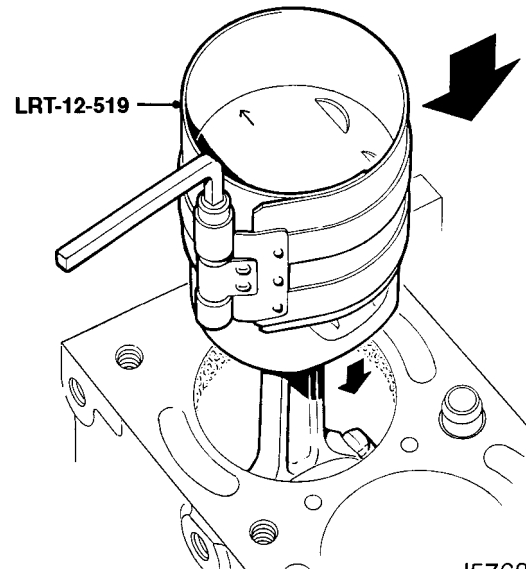

J5768

4. Fit ring clamp **LRT-12-519** to each piston in turn and compress piston rings.
5. Insert each piston and connecting rod into its respective cylinder bore ensuring arrow on piston crown points towards timing belt end of engine.
6. Fit big-end bearings.
7. Fit sump.
8. Fit cylinder head.

# ENGINE

## FLYWHEEL AND STARTER RING GEAR

### Flywheel - remove

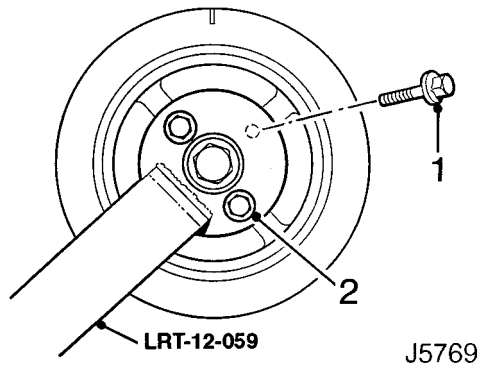

1. Remove 4 bolts securing crankshaft pulley to timing gear.
2. Fit holding tool **LRT-12-059** to crankshaft pulley, use 2 pulley bolts to retain tool.
3. Remove timing pin **LRT-12-058** from flywheel.
4. Restrain crankshaft using holding tool **LRT-12-059**. Remove and discard 6 bolts securing flywheel to crankshaft.
5. Using assistance, remove flywheel.



**CAUTION:** Do not allow crankshaft to rotate.

### Starter ring gear - remove

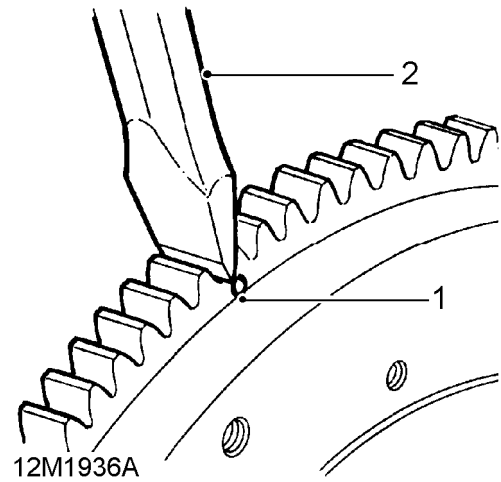

1. Drill a 3 mm diameter hole at the root of 2 teeth.
2. Using a cold chisel, break ring gear, remove gear from flywheel.



**WARNING:** Suitable eye protection must be worn.



### Starter ring gear - refit

---

1. Heat ring gear evenly to 350° C indicated by a light blue colour.
2. Locate ring gear on flywheel and press on to flange.



**WARNING: Handle hot ring gear with care.**

3. Allow to air cool.

### Flywheel - refit

---

1. *Original crankshaft:* Using an old flywheel bolt with 2 saw cuts at an angle of 45° to the bolt shank, clean flywheel bolt holes in crankshaft.



**CAUTION: Do not use a tap.**

2. Using assistance, position flywheel on crankshaft.
3. Fit new flywheel securing bolts, restrain crankshaft using tool **LRT-12-059**; tighten bolts to 110 Nm.
4. Rotate crankshaft until timing pin **LRT-12-058** can be fitted to hole in flywheel.
5. Remove crankshaft holding tool **LRT-12-059**.

# ENGINE

## SUMP AND OIL STRAINER

### Sump - remove

1. Remove oil pump

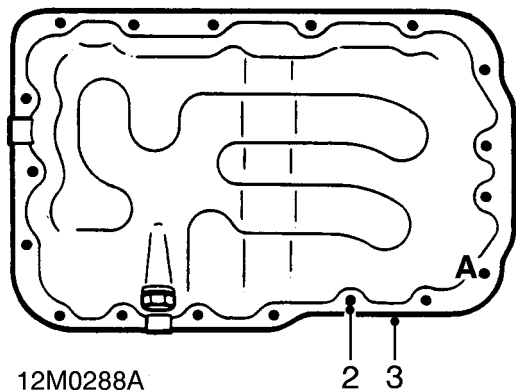

2. Remove 18 bolts securing sump to crankcase noting fitted position of longest bolt **A**.

 **NOTE: Patchlok bolts may be re-used provided threads are undamaged.**

3. Remove sump, discard gasket.

### Oil strainer - remove

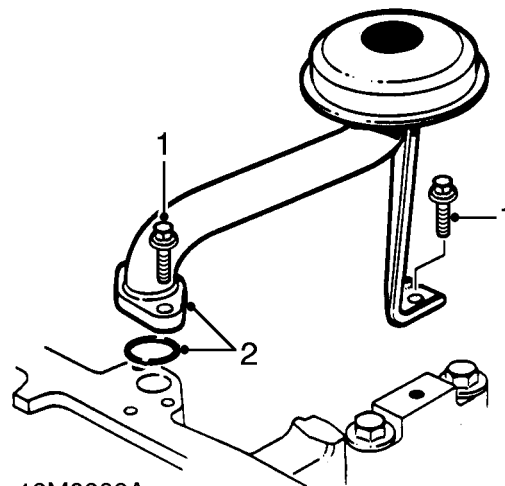

1. Remove 3 bolts securing oil strainer.
2. Remove strainer, discard 'O' ring from oil pick-up pipe.



### Oil strainer - refit

1. Ensure oil strainer gauze and pick-up pipe is clean.
2. Ensure bolt holes in cylinder block and main bearing cap are clean and dry.
3. Lubricate a new 'O' ring with engine oil and fit to oil pick-up pipe.
4. Fit oil strainer, fit bolts and tighten to 8 Nm.

### Sump - refit

1. Remove all traces of gasket material from sump and cylinder block using gasket removal spray and a plastic scraper.
2. Remove all traces of sealant from sump and front main bearing cap using suitable solvent.
3. Ensure bolt holes in cylinder block are clean and dry.

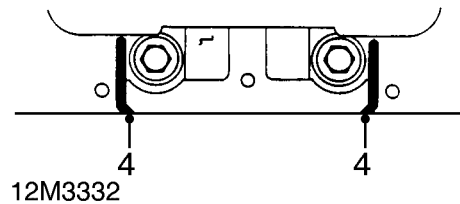

4. Apply beads of sealant from kit, Part Number GUG 705548GM to front main bearing cap.



**CAUTION: Front main bearing caps fitted to later engines have a groove machined across either side of cap; it is essential that grooves are completely filled with sealant.**

5. Fit a new sump gasket ensuring that dimples on gasket are located in sump flange recesses and that gasket lays flat on sump flange.
6. Position sump on cylinder block.

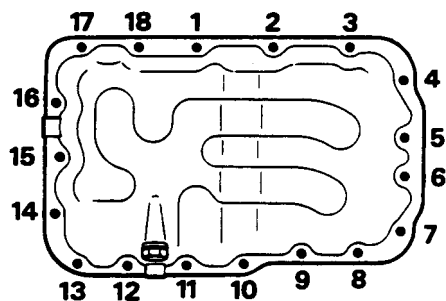

12M0303A

7. Fit and finger tighten sump bolts ensuring that longest bolt is fitted at position 7.



**NOTE:** Patchlok bolts may be re-used provided threads are clean and undamaged.

8. Tighten bolts in sequence shown to 25 Nm.
9. Fit oil pump.

## CRANKSHAFT, MAIN AND BIG-END BEARINGS

### Crankshaft rear oil seal/gearbox adaptor plate - remove

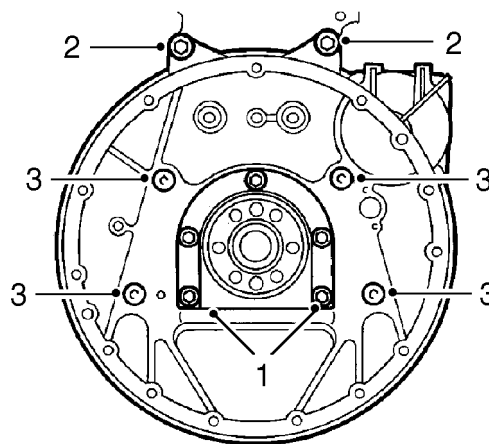

J5772A

1. Remove 5 bolts securing crankshaft rear oil seal housing, remove and discard housing and oil seal.



**NOTE:** Dowel located.

2. Remove 2 bolts securing gearbox adaptor plate to cylinder block.
3. Remove 4 Torx screws securing gearbox adaptor plate to cylinder block; remove plate.



**NOTE:** Dowel located.





### Crankshaft end-float - check

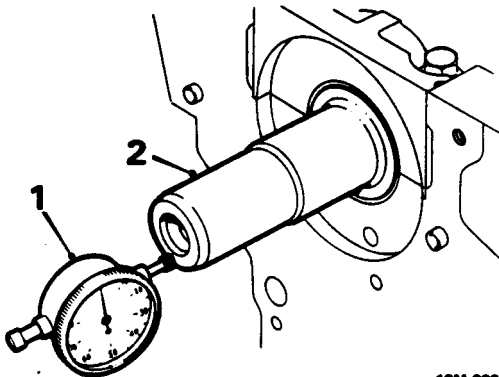

12M 0291

1. Attach a magnetic base DTI gauge to front of cylinder block with stylus of gauge on end of crankshaft.
2. Move crankshaft rearwards and zero gauge.
3. Move crankshaft forwards, record end-float reading obtained; remove DTI gauge.  
Crankshaft end-float = 0.03 to 0.2 mm  
Thrust washer halves thickness:  
Standard = 2.31 to 2.36 mm  
Oversize = 2.38 to 2.43 mm  
Fit appropriate size thrust washers to achieve correct end-float.



**CAUTION: Thrust washers must be renewed in complete sets only.**

### Big-end bearings - remove

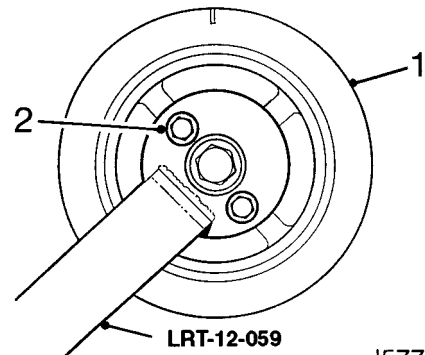

LRT-12-059

J5774

1. Position timing gear and crankshaft pulley on crankshaft.
2. Fit holding tool **LRT-12-059** to crankshaft pulley, use 2 pulley bolts to retain tool.

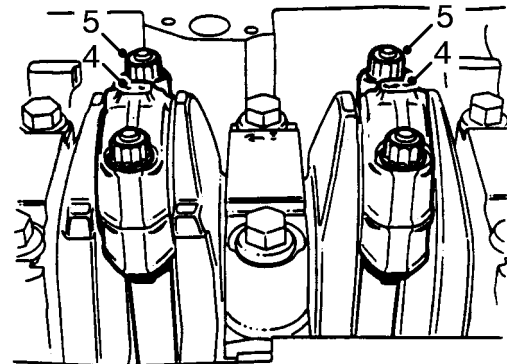

12M3335

3. Rotate crankshaft to gain access to Numbers 2 and 3 big-end bearing cap nuts.



**CAUTION: Do not rotate crankshaft more than 45° in either direction.**

4. Suitably identify bearing caps to their respective connecting rods; make alignment marks to ensure correct refitting.
5. Remove 2 nuts securing each bearing cap, remove bearing caps and big-end bearing shells; discard bearing shells.



**CAUTION: Keep bearing caps and nuts in their fitted order.**

6. Repeat above operations for Numbers 1 and 4 big-end bearings.

7. Fit a length of plastic tubing over each connecting rod bolt.
8. Push each piston up its respective bore, remove big-end bearing shells from connecting rods; discard bearing shells.
9. Clean bearing caps and bearing shell recesses in connecting rods.



## Crankshaft - remove

1. Remove big-end bearings.
2. Remove holding tool LRT-12-059.

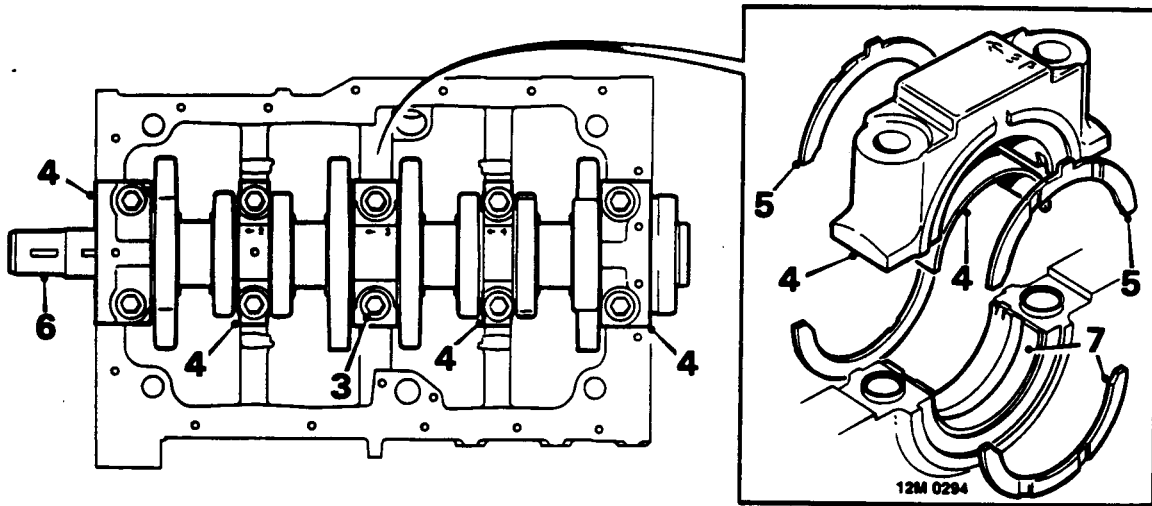

**NOTE:** Ensure that main bearing caps are numbered 1 to 5 and that arrow denoting FRONT is cast on each cap.

3. Starting at centre main bearing cap and working outwards, progressively slacken then remove 10 main bearing cap bolts.



**CAUTION:** Keep bearing cap bolts in their fitted order.

4. Remove 5 main bearing caps and main bearing shells; discard shells.



**CAUTION:** Do not knock bearing caps sideways to remove them or locating dowels will be damaged.

5. Recover 2 thrust washer halves from centre main bearing cap. Discard thrust washers if crankshaft end-float exceeded specified figure.
6. Using assistance, lift crankshaft from cylinder block.
7. Remove 5 main bearing shells and 2 thrust washer halves. Discard thrust washers if crankshaft end-float exceeded specified limits; discard bearing shells.
8. Remove 2 Woodruff keys from crankshaft.
9. Clean crankshaft, blow out oil passages.
10. Clean bearing shell recesses and mating surfaces of cylinder block.
11. Clean main bearing caps.

# ENGINE

---

## Crankshaft - inspection

---

1. Clean crankshaft, ensure all oilways are clear.

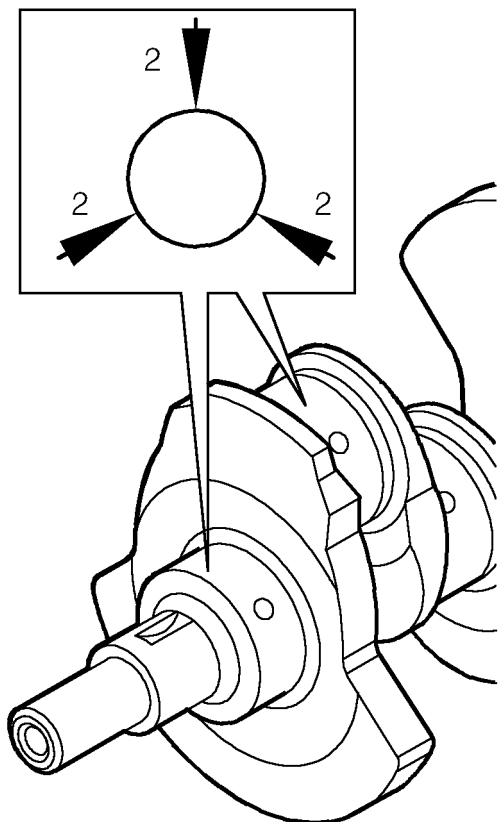

12M2127

2. Check crankshaft journals for wear and ovality, make three checks at 120 ° intervals in centre of journals.

Crankshaft bearing journal diameters:

Main bearings = 54.005 to 54.026 mm

Big-end bearings = 47.648 to 47.661 mm

Maximum out of round - all journals = 0.010 mm



**CAUTION: If crankshaft journals are worn, crankshaft must be replaced. Main and big-end bearings are only available in one size.**

3. Check thrust washers for wear and scoring, replace if evident or if crankshaft end-float exceeded specified limits.

Thrust washer thickness:

Standard = 2.31 to 2.36 mm

Oversize = 2.38 to 2.43 mm

## Crankshaft spigot bearing and bush - inspection

---

1. Check spigot bearing needle rollers and seal for signs of wear, damage and overheating.
2. Check that spigot bearing is not loose in spigot bush.
3. Check that outer end of spigot bearing is flush with end of bush and that end of bush is flush with counterbore in crankshaft.



### Crankshaft spigot bearing and bush - remove

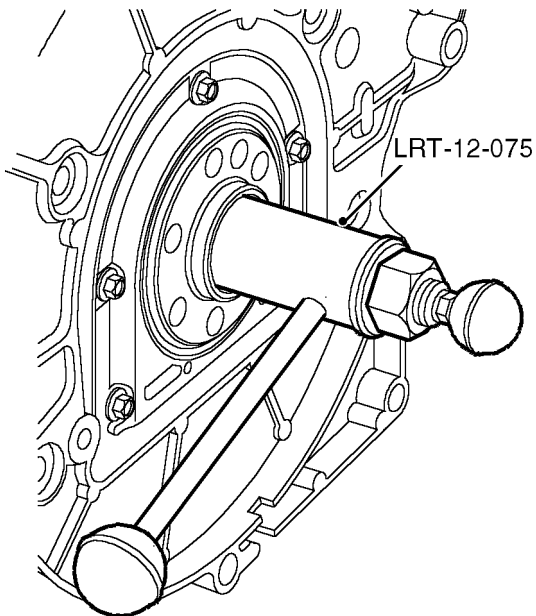

12M3670

1. Remove spigot bearing using tool **LRT-12-075**, discard bearing.

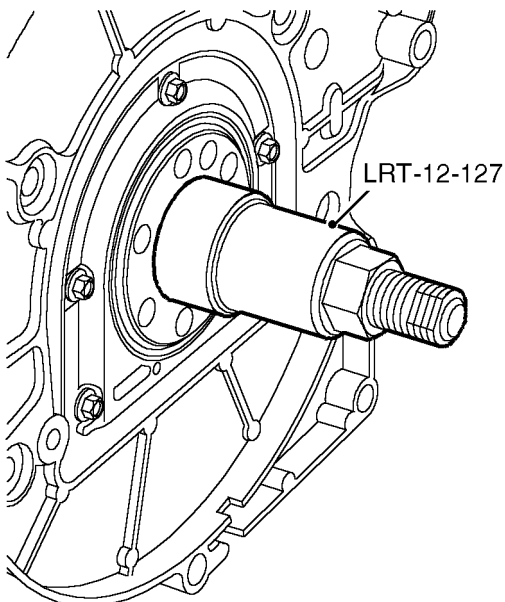

12M3671

2. Remove spigot bush using tool **LRT-12-127**, discard bush.

### Crankshaft spigot bearing and bush - refit

1. Ensure that counterbore in crankshaft is clean and dry.

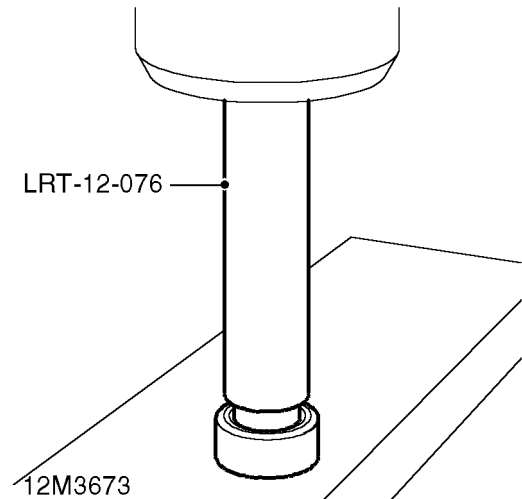

2. Using a suitable hand press and tool **LRT-12-076**, fit new spigot bearing to bush.

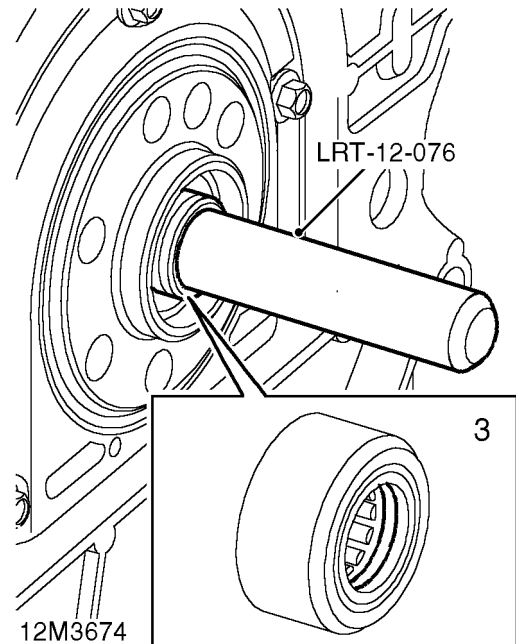

3. Position spigot bearing and bush in crankshaft counterbore ensuring that nylon seal at end of bearing is towards open end of counterbore.
4. Ensuring that spigot bush is kept square to counterbore, fit bush and bearing using tool **LRT-12-076**.

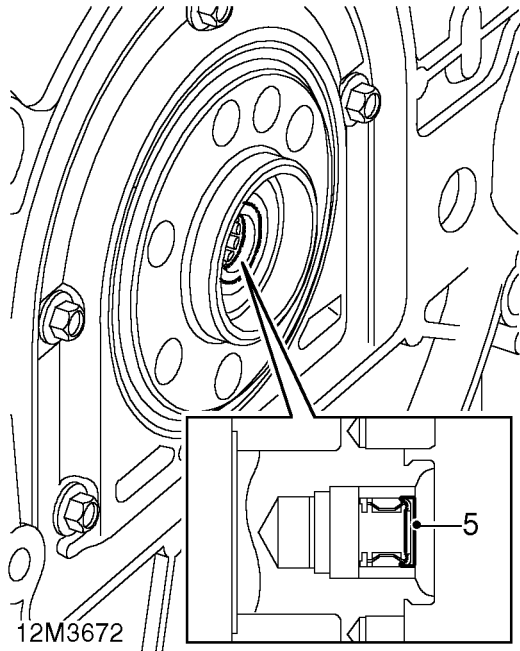

5. Drift bush and bearing in until outer end of bush is flush with counterbore in crankshaft.
6. Apply 0.5 grammes of grease to Specification NLG12, DIN 51285, SPEC. S-MIL-4515-A to bearing rollers.



**CAUTION:** Take care that grease does not fill counterbore behind bearing.



## Crankshaft - refit

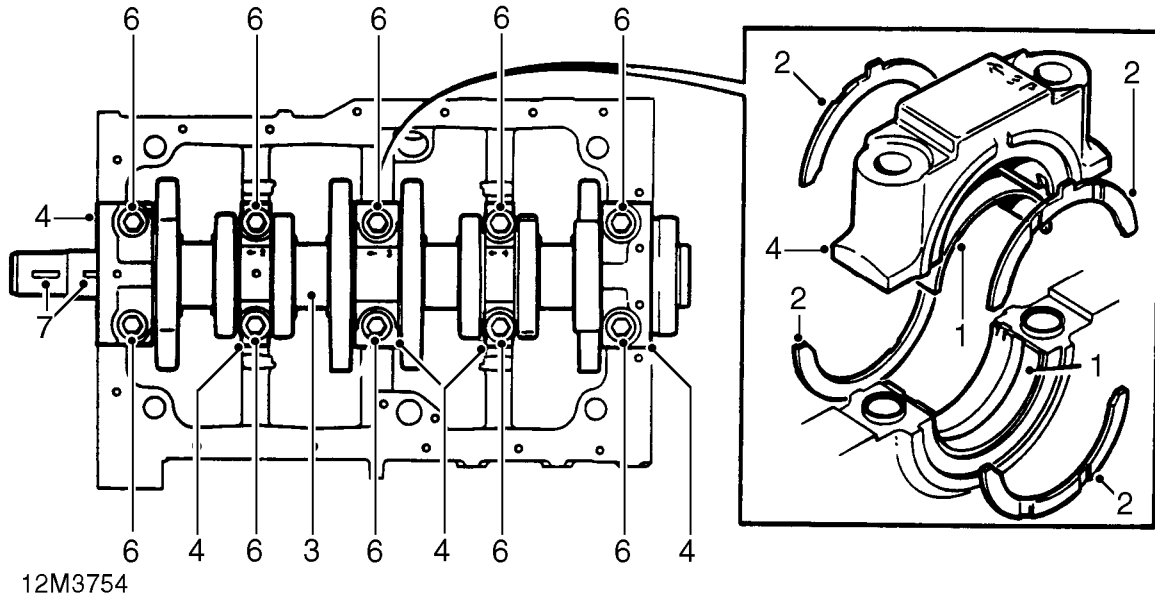

1. Lubricate new main bearing shells with engine oil and fit to cylinder block and main bearing caps.



**NOTE: Front, centre and rear main bearing shells have an oil groove, intermediate main bearing shells are plain.**

2. Lubricate thrust washer halves with engine oil and fit to cylinder block and centre main bearing cap with the oil grooves facing away from the cap.



**NOTE: The two tagged thrust washers are fitted in main bearing cap.**

3. Lubricate crankshaft journals with engine oil and using assistance, position crankshaft in cylinder block.
4. Fit main bearing caps and shells.



**NOTE: Bearing caps are numbered from 1 to 5 with Number 1 bearing cap being nearest to front of cylinder block. Ensure arrows on bearing caps point towards front.**

5. Lightly oil main bearing cap bolts.
6. Fit main bearing cap bolts in their original fitted order and starting from centre main bearing cap and working outwards, tighten bolts progressively to 110 Nm.
7. Fit 2 Woodruff keys in crankshaft.
8. Fit big-end bearings.

# ENGINE

## Big-end bearings - refit

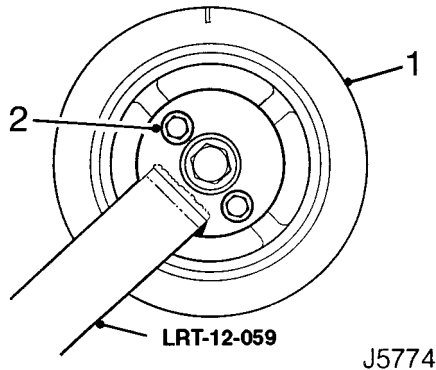

1. Temporarily fit timing gear, crankshaft pulley and holding tool **LRT-12-059** to crankshaft.
2. Use 2 pulley bolts to retain tool.
3. Lubricate new big-end bearing shells and crankshaft journals with engine oil.
4. Rotate crankshaft to bring numbers 2 and 3 big-end journals to BDC, pull connecting rods on to journals and remove plastic sleeving from bolts.



**CAUTION: Do not rotate crankshaft more than 45° in any direction.**

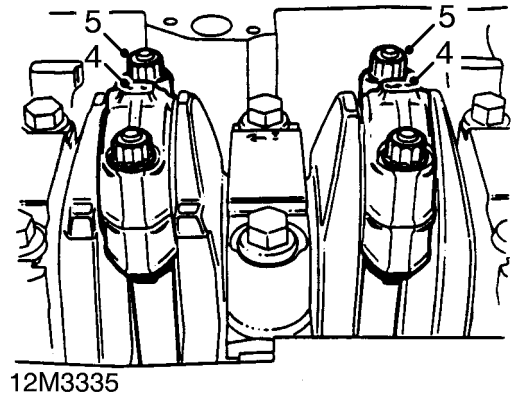

5. Fit big-end bearing caps and shells to their respective connecting rods ensuring that reference marks are aligned.
6. Fit and tighten big-end bearing cap nuts to 55 Nm.



**CAUTION: Ensure nuts are fitted in their original locations.**

7. Repeat above procedures for numbers 1 and 4 big-end bearings.
8. Remove holding tool **LRT-12-059**.





### Gearbox adaptor plate - refit

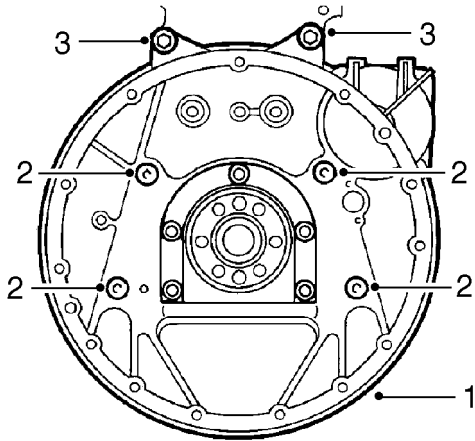

12M3743

1. Position gearbox adaptor plate on locating dowels.
2. Fit 4 Torx screws and tighten to 45 Nm.
3. Fit 2 bolts and tighten to 90 Nm.

### Crankshaft rear oil seal - refit

1. Remove all traces of oil from oil seal running surface on crankshaft and tool **LRT-12-061**.
2. Check that oil seal bolt holes in cylinder block are clean and dry.

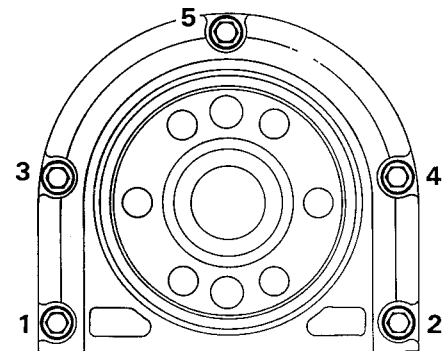
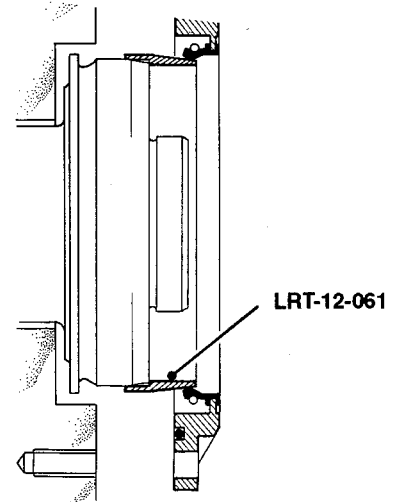

J5780

3. Position tool **LRT-12-061** on crankshaft.



**NOTE:** If oil seal protector is supplied with new oil seal, this should be used as an alternative to **LRT-12-061**.

4. Taking care not to touch sealing lip of oil seal, slide seal and housing on to crankshaft.



**CAUTION:** Do not lubricate oil seal or running surface on crankshaft.

5. Position oil seal and housing on cylinder block.
6. Fit bolts and working in sequence shown, tighten to 8 Nm.
7. Remove tool **LRT-12-061** or oil seal protection sleeve.



---

**DATA**
**Oil pump**

Outer rotor to body clearance . . . . .	0.05 to 0.10 mm
Inner rotor tip clearance . . . . .	0.025 to 0.12 mm
Outer rotor end float . . . . .	0.03 to 0.08 mm

**Oil pressure relief valve**

Spring free length . . . . .	38.9 mm
------------------------------	---------

**Camshaft**

Camshaft end-float . . . . .	0.06 to 0.25 mm
Bearing clearance . . . . .	0.060 to 0.094 mm
Service limit . . . . .	0.15 mm

**Timing belt tensioner**

Spring free length . . . . .	57.5 to 58.5 mm
------------------------------	-----------------

**Cylinder head**

Longitudinal warp - maximum . . . . .	0.1 mm
Transverse warp - maximum . . . . .	0.1 mm
Diagonal warp - maximum . . . . .	0.1 mm
Cylinder head height . . . . .	135.0 to 135.1 mm

**Valve springs**

Free length . . . . .	46.25 mm
Fitted length . . . . .	37.0 mm
Load - valve closed . . . . .	255 ± 12 N
Load - valve open . . . . .	560 ± 22.5 N

**Valves**

## Valve stem diameter:

Inlet . . . . .	7.09 to 7.10 mm
Exhaust . . . . .	7.07 to 7.09 mm

## Valve head diameter:

Inlet . . . . .	31.7 to 31.95 mm
Exhaust . . . . .	29.2 to 29.43 mm
Valve installed height - maximum . . . . .	43.4 mm

## Valve stem to guide clearance:

Inlet . . . . .	0.04 to 0.06 mm
Service limit . . . . .	0.09 mm
Exhaust . . . . .	0.06 to 0.07 mm
Service limit . . . . .	0.10 mm

# ENGINE

---

## Valve guides

Internal diameter - Inlet and Exhaust	7.137 to 7.162 mm
Fitted height above cylinder head:	
Early type - Radiused top	12.0 mm
Later type - Flat, chamfered top	10.3 mm

## Valve seats

Valve seat angle - Inlet and Exhaust	45°
Valve seat width - Inlet and Exhaust	1.5 to 2.0 mm
Valve face angle:	
Inlet and Exhaust	45° to 45°15'

## Crankshaft

End-float	0.03 to 0.2 mm
Thrust washer halves thickness:	
Standard	2.31 to 2.36 mm
Oversize	2.38 to 2.43 mm
Oversize	2.31 to 2.36 mm
Main journal diameter	54.005 to 54.026 mm
Maximum out of round	0.010 mm
Main bearing diametric clearance	0.03 to 0.07 mm
Big-end journal diameter	47.648 to 47.661 mm
Maximum out of round	0.010 mm
Big-end bearing diametric clearance	0.04 to 0.08 mm

## Piston rings

New ring to groove clearance:	
Top compression	0.06 to 0.09 mm
2nd compression	0.05 to 0.07 mm
Oil control rails - expander fitted	0.03 to 0.05 mm
Ring fitted gap:	
Top compression	0.25 to 0.35 mm
2nd compression	0.3 to 0.5 mm
Oil control rails	0.38 to 1.14 mm

## Pistons

Piston diameter:	
Grade A	84.409 to 84.422 mm
Grade B	84.423 to 84.436 mm
Clearance in bore	0.04 mm - maximum

## Cylinder bore

Grade A	84.442 to 84.445 mm
Grade B	84.456 to 84.469 mm



---

**TORQUE FIGURES**

---

Timing belt tensioner bolt .....	30 Nm
+ Camshaft cover bolts .....	8 Nm
Camshaft carrier blanking plate bolts: .....	8 Nm
Camshaft gear bolt .....	65 Nm
+Camshaft carrier bolts .....	25 Nm
Timing belt cover bolts .....	6 Nm
Timing belt backplate bolts .....	6 Nm
Inlet manifold support bracket bolts .....	8 Nm
+ Inlet manifold nuts and bolts .....	25 Nm
+ Exhaust manifold nuts and bolts .....	45 Nm
Spark plugs .....	26 Nm
Engine harness to inlet manifold bolts .....	10 Nm
+ Sump bolts .....	25 Nm
+ Cylinder head bolts - Type A	
Stage 1 .....	45 Nm
Stage 2 .....	80 Nm
Stage 3 .....	Further 90°
+ Cylinder head bolts - Type B	
Stage 1 .....	45 Nm
Stage 2 .....	70 Nm
Stage 3 .....	Further 90°
Crankshaft pulley to timing gear bolts .....	8 Nm
Crankshaft pulley bolt .....	85 Nm
Crankshaft rear oil seal housing bolts .....	8 Nm
Gearbox adaptor plate:	
Torx screws .....	45 Nm
Bolts .....	90 Nm
Oil pump cover plate Torx screws .....	6 Nm
Oil pump to cylinder block:	
M6 bolts .....	8 Nm
M10 bolt .....	45 Nm
Oil strainer bolts .....	8 Nm
Main bearing cap bolts .....	110 Nm
Big-end bearing cap nuts .....	55 Nm
Flywheel bolts .....	110 Nm

+ Correct tightening procedure must be followed.

# ENGINE

---

---

## SERVICE TOOLS

---

LRT-12-034	Compressor Valve Spring
LRT-12-034/1	Adaptor
LRT-12-058	Location Pin Valve Timing
LRT-12-059	Crankshaft Pulley Locking Tool
LRT-12-060	Locking Tool Camshaft Gear
LRT-12-061	Protector Sleeve Crankshaft Rear Oil Seal
LRT-12-064	Replacer Pilot Camshaft Front and Rear Oil Seals
LRT-12-065	Replacer Camshaft Rear Oil Seals
LRT-12-069	Replacer Crankshaft Front Oil Seal
LRT-12-070	Protector Sleeve Crankshaft Front Oil Seal
LRT-12-071	Valve Stem Oil Seal Remover
LRT-12-072	Replacer Camshaft Front Oil Seal
LRT-12-075	Crankshaft Spigot Bearing Remover
LRT-12-076	Crankshaft Spigot Bush and Bearing Replacer
LRT-12-127	Crankshaft Spigot Bush Remover
LRT-12-519	Piston Ring Compressor
LRT-12-501	Handle Set
LRT-12-504	Adjustable Valve Seat Cutter
LRT-12-518	Adjustable Pilot
18G 1765 *	Exhaust Valve Guide Counterbore Reamer
18G 1773 *	Exhaust Valve Guide Reamer

\* Denotes Rover Tool Number