

DISCOVERY



Electrical Troubleshooting Manual



Electrical troubleshooting manual

DISCOVERY

1995 model

CONTENTS

Section Title	
i	Introduction
A1	Multiport Fuel Injection (MFI-V8)
A2	Multiport Fuel Injection (MFI-T16)
A4	300Tdi
A5	300Tdi Glow Plug Control
B1	Starting and Charging
B5	Cruise Control
C1	Ignition and Shift Interlock
D1	Anti-Lock Brake System
E1	Instruments
E2	Warnings and Indicators (except NAS)
E3	Warnings and Indicators (NAS)
E5	Horns
E6	Radio (except NAS)
E7	Radio (NAS)
F1	Front Wipe/Wash
F3	Rear Wipe/Wash
F8	Heated Rear Screen and Mirror Demisters
G4	Multi-Function Unit (MFU)
H1	Headlamps (except NAS)
H2	Headlamps (NAS)
H3	Headlamp Levelling
H4	Side Lamps
H5	Stop Lamps
H6	Direction Indicator Lamps
H7	Reversing Lamps
H9	Rear Fog Guard Lamps
J1	Interior Lamps
J2	Cigar Lighter/Clock
K1	Blower Controls
K2	Compressor Controls
K5	Cooling Fans
L1	Power Windows
L4	Sunroof
L6	Central Locking
M3	Power mirrors
P1	Trailer Auxiliary Socket
T1	Theft Alarm System (except NAS)
T2	Theft Alarm System (NAS 1995)
T3	Theft Alarm System (NAS 1994)
Y1	Power Distribution
Y2	Fuse Details
Y5	Ground Distribution
Z4	Component Location Table
Z5	Component Location Views
Z6	Connector Views
Z8	Harness Routing
Z9	Index

Published by Land Rover
Lode Lane, Solihull, West Midlands,
B92 8NW, England

© Rover Group Limited 1997
Publication Part No LJBEMENL95 (4th Edition)



DISCOVERY

KEY INFORMATION

CIRCUIT DIAGRAMS

D Circuit diagrams are arranged so that current flow is from the top of the diagram (current source) to the bottom of the diagram (earth).

D Only those components that work together in the circuit are shown. If only part of a component is used in the circuit, then only that part of the component is shown.

D Remember:



Entire component



Part of a component

TERMINAL NUMBER

DESIGNATION

50

Battery voltage: Ignition Switch in position III

30

Battery voltage: supplied constantly

15

Battery voltage: Ignition Switch in position II or III

R

Battery voltage: Ignition Switch in positions I, II

31

Earth

See Introduction (i) for additional circuit diagram symbols

DIAGNOSIS

D If the diagram is accompanied by text:

- Read the Circuit Operation before proceeding with the electrical diagnosis.
- Read the Troubleshooting Hints before performing the System Diagnosis.
- Tests follow the System Diagnosis
- When performing the System Diagnosis, be certain that all components disconnected in previous steps are reconnected unless otherwise directed.



Component is disconnected. Backprobe harness connector



Component is connected. Backprobe harness connector



Component is disconnected. Probe component



Component is disconnected. Probe harness connector



Probe in-line connector



INTRODUCTION

This manual is intended for use by trained Land Rover technicians as an aid to diagnosing electrical concerns.

This manual is organized into sections, with most sections containing circuit diagrams. Each section has a unique alpha–numeric code that will normally remain the same from year to year. For example, the Headlights circuit is in Section H1, with the first page of the section numbered H1–1. The following pages of this section will be numbered H1–2, H1–3, H1–4, etc. The manual does not contain any information concerning removal, refit or overhaul of electrical components or harnesses. These details are contained in the Workshop Manual. The following information forms the basis of the troubleshooting routines:

- Circuit Diagrams
- System Diagnosis Flow Charts
- Component Location Table
- Component Locations Views

Additional information, such as Circuit Operation, is also contained in the manual to aid in your understanding of how the different circuits operate.

DESCRIPTION OF MANUAL

Circuit Operation And Diagram

The Circuit Operation information at the beginning of the section will give you an overview of how the circuit works.

The Circuit Diagrams should always be your starting point in using this Electrical Troubleshooting Manual. The diagram shows the electrical current paths when a circuit is operating properly. It is essential to understand how a circuit should work before trying to figure out why it doesn't. Diagrams are shown with the Ignition Switch in the OFF position and other switches in the OFF or 'at rest' position.

Notes are provided after certain switches to clarify switch positions. Abbreviations found in the notes are explained in the Abbreviation Table found in the SYMBOLS section of this chapter.

Circuit Diagrams (schematics) break the entire electrical system into individual circuits. Electrical

components that work together are shown together.

Each diagram is arranged so current flows from positive, at the top of the page, to ground, at the bottom of the page. The 'power' labels at the top of a fuse show when the Battery, Main Light Switch, or Ignition Switch supplies power to that fuse.

Wires that connect to another circuit are shown with an arrowhead pointing in the direction of current flow. The name of the circuit that shares the wiring is provided for reference.

Wire Colour charts are no longer provided on each circuit page. One chart is provided in the SYMBOLS section of this chapter.

'See Fuse Details' means there are more connections to other circuits that are not shown. All such shared circuits are shown on the Fuse Details diagrams. 'See Ground Distribution' means there are more shared ground circuits which are shown on the Ground Distribution diagrams.

No attempt is made on the diagrams to represent components and wiring as they physically appear on the car. For example, a long length of wire is treated no differently in a diagram from one which is only a few centimeters long. The number of cavities for each connector is listed in the Component Location Table rather than illustrated. Similarly, switches and other components are shown as simply as possible, with regard to function only.

Power Distribution

The Power Distribution diagrams are found in Section Y1. These diagrams show how voltage is supplied from the positive Battery terminal to the various circuits in the vehicle.

The individual Circuit Diagrams begin with a fuse or the Ignition Switch. Power Distribution shows the wiring from the Battery to the Fuse Boxes, the Ignition Switch, the Main Lighting Switch, and any circuit fuses not located in a Fuse Box.

Fuse Details

The Fuse Details diagrams are found in Section Y2. These diagrams show all the wiring between each fuse in the Fuse Boxes and the components connected to the output of the fuse. The Fuse Details diagrams are extremely helpful in locating a short circuit that causes a fuse to blow. These diagrams also aid in troubleshooting an inoperative circuit by showing a second circuit using the same fuse. If the second circuit works, then the fuse and certain wires of the inoperative circuit are good.

Ground Distribution

The Ground Distribution diagrams are found in Section Y5. These diagrams show which components share each ground point. This information can often be a time-saver when troubleshooting a poor ground.

For example, if the Fuel Pump does not run, you may suspect an open in its circuit to ground. However, if the Number Plate Lamps work, and they share the same ground point as the Fuel Pump, you know that the ground and the wire up to the common splice are good. You have learned this just by inspecting the diagram and knowing the vehicle's symptoms.

Connector Views

Connector Views are provided in section Z6. All connectors with 2 terminals or more will be shown. Pin-out tables with the appropriate wire colours will also be shown.

Component Location Table

A Component Location Table can be found in Section Z4. Except for the location of obvious components like the Left Headlight, the table lists the location of every component, connector and ground point depicted in the Circuit Diagrams. The table also gives references to Component Location Views located in Section Z5 and cross references to Workshop Manual remove and refit procedure sections. The number of cavities in each connector and the connector colour is also listed. Wires may not be used in all connector cavities.

TROUBLESHOOTING TECHNIQUE

The following five-step troubleshooting procedure is recommended.

(1) Verify the Problem

Check the operation of the circuit to be sure you understand the problem. Do not begin disassembly or testing until you have narrowed down the possible causes.

(2) Analyze the Circuit Diagram (schematic)

Analyze the diagram. Check circuits that share the wiring with the problem circuit. The names of shared circuits are often given on each Circuit Diagram to aid troubleshooting. Shared power and ground circuits can be found in the Power and Ground Distribution sections. Try to operate the shared circuits. If these circuits work, then the shared wiring is OK. The cause must be within the wiring used only by the problem circuit. If several circuits fail at the same time, chances are the power (fuse) or ground circuit is faulty.

(3) Find the Cause

- Narrow down the possible causes.
- Before you replace a component, check power, signal, and ground wires at the component harness connector.

(4) Repair the Problem

Once the specific problem is identified, make the repair. Be sure to use the correct tools and safe procedures.

(5) Check the Repair

Check the operation of the repaired circuit in all modes to make sure you fixed the entire problem. If the problem was a blown fuse, be sure to test all of the circuits on that fuse. Make sure no new problems are present.

TEST EQUIPMENT

Where applicable, Land Rover recommended testers should be used.

Voltmeter and Test Light

Use a voltmeter or test light to check for voltage. While a test light shows whether or not voltage is present, a voltmeter indicates how much voltage there is.

CAUTION: A number of circuits include solid-state devices. Voltages in these circuits should be tested only with a 10-megohm or higher impedance digital multimeter. Never use a test light on circuits that contain solid-state devices. Damage to the device may result.

On circuits without solid-state devices, a test light may be used to check for voltage. A test light is made up of a 12-volt bulb with a pair of leads attached. After grounding one lead, touch the other lead to various points along the circuit where voltage should be present. The bulb will come on if the voltage at the point being tested is greater than 5 volts.

Self-powered Test Light and Ohmmeter

Use a self-powered test light or ohmmeter to check for continuity. The ohmmeter shows how much resistance there is between two points along a circuit. Low resistance means good continuity.

CAUTION: Never use a self-powered test light on circuits that contain solid-state devices. Damage to these devices may result.

Diodes and solid-state devices in a circuit can make an ohmmeter give a false reading. To find out if a component is affecting a measurement, take one reading, reverse the leads, and take a second reading. If the readings differ, the component is affecting the measurement.

Circuits that contain solid-state devices should only be tested with a 10-megohm or higher impedance digital multimeter.

A self-powered test light consists of a light bulb, Battery and two leads. If the leads are touched together, the bulb will go on.

A self-powered test light is only used on an unpowered circuit. First, disconnect the battery or remove the fuse that feeds the circuit you are working on. Select two points along the circuit through which there should be continuity. Connect one lead of the self-powered test light to each point. If there is continuity, the test light's circuit will be completed and the bulb will go on.

Fused Jumper Wire

Use a fused jumper wire to bypass an open circuit. A fuse jumper wire is made up of an in-line fuse holder connected to a set of test leads. Never use a jumper wire across any load. This direct battery short will blow the fuse.

The following symbol represents a fused jumper:

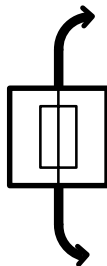

SYMBOLS

The abbreviations and symbols explained here are used throughout the manual; it is necessary to know what they mean in order to use the diagrams effectively.

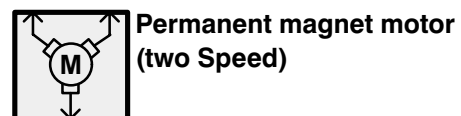
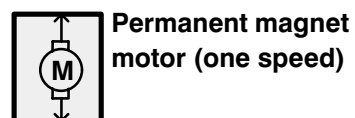
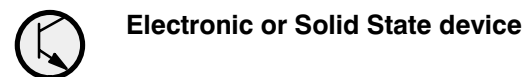
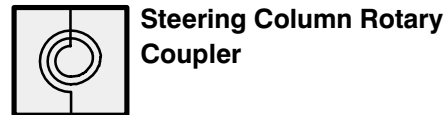
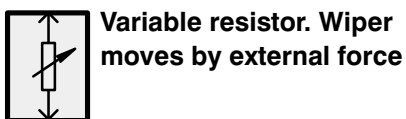
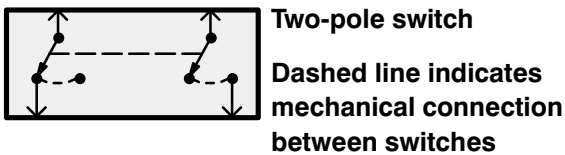
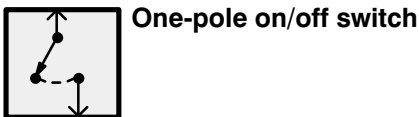
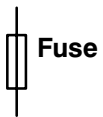
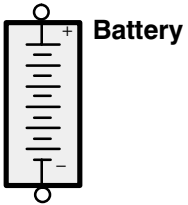

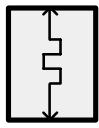

Heating Element

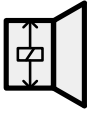

Loudspeaker or horn

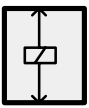

Coil

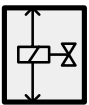

Solenoid



Relay

Switch is drawn into the closed position when current flows through coil

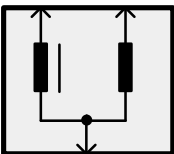

Ignition Coil

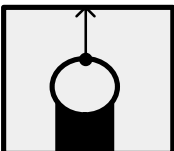

Steering Column
Horn Brush/
Slip Ring



Antenna

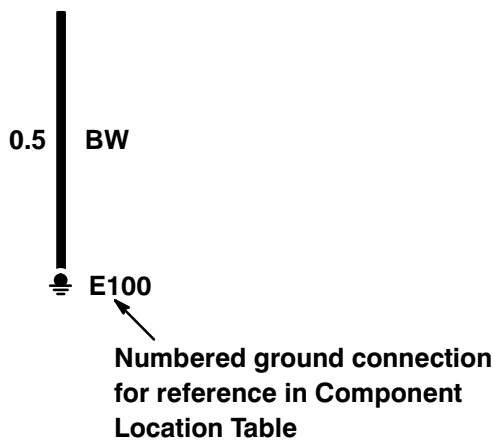
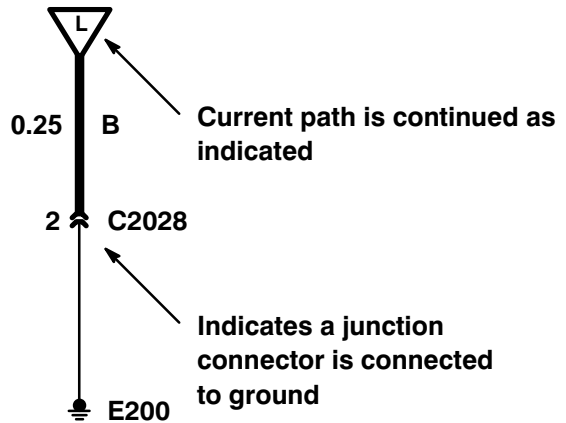
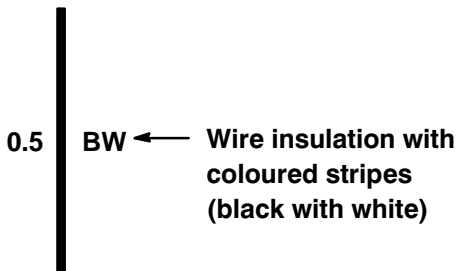
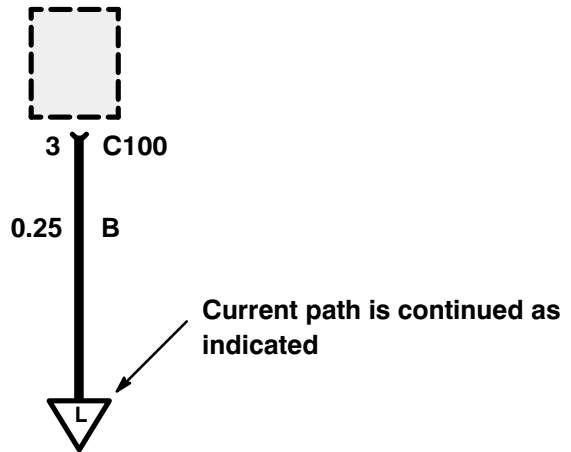
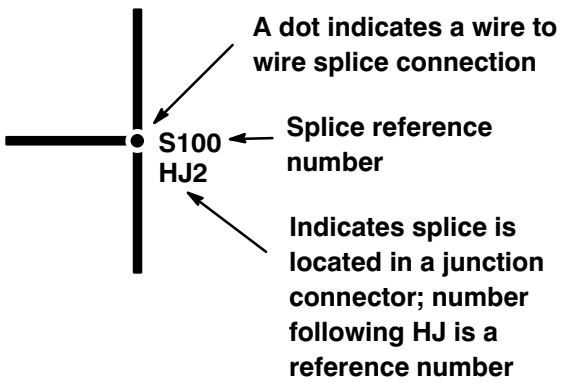
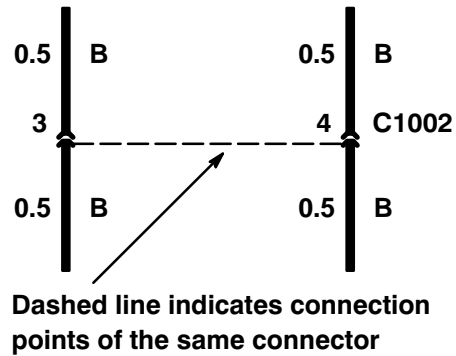
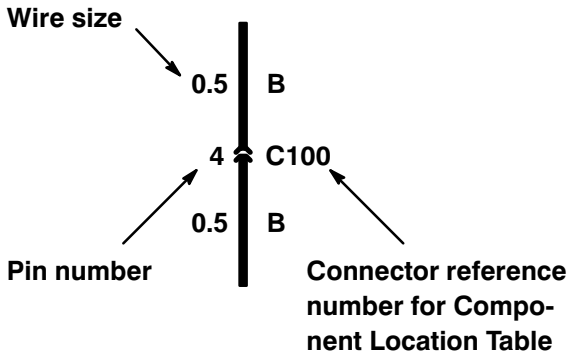

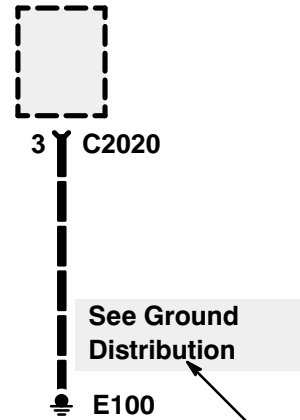
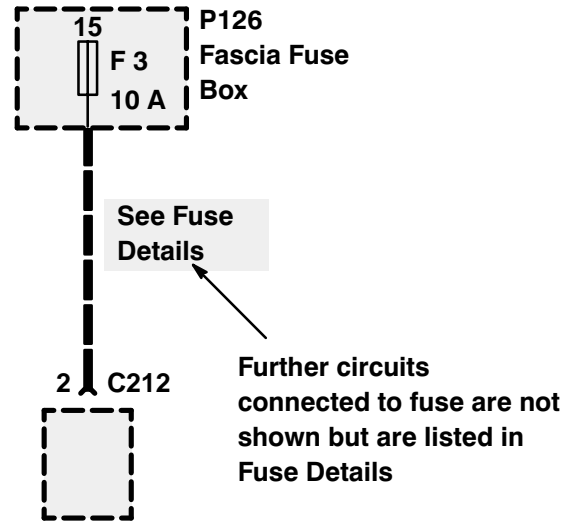
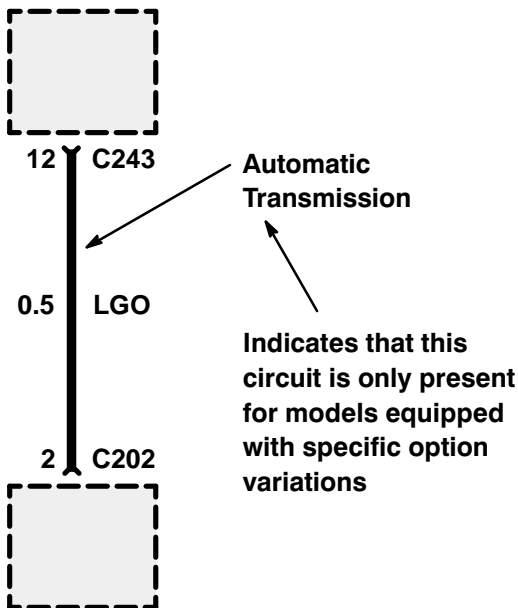
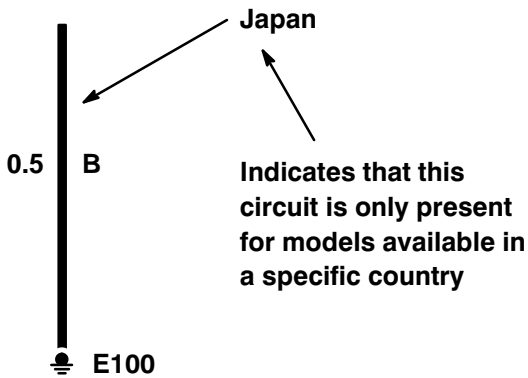
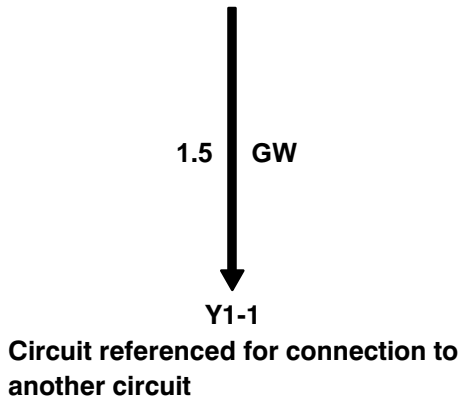

Further circuits connected at ground are not shown but are listed under Ground Distribution

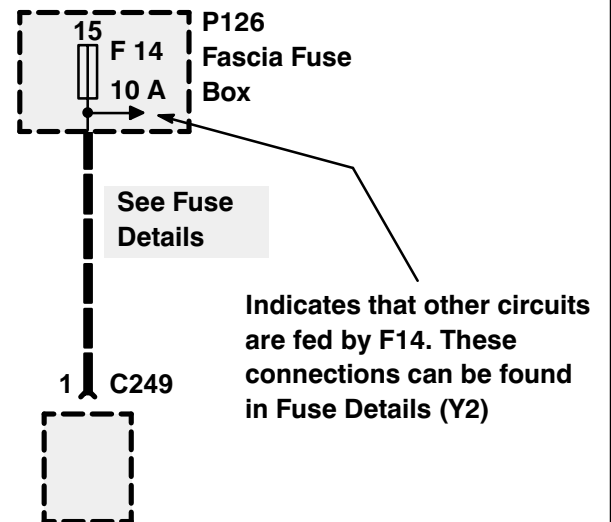

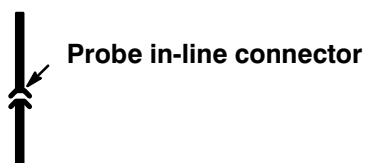
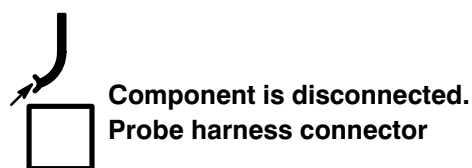
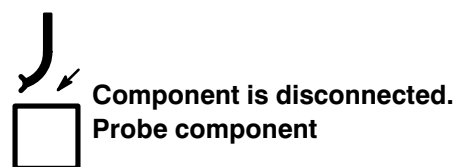
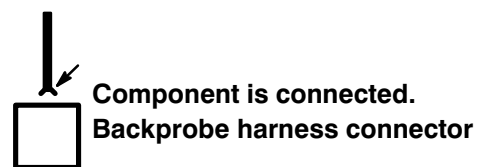
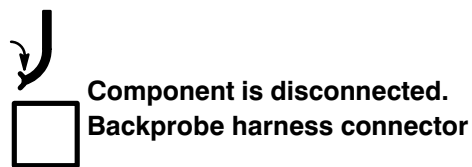
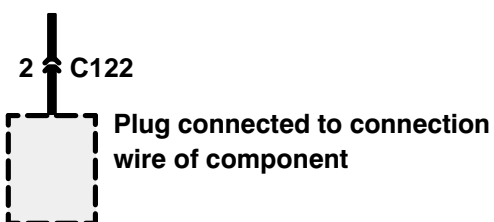
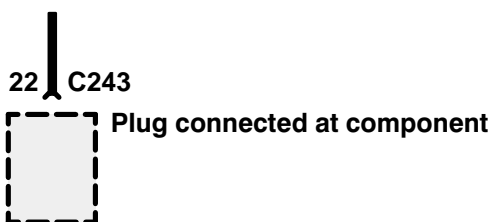
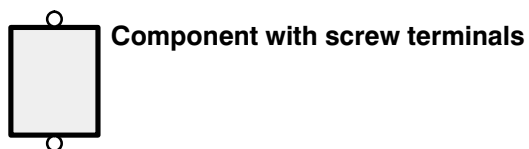

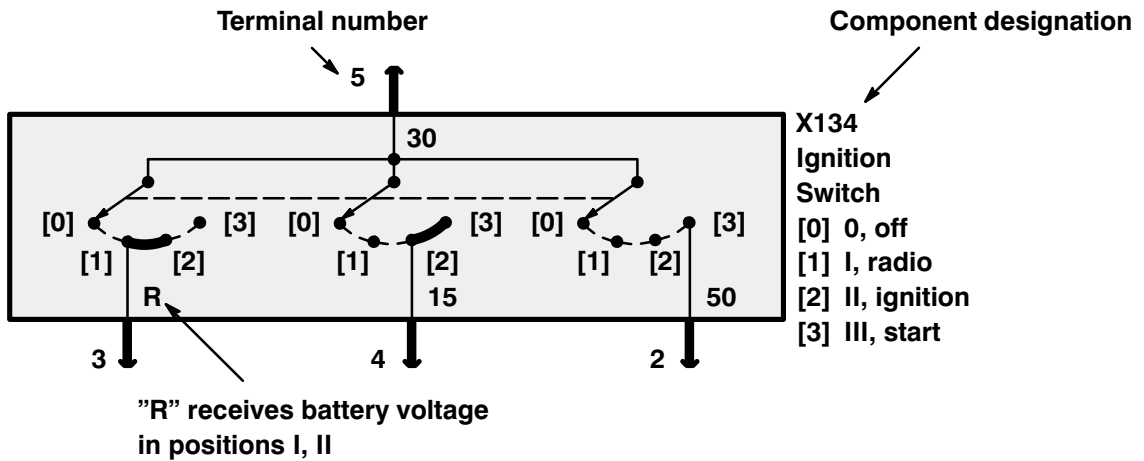

Terminal number	Designation	Terminal number	Designation
50	Battery voltage: Ignition Switch in position III	X	Switched battery voltage through the ignition load relay; ignition switch is in position II or III.
30	Battery voltage: supplied constantly	49	Flasher unit input
15	Battery voltage: Ignition Switch in position II or III	49a	Flasher unit output
R	Battery voltage: Ignition Switch in positions I, II	56a	High beam
31	Ground	56b	Low beam
		85	End of relay coil
		86	Start of relay coil
		87	Relay contact
		87a	Relay contact

Definition of Vehicle Component Codes

All components are identified by a letter followed by an arbitrary number assigned to the component. The letter assigned to the component indicates the type of component.

B	Bulbs, Heated Screens, Mirror Demisters, Cigar Lighters, and Heated Washer Jets
K	Relays, Solenoids, Speakers, and Resistors
M	Motors
P	Fuse Boxes and Fusible Links
X	Switches and Sensors
Z	Electronic Control Units, Modules, Shields, Diodes, and Capacitors

Wire Colours

All wires are identified by letters which indicate a certain colour. Wire colour and size will only be shown once if it does not change throughout the circuit. The following chart explains the wire colour abbreviations.

Wire Colour Chart

B - Black	P - Purple
G - Green	R - Red
K - Pink	S - Grey
L - Light	U - Blue
N - Brown	W - White
O - Orange	Y - Yellow

Circuit Qualifiers

Certain abbreviations are used throughout the Electrical Troubleshooting Manual as circuit qualifiers. The following list explains all abbreviations used as qualifiers in the Circuit Diagrams.

ABS	Anti lock Braking System
LHD	Left Hand Drive
RHD	Right Hand Drive
LWB	Long Wheel Base
SWB	Short Wheel Base
NAS	North American Countries
MFI-V8	Multiport Fuel Injection (MFI-V8)
MFI-T16	Multiport Fuel Injection (MFI-T16)
300 Tdi	Tdi Diesel
300 Tdi with EGR	Tdi Diesel with Exhaust Gas Recirculation (EGR)
300 Tdi without EGR	Tdi Diesel without Exhaust Gas Recirculation (EGR)
300 Tdi with EDC	Tdi Diesel with Electronic Diesel Control (EDC)
300 Tdi without EDC	Tdi Diesel without Electronic Diesel Control (EDC)

Switch Positions

Certain abbreviations are used throughout the Electrical Troubleshooting Manual as Switch Position notes. The following list explains all abbreviations used as Switch Position notes in the Circuit Diagrams.

< 100°	Less than 100°
> 100°	More than 100°

Connectors, Grounds, and Splices are identified by a letter followed by a number. Connectors are identified by C, grounds by E, and splices by S. Some splices are contained in junction connectors. These splices are identified by the prefix "HJ" below the splice's reference number. The number assigned to the connector, ground, or splice corresponds to its location in the vehicle.

Connector, Ground, and Splice Identification by Location

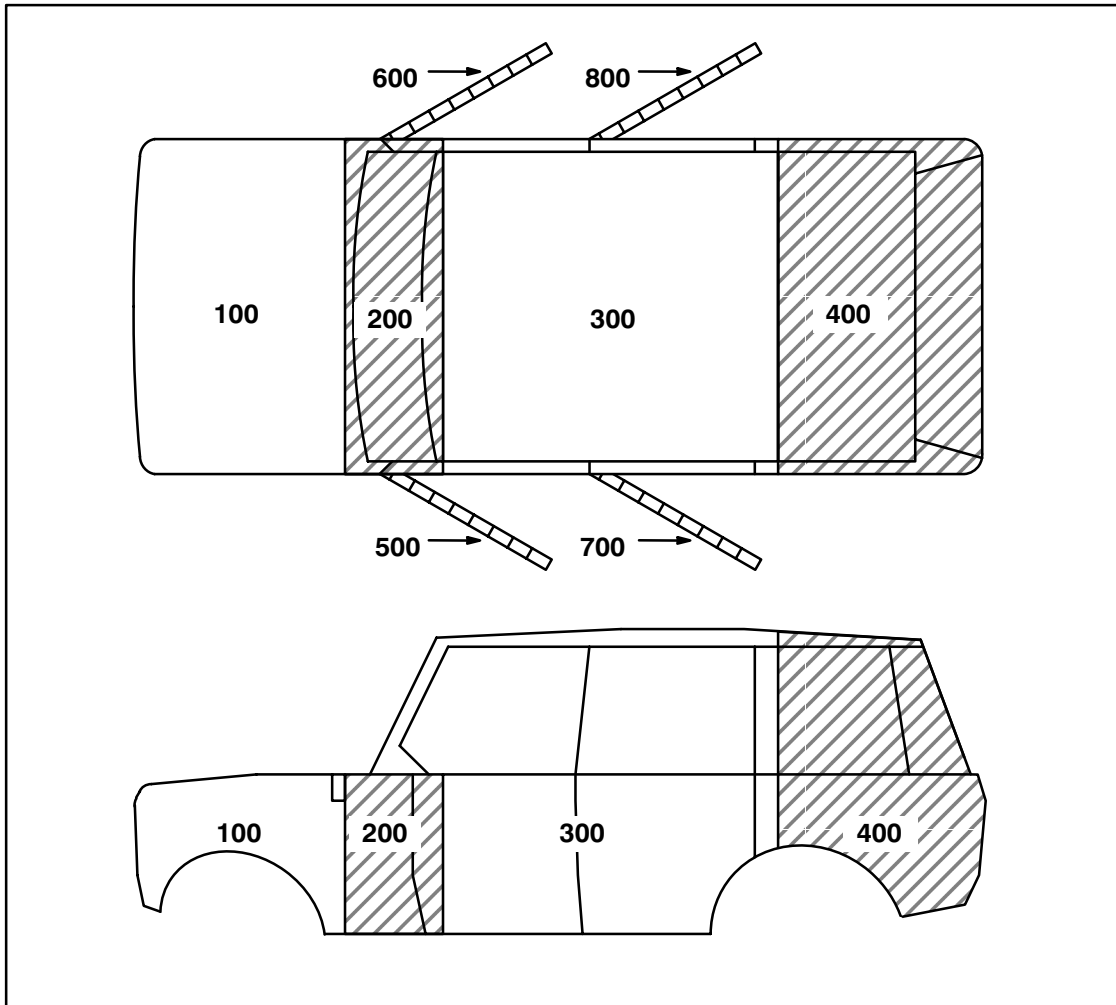

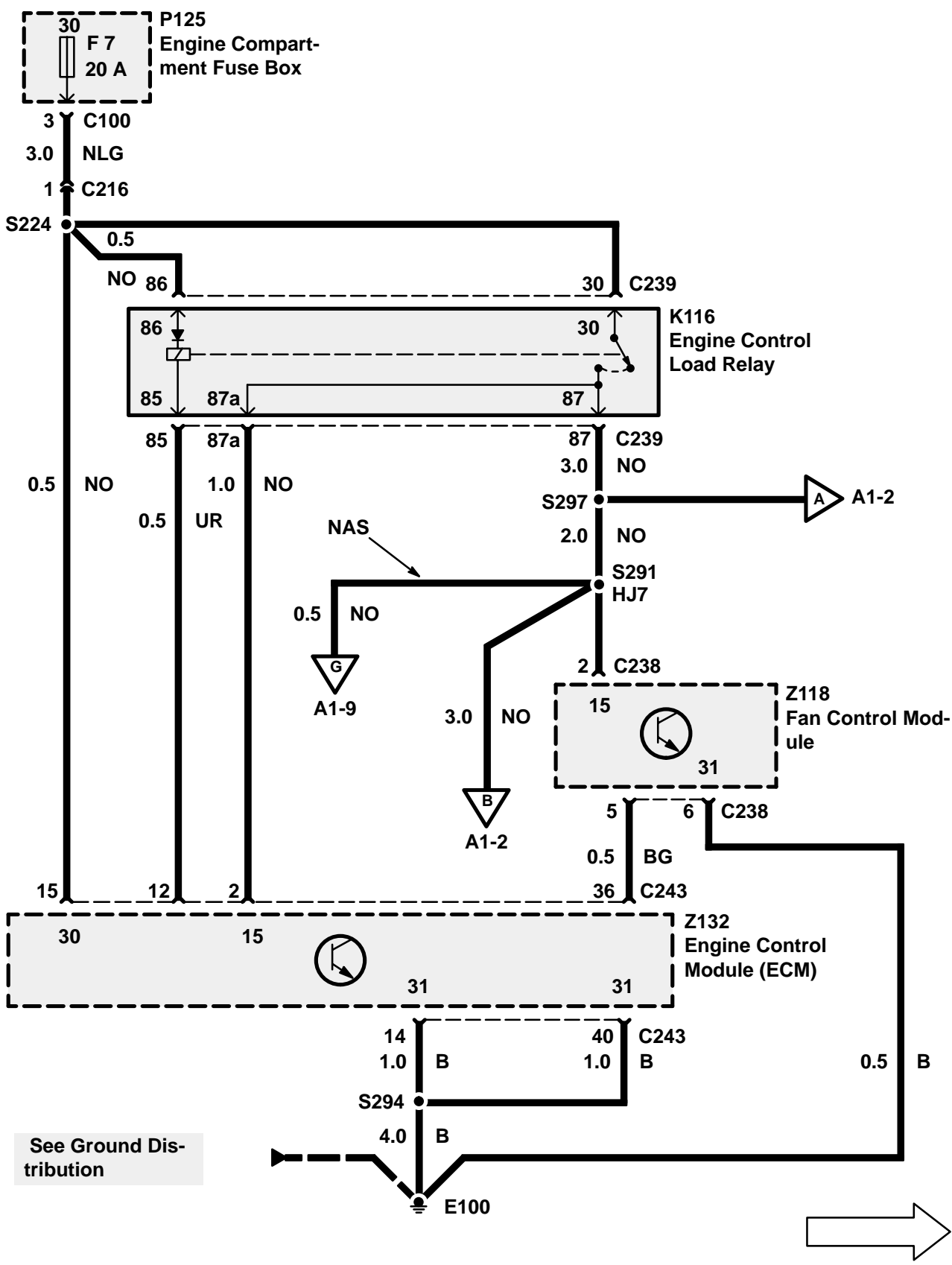

See Ground Distribution

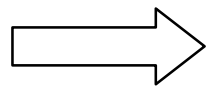

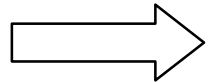
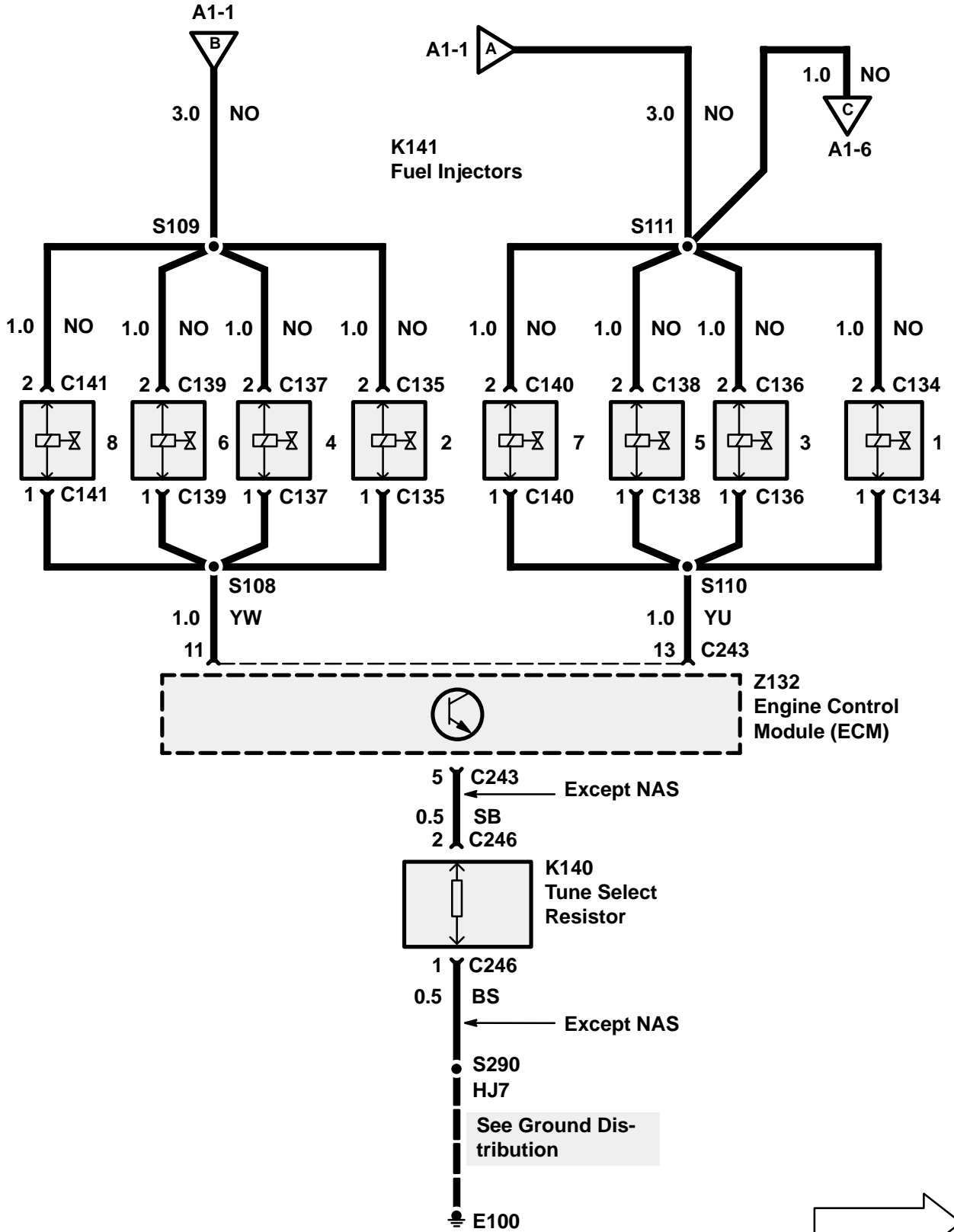
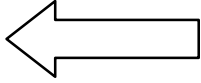

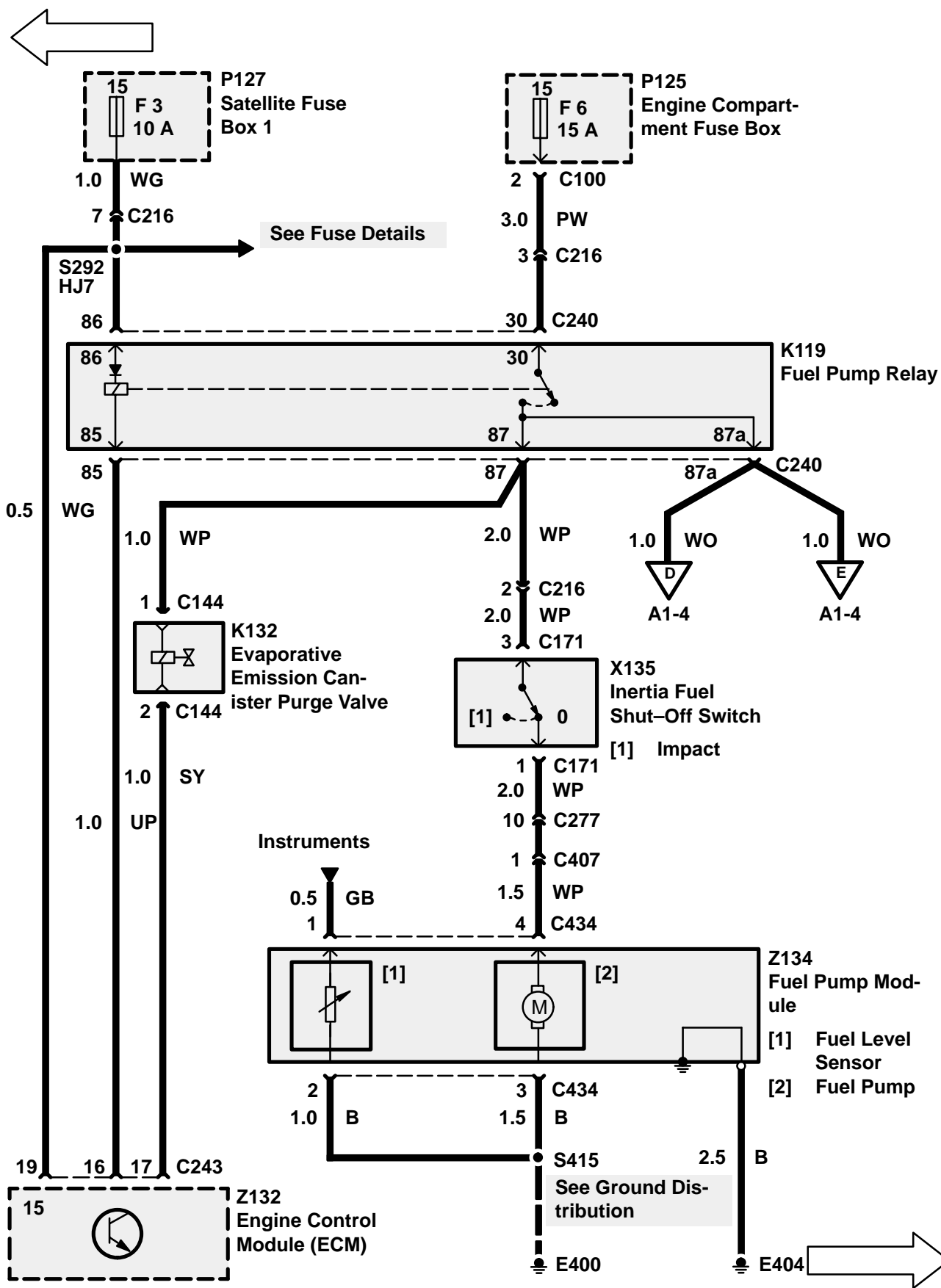

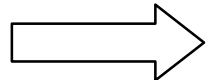
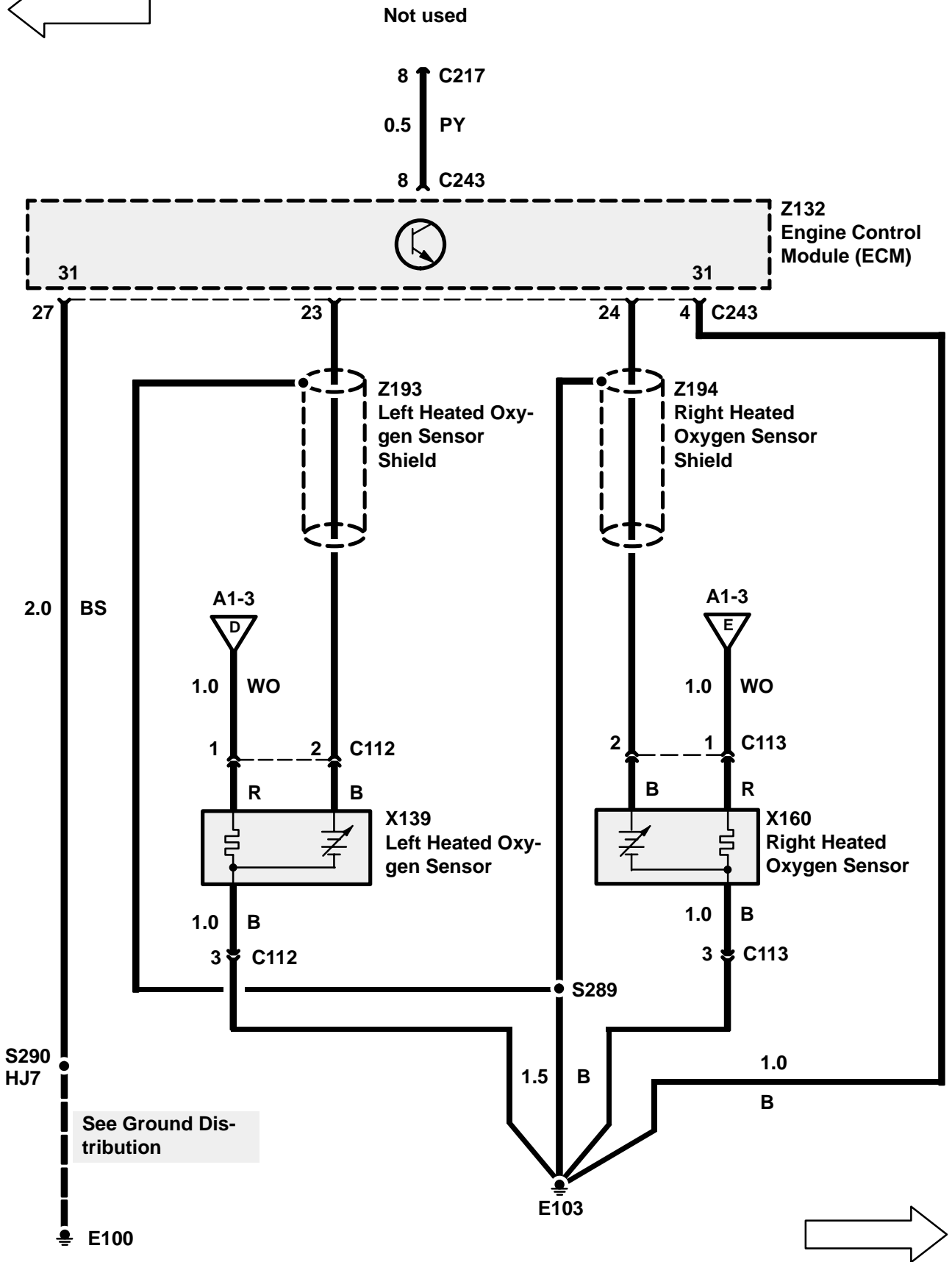
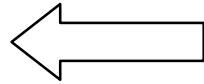

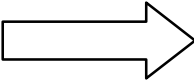
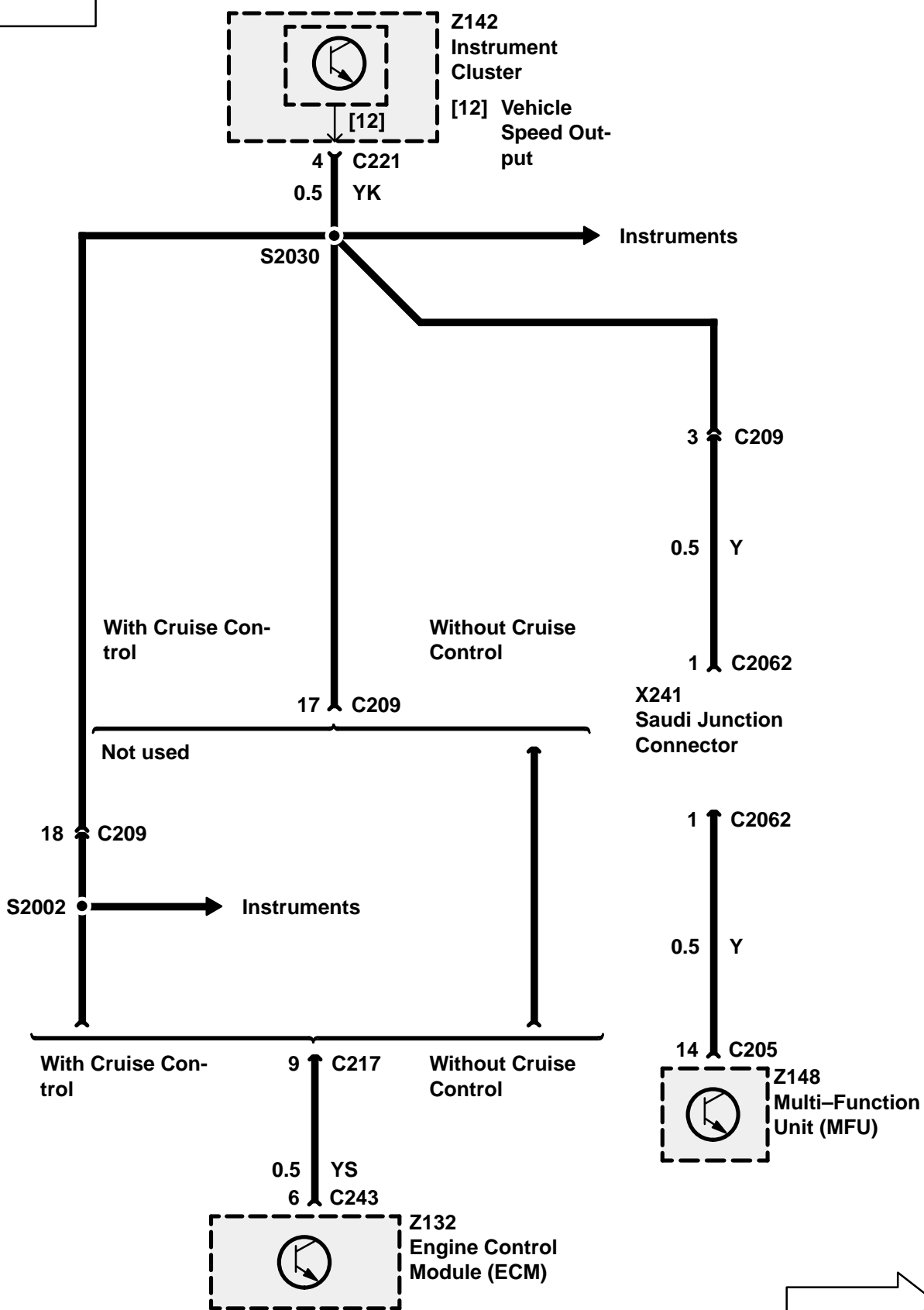
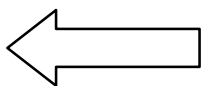

A1 ETM

DISCOVERY

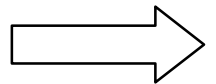
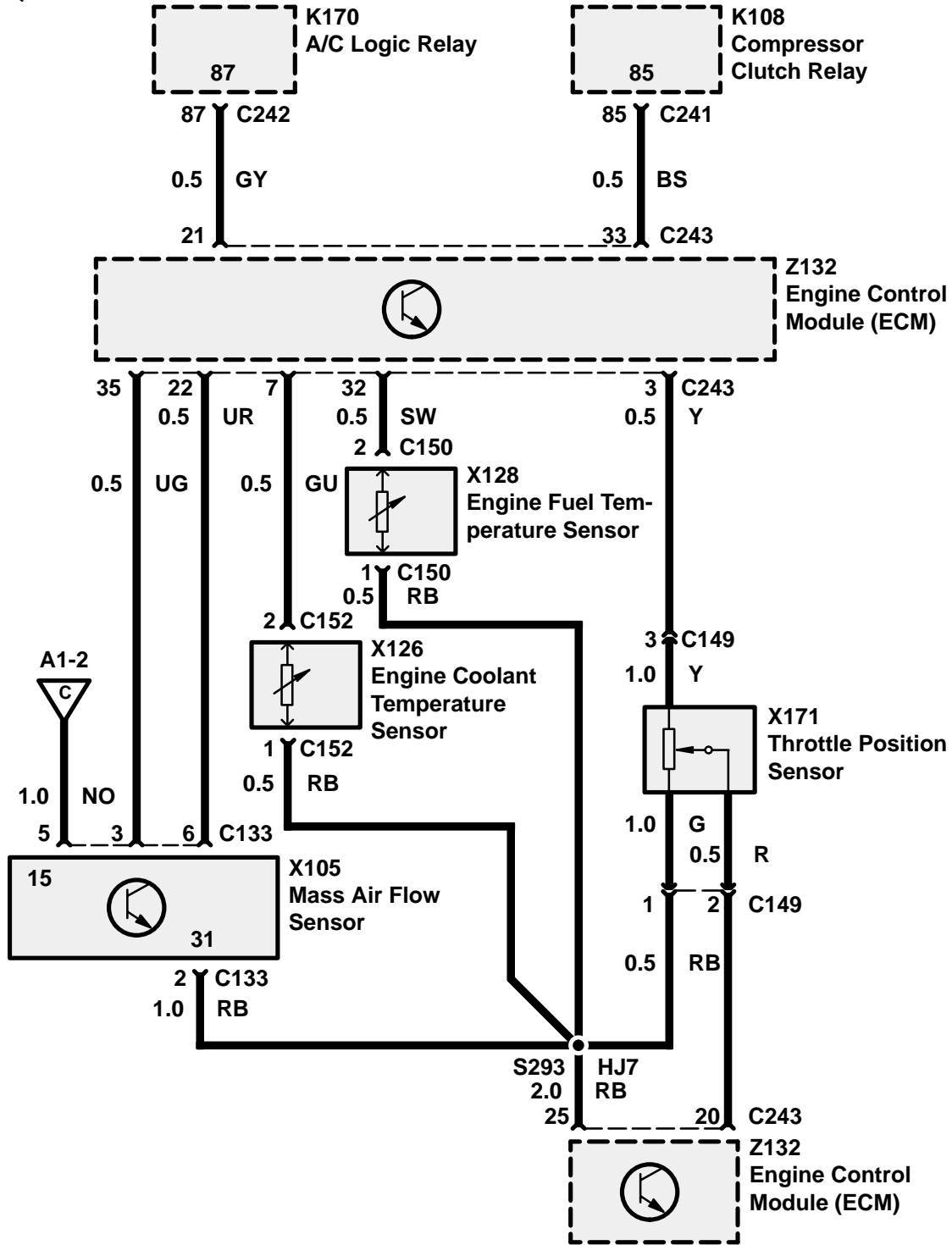
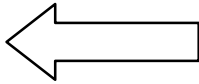

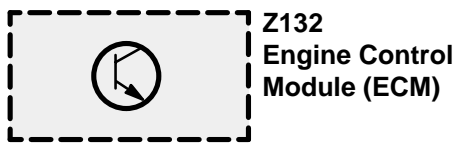
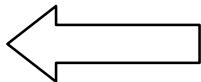

34 C243

0.5 OB

10 C217

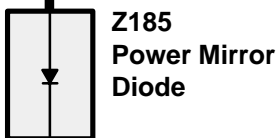

0.5 BY

9 C105

0.5 YB

Automatic Transmission

Manual Transmission

S322 0.5 BY Starting and Charging

5 C323 B

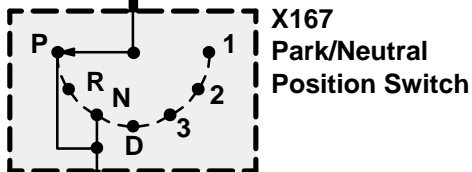

0.5 BG

4 C323 BO

0.5 BO

With Theft Alarm

11 C105

Without Theft Alarm

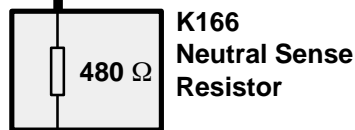

0.5 B See Ground Distribution

5 C105

S288 HJ11 See Ground Distribution

E201



1 C274

2 C274 See Ground Distribution

E200

1 C274

0.5 B

2 C274

See Ground Distribution

E200

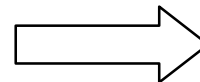

A1 ETM

DISCOVERY

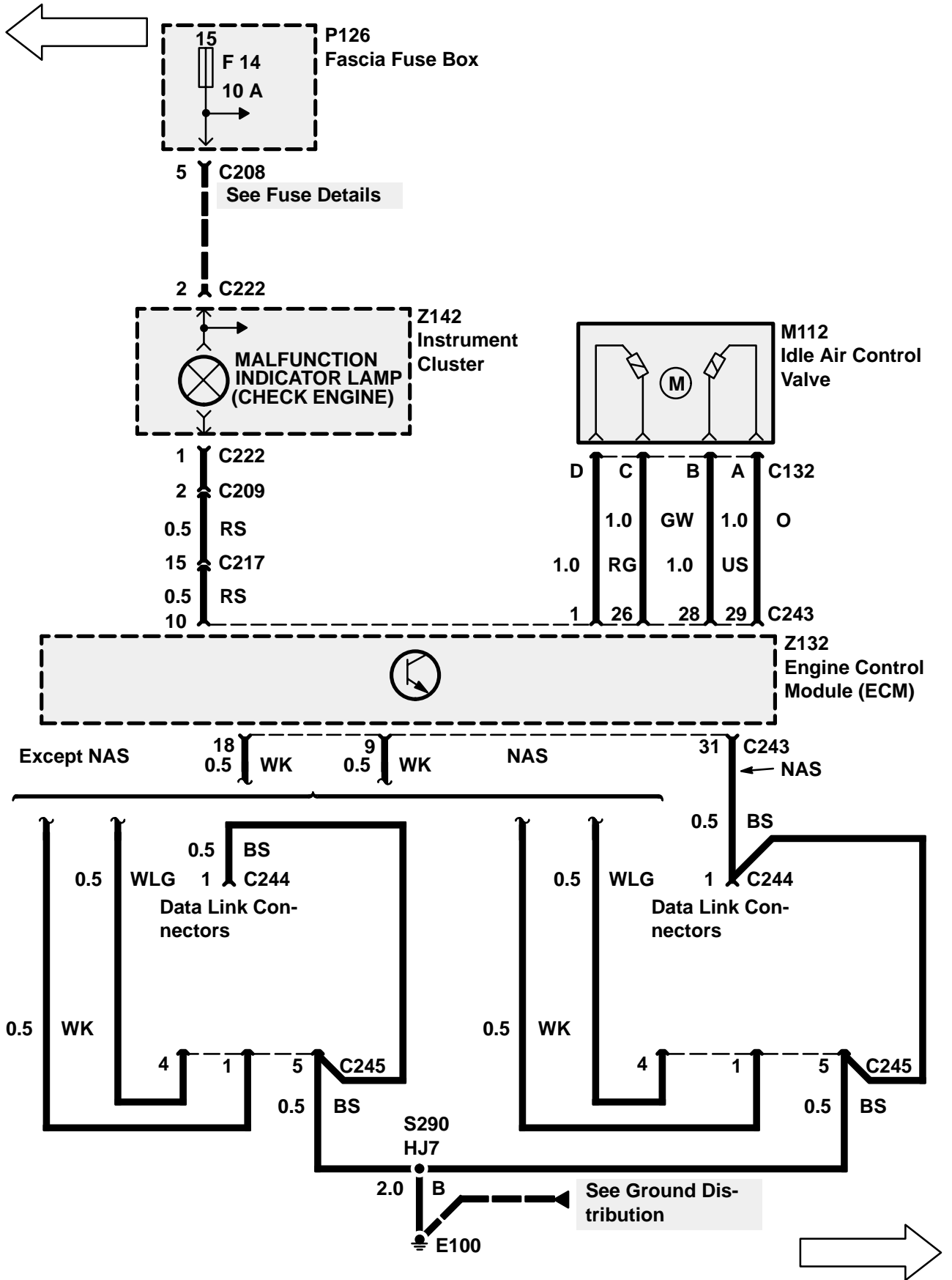

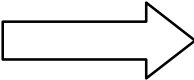
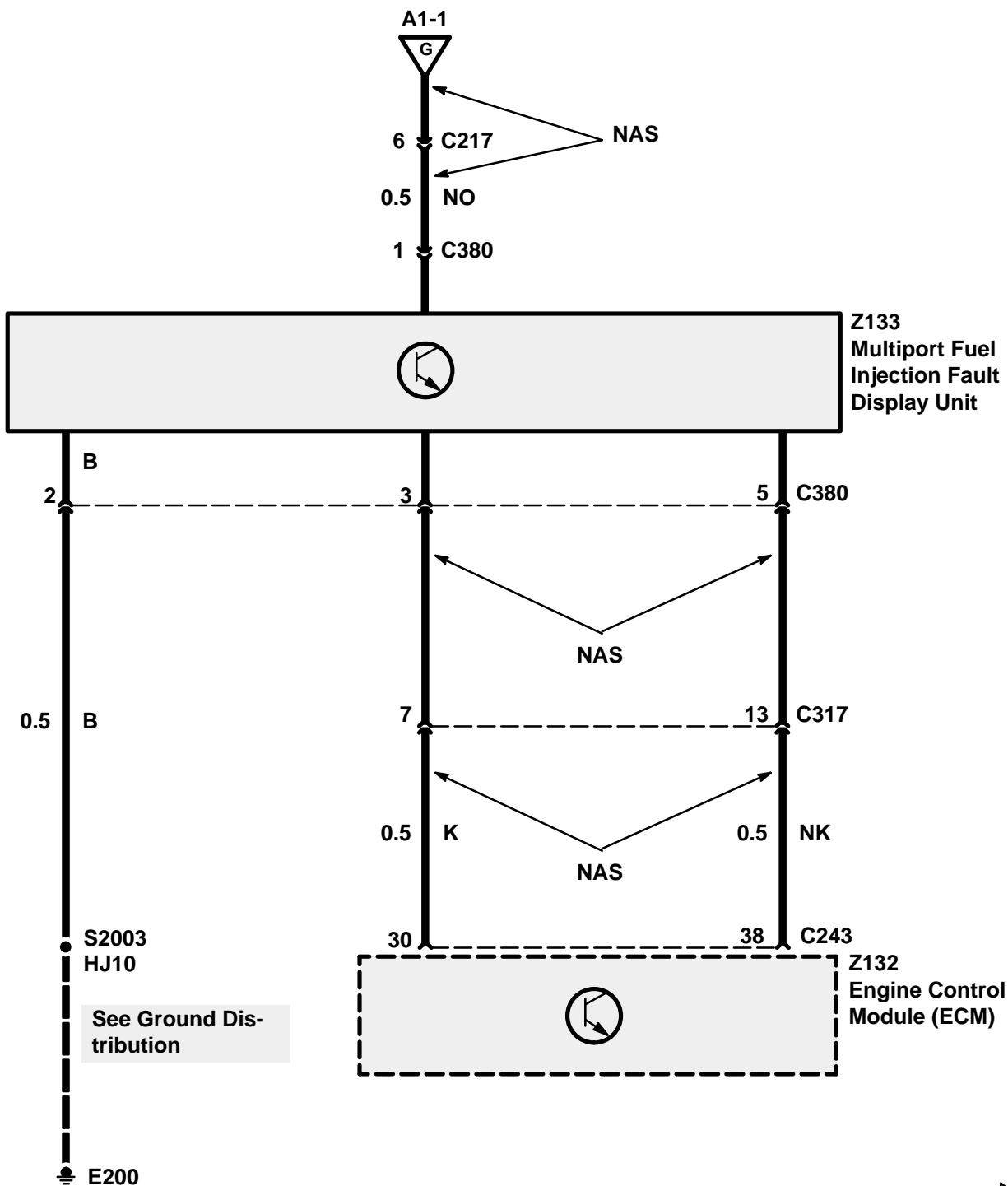
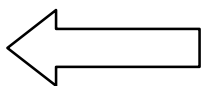

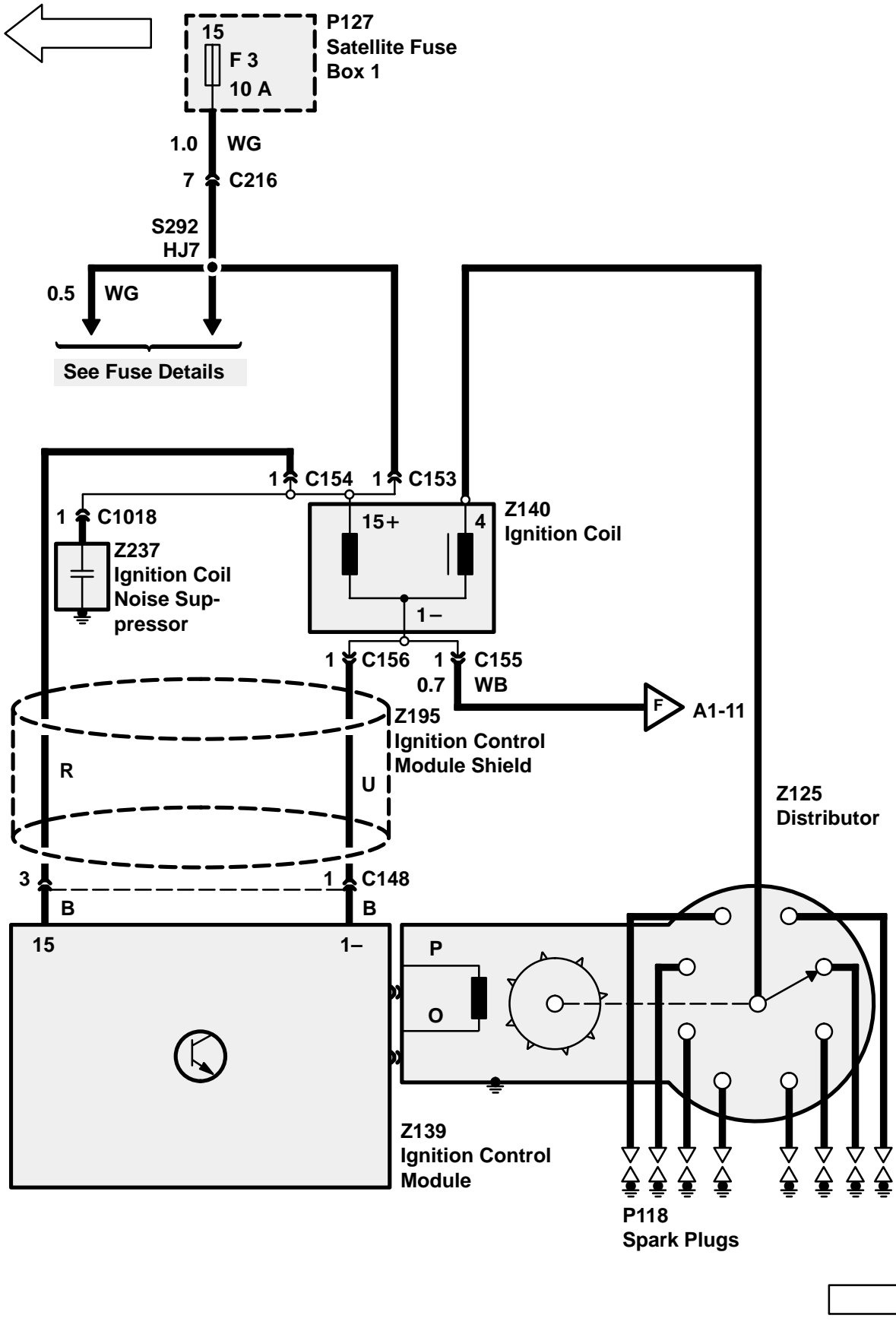

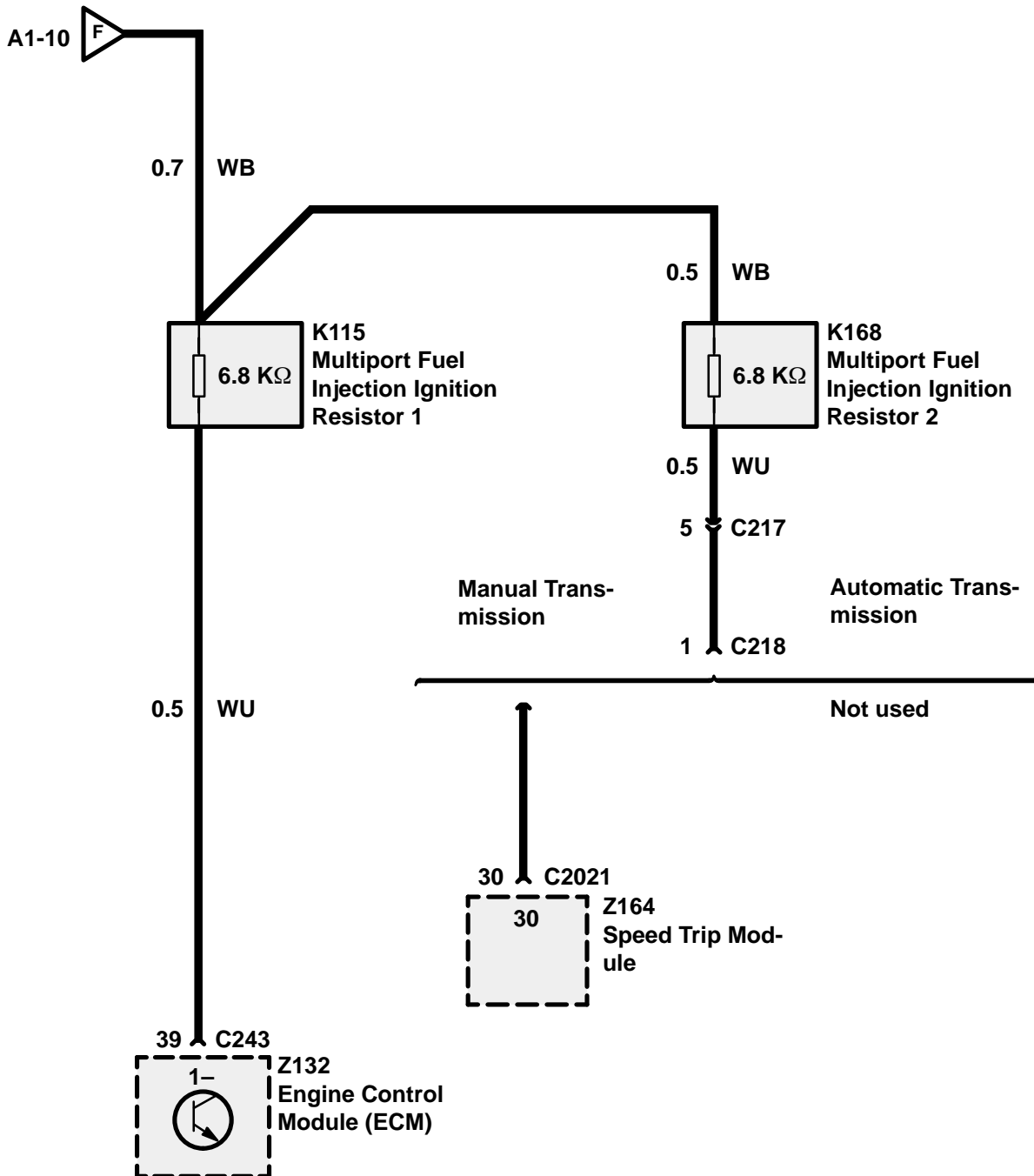
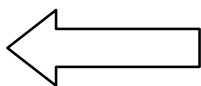

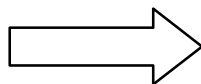
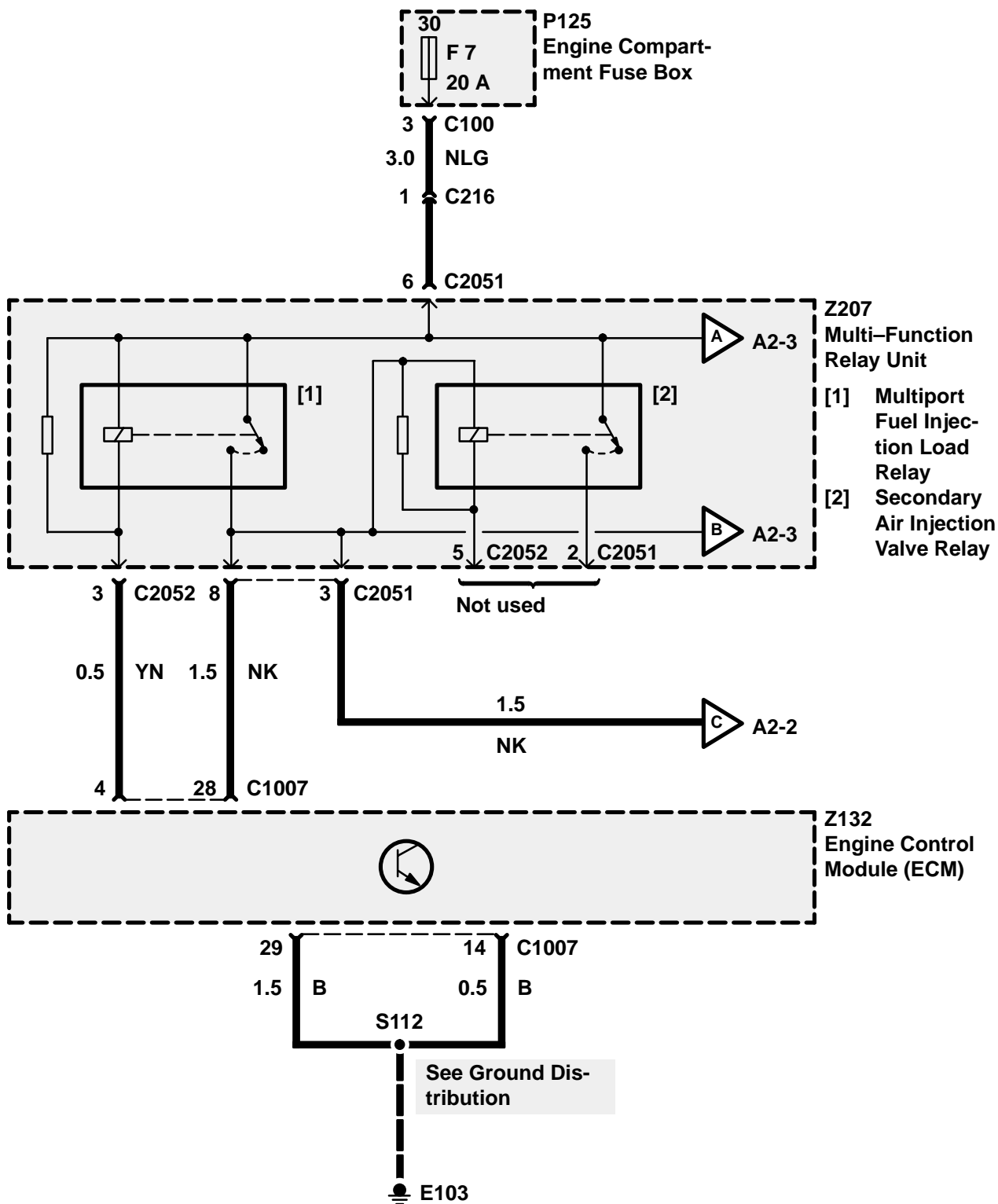

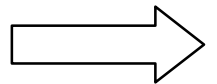
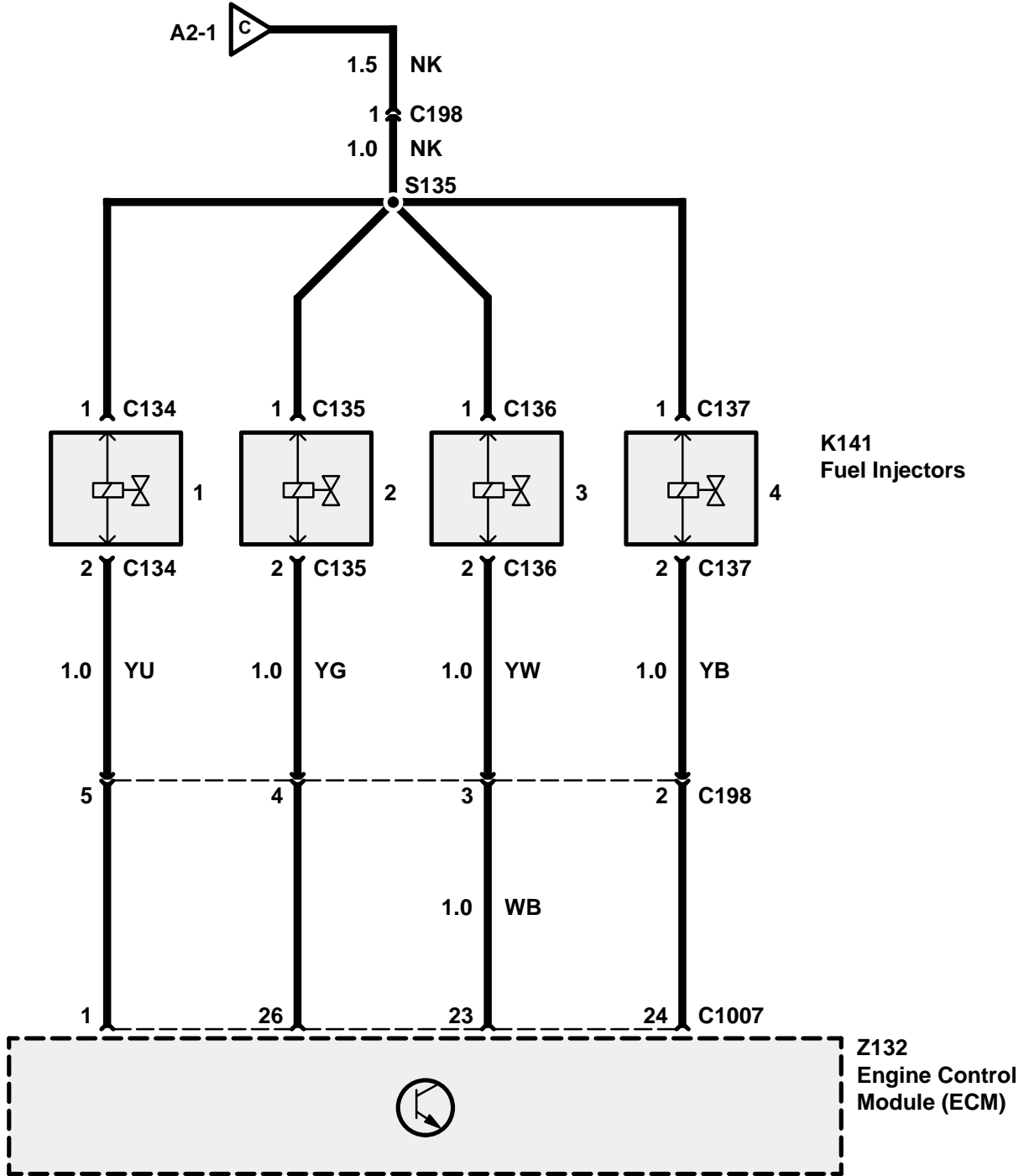
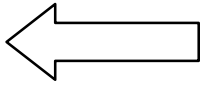

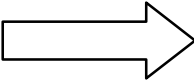
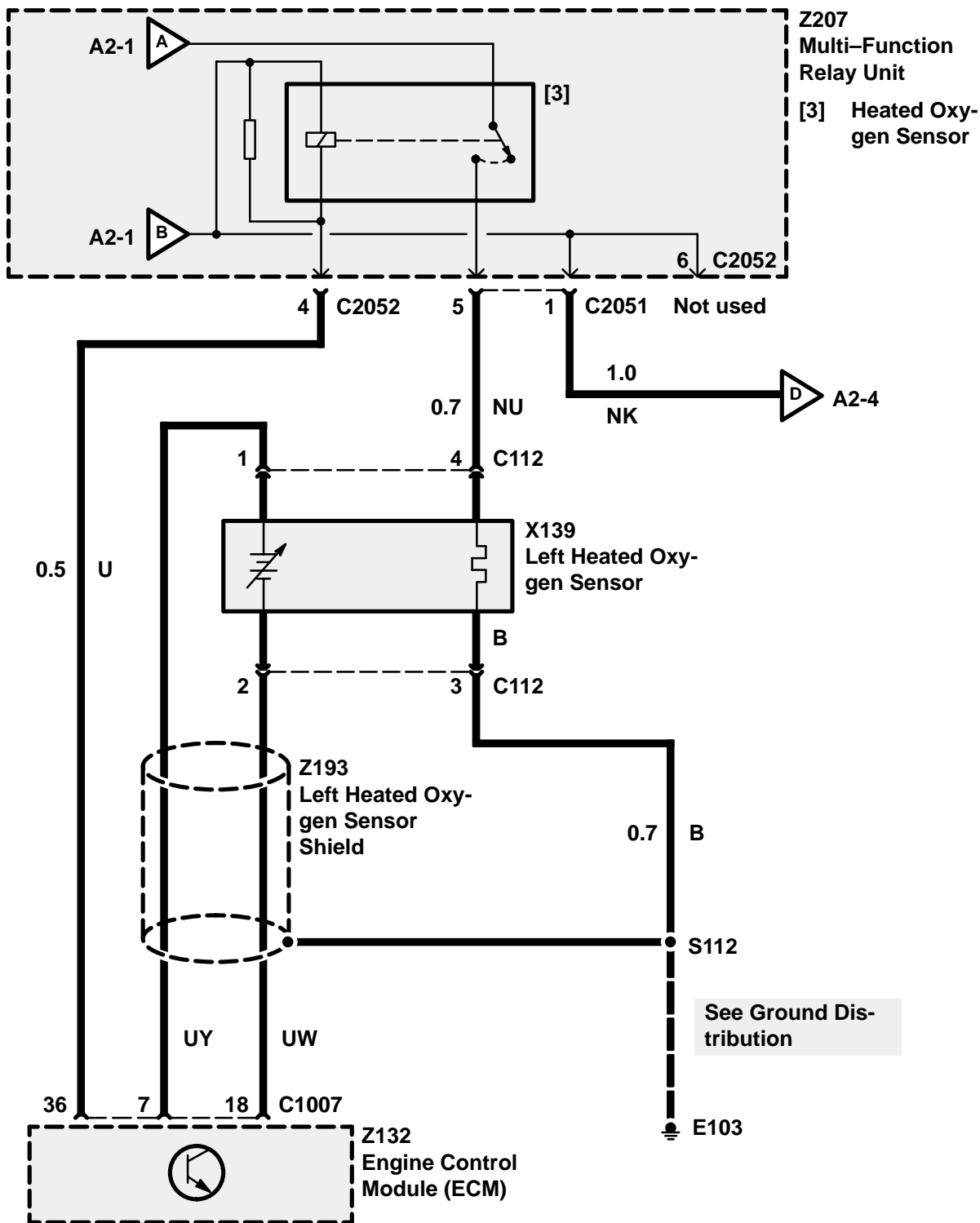
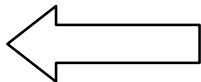

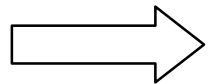
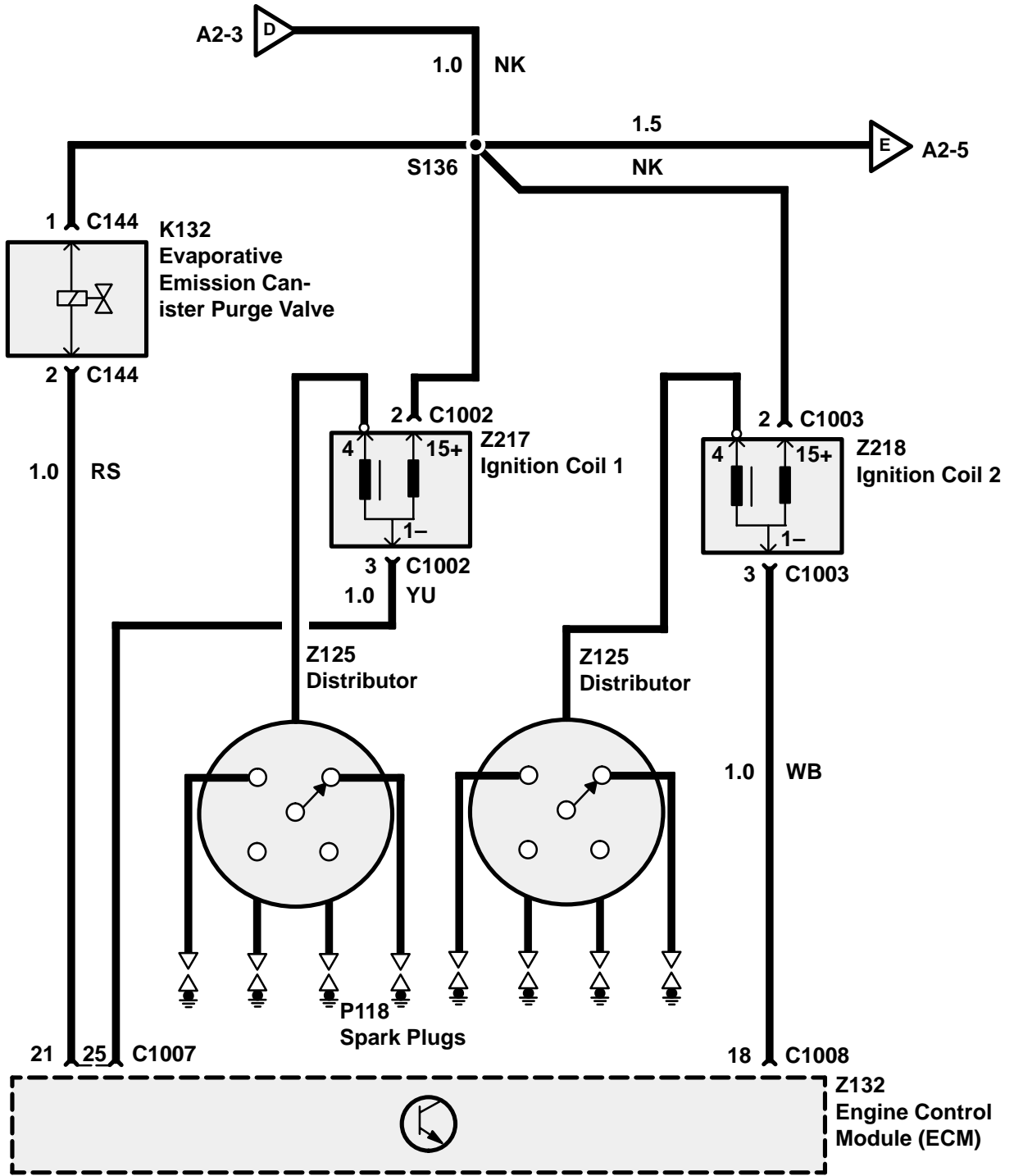
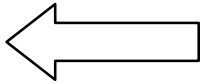

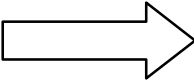
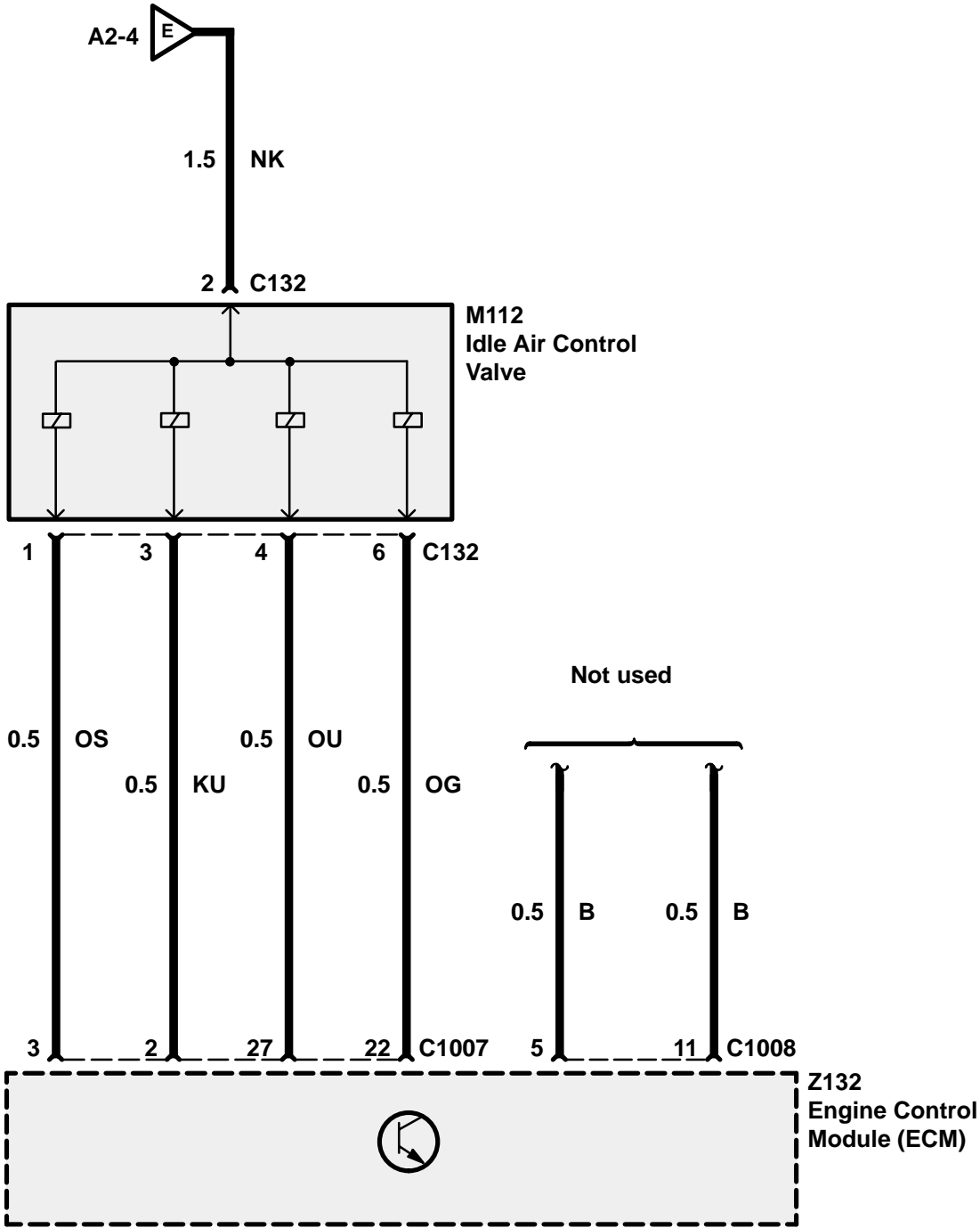
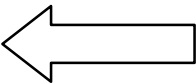

A2 ETM

DISCOVERY

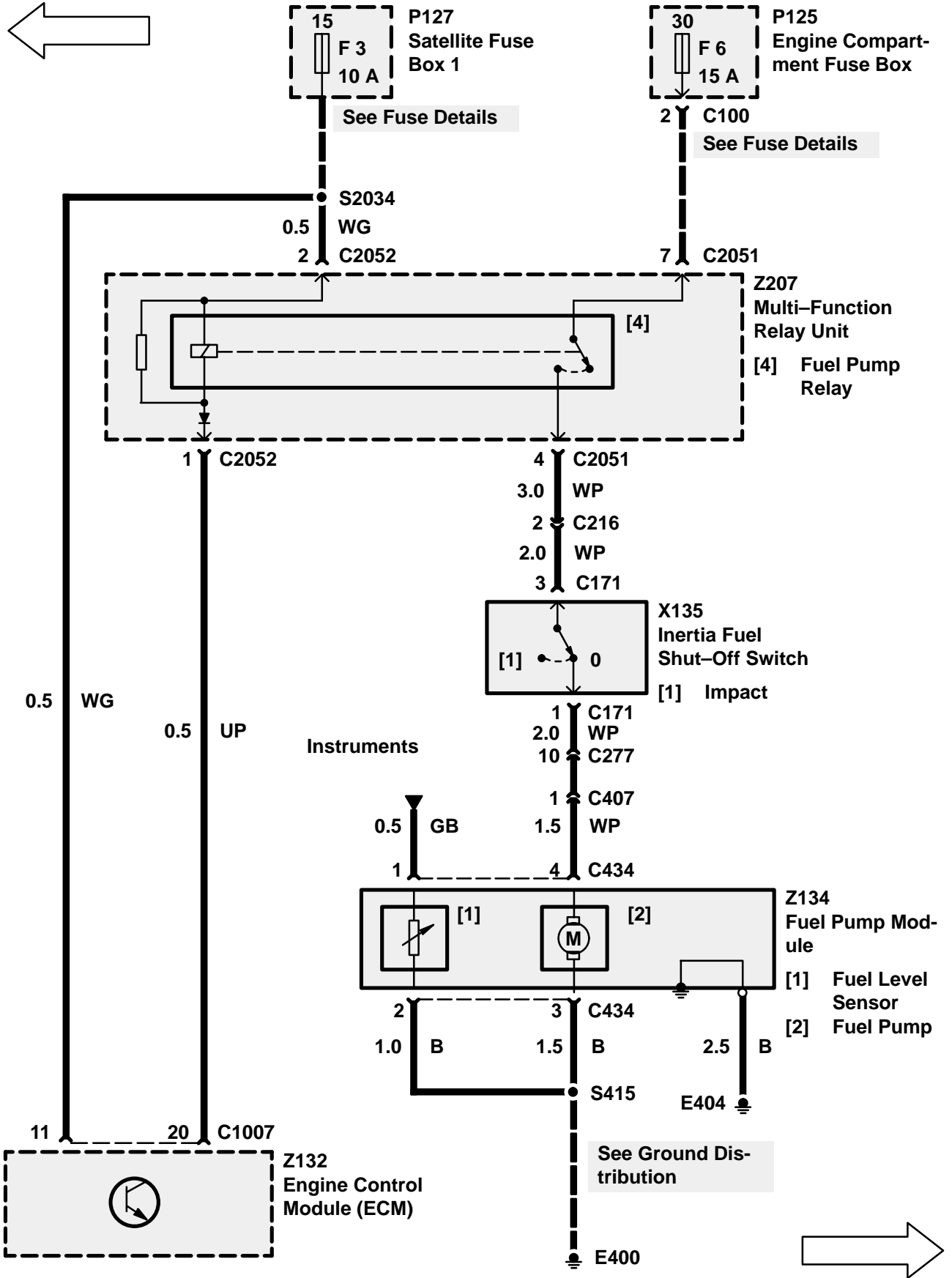

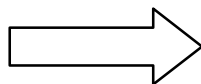
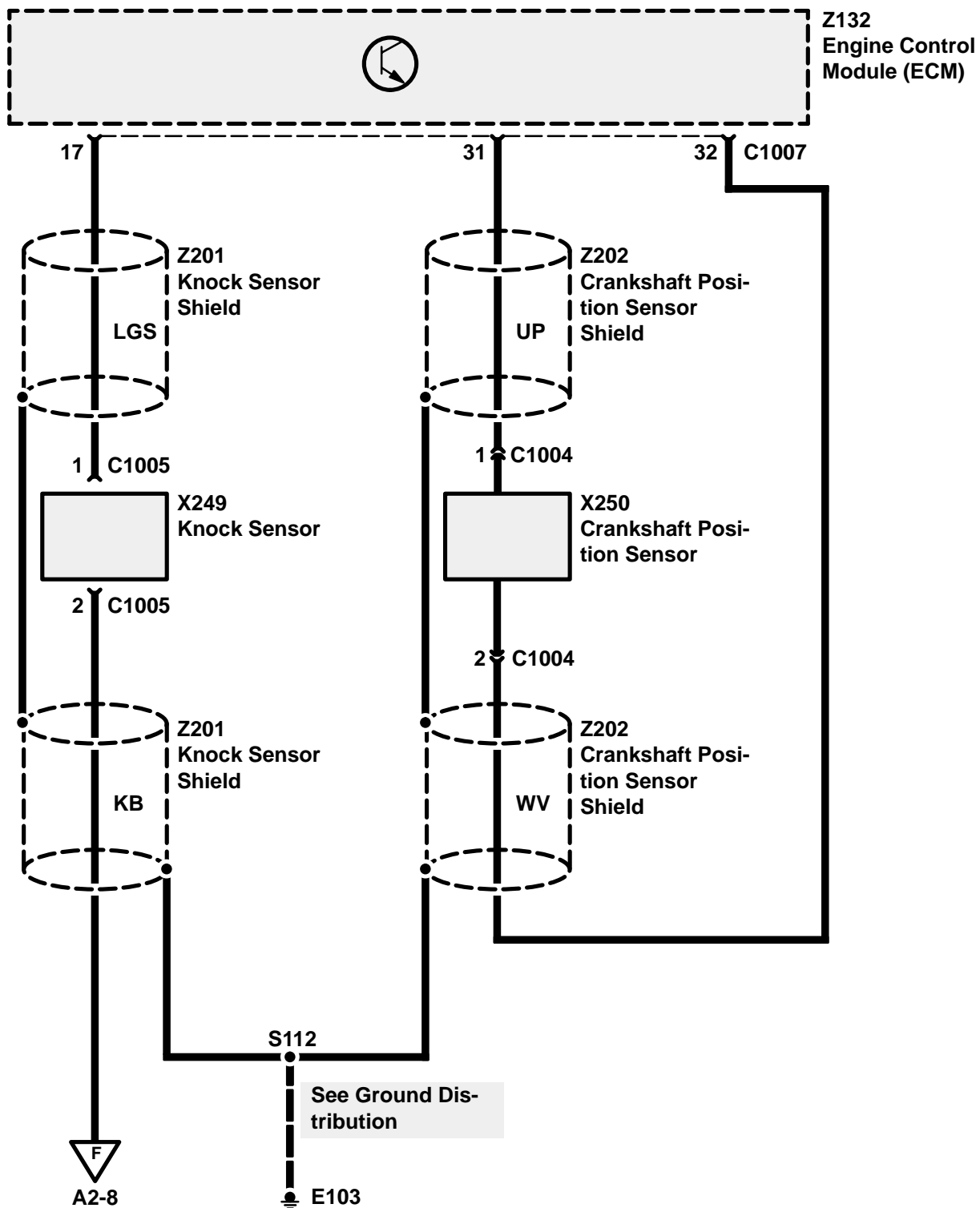
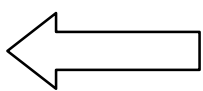

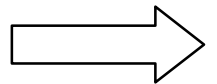
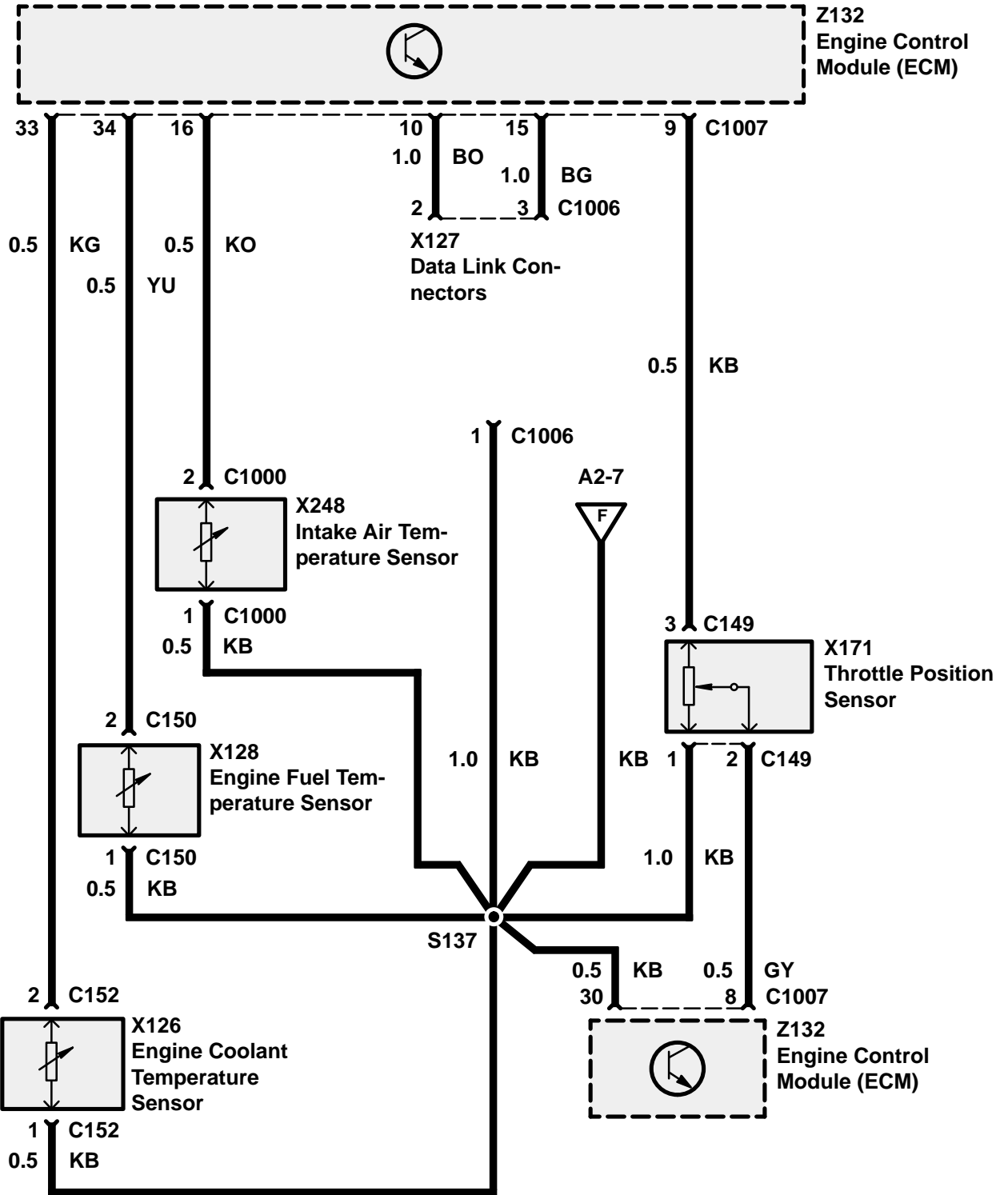
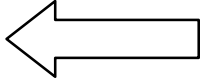

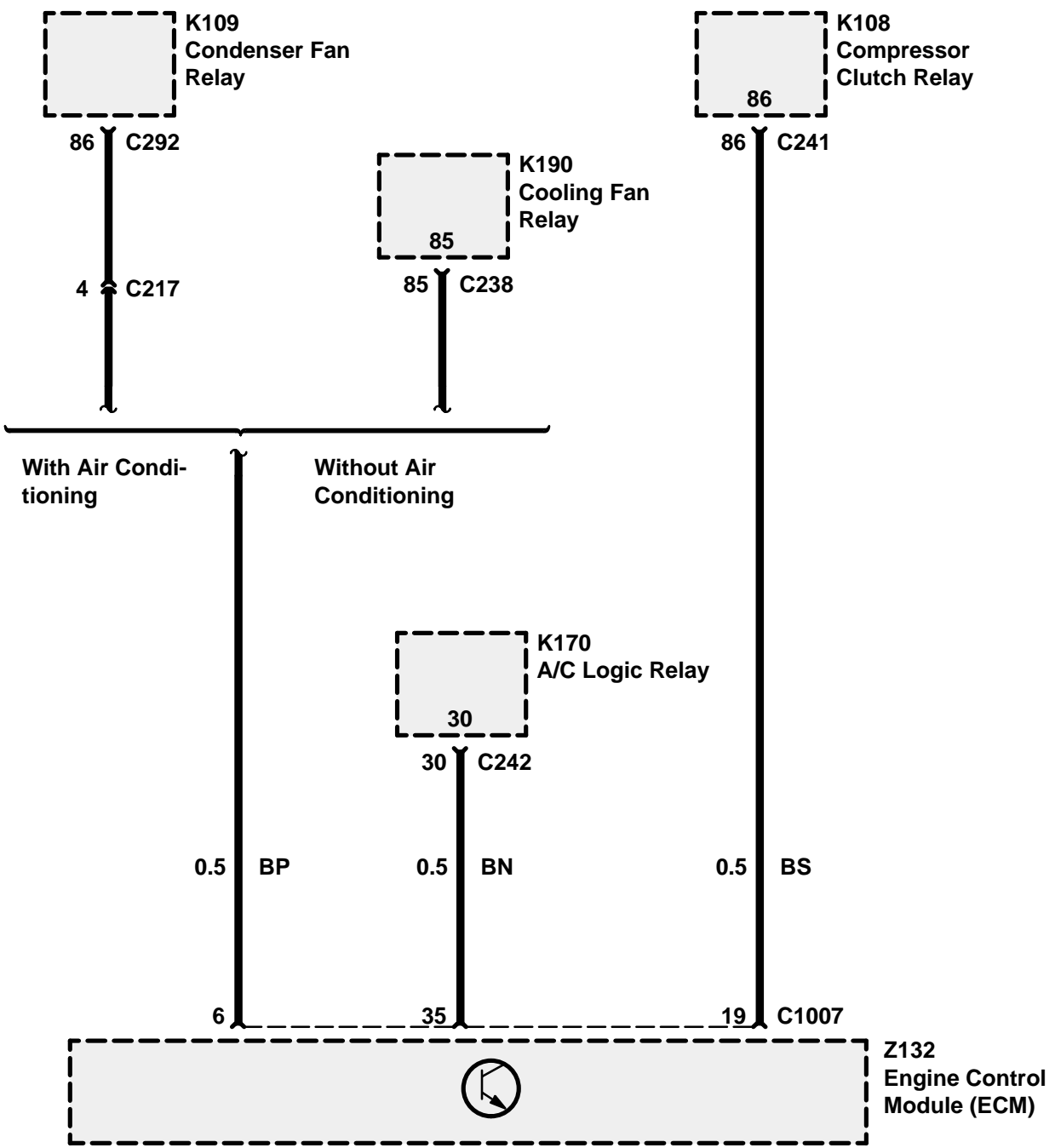
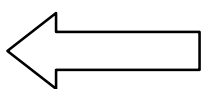

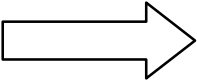
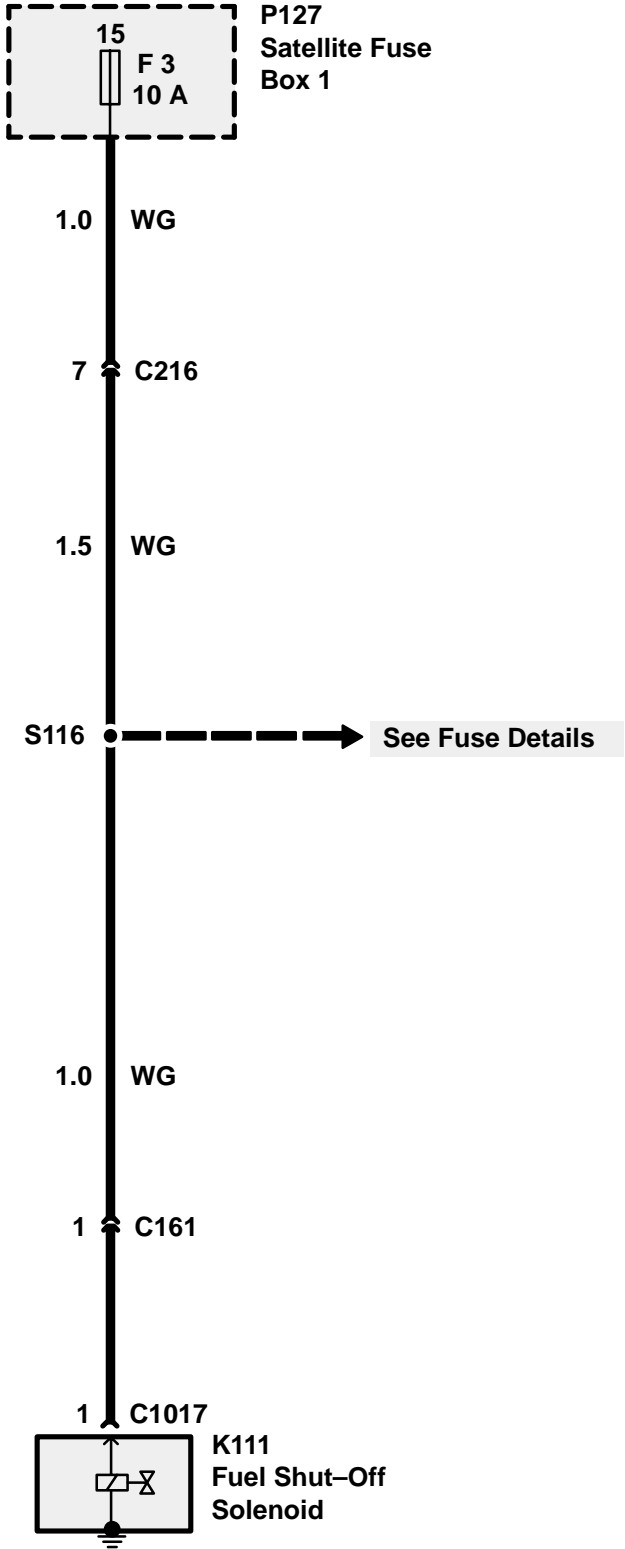

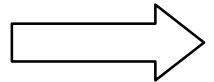
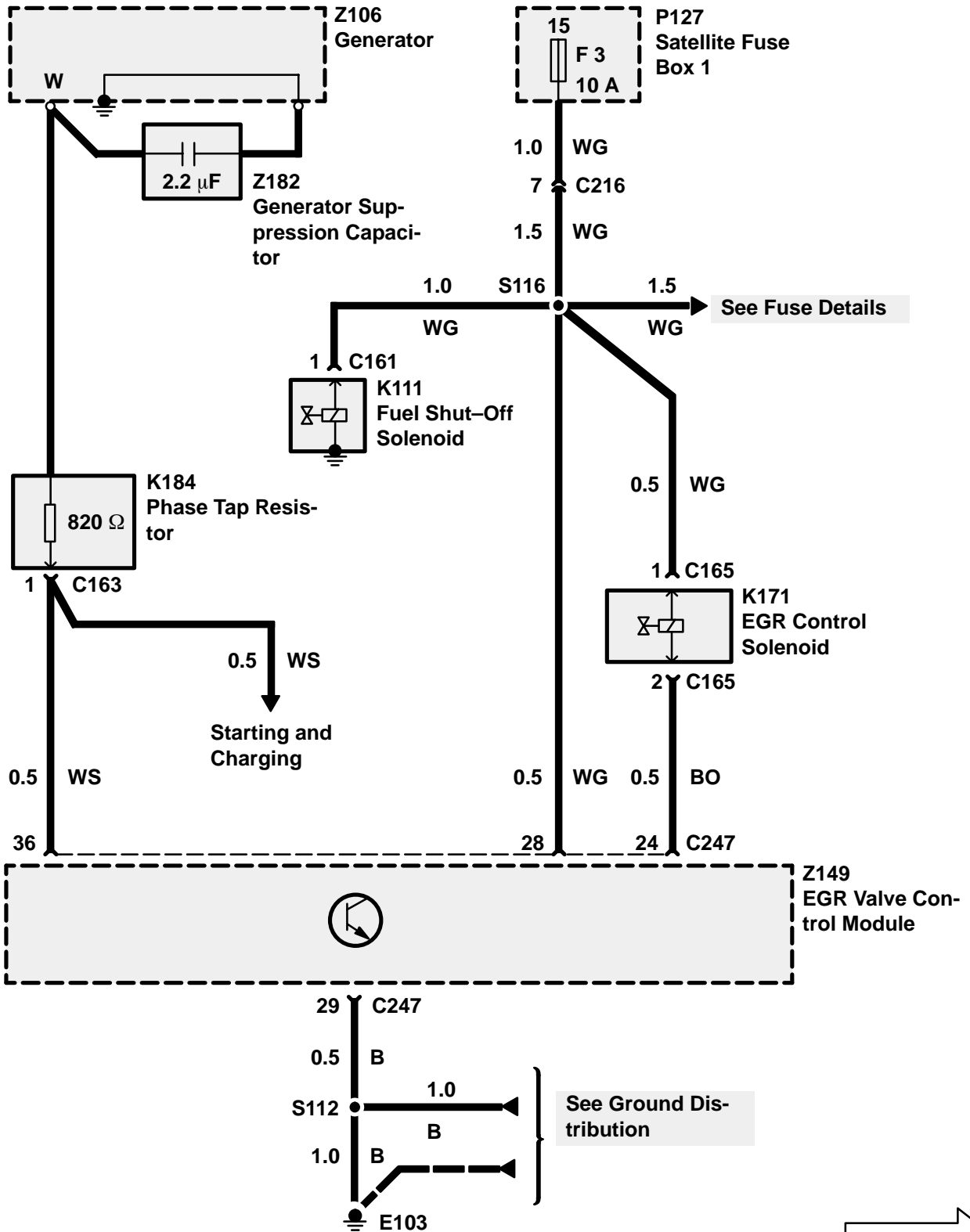
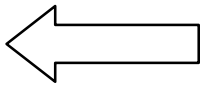

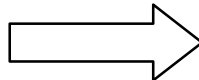
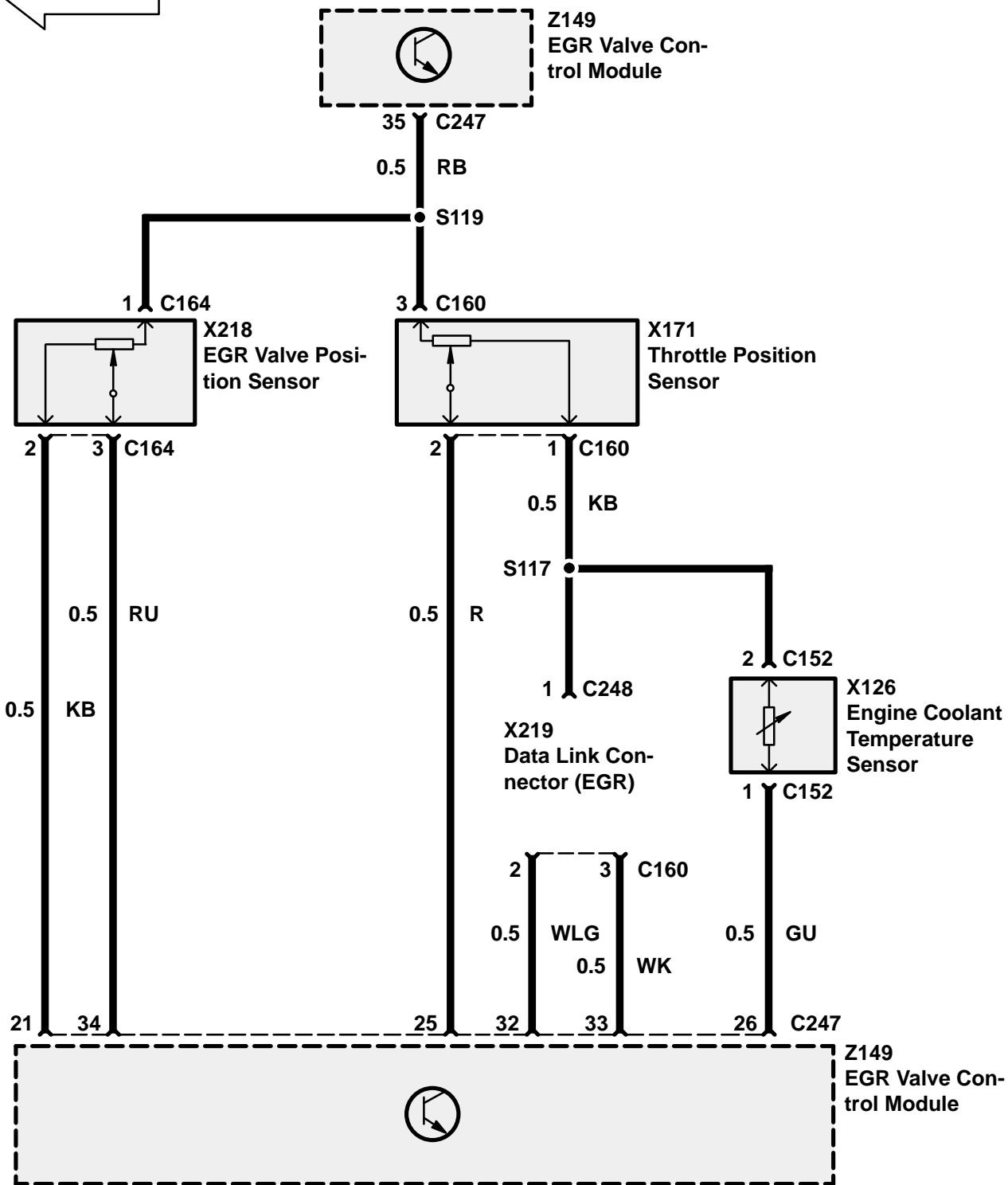
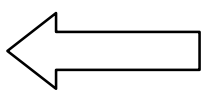

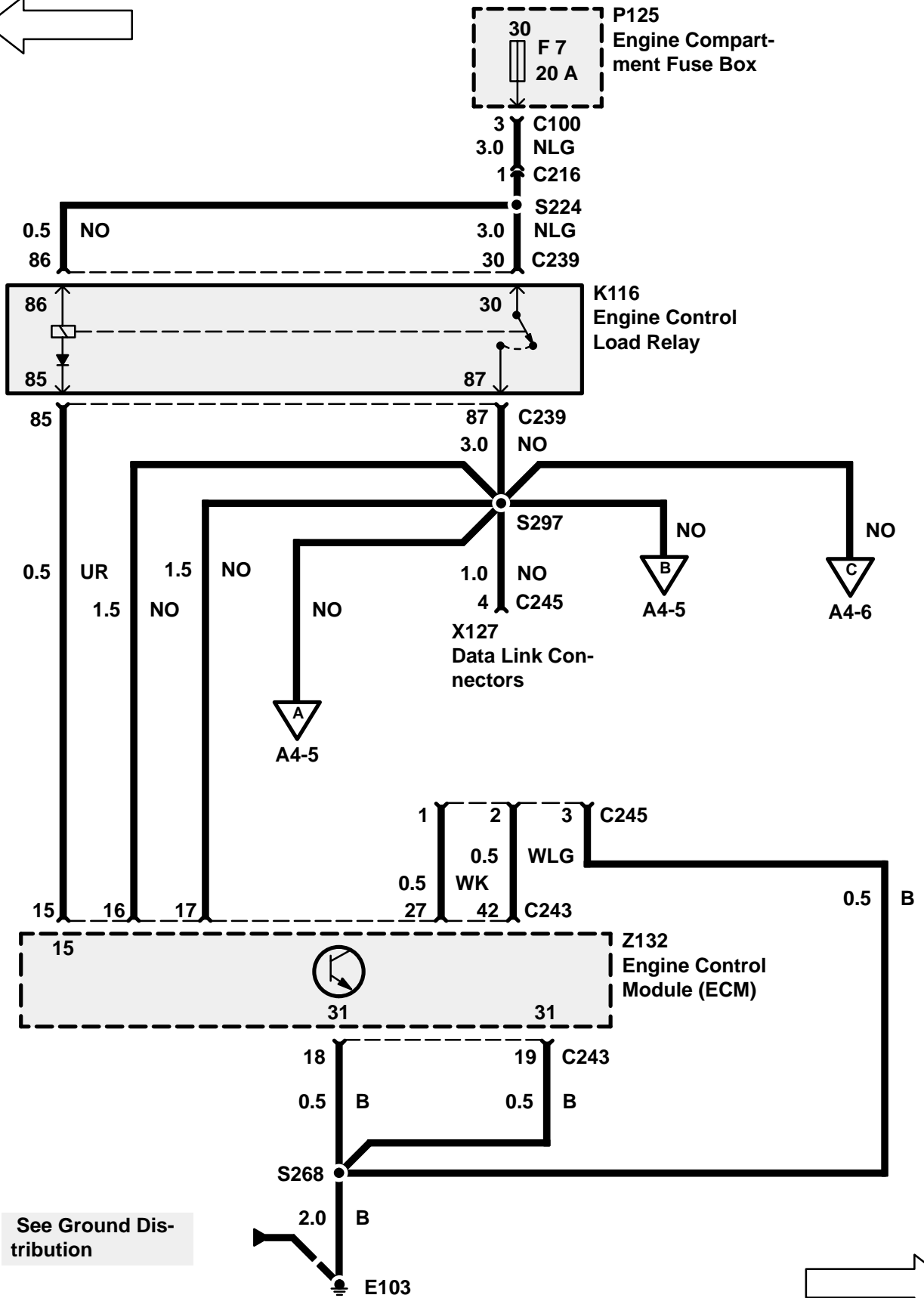
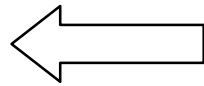

See Ground Distribution

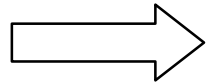

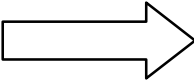
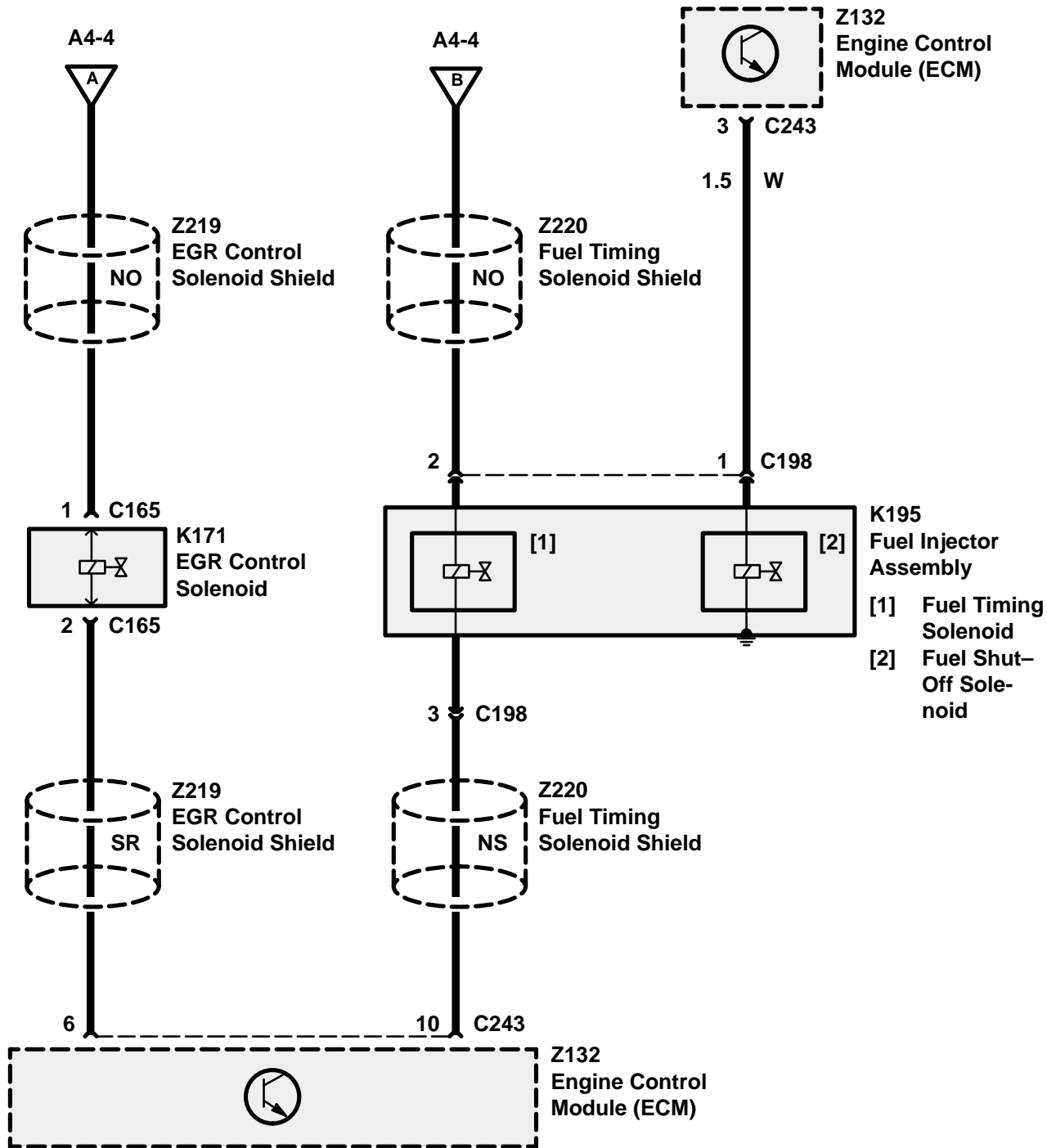
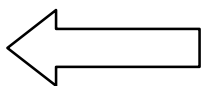

A4 ETM

DISCOVERY

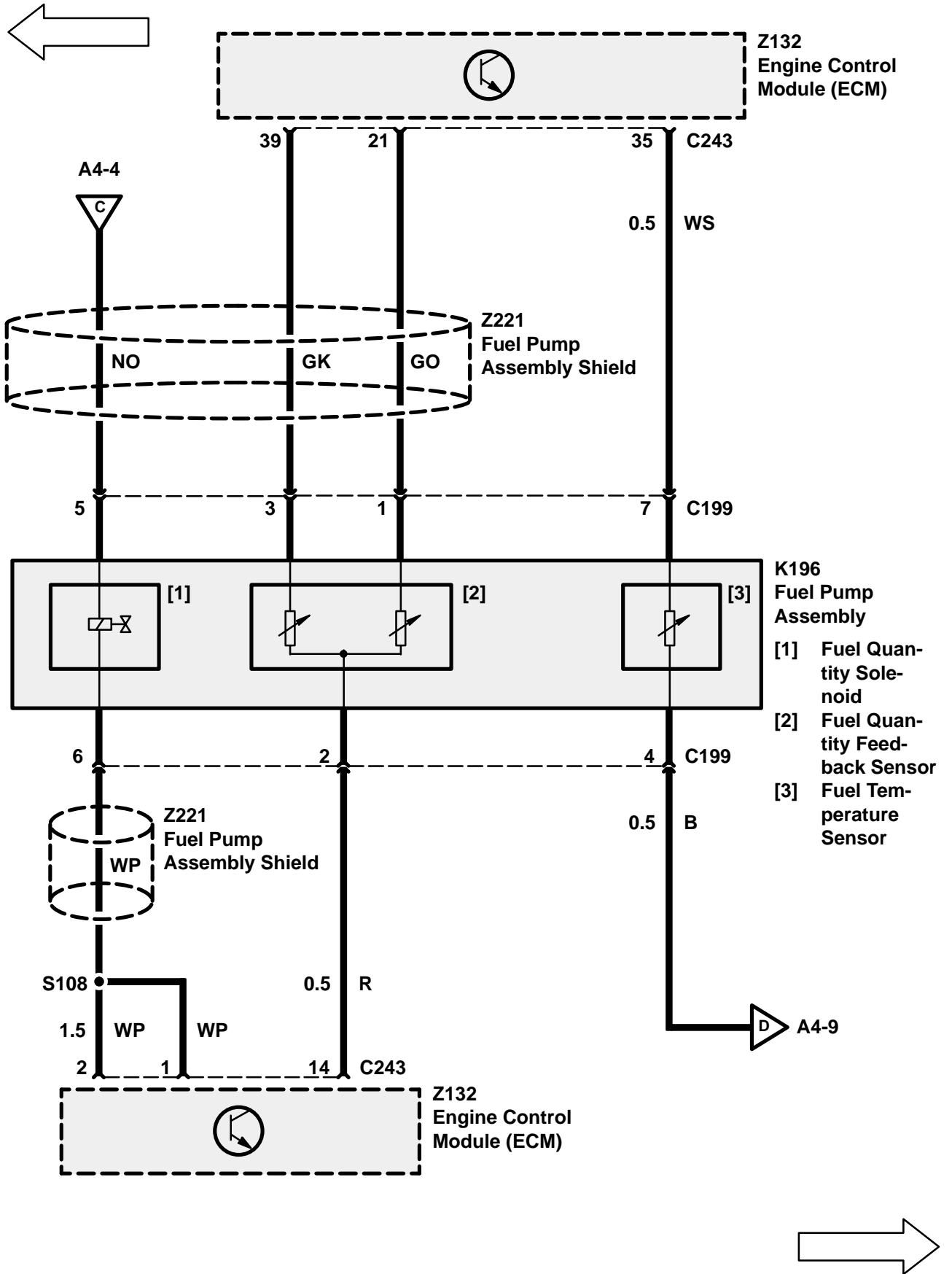

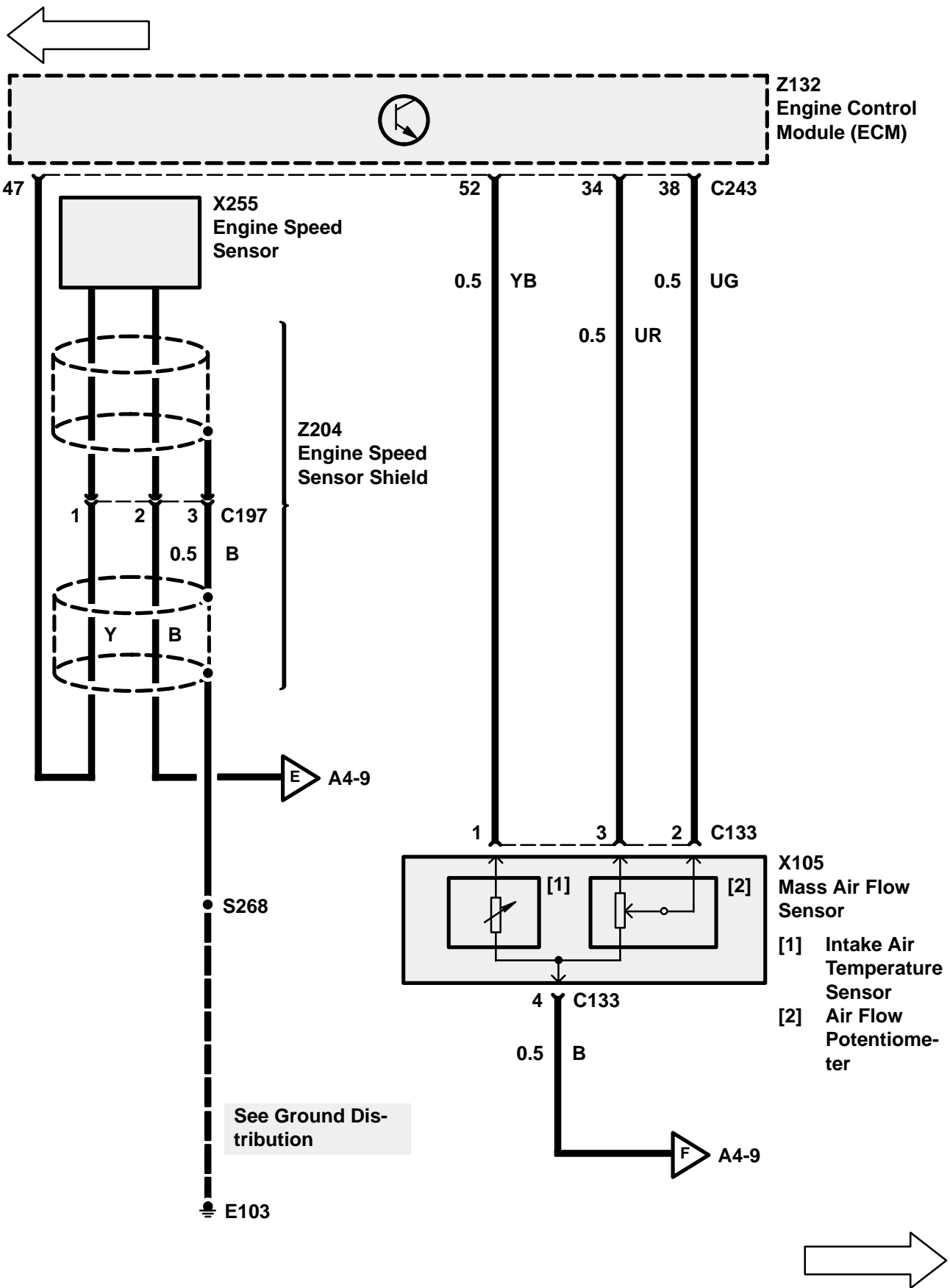

A4 ETM

DISCOVERY

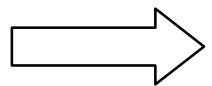
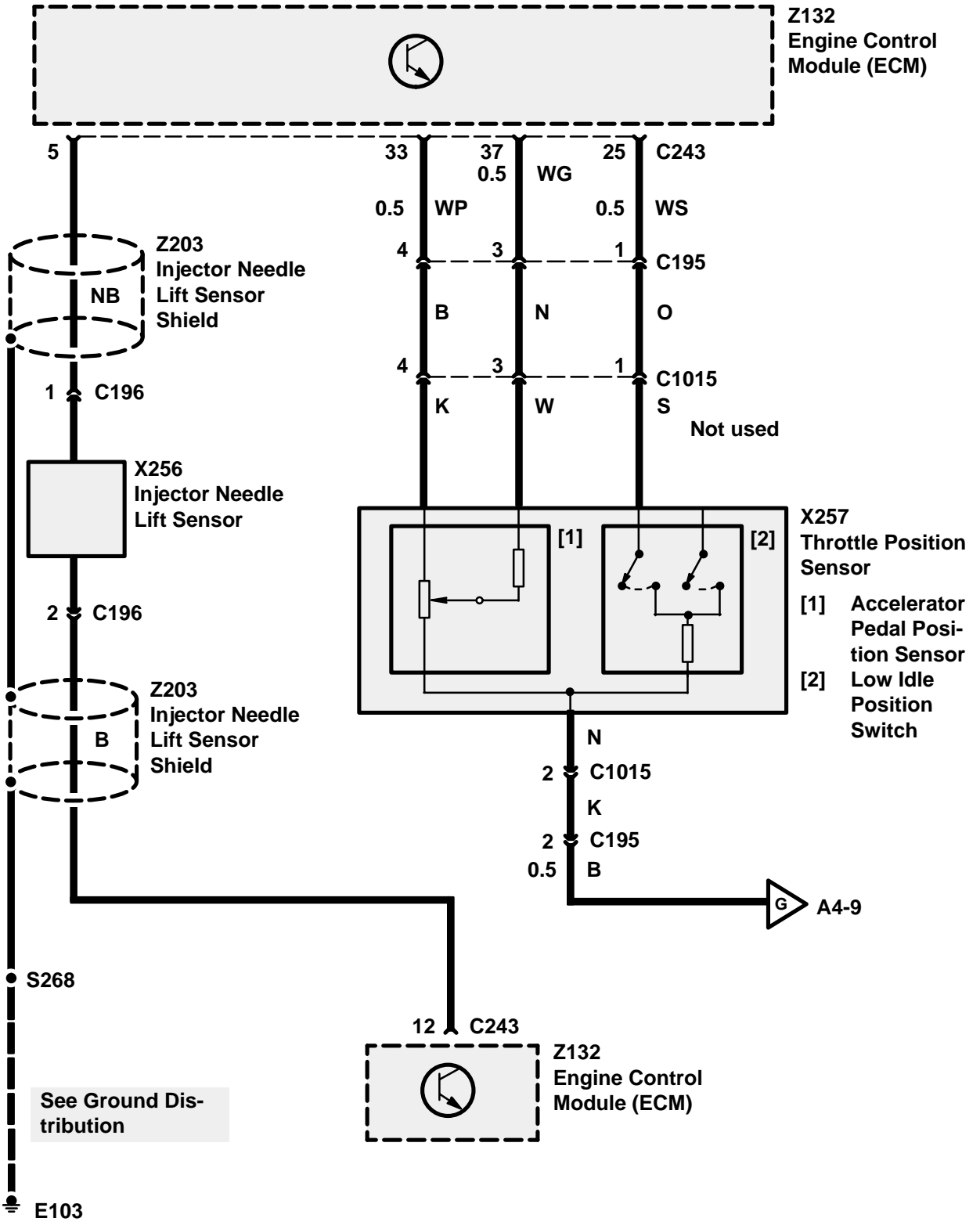
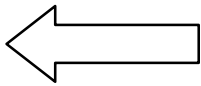

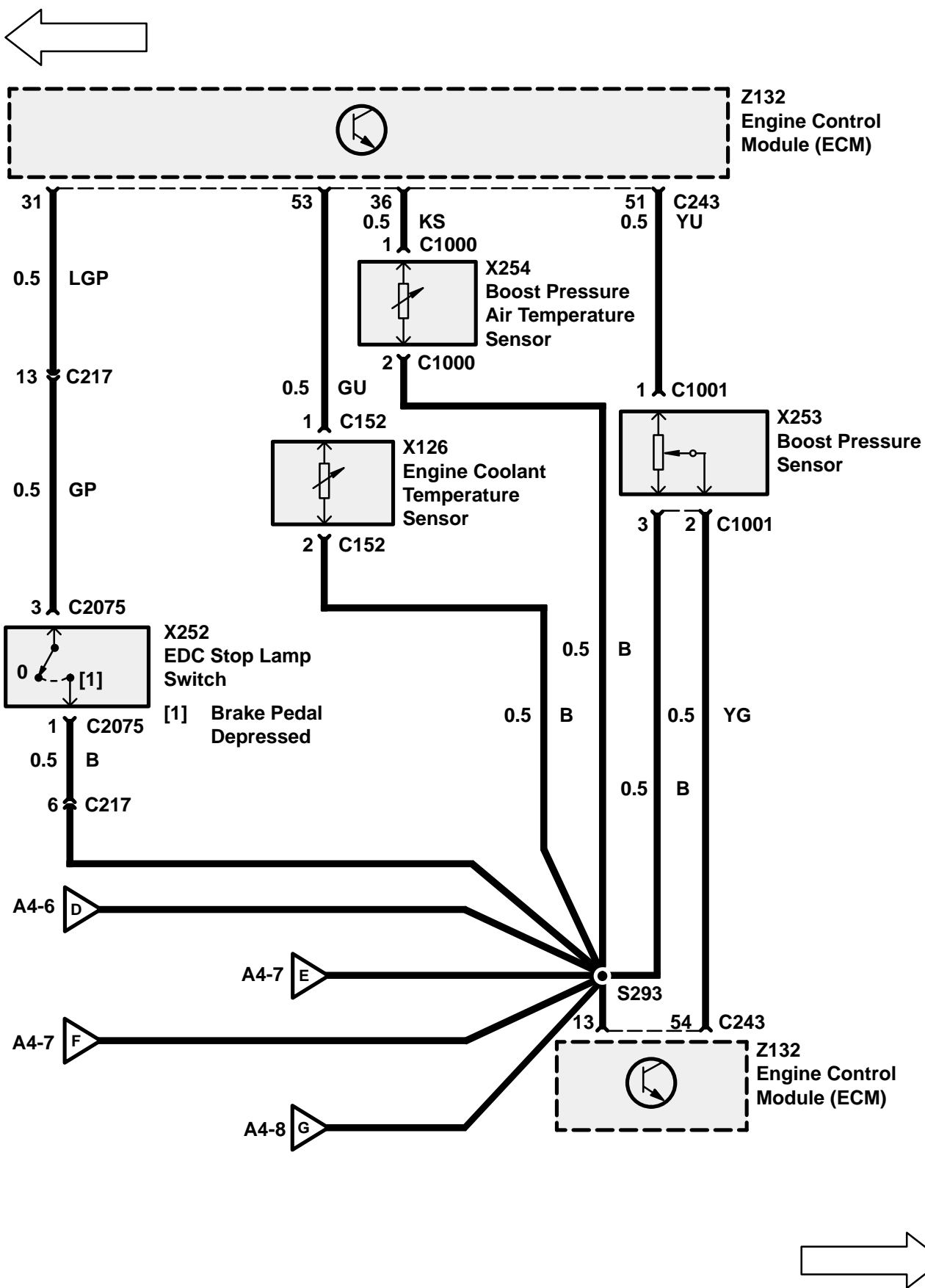

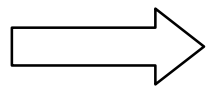
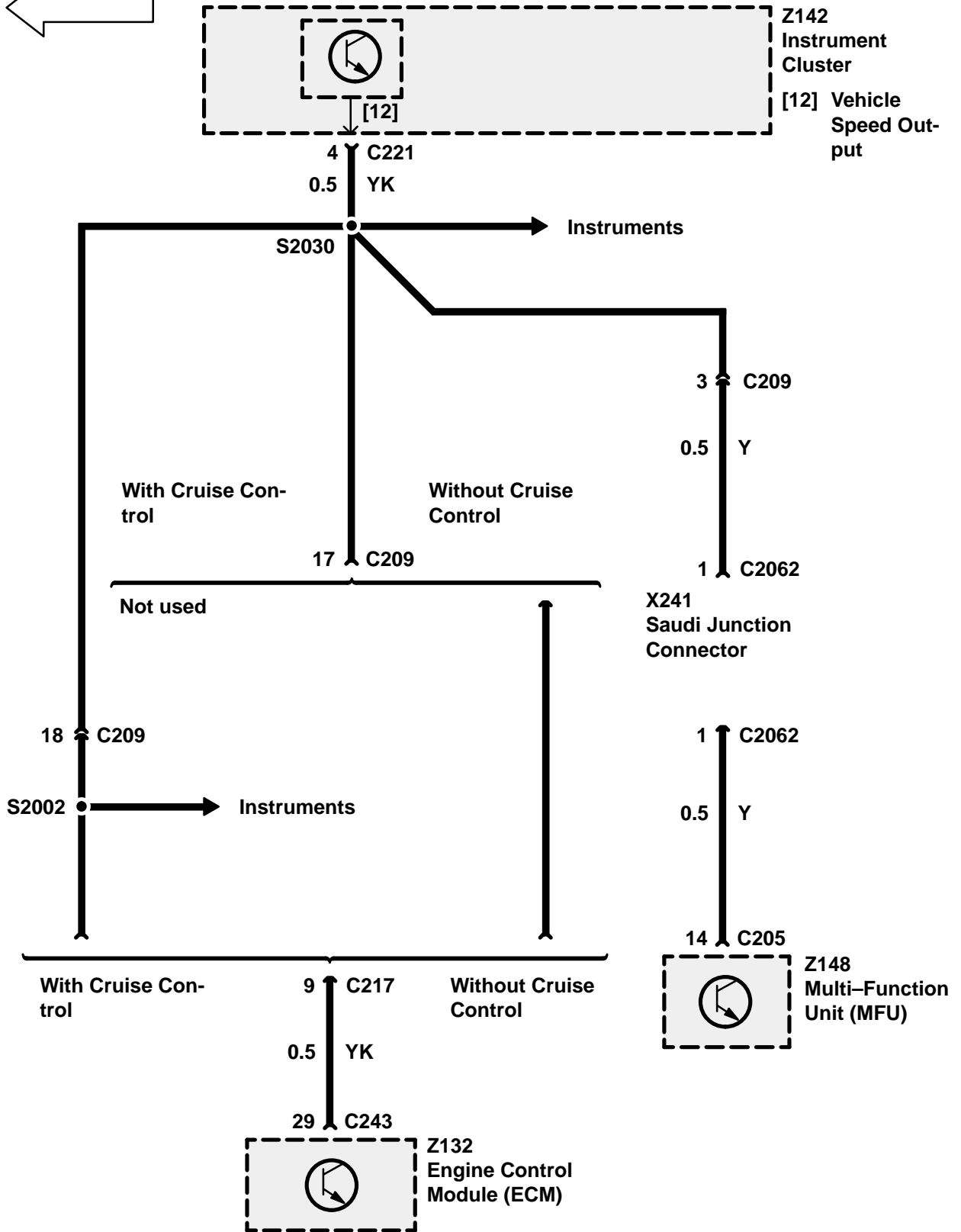
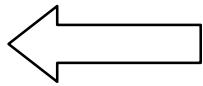

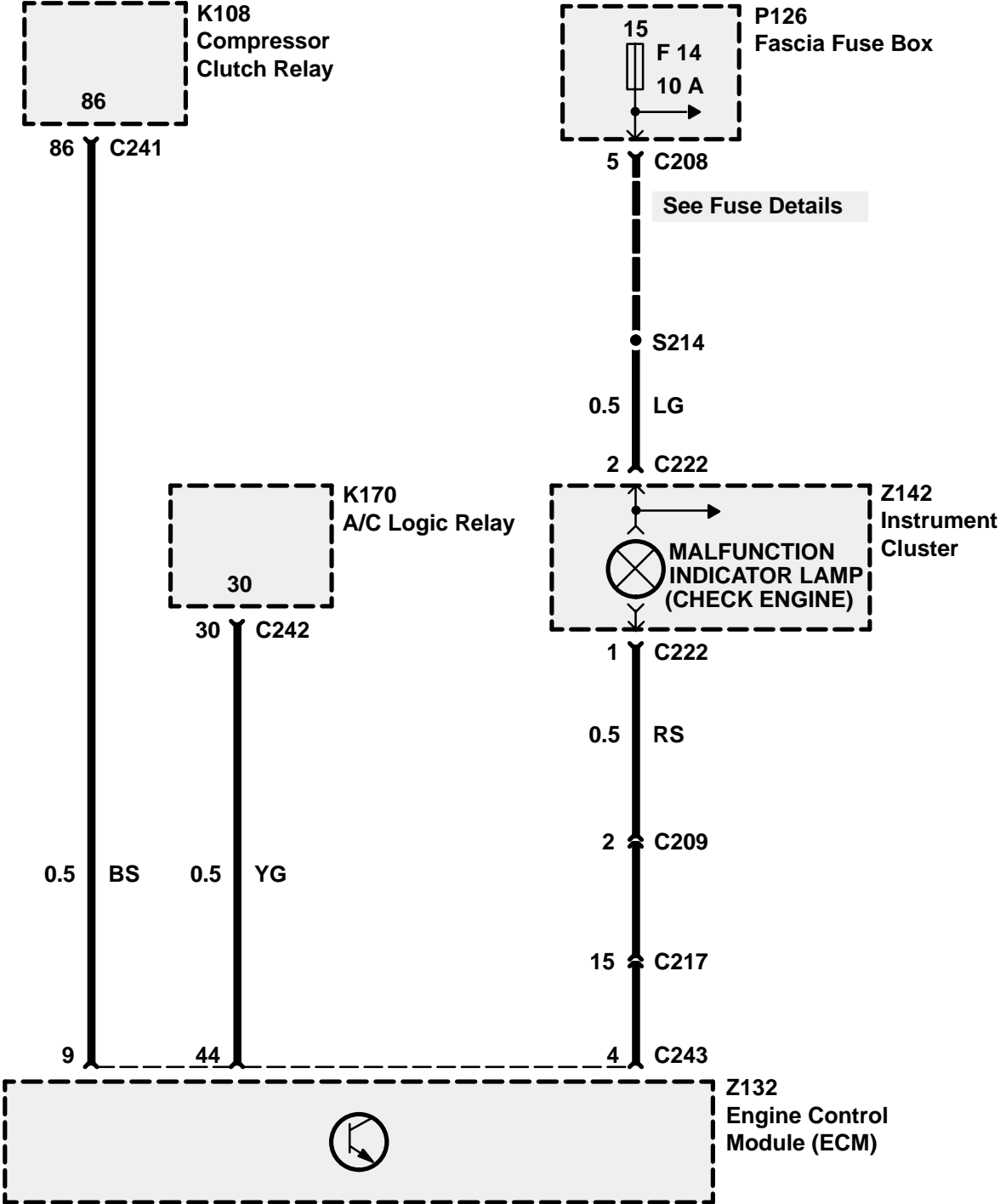
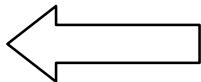

See Fuse Details

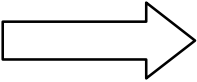

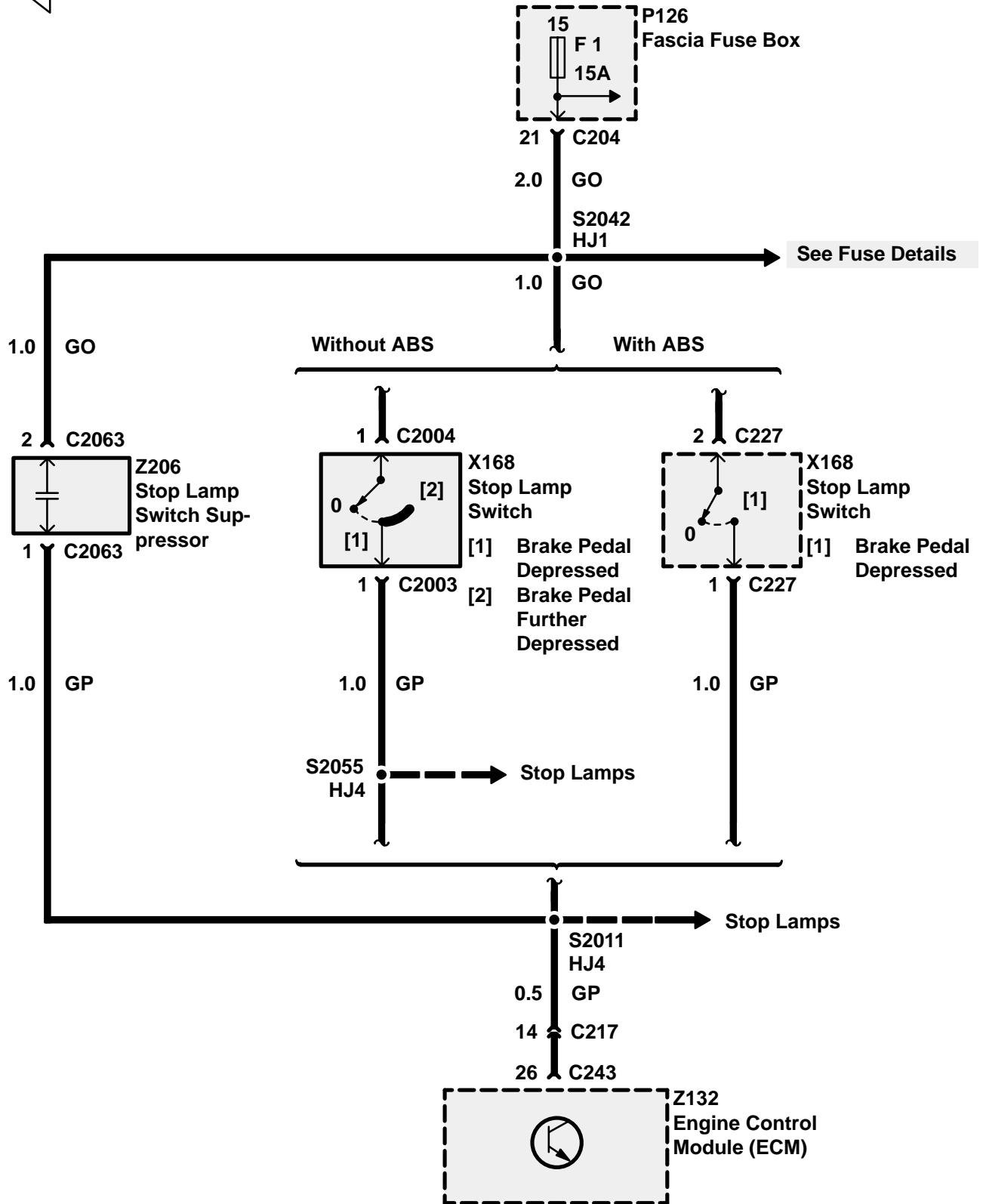
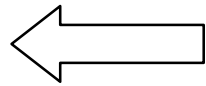

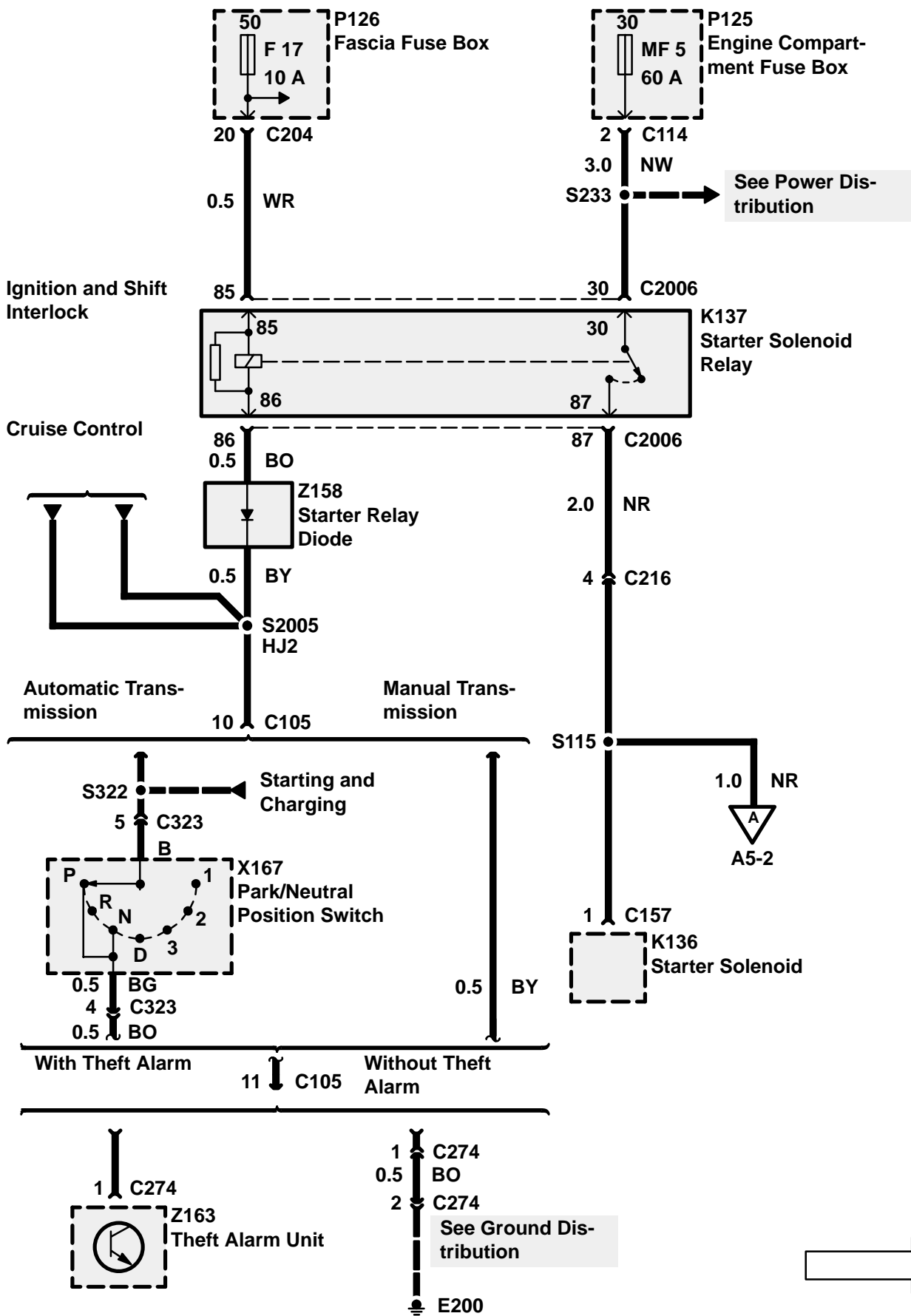

A5 ETM

DISCOVERY

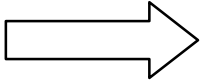
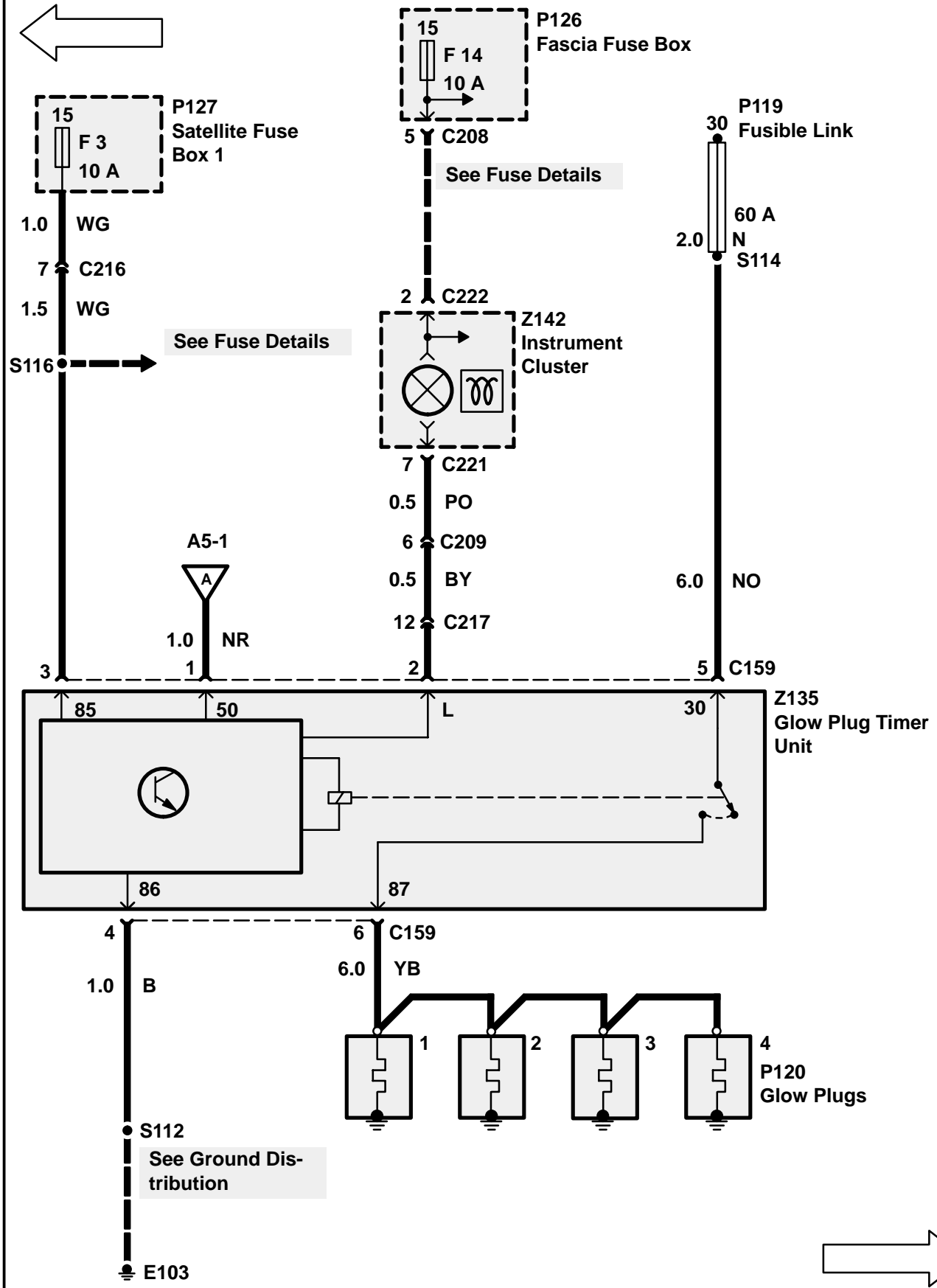

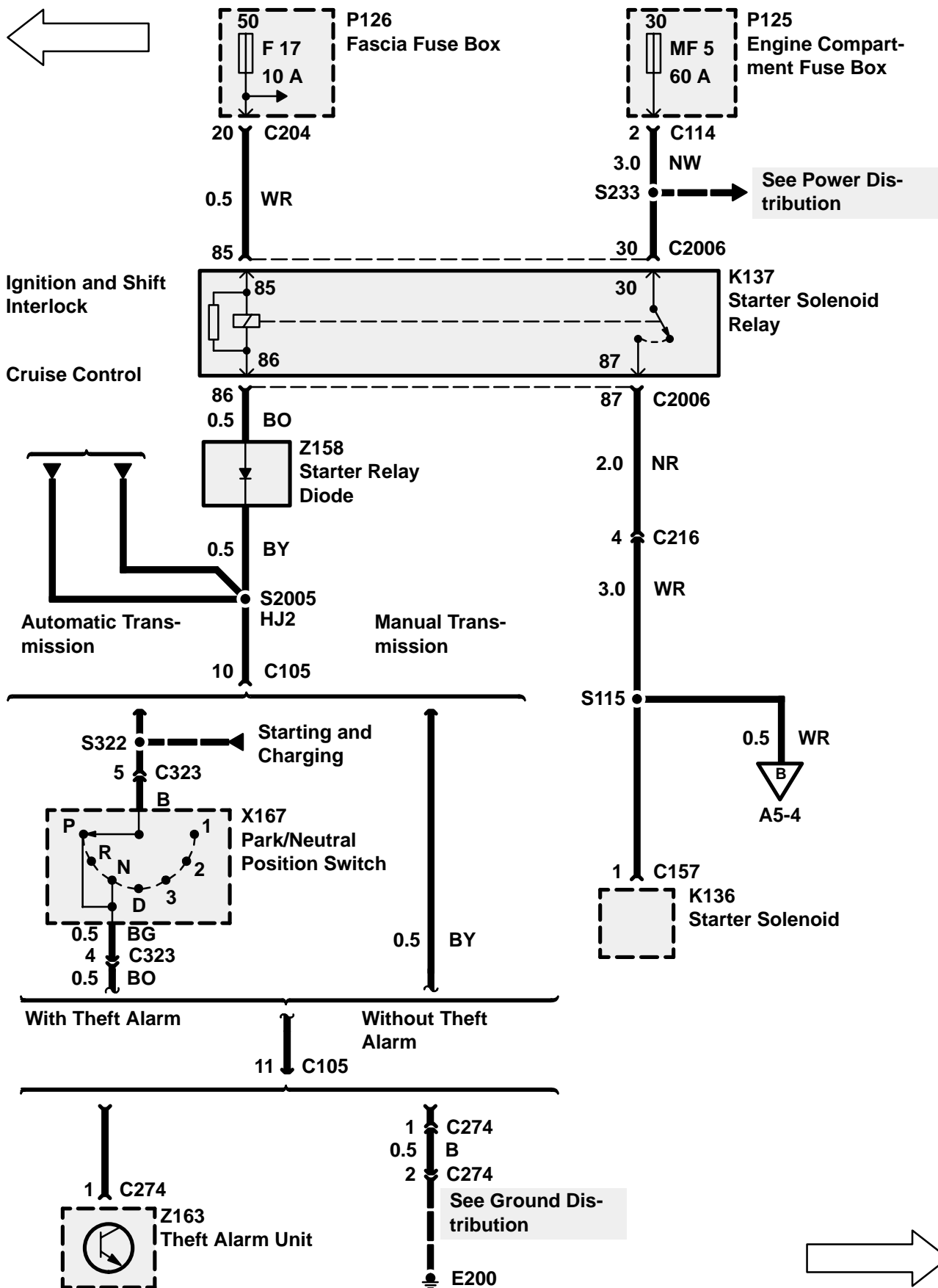

A5 ETM

DISCOVERY

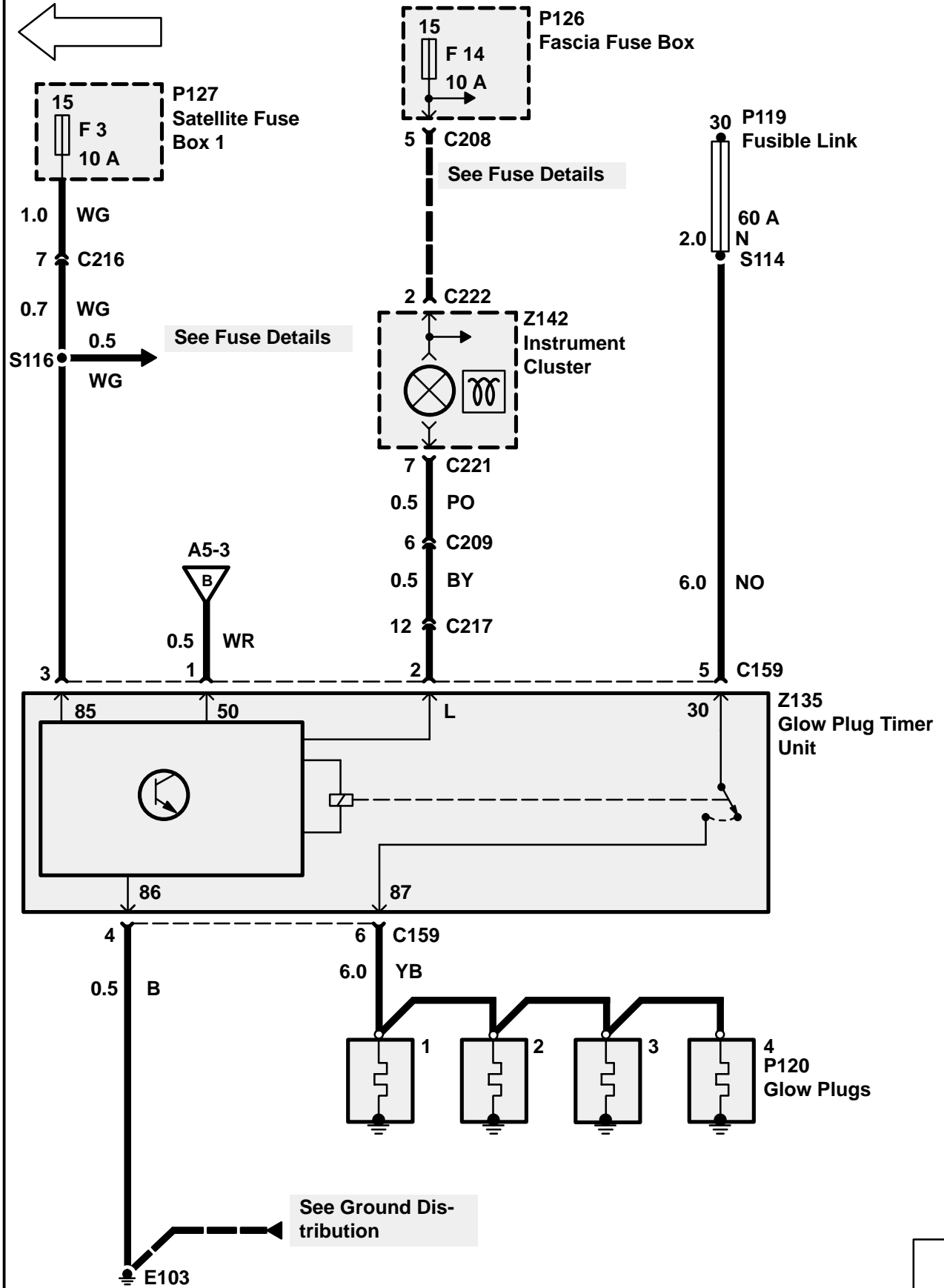

CIRCUIT OPERATION**Starting System**

Putting the Ignition Switch (X134) in position III applies battery voltage to the Starter Solenoid Relay (K137). The Starter Solenoid Relay (K137) energizes and applies battery voltage to the Starter Solenoid (K136) and Starter (M134).

On manual transmission vehicles equipped with a theft alarm, the Theft Alarm Unit (Z163) provides a ground circuit to the Starter Solenoid Relay's (K137) 86 terminal.

On automatic transmission vehicles equipped with a theft alarm, the Theft Alarm Unit (Z163) provides a ground circuit to the Starter Solenoid Relay's (K137) 86 terminal via the Park/Neutral Position Switch (X167).

If the theft alarm is activated, the Theft Alarm Unit (Z163) will interrupt the Starter Solenoid Relay's (K137) ground path and prevent starting the engine.

For vehicles not equipped with Theft Alarm, a black wire is used to short pins 1 and 2 of C274.

Charging System

When the Ignition Switch (X134) is in position II, battery voltage is applied to the charging system fault light. When the Generator (Z106) is being turned by the engine, its stator windings are excited by voltage applied to the Generator (Z106) via the charging system fault light. The Generator (Z106) begins to produce electricity in order to charge the vehicle Battery (P104). If the Generator (Z106) fails to produce power, the Generator (Z106) grounds the fault light control wire, causing the charging system fault light to glow.

The tachometer displays engine speed in rpm. Voltage pulses are taken from the Generator (Z106) and are generated when the engine drive belt turns the Generator pulley. The tachometer responds to the frequency of the voltage pulses, which increases proportionally to that of the engine speed.

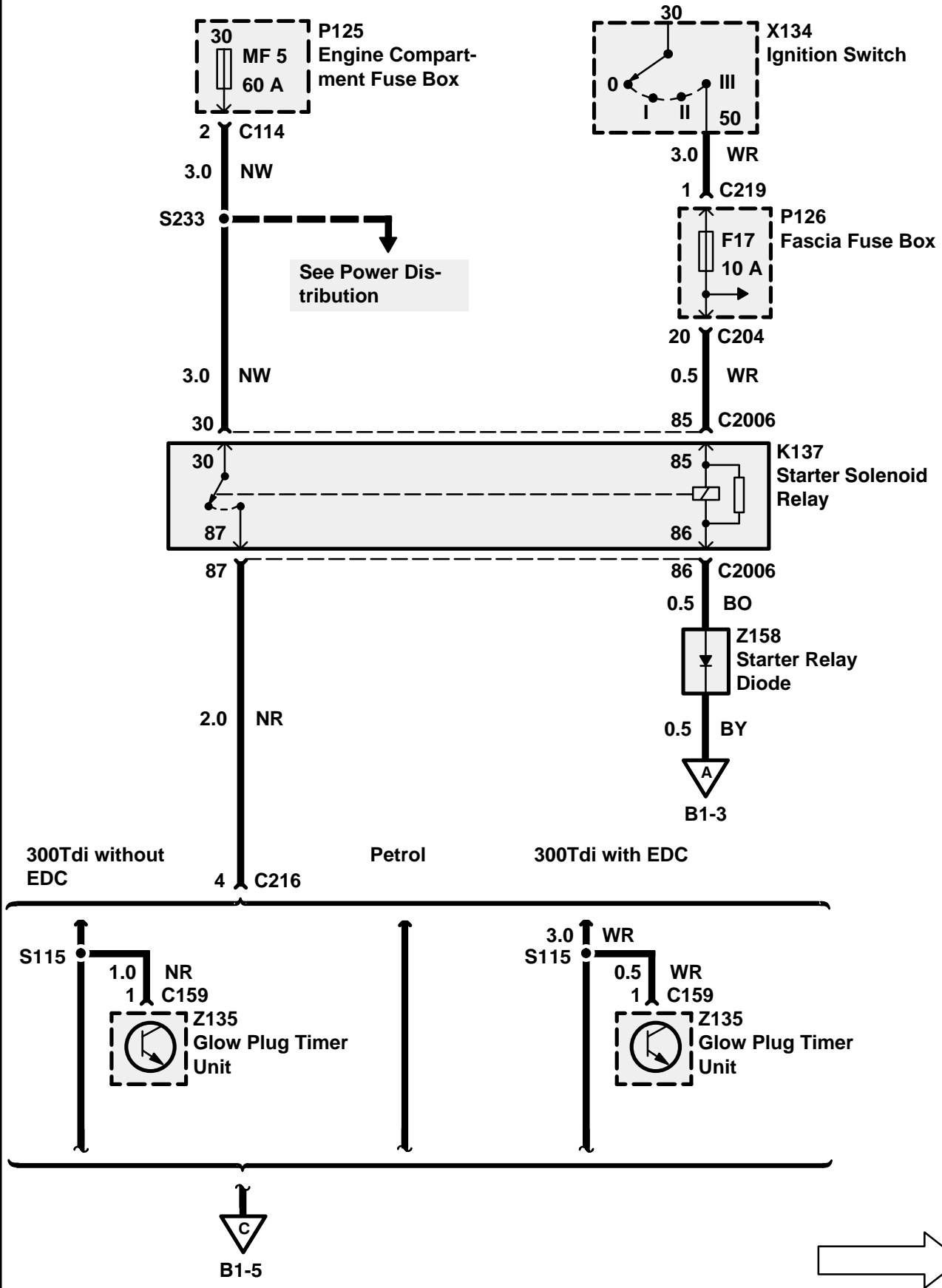

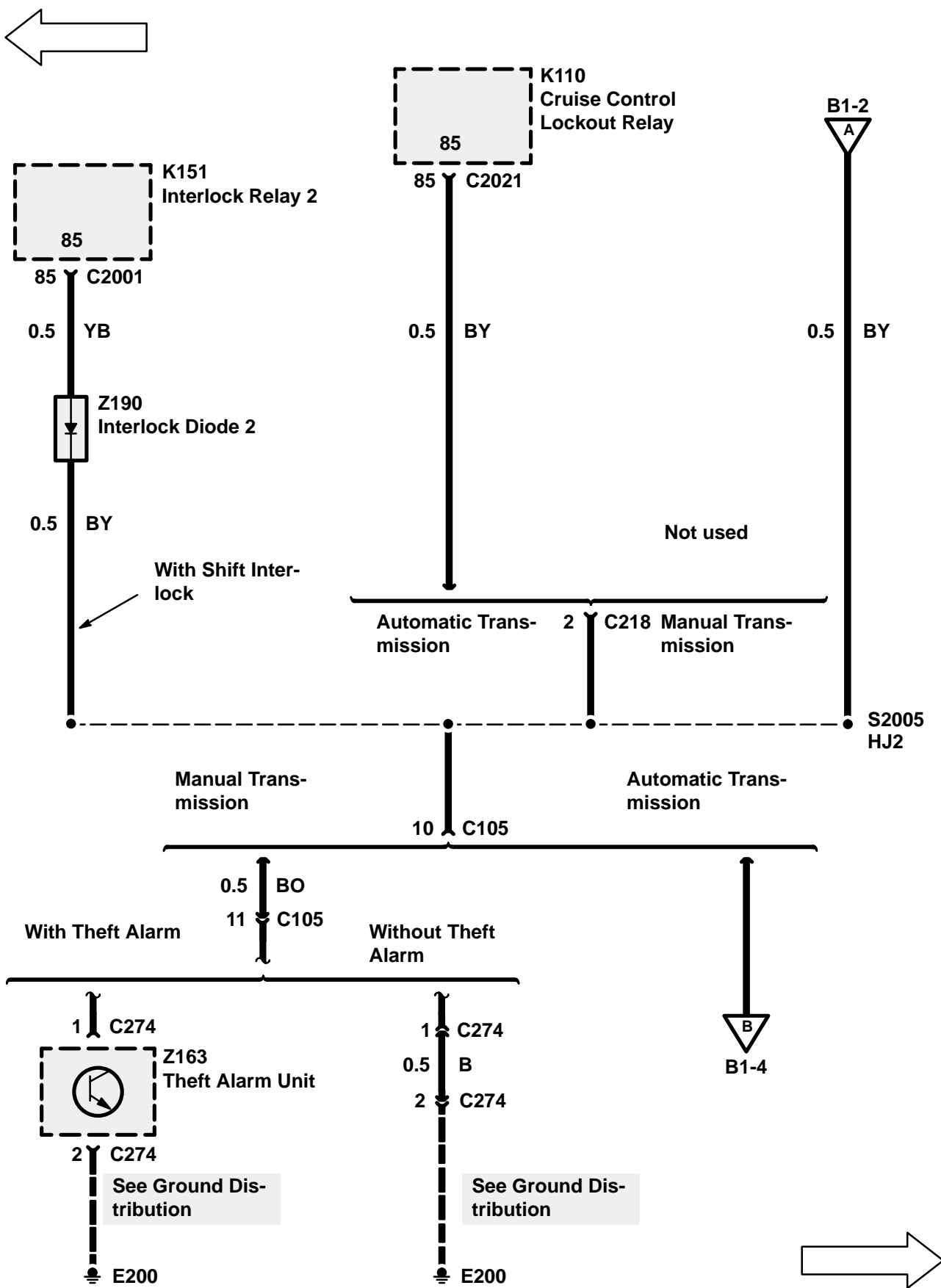

B1 ETM

DISCOVERY

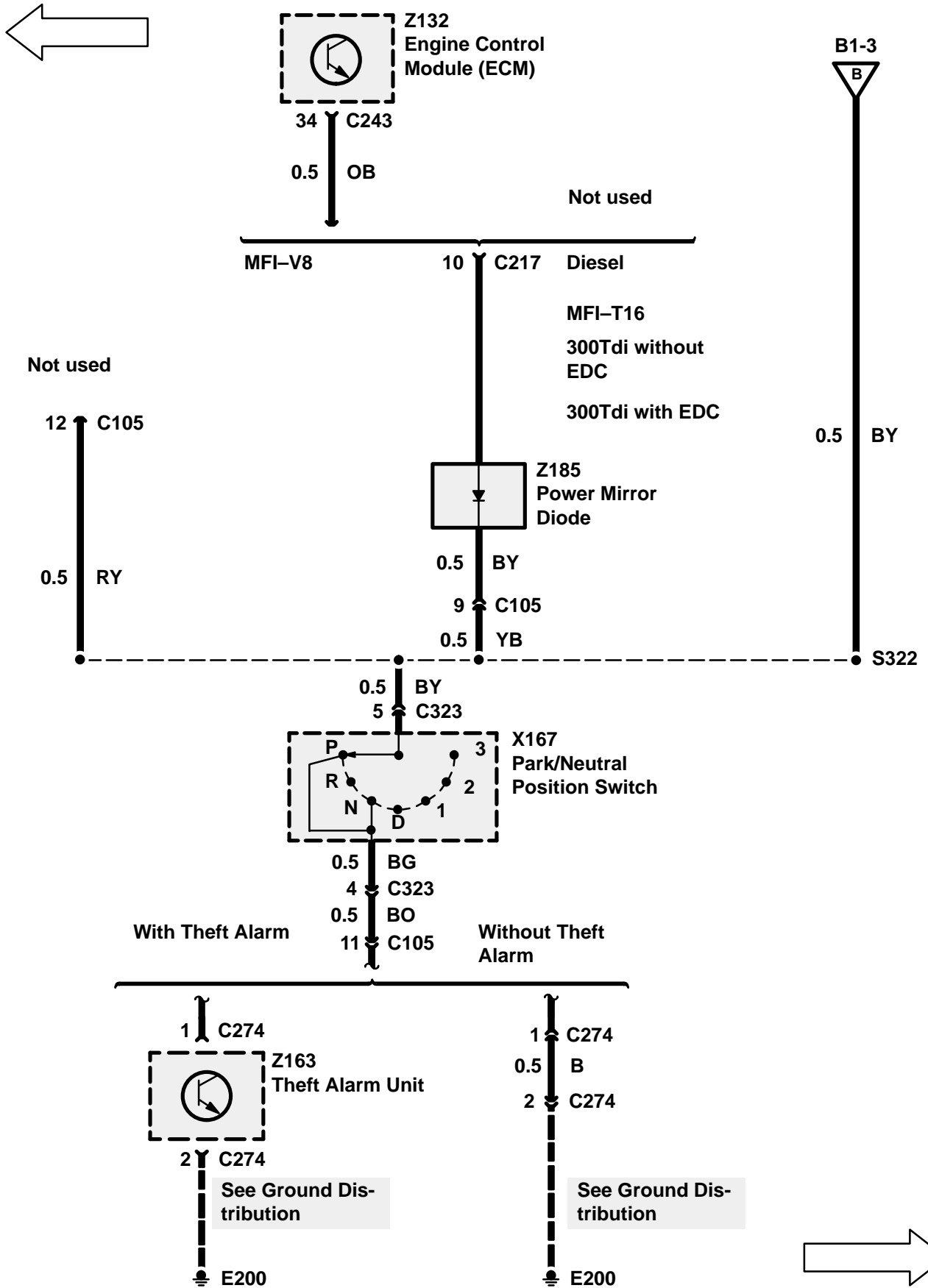

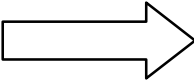
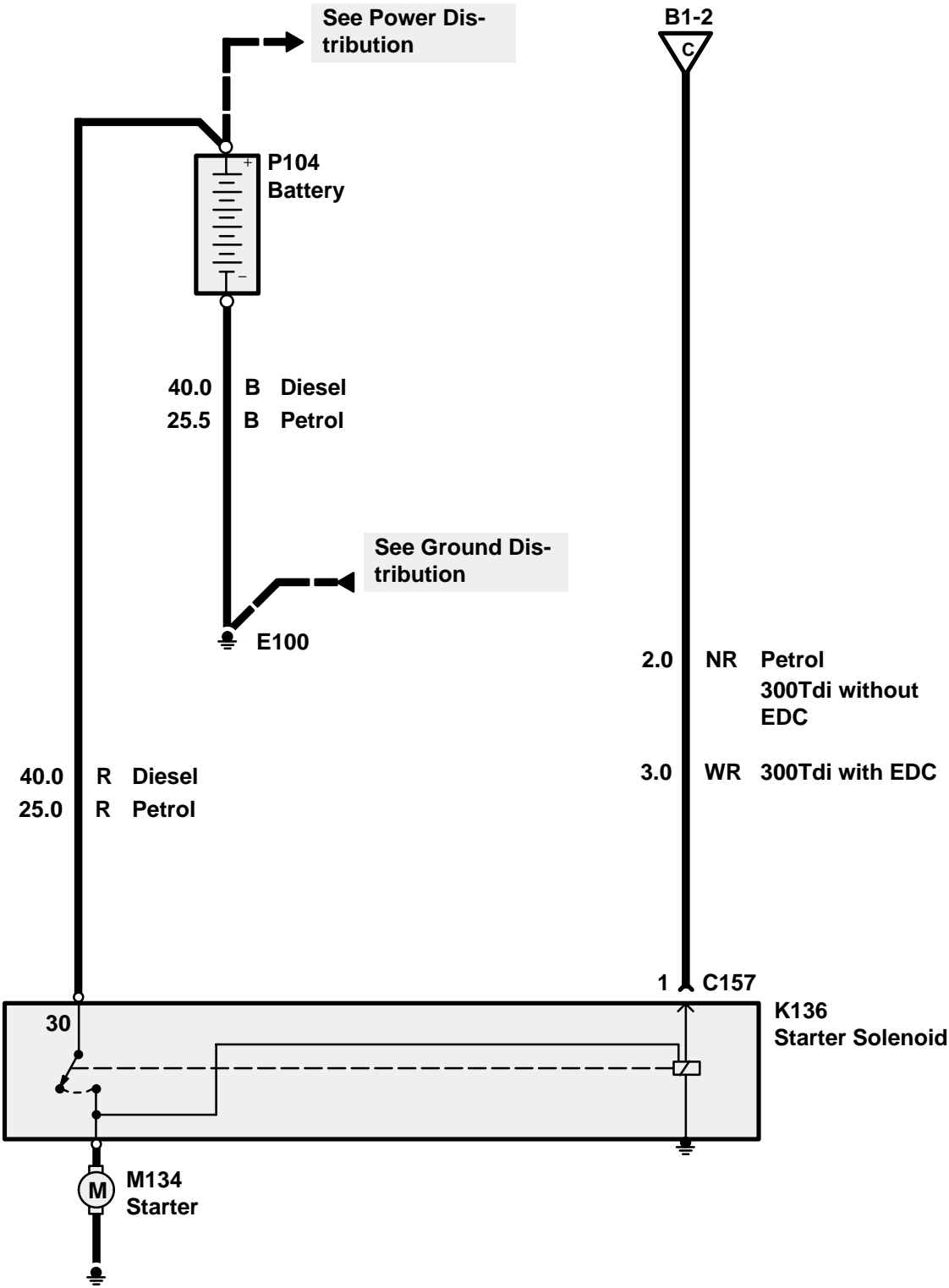
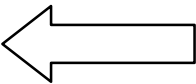

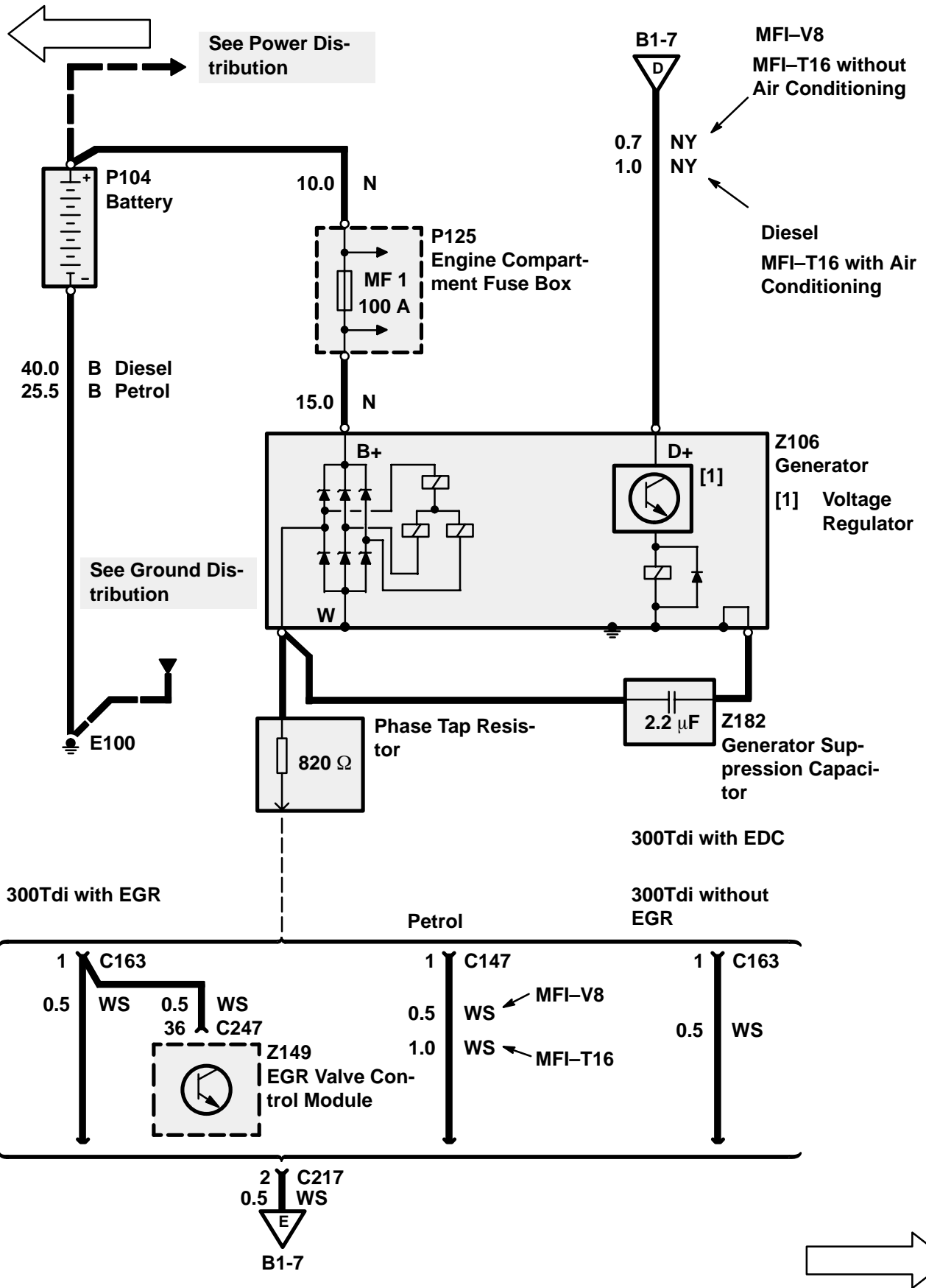

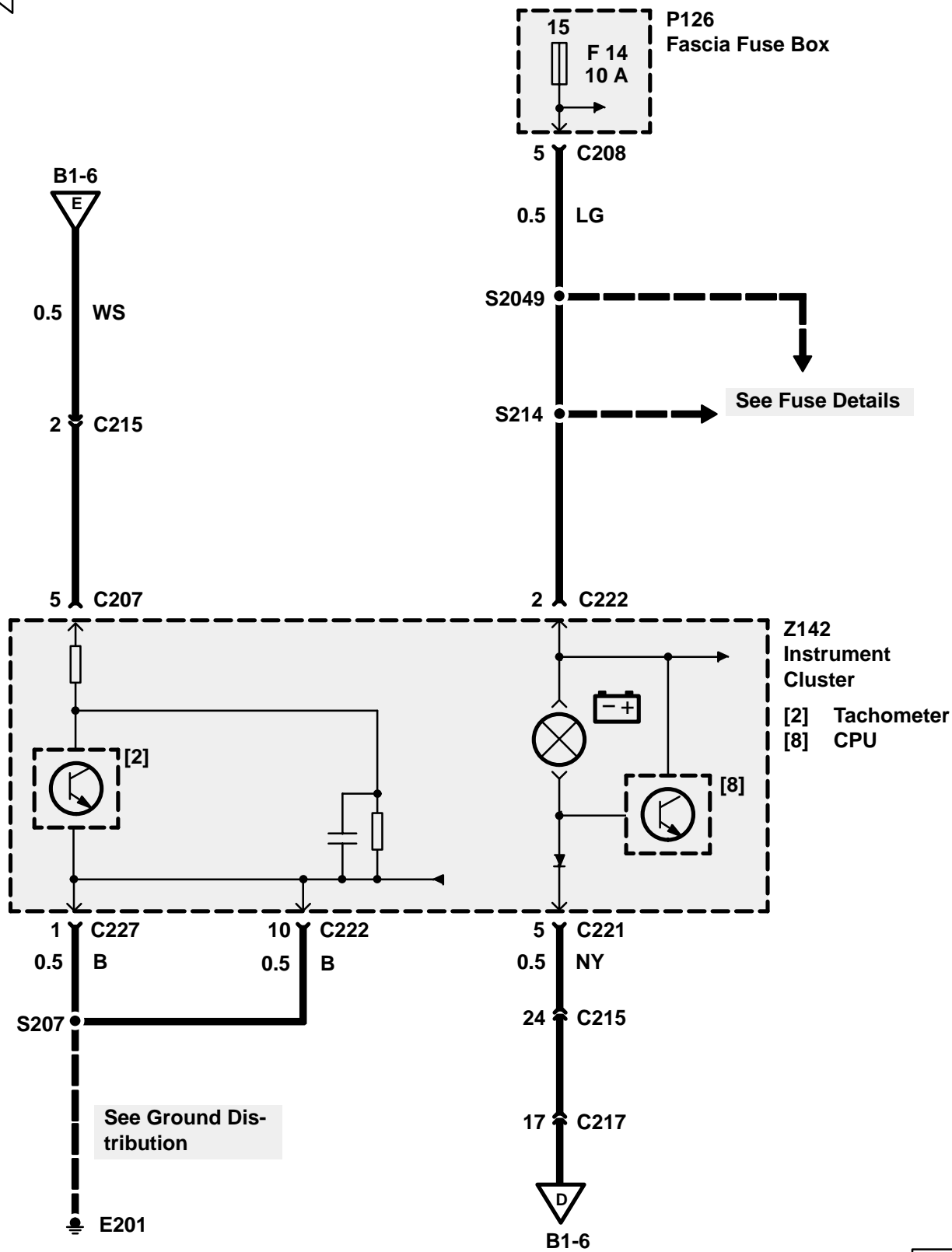
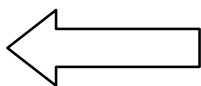

TROUBLESHOOTING HINTS

1. If the Starter Solenoid (K136) does not click, check the Park/Neutral Position Switch (X167) and the Theft Alarm Unit (Z163).

SYSTEM DIAGNOSIS

1. If the Starter Solenoid (K136) does not click and the engine does not crank, do Test A.
2. If the Starter Solenoid (K136) clicks but the engine does not crank or cranks slowly, do Test B.
3. If the charge warning light does not light with the engine off and the Ignition Switch (X134) in position II, do Test C.
4. If the charge warning light stays lit with the engine running, do Test D.

Test A

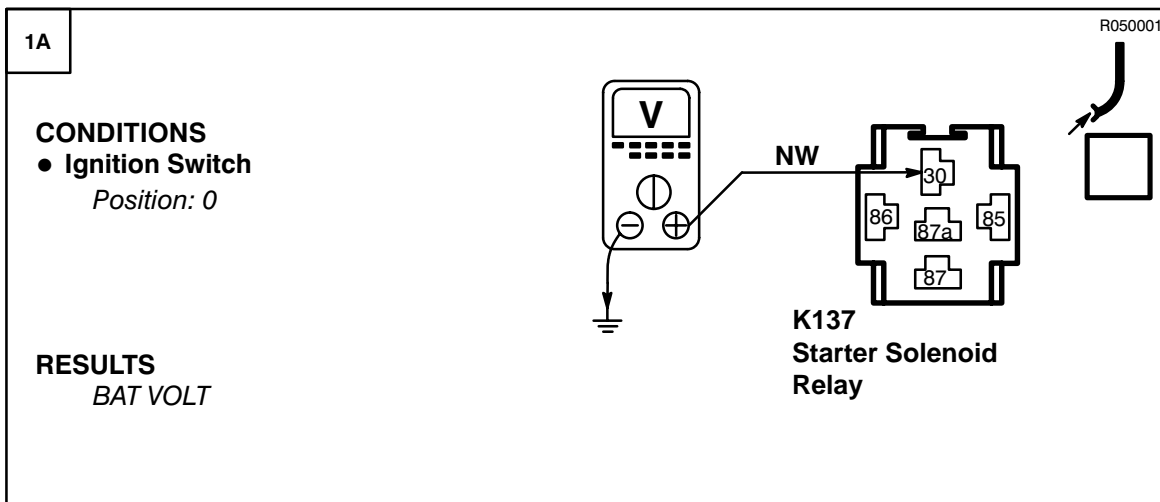

~~OK~~ **PROBLEM CAUSE**
- NW Wire

OK

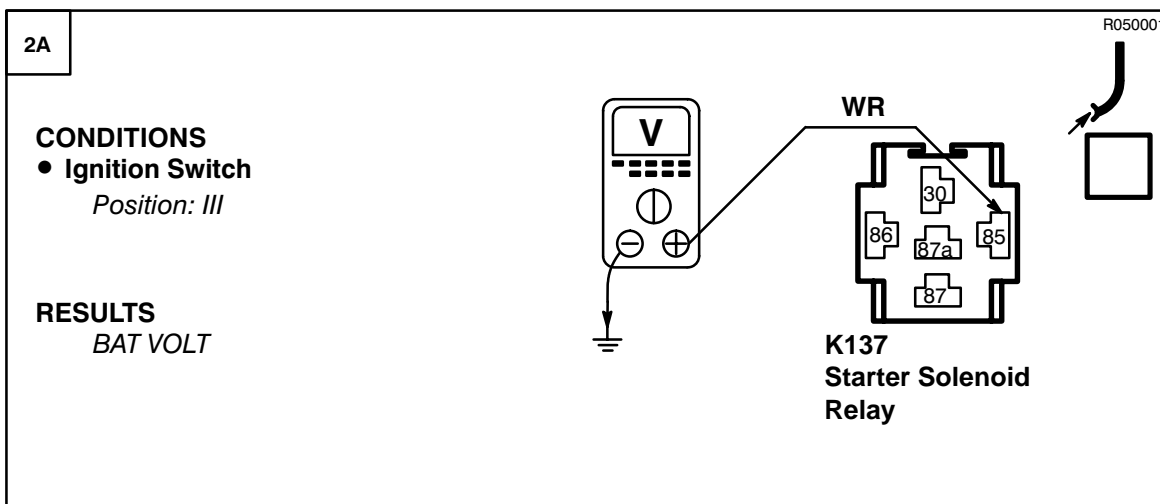
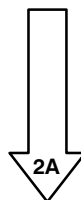

~~OK~~ **PROBLEM CAUSE**
- F17 Fuse
- WR Wire
- Ignition Switch

OK

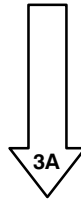

B1 ETM

DISCOVERY

R050001

2A
3A

CONDITIONS

- Ignition Switch
Position: 0

RESULTS
BAT VOLT

**K137
Starter Solenoid
Relay**



PROBLEM CAUSE

- B Wire
- Starter Solenoid

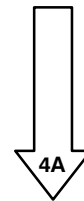

R050001

4A

CONDITIONS

- Ignition Switch
Position: 0
- Gear Selector
P/N

RESULTS
Starter (M134) cranks engine

**K137
Starter Solenoid
Relay**



PROBLEM CAUSE

- NR Wire
- Starter Solenoid
- Starter

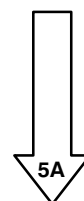

4A

5A

CONDITIONS

- Ignition Switch
Position: III
- Gear Selector
P/N

RESULTS
Starter (M134) cranks engine

R050001

**K137
Starter Solenoid
Relay**

- OK** PROBLEM CAUSE
- BY, BO Wire
 - Starter Relay Diode
 - Park/Neutral Position Switch
 - Theft Alarm Unit

- OK** PROBLEM CAUSE
- Starter Solenoid Relay

Test B

1B

CONDITIONS

- Ignition Switch
Position: III

RESULTS
Less than 0.5V

**M134
Starter**

- OK** PROBLEM CAUSE
- R Wire
 - Battery Terminal Connection
 - Starter Solenoid
 - Starter Solenoid (K136) terminal connection

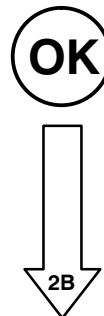

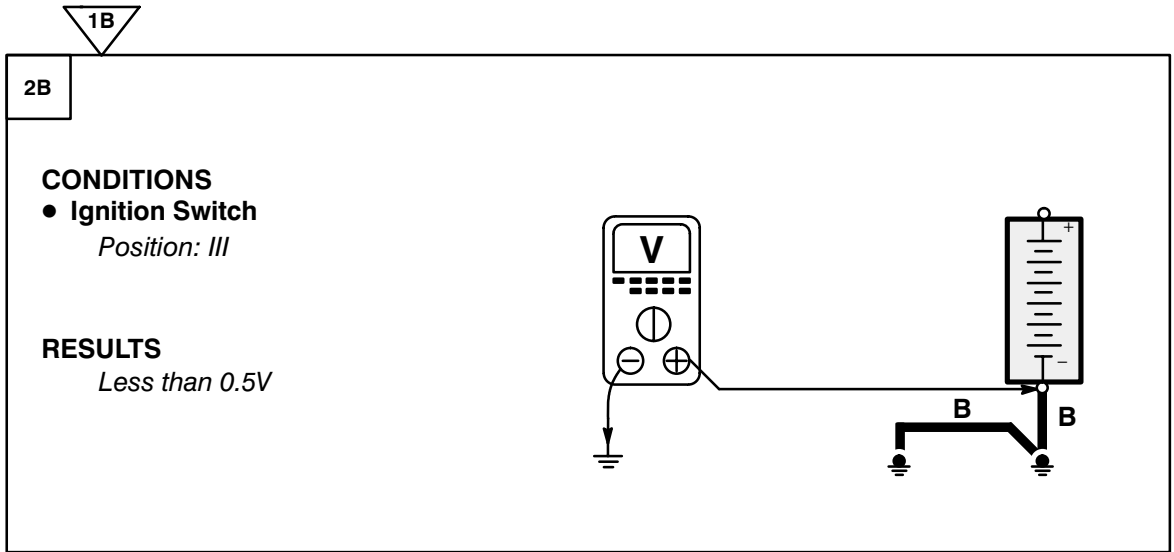

PROBLEM CAUSE

- B Wire
- Battery Terminal Connection
- Ground Connections



PROBLEM CAUSE

- Starter Solenoid
- Starter

Test C

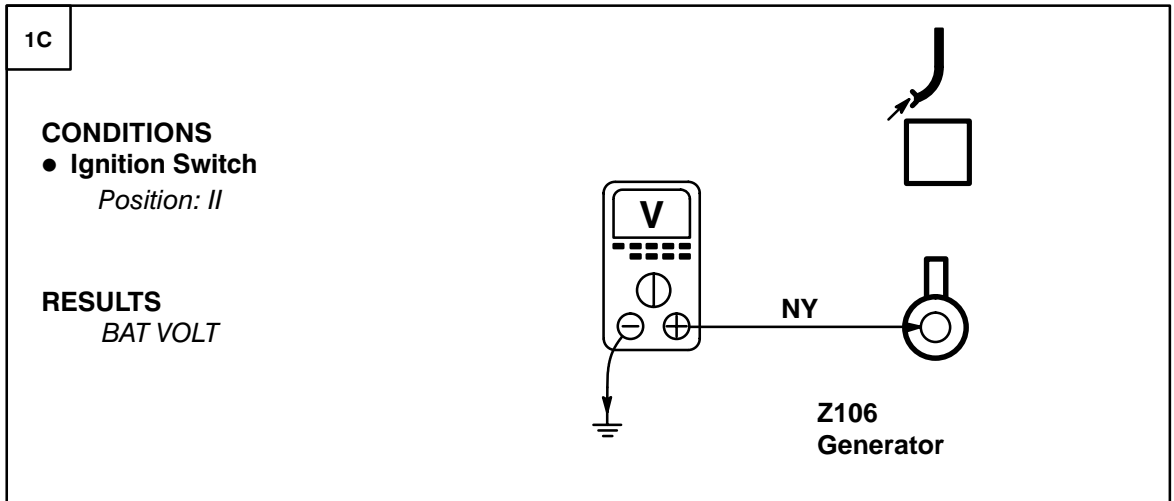

PROBLEM CAUSE

- NY Wire
- Bulb
- Instrument Cluster



PROBLEM CAUSE

- Generator

Test D

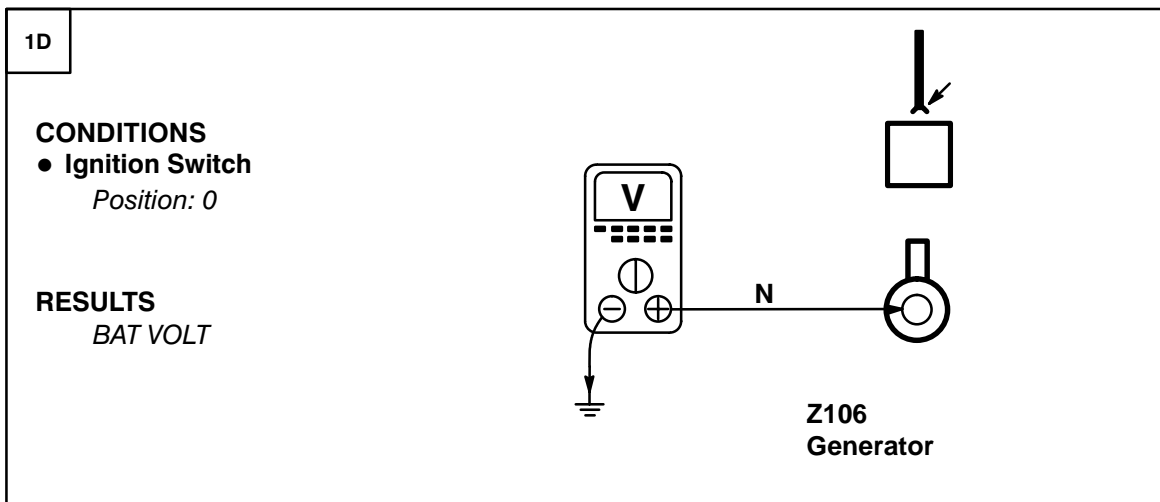

~~OK~~ PROBLEM CAUSE
- N Wire

OK

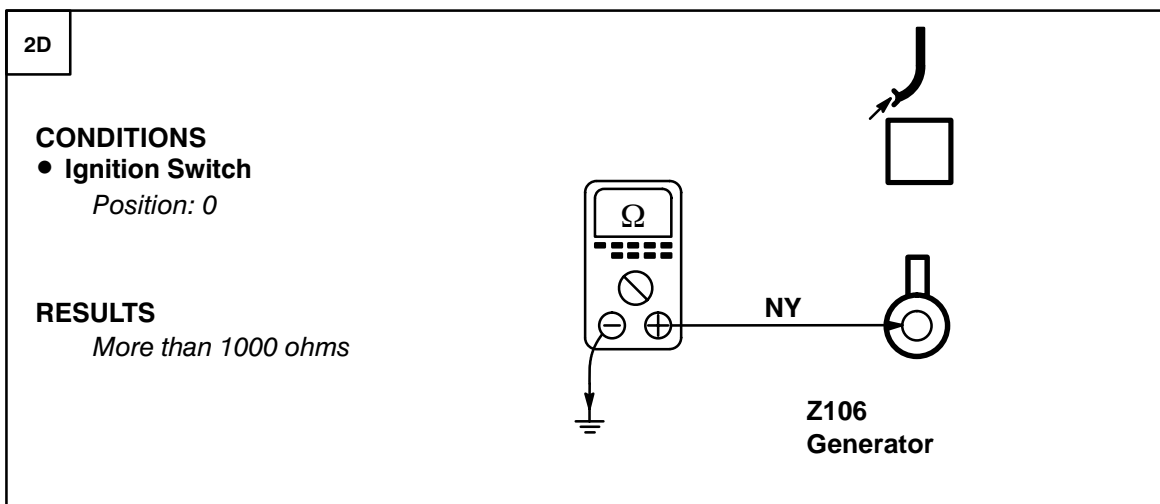
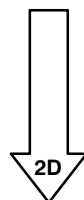

~~OK~~ PROBLEM CAUSE
- NY Wire
- Instrument Cluster

OK PROBLEM CAUSE
- Generator

CIRCUIT OPERATION

With the Cruise Control Switch (X115) on, voltage from Fuse F18 is applied to the Cruise Control ECU (Z121), Cruise Control Vacuum Pump (M103), Steering Wheel Cruise Switches (X266) through the WY wire, Rotary Coupler (Z104) and PB wire. The Cruise Control ECU (Z121) is grounded at terminal 8 through the B wire to E200.

Cruise Control Vacuum Pump (M103)

With the Cruise Control Switch (X115) on, voltage is applied to the Cruise Control Vacuum Pump (M103) through the WU wire. When a cruise speed is set, the Cruise Control ECU (Z121) applies ground through the BR wire to operate the pump motor and applies ground through the BY wire to close the normally open solenoid valve in the pump. The pump applies vacuum to the actuator.

SET/ACCEL

To set a cruise speed, the Cruise Control Switch (X115) must be on and vehicle speed must exceed 28 mph (45 km/h). When the SET/ACCEL Switch is depressed under these conditions, voltage from Fuse F18 is applied to terminal 3 of the Cruise Control ECU (Z121) through the closed Cruise Control Switch (X115) and Steering Wheel Cruise Switches (X266), causing the vacuum pump to operate. When the SET/ACCEL Switch is released, voltage is removed from terminal 3, signalling the ECU to set the speed.

RES/DECEL

When the RES/DECEL Switch is depressed, voltage is applied to terminal 4 of the Cruise Control ECU (Z121). This voltage signals the ECU to disengage the system and the vehicle slows down. When the switch is depressed a second time, voltage is again applied to the ECU and the vehicle returns to the previously set speed.

Speed Input

Terminal 11 of the Cruise Control ECU (Z121) monitors the Vehicle Speed output signal from the Instrument Cluster (Z142) through the YK wire. This signal is a pulsing voltage and its frequency changes with vehicle speed.

System Disable

The Cruise Control System can be disabled in one of four ways:

1. The Cruise Control Switch (X115) is put in the 0 position, removing power from the Cruise Control ECU (Z121) and vacuum pump, and erasing the set speed memory.
2. The RES/DECEL Switch is depressed, signalling the Cruise Control ECU (Z121) to disengage the system.
3. The brake pedal is depressed and a vacuum valve in the Brake Switch Vent Valve opens (X112). This vents vacuum to the actuator valve and releases the throttle.

4. The Voltage applied to Cruise Control ECU (Z121) terminal 9 is interrupted, causing the Cruise Control ECU (Z121) to turn off the vacuum pump and de-energize the vacuum solenoid valve. This voltage path is interrupted when the brake pedal is depressed, the Clutch Pedal is depressed, or the vehicle is in Park or Neutral. With the brake pedal depressed, the Brake Switch Vent Valve (X112) moves to 1 and the circuit is interrupted. With the vehicle in Park or Neutral the Park/Neutral Position Switch (X167) energizes the Cruise Control Lockout Relay (K110) by grounding the relay's coil. The relay then opens its contacts, interrupting the circuit. With the clutch pedal depressed, the Clutch Switch (X200) moves to 1 and the circuit is interrupted.

Road Test

CAUTION: DO NOT ENGAGE CRUISE CONTROL WHEN VEHICLE IS BEING USED IN LOW TRANSFER GEARS

WARNING: The use of cruise control is not recommended on winding, snow covered or slippery roads, or in heavy traffic conditions where a constant speed cannot be maintained.

1. Start the engine and depress the Cruise Control Switch (X115) to activate the Cruise Control System. Accelerate to approximately 30 mph (50 km/h) and press the SET/ACCEL Switch. Immediately release the switch and remove foot from the accelerator pedal. The vehicle should maintain the speed at which the SET/ACCEL Switch was pressed.
2. Press the SET/ACCEL Switch and hold at that position. The vehicle should accelerate smoothly until the switch is released. The vehicle should now maintain the new speed at which the SET/ACCEL Switch was released.
3. Press the RES/DECEL Switch while the vehicle is in the cruise control mode. The cruise control should disengage. Slow to approximately 35 mph (55 km/h) and press the RES/DECEL Switch. Immediately release the switch and remove foot from the accelerator. The vehicle should smoothly accelerate to the previously set speed. Increase speed using the accelerator pedal. Releasing the pedal should return the vehicle to the previously set speed.
4. Depressing the brake pedal should immediately disengage the Cruise Control System and return the vehicle to driver's control at accelerator pedal. Press the RES/DECEL Switch and the vehicle should accelerate to the previously set speed without operation of the accelerator pedal.
5. Press the RES/DECEL Switch and allow the vehicle to decelerate to below 26 mph (42 km/h). Press the RES/DECEL Switch and the Cruise Control System should remain disengaged.
6. Press the SET/ACCEL Switch below 28 mph (45 km/h) and the Cruise Control System should remain disengaged. Accelerate the vehicle above 28 mph (45 km/h), press the RES/DECEL Switch and remove foot from the accelerator pedal. The vehicle should smoothly adjust to the previously memorized speed.
7. Pressing the Cruise Control Switch (X115) should immediately disengage the Cruise Control System and erase the previously set speed from ECU memory.

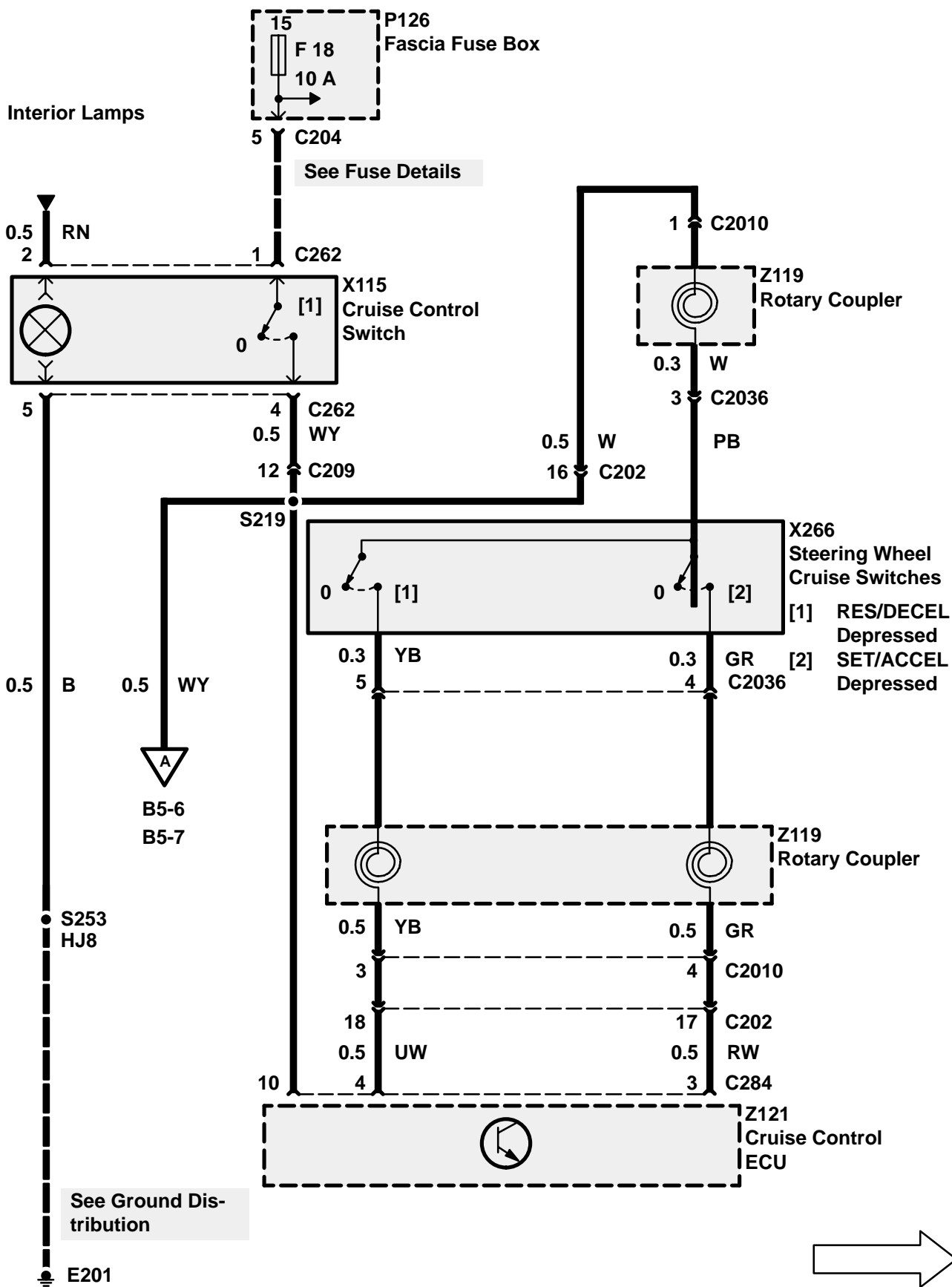

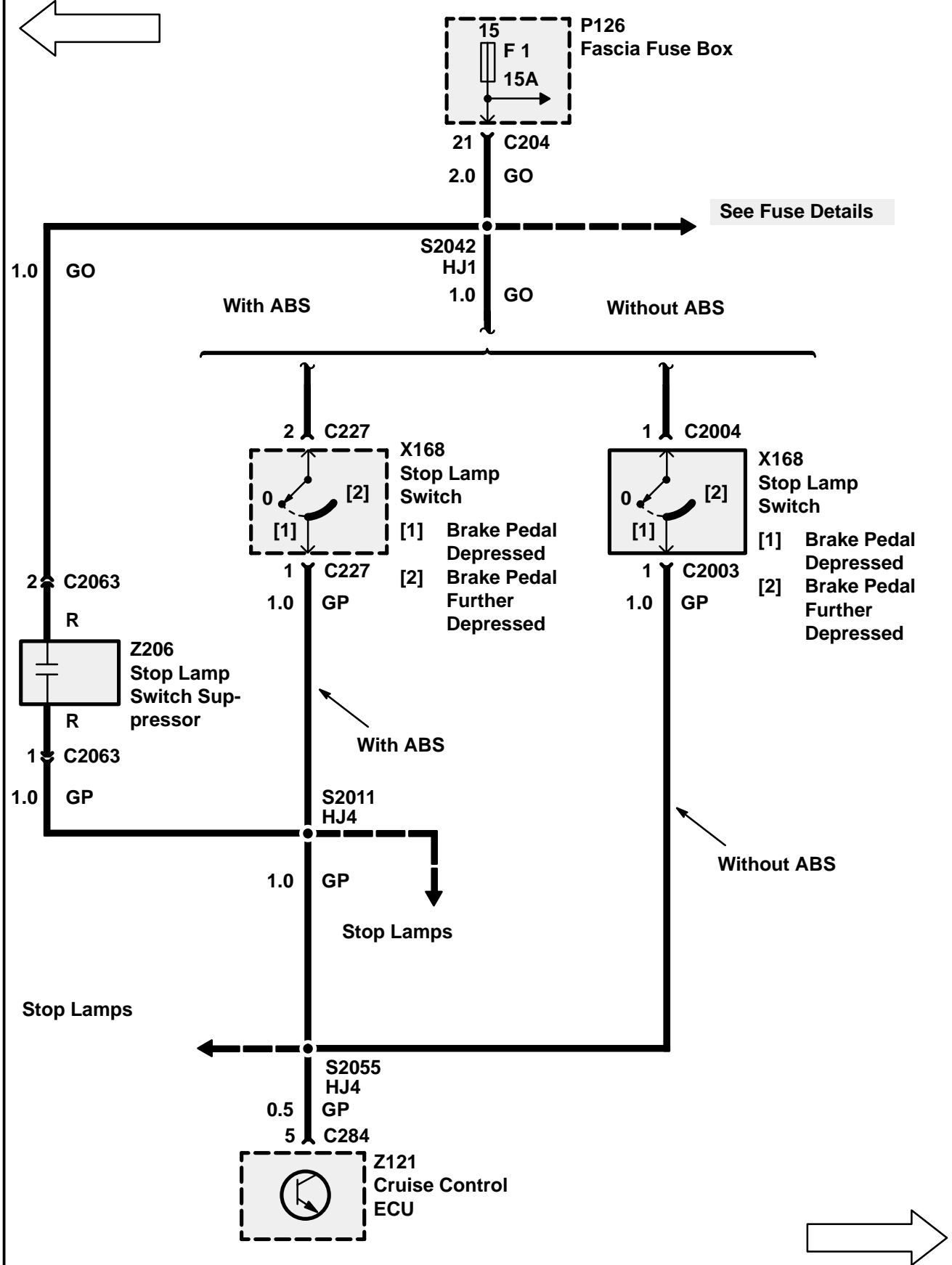

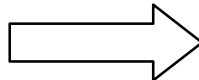
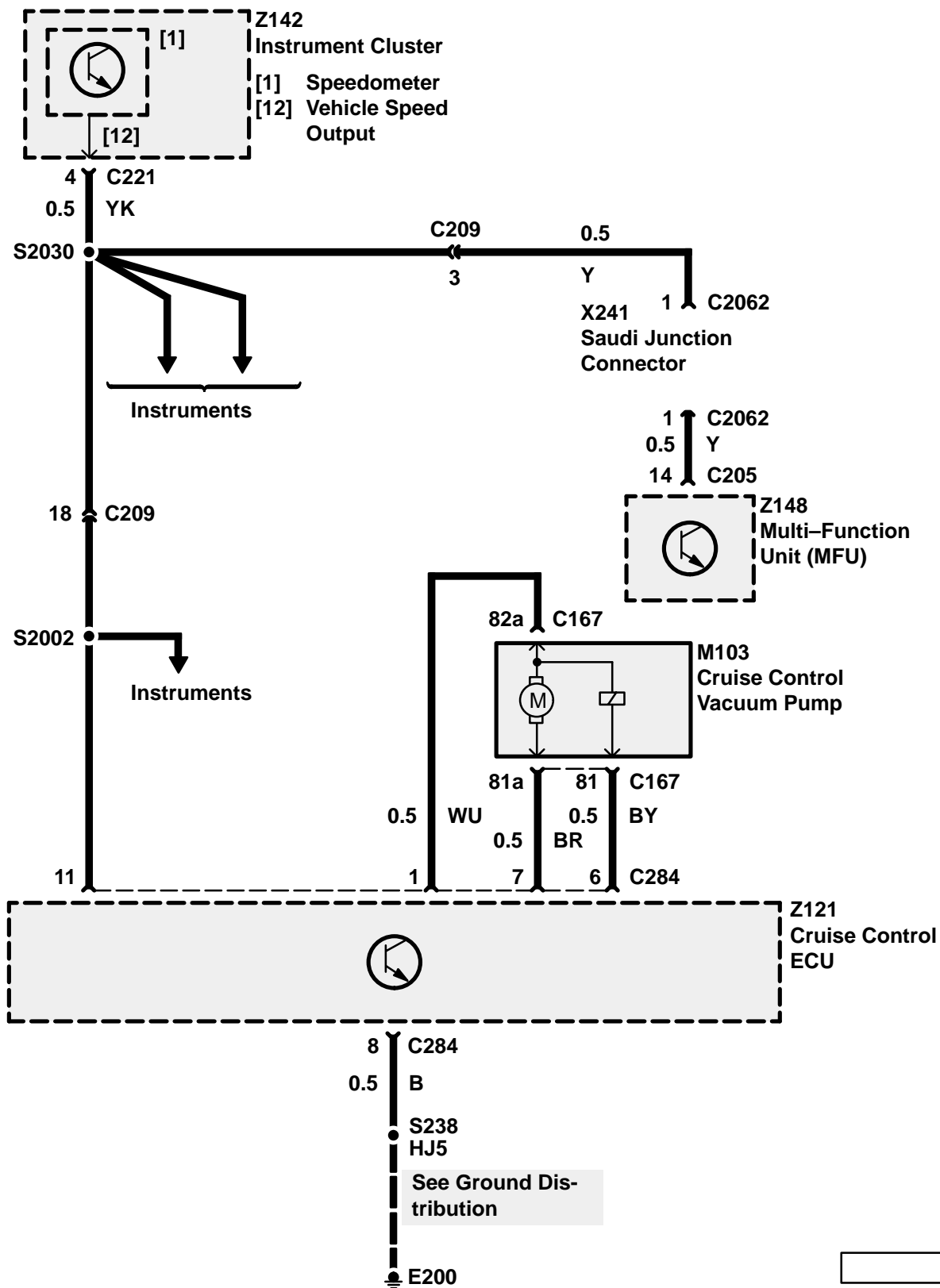
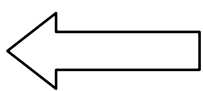

B5 ETM

DISCOVERY

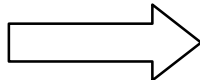
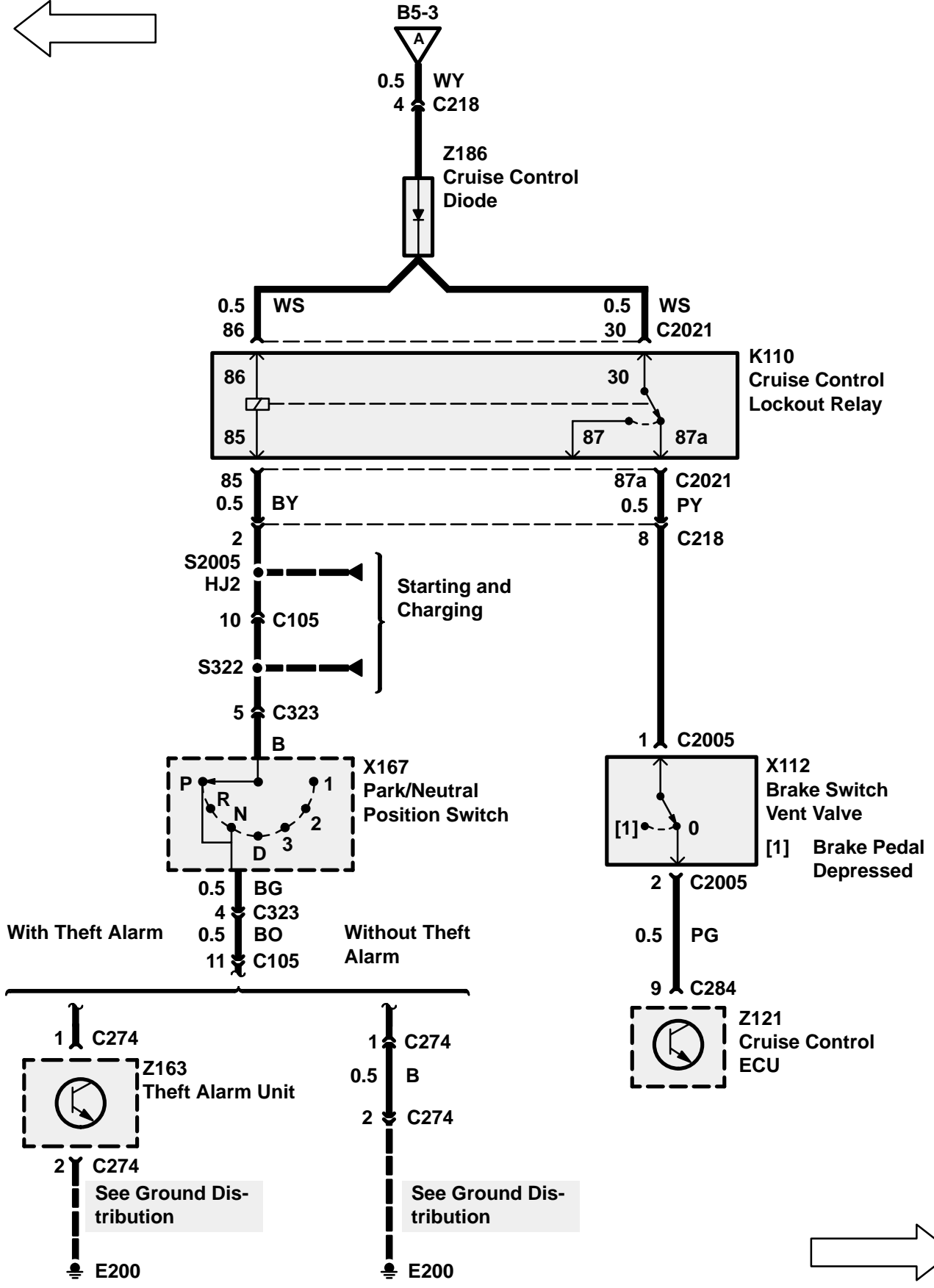
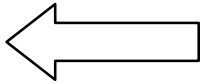

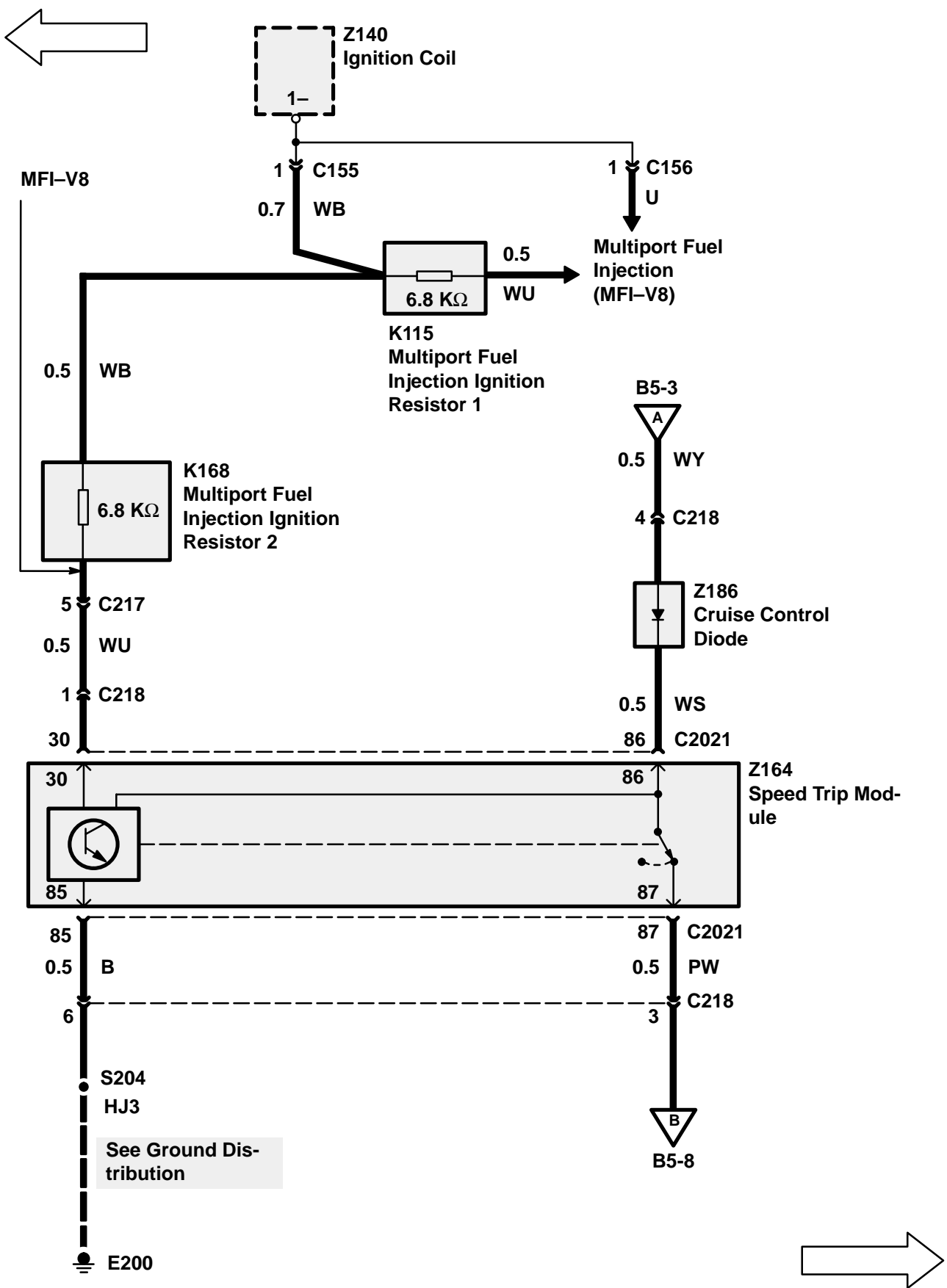

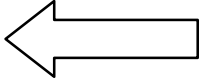

DISCOVERY

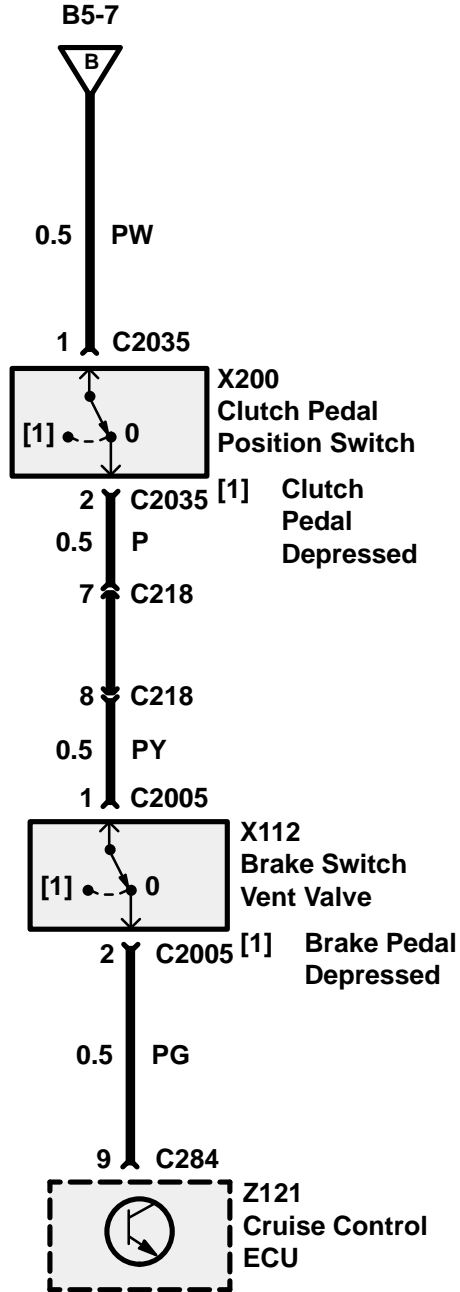

TROUBLESHOOTING HINTS

5. If the cruise control system operates but the cruise control switch light does not illuminate, check the bulb, B wire and RN wire.
6. Inspect vacuum hoses for kinks and restrictions.
7. Inspect actuator linkage for restrictions and adjustment.

SYSTEM DIAGNOSIS

1. If the cruise control system does not operate correctly and the vehicle is equipped with a manual transmission, do Test A.
2. If the cruise control system does not operate correctly and the vehicle is equipped with an automatic transmission, do Test B.

Test A

R150001

1A

CONDITIONS

- Ignition Switch
Position: II

RESULTS

- Cruise Control Switch
On = BAT VOLT
Off = 0V

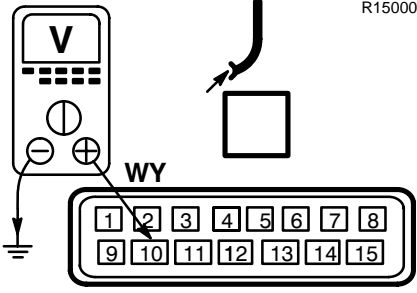

**Z121
Cruise Control
ECU**



PROBLEM CAUSE

- F18 Fuse
- WY Wire
- GLG Wire
- Cruise Control Switch

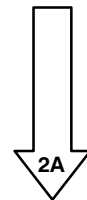

R150001

2A

CONDITIONS

- Ignition Switch
Position: II
- Cruise Control Switch
On
- Engine running

RESULTS

- Brake Switch Vent Valve
BAT VOLT = Released
- Clutch Pedal Position Switch
0V = Depressed

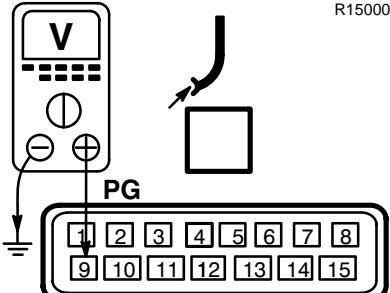

**Z121
Cruise Control
ECU**

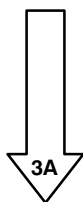

GO TO TEST C

2A

3A

CONDITIONS

- Ignition Switch
Position: II
- Cruise Control Switch
On
- Engine running

RESULTS

- Clutch Pedal Position Switch
BAT VOLT = Released
0V = Depressed

R020032

X112
Brake Switch
Vent Valve

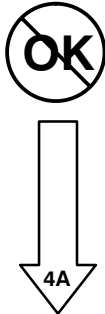

OK

PROBLEM CAUSE

- PG Wire
- Brake Switch Vent Valve

4A

CONDITIONS

- Ignition Switch
Position: II
- Cruise Control Switch
On
- Engine running

RESULTS

BAT VOLT

R020032

X200
Clutch Pedal
Position Switch

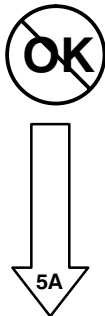

OK

PROBLEM CAUSE

- P Wire
- PY Wire
- Clutch Pedal Position Switch

4A

5A

R050001

CONDITIONS

- Ignition Switch
Position: II
- Cruise Control Switch
On
- Engine running

RESULTS

BAT VOLT

**Z164
Speed Trip Mod-
ule**



- PROBLEM CAUSE**
- WU, WB Wire
 - WS, WY Wire
 - Multiport Fuel Injection Ignition Resistor 2
 - Cruise Control Diode

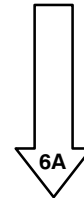

6A

6A

R050001

CONDITIONS

- Ignition Switch
Position: 0

RESULTS

Less than 1 ohm

**Z164
Speed Trip Mod-
ule**



- PROBLEM CAUSE**
- Speed Trip Mod-
ule



- PROBLEM CAUSE**
- PW Wire
 - B Wire

Test B

1B

R150001

CONDITIONS

- Ignition Switch
Position: II

RESULTS

- Cruise Control Switch
On = BAT VOLT
Off = 0V

Z121
Cruise Control
ECU



PROBLEM CAUSE

- F18 Fuse
- WY Wire
- GLG Wire
- Cruise Control Switch

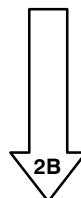

2B

R150001

CONDITIONS

- Ignition Switch
Position: II
- Cruise Control Switch
On
- Gear Selector
D

RESULTS

- Brake Switch Vent Valve
BAT VOLT = Released
0V = Depressed

Z121
Cruise Control
ECU

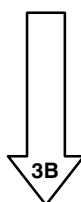

GO TO TEST C

2B

3B

R020032

CONDITIONS

- Ignition Switch
Position: II
- Gear Selector
D

RESULTS

- Cruise Control Switch
On = BAT VOLT
Off = 0V

X112
Brake Switch
Vent Valve

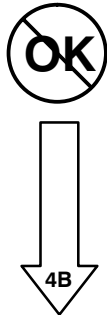

OK

PROBLEM CAUSE

- PG Wire
- Brake Switch Vent Valve

4B

R050001

CONDITIONS

- Ignition Switch
Position: II

RESULTS

- Cruise Control Switch
On = BAT VOLT
Off = 0V

K110
Cruise Control
Lockout Relay

~~OK~~

PROBLEM CAUSE

- WS Wire
- WY Wire
- Cruise Control Diode

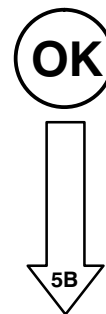

4B

5B

CONDITIONS

- Ignition Switch
Position: 0

RESULTS

- Gear Selector

<i>P = 0-1 Ω</i>	<i>3 = >100 Ω</i>
<i>R = >100 Ω</i>	<i>2 = >100 Ω</i>
<i>N = 0-1 Ω</i>	<i>1 = >100 Ω</i>
<i>D = >100 Ω</i>	

K110
Cruise Control
Lockout Relay



PROBLEM CAUSE

- BY Wire
- BO Wire
- Park/Neutral Position Switch



PROBLEM CAUSE

- PY Wire
- Cruise Control Lockout Relay

Test C

1C

CONDITIONS

- Ignition Switch
Position: 0
- Cruise Control Switch
On

RESULTS

- Steering Wheel Cruise Switches
SET/ACCEL Switch

<i>On</i>	<i>= BAT VOLT</i>
<i>Off</i>	<i>= 0V</i>

Z121
Cruise Control
ECU



PROBLEM CAUSE

- RW, W, PB Wire
- WY, GR Wire
- Rotary Coupler
- Steering Wheel Cruise Switches

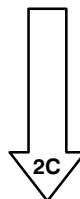

R150001

1C

2C

CONDITIONS

- Ignition Switch
Position: II

RESULTS

- Brake Pedal
BAT VOLT = Depressed
0V = Released

**Z121
Cruise Control
ECU**



PROBLEM CAUSE

- GP Wire
- F1 Fuse
- GO Wire
- Stop Lamp Switch

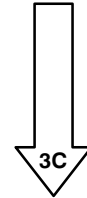

R150001

3C

CONDITIONS

- Ignition Switch
Position: 0

RESULTS

0-1 Ω

**Z121
Cruise Control
ECU**



PROBLEM CAUSE

- B Wire

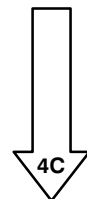

3C

4C

CONDITIONS

- Ignition Switch
Position: II
- Cruise Control Switch
On

RESULTS

- Steering Wheel Cruise Switches
RES/DECEL Switch
Off = 0V
On = BAT VOLT

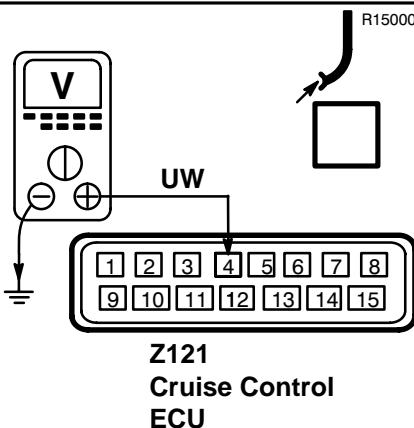

Z121
Cruise Control
ECU

~~OK~~ PROBLEM CAUSE

- UW, YB Wire
- Steering Wheel Cruise Switches

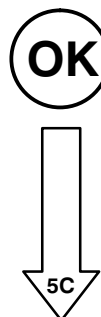

5C

CONDITIONS

- Ignition Switch
Position: II

RESULTS

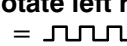
- Right rear wheel on ground
- Rotate left rear wheel
=  0V - BAT VOLT

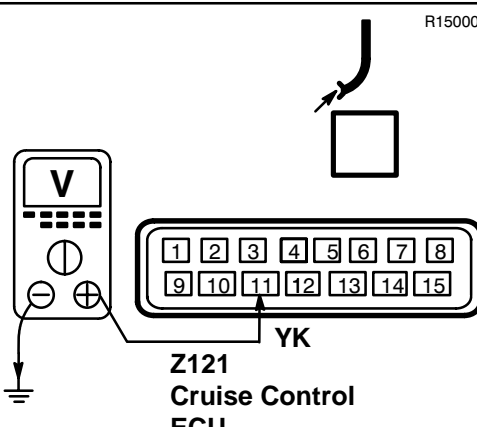

Z121
Cruise Control
ECU

~~OK~~ PROBLEM CAUSE

- YK Wire

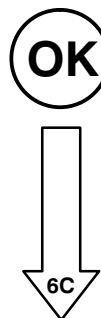

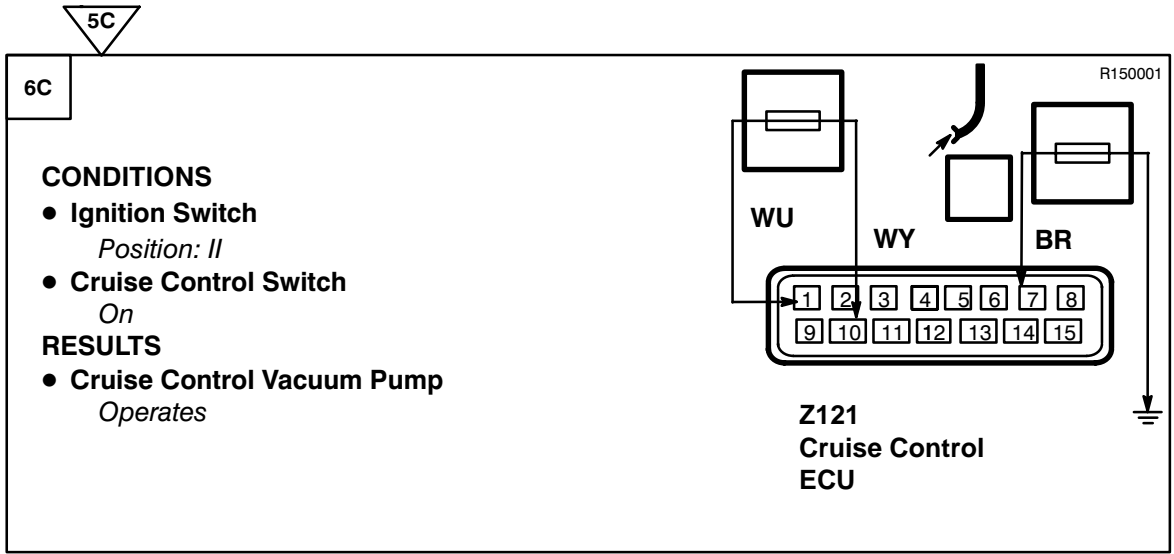

~~OK~~ GO TO TEST D

OK

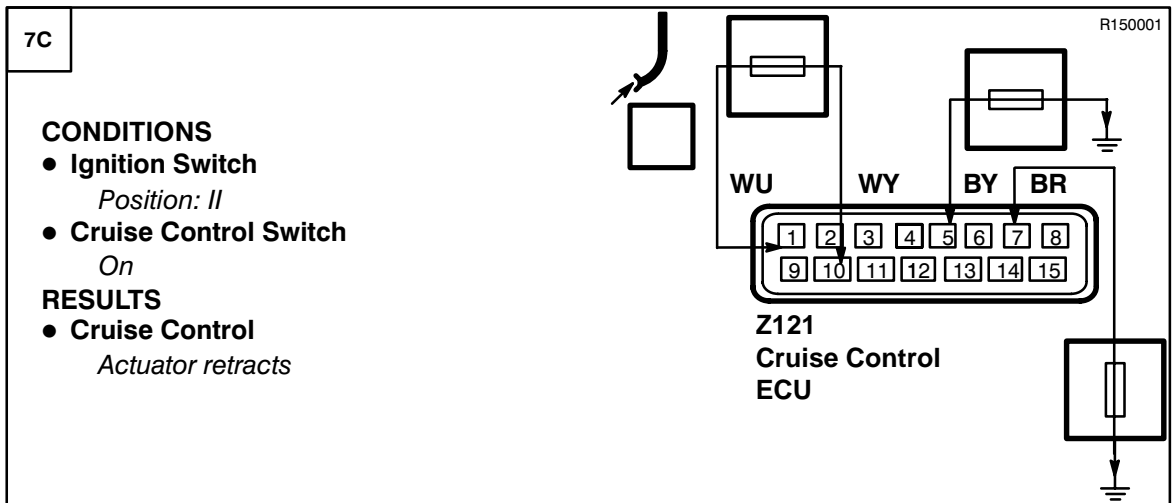
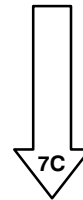

~~OK~~ GO TO TEST D

OK PROBLEM CAUSE
- Cruise Control
ECU

Test D

1D

R030023

CONDITIONS

- Ignition Switch
Position: II
- Cruise Control Switch
On

RESULTS
BAT VOLT

M103
Cruise Control
Vacuum Pump

~~OK~~ PROBLEM CAUSE
- WU Wire

OK

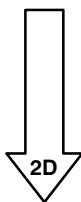

2D

R030031

CONDITIONS

- Ignition Switch
Position: 0

RESULTS

- Cruise Control Vacuum Pump
Operates

M103
Cruise Control
Vacuum Pump

~~OK~~ PROBLEM CAUSE
- BR Wire
- Cruise Control
Vacuum Pump

OK

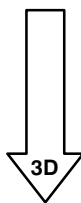

B5 ETM

DISCOVERY

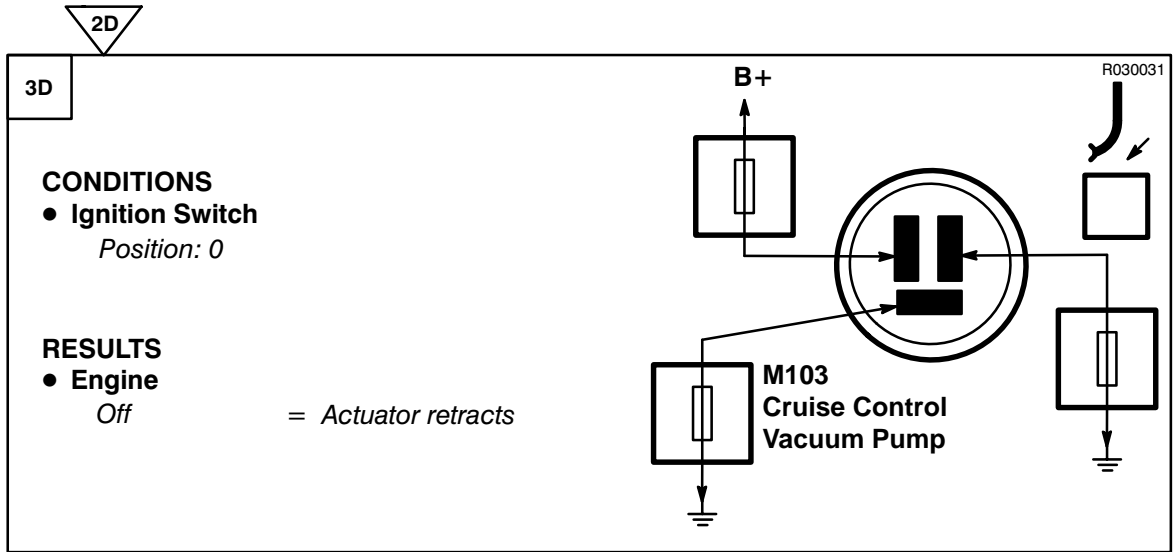

PROBLEM CAUSE

- Vacuum leak or restriction
- Brake Switch Vent Valve
- Cruise Control Vacuum Pump



PROBLEM CAUSE

- BY Wire

CIRCUIT OPERATION

Selector Interlock

When the gear selector is in the park position, the solenoid inside the Transmission Range Selector Switch (Z110) is de-energized and prevents the selector from being moved into another gear. To free the selector, the Ignition Switch (X134) must be in position II and the brake pedal must be depressed. When this occurs, voltage from Fuse F1 is applied to the Transmission Range Selector through the closed Stop Lamp Switch (X168). The solenoid inside the Transmission Range Selector Switch is grounded at E200 through the selector switch, the KS wire and the B wire. The solenoid now energizes, freeing the selector.

Ignition Key Interlock

On vehicles equipped with the interlock safety feature the vehicle must be in park and the transfer case in high or low gear before the key can be removed from the ignition. If the gear selector or transfer gear were out of gear, the key must be cycled before removal.

If the vehicle is not in park, voltage from Fuse F12 is applied to the Key Barrel Switch (X230) through the closed contacts of the Transmission Range Selector Switch (Z110). When the ignition switch is placed in the 0 position, the Key Barrel Switch (X230) closes to energize the solenoid and prevent key removal.

If the key is in the ignition and the transfer box is in the neutral position, Interlock Relay 1 (K153) is de-energized since the relay coil is not grounded by the Transfer Box Position Switch (X175). When the relay is de-energized, voltage is applied to the Key Barrel Switch (X230) through the relay's switch contacts and the Key-In Switch (X229) causing the solenoid to energize and prevent key removal.

If the transfer box is in the "H" or "L" position, the Interlock Relay 1 (K153) is energized, since the relay coil is grounded by the Transfer Box Position Switch (X175). When the relay is energized, voltage to the Key Barrel Switch (X230) is interrupted. The Ignition Key Lock Solenoid (K191) is then disabled, allowing removal of the key.

Terminal 3 of the Multifunction Unit (MFU) (Z148) is provided with ground with the Transfer Box Position Switch (X175) in "H" or "L" position. Switched to

neutral position this permanent ground connection is interrupted. Then an internal sounder of the Multifunction Unit (MFU) (Z148) provides a warning chime to the driver.

Transfer Box Interlock (NAS vehicles with automatic transmission only)

The Transfer Box Interlock safety feature is designed to prevent the transfer case shifter from being shifted out of "H" or "L" unless the vehicle's gear selector is in the neutral position.

When the gear selector is placed in the neutral position, voltage is applied to the Interlock Relay 2's coil through the Transmission Range Selector Switch (Z110). The relay's coil is grounded through the Park/Neutral Position Switch (X167).

Interlock Relay 2 now energizes and applies voltage from Fuse F13 to the Transfer Box Solenoid (K154). When the Transfer Box Solenoid (K154) is energized the transfer box shifter can be operated.

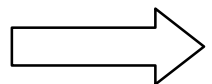
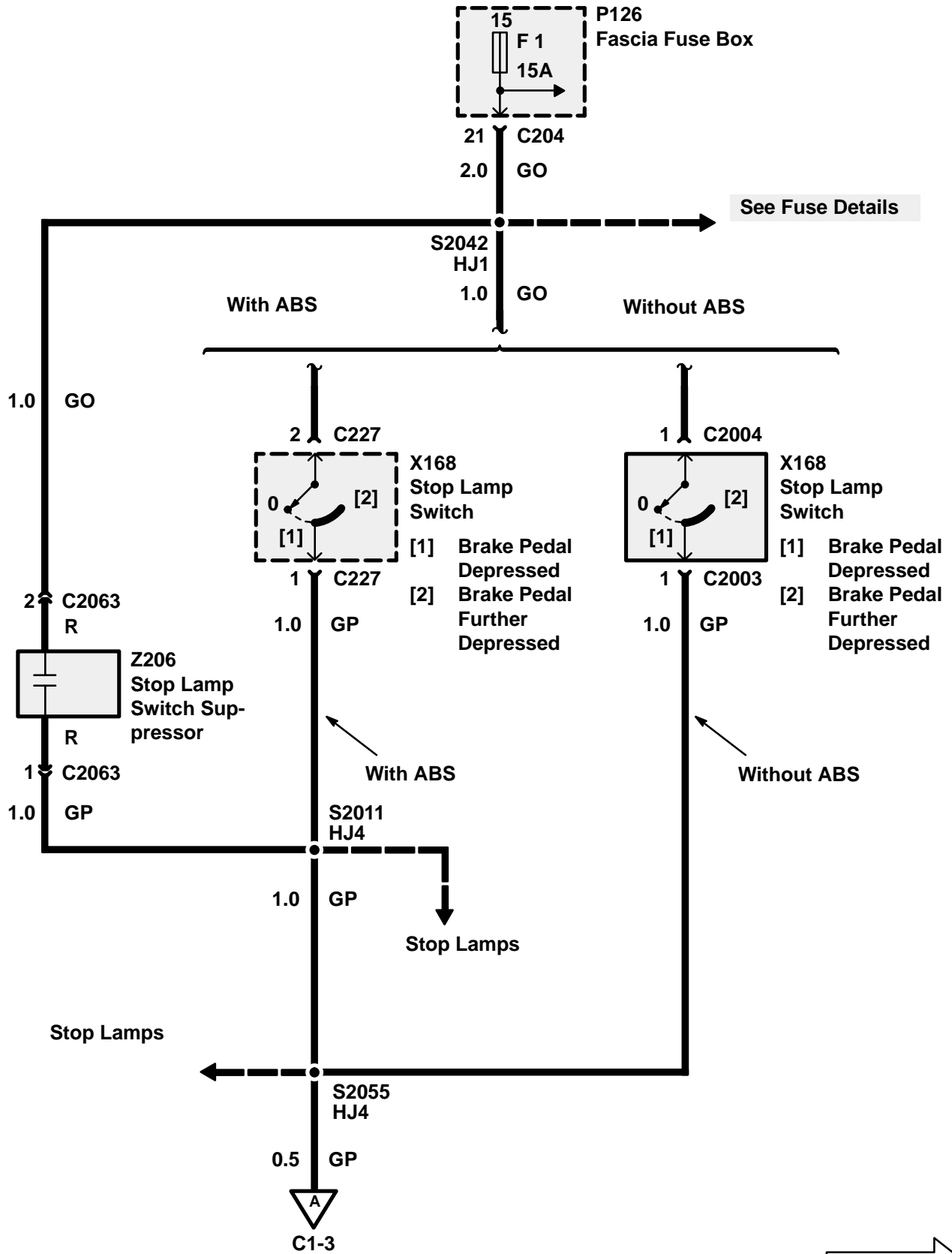

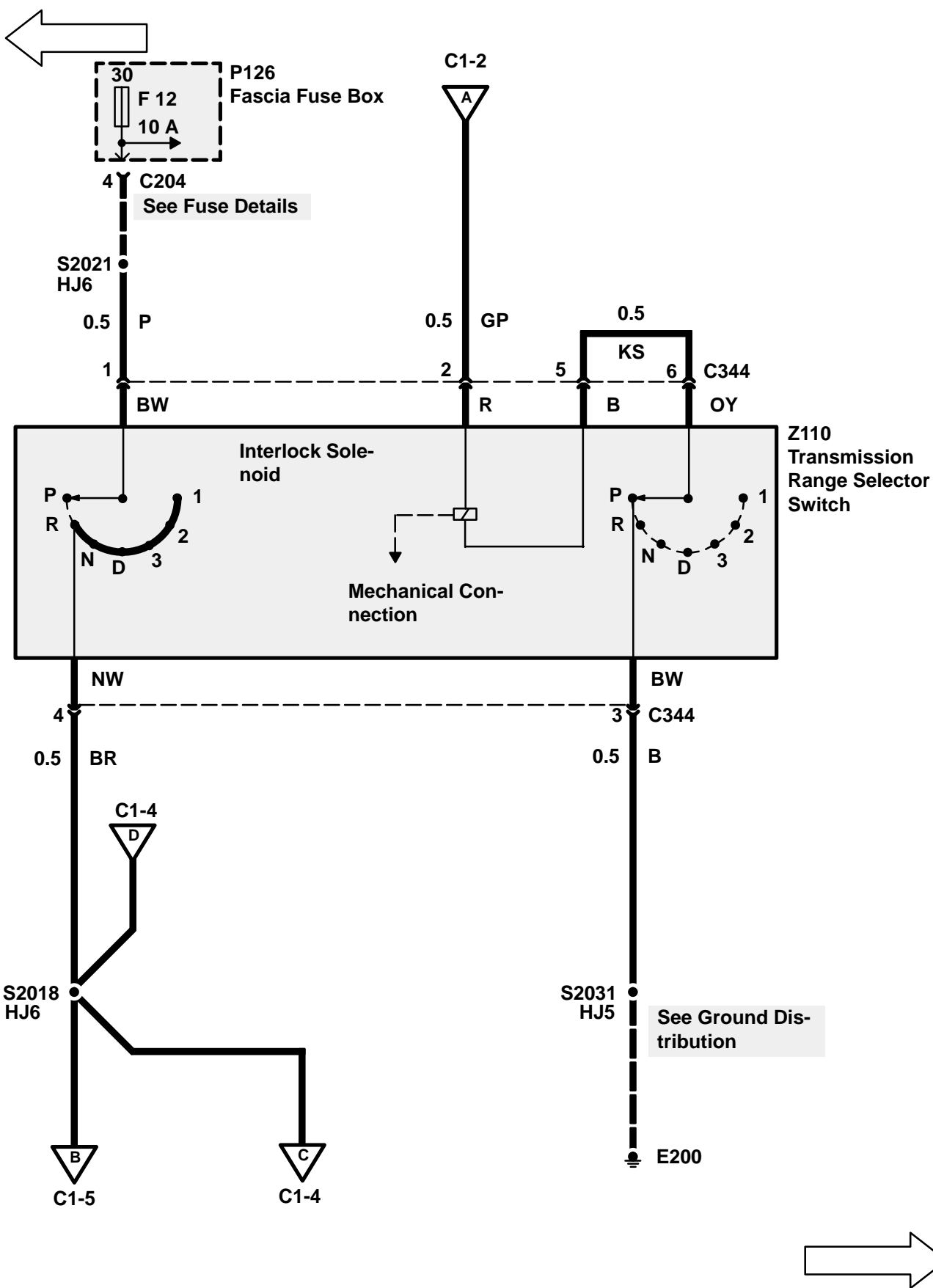

C1 ETM

DISCOVERY

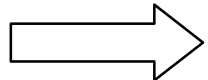
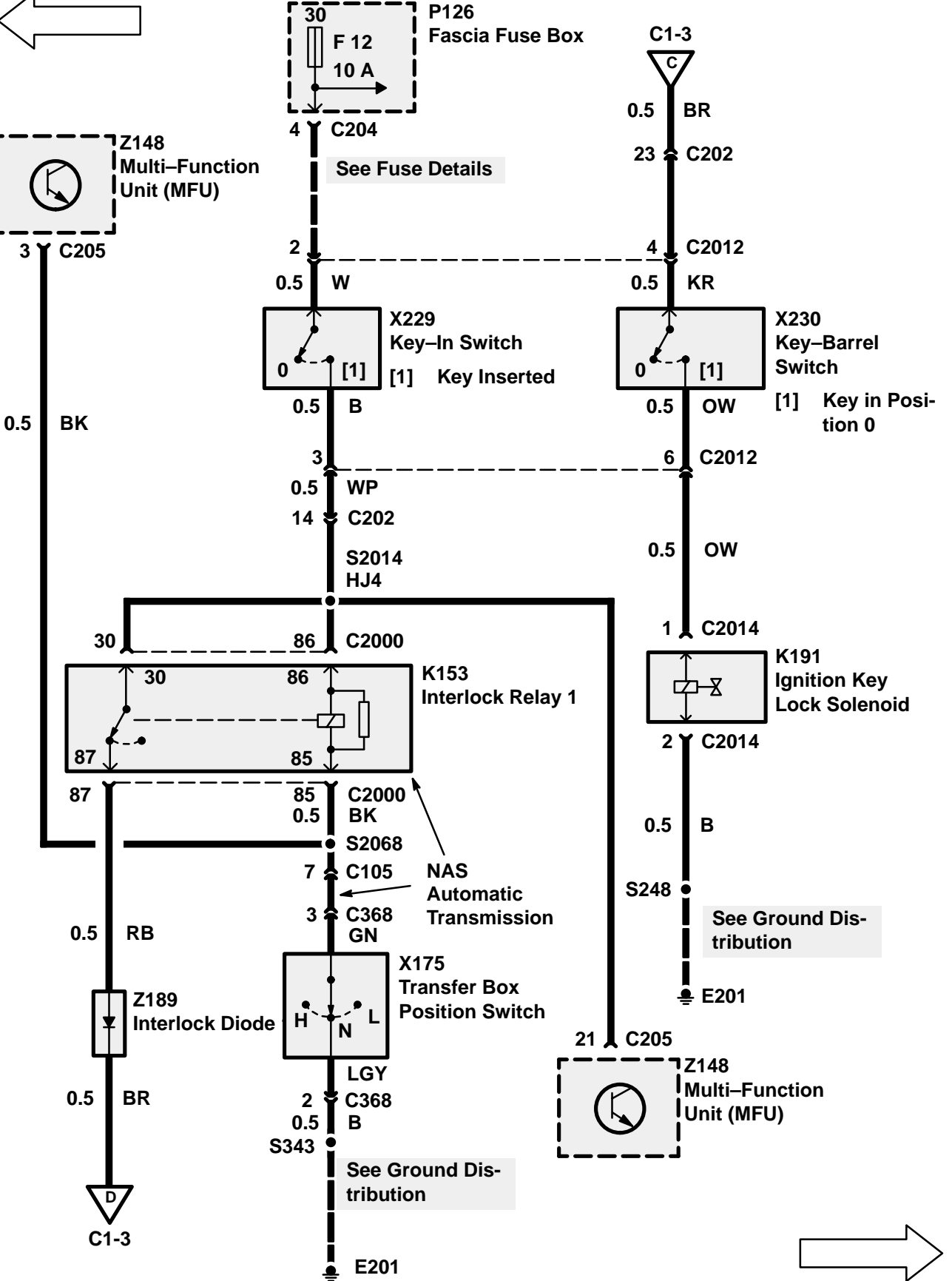
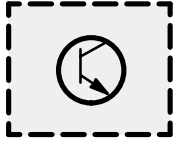
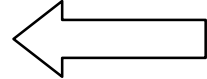

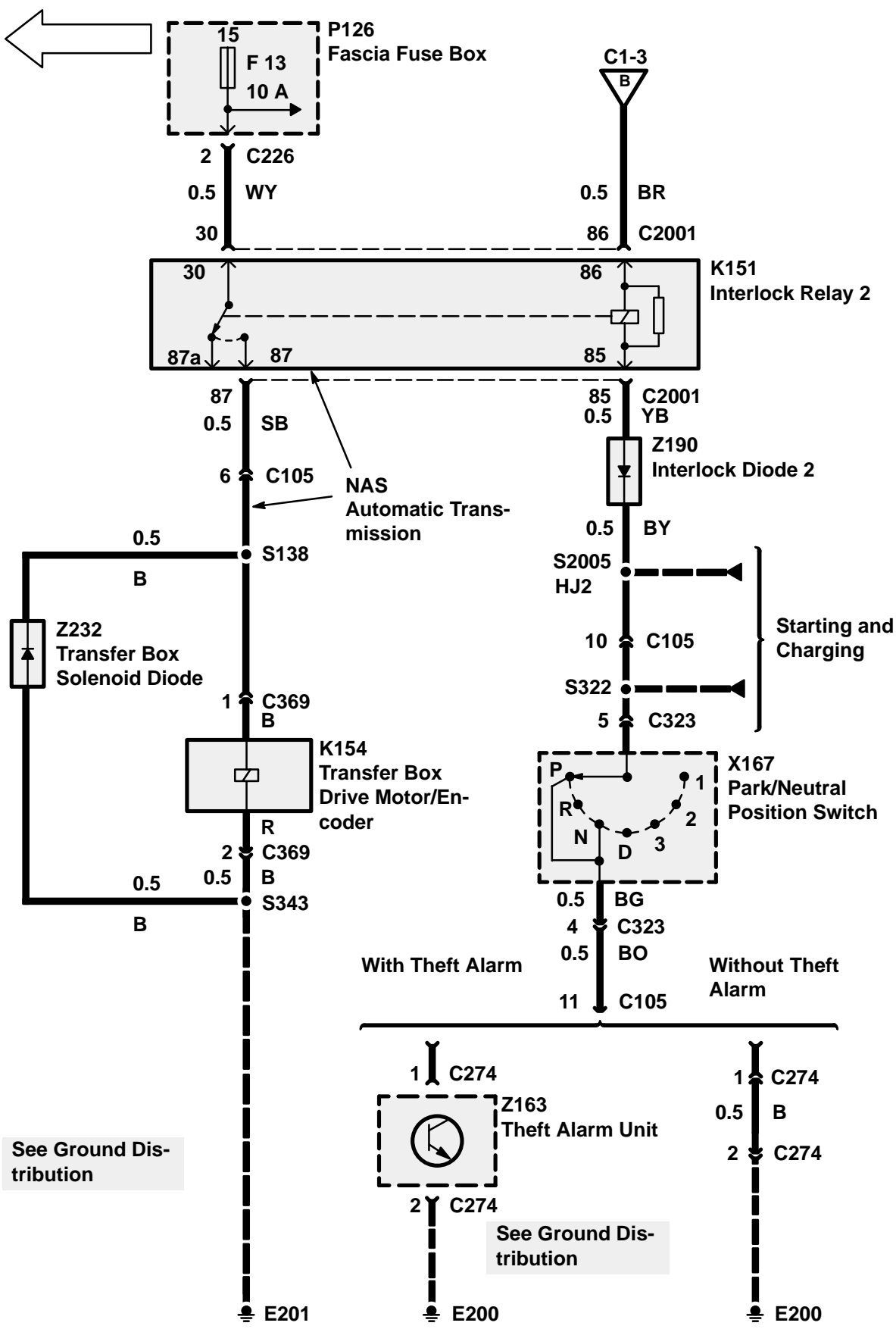

See Ground Distribution

See Ground Distribution

SYSTEM DIAGNOSIS

3. If the transmission range selector cannot be shifted out of park, do Test A.
4. If the ignition key cannot be removed with the transmission range selector in park and the transfer box in "H" or "L", do Test B.
5. If the transfer box can be shifted out of "H" or "L" while in any gear except neutral, do Test C.
6. If the ignition key can be removed with the transmission range selector in any gear except park or with the transfer box in the neutral position, do Test D.
7. If the transfer box cannot be shifted into "N", "H", or "L", with the ignition key inserted and gear selector in "N", do Test F.

Test A

1A

R060016

CONDITIONS

- Ignition Switch
Position: II

RESULTS

- Brake Pedal
BAT VOLT= Depressed
- Brake Pedal
0V= Released

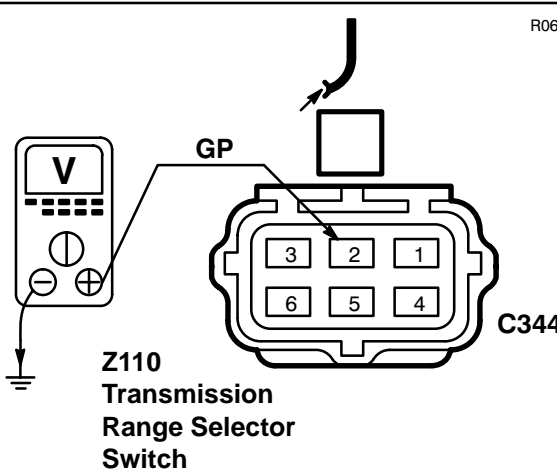

Z110
Transmission
Range Selector
Switch



PROBLEM CAUSE

- GP Wire
- GO Wire
- F1 Fuse
- Stop Lamp Switch

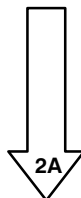

2A

R060016

CONDITIONS

- Ignition Switch
Position: 0

RESULTS

Less than 1 ohm

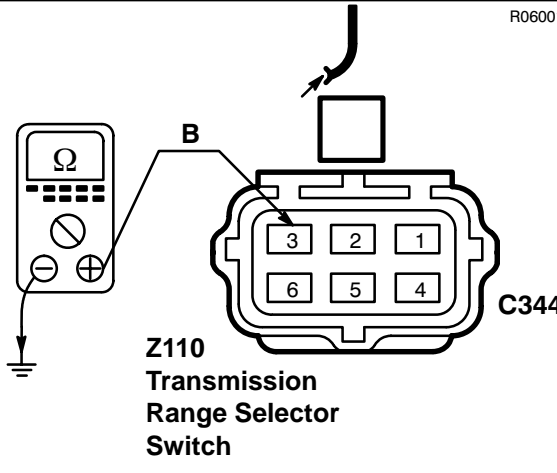

Z110
Transmission
Range Selector
Switch



PROBLEM CAUSE

- B Wire

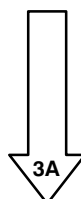

C1 ETM

DISCOVERY

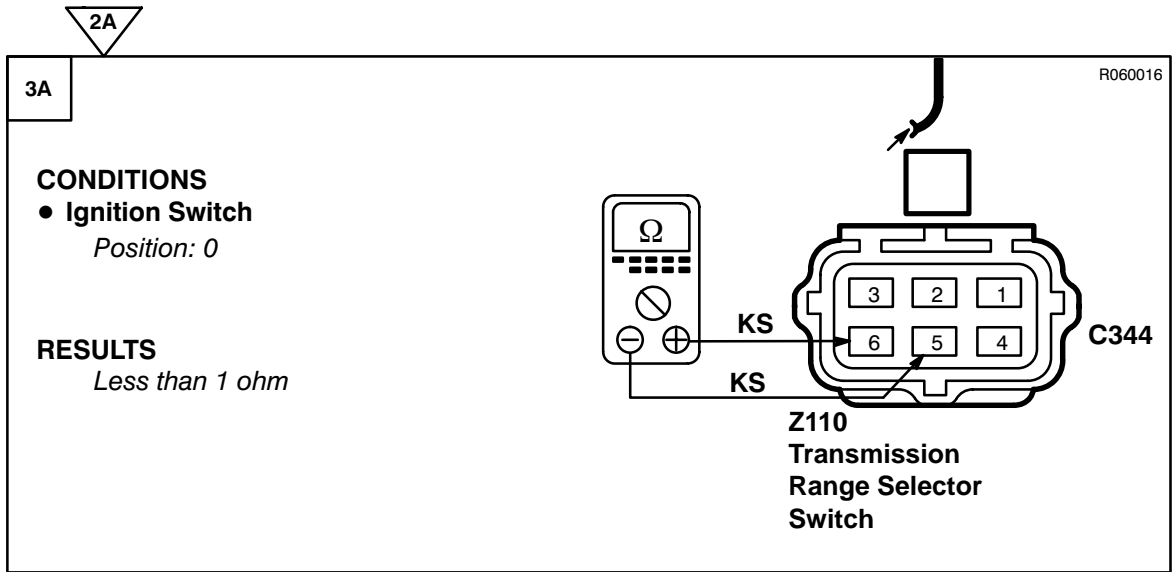

~~OK~~ PROBLEM CAUSE
- KS Wire

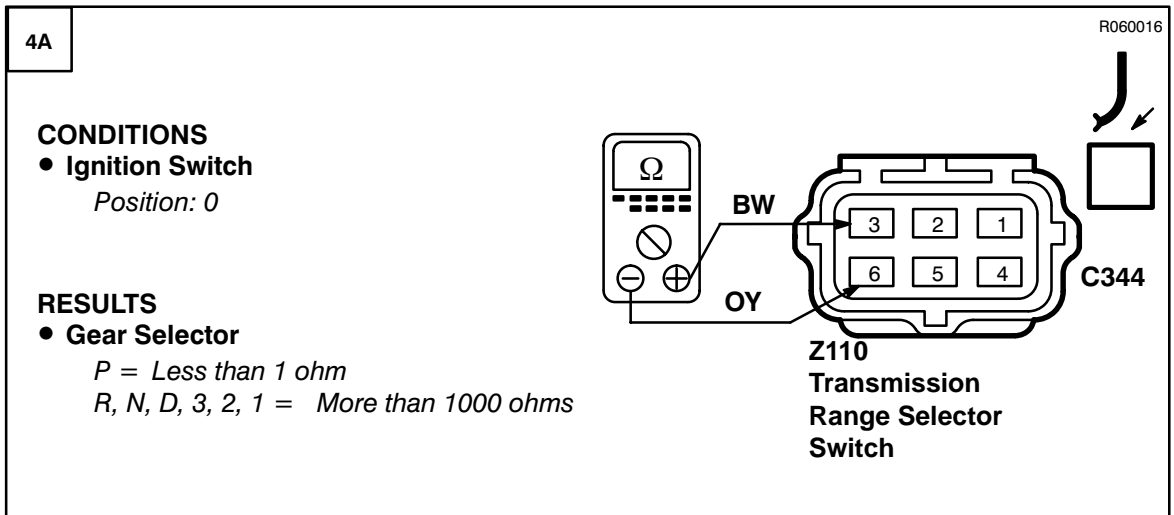
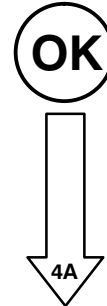

~~OK~~ PROBLEM CAUSE
- Microswitch
(Gear Selector)

OK PROBLEM CAUSE
- Interlock Sole-
noid

Test B

R020022

1B

CONDITIONS

- Ignition Switch
Position: 0
- Gear Selector
P
- Transfer Box Position Switch
H or L

RESULTS
0V

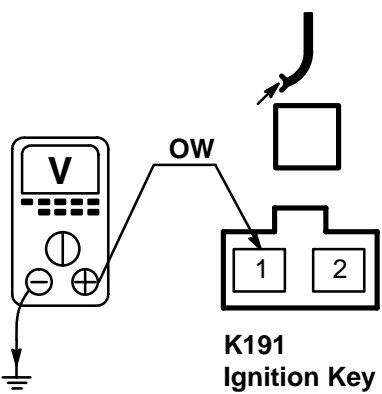

K191
Ignition Key
Lock Solenoid

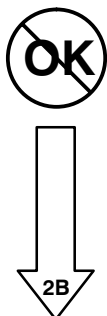

OK **PROBLEM CAUSE**
- Ignition Key
Lock Solenoid

R060016

2B

CONDITIONS

- Ignition Switch
Position: 0

RESULTS

- Gear Selector
P = More than 10K ohms

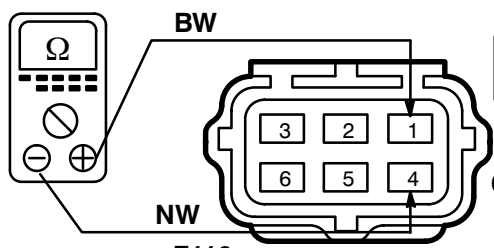

Z110
Transmission
Range Selector
Switch

OK **PROBLEM CAUSE**
- Transmission
Range Selector
Switch

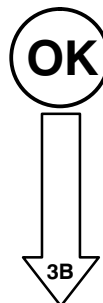

C1 ETM

DISCOVERY

2B
R050001

3B

CONDITIONS

- Ignition Switch
Position: II
- Transfer Box Position Switch
H or L

RESULTS
BAT VOLT

K153 Interlock Relay 1



PROBLEM CAUSE

- BK, WP, B Wire
- Key-In Switch
- Transfer Box Position Switch



PROBLEM CAUSE

- Interlock Relay 1

Test C

1C
R050001

CONDITIONS

- Ignition Switch
Position: 0

RESULTS
More than 10K ohms

K151 Interlock Relay 2



PROBLEM CAUSE

- Interlock Relay 2



PROBLEM CAUSE

- BY, YB Wire
- Transfer Box Drive Motor/Encoder
- Park/Neutral Position Switch

Test D

1D

R020022

CONDITIONS

- Ignition Switch
Position: II
- Gear Selector
P

RESULTS

- Transfer Box Position Switch
N = BAT VOLT

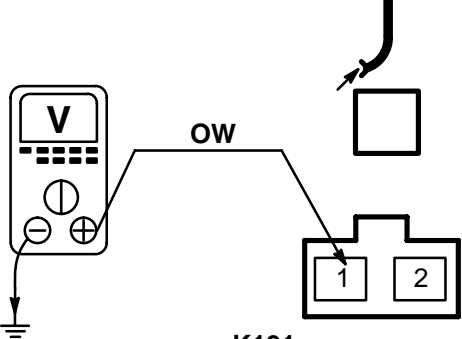

**K191
Ignition Key
Lock Solenoid**

~~OK~~ GO TO TEST E

OK

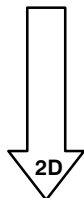

2D

R020022

CONDITIONS

- Ignition Switch
Position: II
- Transfer Box Position Switch
H or L

RESULTS

- Gear Selector
P = 0 VOLTS
R, N, D, 3, 2, 1 = BAT VOLT

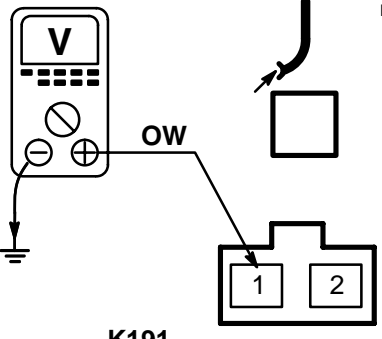

**K191
Ignition Key
Lock Solenoid**

~~OK~~ **PROBLEM CAUSE**

- BR, OW Wire
- Transmission Range Selector Switch
- Key-Barrel Switch

OK **PROBLEM CAUSE**

- Ignition Key Lock Solenoid

Test E

R050001

1E

CONDITIONS

- Ignition Switch
Position: II

RESULTS
BAT VOLT

**K153
Interlock Relay 1**



PROBLEM CAUSE

- WP Wire
- Key-In Switch

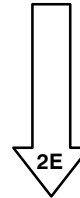

R050001

2E

CONDITIONS

- Ignition Switch
Position: II
- Transfer Box Position Switch
N

RESULTS
More than 10K ohms

**K153
Interlock Relay 1**



PROBLEM CAUSE

- BK Wire
- Transfer Box Position Switch

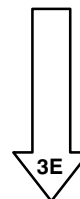

2E

3E

R050001

CONDITIONS

- Ignition Switch
Position: 0
- Gear Selector
P

RESULTS
Ignition key cannot be removed

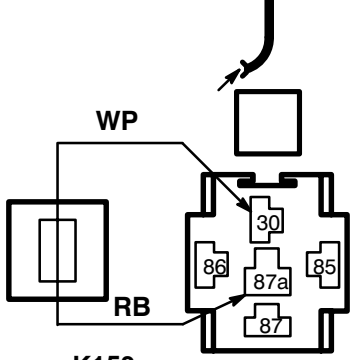

K153
Interlock Relay 1

OK PROBLEM CAUSE

- RB Wire
- BR Wire
- Interlock Diode 1

OK PROBLEM CAUSE

- Interlock Relay 1

Test F

1F

R050001

CONDITIONS

- Ignition Switch
Position: II

RESULTS

- Gear Selector
N = BAT VOLT

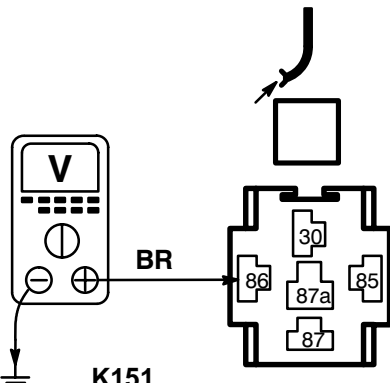

K151
Interlock Relay 2

OK PROBLEM CAUSE

- BR Wire
- Transmission Range Selector Switch

OK

↓

2F

C1 ETM

DISCOVERY

1F

2F

CONDITIONS

- Ignition Switch
Position: II

RESULTS

BAT VOLT

K151 Interlock Relay 2

R050001



PROBLEM CAUSE

- F13 Fuse
- WY Wire

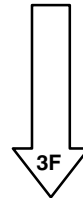

3F

CONDITIONS

- Ignition Switch
Position: 0
- Gear Selector
N

RESULTS

Less than 1 ohm

K151 Interlock Relay 2

R050001



PROBLEM CAUSE

- YB, BY, BO Wire
- Interlock Diode 2
- Park/Neutral Position Switch
- Theft Alarm Unit

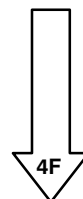

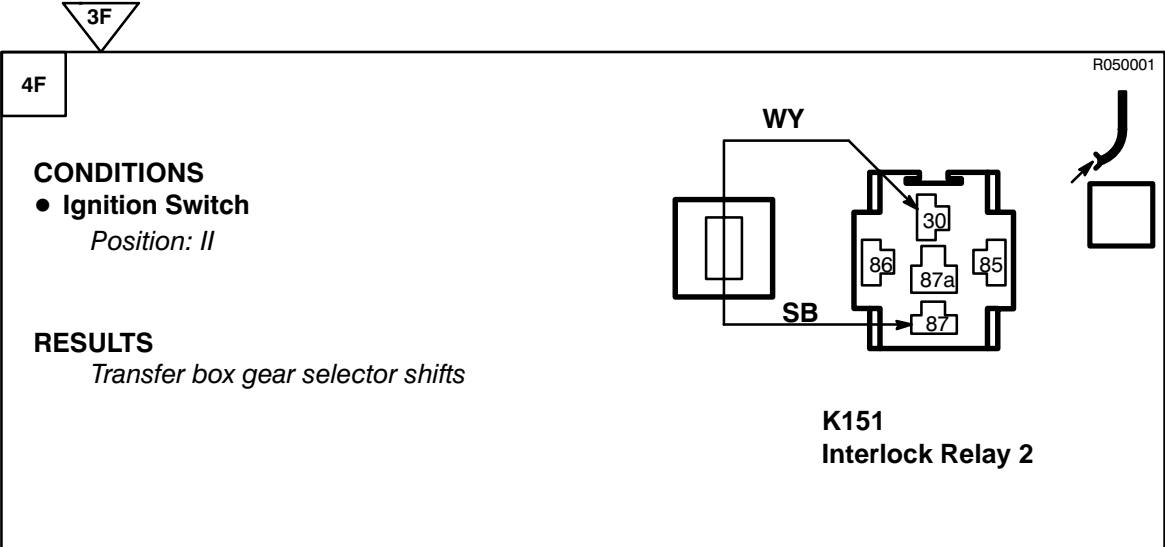

- PROBLEM CAUSE**
- SB Wire
 - B Wire
 - Transfer Box Drive Motor/Encoder



- PROBLEM CAUSE**
- Interlock Relay 2

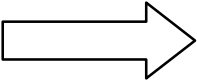
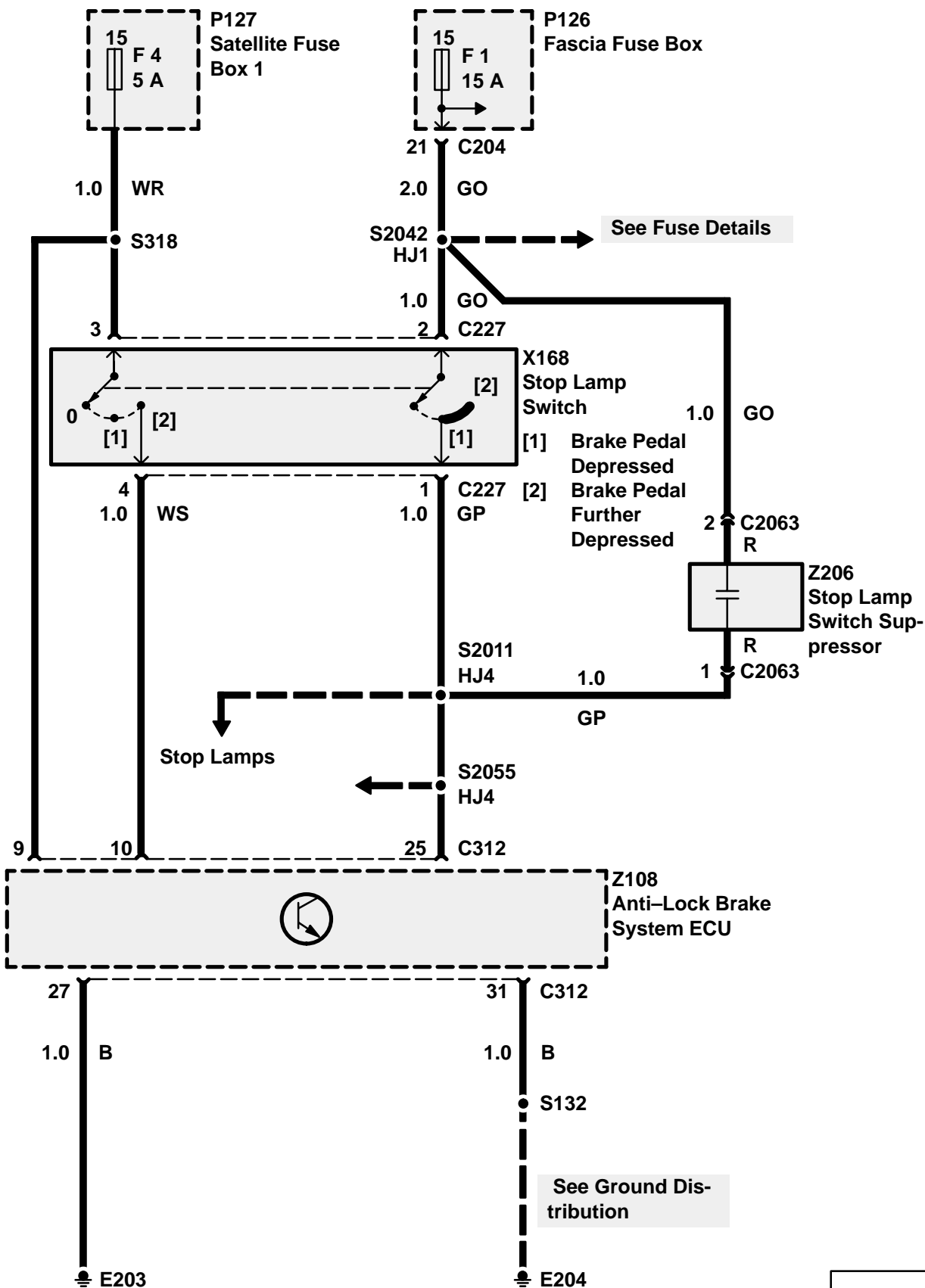

D1 ETM

DISCOVERY

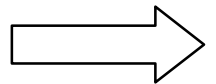
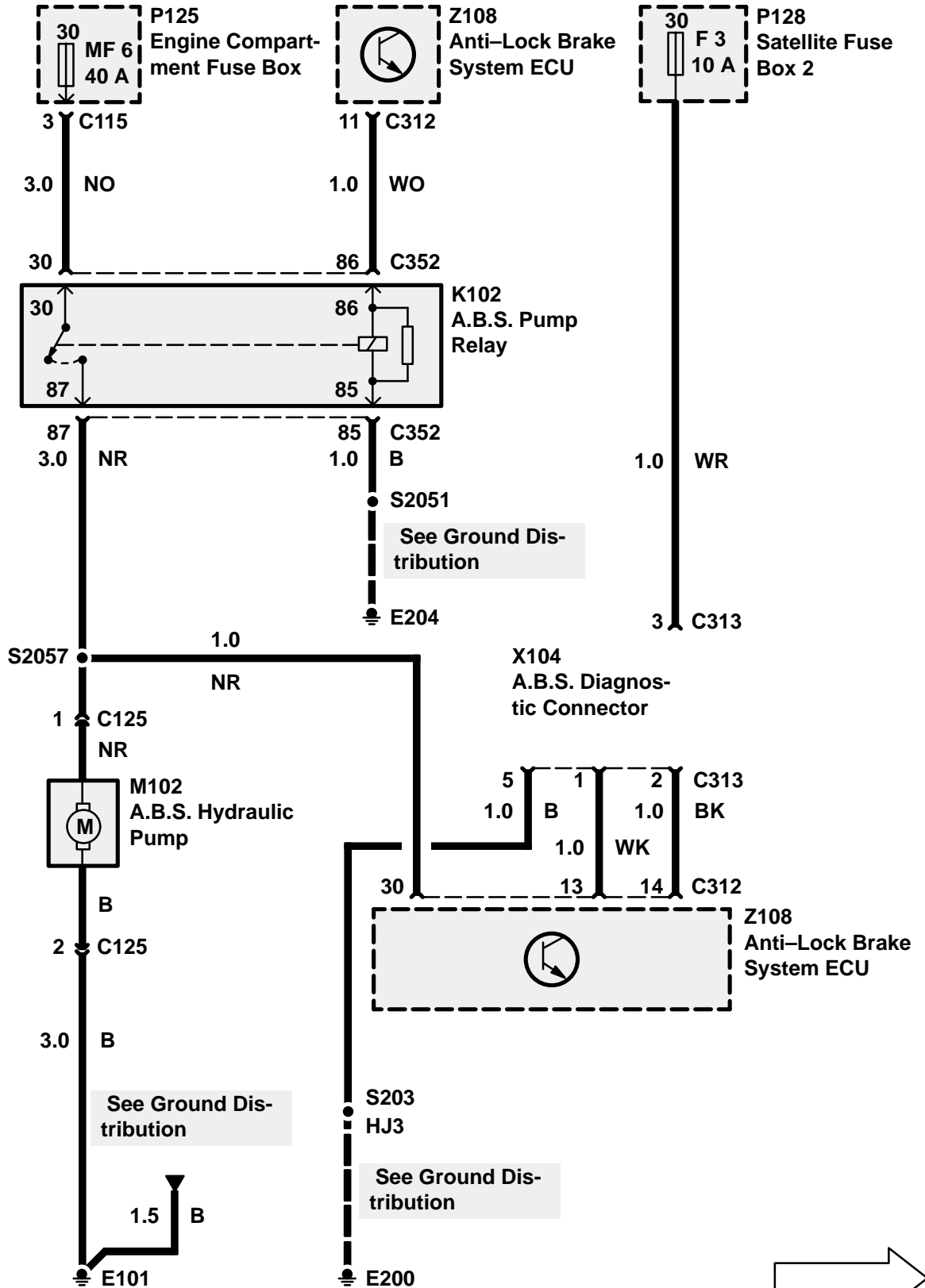
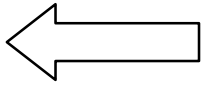

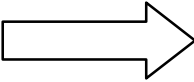
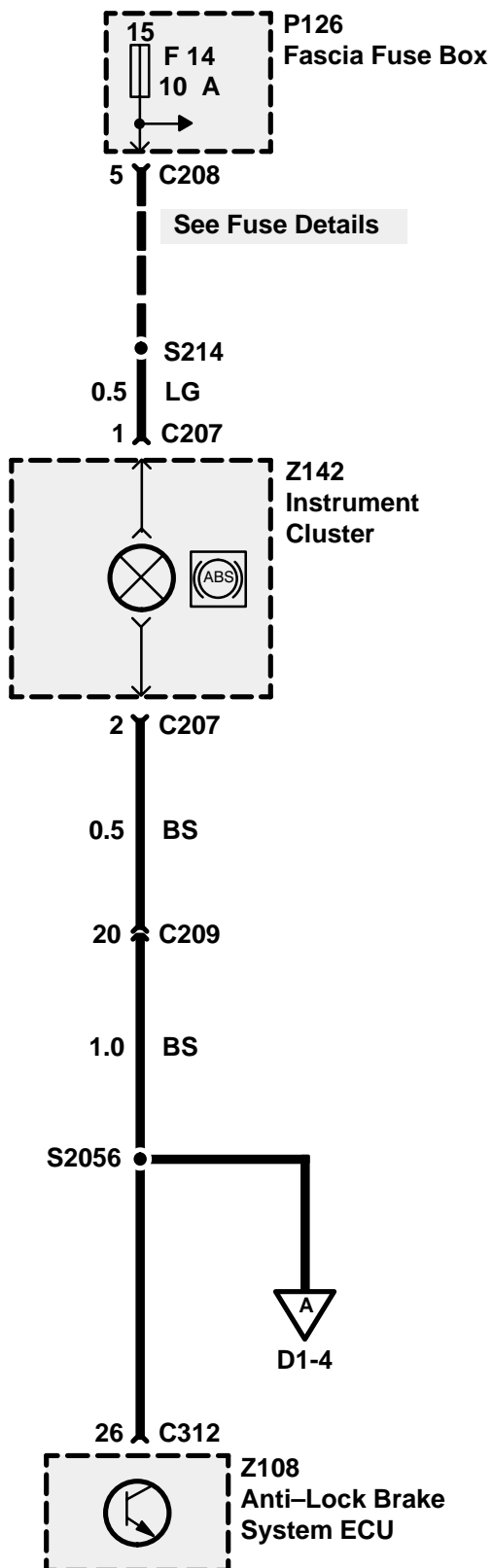
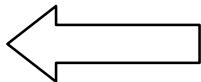

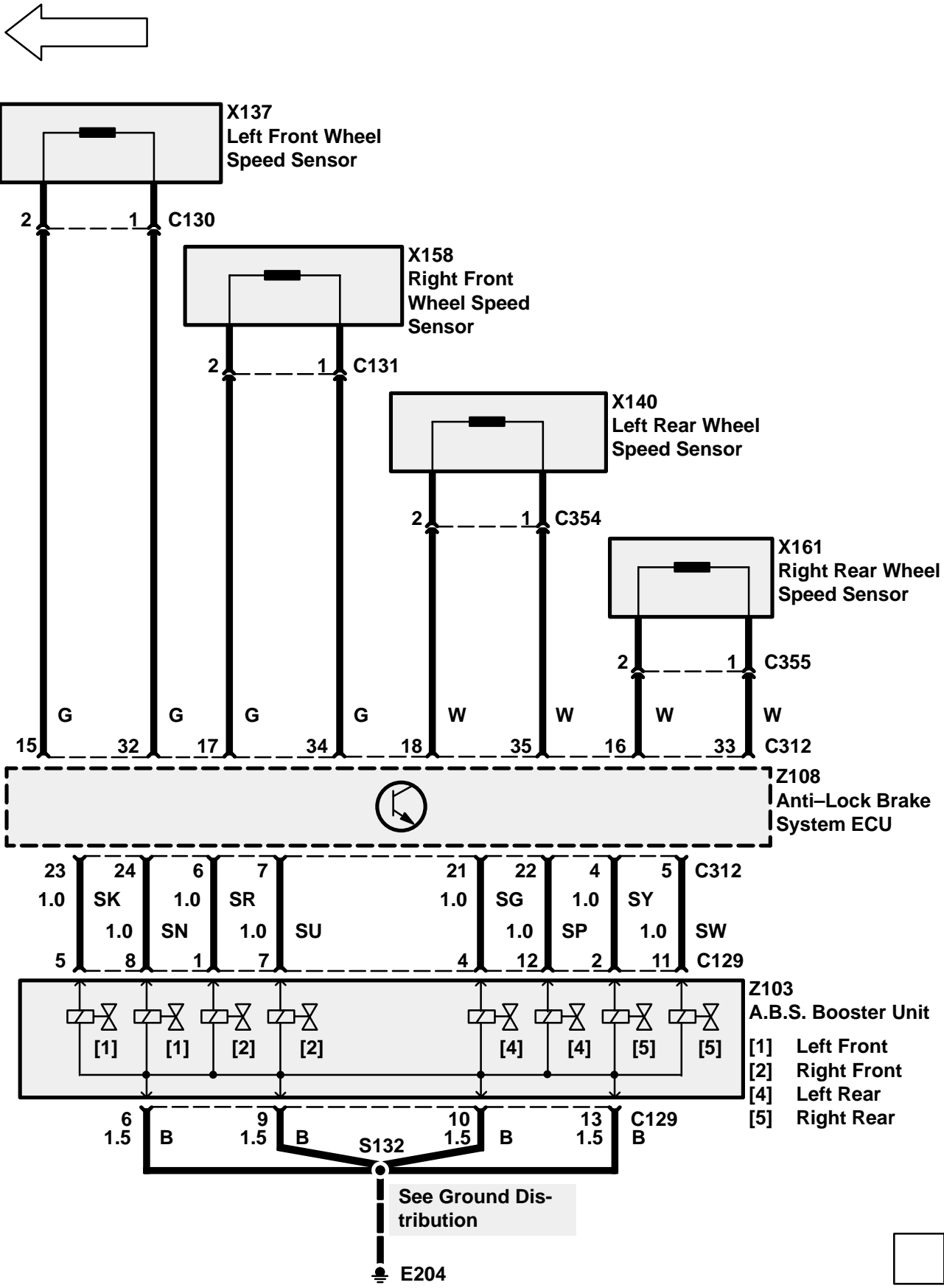

CIRCUIT OPERATION

Engine Coolant Temperature Gauge

The Engine Coolant Temperature Gauge Sensor (X114) has approximately 136 ohms resistance when the coolant temperature is low. As coolant temperature increases, the resistance of the sensor decreases. This varying resistance causes the current through the sensor to change and the gauge to register the temperature. When the coolant is hot, the resistance of the sensor is approximately 17 ohms.

Fuel Gauge

When the fuel tank level is low, the resistance of the fuel gauge sender is approximately 245 ohms. As the fuel level increases, the resistance of the sender decreases, causing the gauge to register the change. When the fuel tank is full, the resistance of the sender is approximately 19 ohms. When the fuel gauge sender's resistance falls below approximately 25 ohms (6 liters/1.5 US gallons), the fuel warning light will illuminate to warn the driver.

Speedometer

The Vehicle Speed Sensor (X190) sends a signal to the speedometer in the form of voltage pulses. The pulses are filtered by a Vehicle Speed Sensor Buffer inside the speedometer. The voltage alternates between battery voltage and 0 volts 6 times per wheel revolution. The speed sensor signal is also sent to the Cruise Control ECU (Z121), the Service Reminder Unit (NAS) (Z126), the Multifunction Unit (MFU) (Z148) (Persian Gulf States), and the Engine Control Module (Z132).

Tachometer

The tachometer displays engine speed in rpm. Voltage pulses are taken from the Generator (Z106) and are generated when the engine drive belt turns the Generator pulley. The tachometer responds to the frequency of the voltage pulses, which increases proportionally to that of the engine speed.

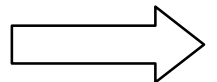
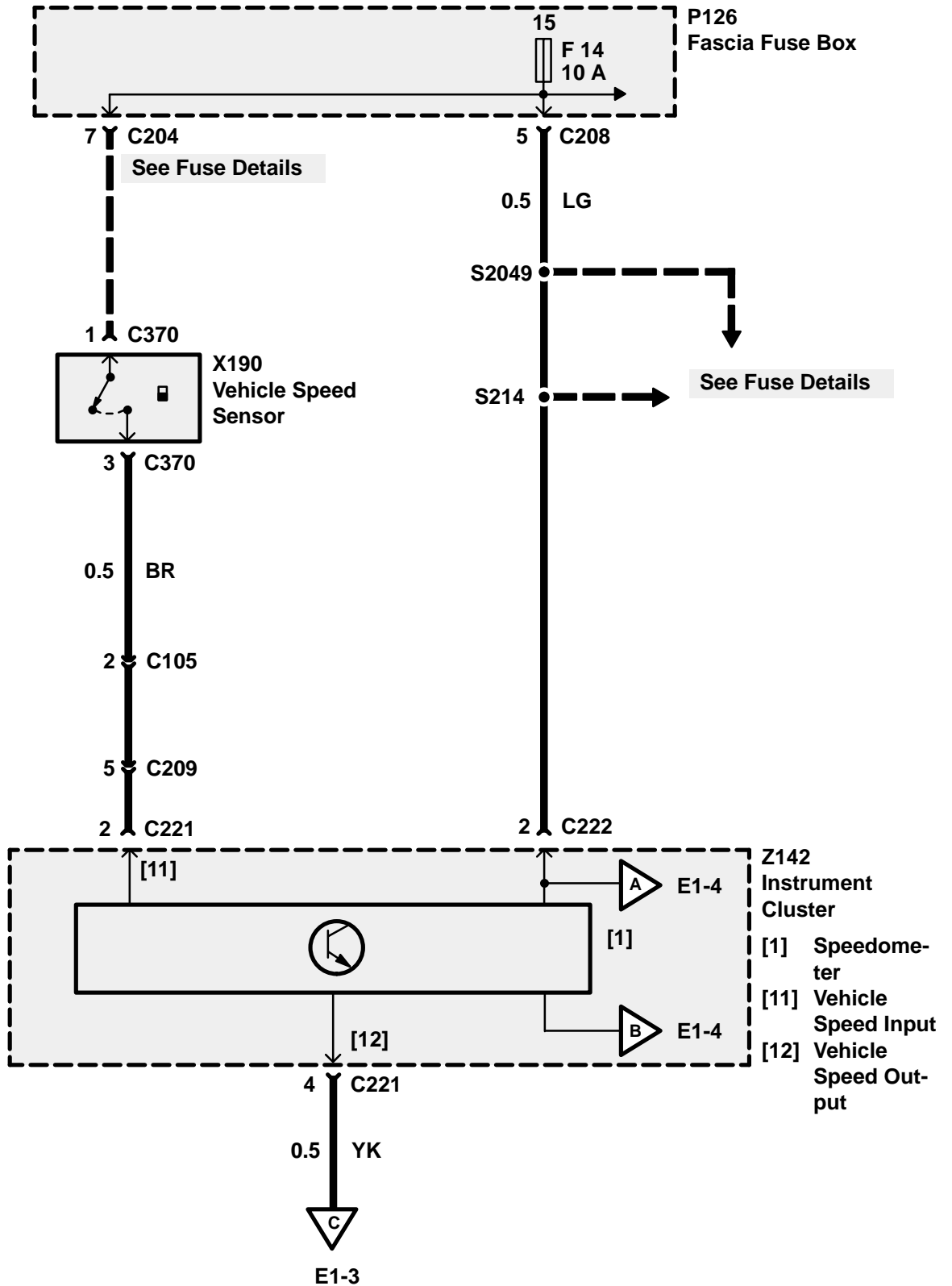

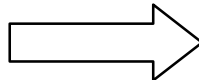
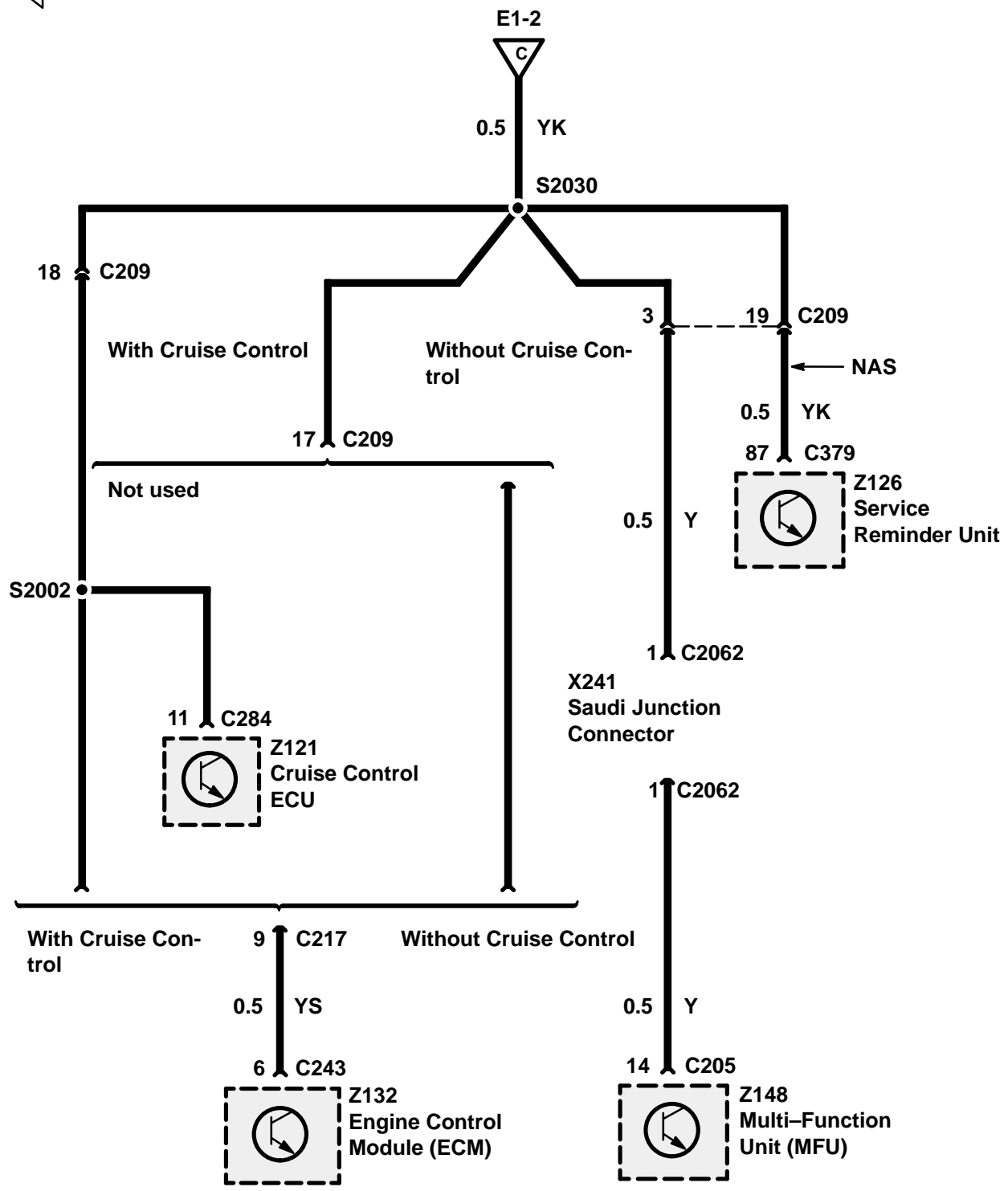
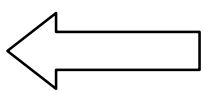

E1 ETM

DISCOVERY

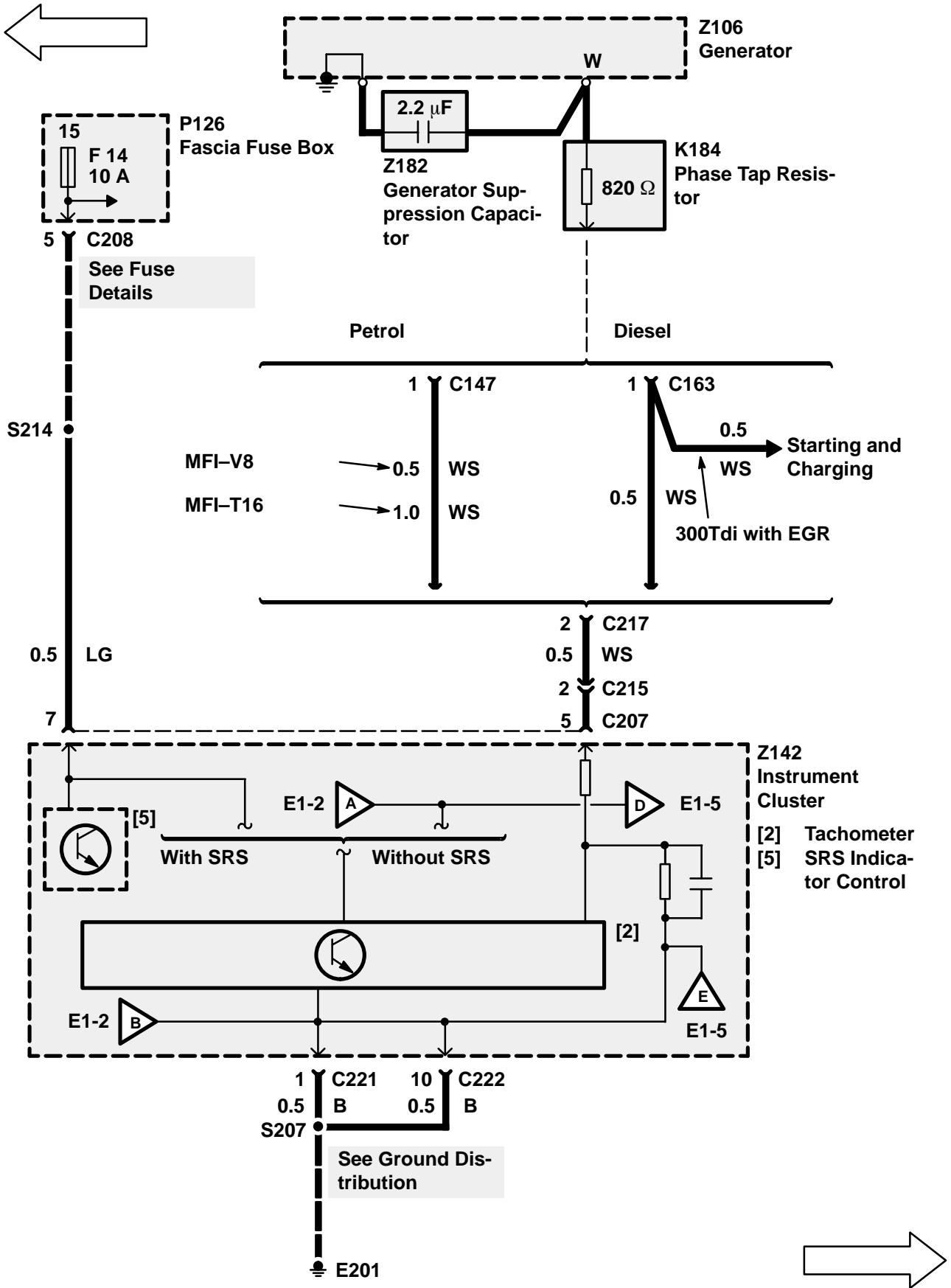

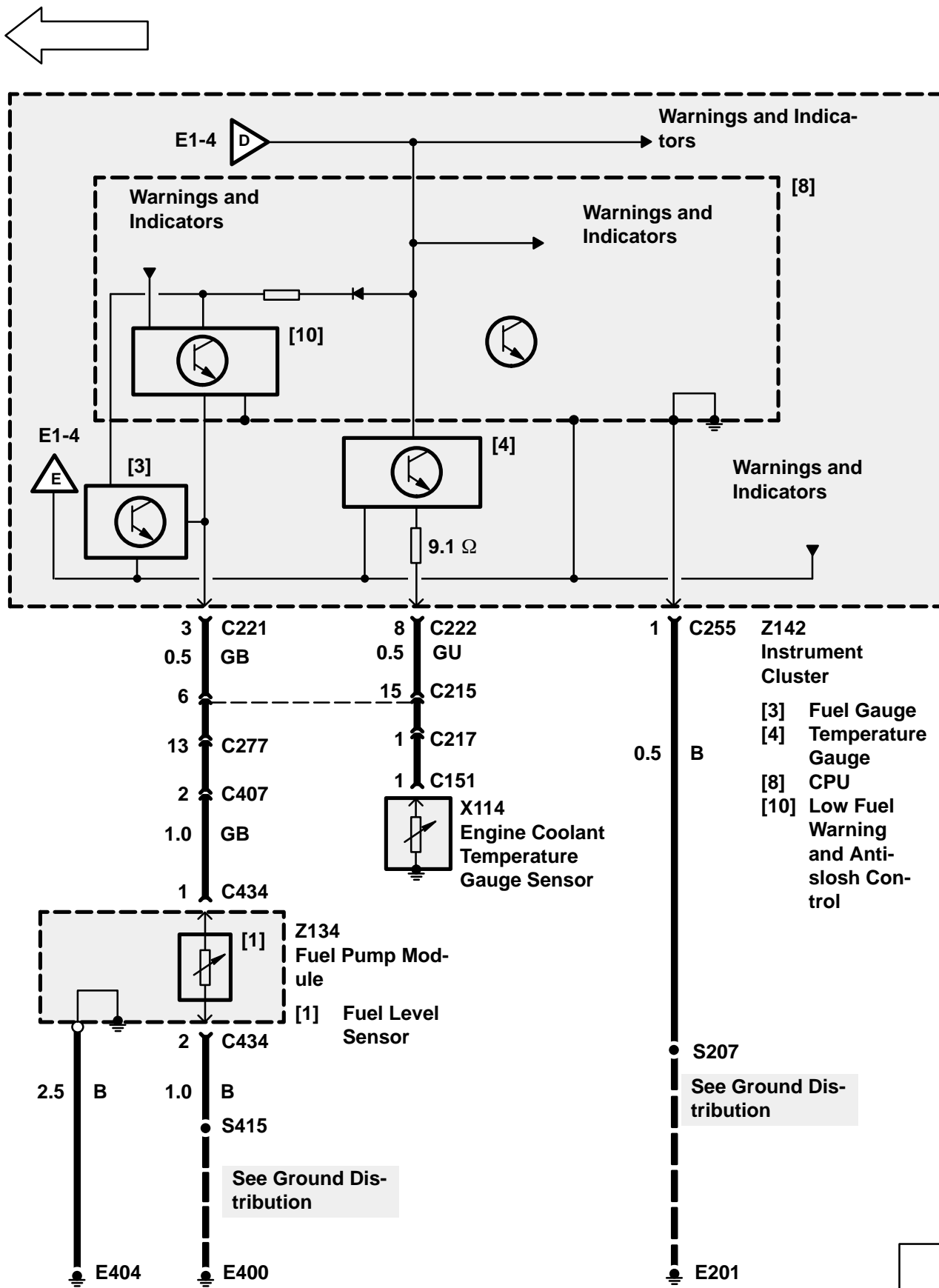

SYSTEM DIAGNOSIS

8. If no instruments operate, do Test A.
9. If the coolant temperature gauge reads hot with coolant cool, do Test B.
10. If the coolant temperature gauge reads cool with coolant hot, do Test B.
11. If the fuel gauge reads empty with fuel in the tank, do Test C.
12. If the fuel gauge reads full when the tank is empty, do Test C.
13. If the speedometer does not operate, do Test D.
14. If the tachometer does not operate, do Test E.

Test A

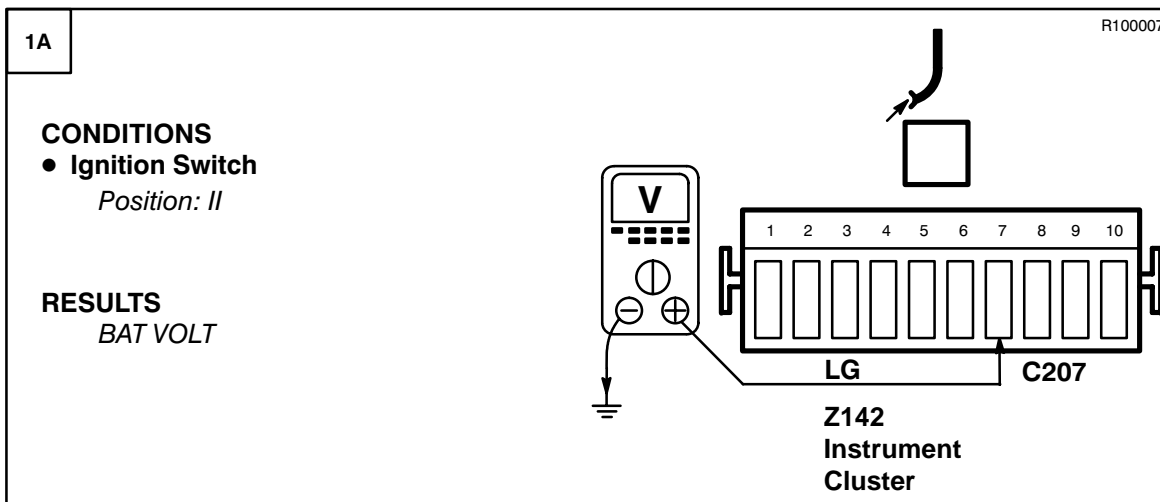

~~OK~~ **PROBLEM CAUSE**
 - LG Wire
 - F14 Fuse

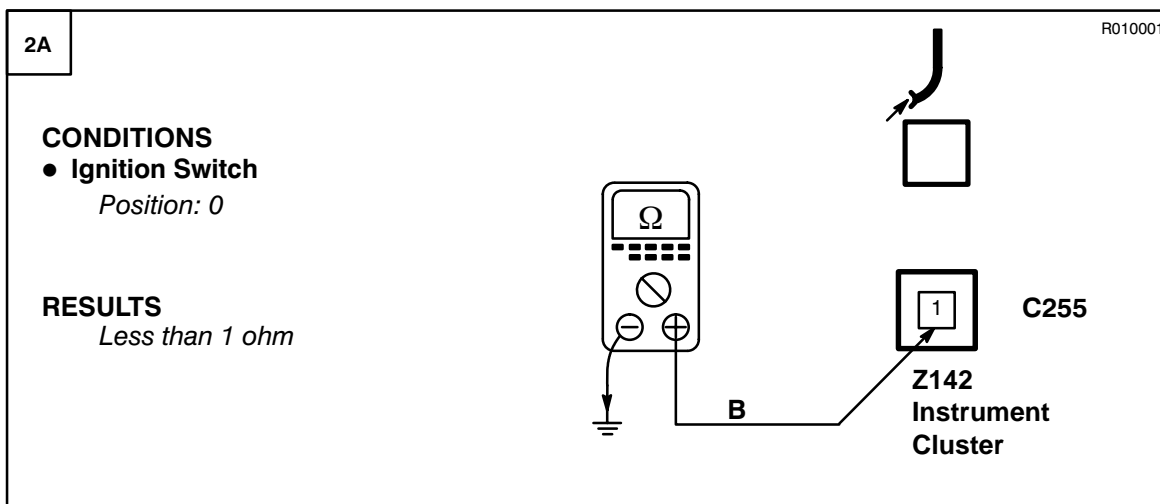
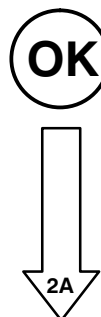

~~OK~~ **PROBLEM CAUSE**
 - B Wire

OK **PROBLEM CAUSE**
 - Instrument
 Cluster

Test B

R010001

1B

CONDITIONS

- Ignition Switch
Position: II

RESULTS
BAT VOLT

GU

X114
Engine Coolant
Temperature
Gauge Sensor



- PROBLEM CAUSE**
- GU Wire
 - Instrument Cluster
 - Coolant Temperature Gauge



- PROBLEM CAUSE**
- Engine Coolant Temperature Gauge Sensor

Test C

R040001

1C

CONDITIONS

- Ignition Switch
Position: II

RESULTS
5V

GB

Z134
Fuel Pump Mod-
ule



- PROBLEM CAUSE**
- GB Wire
 - Instrument Cluster
 - Fuel Gauge

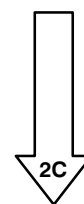

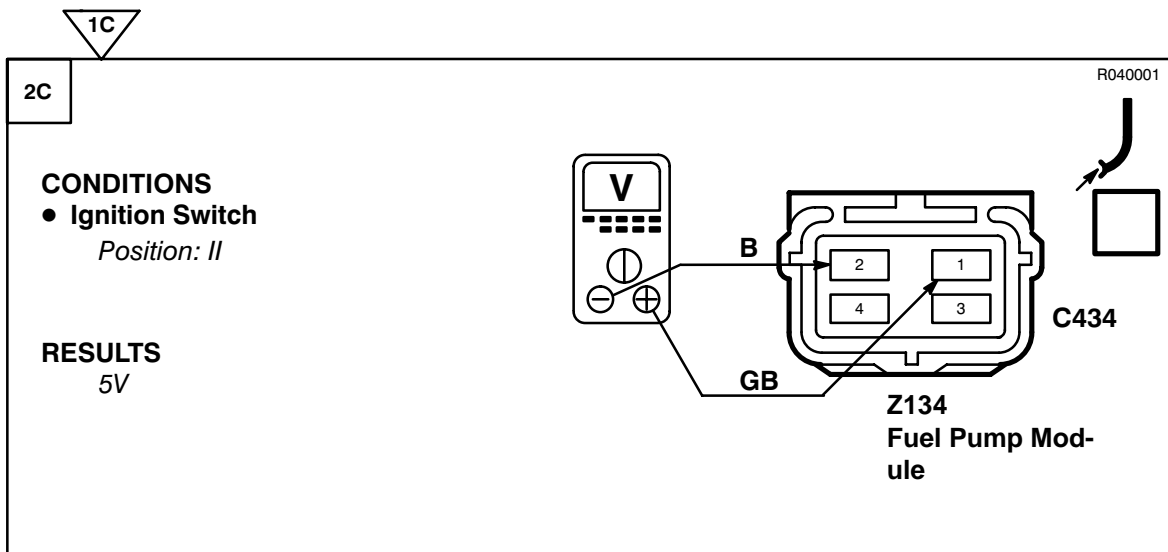

OK PROBLEM CAUSE
- B Wire

OK PROBLEM CAUSE
- Fuel Pump Module

Test D

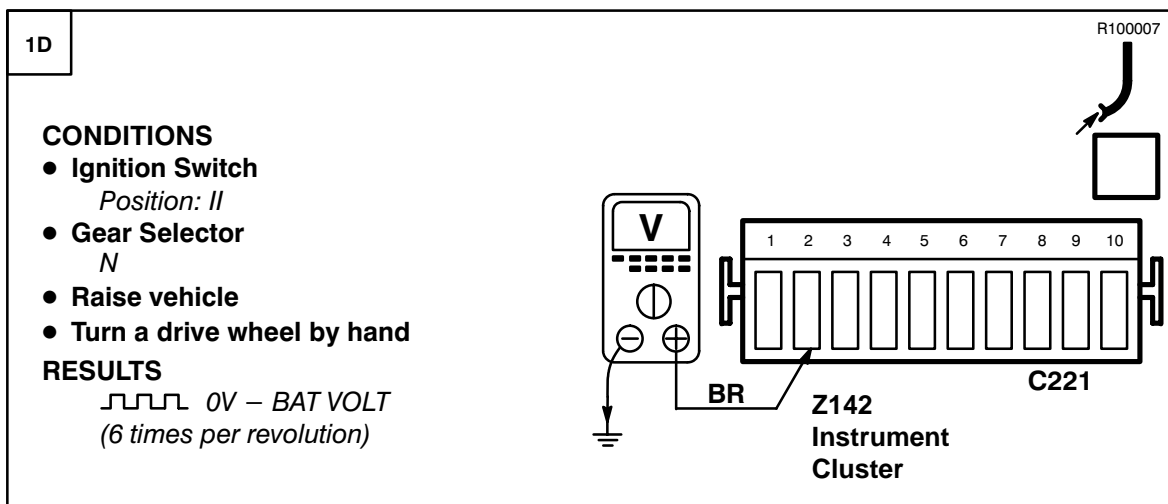

OK PROBLEM CAUSE
- GY Wire
- BR Wire
- Vehicle Speed Sensor

OK PROBLEM CAUSE
- Instrument Cluster
- Speedometer

Test E

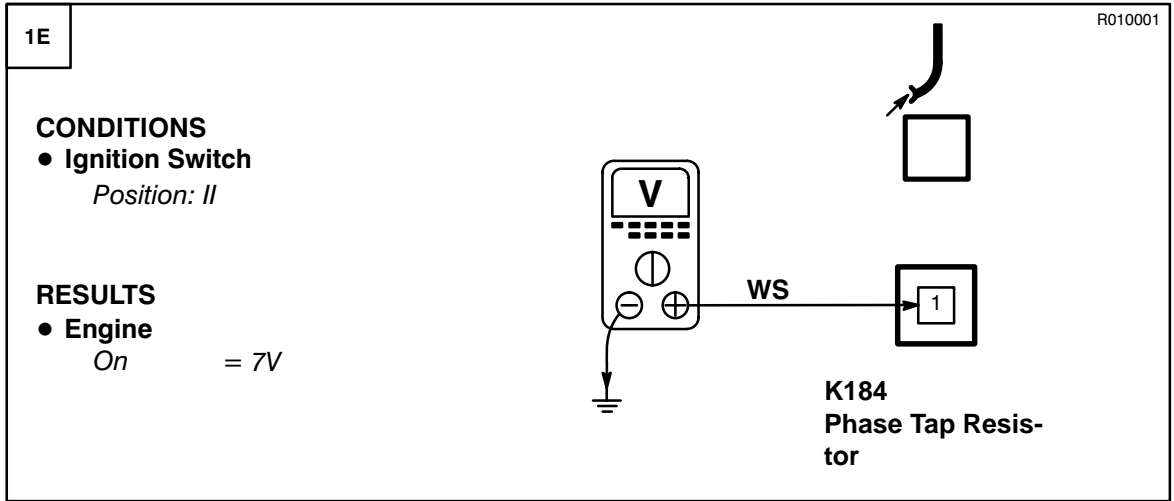

- PROBLEM CAUSE**
- Generator
 - Phase Tap Resistor



- PROBLEM CAUSE**
- WS Wire
 - Instrument Cluster
 - Tachometer

CIRCUIT OPERATION**Charge Warning Light**

The charge warning light receives battery voltage with the Ignition Switch (X134) in position II. This warning light is grounded by the Generator (Z106) if the Generator is not producing normal power output or the Generator stops turning.

ABS Warning Light

The ABS warning light receives battery voltage with the Ignition Switch (X134) in position II. It is grounded by the Anti-Lock Brake System ECU (Z108) or the ABS Warning Relay (K103) in the event of an ABS problem.

Brake Warning Light

The brake warning light receives battery voltage with the Ignition Switch (X134) in position II. It is grounded by the Brake Fluid Level Switch (X111) when the brake fluid level is low. It may also be grounded when the Handbrake Switch (X191) is closed.

Oil Pressure Warning Light

The oil pressure warning light receives battery voltage with the Ignition Switch (X134) in position II. If the engine oil pressure is very low, the Oil Pressure Switch (X149) will apply ground to the warning light.

Transmission/Transfer Box Oil Temperature Warning Light

The transmission/transfer box oil temperature warning light is grounded by the Automatic Transmission Oil Temperature Switch (X108) when the temperature of the transmission fluid exceeds 130°C (266°F). The warning light is also grounded by the Transfer Box Oil Temperature Switch (X174) when the temperature of the transfer box fluid exceeds 145°C (266°F).

MFI-V8 AND 300Tdi With EDC**Malfunction Indicator Lamp (Check Engine)**

The Malfunction Indicator Lamp (Check Engine) is grounded by the Engine Control Module (ECM) (Z132) when a diagnostic trouble code is set.

Diesel**Glow Plug Indicator**

The Glow Plug Indicator is grounded by the Glow Plug Timer Unit (Z135) to indicate that the Glow Plugs have been activated.

Hazard Indicator

If the Hazard Switch (X220) is depressed, a pulsing voltage is applied to the Hazard Indicator which is permanently grounded by ground E201.

Direction Indicator

If the Direction Indicator Switch (X116) is turned on, a pulsing voltage is applied from the Flasher Unit (Z128) to the Direction Indicator which is permanently grounded by ground E201.

Trailer Indicator

With the Direction Indicator Switch (X116) turned on, the Flasher Unit (Z128) also applies a pulsing voltage to the Trailer Indicator which is permanently grounded by ground E201.

SRS Indicators

The SRS Indicators are controlled by the Air Bag Diagnostic Control Module (Z151) and the SRS Indicator Control Circuit of the Instrument Cluster (Z142) to indicate SRS System faults.

Low Fuel Warning Indicator

When the fuel gauge sender's resistance falls below approximately 25 Ohms (6 liters/1.5 US gallons), the Low Fuel Warning Indicator will illuminate to warn the driver.

Main Beam Indicator

With the Headlamps turned on the Main Lighting Switch (X145), battery voltage is applied to the Main Beam Indicator which is also permanently grounded by ground E201.

Differential Lock Indicator

The Differential Lock Indicator receives battery voltage with the Ignition Switch (X134) in position II. It is grounded by the Differential Lock Switch (X238) when the Differential is locked.

Fasten Seat Belt Indicator

The Fasten Seat Belt Indicator receives battery voltage with the Ignition Switch (X134) in position II.

The indicator is also grounded through the Multifunction Unit (MFU) (Z148) and the Driver's Seat Buckle Switch (X120).

If the Driver's Seat Belt is buckled the Driver's Seat Belt Buckle Switch opens and the Indicator turns off.

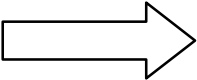
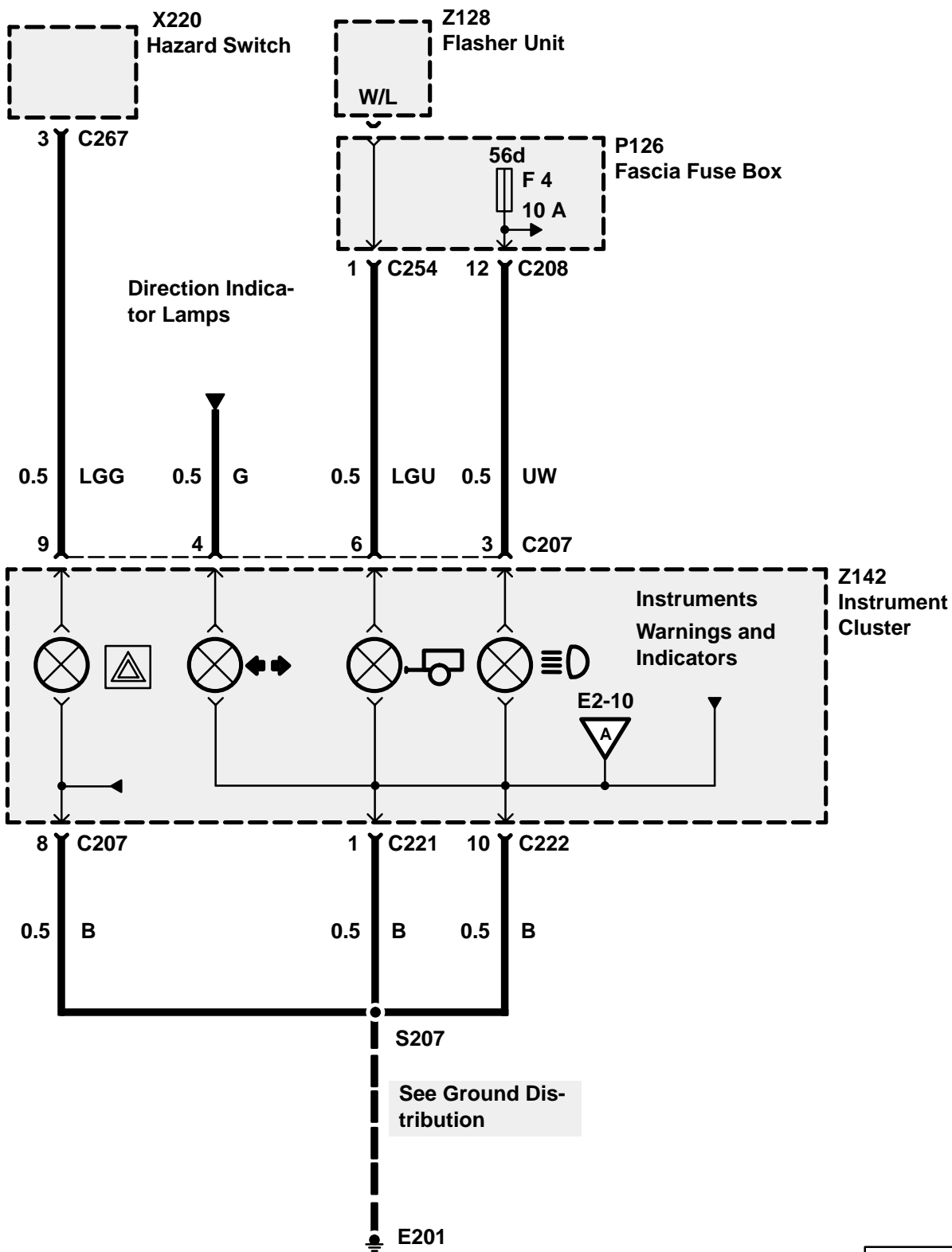

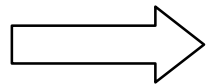
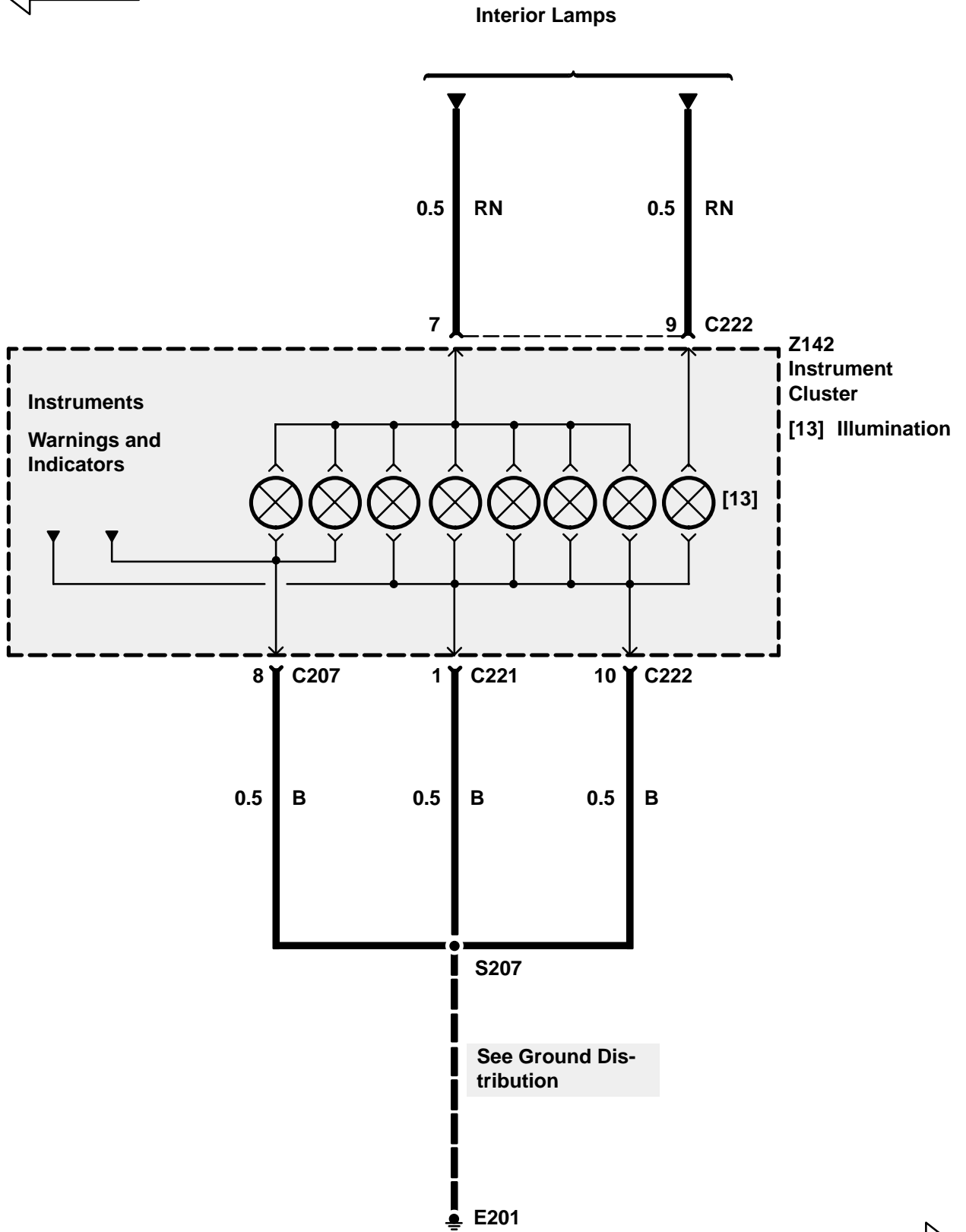
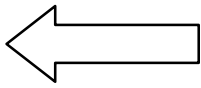

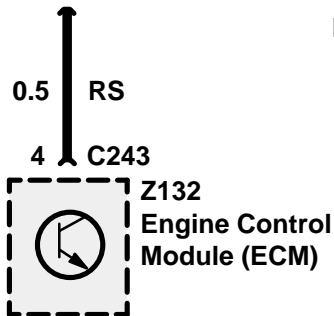
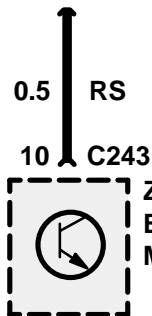
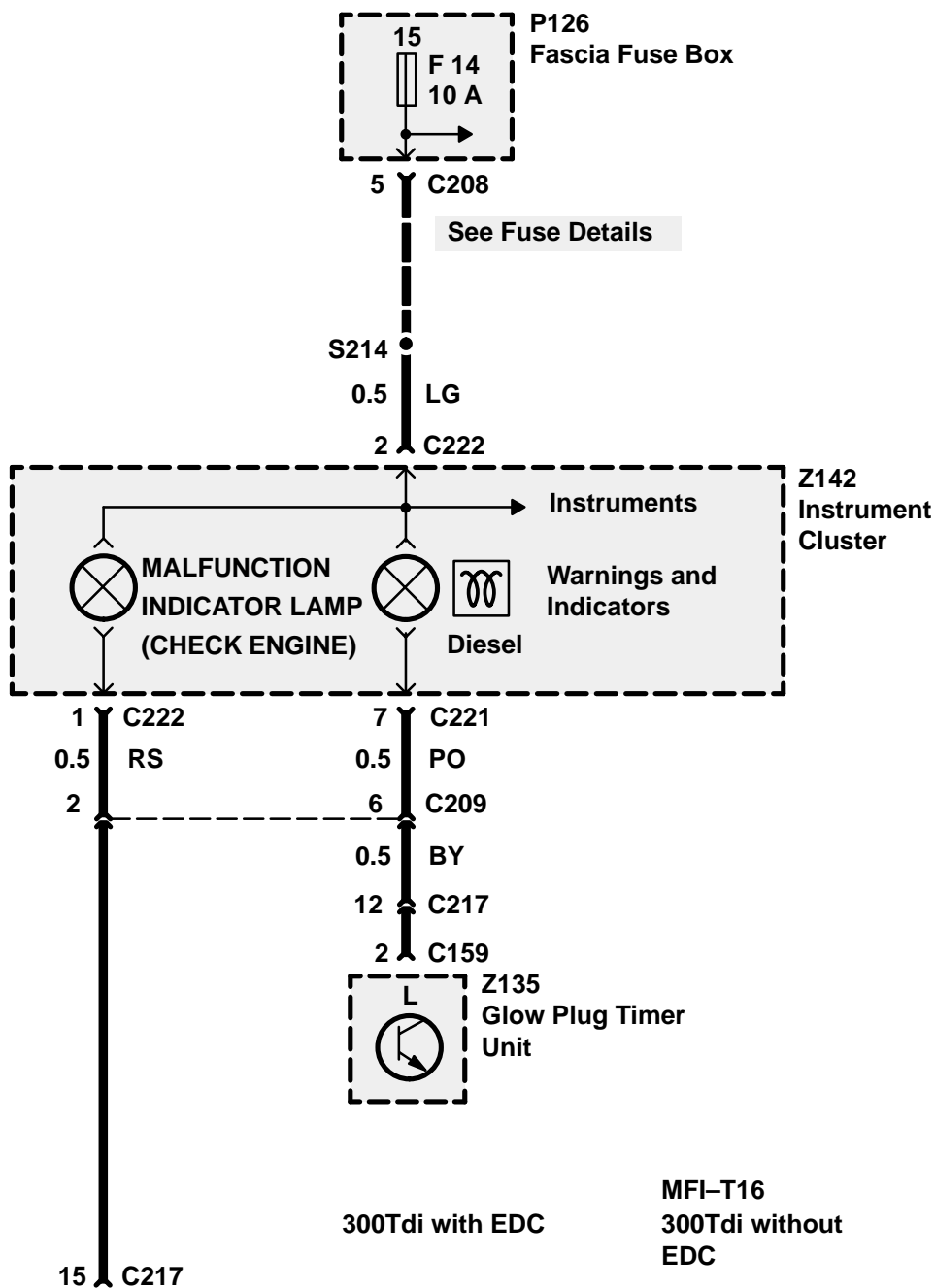
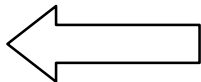

Not used

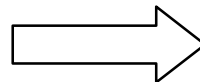

E2 ETM

DISCOVERY

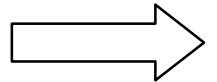
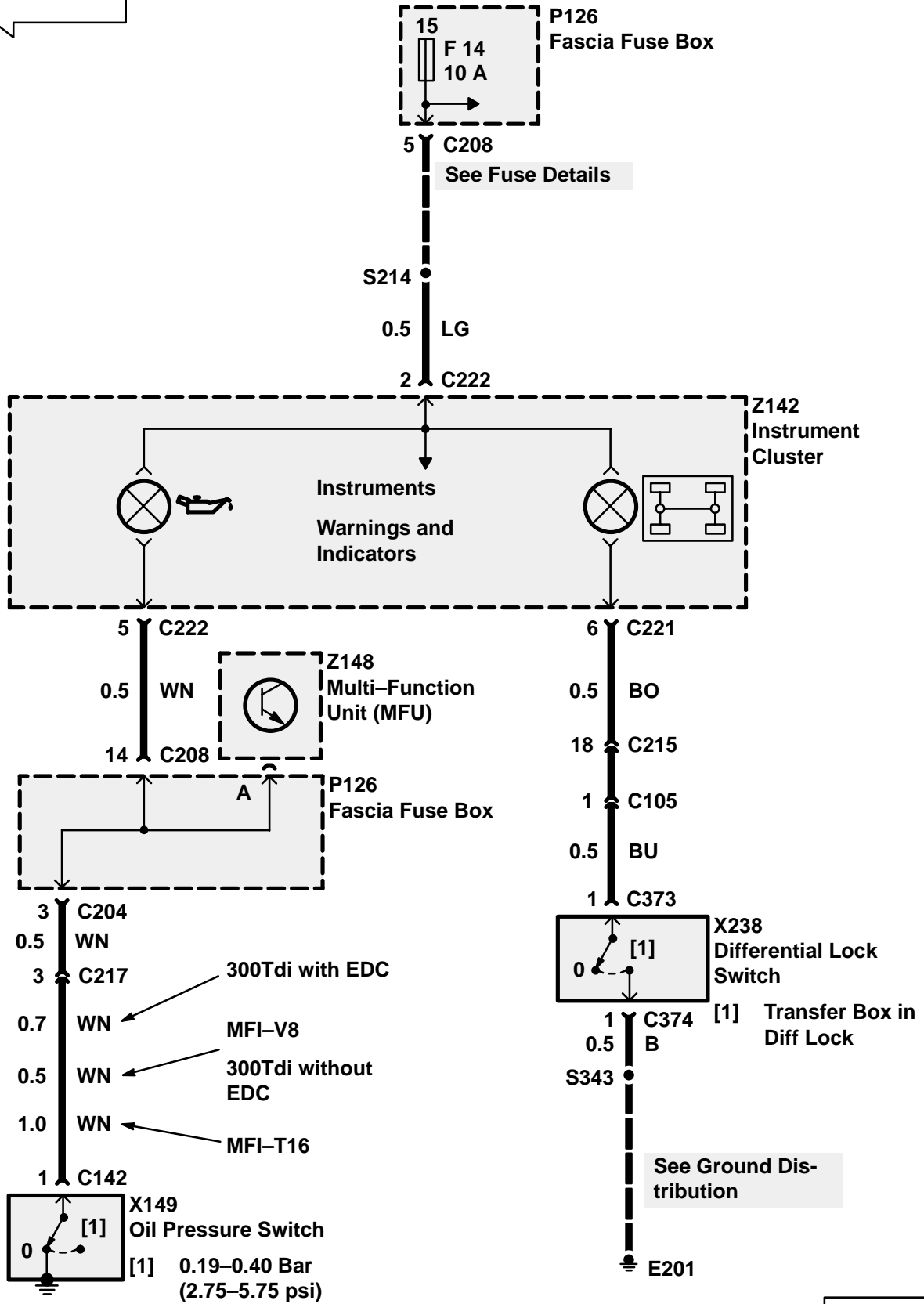
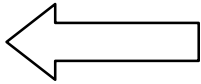

DISCOVERY

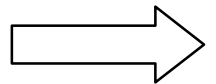
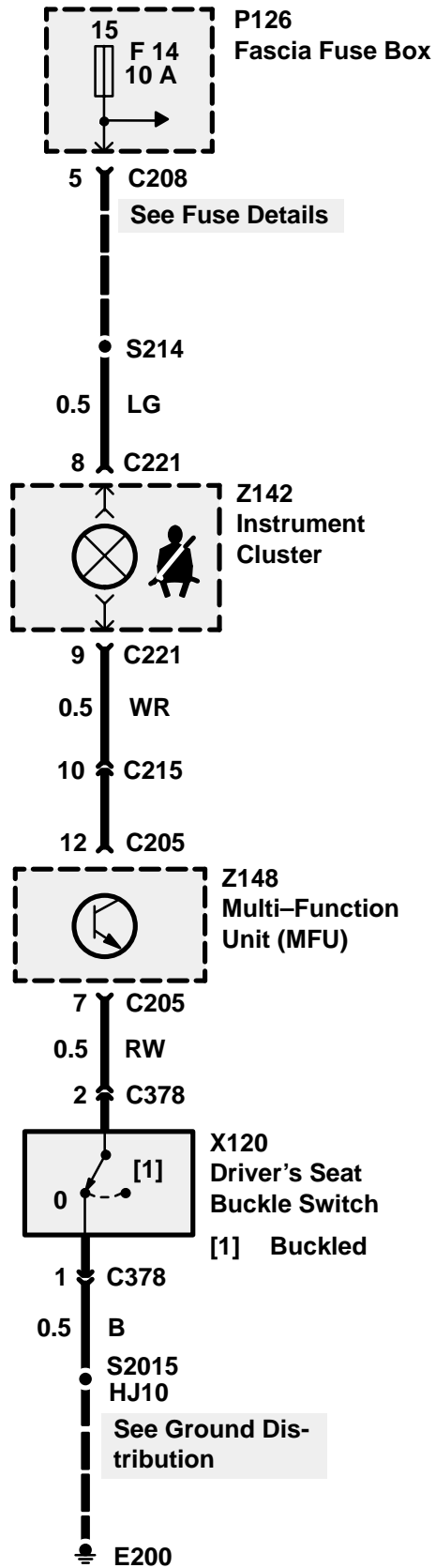
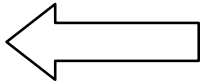

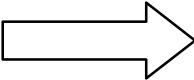
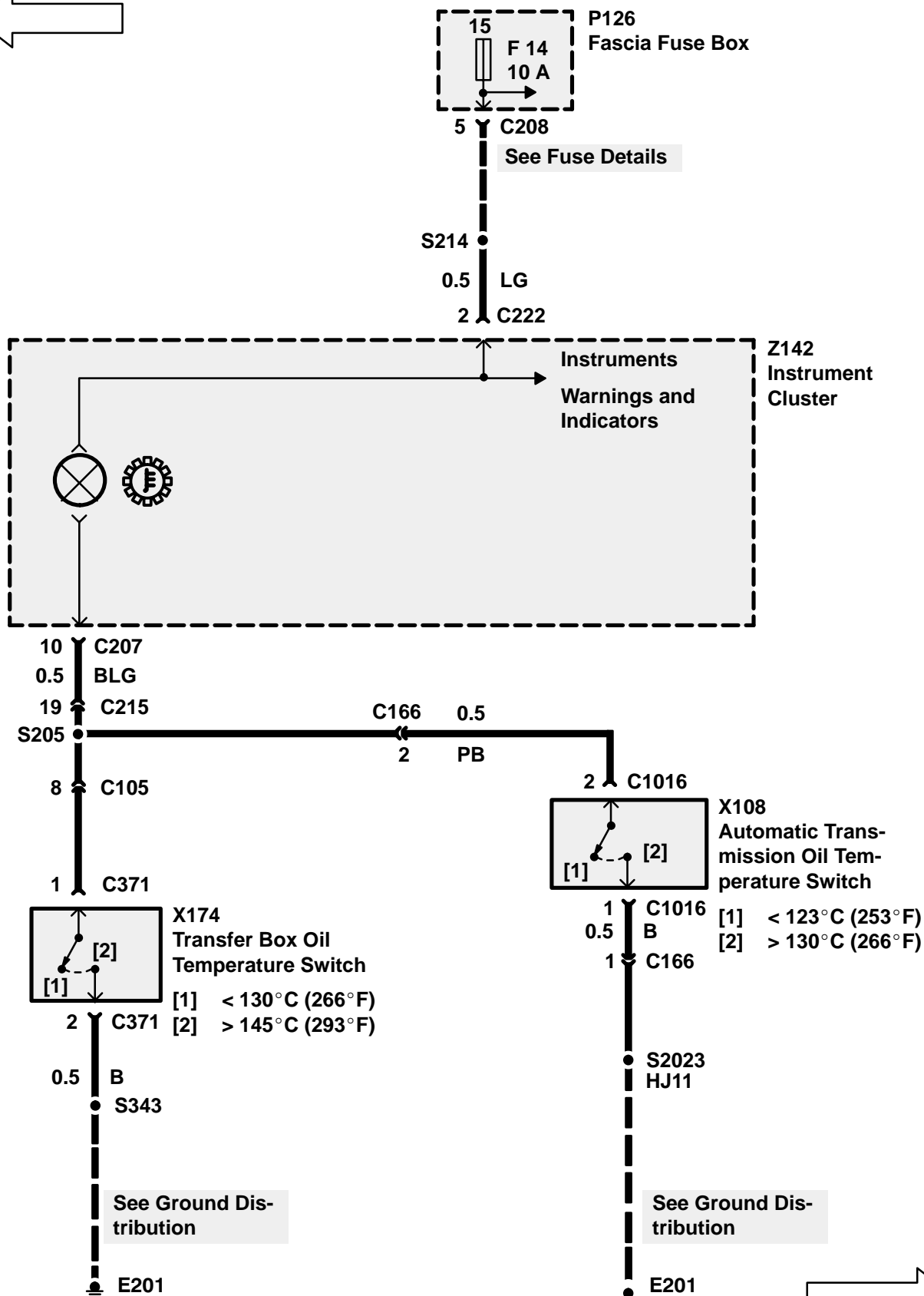
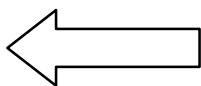

E2 ETM

DISCOVERY

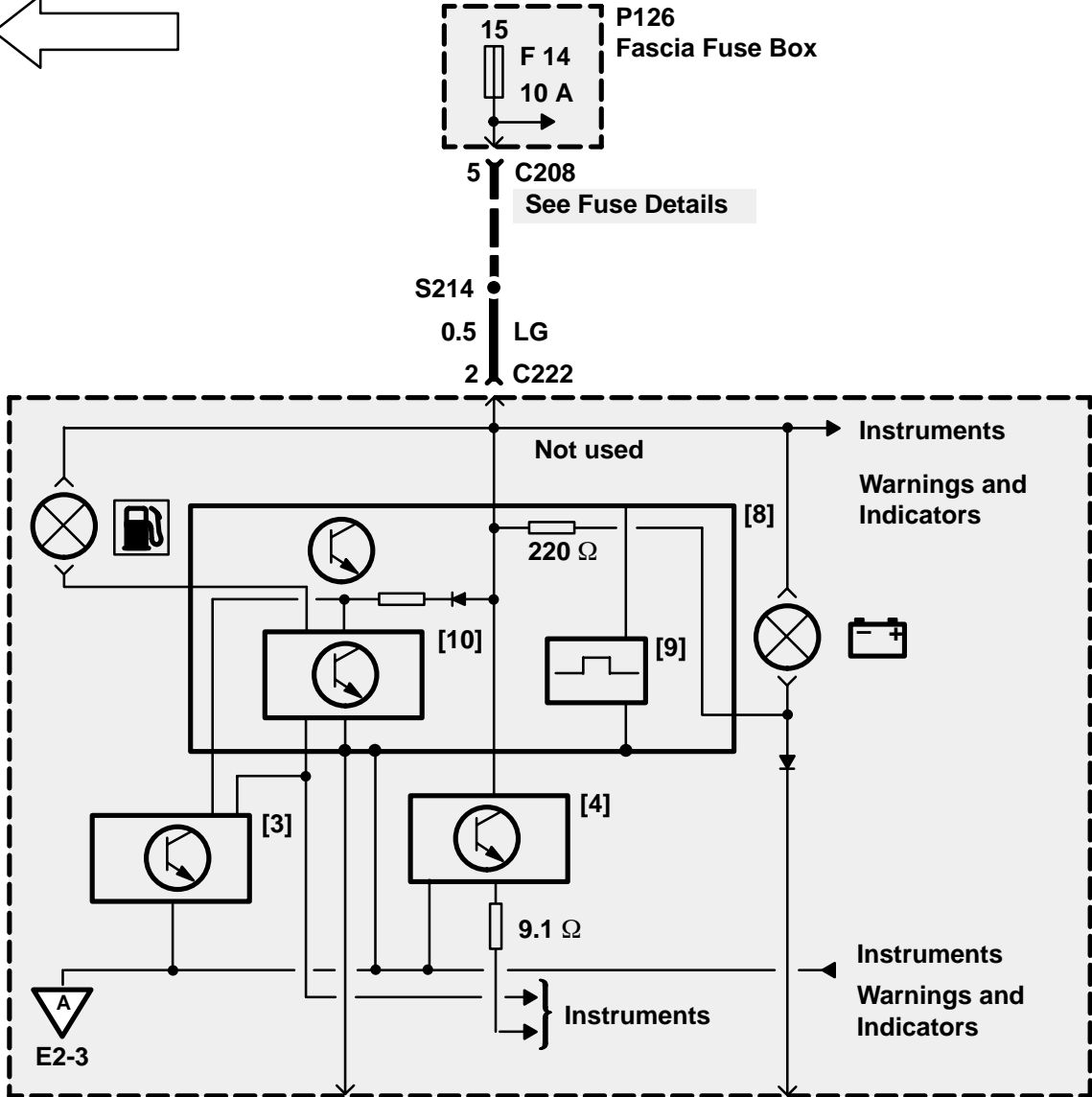
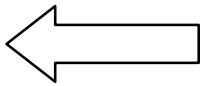

Z142
Instrument
Cluster

- [3] Fuel Gauge
- [4] Temperature Gauge
- [8] CPU
- [9] 3-Sec. Timer
- [10] Low Fuel Warning and Anti-slosh Control

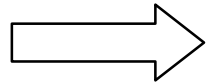
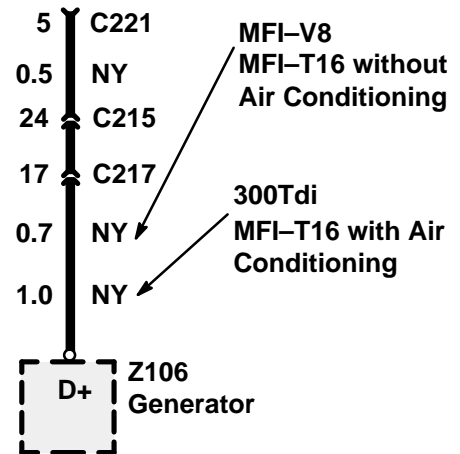

E2 ETM

DISCOVERY

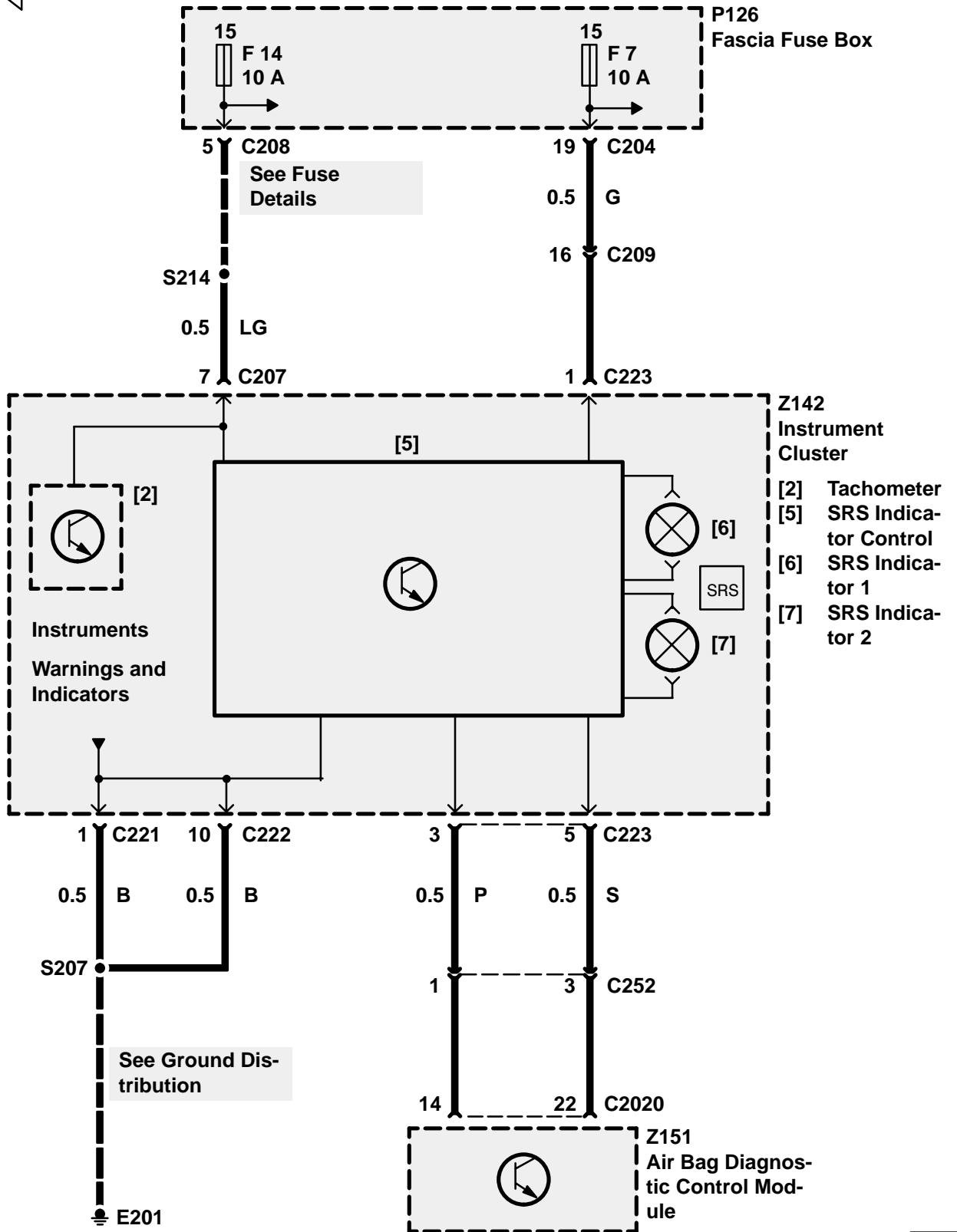
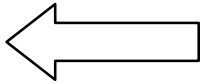

TROUBLESHOOTING HINTS

If more than one warning light is out, check power and ground wires common to all affected warning lights. If they are OK, replace Instrument Cluster (Z142). If the Brake Warning Light does not operate at all, check Instrument Cluster (Z142) and K Wire.

SYSTEM DIAGNOSIS

15. If the Charge Warning Light does not operate, go to Section B1.
16. If the Oil Pressure Warning Light remains illuminated with the oil pressure OK, do Test A.
17. If the Malfunction Indicator Lamp (Check Engine) does not operate, do Test B for MFI-V8 engines, Test C for 300TDI with EDC engines.
18. If the Glow Plug Indicator does not operate, do Test D.
19. If the Brake Warning Light does not operate with the Brake Fluid Level low, do Test E.
20. If the Brake Warning Light does not operate with the Handbrake applied, do Test F.
21. If the Differential Lock Indicator remains on after the differential lock has been disengaged, transmission "wind up" may be present. Drive the vehicle in reverse for a short distance, then drive forward for a short distance. If the light remains on after driving in reverse, do Test G.
22. If the Fasten Seat Belt Indicator does not operate with the ignition on, do Test H.
23. If the Transmission/Transfer Box Oil Temperature Warning Light is illuminated with both the Transfer Box Oil Temperature and the Automatic Transmission Oil Temperature OK, do Test I.
24. If a warning light exhibits any symptom not mentioned above, check the associated bulb, wires, switches, and components.

Test A

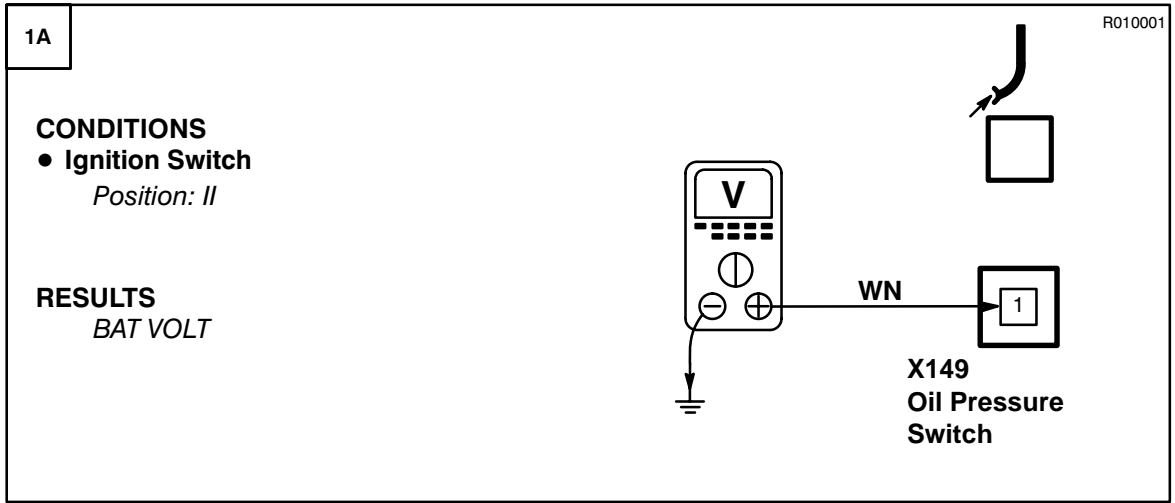

OK PROBLEM CAUSE
- WN Wire

OK PROBLEM CAUSE
- Oil Pressure
Switch

Test B

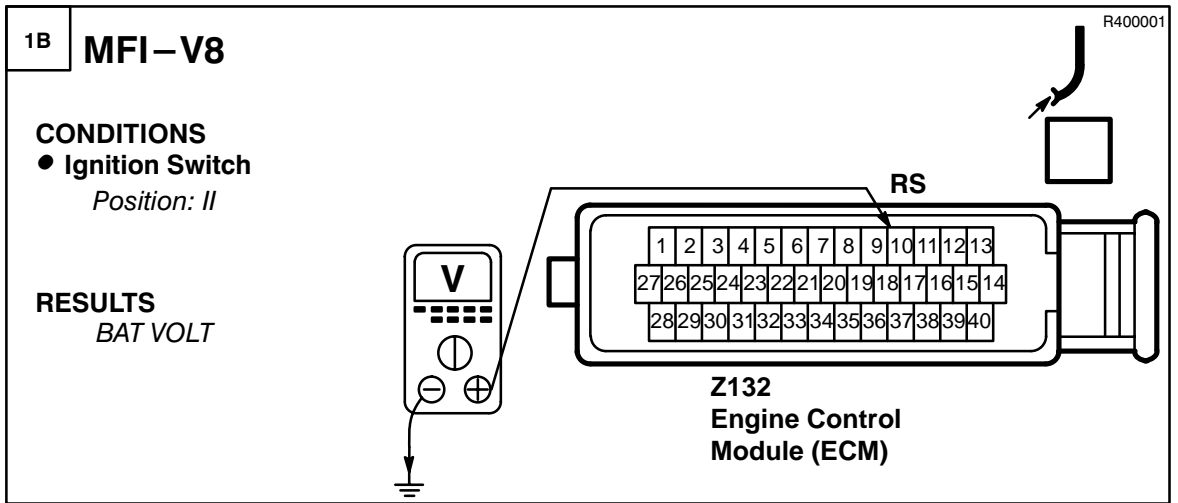

OK

↓

2B

OK PROBLEM CAUSE
- Engine Control
Module (ECM)

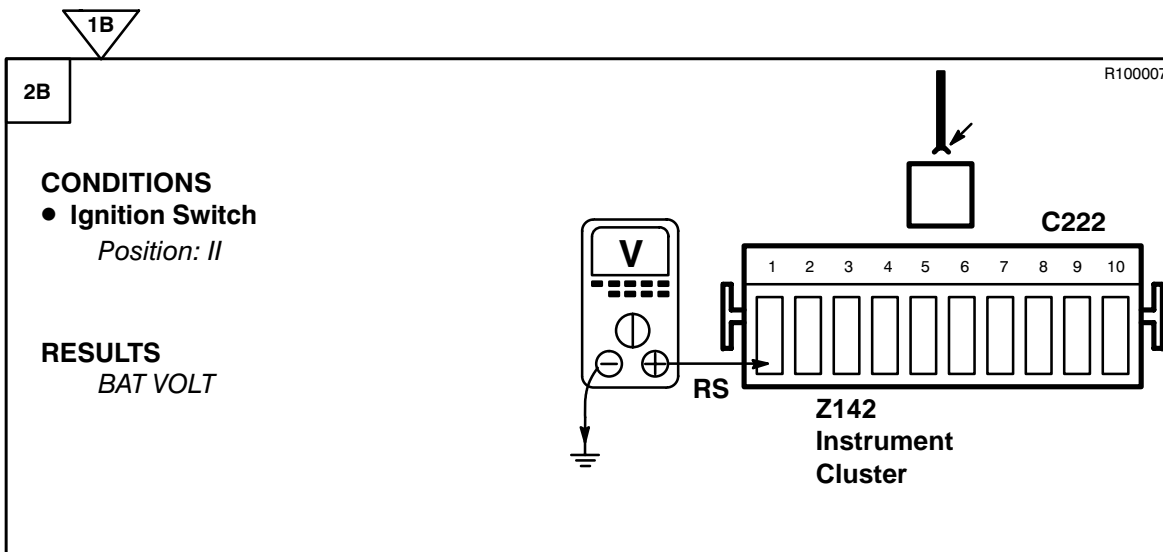

CONDITIONS
 • Ignition Switch
 Position: II

RESULTS
 BAT VOLT



PROBLEM CAUSE
 - Instrument Cluster



PROBLEM CAUSE
 - LG Wire
 - RS Wire

Test C

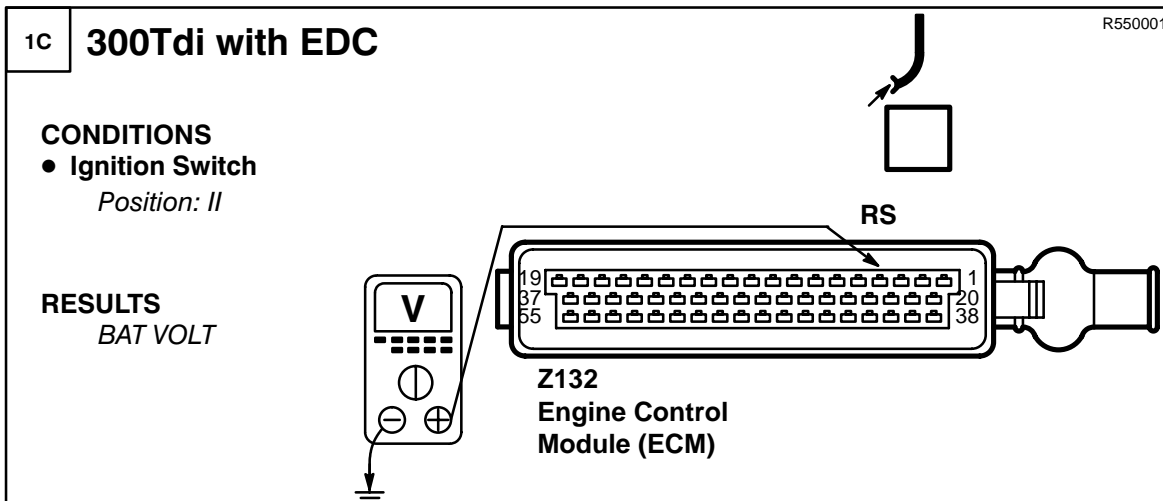

CONDITIONS
 • Ignition Switch
 Position: II

RESULTS
 BAT VOLT

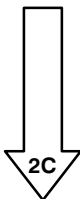

PROBLEM CAUSE
 - Engine Control Module (ECM)

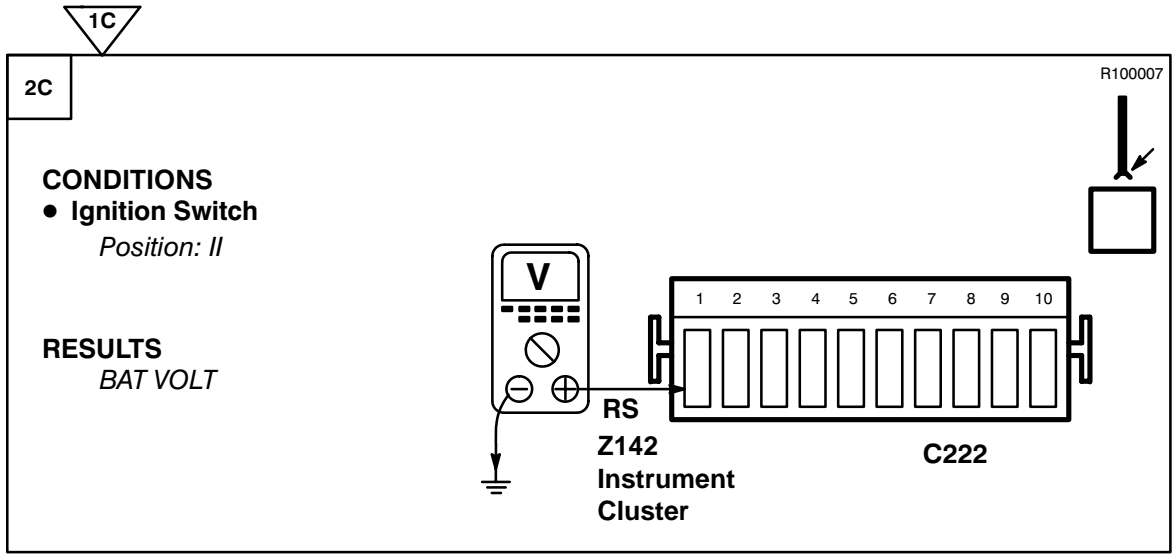

PROBLEM CAUSE
- Instrument Cluster



PROBLEM CAUSE
- LG Wire
- RS Wire

Test D

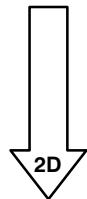
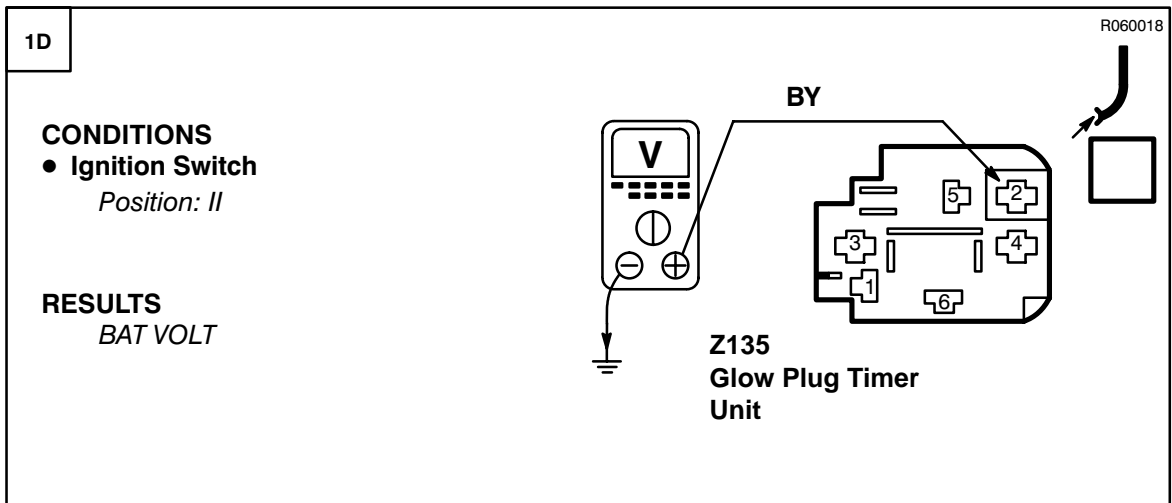

PROBLEM CAUSE
- Glow Plug Timer Unit

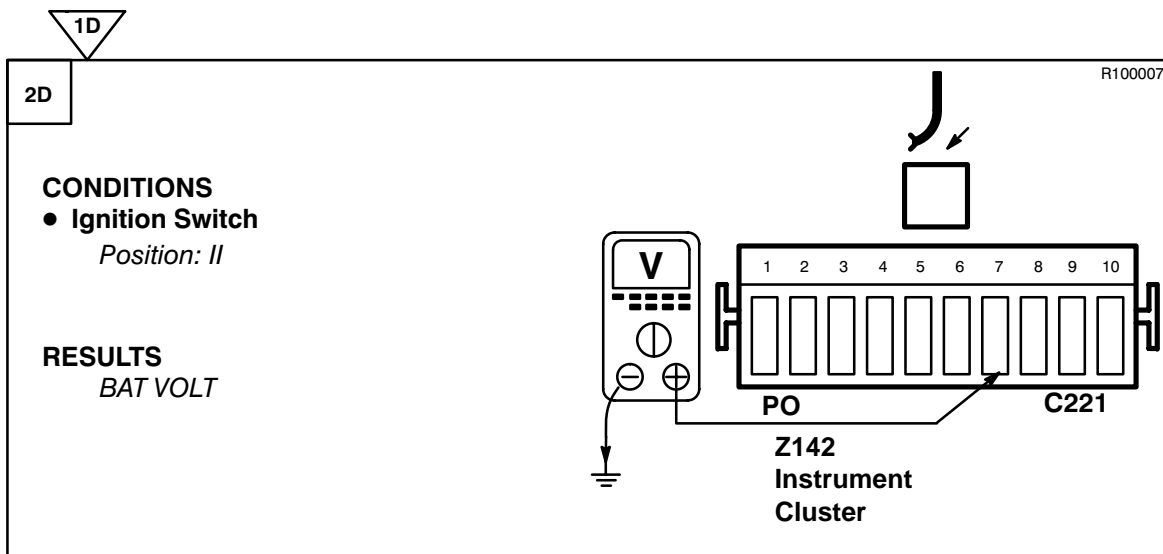

PROBLEM CAUSE
- Instrument Cluster



PROBLEM CAUSE
- PO Wire
- BY Wire

Test E

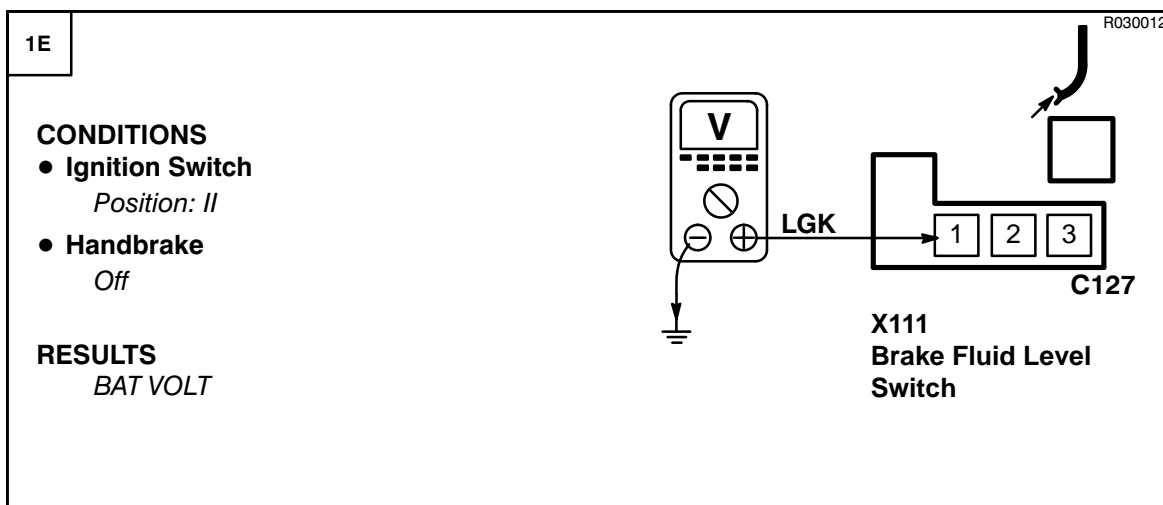

PROBLEM CAUSE
- LGK Wire
- Instrument Cluster



PROBLEM CAUSE
- B Wire
- Brake Fluid Level Switch

Test F

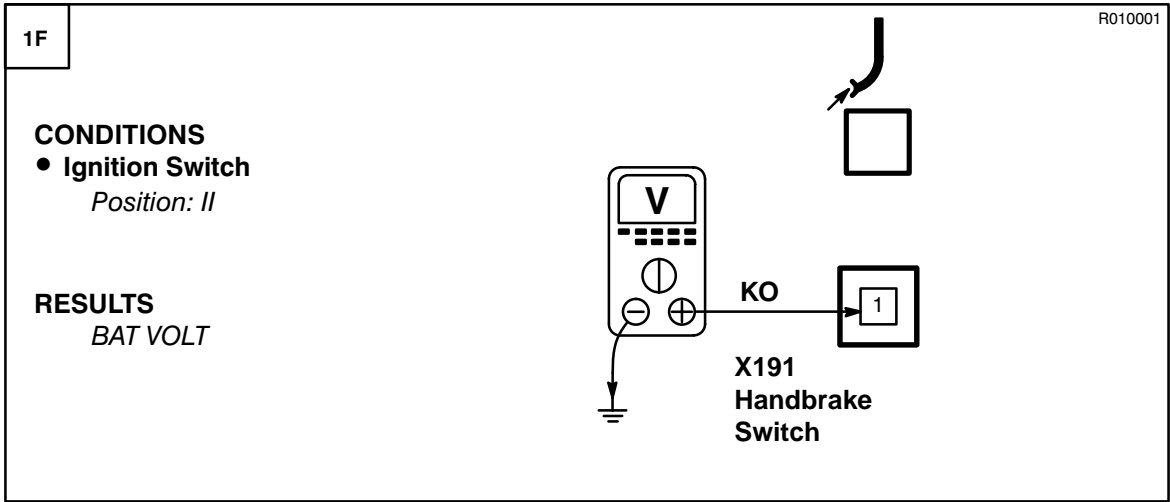

OK PROBLEM CAUSE
- KO Wire

OK PROBLEM CAUSE
- Handbrake Switch

Test G

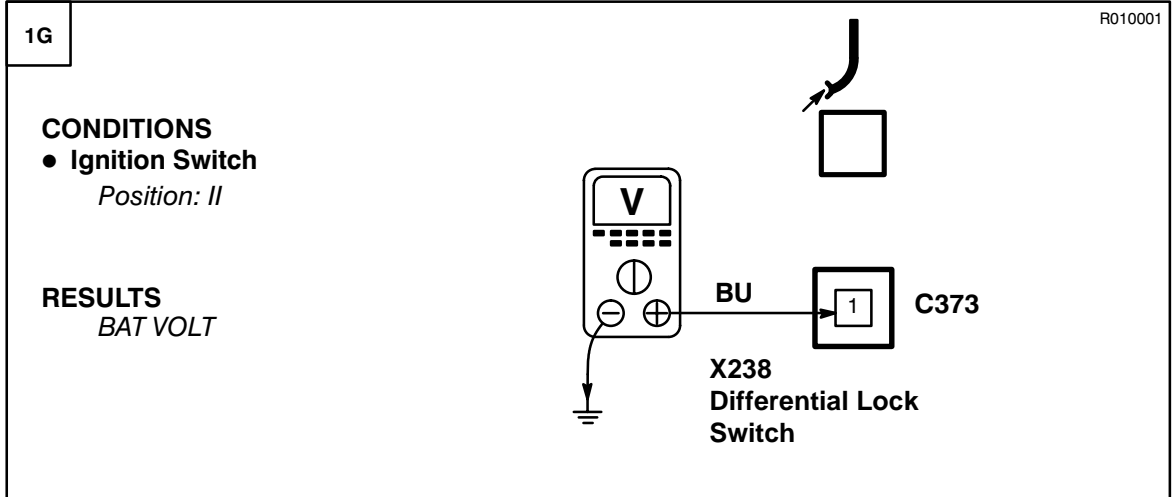

OK PROBLEM CAUSE
- LG Wire
- BO Wire
- BU Wire

OK PROBLEM CAUSE
- B Wire
- Differential Lock
Switch

Test H

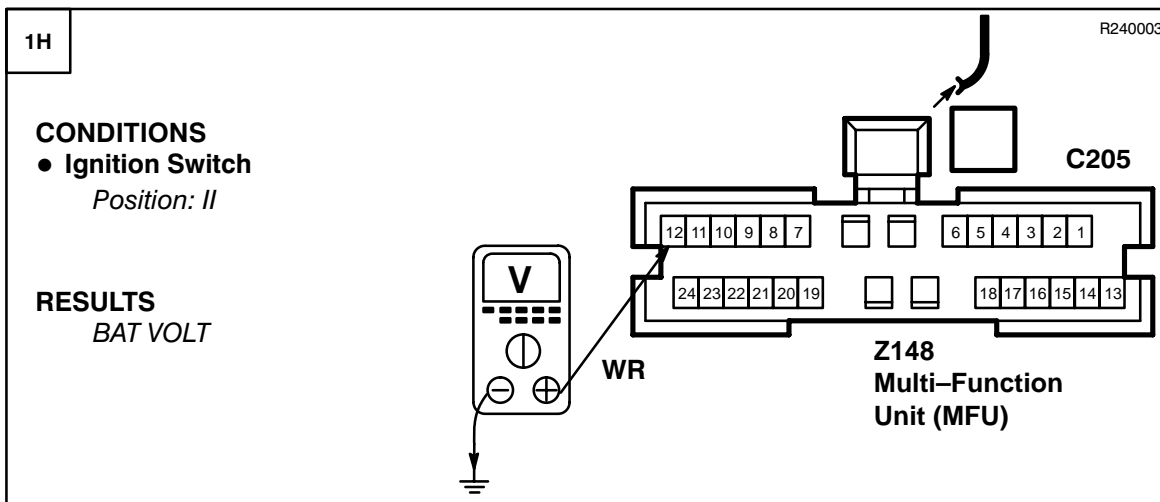

1H

CONDITIONS

- Ignition Switch
Position: II

RESULTS

BAT VOLT



PROBLEM CAUSE

- WR Wire
- LG Wire
- Instrument Cluster

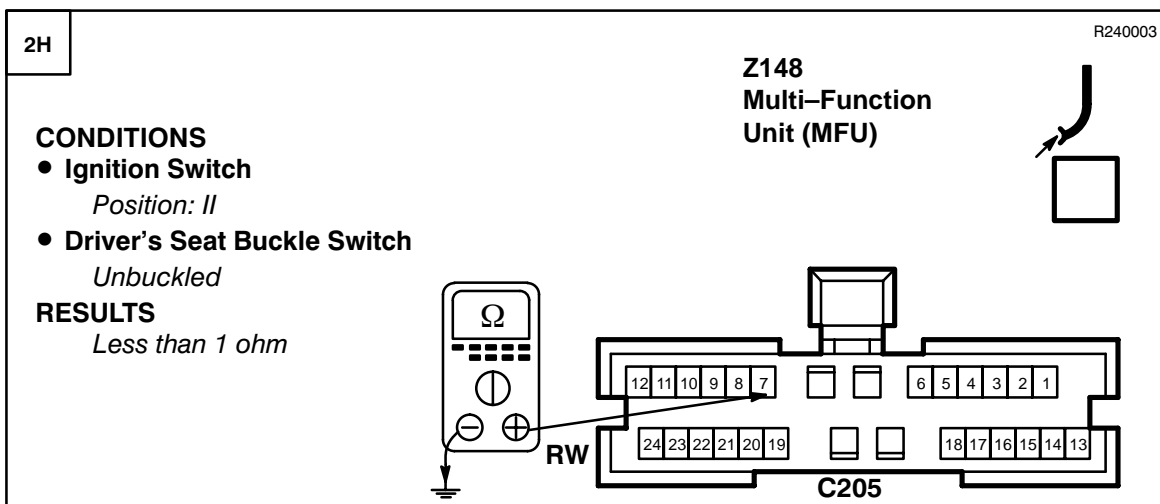

2H

CONDITIONS

- Ignition Switch
Position: II
- Driver's Seat Buckle Switch
Unbuckled

RESULTS

Less than 1 ohm



PROBLEM CAUSE

- RW Wire
- B Wire
- Driver's Seat Buckle Switch



PROBLEM CAUSE

- Multi-Function Unit (MFU)

Test I

R020003

11

CONDITIONS

- Ignition Switch
Position: II

RESULTS
BAT VOLT

X108
Automatic Transmission Oil Temperature Switch



- PROBLEM CAUSE**
- BLG, PB Wire
 - Transfer Box Oil Temperature Switch



- PROBLEM CAUSE**
- B Wire
 - Automatic Transmission Oil Temperature Switch

CIRCUIT OPERATION**Charge Warning Light**

The charge warning light receives battery voltage with the Ignition Switch (X134) in position II. This warning light is grounded by the Generator (Z106) if the Generator is not producing normal power output or the Generator stops turning.

ABS Warning Light

The ABS warning light receives battery voltage with the Ignition Switch (X134) in position II. It is grounded by the Anti-Lock Brake System ECU (Z108) or the ABS Warning Relay (K103) in the event of an ABS problem.

Brake Warning Light

The brake warning light receives battery voltage with the Ignition Switch (X134) in position II. It is grounded by the Brake Fluid Level Switch (X111) when the brake fluid level is low. It may also be grounded when the Handbrake Switch (X191) is closed.

Oil Pressure Warning Light

The oil pressure warning light receives battery voltage with the Ignition Switch (X134) in position II. If the engine oil pressure is very low, the Oil Pressure Switch (X149) will apply ground to the warning light.

Transmission/Transfer Box Oil Temperature Warning Light

The transmission/transfer box oil temperature warning light is grounded by the Automatic Transmission Oil Temperature Switch (X108) when the temperature of the transmission fluid exceeds 130°C (266°F). The warning light is also grounded by the Transfer Box Oil Temperature Switch (X174) when the temperature of the transfer box fluid exceeds 145°C (266°F).

MFI-V8 and 300Tdi with EDC**Malfunction Indicator Lamp (Check Engine)**

The Malfunction Indicator Lamp (Check Engine) is grounded by the Engine Control Module (ECM) (Z132) when a diagnostic trouble code is set.

Service Reminder Indicator

The Service Reminder Indicator receives battery voltage with the Ignition Switch (X134) in position II. The Service Reminder Unit (Z126) grounds the Service Reminder Indicator when the vehicle requires service. The Service Reminder Indicator is also grounded by a 3 second timer as a bulb check.

Hazard Indicator

If the Hazard Switch (X220) is depressed, a pulsing voltage is applied to the Hazard Indicator which is permanently grounded by ground E201.

Direction Indicator

If the Direction Indicator Switch (X116) is turned on, a pulsing voltage is applied from the Flasher Unit (Z128) to the Direction Indicator which is permanently grounded by ground E201.

Trailer Indicator

With the Direction Indicator Switch (X116) turned on, the Flasher Unit (Z128) also applies a pulsing voltage to the Trailer Indicator which is permanently grounded by ground E201.

SRS Indicators

The SRS Indicators are controlled by the Air Bag Diagnostic Control Unit (Z151) and the SRS Indicator Control Circuit of the Instrument Cluster (Z142) to indicate SRS System faults.

Low Fuel Warning Indicator

When the fuel gauge sender's resistance falls below approximately 25 Ohms (6 liters/1.5 US gallons), the Low Fuel Warning Indicator will illuminate to warn the driver. The Low Fuel Warning Indicator is grounded by a 3 second timer as a bulb check.

Main Beam Indicator

With the Headlamps turned on the Main Lighting Switch (X145), battery voltage is applied to the Main Beam Indicator which is also permanently grounded by ground E201.

Differential Lock Indicator

The Differential Lock Indicator receives battery voltage with the Ignition Switch (X134) in position II. It is grounded by the Differential Lock Switch (X238) when the Differential is locked.

Fasten Seat Belt Indicator

The Fasten Seat Belt Indicator receives battery voltage with the Ignition Switch (X134) in position II.

The indicator is also grounded through the Multifunction Unit (MFU) (Z148) and the Driver's Seat Buckle Switch (X120).

If the Driver's Seat Belt is buckled the Driver's Seat Belt Buckle Switch opens and the Indicator turns off.

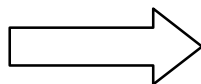
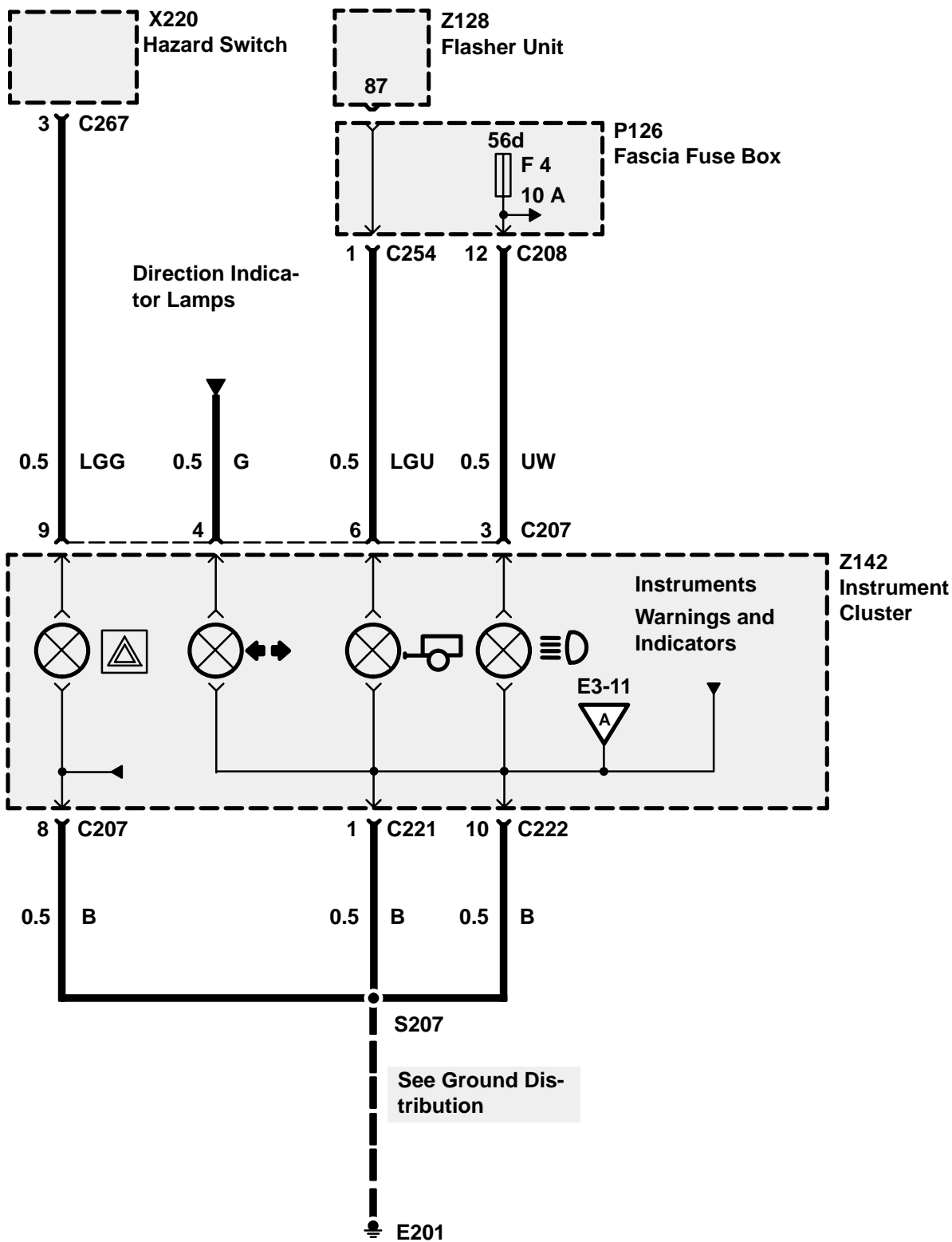

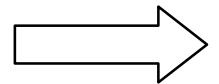
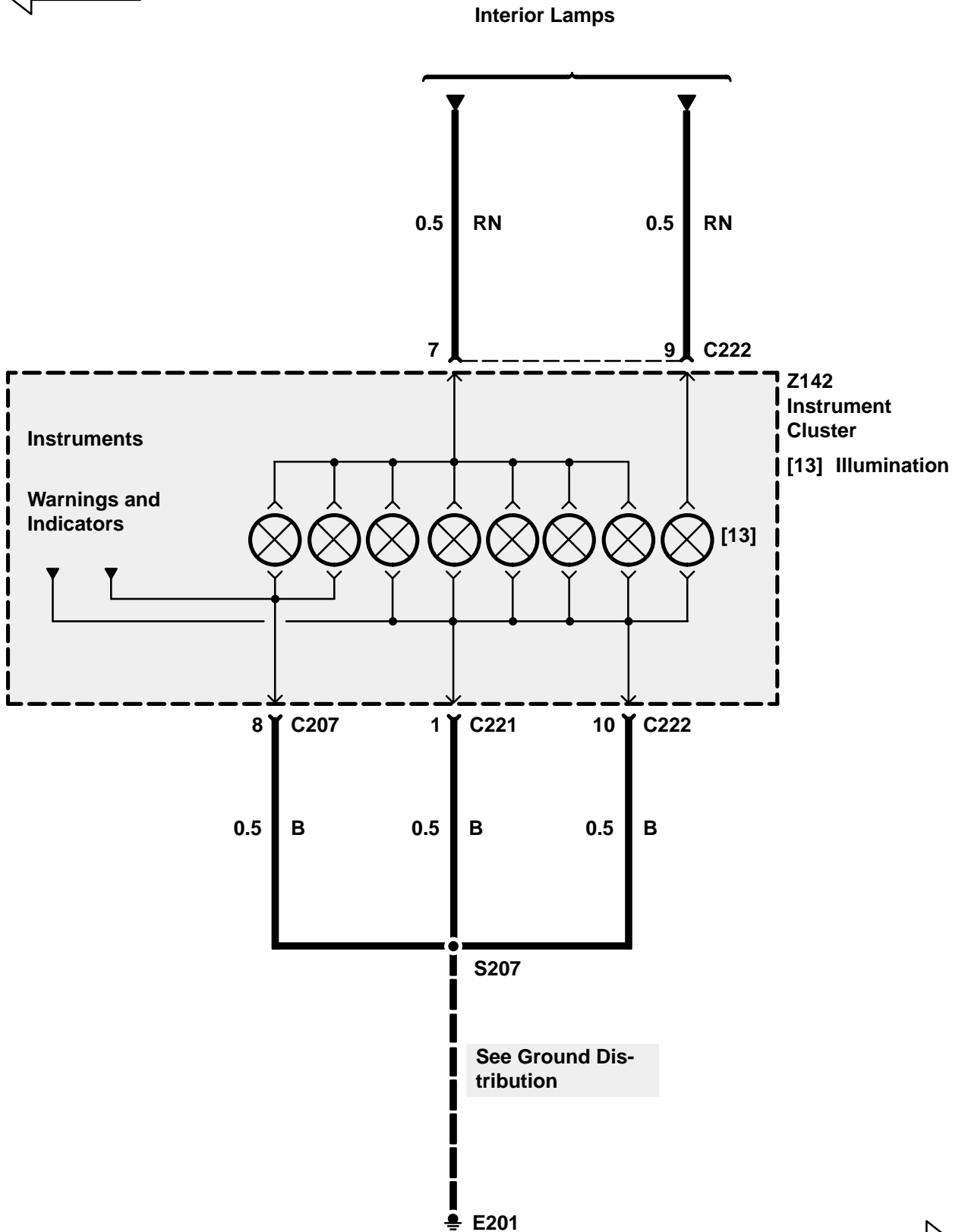

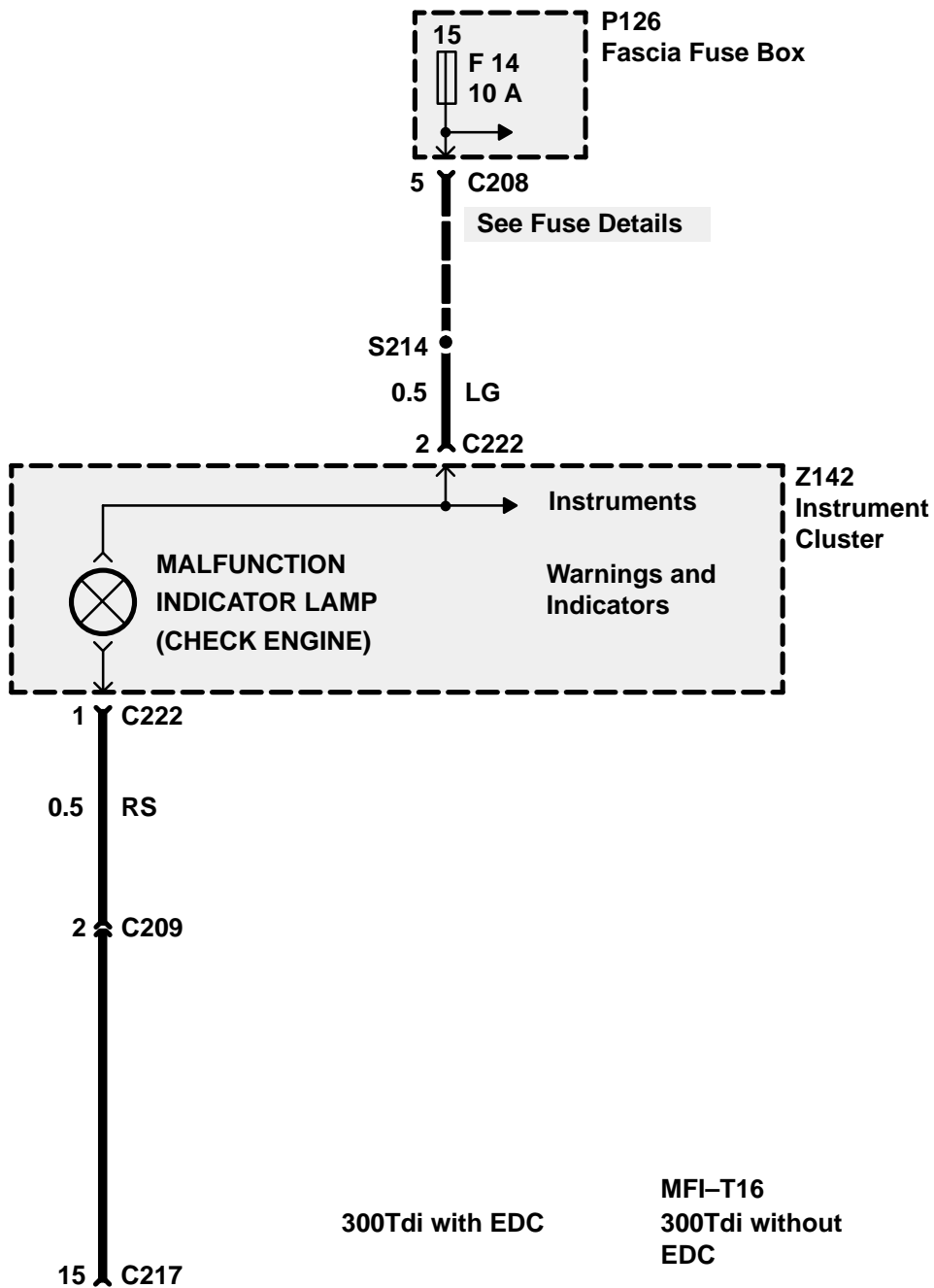
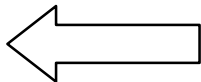

MFI-V8

300Tdi with EDC

MFI-T16
300Tdi without EDC

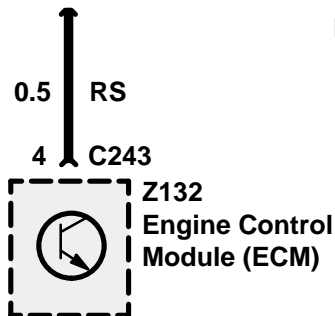
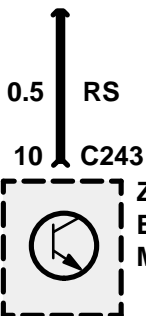

Not used

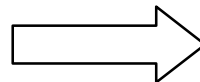

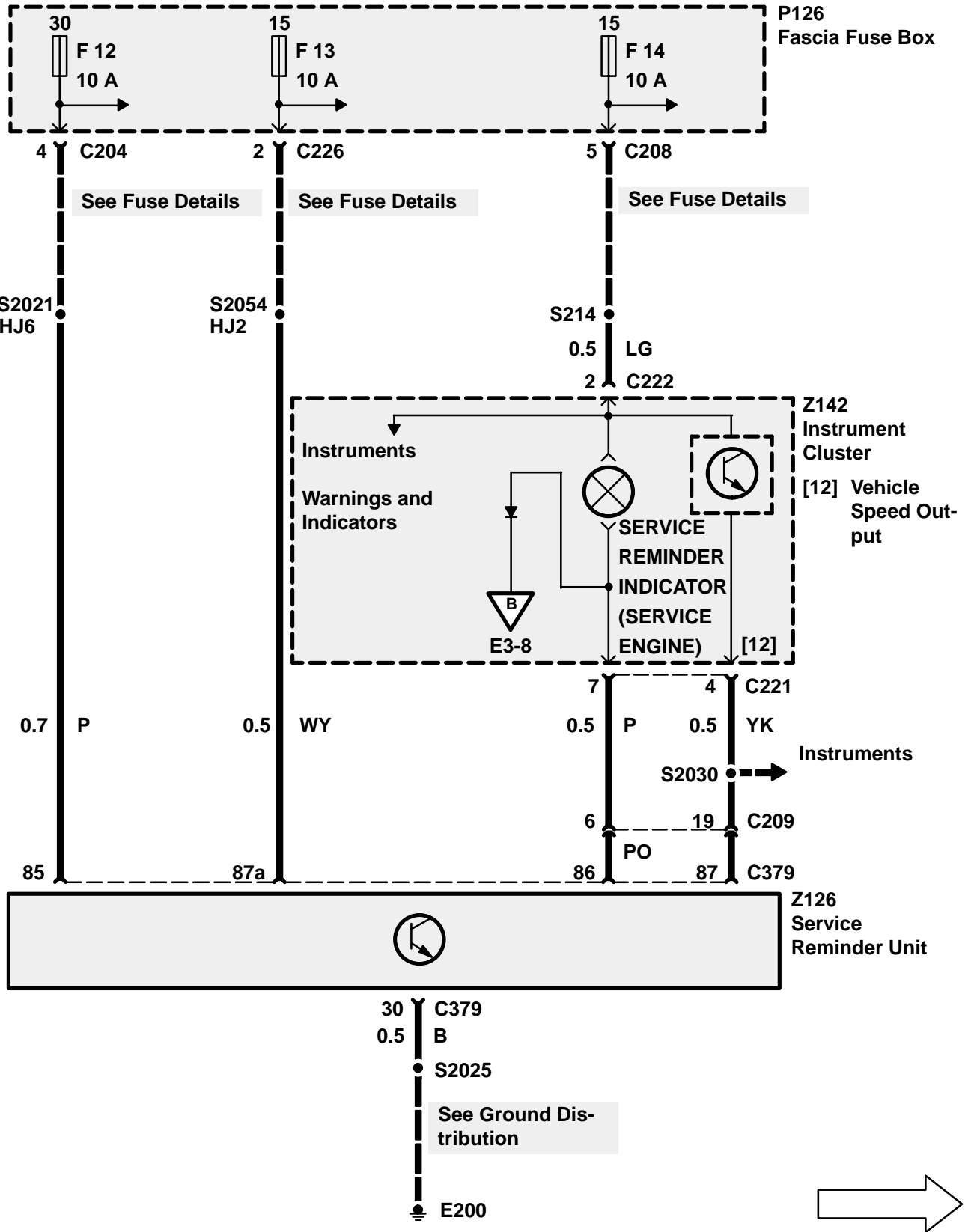

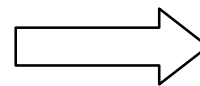
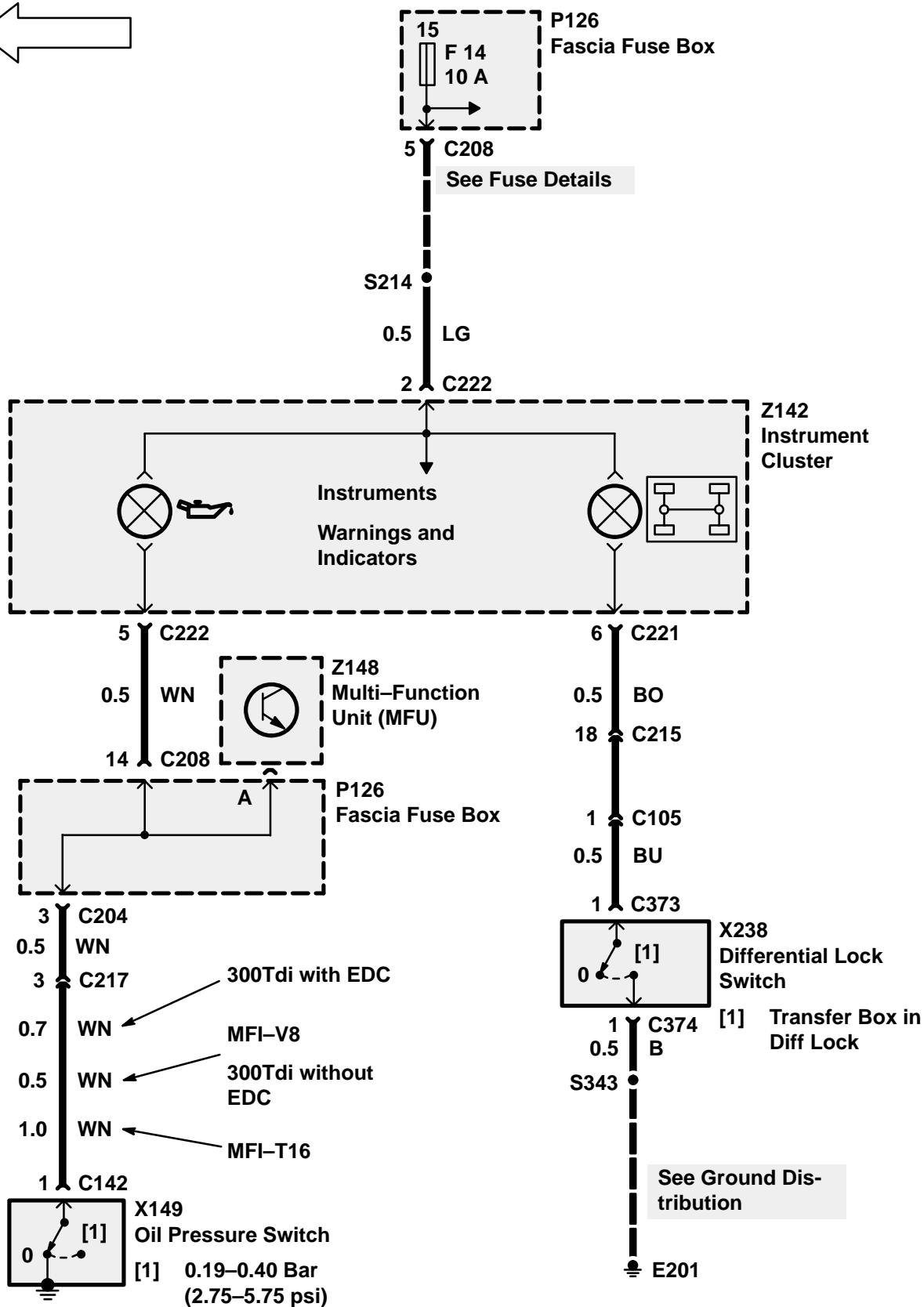
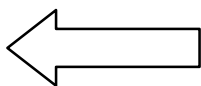

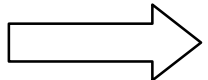
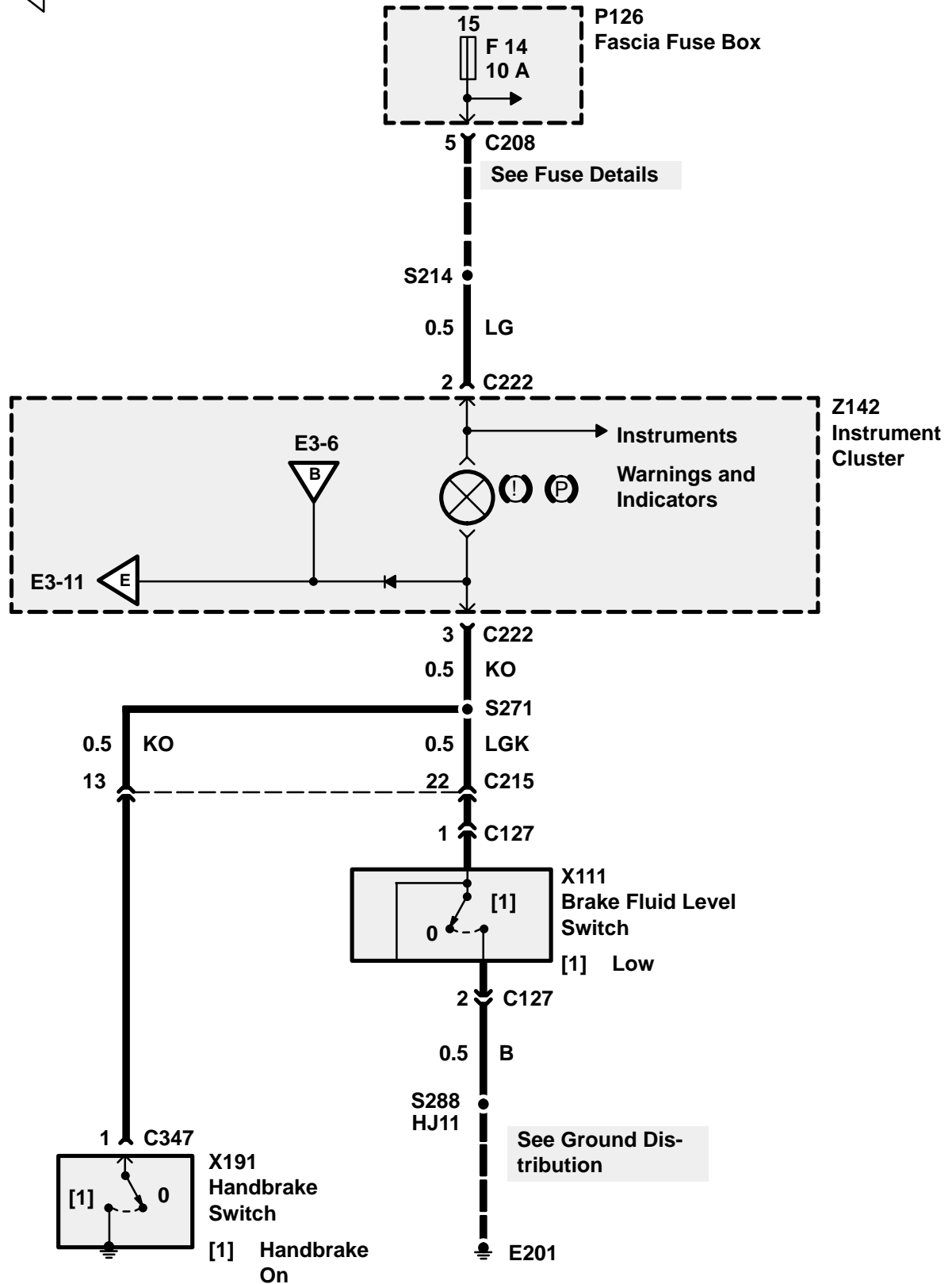
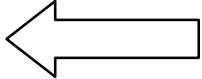

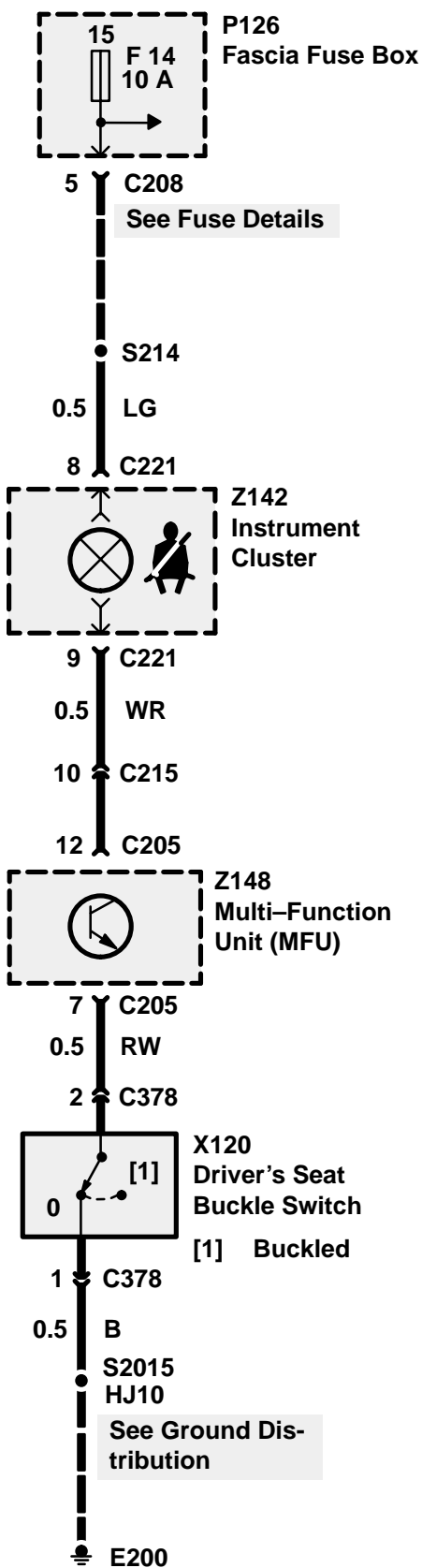
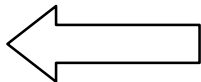

See Fuse Details

Z142 Instrument Cluster

Z148 Multi-Function Unit (MFU)

X120 Driver's Seat Buckle Switch
[1] Buckled

See Ground Distribution

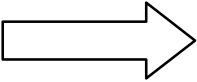

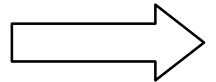
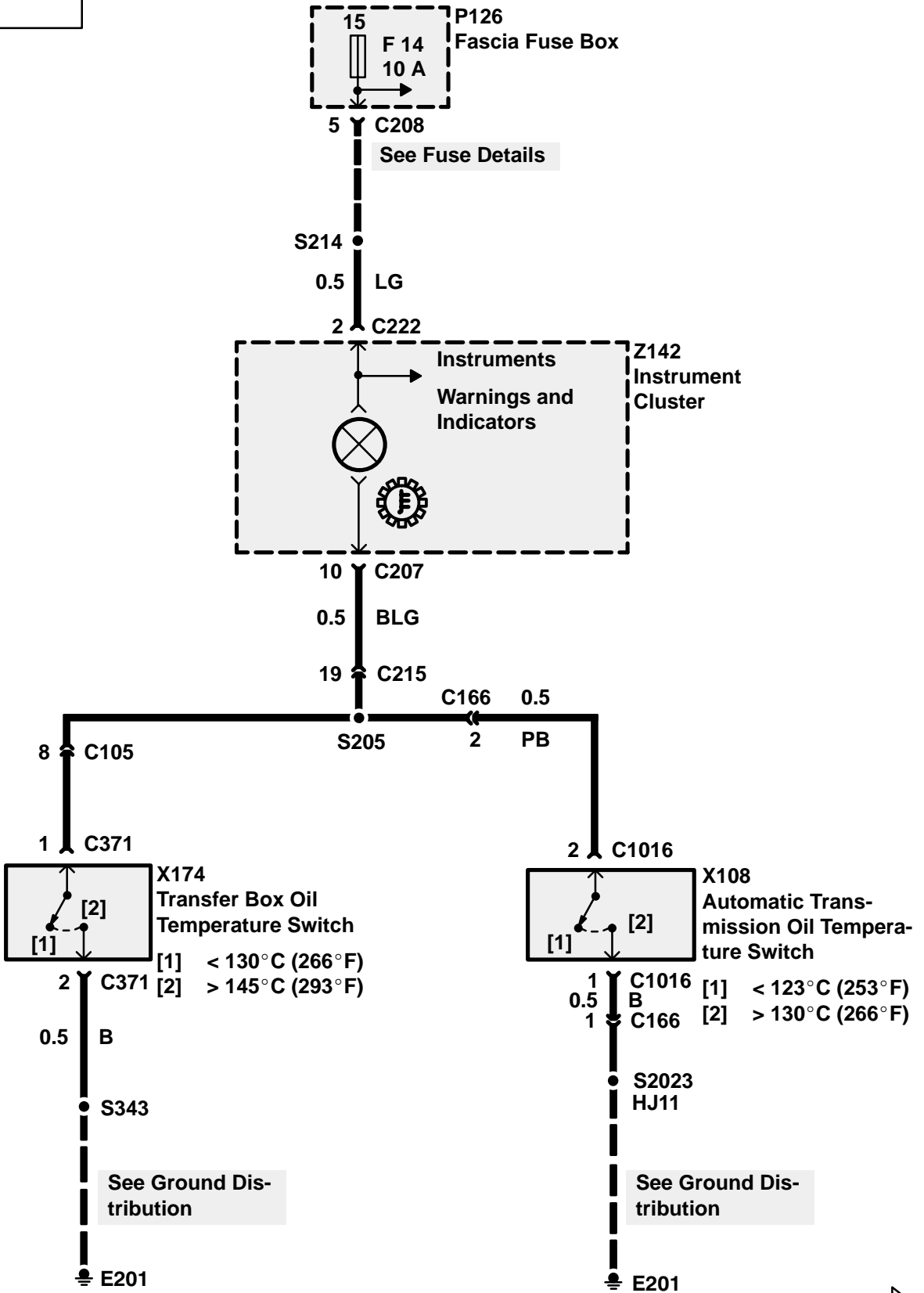
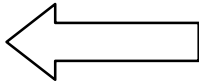

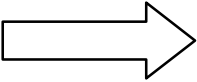
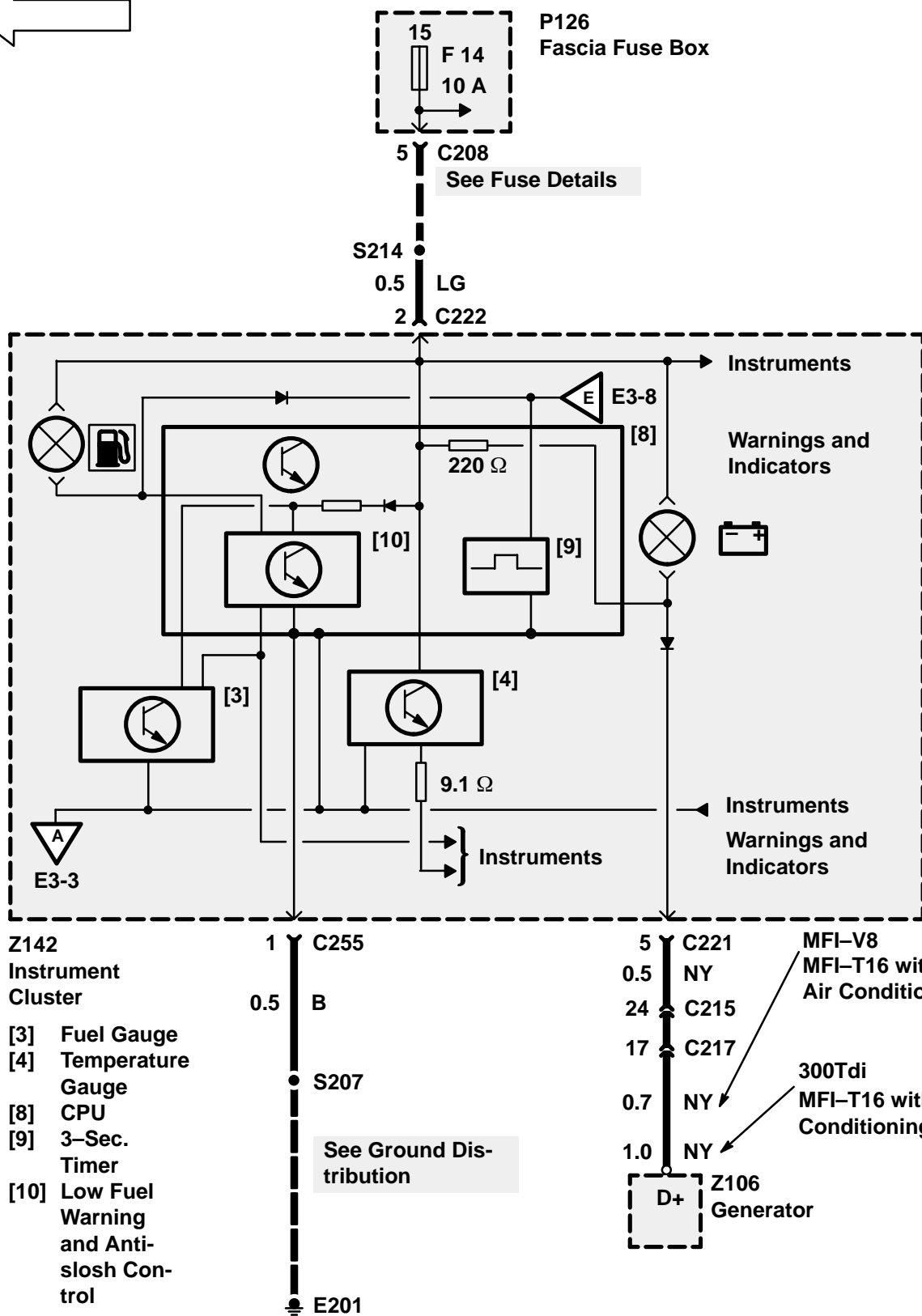
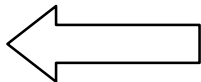

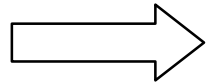
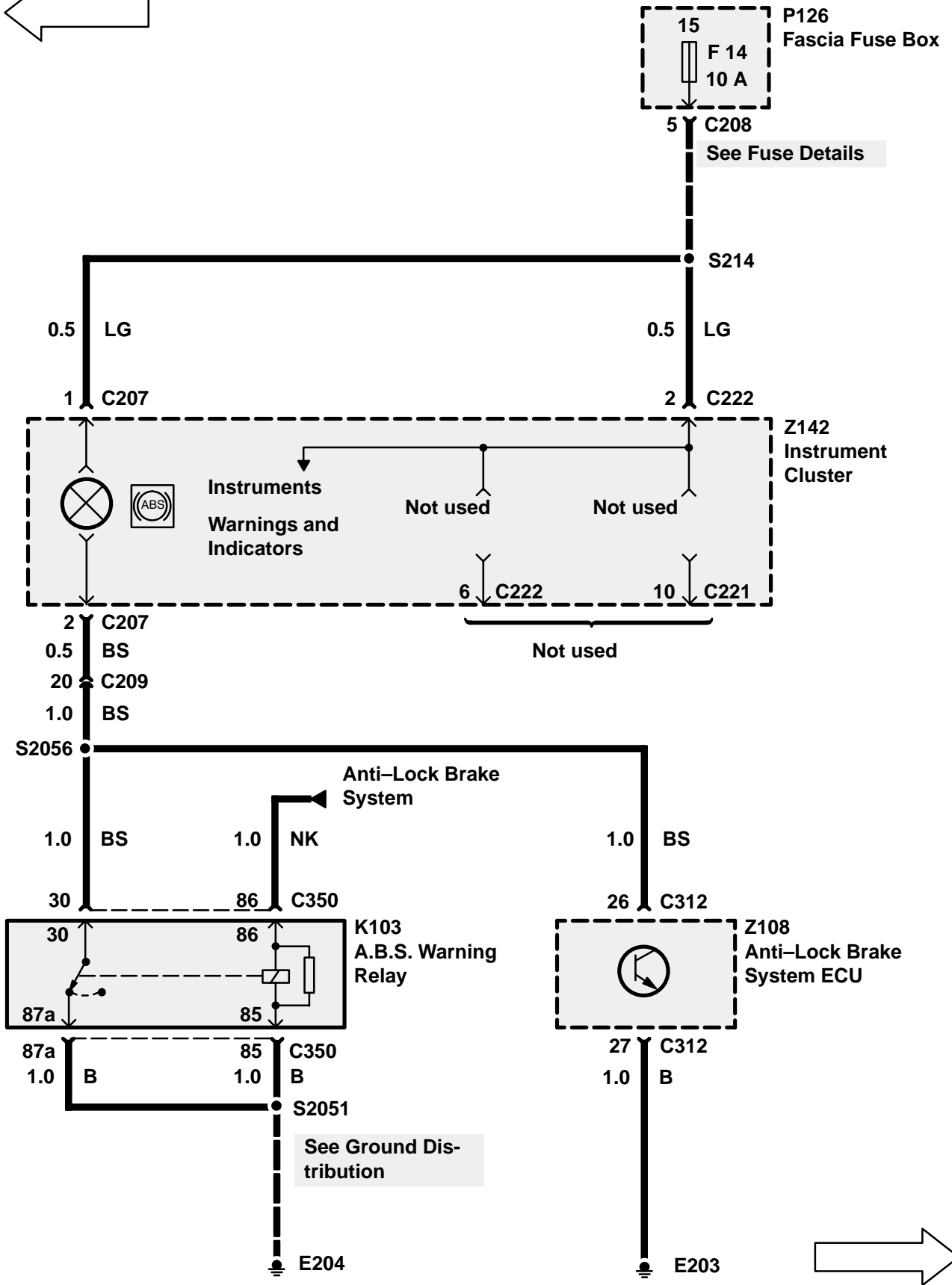
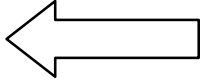

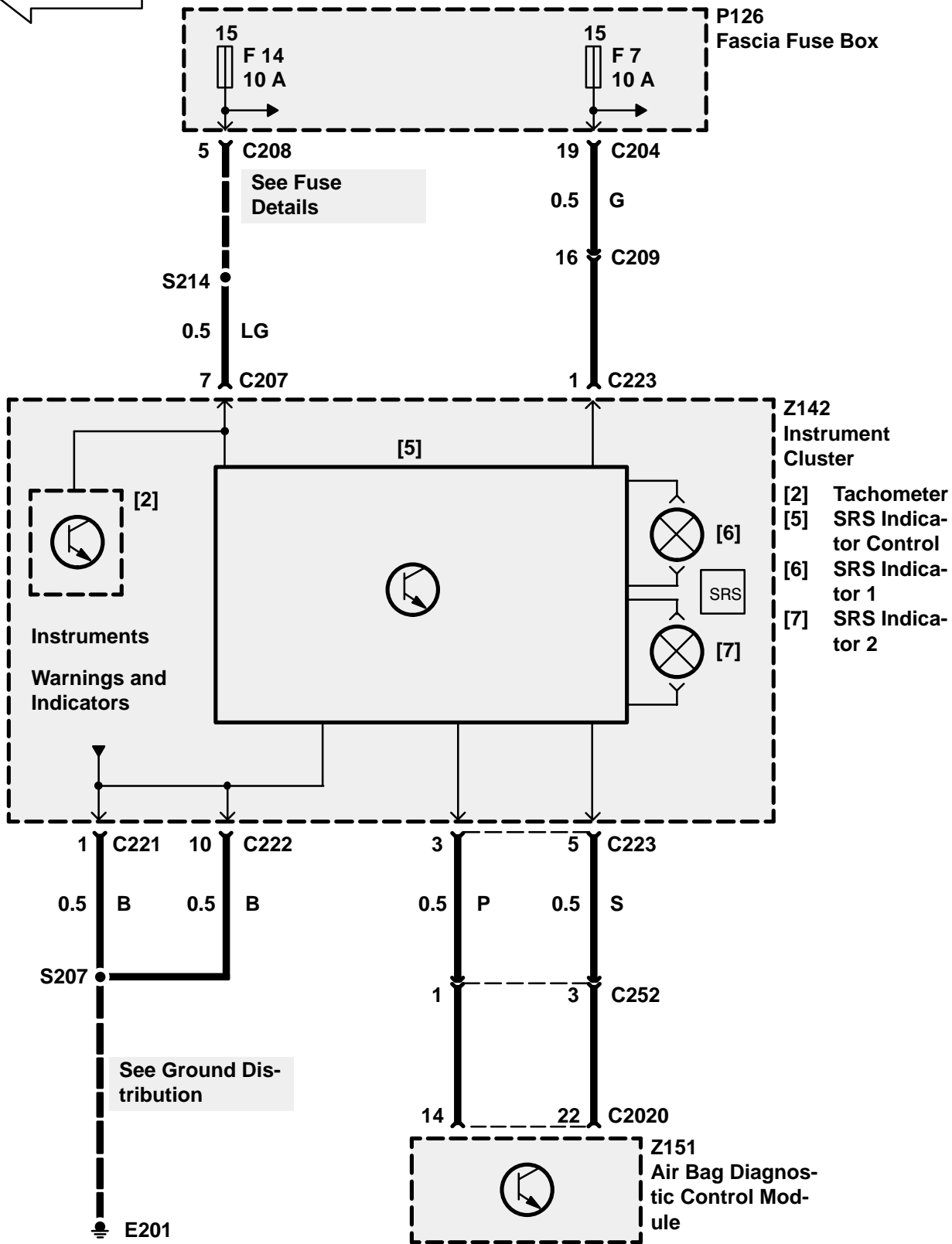
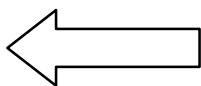

TROUBLESHOOTING HINTS

If more than one warning light is out, check power and ground wires common to all affected warning lights. If they are OK, replace Instrument Cluster (Z142).

If the Brake Warning Light does not operate at all, check Instrument Cluster (Z142) and K Wire.

For Australian Vehicles:

The Brake Warning Light and the Service Reminder Indicator (Service Engine) should illuminate, as a bulb test, with ignition on. If not, replace the Instrument Cluster (Z142). If both indicators don't turn off with the engine running, replace Instrument Cluster (Z142).

SYSTEM DIAGNOSIS

25. If the Charge Warning Light does not operate, go to Section B1.
26. If the Oil Pressure Warning Light remains illuminated with the oil pressure OK, do Test A.
27. If the Malfunction Indicator Lamp (Check Engine) does not operate, do Test B For MFI-V8 engines, Test C for 300Tdi with EDC engines.
28. If the Service Reminder Indicator (Service Engine) does not operate, do Test D.
29. If the Brake Warning Light does not operate with the Brake Fluid Level low, do Test E.
30. If the Brake Warning Light does not operate with the Handbrake applied, do Test F.
31. If the Differential Lock Indicator remains on after the differential lock has been disengaged, transmission "wind up" may be present. Drive the vehicle in reverse for a short distance, then drive forward for a short distance. If the light remains on after driving in reverse, do Test G.
32. If the Fasten Seat Belt Indicator does not operate with the ignition on, do Test H.
33. If the Transmission/Transfer Box Oil Temperature Warning Light is illuminated with both the Transfer Box Oil Temperature and the Automatic Transmission Oil Temperature OK, do Test I.
34. If a warning light exhibits any symptom not mentioned above, check the associated bulb, wires, switches, and components.

Test A

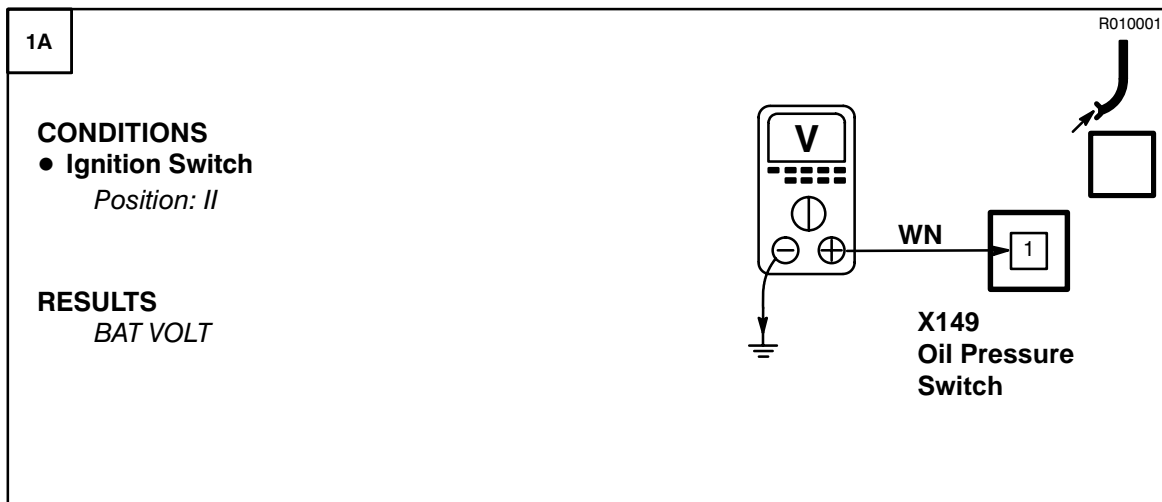

PROBLEM CAUSE
- WN Wire



PROBLEM CAUSE
- Oil Pressure
Switch

Test B

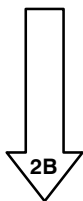
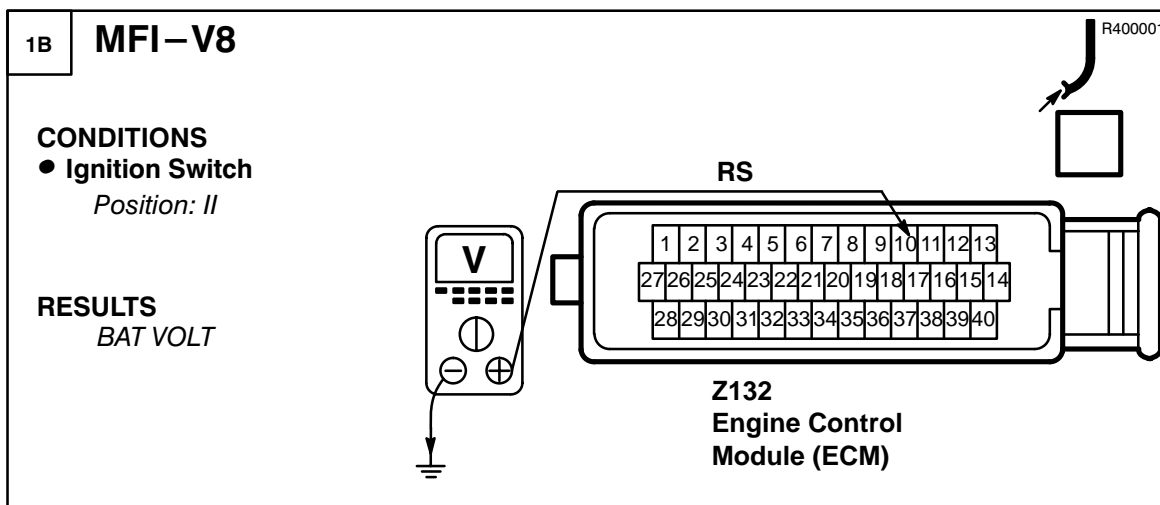

2B



PROBLEM CAUSE
- Engine Control
Module (ECM)

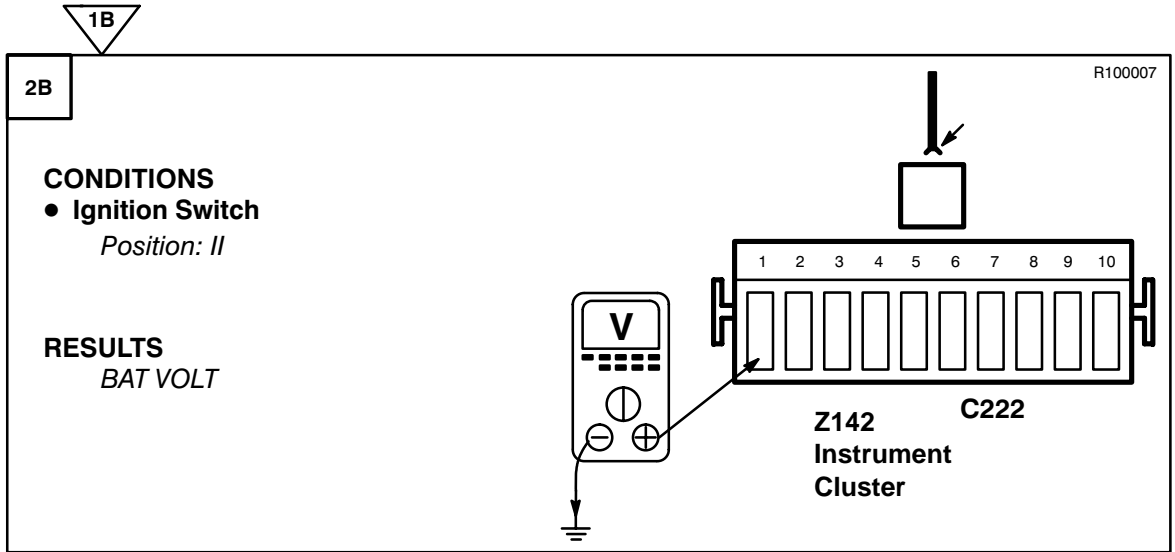

PROBLEM CAUSE
- Instrument
Cluster



PROBLEM CAUSE
- LG Wire
- RS Wire

Test C

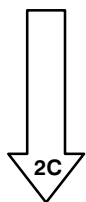
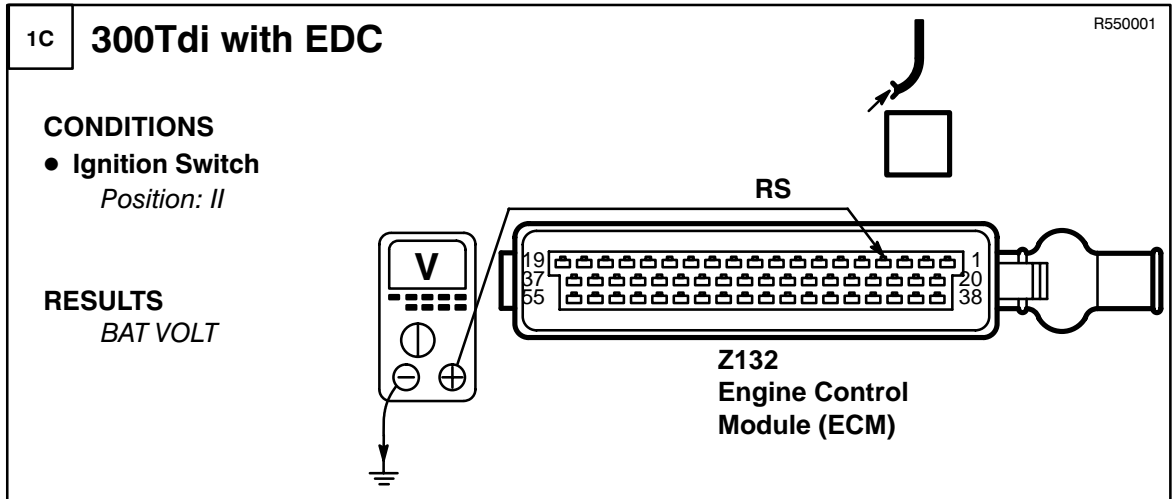

PROBLEM CAUSE
- Engine Control
Module (ECM)

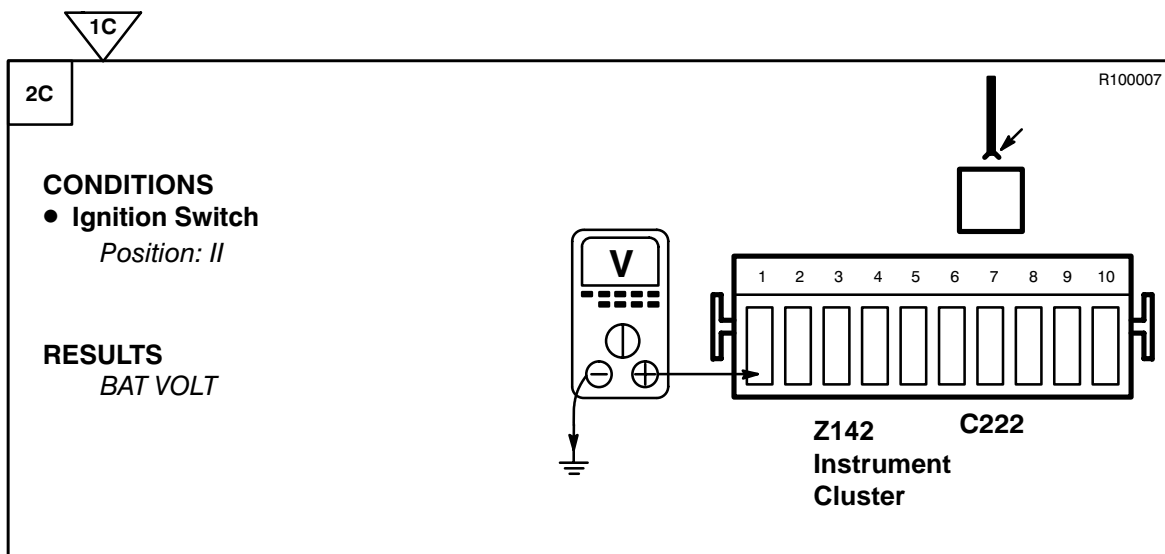

PROBLEM CAUSE
 - Instrument Cluster



PROBLEM CAUSE
 - LG Wire
 - RS Wire

Test D

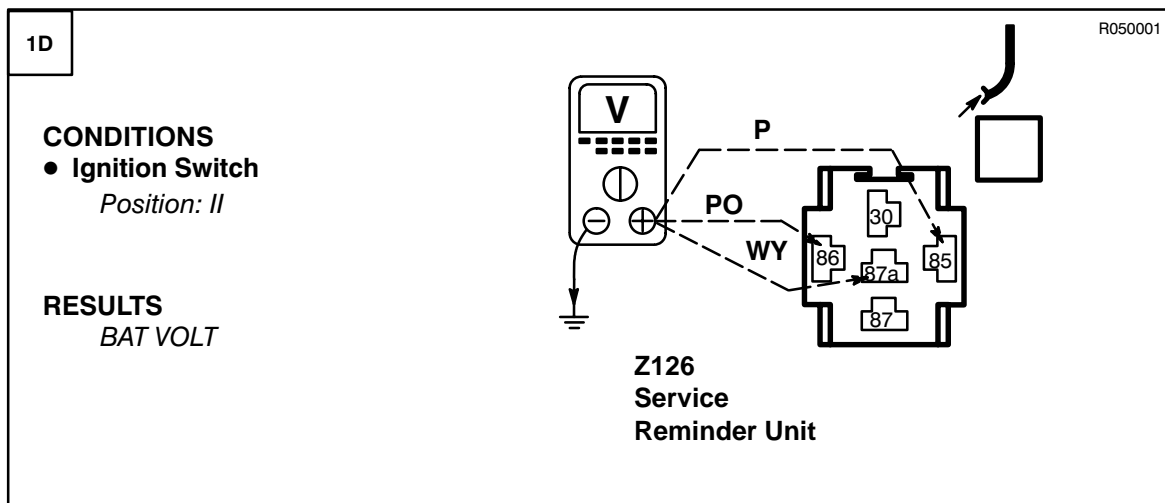

PROBLEM CAUSE
 - PO Wire
 - WY, P Wire
 - Instrument Cluster

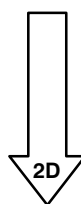

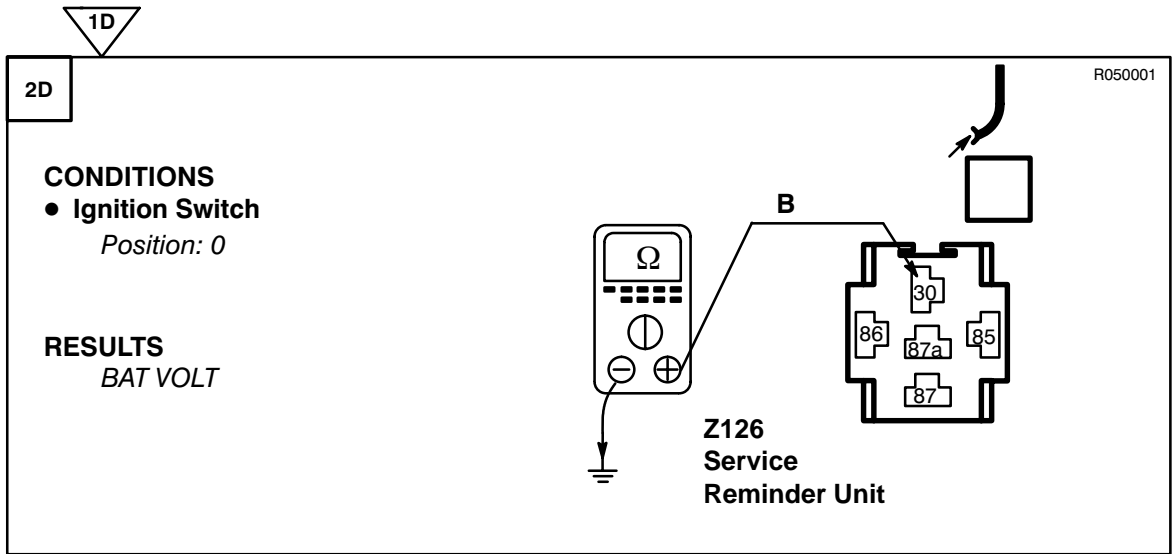

PROBLEM CAUSE
- B Wire



PROBLEM CAUSE
- Service
Reminder Unit

Test E

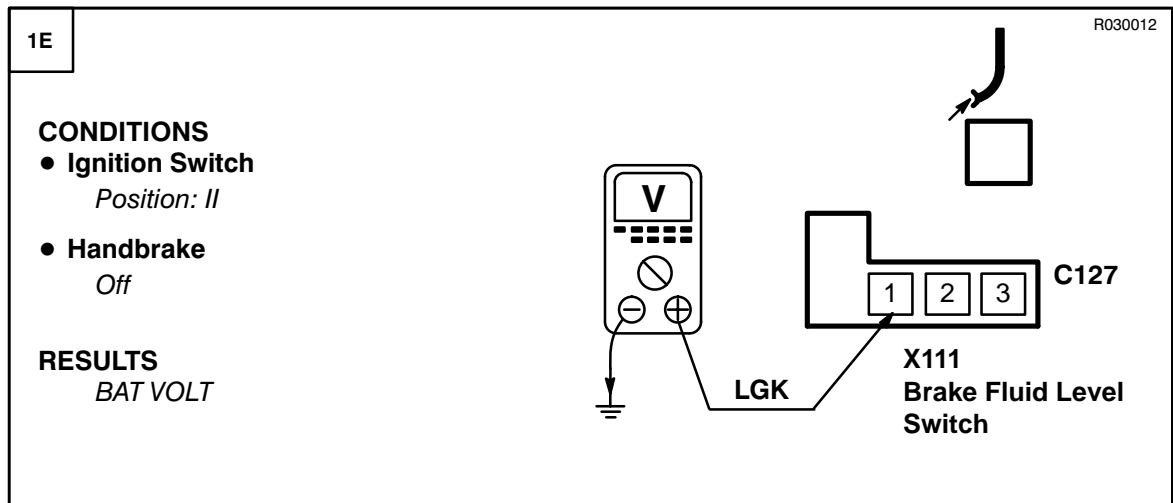

PROBLEM CAUSE
- KO, LG Wire
- Instrument
Cluster



PROBLEM CAUSE
- B Wire
- Brake Fluid Level
Switch

Test F

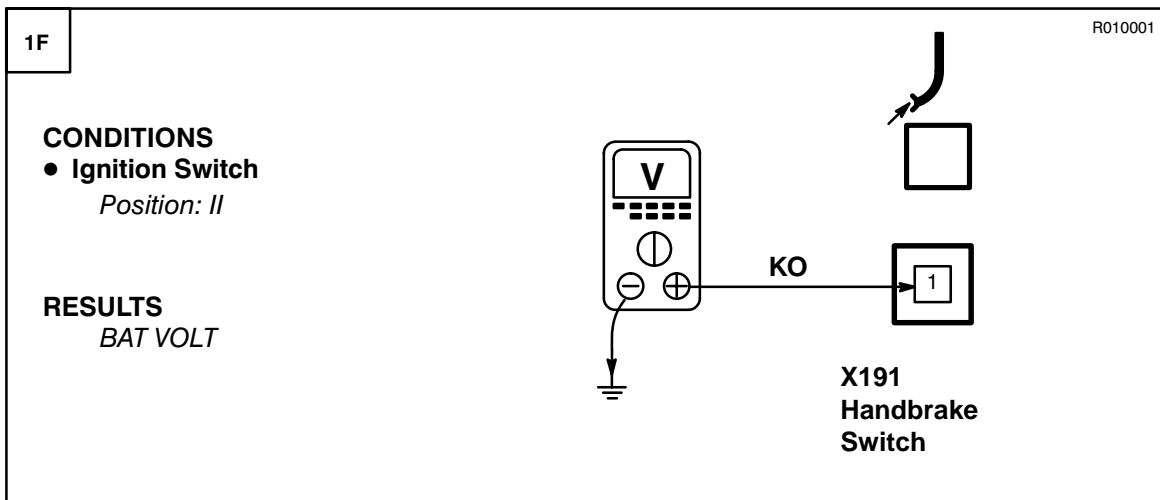

PROBLEM CAUSE
- KO Wire



PROBLEM CAUSE
- Handbrake
Switch

Test G

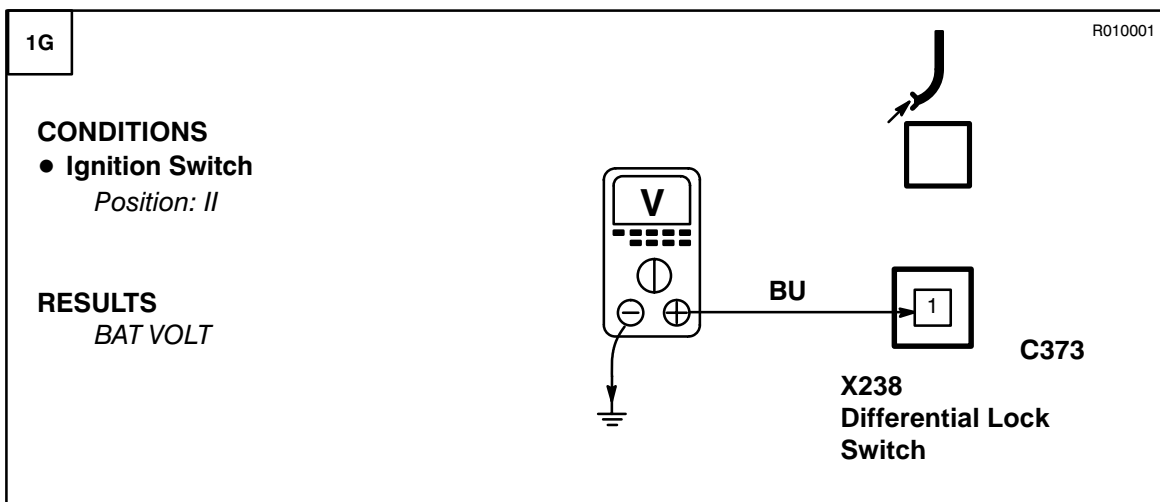

PROBLEM CAUSE
- LG Wire
- BO Wire
- BU Wire



PROBLEM CAUSE
- B Wire
- Differential Lock
Switch

Test H

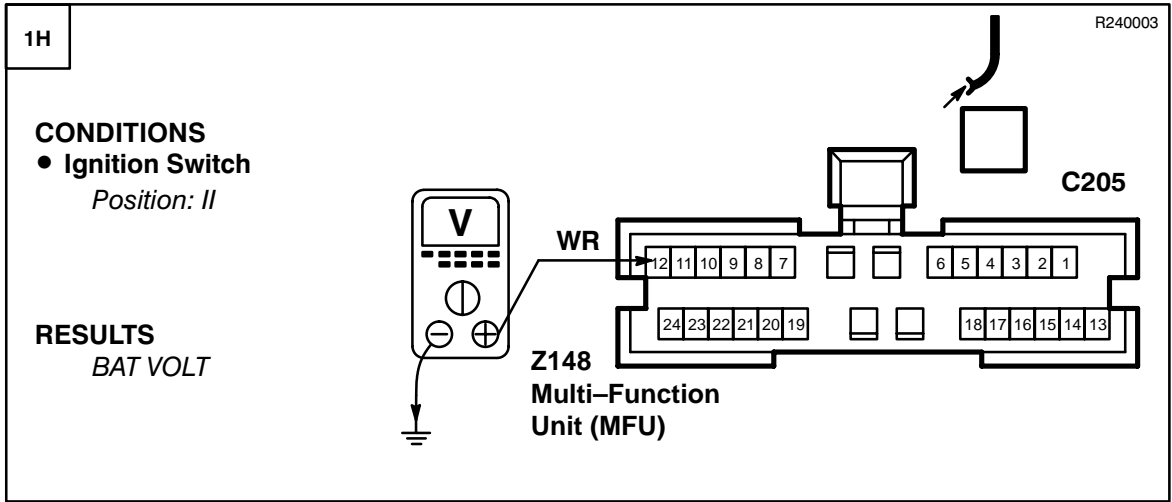

PROBLEM CAUSE

- WR Wire
- LG Wire
- Instrument Cluster

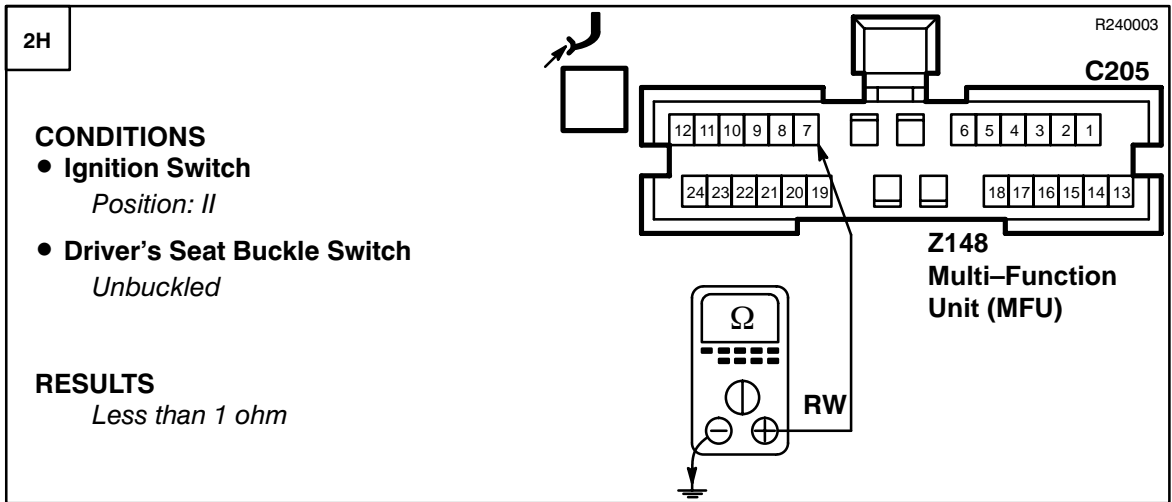
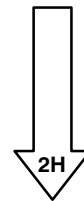

PROBLEM CAUSE

- RW Wire
- B Wire
- Driver's Seat Buckle Switch



PROBLEM CAUSE

- Multi-Function Unit (MFU)

Test I

11	<p>CONDITIONS</p> <ul style="list-style-type: none"> • Ignition Switch <i>Position: II</i> <p>RESULTS <i>BAT VOLT</i></p>	<p style="text-align: center;">X108 Automatic Transmission Oil Temperature Switch</p>
----	--	--



- PROBLEM CAUSE**
- BLG, PB Wire
 - Transfer Box Oil Temperature Switch



- PROBLEM CAUSE**
- B Wire
 - Automatic Transmission Oil Temperature Switch

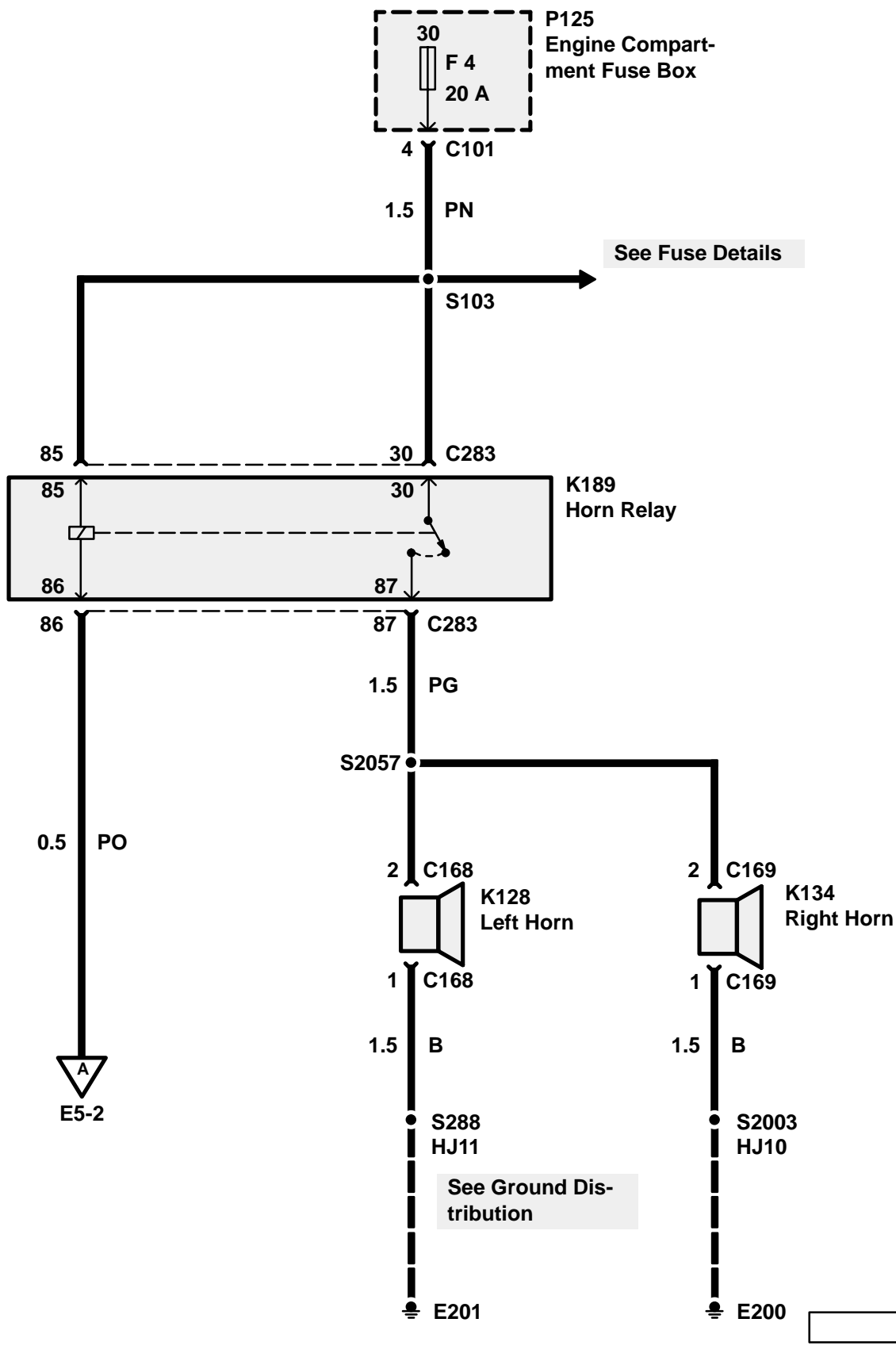

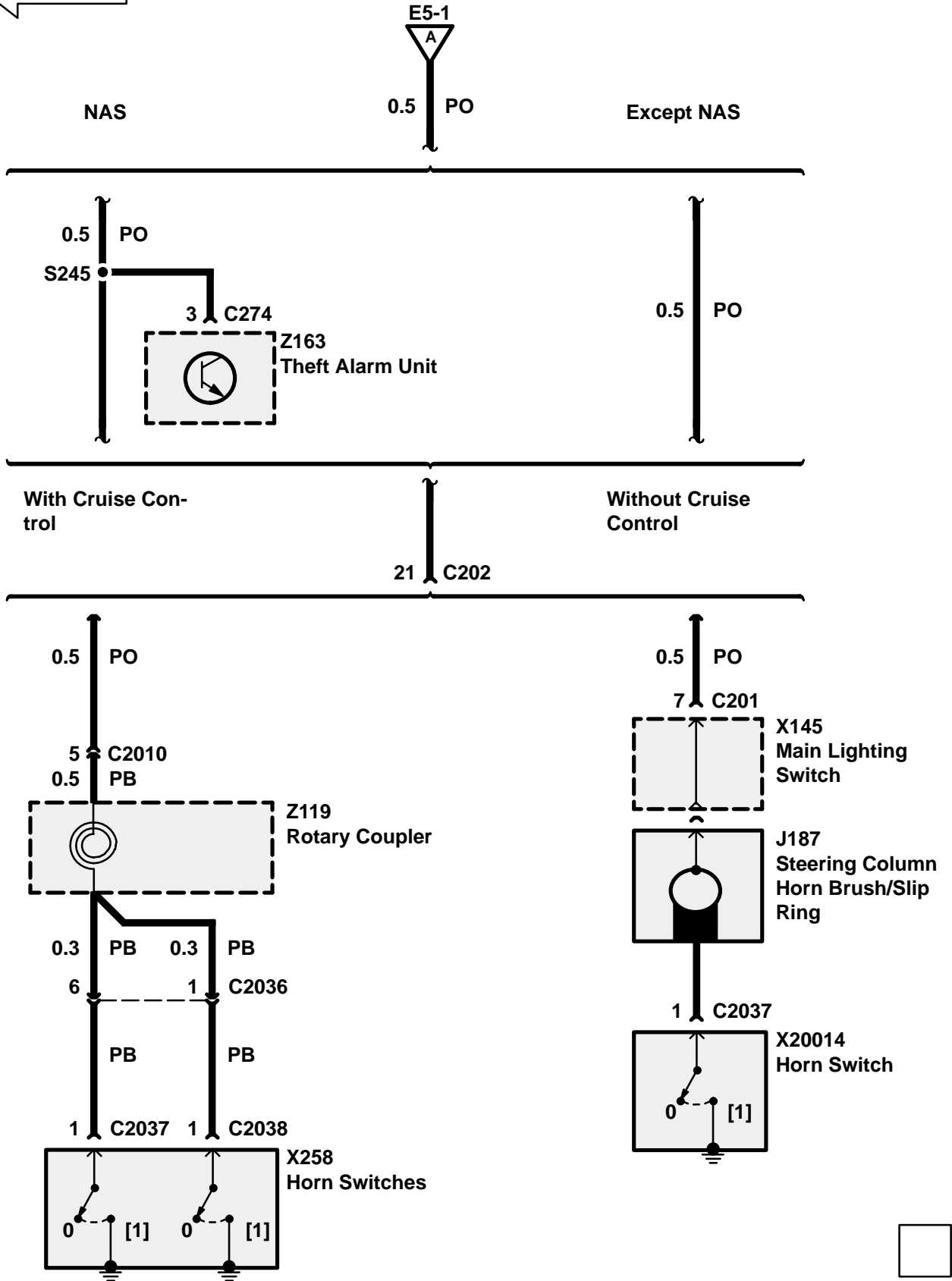
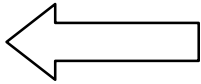

CIRCUIT OPERATION

The new audio system consists of a new head unit and for mid/high range it is equipped with a subwoofer and subwoofer amplifier. For mid and high range the system also is equipped with a radio waveband switch and a tune switch, a volume up and a volume down switch which are located on the fascia next to the instrument cluster.

The control head is equipped with an anti-theft feature which makes the unit inoperative once battery power is removed. A security code must be entered to restore power to the unit. On every level the system is equipped with two rear and two front speakers.

Battery voltage is provided to the control head at all times through the P wire. In addition to monitoring the anti-theft feature, this input keeps the present station memory alive. Whenever battery power to the unit is lost, the anti-theft code must be entered and the present stations must be reprogrammed.

When the Radio (Z111) and the ignition are turned on, the voltage signal through the LGO wire and the control head 'wakes up' the unit. The Radio (Z111) plays, the VF display comes on and the control unit buttons illuminate. The VF display is dimmed when the headlights or park lights are turned on. When the lights are on, voltage from fuse F8 of the Fascia Fusebox (P126) is applied to the Radio (Z111) terminal 6, connector 230 signalling the Radio (Z111) to dim the display.

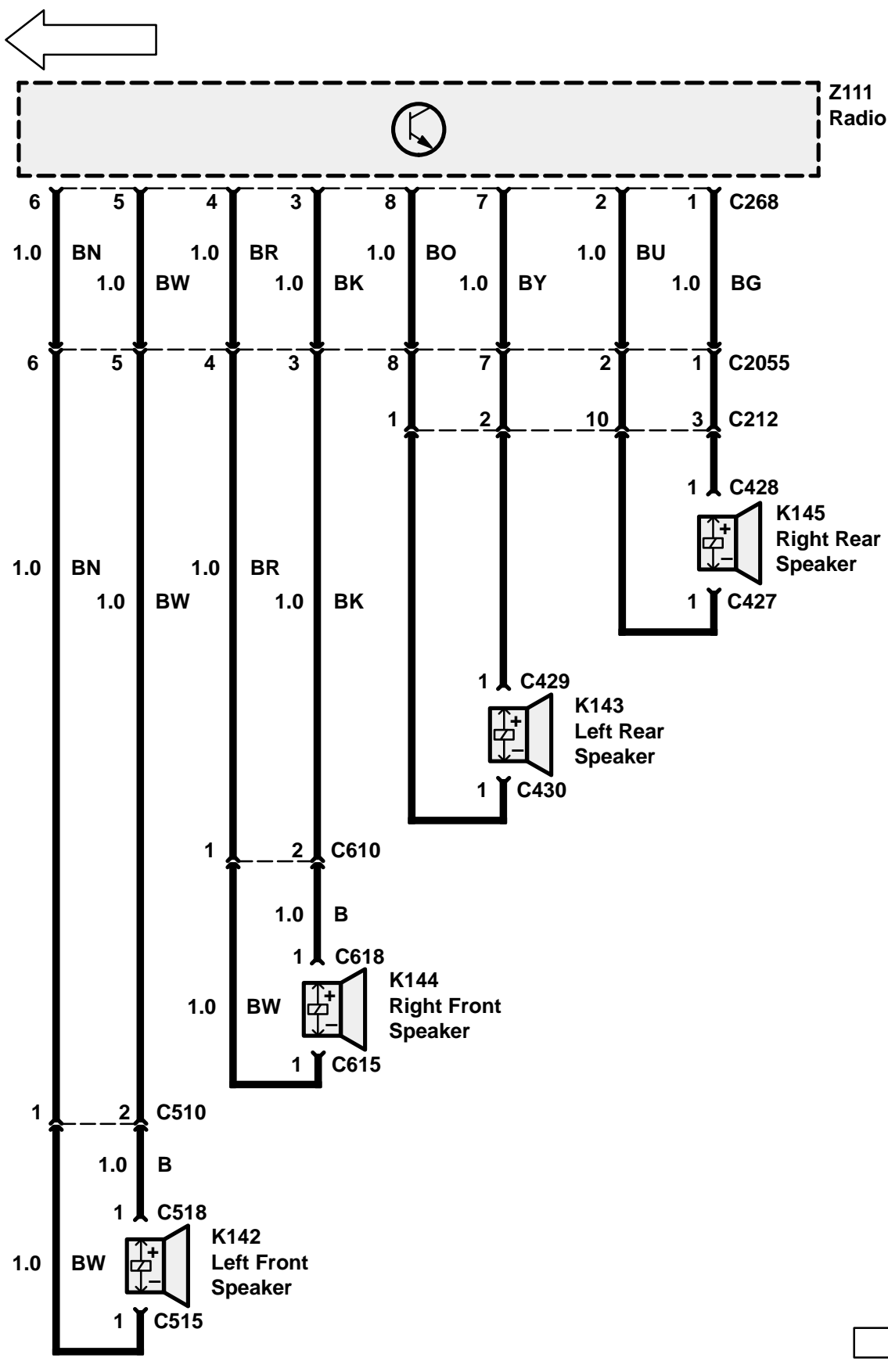

E6 ETM

DISCOVERY

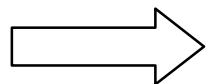
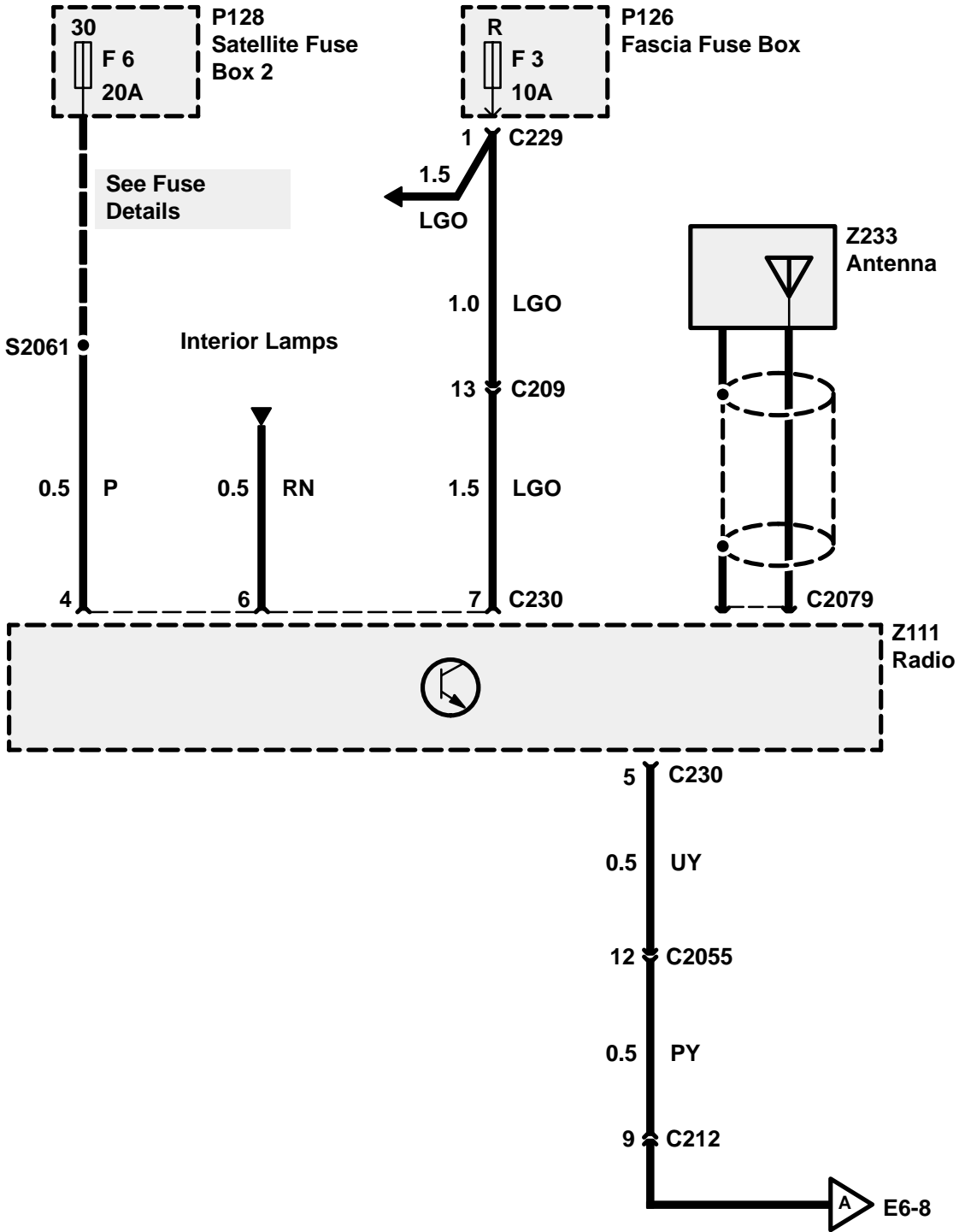
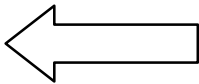

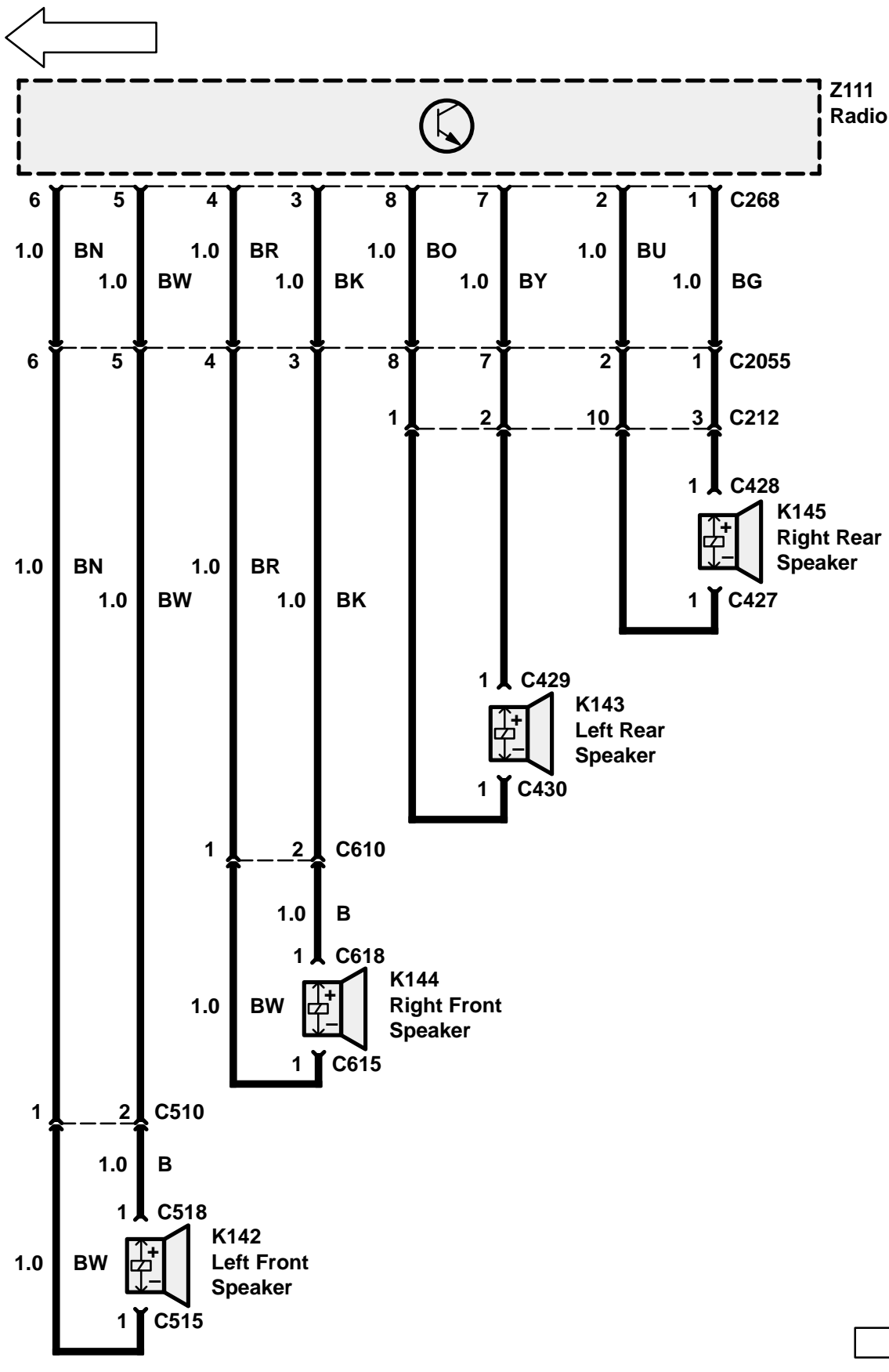

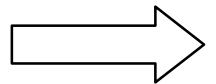
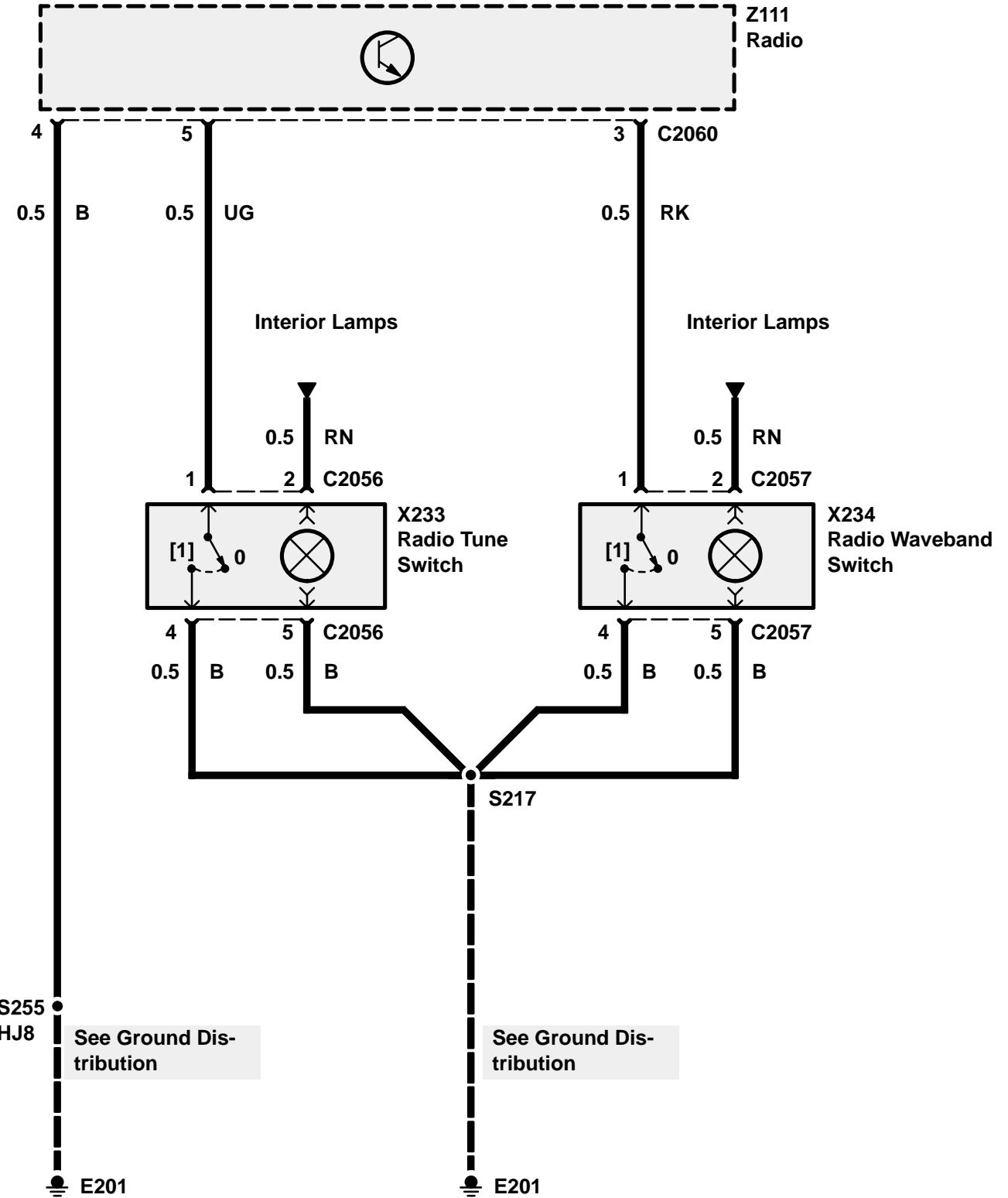
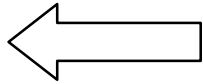

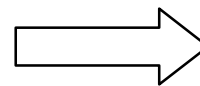
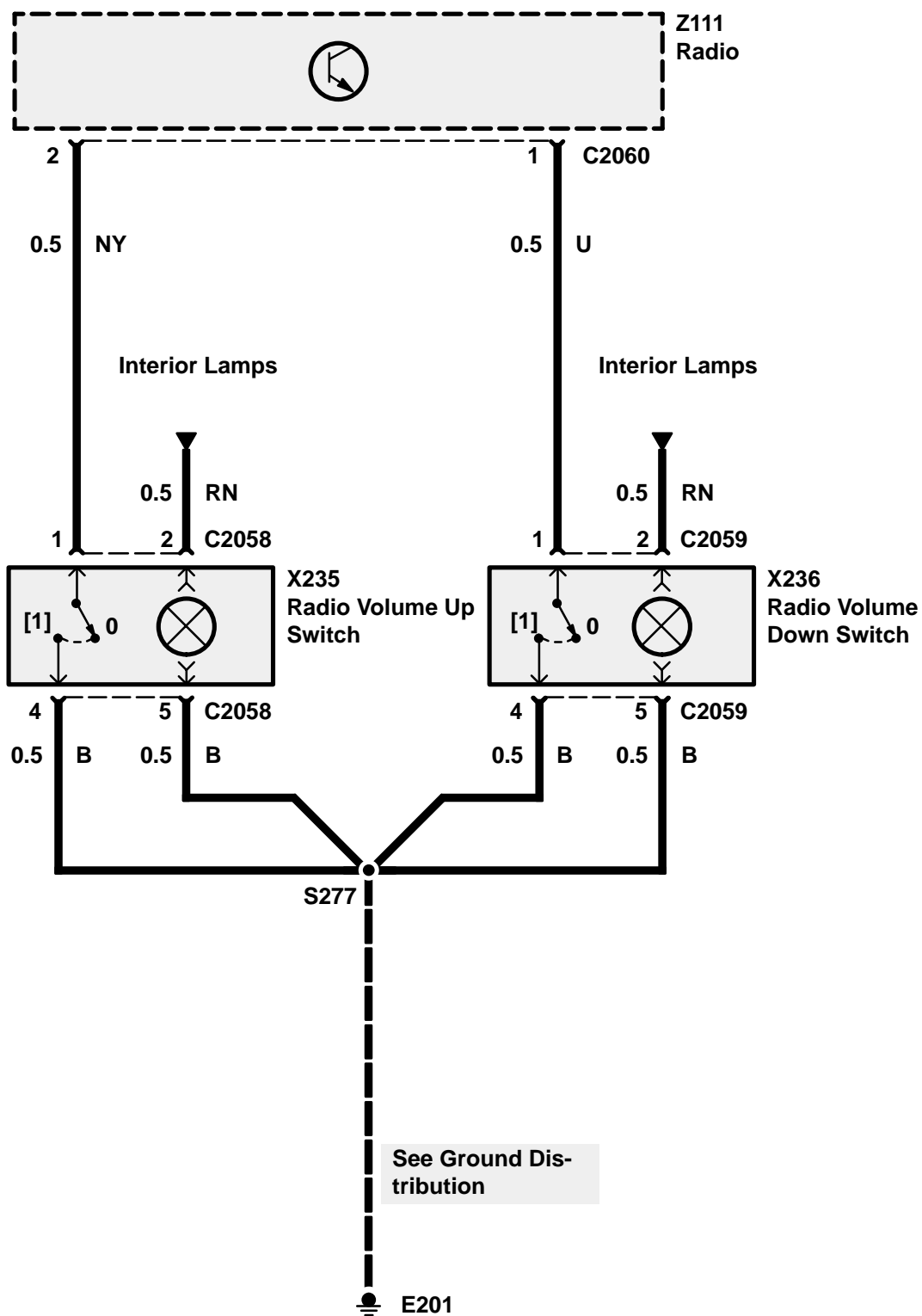
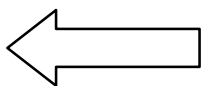

E6 ETM

DISCOVERY

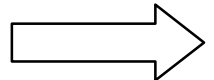
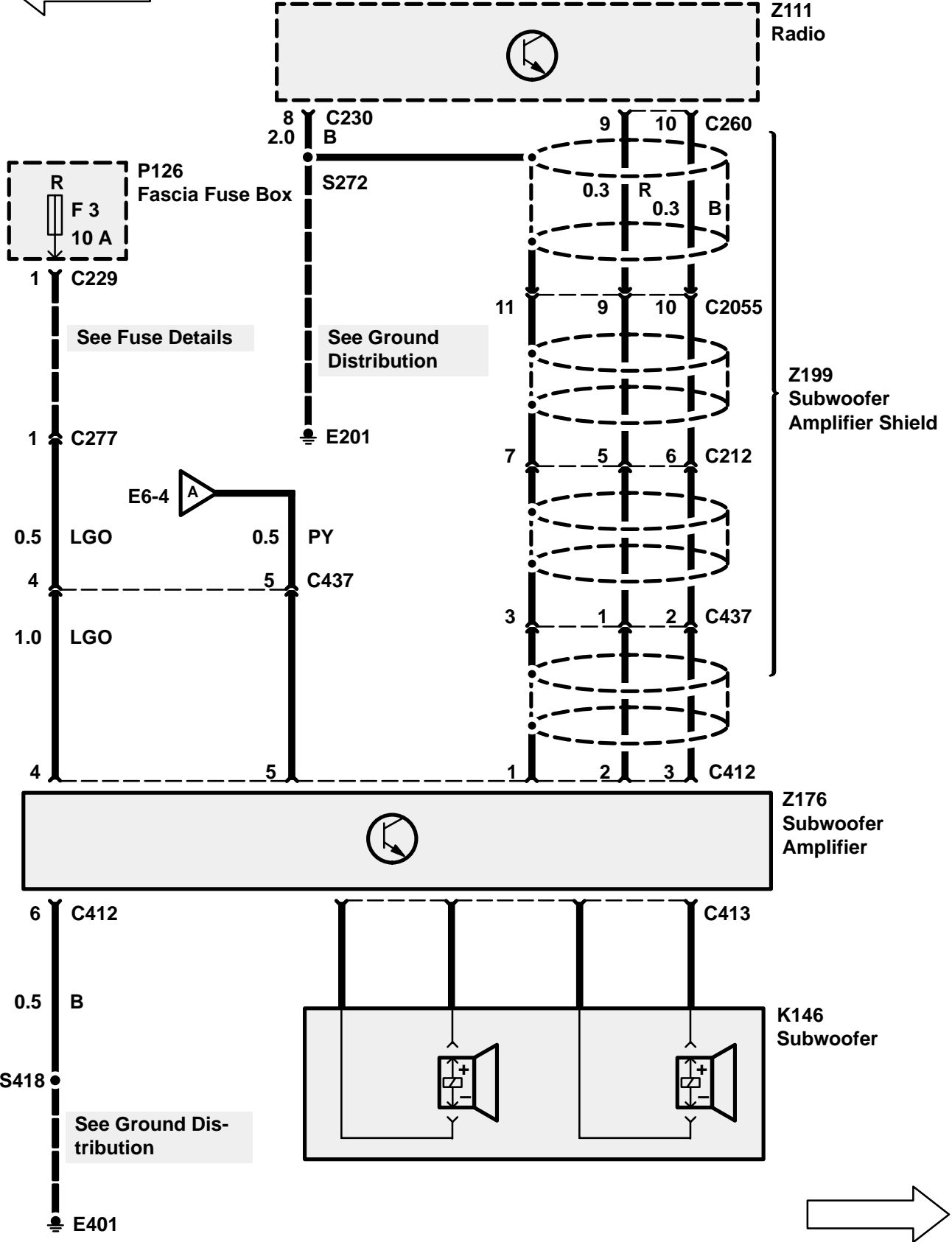
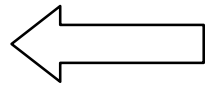

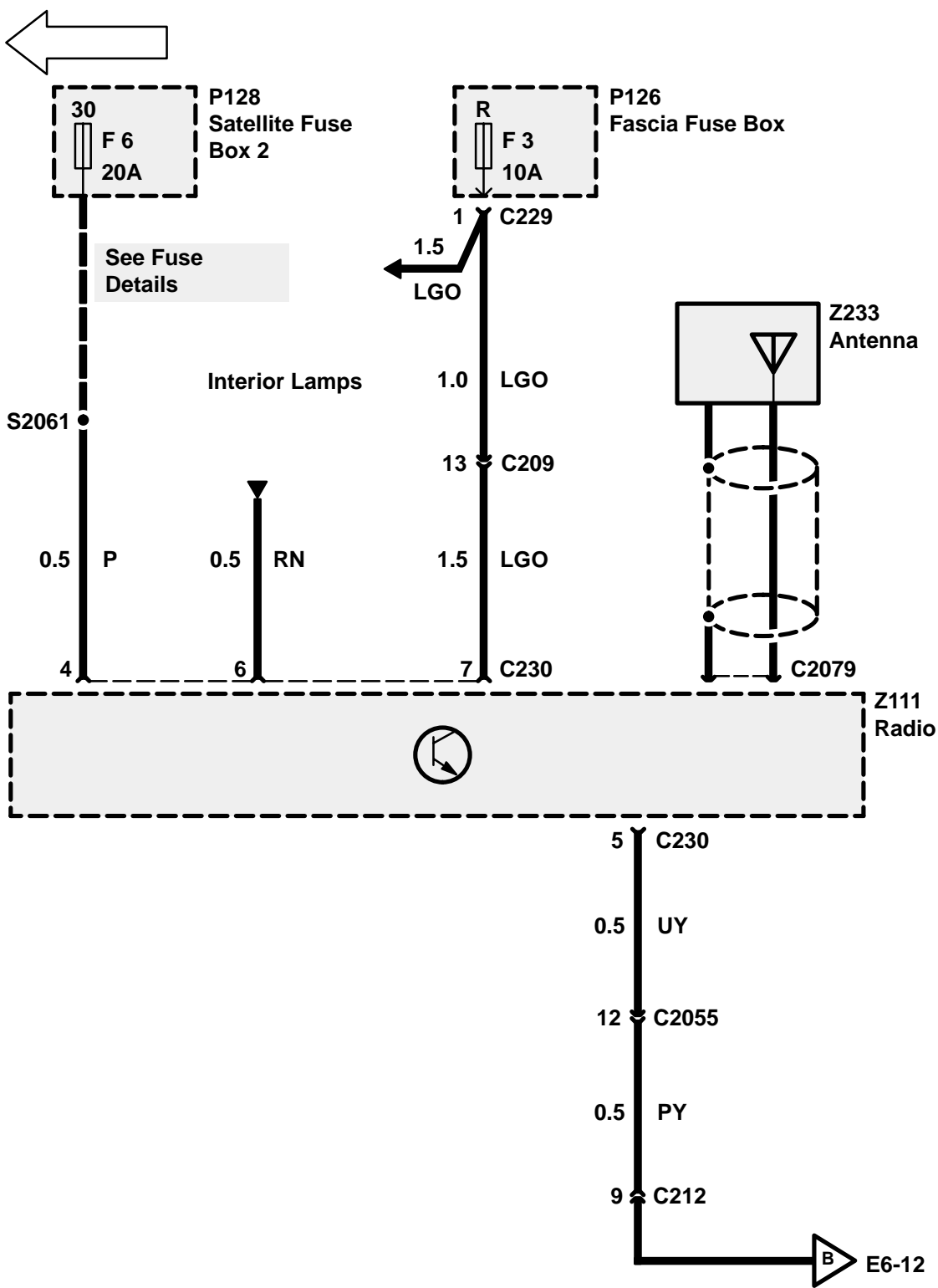

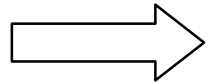
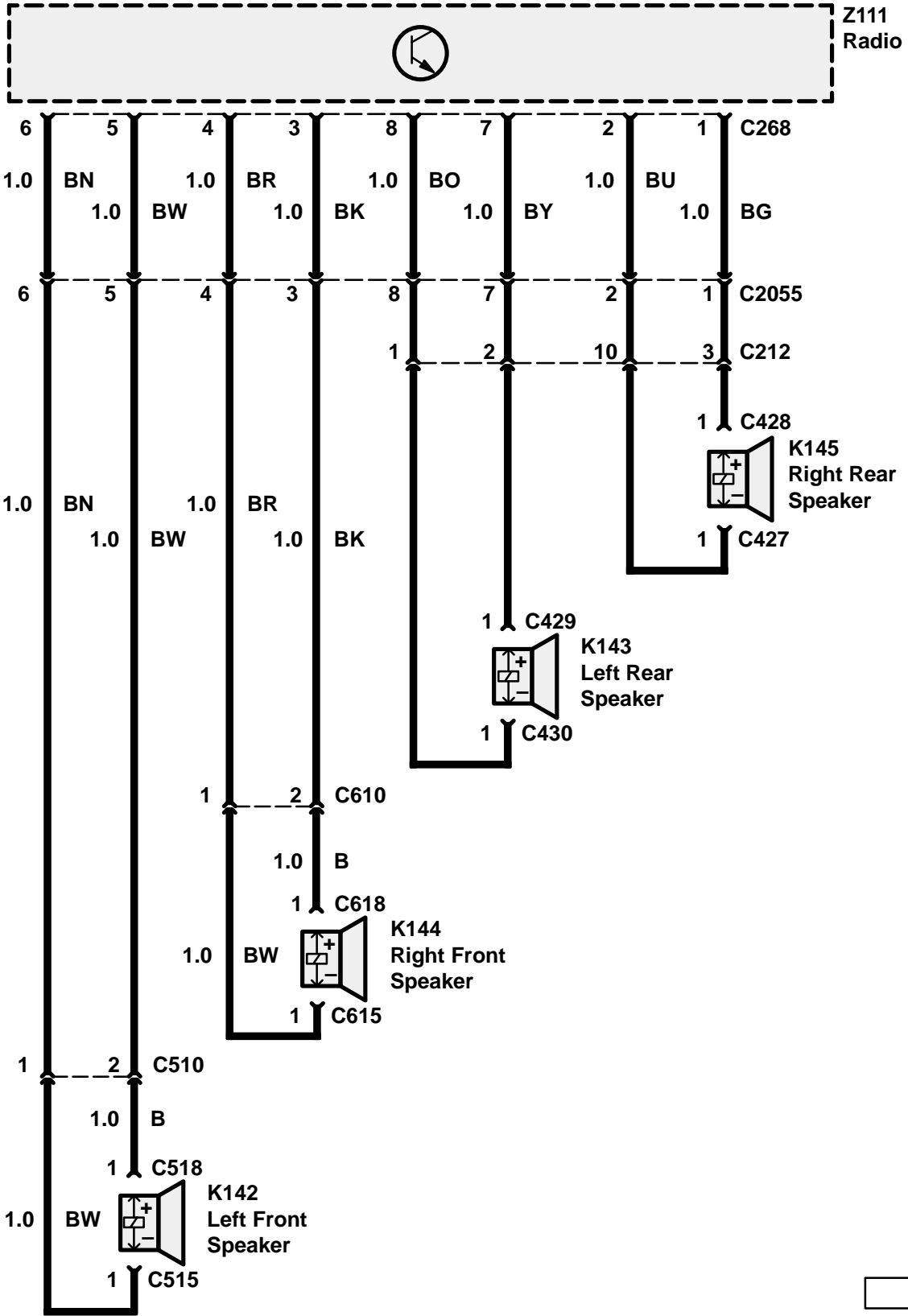
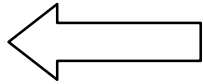

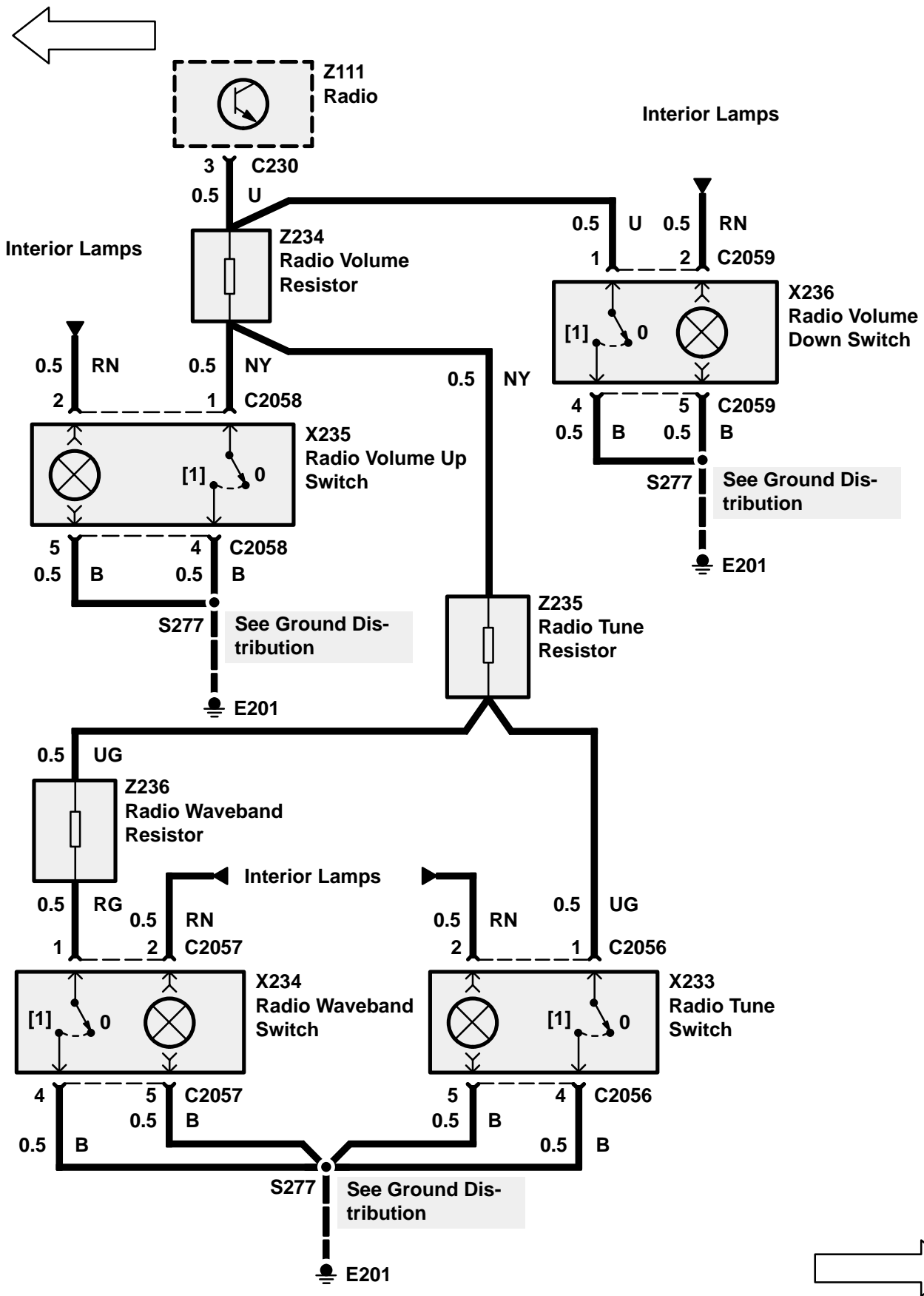

E6 ETM

DISCOVERY

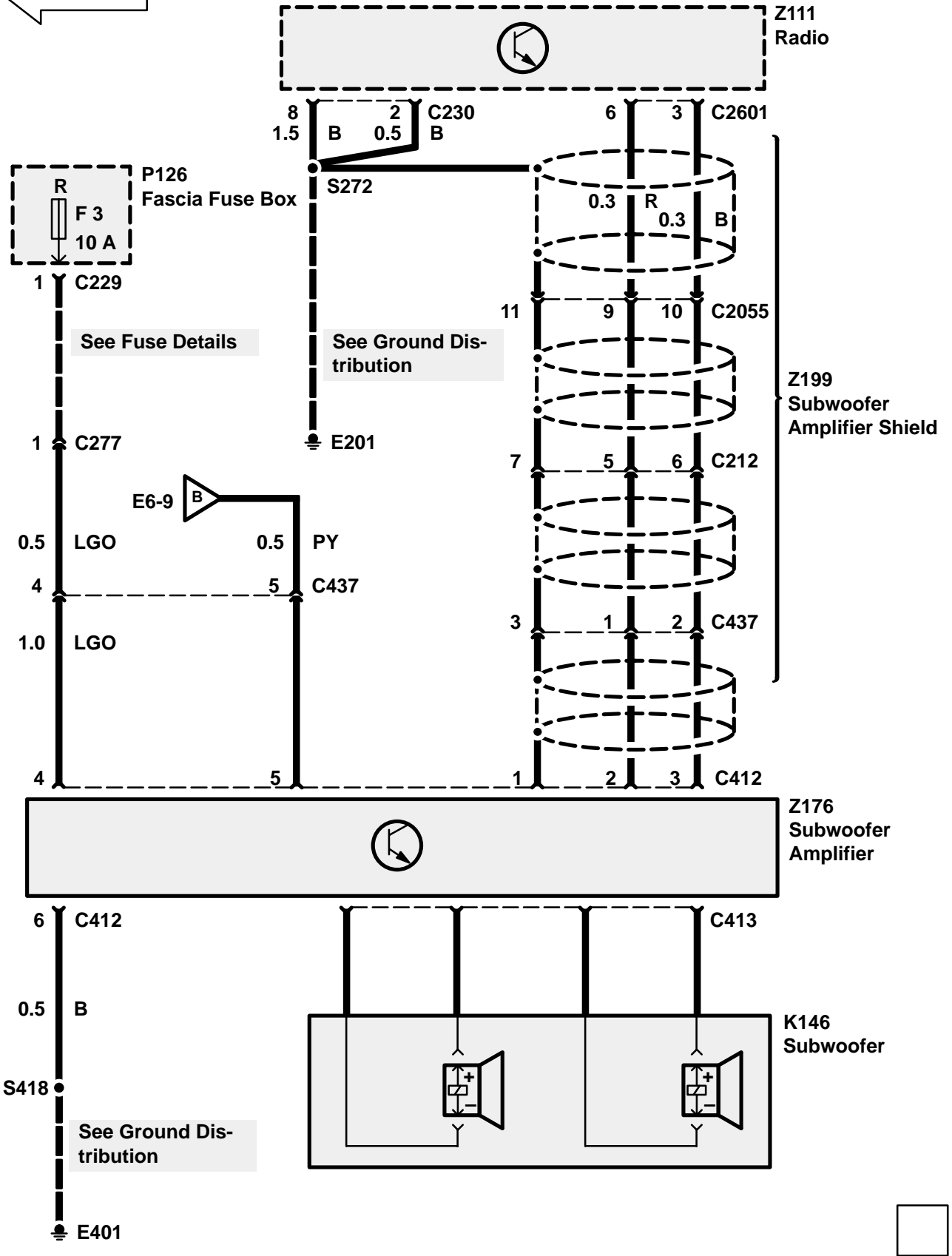
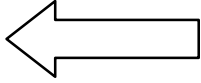

TROUBLESHOOTING HINTS

1. Check fuses F6 in the Satellite Fusebox 2 (P128) and F3 in the Fascia Fusebox (P126).
2. Check that Radio (Z111) connectors and coaxial cable are tight and properly connected.
3. For proper Radio (Z111) noise diagnosis, take the vehicle outside where signals are strong. Close the hood and keep away from metal buildings or other sources of Radio interference.
4. If Radio (Z111) noise is excessive when an accessory is on, install a Radio noise suppression capacitor to the power lead of that accessory.
5. If Radio (Z111) noise is excessive at all times, check antenna wiring. If OK, check spark plugs, spark plug wiring and wiring close to the ignition system which could transmit noise to the Radio (Z111) wiring.
6. If the Radio (Z111) is inoperative and 'code' is being shown on the display, follow the instructions below.
7. If radio scans past all frequencies when in seek mode and hiss is present over most stations, substitute antenna with a known good antenna. If the reception is still inadequate, replace radio.

Security Code Instructions

1. Obtain 5-digit security code from vehicle owner or manufacturer.
2. Enter the code number using the Radio (Z111) push-button selectors.

NOTE: If the correct code is not entered in 3 successive attempts, the Radio (Z111) will not accept another entry until the Radio has been left on for 1 hour with the ignition on.

NOTE: When entering the code, be sure to complete the sequence numbering of that 5-digit code even if you made a mistake. For example, if the correct code number sequence is 43215 and you mistakenly enter 42 instead of 43, continue the code number sequence of 215 to complete that entry. A 'beep' will sound, 'code' will still be displayed and the Radio will not operate. Re-enter the correct code 43215 and the Radio will operate.

NOTE: If an audible 'beep' is heard while entering the code, STOP immediately. Begin entering the

code again, starting with the first number of the 5-digit code.

NOTE: If a push-button is touched accidentally when the ignition is off, a warning tone will sound. Turn the ignition on and the tone will stop.

SYSTEM DIAGNOSIS

1. If the Radio (Z111) does not operate at all on vehicles equipped with the Low Line Radio, do Test A.
2. If the Radio (Z111) does not operate at all on vehicles equipped with the Mid Line Radio, do Test B.
3. If the Radio (Z111) does not operate at all on vehicles equipped with the High Line Radio, do Test C.
4. If VF display does not dim when headlamps or park lamps are turned on, do Test D.
5. If one or more speakers do not operate, do Test E.
6. If the Subwoofer (K146) does not operate, do Test F.
7. If none of Remote Radio Waveband, Tune, Volume Up, or Volume Down Switches operate for the Mid Line Radio, do Test R.
8. If the Radio Waveband Switch (X234) does not operate, do Test J for the Mid Line Radio, Test N for the High Line Radio.
9. If the Radio Tune Switch (X233) does not operate, do Test K for the Mid Line Radio, Test O for the High Line Radio.
10. If the Radio Volume Up Switch (X235) does not operate, do Test L for the Mid Line Radio, Test P for the High Line Radio.
11. If the Radio Volume Down Switch (X236) does not operate, do Test M for the Mid Line Radio, Test Q for the High Line Radio.

Test A

R080017

1A

Low Line Radio

CONDITIONS

- Ignition Switch
Position: II

RESULTS
BAT VOLT



PROBLEM CAUSE

- P Wire
- LGO Wire
- F6 Fuse
- F3 Fuse
- B Wire



PROBLEM CAUSE

- Radio

Test B

R080017

1B

Mid Line Radio

CONDITIONS

- Ignition Switch
Position: II

RESULTS
BAT VOLT



PROBLEM CAUSE

- P Wire
- F6 Fuse
- F3 Fuse
- B Wire
- LGO Wire

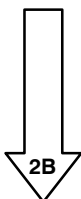

E6 ETM

DISCOVERY

R050019

1B

2B

CONDITIONS

- Ignition Switch
Position: 0

RESULTS

Less than 1 ohm

C2060

**Z111
Radio**



PROBLEM CAUSE
- B Wire



PROBLEM CAUSE
- Radio

Test C

R0800017

1C

High Line Radio

CONDITIONS

- Ignition Switch
Position: 0

RESULTS

BAT VOLT

C230

**Z111
Radio**



PROBLEM CAUSE
- P Wire
- F6 Fuse
- B Wire

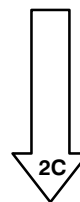

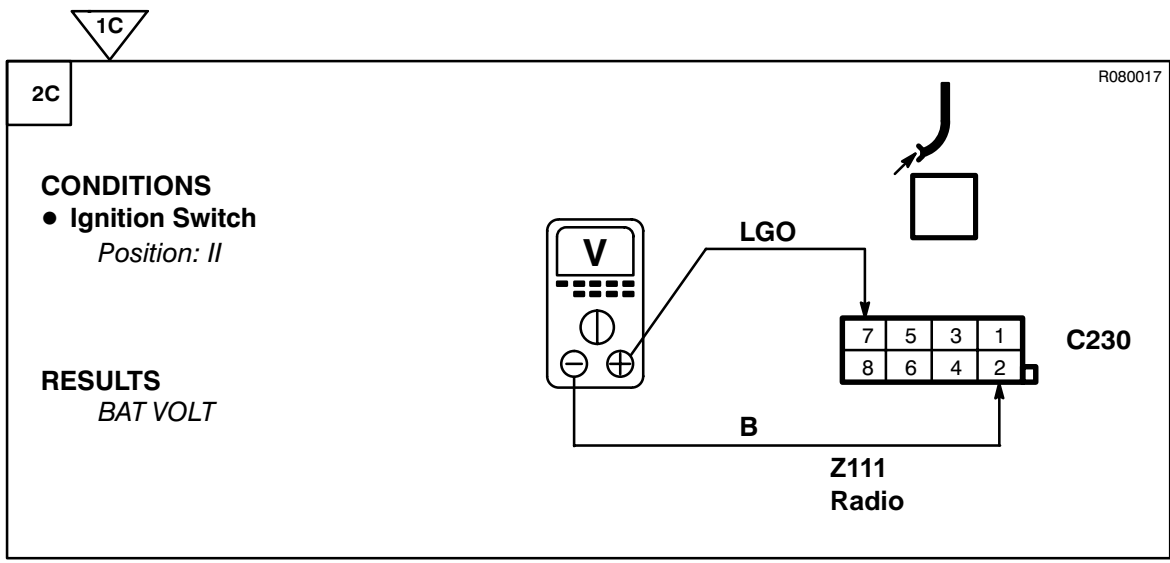

OK PROBLEM CAUSE

- LGO Wire
- F3 Fuse
- B Wire

OK PROBLEM CAUSE

- Radio

Test D

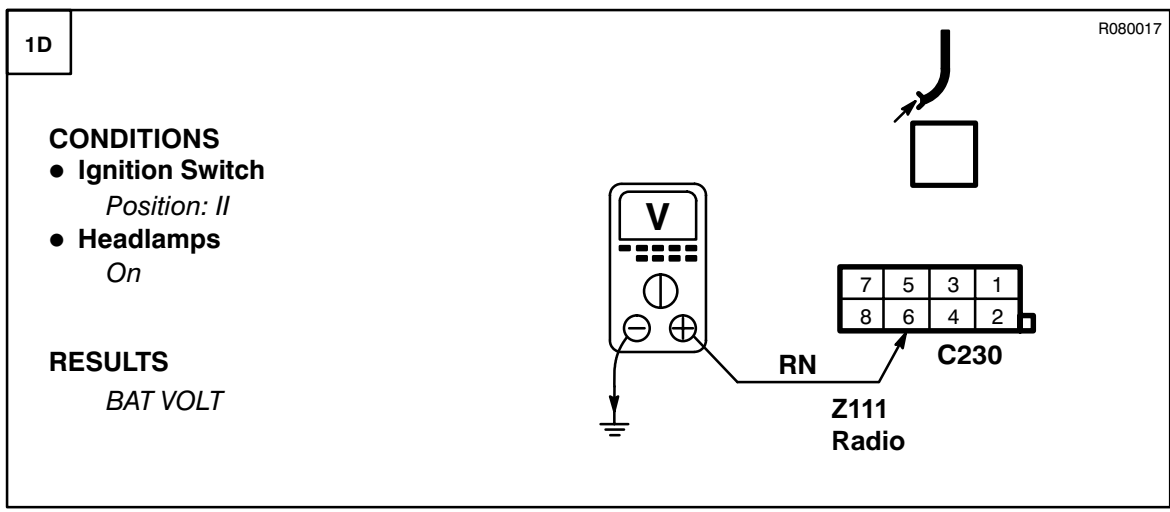

OK PROBLEM CAUSE

- RN Wire

OK PROBLEM CAUSE

- Radio

Test E

R010001

1E

CONDITIONS

- Connect for less than 1 second

RESULTS

Speaker 'pops'

J2120 Speaker



PROBLEM CAUSE
- Speaker



PROBLEM CAUSE
- Speaker Wiring
- Radio

Test F

R060012

1F

CONDITIONS

- Ignition Switch
Position: I

RESULTS

BAT VOLT

Z176 Subwoofer Amplifier



PROBLEM CAUSE
- LGO Wire
- B Wire

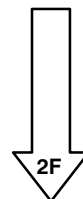

1F

2F

R060012

CONDITIONS

- Ignition Switch
Position: II
- Radio
On

RESULTS
BAT VOLT

Z176
Subwoofer
Amplifier

~~OK~~ **PROBLEM CAUSE**

- UY Wire
- PY Wire
- Radio

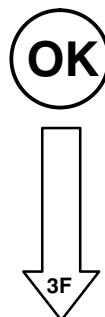

3F

R060012

CONDITIONS

- Ignition Switch
Position: 0

RESULTS
Less than 1 ohm

Z176
Subwoofer
Amplifier

~~OK~~ **PROBLEM CAUSE**

- B Wire

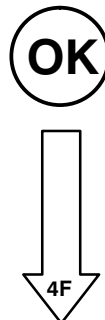

3F

4F

CONDITIONS

- Ignition Switch
Position: 0
- Radio
Disconnected

RESULTS
More than 10K ohms

R060012

**Z176
Subwoofer
Amplifier**

C412



PROBLEM CAUSE

- R Wire
- B Wire



**MID LINE RADIO
GO TO TEST G
HIGH LINE RADIO
GO TO TEST H**

Test G

1G

Mid Line Radio

CONDITIONS

- Ignition Switch
Position: 0

RESULTS
0 Ω

R100011

R060012

**Z111
Radio**

C260

**Z176
Subwoofer
Amplifier**

C412



PROBLEM CAUSE

- R Wire
- B Wire



GO TO TEST I

Test H

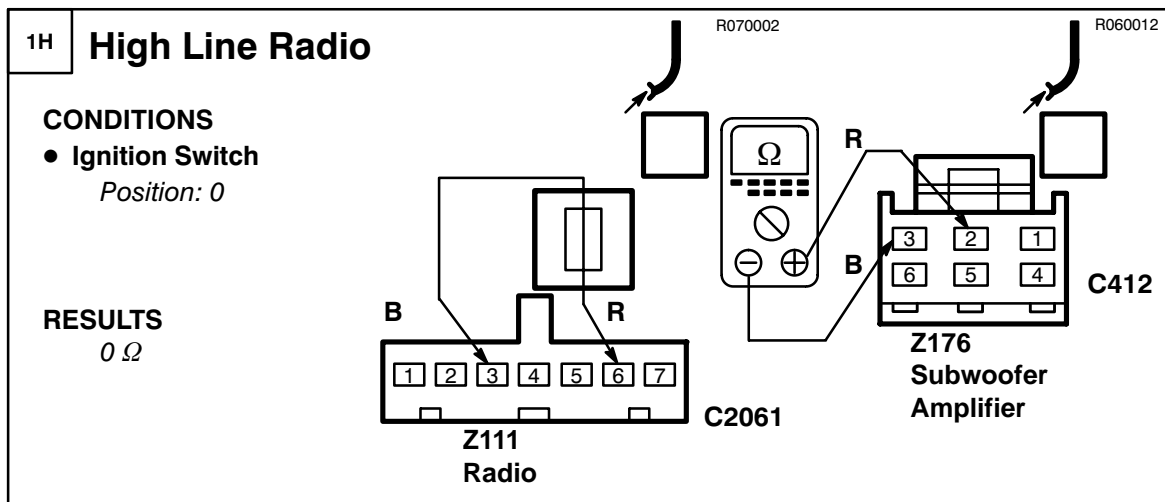

PROBLEM CAUSE

- R Wire
- B Wire



GO TO TEST I

Test I

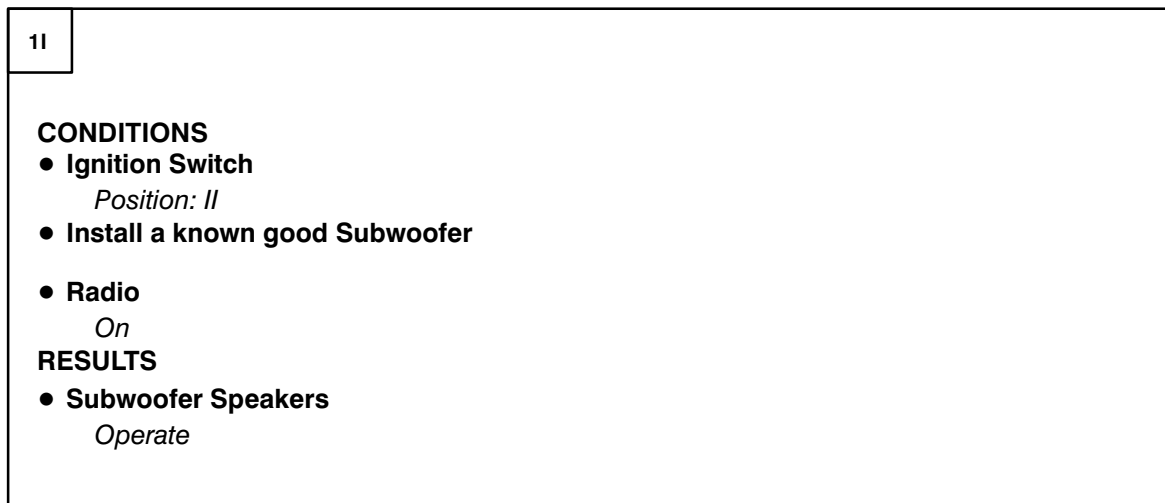

PROBLEM CAUSE

- Subwoofer Amplifier
- Radio
- Subwoofer Wiring



PROBLEM CAUSE

- Subwoofer

Test J

1J Mid Line Radio R050019

CONDITIONS

- Ignition Switch
Position: 0
- Radio Waveband Switch
On

RESULTS
Less than 1 ohm



PROBLEM CAUSE

- RK Wire
- B Wire
- Radio Waveband Switch



PROBLEM CAUSE

- Radio

Test K

1K Mid Line Radio R050019

CONDITIONS

- Ignition Switch
Position: 0
- Radio Tune Switch
On

RESULTS
Less than 1 ohm



PROBLEM CAUSE

- UG Wire
- B Wire
- Radio Tune Switch



PROBLEM CAUSE

- Radio

Test L

R050019

1L

Mid Line Radio

CONDITIONS

- Ignition Switch
Position: 0
- Radio Volume Up Switch
On

RESULTS
Less than 1 ohm

**Z111
Radio**



- PROBLEM CAUSE**
- NY Wire
 - B Wire
 - Radio Volume Up Switch



- PROBLEM CAUSE**
- Radio

Test M

R050019

1M

Mid Line Radio

CONDITIONS

- Ignition Switch
Position: 0
- Radio Volume Down Switch
On

RESULTS
Less than 1 ohm

**Z111
Radio**



- PROBLEM CAUSE**
- U Wire
 - B Wire
 - Radio Volume Down Switch



- PROBLEM CAUSE**
- Radio

Test N

1N
High Line Radio
R050002.02

CONDITIONS

- Ignition Switch
Position: 0
- Radio Waveband Switch
On

RESULTS

Less than 1 ohm

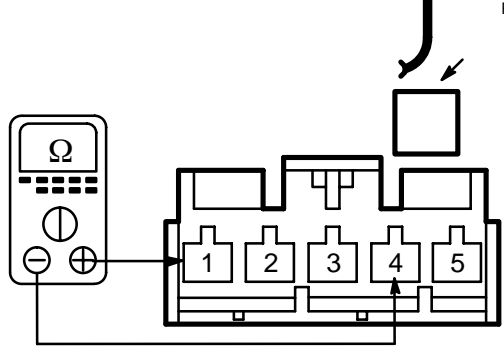

X234
Radio Waveband
Switch



PROBLEM CAUSE
- Radio Waveband
Switch



PROBLEM CAUSE
- Radio Waveband Resistor
- Radio Tune Resistor
- Radio Volume Resistor
- RG, UG, NY, U, B Wire
- Radio

Test O

1O
High Line Radio
R050002.02

CONDITIONS

- Ignition Switch
Position: 0
- Radio Tune Switch
On

RESULTS

Less than 1 ohm

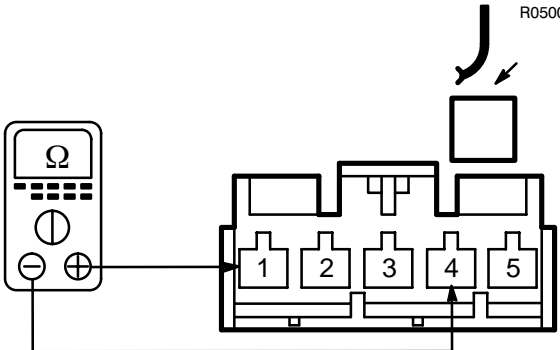

X233
Radio Tune
Switch



PROBLEM CAUSE
- Radio Tune
Switch



PROBLEM CAUSE
- Radio Tune Resistor
- Radio Volume Resistor
- UG, NY, U, B Wire
- Radio

Test P

1P

High Line Radio

R050002.02

CONDITIONS

- Ignition Switch
Position: 0
- Radio Volume Up Switch
On

RESULTS
Less than 1 ohm

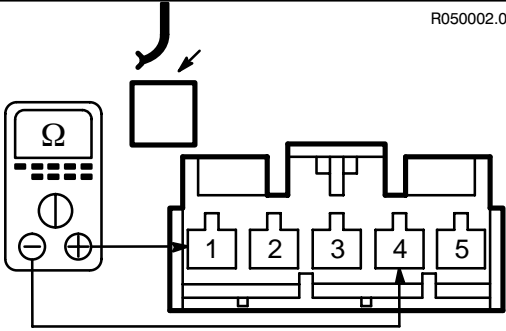

X235
Radio Volume Up
Switch

OK PROBLEM CAUSE
- Radio Volume Up
Switch

OK PROBLEM CAUSE
- Radio
- NY, U, B Wire
- Radio Volume
Resistor

Test Q

1Q

High Line Radio

R050002.02

CONDITIONS

- Ignition Switch
Position: 0
- Radio Volume Down Switch
On

RESULTS
Less than 1 ohm

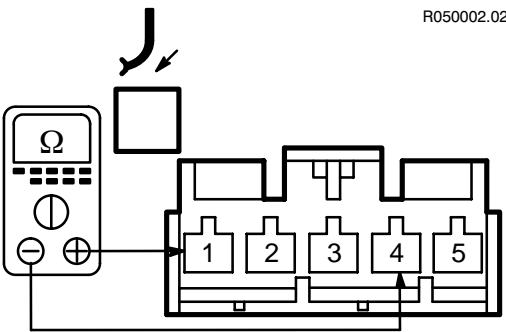

X236
Radio Volume
Down Switch

OK PROBLEM CAUSE
- Radio Volume
Down Switch

OK PROBLEM CAUSE
- U, B Wire
- Radio

Test R

1R Mid Line Radio

CONDITIONS

- Ignition Switch
Position: 0

RESULTS
Less than 1 ohm



PROBLEM CAUSE
- B Wire



PROBLEM CAUSE
- Radio

CIRCUIT OPERATION

The new audio system consists of a new head unit connected to a Radio Tune switch, a Waveband Switch, a Volume up and a Volume down switch which are located on the fascia next to the Instrument Cluster. The system is also equipped with an amplifier, a subwoofer, a subwoofer amplifier and a CD changer which is connected to the Radio with a DIN cable. The amplifier is connected to power via a Power Amplifier Relay which is energized with Ignition on.

The control head is equipped with an anti-theft feature which makes the unit inoperative once battery power is removed. A security code must be entered to restore power to the unit. The system is equipped with two rear and two front speakers.

Battery voltage is provided to the control head at all times through the P wire. In addition to monitoring the anti-theft feature, this input keeps the present station memory alive. Whenever battery power to the unit is lost, the anti-theft code must be entered and the present stations must be reprogrammed.

When the Radio (Z111) and the ignition are turned on, the voltage signal through the LGO wire and the control head 'wakes up' the unit. The Radio (Z111) plays, the VF display comes on and the control unit buttons illuminate. The VF display is dimmed when the headlights or park lights are turned on. When the lights are on, voltage from fuse F8 of the Fascia Fusebox (P126) is applied to the Radio (Z111) terminal 6, Connector 230 signalling the Radio (Z111) to dim the display.

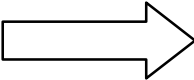
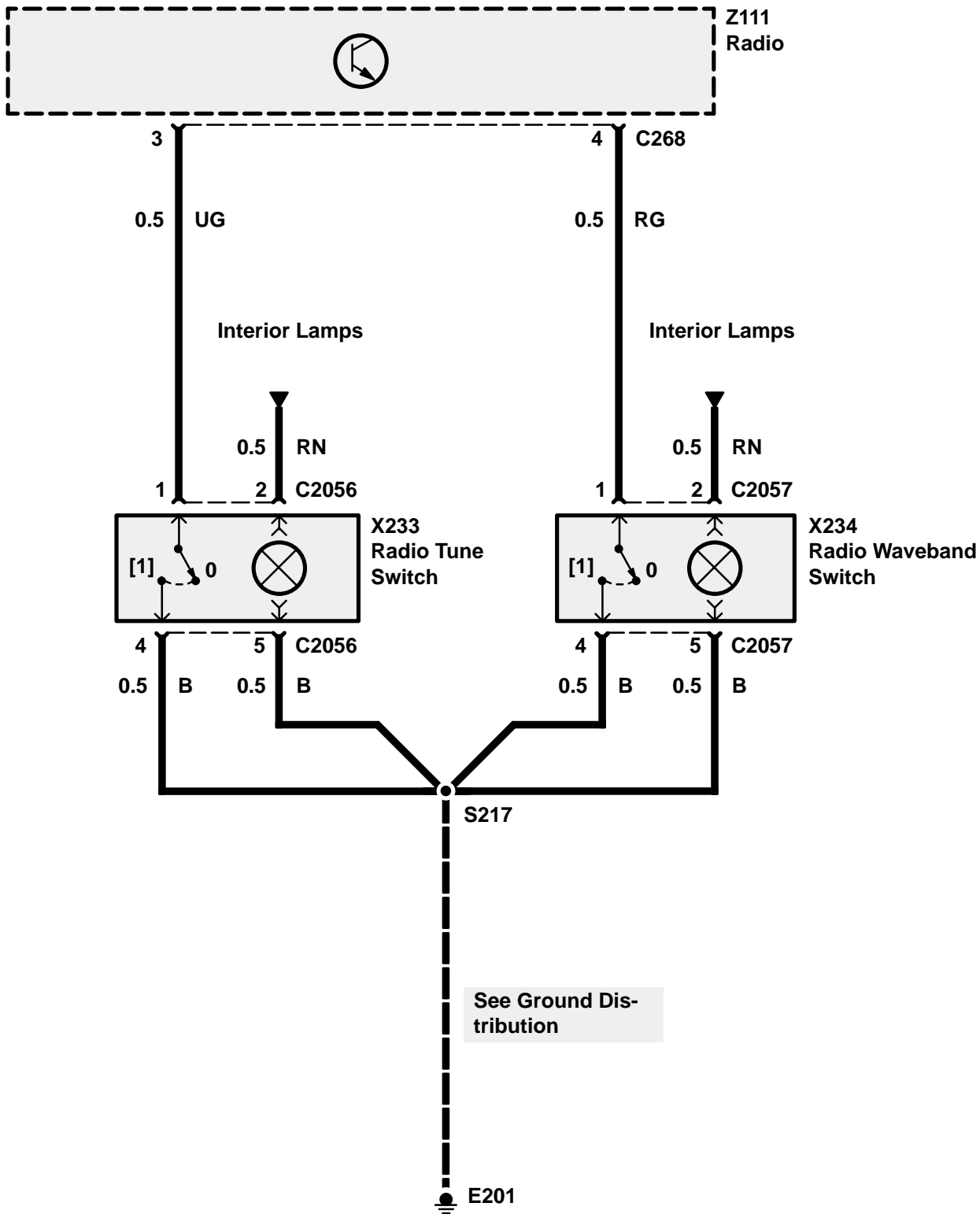
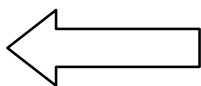

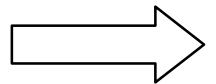
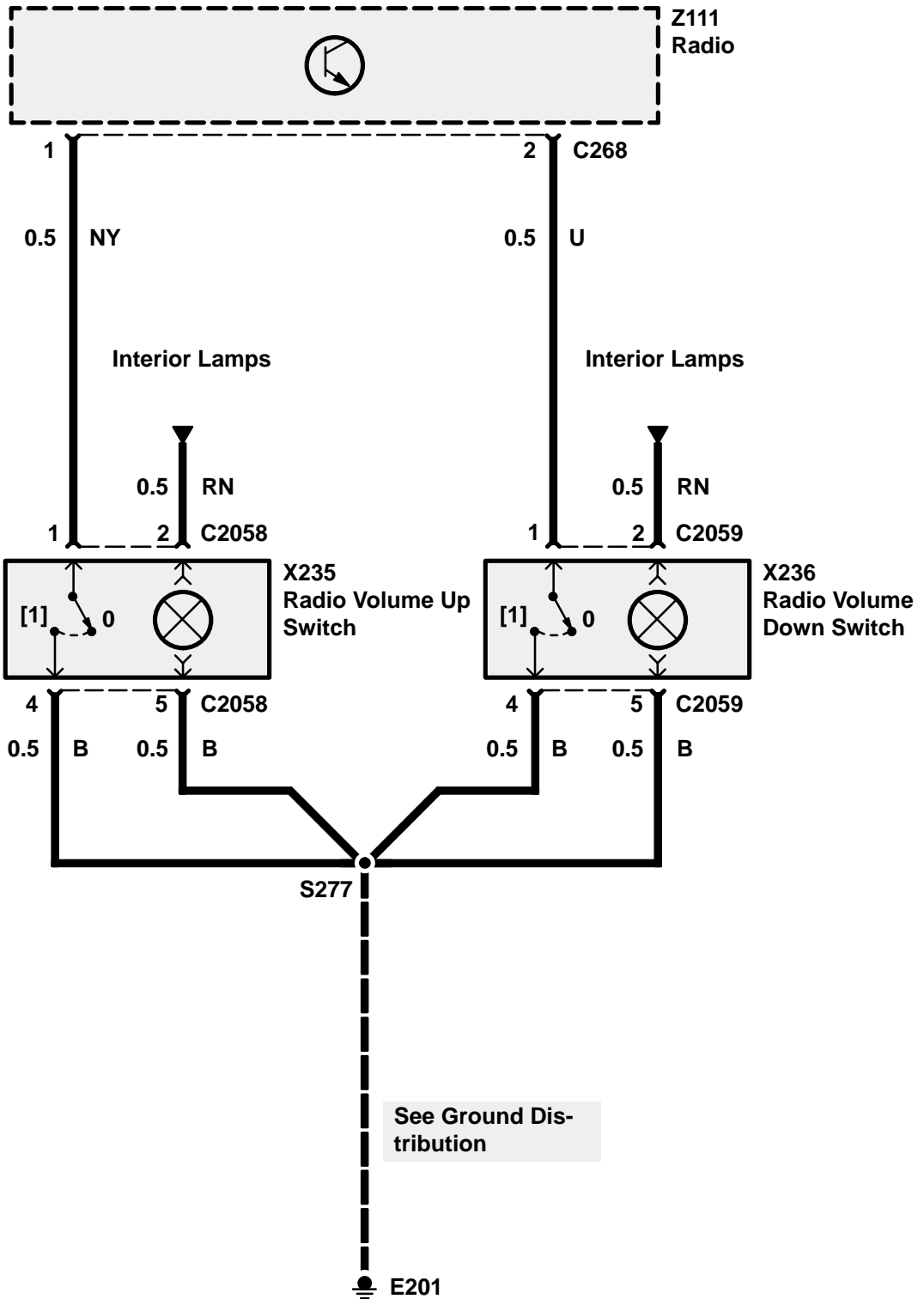
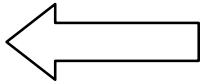

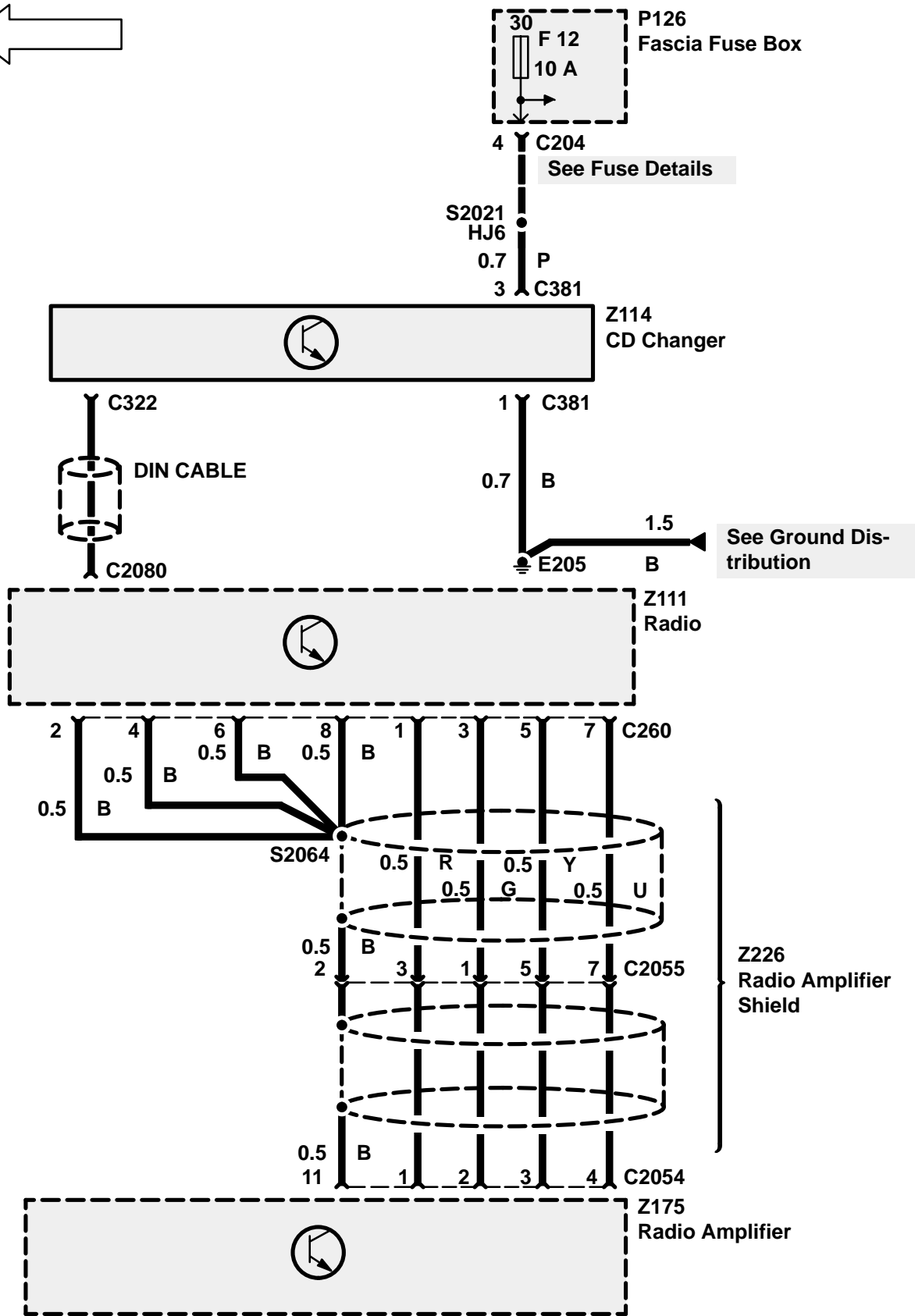
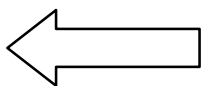

See Ground Distribution

See Fuse Details

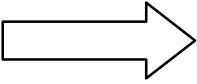

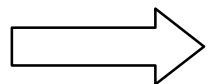
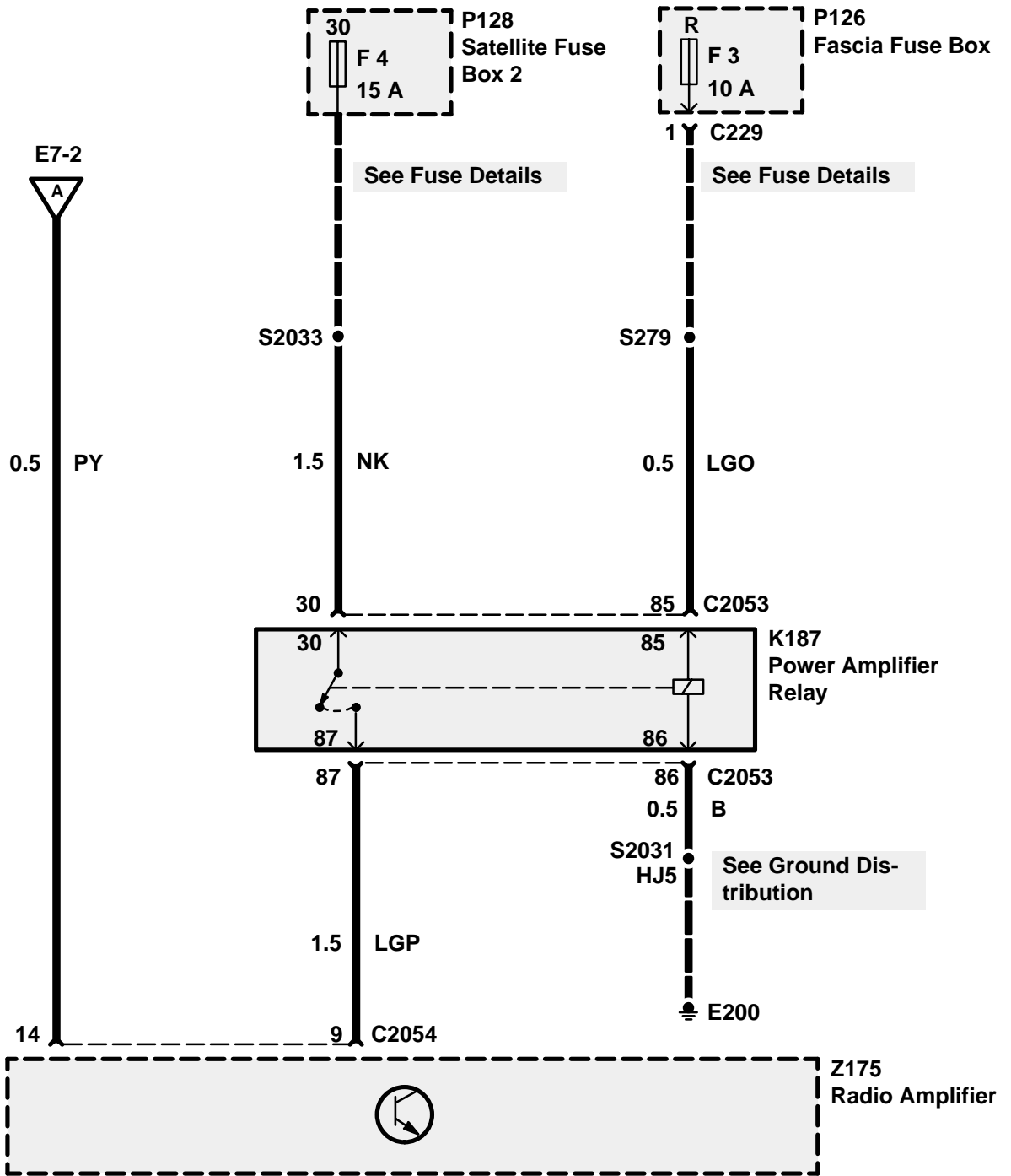
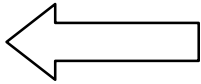

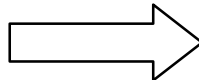
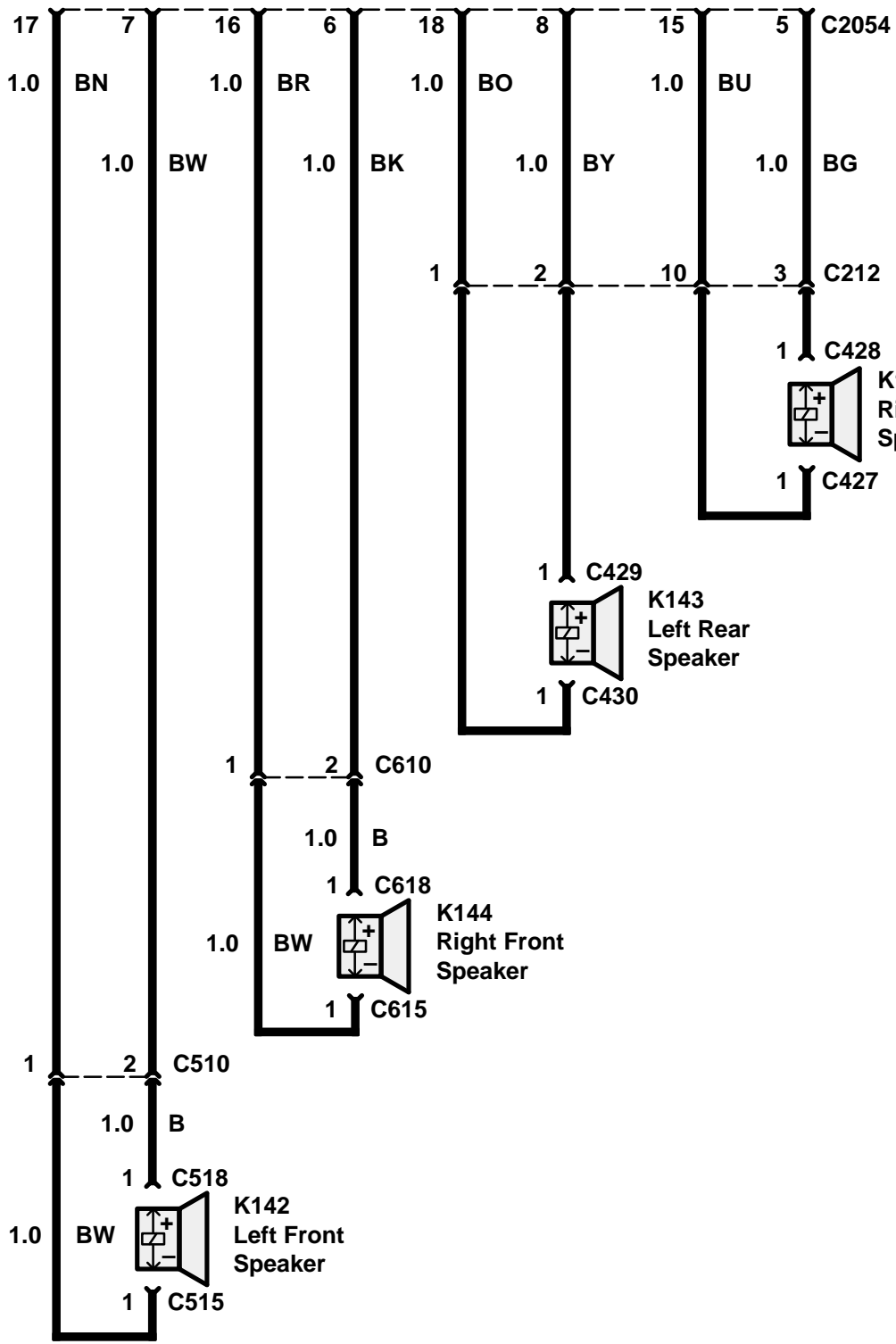
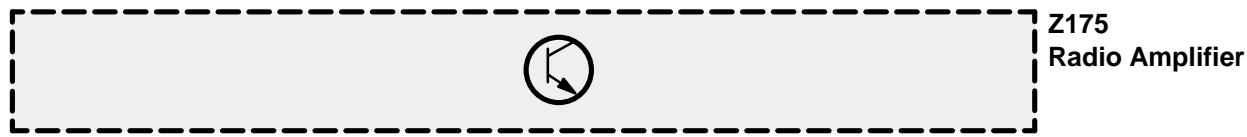
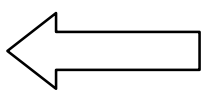

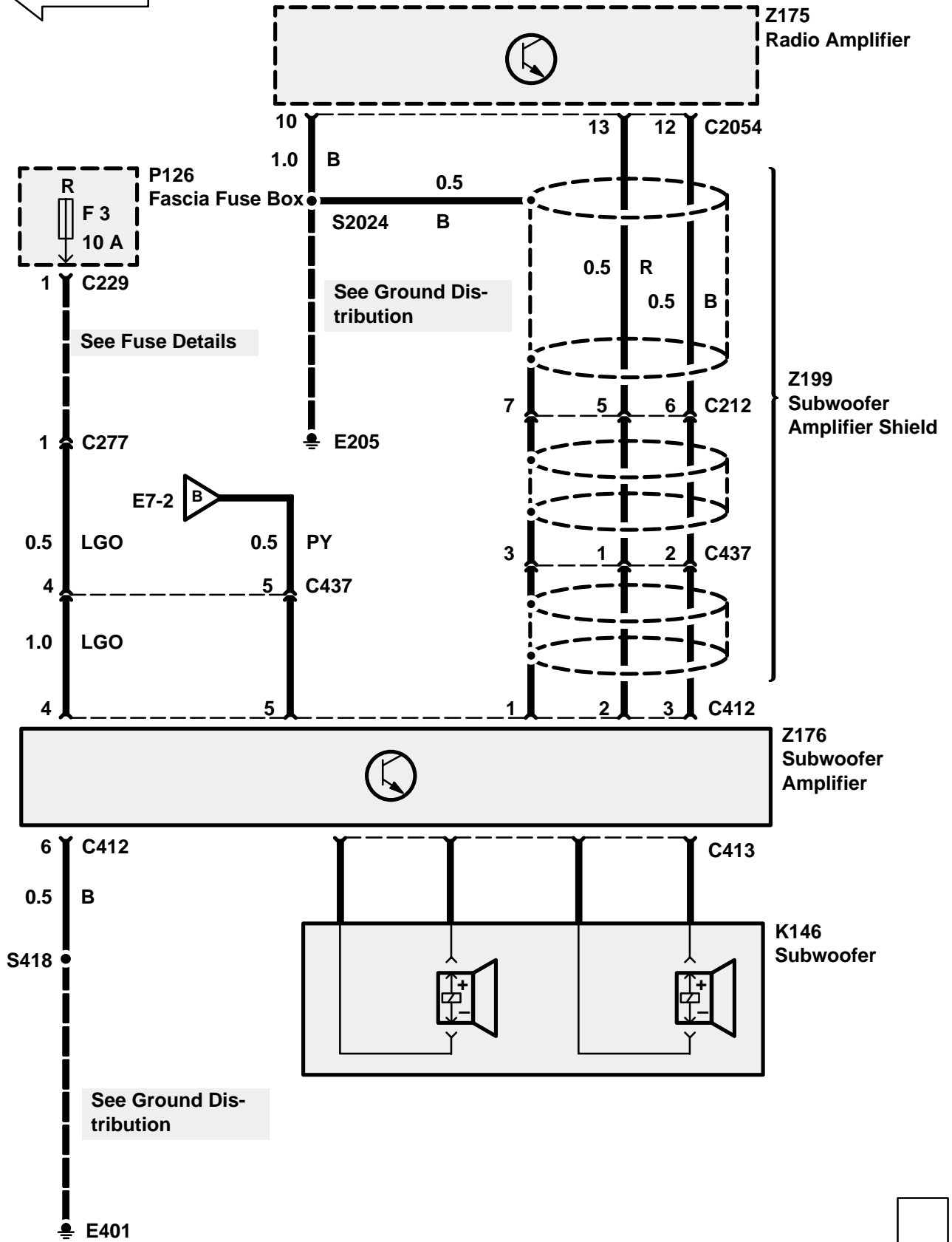
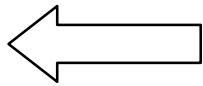

TROUBLESHOOTING HINTS

12. Check fuses F6 of Satellite Fusebox 2 (P128) and F3 of Fascia Fusebox (P126).
13. Check that Radio (Z111) connectors and coaxial cable are tight and properly connected.
14. For proper Radio (Z111) noise diagnosis, take the vehicle outside where signals are strong. Close the hood and keep away from metal buildings or other sources of Radio interference.
15. If Radio (Z111) noise is excessive when an accessory is on, install a Radio noise suppression capacitor to the power lead of that accessory.
16. If Radio (Z111) noise is excessive at all times, check antenna wiring. If OK, check spark plugs, spark plug wiring and wiring close to the ignition system which could transmit noise to the Radio (Z111) wiring.
17. If only the CD Changer does not operate, check power, ground, and DIN Cable. If OK, check Radio and CD Changer.
18. If the Radio (Z111) is inoperative and 'code' is being shown on the display, follow the instructions below.
19. If Radio scans past all frequencies when in seek mode and hiss is present over most stations, substitute antenna with a known good antenna. If the reception is still inadequate, replace Radio.

Security Code Instructions

1. Obtain 5-digit security code from vehicle owner or manufacturer.
2. Enter the code number using the Radio (Z111) push-button selectors.

NOTE: If the correct code is not entered in 3 successive attempts, the Radio (Z111) will not accept another entry until the Radio has been left on for 1 hour with the ignition on.

NOTE: When entering the code, be sure to complete the sequence numbering of that 5-digit code even if you made a mistake. For example, if the correct code number sequence is 43215 and you mistakenly enter 42 instead of 43, continue the code number sequence of 215 to complete that entry. A 'beep' will sound, 'code' will still be displayed and the Radio will not operate. Re-enter the correct code 43215 and the Radio will operate.

NOTE: If an audible 'beep' is heard while entering the code, STOP immediately. Begin entering the code again, starting with the first number of the 5-digit code.

NOTE: If a push-button is touched accidentally when the ignition is off, a warning tone will sound. Turn the ignition on and the tone will stop.

SYSTEM DIAGNOSIS

1. If the Radio (Z111) does not operate at all, do Test A.
2. If VF display does not dim when head lamps or park lamps are turned on, do Test B.
3. If one or more speakers do not operate, do Test C.
4. If the Radio (Z111) appears to operate properly, but the Subwoofer (K146) and/or none of the Speakers operate, do Test D.
5. If the Subwoofer (K146) does not operate, do Test E.
6. If none of the Remote Radio Waveband, Tune, Volume Up, or Volume Down Switches operate for the Mid Line Radio, do Test J.
7. If the Radio Waveband Switch (X234) does not operate, do Test F.
8. If the Radio Tune Switch (X233) does not operate, do Test G.
9. If the Radio Volume Up Switch (X235) does not operate, do Test H.
10. If the Radio Volume Down Switch (X236) does not operate, do Test I.

Test A

R080017

1A

CONDITIONS

- Ignition Switch
Position: II

RESULTS
BAT VOLT

Z111
Radio

~~OK~~ **PROBLEM CAUSE**

- P Wire
- LGO Wire
- F6 Fuse
- F3 Fuse
- B Wire

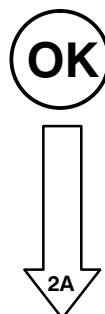

R080016

2A

CONDITIONS

- Ignition Switch
Position: 0

RESULTS
Less than 1 ohm

Z111
Radio

~~OK~~ **PROBLEM CAUSE**

- B Wire

OK **PROBLEM CAUSE**

- Radio

Test B

R080017

1B

CONDITIONS

- Ignition Switch
Position: II
- Headlamps
On

RESULTS
BAT VOLT

Z111
Radio

C230



PROBLEM CAUSE
- RN Wire



PROBLEM CAUSE
- Radio

Test C

R010001

1C

CONDITIONS

- Connect at suspect connector
- Connect for less than 1 second

RESULTS
Speaker 'pops'

J2120
Speaker



PROBLEM CAUSE
- Speaker



PROBLEM CAUSE
- Speaker Wiring
- Radio

Test D

1D

CONDITIONS

- Ignition Switch
Position: II
- Radio
On

RESULTS
BAT VOLT

R180002

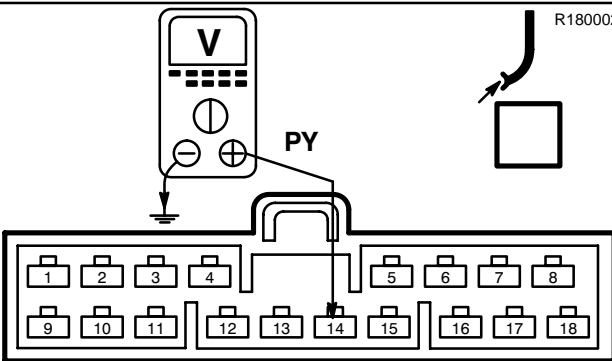

**Z175
Radio Amplifier**

OK PROBLEM CAUSE

- UY Wire
- PY Wire
- Radio

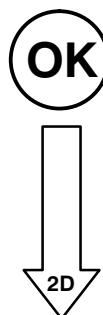

2D

CONDITIONS

- Ignition Switch
Position: II

RESULTS
BAT VOLT

R050001

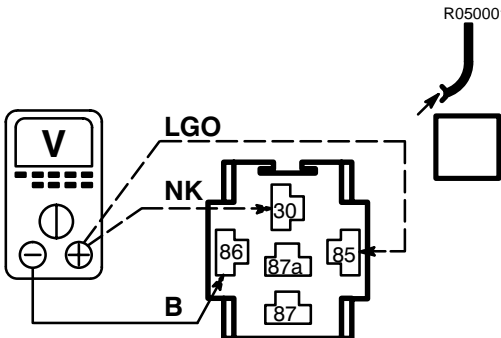

**K187
Power Amplifier
Relay**

OK PROBLEM CAUSE

- F4 Fuse
- F3 Fuse
- NK Wire
- LGO Wire
- B Wire

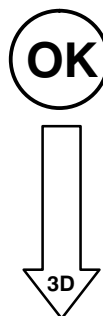

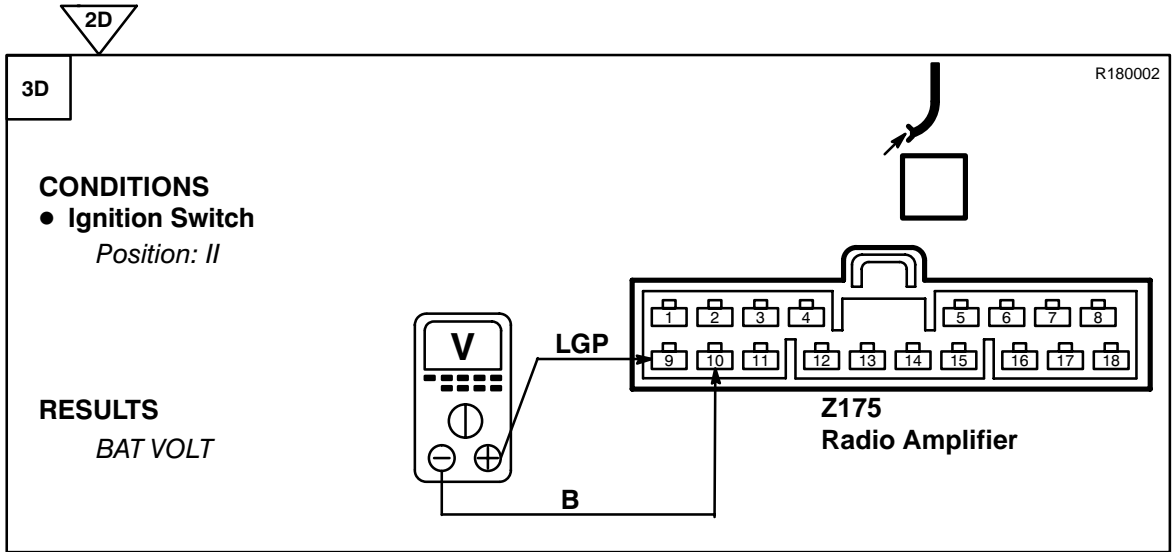

PROBLEM CAUSE

- LGP Wire
- B Wire
- Power Amplifier Relay

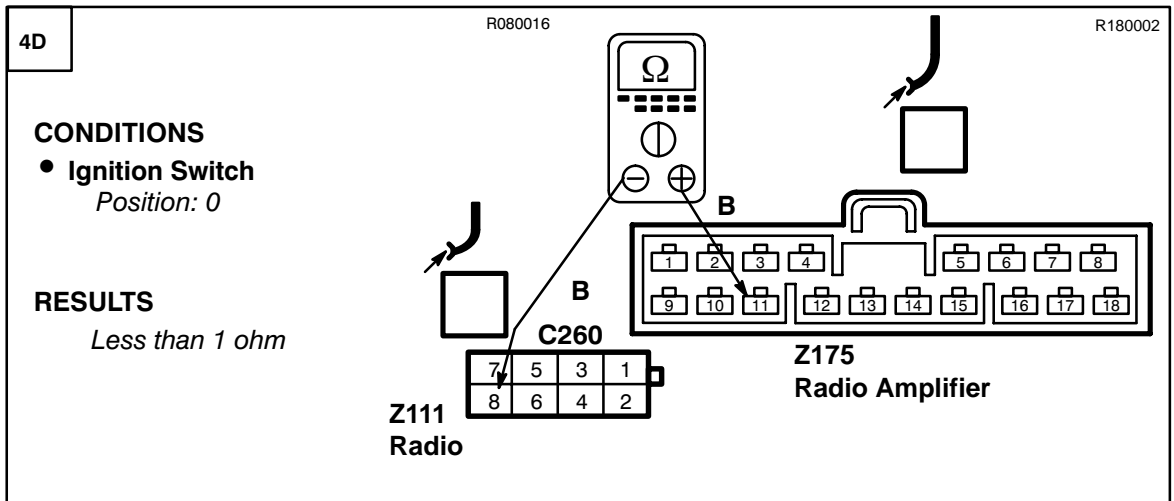
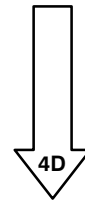

PROBLEM CAUSE

- B Wire

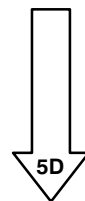

4D

5D

R080016

CONDITIONS

- Ignition Switch
Position: 0
- Radio Amplifier
Disconnected

RESULTS
Less than 1 ohm

~~OK~~ PROBLEM CAUSE
- B Wire

OK

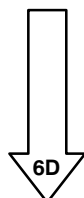

6D

6D

R180002

CONDITIONS

- Ignition Switch
Position: 0

RESULTS
Less than 1 ohm

~~OK~~ PROBLEM CAUSE
- G Wire
- R Wire

OK

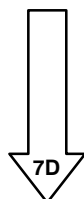

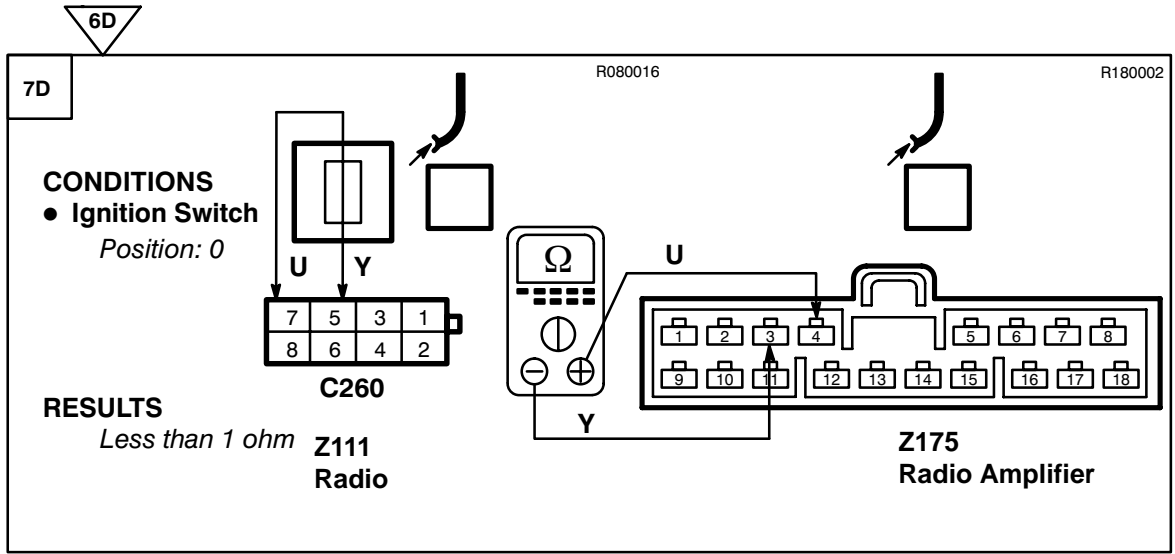

PROBLEM CAUSE

- U Wire
- Y Wire



PROBLEM CAUSE

- Radio
- Radio Amplifier

Test E

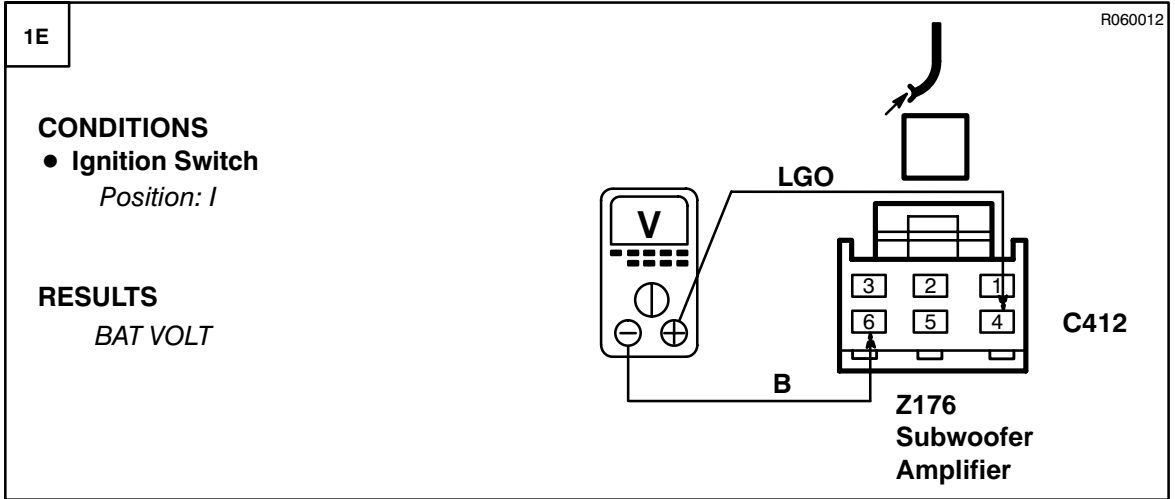

PROBLEM CAUSE

- LGO Wire
- B Wire

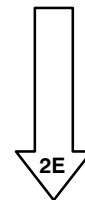

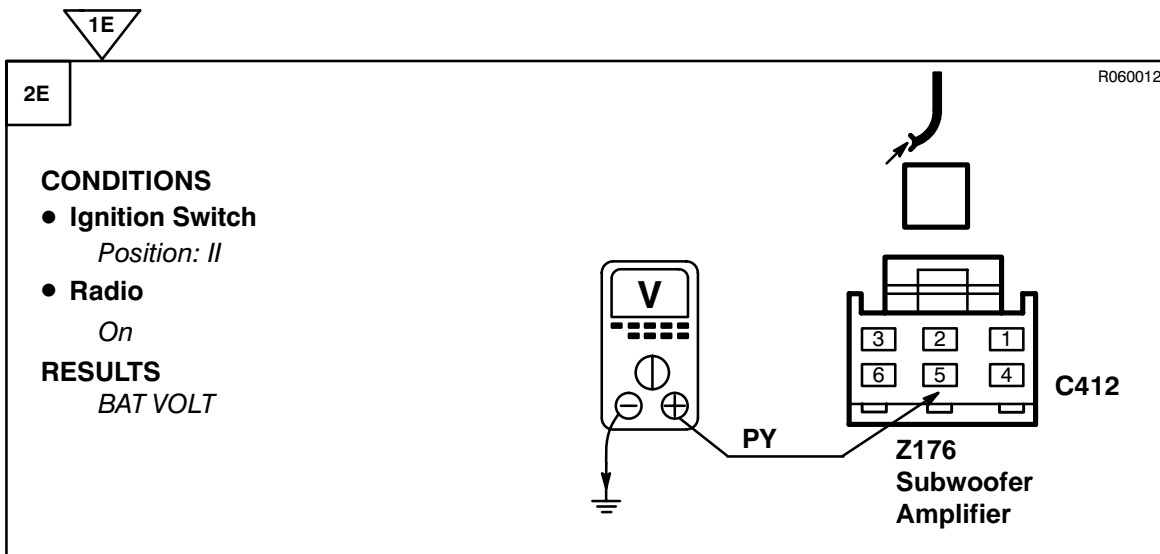

~~OK~~ **PROBLEM CAUSE**
- PY Wire

OK

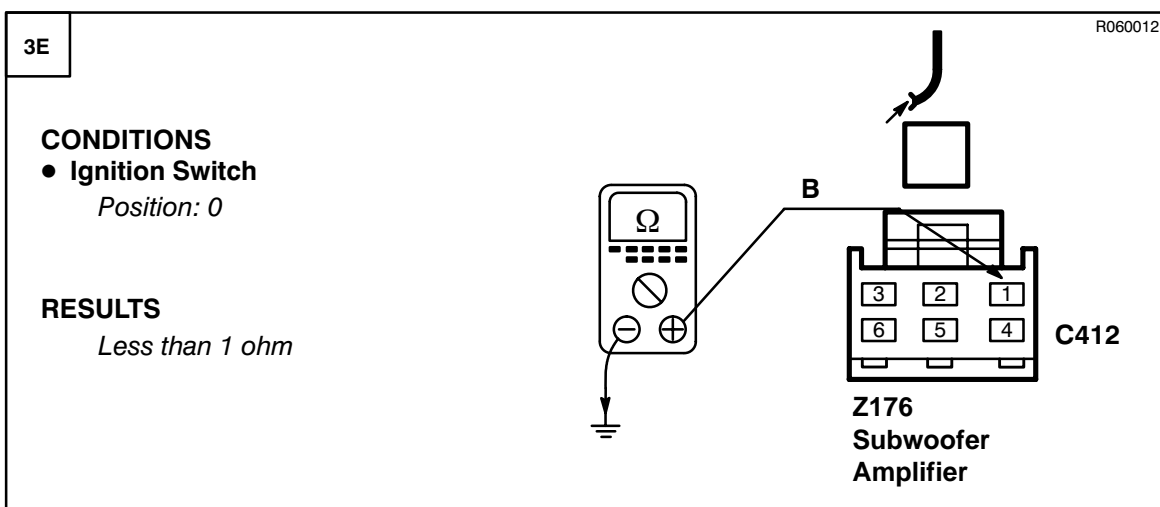
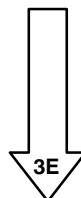

~~OK~~ **PROBLEM CAUSE**
- B Wire

OK

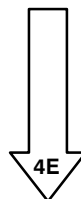

R060012

4E

CONDITIONS

- Ignition Switch
Position: 0
- Radio Amplifier
Disconnected

RESULTS
More than 10K ohms

**Z176
Subwoofer
Amplifier**



PROBLEM CAUSE

- R Wire
- B Wire

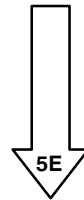

R060012

5E

CONDITIONS

- Ignition Switch
Position: 0

RESULTS
0 Ω

**Z175
Radio Amplifier**

**Z176
Subwoofer
Amplifier**



PROBLEM CAUSE

- R Wire
- B Wire

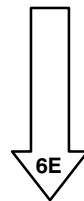

5E

6E

CONDITIONS

- Ignition Switch
Position: II
- Install a known good Subwoofer
- Radio
On

RESULTS

- Install a known good Subwoofer
Operate



PROBLEM CAUSE

- Subwoofer Amplifier
- Radio
- Subwoofer Wiring



PROBLEM CAUSE

- Subwoofer

Test F

1F

R080016

CONDITIONS

- Ignition Switch
Position: 0
- Radio Waveband Switch
On

RESULTS

- Less than 1 ohm



PROBLEM CAUSE

- B Wire
- RG Wire
- Radio Waveband Switch



- Radio

Test G

1G

R080016

CONDITIONS

- Ignition Switch
Position: 0
- Radio Tune Switch
On

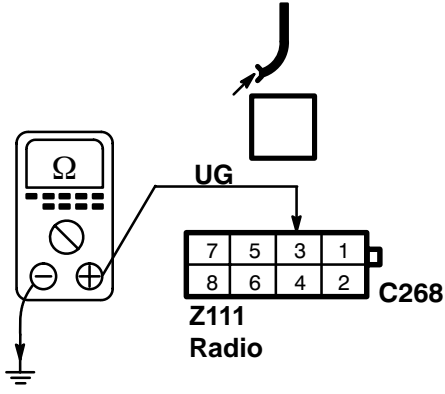

RESULTS
Less than 1 ohm

**PROBLEM CAUSE**

- UG Wire
- B Wire
- Radio Tune Switch

**PROBLEM CAUSE**

- Radio

Test H

1H

R080016

CONDITIONS

- Ignition Switch
Position: 0
- Radio Volume Up Switch
On

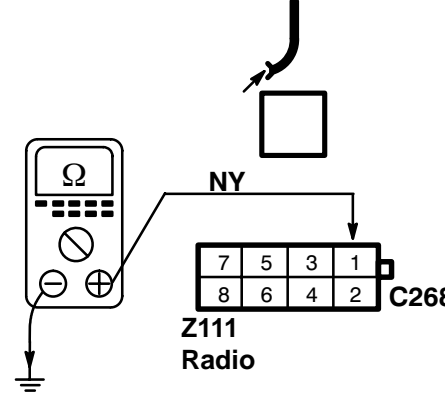

RESULTS
Less than 1 ohm

**PROBLEM CAUSE**

- NY Wire
- B Wire
- Radio Volume Up Switch

**PROBLEM CAUSE**

- Radio

Test I

R080016

1I

CONDITIONS

- Ignition Switch
Position: 0
- Radio Volume Down Switch
On

RESULTS
Less than 1 ohm

Z111 Radio

C268



PROBLEM CAUSE

- U Wire
- B Wire
- Radio Volume Down Switch



PROBLEM CAUSE

- Radio

Test J

R080016

1J

CONDITIONS

- Ignition Switch
Position: 0

RESULTS
Less than 1 ohm

Z111 Radio

C268



PROBLEM CAUSE

- B Wire



PROBLEM CAUSE

- Radio

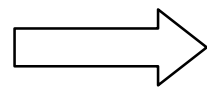
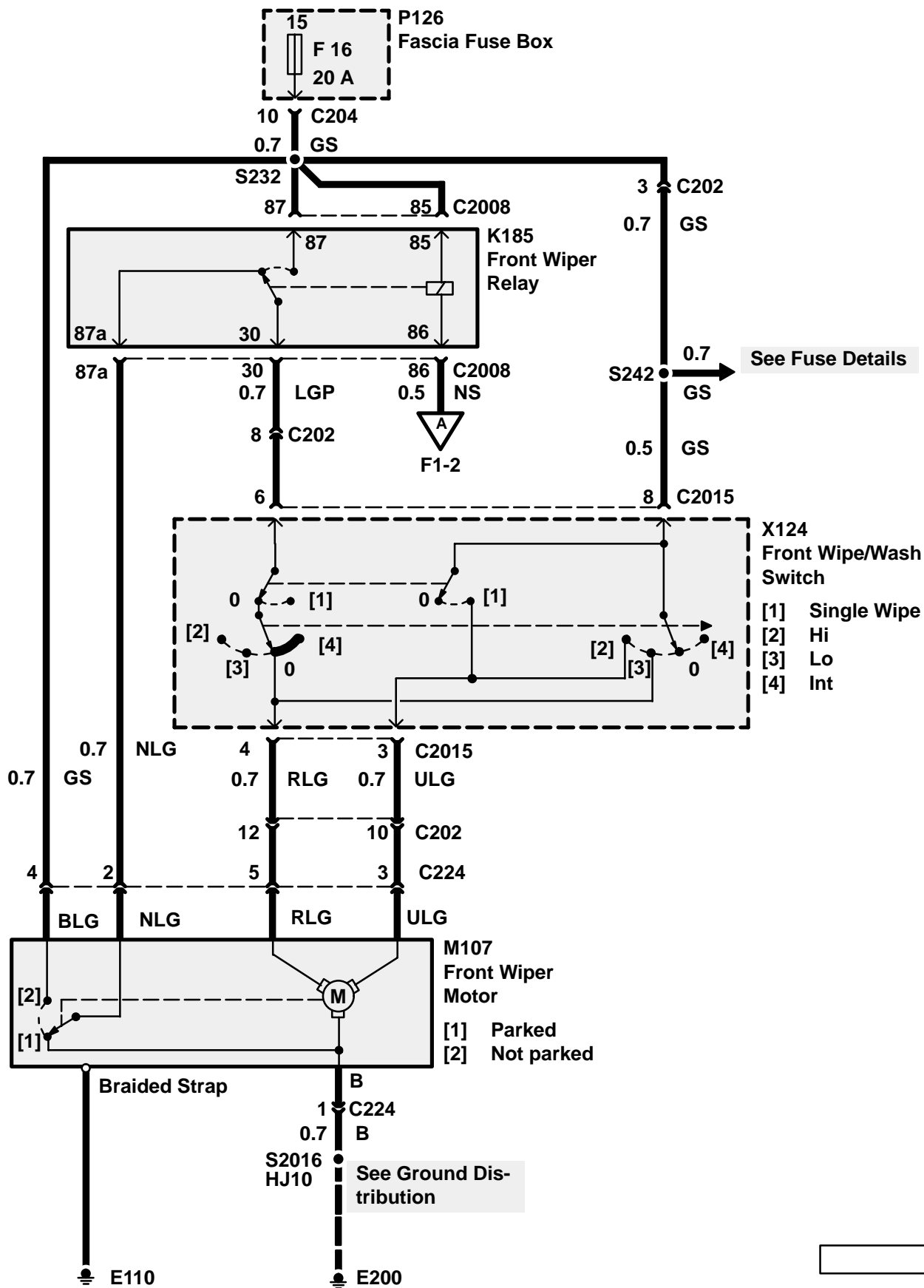

F1 ETM

DISCOVERY

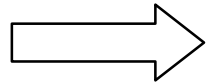
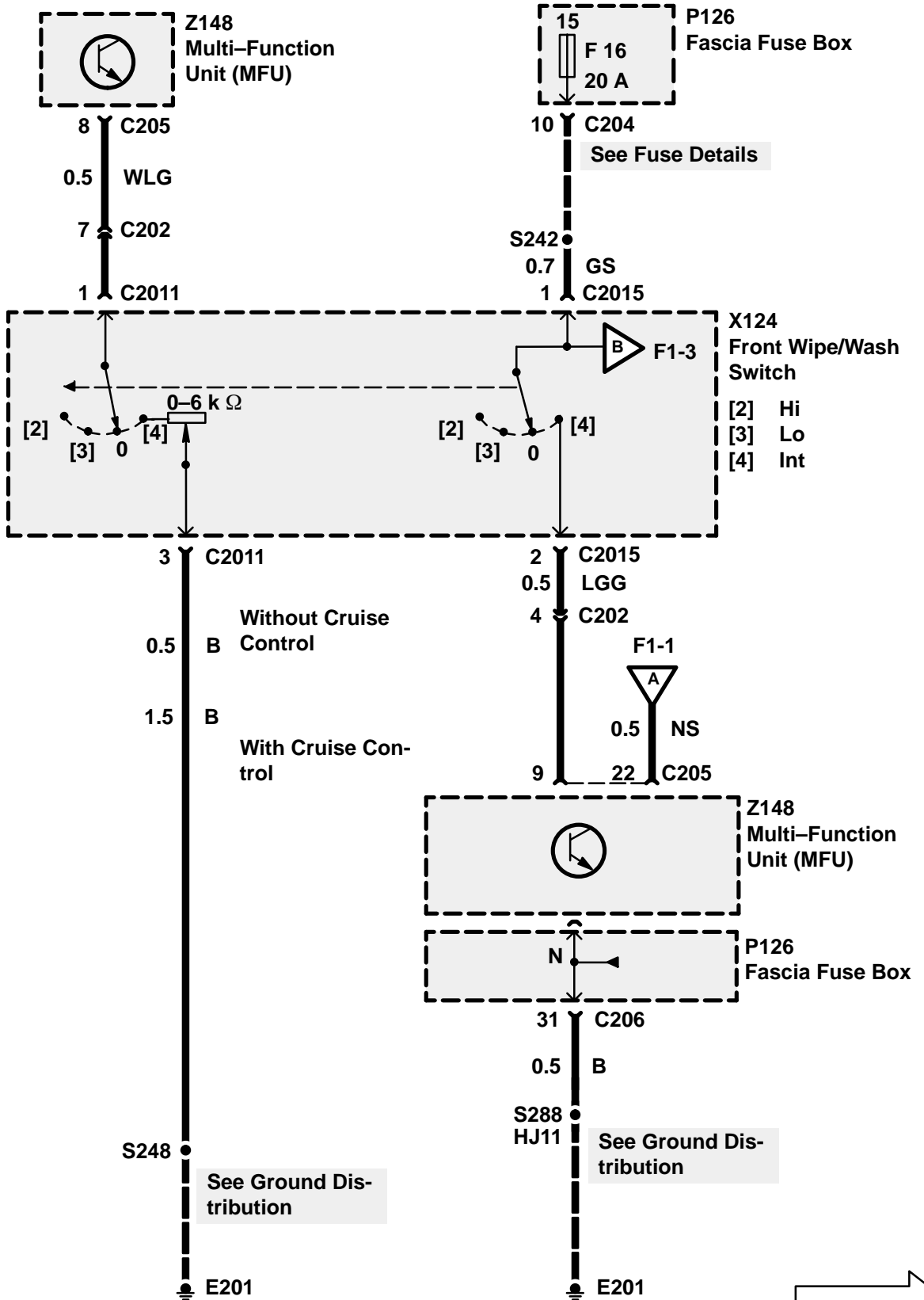
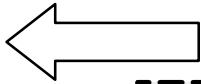

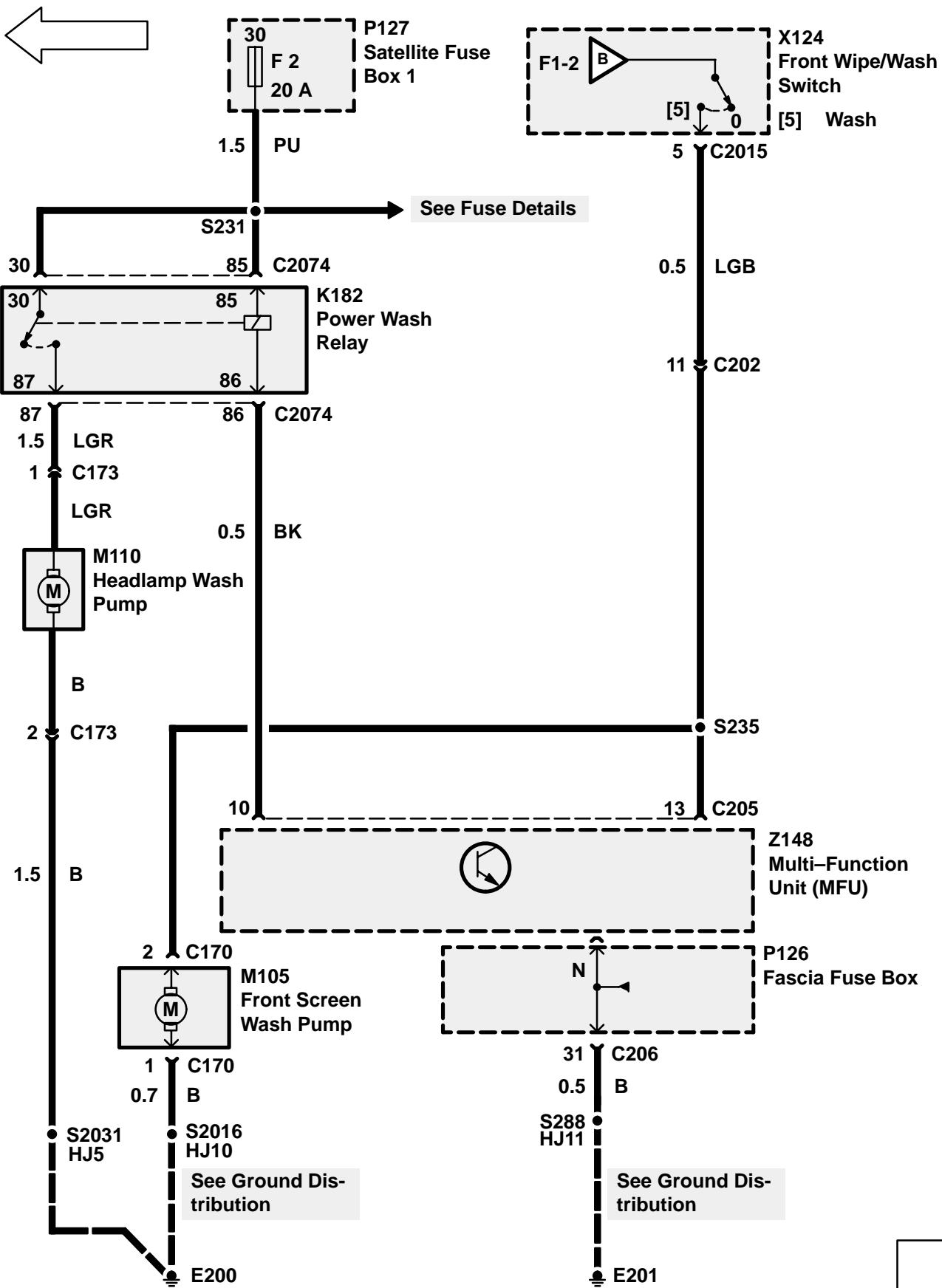

CIRCUIT OPERATION**Washer**

The Rear Screen Wash Pump (M119) motor is grounded at all times. The motor runs when battery voltage is applied to the motor through the Rear Screen Wash Switch (X222) when the switch is switched to the WASH position.

Wiper

When the Rear Screen Wipe Switch (X221) is pulled to the WIPE position, the Multifunction Unit (MFU) (Z148) applies ground to the Rear Wipe Relay (K183). Battery voltage is then applied to the Rear Wiper Motor (M120) from Fuse F18.

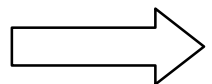
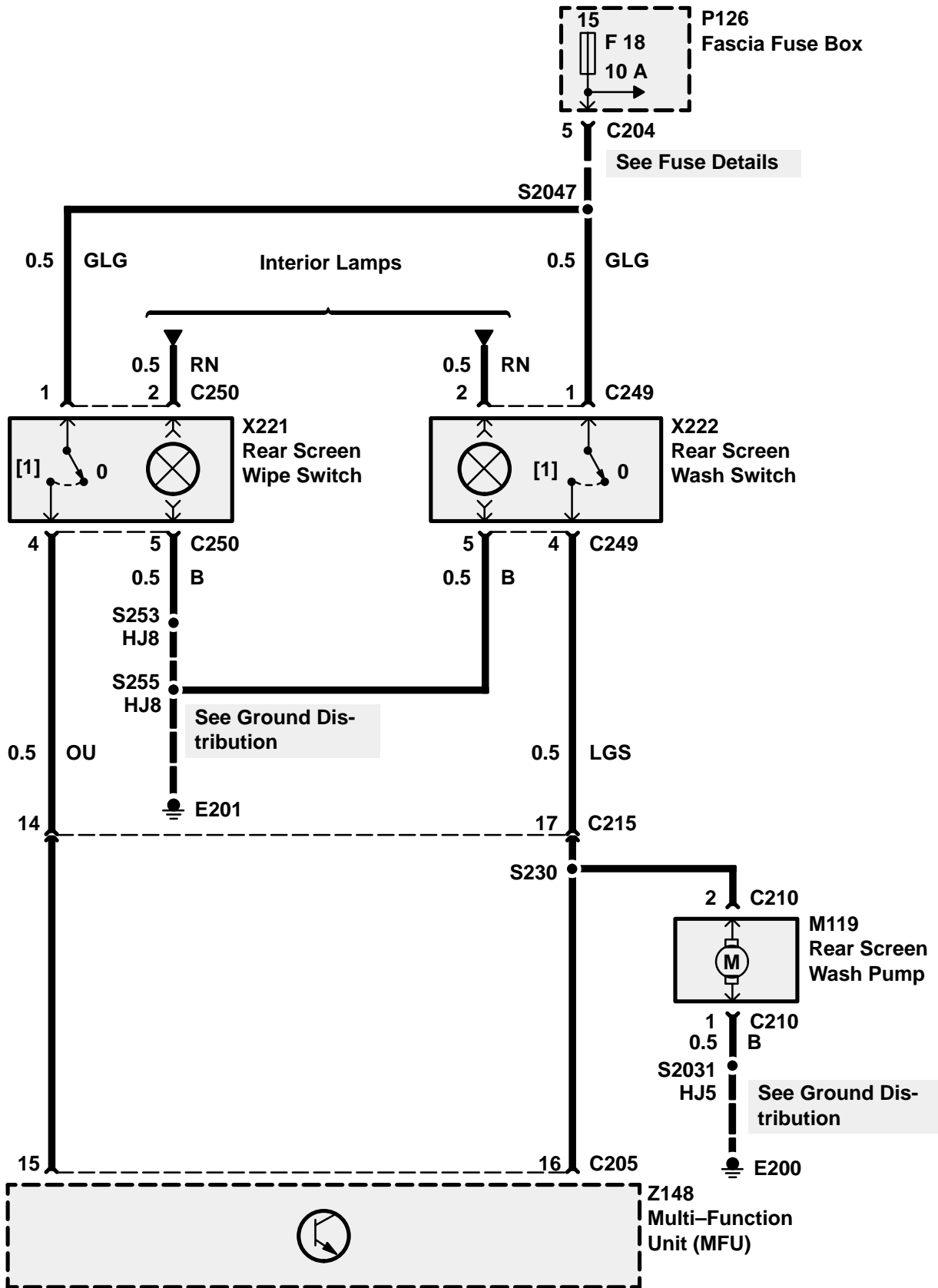

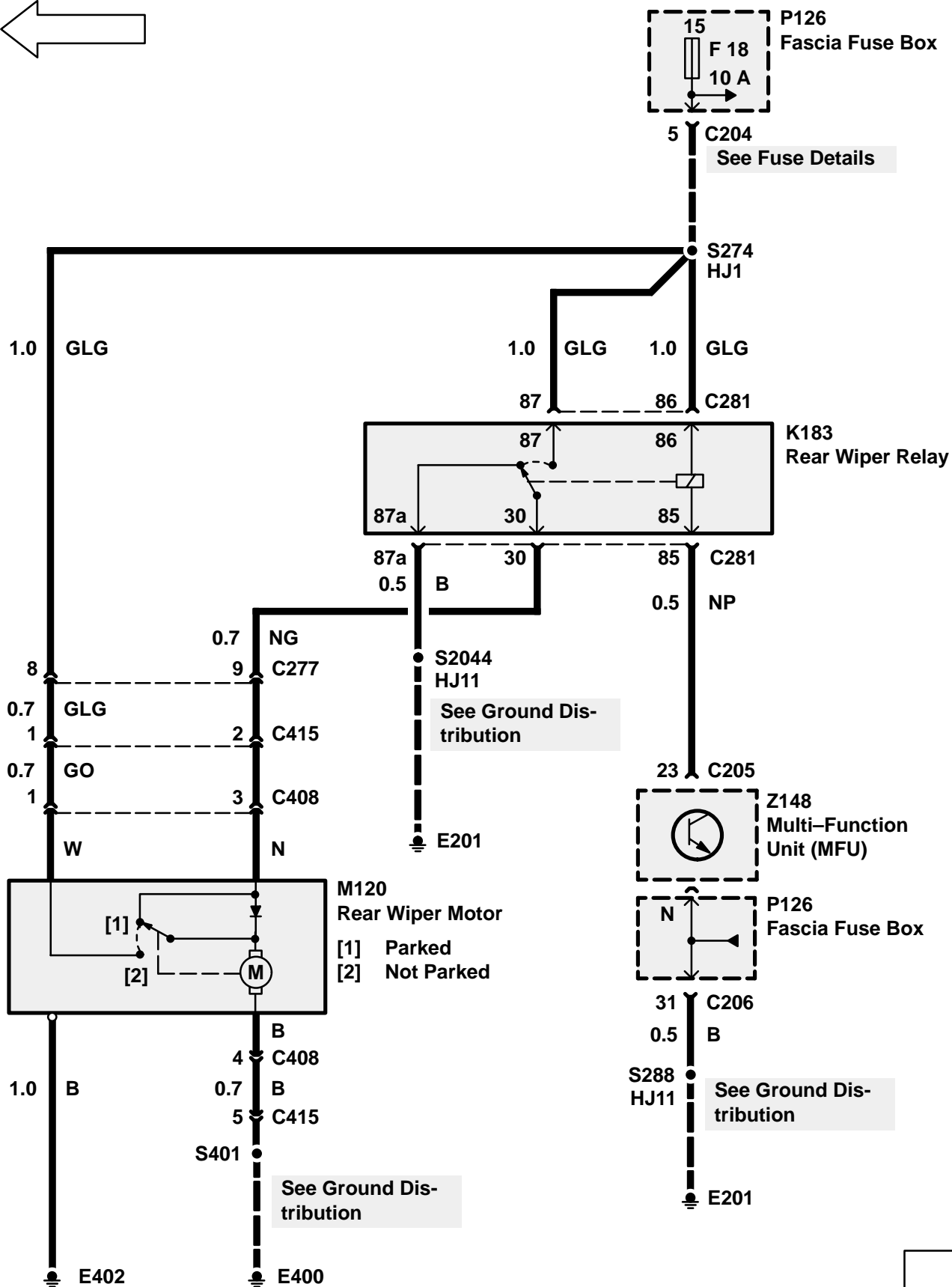
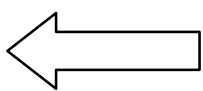

TROUBLESHOOTING HINTS

11. If the washer does not operate, check the washer fluid hoses for kinks or blockage.
12. If the wiper does not operate only when washer is requested, check LGS wire and Multifunction Unit (MFU) (Z148).
13. If the wiper operates with tailgate open, check Tailgate Switch (X170) and PB wires.
14. If the sunroof operates, see section L4, Sunroof.
15. If the washer runs continuously, replace the Rear Screen Wash Switch (X222).
16. If wiper and washer do not operate, check GLG wire and Fuse F18.
17. If the wiper will not return to it's parked position when the ignition switch is turned off, check sunroof operation within 45 seconds after turning the ignition off. If the sunroof does not operate check Sunroof Load Relay (K138) and Window Lift ECU (Z147), otherwise check Rear Wiper Motor (M120).

SYSTEM DIAGNOSIS

1. If the wiper does not operate, do Test A.
2. If the washer does not operate, do Test B.
3. If the wiper runs with Rear Screen Wipe Switch (X221) off, do Test C.

Test A

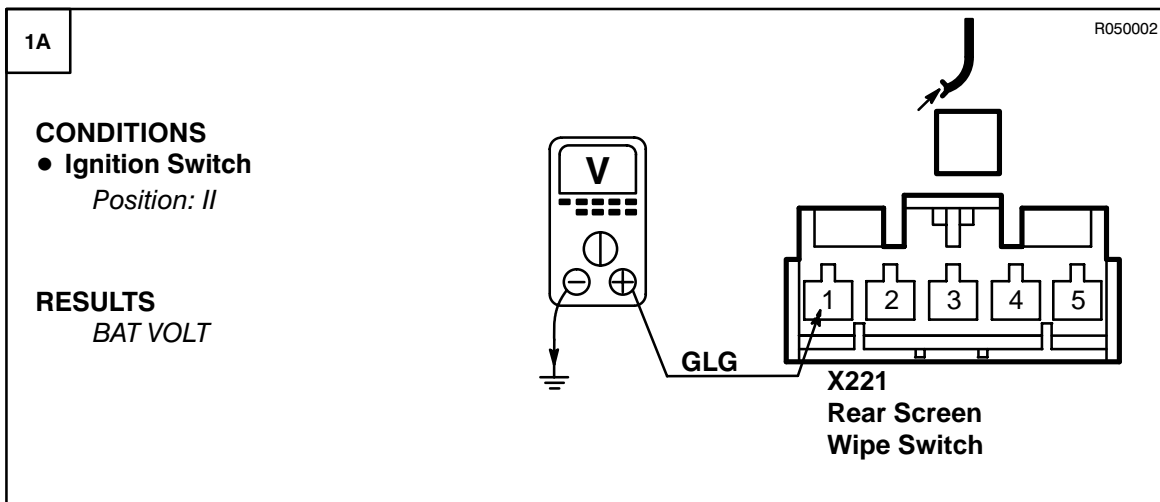

~~OK~~ PROBLEM CAUSE
- GLG Wire

OK

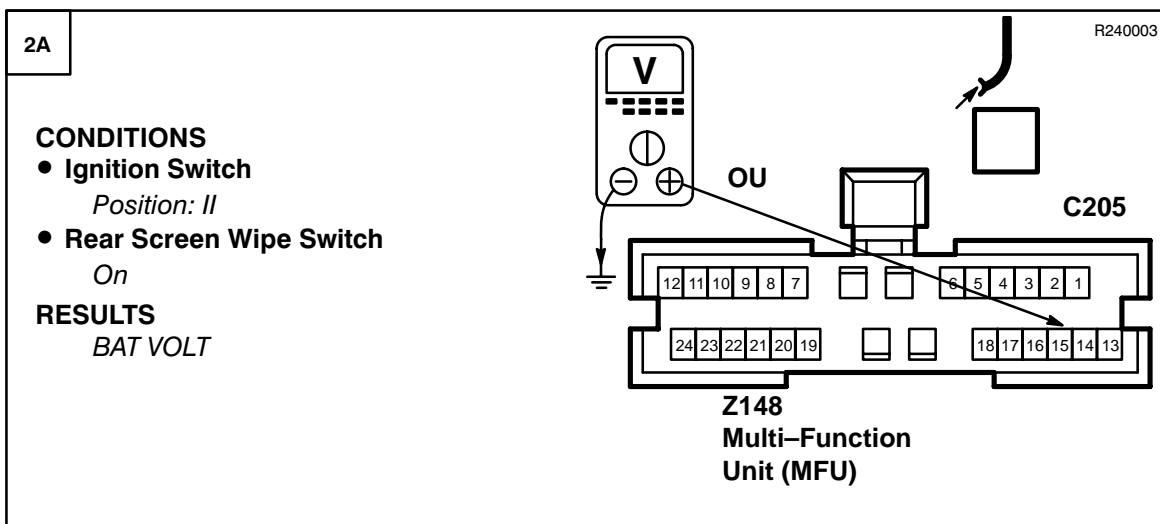
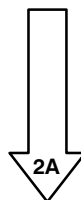

~~OK~~ PROBLEM CAUSE
- OU Wire
- Rear Screen
Wipe Switch

OK

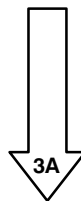

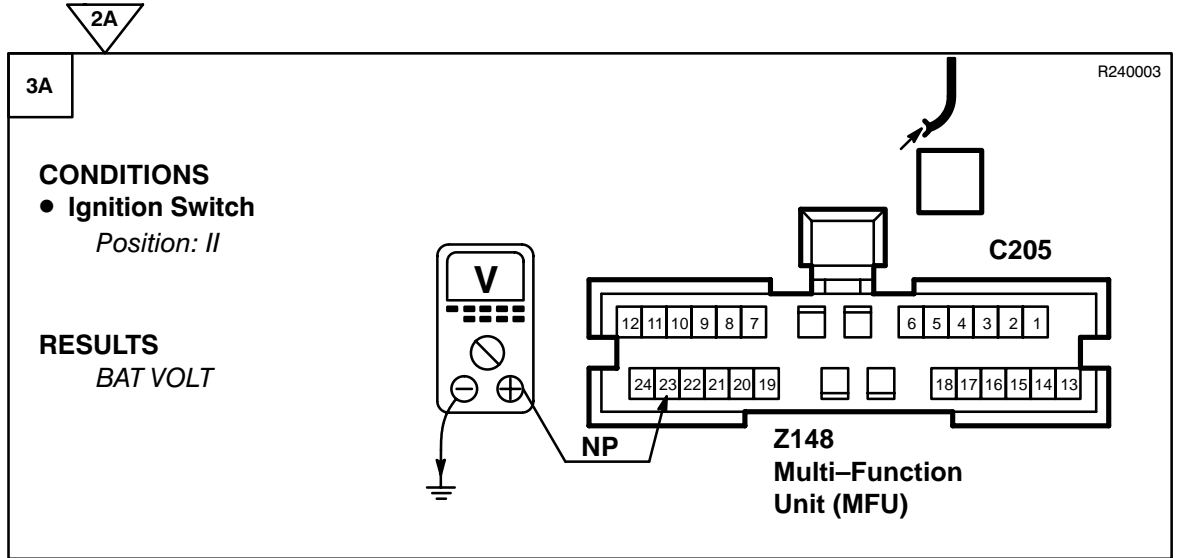

- PROBLEM CAUSE**
- GLG Wire
 - NP Wire
 - Rear Wiper Relay

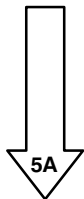
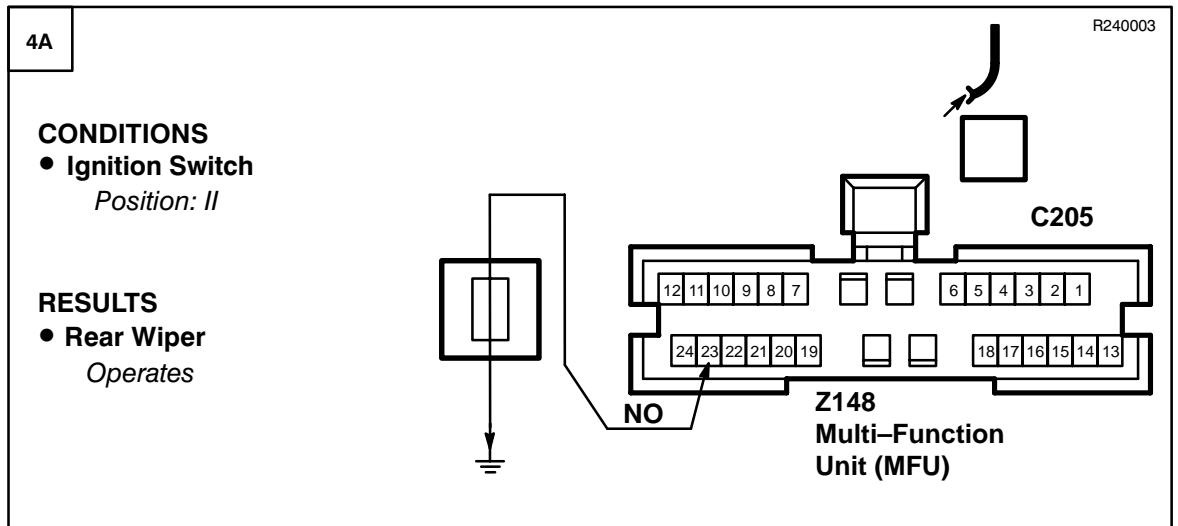
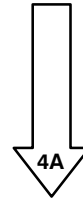

- PROBLEM CAUSE**
- B Wire
 - Fascia Fuse Box
- Multi-Function Unit (MFU)

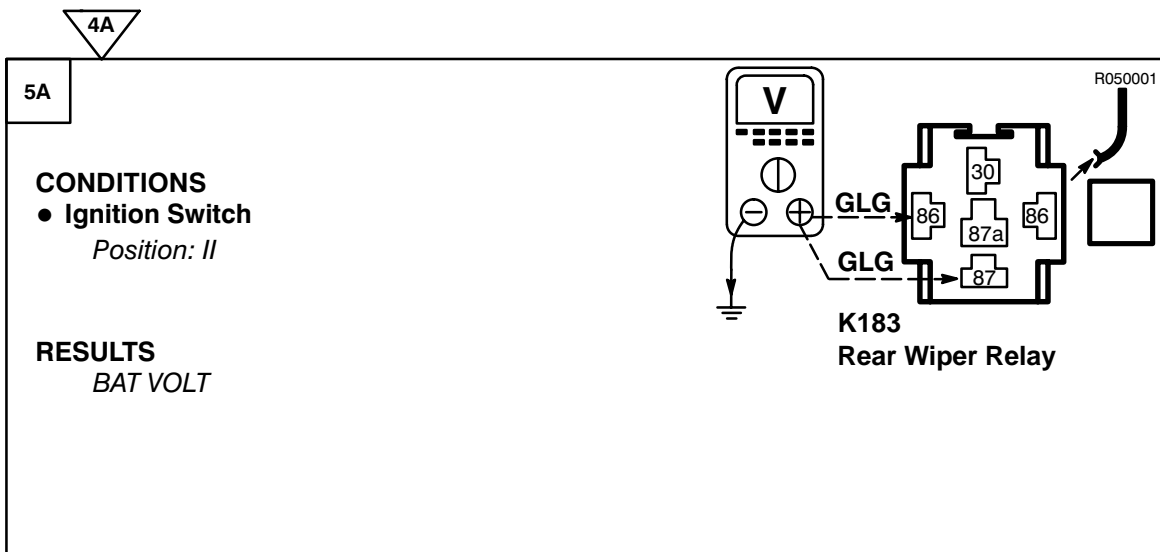

OK PROBLEM CAUSE

- GLG Wire
- F18 Fuse

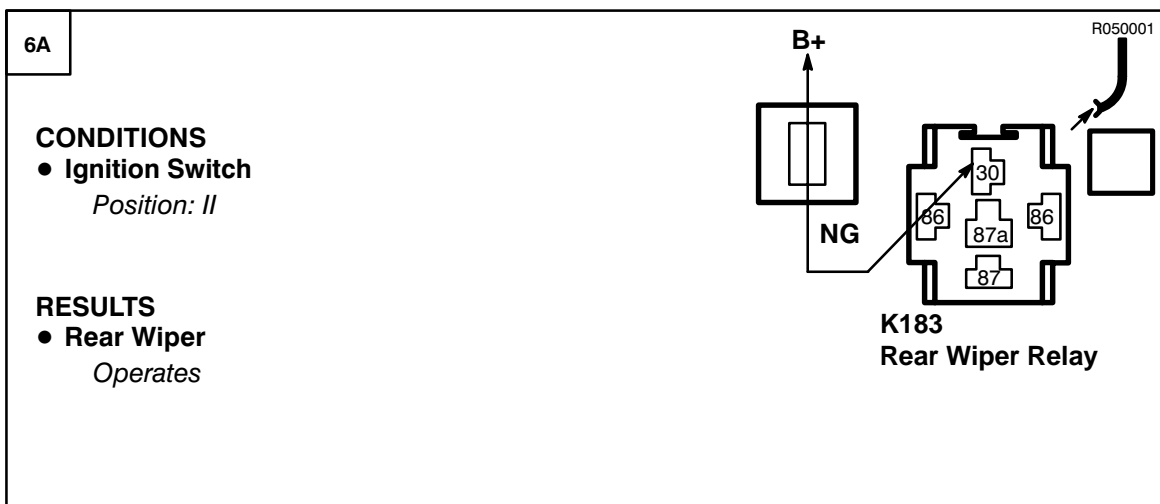
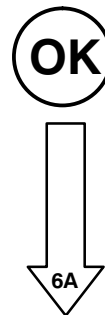

OK PROBLEM CAUSE

- NG Wire
- B Wire
- Rear Wiper Motor

OK PROBLEM CAUSE

- Rear Wiper Relay

Test B

1B

R020037

CONDITIONS

- Ignition Switch
Position: II
- Rear Screen Wash Switch
WASH

RESULTS
BAT VOLT

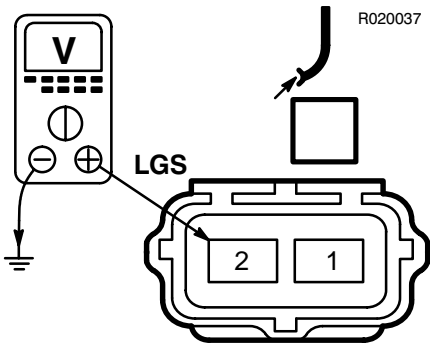

M119
Rear Screen Wash Pump



PROBLEM CAUSE

- GLG Wire
- LGS Wire
- Rear Screen Wash Switch

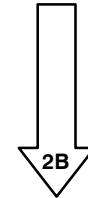

2B

R020037

CONDITIONS

- Ignition Switch
Position: 0

RESULTS

- Rear Wiper
Less than 2 ohms

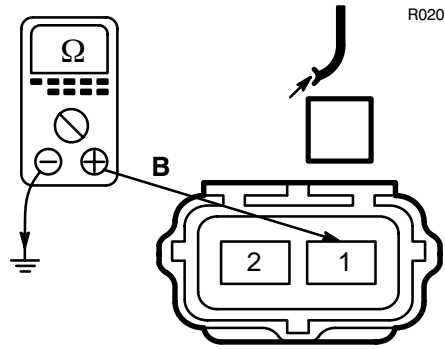

M119
Rear Screen Wash Pump



PROBLEM CAUSE

- B Wire



PROBLEM CAUSE

- Rear Screen Wash Pump

Test C

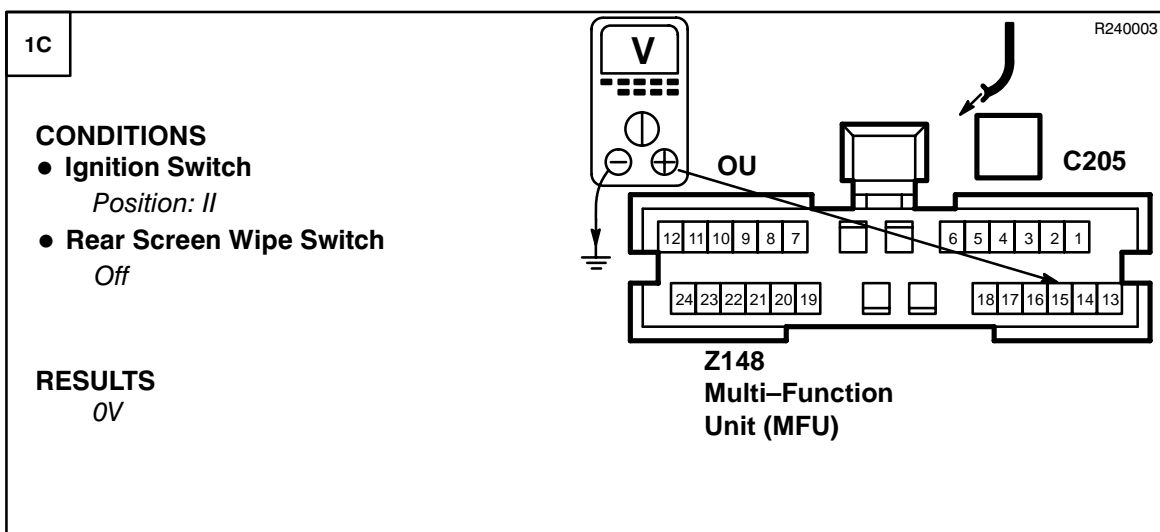

OK PROBLEM CAUSE
- Rear Screen Wipe Switch

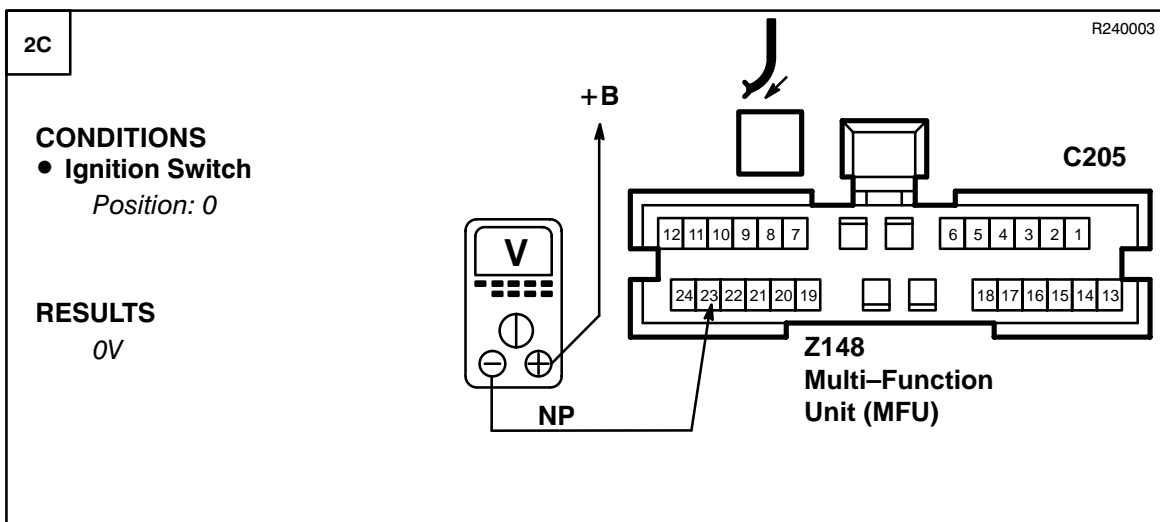
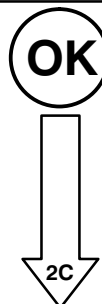

OK PROBLEM CAUSE
- Multi-Function Unit (MFU)

OK PROBLEM CAUSE
- Rear Wiper Relay

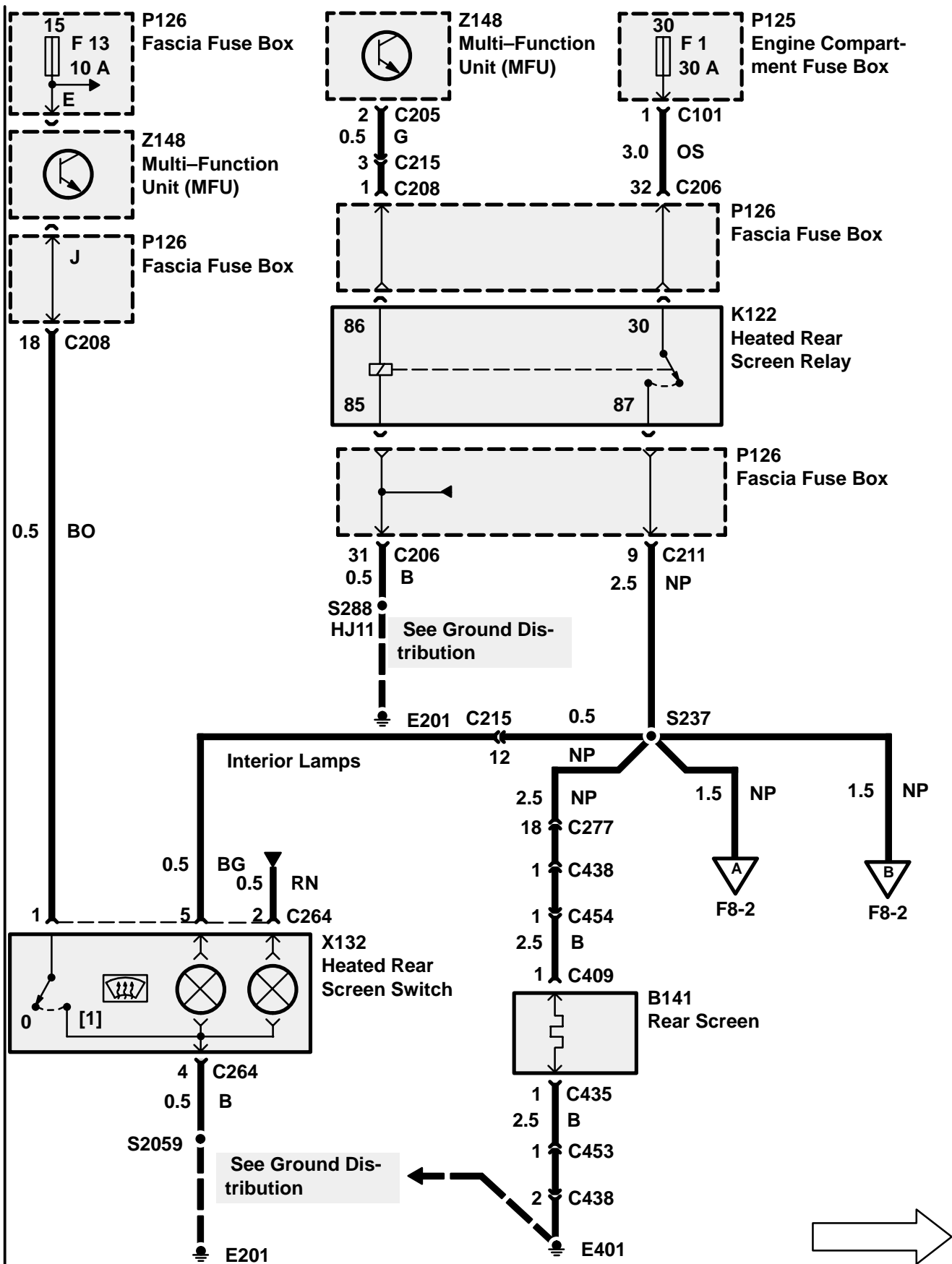

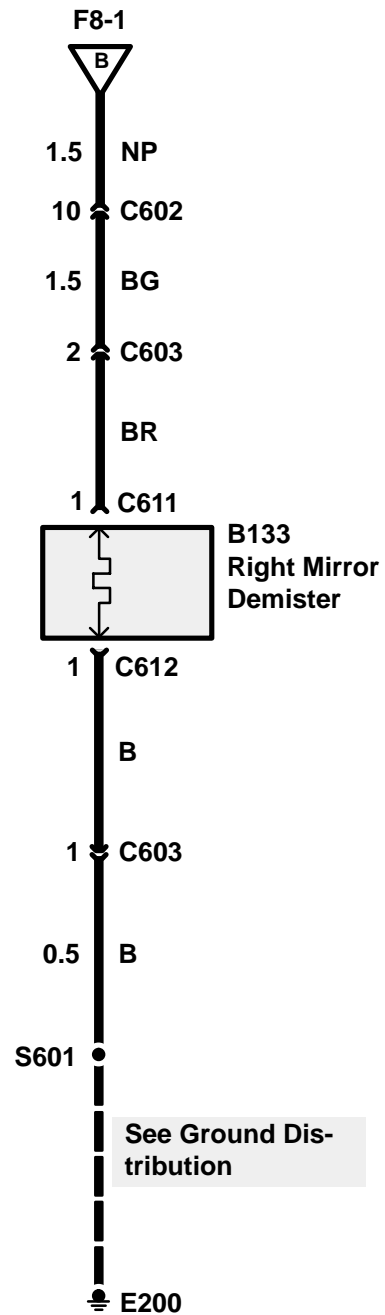
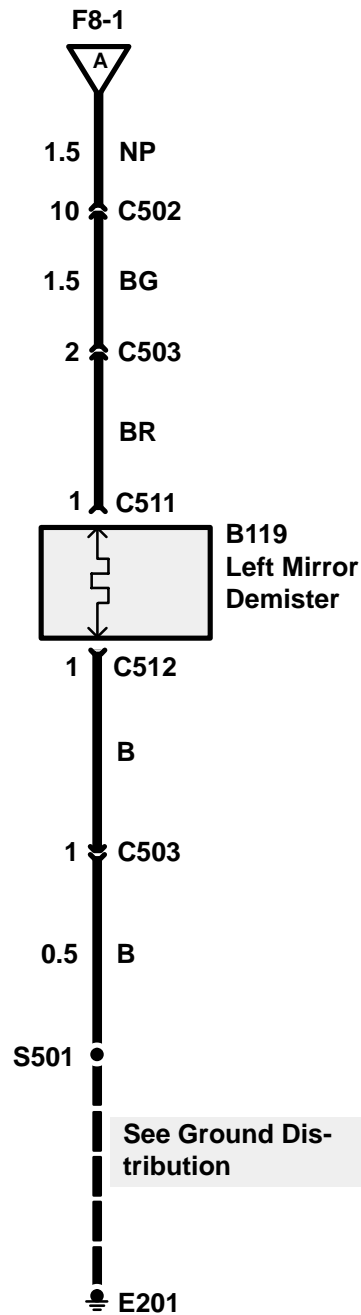
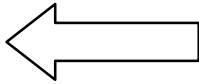

CIRCUIT OPERATION

Multi-Function Unit (MFU)

The multi-function unit (MFU) is mounted on the rear of the passenger compartment fusebox and has an input to operation of the following:

- Heated rear screen
- Courtesy lights
- Side and headlights
- Rear fog guard lamps
- Headlamp power wash
- Front wipers
- Rear wash/wipe

Diagnostic Procedure

1. Close all doors and the tailgate.

NOTE: If the oil pressure switch goes open circuit (engine is started) during the following procedure, the MFU will exit the diagnostic mode immediately.

2. Press and hold the heated rear screen switch and switch on the ignition.
3. Release the heated rear screen switch within 2 seconds and the MFU will beep to indicate that it's in diagnostic mode 1.
4. Press the heated rear screen switch; the MFU will beep twice. In turn, operate each of the following switches, rear fog guard lamps, side lights, headlights, front wiper, and rear wiper. The MFU will beep twice each time a switch is operated.
5. Pressing the heated rear screen again will cause the MFU to enter diagnostic mode 2.
6. The MFU will provide outputs to the following in order given below:
 - Heated rear screen relay energised for 2 seconds
 - Courtesy lights energised for 2 seconds
 - Dim dip relay energised for 2 seconds
 - Rear fog guard lamp energised for 2 seconds
 - Headlamp power wash energised for half a second

- Front wiper energised for half a second
 - Rear wipe/wash energised for half a second
7. The MFU will then exit the diagnostic mode.

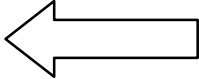

Warnings and Indicators (except NAS)
Warnings and Indicators (NAS)

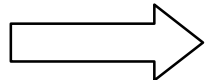
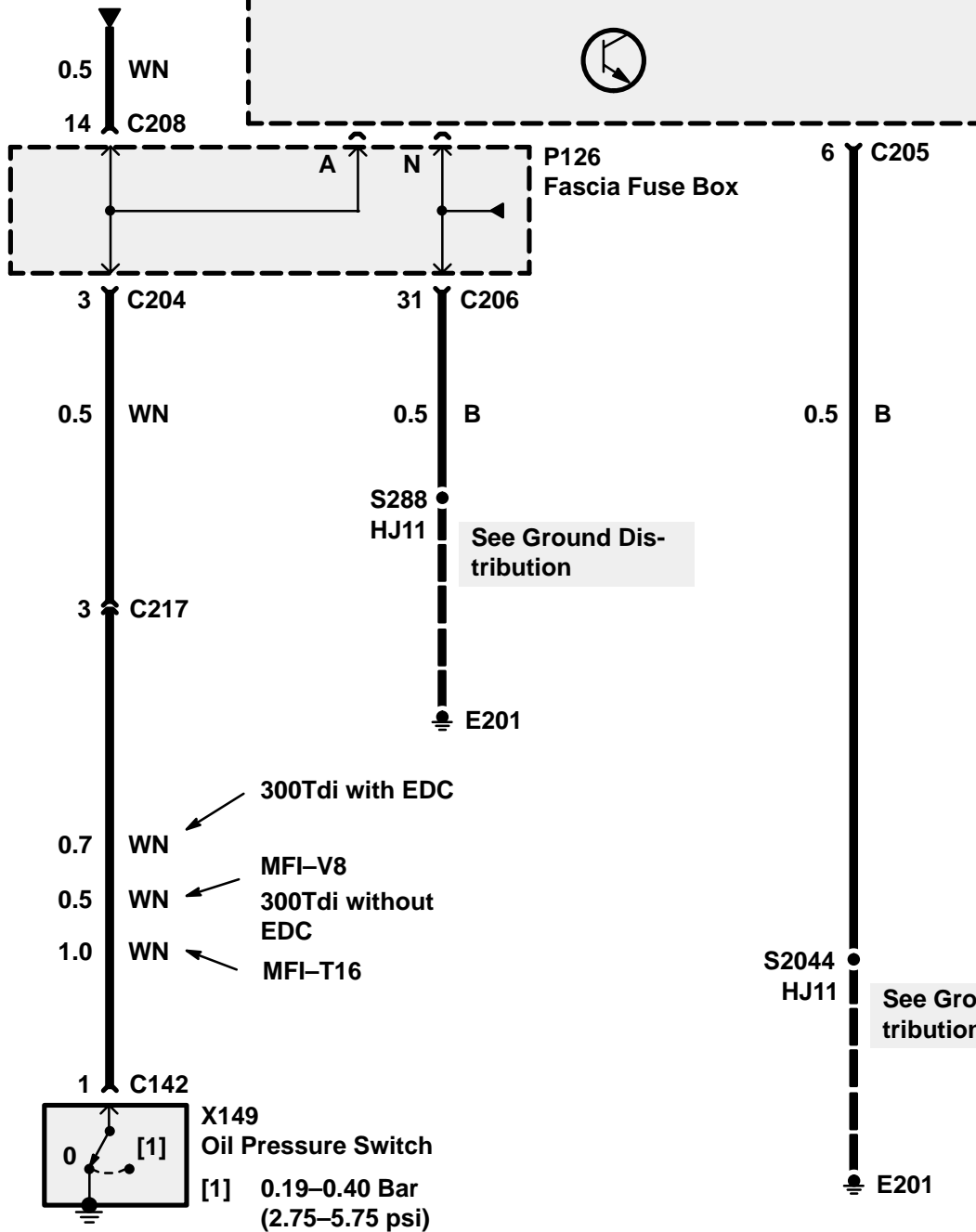
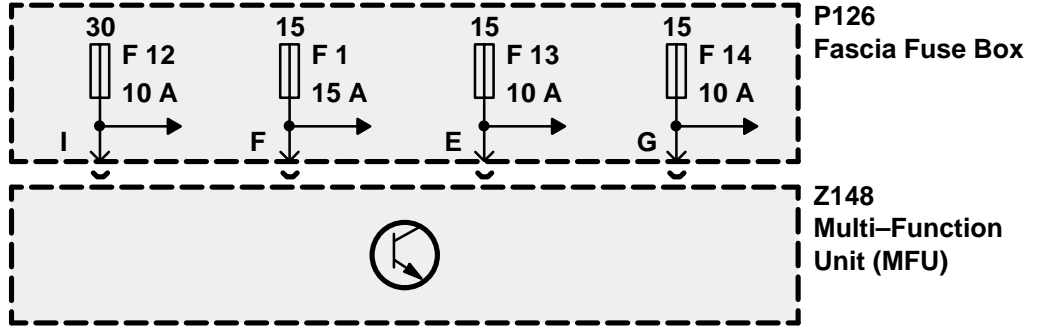

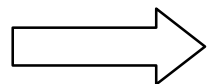
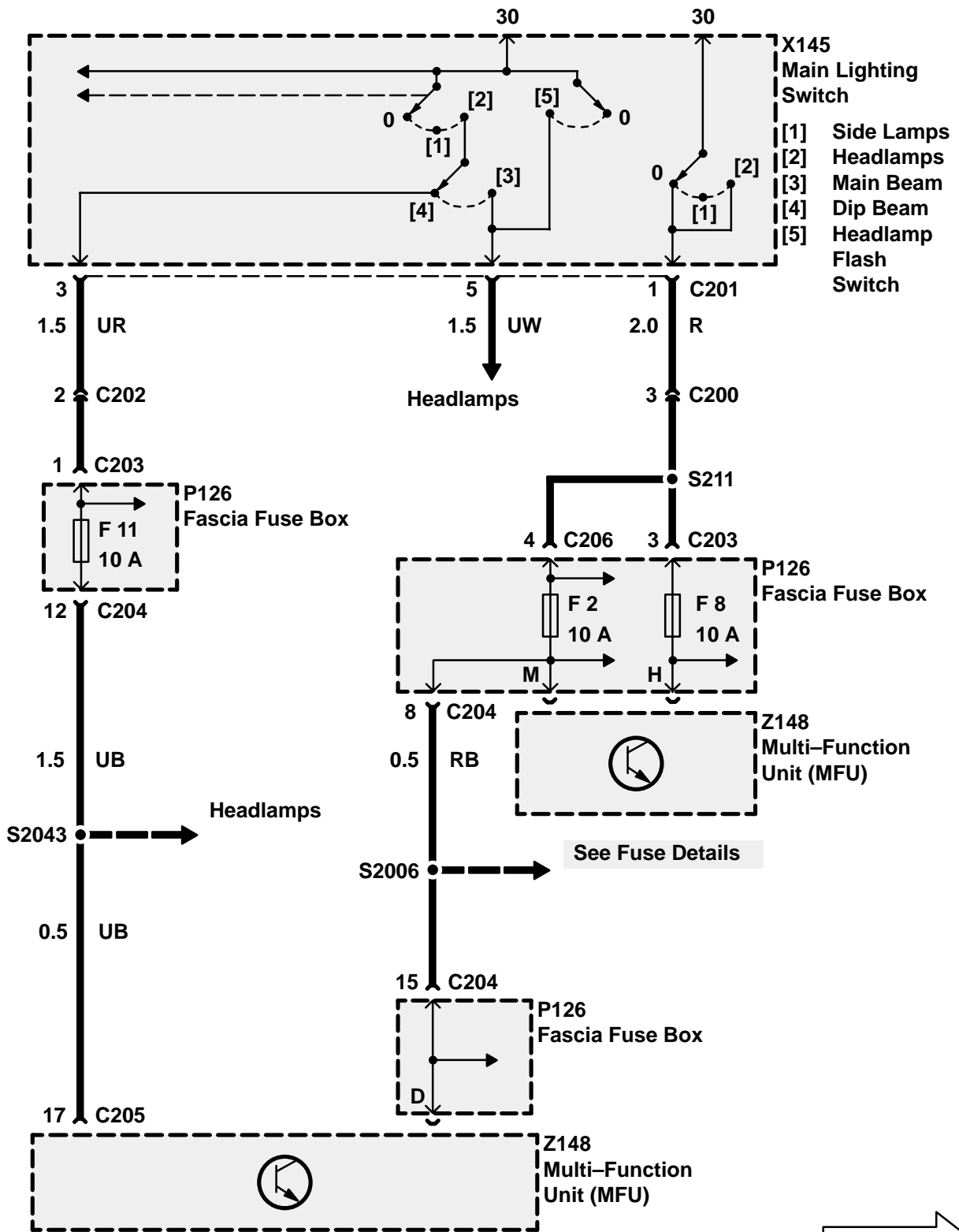
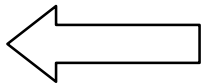

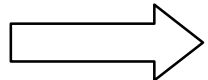
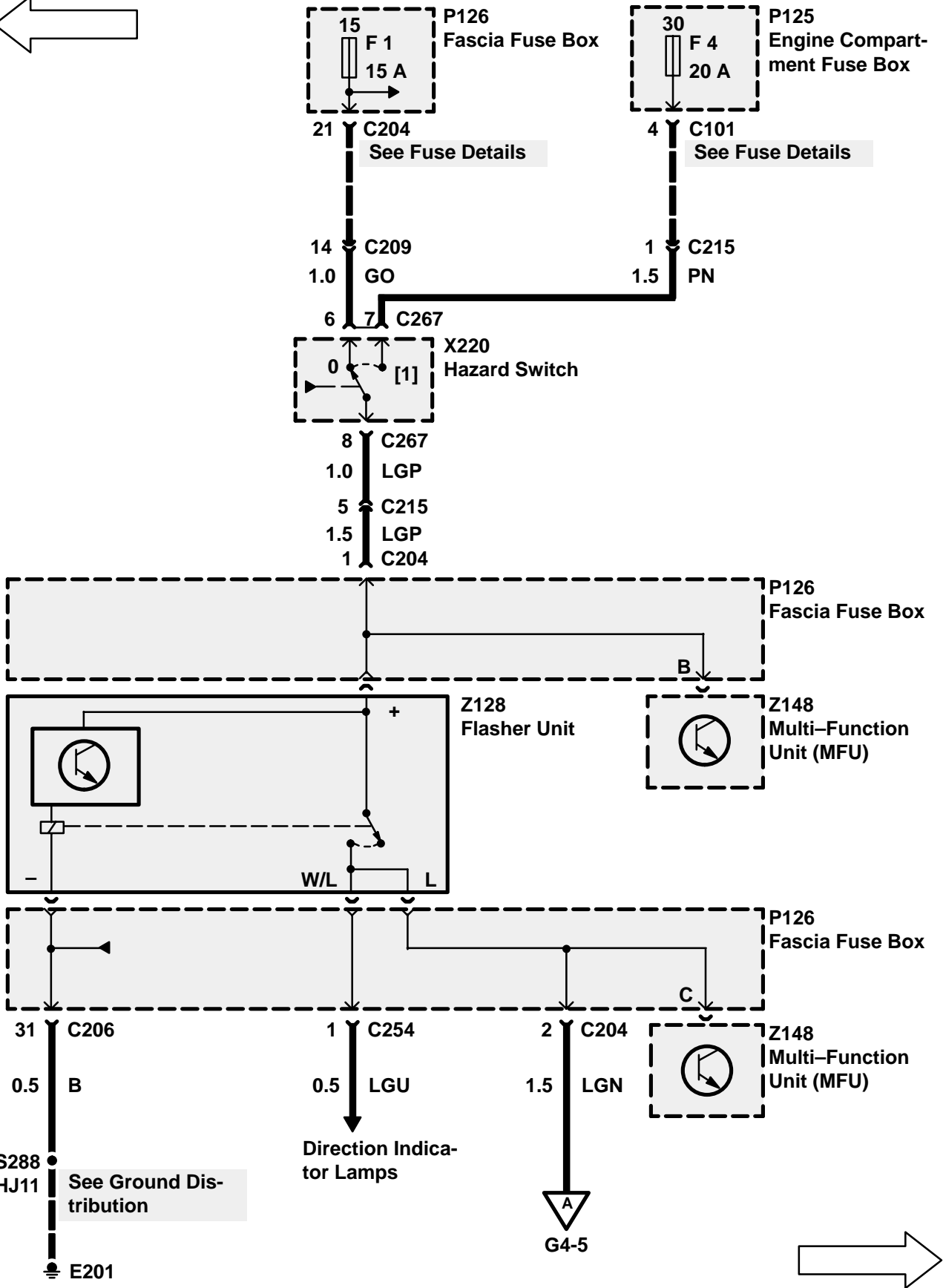
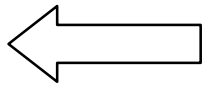

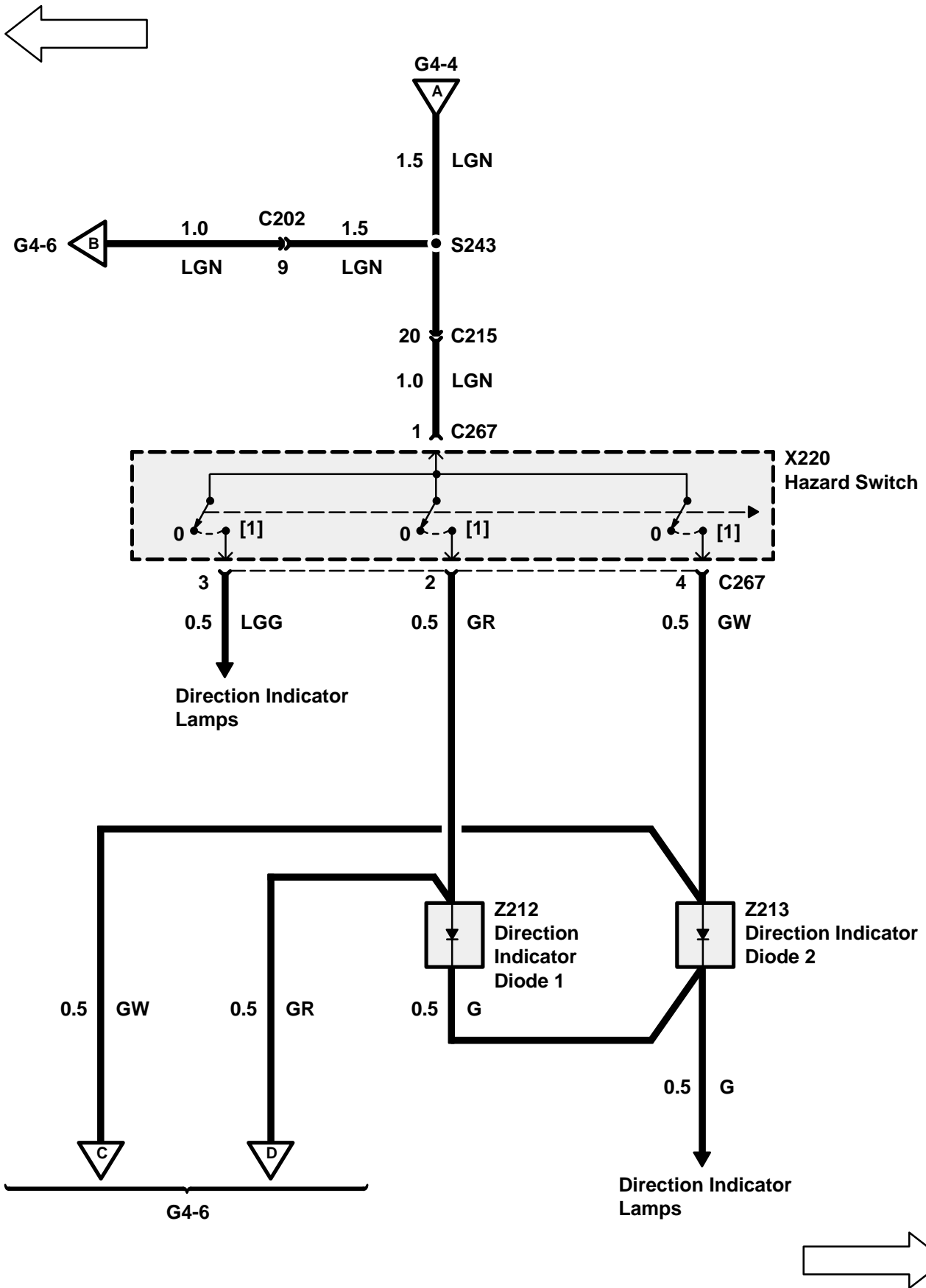

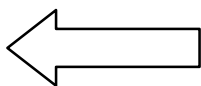

Interior Lamps

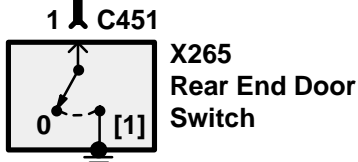
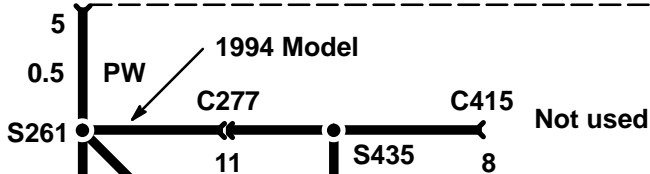
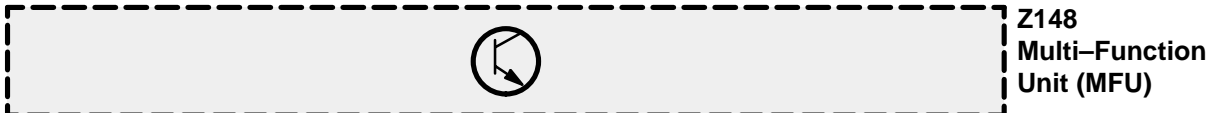
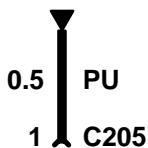

Except NAS NAS

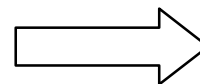
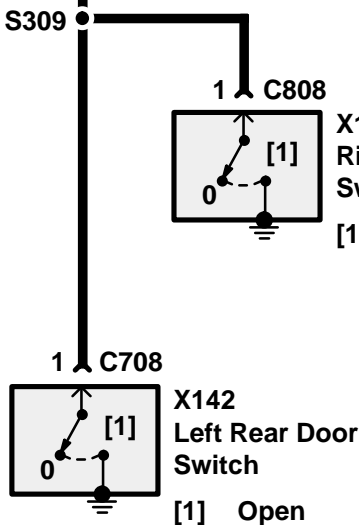
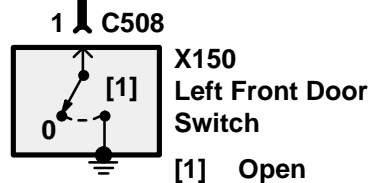
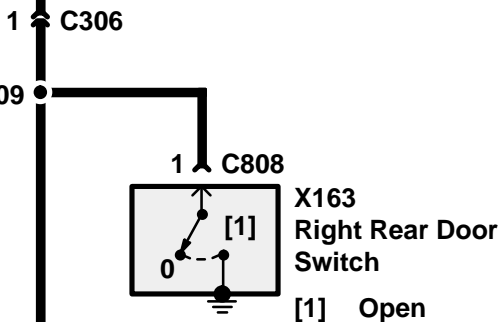
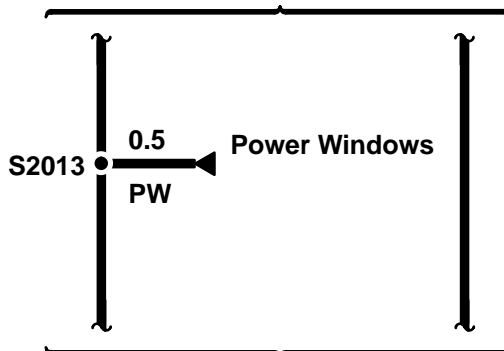
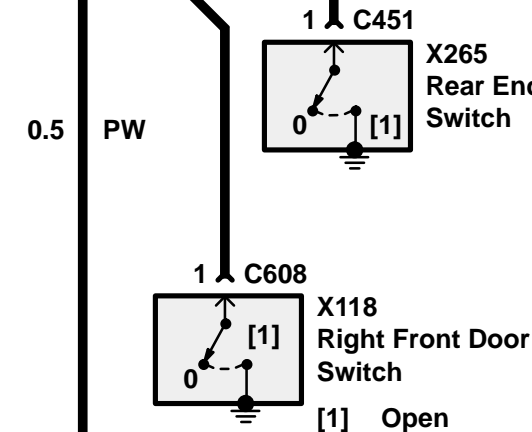

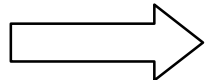
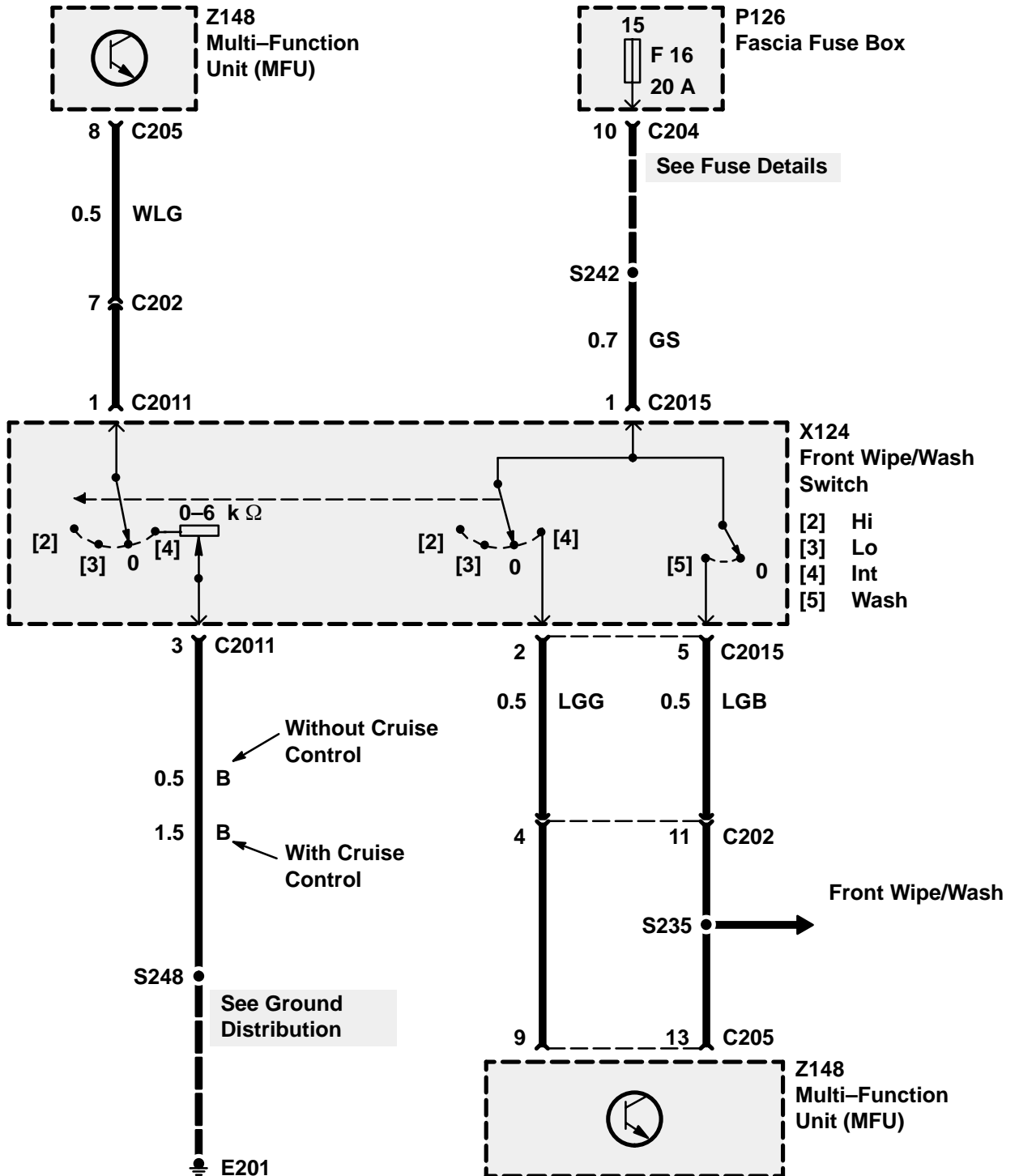
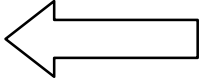

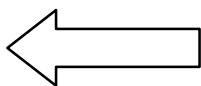

Front Wipe/Wash

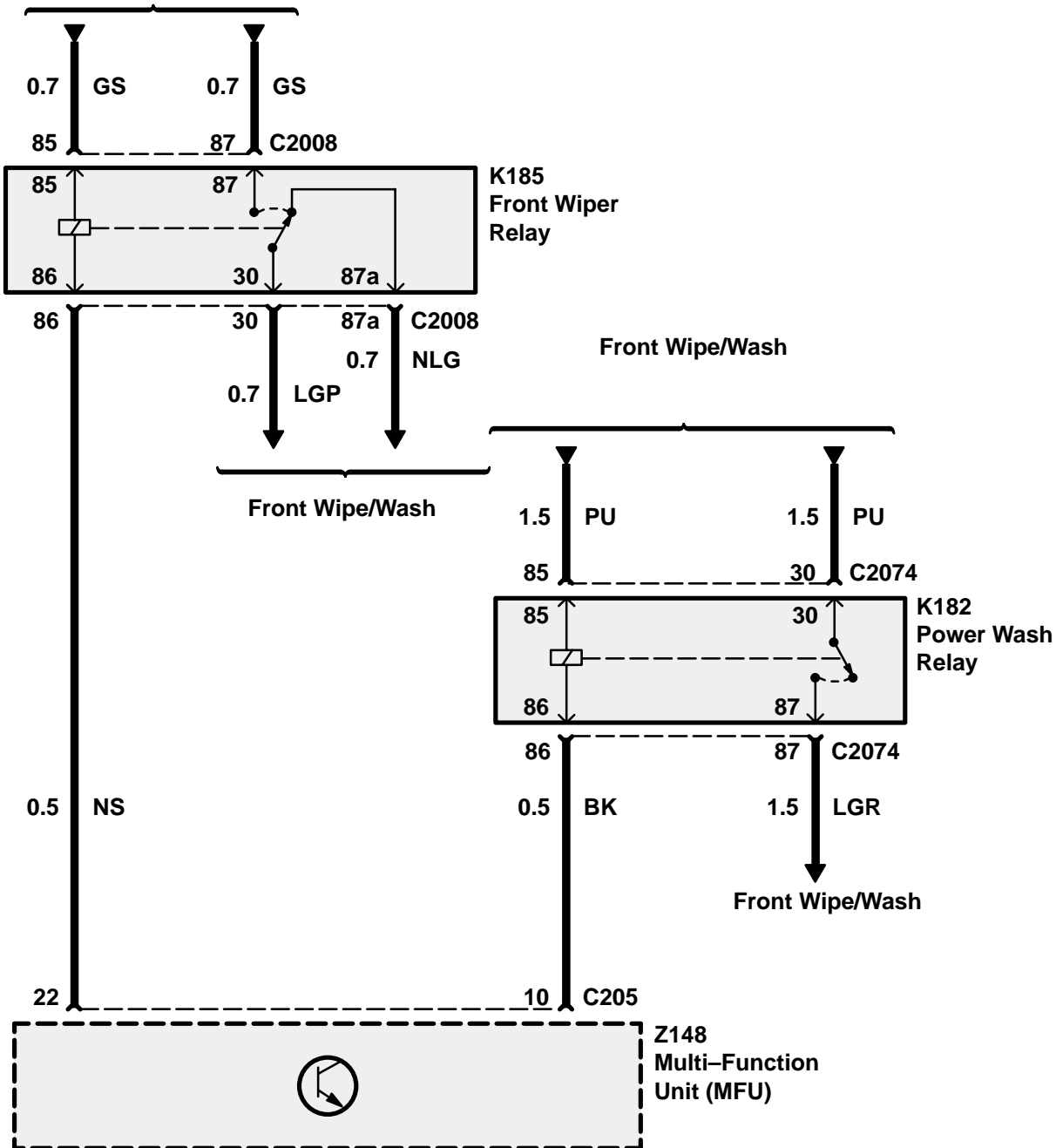

Front Wipe/Wash

Front Wipe/Wash

Front Wipe/Wash

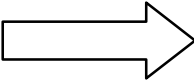

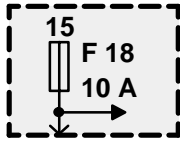

P126
Fascia Fuse Box

5 C204

See Fuse Details

S2047

0.5 GLG

0.5 GLG

1 C250

1 C249

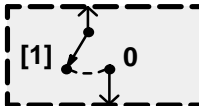

X221
Rear Screen
Wipe Switch

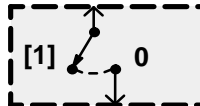

X222
Rear Screen
Wash Switch

4 C250

4 C249

0.5 OU

0.5 LGS

Rear Wipe/Wash



K183
Rear Wiper Relay

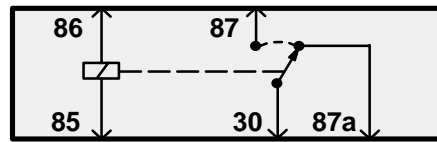

85 30 87a C281

0.5 NP 0.7 NG 0.5 B

Rear Wipe/Wash

14

17 C215

S230

Rear Wipe/Wash

15

16

23 C205

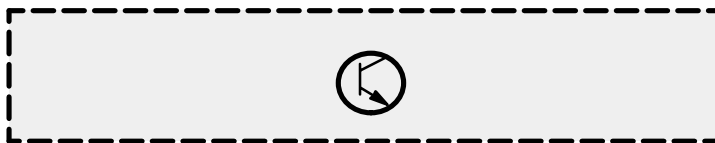

Z148
Multi-Function
Unit (MFU)

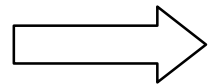

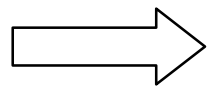
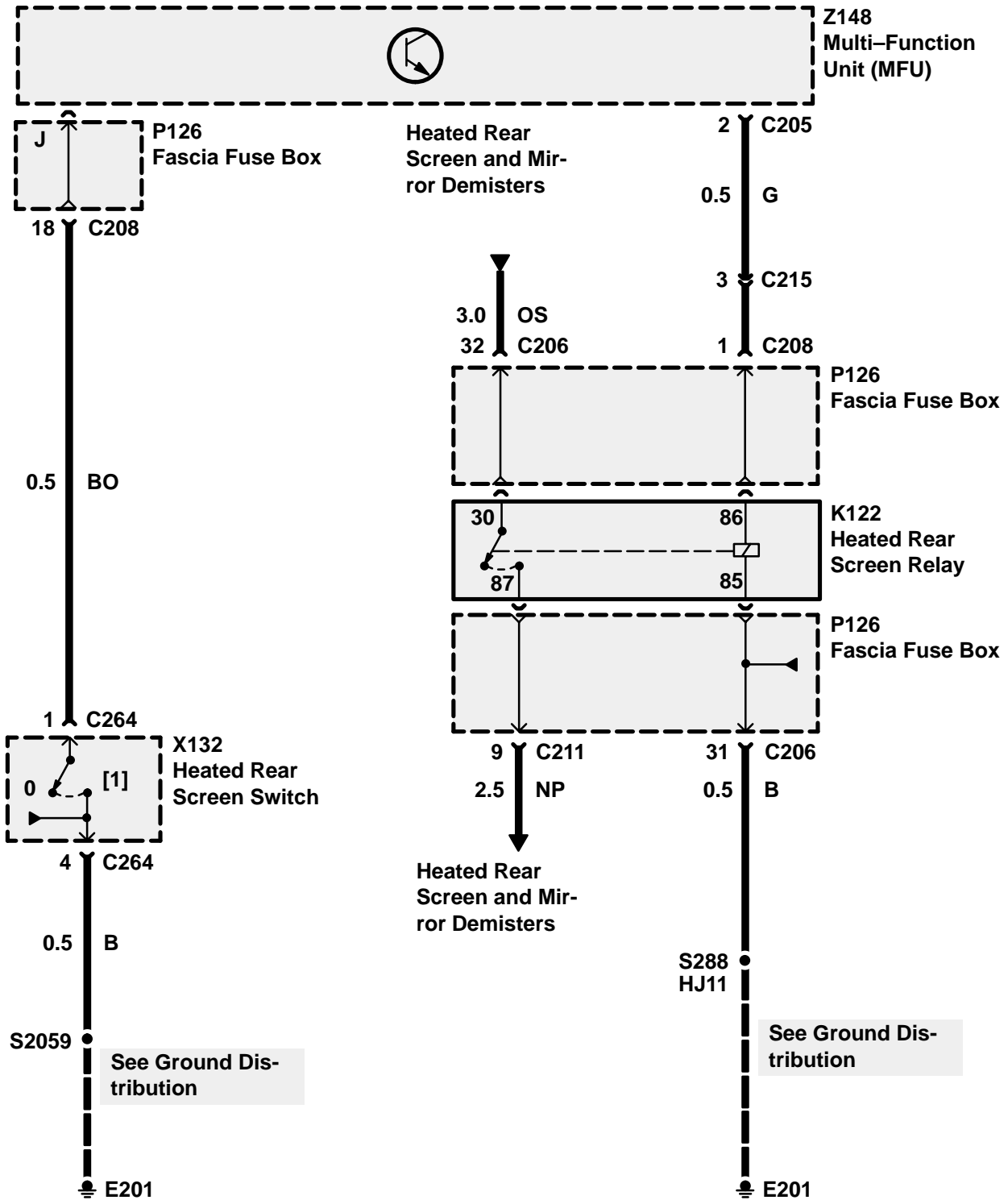
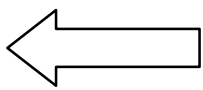

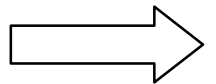
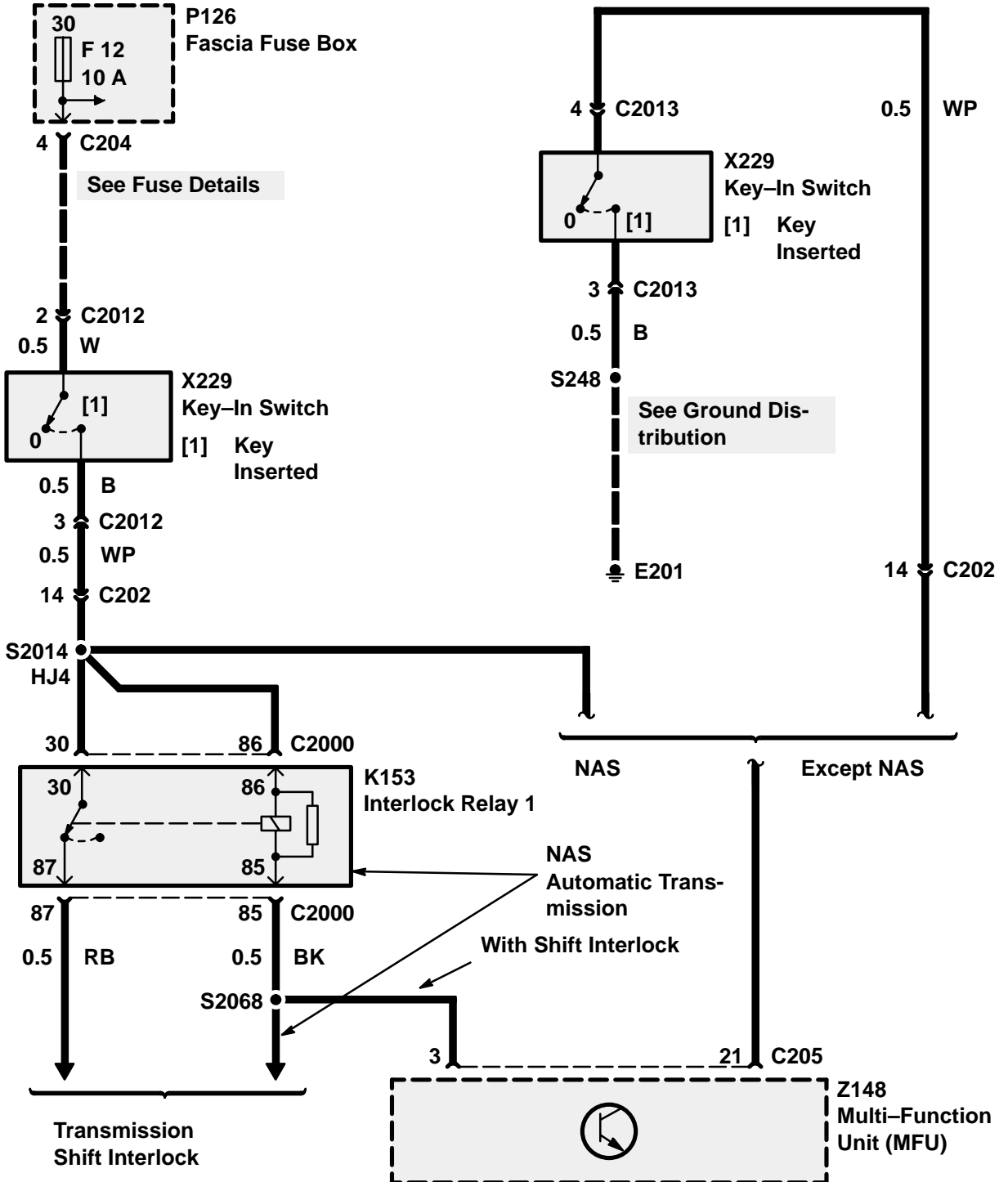
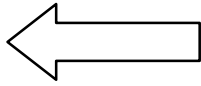

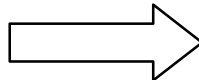
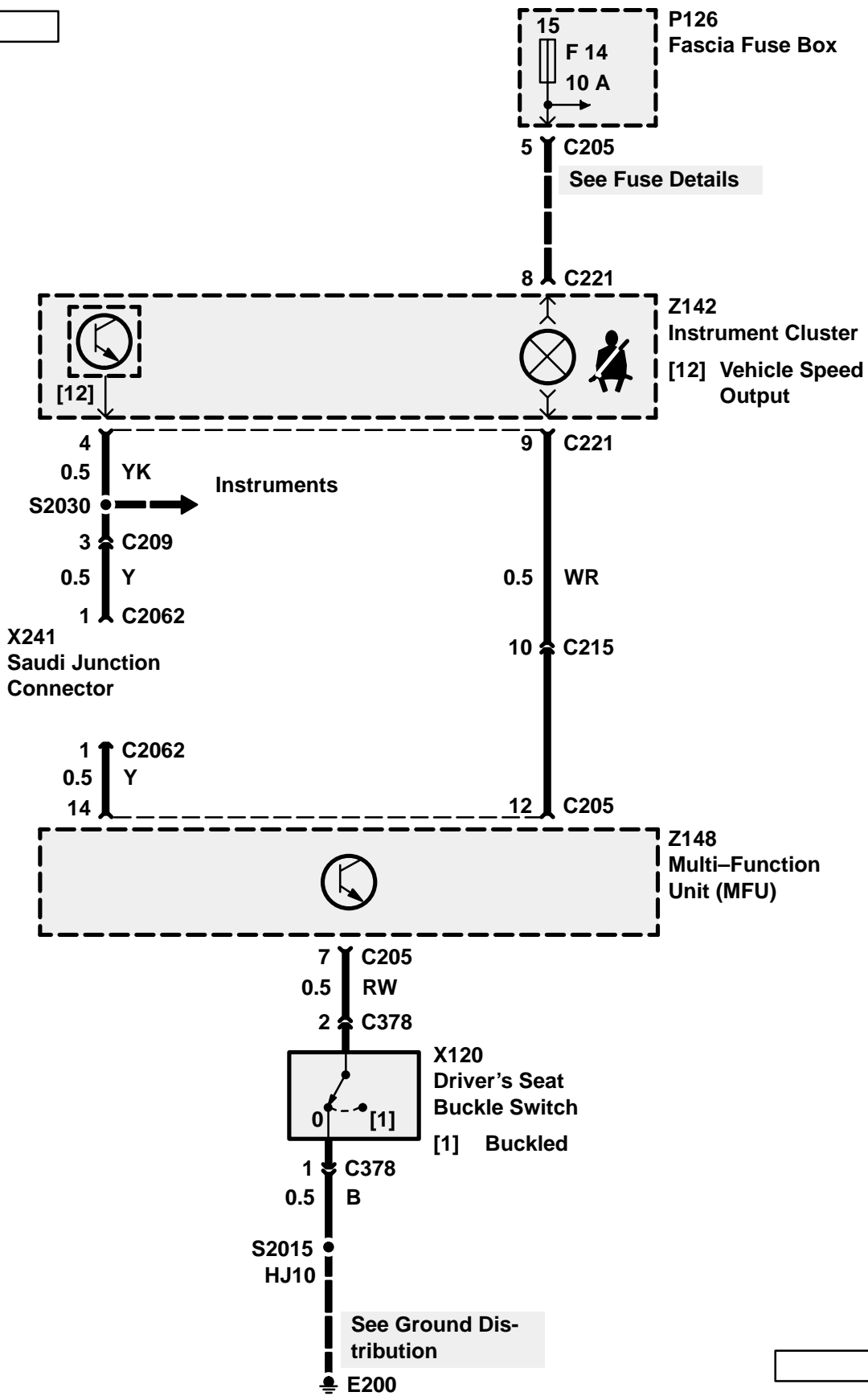
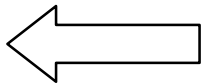

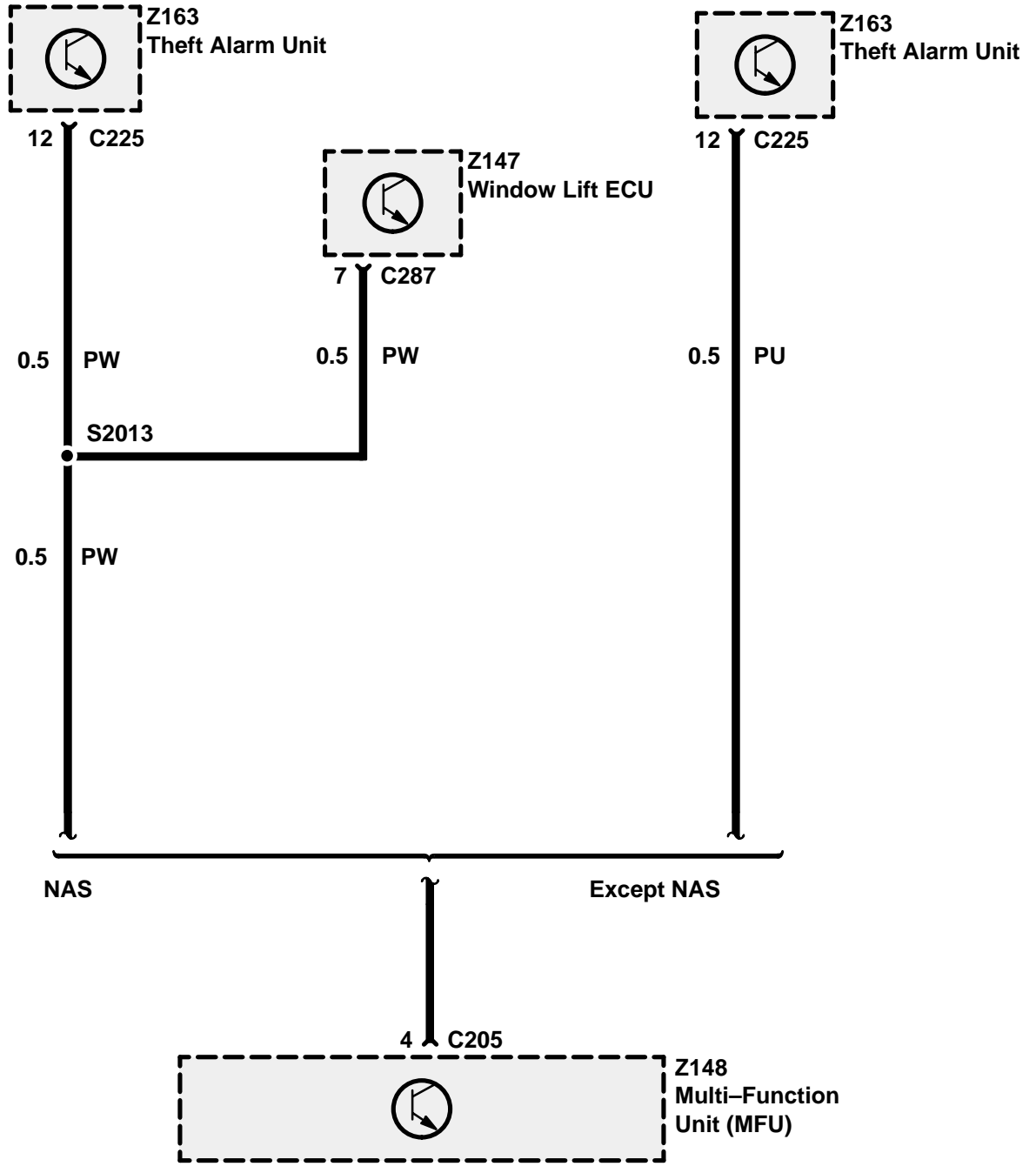
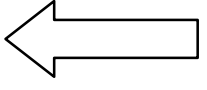

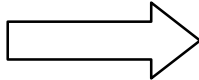
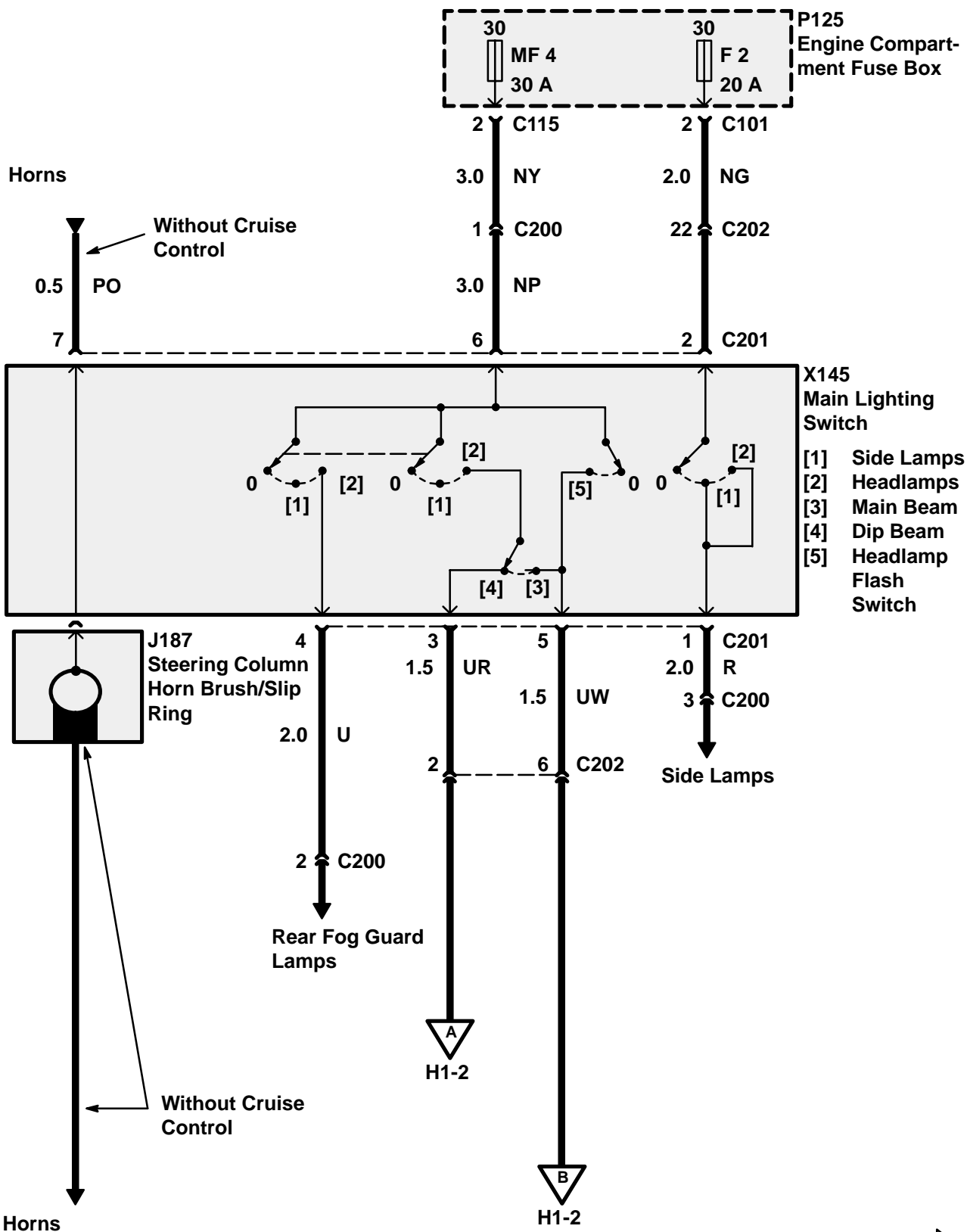

H1 ETM

DISCOVERY

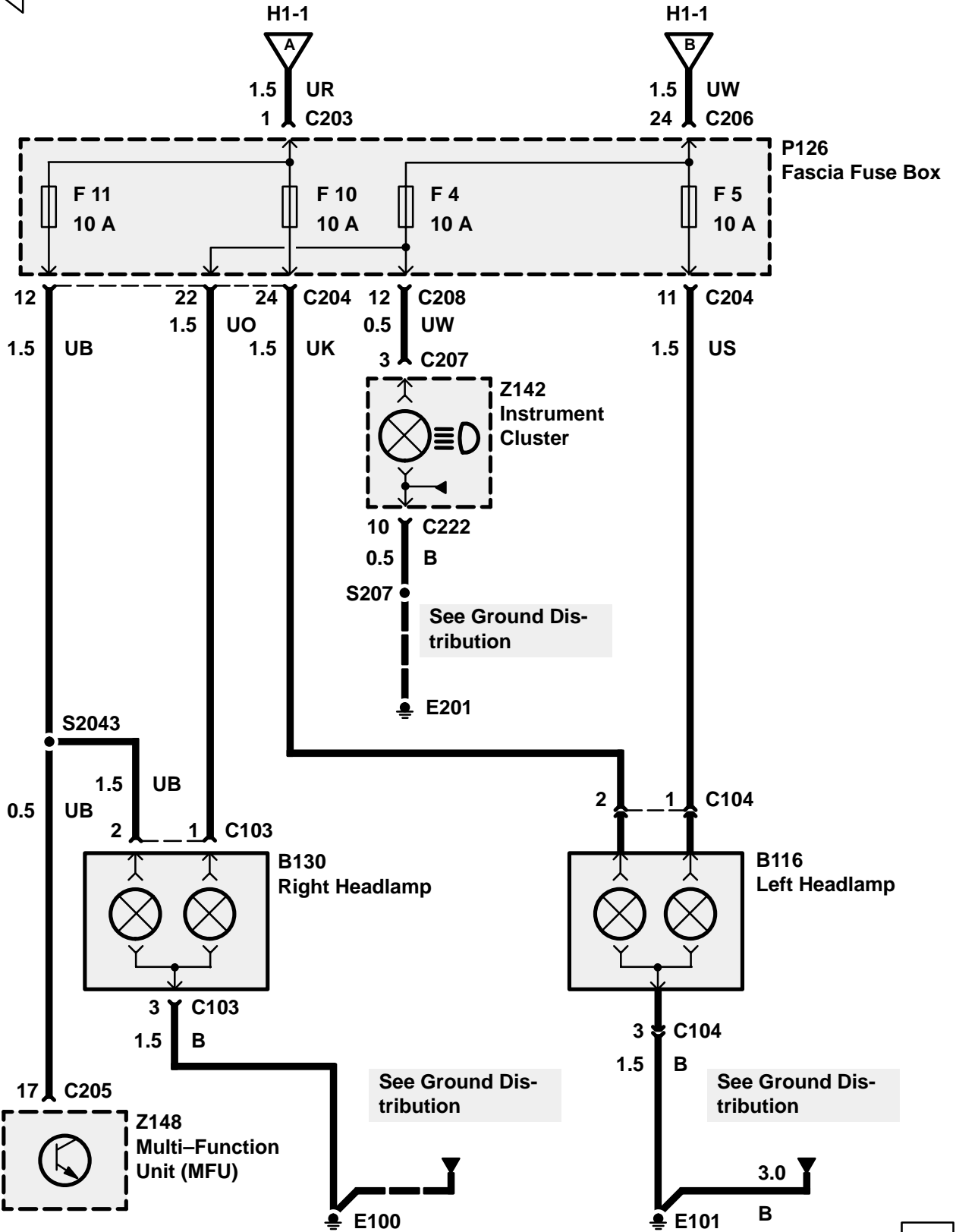
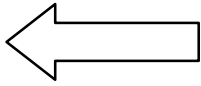

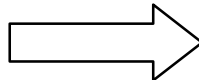
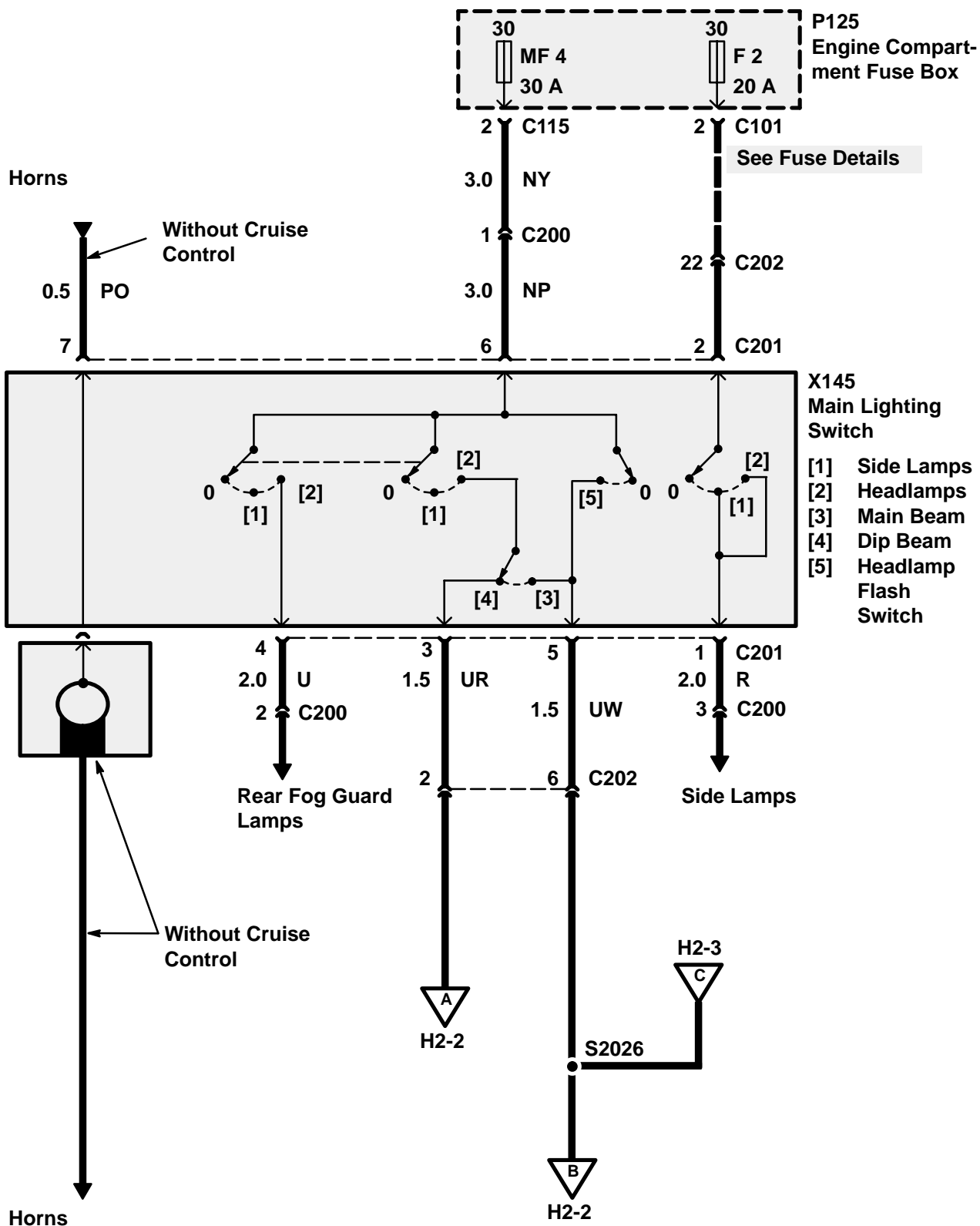

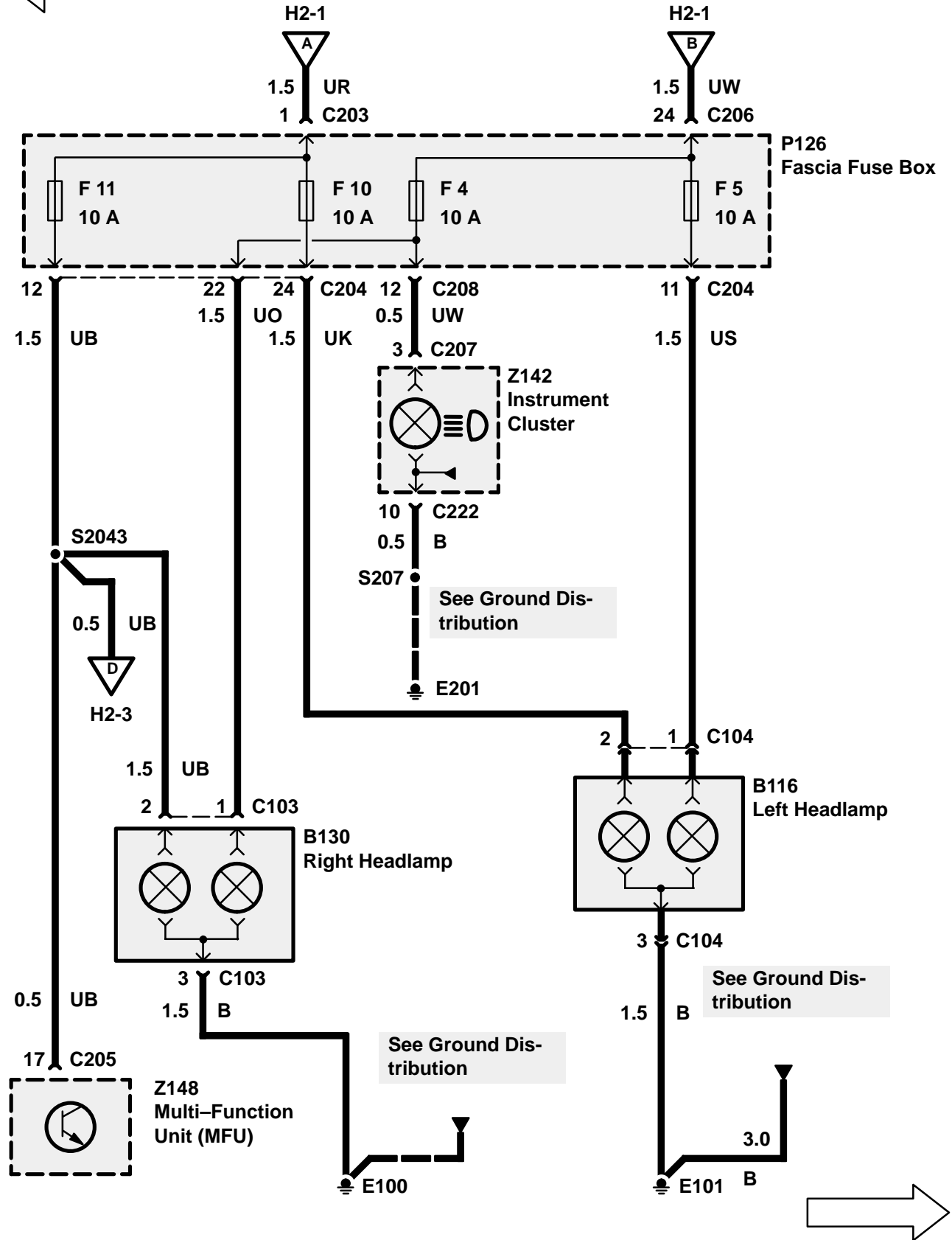

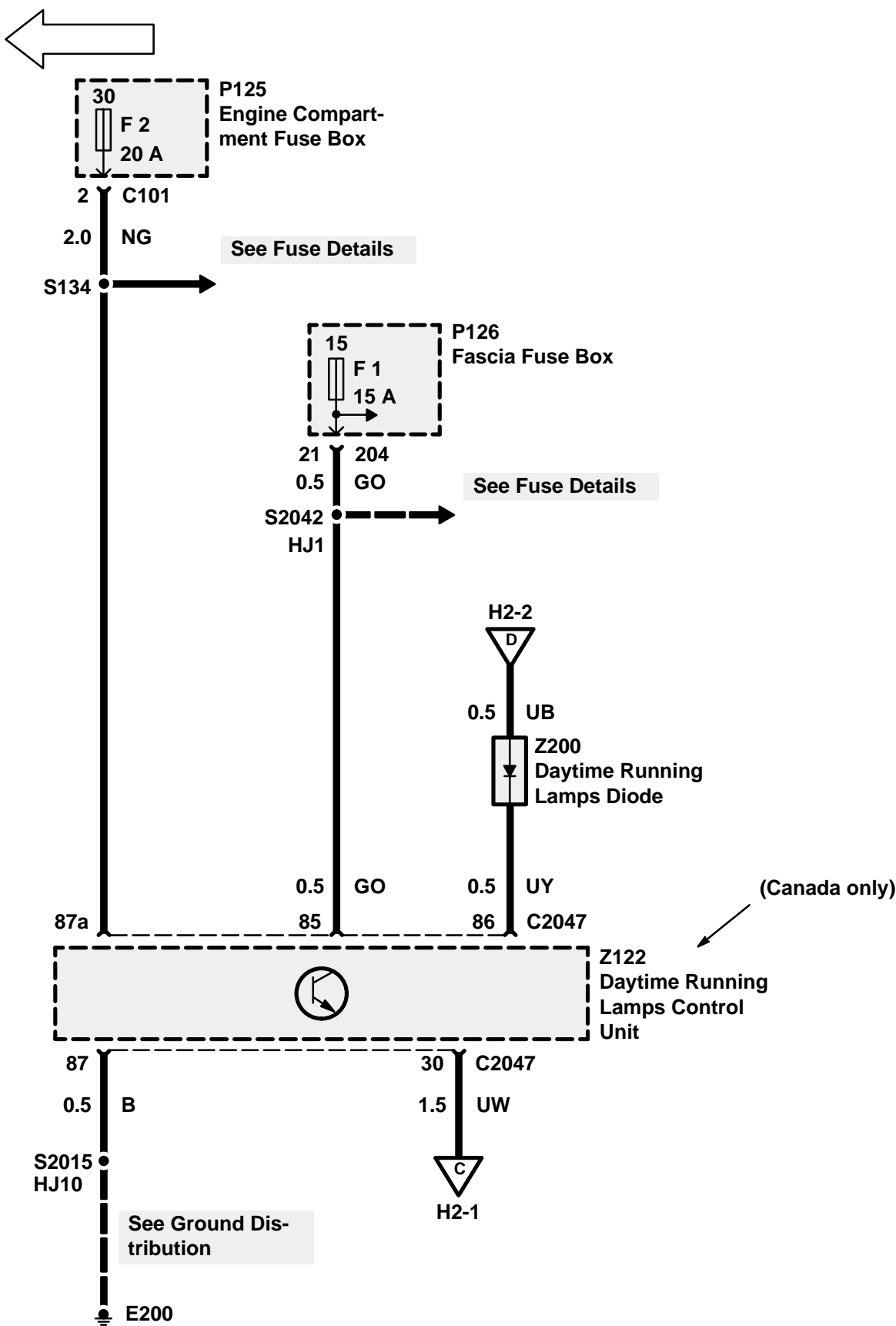

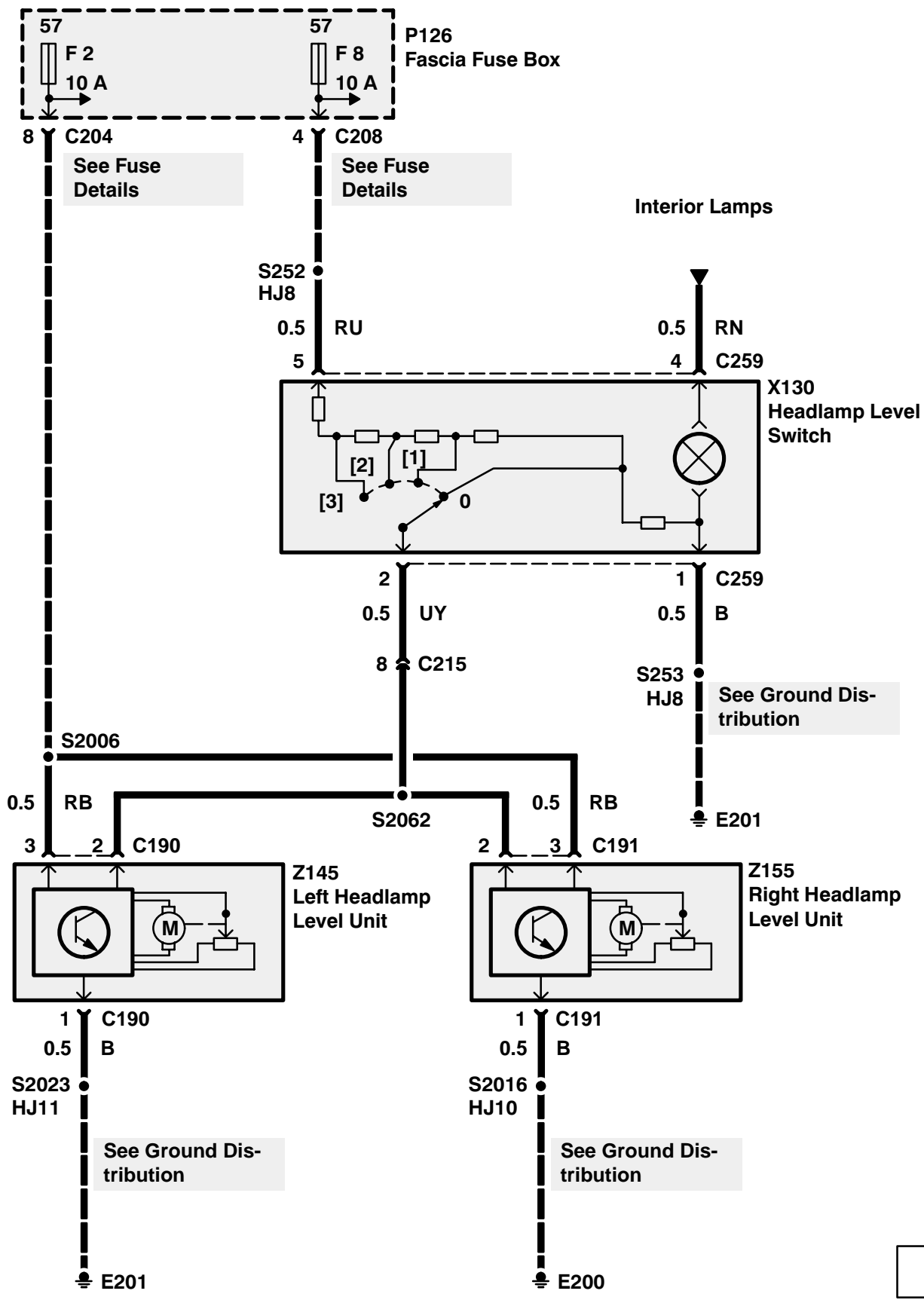

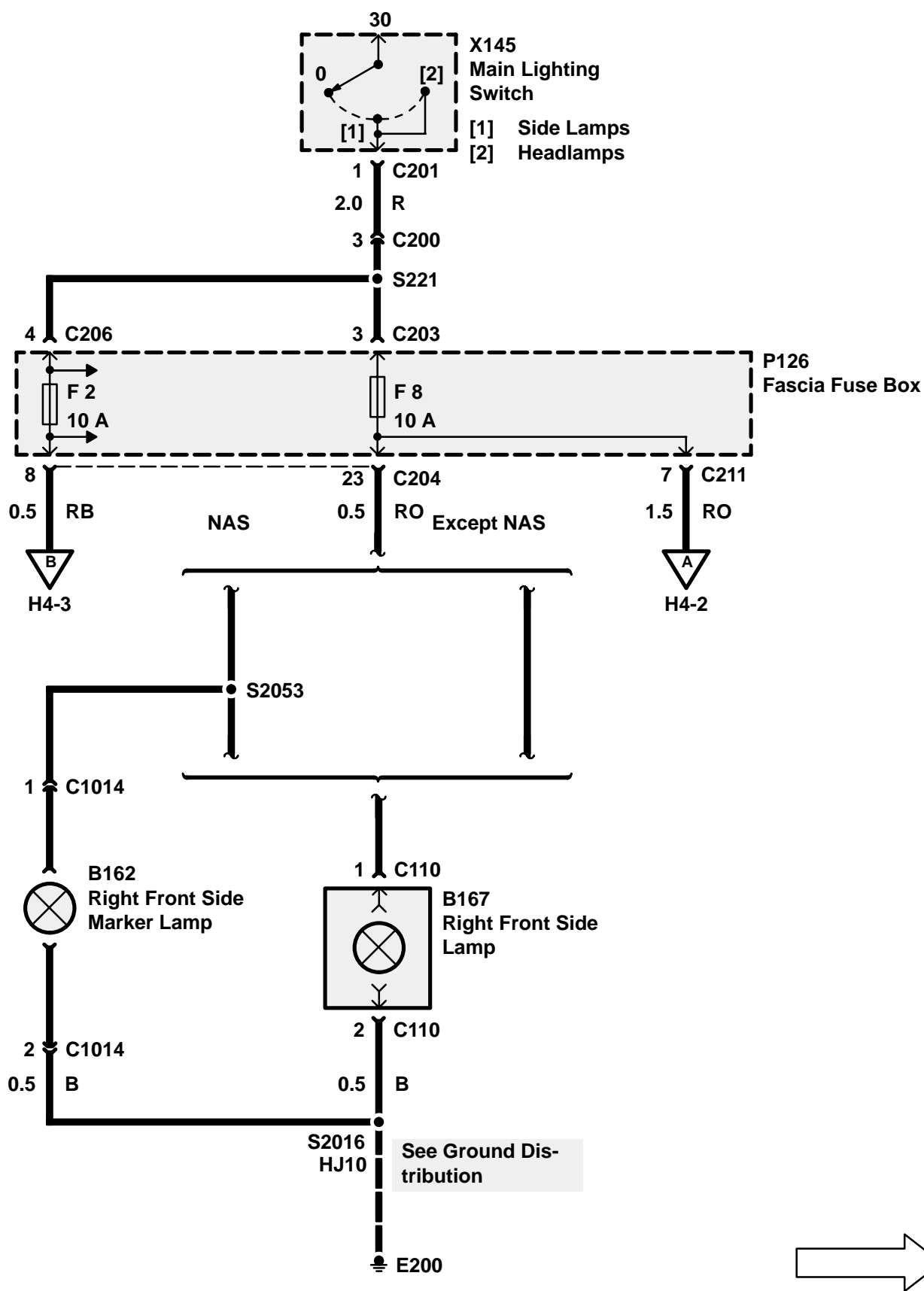

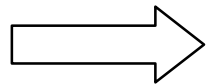
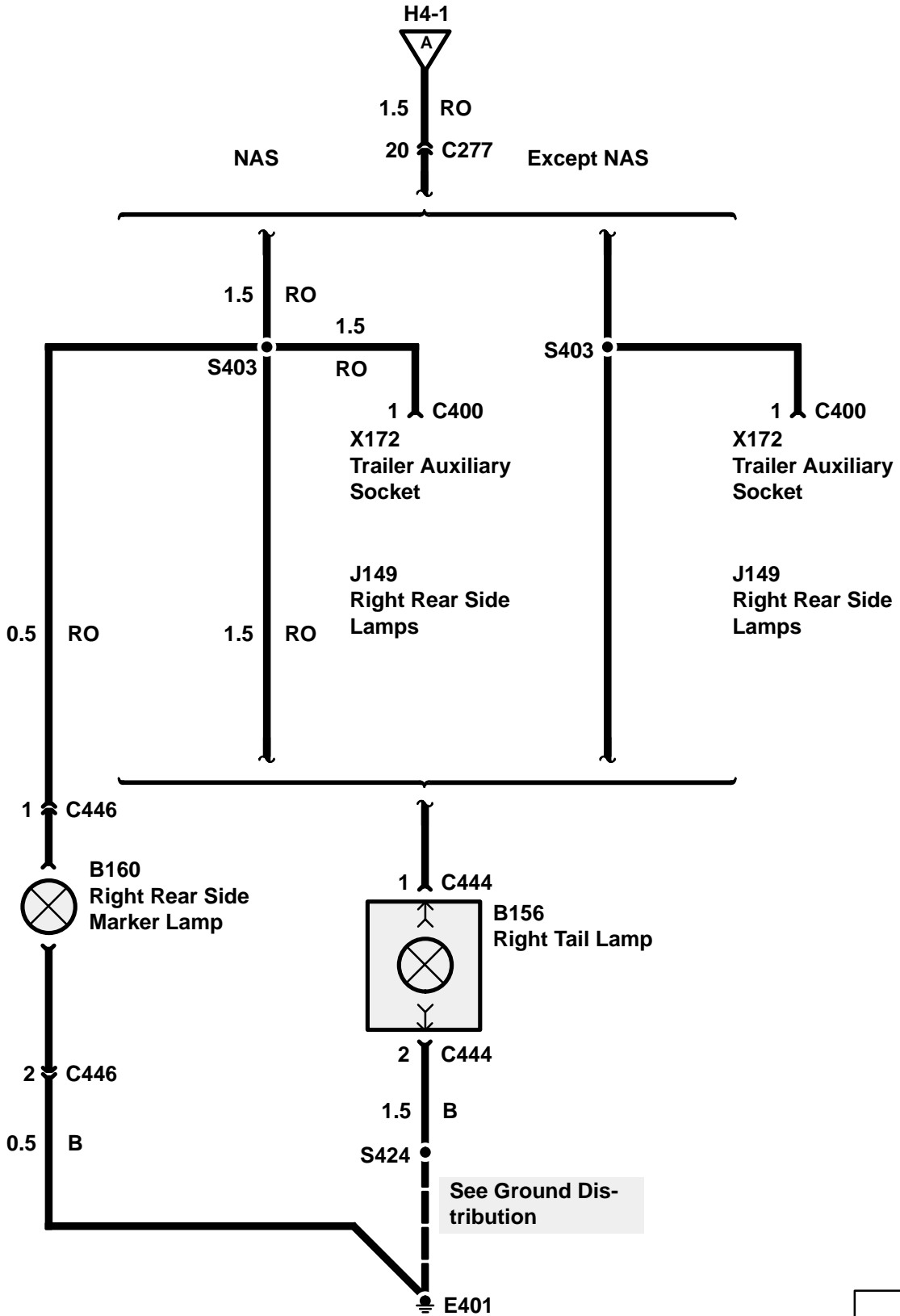
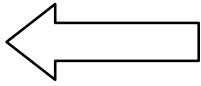

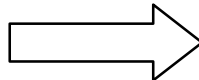
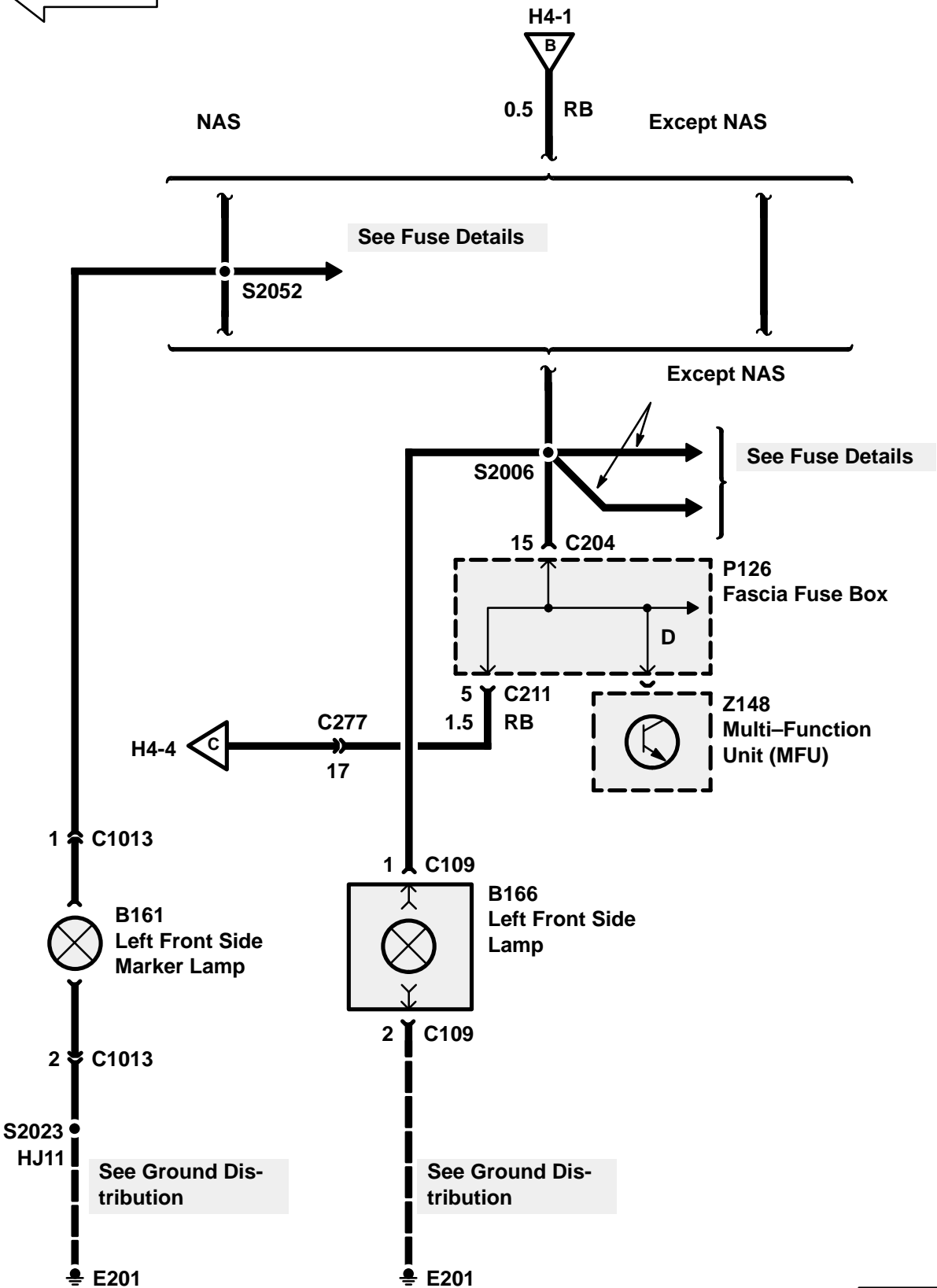
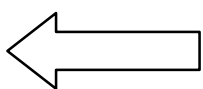

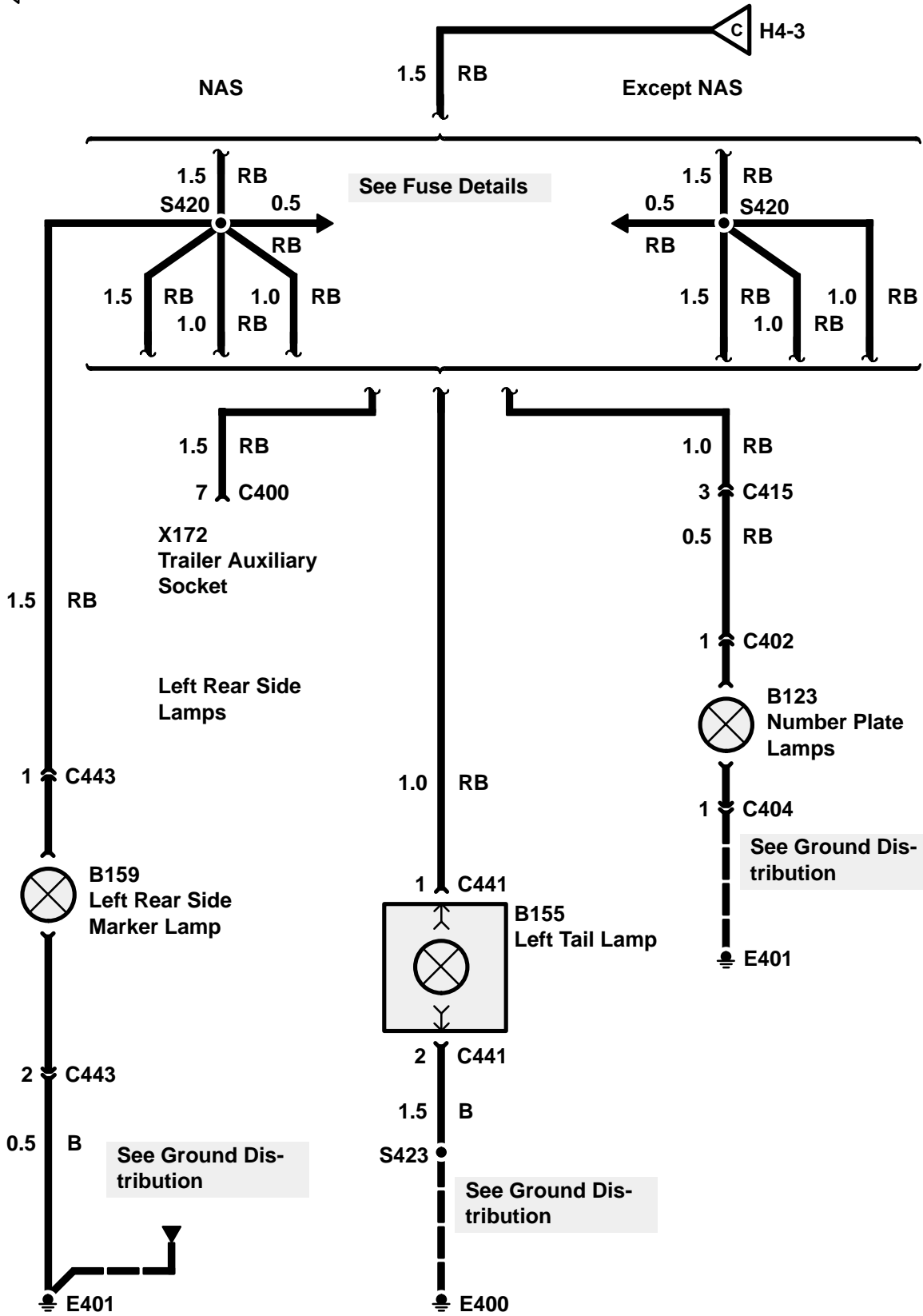
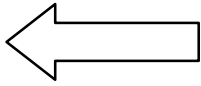

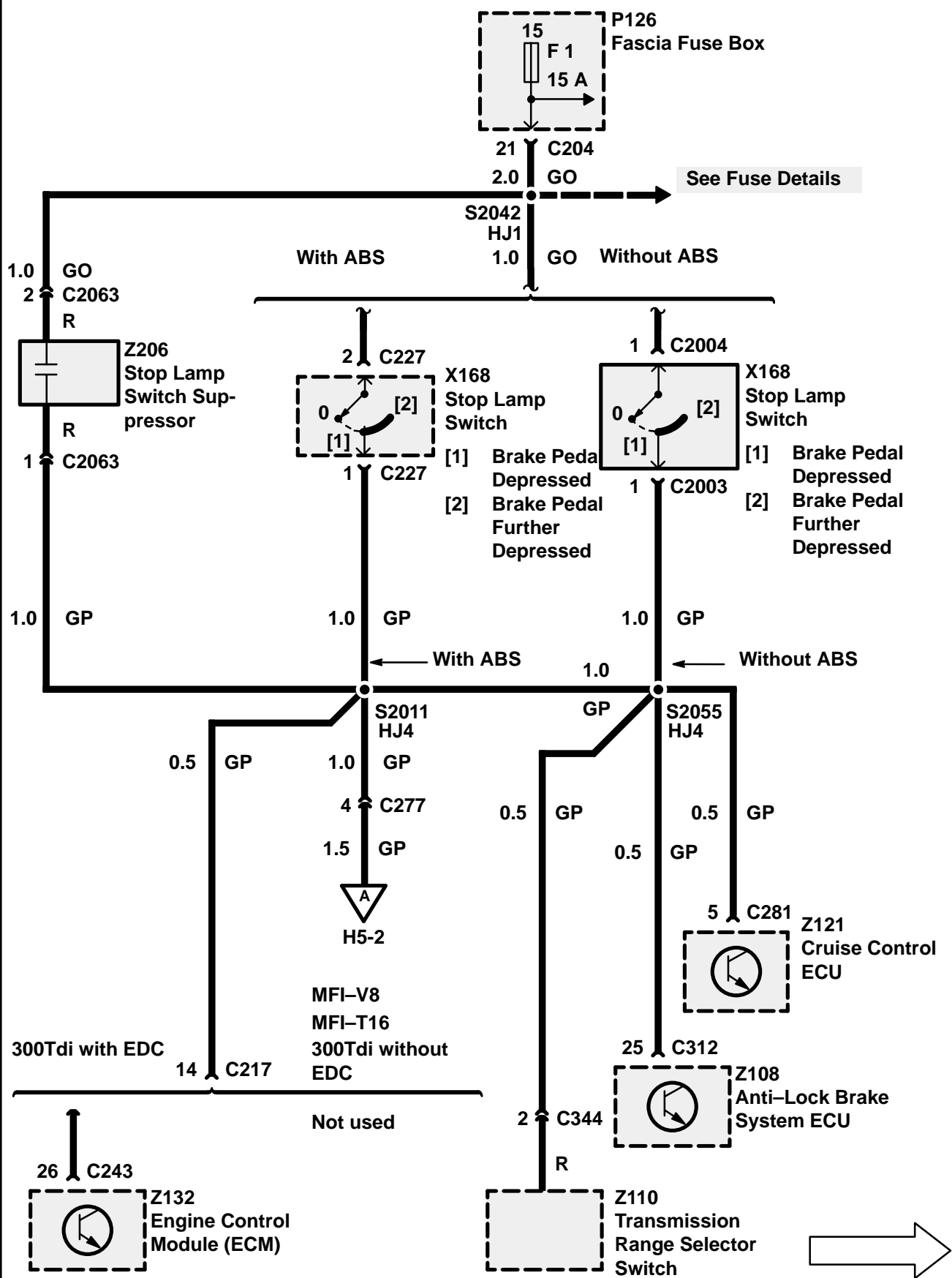

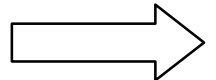
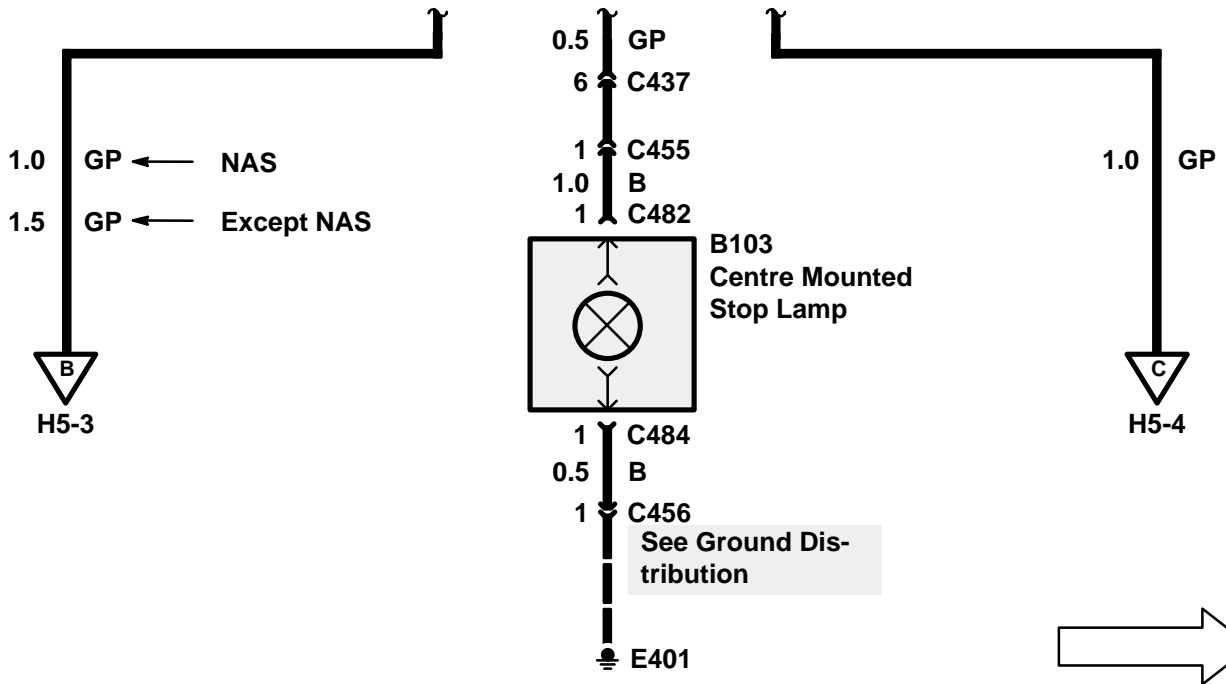
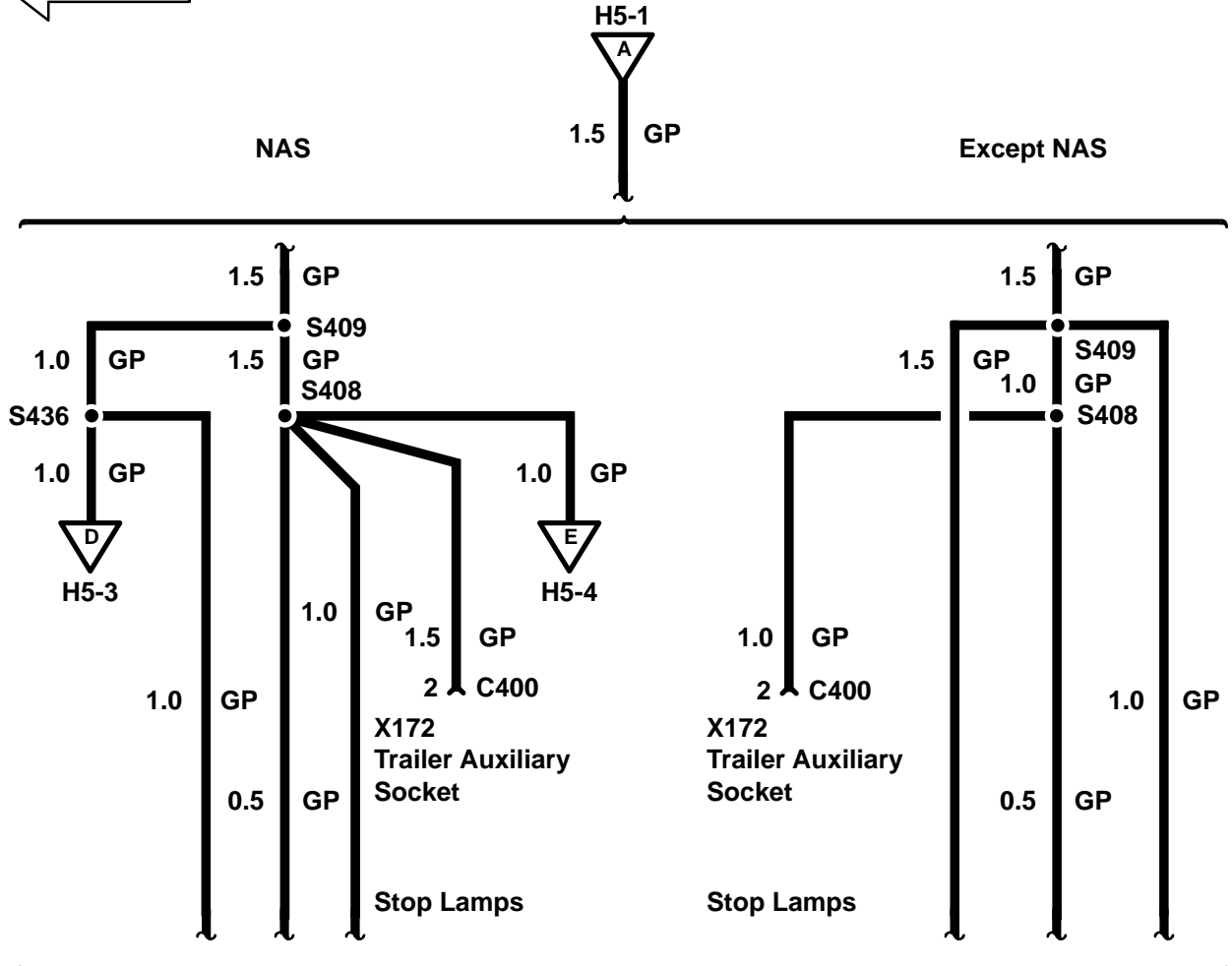
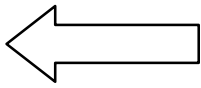

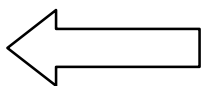

Rear Fog Guard Lamps

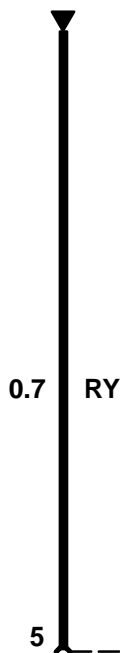

Reversing Lamps

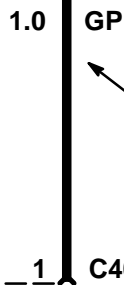
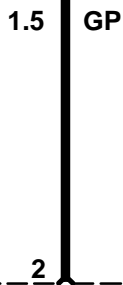
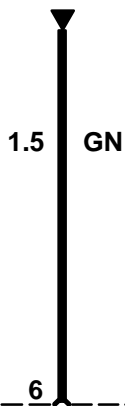

NAS

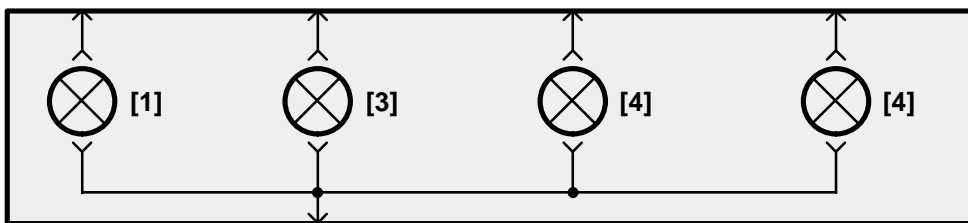

- [1] Rear Fog Lamp
- [3] Reverse Lamp
- [4] Stop Lamp

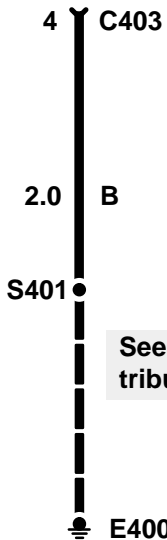

See Ground Distribution

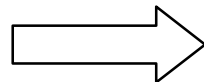

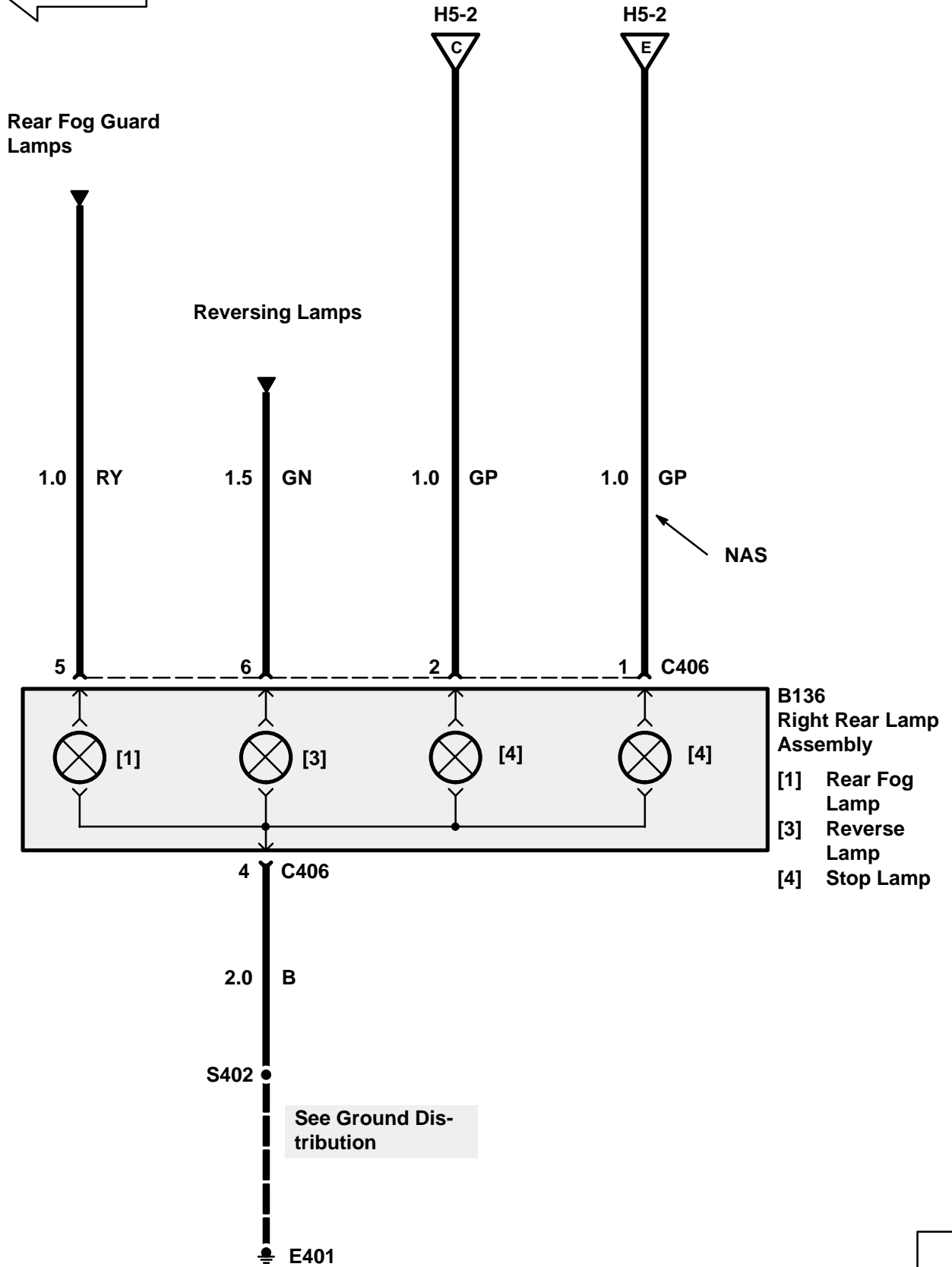
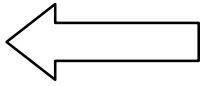

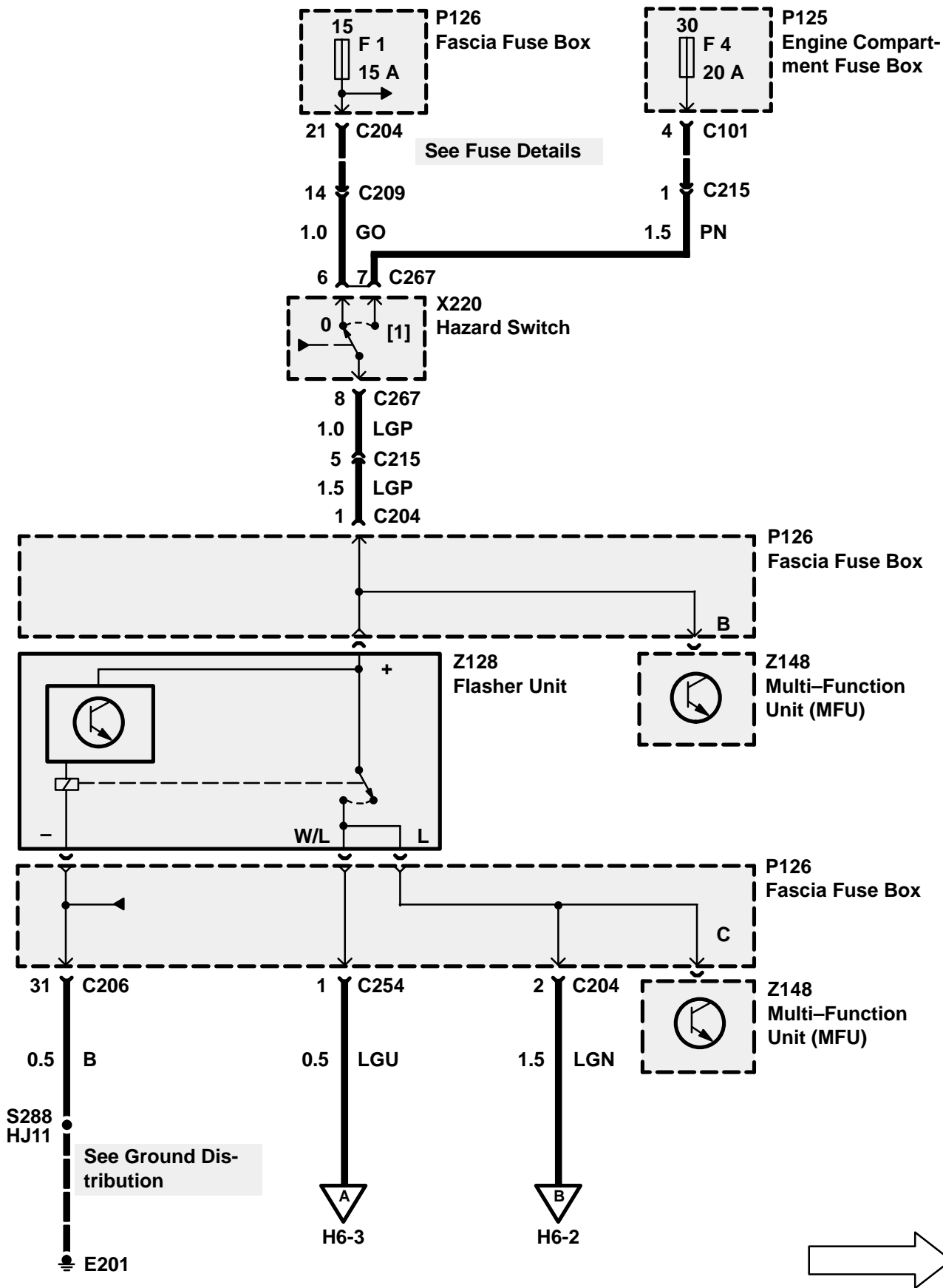

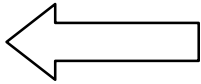

Interior Lamps

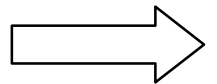
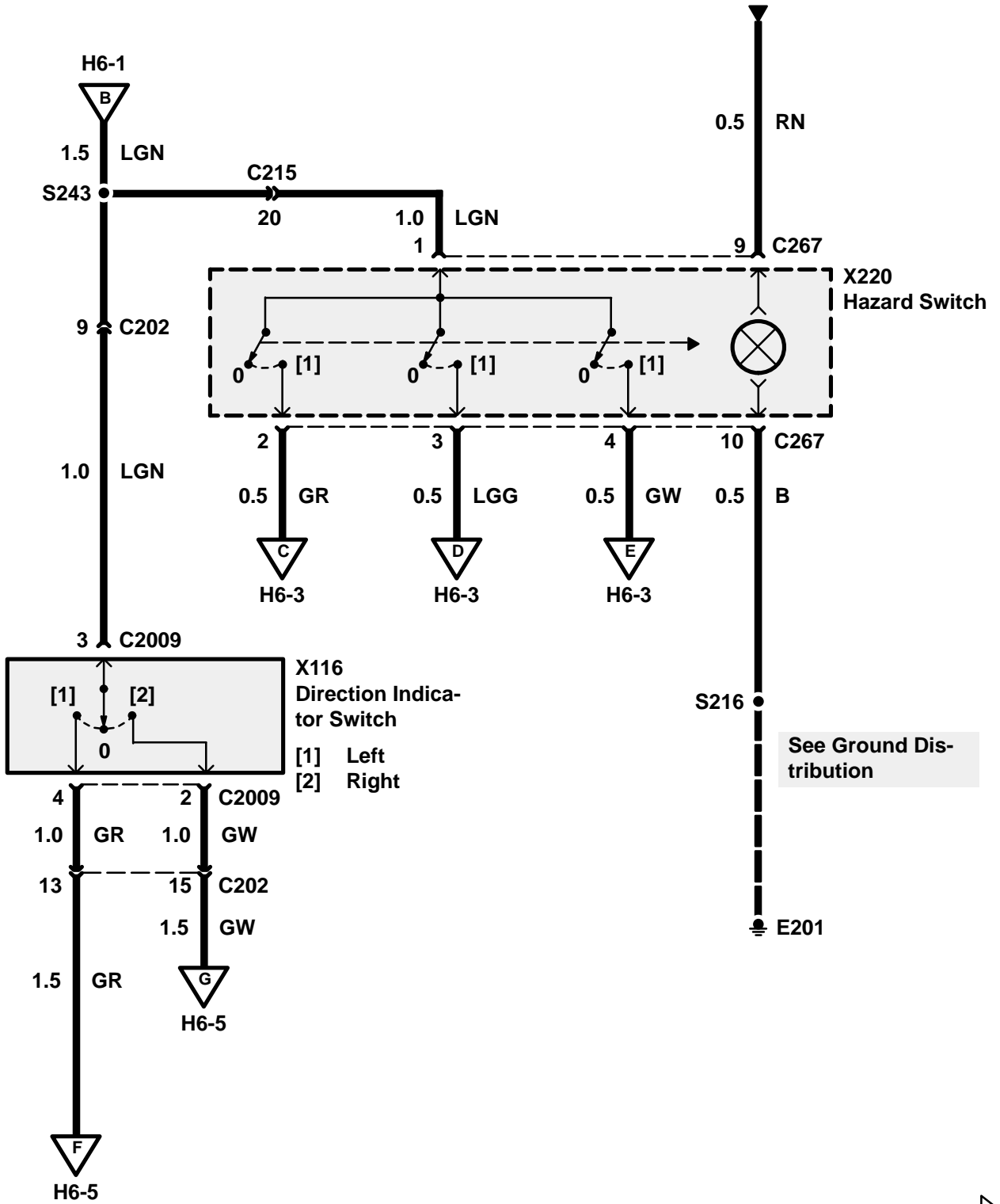

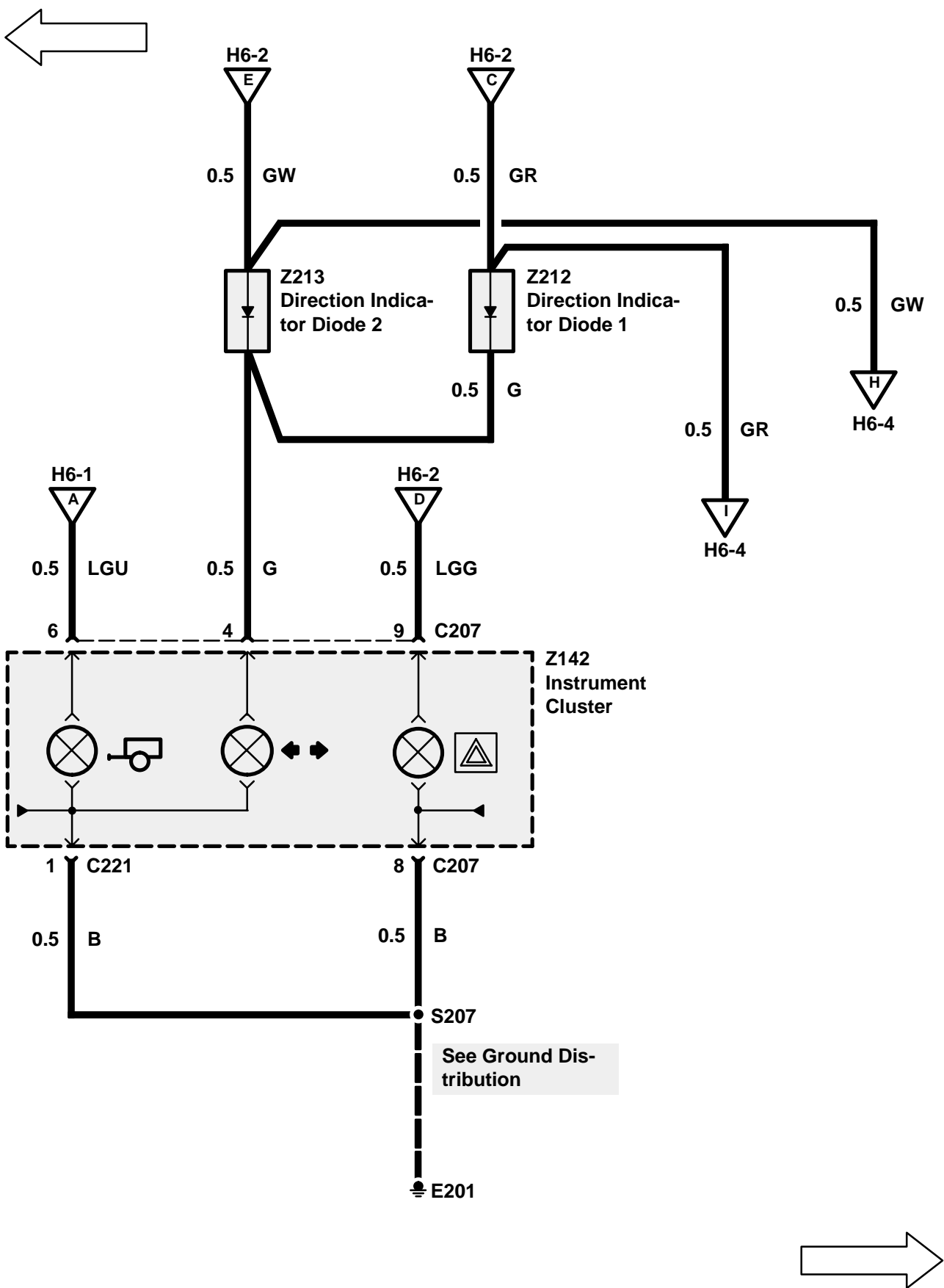

H6 ETM

DISCOVERY

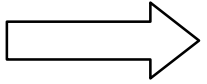
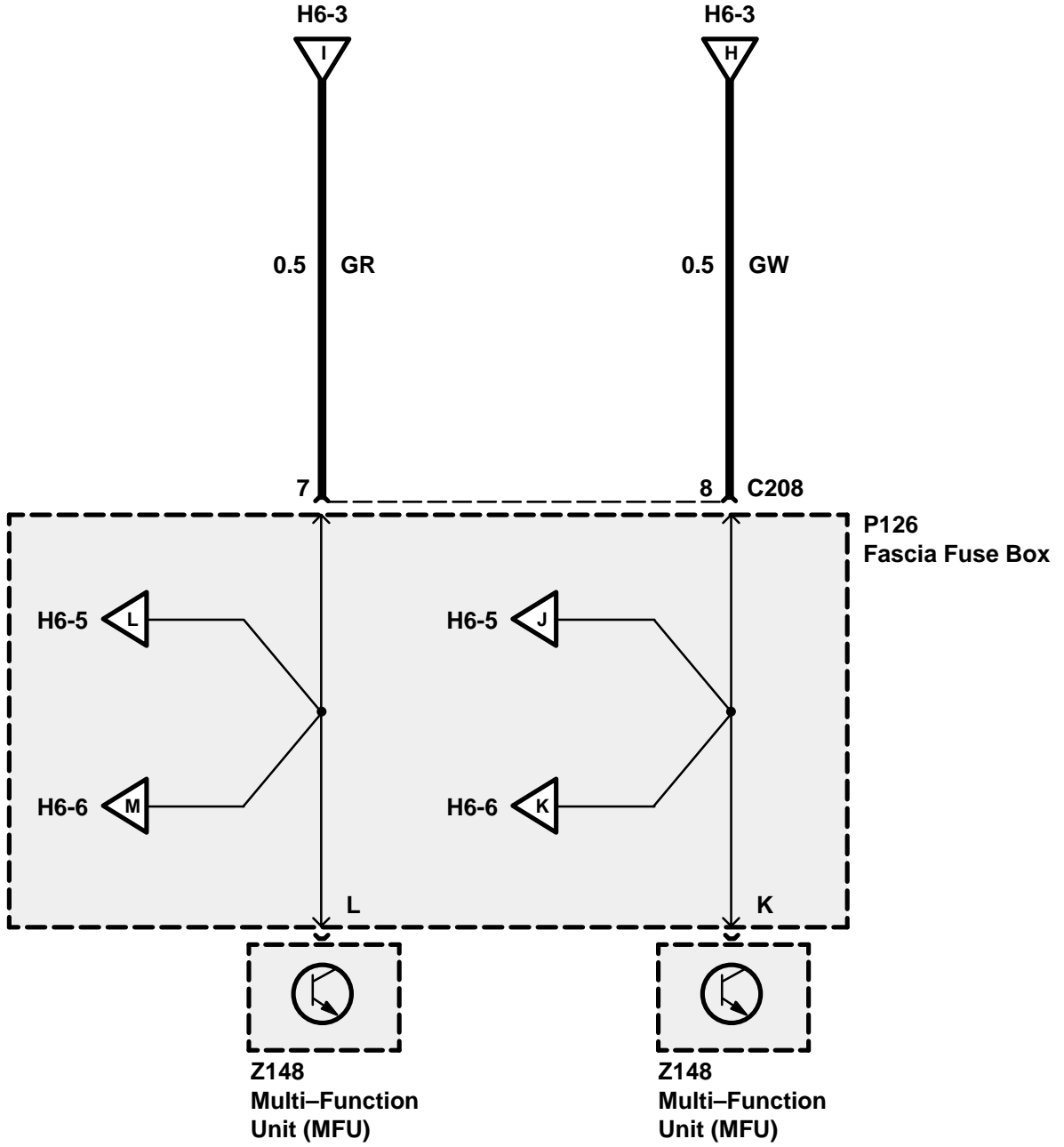
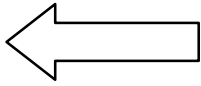

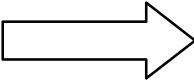
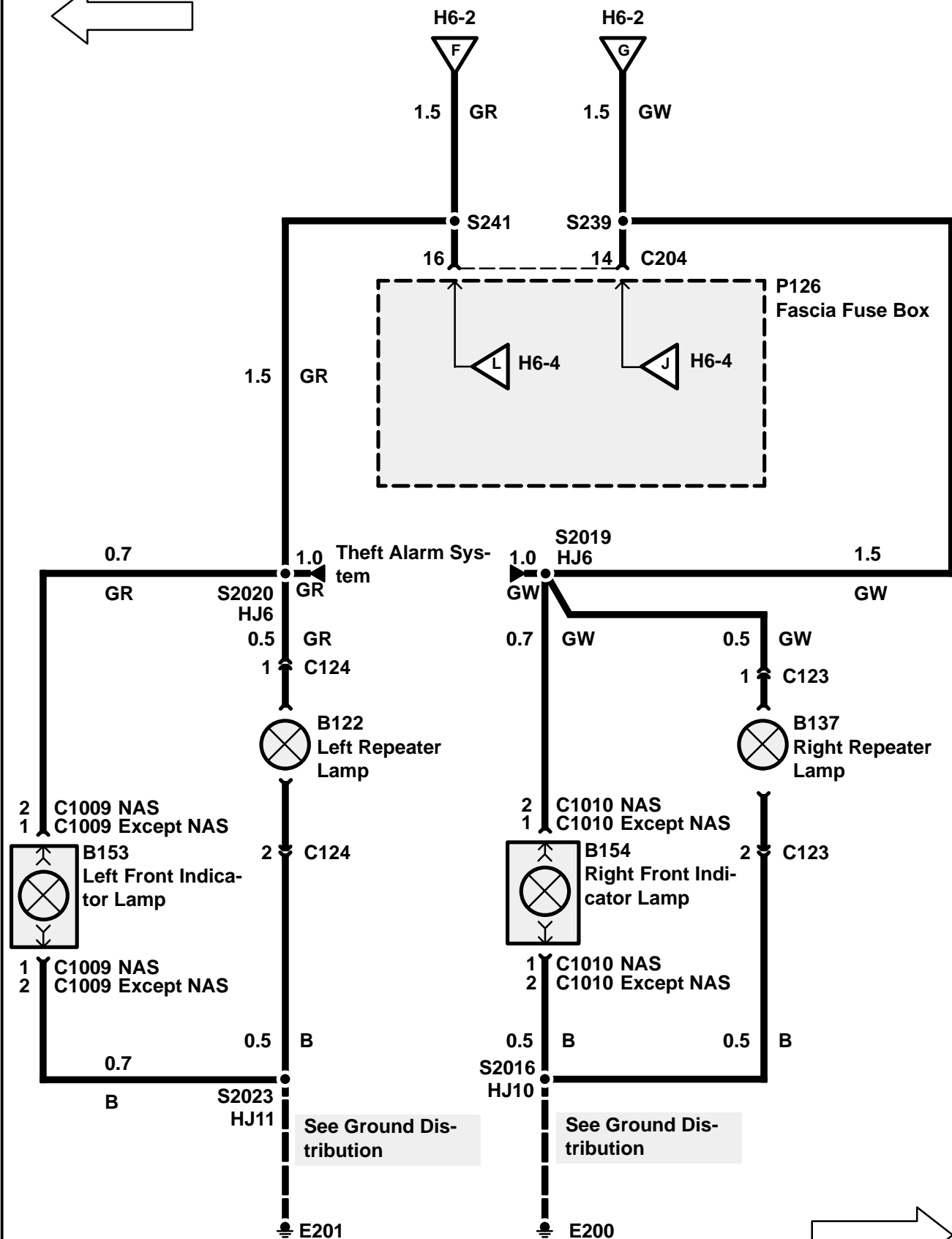
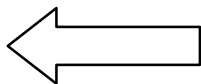

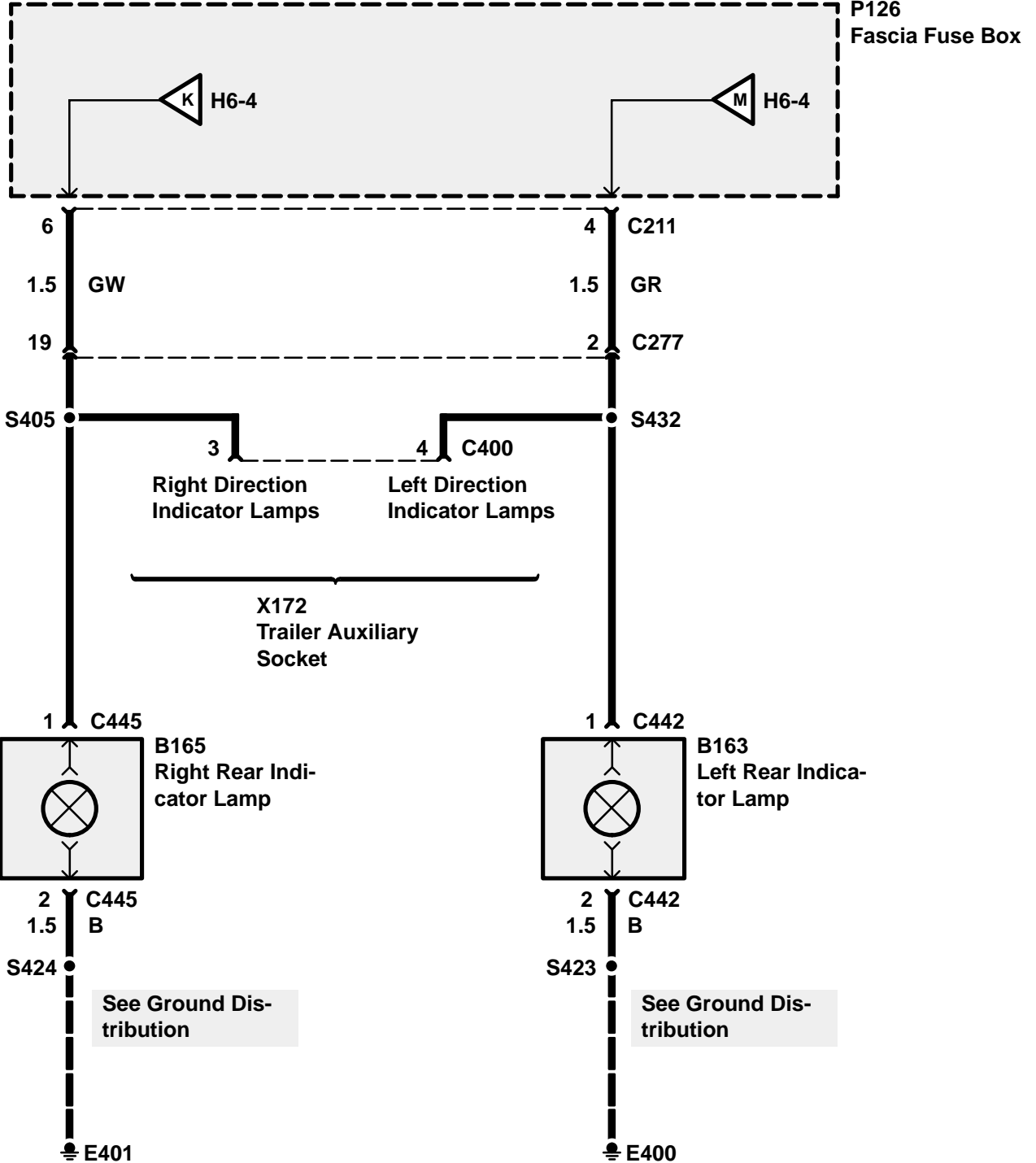
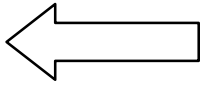

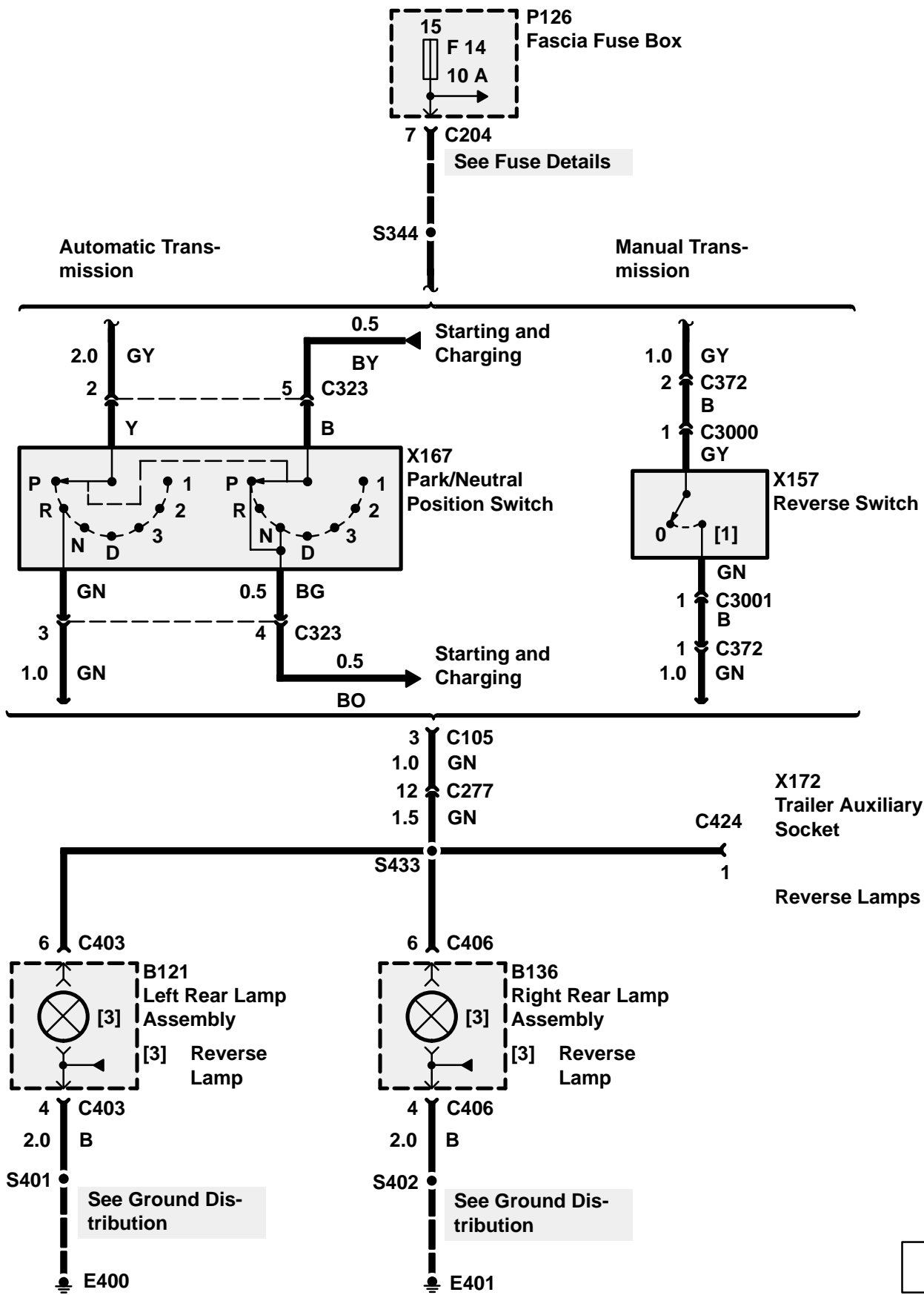

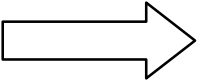
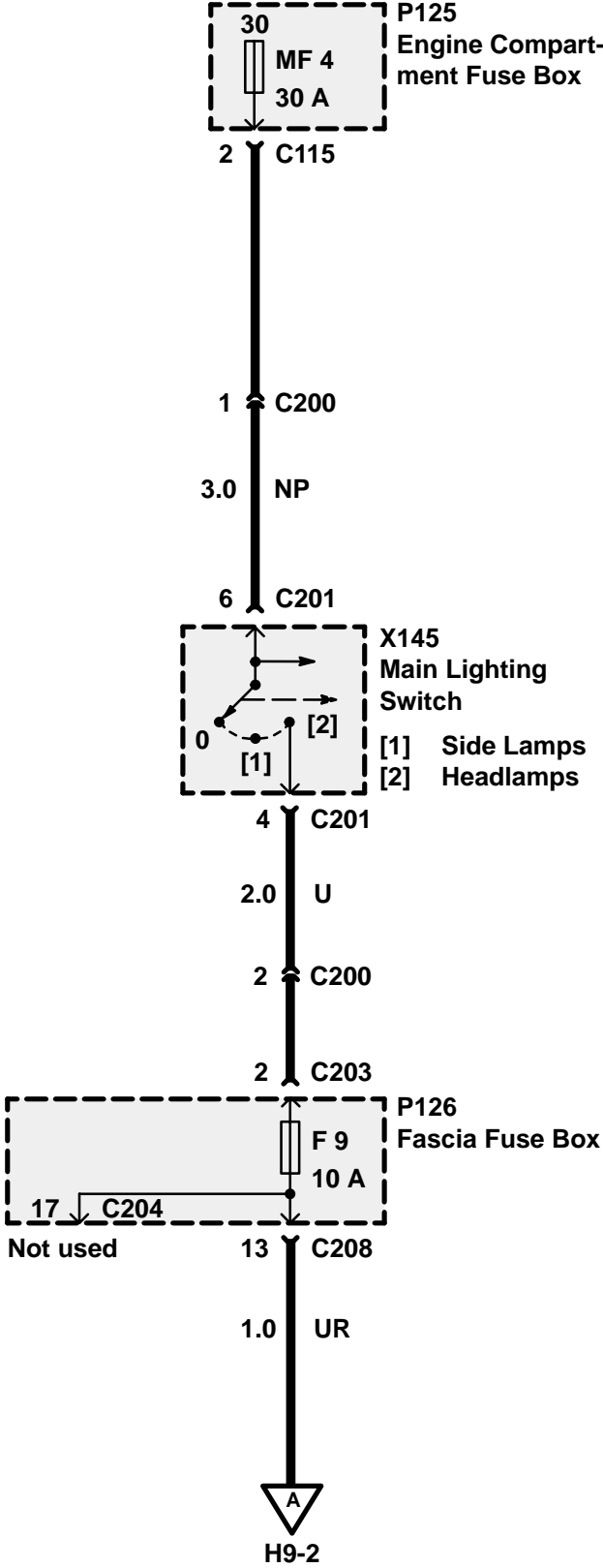

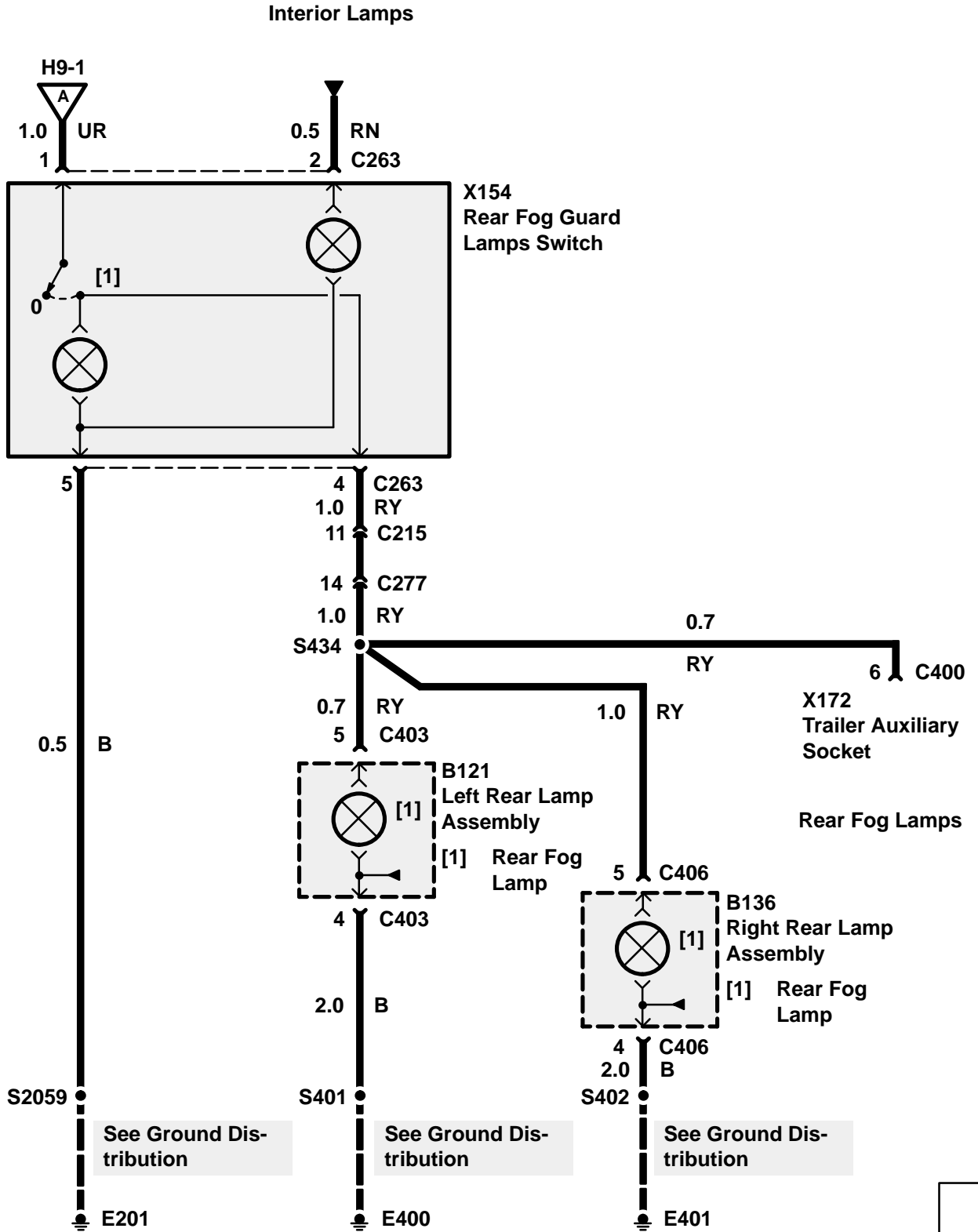

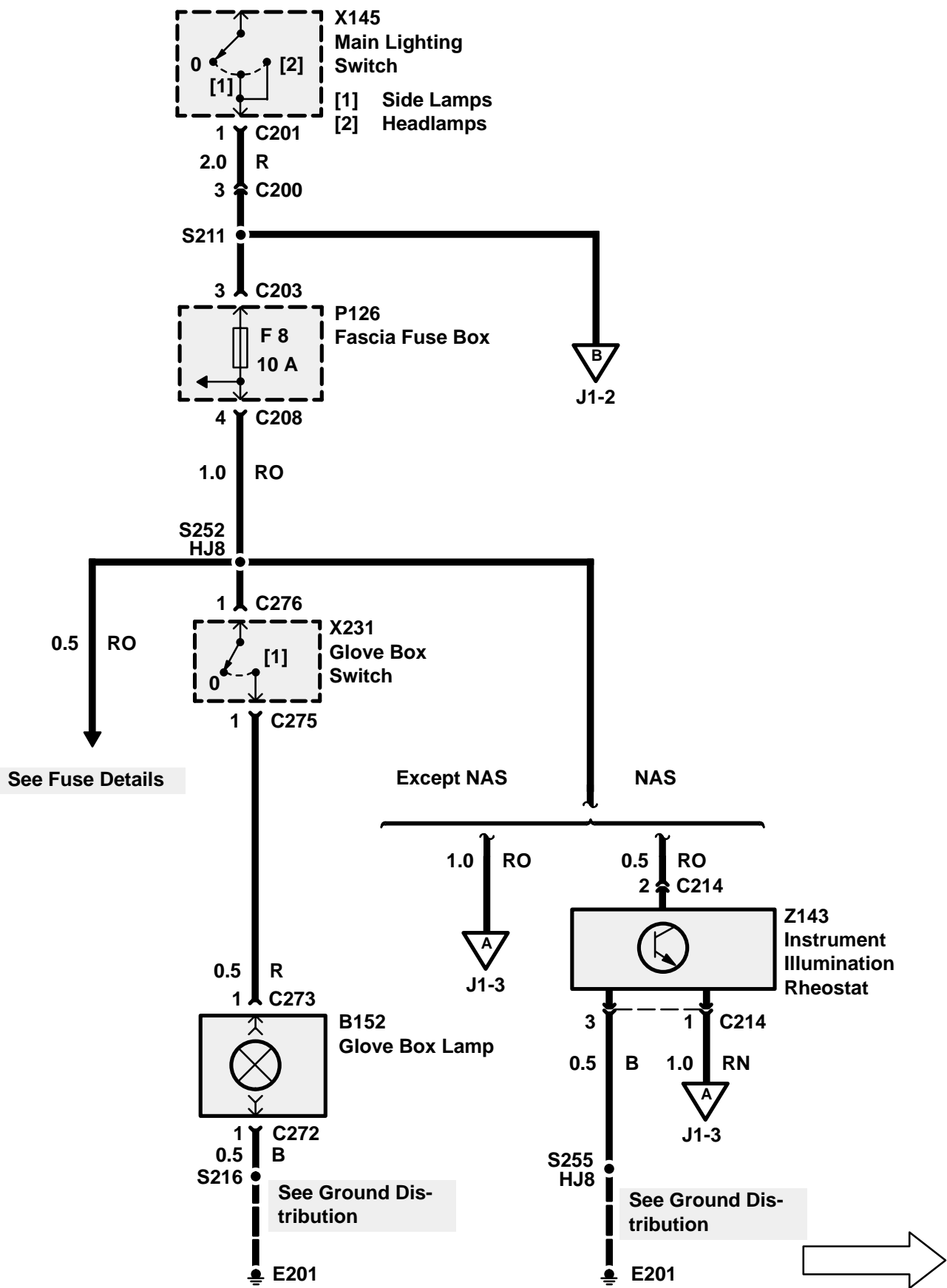

J1 ETM

DISCOVERY

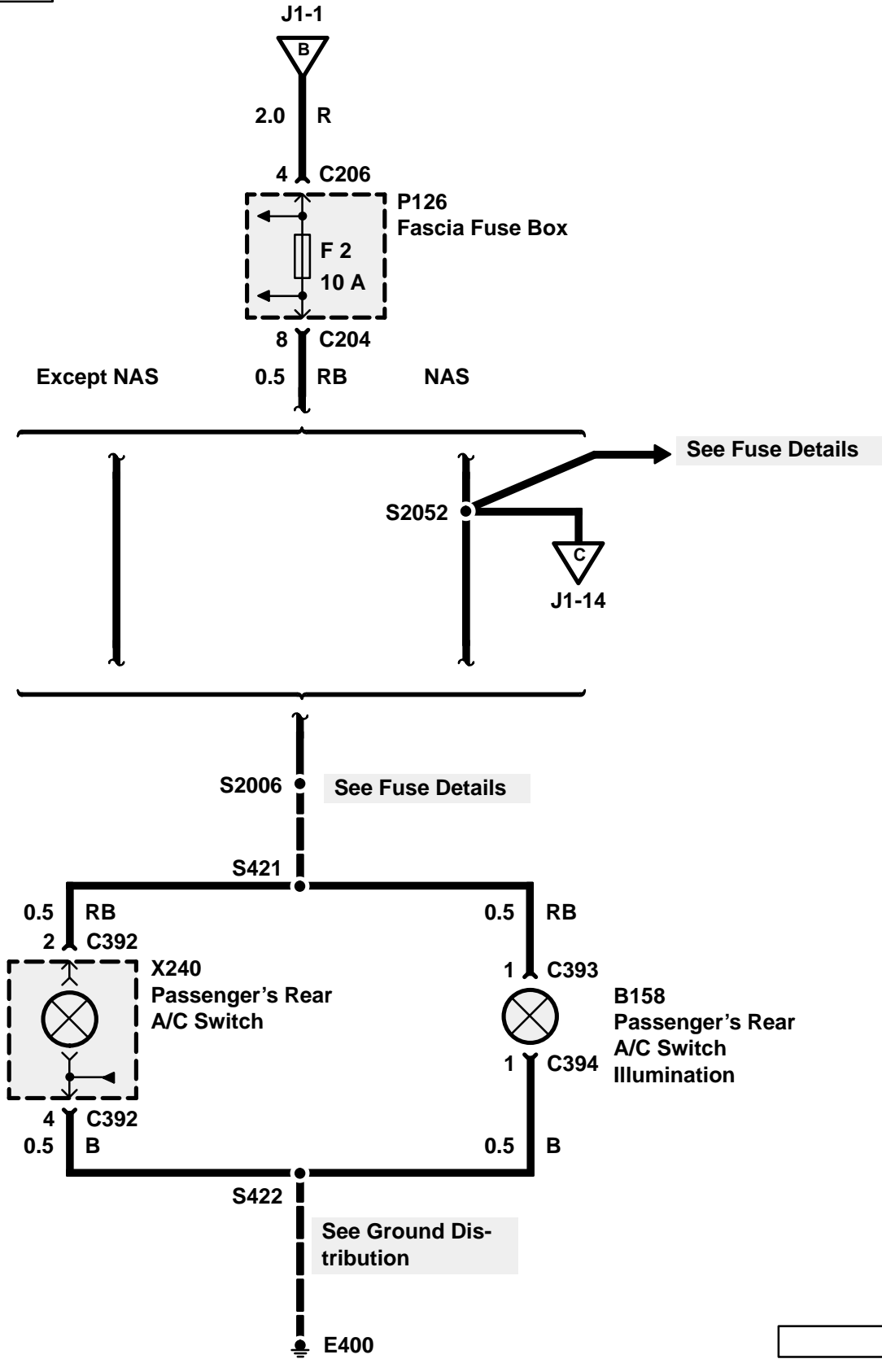
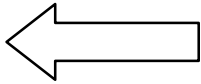

See Fuse Details

See Fuse Details

See Ground Distribution

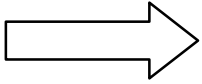

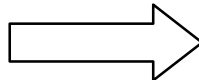
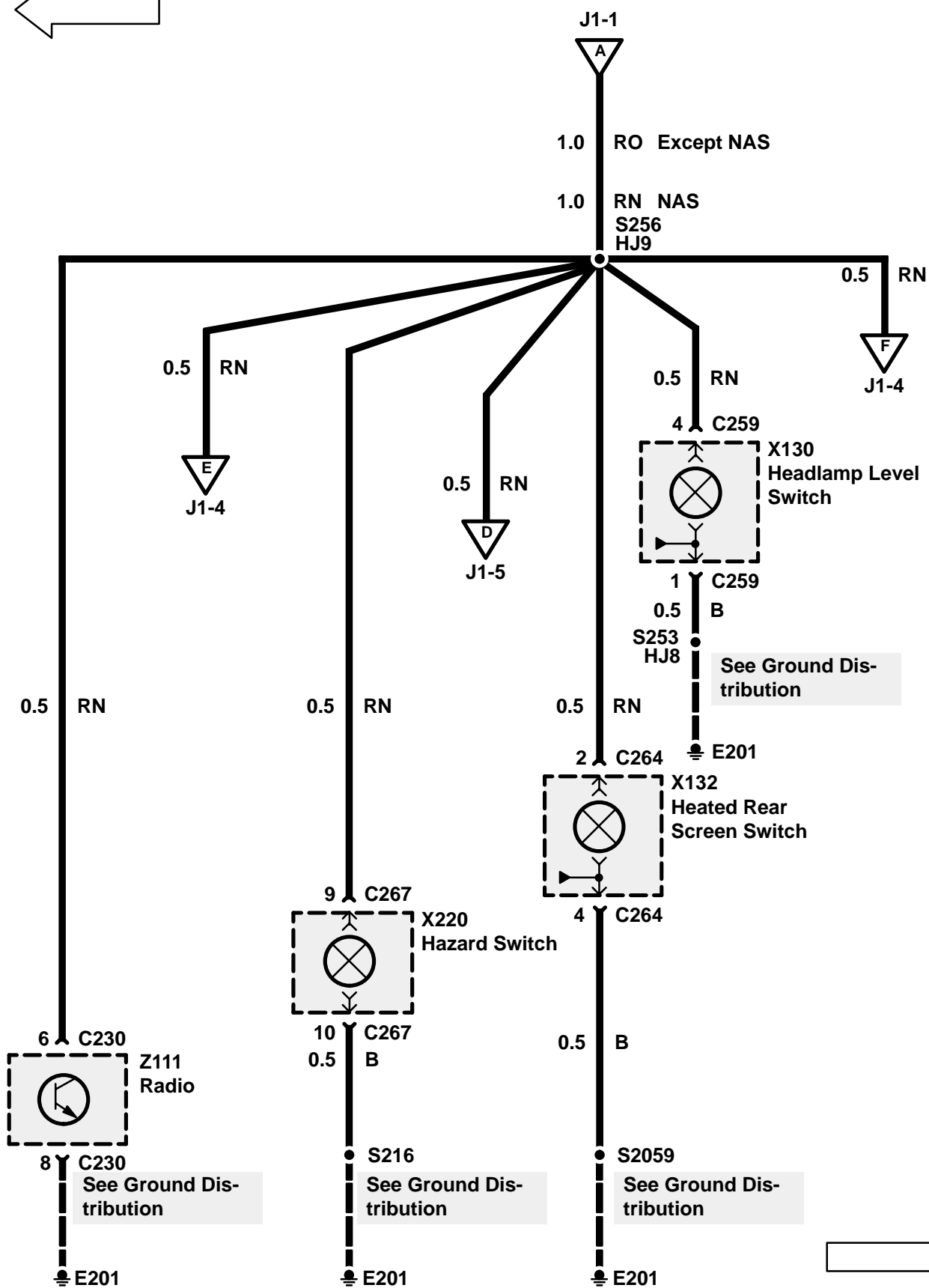
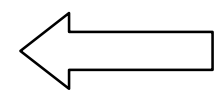

J1 ETM

DISCOVERY

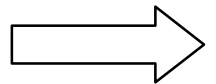
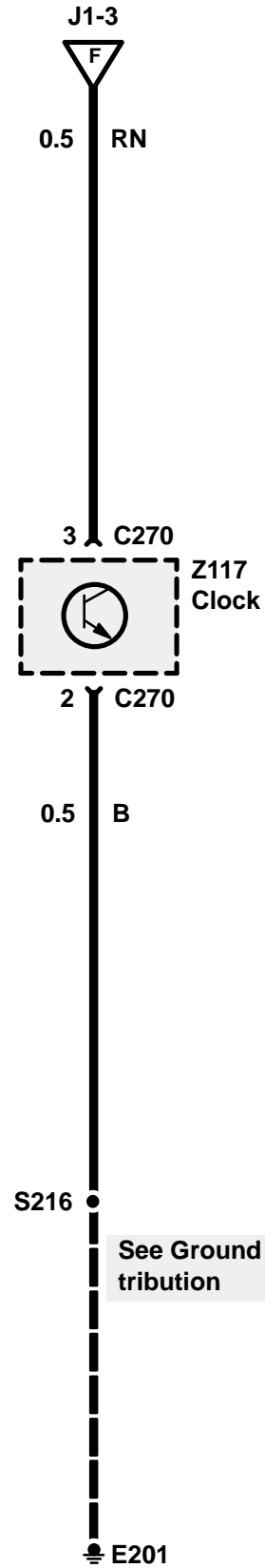
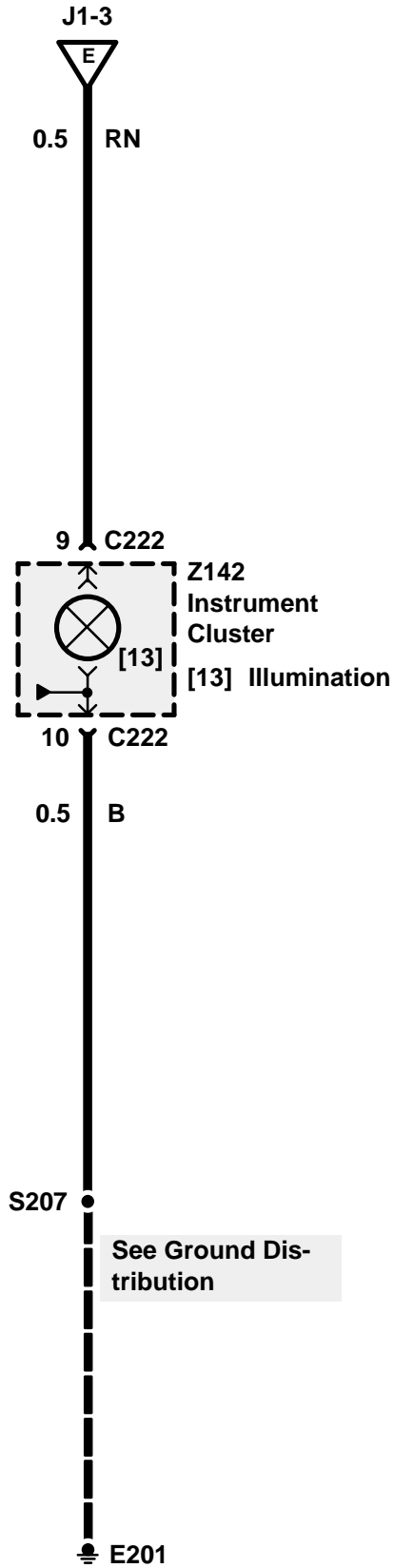
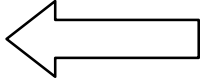

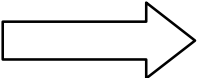
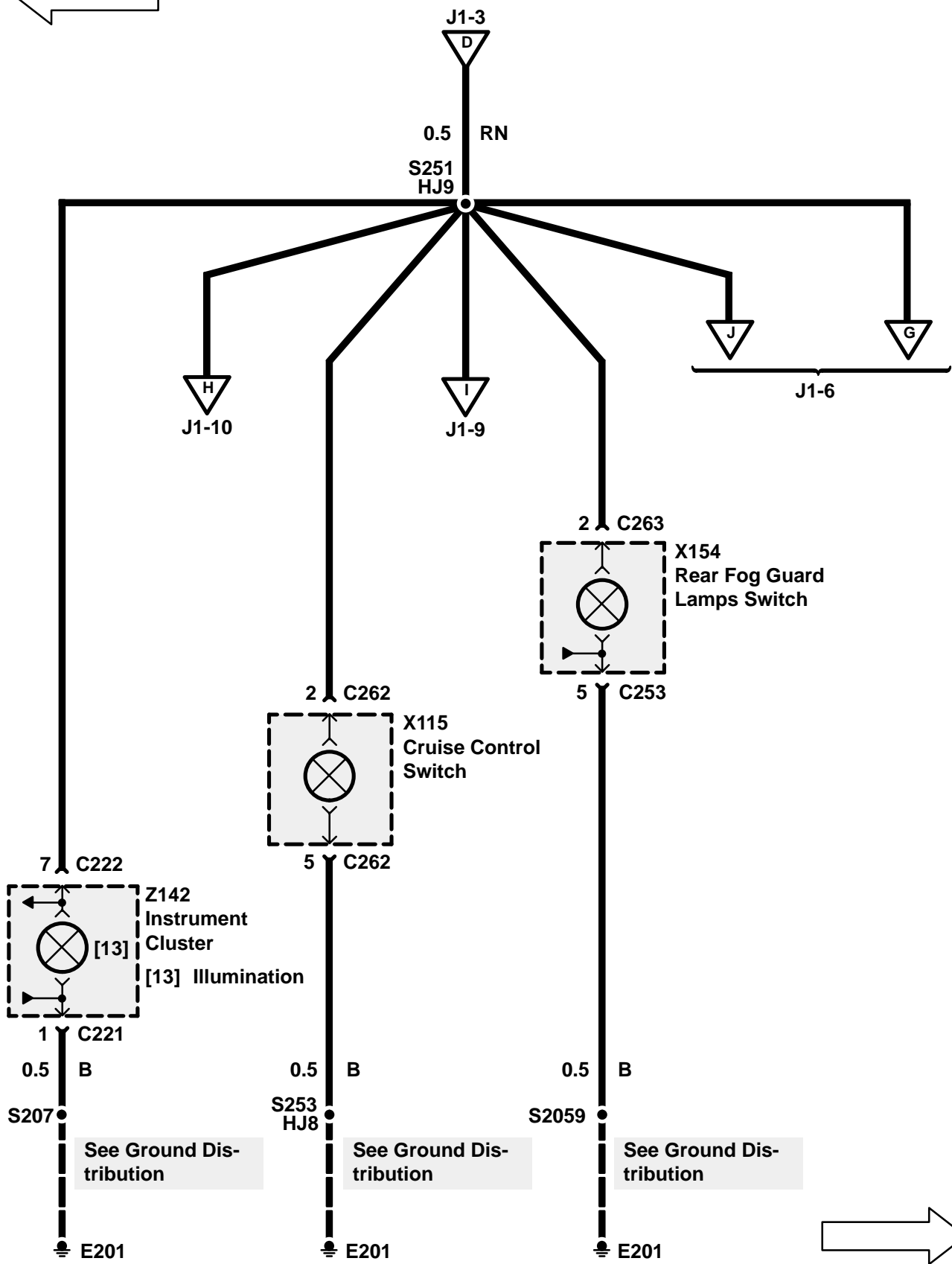
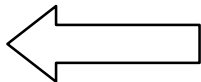

J1 ETM

DISCOVERY

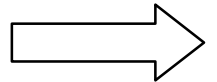
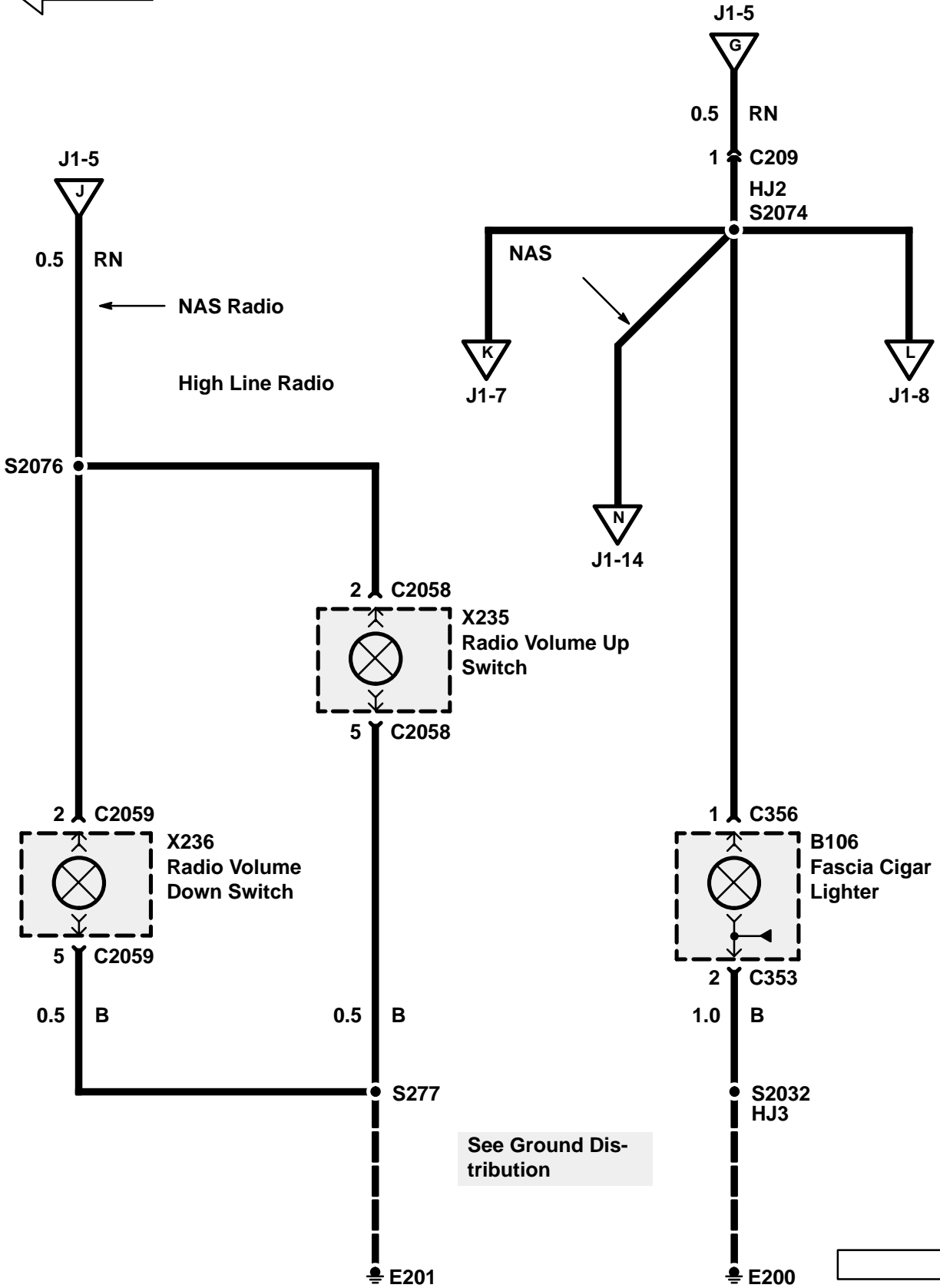
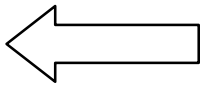

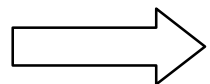
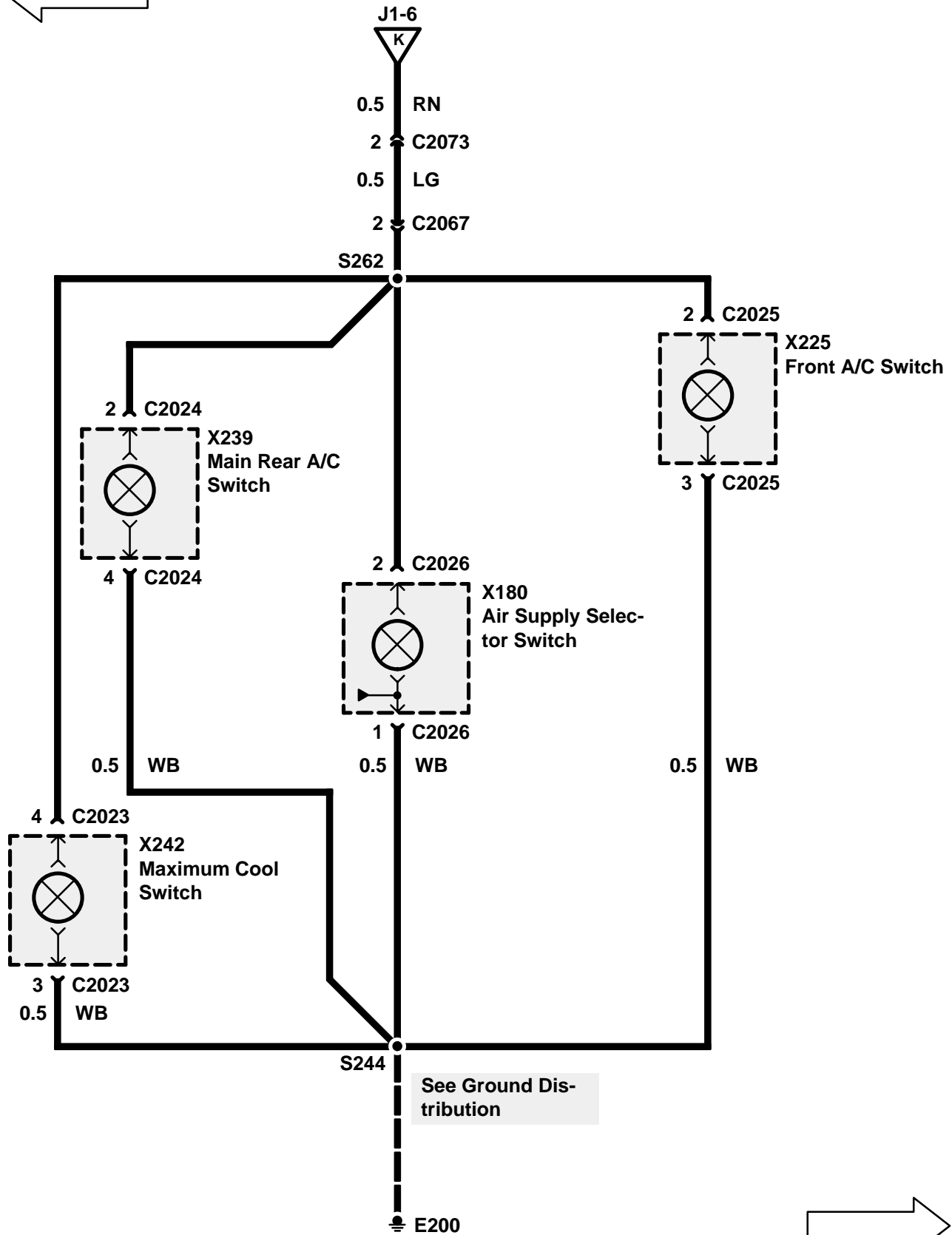
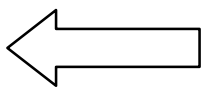

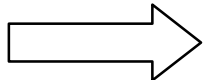
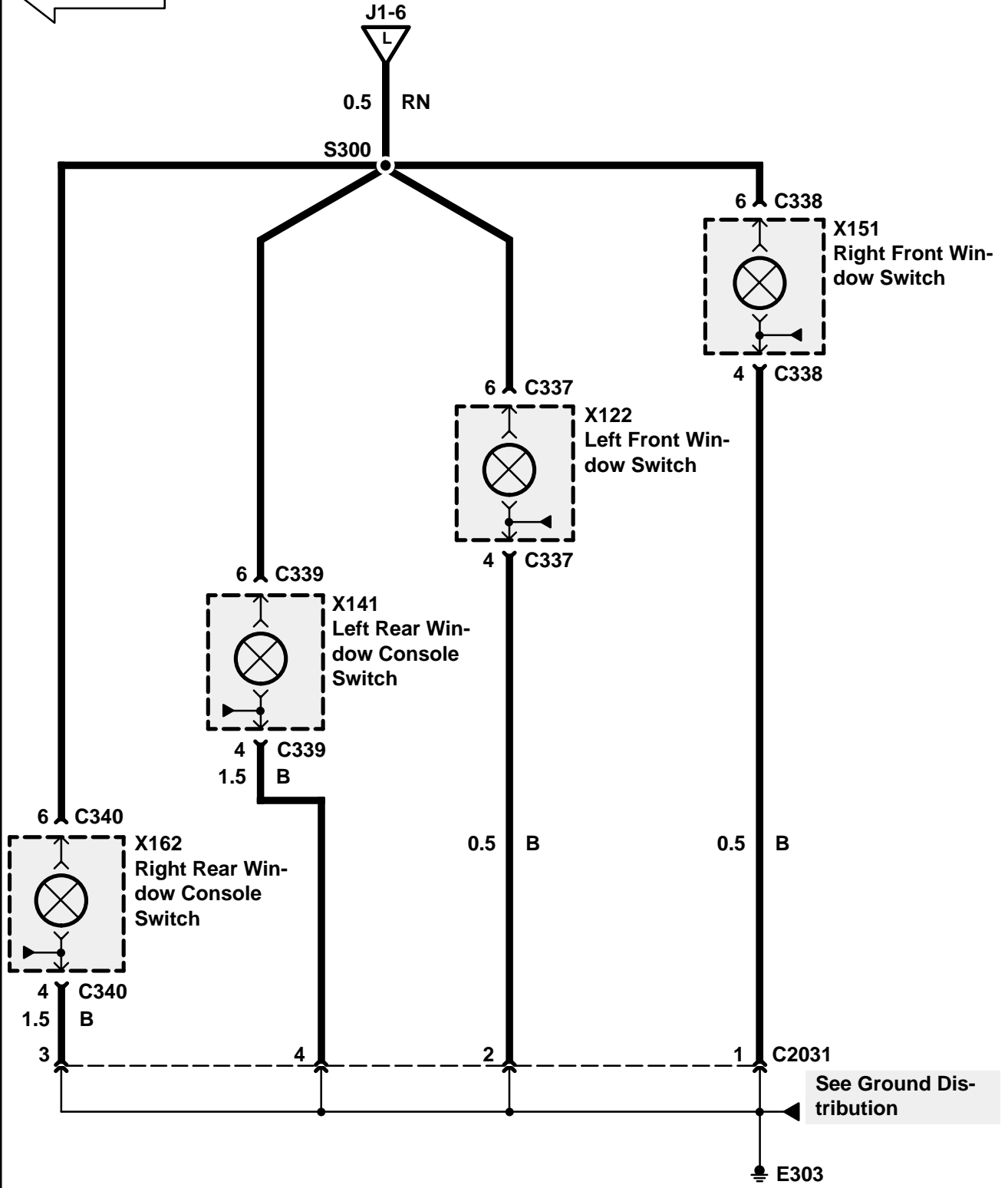
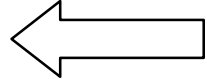

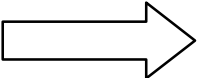
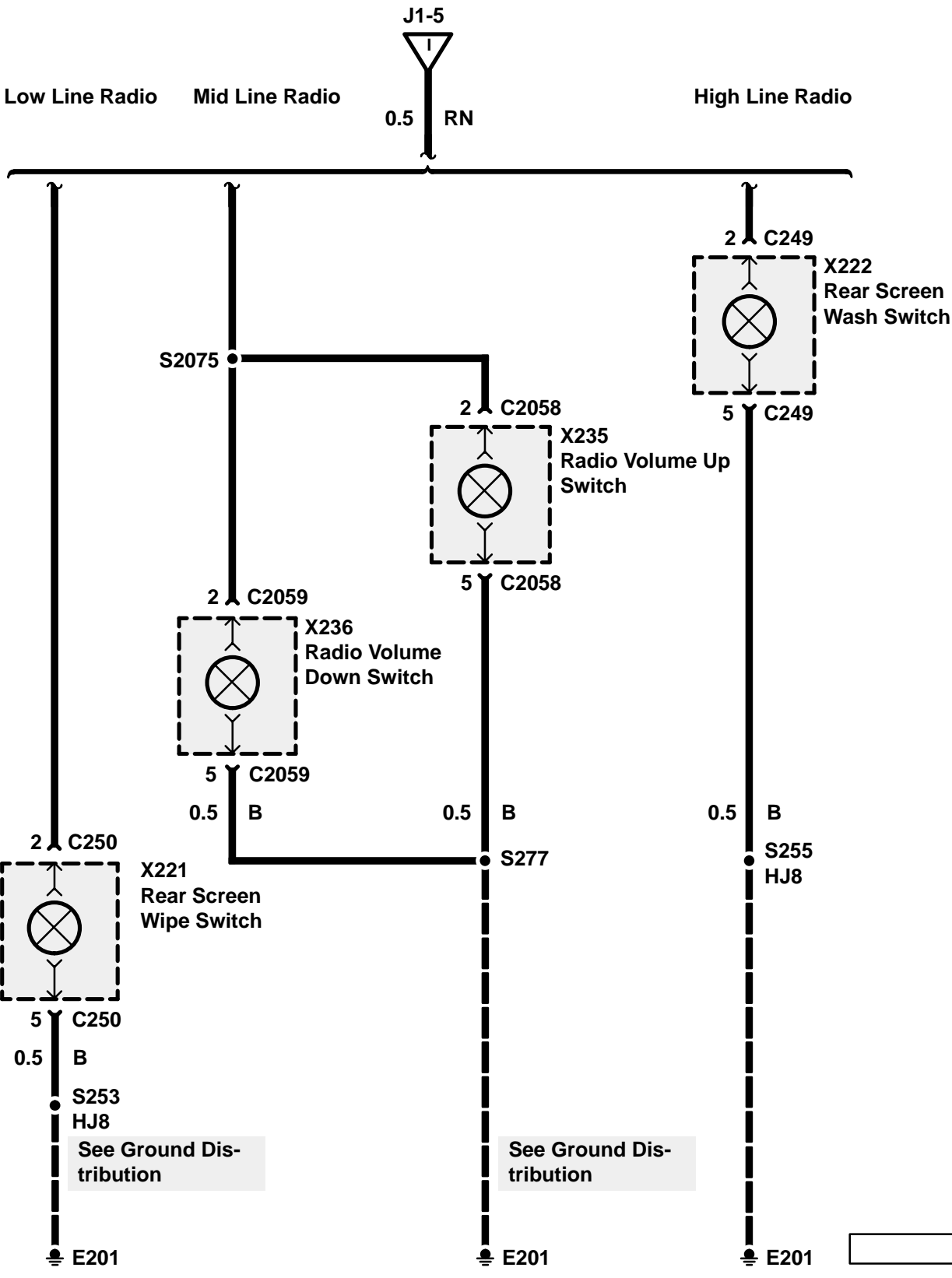
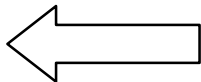

J1 ETM

DISCOVERY

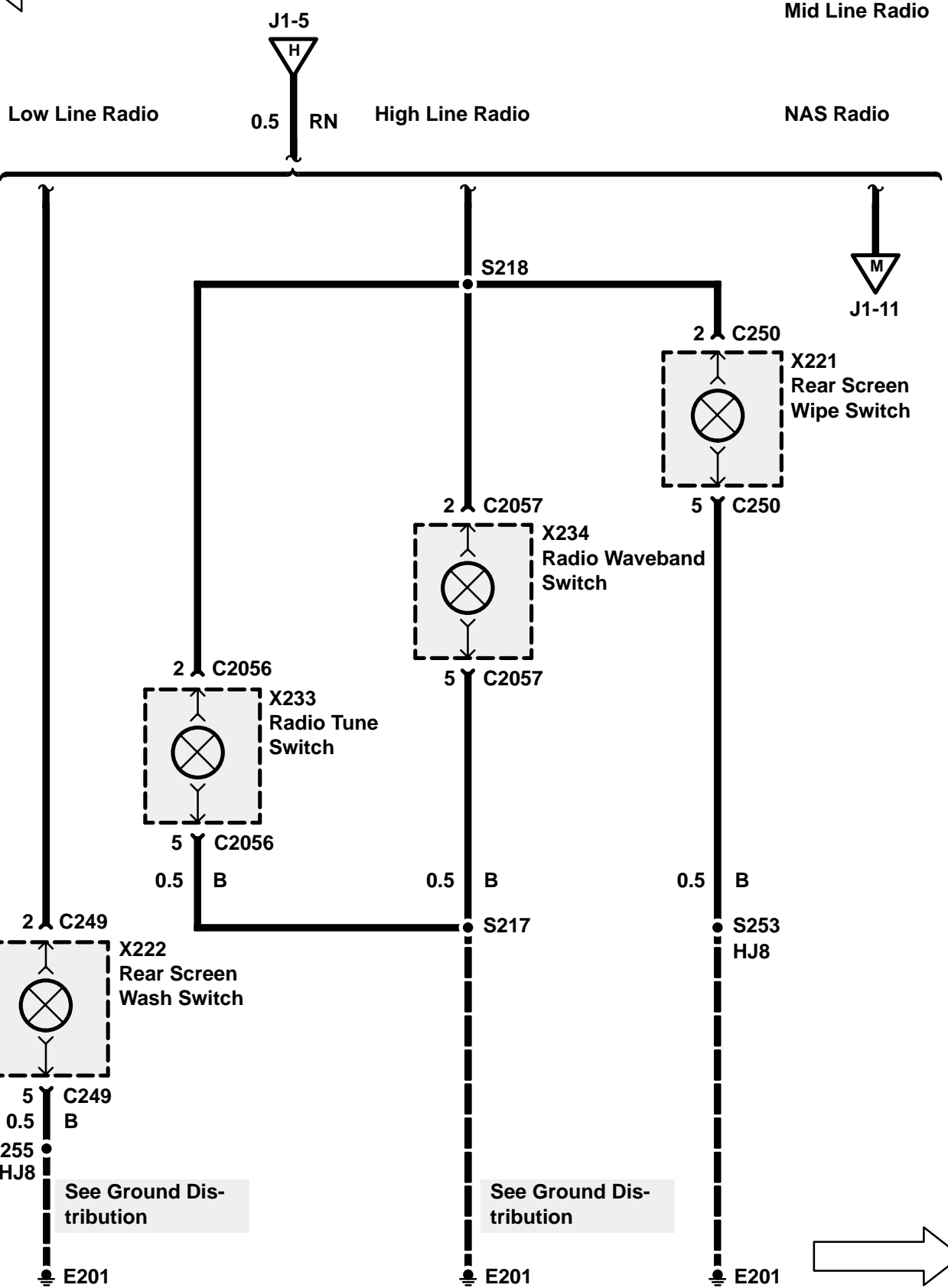
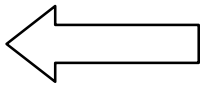

Mid Line Radio

Low Line Radio

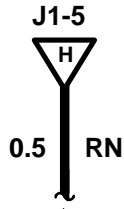

High Line Radio

NAS Radio



X221
Rear Screen
Wipe Switch

X234
Radio Waveband
Switch

X233
Radio Tune
Switch

X222
Rear Screen
Wash Switch

See Ground Dis-
tribution

See Ground Dis-
tribution

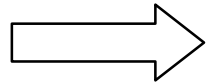

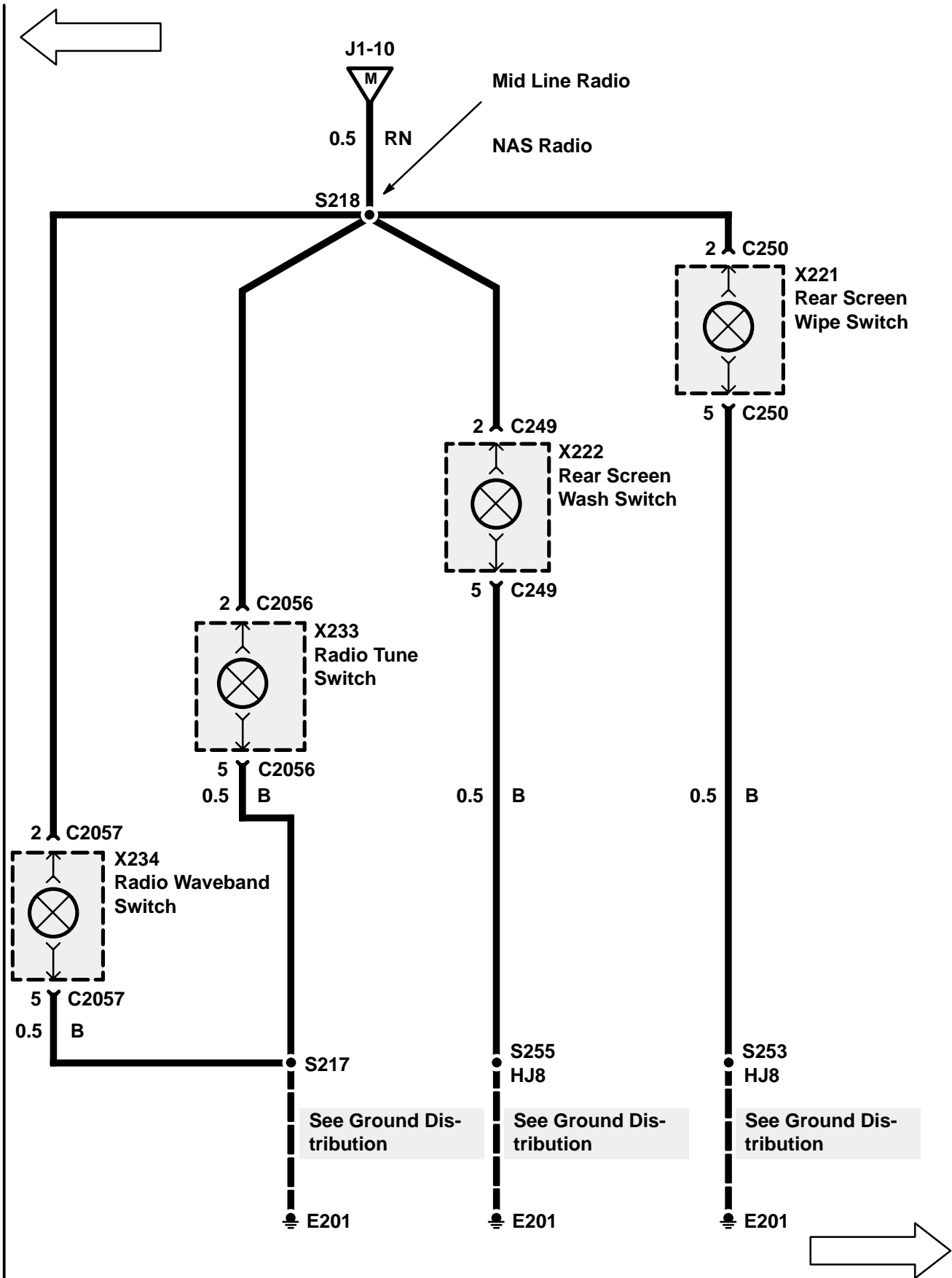

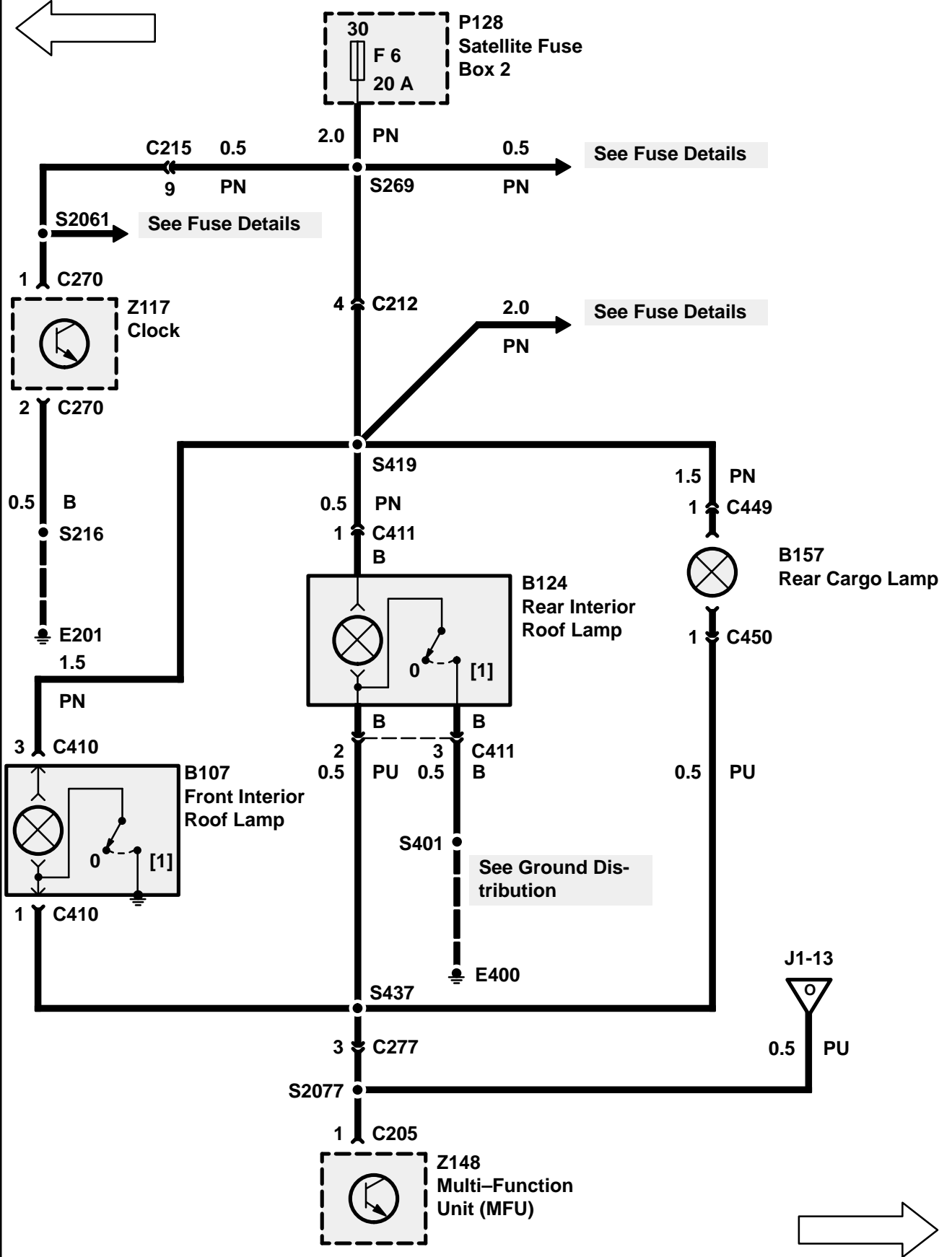

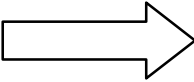
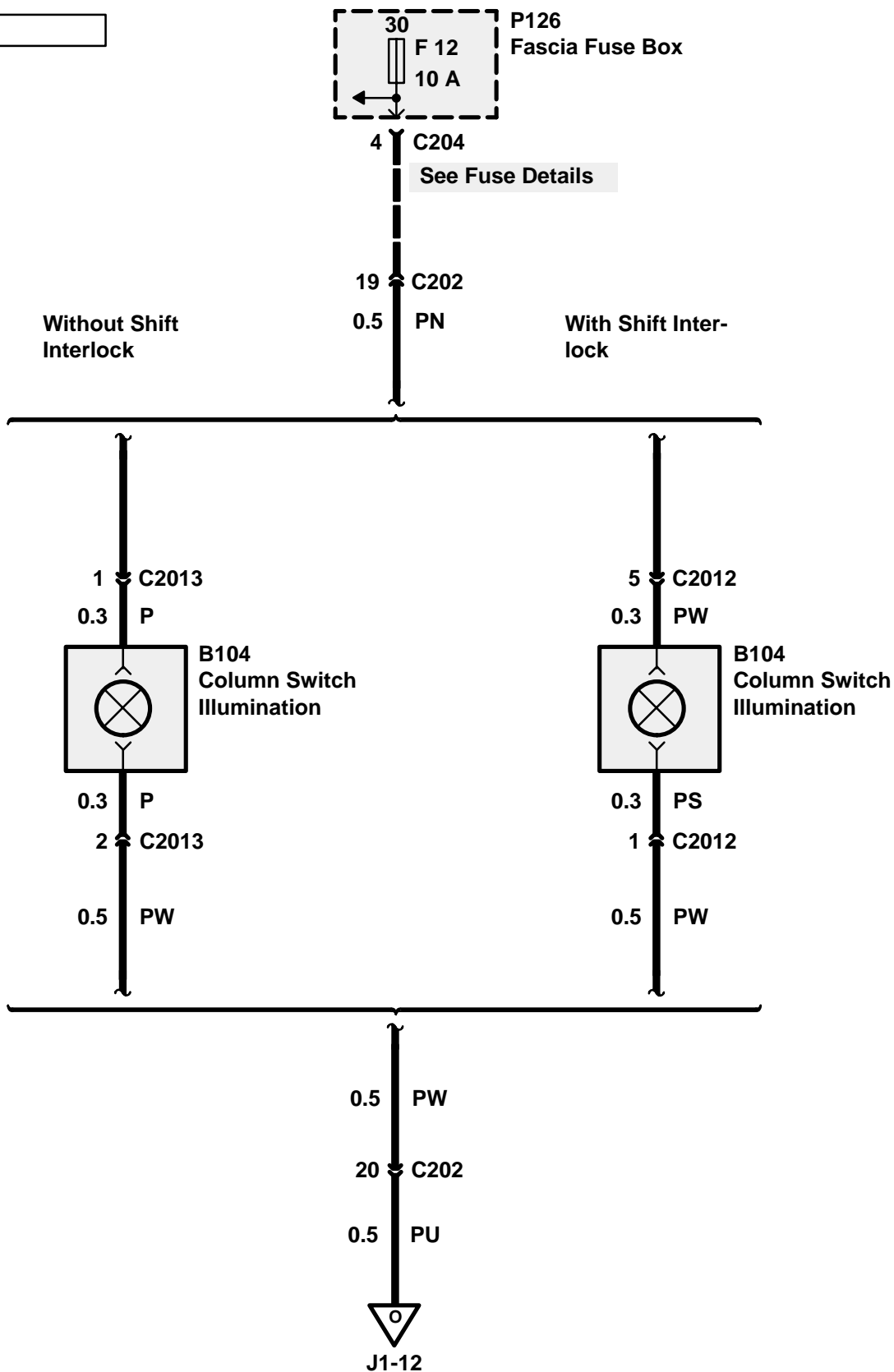
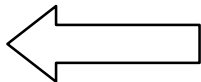

J1 ETM

DISCOVERY

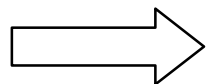
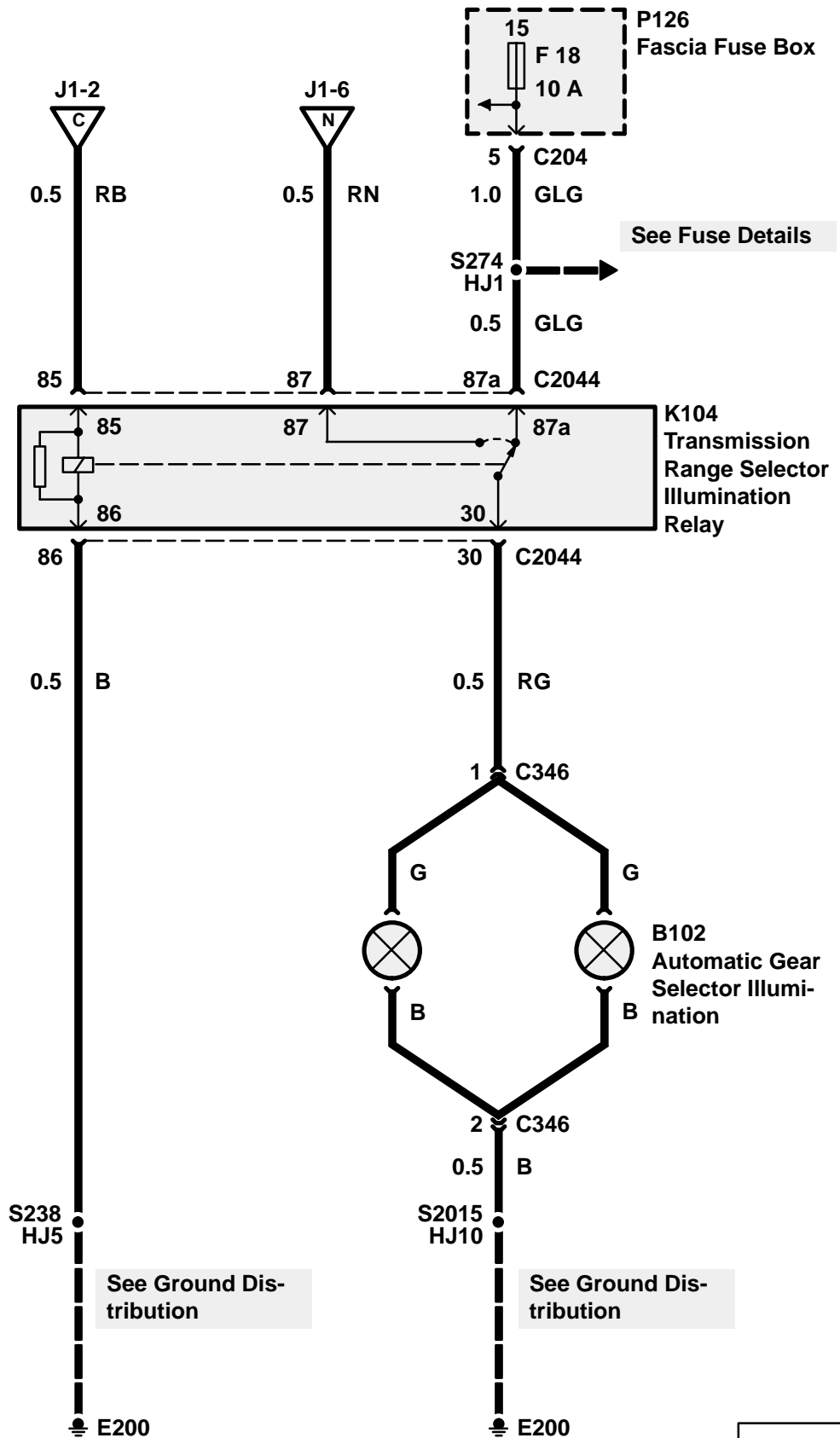
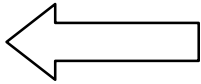

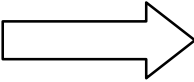
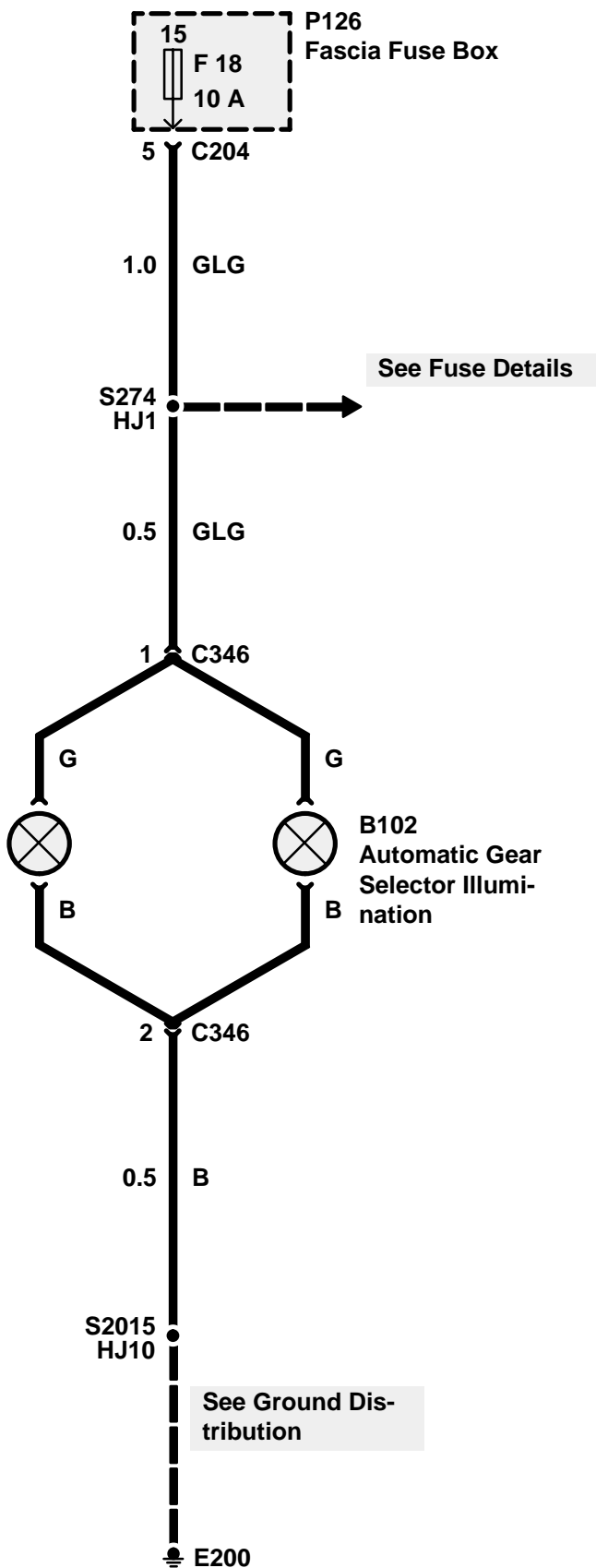
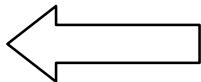

J1 ETM

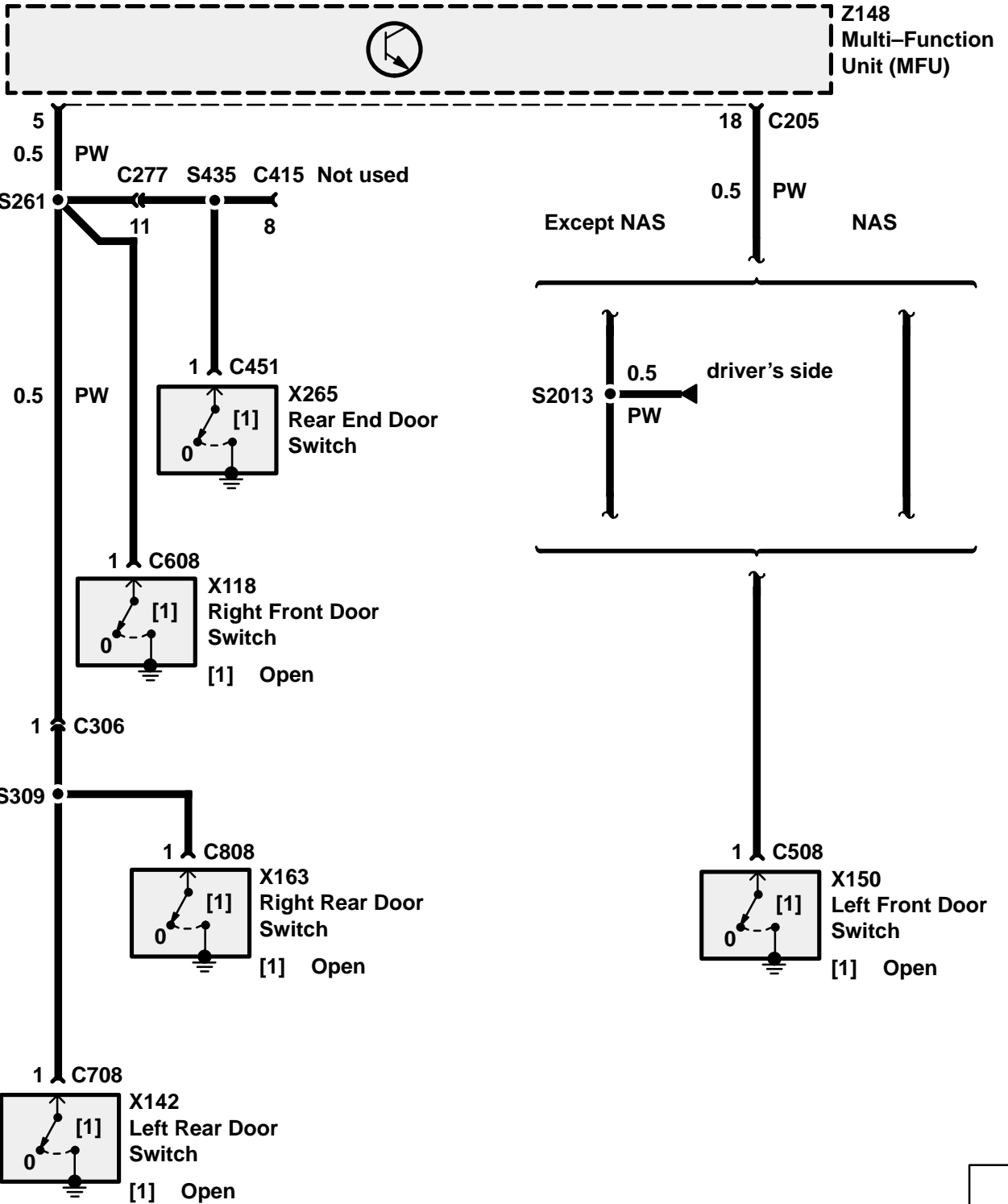
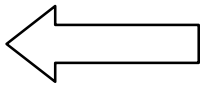

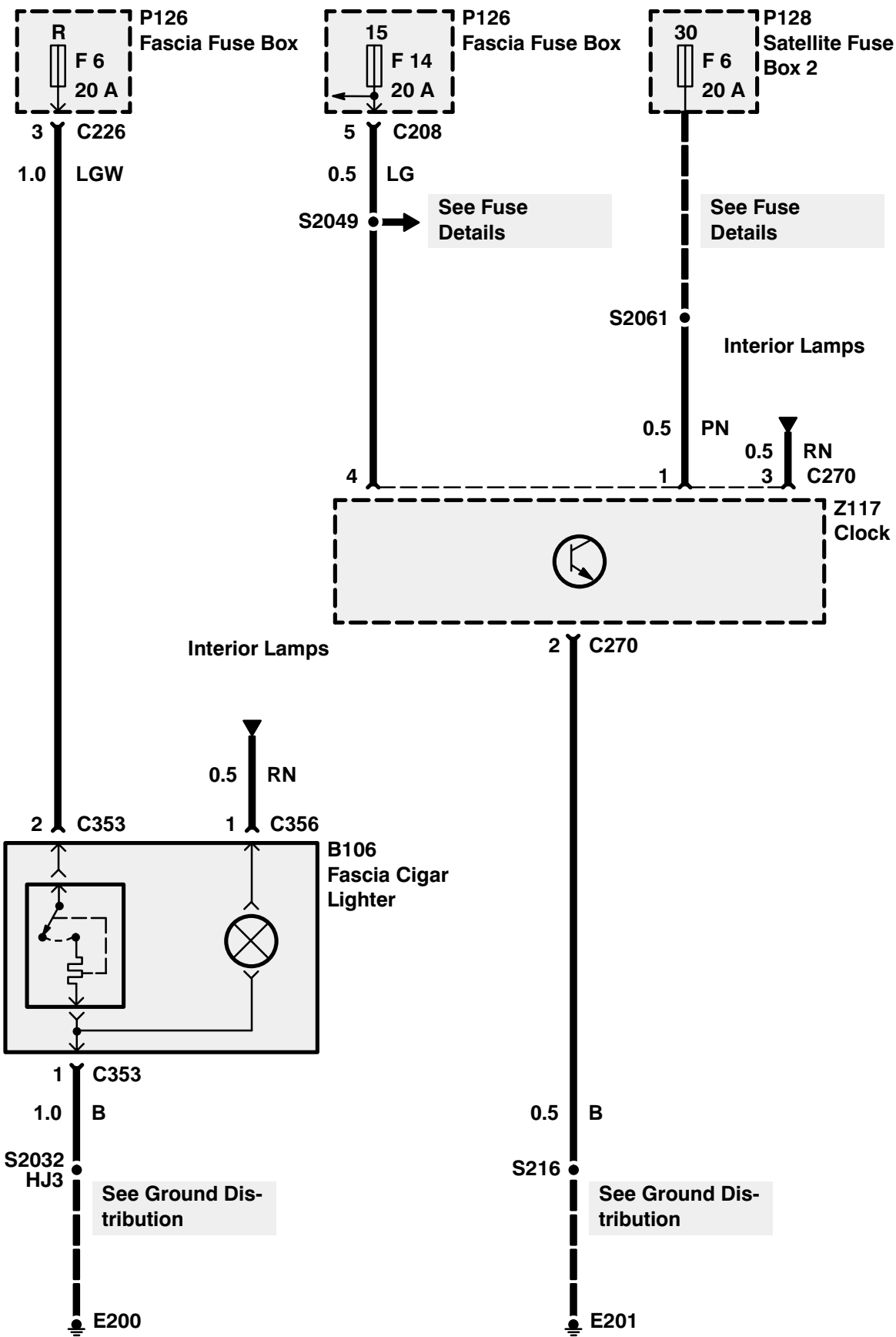

CIRCUIT OPERATION**Front Blower**

With the Ignition Switch (X134) in position II, battery voltage is applied to the Ignition Load Relay (K127). The relay is energized, applying battery voltage to the Front Blower Motor Relay (K192). When the Front Fan Speed Switch (X247) is turned to position I, ground is applied to terminal 85 of the Front Blower Motor Relay (K192). The relay is energized, applying battery voltage to terminal 2 of the Front Blower Motor (M101). Ground is applied to the Front Blower Motor (M101) through all three resistors of the Front Blower Resistor Unit (Z214). The Front Blower Motor (M101) then runs at low speed. When the Front Fan Speed Switch (X247) is turned to position II, the Front Blower Motor Relay (K192) remains energized. Battery voltage is still applied to terminal 2 of the Front Blower Motor (M101). Ground is now applied to the Front Blower Motor (M101) through two resistors of the Front Blower Resistor Unit (Z214) and the Front Fan Speed Switch (X247). The motor then runs at the low-medium speed. When the Front Fan Speed Switch (X247) is turned to position III, the Front Blower Motor Relay (K192) remains energized. Ground is now applied to the Front Blower Motor (M101) through one resistor of the Front Blower Resistor Unit (Z214) and the Front Fan Speed Switch (X247). The motor then runs at the medium-high speed. When the Front Fan Speed Switch (X247) is turned to position IV, the Front Blower Motor Relay (K192) remains energized. Ground is now applied directly to the Front Blower Motor (M101) through the Front Fan Speed Switch (X247). The motor then runs at high speed.

Fresh Air Mode

With the Ignition Switch (X134) in position II, battery voltage is applied to the Ignition Load Relay (K127). The relay is energized, applying battery voltage to the Air Recirculation Solenoid In-Line Fuse (P138) and Air Recirculation Solenoid (K123). When the Air Supply Selector Switch is moved to the Fresh Air position, ground is applied to the Air Recirculation Solenoid (K123). The solenoid now opens the fresh air intake flap allowing fresh air to enter the vehicle cabin. When the fresh air intake flap has been fully opened, the microswitch inside the Air Recirculation Solenoid (K123) moves to the

Fresh Air position interrupting the ground supply. The solenoid now stops and remains in the Fresh Air position.

Recirculated Air Mode

With the Ignition Switch (X134) in position II, battery voltage is applied to the Ignition Load Relay (K127). The relay is energized, applying battery voltage to the Air Recirculation Solenoid In-Line Fuse (P138) and Air Recirculation Solenoid (K123). When the Air Supply Selector Switch is moved to Recirculate Air position, ground is applied to the Air Recirculation Solenoid (K123). The solenoid now closes the fresh air intake flap allowing only the air inside the vehicle cabin to circulate. When the fresh air intake flap has been fully closed, the microswitch inside the Air Recirculation Solenoid (K123) moves to the Recirculate Air position interrupting the ground supply. The solenoid now stops and remains in the Recirculate Air position.

Heated Air

With the Ignition Switch (X134) in position II, battery voltage is applied to the Ignition Load Relay (K127). The relay is energized, applying battery voltage to the Left Maximum Cool Switch (X267). When the Left and Right Temperature Controls are turned to the maximum cool position, the Left Maximum Cool Switch (X267) and Right Maximum Cool Switch (X268) close. Battery voltage is now applied to the Water Valve (K206). The Water Valve (K206) closes and prevents heated engine coolant from entering the heater matrix. When one or both of the Temperature Controls are not in the maximum cool position, battery voltage is not applied to the Water Valve (K206). The valve then opens and allows heated engine coolant to enter the heater matrix.

Rear Blower

With the Ignition Switch (X134) in position II, battery voltage is applied to the Ignition Load Relay (K127). The relay is energized, applying battery voltage to the Rear Blower Motor Relay (K193), the Rear A/C Fan Speed Relay (K205) and the Rear A/C Control Relay (K194).

When the Rear A/C System is turned on, the Rear A/C Switch Amplifier provides ground to the Rear A/C Control Relay (K194). The relay is energized, applying ground to the Rear A/C Fan Speed Relay (K205). The Rear A/C Fan Speed Relay (K205) then energizes. When the Passenger's Rear Fan Speed Switch (X246) is turned to position I, ground is applied to terminal 85 of the Rear Blower Motor Relay (K193) through the closed switch contacts of the Rear A/C Fan Speed Relay (K205). The Rear Blower Motor Relay (K193) energizes, applying battery voltage to terminal 1 of the Rear Blower Motor (M145).

Ground is applied to the Rear Blower Motor (M145) through all three resistors of the Rear Blower Resistor Unit (Z215). The Rear Blower Motor (M145) then runs at low speed. When the Passenger's Rear Fan Speed Switch (X246) is turned to position II, the Rear Blower Motor Relay (K193) remains energized. Battery voltage is still applied to terminal 1 of the Rear Blower Motor (M145). Ground is now applied to the Rear Blower Motor (M145) through two resistors of the Rear Blower Motor Resistor Unit (Z215) and the Passenger's Rear Fan Speed Switch (X246). The

motor then runs at the low–medium speed. When the Passenger's Rear Fan Speed Switch (X246) is turned to position III, the Rear Blower Motor Relay (K193) remains energized. Ground is now applied to the Rear Blower Motor (M145) through one resistor of the Rear Blower Motor Resistor Unit (Z215) and the Passenger's Rear Fan Speed Switch (Z246).

The motor then runs at medium–high speed. When the Passenger's Rear Fan Speed Switch (X246) is turned to position IV, the Rear Blower Motor Relay (K193) remains energized. Ground is now applied directly to the Rear Blower Motor (M145) through the Passenger's Rear Fan Speed Switch (X246). The motor then runs at high speed.

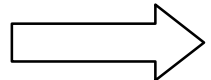
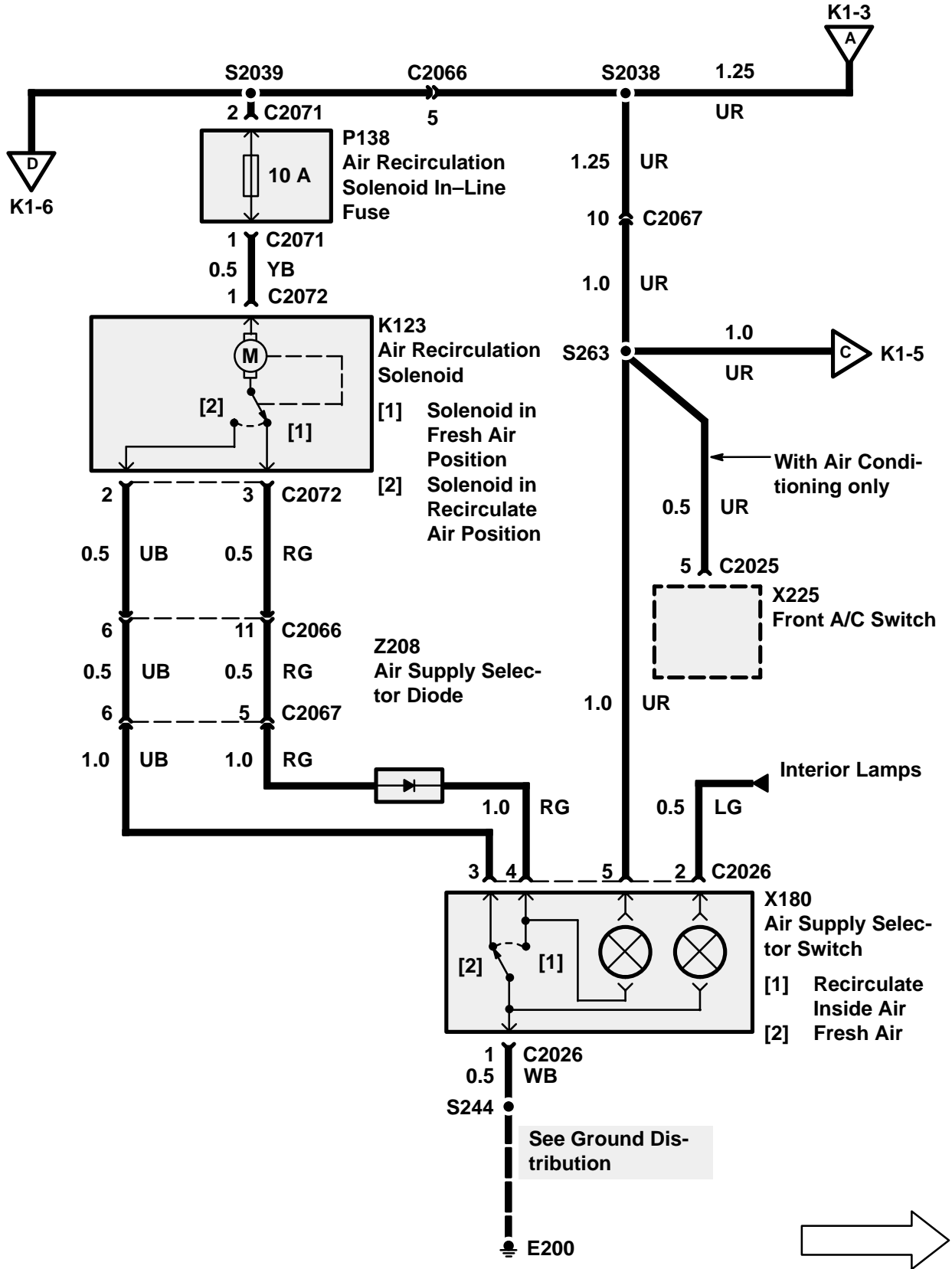
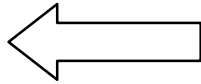

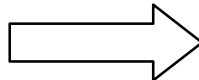
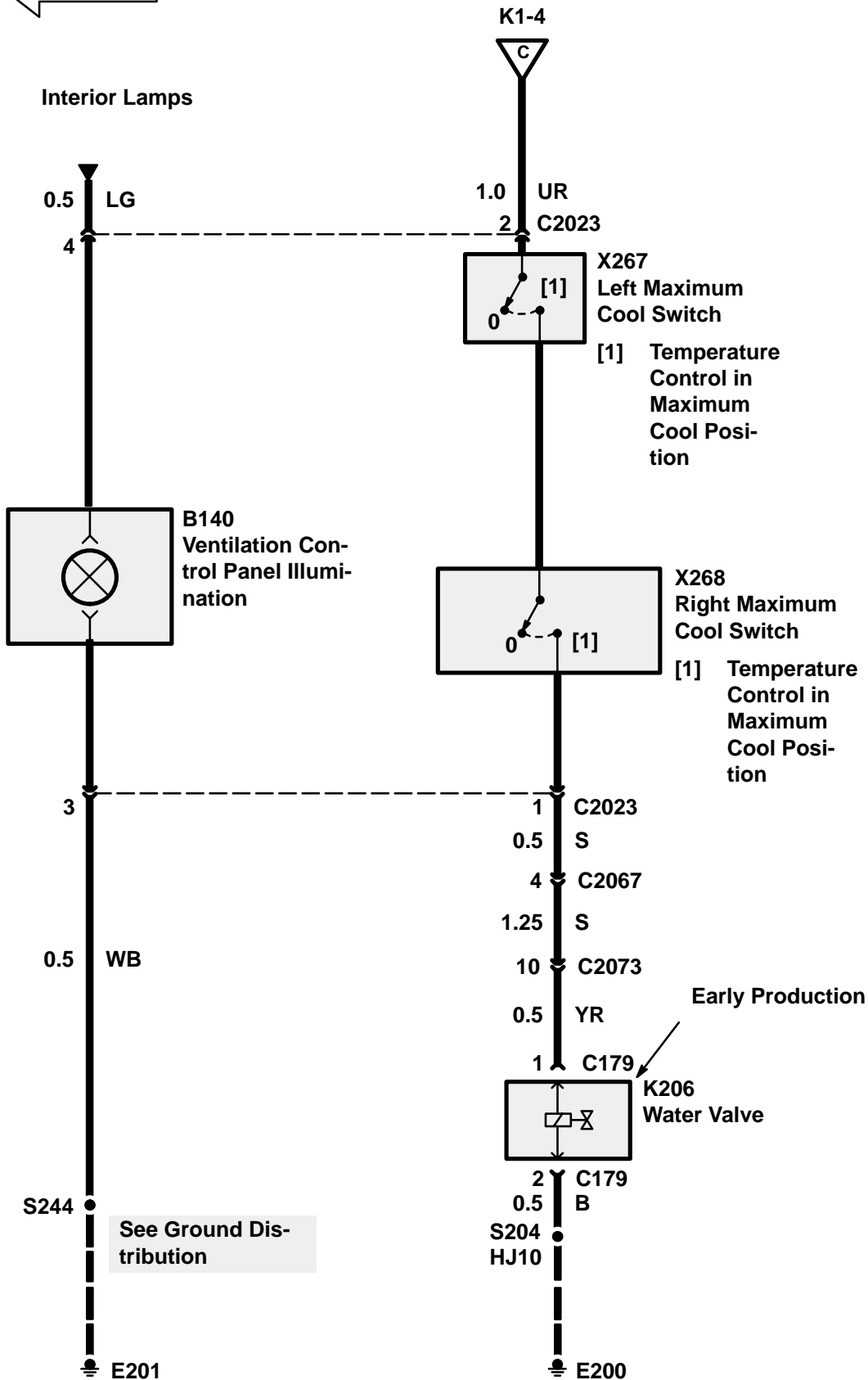
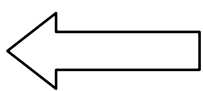

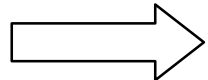
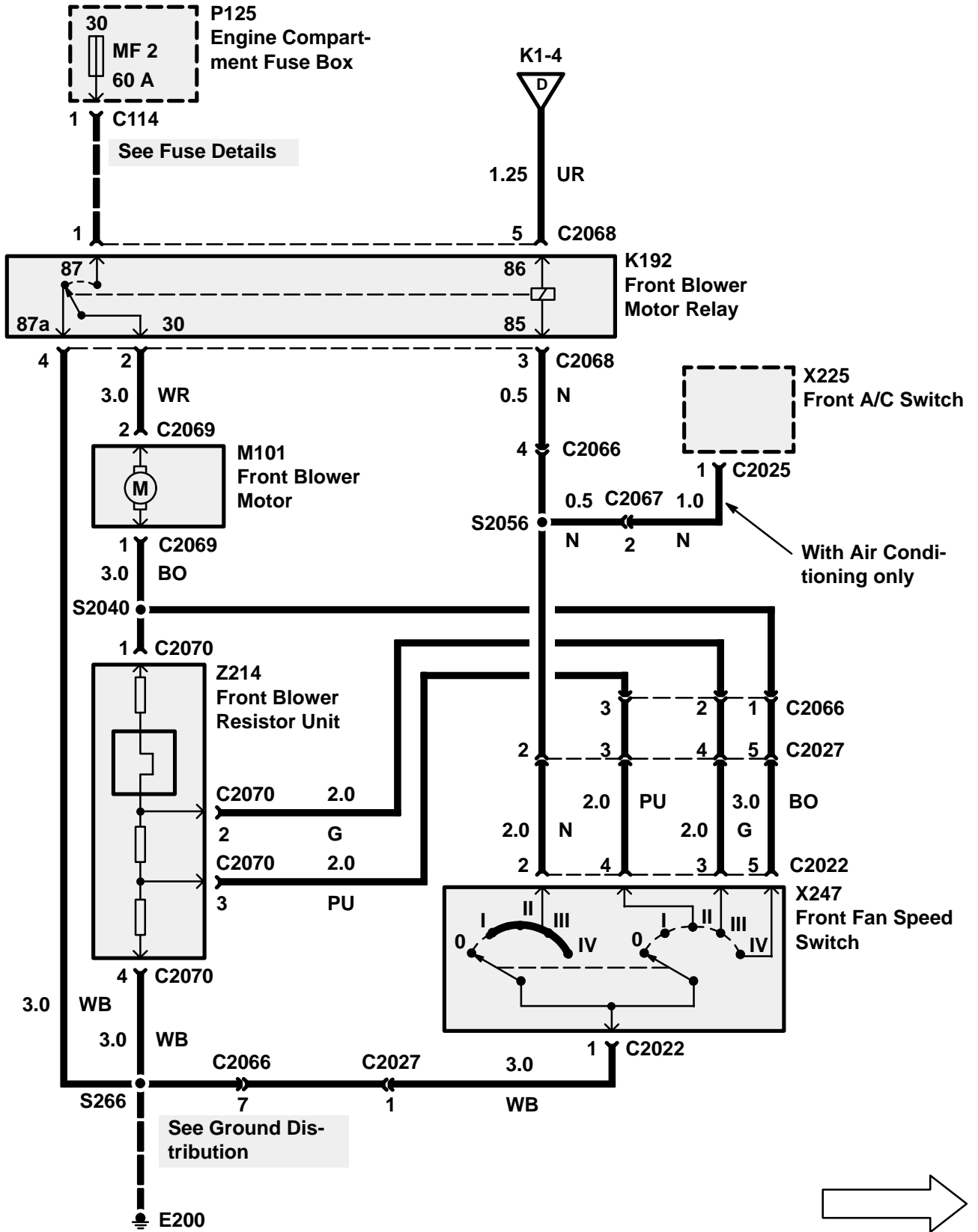
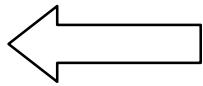

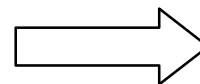
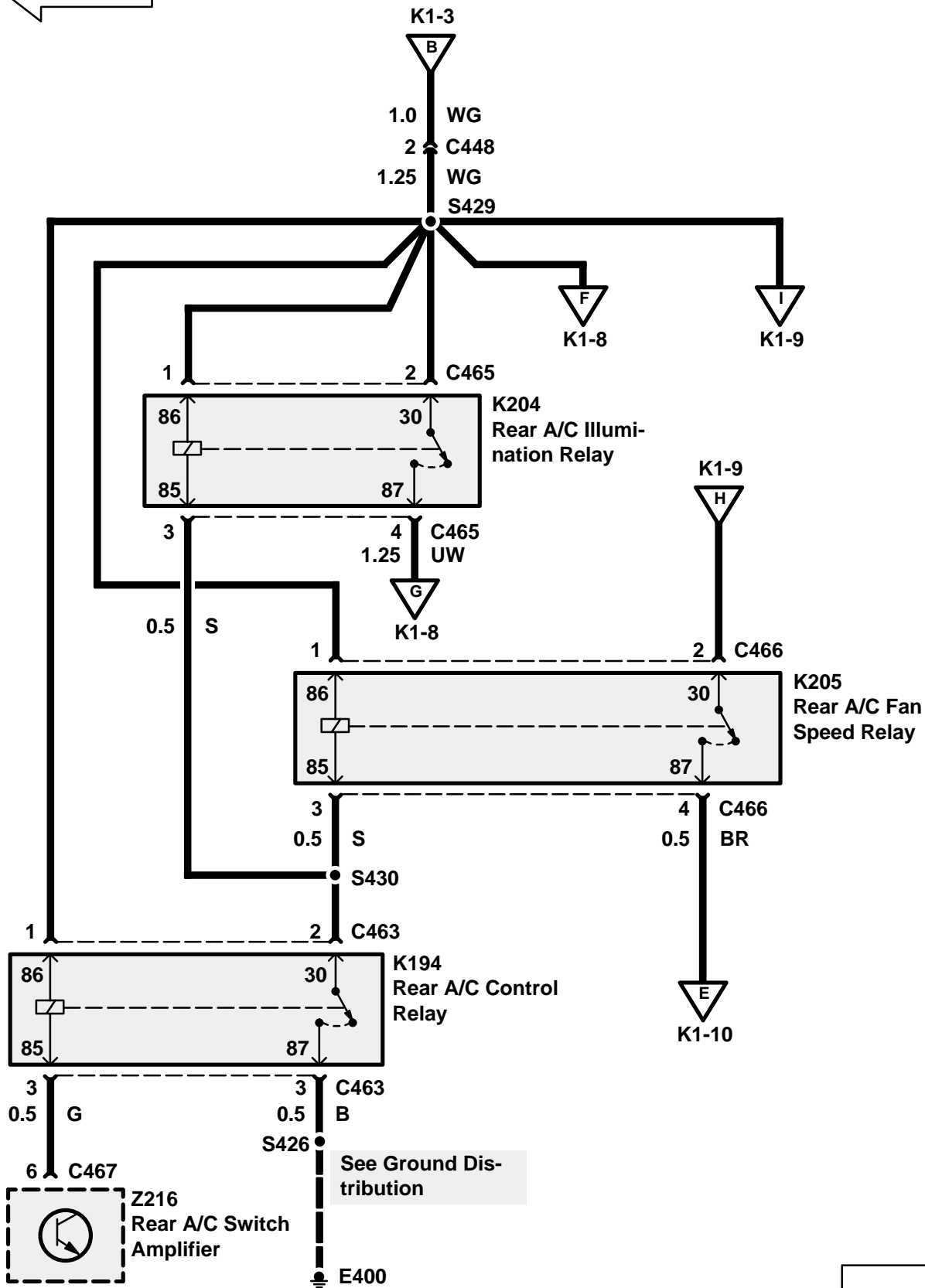
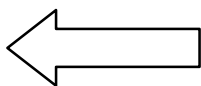

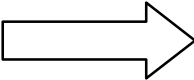
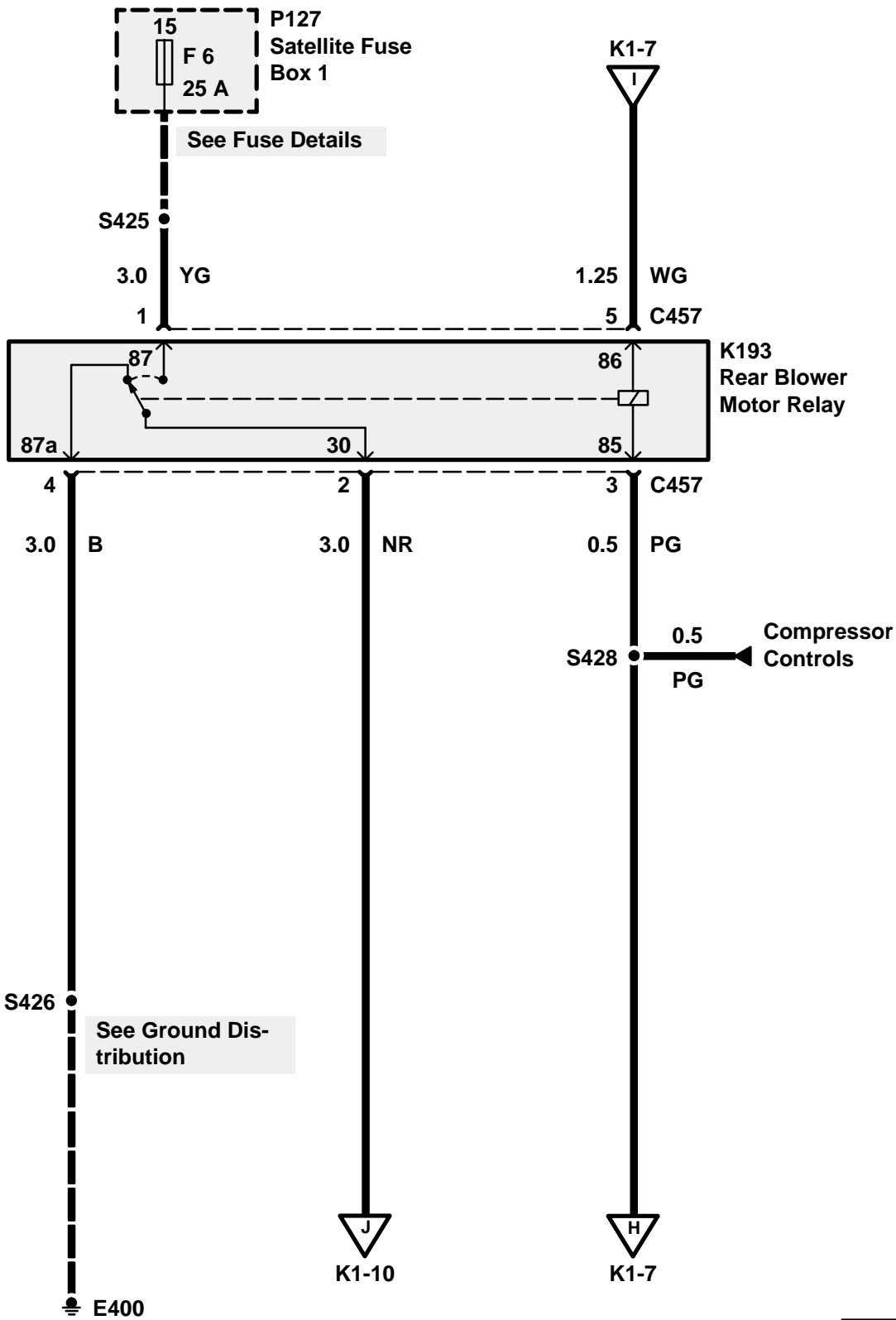
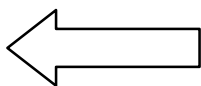

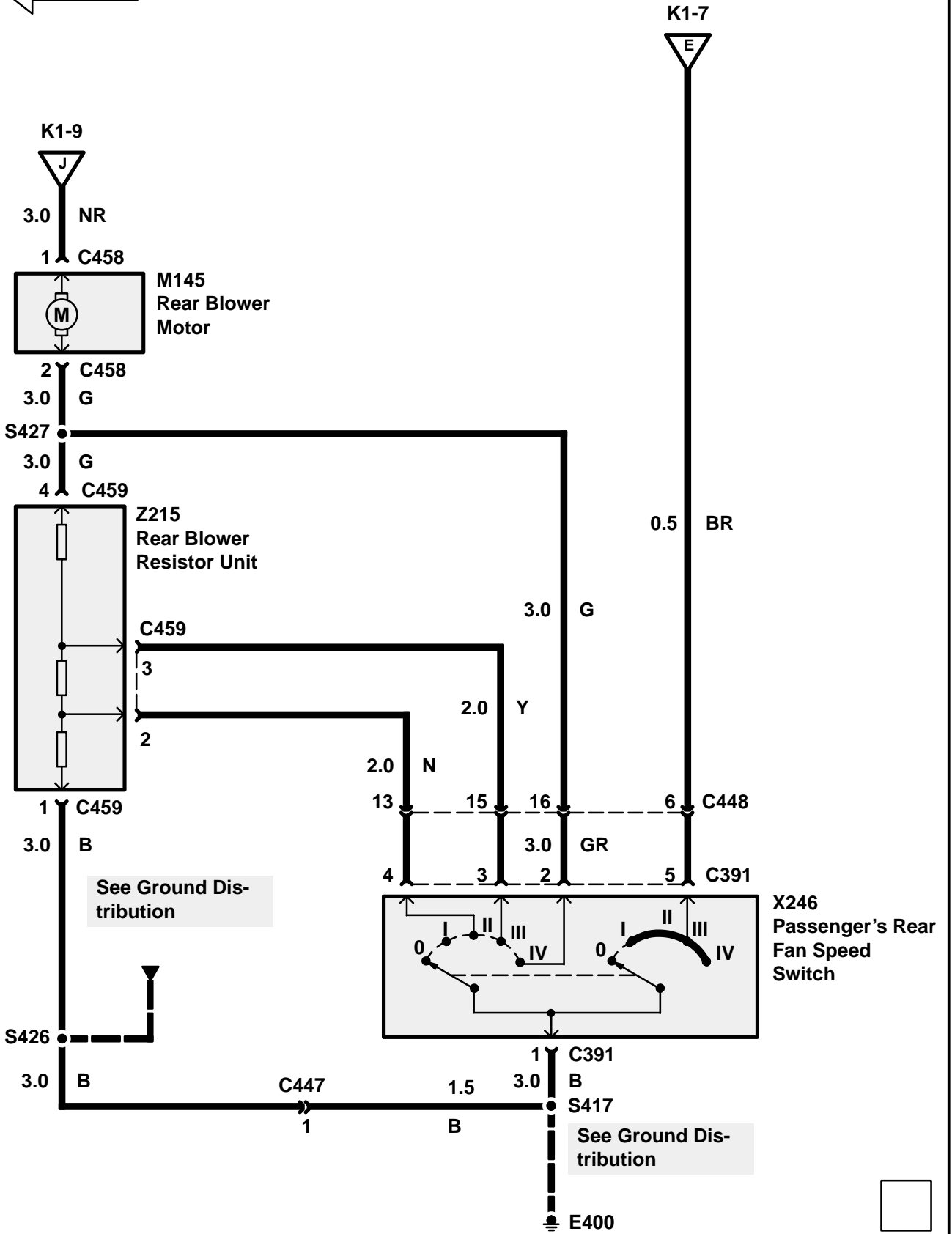
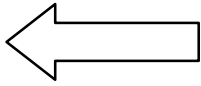

TROUBLESHOOTING HINTS

4. Check Maxi-Fuse[®] MF2 of the Engine Compartment Fuse Box (P125).
 5. Check Fuse F15 of the Fascia Fuse Box (P126).
 6. Check Fuse F6 of the Satellite Fuse Box 1 (P127).
 7. If the Front Blower Motor (M101) does not stop running with the Front Fan Speed Switch (X247) in Position 0, replace the Front Fan Speed Switch (X247).
 8. If the Rear Blower Motor (M145) does not stop running with the Passenger's Rear Fan Speed Switch (X246) in Position O, replace the Passenger's Rear Fan Speed Switch (X246).
 9. If fresh air does not enter the vehicle cabin with the Air Supply Selector Switch (X180) in the Outside Air position, check the Air Recirculation Solenoid (K123) and linkage for sticking or binding.
 10. If the blower motor(s) operate with the ignition key removed, replace the Ignition Load Relay (K127).
 11. If the blower motor(s) run but not at the speed indicated by the Fan Speed Switches, replace the appropriate Fan Speed Switch.
7. With the engine running and the Fan Speed Switch (X179) in position III, put the Air Supply Selector Switch (X180) to Recirculation mode. Place a piece of paper in front of the fresh air intake vents on the vehicle hood. If the paper is drawn toward the vents, do Test D.
 8. With the engine running and the Fan Speed Switch (X179) in position III, put the Air Supply Selector Switch (X180) to Fresh Air Mode. Place a piece of paper in front of the recirculation air intake vents. If the paper is drawn toward the intake, do Test D.

SYSTEM DIAGNOSIS

1. If the Blower Motor(s) do not run at any speed, do Test A.
2. If the Front Blower Motor (M101) does not run at any speed, but the Rear Blower Motor (M145) operates correctly, do Test B.
3. If the Rear Blower Motor (M145) does not run at any speed, but the Front Blower Motor (M101) operates correctly, do Test E.
4. If the Front Blower Motor (M101) runs in some but not all Fan Speed Switch (X247) positions, do Test C.
5. If the Rear Blower Motor (M145) runs in some but not all Rear Fan Speed Switch (X246) positions, do Test F.
6. If the Air Supply Selector Switch (X180) does not allow the driver to change between recirculation and fresh air modes, do Test D.

Test A

1A

R050001

CONDITIONS

- Ignition Switch
Position: II

RESULTS
BAT VOLT

**K127
Ignition Load
Relay**



PROBLEM CAUSE

- F15 Fuse
- LGP Wire
- B Wire

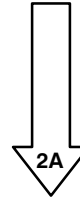

2A

R050001

CONDITIONS

- Ignition Switch
Position: 0

RESULTS
BAT VOLT

**K127
Ignition Load
Relay**



PROBLEM CAUSE

- F6 Fuse
- NG Wire

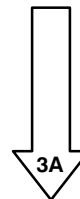

2A

3A

CONDITIONS

- Ignition Switch
Position: II
- Front Fan Speed Switch
Position: III

RESULTS

- Front Blower Motor
Operates

**K127
Ignition Load
Relay**

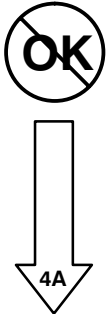

OK **PROBLEM CAUSE**
- Ignition Load Relay

4A

CONDITIONS

- Ignition Switch
Position: 0

RESULTS
BAT VOLT

**K192
Front Blower
Motor Relay**

OK **PROBLEM CAUSE**
- MF2 Maxi-Fuse
- NK Wire
- R Wire

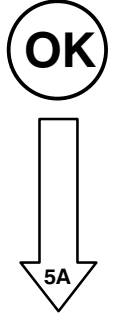

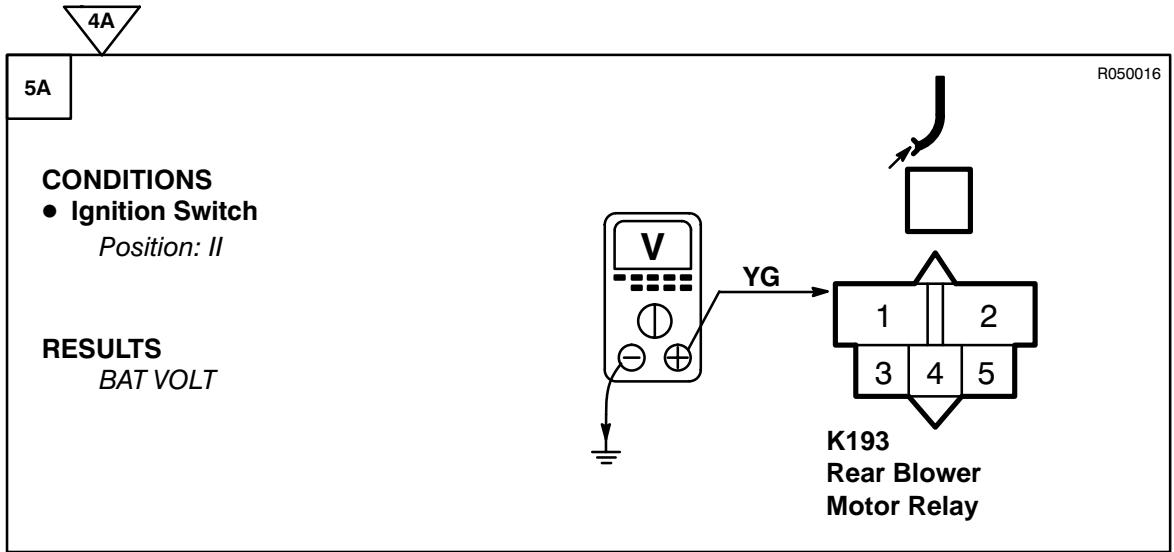

PROBLEM CAUSE

- YG Wire
- NG Wire



PROBLEM CAUSE

- WG Wire
- UR Wire

Test B

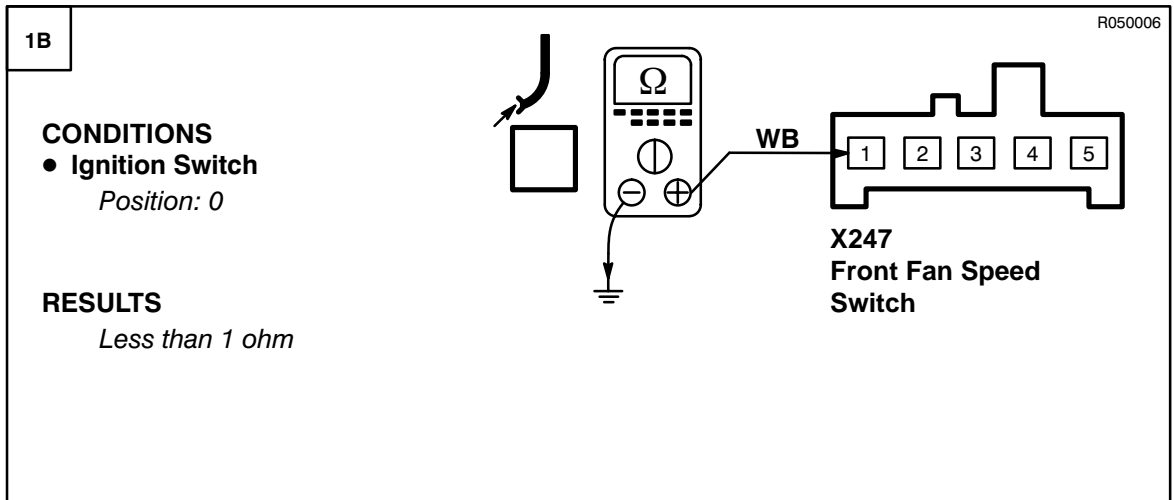

PROBLEM CAUSE

- WB Wire
- B Wire

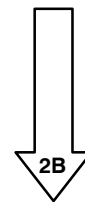

1B

2B

R050016

CONDITIONS

- Ignition Switch
Position: 0
- Front Fan Speed Switch
Position: I
Position: II
Position: III
Position: IV

RESULTS
Less than 1 ohm

K192
Front Blower
Motor Relay

WB

~~OK~~ PROBLEM CAUSE

- N Wire
- WB Wire
- Front Fan Speed Switch

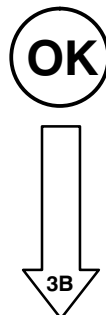

3B

R020049

CONDITIONS

- Ignition Switch
Position: II
- Front Fan Speed Switch
Position: I

RESULTS
BAT VOLT

M101
Front Blower
Motor

WR

~~OK~~ PROBLEM CAUSE

- WR Wire
- Front Blower Motor Relay

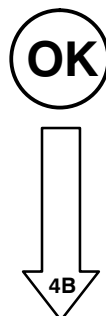

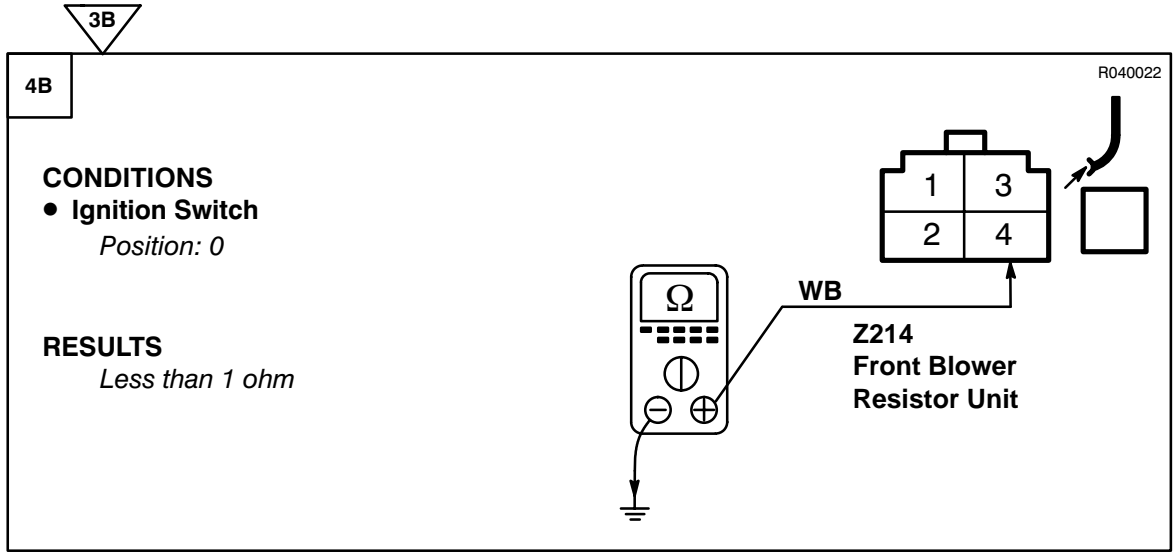

PROBLEM CAUSE
- WB Wire

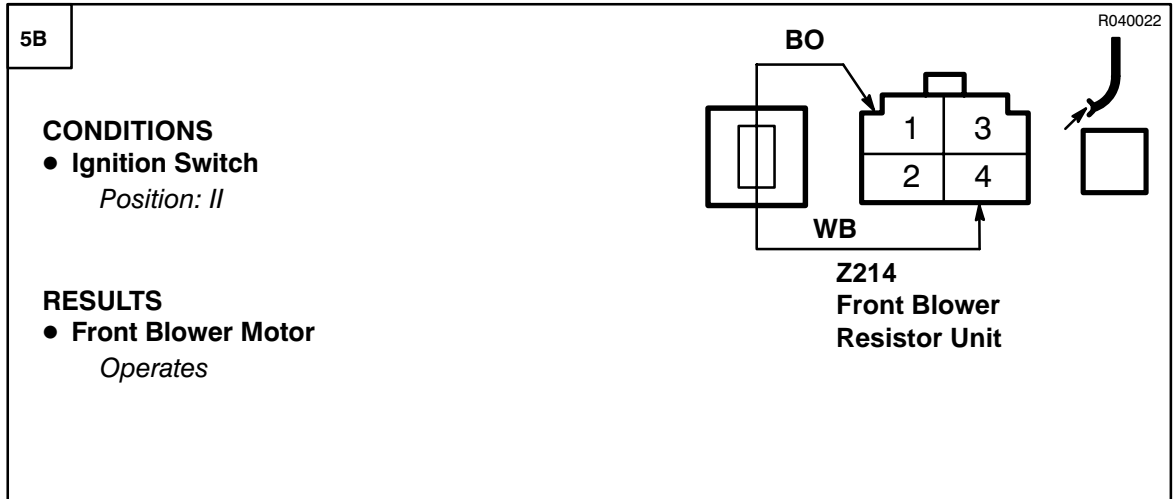
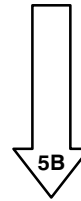

PROBLEM CAUSE
- BO Wire
- Front Blower
Motor



PROBLEM CAUSE
- Front Blower
Resistor Unit

Test C

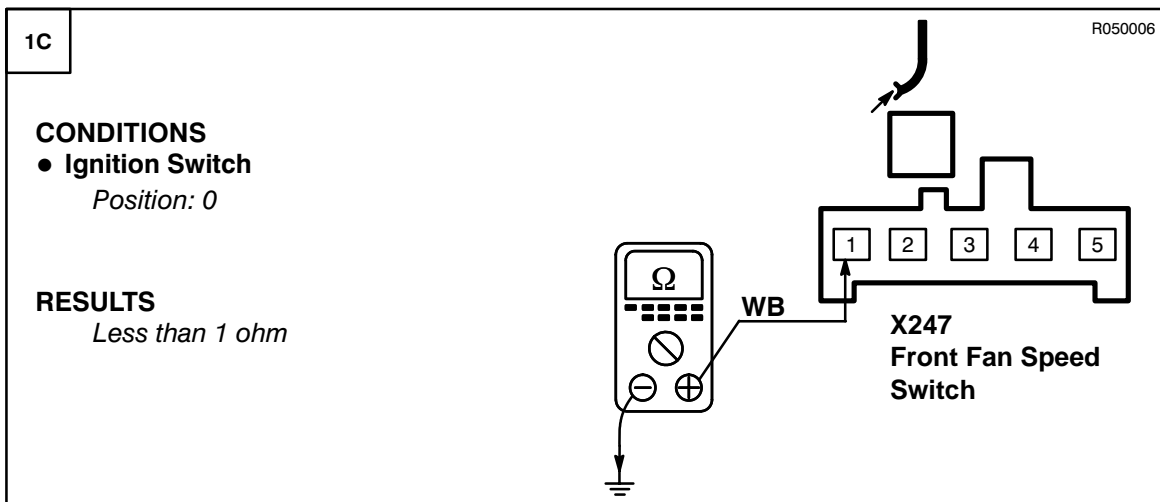

~~OK~~ PROBLEM CAUSE

- WB Wire
- B Wire

OK

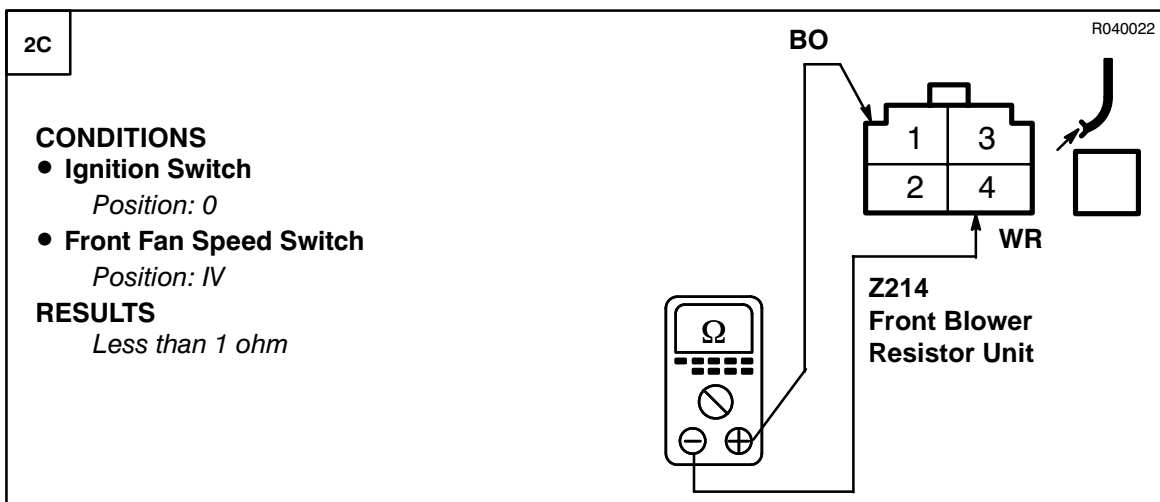
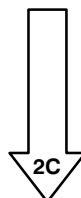

~~OK~~ PROBLEM CAUSE

- BO Wire
- WB Wire
- Front Fan Speed Switch

OK

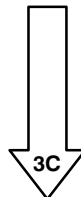

3C
2C
R040022

CONDITIONS

- Ignition Switch
Position: 0
- Front Fan Speed Switch
Position: III

RESULTS

Less than 1 ohm

**Z214
Front Blower
Resistor Unit**



PROBLEM CAUSE

- G Wire
- Front Fan Speed Switch

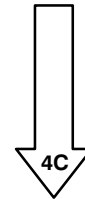

4C
R040022

CONDITIONS

- Ignition Switch
Position: 0
- Front Fan Speed Switch
Position: II

RESULTS

Less than 1 ohm

**Z214
Front Blower
Resistor Unit**



PROBLEM CAUSE

- PU Wire
- Front Fan Speed Switch



PROBLEM CAUSE

- Front Blower Resistor Unit

Test D

1D

R040005

CONDITIONS

- Ignition Switch
Position: II

RESULTS
BAT VOLT

OK PROBLEM CAUSE

- UR Wire
- YB Wire
- Air Recirculation Solenoid In-Line Fuse

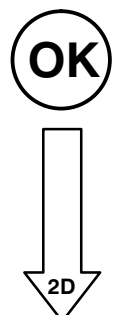

2D

R050002

CONDITIONS

- Ignition Switch
Position: 0

RESULTS
Less than 1 ohm

OK PROBLEM CAUSE

- WB Wire
- B Wire

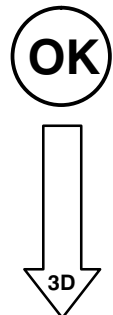

2D
3D
R040005

CONDITIONS

- Ignition Switch
Position: 0
- Air Supply Selector Switch
Fresh Air Mode

RESULTS
Less than 1 ohm

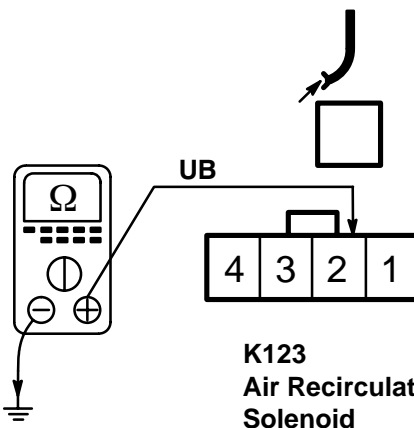

K123
Air Recirculation Solenoid



PROBLEM CAUSE

- UB Wire
- Air Supply Selector Switch

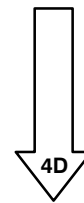

4D
R040005

CONDITIONS

- Ignition Switch
Position: 0
- Air Supply Selector Switch
Recirculation Mode

RESULTS
Less than 1 ohm

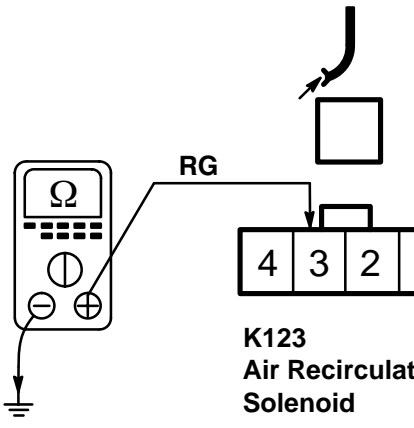

K123
Air Recirculation Solenoid



PROBLEM CAUSE

- RG Wire
- Air Supply Selector Switch
- Air Supply Selector Diode



PROBLEM CAUSE

- Air Recirculation Solenoid

Test E

1E

R050006

CONDITIONS

- Ignition Switch
Position: 0

RESULTS
Less than 1 ohm

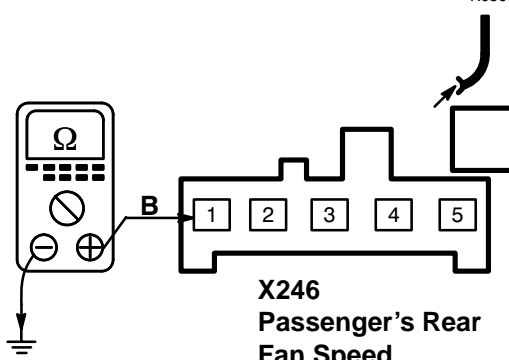

X246
Passenger's Rear
Fan Speed
Switch

~~OK~~ **PROBLEM CAUSE**
- B Wire

OK

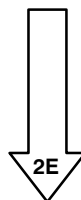

2E

R040022

CONDITIONS

- Ignition Switch
Position: 0
- Passenger's Rear Fan Speed Switch
Position: I
Position: II
Position: III
Position: IV

RESULTS
Less than 1 ohm

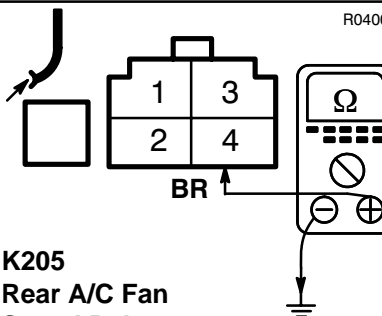

K205
Rear A/C Fan
Speed Relay

~~OK~~ **PROBLEM CAUSE**
- BR Wire
- Passenger's Rear
Fan Speed
Switch

OK

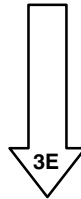

K1 ETM

DISCOVERY

R050016

2E
3E

CONDITIONS

- Ignition Switch
Position: II

RESULTS
BAT VOLT

K193
Rear Blower Motor Relay



PROBLEM CAUSE

- YG Wire
- WB Wire
- B Wire

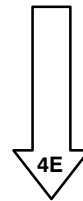

R040022

4E

CONDITIONS

- Ignition Switch
Position: II

RESULTS
BAT VOLT

K205
Rear A/C Fan Speed Relay



PROBLEM CAUSE

- WG Wire

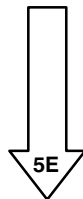

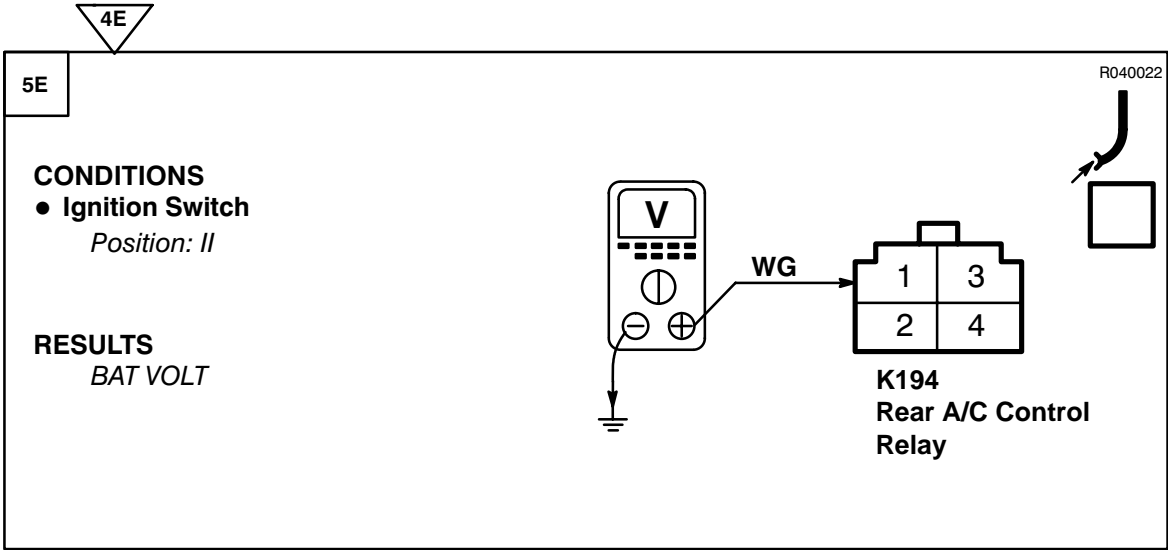

~~OK~~ PROBLEM CAUSE
- WG Wire

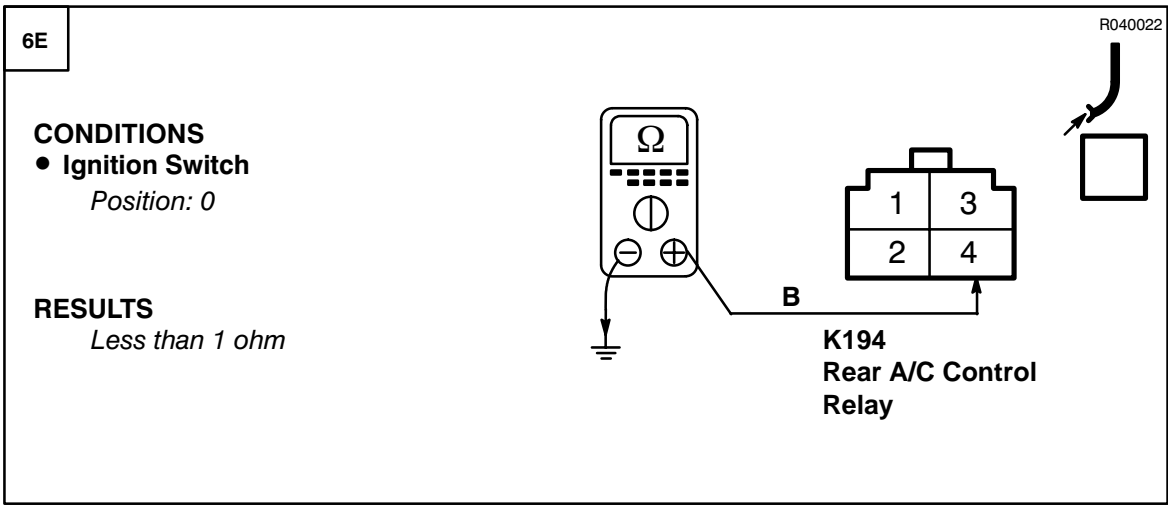
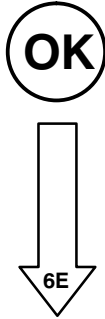

~~OK~~ PROBLEM CAUSE
- B Wire

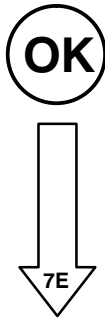

6E
7E

CONDITIONS

- Ignition Switch
Position: II
- Passenger's Rear Fan Speed Switch
Position: I

RESULTS

- Rear Blower Motor
Operates

K194
Rear A/C Control B
Relay

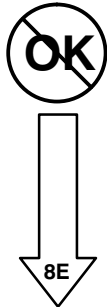

- OK

PROBLEM CAUSE

 - G Wire
 - Rear A/C Control Relay
 - Rear A/C Switch Amplifier

8E
8E

CONDITIONS

- Ignition Switch
Position: II
- Passenger's Rear Fan Speed Switch
Position: I
- Rear A/C
On

RESULTS

- Rear Blower Motor
Operates

K205
Rear A/C Fan
Speed Relay

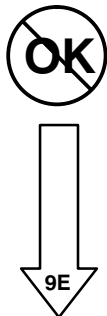

- OK

PROBLEM CAUSE

 - S Wire
 - Rear A/C Fan Speed Relay

8E

9E

CONDITIONS

- Ignition Switch
Position: II
- Passenger's Rear Fan Speed Switch
Position: I
- Rear A/C
On

RESULTS
Less than 1 ohm

~~OK~~ PROBLEM CAUSE
- PG Wire

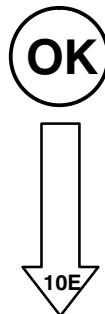

10E

10E

CONDITIONS

- Ignition Switch
Position: II
- Passenger's Rear Fan Speed Switch
Position: I
- Rear A/C
On

RESULTS

- Rear Blower Motor
Operates

~~OK~~ PROBLEM CAUSE
- NR Wire
- Rear Blower Motor

~~OK~~ PROBLEM CAUSE
- Rear Blower Motor Relay

Test F

1F

R050006

CONDITIONS

- Ignition Switch
Position: 0

RESULTS
Less than 1 ohm

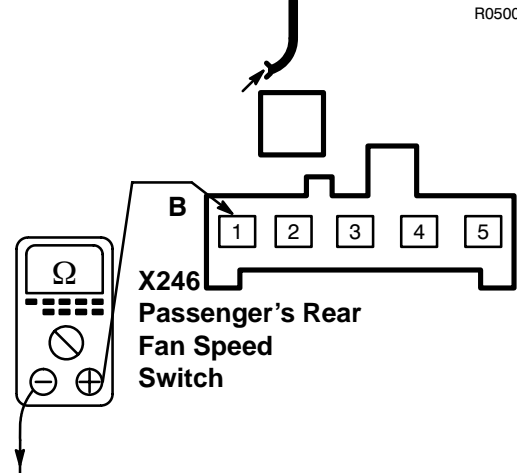

X246
Passenger's Rear Fan Speed Switch



PROBLEM CAUSE
- B Wire

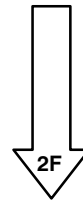

2F

R040022

CONDITIONS

- Ignition Switch
Position: 0
- Passenger's Rear Fan Speed Switch
Position: IV

RESULTS
Less than 1 ohm

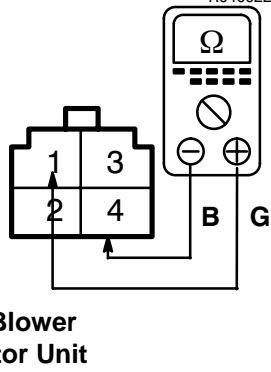

Z215
Rear Blower Resistor Unit



PROBLEM CAUSE
- B Wire
- G Wire
- Passenger's Rear Fan Speed Switch

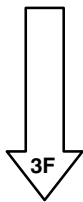

2F

3F

CONDITIONS

- Ignition Switch
Position: 0
- Passenger's Rear Fan Speed Switch
Position: III

RESULTS
Less than 1 ohm

Z215
Rear Blower
Resistor Unit

R040022



PROBLEM CAUSE

- Y Wire
- Passenger's Rear Fan Speed Switch

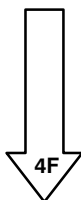

4F

CONDITIONS

- Ignition Switch
Position: 0
- Passenger's Rear Fan Speed Switch
Position: II

RESULTS
Less than 1 ohm

Z215
Rear Blower
Resistor Unit

R040022



PROBLEM CAUSE

- N Wire
- Passenger's Rear Fan Speed Switch



PROBLEM CAUSE

- Rear Blower Resistor Unit

CIRCUIT OPERATION**Compressor Control (MFI–V8) (300Tdi with EDC)**

With the Ignition Switch (X134) in position II, battery voltage is applied to the Ignition Load Relay (K127). The relay is energized, applying battery voltage to the Compressor Clutch Relay (K108) and the A/C Logic Relay (K170). When the Front Fan Speed Switch (X247) is turned to positions I, II, III, or IV and the Front A/C Switch (X225) is turned On, ground is provided to terminal 86 of the A/C Logic Relay (K170) through the closed contacts of the A/C Dual Pressure Switch (X102) and the Front A/C Evaporator Temperature Switch (X101).

The relay is energized, applying battery voltage to the Engine Control Module (ECM) (Z132), signalling the ECM that compressor operation has been requested. The ECM then provides ground to the coil of the Compressor Clutch Relay (K108). The relay is energized, applying battery voltage to the Compressor Clutch (K107). Compressor Clutch operation is now controlled by the status of the A/C Dual Pressure Switch (X102) and the Front A/C Evaporator Temperature Switch (X101).

The Front A/C Evaporator Temperature Switch (X101) is fitted in the airflow out of the front evaporator to sense the temperature of the exterior fins. Should ice begin to form, due to low temperature, the switch will open. The A/C Dual Pressure Switch (X102) monitors refrigerant pressure in the high pressure line, should pressure become too high or too low the switch will open. When one or both of these switches open the ground supply to terminal 86 of the A/C Logic Relay (K170) will be interrupted. The relay de-energizes, removing battery voltage from the Engine Control Module (ECM) (Z132), signalling the ECM that compressor operation should be turned off. The ECM removes the ground supply to the coil of the Compressor Clutch Relay (K108). The relay then de-energizes, removing battery voltage from the Compressor Clutch (K107), disengaging the Compressor.

Compressor Control (MFI–T16)

With the Ignition Switch (X134) in position II, battery voltage is applied to the Compressor Clutch Relay (K108) and the A/C Logic Relay (K170). When the Front Fan Speed Switch (X247) is turned

to positions I, II, III, or IV and the Front A/C Switch (X225) is turned On, ground is provided to terminal 85 of the A/C Logic Relay (K170) through the closed contacts of the A/C Dual Pressure Switch (X102) and the Front A/C Evaporator Temperature Switch (X101).

The relay is energized, applying ground to terminal 35 of the Engine Control Module (ECM) (Z132), signalling the ECM that compressor operation has been requested. The ECM then provides ground to the terminal 85 of the Compressor Clutch Relay (K108). The relay is energized, applying battery voltage to the Compressor Clutch (K107). Compressor Clutch operation is now controlled by the status of the A/C Dual Pressure Switch (X102) and the Front A/C Evaporator Temperature Switch (X101).

The Front A/C Evaporator Temperature Switch (X101) is fitted in the airflow out of the front evaporator to sense the temperature of the exterior fins. Should ice begin to form, due to low temperature, the switch will open. The A/C Dual Pressure Switch (X102) monitors refrigerant pressure in the high pressure line, should pressure become too high or too low the switch will open. When one or both of these switches open, the ground supply to terminal 85 of the A/C Logic Relay (K170) will be interrupted. The relay de-energizes, removing the ground supply from terminal 35 of the Engine Control Module (ECM) (Z132), signalling the ECM that compressor operation should be turned off. The ECM removes the ground supply to terminal 86 of the Compressor Clutch Relay (K108). The relay then de-energizes, removing battery voltage from the Compressor Clutch (K107), disengaging the Compressor.

Compressor Control (300Tdi without EDC)

With the Ignition Switch (X134) in position II, battery voltage is applied to the Ignition Load Relay (K127). The relay is energized, applying battery voltage to the Compressor Clutch Relay (K108). When the Front Fan Speed Switch (X247) is turned to positions I, II, III, or IV and the Front A/C Switch (X225) is turned On, ground is provided to terminal 86 of the Compressor Clutch Relay (K108) through the closed contacts of the A/C Dual Pressure Switch (X102), the Front A/C Evaporator Temperature Switch (X101), and the Compressor Clutch Cut-out Switch (X259).

The relay is energized, applying battery voltage to the Compressor Clutch (K107). Compressor Clutch operation is now controlled by the status of the A/C Dual Pressure Switch (X102), the Front A/C Evaporator Temperature Switch (X101), and the Compressor Clutch Cut-out Switch (X259).

The Front A/C Evaporator Temperature Switch (X101) is fitted in the airflow out of the front evaporator to sense the temperature of the exterior fins. Should ice begin to form, due to low temperature, the switch will open. The A/C Dual Pressure Switch (X102) monitors refrigerant pressure in the high pressure line, should pressure become too high or too low the switch will open. When one or more of these switches open, the ground supply to terminal 86 of the Compressor Clutch Relay (K108) will be interrupted. The relay de-energizes, removing battery voltage from the Compressor Clutch (K107), disengaging the Compressor.

Rear A/C Refrigerant Control Valve

When front A/C has been selected and the Compressor Clutch (K107) is engaged, the Compressor Clutch Relay (K108) is energized and voltage is applied on the BG wires to the Rear A/C Refrigerant Control Valve (K207). When rear A/C is selected a ground signal is applied to the Rear A/C Switch Amplifier (Z216). The Rear A/C Switch Amplifier (Z216) then applies a ground signal to energise the Rear A/C Control Relay (K194) and the Rear A/C Fan Speed Relay (K205). When the Passenger's Rear Fan Speed Switch (X246) is in any position other than Off, ground is applied to the Rear A/C Refrigerant Control Valve (K207) through the closed contacts of the Passenger's Rear Fan Speed Switch (X246), BR wire, closed contacts of

the Rear A/C Fan Speed Relay (K205), PG wire, UB wire, Rear A/C Refrigerant Control Valve Diode (Z228), P wire, closed contacts of the Rear A/C Evaporator Temperature Switch (X260), and the RG wire.

The Rear A/C Evaporator Temperature Switch (X260) senses the temperature of the exterior fins. Should ice begin to form due to low temperature, the switch will open and the ground supply to the Rear A/C Refrigerant Control Valve (K207) will then be interrupted. The valve de-energises and refrigerant flow is interrupted.

The Rear A/C Refrigerant Control Valve (K207) will also be de-energised if one or more of the following conditions occurs:

1. The Front A/C Switch (X225) has been turned OFF.
2. The Front Fan Speed Switch (X247) has been turned OFF.
3. The Rear A/C switches have been turned OFF.
4. The Passenger's Rear Fan Speed Switch (X246) has been turned OFF.
5. The ECM determines that compressor clutch operation is no longer required.
6. Compressor Clutch (K107) operation has been disabled by the A/C Dual Pressure Switch (X102) or the Front A/C Evaporator Temperature Switch (X101).
7. Compressor Clutch (K107) operation has been disabled by the Compressor Clutch Cut-Out Switch (X259) (300Tdi Without EDC Only).

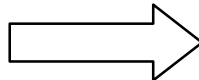
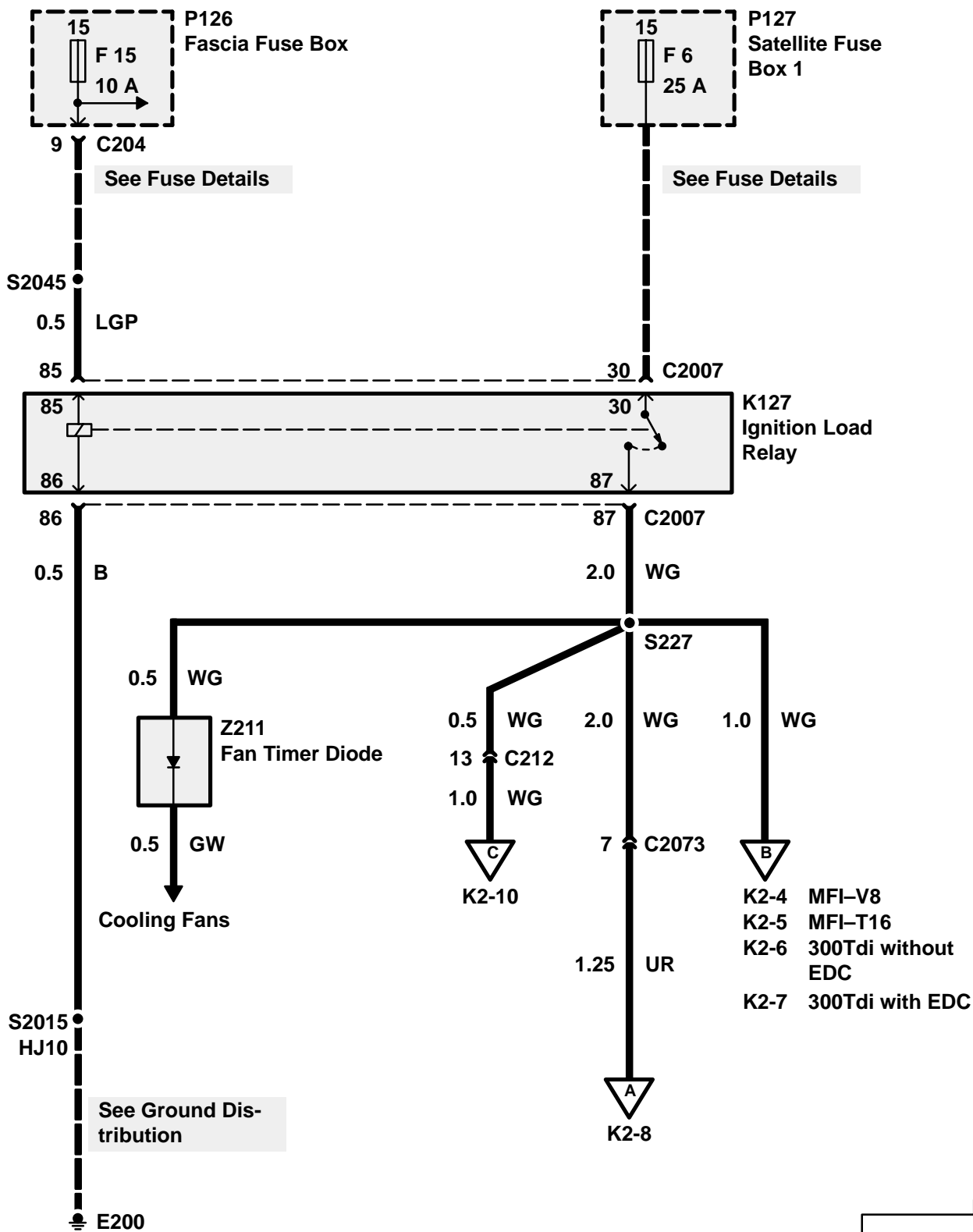

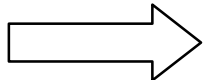
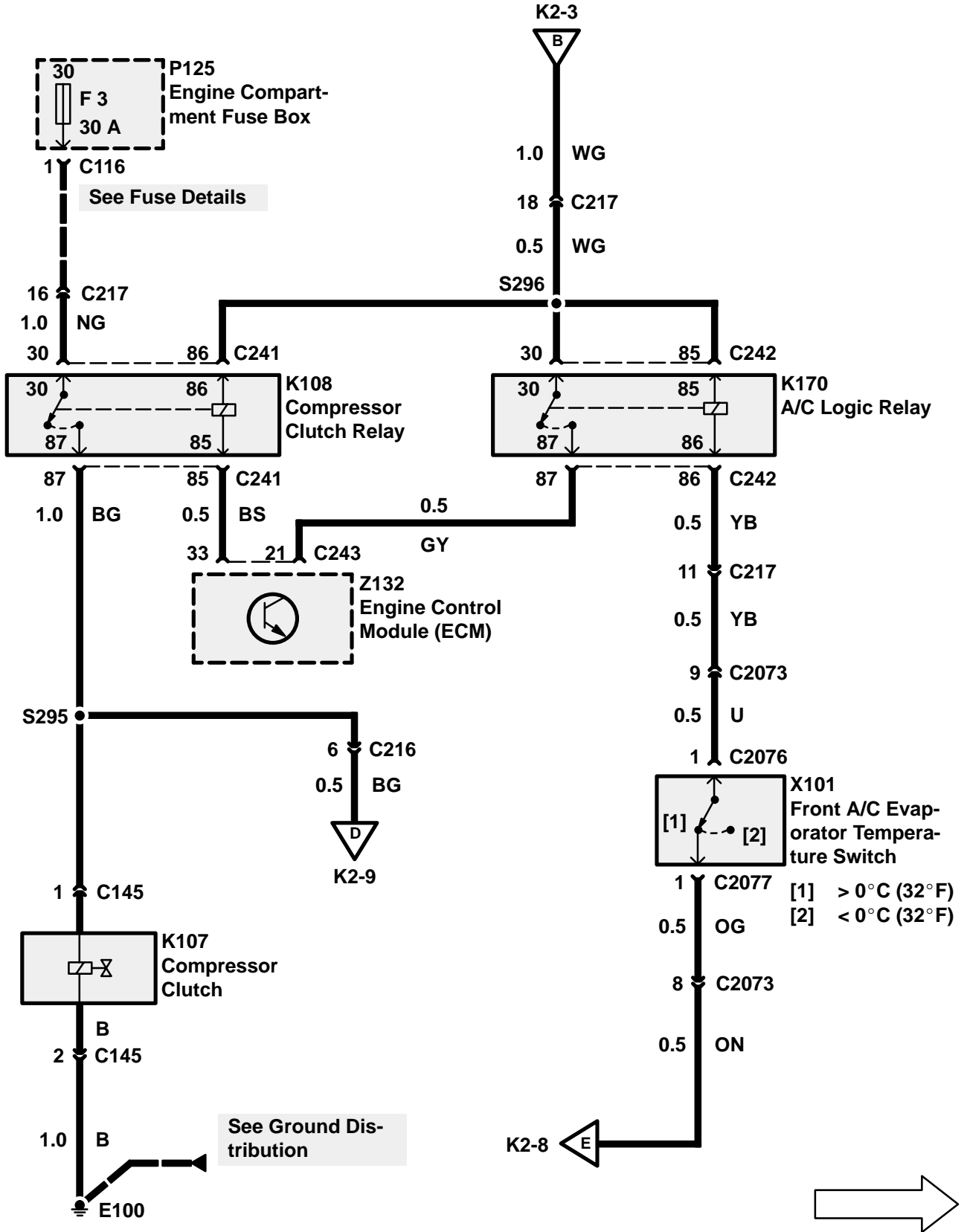
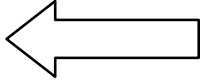

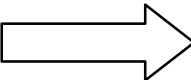
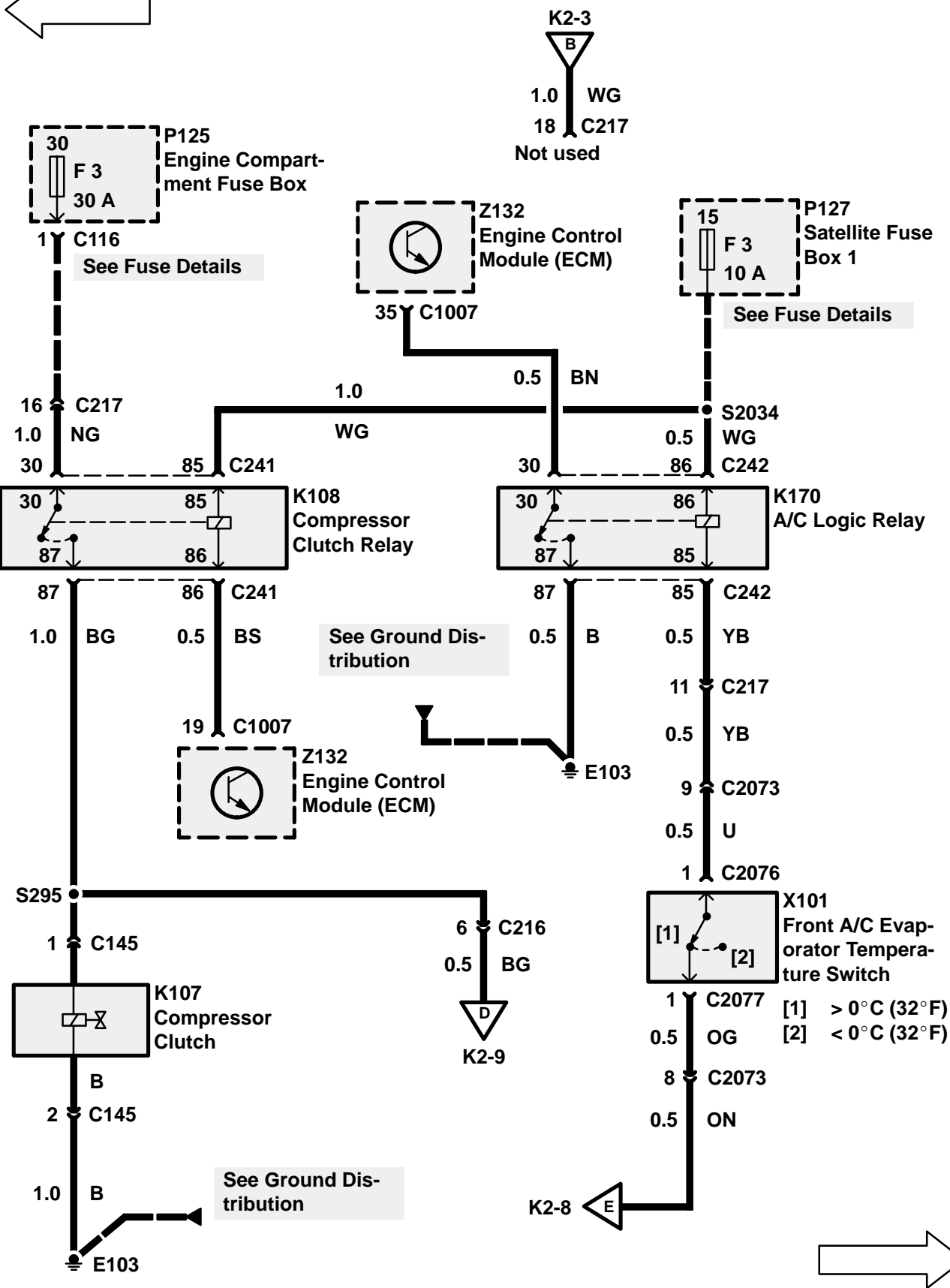
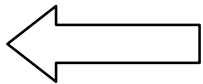

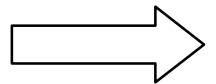
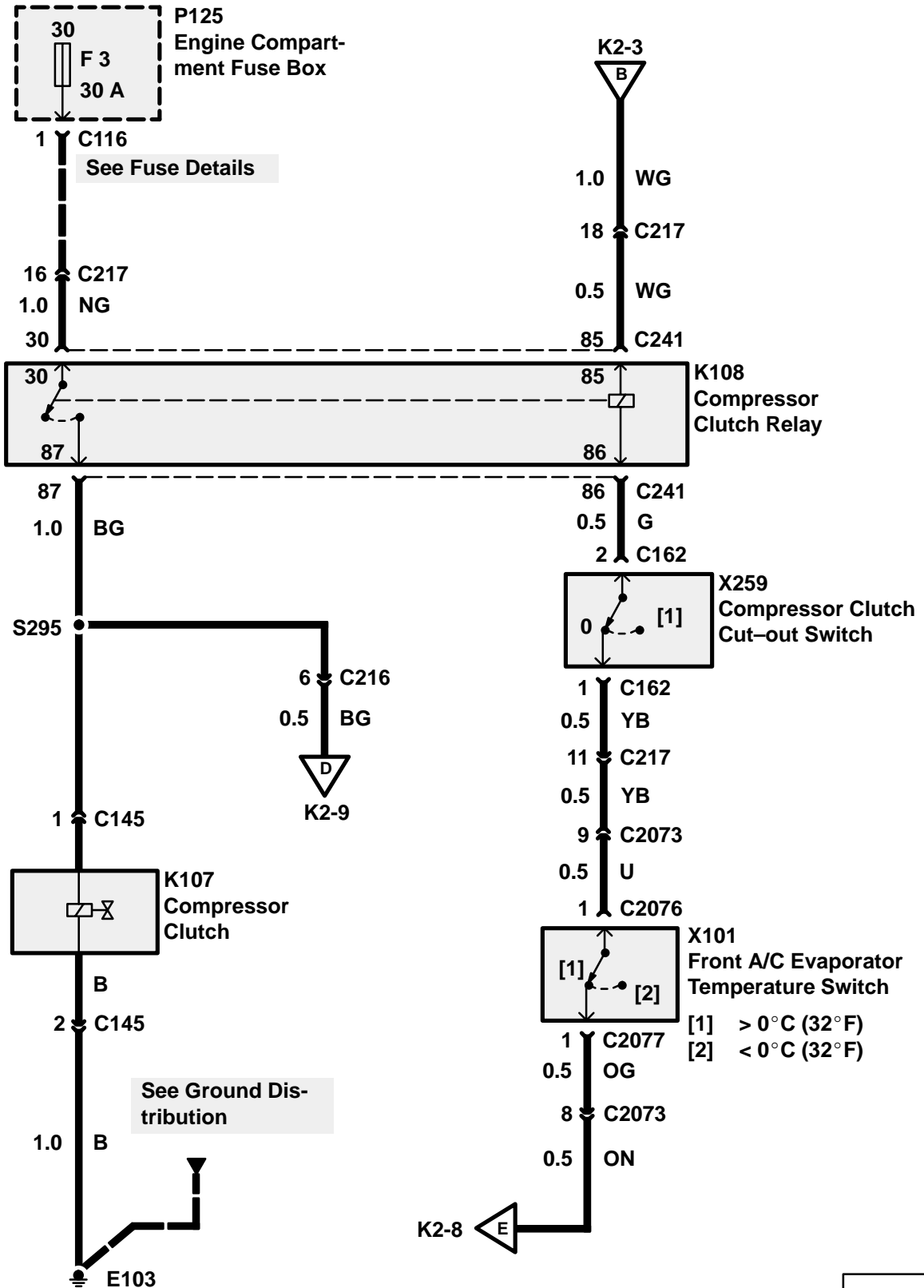
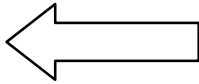

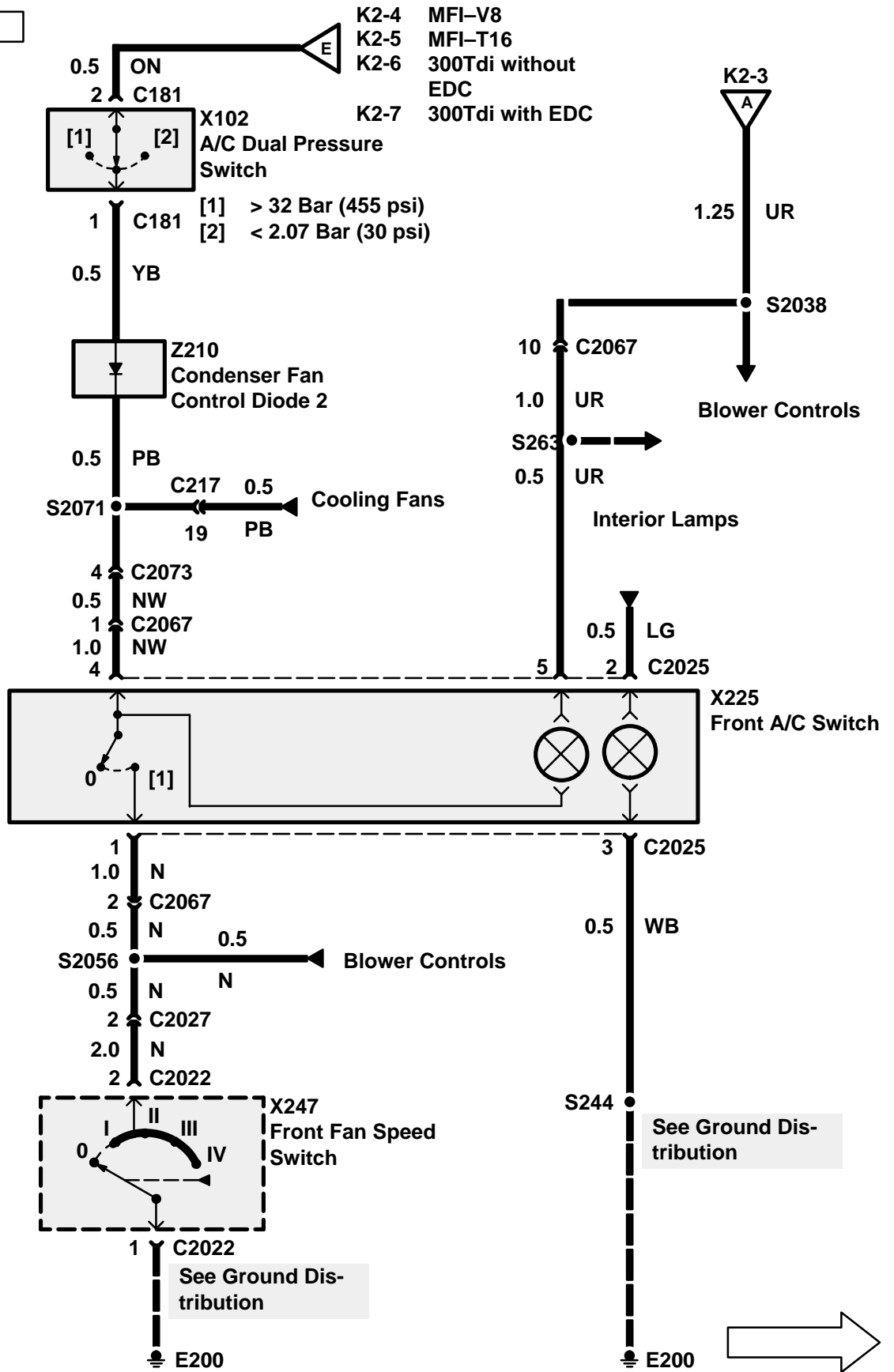

TROUBLESHOOTING HINTS

9. If the Blower Motor(s) do not operate normally, refer to Blower Controls, Section K1.
10. Check Fuse F3 of the Engine Compartment Fuse Box (P125), F3 of the Satellite Fuse Box, and Fuse F15 of the Fascia Fuse Box (P126).
11. Verify that refrigerant pressure is OK before preceeding with the following diagnostic text.

SYSTEM DIAGNOSIS (MFI-V8)

1. If the A/C Compressor Clutch (K107) does not engage in any mode, do Test A.
2. If the Compressor Clutch (K107) remains engaged with the A/C off, do Test F.

SYSTEM DIAGNOSIS (MFI-T16)

1. If the A/C Compressor Clutch (K107) does not engage in any mode, do Test B.
2. If the Compressor Clutch (K107) remains engaged with the A/C off, do Test G.

SYSTEM DIAGNOSIS (300TDI WITHOUT EDC)

1. If the A/C Compressor Clutch (K107) does not engage in any mode, do Test C.
2. If the Compressor Clutch (K107) remains engaged with the A/C off, do Test H.

SYSTEM DIAGNOSIS (300TDI WITH EDC)

1. If the A/C Compressor Clutch (K107) does not engage in any mode, do Test D.
2. If the Compressor Clutch (K107) remains engaged with the A/C off, do Test I.

Test A

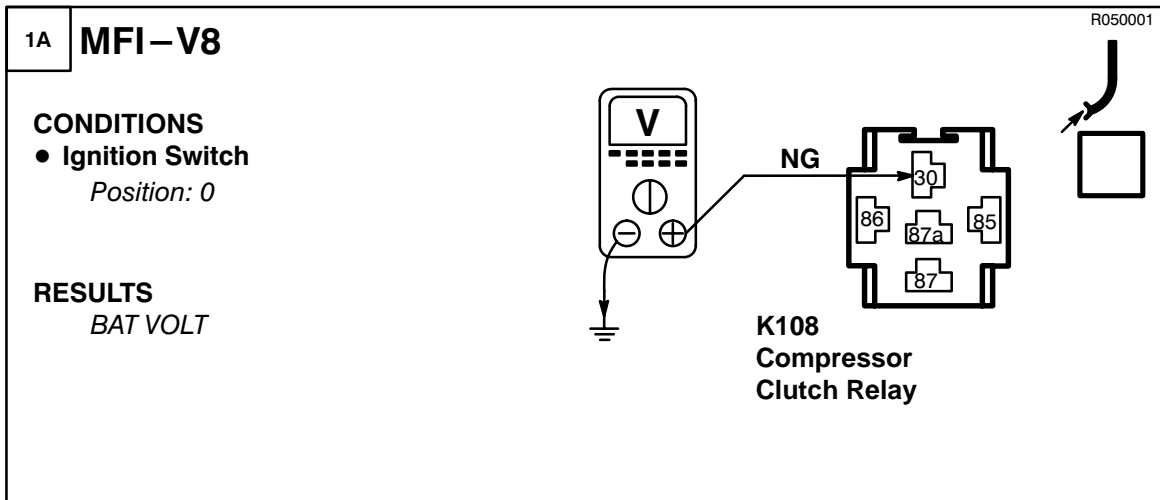

PROBLEM CAUSE

- F3 Fuse
- NG Wire

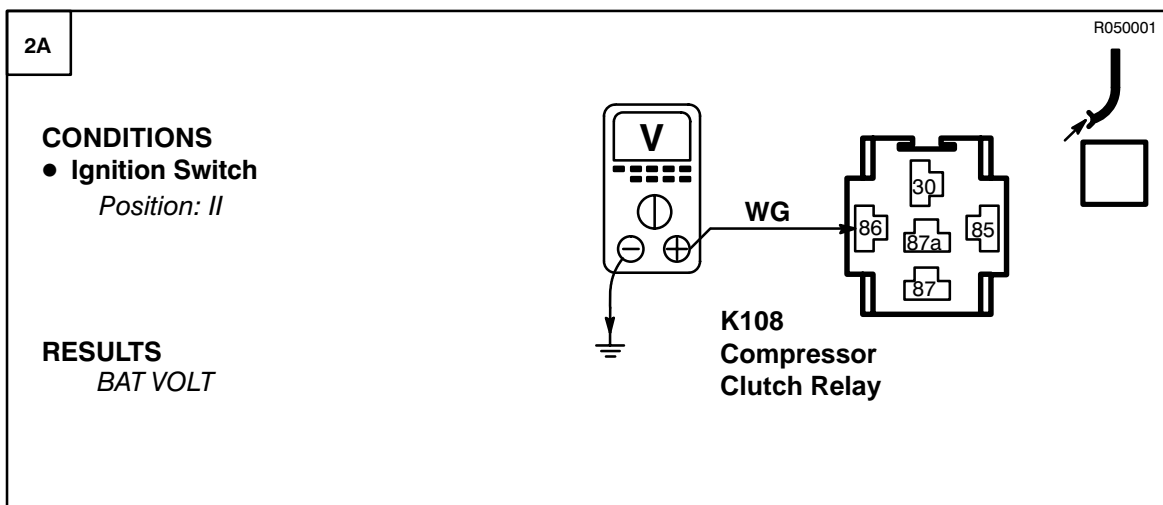
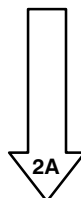

PROBLEM CAUSE

- WG Wire

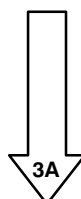

3A
2A
R050001

CONDITIONS

- Ignition Switch
Position: 0

RESULTS

- Compressor Clutch
Operates

K108
Compressor Clutch Relay



PROBLEM CAUSE

- BG Wire
- B Wire
- Compressor Clutch

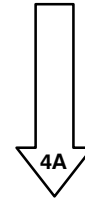

4A
R050001

CONDITIONS

- Ignition Switch
Position: II
- Engine
On
- Front Fan Speed Switch
Position: I
- Front A/C Switch
On

RESULTS

BAT VOLT

K108
Compressor Clutch Relay

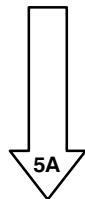

PROBLEM CAUSE

- Compressor Clutch Relay

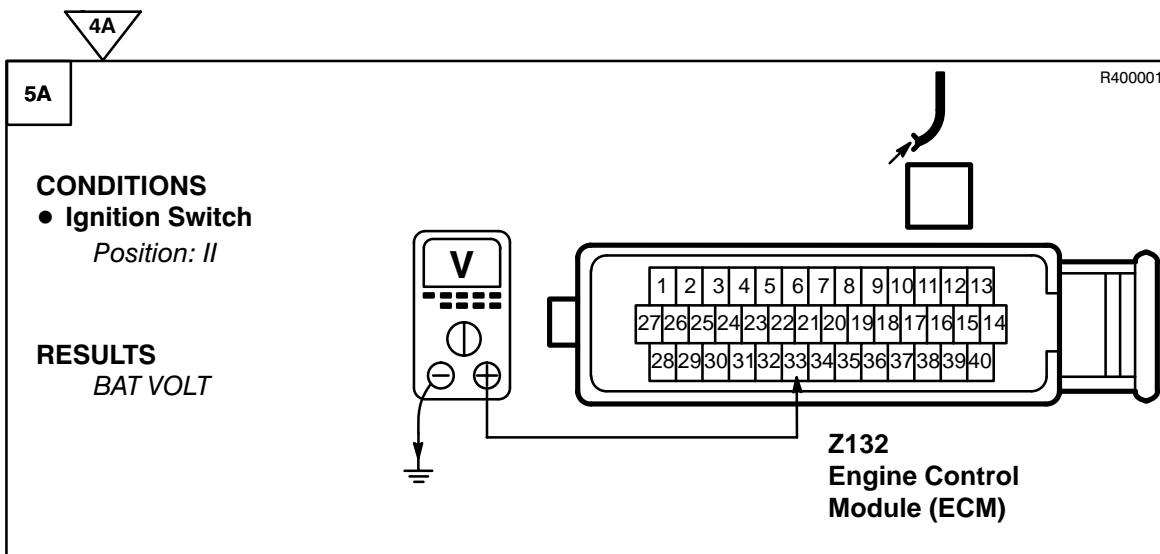

~~OK~~ PROBLEM CAUSE
- BS Wire

OK

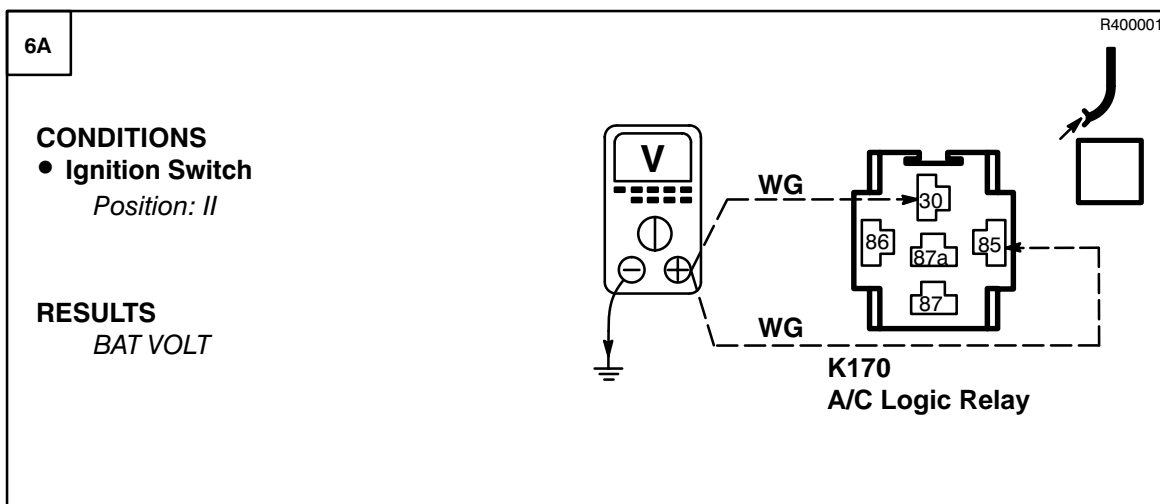
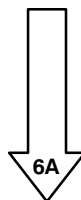

~~OK~~ PROBLEM CAUSE
- WG Wire

OK

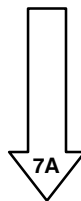

7A
6A
R050001

CONDITIONS

- Ignition Switch
Position: II
- Engine
On

RESULTS

- Compressor Clutch
Operates

**K170
A/C Logic Relay**



PROBLEM CAUSE

- GY Wire
- Engine Control Module (ECM)

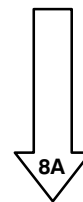

8A
R050001

CONDITIONS

- Ignition Switch
Position: II
- Engine
On

RESULTS

- Compressor Clutch
Operates

**K170
A/C Logic Relay**



PROBLEM CAUSE

- A/C Logic Relay

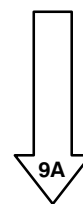

8A

9A

CONDITIONS

- Ignition Switch
Position: II
- Engine
On
- Front Fan Speed Switch
Position: I
- Front A/C Switch
On

RESULTS
Less than 2 ohms

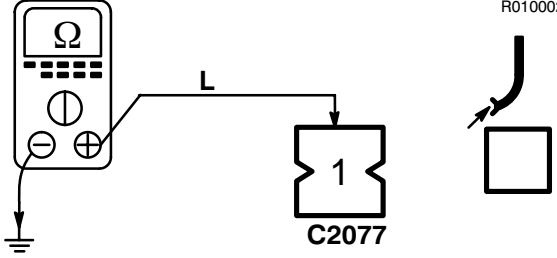

R010002

X101
Front A/C Evaporator Temperature Switch



GO TO TEST E



PROBLEM CAUSE

- YB Wire
- G Wire
- Front A/C Evaporator Temperature Switch

Test B

1B **MFI-T16**

CONDITIONS

- Ignition Switch
Position: 0

RESULTS
BAT VOLT

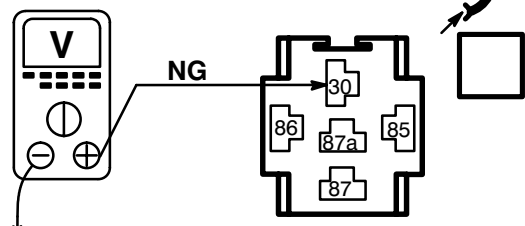

R050001

K108
Compressor Clutch Relay



PROBLEM CAUSE

- F3 Fuse
- NG Wire

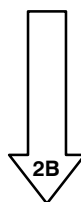

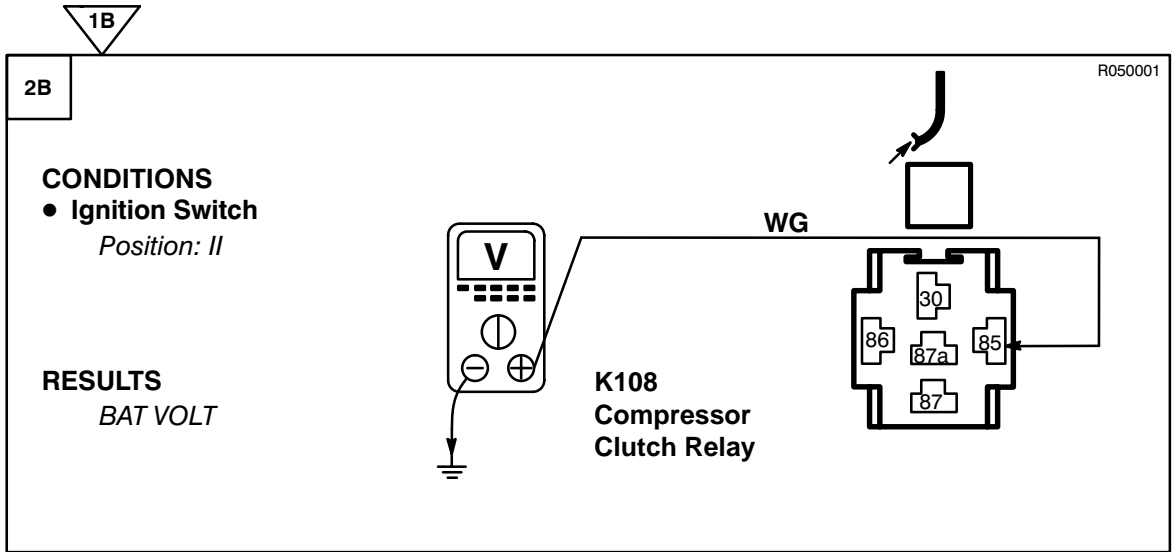

PROBLEM CAUSE

- F3 Fuse
- WG Wire

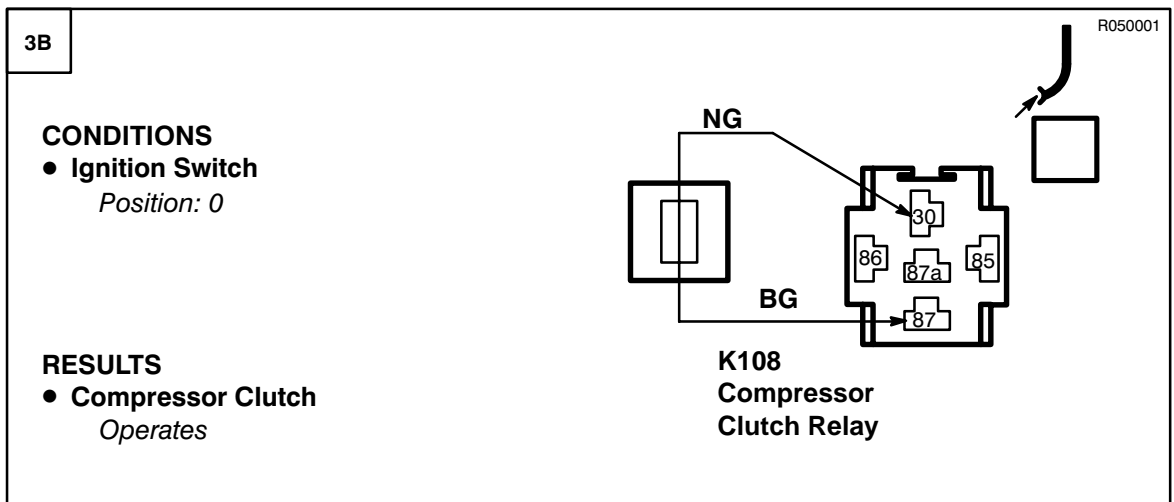
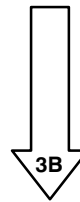

PROBLEM CAUSE

- BG Wire
- B Wire
- Compressor Clutch

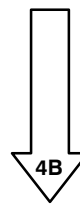

3B

4B

CONDITIONS

- Ignition Switch
Position: II
- Engine
On
- Front Fan Speed Switch
Position: I
- Front A/C Switch
On

RESULTS
BAT VOLT

K108
Compressor
Clutch Relay

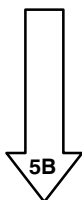

PROBLEM CAUSE
- Compressor
Clutch Relay

5B

CONDITIONS

- Ignition Switch
Position: II

RESULTS
BAT VOLT

Z132
Engine Control
Module (ECM)



PROBLEM CAUSE
- BS Wire

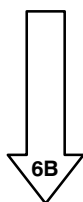

5B
6B
R050001

CONDITIONS

- Ignition Switch
Position: II

RESULTS

BAT VOLT

**K170
A/C Logic Relay**

OK

PROBLEM CAUSE

- WG Wire
- B Wire
- E103

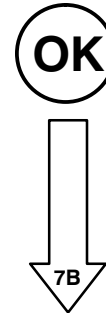

7B
R050001

CONDITIONS

- Ignition Switch
Position: II
- Engine
On

RESULTS

- Compressor Clutch
Operates

**K170
A/C Logic Relay**

OK

PROBLEM CAUSE

- BN Wire
- Engine Control Module (ECM)

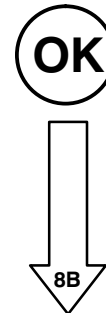

7B

8B

R050001

CONDITIONS

- Ignition Switch
Position: II
- Engine
On

RESULTS

- Compressor Clutch
Operates

YB

K170
A/C Logic Relay

~~OK~~ PROBLEM CAUSE
- A/C Logic Relay

OK

↓

9B

9B

R010002

CONDITIONS

- Ignition Switch
Position: II
- Engine
On
- Front Fan Speed Switch
Position: I
- Front A/C Switch
On

RESULTS

Less than 2 ohms

L

1

C2077

X101
Front A/C Evaporator Temperature Switch

~~OK~~ GO TO TEST E

OK

- YB Wire
- G Wire
- Front A/C Evaporator Temperature Switch

Test C

1C
300Tdi without EDC
R050001

CONDITIONS

- Ignition Switch
Position: 0

RESULTS
BAT VOLT

K108
Compressor
Clutch Relay



PROBLEM CAUSE

- F3 Fuse
- NG Wire

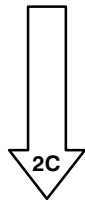

2C

R050001

CONDITIONS

- Ignition Switch
Position: II

RESULTS
BAT VOLT

K108
Compressor
Clutch Relay



PROBLEM CAUSE

- WG Wire

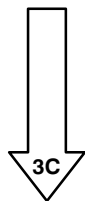

2C

3C

R050001

CONDITIONS

- Ignition Switch
Position: 0

RESULTS

- Compressor Clutch
Operates

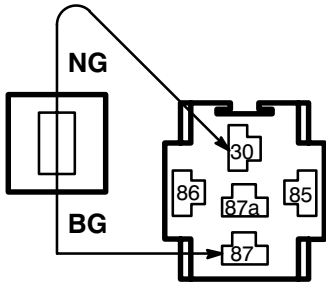

**K108
Compressor
Clutch Relay**



PROBLEM CAUSE

- BG Wire
- B Wire
- Compressor Clutch

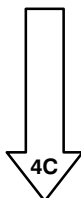

4C

R050001

CONDITIONS

- Ignition Switch
Position: II
- Engine
On
- Front Fan Speed Switch
Position: I
- Front A/C Switch
On

RESULTS

BAT VOLT

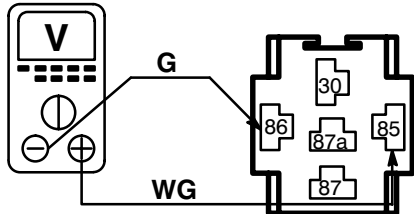

**K108
Compressor
Clutch Relay**

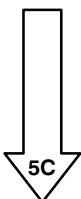

PROBLEM CAUSE

- Compressor Clutch Relay

4C

5C

CONDITIONS

- Ignition Switch
Position: II
- Engine
On
- Front Fan Speed Switch
Position: I
- Front A/C Switch
On

RESULTS
Less than 2 ohms

X259
Compressor
Clutch Cut-out
Switch

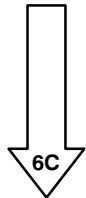

PROBLEM CAUSE

- G Wire
- Compressor Clutch Cut-out Switch

6C

CONDITIONS

- Ignition Switch
Position: II
- Engine
On
- Front Fan Speed Switch
Position: I
- Front A/C Switch
On

RESULTS
Less than 2 ohms

X101
Front A/C Evap-
orator Tempera-
ture Switch



GO TO TEST E



PROBLEM CAUSE

- YB Wire
- G Wire
- Front A/C Evap-
orator Tempera-
ture Switch

Test D

1D 300Tdi with EDC R050001

CONDITIONS

- Ignition Switch
Position: 0

RESULTS
BAT VOLT

**K108
Compressor
Clutch Relay**

~~OK~~ **PROBLEM CAUSE**

- F3 Fuse
- NG Wire

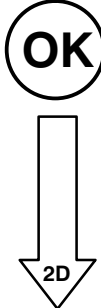

2D R050001

CONDITIONS

- Ignition Switch
Position: II

RESULTS
BAT VOLT

**K108
Compressor
Clutch Relay**

~~OK~~ **PROBLEM CAUSE**

- WG Wire

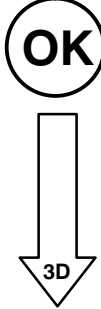

2D
R050001

3D

CONDITIONS

- Ignition Switch
Position: 0

RESULTS

- Compressor Clutch
Operates

**K108
Compressor
Clutch Relay**



PROBLEM CAUSE

- BG Wire
- B Wire
- Compressor Clutch

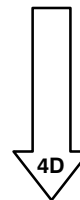

4D
R050001

CONDITIONS

- Ignition Switch
Position: II
- Engine
On
- Front Fan Speed Switch
Position: I
- Front A/C Switch
On

RESULTS

BAT VOLT

**K108
Compressor
Clutch Relay**

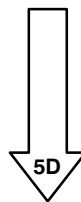

PROBLEM CAUSE

- Compressor Clutch Relay

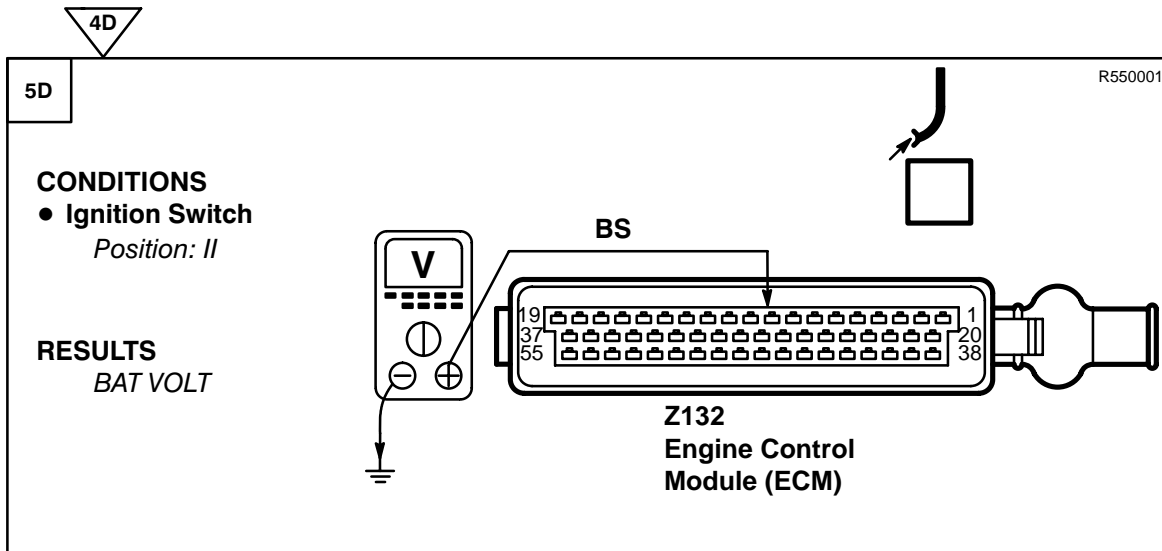

~~OK~~ PROBLEM CAUSE
- BS Wire

OK

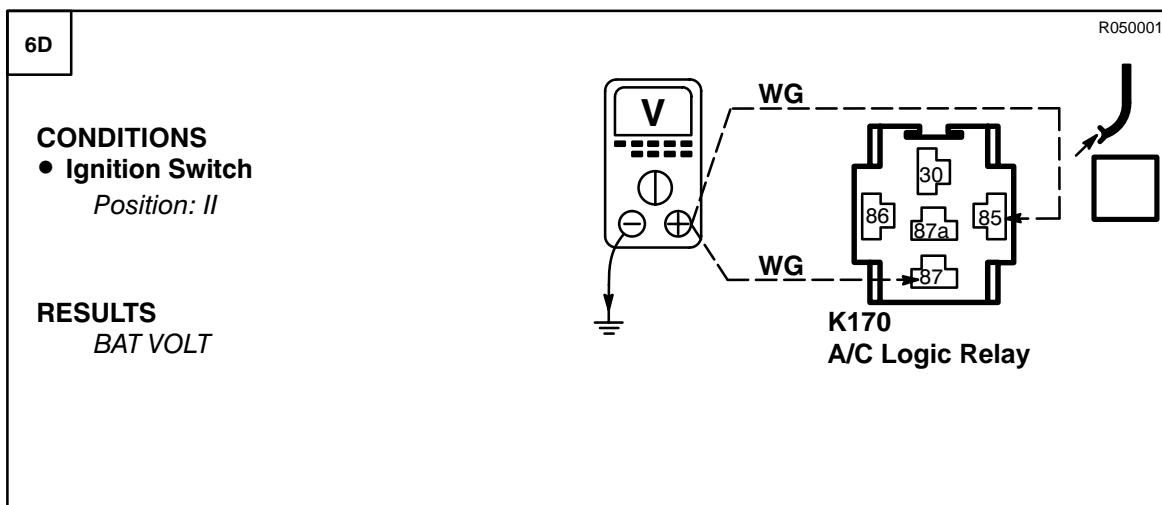
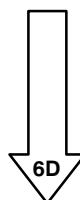

~~OK~~ PROBLEM CAUSE
- WG Wire

OK

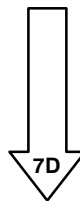

6D
7D
R050001

CONDITIONS

- Ignition Switch
Position: II
- Engine
On

RESULTS

- Compressor Clutch
Operates

**K170
A/C Logic Relay**



PROBLEM CAUSE

- YG Wire
- Engine Control Module (ECM)

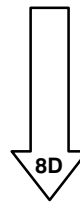

8D
R050001

CONDITIONS

- Ignition Switch
Position: II
- Engine
On

RESULTS

- Compressor Clutch
Operates

**K170
A/C Logic Relay**



PROBLEM CAUSE

- A/C Logic Relay

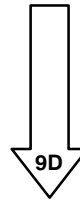

8D

9D

CONDITIONS

- Ignition Switch
Position: II
- Engine
On
- Front Fan Speed Switch
Position: I
- Front A/C Switch
On

RESULTS
Less than 2 ohms

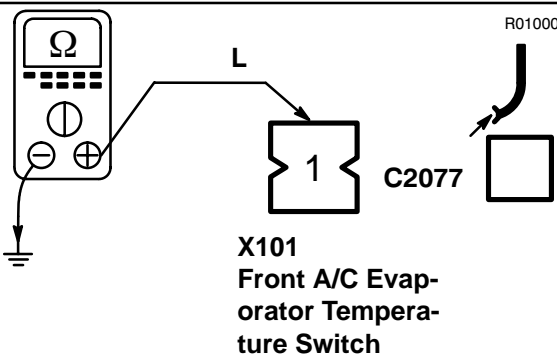

R010002

~~OK~~ GO TO TEST E

OK PROBLEM CAUSE

- YB Wire
- G Wire
- Front A/C Evaporator Temperature Switch

Test E

1E

CONDITIONS

- Ignition Switch
Position: II
- Engine
On
- Front Fan Speed Switch
Position: I
- Front A/C Switch
On

RESULTS
Less than 2 ohms

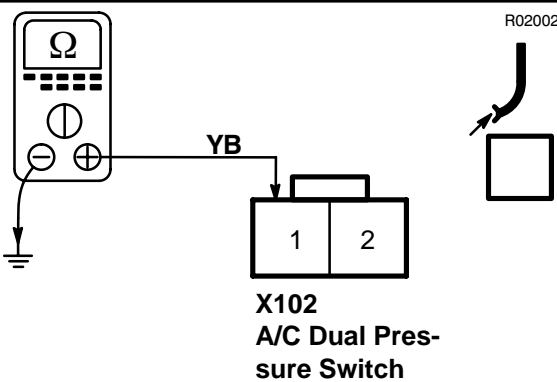

R020023

~~OK~~

↓

2E

OK PROBLEM CAUSE

- ON Wire
- L Wire
- A/C Dual Pressure Switch

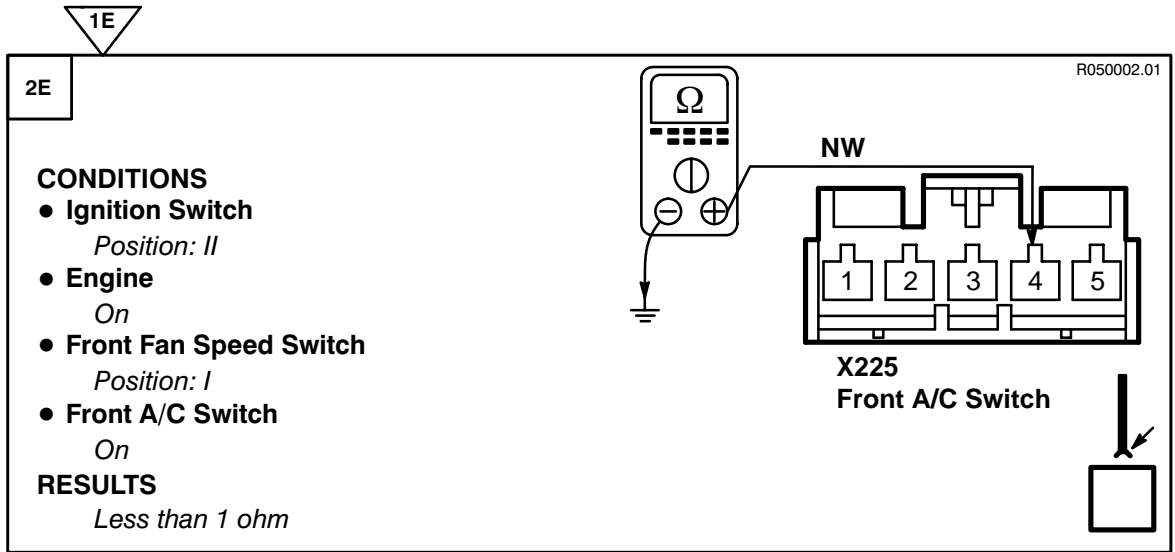

- PROBLEM CAUSE**
- N Wire
 - Front A/C Switch



- PROBLEM CAUSE**
- YB Wire
 - PB Wire
 - NW Wire
 - Condenser Fan Control Diode 2

Test F

1F

MFI-V8

R050001

CONDITIONS

- Ignition Switch
Position: II
- Front Fan Speed Switch
Position: 0

RESULTS
OV

K108
Compressor
Clutch Relay

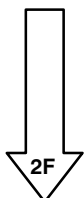

PROBLEM CAUSE
- Compressor
Clutch Relay

2F

Z132

R400001

CONDITIONS

- Ignition Switch
Position: II
- Front Fan Speed Switch
Position: 0

RESULTS
OV

Z132
Engine Control
Module (ECM)

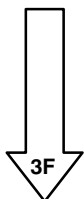

PROBLEM CAUSE
- BS Wire
- Engine Control
Module (ECM)

2F
R050001

3F

CONDITIONS

- Ignition Switch
Position: 0
- Front Fan Speed Switch
Position: 0

RESULTS
More than 10K ohms

**K170
A/C Logic Relay**



PROBLEM CAUSE
- A/C Logic Relay

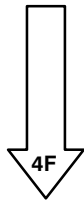

4F
R010002

4F

CONDITIONS

- Ignition Switch
Position: 0
- Front Fan Speed Switch
Position: 0

RESULTS
More than 10K ohms

**X101
Front A/C Evap-
orator Tempera-
ture Switch**



GO TO TEST J

PROBLEM CAUSE
- YB Wire
- G Wire
- Front A/C Evap-
orator Tempera-
ture Switch

Test G

1G
MFI-T16
R050001

CONDITIONS

- Ignition Switch
Position: II
- Front Fan Speed Switch
Position: 0

RESULTS
0V

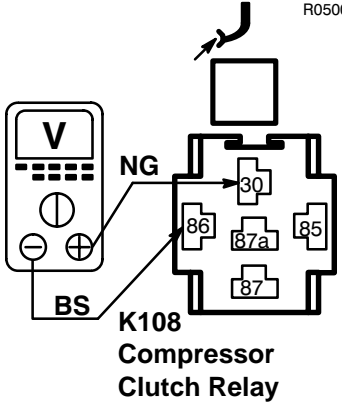

K108
Compressor Clutch Relay

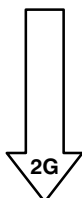

PROBLEM CAUSE
- Compressor Clutch Relay

2GR360001

CONDITIONS

- Ignition Switch
Position: II
- Front Fan Speed Switch
Position: 0

RESULTS
More than 10K ohms

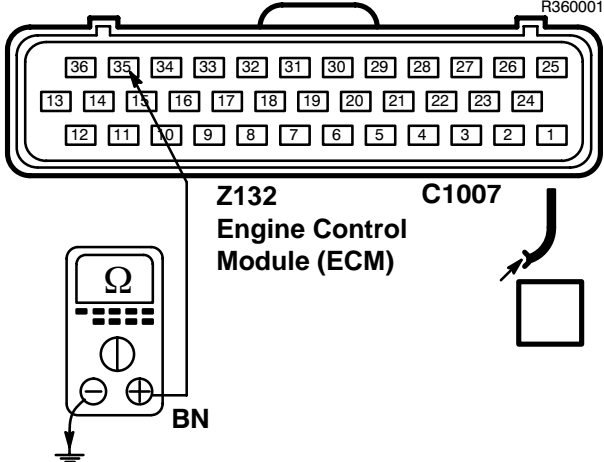

Z132
Engine Control Module (ECM)

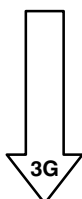

PROBLEM CAUSE
- BS Wire
- Engine Control Module (ECM)

2G

3G

CONDITIONS

- Ignition Switch
Position: 0
- Front Fan Speed Switch
Position: 0

RESULTS
More than 10K ohms

**K170
A/C Logic Relay**

R050001

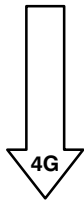

PROBLEM CAUSE
- A/C Logic Relay

4G

4G

CONDITIONS

- Ignition Switch
Position: 0
- Front Fan Speed Switch
Position: 0

RESULTS
More than 10K ohms

**X101
Front A/C Evaporator Temperature Switch**

R050002



GO TO TEST J



PROBLEM CAUSE
- YB Wire
- G Wire
- Front A/C Evaporator Temperature Switch

Test H

1H 300Tdi without EDC R050001

CONDITIONS

- Ignition Switch
Position: II
- Front Fan Speed Switch
Position: 0

RESULTS
0V

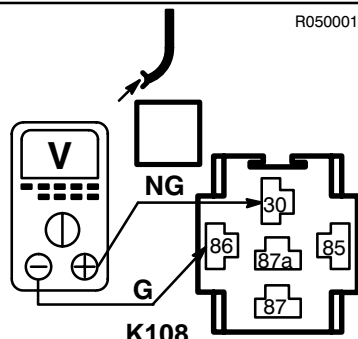

K108
Compressor Clutch Relay

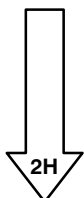

PROBLEM CAUSE

- Compressor Clutch Relay

2H R010002

CONDITIONS

- Ignition Switch
Position: 0
- Front Fan Speed Switch
Position: 0

RESULTS
More than 10K ohms

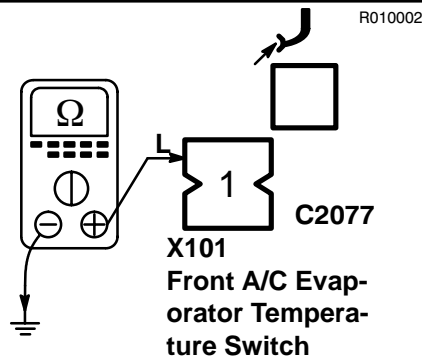

X101
Front A/C Evaporator Temperature Switch



GO TO TEST J



PROBLEM CAUSE

- G, YB Wire
- Compressor Clutch Cut-out Switch
- Front A/C Evaporator Temperature Switch

Test I

11
300Tdi with EDC
R050001

CONDITIONS

- Ignition Switch
Position: II
- Front Fan Speed Switch
Position: 0

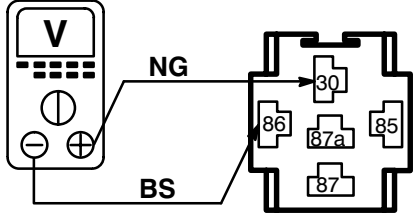

**K108
Compressor
Clutch Relay**

RESULTS
0V

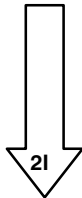

PROBLEM CAUSE
- Compressor
Clutch Relay

21

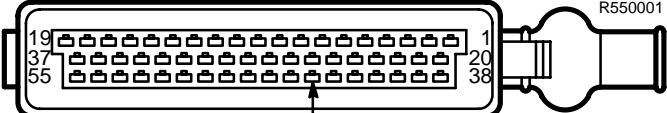

R550001

CONDITIONS

- Ignition Switch
Position: II
- Front Fan Speed Switch
Position: 0

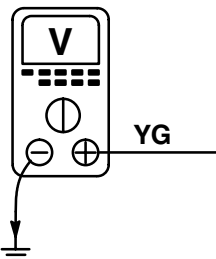

**Z132
Engine Control
Module (ECM)**

RESULTS
0V

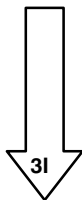

PROBLEM CAUSE
- BS Wire
- Engine Control
Module (ECM)

R050001

21
31

CONDITIONS

- Ignition Switch
Position: 0
- Front Fan Speed Switch
Position: 0

RESULTS
More than 10K ohms

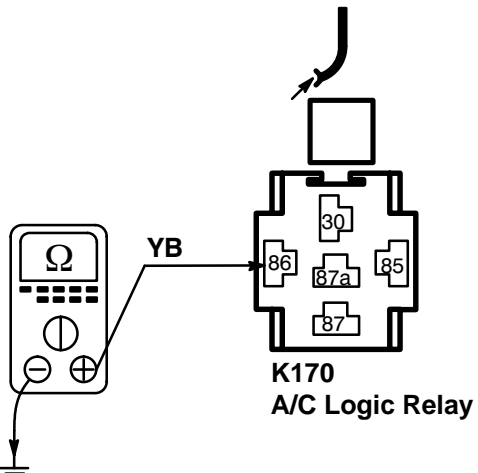

**K170
A/C Logic Relay**



PROBLEM CAUSE
- A/C Logic Relay

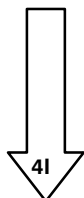

R010002

41
41

CONDITIONS

- Ignition Switch
Position: 0
- Front Fan Speed Switch
Position: 0

RESULTS
More than 10K ohms

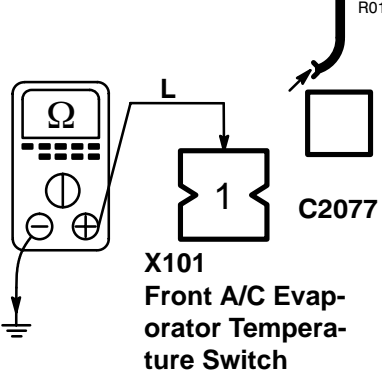

**X101
Front A/C Evap-
orator Tempera-
ture Switch**



GO TO TEST J

PROBLEM CAUSE
- YB Wire
- G Wire
- Front A/C Evap-
orator Tempera-
ture Switch

Test J

1J

CONDITIONS

- Ignition Switch
Position: 0
- Front Fan Speed Switch
Position: 0

RESULTS

More than 10K ohms

R050002

X225
Front A/C Switch



- PROBLEM CAUSE**
- N Wire
 - Front Fan Speed Switch



- PROBLEM CAUSE**
- L, ON, YB Wire
 - PB, NW Wire
 - A/C Dual Pressure Switch

 - Condenser Fan Control Diode 2

 - Front A/C Switch

CIRCUIT OPERATION

Condenser Fan Operation (MFI-V8)

The Condenser Fans Motors (M113, M121) on vehicles equipped with MFI-V8 engines operate when any of the following conditions occur:

3. Coolant temperature exceeds 100°C (212°F).
4. The air conditioning system is operating.
5. The Engine Control Module (ECM) (Z132) determines that fuel temperature exceeds 70°C and coolant temperature exceeds 110°C after engine shutdown. When this occurs, the fans are turned on for approximately 10 minutes after the engine is shut off.

Operation with High Coolant Temperature (MFI-V8)

When the Ignition Switch (X134) is in position II, battery voltage is applied to the Ignition Load Relay (K127). The relay is energized, applying battery voltage to the Condenser Fan Relay (K109) and the Fan Control Module (Z118). If the coolant temperature exceeds 100°C (212°F), the Condenser Fan Coolant Temperature Switch (X113) closes and energizes the Condenser Fan Relay (K109) by applying ground to the relay's coil. When the relay is energized, voltage from fuse F3 is applied to the Condenser Fan Motors (M113, M121) through the relay's contacts.

Fan Operation with A/C (MFI-V8)

With the Ignition Switch (X134) in position II, battery voltage is applied to the Ignition Load Relay (K127). The relay is energized, applying battery voltage to the Condenser Fan Relay (K109). When the Front A/C Switch (X225) is turned On and the Front Fan Speed Switch (X247) is turned to positions I, II, III, or IV, ground is applied to terminal 86 of the Condenser Fan Relay. The relay energizes, applying battery voltage from fuse F3 to the Condenser Fan Motors (M113, M121).

Operation with the Engine Off (MFI-V8)

The Engine Control Module (Z132) monitors fuel temperature and coolant temperature through sensors. When the ECM determines that fuel temperature is above 70°C and coolant

temperature exceeds 110°C after engine shutdown, the ECM will command fan operation for approximately 10 minutes. The ECM turns on the fans by momentarily grounding the Fan Control Module (Z118) through the BG wire. When the timer unit is grounded, it starts a solid state timer and begins to apply ground from its terminal 9 to the Condenser Fan Relay (K109) through the BP wire. With the Condenser Fan Relay energized, voltage from fuse F3 is applied to the Condenser Fan Motors (M113, M121) through the relay contacts.

Cooling Fan and Condenser Fan Operation (MFI–T16)

The Cooling Fan 1 (M141) or Cooling Fans (M141, M142) and Condenser Fan Motors (M113, M121) on vehicles equipped with MFI–T16 engines operate when any of the following conditions occur:

1. The A/C system is operating.
2. The Engine Control Module (ECM) determines that Cooling Fan and/or Condenser Fan Motor operation is required.

Cooling Fan Operation without A/C (MFI–T16)

With the Ignition Switch (X134) in position II, battery voltage is applied to the Cooling Fan Relay (K190) from fuse F3 of the Satellite Fuse Box 1 (P127). When Cooling Fan Operation is required, the Engine Control Module (ECM) (Z132) grounds terminal 86 of the Cooling Fan Relay (K190). The relay energizes, applying battery voltage from fuse F3 of the Engine Compartment Fuse Box (P125) to the Cooling Fan 1 (M141). When Cooling Fan Operation is no longer required, the ECM removes the ground supply to the Cooling Fan Relay (K190). The Relay de–energizes, removing the voltage supply to the Cooling Fan 1 (M141).

Cooling Fan and Condenser Fan Operation with A/C (MFI–T16)

With the Ignition Switch (X134) in position II, battery voltage is applied to the Ignition Load Relay (K127). The relay is energized, applying battery voltage to the Condenser Fan Relay (K109). When Cooling Fan and Condenser Fan operation is required, the Engine Control Module (ECM) (Z132) grounds terminal 86 of the Condenser Fan Relay (K109). The Relay energizes, applying battery voltage from fuse F3 of the Engine Compartment Fuse Box (P125) to the Cooling Fans (M141, 142) and the Condenser Fan Motors (M113, M121). When Cooling Fan and Condenser Fan operation is no longer required, the ECM removes the ground supply to the Condenser Fan Relay (K109). The relay de–energizes, removing the voltage supply to the Cooling Fans (M141, M142) and the Condenser Fan Motors (M113, M121).

Condenser Fan Operation (300Tdi)

The Condenser Fan Motors (M113, M121) on vehicles equipped with diesel engines operate when any one of the following conditions occur:

1. Coolant temperature exceeds 100°C (212°F).
2. The A/C is operating.

Condenser Fan with High Coolant Temperature Operation (300Tdi)

When the Ignition Switch (X134) is in position II, battery voltage is applied to the Ignition Load Relay (K127). The relay is energized, applying battery voltage to the Condenser Fan Relay (K109). If the Coolant Temperature exceeds 100°C (212°F), the Condenser Fan Coolant Temperature Switch (X113) closes and energizes the Condenser Fan Relay (K109) by applying ground to the relay's coil. When the relay is energized, voltage from fuse F3 is applied to the Condenser Fan Motors (M113, M121) through the relay's contacts.

Fan Operation with A/C (300Tdi)

With the Ignition Switch (X134) in position II, battery voltage is applied to the Ignition Load Relay (K127). The relay is energized, applying battery voltage to the Condenser Fan Relay (K109) when the Front A/C Switch (X225) is turned on and the Front Fan Speed Switch (X247) is turned to positions I, II, III, or IV, ground is applied to terminal 86 of the Condenser Fan Relay (K109). The relay energizes, applying battery voltage from fuse F3 to the Condenser Fan Motors (M113, M121).

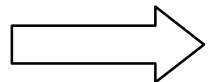
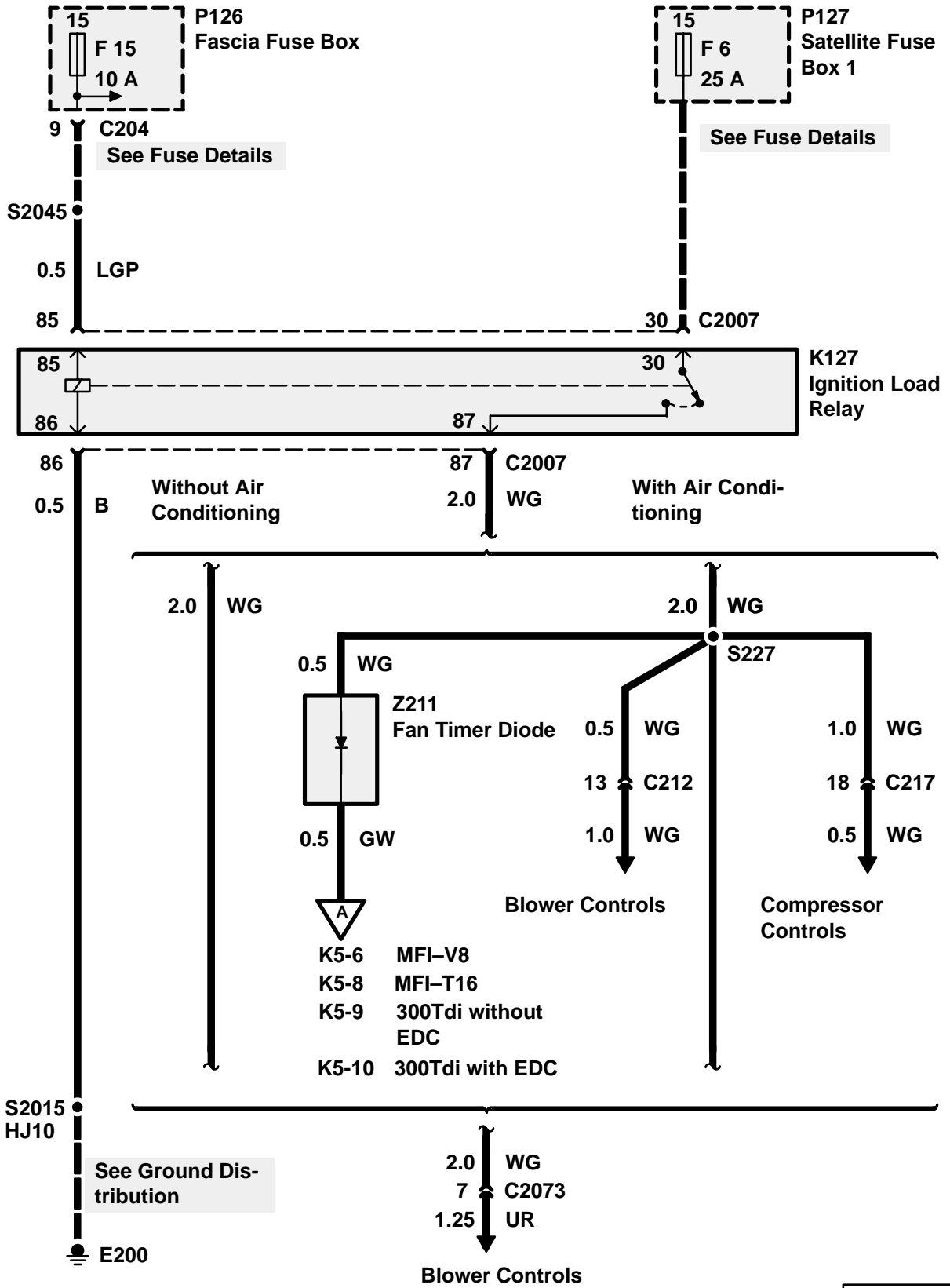

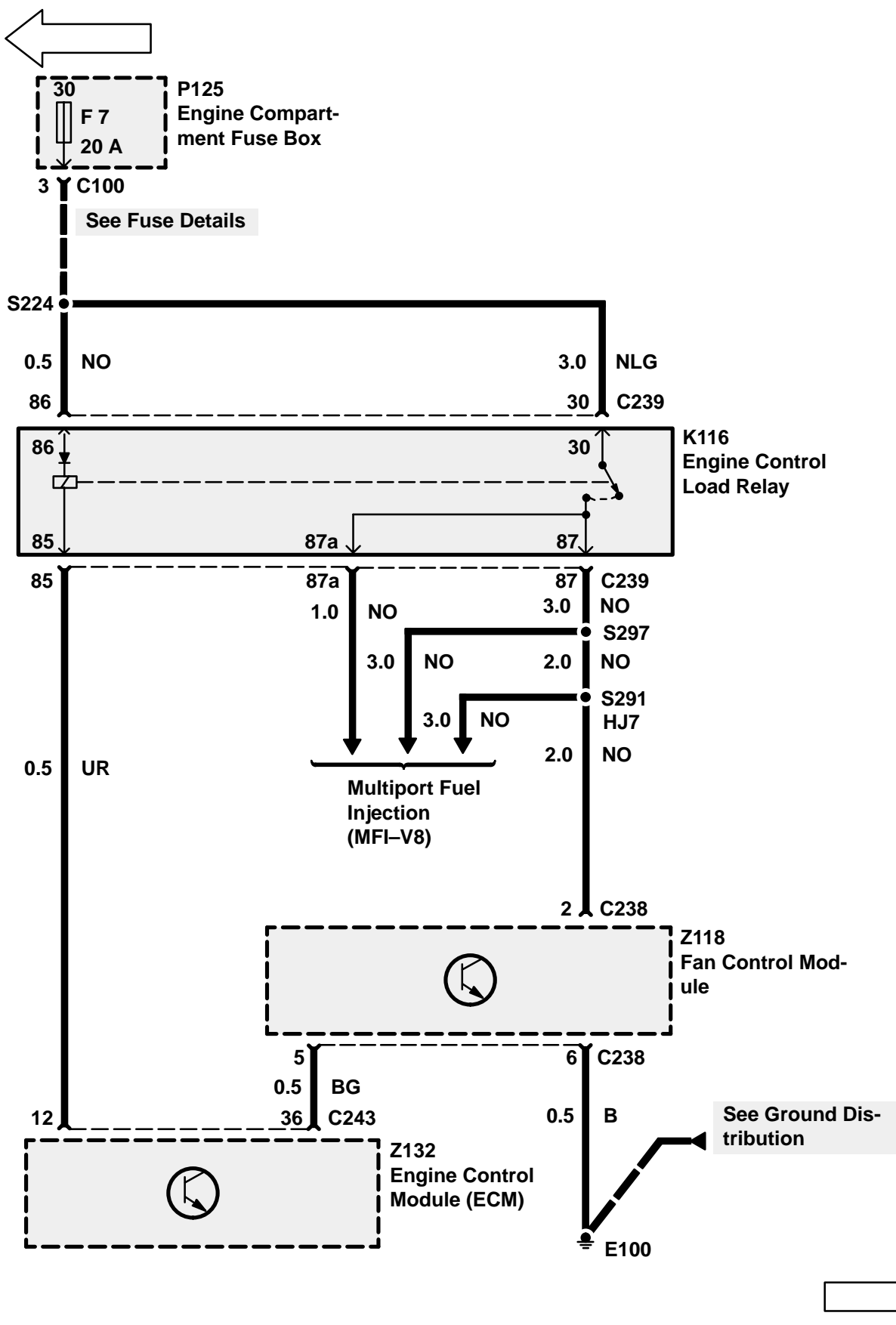

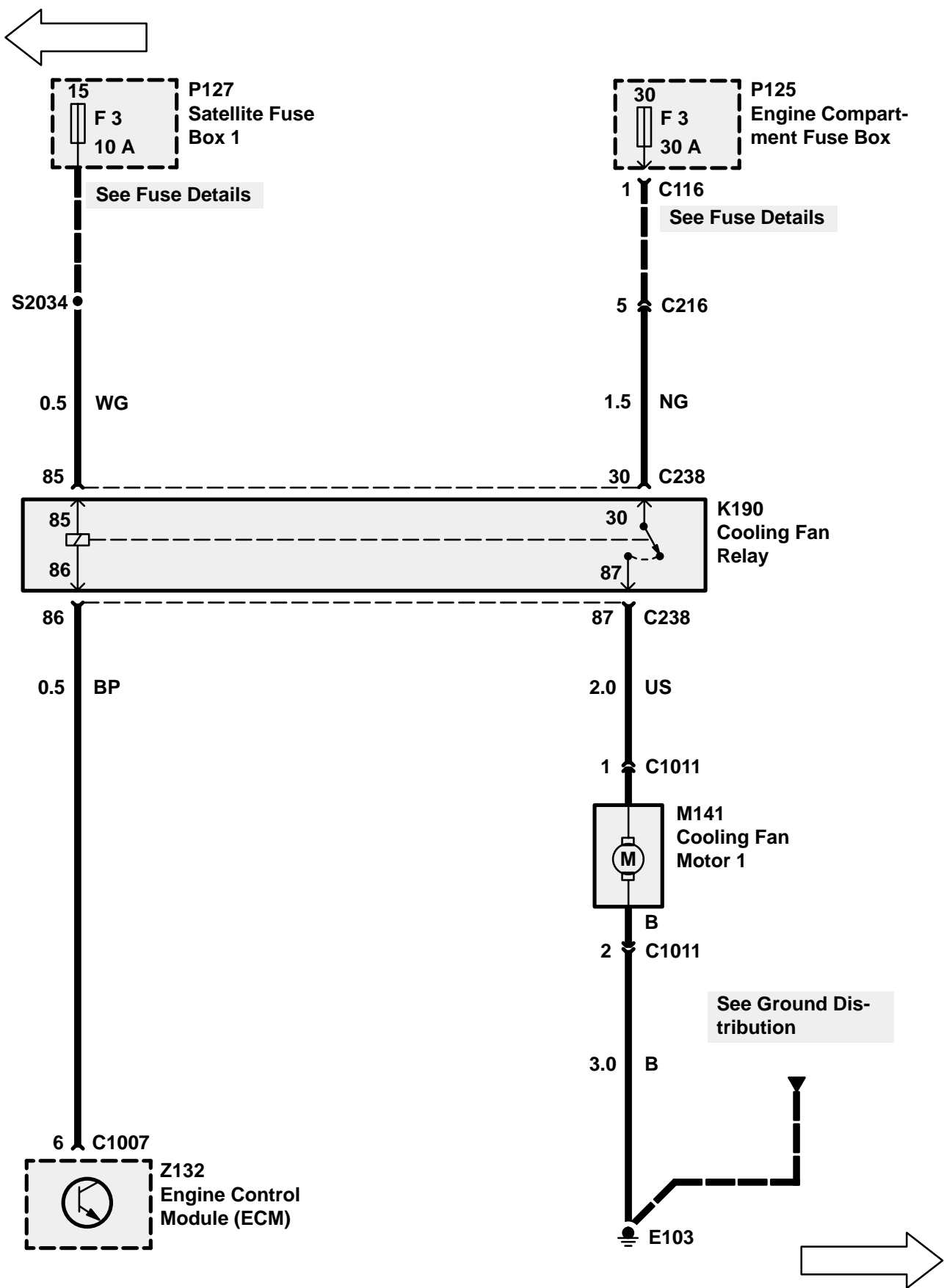

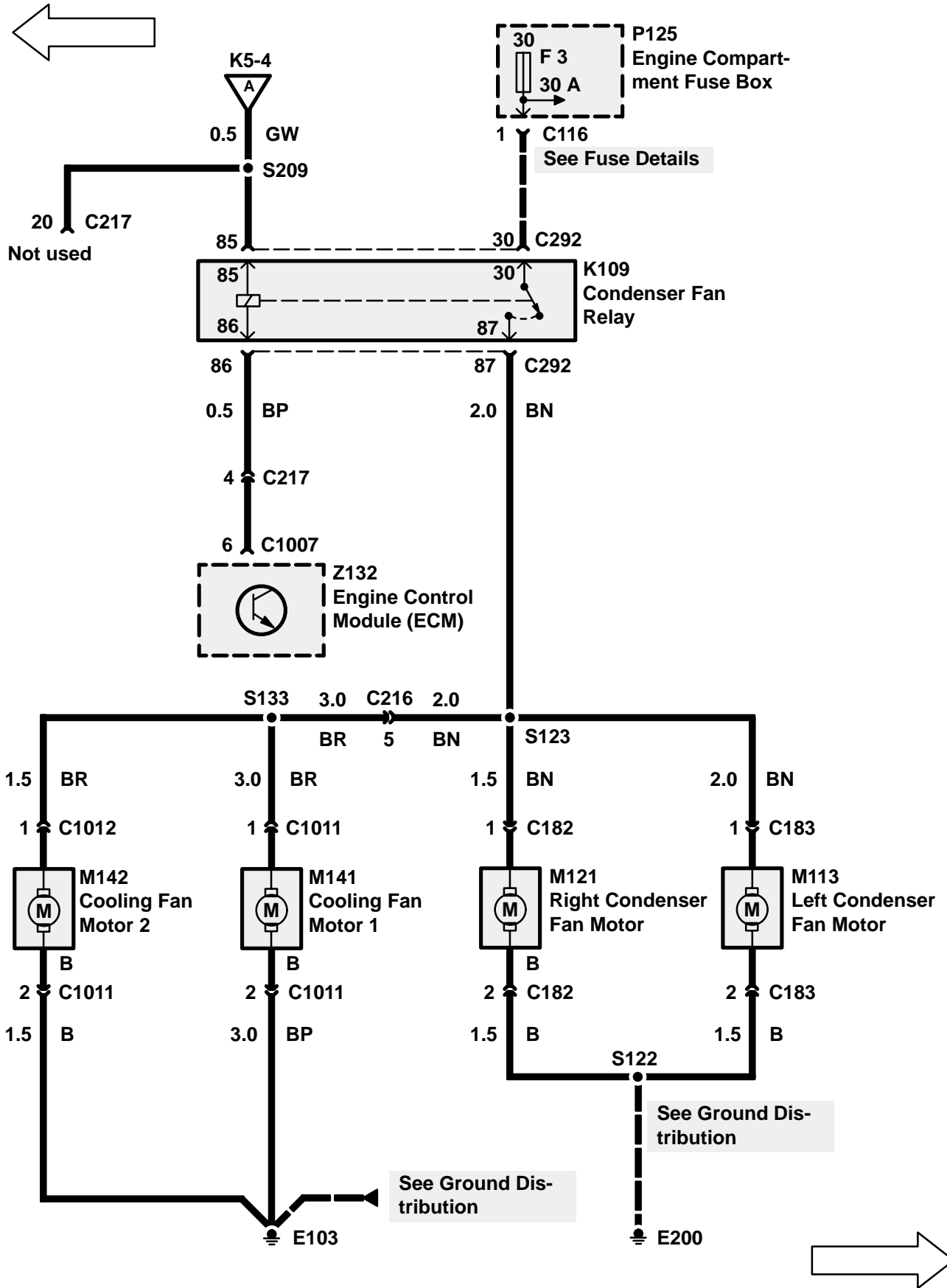

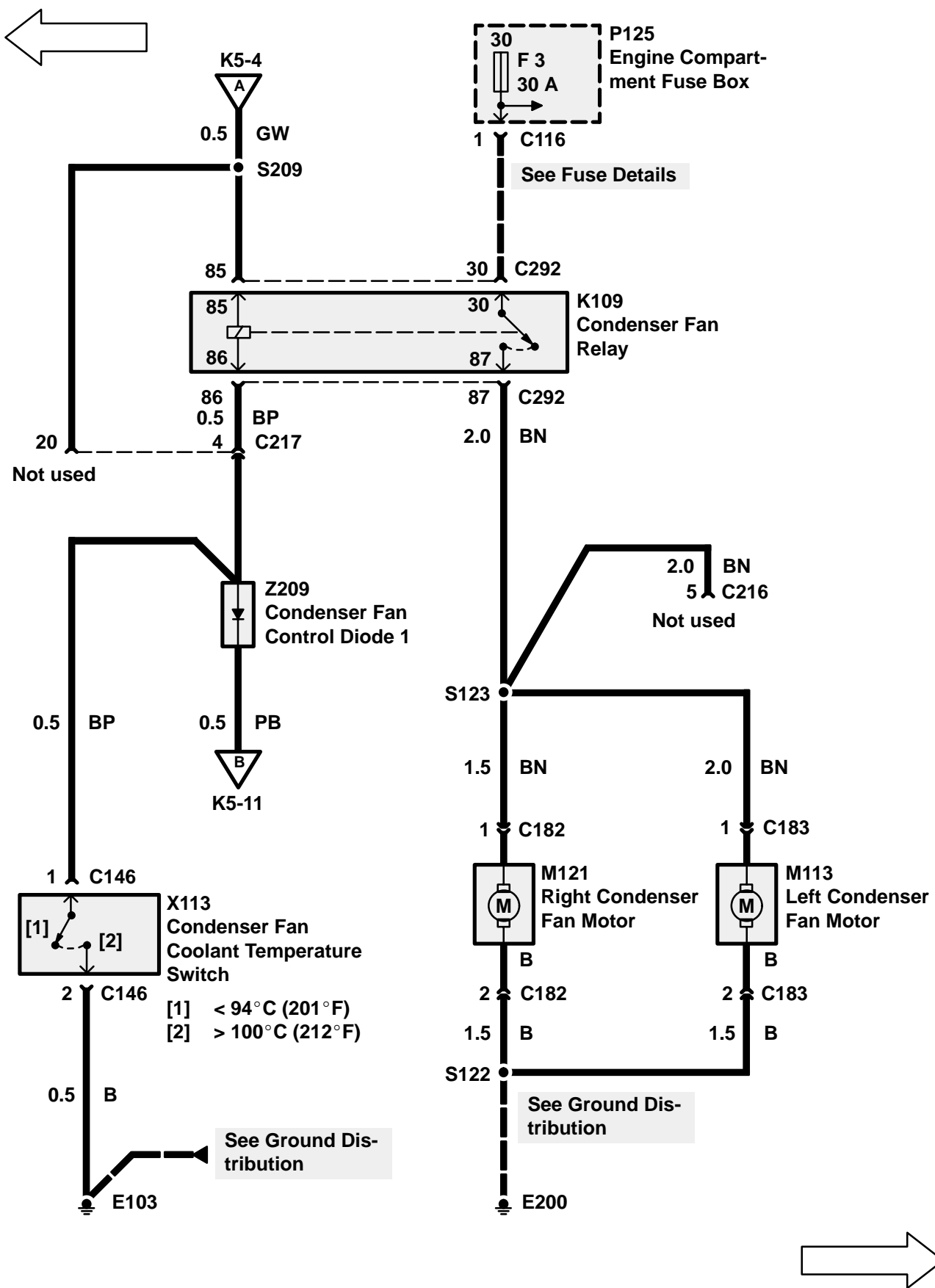

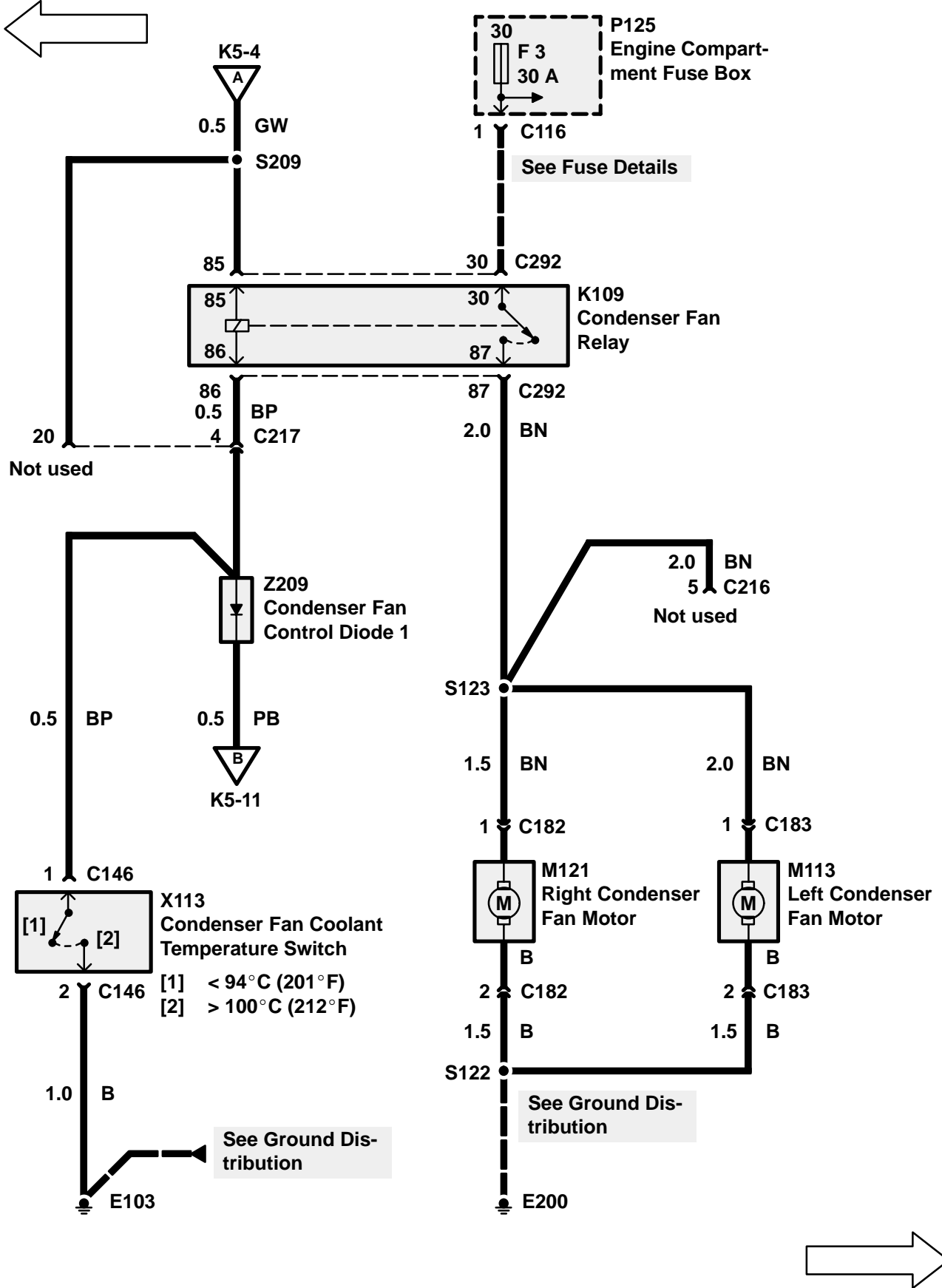

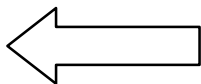

Compressor Controls

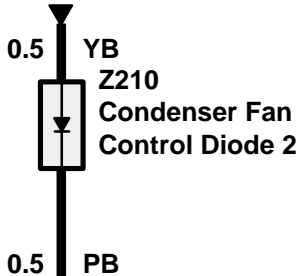

- K5-6 MFI-V8
- K5-9 300Tdi without EDC
- K5-10 300Tdi with EDC

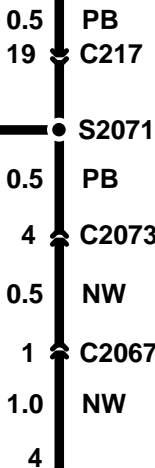

Compressor Controls

Interior Lamps

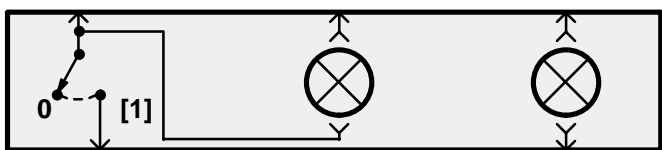
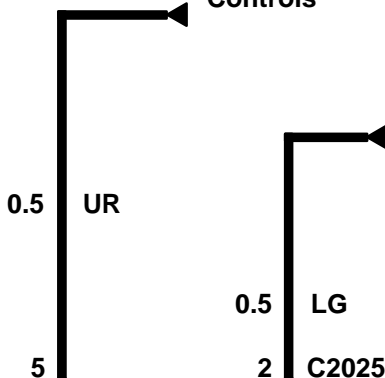

X225 Front A/C Switch

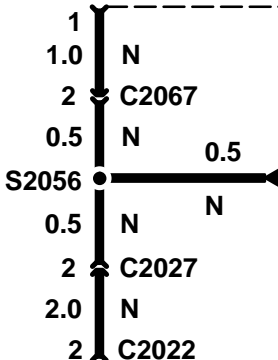

Blower Controls

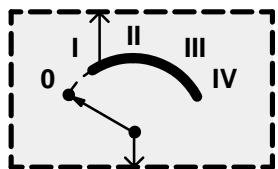
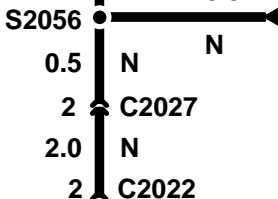

X247 Front Fan Speed Switch

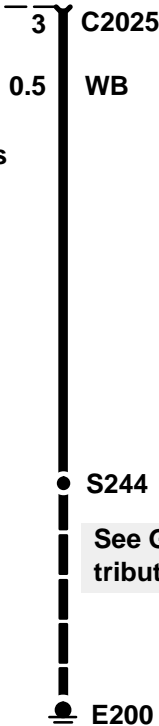
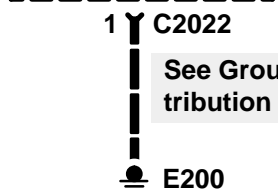

TROUBLESHOOTING HINTS

1. Check Fuses F3, and F7 in the Engine Compartment Fuse Box (P125).
2. Check Fuse F15 in the Fuse Box.
3. If the Blower Motor(s) do not operate normally, refer to Blower Controls, Section K1.

SYSTEM DIAGNOSIS (MFI–V8)

1. If the Condenser Fans do not turn on when the A/C is turned on, do Test A, the Condenser Fan Relay (K109) test.
2. If only one of the Condenser Fans operate, do Test H, the Condenser Fan Motor (M113, M121) test.
3. If the Condenser Fans do not turn on when coolant temperature exceeds 100°C (212°F), do Test J, the Temperature Switch (X113) test.
4. If the Condenser Fans do not stay on after the ignition has been turned off, fuel temperature exceeds 70°C and coolant temperature exceeds 110°C, do Test K, the Fan Control Module (Z118) test.

SYSTEM DIAGNOSIS (MFI–T16)

1. For models without A/C, if the Cooling Fan does not operate, do Test B, the Cooling Fan Relay (K190) test.
2. For models with A/C, if the fans do not operate, do Test C, the Condenser Fan Relay (K109) test.
3. If only one of the Condenser Fans operate, do Test H, the Condenser Fan Motor (M113, M121) test.
4. If only one of the Cooling Fans operate, do Test I, the Cooling Fan (M141, M142) test.

SYSTEM DIAGNOSIS (300TDI WITH EDC)

1. If the Condenser Fans do not turn on when the A/C is turned on, do Test D, the Condenser Fan Relay (K109) test.
2. If only one of the Condenser Fans operate, do test H, the Condenser Fan Motor (M113, M121) test.

3. If the Condenser Fans do not turn on when coolant temperature exceeds 100°C (212°F), do Test J, the Temperature Switch (X113) test.

SYSTEM DIAGNOSIS (300TDI WITHOUT EDC)

1. If the Condenser Fans do not turn on when the A/C is turned on, do Test E, the Condenser Fan Relay (K109) test.
2. If only one of the Condenser Fans operate, do Test H, the Condenser Fan Motor (M113, M121) test.
3. If the Condenser Fans do not turn on when the coolant temperature exceeds 100°C (212°F), do Test J, the Temperature Switch (X113) test.

Test A

R050001

1A

Condenser Fan Relay Test
MFI-V8

CONDITIONS

- Ignition Switch
Position: 0

RESULTS
BAT VOLT

K109
Condenser Fan
Relay

OK PROBLEM CAUSE
 - F3 Fuse
 - NG Wire

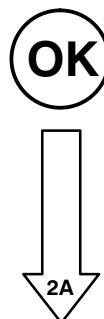

R050001

2A

CONDITIONS

- Ignition Switch
Position: II
- Engine
On

RESULTS
BAT VOLT

K109
Condenser Fan
Relay

OK PROBLEM CAUSE
 - GW Wire
 - Fan Timer Diode

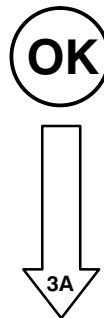

2A

3A

CONDITIONS

- Ignition Switch
Position: II
- Front Fan Speed Switch
Position: I
- Front A/C Switch
A/C Mode

RESULTS

Less than 1 ohm

Z118
Fan Control Mod-
ule

R090002



GO TO TEST F

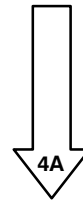

4A

CONDITIONS

- Ignition Switch
Position: 0

RESULTS

- M113, M121 Condenser Fan Motors
Operate

K109
Condenser Fan
Relay

R050001



PROBLEM CAUSE
- BN Wire



PROBLEM CAUSE
- BP Wire
- Condenser Fan
Relay

Test B

1B Cooling Fan Relay Test
MFI-T16 R050001

CONDITIONS
• Ignition Switch
Position: 0

RESULTS
BAT VOLT

K190 Cooling Fan Relay



PROBLEM CAUSE
- F3 Fuse
- NG Wire

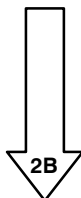

2B R050001

CONDITIONS
• Ignition Switch
Position: II

RESULTS
BAT VOLT

K190 Cooling Fan Relay



PROBLEM CAUSE
- F3 Fuse
- WG Wire

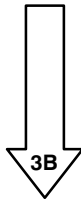

R020011

2B

3B

CONDITIONS

- Ignition Switch
Position: 0

RESULTS

Less than 1 ohm

B

**M141
Cooling Fan
Motor 1**



PROBLEM CAUSE

- B Wire
- E103

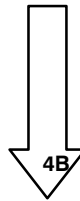

R360001

4B

CONDITIONS

- Ignition Switch
Position: II

RESULTS

- Cooling Fan Motor 1
Operates

BP

**Z132
Engine Control
Module (ECM)**

C1007

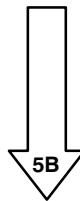

PROBLEM CAUSE

- BP Wire
- Engine Control Module (ECM)

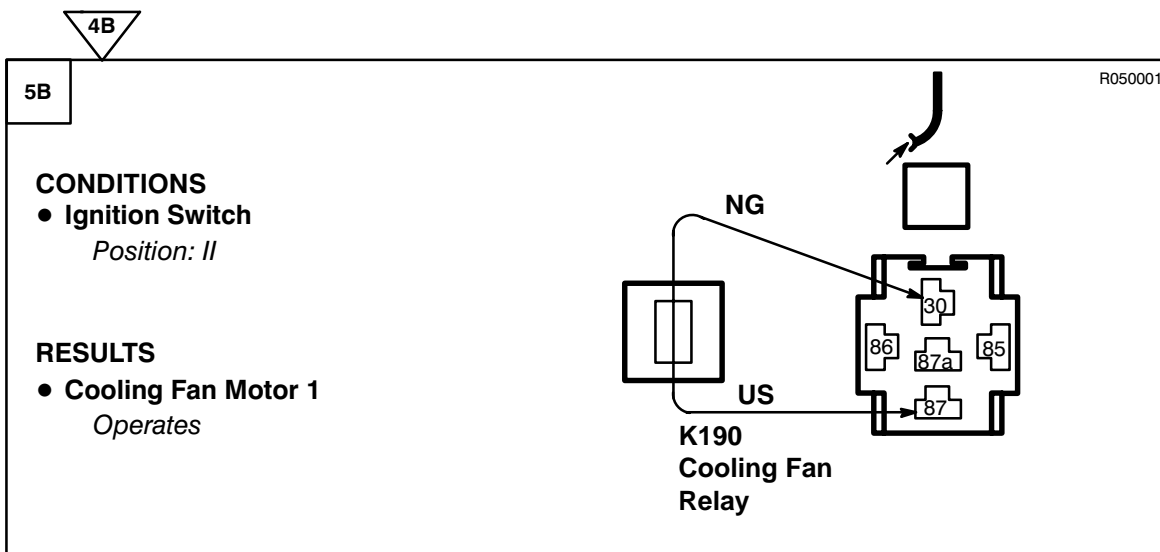

OK PROBLEM CAUSE

- US Wire
- Cooling Fan Motor 1

OK PROBLEM CAUSE

- Cooling Fan Relay

Test C

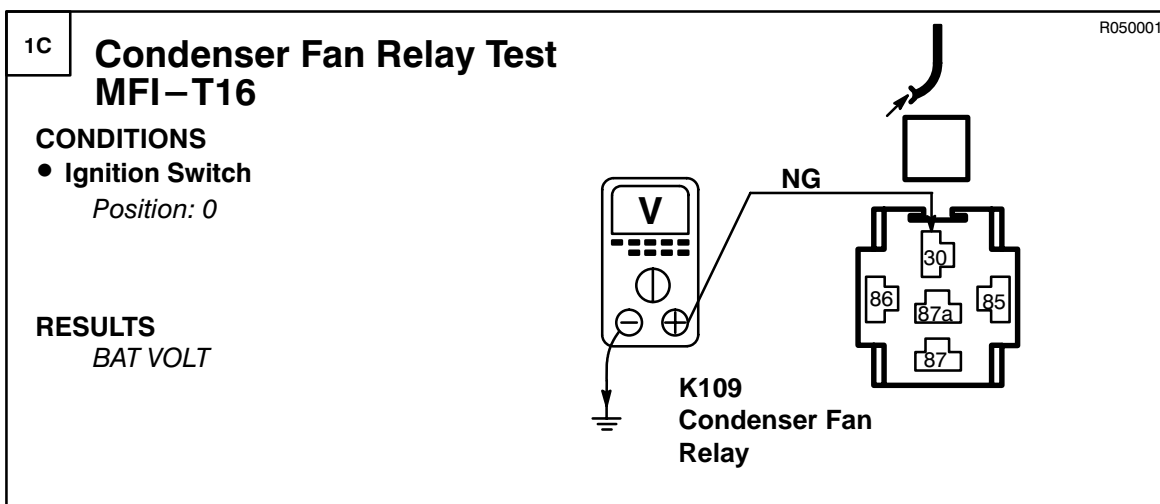

OK PROBLEM CAUSE

- F3 Fuse
- NG Wire

OK

↓

2C

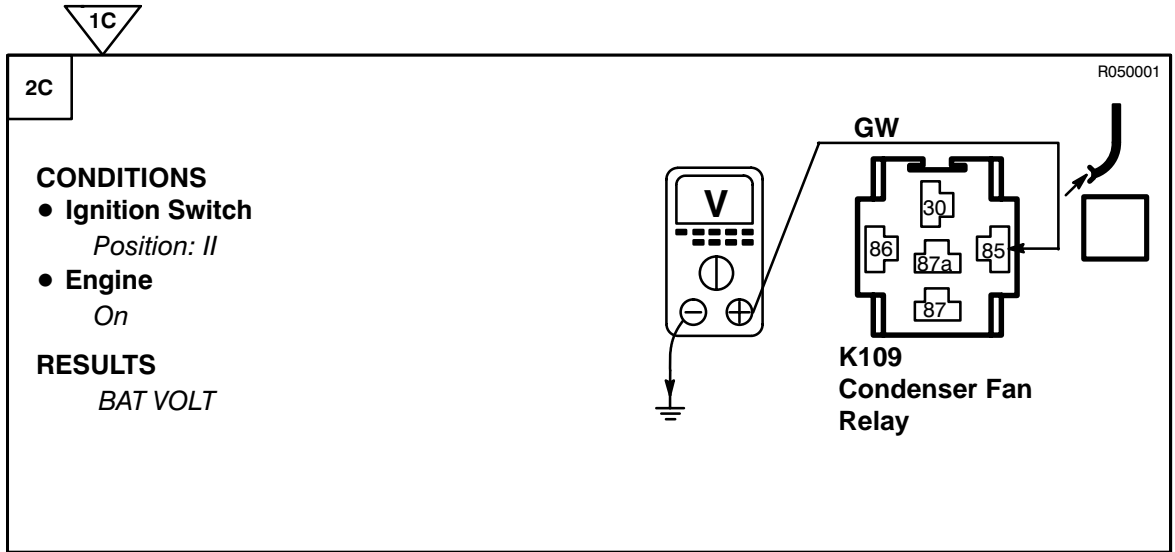

PROBLEM CAUSE

- GW Wire
- Fan Timer Diode

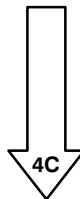
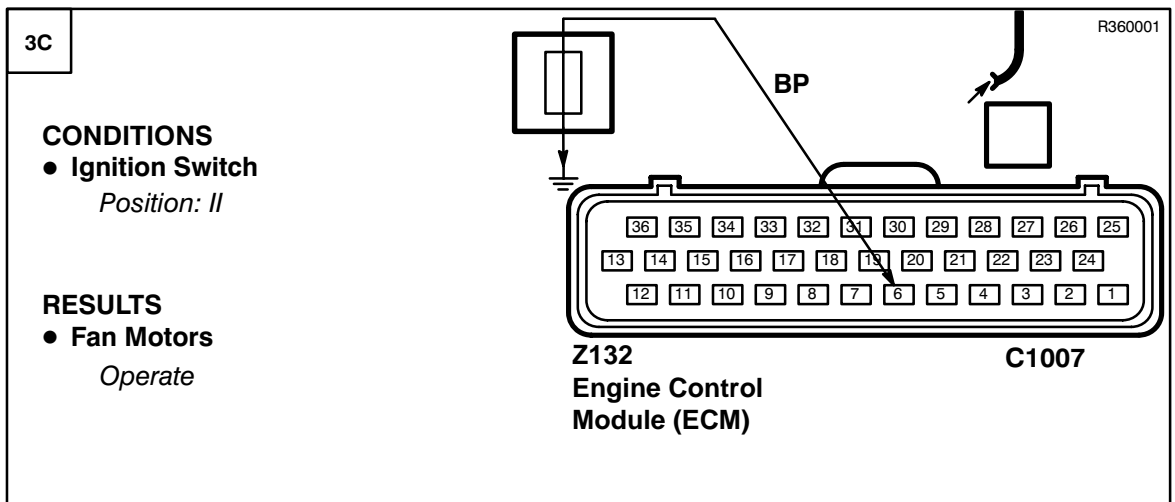
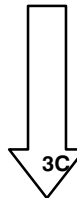

PROBLEM CAUSE

- BP Wire
- Engine Control Module (ECM)

3C

4C

R050001

CONDITIONS

- Ignition Switch
Position: 0

RESULTS

- Fan Motors
Operate

NG

BN

K109
Condenser Fan
Relay

~~OK~~ PROBLEM CAUSE
- BN Wire

OK PROBLEM CAUSE
- Condenser Fan
Relay

Test D

1D

**Condenser Fan Relay Test
300Tdi with EDC**

R050001

CONDITIONS

- Ignition Switch
Position: 0

RESULTS

BAT VOLT

NG

K109
Condenser Fan
Relay

~~OK~~ PROBLEM CAUSE
- F3 Fuse
- NG Wire

OK

↓
2D

1D

2D

CONDITIONS

- Ignition Switch
Position: II
- Engine
On

RESULTS
BAT VOLT

R050001

K109
Condenser Fan Relay

OK **PROBLEM CAUSE**

- GW Wire
- Fan Timer Diode

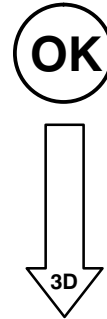

3D

CONDITIONS

- Ignition Switch
Position: II
- Front Fan Speed Switch
Position: I
- Front A/C Switch
A/C Mode

RESULTS
Less than 1 ohm

R050001

K109
Condenser Fan Relay

OK **GO TO TEST G**

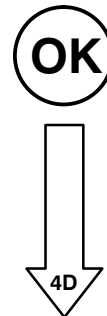

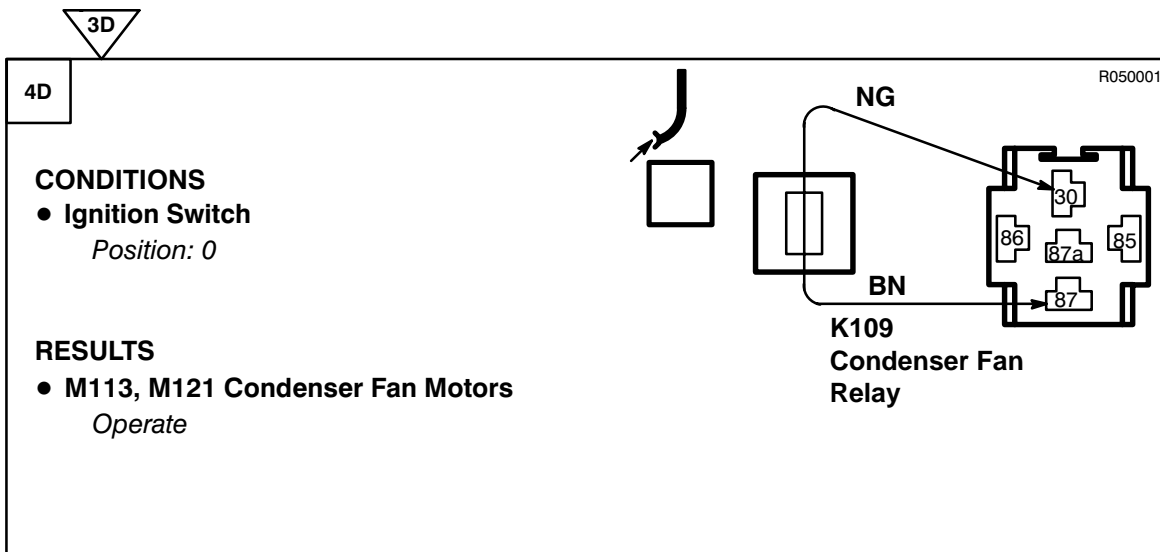

PROBLEM CAUSE
- BN, B Wire



PROBLEM CAUSE
- Condenser Fan
Relay

Test E

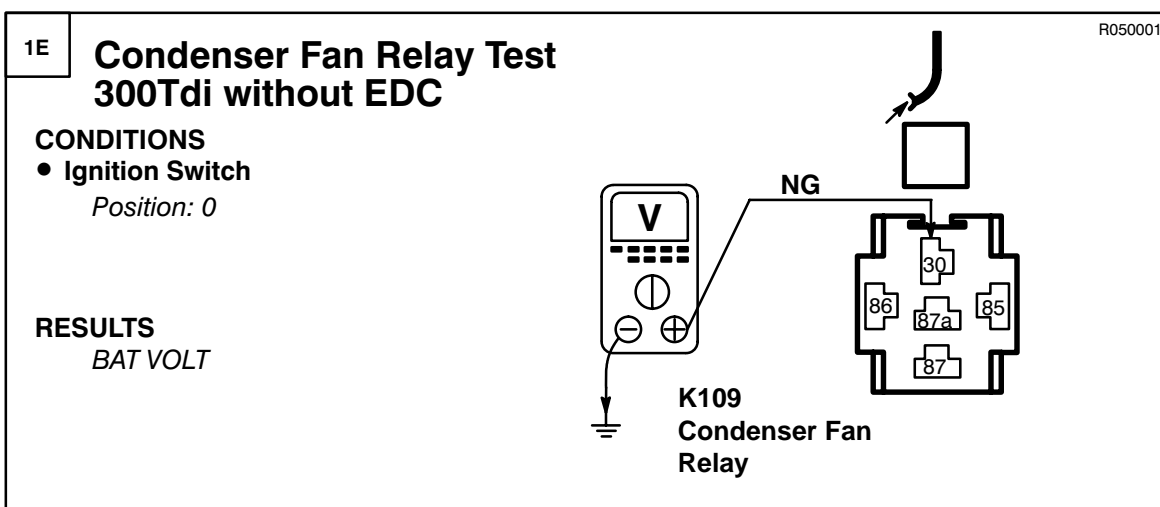

PROBLEM CAUSE
- F3 Fuse
- NG Wire

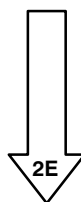

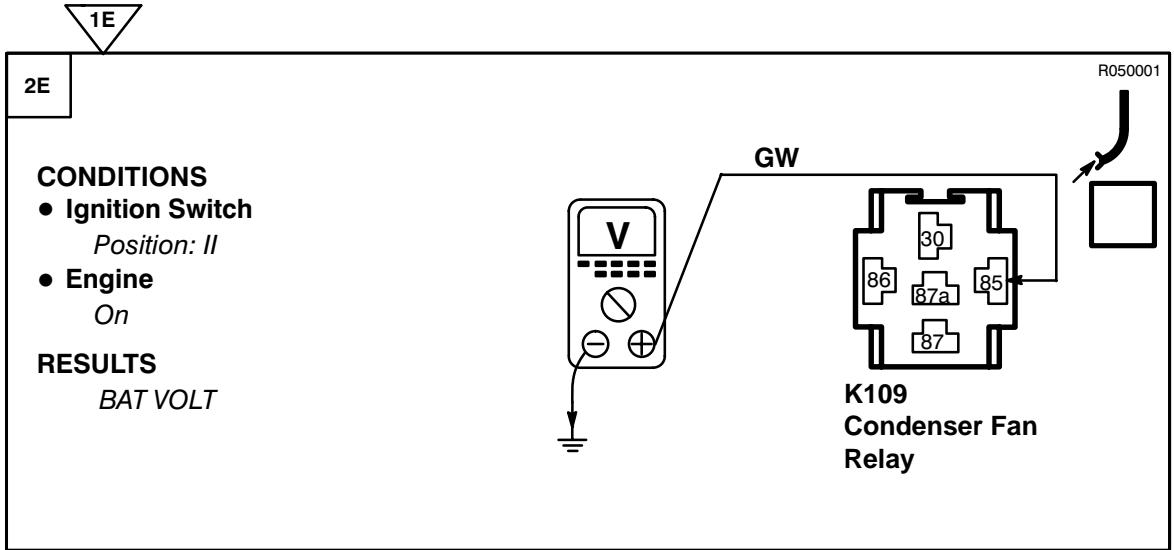

PROBLEM CAUSE

- GW Wire
- Fan Timer Diode

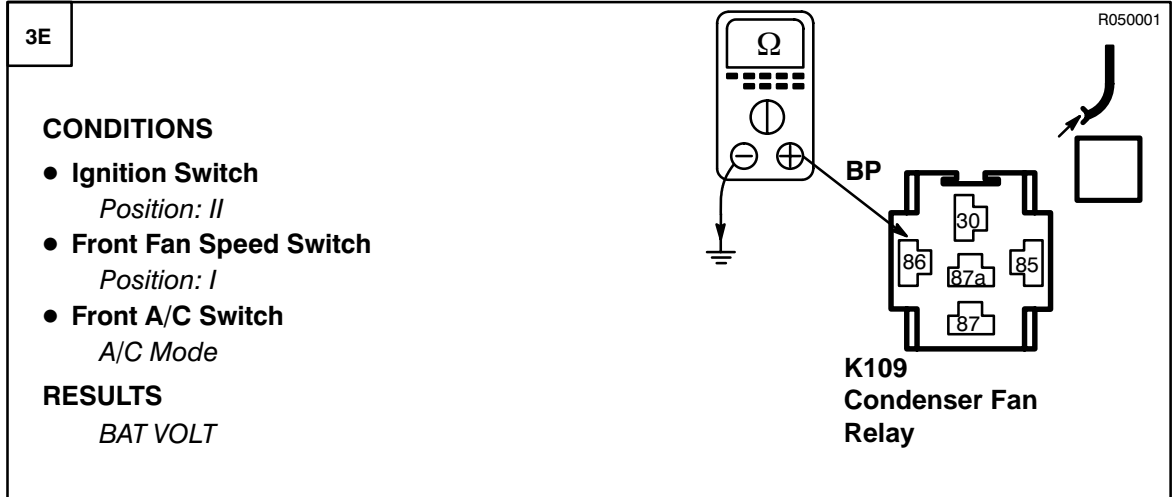
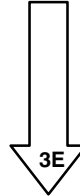

GO TO TEST G

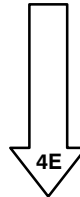

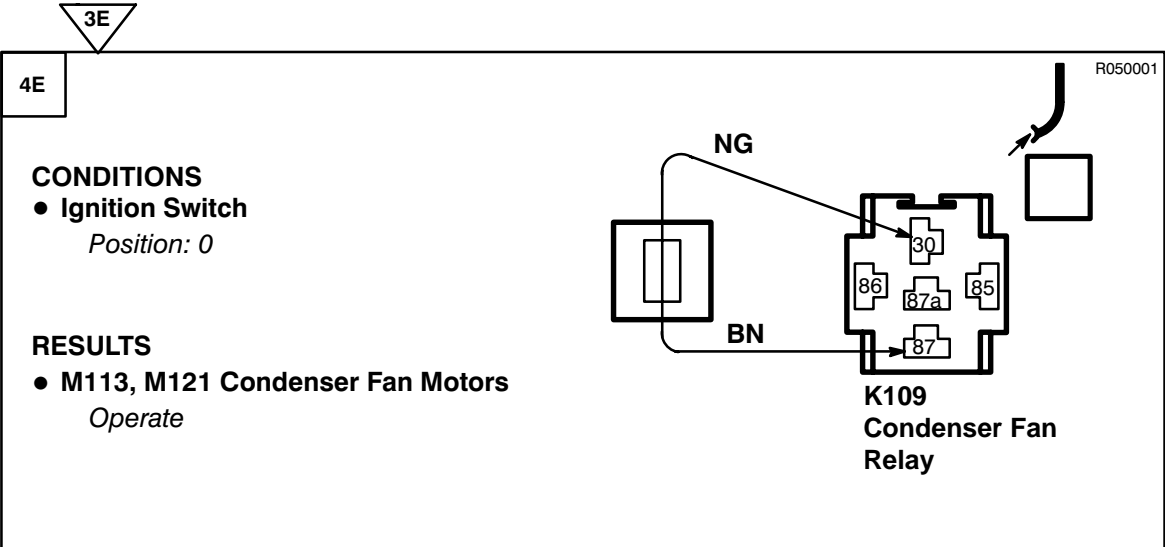

OK PROBLEM CAUSE
- BN, B Wire

OK PROBLEM CAUSE
- Condenser Fan
Relay

Test F

1F A/C Mode**CONDITIONS**

- Ignition Switch
Position: II
- Front Fan Speed Switch
Position: I
- Front A/C Switch
A/C Mode

RESULTS

- Compressor Clutch
On
- Front Blower Motor
On

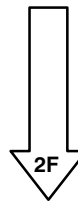

GO TO SECTION K1

**2F****CONDITIONS**

- Ignition Switch
Position: II
- Front Fan Speed Switch
Position: I
- Front A/C Switch
A/C Mode

RESULTS

- M113, M121 Condenser Fan Motors
Operate

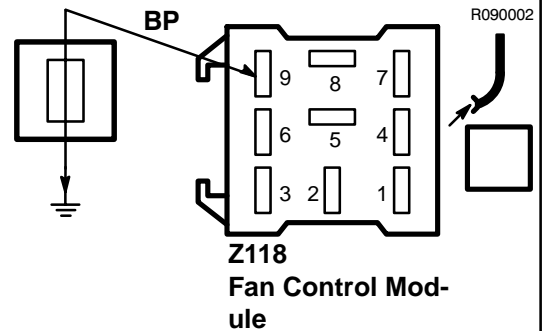
PROBLEM CAUSE
- BP WirePROBLEM CAUSE
- PB Wire
- Condenser Fan
Control Diode 1

Test G

1G A/C Mode

CONDITIONS

- **Ignition Switch**
Position: II
- **Front Fan Speed Switch**
Position: I
- **Front A/C Switch**
A/C Mode

RESULTS

- **Compressor Clutch**
On
- **Front Blower Motor**
On



GO TO SECTION K1

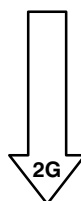

2G

CONDITIONS

- **Ignition Switch**
Position: II
- **Front Fan Speed Switch**
Position: I
- **Front A/C Switch**
A/C Mode

RESULTS

- **M113, M121 Condenser Fan Motors**
Operate

R200003



PROBLEM CAUSE
- BP Wire



PROBLEM CAUSE
- PB Wire
- Condenser Fan Control Diode 1

Test H

1H **Condenser Fan Motor Test**

CONDITIONS

- Ignition Switch
Position: II
- Front Fan Speed Switch
Position: I
- Front A/C Switch
A/C Mode

RESULTS
BAT VOLT

R020011

C182
C183

J2172
M113, M121 Con-
denser Fan
Motor

OK PROBLEM CAUSE
- BN Wire

OK



2H

CONDITIONS

- Ignition Switch
Position: 0

RESULTS
Less than 1 ohm

R020011

C182
C183

J2172
M113, M121 Con-
denser Fan
Motor

OK PROBLEM CAUSE
- B Wire
- Ground Con-
nections

OK PROBLEM CAUSE
- M113, M121 Con-
denser Fan
Motor

Test I

11 Cooling Fan Motor Test R020011

CONDITIONS

- Ignition Switch
Position: II
- Front Fan Speed Switch
Position: I
- Front A/C Switch
A/C Mode

RESULTS
BAT VOLT

J3535
M141, M142
Cooling Fan
Motor

~~OK~~ PROBLEM CAUSE
- BR Wire

OK

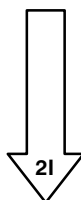

21 R020011

CONDITIONS

- Ignition Switch
Position: 0

RESULTS
Less than 1 ohm

J3535
M141, M142
Cooling Fan
Motor

C1011
C1012

~~OK~~ PROBLEM CAUSE
- B Wire
- Ground Connections

OK PROBLEM CAUSE
- M141, M142
Cooling Fan
Motor

Test J

R020003

1J

Temperature Switch Test

CONDITIONS

- Ignition Switch
Position: II

RESULTS
BAT VOLT

X113
Condenser Fan
Coolant Tem-
perature Switch



PROBLEM CAUSE
- BP Wire

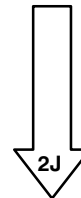

R020003

2J

CONDITIONS

- Ignition Switch
Position: II

RESULTS

- M113, M121 Condenser Fan Motors
Operate

X113
Condenser Fan
Coolant Tem-
perature Switch



PROBLEM CAUSE
- B Wire
- E100 Petrol
- E103 Diesel



PROBLEM CAUSE
- Condenser Fan
Coolant Tem-
perature Switch

Test K

R090002

1K

Fan Timer Test

CONDITIONS

- Ignition Switch
Position: II
- Engine
On

RESULTS
BAT VOLT

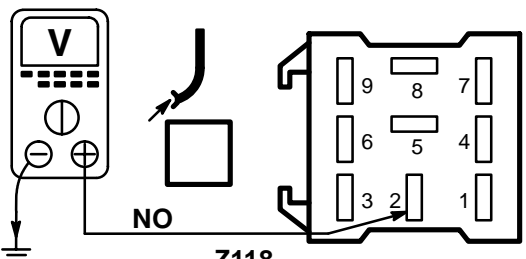

Z118
Fan Control Mod-
ule

~~OK~~ PROBLEM CAUSE
- NO Wire

OK

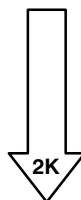

R090002

2K

CONDITIONS

- Ignition Switch
Position: 0

RESULTS
Less than 1 ohm

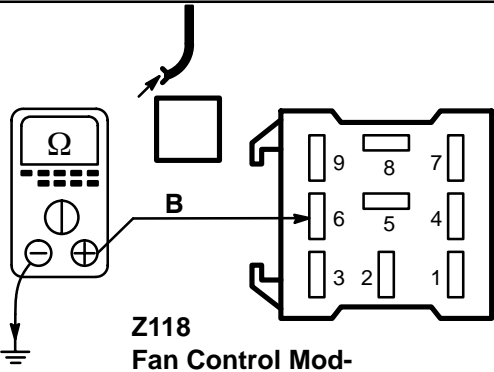

Z118
Fan Control Mod-
ule

~~OK~~ PROBLEM CAUSE
- B Wire
- E100

OK

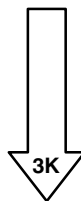

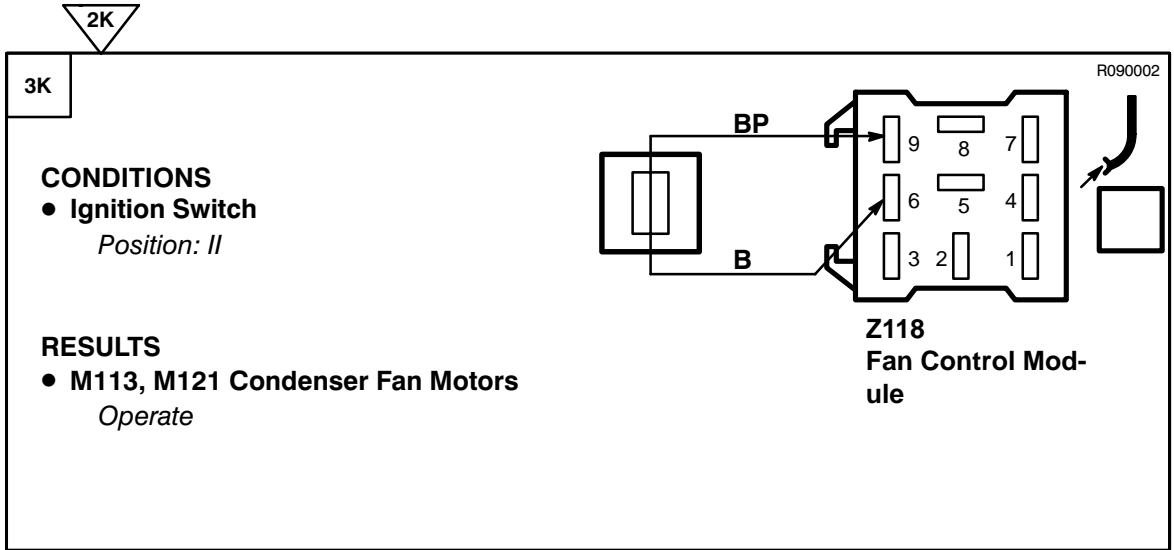

PROBLEM CAUSE

- BP Wire
- B Wire

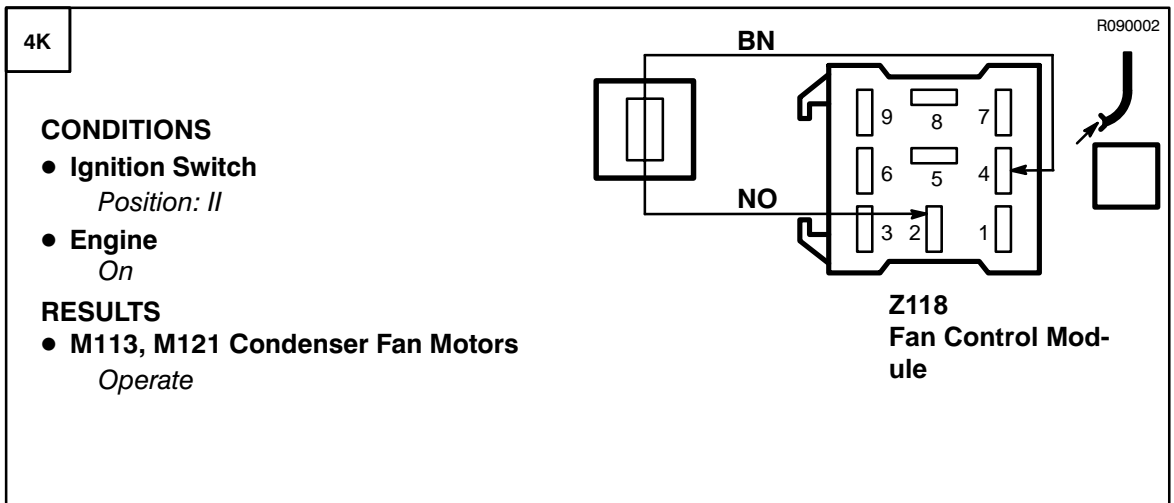
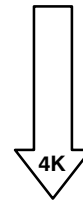

PROBLEM CAUSE

- BN Wire

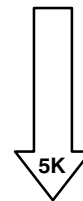

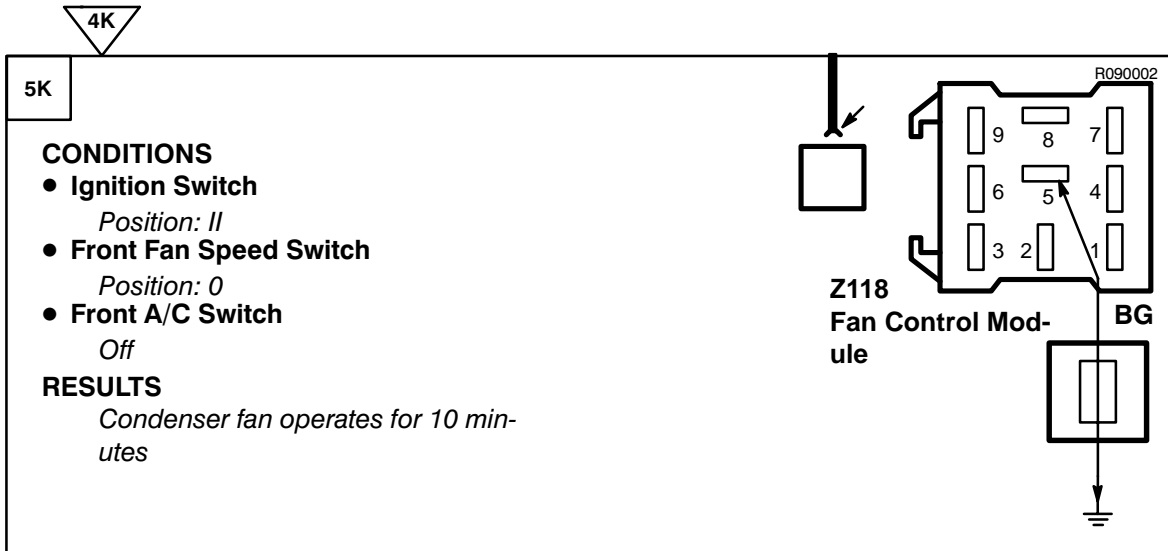

OK PROBLEM CAUSE
- Fan Control Module

OK PROBLEM CAUSE
- BG Wire
- Engine Control Module (ECM)

CIRCUIT OPERATION

Voltage for window lift and sunroof operation is provided to the Window Lift ECU (Z147) from fuses F1 and F2. The Window Lift ECU is grounded through the C wire at ground E200.

Timeout Feature

Fuse F15 applies voltage to the Window Lift ECU terminal 3 when the ignition switch is on. When the ignition switch is turned off, the absence of voltage at terminal 3 signals the Window Lift ECU to start the timeout feature. When the timeout feature is activated, the Window Lift ECU will allow window and sunroof operation for an additional 45 seconds.

The timeout feature will be cancelled if the driver's door is opened and then closed. The Window Lift ECU monitors the door's position at terminal 7.

Front Window Operation

When a Front Window Switch is operated, the switch grounds one of four Window Lift ECU input terminals. This signals the Window Lift ECU to apply voltage and ground to the respective window motor. If the front window switch is held in the down position for more than 1/2 second, the express down feature is activated. The Window Lift ECU will operate the window motor until it is completely lowered.

Rear Window

The Window Lift ECU terminal E supplies voltage to the Rear Window Console and door switches for rear window operation.

When a window console switch is in the 'DOWN' position, voltage is applied to the window motor through the 'up' switch contacts. The window motors operate because they are grounded through the 'down' contacts of the window console switch. When a switch is in the UP position, the polarity applied to the window motor is reversed, causing the motor to run in the opposite direction and the window to close.

Rear Window Isolation Switch (X187)

The Rear Window Isolation Switch (X187) is placed in series with the ground supply to the Rear Window Door Switches (X188, X189). If the isolation switch is opened, the ground supply is interrupted, preventing rear window operation using the rear door switches.

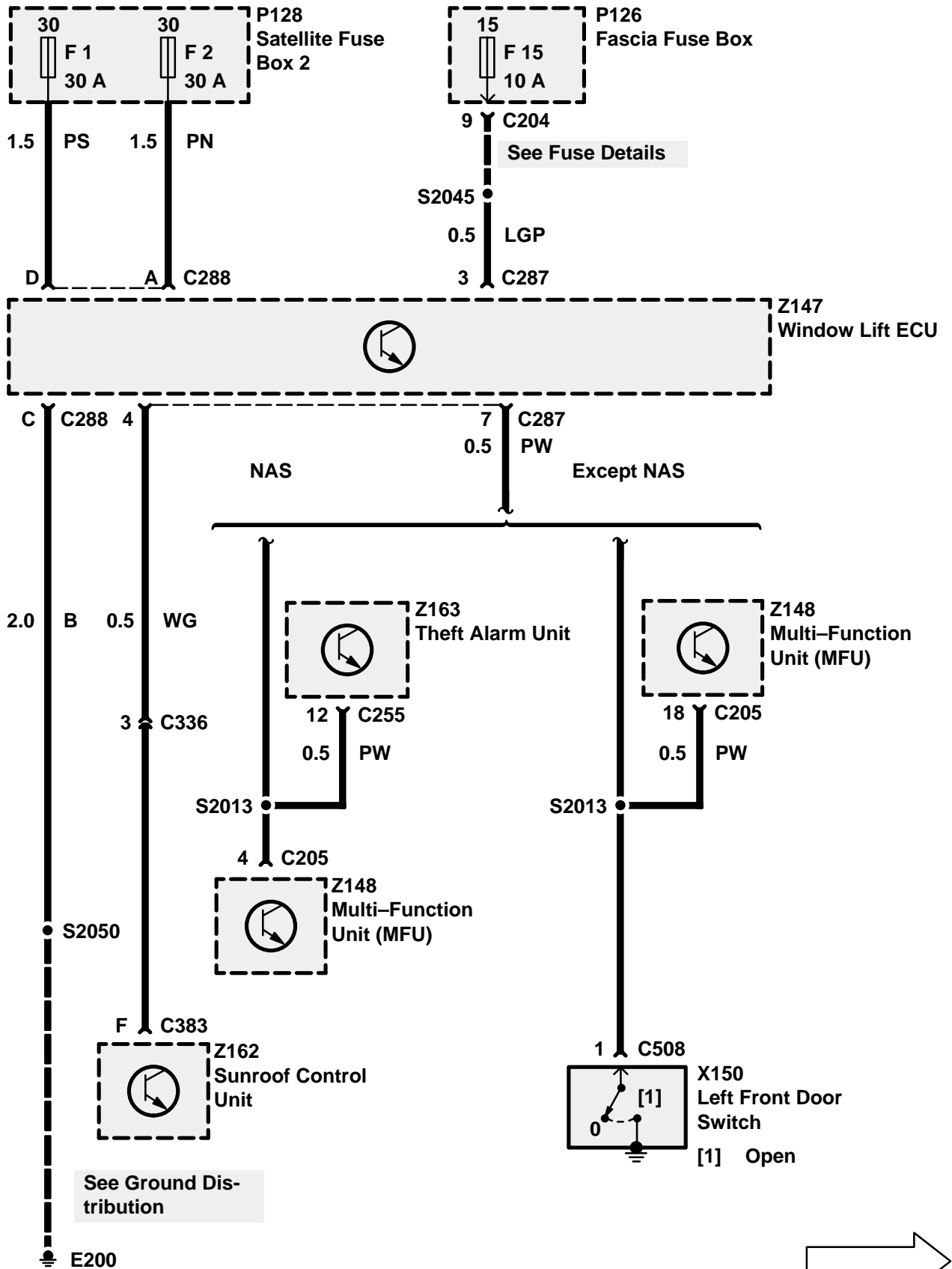

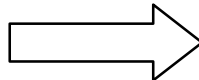
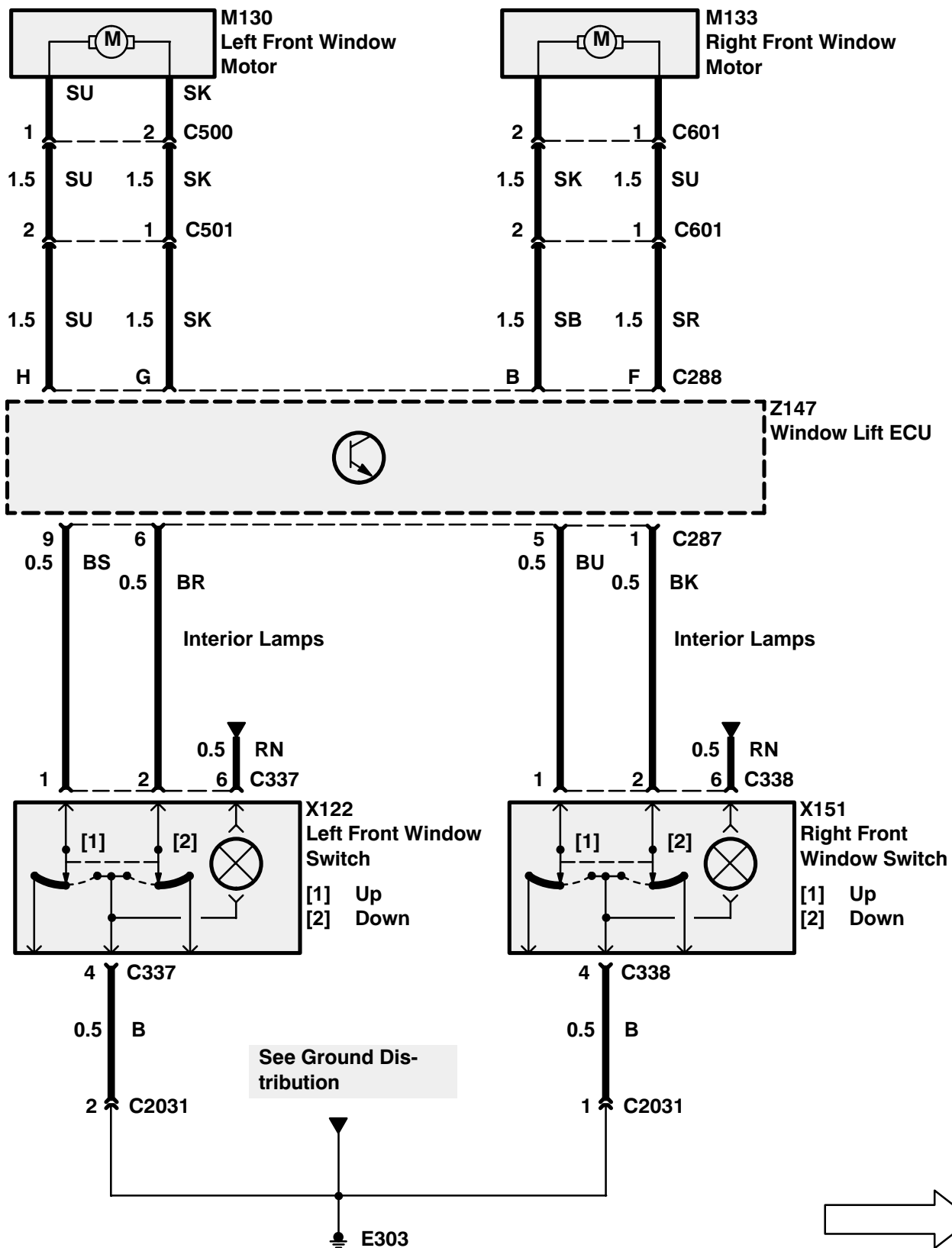
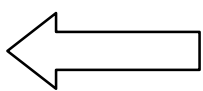

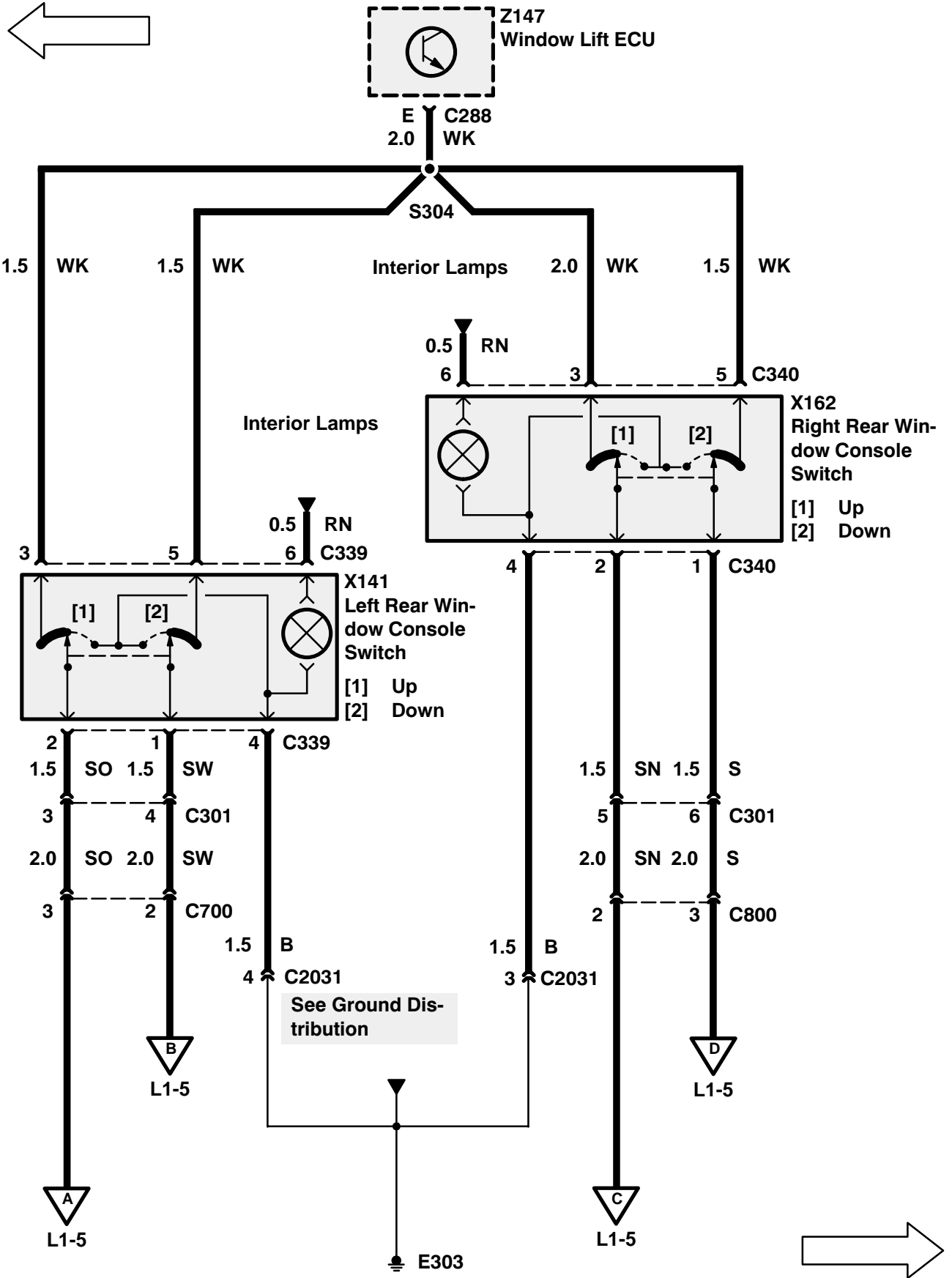

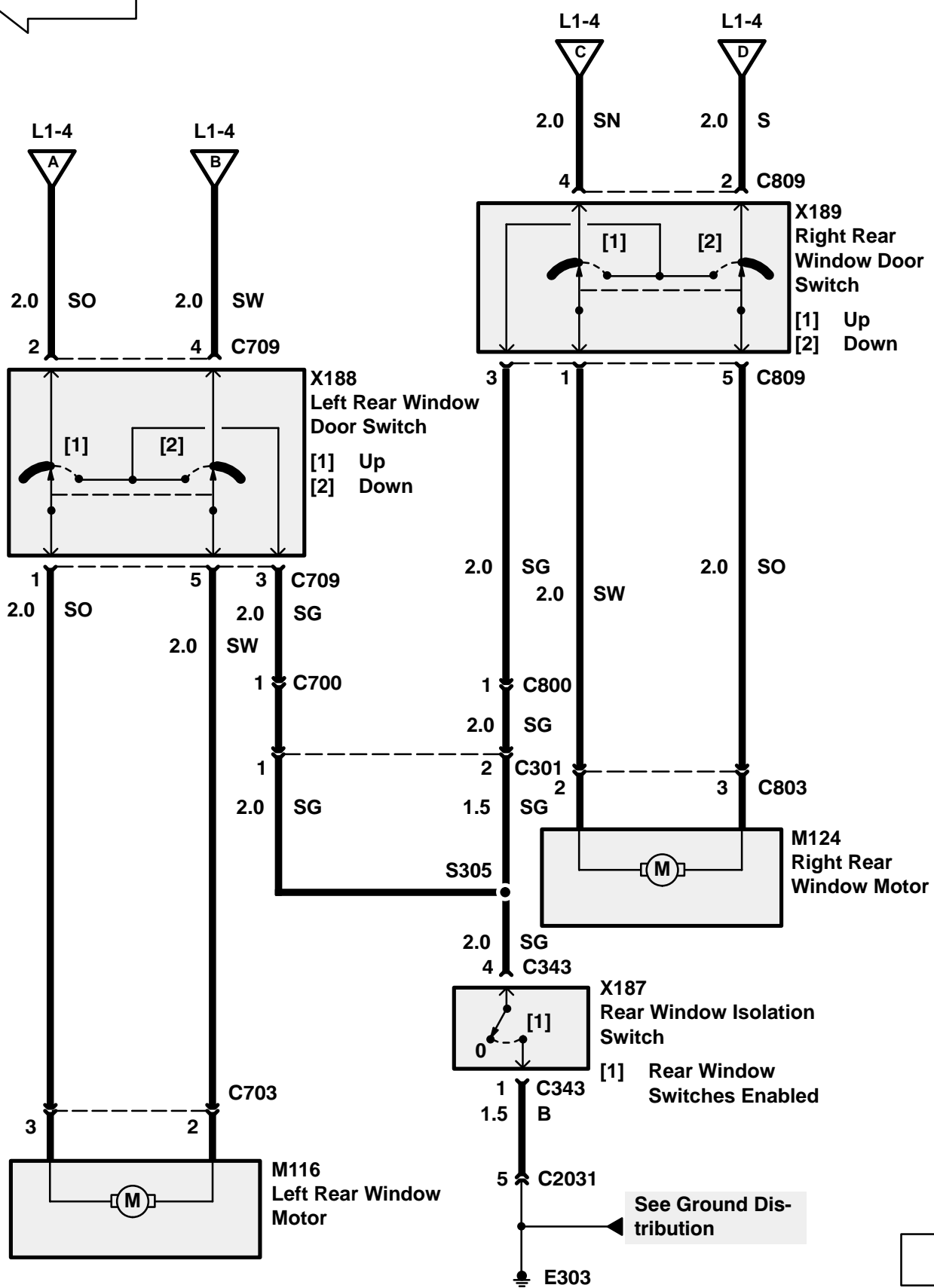
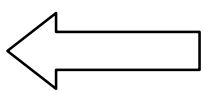

TROUBLESHOOTING HINTS

3. If the one touch window feature does not operate but the window operates, replace the Window Lift ECU (Z147).

SYSTEM DIAGNOSIS

1. If none of the windows operate, do Test A.
2. If both rear windows do not operate from the rear door switches but do operate when the centre console switches are used, do test B.
3. If the rear windows do not operate from the centre console switches and the rear door switches, do Test C.
4. If one rear window does not operate from the centre console and door switch, do Test D.
5. If a rear window does not operate using the door switch but does operate from the centre console switch, do Test F.
6. If a rear window does not operate from the centre console switch but does work when the door switch is used, do Test E.
7. If a front window does not operate, do Test G.
8. If the window timeout feature does not operate, do test H.

Test A

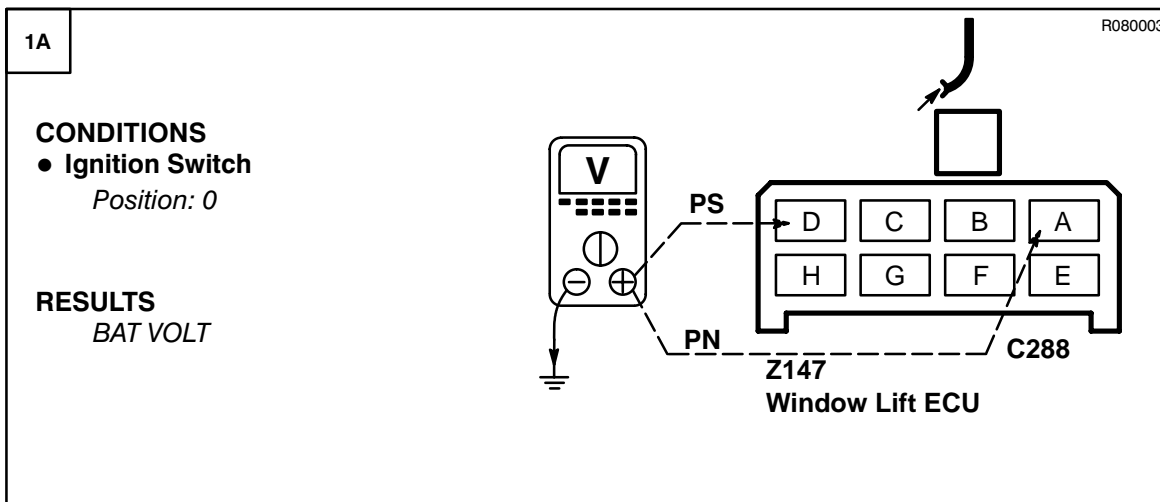

~~OK~~ **PROBLEM CAUSE**

- F1 Fuse
- PS Wire
- F2 Fuse
- PN Wire

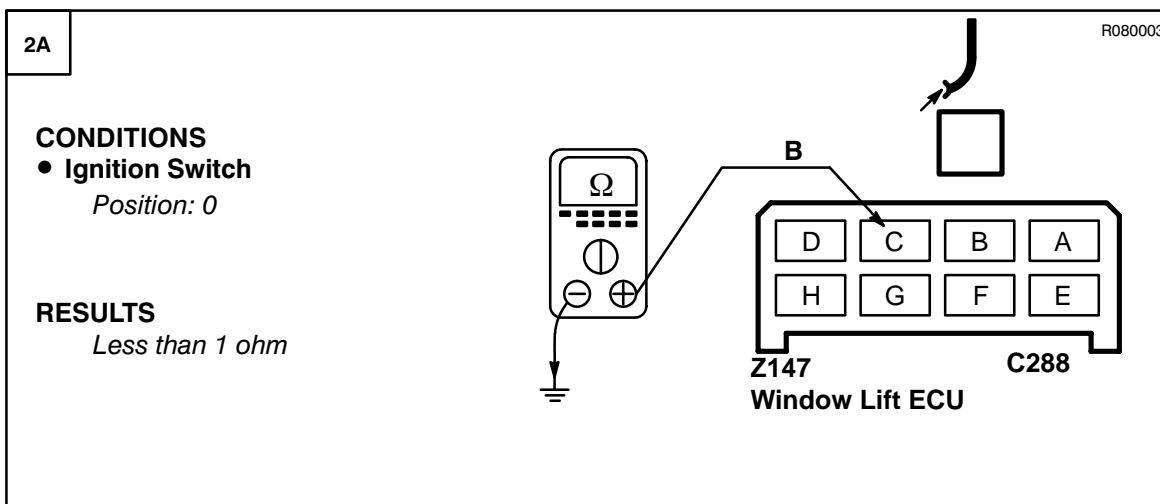
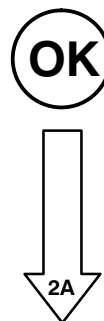

~~OK~~ **PROBLEM CAUSE**

- B Wire

OK **PROBLEM CAUSE**

- Window Lift ECU

Test B

R060019

1B

CONDITIONS

- Ignition Switch
Position: I
- Rear Window Isolation Switch
On

RESULTS

Less than 1 ohm

X187
Rear Window
Isolation Switch



PROBLEM CAUSE

- Rear Window Isolation Switch



PROBLEM CAUSE

- B Wire
- SG Wire

Test C

R080003

1C

CONDITIONS

- Ignition Switch
Position: II

RESULTS
Rear windows operate when switches are operated

**Z147
Window Lift ECU**

OK PROBLEM CAUSE
- WK Wire

OK PROBLEM CAUSE
- Window Lift ECU

Test D

R050008

1D

CONDITIONS

- Ignition Switch
Position: II

RESULTS
BAT VOLT

**J902
X188, X189 Rear
Window Door
Switch**

OK GO TO TEST E

OK
↓
2D

R030021

1D

2D

CONDITIONS

- Ignition Switch
Position: II

RESULTS
BAT VOLT

J903
M116, M124 Rear
Window Motor

~~OK~~ **PROBLEM CAUSE**

- SW Wire
- SO Wire
- X188, X189 Rear Window Door Switch

OK

↓

3D

R030021

3D

CONDITIONS

- Ignition Switch
Position: II

RESULTS

- X188, X189 Rear Window Door Switch

↓ = 0 VOLT
Off = BAT VOLT

J903
M116, M124 Rear
Window Motor

~~OK~~ **PROBLEM CAUSE**

- SW Wire
- SO Wire
- X188, X189 Rear Window Door Switch

OK

↓

4D

3D

4D

CONDITIONS

- Ignition Switch
Position: II

RESULTS

- X188, X189 Rear Window Door Switch

▲ = 0 VOLT
Off = BAT VOLT

SO J752 (Left)

SW J753 (Right)

J903
M116, M124 Rear Window Motor

R030021



PROBLEM CAUSE

- SO Wire
- SW Wire
- X188, X189 Rear Window Door Switch



PROBLEM CAUSE

- M116, M124 Rear Window Motor

Test E

1E

PROBLEM CAUSE

- Ignition Switch
Position: II

RESULTS

BAT VOLT

WK

WK

J901
X141, X162 Rear Window Console Switch

R070008



PROBLEM CAUSE

- WK Wire

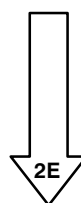

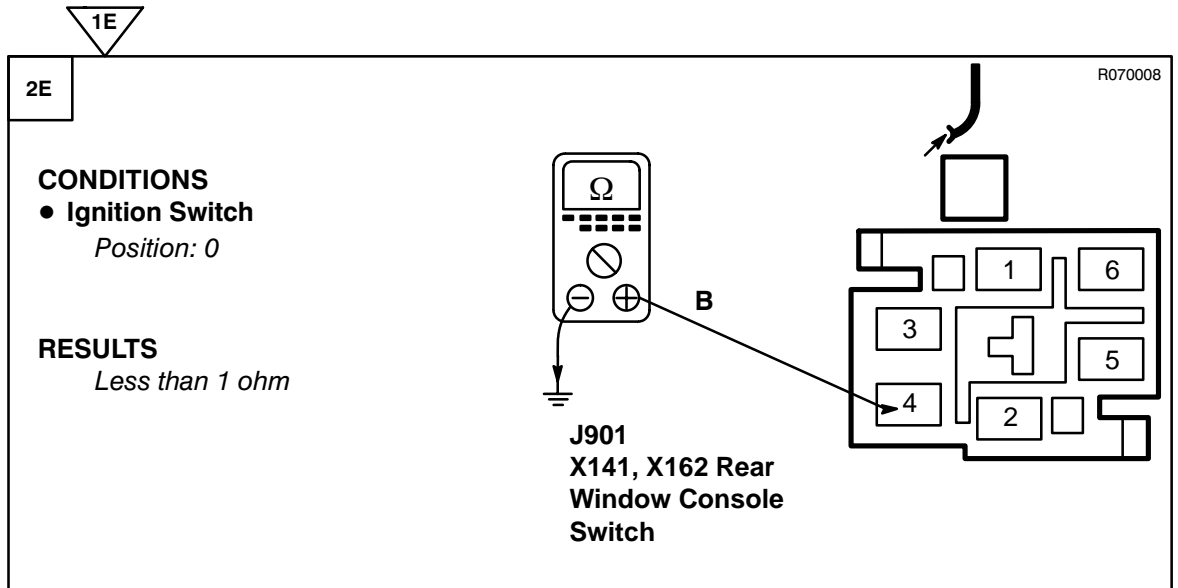

OK PROBLEM CAUSE
- B Wire

OK PROBLEM CAUSE
- S, SO Wire
- SN, SW Wire
- X141, X162 Rear Window Console Switch

Test F

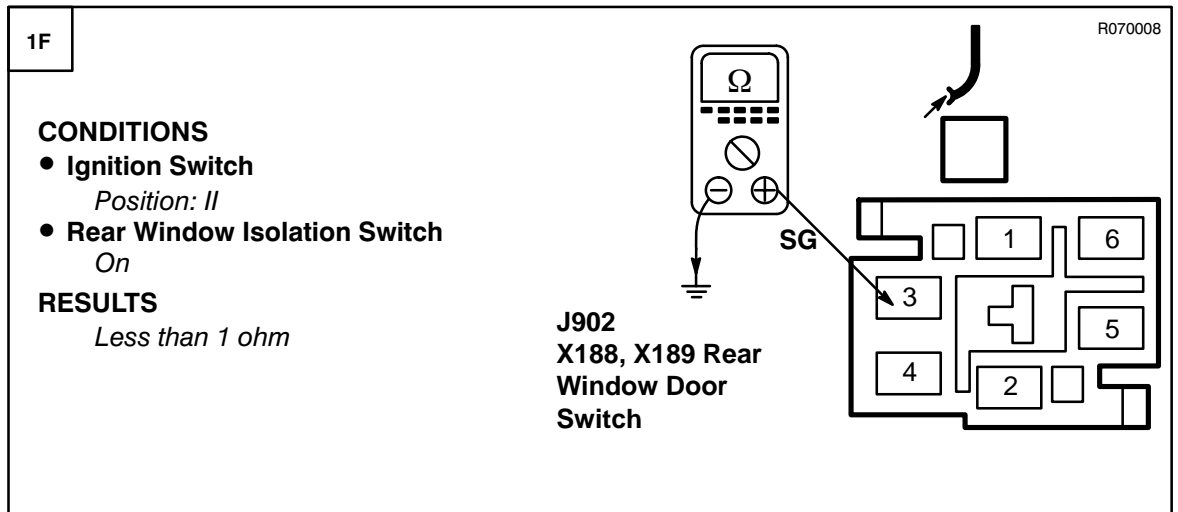

OK PROBLEM CAUSE
- SG Wire

OK PROBLEM CAUSE
- X188, X189 Rear Window Door Switch

Test G

1G

R100005

CONDITIONS

- Ignition Switch
Position: 0

RESULTS

- X122, X151 Front Window Switch
 - ▲ = Less than 1 ohm
 - ▼ = More than 10K ohms



GO TO TEST H

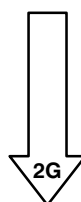

2G

R100005

CONDITIONS

- Ignition Switch
Position: 0

RESULTS

- X122, X151 Front Window Switch
 - ▼ = Less than 1 ohm
 - ▲ = More than 10K ohms



GO TO TEST H

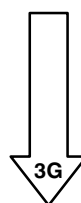

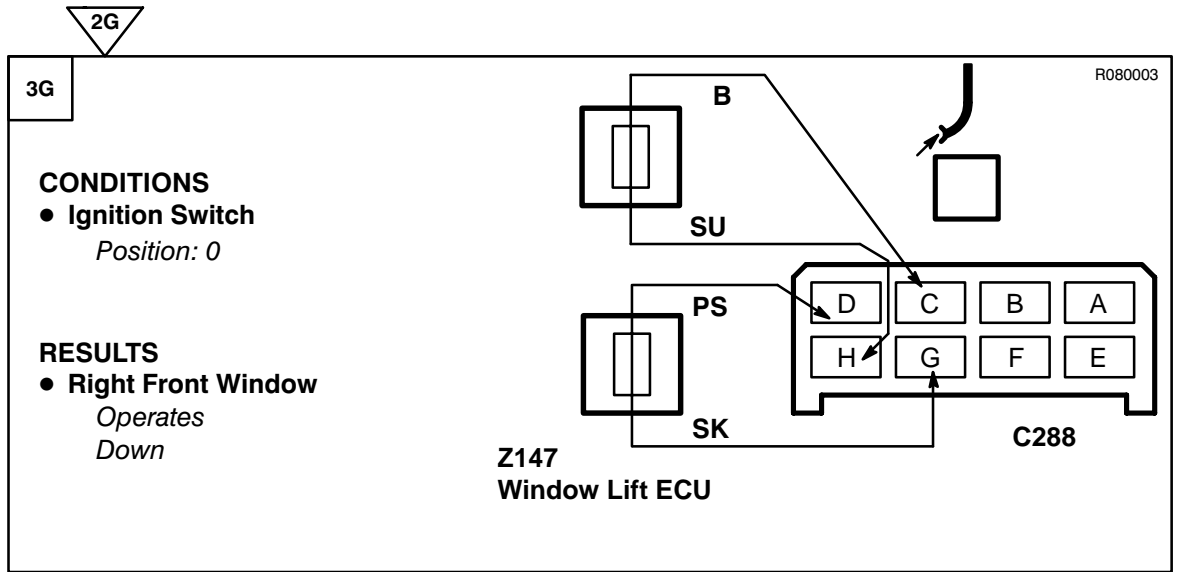

PROBLEM CAUSE

- SU Wire
- SK Wire
- Right Front Window Motor

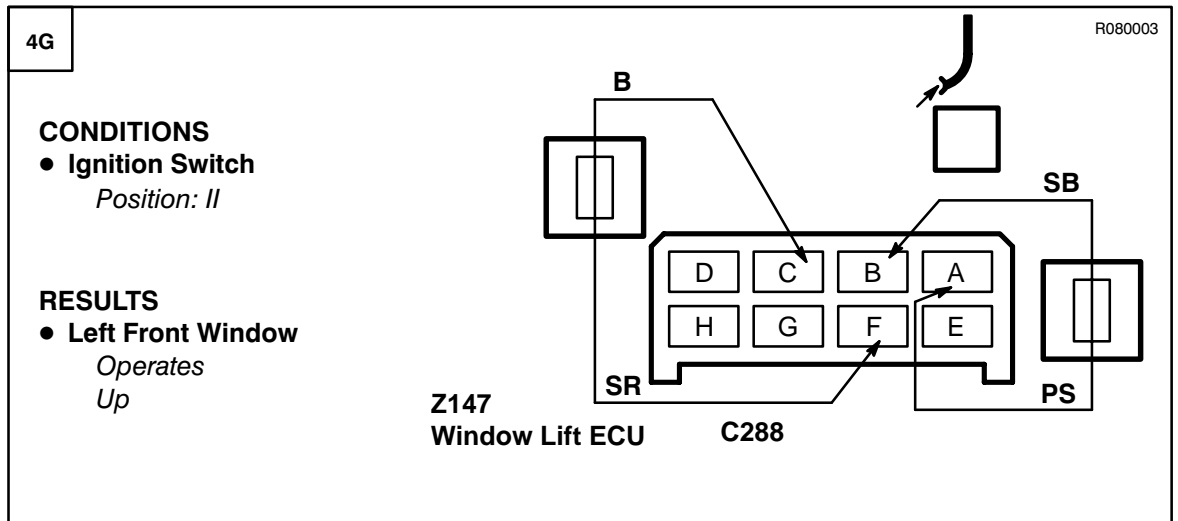
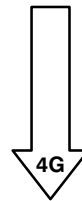

PROBLEM CAUSE

- SB Wire
- SR Wire
- Left Front Window Motor



PROBLEM CAUSE

- Window Lift ECU

Test H

R100005

1H

CONDITIONS

- Ignition Switch
Position: 0

RESULTS

- Right Front Door
Open = Less than 1 ohm
Closed = More than 10K ohms

Z147
Window Lift ECU

PW

C287



PROBLEM CAUSE

- PW Wire
- Right Front Door Switch



PROBLEM CAUSE

- Window Lift ECU

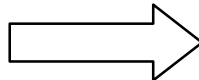
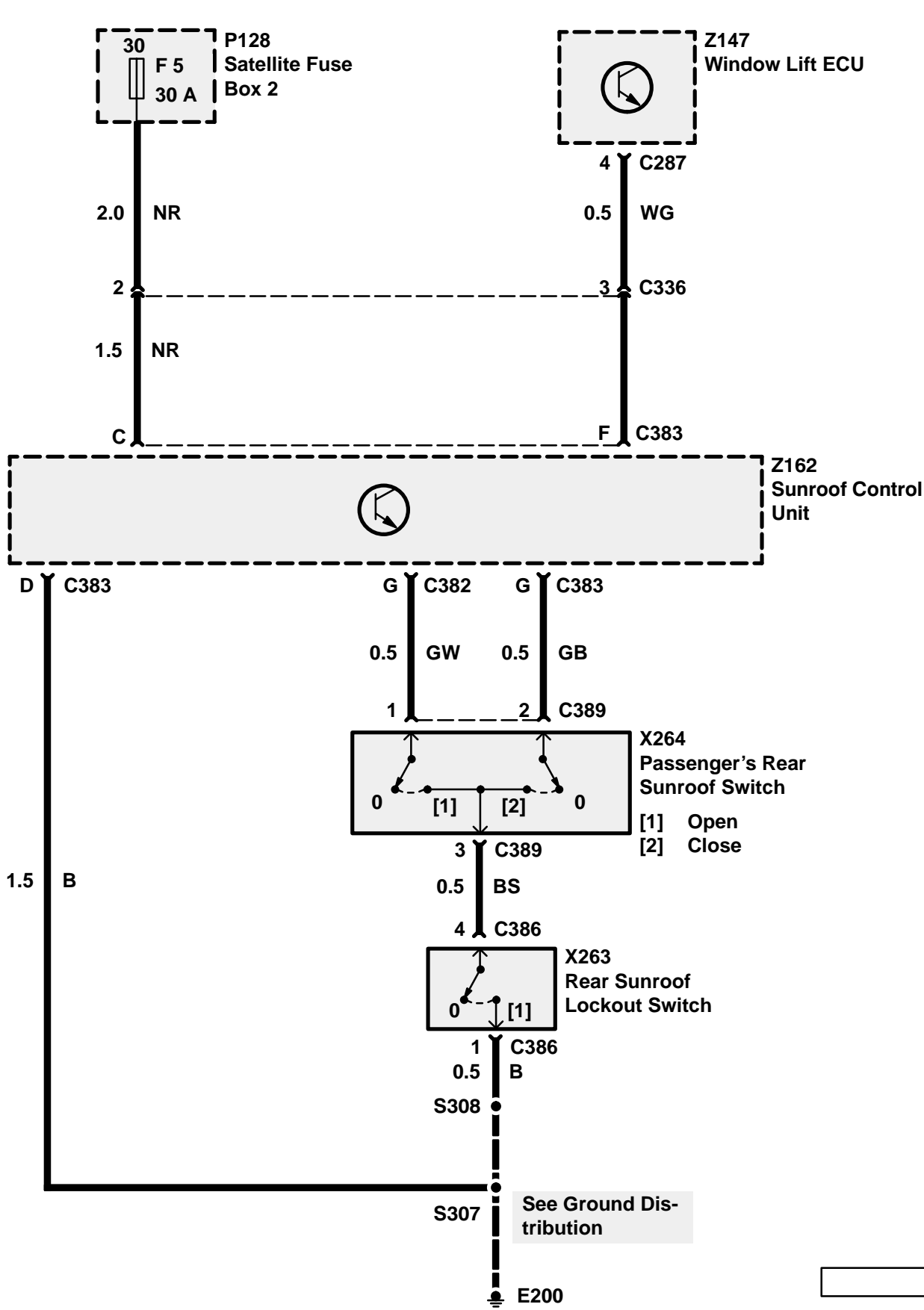

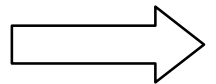
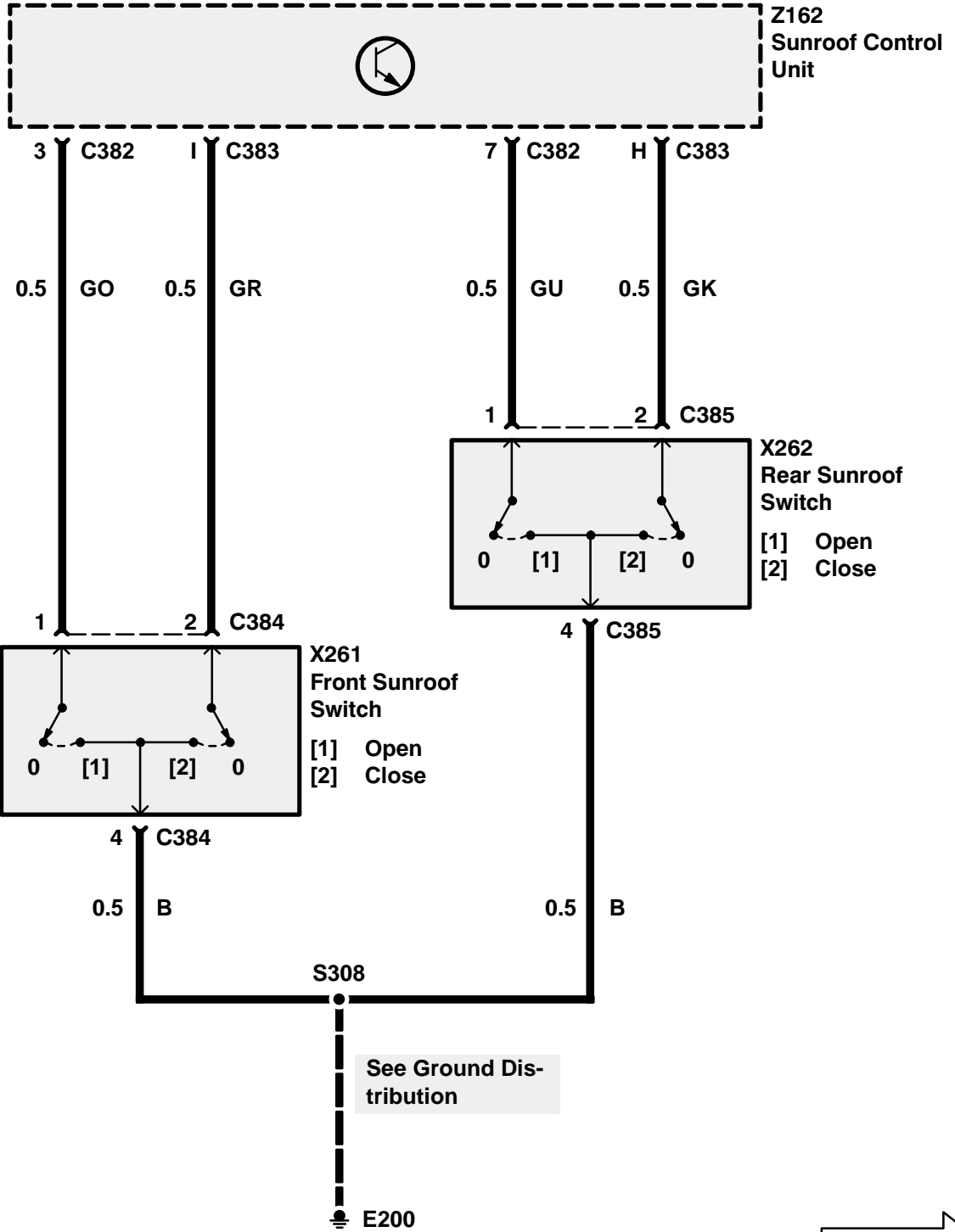
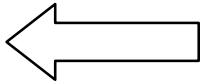

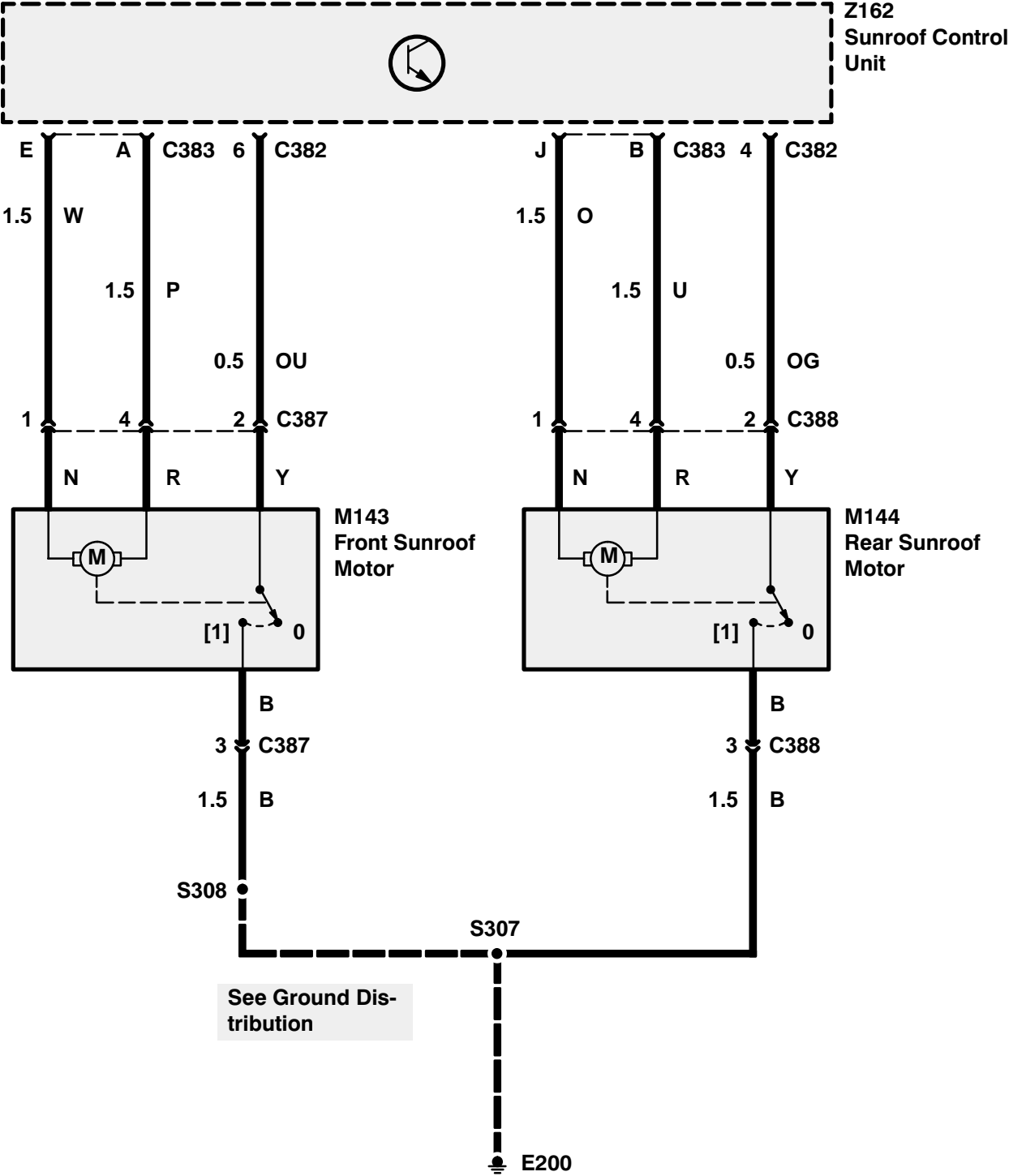
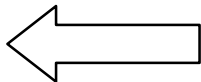

CIRCUIT OPERATION

The locking functions on Models with the Theft Alarm System are controlled by the Theft Alarm Unit (Z163). Refer to the Theft Alarm System (T1). The locking functions on models without the Theft Alarm System are controlled by the Left Front Door Lock Actuator (M114).

The four doors and the tailgate are locked or unlocked using the left front exterior key or the interior door sill knob. The rear doors can be independently locked or unlocked from the inside by using the appropriate door sill knob. These can be overridden when the lock controls in the left front door are used. The right front door and the rear doors may be locked or unlocked in isolation, from the outside using the key or from the inside using the door sill knob.

Lock

When the doors are locked by the by the left front exterior key or the interior door sill knob the internal microswitches in the Left Front Door Lock Actuator (M114) move to the "Lock" Position. Voltage from fuse F4 is applied to the lock actuators through the K wires. The lock actuators are grounded at E201 through the microswitch contacts and the O wires. The doors and the tailgate now lock. The solid state load sensor/timer ensure that the motors operate only for the time required to lock or unlock the doors and the tailgate.

Unlock

When the doors are unlocked by the left front exterior key or the interior door sill knob the internal microswitches in the Left Front Door Lock Actuator (M114) move to the "Unlock Position". Voltage from Fuse F4 is applied to the lock actuators through the O wires. The lock actuators are grounded at E201 through the microswitch contacts and the K wires. Since the polarity of the voltage is now reversed the doors and the tailgate unlock.

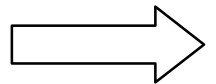
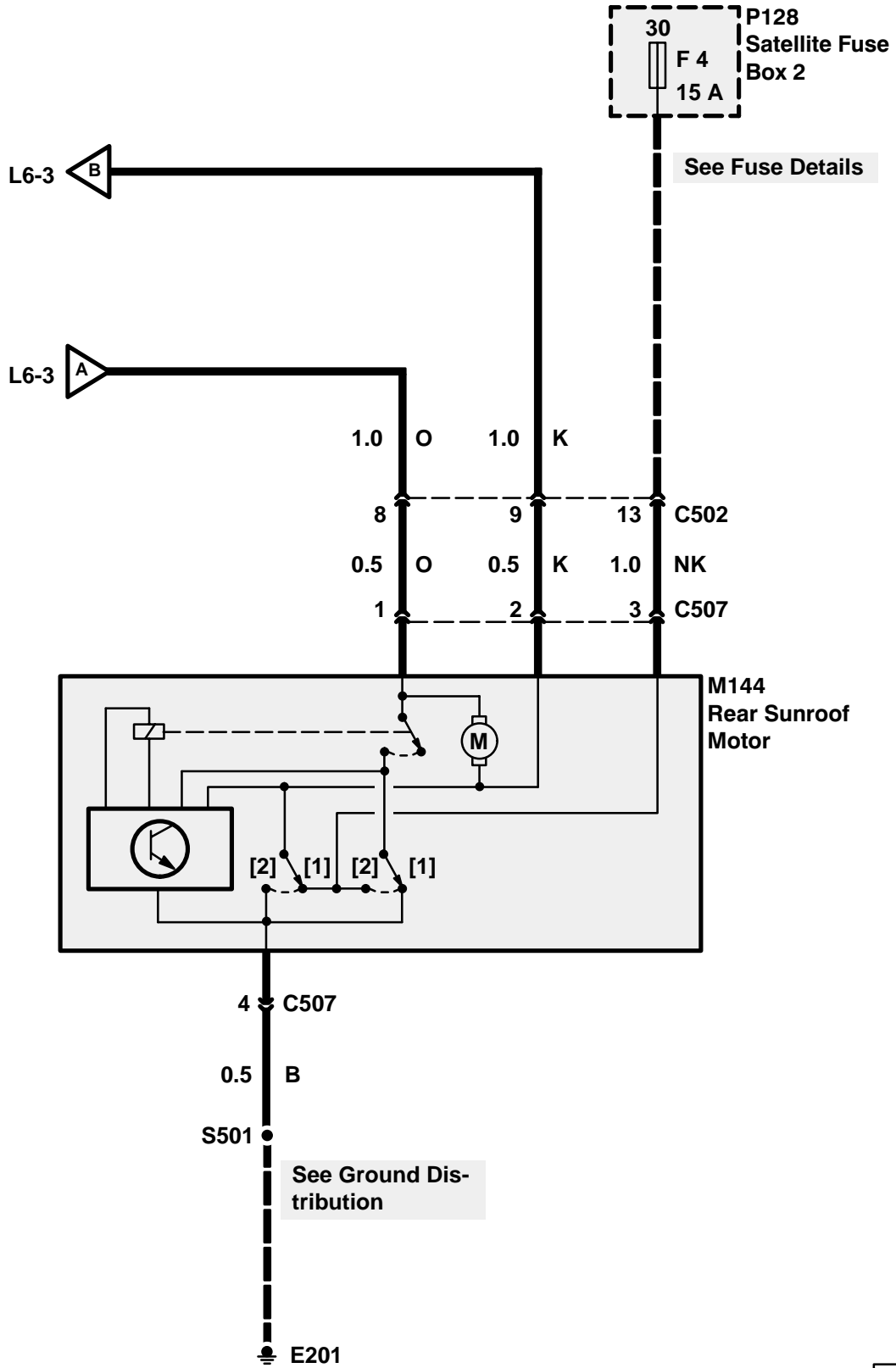

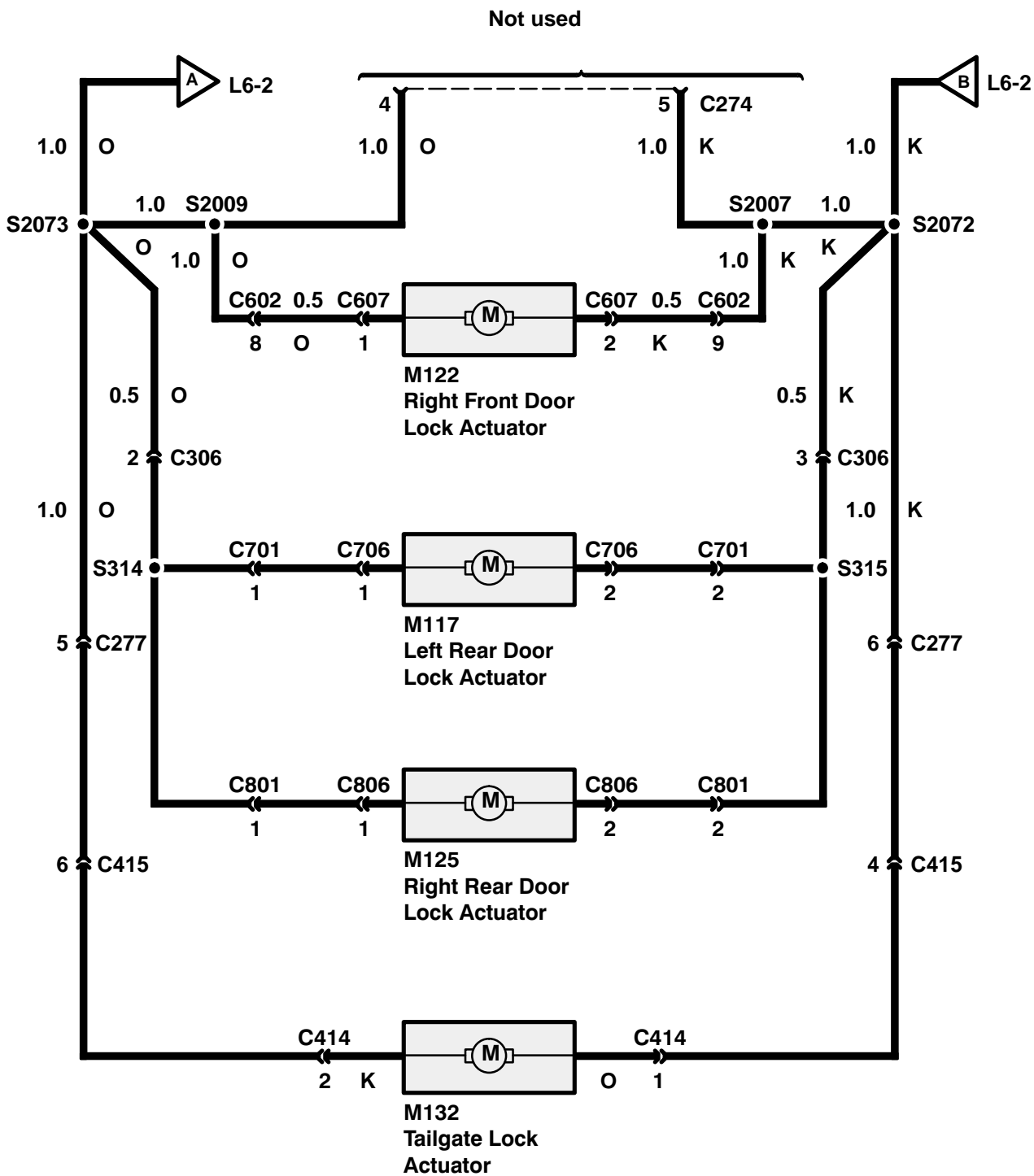
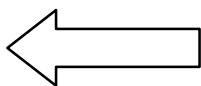

TROUBLESHOOTING HINTS

9. Check Fuse F4 of Satellite Fuse Box 2.
10. If all the central locking functions except the left front door operate, replace the Left Front Door Lock Actuator (M114).
11. If only the left front door operates, check K and O wires.

SYSTEM DIAGNOSIS

1. If the central locking functions do not operate at all, do Test A.
2. If the Right Front Door Actuator (M122) does not operate, do Test B.
3. If the Tailgate Lock Actuator (M132) does not operate, do Test C.
4. If both Rear Door Lock Actuators (M117, M125) do not operate, do Test D.

Test A

1A

R040029

CONDITIONS

- Ignition Switch
Position: 0

RESULTS
BAT VOLT

M114
Left Front Door
Lock Actuator



PROBLEM CAUSE

- F4 Fuse
- NK Wire
- B Wire



PROBLEM CAUSE

- Left Front Door
Lock Actuator

Test B

1B

R020029

CONDITIONS

- Ignition Switch
Position: 0
- All doors
Locked
- Unlock Right Front Door

RESULTS
BAT VOLT (Momentary)

M122
Right Front Door
Lock Actuator



PROBLEM CAUSE

- O Wire
- K Wire



PROBLEM CAUSE

- Right Front Door
Lock Actuator

Test C

1C

R020031

CONDITIONS

- Ignition Switch
Position: 0
- All doors
Unlocked
- Lock Right Front Door

RESULTS
BAT VOLT (Momentary)

M132
Tailgate Lock
Actuator



PROBLEM CAUSE
- K Wire

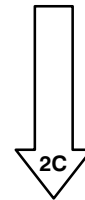

2C

R020031

CONDITIONS

- Ignition Switch
Position: 0
- All doors
Locked
- Unlock Right Front Door

RESULTS
BAT VOLT (Momentary)

M132
Tailgate Lock
Actuator



PROBLEM CAUSE
- O Wire



PROBLEM CAUSE
- Tailgate Lock
Actuator

Test D

R020029

1D

CONDITIONS

- Ignition Switch
Position: 0
- All doors
Unlocked
- Lock Right Front Door

RESULTS
BAT VOLT (Momentary)

J2176
M117, M125 Rear Door Lock Actuator

~~OK~~ PROBLEM CAUSE
- K Wire

OK

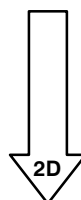

R020029

2D

CONDITIONS

- Ignition Switch
Position: 0
- All doors
Locked
- Unlock Right Front Door

RESULTS
BAT VOLT (Momentary)

J2176
M117, M125 Rear Door Lock Actuator

~~OK~~ PROBLEM CAUSE
- O Wire

OK PROBLEM CAUSE
- M117, M125 Rear Door Lock Actuator

CIRCUIT OPERATION

When the Ignition Switch (X134) is in position II, voltage is supplied to the power mirrors circuit by fuse F18.

Left/Right Movement

When a selected mirror is moved to the left by the Mirror Adjustment Switch (X146) the internal contacts move to the "Move Down or Left" and the "Move Left" positions. The Left/Right Motor of the selected actuator is grounded at E201 through the SW wires and the switch contacts. Voltage is applied to the Left/Right Motor through the BP, BU wires. The mirror now moves left.

When a selected mirror is moved to the right by the Mirror Adjustment Switch (X146) the internal contacts move to the "Move up or Right" and the "Move Right" positions. The Left/Right Motor of the selected actuator is grounded at E201 through the BU, BP wires and the switch contacts. Voltage is applied to the Left/Right Motor through the SW wires. Since the polarity of the voltage to the motor has been reversed, the mirror now moves right.

Up/Down Movement

When a selected mirror is moved down by the Mirror Adjustment Switch (X146) the internal contacts move to the "Move Down or Left" and the "Move Down" positions. The Up/Down Motor of the selected actuator is grounded at E201 through the SW wires and the switch contacts. Voltage is applied to the Up/Down Motor through the BK, BN wires. The mirror now moves down.

When a selected mirror is moved up by the Mirror Adjustment Switch (X146) the internal contacts move to the "Move Up or Right" and the "Move Up" positions. The Up/Down Motor of the selected actuator is grounded at E201 through the BN, BK wires and the switch contacts. Voltage is applied to the Up/Down Motor through the SW wires. Since the polarity of the voltage to the motor has been reversed, the mirror now moves up.

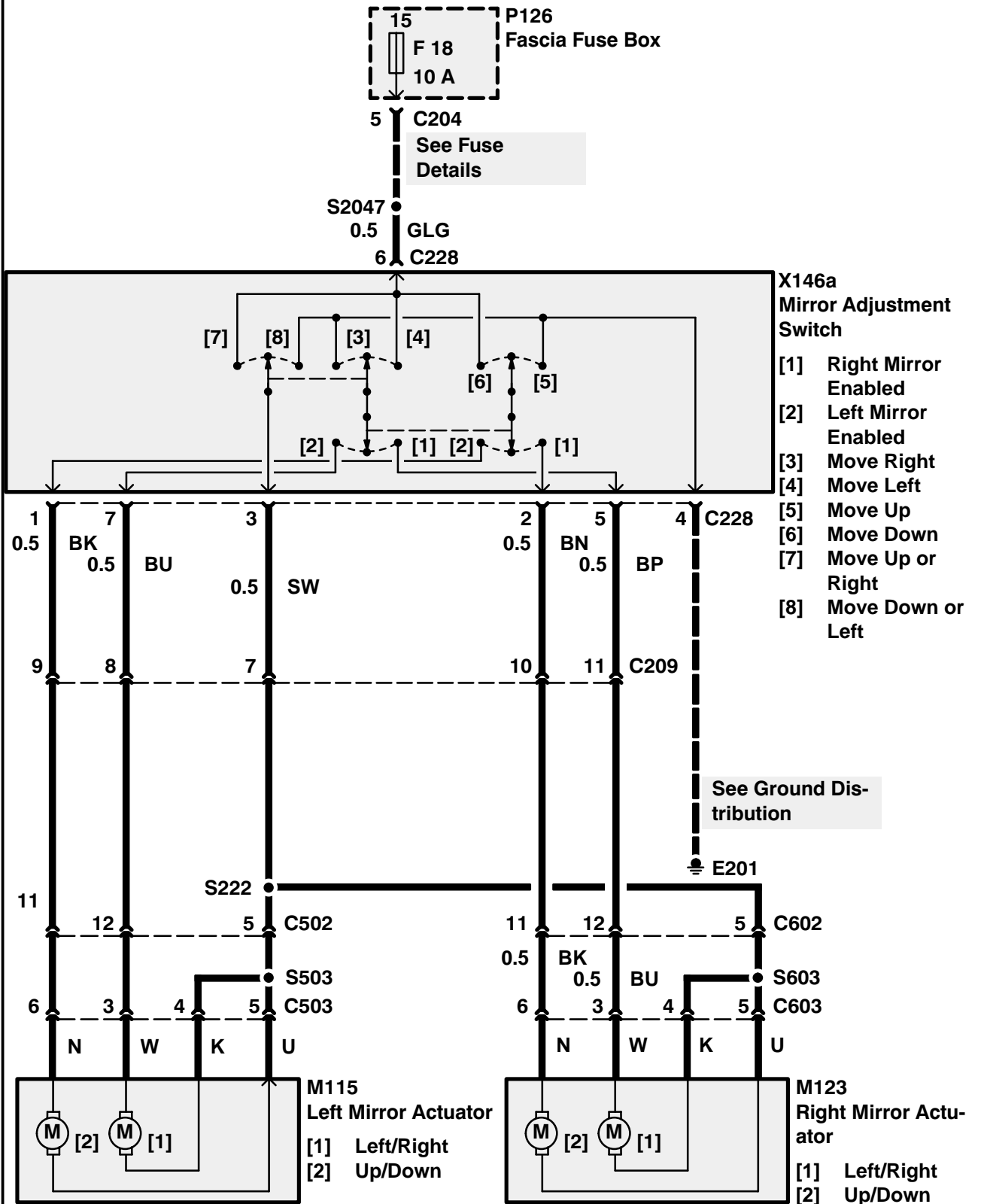

SYSTEM DIAGNOSIS

1. If the mirrors do not operate at all, do Test A.
2. If only one mirror does not operate, do test B, the Mirror Actuator (M115, M123) test.
3. If one or both mirrors operate in some, but not all switch positions, do Test A.

Test A

R080015

1A

CONDITIONS

- Ignition Switch
Position: II

RESULTS
BAT VOLT

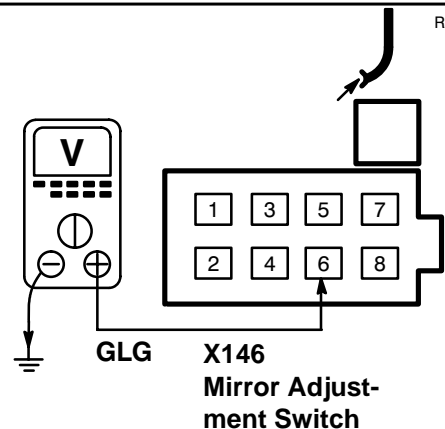

**X146
Mirror Adjust-
ment Switch**



PROBLEM CAUSE

- F18 Fuse
- GLG Wire

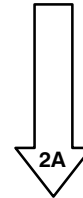

R080015

2A

CONDITIONS

- Ignition Switch
Position: II

RESULTS
Less than 1 ohm

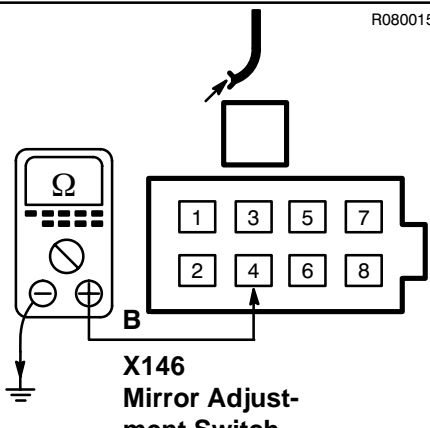

**X146
Mirror Adjust-
ment Switch**



PROBLEM CAUSE

- B Wire
- Ground Connections

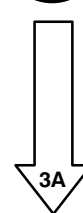

R060008

2A

3A

CONDITIONS

- Ignition Switch
Position: II

RESULTS

- Mirror Adjustment Switch
*Move Left or Up
BAT VOLT
Neutral
0V*

J2170
M115, M123 Mir-
ror Actuator

~~OK~~ **PROBLEM CAUSE**

- SW Wire
- Mirror Adjust-
ment Switch

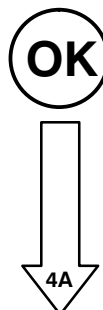

R060008

4A

4A

CONDITIONS

- Ignition Switch
Position: II

RESULTS

- Mirror Adjustment Switch
*Move Right or Down
Less than 1 ohm
Neutral
More than 10K ohms*

J2170
M115, M123 Mir-
ror Actuator

~~OK~~ **PROBLEM CAUSE**

- Mirror Adjust-
ment Switch

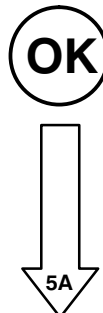

R060008

4A

5A

CONDITIONS

- Ignition Switch
Position: II
- Mirror Adjustment Switch
Right Mirror Enabled

RESULTS

- Mirror Adjustment Switch
Left
BAT VOLT
- Neutral*
0V

M123
Right Mirror
Actuator



PROBLEM CAUSE

- BU, BP Wire
- Mirror Adjust-ment Switch

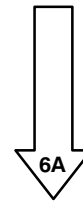

R060008

6A

CONDITIONS

- Ignition Switch
Position: II
- Mirror Adjustment Switch
Right Mirror Enabled

RESULTS

- Mirror Adjustment Switch
Right
Less than 1 ohm
- Neutral*
More than 10K ohms

M123
Right Mirror
Actuator



PROBLEM CAUSE

- Mirror Adjust-ment Switch

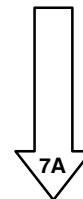

6A

7A

R060008
C603

CONDITIONS

- Ignition Switch
Position: II
- Mirror Adjustment Switch
Right Mirror Enabled

RESULTS

- Mirror Adjustment Switch
Down
BAT VOLT
- Neutral*
0V

M123
Right Mirror
Actuator

~~OK~~ **PROBLEM CAUSE**

- BK, BN Wire
- Mirror Adjust-ment Switch

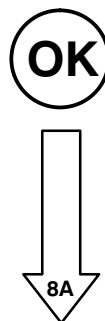

8A

R060008
C603

CONDITIONS

- Ignition Switch
Position: II
- Mirror Adjustment Switch
Right Mirror Enabled

RESULTS

- Mirror Adjustment Switch
Up
Less than 1 ohm
- Neutral*
More than 10K ohms

M123
Right Mirror
Actuator

~~OK~~ **PROBLEM CAUSE**

- Mirror Adjust-ment Switch

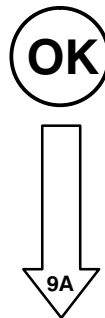

8A

9A

CONDITIONS

- Ignition Switch
Position: II
- Mirror Adjustment Switch
Left Mirror Enabled

RESULTS

- Mirror Adjustment Switch
Left
BAT VOLT
Neutral
0V

M115
Left Mirror Actuator

R060008



PROBLEM CAUSE

- BU Wire
- Mirror Adjustment Switch

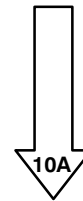

10A

10A

CONDITIONS

- Ignition Switch
Position: II
- Mirror Adjustment Switch
Left Mirror Enabled

RESULTS

- Mirror Adjustment Switch
Right
Less than 1 ohm
Neutral
More than 10K ohms

M115
Left Mirror Actuator

R060008



PROBLEM CAUSE

- Mirror Adjustment Switch

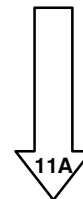

10A

11A

CONDITIONS

- Ignition Switch
Position: II
- Mirror Adjustment Switch
Left Mirror Enabled

RESULTS

- Mirror Adjustment Switch
Down
BAT VOLT
Neutral
0V

R060008
C503

M115
Left Mirror Actuator

OK PROBLEM CAUSE

- BK Wire
- Mirror Adjustment Switch

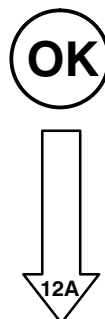

12A

CONDITIONS

- Ignition Switch
Position: II
- Mirror Adjustment Switch
Left Mirror Enabled

RESULTS

- Mirror Adjustment Switch
Up
Less than 1 ohm
Neutral
More than 10K ohms

R060008
C503

M115
Left Mirror Actuator

OK PROBLEM CAUSE

- Mirror Adjustment Switch

OK PROBLEM CAUSE

- M115, M123 Mirror Actuator

Test B

R060008

1B

CONDITIONS

- Ignition Switch
Position: II
- Mirror Adjustment Switch
Select suspect mirror

RESULTS

- Mirror Adjustment Switch
Move Right or Down
BAT VOLT
Move Left or Up
0V



PROBLEM CAUSE

- SW Wire
- Mirror Adjust-ment Switch

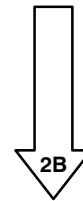

R060008

2B

CONDITIONS

- Ignition Switch
Position: II
- Mirror Adjustment Switch
Select suspect mirror

RESULTS

- Mirror Adjustment Switch
Left
BAT VOLT
Right
0V



PROBLEM CAUSE

- BU, BP Wire
- Mirror Adjust-ment Switch

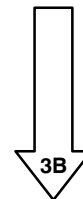

3B
2B

CONDITIONS

- Ignition Switch
Position: II
- Mirror Adjustment Switch
Select suspect mirror

RESULTS

- Mirror Adjustment Switch
Down
BAT VOLT
- Up*
0V

R060008

J2170
M115, M123 Mir-
ror Actuator



PROBLEM CAUSE

- BK, BN Wire
- Mirror Adjust-
ment Switch



PROBLEM CAUSE

- M115, M123 Mir-
ror Actuator

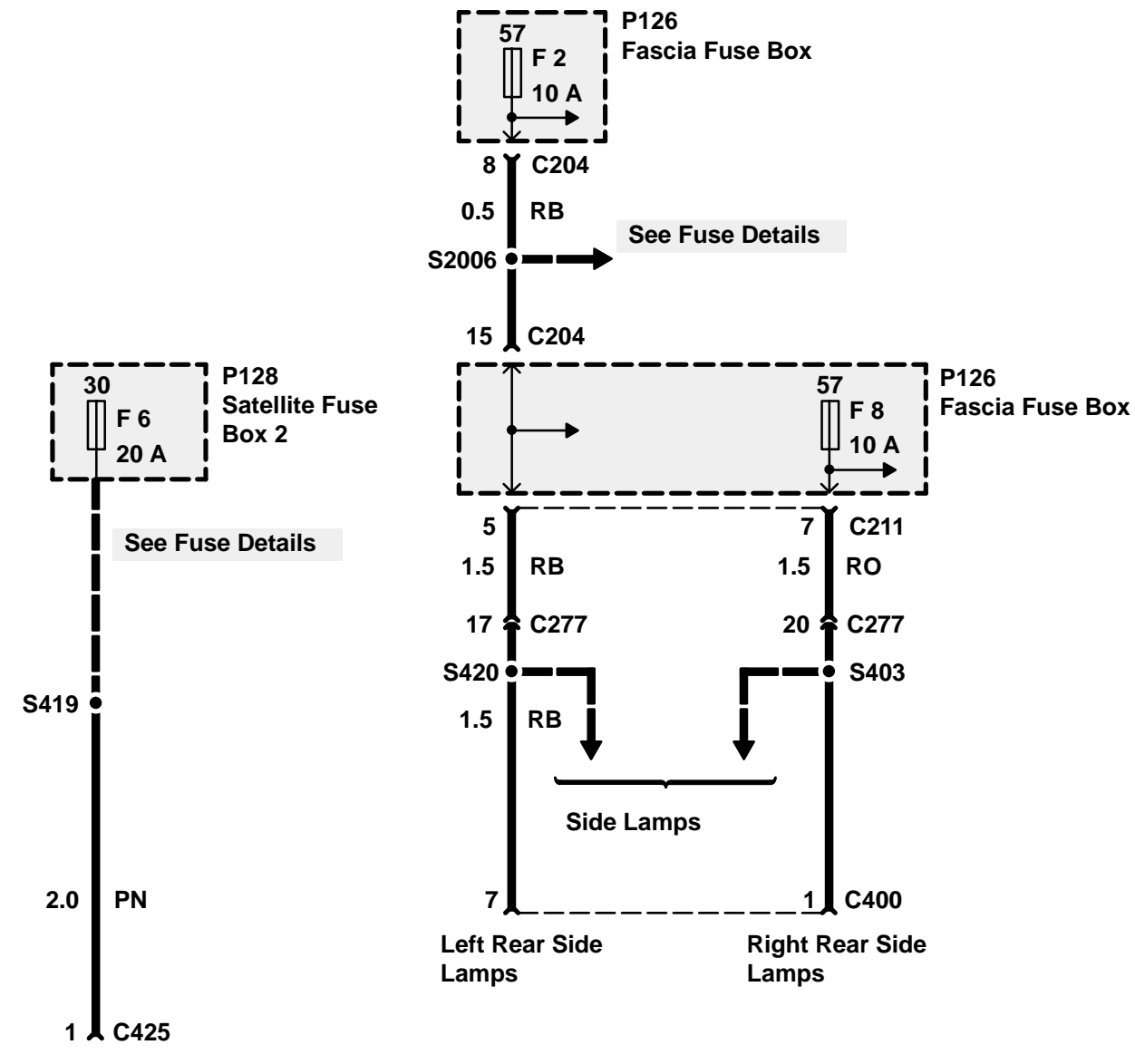

X172
Trailer Auxiliary
Socket

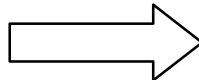
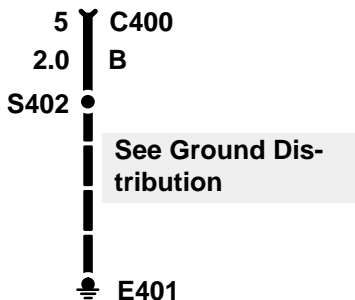

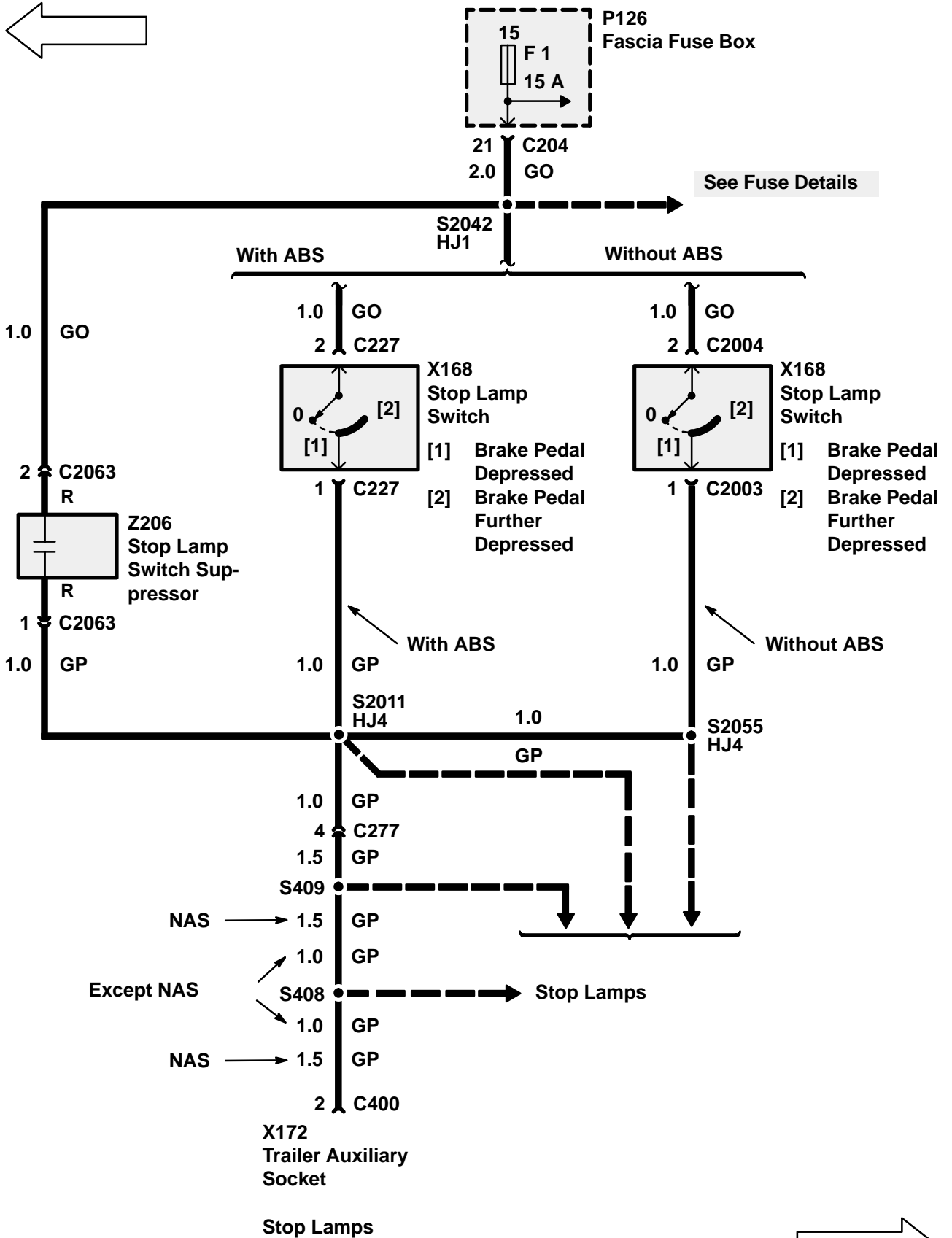

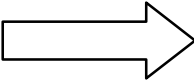
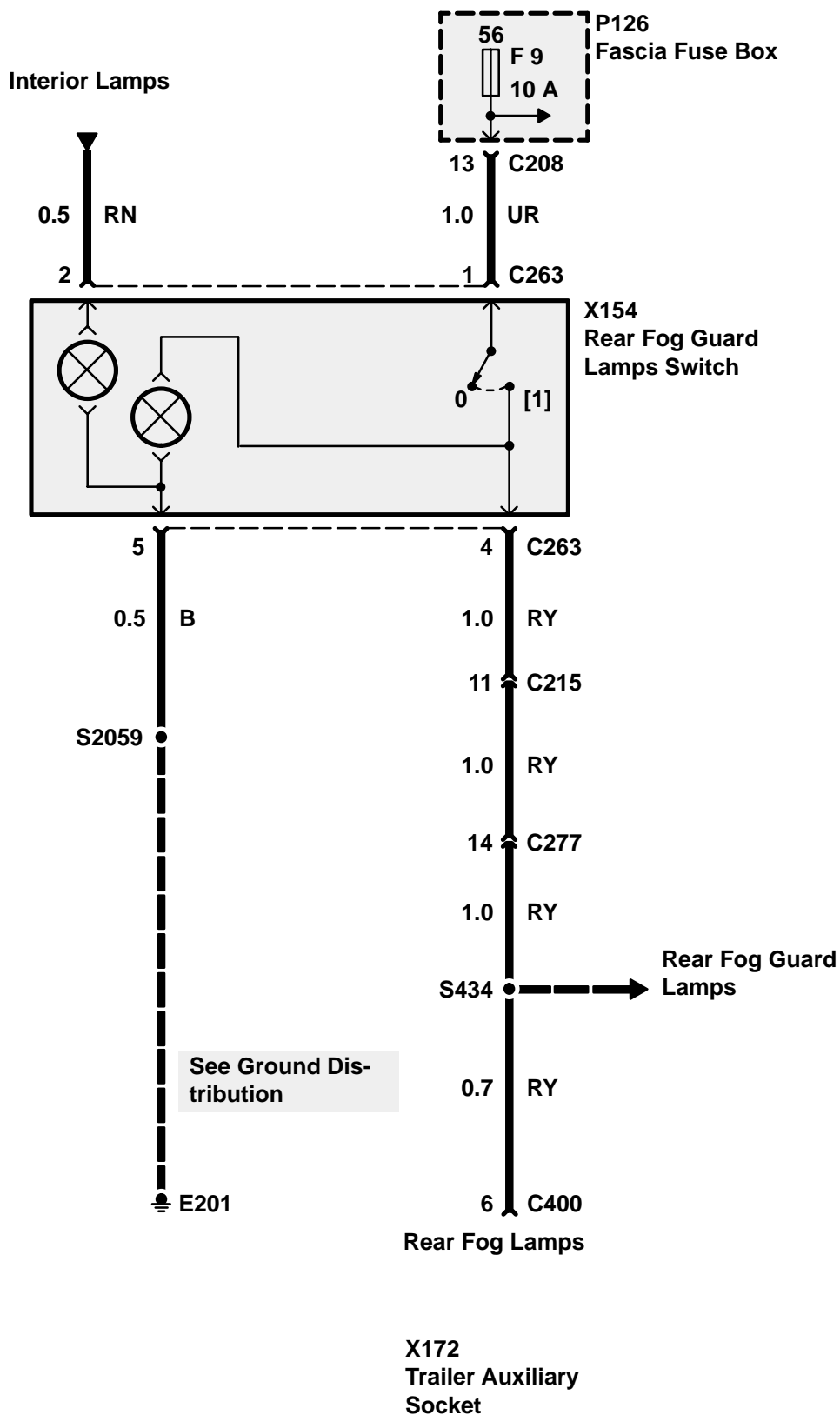
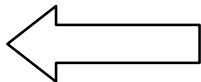

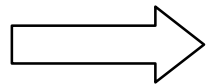
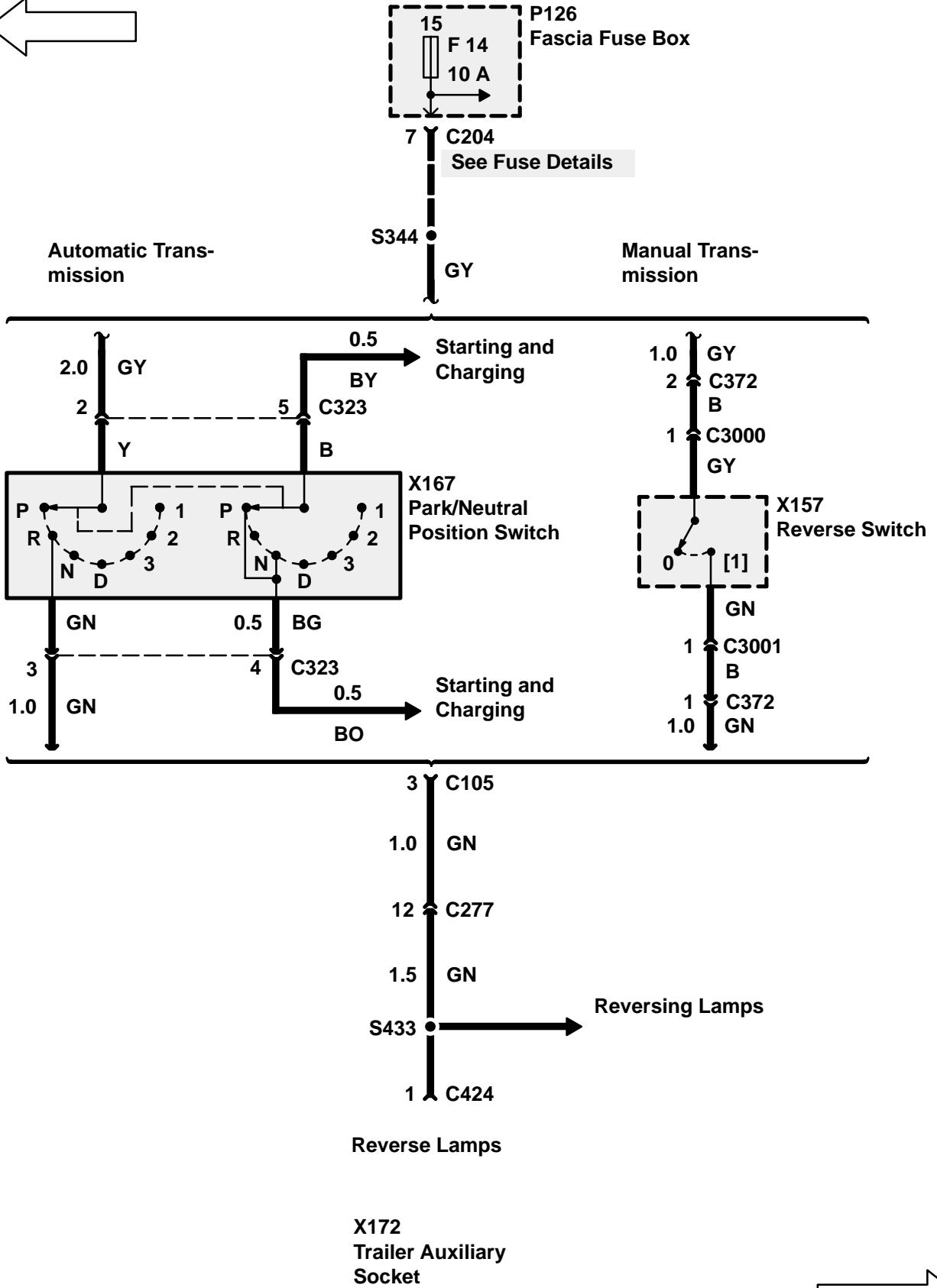
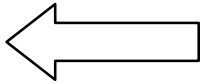

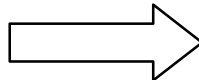
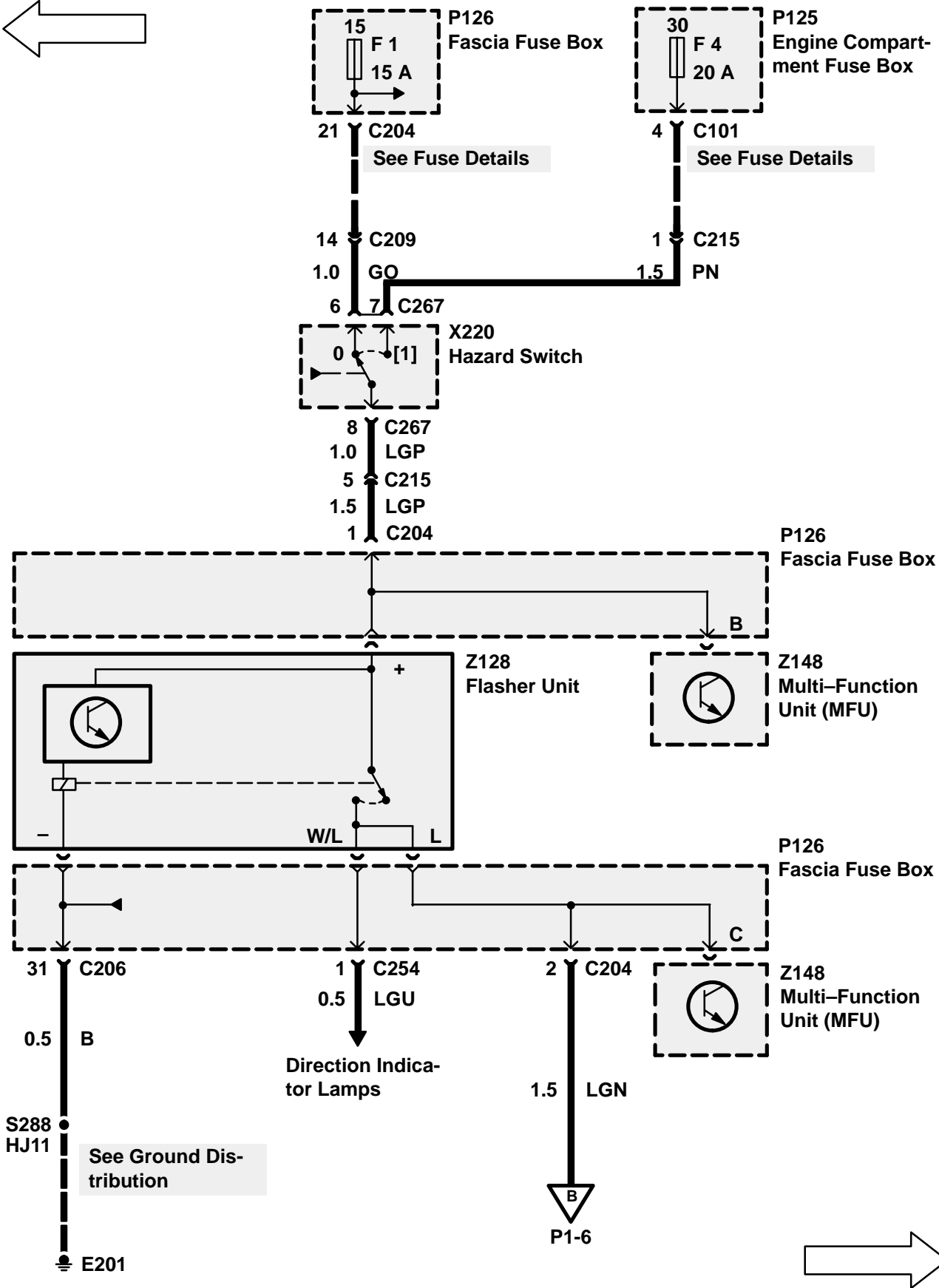
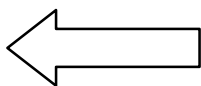

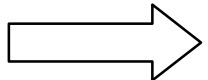
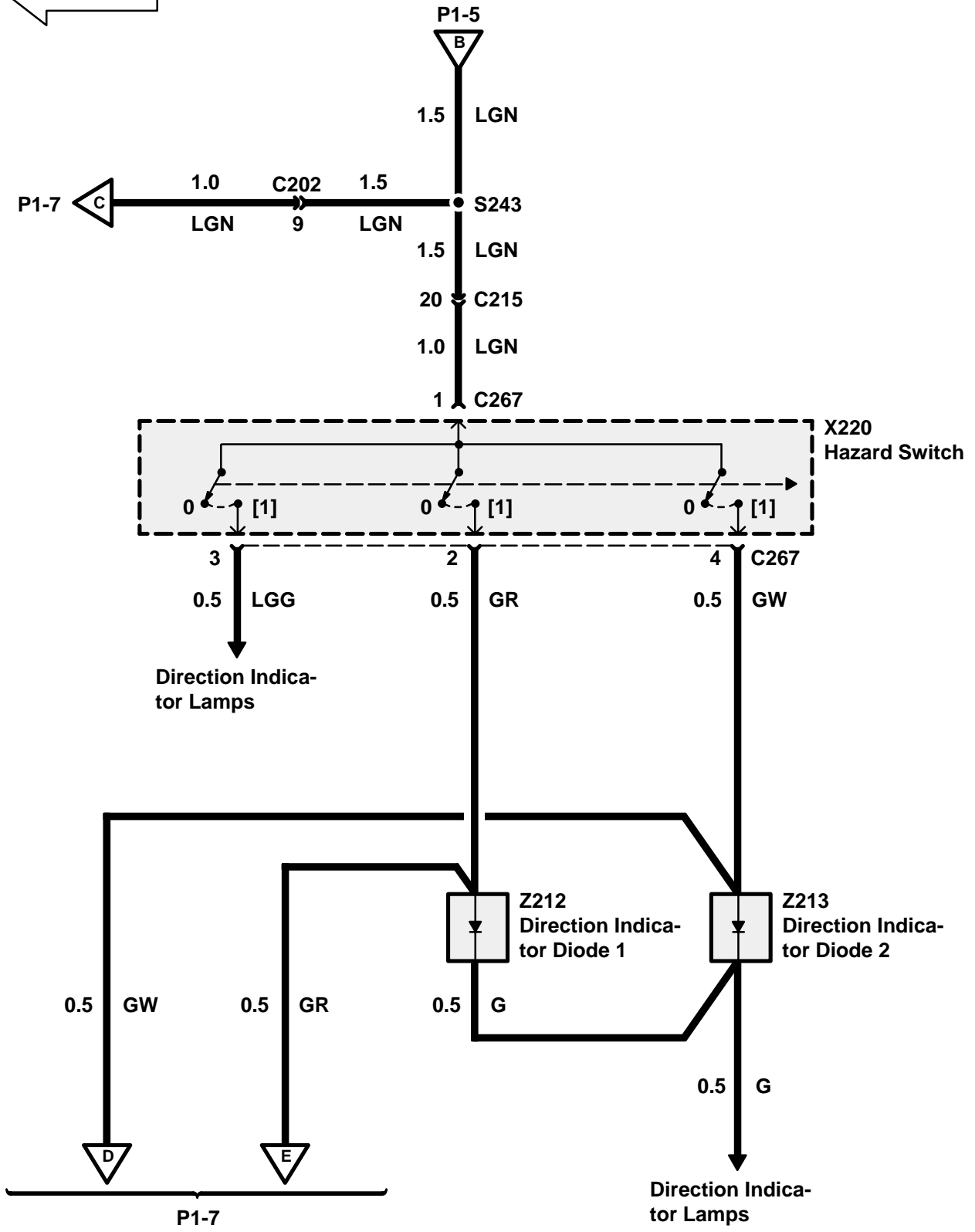
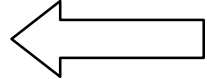

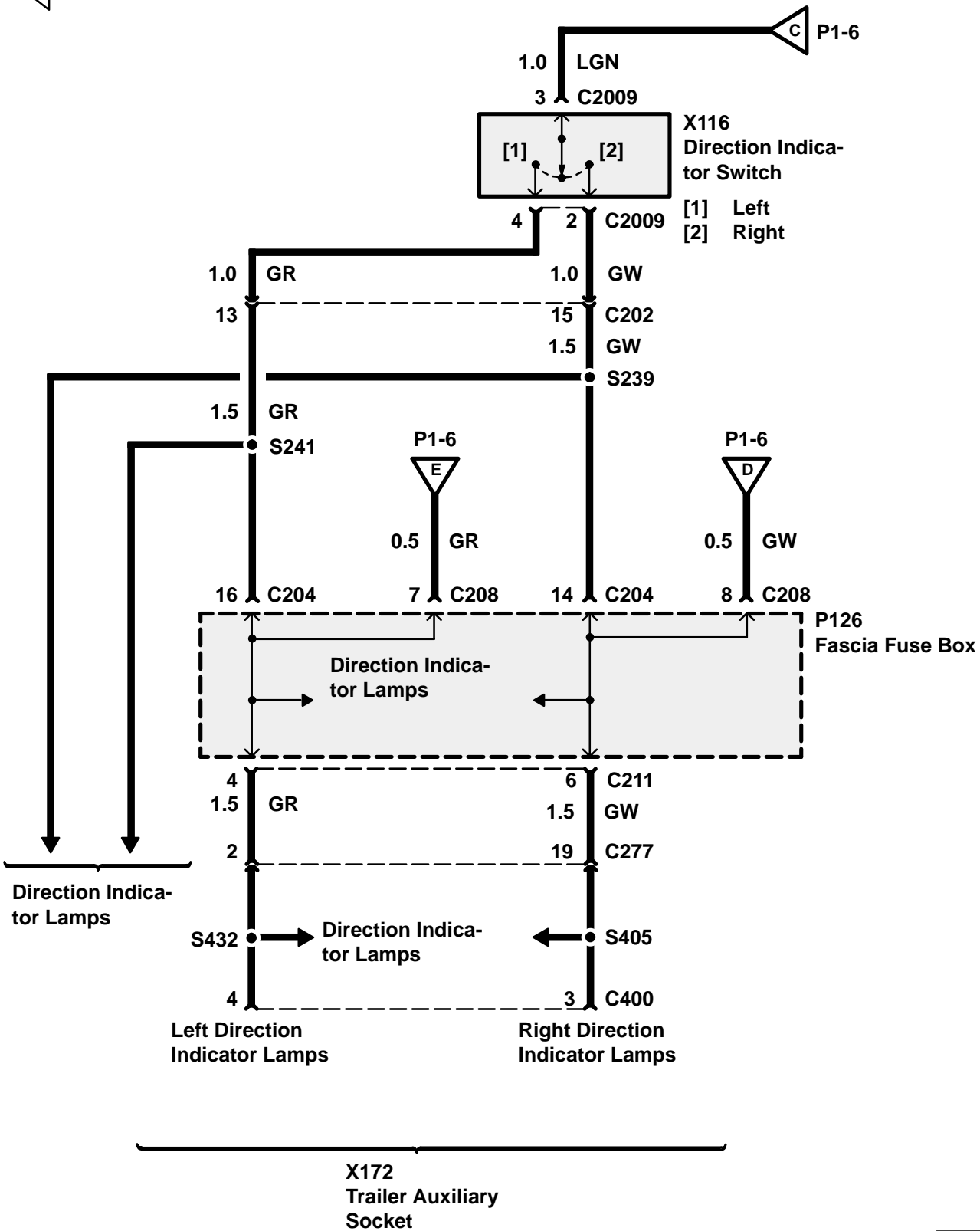
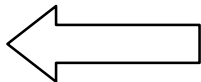

CIRCUIT OPERATION

For 1995 models a vehicle alarm system is available as original equipment. The main function of the system is to offer easy-to-use remote locking and unlocking of the vehicle without having to actively select the alarm function.

ALARM COMPONENTS

4. Theft Alarm Unit (Z163) and Theft Alarm Relay (K159)
5. Alarm Bonnet Switch (X212)
6. Tailgate Switch (X170)
7. Horns (K128, K134) and Horn Relay (K189)
8. Theft Alarm LED (B151)
9. Alarm Sensor (X213) (Not on all vehicles!)
10. Front Door Key Switches (X201, X202)
11. Lock Actuators (M114, M122, M117, M125, M132)
12. Handset Transmitter (two supplied)

ANTI-THEFT SYSTEM FUNCTION

Perimetric Protection

Using the key in the correct sequence will turn on and off perimetric protection only. When fully perimetrically armed, all doors, tailgate, and bonnet are protected against unauthorized access. If the door key is used in the normal manner the driver will be unaware of the door key sequence. The time taken to lock or unlock with the key must be less than 5 seconds. To prevent unauthorized tampering, the alarm will sound if the key is held in the unlocked position for longer than 5 seconds when armed. Cranking is disabled when perimetric protection is armed.

NOTE: When key is turned left or right, the key switch input will be activated in conjunction with the sill button switch when links are operated.

Volumetric Protection

Using the handset transmitter will turn On and Off volumetric protection. In volumetric mode the vehicle interior is protected using the Alarm Sensor (X213). Using the handset also arms and disarms the vehicle perimetrically. Cranking is disabled

when volumetric and perimetric protection is armed.

NOTE: If armed volumetrically, the vehicle CANNOT be disarmed using the key.

Alarm Sounder (Z171)

When an intrusion is detected the Alarm Sounder (Z171) will sound intermittently (Switzerland and Denmark continuous horn sound) and the hazard lights flash (where territorial regulations allow) for 30 seconds. The alarm must be retriggered before the Alarm Sounder (Z171) will sound again.

Vehicle Status Indication

Vehicle status is indicated by up to three devices: (a) Alarm Sounder (Z171), (b) hazard lights, (c) Theft Alarm LED (B151). When the vehicle arms in either mode, the hazard lights will flash three times and the LED will flash rapidly for 10 seconds. LED will then flash at a slower rate while vehicle is armed. When the vehicle disarms, hazard lights will flash once and LED will extinguish. If LED remains lit, it indicates that the alarm has been triggered. Turning on ignition or arming the alarm will extinguish LED. The LED will give a long pulse flash to indicate the Alarm Sensor (X213) being activated.

Central Locking

Central Locking is controlled by the Theft Alarm Unit (Z163) and may be operated by the key, sill button(s) or handset. The system works on both front doors on four door vehicles or driver's door on two door vehicles.

NOTE: The central door locking system will shut down for a period after more than 15 consecutive operations.

Inertia Switch

An inertia switch is incorporated in the Theft Alarm Unit (Z163). If ignition is on and the vehicle receives an impact sufficient to activate the inertia switch, the unit will signal to unlock central locking actuators and flash hazard lights. Central locking will remain disabled for 30 seconds. To reset, turn ignition off and then on after the 30 second period has elapsed.

Alarm Sensor (X213)

The sensor operates by emitting an air pressure carrier wave and receiving the wave back. Any disturbance within the vehicle which disturbs the wave will be detected, triggering the alarm. When the volumetric sensor is activated it monitors movement within the vehicle for 15 seconds before detecting and responding to intrusions. If the sensor detects movement within the vehicle it delays arming until a 15 second quiet period has elapsed. If continuous movement is detected, the alarm will not arm volumetrically.

Radio Frequency System

The RF system uses four frequencies according to market. If the coaxial aerial is not fitted, system performance will be impaired. Both ECU and handset have a colour-coded label.

Frequency Colour Territory ECU/Handset:

418.0 MHz, Pink/pink: UK, Ireland

224.5 MHz, Yellow/yellow: France

433.92 MHz, Blue/blue: Europe (not France, Switzerland, Italy, Denmark)

433.92 MHz, White/blue: Switzerland, Denmark

315.0 MHz, Green/green: Rest of World, Italy, Australia

315.0 MHz, Orange/green: Gulf, Japan

Partially armed mode

If a door, tailgate or bonnet is left open when the system is armed, the LED will not light for 10 seconds indicating a mislock condition. Hazard lights will not flash. If an open door or tailgate is causing the mislock, the starter motor is disabled. The alarm will sound if ignition is turned to start position. If an open bonnet is causing the mislock, the starter motor is disabled. The alarm will arm the volumetric part of the system. If the door, tailgate or bonnet is subsequently closed, after a 5 second delay, the doors will unlock and immediately lock, and the system will fully arm.

Handset Transmitter

The handset LED will give one flash when button is pressed momentarily. If button is held down the LED will light again after 2 seconds for 2 seconds, and extinguish until button is released and repressed. The handset contains unique information distinguishing it from other transmitters. It also contains a set of 'random' rolling codes programmed into the ECU before leaving the factory. Each time the handset is pressed a different code is transmitted to the ECU.

If the handset is operated more than four times outside the vehicle range (6 metres) or power supply is removed, it will be necessary to re-synchronise handset and the ECU by pressing the handset three times within range and within 5 seconds.

NOTE: If both handsets are lost or damaged when system is armed, it will be necessary to fit a new ECU with two matching handsets.

Handset Batteries

If handset LED flashes continuously when button is pressed, the batteries need replacing. The hazard lights will flash one 3 second pulse, instead of three times upon arming vehicle.

Power Up Mode

The alarm system always remembers the state it was left in when power was removed. If the alarm powers up in an armed state and is subsequently triggered, it will give a warning that it will fully trigger unless disarmed. This warning consists of

short horn pulses every two seconds for 15 seconds.

New Born Mode

When the ECU is first produced, it will be in its 'new born' mode. In this mode it will respond to any remote of the right frequency. This mode will be cancelled when the ECU has received ten valid handset signals without power interruption.

Engine Cranking

It is only possible to crank the engine when ignition is ON and alarm is disabled.

BUILT IN TEST PROCEDURE

The built in test procedure is accessed as follows:

1. Starting conditions: ignition off, doors unlocked, bonnet switch depressed.
2. Carry out instructions 3 to 7 within 8 seconds.
3. Release bonnet switch.
4. Switch ignition ON.
5. Lock doors.
6. Switch ignition OFF.
7. Switch ignition ON.

If alarm is correctly accessed, horn will sound and LED will flash. The following checks can be made:

8. Open and close any door or tailgate – LED will light.
9. Depress bonnet switch – hazards will flash.
10. Check engine cranking is disabled. Do not turn off ignition.
11. Check ultrasonic by operating handset, LED will emit one 5 second flash, and will flash if interior is disturbed.

NOTE: If ECU is in new born mode, any handset of the right frequency will work. If not, initialised handset is required. See Handset Initialisation.

12. Turn OFF ignition or press handset to end test procedure. Horn will sound as before to indicate end of test mode.

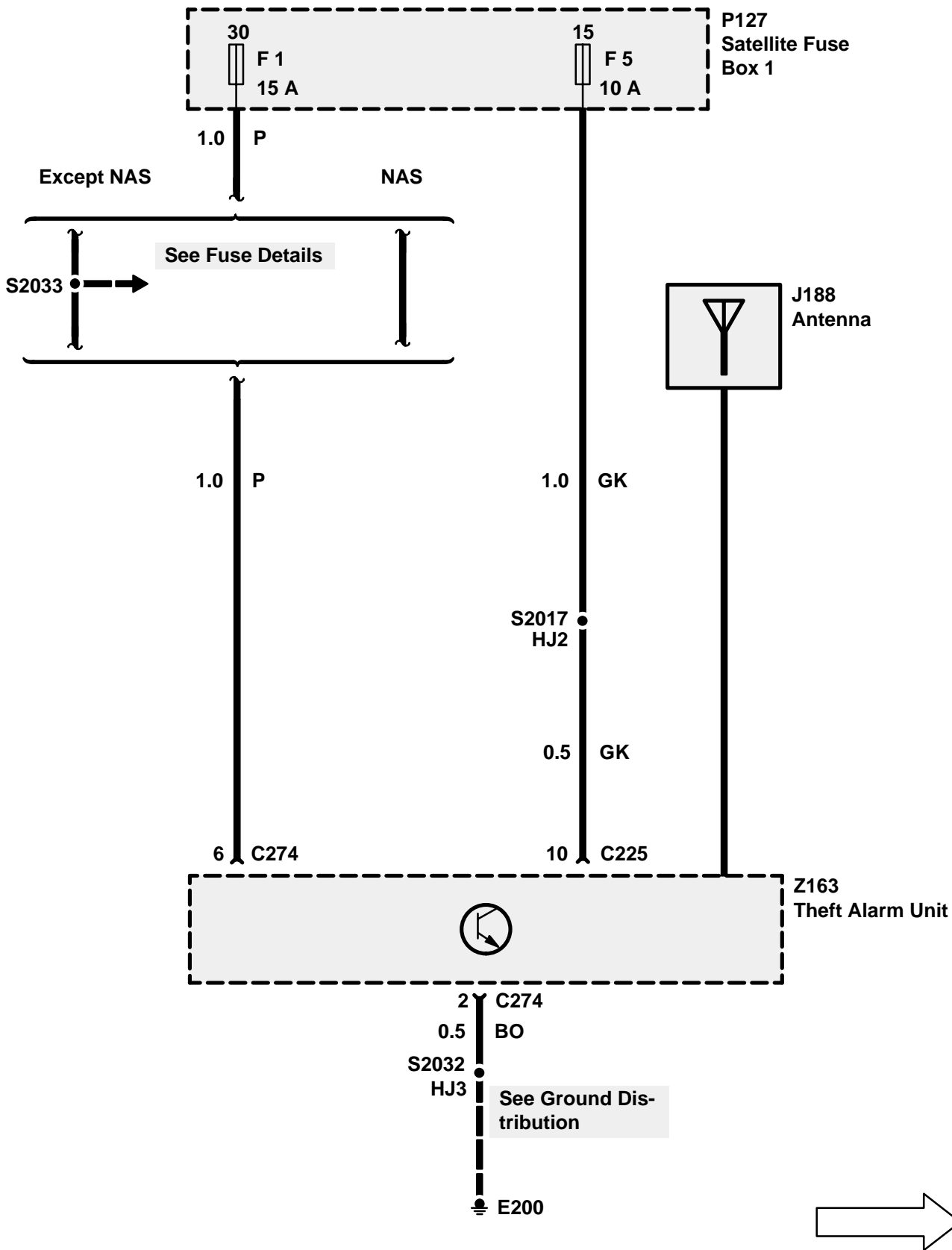

DISCOVERY

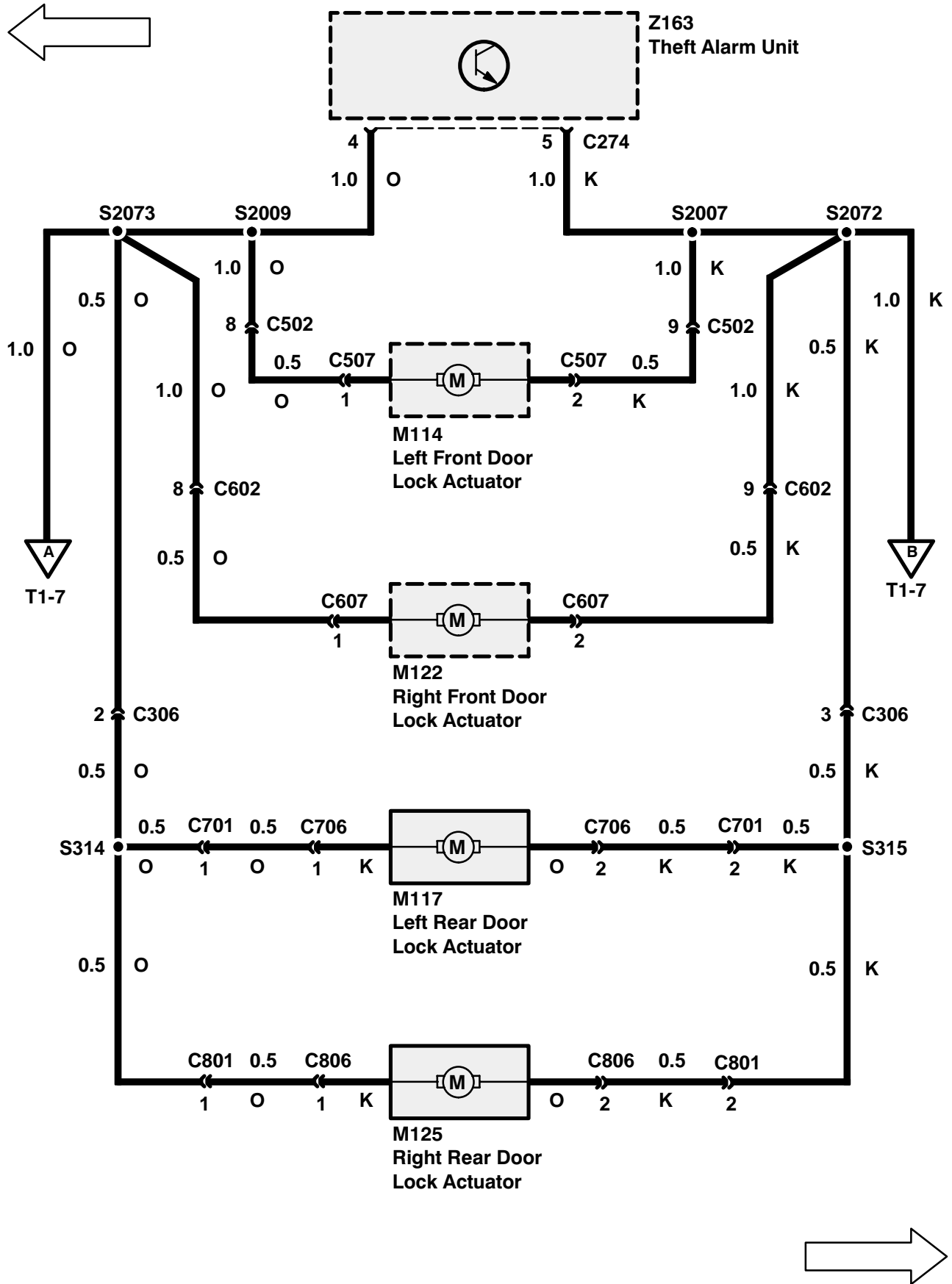

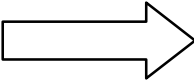
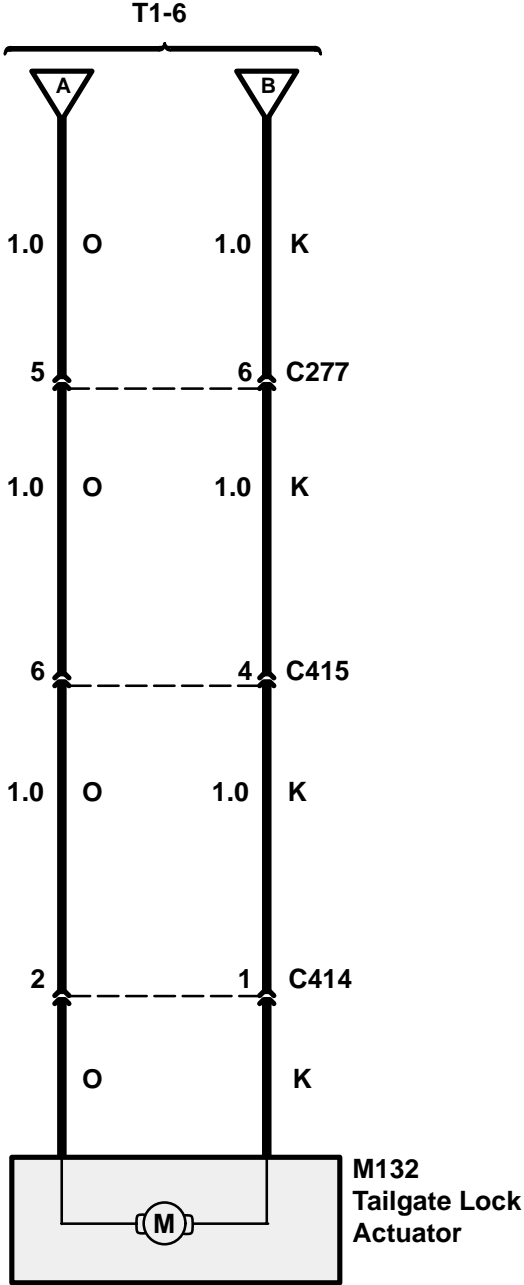
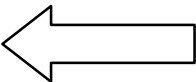

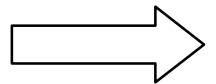
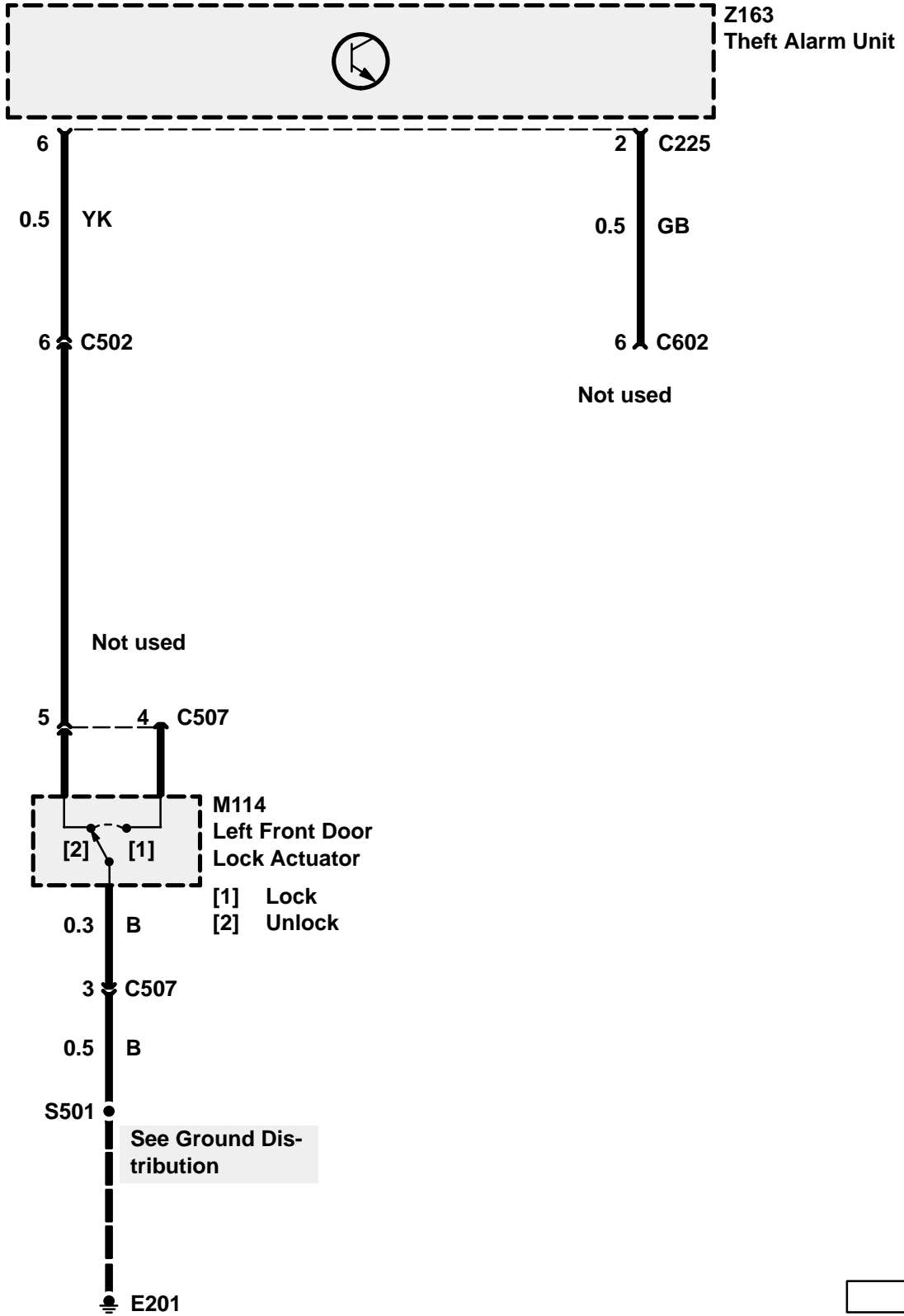
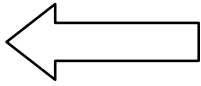

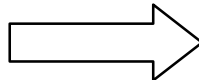
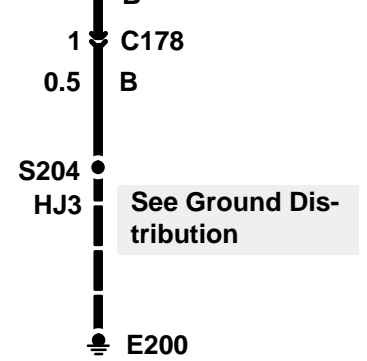
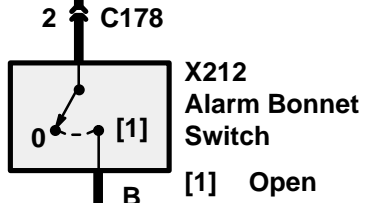
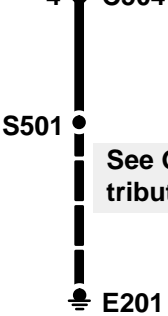
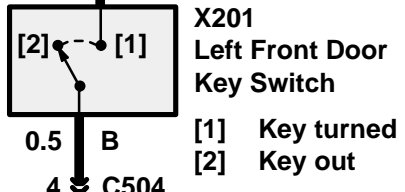
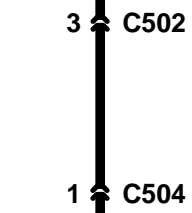
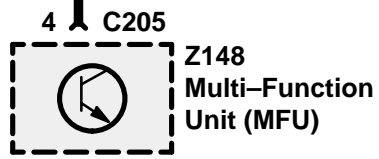
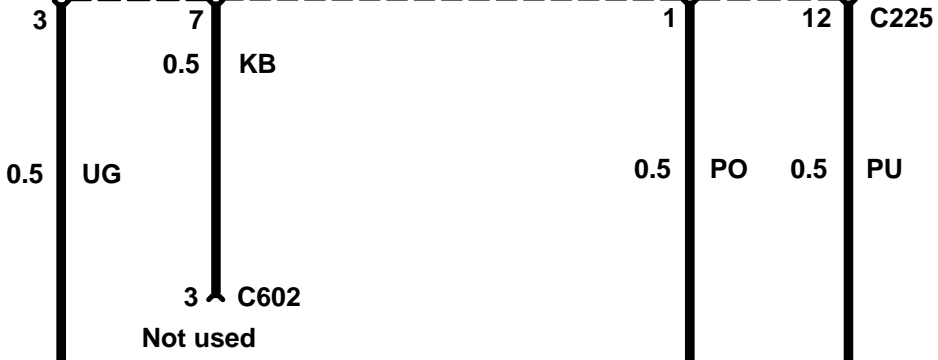
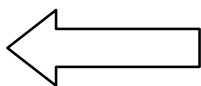

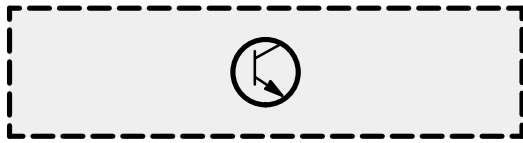
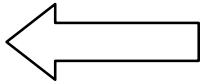

Z163 Theft Alarm Unit

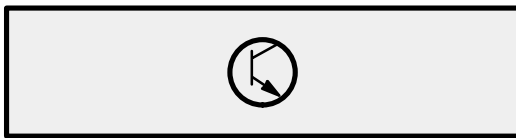
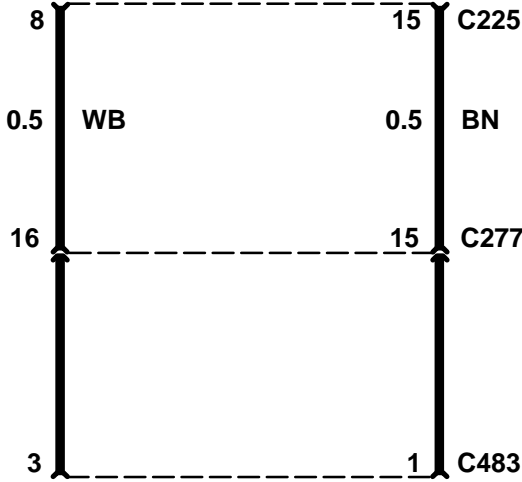
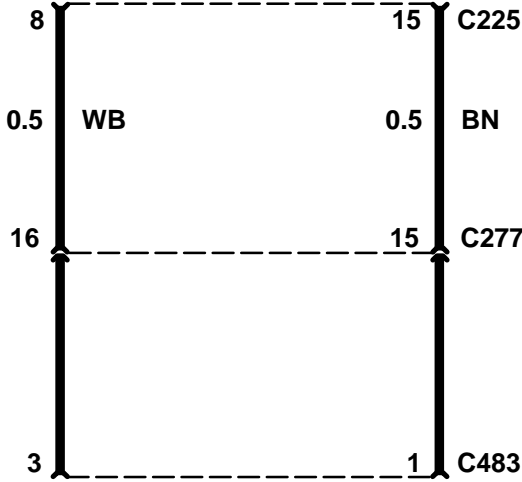

X213 Alarm Sensor

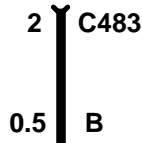
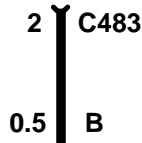

See Ground Distribution

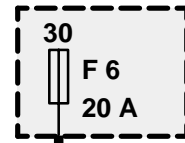
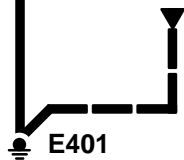
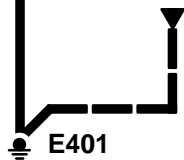

P128 Satellite Fuse Box 2

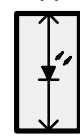
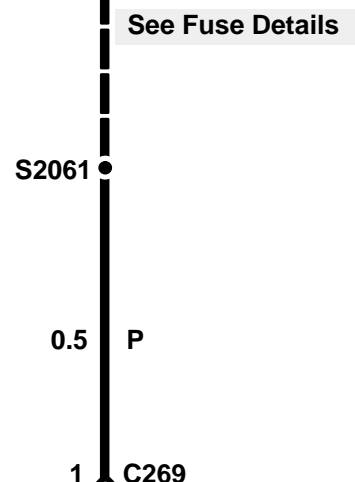
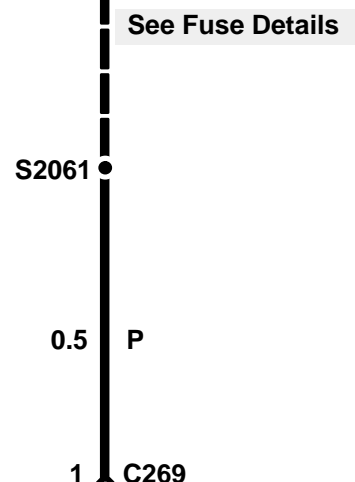

B151 Theft Alarm LED

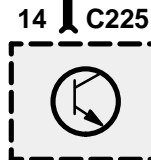

Z163 Theft Alarm Unit

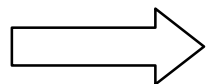

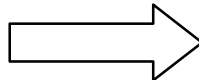
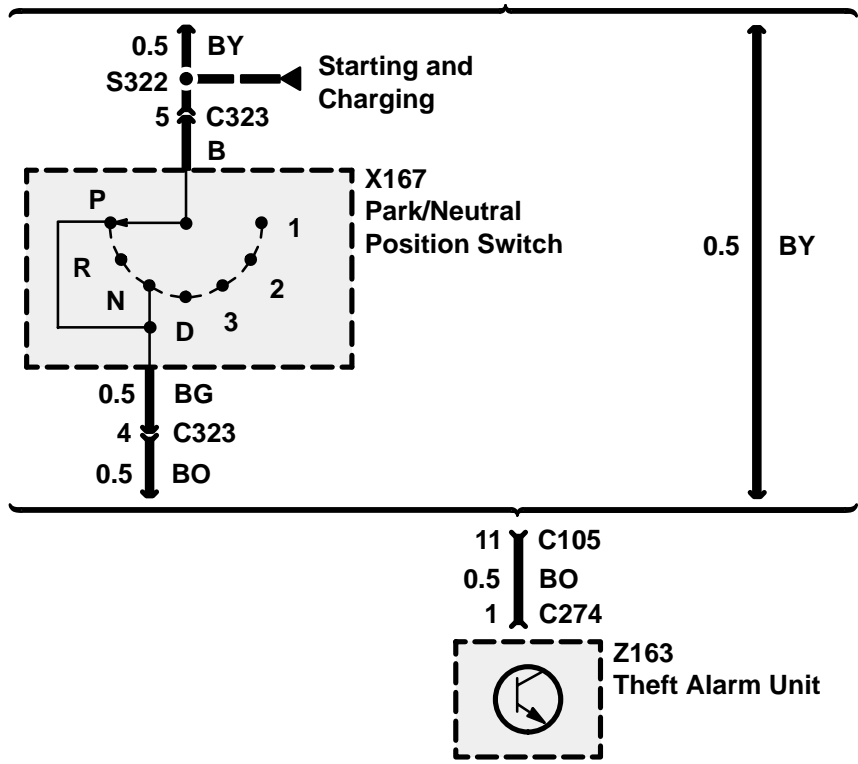
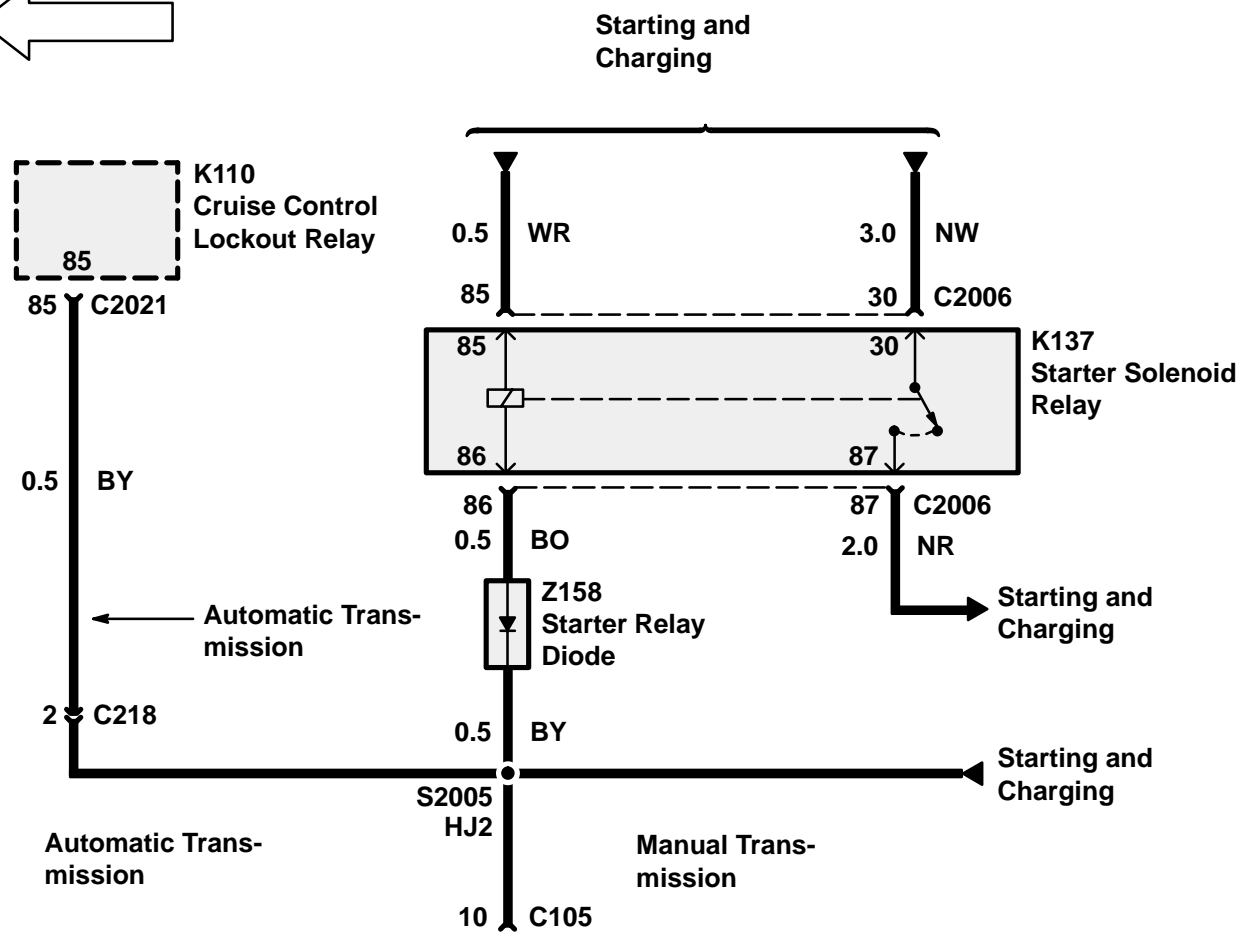
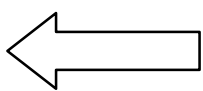

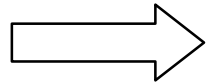
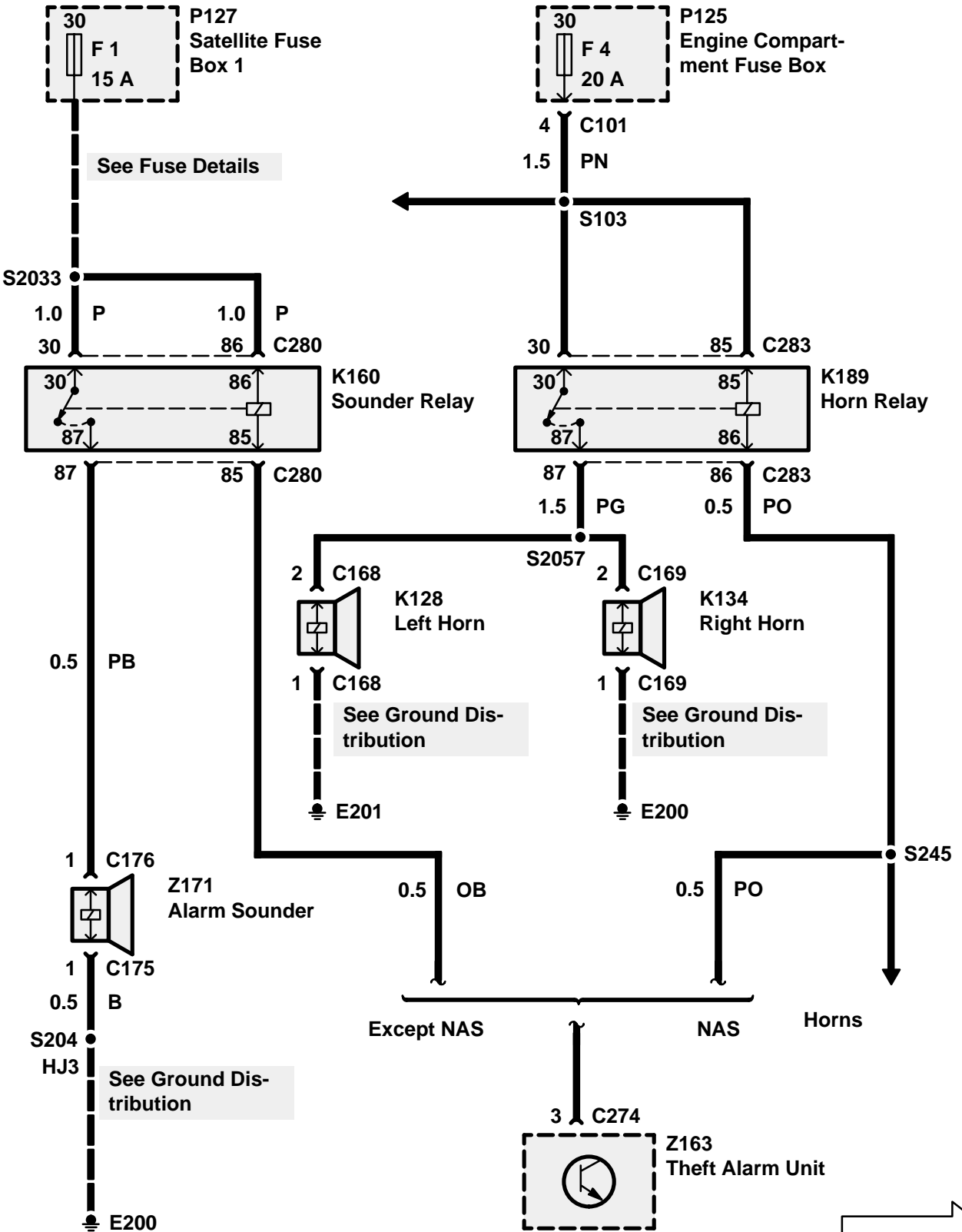
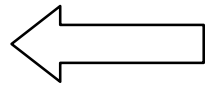

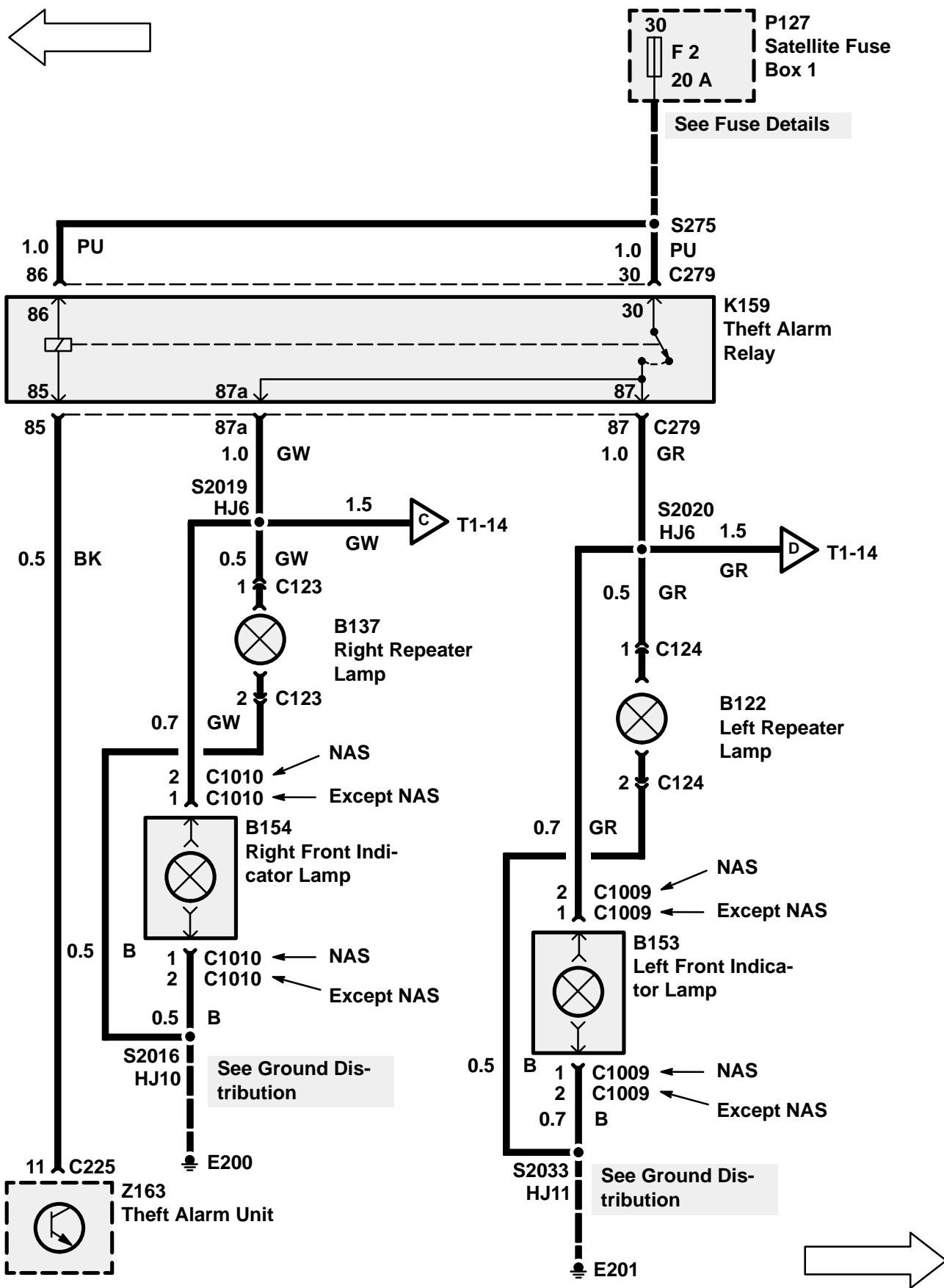

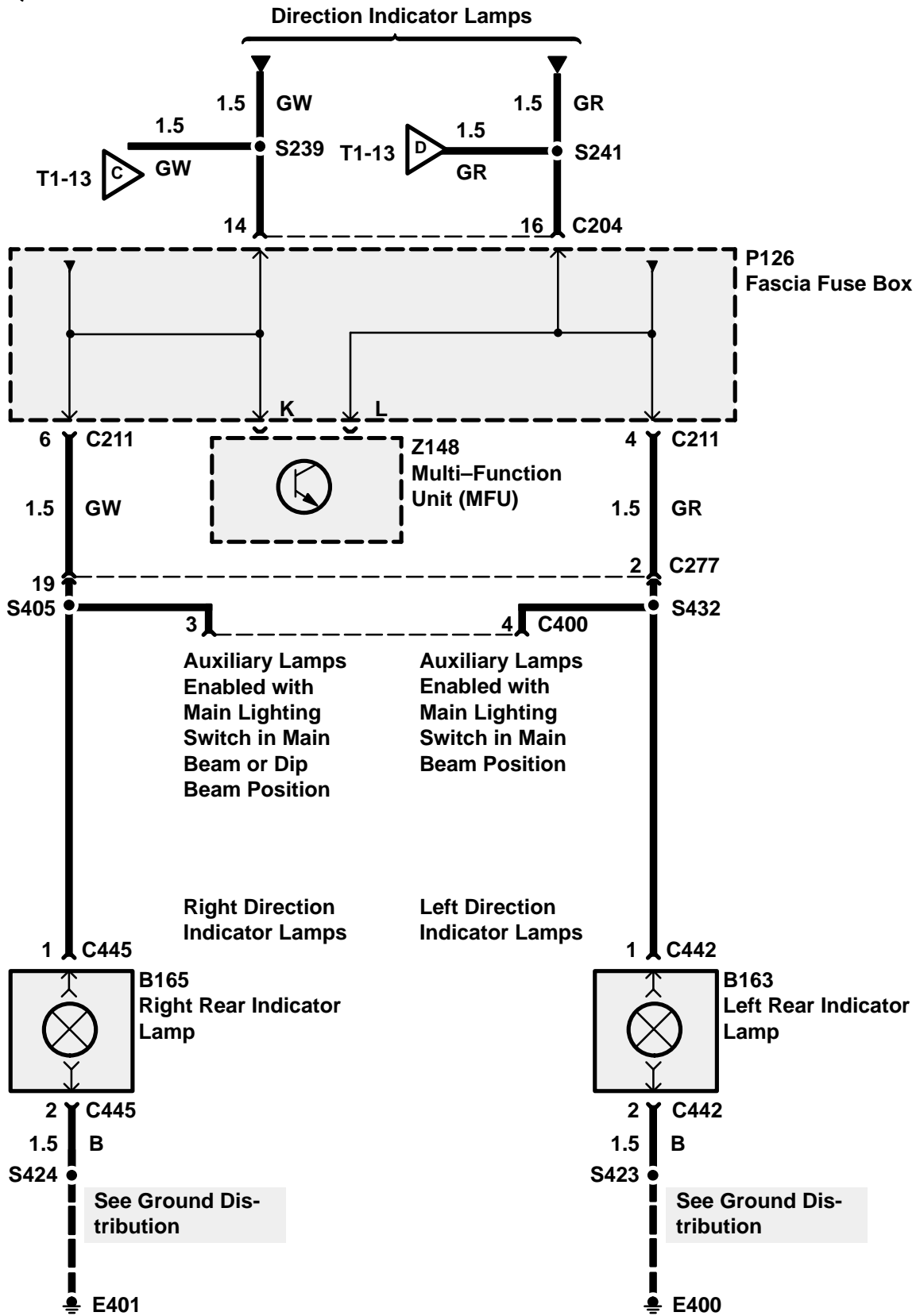
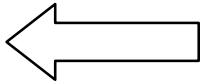

TROUBLESHOOTING HINTS

13. Check Fuses F1, F2 and F5 in Satellite Fuse Box 1.
14. Check Fuse F5 in Satellite Fuse Box 2.
15. If the interior lights do not come on when a door is open, check suspect door switch and associated wiring.
16. If all of the lock actuators do not operate, check O and K Wire. If OK, replace Theft Alarm Unit (Z163).

SYSTEM DIAGNOSIS

1. If the system will not arm, do Test A.
2. If the system arms, but will not trigger at all, do Test C.
3. For Except NAS Vehicles:
If the Alarm Sounder (Z171) does not sound when triggered, do Test C.
For NAS Vehicles:
If the Horns (K128, K134) do not sound when triggered, do Test D.
4. If the hazard lights do not flash when triggered, do Test H.
5. If the system will not trigger when the bonnet is open, do Test I.
6. If the alarm is set using the remote and the system does not trigger the alarm when there is motion inside the vehicle, do Test J.
7. If the Theft Alarm LED (B151) does not operate, do Test E.
8. For Except NAS Vehicles:
If the Alarm Sounder (Z171) sounds continuously, do Test F.
For NAS Vehicles:
If the Horns sound (K128, K134) continuously, do Test G.
9. If the system will not disarm, do Test A.
10. If a Front Door Lock Actuator (M114, M122) does not operate, do Test K.
11. If the doors unlock themselves after operating the door locks, do Test L.
12. If the central locking function does not operate from one of the front doors, do Test M.
13. If the Tailgate Lock Actuator (M132) does not operate, do Test N.
14. If both Rear Door Lock Actuators (M117, M125) do not operate, do Test O.

Test A

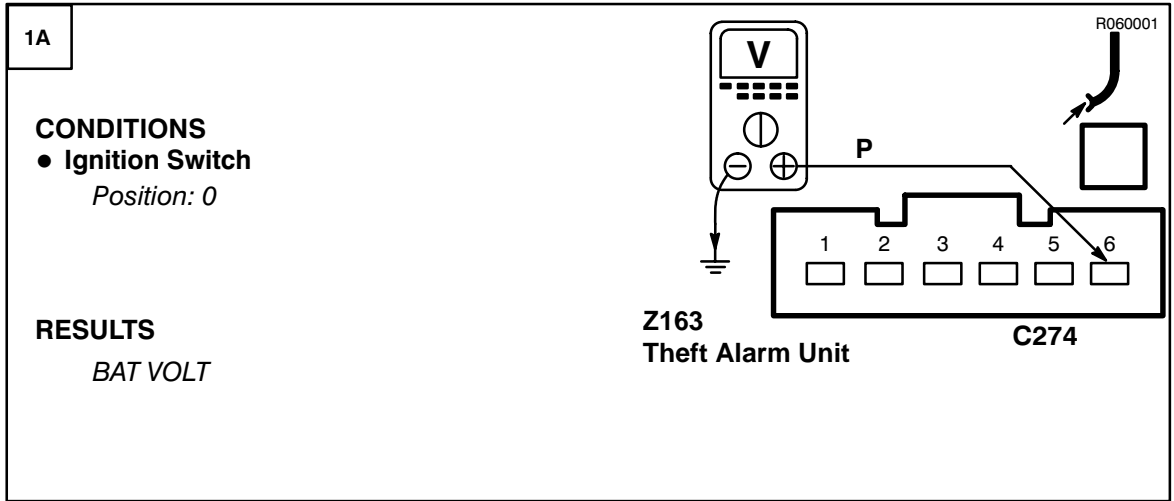

PROBLEM CAUSE
- P Wire

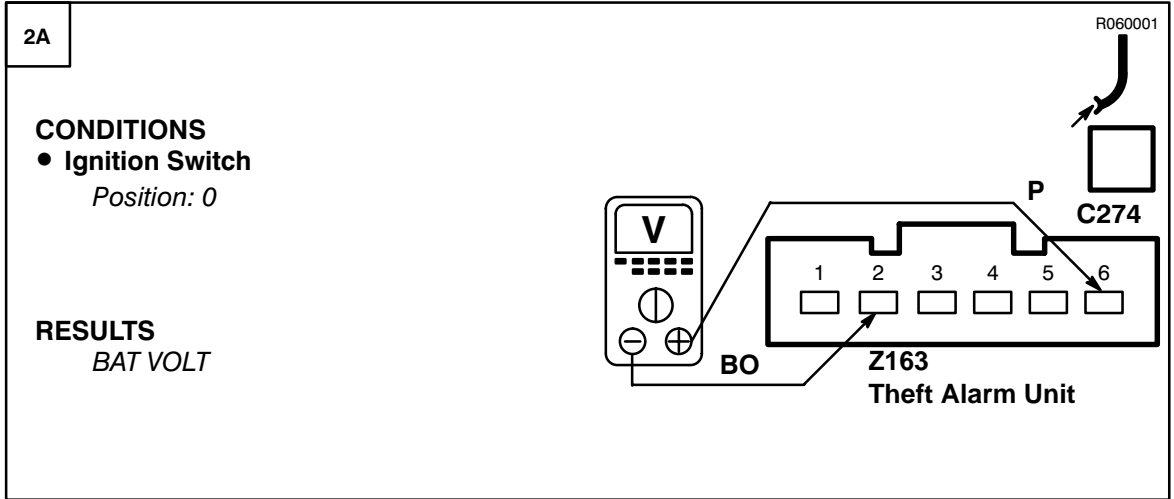
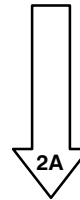

PROBLEM CAUSE
- BO Wire

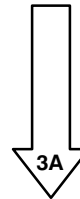

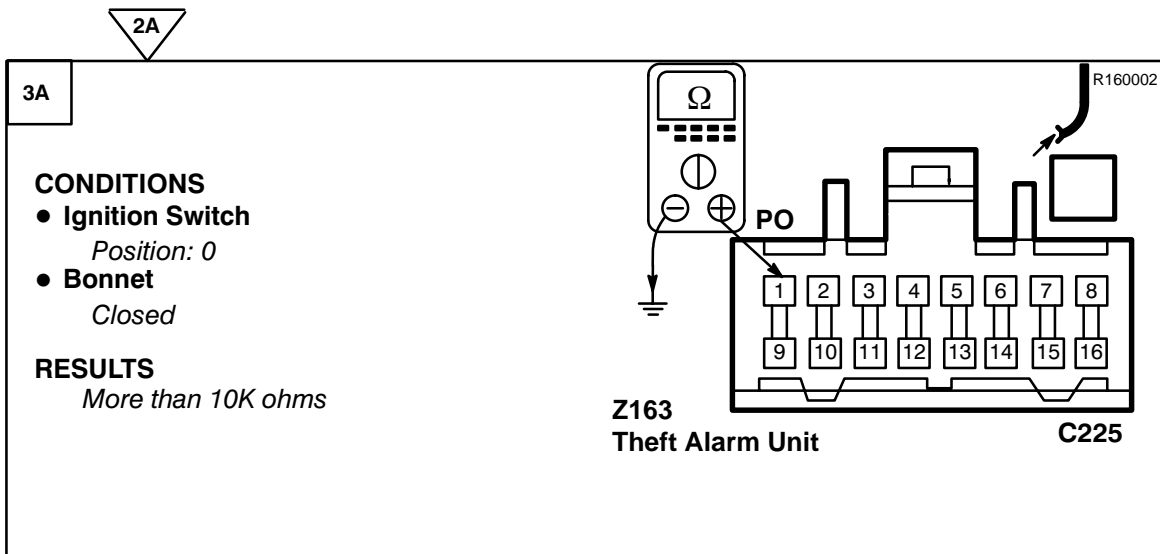

PROBLEM CAUSE
- PO Wire
- Alarm Bonnet Switch

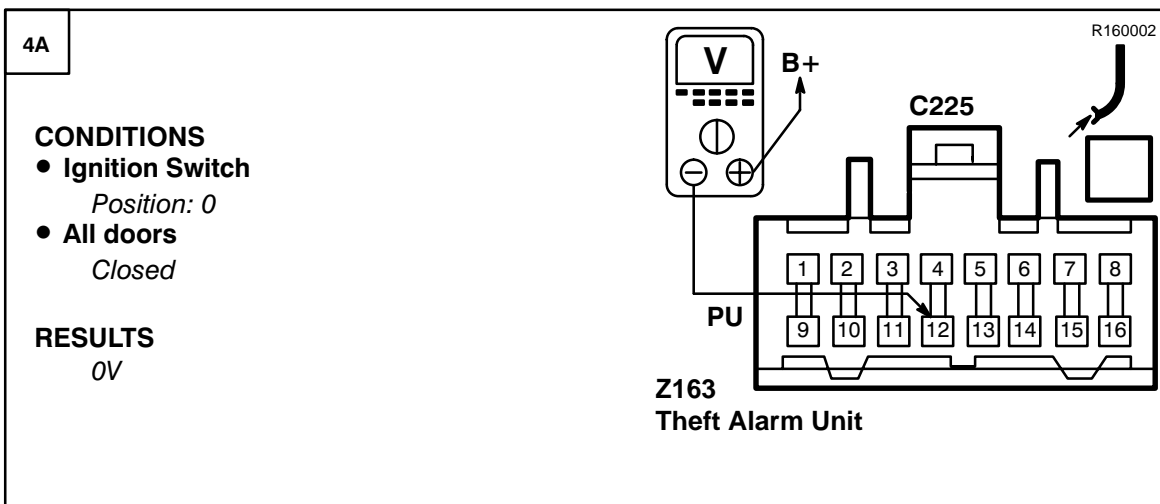
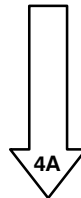

GO TO TEST B

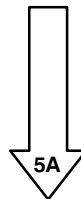

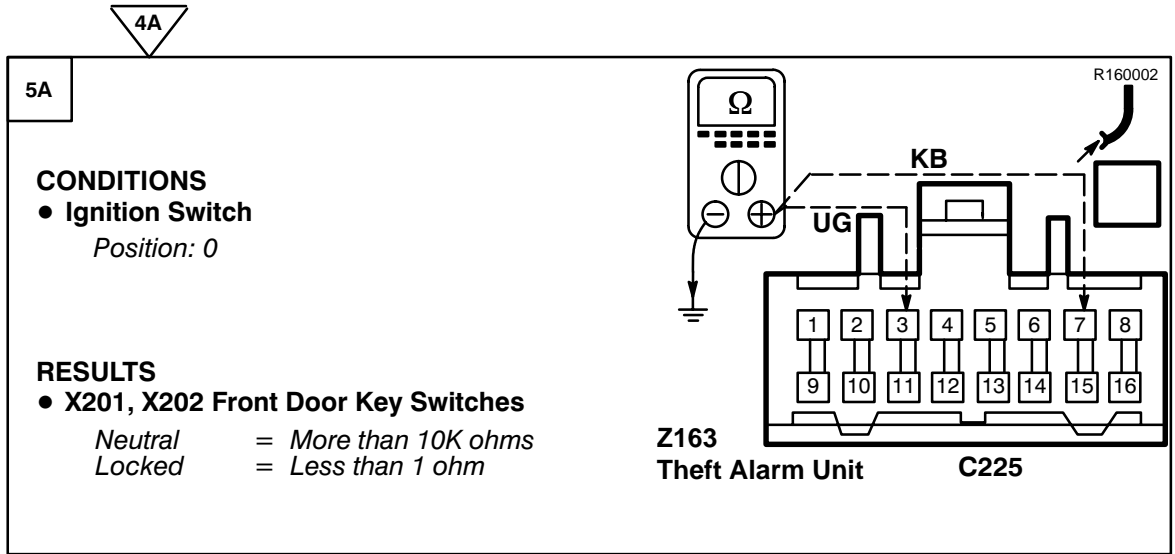

PROBLEM CAUSE

- UG Wire
- KB Wire
- B Wire
- X201, X202 Front Door Key Switches

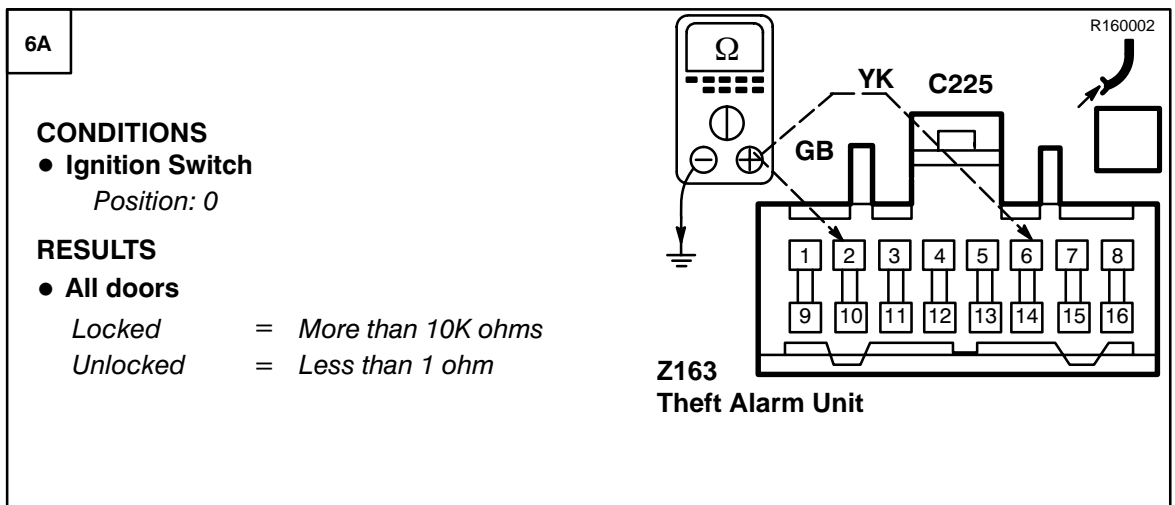
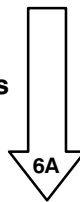

PROBLEM CAUSE

- YK, GB Wire
- B Wire

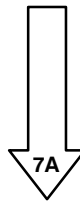

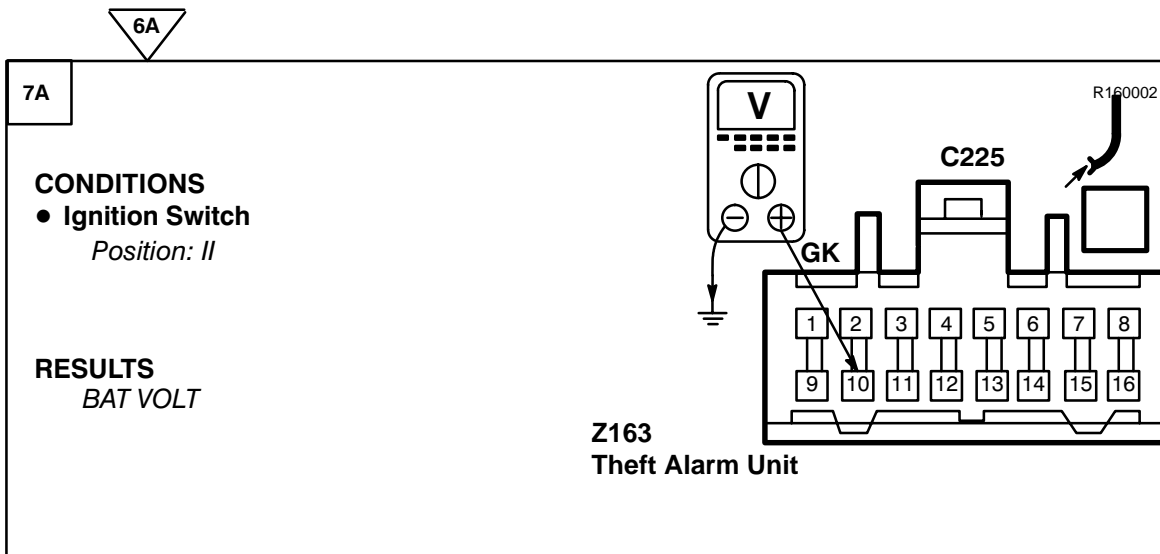

7A

CONDITIONS

- Ignition Switch
Position: II

RESULTS
BAT VOLT



PROBLEM CAUSE
- GK Wire



PROBLEM CAUSE
- Theft Alarm Unit

Test B

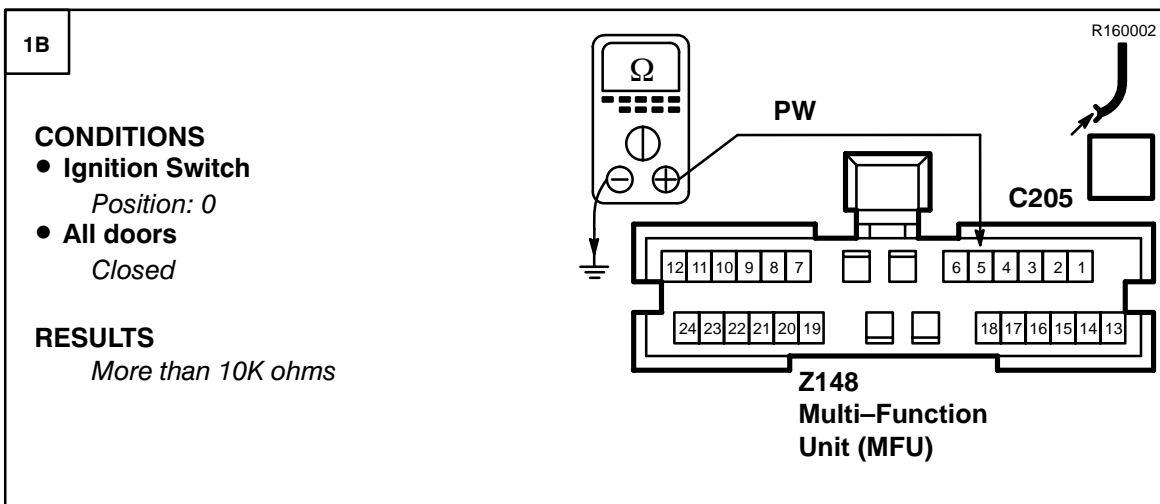

1B

CONDITIONS

- Ignition Switch
Position: 0
- All doors
Closed

RESULTS
More than 10K ohms



PROBLEM CAUSE
- PW Wire
- Right Front Door Switch
- Left Rear Door Switch
- Right Rear Door Switch
- Rear End Door Switch

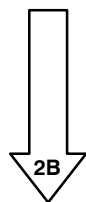

T1 ETM

DISCOVERY

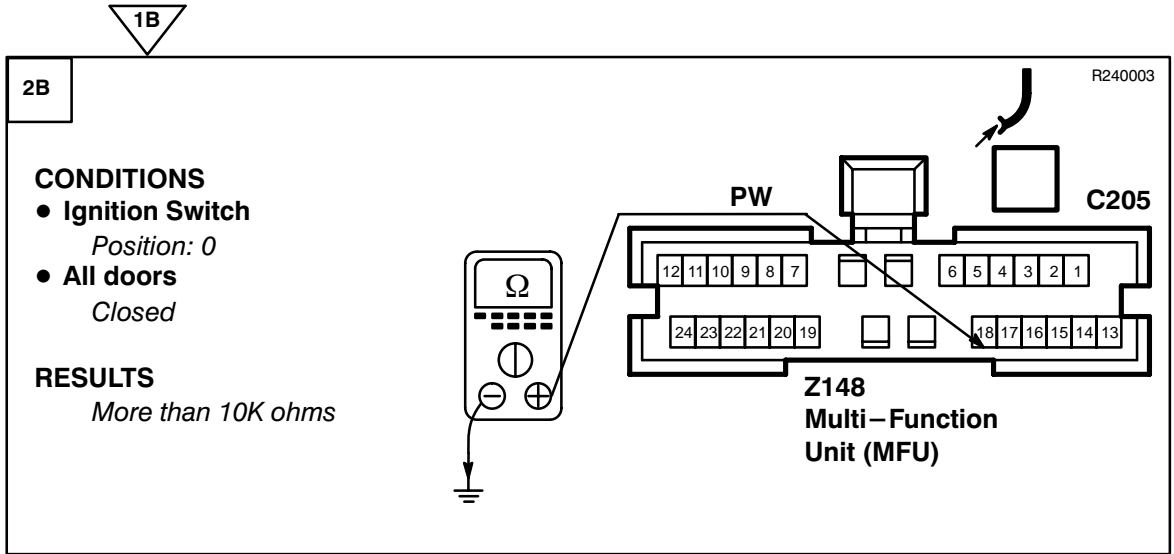

OK PROBLEM CAUSE
- PW Wire
- Left Front Door Switch

OK PROBLEM CAUSE
- PU Wire
- Multi-Function Unit (MFU)

Test C

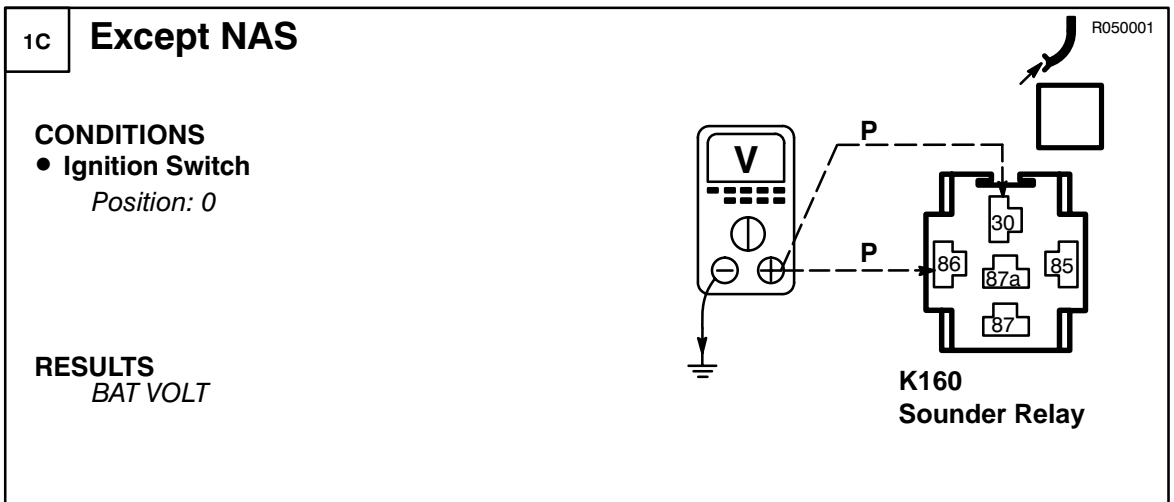

OK PROBLEM CAUSE
- P Wire

OK

↓
2C

1C

2C

CONDITIONS

- Ignition Switch
Position: 0

RESULTS

- Alarm Sounder
Operates

**K160
Sounder Relay**

OK PROBLEM CAUSE
- PB Wire
- Alarm Sounder

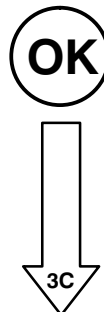

3C

CONDITIONS

- Ignition Switch
Position: 0

RESULTS

- Alarm Sounder
Operates

**Z163
Theft Alarm Unit**

OK PROBLEM CAUSE
- OB Wire
- Sounder Relay

OK PROBLEM CAUSE
- Theft Alarm Unit

Test D

R050001

1D NAS

CONDITIONS

- Ignition Switch
Position: 0

RESULTS

BAT VOLT

**K189
Horn Relay**

~~OK~~ PROBLEM CAUSE
- PN Wire

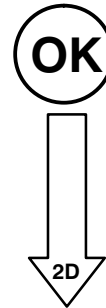

R050001

2D

CONDITIONS

- Ignition Switch
Position: 0

RESULTS

- Horns
Operate

**K189
Horn Relay**

~~OK~~ PROBLEM CAUSE
- PG Wire
- Horns

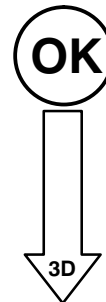

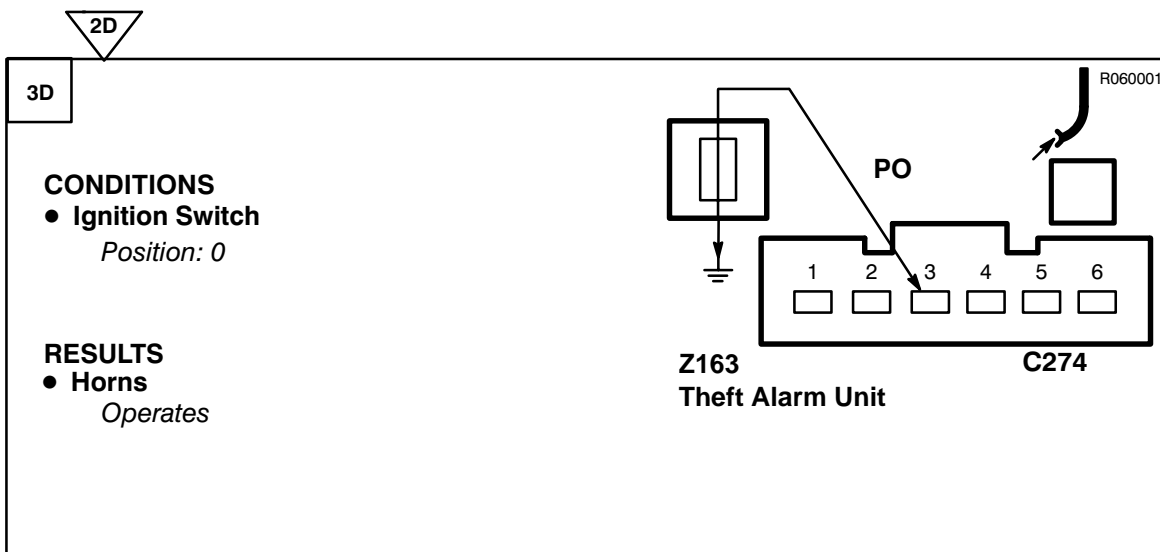

CONDITIONS
 • Ignition Switch
Position: 0

RESULTS
 • Horns
Operates



PROBLEM CAUSE
 - PO Wire
 - Horns



PROBLEM CAUSE
 - Theft Alarm Unit

Test E

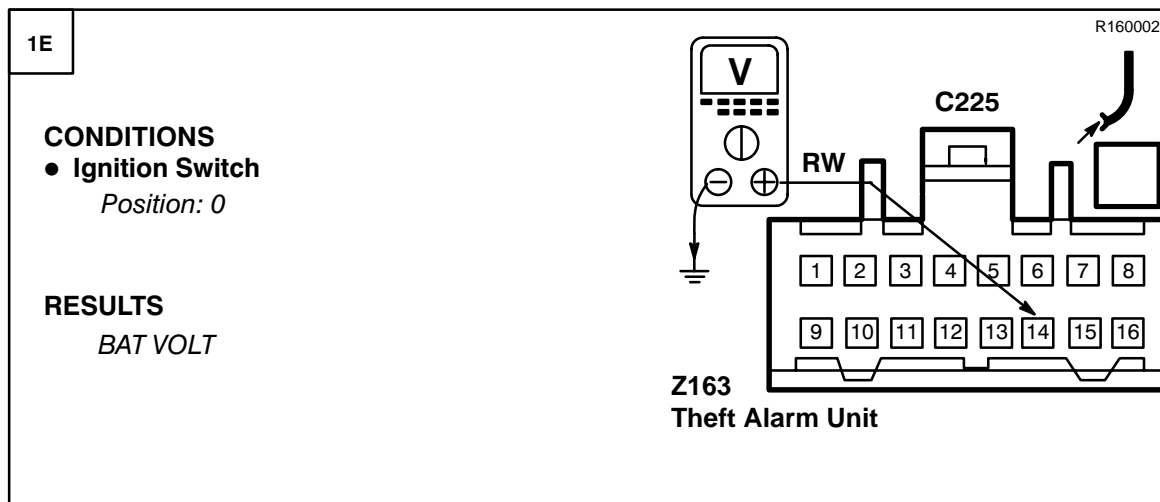

CONDITIONS
 • Ignition Switch
Position: 0

RESULTS
BAT VOLT



PROBLEM CAUSE
 - RW Wire
 - P Wire
 - Theft Alarm LED



PROBLEM CAUSE
 - Theft Alarm Unit

Test F

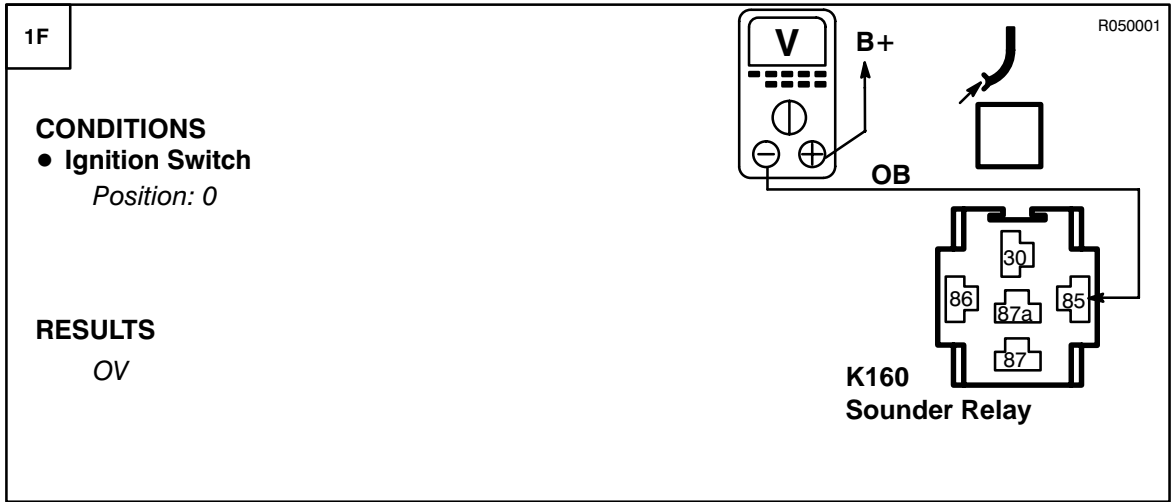

PROBLEM CAUSE

- OB Wire
- Theft Alarm Unit



PROBLEM CAUSE

- Sounder Relay

Test G

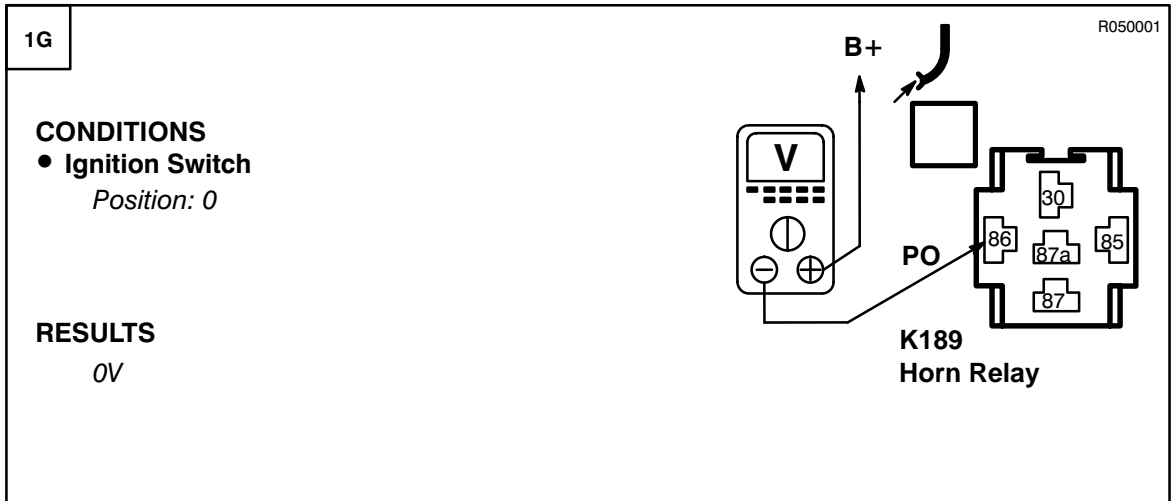

PROBLEM CAUSE

- PO Wire
- Theft Alarm Unit



PROBLEM CAUSE

- Horn Relay

Test H

1H

CONDITIONS

- Ignition Switch
Position: 0

RESULTS
BAT VOLT

K159 Theft Alarm Relay

~~OK~~ **PROBLEM CAUSE**
- PU Wire

OK

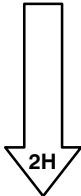

2H

CONDITIONS

- Ignition Switch
Position: 0

RESULTS

- Direction Indicator Lamps
On

K159 Theft Alarm Relay

~~OK~~ **PROBLEM CAUSE**
- GR Wire
- GW Wire

OK

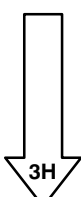

T1 ETM

DISCOVERY

2H

3H

CONDITIONS

- Ignition Switch
Position: 0

RESULTS

- Direction Indicator Lamps
On

Z163
Theft Alarm Unit



PROBLEM CAUSE

- BK Wire
- Theft Alarm Relay



PROBLEM CAUSE

- Theft Alarm Unit

Test I

1I

1I

CONDITIONS

- Ignition Switch
Position: 0
- Bonnet
Open

RESULTS

Less than 1 ohm

Z163
Theft Alarm Unit



PROBLEM CAUSE

- PO Wire
- B Wire
- Alarm Bonnet Switch



PROBLEM CAUSE

- Theft Alarm Unit

Test J

R040006

1J

CONDITIONS

- Ignition Switch
Position: 0

X213 Alarm Sensor

RESULTS
BAT VOLT

~~OK~~ **PROBLEM CAUSE**
- WB Wire
- Theft Alarm Unit

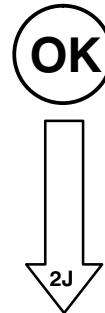

R040006

2J

CONDITIONS

- Ignition Switch
Position: 0

X213 Alarm Sensor

RESULTS
Less than 1 ohm

~~OK~~ **PROBLEM CAUSE**
- B Wire

OK **PROBLEM CAUSE**
- BN Wire
- Alarm Sensor
- Theft Alarm Unit

Test K

R060009

1K

CONDITIONS

- Ignition Switch
Position: II
- All doors
Locked
- Unlock a front door

RESULTS
BAT VOLT (Momentary)

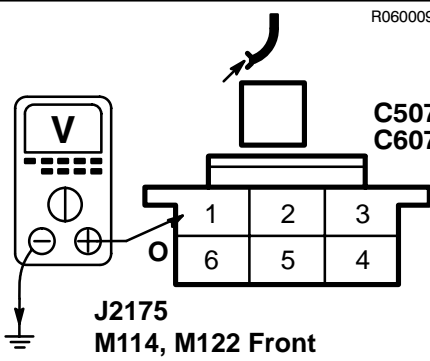

C507
C607

J2175
M114, M122 Front
Door Lock Actua-
tor

OK PROBLEM CAUSE
- O Wire

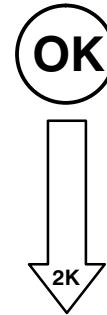

R060009

2K

CONDITIONS

- Ignition Switch
Position: II
- All doors
Unlocked
- Lock a front door

RESULTS
BAT VOLT (Momentary)

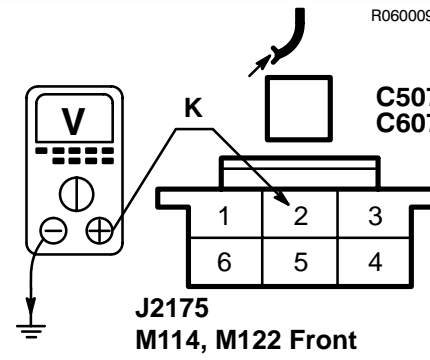

C507
C607

J2175
M114, M122 Front
Door Lock Actua-
tor

OK PROBLEM CAUSE
- K Wire

OK PROBLEM CAUSE
- M114, M122 Front
Door Lock Actua-
tor

Test L

1L

R160002

CONDITIONS

- Ignition Switch
Position: 0
- All doors
Locked

RESULTS
More than 1000 ohms

Z163
Theft Alarm Unit

C225



PROBLEM CAUSE

- GB Wire
- YK Wire
- Right Front Door Lock Actuator

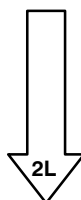

2L

R160002

CONDITIONS

- Ignition Switch
Position: 0
- All doors
Locked

RESULTS
More than 1000 ohms

Z163
Theft Alarm Unit

C225



PROBLEM CAUSE

- YK Wire
- Left Front Door Lock Actuator



PROBLEM CAUSE

- Theft Alarm Unit

Test M

1M

CONDITIONS

- Ignition Switch
Position: 0
- All doors
Unlocked

RESULTS
Less than 1 ohm

Z163
Theft Alarm Unit

C225

~~OK~~ SHORTING LINK 2

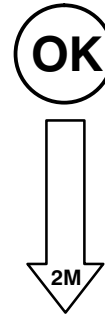

2M

CONDITIONS

- Ignition Switch
Position: 0
- All doors
Unlocked

RESULTS
Less than 1 ohm

Z163
Theft Alarm Unit

C225

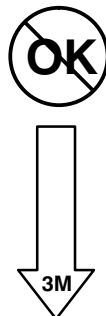

OK PROBLEM CAUSE
- Theft Alarm Unit

R060009

2M
3M

CONDITIONS

- Ignition Switch
Position: 0

RESULTS

Less than 1 ohm

J2175
M114, M122 Front Door Lock Actuator



PROBLEM CAUSE
- B Wire

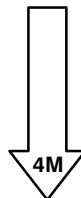

R060009

4M

CONDITIONS

- Ignition Switch
Position: II
- All doors
Locked

RESULTS

- All doors
Unlock

J2175
M114, M122 Front Door Lock Actuator



PROBLEM CAUSE
- YK Wire
- GB Wire
- Theft Alarm Unit



PROBLEM CAUSE
- M114, M122 Front Door Lock Actuator

Test N

R020029

1N

CONDITIONS

- Ignition Switch
Position: 0
- All doors
Unlocked
- Lock a front door

RESULTS
BAT VOLT (Momentary)

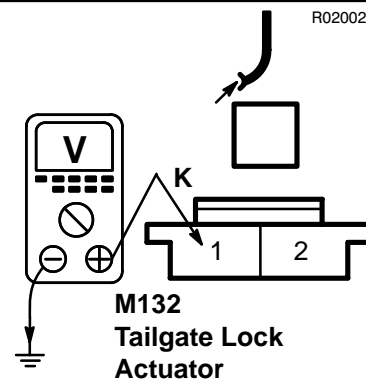

M132
Tailgate Lock
Actuator

~~OK~~ PROBLEM CAUSE
- K Wire

OK

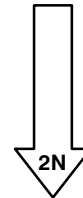

R020029

2N

CONDITIONS

- Ignition Switch
Position: 0
- All doors
Locked
- Unlock a front door

RESULTS
BAT VOLT (Momentary)

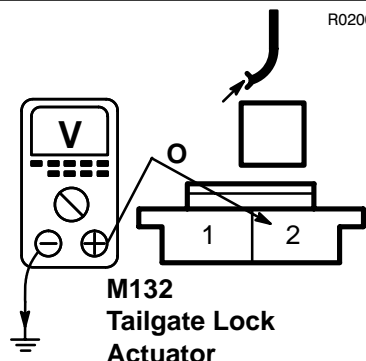

M132
Tailgate Lock
Actuator

~~OK~~ PROBLEM CAUSE
- O Wire

OK PROBLEM CAUSE
- Tailgate Lock
Actuator

Test O

R020029

10

CONDITIONS

- Ignition Switch
Position: 0
- All doors
Unlock
- Lock a front door

RESULTS
BAT VOLT (Momentary)

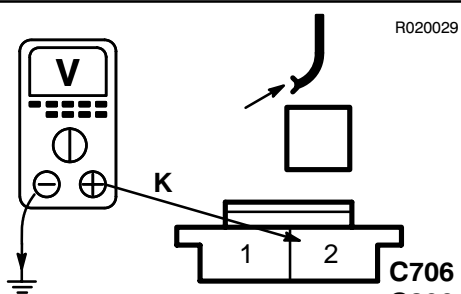

J2176
M117, M125 Rear
Door Lock Actua-
tor

C706
C806



PROBLEM CAUSE
- K Wire

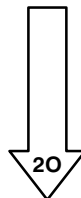

R020029

20

CONDITIONS

- Ignition Switch
Position: 0
- All doors
Locked
- Unlock a front door

RESULTS
BAT VOLT (Momentary)

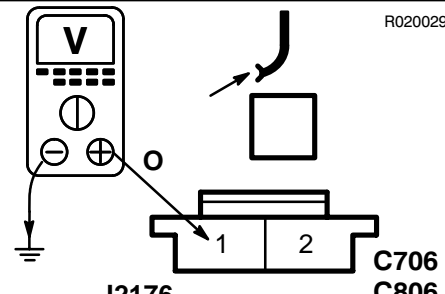

J2176
M117, M125 Rear
Door Lock Actua-
tor

C706
C806



PROBLEM CAUSE
- O Wire



PROBLEM CAUSE
- M117, M125 Rear
Door Lock Actua-
tor

CIRCUIT OPERATION

The main function of the system is to offer easy-to-use remote locking and unlocking of the vehicle without having to actively select the alarm function.

ALARM COMPONENTS

15. Theft Alarm Unit (Z163) and Theft Alarm Relay (K159)
16. Alarm Bonnet Switch (X212)
17. Tailgate Switch (X170)
18. Horns (K128, K134) and Horn Relay (K189)
19. Theft Alarm LED (B151)
20. Front Door Key Switches (X201, X202)
21. Lock Actuators (M114, M122, M117, M125, M132)
22. Handset Transmitter (two supplied)

ANTI-THEFT SYSTEM FUNCTION

Perimetric Protection

Using the key in the correct sequence will turn on and off perimetric protection only. When fully perimetrically armed, all doors, tailgate, and bonnet are protected against unauthorized access. If the door key is used in the normal manner the driver will be unaware of the door key sequence. The time taken to lock or unlock with the key must be less than 5 seconds. To prevent unauthorized tampering, the alarm will sound if the key is held in the unlocked position for longer than 5 seconds when armed. Cranking is disabled when perimetric protection is armed.

NOTE: When key is turned left or right, the key switch input will be activated in conjunction with the sill button switch when links are operated.

Horns (K128, K134)

When an intrusion is detected the Horns (K128, K134) will sound intermittently and the hazard lights flash (where territorial regulations allow) for 30 seconds. The alarm must be retriggered before the Horns (K128, K134) will sound again.

Interior Lights

When the doors are unlocked by the Theft Alarm Unit (Z163), the interior lights are also turned on. This helps to prevent unauthorized entry, in poor lighting conditions, after the system has been disarmed.

Vehicle Status Indication

Vehicle status is indicated by up to three devices: (a) Alarm Sounder (Z171), (b) hazard lights, (c) Theft Alarm LED (B151). When the vehicle arms in either mode, the hazard lights will flash three times and the LED will flash rapidly for 10 seconds. LED will then flash at a slower rate while vehicle is armed. When the vehicle disarms, hazard lights will flash once and LED will extinguish. If LED remains lit, it indicates that the alarm has been triggered. Turning on ignition or arming the alarm will extinguish LED.

Central Locking

Central Locking is controlled by the Theft Alarm Unit (Z163) and may be operated by the key, sill button(s) or handset. The system works on both front doors on four door vehicles or driver's door on two door vehicles.

NOTE: The central door locking system will shut down for a period after more than 15 consecutive operations.

Inertia Switch

An inertia switch is incorporated in the Theft Alarm Unit (Z163). If ignition is on and the vehicle receives an impact sufficient to activate the inertia switch, the unit will signal to unlock central locking actuators and flash hazard lights. Central locking will remain disabled for 30 seconds. To reset, turn ignition off and then on after the 30 second period has elapsed.

Radio Frequency System

The RF system uses four frequencies according to market. If the coaxial aerial is not fitted, system performance will be impaired. Both ECU and handset have a colour-coded label.

Frequency Colour ECU/Handset:

315.0 MHz, Green/green

Partially armed mode

If a door, tailgate or bonnet is left open when the system is armed, the LED will not light for 10 seconds indicating a mislock condition. Hazard lights will not flash. If an open door or tailgate is causing the mislock, the starter motor is disabled. The alarm will sound if ignition is turned to start position. If an open bonnet is causing the mislock, the starter motor is disabled. If the door, tailgate or bonnet is subsequently closed, after a 5 second delay, the doors will unlock and immediately lock, and the system will fully arm.

Handset Transmitter

The handset LED will give one flash when button is pressed momentarily. If button is held down the LED will light again after 2 seconds for 2 seconds, and extinguish until button is released and repressed.

Handset Batteries

If handset LED flashes continuously when button is pressed, the batteries need replacing. The hazard lights will flash one 3 second pulse, instead of three times upon arming vehicle.

Power Up Mode

The alarm system always remembers the state it was left in when power was removed. If the alarm powers up in an alarmed state and is subsequently triggered, it will give a warning that it will fully trigger unless disarmed. This warning consists of short horn pulses every two seconds for 15 seconds.

New Born Mode

When the ECU is first produced, it will be in its 'new born' mode. In this mode it will respond to any remote of the right frequency. This mode will be cancelled when the ECU has received ten valid handset signals without power interruption.

Engine Cranking

It is only possible to crank the engine when ignition is ON and alarm is disabled.

BUILT IN TEST PROCEDURE

The built in test procedure is accessed as follows:

1. Starting conditions: ignition off, doors unlocked, bonnet switch depressed.
2. Carry out instructions 3 to 7 within 8 seconds.
3. Release bonnet switch.
4. Switch ignition ON.
5. Lock doors.
6. Switch ignition OFF.
7. Switch ignition ON.

If alarm is correctly accessed, horn will sound and LED will flash. The following checks can be made:

8. Open and close any door or tailgate – LED will light.
9. Depress bonnet switch – hazards will flash.
10. Check engine cranking is disabled. Do not turn off ignition.
11. Check ultrasonic by operating handset, LED will emit one 5 second flash, and will flash if interior is disturbed.

NOTE: If ECU is in new born mode, any handset of the right frequency will work. If not, initialised handset is required. See Handset Initialisation.

12. Turn OFF ignition or press handset to end test procedure. Horn will sound as before to indicate end of test mode.

HANDSET INITIALISATION

New handsets are supplied in pairs. If a new handset is required, it will require initialisation to the Theft Alarm Unit (Z163) using the following procedure:

1. Starting conditions: ignition off, doors unlocked, bonnet switch depressed.
2. Carry out instructions 3 to 9 within 8 seconds.
3. Switch ignition ON.
4. Switch ignition OFF.
5. Lock doors.
6. Unlock doors.
7. Release bonnet switch.
8. Switch ignition ON.

9. Switch ignition OFF.

If alarm is correctly accessed, horn will sound and LED will light. It is now possible to programme two handsets of correct frequency to vehicle alarm ECU. This must be carried out within two minutes.

10. Press and hold down button on first handset until dash LED flashes.
11. Repeat instruction 10. for second handset.
12. The LED will extinguish if both handsets have been initialised correctly.

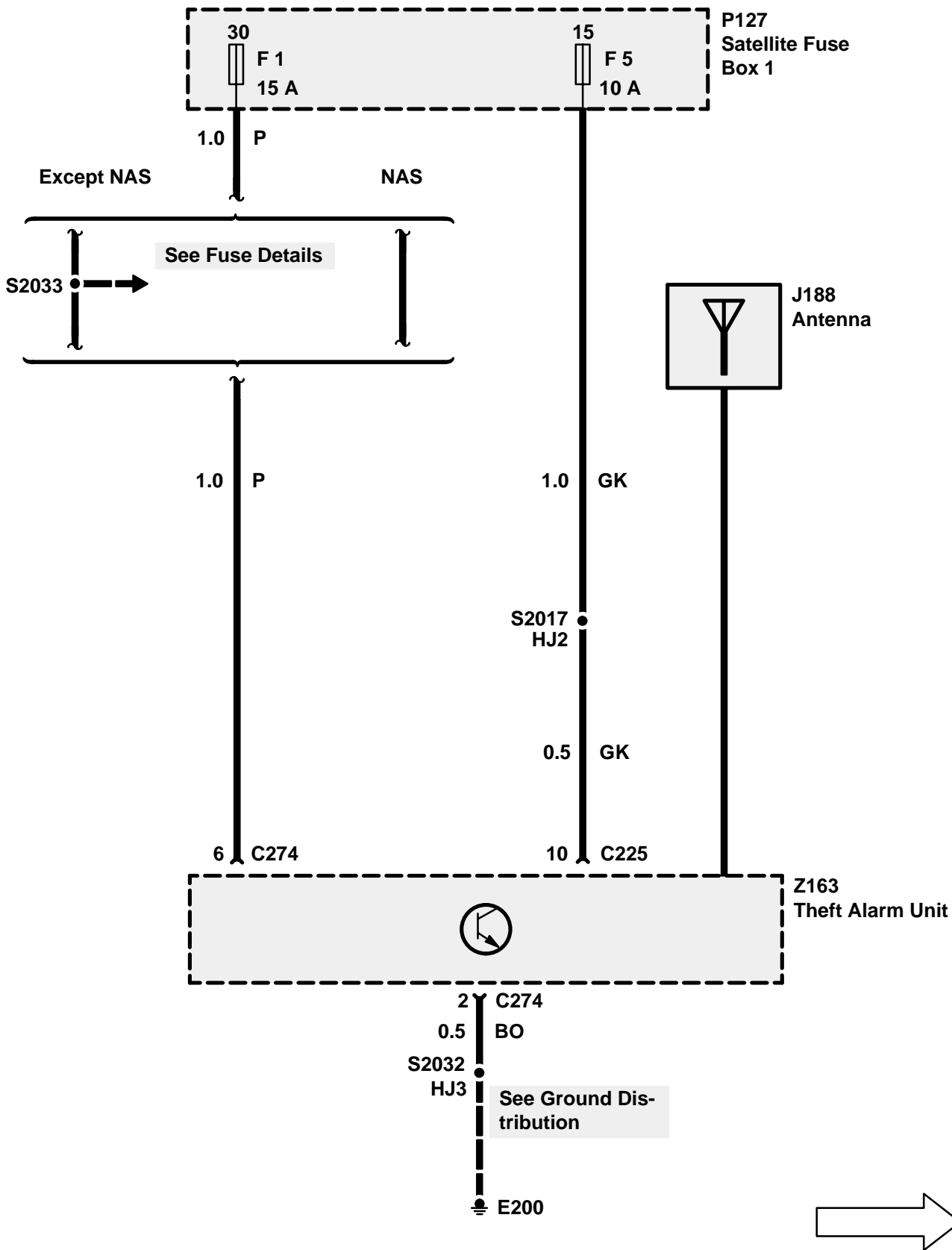

T2 ETM

DISCOVERY

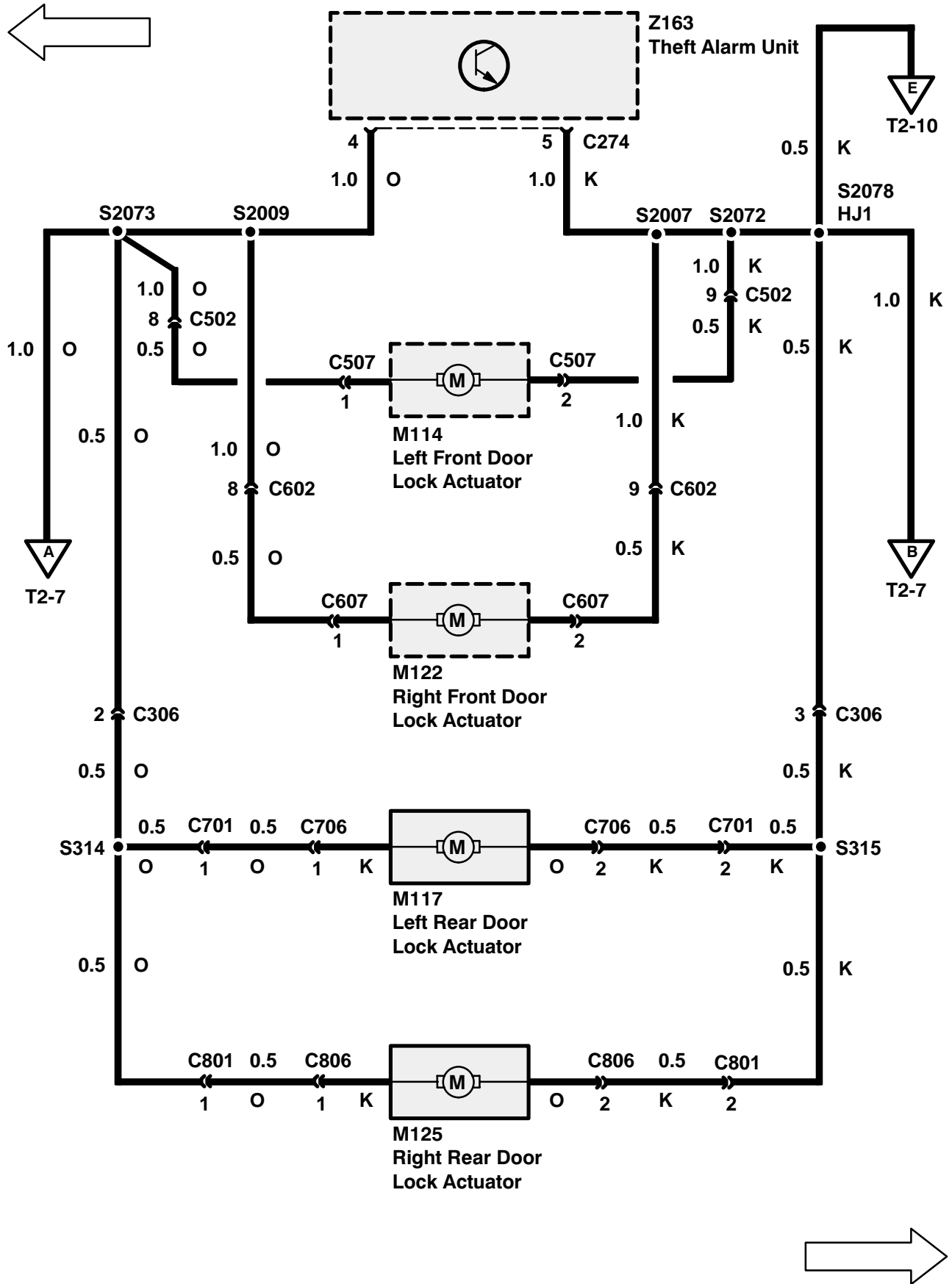

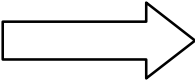
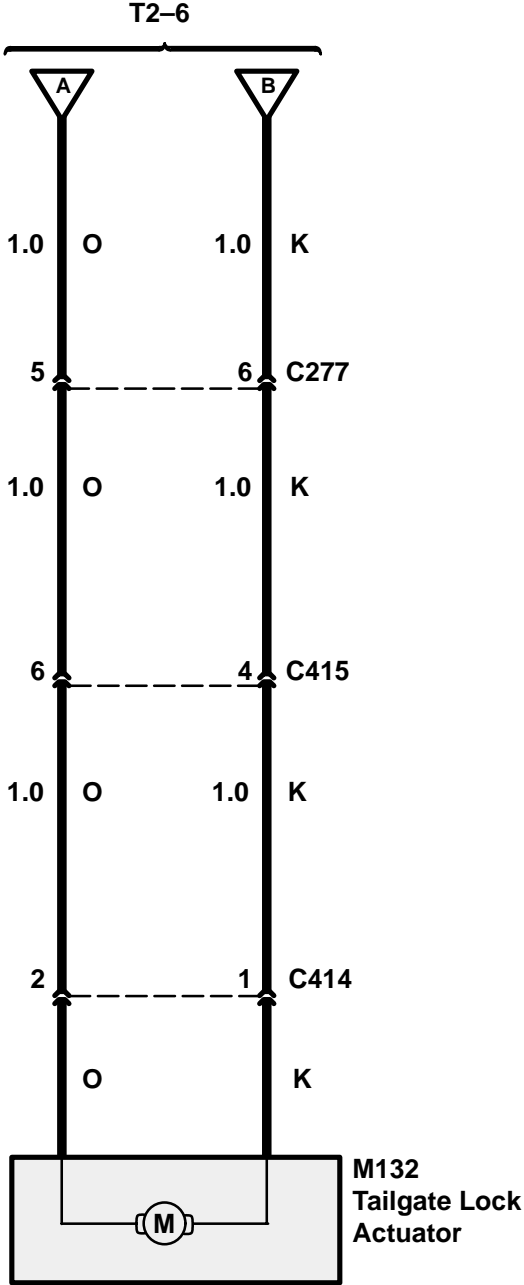
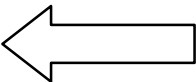

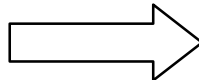
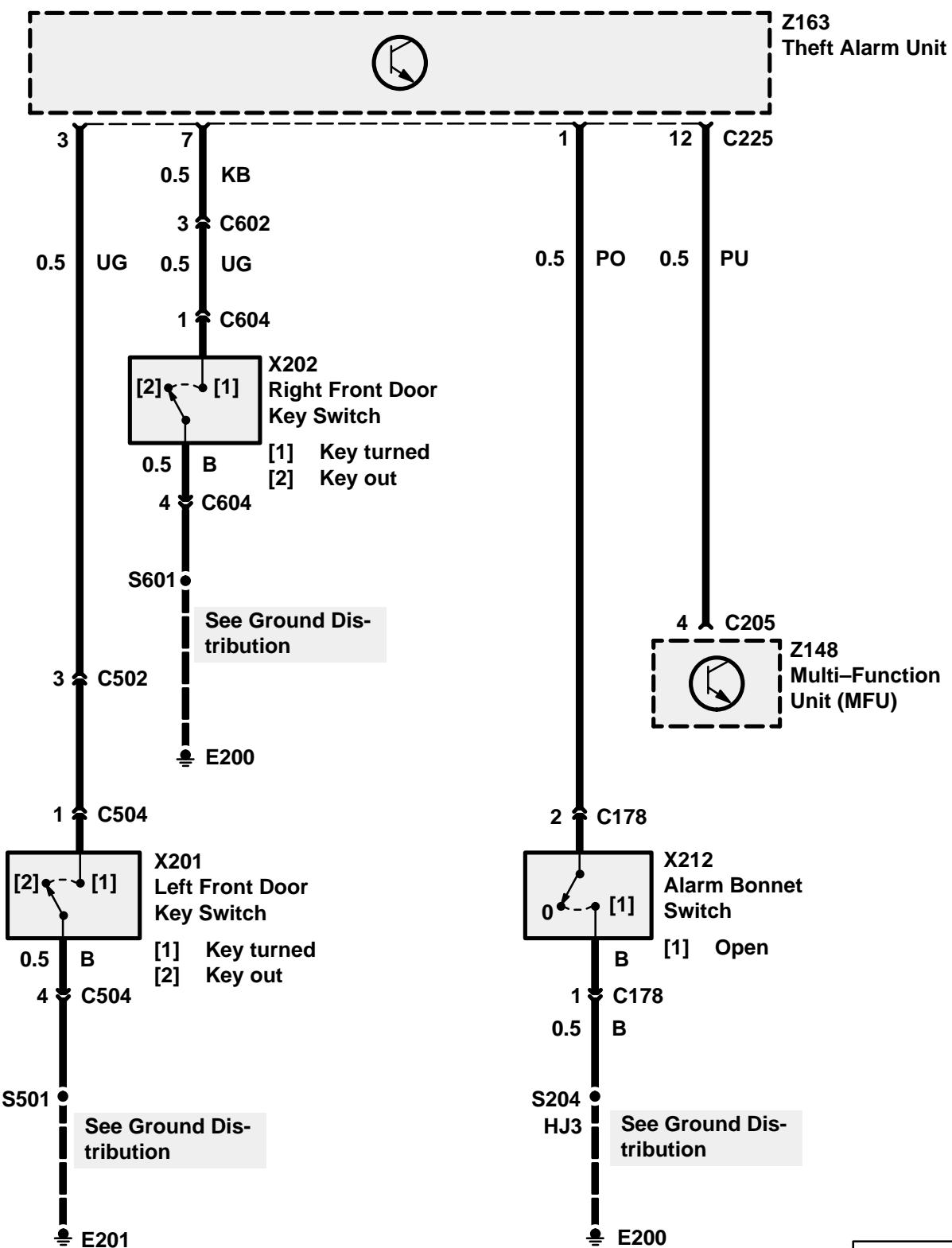
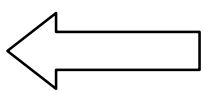

T2 ETM

DISCOVERY

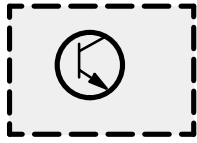
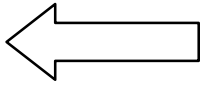

Z163
Theft Alarm Unit

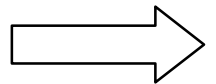
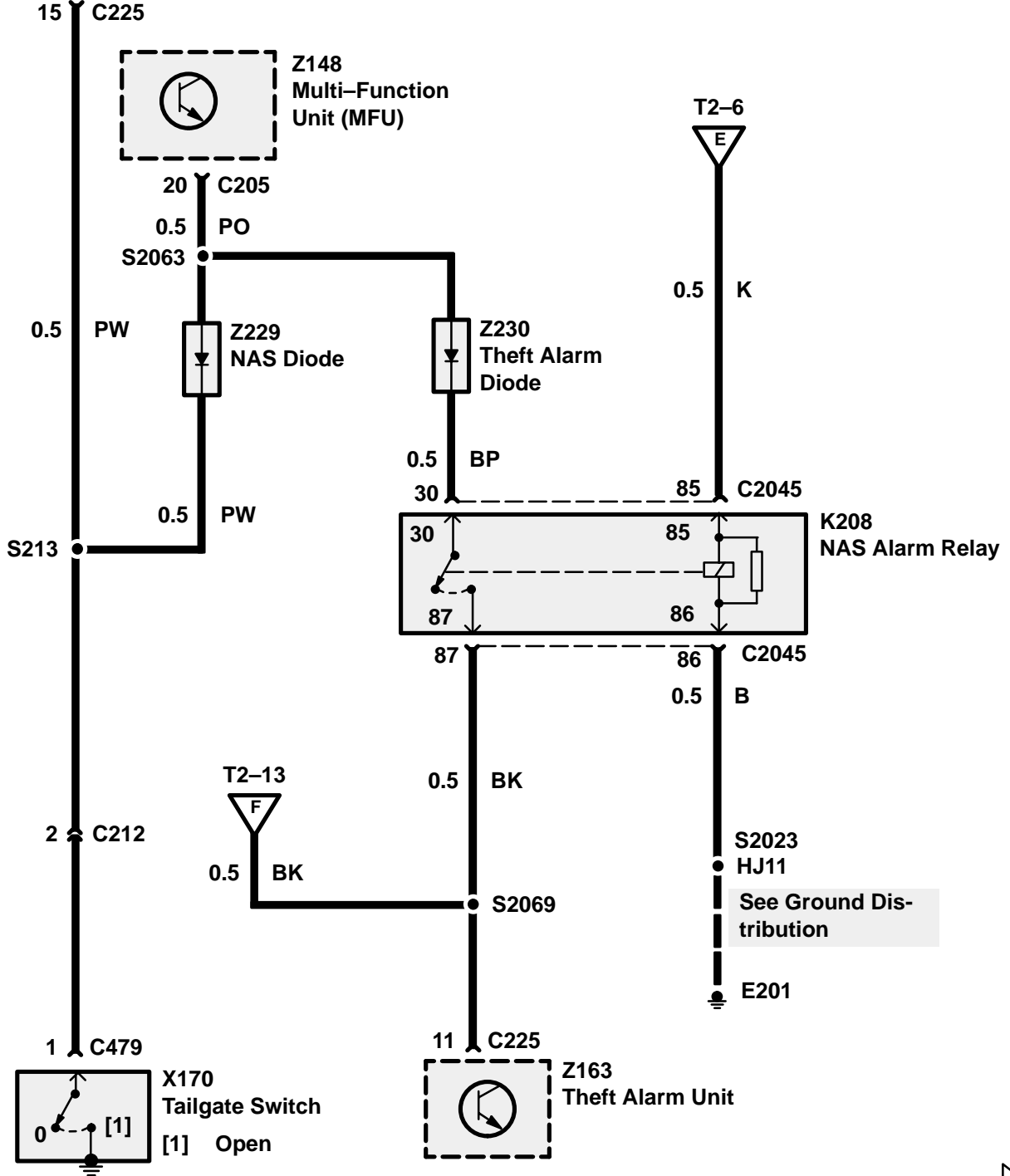

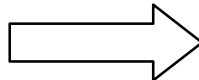
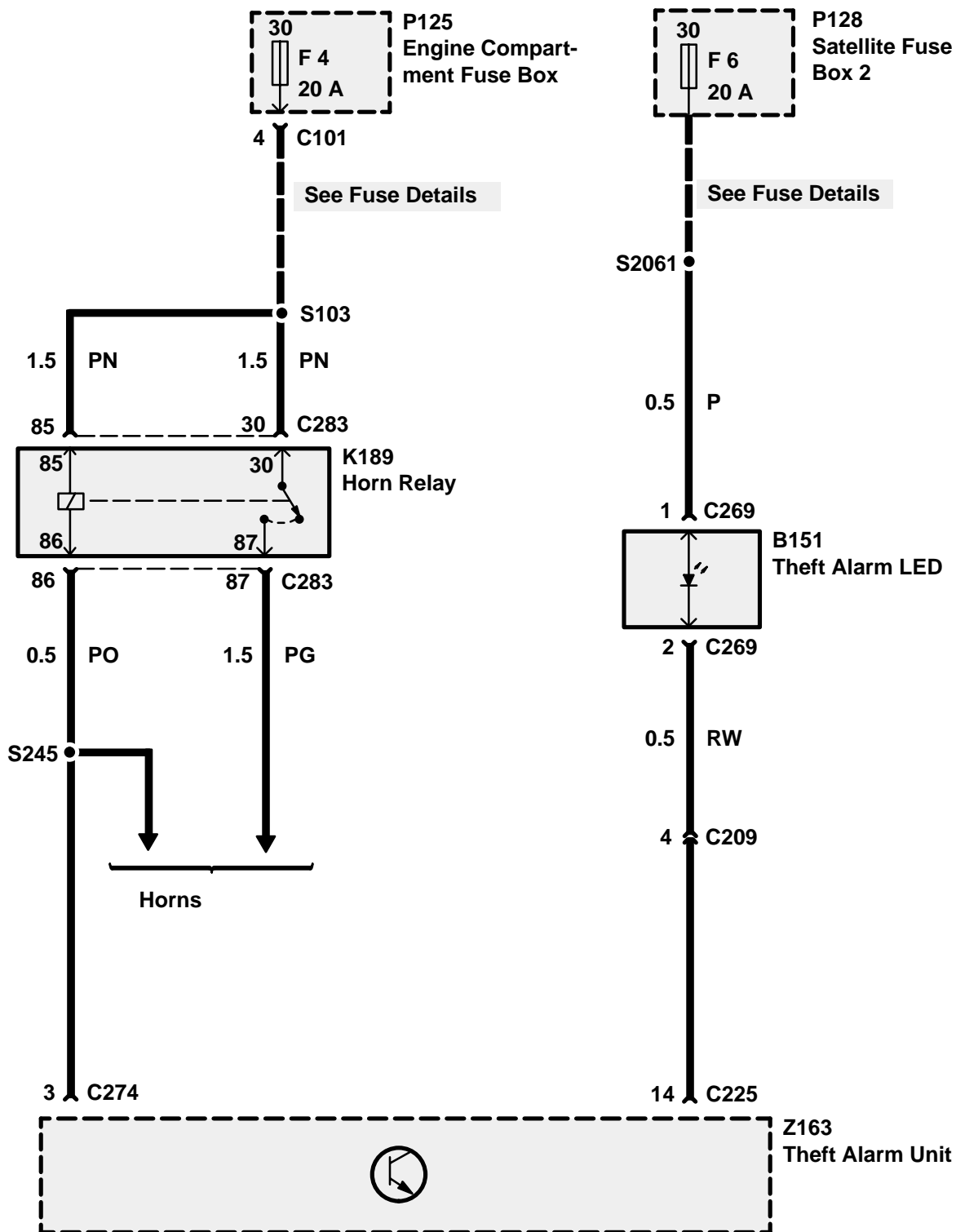
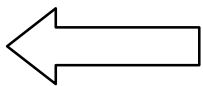

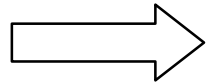
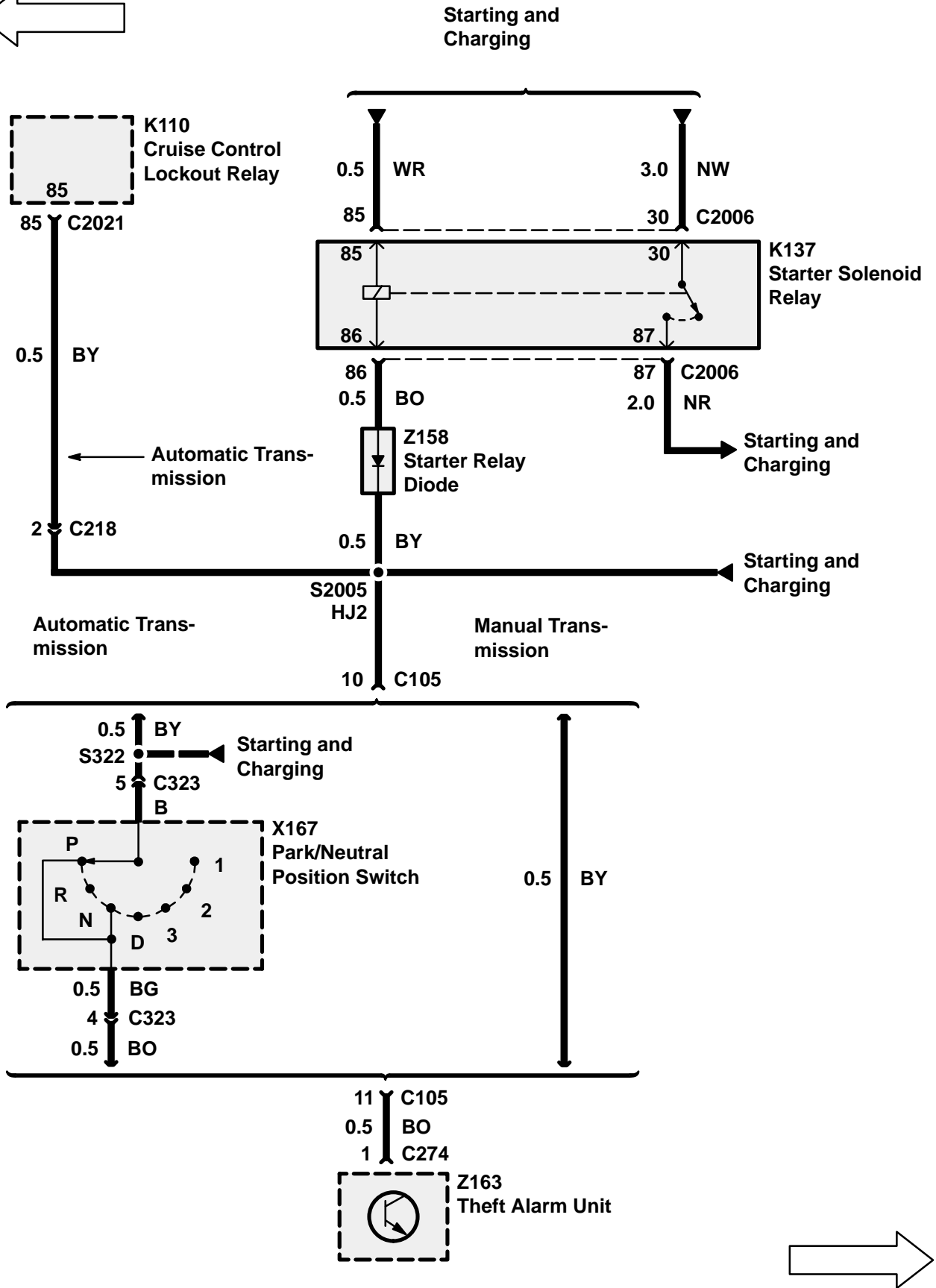
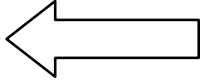

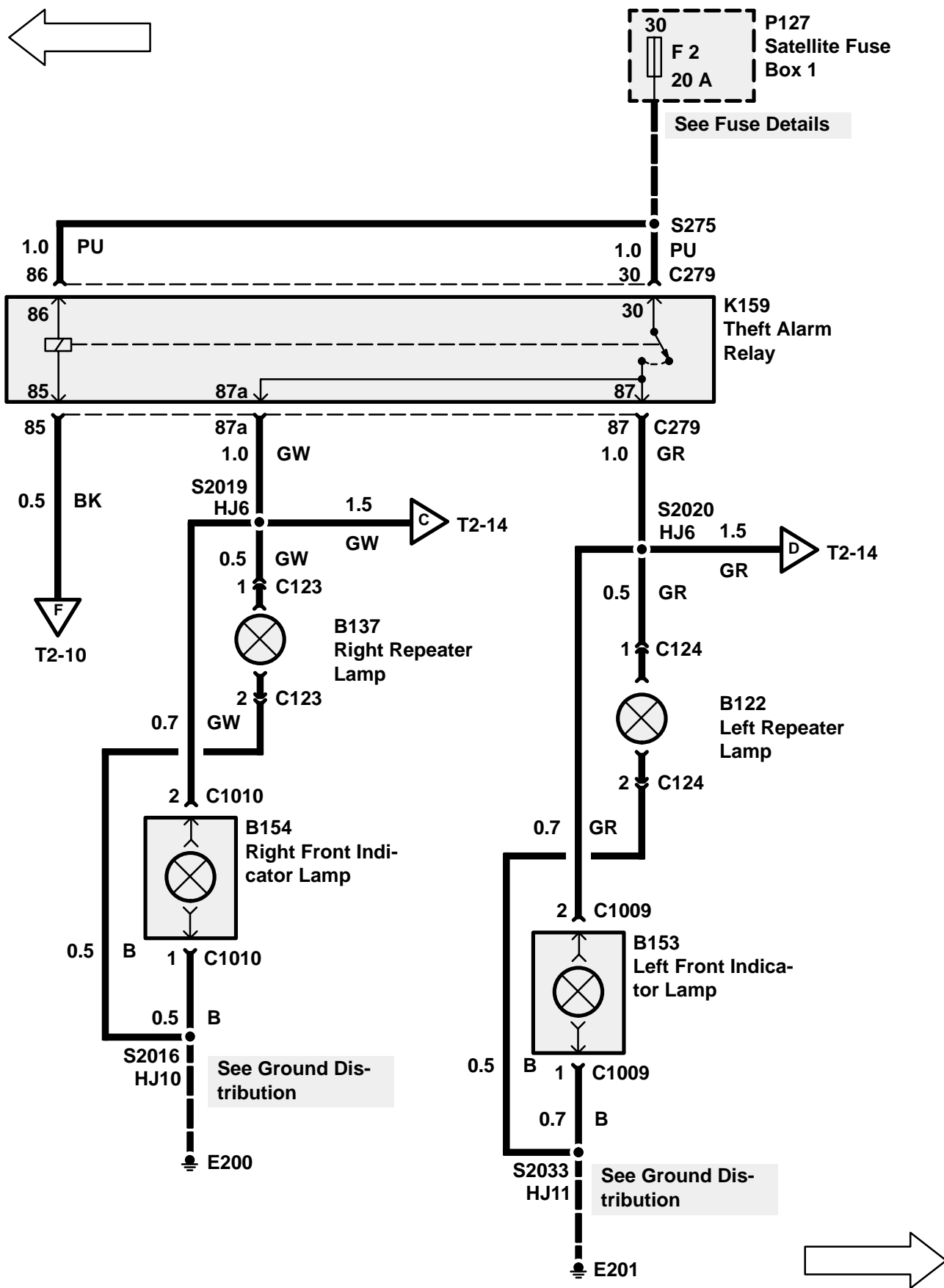

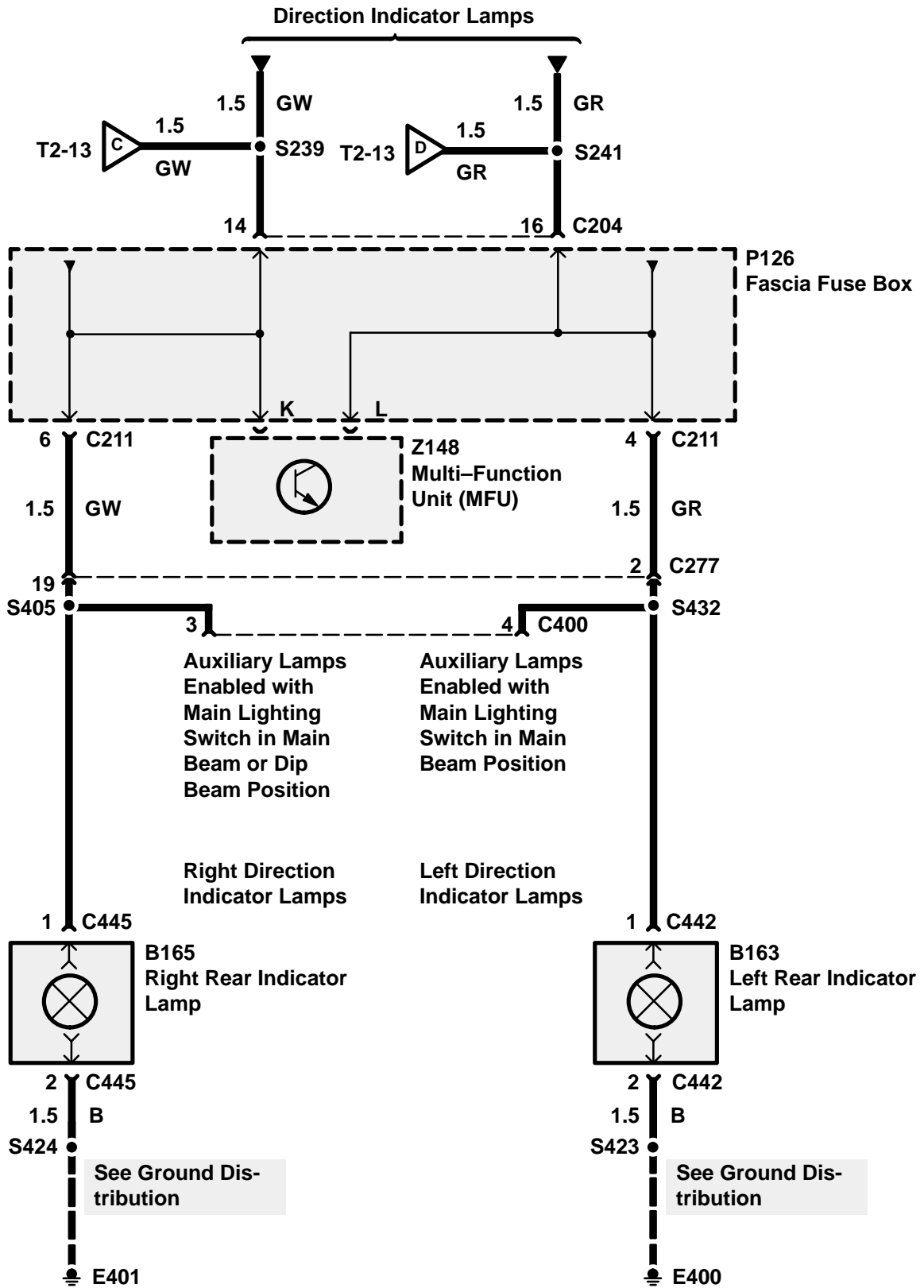
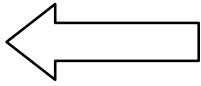

TROUBLESHOOTING HINTS

13. Check Fuses F1, F2 and F5 in Satellite Fuse Box 1.
14. Check Fuse F5 in Satellite Fuse Box 2.
15. If the interior lights do not come on when a door is open, check suspect door switch and associated wiring.
16. If all of the lock actuators do not operate, check O and K Wire. If OK, replace Theft Alarm Unit (Z163).

SYSTEM DIAGNOSIS

1. If the system will not arm, do Test A.
2. If the system arms, but will not trigger at all, do Test C.
3. If the Horns (K128, K134) do not sound when triggered, do Test C.
4. If the hazard lights do not flash when triggered, do Test F.
5. If the system will not trigger when the bonnet is open, do Test G.
6. If the Theft Alarm LED (B151) does not operate, do Test D.
7. If the Horns (K128, K134) sound continuously, do Test E.
8. If the system will not disarm, do Test A.
9. If a Front Door Lock Actuator (M114, M122) does not operate, do Test H.
10. If the doors unlock themselves after operating the door locks, do Test I.
11. If the central locking function does not operate from one of the front doors, do Test J.
12. If the Tailgate Lock Actuator (M132) does not operate, do Test K.
13. If both Rear Door Lock Actuators (M117, M125) do not operate, do Test L.

Test A

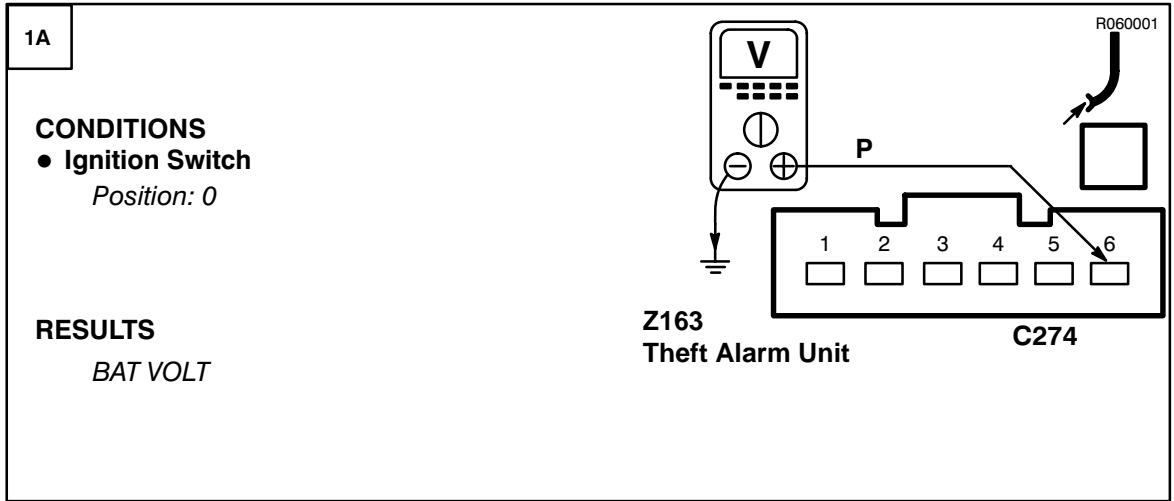

PROBLEM CAUSE
- P Wire

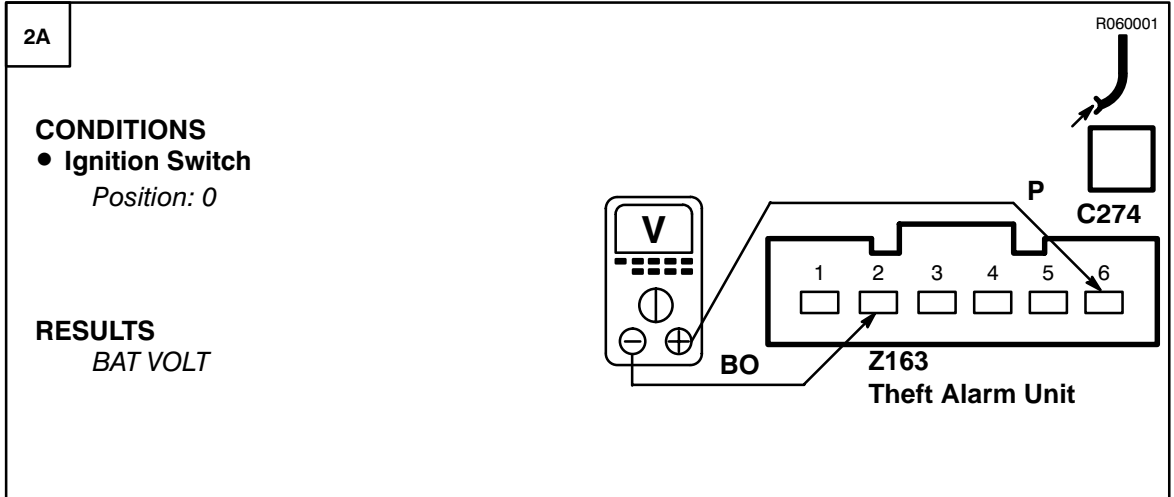
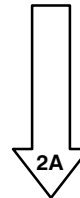

PROBLEM CAUSE
- BO Wire

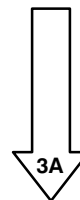

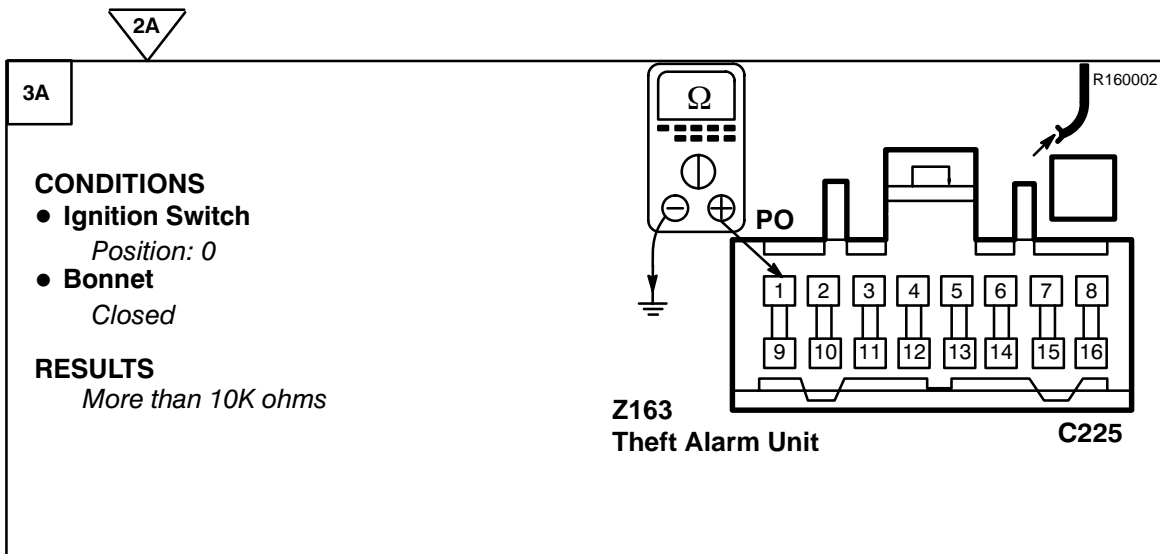

OK PROBLEM CAUSE
 - PO Wire
 - Alarm Bonnet Switch

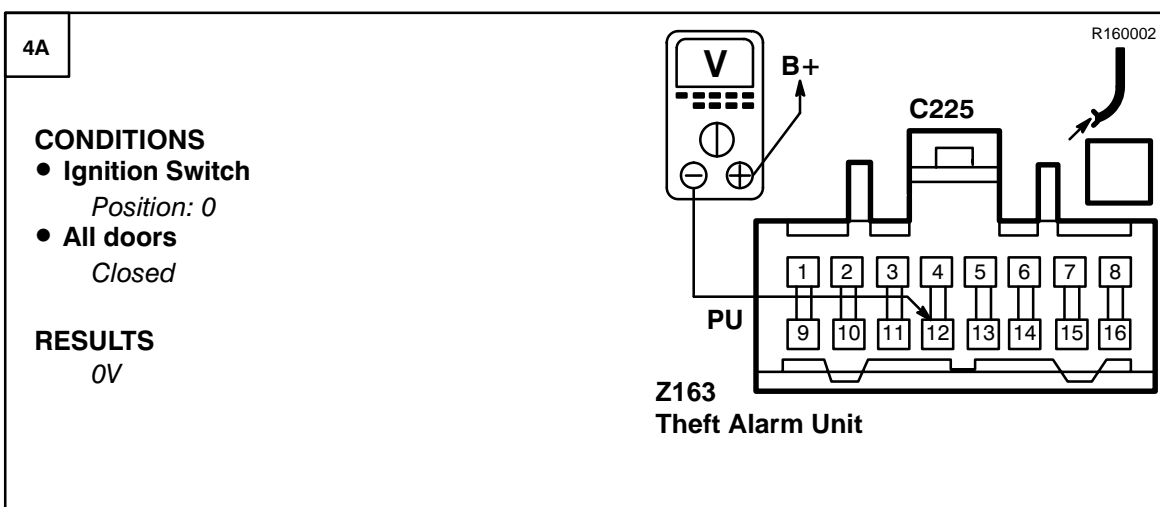
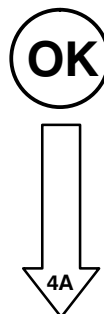

OK GO TO TEST B

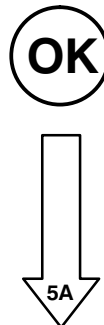

T2 ETM

DISCOVERY

5A

CONDITIONS

- Ignition Switch
Position: 0

RESULTS

- X201, X202 Front Door Key Switches

Neutral	= More than 10K ohms
Locked	= Less than 1 ohm

Z163
Theft Alarm Unit **C225**



PROBLEM CAUSE

- UG Wire
- KB Wire
- B Wire
- X201, X202 Front Door Key Switches

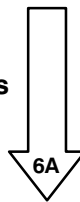

6A

CONDITIONS

- Ignition Switch
Position: 0

RESULTS

- All doors

Locked	= More than 10K ohms
Unlocked	= Less than 1 ohm

Z163
Theft Alarm Unit



PROBLEM CAUSE

- YK, GB Wire
- B Wire

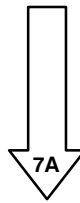

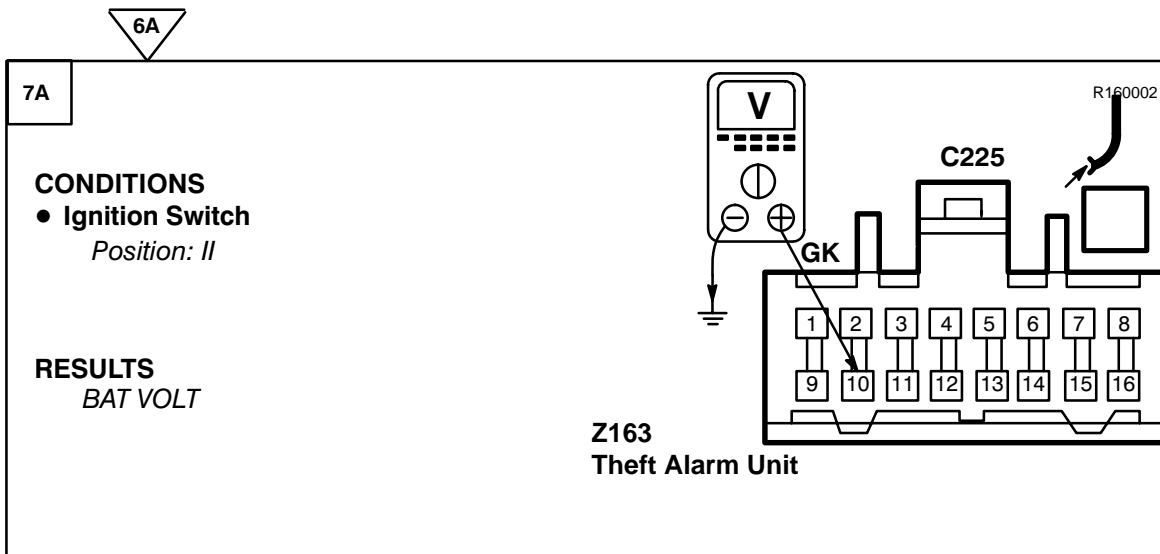

PROBLEM CAUSE
- GK Wire



PROBLEM CAUSE
- Theft Alarm Unit

Test B

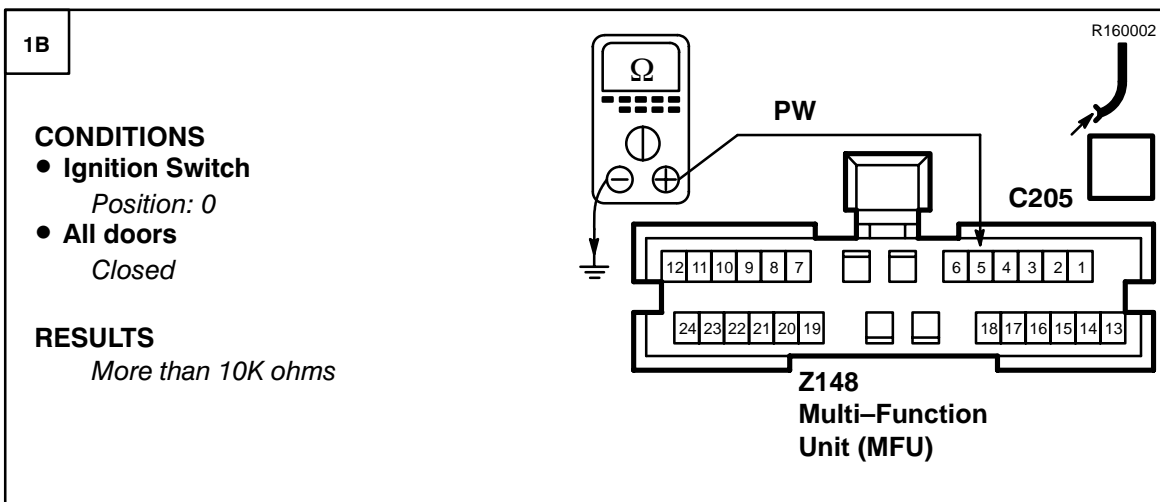

PROBLEM CAUSE

- PW Wire
- Right Front Door Switch
- Left Rear Door Switch
- Right Rear Door Switch
- Rear End Door Switch

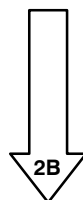

T2 ETM

DISCOVERY

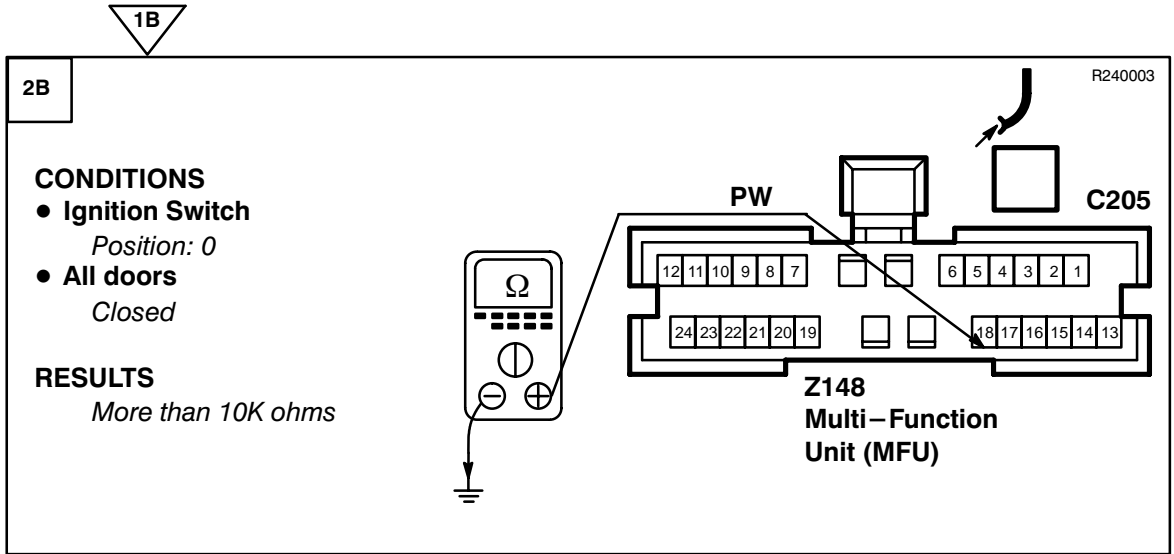

PROBLEM CAUSE
 - PW Wire
 - Left Front Door Switch



PROBLEM CAUSE
 - PU Wire
 - Multi-Function Unit (MFU)

Test C

1C	NAS	R050001
<p>CONDITIONS</p> <ul style="list-style-type: none"> • Ignition Switch <i>Position: 0</i> 		
<p>RESULTS</p> <p><i>BAT VOLT</i></p>		

OK PROBLEM CAUSE
- PN Wire

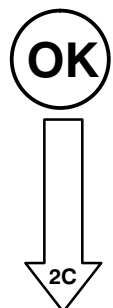

2C		R050001
<p>CONDITIONS</p> <ul style="list-style-type: none"> • Ignition Switch <i>Position: 0</i> 		
<p>RESULTS</p> <ul style="list-style-type: none"> • Horns <i>Operate</i> 		

OK PROBLEM CAUSE
- PG Wire
- Horns

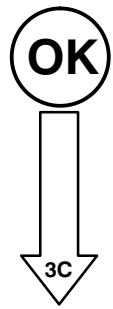

T2 ETM

DISCOVERY

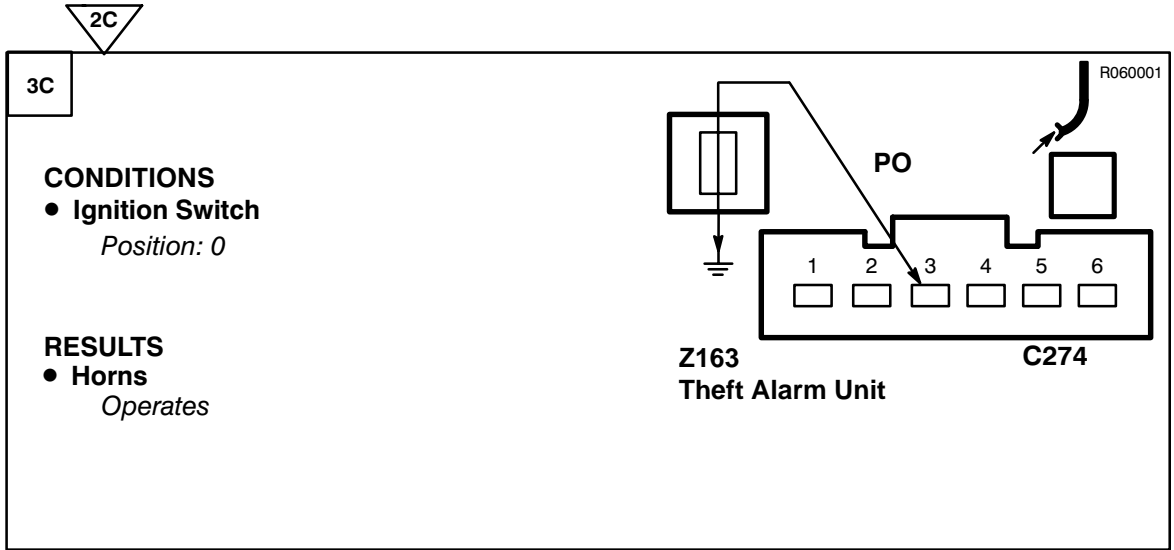

PROBLEM CAUSE

- PO Wire
- Horns



PROBLEM CAUSE

- Theft Alarm Unit

Test D

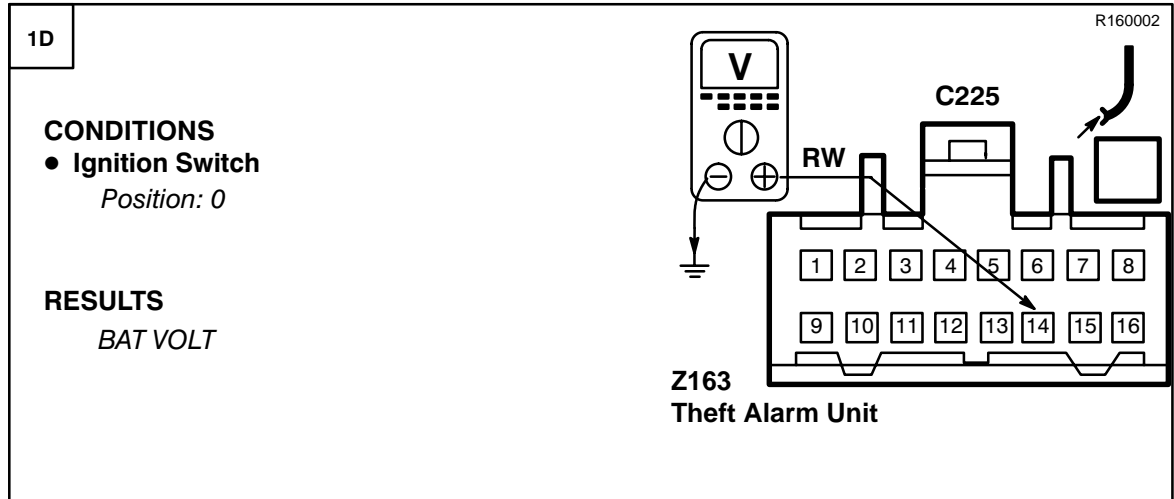

PROBLEM CAUSE

- RW Wire
- P Wire
- Theft Alarm LED



PROBLEM CAUSE

- Theft Alarm Unit

Test E

1E

CONDITIONS

- Ignition Switch
Position: 0

RESULTS
0V

R050001

**K189
Horn Relay**



PROBLEM CAUSE
- PO Wire
- Theft Alarm Unit



PROBLEM CAUSE
- Horn Relay

Test F

1F

CONDITIONS

- Ignition Switch
Position: 0

RESULTS
BAT VOLT

R050001

**K159
Theft Alarm
Relay**



PROBLEM CAUSE
- PU Wire

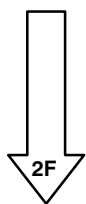

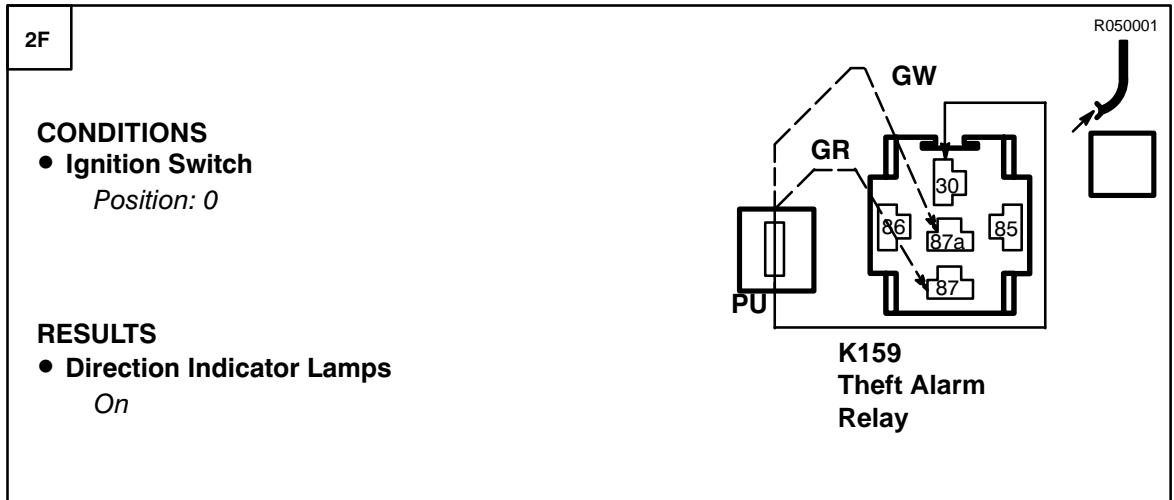

PROBLEM CAUSE
- GR Wire
- GW Wire

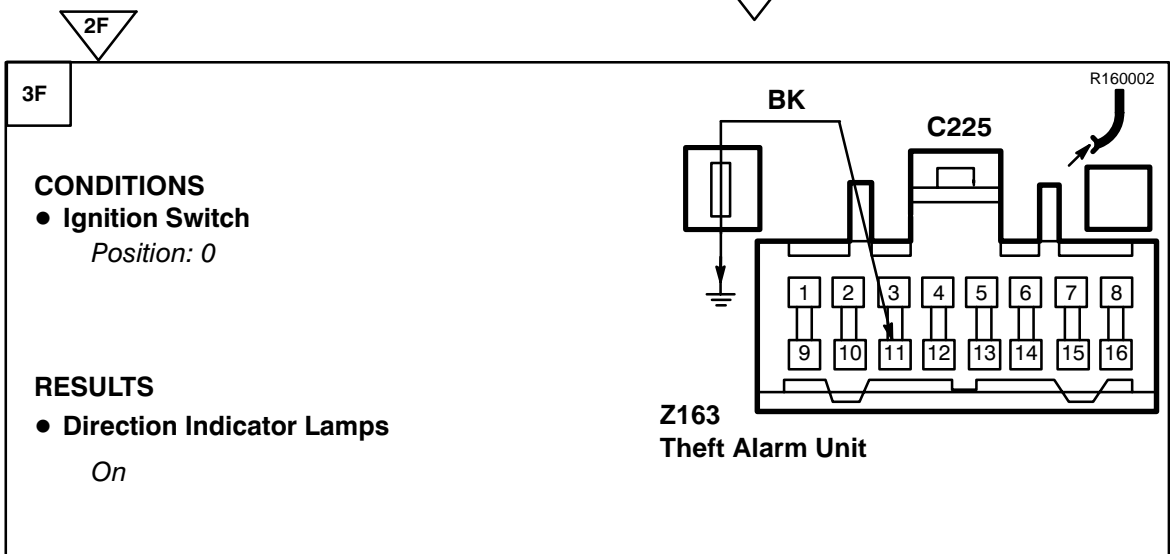
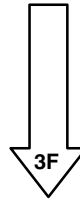

PROBLEM CAUSE
- BK Wire
- Theft Alarm
Relay



PROBLEM CAUSE
- Theft Alarm Unit

Test G

1G

R160002

CONDITIONS

- Ignition Switch
Position: 0
- Bonnet
Open

RESULTS
Less than 1 ohm

Z163
Theft Alarm Unit



PROBLEM CAUSE

- PO Wire
- B Wire
- Alarm Bonnet Switch



PROBLEM CAUSE

- Theft Alarm Unit

Test H

1H

R060009

CONDITIONS

- Ignition Switch
Position: II
- All doors
Locked
- Unlock a front door

RESULTS
BAT VOLT (Momentary)

J2175
M114, M122 Front Door Lock Actuator



PROBLEM CAUSE

- O Wire

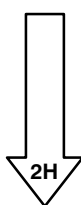

2H	<p style="text-align: right;">R060009</p> <div style="display: flex; justify-content: space-between;"> <div style="width: 60%;"> <p>CONDITIONS</p> <ul style="list-style-type: none"> • Ignition Switch <i>Position: II</i> • All doors <i>Unlocked</i> • Lock a front door <p>RESULTS <i>BAT VOLT (Momentary)</i></p> </div> <div style="width: 35%; text-align: center;"> <p>J2175 M114, M122 Front Door Lock Actuator</p> </div> </div>
----	---



PROBLEM CAUSE
- K Wire



PROBLEM CAUSE
- M114, M122 Front Door Lock Actuator

Test I

11

R160002

CONDITIONS

- Ignition Switch
Position: 0
- All doors
Locked

RESULTS
More than 1000 ohms

Z163
Theft Alarm Unit

C225



PROBLEM CAUSE

- GB Wire
- YK Wire
- Right Front Door Lock Actuator

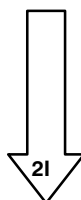

21

R160002

CONDITIONS

- Ignition Switch
Position: 0
- All doors
Locked

RESULTS
More than 1000 ohms

Z163
Theft Alarm Unit

C225



PROBLEM CAUSE

- YK Wire
- Left Front Door Lock Actuator



PROBLEM CAUSE

- Theft Alarm Unit

Test J

1J

CONDITIONS

- Ignition Switch
Position: 0
- All doors
Unlocked

RESULTS
Less than 1 ohm

Z163
Theft Alarm Unit

C225

~~OK~~ SHORTING LINK 2

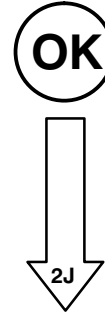

2J

CONDITIONS

- Ignition Switch
Position: 0
- All doors
Unlocked

RESULTS
Less than 1 ohm

Z163
Theft Alarm Unit

C225

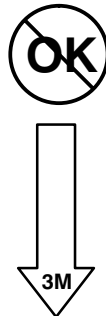

OK PROBLEM CAUSE
- Theft Alarm Unit

R060009

2J
3J

CONDITIONS

- Ignition Switch
Position: 0

RESULTS

Less than 1 ohm

J2175
M114, M122 Front Door Lock Actuator



PROBLEM CAUSE
- B Wire

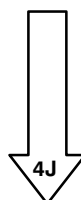

R060009

4J

CONDITIONS

- Ignition Switch
Position: II
- All doors
Locked

RESULTS

- All doors
Unlock

J2175
M114, M122 Front Door Lock Actuator



PROBLEM CAUSE
- YK Wire
- GB Wire
- Theft Alarm Unit



PROBLEM CAUSE
- M114, M122 Front Door Lock Actuator

Test K

R020029

1K

CONDITIONS

- Ignition Switch
Position: 0
- All doors
Unlocked
- Lock a front door

RESULTS
BAT VOLT (Momentary)

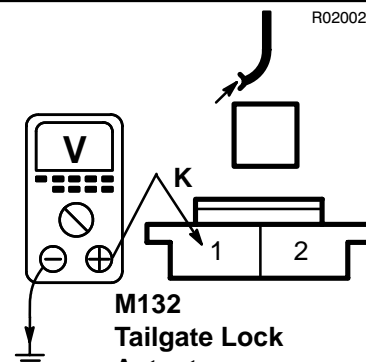

M132
Tailgate Lock
Actuator

~~OK~~ PROBLEM CAUSE
- K Wire

OK

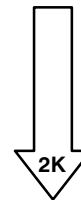

R020029

2K

CONDITIONS

- Ignition Switch
Position: 0
- All doors
Locked
- Unlock a front door

RESULTS
BAT VOLT (Momentary)

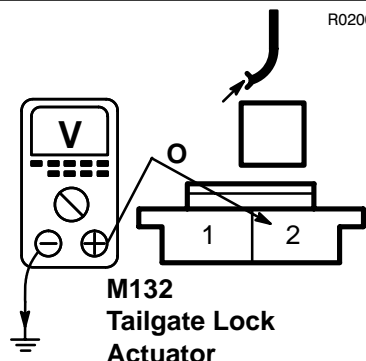

M132
Tailgate Lock
Actuator

~~OK~~ PROBLEM CAUSE
- O Wire

OK PROBLEM CAUSE
- Tailgate Lock
Actuator

Test L

1L

R020029

CONDITIONS

- Ignition Switch
Position: 0
- All doors
Unlock
- Lock a front door

RESULTS
BAT VOLT (Momentary)

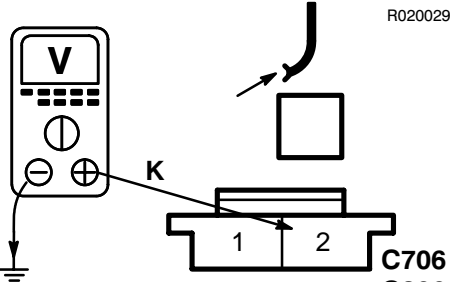

J2176
M117, M125 Rear
Door Lock Actua-
tor
C706
C806



PROBLEM CAUSE
- K Wire

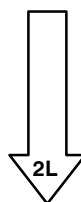

2L

R020029

CONDITIONS

- Ignition Switch
Position: 0
- All doors
Locked
- Unlock a front door

RESULTS
BAT VOLT (Momentary)

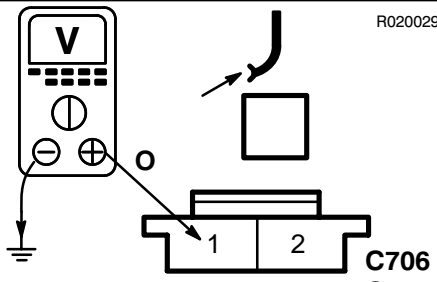

J2176
M117, M125 Rear
Door Lock Actua-
tor
C706
C806



PROBLEM CAUSE
- O Wire



PROBLEM CAUSE
- M117, M125 Rear
Door Lock Actua-
tor

CIRCUIT OPERATION

The main function of the system is to offer easy-to-use remote locking and unlocking of the vehicle without having to actively select the alarm function.

ALARM COMPONENTS

14. Theft Alarm Unit (Z163) and Theft Alarm Relay (K159)
15. Alarm Bonnet Switch (X212)
16. Tailgate Switch (X170)
17. Horns (K128, K134) and Horn Relay (K189)
18. Theft Alarm LED (B151)
19. Front Door Key Switches (X201, X202)
20. Lock Actuators (M114, M122, M117, M125, M132)
21. Handset Transmitter (two supplied)

ANTI-THEFT SYSTEM FUNCTION

Perimetric Protection

Using the key in the correct sequence will turn on and off perimetric protection only. When fully perimetrically armed, all doors, tailgate, and bonnet are protected against unauthorized access. If the door key is used in the normal manner the driver will be unaware of the door key sequence. The time taken to lock or unlock with the key must be less than 5 seconds. To prevent unauthorized tampering, the alarm will sound if the key is held in the unlocked position for longer than 5 seconds when armed. Cranking is disabled when perimetric protection is armed.

NOTE: When key is turned left or right, the key switch input will be activated in conjunction with the sill button switch when links are operated.

Horns (K128, K134)

When an intrusion is detected the Horns (K128, K134) will sound intermittently and the hazard lights flash (where territorial regulations allow) for 30 seconds. The alarm must be retriggered before the Horns (K128, K134) will sound again.

Vehicle Status Indication

Vehicle status is indicated by up to three devices: (a) Alarm Sounder (Z171), (b) hazard lights, (c) Theft Alarm LED (B151). When the vehicle arms in either mode, the hazard lights will flash three times and the LED will flash rapidly for 10 seconds. LED will then flash at a slower rate while vehicle is armed. When the vehicle disarms, hazard lights will flash once and LED will extinguish. If LED remains lit, it indicates that the alarm has been triggered. Turning on ignition or arming the alarm will extinguish LED.

Central Locking

Central Locking is controlled by the Theft Alarm Unit (Z163) and may be operated by the key, sill button(s) or handset. The system works on both front doors on four door vehicles or driver's door on two door vehicles.

NOTE: The central door locking system will shut down for a period after more than 15 consecutive operations.

Inertia Switch

An inertia switch is incorporated in the Theft Alarm Unit (Z163). If ignition is on and the vehicle receives an impact sufficient to activate the inertia switch, the unit will signal to unlock central locking actuators and flash hazard lights. Central locking will remain disabled for 30 seconds. To reset, turn ignition off and then on after the 30 second period has elapsed.

Radio Frequency System

The RF system uses four frequencies according to market. If the coaxial aerial is not fitted, system performance will be impaired. Both ECU and handset have a colour-coded label.

Frequency Colour ECU/Handset:

315.0 MHz, Green/green

Partially armed mode

If a door, tailgate or bonnet is left open when the system is armed, the LED will not light for 10 seconds indicating a mislock condition. Hazard lights will not flash. The alarm will sound if ignition is turned to start position. If the door, tailgate or bonnet is subsequently closed, after a 5 second delay, the doors will unlock and immediately lock, and the system will fully arm.

Handset Transmitter

The handset LED will give one flash when button is pressed momentarily. If button is held down the LED will light again after 2 seconds for 2 seconds, and extinguish until button is released and repressed.

Handset Batteries

If handset LED flashes continuously when button is pressed, the batteries need replacing. The hazard lights will flash one 3 second pulse, instead of three times upon arming vehicle.

Power Up Mode

The alarm system always remembers the state it was left in when power was removed. If the alarm powers up in an alarmed state and is subsequently triggered, it will give a warning that it will fully trigger unless disarmed. This warning consists of short horn pulses every two seconds for 15 seconds.

New Born Mode

When the ECU is first produced, it will be in its 'new born' mode. In this mode it will respond to any remote of the right frequency. This mode will be cancelled when the ECU has received ten valid handset signals without power interruption.

Engine Cranking

It is only possible to crank the engine when ignition is ON and alarm is disabled.

BUILT IN TEST PROCEDURE

The built in test procedure is accessed as follows:

1. Starting conditions: ignition off, doors unlocked, bonnet switch depressed.
2. Carry out instructions 3 to 7 within 8 seconds.
3. Release bonnet switch.
4. Switch ignition ON.
5. Lock doors.
6. Switch ignition OFF.
7. Switch ignition ON.

If alarm is correctly accessed, horn will sound and LED will flash. The following checks can be made:

8. Open and close any door or tailgate – LED will light.
9. Depress bonnet switch – hazards will flash.
10. Check engine cranking is disabled. Do not turn off ignition.
11. Check ultrasonic by operating handset, LED will emit one 5 second flash, and will flash if interior is disturbed.

NOTE: If ECU is in new born mode, any handset of the right frequency will work. If not, initialised handset is required. See Handset Initialisation.

12. Turn OFF ignition or press handset to end test procedure. Horn will sound as before to indicate end of test mode.

HANDSET INITIALISATION

New handsets are supplied in pairs. If a new handset is required, it will require initialisation to the Theft Alarm Unit (Z163) using the following procedure:

1. Starting conditions: ignition off, doors unlocked, bonnet switch depressed.
2. Carry out instructions 3 to 9 within 8 seconds.
3. Switch ignition ON.
4. Switch ignition OFF.
5. Lock doors.
6. Unlock doors.
7. Release Bonnet Switch.
8. Switch ignition ON.

9. Switch ignition OFF.

If alarm is correctly accessed, horn will sound and LED will light. It is now possible to programme two handsets of correct frequency to vehicle alarm ECU. This must be carried out within two minutes.

10. Press and hold down button on first handset until dash LED flashes.
11. Repeat instruction 10. for second handset.
12. The LED will extinguish if both handsets have been initialised correctly.

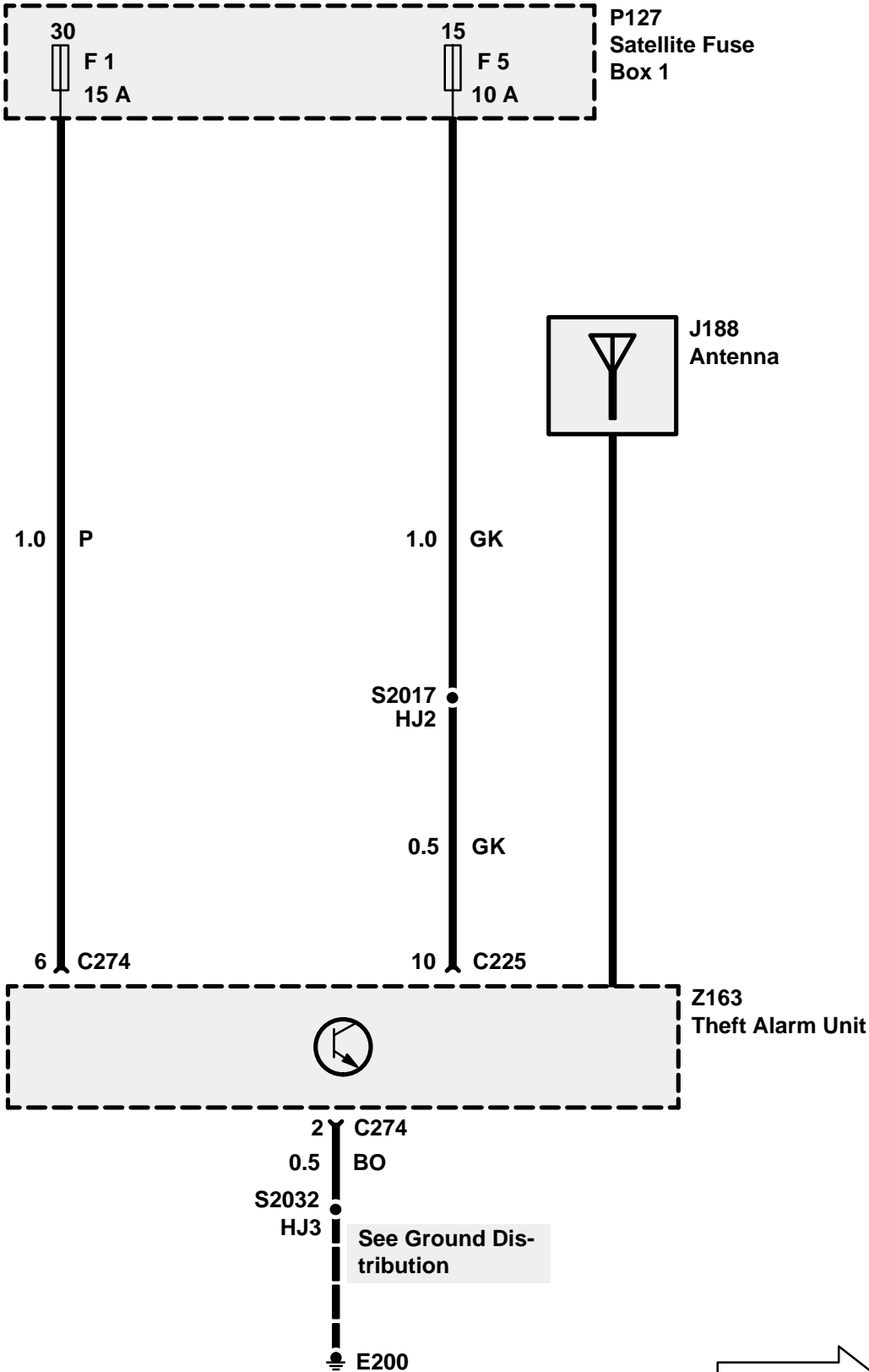

T3 ETM

DISCOVERY

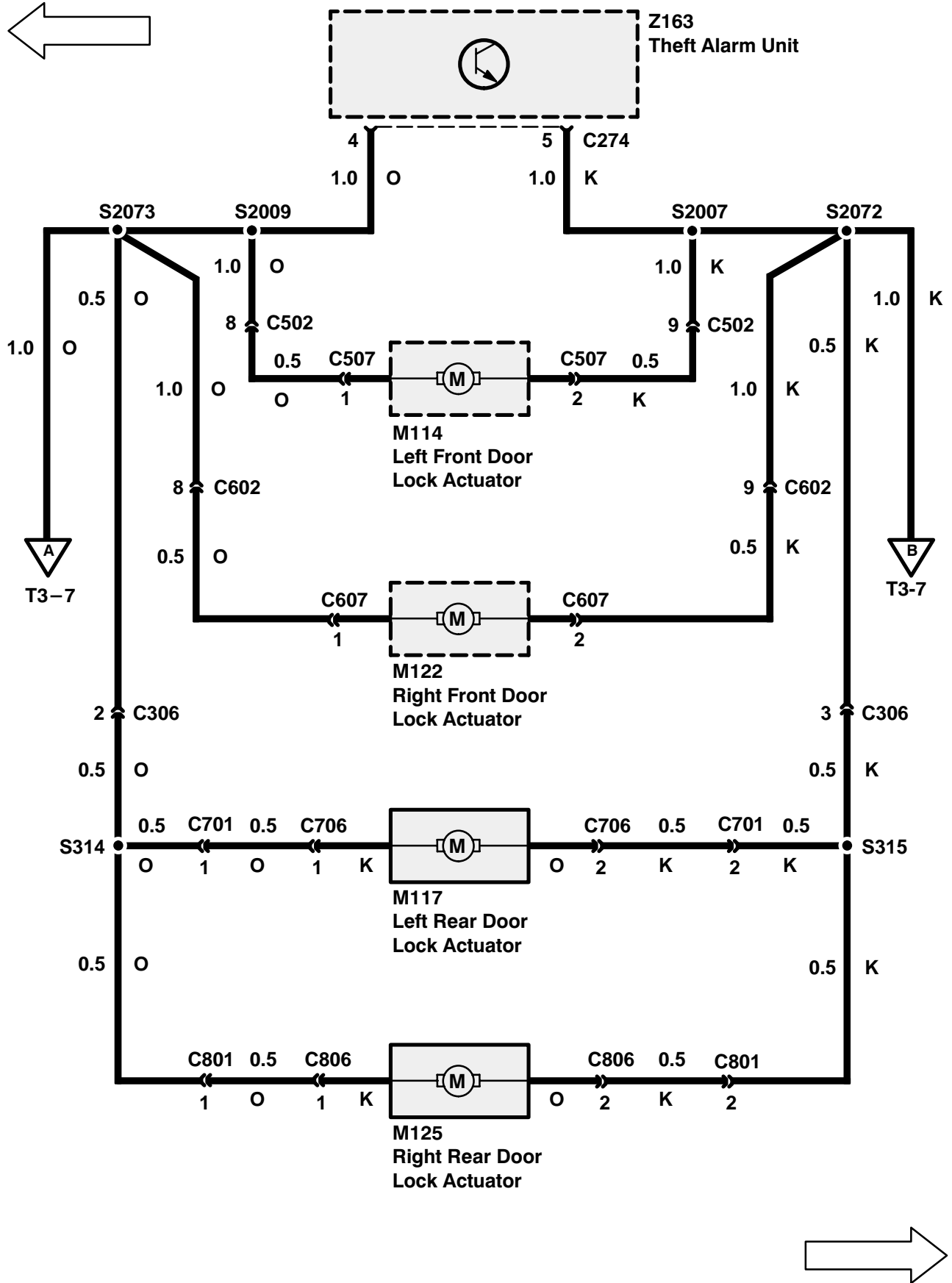

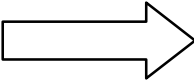
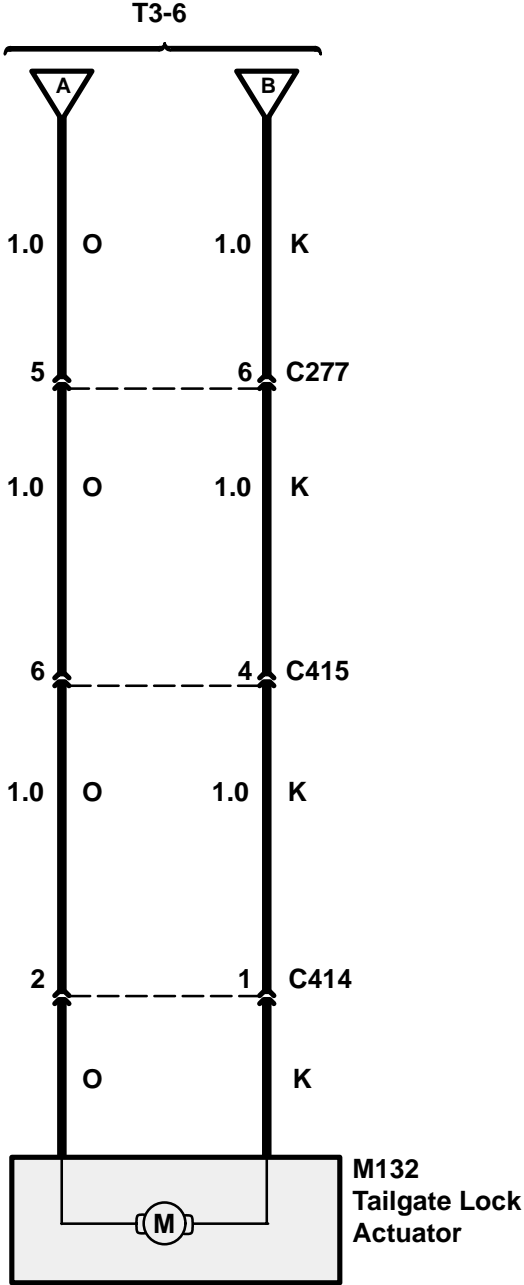
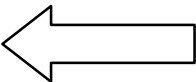

T3 ETM

DISCOVERY

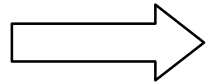
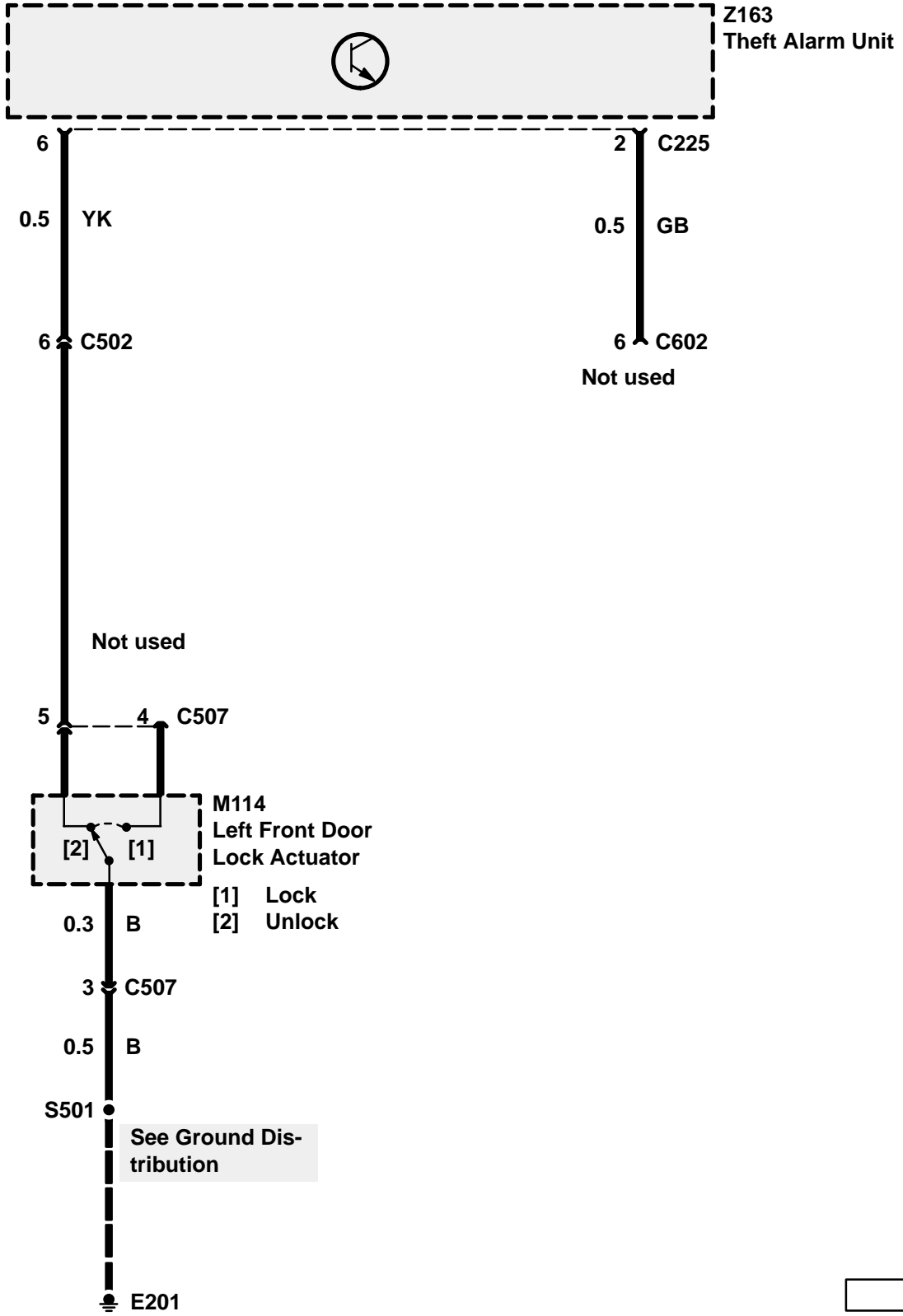
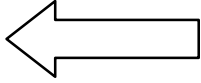

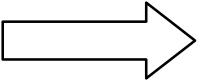
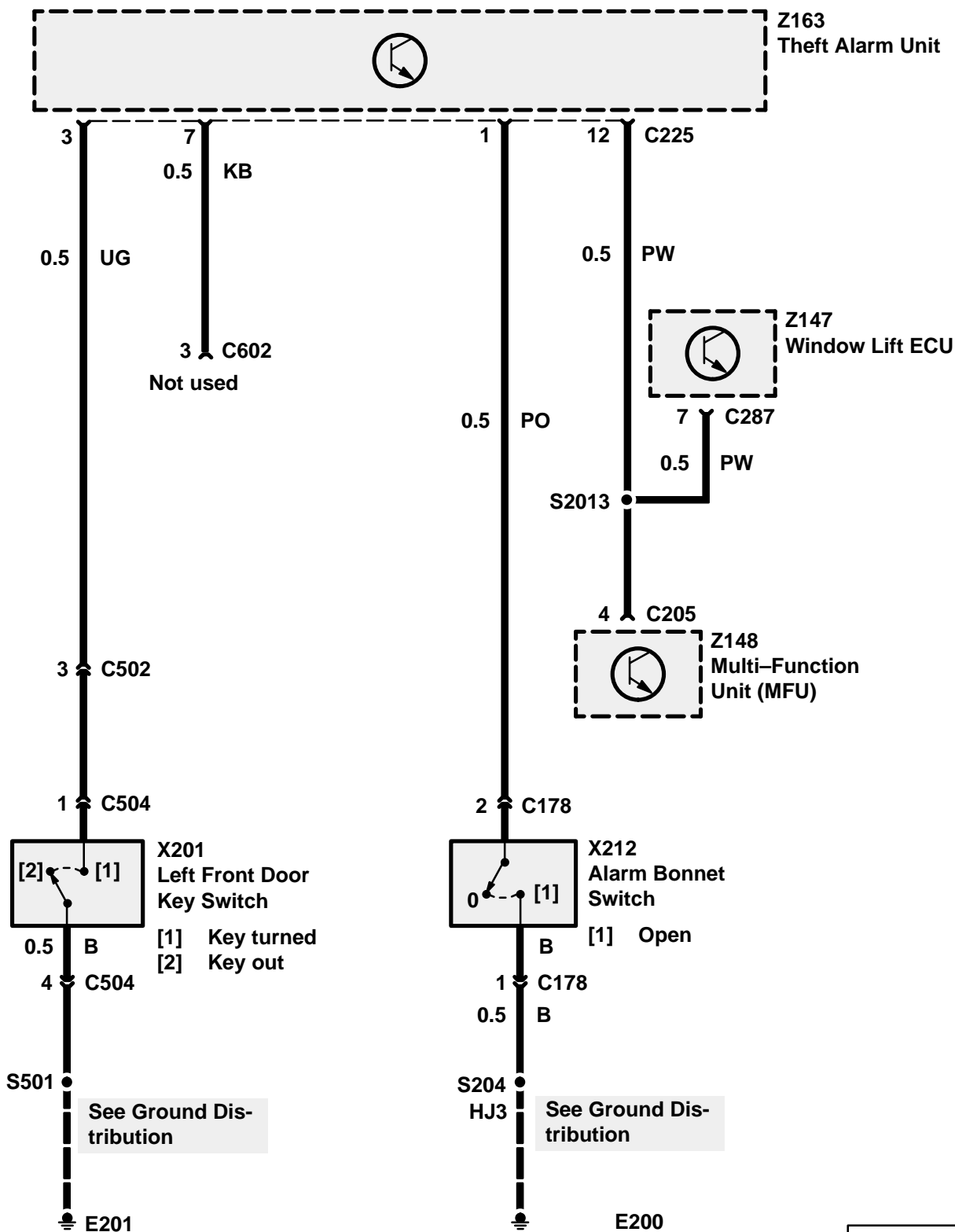
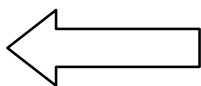

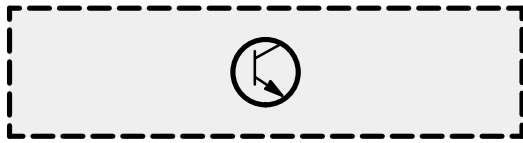
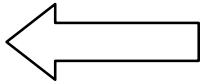

Z163 Theft Alarm Unit

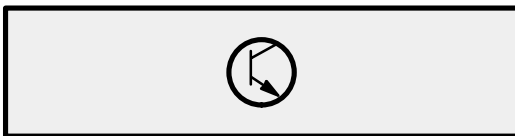
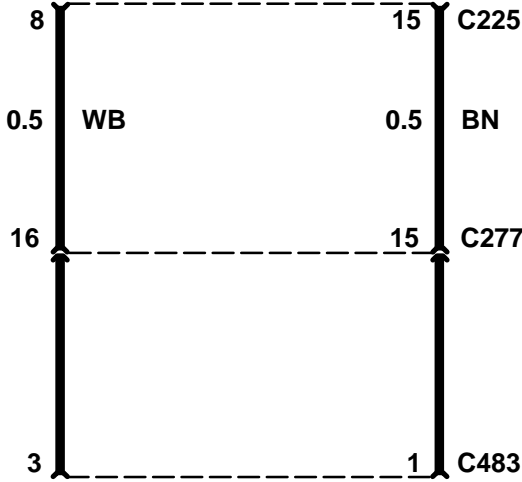
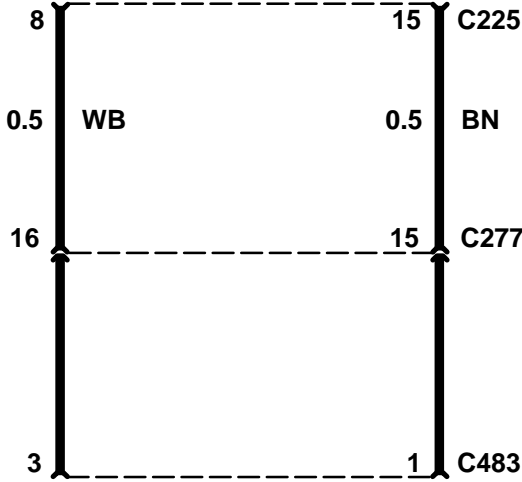

X213 Alarm Sensor

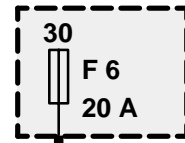
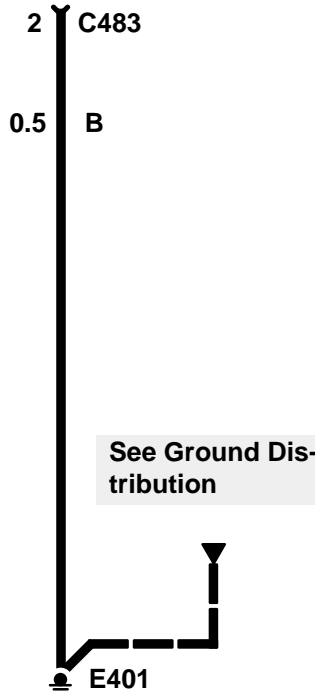
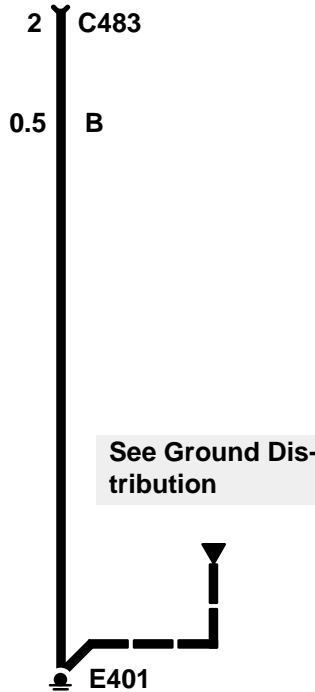

P128 Satellite Fuse Box 2

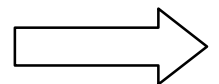
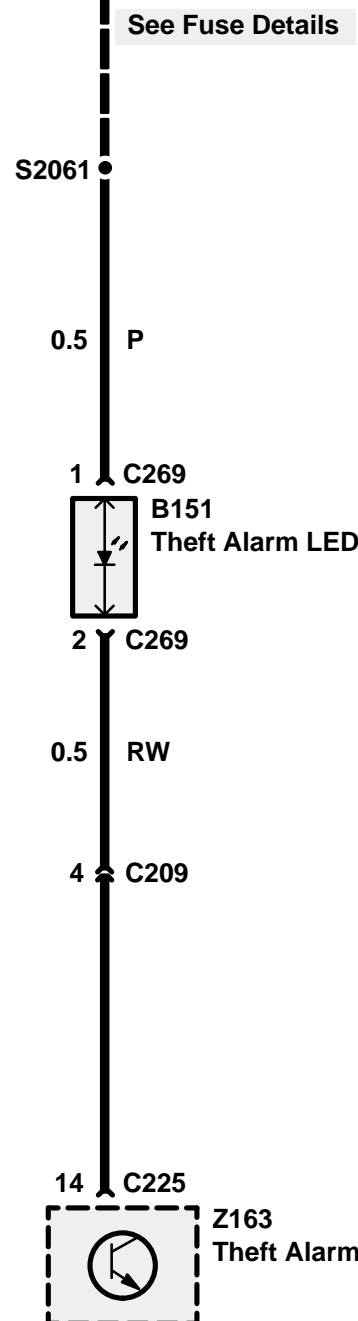
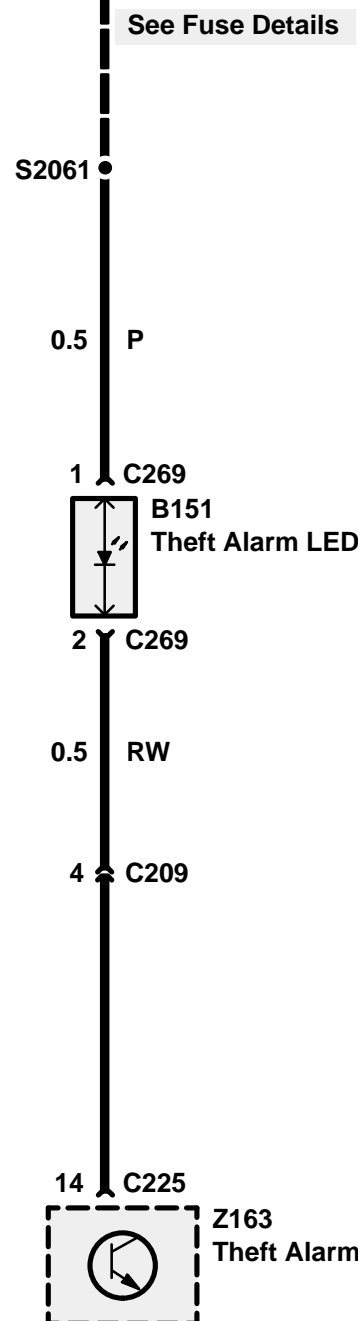

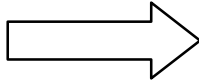
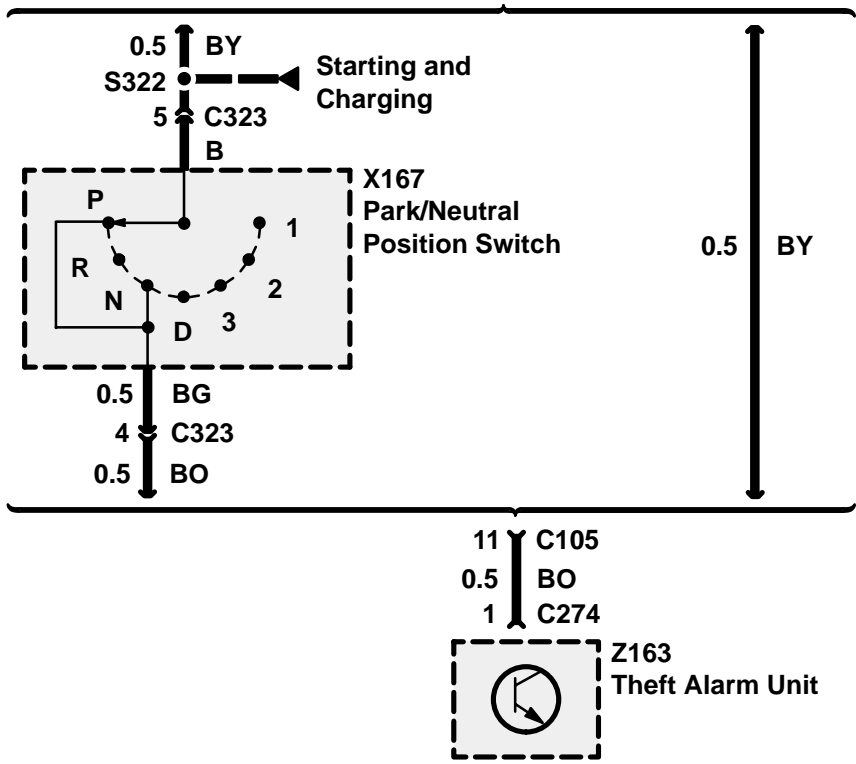
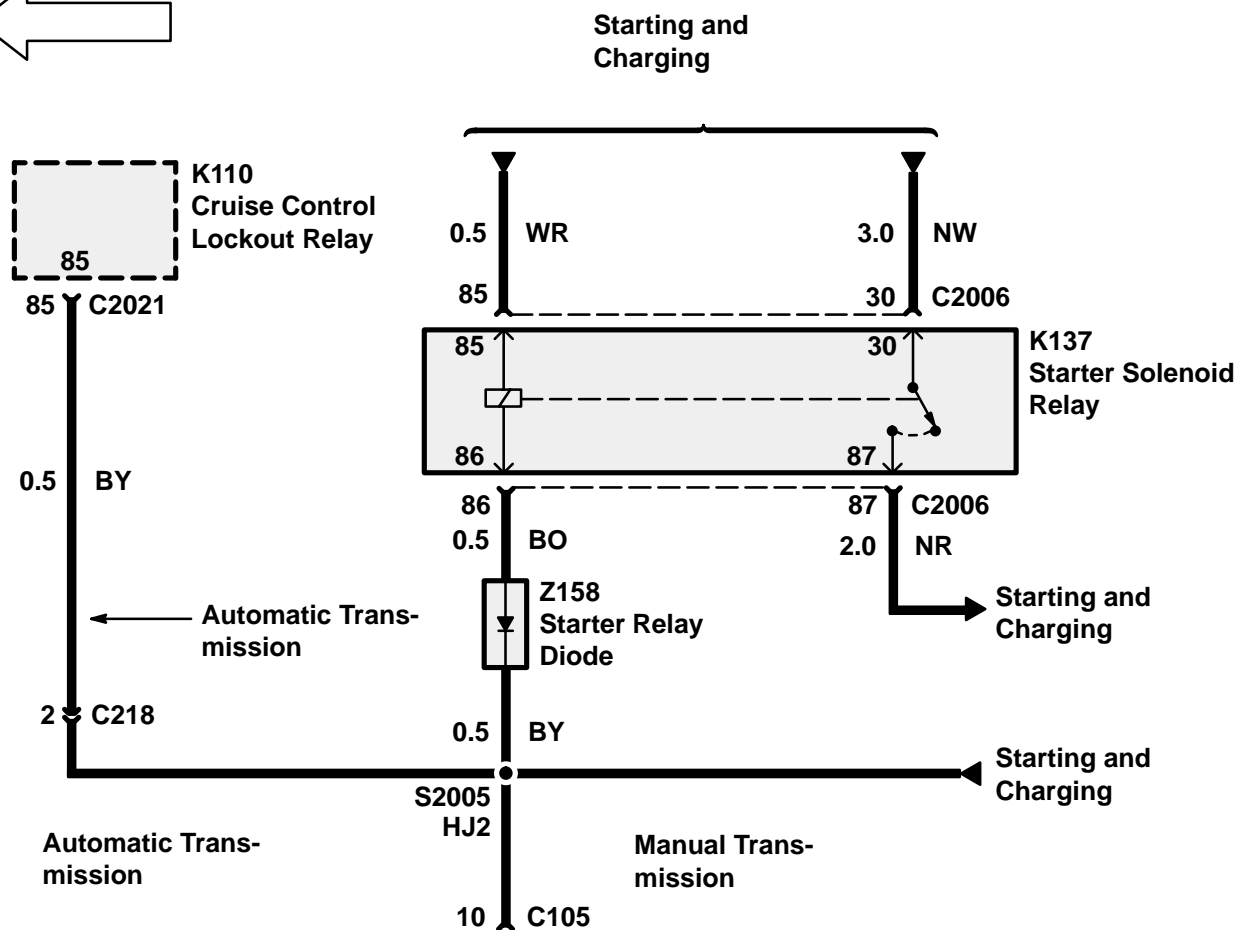
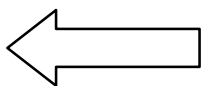

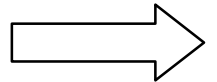
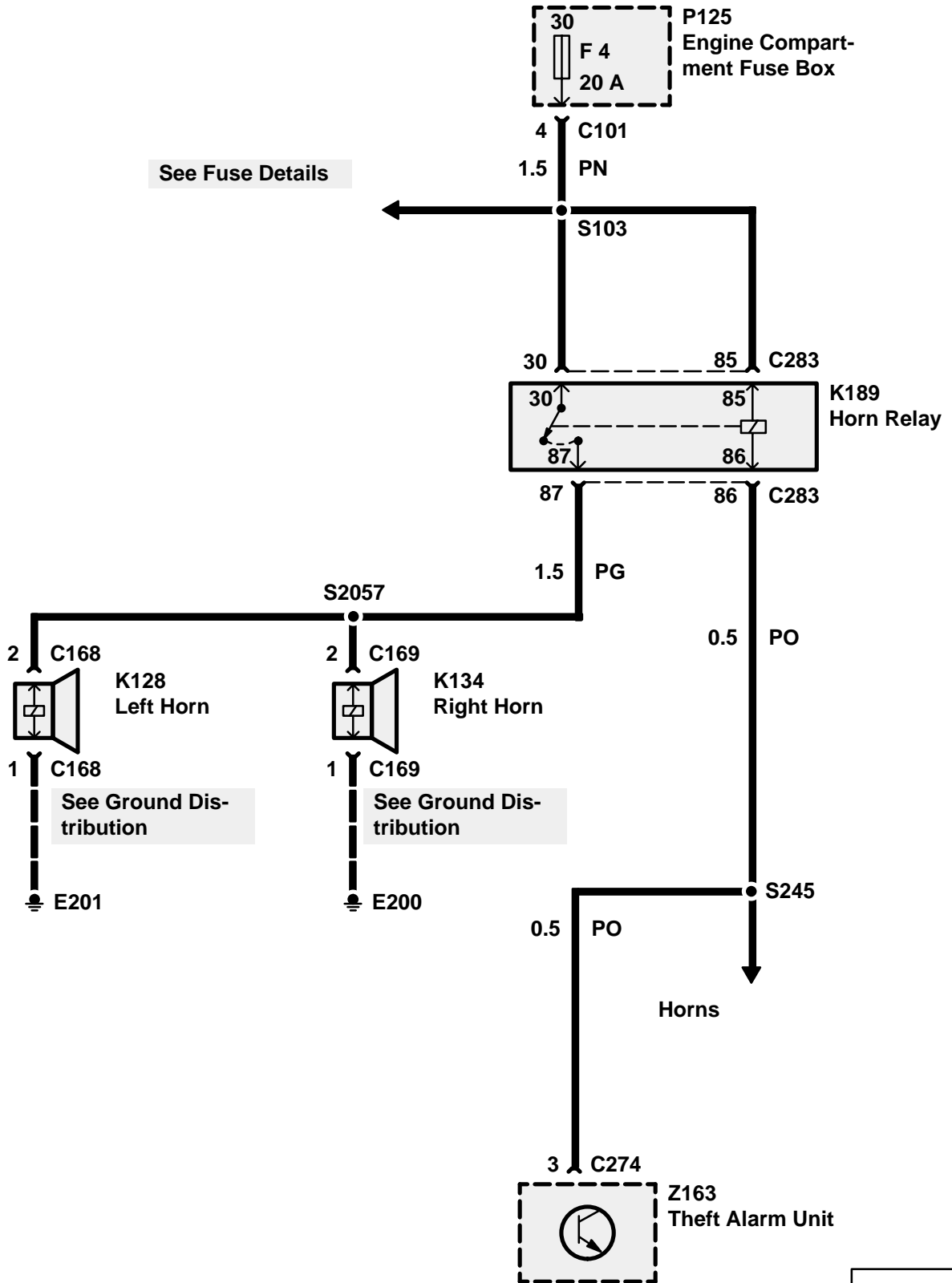
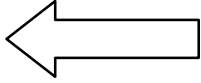

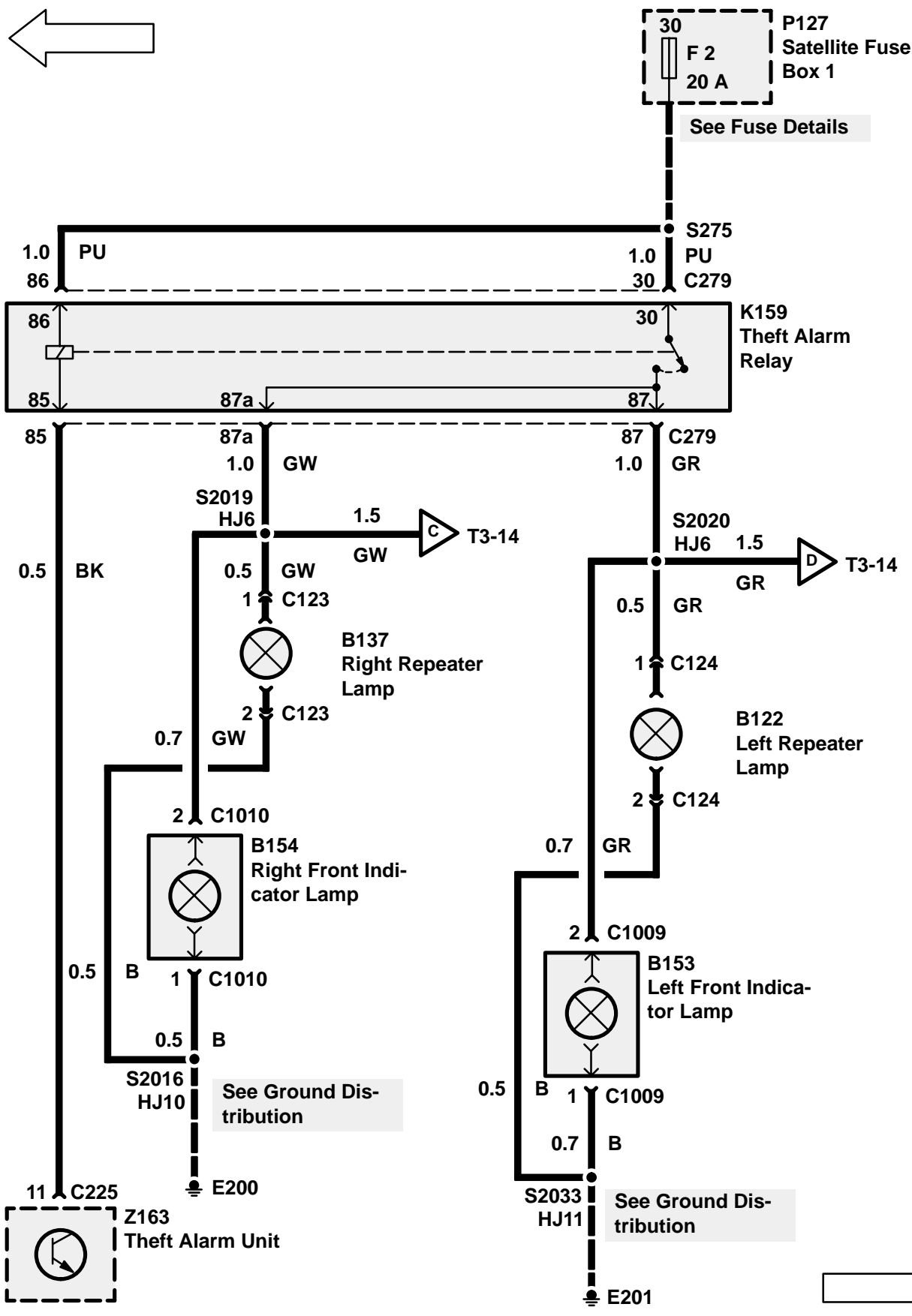

T3 ETM

DISCOVERY

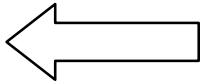

Direction Indicator Lamps

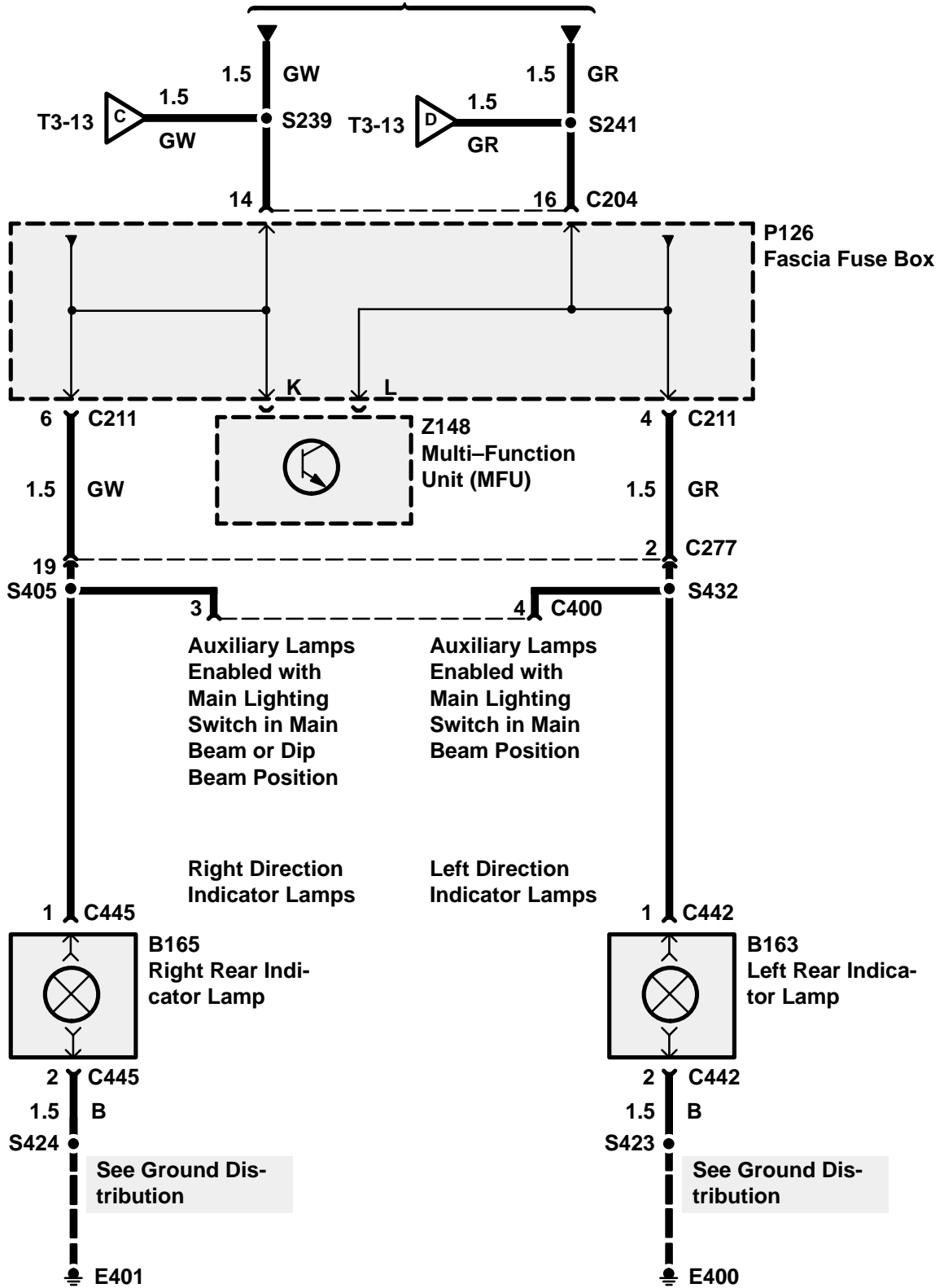

TROUBLESHOOTING HINTS

13. Check Fuses F1, F2 and F5 in Satellite Fuse Box 1.
14. Check Fuse F5 in Satellite Fuse Box 2.
15. If the interior lights do not come on when a door is open, check suspect door switch and associated wiring.
16. If all of the lock actuators do not operate, check O and K Wire. If OK, replace Theft Alarm Unit (Z163).

SYSTEM DIAGNOSIS

1. If the system will not arm, do Test A.
2. If the system arms, but will not trigger at all, do Test D.
3. If the Horns (K128, K134) do not sound when triggered, do Test D.
4. If the hazard lights do not flash when triggered, do Test H.
5. If the system will not trigger when the bonnet is open, do Test I.
6. If the alarm is set using the remote and the system does not trigger the alarm when there is motion inside the vehicle, do Test J.
7. If the Theft Alarm LED (B151) does not operate, do Test E.
8. If the Horns (K128, K134) sound continuously, do Test G.
9. If the system will not disarm, do Test A.
10. If a Front Door Lock Actuator (M114, M122) does not operate, do Test K.
11. If the doors unlock themselves after operating the door locks, do Test L.
12. If the central locking function does not operate from one of the front doors, do Test M.
13. If the Tailgate Lock Actuator (M132) does not operate, do Test N.
14. If both Rear Door Lock Actuators (M117, M125) do not operate, do Test O.

Test A

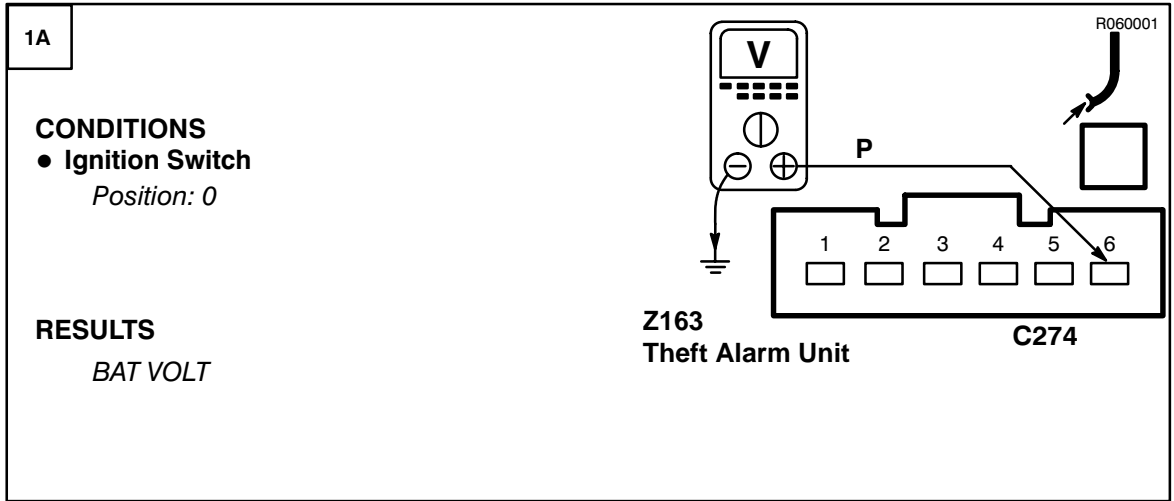

PROBLEM CAUSE
- P Wire

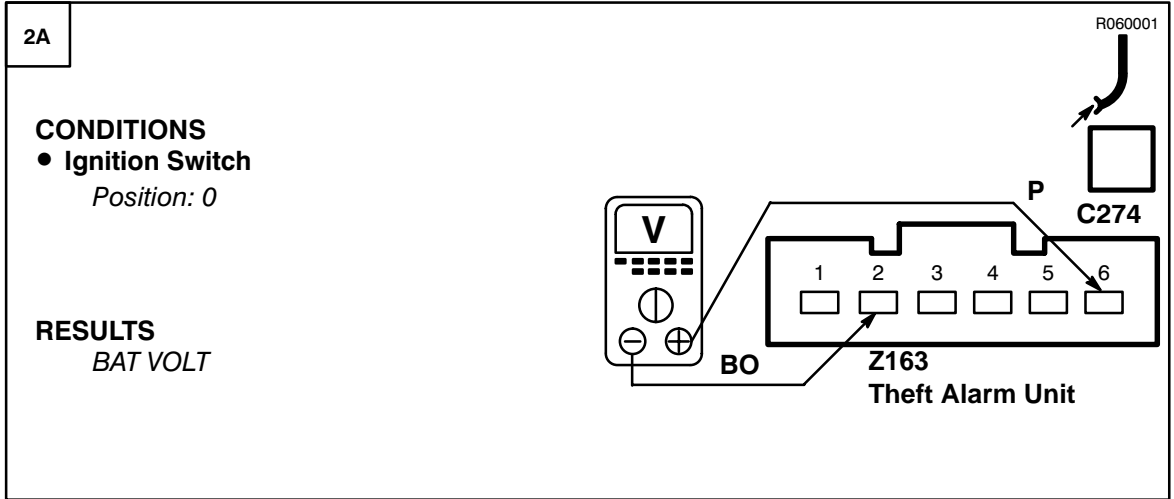
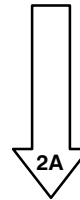

PROBLEM CAUSE
- BO Wire

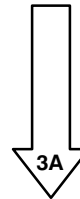

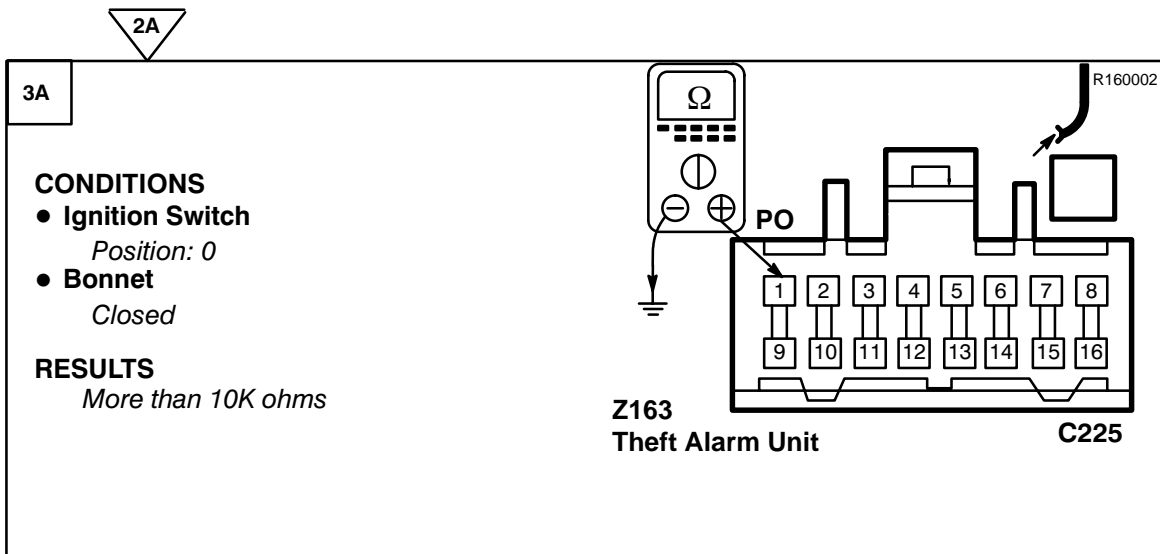

OK PROBLEM CAUSE
 - PO Wire
 - Alarm Bonnet Switch

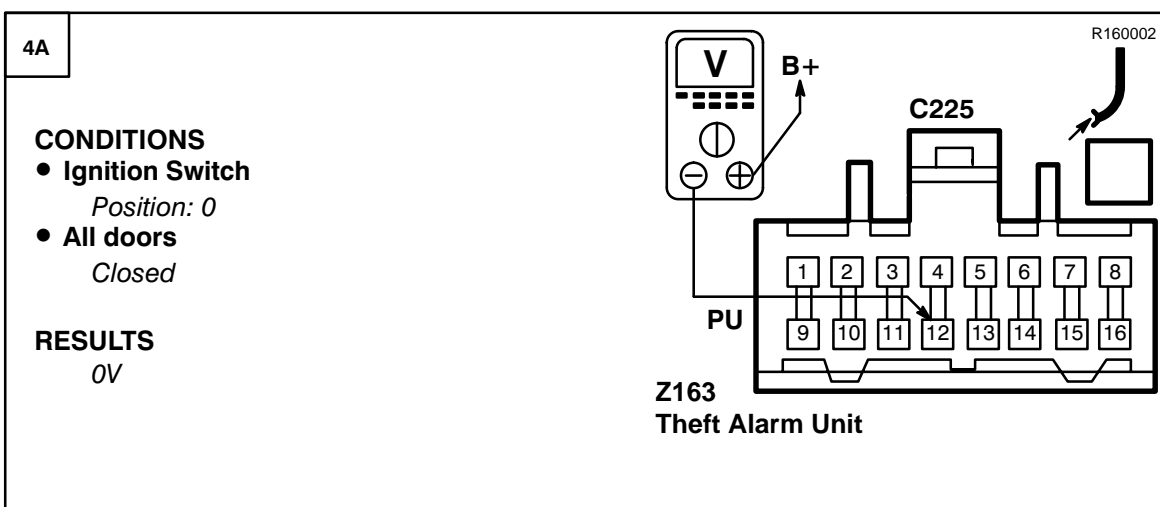
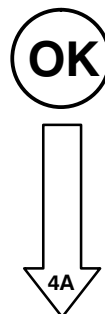

OK GO TO TEST B

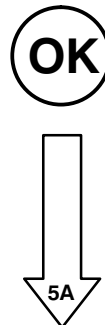

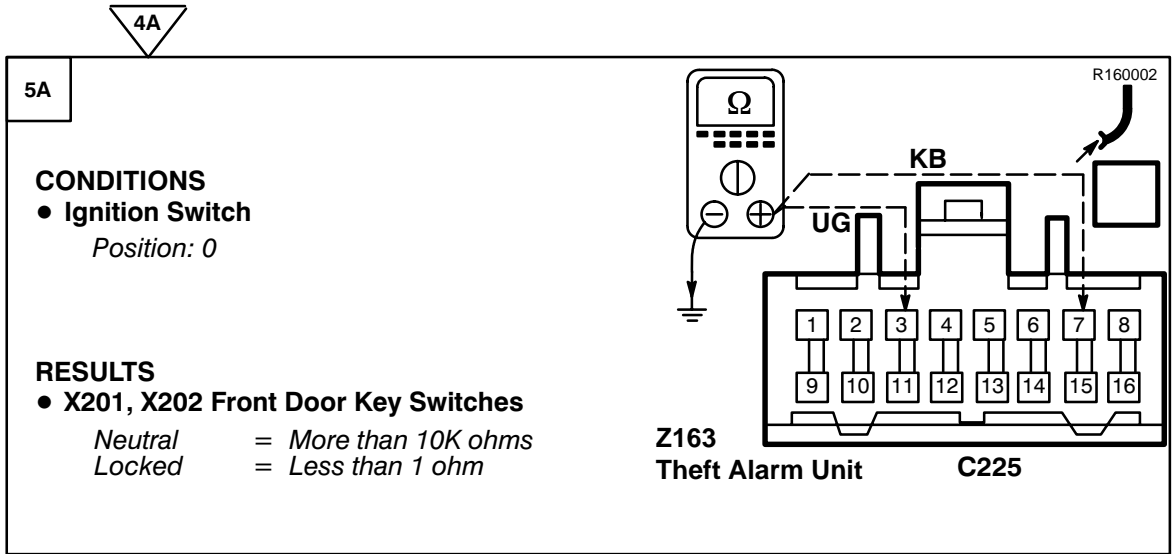

PROBLEM CAUSE

- UG Wire
- KB Wire
- B Wire
- X201, X202 Front Door Key Switches

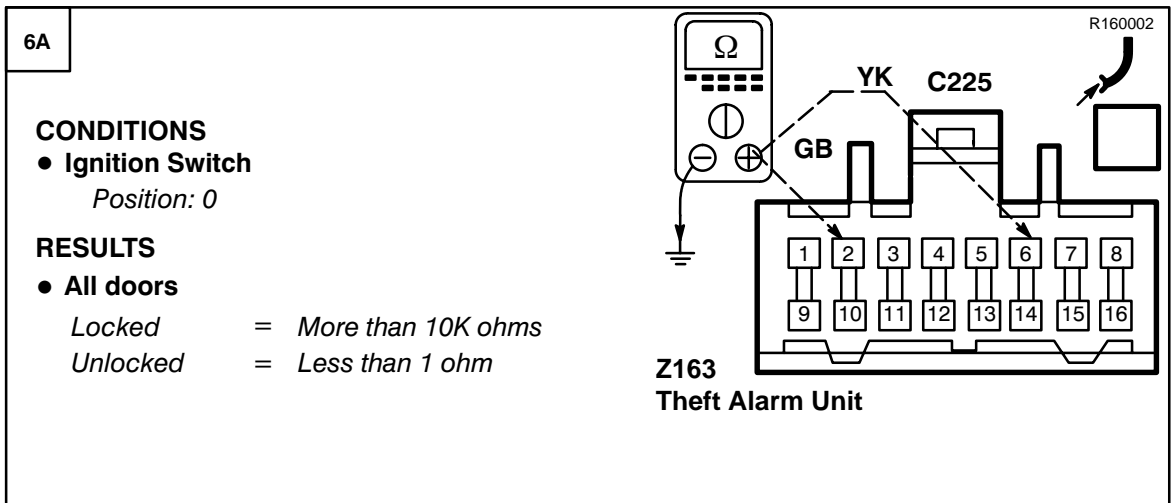
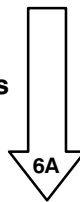

PROBLEM CAUSE

- YK, GB Wire
- B Wire

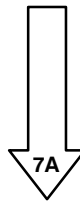

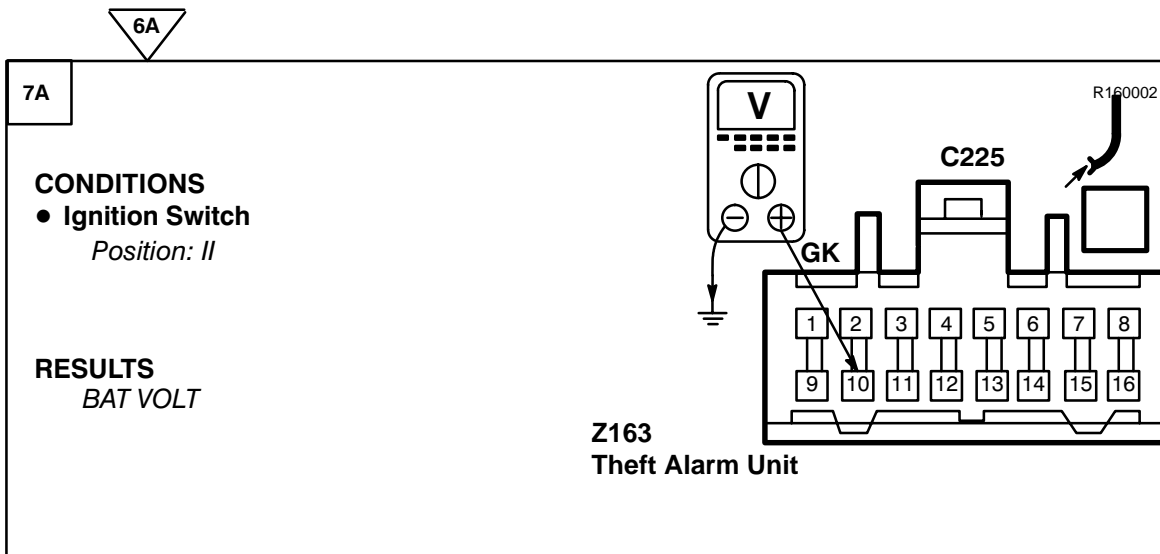

PROBLEM CAUSE
- GK Wire



PROBLEM CAUSE
- Theft Alarm Unit

Test B

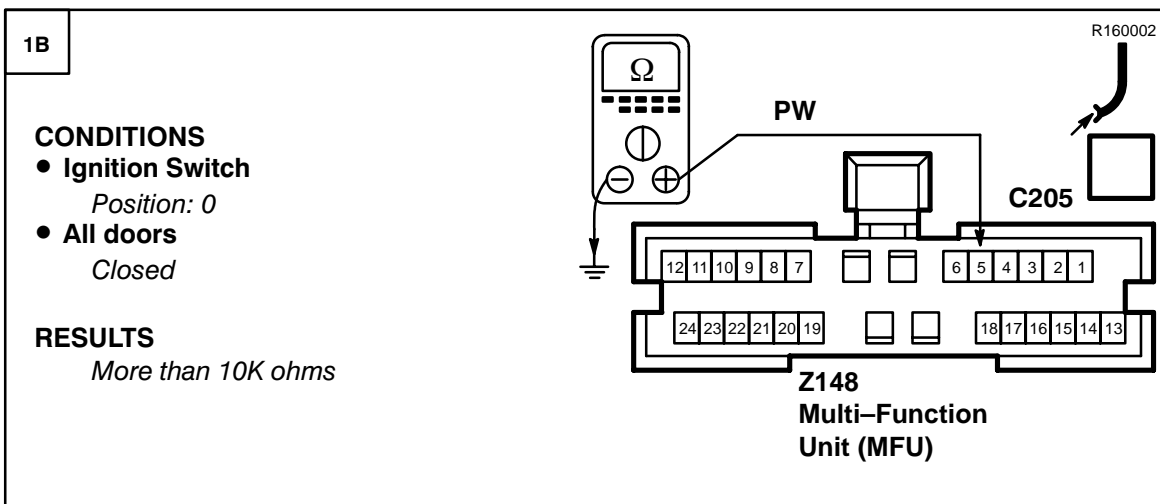

PROBLEM CAUSE

- PW Wire
- Right Front Door Switch
- Left Rear Door Switch
- Right Rear Door Switch
- Rear End Door Switch

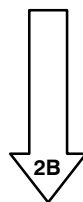

T3 ETM

DISCOVERY

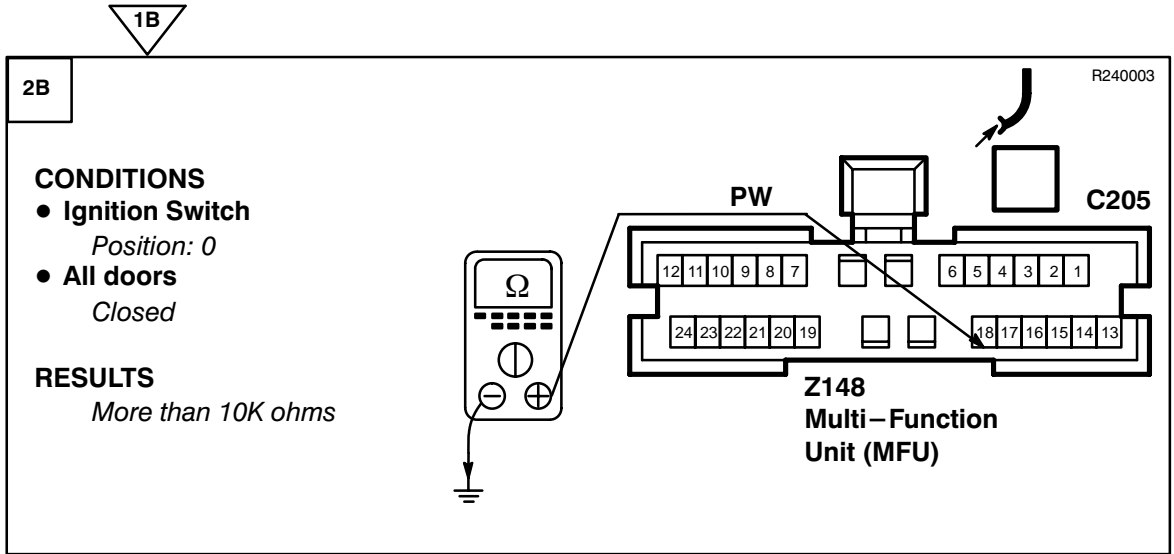

PROBLEM CAUSE

- PW Wire
- Left Front Door Switch



PROBLEM CAUSE

- PU Wire
- Multi-Function Unit (MFU)

Test D

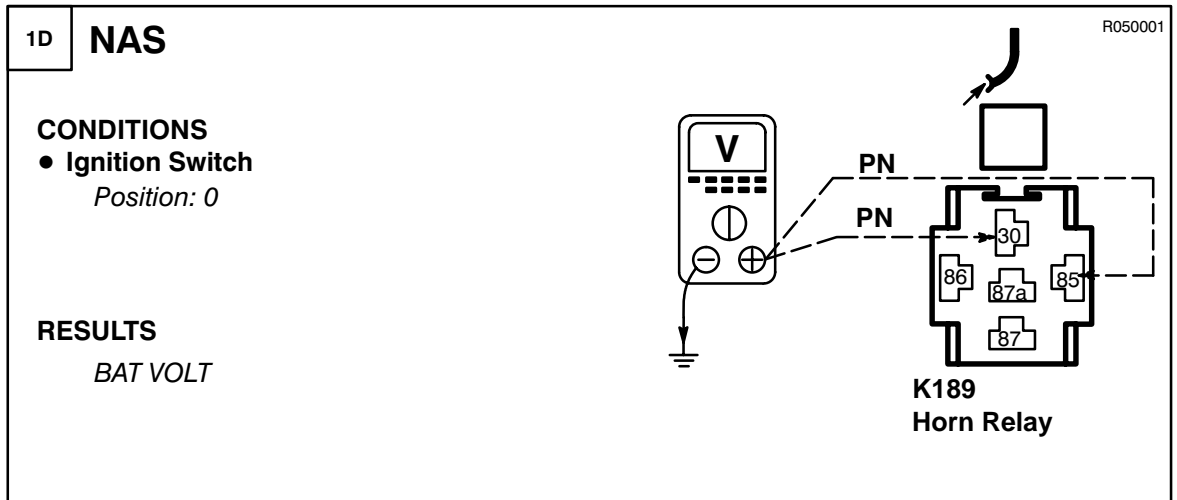

PROBLEM CAUSE

- PN Wire

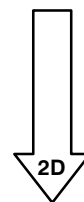

1D

2D

R050001

CONDITIONS

- Ignition Switch
Position: 0

RESULTS

- Horns
Operate

K189
Horn Relay

OK PROBLEM CAUSE
- PG Wire
- Horns

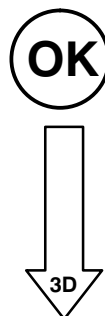

3D

R060001

CONDITIONS

- Ignition Switch
Position: 0

RESULTS

- Horns
Operates

Z163
Theft Alarm Unit

C274

OK PROBLEM CAUSE
- PO Wire
- Horns

OK PROBLEM CAUSE
- Theft Alarm Unit

Test E

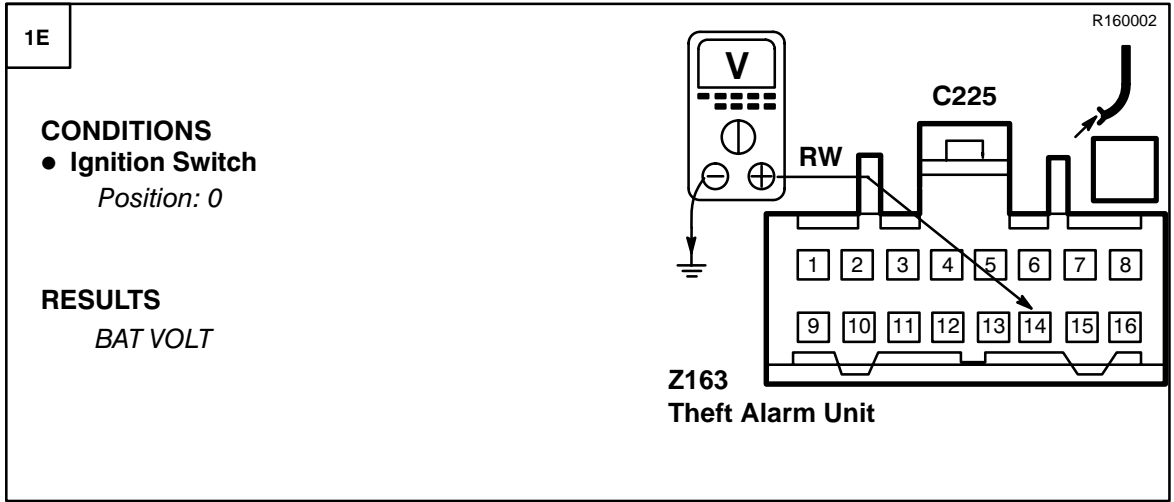

PROBLEM CAUSE

- RW Wire
- P Wire
- Theft Alarm LED



PROBLEM CAUSE

- Theft Alarm Unit

Test G

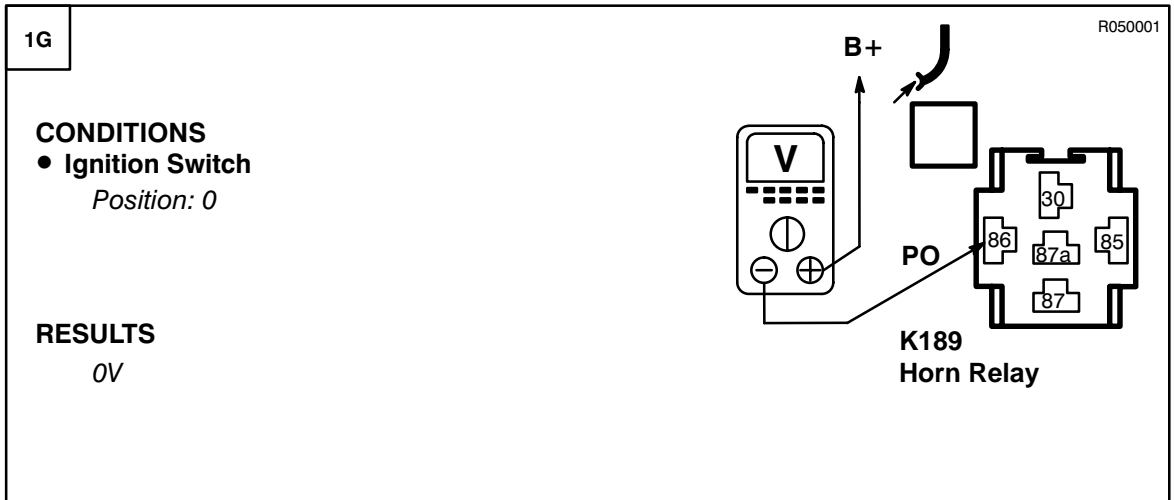

PROBLEM CAUSE

- PO Wire
- Theft Alarm Unit



PROBLEM CAUSE

- Horn Relay

Test H

1H

CONDITIONS

- Ignition Switch
Position: 0

RESULTS
BAT VOLT

R050001

K159
Theft Alarm
Relay

~~OK~~ PROBLEM CAUSE
- PU Wire

OK

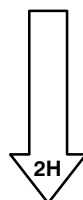

2H

CONDITIONS

- Ignition Switch
Position: 0

RESULTS

- Direction Indicator Lamps
On

R050001

K159
Theft Alarm
Relay

~~OK~~ PROBLEM CAUSE
- GR Wire
- GW Wire

OK

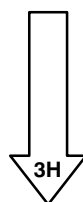

T3 ETM

DISCOVERY

2H

3H

CONDITIONS

- Ignition Switch
Position: 0

RESULTS

- Direction Indicator Lamps
On

Z163
Theft Alarm Unit

OK PROBLEM CAUSE

- BK Wire
- Theft Alarm Relay

OK PROBLEM CAUSE

- Theft Alarm Unit

Test I

1I

CONDITIONS

- Ignition Switch
Position: 0
- Bonnet
Open

RESULTS

Less than 1 ohm

Z163
Theft Alarm Unit

OK PROBLEM CAUSE

- PO Wire
- B Wire
- Alarm Bonnet Switch

OK PROBLEM CAUSE

- Theft Alarm Unit

Test J

1J

R040006

CONDITIONS

- Ignition Switch
Position: 0

RESULTS
BAT VOLT

**X213
Alarm Sensor**

~~OK~~ **PROBLEM CAUSE**
- WB Wire
- Theft Alarm Unit

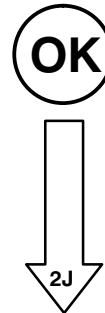

2J

R040006

CONDITIONS

- Ignition Switch
Position: 0

RESULTS
Less than 1 ohm

**X213
Alarm Sensor**

~~OK~~ **PROBLEM CAUSE**
- B Wire

OK **PROBLEM CAUSE**
- BN Wire
- Alarm Sensor
- Theft Alarm Unit

Test K

R060009

C507
C607

J2175
M114, M122 Front
Door Lock Actua-
tor

1K

CONDITIONS

- Ignition Switch
Position: II
- All doors
Locked
- Unlock a front door

RESULTS
BAT VOLT (Momentary)

~~OK~~ PROBLEM CAUSE
- O Wire

OK

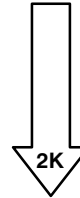

R060009

C507
C607

J2175
M114, M122 Front
Door Lock Actua-
tor

2K

CONDITIONS

- Ignition Switch
Position: II
- All doors
Unlocked
- Lock a front door

RESULTS
BAT VOLT (Momentary)

~~OK~~ PROBLEM CAUSE
- K Wire

OK PROBLEM CAUSE
- M114, M122 Front
Door Lock Actua-
tor

Test L

1L

R160002

CONDITIONS

- Ignition Switch
Position: 0
- All doors
Locked

RESULTS
More than 1000 ohms

Z163
Theft Alarm Unit

C225



PROBLEM CAUSE

- GB Wire
- YK Wire
- Right Front Door Lock Actuator

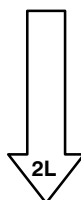

2L

R160002

CONDITIONS

- Ignition Switch
Position: 0
- All doors
Locked

RESULTS
More than 1000 ohms

Z163
Theft Alarm Unit

C225



PROBLEM CAUSE

- YK Wire
- Left Front Door Lock Actuator



PROBLEM CAUSE

- Theft Alarm Unit

Test M

1M

R160002

CONDITIONS

- Ignition Switch
Position: 0
- All doors
Unlocked

RESULTS
Less than 1 ohm

Z163 Theft Alarm Unit C225

~~OK~~ SHORTING LINK 2

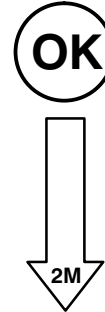

2M

R160002

CONDITIONS

- Ignition Switch
Position: 0
- All doors
Unlocked

RESULTS
Less than 1 ohm

Z163 Theft Alarm Unit C225

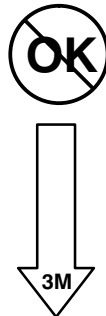

OK PROBLEM CAUSE
- Theft Alarm Unit

R060009

2M
3M

CONDITIONS

- Ignition Switch
Position: 0

RESULTS

Less than 1 ohm

J2175
M114, M122 Front Door Lock Actuator



PROBLEM CAUSE
- B Wire

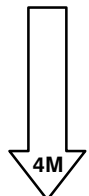

R060009

4M

CONDITIONS

- Ignition Switch
Position: II
- All doors
Locked

RESULTS

- All doors
Unlock

J2175
M114, M122 Front Door Lock Actuator



PROBLEM CAUSE
- YK Wire
- GB Wire
- Theft Alarm Unit



PROBLEM CAUSE
- M114, M122 Front Door Lock Actuator

Test N

R020029

1N

CONDITIONS

- Ignition Switch
Position: 0
- All doors
Unlocked
- Lock a front door

RESULTS
BAT VOLT (Momentary)

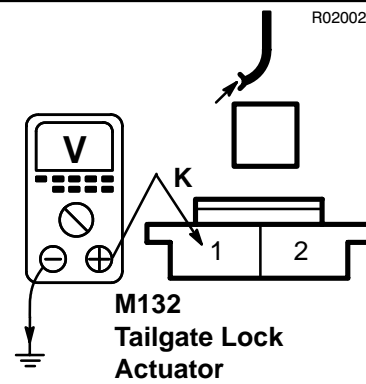

M132
Tailgate Lock
Actuator

~~OK~~ PROBLEM CAUSE
- K Wire

OK

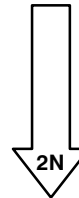

R020029

2N

CONDITIONS

- Ignition Switch
Position: 0
- All doors
Locked
- Unlock a front door

RESULTS
BAT VOLT (Momentary)

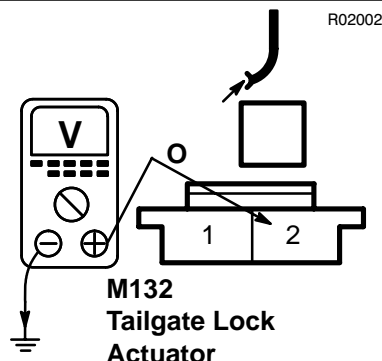

M132
Tailgate Lock
Actuator

~~OK~~ PROBLEM CAUSE
- O Wire

OK PROBLEM CAUSE
- Tailgate Lock
Actuator

Test O

R020029

10

CONDITIONS

- Ignition Switch
Position: 0
- All doors
Unlock
- Lock a front door

RESULTS
BAT VOLT (Momentary)

J2176
M117, M125 Rear
Door Lock Actua-
tor



PROBLEM CAUSE
- K Wire

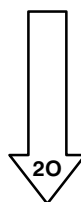

R020029

20

CONDITIONS

- Ignition Switch
Position: 0
- All doors
Locked
- Unlock a front door

RESULTS
BAT VOLT (Momentary)

J2176
M117, M125 Rear
Door Lock Actua-
tor



PROBLEM CAUSE
- O Wire



PROBLEM CAUSE
- M117, M125 Rear
Door Lock Actua-
tor

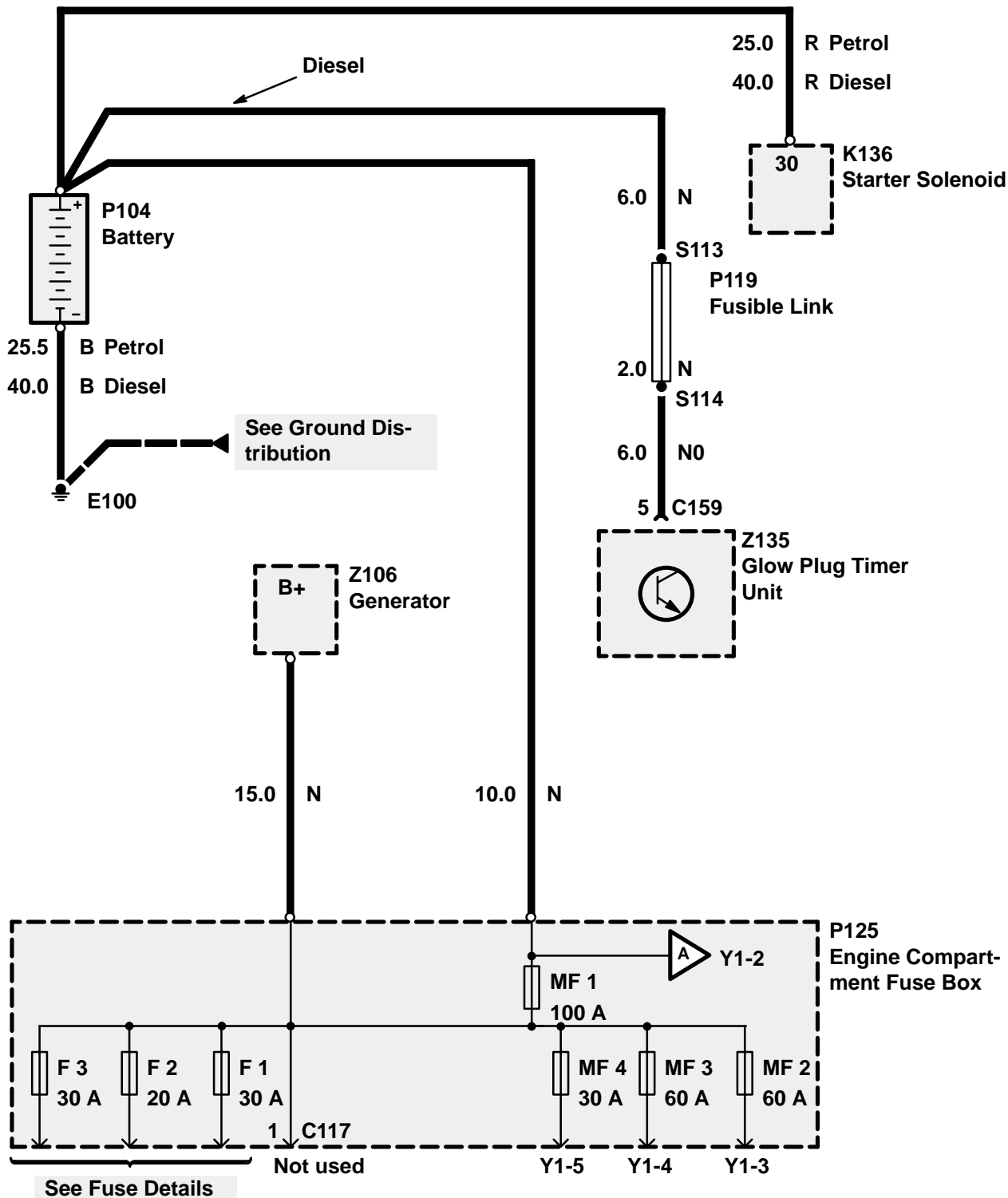

Y1 ETM

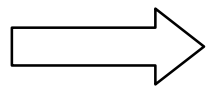
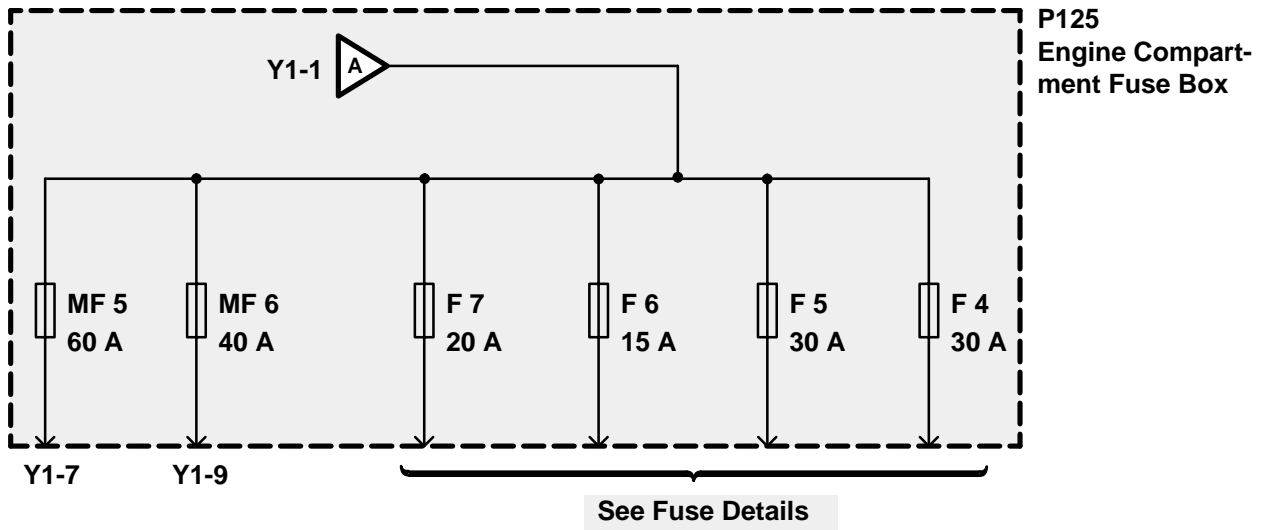
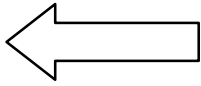

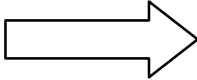
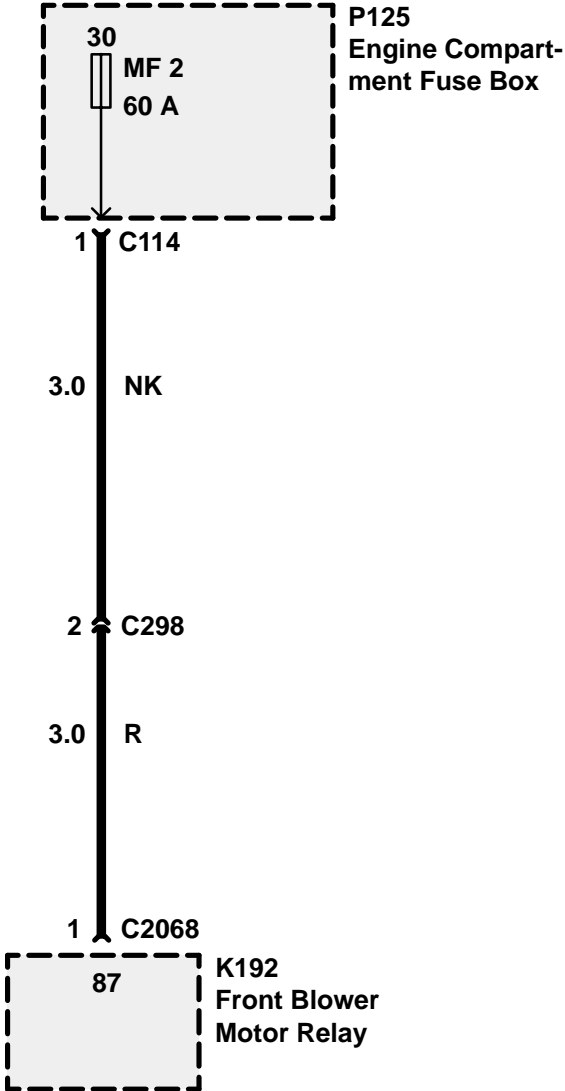
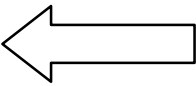

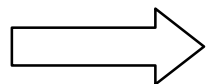
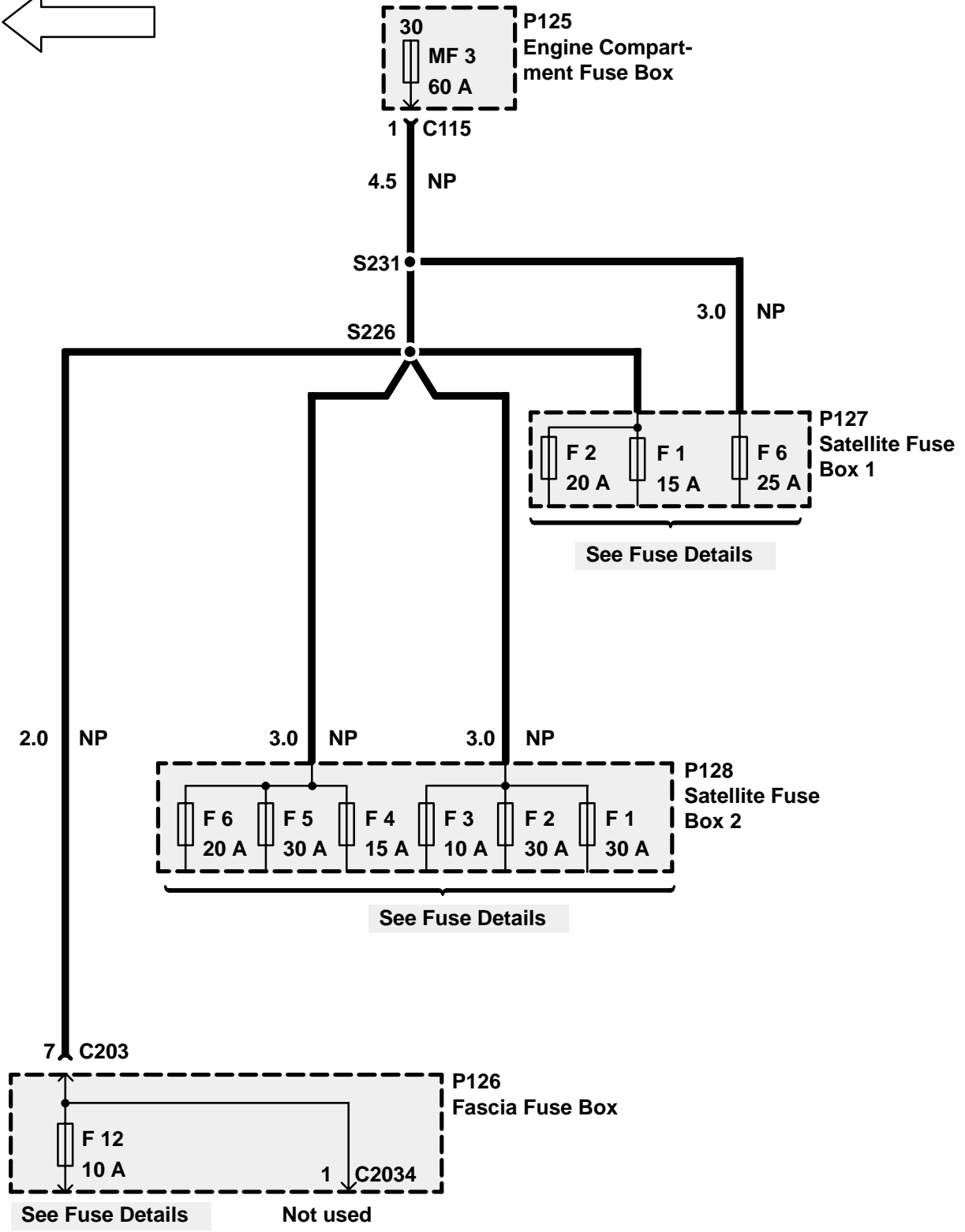
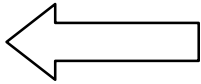

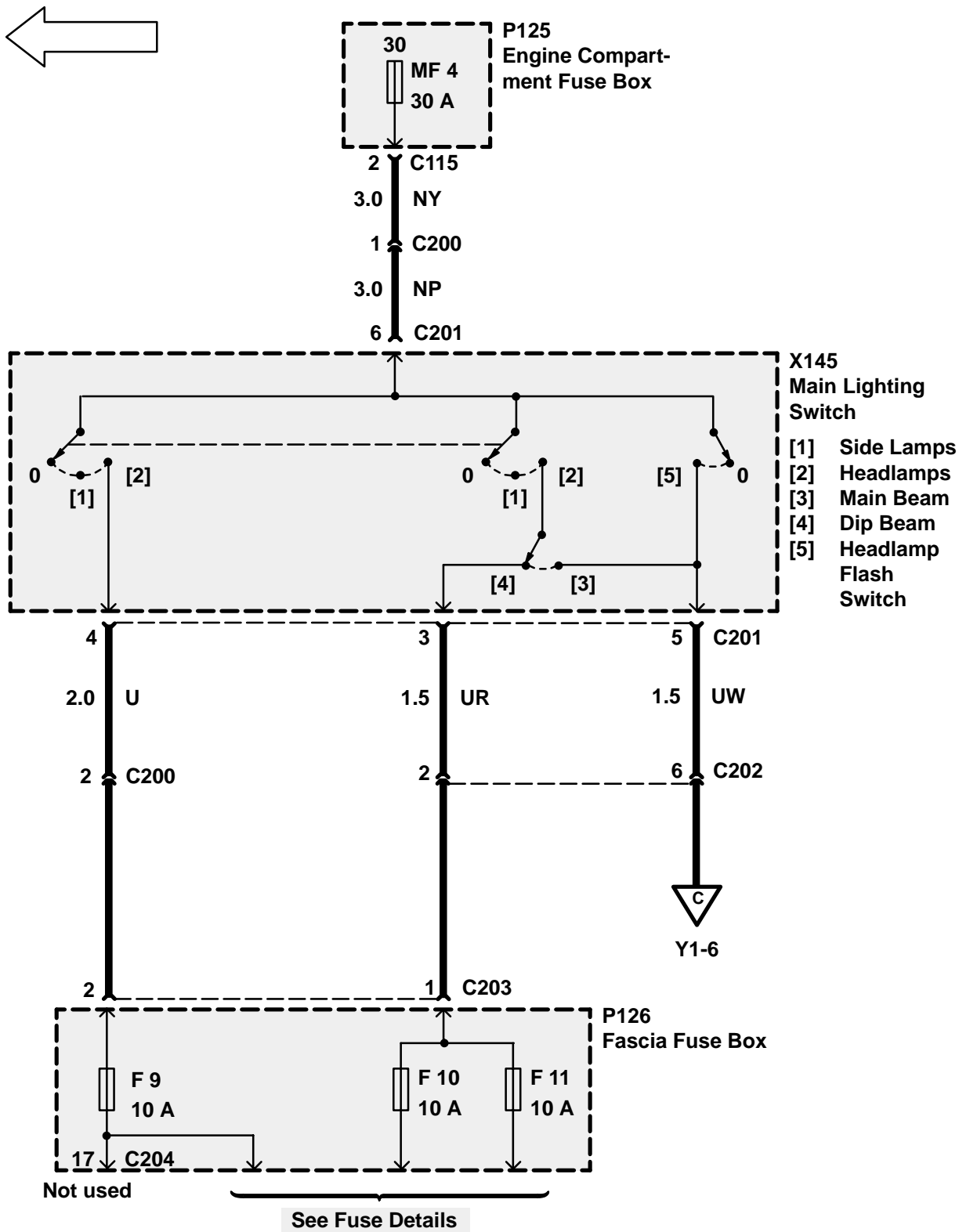

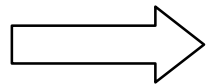
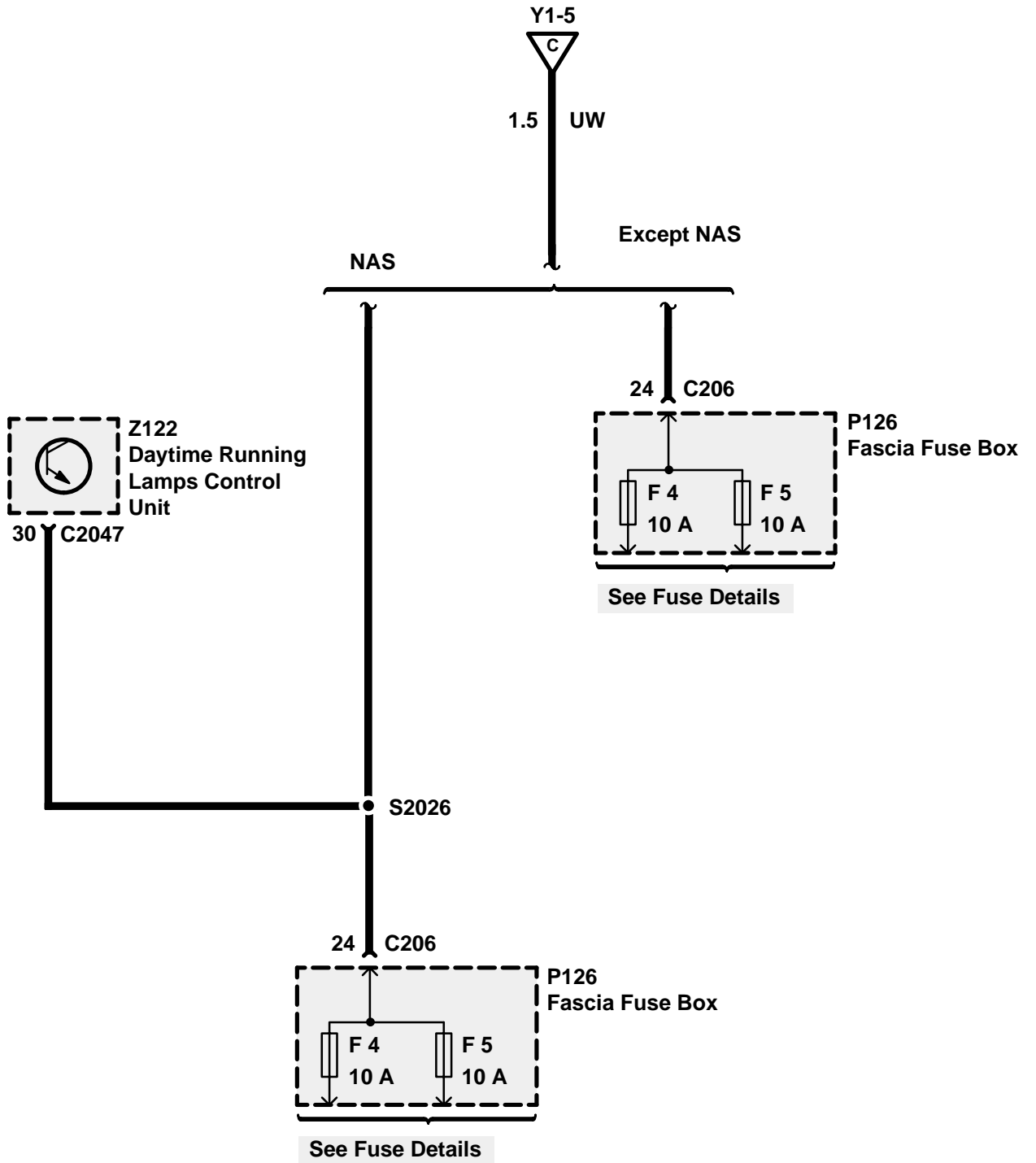
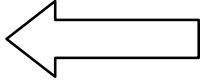

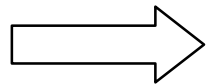
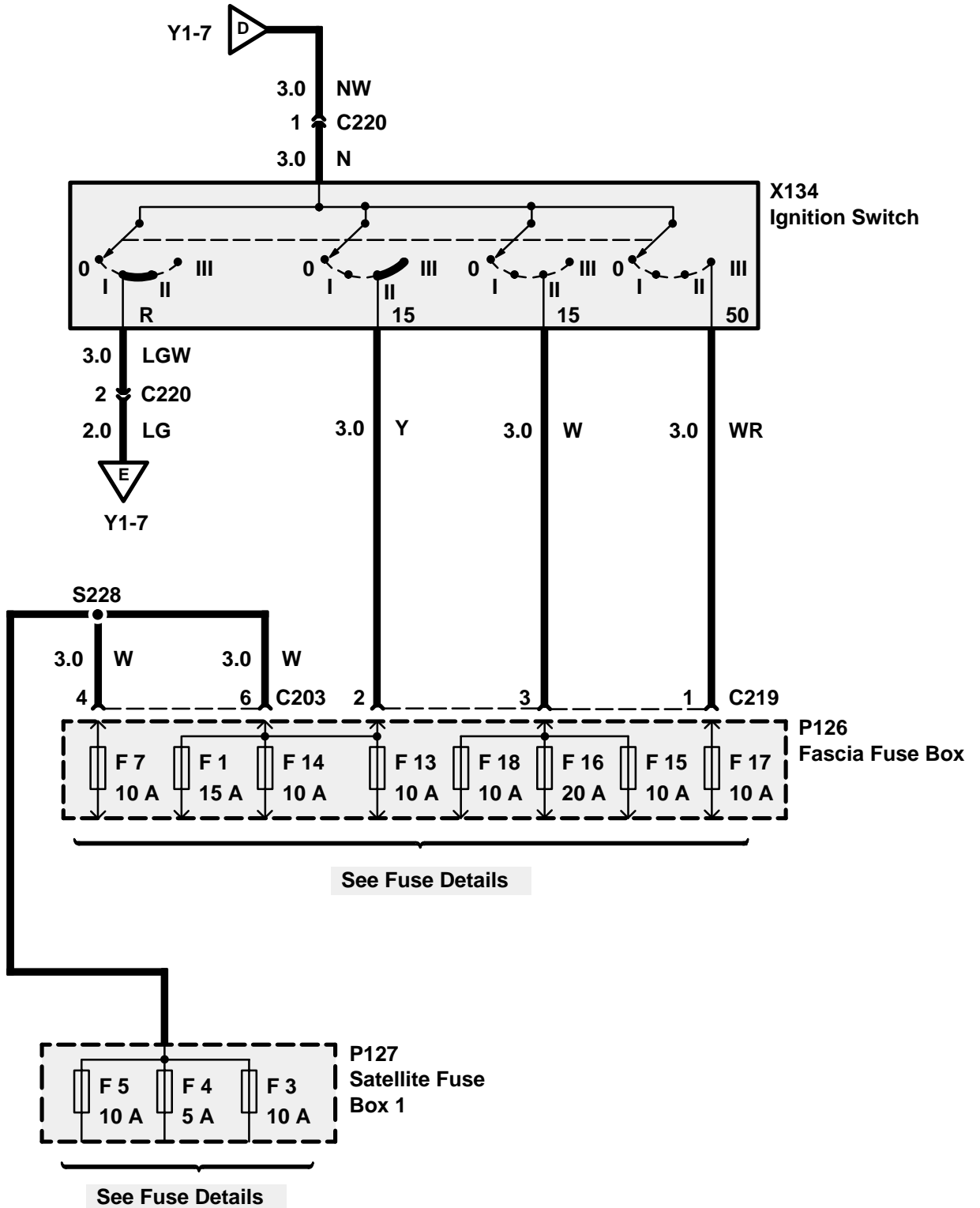
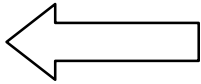

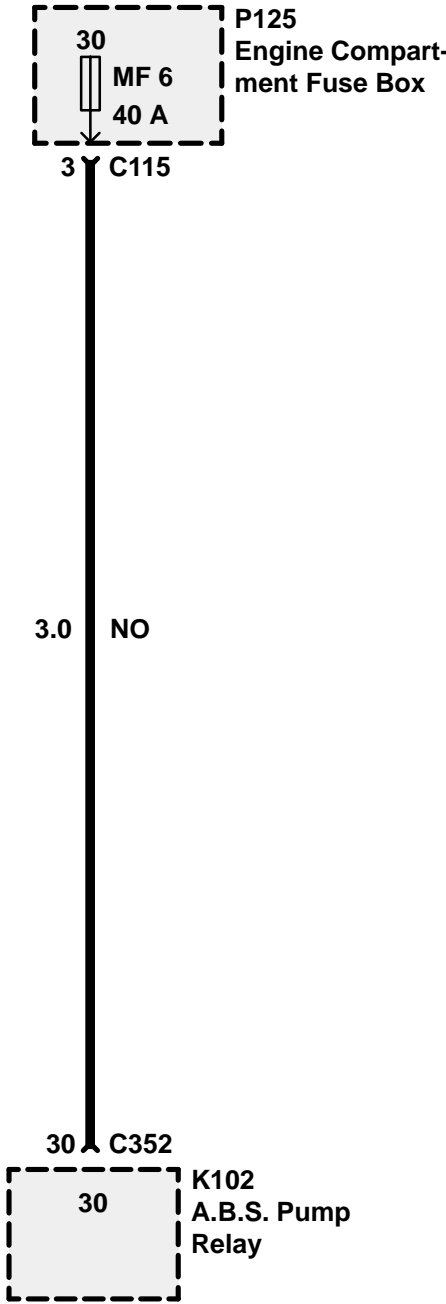
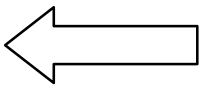

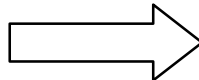
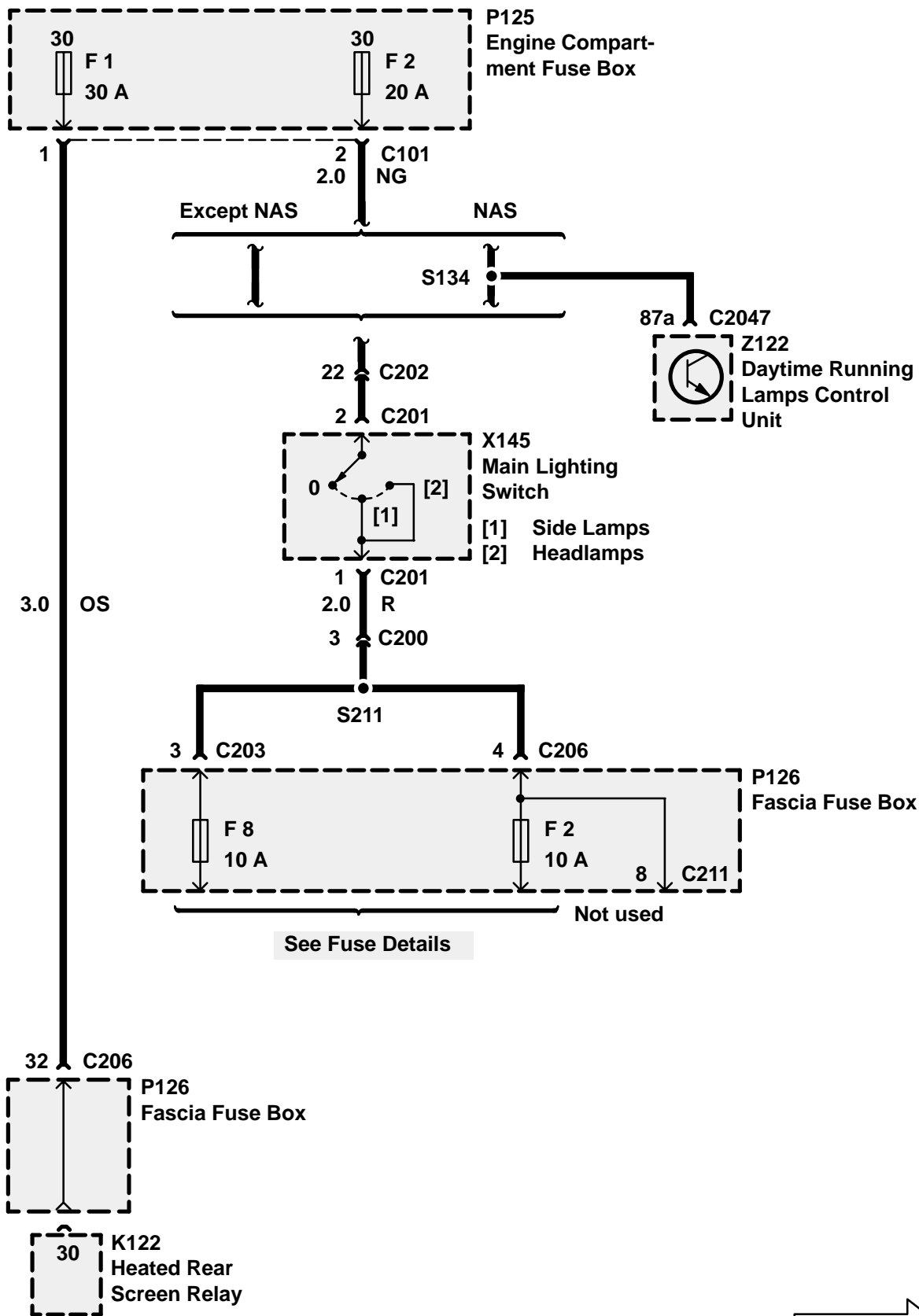

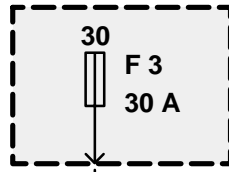
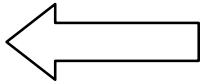

With Air Conditioning

Without Air Conditioning

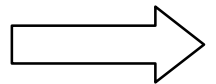
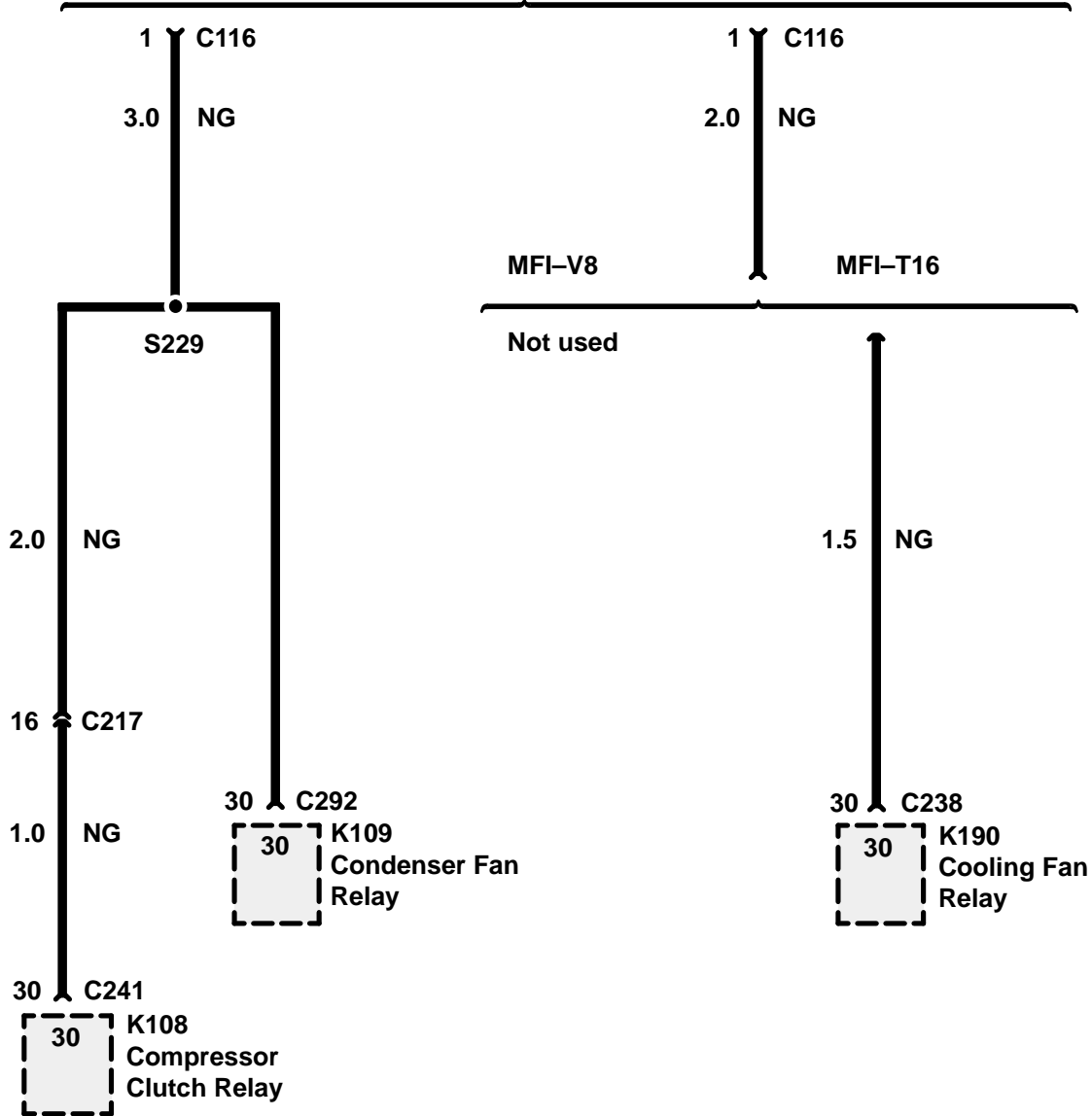

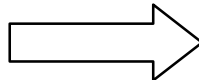
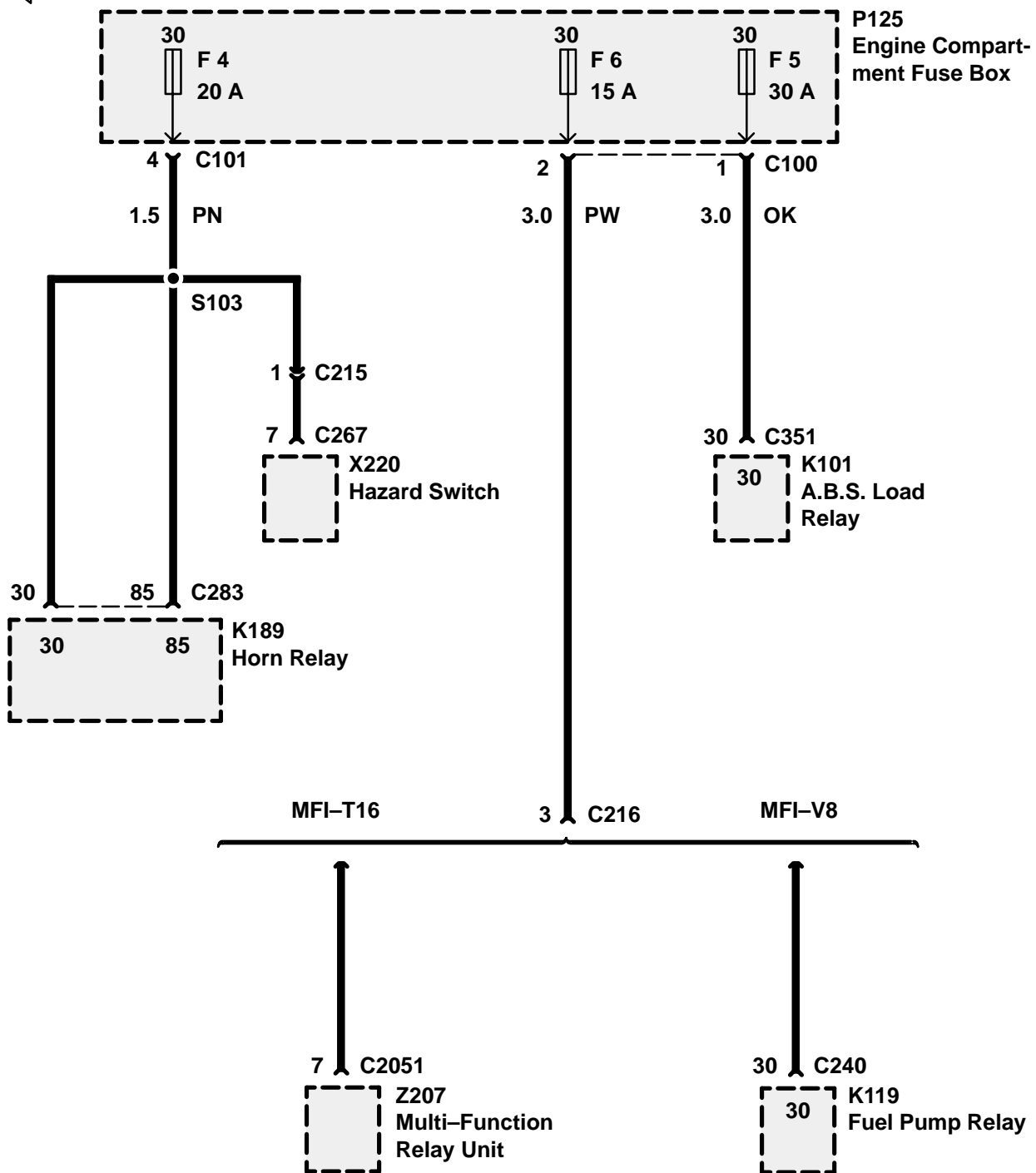
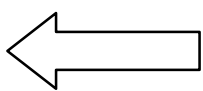

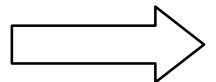
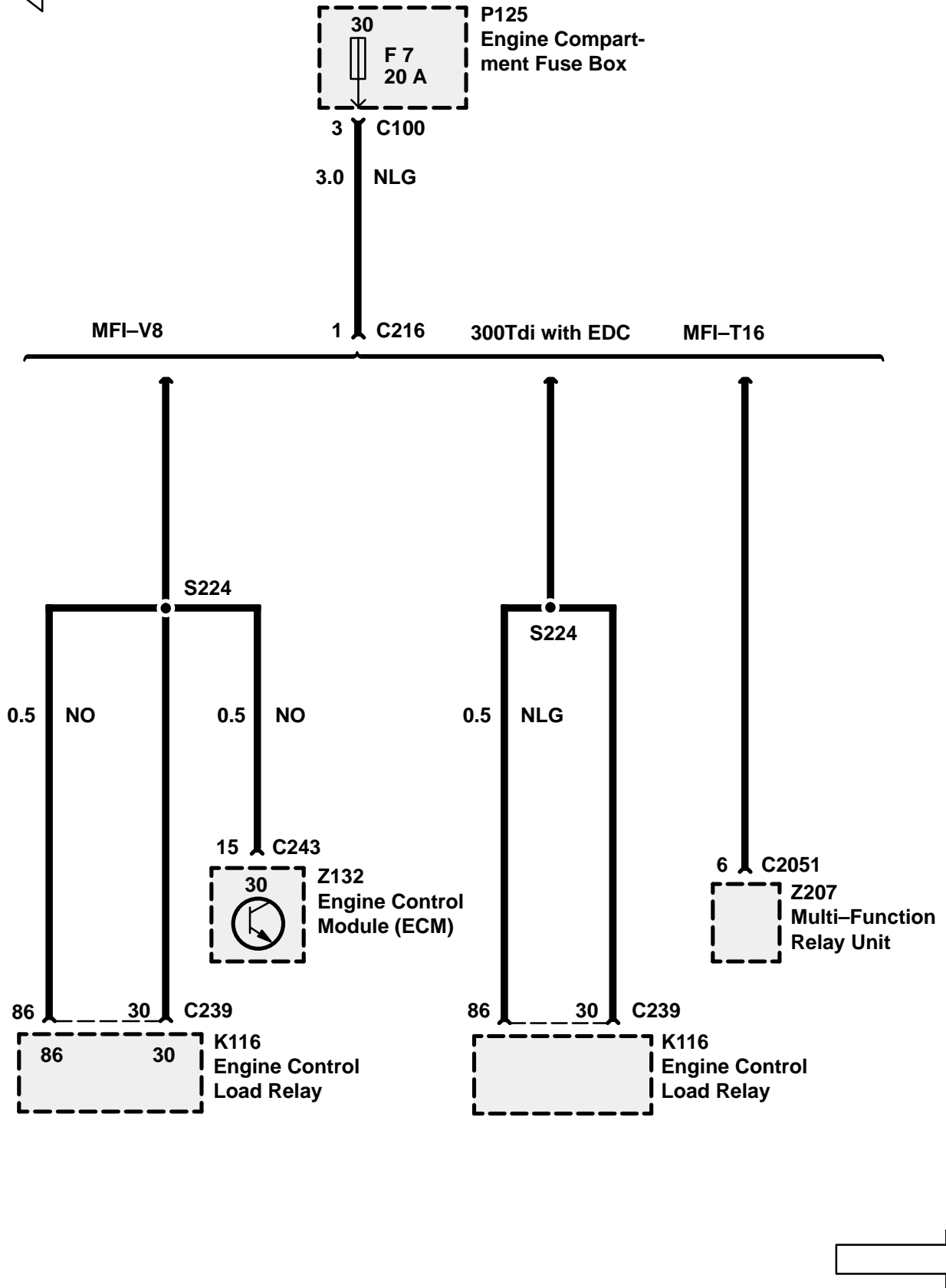
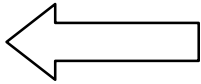

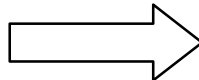
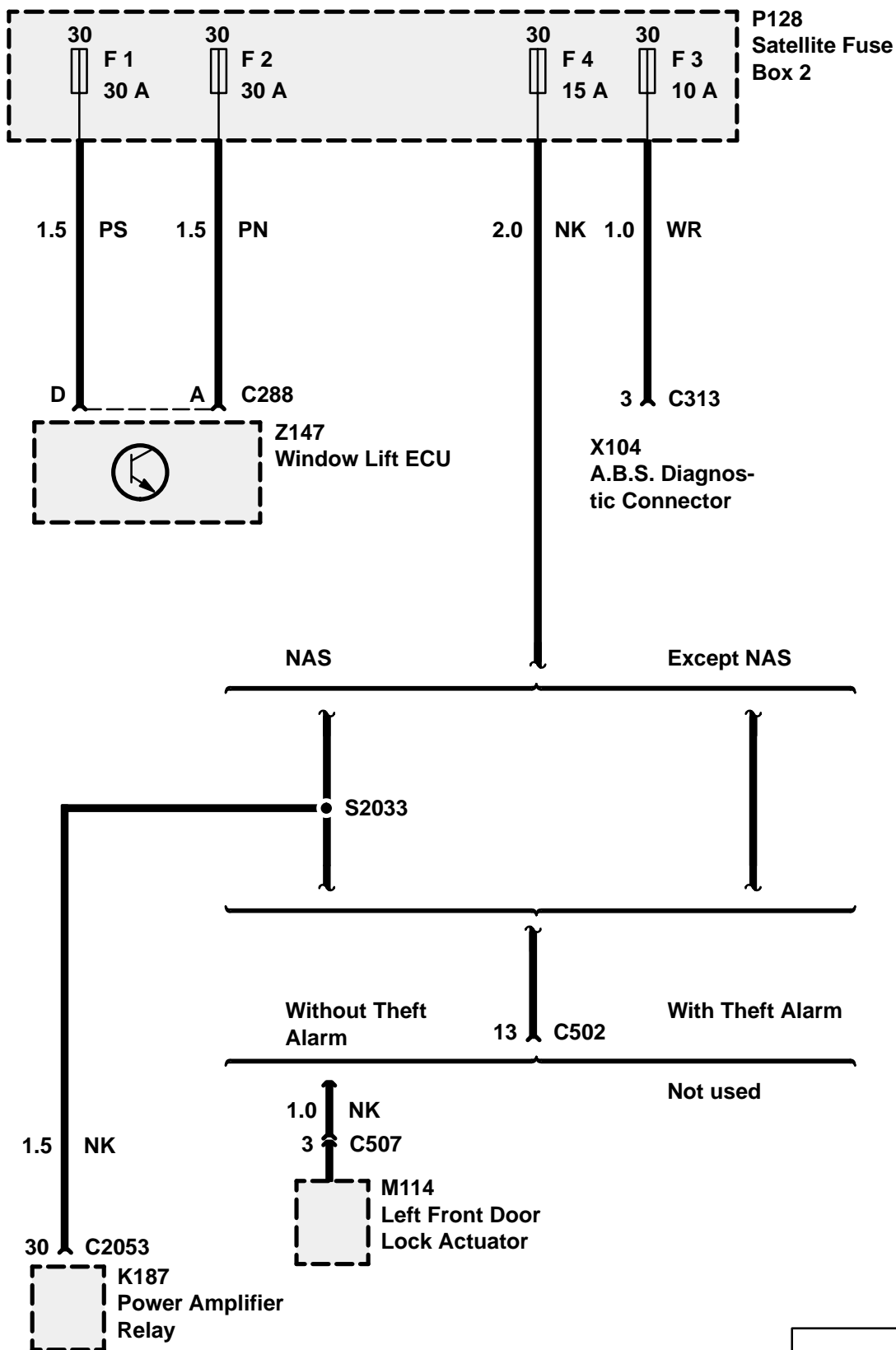
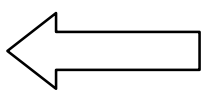

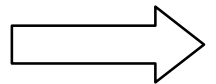
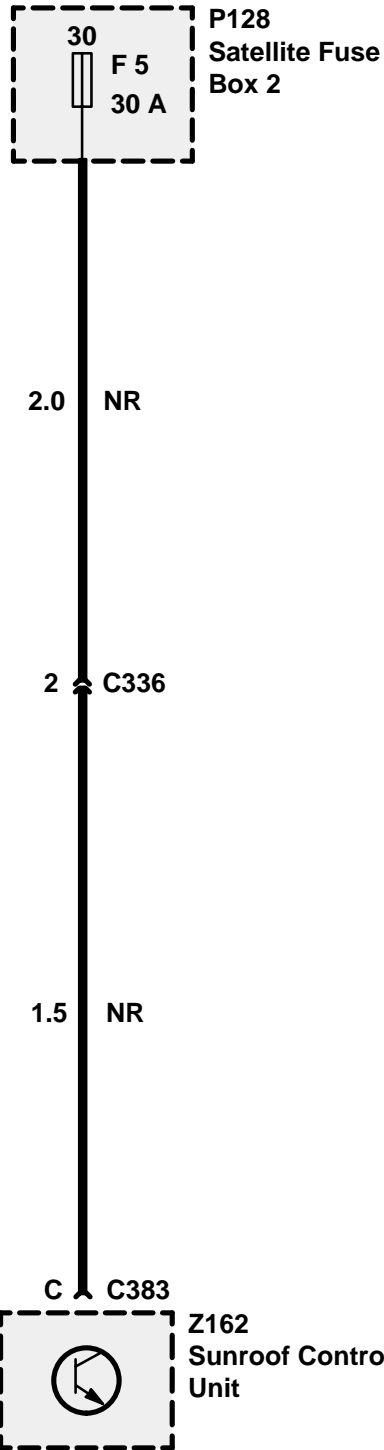
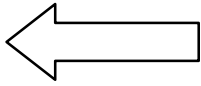

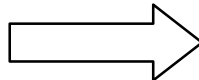
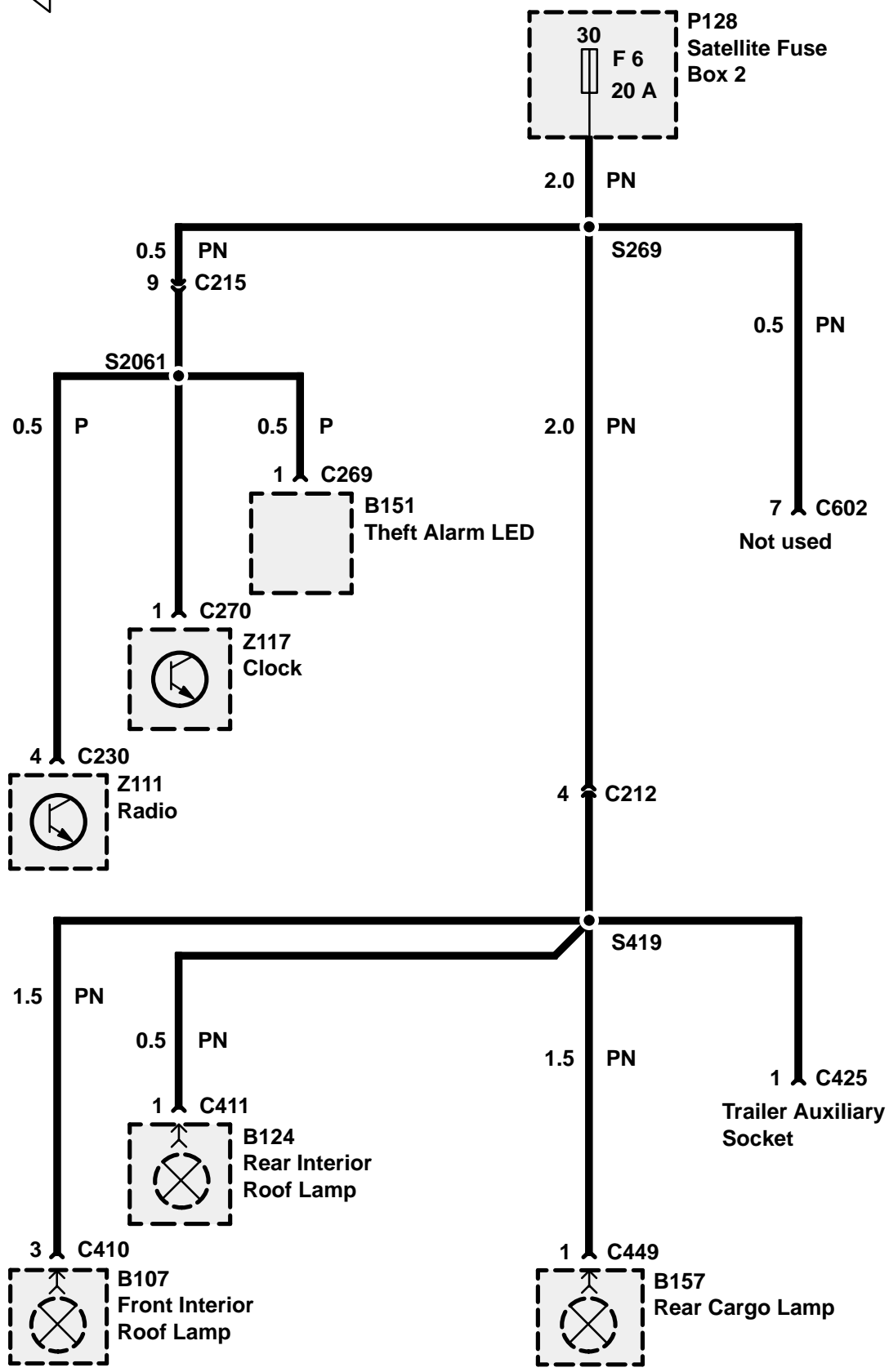
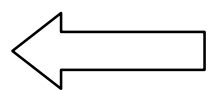

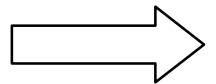
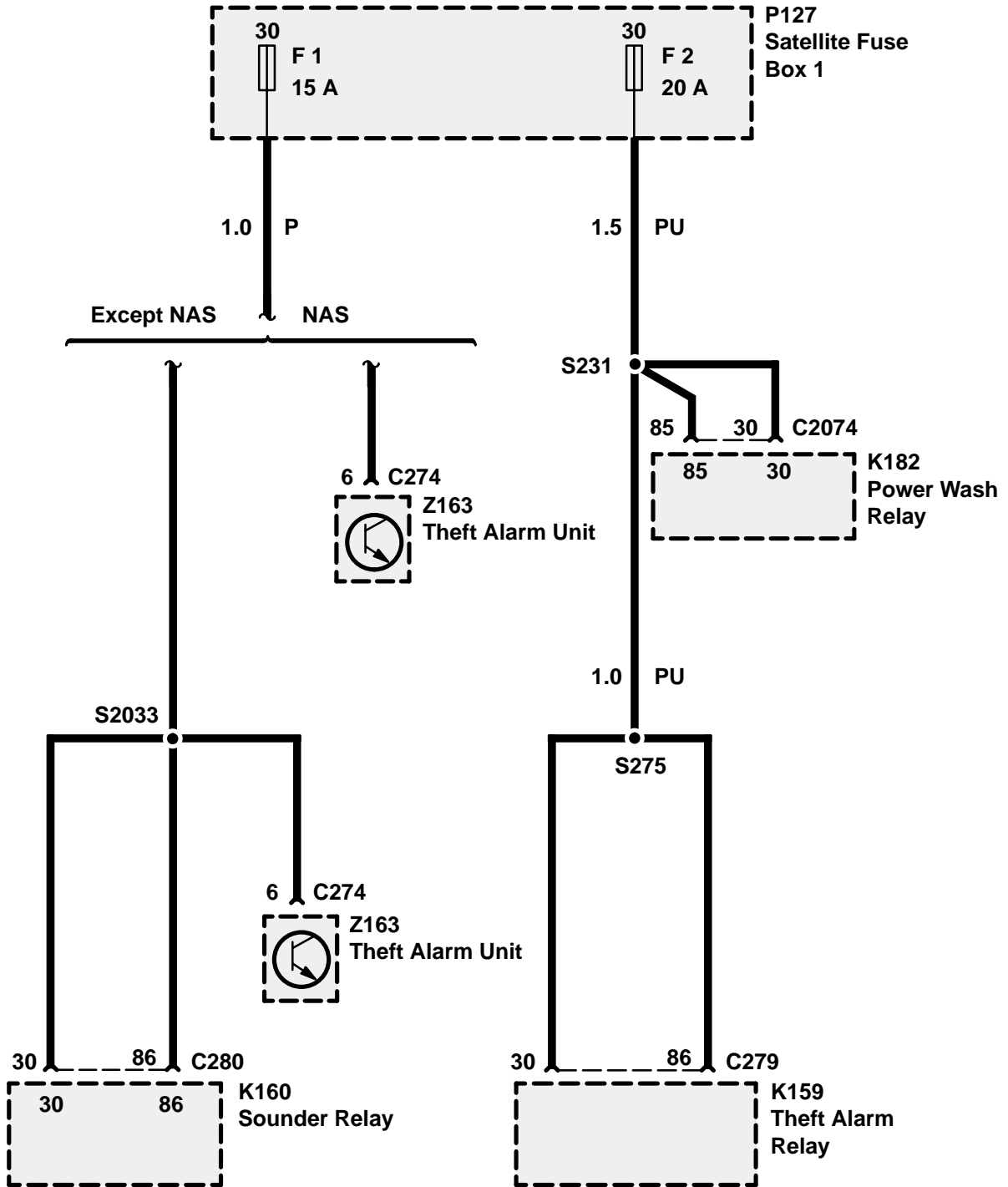
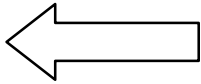

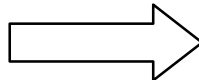
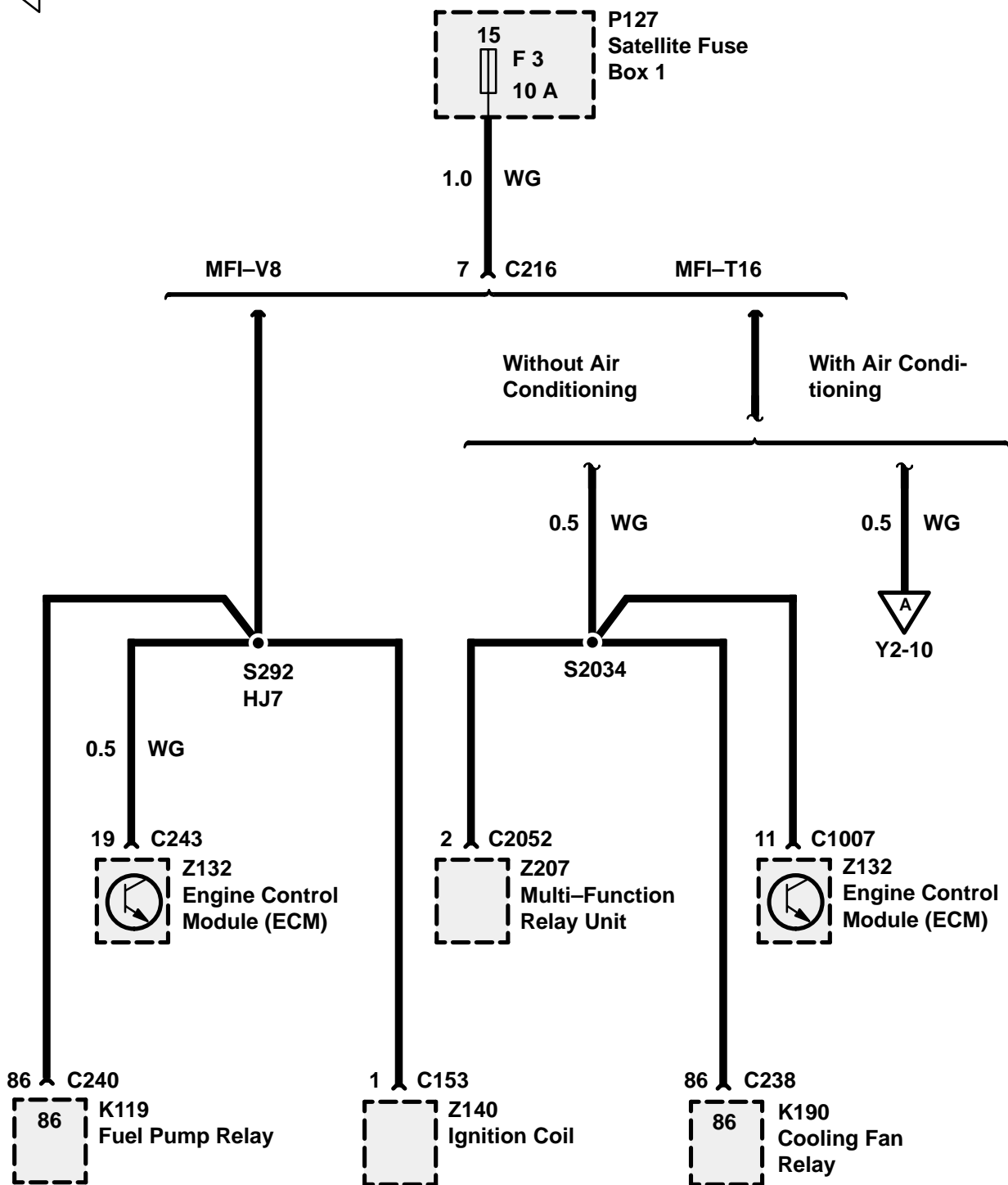
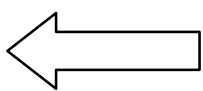

Y2 ETM

DISCOVERY

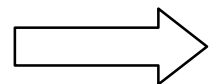
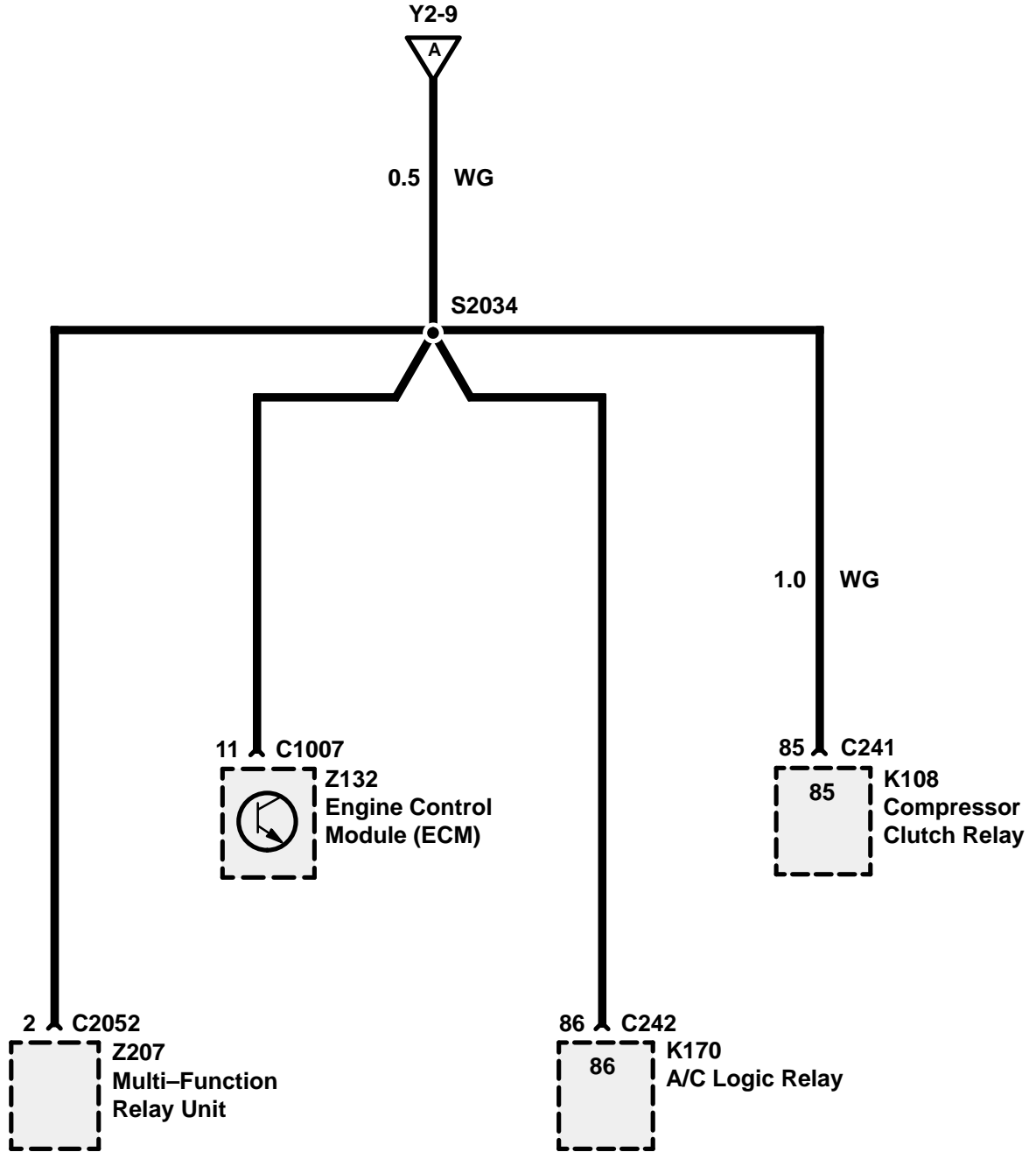
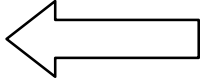

Y2 ETM

DISCOVERY

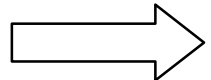
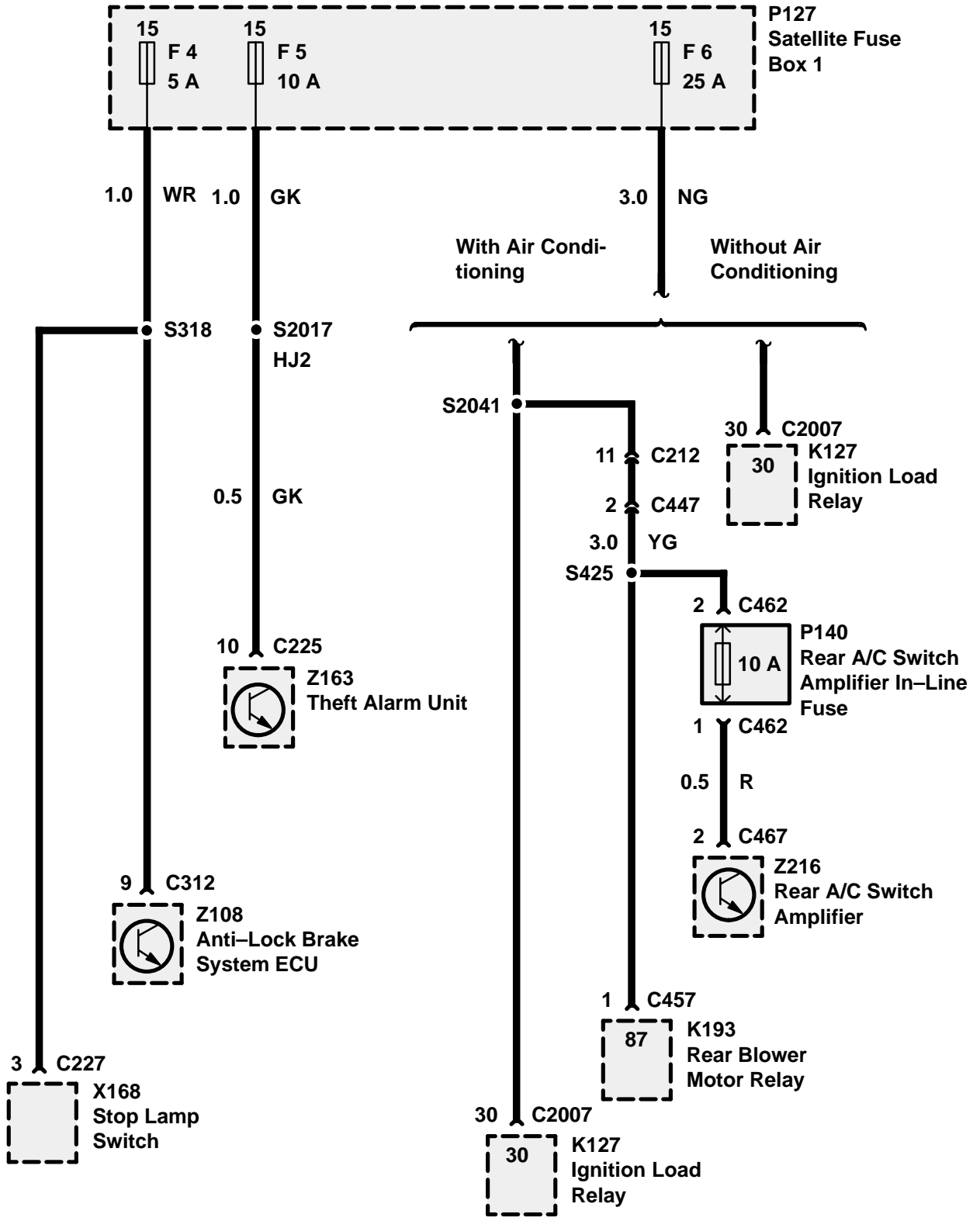
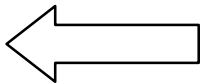

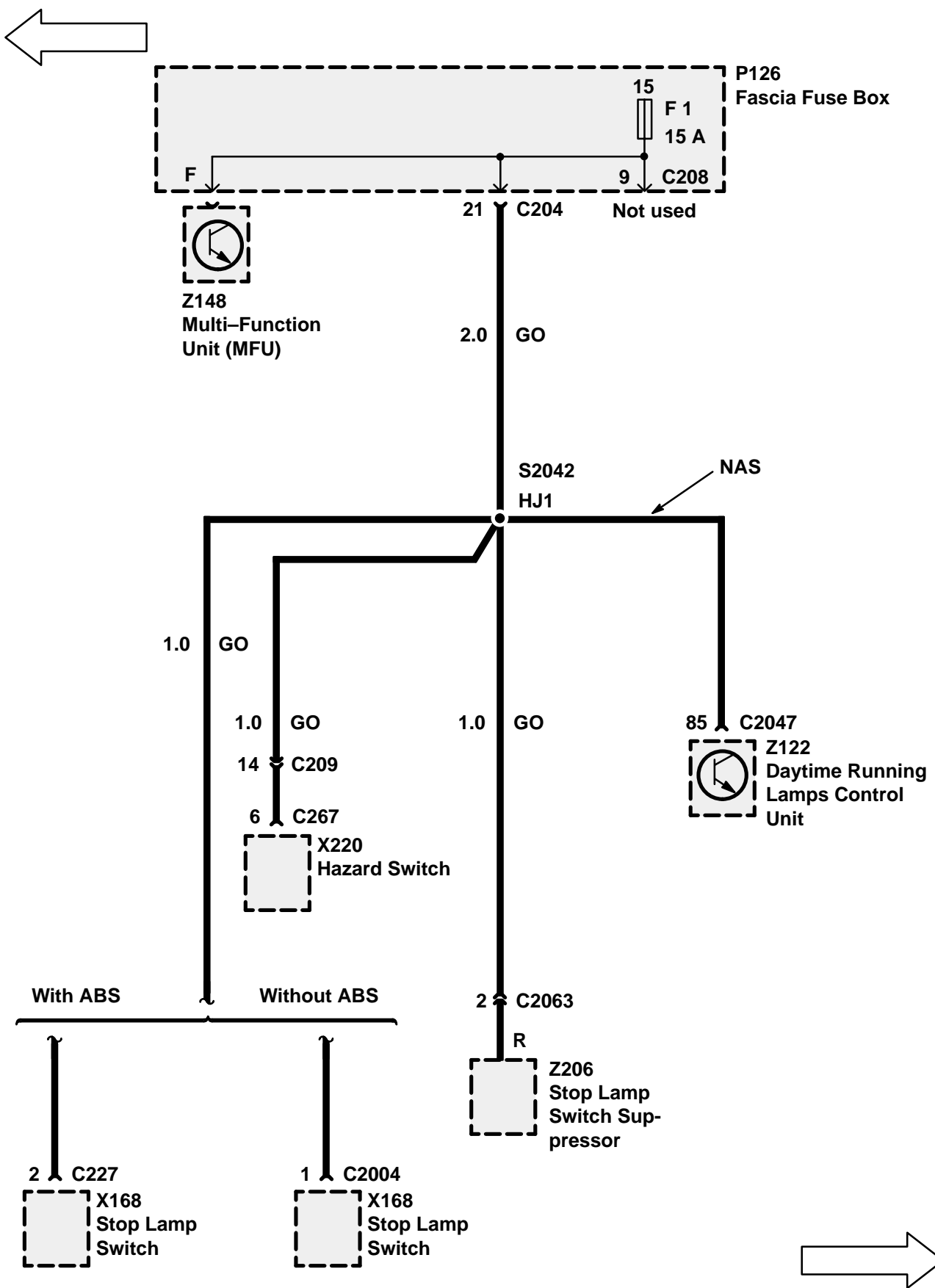

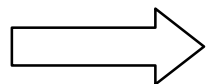
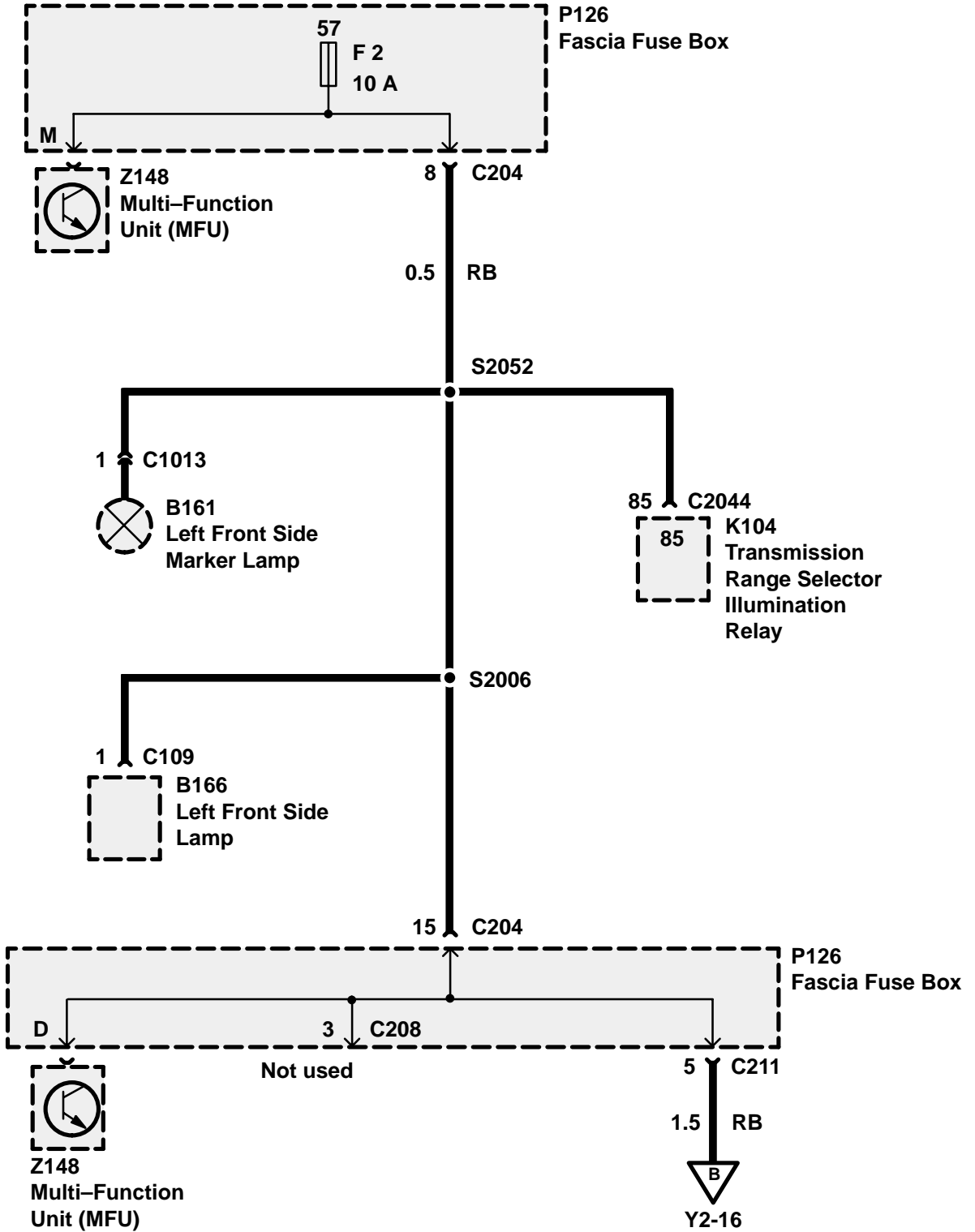
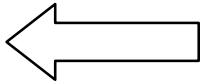

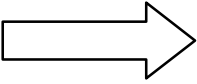
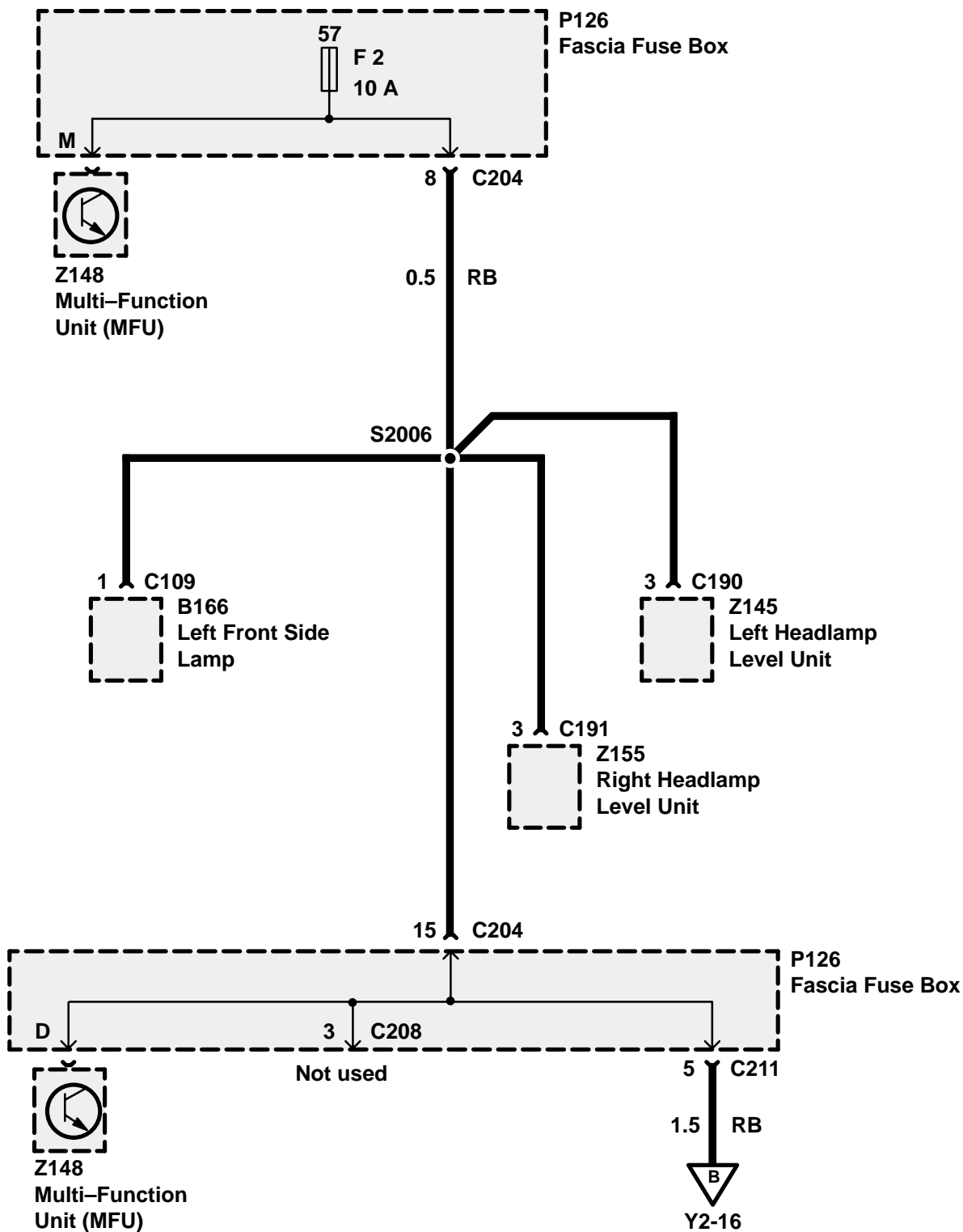
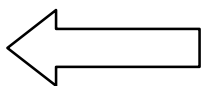

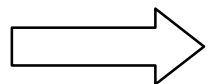
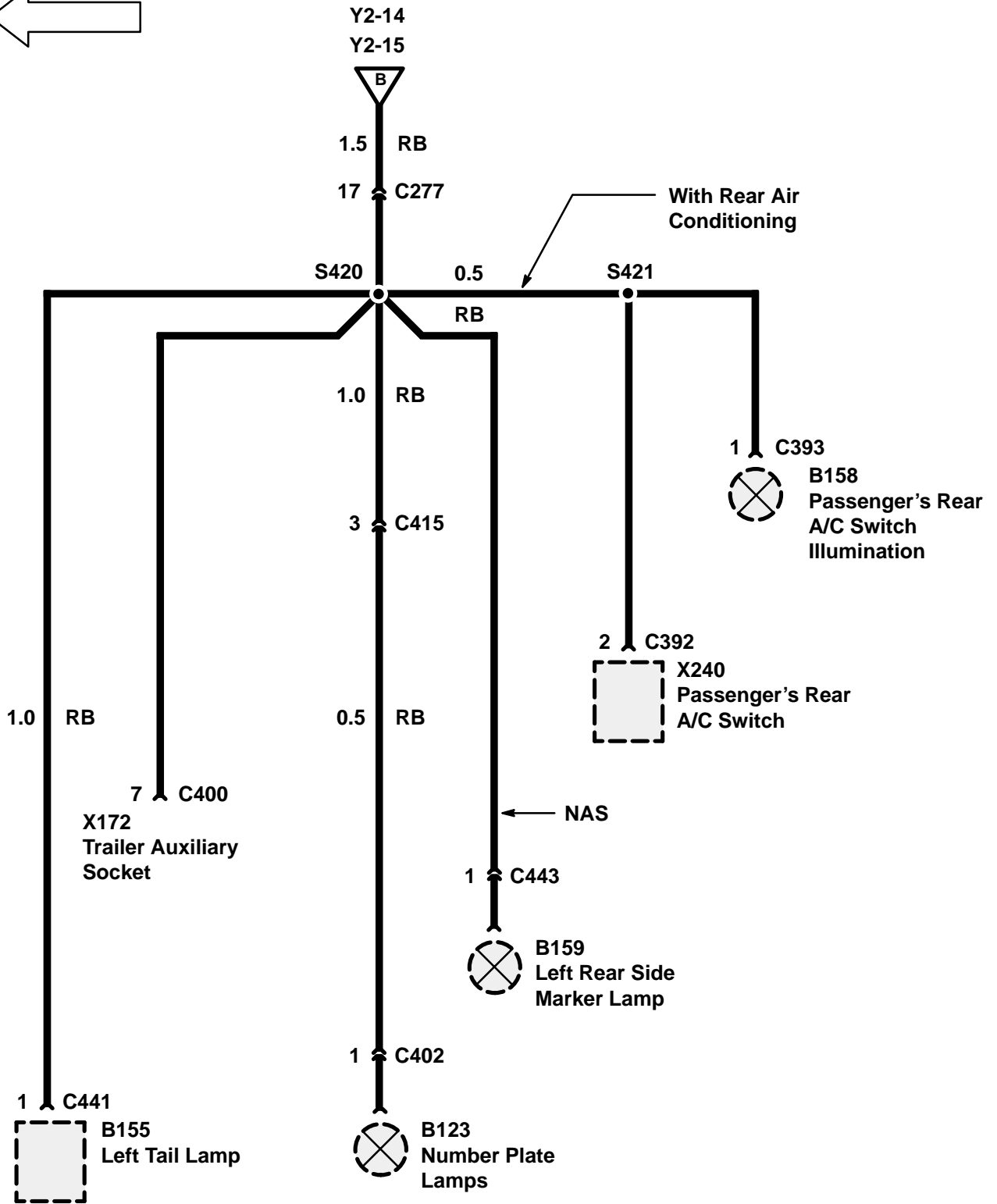
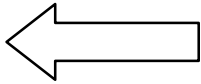

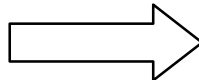
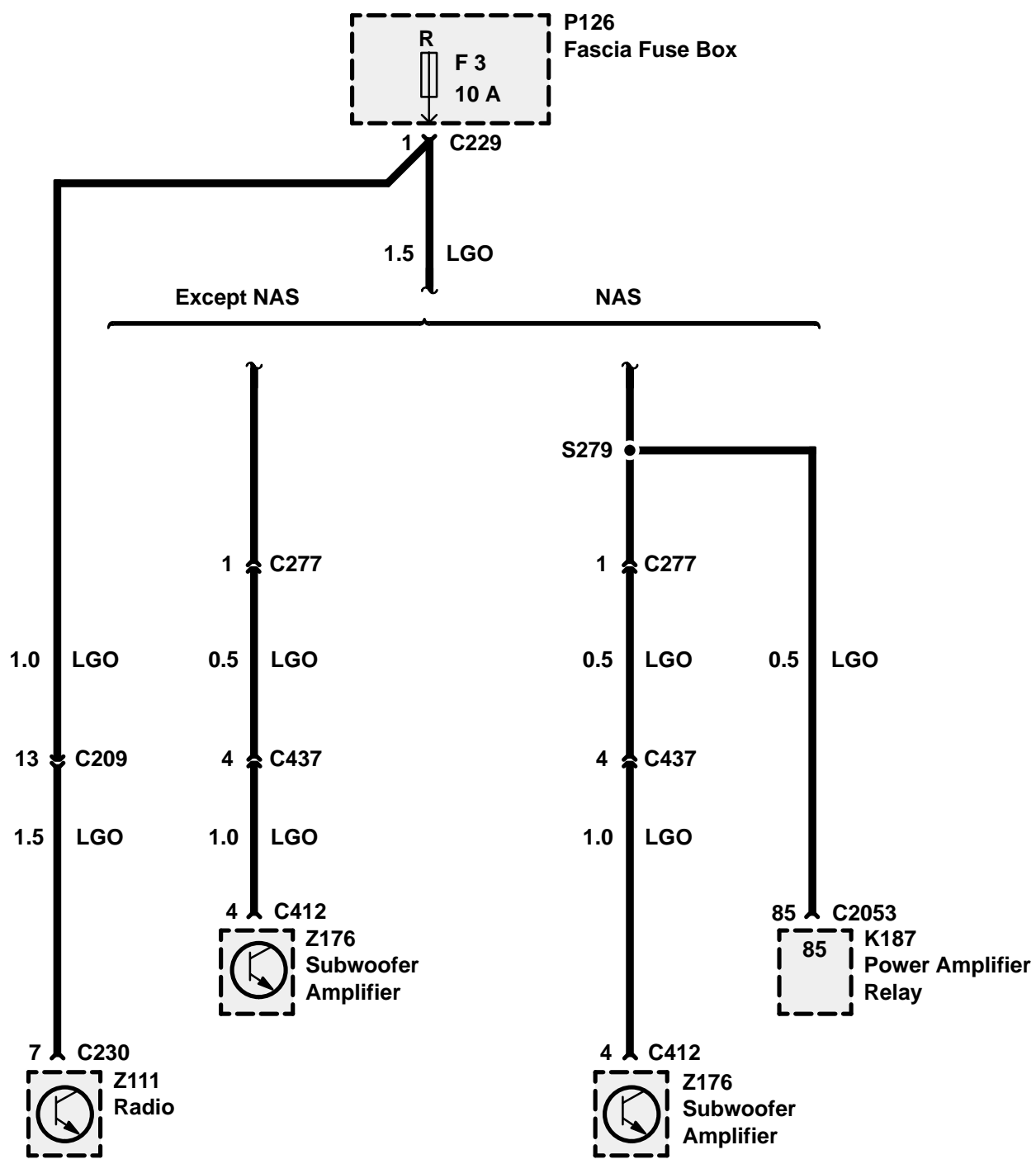
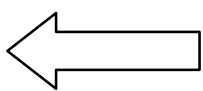

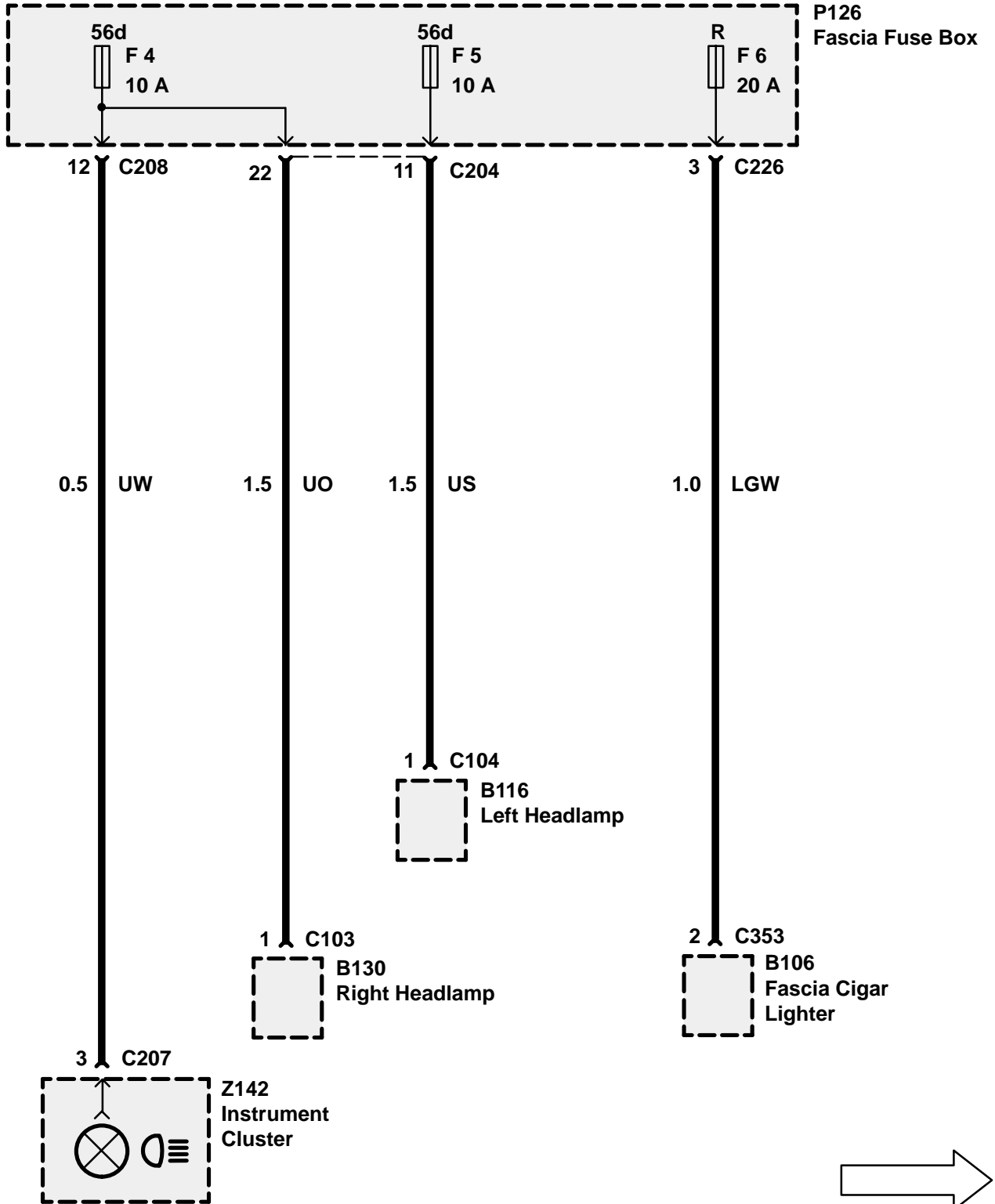
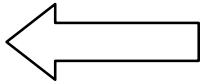

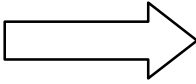
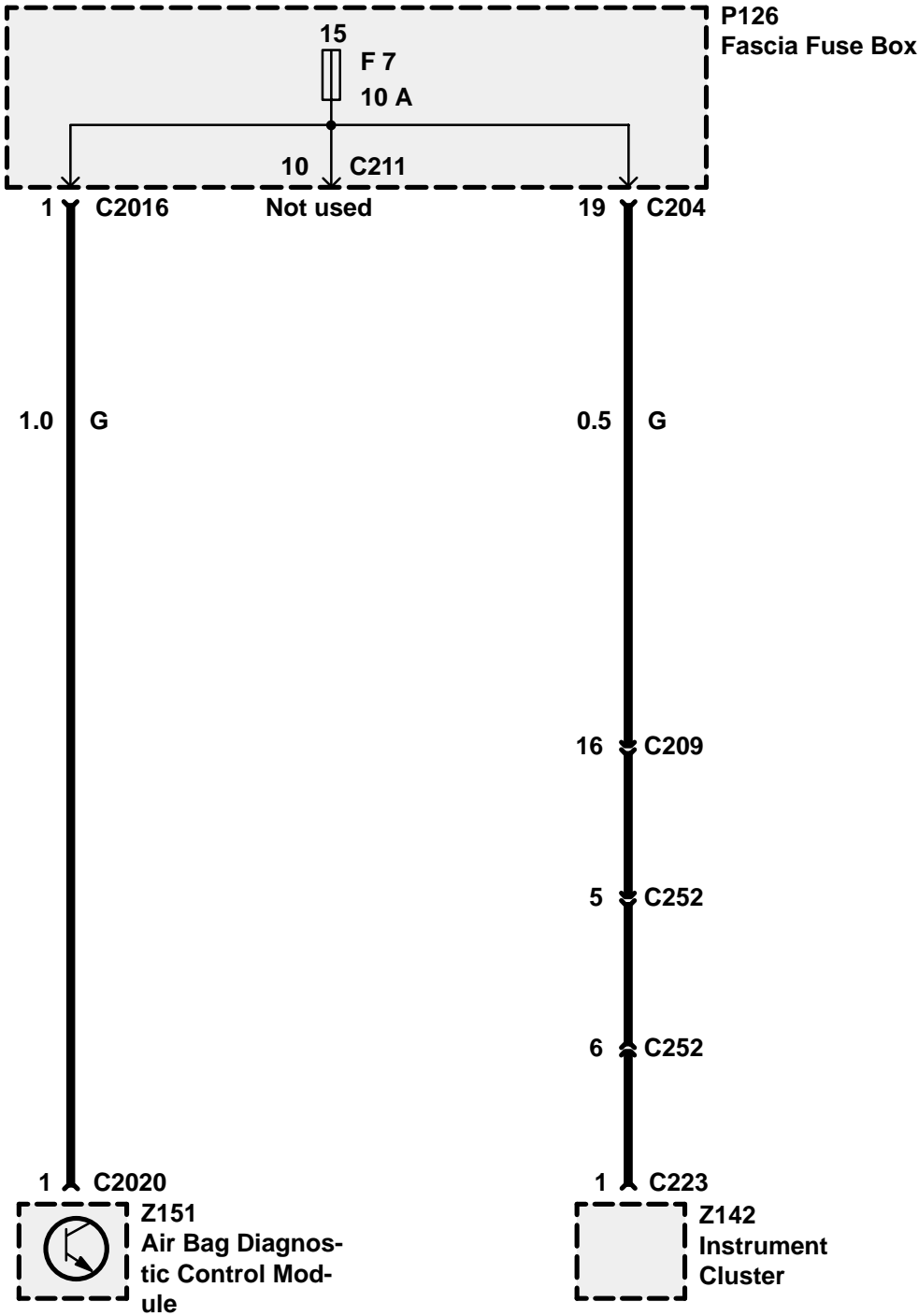
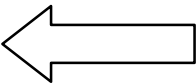

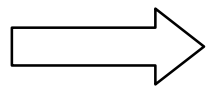
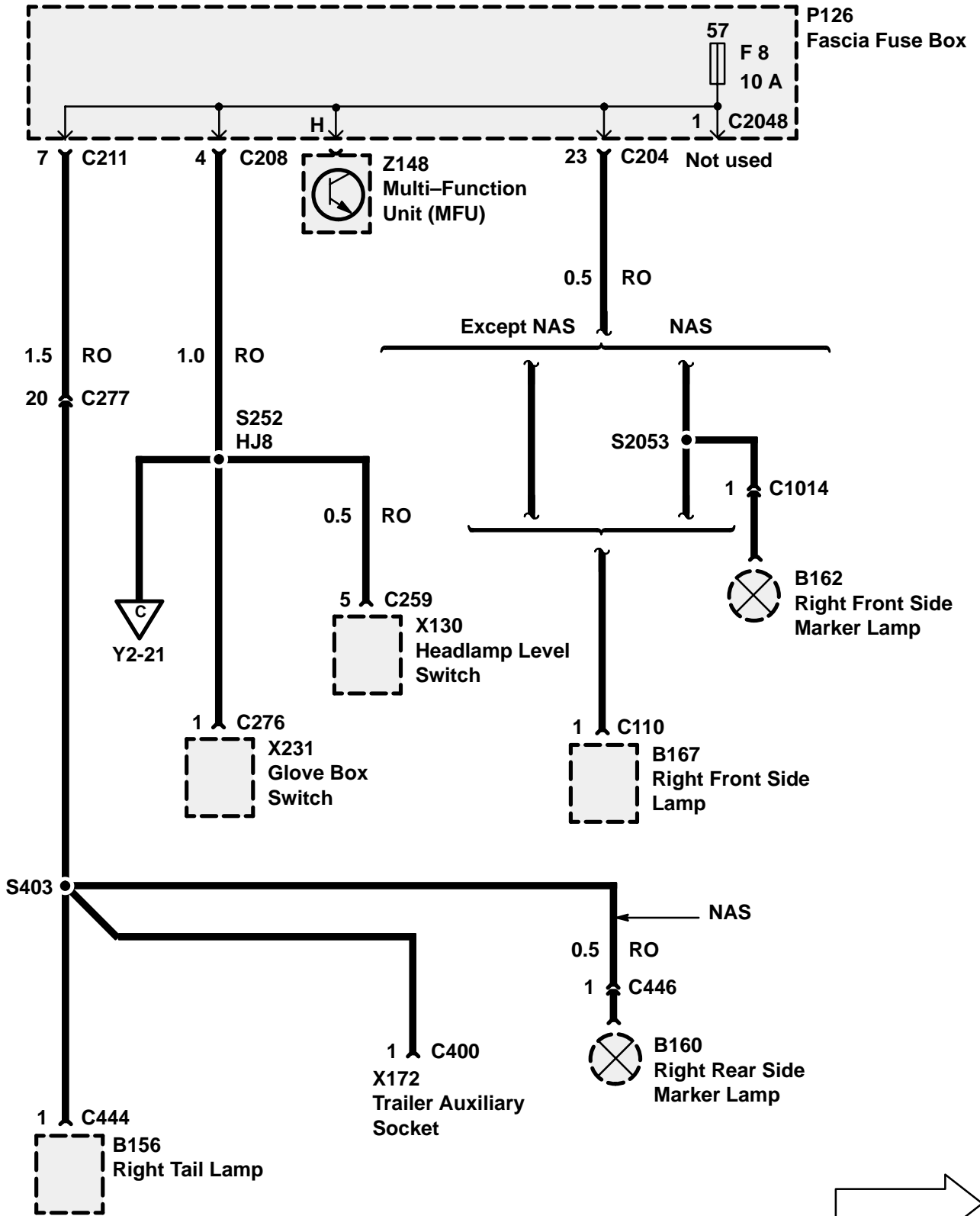
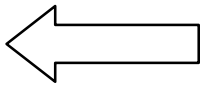

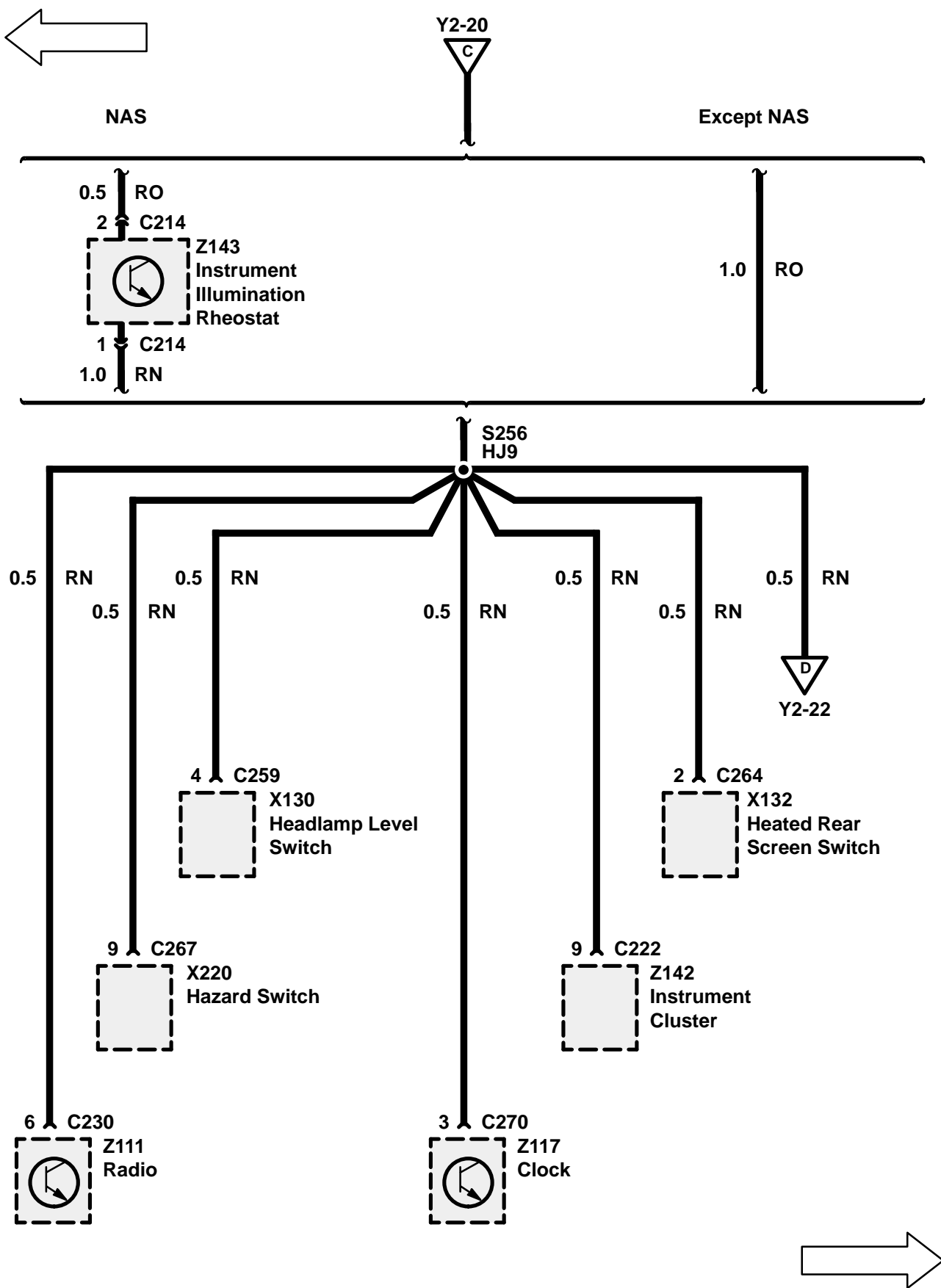

Y2 ETM

DISCOVERY

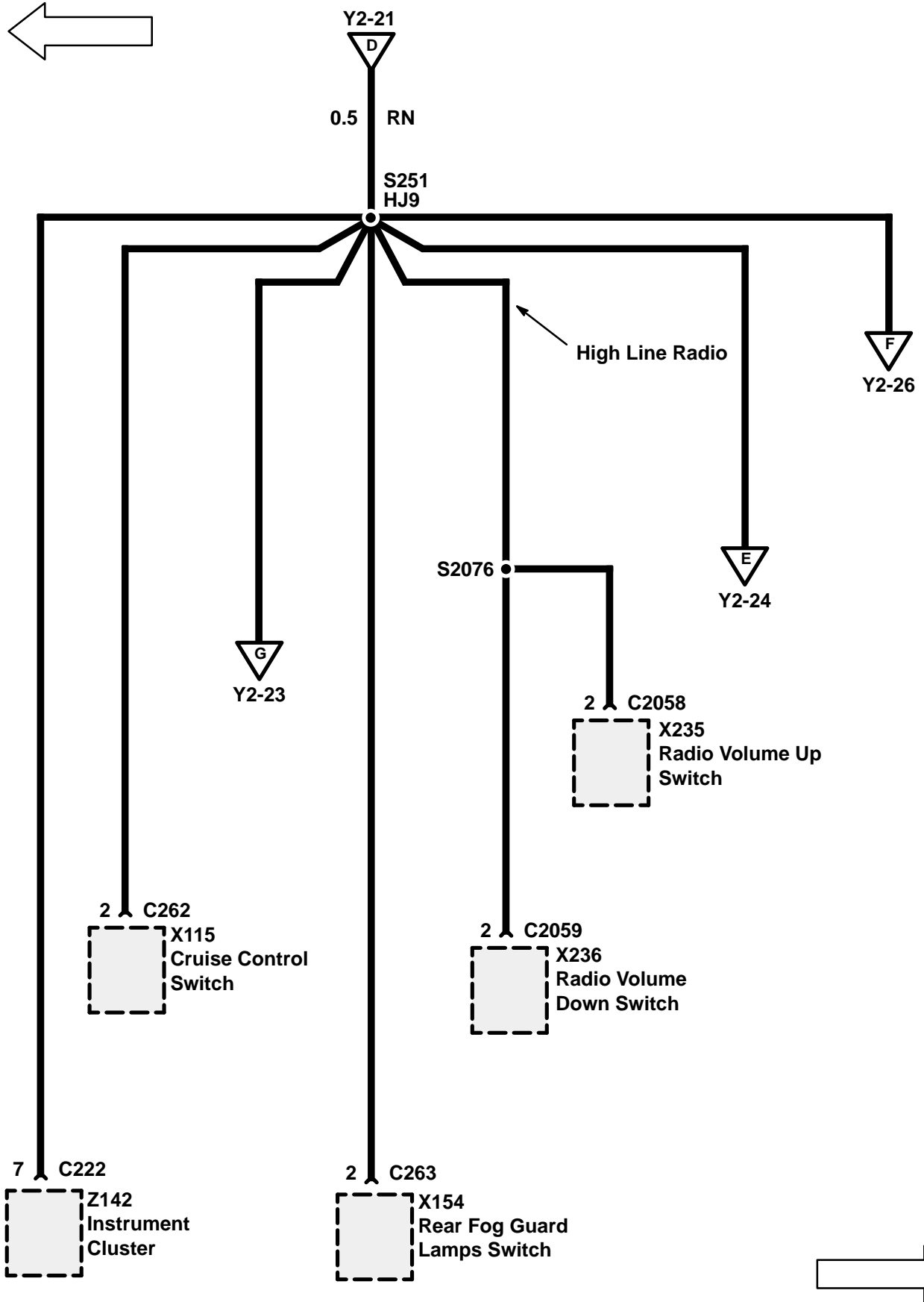

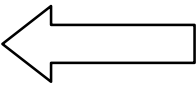

Low Line Radio

Mid Line Radio

High Line Radio



S2075

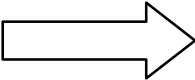
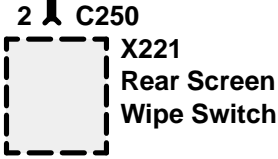
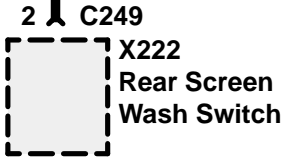
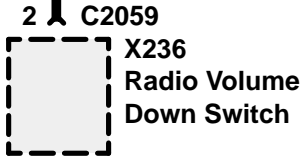
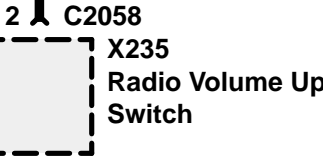

Y2 ETM

DISCOVERY

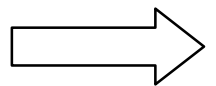
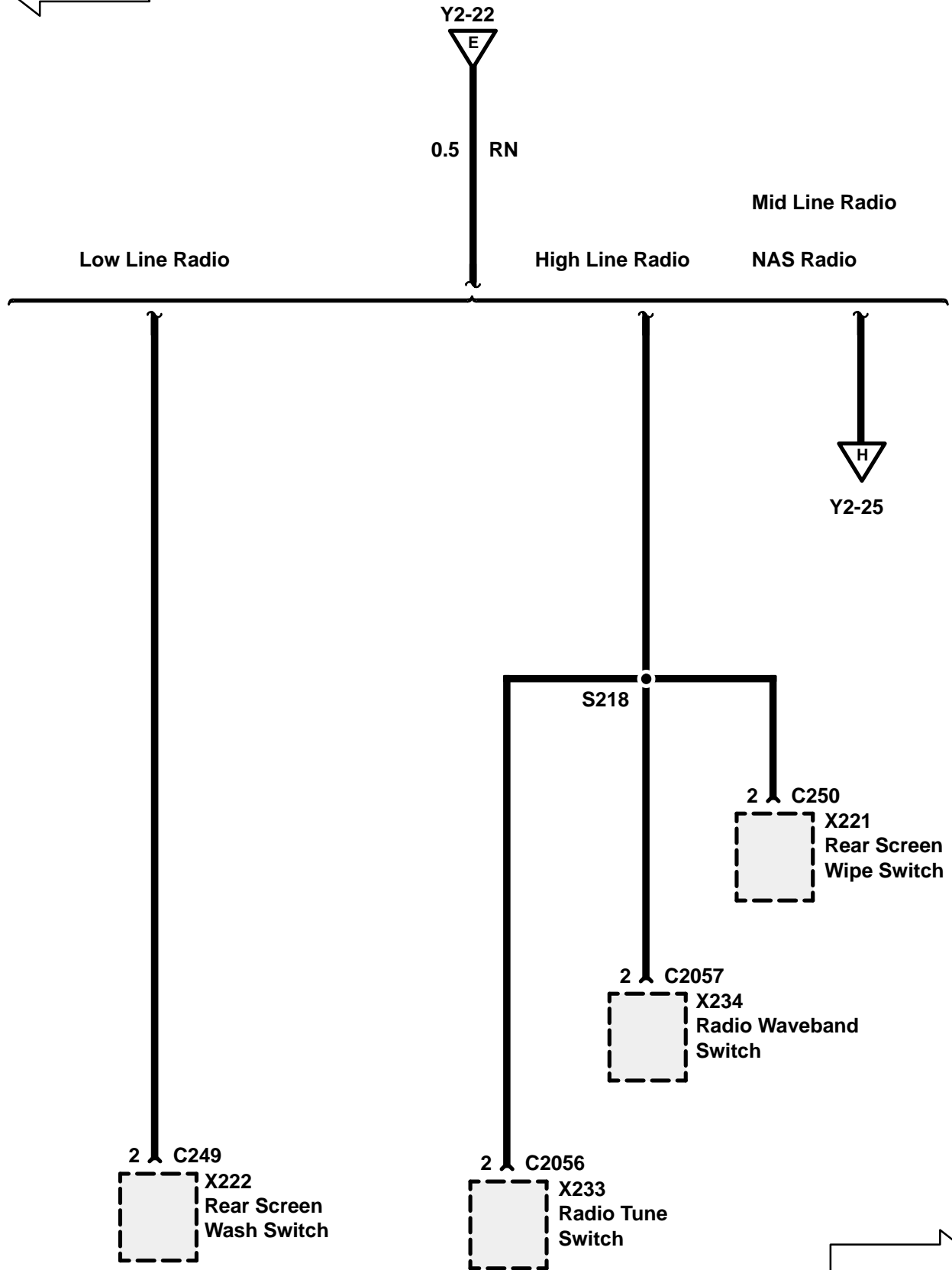
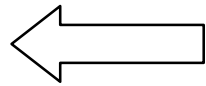

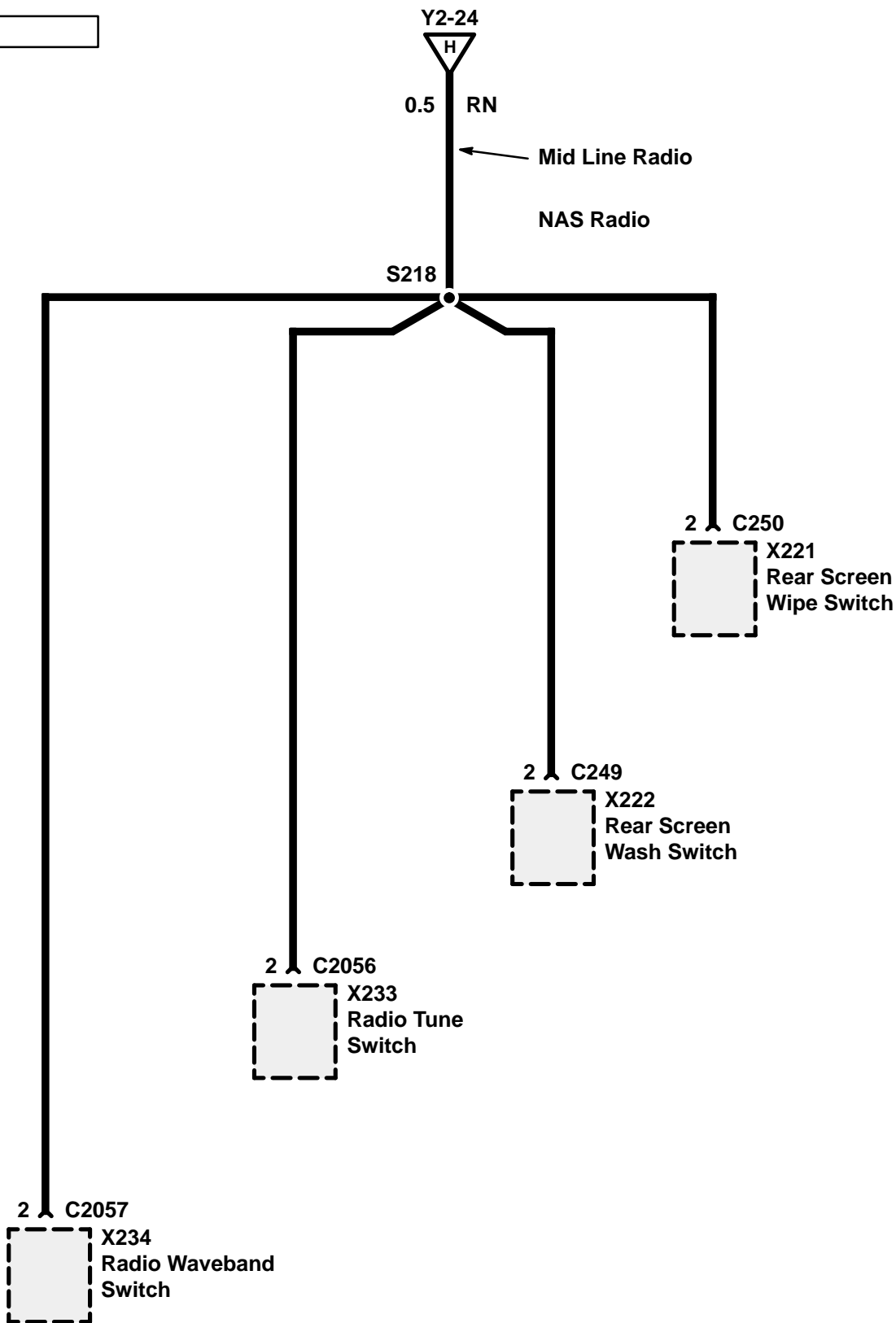
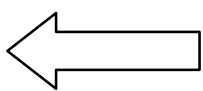

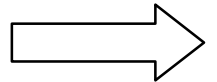
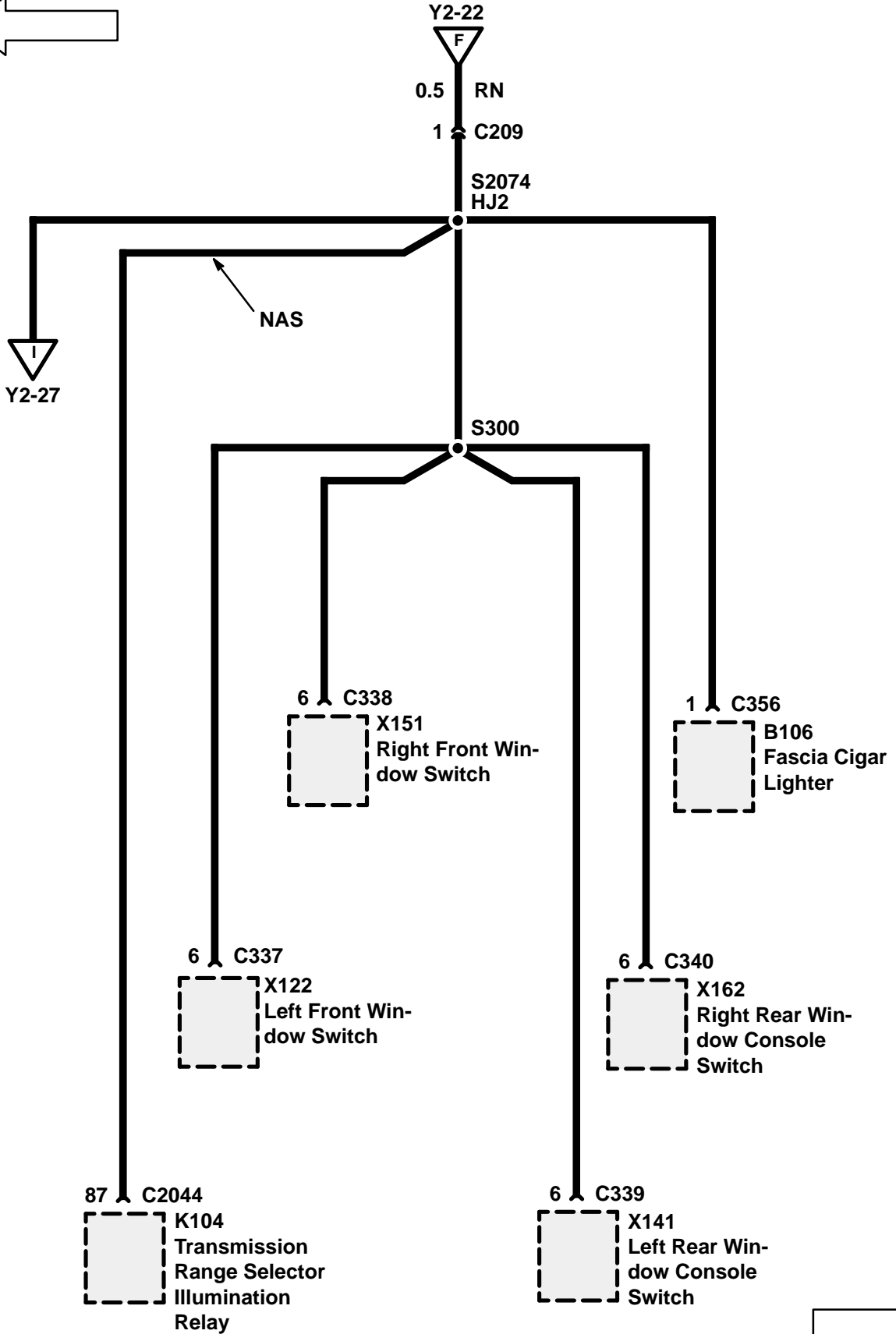
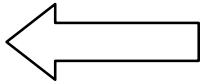

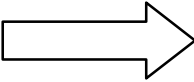
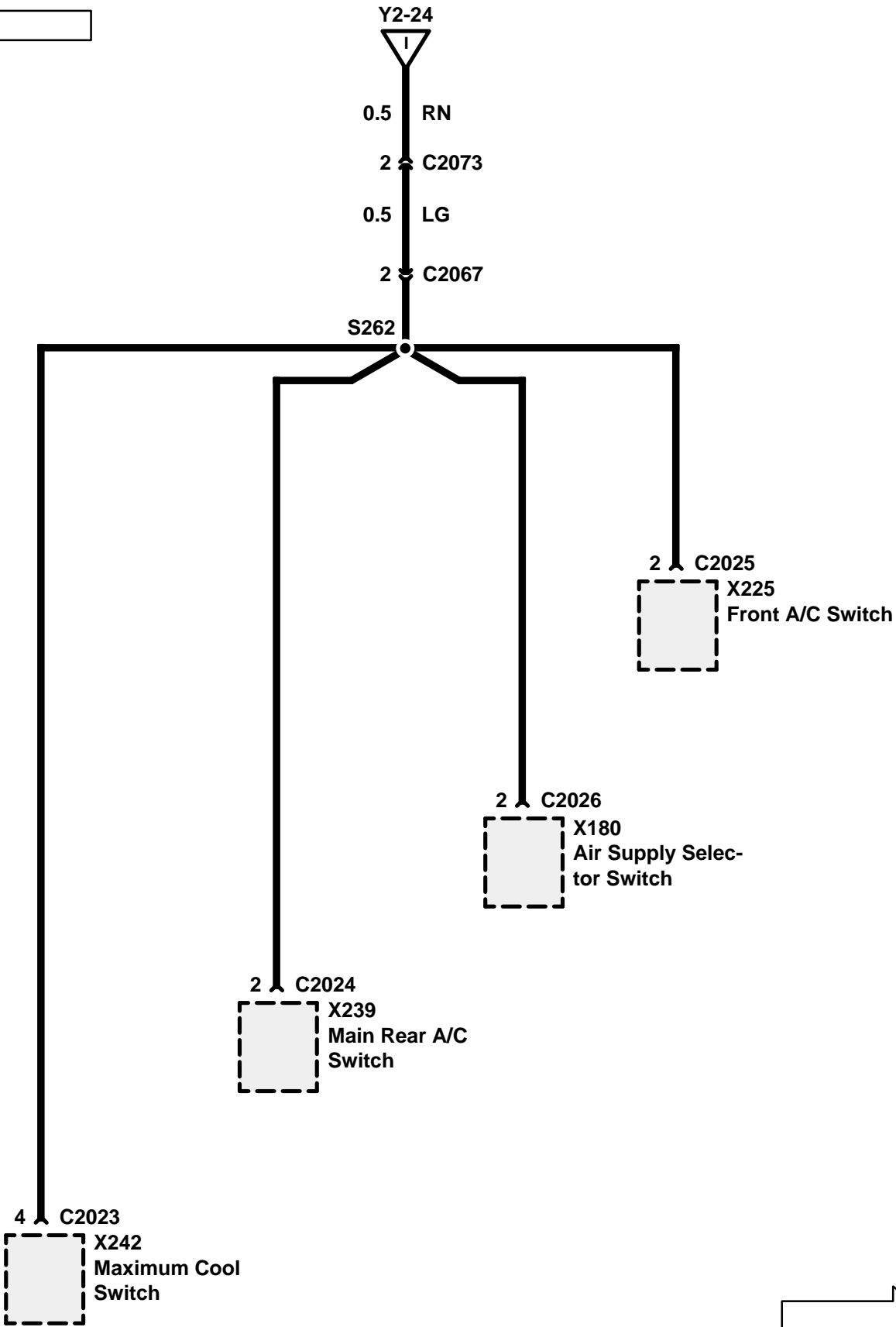
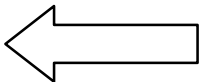

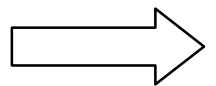
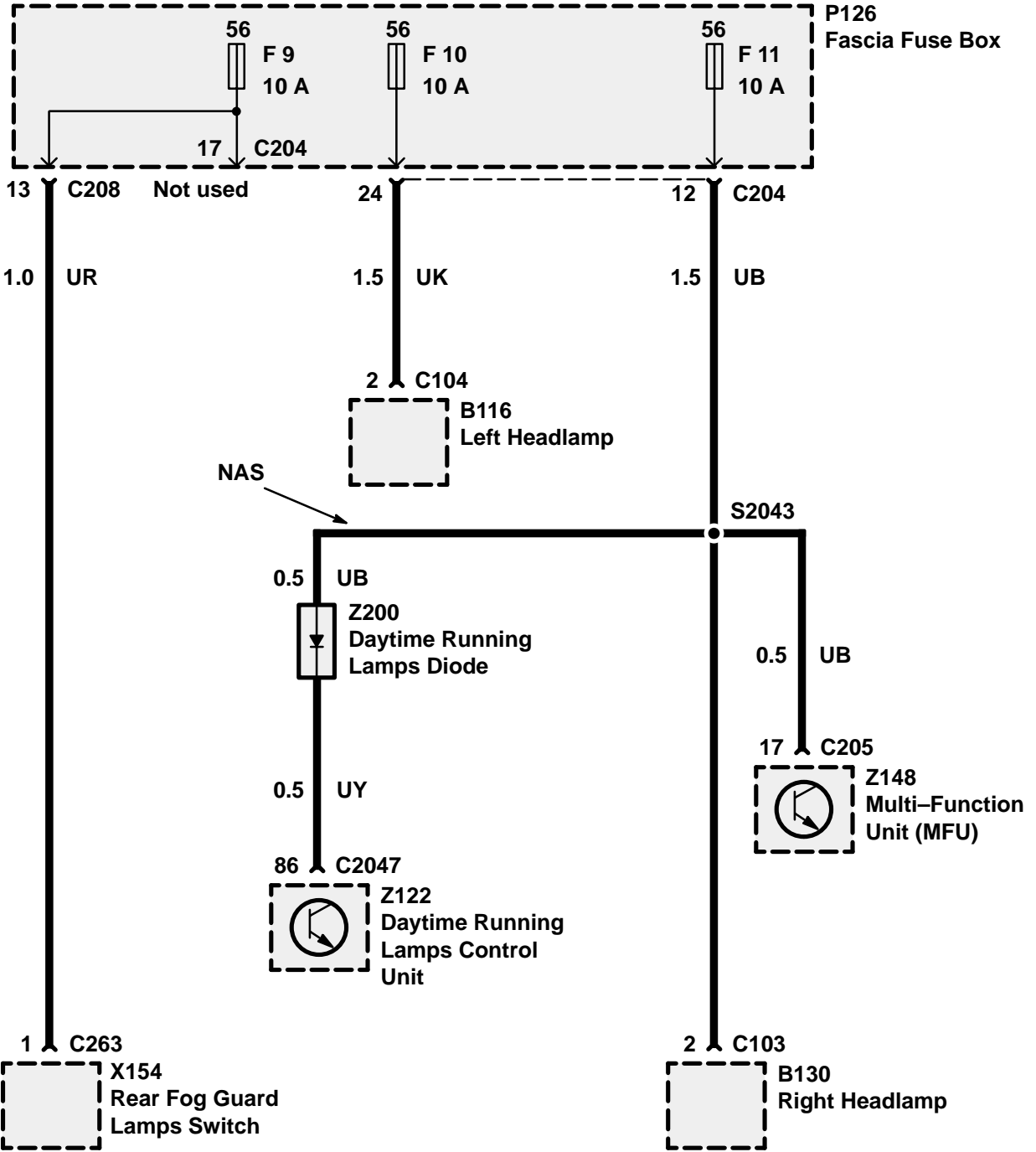
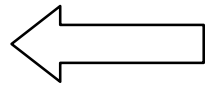

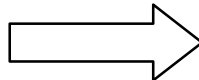
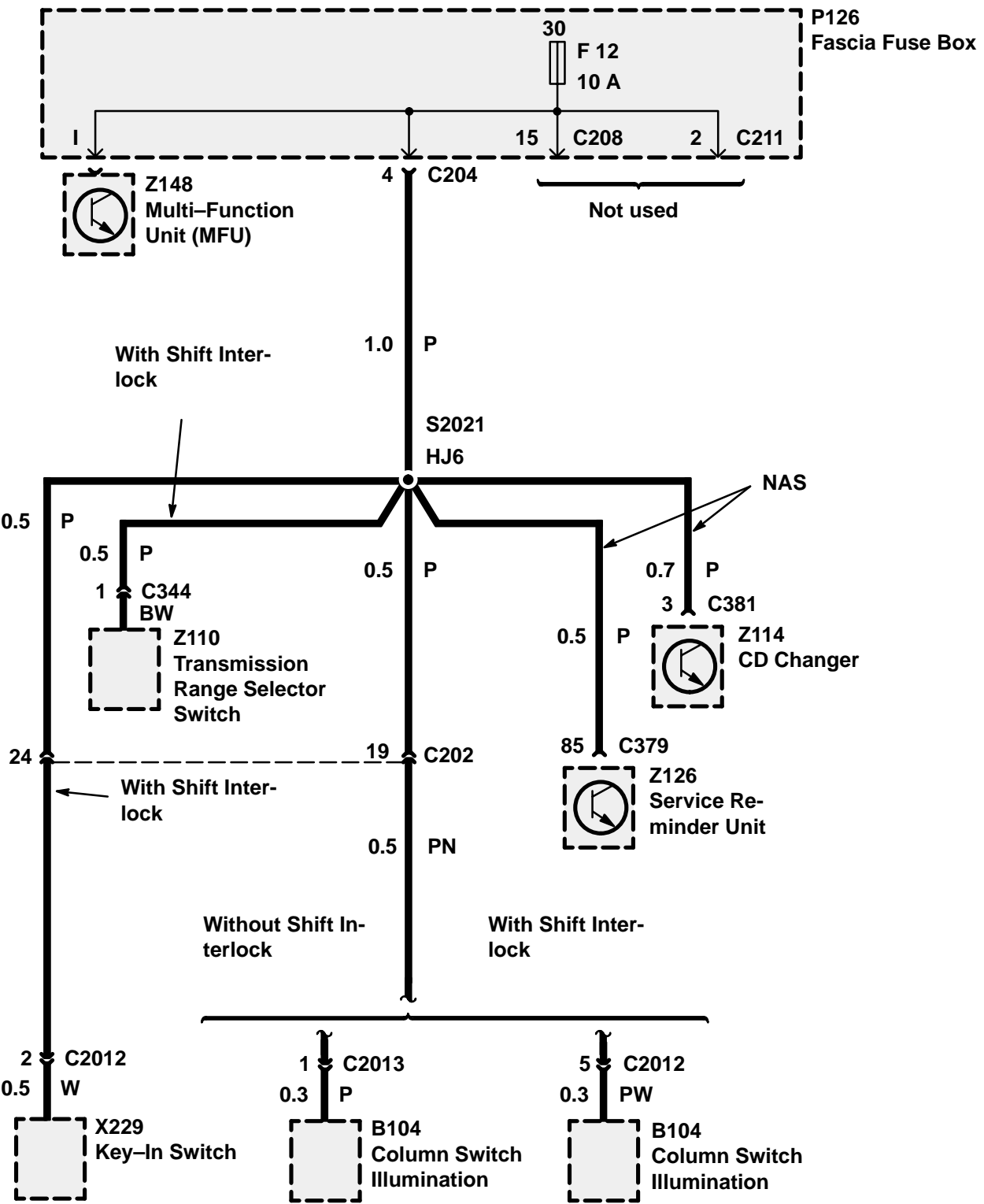
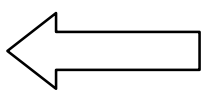

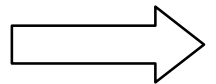
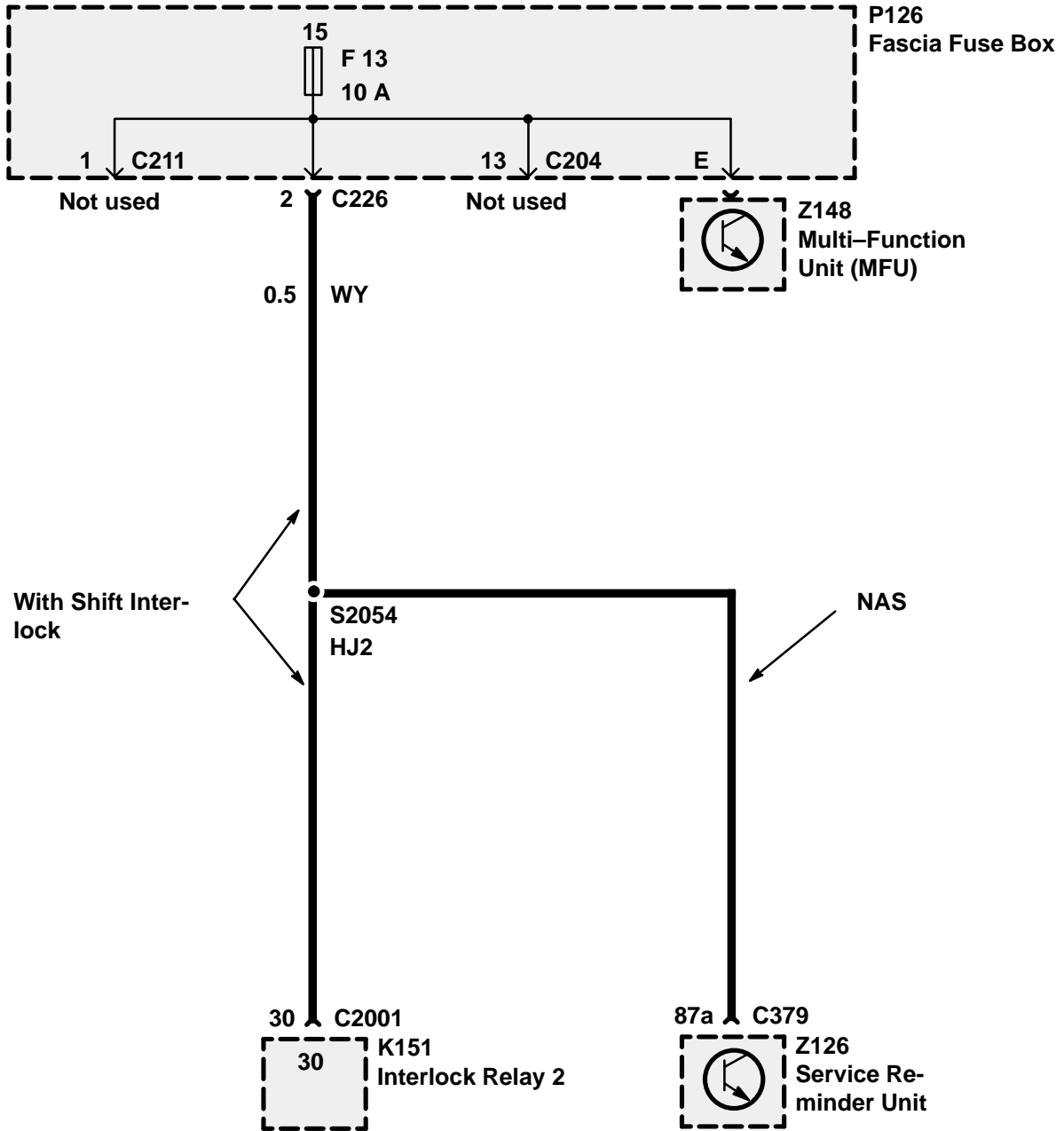
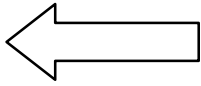

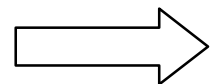
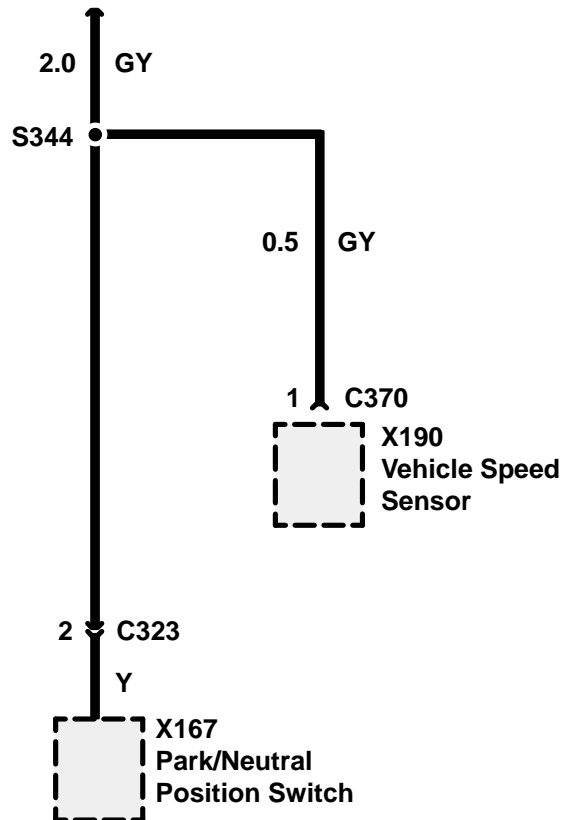
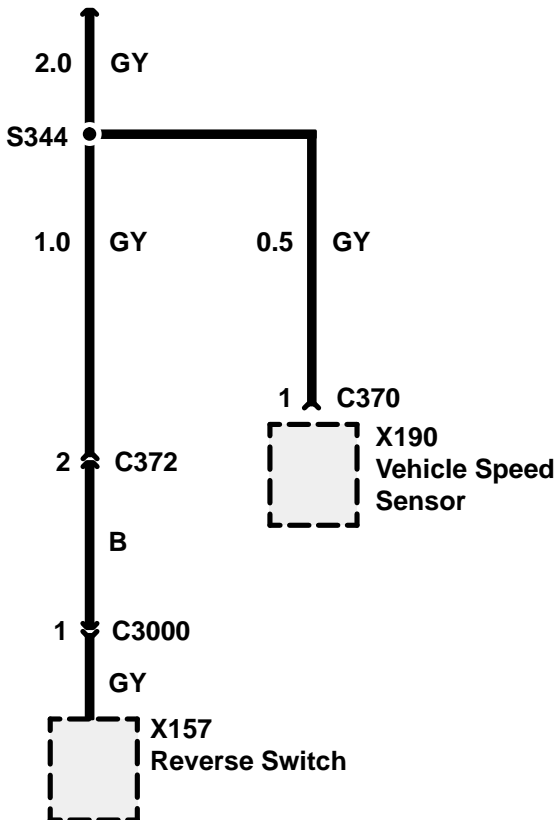
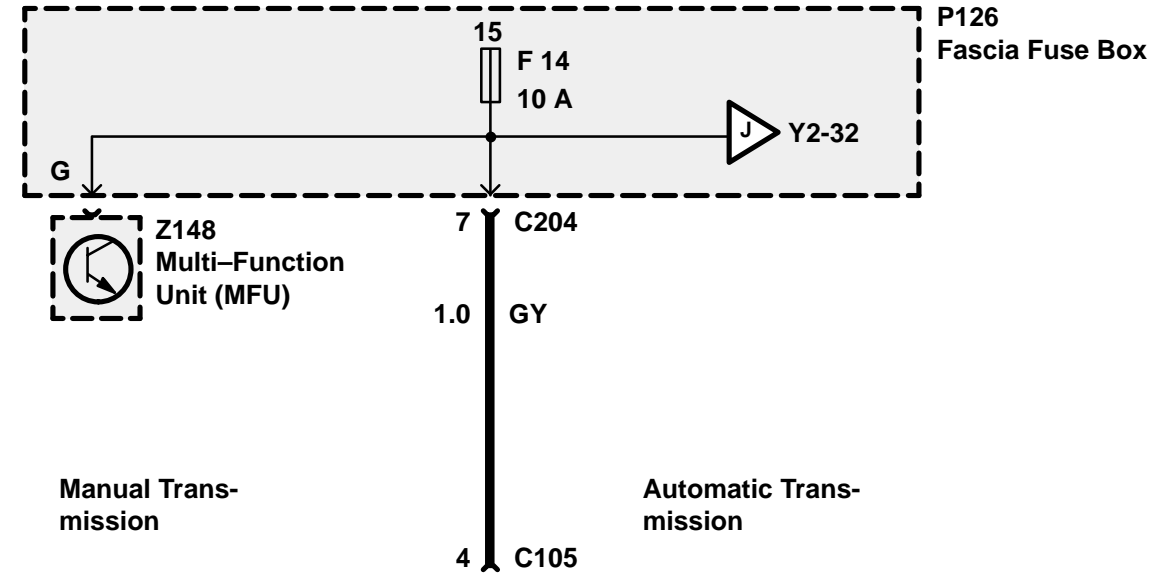
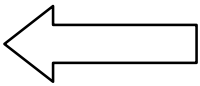

Y2 ETM

DISCOVERY

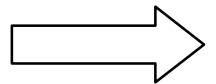
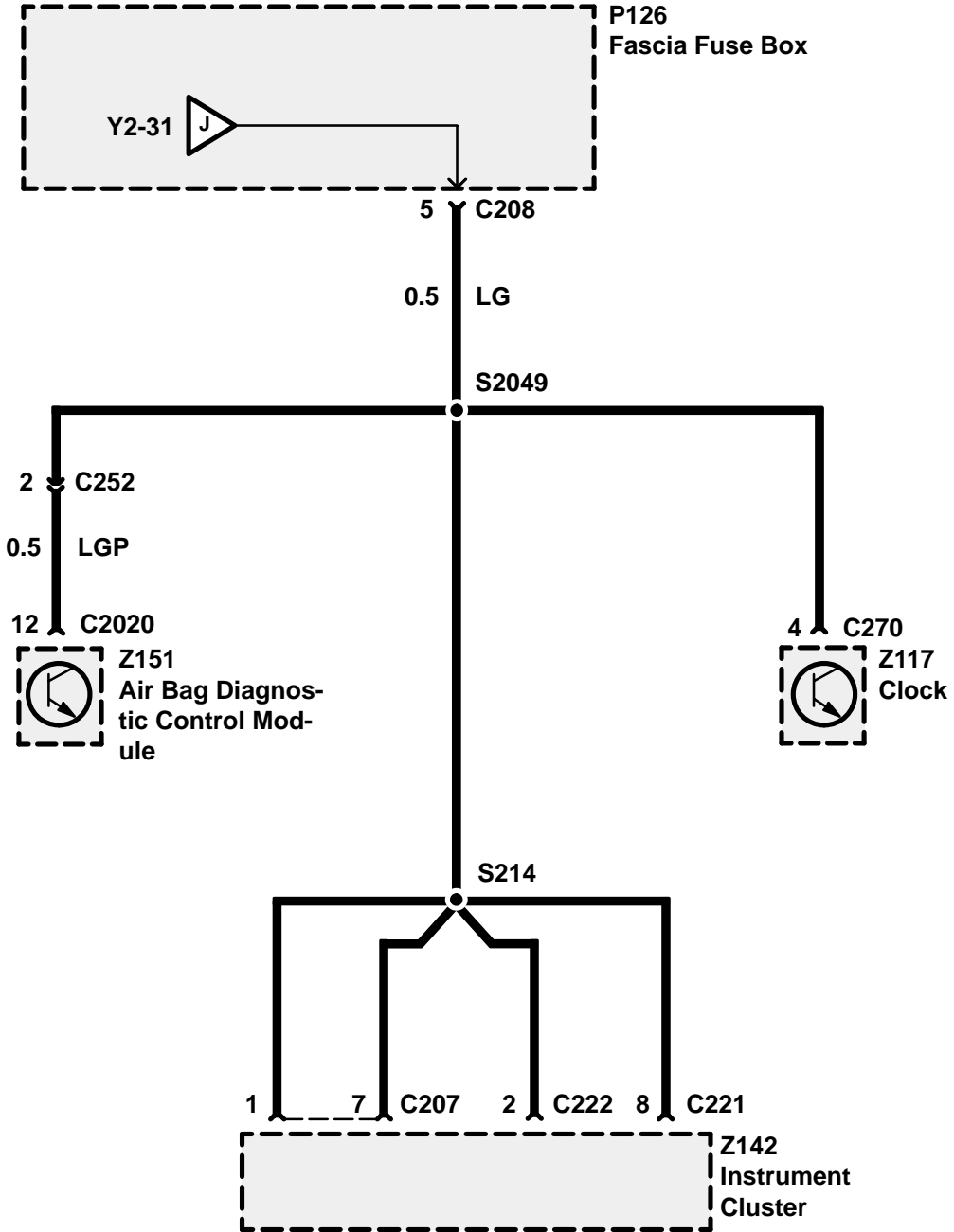
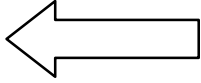

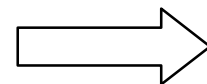
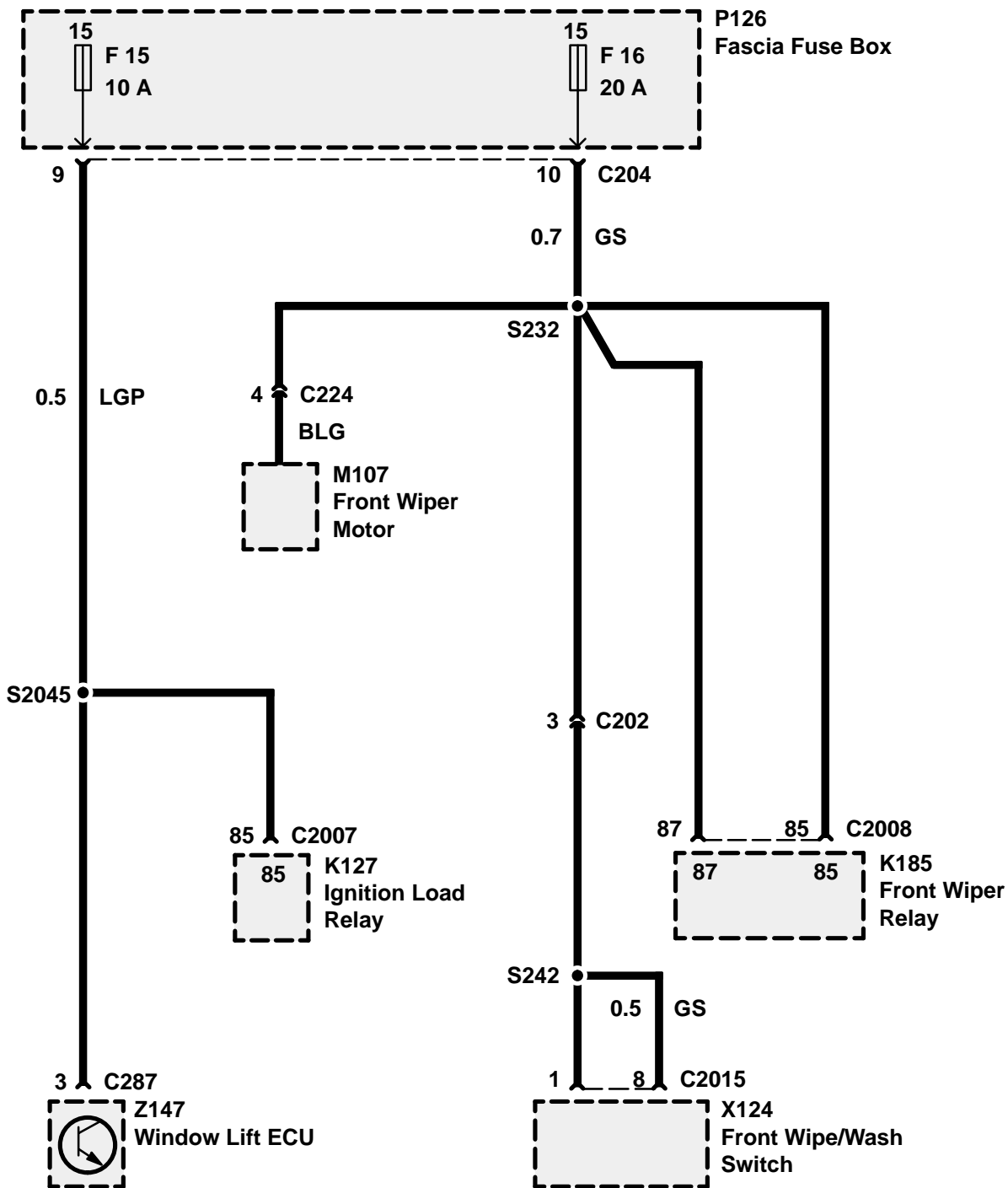
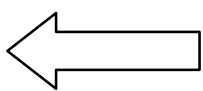

Y2 ETM

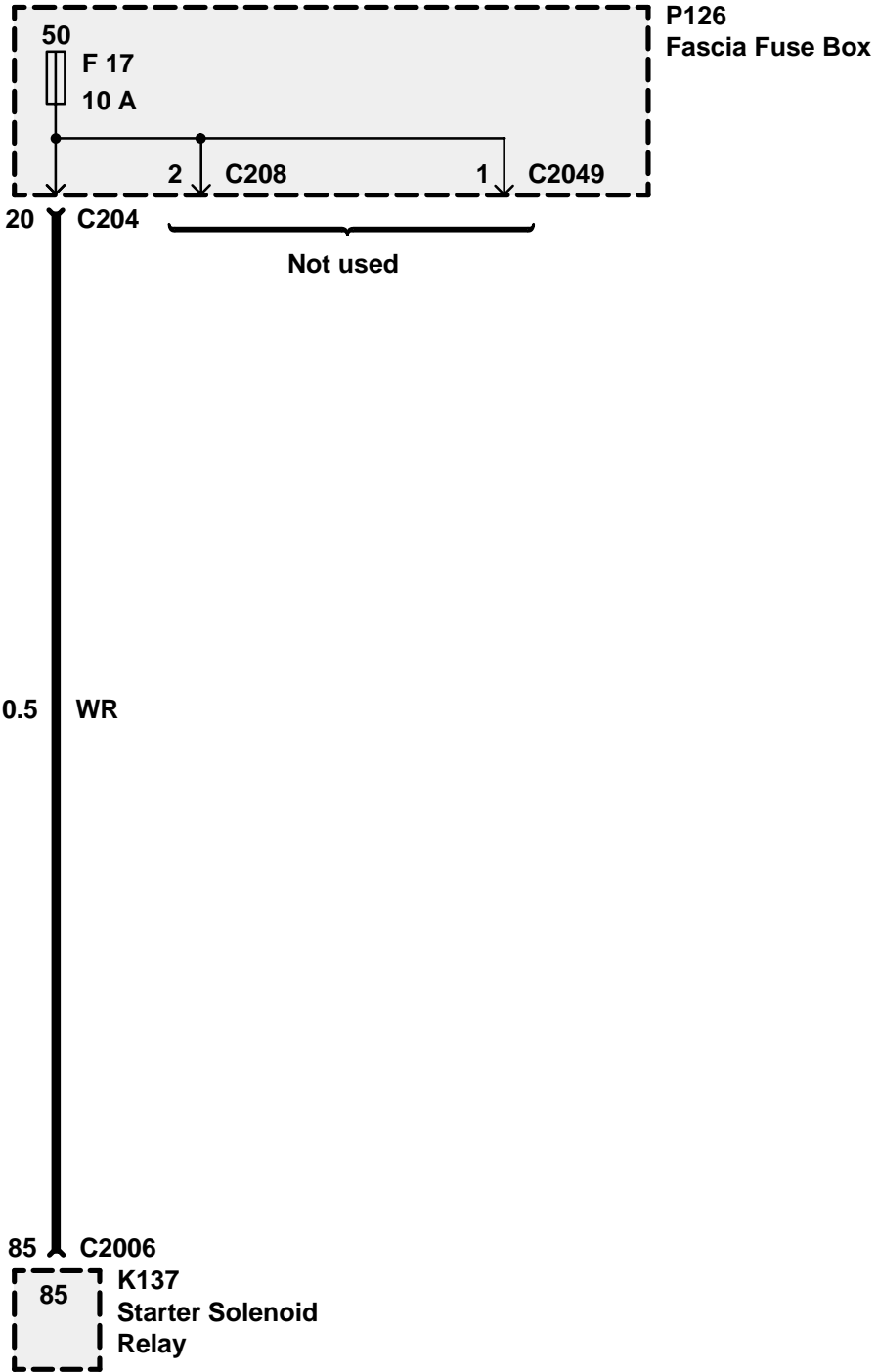
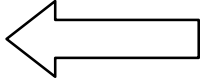

P126
Fascia Fuse Box

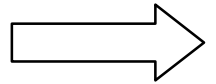

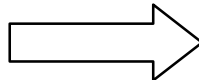
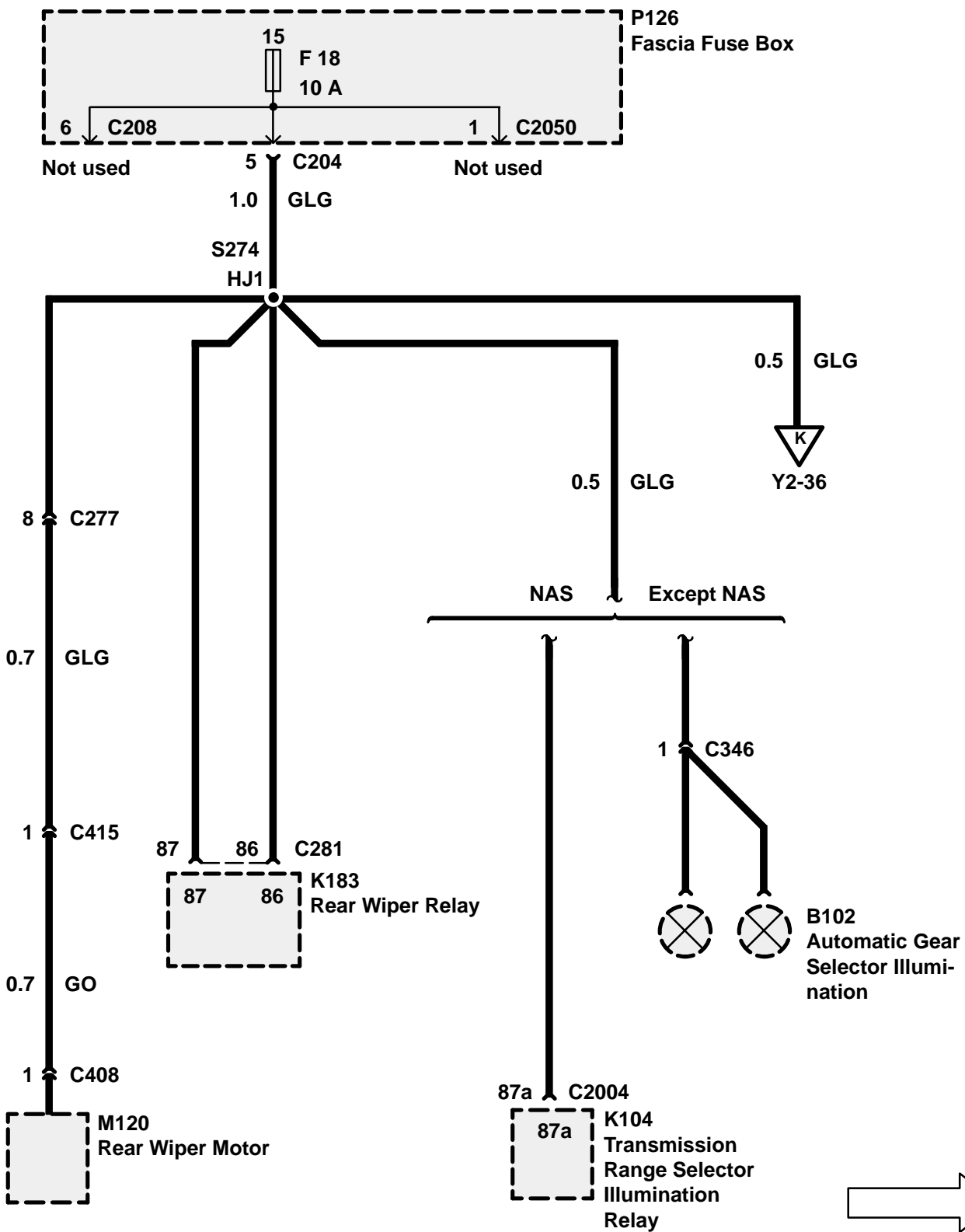
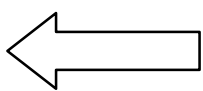

Y2 ETM

DISCOVERY

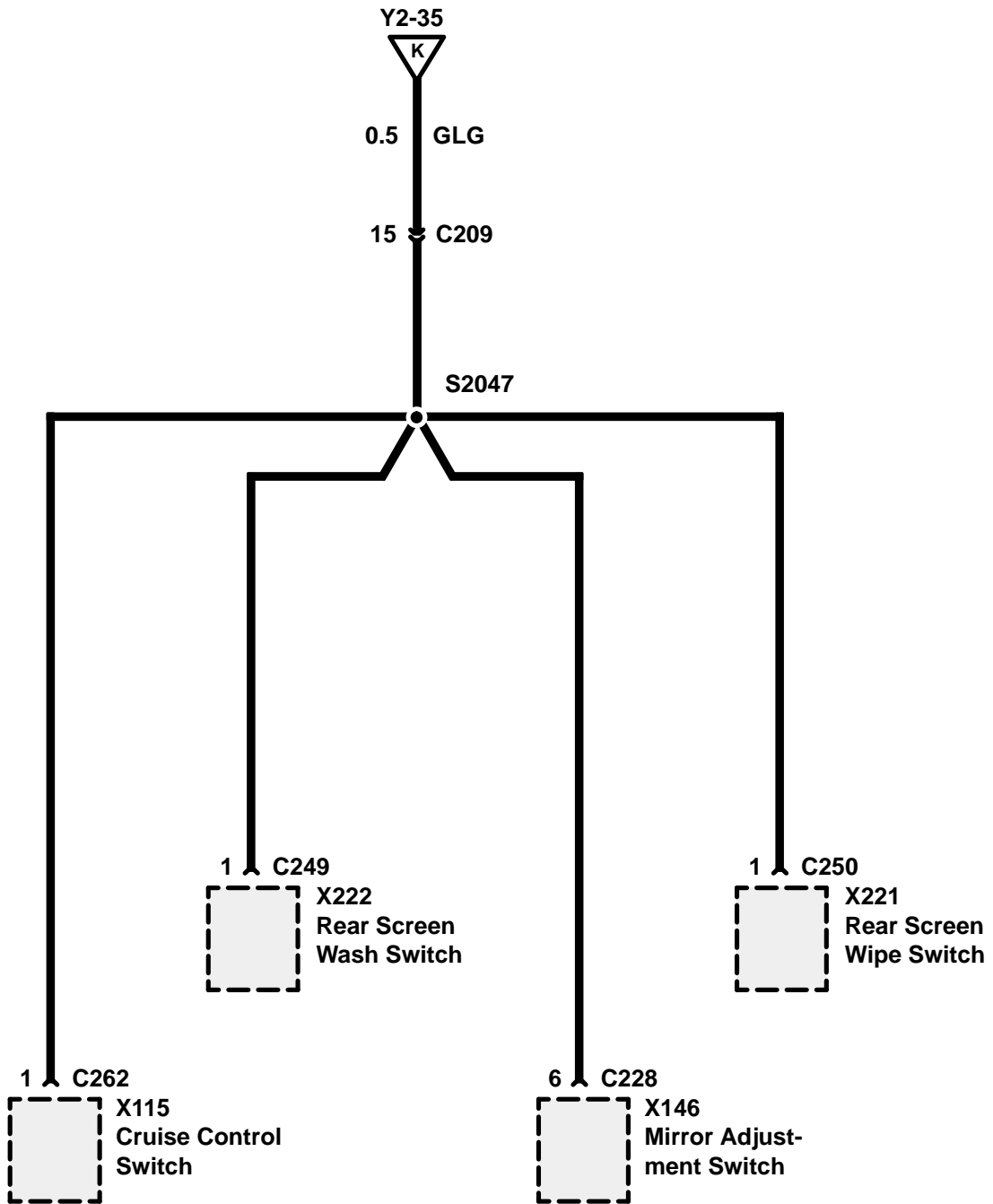
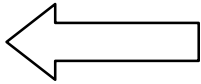

GROUND AND SPLICE INDEX

Ground	Page	Splice	Page
E100	Y5-2, 3	S217	Y5-22
E101	Y5-4	S238/HJ3	Y5-16
E148	Y5-2	S244	Y5-20
E103 MFI-V8	Y5-5	S248	Y5-32
E103 MFI-T16	Y5-6, 7	S253/HJ8	Y5-23
E103 300Tdi without EDC	Y5-8	S255/HJ8	Y5-24
E103 300Tdi with EDC	Y5-9, 10	S266	Y5-13
E104	Y5-11	S268	Y5-9
E105	Y5-11	S272	Y5-34, 35
E106	Y5-11	S277	Y5-22
E107	Y5-5	S288/HJ11	Y5-28
E108	Y5-11	S289	Y5-5
E109	Y5-2	S290/HJ7	Y5-3
E110	Y5-11	S294	Y5-3
E200	Y5-12, 13, 14, 15, 16, 17, 18, 19, 20, 21	S2003/HJ10	Y5-20
E201	Y5-22, 23, 24, 25, 26, 27, 28, 29, 30, 31, 32, 33, 34, 35	S2005/HJ2	Y5-15
E203	Y5-36	S2015/HJ10	Y5-21
E204	Y5-36	S2016/HJ10	Y5-19
E303	Y5-37	S2023/HJ11	Y5-31
E400	Y5-38, 39, 40	S2024	Y5-33
E401	Y5-41, 42	S2025/HJ5	Y5-17
E404	Y5-39	S2031/HJ5	Y5-17
Splice	Page	S2032/HJ3	Y5-16
S112	Y5-6, 8	S2044/HJ11	Y5-28
S122	Y5-13	S2050	Y5-12
S132	Y5-36	S2051	Y5-36
S203/HJ3	Y5-16	S307	Y5-12
S204/HJ3	Y5-16	S343	Y5-26, 27
S207	Y5-24	S401	Y5-40
S216	Y5-23	S402	Y5-42
		S415	Y5-39
		S417	Y5-38
		S418	Y5-41
		S422	Y5-38
		S423	Y5-40
		S424	Y5-42
		S426	Y5-38
		S501	Y5-29
		S601	Y5-14

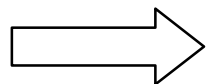
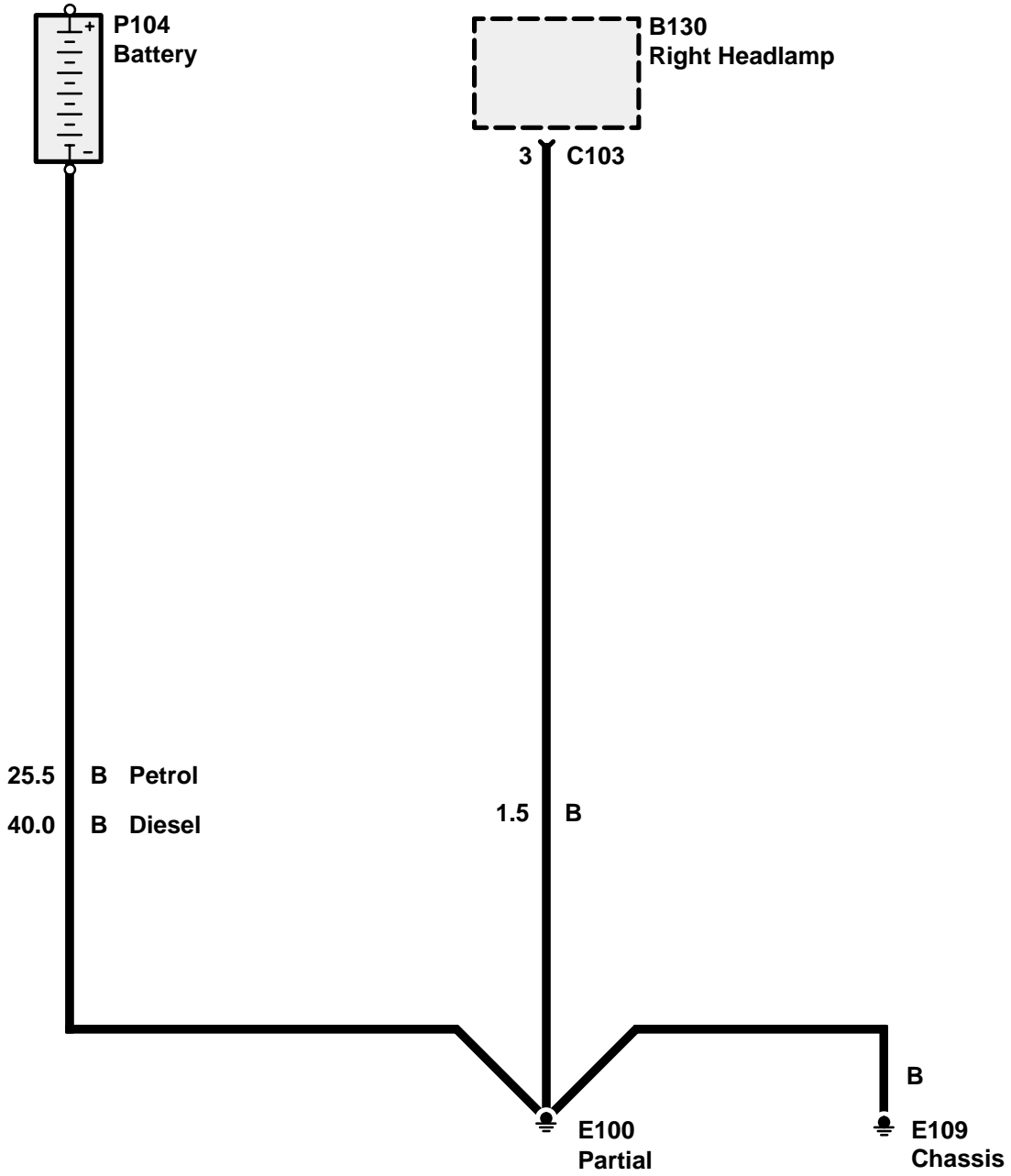

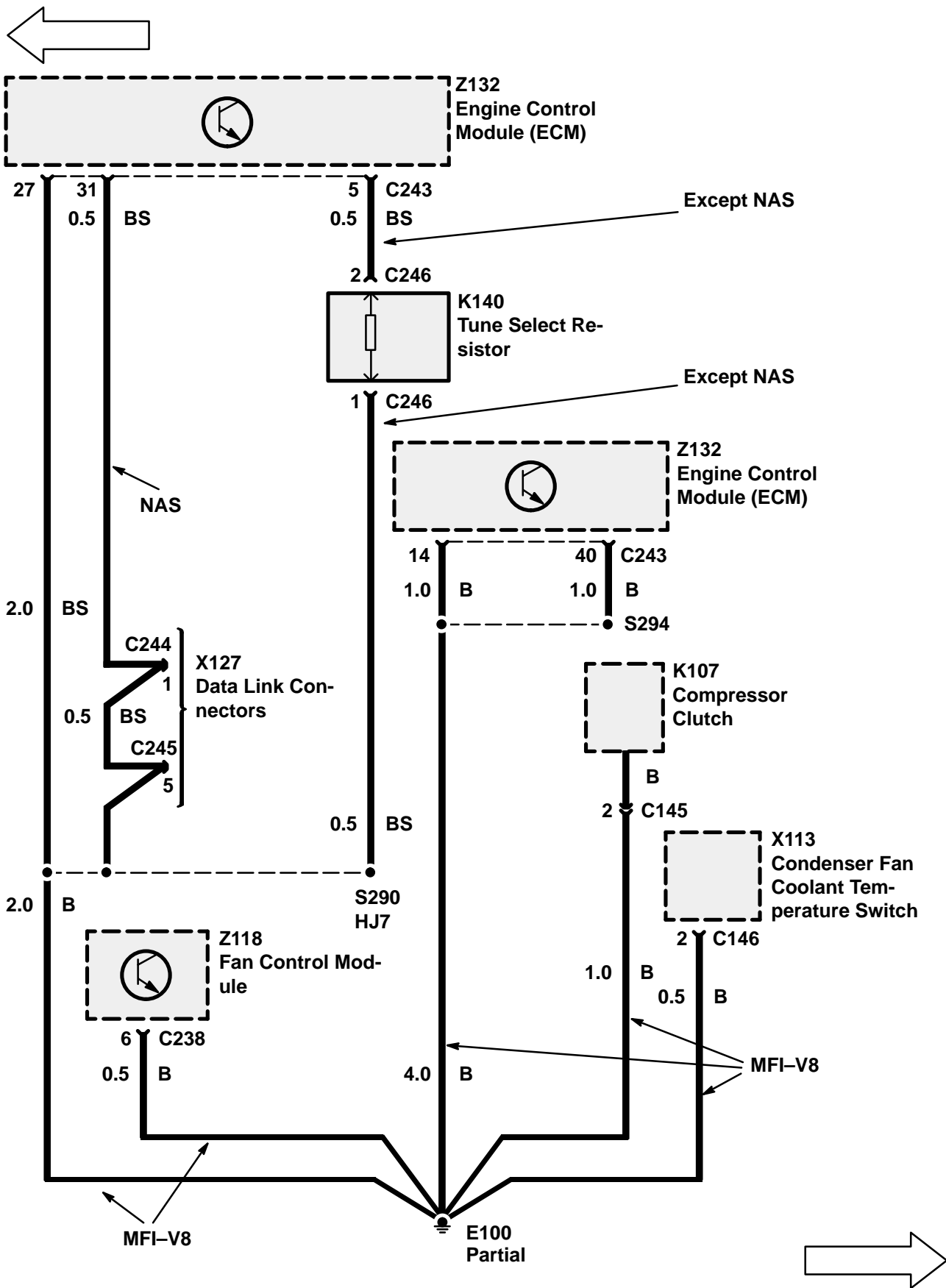

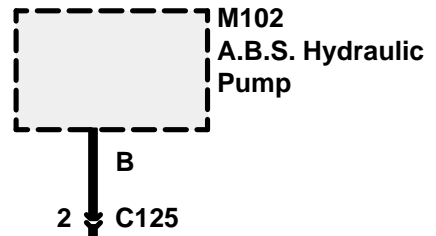
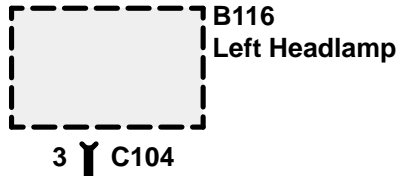
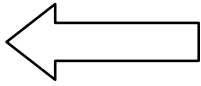

1.5 B

3.0 B

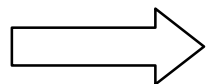

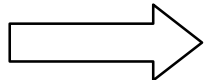
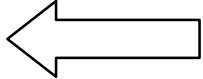
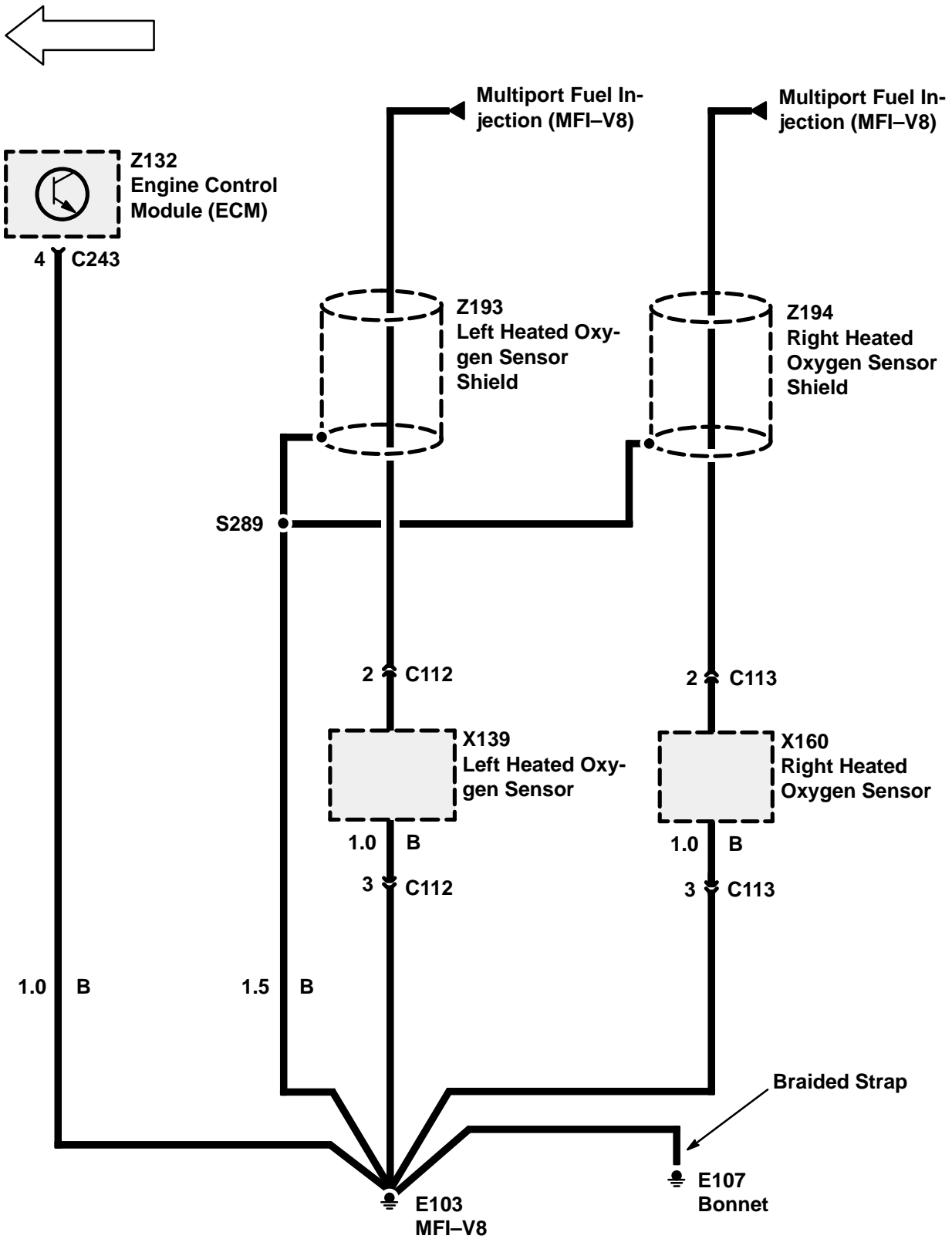

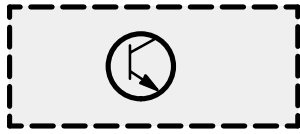
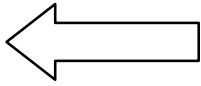

Z132
Engine Control
Module (ECM)

29 14 C1007



X139
Left Heated Oxy-
gen Sensor

3 C112

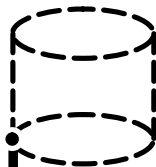

Z193
Left Heated Oxy-
gen Sensor
Shield

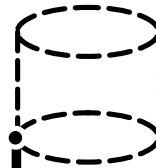

Z201
Knock Sensor
Shield

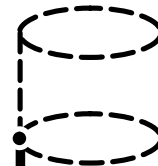

Z202
Crankshaft Posi-
tion Sensor
Shield

1.5 B 0.5 B 0.7 B

S112

1.5 B



Y5-7

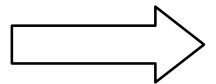

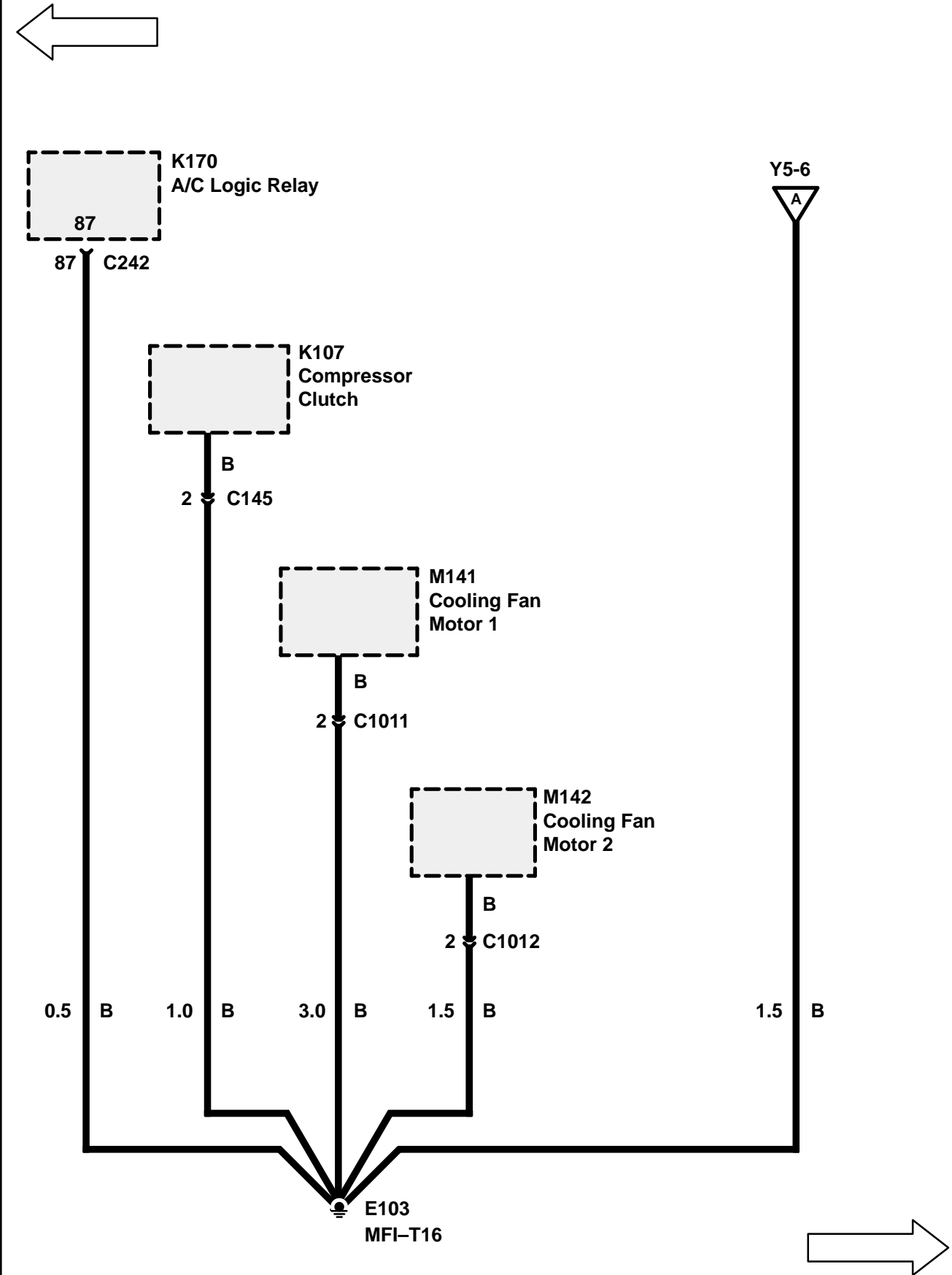

Y5 ETM

Ground Distribution (300Tdi without EDC)

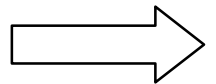
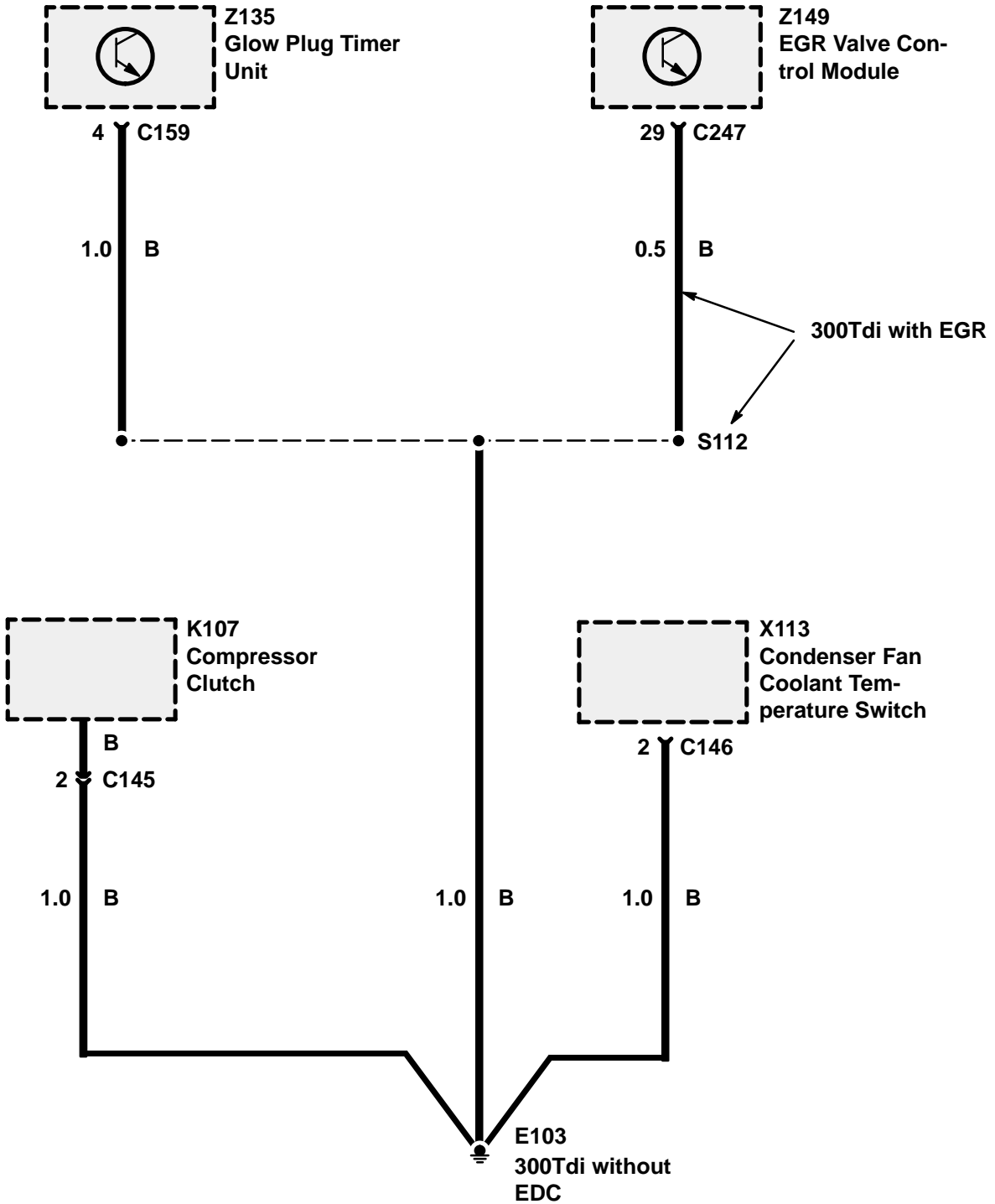

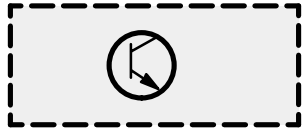

19 18 C243

X127
Data Link Con-
nectors

3 C245

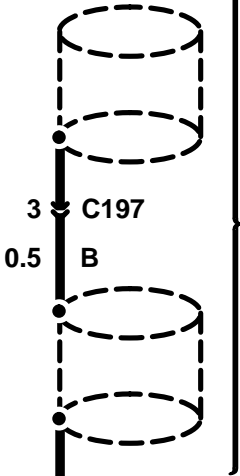
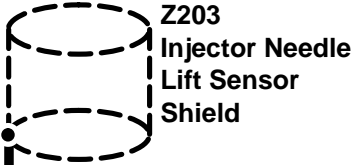

3 C197
0.5 B

0.5 B 0.5 B 0.5 B

S268

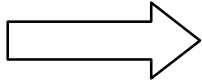
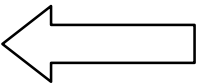
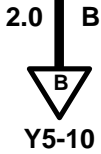

Y5 ETM

DISCOVERY

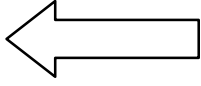

Z135
Glow Plug Timer
Unit

4 C159

Y5-9
B



X113
Condenser Fan
Coolant Tem-
perature Switch

2 C146



K107
Compressor
Clutch

2 C145

0.5 B

0.5 B

2.0 B

1.0 B



E103
300Tdi with EDC

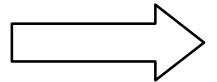

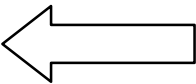

Braided Strap



Braided Strap

Braided Strap

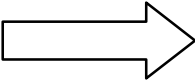

Y5 ETM

DISCOVERY

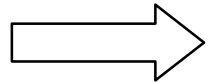
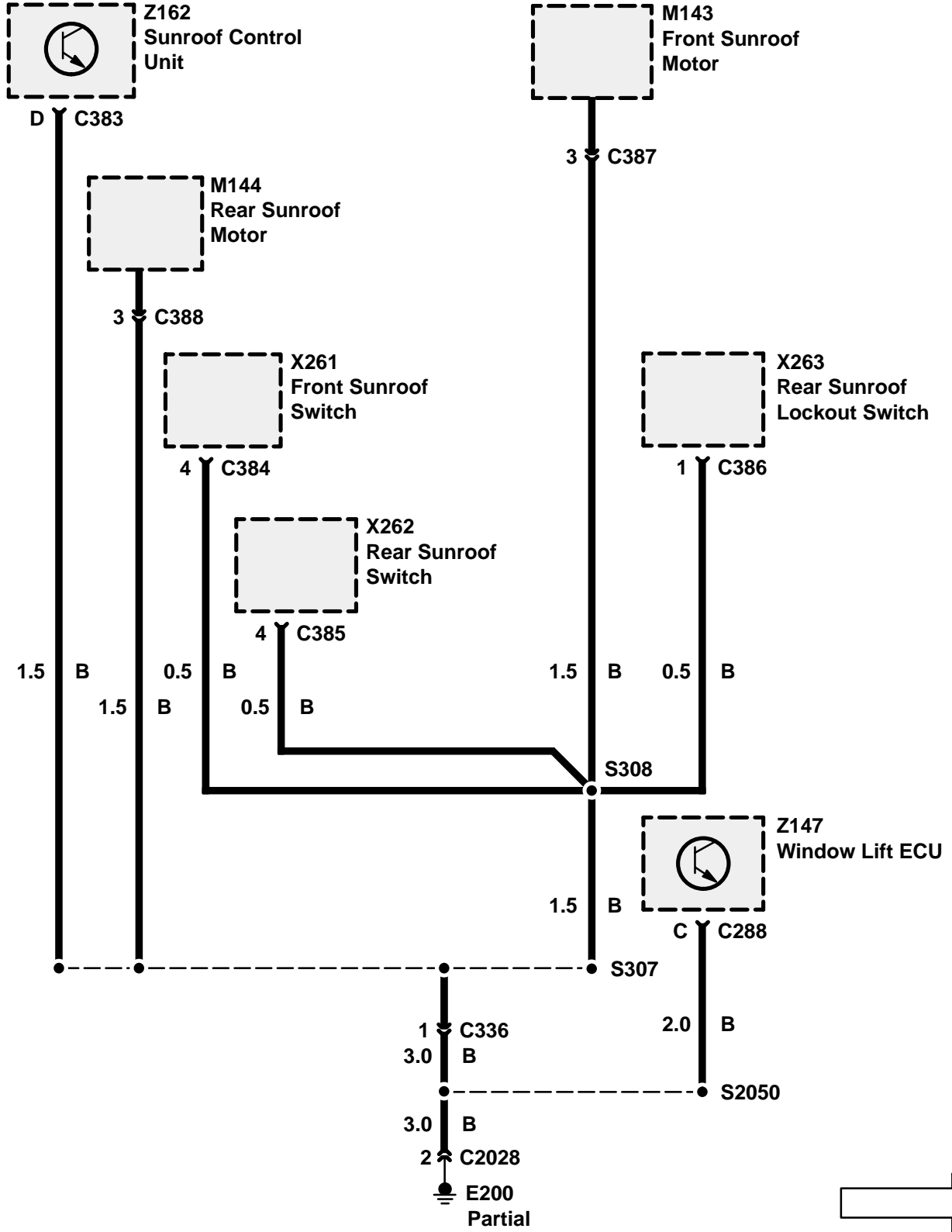
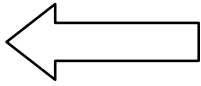

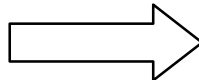
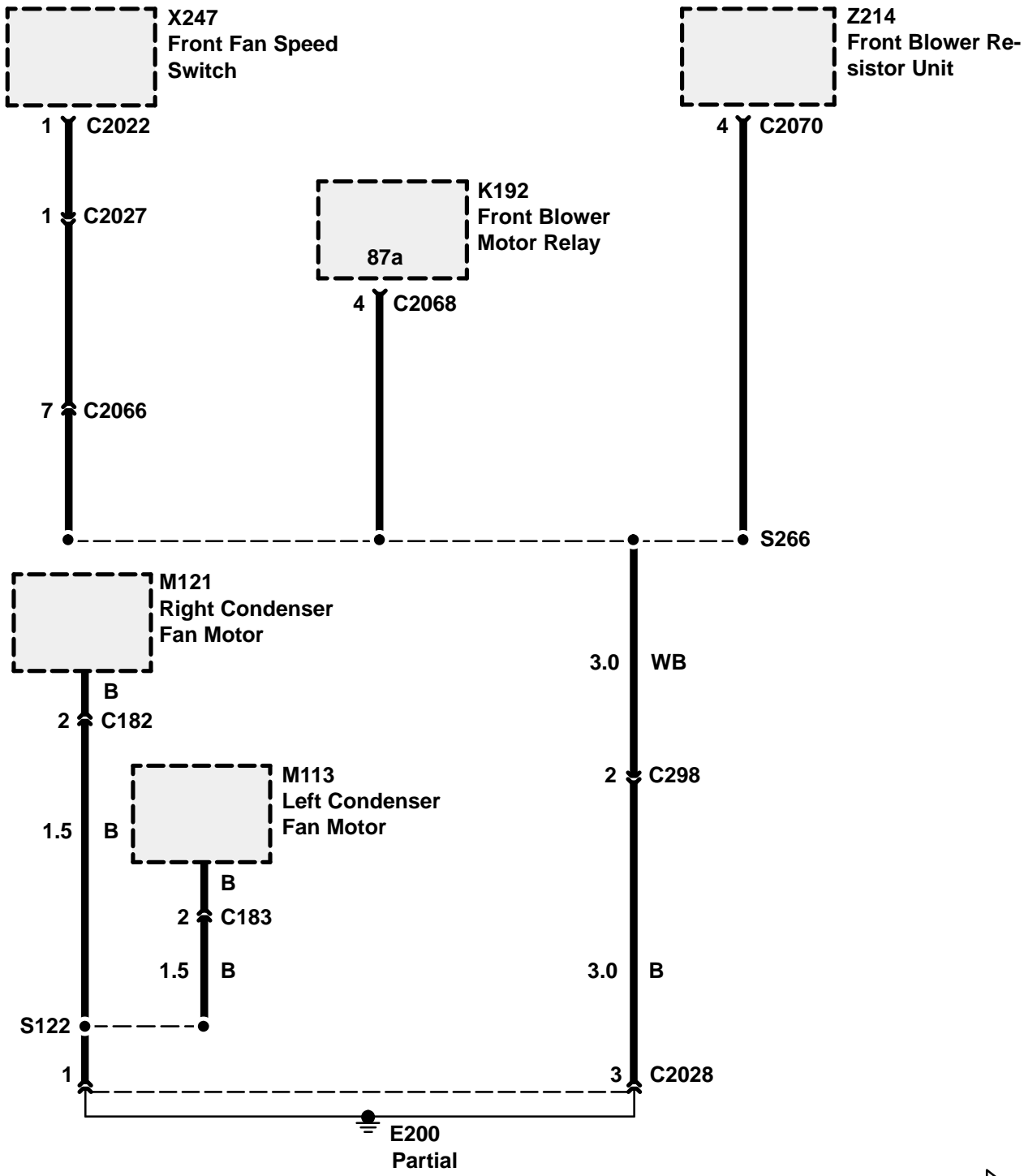
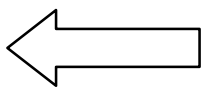

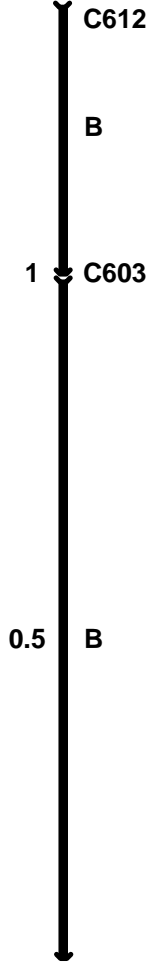
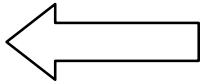

Not used

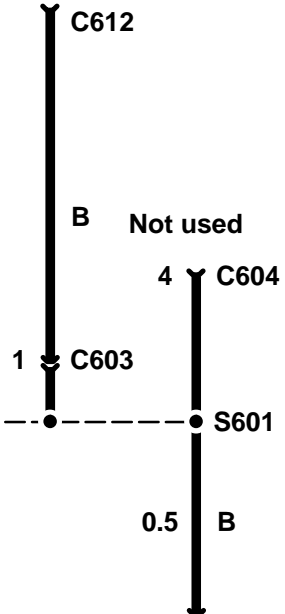
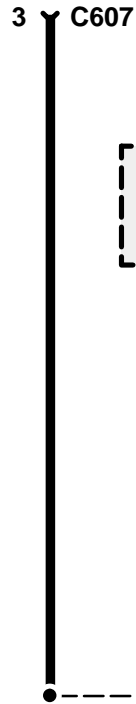

Without Theft Alarm

With Theft Alarm

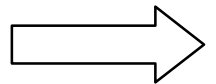
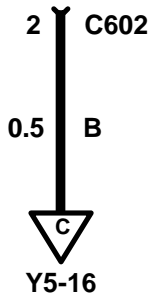

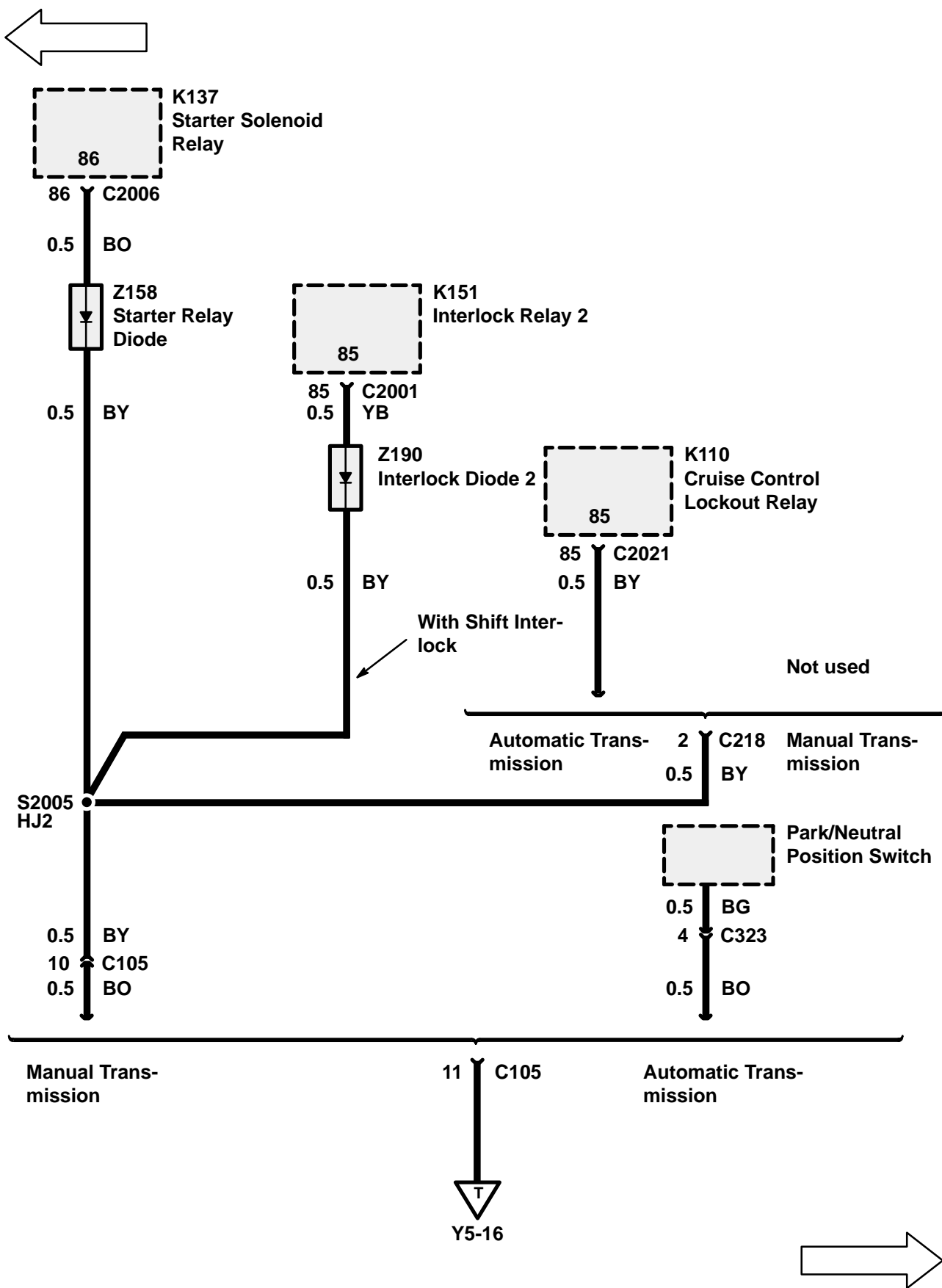

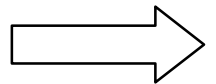
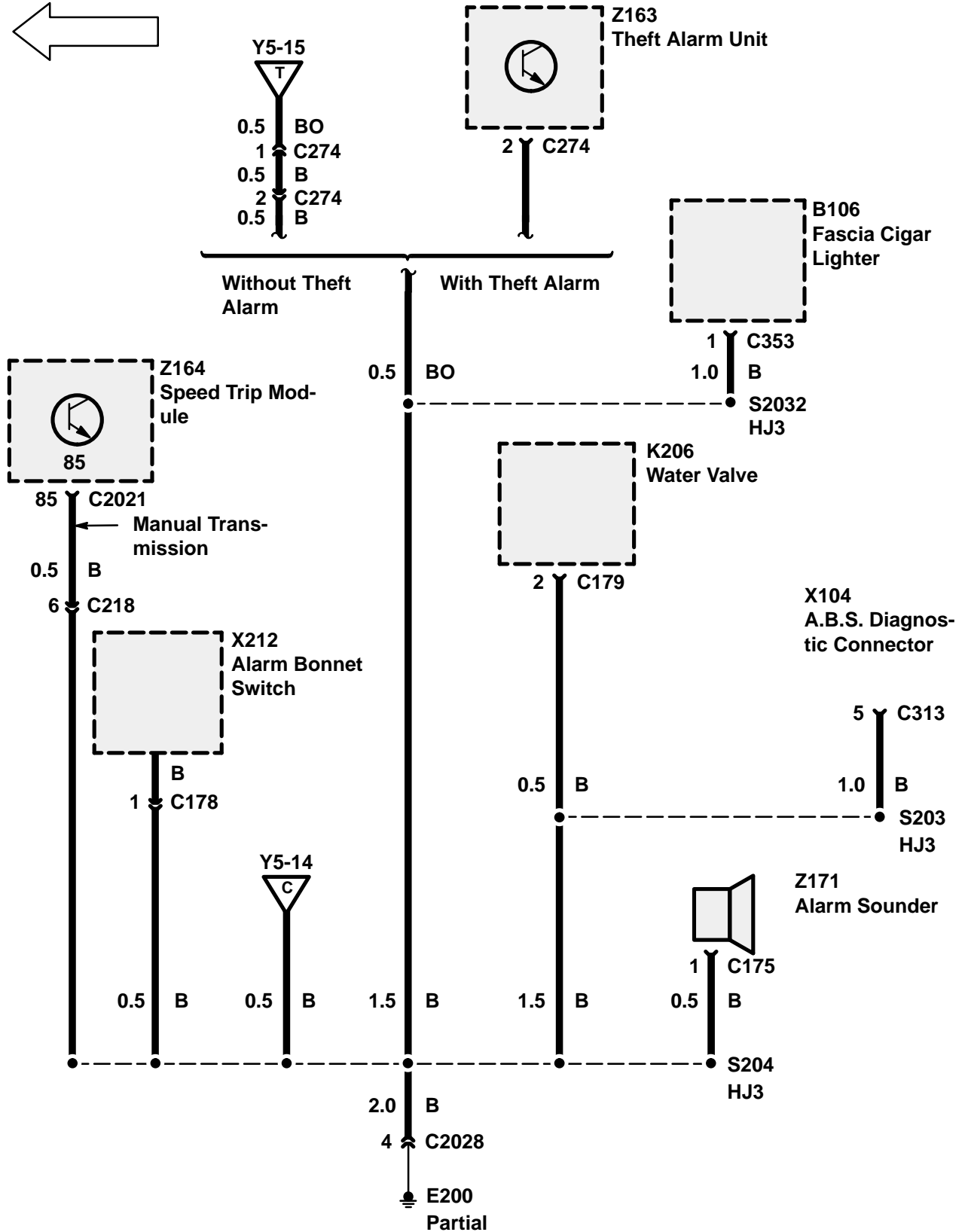

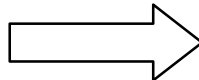
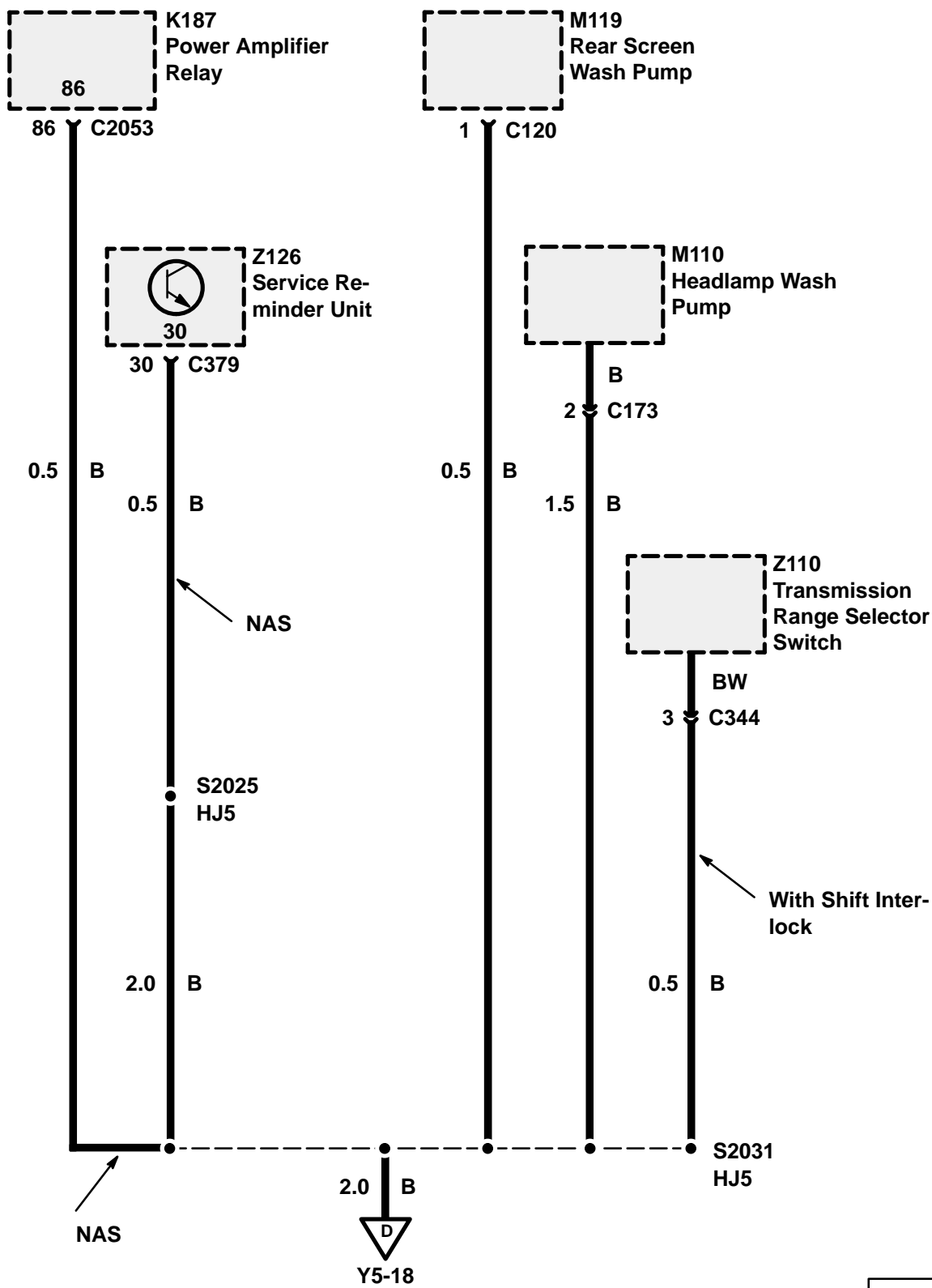
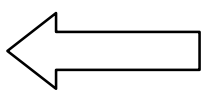

Y5 ETM

DISCOVERY

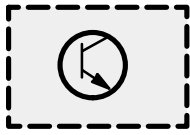
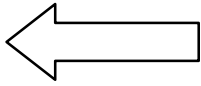

Z121
Cruise Control
ECU



K104
Transmission
Range Selector
Illumination
Relay

8 C284

86 C2044

0.5 B

0.5 B

NAS

Y5-17



2.0 B

S238
HJ5

2.0 B

5 C2028

E200
Partial

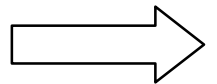

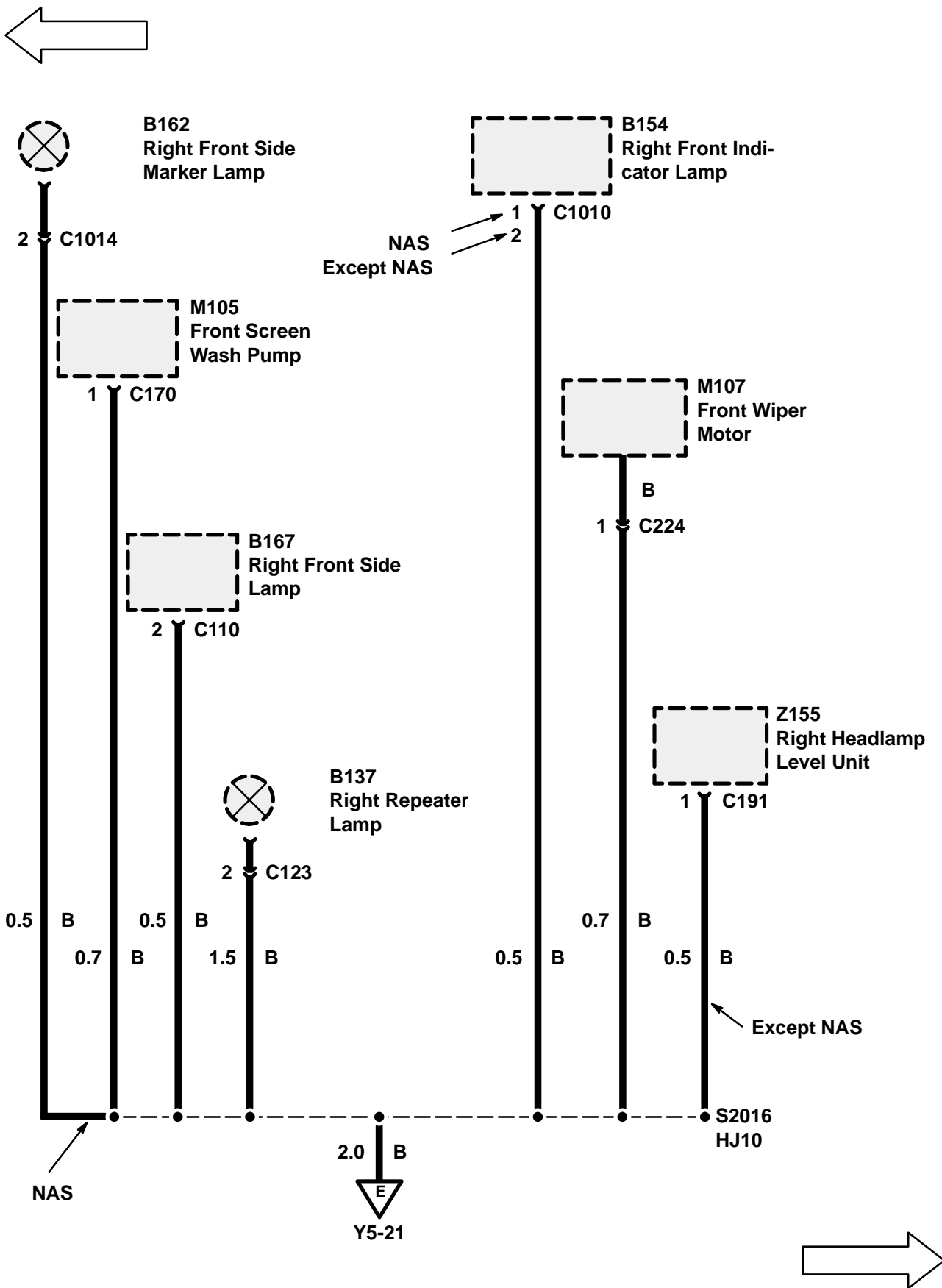

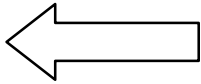

X242
Maximum Cool
Switch

3 C2023



X180
Air Supply Selec-
tor Switch

1 C2026



X225
Front A/C Switch

3 C2025

0.5

WB

0.5

WB

0.5

WB

0.5

WB



X239
Main Rear A/C
Switch

4 C2024

0.5 WB

S244

8 C2067

0.5 P

3 C2073

0.5 B



Z133
Multiport Fuel In-
jection Fault Dis-
play Unit

B

2 C380

NAS

0.5 B



K134
Right Horn

1 C169

1.5 B

S2003

HJ10

0.5 B



Y5-21

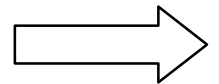

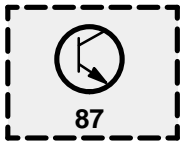
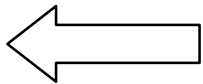

Z122 Daytime Running Lamps Control Unit

87

87 C2047



X120 Driver's Seat Buckle Switch

1 C378



K127 Ignition Load Relay

86

86 C2007

0.5

0.5

0.5

0.5

NAS

2.0 B

6 C2028

E200 Partial



B

2 C346



B

B102 Automatic Gear Selector Illumination

Y5-19 E

2.0 B

Y5-20 F

0.5 B

S2015 HJ10

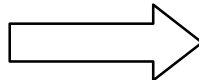

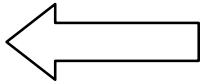

X233
Radio Tune
Switch

4 5 C2056



X234
Radio Waveband
Switch

4 5 C2057

S217



X235
Radio Volume Up
Switch

4 5 C2058



X236
Radio Volume Down
Switch

4 5 C2059

S277

0.5 B



Y5-23

0.5 B



Y5-23

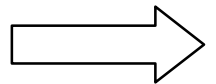

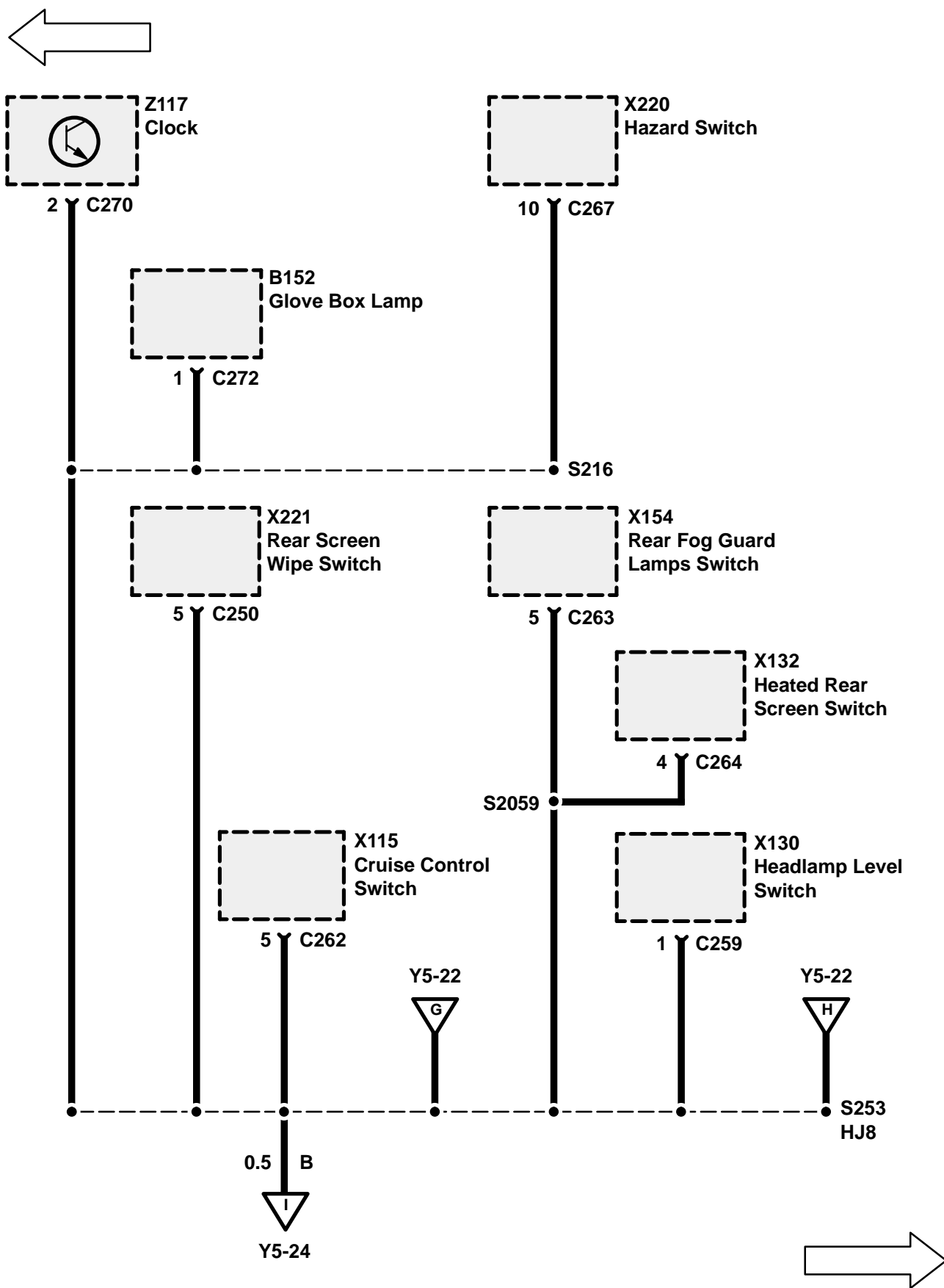

Y5 ETM

DISCOVERY

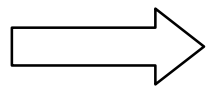
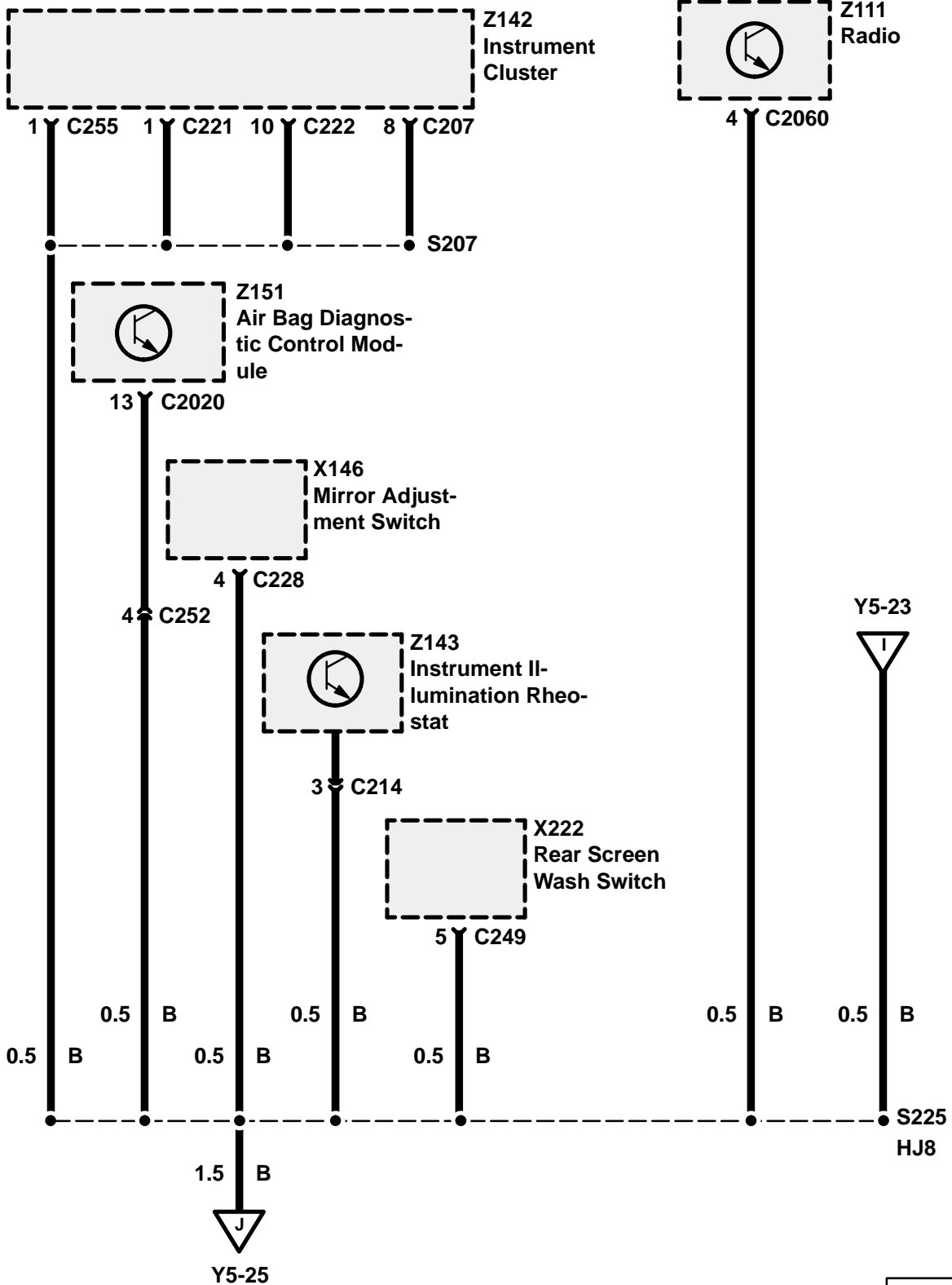
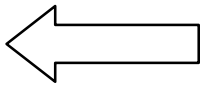

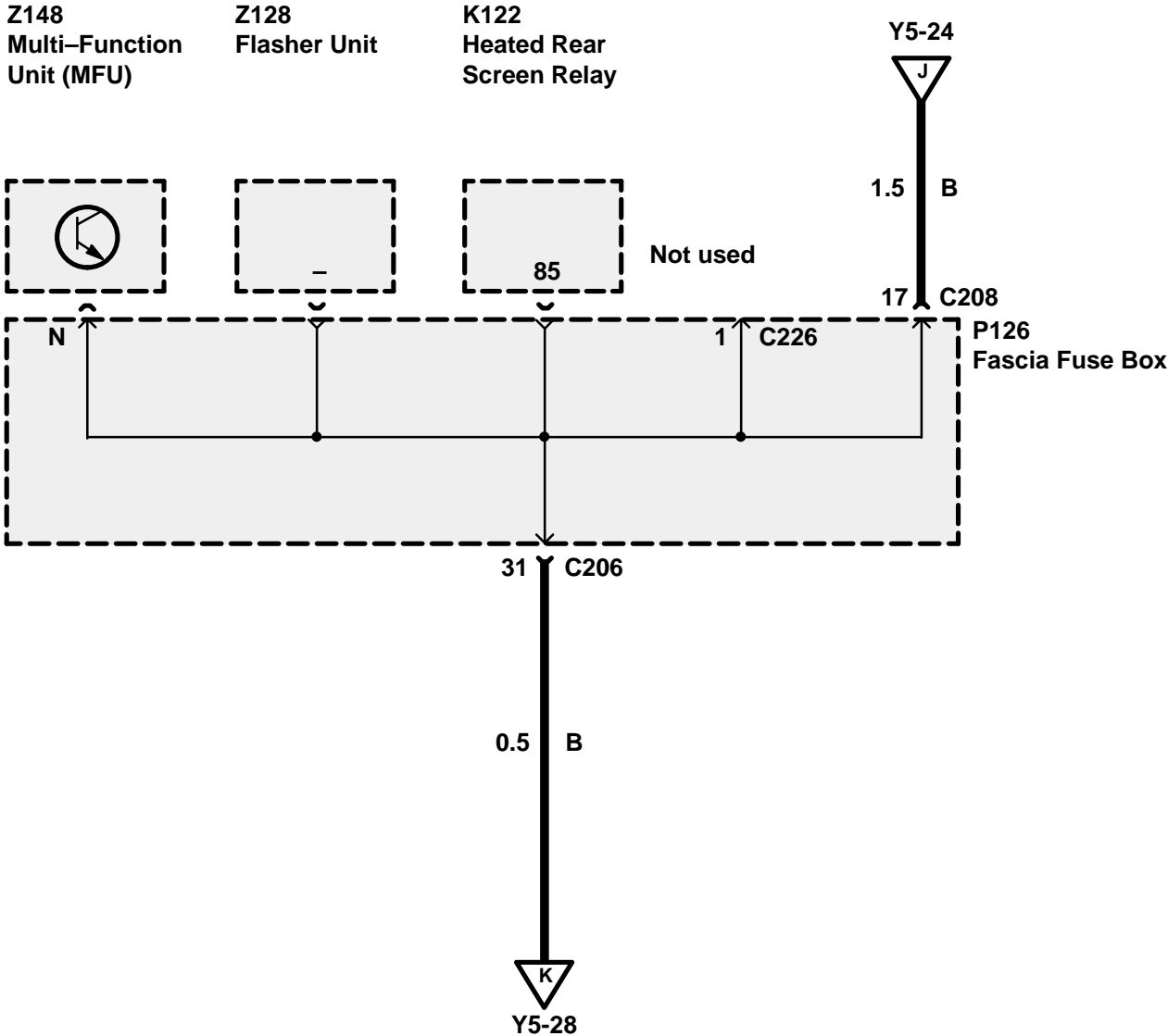
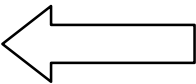

Y5 ETM

DISCOVERY



NAS Automatic Transmission



K154
Transfer Box
Drive Motor/Encoder



X174
Transfer Box Oil
Temperature
Switch

R
2 C369

2 C371



X175
Transfer Box
Position Switch



X238
Differential Lock
Switch

LGY
2 C368

1 C374



Z232
Transfer Box So-
lenoid Diode

0.5 B

0.5 B

0.5 B

0.5 B

0.5 B



S343



Y5-27

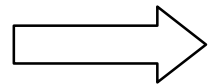

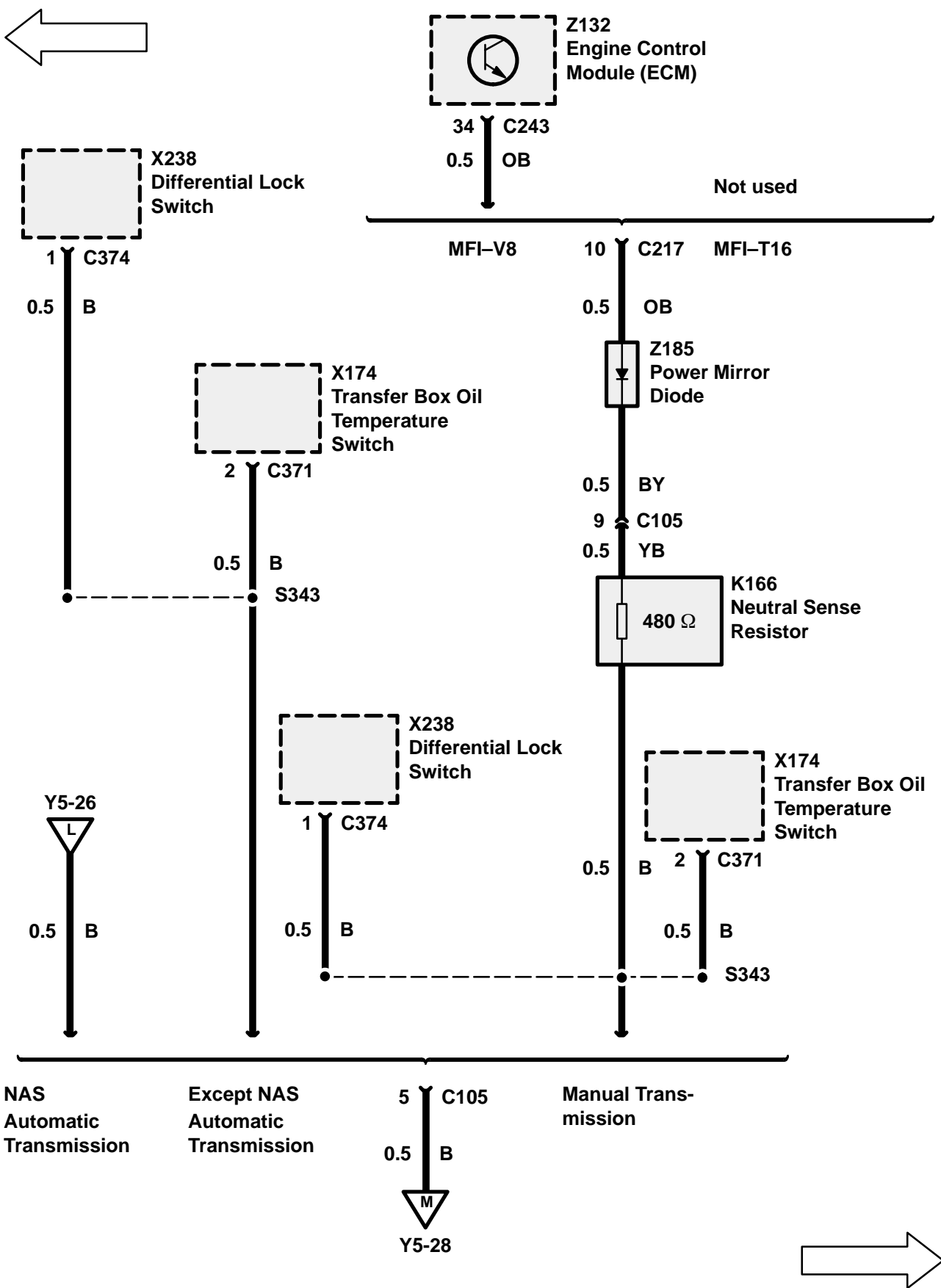

Y5 ETM

DISCOVERY

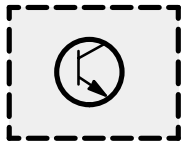
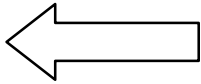

Z148
Multi-Function
Unit (MFU)

6 C205
0.5 B



B166
Left Front Side
Lamp

2 C109

NAS



K183
Rear Wiper Relay

87a C281

0.5 B



X111
Brake Fluid Level
Switch

2 C127

S2044
HJ11



K174
Accessory Relay

86 C282

Y5-25
K



K128
Left Horn

1 C168

Y5-27
M

2.0 B

0.5 B

1.5 B

0.5 B

0.5 B

0.5 B

0.5 B

2.0 B

S288
HJ11



Y5-31

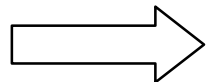

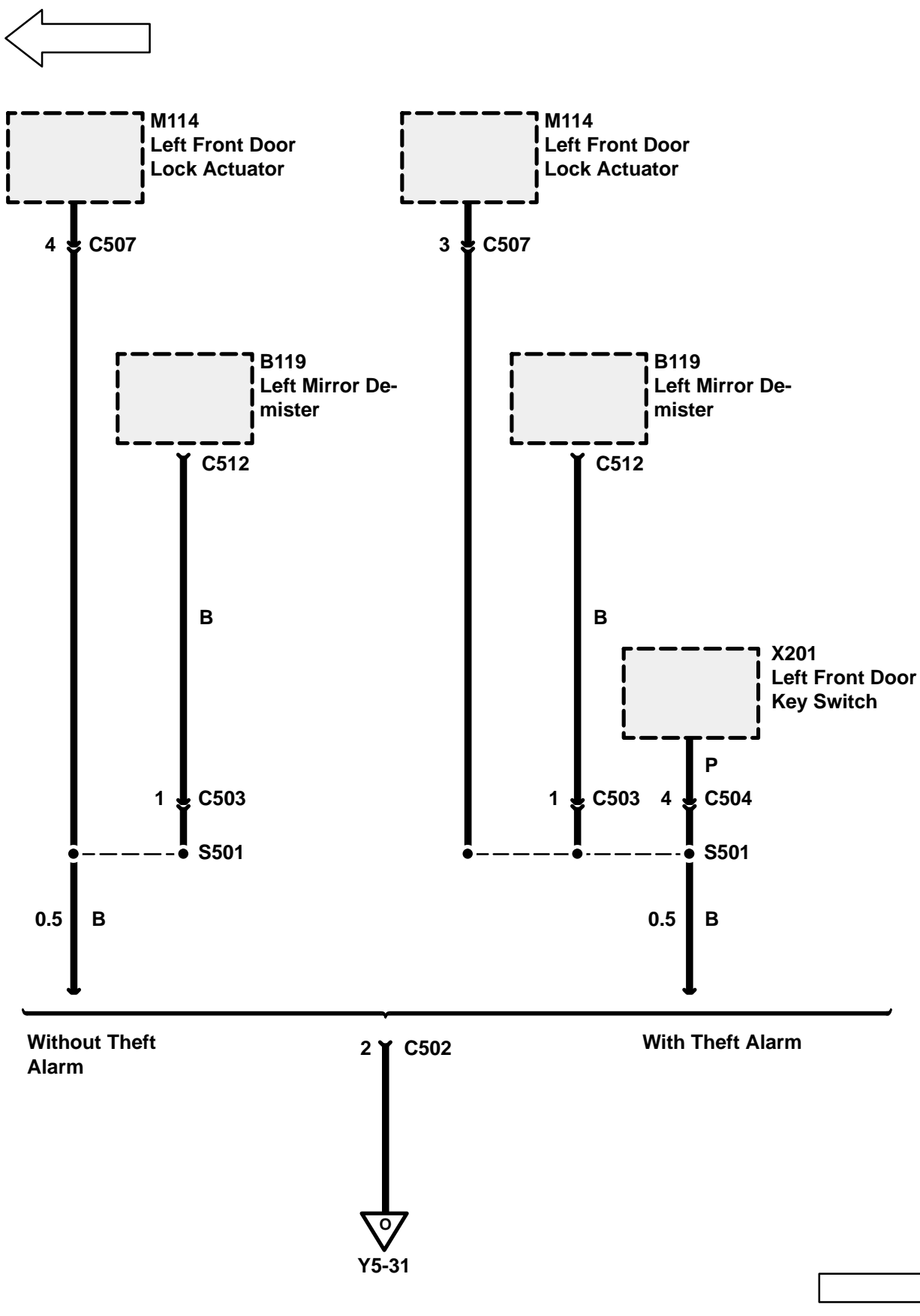

Y5 ETM

DISCOVERY

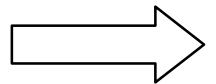
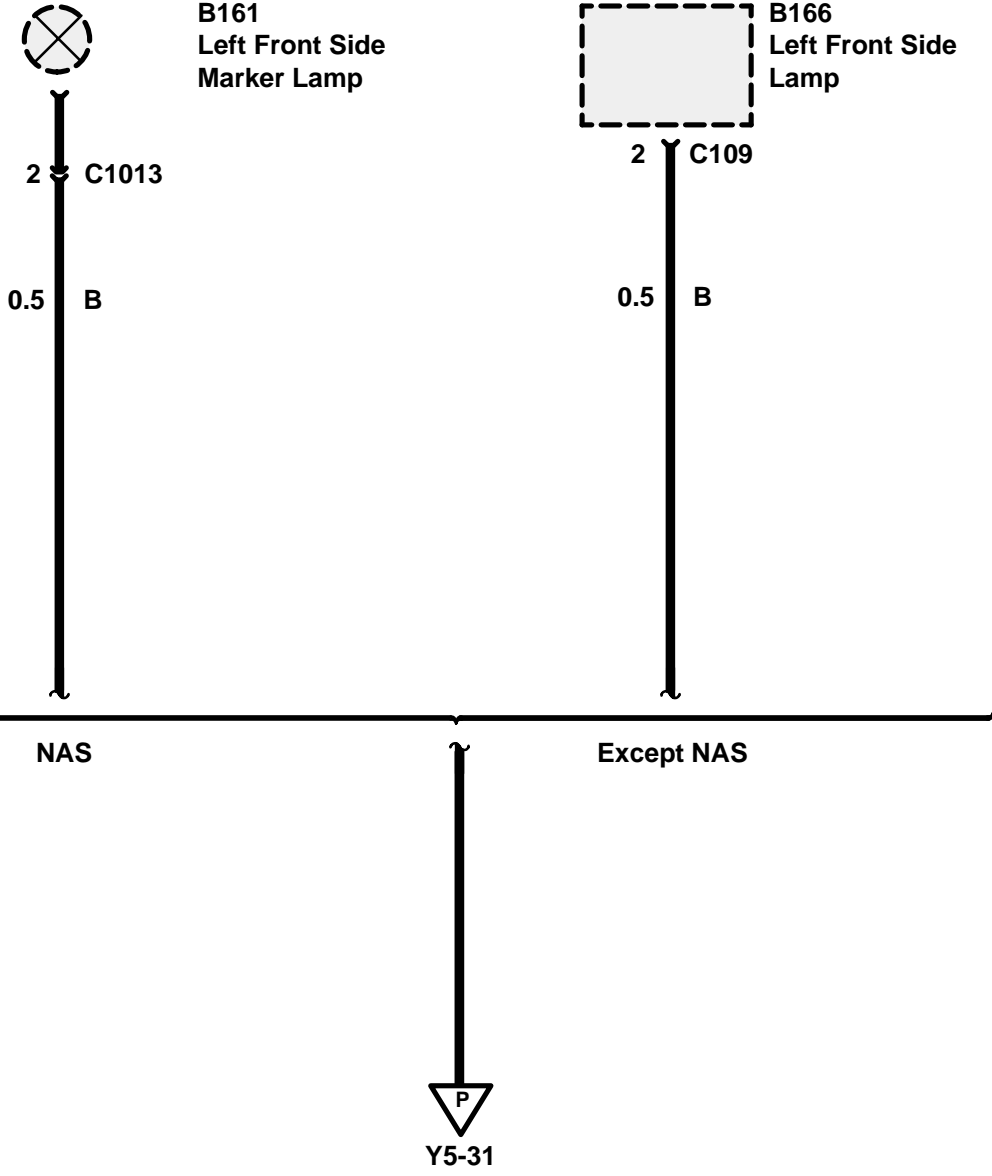
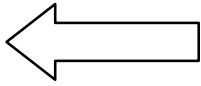

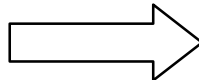
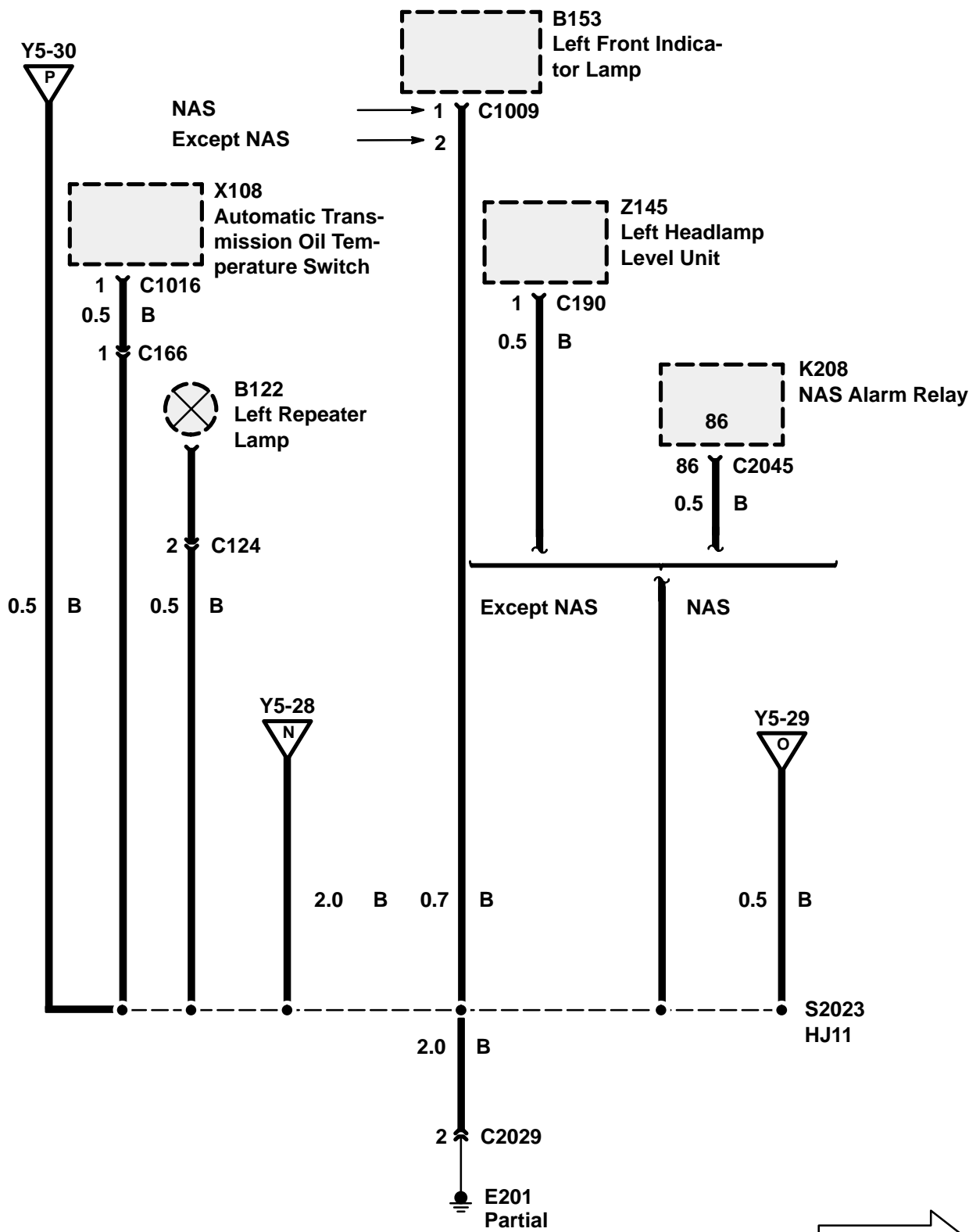
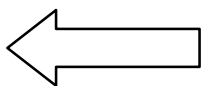

Y5 ETM

DISCOVERY

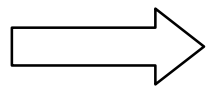
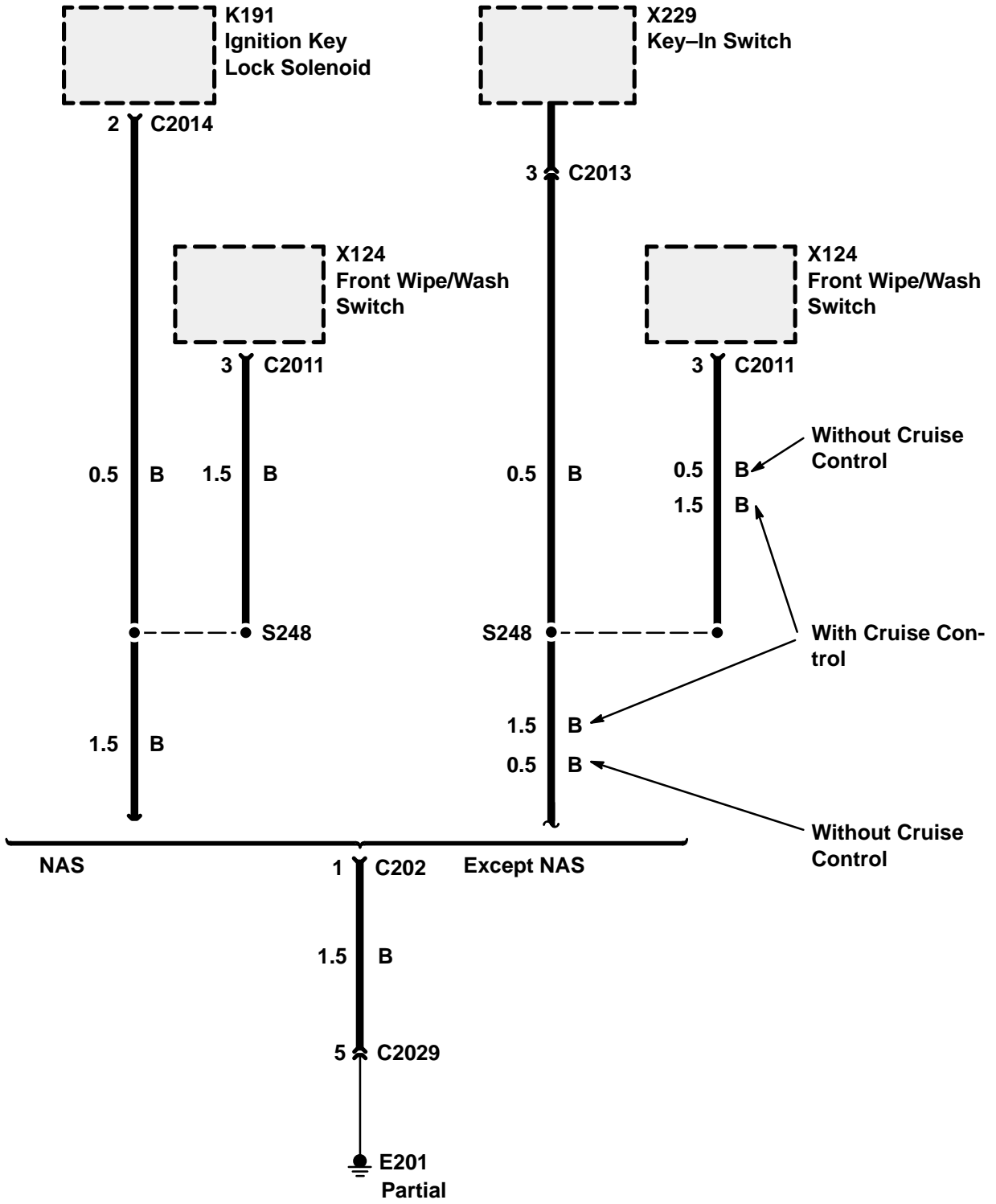
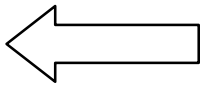

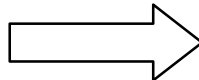
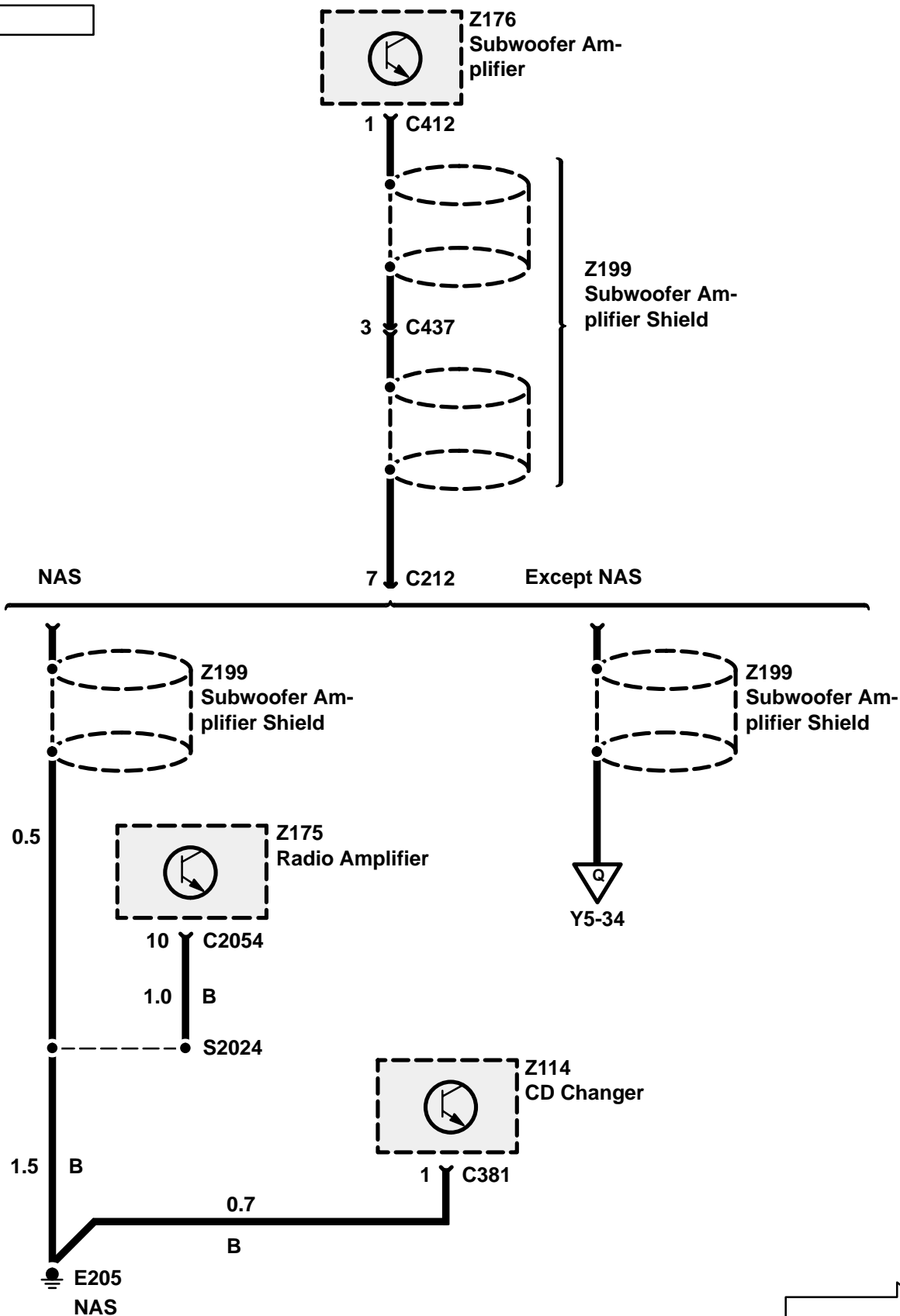
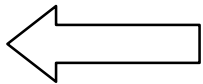

Y5 ETM

DISCOVERY

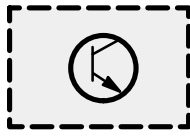
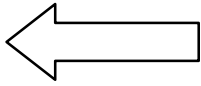

Z111 Radio

8 C230

1.5 B

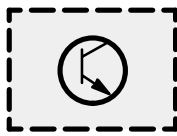

Z111 Radio

8 C230

2.0 B

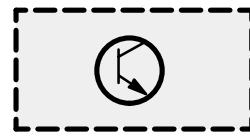

Z111 Radio

2 8 C230

0.5 B 1.5 B

Y5-33



11 C2055

Z199 Subwoofer Amplifier Shield



S272 S272

2.0 B

1.5 B

Low Line Radio

Mid Line Radio

13 C2055

High Line Radio

1.5 B

Except NAS



Y5-35

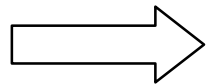

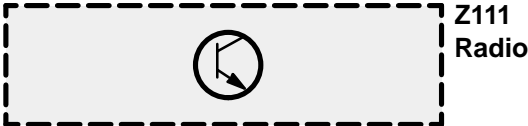
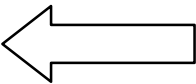

8 C230

5 C268



Not used
13 C2055

1.5 B

0.5 B

1.5 B

1.5 B

1.0 B

10 C2055

1.5 B

S272

NAS

Except NAS

6 C2029

E201
Partial

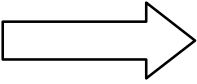

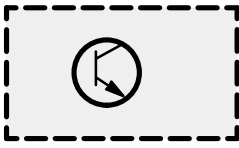
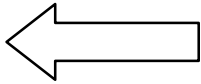

Z108
Anti-Lock Brake
System ECU

27 31 C312



Z103
A.B.S. Booster
Unit

6 9 10 13 C129



K102
A.B.S. Pump
Relay

85 C352



K101
A.B.S. Load
Relay

85 C351



K103
A.B.S. Warning
Relay

87a 85 C350

87a 85 S2051

1.0

B

1.0

B

1.5

B

1.5

B

1.5

B

1.5

B

1.0

B

S132

6.0

B

E204

E203

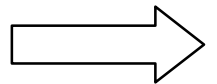

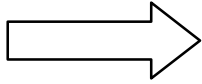
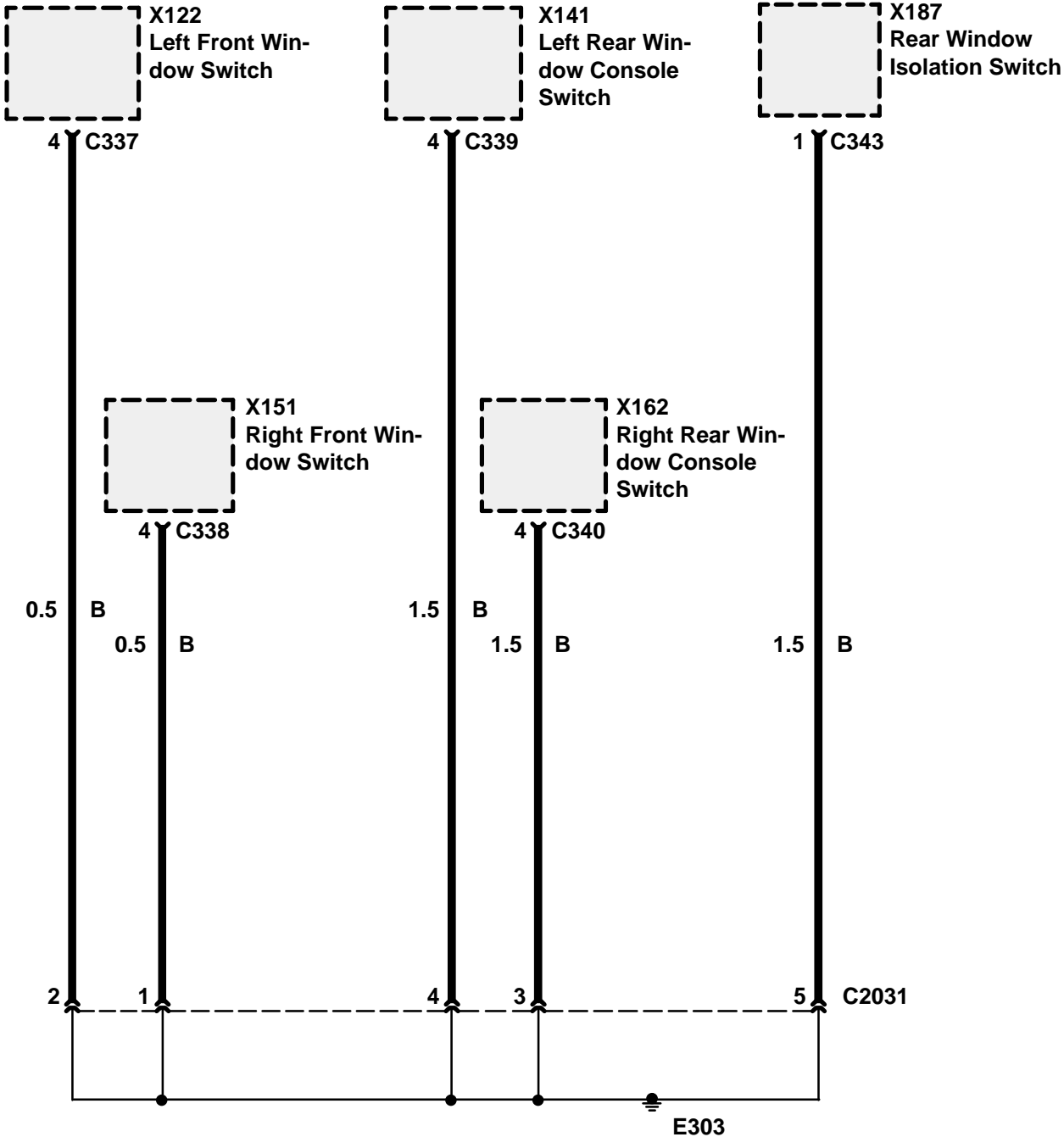
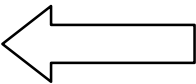

Y5 ETM

DISCOVERY

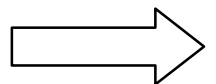
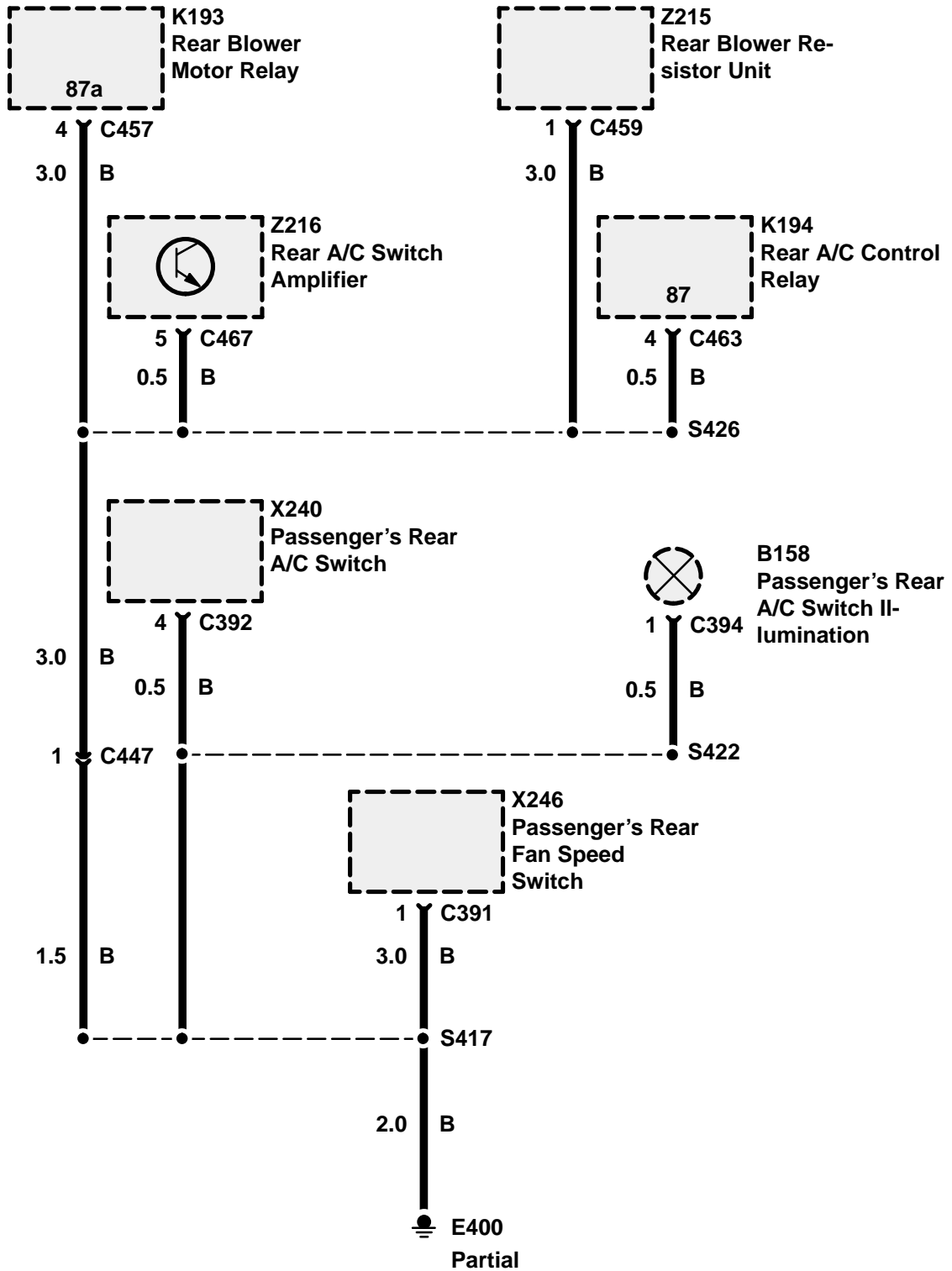
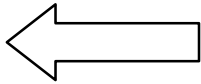

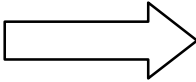
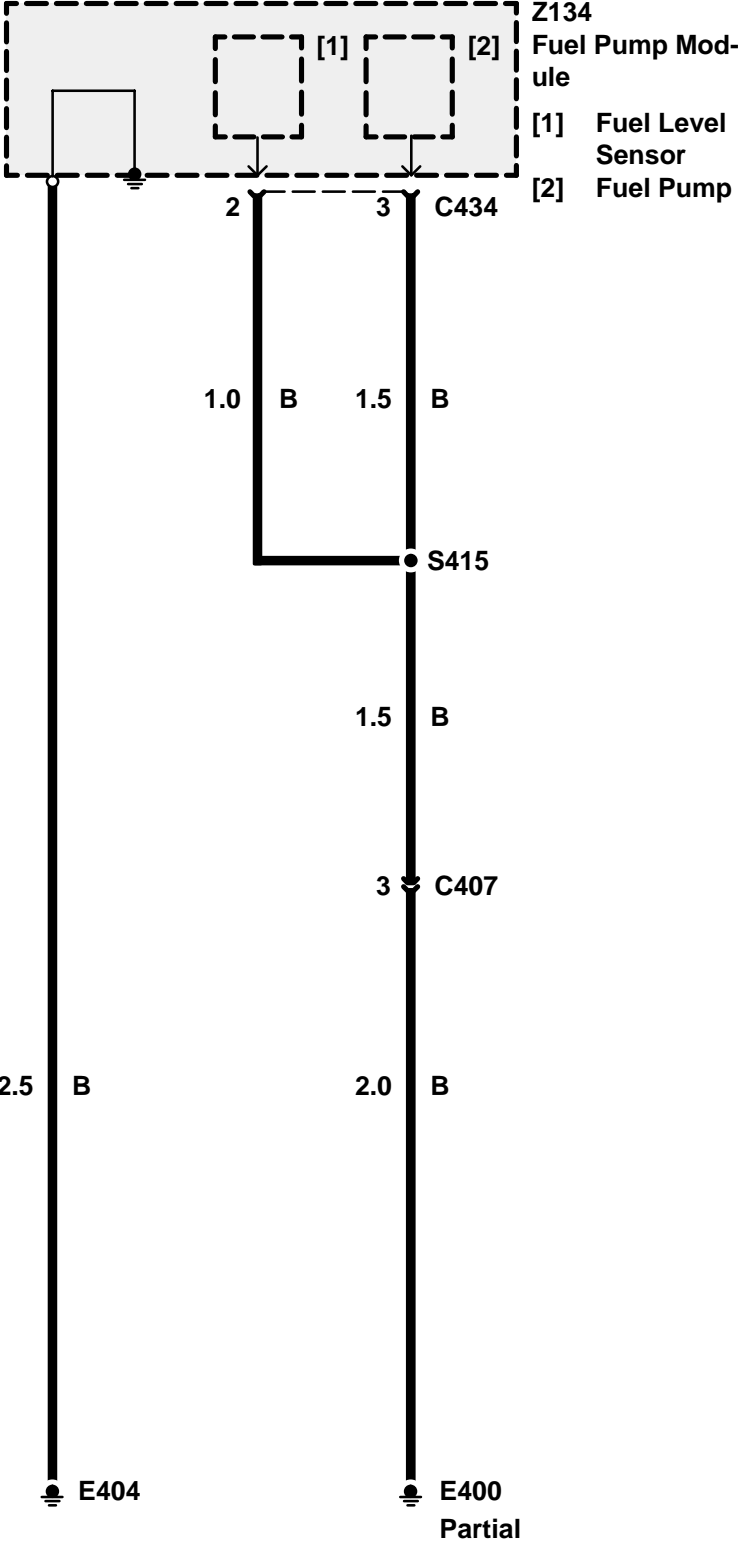
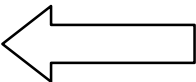

Y5 ETM

DISCOVERY

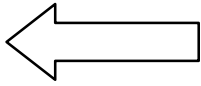

B121
Left Rear Lamp
Assembly

4 C403



B155
Left Tail Lamp

2 C441



M120
Rear Wiper Motor

4 C408



B163
Left Rear Indica-
tor Lamp

2 C442



B124
Rear Interior
Roof Lamp

B

3 C411

1.5 B

1.5 B

S423

2.0 B

0.7 B

0.5 B

5 C415

S401

2.5 B

E400
Partial

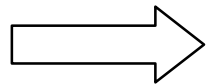

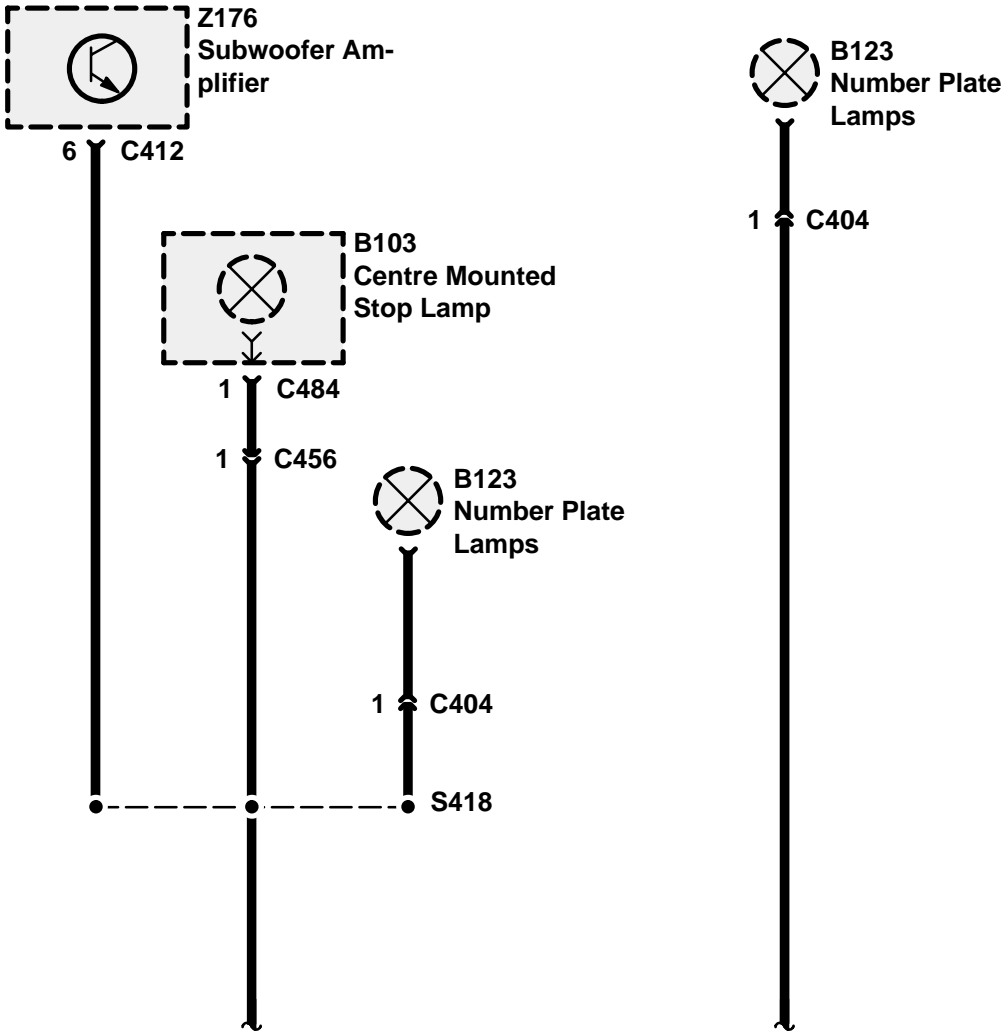
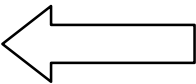

With Subwoofer

Without Subwoofer

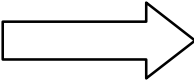
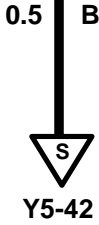

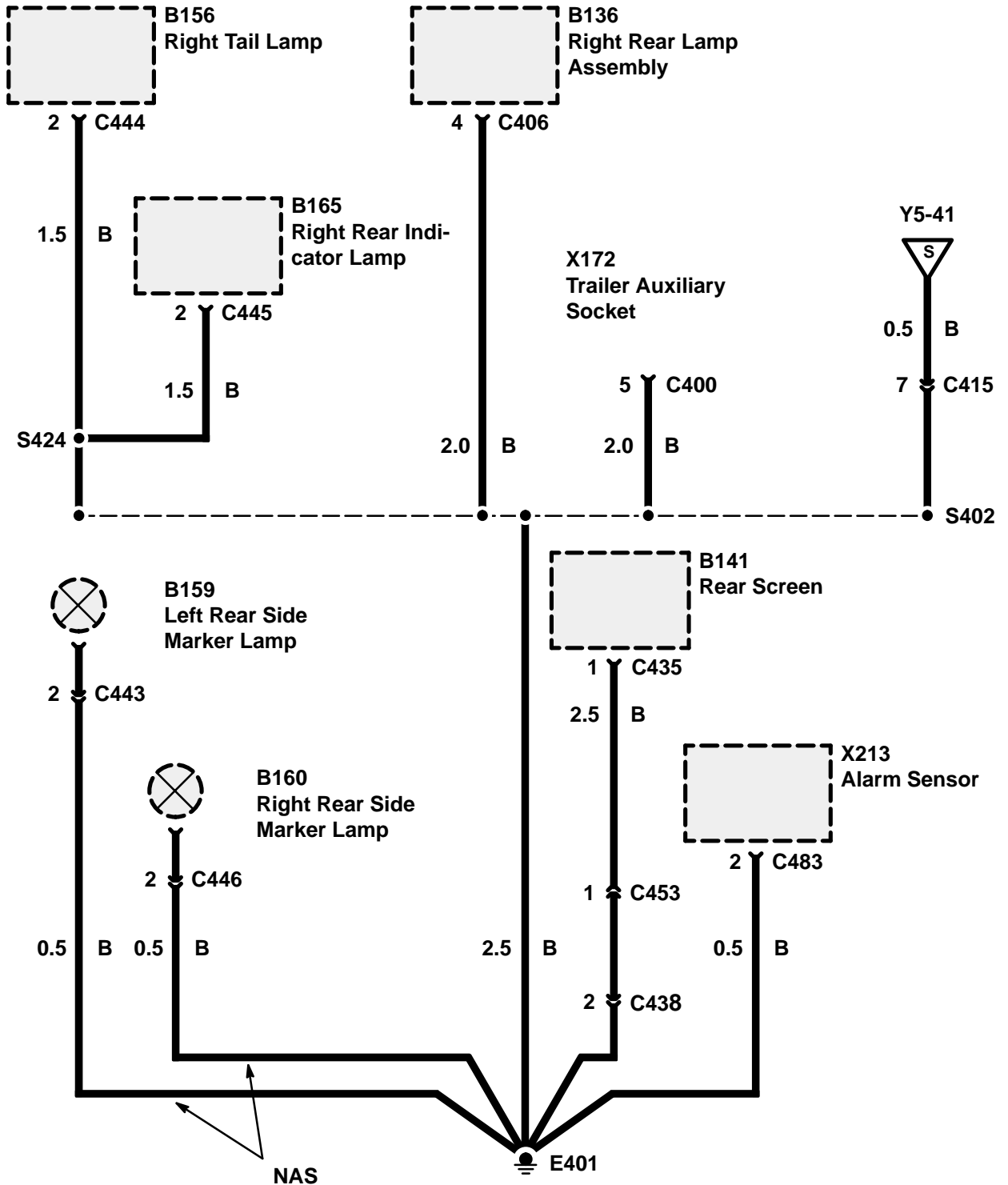

Component	Location	Manual	View
A.B.S. Booster Unit (Z103)	LH rear of engine compartment	70	3
A.B.S. Hydraulic Pump (M102)	LH rear of engine compartment	70	3
A.B.S. Load Relay (K101) (Except NAS)	behind RH side of fascia on bracket	70	195
A.B.S. Load Relay (K101) (NAS)	behind RH side of fascia on bracket	70	199
A.B.S. Pump Relay (K102) (Except NAS)	behind RH side of fascia on bracket	70	196
A.B.S. Pump Relay (K102) (NAS)	behind RH side of fascia on bracket	70	200
A.B.S. Warning Relay (K103) (Except NAS)	behind RH side of fascia on bracket	70	195
A.B.S. Warning Relay (K103) (NAS)	behind RH side of fascia on bracket	70	199
A/C Dual Pressure Switch (X102) (MFI-V8) (MFI-T16) (300Tdi)	RH rear of engine compartment	82	95
A/C Dual Pressure Switch (X102) (SFI-V8)	RH rear of engine compartment	82	98
A/C Logic Relay (K170)	behind RH footwell trim panel	82	209
Accessory Relay (K174)	behind LH footwell trim panel	86	121
Air Bag Diagnostic Control Module (Z151)	beneath centre console	76	166
Air Recirculation Solenoid (K123)	behind RH side of fascia right of heater evaporator unit	82	183
Air Recirculation Solenoid In-Line Fuse (P138)	behind RH side of fascia	82	179
Air Supply Selector Diode (Z208)	Heater Switch Wire Harness near C2067	82	152
Air Supply Selector Switch (X180)	centre of fascia	82	161
Alarm Bonnet Switch (X212)	LH side of engine compartment	86	262
Alarm Sensor (X213)	Top of LH B-Post	86	272
Alarm Sounder (Z171) (300Tdi)	RH front of engine compartment	86	51
Alarm Sounder (Z171) (MFI-V8) (MFI-T16)	RH front of engine compartment	86	49
Anti-Lock Brake System ECU (Z108)	behind RH side of fascia on bracket	70	184
Automatic Transmission Oil Temperature Switch (X108)	lower LH front of engine compartment	86	31
Battery Backed Up Alarm Sounder (Z272)	RH front of engine compartment	86	57
Boost Pressure Air Temperature Sensor (X254)	top rear of engine	19	27
Boost Pressure Sensor (X253)	LH rear of engine compartment	19	13
Brake Fluid Level Switch (X111)	LH rear of engine compartment top of brake fluid reservoir	70	2
Brake Switch Vent Valve (X112)	behind LH side of fascia on brake pedal support	19	149

Component	Location	Manual	View
Camshaft Position Sensor (Z262)	lower front of engine near oil filter	19	48
CD Changer (Z114)	beneath RH front seat	86	230
Clock (Z117)	centre of fascia	86	155
Clutch Pedal Position Switch (X200)	behind LH side of fascia near steering column	86	130
Column Switch Illumination (B104)	top of steering column on Ignition Switch	86	144
Compressor Clutch (K107) (300Tdi with EDC)	RH side of engine on front of A/C compressor	82	69
Compressor Clutch (K107) (300Tdi without EDC)	RH side of engine on front of A/C compressor	82	68
Compressor Clutch (K107) (MFI-T16)	RH side of engine on front of A/C compressor	82	
Compressor Clutch (K107) (MFI-V8)	RH side of engine on front of A/C compressor	82	58
Compressor Clutch (K107) (SFI-V8)	top RH side of engine on front of A/C compressor ..	82	62
Compressor Clutch Cut-out Switch (X259)	RH front of engine	82	64
Compressor Clutch Relay (K108) (300Tdi with EDC) ..	behind RH footwell trim panel	82	212
Compressor Clutch Relay (K108) (MFI-V8) (MFI-T16) (300Tdi without EDC)	behind RH footwell trim panel	82	208
Compressor Clutch Relay (K108) (SFI-V8)	behind RH footwell trim panel	82	210
Condenser Fan Control Diode 1 (Z209)	Engine Wire Harness near C217	82	178
Condenser Fan Control Diode 2 (Z210)	Main Wire Harness behind RH side of fascia near C2073	82	176
Condenser Fan Coolant Temperature Switch (X113) (300Tdi with EDC)	RH front of engine on thermostat housing	82	63
Condenser Fan Coolant Temperature Switch (X113) (300Tdi without EDC)	RH front of engine	82	65
Condenser Fan Coolant Temperature Switch (X113) (MFI-V8)	top centre front of engine	82	75
Condenser Fan Relay (K109) (Except NAS)	behind RH side of fascia on bracket	86	193
Condenser Fan Relay (K109) (NAS)	behind RH side of fascia on bracket	86	198
Cooling Fan Motor 1 (M141) (MFI-T16 with Air Conditioning)	front of engine compartment	82	
Cooling Fan Motor 1 (M141) (MFI-T16 without Air Conditioning)	front of engine compartment	82	39
Cooling Fan Motor 2 (M142)	front of engine compartment	82	
Cooling Fan Relay (K190) ..	behind RH footwell trim panel	82	206
Crankshaft Position Sensor (X250) (MFI-T16)	lower RH rear of engine	19	87

Component	Location	Manual	View
Crankshaft Position Sensor (X250) (SFI-V8)	lower LH rear of engine	19	103
Cruise Control Diode (Z186) (Except NAS)	Cruise Control Wire Harness near C218	19	196
Cruise Control Diode (Z186) (NAS)	Cruise Control Wire Harness near C218	19	200
Cruise Control Disable Relay (K234)	behind RH footwell trim panel	19	212
Cruise Control ECU (Z121)	behind RH side of fascia on bracket	19	186
Cruise Control Lockout Relay (K110) (Except NAS)	behind RH side of fascia on bracket	19	197
Cruise Control Lockout Relay (K110) (NAS)	behind RH side of fascia on bracket	19	201
Cruise Control Switch (X115)	centre of fascia	19	156
Cruise Control Vacuum Pump (M103)	LH front corner of engine compartment	19	28
Data Link Connector (EGR) (X219) (300Tdi with EGR)	behind RH side of fascia	19	191
Data Link Connector (MFI) (X321) (MFI-T16)	RH rear corner of engine compartment	19	92
Data Link Connector (MFI) (X321) (MFI-V8)	behind RH side of fascia	19	189
Data Link Connector (OBDII) (X318)	behind LH side of fascia	19	151
Daytime Running Lamps Control Unit (Z122)	behind RH side of fascia on bracket	86	200
Daytime Running Lamps Diode (Z200)	Main Wire Harness behind RH side of fascia near HJ2	86	180
Diesel Immobilisation Unit (DDS) (Z276)	RH side of engine on injector pump	19	265
Differential Lock Switch (X238)	top RH side of transfer box	86	118
Direction Indicator Diode 1 (Z212)	behind instrument cluster	86	147
Direction Indicator Diode 2 (Z213)	behind instrument cluster	86	146
Direction Indicator Switch (X116)	top of steering column	86	133
Distributor (Z125) (MFI-T16)	top rear of engine	86	
Distributor (Z125) (MFI-V8)	top centre front of engine	86	24
Driver's Seat Buckle Switch (X120)	inside driver's seat belt buckle assembly	86	
Driver's Underseat Fuse Box (P108)	beneath LH front seat	86	225
EGR Control Solenoid (K171)	LH front of engine compartment	19	30
EGR Valve Control Module (Z149)	behind RH side of fascia	19	188
EGR Valve Position Sensor (X218)	LH side of engine	19	8
Electrochromic Rear View Mirror (B110)	front centre of roof	86	173
Engine Compartment Fuse Box (P125) (300Tdi)	RH front of engine compartment	86	51

Component	Location	Manual	View
Engine Compartment Fuse Box (P125) (MFI-V8) (MFI-T16)	RH front of engine compartment	86	49
Engine Compartment Fuse Box (P125) (SFI-V8)	RH front of engine compartment	86	50
Engine Control Load Relay (K116) (300Tdi with EDC) ..	behind RH footwell trim panel	19	211
Engine Control Load Relay (K116) (MFI-V8)	behind RH footwell trim panel	19	207
Engine Control Module (ECM) (Z132) (300Tdi with EDC)	behind RH side of fascia	19	211
Engine Control Module (ECM) (Z132) (MFI-T16) ...	RH rear corner of engine compartment	19	93
Engine Control Module (ECM) (Z132) (MFI-V8)	behind RH side of fascia	19	188
Engine Control Module (ECM) (Z132) (SFI-V8)	RH rear corner of engine compartment	19	94
Engine Coolant Temperature Gauge Sensor (X114) (300Tdi with EDC)	RH front of engine on thermostat housing	86	63
Engine Coolant Temperature Gauge Sensor (X114) (300Tdi without EDC)	RH front of engine	86	64
Engine Coolant Temperature Gauge Sensor (X114) (MFI-T16)	top LH front of engine	86	17
Engine Coolant Temperature Gauge Sensor (X114) (MFI-V8)	top LH front of engine on intake manifold	86	15
Engine Coolant Temperature Gauge Sensor (X114) (SFI-V8)	top LH front of engine	86	18
Engine Coolant Temperature Sensor (X126) (300Tdi with EDC)	top centre of engine	19	27
Engine Coolant Temperature Sensor (X126) (300Tdi without EDC)	top centre of engine	19	26
Engine Coolant Temperature Sensor (X126) (MFI-T16) ..	top LH front of engine	19	17
Engine Coolant Temperature Sensor (X126) (MFI-V8) ...	top LH front of engine on intake manifold	19	15
Engine Coolant Temperature Sensor (X126) (SFI-V8)	top LH front of engine	19	18
Engine Fuel Temperature Sensor (X128) (MFI-T16) ..	top RH side of engine	19	60
Engine Fuel Temperature Sensor (X128) (MFI-V8) ...	top LH front of engine on fuel rail	19	15
Engine Fuel Temperature Sensor (X128) (SFI-V8)	top LH side of engine on fuel rail	19	19
Engine Immobilisation Control Unit (Spider) (Z271)	behind centre of fascia above heater evaporator unit	86	159
Engine Speed Sensor (X255)	RH rear of engine	19	84

Component	Location	Manual	View
Evaporative Emission Canister Purge Valve (K132) (MFI-T16)	RH rear of engine compartment	17	92
Evaporative Emission Canister Purge Valve (K132) (MFI-V8)	RH side of engine compartment	17	91
Evaporative Emission Canister Purge Valve (K132) (SFI-V8)	RH rear of engine compartment	17	54
Evaporative Emission Canister Vent Seal Valve (K233)	RH front of engine compartment on Evaporative Emission Canister Vent Seal Valve	19	54
Fan Control Module (Z118) .	behind RH footwell trim panel	82	208
Fan Timer Diode (Z211)	Main Wire Harness behind RH side of fascia near HJ10	82	180
Fascia Cigar Lighter (B106) .	in front of centre console	86	162
Fascia Fuse Box (P126)	behind LH side of fascia	86	124
Flasher Unit (Z128)	behind LH side of fascia on Fascia Fuse Box	86	125
Fog Lamps Relay (K232) ...	behind LH footwell trim panel	86	123
Front A/C Evaporator Temperature Switch (X101) .	LH side of heater evaporator unit	82	154
Front A/C Switch (X225) ...	centre of fascia	82	160
Front Blower Motor (M101) .	behind RH side of fascia right of heater evaporator unit	82	179
Front Blower Motor Relay (K192)	behind RH side of fascia right of heater evaporator unit	82	183
Front Blower Resistor Unit (Z214)	behind RH side of fascia right of heater evaporator unit	80	175
Front Fan Speed Switch (X247)	centre of fascia	82	160
Front Fog Lamps Relay (K230)	behind RH side of fascia on bracket	86	194
Front Fog Lamps Switch (X270)	centre of fascia	86	156
Front Interior Roof Lamp (B107)	front centre of roof	86	171
Front Screen Wash Pump (M105)	RH rear corner of engine compartment on wash fluid reservoir	84	99
Front Sunroof Motor (M143)	front centre of roof	76	174
Front Sunroof Switch (X261)	front centre of roof	76	172
Front Wipe/Wash Switch (X124)	top of steering column	84	144
Front Wiper Motor (M107) ..	LH side of bulkhead	84	1
Front Wiper Relay (K185) ..	behind RH footwell trim panel	84	203
Fuel Injector Assembly (K195)	RH side of engine	19	72
Fuel Injectors (K141) (MFI-T16)	top centre of engine	19	25
Fuel Injectors (K141) (MFI-V8)	top centre of engine	19	14
Fuel Injectors (K141) (SFI-V8)	top centre of engine	19	20
Fuel Pressure Sensor (X320)	top of fuel tank	19	274
Fuel Pump Assembly (K196)	RH side of engine	19	71

Component	Location	Manual	View
Fuel Pump Module (Z134) (Except NAS)	top of fuel tank	86	256
Fuel Pump Module (Z134) (NAS)	top of fuel tank	86	274
Fuel Pump Relay (K119) . . .	behind RH footwell trim panel	86	207
Fuel Shut-Off Solenoid (K111)	RH side of engine on injector pump	19	66
Fusible Link (P119)	RH front of engine compartment behind battery	86	51
Generator (Z106) (300Tdi) .	lower LH side of engine	86	23
Generator (Z106) (MFI-T16 with Air Conditioning)	LH front of engine	86	
Generator (Z106) (MFI-T16 without Air Conditioning) . . .	RH side of engine	86	80
Generator (Z106) (MFI-V8) .	top centre front of engine	86	76
Generator (Z106) (SFI-V8) .	top front of engine	86	61
Generator Suppression Capacitor (Z182) (300Tdi) ..	lower LH side of engine on Generator	86	23
Generator Suppression Capacitor (Z182) (MFI-T16 with Air Conditioning)	LH front of engine on Generator	86	
Generator Suppression Capacitor (Z182) (MFI-T16 without Air Conditioning) . . .	RH side of engine on Generator	86	80
Generator Suppression Capacitor (Z182) (MFI-V8) .	top centre front of engine on Generator	86	76
Generator Suppression Capacitor (Z182) (SFI-V8) .	top front of engine on Generator	86	61
Glow Plugs (P120)	RH side of engine	19	70
Glow Plug Timer Unit (Z135)	RH side of engine compartment	19	55
Handbrake Switch (X191) . .	beneath centre console on handbrake lever	86	168
Hazard Switch (X220)	centre of fascia	86	155
Headlamp Level Switch (X130)	top LH side of fascia left of steering column	86	138
Headlamp Wash Pump (M110)	RH rear corner of engine compartment on wash fluid reservoir	86	99
Heated Front Screen Fuse Block (P114)	behind RH side of fascia	86	185
Heated Front Screen In-Line Maxi-Fuse (P139) (MFI-V8) (MFI-T16) (300Tdi)	RH side of engine compartment	86	263
Heated Front Screen In-Line Maxi-Fuse (P139) (SFI-V8)	RH side of engine compartment	86	264
Heated Front Screen Relay (K121)	behind RH side of fascia	86	185
Heated Front Screen Switch (X131)	centre of fascia	86	268
Heated Rear Screen Relay (K122)	behind LH side of fascia on Fascia Fuse Box	86	125
Heated Rear Screen Switch (X132)	top LH side of fascia near Instrument Cluster	86	140
Horn Relay (K189)	behind LH footwell trim panel	86	121
Horn Switches (X258)	in steering wheel	86	132
Idle Air Control Valve (M112) (MFI-T16)	RH front of engine	19	59

Component	Location	Manual	View
Idle Air Control Valve (M112) (MFI-V8)	top rear of engine	19	79
Idle Air Control Valve (M112) (SFI-V8)	top LH side of engine	19	21
Ignition Coil (Z140) (MFI-V8)	LH front of engine compartment	86	36
Ignition Coil 1 (Z217) (MFI-T16)	top rear of engine	86	
Ignition Coil 2 (Z218) (MFI-T16)	top rear of engine	86	
Ignition Coil Noise Suppressor (Z237)	LH front corner of engine compartment on Ignition Coil	86	38
Ignition Coils (Z261) (SFI-V8)	top rear of engine	86	5
Ignition Control Module (Z139)	LH front of engine compartment near Ignition Coil	86	38
Ignition Key Lock Solenoid (K191)	top of steering column	86	136
Ignition Load Relay (K127)	behind RH footwell trim panel	86	204
Ignition Switch (X134)	top of steering column	86	134
Inertia Fuel Shut-Off Switch (X135) (MFI-V8) (MFI-T16) (300Tdi)	RH rear of engine compartment	19	97
Inertia Fuel Shut-Off Switch (X135) (SFI-V8)	RH rear of engine compartment	19	98
Injector Needle Lift Sensor (X256)	RH rear of engine	19	84
Instrument Cluster (Z142)	top LH side of fascia	86	145
Instrument Illumination Rheostat (Z143)	top LH side of fascia near Instrument Cluster	86	139
Intake Air Temperature Sensor (X248) (MFI-T16)	RH rear of engine	19	
Intake Air Temperature Sensor (X311) (SFI-V8)	LH side of engine compartment on air cleaner	19	12
Interlock Diode 1 (Z189)	Main Wire Harness near Cruise Control ECU	86	181
Interlock Diode 2 (Z190)	Main Wire Harness near Cruise Control ECU	86	181
Interlock Relay 1 (K153)	behind RH side of fascia above glove box	86	181
Interlock Relay 2 (K151)	behind RH side of fascia above glove box	86	181
Key-Barrel Switch (X230)	top of steering column on Ignition Switch	86	135
Key-In Switch (X229) (Without Shift Interlock)	top of steering column on Ignition Switch	86	134
Key-In Switch (X229) (With Shift Interlock)	top of steering column on Ignition Switch	86	135
Knock Sensor (X249) (MFI-T16)	RH side of engine	19	60
Left Antenna Amplifier (Z177)	LH rear of roof behind trim panel	86	273
Left Condenser Fan Motor (M113)	behind front grille	86	41
Left Front Door Key Switch (X201)	in top rear of LH front door at door handle	86	218
Left Front Door Lock Actuator (M114)	in rear of LH front door	76	217
Left Front Door Switch (X150)	front of LH front door jamb	86	213

Component	Location	Manual	View
Left Front Indicator Lamp (B153)	LH front of vehicle	86	34
Left Front Seat Control Switch (X152)	LH side of centre console	86	169
Left Front Side Lamp (B166)	LH front of vehicle	86	44
Left Front Side Marker Lamp (B161)	LH front of vehicle	86	33
Left Front Wheel Speed Sensor (X137)	behind LH front wheel	70	107
Left Front Window Motor (M130)	in front of LH front door	86	219
Left Front Window Switch (X122)	in rear of centre console	86	164
Left Headlamp (B116)	LH front of vehicle	86	43
Left Headlamp Level Unit (Z145)	behind LH headlamp	86	35
Left Heated Oxygen Sensor (Post Catalyst) (X289) (SFI-V8)	beneath LH side of vehicle	19	109
Left Heated Oxygen Sensor (X139) (MFI-T16)	lower LH side of engine compartment	19	10
Left Heated Oxygen Sensor (X139) (MFI-V8)	lower LH rear of engine compartment	19	101
Left Heated Oxygen Sensor (X139) (SFI-V8)	lower LH rear of engine compartment	19	102
Left Horn (K128)	behind LH side of front grille	86	40
Left Knock Sensor (X295) (SFI-V8)	lower LH side of engine	19	104
Left Mirror Actuator (M115)	top front of LH front door	76	216
Left Rear Door Lock Actuator (M117)	inside front of LH rear door	76	222
Left Rear Door Switch (X142)	in lower part of LH B-post	86	221
Left Rear Indicator Lamp (B163)	LH side of rear bumper	86	257
Left Rear Lamp Assembly (B121)	LH rear of luggage compartment	86	239
Left Rear Side Marker Lamp (B159)	LH side of rear bumper	86	259
Left Rear Wheel Speed Sensor (X140)	behind LH rear wheel	70	108
Left Rear Window Console Switch (X141)	in rear of centre console	86	165
Left Rear Window Door Switch (X188)	inside front of LH rear door	86	223
Left Rear Window Motor (M116)	inside front of LH rear door	86	224
Left Repeater Lamp (B122)	LH front side of vehicle	86	32
Left Seat Heat Relay (K129)	beneath LH front seat	86	229
Left Seat Heat Switch (X143)	in rear of centre console	86	269
Left Seat Power Relay (K113)	beneath LH front seat	86	226
Left Seat Power Relay Diode (Z223)	beneath centre console	86	

Component	Location	Manual	View
Left Tail Lamp (B155)	LH side of rear bumper	86	257
Left Vanity Mirror Lamp (B186)	LH front of roof	86	215
Main Lighting Switch (X145)	top of steering column	86	133
Main Rear A/C Switch (X239)	centre of fascia	82	161
Mass Air Flow Sensor (X105) (300Tdi with EDC)	LH side of engine compartment on air intake assembly	19	13
Mass Air Flow Sensor (X105) (MFI-V8)	LH side of engine compartment on air intake assembly	19	11
Mass Air Flow Sensor (X105) (SFI-V8)	LH side of engine compartment on air intake assembly	19	12
Mirror Adjustment Switch (X146a)	top LH side of fascia left of steering column	86	138
Multi-Function Relay Unit (Z207) (MFI-T16)	behind RH side of fascia	19	205
Multi-Function Relay Unit (Z207) (SFI-V8)	RH rear of engine compartment	19	78
Multi-Function Unit (MFU) (Z148)	behind LH side of fascia on Fascia Fuse Box	86	127
Multiport Fuel Injection Ignition Resistor 1 (K115)	LH front of engine compartment near Ignition Coil	86	36
Multiport Fuel Injection Ignition Resistor 2 (K168)	LH front of engine compartment near Ignition Coil	86	36
Neutral Sense Diode (Z273)	Main Wire Harness behind RH side of fascia near C2073	86	177
Neutral Sense Resistor (K166)	Gearbox Wire Harness near C105	86	
Oil Pressure Switch (X149) (300Tdi with EDC)	lower RH side of engine	86	71
Oil Pressure Switch (X149) (300Tdi with EGR)	lower RH side of engine	86	67
Oil Pressure Switch (X149) (300Tdi without EGR)	lower RH side of engine	86	66
Oil Pressure Switch (X149) (MFI-T16)	lower RH side of engine near oil filter	86	47
Oil Pressure Switch (X149) (MFI-V8)	lower RH side of engine near oil filter	86	46
Oil Pressure Switch (X149) (SFI-V8)	lower RH side of engine near oil filter	86	48
Park/Neutral Position Switch (X167)	LH side of transmission	86	113
Passenger's Rear A/C Switch (X240)	centre of roof	82	231
Passenger's Rear Fan Speed Switch (X246)	centre of roof	82	231
Passenger's Rear Sunroof Switch (X264)	centre of roof	76	233
Passenger's Underseat Fuse Box (P116)	beneath LH front seat	86	225
Passive Immobilisation Coil (Z270)	top of steering column on Ignition Switch	86	137
Phase Tap Resistor (K184) (300Tdi)	lower LH side of engine on Generator	86	23

Component	Location	Manual	View
Phase Tap Resistor (K184) (MFI-T16 with Air Conditioning)	LH front of engine on Generator	86	
Phase Tap Resistor (K184) (MFI-T16 without Air Conditioning)	RH side of engine on Generator	86	80
Phase Tap Resistor (K184) (MFI-V8)	top centre front of engine on Generator	86	76
Phase Tap Resistor (K184) (SFI-V8)	top front of engine on Generator	86	61
Power Amplifier Relay (K187)	behind RH side of fascia above glove box	86	182
Power Wash Relay (K182) (Except NAS)	behind RH side of fascia on bracket	86	193
Power Wash Relay (K182) (NAS)	behind RH side of fascia on bracket	86	198
Radio (Z111) (High Line Radio)	centre of fascia	86	158
Radio (Z111) (Low Line Radio) (Mid Line Radio)	centre of fascia	86	157
Radio Amplifier (Z175)	behind RH side of fascia	86	187
Radio Tune Resistor (Z235)	Fascia Wire Harness behind instrument cluster near Rear Screen Wipe Switch	86	147
Radio Tune Switch (X233) ..	top LH side of fascia near Instrument Cluster	86	143
Radio Volume Down Switch (X236)	top LH side of fascia near Instrument Cluster	86	141
Radio Volume Resistor (Z234)	Fascia Wire Harness behind instrument cluster near Heated Rear Screen Switch	86	146
Radio Volume Up Switch (X235)	top LH side of fascia near Instrument Cluster	86	141
Radio Waveband Resistor (Z236)	Fascia Wire Harness behind instrument cluster near Rear Screen Wipe Switch	86	147
Radio Waveband Switch (X234)	top LH side of fascia near Instrument Cluster	86	143
Rear A/C Control Relay (K194)	LH side of luggage compartment on rear A/C evap- orator	82	236
Rear A/C Evaporator Temperature Switch (X260) .	LH side of luggage compartment on rear A/C evap- orator	82	237
Rear A/C Fan Speed Relay (K205)	LH side of luggage compartment on rear A/C evap- orator	82	238
Rear A/C Illumination Relay (K204)	LH side of luggage compartment on rear A/C evap- orator	82	237
Rear A/C Refrigerant Control Valve Diode (Z228)	LH rear of luggage compartment near C448	82	240
Rear A/C Refrigerant Control Valve (K207)	LH side of luggage compartment on rear A/C evap- orator	82	236
Rear A/C Relay Diode (Z275)	LH rear of luggage compartment near C448	82	240
Rear A/C Switch Amplifier (Z216)	LH side of luggage compartment on rear A/C evap- orator	82	235
Rear A/C Switch Amplifier In-Line Fuse (P140)	LH rear of luggage compartment behind trim panel .	82	239
Rear Blower Motor (M145) .	LH side of luggage compartment on rear A/C evap- orator	82	235

Component	Location	Manual	View
Rear Blower Motor Relay (K193)	LH side of luggage compartment on rear A/C evaporator	82	238
Rear Blower Resistor Unit (Z215)	LH side of luggage compartment on rear A/C evaporator	82	
Rear End Door Switch (X265)	in RH side of tailgate door jamb	86	246
Rear Fog Guard Lamps Switch (X154)	top LH side of fascia near Instrument Cluster	86	140
Rear Fog Lamps Relay (K231)	behind RH side of fascia on bracket	86	194
Rear Interior Roof Lamp (B124)	centre of roof	86	232
Rear Screen Wash Pump (M119)	RH rear corner of engine compartment on wash fluid reservoir	86	99
Rear Screen Wash Switch (X222)	top LH side of fascia near Instrument Cluster	86	142
Rear Screen Wipe Switch (X221)	top LH side of fascia near Instrument Cluster	86	142
Rear Sunroof Lockout Switch (X263)	front centre of roof	76	173
Rear Sunroof Motor (M144)	centre of roof	76	234
Rear Sunroof Switch (X262)	front centre of roof	76	172
Rear Window Isolation Switch (X187)	in rear of centre console	86	165
Rear Wiper Motor (M120)	RH side of tailgate	84	248
Rear Wiper Relay (K183)	behind LH footwell trim panel	86	122
Reverse Switch (X157)	LH side of transmission	86	115
Right Antenna Amplifier (Z178)	RH rear of roof behind trim panel	86	273
Right Condenser Fan Motor (M121)	behind front grille	82	42
Right Front Door Lock Actuator (M122)	in rear of RH front door	76	220
Right Front Door Switch (X118)	front of RH front door jamb	86	213
Right Front Indicator Lamp (B154)	RH front of vehicle	86	34
Right Front Seat Control Switch (X121)	RH side of centre console	86	170
Right Front Side Lamp (B167)	RH front of vehicle	86	44
Right Front Side Marker Lamp (B162)	RH front of vehicle	86	33
Right Front Wheel Speed Sensor (X158)	behind RH front wheel	70	107
Right Front Window Motor (M133)	in front of RH front door	86	219
Right Front Window Switch (X151)	in rear of centre console	86	164
Right Headlamp (B130)	RH front of vehicle	86	43
Right Headlamp Level Unit (Z155)	behind RH headlamp	86	35

Component	Location	Manual	View
Right Heated Oxygen Sensor (Post Catalyst) (X290) (SFI-V8)	beneath RH side of vehicle	19	110
Right Heated Oxygen Sensor (X160) (MFI-V8)	lower RH rear of engine compartment	19	88
Right Heated Oxygen Sensor (X160) (SFI-V8)	lower RH rear of engine compartment	19	89
Right Horn (K134)	behind RH side of front grille	86	40
Right Knock Sensor (X296) (SFI-V8)	lower RH side of engine near Starter	19	105
Right Mirror Actuator (M123)	top front of RH front door	86	216
Right Rear Door Lock Actuator (M125)	inside front of RH rear door	76	222
Right Rear Door Switch (X163)	in lower part of RH B-post	86	221
Right Rear Indicator Lamp (B165)	RH side of rear bumper	86	258
Right Rear Lamp Assembly (B136)	RH rear of luggage compartment	86	244
Right Rear Side Marker Lamp (B160)	RH side of rear bumper	86	259
Right Rear Wheel Speed Sensor (X161)	behind RH rear wheel	70	108
Right Rear Window Console Switch (X162)	in rear of centre console	86	165
Right Rear Window Door Switch (X189)	inside front of RH rear door	86	223
Right Rear Window Motor (M124)	inside front of RH rear door	86	224
Right Repeater Lamp (B137)	RH front side of vehicle	86	32
Right Seat Heat Relay (K135)	beneath LH front seat	86	229
Right Seat Heat Switch (X164)	in rear of centre console	86	269
Right Seat Power Relay (K131)	beneath LH front seat	86	226
Right Seat Power Relay Diode (Z222)	beneath centre console	86	
Right Tail Lamp (B156)	RH side of rear bumper	86	258
Right Vanity Mirror Lamp (B187)	RH front of roof	86	215
Rotary Coupler (Z119)	top of steering column	76	134
Satellite Fuse Box 1 (P127) .	behind LH side of fascia on Fascia Fuse Box	86	124
Satellite Fuse Box 2 (P128) .	behind LH side of fascia on Fascia Fuse Box	86	124
Saudi Junction Connector (X241)	behind LH side of fascia near Fascia Fuse Box	86	130
Seat Base Motor (M126) ...	underside of respective front seat	86	228
Seat Height (Front) Motor (M127)	underside of respective front seat	86	227
Seat Height (Rear) Motor (M128)	underside of respective front seat	86	228
Seat Recline Motor (M129) .	underside of respective front seat	86	227
Service Reminder Unit (Z126)	behind RH footwell trim panel	86	210

Component	Location	Manual	View
Sounder Relay (K160)	behind LH footwell trim panel	86	123
Speed Trip Module (Z164) (Except NAS)	behind RH side of fascia on bracket	19	197
Speed Trip Module (Z164) (NAS)	behind RH side of fascia on bracket	19	201
Starter (M134) (300Tdi with EDC)	lower LH side of engine	86	9
Starter (M134) (300Tdi without EDC)	lower LH side of engine	86	8
Starter (M134) (MFI-T16)	lower RH side of engine	86	86
Starter (M134) (MFI-V8)	lower RH side of engine	86	85
Starter (M134) (SFI-V8)	lower RH rear of engine	86	106
Starter Relay Diode (Z158)	Main Wire Harness near Starter Solenoid Relay	86	202
Starter Solenoid (K136) (300Tdi with EDC)	lower LH side of engine	86	9
Starter Solenoid (K136) (300Tdi without EDC)	lower LH side of engine	86	8
Starter Solenoid (K136) (MFI-T16)	lower RH side of engine	86	86
Starter Solenoid (K136) (MFI-V8)	lower RH side of engine	86	85
Starter Solenoid (K136) (SFI-V8)	lower RH rear of engine	86	106
Starter Solenoid Relay (K137)	behind RH footwell trim panel	86	204
Steering Wheel Cruise Switches (X266)	in steering wheel	19	132
Stop Lamp Switch (X168)	behind LH side of fascia on brake pedal support	86	150
Stop Lamp Switch Suppressor (Z206)	behind LH side of fascia near steering column	86	150
Subwoofer (K146)	LH side of tailgate	86	251
Subwoofer Amplifier (Z176)	LH side of tailgate on Subwoofer	86	251
Sunroof Control Unit (Z162)	front centre of roof	76	174
Tailgate Diode (Z277)	behind LH side of fascia right of steering column	86	149
Tailgate Lock Actuator (M132)	LH side of tailgate	76	249
Theft Alarm Unit (Z163)	behind RH side of fascia on bracket	86	192
Throttle Position Sensor (X171) (300Tdi with EGR)	RH side of engine on injector pump	19	67
Throttle Position Sensor (X171) (MFI-T16)	RH front of engine	19	59
Throttle Position Sensor (X171) (MFI-V8)	top LH front of engine	19	16
Throttle Position Sensor (X171) (SFI-V8)	top LH side of engine	19	21
Throttle Position Sensor (X257) (300Tdi with EDC)	behind LH side of fascia	19	
Trailer Auxiliary Socket (X172)	RH rear of luggage compartment behind trim panel	86	260
Transfer Box Oil Temperature Switch (X174)	LH side of transfer box	86	116
Transfer Box Position Switch (X175)	top RH side of transfer box	86	119

Component	Location	Manual	View
Transfer Box Solenoid (K161)	top RH side of transfer box	86	119
Transfer Box Solenoid Diode (Z232)	Gearbox Wire Harness near Differential Lock Switch	86	
Transmission Range Selector Illumination Relay (K104)	behind RH side of fascia above glove box	86	182
Transmission Range Selector Switch (Z110)	beneath centre console near transmission range selector	86	163
Tune Select Resistor (K140)	behind RH side of fascia	19	190
Vehicle Speed Sensor (X190)	LH side of transfer box	86	117
Window Lift Diodes (Z278)	behind RH side of fascia	86	
Window Lift ECU (Z147)	behind RH side of fascia on bracket	86	184
Connector	Location		View
C100 (3-W)	RH front of engine compartment on Engine Compartment Fuse Box		56
C101 (4-W)	RH front of engine compartment on Engine Compartment Fuse Box		56
C103 (3-B)	RH front of engine compartment on Right Headlamp		43
C104 (3-B)	LH front of engine compartment on Left Headlamp		43
C105 (13-B)	LH rear corner of engine compartment		2
C109 (2-B)	LH front of engine compartment on Left Front Side Lamp		44
C110 (2-B)	RH front of engine compartment on Right Front Side Lamp		44
C112 (3-W) (MFI-V8)	LH rear corner of engine to Left Heated Oxygen Sensor		101
C112 (4-B) (MFI-T16)	lower LH side of engine to Left Heated Oxygen Sensor		10
C112 (4-R) (SFI-V8)	lower LH rear of engine to Left Heated Oxygen Sensor		5
C113 (3-W) (MFI-V8)	RH rear corner of engine to Right Heated Oxygen Sensor		79
C113 (4-B) (SFI-V8)	lower RH rear of engine to Right Heated Oxygen Sensor		90
C114 (2-W)	RH front of engine compartment on Engine Compartment Fuse Box		56
C115 (3-W)	RH front of engine compartment on Engine Compartment Fuse Box		56
C116 (1-W)	RH front of engine compartment on Engine Compartment Fuse Box		56
C118 (1-W) (MFI-V8) (MFI-T16) (300Tdi)	RH front of engine compartment		263
C118 (1-W) (SFI-V8)	RH front of engine compartment		264
C120 (2-W)	RH rear corner of engine compartment on Rear Screen Wash Pump		99
C121 (2-B)	LH rear corner of engine compartment to Heated Front Screen		261
C122 (2-B)	RH rear corner of engine compartment to Heated Front Screen		266
C123 (2-B)	RH front side of vehicle on Right Repeater Lamp		32
C124 (2-B)	LH front side of vehicle on Left Repeater Lamp		32
C125 (2-B)	LH rear of engine compartment to A.B.S. Hydraulic Pump		3
C127 (3-B)	LH rear of engine compartment on Brake Fluid Level Switch		2
C129 (13-B)	LH rear of engine compartment on A.B.S. Booster Unit		3
C130 (2-WB)	LH rear of engine compartment to Left Front Wheel Speed Sensor		3
C131 (2-WB) (MFI-V8) (MFI-T16) (300Tdi)	RH side of engine compartment to Right Front Wheel Speed Sensor		52
C131 (2-WB) (SFI-V8)	RH side of engine compartment to Right Front Wheel Speed Sensor		82
C132 (4-B) (MFI-V8)	top rear of engine on Idle Air Control Valve		79

Connector	Location	View
C132 (4-B) (SFI-V8)	top LH side of engine on Idle Air Control Valve	21
C132 (6-B) (MFI-T16)	RH front of engine on Idle Air Control Valve	59
C133 (3-B) (SFI-V8)	LH side of engine compartment on Mass Air Flow Sensor	12
C133 (5-B) (300Tdi with EDC)	LH side of engine compartment on Mass Air Flow Sensor	13
C133 (6-B) (MFI-V8)	LH side of engine compartment on Mass Air Flow Sensor	11
C134 (2-B) (MFI-T16)	top centre of engine on Fuel Injectors	25
C134 (2-B) (MFI-V8)	top LH side of engine on Fuel Injectors	14
C134 (2-B) (SFI-V8)	top LH front of engine on Fuel Injectors	19
C135 (2-B) (MFI-T16)	top centre of engine on Fuel Injectors	25
C135 (2-B) (MFI-V8)	top RH side of engine on Fuel Injectors	73
C135 (2-B) (SFI-V8)	top centre of engine on Fuel Injectors	74
C136 (2-B) (MFI-T16)	top centre of engine on Fuel Injectors	25
C136 (2-B) (MFI-V8)	top LH side of engine on Fuel Injectors	14
C136 (2-B) (SFI-V8)	top centre of engine on Fuel Injectors	20
C137 (2-B) (MFI-T16)	top centre of engine on Fuel Injectors	25
C137 (2-B) (MFI-V8)	top RH side of engine on Fuel Injectors	73
C137 (2-B) (SFI-V8)	top centre of engine on Fuel Injectors	74
C138 (2-B) (MFI-V8)	top LH side of engine on Fuel Injectors	14
C138 (2-B) (SFI-V8)	top centre of engine on Fuel Injectors	20
C139 (2-B) (MFI-V8)	top RH side of engine on Fuel Injectors	73
C139 (2-B) (SFI-V8)	top centre of engine on Fuel Injectors	74
C140 (2-B) (MFI-V8)	top LH rear of engine on Fuel Injectors	4
C140 (2-B) (SFI-V8)	top LH rear of engine on Fuel Injectors	6
C141 (2-B) (MFI-V8)	top RH side of engine on Fuel Injectors	79
C141 (2-B) (SFI-V8)	top RH side of engine on Fuel Injectors	74
C142 (2-N) (MFI-T16)	lower RH side of engine on Oil Pressure Switch	47
C144 (2-B) (MFI-T16)	RH rear of engine compartment on Evaporative Emission Canister Purge Valve	92
C144 (2-B) (MFI-V8)	RH side of engine compartment on Evaporative Emission Canister Purge Valve	91
C144 (2-B) (SFI-V8)	RH rear of engine compartment on Evaporative Emission Canister Purge Valve	54
C145 (2-W) (300Tdi with EDC)	RH side of engine to Compressor Clutch	69
C145 (2-W) (300Tdi without EDC)	RH side of engine to Compressor Clutch	68
C145 (2-W) (MFI-T16)	RH side of engine to Compressor Clutch	
C145 (2-W) (MFI-V8)	top RH side of engine to Compressor Clutch	58
C145 (2-W) (SFI-V8)	top RH side of engine to Compressor Clutch	62
C146 (2-B) (300Tdi with EDC)	RH front of engine on Condenser Fan Coolant Temperature Switch	63
C146 (2-B) (300Tdi without EDC)	RH front of engine on Condenser Fan Coolant Temperature Switch	65
C146 (2-B) (MFI-V8)	top centre front of engine on Condenser Fan Coolant Temperature Switch	75

Connector	Location	View
C148 (2-B)	top centre front of engine to Distributor	24
C149 (3-B) (MFI-T16)	RH front of engine on Throttle Position Sensor	59
C149 (3-B) (MFI-V8)	top LH front of engine to Throttle Position Sensor	16
C149 (3-B) (SFI-V8)	top LH side of engine on Throttle Position Sensor	21
C150 (2-S) (MFI-T16)	RH side of engine on Engine Fuel Temperature Sensor	60
C150 (2-S) (MFI-V8)	top LH front of engine on Engine Fuel Temperature Sensor	15
C150 (2-S) (SFI-V8)	top LH side of engine on Engine Fuel Temperature Sensor	19
C152 (2-N) (300Tdi with EDC)	top centre of engine on Engine Coolant Temperature Sensor	27
C152 (2-N) (300Tdi without EDC)	top centre of engine on Engine Coolant Temperature Sensor	26
C152 (2-N) (MFI-T16)	top LH front of engine on Engine Coolant Temperature Sensor	17
C152 (2-N) (MFI-V8)	top LH front of engine on Engine Coolant Temperature Sensor	15
C152 (2-N) (SFI-V8)	top LH front of engine on Engine Coolant Temperature Sensor	18
C153 (1-B)	LH front of engine compartment on Ignition Coil	37
C154 (1-W)	LH front of engine compartment on Ignition Coil	37
C155 (1-B)	LH front of engine compartment on Ignition Coil	37
C156 (1-W)	LH front of engine compartment on Ignition Coil	37
C159 (6-B)	RH side of engine compartment on Glow Plug Timer Unit	55
C160 (3-B)	RH side of engine to Throttle Position Sensor	81
C161 (1-W) (300Tdi without EGR)	RH side of engine to Fuel Shut-Off Solenoid	66
C162 (2-B)	RH front of engine on Compressor Clutch Cut-out Switch	64
C164 (3-B)	LH side of engine on EGR Valve Position Sensor	8
C165 (2-B) (300Tdi without EDC)	LH front of engine compartment on EGR Control Solenoid	30
C165 (2-S) (300Tdi with EDC)	LH front of engine compartment on EGR Control Solenoid	30
C166 (2-B)	lower LH front of engine compartment on Automatic Transmission Oil Temperature Switch	31
C167 (3-W)	LH front corner of engine compartment on Cruise Control Vacuum Pump	28
C168 (2-B)	behind LH side of front grille on Left Horn	40
C169 (2-B)	behind RH side of front grille on Right Horn	40
C170 (2-R)	RH rear corner of engine compartment on Front Screen Wash Pump ..	99
C171 (3-B) (MFI-V8) (MFI-T16) (300Tdi)	RH rear of engine compartment on Inertia Fuel Shut-Off Switch	97
C171 (3-B) (SFI-V8)	RH rear of engine compartment on Inertia Fuel Shut-Off Switch	98
C173 (2-B)	RH rear corner of engine compartment on Headlamp Wash Pump	99
C178 (2-B)	LH side of engine compartment to Alarm Bonnet Switch	262
C181 (2-S) (MFI-V8) (MFI-T16) (300Tdi)	RH rear of engine compartment on A/C Dual Pressure Switch	95
C181 (2-S) (SFI-V8)	RH rear of engine compartment on A/C Dual Pressure Switch	98
C182 (2-B)	behind front grille to Right Condenser Fan Motor	42
C183 (2-B)	behind front grille to Left Condenser Fan Motor	41
C190 (3-B)	behind LH headlamp on Left Headlamp Level Unit	35

Connector	Location	View
C191 (3-B)	behind RH headlamp on Right Headlamp Level Unit	35
C195 (4-W)	RH rear of engine compartment	96
C196 (2-NU)	RH rear of engine to Injector Needle Lift Sensor	84
C197 (3-B)	RH rear of engine to Engine Speed Sensor	84
C198 (3-W) (300Tdi with EDC)	RH side of engine to Fuel Injector Assembly	72
C198 (6-B) (MFI-T16)	top rear of engine to Fuel Injectors	83
C199 (8-W)	RH side of engine to Fuel Pump Assembly	71
C201 (7-W)	top of steering column on Main Lighting Switch	133
C203 (7-W)	behind LH side of fascia on Fascia Fuse Box	128
C204 (24-W)	behind LH side of fascia on Fascia Fuse Box	127
C205 (24-B)	behind LH side of fascia on Multi-Function Unit (MFU)	127
C206 (4-W)	behind LH side of fascia on Fascia Fuse Box	128
C207 (10-B)	on Instrument Cluster	145
C208 (18-W)	behind LH side of fascia on Fascia Fuse Box	126
C209 (20-R)	behind LH side of fascia LH side of heater evaporator unit	153
C211 (10-W)	behind LH side of fascia on Fascia Fuse Box	128
C212 (14-W)	behind LH side of fascia near Fascia Fuse Box	129
C214 (3-BU)	top LH side of fascia to Instrument Illumination Rheostat	139
C215 (24-Y)	behind LH side of fascia LH side of heater evaporator unit	153
C216 (7-N)	behind RH side of fascia right of heater evaporator unit	178
C217 (24-W)	behind RH side of fascia right of heater evaporator unit	178
C218 (8-W) (Except NAS)	behind RH side of fascia on bracket	197
C218 (8-W) (NAS)	behind RH side of fascia on bracket	201
C219 (4-W)	behind LH side of fascia on Fascia Fuse Box	126
C220 (3-N)	behind LH side of fascia to Ignition Switch	149
C221 (10-W)	on Instrument Cluster	147
C222 (10-W)	on Instrument Cluster	145
C223 (5-U)	on Instrument Cluster	145
C224 (6-W)	behind LH side of fascia to Front Wiper Motor	148
C225 (26-S)	behind RH side of fascia on Theft Alarm Unit	192
C226 (3-W)	behind LH side of fascia on Fascia Fuse Box	128
C227 (4-B)	behind LH side of fascia on Stop Lamp Switch	150
C228 (8-B)	behind LH side of fascia on Mirror Adjustment Switch	138
C229 (1-W)	behind LH side of fascia on Fascia Fuse Box	127
C230 (8-S) (High Line Radio)	centre of fascia on Radio	158
C230 (8-S) (Low Line Radio) (Mid Line Radio)	centre of fascia on Radio	157
C232 (2-S)	RH A-post to Right Front Tweeter	214
C238 (5-Y) (MFI-T16)	behind RH footwell trim panel on Cooling Fan Relay	206
C238 (9-B) (MFI-V8)	behind RH footwell trim panel on Fan Control Module	208
C239 (5-B) (MFI-V8)	behind RH footwell trim panel on Engine Control Load Relay	207
C239 (5-Y) (300Tdi with EDC)	behind RH footwell trim panel on Engine Control Load Relay	211

Connector	Location	View
C240 (5-U)	behind RH footwell trim panel on Fuel Pump Relay	207
C241 (5-Y) (300Tdi with EDC)	behind RH footwell trim panel on Compressor Clutch Relay	212
C241 (5-Y) (MFI-V8) (MFI-T16) (300Tdi)	behind RH footwell trim panel on Compressor Clutch Relay	208
C241 (5-Y) (SFI-V8)	behind RH footwell trim panel on Compressor Clutch Relay	210
C242 (5-Y)	behind RH footwell trim panel on A/C Logic Relay	209
C243 (40-B) (MFI-V8)	behind RH side of fascia on Engine Control Module (ECM)	188
C243 (55-B) (300Tdi with EDC)	behind RH side of fascia on Engine Control Module (ECM)	211
C245 (5-W)	behind RH side of fascia Data Link Connector (MFI)	189
C246 (2-U)	behind RH side of fascia on Tune Select Resistor	190
C247 (16-B)	behind RH side of fascia on EGR Valve Control Module	188
C248 (3-W)	behind RH side of fascia Data Link Connector (EGR)	191
C249 (5-G)	top LH side of fascia on Rear Screen Wash Switch	142
C250 (5-W)	top LH side of fascia on Rear Screen Wipe Switch	142
C252 (6-R)	behind LH side of fascia near steering column	131
C254 (1-W)	behind LH side of fascia on Fascia Fuse Box	126
C255 (1-B)	on Instrument Cluster	145
C259 (6-W)	behind LH side of fascia on Headlamp Level Switch	138
C260 (10-R)	centre of fascia on Radio	157
C262 (5-U)	centre of fascia on Cruise Control Switch	156
C263 (5-B)	top LH side of fascia on Rear Fog Guard Lamps Switch	140
C264 (5-U)	top LH side of fascia on Heated Rear Screen Switch	140
C265 (5-B)	centre of fascia on Heated Front Screen Switch	268
C267 (10-W)	centre of fascia on Hazard Switch	155
C268 (8-N) (High Line Radio)	centre of fascia on Radio	158
C268 (8-N) (Low Line Radio) (Mid Line Radio)	centre of fascia on Radio	157
C270 (4-B)	centre of fascia on Clock	155
C274 (12-W)	behind RH side of fascia on Theft Alarm Unit	192
C277 (23-W)	behind LH side of fascia near Fascia Fuse Box	129
C280 (5-W)	behind LH footwell trim panel on Sounder Relay	123
C281 (5-G)	behind LH footwell trim panel on Rear Wiper Relay	122
C282 (5-Y)	behind LH footwell trim panel on Accessory Relay	121
C283 (5-Y)	behind LH footwell trim panel on Horn Relay	121
C284 (15-B)	behind RH side of fascia on Cruise Control ECU	186
C287 (10-W)	behind RH side of fascia on Window Lift ECU	184
C288 (8-W)	behind RH side of fascia on Window Lift ECU	184
C292 (5-Y) (Except NAS)	behind RH side of fascia on Condenser Fan Relay	193
C292 (5-Y) (NAS)	behind RH side of fascia on Condenser Fan Relay	198
C294 (4-W)	behind RH side of fascia on Heated Front Screen Relay	185
C298 (3-W)	behind RH side of fascia	183
C300 (4-B)	centre of roof to Rear Interior Roof Lamp	232
C301 (6-W)	beneath centre console	167

Connector	Location	View
C306 (3-W)	beneath centre console	167
C307 (2-BW)	beneath RH front seat	271
C309 (2-BW)	beneath LH front seat	271
C316 (6-B)	RH side of centre console on Right Front Seat Control Switch	170
C317 (6-B)	RH side of centre console on Right Front Seat Control Switch	170
C318 (9-R)	beneath RH front seat	230
C319 (6-B)	LH side of centre console on Left Front Seat Control Switch	169
C320 (6-B)	LH side of centre console on Left Front Seat Control Switch	169
C321 (9-U)	beneath LH front seat	226
C323 (5-B)	LH side of transmission to Park/Neutral Position Switch	113
C334 (3-B)	front centre of roof to Electrochromic Rear View Mirror	173
C335 (4-B)	Top of LH B-Post on Alarm Sensor	272
C337 (7-G)	in rear of centre console on Left Front Window Switch	164
C338 (7-W)	in rear of centre console on Right Front Window Switch	164
C339 (7-Y)	in rear of centre console on Left Rear Window Console Switch	165
C340 (7-R)	in rear of centre console on Right Rear Window Console Switch	165
C341 (5-W)	in rear of centre console on Left Seat Heat Switch	269
C342 (5-G)	in rear of centre console on Right Seat Heat Switch	269
C343 (7-N)	in rear of centre console on Rear Window Isolation Switch	165
C344 (6-B)	beneath centre console to Transmission Range Selector Switch	163
C346 (2-U)	beneath centre console to Automatic Gear Selector Illumination	163
C348 (5-Y)	beneath LH front seat on Left Seat Power Relay	226
C349 (5-W)	beneath LH front seat on Left Seat Heat Relay	229
C350 (3-W)	front centre of roof on Front Interior Roof Lamp	171
C351 (2-B)	RH front of roof to Right Vanity Mirror Lamp	215
C352 (2-B)	LH front of roof to Left Vanity Mirror Lamp	215
C353 (2-W)	beneath centre console on Fascia Cigar Lighter	162
C354 (29-R)	beneath centre console on Air Bag Diagnostic Control Module	166
C356 (1-B)	beneath centre console on Fascia Cigar Lighter	162
C357 (5-W)	beneath LH front seat on Right Seat Heat Relay	229
C358 (5-Y)	beneath LH front seat on Right Seat Power Relay	226
C368 (3-B)	top RH side of transfer box to Transfer Box Position Switch	119
C369 (2-B)	top RH side of transfer box to Transfer Box Solenoid	119
C370 (3-B)	LH side of transfer box on Vehicle Speed Sensor	117
C371 (2-B)	LH side of transfer box on Transfer Box Oil Temperature Switch	116
C372 (2-B)	on top of transmission	114
C378 (2-B)	beneath LH front seat to Driver's Seat Buckle Switch	229
C381 (3-W)	beneath RH front seat on CD Changer	230
C382 (8-W)	front centre of roof on Sunroof Control Unit	174
C383 (10-W)	front centre of roof on Sunroof Control Unit	174
C384 (7-G)	front centre of roof on Front Sunroof Switch	172
C385 (7-W)	front centre of roof on Rear Sunroof Switch	172
C386 (5-S)	front centre of roof on Rear Sunroof Lockout Switch	173
C387 (4-W)	front centre of roof to Front Sunroof Motor	174

Connector	Location	View
C388 (4-W)	centre of roof to Rear Sunroof Motor	234
C389 (3-W)	centre of roof to Passenger's Rear Sunroof Switch	233
C391 (5-W)	centre of roof on Passenger's Rear Fan Speed Switch	231
C392 (5-U)	centre of roof on Passenger's Rear A/C Switch	231
C398 (2-W)	underside of LH front seat	270
C399 (5-W)	underside of LH front seat	270
C400 (7-B)	RH rear of luggage compartment Trailer Auxiliary Socket	260
C402 (1-B)	LH side of tailgate to Number Plate Lamps	250
C403 (6-W)	LH rear of luggage compartment on Left Rear Lamp Assembly	239
C404 (1-B)	LH side of tailgate to Number Plate Lamps	250
C406 (6-W)	RH rear of luggage compartment on Right Rear Lamp Assembly	244
C407 (6-B)	beneath LH rear of vehicle	252
C408 (3-B)	RH side of tailgate on Rear Wiper Motor	248
C412 (6-W)	LH side of tailgate on Subwoofer Amplifier	251
C413 (4-W)	LH side of tailgate on Subwoofer Amplifier	251
C414 (2-W)	LH side of tailgate to Tailgate Lock Actuator	249
C415 (8-W)	in RH side of tailgate door jamb	246
C424 (1-B)	RH rear of luggage compartment Trailer Auxiliary Socket	245
C425 (1-B)	RH rear of luggage compartment Trailer Auxiliary Socket	245
C426 (1-B)	RH rear of roof behind trim panel on Right Antenna Amplifier	273
C431 (1-B)	LH rear of roof behind trim panel on Left Antenna Amplifier	273
C434 (4-B) (Except NAS)	top of fuel tank to Fuel Pump Module	256
C434 (4-B) (NAS)	top of fuel tank to Fuel Pump Module	274
C437 (6-W)	in RH side of tailgate door jamb	246
C438 (2-W)	in RH side of tailgate door jamb	246
C441 (2-R)	behind LH side of rear bumper on Left Tail Lamp	257
C442 (2-B)	behind LH side of rear bumper on Left Rear Indicator Lamp	257
C443 (2-B)	behind LH side of rear bumper on Left Rear Side Marker Lamp	259
C444 (2-R)	behind RH side of rear bumper on Right Tail Lamp	258
C445 (2-B)	behind RH side of rear bumper on Right Rear Indicator Lamp	258
C446 (2-B)	behind RH side of rear bumper on Right Rear Side Marker Lamp	259
C447 (2-W)	LH rear of luggage compartment	240
C448 (16-W)	LH rear of luggage compartment	240
C453 (1-B)	LH side of tailgate	250
C454 (1-B)	RH side of tailgate to Rear Screen	247
C455 (1-B)	RH side of tailgate	247
C456 (1-B)	LH side of tailgate	250
C457 (5-W)	LH side of luggage compartment on Rear Blower Motor Relay	238
C458 (2-B)	LH side of luggage compartment on Rear Blower Motor	235
C459 (4-B)	LH side of luggage compartment on Rear Blower Resistor Unit	
C462 (2-B)	LH rear of luggage compartment on Rear A/C Switch Amplifier In-Line Fuse	239
C463 (4-W)	LH side of luggage compartment on Rear A/C Control Relay	236

Connector	Location	View
C464 (2-S)	LH side of luggage compartment on Rear A/C Refrigerant Control Valve	236
C465 (4-W)	LH side of luggage compartment on Rear A/C Illumination Relay	237
C466 (4-W)	LH side of luggage compartment on Rear A/C Fan Speed Relay	238
C467 (6-W)	LH side of luggage compartment on Rear A/C Switch Amplifier	235
C484 (3-B)	top of fuel tank to Fuel Pressure Sensor	274
C485 (2-W)	beneath RH rear of vehicle to Left Rear Wheel Speed Sensor	254
C486 (2-W)	beneath LH rear of vehicle to Right Rear Wheel Speed Sensor	253
C487 (6-W)	RH rear of luggage compartment on E401	243
C489 (2-)	RH side of tailgate on Rear Wiper Motor	248
C500 (2-B)	in front of LH front door to Left Front Window Motor	219
C503 (6-W)	top front of LH front door to Left Mirror Actuator	216
C504 (4-W)	in top rear of LH front door to Left Front Door Key Switch	218
C507 (4-W) (Without Theft Alarm)	in rear of LH front door to Left Front Door Lock Actuator	217
C507 (6-W) (With Theft Alarm)	in rear of LH front door to Left Front Door Lock Actuator	217
C600 (2-B)	in front of RH front door to Right Front Window Motor	219
C603 (6-W)	top front of RH front door to Right Mirror Actuator	216
C607 (2-W) (Without Theft Alarm)	in rear of RH front door to Right Front Door Lock Actuator	220
C607 (6-W) (With Theft Alarm)	in rear of RH front door to Right Front Door Lock Actuator	220
C703 (2-B)	inside front of LH rear door to Left Rear Window Motor	224
C706 (2-W)	inside front of LH rear door to Left Rear Door Lock Actuator	222
C709 (5-W)	inside front of LH rear door on Left Rear Window Door Switch	223
C803 (2-B)	inside front of RH rear door to Right Rear Window Motor	224
C806 (2-W)	inside front of RH rear door to Right Rear Door Lock Actuator	222
C809 (5-W)	inside front of RH rear door on Right Rear Window Door Switch	223
C1000 (2-B) (SFI-V8)	LH side of engine compartment on Intake Air Temperature Sensor	12
C1000 (2-G) (300Tdi with EDC)	top rear of engine on Boost Pressure Air Temperature Sensor	27
C1000 (2-G) (MFI-T16)	RH rear of engine on Intake Air Temperature Sensor	
C1001 (3-B)	LH rear of engine compartment on Boost Pressure Sensor	13
C1002 (3-B) (MFI-T16)	top rear of engine on Ignition Coil 1	
C1002 (6-B) (SFI-V8)	top rear of engine to Ignition Coils	5
C1003 (3-B)	top rear of engine on Ignition Coil 2	
C1004 (2-B) (SFI-V8)	lower LH rear of engine on Crankshaft Position Sensor	103
C1004 (2-U) (MFI-T16)	lower RH rear of engine to Crankshaft Position Sensor	87
C1005 (2-W)	RH side of engine on Knock Sensor	60
C1006 (3-W)	RH rear corner of engine compartment Data Link Connector (MFI)	92
C1007 (36-B)	RH rear corner of engine compartment on Engine Control Module (ECM)	93
C1008 (18-B)	RH rear corner of engine compartment on Engine Control Module (ECM)	93
C1009 (2-B)	LH front of vehicle on Left Front Indicator Lamp	34

Connector	Location	View
C1010 (2-B)	RH front of vehicle on Right Front Indicator Lamp	34
C1011 (2-W) (MFI-T16 with Air Conditioning)	front of engine compartment to Cooling Fan Motor 1	
C1011 (2-W) (MFI-T16 without Air Conditioning)	front of engine compartment to Cooling Fan Motor 1	39
C1012 (2-W)	front of engine compartment to Cooling Fan Motor 2	
C1013 (2-B)	LH front of vehicle on Left Front Side Marker Lamp	33
C1014 (2-B)	RH front of vehicle on Right Front Side Marker Lamp	33
C1017 (36-R)	RH rear corner of engine compartment on Engine Control Module (ECM)	94
C1018 (1-W)	LH front of engine compartment on Ignition Coil	37
C1019 (4-RB)	beneath LH side of vehicle to Left Heated Oxygen Sensor (Post Catalyst)	112
C1020 (4-B)	beneath RH side of vehicle to Right Heated Oxygen Sensor (Post Catalyst)	111
C1021 (3-B)	lower RH side of engine to Camshaft Position Sensor	48
C1022 (2-B)	lower LH side of engine on Left Knock Sensor	104
C1023 (2-B)	lower RH side of engine on Right Knock Sensor	105
C1024 (2-B)	LH front of engine compartment to Left Front Fog Lamp	43
C1025 (2-B)	RH front of engine compartment to Right Front Fog Lamp	43
C1026 (13-BU)	RH rear corner of engine compartment	100
C1027 (13-B)	RH rear corner of engine compartment	100
C1028 (4-B)	RH rear corner of engine compartment	100
C1029 (8-B)	RH rear of engine compartment on Multi-Function Relay Unit	78
C1030 (6-B)	RH rear of engine compartment on Multi-Function Relay Unit	78
C1031 (4-N)	RH front of engine compartment on Battery Backed Up Alarm Sounder	57
C1032 (36-B)	RH rear corner of engine compartment on Engine Control Module (ECM)	94
C1033 (18-B)	RH rear corner of engine compartment on Engine Control Module (ECM)	94
C1034 (2-B)	RH front of engine compartment on Evaporative Emission Canister Vent Seal Valve	54
C1035 (3-B)	LH front of engine compartment on Ignition Control Module	38
C1036 (3-B)	LH front of engine compartment to Ignition Control Module	38
C1040 (3-B)	RH side of engine to Diesel Immobilisation Unit (DDS)	265
C2000 (5-Y)	behind RH side of fascia on Interlock Relay 1	181
C2001 (5-Y)	behind RH side of fascia on Interlock Relay 2	181
C2005 (2-W)	behind LH side of fascia on Brake Switch Vent Valve	149
C2006 (5-Y)	behind RH footwell trim panel on Starter Solenoid Relay	204
C2007 (5-Y)	behind RH footwell trim panel on Ignition Load Relay	204
C2008 (5-G)	behind RH footwell trim panel on Front Wiper Relay	203
C2009 (4-W)	top of steering column on Direction Indicator Switch	133
C2010 (6-W)	top of steering column to Rotary Coupler	134
C2011 (6-W)	top of steering column on Front Wipe/Wash Switch	144
C2012 (8-W)	top of steering column	135

Connector	Location	View
C2013 (4-B)	top of steering column	144
C2014 (2-B)	top of steering column on Ignition Key Lock Solenoid	136
C2015 (8-W)	top of steering column on Front Wipe/Wash Switch	144
C2016 (1-W)	behind LH side of fascia on Fascia Fuse Box	126
C2021 (5-B) (Except NAS) (Manual Transmission)	behind RH side of fascia on Speed Trip Module	197
C2021 (5-B) (NAS) (Manual Transmission)	behind RH side of fascia on Speed Trip Module	201
C2021 (5-G) (Except NAS) (Automatic Transmission)	behind RH side of fascia on Cruise Control Lockout Relay	197
C2021 (5-G) (NAS) (Automatic Transmission)	behind RH side of fascia on Cruise Control Lockout Relay	201
C2022 (5-W)	behind heater and A/C control panel on Front Fan Speed Switch	160
C2023 (4-W)	behind heater and A/C control panel	160
C2024 (5-U)	behind heater and A/C control panel on Main Rear A/C Switch	161
C2025 (5-W)	behind heater and A/C control panel on Front A/C Switch	160
C2026 (5-B)	behind heater and A/C control panel on Air Supply Selector Switch	161
C2027 (5-W)	behind LH side of fascia LH side of heater evaporator unit	152
C2028 (6-W)	behind RH footwell trim panel on E200	203
C2029 (6-W)	behind LH footwell trim panel on E201	120
C2035 (2-W)	behind LH side of fascia on Clutch Pedal Position Switch	130
C2036 (7-BW)	in steering wheel to Rotary Coupler	132
C2044 (5-G)	behind RH side of fascia on Transmission Range Selector Illumination Relay	182
C2047 (5-B)	behind RH side of fascia on Daytime Running Lamps Control Unit	200
C2051 (8-B)	behind RH side of fascia on Multi-Function Relay Unit	205
C2052 (6-B)	behind RH side of fascia on Multi-Function Relay Unit	205
C2053 (5-Y)	behind RH side of fascia on Power Amplifier Relay	182
C2054 (18-W)	behind RH side of fascia on Radio Amplifier	187
C2055 (13-W)	behind LH side of fascia LH side of heater evaporator unit	153
C2056 (5-B)	top LH side of fascia on Radio Tune Switch	143
C2057 (5-U)	top LH side of fascia on Radio Waveband Switch	143
C2058 (5-W)	top LH side of fascia on Radio Volume Up Switch	141
C2059 (5-G)	top LH side of fascia on Radio Volume Down Switch	141
C2060 (5-W)	centre of fascia to Radio	157
C2061 (7-B)	centre of fascia on Radio	158
C2062 (1-B)	behind LH side of fascia Saudi Junction Connector	130
C2063 (2-B)	behind LH side of fascia to Stop Lamp Switch Suppressor	150
C2066 (8-W)	behind RH side of fascia right of heater evaporator unit	175
C2067 (10-W)	behind LH side of fascia LH side of heater evaporator unit	152
C2068 (5-W)	behind RH side of fascia on Front Blower Motor Relay	183
C2069 (2-B)	behind RH side of fascia on Front Blower Motor	179
C2070 (4-B)	behind RH side of fascia on Front Blower Resistor Unit	175
C2071 (2-B)	behind RH side of fascia on Air Recirculation Solenoid In-Line Fuse	179
C2072 (4-Y)	behind RH side of fascia on Air Recirculation Solenoid	183

Connector	Location	View
C2073 (10-W)	behind RH side of fascia right of heater evaporator unit	176
C2074 (5-Y) (Except NAS)	behind RH side of fascia on Power Wash Relay	193
C2074 (5-Y) (NAS)	behind RH side of fascia on Power Wash Relay	198
C2079 (2-B)	centre of fascia on Radio	157
C2080 (-B)	centre of fascia on Radio	158
C2082 (6-W)	behind LH side of fascia near Fascia Fuse Box	129
C2083 (16-S)	behind LH side of fascia Data Link Connector (OBDII)	151
C2084 (35-B)	behind RH side of fascia on Anti-Lock Brake System ECU	184
C2085 (3-W)	behind RH footwell trim panel	184
C2089 (5-W)	behind LH footwell trim panel on Fog Lamps Relay	123
C2090 (5-Y)	behind RH side of fascia on Front Fog Lamps Relay	194
C2091 (5-G)	behind RH side of fascia on Rear Fog Lamps Relay	194
C2092 (5-G) (Except NAS)	behind RH side of fascia on A.B.S. Warning Relay	195
C2092 (5-G) (NAS)	behind RH side of fascia on A.B.S. Warning Relay	199
C2093 (5-Y) (Except NAS)	behind RH side of fascia on A.B.S. Load Relay	195
C2093 (5-Y) (NAS)	behind RH side of fascia on A.B.S. Load Relay	199
C2094 (4-B) (Except NAS)	behind RH side of fascia on A.B.S. Pump Relay	196
C2094 (4-B) (NAS)	behind RH side of fascia on A.B.S. Pump Relay	200
C2095 (9-B) (With Immobilisation)	behind centre of fascia on Engine Immobilisation Control Unit (Spider)	159
C2095 (9-B) (Without Immobilisation)	behind centre of fascia above heater evaporator unit	159
C2096 (2-B)	top of steering column to Passive Immobilisation Coil	137
C2097 (4-W)	behind LH side of fascia near steering column	131
C2098 (5-G)	centre of fascia on Front Fog Lamps Switch	156
C2100 (2-W)	behind LH footwell trim panel	120
C2101 (13-W)	behind LH footwell trim panel	120
C2102 (2-W)	behind LH footwell trim panel	120
C2103 (2-W)	behind RH footwell trim panel	202
C2104 (13-W)	behind RH footwell trim panel	202
C2105 (2-W)	behind RH footwell trim panel	202
C2106 (5-R)	behind RH footwell trim panel on Service Reminder Unit	210
C2107 (5-W)	behind RH footwell trim panel on Cruise Control Disable Relay	212
C2110 (2-S)	LH A-post to Left Front Tweeter	214
C2113 (1-B)	behind LH side of fascia near C209	153
C2114 (1-B)	behind LH side of fascia near C209	153
C3000 (1-B)	on top of transmission to Reverse Switch	114
C3001 (1-B)	on top of transmission to Reverse Switch	114
C3003 (6-W)	beneath centre console on E303	168
C3004 (3-W)	in lower part of LH B-post	221
C3005 (2-W)	in lower part of LH B-post	221
C3006 (3-W)	in lower part of RH B-post	221
C3007 (2-W)	in lower part of RH B-post	221
C3011 (6-W)	beneath LH front seat on E301	225

Ground	Location	View
E100 (MFI-V8) (MFI-T16) ..	RH front of engine compartment behind battery	49
E100 (300Tdi)	RH front of engine compartment behind battery	51
E100 (SFI-V8)	RH front of engine compartment behind battery	50
E101 (MFI-V8) (MFI-T16) (SFI-V8)	LH front of engine compartment on fender well	29
E101 (300Tdi)	LH front of engine compartment on fender well	30
E102(MFI-V8) (MFI-T16) ...	RH side of engine compartment on fender well	52
E102(300Tdi)	RH side of engine compartment on fender well	53
E102(SFI-V8)	RH side of engine compartment on fender well	77
E103 (MFI-V8)	LH rear corner of engine below valve cover	7
E104	lower LH rear of engine compartment on frame rail	
E105	LH front of engine compartment on Ignition Coil	36
E106	lower LH side of engine	22
E108	near Starter	
E109	lower RH side of engine compartment on frame rail	45
E110	LH side of bulkhead	1
E200	behind RH footwell trim panel	203
E201	behind LH footwell trim panel	120
E203	behind LH side of fascia	129
E204	behind LH footwell trim panel	120
E205	behind RH footwell trim panel	203
E301	beneath LH front seat	225
E303	beneath centre console	168
E400	LH rear of luggage compartment	241
E401	RH rear of luggage compartment	243
E404 (NAS)	beneath RH rear of vehicle near fuel filler pipe	275
E404 (Except NAS)	beneath RH rear of vehicle near fuel filler pipe	255
Splice	Location	View
HJ1 (20-S)	behind LH side of fascia near steering column	149
HJ2 (20-U)	behind RH side of fascia near C298	180
HJ3 (20-S)	behind RH side of fascia	177
HJ4 (20-U) (Except NAS) ...	behind RH side of fascia near C298	193
HJ4 (20-S) (NAS)	behind RH side of fascia near C298	198
HJ5 (20-S)	behind RH side of fascia	177
HJ6 (20-G)	behind RH side of fascia near C2073	177
HJ7 (20-U)	behind RH side of fascia	190
HJ8 (20-S)	behind instrument cluster	147
HJ9 (20-S)	behind instrument cluster	146
HJ10 (20-S)	behind RH side of fascia	180
HJ11 (20-S)	behind LH footwell trim panel	122
HJ12 (20-G)	LH rear corner of roof behind trim panel	242
HJ13 (20-S)	behind LH side of fascia left of steering column	267

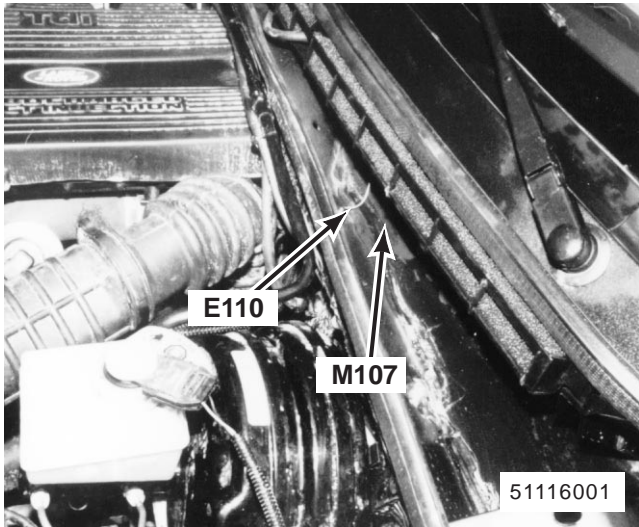

1. LH side of bulkhead
M107 Front Wiper Motor
E110

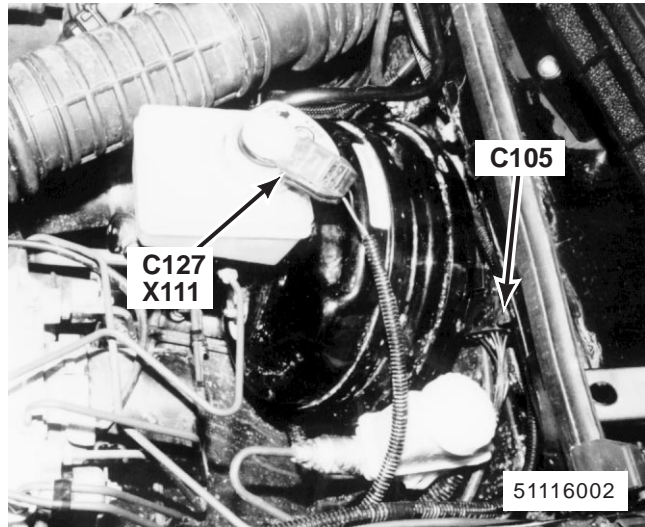

2. LH rear of engine compartment
X111 Brake Fluid Level Switch
C127 (3-B)
C105 (13-B)

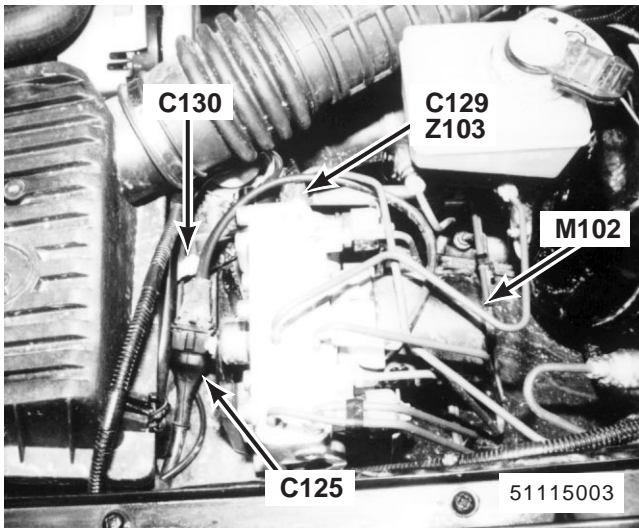

3. LH rear corner of engine compartment
M102 A.B.S. Hydraulic Pump
Z103 A.B.S. Booster Unit
C125 (2-B)
C129 (13-B)
C130 (2-W)

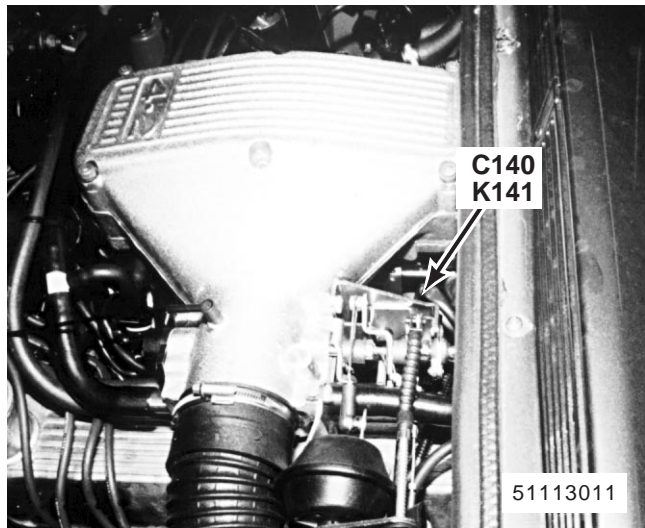

4. LH rear of engine MFI-V8
K141 Fuel Injectors
C140 (2-B)

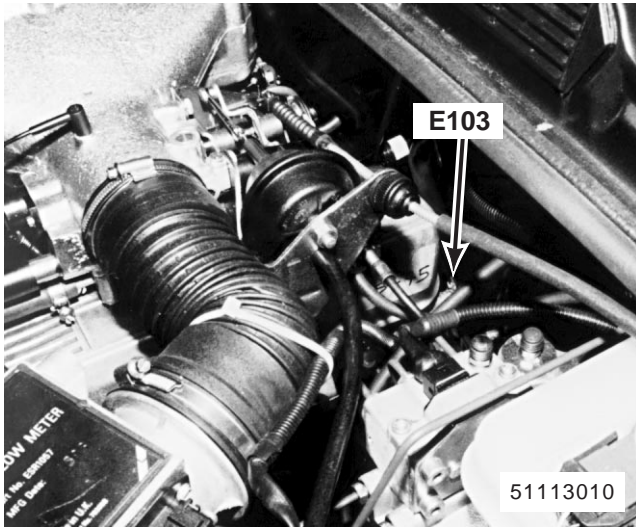

5. LH rear of engine MFI-V8
E103

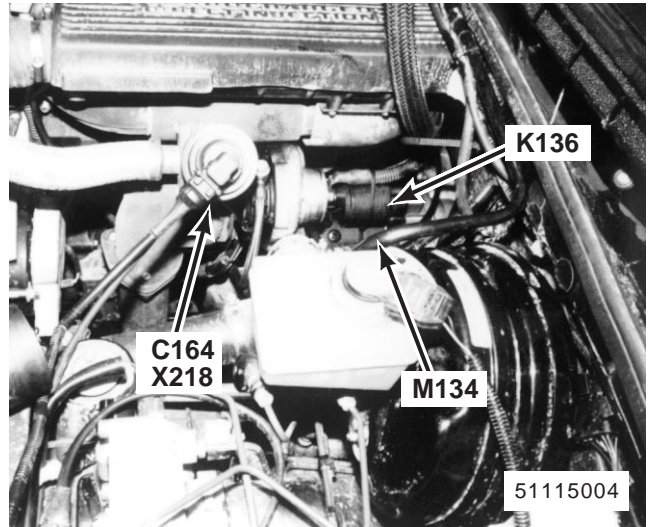

6. lower LH side of engine 300Tdi without EDC
K136 Starter Solenoid
M134 Starter
X218 EGR Valve Position Sensor
C164 (3-B)

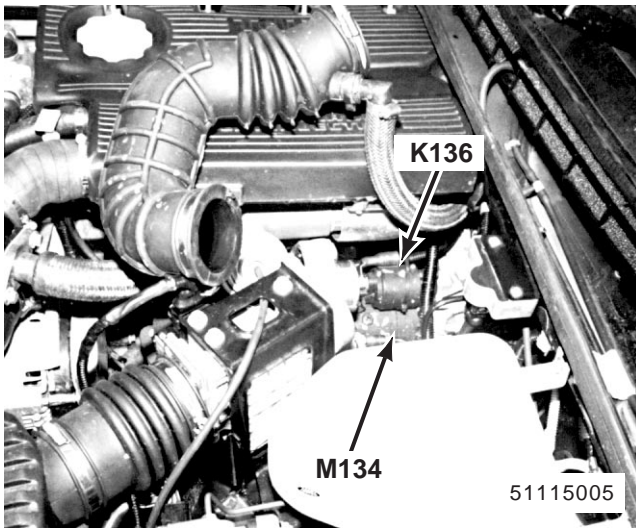

7. lower LH side of engine 300Tdi with EDC
K136 Starter Solenoid
M134 Starter

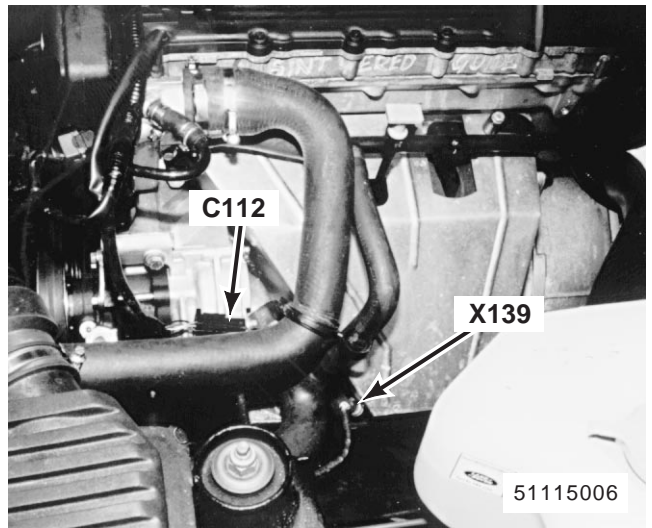

8. lower LH side of engine MFI-T16
X139 Left Heated Oxygen Sensor
C112 (4-B)

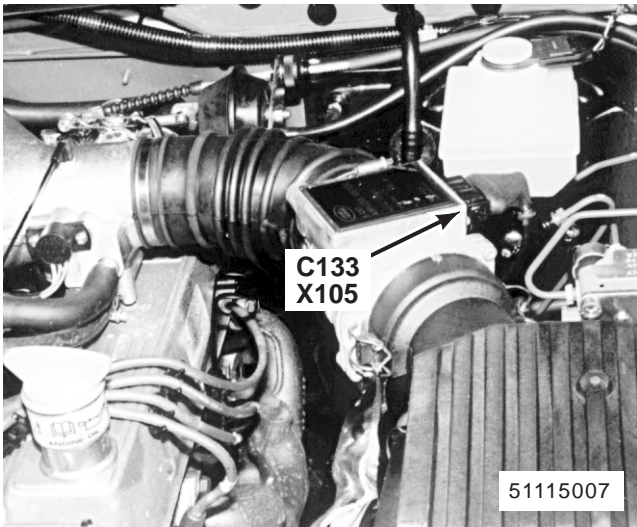

9. LH side of engine MFI-V8
X105 Mass Air Flow Sensor
C133 (6-B)

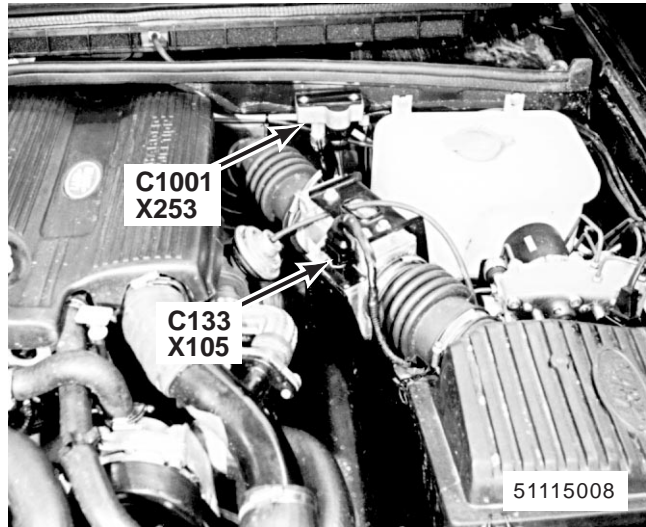

10. LH rear of engine compartment 300Tdi with EDC
X105 Mass Air Flow Sensor
X253 Boost Pressure Sensor
C1001 (3-B)
C133 (5-B)

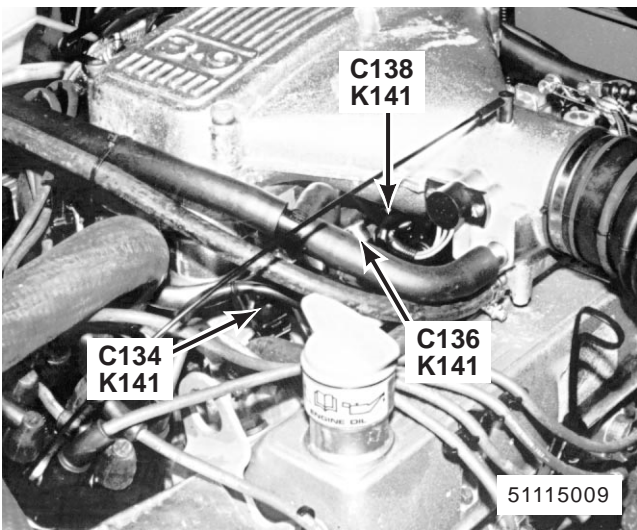

11. LH side of engine MFI-V8
K141 Fuel Injectors
C134 (2-B)
C136 (2-B)
C138 (2-B)

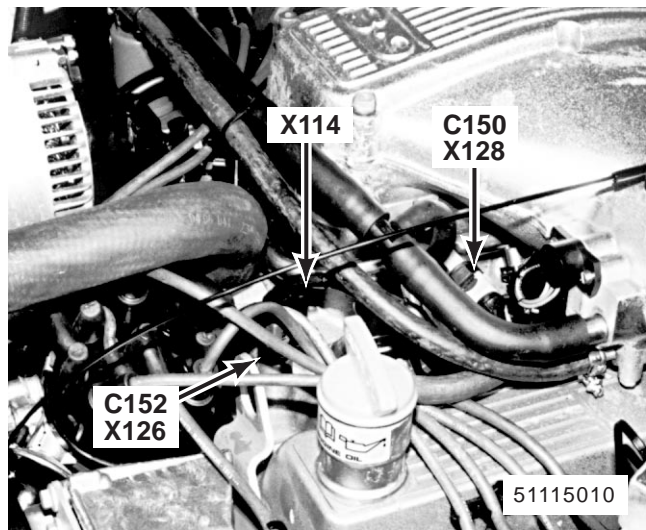

12. LH side of engine MFI-V8
X114 Engine Coolant Temperature Gauge Sensor
X126 Engine Coolant Temperature Sensor
X128 Engine Fuel Temperature Sensor
C150 (2-U)
C152 (2-N)

Z5 ETM

DISCOVERY

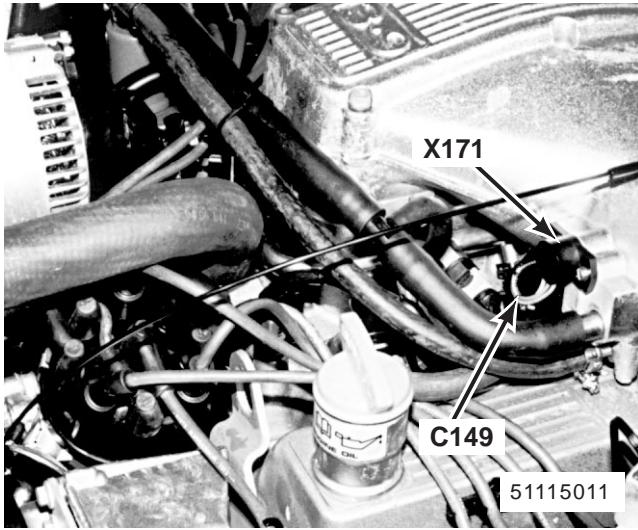

13. LH side of engine MFI-V8
 X171 Throttle Position Sensor
 C149 (3-B)

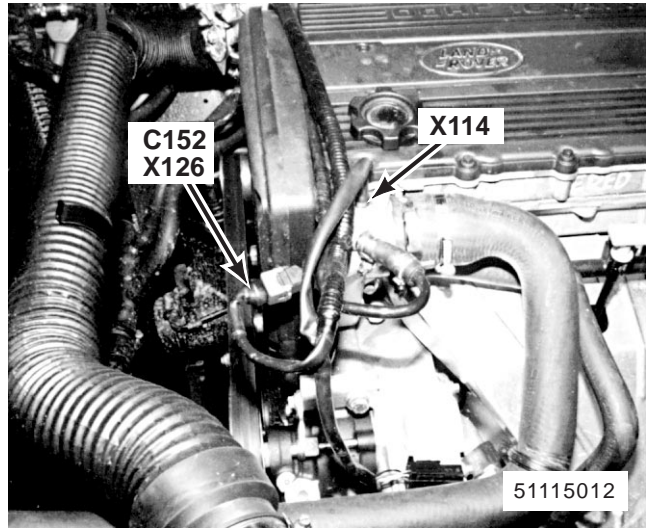

14. LH front of engine MFI-T16
 X114 Engine Coolant Temperature Gauge Sensor
 X126 Engine Coolant Temperature Sensor
 C152 (2-N)

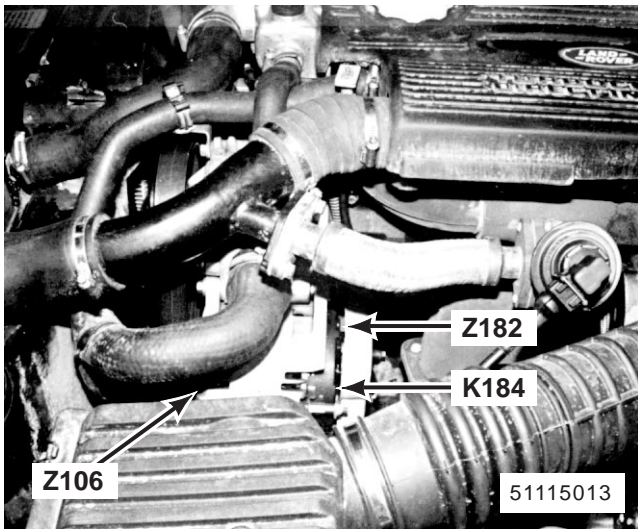

15. lower LH side of engine 300Tdi
 K184 Phase Tap Resistor
 Z182 Generator Suppression Capacitor
 Z106 Generator

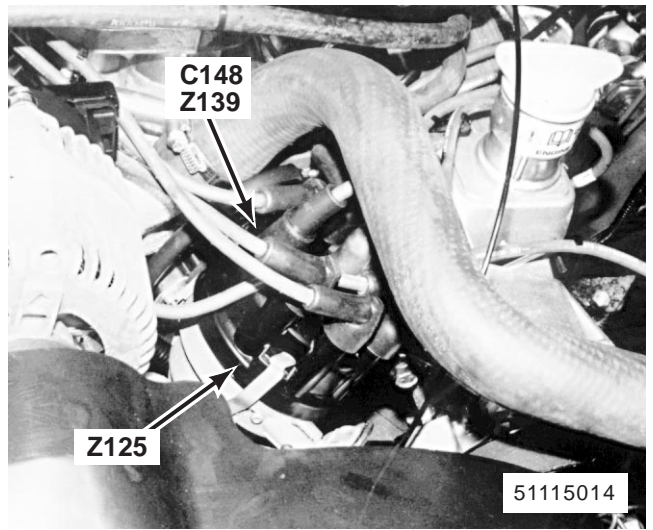

16. top centre front of engine MFI-V8
 Z125 Distributor
 Z139 Ignition Control Module
 C148 (3-B)

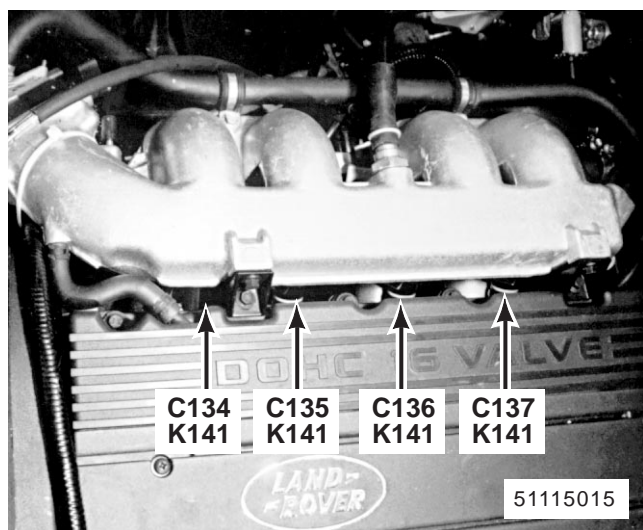

17. top centre front of engine MFI-T16

K141 Fuel Injectors

C134 (2-B)

C135 (2-B)

C136 (2-B)

C137 (2-B)

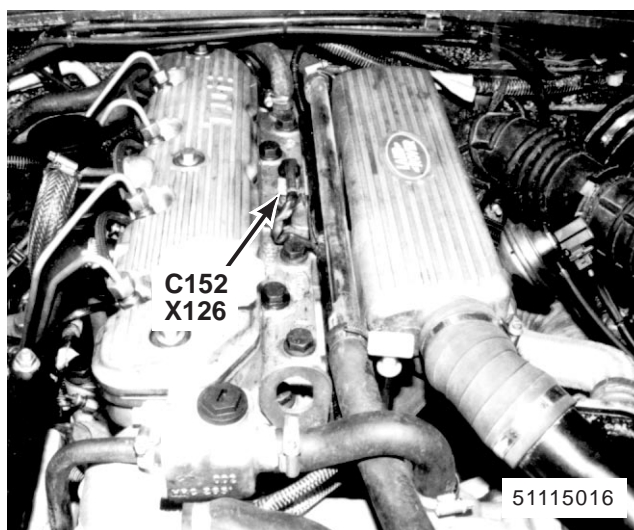

18. top centre front of engine 300Tdi without EDC

X126 Engine Coolant Temperature Sensor

C152 (2-N)

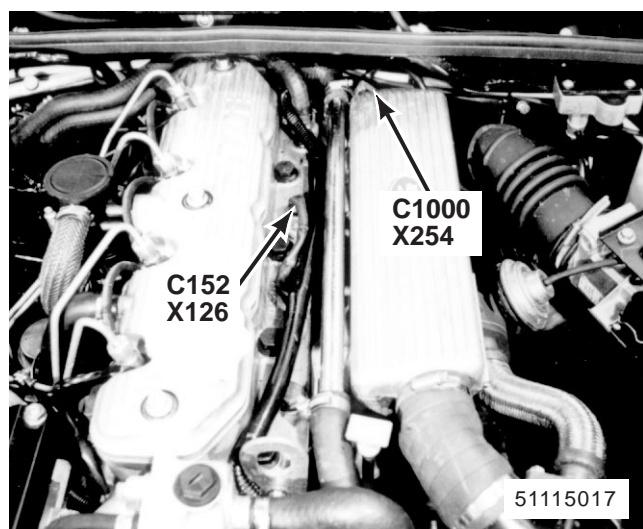

19. top centre front of engine 300Tdi with EDC

X126 Engine Coolant Temperature Sensor

X254 Boost Pressure Air Temperature Sensor

C1000 (2-G)

C152 (2-N)

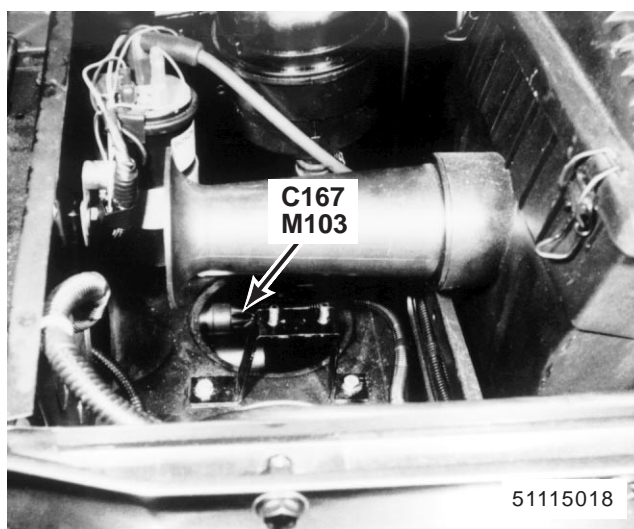

20. LH front corner of engine compartment (MFI-V8 shown; others similar)

M103 Cruise Control Vacuum Pump

C167 (3-B)

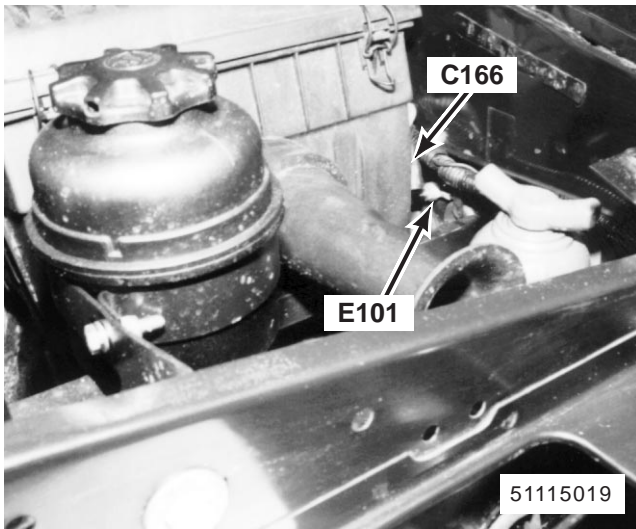

21. LH front of engine compartment MFI-V8
MFI-T16
C166 (2-B)
E101

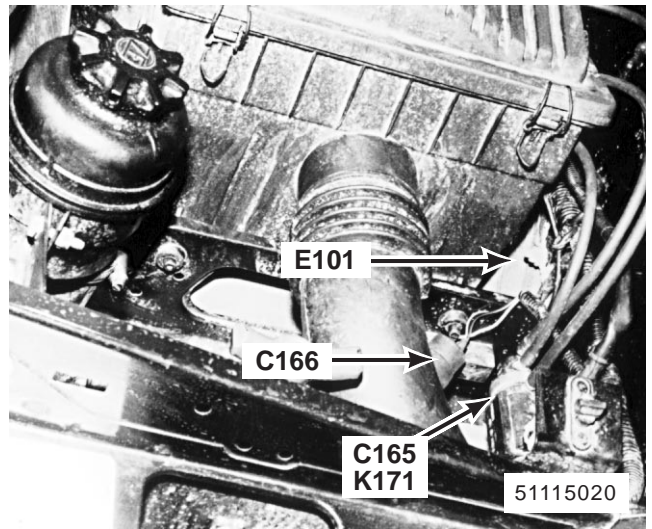

22. LH front of engine compartment 300Tdi
K171 EGR Control Solenoid
C165 (2-B)
C166 (2-B)
E101

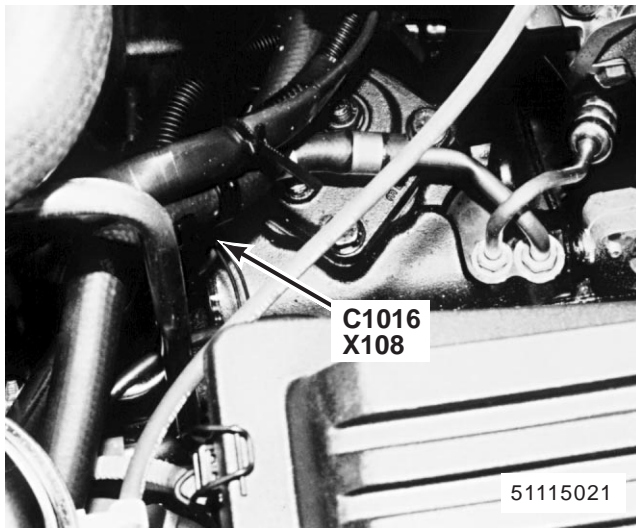

23. lower LH front of engine compartment (MFI-V8 shown; others similar)
X108 Automatic Transmission Oil Temperature Switch
C1016 (2-B)

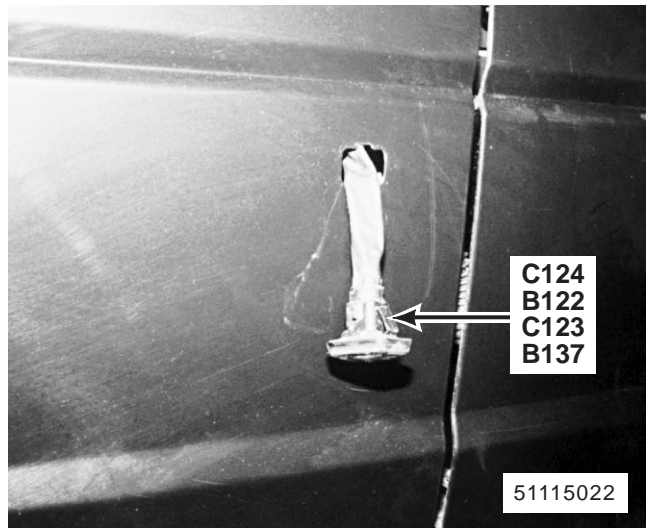

24. LH front side of vehicle (RH similar)
B122 Left Repeater Lamp
B137 Right Repeater Lamp
C123 (2-B) (Right)
C124 (2-B) (Left)

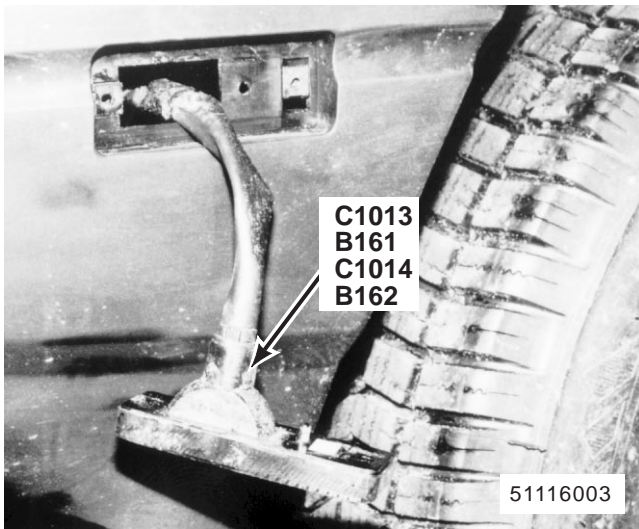

25. LH front of vehicle (RH similar)
 B161 Left Front Side Marker Lamp
 B162 Right Front Side Marker Lamp
 C1013 (2-B) (Left)
 C1014 (2-B) (Right)

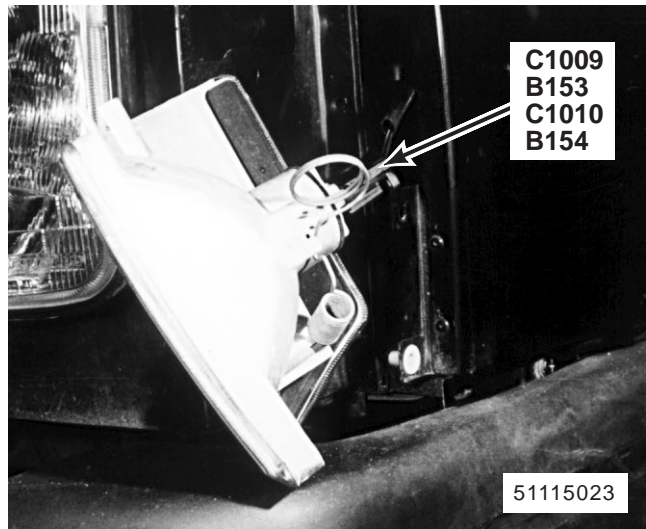

26. LH front of vehicle (RH similar)
 B153 Left Front Indicator Lamp
 B154 Right Front Indicator Lamp
 C1009 (2-B) (Left)
 C1010 (2-B) (Right)

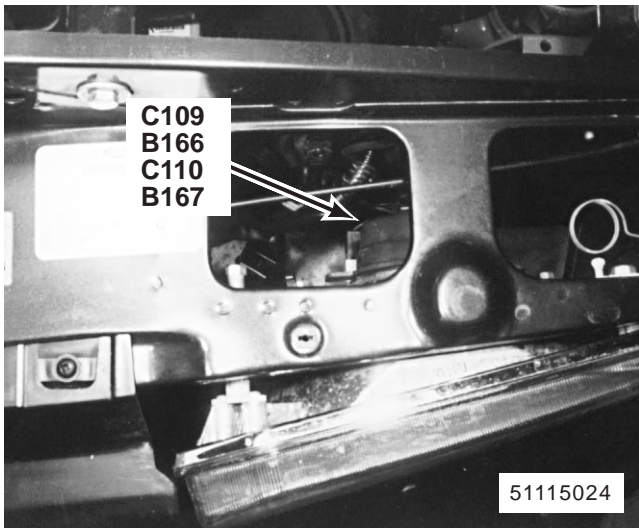

27. LH front of engine compartment (RH similar)
 B166 Left Front Side Lamp
 B167 Right Front Side Lamp
 C109 (2-W) (Left)
 C110 (2-W) (Right)

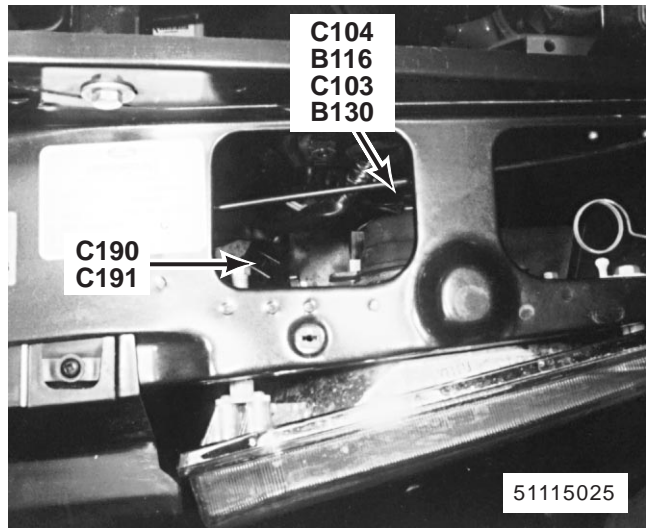

28. LH front of engine compartment (RH similar)
 B116 Left Headlamp
 B130 Right Headlamp
 C103 (3-B) (Right)
 C104 (3-B) (Left)
 C190 (3-B) (Left)
 C191 (3-B) (Right)

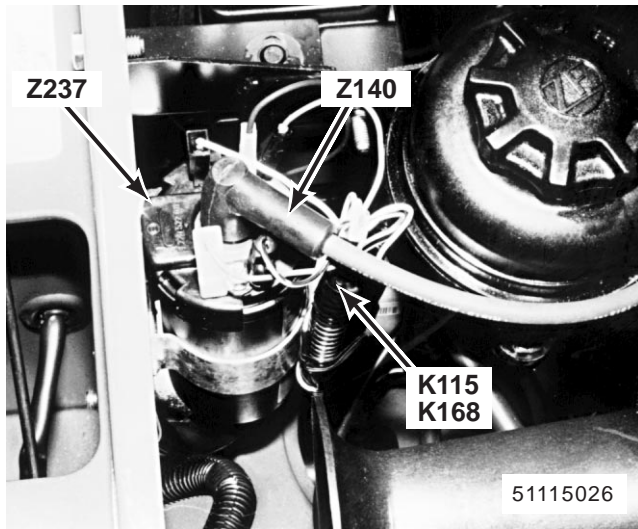

29. LH front corner of engine compartment MFI-V8

- K115 Multiport Fuel Injection Ignition Resistor 1
- K168 Multiport Fuel Injection Ignition Resistor 2
- Z140 Ignition Coil
- Z237 Ignition Coil Noise Suppressor

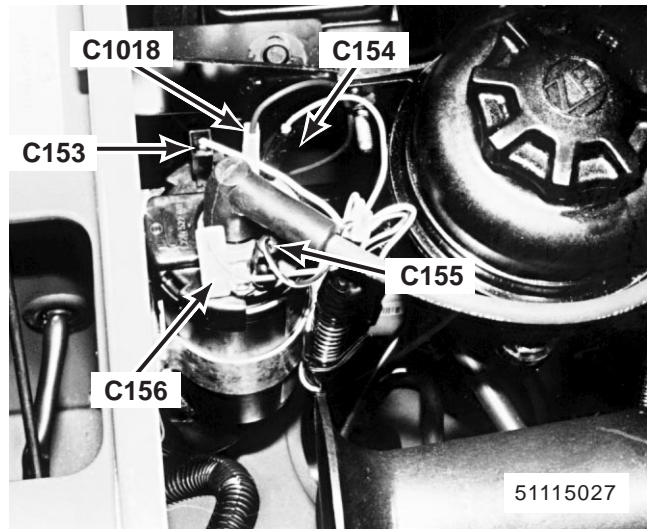

30. LH front corner of engine compartment MFI-V8

- C153 (1-B)
- C154 (1-B)
- C155 (1-B)
- C156 (1-W)
- C1018 (1-W)

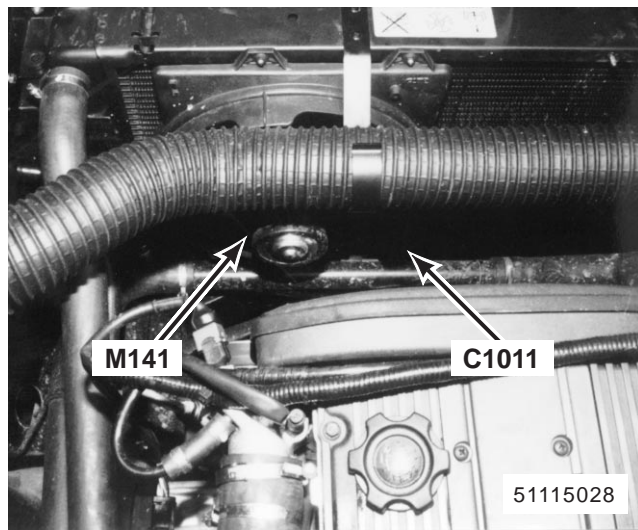

31. front of engine compartment MFI-T16 without Air Conditioning

- M141 Cooling Fan Motor 1
- C1011 (2-W)

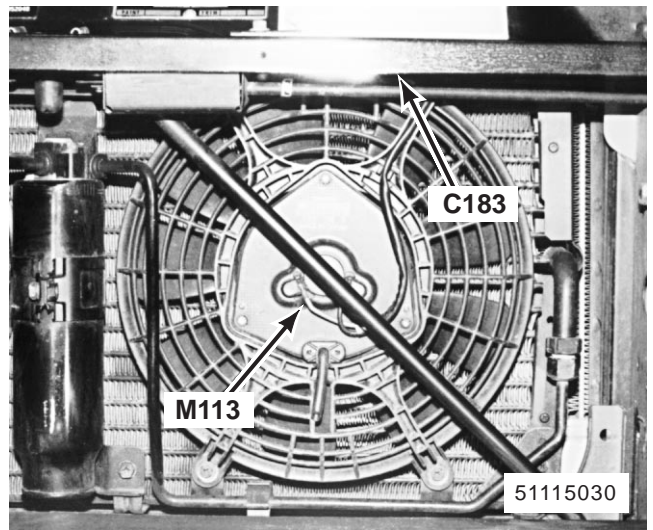

32. behind front grille

- M113 Left Condenser Fan Motor
- C183 (2-B)

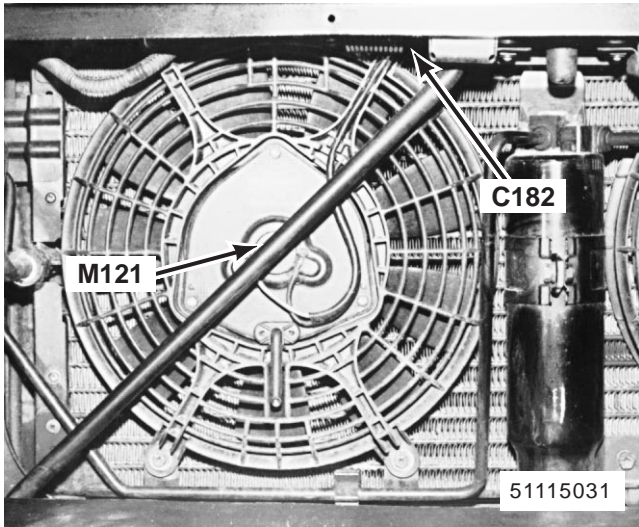

33. behind front grille
M121 Right Condenser Fan Motor
C182 (2-B)

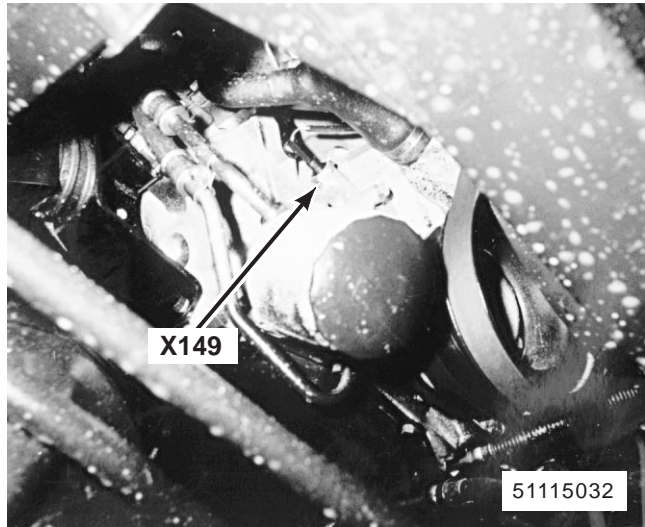

34. lower RH side of engine MFI-V8
X149 Oil Pressure Switch



35. lower RH side of engine MFI-T16
X149 Oil Pressure Switch
C142 (2-N)

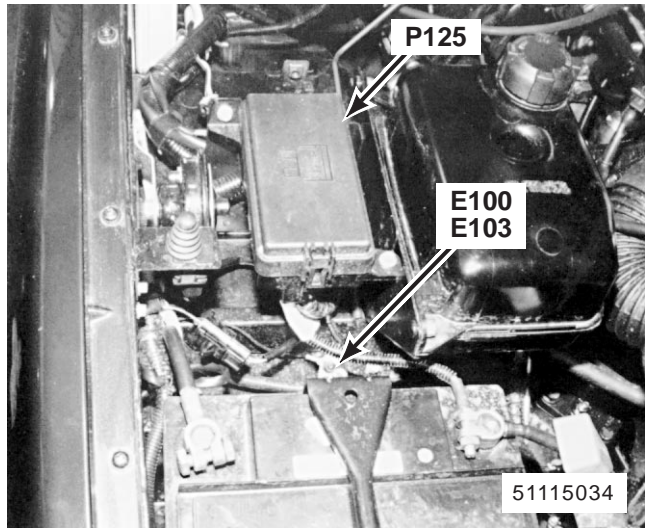

36. RH front of engine compartment MFI-V8 MFI-T16
P125 Engine Compartment Fuse Box
E100
E103 MFI-T16

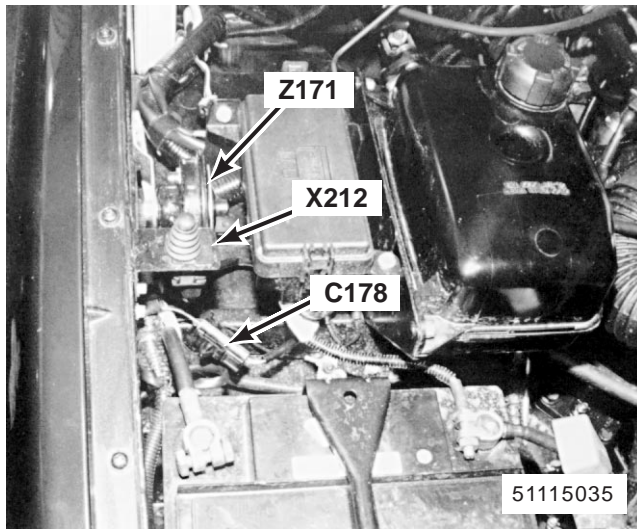

37. RH front of engine compartment MFI-V8
MFI-T16
X212 Alarm Bonnet Switch
Z171 Alarm Sounder
C178 (2-B)

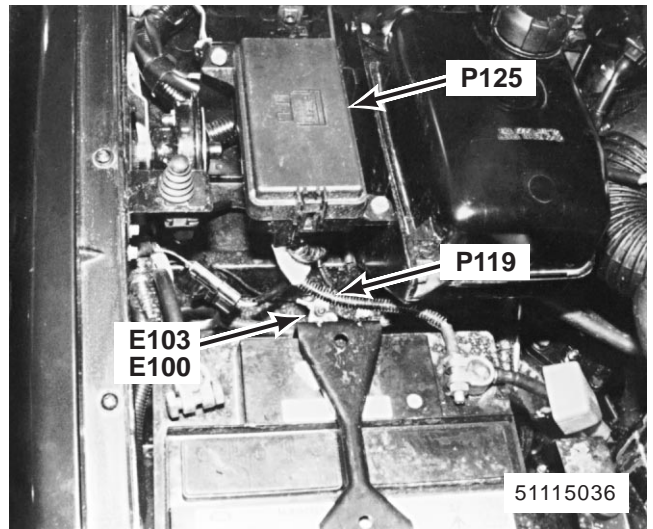

38. RH front of engine compartment 300Tdi
P119 Fusible Link
P125 Engine Compartment Fuse Box
E100
E103

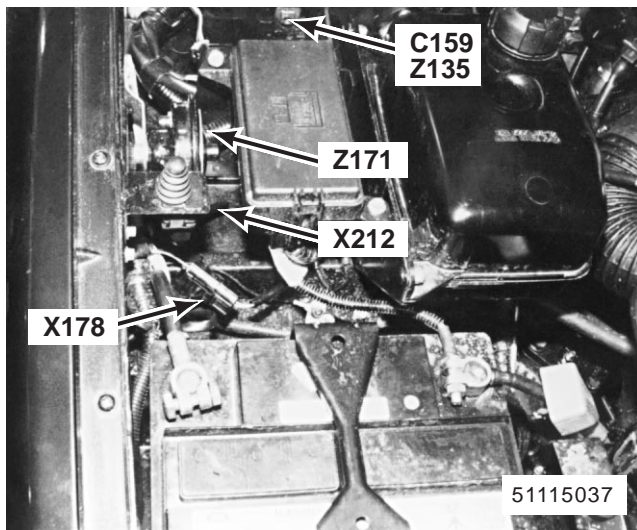

39. RH front of engine compartment 300Tdi
X212 Alarm Bonnet Switch
Z135 Glow Plug Timer Unit
Z171 Alarm Sounder
C159 (6-B)
C178 (2-B)

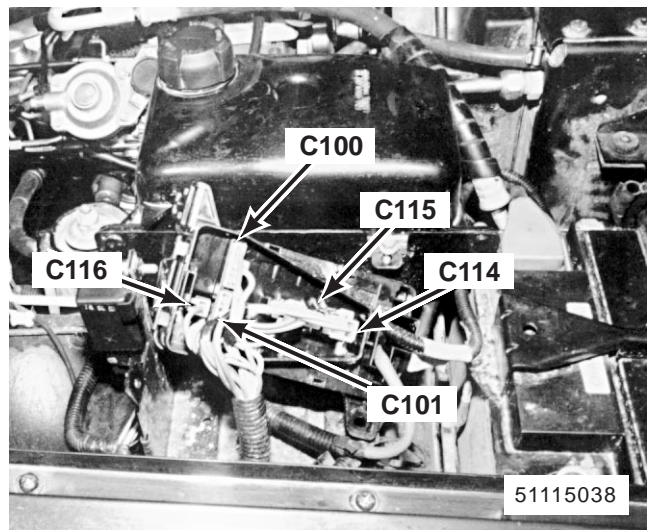

40. RH front of engine compartment
C100 (3-W)
C101 (4-W)
C114 (2-W)
C115 (3-W)
C116 (1-W)

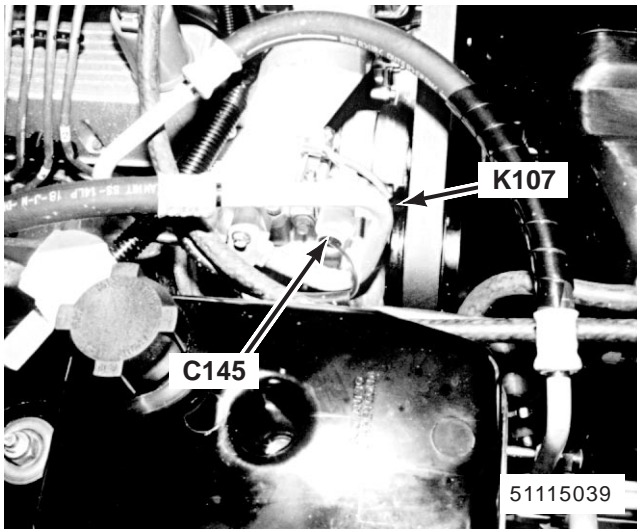

41. RH side of engine MFI-V8
K107 Compressor Clutch
C145 (2-W)

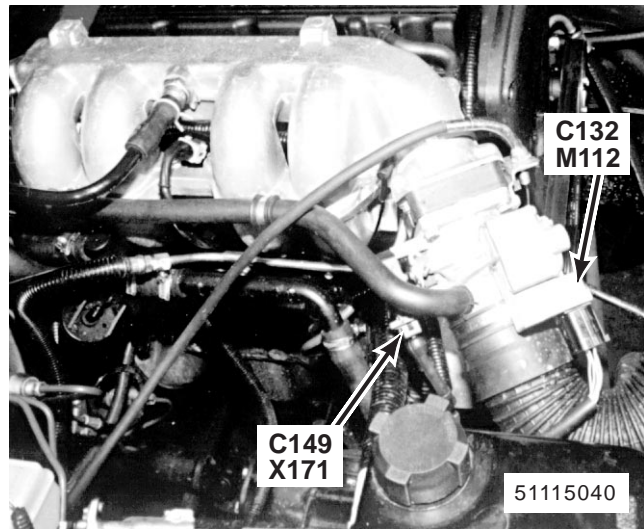

42. RH front of engine MFI-T16
M112 Idle Air Control Valve
X171 Throttle Position Sensor
C132 (6-B)
C149 (3-B)

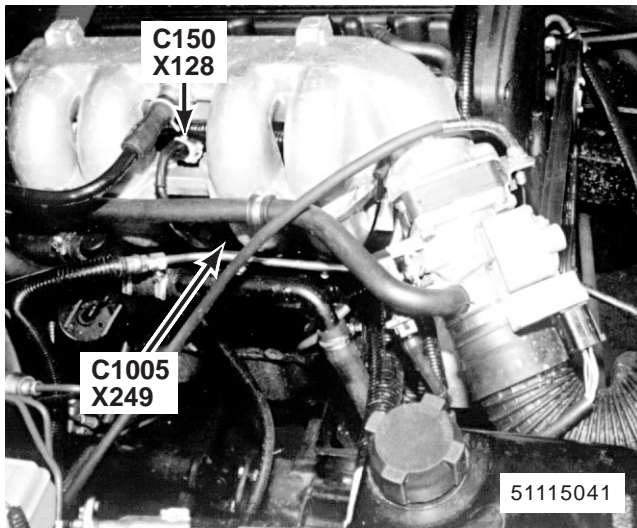

43. RH side of engine MFI-T16
X128 Engine Fuel Temperature Sensor
X249 Knock Sensor
C150 (2-S)
C1005 (2-W)

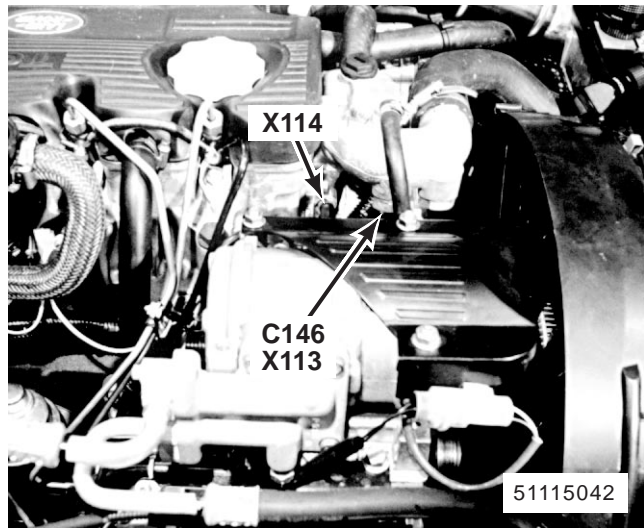

44. RH front of engine 300Tdi with EDC
X113 Condenser Fan Coolant Temperature Switch
X114 Engine Coolant Temperature Gauge Sensor
C146 (2-B)

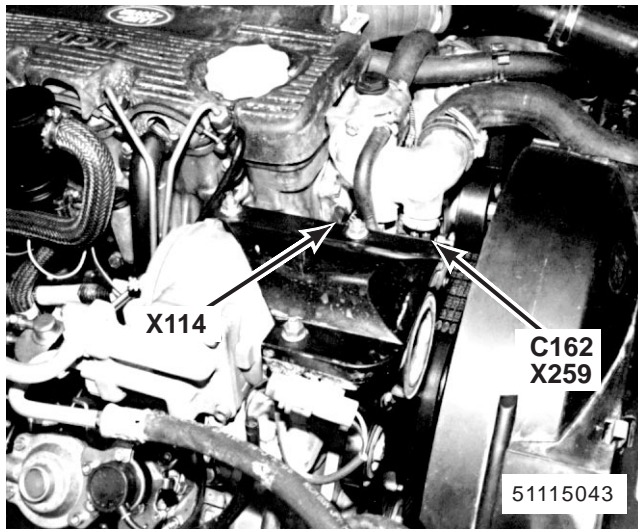

45. RH front of engine 300Tdi without EDC
 X114 Engine Coolant Temperature Gauge Sensor
 X259 Compressor Clutch Cut-out Switch
 C162 (2-B)

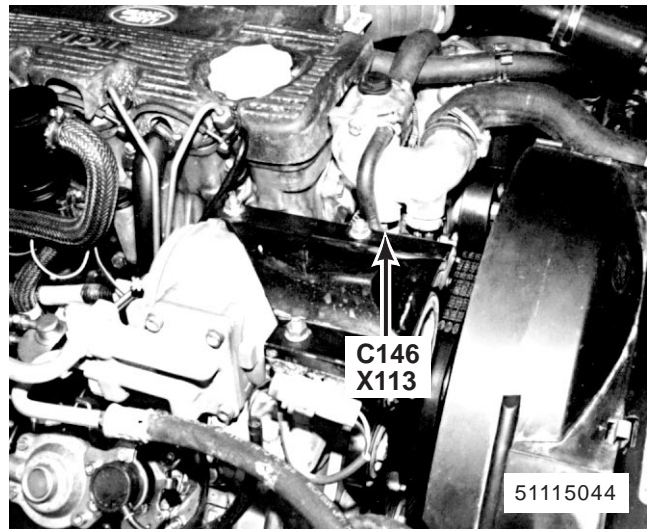

46. RH front of engine 300Tdi without EDC
 X113 Condenser Fan Coolant Temperature Switch
 C146 (2-B)

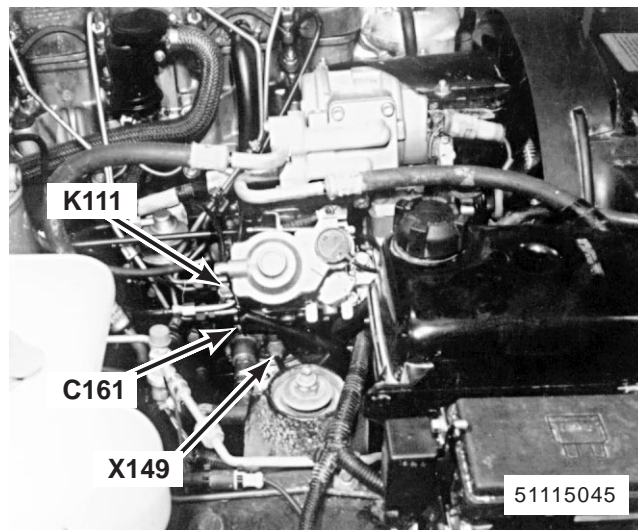

47. RH side of engine 300Tdi without EGR
 K111 Fuel Shut-Off Solenoid
 X149 Oil Pressure Switch
 C161 (1-W)

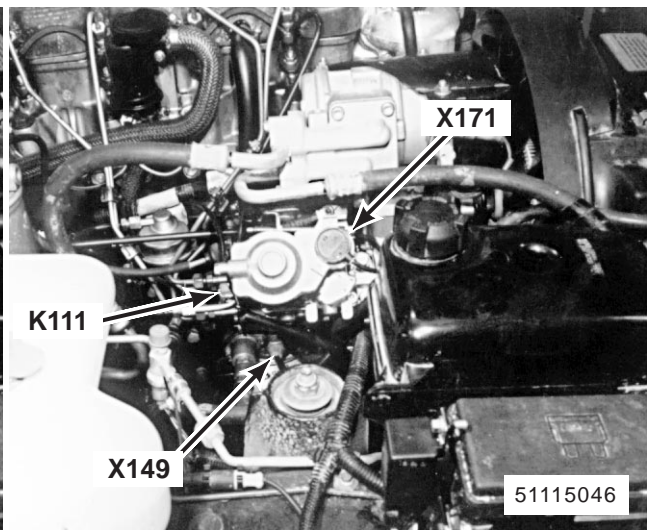

48. RH side of engine 300Tdi with EGR
 K111 Fuel Shut-Off Solenoid
 X149 Oil Pressure Switch
 X171 Throttle Position Sensor

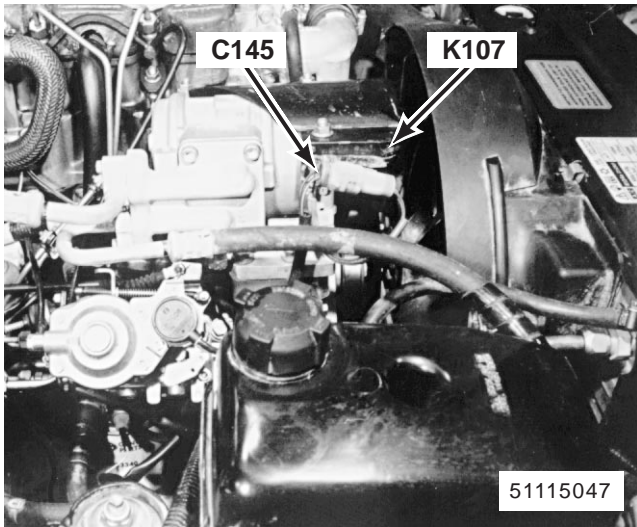

49. RH side of engine 300Tdi without EDC
K107 Compressor Clutch
C145 (2-W)

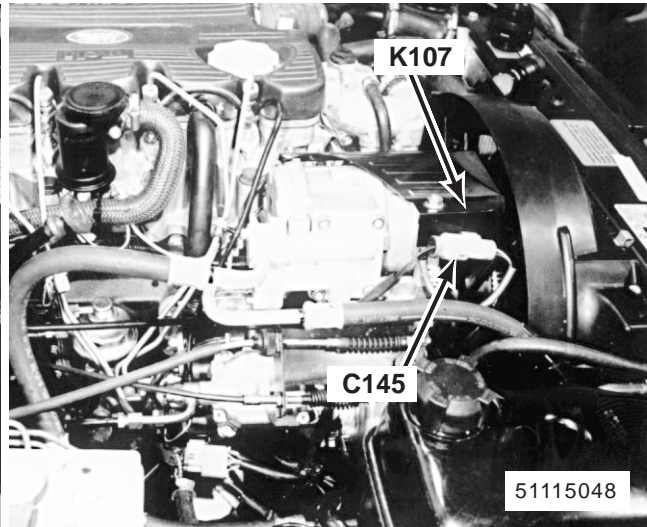

50. RH side of engine 300Tdi with EDC
K107 Compressor Clutch
C145 (2-W)

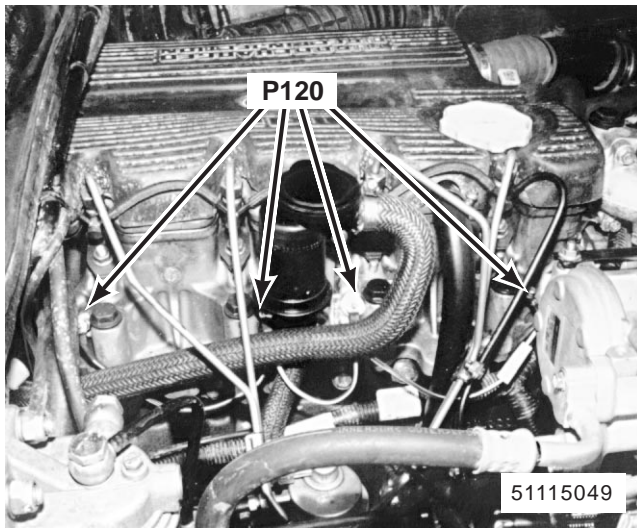

51. RH side of engine 300Tdi
P120 Glow Plugs

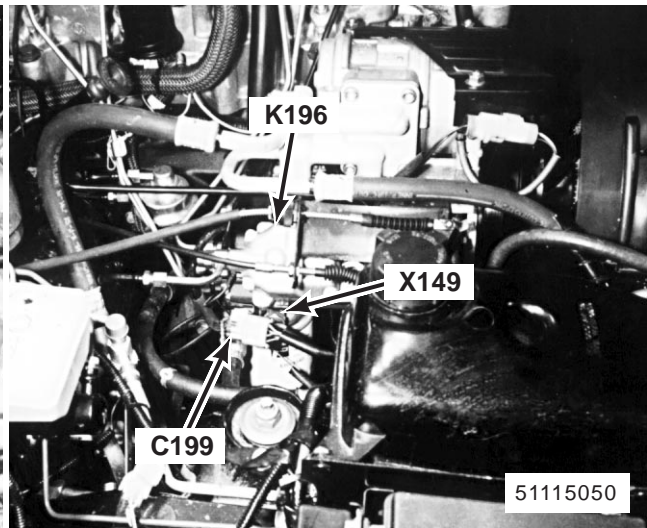

52. RH side of engine 300Tdi with EDC
K196 Fuel Pump Assembly
X149 Oil Pressure Switch
C199 (8-W)

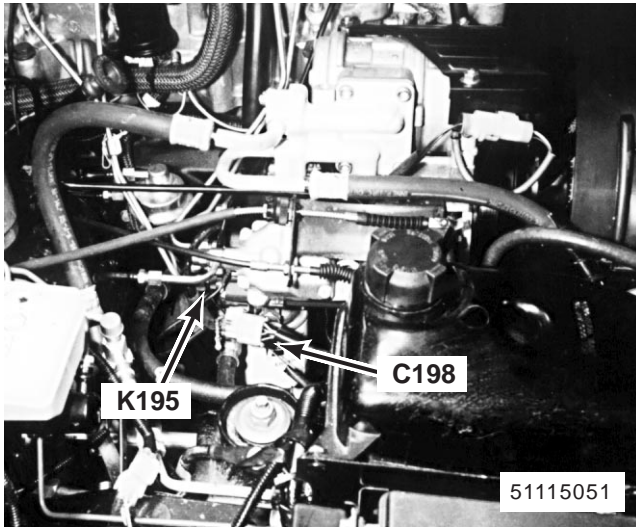

53. RH side of engine 300Tdi with EDC
K195 Fuel Injector Assembly
C198 (3-W)

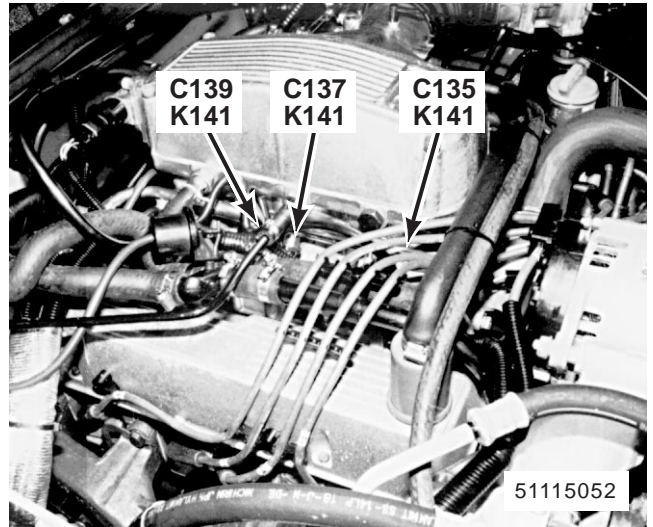

54. RH side of engine MFI-V8
K141 Fuel Injectors
C135 (2-B)
C137 (2-B)
C139 (2-B)

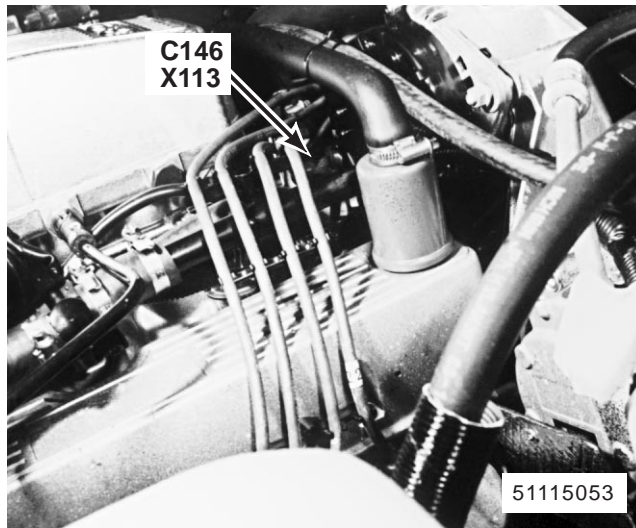

55. RH front of engine MFI-V8
X113 Condenser Fan Coolant Temperature Switch
C146 (2-B)

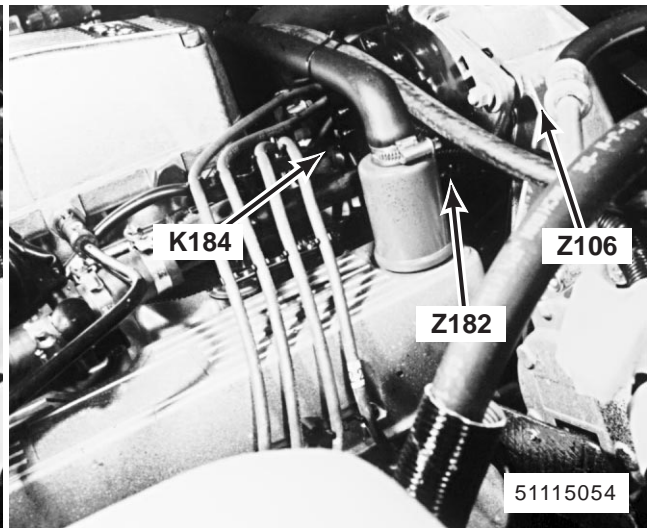

56. RH front of engine MFI-V8
K184 Phase Tap Resistor
Z106 Generator
Z182 Generator Suppression Capacitor

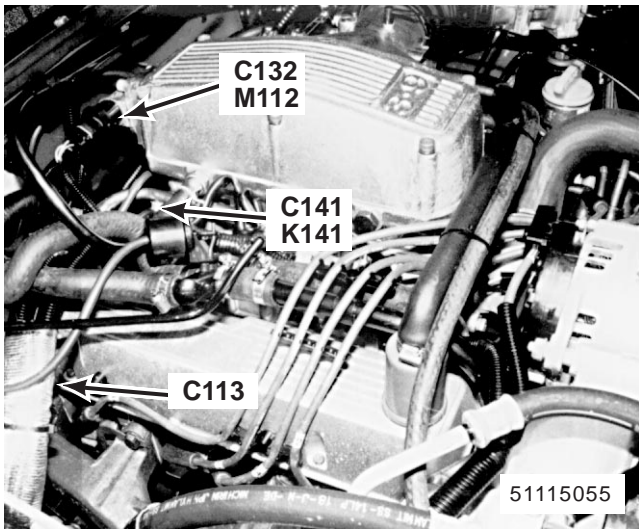

57. RH side of engine MFI-V8
 K141 Fuel Injectors
 M112 Idle Air Control Valve
 C113 (3-W)
 C132 (4-B)
 C141 (2-B)

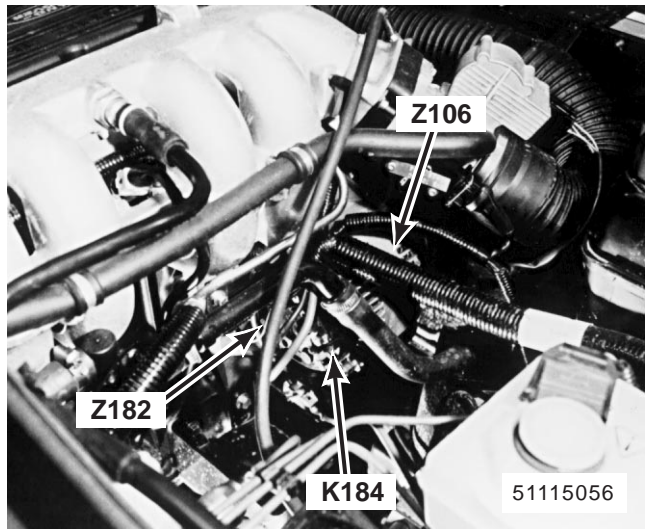

58. RH side of engine MFI-T16 without Air Conditioning
 K184 Phase Tap Resistor
 Z106 Generator
 Z182 Generator Suppression Capacitor

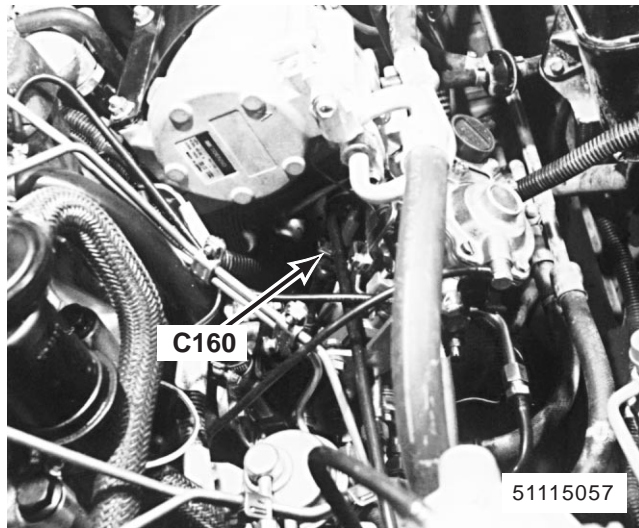

59. RH side of engine 300Tdi with EGR
 C160 (3-B)

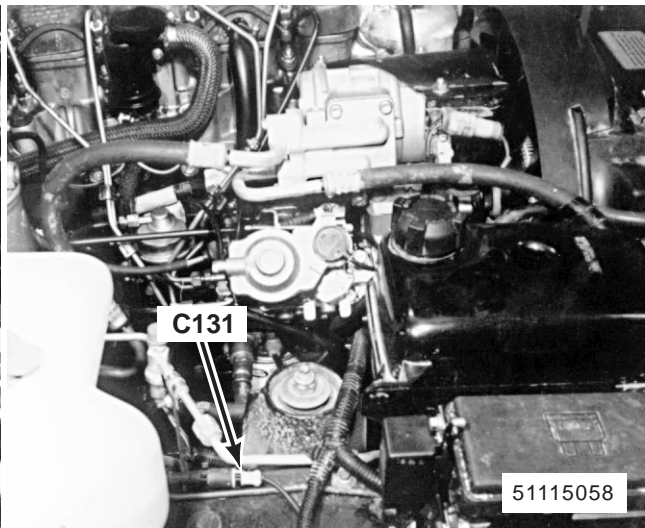

60. RH side of engine compartment
 C131 (2-W)

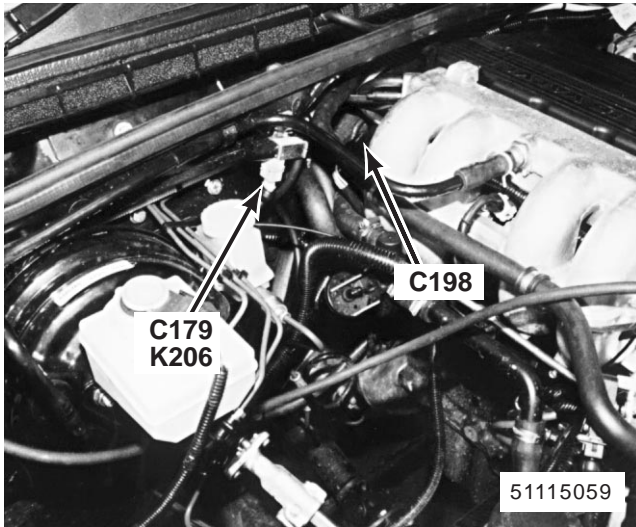

61. RH rear corner of engine compartment MFI-T16
 K206 Water Valve
 C179 (2-U)
 C198 (6-B)

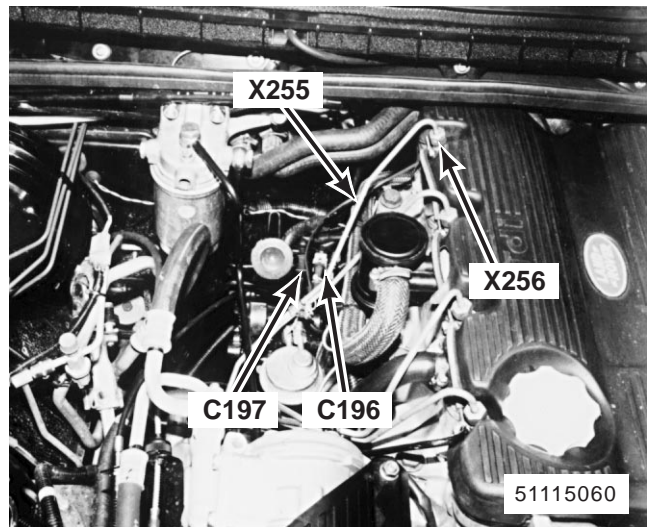

62. RH rear of engine 300Tdi with EDC
 X255 Engine Speed Sensor
 X256 Injector Needle Lift Sensor
 C196 (2-NU)
 C197 (3-B)

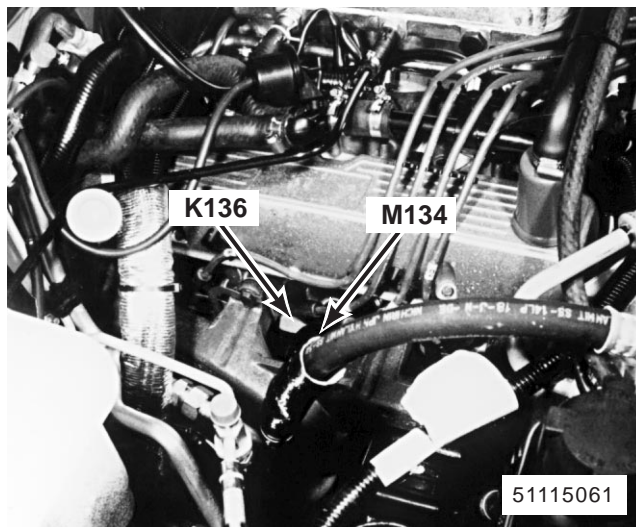

63. lower RH side of engine MFI-V8
 K136 Starter Solenoid
 M134 Starter

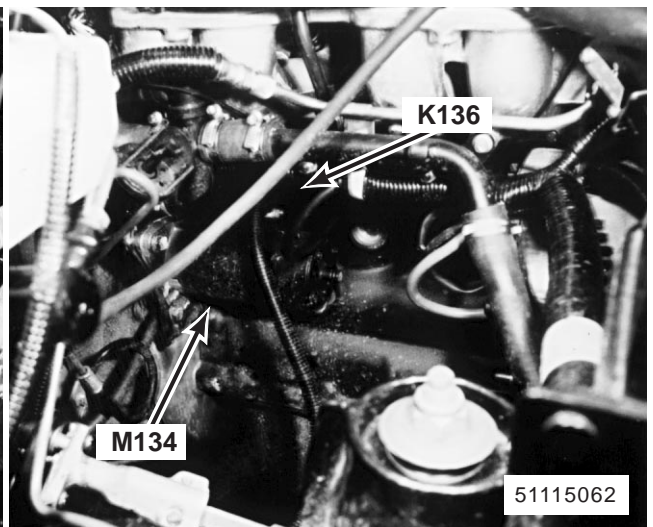

64. lower RH side of engine MFI-T16
 K136 Starter Solenoid
 M134 Starter

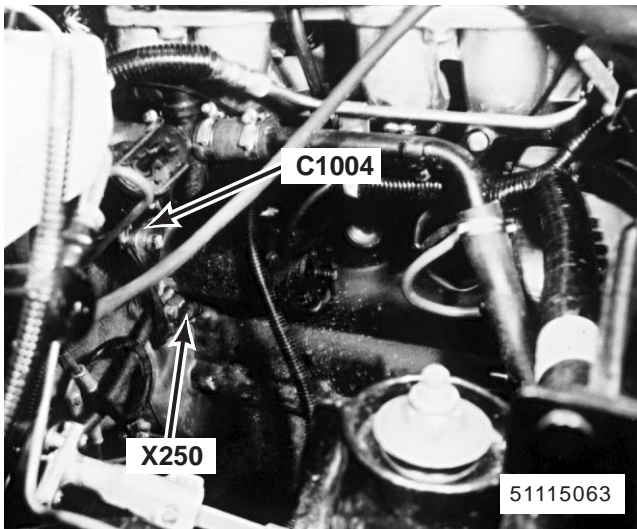

65. lower RH side of engine MFI-T16
X250 Crankshaft Position Sensor
C1004 (2-U)

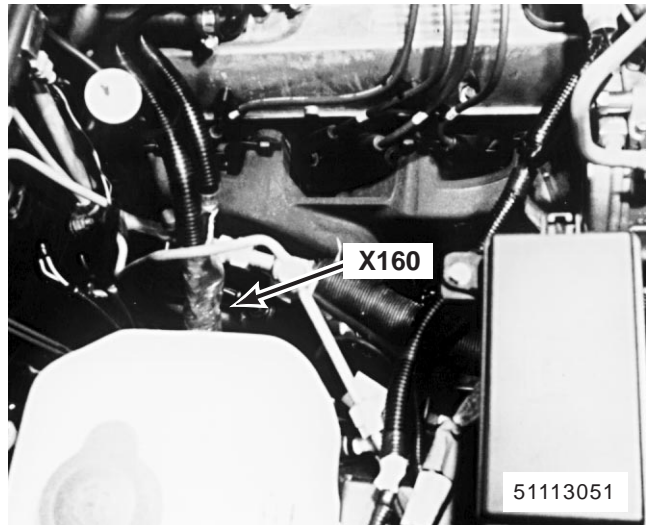

66. lower RH side of engine MFI-V8
X160 Right Heated Oxygen Sensor

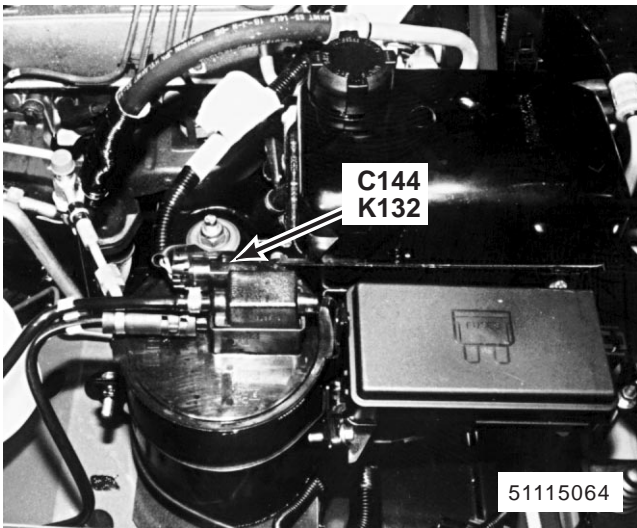

67. RH side of engine compartment MFI-V8
K132 Evaporative Emission Canister Purge Valve
C144 (2-RU)

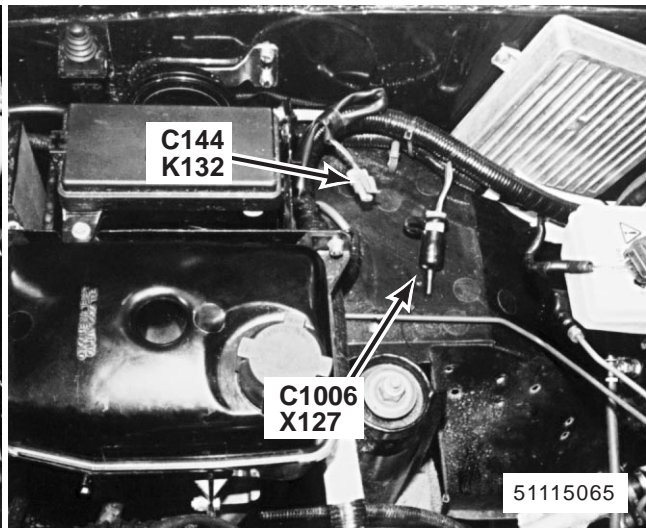

68. RH rear corner of engine compartment MFI-T16
K132 Evaporative Emission Canister Purge Valve
X127 Data Link Connectors
C144 (2-RU)
C1006 (3-W)

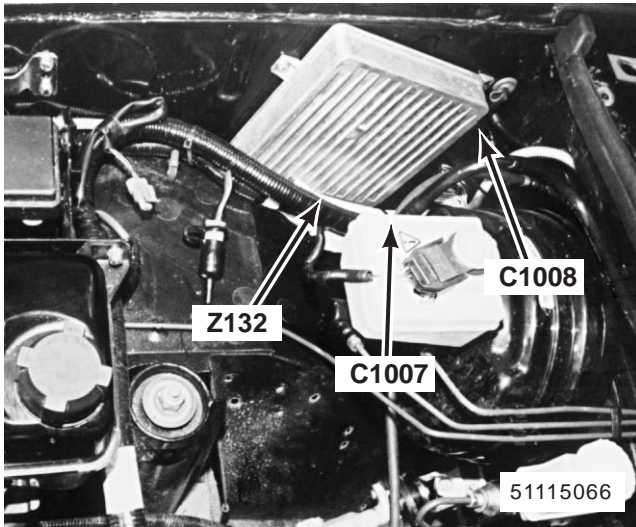

69. RH rear corner of engine compartment MFI-T16
 Z132 Engine Control Module (ECM)
 C1007 (36-B)
 C1008 (18-B)

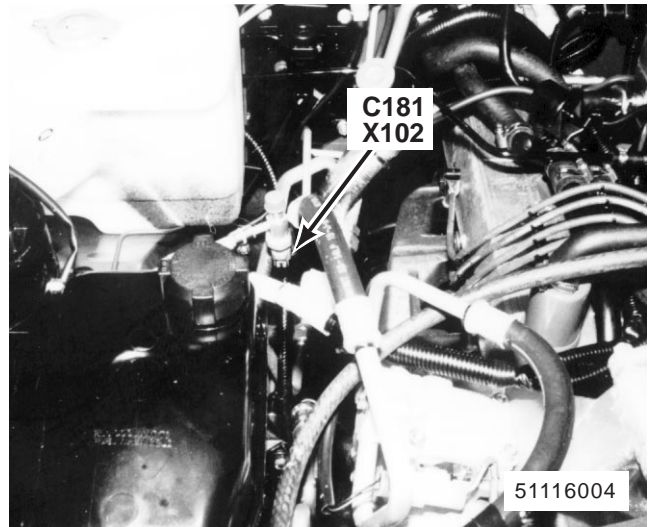

70. RH rear corner of engine compartment X102 A/C Dual Pressure Switch
 C181 (2-S)

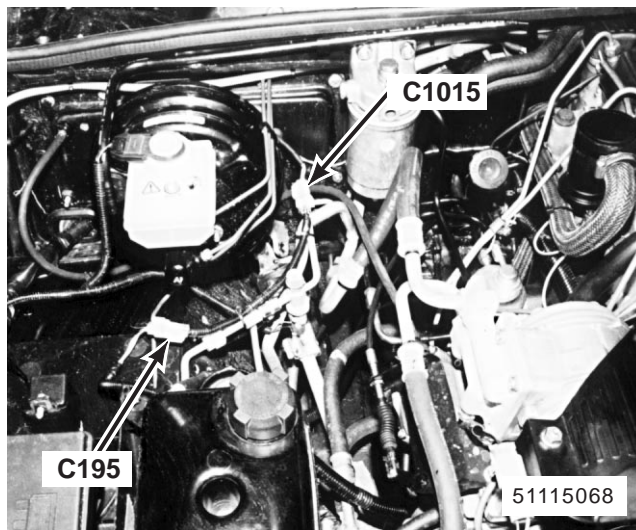

71. RH rear corner of engine compartment 300Tdi with EDC
 C195 (4-W)
 C1015 (4-W)

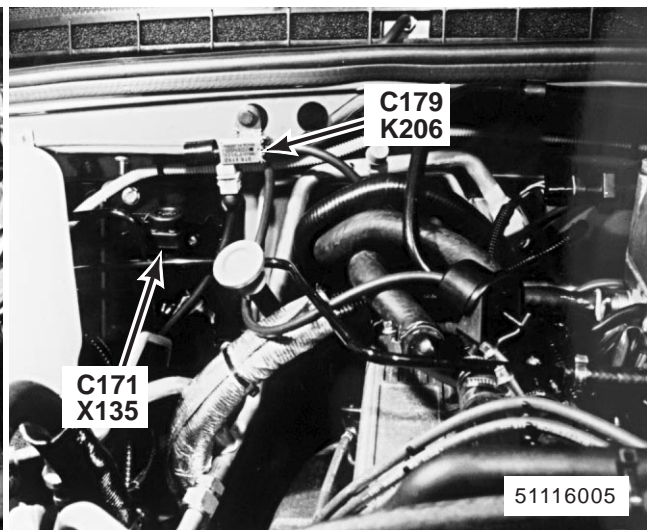

72. RH rear corner of engine compartment K206 Water Valve
 X135 Inertia Fuel Shut-Off Switch
 C171 (3-B)
 C179 (2-U)

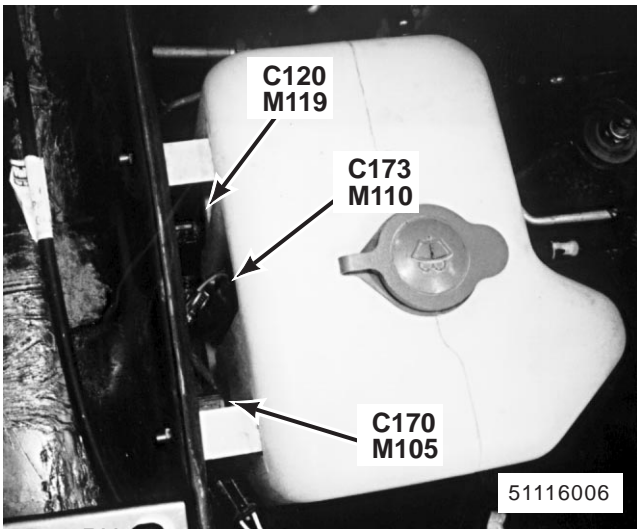

73. RH rear corner of engine compartment
 M119 Rear Screen Wash Pump
 M110 Headlamp Wash Pump
 M105 Front Screen Wash Pump
 C120 (2-B)
 C173 (2-B)
 C170 (2-R)

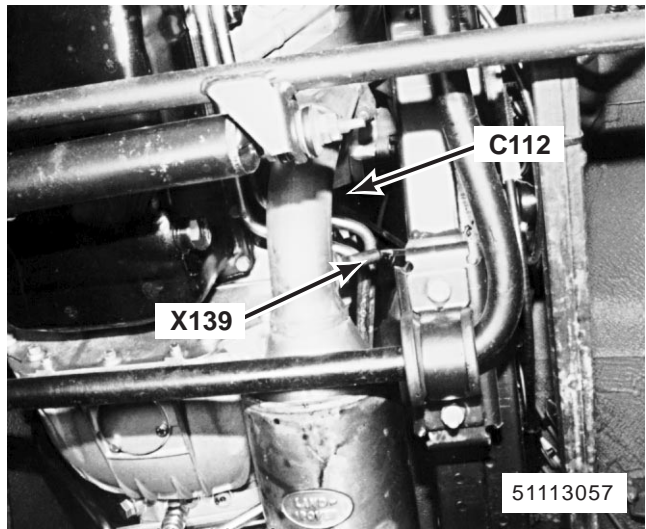

74. lower LH side of engine compartment MFI-V8
 X139 Left Heated Oxygen Sensor
 C112 (3-W)

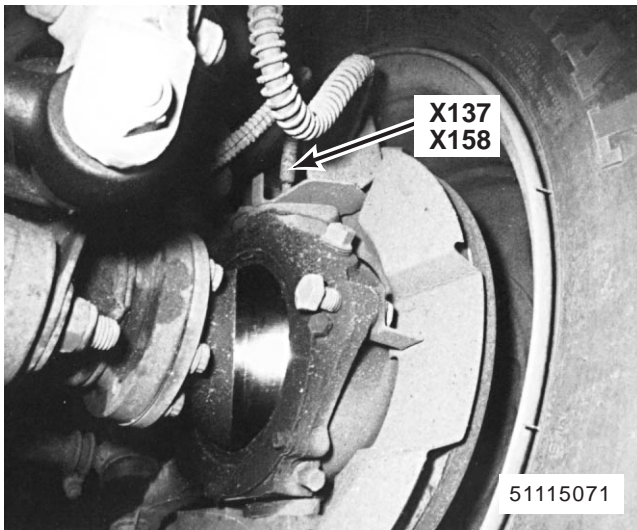

75. behind LH front wheel (RH front wheel similar)
 X137 Left Front Wheel Speed Sensor
 X158 Right Front Wheel Speed Sensor

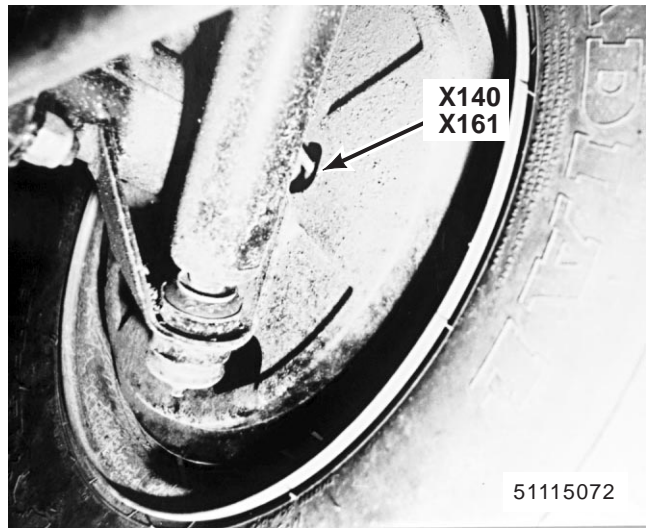

76. behind LH rear wheel (RH rear wheel similar)
 X140 Left Rear Wheel Speed Sensor
 X161 Right Rear Wheel Speed Sensor

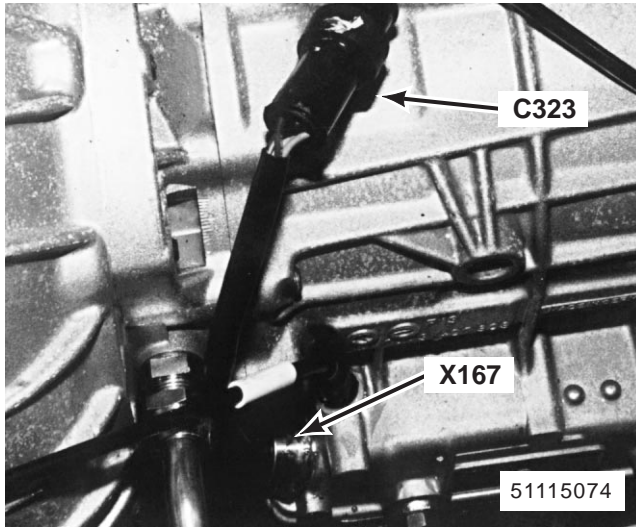

77. LH side of transmission
X167 Park/Neutral Position Switch
C323 (5-B)

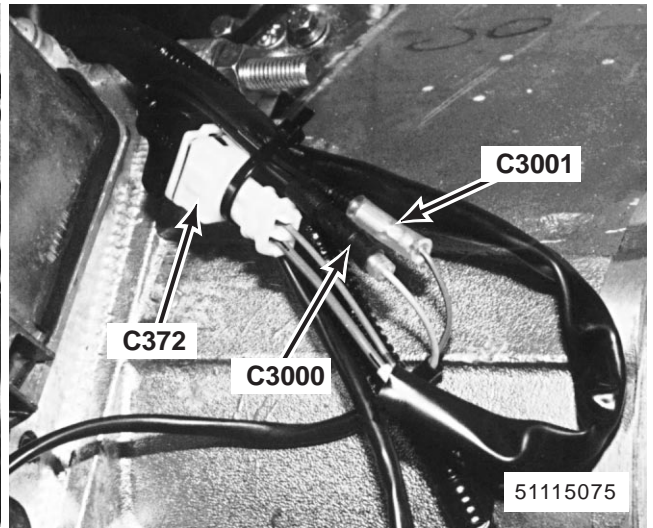

78. LH side of transmission
C372 (2-W)
C3000 (1-B)
C3001 (1-B)

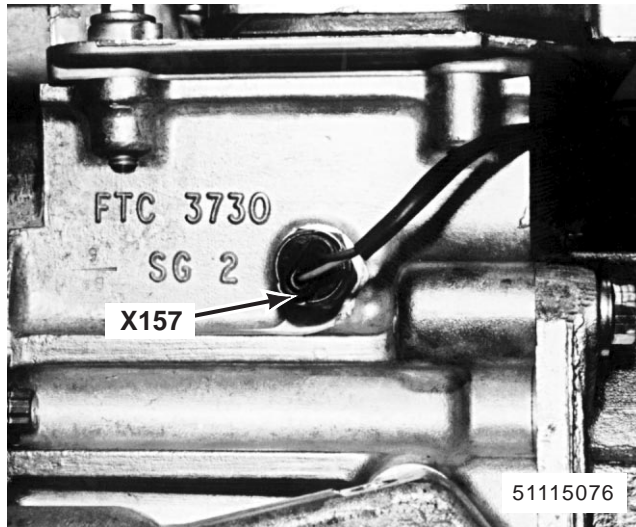

79. LH side of transmission
X157 Reverse Switch

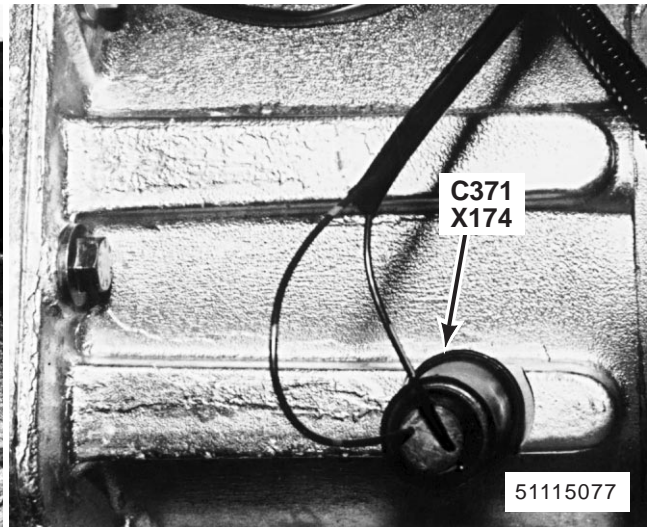

80. LH side of transfer box
X174 Transfer Box Oil Temperature Switch
C371 (2-B)

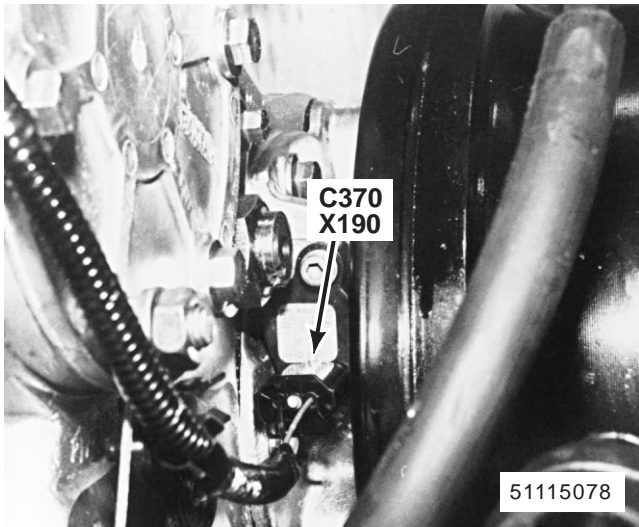

81. LH side of transfer box
X190 Vehicle Speed Sensor
C370 (3-B)

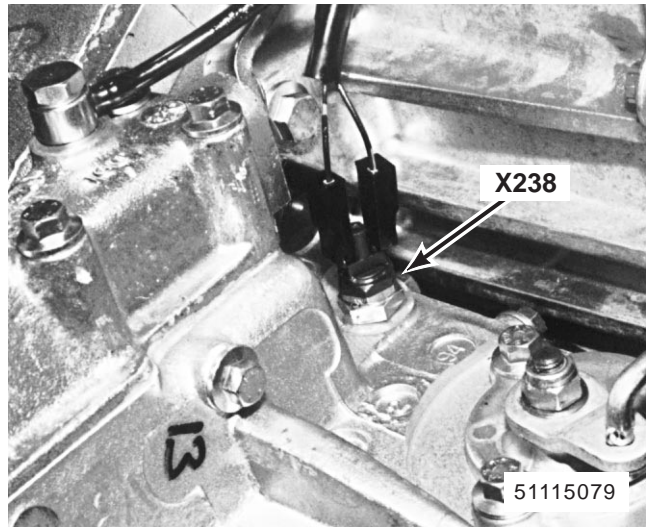

82. top RH side of transfer box
X238 Differential Lock Switch

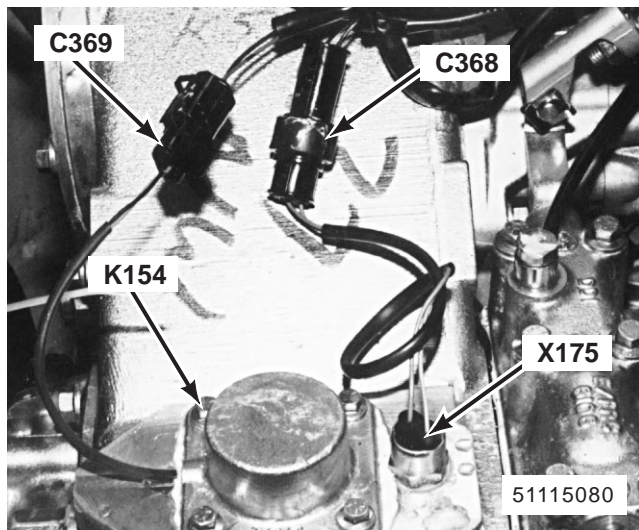

83. top RH side of transfer box
K154 Transfer Box Solenoid
X175 Transfer Box Position Switch
C368 (3-B)
C369 (2-B)

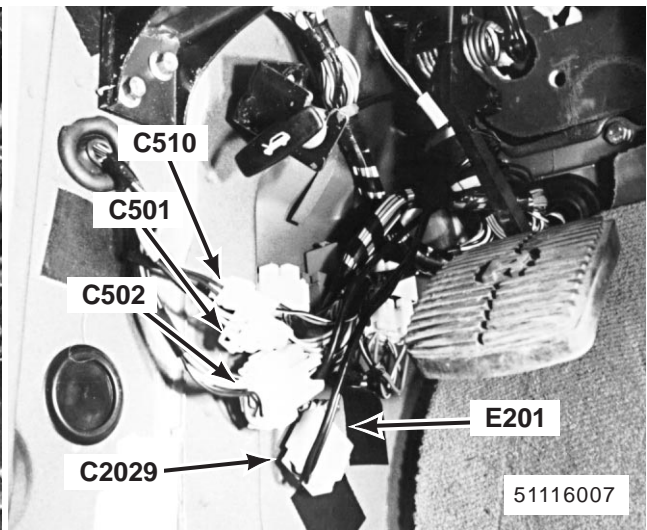

84. behind LH footwell trim panel
E201
C501 (2-W)
C502 (13-W)
C510 (2-W)
C2029 (6-W)

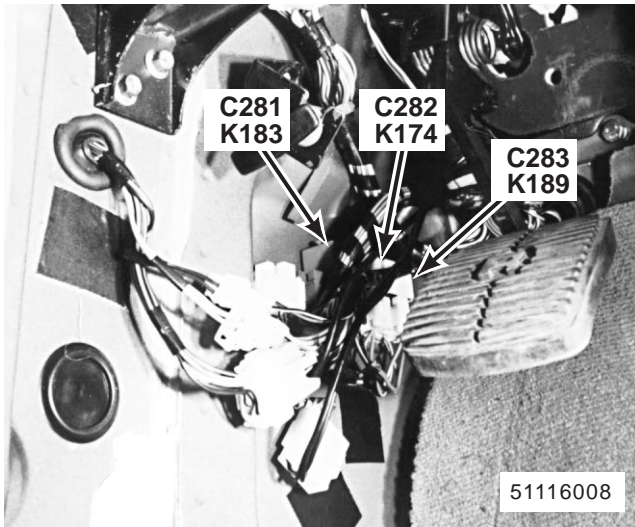

85. behind LH footwell trim panel
 K183 Rear Wiper Relay
 K174 Accessory Relay
 K189 Horn Relay
 C281 (5-G)
 C282 (5-Y)
 C283 (5-Y)

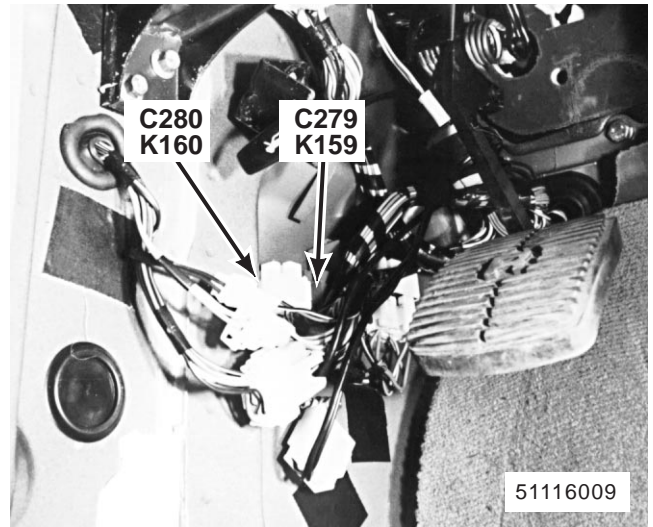

86. behind LH footwell trim panel
 K160 Sounder Relay
 K159 Theft Alarm Relay
 C279 (5-N)
 C280 (5-W)

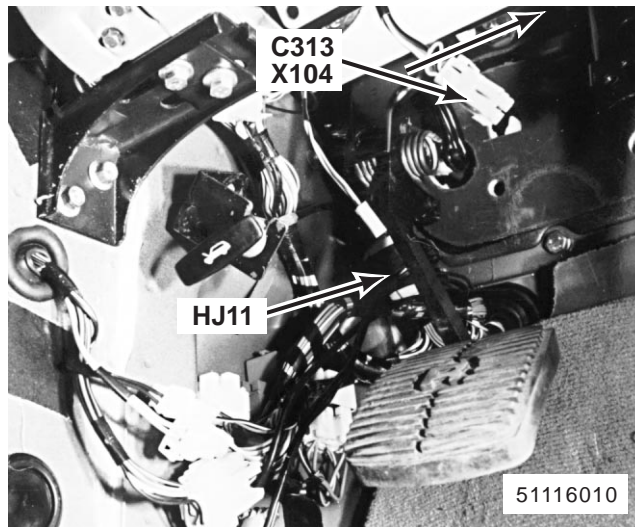

87. behind LH footwell trim panel
 X104 A.B.S. Diagnostic Connector
 C313 (5-U)
 HJ11 (20-S)

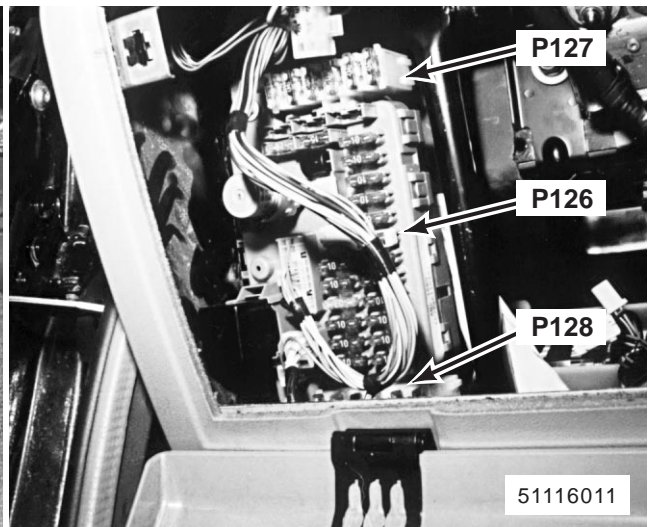

88. behind LH side of fascia left of steering column
 P126 Fascia Fuse Box
 P127 Satellite Fuse Box 1
 P128 Satellite Fuse Box 2

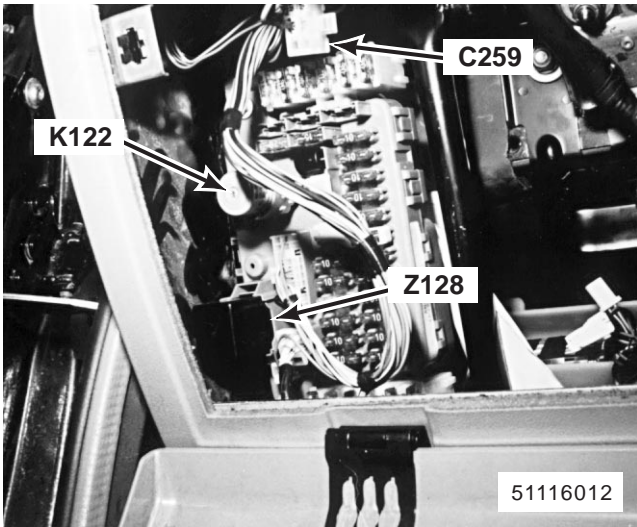

89. behind LH side of fascia left of steering column
 K122 Heated Rear Screen Relay
 Z128 Flasher Unit
 C259 (6-W)

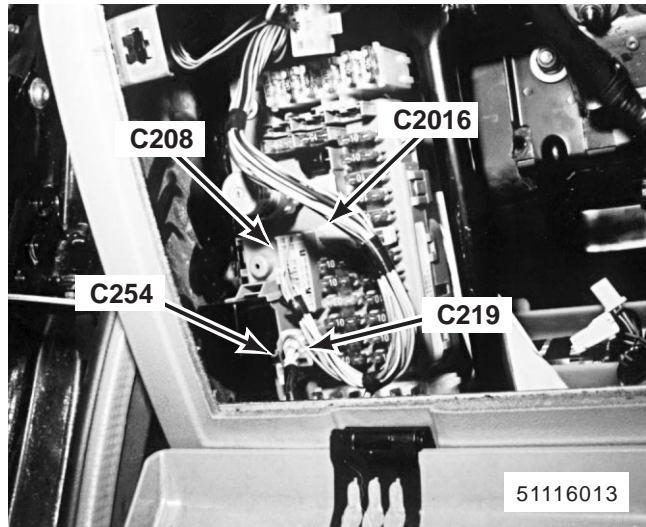

90. behind LH side of fascia left of steering column
 C208 (18-W)
 C219 (4-W)
 C254 (1-W)
 C2016 (1-W)

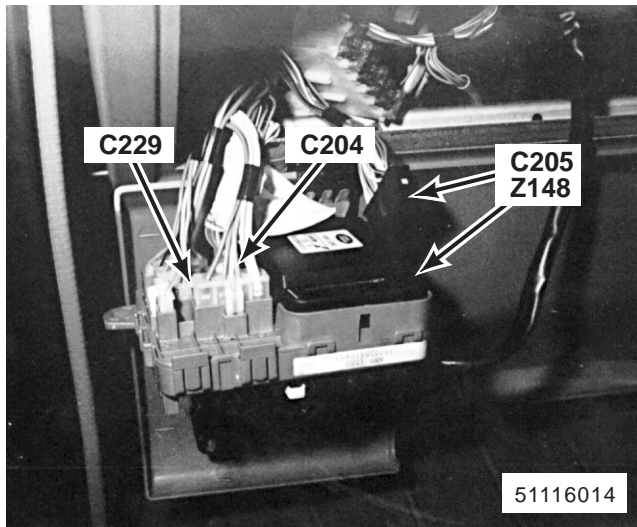

91. behind LH side of fascia left of steering column
 Z148 Multi-Function Unit (MFU)
 C204 (24-W)
 C205 (24-B)
 C229 (1-W)

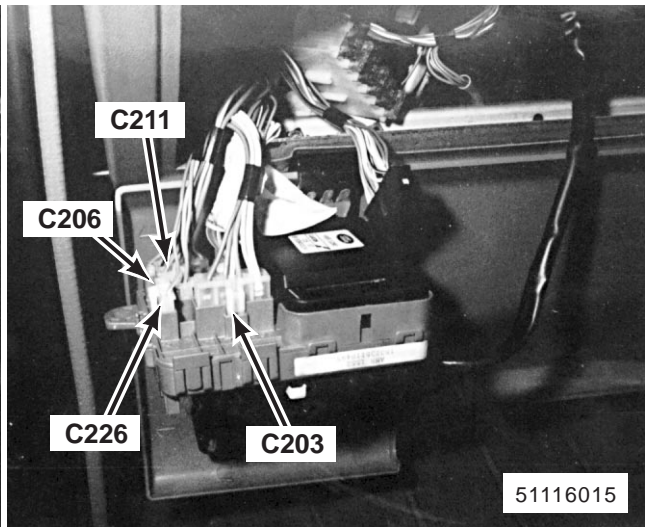

92. behind LH side of fascia left of steering column
 C203 (7-W)
 C206 (4-W)
 C211 (10-W)
 C226 (3-W)



93. behind LH side of fascia left of steering column
 X241 Saudi Junction Connector
 C2062 (1-B)

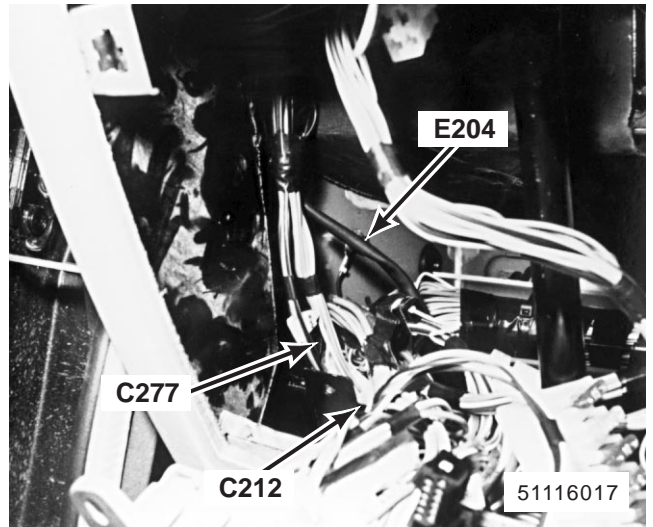

94. behind LH side of fascia left of steering column
 E204
 C277 (2-W)
 C212 (14-W)

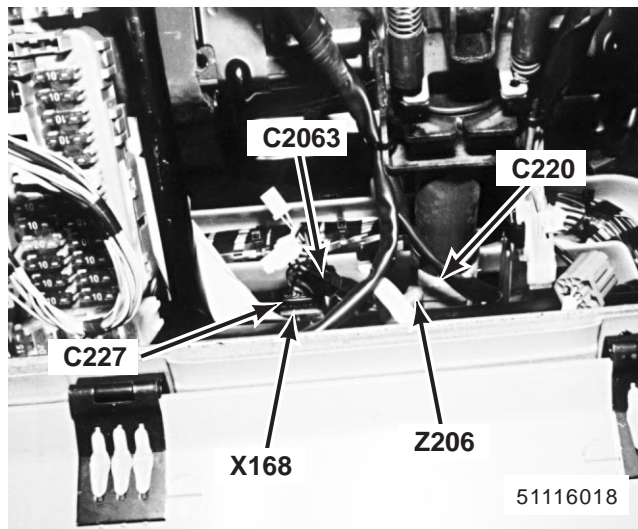

95. behind LH side of fascia
 X168 Stop Lamp Switch
 Z206 Stop Lamp Switch Suppressor
 C220 (3-N)
 C227 (4-B)
 C2063 (2-B)

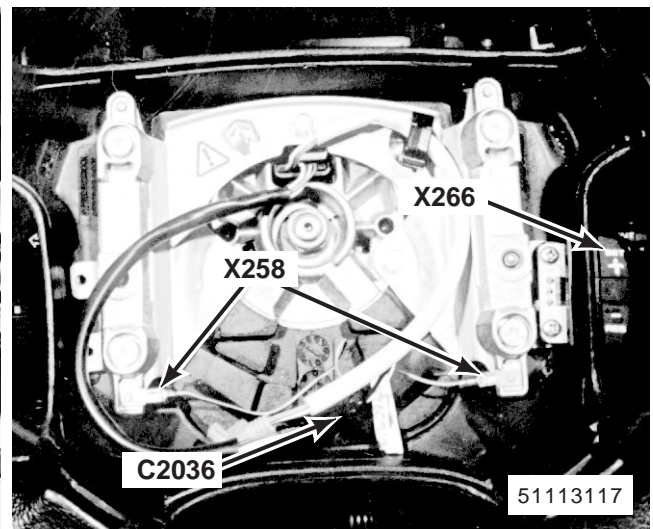

96. in steering wheel
 X258 Horn Switches
 X266 Steering Wheel Cruise Switches
 C2036 (7-B)

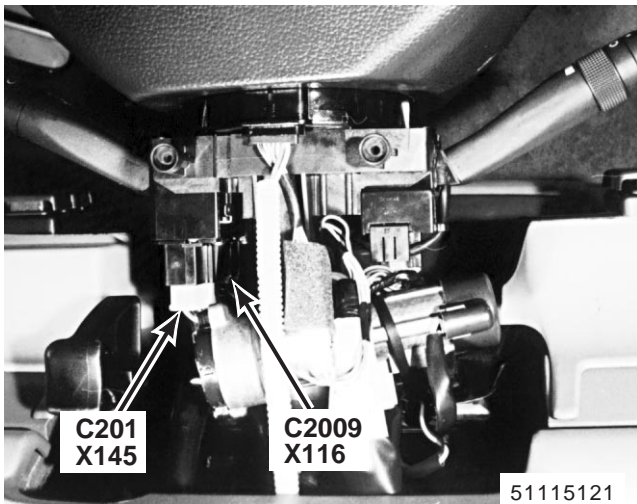

97. underside of steering column
 X116 Direction Indicator Switch
 X145 Main Lighting Switch
 C201 (7-W)
 C2009 (4-W)

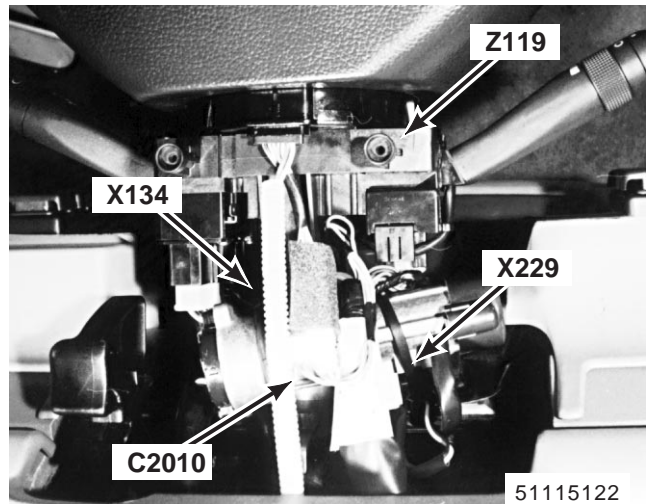

98. underside of steering column
 X134 Ignition Switch
 X229 Key-In Switch
 Z119 Rotary Coupler
 C2010 (6-W)

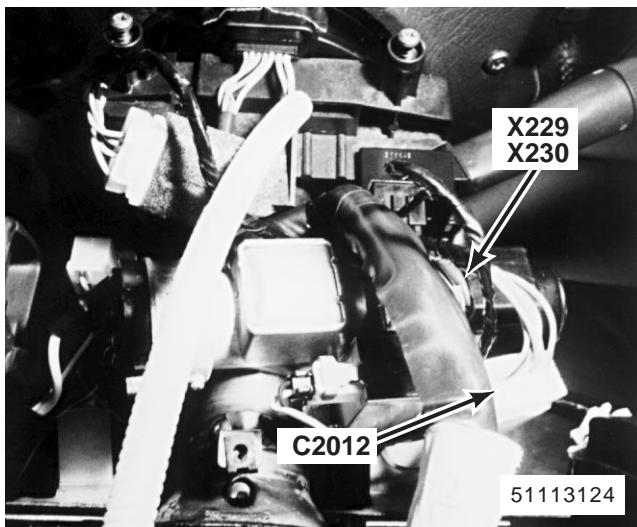

99. underside of steering column
 X229 Key-In Switch
 X230 Key-Barrel Switch
 C2012 (8-W)

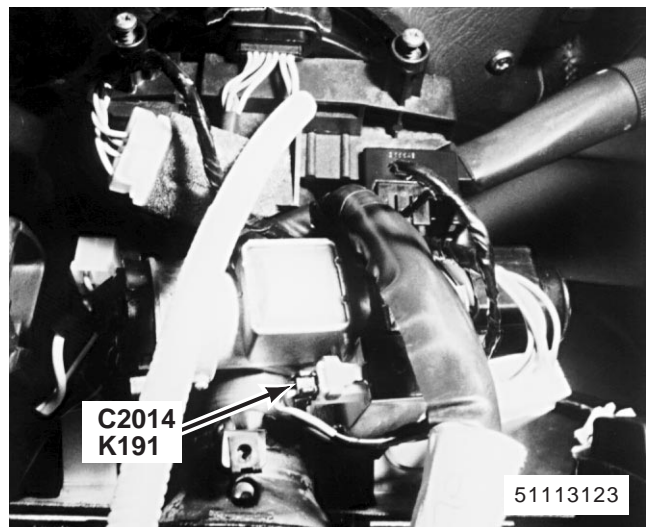

100. underside of steering column
 K191 Ignition Key Lock Solenoid
 C2014 (2-B)

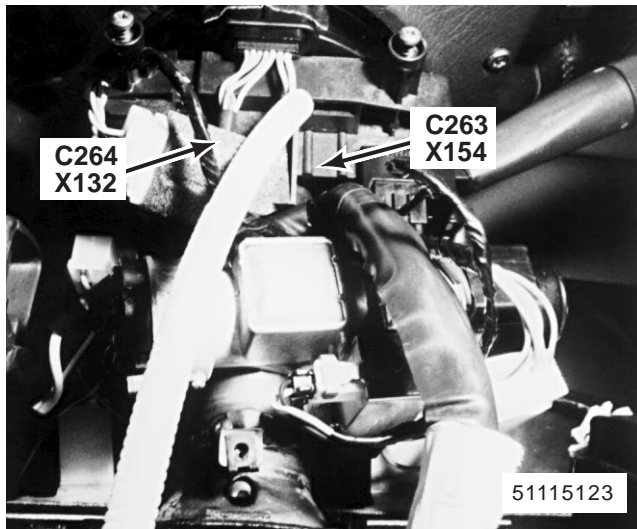

101. top LH side of fascia
 X132 Heated Rear Screen Switch
 X154 Rear Fog Guard Lamps Switch
 C263 (5-U)
 C264 (5-U)

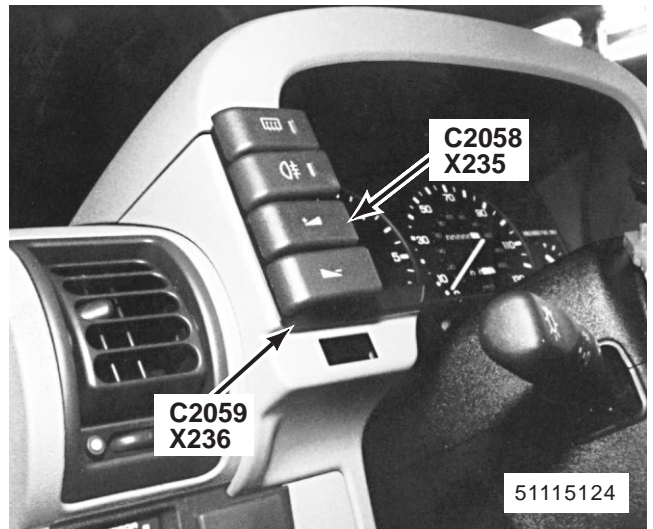

102. top LH side of fascia
 X235 Radio Volume Up Switch
 X236 Radio Volume Down Switch
 C2058 (5-W)
 C2059 (5-G)

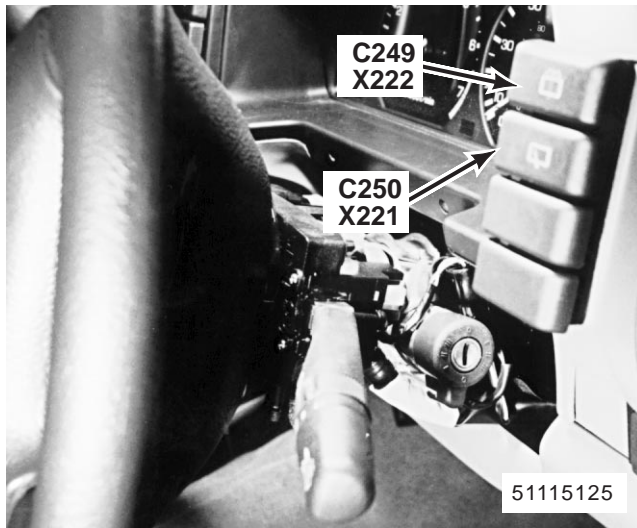

103. top LH side of fascia
 X221 Rear Screen Wipe Switch
 X222 Rear Screen Wash Switch
 C249 (5-G)
 C250 (5-W)

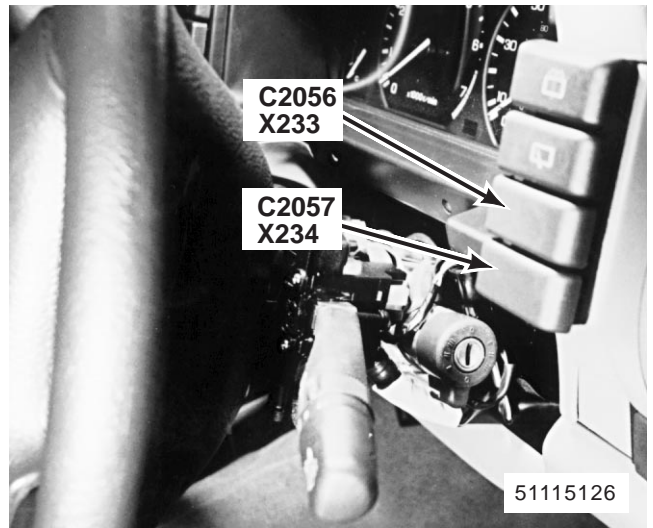

104. top LH side of fascia
 X233 Radio Tune Switch
 X234 Radio Waveband Switch
 C2056 (5-U)
 C2057 (5-U)

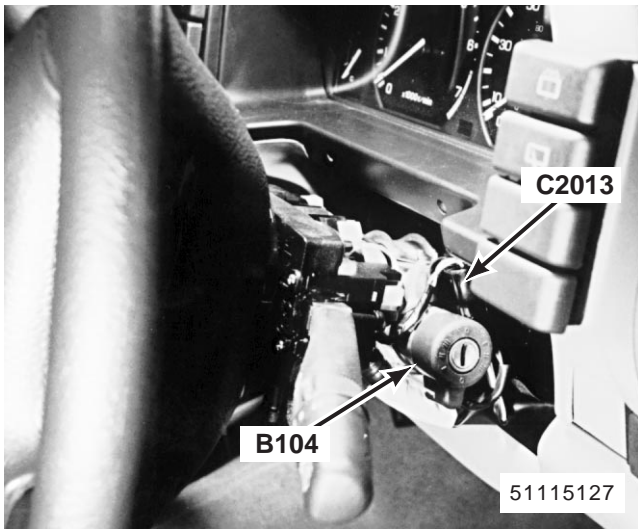

105. top of steering column
 B104 Column Switch Illumination
 C2013 (4-B)

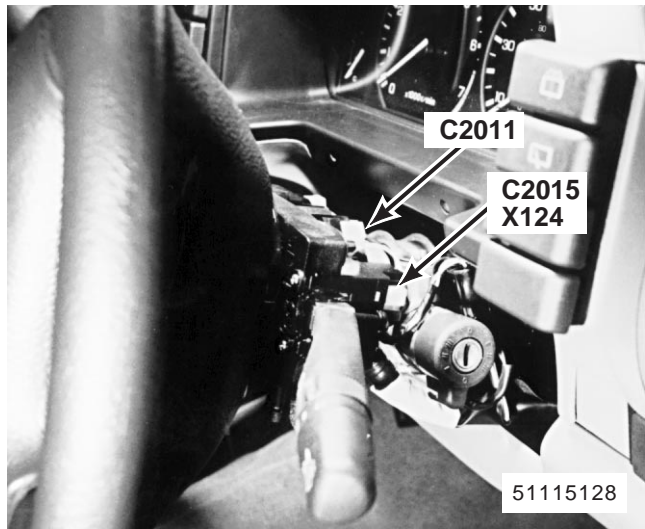

106. top of steering column
 X124 Front Wipe/Wash Switch
 C2011 (6-W)
 C2015 (8-W)

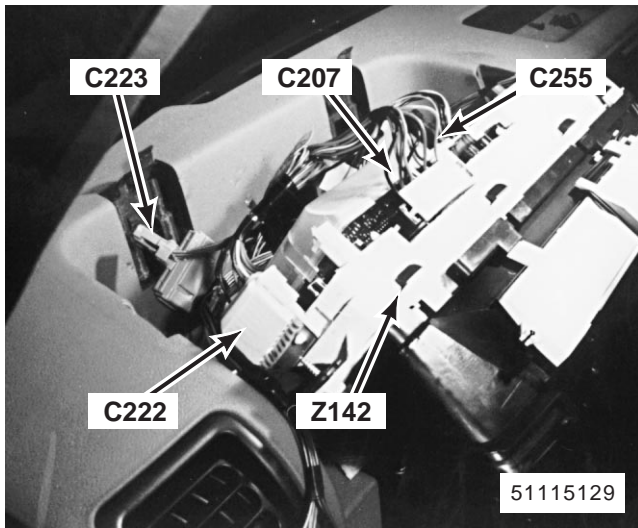

107. behind instrument cluster
 Z142 Instrument Cluster,
 C207 (10-B)
 C222 (10-W)
 C223 (5-U)
 C255 (1-B)

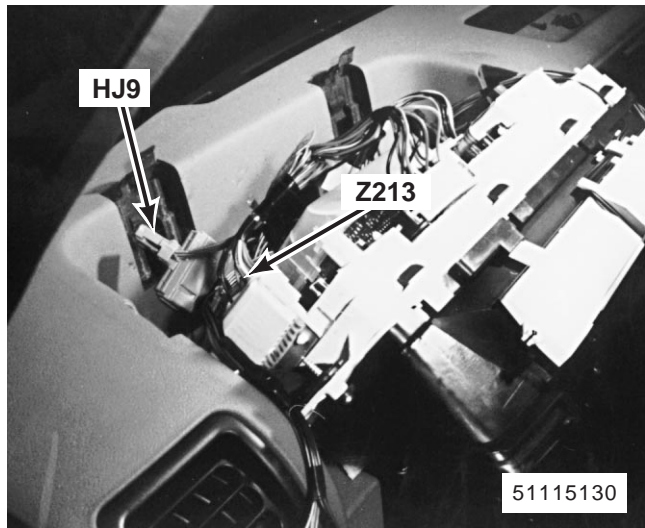

108. behind instrument cluster
 Z213 Direction Indicator Diode 2
 HJ9 (20-S)

Z5 ETM

DISCOVERY

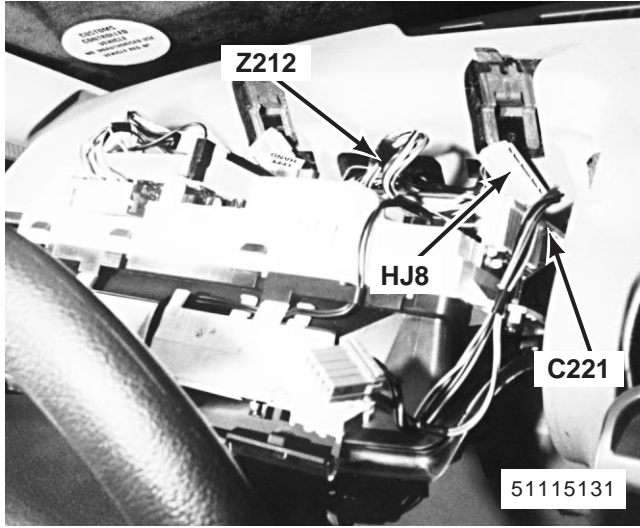

109. behind instrument cluster
 Z212 Direction Indicator Diode 1
 C221 (10-W)
 HJ8 (20-S)

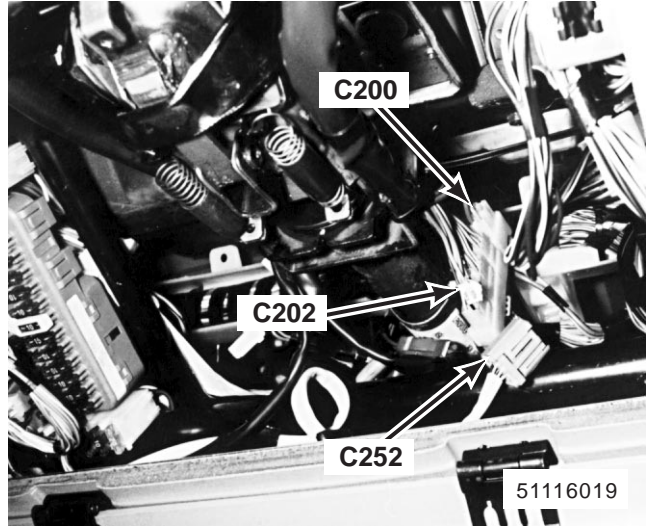

110. behind LH side of fascia
 C200 (4-W)
 C202 (24-W)
 C252 (6-R)

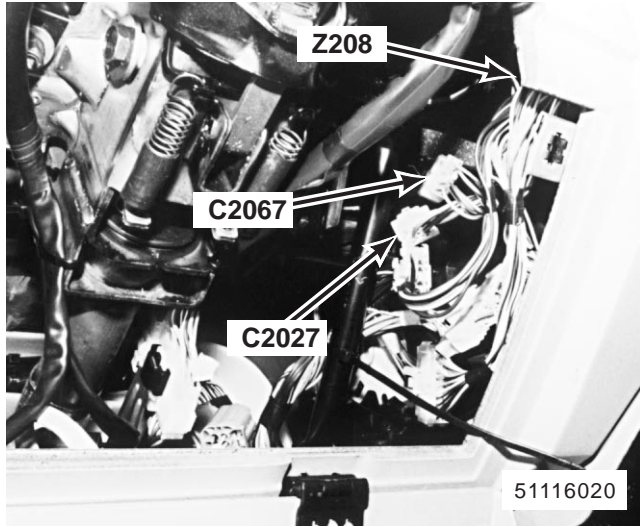

111. behind LH side of fascia right of steering column
 Z208 Air Supply Selector Diode
 C2027 (5-W)
 C2067 (10-W)

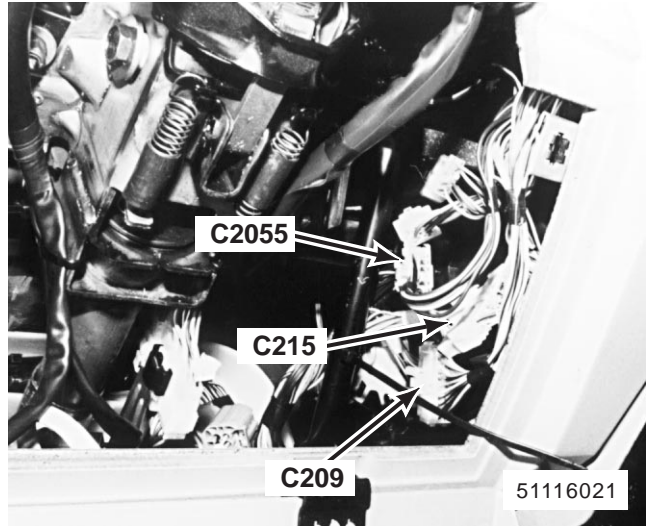

112. behind LH side of fascia right of steering column
 C209 (24-W)
 C215 (24-Y)
 C2055 (13-W)

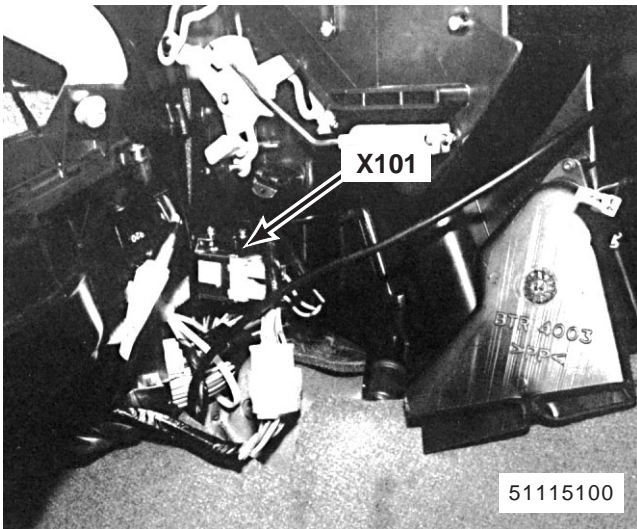

113. LH side of heater evaporator unit
X101 Front A/C Evaporator Temperature Switch



114. centre of fascia
Z111 Radio
C260 (10-K)
C230 (8-S)
C268 (8-N)



115. centre of fascia
X220 Hazard Switch
B151 Theft Alarm LED
C267 (10-B)
C269 (2-)



116. centre of fascia
Z117 Clock
X115 Cruise Control Switch
C270 (4-B)
C262 (5-U)

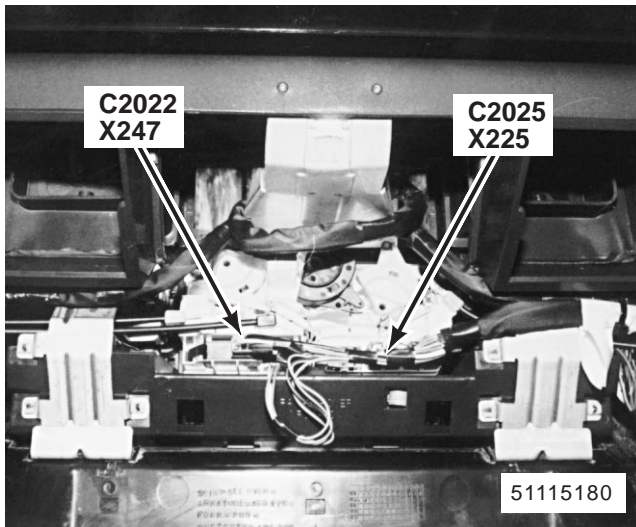

117. behind heater and A/C control panel
 X247 Front Fan Speed Switch
 X225 Front A/C Switch
 C2022 (5-W)
 C2025 (5-W)

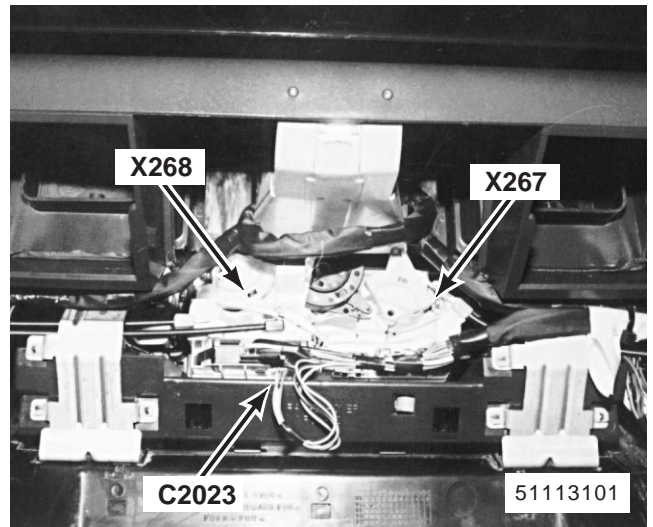

118. behind heater and A/C control panel
 X267 Left Maximum Cool Switch
 X268 Right Maximum Cool Switch
 C2023 (4-W)

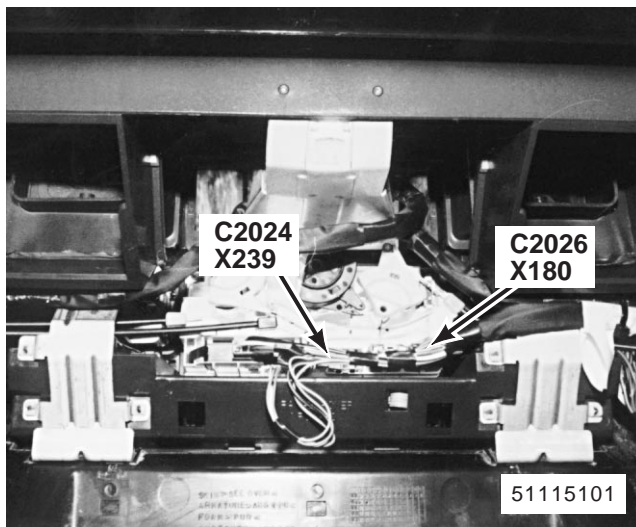

119. behind heater and A/C control panel
 X180 Air Supply Selector Switch
 X239 Main Rear A/C Switch
 C2024 (5-W)
 C2026 (5-B)

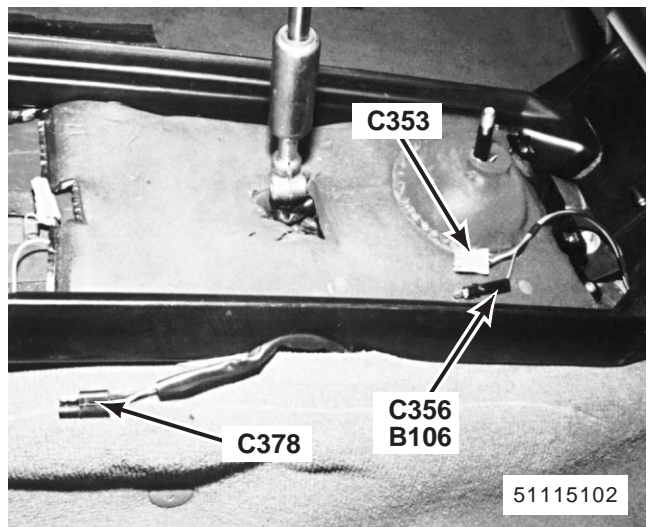

120. beneath centre console
 B106 Fascia Cigar Lighter
 C353 (2-W)
 C356 (1-B)
 C378 (2-B)

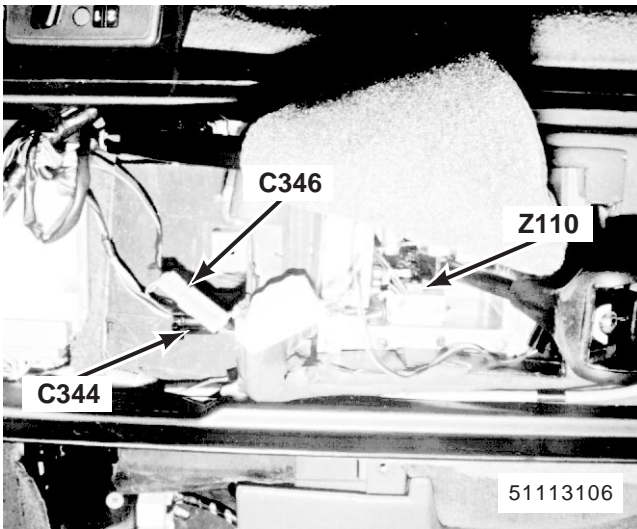

121. beneath centre console
 Z110 Transmission Range Selector Switch
 C344 (6-B)
 C346 (2-U)

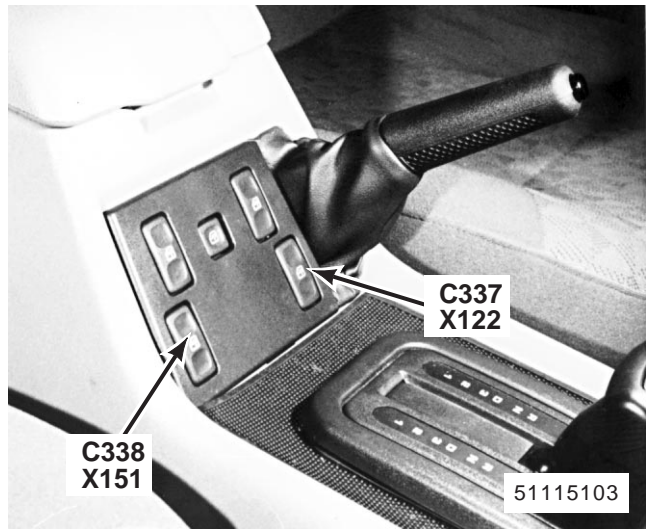

122. in rear of centre console
 X122 Left Front Window Switch
 X151 Right Front Window Switch
 C337 (7-G)
 C338 (7-W)

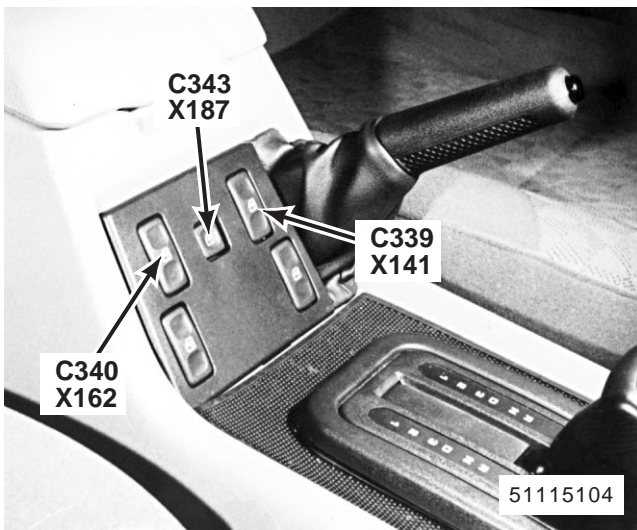

123. in rear of centre console
 X141 Left Rear Window Console Switch
 X162 Right Rear Window Console Switch
 X187 Rear Window Isolation Switch
 C339 (7-Y)
 C340 (7-R)
 C343 (7-N)

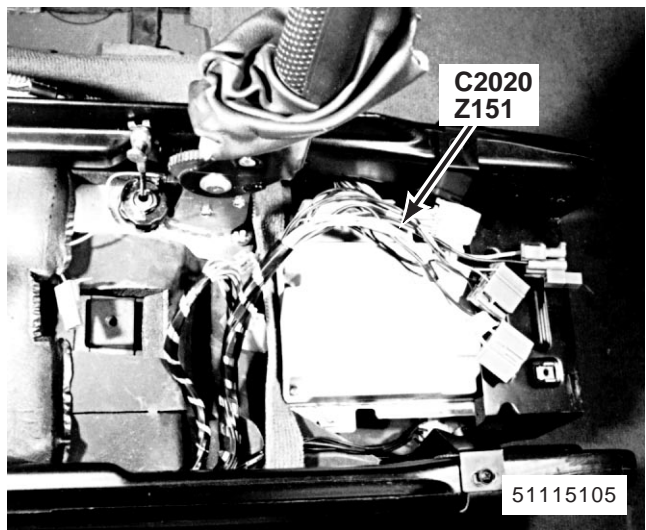

124. beneath centre console
 Z151 Air Bag Diagnostic Control Module
 C2020 (29-R)

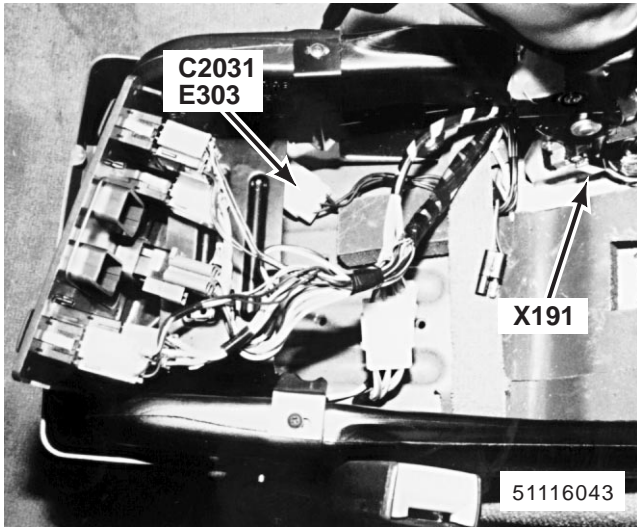

125. beneath centre console
 X191 Handbrake Switch
 C2031 (6-W)
 E303

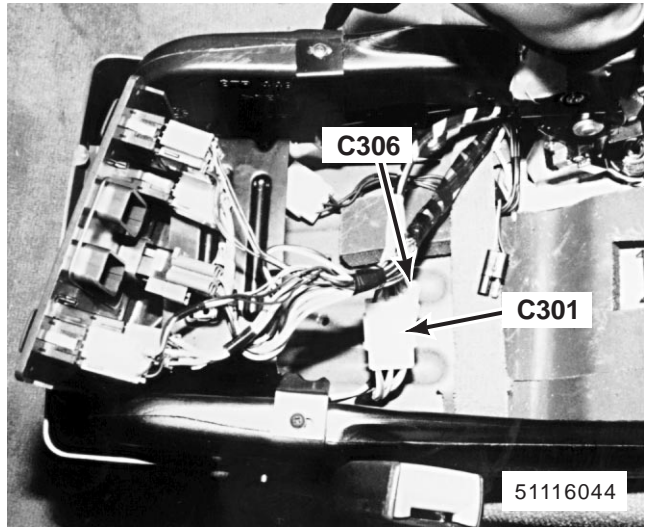

126. beneath centre console
 C301 (6-W)
 C306 (3-W)

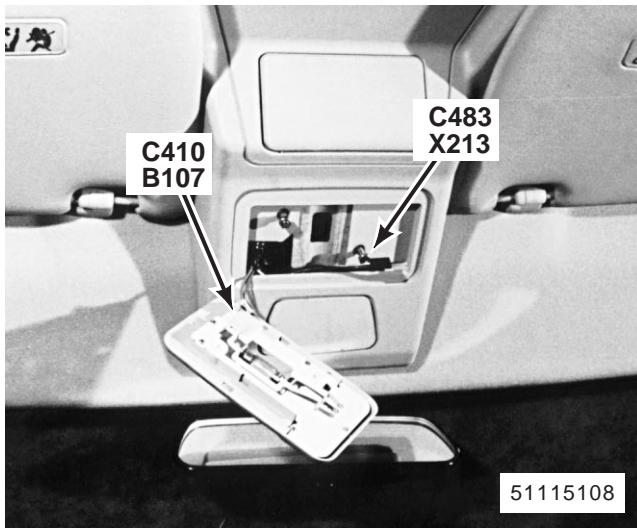

127. front centre of roof
 B107 Front Interior Roof Lamp
 X213 Alarm Sensor
 C410 (3-W)
 C483 (4-B)

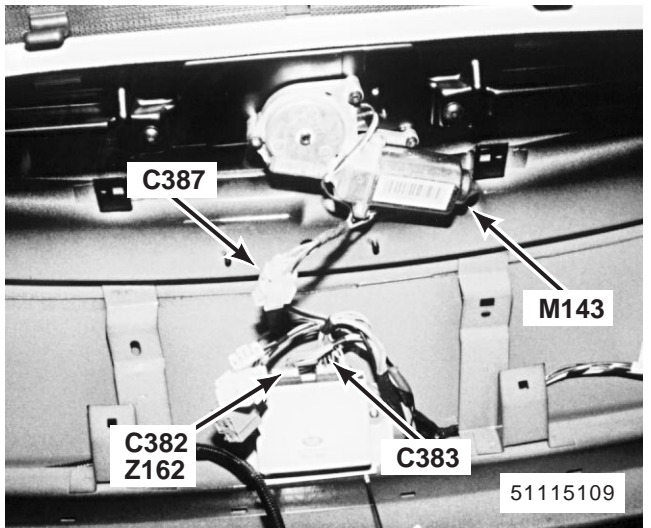

128. front centre of roof
 Z162 Sunroof Control Unit
 M143 Front Sunroof Motor
 C382 (8-W)
 C383 (10-W)
 C387 (4-W)

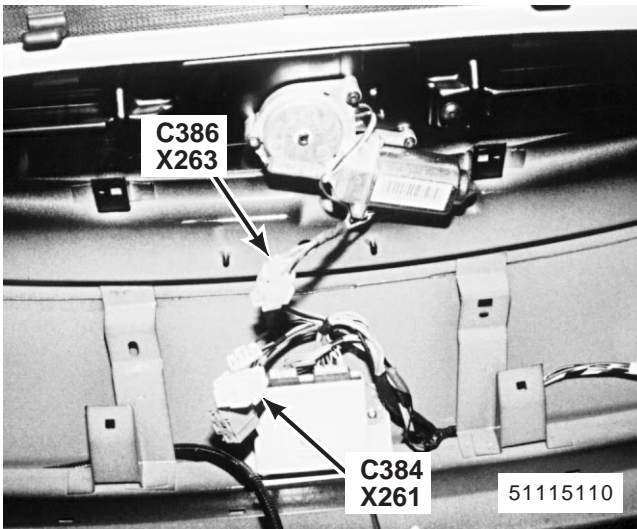

129. front centre of roof
 X261 Front Sunroof Switch
 X263 Rear Sunroof Lockout Switch
 C384 (7-G)
 C386 (5-S)

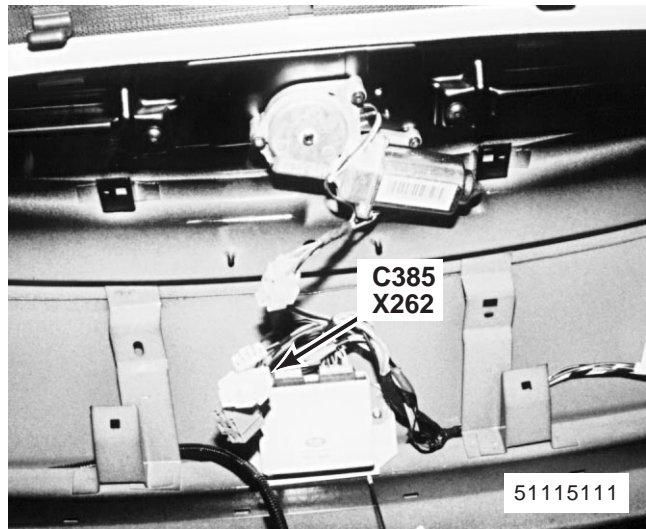

130. front centre of roof
 X262 Rear Sunroof Switch
 C385 (7-W)

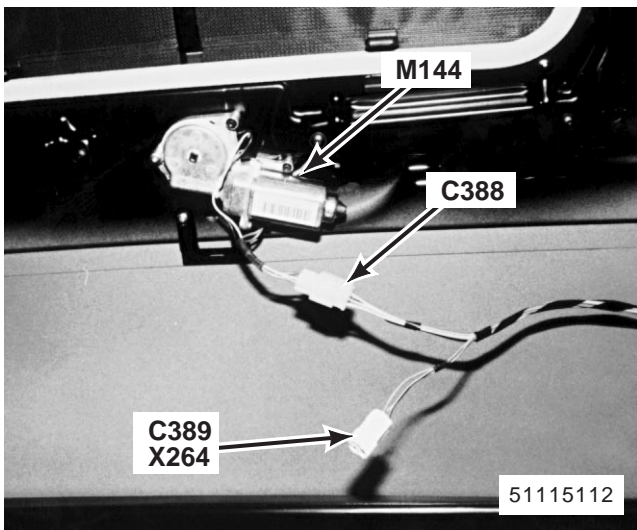

131. centre of roof
 M144 Rear Sunroof Motor
 X264 Passenger's Rear Sunroof Switch
 C388 (4-W)
 C389 (3-W)

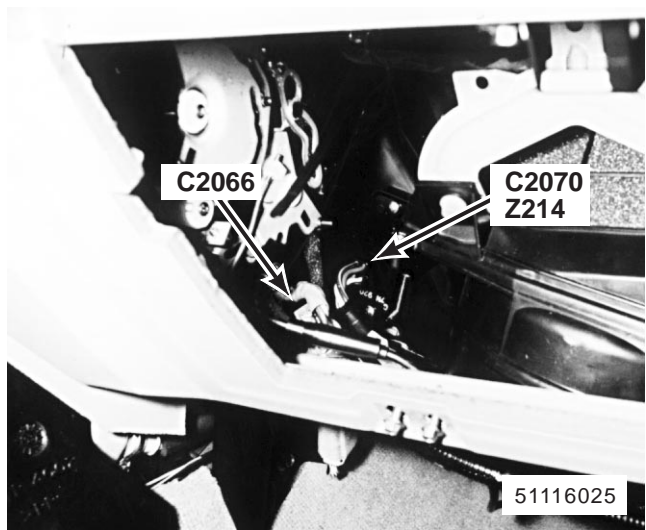

132. behind RH side of fascia right of heater evaporator unit
 Z214 Front Blower Resistor Unit
 C2066 (8-W)
 C2070 (4-B)

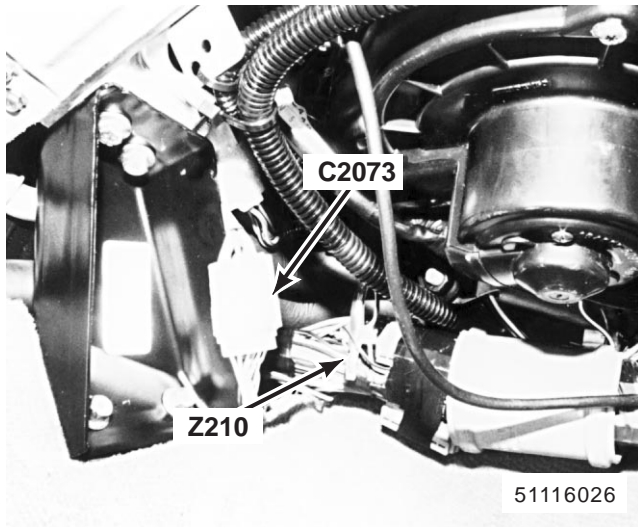

133. behind RH side of fascia
 Z210 Condenser Fan Control Diode 2
 C2073 (10-W)

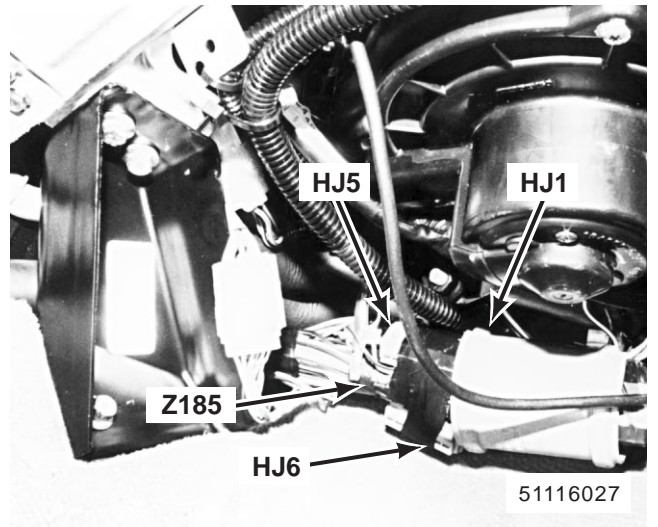

134. behind RH side of fascia
 Z185 Power Mirror Diode
 HJ1 (20-S)
 HJ5 (20-S)
 HJ6 (20-G)

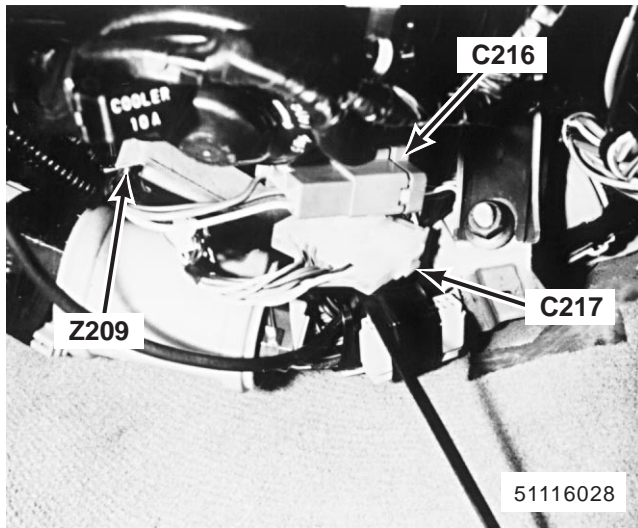

135. behind RH side of fascia
 Z209 Condenser Fan Control Diode 1
 C216 (7-N)
 C217 (20-W)

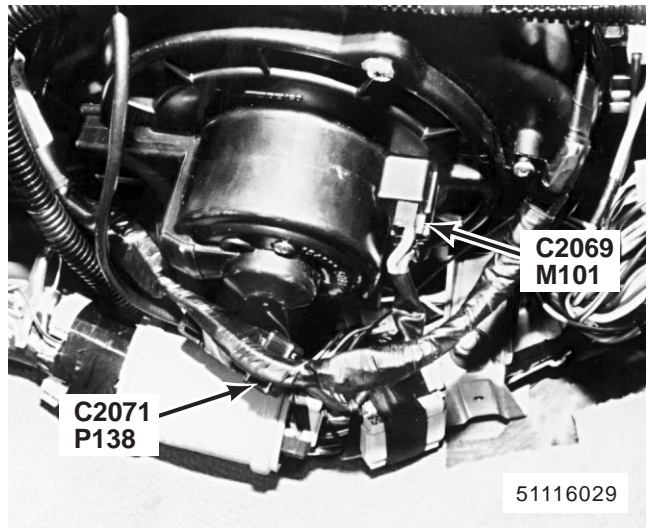

136. behind RH side of fascia
 M101 Front Blower Motor
 P138 Air Recirculation Solenoid In-Line Fuse
 C2069 (2-B)
 C2071 (2-B)

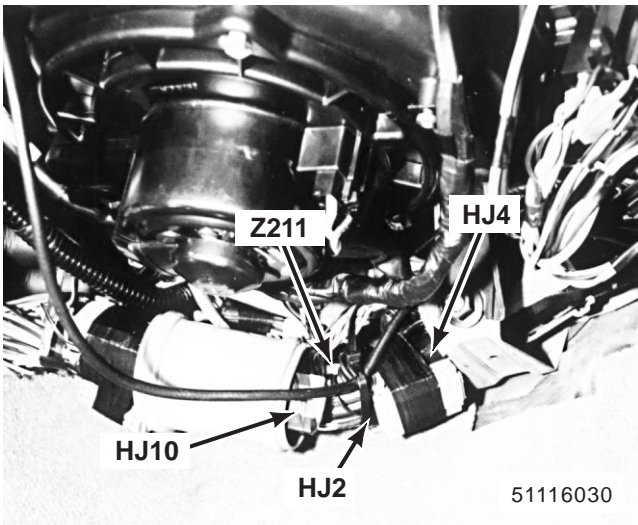

137. behind RH side of fascia
 Z211 Fan Timer Diode
 HJ2 (20-S)
 HJ4 (20-S)
 HJ10 (20-S)

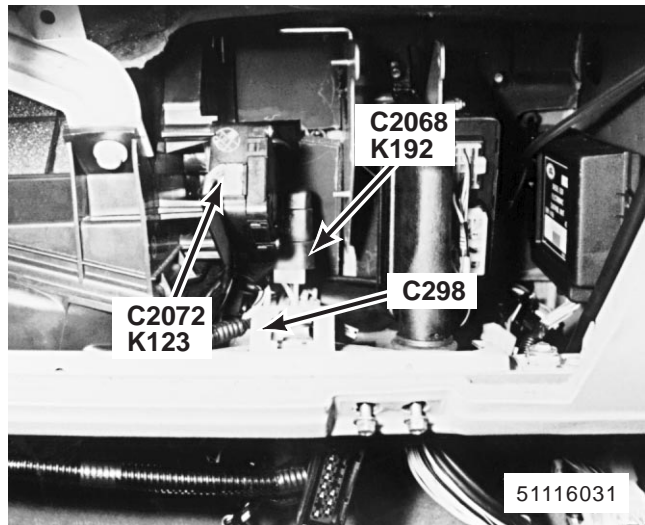

138. behind RH side of fascia
 K123 Air Recirculation Solenoid
 K192 Front Blower Motor Relay
 C298 (3-W)
 C2068 (5-W)
 C2072 (4-Y)

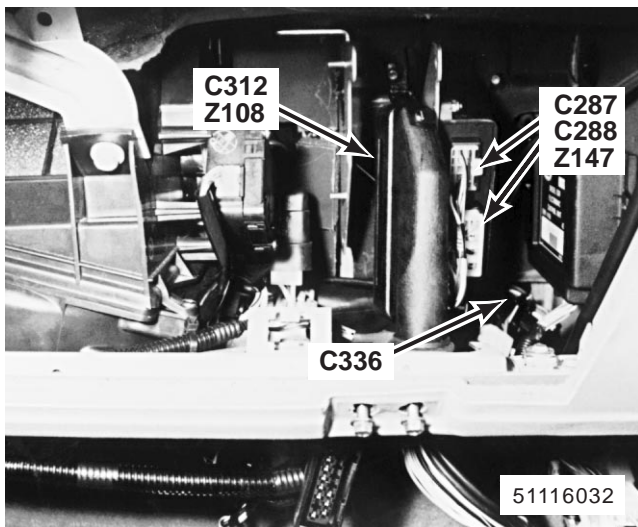

139. behind RH side of fascia
 Z108 Anti-Lock Brake System ECU
 Z147 Window Lift ECU
 C287 (10-W)
 C288 (8-W)
 C312 (35-B)
 C336 (3-W)

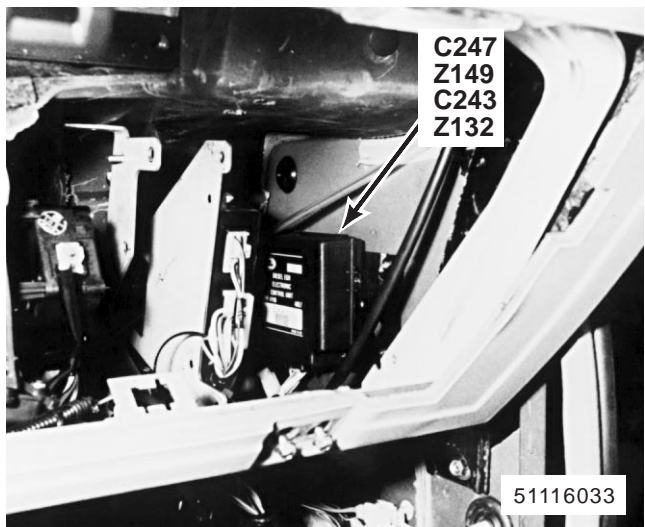

140. behind RH side of fascia MFI-V8 300Tdi with EDC 300Tdi with EGR
 Z132 Engine Control Module (ECM) MFI-V8 300Tdi with EDC
 Z149 EGR Valve Control Module 300Tdi with EGR
 C243 (40-B) MFI-V8
 C243 (55-B) 300Tdi with EDC
 C247 (16-B) 300Tdi with EGR

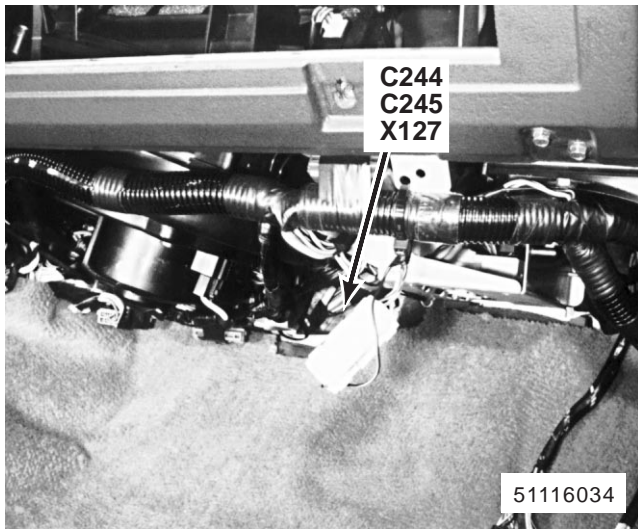

141. behind RH side of fascia MFI-V8
X127 Data Link Connectors
C244 (5-W)
C245 (5-W)

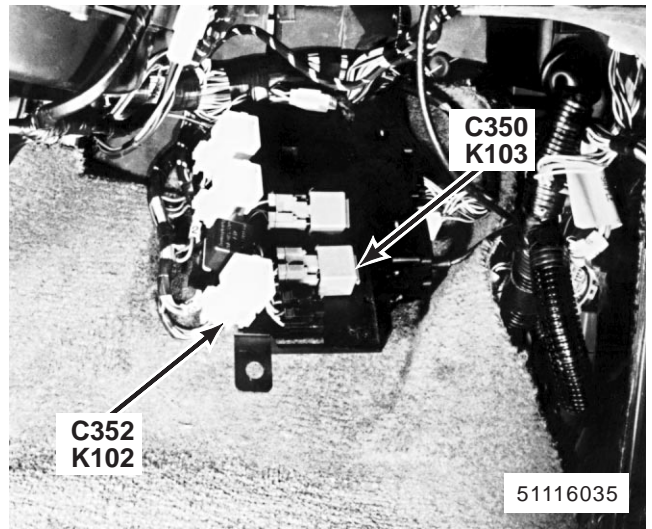

142. behind RH side of fascia
K102 A.B.S. Pump Relay
K103 A.B.S. Warning Relay
C350 (5-G)
C352 (5-B)

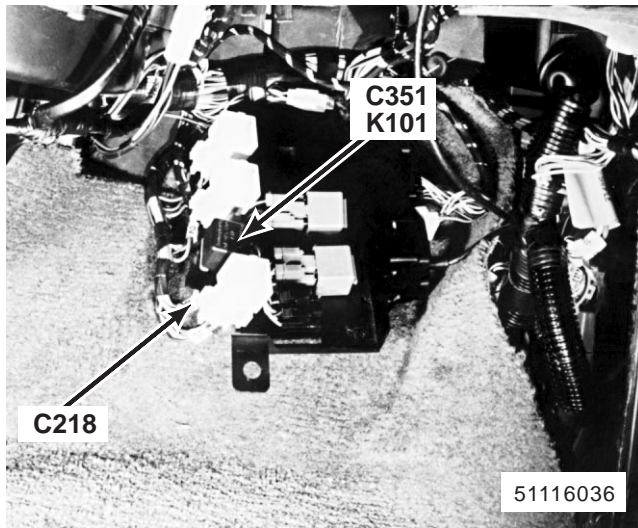

143. behind RH side of fascia
K101 A.B.S. Load Relay
C218 (8-W)
C351 (5-Y)

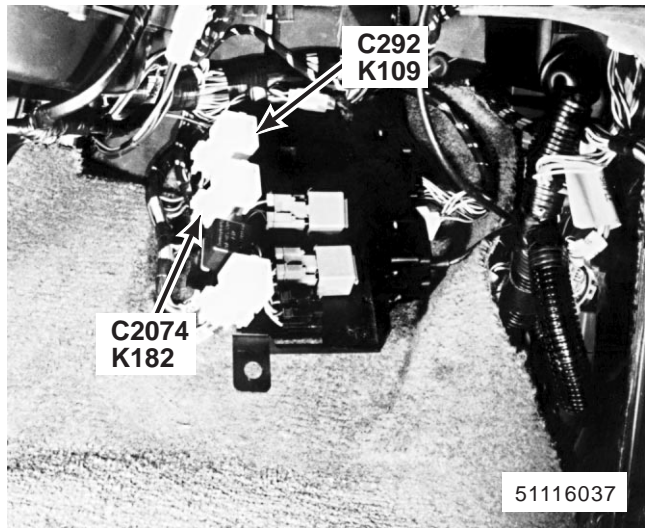

144. behind RH side of fascia
K109 Condenser Fan Relay
K182 Power Wash Relay
C292 (5-Y)
C2074 (5-Y)

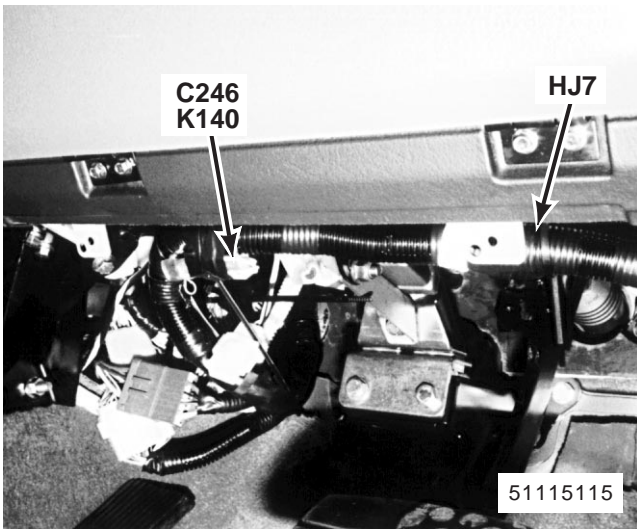

145. behind RH side of fascia
 K140 Tune Select Resistor
 C246 (2-U)
 HJ7 (20-U)

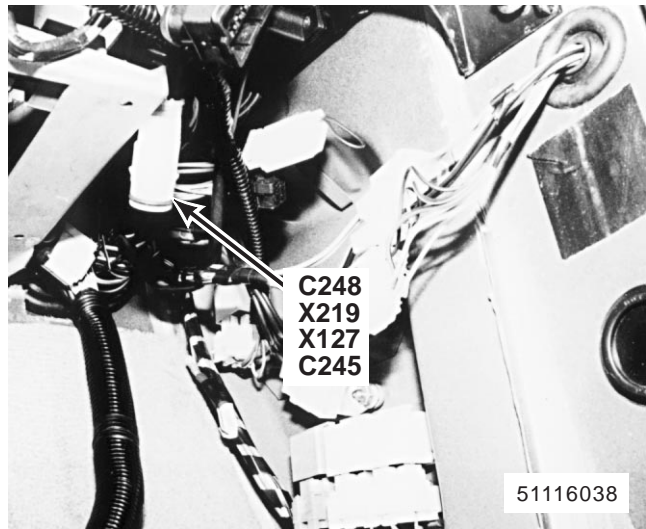

146. behind RH side of fascia 300Tdi
 X127 Data Link Connectors 300Tdi with EDC
 X219 Data Link Connector (EGR) 300Tdi without EDC
 C248 (3-W) 300Tdi without EDC
 C245 (4-W) 300Tdi with EDC

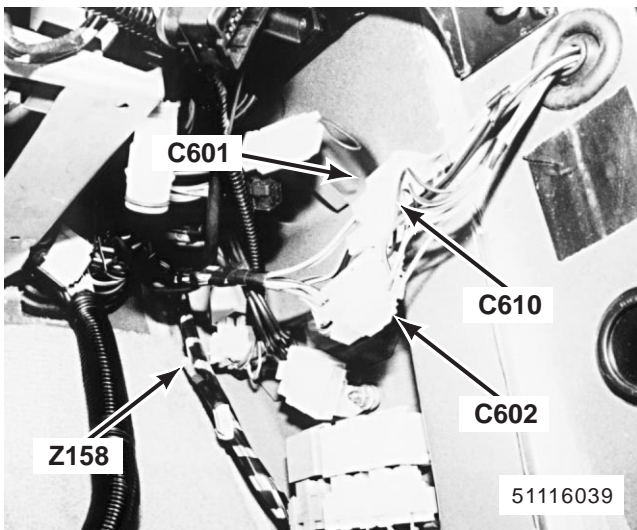

147. behind RH footwell trim panel
 Z158 Starter Relay Diode
 C601 (2-W)
 C602 (13-W)
 C610 (2-W)

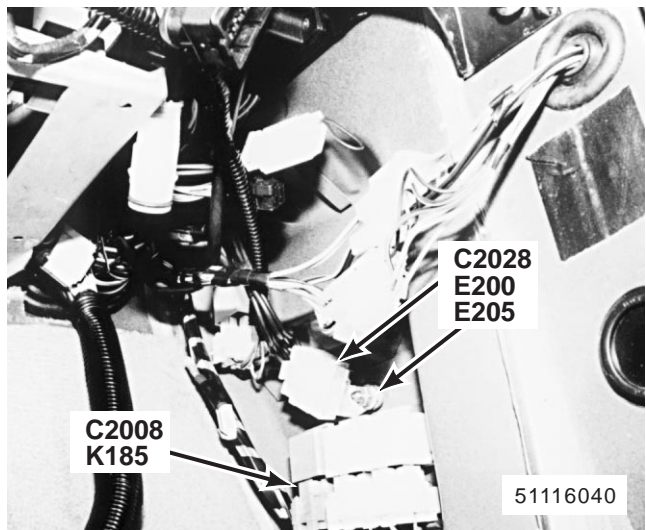

148. behind RH footwell trim panel
 K185 Front Wiper Relay
 C2008 (5-G)
 C2028 (6-W)
 E200
 E205

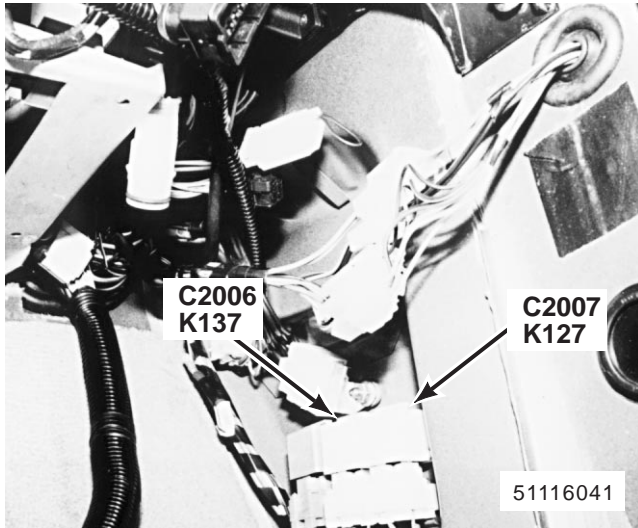

149. behind RH footwell trim panel
 K127 Ignition Load Relay
 K137 Starter Solenoid Relay
 C2006 (5-Y)
 C2007 (5-Y)

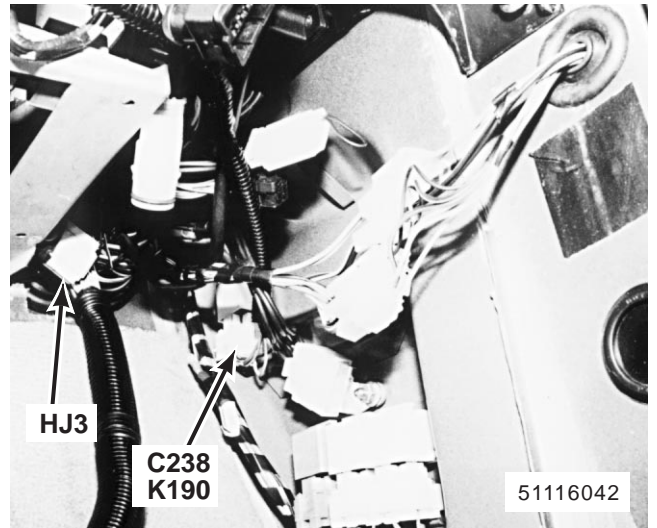

150. behind RH footwell trim panel
 K190 Cooling Fan Relay
 C238 (5-Y)
 HJ3 (20-S)

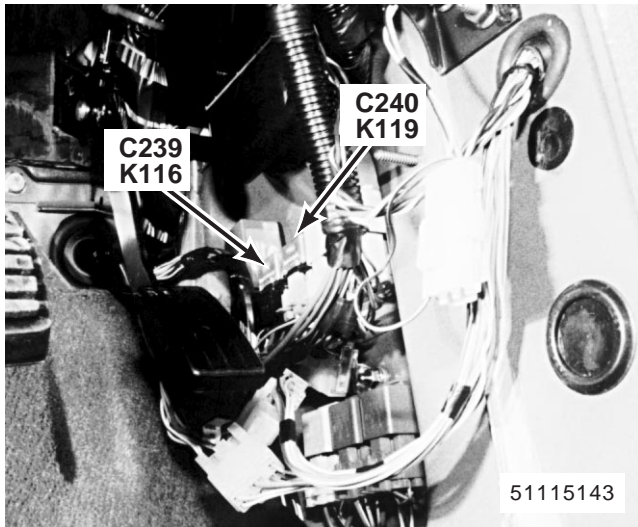

151. behind RH footwell trim panel (MFI-V8 shown; others similar)
 K116 Engine Control Load Relay
 K119 Fuel Pump Relay
 C239 (5-U)
 C240 (5-Y)

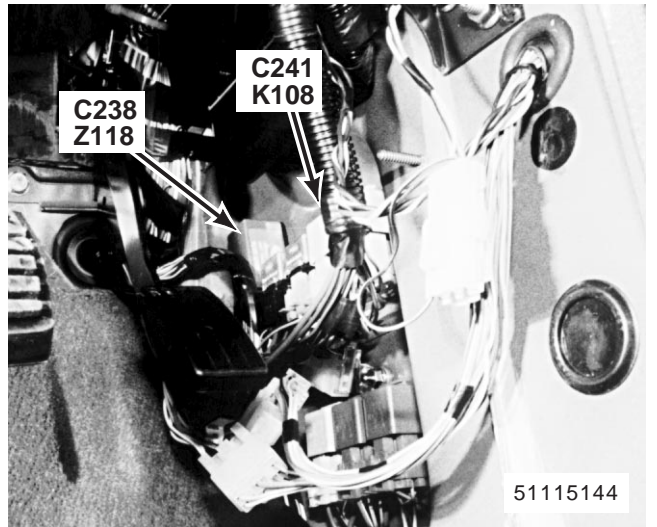

152. behind RH footwell trim panel (MFI-V8 shown; others similar)
 K108 Compressor Clutch Relay
 Z118 Fan Control Module
 C238 (9-B)
 C241 (5-Y)

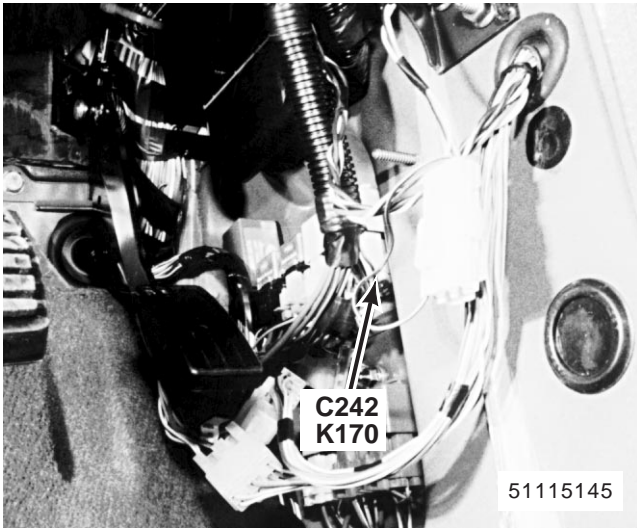

153. behind RH footwell trim panel (MFI-V8 shown; others similar)
K170 A/C Logic Relay
C242 (5-B)

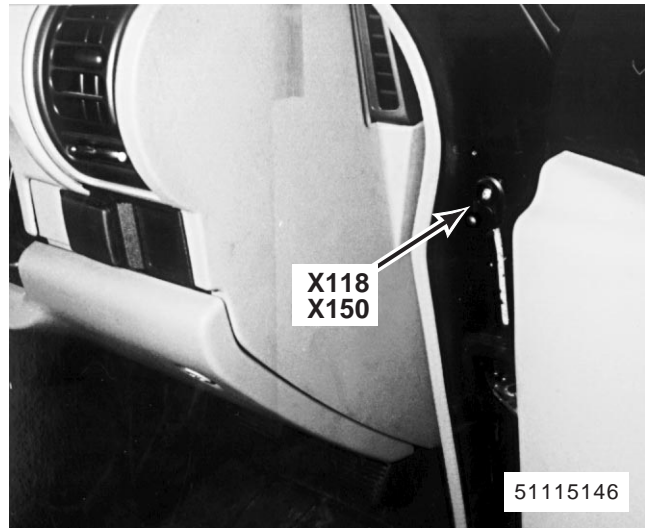

154. front of RH front door jamb (LH similar)
X118 Right Front Door Switch
X150 Left Front Door Switch

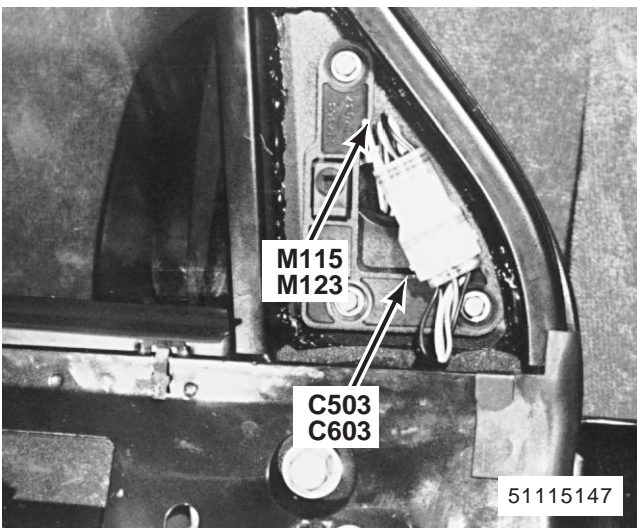

155. top front of LH front door (RH similar)
M115 Left Mirror Actuator
M123 Right Mirror Actuator
C503 (6-W) (Left)
C603 (6-W) (Right)

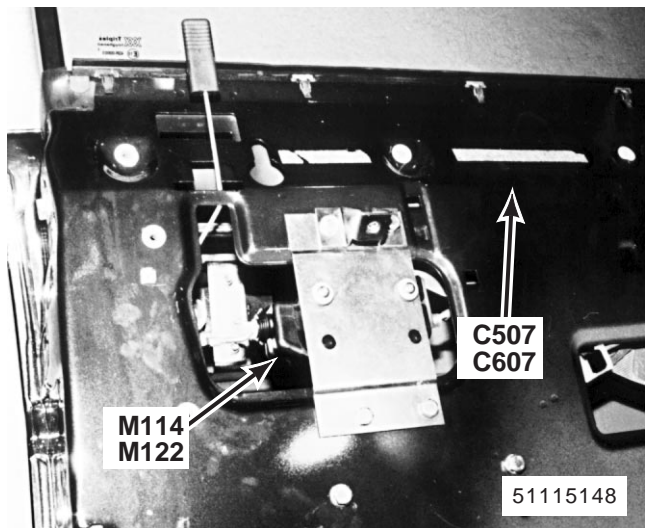

156. in rear of LH front door (RH similar)
M114 Left Front Door Lock Actuator
M122 Right Front Door Lock Actuator
C507 (4-W) (Left) Without Theft Alarm
C507 (6-W) (Left) With Theft Alarm
C607 (2-W) (Right) NAS
C607 (4-W) (Right) Without Theft Alarm
C607 (6-W) (Right) With Theft Alarm

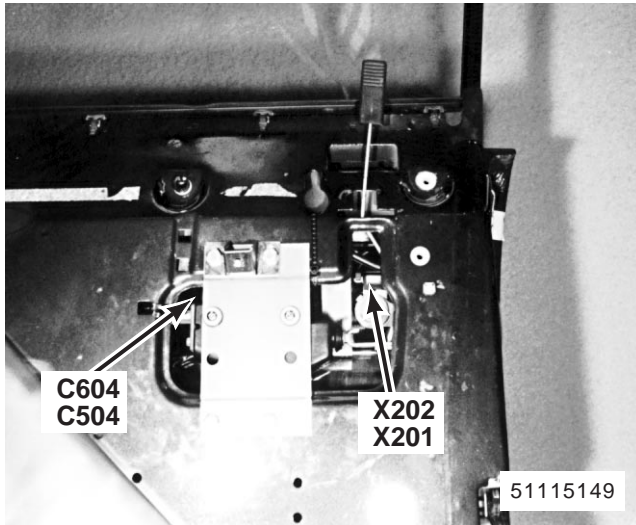

157. in top rear of RH front door (LH similar)
 X201 Left Front Door Key Switch
 X202 Right Front Door Key Switch
 C504 (4-W) (Left)
 C604 (4-W) (Right)

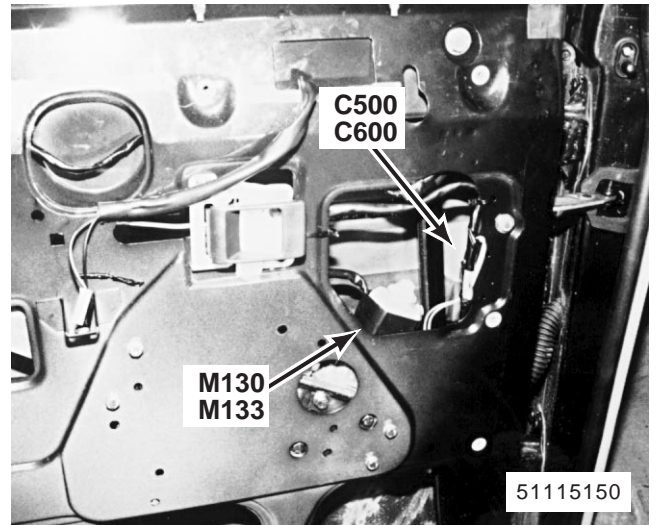

158. in front of LH front door (RH similar)
 M130 Left Front Window Motor
 M133 Right Front Window Motor
 C500 (2-B) (Left)
 C600 (2-B) (Right)

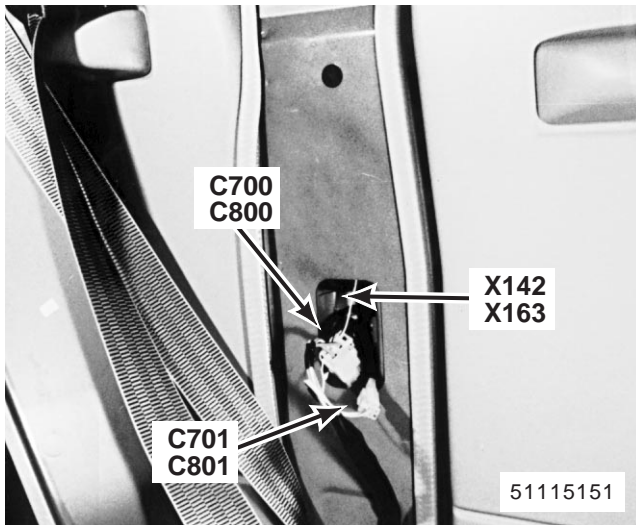

159. in lower part of LH B-post (RH similar)
 X142 Left Rear Door Switch
 X163 Right Rear Door Switch
 C700 (3-W) (Left)
 C800 (3-W) (Right)
 C701 (2-W) (Left)
 C801 (2-W) (Right)

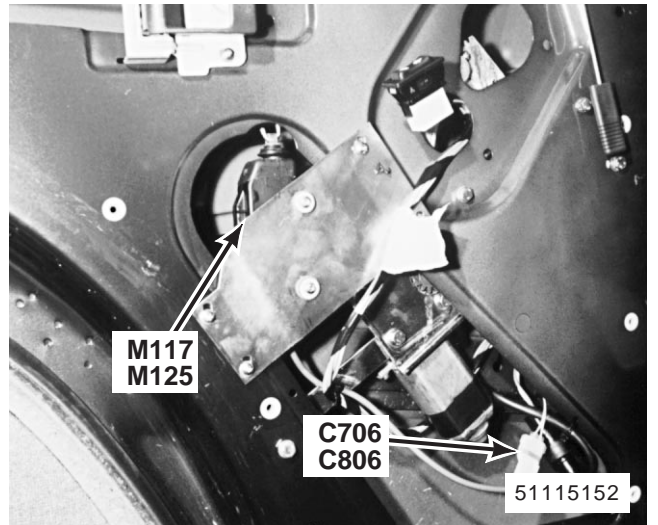

160. inside front of LH rear door (RH similar)
 M117 Left Rear Door Lock Actuator
 M125 Right Rear Door Lock Actuator
 C706 (2-W) (Left)
 C806 (2-W) (Right)

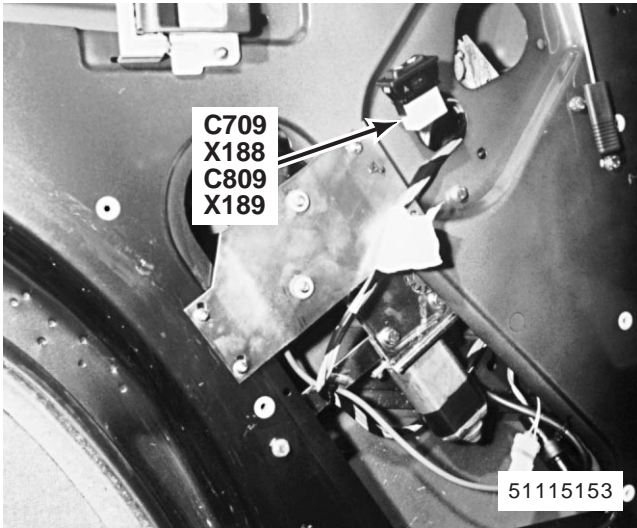

161. inside front of LH rear door (RH similar)
 X188 Left Rear Window Door Switch
 X189 Right Rear Window Door Switch
 C709 (5-W) (Left)
 C809 (5-W) (Right)

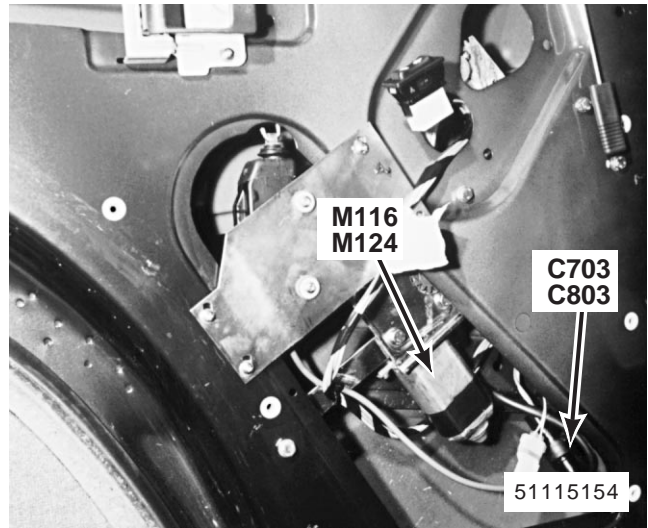

162. inside front of LH rear door (RH similar)
 M116 Left Rear Window Motor
 M124 Right Rear Window Motor
 C703 (3-B) (Left)
 C803 (3-B) (Right)

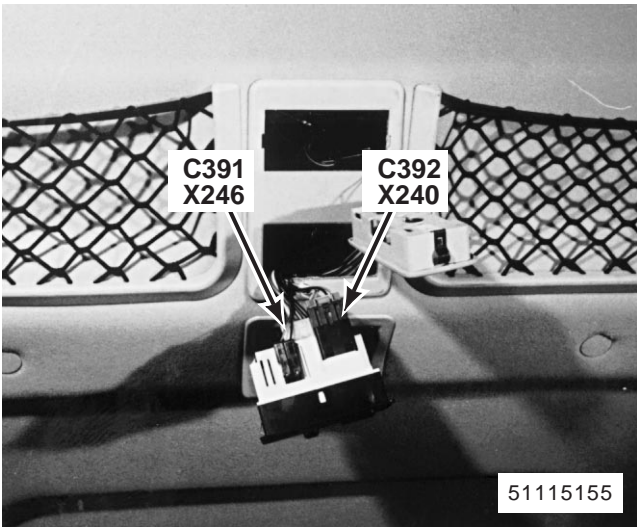

163. centre of roof
 X240 Passenger's Rear A/C Switch
 X246 Passenger's Rear Fan Speed Switch
 C391 (5-W)
 C392 (5-U)

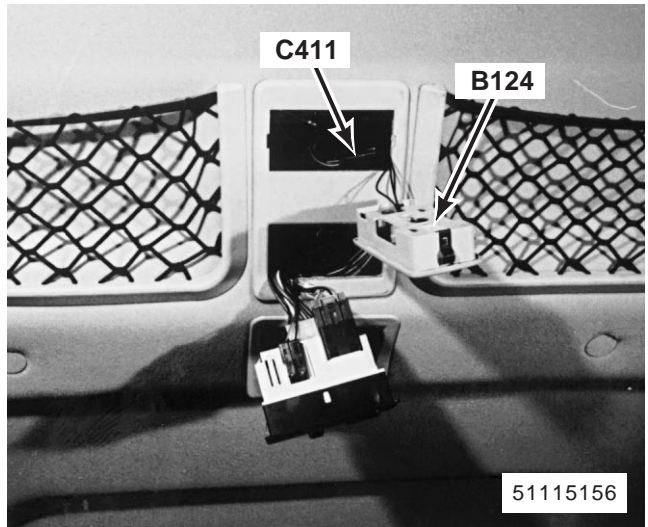

164. centre of roof
 B124 Rear Interior Roof Lamp
 C411 (4-B)

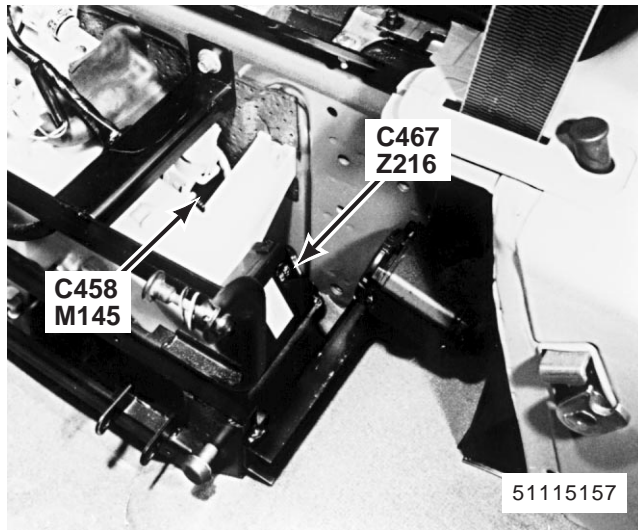

165. LH side of luggage compartment behind trim panel
 M145 Rear Blower Motor
 Z216 Rear A/C Switch Amplifier
 C458 (2-B)
 C467 (6-W)

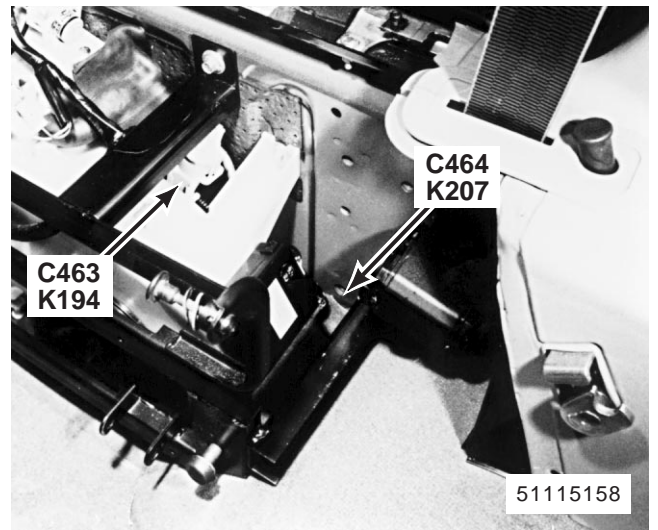

166. LH side of luggage compartment behind trim panel
 K194 Rear A/C Control Relay
 K207 Rear A/C Refrigerant Control Valve
 C463 (4-W)
 C464 (2-S)

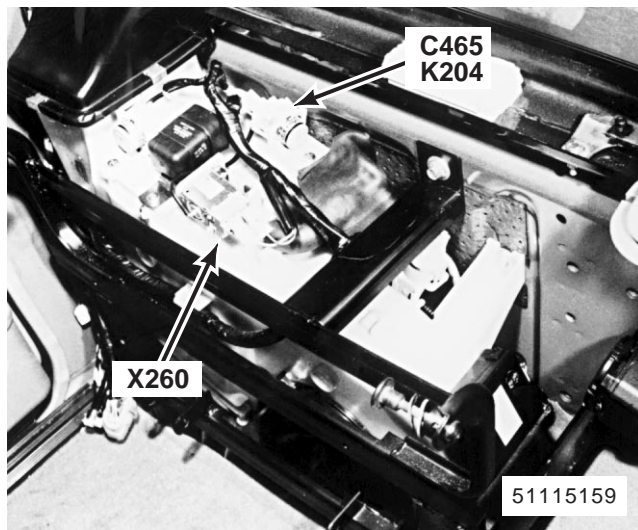

167. LH side of luggage compartment behind trim panel
 X260 Rear A/C Evaporator Temperature Switch
 K204 Rear A/C Illumination Relay
 C465 (4-W)

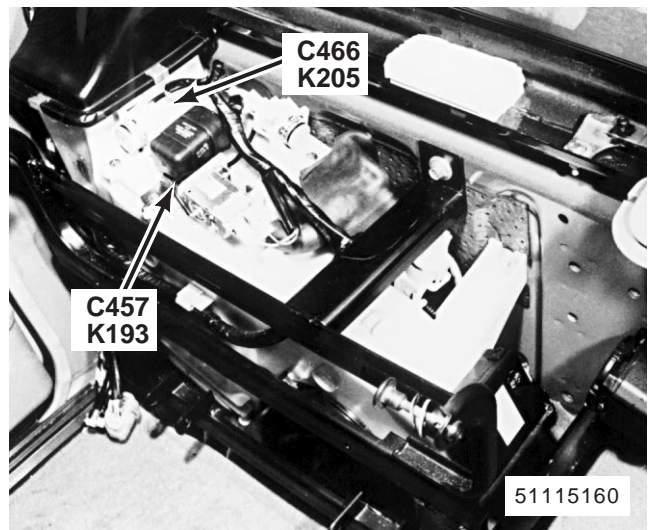

168. LH side of luggage compartment behind trim panel
 K193 Rear Blower Motor Relay
 K205 Rear A/C Fan Speed Relay
 C457 (5-W)
 C466 (4-W)

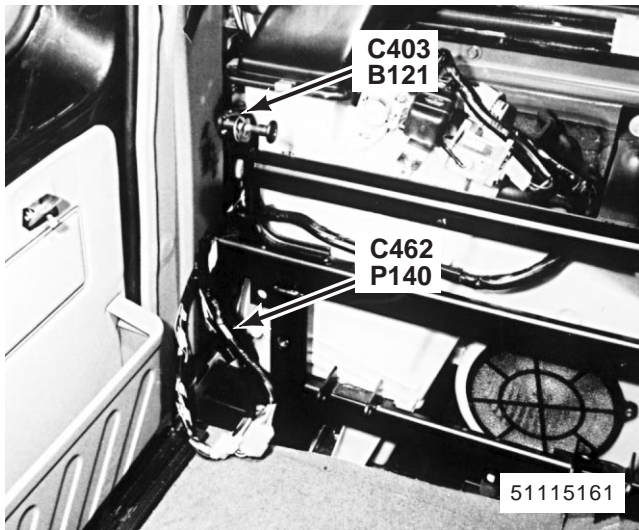

169. LH side of luggage compartment behind trim panel
 B121 Left Rear Lamp Assembly
 P140 Rear A/C Switch Amplifier In-Line Fuse
 C403 (6-W)
 C462 (2-B)

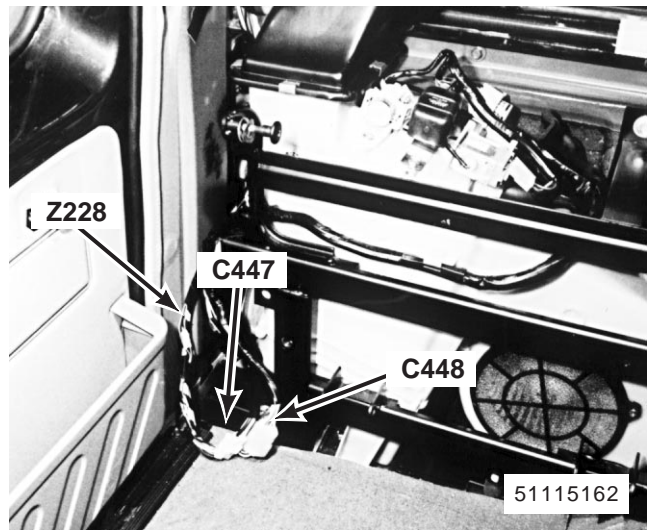

170. LH side of luggage compartment behind trim panel
 Z228 Rear A/C Refrigerant Control Valve Diode
 C447 (2-W)
 C448 (16-W)

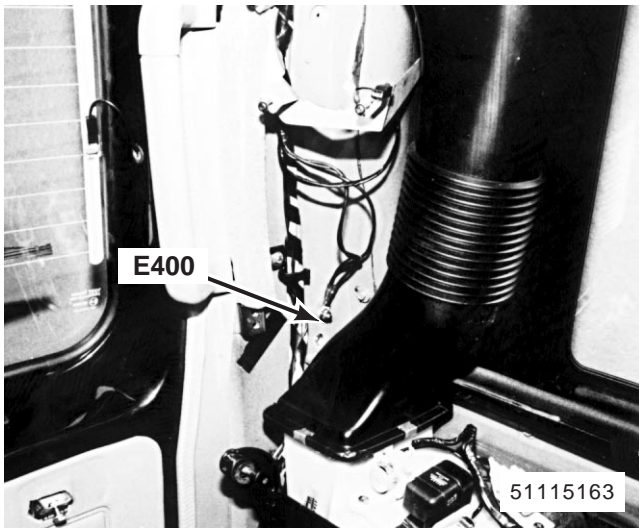

171. LH side of luggage compartment behind trim panel
 E400



172. RH rear of luggage compartment behind trim panel
 E401

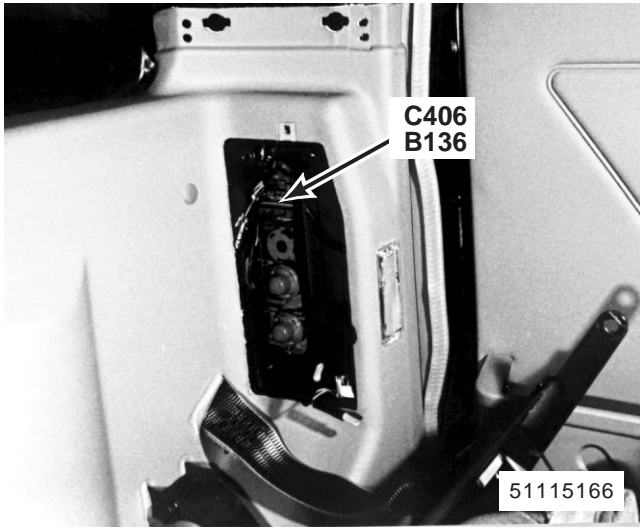

173. RH rear of luggage compartment behind trim panel
 B136 Right Rear Lamp Assembly
 C406 (6-W)

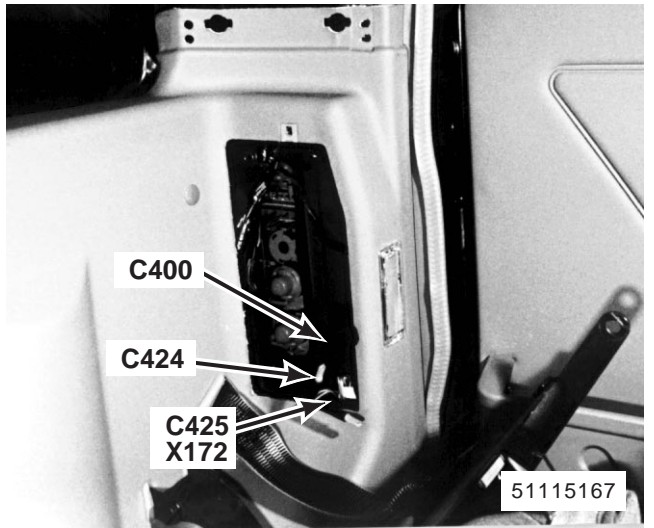

174. RH rear of luggage compartment behind trim panel
 X172 Trailer Auxiliary Socket
 C400 (7-B)
 C424 (1-B)
 C425 (1-B)

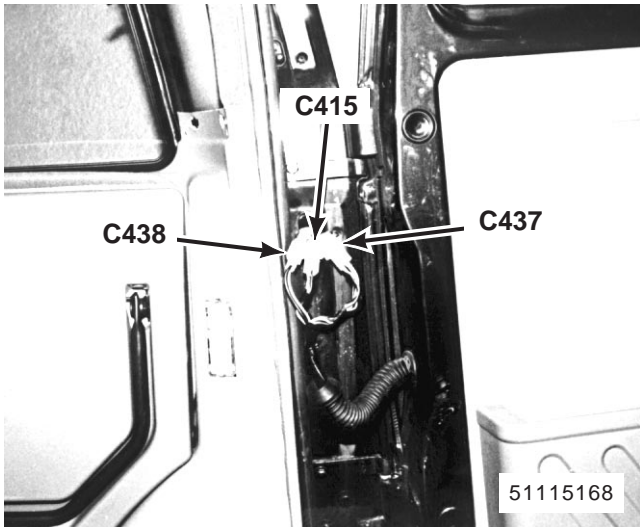

175. in RH side of tailgate door jamb
 C415 (8-W)
 C437 (6-W)
 C438 (2-W)

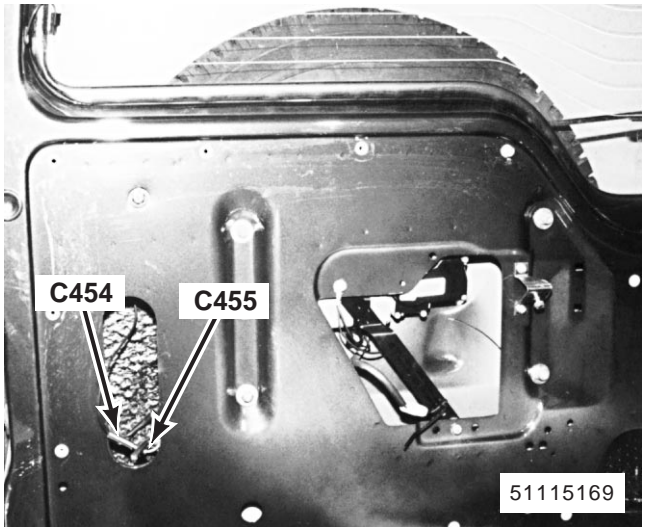

176. RH side of tailgate
 C454 (1-B)
 C455 (1-B)

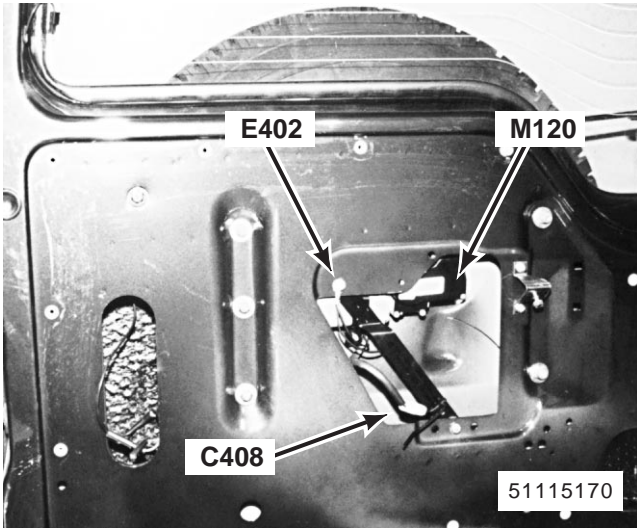

177. RH side of tailgate
M120 Rear Wiper Motor
C408 (4-W)
E402

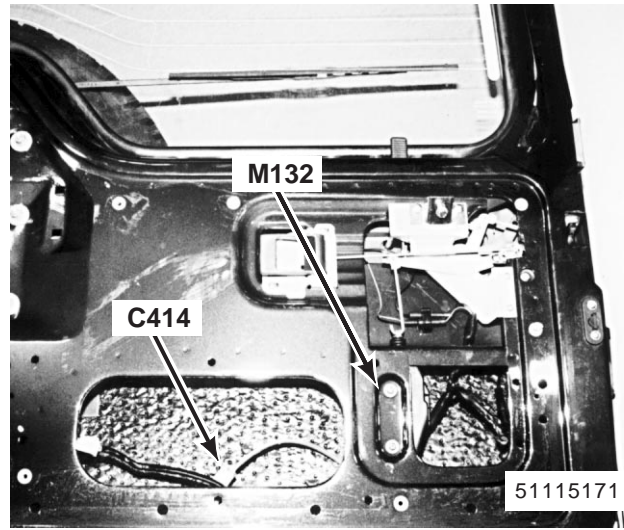

178. LH side of tailgate
M132 Tailgate Lock Actuator
C414 (2-W)

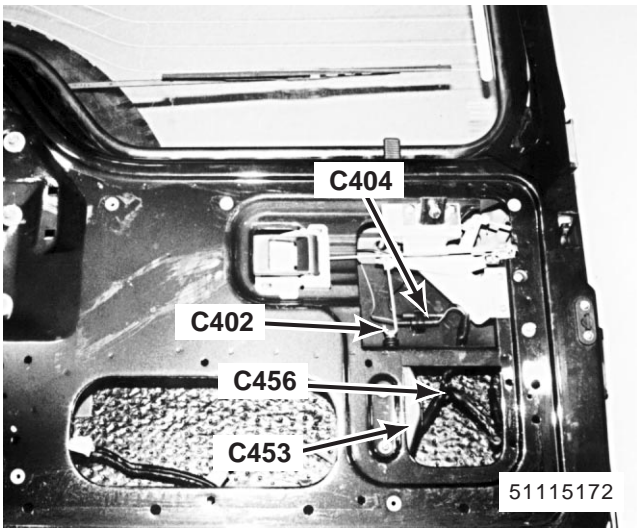

179. LH side of tailgate
C402 (1-B)
C404 (1-B)
C453 (1-B)
C456 (1-B)

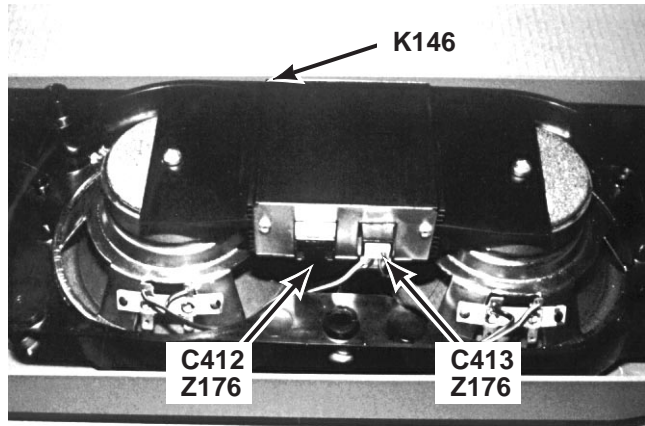

180. rear of Subwoofer
K146 Subwoofer
Z176 Subwoofer Amplifier
C412 (6-W)
C413 (4-W)

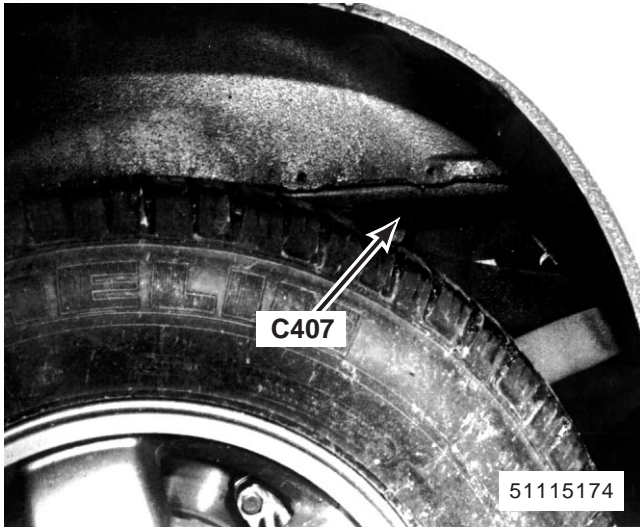

181. beneath LH rear of vehicle
C407 (3-B)

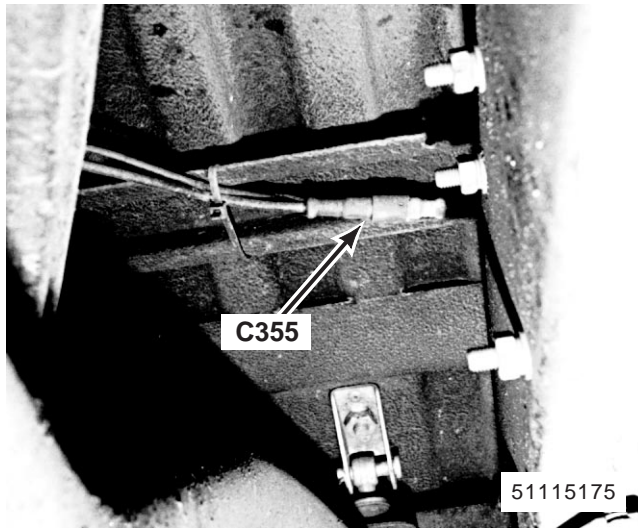

182. beneath LH rear of vehicle
C355 (2-W)

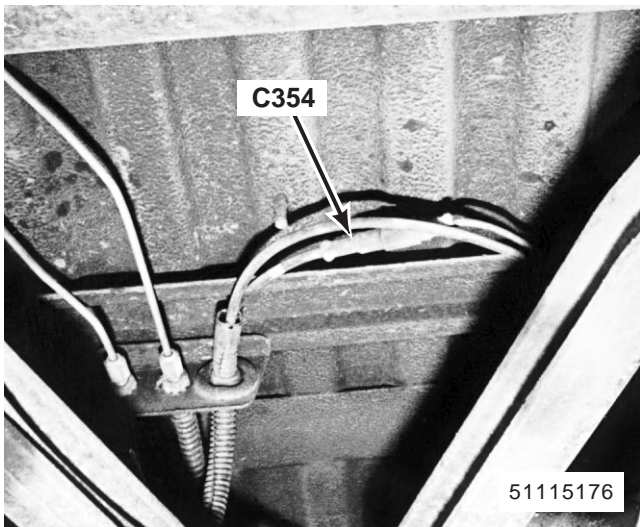

183. beneath RH rear of vehicle
C354 (2-W)

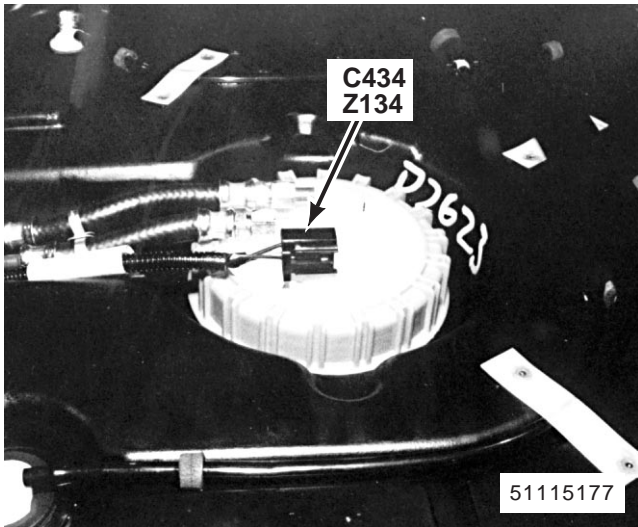

184. top of fuel tank
Z134 Fuel Pump Module
C434 (4-B)

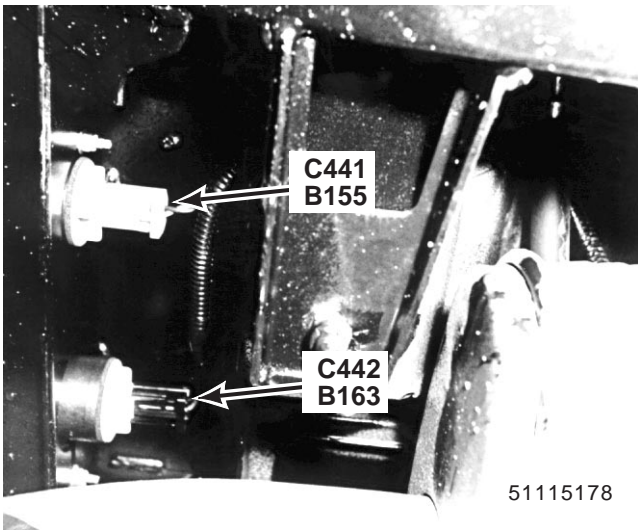

185. behind LH side of rear bumper
 B155 Left Tail Lamp
 B163 Left Rear Indicator Lamp
 C441 (2-R)
 C442 (2-B)

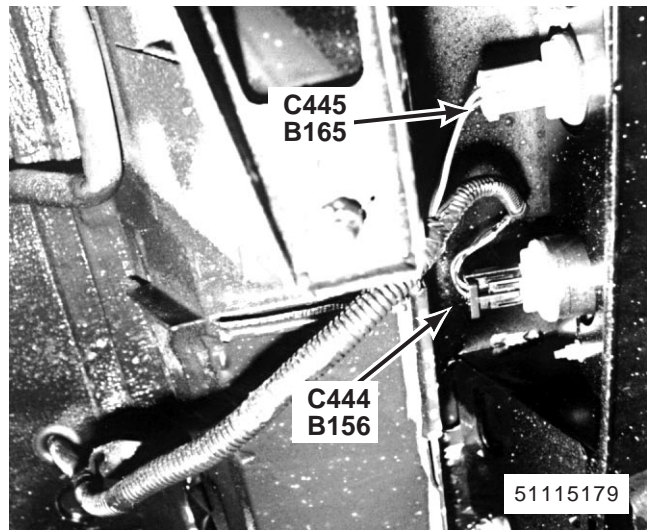

186. behind RH side of rear bumper
 B165 Right Rear Indicator Lamp
 B156 Right Tail Lamp
 C444 (2-B)
 C445 (2-R)



187. LH side of rear bumper (RH similar)
 B159 Left Rear Side Marker Lamp
 B160 Right Rear Side Marker Lamp
 C443 (2-B)
 C446 (2-B)

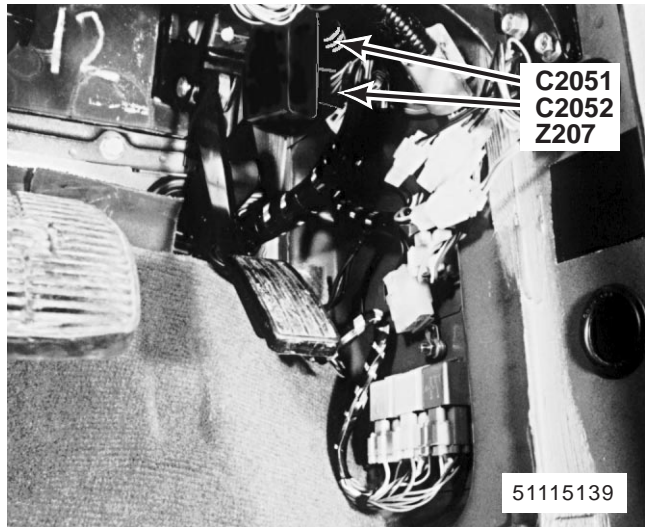

188. behind RH side of fascia
 Z207 Multi-Function Relay Unit
 C2051 (8-B)
 C2052 (6-B)

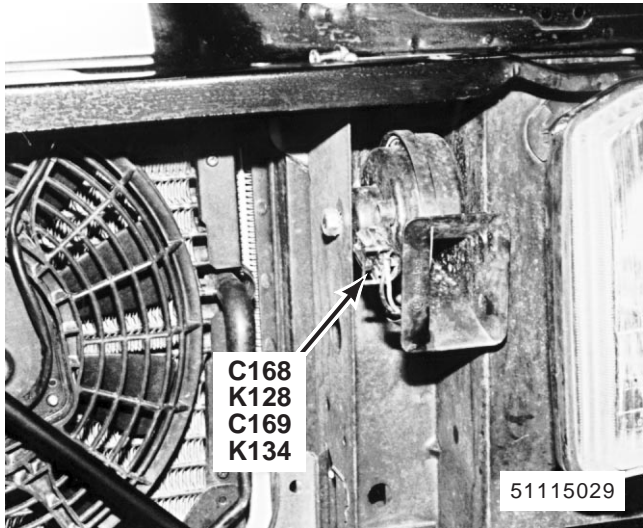

189. LH front of vehicle (RH similar)

K128 Left Horn

K134 Right Horn

C168 (2-B) (Left)

C169 (2-B) (Right)

C100

R030016

R030005



1	OK
2	PW
3	NLG

C103

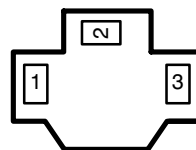

1	UO
2	UB
3	B

C101

LC00100A

R040005

LC00103A

R030005

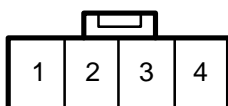

1	OS	3	-
2	NG	4	PN

C104

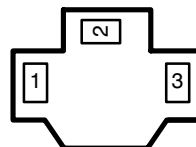

1	US
2	UK
3	B

LC00101A

R130001

C105

LC00104A

R130002

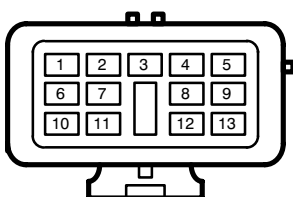

1	BU	6	SB	11	BO/BY
2	BR	7	BK	12	RY
3	GN	8	BLG	13	-
4	GY	9	YB		
5	B	10	BY		

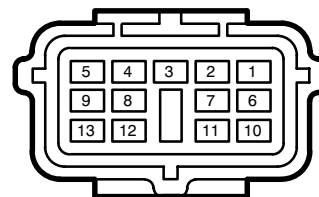

1	BO	6	SB	11	BO
2	BR	7	BK	12	-
3	GN	8	BLG	13	-
4	GY	9	BY		
5	B	10	BY		

LC00105C

LC00105C

C109

R020002

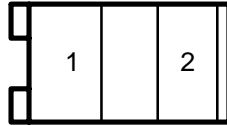

1	RB
2	B

C113

R030025

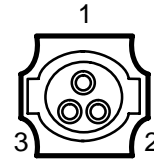

1	WO
2	CORE
3	B

C110

LC00109C
R020002

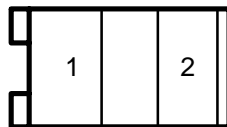

1	RO
2	B

C114

LC00113A
R020023

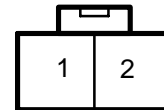

1	NK
2	NW

R030025

C112

LC00110C

LC00114A
R040001

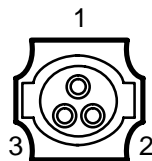

1	WO
2	CORE
3	B

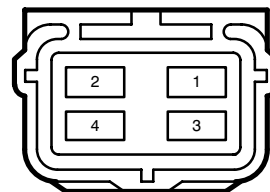

1	UY	3	B
2	UW	4	NU

LC00112C

LC00112C

R030019

R020007

C115

C124

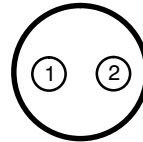
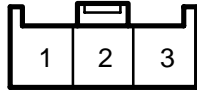

1	NP
2	NP
3	NO

1	GR
2	B

LC00115C

LC00124C

R020037

R020025

C120

C125

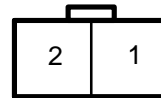
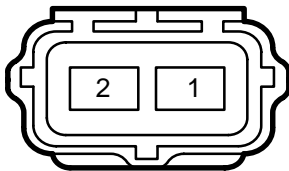

1	B
2	LGS

1	NR
2	B

LC00120A

LC00125C

R020007

R030012

C123

C127

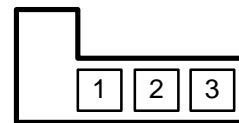
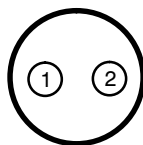

1	GW
2	B

1	LGK
2	B
3	-

LC00123C

LC00127C

C129

R130002

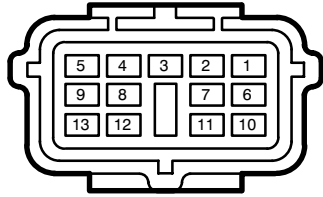

1	SR	6	B	11	SW
2	SY	7	SU	12	SP
3	-	8	SN	13	B
4	SG	9	B		
5	SK	10	B		

LC00129C

R020007

C130

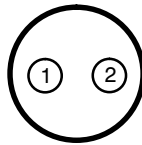

1	G
2	G

LC00130A

R040019

C132

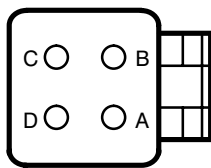

A	O	C	GW
B	US	D	RG

LC00132C

C131

R020007

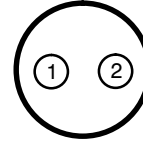

1	G
2	G

LC00131A

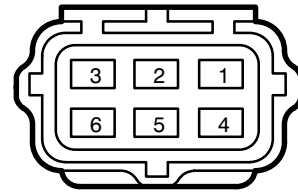

1	OS	4	OU
2	NK	5	-
3	KU	6	OG

R060016

LC00132C

R060004

C133

R050007

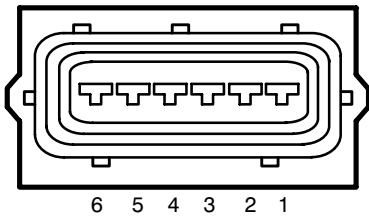

1	-	4	-
2	RB	5	NO
3	UG	6	UR

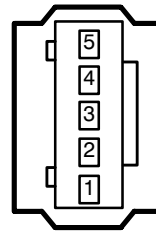

1	YB	4	B
2	UG	5	-
3	UR		

LC00133C

R020038

C134

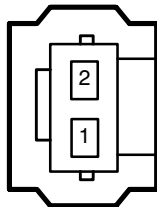

1	YU/NK
2	NO/YU

LC00133C

R020038

C136

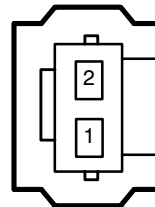

1	YU/NK
2	NO/YW

LC00134C

R020038

C135

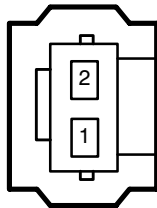

1	YW/NK
2	NO/YG

LC00136C

R020038

C137

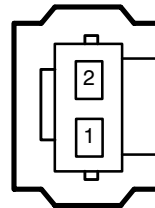

1	YW/NK
2	NO/YB

LC00135C

LC00137C

R020038

C138

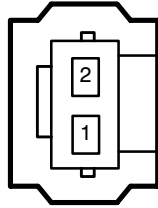

1	YU
2	NO

R020038

C141

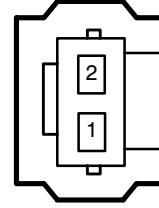

1	YW
2	NO

LC00138C

R020038

C140

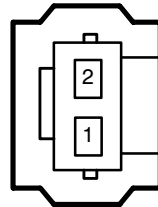

1	YU
2	NO

LC00141A

R020038

C142

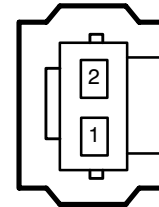

1	WN
2	-

LC00140A

R020009

C144

LC00142C

R020045

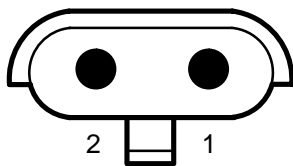

1	WP
2	SY

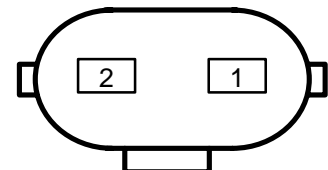

1	NK
2	RS

LC00144C

LC00144C

C145

R020011

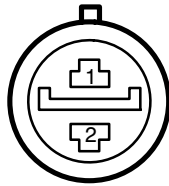

1	BG
2	B

LC00145A
R020020

C146



1	BP
2	B

LC00146A

R030022

C149

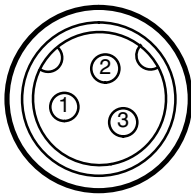

1	RB
2	R
3	Y

LC00149C

C148

R030002

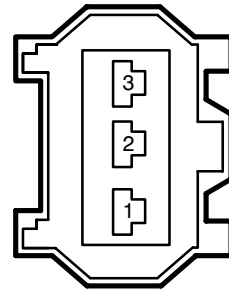

1	U
2	-
3	R

LC00148A

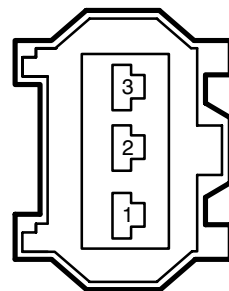

1	KP
2	GY
3	KB

LC00149C

R020038

R060018

C150

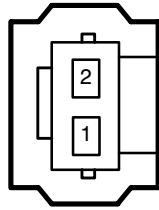

1	RB/YU
2	SW/KB

C159

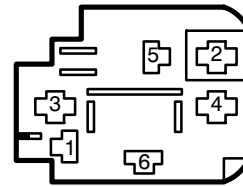

1	WR	4	B
2	BY	5	NO
3	WG	6	YB

LC00150C

LC00159A

R020038

R020038

C152

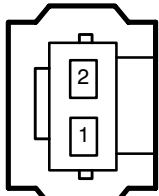

1	GU/RB/KB
2	B/GU/KG

C165

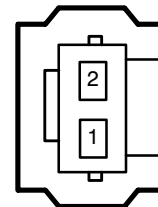

1	WG
2	BO

LC00152C

LC00165A

R020006

R020054

C166

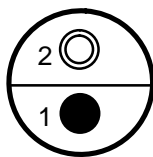

1	B
2	BLG

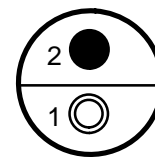

1	B
2	PB

LC00166C

LC00166C

R030023

R020037

C167

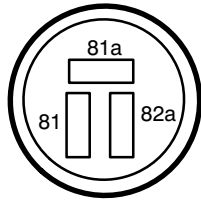

81	BY
81A	BR
82A	WU

C170

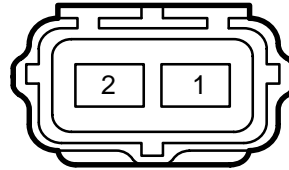

1	B
2	LGB

LC00167A

LC00170A

R020037

R030003

C168

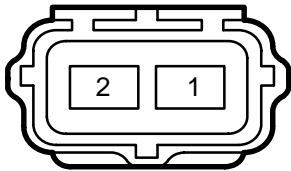

1	B
2	PG

C171

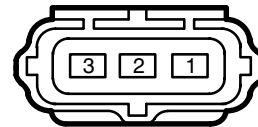

1	WP
2	-
3	WP

LC00168A

LC00171A

R020037

R020015

C169

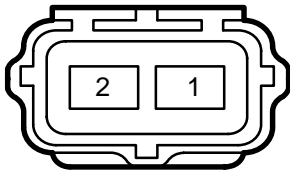

1	B
2	PG

C173

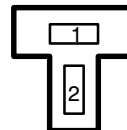

1	LGR
2	B

LC00169A

LC00173A

C177

R020037

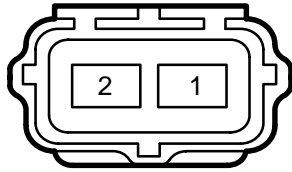

1	NY
2	NO

C181

R020031

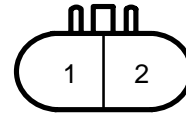

1	YB
2	ON

C178

LC00177F
R020037

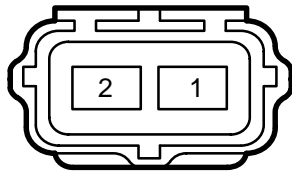

1	B
2	PO

C182

LC00181C
R020011

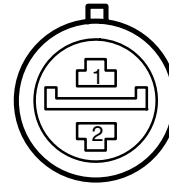

1	BN
2	B

C179

LC00178A
R020036

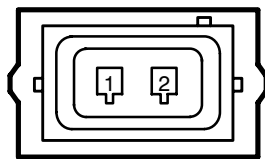

1	YR
2	B

C183

LC00182A
R020011

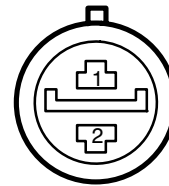

1	BN
2	B

LC00179C

LC00183A

R030002

R030002

C190

C191

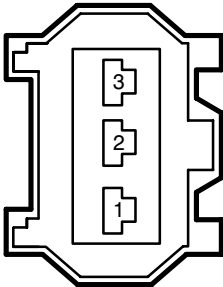
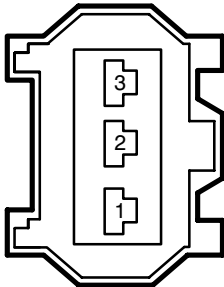

1	B
2	UY
3	RB

1	B
2	UY
3	RB

LC00190C

LC00191C

R040011

R040017

C195

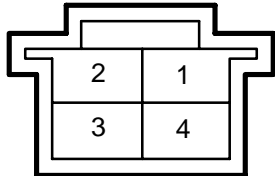
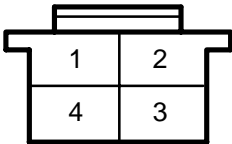

1	WS	3	WG
2	B	4	WP

1	O	3	N
2	K	4	B

LC00195C

LC00195C

R020038

R030002

C196

C197

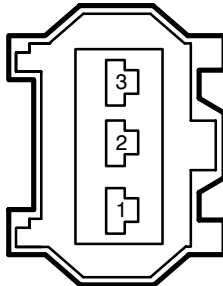
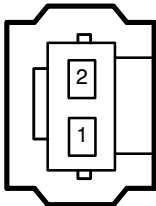

1	NB
2	B

1	Y
2	B
3	B

LC00196C

LC00197C

R060016

C198

R030028

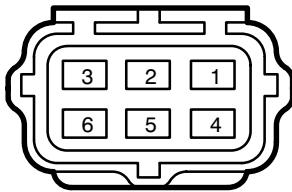

1	NK	4	YG
2	YB	5	YU
3	WB	6	-

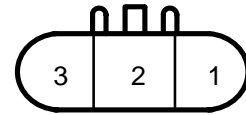

1	WO
2	NO
3	NS

LC00198C

R080018

C199

LC00198C
R030002

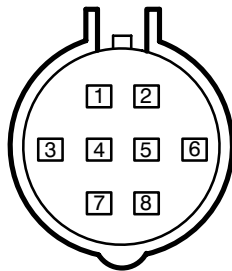

1	GO	5	NO
2	R	6	WP
3	GK	7	WS
4	B	8	-

C1001

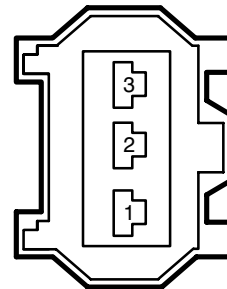

1	YU
2	YG
3	B

LC00199C

R020038

C1000

LC01001C
R030002

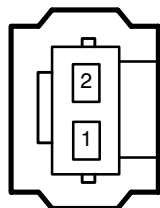

1	KO/KS
2	KB/B

C1002

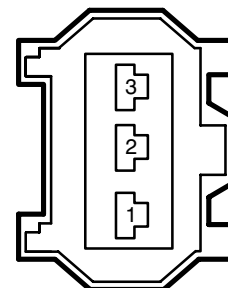

1	-
2	NK
3	YU

LC001000C

LC01002C

R030002

R020038

C1003

C1005

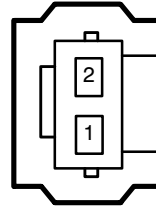
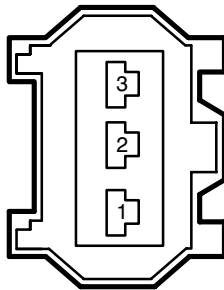

1	-
2	NK
3	WB

1	KB
2	LGS

LC01003C

LC01005C

R020038

R030024

C1004

C1006

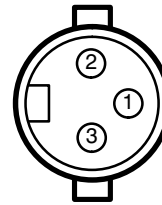
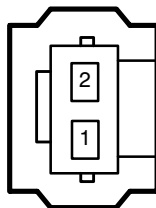

1	WU
2	UP

1	KB
2	BO
3	-

LC01004C

LC01006C

R360001

C1007

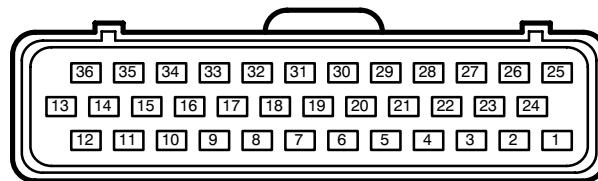

1	YU	7	UY	13	-	19	BS	25	YU	31	UP
2	KU	8	GY	14	B	20	UP	26	YG	32	WU
3	OS	9	KP	15	BG	21	RS	27	OU	33	KG
4	YN	10	BO	16	KO	22	OG	28	NK	34	YU
5	-	11	WG	17	LGS	23	WB	29	B	35	BN
6	BP	12	-	18	UW	24	YB	30	KB	36	U

LC01007C

C1008

R180005

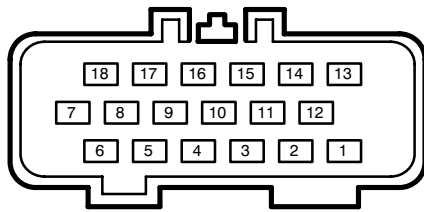

1	-	6	-	11	B	16	-
2	-	7	-	12	-	17	-
3	-	8	-	13	-	18	WB
4	-	9	-	14	-		
5	B	10	-	15	-		

C1011

R020011

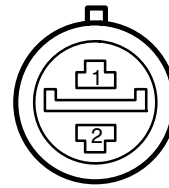

1	US/BR
2	B

C1009

LC01008C

R020037

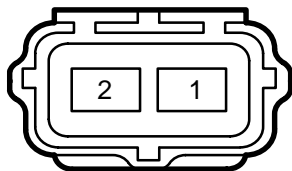

1	B/GR
2	GR/B

C1012

LC01011C

R020011

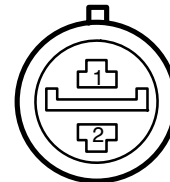

1	BR
2	B

C1010

LC01009F

R020037

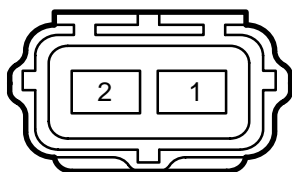

1	B
2	GW

C1013

LC01012C

R020007

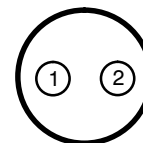

1	RB
2	B

LC01010F

LC01013C

R020007

C1014

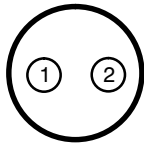

1	RO
2	B

R020003

C1016

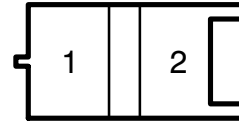

1	B
2	PB

LC01014C
R040011

C1015

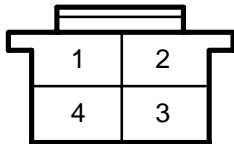

1	O	3	N
2	K	4	B

LC010016C

LC010015C

R040018

C200

R040015

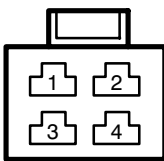

1	NP	3	R
2	U	4	-

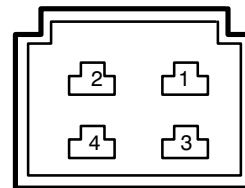

1	NP	3	R
2	U	4	-

LC00200C

LC00200C

R070011

C201

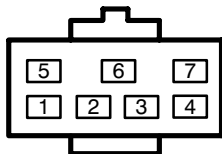

1	R	5	UW
2	NG	6	NP
3	UR	7	PO
4	U		

LC00201A

R240004

R240001

C202

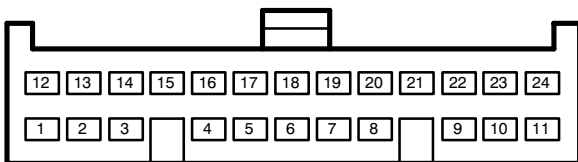

1	B	7	WLG	13	GR	19	P
2	UR	8	LGP	14	WP	20	PU
3	GR	9	LGN	15	GW	21	PO
4	LGG	10	ULG	16	WY	22	NG
5	-	11	LGB	17	RW	23	BR
6	UW	12	RLG	18	UW	24	P

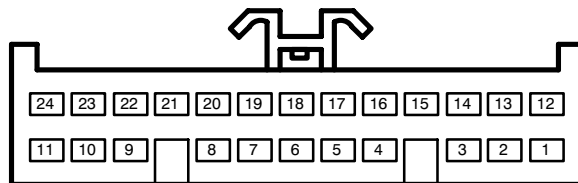

1	B	7	WLG	13	GR	19	PN
2	UR	8	LGP	14	WP	20	PW
3	GS	9	LGN	15	GW	21	PO
4	LGG	10	ULG	16	WY	22	NG
5	-	11	LGB	17	RW	23	BR
6	UW	12	RLG	18	UW	24	P

LC00202C

R070005

LC00202C

R240004

C203

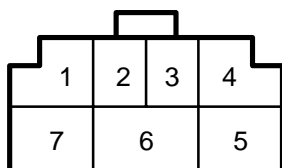

1	UR	5	LGW
2	U	6	W
3	R	7	NP
4	W		

LC00203A

C204

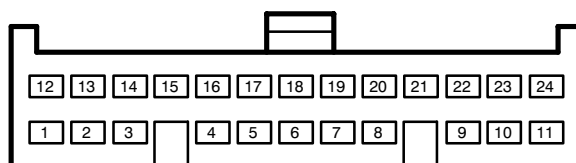

1	LGP	7	GY	13	-	19	G
2	LGN	8	RB	14	GW	20	WR
3	WN	9	LGP	15	RB	21	GO
4	P	10	GS	16	GR	22	UO
5	GLG	11	US	17	-	23	RO
6	-	12	UB	18	-	24	UK

LC00204C

R240003

R100007

C205

C207

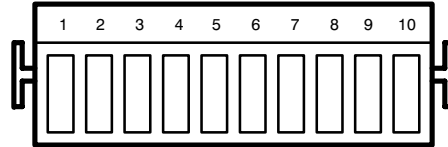
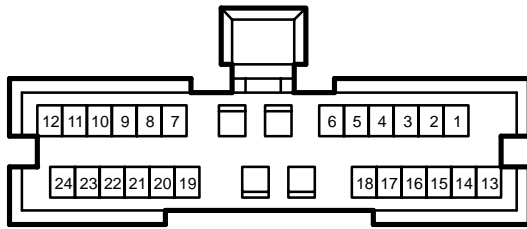

1	PU	7	RW	13	LGB	19	-
2	G	8	WLG	14	Y	20	-
3	BK	9	LGG	15	OU	20	PW/PO
4	PW/PU	10	BK	16	LGS	21	WP
5	PW	11	-	17	UB	22	NS
6	B	12	WR	18	PW	23	NP
				24	-		

1	LG	4	G	6	LGU	8	B
2	BS	5	WS	7	LG	9	LGG
3	UW					10	BLG

LC00205F

LC00207C

R040014

R180004

C206

C208

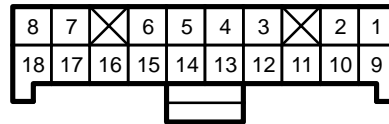
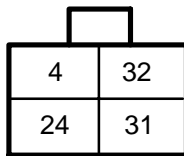

4	R	31	B
24	UW	32	OS

1	G	6	-	11	-	16	-
2	-	7	GR	12	UW	17	B
3	-	8	GW	13	UR	18	BO
4	RO	9	-	14	WN		
5	LG	10	-	15	-		

LC00206A

LC00208C

R200002

R200007

C209

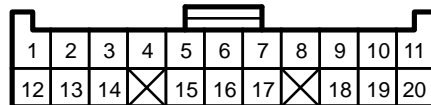
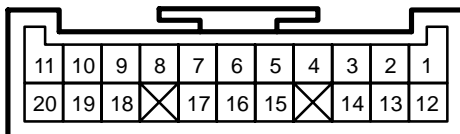

1	RN	6	BY/PO	11	BP	16	G
2	RS	7	SW	12	WY	17	YK
3	Y	8	BU	13	LGO	18	YK
4	RW	9	BK	14	GO	19	YK
5	BR	10	BN	15	GLG	20	BS

1	RN	6	PO	11	BP	16	G
2	RS	7	SW	12	WY	17	YK
3	YK	8	BU	13	LGO	18	YK
4	RW	9	BK	14	GO	19	YK
5	BR	10	BN	15	GLG	20	BS

LC00209F

LC00209F

R100004

C211

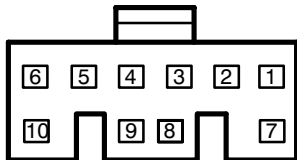

1	-	4	GR	6	GW	8	-
2	-	5	RB	7	RO	9	ND
3	-					10	-

LC0100211C

R140002

C212

R140007

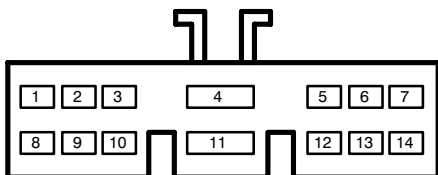

1	BO	6	B	11	NG
2	BY	7	SCR	12	UW
3	BG	8	BG	13	WG
4	PN	9	BY	14	W
5	R	10	BU		

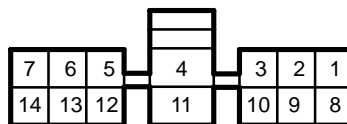

1	BO	6	B	11	NG
2	BY	7	SCR	12	YO
3	BG	8	BG	13	WG
4	PN	9	PY	14	YU
5	R	10	BU		

LC00212C

R030026

LC00212C

C214

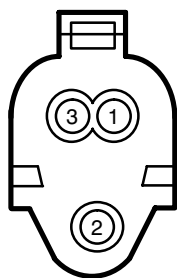

1	RN
2	RO
3	B

LC00214A

R240005

C215

R240002

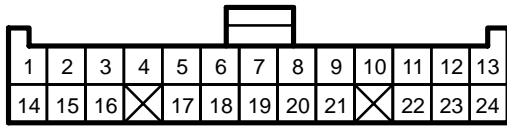

1	PN	7	-	13	KO	19	BLG
2	WS	8	UY	14	OU	20	LGN
3	G	9	PN	15	GU	21	-
4	-	10	WR	16	-	22	LGK
5	LGP	11	RY	17	LGS	23	-
6	GB	12	BG	18	BO	24	NY

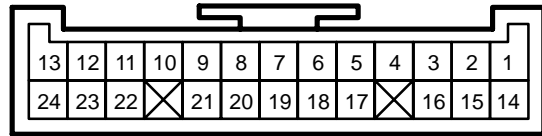

1	PN	7	-	13	KO	19	BLG
2	WS	8	UY	14	OU	20	LGN
3	G	9	PN	15	GU	21	-
4	-	10	WR	16	-	22	LGK
5	LGP	11	RY	17	LGS	23	-
6	GP	12	NP	18	BO	24	NY

LC00215C

R070009

C216

LC00215C

R070010

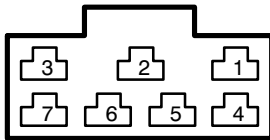

1	NLG	5	BR
2	WP	6	BG
3	PW	7	WG
4	NR		

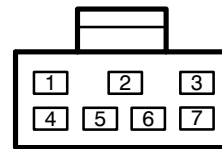

1	NLG	5	BN/NG
2	WP	6	BG
3	PW	7	WG
4	NR		

LC00216C

R200005

C217

LC00216C

R200006

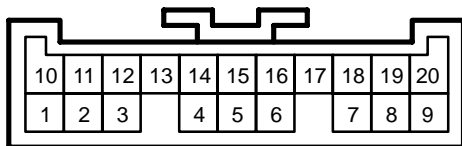

1	GU	6	NO/B	11	YB	16	NG
2	WS	7	K	12	BY	17	NY
3	WN	8	-	13	GP/NK	18	WG
4	BP	9	YK	14	GP	19	PB
5	WU	10	OB	15	RS	20	GW

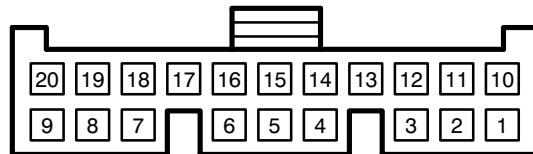

1	GU	6	B/NU	11	YB	16	NG
2	WS	7	K	12	BY	17	NY
3	WN	8	-	13	GP/NK	18	WG
4	BP	9	YK	14	GP	19	PB
5	WU	10	OB	15	RS	20	GW

LC00217F

LC00217F

R080012

C218

R080011

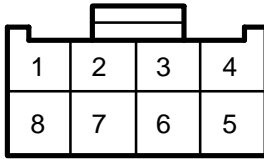

1	WU	5	-
2	BY	6	B
3	PW	7	P
4	WY	8	PY

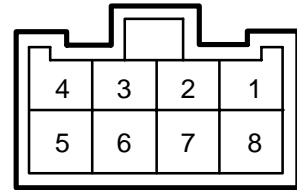

1	WU	5	-
2	-	6	B
3	PW	7	P
4	WY	8	P

LC00218C

R030017

C220

LC00218C

R100007

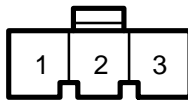

1	NW
2	LG
3	-

C222

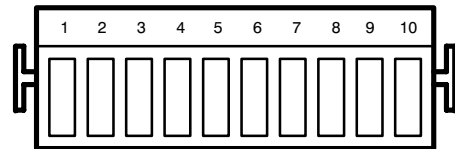

1	RS	4	-	6	-	8	GU
2	LG	5	WN	7	RN	9	RN
3	KO					10	B

LC00220A

R100007

C221

LC00222C

R050005

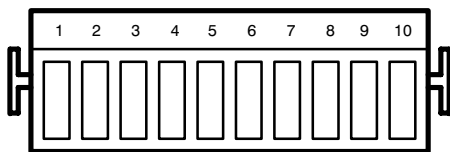

1	B	4	YK	6	BO	8	LG
2	BR	5	NY	7	PO	9	WR
3	GB					10	-

C223

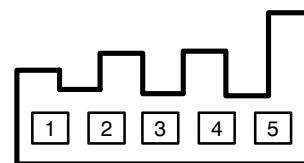

1	G	4	-
2	-	5	S
3	P		

LC00221C

LC00223A

R060008

C224

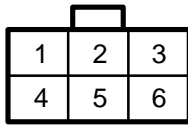

1	B	4	GS
2	NLG	5	RLG
3	ULG	6	-

R040007

C227

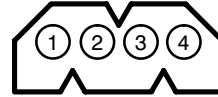

1	GP	3	WR
2	GO	4	WS

LC00224A

R160002

C225

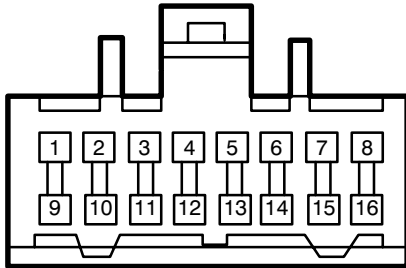

1	PO	5	-	9	-	13	-
2	GB	6	YK	10	GK	14	RW
3	UG	7	KB	11	BK	15	BN
4	-	8	WB	12	PW/PU	16	PW

LC00227C

R080015

C228

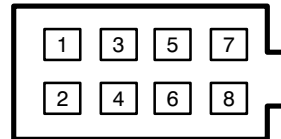

1	BK	5	BP
2	BN	6	GLG
3	SW	7	BU
4	B	8	-

LC00225F

R030019

C226



1	-
2	WY
3	LGW

LC00228C

R080017

C230

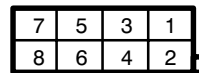

1	-	5	UY
2	B	6	RN
3	U	7	LGO
4	P	8	B

LC00226A

LC00230C

R090002

R050001

C238

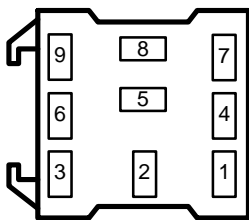

1	-	4	BR	7	-
2	NO	5	BG	8	GW
3	-	6	B	9	PB

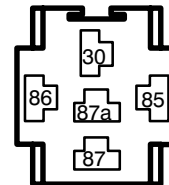

30	NG	87	US
85	BP	87A	-
86	WG		

LC00238C

LC00238C

R050001

R050001

C239

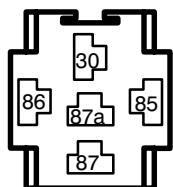

30	NLG	87	NO
85	UR	87A	NO
86	NO		

C241

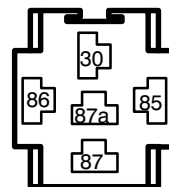

30	NG	87	WG/BS
85	BS	87A	BG
86	WG		

LC00239C

LC00241C

R050001

R050001

C240

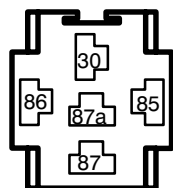

30	PW	87	WP
85	UP	87A	WO
86	WG		

C242

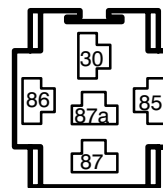

30	WG/BN/NG/YG	87	GY/B/BG/WG
85	WG/YB	87a	-
86	YB/WG/G		

LC00240A

LC00242C

R40001

C243

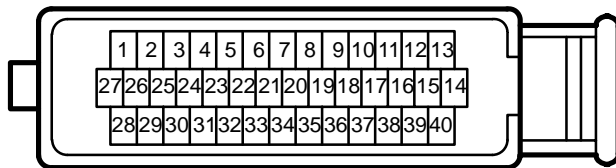

1	RG	7	GU	13	YU	19	WG	25	RB	31	BS	37	-
2	NO	8	PY	14	B	20	R	26	GW	32	SW	38	NK
3	Y	9	WLG	15	NO	21	GY	27	BS	33	BS	39	WU
4	B	10	RS	16	UP	22	UR	28	US	34	OB	40	B
5	SB	11	YW	17	SY	23	CORE	29	O	35	UG		
6	YK	12	UR	18	WK	24	CORE	30	K	36	BG		

LC00243C

R550001

C243

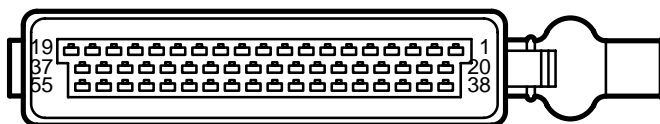

1	WP	8	-	15	UR	22	-	29	YK	36	KS	43	-	50	-
2	WP	9	BS	16	NO	23	-	30	-	37	WG	44	YG	51	YU
3	W	10	NS	17	NO	24	-	31	LGP	38	UG	45	-	52	YB
4	RS	11	-	18	B	25	WS	32	-	39	GK	46	-	53	GU
5	NB	12	B	19	B	26	GP	33	WP	40	-	47	Y	54	YG
6	SR	13	B	20	-	27	WK	34	UR	41	-	48	-	55	WG
7	-	14	R	21	GO	28	-	35	WS	42	WLG	49	-		

LC00243C

R050012

C244

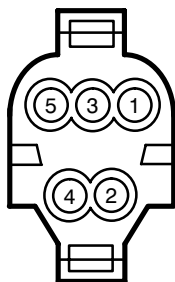

1	BS	4	-
2	-	5	-
3	-		

LC00244A

R050013

R040013

C245

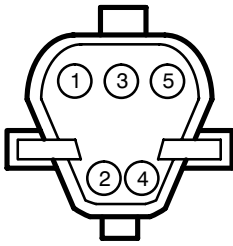

1	WK	4	WLG
2	-	5	BS
3	-		

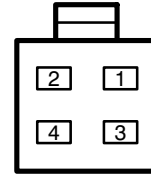

1	WK	3	B
2	WLG	4	NO

LC00245C

LC00245C

R020033

R030024

C246

C248

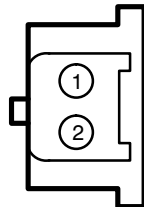

1	BS
2	SB

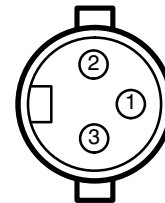

1	KB
2	WLG
3	WK

LC00246A

LC00248A

R160003

R050002.03

C247

C249

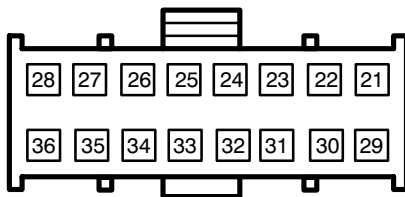

21	KB	25	R	29	B	33	WK
22	-	26	GU	30	-	34	RU
23	-	27	-	31	-	35	RB
24	BO	28	WG	32	WLG	36	WS

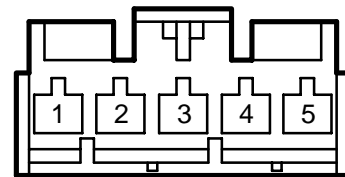

1	GLG	4	LGS
2	RN	5	B
3	-		

LC00247A

LC00249A

R050002.00

C250

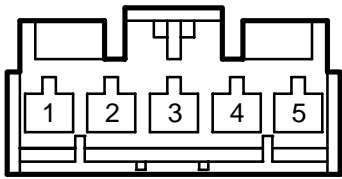

1	GLG	4	OU
2	RN	5	B
3	-		

LC00250A

R060017

R060016

C252

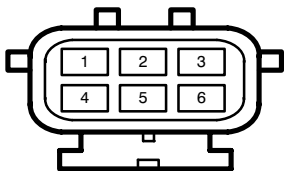

1	P	4	B
2	LGP	5	G
3	S	6	G

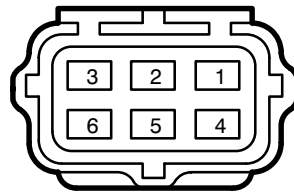

1	P	4	B
2	LG	5	G
3	S	6	G

LC00252C

R060007

LC00252C

R100011

C259

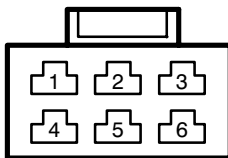

1	B	4	RN
2	UY	5	RO
3	-	6	-

C260

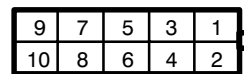

1	R	4	B	6	B	8	B
2	B	5	Y	7	U	9	R
3	G					10	B

LC00259C

LC00260C

R050002.02

R100008

C262

C267

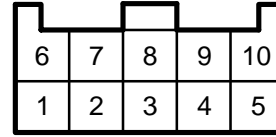
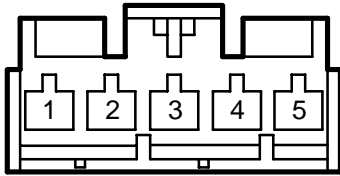

1	GLG	4	WY
2	RN	5	B
3	-		

1	LGN	4	GW	6	GO	8	LGP
2	GR	5	-	7	PN	9	RN
3	LGG					10	B

LC00262A

LC00267C

R050002.01

R080016

C263

C268

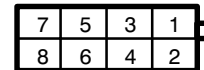
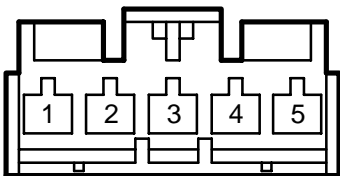

1	UR	4	RY
2	RN	5	B
3	-		

1	NY/BG	5	B/BW
2	U/BU	6	BN
3	UG/BK	7	BY
4	RG/BR	8	BO

LC00263A

LC00268C

R050002.02

R020027

C264

C269

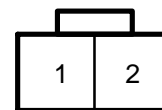
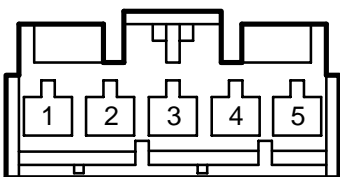

1	BO	4	B
2	RN	5	BG
3	-		

1	P
2	RW

LC00264C

LC00269C

R040008

R060001

C270

C274

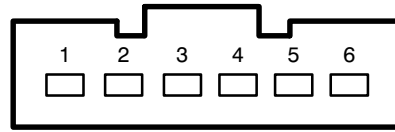
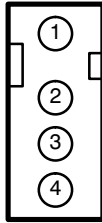

1	PN	3	RN
2	B	4	LG

1	BO	4	O
2	BO	5	K
3	OB/PO	6	P

LC00270C

LC00274F

R230001

C277

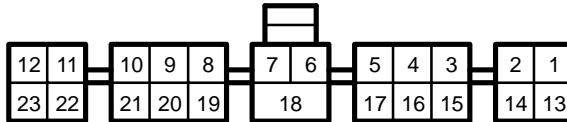

1	LGO	7	-	13	GP	19	GW
2	GR	8	GLG	14	RY	20	RO
3	PU	9	NG	15	BN	21	-
4	GP	10	WP	16	WB	22	-
5	O	11	PW	17	RB	23	-
6	K	12	GN	18	NP		

LC00277C

C277

R230002

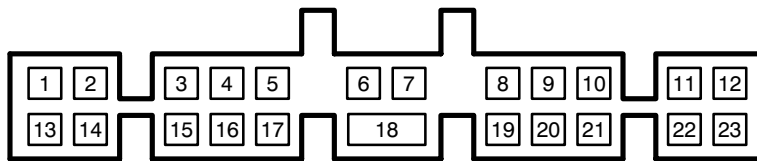

1	LGO	7	-	13	GB	19	GW
2	GR	8	GLG	14	RY	20	RO
3	PU	9	NG	15	BN	21	RO
4	GP	10	WP	16	WB	22	-
5	O	11	PW	17	RB	23	-
6	K	12	GN	18	NP		

LC00277C

R050001

R050001

C279

C282

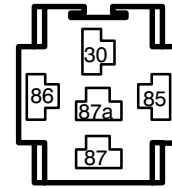
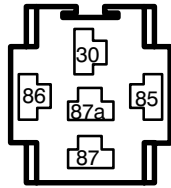

30	PU	86	PU
85	BK	87	GR
87A	GW		

30	NW	86	LG
85	B	87	LGW
87A	-		

LC00279A

LC00282A

R050001

R050001

C280

C283

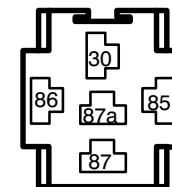
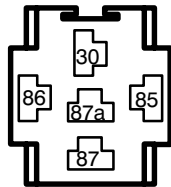

30	P	86	P
85	OB	87	PB
87A	-		

30	PN	86	PO
85	PN	87	PG
87A	-		

LC00280C

LC00283A

R050001

R150001

C281

C284

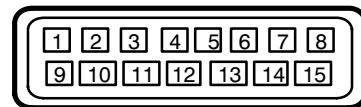
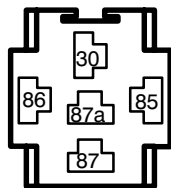

30	NG	86	GLG
85	NP	87	GLG
87A	B		

1	WU	6	BY	11	YK
2	-	7	BR	12	-
3	RW	8	B	13	-
4	UW	9	PG	14	-
5	GP	10	WY	15	-

LC00281C

LC00284A

R100005

R050001

C287

C292

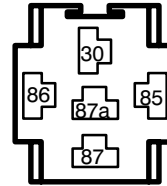
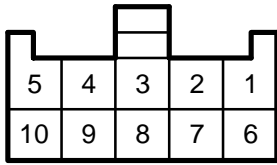

1	BK	4	WG	6	BR	8	-
2	-	5	BU	7	PW	9	BS
3	LGP					10	-

30	NG	86	BP
85	GW	87	BN
87A	-		

LC00287C

LC00292A

R080003

C288

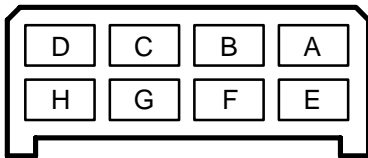

A	PN	E	WK
B	SB	F	SR
C	B	G	SK
D	PS	H	SU

LC00288A

R030004

R030007

C298

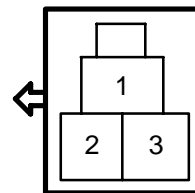
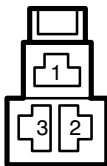

1	-
2	B
3	R

1	-
2	WB
3	R

LC00298A

LC00298A

R050001

C2000

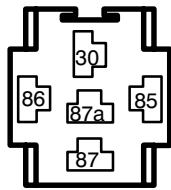

30	WP	86	WP
85	BK	87	RB
87A	-		

R050001

C2006

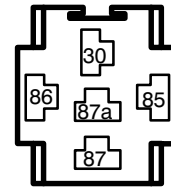

30	NW	86	BO
85	WR	87	NR
87A	-		

LC02000A

R050001

C2001

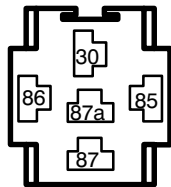

30	WY	86	BR
85	YB	87	SB
87A	-		

LC02006A

R050001

C2007

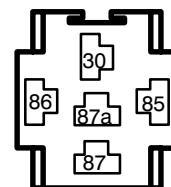

30	NG	86	B
85	LGP	87	WG
87A	-		

LC02001A

R020032

C2005

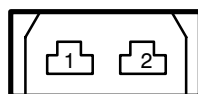

1	PY
2	PG

LC02005A

LC02007C

R050001

C2008

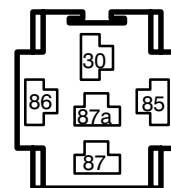

30	LGP	86	NS
85	GS	87	GS
87A	NLG		

LC02008A

R040012

R080006

C2009

C2012

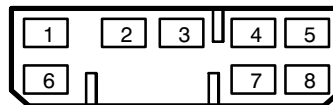
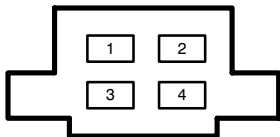

1	-	3	LGN
2	GW	4	GR

1	PW	5	PN
2	P	6	OW
3	WP	7	-
4	BR	8	-

LC02009A

LC02012A

R060005

R040001

C2010

C2013

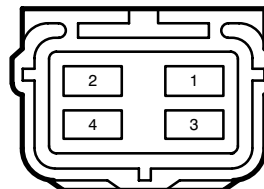
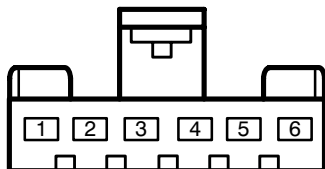

1	WY	4	RW
2	-	5	PO
3	UW	6	-

1	PN	3	B
2	PW	4	WP

LC02010A

LC02013A

R060013

R020022

C2011

C2014

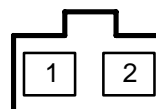
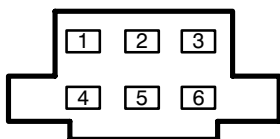

1	WLG	4	-
2	-	5	-
3	B	6	-

1	OW
2	B

LC02011A

LC02014A

C2015

R080009

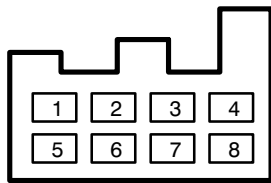

1	GS	5	LGB
2	LGG	6	LGB
3	ULG	7	-
4	RLG	8	GS

C2023

R040004

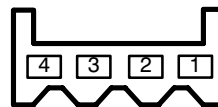

1	S	3	WB
2	UR	4	LG

C2021

LC02015A

R050001

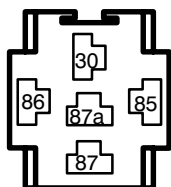

30	WS/WU	86	WS
85	BY/B	87	PW
87A	PY		

C2024

LC02023A

R050002.02

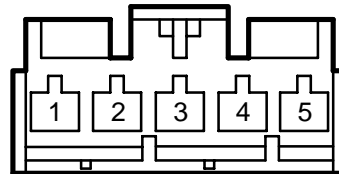

1	W	4	WB
2	LG	5	UW
3	-		

C2022

LC02021A

R050006

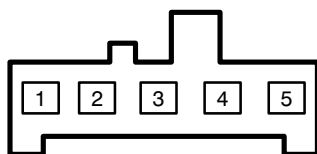

1	WB	4	PU
2	BO	5	N
3	G		

C2025

LC02024C

R050002.02

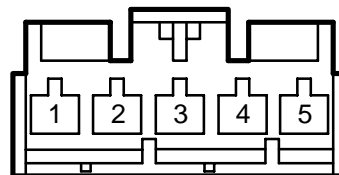

1	N	4	NW
2	LG	5	UR
3	WB		

LC02022A

LC02025A

R050002.00

C2026

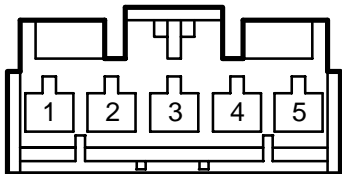

1	WB	4	RG
2	LG	5	UR
3	UB		

LC02026A

R050003

C2027

R050018

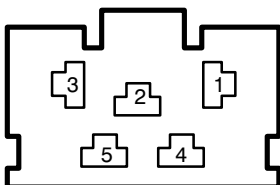

1	WB	4	G
2	N	5	BO
3	PU		

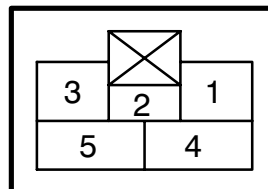

1	WB	4	G
2	N	5	BO
3	PU		

LC02027A

R060007

C2028

LC02027A

R060007

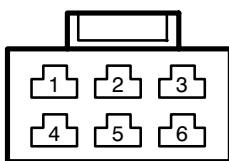

1	B	4	B
2	B	5	B
3	B	6	B

C2029

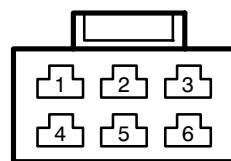

1	B	4	B
2	B	5	B
3	B	6	-

LC02028A

LC02029A

C2031

R060007

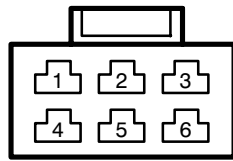

1	B	4	B
2	B	5	B
3	B	6	-

C2044

R050001

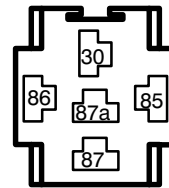

30	RG	86	B
85	RB	87	RN
87A	GLG		

LC02031C

LC02044F

R020032

R050001

C2035

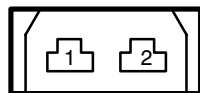

1	PW
2	P

C2045

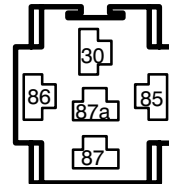

30	BP	86	B
85	K	87	BK
87a	-		

LC02035A

LC02045F

R070001

R050001

C2036

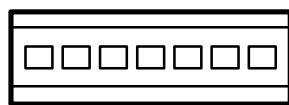

1	PB	5	YB
2	W	6	PB
3	R	7	PB
4	GR		

C2047

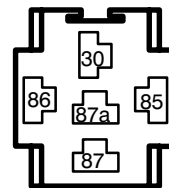

30	UW	86	UY
85	GO	87	B
87A	NG		

LC02036A

LC02047F

R080019

R050001

C2051

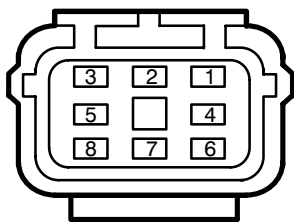

1	NK	5	NU
2	-	6	NLG
3	NK	7	PW
4	WP	8	NK

C2053

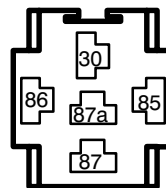

30	NK	86	B
85	LGO	87	LGP
87A	-		

LC02051C

LC02053C

R060016

R180002

C2052

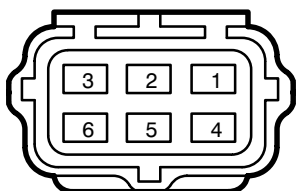

1	UP	4	U
2	WG	5	-
3	YN	6	-

C2054

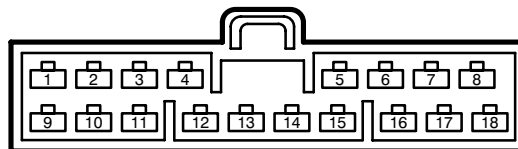

1	R	6	BK	11	B	16	BR
2	G	7	BW	12	B	17	BN
3	Y	8	BY	13	R	18	BO
4	U	9	LGP	14	PY		
5	BG	10	B	15	BU		

LC02052C

LC02054C

R130008

R130004

C2055

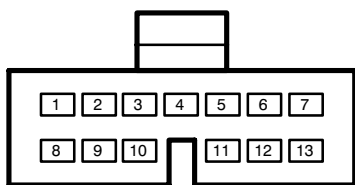

1	G/BG	6	BN	11	SCR
2	B/BU	7	U/BY	12	UY
3	R/BK	8	BO	13	B
4	BR	9	R		
5	Y/YB	10	B		

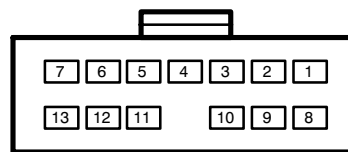

1	G/BG	6	BW/BN	11	SCR
2	B/BU	7	U/BY	12	PY
3	R/BK	8	BO	13	B
4	BR	9	R		
5	Y/BW	10	B		

LC02055C

LC02055C

C2056

R050002.00

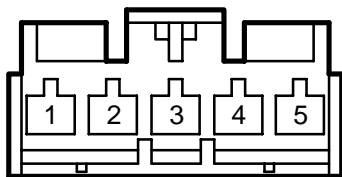

1	UG	4	B
2	RN	5	B
3	-		

C2059

R050002.10

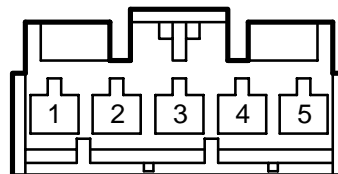

1	U	4	B
2	RN	5	B
3	-		

C2057

LC02056C

R050002.10

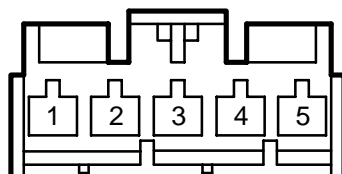

1	RG	4	B
2	RN	5	B
3	-		

C2060

LC02059C

R050019

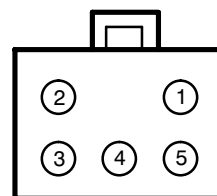

1	U	4	B
2	NY	5	UG
3	RK		

C2058

LC02057C

R050002.00

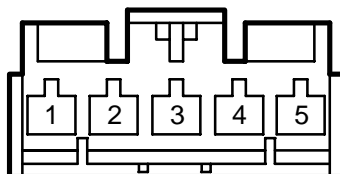

1	NY	4	B
2	RN	5	B
3	-		

C2061

LC02060C

R070002

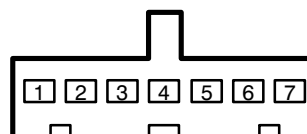

1	-	5	-
2	-	6	R
3	B	7	-
4	-		

LC02058C

LC02061C

R020010

C2063

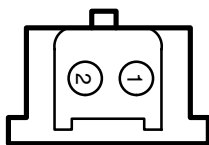

1	GP
2	GO

LC02063C

R080001

C2066

R080002

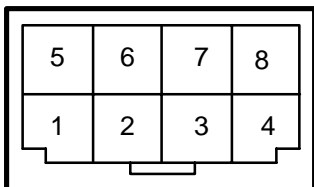

1	BO	5	UR
2	G	6	UB
3	PU	7	WB
4	N	8	RG

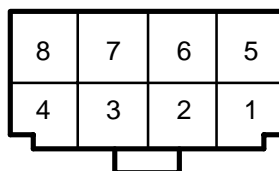

1	BO	5	UR
2	G	6	UB
3	PU	7	WB
4	N	8	RG

LC02066A

R100003

C2067

LC02066A

R100001

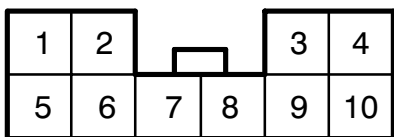

1	NW	4	S	6	UB	8	WB
2	N	5	RG	7	UW	9	W
3	LG			10	UR		

LC02067A

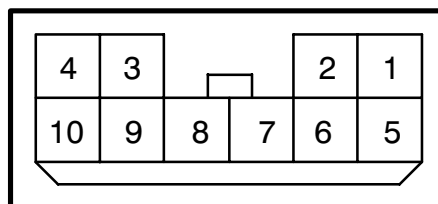

1	NW	4	S	6	UB	8	WB
2	N	5	RG	7	UW	9	W
3	LG			10	UR		

LC02067A

R050016

C2068

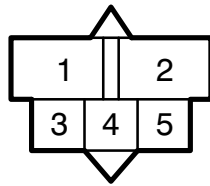

1	R	4	WB
2	WR	5	UR
3	N		

R020046

C2071

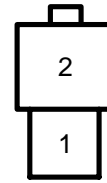

1	YB
2	UR

LC02068A
R020049

C2069

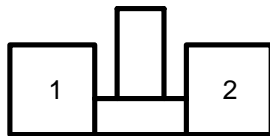

1	BO
2	WR

LC02071A
R030015

C2072

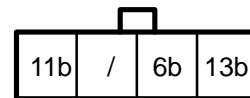

1	YB
2	UB
3	RG

LC02069A
R040022

C2070

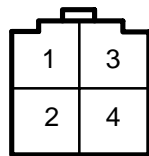

1	BO	3	PU
2	G	4	WB

LC02072A
R100003

C2073

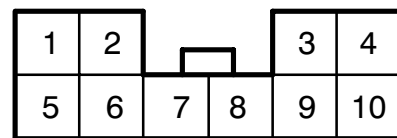

1	YO	4	PB	6	-	8	ON
2	RN	5	YU	7	WG	9	YB
3	B					10	YR

LC02070A

LC02073C

R050001

R030020

C2074

C2075

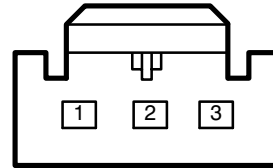
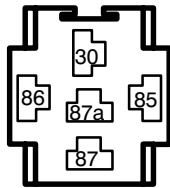

30	PU	86	BK
85	PU	87	LGR
87A	-		

1	B
2	-
3	GP

LC02074A

LC0275C

R060007

R060006

C301

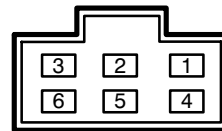
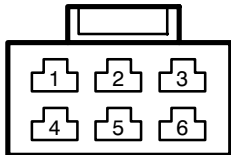

1	SG	4	SW
2	SG	5	SN
3	SO	6	S

1	SG	4	SW
2	SG	5	SN
3	SO	6	S

LC00301A

LC00301A

R030010

R030009

C306

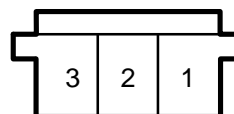

1	PW
2	O
3	K

1	PW
2	O
3	K

LC00306A

LC00306A

R350002

C312

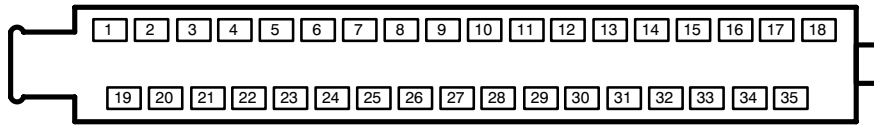

1	NK	6	SR	11	WO	16	W	21	SG	26	BS	31	B
2	-	7	SU	12	-	17	G	22	SP	27	B	32	G
3	-	8	BG	13	WK	18	W	23	SK	28	-	33	W
4	SY	9	WG	14	BK	19	NK	24	SN	29	-	34	G
5	SW	10	WS	15	G	20	-	25	GP	30	NR	35	W

LC00312C

R050009

C323

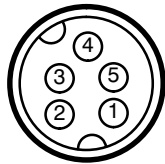

1	-	4	BO
2	GY	5	BY
3	GN		

R030007

LC00323A

R030008

C336

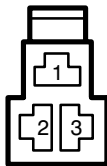

1	B
2	NR
3	WG



1	B
2	NR
3	WG

LC00336C

LC00336C

R070008

R060019

C338

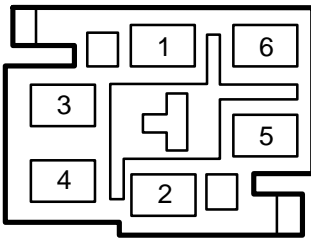

1	BU	5	-
2	BK	6	RN
3	-	7	-
4	B		

LC00338A

LC00343A

R070008

R060016

C339

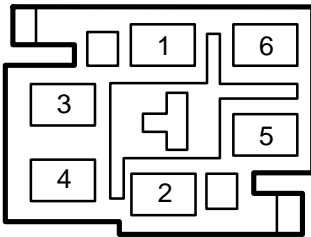

1	SW	5	WK
2	SO	6	RN
3	WK	7	-
4	B		

LC00339C

LC00344A

R070008

R060019

C340

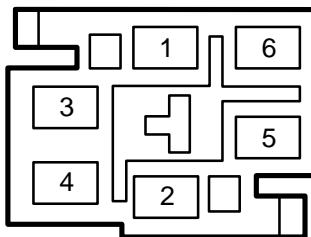

1	S	5	WK
2	SN	6	RN
3	WK	7	-
4	B		

LC00340C

LC00345C

C343

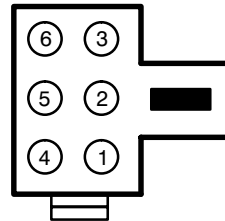

1	B	4	SG
2	-	5	-
3	-	6	-

C344

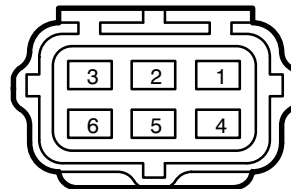

1	P	4	BR
2	GP	5	KS
3	B	6	KS

C345

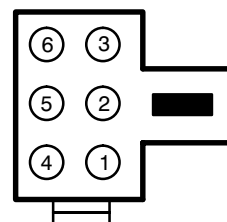

1	B	4	SG
2	-	5	-
3	-	6	-

C346

R020033

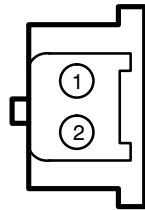

1	GLG/RG
2	B

C352

R050001

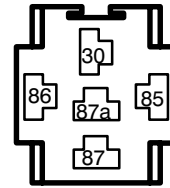

30	NO	86	WO
85	B	87	NR
87A	-		

C350

LC00346C

R050001

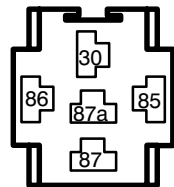

30	BS	87	-
86	NK	85	B
87A	B		

C353

LC00352C

R020015

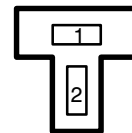

1	B
2	LGW

C351

LC00350C

R050001

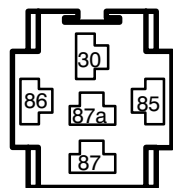

30	OK	86	BG
85	B	87	NK
87A	-		

C354

LC00353A

R020007

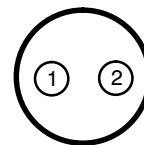

1	W
2	W

LC00351C

LC00354A

C355

R020007

R030003

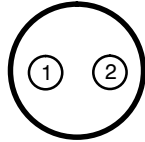

1	W
2	W

C370

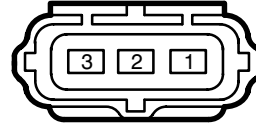

1	GY
2	-
3	BR

LC00355A

LC00370A

R030021

R020003

C368

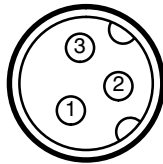

1	-
2	B
3	BK

C371

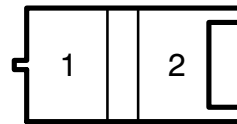

1	BLG
2	B

LC00368A

LC00371A

R020037

R020038

C369

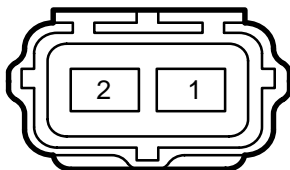

1	SB
2	B

C372

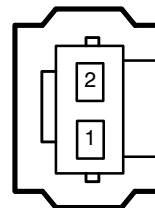

1	GN
2	GY

LC00369A

LC00372A

C379

R050001

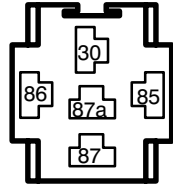

30	B	87	YK
85	P	87A	WY
86	PO		

LC00379F

R050014

C380

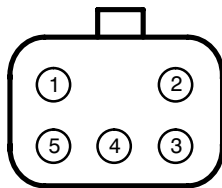

1	NO	4	
2	B	5	NK
3	K		

LC00380F

R030018

C381

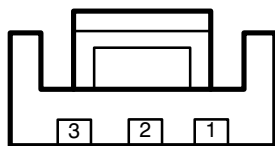

1	B
2	
3	P

LC00381C

C382

R080008

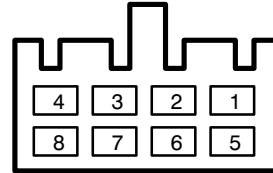

1		5	
2		6	GW
3	GO	7	GU
4	OG	8	OU

LC00382C

R100006

C383

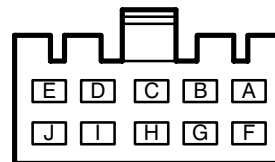

A	P	D	B	F	WG	H	GK
B	U	E	W	G	GB	I	GR
C	NR					J	O

LC00383C

R070008

C384

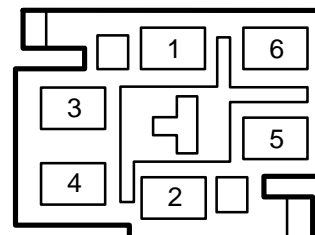

1	GO	5	
2	GR	6	
3		7	
4	B		

LC00384C

R070008

R040018

C385

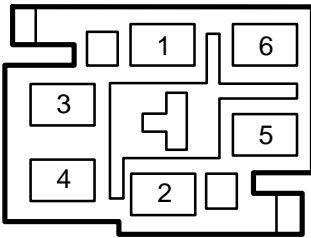

1	GU	5	
2	GK	6	
3		7	
4	B		

LC00385C

LC00388C

R050002.00

R030027

C386

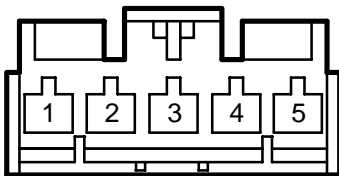

1	B	4	BS
2		5	
3			

LC00386C

LC00389C

R040018

R020033

C387

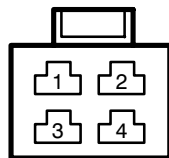

1	W	3	B
2	OU	4	P

LC00387C

LC00390C

C388

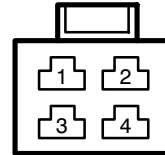

1	O	3	B
2	OG	4	U

C389

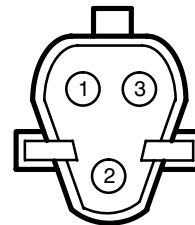

1	GW
2	GB
3	BS

C390

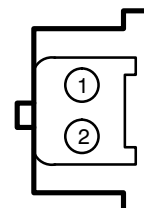

1	BS
2	

C391

R050006

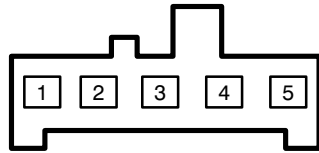

1	B	4	N
2	GR	5	BR
3	Y		

C403

R060003

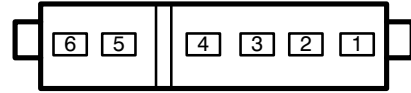

1	GP	4	B
2	GP	5	RY
3	-	6	GN

C392

LC00391C

R050002.02

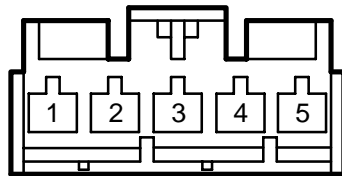

1	LGW	4	B
2	RB	5	UW
3			

C406

LC00403C

R060003

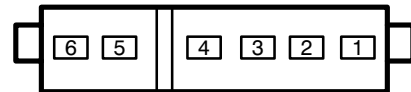

1	GP	4	B
2	GP	5	RY
3	-	6	GN

C400

LC00392C

R070003

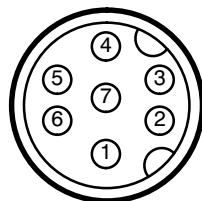

1	RO	5	B
2	GP	6	RY
3	GW	7	RB
4	GR		

LC00406C

LC00400A

R030001

R030003

C407

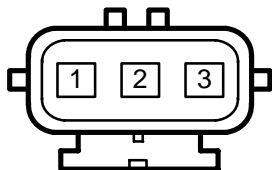

1	WP
2	GB
3	B

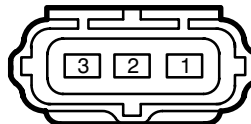

1	WP
2	GB
3	B

LC00407A

LC00407A

R040026

R040024

C408

C411

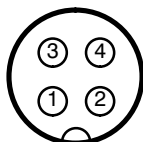

1	GO	3	NG
2	-	4	B

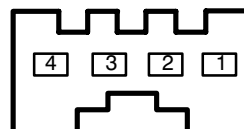

1	PN	3	B
2	PU	4	-

LC00408C

LC00411C

R030014

R060012

C410

C412

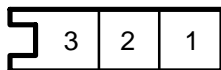

1	PU
2	-
3	PN

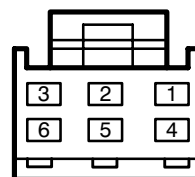

1	SCR	4	LGO
2	R	5	PY
3	B	6	B

LC00410C

LC00412C

C414

R020031

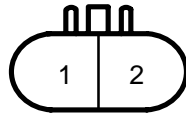

1	K
2	O

LC00414C

R080014

C415

R080013

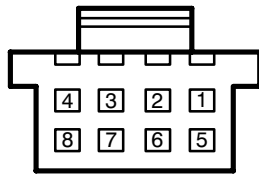

1	GLG	5	B
2	NG	6	O
3	RB	7	B
4	K	8	PW

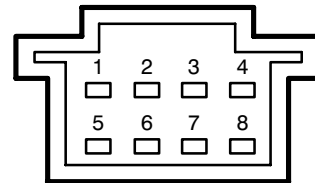

1	GO	5	B
2	NG	6	O
3	RB	7	B
4	K	8	-

LC00415C

R040001

LC00415C

C434

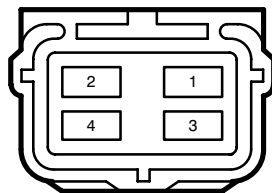

1	GB	3	B
2	B	4	WP

LC00434A

R060011

C437

R060010

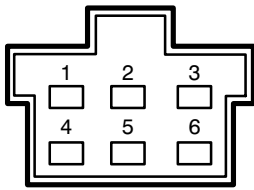

1	R	4	LGO
2	B	5	PY
3	SCR	6	GP

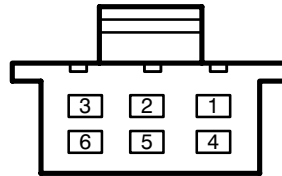

1	R	4	LGO
2	B	5	PY
3	SCR	6	GP

LC00437C

LC00437C

R020041

C438

R020018

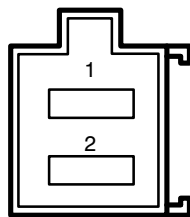

1	NP
2	B

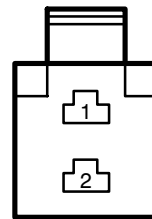

1	NP
2	B

LC00438C

LC00438C

R020037

C442

R020034

C443

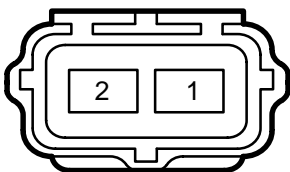

1	GR
2	B

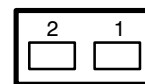

1	RB
2	B

LC00442C

LC00443C

C444

R020037

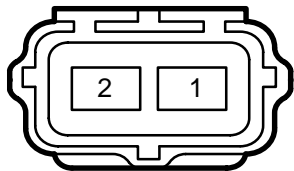

1	RO
2	B

C445

R020037

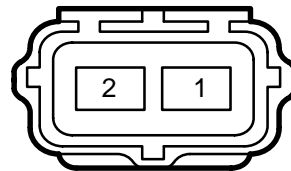

1	GW
2	B

LC00444C

LC00445C

R020050

R020014

C447

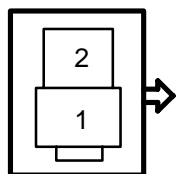

1	G
2	B

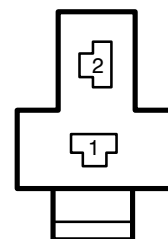

1	B
2	NG

LC00447C

LC00447C

R160001

R160005

C448

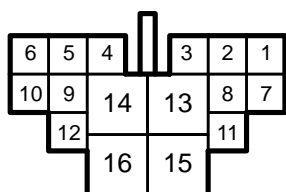

1	-	5	LGW	9	P	13	N
2	WG	6	BR	10	-	14	-
3	BG	7	-	11	-	15	Y
4	UW	8	W	12	UB	16	GR

LC00448C

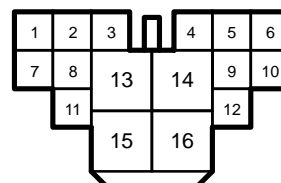

1	-	5	GW	9	V	13	BR
2	WG	6	BR	10	-	14	-
3	BG	7	-	11	-	15	Y
4	LW	8	YL	12	VG	16	G

LC00448C

C457

R050016

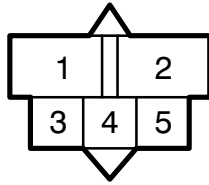

1	YG	4	B
2	NR	5	WG
3	VG		

C462

R020046

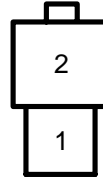

1	R
2	YG

C458

LC00457C

R020047



1	BRB
2	G

C463

LC00462C

R040023

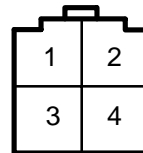

1	WG	3	LG
2	GR	4	B

C459

LC00458C

R040022

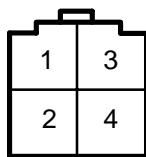

1	B	3	Y
2	BR	4	G

C464

LC00463C

R020048

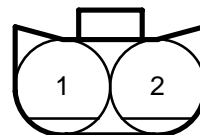

1	BG
2	RG

LC00459C

LC00464C

C465

R040023

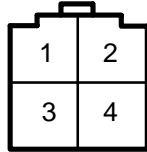

1	WG	3	G
2	WG	4	LW

C483

R040006

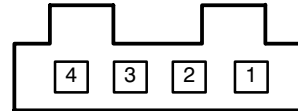

1	BN	3	WB
2	B	4	-

C466

LC00465C

R040023

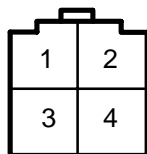

1	WG	3	G
2	VG	4	N

C485

LC00483C

R030030

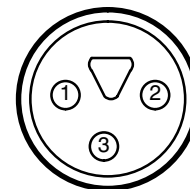

1	-
2	BW
3	BW

C467

LC00466C

R060020

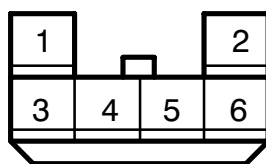

1	WG	4	GW
2	R	5	B
3	Y	6	LG

C500

LC00485C

R020008

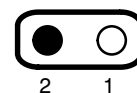

1	SU
2	SK

LC00467C

LC00500C

R020021

R020021

C501

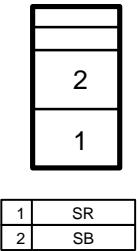
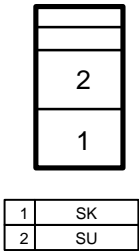

LC00501C

LC00501C

C501

R020001

R020021

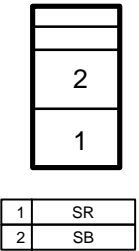
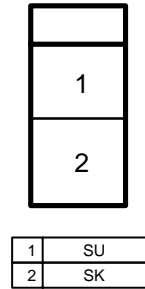

LC00501C

LC00501C

R130006

R130005

C502

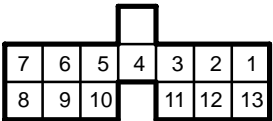
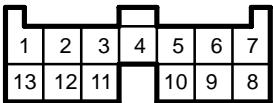

1	-	6	YK	11	BK
2	B	7	-	12	BU
3	UG	8	O	13	NK
4	-	9	K		
5	SW	10	BG		

1	-	6	YK	11	BK
2	B	7	PN	12	BU
3	UG	8	O	13	NK
4	-	9	K		
5	SW	10	NP		

LC00502F

LC00502F

C503

R060008

R040016

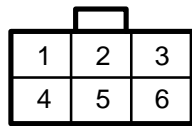

1	B	4	SW
2	BG	5	SW
3	BU	6	BK

C504

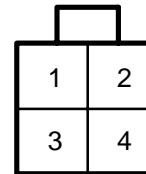

1	UG	3	-
2	-	4	B

LC00503C

LC00504C

R020053

R040011

C507

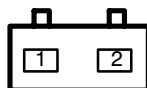

1	O
2	K

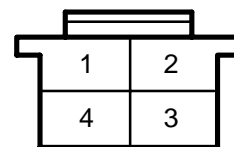

1	O	3	NK
2	K	4	B

LC00507C

LC00507C

C507

R060009

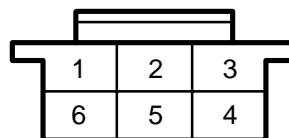

1	O	4	-
2	K	5	YK
3	B	6	-

LC00507C

R020030

R020028.00

C510

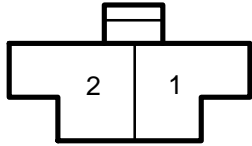

1	BN
2	BW

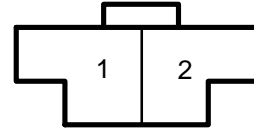

1	BW
2	B

LC00510C

LC00510C

R020008

C600

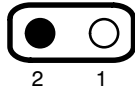

1	SU
2	SK

LC00600C

R020021

C601

R020021



1	SK
2	SU

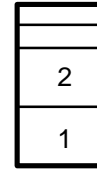

1	SR
2	SB

LC00601C

R020001

C601

LC00601C

R020021



1	SU
2	SK

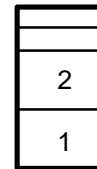

1	SR
2	SB

LC00601C

R130006

C602

LC00601C

R130005

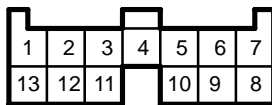

1	-	6	YK	11	BK
2	B	7	-	12	BU
3	UG	8	O	13	NK
4	-	9	K		
5	SW	10	BG		

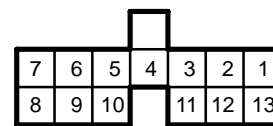

1	-	6	GB	11	BN
2	B	7	-	12	BP
3	KB	8	O	13	-
4	-	9	K		
5	SW	10	NP		

LC00602F

LC00602F

R060008

R040016

C603

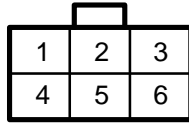

1	B	4	SW
2	BG	5	SW
3	BU	6	BK

C604

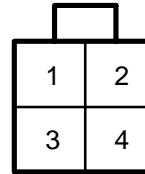

1	UG	3	-
2	-	4	B

LC00603C

LC00604C

R020053

R040011

C607

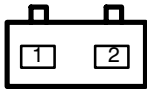

1	O
2	K

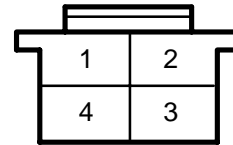

1	O	3	NK
2	K	4	B

LC00607C

LC00607C

R060009

C607

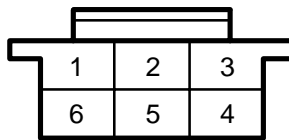

1	O	4	-
2	K	5	YK
3	B	6	-

LC00607C

R020030

C610

R020028.00

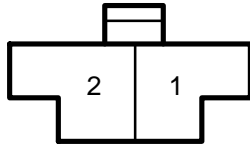

1	BN
2	BW

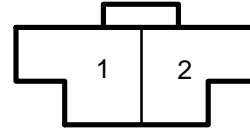

1	BW
2	B

LC00610C

LC00610C

R030006

R030007

C700

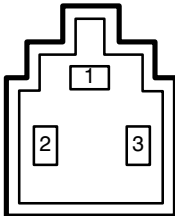

1	SG
2	SW
3	SO

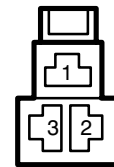

1	SG
2	SW
3	SO

LC00700C

LC00700C

R020012

R020028.01

C701

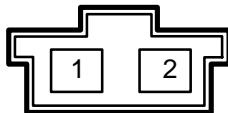

1	O
2	K

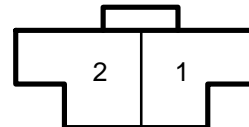

1	O
2	K

LC00701C

LC00701C

C703

R030021

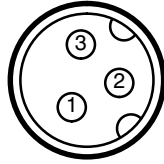

1	-
2	SW
3	SO

LC00703C

C709

R050008

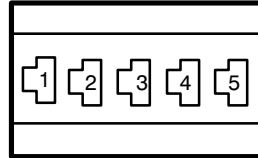

1	SO	4	SW
2	SO	5	SW
3	SG		

LC00704C

C706

R020029

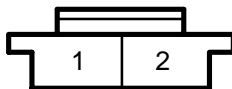

1	O
2	K

LC00706C

R030006

C800

R030008

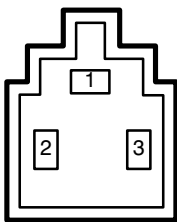

1	SG
2	SN
3	S

LC00800C

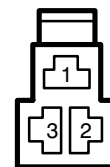

1	SG
2	SN
3	S

LC00800C

R020012

R020028.01

C801

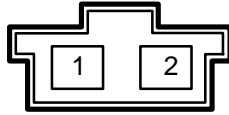

1	O
2	K

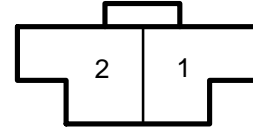

1	O
2	K

LC00801C

LC00801C

R030021

R050008

C803

C809

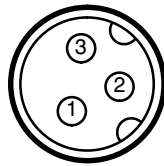

1	-
2	SW
3	SO

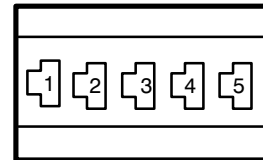

1	SW	4	SN
2	S	5	SO
3	SG		

LC00803C

LC00809C

R020029

C806

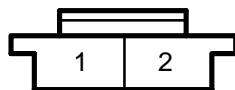

1	O
2	K

LC00806C

R200001

HJ1

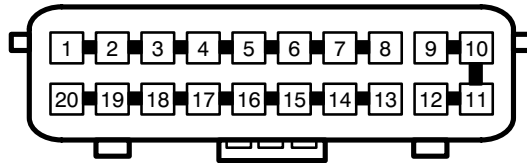

S2042

1	GO
2	GO
3	GO
4	GO
5	GO
6	GO
7	-
8	-

S274

13	GLG
14	GLG
15	GLG
16	GLG
17	GLG
18	GLG
19	-
20	-

LC00HJ1F

R200008

HJ2

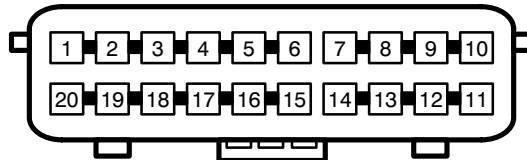

S2074

1	RN
2	RN
3	RN
4	RN
5	-
6	RN

S2054

7	WY
8	WY
9	WY
10	-

S2017

11	GK
12	GK
13	-
14	-

S2005

15	-
16	-
17	BY
18	BY
19	BY
20	BY

LC00HJ2F

R200001

HJ3

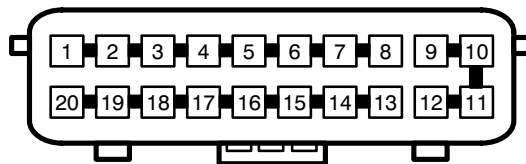

S204

1	B
2	B
3	B
4	B
5	B
6	-
7	B
8	B

S2032

9	B
10	BO
11	B
12	-

S203

13	B
14	-
15	B
16	-
17	-
18	-
19	-
20	B

LC00HJ3F

R200001

HJ4

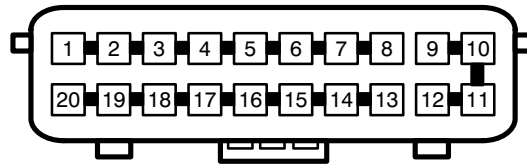

S2055

1	GP
2	-
3	GP
4	GP
5	GP
6	GP
7	GP
8	GP

S2014

9	WP
10	WP
11	WP
12	WP

S2011

13	-
14	GP
15	GP
16	GP
17	GP
18	GP
19	GP
20	GP

LC00HJ4F

R200001

HJ5

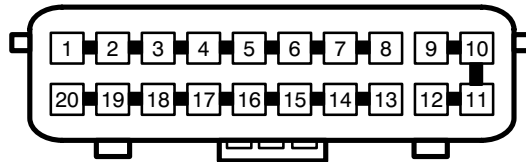

S2031

1	B
2	B
3	-
4	B
5	-
6	B
7	B
8	B

S238

9	B
10	B
11	B
12	B

S2025

13	-
14	B
15	-
16	-
17	-
18	-
19	-
20	B

LC00HJ5F

R200009

HJ6

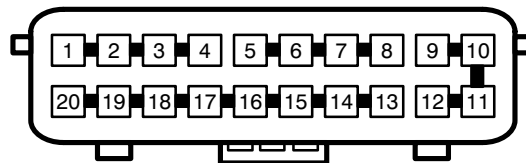

S2019

1	GW
2	GW
3	GW
4	GW

S2020

5	GR
6	GR
7	GR
8	GR

S2018

9	BR
10	BR
11	BR
12	BR

S2021

13	P
14	P
15	-
16	P
17	P
18	P
19	-
20	-

LC00HJ6F

R200008

HJ7

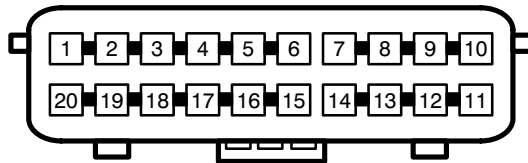

S290

1	BS
2	B
3	BS
4	BS
5	-
6	BS

S291

7	NO
8	NO
9	NO
10	NO

S292

11	WG
12	WG
13	WG
14	WG

S293

15	RB
16	RB
17	RB
18	RB
19	RB
20	-

LC00HJ7C

R200001

HJ8

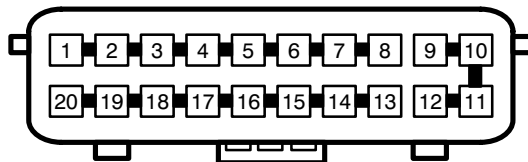

S253

1	B
2	B
3	B
4	B
5	B
6	B
7	B
8	B

S252

9	RO
10	RO
11	RO
12	RO

S255

13	B
14	B
15	B
16	B
17	B
18	B
19	B
20	B

LC00HJ8C

R200001

HJ9

LC00HJ2F

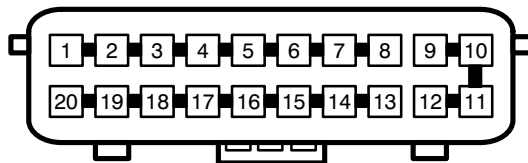

S256

1	RO
2	RN
3	RN
4	RN
5	RN
6	RN
7	RN
8	RN

S251

13	RN
14	RN
15	RN
16	RN
17	RN
18	RN
19	RN
20	RN

LC00HJ9C

LC00HJ2F

R200001

HJ10

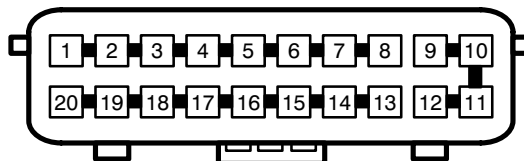

S2018

1	B
2	B
3	B
4	B
5	B
6	B
7	B
8	B

S2003

9	B
10	B
11	B
12	B

S2016

13	B
14	B
15	B
16	B
17	B
18	B
19	B
20	B

LC0HJ10F

R200001

HJ11

LC00HJ2F

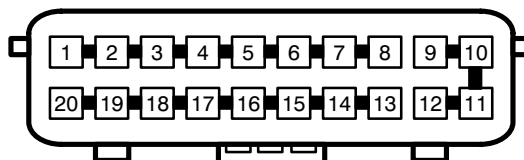

S2033

1	B
2	B
3	B
4	B
5	B
6	B
7	B
8	B

S2044

10	B
11	B
12	B

S288

13	B
14	B
15	B
16	B
17	B
18	B
19	B
20	B

LC0HJ11F

LC00HJ2F

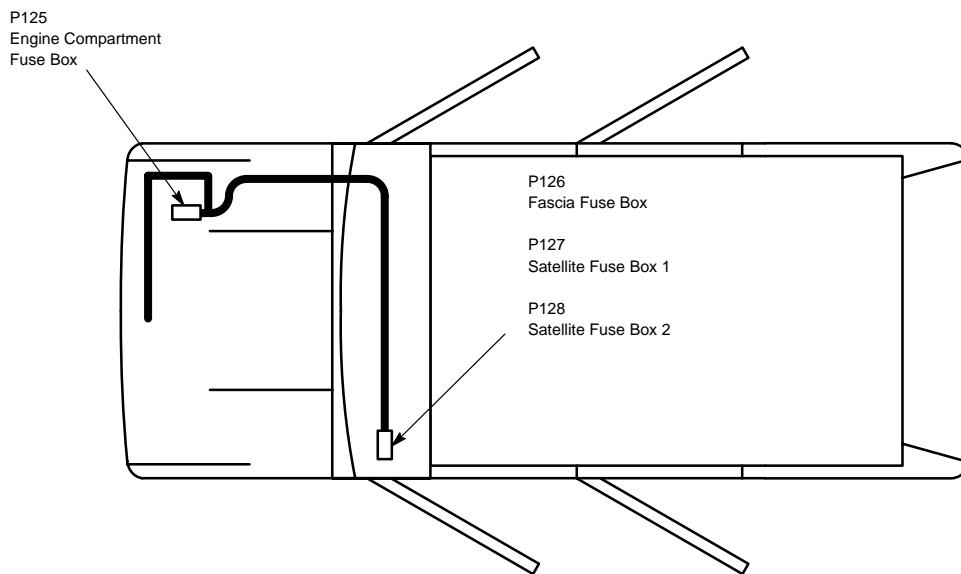

Main Harness (Partial)

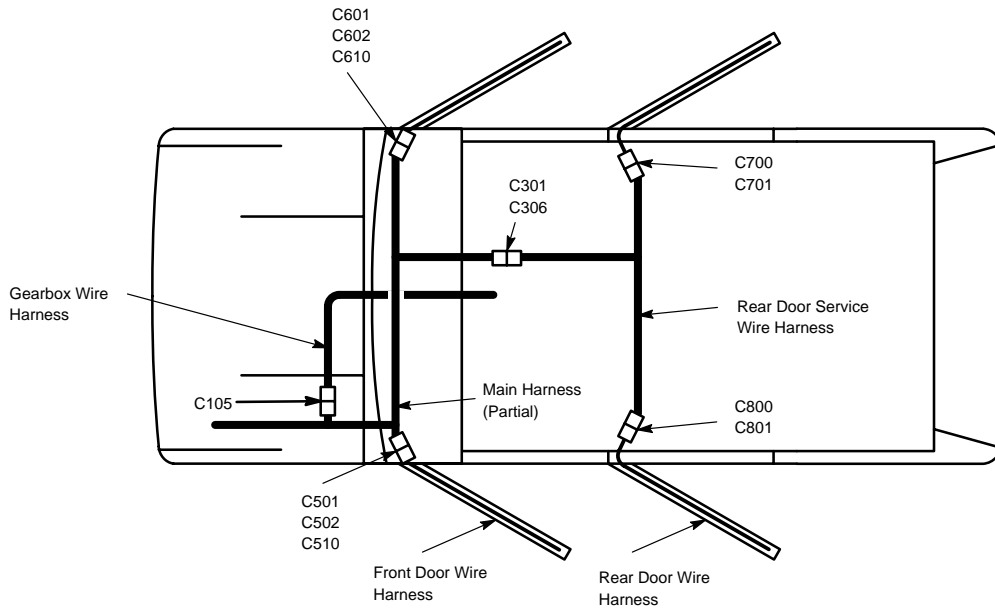
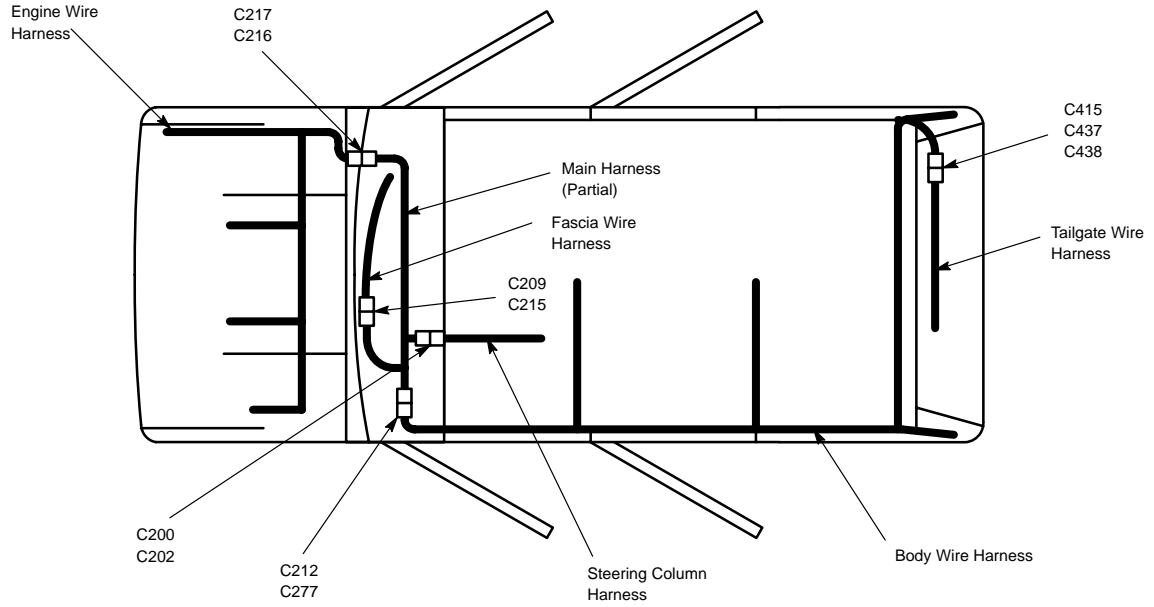

Air Recirculation Solenoid In-Line Fuse (P138)	K1-4
Anti-Lock Brake System	D1-1
Blower Controls	K1-1
Central Locking	L6-1
Cigar Lighter/Clock	J2-1
Component Location Table	Z4-1
Component Location Views	Z5-1
Compressor Controls	K2-1
Connector Views	Z6-1
Cooling Fans	K5-1
Cruise Control	B5-1
Direction Indicator Lamps	H6-1
Front Wipe/Wash	F1-1
Fuse Details	Y2-1
Engine Compartment Fuse Box (P125)	
F1	Y2-1
F2	Y2-1
F3	Y2-2
F4	Y2-3
F5	Y2-3
F6	Y2-3
F7	Y2-4
Fascia Fuse Box (P126)	
F1	Y2-13
F2	Y2-14,15
F3	Y2-17
F4	Y2-18
F5	Y2-18
F6	Y2-18
F7	Y2-19
F8	Y2-20
F9	Y2-28
F10	Y2-28
F11	Y2-28
F12	Y2-29
F13	Y2-30
F14	Y2-31
F15	Y2-33
F16	Y2-33

F17	Y2-34
F18	Y2-35
Satellite Fuse Box 1 (P127)	
F1	Y2-8
F2	Y2-8
F3	Y2-9,11
F4	Y2-12
F5	Y2-12
F6	Y2-12
Satellite Fuse Box 2 (P128)	
F1	Y2-5
F2	Y2-5
F3	Y2-5
F4	Y2-5
F5	Y2-6
F6	Y2-7
Ground Distribution	Y5-1
Harness Routing	Z8-1
Headlamp Leveling	H3-1
Headlamps (except NAS)	H1-1
Headlamps (NAS)	H2-1
Horns	E5-1
Ignition and Shift Interlock	C1-1
Instruments	E1-1
Interior Lamps	J1-1
Introduction	i-1
Lights	
Direction Indicator Lamps	H6-1
Fascia Cigar Lighter (B106)	J2-1
Front Interior Roof Lamp (B107)	J1-12
Glove Box Lamp (B152)	J1-1
Headlamps (except NAS)	H1-1
Headlamps (NAS)	H2-1
Interior Lamps	J1-1
Left Repeater Lamp (B122)	H6-5
Rear Fog Guard Lamps	H9-1
Rear Interior Roof Lamp (B124)	J1-12
Reversing Lamps	H7-1

Right Repeater Lamp (B137)	H6-5
Side Lamps	H4-1
Stop Lamps	H5-1
Multi-Function Unit (MFU)	G4-1
Multiport Fuel Injection (MFI – T16)	A2-1
Multiport Fuel Injection (MFI – V8)	A1-1
Power Distribution	Y1-1
Engine Compartment Fuse Box (P125)	
MF1	Y1-1
MF2	Y1-3
MF3	Y1-4
MF4	Y1-5
MF5	Y1-7
MF6	Y1-9
Fusible Link (P119)	Y1-1
Power Mirrors	M3-1
Power Windows	L1-1
Radio (except NAS)	E6-1
Radio (NAS)	E7-1
Rear A/C Switch Amplifier In-Line Fuse (P140)	K1-8
Rear Fog Guard Lamps	H9-1
Rear Wipe/Wash	F3-1
Reversing Lamps	H7-1
Side Lamps	H4-1
Starting and Charging	B1-1
Stop Lamps	H5-1
Sunroof	L4-1
Theft Alarm System	T1-1
Trailer Auxiliary Socket	P1-1
Warnings and Indicators (except NAS)	E2-1
Warnings and Indicators (NAS)	E3-1
300Tdi	A4-1
300Tdi Glow Plug Control	A5-1