

PAJERO SPORT

WORKSHOP MANUAL

FOREWORD

This Workshop Manual contains procedures for service mechanics, including removal, disassembly, inspection, adjustment, reassembly and installation. Use the following manuals in combination with this manual as required.

TECHNICAL INFORMATION MANUAL	PYJE9804
WORKSHOP MANUAL	
ENGINE GROUP	PWEE□□□□ (Looseleaf edition)
ELECTRICAL WIRING	PHJE9810
BODY REPAIR MANUAL	PBJE9808
PARTS CATALOGUE	B603D509A□

All information, illustrations and product descriptions contained in this manual are current as at the time of publication. We, however, reserve the right to make changes at any time without prior notice or obligation.



General	00
Engine	11
Engine Lubrication	12
Fuel	13
Engine Cooling	14
Intake and Exhaust	15
Engine Electrical	16
Engine and Emission Control	17
Clutch	21
Manual Transmission	22
Propeller Shaft	25
Front Axle	26
Rear Axle	27
Wheel and Tyre	31
Power Plant Mount	32
Front Suspension	33
Rear Suspension	34
Service Brakes	35
Parking Brakes	36
Steering	37
Body	42
Exterior	51
Interior and Supplemental Restraint System (SRS)	52
Chassis Electrical	54
Heater, Air Conditioner and Ventilation	55

WARNINGS REGARDING SERVICING OF SUPPLEMENTAL RESTRAINT SYSTEM (SRS) EQUIPPED VEHICLE

WARNING!

- (1) Improper service or maintenance of any component of the SRS or any SRS-related component, can lead to personal injury or death to service personnel (from inadvertent firing of the air bag) or to the driver and passenger (from rendering the SRS inoperative).**
- (2) SRS components should not be subjected to heat over 93°C, so remove the SRS-ECU, air bag module (driver's side and front passenger's side), clock spring, front impact sensors before drying or baking the vehicle after painting.**
- (3) Service or maintenance of any SRS component or SRS-related component must be performed only at an authorized MITSUBISHI dealer.**
- (4) MITSUBISHI dealer personnel must thoroughly review this manual, and especially its GROUP 52B – Supplemental Restraint System (SRS), before beginning any service or maintenance of any component of the SRS or any SRS-related component.**

NOTE

Section titles with asterisks (*) in the table of contents in each group indicate operations requiring warnings.

GENERAL

CONTENTS

00109001516

HOW TO USE THIS MANUAL	2	VEHICLE IDENTIFICATION	16
Scope of Maintenance, Repair and Servicing Explanations	2	Vehicle Information Code Plate	16
Definition of Terms	2	Models	17
Indication of Tightening Torque	2	Model Code	17
Model Indications	3	Chassis Number	18
Explanation of Manual Contents	4	Engine Model Number	19
HOW TO USE TROUBLESHOOTING/ INSPECTION SERVICE POINTS	6	MAJOR SPECIFICATIONS	20
Troubleshooting Contents	6	PRECAUTIONS BEFORE SERVICE	21
Diagnosis Function	7	SUPPLEMENTAL RESTRAINT SYSTEM (SRS)	25
How to Use the Inspection Procedures	9	SRS Service Precautions	26
Connector Measurement Service Points	10	SUPPORT LOCATIONS FOR LIFTING AND JACKING	28
Connector Inspection	11	Support Positions for a Garage Jack and Axle Stands	28
Inspection Service Points for a Blown Fuse ...	12	Support Positions for a Single-Post Lift or Double-Post Lift and H-BAR Lift	29
Points to Note for Intermittent Malfunctions	12	STANDARD PARTS-TIGHTENING-TORQUE TABLE	30
TREATMENT BEFORE/AFTER THE FORDING A STREAM	13		
Inspection and Service before Fording a Stream	13		
Inspection and Service after Fording a Stream	15		

HOW TO USE THIS MANUAL

00100010418

SCOPE OF MAINTENANCE, REPAIR AND SERVICING EXPLANATIONS

This manual provides explanations, etc. concerning procedures for the inspection, maintenance, repair and servicing of the subject model. Note, however, that for engine and transmission-related component parts, this manual covers only on-vehicle inspections, adjustments, and the removal and installation procedures for major components.

For detailed information concerning the inspection, checking, adjustment, disassembly and reassembly of the engine, transmission and major components after they have been removed from the vehicle, please refer to separate manuals covering the engine and the transmission.

ON-VEHICLE SERVICE

“On-vehicle Service” is procedures for performing inspections and adjustments of particularly important locations with regard to the construction and for maintenance and servicing, but other inspection (for looseness, play, cracking, damage, etc.) must also be performed.

INSPECTION

Under this title are presented inspection and checking procedures to be performed by using special tools and measuring instruments and by feeling, but, for actual maintenance and servicing procedures, visual inspections should always be performed as well.

DEFINITION OF TERMS

STANDARD VALUE

Indicates the value used as the standard for judging the quality of a part or assembly on inspection or the value to which the part or assembly is corrected and adjusted. It is given by tolerance.

LIMIT

Shows the standard for judging the quality of a part or assembly on inspection and means the maximum or minimum value within which the part or assembly must be kept functionally or in strength. It is a value established outside the range of standard value.

REFERENCE VALUE

Indicates the adjustment value prior to starting the work (presented in order to facilitate assembly and adjustment procedures, and so they can be completed in a shorter time).

CAUTION

Indicates the presentation of information particularly vital to the worker during the performance of maintenance and servicing procedures in order to avoid the possibility of injury to the worker, or damage to component parts, or a reduction of component or vehicle function or performance, etc.

INDICATION OF TIGHTENING TORQUE

The tightening torque shown in this manual is a basic value with a tolerance of $\pm 10\%$ except the following cases when the upper and lower limits of tightening torque are given.

- (1) The tolerance of the basic value is within $\pm 10\%$.
- (2) Special bolts or the like are in use.
- (3) Special tightening methods are used.

MODEL INDICATIONS

The following abbreviations are used in this manual for classification of model types.

- M/T: Indicates the manual transmission, or models equipped with the manual transmission.
- SOHC: Indicates an engine with the single overhead camshaft, or a model equipped with such an engine.
- MPI: Indicates the multipoint injection, or engines equipped with the multipoint injection.
- DIESEL: Indicates a diesel engine, or models equipped with such an engine.
- 4WD: Indicates the 4 wheel-drive vehicles.

EXPLANATION OF MANUAL CONTENTS

Indicates procedures to be performed before the work in that section is started, and procedures to be performed after the work in that section is finished.

Component Diagram
A diagram of the component parts is provided near the front of each section in order to give a reader a better understanding of the installed condition of component parts.

Indicates (by symbols) where lubrication is necessary.

Maintenance and Servicing Procedures
The numbers provided within the diagram indicate the sequence for maintenance and servicing procedures.





- Removal steps:
The part designation number corresponds to the number in the illustration to indicate removal steps.
- Disassembly steps:
The part designation number corresponds to the number in the illustration to indicate disassembly steps.
- Installation steps:
Specified in case installation is impossible in reverse order of removal steps. Omitted if installation is possible in reverse order of removal steps.
- Reassembly steps:
Specified in case reassembly is impossible in reverse order of disassembly steps. Omitted if reassembly is possible in reverse order of disassembly steps.

Classifications of Major Maintenance/Service Points
When there are major points relative to maintenance and servicing procedures (such as essential maintenance and service points, maintenance and service standard values, information regarding the use of special tools, etc.), these are arranged together as major maintenance and service points and explained in detail.

◀A▶ : Indicates that there are essential points for removal or disassembly.
▶A◀ : Indicates that there are essential points for installation or reassembly.

Symbols for Lubrication, Sealants and Adhesives

Information concerning the locations for lubrication and for application of sealants and adhesives is provided, by using symbols, in the diagram of component parts or on the page following the component parts page, and explained.

-  : Grease (multipurpose grease unless there is a brand or type specified)
-  : Sealant or adhesive
-  : Brake fluid or automatic transmission fluid
-  : Engine oil, gear oil or air conditioner compressor oil
-  : Adhesive tape or butyl rubber tape

Indicates the group title. Indicates the section title. Indicates the group number. Indicates the page number.

STEERING – Power Steering Oil Pump 37A-29

POWER STEERING GEAR BOX
REMOVAL AND INSTALLATION

12000039

Pre-removal Operation
(1) Power Steering Fluid Draining (Refer to P. 37A-10.)
(2) Air Cleaner Assembly Removal
(3) Under Cover Removal (Refer to GROUP 42 – Under Cover.)

<2WD>

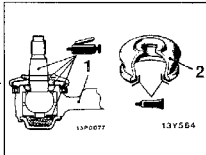
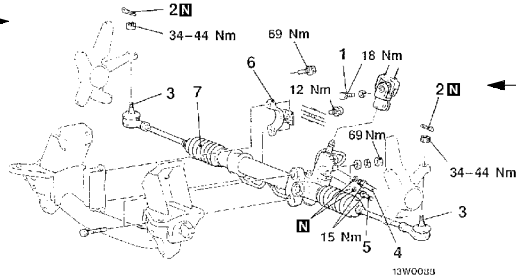

Sealant: 3M ATD Part No. 8661 or equivalent

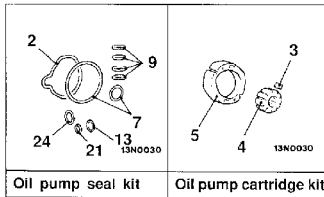

Oil pump seal kit Oil pump cartridge kit

Removal steps

1. Lower shaft assembly and gear box connecting bolt
2. Split pin
3. Connection for tie-rod end and knuckle
4. Connection for return tube
5. Connection for pressure tube
6. Clamp
7. Gear box assembly

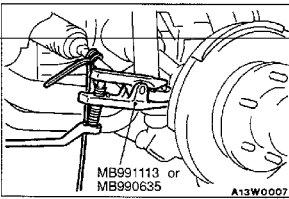

REMOVAL SERVICE POINTS

◀A▶ TIE-ROD END DISCONNECTION

Caution

1. Using the special tool, loosen the tie rod end mounting nut. Only loosen the nut; do not remove it from the ball joint.
2. Support the special tool with a cord, etc. to prevent it from coming off.

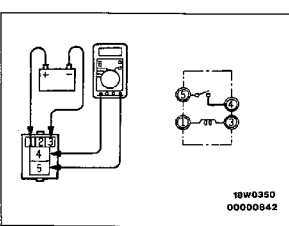

HEADLAMP RELAY CONTINUITY INSPECTION

Battery voltage	Terminal No.			
	1	3	4	5
Power is not supplied	○—○	○—○	○—○	○—○
Power is supplied	⊕—○	⊕—○	○—○	○—○

N denotes non-re-usable part.

Denotes tightening torque. For bolts and nuts which do not have a tightening torque listed, refer to the "Standard Parts-tightening-torque Table".

Repair kit or set parts are shown. (Only very frequently used parts are shown.)

Operating procedures, cautions, etc. on removal, installation, disassembly and reassembly are described.

○—○ indicates that there is a continuity between the terminals.
⊕—○ indicates terminals to which battery voltage is applied.

35A-26 BASIC BRAKE SYSTEM – Master Cylinder and Brake Booster

Lubrication and sealing points

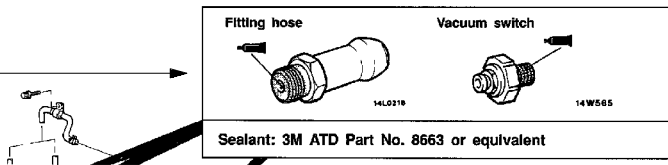

The title of the page (following the page on which the diagram of component parts is presented) indicating the locations of lubrication and sealing procedures.

HOW TO USE TROUBLESHOOTING/INSPECTION SERVICE POINTS

00100020220

Troubleshooting of electronic control systems for which the MUT-II can be used follows the basic outline described below. Furthermore, even in systems for which the MUT-II cannot be used, part of these systems still follow this outline.

TROUBLESHOOTING CONTENTS

1. STANDARD FLOW OF DIAGNOSIS TROUBLESHOOTING

The troubleshooting sections follow the basic diagnosis flow which is given below. If the diagnosis flow is different from that given below, or if additional explanation is required, the details of such differences or additions will also be listed.

Diagnosis method

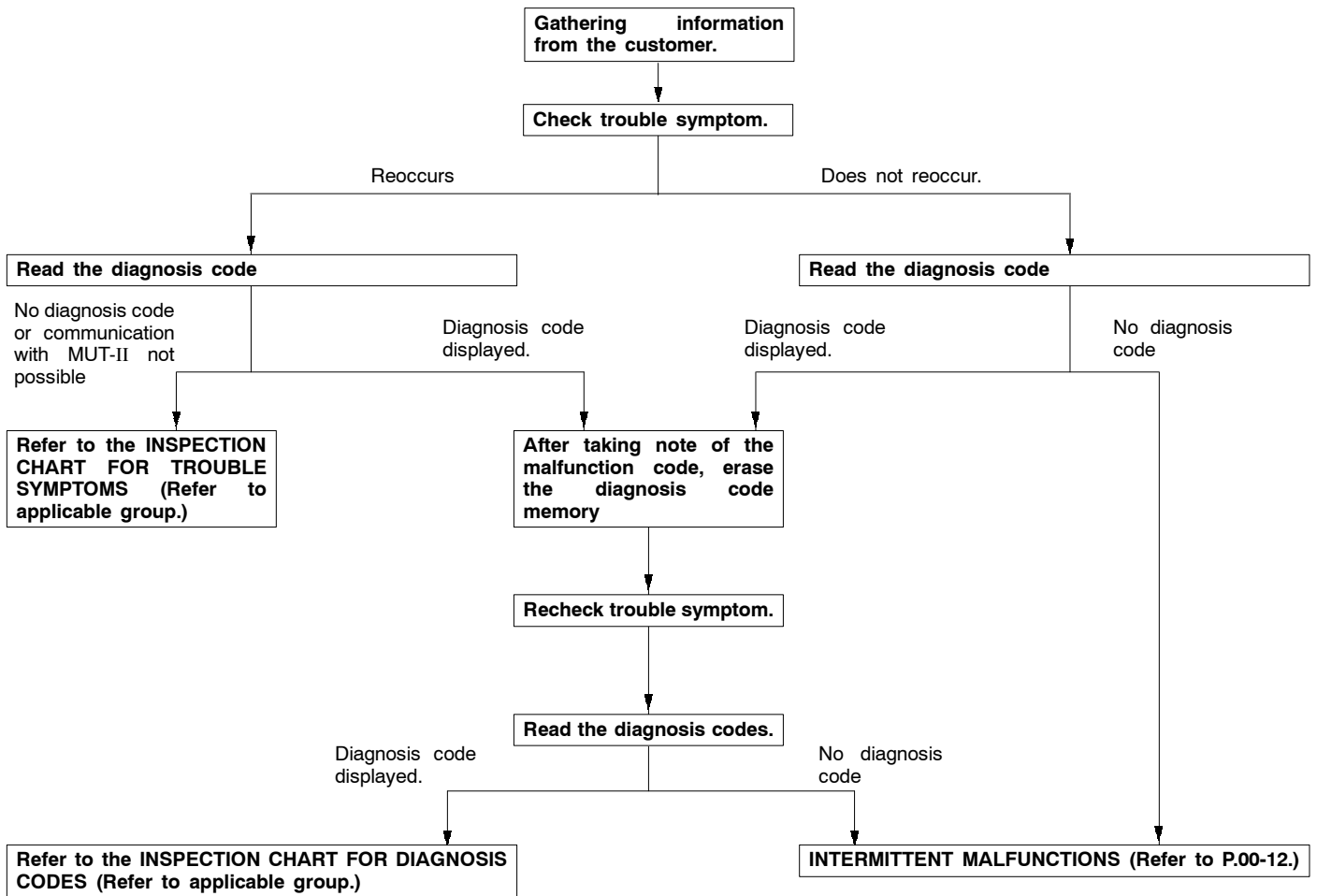

2. SYSTEM OPERATION AND SYMPTOM VERIFICATION TESTS

If verification of the trouble symptoms is difficult, procedures for checking operation and verifying trouble symptoms are shown.

3. DIAGNOSIS FUNCTION

Details which are different from those in the “Diagnosis Function” section on the next page are listed.

4. INSPECTION CHART FOR DIAGNOSIS CODES**5. INSPECTION PROCEDURE FOR DIAGNOSIS CODES**

Indicates the inspection procedures corresponding to each diagnosis code. (Refer to P.00-9 for how to read the inspection procedures.)

6. INSPECTION CHART FOR TROUBLE SYMPTOMS

If there are trouble symptoms even though the results of inspection using the MUT-II show that all diagnosis codes are normal, inspection procedures for each trouble symptom will be found by means of this chart.

7. INSPECTION PROCEDURE FOR TROUBLE SYMPTOM

Indicates the inspection procedures corresponding to each trouble symptoms classified in the Inspection Chart for Trouble Symptoms. (Refer to P.00-9 for how to read the inspection procedures.)

8. SERVICE DATA REFERENCE TABLE

Inspection items and normal judgement values have been provided in this chart as reference information.

9. CHECK AT ECU TERMINALS

Terminal numbers for the ECU connectors, inspection items and standard values have been provided in this chart as reference information.

10. INSPECTION PROCEDURES USING AN OSCILLOSCOPE

When there are inspection procedures using an oscilloscope, these are listed here.

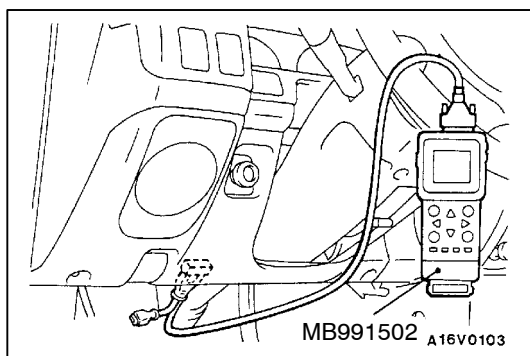
**DIAGNOSIS FUNCTION****METHOD OF READING DIAGNOSIS CODES****WHEN USING THE MUT-II**

Connect the MUT-II to the diagnosis connector and take a reading of the diagnosis codes.

Caution

Turn off the ignition switch before connecting or disconnecting the MUT-II.

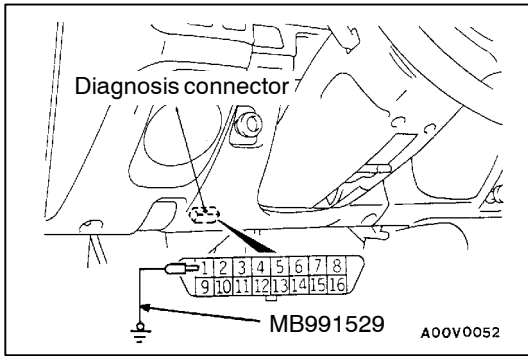

WHEN USING THE WARNING LAMP

1. Use the special tool to earth No.1 terminal (diagnosis control terminal) of the diagnosis connector.
2. Turn on the ignition switch.
3. Read out a diagnosis code by observing how the warning lamp flashes.

Applicable systems

System name	Warning lamp name
MPI	Engine warning lamp
Auto-cruise	Auto-cruise control indicator
ABS	ABS warning lamp

Indication of diagnosis code by warning lamp

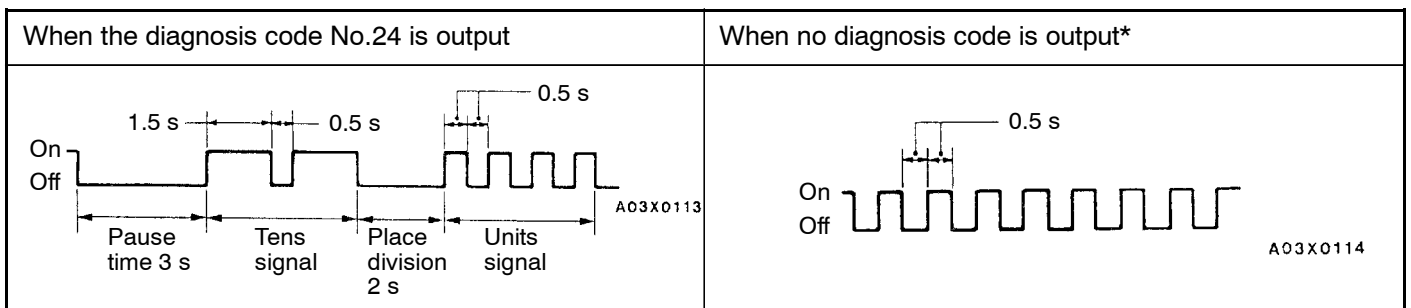

METHOD OF ERASING DIAGNOSIS CODES

WHEN USING THE MUT-II

Connect the MUT-II to the diagnosis connector and erase the diagnosis code.

Caution

Turn off the ignition switch before connecting or disconnecting the MUT-II.

WHEN NOT USING THE MUT-II

1. Turn the ignition switch to OFF.
2. After disconnecting the battery cable from the battery (-) terminal for 10 seconds or more, reconnect the cable.
3. After the engine has warmed up, run it at idle for about 15 minutes.

HOW TO USE THE INSPECTION PROCEDURES

The causes of a high frequency of problems occurring in electronic circuitry are generally the connectors, components, the ECU and the harnesses between connectors, in that order. These inspection procedures follow this order, and they first try to discover a problem with a connector or a defective component.

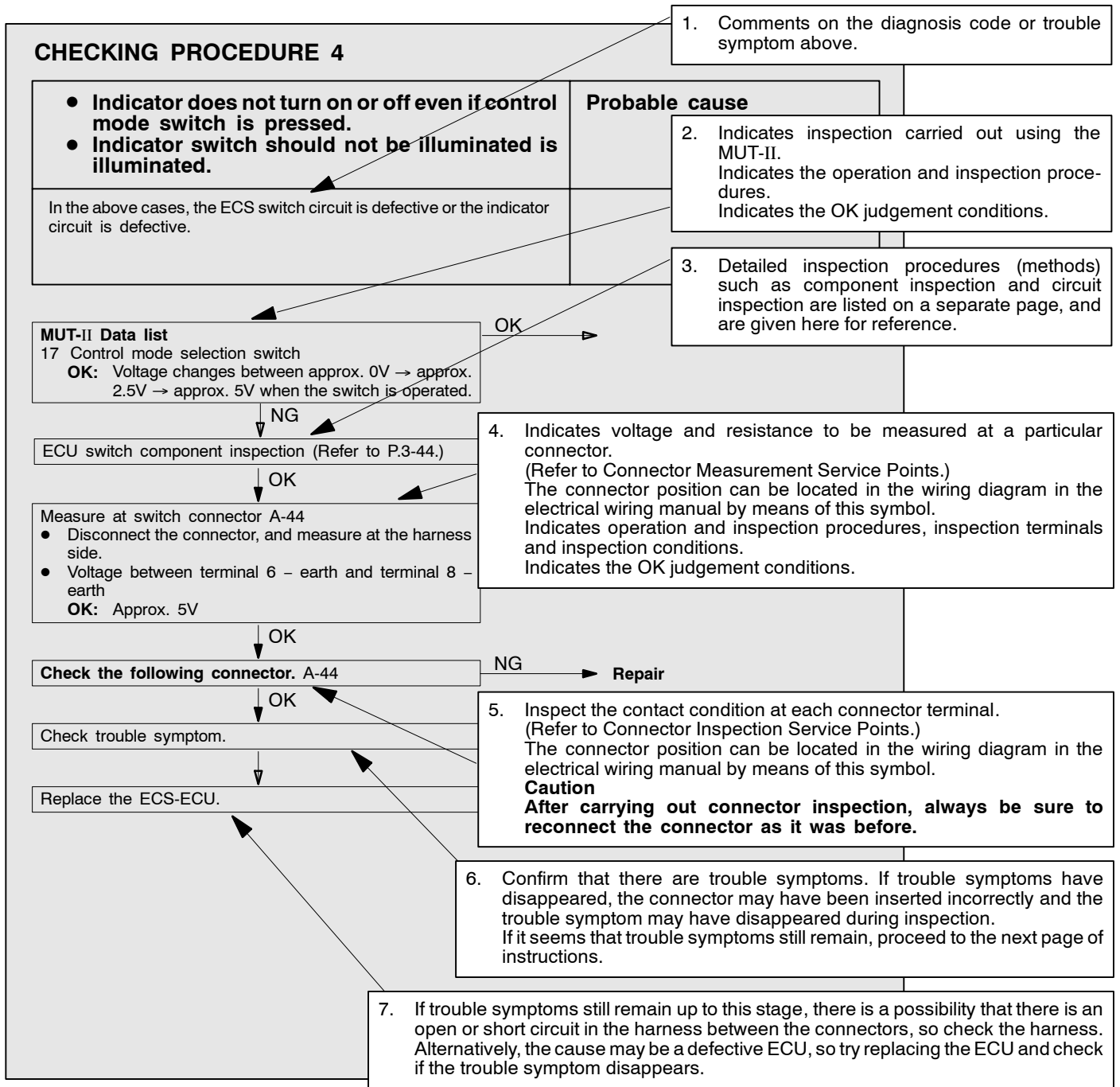

HARNESS INSPECTION

Check for an open or short circuit in the harness between the terminals which were defective according to the connector measurements. Carry out this inspection while referring to the electrical wiring manual. Here, “Check harness between power supply and terminal xx” also includes checking for blown fuses. For inspection service points when there is a blown fuse, refer to “Inspection Service Points for a Blown Fuse.”

MEASURES TO TAKE AFTER REPLACING THE ECU

If the trouble symptoms have not disappeared even after replacing the ECU, repeat the inspection procedure from the beginning.

CONNECTOR MEASUREMENT SERVICE POINTS

Turn the ignition switch to OFF when connecting/disconnecting the connectors, and turn the ignition switch to ON when measuring if there are no instructions to be contrary.

IF INSPECTING WITH THE CONNECTOR CONNECTED (WITH CIRCUIT IN A CONDITION OF CONTINUITY)

Waterproof Connectors

Be sure to use the special tool (harness connector). Never insert a test bar from the harness side, because to do so will reduce the waterproof performance and result in corrosion.

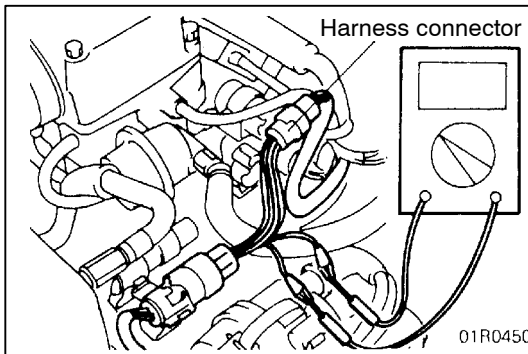

Ordinary (non-waterproof) Connectors

Check by inserting the test bar from the harness side. Note that if the connector (control unit, etc.) is too small to permit insertion of the test bar, it should not be forced; use a special tool (the extra-thin probe in the harness set for checking for this purpose).

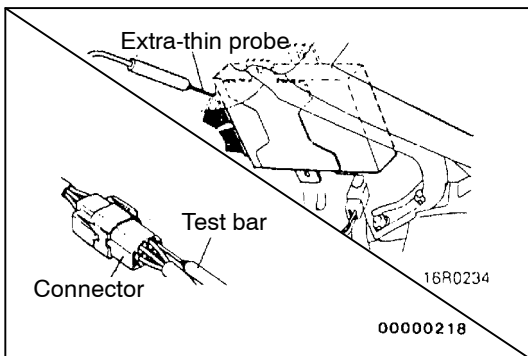

IF INSPECTING WITH THE CONNECTOR DISCONNECTED

<When Inspecting a Female Pin>

Use the special tool (inspection harness for connector pin contact pressure in the harness set for inspection). The inspection harness for connector pin contact pressure should be used. the test bar should never be forcibly inserted, as it may cause a defective contact.

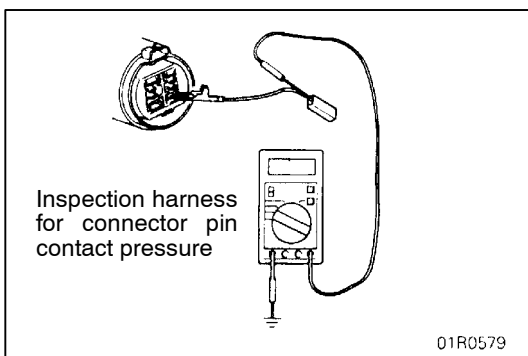

<When Inspecting a Male Pin>

Touch the pin directly with the test bar.

Caution

At this time, be careful not to short the connector pins with the test bars. To do so may damage the circuits inside the ECU.

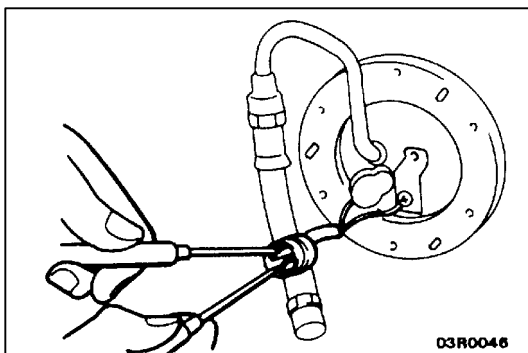

Connector disconnected or improperly connected

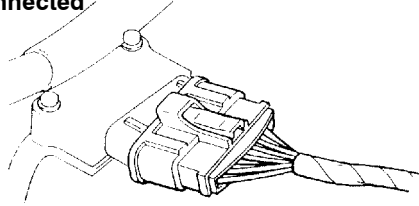

16S0256

Defective connector contact

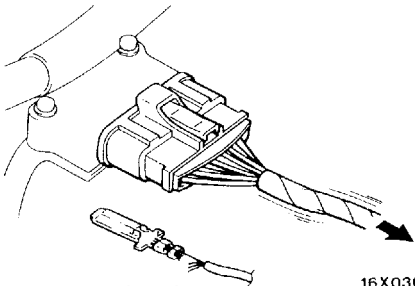

Harness wire breakage at terminal section

16X0369

Low contact pressure

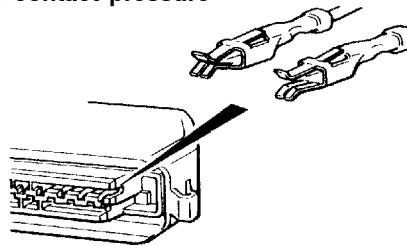

16S0254
00000219

CONNECTOR INSPECTION

VISUAL INSPECTION

- Connector is disconnected or improperly connected
- Connector pins are pulled out
- Due to harness tension at terminal section
- Low contact pressure between male and female terminals
- Low connection pressure due to rusted terminals or foreign matter lodged in terminals

CONNECTOR PIN INSPECTION

If the connector pin stopper is damaged, the terminal connections (male and female pins) will not be perfect even if the connector body is connected, and the pins may pull out of the reverse side of the connector. Therefore, gently pull the harnesses one by one to make sure that no pins pull out of the connector.

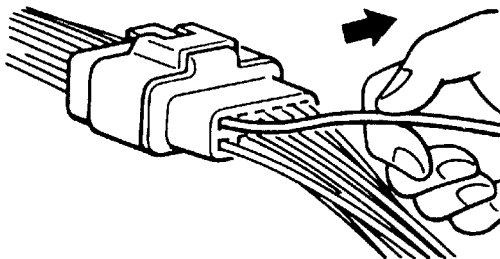

16R1317

CONNECTOR ENGAGEMENT INSPECTION

Use the special tool (connector pin connection pressure inspection harness of the inspection harness set) to inspect the engagement of the male pins and females pins. (Pin drawing force : 1 N or more)

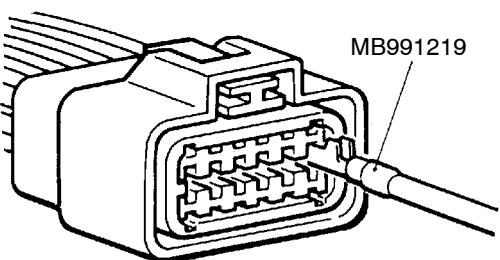

MB991219

16R1318

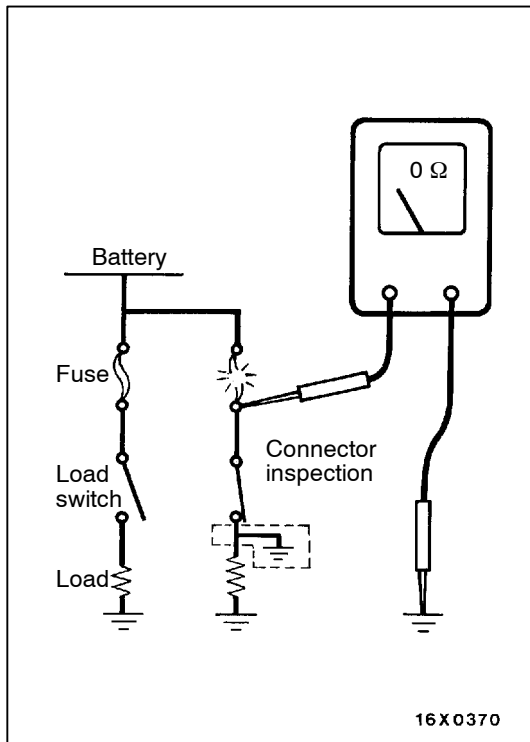

INSPECTION SERVICE POINTS FOR A BLOWN FUSE

Remove the fuse and measure the resistance between the load side of the fuse and the earth. Set the switches of all circuits which are connected to this fuse to a condition of continuity. If the resistance is almost 0 Ω at this time, there is a short somewhere between these switches and the load. If the resistance is not 0 Ω, there is no short at the present time, but a momentary short has probably caused the fuse to blow.

The main causes of a short circuit are the following.

- Harness being clamped by the vehicle body
- Damage to the outer casing of the harness due to wear or heat
- Water getting into the connector or circuitry
- Human error (mistakenly shorting a circuit, etc.)

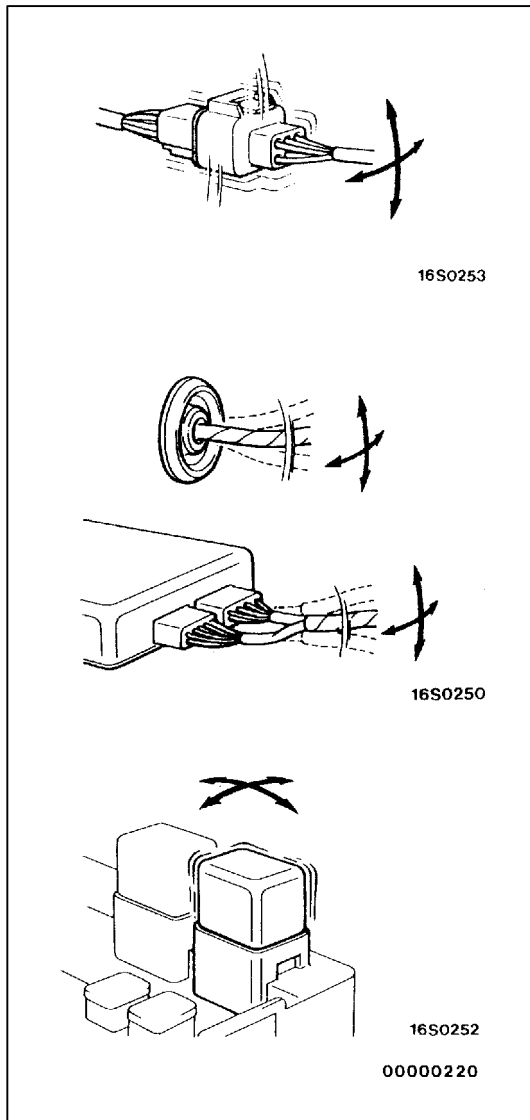

POINTS TO NOTE FOR INTERMITTENT MALFUNCTIONS

Intermittent malfunctions often occur under certain conditions, and if these conditions can be ascertained, determining the cause becomes simple. In order to ascertain the conditions under which an intermittent malfunction occurs, first ask the customer for details about the driving conditions, weather conditions, frequency of occurrence and trouble symptoms, and then try to recreate the trouble symptoms. Next, ascertain whether the reason why the trouble symptom occurred under these conditions is due to vibration, temperature or some other factor. If vibration is thought to be the cause, carry out the following checks with the connectors and components to confirm whether the trouble symptom occurs.

The objects to be checked are connectors and components which are indicated by inspection procedures or given as probable causes (which generates diagnosis codes or trouble symptoms.)

- Gently shake the connector up, down and to the left and right.
- Gently shake the wiring harness up, down and to the left and right.
- Gently rock each sensor and relay, etc. by hand.
- Gently shake the wiring harness at suspensions and other moving parts.

NOTE

If determining the cause is difficult, the flight recorder function of the MUT-II can also be used.

TREATMENT BEFORE/AFTER FORDING A STREAM

00100060062

INSPECTION AND SERVICE BEFORE FORDING A STREAM

Vehicles which are driven through water, or which may possibly be driven through water, should be subjected to the following inspections and maintenance procedures in advance.

- Seal the speedometer cable with a water-resistant grease or tape.
- Inspect the dust boot and breather hose for cracks or damage, and replace them if cracks or damage are found.

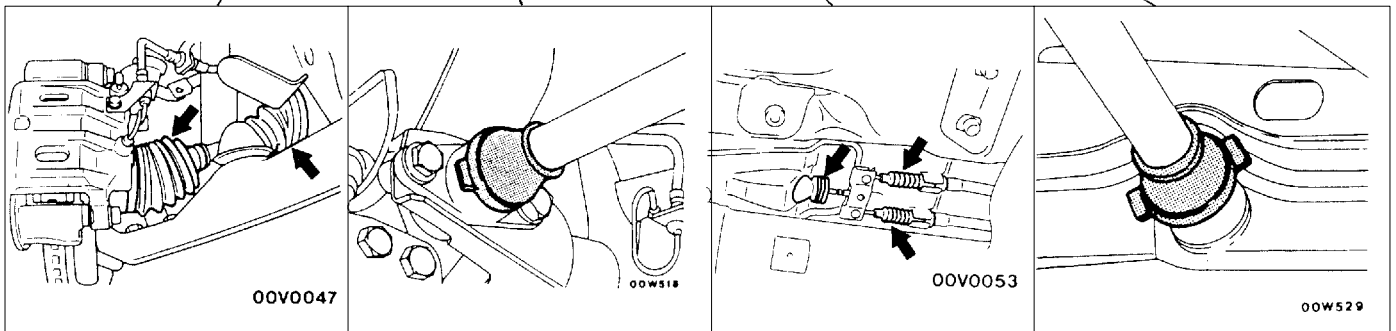
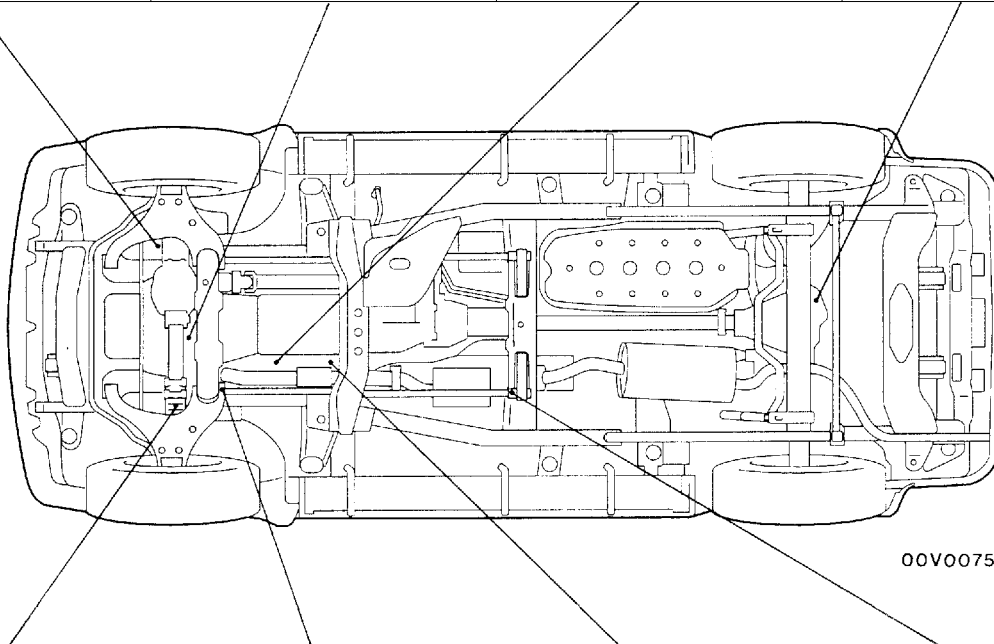
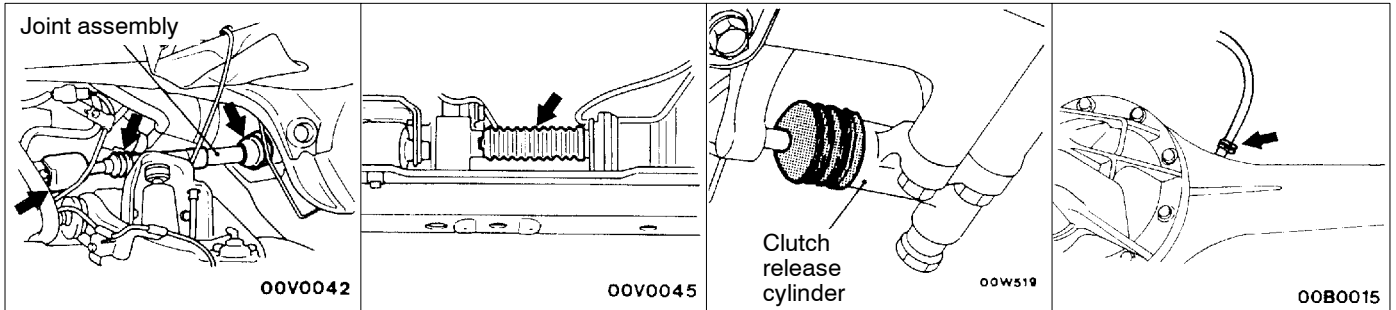

00009306

- Apply grease to the lubricating points of the front suspension, steering linkage and propeller shaft.

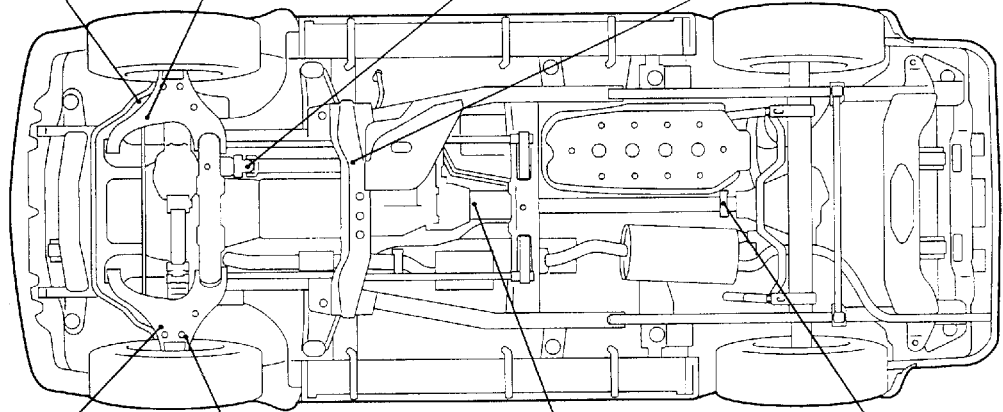
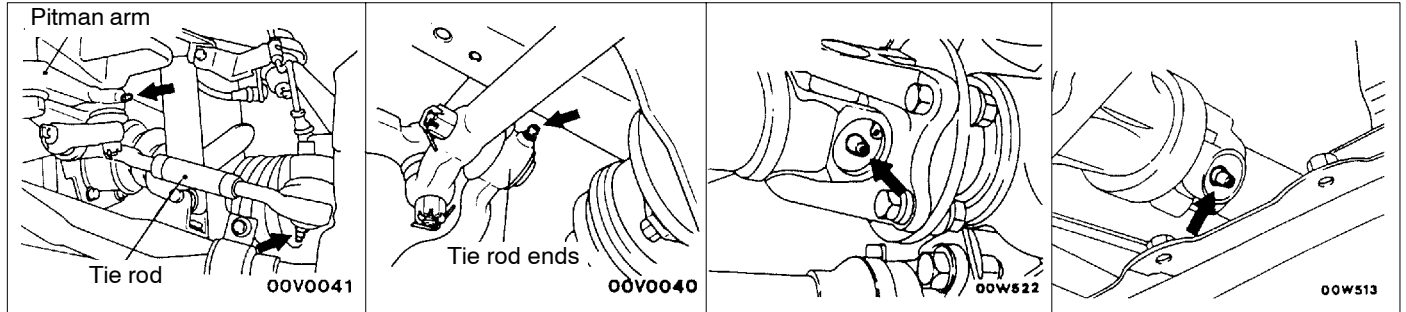

00V0075

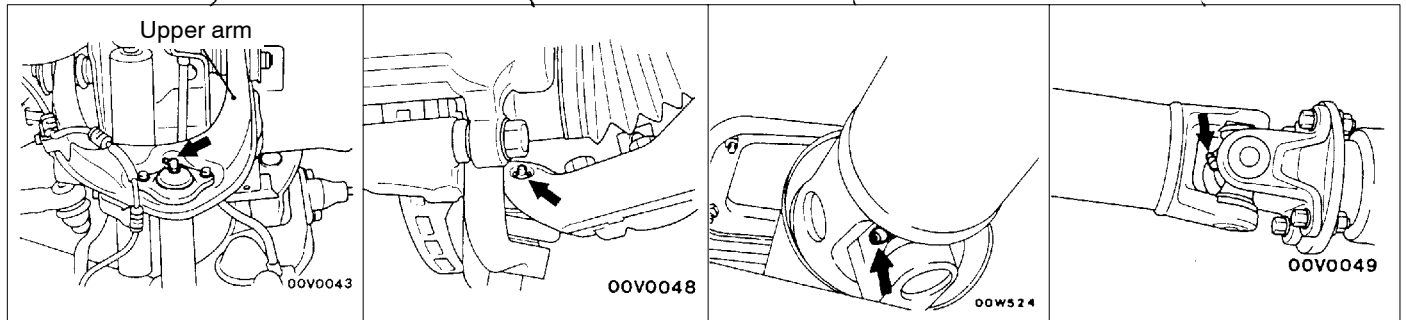

INSPECTION AND SERVICE AFTER FORDING A STREAM

After fording a stream, check the following points. If abnormal condition is evident, clean, replace or lubricate.

- Check for water, mud, sand, etc. in the rear brake drum, clutch housing, starter motor, brake pipe and fuel pipe.
- Check for water in the fluid or oil inside the front differential, rear differential, transmission and transfer.
- Apply grease to the lubricating points of the front suspension, steering linkage and propeller shaft.
- Check all boots and breather hoses for cracks and damage.

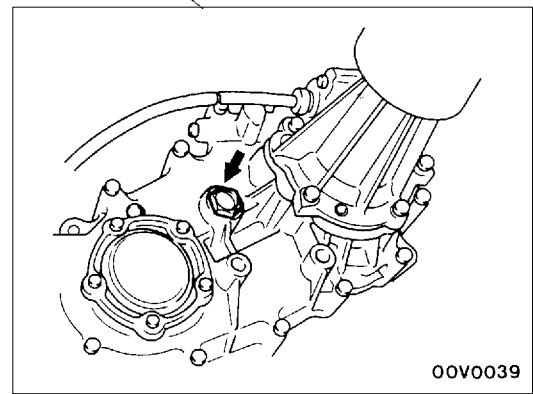
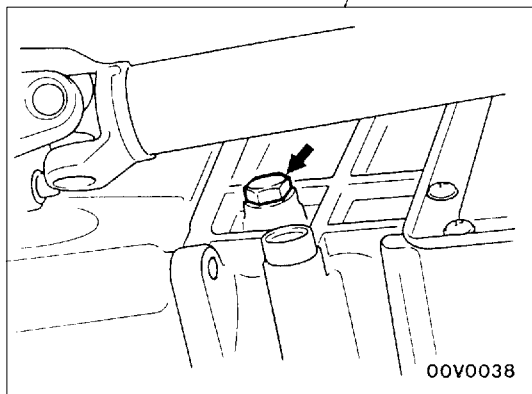
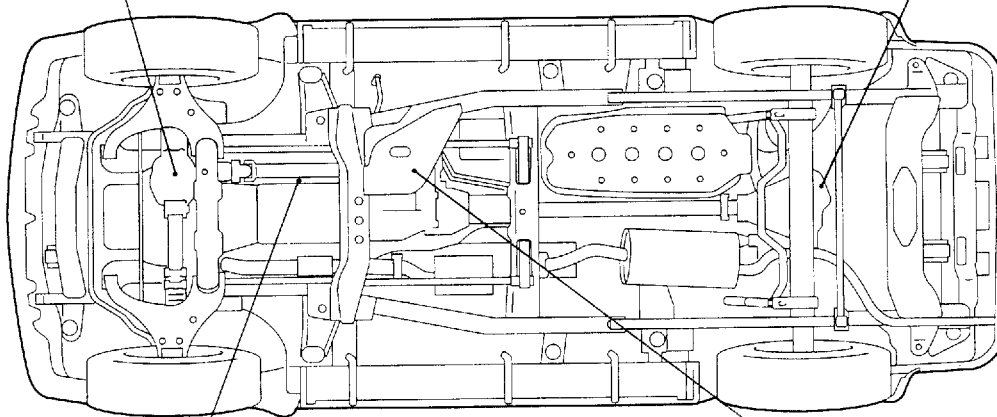
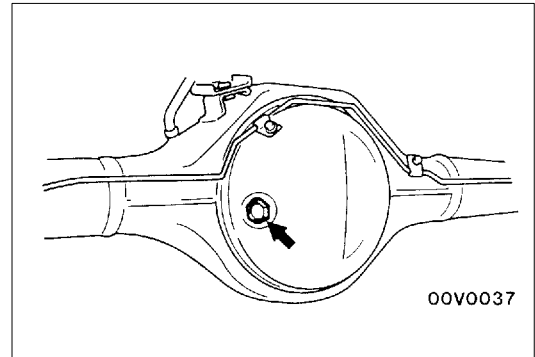
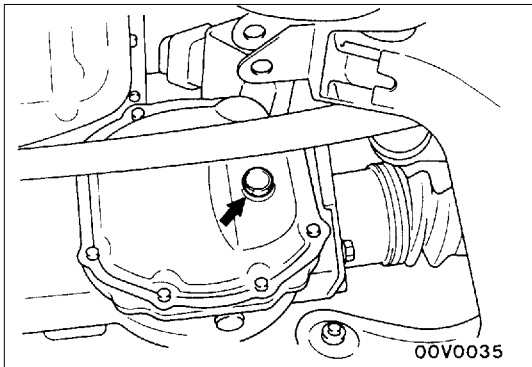

00009308

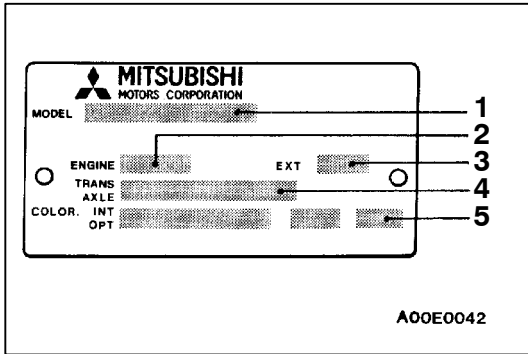
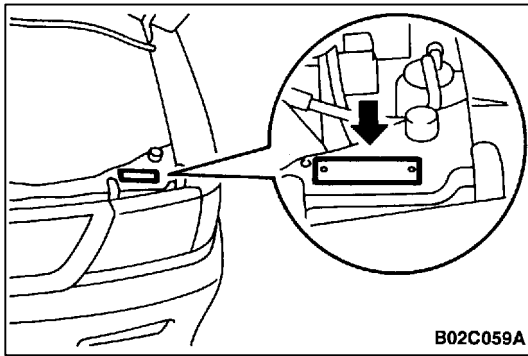

VEHICLE IDENTIFICATION

00100540177

VEHICLE INFORMATION CODE PLATE

LOCATION

Vehicle information code plate is riveted onto the headlamp support panel in the engine compartment.

CODE PLATE DESCRIPTION

The plate shows model code, engine model, transmission model, and body colour code.

No.	Item	Contents	
1	MODEL	K96WGNHER6	K96WG: Vehicle model
			NHER6: Model series
2	ENGINE	6G72	Engine model
3	EXT	B60B	Exterior code
4	TRANS AXLE	V5MT1 4636	V5MT1: Transmission code
			4636: Rear differential reduction
5	COLOR INT OPT	B60 41H 03V	B60: Body colour code
			41H: Interior code
			03V: Equipment code

For monotone colour vehicles, the body colour code shall be indicated. For two-tone colour vehicles, each colour code only shall be indicated in series.

MODELS

00100550132

Model code		Engine model	Transmission model	Fuel supply system
K96WG	NHEL6	6G72-SOHC (2,972 mL)	V5MT1(4WD-5M/T)	MPI
	NHER6			
K94W	NUFL6	4D56 (2,477 mL)		Fuel injection
	NUFR6			
K94WG	NHFL6			
	NHFR6			

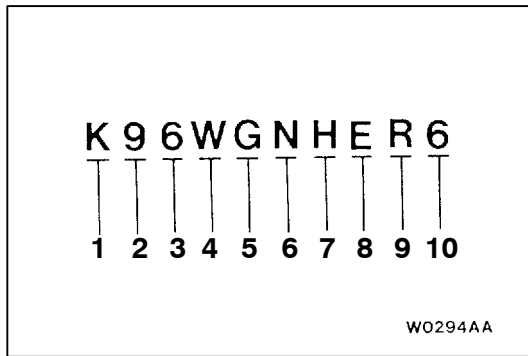

MODEL CODE

00100040400

No.	Items	Contents
1	Vehicle line	K: Challenger
2	Drive system	9: 4WD
3	Engine system	4: 2,477 mL Diesel engine
		6: 2,972 mL Petrol engine
4	Group	W: Wagon
5	Vehicle width	G: Wide fender
6	Transmission type	N: 5-speed manual transmission
7	Vehicle grade	U: GLX
		H: GLS
8	Specified engine feature	E: MPI
		F: I/C T/C

No.	Items	Contents
9	Steering wheel location	L: Left hand
		R: Right hand
10	Destination	8: For Europe

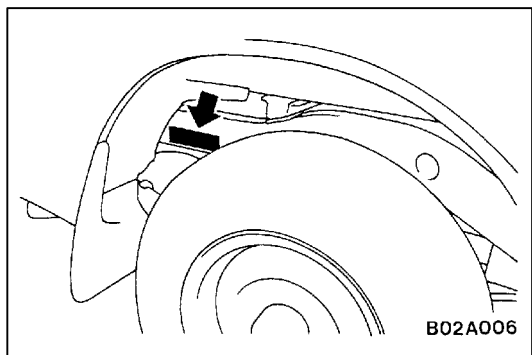

CHASSIS NUMBER

00100560142

The chassis number is stamped on the side wall of the frame near the rear wheel (R.H.).

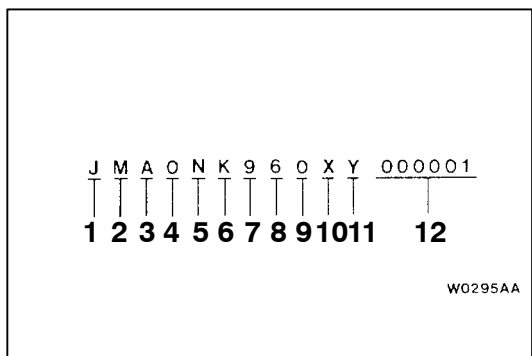

No.	Items	Contents
1	Fixed figure	J Asia
2	Distribution channel	M Japan channel
3	Destination	A Right hand drive
		B Left hand drive
4	Body style	0 4 door tailgate
5	Transmission type	N 5-speed manual transmission
6	Vehicle line	K Pajero sport
7	Body type	9 4WD
8	Engine type	4 4D56: 2,477 mL diesel engine
		6 6G72: 2,972 mL petrol engine
9	Body style	0 Frame
10	Model year	X 1999

No.	Items		Contents
11	Plant	Y,P	Ooe Plant of Nagoya Motor Vehicle Works
12	Serial number	-	-

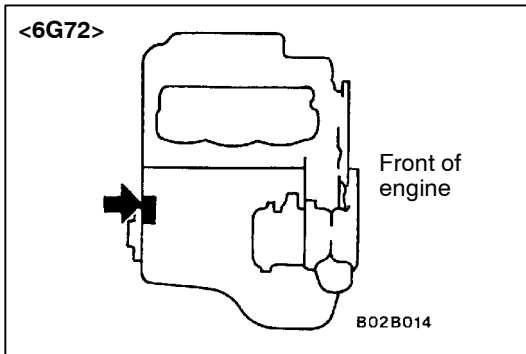

ENGINE MODEL NUMBER

1. The engine model number is stamped at the cylinder block as shown in the following.

Engine model	Engine displacement mL
6G72	2,972
4D56	2,477

2. The engine serial number is stamped near the engine model number.

Engine serial number	AA0201 to YY9999
----------------------	------------------

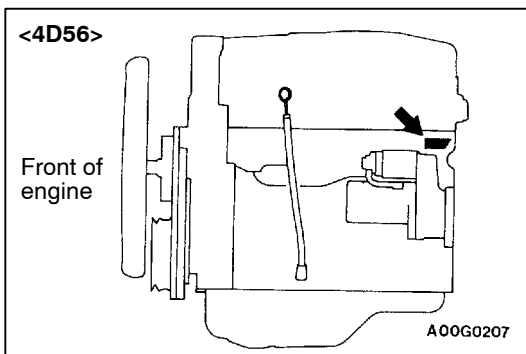

MAJOR SPECIFICATIONS

00100090382

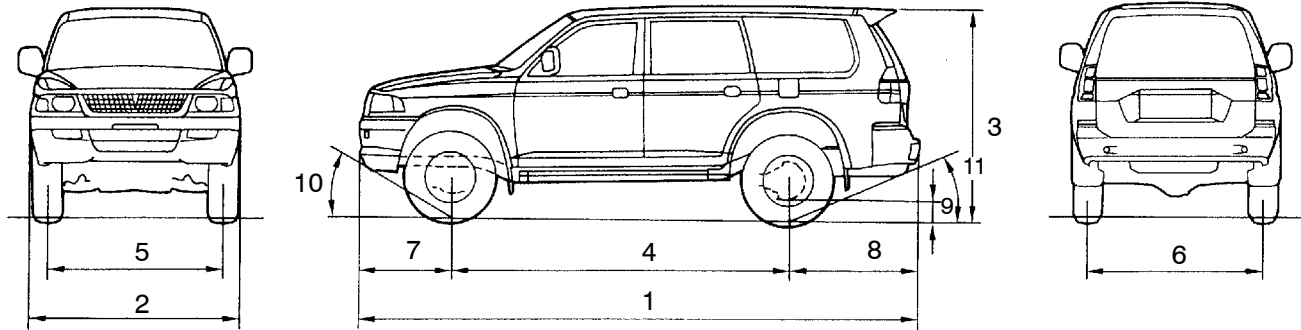

T0303AA

Items		K96WGNHE L6/R6	K94WNUF L6/R6	K94WGNHF L6/R6	
Vehicle dimensions mm	Overall length	1	4,545	4,545	
	Overall width	2	1,775	1,695	
	Overall height (unladen)	3	1,730	1,720	
	Wheelbase	4	2,725	2,725	
	Tread-front	5	1,465	1,420	
	Tread-rear	6	1,480	1,435	
	Overhang-front	7	765	765	
	Overhang-rear	8	1,055	1,055	
	Ground clearance (unladen)	9	215	205	
	Angle of approach degrees	10	37°	36°	
	Angle of departure degrees	11	26°	25°	
Vehicle weight kg	Kerb weight		1,845	1,825	1,895
	Max. gross vehicle weight rating		2,510	2,510	2,510
	Max. axle weight rating-front		1,110	1,110	1,145
	Max. axle weight rating-rear		1,400	1,400	1,365
	Max. trailer weight	With brake	2,800	2,800	2,800
		Without brake	750	750	750
Max. trailer-nose weight		115	115	115	
Seating capacity		5	5	5	
Engine	Model No.	6G72	4D56	4D56	
	Total displacement mL	2,972	2,477	2,477	
Transmission	Model No.	V5MT1	V5MT1	V5MT1	
	Type	5-speed manual	5-speed manual	5-speed manual	
Fuel system	Fuel supply system	MPI	Fuel injection	Fuel injection	

PRECAUTIONS BEFORE SERVICE

00100050410

SUPPLEMENTAL RESTRAINT SYSTEM (SRS)

1. Items to follow when servicing SRS
 - (1) Be sure to read GROUP 52B – Supplemental Restraint System (SRS).
For safe operations, please follow the directions and heed all warnings.
 - (2) Always use the designated special tools and test equipment.
 - (3) Wait at least 60 seconds after disconnecting the battery cable before doing any further work.
The SRS system is designed to retain enough voltage to deploy the air bag even after the battery has been disconnected. Serious injury may result from unintended air bag deployment if work is done on the SRS system immediately after the battery cable is disconnected.
 - (4) Never attempt to disassembly or repair the SRS components, (SRS-ECU, air bag module and clock spring, front impact sensor). If faulty, replace it.
 - (5) Warning labels must be heeded when servicing or handling SRS components. Warning labels are located in the following locations.
 - Hood
 - Sun visor
 - Glove box
 - SRS-ECU
 - Steering wheel
 - Air bag module
 - Clock spring
 - Instrument panel
 - Frame
 - (6) Store components removed from the SRS in a clean and dry place.
The air bag module should be stored on a flat surface and placed so that the pad surface is facing upward.
Do not place anything on top of it.
 - (7) Be sure to deploy the air bag before disposing of the air bag module or disposing of a vehicle equipped with an air bag. (Refer to GROUP 52B – Air Bag Module Disposal Procedures.)
 - (8) Whenever you finish servicing the SRS, check the SRS warning lamp operation to make sure that the system functions properly.
2. Observe the following when carrying out operations on places where SRS components are installed, including operations not directly related to the SRS air bag.
 - (1) When removing or installing parts do not allow any impact or shock to the SRS components.
 - (2) SRS components should not be subjected to heat over 93°C, so remove the SRS components before drying or baking the vehicle after painting.
After re-installing them, check the SRS warning lamp operation to make sure that the system functions properly.

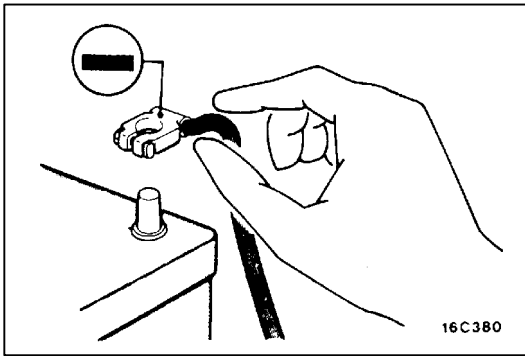

SERVICING THE ELECTRICAL SYSTEM

Before replacing a component related to the electrical system and before undertaking any repair procedures involving the electrical system, be sure to first disconnect the negative (-) cable from the battery in order to avoid damage caused by short-circuiting.

Caution

Before connecting or disconnecting the negative (-) cable, be sure to turn off the ignition switch and the lighting switch.

(If this is not done, there is the possibility of semiconductor parts being damaged.)

APPLICATION OF ANTI-CORROSION AGENTS AND UNDERCOATS

If oil or grease gets onto the oxygen sensor, it will cause a drop in the performance of the sensor.

Cover the oxygen sensor with a protective cover when applying anti-corrosion agents and undercoats.

PRE-INSPECTION CONDITION

“Pre-inspection condition” refers to the condition that the vehicle must be in before proper engine inspection can be carried out. If you see the words “Set the vehicle to the pre-inspection condition.” in this manual, it means to set the vehicle to the following condition.

- Engine coolant temperature: 80–90°C
- Lamps, electric cooling fan and all accessories: OFF
- M/T: Neutral

VEHICLE WASHING

If high-pressure car-washing equipment or steam car-washing equipment is used to wash the vehicle, be sure to note the following information in order to avoid damage to plastic components, etc.

- Spray nozzle distance: Approx. 40 cm or more
- Spray pressure: 3,900 kPa or less
- Spray temperature: 82°C or less
- Time of concentrated spray to one point: within 30 sec.

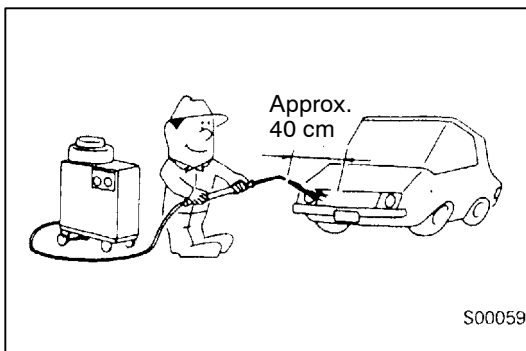

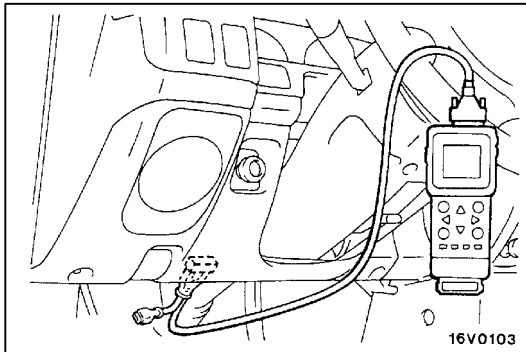
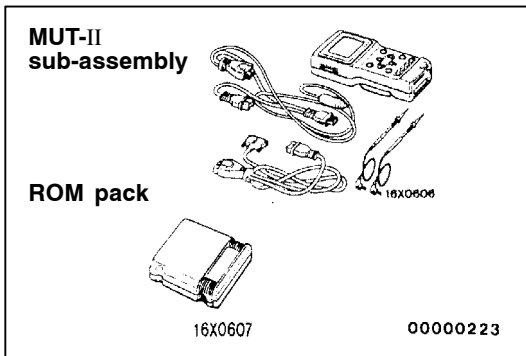

MUT-II

Refer to the "MUT-II REFERENCE MANUAL" or "MUT-II OPERATING INSTRUCTIONS" for instructions on handling the MUT-II.

Connect the MUT-II to the diagnosis connector as shown in the illustration.

Caution

Connection and disconnection of the MUT-II should always be made with the ignition switch in the OFF position.

IN ORDER TO PREVENT VEHICLES FROM FIRE

"Improper installation of electrical or fuel related parts could cause a fire. In order to retain the high quality and safety of the vehicle, it is important that any accessories that may be fitted or modifications/repairs that may be carried out which involve the electrical or fuel systems, MUST be carried out in accordance with MMC's information/Instructions".

ENGINE OILS

Health Warning

Prolonged and repeated contact with mineral oil will result in the removal of natural fats from the skin, leading to dryness, irritation and dermatitis. In addition, used engine oil contains potentially harmful contaminants which may cause skin cancer. Adequate means of skin protection and washing facilities must be provided.

Recommended Precautions

The most effective precaution is to adapt working practices which prevent, as far as practicable, the risk of skin contact with mineral oils, for example by using enclosed systems for handling used engine oil and by degreasing components, where practicable, before handling them.

Other precautions:

- Avoid prolonged and repeated contact with oils, particularly used engine oils.
- Wear protective clothing, including impervious gloves where practicable.
- Avoid contaminating clothes, particularly underpants, with oil.
- Do not put oily rags in pockets, the use of overalls without pockets will avoid this.
- Do not wear heavily soiled clothing and oil-impregnated foot-wear. Overalls must be cleaned regularly and kept separately from personal clothing.
- Where there is a risk of eye contact, eye protection should be worn, for example, chemical goggles or face shields; in addition an eye wash facility should be provided.
- Obtain First Aid treatment immediately for open cuts and wounds.
- Wash regularly with soap and water to ensure all oil is removed, especially before meals (skin cleansers and nail brushes will help). After cleaning, the application of preparations containing lanolin to replace the natural skin oils is advised.
- Do not use petrol, kerosine, diesel fuel, gas oil, thinners or solvents for cleaning skin.
- Use barrier creams, applying them before each work period, to help the removal of oil from the skin after work.
- If skin disorders develop, obtain medical advice without delay.

SUPPLEMENTAL RESTRAINT SYSTEM (SRS)

00100590110

To improve safety, the SRS is available as optional part. The SRS consists of two air bag modules, SRS air bag control unit (SRS-ECU), front impact sensors, SRS warning lamp and clock spring. One air bag is located in the centre of the steering wheel and another above the glove box. Each air bag has a folded air bag and an inflator unit. The control unit under the floor console monitors the system and has a safing G-sensor and an analog G-sensor. The front impact sensors are installed in the fender

shield panel. The warning lamp on the instrument panel indicates the operational status of the SRS. The clock spring is installed in the steering column. Only authorized service personnel should do work on or around the SRS components. Those service personnel should read this manual carefully before starting any such work. Extreme care must be used when servicing the SRS to avoid injury to the service personnel (by inadvertent deployment of the air bags) or the driver (by rendering the SRS inoperative).

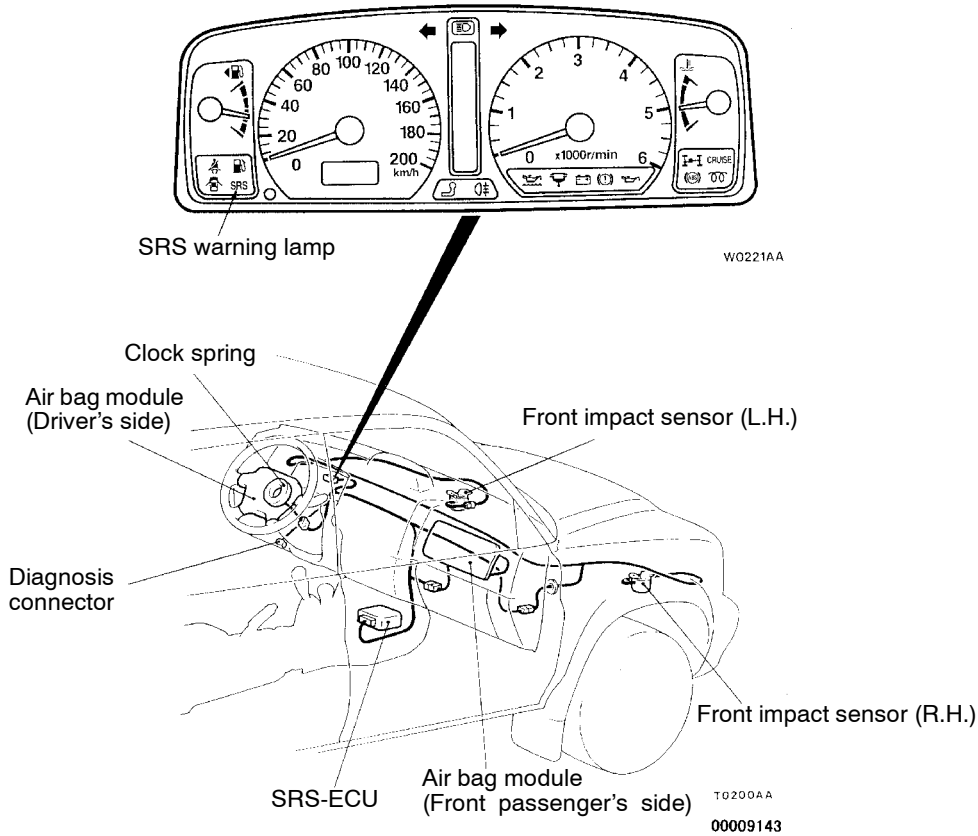

SRS SERVICE PRECAUTIONS

1. In order to avoid injury to yourself or others from accidental deployment of the air bag during servicing, read and carefully follow all the precautions and procedures described in this manual.
2. Do not use any electrical test equipment on or near SRS components, except those specified on GROUP 52B.
3. **Never Attempt to Repair the Following Components:**

- SRS air bag control unit (SRS-ECU)
 - Front impact sensor
 - Clock Spring
 - Air Bag Module
- If any of these components are diagnosed as faulty, they should only be replaced, in accordance with the INDIVIDUAL COMPONENTS SERVICE procedures in this manual on GROUP 52B.

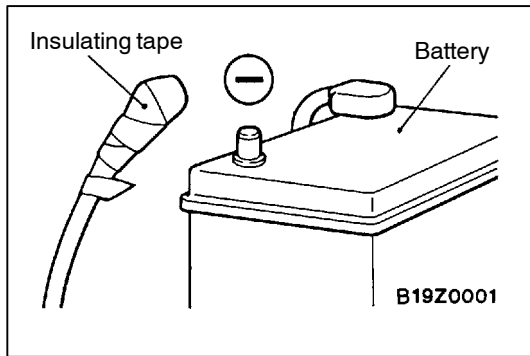

4. **After disconnecting the battery cable, wait 60 seconds or more before proceeding with the following work. The SRS system is designed to retain enough voltage to deploy the air bag for a short time even after the battery has been disconnected, so serious injury may result from unintended air bag deployment if work is done on the SRS system immediately after the battery cables are disconnected.**

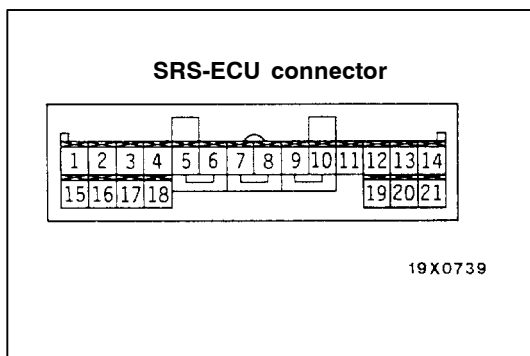

5. Do not attempt to repair the wiring harness connectors of the SRS. If any of the connectors are diagnosed as faulty, replace the wiring harness. If the wires are diagnosed as faulty, replace or repair the wiring harness according to the following table.

SRS-ECU terminal No.	Harness connector (No. of terminals, colour)	Destination of harness	Corrective action
1 to 4	21 pins, yellow	–	–
5		Body wiring harness → Clock spring → Air bag module (Driver's side)	Correct or replace each wiring harness. Replace clock spring.
6			
7		Body wiring harness → Air bag module (Front passenger's side)	Correct or replace each wiring harness.
8			
9,10		–	–
11		Body wiring harness → Diagnosis connector	Correct or replace each wiring harness.
12, 17		Body wiring harness → Front wiring harness → Front impact sensor (L.H.)	Sensor cable* installation procedures (Refer to P.52B-38.)
13		Body wiring harness → Junction block (fuse No.2)	Correct or replace each wiring harness.
14		Body wiring harness → Junction block (fuse No.4)	
15		Body wiring harness → SRS warning lamp	
16		–	–
18, 19		Body wiring harness → Front wiring harness → Front impact sensor (R.H.)	Sensor cable* installation procedures (Refer to P.52B-38.)
20		Body wiring harness → Earth	Correct or replace body wiring harness.
21			

NOTE

*: The sensor cable is available as service part.

6. SRS components should not be subjected to heat over 93°C, so remove the SRS-ECU, air bag module, clock spring and front impact sensors before drying or baking the vehicle after painting.
7. Whenever you finish servicing the SRS, check warning lamp operation to make sure that the system functions properly. (Refer to GROUP 52B.)
8. Make certain that the ignition switch is OFF when the MUT-II is connected or disconnected.
9. If you have any questions about the SRS, please contact your local distributor.

NOTE

SERIOUS INJURY CAN RESULT FROM UNINTENDED AIR BAG DEPLOYMENT, SO USE ONLY THE PROCEDURES AND EQUIPMENT SPECIFIED IN THIS MANUAL.

SUPPORT LOCATIONS FOR LIFTING AND JACKING

00100070096

Caution

Do not support the vehicles at locations other than specified supporting points. If do so, this will cause damage, etc.

SUPPORT POSITIONS FOR A GARAGE JACK AND AXLE STANDS

AXLE STANDS

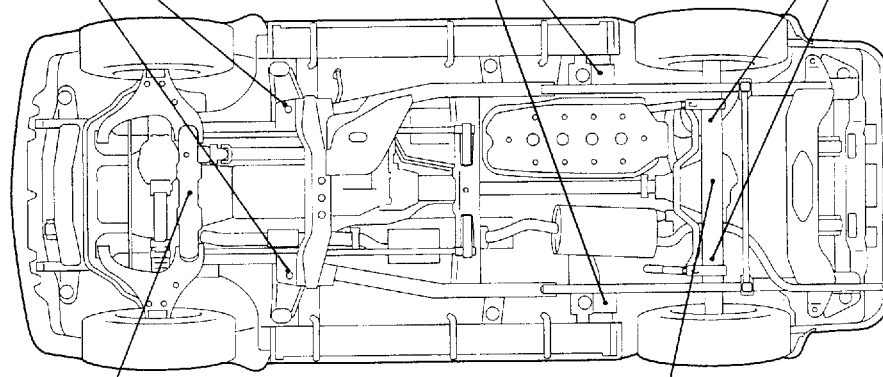
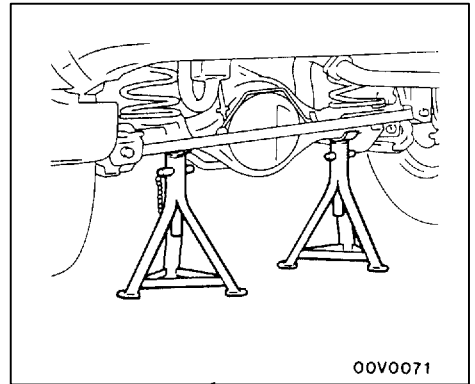
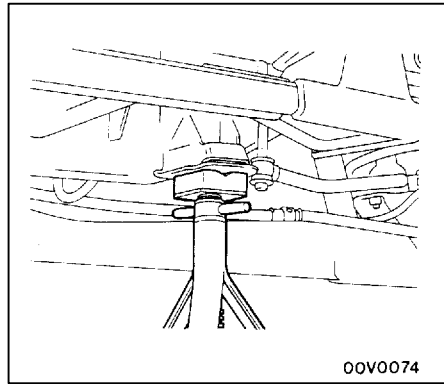
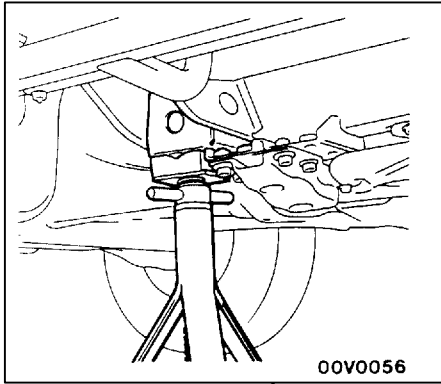

00V0075

GARAGE JACK

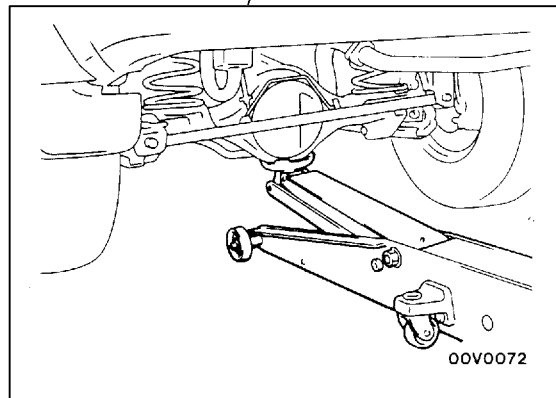
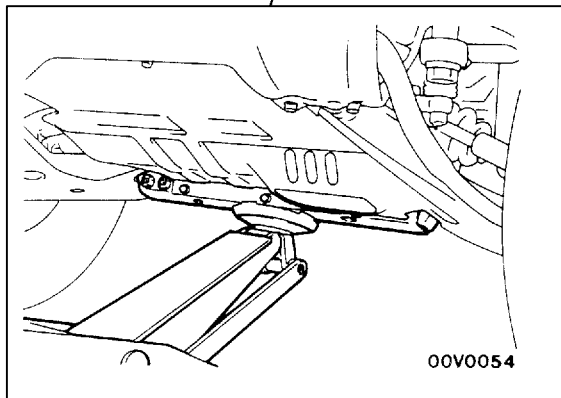

SUPPORT POSITIONS FOR A SINGLE-POST LIFT OR DOUBLE-POST LIFT AND H-BAR LIFT

Caution

When service procedures require removing rear suspension, spare tyre and rear bumper, place additional weight on rear end of vehicle or

anchor vehicle to hoist to prevent tipping of centre of gravity changes.

DOUBLE-POST LIFT

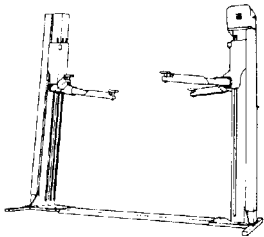

00E610

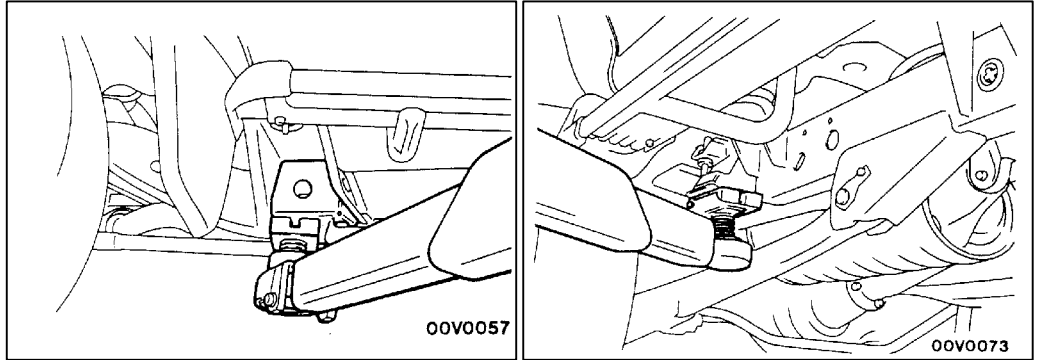

SINGLE-POST LIFT

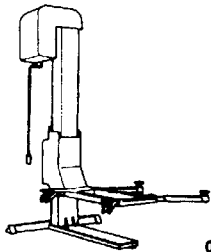

00E609

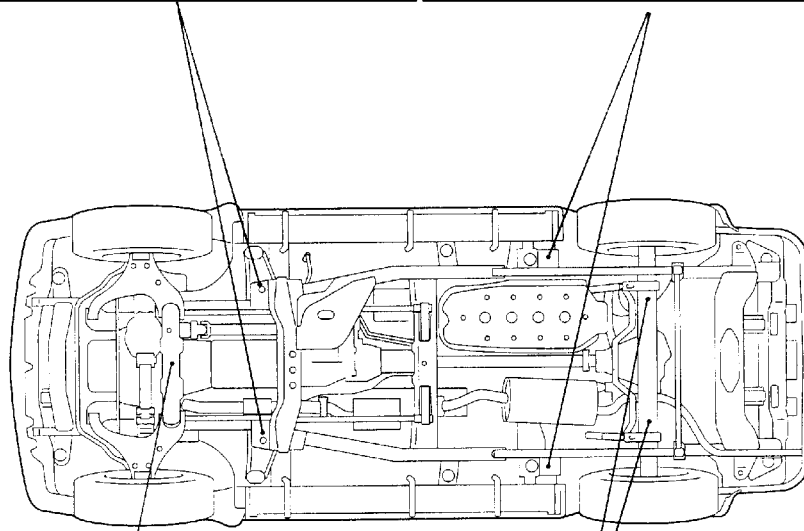

00V0075

H-BAR LIFT

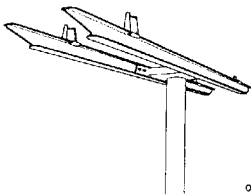

00E611

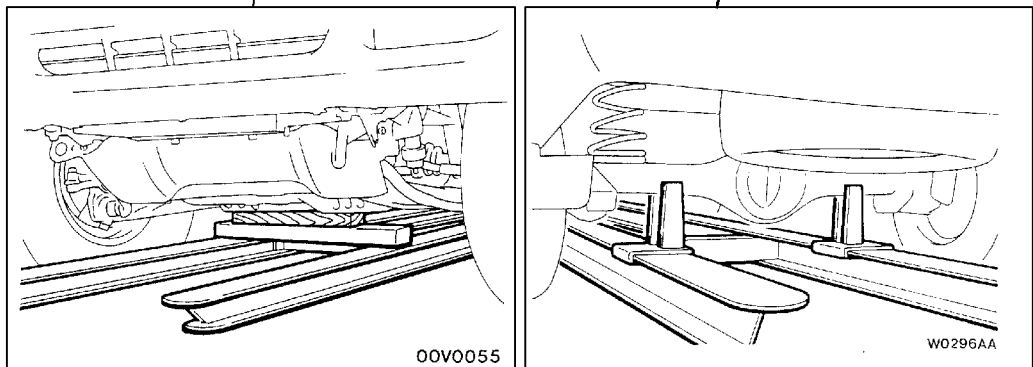

STANDARD PARTS-TIGHTENING-TORQUE TABLE

00100110033

Each torque value in the table is a standard value for tightening under the following conditions.

- (1) Bolts, nuts and washers are all made of steel and plated with zinc.
- (2) The threads and bearing surface of bolts and nuts are all in dry condition.

The values in the table are not applicable:

- (1) If toothed washers are inserted.
- (2) If plastic parts are fastened.
- (3) If bolts are tightened to plastic or die-cast inserted nuts.
- (4) If self-tapping screws or self-locking nuts are used.

Standard bolt and nut tightening torque

Thread size		Torque Nm		
Bolt nominal diameter (mm)	Pitch (mm)	Head mark "4"	Head mark "7"	Head mark "8"
M5	0.8	2.5	4.9	5.9
M6	1.0	4.9	8.8	9.8
M8	1.25	12	22	25
M10	1.25	24	44	52
M12	1.25	41	81	96
M14	1.5	72	137	157
M16	1.5	111	206	235
M18	1.5	167	304	343
M20	1.5	226	412	481
M22	1.5	304	559	647
M24	1.5	392	735	853

Flange bolt and nut tightening torque

Thread size		Torque Nm		
Bolt nominal diameter (mm)	Pitch (mm)	Head mark "4"	Head mark "7"	Head mark "8"
M6	1.0	4.9	9.8	12
M8	1.25	13	24	28
M10	1.25	26	49	57
M10	1.5	24	44	54
M12	1.25	46	93	103
M12	1.75	42	81	96

ENGINE

CONTENTS

11109000832

ENGINE <6G7>	11A
ENGINE <4D5>	11B



ENGINE <6G7>

CONTENTS

11109000849

GENERAL INFORMATION	3	CRANKSHAFT PULLEY	18
SERVICE SPECIFICATIONS	4	CAMSHAFT	19
SEALANT	5	CAMSHAFT OIL SEAL	21
SPECIAL TOOLS	6	OIL PAN AND OIL SCREEN	23
ON-VEHICLE SERVICE	8	CYLINDER HEAD GASKET	25
Drive Belt Tension Check and Adjustment	8	TIMING BELT	28
Ignition Timing Check	12	CRANKSHAFT FRONT OIL SEAL	34
Idle Speed Check	12	CRANKSHAFT REAR OIL SEAL	35
Idle Mixture Check	13	ENGINE ASSEMBLY	36
Compression Pressure Check	13		
Manifold Vacuum Check	14		
Lash Adjuster Check	15		

GENERAL INFORMATION

11100010612

Items		Specifications
Total displacement mL		2,972
Bore x Stroke mm		91.1 x 76.0
Compression ratio		9.0
Combustion chamber		Pentroof type
Camshaft arrangement		SOHC
Number of valve	Intake	12
	Exhaust	12
Valve timing	Intake	Opening BTDC 19°, Closing ABDC 45°
	Exhaust	Opening BBDC 49°, Closing ATDC 15°
Fuel system		Electronic control multipoint fuel injection
Rocker arm		Roller type
Auto-lash adjuster		Equipped

SERVICE SPECIFICATIONS

11100030687

Items			Standard value	Limit
Alternator drive belt tension	Vibration frequency Hz	When checked	At A: 197 – 241 At B: 133 – 164	–
		When a used belt is installed	At A: 209 – 231 At B: 142 – 157	–
		When a new belt is installed	At A: 279 – 311 At B: 189 – 211	–
	Tension N	When checked	At A: 392 – 588 At B: 392 – 588	–
		When a used belt is installed	At A: 441 – 539 At B: 441 – 539	–
		When a new belt is installed	At A: 784 – 980 At B: 784 – 980	–
	Deflection (Reference value) mm	When checked	At A: 6.5 – 9.0 At B: 9.0 – 12.5	–
		When a used belt is installed	At A: 7.0 – 8.5 At B: 10.0 – 12.0	–
		When a new belt is installed	At A: 4.0 – 5.5 At B: 6.0 – 7.5	–
Power steering oil pump drive belt tension	Vibration frequency Hz	When checked	90 – 117	–
		When a used belt is installed	98 – 111	–
		When a new belt is installed	117 – 138	–
	Tension N	When checked	294 – 490	–
		When a used belt is installed	343 – 441	–
		When a new belt is installed	490 – 686	–
	Deflection (Reference value) mm	When checked	13.0 – 17.0	–
		When a used belt is installed	14.0 – 16.0	–
		When a new belt is installed	11.0 – 13.0	–
A/C compressor drive belt tension	Vibration frequency Hz	When checked	207 – 232	–
		When a used belt is installed	207 – 232	–
		When a new belt is installed	243 – 264	–
	Tension N	When checked	392 – 490	–
		When a used belt is installed	392 – 490	–
		When a new belt is installed	539 – 637	–
	Deflection (Reference value) mm	When checked	5.6 – 6.4	–
		When a used belt is installed	5.6 – 6.4	–
		When a new belt is installed	4.3 – 5.1	–

Items	Standard value	Limit
Basic ignition timing mm	5° BTDC ± 3°	–
Ignition timing	Approx. 15° BTDC	–
Idle speed r/min	700 ± 100	–
CO contents %	0.5 or less	–
Compression pressure (at engine speed of 250 – 400 r/min) kPa	1,180	Min. 875
Compression pressure difference of all cylinder kPa	–	Max. 100
Intake manifold vacuum kPa	–	Min. 60
Auto tensioner rod depth (mm)	Within 1	–
Timing belt tension torque Nm	4.4	–
Auto tensioner rod protrusion amount mm	3.8 – 5.0	–

SEALANT



11100050447

Items	Specified sealant	Remarks
Oil pan	MITSUBISHI GENUINE PART MD970389 or equivalent	Semi-drying sealant

SPECIAL TOOLS

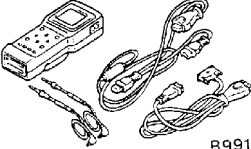
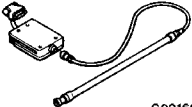
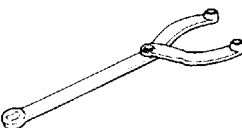
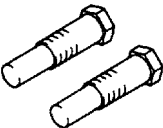
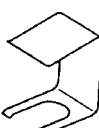
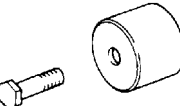
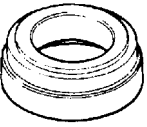
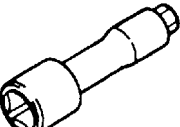
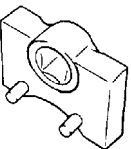
11100060662

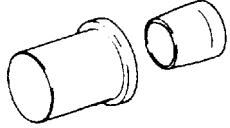
Tool	Number	Name	Use
 <p>B991502</p>	MB991502	MUT-II sub assembly	<ul style="list-style-type: none"> ● Measuring drive belt tension ● Checking the ignition timing ● Checking the idle speed
 <p>C991668</p>	MB991668	Belt tension meter set	Measuring drive belt tension (used together with MUT-II)
	MB990767	End yoke holder	<ul style="list-style-type: none"> ● Supporting of crankshaft pulley ● Supporting of camshaft sprocket
	MD998715	Crankshaft pulley holder pin	
	MD998443	Auto-lash adjuster holder	Supporting of auto-lash adjuster
	MD998713	Camshaft oil seal installer	Press-in of the camshaft oil seal
	MB991559	Camshaft oil seal adapter	Press-fitting the camshaft oil seal (left bank side)
	MD998051	Cylinder head bolt wrench	Removal and installation of the cylinder head bolt
	MD998767	Tension pulley socket wrench	Timing belt tension adjustment

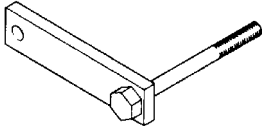
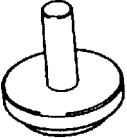
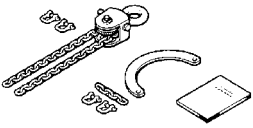
Tool	Number	Name	Use
	MD998717	Crankshaft front oil seal installer	Press-in of the crankshaft front oil seal
	MD998769	Crankshaft pulley spacer	Operating the crankshaft when installing the timing belt
	MD998781	Flywheel stopper	Securing the flywheel
	MD998718	Crankshaft rear oil seal installer	Press-fitting the crankshaft rear oil seal
 <p data-bbox="347 1125 412 1142">B991683</p>	MB991683	Sling chain set	Removal and installation of engine assembly

ON-VEHICLE SERVICE

11100090623

DRIVE BELT TENSION CHECK AND ADJUSTMENT

ALTERNATOR DRIVE BELT TENSION CHECK

Inspect the drive belt following the instructions below.

Standard value:

Vibration frequency Hz	At A	197 – 241
	At B	133 – 164
Tension N	At A	392 – 588
	At B	392 – 588
Deflection (Reference value) mm	At A	6.5 – 9.0
	At B	9.0 – 12.5

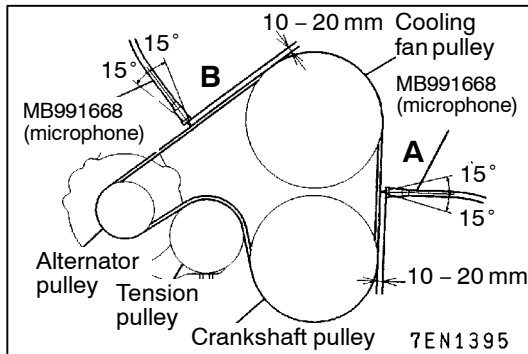

<When using MUT-II>

1. Connect the special tool (belt tension meter set) to the MUT-II.
2. Connect the MUT-II to the diagnosis connector.
3. Turn on the ignition switch and select "Belttension measurement" from the MUT-II menu screen.
4. As shown in the illustration, keep the microphone (MB991668) 10 to 20mm away from the back side of the belt perpendicularly (within an inclination of ± 15 degrees).
5. With your finger tip lightly tap the centre of the belt between the pulleys in the location shown by the arrow in the illustration to check whether the belt frequency is within the standard.

Caution

1. Measure when the belt surface temperature is close to room temperature.
2. Make sure that water or oil, etc., does not get on the microphone.
3. If a strong wind blows or noise is made close to the microphone during measure, the meter will show a value that differs from the actual value.
4. If the measurement is taken with the microphone touching the belt, the meter will show a value that differs from the actual value.
5. Do not measure while the engine is running.

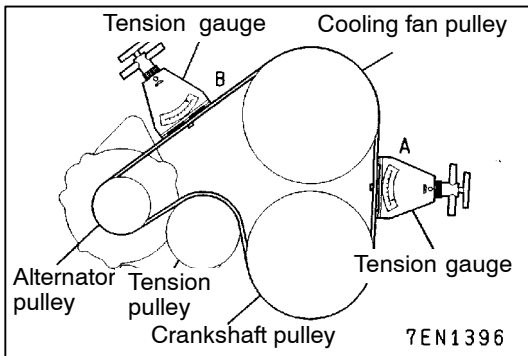

<When using a tension meter>

Use a belt tension gauge to check if the belt tension is within the standard value.

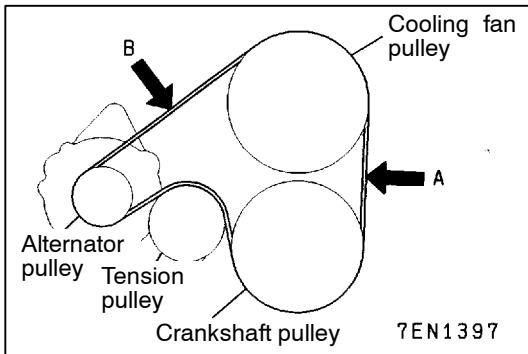

<When checking the deflection>

Apply 98N of pressure against the location between the pulleys shown by the arrow in the illustration to check if the deflection is within the standard value.

ALTERNATOR DRIVE BELT TENSION ADJUSTMENT

1. Loosen the nut of the alternator pivot bolt.
2. Loosen the lock bolt.
3. Turn the adjusting bolt to adjust the belt tension frequency, to put the belt tension or deflection within the standard value.

Standard value:

Items		When a used belt is installed	When a new belt is installed
Vibration frequency	At A	209 – 231	279 – 311
	At B	142 – 157	189 – 211
Tension N	At A	441 – 539	784 – 980
	At B	441 – 539	784 – 980
Deflection mm (reference value)	At A	7.0 – 8.5	4.0 – 5.5
	At B	10.0 – 12.0	6.0 – 7.5

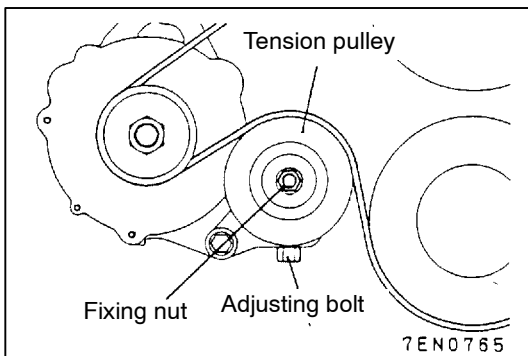

4. Tighten the fixing nut.

Tightening torque: 49 Nm

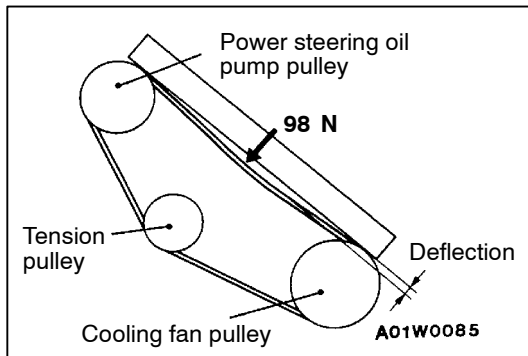

POWER STEERING OIL PUMP DRIVE BELT TENSION CHECK AND ADJUSTMENT

11100110237

1. Check if the belt tension is within the standard value using one of the methods below.

Standard value:

Items	When checked	When a new belt is installed	When a used belt is installed
Vibration frequency Hz	90 – 117	117 – 138	98 – 111
Tension N	294 – 490	490 – 686	343 – 441
Deflection (reference value) mm	13.0 – 17.0	11.0 – 13.0	14.0 – 16.0

<When measuring the vibration frequency>

With your finger tip lightly tap the centre of the belt between the pulleys in the location shown by the arrow in the illustration and then measure the belt vibration frequency.

NOTE

Refer to P.11A-8 for information regarding the vibration frequency measurement method using the MUT-II.

<When measuring the tension>

Use a belt tension gauge to measure the belt tension.

<When measuring the deflection>

Apply 98N of pressure against the location between the pulleys shown by the arrow in the illustration and then measure the deflection.

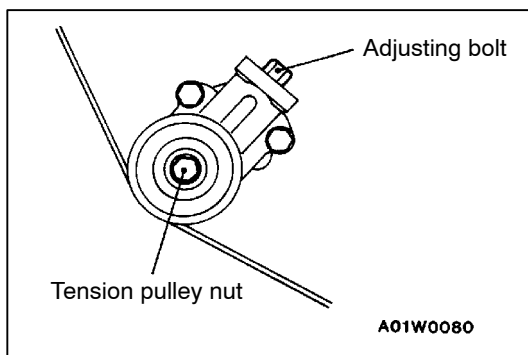

2. If the tension or deflection is outside the standard value, adjust by the following procedure.

- (1) Loosen the tension pulley nut.
- (2) Adjust the amount of belt deflection using adjusting bolt.
- (3) Tighten the tension pulley nut.

Tightening torque: 48 Nm

- (4) Check the belt deflection amount and tension, and readjust if necessary.

Caution

Check after turning the crankshaft once or more clockwise (right turn).

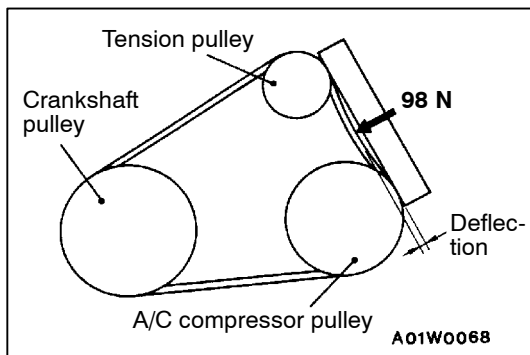

AIR CONDITIONER COMPRESSOR DRIVE BELT TENSION CHECK AND ADJUSTMENT

11100100265

1. Check if the belt tension is within the standard value using one of the methods below.

Standard value:

Items	When checked	When a new belt is installed	When a used belt is installed
Vibration frequency Hz	207 – 232	243 – 264	207 – 232
Tension N	392 – 490	539 – 637	392 – 490
Deflection (reference value) mm	5.6 – 6.4	4.3 – 5.1	5.6 – 6.4

<When measuring the vibration frequency>

With your finger tip lightly tap the centre of the belt between the pulleys in the location shown by the arrow in the illustration and then measure the belt vibration frequency.

NOTE

Refer to P.11A-8 for information regarding the vibration frequency measurement method using the MUT-II.

<When measuring the tension>

Use a belt tension gauge to measure the belt tension.

<When measuring the deflection>

Apply 98N of pressure against the location between the pulleys shown by the arrow in the illustration and then measure the deflection.

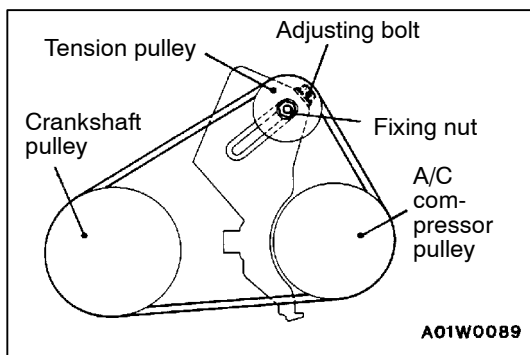

2. If the tension or deflection is outside the standard value, adjust by the following procedure.
 - (1) Loosen tension pulley fixing nut.
 - (2) Adjust belt tension with adjusting bolt.
 - (3) Tighten fixing nut.
 - (4) Check the belt deflection amount and tension, and readjust if necessary.

Caution

Check after turning the crankshaft once or more clockwise (right turn).

IGNITION TIMING CHECK

11100170488

1. Before inspection, set the vehicle to the pre-inspection condition.
2. Connect the MUT-II to the diagnosis connector.
3. Set up a timing light.
4. Start the engine and run at idle.
5. Check that engine idle speed is within the standard value.

Standard value: 700 ± 100 r/min

6. Select No. 17 of the MUT-II Actuator test.
7. Check that basic ignition timing is within the standard value.

Standard value: 5° BTDC ± 3°

8. If the basic ignition timing is outside the standard value, inspect the MPI system while referring to GROUP 13A – Troubleshooting.
9. Press the MUT-II clear key (Select a forced driving cancel mode) to release the Actuator test.

Caution

If the test is not cancelled, a forced driving will continue for 27 minutes. Driving under this condition may damage the engine.

10. Check that ignition timing is at the standard value.

Standard value: approx. 15° BTDC**NOTE**

- (1) Ignition timing is variable within about ± 7°, even under normal operating.
- (2) And it is automatically further advanced by about 5° from standard value at higher altitudes.

IDLE SPEED CHECK

11100190590

1. Before inspection, set the vehicle to the pre-inspection condition.
2. Turn the ignition switch to OFF and connect the MUT-II to the diagnosis connector.
3. Check the basic ignition timing. Adjust if necessary.

Standard value: 5° BTDC ± 3°

4. Run the engine at idle for 2 minutes.
5. Check the idle speed. Select item No. 22 and take a reading of the idle speed.

Curb idle speed: 700 ± 100 r/min**NOTE**

The idle speed is controlled automatically by the idle speed control (ISC) system.

6. If the idle speed is outside the standard value, inspect the MPI components by referring to GROUP 13A – Troubleshooting.

IDLE MIXTURE CHECK

11100210548

1. Before inspection, set the vehicle to the pre-inspection condition.
2. Turn the ignition switch to OFF and connect the MUT-II to the diagnosis connector.
3. Check that the basic ignition timing is within the standard value.

Standard value: 5° BTDC ± 3°

4. Run the engine at 2500 r/min for 2 minutes.
5. Set the CO, HC tester.
6. Check the CO contents and the HC contents at idle.

CO contents: 0.5% or less

HC contents: 100 ppm or less

7. If there is a deviation from the standard value, check the following items:
 - Diagnosis output
 - Closed-loop control (When the closed-loop control is normal, the output signal of the oxygen sensor changes between 0 – 400 mV and 600 – 1,000 mV at idle.)
 - Fuel pressure
 - Injector
 - Ignition coil, spark plug cable, spark plug
 - Evaporative emission control system
 - Compression pressure

NOTE

Replace the three way catalyst when the CO contents are not within the standard value, even though the result of the inspection is normal on all items.

COMPRESSION PRESSURE CHECK

11100260703

1. Before inspection, check engine oil, the starter and battery are normal. Also, set the vehicle to the pre-inspection condition.
2. Remove all the spark plugs.
3. Disconnect the crankshaft angle sensor connector.

NOTE

Doing this will prevent the engine control unit from carrying out ignition and fuel injection.

4. Cover the spark plug hole with a shop towel etc. and crank the engine. Then check that no foreign material is adhering to the shop towel.

Caution

- (1) **Keep away from the spark plug hole when cranking.**
- (2) **If compression is measured with water, oil, fuel, etc., that has come from cracks inside the cylinder, these materials will become heated and will gush out from the spark plug hole, which is dangerous.**

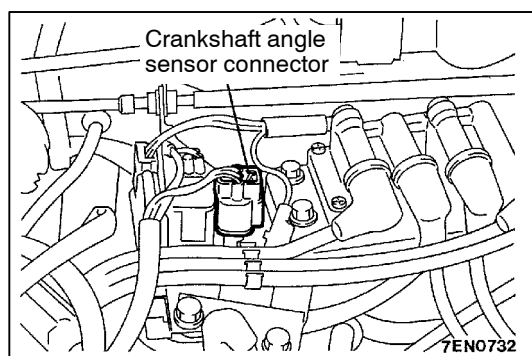

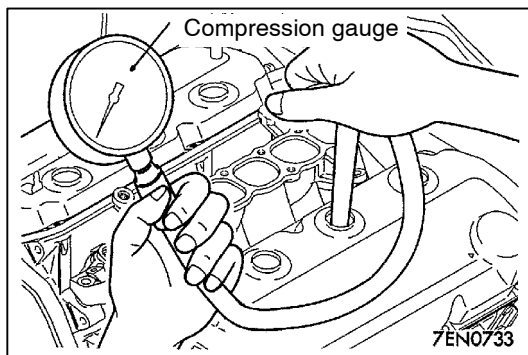

5. Set compression gauge to one of the spark plug hole.
6. Turn over the engine and measure the compression pressure.

Standard value (at engine speed of 250 – 400 r/min):
1,180 kPa

Limit (at engine speed of 250 – 400 r/min):
Min. 875 kPa

7. Measure the compression pressure for all the cylinders and check that the pressure differences of the cylinders are below the limit.

Limit: Max. 100 kPa

8. If there is a cylinder with compression or a compression difference that is outside the limit, pour a small amount of engine oil through the spark plug hole, and repeat the operations in step 6 and 7.
 - (1) If the compression increases after oil is added, the cause of the malfunction is a worn or damaged piston ring and/or cylinder inner surface.
 - (2) If the compression does not rise after oil is added the cause is a burnt or defective valve seat, or pressure is leaking from the gasket.
9. Connect the crank angle sensor connector.
10. Install the spark plugs.
 Use the MUT-II to erase the self-diagnosis codes or disconnect the battery cable from the battery (-) terminal for 10 seconds or more and then reconnect the cable.

NOTE

This will erase the diagnosis code resulting from the crankshaft angle sensor connector being disconnected.

MANIFOLD VACUUM CHECK

11100270577

1. Start the engine and allow it to warm up until the temperature of the engine coolant reaches 85 to 95°C.
2. Connect the MUT-II to the diagnosis connector.

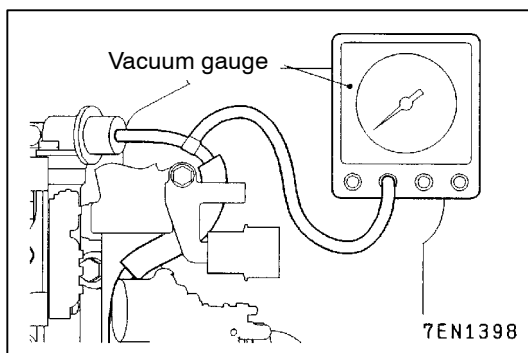

3. Attach a three-way union to the vacuum hose between the fuel pressure regulator and the air intake plenum, and connect a vacuum gauge.
4. Start the engine and check that idle speed is within the standard value.

Standard value: 700 ± 100 r/min

5. Check the intake manifold vacuum.

Limit: Min. 60 kPa

LASH ADJUSTER CHECK

11100290672

If an abnormal noise (knocking) that seems to be coming from the lash adjuster is heard after starting the engine and does not stop, carry out the following check.

NOTE

- (1) The abnormal noise which is caused by a problem with the lash adjusters is generated after the engine is started, and will vary according to the engine speed. However, this noise is not related to the actual engine load.

Because of this, if the noise does not occur immediately after the engine is started, if it does not change in accordance with the engine speed, or if it changes in accordance with the engine load, the source of the noise is not the lash adjusters.

- (2) If there is a problem with the lash adjusters, the noise will almost never disappear, even if the engine has been run at idle to let it warm up.

The only case where the noise might disappear is if the oil in the engine has not been looked after properly and oil sludge has caused the lash adjusters to stick.

1. Start the engine.
2. Check that the noise occurs immediately after the engine is started, and that the noise changes in accordance with changes in the engine speed.

If the noise does not occur immediately after the engine is started, or if it does not change in accordance with the engine speed, the problem is not being caused by the lash adjusters, so check for some other cause of the problem. Moreover, if the noise does not change in accordance with the engine speed, the cause of the problem is probably not with the engine. (In these cases, the lash adjusters are normal.)

3. While the engine is idling, check that the noise level does not change when the engine load is varied (for example, by shifting from N → D).

If the noise level changes, the cause of the noise is probably parts striking because of worn crankshaft bearings or connecting rod bearings. (In such cases, the lash adjusters are normal.)

4. After the engine has warmed up, run it at idle and check if any noise can be heard.

If the noise has become smaller or has disappeared, the cause of the noise was probably that oil sludge had caused the lash adjusters to become stuck. If this happens, clean the lash adjusters (Refer to Engine Workshop Manual). If the noise level does not change, go to step 5.

5. Bleed the air from the lash adjusters. (Refer to P.11A-16.)
6. If the noise does not disappear even after the air has been bled from the lash adjusters, clean the lash adjusters (Refer to Engine Workshop Manual).

<LASH ADJUSTER AIR BLEEDING>

NOTE

- (1) If the vehicle is parked on a slope for a long period of time, the amount of oil inside the lash adjuster will decrease, and air may get into the high pressure chamber when starting the engine.
- (2) After parking the vehicle for long periods, the oil drains out of the oil passage, and it takes time for the oil to be supplied to the lash adjuster, so air can get into the high pressure chamber.
- (3) If either of the above situations occur, the abnormal noise can be eliminated by bleeding the air from inside the lash adjusters.

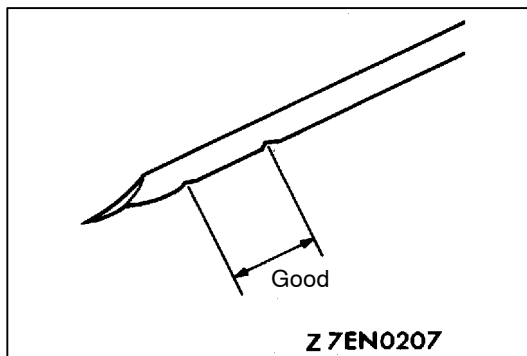

1. Check the engine oil and replenish or replace the oil if necessary.

NOTE

- (1) If there is a only small amount of oil, air will be drawn in through the oil screen and will get into the oil passage.
- (2) If the amount of oil is greater than normal, then the oil will being mixed by the crankshaft and a large amount of air may get mixed into the oil.
- (3) If the oil is degenerated, air and oil will not separate easily in oil, and the amount of air mixed into the oil will increase.

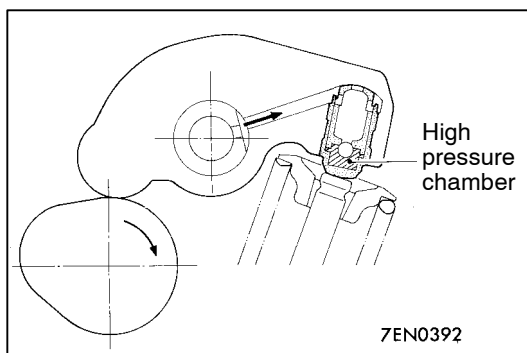

- (4) If the air which has been mixed in with the oil due to any of the above reasons gets into the high pressure chamber of the lash adjuster, the air inside the high pressure chamber will be compressed when the valve is open and the lash adjuster will over-compress, resulting in abnormal noise when the valve closes. This is the same effect as if the valve clearance is adjusted to be too large by mistake. If the air inside the lash adjusters is then released, the operation of the lash adjusters will return to normal.

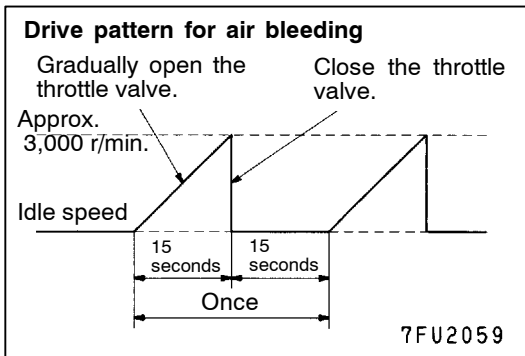

2. Run the engine at idle for 1 – 3 minutes to let it warm up.
3. With no load on the engine, repeat the drive pattern shown in the illustration at left and check if the abnormal noise disappears. (The noise should normally disappear after 10 – 30 repetitions, but if there is no change in the noise level after 30 repetitions or more, the problem is probably not due to air inside the lash adjusters.)
4. After the noise has disappeared, repeat the drive pattern shown in the illustration at left a further 5 times.
5. Run the engine at idle for 1 – 3 minutes and check that the noise has disappeared.

CRANKSHAFT PULLEY

REMOVAL AND INSTALLATION

Pre-removal Operation

- Skid Plate and Under Cover Removal

Post-installation Operation

- Drive Belt Tension Adjustment (Refer to P.11A-8.)
- Skid Plate and Under Cover Installation

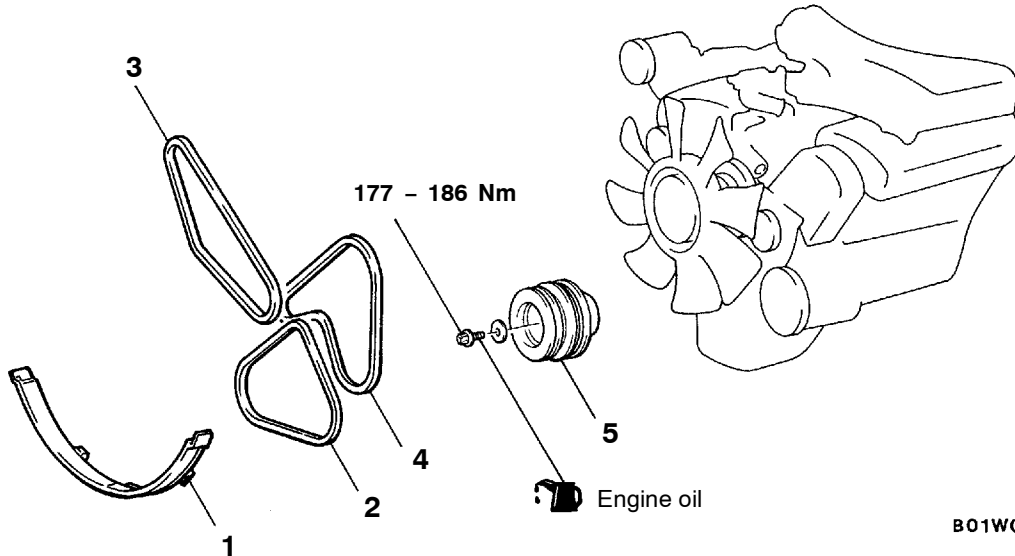

B01W0059

Removal steps

1. Radiator shroud cover
2. Drive belt (for A/C)
3. Drive belt (for power steering oil pump)
4. Drive belt (for alternator)
5. Crankshaft pulley

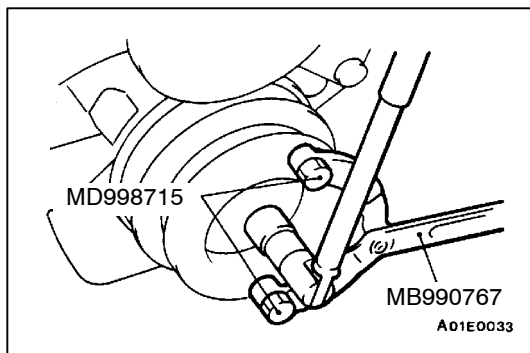

REMOVAL SERVICE POINT

◀▶ CRANKSHAFT PULLEY REMOVAL

Use special tools to remove the crankshaft pulley from the crankshaft.

INSTALLATION SERVICE POINT

▶A◀ CRANKSHAFT PULLEY INSTALLATION

Use special tools in the same way as during removal to install the crankshaft pulley.

CAMSHAFT

11200190661

REMOVAL AND INSTALLATION

Pre-removal and Post-installation Operation

- Cylinder Head Assembly Removal and Installation (Refer to P.11A-25.)

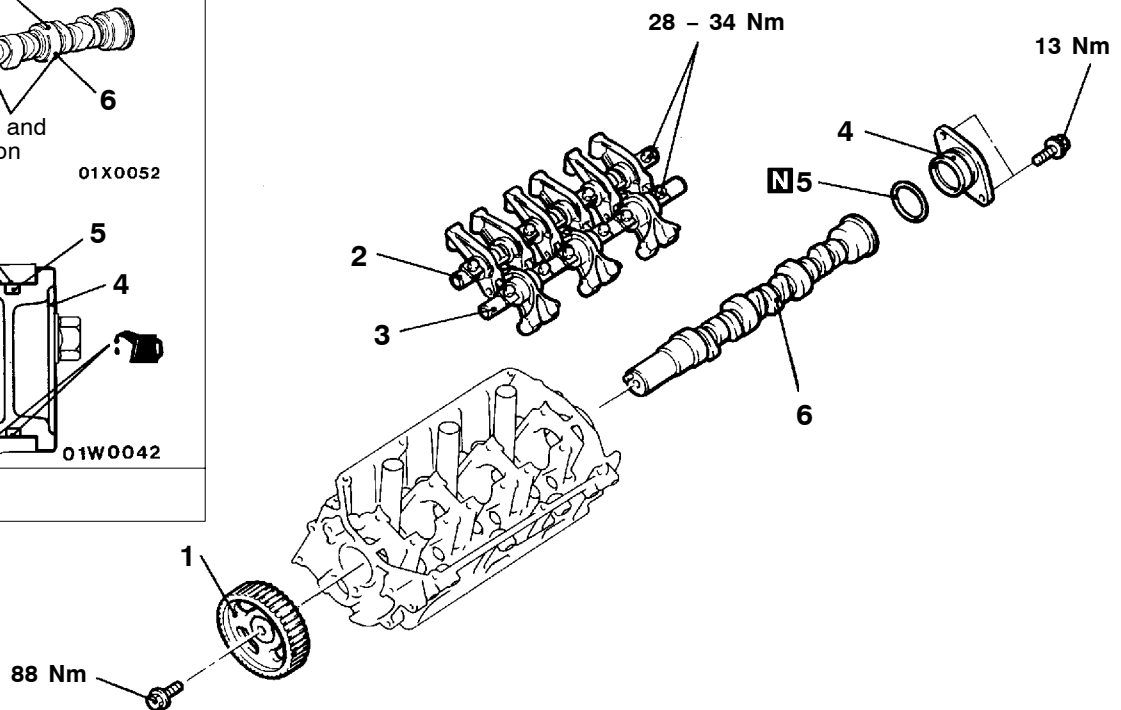
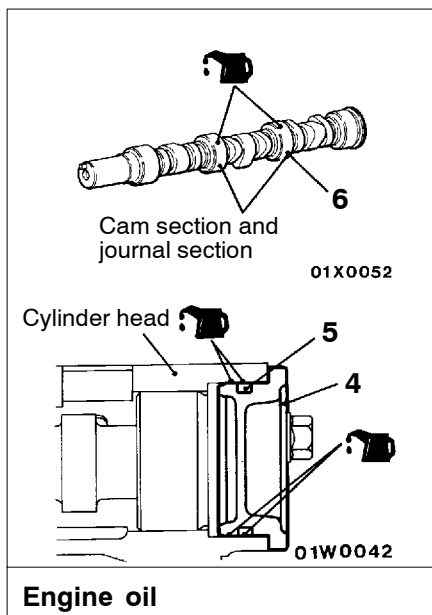

01W0055
00000859

Removal steps

- | | | |
|-----|-----|---|
| ◀A▶ | ▶B◀ | 1. Camshaft sprocket |
| ◀B▶ | ▶A◀ | 2. Rocker arm and shaft assembly (intake side) |
| ◀B▶ | ▶A◀ | 3. Rocker arm and shaft assembly (exhaust side) |
| | | 4. Thrust case |
| | | 5. O-ring |
| | | 6. Camshaft |

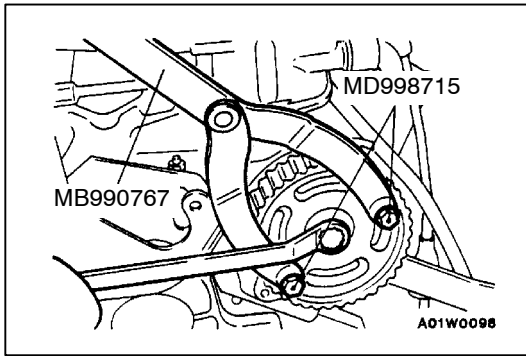

REMOVAL SERVICE POINTS

◀A▶ CAMSHAFT SPROCKET REMOVAL

Use special tools to remove the camshaft sprocket.

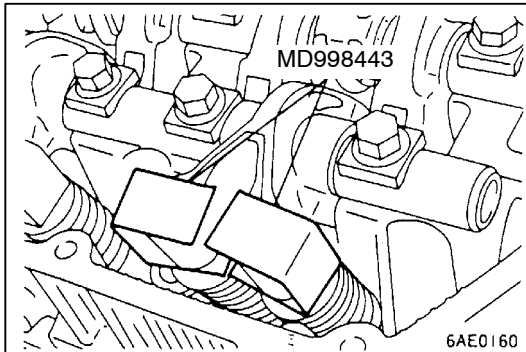

◀B▶ ROCKER ARM AND SHAFT ASSEMBLY REMOVAL

1. Install special tool as shown in the illustration so that the lash adjusters will not fall out.
2. Loosen the rocker arm and shaft assembly mounting bolt, and then remove the rocker arm and shaft assembly with the bolt still attached.

Caution

Never disassemble the rocker arm and shaft assembly.

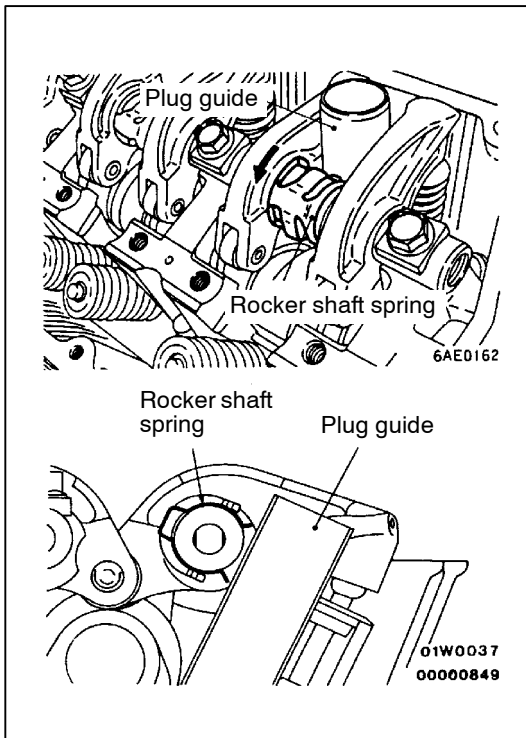

INSTALLATION SERVICE POINTS

▶A▶ ROCKER ARM AND SHAFT ASSEMBLY INSTALLATION

1. Temporarily tighten the rocker shaft with the bolt so that all rocker arms on the inlet valve side do not push the valves.
2. Fit the rocker shaft spring from the above and position it so that it is right angles to the plug guide.

NOTE

Install the rocker shaft spring before installing the rocker arm and rocker arm shaft on the exhaust side.

3. Tighten the rocker arm and shaft assembly mounting bolt to the specified torque.

Tightening torque: 28 – 34 Nm

4. Remove the special tool for fixing the lash adjuster.

▶B◀ CAMSHAFT SPROCKET INSTALLATION

Use special tools in the same way as during removal to install the camshaft sprocket.

**CAMSHAFT OIL SEAL
REMOVAL AND INSTALLATION**

11200200012

Pre-removal and Post-installation Operation

- Timing Belt Removal and Installation
(Refer to P.11A-28.)

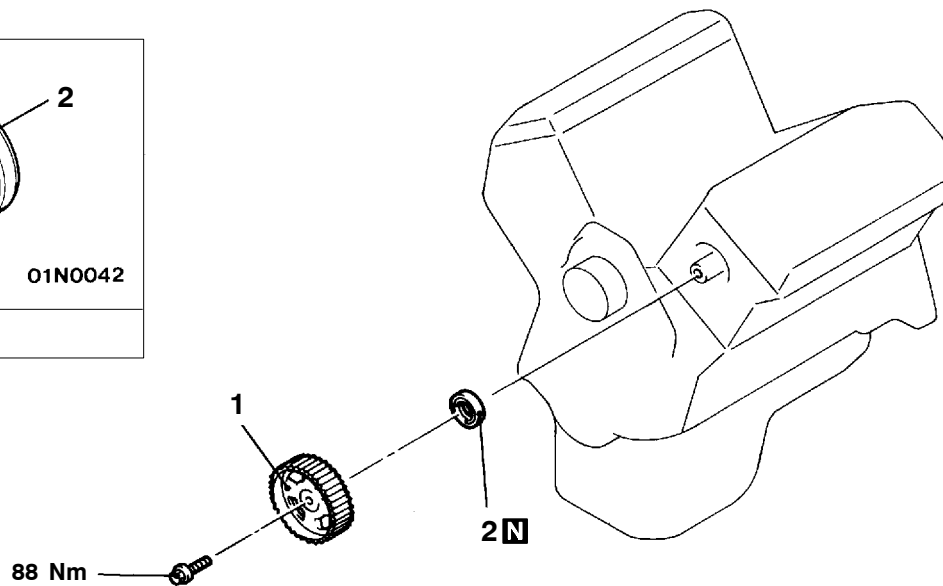
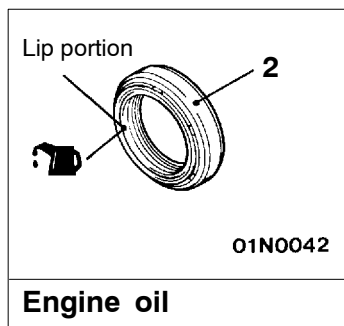

01W0056
00000863

Removal steps

- ◀A▶ ▶B◀ 1. Camshaft sprocket
◀B▶ ▶A◀ 2. Camshaft oil seal

REMOVAL SERVICE POINTS

◀A▶ CAMSHAFT SPROCKET REMOVAL

Use special tools to remove the camshaft sprocket.

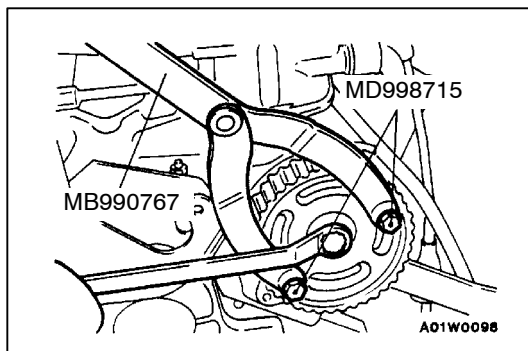

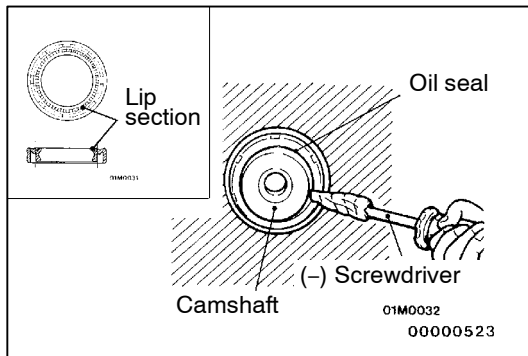

◀B▶ CAMSHAFT OIL SEAL REMOVAL

1. Make a notch in the oil seal lip section with a knife, etc.
2. Cover the end of a flat-tipped screwdriver with a shop towel and insert into the notched section of the oil seal, and pry out the oil seal to remove it.

Caution

Be careful not to damage the camshaft and the cylinder head.

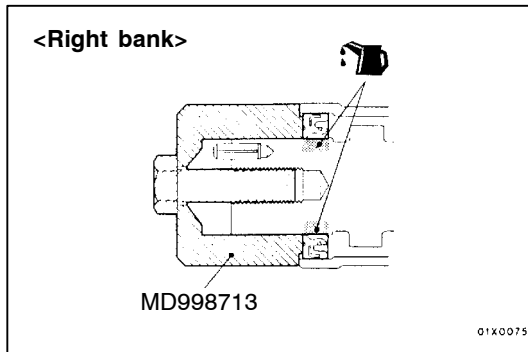

INSTALLATION SERVICE POINTS

▶A▶ CAMSHAFT OIL SEAL INSTALLATION

1. Apply engine oil to the camshaft oil seal lip.
2. Use special tools to press-fit the camshaft oil seal.

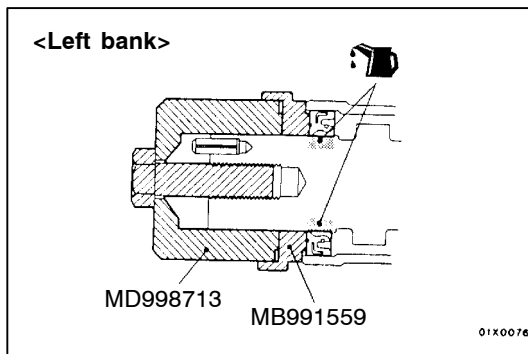

▶B▶ CAMSHAFT SPROCKET INSTALLATION

Use special tools in the same way as during removal to install the camshaft sprocket.

OIL PAN AND OIL SCREEN

REMOVAL AND INSTALLATION

Pre-removal and Post-installation Operation

- Skid Plate and Under Cover Removal and Installation
- Engine Oil Draining and Refilling (Refer to GROUP 12 – On-vehicle Service.)
- Alternator Removal and Installation (Refer to GROUP 16 – Alternator.)
- Stabilizer Bar Removal and Installation (Refer to GROUP 33A – Stabilizer Bar.)
- Front Exhaust Pipe Removal and Installation (Refer to GROUP 15 – Exhaust Pipe and Main Muffler.)
- Actuator Assembly and Heat Protector Removal and Installation (Refer to GROUP 26 – Inner Shaft.)

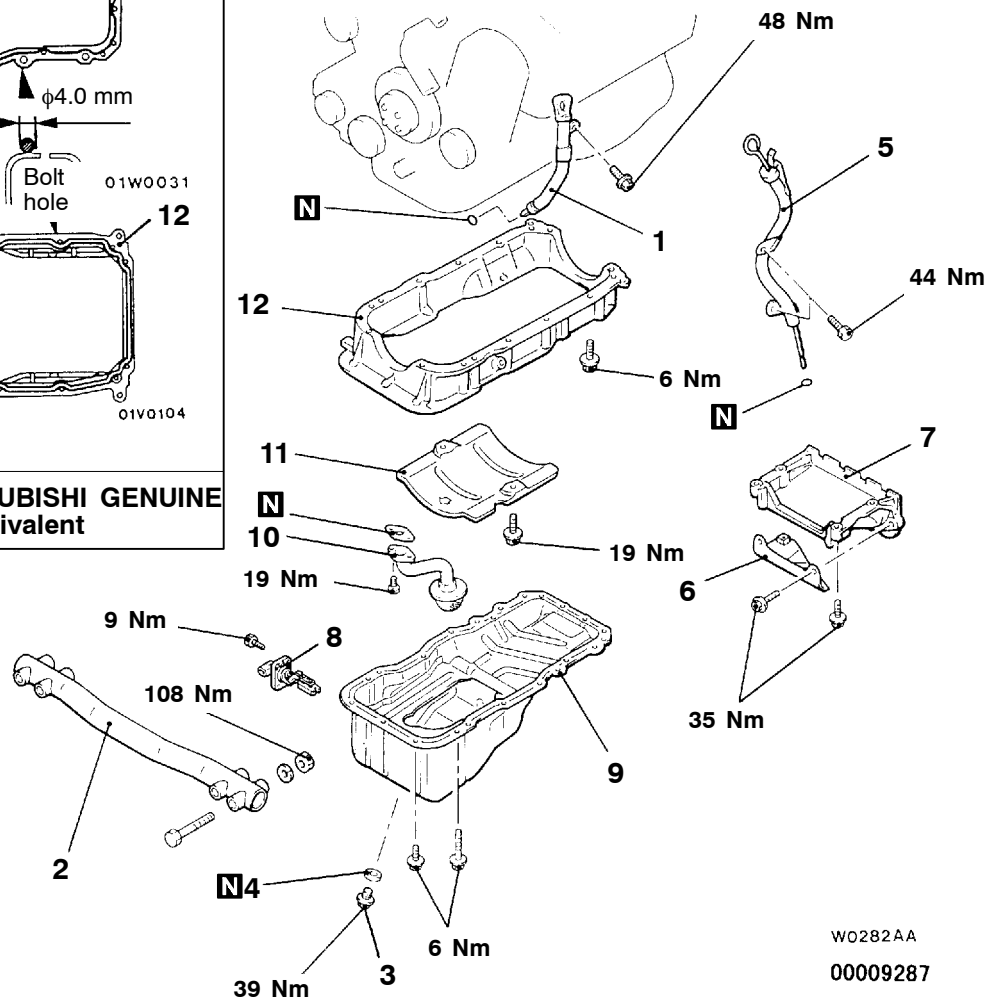
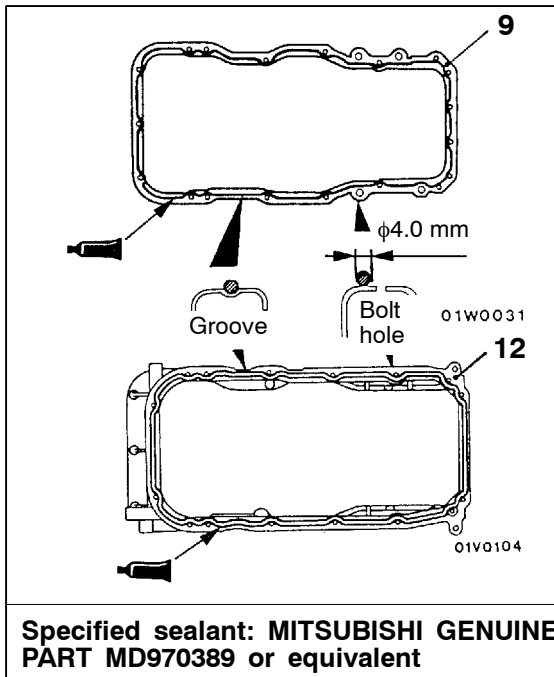

W0282AA
00009287

Removal steps

- | | | | |
|-----|---------------------------------|-----|----------------------|
| ▶C◀ | 1. Oil dipstick assembly | ▶B◀ | 7. Transmission stay |
| | 2. Crossmember assembly | ▶A◀ | 8. Oil level sensor |
| | 3. Drain plug | ▶A◀ | 9. Oil pan lower |
| | 4. Drain plug gasket | ▶A◀ | 10. Oil screen |
| | 5. A/T oil dipstick assembly | | 11. Baffle plate |
| | 6. Exhaust pipe support bracket | | 12. Oil pan upper |

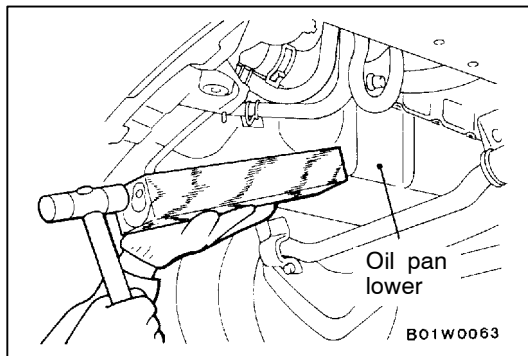

REMOVAL SERVICE POINT

◀A▶ OIL PAN LOWER REMOVAL

1. Remove the oil pan, lower installation bolt.
2. Place a wooden block to the oil pan, lower as shown in the figure and remove by tapping with a hammer.

Caution

The use of an oil pan remover (MD998727) can damage the oil pan, upper (aluminum made).

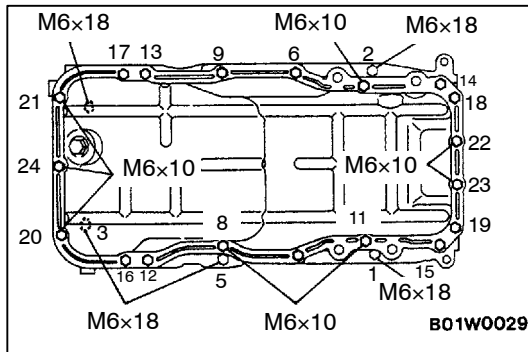

INSTALLATION SERVICE POINTS

▶A▶ OIL PAN LOWER INSTALLATION

1. Tighten the bolts in order of the numbers shown in the illustration.
2. Be careful when installing, as there are two different lengths of bolt.

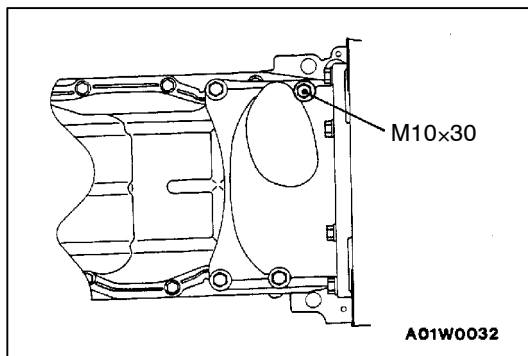

▶B▶ TRANSMISSION STAY INSTALLATION

Be careful when installing, as the bolts indicated in the illustration have different lengths from the other bolts.

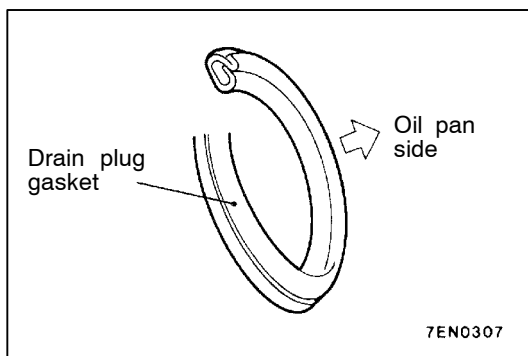

▶C▶ DRAIN PLUG GASKET INSTALLATION

Replace the gasket with a new gasket. Install the new gasket in the direction shown in the illustration.

INSPECTION

11200260089

- Check the oil pan for cracks.
- Check the oil pan sealant-coated surface for damage and deformation.
- Check the oil screen for cracked, clogged or damaged wire net and pipe.

CYLINDER HEAD GASKET

REMOVAL AND INSTALLATION

Pre-removal and Post-installation Operation

- Intake Manifold Removal and installation (Refer to GROUP 15 – Intake Manifold.)
- Timing Belt Removal and installation (Refer to P.11A-28.)
- Front Exhaust Pipe Removal and Installation (Refer to GROUP 15 – Exhaust Pipe and Main Muffler.)

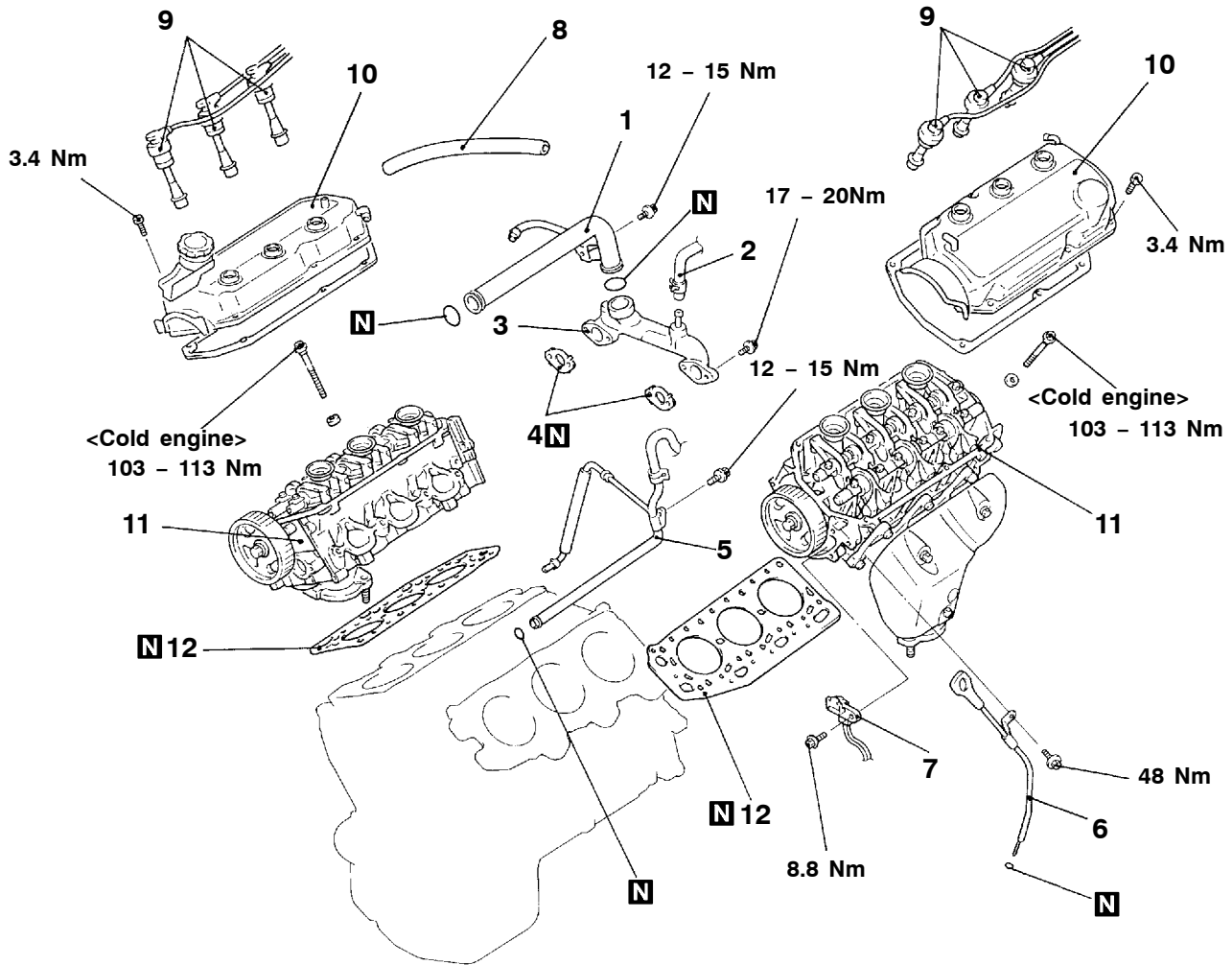

A01V0097

Removal steps

- | | |
|---|--|
| <p>1. Water outlet pipe assembly</p> <p>2. Heater hose connection</p> <p>3. Water passage assembly</p> <p>4. Gasket</p> <p>5. Water pipe and hose assembly</p> <p>6. Oil dipstick assembly <when removing left bank only></p> | <p>7. Camshaft position sensor <when removing left bank only></p> <p>8. Breather hose</p> <p>9. Spark plug cable</p> <p>10. Rocker cover</p> <p>11. Cylinder head assembly</p> <p>12. Cylinder head gasket</p> |
|---|--|

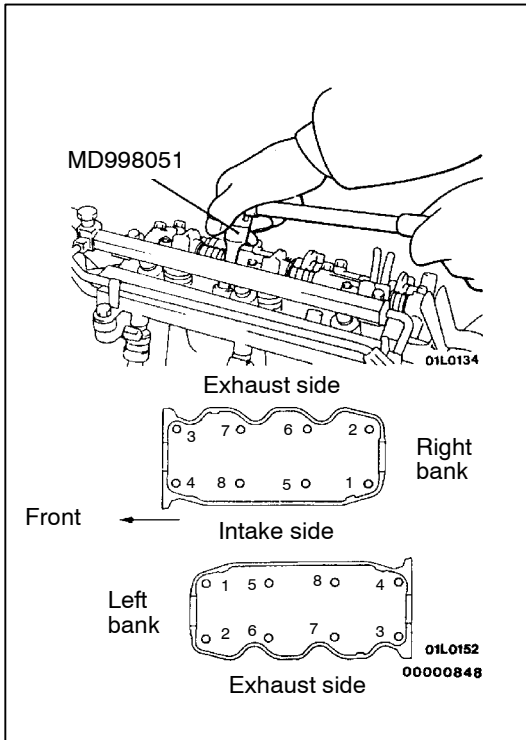

REMOVAL SERVICE POINTS

◀A▶ CYLINDER HEAD ASSEMBLY REMOVAL

Use special tool to tighten each bolt two or three steps in the order shown in the illustration.

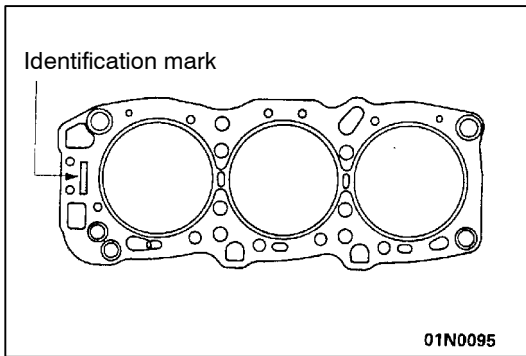

II INSTALLATION SERVICE POINTS

▶A◀ CYLINDER HEAD GASKET INSTALLATION

1. Degrease the cylinder head and cylinder block gasket mounting surfaces.
2. Make sure that the gasket has the proper identification mark for the engine.
3. Lay the cylinder head gasket on the cylinder block with the identification mark at the front top.

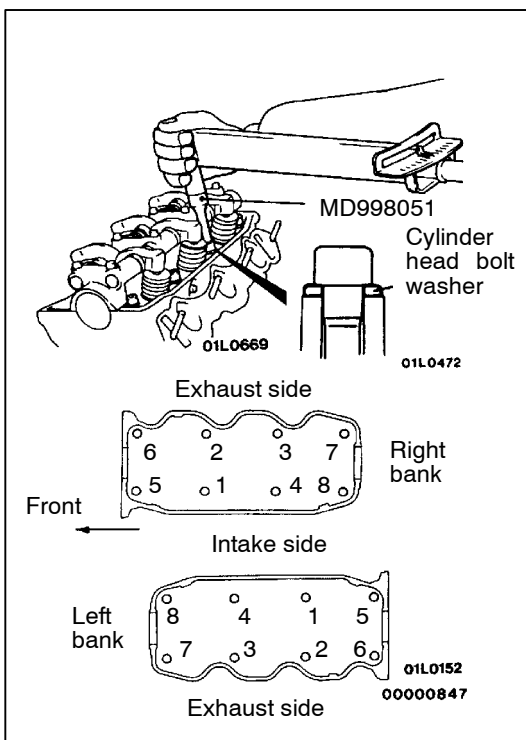

▶B◀ CYLINDER HEAD ASSEMBLY INSTALLATION

1. Use a scraper to clean the gasket surface of the cylinder head assembly.

Caution

Be careful that no foreign material gets into the cylinder, coolant passages or oil passages. Engine damage may result.

2. Using special tool and a torque wrench, tighten the bolts to the specified torque in the order shown in the illustration. (in two or three cycles)

Tightening torque: 103 – 113 Nm

Caution

Install the head bolt washers with the beveled side facing upwards as shown in the illustration.

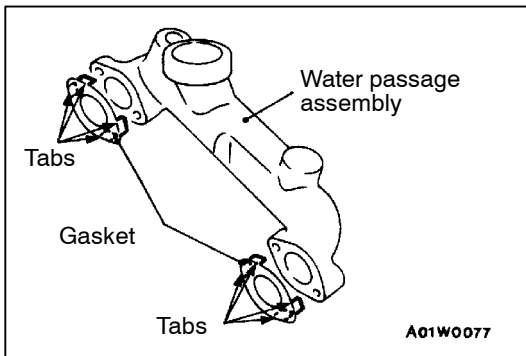

►◀ GASKET/WATER PASSAGE ASSEMBLY INSTALLATION

Bend the tabs onto the water passage assembly. Then install the water passage assembly to the cylinder head so that the gasket doesn't slip.

TIMING BELT

REMOVAL AND INSTALLATION

Pre-removal Operation

- Engine Coolant Draining and Refilling (Refer to GROUP 14 – On-vehicle Service.)
- Cooling Fan Removal (Refer to GROUP 14 – Cooling Fan.)
- Alternator Removal and Installation (Refer to GROUP 16 – Alternator.)

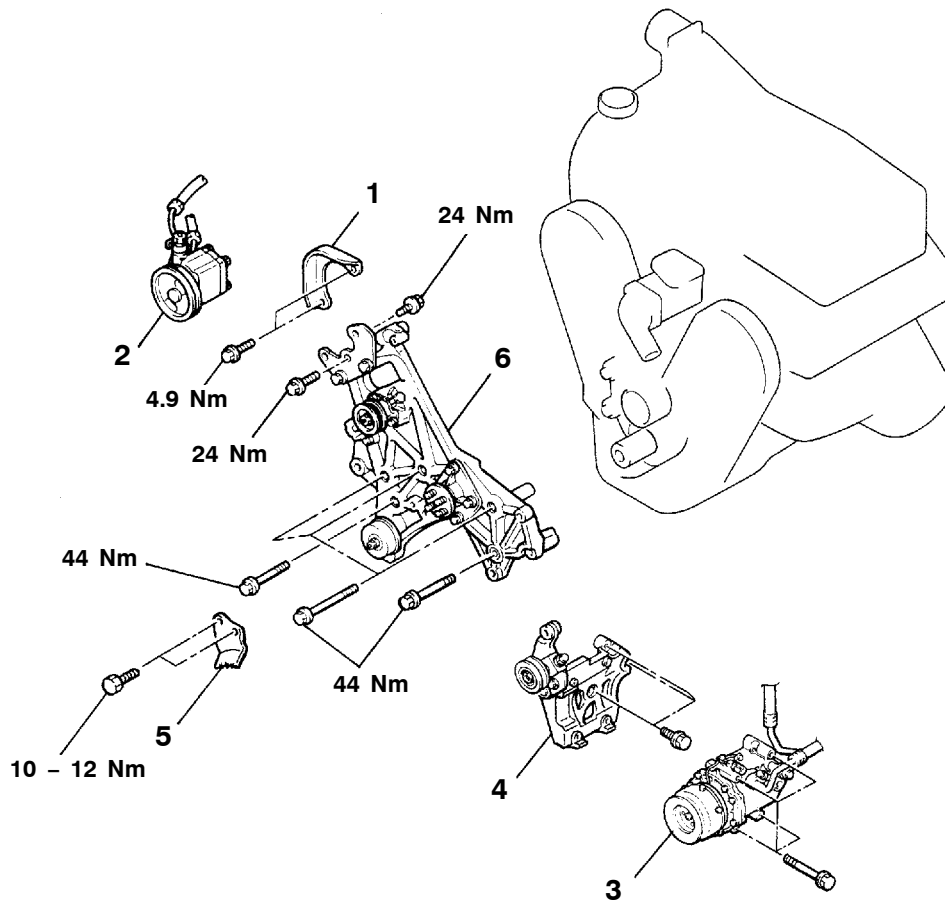

A01V0122

Removal steps

1. Cover
2. Power steering oil pump assembly
3. A/C compressor assembly
4. Compressor bracket
5. Timing indicator bracket
6. Accessory mount assembly



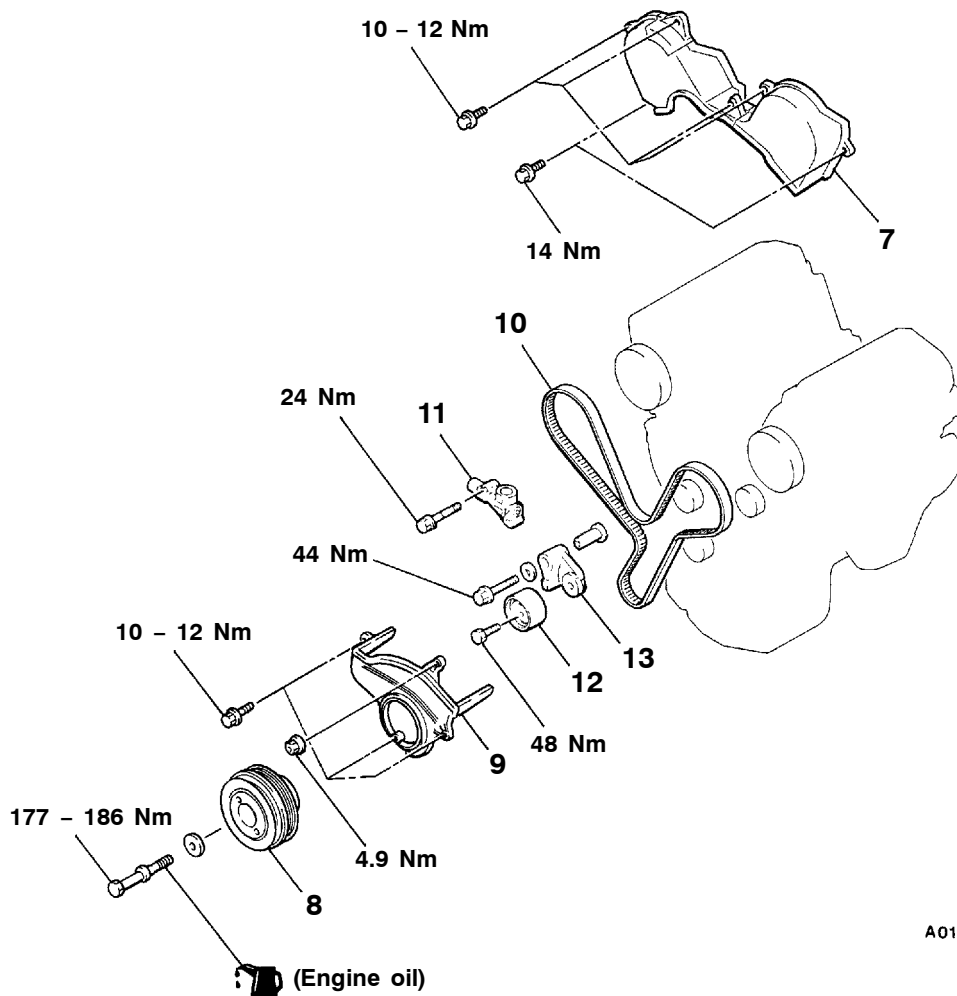

A01V0113

- ◀B▶ ▶C▶ 7. Timing belt upper cover assembly
- ◀C▶ ▶B▶ ▶A▶ 8. Crankshaft pulley
- ▶C▶ ▶B▶ ▶A▶ 9. Timing belt lower cover assembly
- ▶C▶ ▶B▶ ▶A▶ 10. Timing belt
- ▶C▶ ▶B▶ ▶A▶ 11. Auto-tensioner
- ▶C▶ ▶B▶ ▶A▶ 12. Tension pulley
- ▶C▶ ▶B▶ ▶A▶ 13. Tensioner arm assembly

REMOVAL SERVICE POINTS

◀A▶ POWER STEERING OIL PUMP ASSEMBLY / A/C COMPRESSOR ASSEMBLY REMOVAL

1. Do not disconnect the hoses to remove the pump and compressor.
2. Support the removed pump and compressor with a wire, etc. so that they will not get in the way while working.

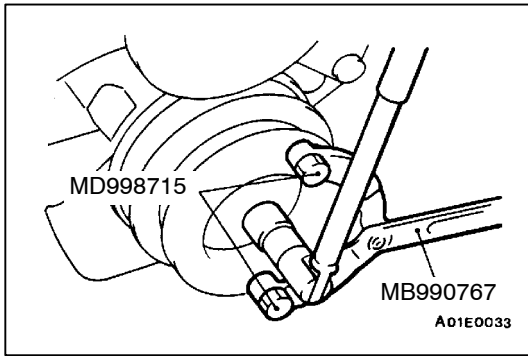

◀B▶ CRANKSHAFT PULLEY REMOVAL

Use special tools to remove the crankshaft pulley from the crankshaft.

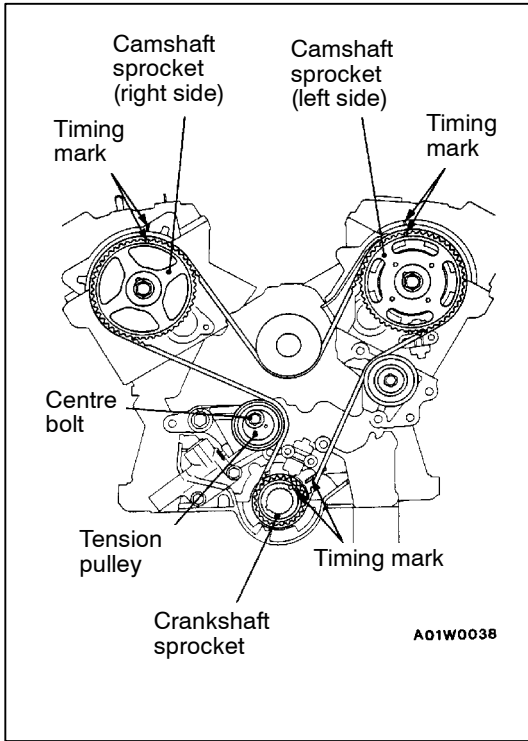

◀C▶ TIMING BELT REMOVAL

1. Turn the crankshaft clockwise to align each timing mark and to set the No. 1 cylinder to compression top dead centre.

Caution

Never turn the crankshaft counterclockwise.

2. If the timing belt is to be reused, chalk mark the flat side of the belt with an arrow indicating the clockwise direction.
3. Loosen the centre bolt of the tension pulley, and then remove the timing belt.

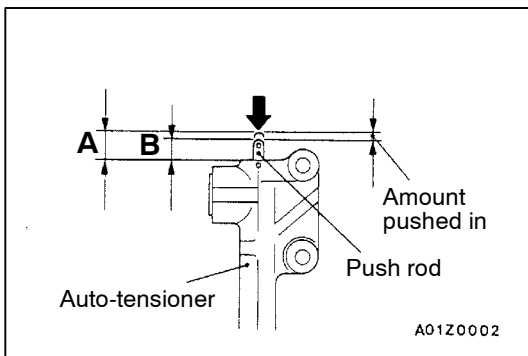

INSTALLATION SERVICE POINTS

▶A◀ AUTO-TENSIONER INSTALLATION

1. While holding the auto-tensioner by hand, press the end of the push rod against a metal surface (such as the cylinder block) with a force of 98 – 196 Nm and measure how far the push rod is pushed in.

Standard value: Within 1 mm

A: Length when no force is applied

B: Length when force is applied

A – B: Amount pushed in

2. If it is not within the standard value, replace the auto-tensioner.

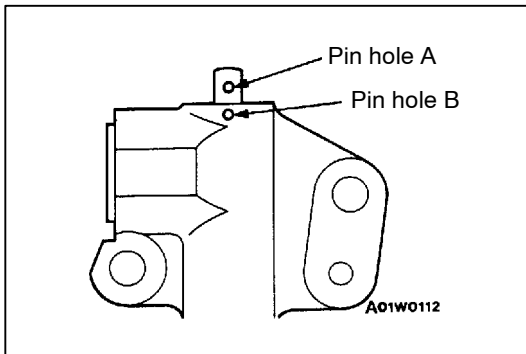
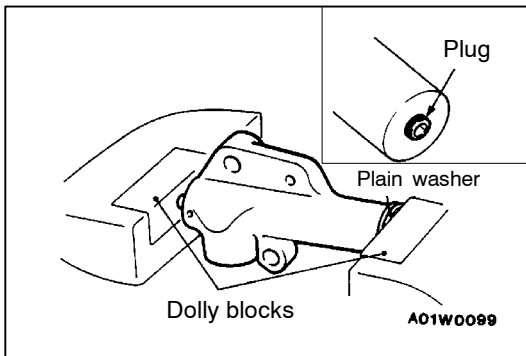

- Place two dolly blocks in a vice as shown in the illustration, and then place the auto-tensioner in the vice.

Caution

- Place the auto-tensioner perpendicular to the jaws of the vice.
- If there is a plug at the base of the aut-tensioner, insert a plain washer onto the end of the auto-tensioner to protect the plug.

- Slowly compress the push rod of the auto-tensioner until pin hole A in the push rod is aligned with pin hole B in the cylinder.

Caution

Never compress the push rod too fast, or the push rod may be damaged.

- Insert the setting pin into the pin holes once they are aligned.

NOTE

If replacing the auto-tensioner, the pin will already be inserted into the pin holes of the new part.

- Install the auto-tensioner to the engine.

Caution

Do not remove the setting pin from the auto-tensioner.

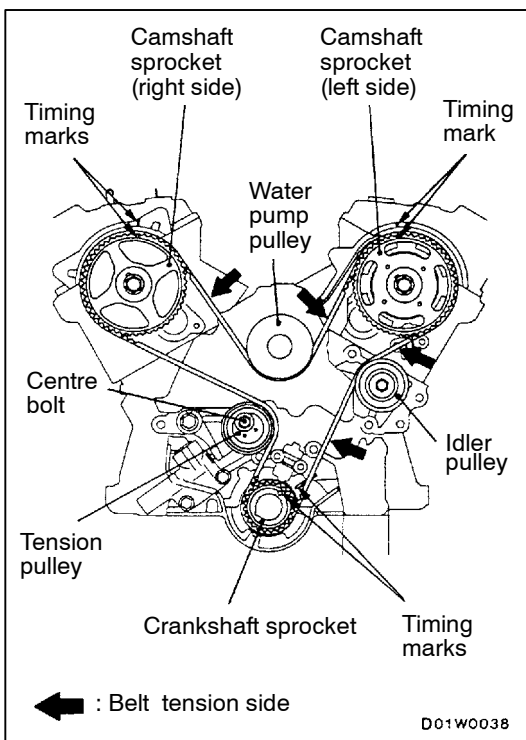
**►B◀ TIMING BELT INSTALLATION**

- Align the timing marks of the camshaft sprocket with those of crankshaft sprocket.
- Install the timing belt by the following procedure so that there is no deflection in the timing belt between each sprocket and pulley.
 - Crankshaft sprocket
 - Idler pulley
 - Camshaft sprocket (Left side)
 - Water pump pulley
 - Camshaft sprocket (Right side)
 - Tension pulley

Caution

The camshaft sprocket (right side) can turn easily due to the spring force applied, so be careful not to get your fingers caught.

- Turn the camshaft sprocket counterclockwise until the tension side of the timing belt is firmly stretched. Check all timing marks again.

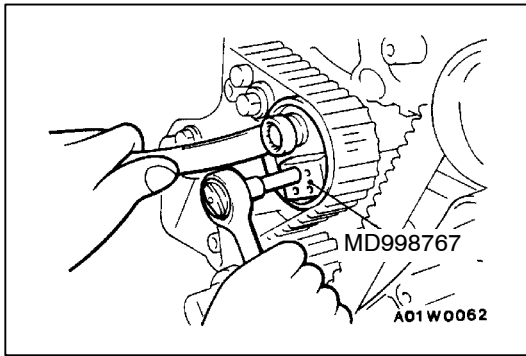

- Use special tool to push the tensioner pulley into the timing belt, and then temporarily tighten the centre bolt.

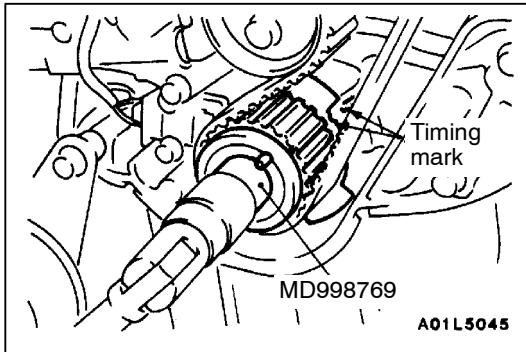

- Use special tool to turn the crankshaft 1/4 turn counterclockwise and then turn it again clockwise until the timing marks are aligned.

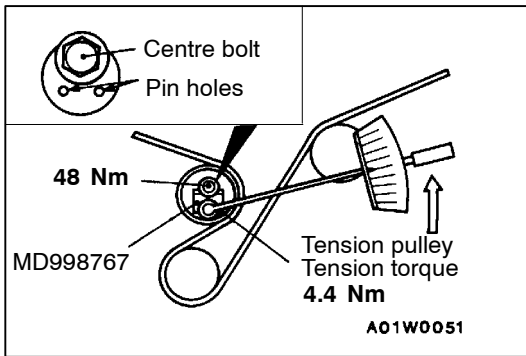

- Loosen the centre bolt of the tensioner pulley. Use special tool and a torque wrench to apply the standard torque to the timing belt as shown in the illustration. Then tighten the centre bolt to the specified torque.

Standard value: 4.4 Nm
 <Timing belt tension torque>

Caution
 When tightening the centre bolt, be careful that the tensioner pulley does not turn with the bolt.

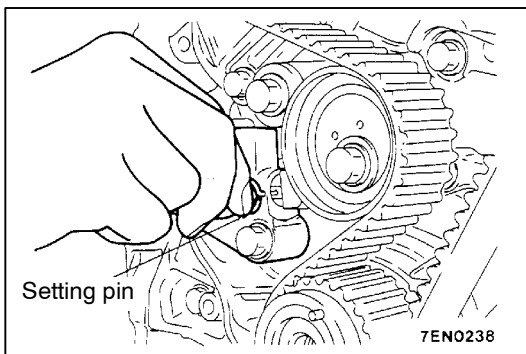

- Remove the setting pin that has been inserted into the auto-tensioner.
- Turn the crankshaft two turns clockwise to align the timing marks.

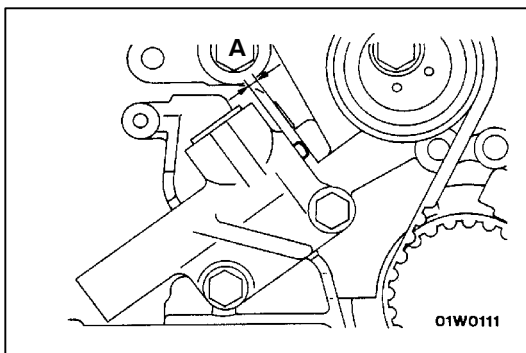

- Wait for at least five minutes, and then check that the auto-tensioner pushrod extends within the standard value.

Standard value (A): 3.8 – 5.0 mm

- If no, repeat the operation in steps (5) to (9) above.
- Check again that the timing marks of each sprocket are aligned.

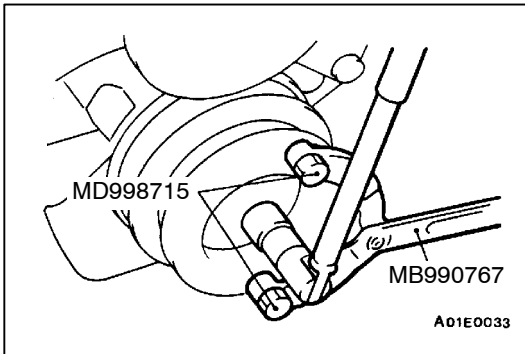
**►◀ CRANKSHAFT PULLEY INSTALLATION**

Use special tools to install the crankshaft pulley.

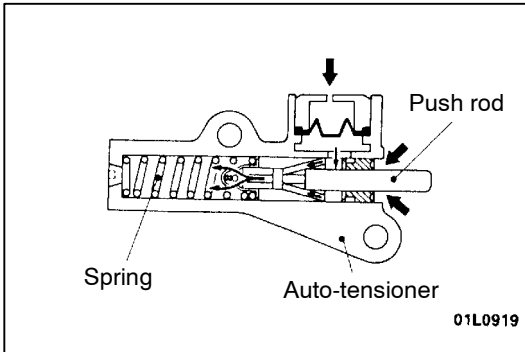
**INSPECTION**

11200440131

AUTO-TENSIONER

- Check the auto-tensioner for possible leaks.
- Check the push rod for cracks.

CRANKSHAFT FRONT OIL SEAL

REMOVAL AND INSTALLATION

Pre-removal and Post-installation Operation

- Timing Belt Removal and Installation (Refer to P.11A-28.)

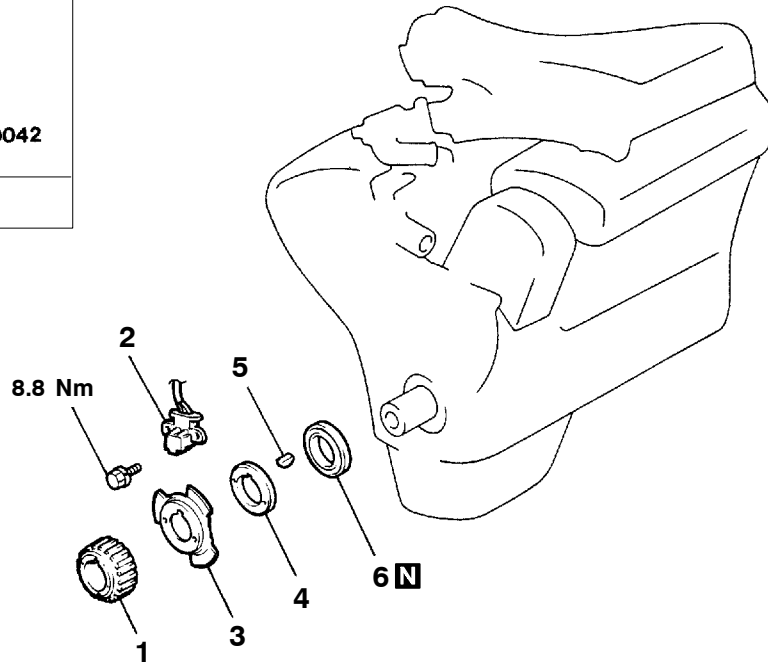
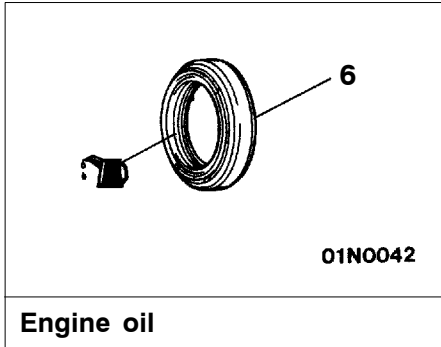

01V0112
00006159

Removal steps

1. Crankshaft sprocket
2. Crankshaft angle sensor
3. Crankshaft sensing blade
4. Crankshaft spacer
5. Key
6. Crankshaft front oil seal

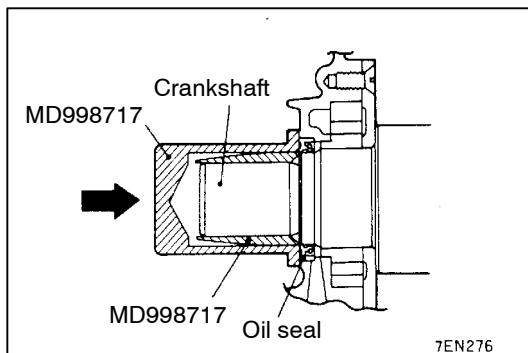

INSTALLATION SERVICE POINT

▶◀ CRANKSHAFT FRONT OIL SEAL INSTALLATION

1. Apply a small amount of engine oil to the oil seal lip and then insert.
2. Using special tool, tap the oil seal into the front case.

CRANKSHAFT REAR OIL SEAL

REMOVAL AND INSTALLATION

Pre-removal and Post-installation Operation

- Transmission and Transfer Assembly Removal and Installation (Refer to GROUP 22 – Transmission Assembly.)

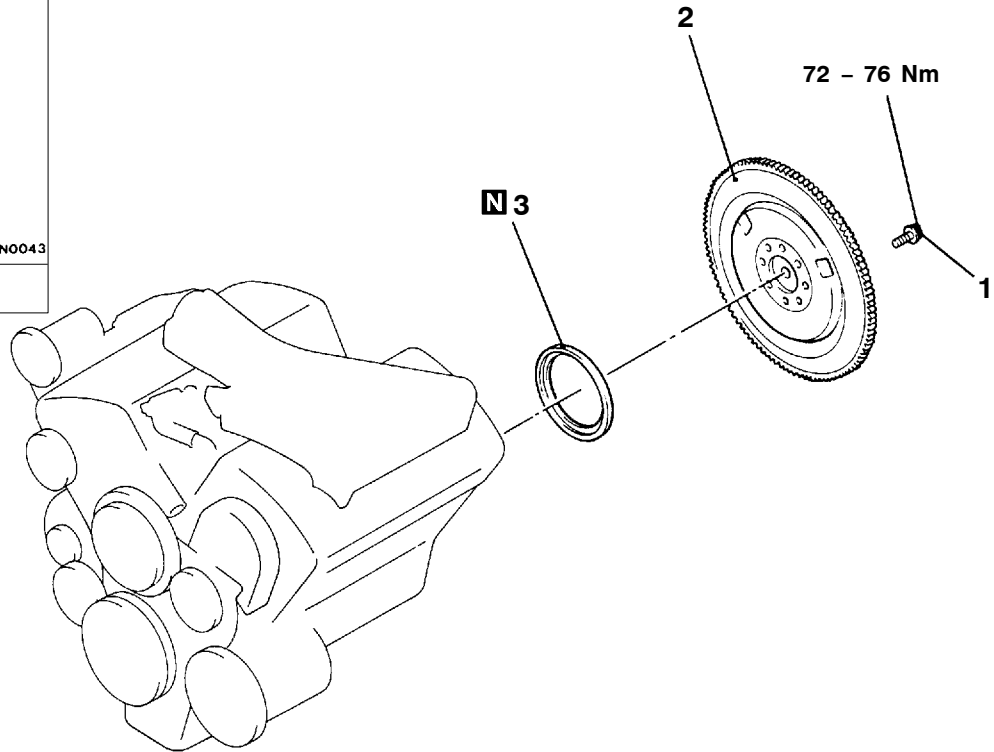
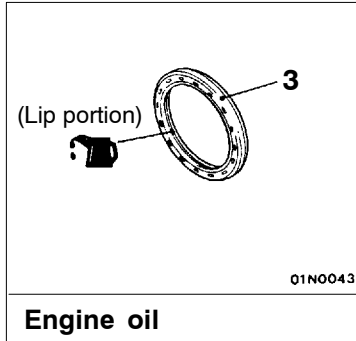

W0283AA
00009288

Removal steps

- Clutch cover and clutch disc
- ◀A▶ ▶B▶ 1. Flywheel bolt

- ▶A▶ 2. Flywheel
3. Crankshaft rear oil seal

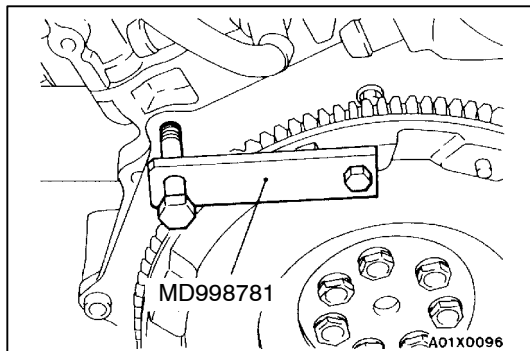

REMOVAL SERVICE POINT

◀A▶ FLYWHEEL BOLT REMOVAL

Use special tool to secure the flywheel and remove the flywheel bolt.

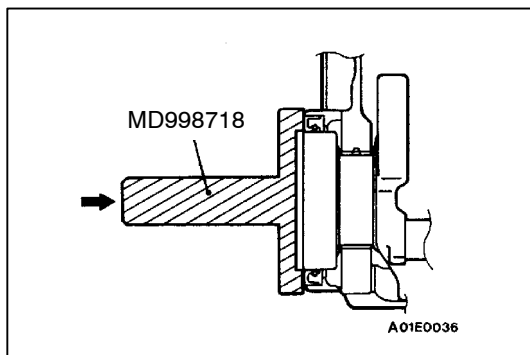

INSTALLATION SERVICE POINTS

▶A◀ CRANKSHAFT REAR OIL SEAL INSTALLATION

1. Apply a small amount of engine oil to the entire circumference of the oil seal lip.
2. Use special tool to tap in the oil seal as shown in the illustration.

▶B◀ FLYWHEEL BOLT INSTALLATION

Use special tool in the same way as during removal to install the flywheel bolt.

ENGINE ASSEMBLY

11200100992

REMOVAL AND INSTALLATION

Caution

*: Indicates parts which should be initially tightened, and then fully tightened after placing the vehicle horizontally and loading the full weight of the engine on the vehicle body.

Pre-removal Operation

- Hood Removal (Refer to GROUP 42 – Hood.)
- Fuel Line Pressure Releasing (Refer to GROUP 13A – On-vehicle Service.)
- Air Cleaner and Air Intake Hose Removal (Refer to GROUP 15 – Air Cleaner.)
- Battery Removal
- Radiator Removal (Refer to GROUP 14 – Radiator.)
- Front Exhaust Pipe Removal (Refer to GROUP 15 – Exhaust Pipe and Main Muffler.)
- Transmission Assembly Removal (Refer to GROUP 22 – Transmission Assembly.)

Post-installation Operation

- Transmission Assembly Installation (Refer to GROUP 22 – Transmission Assembly.)
- Front Exhaust Pipe Installation (Refer to GROUP 15 – Exhaust Pipe and Main Muffler.)
- Radiator Installation (Refer to GROUP 14 – Radiator.)
- Battery installation
- Air Cleaner and Air Intake Hose Installation (Refer to GROUP 15 – Air Cleaner.)
- Hood Installation (Refer to GROUP 42 – Hood.)
- Drive Belt Tension Adjustment (Refer to P.11A-8.)
- Accelerator Cable Adjustment (Refer to GROUP 17 – On-vehicle Service.)

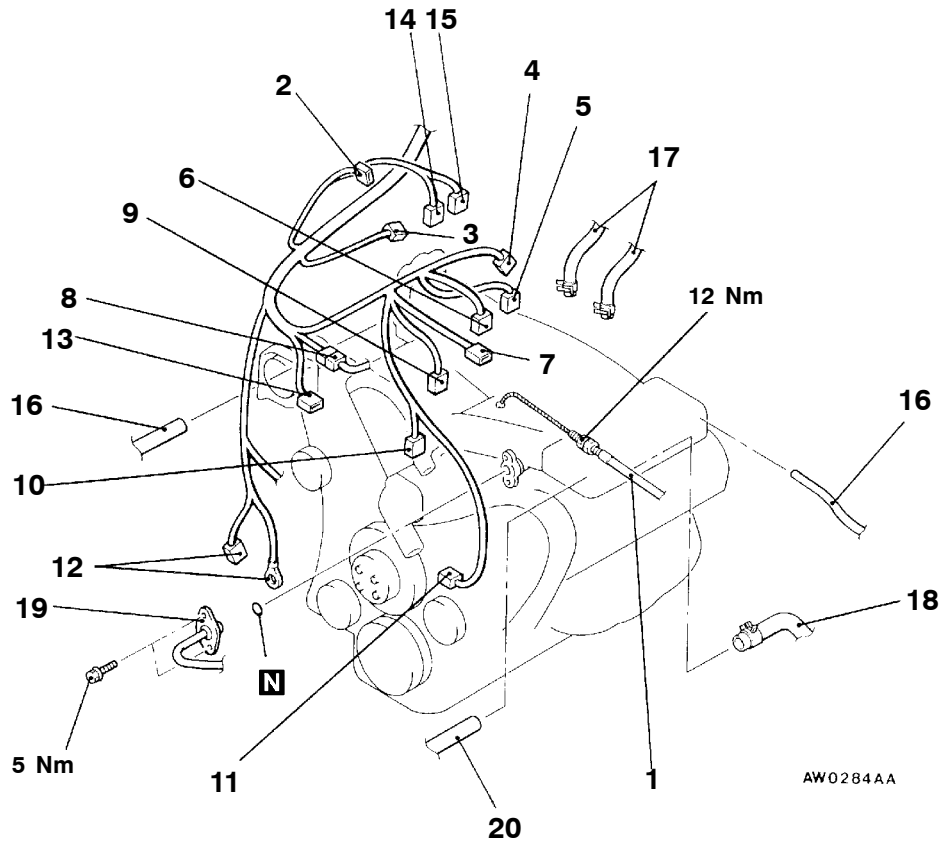

Removal steps

- | | |
|--|--|
| 1. Accelerator cable connection | 11. Oil pressure switch connector |
| 2. Throttle position sensor connector | 12. Alternator connector |
| 3. Idle speed control servo connector | 13. Ignition coil connector |
| 4. Power transistor connector | 14. EGR solenoid valve |
| 5. Camshaft position sensor connector | 15. Purge control solenoid valve |
| 6. Crank angle sensor connector | 16. Vacuum hose connection |
| 7. Capacitor connector | 17. Heater hose connection |
| 8. Injector harness connector | 18. Fuel return hose connection |
| 9. Engine coolant temperature gauge unit connector | 19. High-pressure fuel hose connection |
| 10. Engine coolant temperature sensor connector | 20. PCV hose connection |

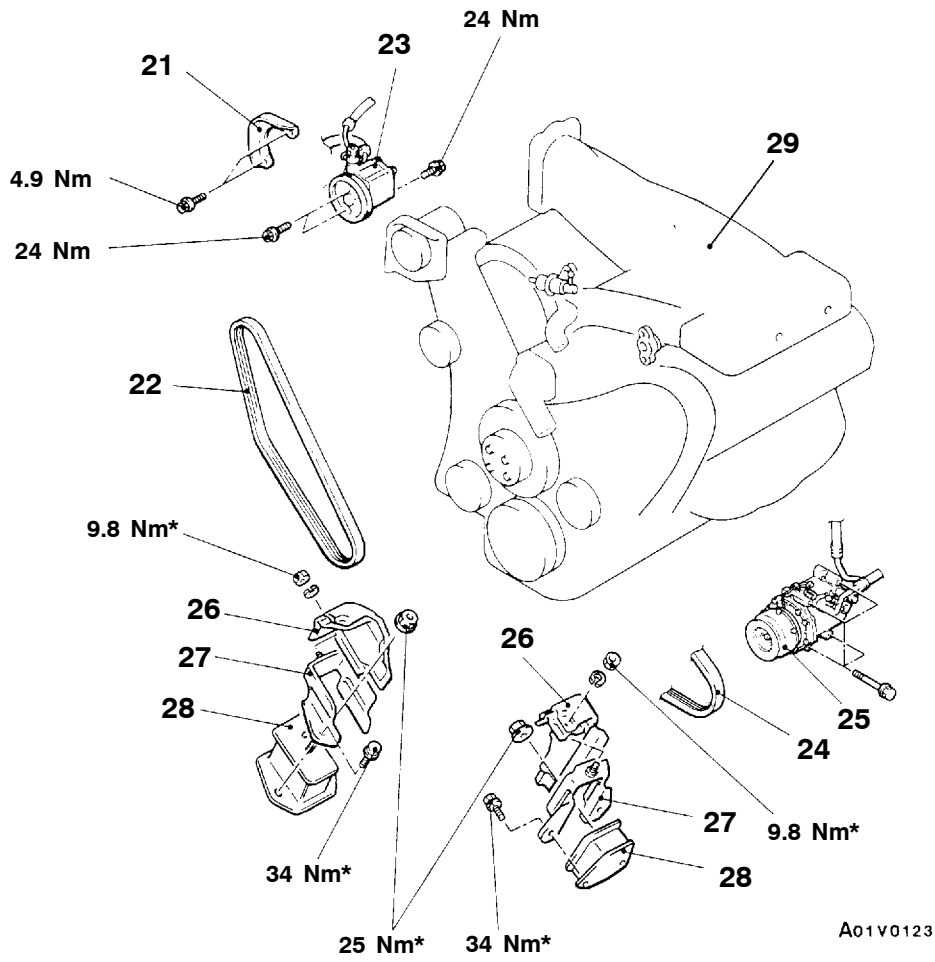

- 21. Power steering drive belt cover
- 22. Drive belt (for power steering)
- 23. Power steering oil pump assembly
- 24. Drive belt (for A/C)



- 25. A/C compressor assembly
- 26. Heat protector
- 27. Front insulator stopper



- 28. Front engine support insulator
- 29. Engine assembly

REMOVAL SERVICE POINTS**◀A▶ POWER STEERING OIL PUMP ASSEMBLY AND A/C COMPRESSOR ASSEMBLY REMOVAL**

1. Remove the oil pump and A/C compressor (with the hose attached).
2. Suspend the removed oil pump (by using wire or similar material) at a place where no damage will be caused during removal/installation of the engine assembly.

◀B▶ ENGINE ASSEMBLY REMOVAL

1. Check that all cables, hoses, harness connectors, etc. are disconnected from the engine.
2. Lift the special tool (MB991683) and chain block slowly to remove the engine assembly upward from the engine compartment.

INSTALLATION SERVICE POINT**▶A◀ ENGINE ASSEMBLY INSTALLATION**

Install the engine assembly. When doing so, check carefully that all pipes and hoses are connected, and that none are twisted, damaged, etc.

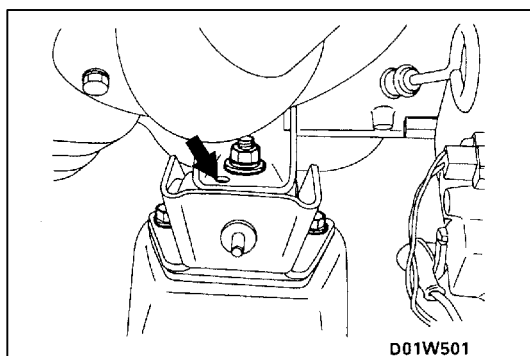
**▶B◀ FRONT ENGINE SUPPORT INSULATOR INSTALLATION**

Make sure that the locating boss and hole are in alignment.

Caution

Do not distort rubber portions, and never stain rubber portions with fuel or oil.

NOTES

ENGINE <4D5>

CONTENTS

11109000825

GENERAL INFORMATION	2	Timing Belt Tension Adjustment	14
SERVICE SPECIFICATIONS	3	Timing Belt B Tension Adjustment	15
SEALANTS	3	CRANKSHAFT PULLEY	17
SPECIAL TOOLS	4	CAMSHAFT AND CAMSHAFT OIL SEAL ..	18
ON-VEHICLE SERVICE	5	OIL PAN AND OIL SCREEN	21
Drive Belt Tension Check and Adjustment	5	CYLINDER HEAD GASKET	23
Valve Clearance Check and Adjustment	8	TIMING BELT AND TIMING BELT B	26
Injection Timing Check and Adjustment	9	CRANKSHAFT FRONT OIL SEAL	30
Idle Speed Check and Adjustment	12	CRANKSHAFT REAR OIL SEAL	31
Idle-up Mechanism Check and Adjustment-For A/C	12	ENGINE ASSEMBLY	33
Compression Pressure Check	13		

GENERAL INFORMATION

11100010339

Items	4D56	
Total displacement mL	2,477	
Bore x Stroke mm	91.1 x 95.0	
Compression ratio	21	
Combustion chamber	Vortex chamber type	
Camshaft arrangement	SOHC	
Number of valve	Intake	4
	Exhaust	4
Valve timing	Intake	Opening BTDC 20°, Closing ABDC 49°
	Exhaust	Opening BBDC 55°, Closing ATDC 22°
Fuel system	Distribution type injection pump	
Rocker arm	Roller type	
Adjusting screw	Elephant foot type	

SERVICE SPECIFICATIONS

11100030670

Items			Standard value	Limit
Alternator drive belt tension (for each belt)	Tension N	When checked	245 – 441	–
		When a used belt is installed	294 – 392	–
		When a new belt is installed	392 – 588	–
	Deflection (Reference value) mm	When checked	12.0 – 17.0	–
		When a used belt is installed	13.0 – 16.0	–
		When a new belt is installed	10.0 – 13.0	–
Power steering oil pump drive belt tension	Tension N	When checked	294 – 490	–
		When a used belt is installed	343 – 441	–
		When a new belt is installed	490 – 686	–
	Deflection (Reference value) mm	When checked	8.0 – 12.0	–
		When a used belt is installed	9.0 – 11.5	–
		When a new belt is installed	6.0 – 8.0	–
A/C compressor drive belt tension	Tension N	When checked	343 – 441	–
		When a used belt is installed	343 – 441	–
		When a new belt is installed	490 – 558	–
	Deflection (Reference value) mm	When checked	6.5 – 7.5	–
		When a used belt is installed	6.5 – 7.5	–
		When a new belt is installed	5.2 – 6.0	–
Valve clearance (at hot) mm			0.25	–
Injection timing (Value indicated on dial gauge mm)			9° ATDC (1 ± 0.03)	–
Idle speed r/min			750 ± 100	–
Compression pressure kPa			3,040	Min. 2,200
Compression pressure difference of all cylinder (at engine speed of 280 r/min) kPa			–	Max. 300
Timing belt tension mm			4 – 5	–
Timing belt B tension mm			4 – 5	–





SEALANTS

11100050270

Items	Specified sealant	Remarks
Oil pan	MITSUBISHI GENUINE PART MD970389 or equivalent	Semi-drying sealant
Semi-circular packing and rocker cover seal, and cylinder head seal	3M ATD Part No. 8660 or equivalent	

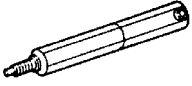
SPECIAL TOOLS

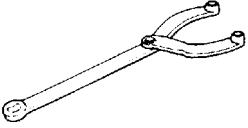
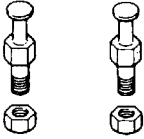
11100060327

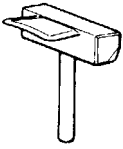
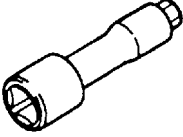
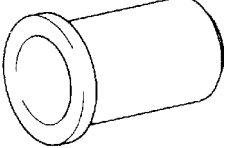
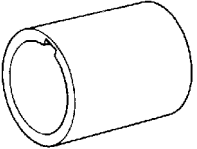
Tool	Number	Name	Use
	MD998384	Prestroke measuring adapter	Adjustment of the injection timing
	MD998721	Crankshaft pulley holder	Holding the crankshaft pulley
	MB990767	End yoke holder	Holding the camshaft sprocket
	MD998719	Crankshaft pulley holder pin	
	MD998381	Camshaft oil seal installer	Installing the camshaft oil seal
	MD998727	Oil pan remover	Removal of oil pan
	MD998051	Cylinder head bolt wrench	Removal and installation of the cylinder head bolt
	MD998382	Crankshaft front oil seal installer	Installing the crankshaft front oil seal
	MD998383	Crankshaft front oil seal guide	

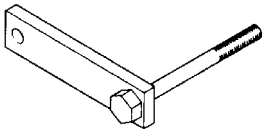
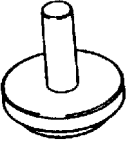
Tool	Number	Name	Use
	MD998781	Flywheel stopper	Securing the flywheel
	MD998376	Crankshaft rear oil seal installer	Press-fitting the crankshaft rear oil seal

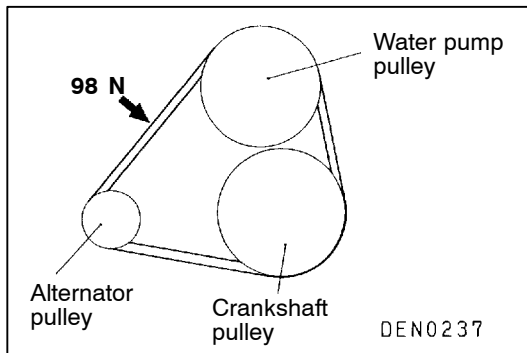

ON-VEHICLE SERVICE

11100090333

DRIVE BELT TENSION CHECK AND ADJUSTMENT

ALTERNATOR DRIVE BELT TENSION CHECK

Use a belt tension gauge to check that the belt tension is at the standard value at a point half-way between the two pulleys as shown in the illustration. In addition, press this section with a force of 98 N and check that the amount of belt deflection is at the standard value.

Standard value (for each belt):

Tension N	245 – 441
Deflection (Reference value) mm	12.0 – 17.0

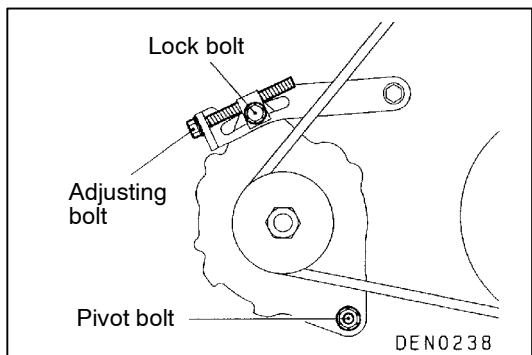

ALTERNATOR DRIVE BELT TENSION ADJUSTMENT

1. Loosen the nut of the alternator pivot bolt.
2. Loosen the lock bolt.
3. Use the adjusting bolt to adjust the belt tension and belt deflection to the standard values.

Standard value (for each belt):

Items	When a used belt is installed	When a new belt is installed
Tension N	294 – 392	392 – 588
Deflection (Reference value) mm	13.0 – 16.0	10.0 – 13.0

4. Tighten the nut of the alternator pivot bolt.

Tightening torque: 44 Nm

5. Tighten the lock bolt.

Tightening torque: 22 Nm

6. Tighten the adjusting bolt.

Tightening torque: 5 Nm

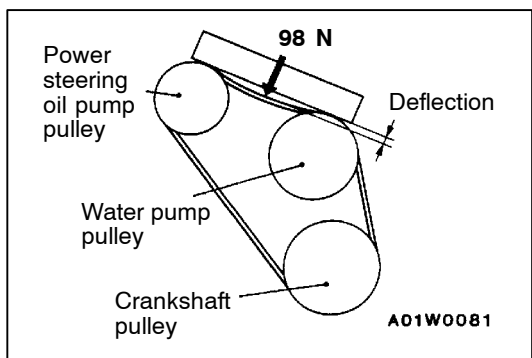

POWER STEERING OIL PUMP DRIVE BELT TENSION CHECK AND ADJUSTMENT

11100110152

1. Use a belt tension gauge to check that the belt tension is at the standard value at a point half-way between the two pulleys (indicated by an arrow in the illustration). In addition, press this section with a force of 98 N and check that the amount of belt deflection is at the standard value.

Standard value:

Items	When checked	When a used belt is installed	When a new belt is installed
Tension N	294 – 490	343 – 441	490 – 686
Deflection (Reference value) mm	8.0 – 12.0	9.0 – 11.5	6.0 – 8.0

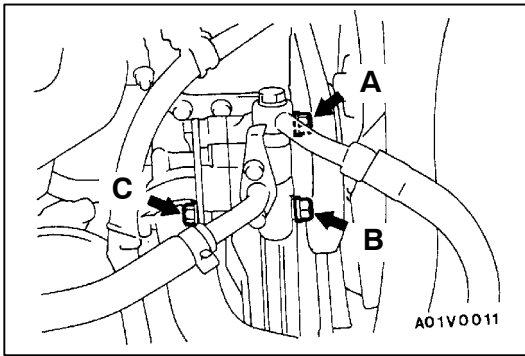

2. If the tension or deflection is outside the standard value, adjust by the following procedure.

- (1) Loosen power steering oil pump fixing bolts A, B and C.
- (2) Adjust the amount of belt deflection using adjusting bolt D.
- (3) Tighten fixing bolts A, B and C.

Tightening torque: 22 Nm

- (4) Check the belt deflection amount and tension, and readjust if necessary.

Caution

Check after turning the crankshaft once or more clockwise (right turn).

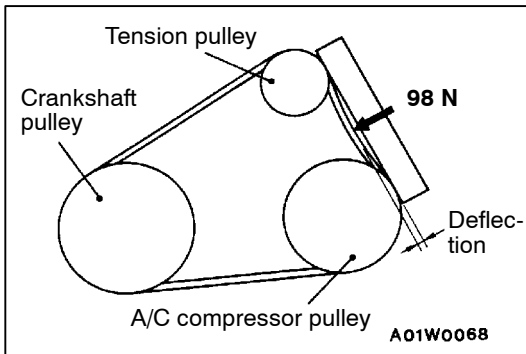

AIR CONDITIONER COMPRESSOR DRIVE BELT TENSION CHECK AND ADJUSTMENT

11100100258

1. Use a belt tension gauge to check that the belt tension is at the standard value at a point half-way between the two pulleys (indicated by an arrow in the illustration). In addition, press this section with a force of 98 N and check that the amount of belt deflection is at the standard value.

Standard value:

Items	When checked	When a used belt is intalled	When a new belt is installed
Tension N	343 – 441	343 – 441	490 – 588
Deflection (Reference value) mm	6.5 – 7.5	6.5 – 7.5	5.2 – 6.0

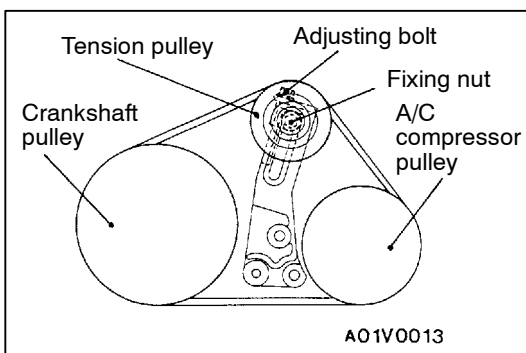

2. If the tension or deflection is outside the standard value, adjust by the following procedure.

- (1) Loosen tension pulley fixing nut.
- (2) Adjust belt tension with adjusting bolt.
- (3) Tighten fixing nut.

- (4) Check the belt deflection amount and tension, and readjust if necessary.

Caution

Check after turning the crankshaft once or more clockwise (right turn).

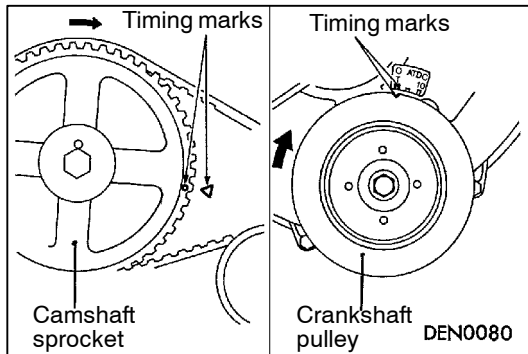

VALVE CLEARANCE CHECK AND ADJUSTMENT

11100150109

1. Start the engine and allow it to warm up until the engine coolant temperature reaches 80 to 90 °C.
2. Remove the timing belt upper cover.
3. Remove the rocker cover.
4. Align the camshaft sprocket timing marks and set the No. 1 cylinder at top dead centre.

Caution

The crankshaft should always be turned in a clockwise direction.

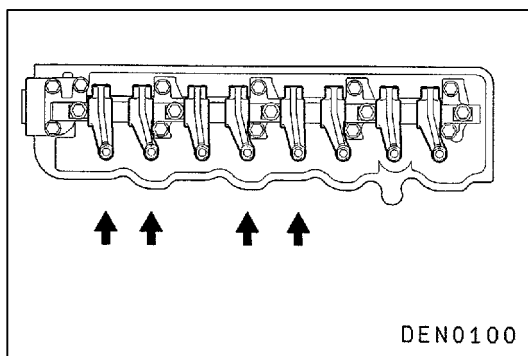

5. Measure the valve clearance at the places indicated by arrows in the illustration.

Standard value: 0.25 mm

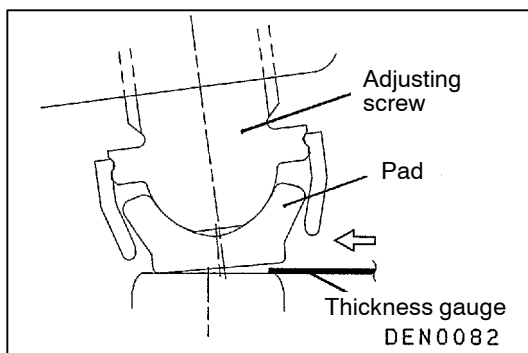

NOTE

Insert the thickness gauge from the centre of the cylinder head towards the outside so that it doesn't touch the pad.

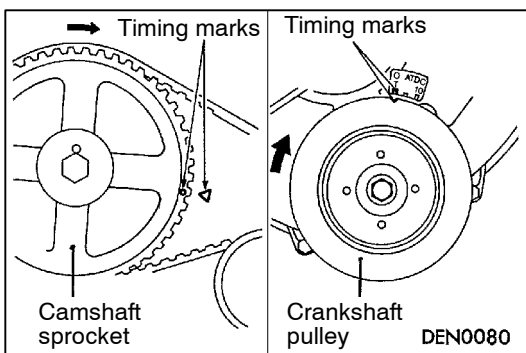
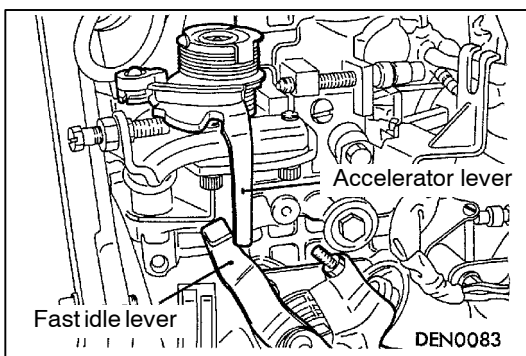
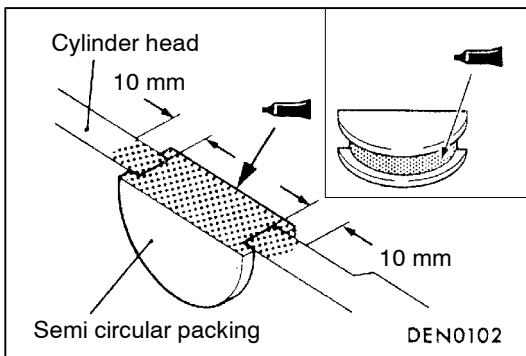
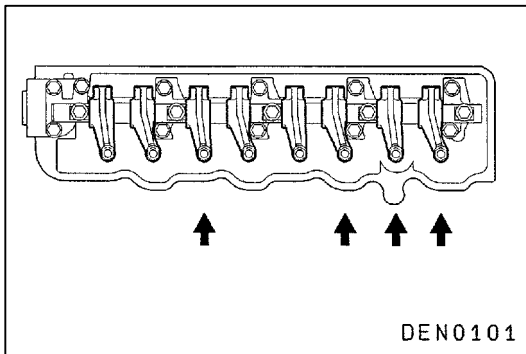
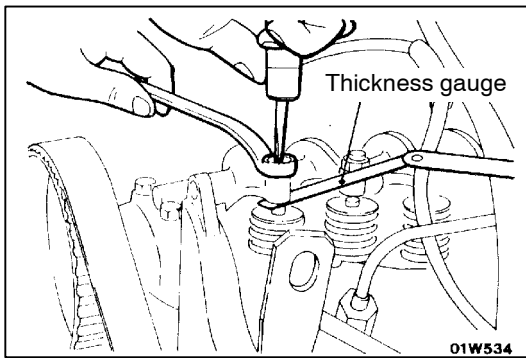

6. If the clearance is outside the standard value, loosen the lock nut of the rocker arm and adjust by turning the adjusting screw while using a thickness gauge to measure the clearance.
7. Tighten the lock nut while holding the adjusting screw with a screwdriver so that it doesn't turn.
8. Turn the crankshaft 360° clockwise to bring No. 4 cylinder to the top dead centre position.

9. Measure the valve clearances at the places indicated by arrows in the illustration. If the clearance is not within the standard value, repeat steps 7 and 8 above.

10. Apply specified sealant to the section of the semi-circular packing shown in the illustration.

Specified sealant: 3M ATD Part No. 8660 or equivalent

11. Install the rocker cover.
12. Install the timing belt upper cover.

INJECTION TIMING CHECK AND ADJUSTMENT

11100180085

1. Warm up the engine and then check to be sure that the fast idle lever is separated from the accelerator lever.
2. Remove all of the glow plugs.
3. Remove the timing belt upper cover.

4. Align the timing marks of the camshaft sprocket and set the No. 1 cylinder to the top dead centre position.

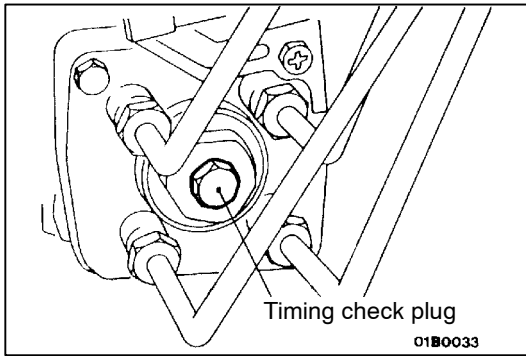

- Remove the timing check plug at the rear of the injection pump.

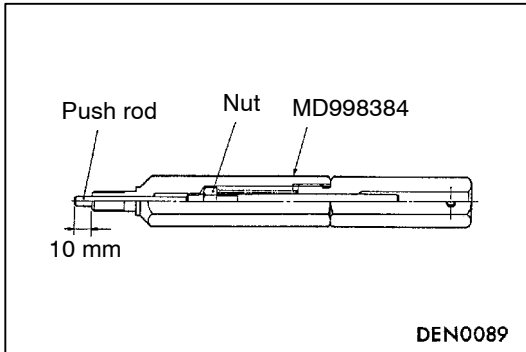

- Before installation of special tool, make sure that push rod is protruding by 10 mm. Protrusion of push rod can be adjusted with an inner nut.
- Connect the dial gauge to the special tool.

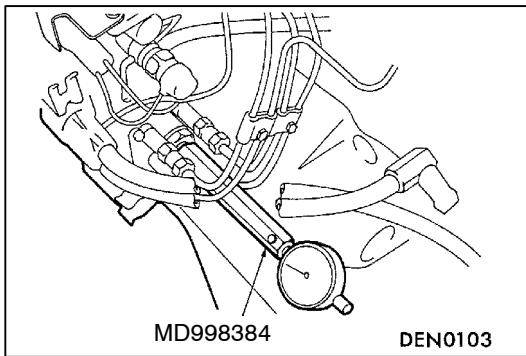

- Install the special tool to the check plug at the rear of the injection pump.

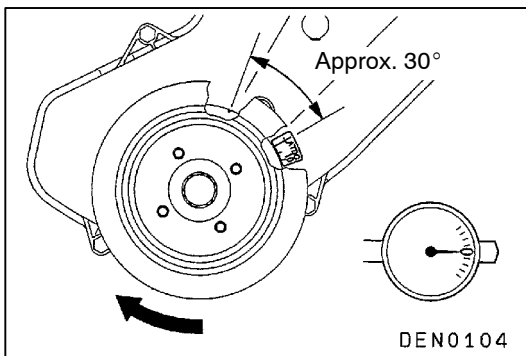

- Turn the crankshaft clockwise to move the No. 1 cylinder approximately 30° before compression top dead centre.
- Set the needle of the dial gauge to 0.
- Check that the needle doesn't move even if the crankshaft is turned slightly (2 – 3°) in both clockwise and anti-clockwise direction.

NOTE

If the needle moves, the notch is not positioned properly, so once again move the No. 1 cylinder approximately 30° before compression top dead centre.

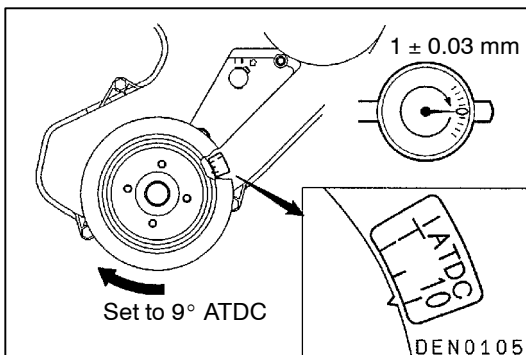

- Turn the crankshaft clockwise to align the No. 1 cylinder to 9° ATDC.
- Check that the value indicated on the dial gauge is at the standard value.

Standard value: 1 ± 0.03 mm

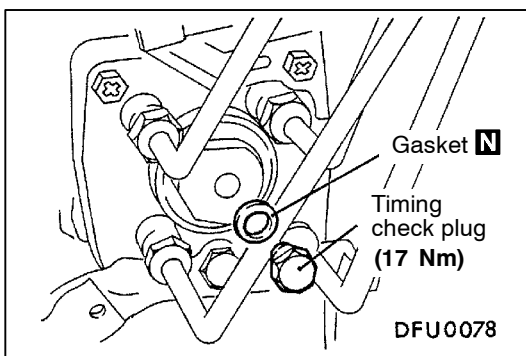
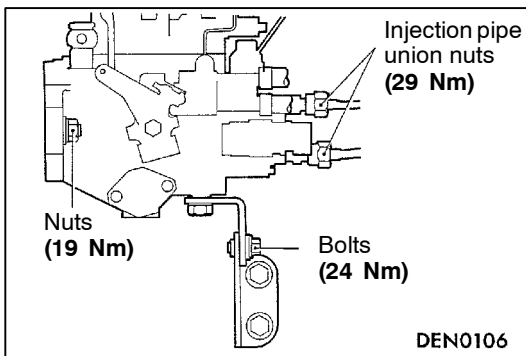
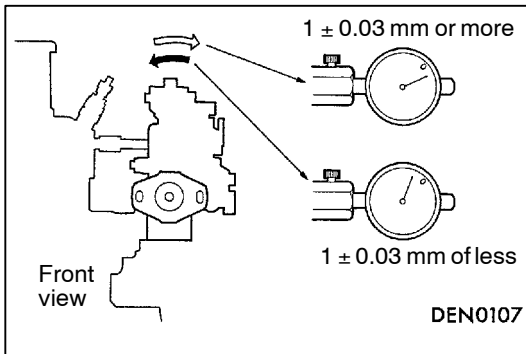
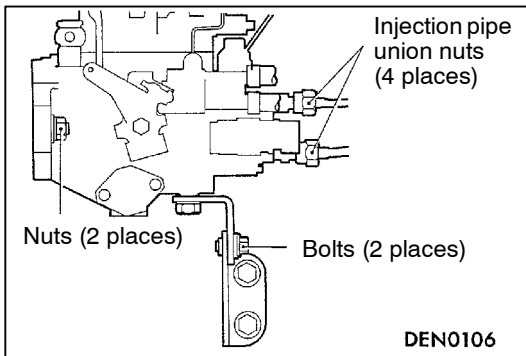

14. If the needle is outside the standard value, adjust the injection timing by the following procedure.

- (1) Loosen the injection pipe union nuts (4 places) on the injection pump. (Do not remove the union nuts.)

Caution

When loosening the nuts, hold the delivery valve holders with a spanner so that they don't turn at the same time.

- (2) Loosen the upper mounting nuts and the lower mounting bolts of the injection pump. (Do not remove the nut and bolt.)
- (3) Tilt the injection pump to the left and right and adjust the needle on the dial gauge so that the display value is uniform.
- (4) Provisionally tighten the mounting nut and bolt of the injection pump.
- (5) Repeat steps 9 – 13 to check if the adjustment has been made correctly.

- (6) Tighten the mounting nuts and bolts to the specified torque.
- (7) Tighten the injection pump union nuts to the specified torque.

Caution

When tightening the nuts, hold the delivery valve holders with a spanner so that they don't turn at the same time.

15. Remove the special tool.

16. Install a new gasket to the timing check plug.

17. Tighten the timing check plug to the specified torque.

IDLE SPEED CHECK AND ADJUSTMENT

11100190347

NOTE

Check that the injection timing is normal

1. Before inspection, set the vehicle to the pre-inspection condition.

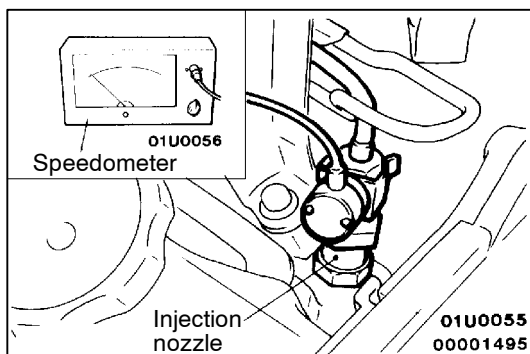

2. Connect the speedometer to the injection nozzle or the injection pipe.

Caution

When the speedometer is connected to the injection pipe, the pipe mounting clamps should all be removed.

3. Start the engine and run it at idle.
4. Check the idle speed.

Standard value: 750 ± 100 r/min

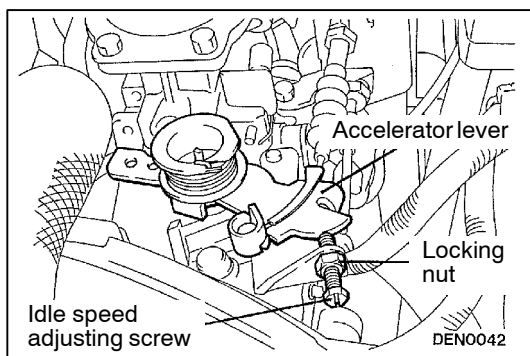

5. If not within the standard value, loosen idle adjusting screw lock nut and adjust the idle speed by rotating adjusting screw. And tighten locking nut.

IDLE-UP MECHANISM CHECK AND ADJUSTMENT-FOR A/C

11100230032

Refer to GROUP 55 – On-vehicle Service.

COMPRESSION PRESSURE CHECK

11100260697

1. Before inspection, check that the engine oil, starter and battery are normal. In addition, set the vehicle to the pre-inspection condition.
2. Remove all of the glow plugs.

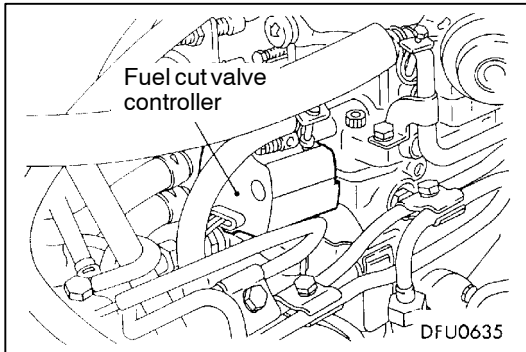
Caution**Be careful not to subject the glow plugs to any shocks.**

3. Disconnect the fuel cut valve controller connector.

NOTE

Doing this will prevent carrying out fuel injection.

4. Cover the glow plug hole with a shop towel etc., and after the engine has been cranked, check that no foreign material is adhering to the shop towel.

Caution

- (1) Keep away from the glow plug hole when cranking
- (2) If compression is measured with water, oil, fuel, etc., that has come from cracks inside the cylinder, these materials will become heated and will gush out from glow plug hole, which is dangerous.

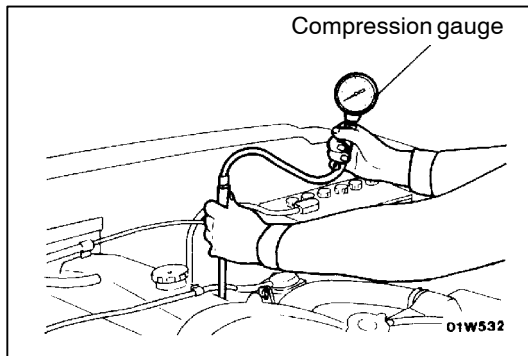

5. Set compression gauge to one of the glow plug holes.
6. Crank the engine and measure the compression pressure.

**Standard value (at engine speed of 280 r/min):
3,040 kPa**

Limit (at engine speed of 280 r/min): min. 2,200 kPa

7. Measure the compression pressure for all the cylinders, and check that the pressure differences of the cylinders are below the limit.

Limit: max 300 kPa

8. If there is a cylinder with compression or a compression difference that is outside the limit, pour a small amount of engine oil through the glow plug hole, and repeat the operations in steps (6) and (7).
 - (1) If the compression increases after oil is added, the cause of the malfunction is a worn or damaged piston ring and/or cylinder inner surface.
 - (2) If the compression does not rise after oil is added, the cause is a burnt or defective valve seat, or pressure is leaking from the gasket.
9. Connect the fuel cut solenoid valve connector or fuel cut valve controller connector.
10. Install the glow plugs.

Tightening torque: 18 Nm

TIMING BELT TENSION ADJUSTMENT

11100280136

1. Remove timing belt upper cover.
2. Turn the crankshaft in the clockwise direction and check the timing belt around its entire circumference for abnormalities.

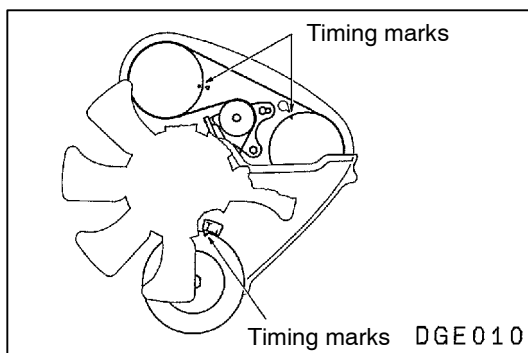

3. Align the timing marks on the sprockets with the timing marks on the front upper case.

Caution

When aligning the timing mark, be sure not to turn the crankshaft in the counterclockwise direction as this can cause improper belt tension.

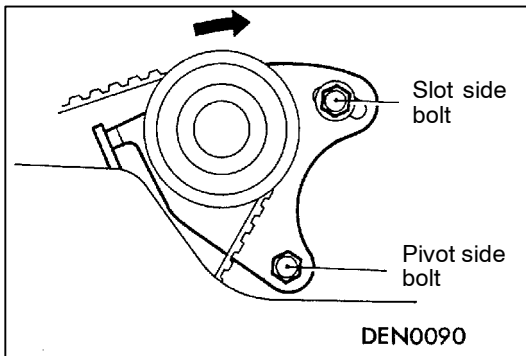

4. Loosen the tensioner pivot side bolt 1 turn and slot side bolt 1 or 2 turns.

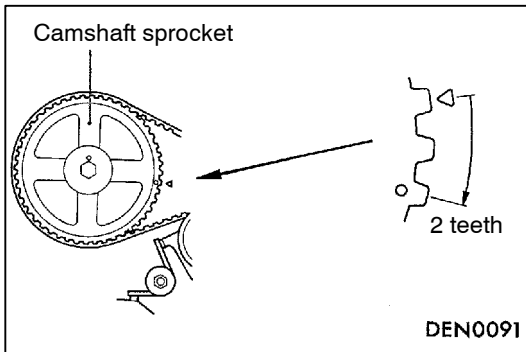

5. Turn the crankshaft clockwise and stop at the second lobe of the camshaft sprocket.
6. First tighten tensioner slot side bolt, and then tighten pivot side bolt to the specified torque.

Tightening torque: 25 Nm

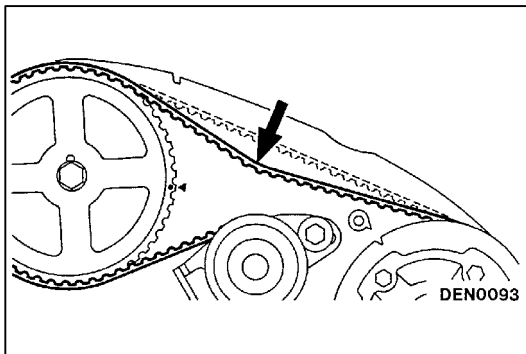

7. Turn the crankshaft anti-clockwise to align the timing marks.
8. Push down belt at a point halfway with a forefinger to check that tension of belt is up to standard value.

Standard value: 4 – 5 mm

9. Mount the timing belt upper cover.

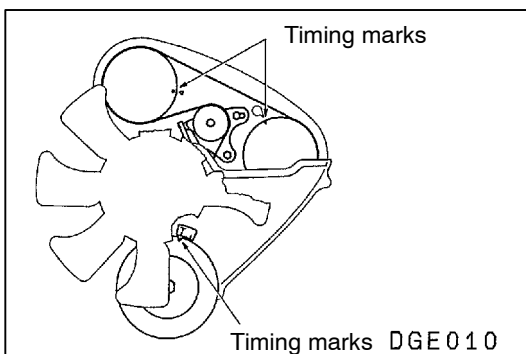

TIMING BELT B TENSION ADJUSTMENT

11100280143

1. Remove timing belt upper cover.
2. Turn the crankshaft in the clockwise direction and check the timing belt around its entire circumference for abnormalities.
3. Align the timing marks on the sprockets with the timing mark on the front upper case.

Caution

When aligning the timing mark, be sure not to turn the crankshaft in the counterclockwise direction as this can cause improper belt tension.

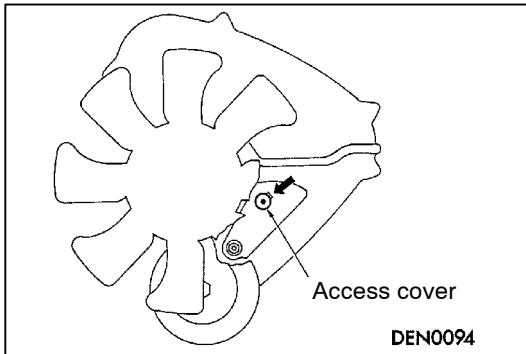

4. Remove the access cover.

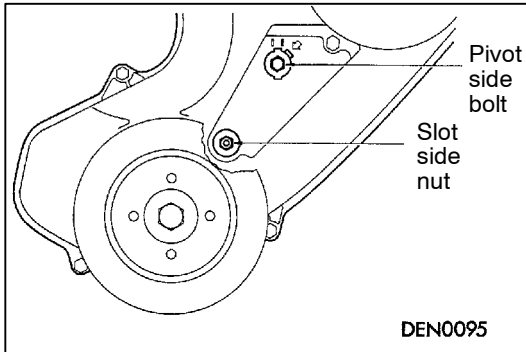

5. Loosen the tensioner pivot side bolt 1 mm and slot side nut 1 or 2 turns.
6. First tighten tensioner slot side nut, and then tighten pivot side bolt to the specified torque.

Tightening torque:

Pivot side bolt 24 Nm

Slot side nut 25 Nm

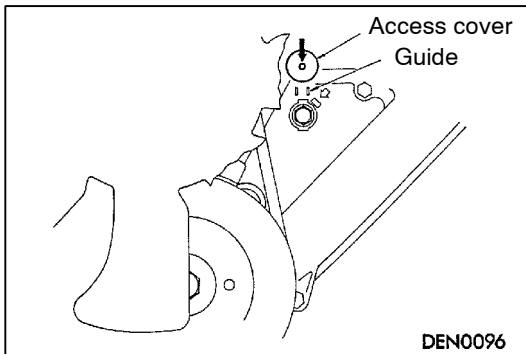

7. Install the access cover while sliding the front lower cover down along the two guides.
8. Install the timing belt upper cover.

CRANKSHAFT PULLEY

11200160426

REMOVAL AND INSTALLATION**Pre-removal Operation**

- Under Cover Removal

Post-installation Operation

- Drive Belt Tension Adjustment (Refer to P.11B-5.)
- Under Cover Installation

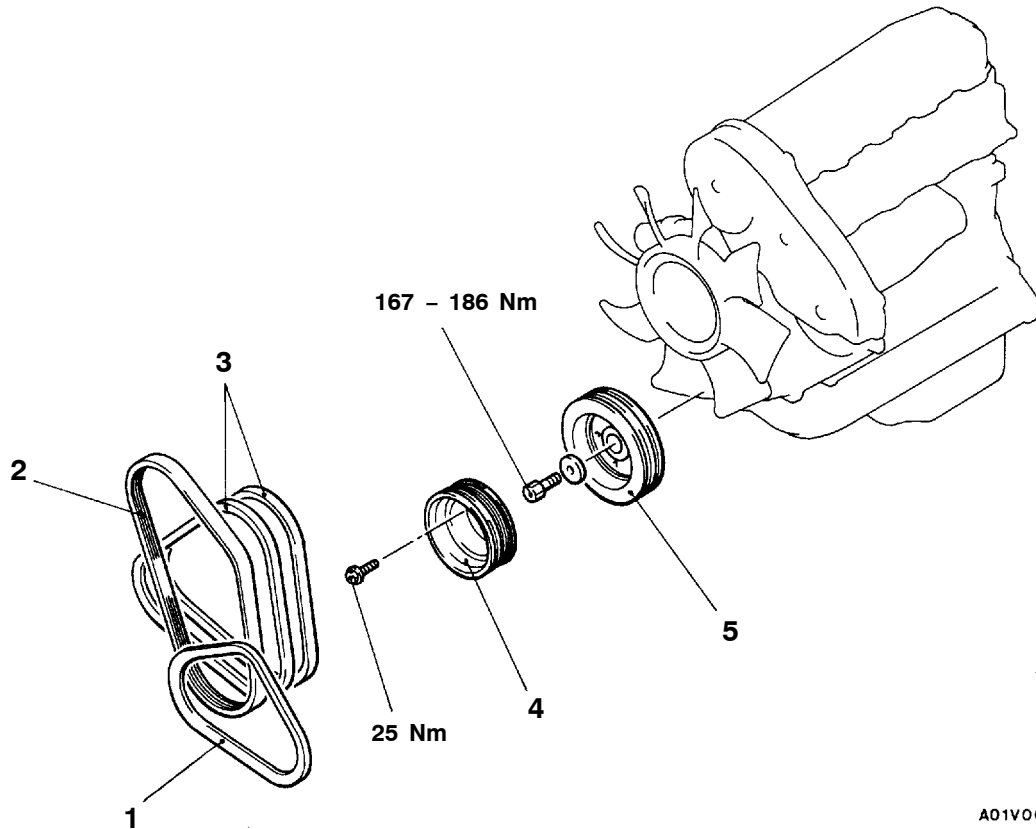

A01V0009

Removal steps

1. Drive belt (for A/C)
2. Drive belt (for power steering)
3. Drive belt (for alternator)
4. Crankshaft pulley (for power steering or A/C)
5. Crankshaft pulley

**REMOVAL SERVICE POINT**

◀A▶ CRANKSHAFT PULLEY REMOVAL

INSTALLATION SERVICE POINT

▶A◀ CRANKSHAFT PULLEY INSTALLATION

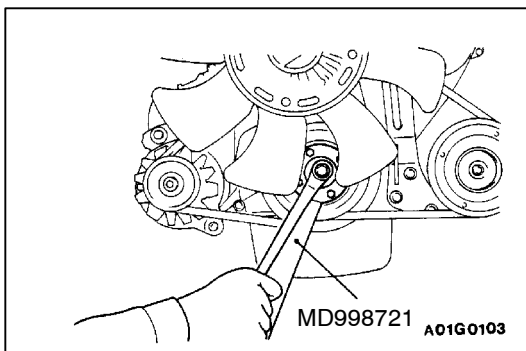

CAMSHAFT AND CAMSHAFT OIL SEAL

REMOVAL AND INSTALLATION

Pre-removal and Post-installation Operation

- Intercooler Removal and Installation
(Refer to GROUP 15.)

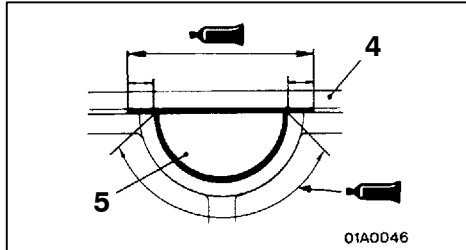

01A0046

Sealant:
3M ATD Part No. 8660 or equivalent

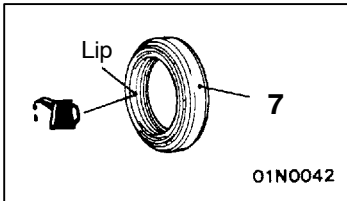

01N0042

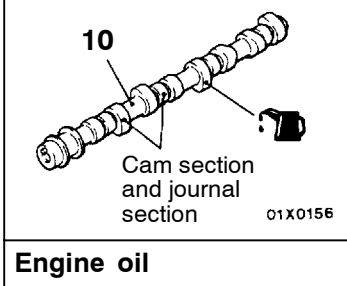

01X0156

Engine oil

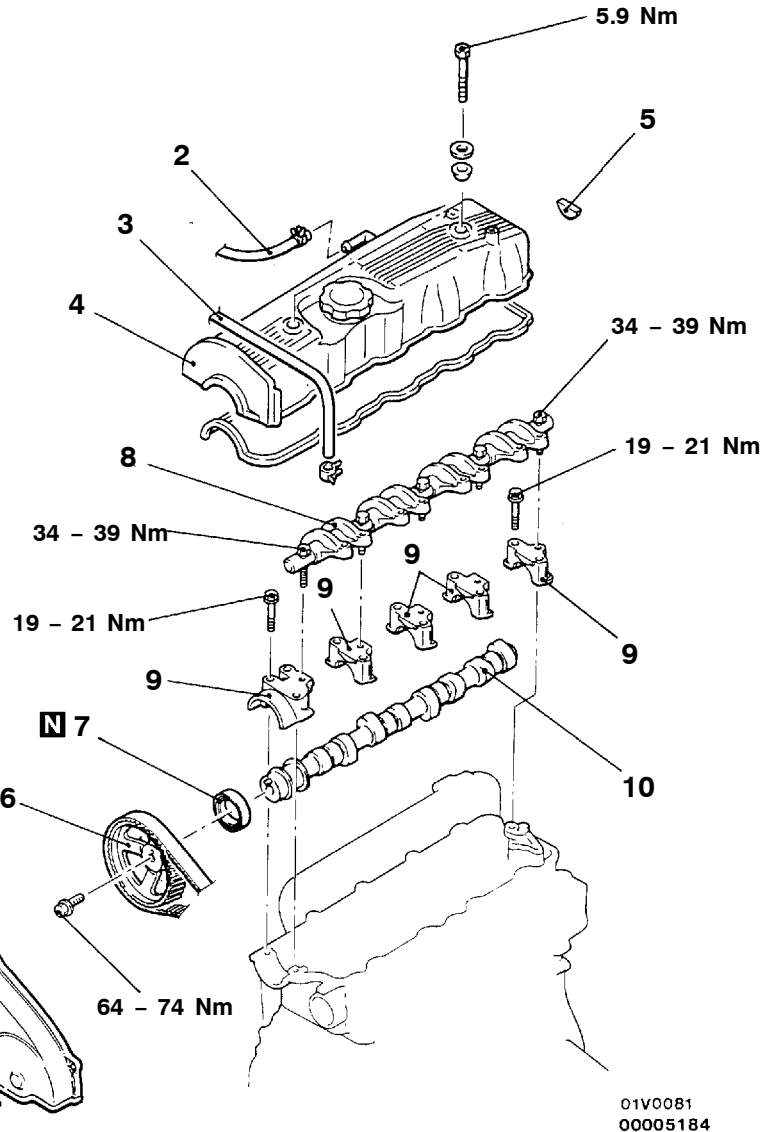

01V0081
00005184

Camshaft removal steps

1. Timing belt upper cover assembly
2. Breather hose connection
3. Boost hose connection
4. Rocker cover
5. Semi-circular packing
6. Camshaft sprocket
7. Camshaft oil seal
8. Rocker arm and shaft assembly
9. Camshaft bearing cap
10. Camshaft



Camshaft oil seal removal steps

1. Timing belt upper cover assembly
6. Camshaft sprocket
7. Camshaft oil seal



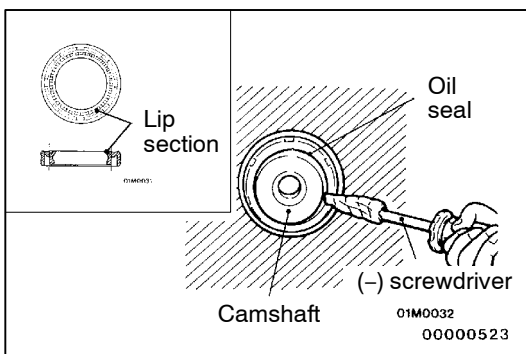
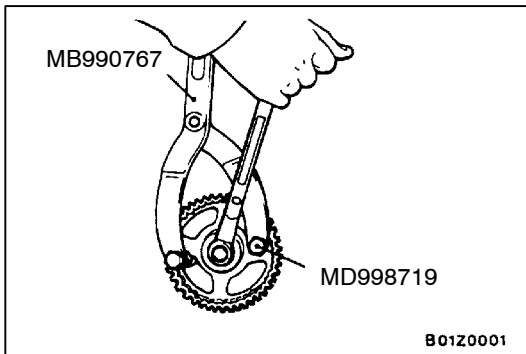
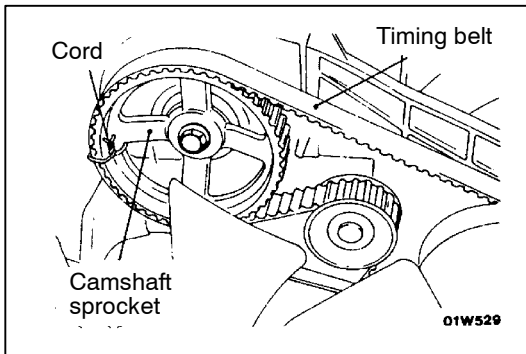
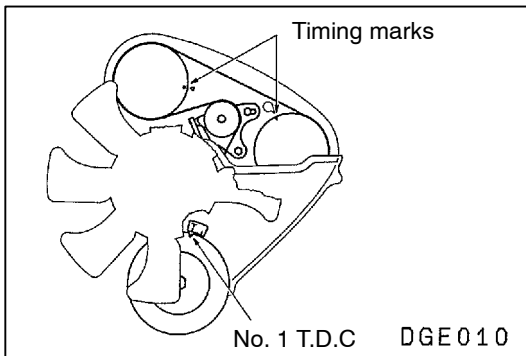

REMOVAL SERVICE POINTS

◀A▶ CAMSHAFT SPROCKET REMOVAL

1. Rotate crankshaft clockwise (to the right) and align timing marks.

Caution

Never turn the crankshaft anticlockwise.

2. Tie the camshaft sprocket and timing belt together with cord so that timing mark is not maladjusted.

3. Use the special tool to stop the camshaft sprocket from turning, and then remove the camshaft sprocket with the timing belt still attached.

Caution

Do not rotate crankshaft after removing camshaft sprocket.

◀B▶ CAMSHAFT OIL SEAL REMOVAL

1. Make a notch in the oil seal lip section with a knife, etc.
2. Cover the end of a (-) screwdriver with a rag and insert into the notched section of the oil seal, and lever out the oil seal to remove it.

Caution

Be careful not to damage the camshaft and the cylinder head.

◀C▶ ROCKER ARM AND SHAFT ASSEMBLY REMOVAL

Loosen the rocker arm and shaft assembly mounting bolt, and then remove the rocker arm and shaft assembly with the bolt still attached.

Caution

Never disassemble the rocker arm and shaft assembly.

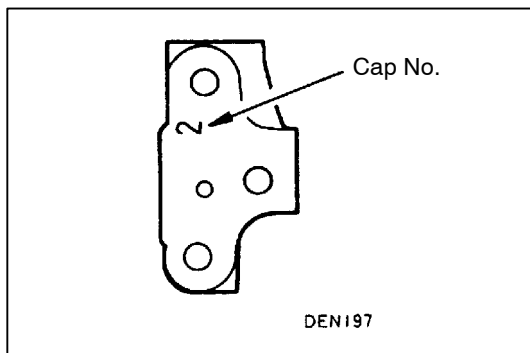

INSTALLATION SERVICE POINTS

►A◄ CAMSHAFT BEARING CAP INSTALLATION

The cap numbers are embossed on the top surface of the bearing caps, so install in the order of the numbers. However, no numbers are embossed on bearing caps 1 and 5.

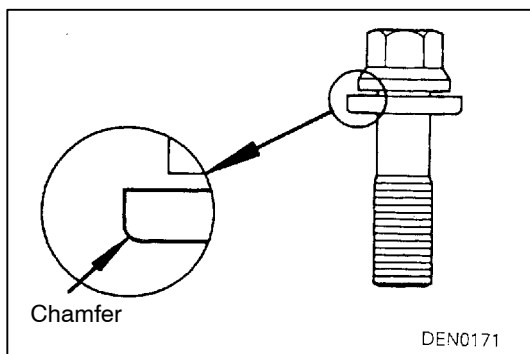

►B◄ ROCKER ARM AND SHAFT ASSEMBLY INSTALLATION

1. Install the rocker arm and shaft assembly to the bearing caps.
2. Set the washer so that it faces in the direction shown in the illustration, and then install the bolt.
3. Check the valve clearance and adjust if necessary. (Refer to P.11B-8.)

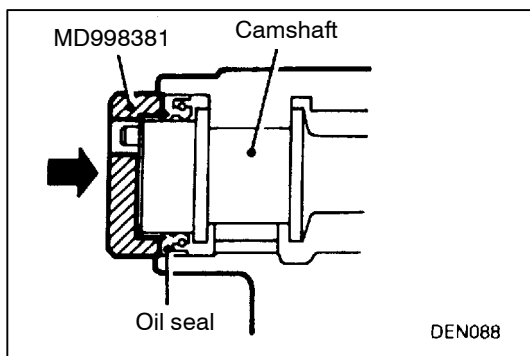

►C◄ CAMSHAFT OIL SEAL INSTALLATION

1. Apply a small amount of engine oil to the entire circumference of the oil seal lip and camshaft.
2. Use the special tool to tap in the oil seal.

NOTE

The oil seal should be tapped in until the distance from the end of the camshaft to the end of the oil seal is as shown in the illustration.

►D◄ CAMSHAFT SPROCKET INSTALLATION

1. Use the special tool in the same way as during removal to stop the camshaft sprocket from turning, and then tighten the bolt to the specified torque.

Tightening torque: 64 – 67 Nm

2. Remove the cord which binds the camshaft sprocket and timing belt.

OIL PAN AND OIL SCREEN

11200250451

REMOVAL AND INSTALLATION

Pre-removal and Post-installation Operation

- Under Cover Removal and Installation
- Crossmember Assembly Removal and Installation
- Engine Oil Draining and Supplying (Refer to GROUP 12 – On-vehicle Service.)
- Alternator Removal and Installation (Refer to GROUP 16 – Alternator.)
- Stabilizer Bar Removal and Installation (Refer to GROUP 33A – Stabilizer Bar.)

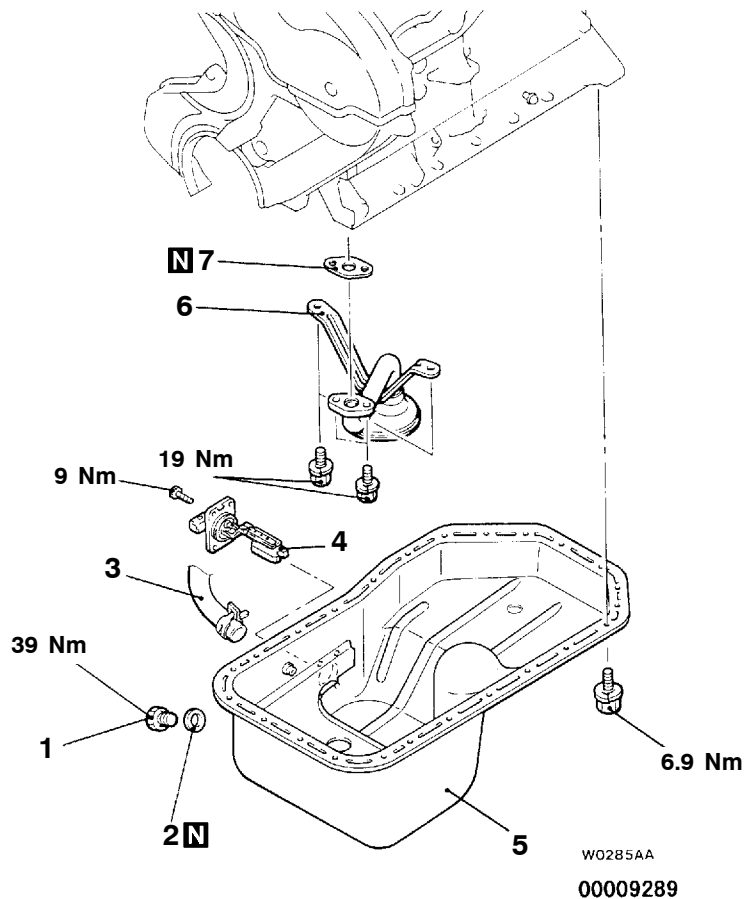
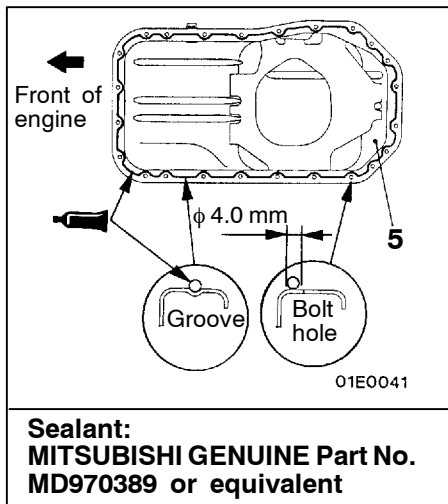

Removal steps

- B◄
1. Drain plug
 2. Drain plug gasket
 3. Oil return hose connection
 4. Oil level sensor

- ◄A► ►A◄
5. Oil pan
 6. Oil screen
 7. Gasket

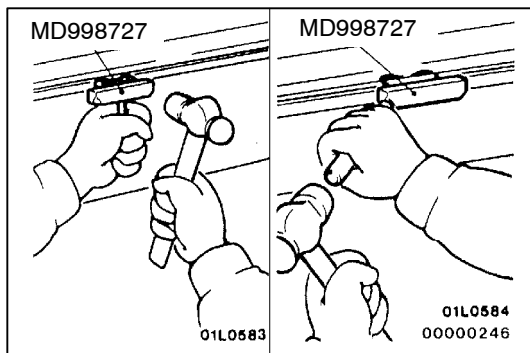

REMOVAL SERVICE POINT

◄A► **OIL PAN REMOVAL**

1. Remove oil pan bolts.
2. Tap the special tool in between the oil pan and cylinder block.
3. Slide the special tool by tapping it at an angle to remove the oil pan.

Caution

The use of a screwdriver or chisel in place of the special tool can damage the gasket seat surface and cause oil leakage.

INSTALLATION SERVICE POINTS**▶A◀ OIL PAN INSTALLATION**

1. Remove sealant from oil pan and cylinder block mating surfaces.
2. Degrease the sealant-coated surface and the engine mating surface.
3. Apply the specified sealant around the gasket surface of oil pan.

Specified sealant:

mitsubishi GENUINE PART No. MD970389 or equivalent

NOTE

The sealant should be applied in a continuous bead approximately 4 mm in diameter.

4. Assemble oil pan to cylinder block within 15 minutes after applying the sealant.

Caution

After installing the oil pan, wait at least 1 hour before starting the engine.

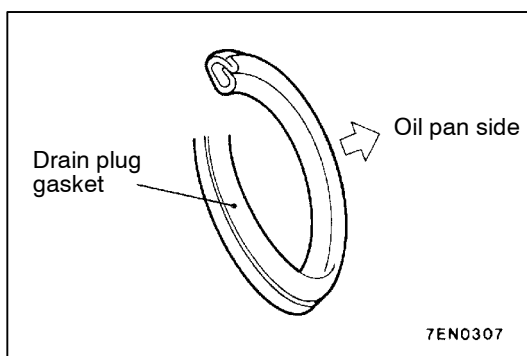
**▶B◀ DRAIN PLUG GASKET INSTALLATION**

Install a new gasket in the direction so that it faces as shown in the illustration.

INSPECTION

11200260041

- Check oil pan for cracks.
- Check oil pan sealant-coated surface for damage and deformation.
- Check oil screen for cracked, clogged or damaged wire net and pipe.

CYLINDER HEAD GASKET

11200401031

REMOVAL AND INSTALLATION

Pre-removal Operation

- Intake and Exhaust Manifold Removal (Refer to GROUP 15.)
- Timing Belt Removal (Refer to P.11B-26.)
- Engine Coolant Draining (Refer to GROUP 14 – On-vehicle Service.)

Post-installation Operation

- Timing Belt Installation (Refer to P.11B-26.)
- Intake and Exhaust Manifold Installation (Refer to GROUP 15.)
- Fuel Line Air Bleeding (Refer to GROUP 13B – On-vehicle Service.)
- Engine Coolant Filling (Refer to GROUP 14 – On-vehicle Service.)

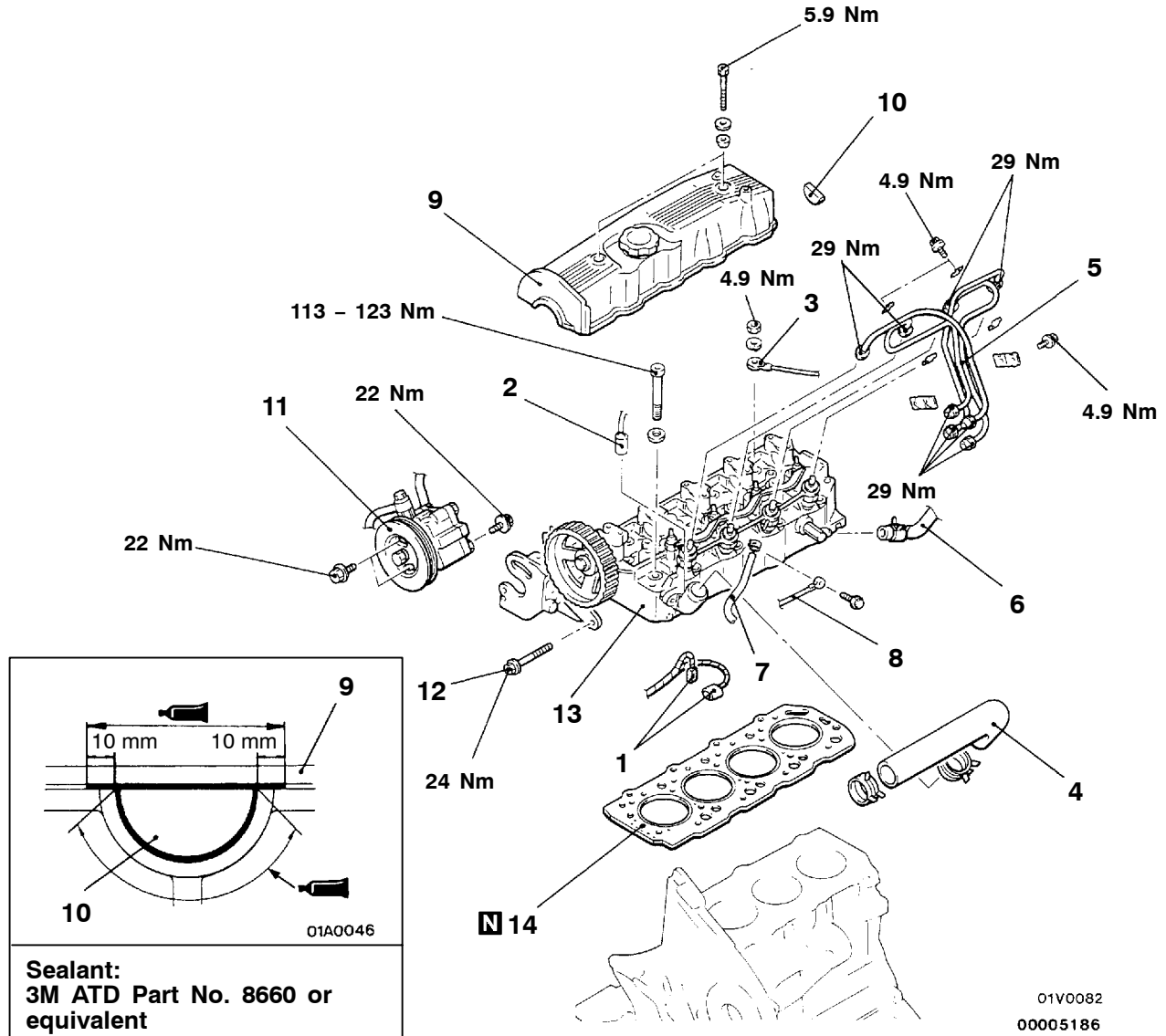

Sealant:
3M ATD Part No. 8660 or equivalent

Removal steps

1. Engine coolant temperature switch connector (for A/C)
2. Engine coolant temperature gauge unit and sensor connector
3. Glow plug terminal
4. Radiator upper hose
5. Fuel injection pipe
6. Heater hose or water by-pass hose connection



7. Fuel hose connection
8. Earth cable connection
9. Rocker cover
10. Semi-circular packing
11. Power steering oil pump assembly
12. Power steering oil pump bracket bolt
13. Cylinder head assembly
14. Cylinder head gasket

REMOVAL SERVICE POINTS

◀A▶ RADIATOR UPPER HOSE DISCONNECTION

After making mating marks on the radiator upper hose and the hose clamp, disconnect the radiator upper hose.

◀B▶ FUEL INJECTION PIPE REMOVAL

When loosening nuts at both ends of injection pipe, hold the delivery holder (for pump side) and the injection nozzle assembly (for nozzle side) with wrench and loosen nut.

Caution

After disconnecting the injection pipe, plug the opening so that no foreign particles get inside the pump or into the injection nozzle.

◀C▶ POWER STEERING OIL PUMP REMOVAL

Remove the power steering oil pump from the bracket with the hose attached.

NOTE

Place the removed power steering oil pump in a place where it will not be a hindrance when removing and installing the engine assembly, and tie it with a cord.

◀D▶ CYLINDER HEAD ASSEMBLY REMOVAL

Use the special tool to tighten each bolt 2 – 3 times in the order shown in the illustration.

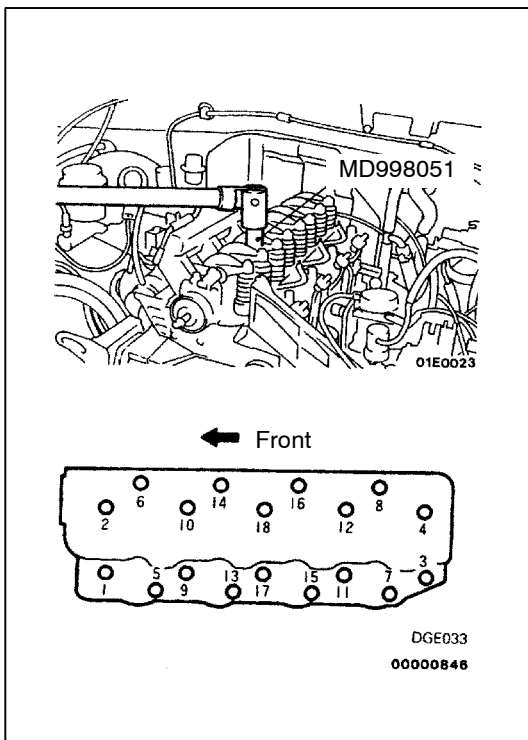
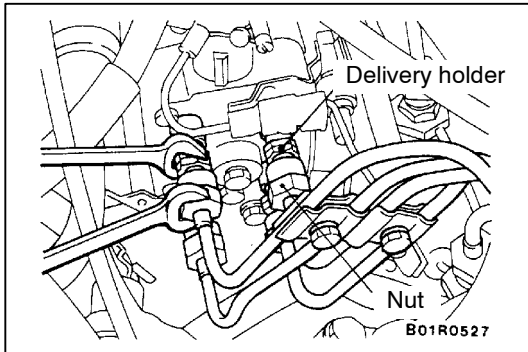

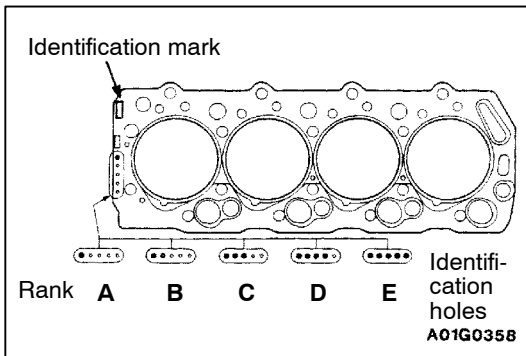

INSTALLATION SERVICE POINTS

►A◄ CYLINDER HEAD GASKET INSTALLATION

1. Wipe off any oil or grease from the gasket mounting surface.
2. Check the rank from the number of identification holes on the cylinder head gasket that was removed, and select a cylinder head gasket of the same rank.

NOTE

The ranks are listed in the parts catalogue.

3. Place the cylinder head gasket on top of the cylinder block so that the identification mark is facing upwards as in the illustration.

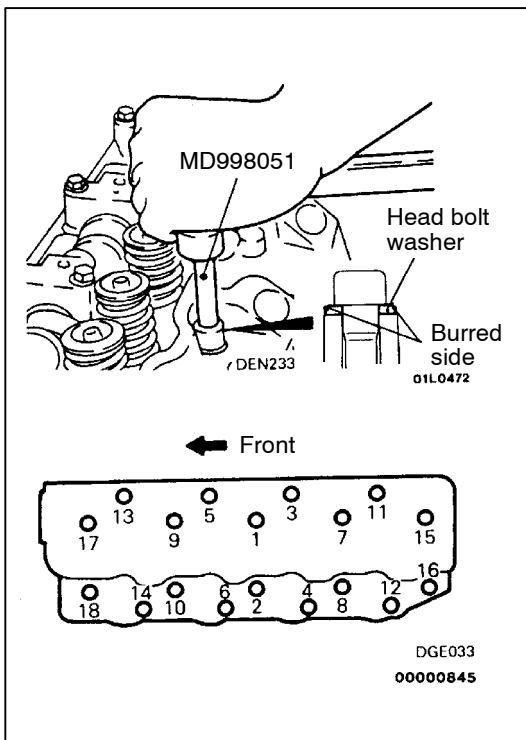

►B◄ CYLINDER HEAD INSTALLATION

Use the special tool to tighten each bolt 2 – 3 times in the order shown in the illustration.

Caution

The head bolt washer should be installed so that the burred side is facing upwards.

►C◄ RADIATOR UPPER HOSE CONNECTION

To reuse the radiator upper hose, align the mating marks that were made during removal, and then install the hose clamp.

►D◄ FUEL INJECTION PIPE INSTALLATION

When tightening the nuts at both ends of the fuel injection pipe, hold the delivery holder (for pump side) and the injection nozzle assembly (for nozzle side) with a wrench, and tighten the nuts to the specified torque.

TIMING BELT AND TIMING BELT B

REMOVAL AND INSTALLATION

Pre-removal Operation

- Cooling Fan Removal (Refer to GROUP 14.)

Post-installation Operation

- Cooling Fan Installation (Refer to GROUP 14.)
- Engine Adjustment (Refer to P.11B-5.)

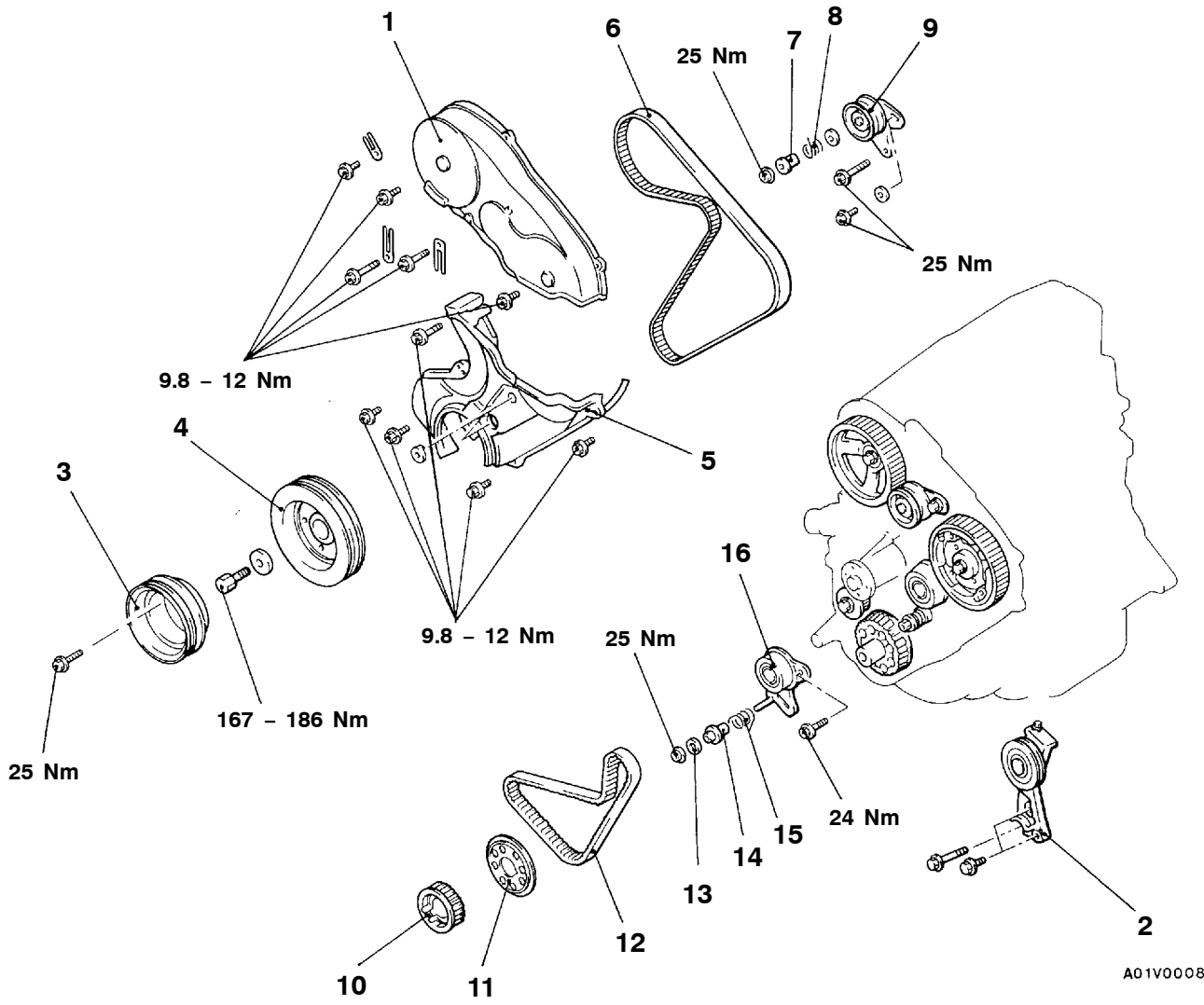

A01V0008

Removal steps

1. Timing belt front upper cover
2. Tension pulley bracket (for A/C)
3. Crankshaft pulley (for power steering and A/C)
4. Crankshaft pulley
5. Timing belt front lower cover
6. Timing belt
7. Tensioner spacer
8. Tensioner spring

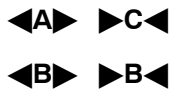

9. Timing belt tensioner assembly
10. Crankshaft sprocket
11. Flange
12. Timing belt B
13. Gasket
14. Tensioner spacer B
15. Tensioner spring B
16. Timing belt tensioner B

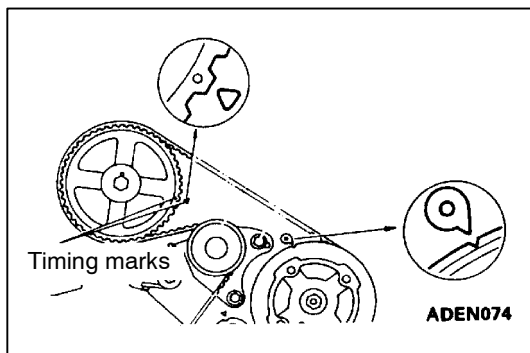
**REMOVAL SERVICE POINTS****◀A▶ CRANKSHAFT PULLEY REMOVAL**

1. Position the No. 1 cylinder at compression TDC and remove the crankshaft pulley.

NOTE

The No. 1 cylinder is at compression TDC when the marks are aligned as shown in the figure.

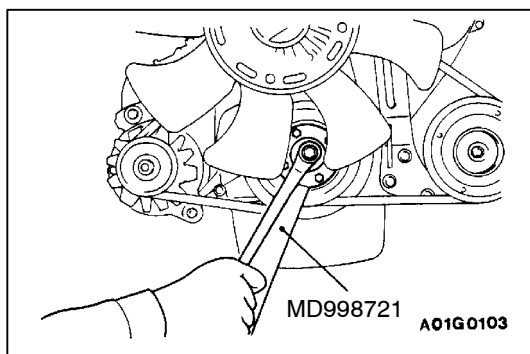

2. Use the special tool to keep crankshaft from turning and remove the bolts.

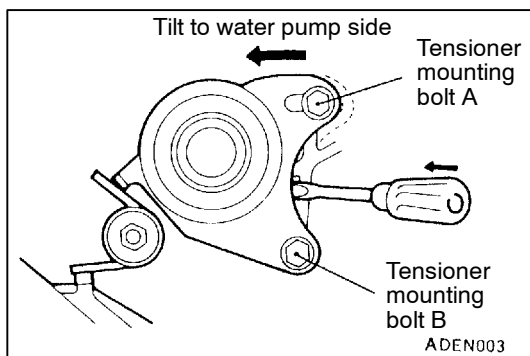
**◀B▶ TIMING BELT REMOVAL**

1. When reinstalling timing belt, mark an arrow at the belt to show rotation direction.
2. Loosen the tensioner mounting bolt A and B.
3. Push timing belt tensioner to water pump side and tighten the tensioner mounting bolt A and B. Secure so that tensioner will not move back.

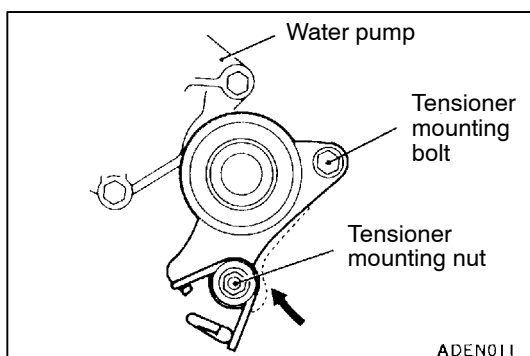
**◀C▶ TIMING BELT B REMOVAL**

1. When reinstalling timing belt B, mark an arrow at the belt to show rotation direction.
2. Loosen the tensioner mounting bolt and nut.
3. Push timing belt tensioner to water pump side and tighten the tensioner mounting bolt and nut. Secure so that tensioner will not move back.

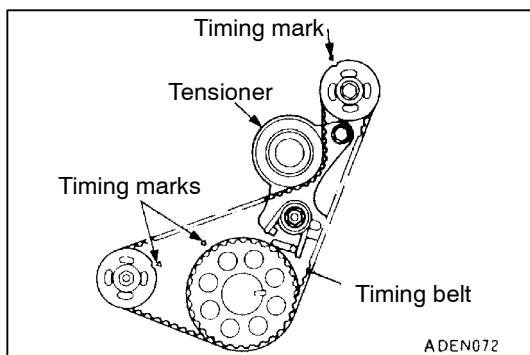
**INSTALLATION SERVICE POINTS****▶A▶ TIMING BELT B INSTALLATION**

1. Align the timing marks of the 3 sprockets.
2. When reusing timing belt B, make sure the arrow mark is pointing in the same direction as when the belt was removed.

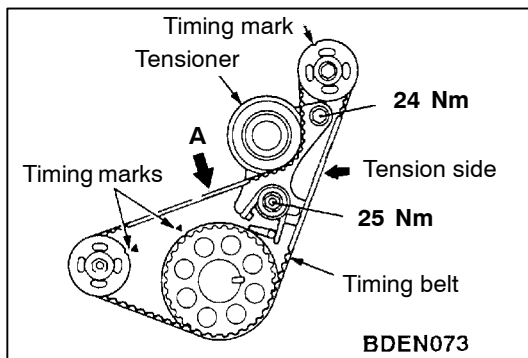

3. Install timing belt B and make sure there is no deflection on the tension side.
4. Press the deflection side of timing belt B (indicated by arrow (A)) with the hand and fully stretch the tensioner side.
5. Make sure that the timing marks are aligned.
6. Loosen the tensioner mounting bolt and nut so that only the pressure of the spring is applied to timing belt B.
7. Tighten the tensioner mounting bolt and nut, tightening the nut first. If the bolt is tightened first, the tensioner will move and tension the belt.

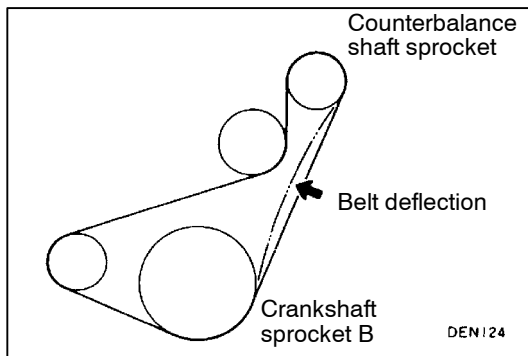

8. Press in the direction of the arrow in the figure with the index finger to check the amount of deflection.

Standard value: 4 – 5 mm

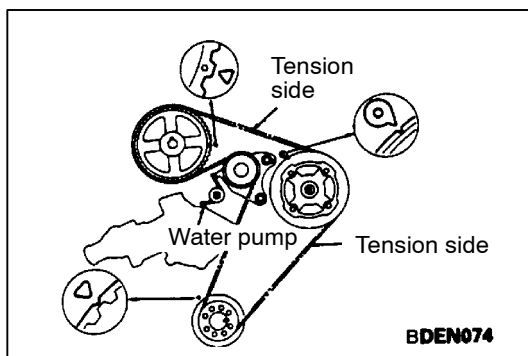

►B◀ TIMING BELT INSTALLATION

1. Align the timing marks of the 3 sprockets.
2. When reusing timing belt, make sure the arrow mark is pointing in the same direction as when the belt was removed.
3. Install the timing belt to the crankshaft sprocket, to injection pump sprocket, to tensioner and to camshaft sprocket in that order. Being careful not to allow deflection on the tension side of the timing belt.

Caution

- (1) Engage the belt on the various sprockets while maintaining tension on the belt of tension side.
- (2) Align the injection pump sprocket with the timing mark, hold the sprocket so that it does not turn and engage the belt.

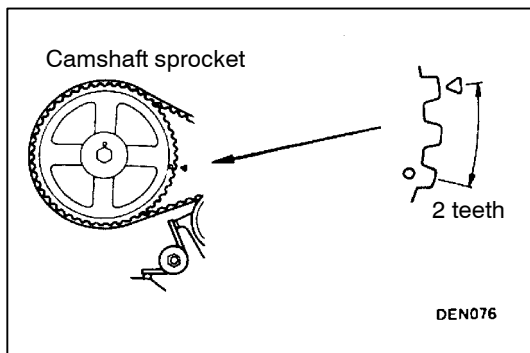

4. Loosen the tensioner mounting bolts and apply tension with the spring.
5. Turn the crankshaft clockwise and stop at the second lobe of the camshaft sprocket.

Caution

- (1) When turning the crankshaft in item (5), strictly observe the specified amount of rotation (2 teeth on the camshaft sprocket) in order to apply a constant force to the tension side of the belt.
- (2) Do not turn the crankshaft counterclockwise.
- (3) Do not touch the belt during adjustment.

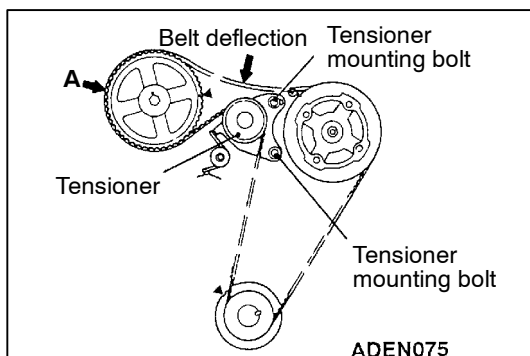

6. Make sure that the part indicated by arrow A does not float upward.
7. Tighten the tensioner mounting bolts, starting with the bolt in the elongated hole. If the lower bolt is tightened first, belt tension will become too tight.

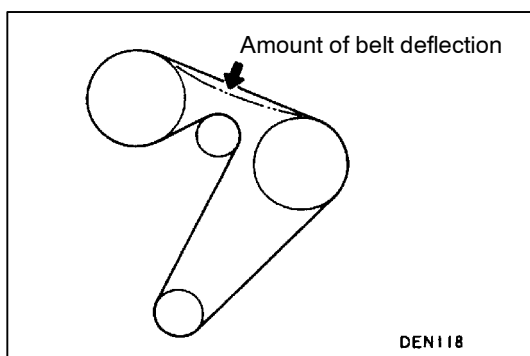

8. Turn the crankshaft anticlockwise and align the timing mark. Next, make sure that the timing marks of all sprockets are aligned.
9. Press on the centre of the bolt with an index finger to check the amount of deflection.

Standard value: 4 – 5 mm

►C◄ CRANKSHAFT PULLEY INSTALLATION

Using the special tool to install the crankshaft pulley as same as removal procedure.

CRANKSHAFT FRONT OIL SEAL

REMOVAL AND INSTALLATION

Pre-removal and Post-installation Operation

- Timing Belt and Timing Belt “B” Removal and Installation (Refer to P.11B-26.)

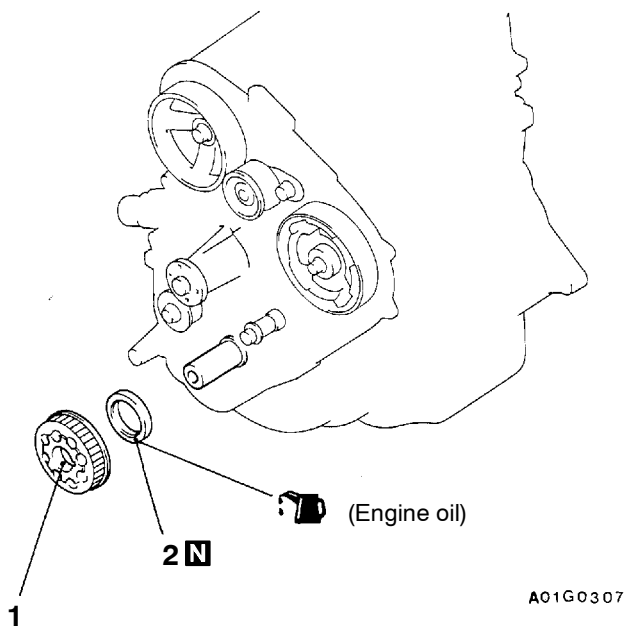

Removal steps

1. Crankshaft sprocket B
2. Oil seal

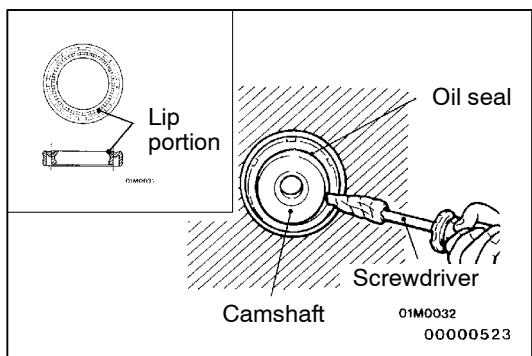

REMOVAL SERVICE POINT

◀A▶ OIL SEAL REMOVAL

1. Cut out a portion in the crankshaft oil seal lip.
2. Cover the tip of a screwdriver with a cloth and apply it to the cutout in the oil seal to pry off the oil seal.

Caution

Be careful not to damage the crankshaft and front case.

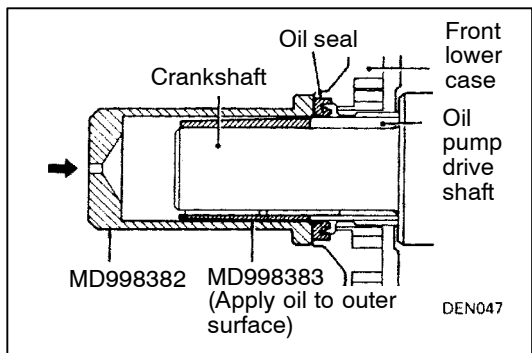

INSTALLATION SERVICE POINT

▶A◀ OIL SEAL INSTALLATION

Apply engine oil to the outside of the special tool (MD998383) and to the oil seal lip, and use the special tool to press-fit the oil seal.

CRANKSHAFT REAR OIL SEAL

REMOVAL AND INSTALLATION

Pre-removal and Post-installation Operation

- Oil Pan Removal and Installation (Refer to P.11-21.)
- Transmission Assembly Removal and Installation (Refer to GROUP 22.)

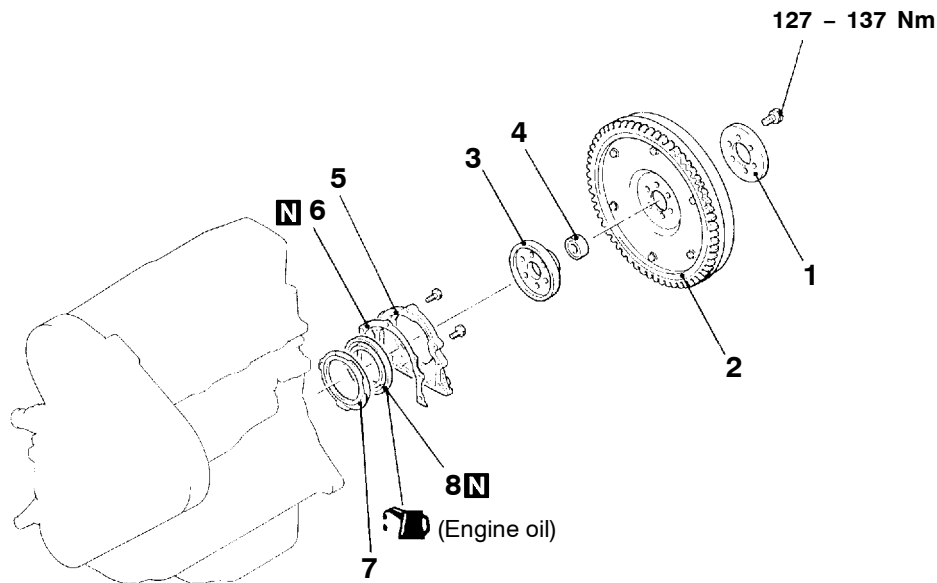

AW0286AA

Removal steps



1. Adapter
2. Flywheel assembly
3. Crankshaft adaptor
4. Ball bearing



5. Oil seal case
6. Gasket
7. Oil separator
8. Oil seal

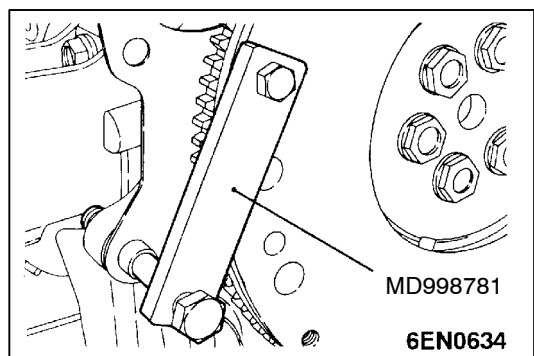

REMOVAL SERVICE POINT

<A> FLYWHEEL ASSEMBLY REMOVAL

Use the special tool to secure the flywheel assembly and remove the bolt.

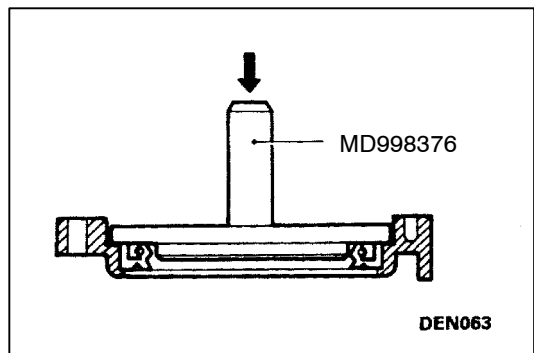

INSTALLATION SERVICE POINTS

<A> OIL SEAL INSTALLATION

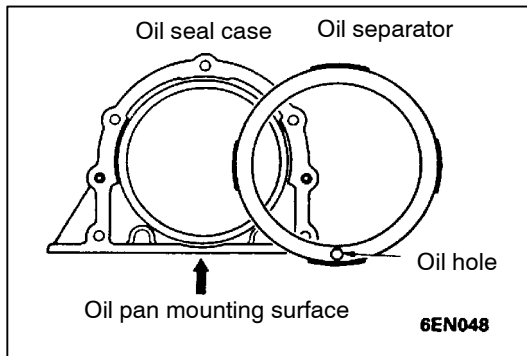
**►B◄ OIL SEPARATOR INSTALLATION**

Install the oil separator in such a way that its oil hole come at the case bottom (indicated by an arrow in the illustration).

►C◄ FLYWHEEL ASSEMBLY INSTALLATION

Use the special tool in the same way as during removal to stop the flywheel assembly from turning, and then tighten the bolt to the specified torque.

Tightening torque: 127 – 137 Nm

ENGINE ASSEMBLY

REMOVAL AND INSTALLATION

Pre-removal Operation

- Hood Removal (Refer to GROUP 42.)
- Intercooler Removal (Refer to GROUP 15.)
- Air Cleaner and Air Intake Hose Removal (Refer to GROUP 15.)
- Brake Master Cylinder Heat Protector Removal
- Battery Removal
- Radiator Removal (Refer to GROUP 14.)
- Transmission and Transfer Assembly Removal (Refer to GROUP 22.)

Post-installation Operation

- Transmission and Transfer Assembly Installation (Refer to GROUP 22.)
- Radiator Installation (Refer to GROUP 14.)
- Battery installation
- Brake Master Cylinder Heat Protector Installation
- Air Cleaner and Air Intake Hose Installation (Refer to GROUP 15.)
- Intercooler Installation (Refer to GROUP 15.)
- Hood Installation (Refer to GROUP 42.)
- Drive Belt Tension Adjustment (Refer to P.11B-5.)
- Accelerator Cable Adjustment (Refer to GROUP 17 – On-vehicle Service.)

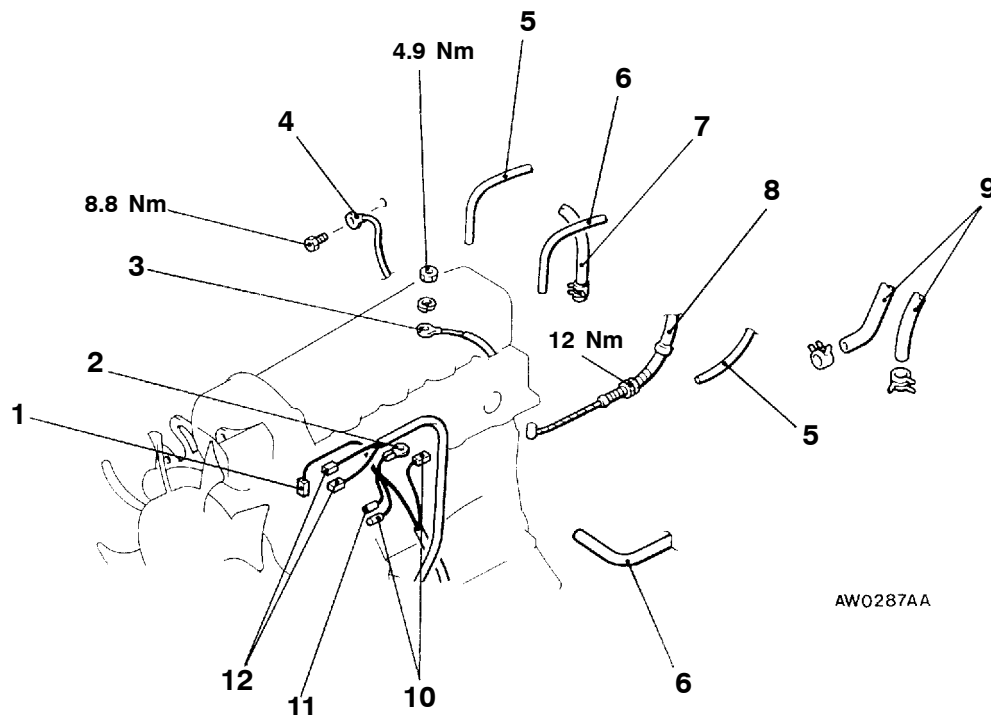
**Removal steps**

1. Engine coolant temperature sensor and gauge unit connector
2. Earth cable connector
3. Glow plug terminal
4. Earth cable connector
5. Vacuum hose connection (for A/C)
6. Vacuum hose connection (for ABS)
7. Brake booster vacuum hose connection
8. Accelerator cable connection
9. Heater hose connections
10. Fuel cut solenoid valve or fuel cut valve controller connector
11. Revolution pick-up sensor connector
12. Engine coolant temperature switch connector (for A/C)

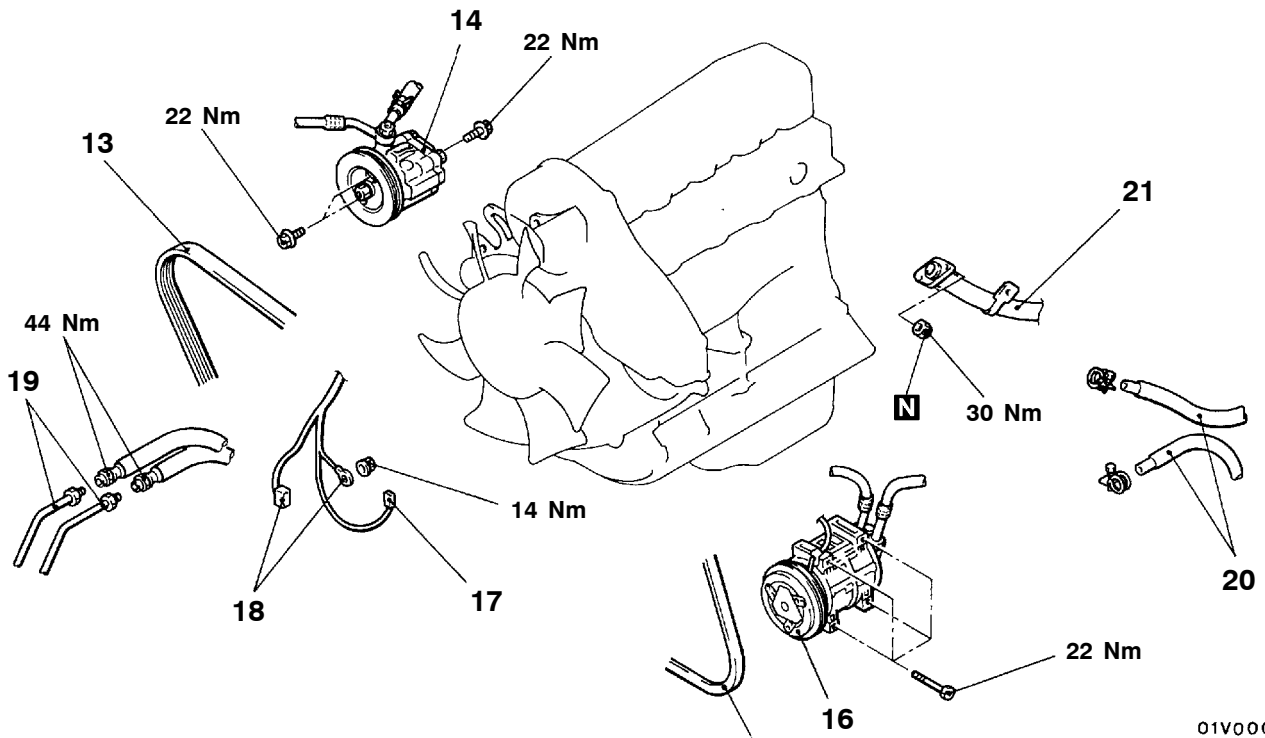

01V0006

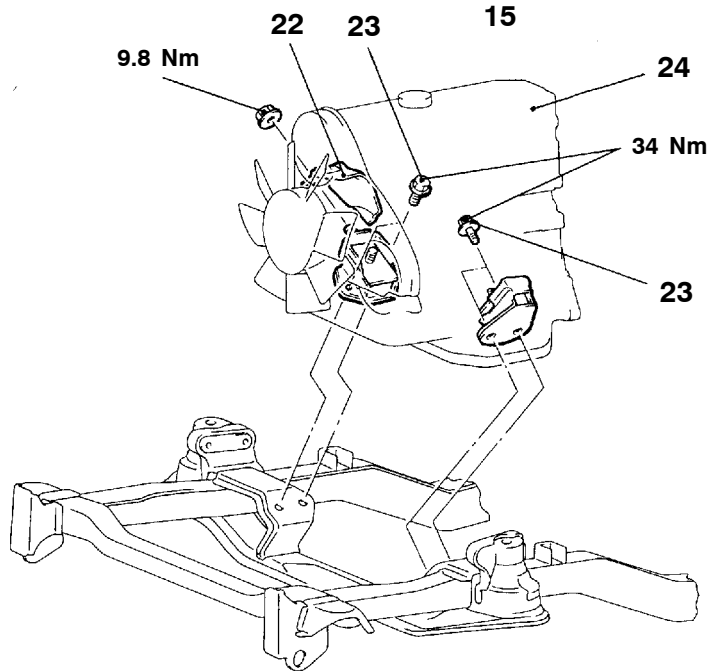

01V0012
00005187



- 13. Drive belt (for Power steering)
- 14. Power steering oil pump assembly
- 15. Drive belt (for A/C)
- 16. A/C compressor assembly
- 17. Engine oil pressure switch connector
- 18. Alternator connector



- 19. Engine oil cooler hose connection
- 20. Fuel hose connections
- 21. Front exhaust pipe connection
- 22. Heat protector
- 23. Engine support front insulator attaching bolt
- 24. Engine assembly

REMOVAL SERVICE POINTS**◀A▶ POWER STEERING OIL PUMP ASSEMBLY AND A/C COMPRESSOR ASSEMBLY REMOVAL**

1. Remove the oil pump and A/C compressor (with the hose attached).
2. Suspend the removed oil pump (by using wire or similar material) at a place where no damage will be caused during removal/installation of the engine assembly.

◀B▶ ENGINE ASSEMBLY REMOVAL

1. Check that all cables, hoses, harness connectors, etc. are disconnected from the engine.
2. Lift the chain block slowly to remove the engine assembly upward from the engine compartment.

INSTALLATION SERVICE POINT**▶A◀ ENGINE ASSEMBLY INSTALLATION**

Install the engine assembly. When doing so, check carefully that all pipes and hoses are connected, and that none are twisted, damaged, etc.

NOTES

ENGINE LUBRICATION

CONTENTS

12109000174

GENERAL INFORMATION	2	Engine Oil Replacement	3
LUBRICANTS	3	Oil Filter Replacement	4
SPECIAL TOOLS	3	Oil Level Warning System Check	5
ON-VEHICLE SERVICE	3	ENGINE OIL COOLER <4D5>	7
Engine Oil Check	3		

GENERAL INFORMATION

12100010176

The lubrication method is a fully force-fed, full-flow filtration type.

The corrugate fin type of engine oil cooler have been adopted, and installed forward of the radiator. <4D5>

Items	6G7, 4D5
Oil pump type	Trochoid type
Drive method	Crankshaft

ENGINE OILS

Health Warning

Prolonged and repeated contact with mineral oil will result in the removal of natural fats from the skin, leading to dryness, irritation and dermatitis. In addition, used engine oil contains potentially

harmful contaminants which may cause skin cancer. Adequate means of skin protection and washing facilities must be provided.

Recommended Precautions

The most effective precaution is to adapt working practices which prevent, as far as practicable, the risk of skin contact with mineral oils, for example by using enclosed systems for handling used engine oil and by degreasing components, where practicable, before handling them.

Other precautions:

- Avoid prolonged and repeated contact with oils, particularly used engine oils.
- Wear protective clothing, including impervious gloves where practicable.
- Avoid contaminating clothes, particularly underpants, with oil.
- Do not put oily rags in pockets, the use of overalls without pockets will avoid this.
- Do not wear heavily soiled clothing and oil-impregnated foot-wear. Overalls must be cleaned regularly and kept separate from personal clothing.

- Where there is a risk of eye contact, eye protection should be worn, for example, chemical goggles or face shields; in addition an eye wash facility should be provided.
- Obtain First Aid treatment immediately for open cuts and wounds.
- Wash regularly with soap and water to ensure all oil is removed, especially before meals (skin cleansers and nail brushes will help). After cleaning, the application of preparations containing lanolin to replace the natural skin oils is advised.
- Do not use petrol, kerosine, diesel fuel, gas oil, thinners or solvents for cleaning skin.
- Use barrier creams, applying them before each work period, to help the removal of oil from the skin after work.
- If skin disorders develop, obtain medical advice without delay.

LUBRICANTS

12100040304

Items		6G7	4D5
Engine oil API classification		SG or higher	CD or higher
Engine oil quantity L	Oil filter	0.3	0.8
	Oil cooler	–	0.4
	Total	4.5	6.5

SPECIAL TOOLS

12100060171

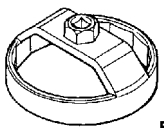
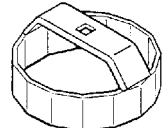
Tool	Number	Name	Use
 B991610	MB991610	Oil filter wrench	Removal and installation of engine oil filter (When using the oil filter of MD352626) <6G7>
 H061590	MH061590	Oil filter wrench	Removal and installation of engine oil filter (When using the oil filter of MD069782 or MD326489) <4D5>

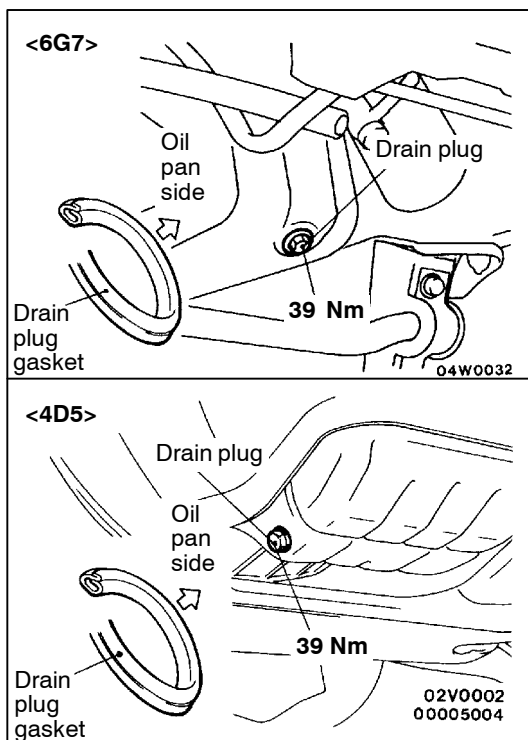

ON-VEHICLE SERVICE

12100090149

ENGINE OIL CHECK

1. Check the engine oil using the oil level gauge.
2. Check that the oil is not excessively dirty, that there is no coolant or petrol mixed in, and that it has sufficient viscosity.

ENGINE OIL REPLACEMENT

12100100286

1. Start the engine and allow it to warm up until the temperature of the coolant reaches 80°C to 90°C.
2. Remove the engine oil filler cap.
3. Remove the drain plug to drain oil.

Caution

Use care as oil could be hot.

4. Install a new drain plug gasket so that it faces in the direction shown in the illustration, and then tighten the drain plug to the specified torque.

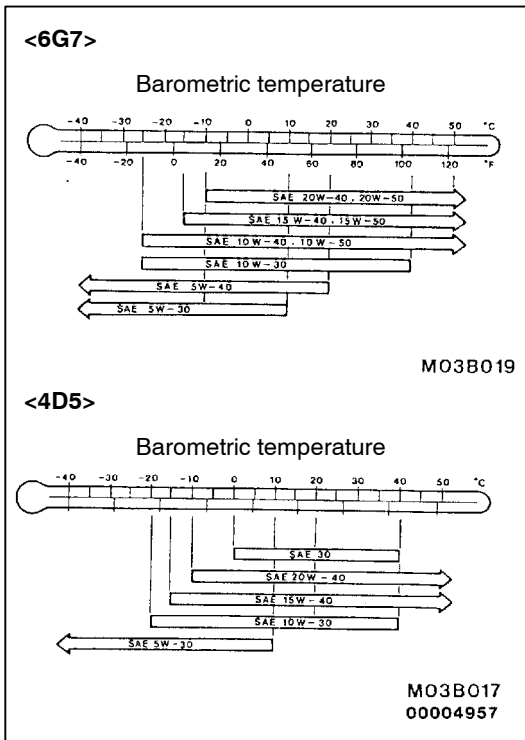

5. Refill with specified quantity of oil.

Specified Engine Oil (API classification):

<6G7> SG or higher
<4D5> CD or higher

Total quantity (Includes volume inside oil filter and oil cooler):

<6G7> 4.5 L
<4D5> 6.5 L

6. Install the engine oil filler cap.
7. Check oil level.

OIL FILTER REPLACEMENT

12100110272

1. Start the engine and allow it to warm up until the temperature of the coolant reaches 80°C to 90°C.
2. Remove the engine oil filler cap.
3. Remove the under cover.
4. Remove the drain plug to drain oil.

Caution

Use care as oil could be hot.

5. Remove the air cleaner, and cover the alternator with a rag so that oil will not get on the alternator. <4D56>
6. Use the respective tool in the following table to remove the engine oil filter.
7. Clean the filter bracket side mounting surface and ensure the old O-ring has been removed.

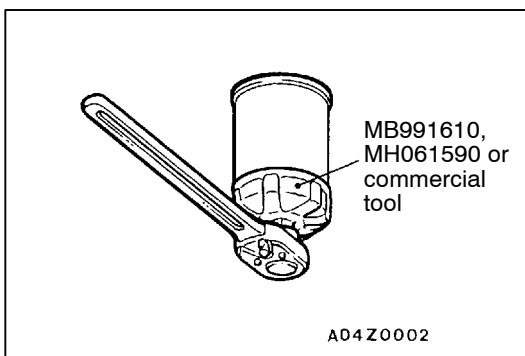

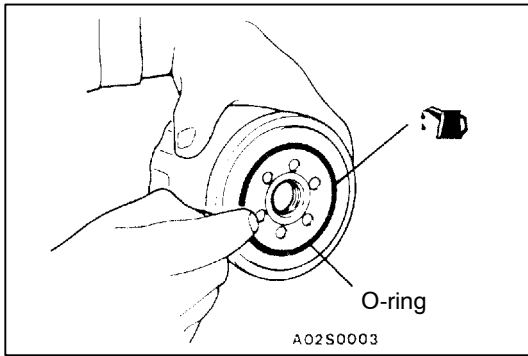

8. Apply a small amount of engine oil to the O-ring of the new oil filter.
9. Once the O-ring of the oil filter is touching the flange, use the respective tool in the following table to tighten to the specified torque.
10. Install the drain plug and refill the engine oil. (Refer to P.12-3, Engine Oil Replacement.)

Specified Engine Oil (API classification):

- <6G7> SG or higher
- <4D5> CD or higher

Total quantity (Includes volume inside oil filter and oil cooler):

- <6G7> 4.5 L
- <4D5> 6.5 L

11. Race the engine a few times, and check to be sure that no engine oil leaks from the installation section of the oil filter.

Number	Engine	Tool	Tightening torque
MD352626	6G7	MB991610 or equivalent tool	Approx. 3/4 turn (14 Nm)
MD069782	4D5	MH061590 or equivalent tool	Approx. 5/8 turn (20 Nm)
MD326489			Approx. 3/4 turn (22 Nm)

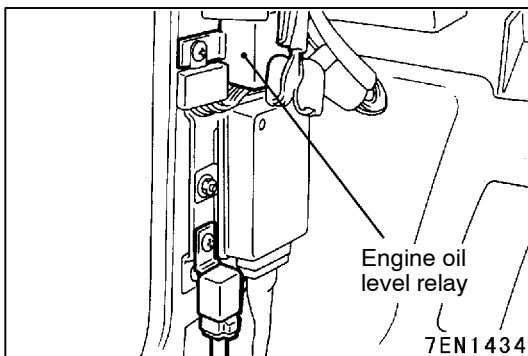

OIL LEVEL WARNING SYSTEM CHECK 12100200054

1. Check that the proper amount of oil has been filled.
2. When the ignition switch is turned to ON (do not start the engine), check that the oil level warning lamp illuminates.

NOTE

If the oil level warning lamp does not illuminate, the cause is probably a blown lamp, or a malfunction in the relay.

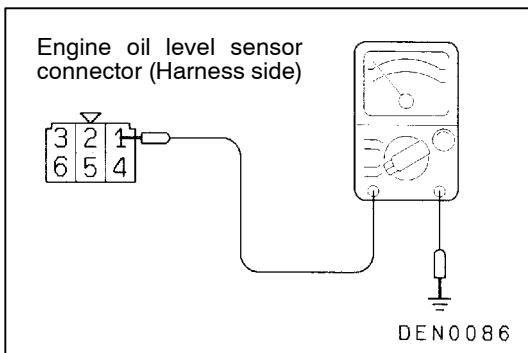

3. When the engine is started, check that the oil level warning lamp turns off.

If the oil level warning lamp will not go out, disconnect the connector of the oil level relay and measure the voltage of the No.1 terminal on the harness side of the connector while idling the engine in order to confirm that it is the same as the battery voltage.

NOTE

- (1) If the voltage at the connector is the same as the battery voltage, the problem is probably a malfunction of either the oil level relay or the oil level sensor.

- (2) If the voltage at the connector is lower than the battery voltage, the problem is probably a malfunction of either the alternator or the wiring harness.
- 4. Disconnect the oil level sensor connector. Check that the oil level warning lamp illuminates after approximately 40 seconds. If the oil level warning lamp does not illuminate, replace the oil level relay.

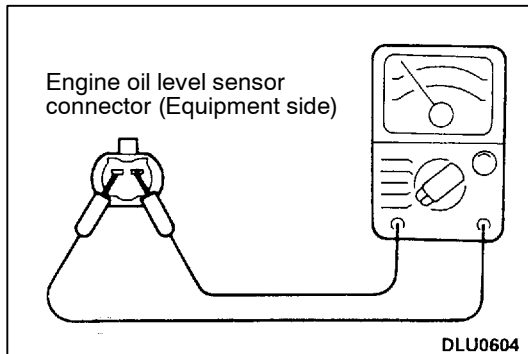

- 5. Check the continuity between the oil level sensor terminals.

Engine oil temperature	Oil level	Continuity
At 50°C or lower	Normal (proper volume)	Continuity
	Low (drained)	Continuity
At 60°C or higher	Normal (proper volume)	Continuity
	Low (drained)	No continuity

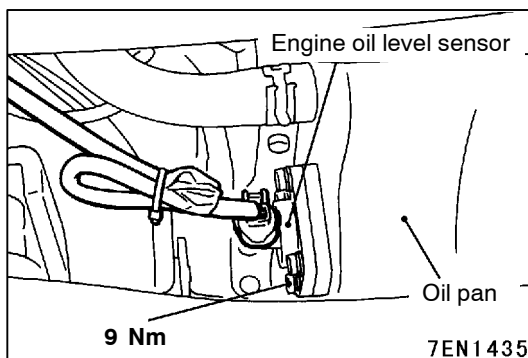

- 6. If there is a defect, replace the oil level sensor.

ENGINE OIL COOLER <4D5>

12100130193

REMOVAL AND INSTALLATION

Pre-removal Operation

- Radiator Grille Removal

Post-installation Operation

- Radiator Grille Installation
- Engine Oil Checking and Supplying (Refer to P.12-3.)

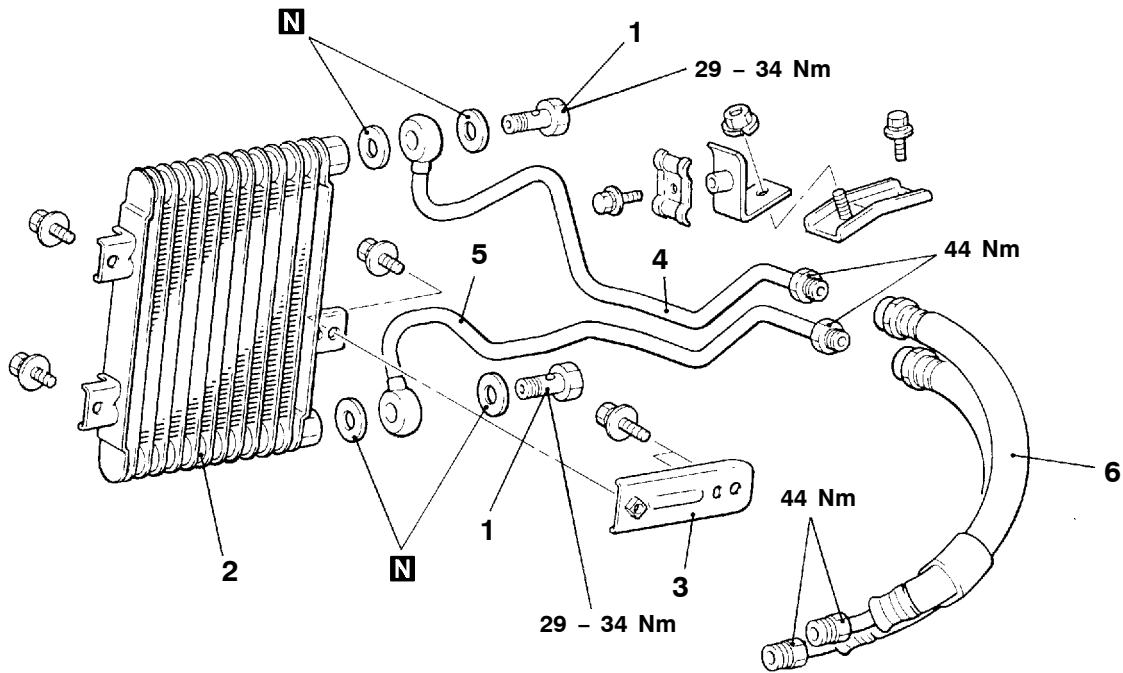

AW0177AA

Oil cooler removal steps



1. Eye bolts
2. Oil cooler assembly
3. Stay

Oil cooler tube and hose removal steps



1. Eye bolts
4. Oil return tube
5. Oil feed tube
- Engine oil filter (Refer to P.12-4.)
- ▶A◀ 6. Oil cooler hose assembly

REMOVAL SERVICE POINT

◀A▶ **EYE BOLTS REMOVAL**

Caution

Be sure to hold the weld nut of the oil cooler while loosening the eye bolt.

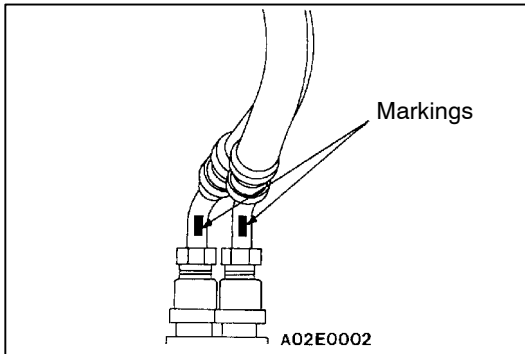

INSTALLATION SERVICE POINTS

►A◄ OIL COOLER HOSE ASSEMBLY (ENGINE SIDE) INSTALLATION

Install the oil cooler hose assembly with the markings facing upwards.

►B◄ EYE BOLT INSTALLATION

1. Provisionally tighten the eye bolt.
2. Align the white markings of the oil feed tube and oil return tube with the clamps, and then tighten them provisionally.
3. Tighten eye bolt to the specified torque.

Caution

Be sure to hold the weld nut of the oil cooler while tightening the eye bolt.

4. Tighten the clamp mounting bolt securely.

FUEL



CONTENTS

13109000720

MULTIPOINT FUEL INJECTION (MPI)	13A
DIESEL FUEL	13B
FUEL SUPPLY	13C



MULTIPOINT FUEL INJECTION (MPI)

CONTENTS

13109000737

GENERAL INFORMATION	3	Fuel Pump Operation Check	83
SERVICE SPECIFICATIONS	6	Component Location	84
SEALANT	6	Control Relay and Fuel Pump Relay Continuity Check	85
SPECIAL TOOLS	6	Intake Air Temperature Sensor Check	85
TROUBLESHOOTING	9	Engine Coolant Temperature Sensor Check	85
ON-VEHICLE SERVICE	76	Throttle Position Sensor Check	86
Throttle Body (Throttle Valve Area) Cleaning	76	Idle Position Switch Check	86
Idle Position Switch and Throttle Position Sensor Adjustment	77	Oxygen Sensor Check	87
Fixed SAS Adjustment	78	Injector Check	88
Basic Idle Speed Adjustment	78	Idle Speed Control (ISC) Servo (Stepper Motor) Check	89
Fuel Pressure Test	80	Purge Control Solenoid Valve Check	90
Fuel Pump Connector Disconnection (How to Reduce the Fuel Line Pressure)	83	EGR Control Solenoid Valve Check	90
		INJECTOR	91
		THROTTLE BODY	93

GENERAL INFORMATION

13100010739

The Multipoint Fuel Injection System consists of sensors which detect the engine conditions, the engine-ECU which controls the system based on signals from these sensors, and actuators which operate under the control of the engine-ECU. The engine-ECU carries out

activities such as fuel injection control, idle speed control and ignition timing control. In addition, the engine-ECU is equipped with several diagnosis modes which simplify troubleshooting when a problem develops.

FUEL INJECTION CONTROL

The injector drive times and injector timing are controlled so that the optimum air/fuel mixture is supplied to the engine to correspond to the continually-changing engine operation conditions.

A single injector is mounted at the intake port of each cylinder. Fuel is sent under pressure from the fuel tank by the fuel pump, with the pressure being regulated by the fuel pressure regulator. The fuel thus regulated is distributed to each of the injectors.

Fuel injection is normally carried out once for each cylinder for every two rotations of the crankshaft. The firing order is 1-2-3-4-5-6.

This is called sequential fuel injection. The engine-ECU provides a richer air/fuel mixture by carrying out "open-loop" control when the engine is cold or operating under high load conditions in order to maintain engine performance. In addition, when the engine is warm or operating under normal conditions, the engine-ECU controls the air/fuel mixture by using the oxygen sensor signal to carry out "closed-loop" control in order to obtain the theoretical air/fuel mixture ratio that provides the maximum cleaning performance from the three way catalyst.

IDLE AIR CONTROL

The idle speed is kept at the optimum speed by controlling the amount of air that bypasses the throttle valve in accordance with changes in idling conditions and engine load during idling. The engine-ECU drives the idle speed control (ISC) motor to keep the engine running at the pre-set idle target speed in accordance with the engine coolant temperature and air

conditioner load. In addition, when the air conditioner switch is turned off and on while the engine is idling, the ISC motor operates to adjust the throttle valve bypass air amount in accordance with the engine load conditions in order to avoid fluctuations in the engine speed.

IGNITION TIMING CONTROL

The power transistor located in the ignition primary circuit turns ON and OFF to control the primary current flow to the ignition coil. This controls the ignition timing in order to provide the optimum ignition timing with respect to the

engine operating conditions. The ignition timing is determined by the engine-ECU from the engine speed, intake air volume, engine coolant temperature and atmospheric pressure.

SELF-DIAGNOSIS FUNCTION

1. When an abnormality is detected in one of the sensors or actuators related to emission control, the engine warning lamp (check engine lamp) illuminates as a warning to the driver.
2. When an abnormality is detected in one of the sensors or actuators, a diagnosis code corresponding to the abnormality is output.
3. The RAM data inside the engine-ECU that is related to the sensors and actuators can be read by means of the MUT-II. In addition, the actuators can be force-driven under certain circumstances.

OTHER CONTROL FUNCTIONS

1. Fuel Pump Control
Turns the fuel pump relay ON so that current is supplied to the fuel pump while the engine is cranking or running.
2. A/C Relay Control
Turns the compressor clutch of the A/C ON and OFF.
3. Purge Control Solenoid Valve Control
Refer to GROUP 17.
4. EGR Control Solenoid Valve Control
Refer to GROUP 17.

GENERAL SPECIFICATIONS

Items		Specifications
Throttle body	Throttle bore mm	60
	Throttle position sensor	Variable resistor type
	Idle speed control servo	Stepper motor type (Stepper motor type by-pass air control system with the air volume limiter)
	Idle position switch	Rotary contact type, within throttle position sensor
Engine-ECU	Identification model No.	E2T63687
Sensors	Air flow sensor	Karman vortex type
	Barometric pressure sensor	Semiconductor type
	Intake air temperature sensor	Thermistor type
	Engine coolant temperature sensor	Thermistor type
	Oxygen sensor	Zirconia type
	Vehicle speed sensor	Magnetic resistive element type
	Camshaft position sensor	Hall element type
	Crank angle sensor	Hall element type
Actuators	Control relay type	Contact switch type
	Fuel pump relay type	Contact switch type
	Injector type and number	Electromagnetic type, 6
	Injector identification mark	EDH210
Fuel pressure regulator	Regulator pressure kPa	329

SYSTEM DIAGRAM

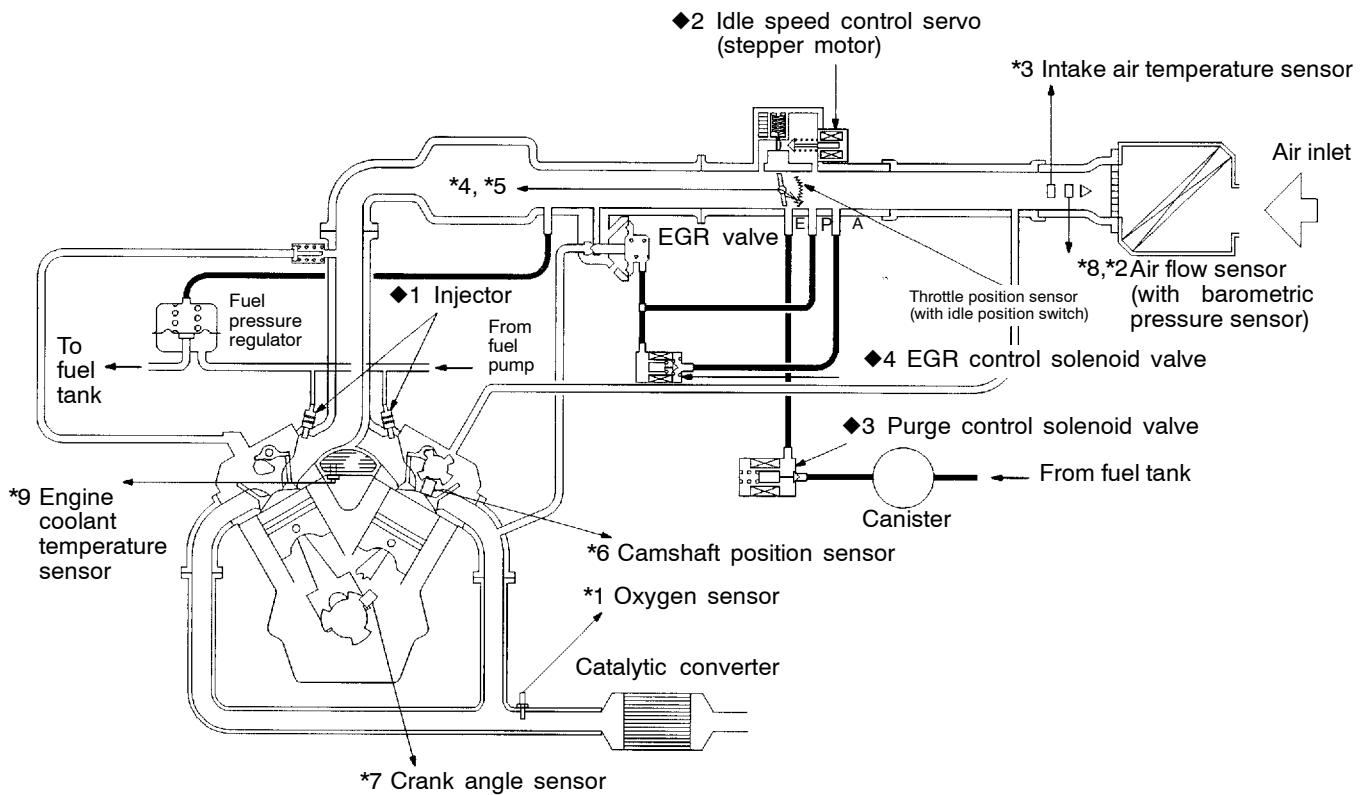
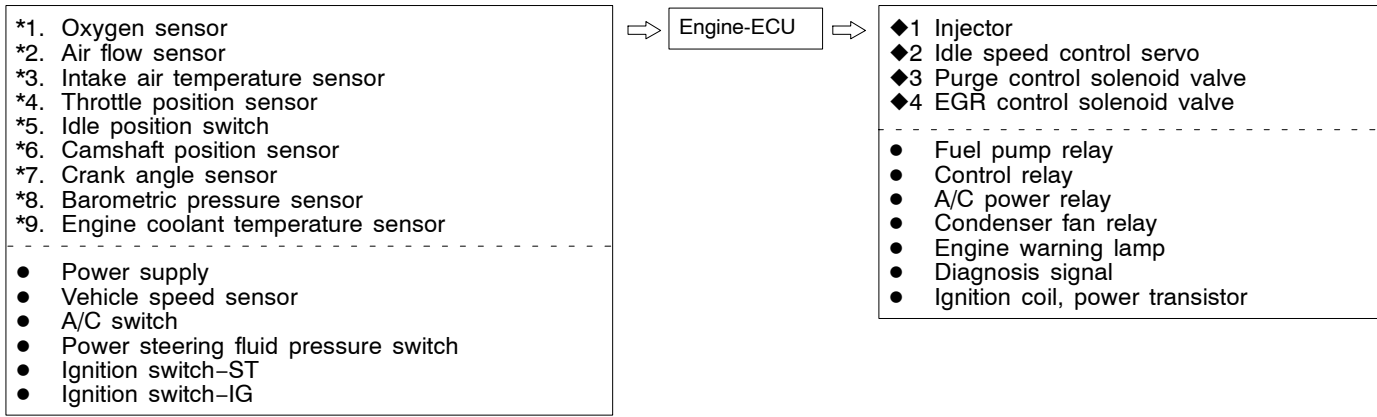

SERVICE SPECIFICATIONS

13100030513

Items		Specifications
Basic idle speed r/min		700 ± 50
Throttle position sensor adjusting voltage mV		400 – 1,000
Throttle position sensor resistance kΩ		3.5 – 6.5
Idle speed control servo coil resistance Ω		28 – 33 (at 20°C)
Intake air temperature sensor resistance kΩ	At 20°C	2.3 – 3.0
	At 80°C	0.30 – 0.42
Engine coolant temperature sensor resistance kΩ	At 20°C	2.1 – 2.7
	At 80°C	0.26 – 0.36
Oxygen sensor output voltage V		0.6 – 1.0
Fuel pressure kPa	Vacuum hose disconnection	324 – 343 at kerb idle
	Vacuum hose connection	Approx. 265 at kerb idle
Injector coil resistance Ω		13 – 16 (at 20°C)



SEALANT



13100050229

Item	Specified sealant	Remark
Engine coolant temperature sensor threaded portion	3M Nut Locking Part No. 4171 or equivalent	Drying sealant

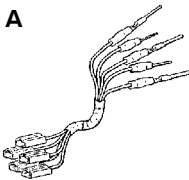
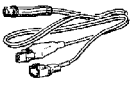
SPECIAL TOOLS

13100060574

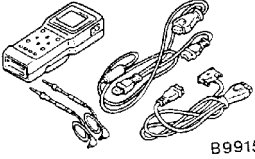
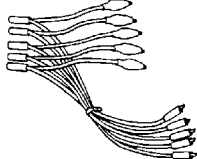
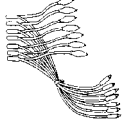
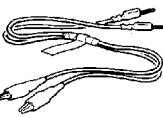
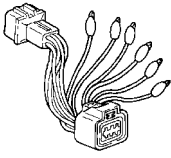
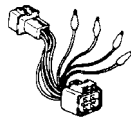
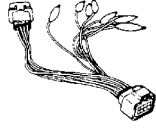
Tool	Number	Name	Use
<p>A</p>  <p>B</p>  <p>C</p>  <p>D</p> 	MB991223 A: MB991219 B: MB991220 C: MB991221 D: MB991222	Harness set A: Test harness B: LED harness C: LED harness adapter D: Probe	Measurement of terminal voltage A: Connector pin contact pressure inspection B: Power circuit inspection C: Power circuit inspection D: Commercial tester connection

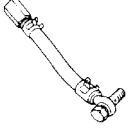
Tool	Number	Name	Use
 <p>B991502</p>	MB991502	MUT-II sub assembly	<ul style="list-style-type: none"> ● Reading diagnosis code ● MPI system inspection ● Measurement of fuel pressure
	MB991348 MB991658	Test harness set	<ul style="list-style-type: none"> ● Adjustment of idle position switch and throttle position sensor ● Inspection using an analyzer
 <p>MB991709</p>	MB991709	Test harness	<ul style="list-style-type: none"> ● Trouble shooting-voltage measurement ● Inspection using an analyzer
	MB991529	Diagnosis code check harness	<ul style="list-style-type: none"> ● Reading diagnosis code ● Adjustment of basic idle speed
	MD998463	Test harness (6-pin, square)	<ul style="list-style-type: none"> ● Inspection of idle speed control servo ● Inspection using an analyzer
	MD998464	Test harness (4-pin, square)	Inspection of oxygen sensor
	MD998474	Test harness (8 pin, square)	Inspection using an analyzer
	MD998478	Test harness (3 pin, triangle)	
	MD998709	Adaptor hose	Measurement of fuel pressure

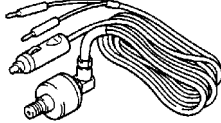
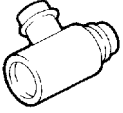
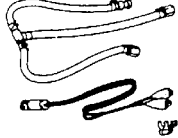
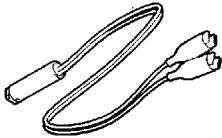
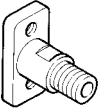
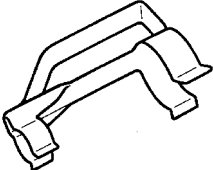
Tool	Number	Name	Use
 <p>B991637</p>	MB991637	Fuel pressure gauge set	Measurement of fuel pressure
	MD998742	Hose adaptor	
	MD998706	Injector test set	Checking the spray condition of injectors
 <p>MB991607</p>	MB991607	Injector test harness	
 <p>MD998741</p>	MD998741	Injector test adaptor	
	MB991692	Clip	

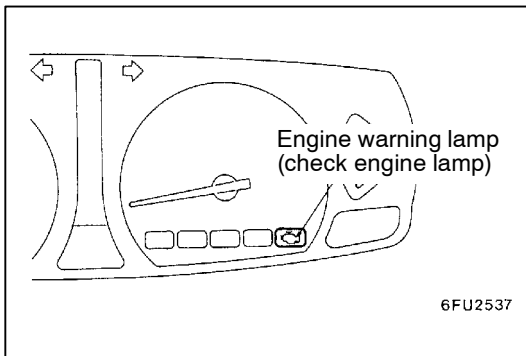

TROUBLESHOOTING

13100850485

DIAGNOSIS TROUBLESHOOTING FLOW

Refer to GROUP 00 – How to Use Troubleshooting/Inspection Service Points.

NOTE

When replacing the engine-ECU, replace immobilizer-ECU and ignition key as well at the same time.

DIAGNOSIS FUNCTION

13100860679

ENGINE WARNING LAMP (CHECK ENGINE LAMP)

If an abnormality occurs in any of the following items related to the Multipoint Fuel Injection (MPI) system, the engine warning lamp will illuminate.

If the lamp remains illuminated or if the lamp illuminates while the engine is running, check the diagnosis code output.

Engine warning lamp inspection items

Engine-ECU
Oxygen sensor
Air flow sensor
Intake air temperature sensor
Throttle position sensor
Engine coolant temperature sensor
Crank angle sensor
Camshaft position sensor
Barometric pressure sensor
Injector
Ignition coil, power transistor
Immobilizer system

METHOD OF READING AND ERASING DIAGNOSIS CODES

Refer to GROUP 00 – How to Use Troubleshooting/Inspection Service Points.

DIAGNOSIS USING DIAGNOSIS 2 MODE

1. Switch the diagnosis mode of the engine control unit to DIAGNOSIS 2 mode using the MUT-II.
2. Carry out a road test.
3. Take a reading of the diagnosis code and repair the problem location.
4. Turn the ignition switch to OFF and then back to ON again.

NOTE

By turning the ignition switch to OFF, the ENGINE-ECU will switch the diagnosis mode from DIAGNOSIS 2 mode to DIAGNOSIS 1 mode.

5. Erase the diagnosis codes.

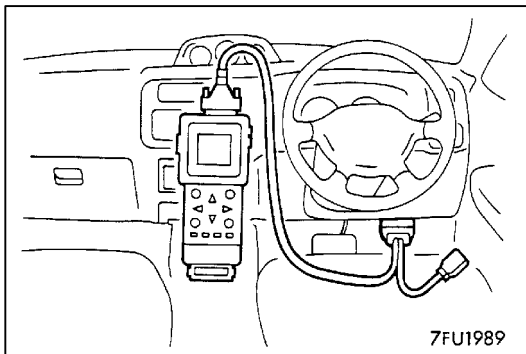
**INSPECTION USING MUT-II DATA LIST AND ACTUATOR TESTING**

1. Carry out inspection by means of the data list and the actuator test function.
If there is an abnormality, check and repair the chassis harnesses and components.
2. After repairing, re-check using the MUT-II and check that the abnormal input and output have returned to normal as a result of the repairs.
3. Erase the diagnosis code memory.
4. Remove the MUT-II.
5. Start the engine again and carry out a road test to confirm that the problem has disappeared.

FAIL-SAFE FUNCTION REFERENCE TABLE

13100910428

When the main sensor malfunctions are detected by the diagnosis function, the vehicle is controlled by means of the pre-set control logic to maintain safe conditions for driving.

Malfunctioning item	Control contents during malfunction
Air flow sensor	<ol style="list-style-type: none"> 1. Uses the throttle position sensor signal and engine speed signal (crank angle sensor signal) to take reading of the basic injector drive time and basic ignition timing from the pre-set mapping. 2. Fixes the ISC servo in the appointed position so idle control is not performed.
Intake air temperature sensor	Controls as if the intake air temperature is 25°C.
Throttle position sensor (TPS)	No increase in fuel injection amount during acceleration due to the throttle position sensor signal.
Engine coolant temperature sensor	Controls as if the engine coolant temperature is 80°C.
Camshaft position sensor	Injects fuel to all cylinders simultaneously. (However, after the ignition switch is turned to ON, the No. 1 cylinder top dead centre is not detected at all.)
Barometric pressure sensor	Controls as if the barometric pressure is 101 kPa.
Ignition coil, power transistor unit	Cut off the fuel supply to cylinders with an abnormal ignition signal.
Oxygen sensor	Air/fuel ratio feed back control (closed loop control) is not performed.

INSPECTION CHART FOR DIAGNOSIS CODES

13100870818

Code No.	Diagnosis item	Reference page
11	Oxygen sensor system	13A-13
12	Air flow sensor system	13A-14
13	Intake air temperature sensor system	13A-14
14	Throttle position sensor system	13A-15
21	Engine coolant temperature sensor system	13A-16
22	Crank angle sensor system	13A-17
23	Camshaft position sensor system	13A-18
24	Vehicle speed sensor system	13A-19
25	Barometric pressure sensor system	13A-20
41	Injector system	13A-21
44	Ignition coil and power transistor unit system (for No. 1 and No. 4 cylinders)	13A-22
52	Ignition coil and power transistor unit system (for No. 2 and No. 5 cylinders)	13A-22
53	Ignition coil and power transistor unit system (for No. 3 and No. 6 cylinders)	13A-22
54	Immobilizer system	13A-23

INSPECTION PROCEDURE FOR DIAGNOSIS CODES

Code No.11 Oxygen sensor system	Probable cause
<p>Range of Check</p> <ul style="list-style-type: none"> • 3 minutes have passed after engine was started. • Engine coolant temperature is approx. 80°C or more. • Intake air temperature is 20 – 50°C • Engine speed is approx. 2,000 – 3,000 r/min • Vehicle is moving at constant speed on a flat, level road surface <p>Set conditions</p> <ul style="list-style-type: none"> • The oxygen sensor output voltage is around 0.6 V for 30 seconds (does not cross 0.6 V for 30 seconds). • When the range of check operations given above which accompany starting of the engine are carried out four time in succession, a problem is detected after each operation. 	<ul style="list-style-type: none"> • Malfunction of the oxygen sensor • Improper connector contact, open circuit or short-circuited harness wire • Malfunction of the engine-ECU

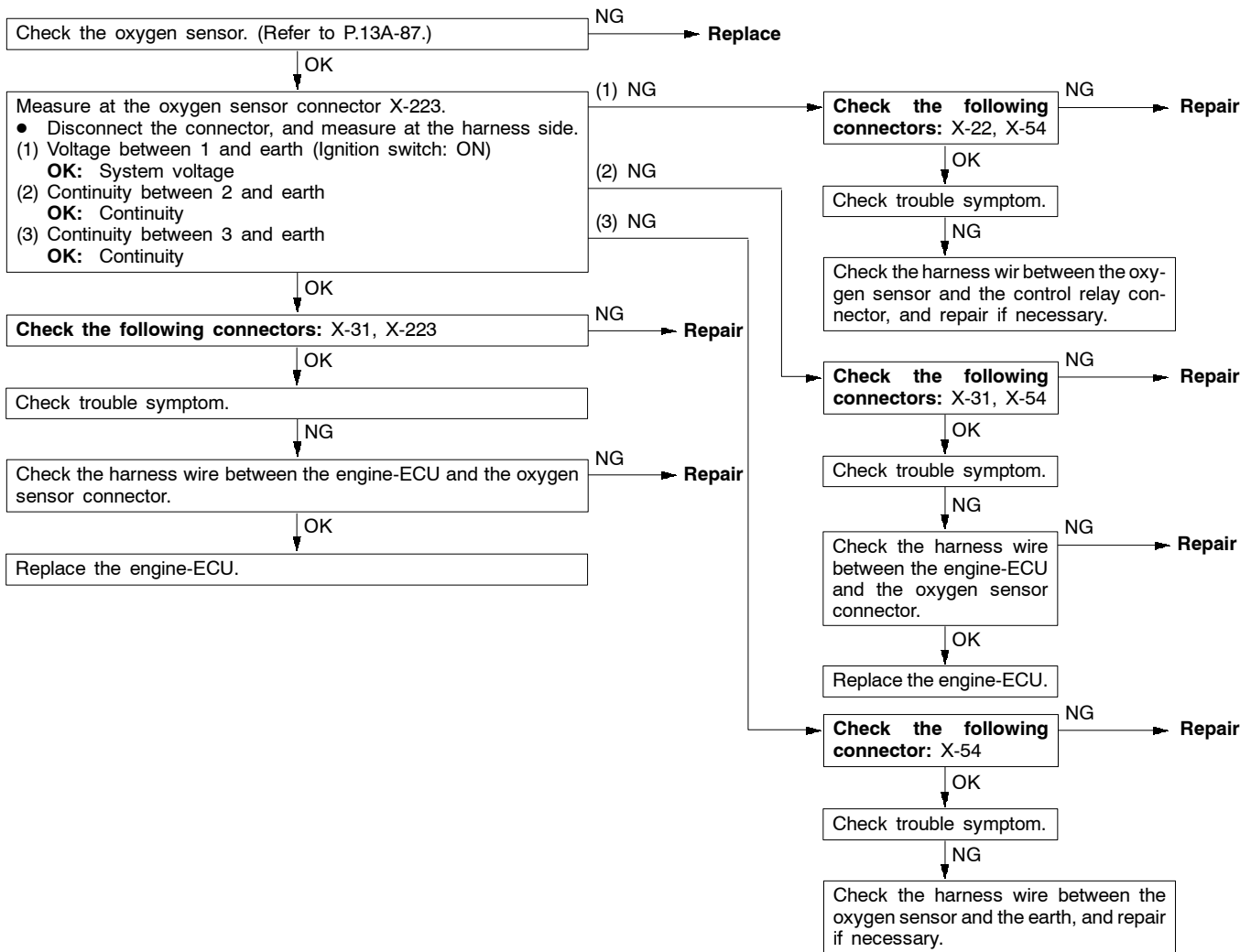

Code No. 12 Air flow sensor system	Probable cause
<p>Range of Check</p> <ul style="list-style-type: none"> Engine speed is 500 r/min or more. <p>Set conditions</p> <ul style="list-style-type: none"> Sensor output frequency is 3 Hz or less for 4 seconds. 	<ul style="list-style-type: none"> Malfunction of the air flow sensor Improper connector contact, open circuit or short-circuited harness wire of the air flow sensor Malfunction of the engine-ECU

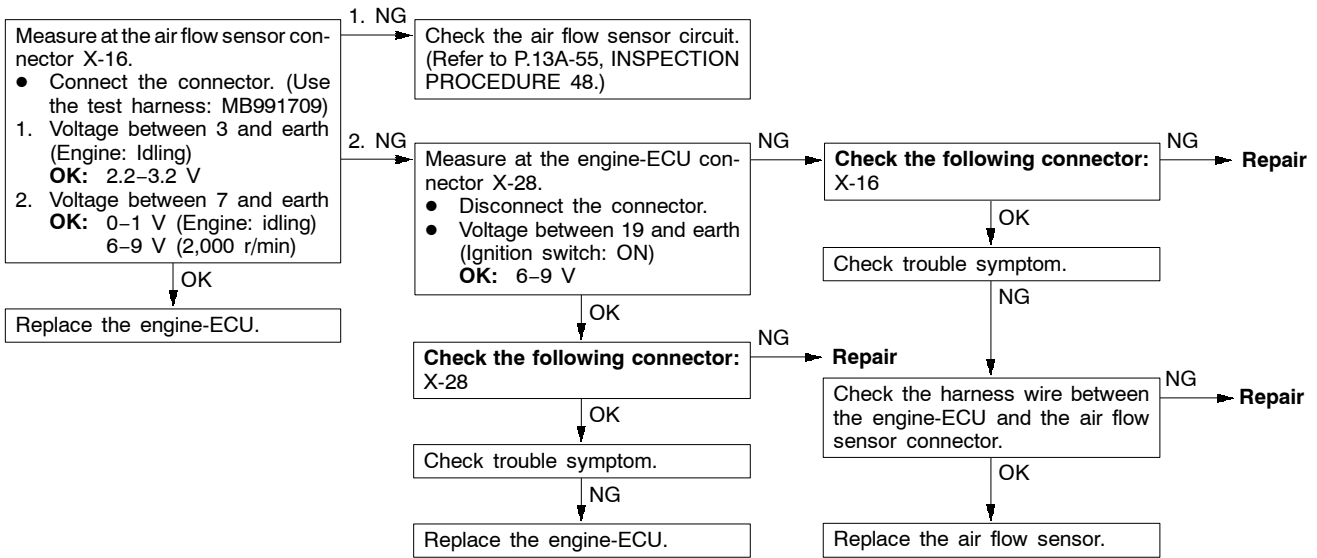

Code No. 13 Intake air temperature sensor system	Probable cause
<p>Range of Check</p> <ul style="list-style-type: none"> Ignition switch: ON Excluding 60 seconds after the ignition switch is turned to ON or immediately after the engine starts. <p>Set conditions</p> <ul style="list-style-type: none"> Sensor output voltage is 4.6 V or more (corresponding to an intake air temperature of -45°C or less) for 4 seconds. <p>or</p> <ul style="list-style-type: none"> Sensor output voltage is 0.2V or less (corresponding to an intake air temperature of 125°C or more) for 4 seconds. 	<ul style="list-style-type: none"> Malfunction of the intake air temperature sensor Improper connector contact, open circuit or short-circuited harness wire of the intake air temperature sensor circuit Malfunction of the engine-ECU

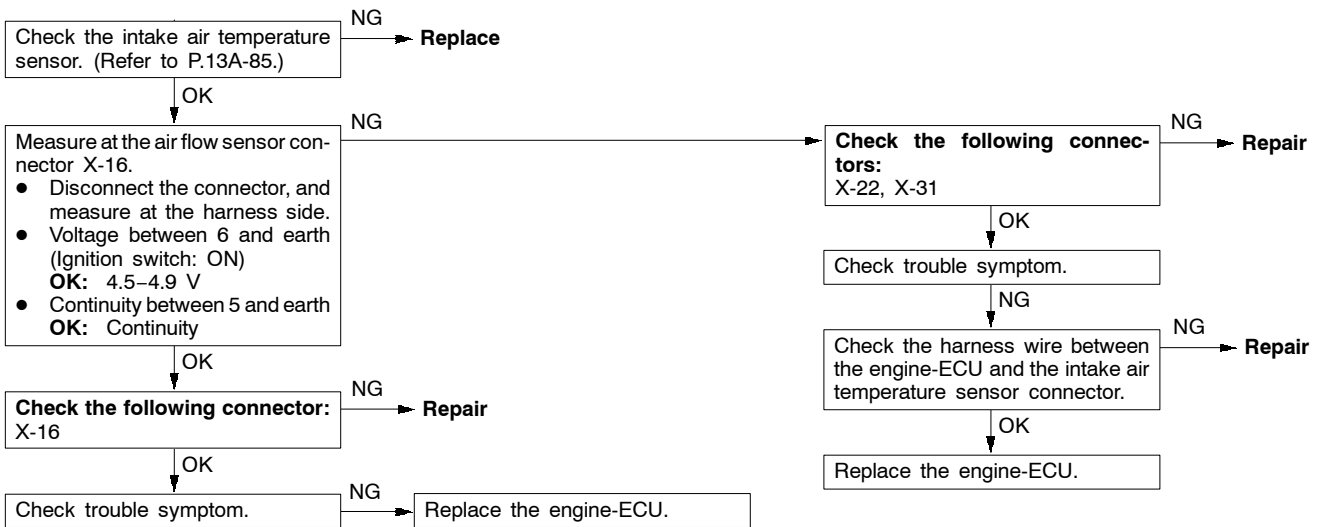

Code No. 14 Throttle position sensor system	Probable cause
<p>Range of Check</p> <ul style="list-style-type: none"> Ignition switch: ON Excluding 60 seconds after the ignition switch is turned to ON or immediately after the engine starts. <p>Set conditions</p> <ul style="list-style-type: none"> When the idle position switch is ON, the sensor output voltage is 2 V or more for 4 seconds. <p>or</p> <ul style="list-style-type: none"> The sensor output voltage is 0.2 V or less for 4 seconds. 	<ul style="list-style-type: none"> Malfunction of the throttle position sensor or maladjustment Improper connector contact, open circuit or short-circuited harness wire of the throttle position sensor circuit Improper "ON" state of idle position switch Short circuit of the idle position switch signal line Malfunction of the engine-ECU

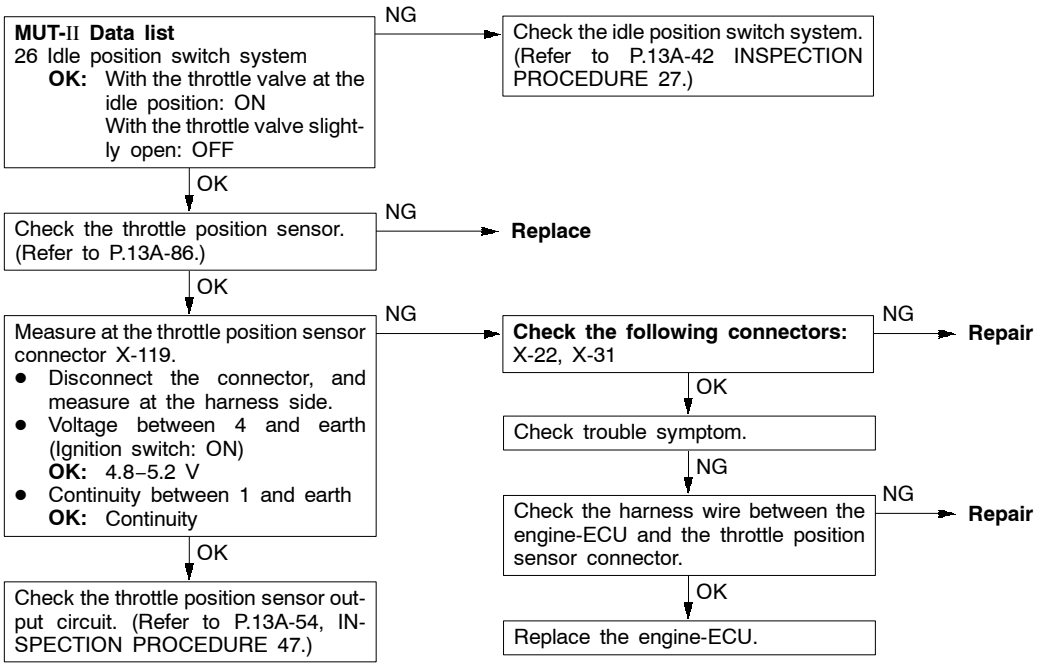

Code No. 21 Engine coolant temperature sensor system	Probable cause
<p>Range of Check</p> <ul style="list-style-type: none"> Ignition switch: ON Excluding 60 seconds after the ignition switch is turned to ON or immediately after the engine starts. <p>Set conditions</p> <ul style="list-style-type: none"> Sensor output voltage is 4.6 V or more (corresponding to an engine coolant temperature of -45°C or less) for 4 seconds. <p>or</p> <ul style="list-style-type: none"> Sensor output voltage is 0.1 V or less (corresponding to an engine coolant temperature of 140°C or more) for 4 seconds. 	<ul style="list-style-type: none"> Malfunction of the engine coolant temperature sensor Improper connector contact, open circuit or short-circuited harness wire of the engine coolant temperature sensor circuit Malfunction of the engine-ECU
<p>Range of Check</p> <ul style="list-style-type: none"> Ignition switch: ON Engine speed is approx. 50 r/min or more <p>Set conditions</p> <ul style="list-style-type: none"> The sensor output voltage increases from 1.6 V or less (corresponding to an engine coolant temperature of 40°C or more) to 1.6 V or more (corresponding to an engine coolant temperature of 40°C or less). After this, the sensor output voltage is 1.6 V or more for 5 minutes. 	

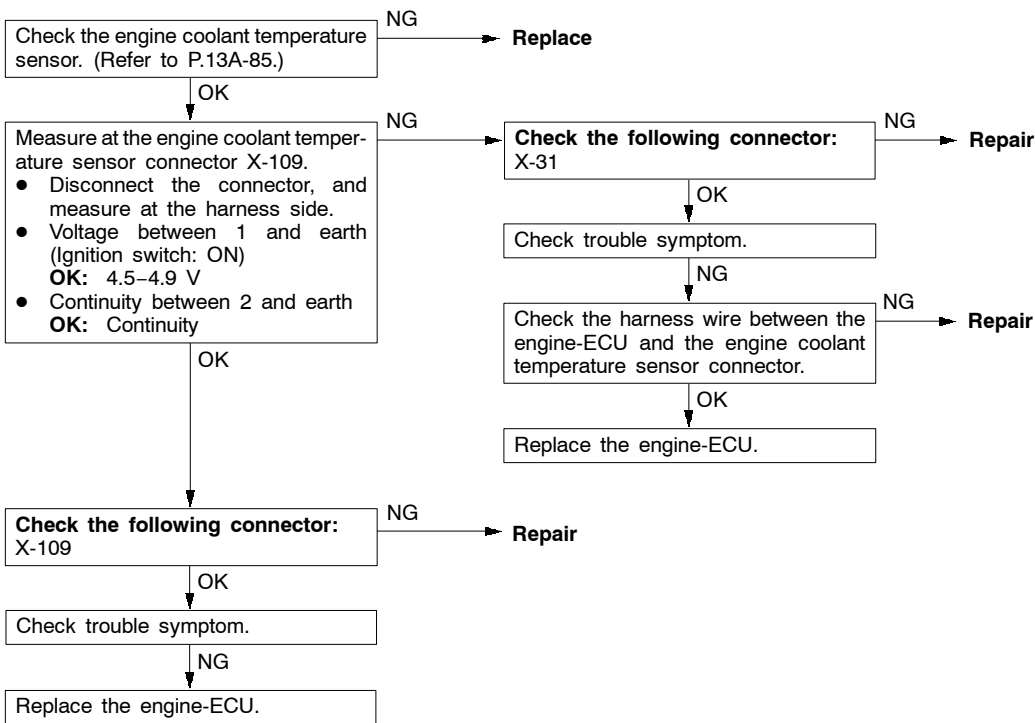

Code No. 22 Crank angle sensor system	Probable cause
<p>Range of Check</p> <ul style="list-style-type: none"> Engine is cranking. <p>Set conditions</p> <ul style="list-style-type: none"> Sensor output voltage does not change for 4 seconds (no pulse signal input.) 	<ul style="list-style-type: none"> Malfunction of the crank angle sensor Improper connector contact, open circuit or short-circuited harness wire of the crank angle sensor circuit Malfunction of the engine-ECU

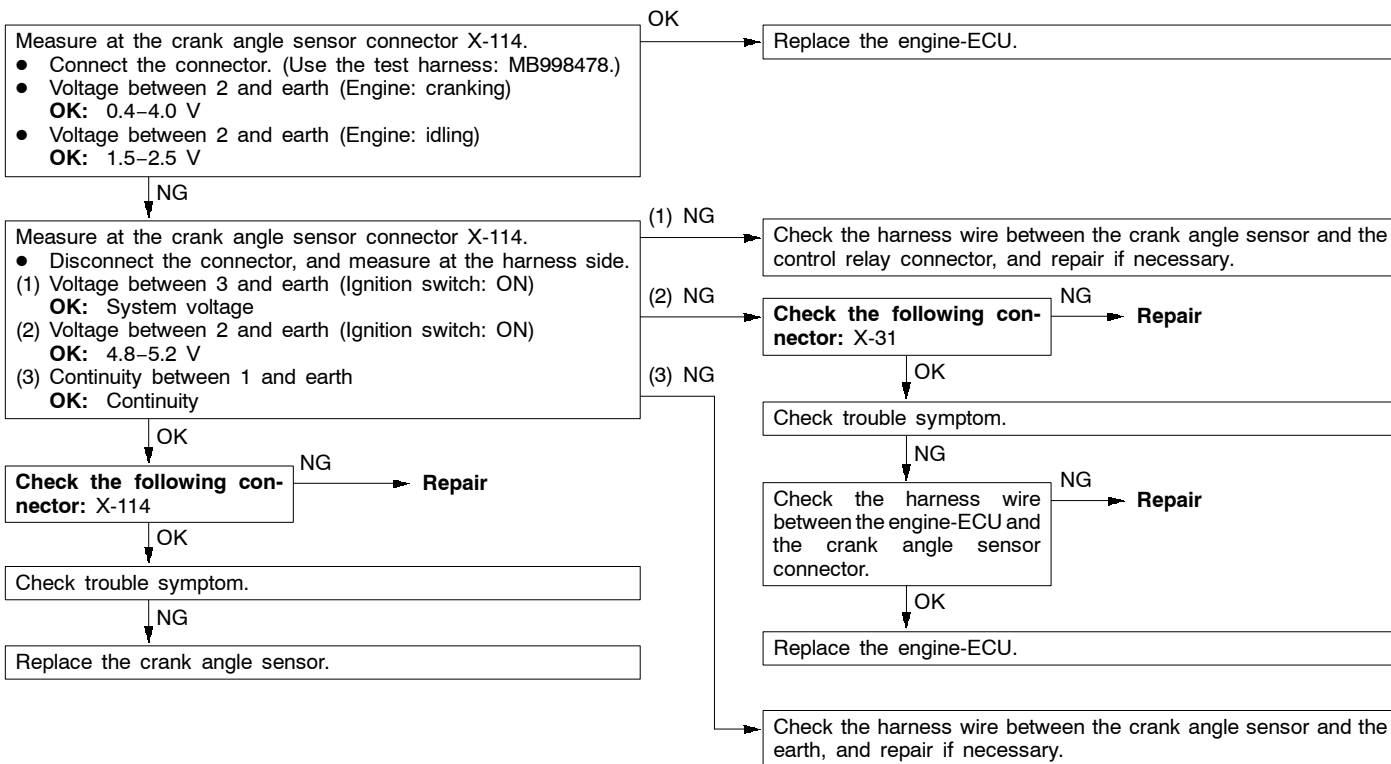

Code No. 23 Camshaft position sensor system	Probable cause
<p>Range of Check</p> <ul style="list-style-type: none"> ● Ignition switch: ON ● Engine speed is approx. 50 r/min or more. <p>Set conditions</p> <ul style="list-style-type: none"> ● Sensor output voltage does not change for 4 seconds (no pulse signal input.) 	<ul style="list-style-type: none"> ● Malfunction of the camshaft position sensor ● Improper connector contact, open circuit or short-circuited harness wire of the camshaft position sensor circuit ● Malfunction of the engine-ECU

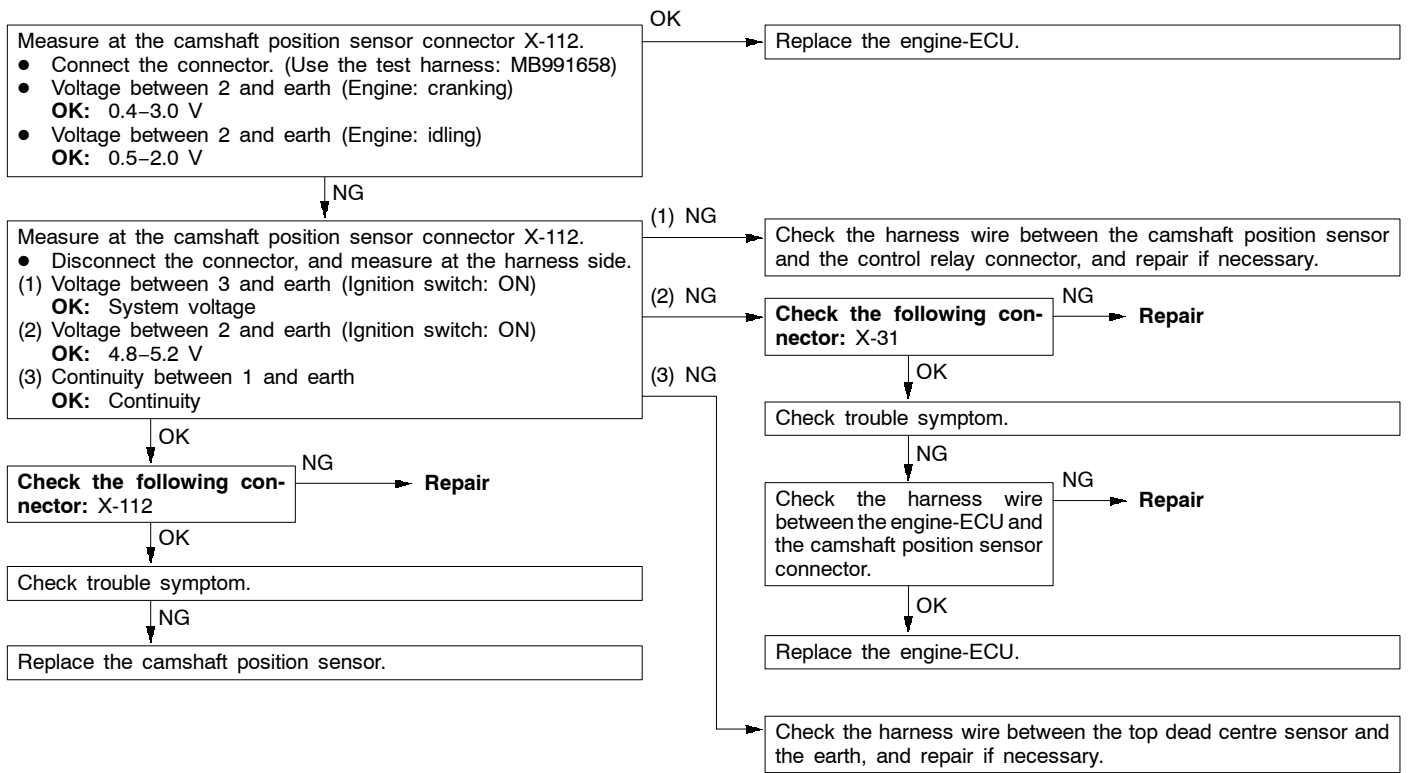

Code No.24 Vehicle speed sensor system	Probable cause
<p>Range of Check</p> <ul style="list-style-type: none"> ● Excluding 60 seconds after the engine starts. ● Idle position switch: Off ● Engine speed is 3,000 r/min. ● Driving under high engine load conditions. <p>Set condition</p> <ul style="list-style-type: none"> ● Sensor output voltage does not changes for 4 seconds (no pulse signal input). 	<ul style="list-style-type: none"> ● Malfunction of the vehicle speed sensor ● Improper connector contact, open circuit or short-circuited harness wire of the vehicle speed sensor ● Malfunction of the engine-ECU

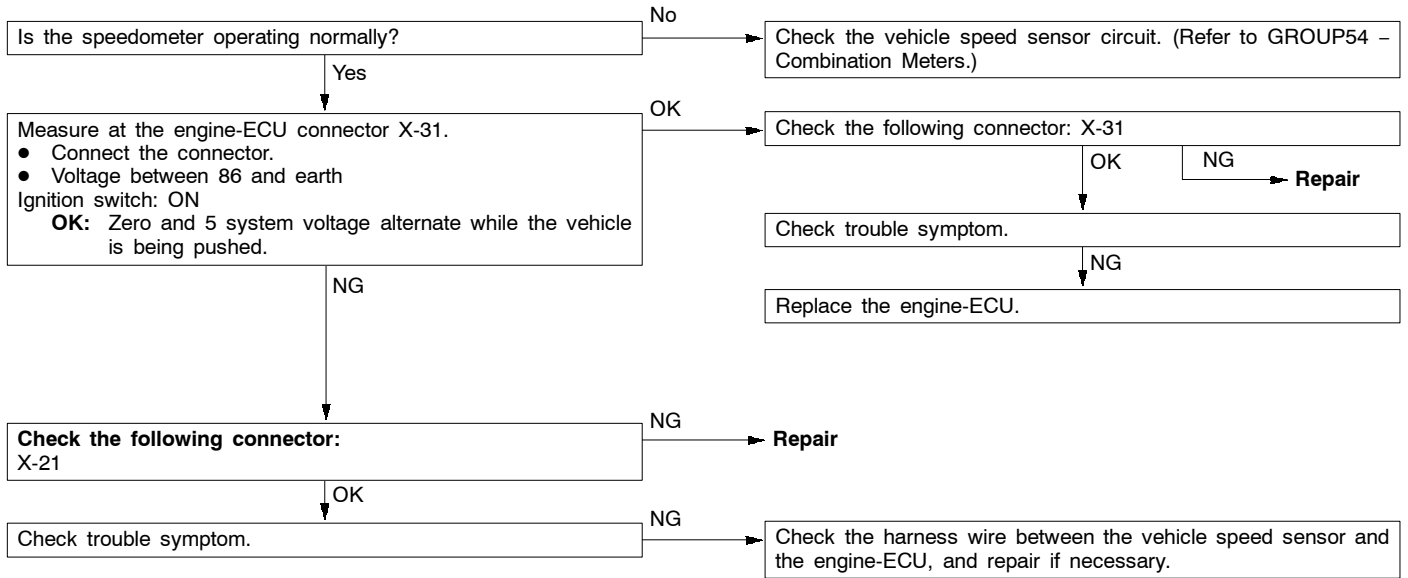

Code No. 41 Injector system	Probable cause
<p>Range of Check</p> <ul style="list-style-type: none"> ● Engine speed is approx. 50–1,000 r/min ● The throttle position sensor output voltage is 1.15 V or less. ● Actuator test by MUT-II is not carried out. <p>Set conditions</p> <ul style="list-style-type: none"> ● Surge voltage of injector coil is not detected for 4 seconds. 	<ul style="list-style-type: none"> ● Malfunction of the injector ● Improper connector contact, open circuit or short-circuited harness wire of the injector circuit ● Malfunction of the engine-ECU

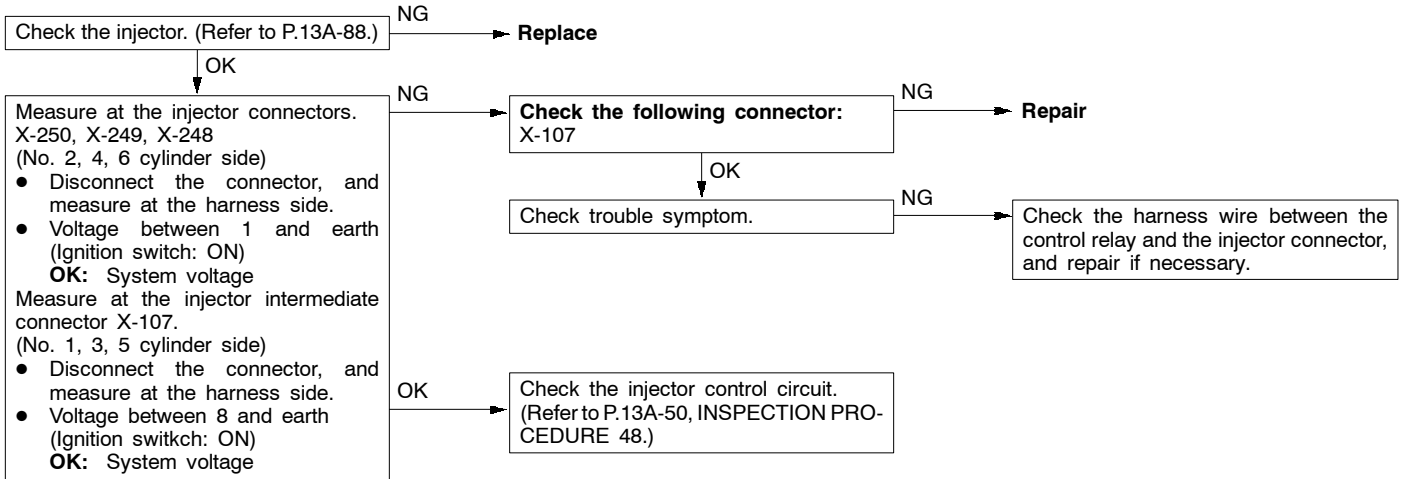

Code No. 44, 52, 53 Ignition coil and power transistor unit system	Probable cause
<p>Range of Check</p> <ul style="list-style-type: none"> • Engine speed is approx. 50 – 4,000 r/min. • Engine is not cranking. <p>Set conditions</p> <ul style="list-style-type: none"> • The ignition signal from the same coil is not input for 4 seconds. <p>However, this excludes cases where no ignition signal is input from any coils.</p>	<ul style="list-style-type: none"> • Malfunction of the ignition coil • Improper connector contact, open circuit or short-circuited harness wire of the ignition primary circuit • Malfunction of the power transistor unit • Malfunction of the engine-ECU

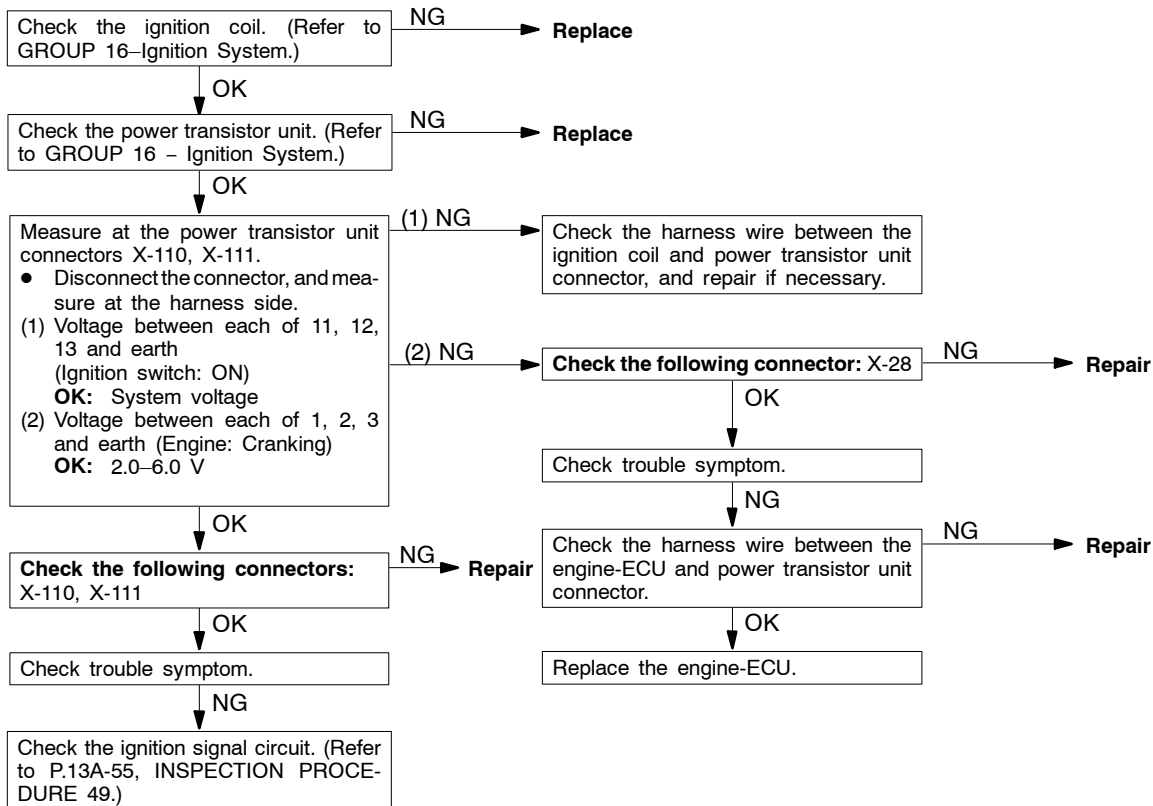

Code No.54 Immobilizer system	Probable cause
Range of Check ● Ignition switch: ON Set Conditions ● Improper communication between the engine-ECU and immobilizer-ECU	● Radio interference of ID codes ● Incorrect ID code ● Malfunction of harness or connector ● Malfunction of immobilizer-ECU ● Malfunction of engine-ECU

NOTE

- (1) If the ignition switches are close each other when starting the engine, radio interference may cause this code to be displayed.
- (2) This code may be displayed when registering the key ID code.

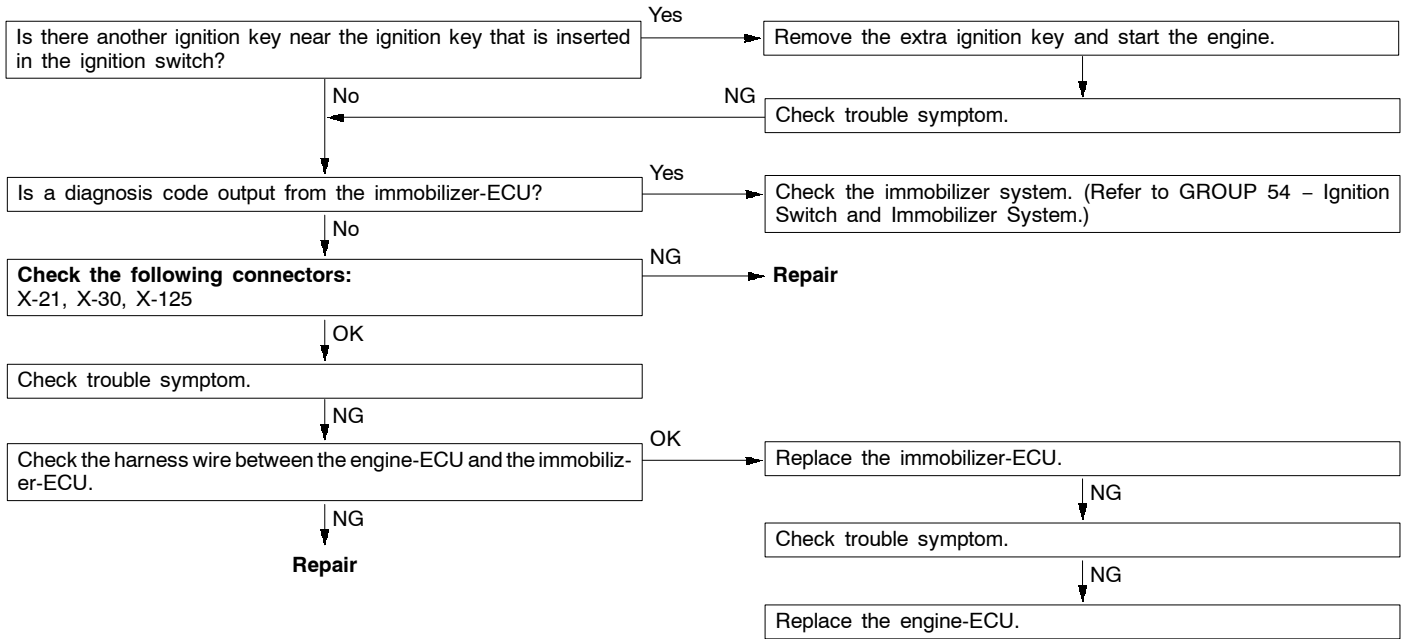

INSPECTION CHART FOR TROUBLE SYMPTOMS

13100880712

Trouble symptom		Inspection procedure No.	Reference page
Communication with MUT-II is impossible.	Communication with all systems is not possible.	1	13A-26
	Communication with engine-ECU only is not possible.	2	13A-26
Engine warning lamp and related parts	The engine warning lamp does not illuminate right after the ignition switch is turned to the ON position.	3	13A-27
	The engine warning lamp remains illuminating and never goes out.	4	13A-28
Starting	No initial combustion (starting impossible)	5	13A-28
	Initial combustion but no complete combustion (starting impossible)	6	13A-29
	Long time to start (improper starting)	7	13A-30
Idling stability (Improper idling)	Unstable idling (Rough idling, hunting)	8	13A-31
	Idling speed is high. (Improper idling speed)	9	13A-32
	Idling speed is low. (Improper idling speed)	10	13A-32
Idling stability (Engine stalls)	When the engine is cold, it stalls at idling. (Die out)	11	13A-33
	When the engine becomes hot, it stalls at idling. (Die out)	12	13A-34
	The engine stalls when starting the car. (Pass out)	13	13A-35
	The engine stalls when decelerating.	14	13A-35
Driving	Hesitation, sag or stumble	15	13A-36
	The feeling of impact or vibration when accelerating	16	13A-36
	The feeling of impact or vibration when decelerating	17	13A-37
	Poor acceleration	18	13A-37
	Surge	19	13A-38
	Knocking	20	13A-38
Dieseling		21	13A-38
Too high CO and HC concentration when idling		22	13A-39
Idling speed is improper when A/C is operating		23	13A-40
A/C condensor fan is inoperative		24	13A-40

PROBLEM SYMPTOMS TABLE (FOR YOUR INFORMATION)

Items		Symptom
Starting	Won't start	The starter is used to crank the engine, but there is no combustion within the cylinders, and the engine won't start.
	Fires up and dies	There is combustion within the cylinders, but then the engine soon stalls.
	Hard starting	Engine starts after cranking a while.
Idling stability	Hunting	Engine speed doesn't remain constant; changes at idle.
	Rough idle	Usually, a judgement can be based upon the movement of the tachometer pointer, and the vibration transmitted to the steering wheel, shift lever, body, etc. This is called rough idle.
	Incorrect idle speed	The engine doesn't idle at the usual correct speed.
	Engine stall (Die out)	The engine stalls when the foot is taken from the accelerator pedal, regardless of whether the vehicles is moving or not.
	Engine stall (Pass out)	The engine stalls when the accelerator pedal is depressed or while it is being used.
Driving	Hesitation Sag	<p>"Hesitation" is the delay in response of the vehicle speed (engine speed) that occurs when the accelerator is depressed in order to accelerate from the speed at which the vehicle is now traveling, or a temporary drop in vehicle speed (engine speed) during such acceleration. Serious hesitation is called "sag".</p> <p style="text-align: right;">1FU0223</p>
	Poor acceleration	Poor acceleration is inability to obtain an acceleration corresponding to the degree of throttle opening, even though acceleration is smooth, or the inability to reach maximum speed.
	Stumble	<p>Engine speed increase is delayed when the accelerator pedal is initially depressed for acceleration.</p> <p style="text-align: right;">1FU0224</p>

Items		Symptom
Driving	Shock	The feeling of a comparatively large impact or vibration when the engine is accelerated or decelerated.
	Surge	This is repeated surging ahead during constant speed travel or during variable speed travel.
	Knocking	A sharp sound like a hammer striking the cylinder walls during driving and which adversely affects driving.
Stopping	Run on (“Dieseling”)	The condition in which the engine continues to run after the ignition switch is turned to OFF. Also called “Dieseling”.

INSPECTION PROCEDURE FOR TROUBLE SYMPTOMS

INSPECTION PROCEDURE 1

Communication with MUT-II is not possible. (Communication with all systems is not possible.)	Probable cause
The cause is probably a defect in the power supply system (including earth) for the diagnosis line.	<ul style="list-style-type: none"> ● Malfunction of the connector ● Malfunction of the harness wire

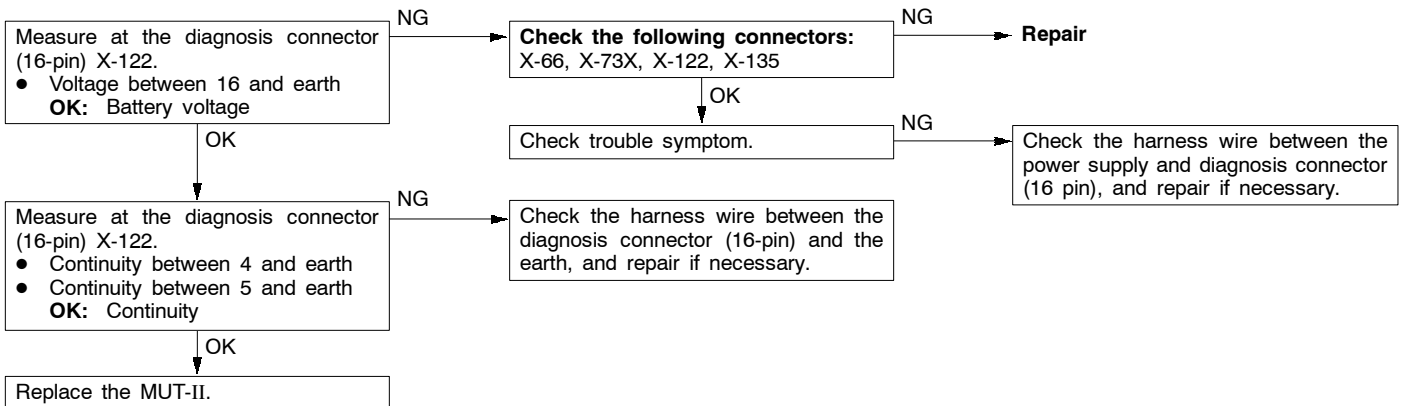

INSPECTION PROCEDURE 2

MUT-II communication with engine-ECU is not possible.	Probable cause
One of the following causes may be suspected. <ul style="list-style-type: none"> ● No power supply to engine-ECU. ● Defective earth circuit of engine-ECU. ● Defective engine-ECU. ● Improper communication line between engine-ECU and MUT-II 	<ul style="list-style-type: none"> ● Malfunction of engine-ECU power supply circuit ● Malfunction of engine-ECU ● Open circuit between engine-ECU and diagnosis connector

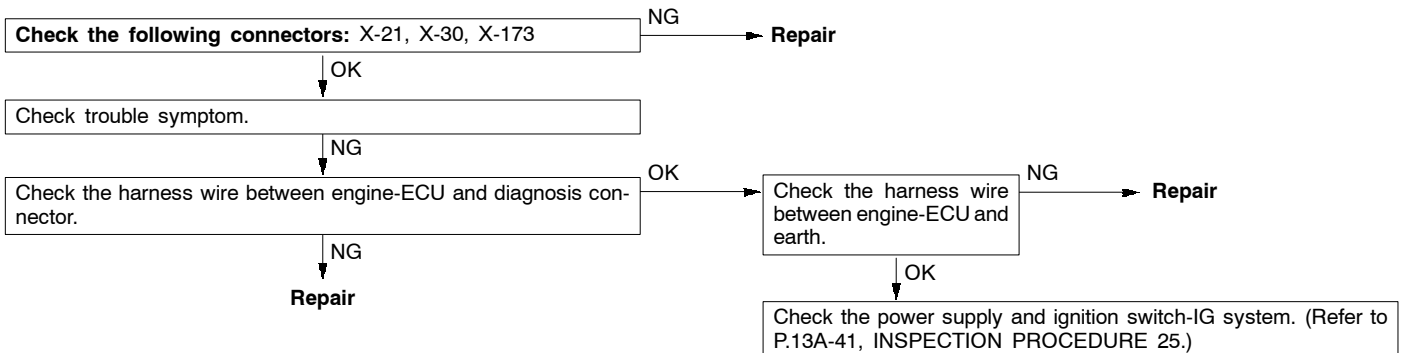

INSPECTION PROCEDURE 3

The engine warning lamp does not illuminate right after the ignition switch is turned to the ON position.	Probable cause
Because there is a burnt-out bulb, the engine-ECU causes the engine warning lamp to illuminate for five seconds immediately after the ignition switch is turned to ON. If the engine warning lamp does not illuminate immediately after the ignition switch is turned to ON, one of the malfunctions listed at right has probably occurred.	<ul style="list-style-type: none"> ● Burnt-out bulb ● Defective warning lamp circuit ● Malfunction of the engine-ECU

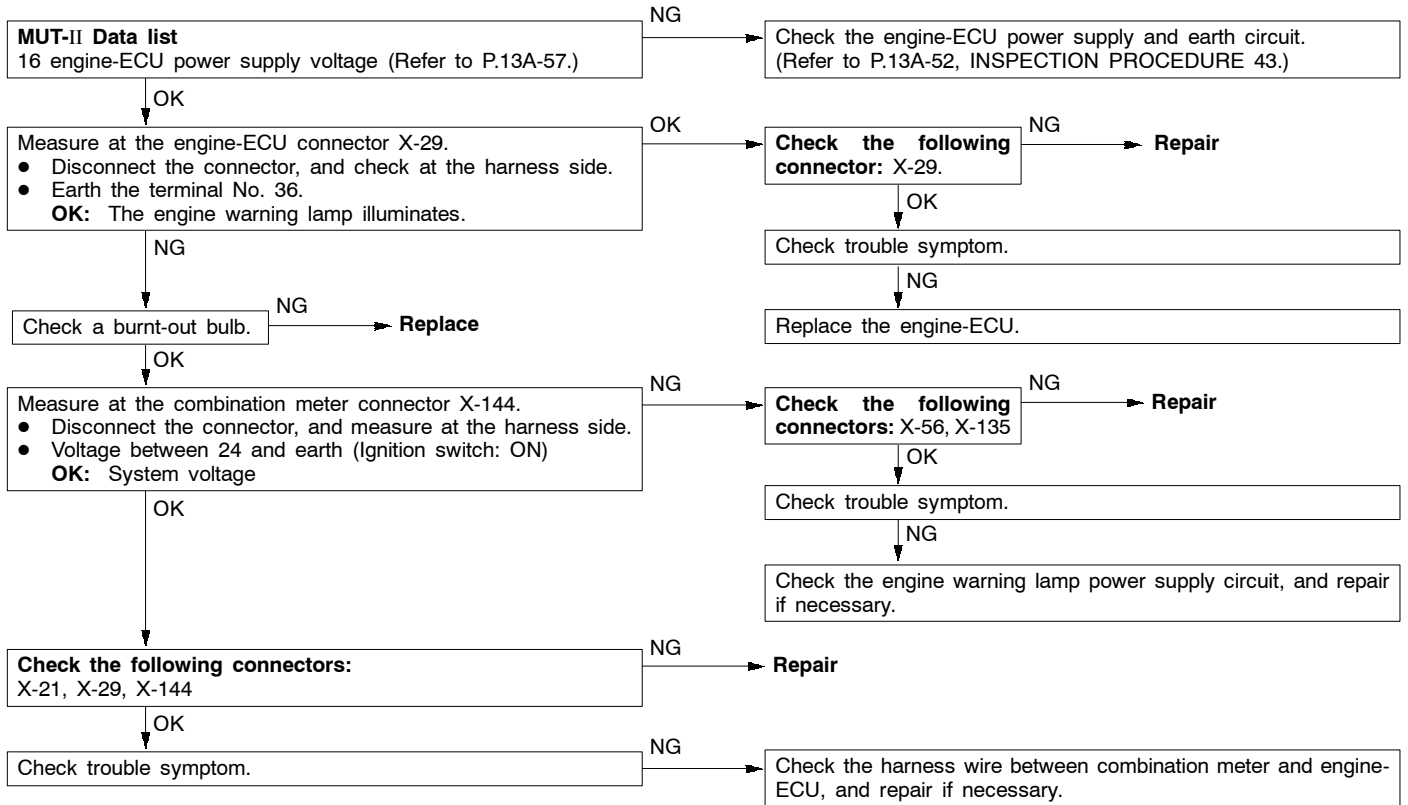

INSPECTION PROCEDURE 4

The engine warning lamp remains illuminating and never goes out.	Probable cause
In cases such as the above, the cause is probably that the engine-ECU is detecting a problem in a sensor or actuator, or that one of the malfunctions listed at right has occurred.	<ul style="list-style-type: none"> ● Short-circuit between the engine warning lamp and engine-ECU ● Malfunction of the engine-ECU

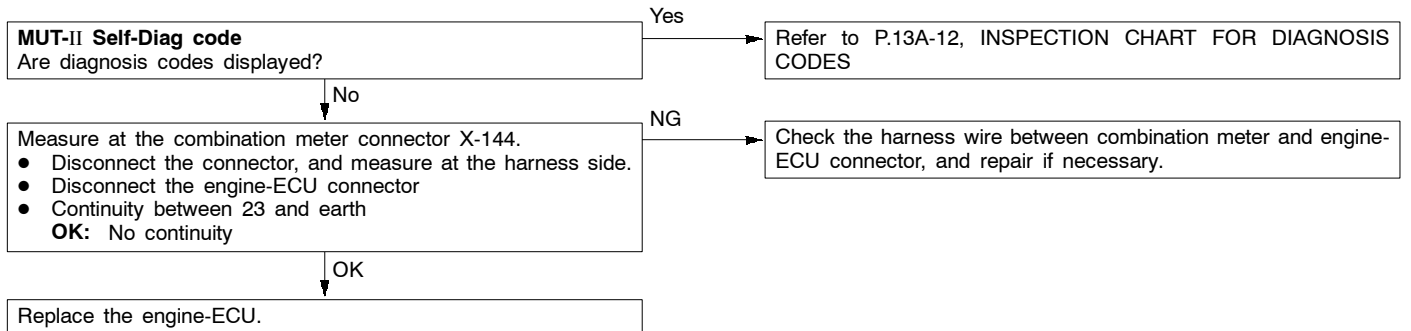

INSPECTION PROCEDURE 5

No initial combustion (starting impossible)	Probable cause
In cases such as the above, the cause is probably that a spark plug is defective, or that the supply of fuel to the combustion chamber is defective. In addition, foreign materials (water, kerosene, etc.) may be mixed with the fuel.	<ul style="list-style-type: none"> ● Malfunction of the ignition system ● Malfunction of the fuel pump system ● Malfunction of the injectors ● Malfunction of the engine-ECU ● Malfunction of the immobilizer system ● Foreign materials in fuel

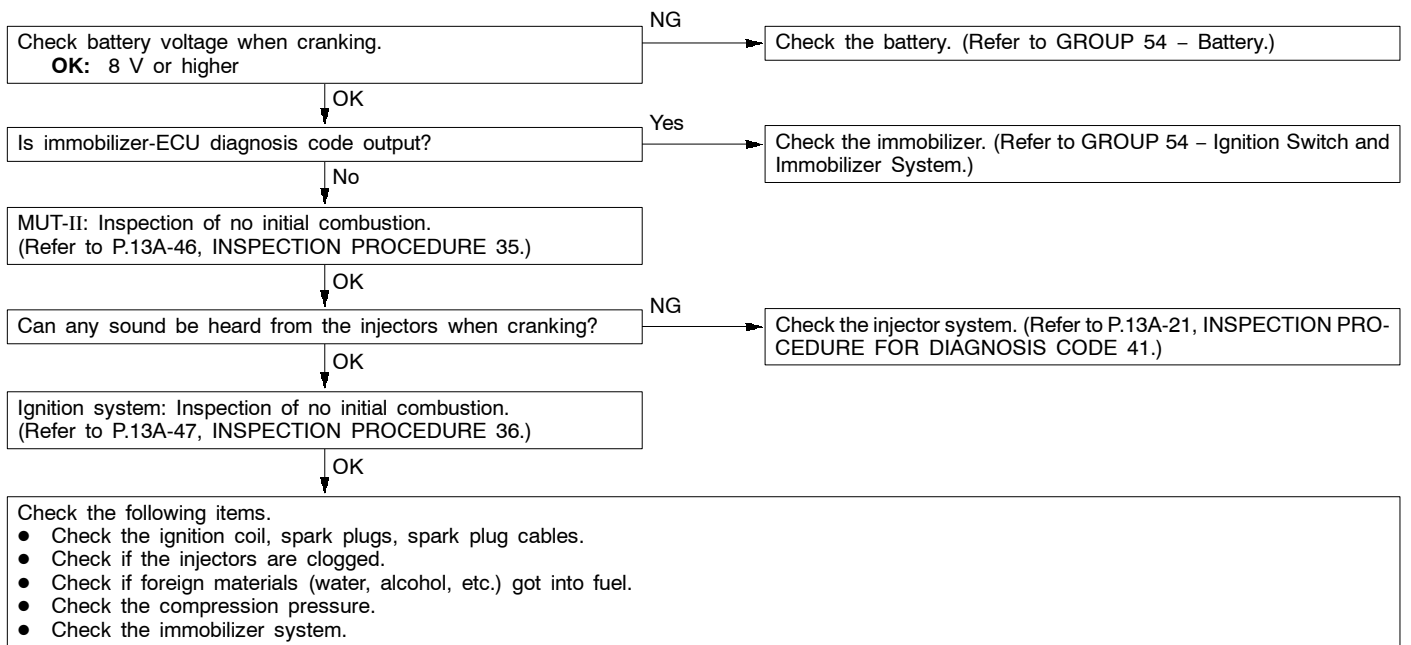

INSPECTION PROCEDURE 6

Initial combustion but no complete combustion (starting impossible)	Probable cause
In such cases as the above, the cause is probably that the spark plugs are generating sparks but the sparks are weak, or the initial mixture for starting is not appropriate.	<ul style="list-style-type: none"> ● Malfunction of the ignition system ● Malfunction of the injector system ● Foreign materials in fuel ● Poor compression ● Malfunction of the engine-ECU

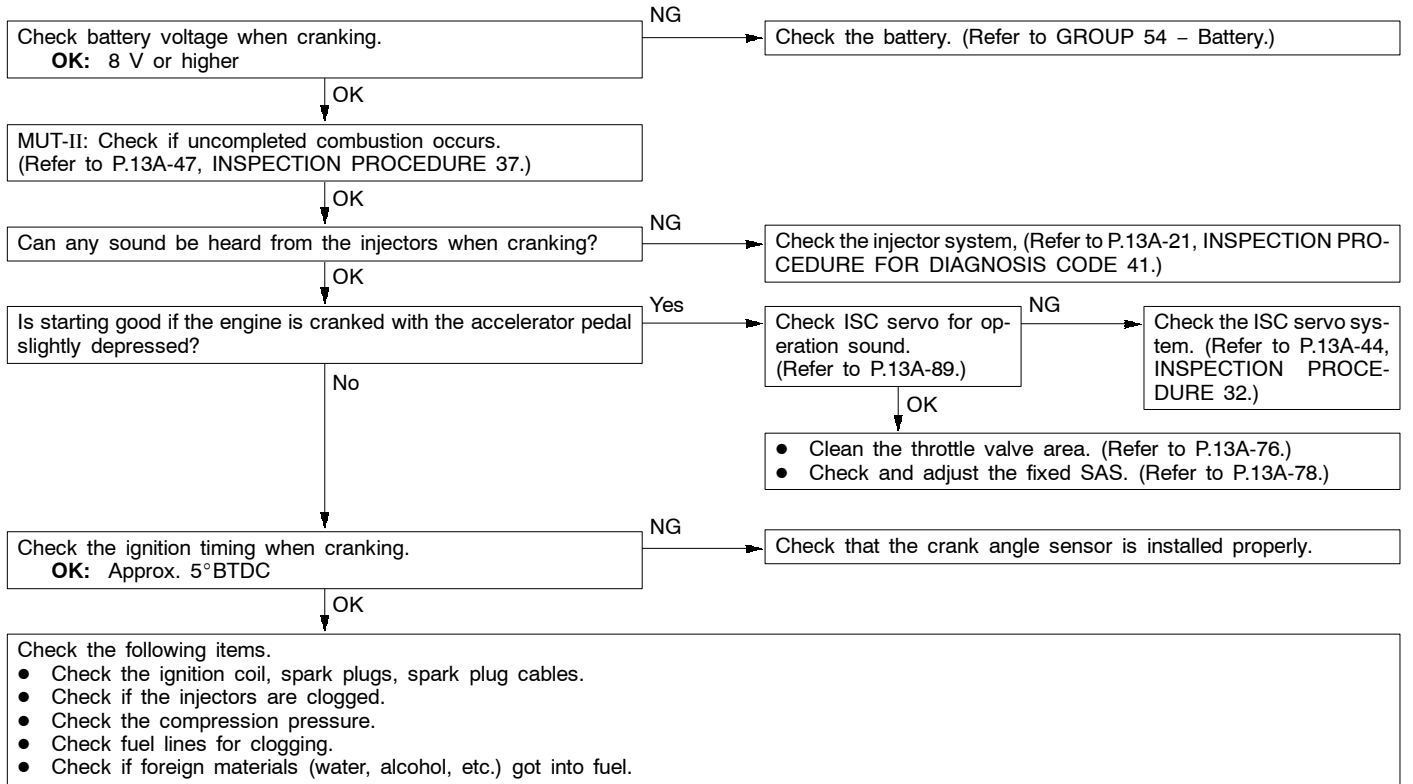

INSPECTION PROCEDURE 7

It takes too long time to start. (Improper starting)	Probable cause
In cases such as the above, the cause is probably that the spark is weak and ignition is difficult, the initial mixture for starting is not appropriate, or sufficient compression pressure is not being obtained.	<ul style="list-style-type: none"> ● Malfunction of the ignition system ● Malfunction of the injector system ● Inappropriate gasoline use ● Poor compression

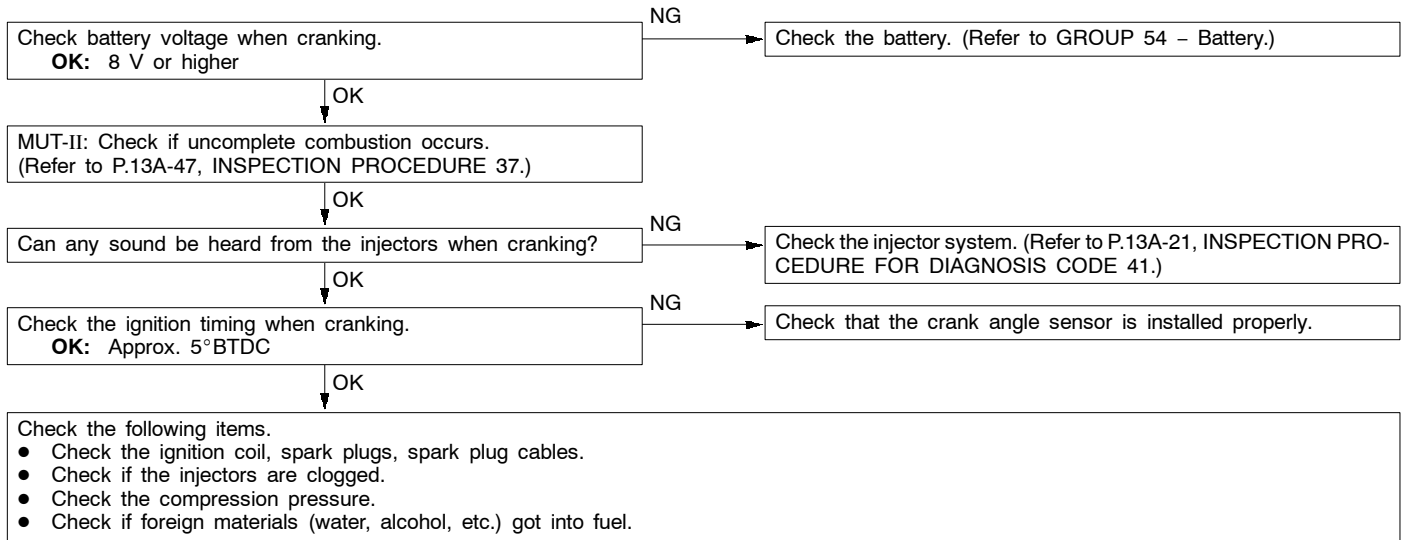

INSPECTION PROCEDURE 8

Unstable idling (Rough idling, hunting)	Probable cause
<p>In cases as the above, the cause is probably that the ignition system, air/fuel mixture, idle speed control (ISC) or compression pressure is defective. Because the range of possible causes is broad, inspection is narrowed down to simple items.</p>	<ul style="list-style-type: none"> ● Malfunction of the ignition system ● Malfunction of air-fuel ratio control system ● Malfunction of the ISC system ● Malfunction of the purge control solenoid valve system ● Malfunction of the EGR control solenoid valve system ● Poor compression ● Drawing air into exhaust system

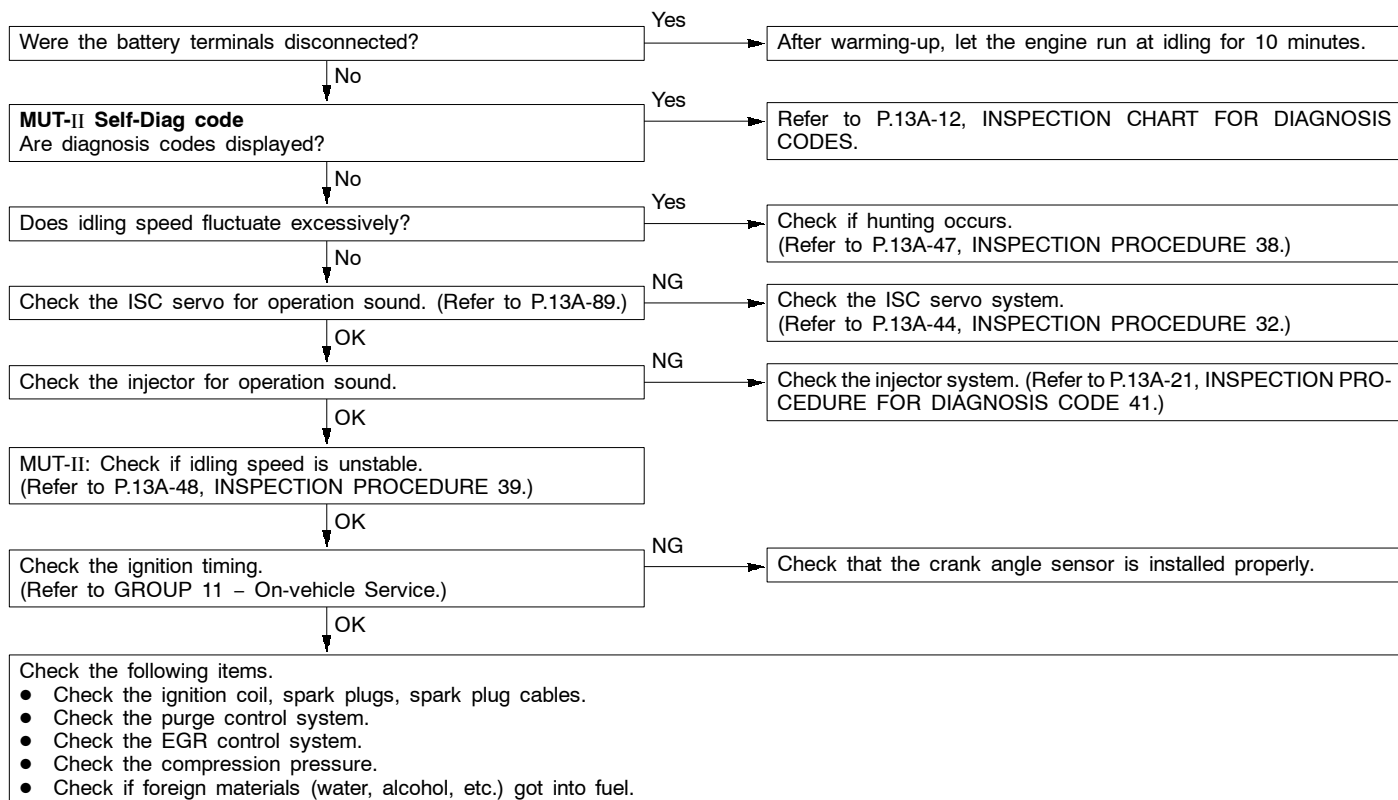

INSPECTION PROCEDURE 9

Idling speed is high. (Improper idling speed)	Probable cause
In such cases as the above, the cause is probably that the intake air volume during idling is too great.	<ul style="list-style-type: none"> ● Malfunction of the ISC servo system ● Malfunction of the throttle body

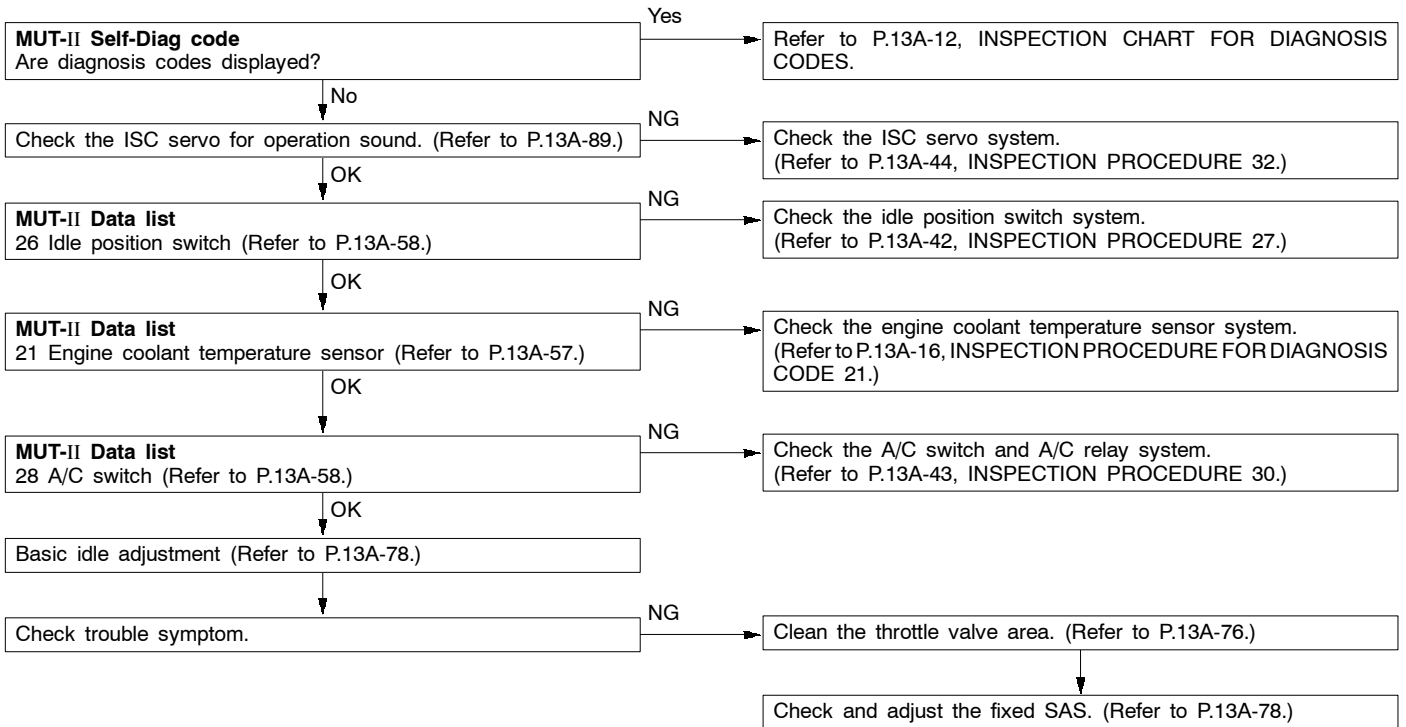

INSPECTION PROCEDURE 10

Idling speed is low. (Improper idling speed)	Probable cause
In cases such as the above, the cause is probably that the intake air volume during idling is too small.	<ul style="list-style-type: none"> ● Malfunction of the ISC servo system ● Malfunction of the throttle body

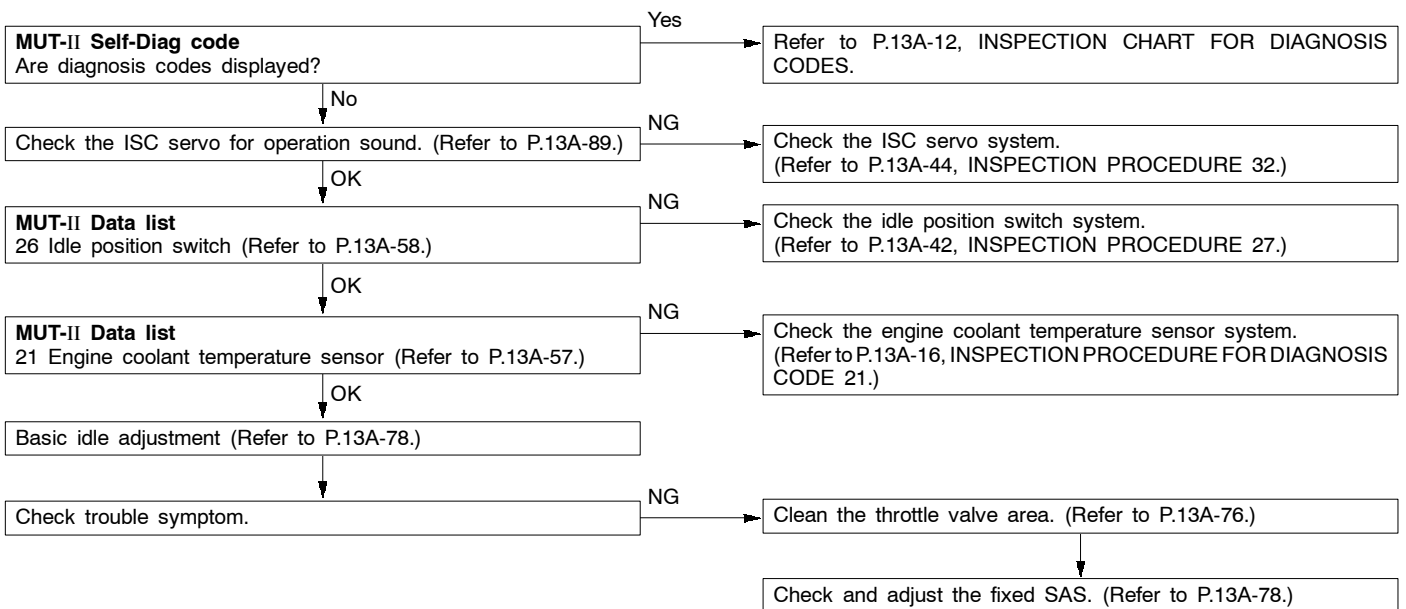

INSPECTION PROCEDURE 11

When the engine is cold, it stalls at idling. (Die out)	Probable cause
In such cases as the above, the cause is probably that the air/fuel mixture is inappropriate when the engine is cold, or that the intake air volume is insufficient.	<ul style="list-style-type: none"> ● Malfunction of the ISC servo system ● Malfunction of the throttle body ● Malfunction of the injector system ● Malfunction of the ignition system

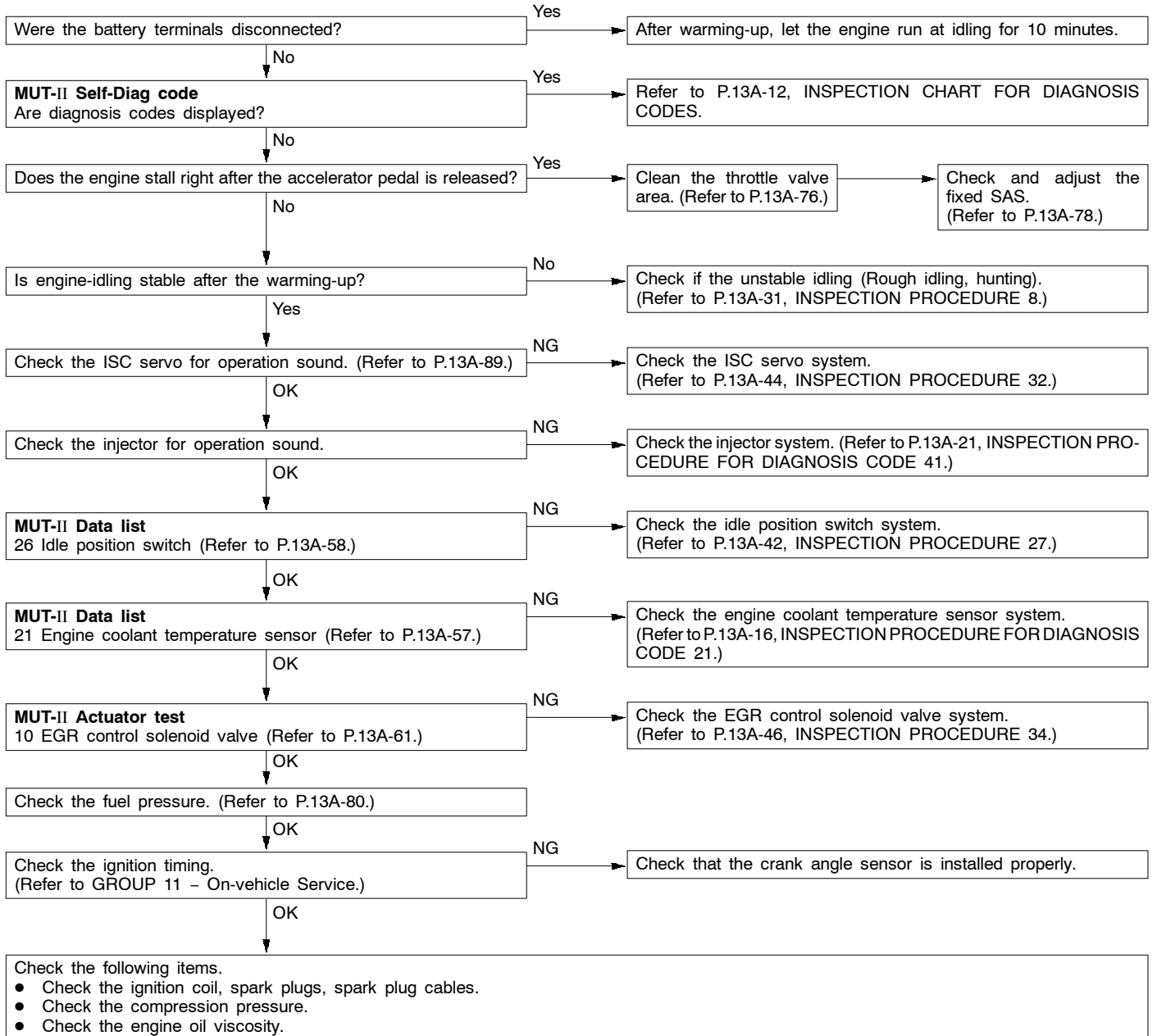

INSPECTION PROCEDURE 12

When the engine becomes hot, it stalls at idling. (Die out)	Probable cause
<p>In such cases as the above, the cause is probably that ignition system, air/fuel mixture, idle speed control (ISC) or compression pressure is defective. In addition, if the engine suddenly stalls, the cause may also be a defective connector contact.</p>	<ul style="list-style-type: none"> ● Malfunction of the ignition system ● Malfunction of air-fuel ratio control system ● Malfunction of the ISC system ● Drawing air into intake system ● Improper connector contact

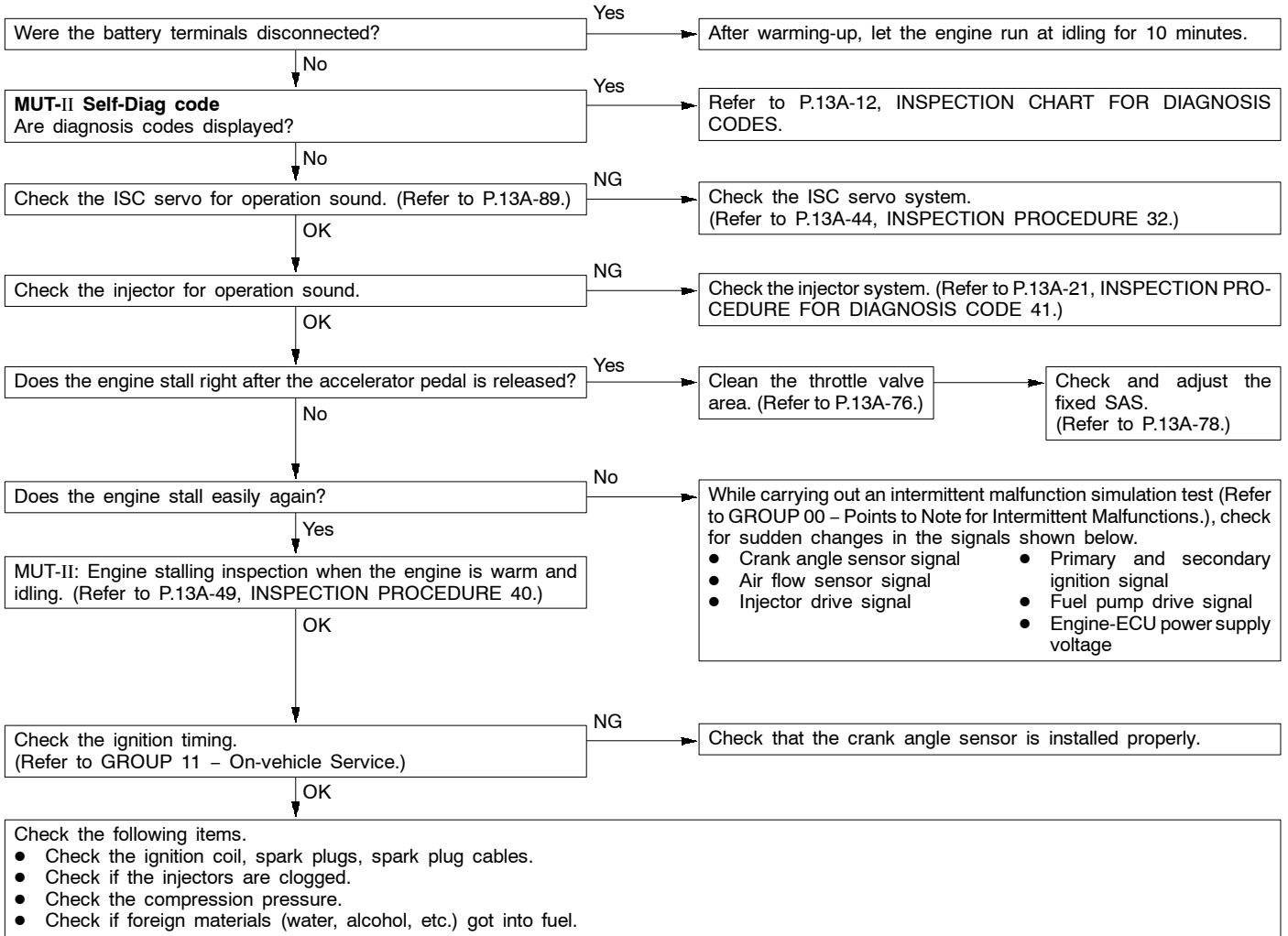

INSPECTION PROCEDURE 13

The engine stalls when starting the car. (Pass out)	Probable cause
In cases such as the above, the cause is probably misfiring due to a weak spark, or an inappropriate air/fuel mixture when the accelerator pedal is depressed.	<ul style="list-style-type: none"> • Drawing air into intake system • Malfunction of the ignition system

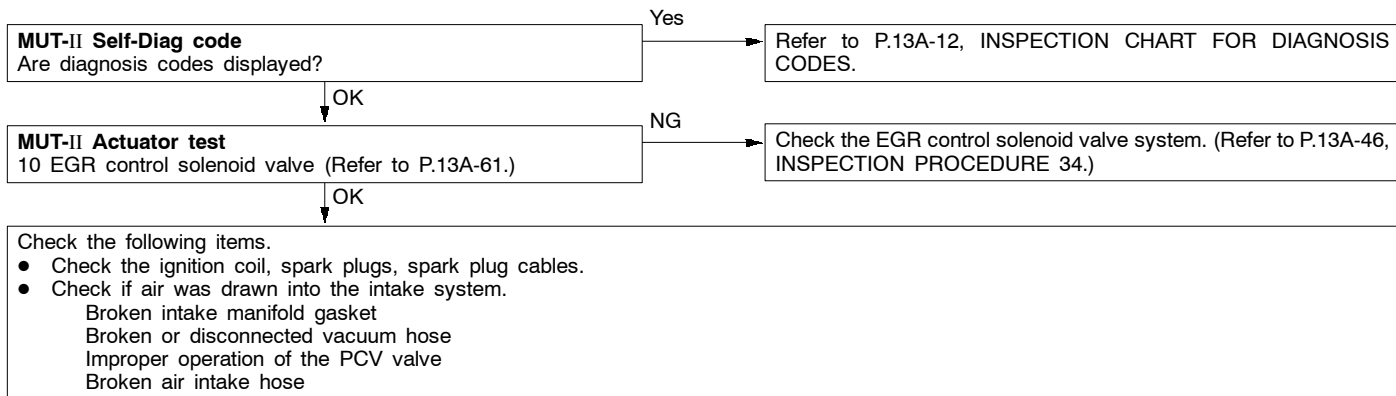

INSPECTION PROCEDURE 14

The engine stalls when decelerating.	Probable cause
In cases such as the above, the cause is probably that the intake air volume is insufficient due to a defective idle speed control (ISC) servo system.	<ul style="list-style-type: none"> • Malfunction of the ISC system

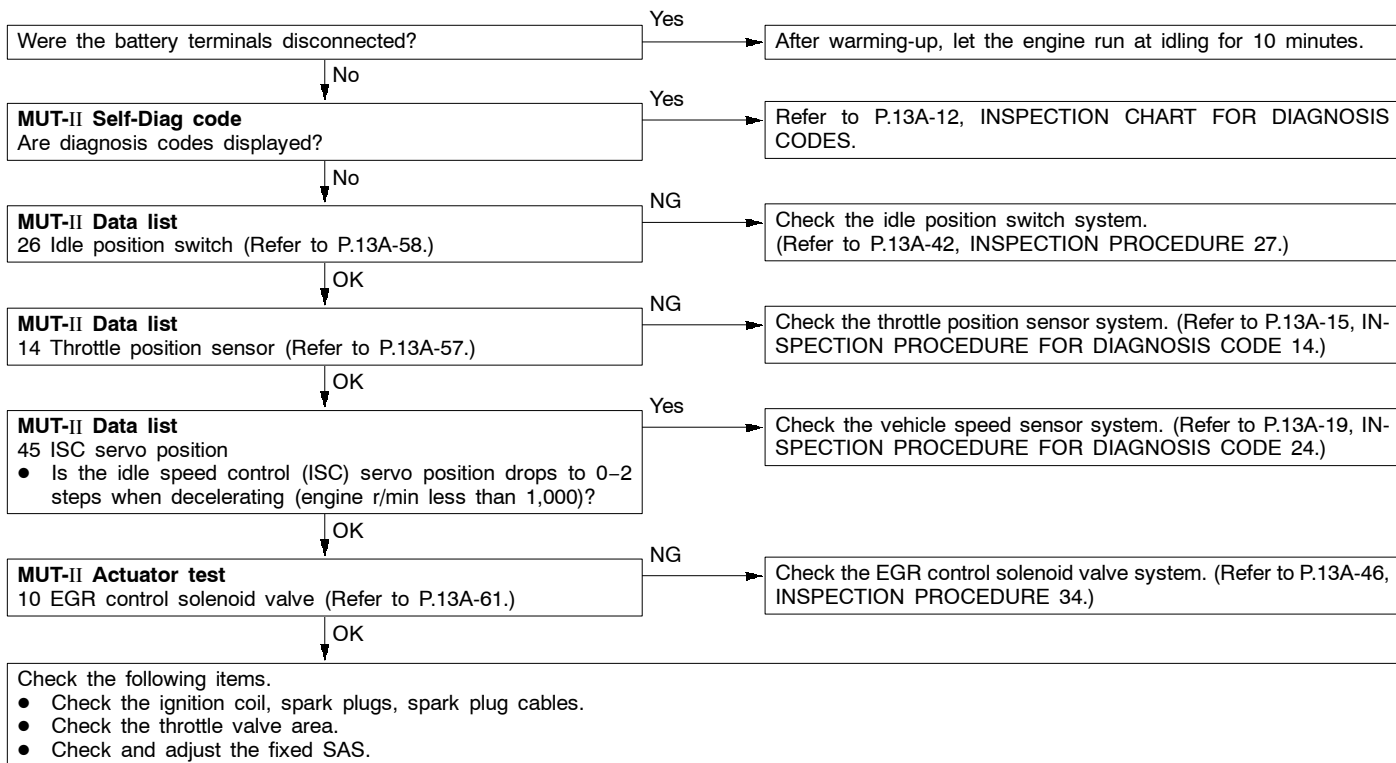

INSPECTION PROCEDURE 15

Hesitation, sag or stumble	Probable cause
In cases such as the above, the cause is probably that ignition system, air/fuel mixture or compression pressure is defective.	<ul style="list-style-type: none"> ● Malfunction of the ignition system ● Malfunction of air-fuel ratio control system ● Malfunction of the fuel supply system ● Malfunction of the EGR control solenoid valve system ● Poor compression

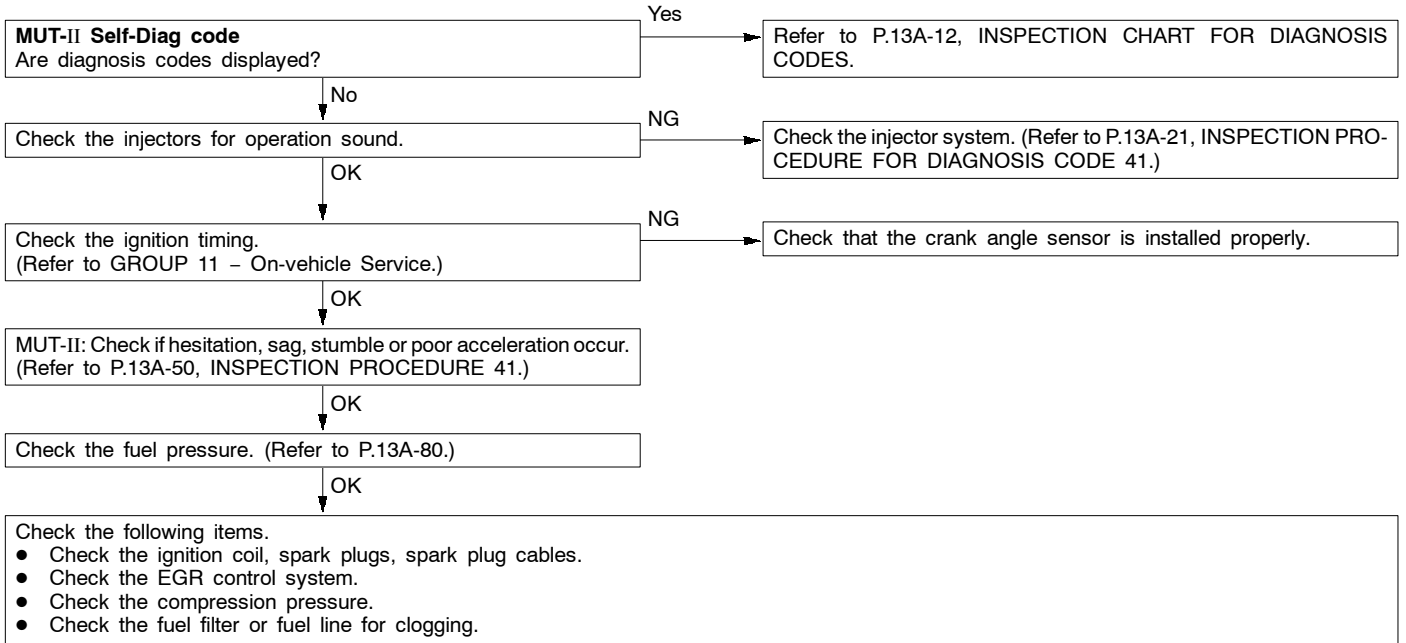

INSPECTION PROCEDURE 16

The feeling of impact or vibration when accelerating	Probable cause
In cases such as the above, the cause is probably that there is an ignition leak accompanying the increase in the spark plug demand voltage during acceleration.	<ul style="list-style-type: none"> ● Malfunction of the ignition system

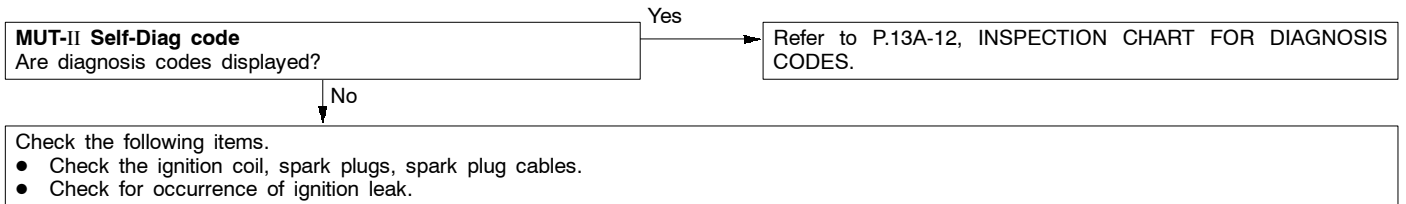

INSPECTION PROCEDURE 17

The feeling of impact or vibration when decelerating.	Probable cause
Malfunction of the ISC system is suspected.	<ul style="list-style-type: none"> Malfunction of the ISC system

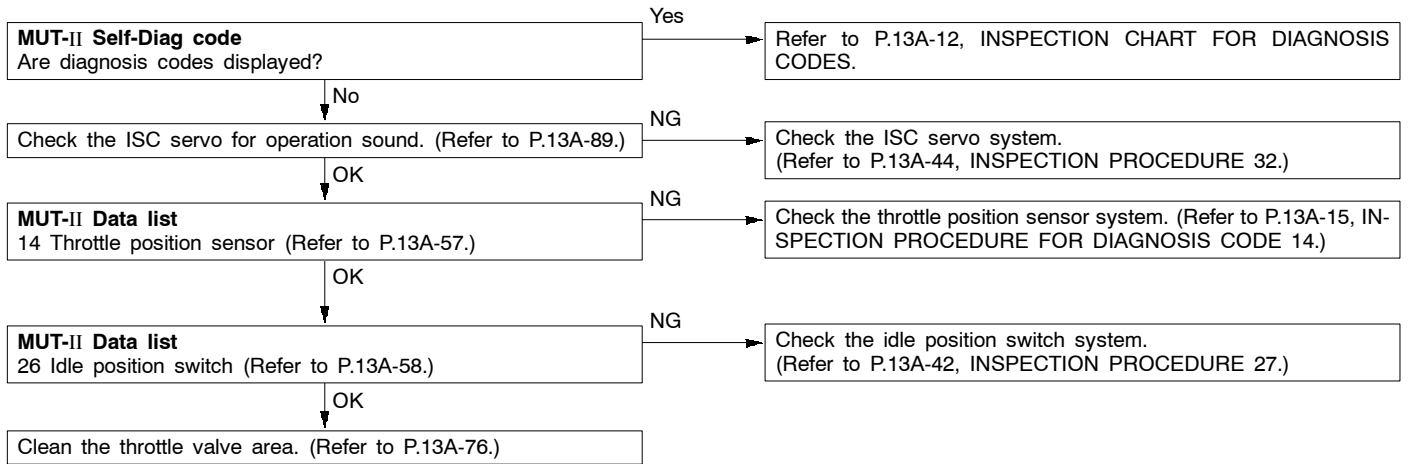

INSPECTION PROCEDURE 18

Poor acceleration	Probable cause
Defective ignition system, abnormal air-fuel ratio, poor compression pressure, etc. are suspected.	<ul style="list-style-type: none"> Malfunction of the ignition system Malfunction of air-fuel ratio control system Malfunction of the fuel supply system Poor acceleration Clogged exhaust system

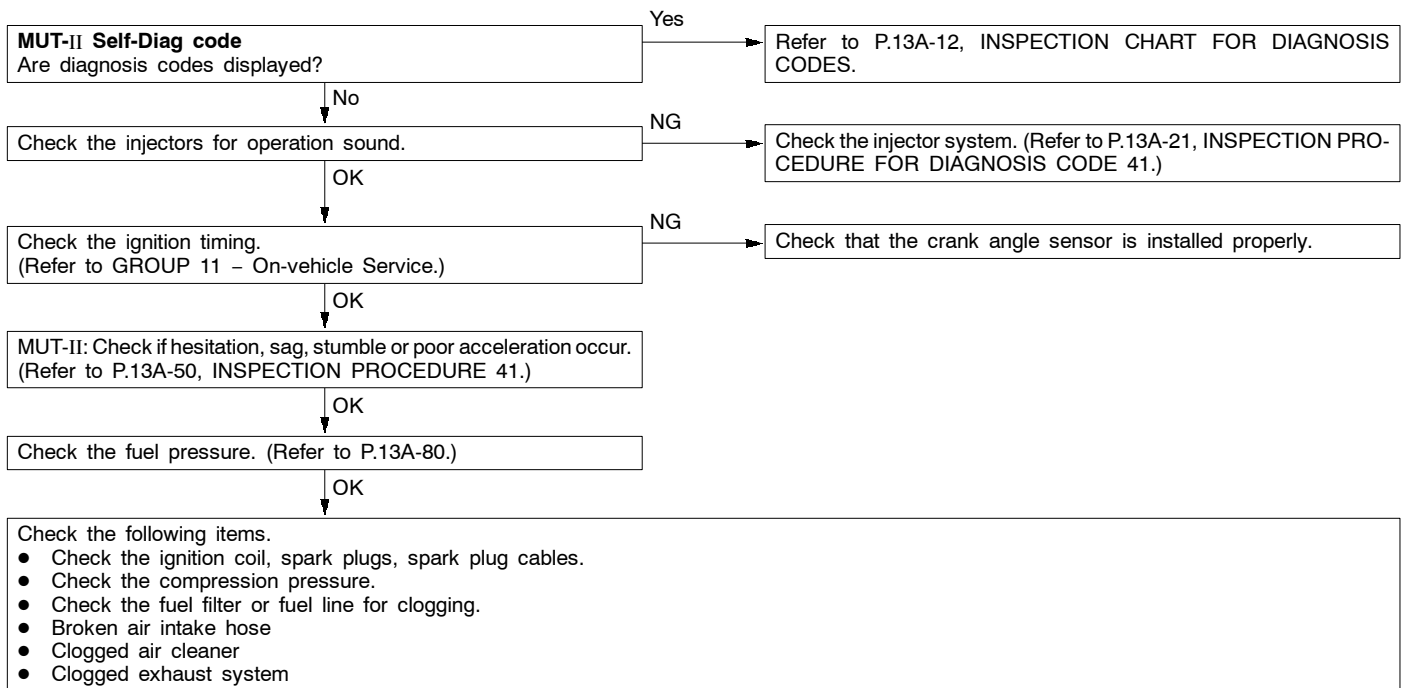

INSPECTION PROCEDURE 19

Surge	Probable cause
Defective ignition system, abnormal air-fuel ratio, etc. are suspected.	<ul style="list-style-type: none"> • Malfunction of the ignition system • Malfunction of air-fuel ratio control system • Malfunction of the EGR control solenoid valve system

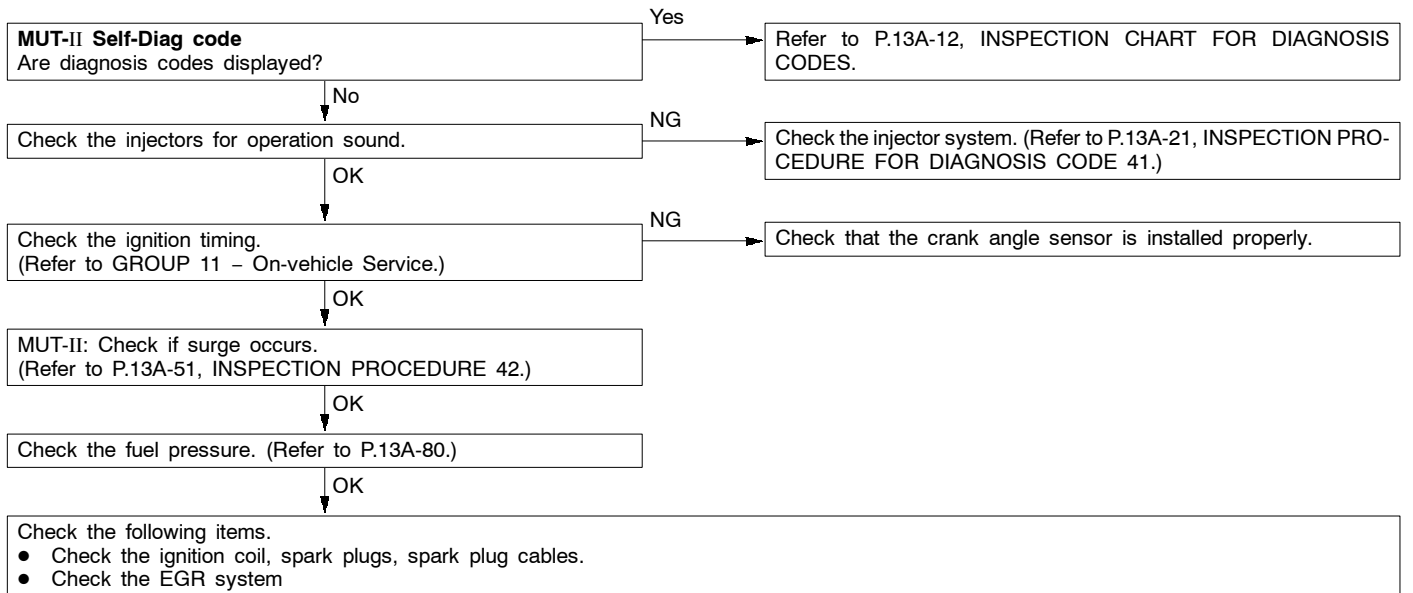

INSPECTION PROCEDURE 20

Knocking	Probable cause
In cases as the above, the cause is probably that the heat value of the spark plug is inappropriate.	<ul style="list-style-type: none"> • Inappropriate heat value of the spark plug

Check the following items.

- Spark plugs
- Check if foreign materials (water, alcohol, etc.) got into fuel.

INSPECTION PROCEDURE 21

Dieseling	Probable cause
Fuel leakage from injectors is suspected.	<ul style="list-style-type: none"> • Fuel leakage from injectors

Check the injectors for fuel leakage.

INSPECTION PROCEDURE 22

Too high CO and HC concentration when idling	Probable cause
Abnormal air-fuel ratio is suspected.	<ul style="list-style-type: none"> ● Malfunction of the air-fuel ratio control system ● Deteriorated catalyst

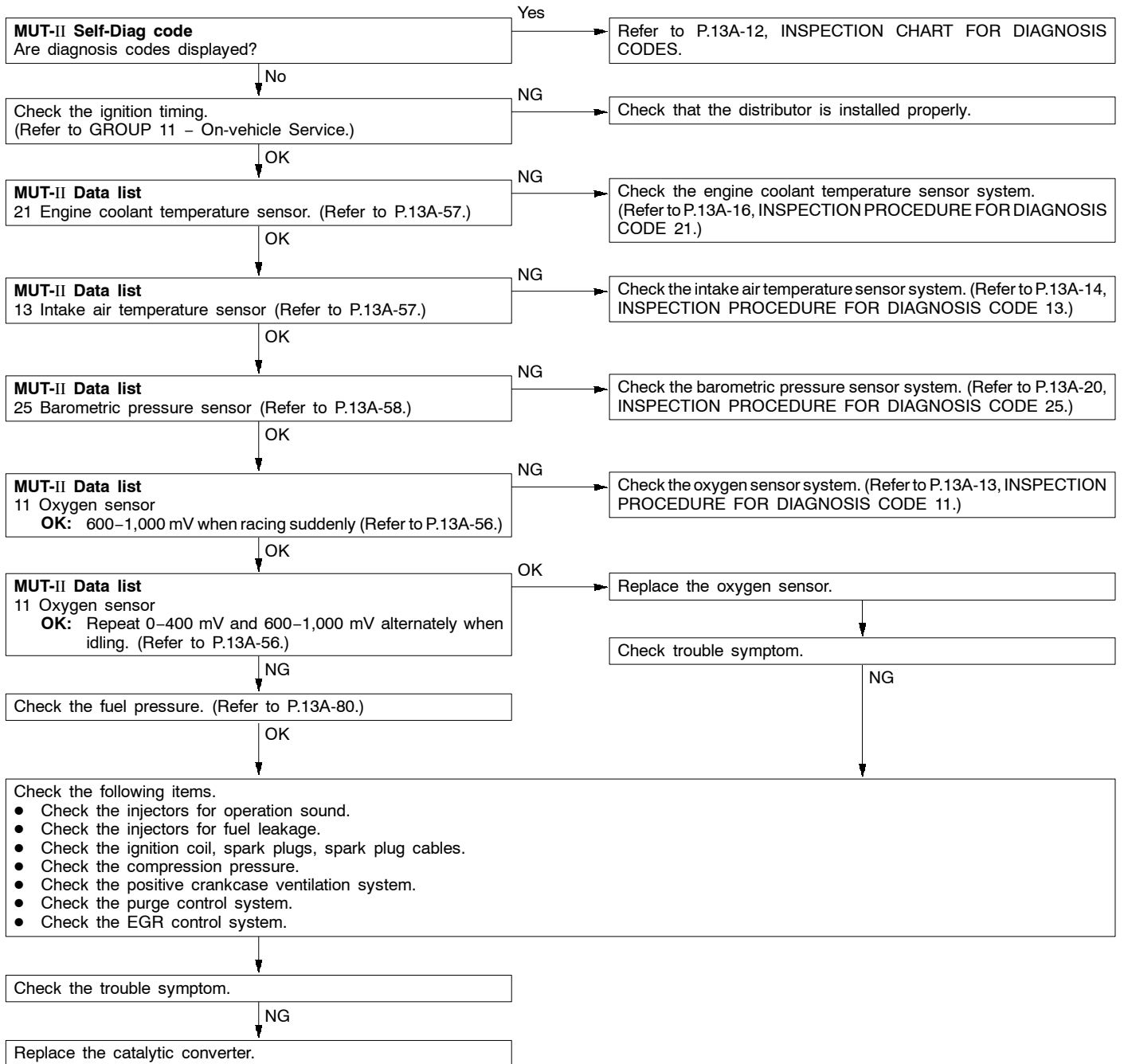

INSPECTION PROCEDURE 23

Idling speed is improper when A/C is operating (A/C switch 2 signal)	Probable cause
<p>The A/C-ECU judges if load caused by air conditioner is high or low, and converts it to A/C switch 2 signal to send the engine-ECU it. Based on this signal, the engine-ECU operates the throttle control servo to control the idle-up speed. If the load is lower than usual, the engine-ECU decreases the idle-up speed.</p>	<ul style="list-style-type: none"> ● Malfunction of the A/C control system ● Improper connector contact, open circuit or short-circuited harness wire ● Malfunction of the engine-ECU

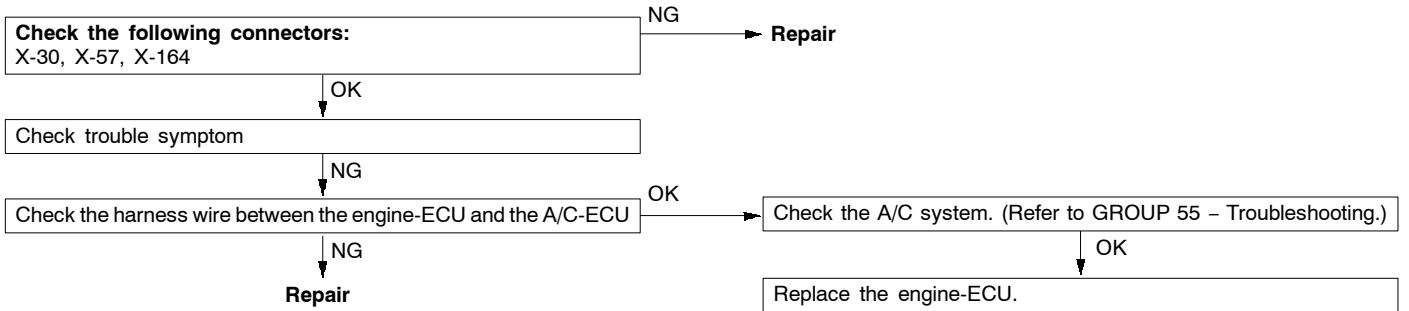

INSPECTION PROCEDURE 24

A/C condenser fan is inoperative	Probable cause
<p>The fan motor relay is controlled by turning on and off the power transistor in the engine-ECU.</p>	<ul style="list-style-type: none"> ● Malfunction of the A/C condenser fan relay ● Malfunction of the condenser fan motor ● Improper connector contact, open circuit or short-circuited harness wire ● Malfunction of the engine-ECU

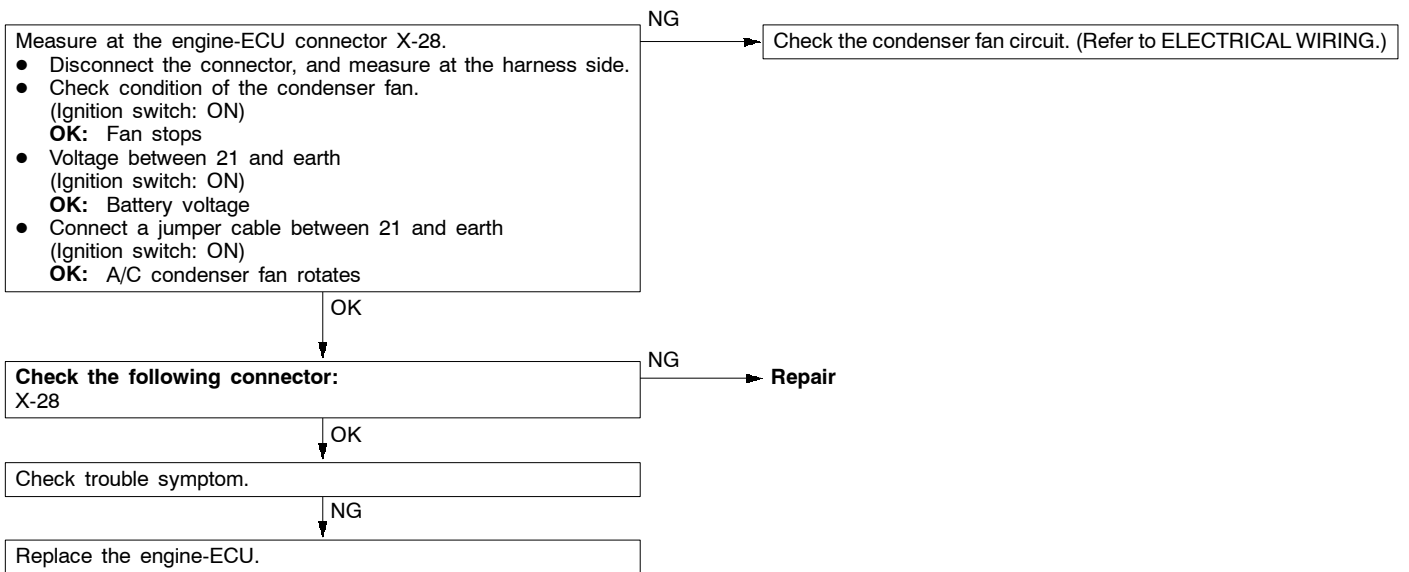

INSPECTION PROCEDURE 25

Power supply system and ignition switch-IG system	Probable cause
When an ignition switch ON signal is input to the engine-ECU, the engine-ECU turns the control relay ON. This causes battery voltage to be supplied to the engine-ECU, injectors and air flow sensor.	<ul style="list-style-type: none"> ● Malfunction of the ignition switch ● Malfunction of the control relay ● Improper connector contact, open circuit or short-circuited harness wire ● Disconnected engine-ECU earth wire ● Malfunction of the engine-ECU

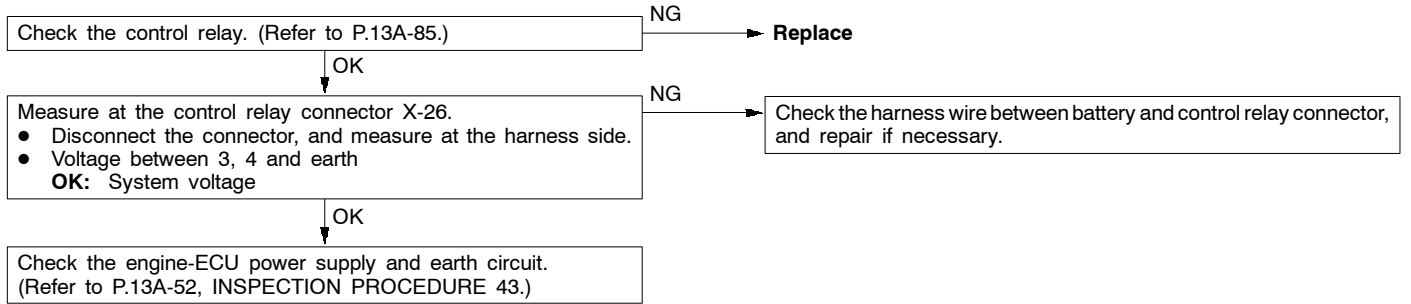

INSPECTION PROCEDURE 26

Fuel pump system	Probable cause
The engine-ECU turns the control relay ON when the engine is cranking or running, and this supplies power to drive the fuel pump.	<ul style="list-style-type: none"> ● Malfunction of the fuel pump relay ● Malfunction of the fuel pump ● Improper connector contact, open circuit or short-circuited harness wire ● Malfunction of the engine-ECU

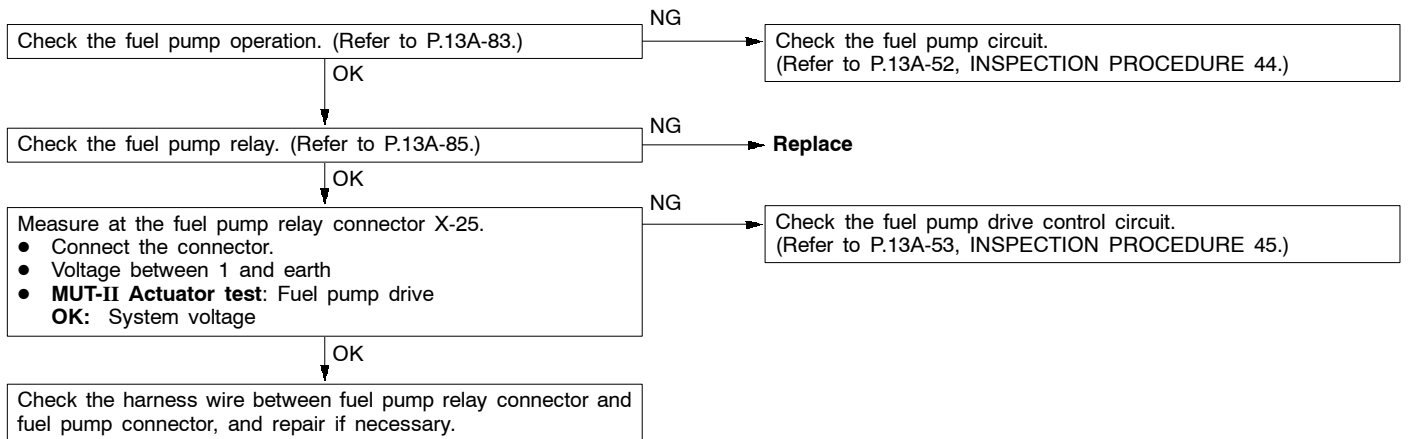

INSPECTION PROCEDURE 27

Idle position switch system	Probable cause
<p>The idle position switch inputs the condition of the accelerator pedal, i.e. whether it is depressed or released (HIGH/LOW), to the engine-ECU. The engine-ECU controls the idle speed control servo based on this input.</p>	<ul style="list-style-type: none"> ● Maladjustment of the accelerator pedal ● Maladjustment of the fixed SAS ● Maladjustment of the idle position switch and throttle position sensor ● Improper connector contact, open circuit or short-circuited harness wire ● Malfunction of the engine-ECU

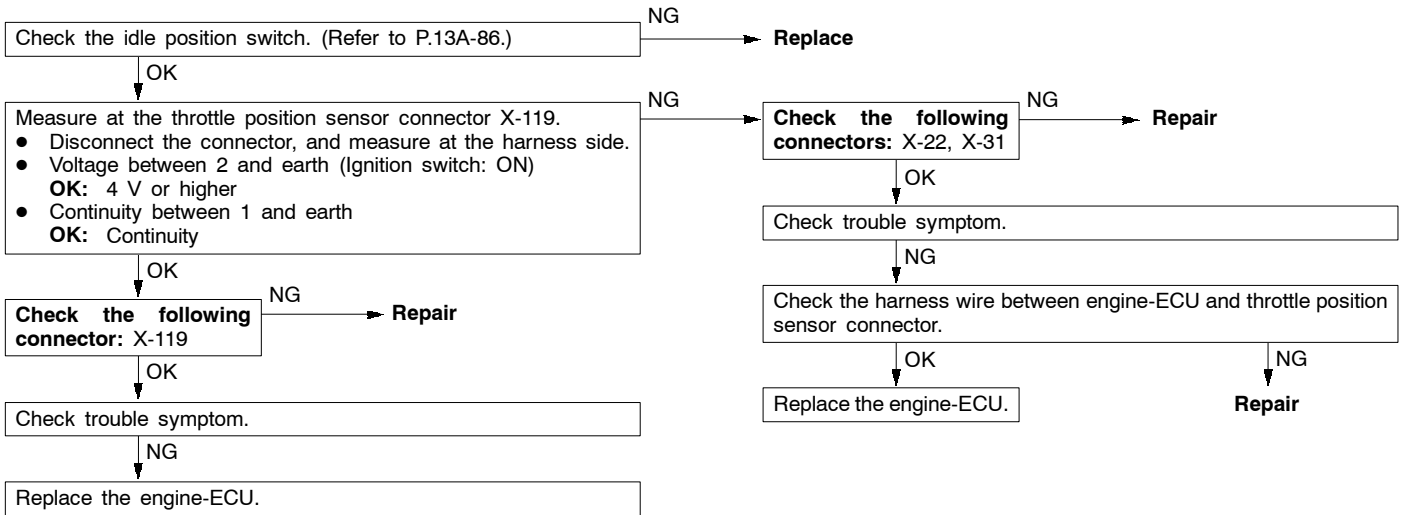

INSPECTION PROCEDURE 28

Ignition switch-ST system	Probable cause
<p>The ignition switch-ST inputs a HIGH signal to the engine-ECU while the engine is cranking. The engine-ECU controls fuel injection, etc. during starting based on this input.</p>	<ul style="list-style-type: none"> ● Malfunction of ignition switch ● Improper connector contact, open circuit or short-circuited harness wire ● Malfunction of the engine-ECU

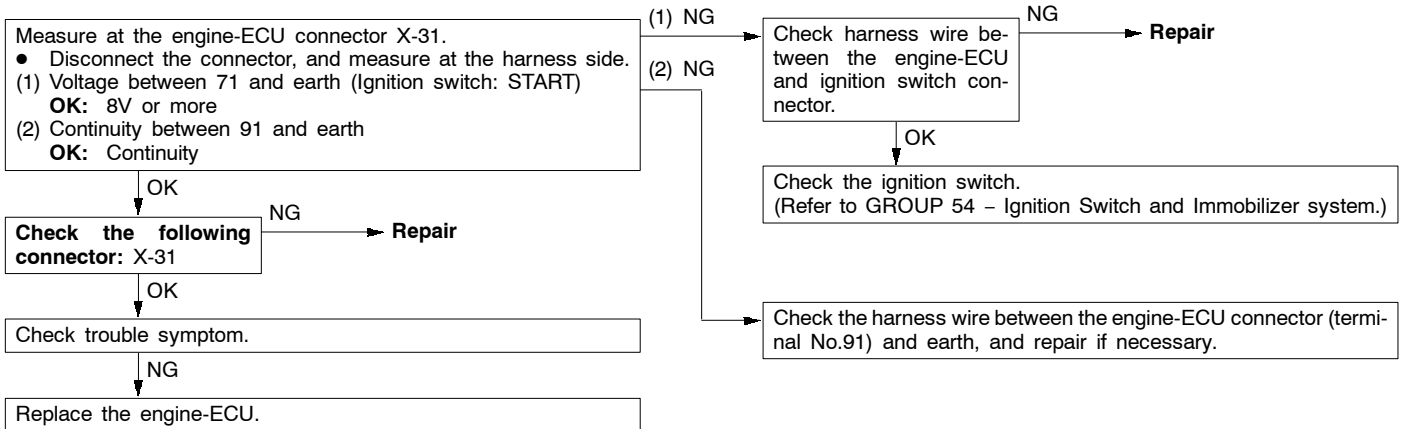

INSPECTION PROCEDURE 29

Power steering fluid pressure switch system	Probable cause
The presence or absence of power steering load is input to the engine-ECU. The engine-ECU controls the idle speed control (ISC) servo based on this input.	<ul style="list-style-type: none"> • Malfunction of power steering fluid pressure switch • Improper connector contact, open circuit or short-circuited harness wire • Malfunction of the engine-ECU

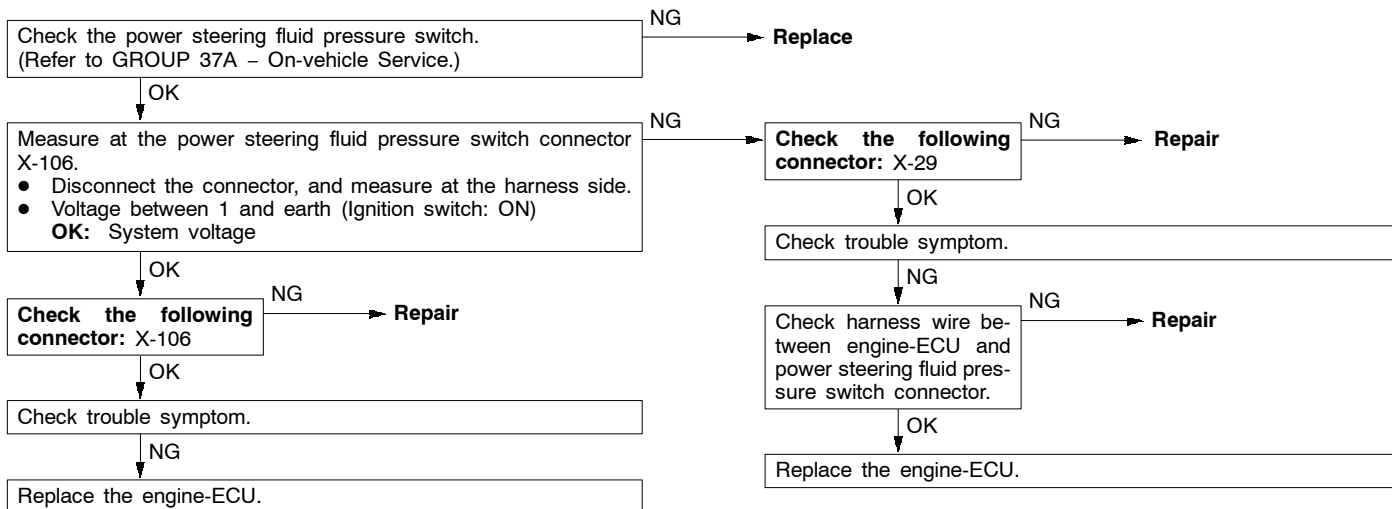

INSPECTION PROCEDURE 30

A/C switch and A/C relay system	Probable cause
When an A/C ON signal is input to the engine-ECU, the engine-ECU carries out control of the idle speed control (ISC) servo, and also operates the A/C compressor magnetic clutch.	<ul style="list-style-type: none"> • Malfunction of A/C control system • Malfunction of A/C switch • Improper connector contact, open circuit or short-circuited harness wire • Malfunction of the engine-ECU

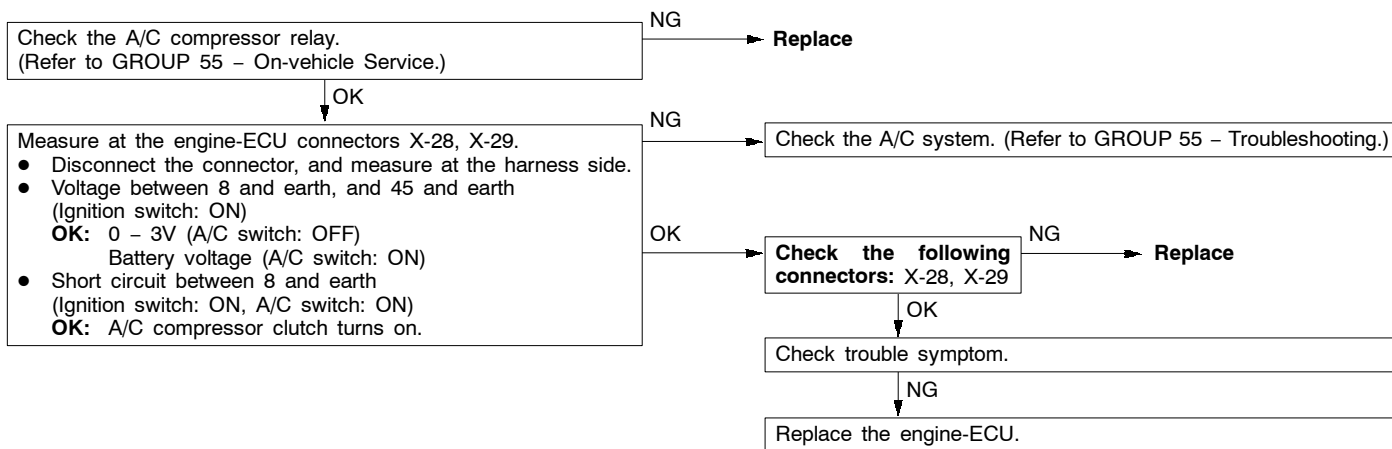

INSPECTION PROCEDURE 31

Ignition circuit system	Probable cause
The engine-ECU interrupts the ignition coil primary current by turning the power transistor inside the engine-ECU ON and OFF.	<ul style="list-style-type: none"> ● Malfunction of ignition switch. ● Malfunction of power transistor unit ● Improper connector contact, open circuit or short-circuited harness wire ● Malfunction of the engine-ECU

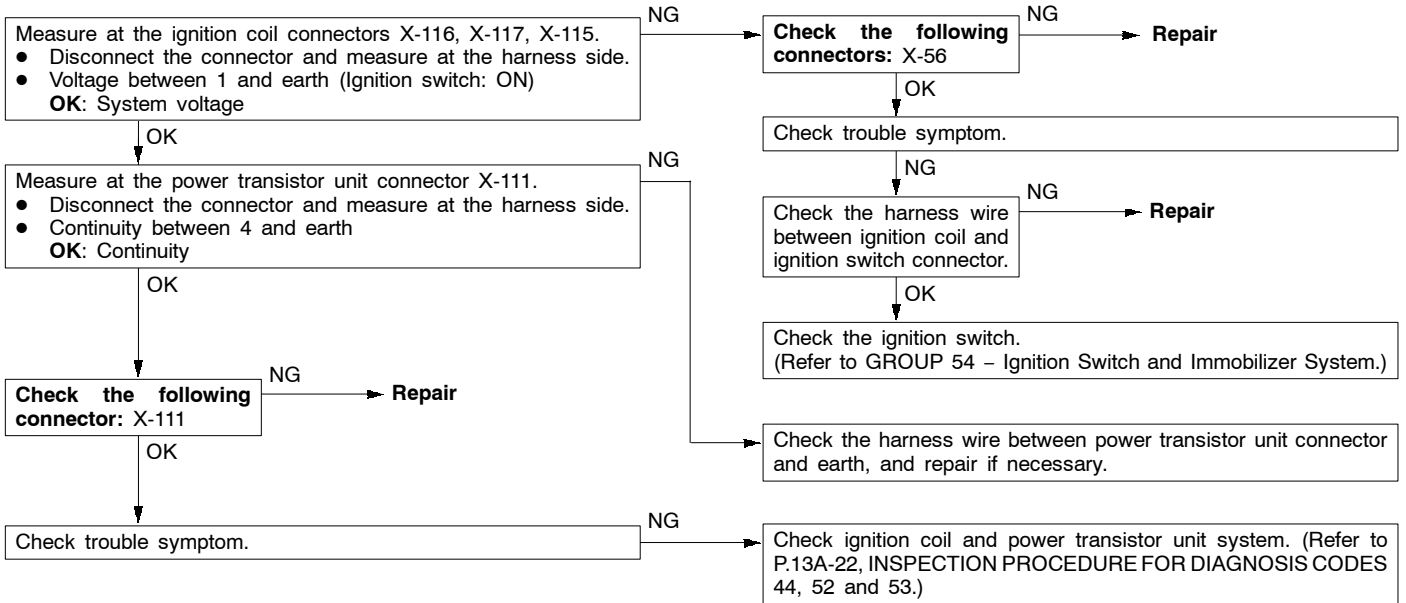

INSPECTION PROCEDURE 32

Idle speed control (ISC) servo (Stepper motor) system	Probable cause
The engine-ECU controls the intake air volume during idling by opening and closing the servo valve located in the bypass air passage.	<ul style="list-style-type: none"> ● Malfunction of ISC servo ● Improper connector contact, open circuit or short-circuited harness wire ● Malfunction of the engine-ECU

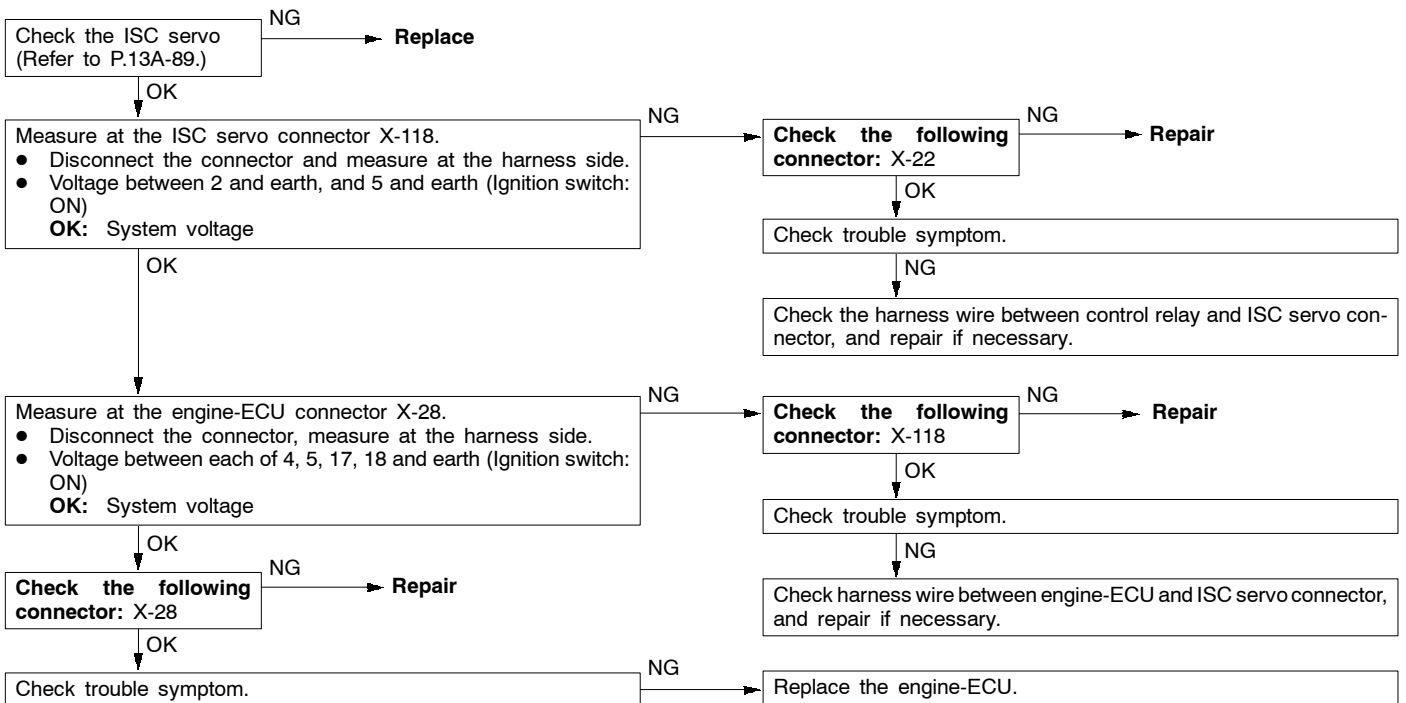

INSPECTION PROCEDURE 33

Purge control solenoid valve system	Probable cause
The purge control solenoid valve controls the purging of air from the canister located inside the intake manifold.	<ul style="list-style-type: none"> ● Malfunction of solenoid valve ● Improper connector contact, open circuit or short-circuited harness wire. ● Malfunction of the engine-ECU

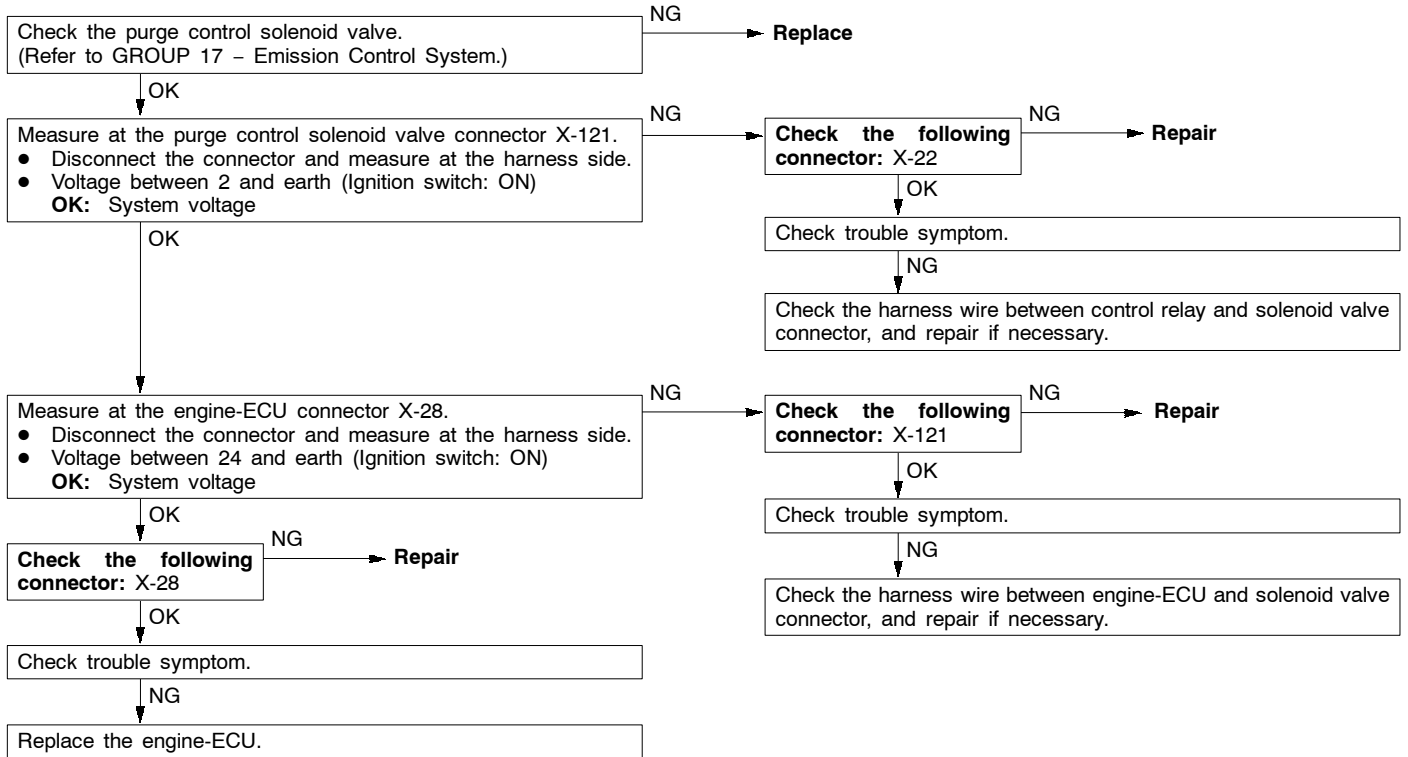

INSPECTION PROCEDURE 34

EGR control solenoid valve system	Probable cause
The EGR control solenoid valve is controlled by the negative pressure resulting from EGR operation leaking to port "A" of the throttle body.	<ul style="list-style-type: none"> ● Malfunction of solenoid valve ● Improper connector contact, open circuit or short-circuited harness wire. ● Malfunction of the engine-ECU

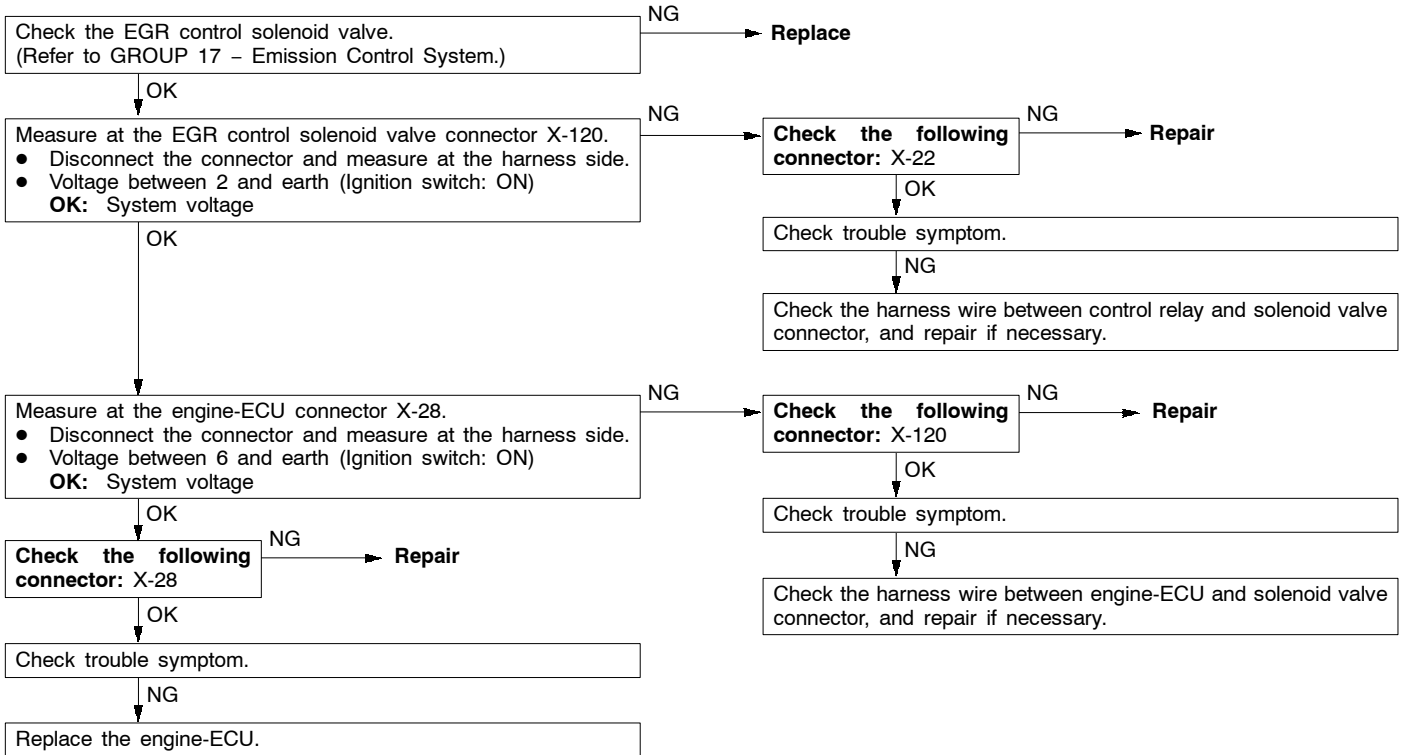

INSPECTION PROCEDURE 35

MUT-II: Inspection of no initial combustion

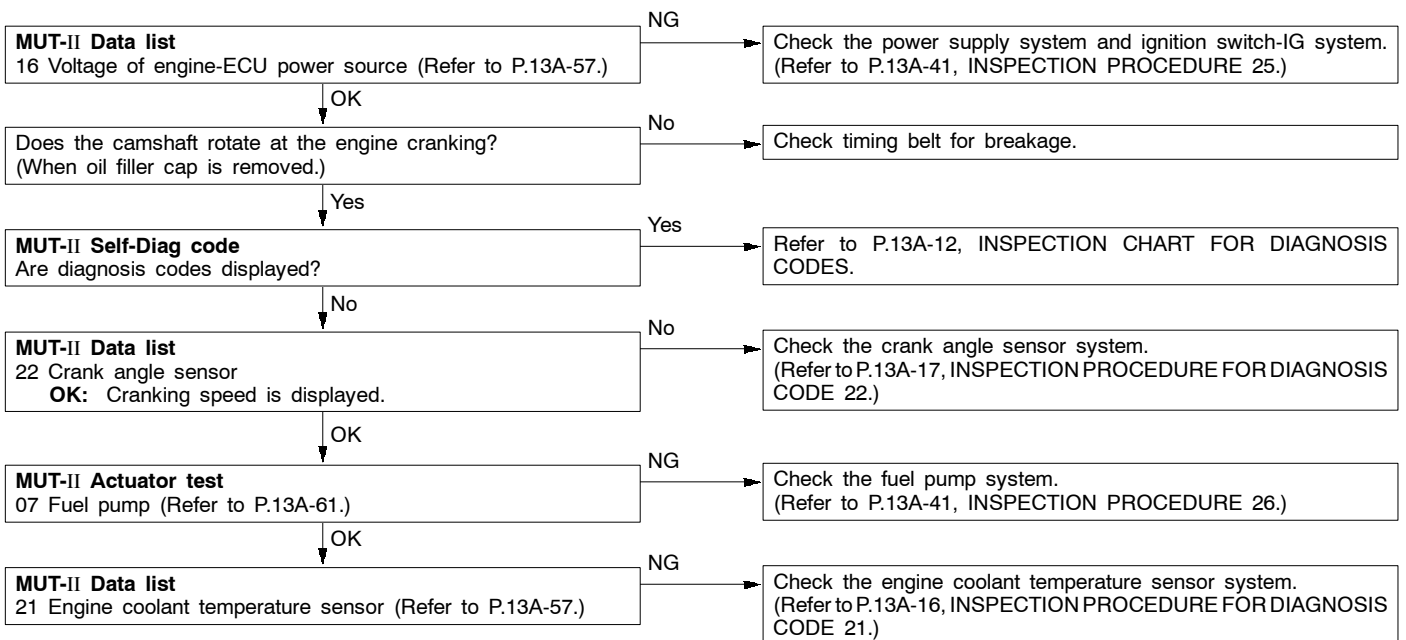

INSPECTION PROCEDURE 36

Ignition system: Inspection of no initial combustion.

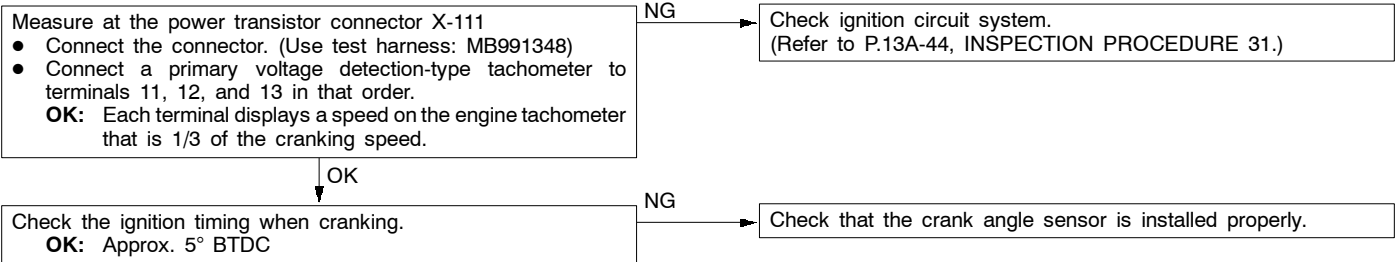

INSPECTION PROCEDURE 37

MUT-II: Check if uncomplete combustion occurs.

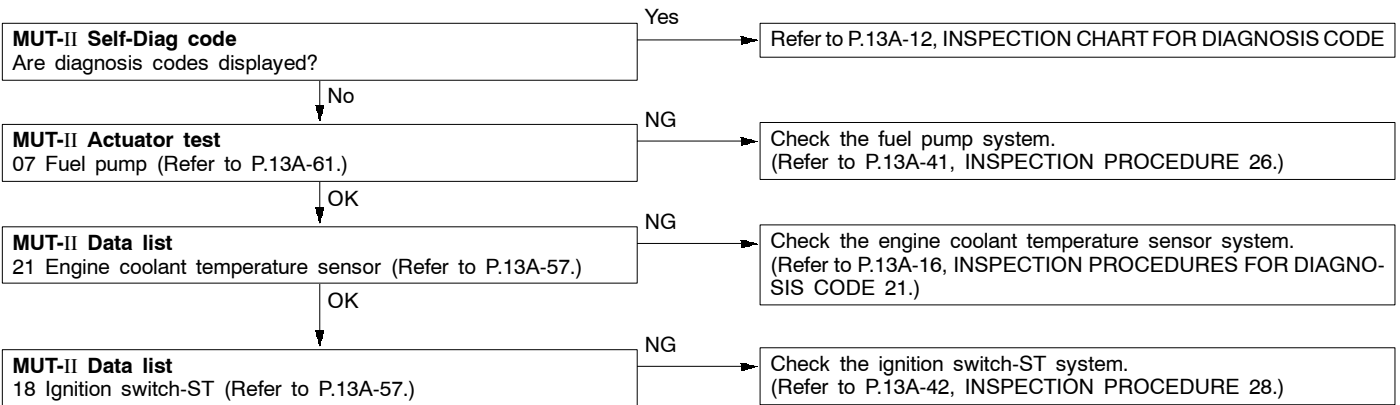

INSPECTION PROCEDURE 38

Check if hunting occurs.

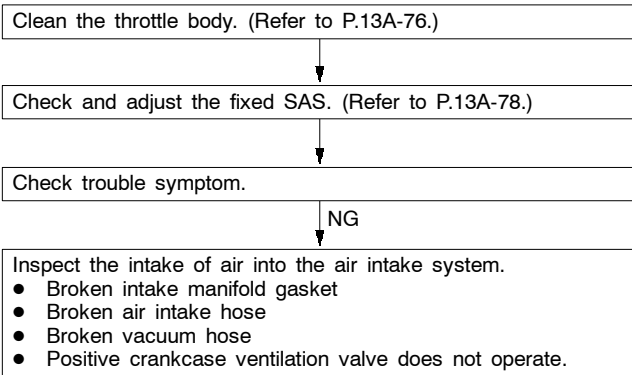

INSPECTION PROCEDURE 39

MUT-II: Check if idling speed is unstable.

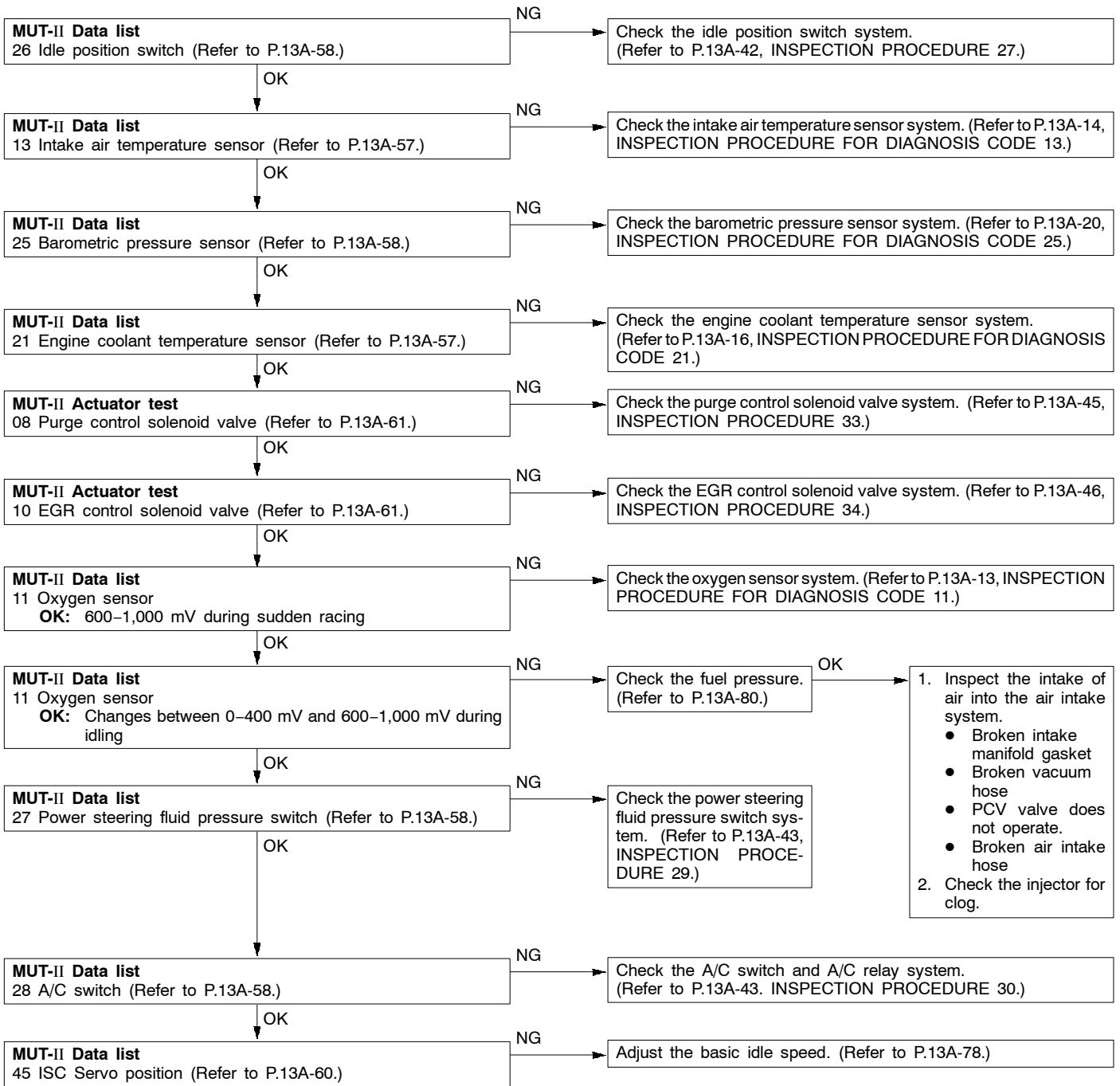

INSPECTION PROCEDURE 40

MUT-II: Engine stalling inspection when the engine is warmed up and idling.

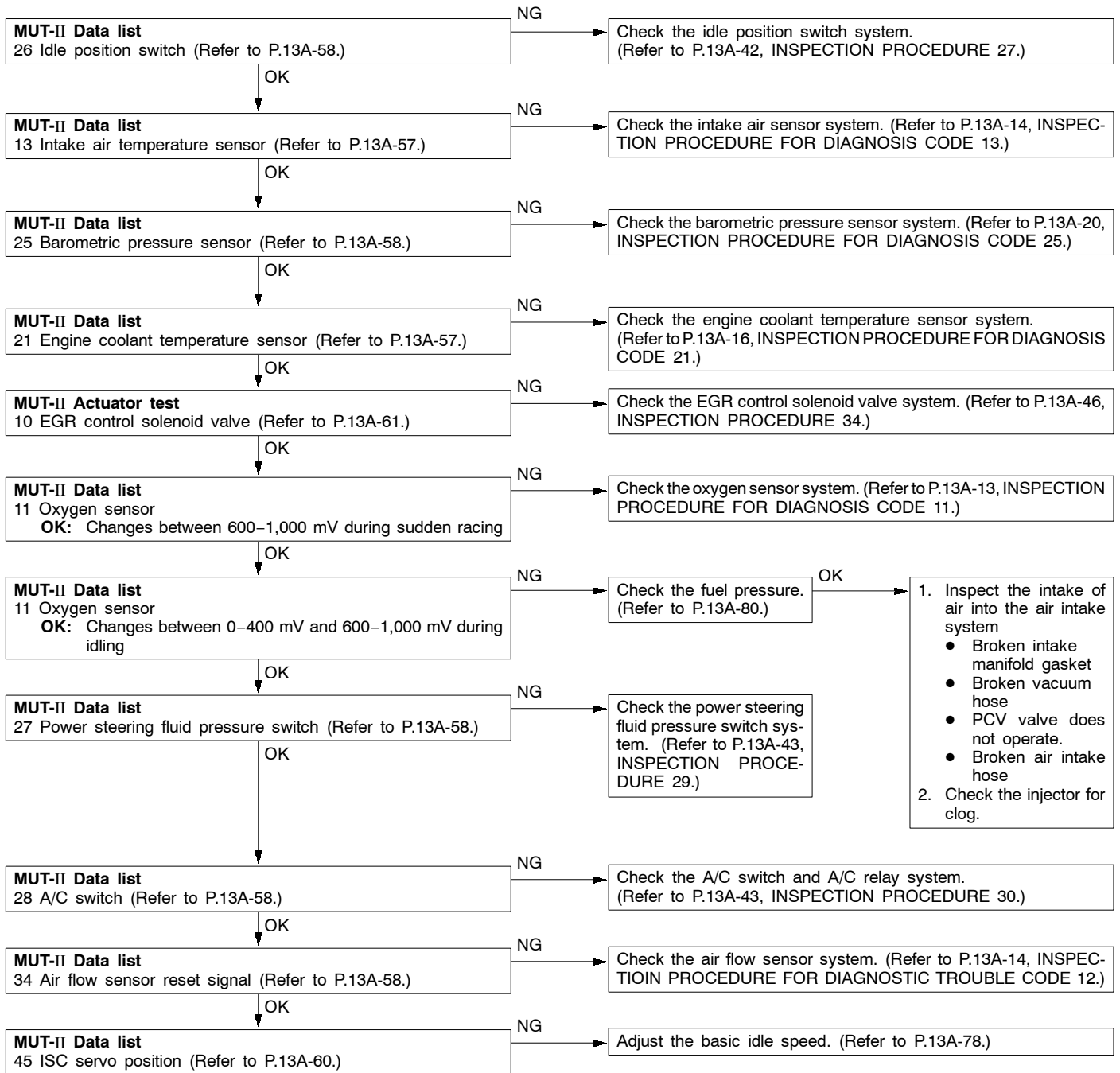

INSPECTION PROCEDURE 41

MUT-II: Check if hesitation, sug, stumble or poor acceleration occurs.

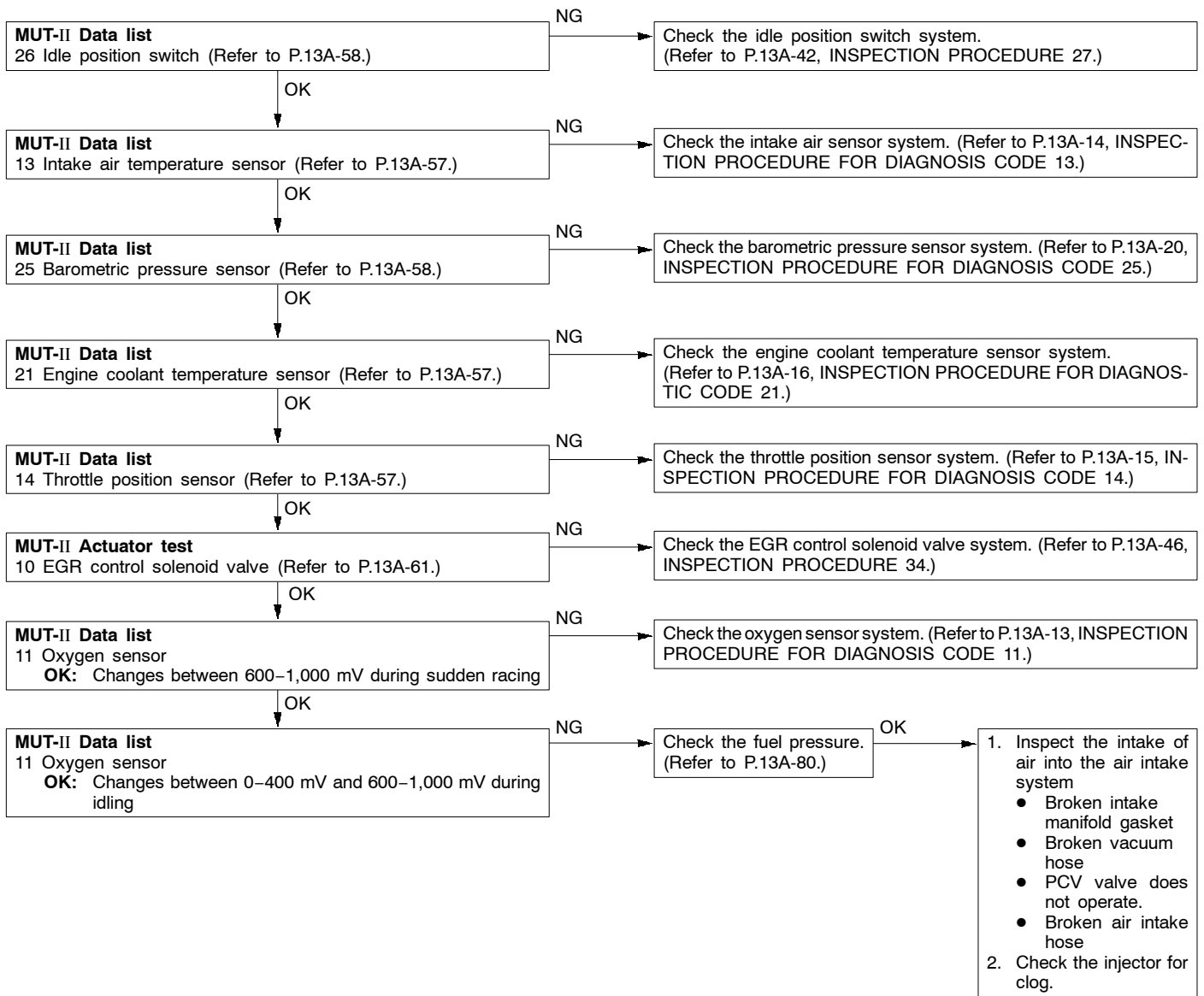

INSPECTION PROCEDURE 42

MUT-II: Check if surge occurs.

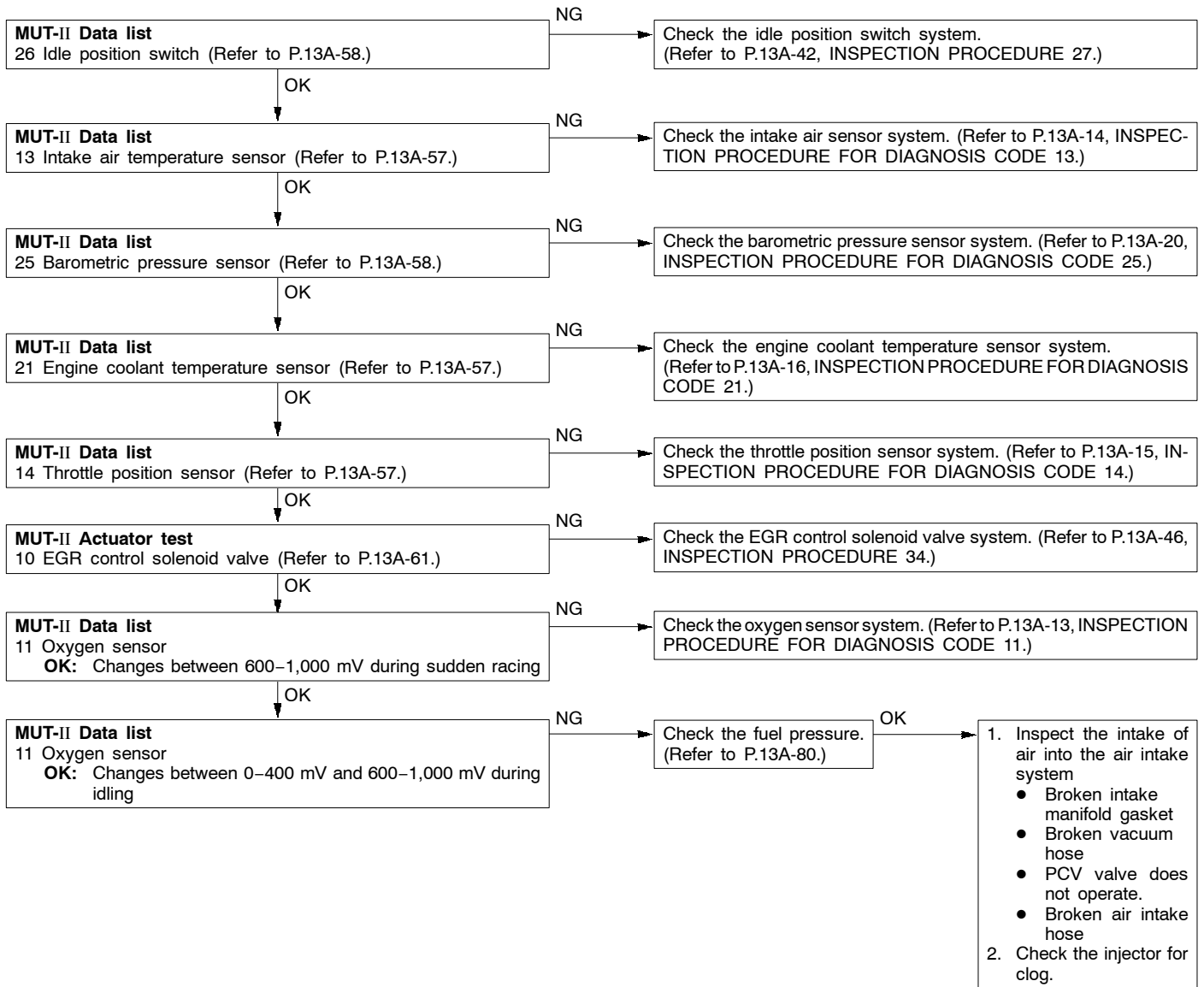

INSPECTION PROCEDURE 43

Check the engine-ECU power supply and earth circuit.

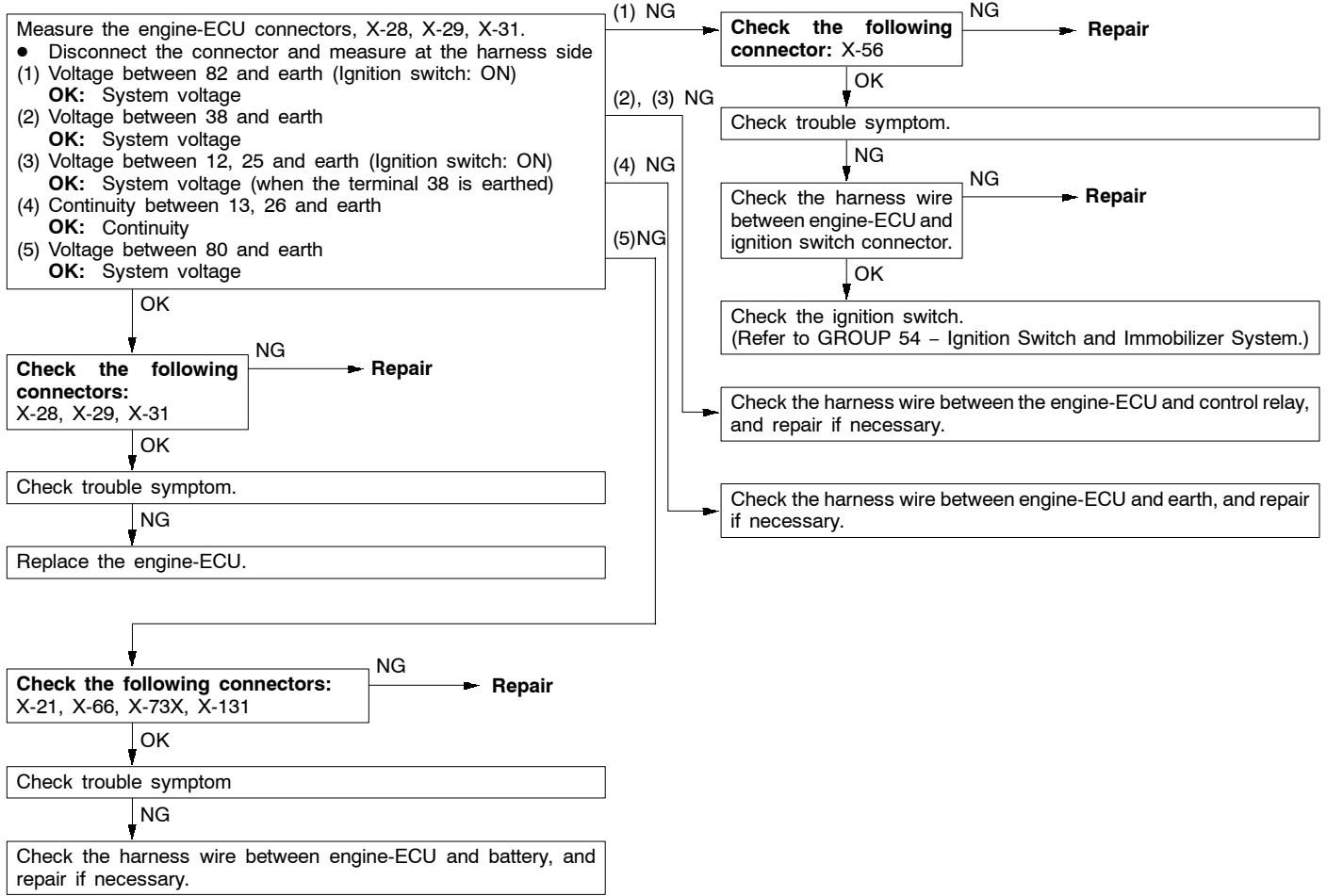

INSPECTION PROCEDURE 44

Check the fuel pump circuit.

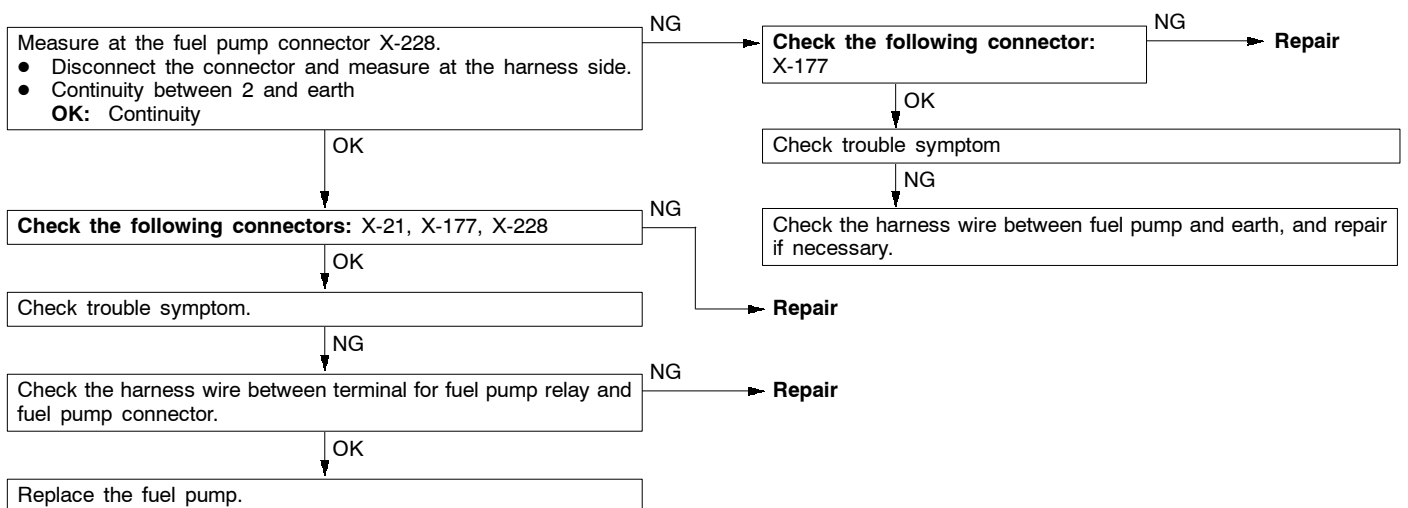

INSPECTION PROCEDURE 45

Check the fuel pump drive control circuit.

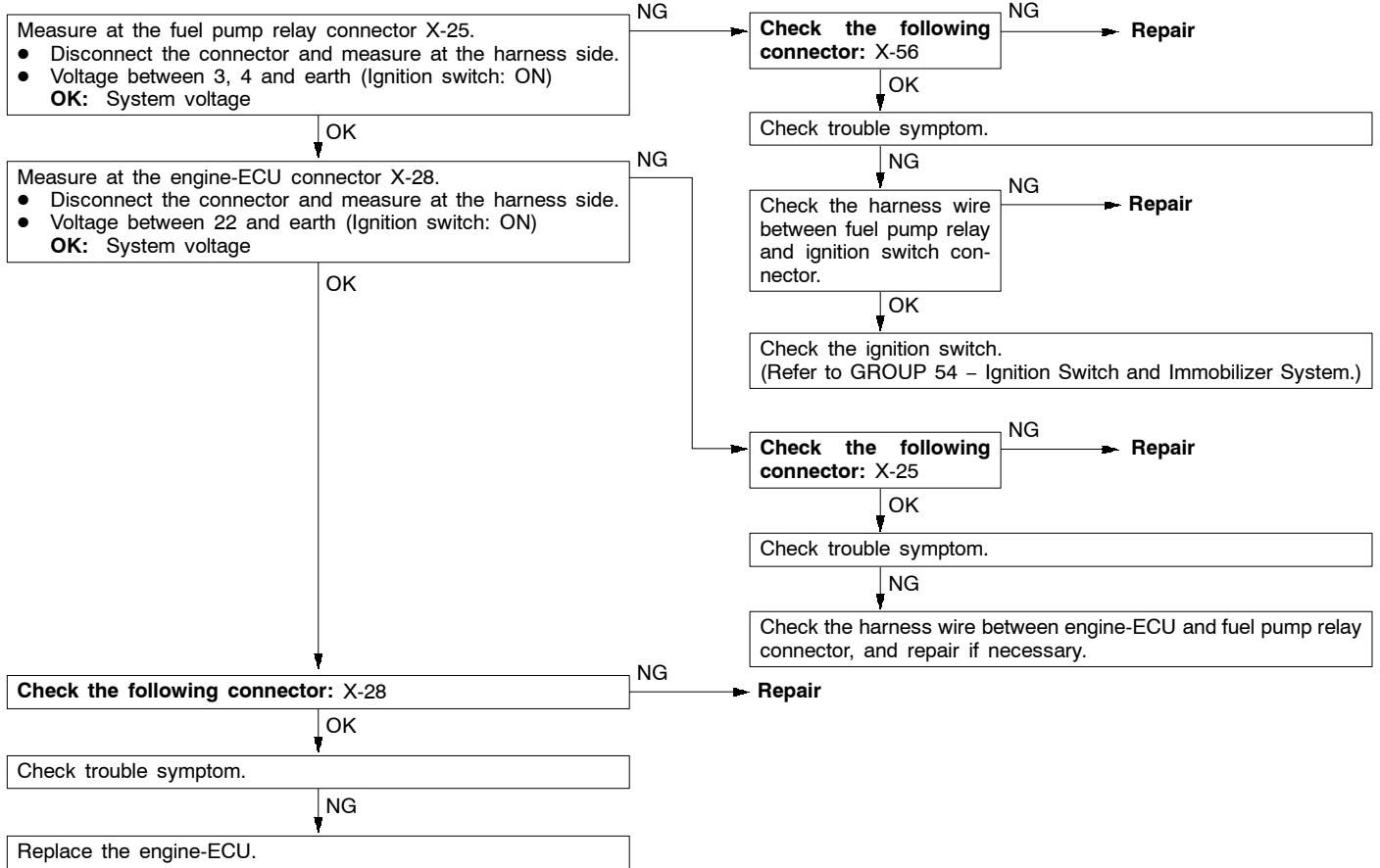

INSPECTION PROCEDURE 46

Check the air flow sensor (AFS) control circuit.

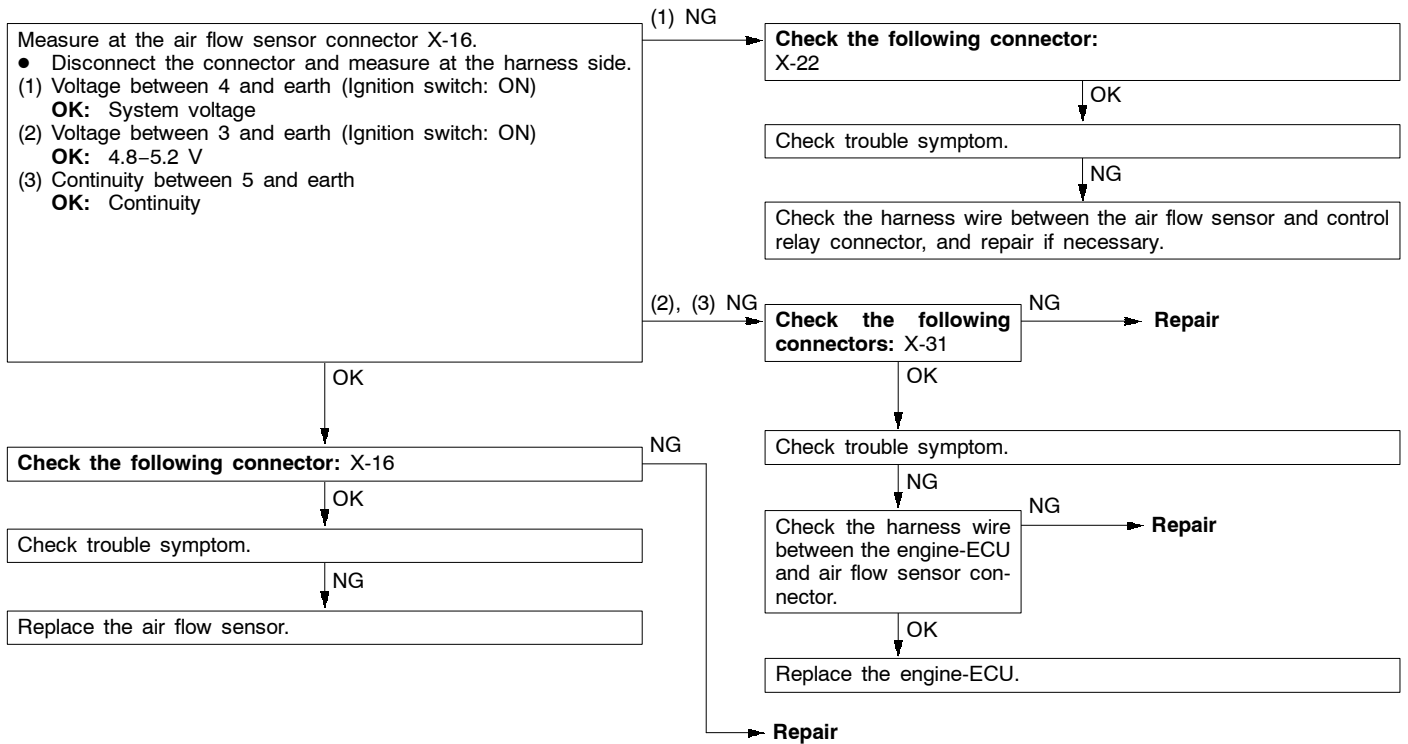

INSPECTION PROCEDURE 47

Check the throttle position sensor (TPS) output circuit.

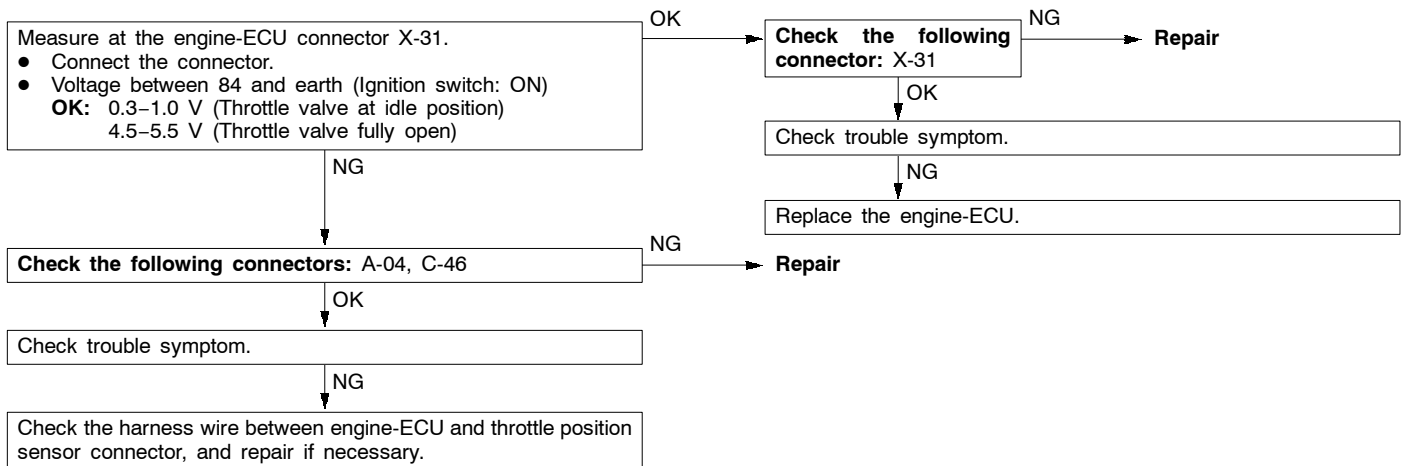

INSPECTION PROCEDURE 48

Check the injector control circuit.

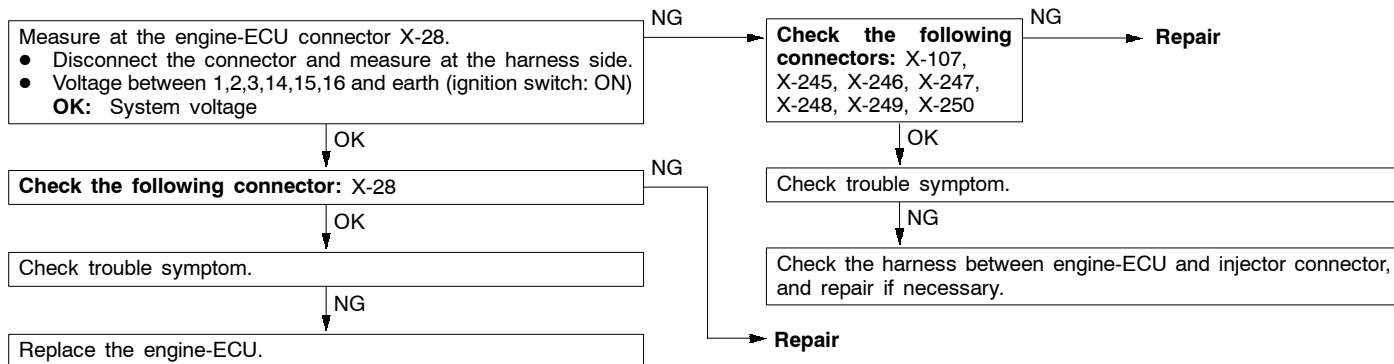

INSPECTION PROCEDURE 49

Check the ignition signal circuit.

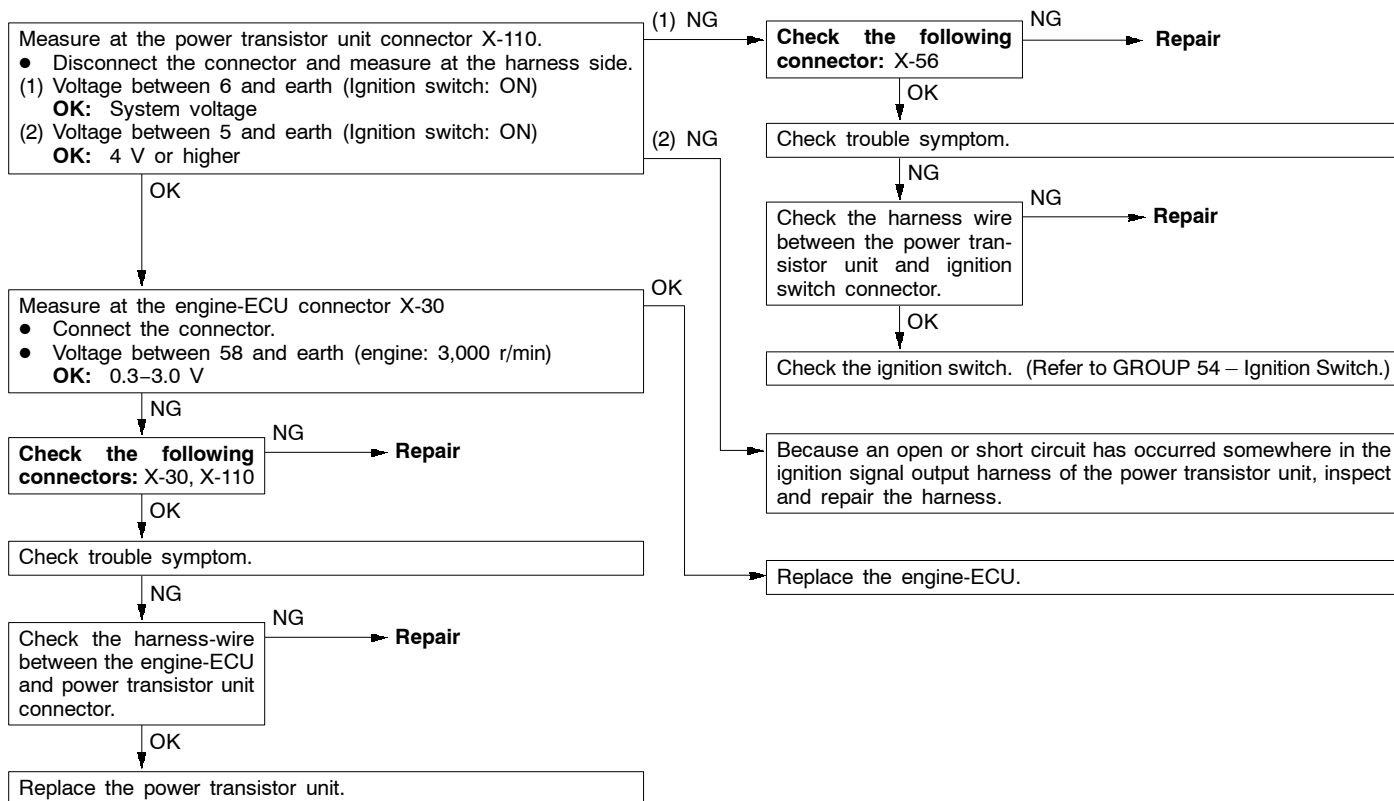

DATA LIST REFERENCE TABLE

Caution

When shifting the select lever to D range, the brakes should be applied so that the vehicle does not move forward.

NOTE

- *1. In a new vehicle [driven approximately 500 km or less], the air flow sensor output frequency is sometimes 10% higher than the standard frequency.
- *2. The idle position switch normally turns off when the voltage of the throttle position sensor is 50 – 100 mV higher than the voltage at the idle position. If the idle position switch turns back on after the throttle position sensor voltage has been by 100 mV and the throttle valve has been opened, the idle position switch and the throttle position sensor need to be adjusted.
- *3. The injector drive time represents the time when the cranking speed is at 250 r/min or below when the power supply voltage is 11 V.
- *4. In a new vehicle [driven approximately 500 km or less], the injector drive time is sometimes 10% longer than the standard time.
- *5. In a new vehicle [driven approximately 500 km or less], the step of the stepper motor is sometimes 30 steps greater than the standard value.

Item No.	Inspection item	Inspection contents	Normal condition	Inspection procedure No.	Reference page	
11	Oxygen sensor	Engine:After having warmed up Air/fuel mixture is made leaner when decelerating, and is made richer when racing.	When at 4,000 r/min, engine is suddenly decelerated	200 mV or less	Code No. 11	13A-13
			When engine is suddenly raced	600 – 1,000 mV		
		Engine:After having warmed up The oxygen sensor signal is used to check the air/fuel mixture ratio, and control condition by the engine-ECU.	Engine is idling	400 mV or less ↑ (Changes) ↓ 600 – 1,000 mV		
			2,500 r/min	400 mV or less ↑ (Changes) ↓ 600 – 1,000 mV		
12	Air flow sensor*1	<ul style="list-style-type: none"> ● Engine coolant temperature: 80 – 95°C ● Lamps and all accessories: OFF ● Transmission: Neutral (A/T: P range) 	Engine is idling	25 – 51 Hz	–	–
			2,500 r/min	74 – 114 Hz		
			Engine is raced	Frequency increases in response to racing		

Item No.	Inspection item	Inspection contents	Normal condition	Inspection procedure No.	Reference page	
13	Intake air temperature sensor	Ignition switch: ON or with engine running	When intake air temperature is -20°C	-20°C	Code No. 13	13A-14
			When intake air temperature is 0°C	0°C		
			When intake air temperature is 20°C	20°C		
			When intake air temperature is 40°C	40°C		
			When intake air temperature is 80°C	80°C		
14	Throttle position sensor	Ignition switch: ON	Set to idle position	300 – 1,000 mV	Code No. 14	13A-15
			Gradually open	Increases in proportion to throttle opening angle		
			Open fully	4,500 – 5,500 mV		
16	Power supply voltage	Ignition switch: ON	System voltage	Procedure No. 25	13A-41	
18	Cranking signal (ignition switch-ST)	Ignition switch: ON	Engine: Stopped	OFF	Procedure No. 28	13A-42
			Engine: Cranking	ON		
21	Engine coolant temperature sensor	Ignition switch: ON or with engine running	When engine coolant temperature is -20°C	-20°C	Code No. 21	13A-16
			When engine coolant temperature is 0°C	0°C		
			When engine coolant temperature is 20°C	20°C		
			When engine coolant temperature is 40°C	40°C		
			When engine coolant temperature is 80°C	80°C		

Item No.	Inspection item	Inspection contents	Normal condition	Inspection procedure No.	Reference page	
22	Crank angle sensor	<ul style="list-style-type: none"> Engine: Cranking Tachometer: Connected 	Compare the engine speed readings on the tachometer and the MUT-II.	Accord	Code No. 22	13A-17
		<ul style="list-style-type: none"> Engine: Idling Idle position switch: ON 	When engine coolant temperature is -20°C	1,275 – 1,475 r/min		
			When engine coolant temperature is 0°C	1,225 – 1,425 r/min		
			When engine coolant temperature is 20°C	1,100 – 1,300 r/min		
			When engine coolant temperature is 40°C	950 – 1,150 r/min		
			When engine coolant temperature is 80°C	600 – 800 r/min		
25	Barometric pressure sensor	Ignition switch: ON	At altitude of 0 m	101 kPa	Code No. 25	13A-20
			At altitude of 600 m	95 kPa		
			At altitude of 1,200 m	88 kPa		
			At altitude of 1,800 m	81 kPa		
26	Idle position switch	Ignition switch: ON Check by operating accelerator pedal repeatedly	Throttle valve: Set to idle position	ON	Procedure No. 27	13A-42
			Throttle valve: Slightly open	OFF*2		
27	Power steering fluid pressure switch	Engine: Idling	Steering wheel stationary	OFF	Procedure No. 29	13A-43
			Steering wheel turning	ON		
28	A/C switch	Engine: Idling (when A/C switch is ON, A/C compressor should be operating.)	A/C switch: OFF	OFF	Procedure No. 30	13A-43
			A/C switch: ON	ON		
34	Air flow sensor reset signal	Engine: After having warmed up	Engine is idling	ON	Code No. 12	13A-14
			2,500 r/min	OFF		

Item No.	Inspection item	Inspection contents	Normal condition	Inspection procedure No.	Reference page	
37	Volumetric efficiency	<ul style="list-style-type: none"> Engine coolant temperature: 80–95 °C Lamps and all accessories: OFF Transmission: Neutral (A/T : P range) 	Engine is idling	15–35 %	–	–
			2,500 r/min	15–35 %		
			Engine is suddenly raced	Volumetric efficiency increases in response to racing		
38	Crank angle sensor	<ul style="list-style-type: none"> Engine: Cranking [reading is possible at 2,000 r/min or less] Tachometer: Connected 	Engine speeds displayed on the MUT-II and tachometer are identical.	–	–	
41	Injectors* ³	Engine: Cranking	When engine coolant temperature is 0°C (injection is carried out for all cylinders simultaneously)	13.8 – 20.6 ms	–	–
			When engine coolant temperature is 20°C	34 – 51 ms		
			When engine coolant temperature is 80°C	8.8 – 13.2 ms		
41	Injectors* ⁴	<ul style="list-style-type: none"> Engine coolant temperature: 80–95°C Lamps and all accessories: OFF Transmission: Neutral (A/T : P range) 	Engine is idling	2.6 – 3.8 ms	–	–
			2,500 r/min	2.3 – 3.5 ms		
			When engine is suddenly raced	Increases		
44	Ignition coils and power transistors	<ul style="list-style-type: none"> Engine: After having warmed up Timing lamp is set. (The timing lamp is set in order to check actual ignition timing.) 	Engine is idling	7–23° BTDC	–	–
			2,500 r/min	27 – 47° BTDC		

Item No.	Inspection item	Inspection contents	Normal condition	Inspection procedure No.	Reference page	
45	ISC (stepper) motor position *5	<ul style="list-style-type: none"> ● Engine coolant temperature: 80–95°C ● Lamps and all accessories: OFF ● Transmission: Neutral (A/T : P range) ● Idle position switch: ON ● Engine: Idling ● When A/C switch is ON, A/C compressor should be operating 	A/C switch: OFF	2–25 STEP	–	–
			A/C switch: OFF → ON	Increases by 10–70 steps		
			<ul style="list-style-type: none"> ● A/C switch: OFF ● Select lever: N range → D range 	Increases by 5–50 steps		
49	A/C relay	Engine: After having warmed up/Engine is idling	A/C switch: OFF	OFF (Compressor clutch is not operating)	Procedure No. 30	13A-43
			A/C switch: ON	ON (Compressor clutch is operating)		

ACTUATOR TEST REFERENCE TABLE

Item No.	Inspection item	Drive contents	Inspection contents	Normal condition	Inspection procedure No.	Reference page
01	Injectors	Cut fuel to No. 1 injector	Engine: After having warmed up/ Engine is idling (Cut the fuel supply to each injector in turn and check cylinders which don't affect idling.)	Idling condition becomes different (becomes unstable).	Code No. 41	13A-21
02		Cut fuel to No. 2 injector				
03		Cut fuel to No. 3 injector				
04		Cut fuel to No. 4 injector				
05		Cut fuel to No. 5 injector				
06		Cut fuel to No. 6 injector				
07	Fuel pump	Fuel pump operates and fuel is recirculated.	<ul style="list-style-type: none"> ● Engine: Cranking ● Fuel pump: Forced driving Inspect according to both the above conditions. 	Pinch the return hose with fingers to feel the pulse of the fuel being recirculated.	Procedure No. 26	13A-41
				Listen near the fuel tank for the sound of fuel pump operation.		
08	Purge control solenoid valve	Solenoid valve turns from OFF to ON.	Ignition switch: ON	Sound of operation can be heard when solenoid valve is driven.	Procedure No.33	13A-45
10	EGR control solenoid valve	Solenoid valve turns from OFF to ON.	Ignition switch: ON	Sound of operation can be heard when solenoid valve is driven.	Procedure No.34	13A-46
17	Basic ignition timing	Set to ignition timing adjustment mode	Engine: Idling Timing light is set	5° BTDC	-	-
21	Condenser fan	Drive the fan motor	<ul style="list-style-type: none"> ● Ignition switch: ON 	Fan motor runs	Procedure No. 24	13A-40

CHECK AT THE ENGINE-ECU TERMINALS

TERMINAL VOLTAGE CHECK CHART

13100920582

Engine-ECU Connector Terminal Arrangement

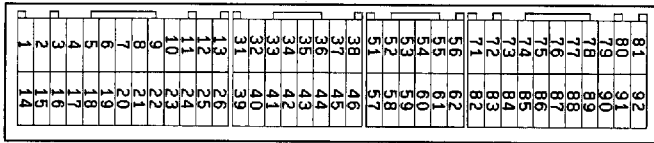

9FU0393

Terminal No.	Check item	Check condition (Engine condition)	Normal condition
1	No. 1 injector	While engine is idling after having warmed up, suddenly depress the accelerator pedal.	From 11 – 14 V, momentarily drops slightly
14	No. 2 injector		
2	No. 3 injector		
15	No. 4 injector		
3	No. 5 injector		
16	No. 6 injector		
4	Stepper motor coil <A1>	Engine: Soon after the warmed up engine is started	10 – 15 V ↔ 0 – 6 V (Changes repeatedly)
17	Stepper motor coil <A2>		
5	Stepper motor coil <B1>		
18	Stepper motor coil <B2>		
6	EGR control solenoid valve	Ignition switch: ON	System Voltage
		While engine is idling, suddenly depress the accelerator pedal.	From system voltage, momentarily drops
8	A/C relay	<ul style="list-style-type: none"> Engine: Idle speed A/C switch: OFF → ON (A/C compressor is operating) 	System voltage or momentarily 6 V or more → 0 – 3 V
10	Power transistor unit (A)	Engine r/min: 3,000 r/min	0.3 – 3.0 V
11	Power transistor unit (B)		
23	Power transistor unit (C)		
12	Power supply	Ignition switch: ON	System voltage
25			
19	Air flow sensor reset signal	Engine: Idle speed	0 – 1 V
		Engine r/min: 3,000 r/min	6 – 9 V

Terminal No.	Check item	Check condition (Engine condition)	Normal condition	
21	Fan motor relay	When the condenser fan is not operating	System voltage	
		When the condenser fan is operating	0 – 3 V	
22	Fuel pump relay	Ignition switch: ON	System voltage	
		Engine: Idle speed	0 – 3 V	
24	Purge control solenoid valve	Ignition switch: ON	System voltage	
		Running at 3,000 r/min while engine is warming up after having been started.	0 – 3 V	
36	Engine warning lamp	Ignition switch: OFF → ON	0 – 3 V → 9 – 13 V (After several seconds have elapsed)	
37	Power steering fluid pressure switch	Engine: Idling after warming up	When steering wheel is stationary	System voltage
			When steering wheel is turned	0 – 3 V
38	Control relay (Power supply)	Ignition switch: OFF	System voltage	
		Ignition switch: ON	0 – 3 V	
44	Anti-lock brake signal	Engine: Idle speed	Battery voltage	
		<ul style="list-style-type: none"> ● After ignition switch is turned ON, at time of first departure ● Vehicle speed: 0 – 10 km/h 	Battery voltage → 0 – 3 V (momentarily)	
45	A/C switch 1	Engine: Idle speed	Turn the A/C switch OFF	0 – 3 V
			Turn the A/C switch ON (A/C compressor is operating)	System voltage
57	A/C switch 2	<ul style="list-style-type: none"> ● Engine: Idling ● Outside air temperature: 25°C or more 	When A/C is MAX. COOL condition (when the load by A/C is high)	0 – 3 V
			When A/C is MAX. HOT condition (When the load by A/C is low)	System voltage
71	Ignition switch – ST	Engine: Cranking	8 V or more	

Terminal No.	Check item	Check condition (Engine condition)		Normal condition
72	Intake air temperature sensor	Ignition switch: ON	When intake air temperature is 0°C	3.2 – 3.8 V
			When intake air temperature is 20°C	2.3 – 2.9 V
			When intake air temperature is 40°C	1.5 – 2.1 V
			When intake air temperature is 80°C	0.4 – 1.0 V
76	Oxygen sensor	Engine: Running at 2,500 r/min after warmed up (Check using a digital type voltmeter)		0 ↔ 0.8 V (Changes repeatedly)
80	Backup power supply	Ignition switch: OFF		System voltage
81	Sensor impressed voltage	Ignition switch: ON		4.5 – 5.5 V
82	Ignition switch – IG	Ignition switch: ON		System voltage
83	Engine coolant temperature sensor	Ignition switch: ON	When engine coolant temperature is 0°C	3.2 – 3.8 V
			When engine coolant temperature is 20°C	2.3 – 2.9 V
			When engine coolant temperature is 40°C	1.3 – 1.9 V
			When engine coolant temperature is 80°C	0.3 – 0.9 V
84	Throttle position sensor	Ignition switch: ON	Set throttle valve to idle position	0.3 – 1.0 V
			Fully open throttle valve	4.5 – 5.5 V
85	Barometric pressure sensor	Ignition switch: ON	When altitude is 0 m	3.7 – 4.3 V
			When altitude is 1,200 m	3.2 – 3.8 V

Terminal No.	Check item	Check condition (Engine condition)		Normal condition
86	Vehicle speed sensor	<ul style="list-style-type: none"> ● Ignition switch: ON ● Move the vehicle slowly forward 		0 ↔ System voltage (Changes repeatedly)
87	Idle position switch	Ignition switch: ON	Set throttle valve to idle position	0 – 1 V
			Slightly open throttle valve	4V or more
88	Top dead centre sensor	Engine: Cranking		0.4 – 3.0 V
		Engine: Idle speed		0.5 – 2.0 V
89	Crank angle sensor	Engine: Cranking		0.4 – 4.0 V
		Engine: Idle speed		1.5 – 2.5 V
90	Air flow sensor	Engine: Idle speed		2.2 – 3.2 V
		Engine r/min: 2,500 r/min		

CHECK CHART FOR RESISTANCE AND CONTINUITY BETWEEN TERMINALS

1. Turn the ignition switch to OFF.
2. Disconnect the engine-ECU connector.
3. Measure the resistance and check for continuity between the terminals of the engine-ECU harness-side connector while referring to the check chart.

NOTE

- (1) When measuring resistance and checking continuity, a harness for checking contact pin pressure should be used instead of inserting a test probe.
- (2) Checking need not be carried out in the order given in the chart.

Caution

If the terminals that should be checked are mistaken, or if connector terminals are not correctly shorted to earth, damage may be caused to the vehicle wiring, sensors, engine-ECU and/or ohmmeter.

Be careful to prevent this!

4. If the ohmmeter shows any deviation from the standard value, check the corresponding sensor, actuator and related electrical wiring, and then repair or replace.
5. After repair or replacement, recheck with the ohmmeter to confirm that the repair or replacement has corrected the problem.

Engine-ECU Harness Side Connector Terminal Arrangement

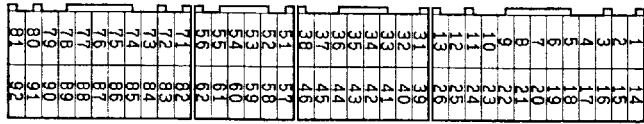

9FU0392

Terminal No.	Inspection item	Normal condition (Check condition)
1 – 12	No. 1 injector	13 – 16 Ω (At 20°C)
14 – 12	No. 2 injector	
2 – 12	No. 3 injector	
15 – 12	No. 4 injector	13 – 16 Ω (At 20°C)
3 – 12	No. 5 injector	
16 – 12	No. 6 injector	
4 – 12	Stepper motor coil (A1)	28 – 33 Ω (At 20°C)
17 – 12	Stepper motor coil (A2)	
5 – 12	Stepper motor coil (B1)	
18 – 12	Stepper motor coil (B2)	
6 – 12	EGR control solenoid valve	36 – 44 Ω (At 20°C)
24 – 12	Purge control solenoid valve	36 – 44 Ω (At 20°C)
13 – Body earth	Engine-ECU earth	Continuity (0 Ω)
26 – Body earth	Engine-ECU earth	
72 – 92	Intake air temperature sensor	5.3 – 6.7 kΩ (When intake air temperature is 0°C)
		2.3 – 3.0 kΩ (When intake air temperature is 20°C)
		1.0 – 1.5 kΩ (When intake air temperature is 40°C)
		0.30 – 0.42 kΩ (When intake air temperature is 80°C)
83 – 92	Engine coolant temperature sensor	5.1 – 6.5 kΩ (When coolant temperature is 0°C)
		2.1 – 2.7 kΩ (When coolant temperature is 20°C)
		0.9 – 1.3 kΩ (When coolant temperature is 40°C)
		0.26 – 0.36 kΩ (When coolant temperature is 80°C)
87 – 92	Idle position switch	Continuity (when throttle valve is at idle position)
		No continuity (when throttle valve is slightly open)

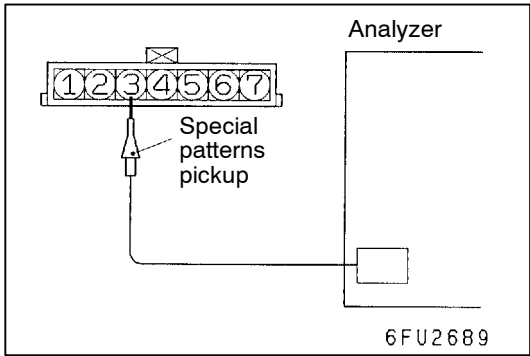

INSPECTION PROCEDURE USING AN ANALYZER

AIR FLOW SENSOR (AFS)

13100930400

Measurement Method

1. Disconnect the air flow sensor connector, and connect the special tool (test harness: MB991709) in between. (All terminals should be connected.)
2. Connect the analyzer special patterns pickup to air flow sensor connector terminal 3.

Alternate Method (Test harness not available)

1. Connect the analyzer special patterns pickup to engine-ECU terminal 90.

Standard Wave Pattern

Observation conditions

Function	Special patterns
Pattern height	Low
Pattern selector	Display
Engine r/min	Idle speed

Standard wave pattern

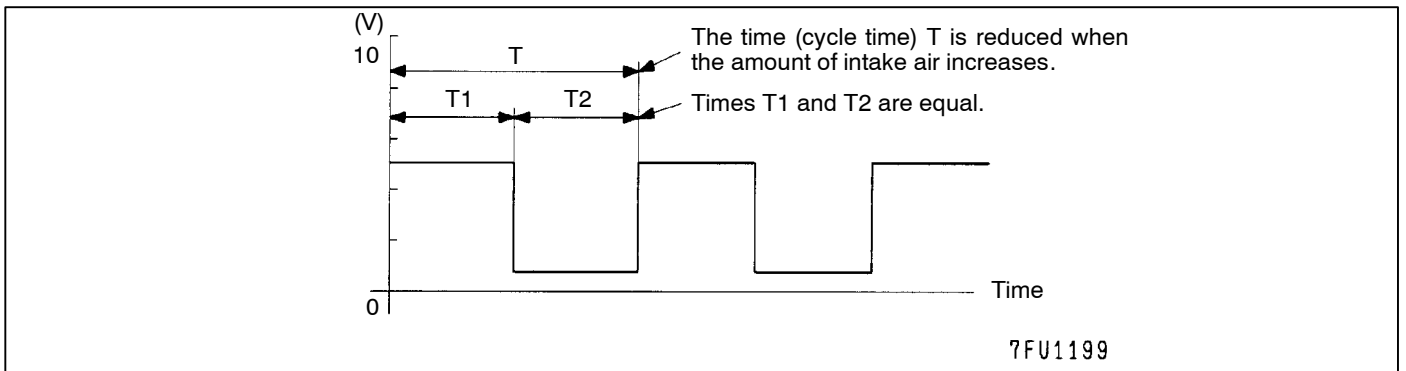

Observation conditions (from conditions above engine speed is increased by racing.)

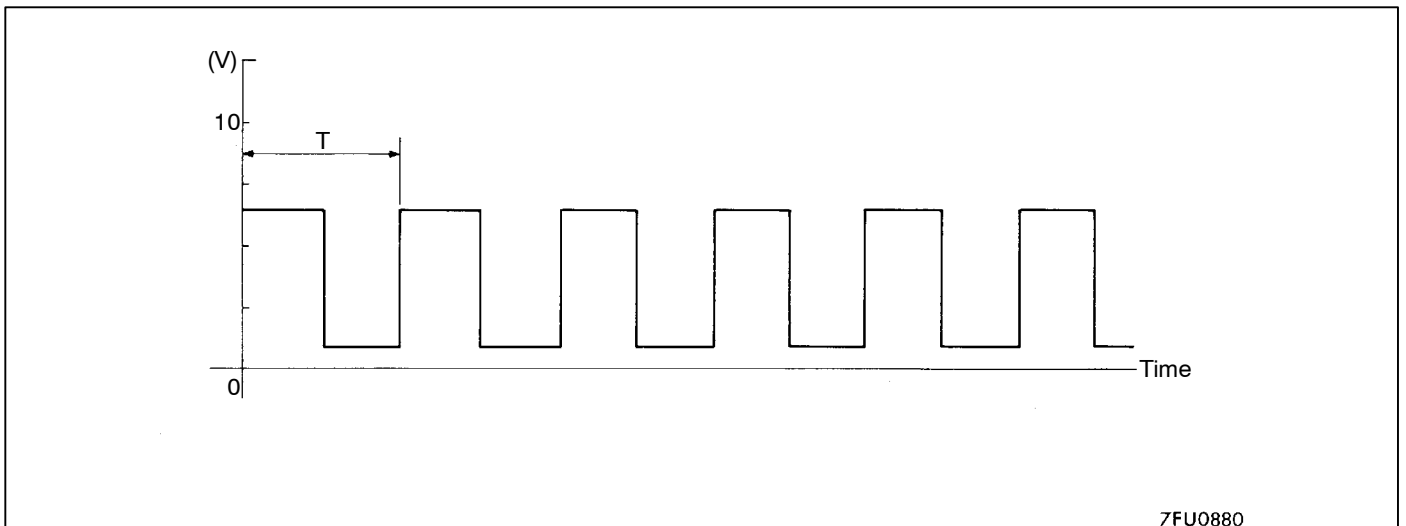

Wave Pattern Observation Points

Check that cycle time T becomes shorter and the frequency increases when the engine speed is increased.

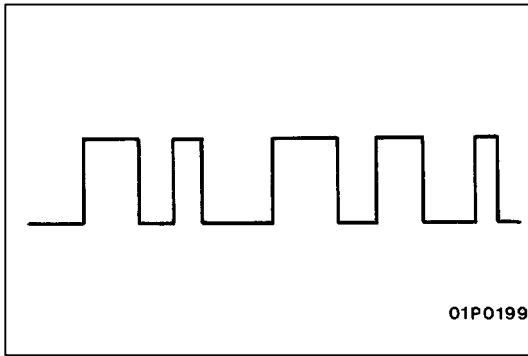

Examples of Abnormal Wave Patterns

- Example 1

Cause of problem

Sensor interface malfunction

Wave pattern characteristics

Rectangular wave pattern is output even when the engine is not started.

- Example 2

Cause of problem

Damaged rectifier or vortex generation column

Wave pattern characteristics

Unstable wave pattern with non-uniform frequency. However, when an ignition leak occurs during acceleration, the wave pattern will be distorted temporarily, even if the air flow sensor is normal.

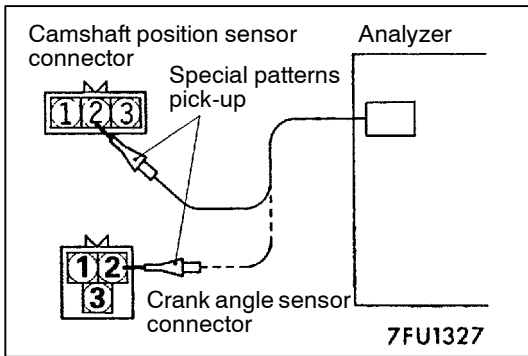

CAMSHAFT POSITION SENSOR AND CRANK ANGLE SENSOR

Measurement Method

1. Disconnect the camshaft position sensor connector and connect the special tool (test harness: MB991658) in between. (All terminals should be connected.)
2. Connect the analyzer special patterns pickup to camshaft position sensor terminal 2.
3. Disconnect the crank angle sensor connector and connect the special tool (test harness: MD998478) in between.
4. Connect the analyzer special patterns pickup to crank angle sensor terminal 2.

Alternate Method (Test harness not available)

1. Connect the analyzer special patterns pickup to engine-ECU terminal 88. (When checking the top dead centre sensor signal wave pattern.)
2. Connect the analyzer special patterns pickup to engine-ECU terminal 89. (When checking the crank angle sensor signal wave pattern.)

Standard Wave Pattern

Observation conditions

Function	Special patterns
Pattern height	Variable
Variable knob	Adjust while viewing the wave pattern
Pattern selector	Display
Engine r/min	Idle speed

Standard wave pattern

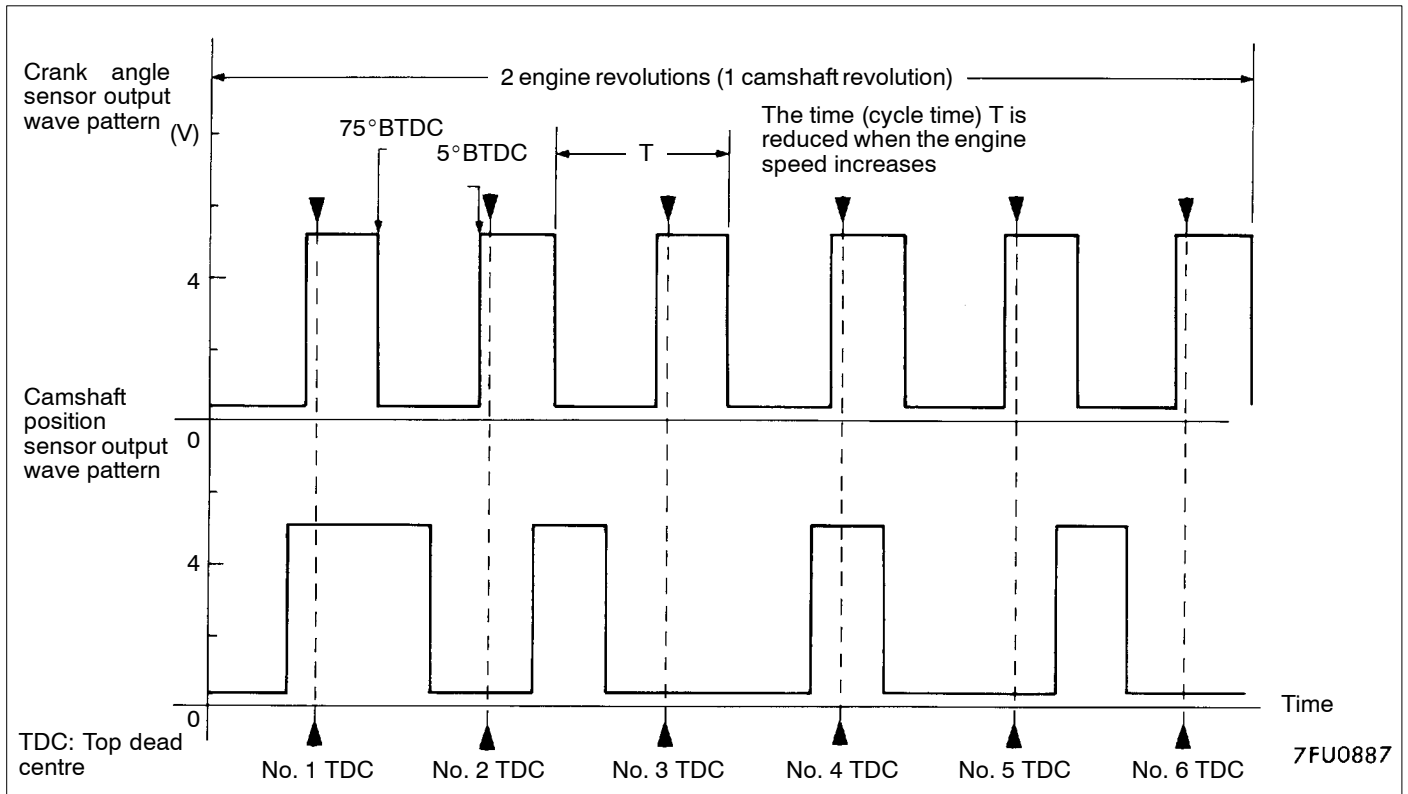

Wave Pattern Observation Points

Check that cycle time T becomes shorter and the frequency increases when the engine speed increases.

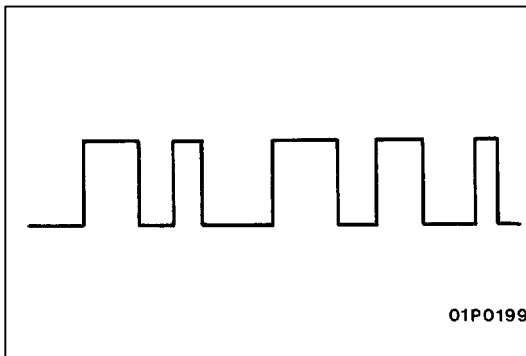

Examples of Abnormal Wave Patterns

- Example 1

Cause of problem

Sensor interface malfunction

Wave pattern characteristics

Rectangular wave pattern is output even when the engine is not started.

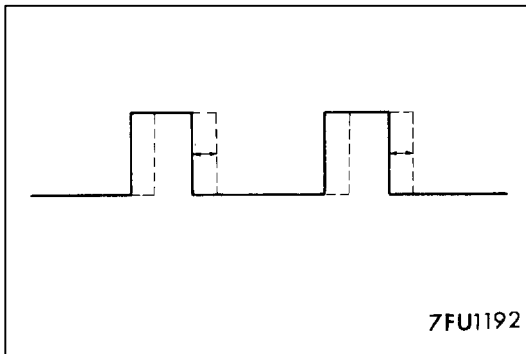

- Example 2

Cause of problem

Loose timing belt

Abnormality in sensor disk

Wave pattern characteristics

Wave pattern is displaced to the left or right.

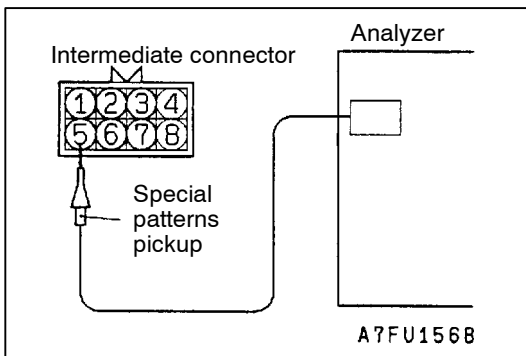

INJECTOR

Measurement Method

1. Disconnect the injector intermediate harness connector, and then connect the special tool (test harness: MD998474) in between. (Both the power supply side and engine-ECU side should be connected.)
2. To measure cylinder No. 1, connect the analyzer special patterns pickup to terminal 3 (red clip [red lead wire] of the special tool). For cylinder No. 2, connect to terminal 2 (yellow clip [yellow lead wire]). For cylinder No. 3, connect to terminal 1 (green clip [green lead wire]). For cylinder No. 4, connect to terminal 7 (white clip [white lead wire]). For cylinder No. 5, connect to terminal 6 (green clip [green and black lead wire]). For cylinder No. 6, connect to terminal 5 (yellow clip [red and yellow lead wire]).

Alternate Method (Test harness not available)

1. Connect the analyzer special patterns pickup to engine-ECU terminal 1. (When checking the No. 1 cylinder.)
2. Connect the analyzer special patterns pickup to engine-ECU terminal 14. (When checking the No. 2 cylinder.)
3. Connect the analyzer special patterns pickup to engine-ECU terminal 2. (When checking the No. 3 cylinder.)
4. Connect the analyzer special patterns pickup to engine-ECU terminal 15. (When checking the No. 4 cylinder.)
5. Connect the analyzer special patterns pickup to engine-ECU terminal 3. (When checking the No. 5 cylinder.)
6. Connect the analyzer special patterns pickup to engine-ECU terminal 16. (When checking the No. 6 cylinder.)

Standard Wave Pattern

Observation conditions

Function	Special patterns
Pattern height	Variable
Variable knob	Adjust while viewing the wave pattern
Pattern selector	Display
Engine r/min	Idle speed

Standard wave pattern

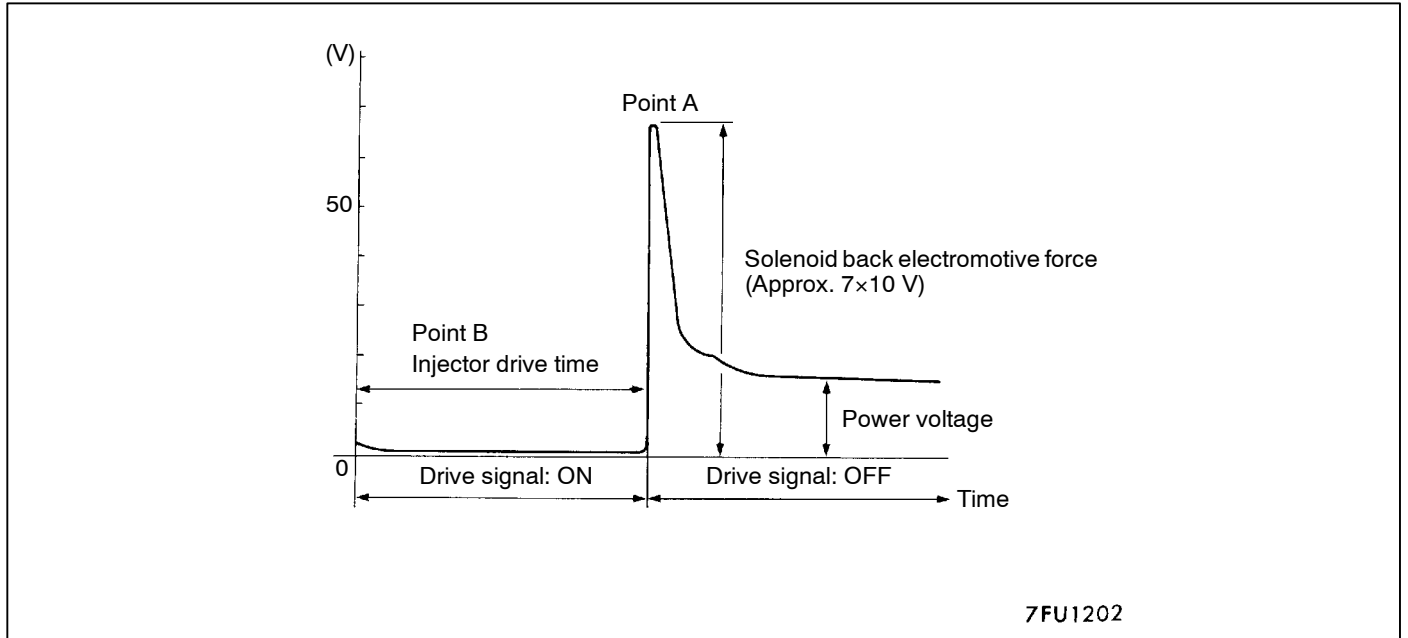

Wave Pattern Observation Points

Explanation of Wave Pattern

Point A: Height of solenoid back electromotive force

Contrast with standard wave pattern	Probable cause
Solenoid coil back electromotive force is low or doesn't appear at all.	Short in the injector solenoid

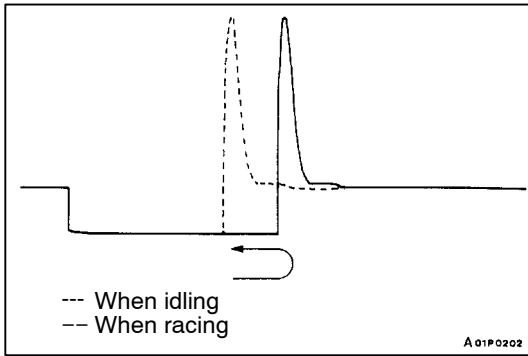

Point B: Injector drive time

- The injector drive time will be synchronized with the MUT-II tester display.
- When the engine is suddenly raced, the drive time will be greatly extended at first, but the drive time will soon match the engine speed.

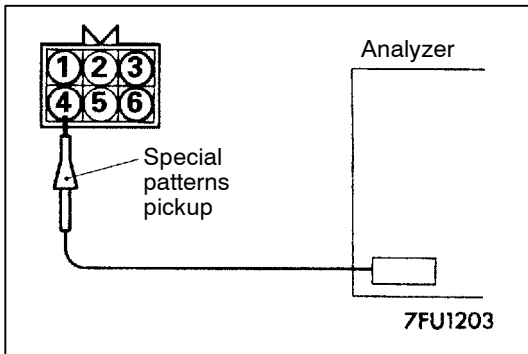

STEPPER MOTOR

Measurement Method

1. Disconnect the stepper motor connector, and connect the special tool (test harness: MD998463) in between.
2. Connect the analyzer special patterns pickup to the stepper motor-side connector terminal 1 (red clip of special tool), terminal 3 (blue clip), terminal 4 (black clip) and terminal 6 (yellow clip) respectively.

Alternate Method (Test harness not available)

1. Connect the analyzer special patterns pickup to engine-ECU terminal 4, connection terminal 5, connection terminal 17, and connection terminal 18 respectively.

Standard Wave Pattern

Observation conditions

Function	Special patterns
Pattern height	High
Pattern selector	Display
Engine condition	When the engine coolant temperature is 20°C or below, turn the ignition switch from OFF to ON (without starting the engine).
	While the engine is idling, turn the A/C switch to ON.
	Immediately after starting the warm engine (approx. 1 minute)

Standard wave pattern

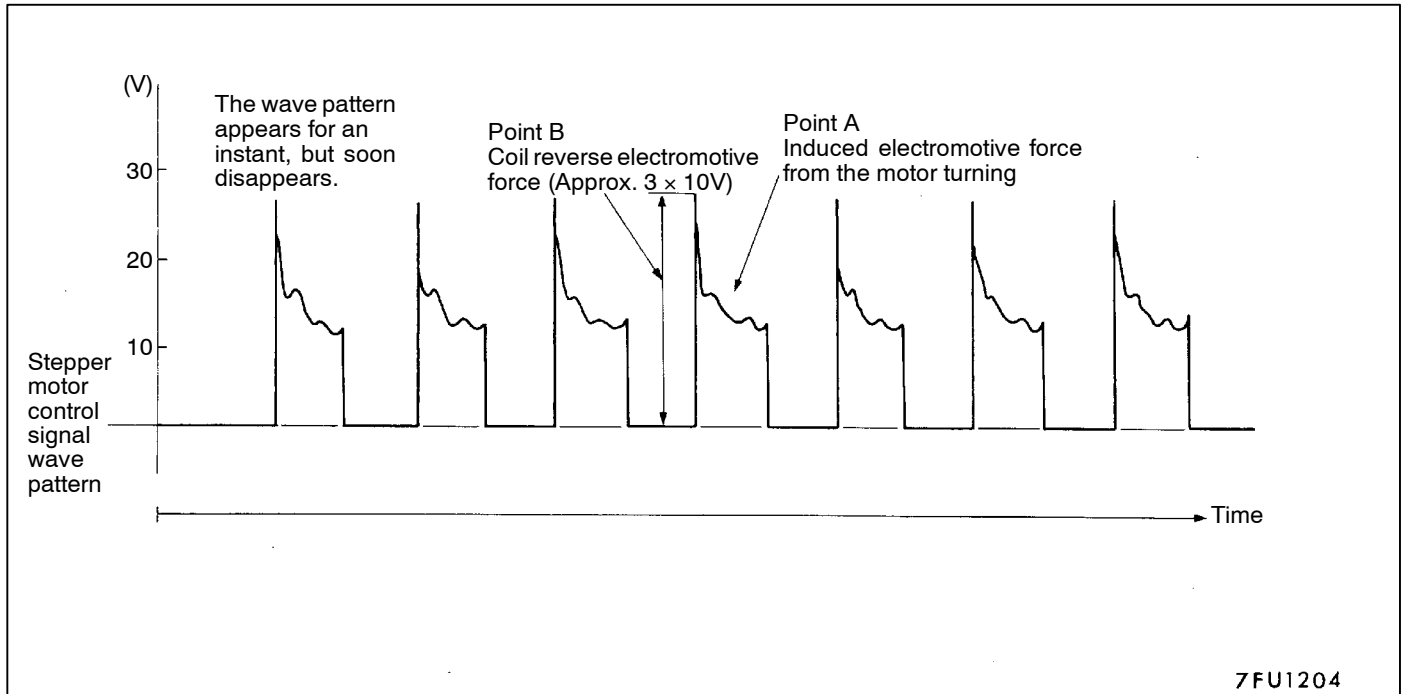

Wave Pattern Observation Points

Check that the standard wave pattern appears when the stepper motor is operating.

Point A: Presence or absence of induced electromotive force from the motor turning. (Refer to the abnormal wave pattern.)

Contrast with standard wave pattern	Probable cause
Induced electromotive force does not appear or is extremely small.	Motor is malfunctioning

Point B: Height of coil reverse electromotive force

Contrast with standard wave pattern	Probable cause
Coil reverse electromotive force does not appear or is extremely small.	Short in the coil

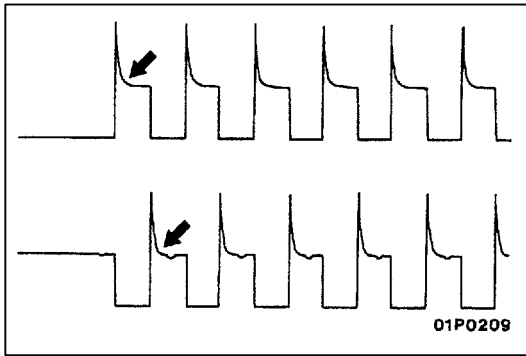

Examples of Abnormal Wave Pattern

- Example 1

Cause of problem

Motor is malfunctioning. (Motor is not operating.)

Wave pattern characteristics

Induced electromotive force from the motor turning does not appear.

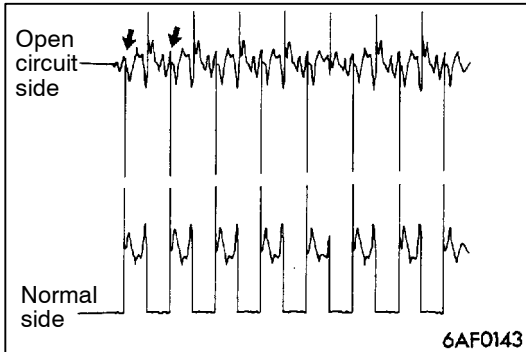

- Example 2

Cause of problem

Open circuit in the line between the stepper motor and the engine-ECU.

Wave pattern characteristics

Current is not supplied to the motor coil on the open circuit side. (Voltage does not drop to 0 V.)

Furthermore, the induced electromotive force waveform at the normal side is slightly different from the normal waveform.

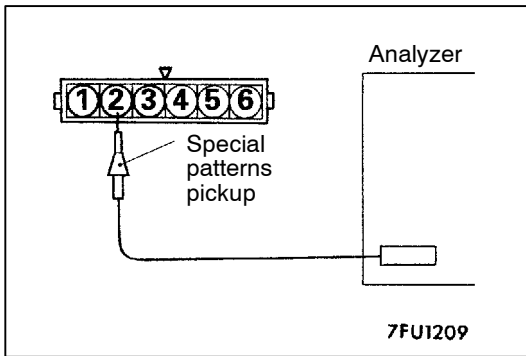

IGNITION COIL AND POWER TRANSISTOR

- Ignition coil primary signal
Refer to GROUP 16 – Ignition System
- Power transistor control signal

Measurement Method

1. Disconnect the power transistor connector, and connect the special tool (test harness: MB991348) in between. (All terminals should be connected.)
2. Connect the analyzer special patterns pickup to the power transistor connector terminal 1 (No. 3 – No. 6), terminal 2 (No. 2 – No. 5) and terminal 3 (No. 1 – No. 4) respectively.

Alternate Method (Test harness not available)

1. Connect the analyzer special patterns pickup to the engine ECU terminal 10 (No. 1 – No. 4), terminal 11 (No. 3 – No. 6), terminal 23 (No. 2 – No. 5) respectively.

Standard Wave Pattern

Observation condition

Function	Special patterns
Pattern height	Low
Pattern selector	Display
Engine r/min	Approx. 1,200 r/min

Standard wave pattern

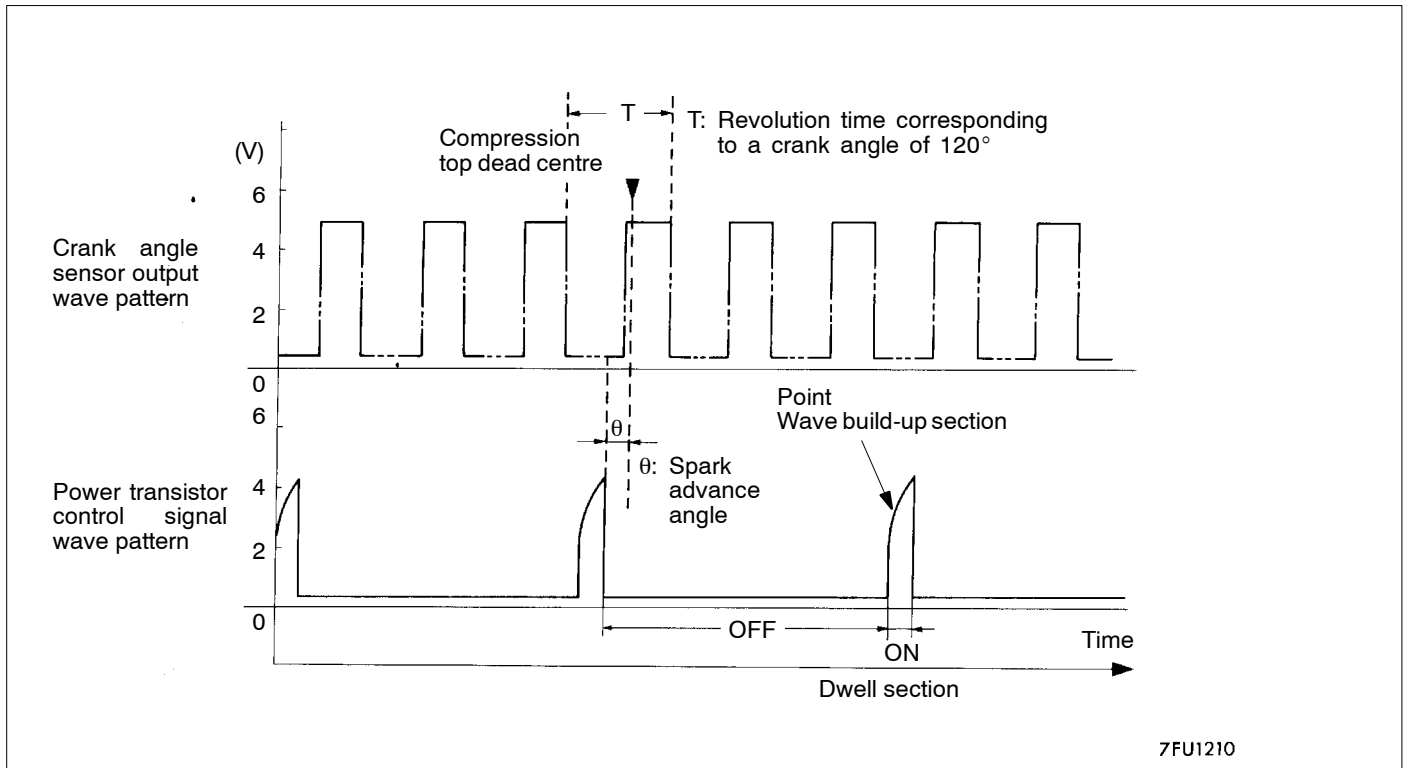

7FU1210

Wave Pattern Observation Points

Point: Condition of wave pattern build-up section and maximum voltage (Refer to abnormal wave pattern examples 1 and 2.)

Condition of wave pattern build-up section and maximum voltage	Probable cause
Rises from approx. 2V to approx. 4.5V at the top-right	Normal
2V rectangular wave	Open-circuit in ignition primary circuit
Rectangular wave at power voltage	Power transistor malfunction

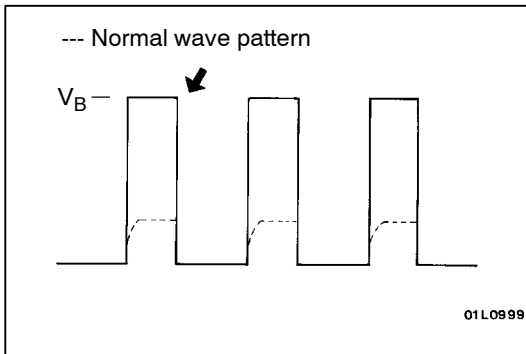
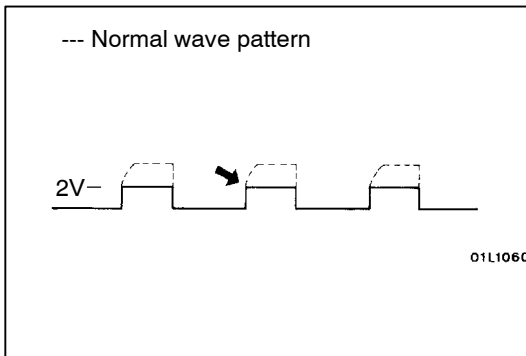

Examples of Abnormal Wave Patterns

- Example 1

Wave pattern during engine cranking

Cause of problem

Open-circuit in ignition primary circuit

Wave pattern characteristics

Top-right part of the build-up section cannot be seen, and voltage value is approximately 2 V too low.

- Example 2

Wave pattern during engine cranking

Cause of problem

Malfunction in power transistor

Wave pattern characteristics

Power voltage results when the power transistor is ON.

ON-VEHICLE SERVICE

13100100498

THROTTLE BODY (THROTTLE VALVE AREA) CLEANING

1. Start the engine and warm it up until the coolant is heated to 80°C or higher and then stop the engine.
2. Remove the air intake hose from the throttle body.

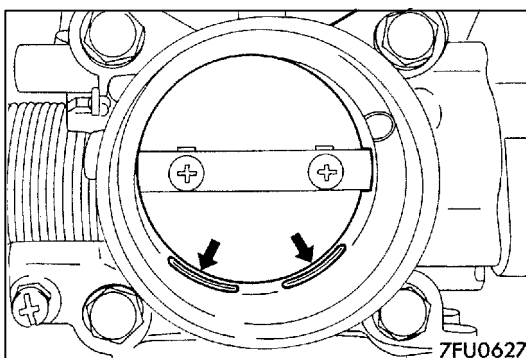

3. Plug the bypass passage inlet of the throttle body.

Caution

Do not allow cleaning solvent to enter the bypass passage.

4. Spray cleaning solvent into the valve through the throttle body intake port and leave it for about 5 minutes.
5. Start the engine, race it several times and idle it for about 1 minute. If the idling speed becomes unstable (or if the engine stalls) due to the bypass passage being plugged, slightly open the throttle valve to keep the engine running.
6. If the throttle valve deposits are not removed, repeat steps 4 and 5.
7. Unplug the bypass passage inlet.
8. Attach the air intake hose.
9. Use the MUT-II to erase the self-diagnosis code.

- Adjust the basic idle speed. (Refer to P.13A-78.)

NOTE

If the engine hunts while idling after adjustment of the basic idle speed, disconnect the (-) cable from the battery for 10 seconds or more, and then reconnect it and run the engine at idle for about 10 minutes.

IDLE POSITION SWITCH AND THROTTLE POSITION SENSOR ADJUSTMENT

13100330453

- Connect the MUT-II to the diagnosis connector.

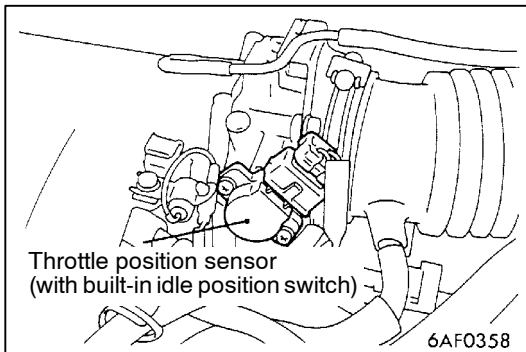

- Insert a thickness gauge as follows:

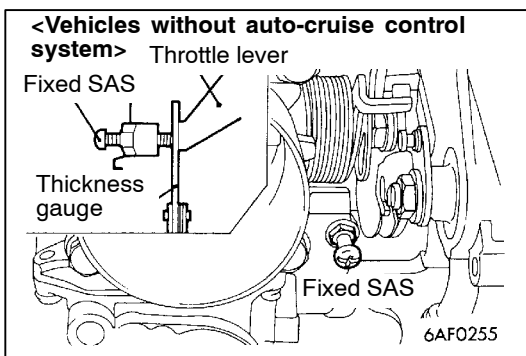

<Vehicles without auto-cruise control system>

Insert a thickness gauge with a thickness of 0.65 mm between the fixed SAS and the throttle lever.

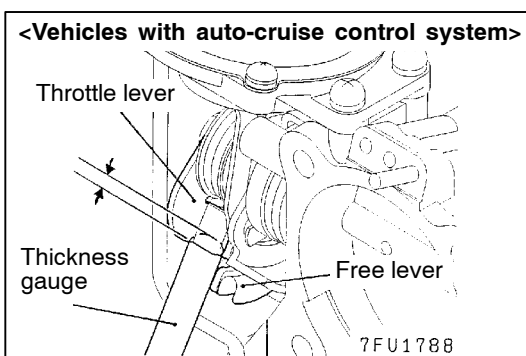

<Vehicles with auto-cruise control system>

Insert a 1.4-mm thick thickness gauge up to approx. 3 mm between the levers shown in the figure.

NOTE

Do not insert the thickness gauge 3 mm or more. If doing that, the throttle lever opening angle becomes larger than the predetermined angle, causing maladjustment.

- Turn the ignition switch to ON (but do not start the engine).
- Loosen the throttle position sensor mounting bolt, and then turn the throttle position sensor clockwise as far as it will go.
- Check that the idle position switch is ON at this position.
- Slowly turn the throttle position sensor counterclockwise and find the point where the idle position switch turns off.
- Securely tighten the throttle position sensor mounting bolt at this point.

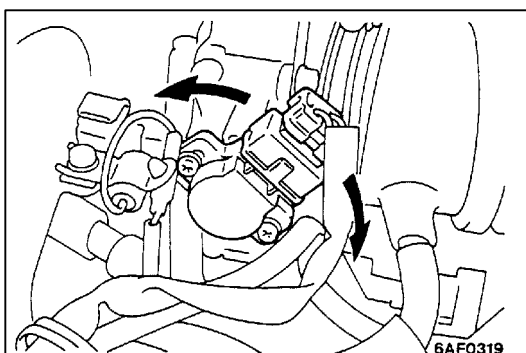

7. Check the throttle position sensor output voltage.

Standard value: 400 – 1,000 mV

8. If there is a deviation from the standard value, check the throttle position sensor and the related harness.
9. Remove the thickness gauge.
10. Turn the ignition switch to OFF.
11. Disconnect the MUT-II.

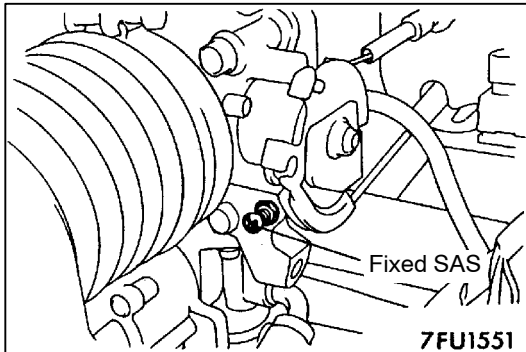

FIXED SAS ADJUSTMENT

13100150462

NOTE

- (1) The fixed SAS should not be moved unnecessarily; it has been precisely adjusted by the manufacturer.
- (2) If the adjustment is disturbed for any reason, readjust as follows.

1. Loosen the tension of the accelerator cable sufficiently.
2. Back out the fixed SAS lock nut.
3. Turn the fixed SAS counterclockwise until it is sufficiently backed out, and fully close the throttle valve.
4. Tighten the fixed SAS until the point where the throttle lever is touched (i.e., the point at which the throttle valve begins to open) is found.
From that point, tighten the fixed SAS 1 1/4 turns.
5. While holding the fixed SAS so that it doesn't move, tighten the lock nut securely.
6. Adjust the tension of the accelerator cable.
7. Adjust the basic idling speed.
8. Adjust the idle position switch and the throttle position sensor (P.13A-77).

BASIC IDLE SPEED ADJUSTMENT

13100180553

NOTE

- (1) The standard idling speed has been adjusted, by the speed adjusting screw (SAS), by the manufacturer, and there should usually be no need for readjustment.
- (2) If the adjustment has been changed by mistake, the idle speed may become too high or the idle speed may drop too low when loads from components such as the A/C are placed on the engine. If this occurs, adjust by the following procedure.
- (3) The adjustment, if made, should be made after first confirming that the spark plugs, the injectors, the idle speed control servo, the compression pressure, etc., are all normal.

1. Before inspection and adjustment, set the vehicle to the pre-inspection condition.
2. Connect the MUT-II to the diagnosis connector.

NOTE

When the MUT-II is connected, the diagnosis control terminal should be earthed.

3. Start the engine and run at idle.
4. Select the item No. 30 of the MUT-II Actuator test.

NOTE

This holds the ISC servo at the basic step to adjust the basic idle speed.

5. Check the idle speed.

Standard value: 700 ± 50 r/min

NOTE

- (1) The engine speed may be 20 to 100 r/min lower than indicated above for a new vehicle [driven approximately 500 km or less], but no adjustment is necessary.
- (2) If the engine stalls or the engine speed is low even though the vehicle has been driven approximately 500 km or more, it is probable that deposits are adhered to the throttle valve, so clean it. (Refer to P.13A-76.)

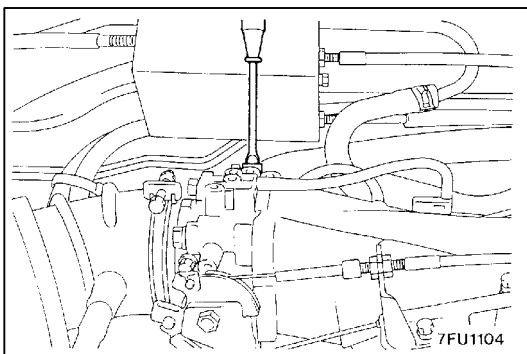

6. If not within the standard value range, turn the speed adjusting screw (SAS) to make the necessary adjustment.

NOTE

If the idling speed is higher than the standard value range even when the SAS is fully closed, check whether or not there is any indication that the fixed SAS has been moved. If there is an indication that it has been moved, adjust the fixed SAS.

7. Press the MUT-II clear key, and release the ISC servo from the Actuator test mode.

NOTE

Unless the ISC servo is released, the Actuator test mode will continue 27 minutes.

8. Switch OFF the ignition switch.
9. Disconnect the MUT-II.
10. Start the engine again and let it run at idle speed for about 10 minutes; check that the idling condition is normal.

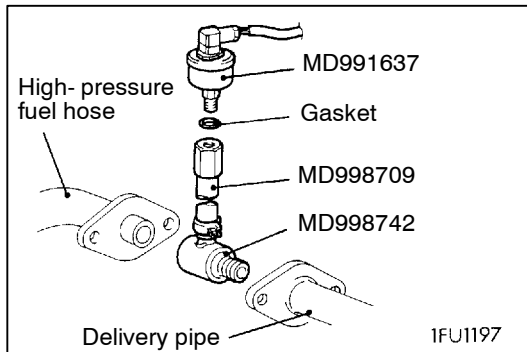
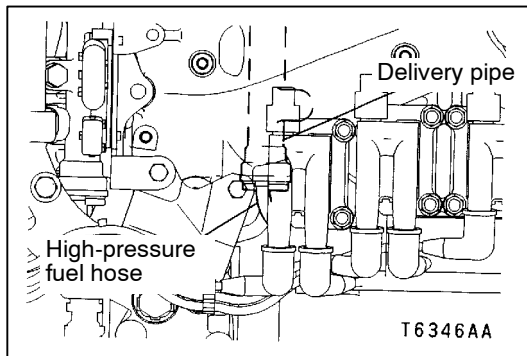

FUEL PRESSURE TEST

13100190563

1. Release residual pressure from the fuel pipe line to prevent fuel from gushing out. (Refer to P.13A-83.)
2. Disconnect the high-pressure fuel hose at the delivery pipe side.

Caution

Cover the hose connection with rags to prevent splash of fuel that could be caused by some residual pressure in the fuel pipe line.

3. Change the fuel pressure measurement special tool adapter.
4. Attach the fuel pressure measurement special tool adapter.

<When using the fuel pressure gauge set (special tool)>

- (1) Attach the fuel pressure measurement special tool between the delivery pipe and the high-pressure hose.
- (2) Pass a gasket over the fuel pressure special measurement tool and then install the tool into the fuel pressure gauge set (special tool).
- (3) Connect the fuel pressure gauge set lead wires to the power supply (cigarette lighter socket) and the MUT-II.

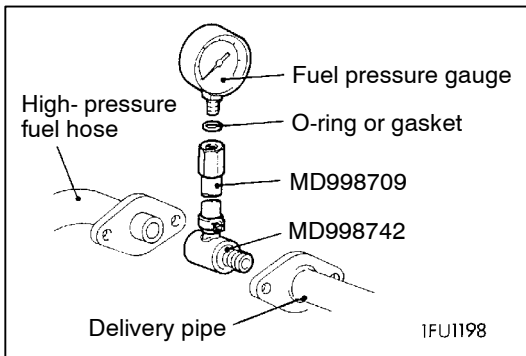

<When using the fuel pressure gauge>

- (1) Place an O-ring or gasket over the fuel pressure measurement special tool and then install the tool into the fuel pressure gauge.
- (2) Install the special tool assembled in 1. above between the delivery pipe and the high-pressure hose.
5. Connect the MUT-II to the diagnosis connector.
6. Turn the ignition switch to ON. (But do not start the engine.)
7. Select "Item No.07" from the MUT-II Actuator test to drive the fuel pump. Check that there are no fuel leaks from any parts.
8. Finish the actuator test or turn the ignition switch to OFF.
9. Start the engine and run at idle.
10. Measure fuel pressure while the engine is running at idle.

Standard value:

Approx. 265 kPa at kerb idle

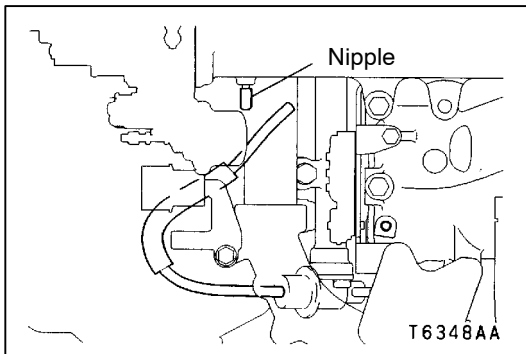

11. Disconnect the vacuum hose from the fuel pressure regulator and measure fuel pressure with the hose end closed by a finger.

Standard value:

324 – 343 kPa at kerb idle

12. Check to see that fuel pressure at idle does not drop even after the engine has been raced several times.
13. Racing the engine repeatedly, hold the fuel return hose lightly with fingers to feel that fuel pressure is present in the return hose.

NOTE

If the fuel flow rate is low, there will be no fuel pressure in the return hose.

14. If any of fuel pressure measured in steps 10 to 13 is out of specification, troubleshoot and repair according to the table.

Symptom	Probable cause	Remedy
<ul style="list-style-type: none"> ● Fuel pressure too low ● Fuel pressure drops after racing ● No fuel pressure in fuel return hose 	Clogged fuel filter	Replace fuel filter
	Fuel leaking to return side due to poor fuel regulator valve seating or settled spring	Replace fuel pressure regulator
	Low fuel pump delivery pressure	Replace fuel pump
Fuel pressure too high	Binding valve in fuel pressure regulator	Replace fuel pressure regulator
	Clogged fuel return hose or pipe	Clean or replace hose or pipe
Same fuel pressure when vacuum hose is connected and when disconnected	Damaged vacuum hose or clogged nipple	Replace vacuum hose or clean nipple

15. Stop the engine and check change of fuel pressure gauge reading. Normal if the reading does not drop within 2 minutes. If it does, observe the rate of drop and troubleshoot and repair according to the table below.

Symptom	Probable cause	Remedy
Fuel pressure drops gradually after engine is stopped	Leaky injector	Replace injector
	Leaky fuel regulator valve seat	Replace fuel pressure regulator
Fuel pressure drops sharply immediately after engine is stopped	Check valve in fuel pump is held open	Replace fuel pump

16. Release residual pressure from the fuel pipe line. (Refer to P.13A-83.)
17. Remove the fuel pressure gauge and special tool from the delivery pipe.

Caution

Cover the hose connection with rags to prevent splash of fuel that could be caused by some residual pressure in the fuel pipe line.

18. Replace the O-ring at the end of the fuel high pressure hose with a new one. Furthermore, apply engine oil to the new O-ring before replacement.
19. Fit the fuel high pressure hose over the delivery pipe and tighten the bolt to specified torque.

Tightening torque: 5 Nm

20. Check for any fuel leaks by following the procedure in step 5.
21. Disconnect the MUT-II

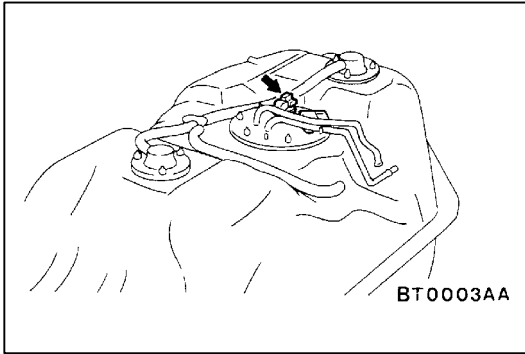

FUEL PUMP CONNECTOR DISCONNECTION (HOW TO REDUCE FUEL LINE PRESSURE)

1310090375

When removing the fuel pipe, hose, etc., release fuel pressure to prevent fuel splay.

1. Disconnect the fuel pump connector.
2. Start the engine and let it run until it stops naturally. Turn the ignition switch OFF.
3. Connect the fuel pump connector.

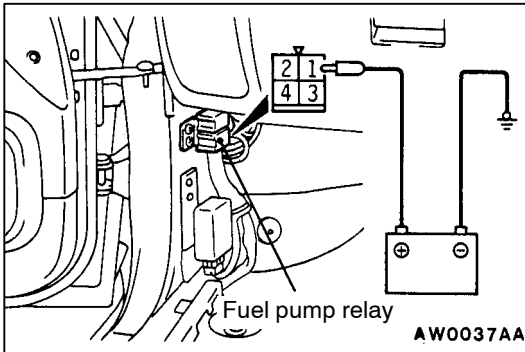

FUEL PUMP OPERATION CHECK

13100200372

1. Check the operation of the fuel pump by using the MUT-II to force-drive the fuel pump.
2. If the fuel pump will not operate, check by using the following procedure. If normal, check the fuel pump drive circuit.
 - (1) Turn OFF the ignition switch.
 - (2) When the connector terminal No.1 at the harness side of the fuel pump relay has been connected to the battery, check if the sound of the fuel pump operation can be heard.

NOTE

As the fuel pump is an in-tank type, the fuel pump sound is hard to hear. Remove the fuel tank filler cap and check from the tank inlet

- (3) Check for fuel pressure by pinching the fuel hose with the fingertips.

COMPONENT LOCATION

13100210658

Name	Symbol	Name	Symbol
A/C relay	G	Engine warning lamp (check engine lamp)	J
A/C switch	K		
Air flow sensor (with intake air temperature sensor and barometric pressure sensor)	A	Idle speed control servo	C
Camshaft position sensor	F	Ignition coil and power transistor unit	E
Control relay and fuel pump relay	M	Injector	H
Crank angle sensor	I	Oxygen sensor	N
Diagnosis connector	L	Power steering fluid pressure switch	B
Engine coolant temperature sensor	D	Throttle position sensor (with idle position switch)	C
Engine-ECU	M	Vehicle speed sensor	O

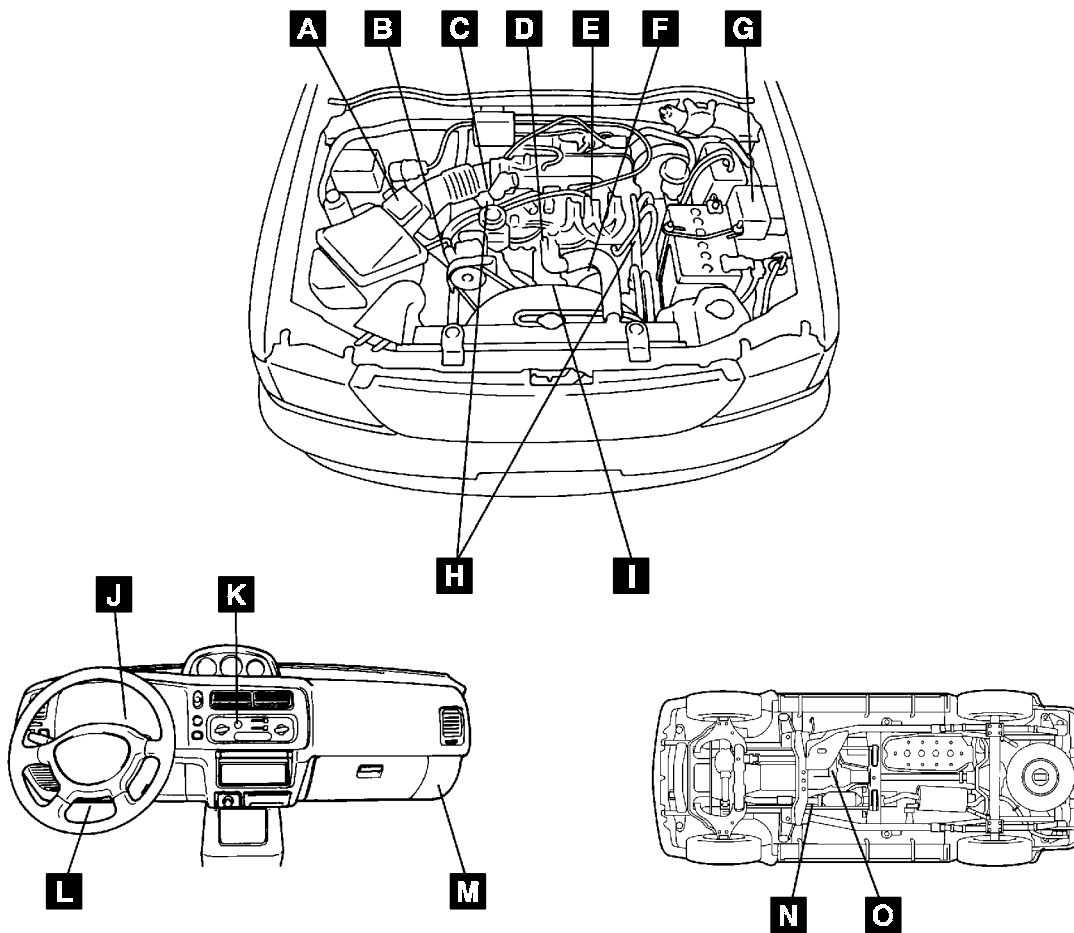

CONTROL RELAY AND FUEL PUMP RELAY CONTINUITY CHECK

13100990262

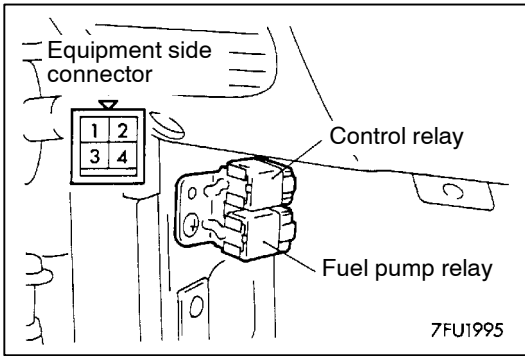

Battery voltage	Terminal No.			
	1	2	3	4
Not supplied		○		○
Supplied	○	⊖	○	⊕

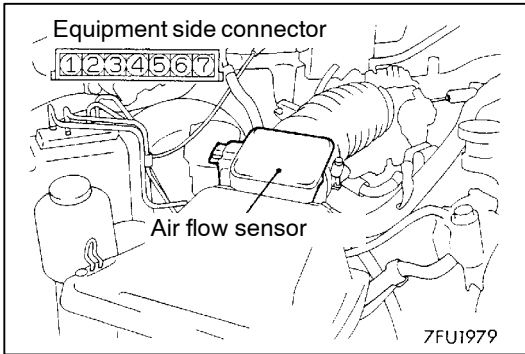

INTAKE AIR TEMPERATURE SENSOR CHECK

13100280321

1. Disconnect the air flow sensor connector.
2. Measure resistance between terminals 4 and 6.

Standard value:

2.3 – 3.0 kΩ (at 20°C)
0.30 – 0.42 kΩ (at 80°C)

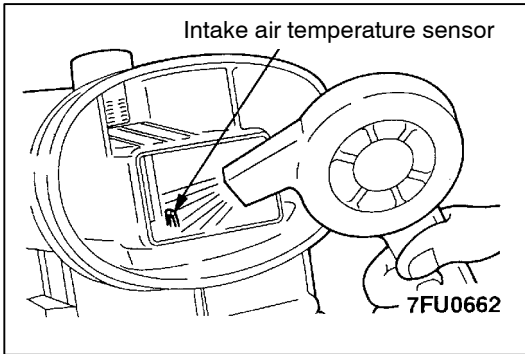

3. Measure resistance while heating the sensor using a hair drier.

Normal condition:

Temperature (°C)	Resistance (kΩ)
Higher	Smaller

4. If the value divides from the standard value or the resistance remains unchanged, replace the air flow sensor.

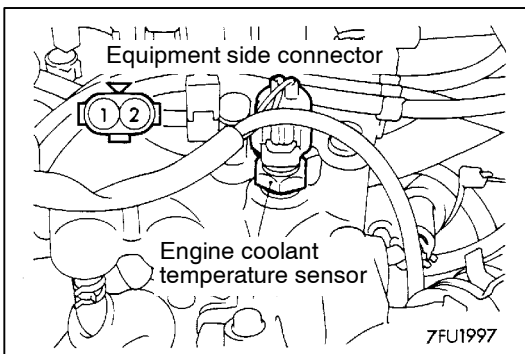

ENGINE COOLANT TEMPERATURE SENSOR CHECK

13100310327

Caution

Be careful not to touch the connector (resin section) with the tool when removing and installing.

1. Remove the engine coolant temperature sensor.
2. With temperature sensing portion of engine coolant temperature sensor immersed in hot water, check resistance.

Standard value:

2.1 – 2.7 kΩ (at 20°C)
0.26 – 0.36 kΩ (at 80°C)

3. If the resistance deviates from the standard value greatly, replace the sensor.

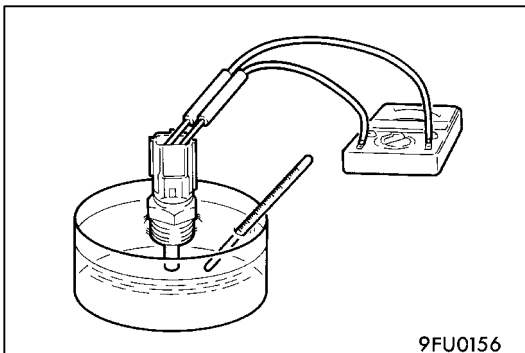

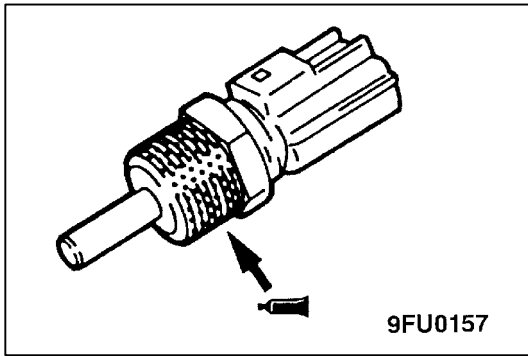

4. Apply sealant to threaded portion.

Specified sealant:

3M Nut Locking Part No.4171 or equivalent

5. Install the engine coolant temperature sensor and tighten it to the specified torque.

Tightening torque: 29 Nm

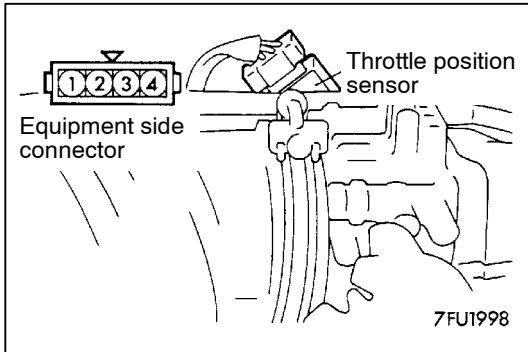

THROTTLE POSITION SENSOR CHECK 1310320467

1. Disconnect the throttle position sensor connector.
2. Measure the resistance between the throttle position sensor side connector terminal 1 and terminal 4.

Standard value: 3.5 – 6.5 kΩ

3. Measure the resistance between the throttle position sensor side connector terminal 1 and terminal 3.

Normal condition:

Throttle valve slowly open until fully open from the idle position	Changes smoothly in proportion to the opening angle of the throttle valve
--	---

4. If the resistance is outside the standard value, or if it doesn't change smoothly, replace the throttle position sensor.

NOTE

For the throttle position sensor adjustment procedure, refer to P.13A-77.

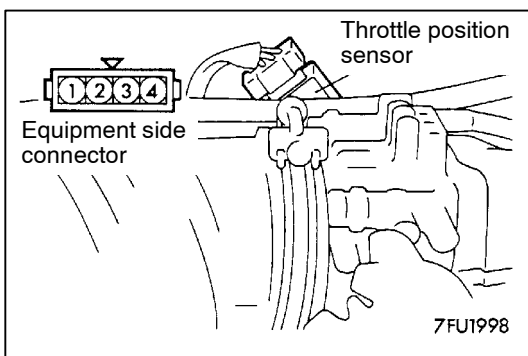

IDLE POSITION SWITCH CHECK 13100330446

1. Disconnect the throttle position sensor connector.
2. Check the continuity between the throttle position sensor connector side terminal 1 and terminal 2.

Normal condition:

Accelerator pedal	Continuity
Depressed	Non-conductive
Released	Conductive (0 Ω)

3. If out of specification, replace the throttle position sensor.

NOTE

After replacement, the idle position switch and throttle position sensor should be adjusted. (Refer to P.13A-77.)

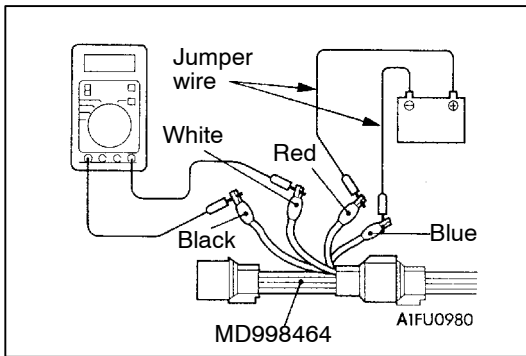
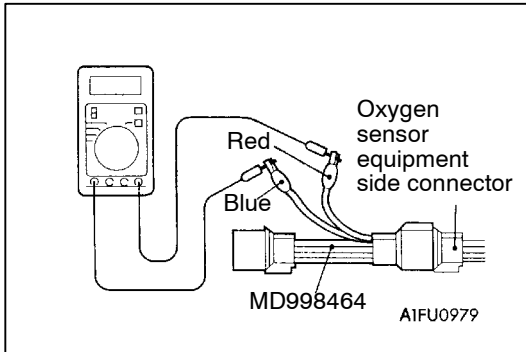
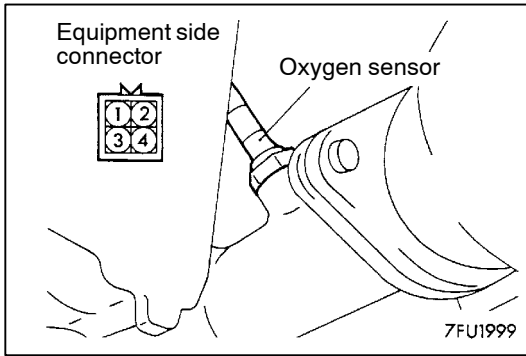

OXYGEN SENSOR CHECK

13100510239

1. Disconnect the oxygen sensor connector and connect the special tool (test harness) to the connector on the oxygen sensor side.
2. Make sure that there is continuity (11 – 18 Ω at 20 °C) between terminal 1 (red clip of special tool) and terminal 3 (blue clip of special tool) on the oxygen sensor connector.
3. If there is no continuity, replace the oxygen sensor.
4. Warm up the engine until engine coolant is 80 °C or higher.
5. Use the jumper wire to connect terminal 1 (red clip) of the oxygen sensor connector to the battery (+) terminal and terminal 3 (blue clip) to the battery (-) terminal.

Caution

Be very careful when connecting the jumper wire; incorrect connection can damage the oxygen sensor.

6. Connect a digital voltage meter between terminal 2 (black clip) and terminal 4 (white clip).
7. While repeatedly racing the engine, measure the oxygen sensor output voltage.

Standard value:

Engine	Oxygen sensor output voltage	Remarks
When racing the engine	0.6 – 1.0 V	If you make the air/fuel ratio rich by racing the engine repeatedly, a normal oxygen sensor will output a voltage of 0.6 – 1.0 V.

8. If the sensor is defective, replace the oxygen sensor.

NOTE

For removal and installation of the oxygen sensor, refer to GROUP 15 – Exhaust Pipe and Main Muffler.

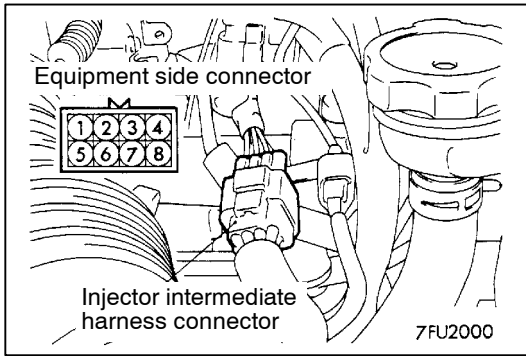

INJECTOR CHECK

Measurement of Resistance between Terminals

1. Disconnect the injector intermediate harness connectors.
2. Measure the resistance between terminals.

Standard value: 13 – 16 Ω (at 20°C)

Injector	Measurement terminal
No. 1 cylinder	8 – 3
No. 2 cylinder	8 – 2
No. 3 cylinder	8 – 1
No. 4 cylinder	8 – 7
No. 5 cylinder	8 – 6
No. 6 cylinder	8 – 5

3. Connect the injector intermediate harness connectors.

Checking the Injection Condition

1. Following the steps below, bleed out the residual pressure within the fuel pipe line to prevent flow of the fuel. (Refer to P.13A-83.)
2. Remove the injector.
3. Arrange the special tools (injector test set, adapter, injector test clip), the fuel pressure regulator and the injector as shown in the illustration below.

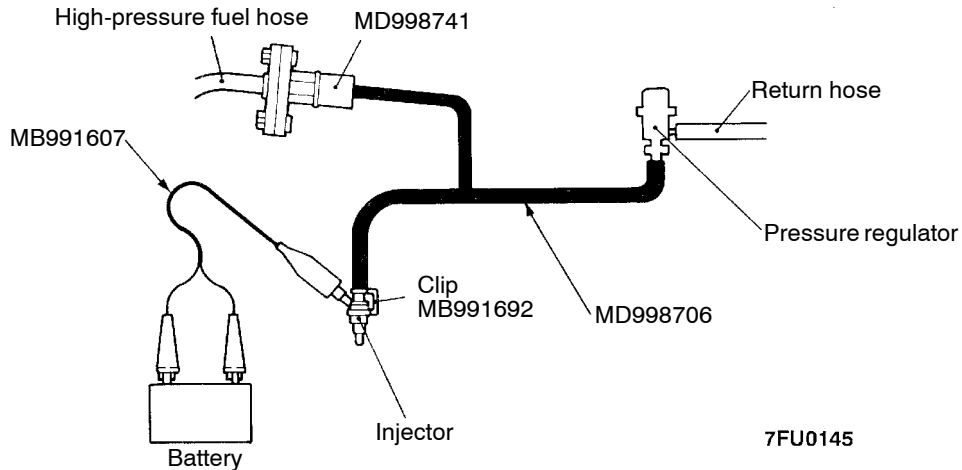

4. Connect the MUT-II to the diagnosis connector.
5. Turn the ignition switch to ON. (But do not start the engine.)
6. Select "Item No.07" from the MUT-II Actuator test to drive the fuel pump.

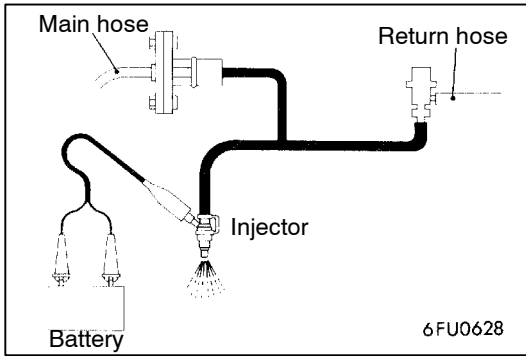

7. Activate the injector and check the atomized spray condition of the fuel.
The condition can be considered satisfactory unless it is extremely poor.

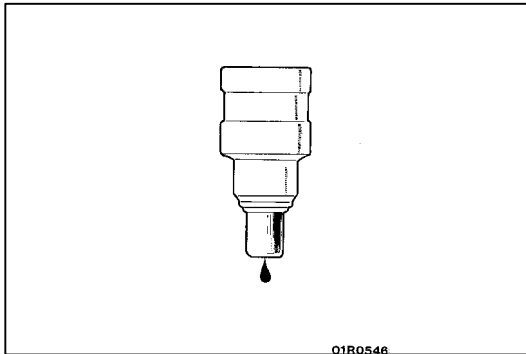

8. Stop the actuation of the injector, and check for leakage from the injector's nozzle.

Standard value: 1 drop or less per minute

9. Activate the injector without activating the fuel pump; then, when the spray emission of fuel from the injector stops, disconnect the special tool and restore it to its original condition.
10. Disconnect the MUT-II.

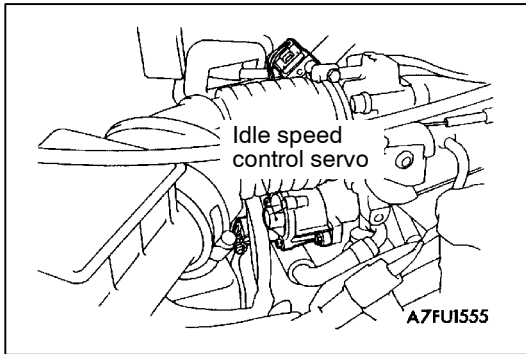

IDLE SPEED CONTROL (ISC) SERVO (STEPPER MOTOR) CHECK

13100540405

Checking the Operation Sound

1. Check that the engine coolant temperature is 20°C or below.

NOTE

Disconnecting the engine coolant temperature sensor connector and connecting the harness-side of the connector to another engine coolant temperature sensor that is at 20°C or below is also okay.

2. Check that the operation sound of the stepper motor can be heard after the ignition is switched ON. (but without starting the motor.)
3. If the operation sound cannot be heard, check the stepper motor's activation circuit.
If the circuit is normal, it is probable that there is a malfunction of the stepper motor or of the engine control unit.

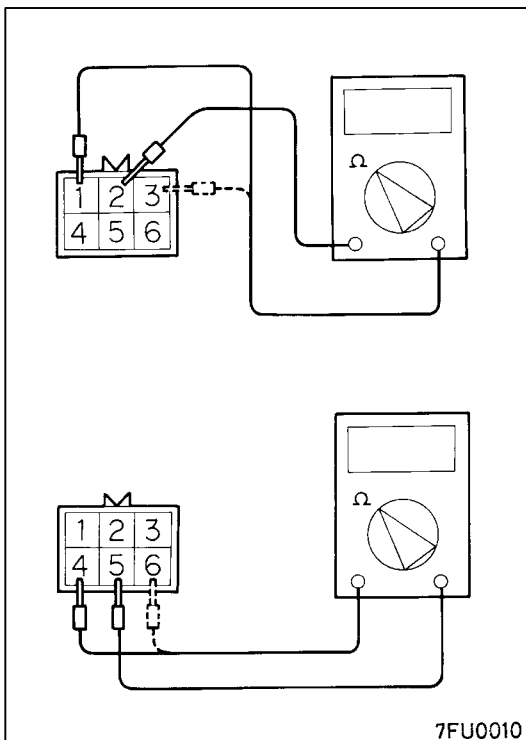

Checking the Coil Resistance

1. Disconnect the idle speed control servo connector and connect the special tool (test harness).
2. Measure the resistance between terminal 2 (white clip of the special tool) and either terminal 1 (red clip) or terminal 3 (blue clip) of the connector at the idle speed control servo side.

Standard value: 28 – 33 Ω (at 20°C)

3. Measure the resistance between terminal 5 (green clip of the special tool) and either terminal 6 (yellow clip) or terminal 4 (black clip) of the connector at the idle speed control servo side.

Standard value: 28 – 33 Ω (at 20°C)

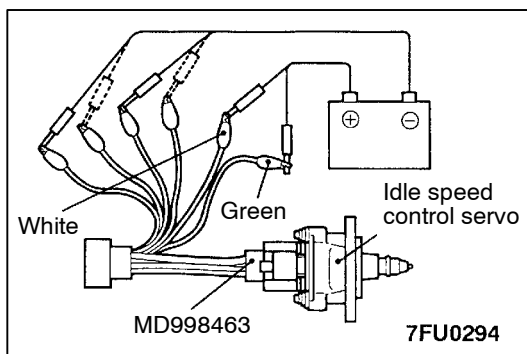
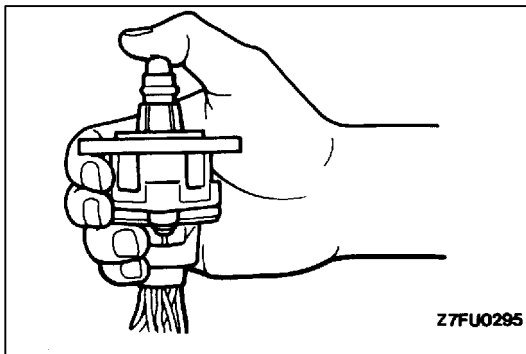

Operational Check

1. Remove the throttle body.
2. Remove the idle speed control servo.
3. Connect the special tool (test harness) to the idle speed control servo connector.
4. Connect the positive (+) terminal of a power supply (approx. 6V) to the white clip and the green clip.
5. With the idle speed control servo as shown in the illustration, connect the negative (-) terminal of the power supply to each clip as described in the following steps, and check whether or not a vibrating feeling (a feeling of very slight vibration of the stepper motor) is generated as a result of the activation of the stepper motor.
 - (1) Connect the negative (-) terminal of the power supply to the red and black clip.
 - (2) Connect the negative (-) terminal of the power supply to the blue and black clip.
 - (3) Connect the negative (-) terminal of the power supply to the blue and yellow clip.
 - (4) Connect the negative (-) terminal of the power supply to the red and yellow clip.
 - (5) Connect the negative (-) terminal of the power supply to the red and black clip.
 - (6) Repeat the tests in sequence from (5) to (1).
6. If, as a result of these tests, vibration is detected, the stepper motor can be considered to be normal.

PURGE CONTROL SOLENOID VALVE CHECK

13100560111

Refer to GROUP 17 – Emission Control System.

EGR CONTROL SOLENOID VALVE CHECK

13100570107

Refer to GROUP 17 – Emission Control System.

INJECTOR

REMOVAL AND INSTALLATION

Pre-removal Operation

- Fuel Line Pressure Reduction (Refer to P.13A-82.)
- Intake Manifold Plenum Removal (Refer to GROUP 15 – Intake Manifold.)

Post-installation Operation

- Intake Manifold Plenum Removal (Refer to GROUP 15 – Intake Manifold.)
- Accelerator Cable Adjustment (Refer to GROUP 17 – On-vehicle Service.)
- Fuel Leakage Inspection

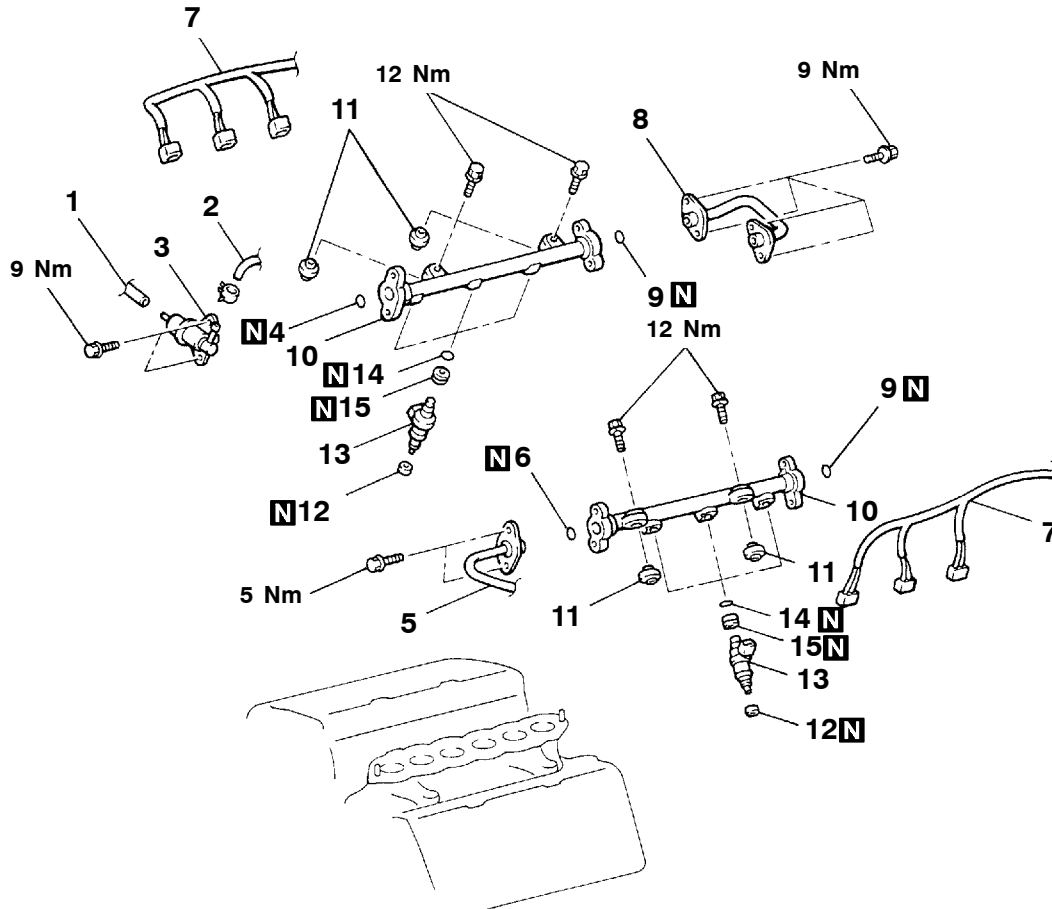

03V0047
00005876

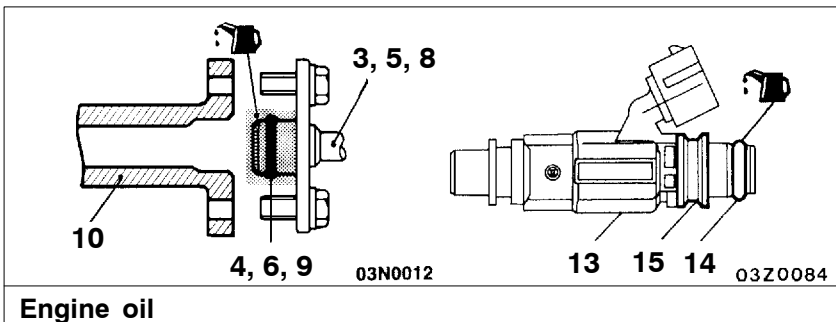

Removal steps

- | | | | |
|-----|---------------------------------------|---------|--------------------|
| ▶A◀ | 1. Vacuum hose | ◀A▶ | 9. O-rings |
| ▶A◀ | 2. Fuel return hose connection | ◀A▶ | 10. Delivery pipes |
| ▶A◀ | 3. Fuel pressure regulator | ◀A▶ ▶A◀ | 11. Insulators |
| | 4. O-ring | | 12. Insulators |
| ▶A◀ | 5. High-pressure fuel hose connection | | 13. Injectors |
| | 6. O-ring | | 14. O-rings |
| | 7. Injector connectors | | 15. Grommets |
| | 8. Fuel pipe | | |

REMOVAL SERVICE POINT**◀A▶ DELIVERY PIPES/INJECTORS REMOVAL**

Remove the delivery pipes (with the injectors attached).

Caution

Do not drop the injector(s).

INSTALLATION SERVICE POINTS**▶A◀ INJECTORS/FUEL PRESSURE
REGULATOR/HIGH-PRESSURE FUEL HOSE
INSTALLATION**

1. Apply a drop of new engine oil to the O-ring.

Caution

Do not let the engine oil get into the delivery pipes or the injectors will be damaged.

2. Turn the injectors. To the right and left to install to the delivery pipes. Repeat for fuel pressure regulator and high-pressure fuel hose.
Be careful not to damage the O-ring. After installing, check that the item turns smoothly.
3. If it does not turn smoothly, the O-ring may be trapped, remove the item, re-install it into the delivery pipes and check again.
4. Tighten the high-pressure fuel hose and fuel pressure regulator to the specified torque.

Tightening torque:

9 Nm <Fuel pressure regulator>

5 Nm <High-pressure fuel hose>

THROTTLE BODY

13100770460

REMOVAL AND INSTALLATION

Pre-removal Operation

- Engine Coolant Draining (Refer to GROUP 14 – On-vehicle Service.)
- Air Cleaner Removal (Refer to GROUP 15 – Air Cleaner.)

Post-installation Operation

- Air Cleaner Installation (Refer to GROUP 15 – Air Cleaner.)
- Engine Coolant Refilling (Refer to GROUP 14 – On-vehicle Service.)
- Accelerator Cable Adjustment (Refer to GROUP 17 – On-vehicle Service.)

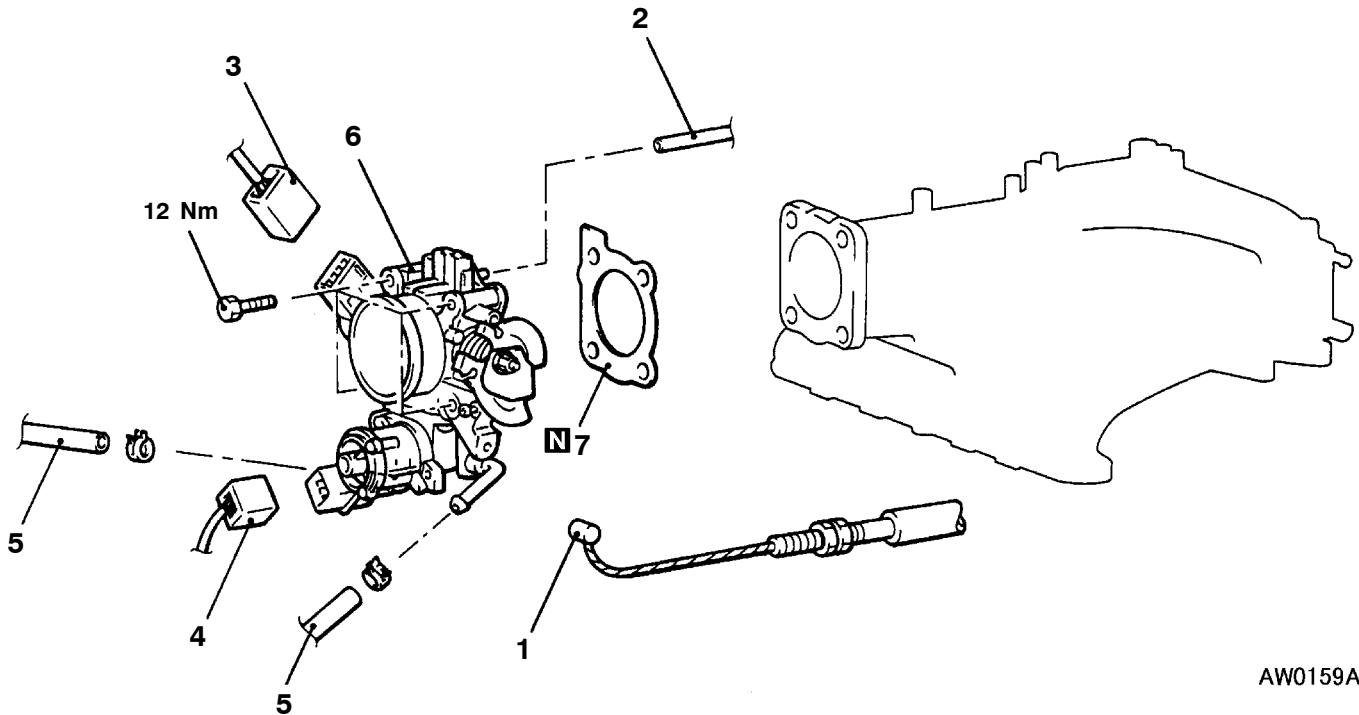

AW0159AA

Removal steps

1. Accelerator cable connection
2. Vacuum hose connection
3. Throttle position sensor connector
4. Idle speed control servo connector

5. Heater hose connector
6. Throttle body
7. Throttle body gasket

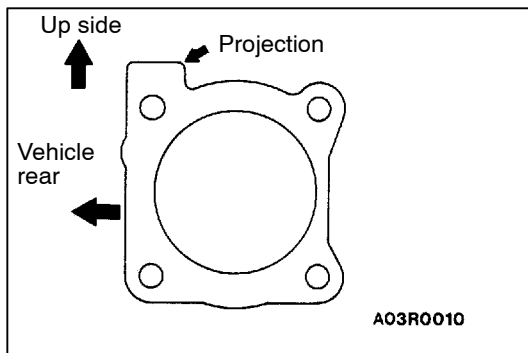

INSTALLATION SERVICE POINT

▶◀ THROTTLE BODY GASKET INSTALLATION

Install the throttle body gasket as shown in the illustration.

Caution

Poor idling etc. may result if the throttle body gasket is installed incorrectly.

DISASSEMBLY AND REASSEMBLY

13100970587

<VEHICLES WITHOUT AUTO-CRUISE CONTROL SYSTEM>

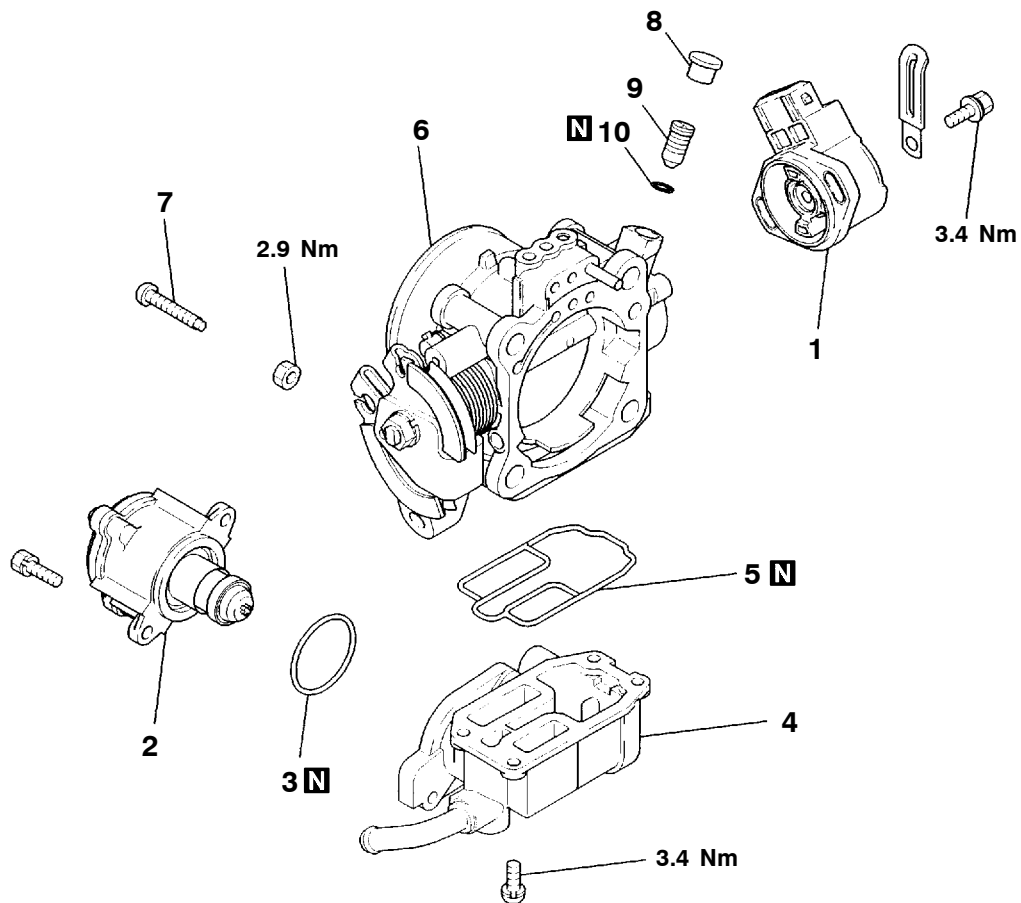

7EN1437

Removal steps

- ▶◀
1. Throttle position sensor
 2. Idle air control motor
 3. O-ring
 4. Idle speed control servo (Stepper motor)
 5. O-ring
 6. Throttle body
 7. Fixed SAS
 8. Cap
 9. Speed adjusting screw
 10. O-ring

NOTE

1. The fixed SAS is correctly adjusted at the factory and should not be removed.
2. If the fixed SAS should happen to have been removed, carry out fixed SAS adjustment.
3. If the speed adjusting screw should happen to have been removed, carry out speed adjusting screw adjustment.

<VEHICLES WITH AUTO-CRUISE CONTROL SYSTEM>

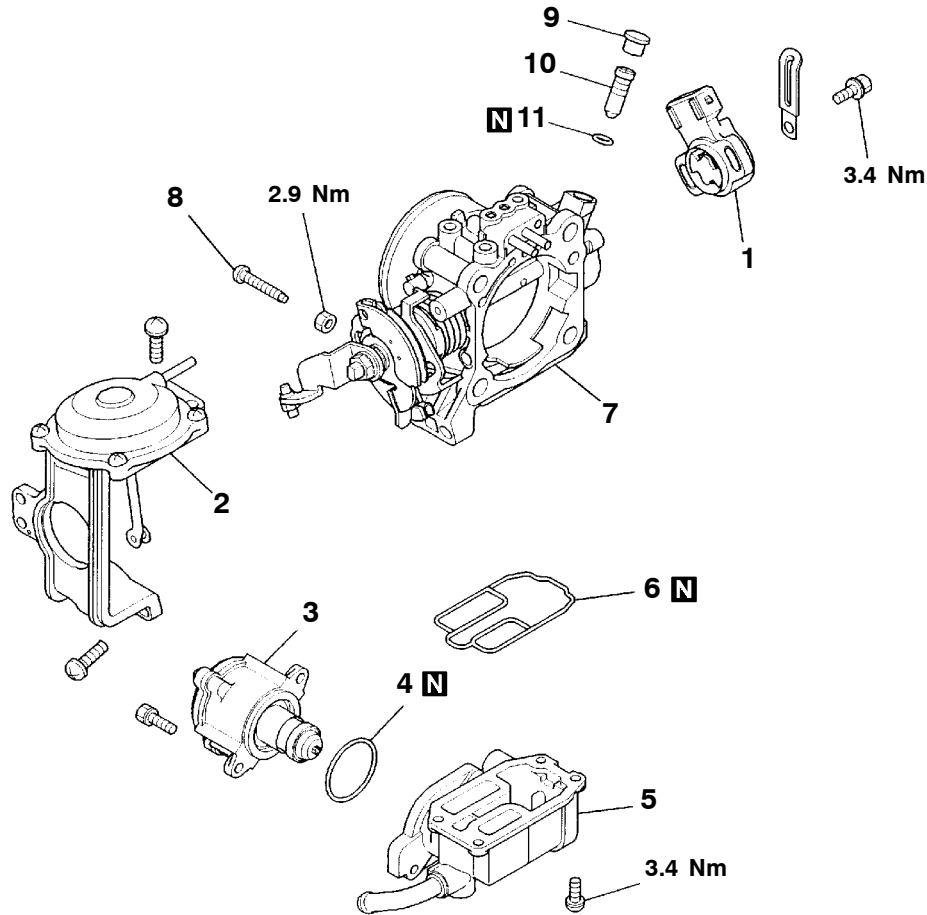

7EN1438

Removal steps

- A◄
1. Throttle position sensor
 2. Lever assembly
 3. Idle air control motor
 4. O-ring
 5. Idle speed control servo (Stepper motor)
 6. O-ring
 7. Throttle body
 8. Fixed SAS
 9. Cap
 10. Speed adjusting screw
 11. O-ring

NOTE

1. The fixed SAS is correctly adjusted at the factory and should not be removed.
2. If the fixed SAS should happen to have been removed, carry out fixed SAS adjustment.
3. If the speed adjusting screw should happen to have been removed, carry out speed adjusting screw adjustment.

CLEANING THROTTLE BODY PARTS

1. Clean all throttle body parts.
Do not use solvent to clean the following parts:
 - Throttle position sensor
 - Accelerator pedal position sensor
 - Idle speed control body assembly
 If these parts are immersed in solvent, their insulation will deteriorate.
Wipe them with cloth only.
2. Check if the vacuum port or passage is clogged. Use compressed air to clean the vacuum passage.

REASSEMBLY SERVICE POINT

▶◀ THROTTLE POSITION SENSOR (TPS) INSTALLATION

1. Install the TPS so that it faces as shown in the illustration, and then tighten it with the screw.
2. Connect a multimeter between terminal (4) (TPS power supply) and terminal (3) (TPS output) of the TPS connector, and check that the resistance increases gradually as the throttle valve is opened slowly to the fully-open position.
3. Check the continuity between terminal (2) (idle position switch) and terminal (1) (earth) of the TPS connector when the throttle valve is fully closed and fully open.

Normal condition:

Throttle valve condition	Continuity
Fully closed	Continuity
Fully open	No continuity

If there is no continuity when the throttle valve is fully closed, turn the TPS body anti-clockwise and then check again.

4. If there is an abnormality, replace the TPS.

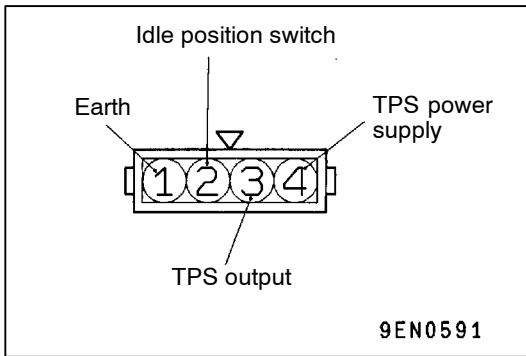
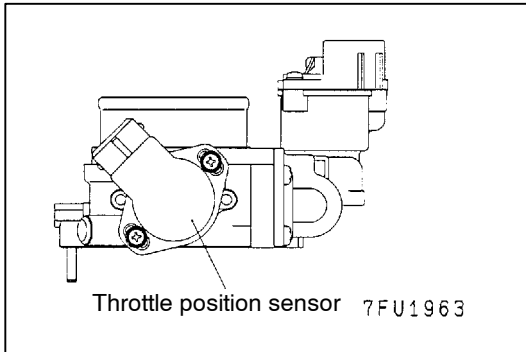

DIESEL FUEL

CONTENTS

1330900061

GENERAL INFORMATION	2	Evacuation of Air from Fuel Line	3
SERVICE SPECIFICATIONS	2	Fuel Filter Cartridge Replacement	3
SPECIAL TOOL	2	Fuel Injection Pump Check	3
ON-VEHICLE SERVICE	2	Boost Compensator Check	4
Fuel Injection Timing Check and Adjustment ...	2	Injection Nozzle Check and Adjustment	4
Engine Idle Speed Check and Adjustment	2	INJECTION NOZZLE	6
Evacuation of Water from Fuel Filter	2	INJECTION PUMP	10

GENERAL INFORMATION

13300010025

The fuel is drawn out of the fuel tank by means of the feed pump which is built into the fuel injection pump. It then passes through the fuel filter and is fed to the injection pump.

The fuel is pressurized by the feed pump, and this fuel pressure is controlled by the regulating valve which is built into the pump. Then, the fuel is compressed by the plunger and injected from the nozzles at high pressure in accordance with the injection sequence.

Engine speed (fuel injection amount) control is carried out by means of a centrifugal-type governor using a flyweight.

Fuel injection timing control is carried out by a hydraulic timer. The hydraulic timer operates by the fuel pressure inside the pump chamber. This pressure is controlled by the regulating valve.

SERVICE SPECIFICATIONS

13300030076

Items	Standard value
Injection timing control solenoid coil resistance Ω	8 – 10
Fuel injection initial pressure kPa	14,710 – 15,690

SPECIAL TOOL

13300060020

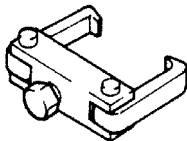
Tool	Number	Name	Use
	MD998388	Injection pump sprocket puller	Fuel injection pump sprocket removal

ON-VEHICLE SERVICE

13300090012

FUEL INJECTION TIMING CHECK AND ADJUSTMENT

Refer to GROUP 11B – On-vehicle Service.

ENGINE IDLE SPEED CHECK AND ADJUSTMENT

13300100012

Refer to GROUP 11B – On-vehicle Service.

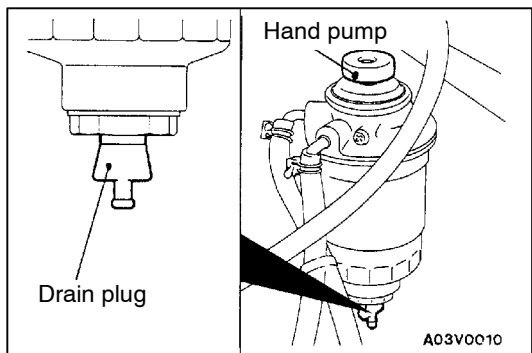

EVACUATION OF WATER FROM FUEL FILTER

13300120063

Water is in the filter when fuel filter warning lamp lights. Evacuate water by the following procedures.

1. Remove the intercooler assembly. (Refer to GROUP 15.)
2. Loosen drain plug.
3. Drain water with hand pump. Finger-tighten drain plug.

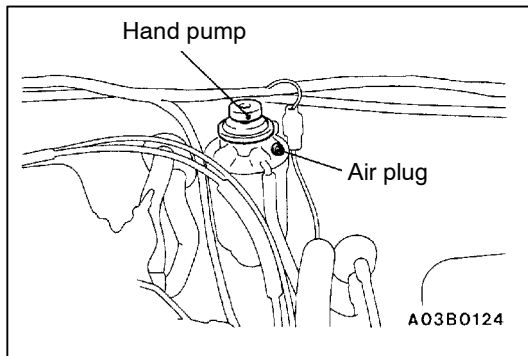
**EVACUATION OF AIR FROM FUEL LINE** 13300130066

Bleed the air from the fuel line after refilling the fuel.

- When fuel is drained for service.
 - When fuel filter is replaced.
 - When main fuel line is removed.
1. Remove the intercooler assembly. (Refer to GROUP 15.)
 2. Loosen fuel filter air plug.
 3. Place rags around air plug hole. Operate hand pump repeatedly until no bubbles come from plug hole. Tighten air plug.
 4. Repeat until hand pump operation becomes stiff.

FUEL FILTER CARTRIDGE REPLACEMENT

13300320043

Refer to GROUP 13C.

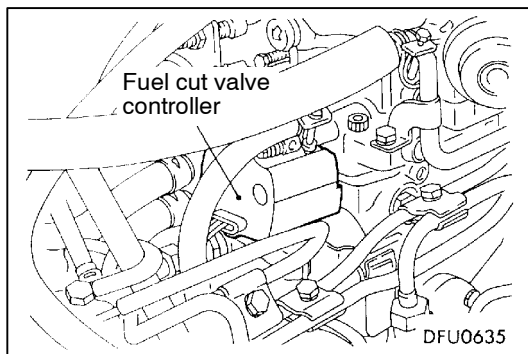
**FUEL INJECTION PUMP CHECK**

13300140052

FUEL CUT VALVE CONTROLLER OPERATION CHECK

When a sound scope is held against the fuel cut valve controller and the ignition switch is turned to "ON", check that the sound of the valve operating can be heard.

If no operating sound can be heard, check the immobilizer system while referring to GROUP 54.

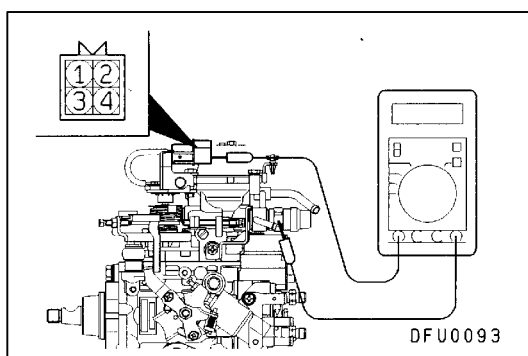
**INJECTION TIMING CONTROL SOLENOID COIL RESISTANCE CHECK**

Measure the resistance between the injection pump connector terminal No.4 (injection timing control solenoid terminal) and the injection pump body.

Standard value: 8 – 10 Ω (at 20 °C)

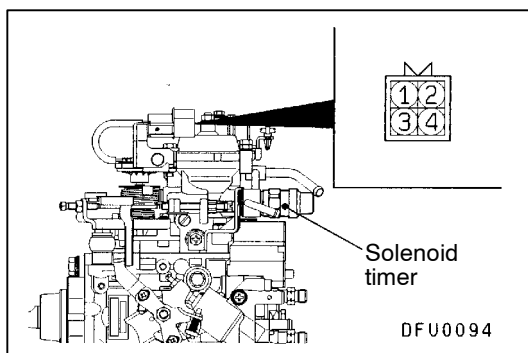
**INJECTION TIMING CONTROL SOLENOID OPERATION CHECK**

Check that operation sound of the injection timing control solenoid can be heard when connecting the injection pump connector terminal No.4 (injection timing control solenoid terminal) and the battery positive terminal.

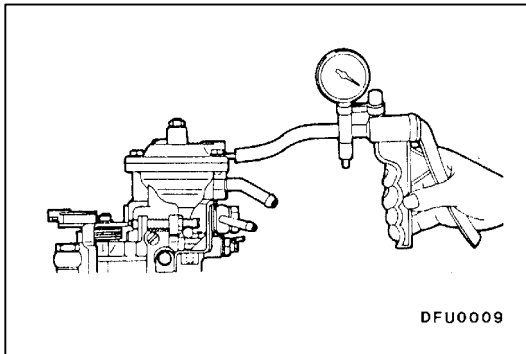
**BOOST COMPENSATOR CHECK**

13300150024

1. Connect a hand pump (pressurization type) to the nipple of the boost compensator.
2. Apply 30 kPa of pressure and check to be sure that the pressure is maintained.

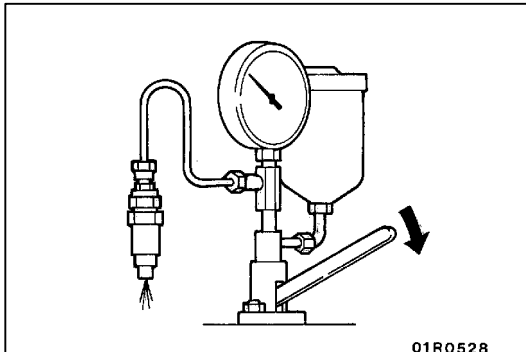
**INJECTION NOZZLE CHECK AND ADJUSTMENT**

13300160065

Caution

Never touch the injection spray that is injected from the nozzle.

FUEL INJECTION INITIAL PRESSURE CHECK

1. Install the injection nozzle to a nozzle tester.
2. Move the lever of the nozzle tester 2 – 3 times to inject fuel and to bleed the air.
3. Gently press down the lever of the nozzle tester, and take a reading of the indication value on the pressure gauge at the point where the needle slowly rises and then suddenly drops.

Standard value (Fuel injection initial pressure):

14,710 – 15,690 kPa

4. If the fuel injection initial pressure is outside the standard value, disassembly the nozzle holder to clean it, and then change the thickness of the shim to adjust the fuel injection initial pressure.

NOTE

- (1) For disassembly, reassembly and adjustment of the nozzle holder, refer to P.13B-8.
- (2) There are 10 shims for adjustment, with thicknesses in the range of 0.10 – 0.80 mm.
- (3) When the shim thickness is increased by 0.1 mm, the fuel injection initial pressure increases by 2,350 kPa.

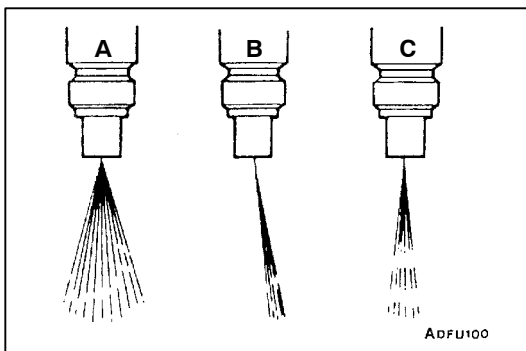
**INJECTION SPRAY CONDITION CHECK**

1. Move the lever of the nozzle tester rapidly (4 – 6 times per second) to eject the fuel continuously. Check to be sure that the injection spray comes out evenly in a cone shape (injection spray angle is 10 °C). The injection spray patterns shown in the illustration at left are wrong.
 - A. Injection angle is tool large
 - B. Bias
 - C. Intermittent fuel injection

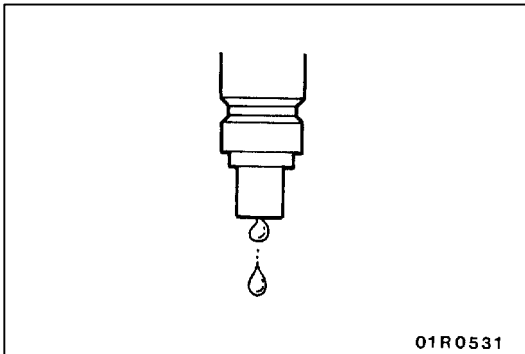

2. Check to be sure that no fuel drips after injection is completed.
3. If there are any drips, disassemble the nozzle, clean it and reinspect, or replace the nozzle.

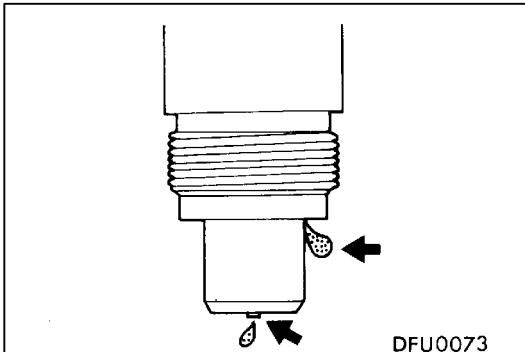

NOZZLE FUEL-TIGHT CHECK

1. Gently raise the lever of the nozzle tester until the pressure inside the nozzle (value displayed on pressure gauge) becomes 12,750 – 13,730 kPa, and after holding this pressure for approximately 10 seconds, check to be sure that there are no fuel leaks from the nozzle.
2. If there are any leaks, disassemble the injection nozzle, clean it and re-inspect, or replace the nozzle.

INJECTION NOZZLE

REMOVAL AND INSTALLATION

Pre-removal and

- Intercooler Removal (Refer to GROUP 15.)

Post-installation Operation

- Intercooler installation (Refer to GROUP 15.)
- Accelerator Cable Adjustment (Refer to GROUP 17 – On-vehicle Service.)

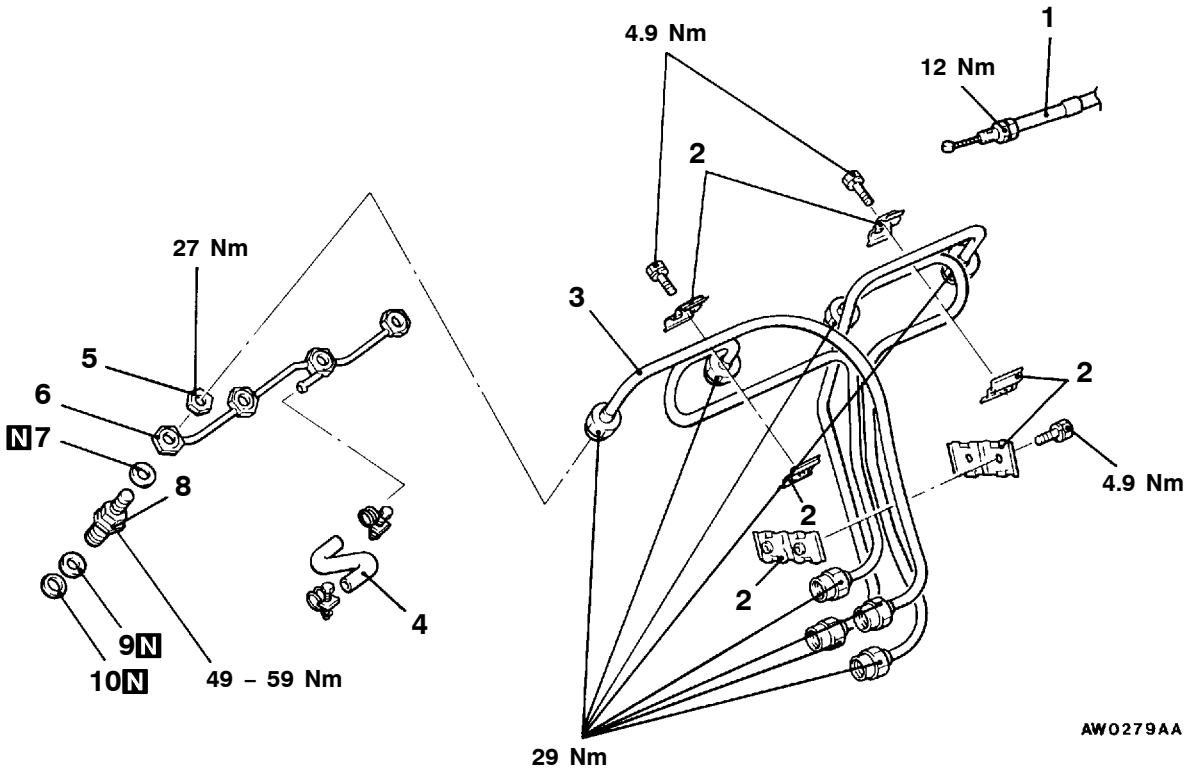

AW0279AA

Removal steps

1. Accelerator cable connection
2. Injection pipe clamp
3. Injection pipe
4. Fuel return hose
5. Nut



6. Fuel return pipe
7. Fuel return pipe gasket
8. Injection nozzle assembly
9. Holder gasket
10. Nozzle gasket

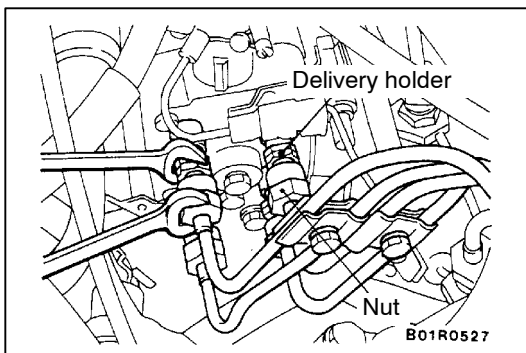

REMOVAL SERVICE POINTS

◀A▶ INJECTION PIPE DISCONNECTION

When loosening nuts at both ends of injection pipe, hold the delivery holder (for pump side) and the injection nozzle assembly (for nozzle side) with wrench and loosen nut.

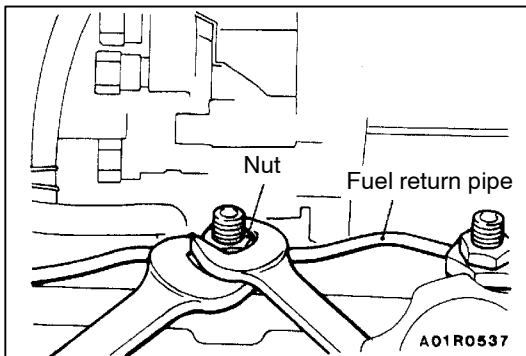

◀B▶ NUT/FUEL RETURN PIPE REMOVAL

1. While using a spanner or similar tool to hold the hexagonal nut of the fuel return pipe, remove the nut.

Caution

If an attempt is made to loosen the nut without first holding the fuel return pipe, the pipe may be broken or otherwise damaged.

2. Disconnect the fuel return pipe.

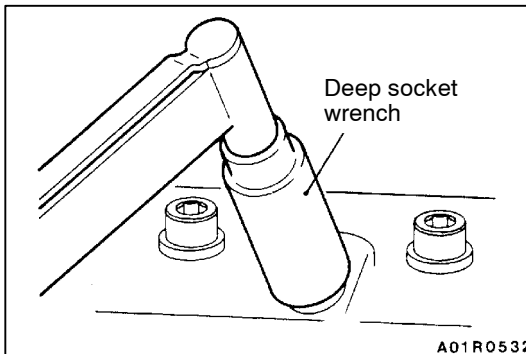

◀C▶ INJECTION NOZZLE ASSEMBLY REMOVAL

Using a deep socket wrench, remove the injection nozzle assembly.

Caution

1. Make a mark on the removed injection nozzle assembly (the cylinder No.).
2. Use a cap to prevent foreign material, etc. from entering the injection nozzle hole.

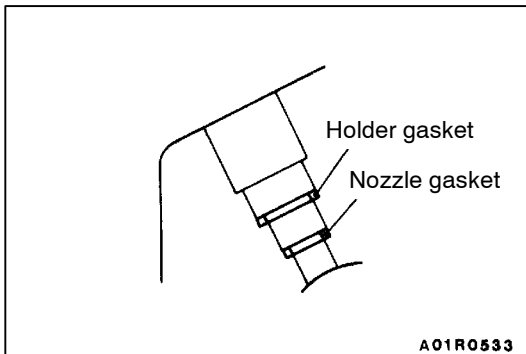

INSTALLATION SERVICE POINT

▶A◀ NOZZLE GASKET/HOLDER GASKET INSTALLATION

Clean the cylinder head's injection nozzle hole, and insert a new gasket.

DISASSEMBLY AND REASSEMBLY

13300350011

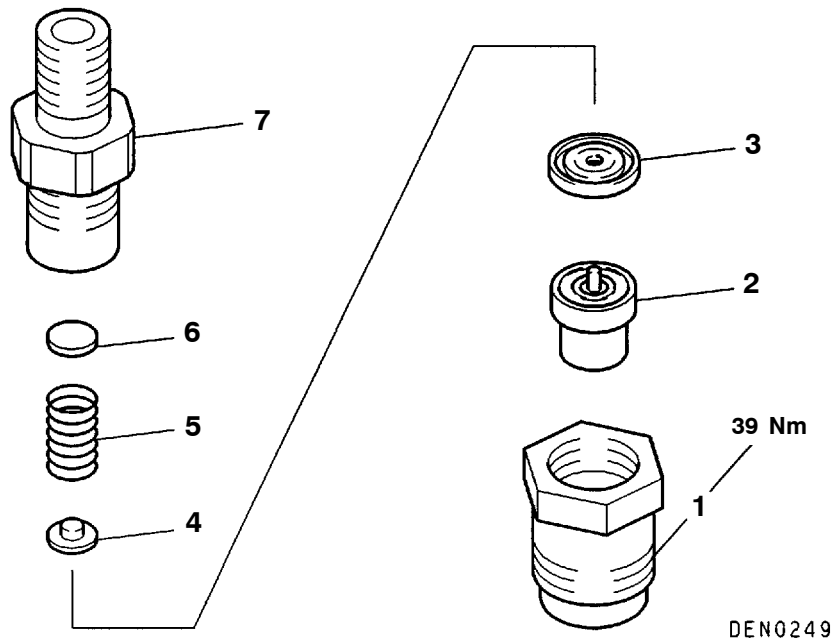

Disassembly steps



1. Retaining nut
2. Nozzle tip
3. Distance piece
4. Retaining pin
5. Pressure ring
6. Shim
7. Nozzle holder body

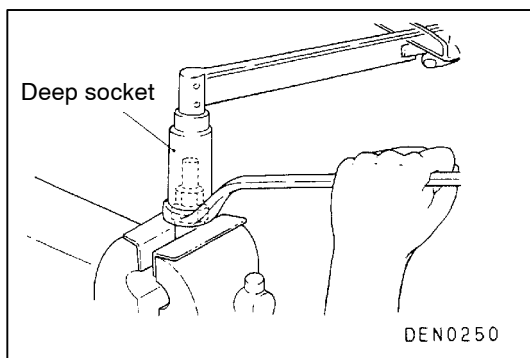

DISASSEMBLY SERVICE POINT

◀A▶ RETAINING NUT REMOVAL

1. Lightly clamp the retaining nut in a vise with soft jaws.
2. Hold the retaining nut with a box wrench, and loosen the nozzle holder body using a deep socket.

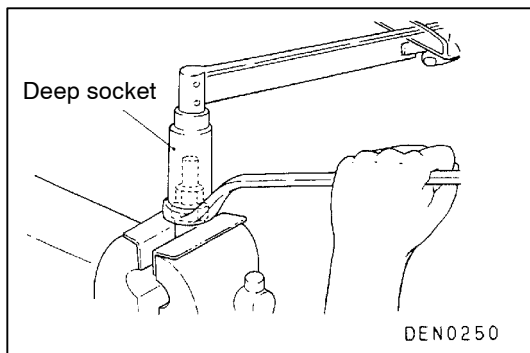

REASSEMBLY SERVICE POINT

▶A◀ RETAINING NUT INSTALLATION

1. Finger-tighten the nozzle holder body.
2. Lightly clamp the retaining nut in a vise with soft jaws.
3. While holding the retaining nut with a box wrench, tighten the nozzle holder body to the specified torque with a deep socket.

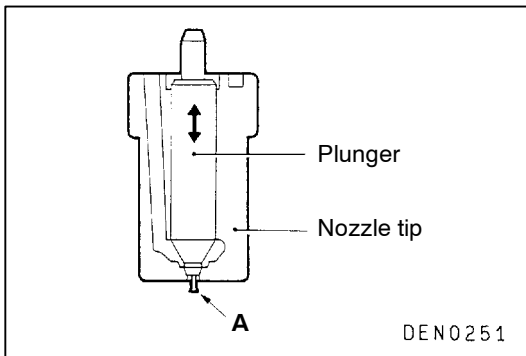

13300360014

INSPECTION**NOZZLE TIP**

1. Check the nozzle tip for carbon deposits. Scrape off carbon deposits with a piece of wood and clean each part with petrol. After cleaning, keep parts submerged in diesel fuel. Take particular care to protect the nozzle tip needle valve from damage.
2. While the nozzle tip is submerged in diesel fuel, check that the needle valve slides smoothly. If the needle valve does not slide smoothly, replace the nozzle tip. When replacing the nozzle tip, completely wash off the anticorrosive oil from the new nozzle tip with clean diesel fuel before using it.
3. Check plunger tip "A" for deformation and breakage. If "A" is damaged or broken, replace it.

DISTANCE PIECE

Check the surface in contact with the nozzle holder body by using minium.

PRESSURE SPRING

Check spring for weakness and breakage.

INJECTION PUMP

REMOVAL AND INSTALLATION

Pre-removal Operation

- Engine Coolant Draining
- Intercooler Removal (Refer to GROUP 15.)
- Timing Belt Removal (Refer to GROUP 11B.)

Post-installation Operation

- Timing Belt Installation (Refer to GROUP 11B.)
- Intercooler Installation (Refer to GROUP 15.)
- Engine Coolant Supplying
- Injection Timing Adjustment (Refer to GROUP 11B – On-vehicle Service.)
- Accelerator Cable Adjustment (Refer to GROUP 17 – On-vehicle Service.)

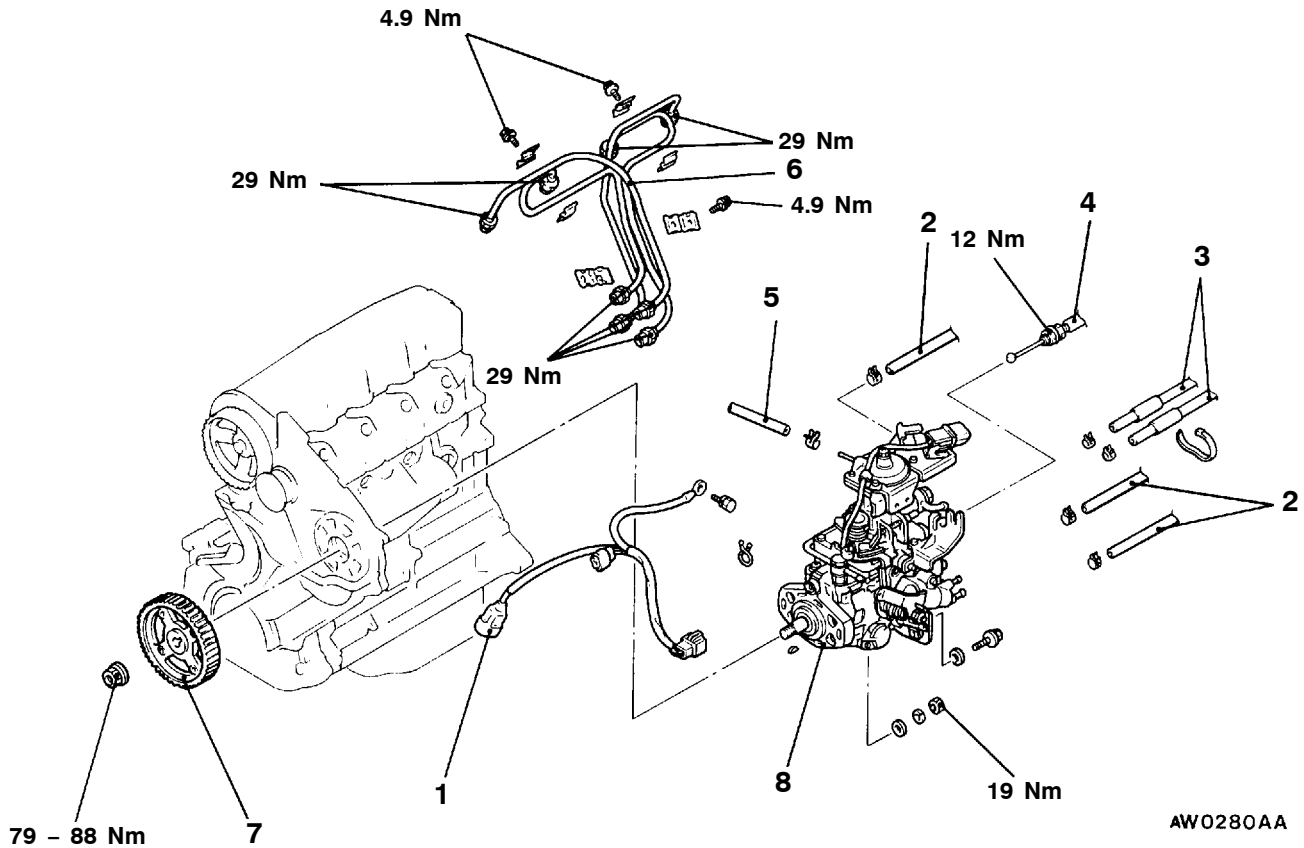

Removal steps

1. Fuel injection pump wiring harness
2. Water hose connection <Vehicles with cold start device>
3. Fuel hoses
4. Accelerator cable connection

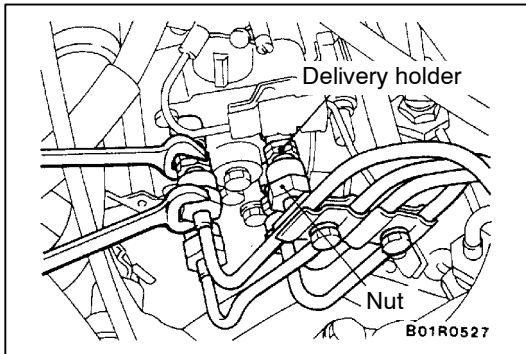

5. Boost hose connection
6. Fuel injection pipe
7. Fuel injection pump sprocket
8. Fuel injection pump

**REMOVAL SERVICE POINTS****◀A▶ INJECTION PIPE REMOVAL**

Loosen the nuts at the end of the injection pipe with the delivery holder (for pump side) and injection nozzle assembly (for nozzle side) retained by a spanner, etc.

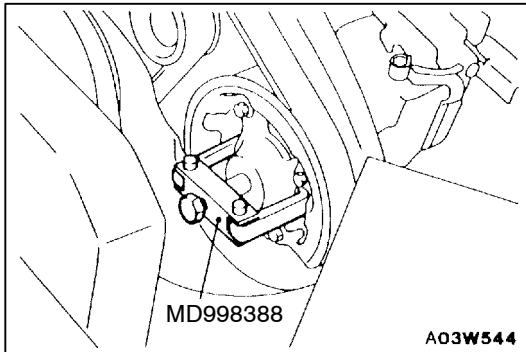
**◀B▶ FUEL INJECTION PUMP SPROCKET REMOVAL**

Remove sprocket installing nut and remove sprocket from pump drive shaft with special tool.

Caution

1. Do not hit pump drive shaft with hammer, etc.
2. When holding injection pump, do not allow to dangle by holding accelerator lever or fast idle lever. Do not remove these levers. Removal will cause injection pump malfunction.

NOTES

FUEL SUPPLY



CONTENTS

1330900054

GENERAL INFORMATION	2	FUEL FILTER <4D5>	6
FUEL TANK	2		



GENERAL INFORMATION

13300010094

The fuel tank is located under the floor below the rear seats.

A fuel cut-off valve has been adopted to prevent fuel from leaking out in the event of a collision.

FUEL TANK

13500190442

REMOVAL AND INSTALLATION

<6G7>

Pre-removal Operation

- Draining Fuel
- Fuel Line Pressure Reduction
(Refer to GROUP 13A – On-vehicle Service.)

Post-installation Operation

- Refilling Fuel
- Fuel Leakage Inspection

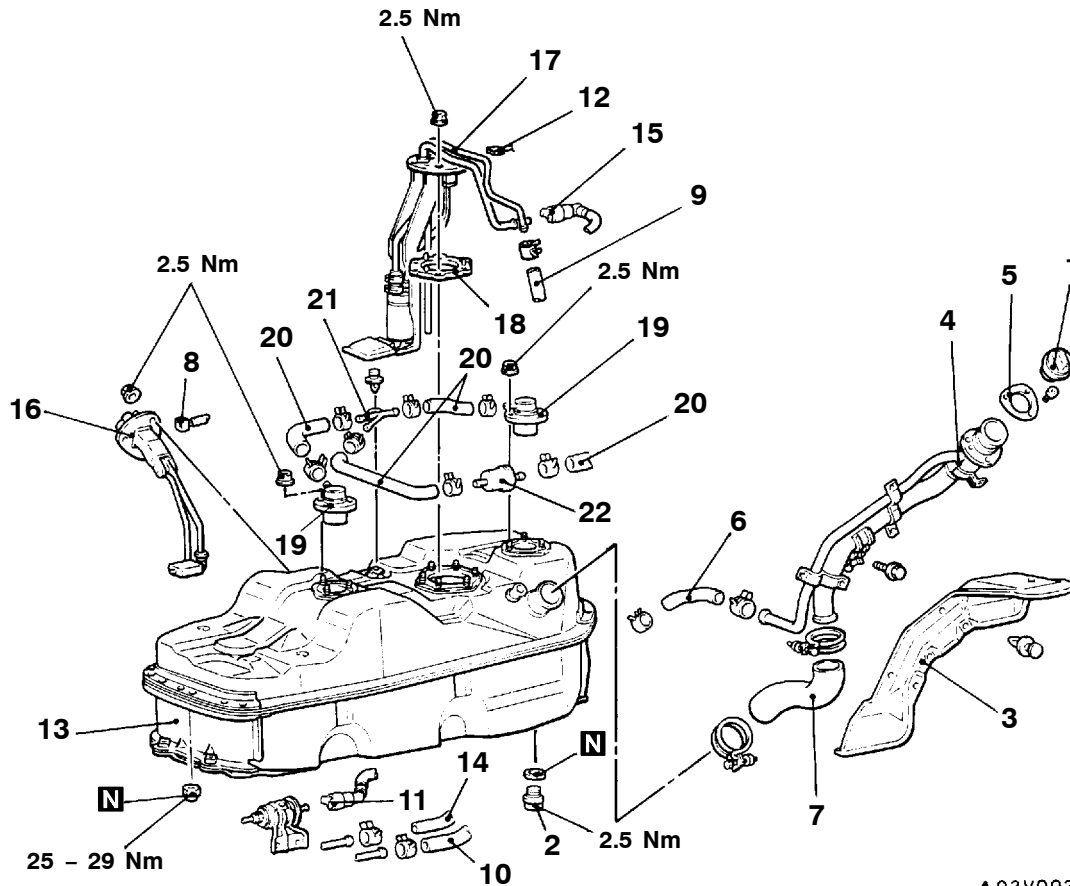

A 03V0039

Removal steps

- | | |
|---|---|
| 1. Fuel filler cap | 12. Fuel pump connector |
| 2. Drain plug | 13. Fuel tank |
| 3. Filler neck protector | 14. Fuel return hose connection
(line side) |
| 4. Filler neck | 15. High-pressure fuel hose connection
(tank side) |
| 5. Packing | 16. Fuel gauge unit |
| 6. Leveling hose | 17. Fuel pump assembly |
| 7. Filler hose | 18. Packing |
| 8. Fuel gauge unit connector | 19. Fuel cut-off valve |
| 9. Return hose connection
(Fuel tank side) | 20. Vapor hose |
| 10. Vapor hose connection (line side) | 21. Connector |
| 11. High-pressure fuel hose connection
(line side) | 22. 2-way valve |



<4D5>

Pre-removal Operation

- Draining Fuel

Post-installation Operation

- Refilling Fuel
- Fuel Leakage Inspection
- Fuel Line Air Bleeding
(Refer to GROUP 13B – On-vehicle Service.)

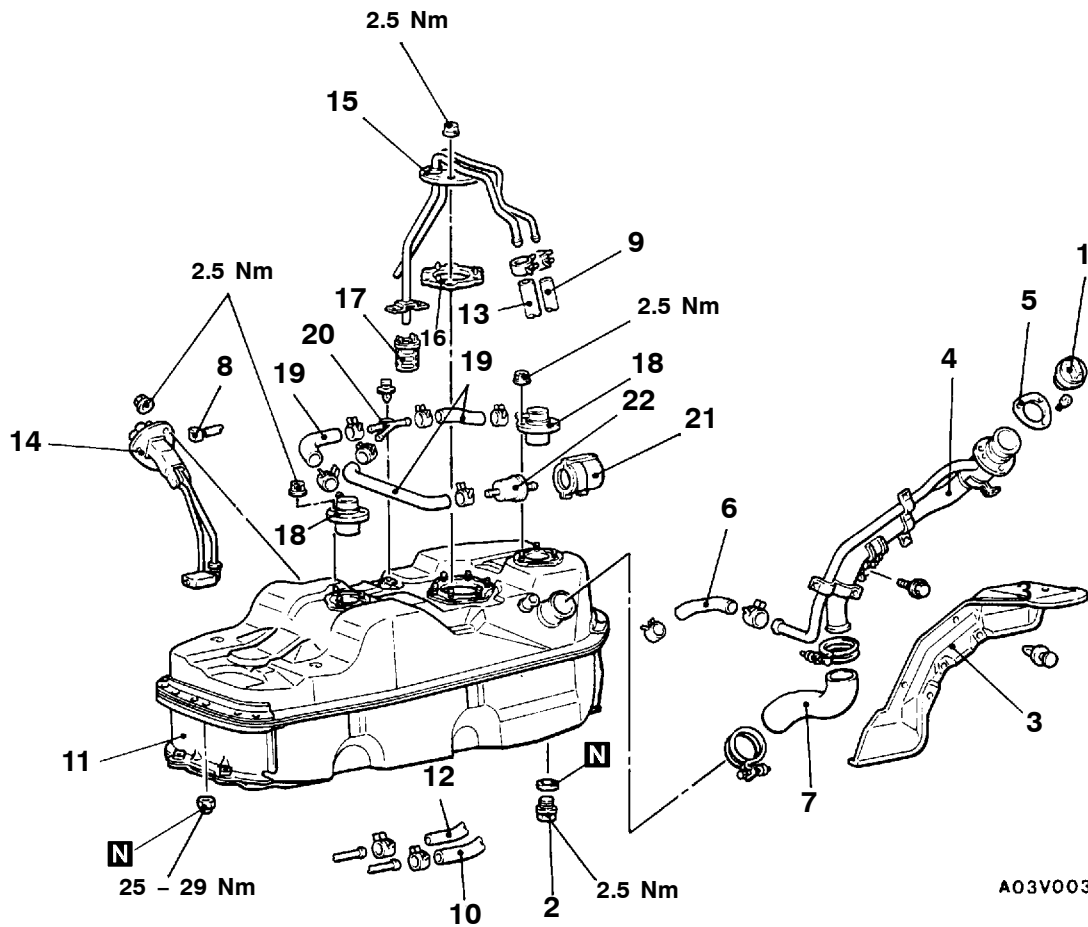

A03V0038

Removal steps

- | | |
|--|---|
| 1. Fuel filler cap | 12. Fuel return hose connection (line side) |
| 2. Drain plug | 13. Main hose connection (line side) |
| 3. Filler neck protector | 14. Fuel gauge unit |
| 4. Filler neck | 15. Fuel pump assembly |
| 5. Packing | 16. Packing |
| 6. Leveling hose | 17. Fuel filter |
| 7. Filler hose | 18. Fuel cut-off valve |
| 8. Fuel gauge unit connector | 19. Vapor hose |
| 9. Return hose connection (Fuel tank side) | 20. Connector |
| 10. Vapor hose connection (line side) | 21. Breather case |
| 11. Fuel tank | 22. Two-way valve |



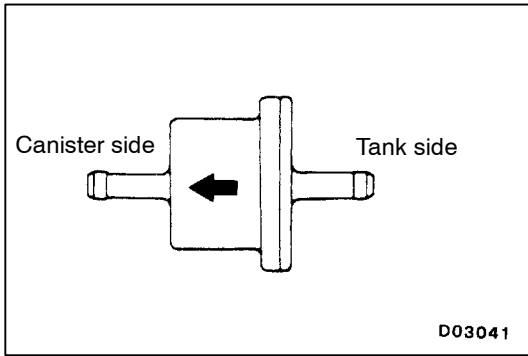

INSTALLATION SERVICE POINTS

▶◀ TWO-WAY VALVE INSTALLATION

Be careful about the installation direction of the two-way valve.

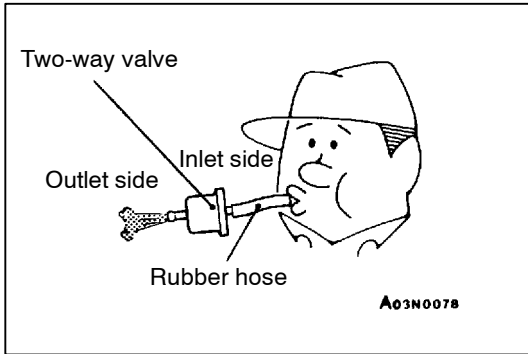

INSPECTION

13500300142

TWO-WAY VALVE SIMPLE CHECK

Attach a clean hose and check the operation of the two-way valve.

Lightly blow from inlet side (fuel tank side).	Air passes through with a slight feeling of resistance.
Lightly blow from outlet side.	Air passes through.

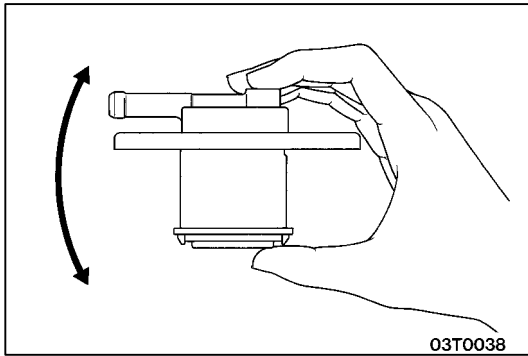

FUEL CUT-OFF VALVE CHECK

If the sound of the float valve moving (knocking sound) can be heard when the valve assembly is gently shaken up and down, then the valve is okay.

FUEL GAUGE UNIT CHECK

Refer to GROUP 54 – Combination Meter.

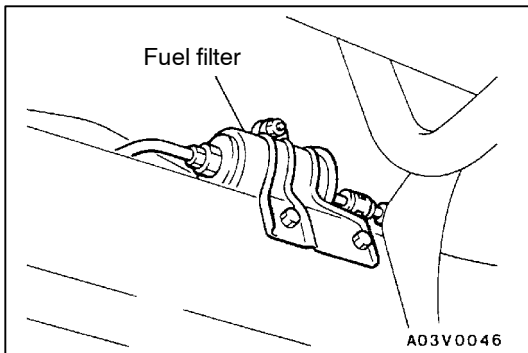

FUEL FILTER REPLACEMENT

13500130185

1. Bleed the residual pressure from inside the fuel line. (Refer to GROUP 13A – On-vehicle Service.)

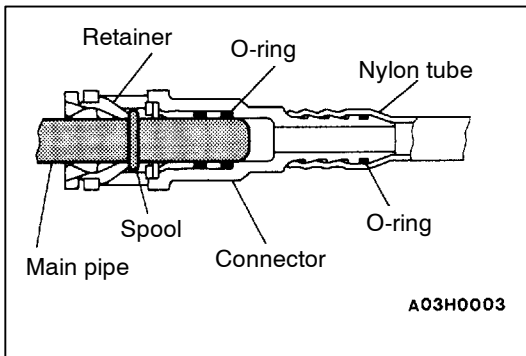

2. Press the high-pressure fuel hose retainer to disengage the connector, and then remove the high-pressure fuel hose.

Caution

As there will be some pressure remaining in the fuel pipe line, cover it with a shop towel to prevent fuel from spraying out.

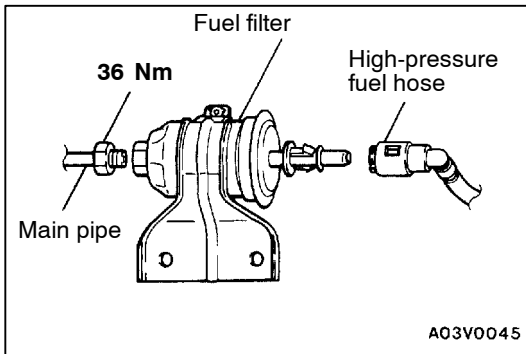

3. Hold the fuel filter with an adjustable wrench and loosen the flare nut. Then disconnect the main pipe connection.
4. Remove the fuel filter.
5. Install the fuel filter, high-pressure fuel hose and tighten the flare nut of the main pipe to the specified torque.

Tightening torque: 36 Nm

6. After installation, check that there are no fuel leaks.
 - (1) Apply battery voltage to the fuel pump drive terminal to operate the fuel pump. (Refer to GROUP 13A – On-vehicle Service.)
 - (2) Check for leaks when fuel pressure is applied.

FUEL FILTER <4D5>

REMOVAL AND INSTALLATION

<Vehicles without fuel line heater>

<Vehicles with fuel line heater>

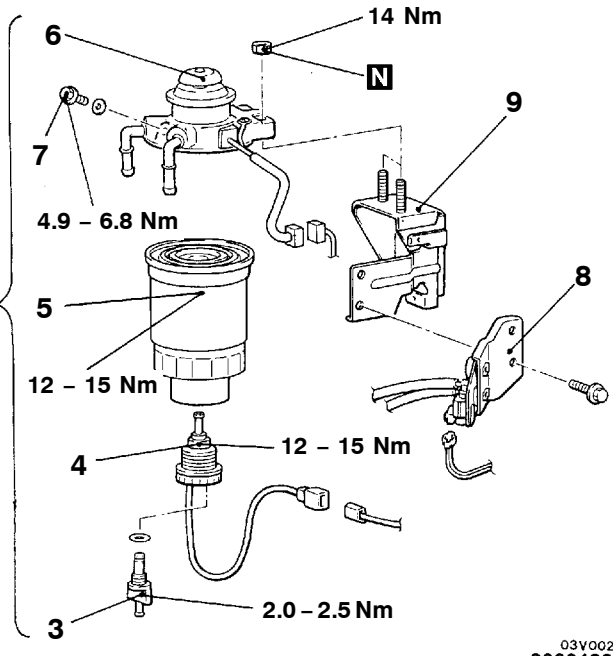
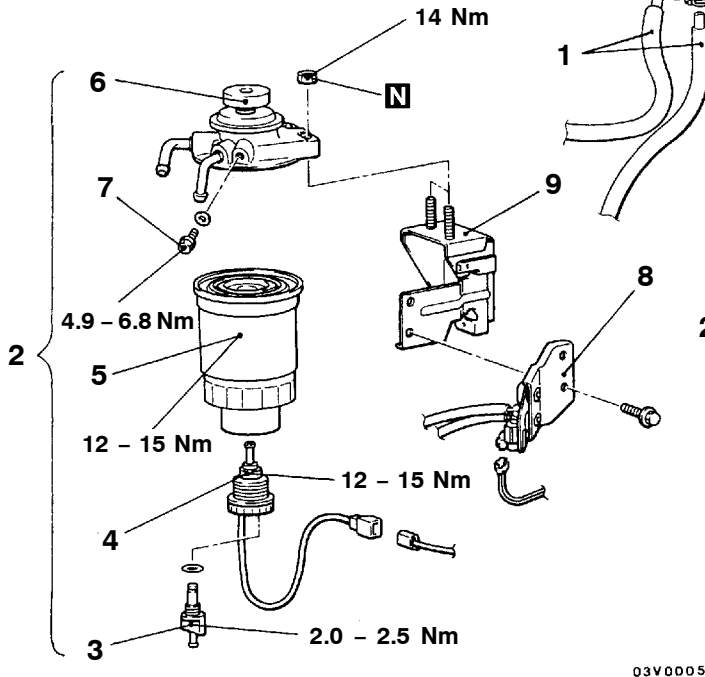

03V0005

03V0020
00004964

Removal steps

- Intercooler assembly (Refer to GROUP 15.)
- ▶◀ 1. Main hose connection
- 2. Fuel filter
- 3. Drain plug
- 4. Water level sensor

- 5. Fuel filter cartridge
- 6. Fuel filter pump
- 7. Breather screw
- 8. Solenoid valve assembly (for A/C)
- 9. Fuel filter bracket

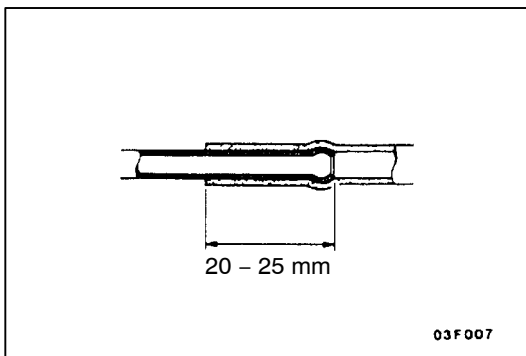

INSTALLATION SERVICE POINT

▶◀ **FUEL MAIN HOSE INSTALLATION**

If the pipe has a stepped part, connect securely up to the stepped part. If the pipe has no stepped part, insert so that the inserted portion is 20 – 25 mm long.

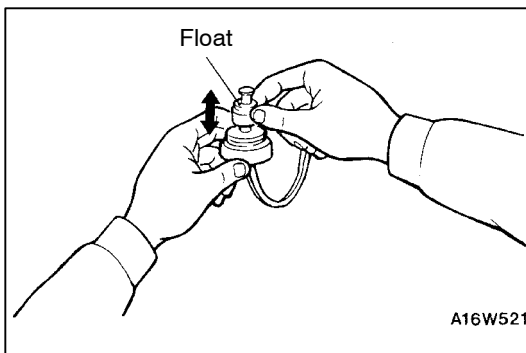

INSPECTION

WATER LEVEL SENSOR CHECK

Connect the circuit tester to the water level sensor connector. The water level sensor is operating correctly if there is continuity when the float is raised, and no continuity when it is lowered.

03F007

A16W521

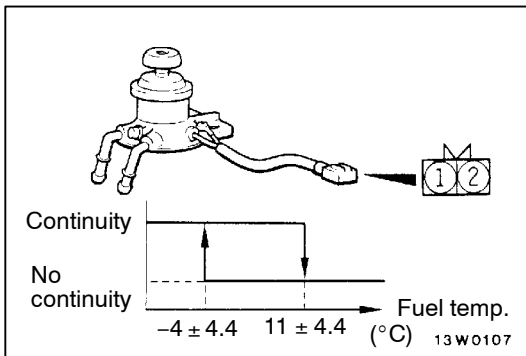

FUEL LINE HEATER CONTINUITY CHECK

There should be continuity between the terminals when the fuel filter pump is cooled -4°C or below and continuity should disappear when the pump is gradually heated. If this is true then the heater is working properly.

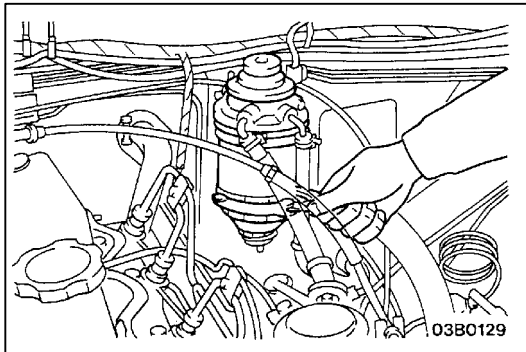

FUEL FILTER CARTRIDGE REPLACEMENT

13500130092

1. Remove the intercooler assembly. (Refer to GROUP 15.)
2. Remove the fuel tank cap to release the pressure inside the fuel tank.
3. Disconnect the water level sensor connector.
4. Use an oil filter wrench to remove the fuel filter cartridge from the fuel filter pump body.

Caution

Cover with a rag to prevent fuel from spraying out.

5. Install a new filter, and bleed the air from fuel line. (Refer to GROUP 13B – On-vehicle Service.)
6. Start the engine, and check that there are no fuel leakage.

NOTES

ENGINE COOLING

CONTENTS

14109000314

GENERAL INFORMATION	2	Engine Coolant Replacement	3
SERVICE SPECIFICATIONS	2	Concentration Measurement	4
LUBRICANT	2	COOLING FAN	6
SEALANTS	2	THERMOSTAT	8
ON-VEHICLE SERVICE	3	WATER PUMP	10
Engine Coolant Leak Checking	3	WATER HOSE AND WATER PIPE	13
Radiator Cap Valve Opening Pressure Check	3	RADIATOR	16

GENERAL INFORMATION

14100010286

The cooling system is designed to keep every part of the engine at appropriate temperature in whatever condition the engine may be operated. The cooling method is of the water-cooled, pressure forced circulation type in which the water pump pressurizes coolant and circulates it throughout the engine. If the coolant temperature exceeds the prescribed temperature, the thermostat opens to circulate the coolant through the radiator as well so that the heat absorbed by the coolant may be radiated into the air.

The water pump is of the centrifugal type and is driven by the drive belt from the crankshaft. The radiator is the corrugated fin, down flow type.

Items			Specifications
Radiator	Performance kJ/h	6G7	203,000
		4D5	230,200

SERVICE SPECIFICATIONS

14100030305

Items		Standard value	Limit
High pressure valve opening pressure of radiator cap kPa		74 – 103	64
Range of coolant antifreeze concentration of radiator %		30 – 60	–
Thermostat	Valve opening temperature of thermostat °C	6G7	88 ± 2.0
		4D5	82 ± 1.5
	Full-opening temperature of thermostat °C	6G7	100
		4D5	95
	Valve lift mm	6G7	10 or more
		4D5	8.5 or more

LUBRICANT

14100040209

Items		Quantity L
MITSUBISHI GENUINE COOLANT OR AN EQUIVALENT	6G7	9.0 (10.0)
	4D5	8.0 (9.0)

NOTE

() indicates figure for vehicles with rear heater.

SEALANTS

14100050226

Items	Specified sealant	Remarks
Cylinder block drain plug	3M Nut Locking Part No. 4171 or equivalent	Drying sealant

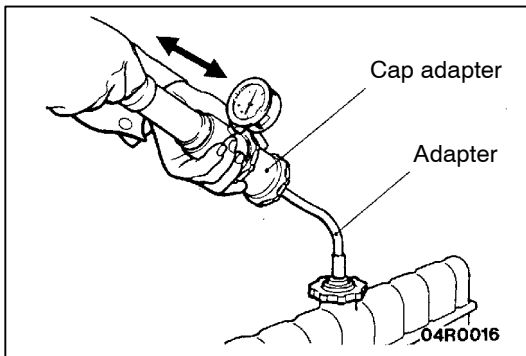

ON-VEHICLE SERVICE

14100100167

ENGINE COOLANT LEAK CHECKING

1. Confirm that the coolant level is up to the filler neck. Install a radiator cap tester and apply 160 kPa pressure, and then check for leakage from the radiator hose or connections.

Caution

- (1) Be sure to completely clean away any moisture from the places checked.
- (2) When the tester is taken out, be careful not to spill any coolant from it.
- (3) Be careful, when installing and removing the tester and when testing, not to deform the filler neck of the radiator.

2. If there is leakage, repair or replace the appropriate part.

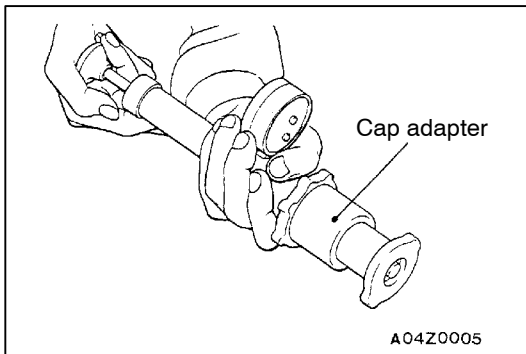

RADIATOR CAP VALVE OPENING PRESSURE CHECK

14100130203

1. Use a cap adapter to attach the cap to the tester.
2. Increase the pressure until the indicator of the gauge stops moving.

Limit: 64 kPa

Standard value: 74 – 103 kPa

3. Replace the radiator cap if the reading does not remain at or above the limit.

NOTE

Be sure that the cap is clean before testing, since rust or other foreign material on the cap seal will cause an improper indication.

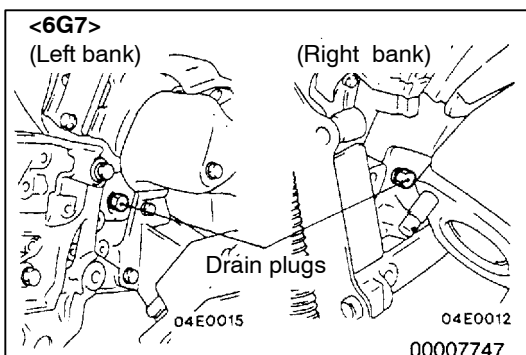

ENGINE COOLANT REPLACEMENT

14100120354

1. Drain the engine coolant by removing the drain plug and then the radiator cap.
2. Remove the cylinder block drain plug from the cylinder block to drain the engine coolant.
3. Remove the reserve tank to drain the engine coolant.
4. When the engine coolant has drained, pour in water from the radiator cap to clean the engine coolant line.

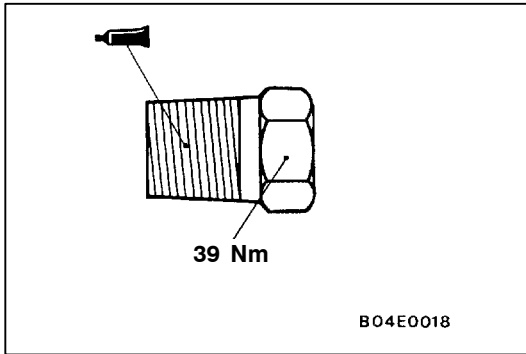
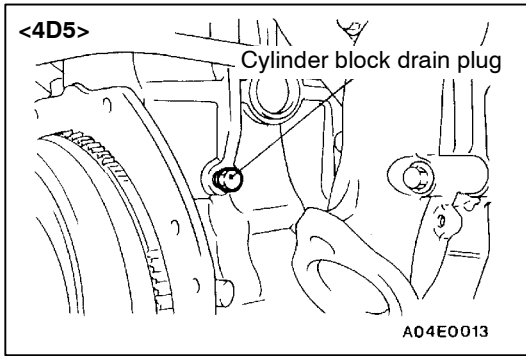

5. Coat the thread of the cylinder block drain plug with the specified sealant and tighten to the specified torque.

Specified sealant:

3M Nut Locking Part No. 4171 or equivalent

6. Securely tighten the radiator drain plug.
7. Install the reserve tank.
8. Remove the air bleed bolt and replace the seal washer.
9. Fill the radiator until the engine coolant flows from the air bleed bolt section, and then close the air bleed bolt.
10. Slowly pour the engine coolant into the mouth of the radiator until the radiator is full, and pour also into the reserve tank up to the FULL line.

Recommended antifreeze:

MITSUBISHI GENUINE COOLANT OR AN EQUIVALENT

Quantity:

<6G7> 9.0 (10.0) L

<4D5> 8.0 (9.0) L

Caution

Do not use alcohol or methanol anti-freeze or any engine coolants mixed with alcohol or methanol anti-freeze. The use of an improper anti-freeze can cause the corrosion of the aluminum components.

NOTE

- (1) () indicates figure for vehicles with rear heater.
- (2) For Norway, the non-amine type of antifreeze should be used.

11. Install the radiator cap securely.
12. Start the engine and warm the engine until the thermostat opens. (Touch the radiator hose with your hand to check that warm water is flowing.)
13. After the thermostat opens, race the engine several times, and then stop the engine.
14. Cool down the engine, and then pour engine coolant into the reserve tank until the level reaches the FULL line. If the level is low, repeat the operation from step 11.

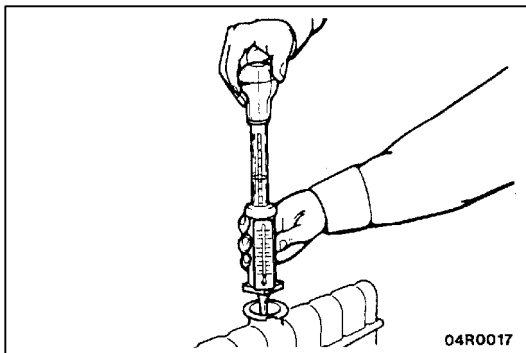

CONCENTRATION MEASUREMENT

14100110146

Measure the temperature and specific gravity of the engine coolant to check the antifreeze concentration.

Standard value: 30 – 60 % (allowable concentration range)

RECOMMENDED ANTIFREEZE

Antifreeze	Allowable concentration
MITSUBISHI GENUINE COOLANT OR AN EQUIVALENT	30 – 60 %

Caution

If the concentration of the anti-freeze is below 30 %, the anti-corrosion property will be adversely affected. In addition, if the concentration is above 60 %, both the anti-freezing and engine cooling properties will decrease, affecting the engine adversely. For these reasons, be sure to maintain the concentration level within the specified range.

COOLING FAN

REMOVAL AND INSTALLATION

- Pre-removal and Post-installation Operation**
- Engine Coolant Draining and Supplying (Refer to P.14-3.)
 - Radiator Upper Hose Removal and Installation (Refer to P.14-12.)

<6G7>

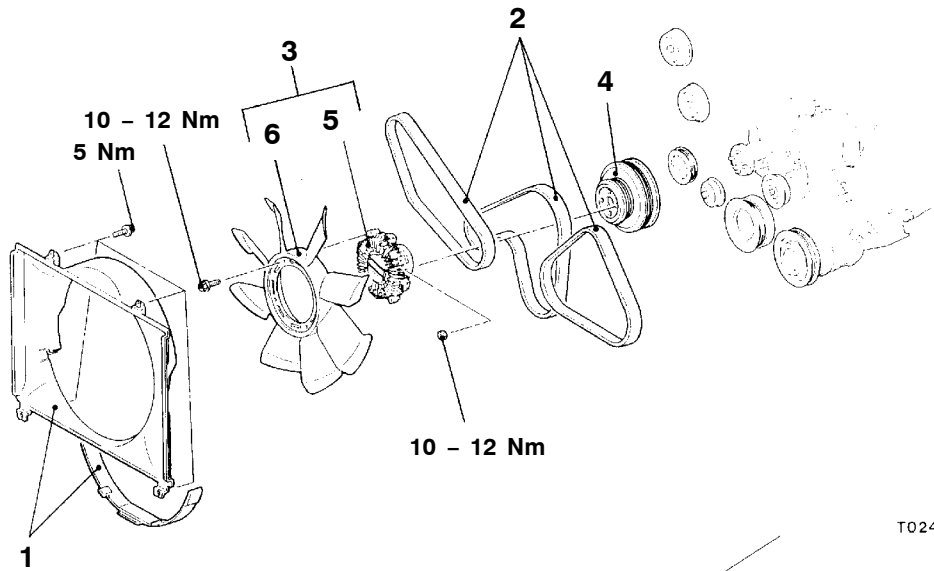

T0241AA

<4D5>

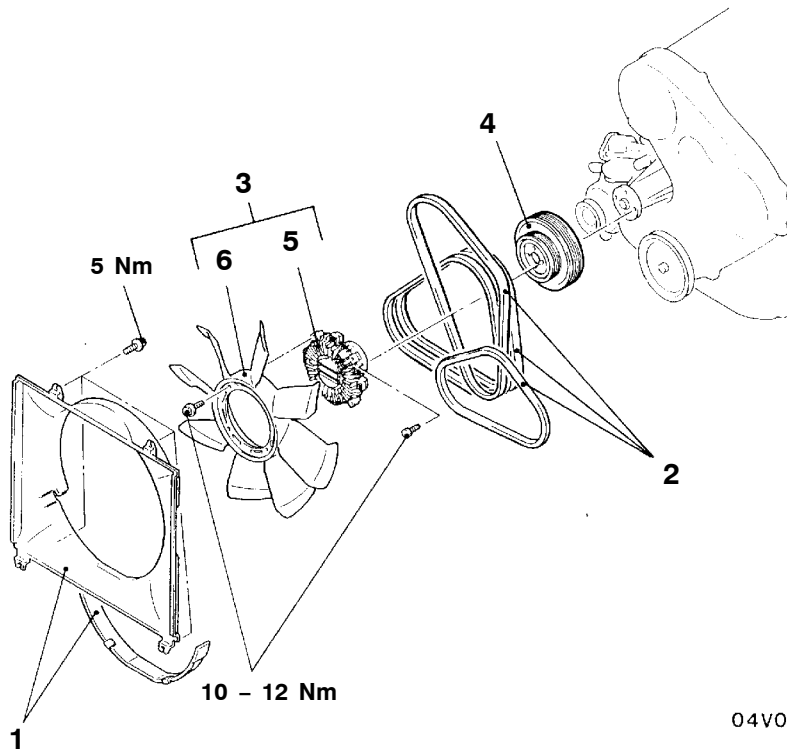

04V0037

00009209

Removal steps

1. Shroud assembly
2. Drive belts
3. Cooling fan and fan clutch assembly

4. Pulley
5. Fan clutch
6. Cooling fan

INSPECTION

14100220023

COOLING FAN CHECK

- Check blades for damage and cracks.
- Check for cracks and damage around bolt holes in fan hub.
- If any portion of fan is damaged or cracked, replace cooling fan.

FAN CLUTCH CHECK

- Check to ensure that fluid in fan clutch is not leaking at case joint and seals. If fluid quantity decreases due to leakage, fan speed will decrease and engine overheating might result.
- When a fan attached to an engine is turned by hand, lightly, it is faulty.
- Check bimetal strip for damage.

THERMOSTAT

14100240371

REMOVAL AND INSTALLATION

Pre-removal and Post-installation Operation

- Engine Coolant Draining and Supplying
(Refer to P.14-3.)

<6G7>

<4D5>

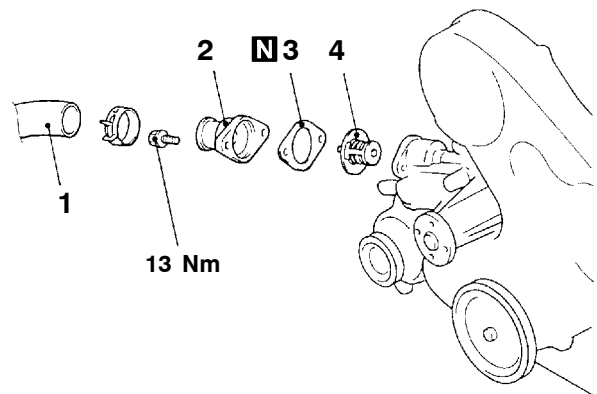
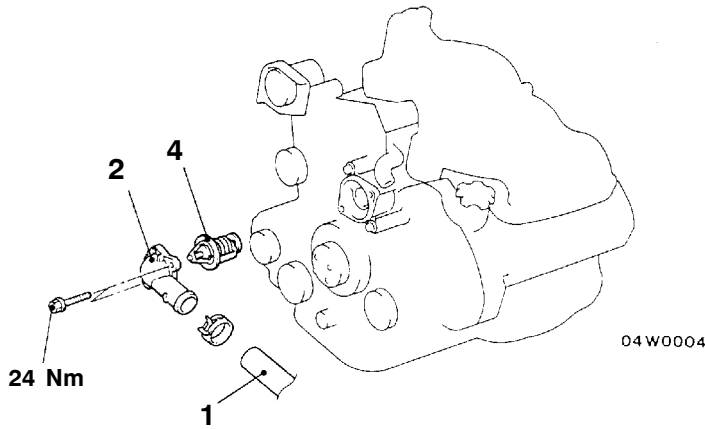

04W0004

04W0007

00009210

Removal steps

- ◀A▶ ▶B▶
1. Radiator lower hose connection
 2. Water inlet fitting

- ▶A▶
3. Water inlet fitting gasket <4D5>
 4. Thermostat

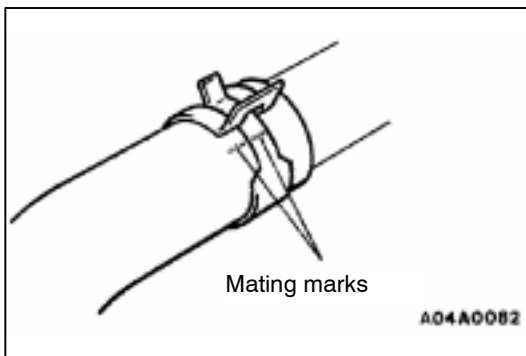

A04A0082

REMOVAL SERVICE POINT

◀A▶ **RADIATOR LOWER HOSE DISCONNECTION**

After making mating marks on the radiator hose and the hose clamp, disconnect the radiator hose.

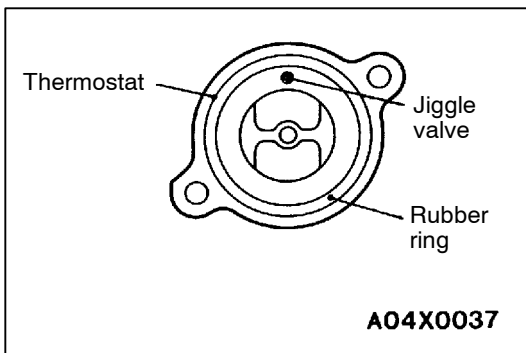

A04X0037

INSTALLATION SERVICE POINT

▶A▶ **THERMOSTAT INSTALLATION**

<6G7>

Install the thermostat so that the jiggle valve is facing straight up, while being careful not to fold over or scratch the rubber ring.

Caution

Make absolutely sure that no oil adheres to the rubber ring of the thermostat. Also be careful not to fold over or scratch the rubber ring when inserting.

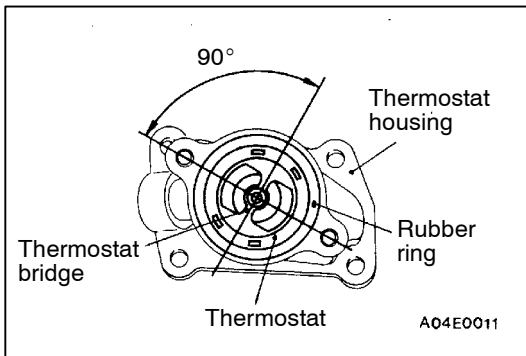

<4D5>

Hold the thermostat at the angle shown in the illustration, and install it while being careful not to wrinkle or damage the rubber ring.

Caution

Do not apply any oil or grease to the rubber ring of the thermostat under any circumstances.

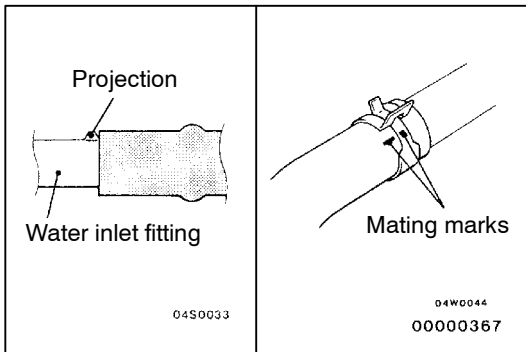

►B◀ **RADIATOR LOWER HOSE CONNECTION**

1. Insert each hose as far as the projection of the water outlet fitting.
2. Align the mating marks on the radiator hose and hose clamp, and then connect the radiator hose.

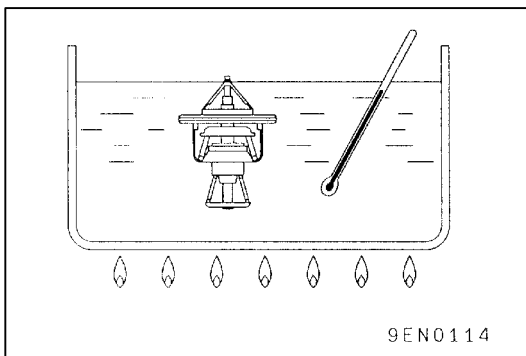

INSPECTION

14100250374

THERMOSTAT CHECK

1. Immerse the thermostat in water, and heat the water while stirring. Check the thermostat valve opening temperature.

Standard value:

Valve opening temperature:

<6G7> $88 \pm 2.0^{\circ}\text{C}$

<4D5> $82 \pm 1.5^{\circ}\text{C}$

2. Check that the amount of valve lift is at the standard value when the water is at the full-opening temperature.

Standard value:

Items	6G7	4D5
Full-opening temperature °C	100	95
Amount of valve lift mm	10.0 or more	8.5 or more

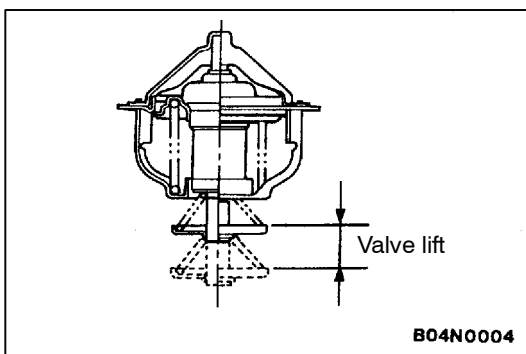

NOTE

Measure the valve height when the thermostat is fully closed, and use this measurement to calculate the valve height when the thermostat is fully open.

WATER PUMP

REMOVAL AND INSTALLATION

Pre-removal and Post-installation Operation

- Engine Coolant Draining and Supplying (Refer to P.14-3.)
- Timing Belt Removal and Installation (Refer to GROUP 11.)
- Thermostat Removal and Installation (Refer to P.14-7.)

<6G7>

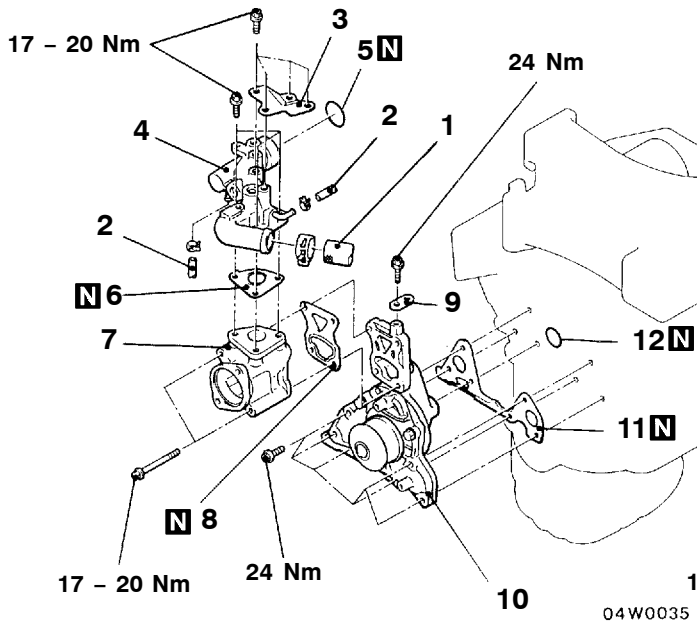

04W0035

<4D5>

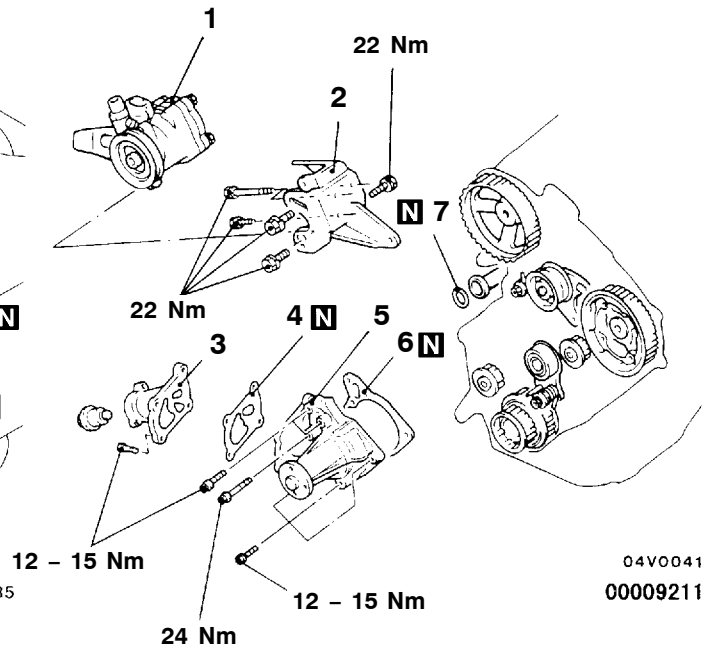

04V0041
00009211

Removal steps

<6G7>

- ◀A▶ ▶C▶ 1. Radiator upper hose connection
- ▶A▶ 2. Water hose connection
- ▶A▶ 3. Water outlet fitting bracket
- ▶A▶ 4. Water outlet fitting assembly
- ▶A▶ 5. O-ring
- ▶A▶ 6. Gasket
- ▶A▶ 7. Thermostat case
- ▶A▶ 8. Gasket
- ▶A▶ 9. Water pump bracket
- ▶B▶ 10. Water pump assembly
- ▶A▶ 11. Gasket
- ▶A▶ 12. O-ring

<4D5>

- Air intake hose (Refer to GROUP 15 – Air Cleaner.)
- ◀B▶ 1. Power steering oil pump
- ▶B▶ 2. Power steering oil pump bracket
- ▶B▶ 3. Thermostat housing
- ▶B▶ 4. Thermostat housing gasket
- ▶B▶ 5. Water pump assembly
- ▶A▶ 6. Gasket
- ▶A▶ 7. O-ring

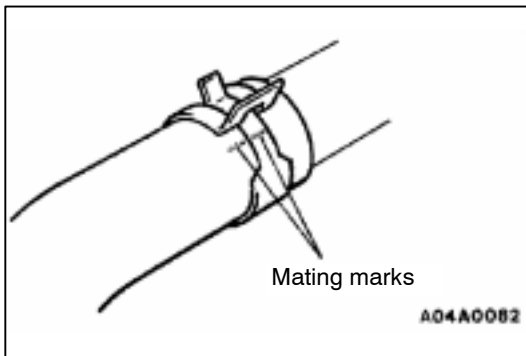
**REMOVAL SERVICE POINT****◀A▶ RADIATOR UPPER HOSE/RADIATOR LOWER HOSE DISCONNECTION**

After making mating marks on the radiator hose and the hose clamp, disconnect the radiator hose.

◀B▶ POWER STEERING OIL PUMP REMOVAL

1. Remove the power steering oil pump from the bracket with the hose still attached.
2. Place the power steering oil pump somewhere where it will not be a hindrance to working, being careful not to put too much strain on the hose.

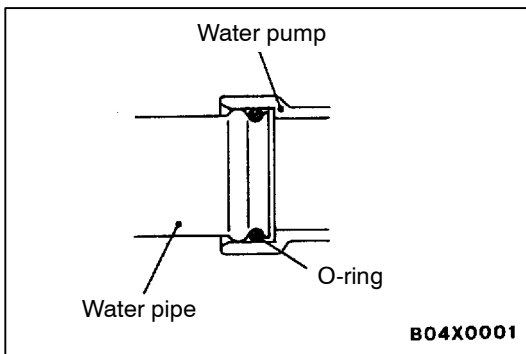
**INSTALLATION SERVICE POINTS****▶A◀ O-RING INSTALLATION**

Rinse the mounting location of the O-ring and water pipe with water, and install the O-ring and water pipe.

Caution

1. **Care must be taken not to permit engine oil or other greases to adhere to the O-ring.**
2. **When inserting the pipe, check to be sure that there is no sand, dirt, etc. on its inner surface.**

►B◄ WATER PUMP ASSEMBLY INSTALLATION

No.	Hardness category (head mark)	Bolt diameter x length mm
1	4T	8 x 25
2		8 x 40
3	7T	8 x 14
4		8 x 20
5		8 x 25
6		8 x 70

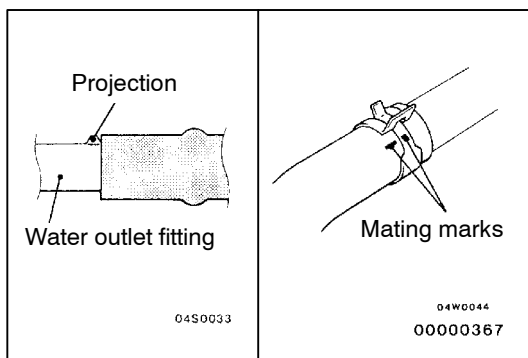
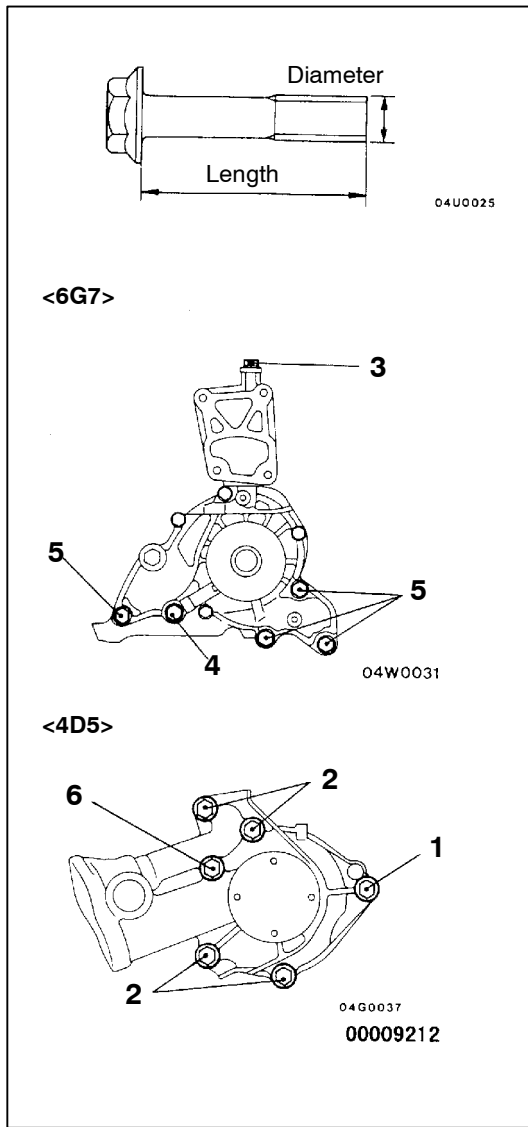

►C◄ RADIATOR UPPER HOSE CONNECTION

1. Insert each hose as far as the projection of the water outlet fitting.
2. Align the mating marks on the radiator hose and hose clamp, and then connect the radiator hose.

WATER HOSE AND WATER PIPE

REMOVAL AND INSTALLATION

<6G7>

Pre-removal and Post-installation Operation

- Engine Coolant Draining and Supplying (Refer to P.14-3.)
- Front Exhaust Pipe and Heat Protector Removal and Installation (Refer to GROUP 15 – Exhaust Pipe and Main Muffler.)
- Intake Manifold Removal and Installation (Refer to GROUP 15 – Intake Manifold.)
- Thermostat Removal and Installation (Refer to P.14-7.)

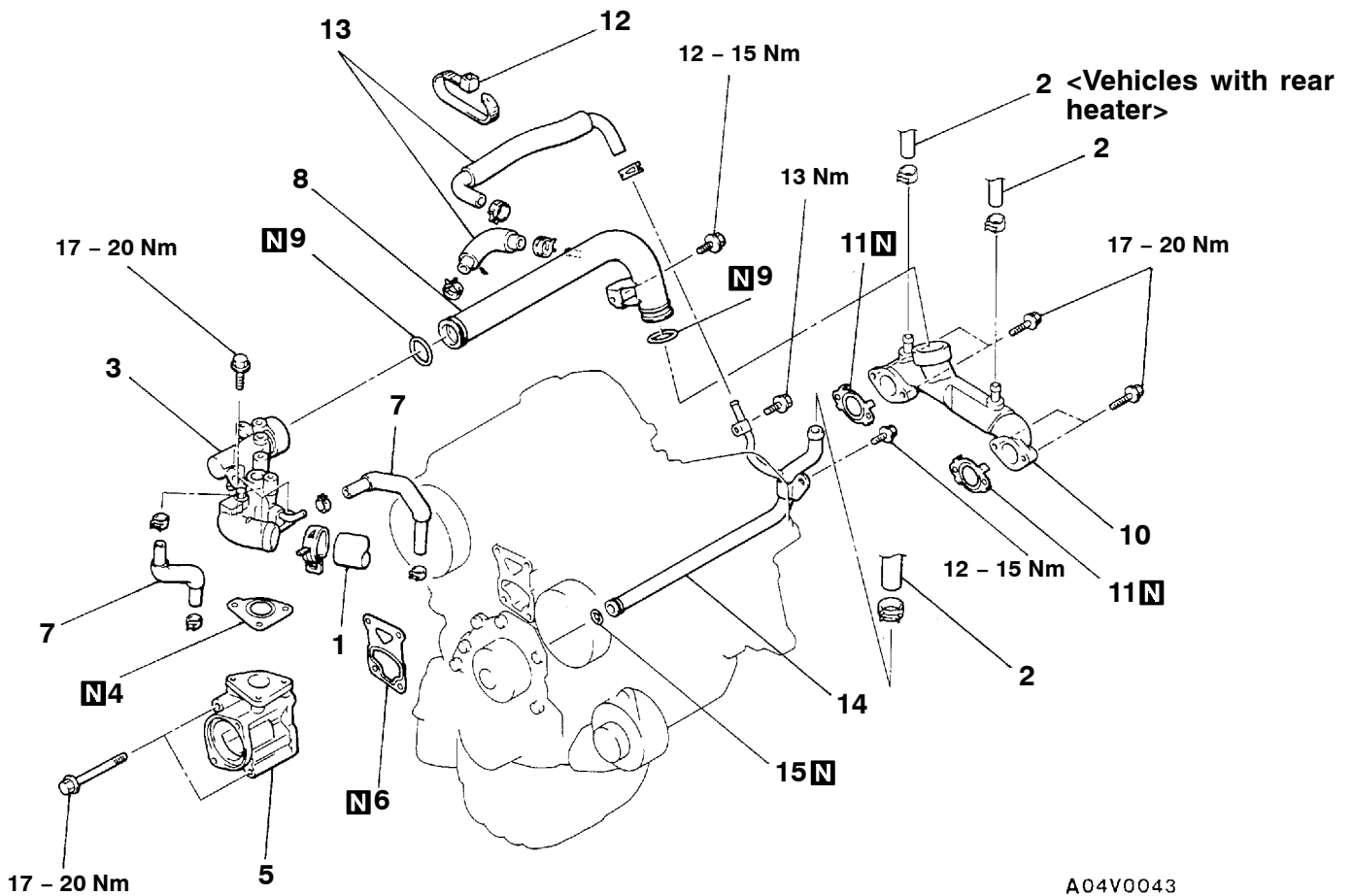

A04V0043

Removal steps

- ◀A▶ ▶D▶ 1. Radiator upper hose connection
- 2. Heater hose connection
- 3. Water outlet fitting assembly
- 4. Gasket
- 5. Thermostat case
- 6. Gasket
- 7. Water hose
- 8. Water outlet pipe assembly

- ▶A▶ 9. O-ring
- ▶C▶ 10. Water passage assembly
- ▶B▶ 11. Gasket
- ▶A▶ 12. Cable band
- ▶A▶ 13. Water hose
- ▶A▶ 14. Water pipe assembly
- ▶A▶ 15. O-ring

<4D5>

Pre-removal and Post-installation Operation

- Engine Coolant Draining and Supplying
(Refer to P.14-3.)
- Injection Pipe Removal and Installation
(Refer to GROUP 13E – Injection Nozzle.)
- Intake, Exhaust Manifold Removal and Installation
(Refer to GROUP 15.)

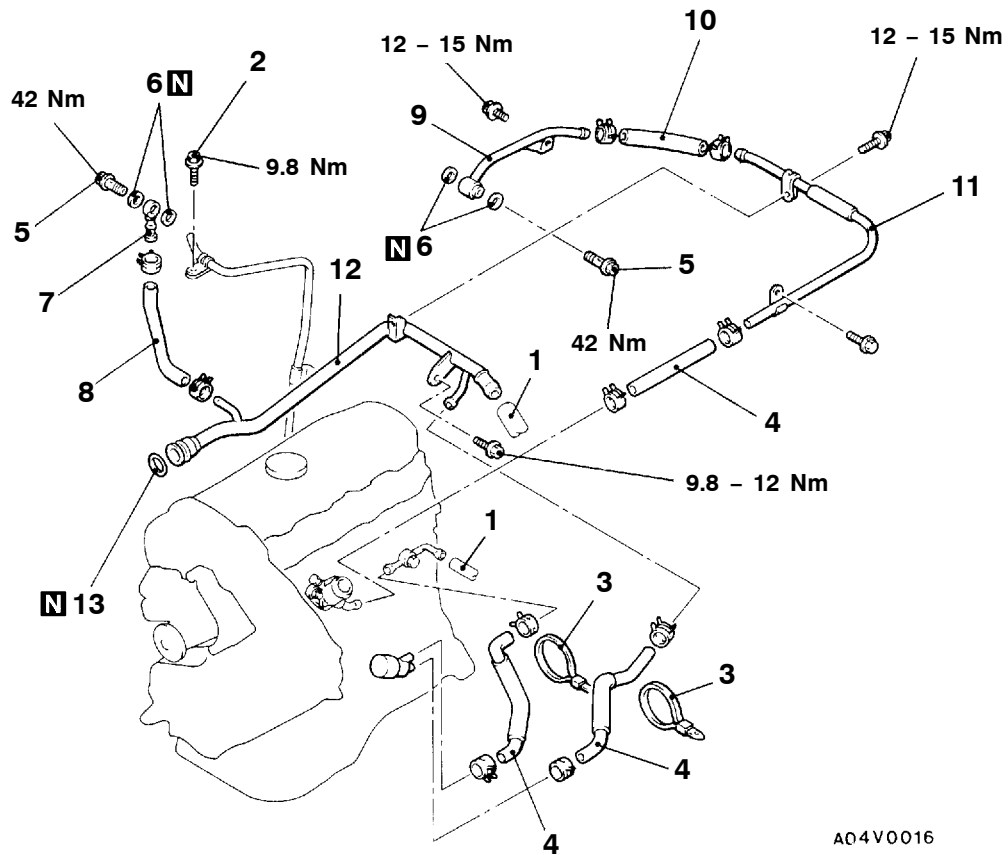

AQ4V0016

Removal steps

- | | |
|---|---|
| <ul style="list-style-type: none"> 1. Heater hose connection 2. Vacuum pipe installation bolt 3. Cable band 4. Water hose 5. Eye bolt 6. Gasket 7. Water pipe assembly A | <ul style="list-style-type: none"> 8. Water hose 9. Water pipe assembly B 10. Water hose 11. Water pipe assembly C 12. Water pipe assembly 13. O-ring |
|---|---|



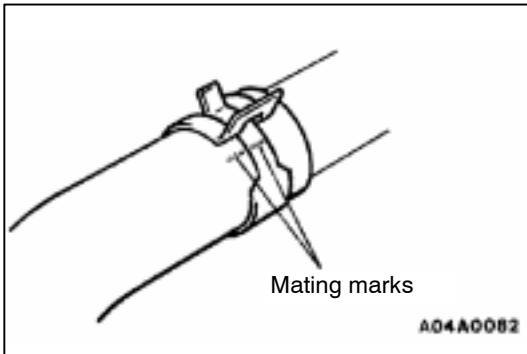

REMOVAL SERVICE POINT

◀A▶ RADIATOR UPPER HOSE DISCONNECTION

After making mating marks on the radiator hose and hose clamp, disconnect the radiator hose.

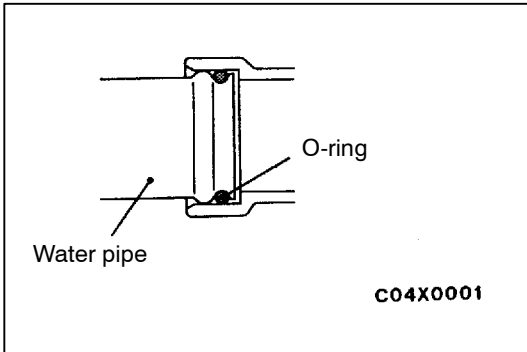

INSTALLATION SERVICE POINTS

▶A◀ O-RING INSTALLATION

Caution

1. Care must be taken not to permit engine oil or other greases to adhere to the O-ring.
2. When inserting the pipe, check to be sure that there is no sand, dirt, etc. on its inner surface.

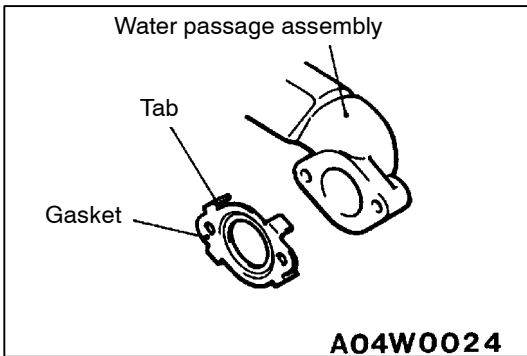

▶B◀ WATER HOSE CONNECTION

To reuse the water hose, align the mating marks that were made during removal, and then install the hose clamp.

▶C◀ GASKET INSTALLATION

Bend over the tabs to secure the gasket to the water passage assembly.

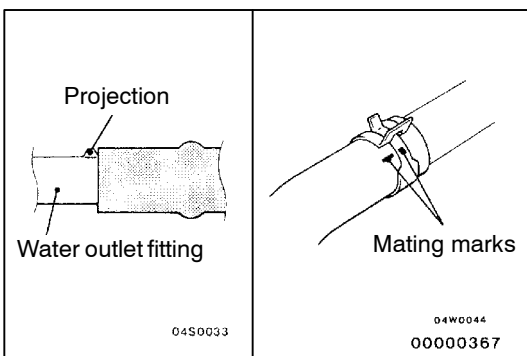

▶D◀ RADIATOR UPPER HOSE CONNECTION

1. Insert each hose as far as the projection of the water outlet fitting.
2. Align the mating marks on the radiator hose and hose clamp, and then connect the radiator hose.

INSPECTION

14100340132

WATER PIPE AND HOSE CHECK

Check the water pipe and hose for cracks, damage and clogs. Replace them if necessary.

RADIATOR

REMOVAL AND INSTALLATION

Pre-removal and Post-installation Operation

- Under Cover and Skid Plate Removal and Installation
- Engine Coolant Draining and Supplying (Refer to P.14-3)
- Intercooler Removal and Installation <4D56> (Refer to GROUP 15 – Intercooler)

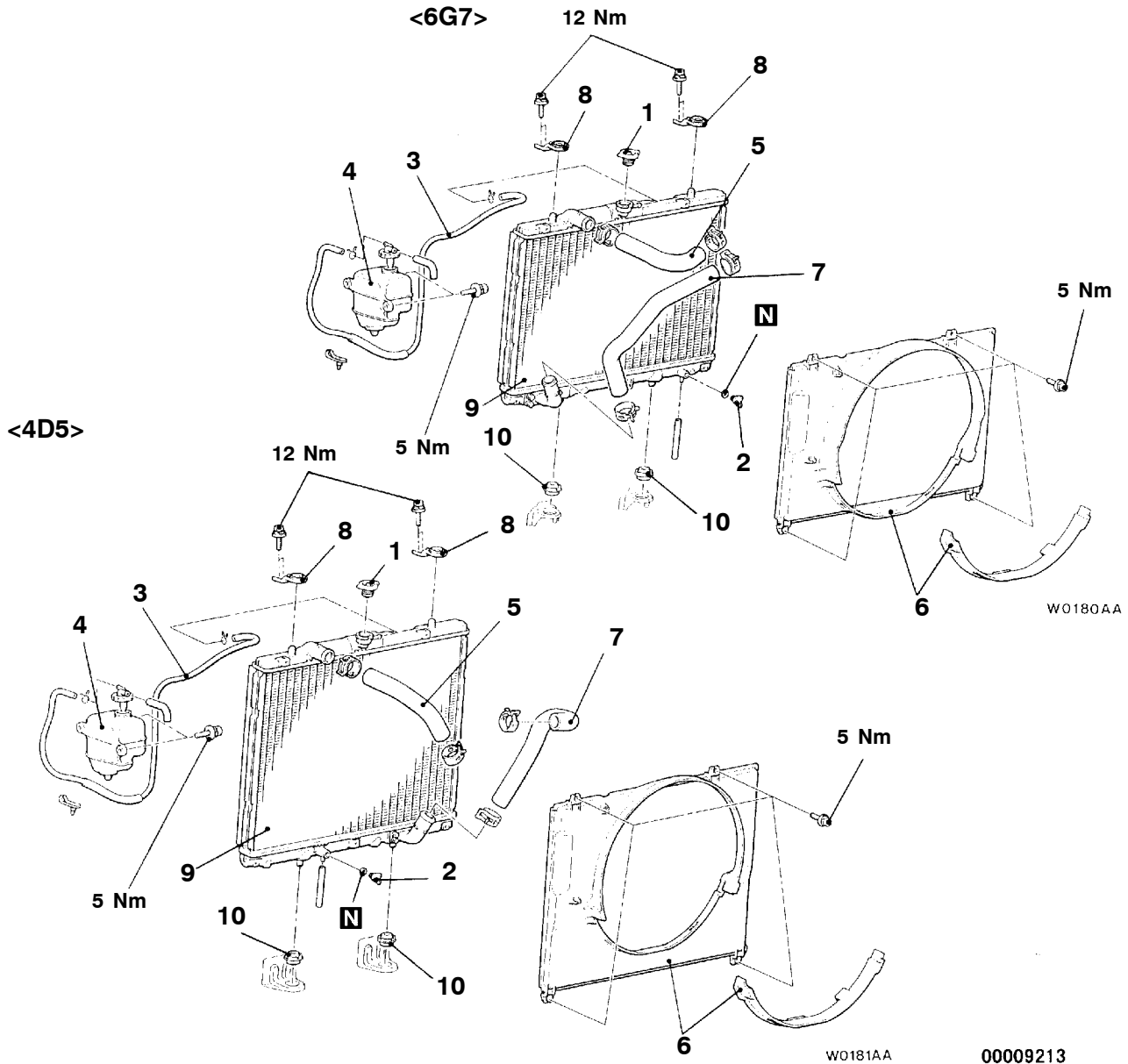

Removal steps

1. Radiator cap
2. Drain plug
3. Rubber hose connection
4. Reserve tank assembly
5. Radiator upper hose

6. Shroud assembly
7. Radiator lower hose
8. Radiator support
9. Radiator
10. Lower insulator

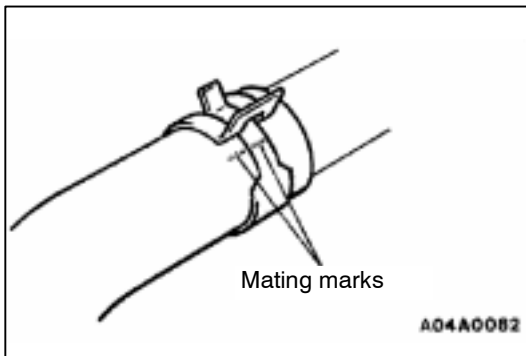

**REMOVAL SERVICE POINTS****◀A▶ RADIATOR UPPER HOSE/RADIATOR LOWER HOSE DISCONNECTION**

After making mating marks on the radiator hose and the hose clamp, disconnect the radiator hose.

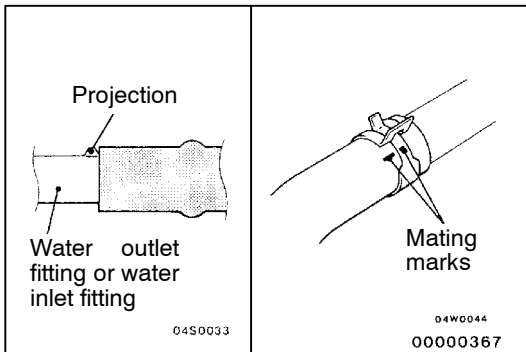
**INSTALLATION SERVICE POINT****▶A◀ RADIATOR LOWER HOSE/RADIATOR UPPER HOSE CONNECTION**

1. Insert each hose as far as the projection of the water inlet fitting.
2. Align the mating marks on the radiator hose and hose clamp, and then connect the radiator hose.

NOTES

INTAKE AND EXHAUST

CONTENTS

15109000311

SERVICE SPECIFICATIONS	2	INTERCOOLER AND INTERCOOLER FAN-ECU	5
SPECIAL TOOL	2	INTAKE MANIFOLD <6G7>	8
ON-VEHICLE SERVICE	2	TURBOCHARGER AND EXHAUST MANIFOLD <4D5>	12
Intake Manifold Vacuum Check <6G7>	2	TURBOCHARGER	15
Turbocharger Supercharging Check <4D5>	2	EXHAUST MANIFOLD <6G7>	18
Waste Gate Actuator Check <4D5>	3	EXHAUST PIPE AND MAIN MUFFLER	19
Power Relay Check	3		
AIR CLEANER	4		

SERVICE SPECIFICATIONS

15100030128

Items		Standard value	Limit
Waste gate actuator activation pressure kPa		Approx. 83	–
Intake air temperature switch °C	OFF (no continuity)	55 or less	–
	ON (continuity)	57 or more	–
Manifold distortion of the installation surface mm		0.15 or less	0.20

SPECIAL TOOL

15100060172

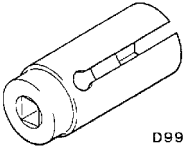
Tool	Number	Name	Use
 D998770	MD998770	Oxygen sensor wrench	Removal/Installation of oxygen sensor <6G7>

ON-VEHICLE SERVICE

15100180236

INTAKE MANIFOLD VACUUM CHECK <6G7>

Refer to GROUP 11A – On-vehicle Service

TURBOCHARGER SUPERCHARGING CHECK
<4D5>

15100100102

Caution

Conduct the driving test in a location where driving at full acceleration can be done with safety. Two person should be in the vehicle when the test is conducted; the person in the passenger seat should read the indications shown by the pressure meter.

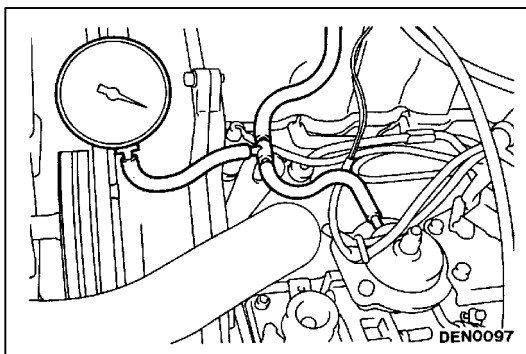

1. Remove the boost compensator hose from the fuel injection pump, and install a pressure gauge as shown in the illustration.
2. Drive at full-throttle acceleration in second gear and then measure the supercharging when the engine speed is about 3,000 r/min.
3. When the indicated supercharging does not become positive pressure, check the following items.
 - Malfunction of the waste gate actuator.
 - Leakage of supercharging pressure.
 - Malfunction of the turbocharger.
4. When the indicated supercharging is 84 kPa or more, supercharging control may be faulty, therefore check the followings.
 - Disconnection or cracks of the waste gate actuator rubber hose.
 - Malfunction of the waste gate actuator.
 - Malfunction of the waste gate valve.

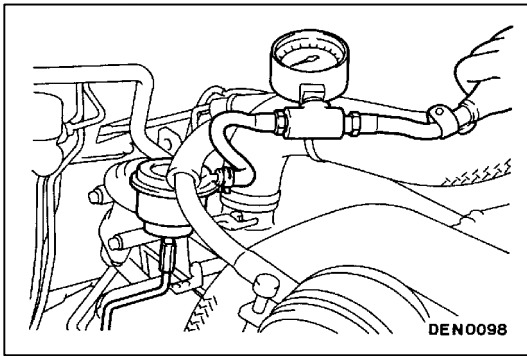

WASTE GATE ACTUATOR CHECK <4D5>

15100120078

1. Connect a manual pump (pressure-application type) to nipple.
2. While gradually applying pressure, check the pressure that begins to activate (approx. 1 mm stroke) the waste gate actuator rod.

Standard value: Approx. 83 kPa

Caution

In order to avoid damage to the diaphragm, do not apply a pressure of 91 kPa or higher.

3. If there is a significant deviation from the standard value, check the actuator or the waste gate valve: replace if necessary.

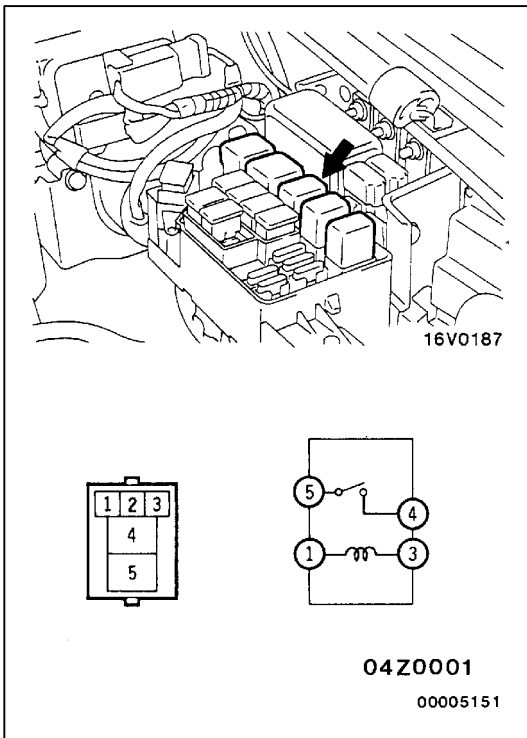

POWER RELAY CHECK

15100620011

INTERCOOLER FAN MOTOR RELAY CONTINUITY CHECK

Battery voltage	Terminal No.			
	1	3	4	5
Power is not supplied	○—○			
Power is supplied	⊕—	—⊖	○—○	

AIR CLEANER

REMOVAL AND INSTALLATION

<6G7>

<Vehicles without pre-cleaner>

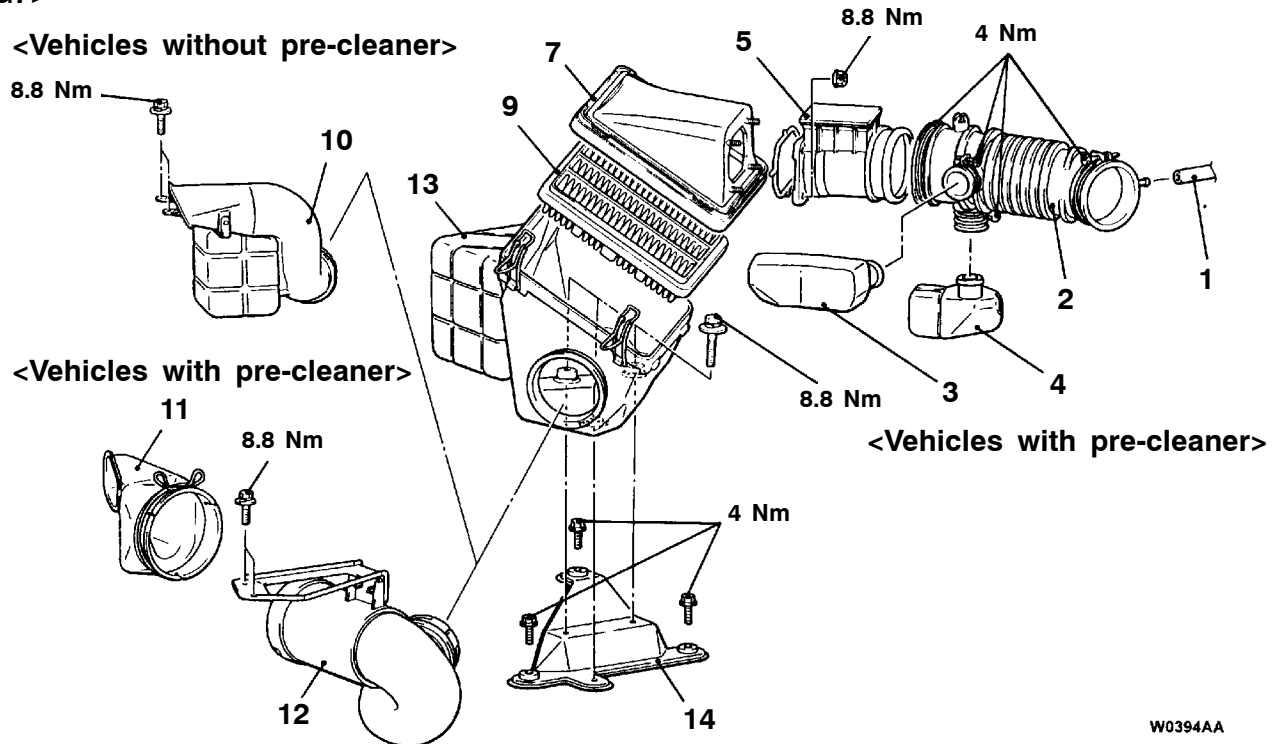

<Vehicles with pre-cleaner>

<Vehicles with pre-cleaner>

W0394AA

<4D5>

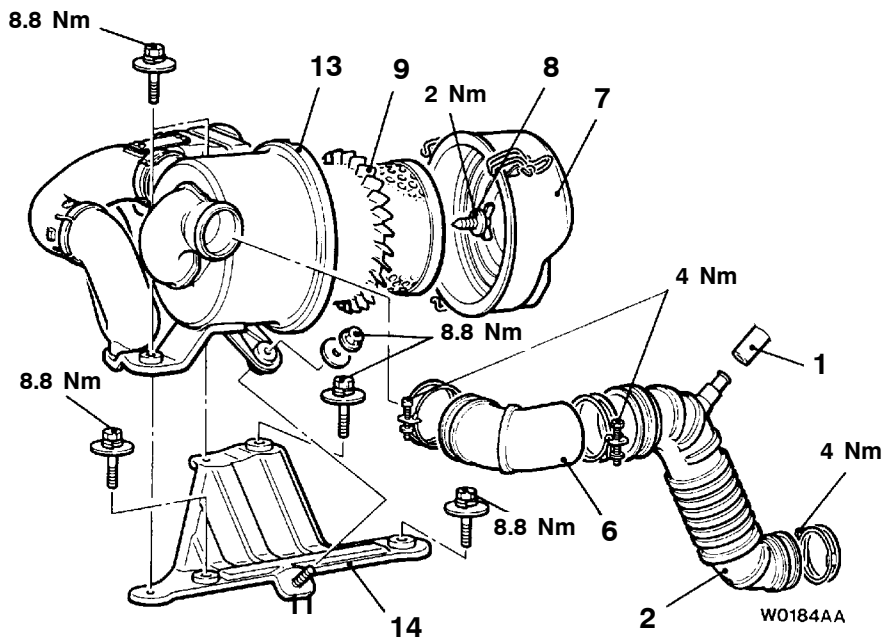

W0184AA

00009214

Removal steps

1. Breather hose connection
2. Air intake hose
3. Resonator
<6G7-Vehicles with pre-cleaner>
4. Resonator <6G7>
5. Air flow sensor assembly <6G7>
6. Air intake hose <4D56>
7. Air cleaner cover
8. Bolt <4D5>
9. Air cleaner element
10. Air duct
<6G7-Vehicles without pre-cleaner>
11. Air duct
<6G7-Vehicles with pre-cleaner>
12. Pre-cleaner assembly
<6G7-Vehicles with pre-cleaner>
13. Air cleaner body
14. Air cleaner bracket

INTERCOOLER AND INTERCOOLER FAN-ECU

15100420079

REMOVAL AND INSTALLATION

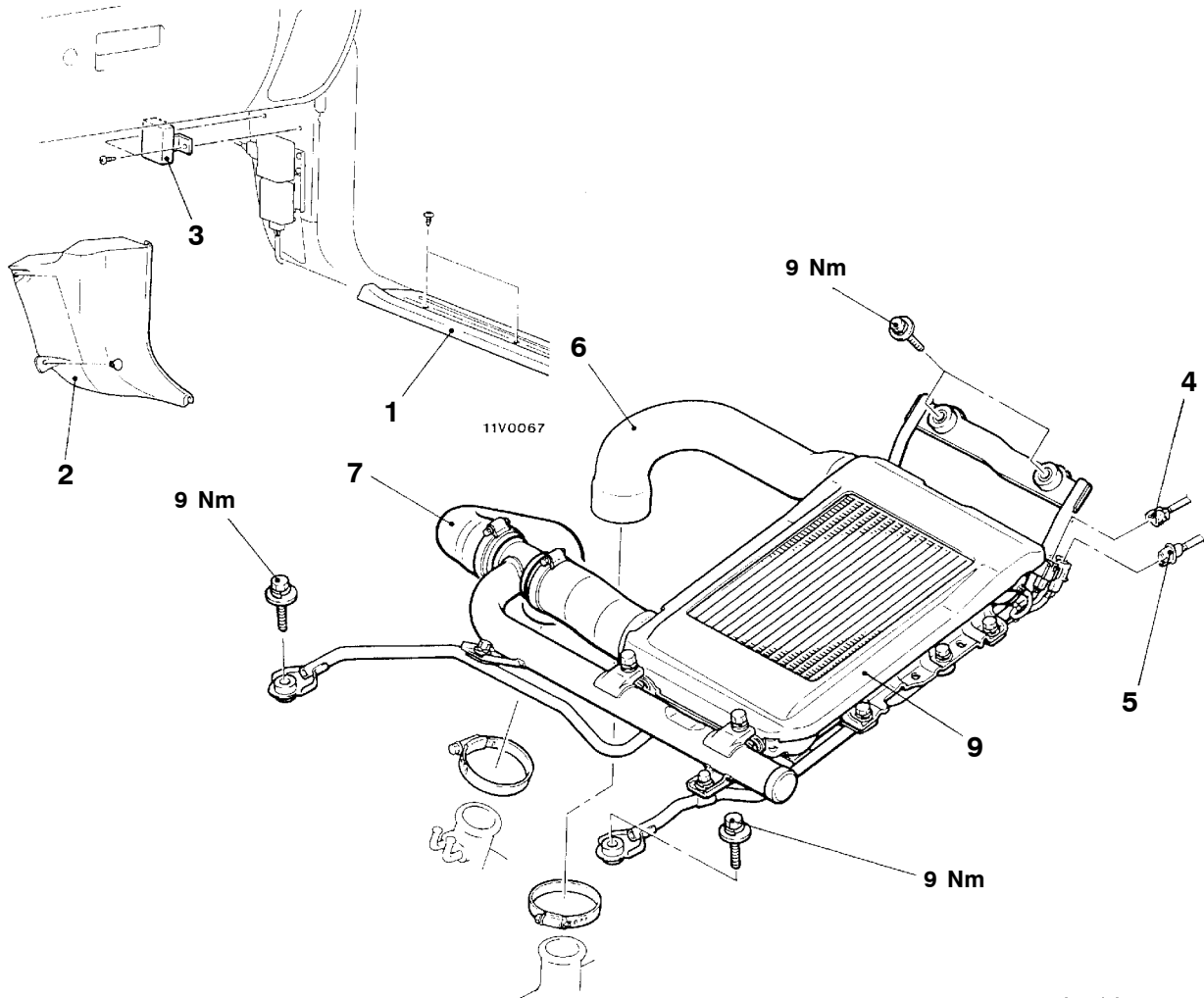

05V0045
00009215

Intercooler fan-ECU removal steps

1. Scuff plate
2. Cowl side trim
3. Intercooler fan-ECU

Intercooler removal steps

4. Intake air temperature switch connector
5. Intercooler fan motor connector
6. Air hose B connection (Intake manifold side)
7. Air hose A-2 connection (Turbocharger side)
8. Intercooler and bracket assembly

DISASSEMBLY AND REASSEMBLY

15100660020

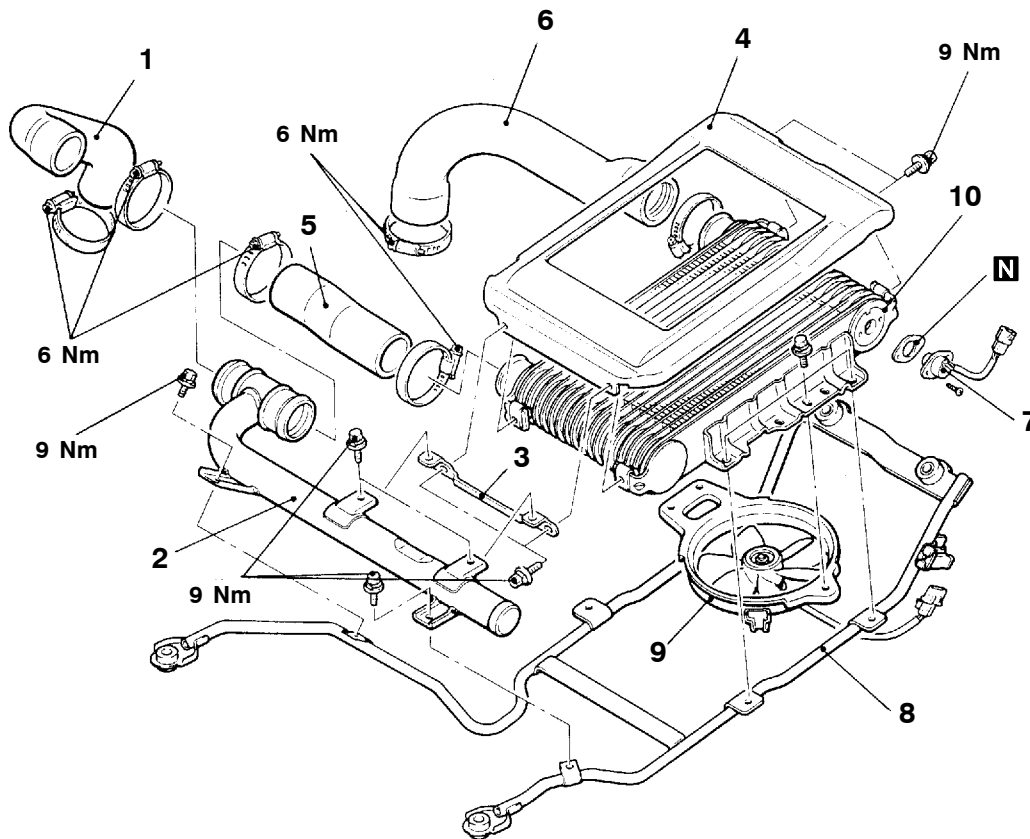

A05V0044

Disassembly steps

- | | |
|------------------------|----------------------------------|
| 1. Air hose A-2 | 6. Air hose B |
| 2. Blanch tube | 7. Intake air temperature switch |
| 3. Blanch tube bracket | 8. Intercooler bracket |
| 4. Intercooler cover | 9. Fan and motor assembly |
| 5. Air hose A-1 | 10. Intercooler |

INSPECTION

15100430027

- Check the intercooler fins for bending damage or foreign matter.
- Check the intercooler hoses for cracking, damage or wear.

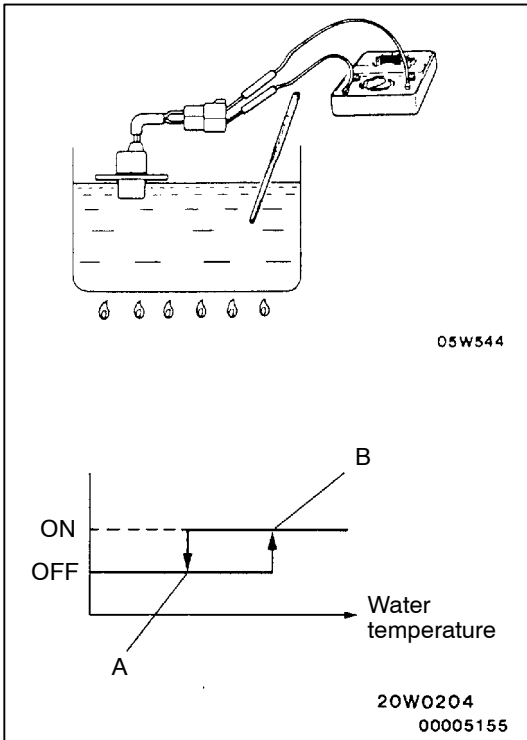

INTAKE AIR TEMPERATURE SWITCH CHECK

15100630014

1. Immerse the intake air temperature switch in the hot water shown in the figure.
2. When changing the water temperature, check for continuity between the terminals with the circuit tester.

Standard value:

Temperature	Continuity
Less than 55 °C (Temperature at point A)	OFF (No continuity)
More than 57 °C (Temperature at point B)	ON (Continuity)

INTAKE MANIFOLD <6G7>

15100300663

REMOVAL AND INSTALLATION

Pre-removal Operation

- Fuel Discharge Prevention (Refer to GROUP 13A – On-vehicle Service.)
- Throttle Body Removal (Refer to GROUP 13A – Throttle Body.)

Post-installation Operation

- Throttle Body installation (Refer to GROUP 13A – Throttle Body.)

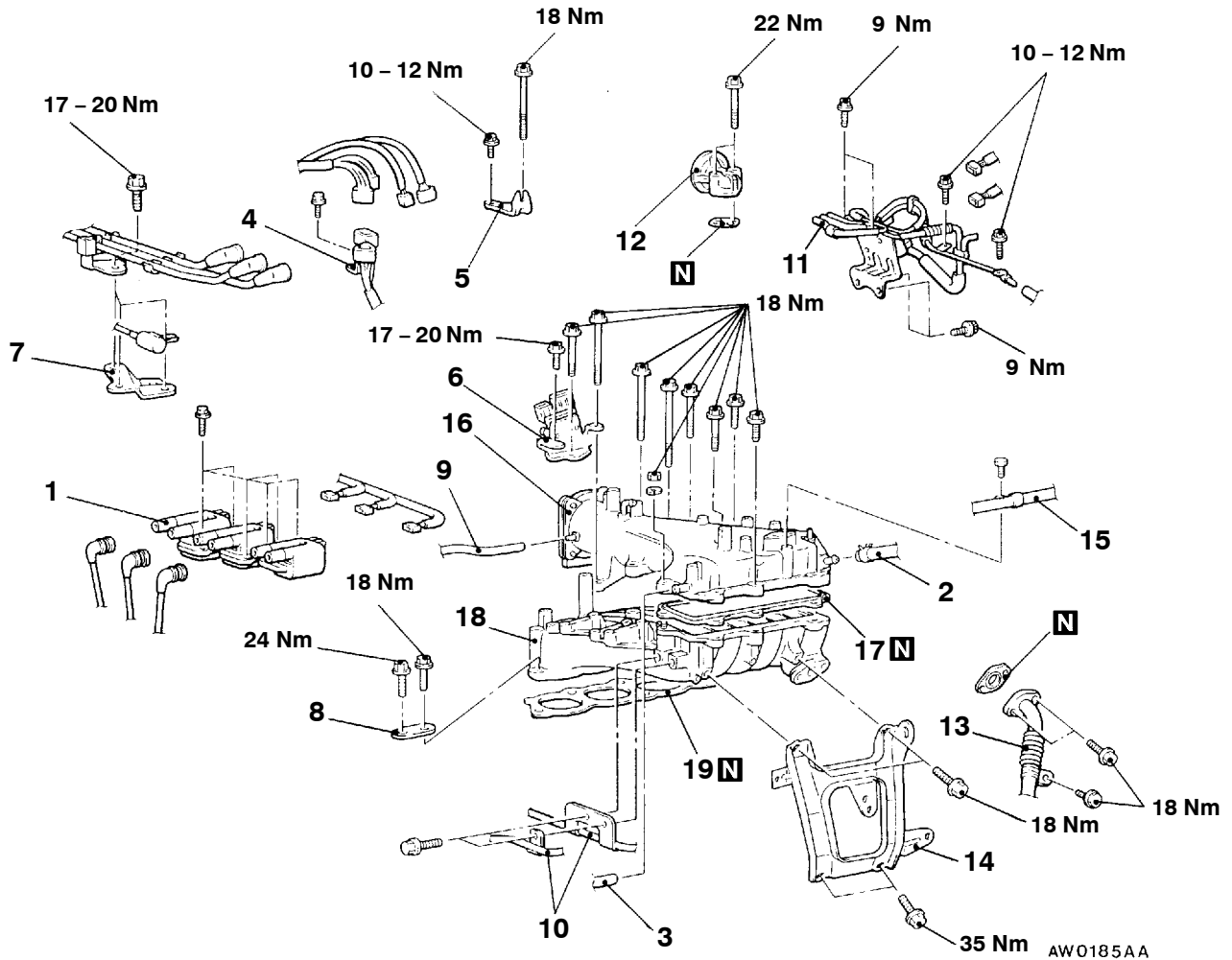
**Removal steps**

- | | |
|---|--|
| <ol style="list-style-type: none"> 1. Ignition coils 2. Brake booster vacuum hose connection 3. PCV hose connection 4. Crankshaft position sensor and cam position sensor connector 5. Accelerator cable bracket 6. Ignition power transistor 7. Water outlet fitting bracket 8. Water pump stay 9. Vacuum hose connection | <ol style="list-style-type: none"> 10. Fuel pipe connection 11. Solenoid valve and vacuum hose assembly 12. EGR valve 13. EGR pipe connection 14. Surge tank stay 15. Throttle cable connection 16. Air intake fitting 17. Air intake fitting gasket 18. Upper intake manifold 19. Surge tank gasket |
|---|--|



AW0185AA

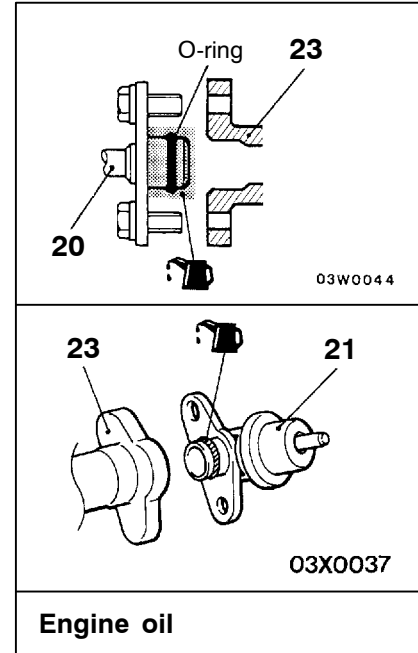
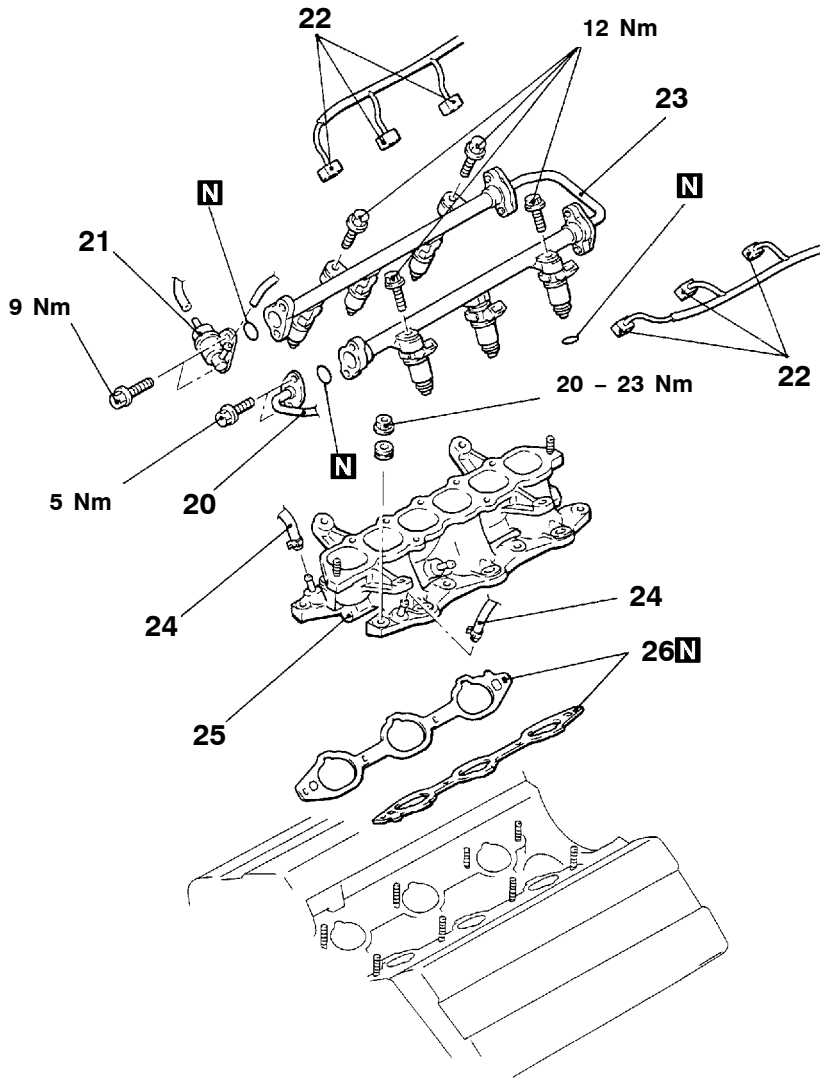

05 W0018
00005336

- ▶C◀ 20. High-pressure fuel hose
- ▶C◀ 21. Fuel pressure regulator
- ▶C◀ 22. Injector connector
- ◀A▶ 23. Injector and delivery pipe assembly
- ▶C◀ 24. Water hose connection
- ▶B◀ 25. Intake manifold
- ▶A◀ 26. Intake manifold gasket

REMOVAL SERVICE POINT

**◀A▶ INJECTOR AND DELIVERY PIPE ASSEMBLY
REMOVAL**

Remove the fuel rail (with the injectors attached to it.)

Caution

Care must be taken when removing the fuel rail not to drop the injector.

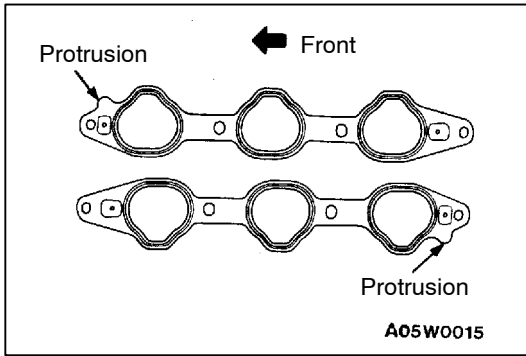

INSTALLATION SERVICE POINTS

▶A◀ INTAKE MANIFOLD GASKET INSTALLATION

Install the gasket with the protrusions in the position illustrated.

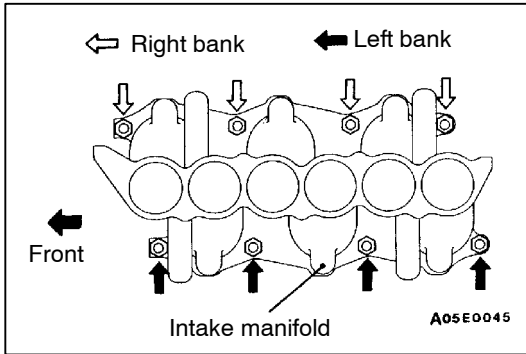

▶B◀ INTAKE MANIFOLD INSTALLATION

Tighten the nuts by the following procedure.

Order	Mounting Nuts	Tightening Torque
1	Right-bank nuts	7 Nm
2	Left-bank nuts	20–23 Nm
3	Right-bank nuts	20–23 Nm
4	Left-bank nuts	20–23 Nm
5	Right-bank nuts	20–23 Nm

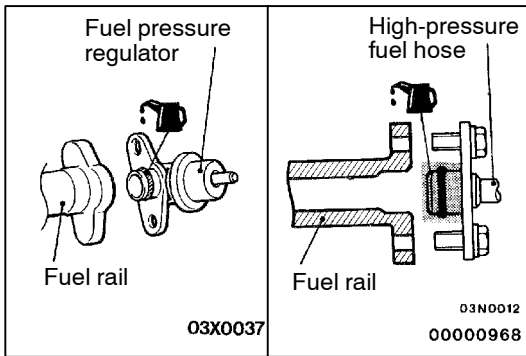

▶C◀ FUEL PRESSURE REGULATOR/HIGH-PRESSURE FUEL HOSE INSTALLATION

When connecting the fuel pressure regulator and the high-pressure fuel hose to the fuel rail, apply a small amount of new engine oil to the O-ring. Then insert the high-pressure fuel hose, being careful not to damage the O-ring.

Caution

Be careful not to let any engine oil get into the fuel rail.

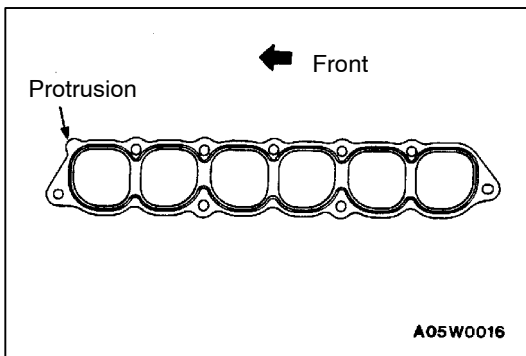

▶D◀ SURGE TANK GASKET INSTALLATION

Install the gasket with the protrusion in the position illustrated.

INSPECTION

15100370039

Check the following points; replace the part if a problem is found.

INTAKE MANIFOLD CHECK

1. Check for damage or cracking of any part.
2. Clogging of the negative pressure (vacuum) outlet port, or clogging of the gas passages.
3. Check deflection of installation surface with straight edge and feeler gauge.

Standard value: 0.15 mm or less

Limit: 0.20 mm

TURBOCHARGER AND EXHAUST MANIFOLD <4D5>

15100450061

REMOVAL AND INSTALLATION

Pre-removal and Post-installation Operation

- Engine Coolant Draining and Supplying
- Air Cleaner Cover and Air Intake Hose Removal and Installation (Refer to P. 15-4.)
- Intercooler Removal and Installation (Refer to P. 15-5.)

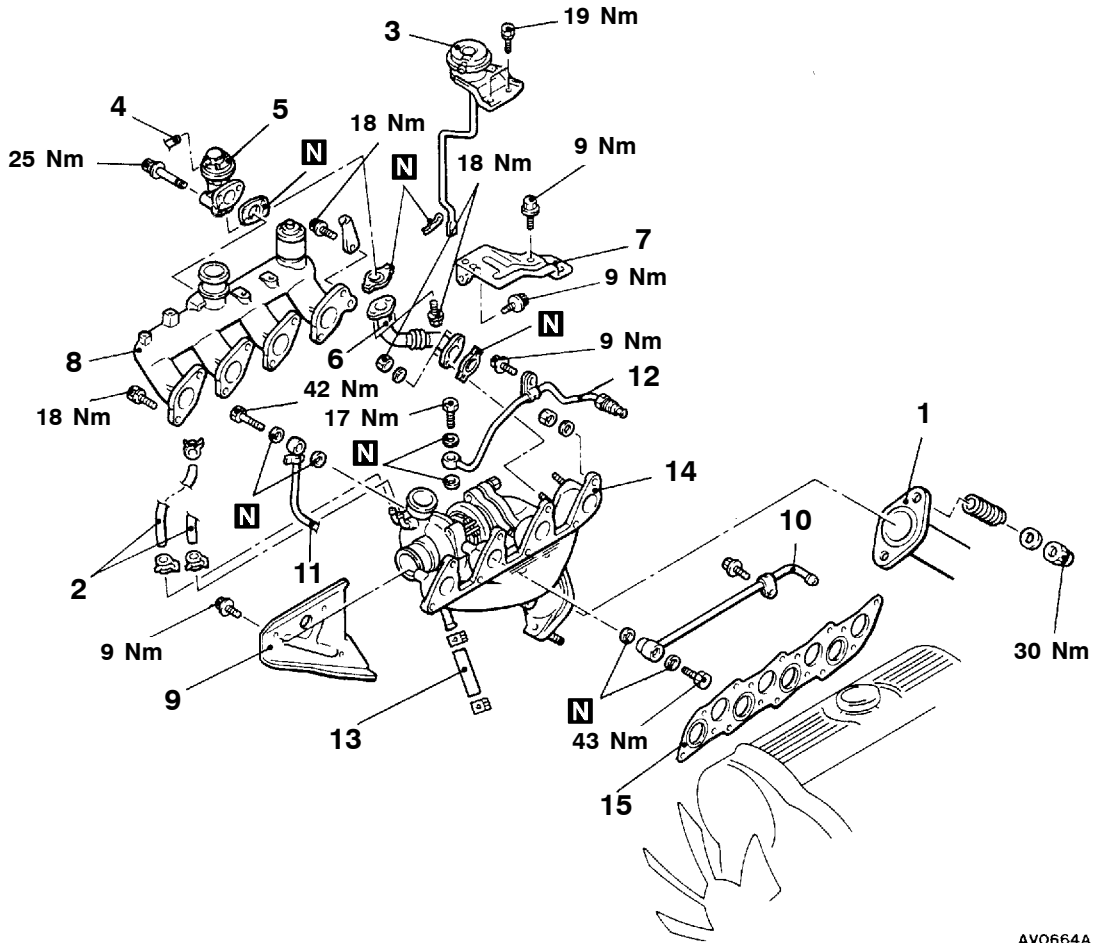

AV0664AA

Removal steps

- | | |
|---|---|
| <ol style="list-style-type: none"> 1. Front exhaust pipe connection 2. Boost hose 3. Waste gate actuator 4. Vacuum hose 5. EGR valve 6. EGR pipe 7. Heat protector A 8. Intake manifold | <ol style="list-style-type: none"> 9. Heat protector 10. Water pipe B 11. Water pipe A 12. Oil pipe 13. Oil return hose connection 14. Exhaust manifold and turbocharger assembly 15. Intake and exhaust manifold gasket |
|---|---|

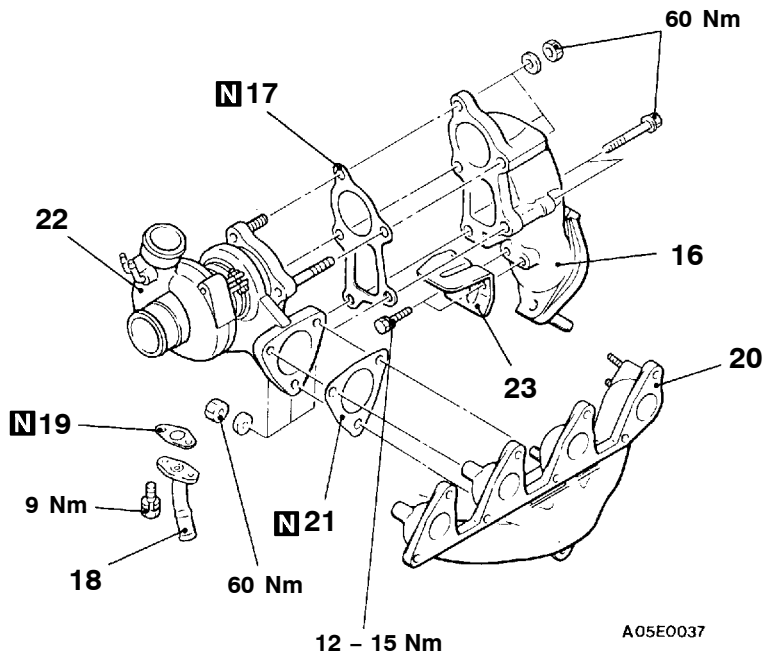

- 16. Exhaust fitting
- 17. Exhaust fitting gasket
- 18. Oil-return pipe
- 19. Oil-return pipe gasket
- 20. Exhaust manifold
- 21. Turbocharger gasket
- ▶A◀ 22. Turbocharger assembly
- 23. Heat protector

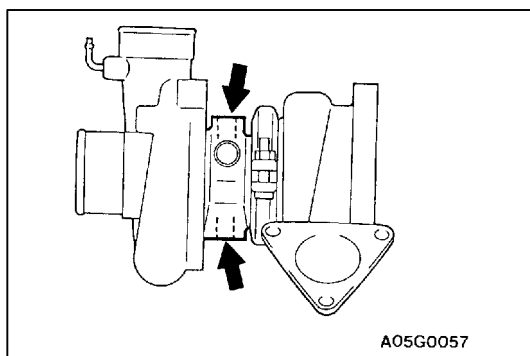

INSTALLATION SERVICE POINT

▶A◀ TURBOCHARGER ASSEMBLY INSTALLATION

1. Clean the alignment surfaces shown in the illustration.
2. Supply clean engine oil from the oil pipe mounting hole of the turbocharger assembly.

Caution

When cleaning, take care that no foreign material gets into the engine coolant or oil passages hole.

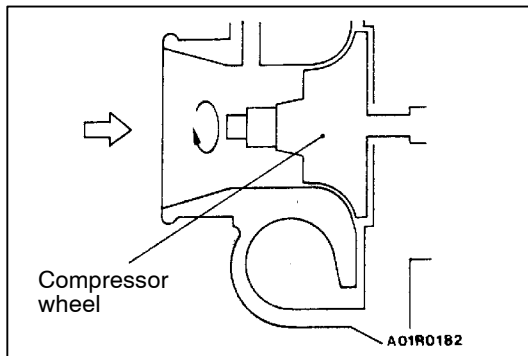
**INSPECTION**

15100640017

TURBOCHARGER ASSEMBLY CHECK

- Visually check the turbine wheel and the compressor wheel for cracking or other damage.
 - Check whether the turbine wheel and the compressor wheel can be easily turned by hand.
 - Check for oil leakage from the turbocharger assembly.
 - Check whether or not the waste gate valve remains open.
- If any problem is found, replace the part after disassembly.

OIL PIPE AND OIL RETURN PIPE CHECK

15100650010

Check the oil pipe and oil return pipe for clogging, bending, or other damage. If there is clogging, clean it.

EXHAUST MANIFOLD CHECK

15100340108

Damage or cracking of any part.

TURBOCHARGER

15100600039

DISASSEMBLY AND REASSEMBLY

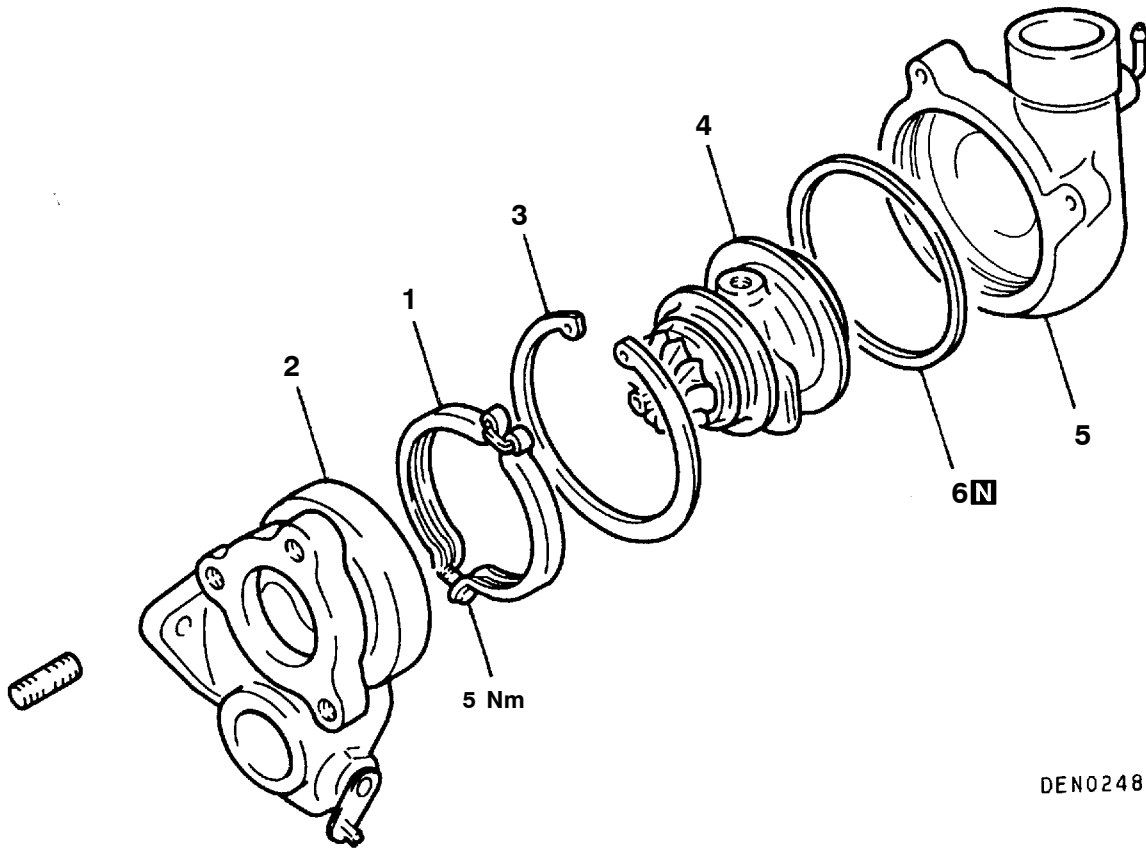

DEN0248

Disassembly steps

- ▶E◀ 1. Coupling
- ▶D◀ 2. Turbine housing
- ◀A▶▶C▶▶B▶ 3. Snap ring
- ▶B▶ 4. Turbine wheel assembly
- ▶A▶ 5. Compressor cover
- ▶A▶ 6. O-ring

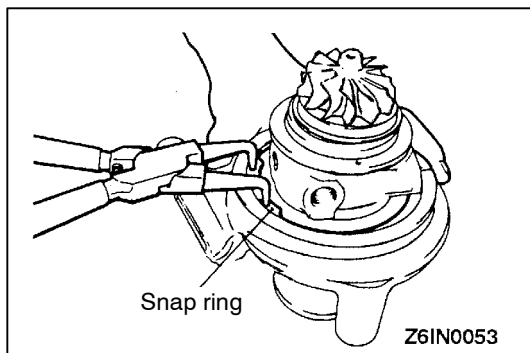

DISASSEMBLY SERVICE POINTS

◀A▶ SNAP RING REMOVAL

Lay the unit with the compressor cover side facing down and using snap ring pliers, remove the compressor cover attaching snap ring.

Caution

When removing the snap ring, hold it with fingers to prevent it from springing away.

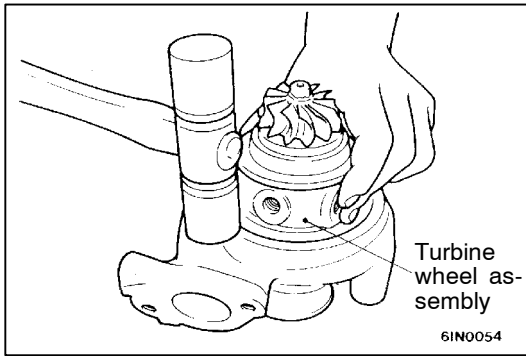

◀B▶ TURBINE WHEEL ASSEMBLY REMOVAL

Remove the turbine wheel assembly, striking the circumference of the compressor cover with a plastic hammer. The turbine wheel assembly may be a little hard to remove due to an O-ring put on the outer circumference.

CLEANING

1. Use a clean cleaning oil commercially available. Do not use corrosive cleaning oils as they could damage to some parts.
2. Use a plastic scraper or hard brush to clean aluminum parts.

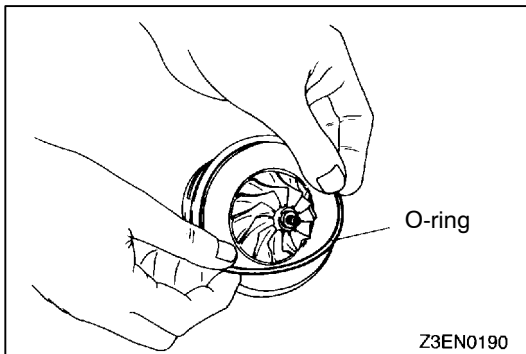

REASSEMBLY SERVICE POINTS

▶A◀ O-RING INSTALLATION

Apply a light coat of engine oil to a new O-ring and fit in the turbine wheel assembly groove.

Caution

When installing the O-ring, use care not to damage it. A damaged O-ring causes oil leaks.

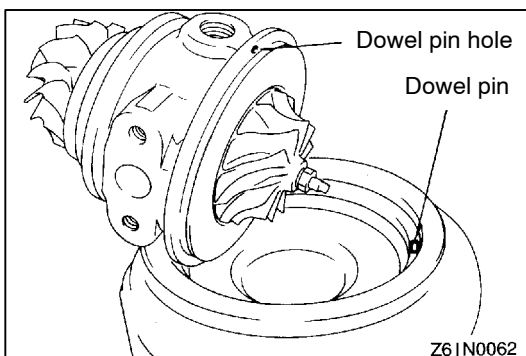

▶B◀ TURBINE WHEEL ASSEMBLY

1. Apply a light coat of engine oil to the periphery of the O-ring.
2. Install the turbine wheel assembly to the compressor cover in relation to the dowel pin.

Caution

Use care not to damage the blades of turbine wheel and compressor wheel.

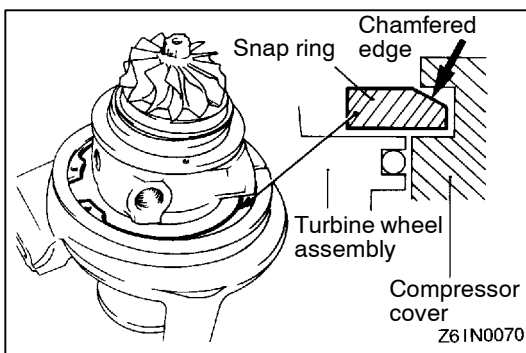

▶C◀ SNAP RING INSTALLATION

Lay the assembly with the compressor cover facing down and fit the snap ring.

Caution

Fit the snap ring with its chamfered side facing up.

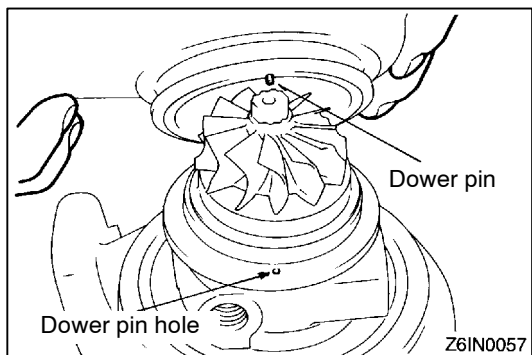

►D◄ TURBINE HOUSING INSTALLATION

Install the turbine housing in relation to the dowel pin.

Caution

Use care not to damage the blades of turbine wheel.

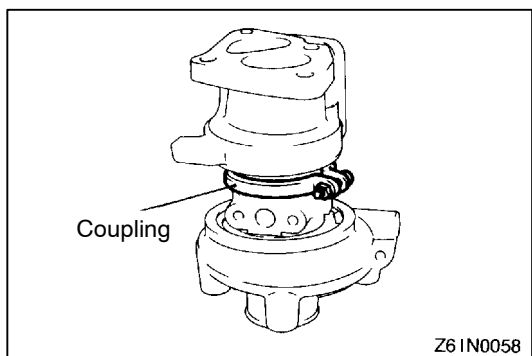

►E◄ COUPLING INSTALLATION

Install the coupling and tighten to specified torque.

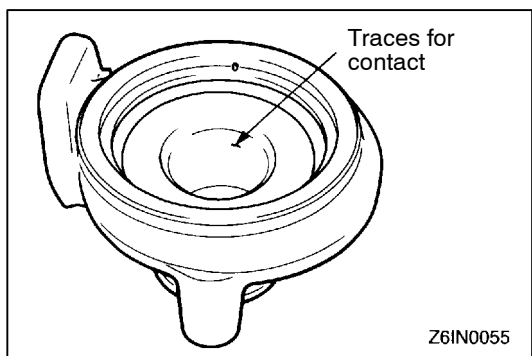

INSPECTION

15100610018

TURBINE HOUSING

1. Check the housing for traces of contact with the turbine wheel, cracks due to overheating, pitching, deformation and other damage. Replace with a new turbine housing if cracked.
2. Operate the waste gate valve lever manually to check that the gate can be operated and closed smoothly.

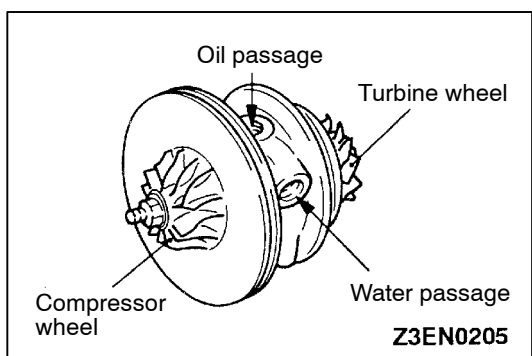

COMPRESSOR COVER

Check the compressor cover for traces of contact with the compressor wheel and other damage.

TURBINE WHEEL ASSEMBLY

1. Check the turbine and compressor wheel blades for bend, burr, damage, corrosion and traces of contact on the back side and replace if defective.
2. Check the oil passage of the turbine wheel assembly for deposit and clogging.
3. In the case of water cooled type, check also the water passage for deposit and clogging.
4. Check the turbine wheel and compressor wheel for light and smooth turning.

OIL PIPE/OIL RETURN PIPE

Correct or replace the oil pipe and oil return pipe if clogged, collapsed, deformed or otherwise damaged.

EXHAUST MANIFOLD <6G7>**REMOVAL AND INSTALLATION****Pre-removal and Post-installation Operation**

- Front Exhaust Pipe Removal and Installation
(Refer to P.15-19.)
- Air Cleaner Removal and Installation
(Refer to P.15-4.)
- Battery and Battery Tray Removal and Installation
- Engine Oil Dipstick Guide Removal and Installation

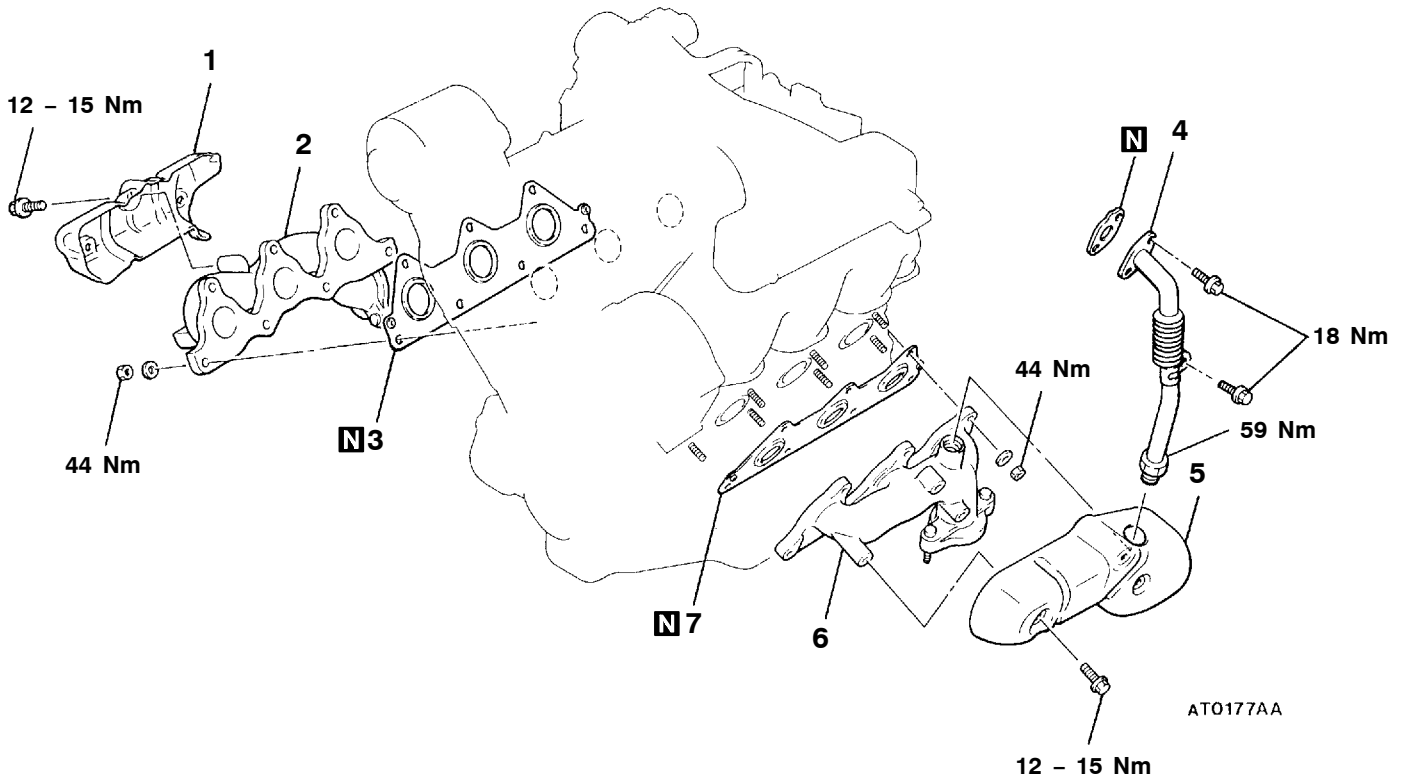
**Removal steps**

- | | |
|-----------------------------------|-----------------------------------|
| 1. Heat protector (R.H.) | 5. Heat protector (L.H.) |
| 2. Exhaust manifold (R.H.) | 6. Exhaust manifold (L.H.) |
| 3. Exhaust manifold gasket (R.H.) | 7. Exhaust manifold gasket (L.H.) |
| 4. EGR pipe | |

INSPECTION

15100340160

Check the following points; replace the part if a problem is found.

EXHAUST MANIFOLD CHECK

1. Check for damage or cracking of any part.
2. Using a straight edge and a feeler gauge, check for distortion of the cylinder head installation surface.

Standard value: 0.15 mm or less

Limit: 0.20 mm

EXHAUST PIPE AND MAIN MUFFLER

15100540461

REMOVAL AND INSTALLATION

- Pre-removal and Post-installation Operation**
- Front Under Cover Removal and Installation

<6G7>

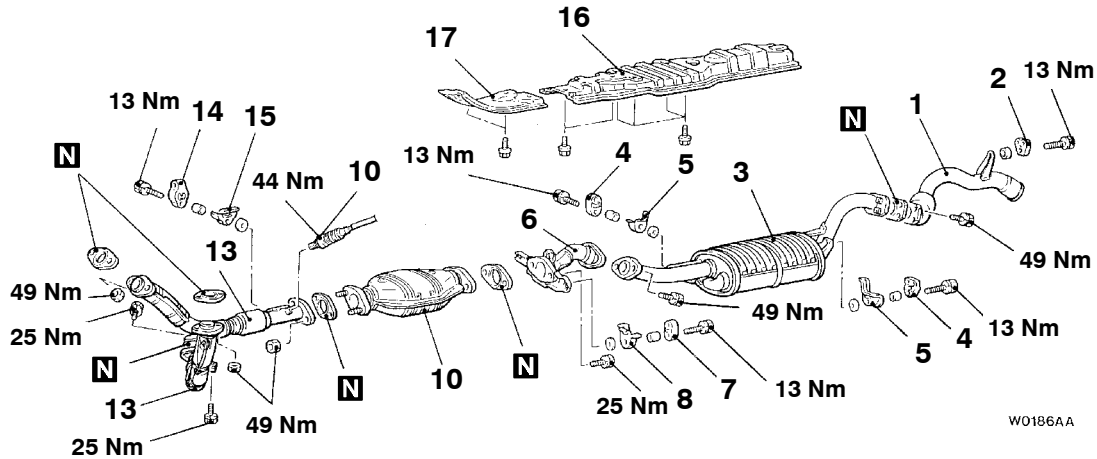

W0186AA

<4D5>

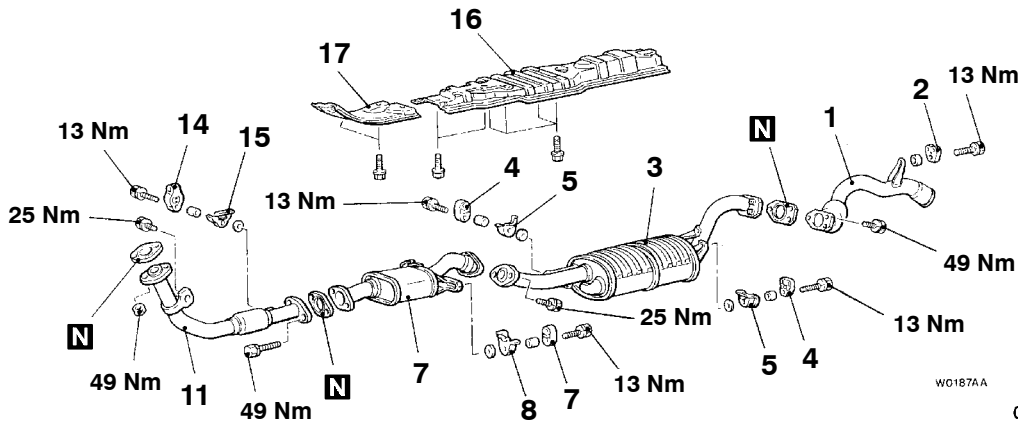

W0187AA

00009216

Main muffler removal steps

1. Tail pipe
2. Hanger
3. Main muffler
4. Hanger
5. Protector

Center exhaust pipe removal steps

6. Center exhaust pipe
7. Hanger
8. Protector

9. Catalytic converter <6G7>

Front exhaust pipe removal steps

- ◀A▶ ▶A▶
10. Oxygen sensor <6G7>
 11. Front exhaust pipe <4D5>
 12. Front exhaust pipe (R.H.) <6G7>
 13. Front exhaust pipe (L.H.) <6G7>
 14. Hanger
 15. Protector
 16. Front floor heat protector B
 17. Front floor heat protector A

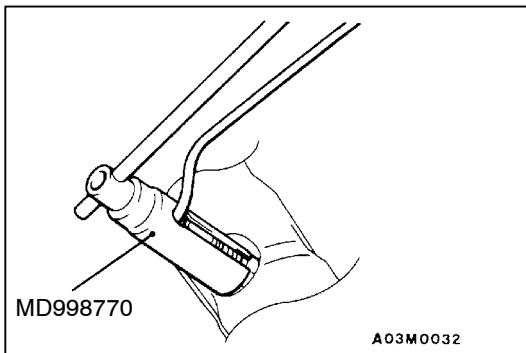
**REMOVAL SERVICE POINT****◀A▶ OXYGEN SENSOR REMOVAL**

Use special tool to remove the oxygen sensor.

INSTALLATION SERVICE POINT**▶A◀ OXYGEN SENSOR INSTALLATION**

Use special tool to install the oxygen sensor.

ENGINE ELECTRICAL

CONTENTS

16109000325

CHARGING SYSTEM	2	ON-VEHICLE SERVICE	28
GENERAL INFORMATION	2	Ignition Coil Check	28
SERVICE SPECIFICATIONS	3	Power Transistor Continuity Check	29
SPECIAL TOOL	3	Resistive Cord Check	30
ON-VEHICLE SERVICE	4	Spark Plug Check	30
Alternator Output Line Voltage Drop Test	4	Waveform Check Using An Analyzer (Ignition Primary and Secondary Voltage Waveforms)	31
Output Current Test	5	CAMSHAFT POSITION SENSOR AND CRANKSHAFT ANGLE SENSOR<6G7> .	38
Regulated Voltage Test	7	GLOW SYSTEM	39
Waveform Check Using An Analyzer	9	GENERAL INFORMATION	39
ALTERNATOR	11	SERVICE SPECIFICATIONS	40
STARTING SYSTEM	18	SEALANT	40
GENERAL INFORMATION	18	ON-VEHICLE SERVICE	41
SERVICE SPECIFICATIONS	19	Self-regulating Glow System Check	41
STARTER MOTOR	19	Glow & EGR Control Unit Check	42
IGNITION SYSTEM	27	Glow Plug Relay Check	44
GENERAL INFORMATION	27	Glow Plug Check	44
SERVICE SPECIFICATIONS	28	Engine Coolant Temperature Sensor Check	45
SPECIAL TOOL	28	GLOW PLUG	46

CHARGING SYSTEM

16100010433

GENERAL INFORMATION

The charging system uses the alternator output to keep the battery charged at a constant level under various electrical loads.

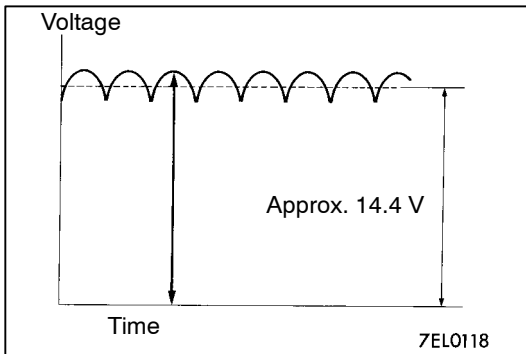

OPERATION

Rotation of the excited field coil generates AC voltage in the stator. This alternating current is rectified through diodes to DC voltage having a waveform shown in the illustration at left. The average output voltage fluctuates slightly with the alternator load condition.

When the ignition switch is turned on, current flows in the field coil and initial excitation of the field coil occurs.

When the stator coil begins to generate power after the engine is started, the field coil is excited by the output current of the stator coil.

The alternator output voltage rises as the field current increases and it falls as the field current decreases. When the battery voltage (alternator S terminal voltage) reaches a regulated voltage

of approximately 14.4 V, the field current is cut off. When the battery voltage drops below the regulated voltage, the voltage regulator regulates the output voltage to a constant level by controlling the field current.

In addition, when the field current is constant, the alternator output voltage rises as the engine speed increases.

SYSTEM DIAGRAM

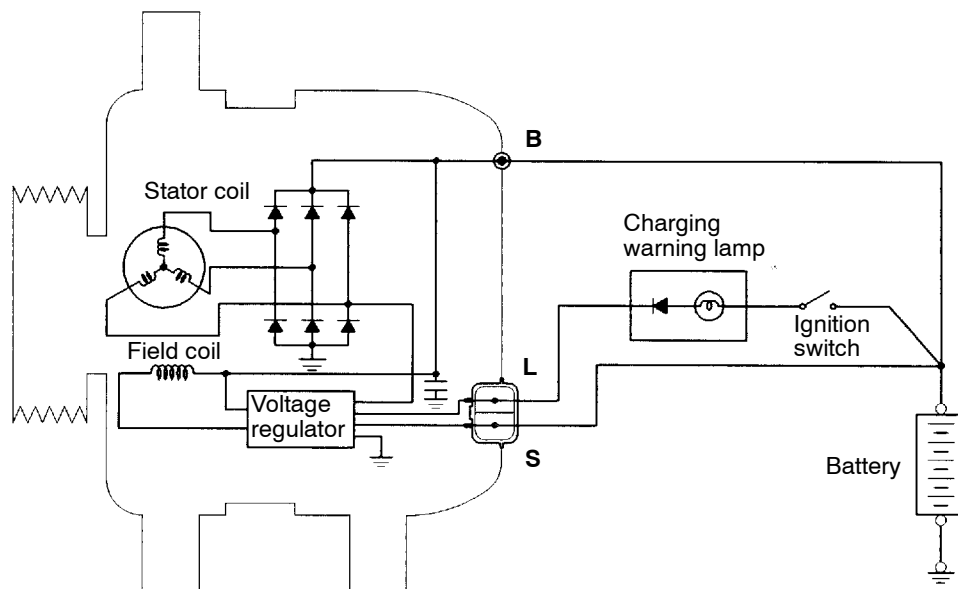

7EN1408

ALTERNATOR SPECIFICATIONS

Items	6G7	4D5
Type	Battery voltage sensing	Battery voltage sensing
Rated output V/A	12/85	12/75
Voltage regulator	Electronic built-in type	Electronic built-in type

SERVICE SPECIFICATIONS

16100030293

Items		Standard value	Limit
Alternator output line voltage drop (at 30A) V		–	Max. 0.3
Regulated voltage ambient temp. at voltage regulator V	–20°C	14.2 – 15.4	–
	20°C	13.9 – 14.9	–
	60°C	13.4 – 14.6	–
	80°C	13.1 – 14.5	–
Output current		–	70% of normal output current
Rotor coil resistance Ω		Approx. 2 – 5	–
Maximum vacuum (at 3,000 r/min) <4D56> kPa		80	–
Protrusion length of brush mm		–	2

SPECIAL TOOL

16100060179

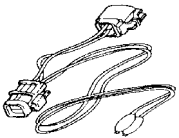
Tool	Number	Name	Use
	MD998467	Alternator test harness	Checking the alternator (S terminal voltage)

ON-VEHICLE SERVICE

16100090512

ALTERNATOR OUTPUT LINE VOLTAGE DROP TEST

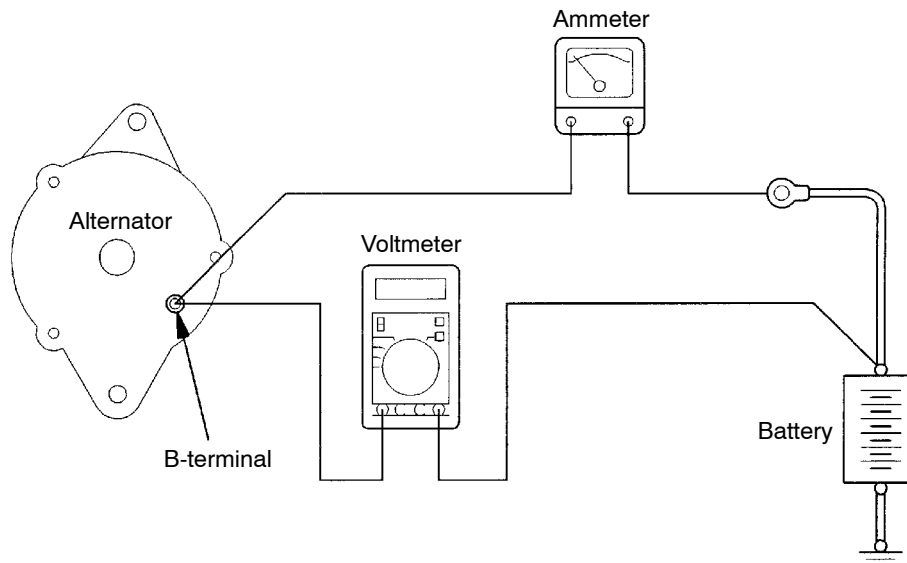

9EN0468

This test determines whether the wiring from the alternator “B” terminal to the battery (+) terminal (including the fusible line) is in a good condition or not.

1. Always be sure to check the following before the test.
 - Alternator installation
 - Alternator drive belt tension (Refer to GROUP 11 – On-vehicle Service.)
 - Fusible link
 - Abnormal noise from the alternator while the engine is running
2. Turn the ignition switch off.
3. Disconnect the negative battery cable.
4. Disconnect the alternator output wire from the alternator “B” terminal and connect a DC test ammeter with a range of 0–100 A in series between the “B” terminal and the disconnected

output wire. (Connect the (+) lead of the ammeter to the “B” terminal, and then connect the (–) lead of the ammeter to the disconnected output wire.)

NOTE

An inductive-type ammeter which enables measurements to be taken without disconnecting the alternator output wire should be recommended. Using this equipment will lessen the possibility of a voltage drop caused by a loose “B” terminal connection.

5. Connect a digital-type voltmeter between the alternator “B” terminal and the battery (+) terminal. (Connect the (+) lead of the voltmeter to the “B” terminal and the connect the (–) lead of the voltmeter to the battery (+) cable.)

6. Reconnect the negative battery cable.
7. Connect a tachometer or the MUT-II. (Refer to GROUP 11 – On-vehicle Service.)
8. Leave the hood open.
9. Start the engine.
10. With the engine running at 2,500 r/min, turn the headlamps and other lamps on and off to adjust the alternator load so that the value displayed on the ammeter is slightly above 30 A.

Adjust the engine speed by gradually decreasing it until the value displayed on the ammeter is 30 A. Take a reading of the value displayed on the voltmeter at this time.

Limit: max. 0.3 V

NOTE

When the alternator output is high and the value displayed on the ammeter does not decrease until 30 A, set the value to 40 A. Read the value displayed on the voltmeter at this time. When the value range is 40 A, the limit is max. 0.4 V.

11. If the value displayed on the voltmeter is above the limit value, there is probably a malfunction in the alternator output wire, so check the wiring between the alternator “B” terminal and the battery (+) terminal (including fusible link). If a terminal is not sufficiently tight or if the harness has become discolored due to overheating, repair and then test again.
12. After the test, run the engine at idle.
13. Turn off all lamps and the ignition switch.
14. Remove the tachometer or the MUT-II.
15. Disconnect the negative battery cable.
16. Disconnect the ammeter and voltmeter.
17. Connect the alternator output wire to the alternator “B” terminal.
18. Connect the negative battery cable.

OUTPUT CURRENT TEST

16100100536

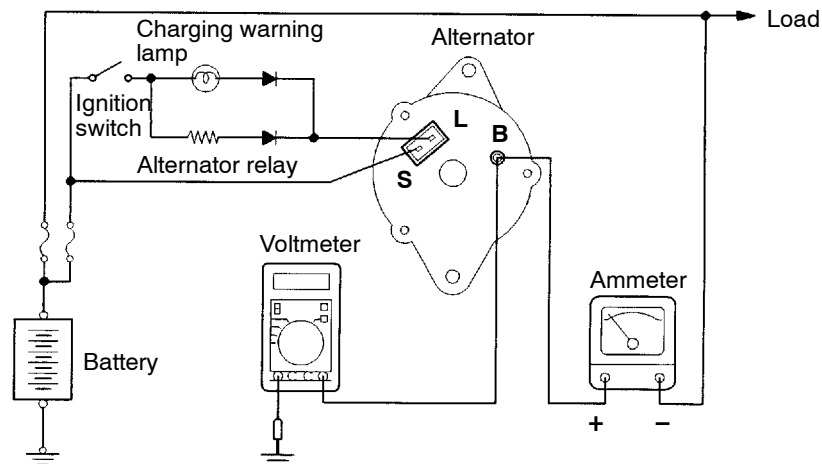

7EN0987

This test determines whether the alternator output current is normal.

1. Before the test, always be sure to check the following.

- Alternator installation
- Battery (Refer to GROUP 54 – Battery.)

NOTE

The battery should be slightly discharged. The load needed by a fully-charged battery is insufficient for an accurate test.

- Alternator drive belt tension (Refer to GROUP 11 – On-vehicle Service.)
- Fusible link
- Abnormal noise from the alternator while the engine is running.

2. Turn the ignition switch off.
3. Disconnect the negative battery cable.
4. Disconnect the alternator output wire from the alternator “B” terminal. Connect a DC test ammeter with a range of 0–100 A in series between the “B” terminal and the disconnected output wire. (Connect the (+) lead of the ammeter to the “B” terminal. Connect the (–) lead of the ammeter to the disconnected output wire.)

Caution

Never use clips but tighten bolts and nuts to connect the line. Otherwise loose connections (e.g. using clips) will lead to a serious accident because of high current.

NOTE

An inductive-type ammeter which enables measurements to be taken without disconnecting the alternator output wire should be recommended.

5. Connect a voltmeter with a range of 0–20 V between the alternator “B” terminal and the earth. (Connect the (+) lead of the voltmeter to the “B” terminal, and then connect the (–) lead of the voltmeter to the earth.)
6. Connect the negative battery cable.
7. Connect a tachometer or the MUT-II. (Refer to GROUP 11 – On-vehicle Service.)
8. Leave the hood open.
9. Check that the reading on the voltmeter is equal to the battery voltage.

NOTE

If the voltage is 0 V, the cause is probably an open circuit in the wire or fusible link between the alternator “B” terminal and the battery (+) terminal.

10. Turn the light switch on to turn on headlamps and then start the engine.
11. Immediately after setting the headlamps to high beam and turning the heater blower switch to the high revolution position, increase the engine speed to 2,500 r/min and read the maximum current output value displayed on the ammeter.

Limit: 70% of normal current output

NOTE

- For the nominal current output, refer to the Alternator Specifications.
 - Because the current from the battery will soon drop after the engine is started, the above step should be carried out as quickly as possible in order to obtain the maximum current output value.
 - The current output value will depend on the electrical load and the temperature of the alternator body.
 - If the electrical load is small while testing, the specified level of current may not be output even though the alternator is normal. In such cases, increase the electrical load by leaving the headlamps turned on for some time to discharge the battery or by using the lighting system in another vehicle, and then test again.
 - The specified level of current also may not be output if the temperature of the alternator body or the ambient temperature is too high. In such cases, cool the alternator and then test again.
12. The reading on the ammeter should be above the limit value. If the reading is below the limit value and the alternator output wire is normal, remove the alternator from the engine and check the alternator.
 13. Run the engine at idle after the test.
 14. Turn the ignition switch off.
 15. Remove the tachometer or the MUT-II.
 16. Disconnect the negative battery cable.
 17. Disconnect the ammeter and voltmeter.
 18. Connect the alternator output wire to the alternator “B” terminal.
 19. Connect the negative battery cable.

REGULATED VOLTAGE TEST

16100110539

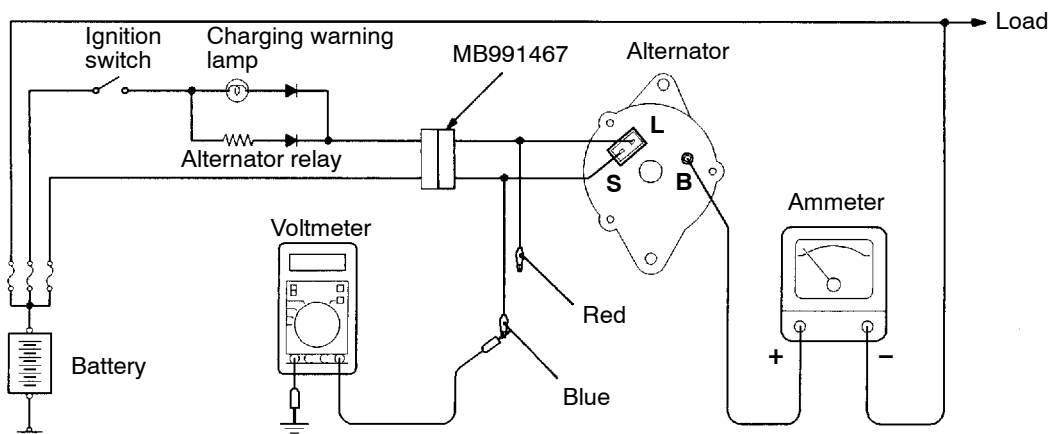

7EN0988

This test determines whether the voltage regulator is correctly controlling the alternator output voltage.

1. Always be sure to check the following before the test.
 - Alternator installation
 - Check that the battery installed in the vehicle is fully charged. (Refer to GROUP 54 – Battery.)
 - Alternator drive belt tension (Refer to GROUP 11 – On-vehicle Service.)
 - Fusible link
 - Abnormal noise from the alternator while the engine is running
2. Turn the ignition switch to the OFF position.
3. Disconnect the negative battery cable.
4. Use the special tool (Alternator test harness: MB991467) to connect a digital voltmeter between the alternator S terminal and earth. (Connect the (+) lead of the voltmeter to the “S” terminal, and then connect the (-) lead of the voltmeter to a secure earth or to the battery (-) terminal.)
5. Disconnect the alternator output wire from the alternator “B” terminal.

6. Connect a DC test ammeter with a range of 0–100 A in series between the “B” terminal and the disconnected output wire. (Connect the (+) lead of the ammeter to the “B” terminal. Connect the (-) lead of the ammeter to the disconnected output wire.)
7. Reconnect the negative battery cable.
8. Connect a tachometer or the MUT-II. (Refer to GROUP 11 – On-vehicle Service.)
9. Turn the ignition switch to the ON position and check that the reading on the voltmeter is equal to the battery voltage.

NOTE

If the voltage is 0 V, the cause is probably an open circuit in the wire or fusible link between the alternator “S” terminal and the battery (+) terminal.

10. Turn all lamps and accessories off.
11. Start the engine.
12. Increase the engine speed to 2,500 r/min.
13. Read the value displayed on the voltmeter when the alternator output current alternator becomes 10 A or less.

14. If the voltage reading conforms to the value in the voltage regulation, then the voltage regulator is operating normally.
If the voltage is not within the standard value, there is a malfunction of the voltage regulator or of the alternator.
15. After the test, lower the engine speed to the idle speed.
16. Turn the ignition switch off.
17. Remove the tachometer or the MUT-II.
18. Disconnect the negative battery cable.
19. Disconnect the ammeter and voltmeter.
20. Connect the alternator output wire to the alternator "B" terminal.
21. Remove the special tool, and return the connector to the original condition.
22. Connect the negative battery cable.

Voltage Regulation Table

Standard value:

Inspection terminal	Voltage regulator ambient temperature °C	Voltage V
Terminal "S"	-20	14.2 – 15.4
	20	13.9 – 14.9
	60	13.4 – 14.6
	80	13.1 – 14.5

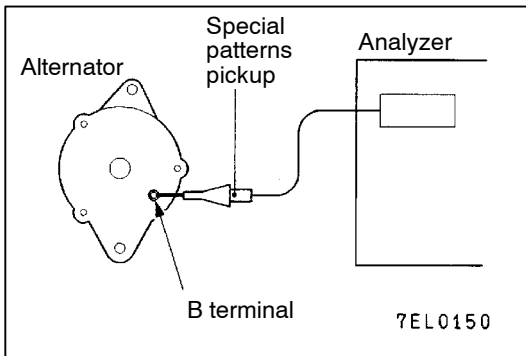

WAVEFORM CHECK USING AN ANALYZER

MEASUREMENT METHOD

16100120259

Connect the analyzer special patterns pick-up to the alternator B terminal.

STANDARD WAVEFORM

Observation Conditions

FUNCTION	SPECIAL PATTERNS
PATTERN HEIGHT	VARIABLE
VARIABLE knob	Adjust while viewing the waveform.
PATTERN SELECTOR	RASTER
Engine speed	Curb idle speed

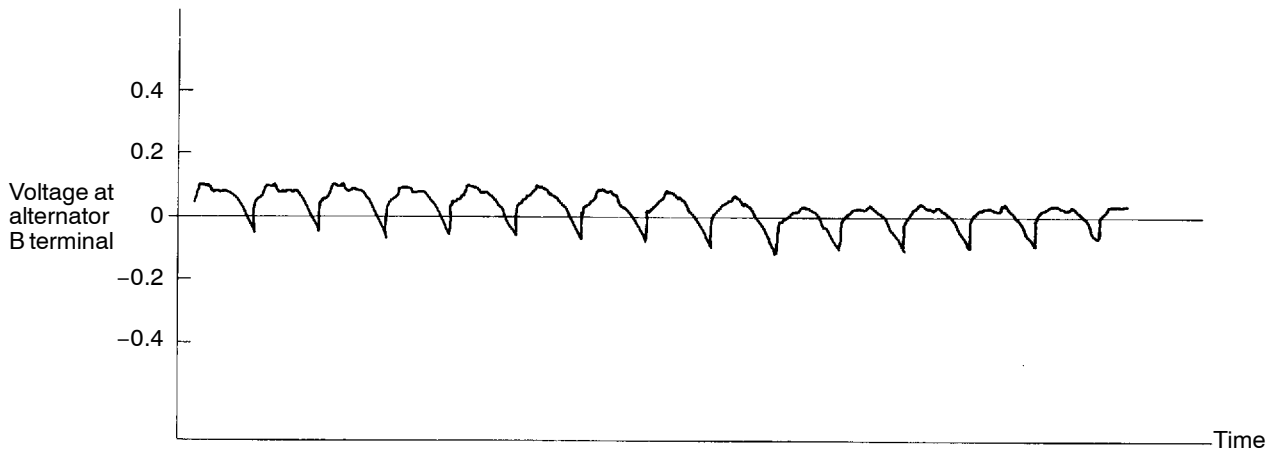

7EL0115

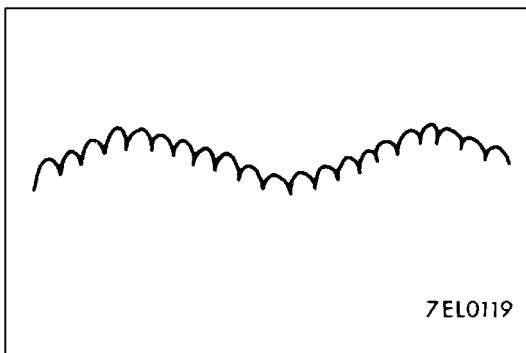

NOTE

The voltage waveform of the alternator B terminal can undulate as shown at left. This waveform is produced when the regulator operates according to fluctuations in the alternator load (current), and is normal for the alternator.





In addition, when the voltage waveform reaches an excessively high value (approx. 2 V or higher at idle), it often indicates an open circuit due to a blown fuse between alternator B terminal and battery, but not a defective alternator.

7EL0119

EXAMPLES OF ABNORMAL WAVEFORMS

NOTE

1. The size of the waveform patterns differs largely, depending on the adjustment of the variable knob on the analyzer.
2. Identification of abnormal waveforms is easier when there is a large output current (regulator is not operating). (Waveforms can be observed when the headlamps are illuminated.)
3. Check the conditions of the charging warning lamp (illuminated/not illuminated). Also, check the charging system totally.

Abnormal waveforms	Problem cause	Abnormal waveforms	Problem cause
Example 1  A7EL0120	Open diode	Example 4  A7EL0123	Short in stator coil
Example 2  A7EL0121	Short in diode	Example 5  A7EL0124	Open supplementary diode
Example 3  A7EL0122	Broken wire in stator coil	NOTE At this time, the charging warning lamp is illuminated.	

ALTERNATOR

16100140521

REMOVAL AND INSTALLATION

Pre-removal Operation

- Under Cover Removal

Post-installation Operation

- Drive Belt Tension Adjustment (Refer to GROUP 11 – On-vehicle Service.)
- Under Cover Installation

<6G7>

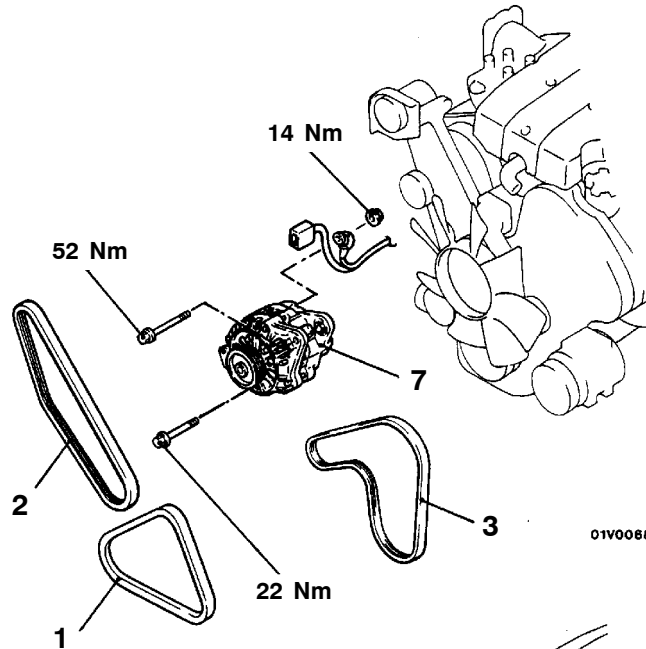

<4D5>

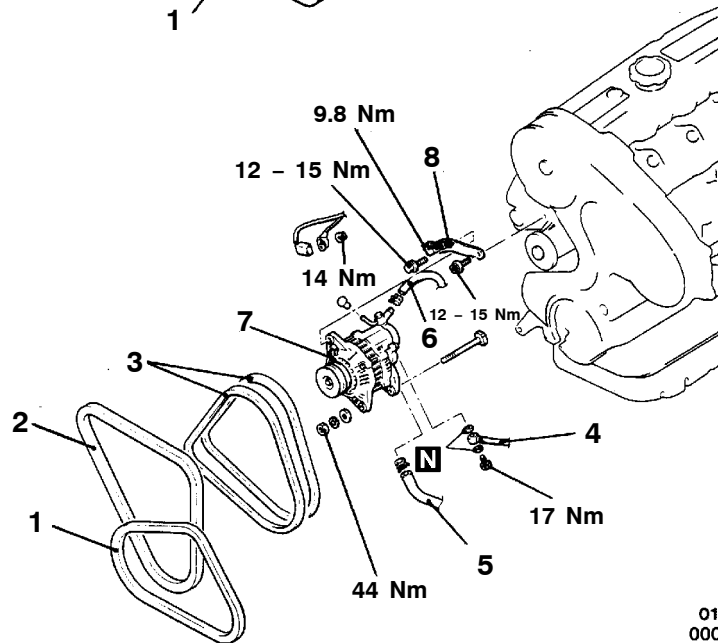

Removal steps

- | | |
|------------------------------------|-------------------------------|
| 1. Drive bolt (for A/C) | 5. Oil return hose connection |
| 2. Drive belt (for power steering) | 6. Vacuum hose connection |
| 3. Drive belt (for alternator) | 7. Alternator |
| 4. Oil pipe connection | 8. Alternator brace assembly |

DISASSEMBLY AND REASSEMBLY

16100160336

<6G7>

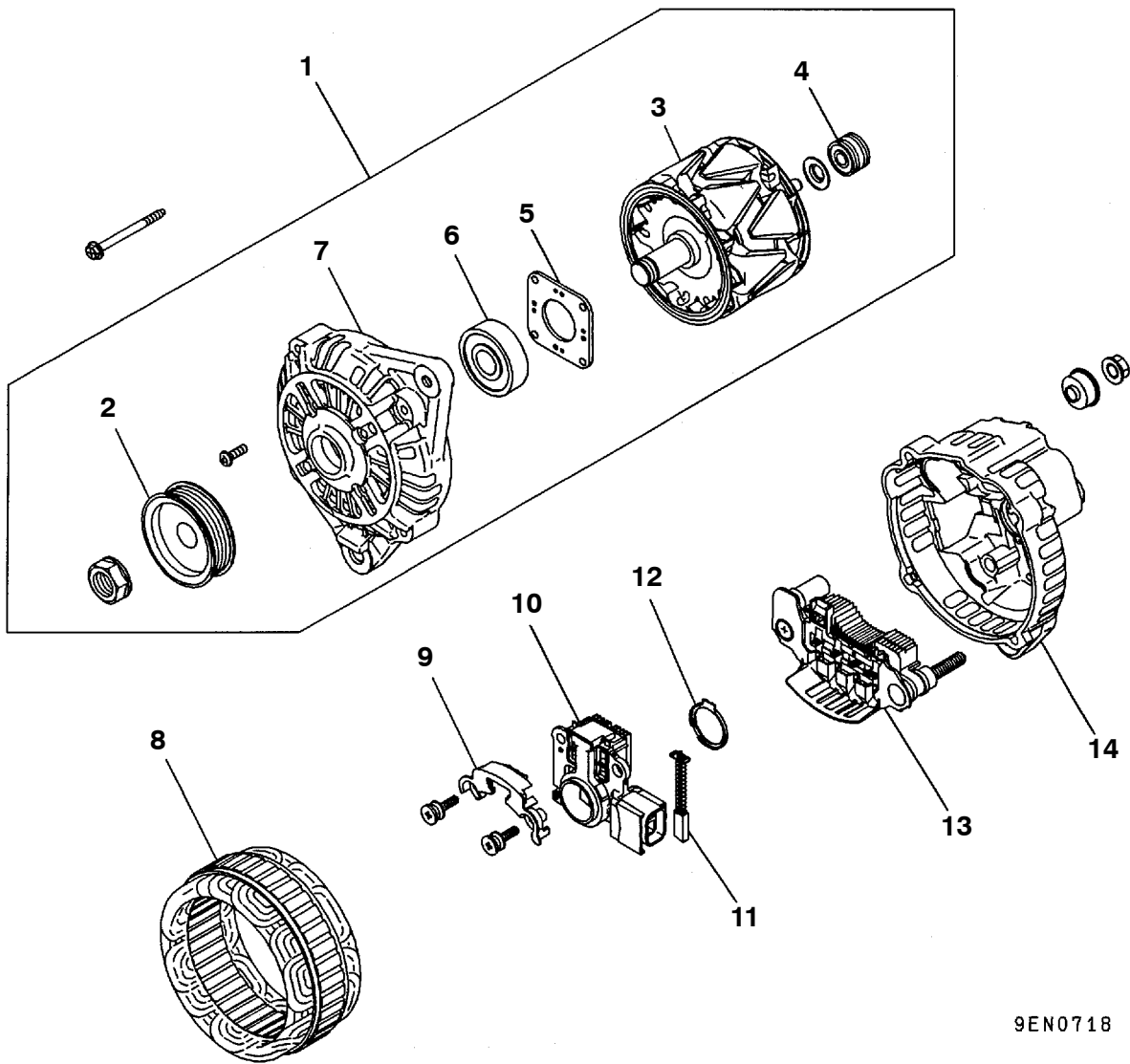

9EN0718

Disassembly steps



1. Front bracket assembly
2. Pulley
3. Rotor
4. Rear bearing
5. Bearing retainer
6. Front bearing
7. Front bracket



8. Stator
9. Plate
10. Regulator assembly
11. Brush
12. Slinger
13. Rectifier assembly
14. Rear bracket

DISASSEMBLY AND REASSEMBLY

<4D5>

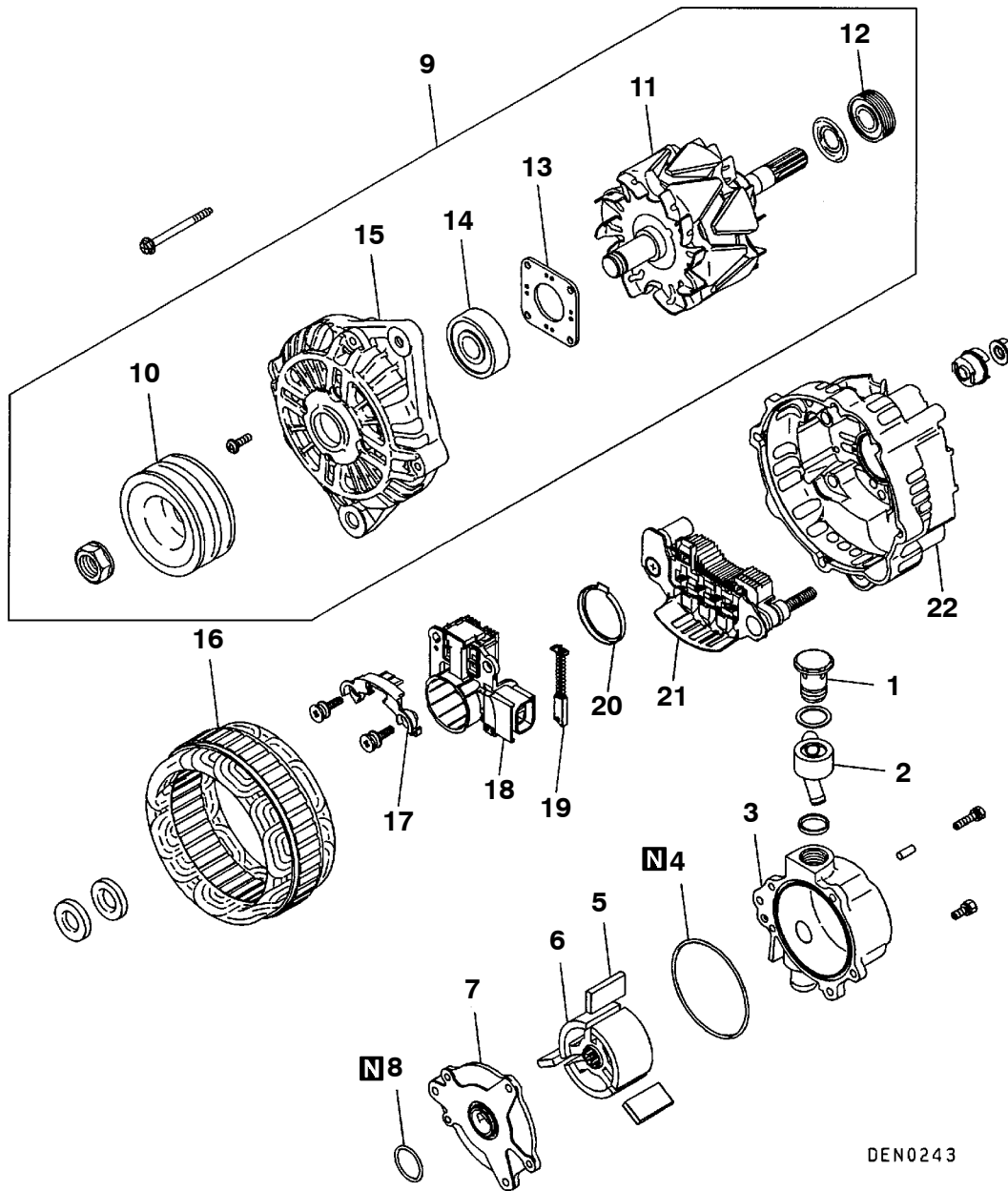

DEN0243

Disassembly steps

- | | | | |
|-----|---------------------------|---------|------------------------|
| | 1. Check valve | | 12. Rear bearing |
| | 2. Nipple | | 13. Bearing retainer |
| | 3. Vacuum pump housing | | 14. Front bearing |
| | 4. O-ring | | 15. Front bracket |
| ▶C◀ | 5. Vane | ◀C▶ | 16. Stator |
| ▶C◀ | 6. Rotor | ◀C▶ ▶A◀ | 17. Plate |
| | 7. Vacuum pump plate | | 18. Regulator assembly |
| | 8. O-ring | | 19. Brush |
| ◀A▶ | 9. Front bracket assembly | | 20. Slinger |
| ◀B▶ | 10. Pulley | | 21. Rectifier assembly |
| ▶B◀ | 11. Rotor | | 22. Rear bracket |

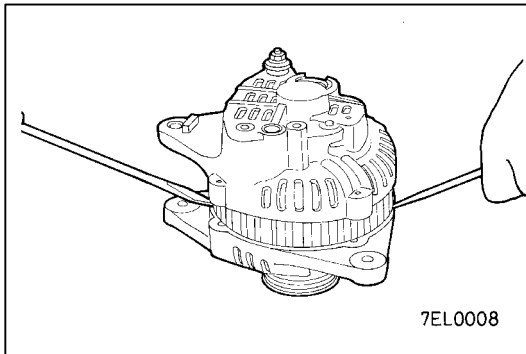
**DISASSEMBLY SERVICE POINTS****◀A▶ FRONT BRACKET REMOVAL**

1. Remove the bolts.
2. Insert a flat-tipped screwdriver between front bracket and stator core and pry downwards.

Caution

Do not insert a screwdriver too deep, as the stator coil will be damaged.

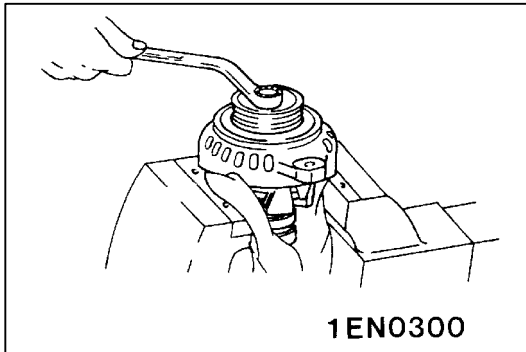
**◀B▶ PULLEY REMOVAL**

With the pulley side facing up, hold the rotor in a vice and remove the pulley.

Caution

Use care not to damage the rotor.

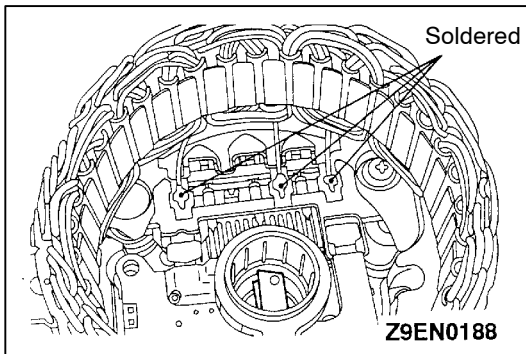
**◀C▶ STATOR REMOVAL/REGULATOR ASSEMBLY REMOVAL**

1. When removing stator, unsolder three stator leads soldered to main diodes on rectifier.
2. When removing rectifier from brush holder, unsolder two soldered points to rectifier.

Caution

- (1) When soldering or unsoldering, use care to make sure that heat of soldering iron is not transmitted to diodes for a long period. Finish soldering or unsoldering in as short a time as possible.
- (2) Use care that no undue force is exerted to leads of diodes.

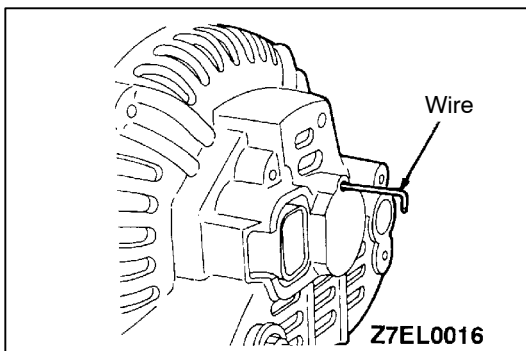
**REASSEMBLY SERVICE POINT****▶A◀ REGULATOR ASSEMBLY INSTALLATION**

Install the regulator assembly, insert a wire into the rear bracket hole while pushing in the brush, and hold the brush.

NOTE

Inserting a wire holds the brush, so that the rotor can be replaced easily.

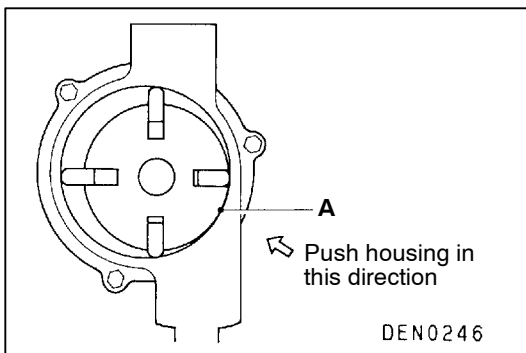
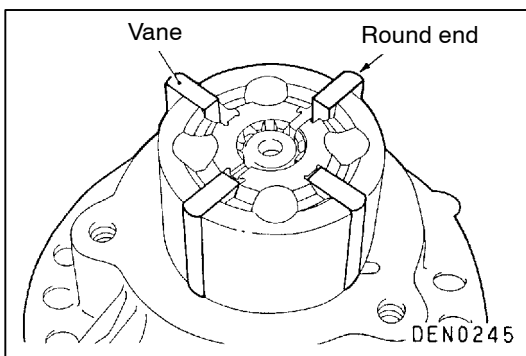
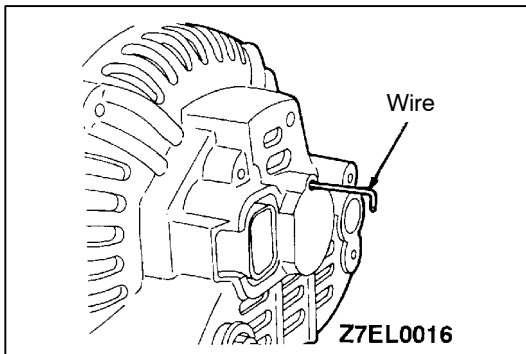
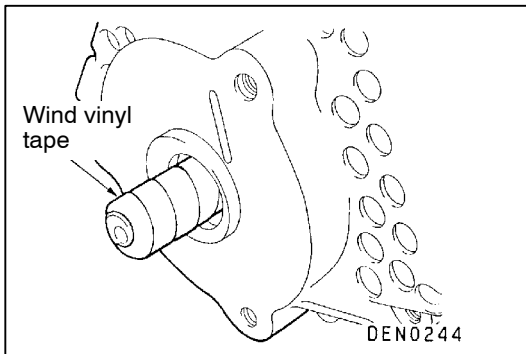
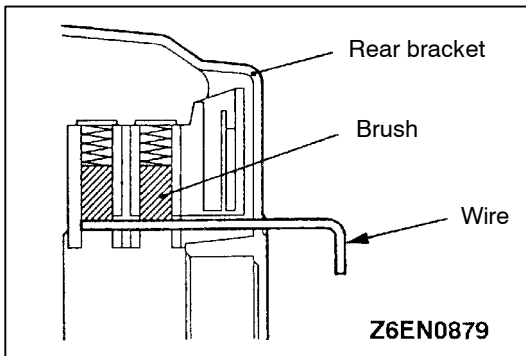

►B◄ ROTOR INSTALLATION

1. When installing the rotor on the alternator rear bracket, wrap vinyl tape around the splined shaft to prevent damage to the oil seal. <4D5>

2. After rotor has been installed, remove the wire.

►C◄ ROTOR/VANES INSTALLATION <4D5>

1. Carefully check the housing, rotor, etc. for chips and foreign matter. Then, apply engine oil and install.
2. Install the vanes with the round end facing outward.
3. Apply grease to the O-ring and fit in the housing groove so that it will not come out from the groove when the bolts are tightened.

4. When tightening the housing, lightly push it in the direction of arrow so as to minimize the clearance at "A" and tighten the bolts uniformly.

NOTE

After assembly, be sure to conduct a performance test to check to see that the maximum vacuum is as specified below.

**Standard value of maximum vacuum:
80.00 kPa or greater at 3,000 r/min**

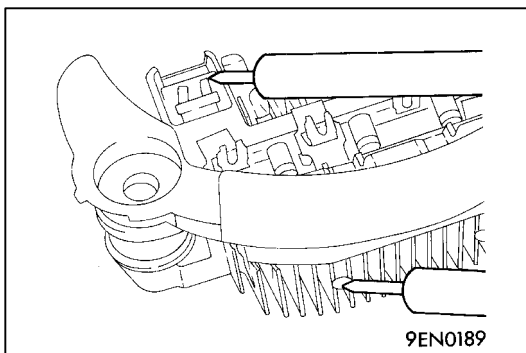
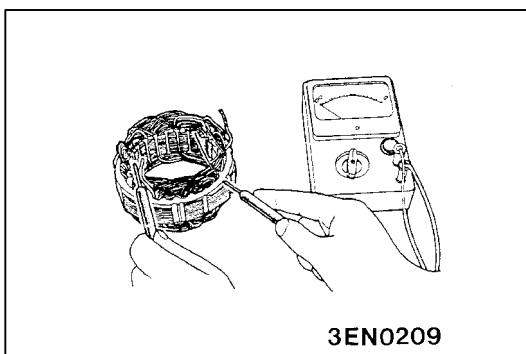
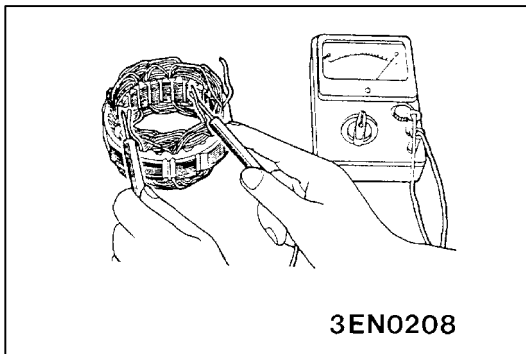
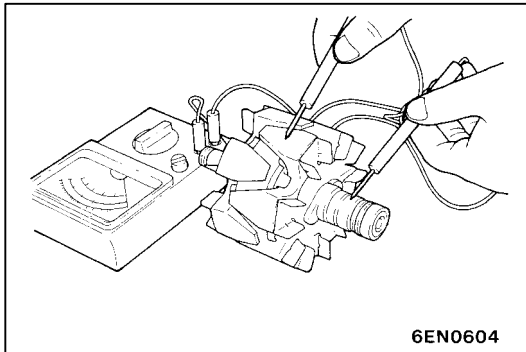
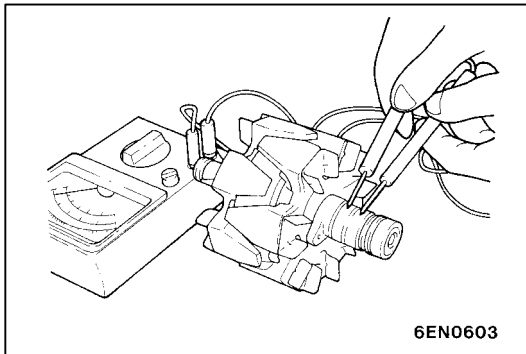

INSPECTION

16100170162

ROTOR

1. Check rotor coil for continuity. Check that there is no continuity between slip rings. If resistance is too small, it means that there is a short circuit. If there is no continuity or if there is a short circuit, replace rotor assembly.

Resistance value: Approx. 2 – 5 Ω

2. Check rotor coil for earthing. Check that there is no continuity between slip ring and core. If there is continuity, replace rotor assembly.

STATOR

1. Make continuity test on stator coil. Check that there is continuity between coil leads. If there is no continuity, replace stator assembly.

2. Check coil for earthing. Check that there is no continuity between coil and core. If there is continuity, replace stator assembly.

RECTIFIERS

1. Check for continuity between positive rectifier and stator coil lead connection terminal with an ohmmeter. If there is continuity in both directions, diode is shorted. Replace rectifier assembly.

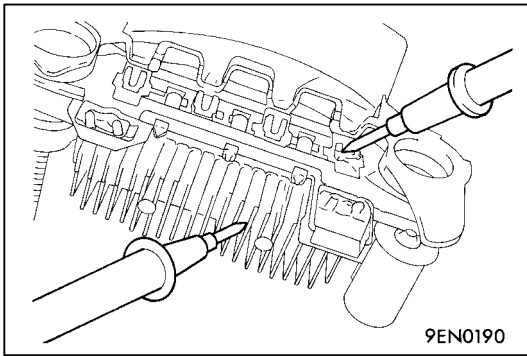

2. Check for continuity between negative rectifier and stator coil lead connection terminal. If there is continuity in both directions, diode is shorted, and rectifier assembly must be replaced.

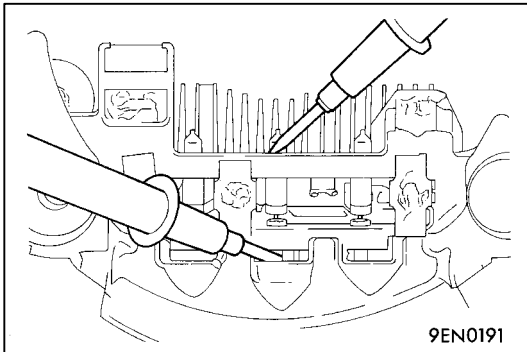

3. Check three diodes for continuity by connecting an ammeter to both ends of each diode. If there is no continuity in both directions, diode is faulty and heatsink assembly must be replaced.

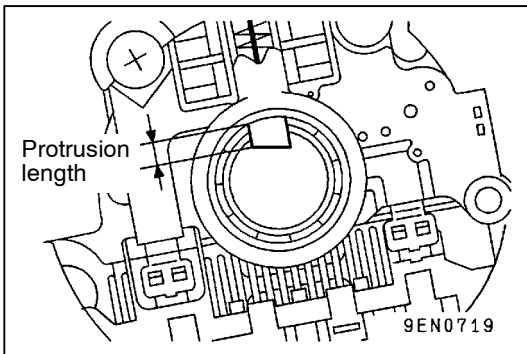

BRUSH

1. Replace the brush if its protrusion length is less than the limit.

Limit: min. 2 mm

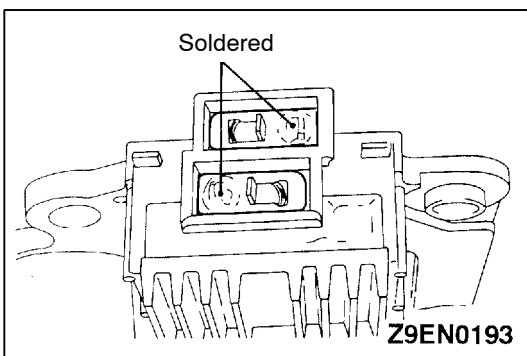

2. Unsolder pigtail and remove old brush and spring.

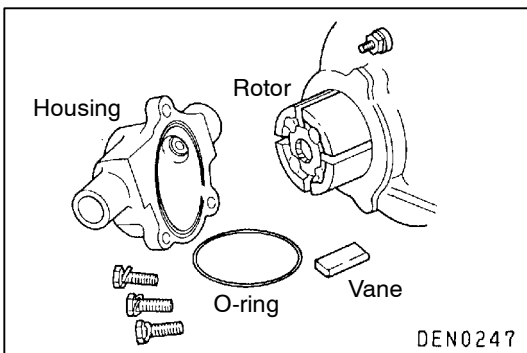

VACUUM PUMP

Check the following and replace if defective.

1. Check the rotor ends for streaks or damage.
2. Check the housing surface in contact with the rotor for streaks or damage.
3. Check the vanes for damage or breaks.

STARTING SYSTEM

16200010368

GENERAL INFORMATION

If the ignition switch is turned to the “START” position, current flows in the pull-in and holding provided inside magnetic switch, attracting the plunger. When the plunger is attracted, the lever connected to the plunger is actuated to engage the starter clutch.

On the other hand, attracting the plunger will turn on the magnetic switch, allowing the B terminal

and M terminal to conduct. Thus, current flows to engage the starter motor.

When the ignition switch is returned to the “ON” position after starting the engine, the starter clutch is disengaged from the ring gear.

An overrunning clutch is provided between the pinion and the armature shaft, to prevent damage to the starter.

SYSTEM DIAGRAM

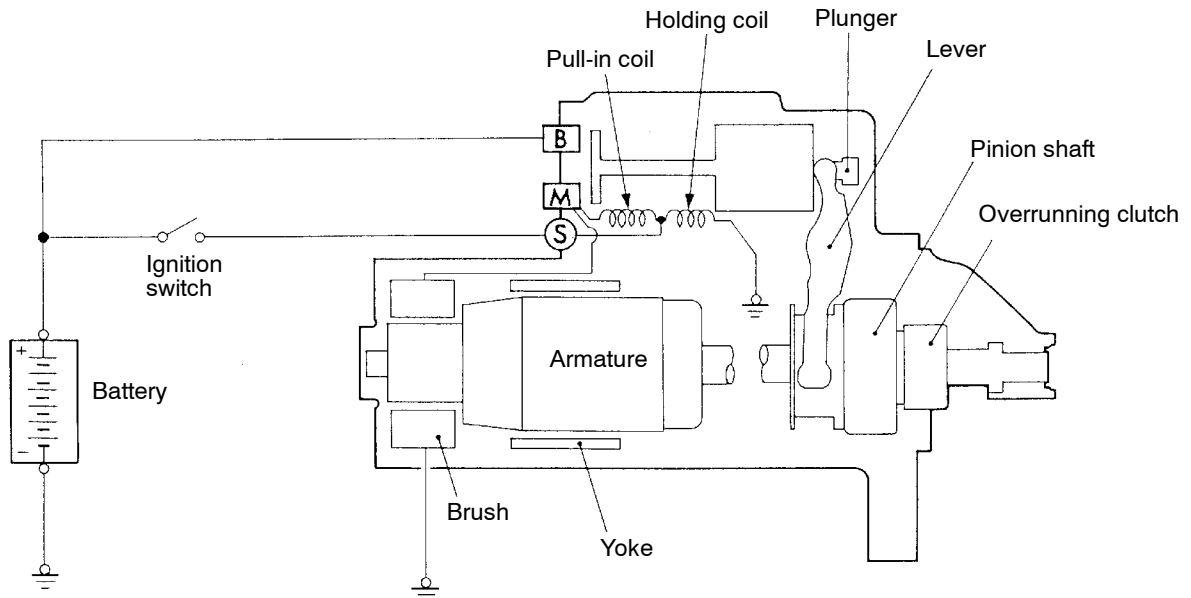

6EN0939

STARTER MOTOR SPECIFICATIONS

Items	6G7	4D5
Type	Reduction drive with planetary gear	Reduction drive with planetary gear
Rated output kW/V	1.2/12	2.2/12
No. of pinion teeth	8	12

SERVICE SPECIFICATIONS

Items	Standard value	Limit
Pinion gap mm	0.5 – 2.0	–
Commutator outer diameter mm	29.4	28.8
Commutator runout mm	–	0.05
Commutator undercut mm	0.5	0.2

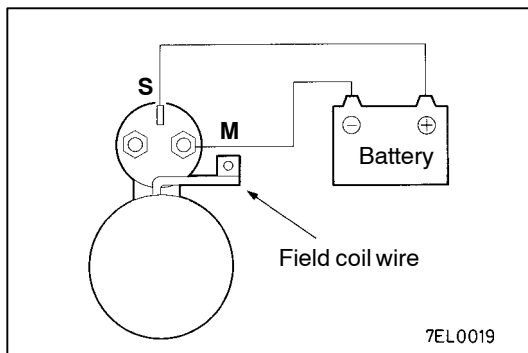
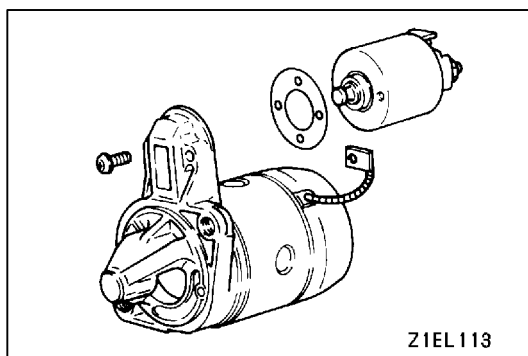
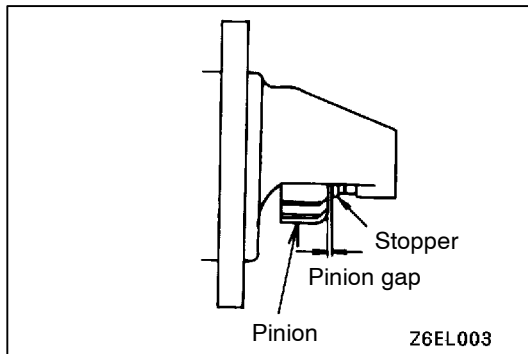
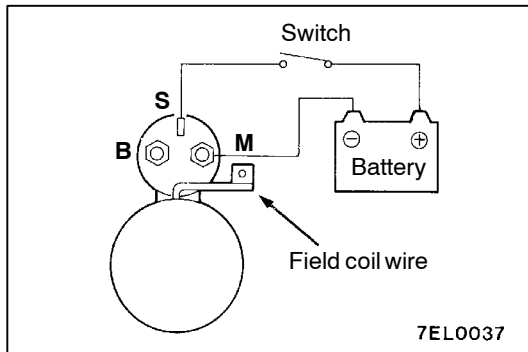

STARTER MOTOR

16200110327

INSPECTION

PINION GAP ADJUSTMENT

1. Disconnect field coil wire from M-terminal of magnetic switch.
2. Connect a 12V battery between S-terminal and M-terminal.
3. Set switch to "ON", and pinion will move out.

Caution

This test must be performed quickly (in less than 10 seconds) to prevent coil from burning.

4. Check pinion to stopper clearance (pinion gap) with a thickness gauge.

Standard value: 0.5 – 2.0 mm

5. If pinion gap is out of specification, adjust by adding or removing gaskets between magnetic switch and front bracket.

MAGNETIC SWITCH PULL-IN TEST

1. Disconnect field coil wire from M-terminal of magnetic switch.
2. Connect a 12V battery between S-terminal and M-terminal.

Caution

This test must be performed quickly (in less than 10 seconds) to prevent coil from burning.

3. If pinion moves out, then pull-in coil is good. If it doesn't, replace magnetic switch.

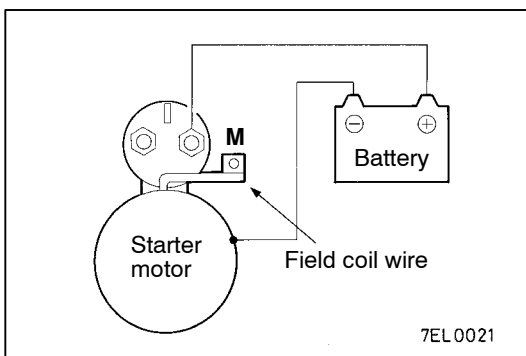
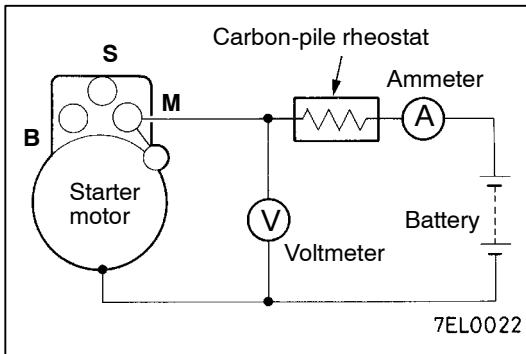
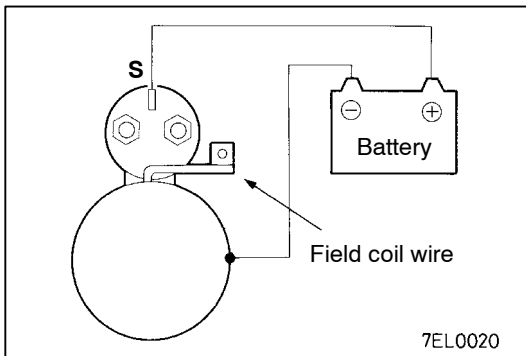

MAGNETIC SWITCH HOLD-IN TEST

1. Disconnect field coil wire from M-terminal of magnetic switch.
2. Connect a 12V battery between S-terminal and body.

Caution

This test must be performed quickly (in less than 10 seconds) to prevent coil from burning.

3. Manually pull out the pinion as far as the pinion stopper position.
4. If pinion remains out, everything is in order. If pinion moves in, hold-in circuit is open. Replace magnetic switch.

FREE RUNNING TEST

1. Place starter motor in a vise equipped with soft jaws and connect a fully-charged 12-volt battery to starter motor as follows:
2. Connect a test ammeter (100-ampere scale) and carbon pile rheostat in series with battery positive post and starter motor terminal.
3. Connect a voltmeter (15-volt scale) across starter motor.
4. Rotate carbon pile to full-resistance position.
5. Connect battery cable from battery negative post to starter motor body.
6. Adjust the rheostat until the battery voltage shown by the voltmeter is 11 V.
7. Confirm that the maximum amperage is within the specifications and that the starter motor turns smoothly and freely.

Current: max. 90 Amps

MAGNETIC SWITCH RETURN TEST

1. Disconnect field coil wire from M-terminal of magnetic switch.
2. Connect a 12V battery between M-terminal and body.

Caution

This test must be performed quickly (in less than 10 seconds) to prevent coil from burning.

3. Pull pinion out and release. If pinion quickly returns to its original position, everything is in order. If it doesn't, replace magnetic switch.

Caution

Be careful not to get your fingers caught when pulling out the pinion.

DISASSEMBLY AND REASSEMBLY <6G7>

16200120290

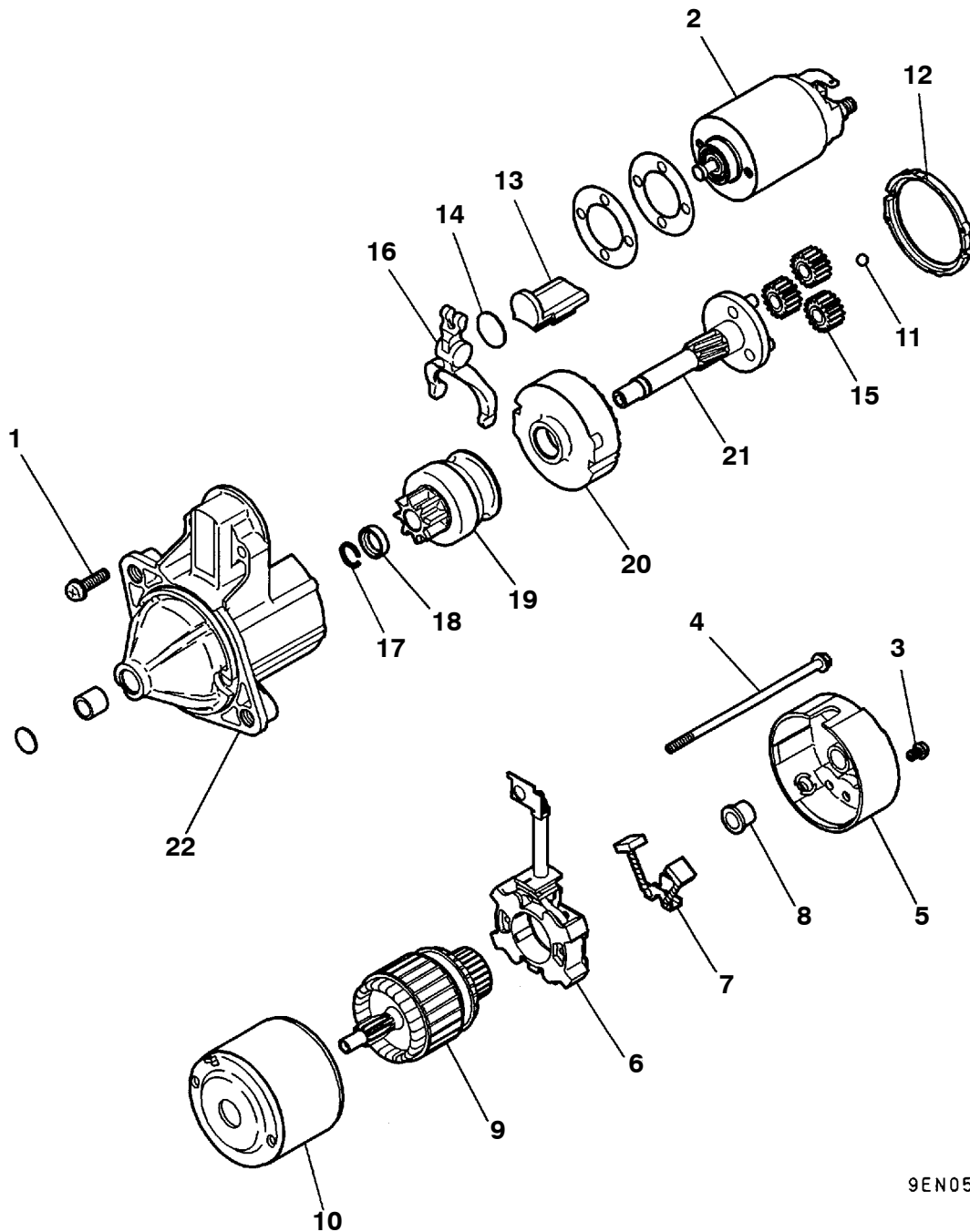

9EN0541

Disassembly steps



1. Screw
2. Magnetic switch
3. Screw
4. Screw
5. Rear bracket
6. Brush holder
7. Brush
8. Rear bearing
9. Armature
10. Yoke assembly
11. Ball



12. Packing A
13. Packing B
14. Plate
15. Planetary gear
16. Lever
17. Snap ring
18. Stop ring
19. Overrunning clutch
20. Internal gear
21. Planetary gear holder
22. Front bracket

DISASSEMBLY AND REASSEMBLY <4D5>

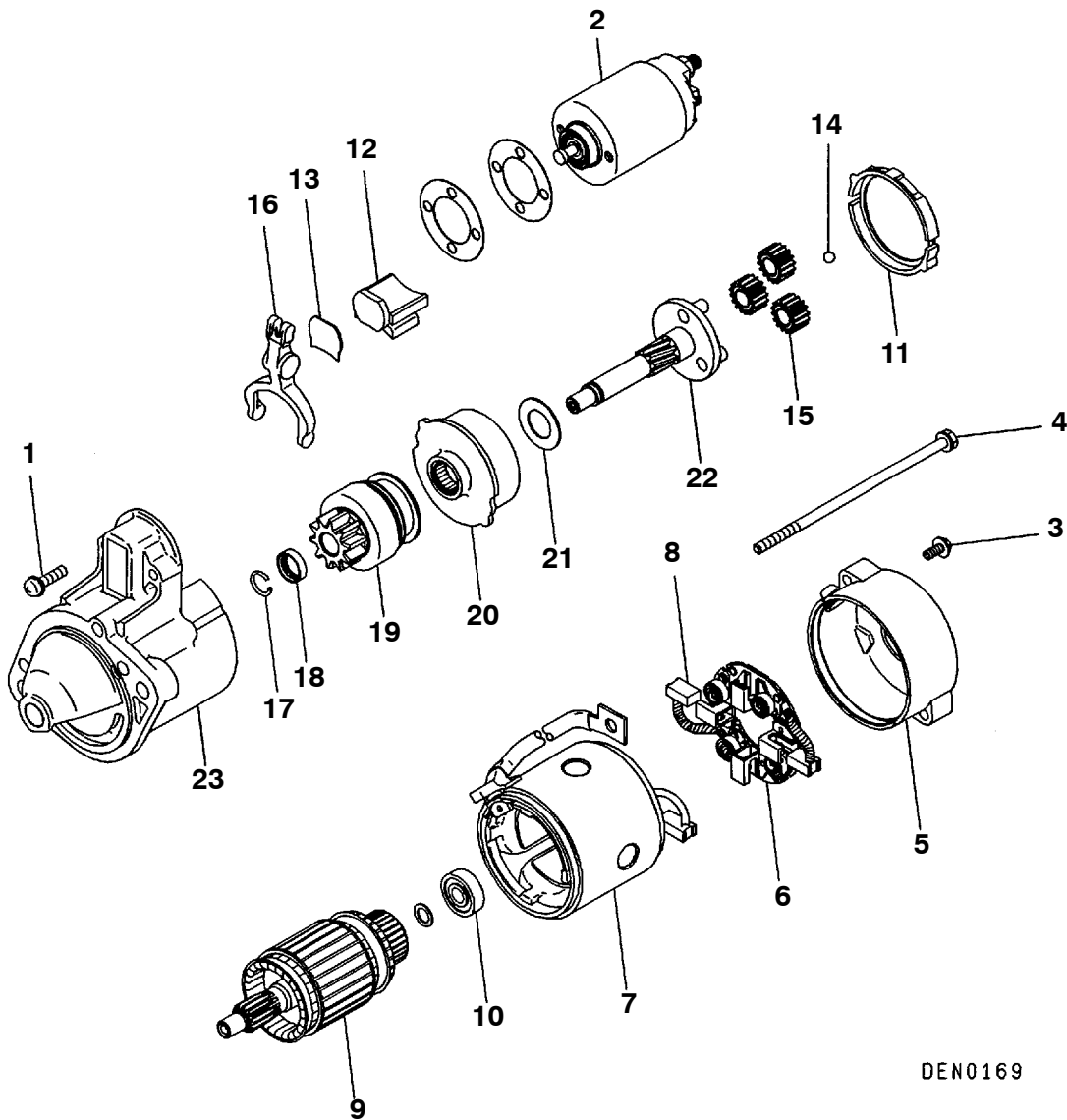

DEN0169

Disassembly steps

◀A▶

- 1. Screw
- 2. Magnetic switch
- 3. Screw
- 4. Screw
- 5. Rear bracket
- 6. Brush holder
- 7. Yoke assembly
- 8. Brush
- 9. Armature
- 10. Bearing
- 11. Packing A
- 12. Packing B

◀B▶

- 13. Plate
- 14. Ball
- 15. Planetary gear
- 16. Lever
- 17. Snap ring
- 18. Stop ring
- 19. Overrunning clutch
- 20. Internal gear
- 21. Washer
- 22. Planetary gear holder
- 23. Front bracket

◀C▶

▶A▶

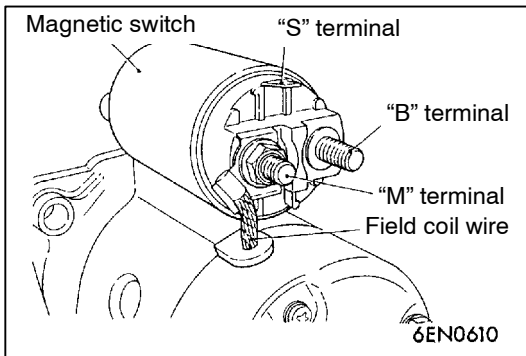
**DISASSEMBLY SERVICE POINTS****◀A▶ MAGNETIC SWITCH REMOVAL**

Disconnect field coil wire from "M" terminal of magnetic switch.

◀B▶ ARMATURE/BALL REMOVAL**Caution**

When removing the armature, take care not to lose the ball (which is used as a bearing) in the armature end.

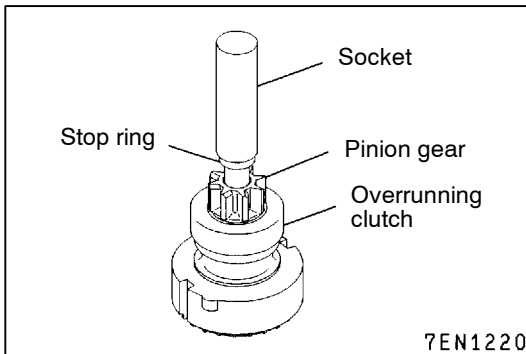
**◀C▶ SNAP RING/STOP RING REMOVAL**

1. Press stop ring off snap ring with a suitable socket.

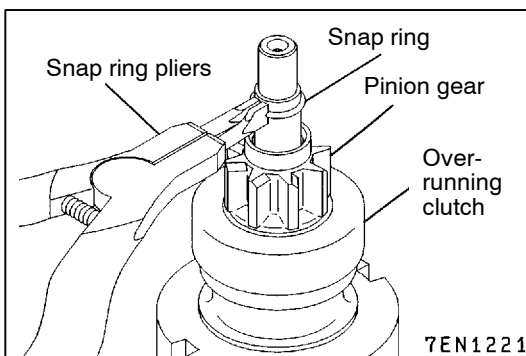

2. Remove snap ring with snap ring pliers and then remove stop ring and overrunning clutch.

STARTER MOTOR PARTS CLEANING

1. Do not immerse parts in cleaning solvent. Immersing the yoke and field coil assembly and/or armature will damage insulation. Wipe motor assembly with a cloth only.
2. Do not immerse drive unit in cleaning solvent. Overrunning clutch is pre-lubricated at the factory and solvent will wash lubrication from clutch.
3. The drive unit may be cleaned with a brush moistened with cleaning solvent and wiped dry with a cloth.

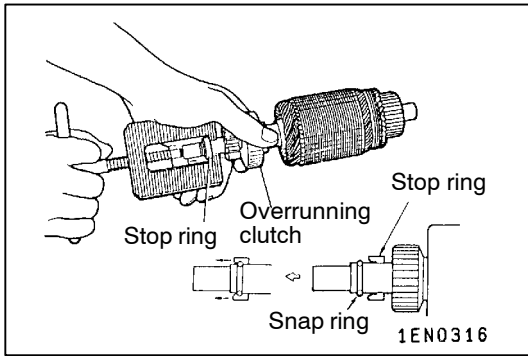

REASSEMBLY SERVICE POINTS

▶◀ STOP RING/SNAP RING INSTALLATION

Using a suitable pulling tool, pull overrunning clutch stop ring over snap ring.

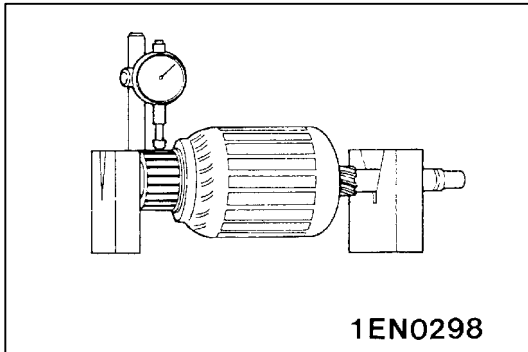

INSPECTION

16200130286

COMMUTATOR CHECK

1. Place the armature in a pair of “V” blocks and check the runout with a dial indicator.

Standard value: 0.05 mm

Limit: 0.1 mm

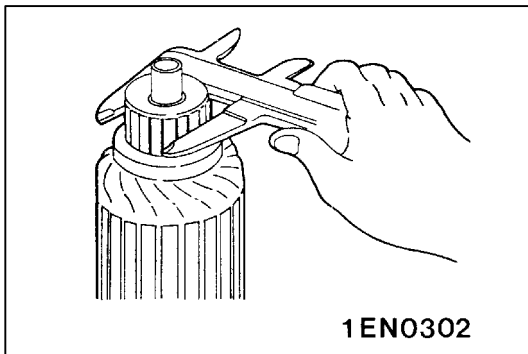

2. Measure the commutator outer diameter.

Standard value: 32.0 mm

Limit: 31.0 mm

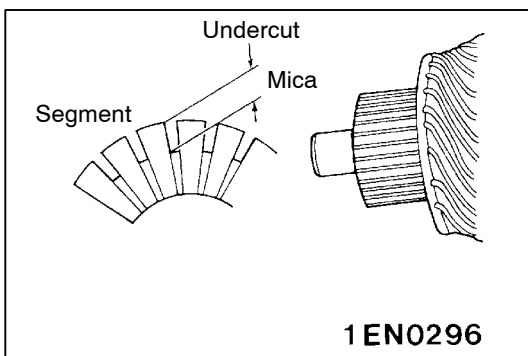

3. Check the undercut depth between segments.

Standard value: 0.5 mm

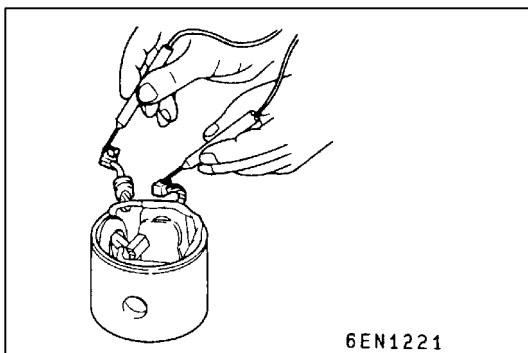

FIELD COIL OPEN-CIRCUIT TEST <4D5>

Check the continuity between field brushes. If there is continuity, the field coil is in order.

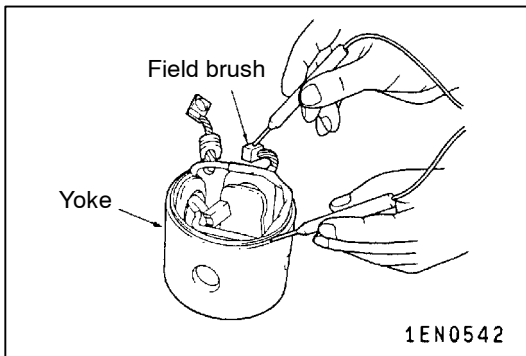
**FIELD COIL GROUND TEST <4D5>**

Check the continuity between field coil brush and yoke. If there is no continuity, the field coil is free from earth.

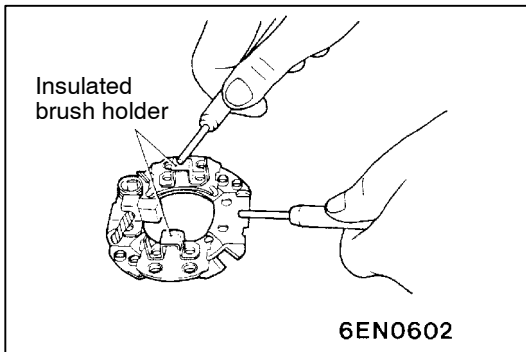
**BRUSH HOLDER CHECK**

Check the continuity between brush holder plate and brush holder.

If there is no continuity, the brush holder is in order.

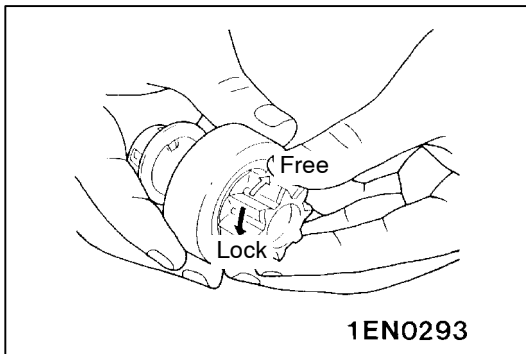
**OVERRUNNING CLUTCH CHECK**

1. While holding clutch housing, rotate the pinion. Drive pinion should rotate smoothly in one direction, but should not rotate in opposite direction. If clutch does not function properly, replace overrunning clutch assembly.
2. Inspect pinion for wear or burrs. If pinion is worn or burred, replace overrunning clutch assembly. If pinion is damaged, also inspect ring gear for wear or burrs.

FRONT AND REAR BRACKET BUSHING CHECK

Inspect bushing for wear or burrs. If bushing is worn or burred, replace front bracket assembly or rear bracket assembly.

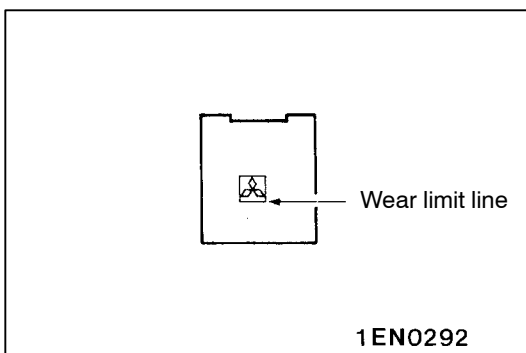
**BRUSH AND SPRING REPLACEMENT****<6G7>**

1. Brushes that are worn beyond wear limit line, or oil-soaked, should be replaced.
2. When replacing ground brush, slide the brush from brush holder by prying retaining spring back.

<4D5>

1. Brushes that are worn beyond wear limit line, or are oil-soaked, should be replaced.
2. When replacing field coil brushes, crush worn brush with pliers, taking care not to damage pigtail.

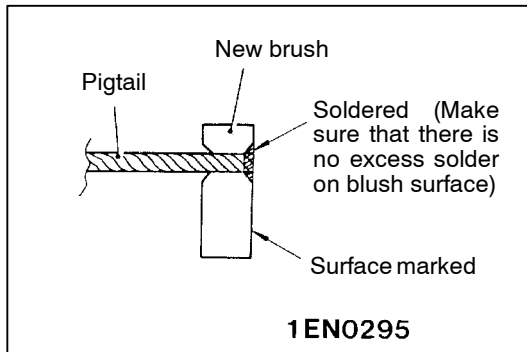

3. Sand pigtail end with sandpaper to ensure good soldering.
4. Insert pigtail into hole provided in new brush and solder it. Make sure that pigtail and excess solder do not come out onto brush surface.
5. When replacing ground brush, slide the brush from brush holder by prying retainer spring back.

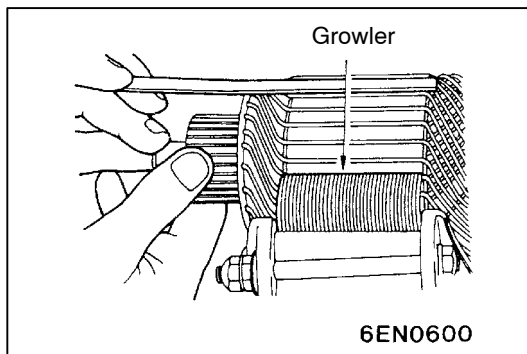
**ARMATURE TEST****ARMATURE SHORT-CIRCUIT TEST**

1. Place armature in a growler.
2. Hold a thin steel blade parallel and just above while rotating armature slowly in growler. A shorted armature will cause blade to vibrate and be attracted to the core. Replace shorted armature.

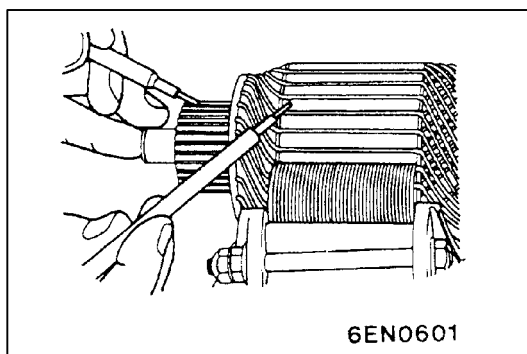
**ARMATURE COIL EARTH TEST**

Check the insulation between each commutator segment and armature coil core. If there is no continuity, the insulation is in order.

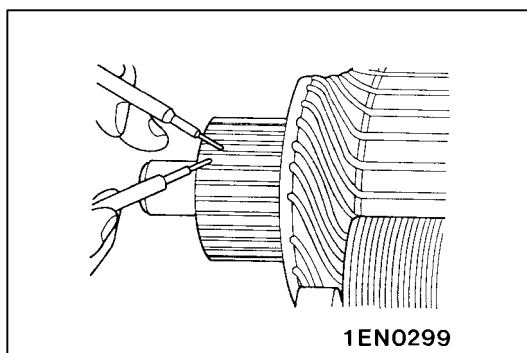
**ARMATURE COIL OPEN-CIRCUIT INSPECTION**

Check the continuity between segments. If there is continuity, the coil is in order.

IGNITION SYSTEM

16300010392

GENERAL INFORMATION

The ignition system has three ignition coils (A, B and C) and three power transistors (A, B and C). Each ignition coil and power transistor supply current to each cylinder pair (the No. 3 and No. 6 cylinders, No. 1 and No. 4 cylinders, and No. 2 and No. 5 cylinder).

When the primary current stops suddenly in the ignition coil A, high voltage appears in the secondary side of the coil.

The high voltage ignites a cylinder pair. But, whenever one cylinder is at the compression stroke, the other cylinder is at the compression stroke, the other cylinder is at the exhaust stroke. So fuel mixture burns only at the compression stroke side cylinder.

In the same way, when the primary current stops suddenly in ignition coil B, the high voltage thus generated is applied to the spark plugs of the No. 1 and No. 4 cylinders, and when the primary current

stops suddenly in ignition coil C, the high voltage thus generated is applied to the spark plugs of No. 2 and No. 5 cylinders.

The engine-ECU controls the three ignition power transistors (A, B and C) to turn them alternately ON and OFF. This causes the primary currents in the ignition coils (A, B and C) to stop alternately and ignite the spark plugs in the order 1 – 2 – 3 – 4 – 5 – 6.

The engine-ECU determines which the ignition coils should be controlled by means of the signals from the camshaft position sensor which is incorporated in the crankshaft. It also detects the crankshaft position in order to ignite at the most appropriate timing in response to the engine operation conditions.

When the engine is cold or operated at high altitudes, the ignition timing is slightly advanced for optimum performance.

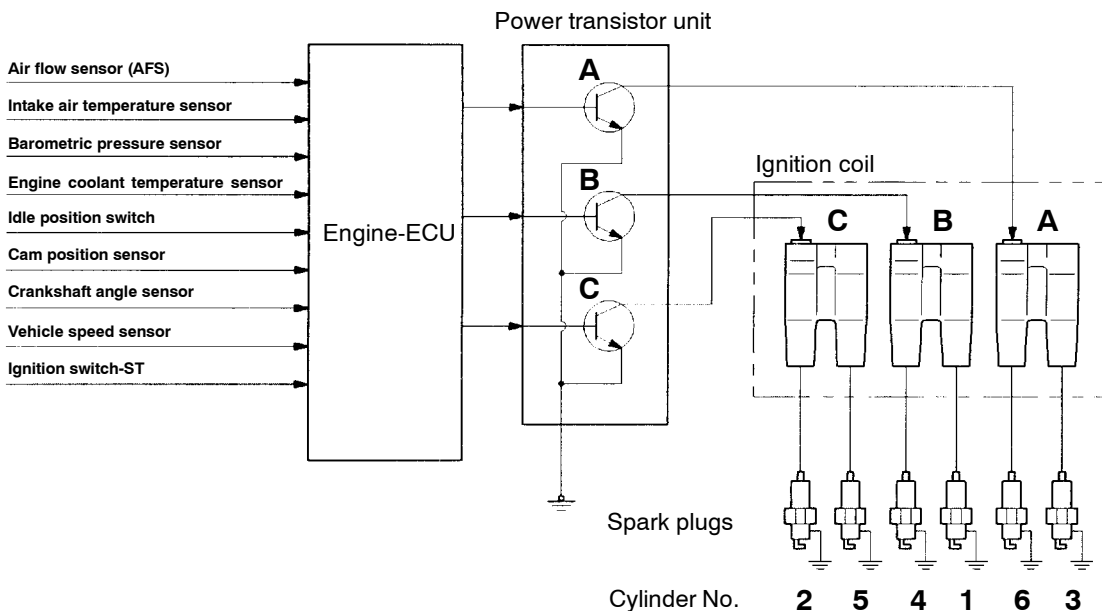

7EN1436

IGNITION COIL SPECIFICATIONS

Items	Specifications
Type	Moulded 3-coil
Identification No.	FC0020, FC0021

SPARK PLUG SPECIFICATIONS

Items	Specifications
NGK	PFR6J-11
DENSO	PK20PR-P11

SERVICE SPECIFICATIONS

16300030336

IGNITION COIL

Items	Standard value
Primary coil resistance Ω	0.74 – 0.90
Secondary coil resistance $k\Omega$	20.1 – 27.3

SPARK PLUG

Item	Standard value	Limit
Spark plug gap mm	1.0 – 1.1	1.3

RESISTIVE CORD

Item	Limit
Resistance $k\Omega$	Max. 22

SPECIAL TOOL

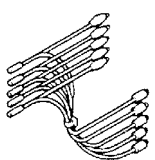
Tool	Number	Name	Use
 B991348	MB991348	Test harness set	Inspection of ignition primary voltage (power transistor connection)

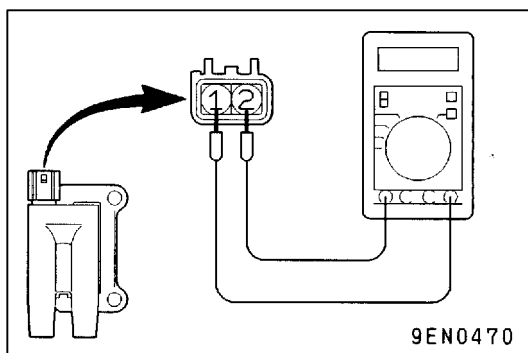

ON-VEHICLE SERVICE

16300120439

IGNITION COIL CHECK

PRIMARY COIL RESISTANCE

Measure the resistance between the terminals for each cylinder (No.1 – No.4, No.2 – No.5, No.3 – No.6) of the ignition coil as shown in the illustration.

Standard value: 0.74 – 0.90 Ω

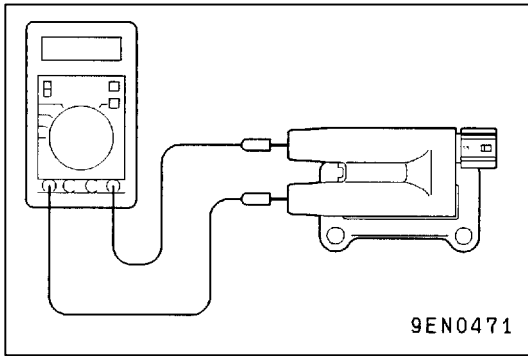

SECONDARY COIL RESISTANCE

Measure the resistance between the high-voltage terminals for each cylinder (No.1 – No.4, No.2 – No.5, No.3 – No.6) of the ignition coil as shown in the illustration.

Standard value: 20.1 – 27.3 kΩ

POWER TRANSISTOR CONTINUITY CHECK

16300130326

Check for continuity between the power transistor terminals. If the power transistor is defective, replace it.

NOTE

An analog-type circuit tester should be used.

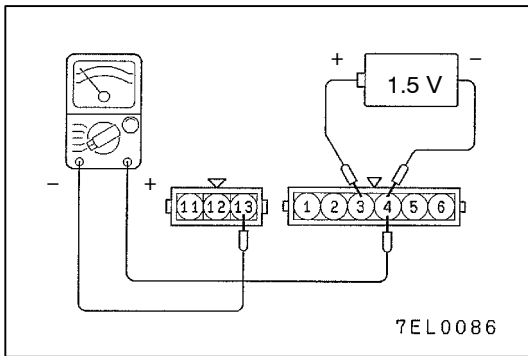

No. 1 – No. 4 coil side

Check the continuity between terminals (4) and (13).

1.5 V Voltage	Terminal No.		
	3	4	13
Applied	⊕	⊖	○
Not applied			

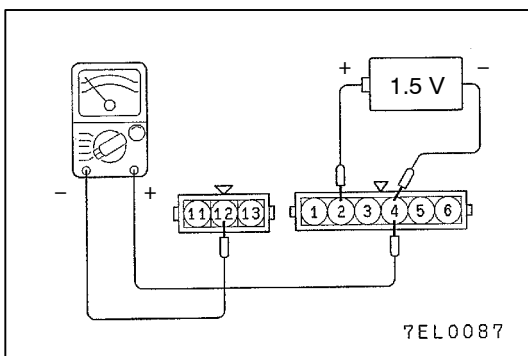

No. 2 – No. 5 coil side

Check the continuity between terminals (4) and (12).

1.5 V Voltage	Terminal No.		
	2	4	12
Applied	⊕	⊖	○
Not applied			

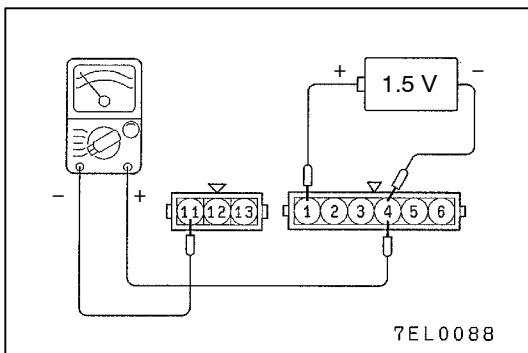

No. 3 – No. 6 coil side

Check the continuity between terminals (4) and (11).

1.5 V Voltage	Terminal No.		
	1	4	11
Applied	⊕	⊖	○
Not applied			

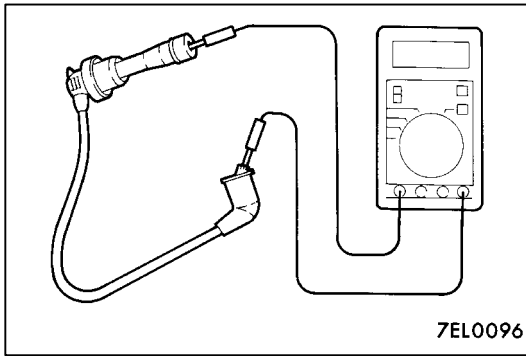
**RESISTIVE CORD CHECK**

16300140138

Measure the resistance of the all spark plug cables.

1. Check cap and coating for cracks.
2. Measure resistance.

Limit: Max. 22 k Ω

SPARK PLUG CHECK

16300150407

1. Remove the air intake plenum.
2. Remove the spark plug cables.

Caution

When pulling off the spark plug cable from the plug always hold the cable cap, not the cable.

3. Remove the spark plugs.

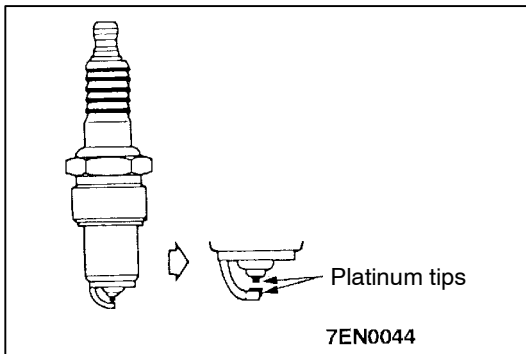

4. Check the plug gap and replace if the limit is exceeded.

Standard value: 1.0–1.1 mm

Limit: 1.3 mm

Caution

- (1) **Do not attempt to adjust the gap of the platinum plug.**
- (2) **Always use a plug cleaner and finish cleaning within 20 seconds. Do not use wire brushes. Otherwise, the platinum tip may be damaged.**

5. Clean the engine plug holes.

Caution

Be careful not to allow foreign matter in cylinders.

6. Install the spark plugs.

**WAVEFORM CHECK USING AN ANALYZER
(Ignition Primary and Secondary Voltage
Waveforms)
Ignition Secondary Voltage Waveform Check**

16300170519

MEASUREMENT METHOD

1. Clamp the secondary pickup around a spark plug cable.

NOTE

- (1) The peak of the ignition voltage will be reversed when the spark plug cables of No.1, No.3, No.5 cylinders are clamped and when the spark plug cables of No.2, No.4 and No.6 cylinders are clamped.
- (2) Because of the two-cylinder simultaneous ignition system, the waves for two cylinder in each group appear during wave observation (No.1 cylinder – No.4 cylinder, No.2 cylinder – No.5 cylinder, No.3 – cylinder – No.6 cylinder). However, wave observation is carried out for the cylinder with the spark plug cable clamped by the secondary pickup.

2. Clamp the spark plug cable with the Trigger pickup.

NOTE

- (1) Clamp the spark plug cable for the No.1, No.3 or No.5 cylinder of the same group with the cylinder that is clamped with the secondary pickup.
- (2) It can be difficult to identify which cylinder waveform is displayed, but the waveform of the cylinder which is clamped with the secondary pickup will be stable, so this can be used as a reference for identification.

STANDARD WAVEFORM

Observation Conditions

FUNCTION	SECONDARY
PATTERN HEIGHT	HIGH (or LOW)
PATTERN SELECTOR	RASTER
Engine Speed	Curb idle speed

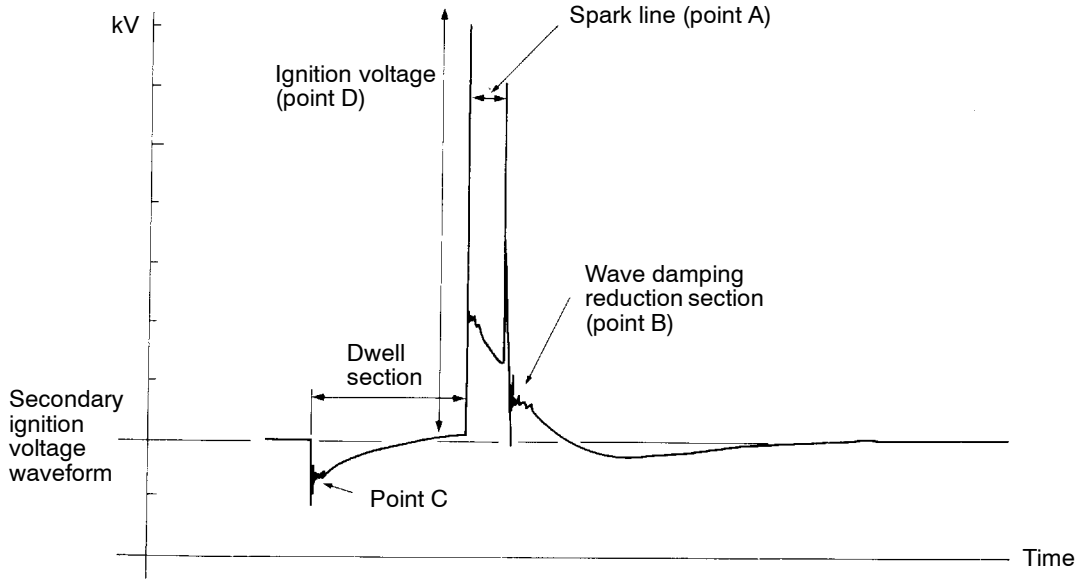

7EL0147

Observation Condition (The only change from previous condition is the pattern selector.)

PATTERN SELECTOR	DISPLAY
------------------	---------

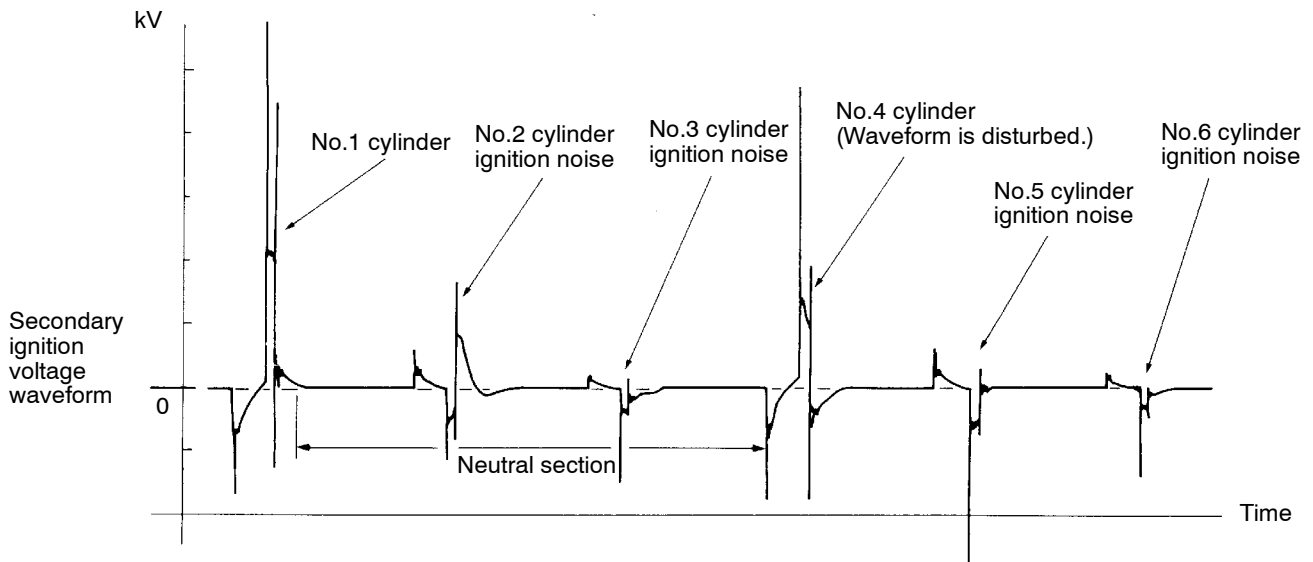

7EL0148

WAVEFORM OBSERVATION POINTS

Point A: The height, length and slope of the spark line show the following trends (Refer to abnormal waveform examples, 1, 2, 3 and 4).

Spark line		Plug gap	Condition of electrode	Compression force	Concentration of air mixture	Ignition timing	Spark plug cable
Length	Long	Small	Normal	Low	Rich	Advanced	Leak
	Short	Large	Large wear	High	Lean	Retarded	High resistance
Height	High	Large	Large wear	High	Lean	Retarded	High resistance
	Low	Small	Normal	Low	Rich	Advanced	Leak
Slope		Large	Plug is fouled	–	–	–	–

Point B: Number of vibration in reduction vibration section (Refer to abnormal waveform example 5)

Number of vibrations	Coil and condenser
Three or more	Normal
Except above	Abnormal





Point C: Number of vibrations at beginning of dwell section (Refer to abnormal waveform example 5)

Number of vibrations	Coil
5-6 or higher	Normal
Except above	Abnormal

Point D: Ignition voltage height (distribution per each cylinder) shows the following trends.

Ignition voltage	Plug gap	Condition of electrode	Compression force	Concentration of air mixture	Ignition timing	Spark plug cable
High	Large	Large wear	High	Lean	Retarded	High resistance
Low	Small	Normal	Low	Rich	Advanced	Leak

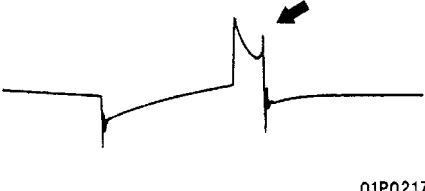
EXAMPLES OF ABNORMAL WAVEFORMS

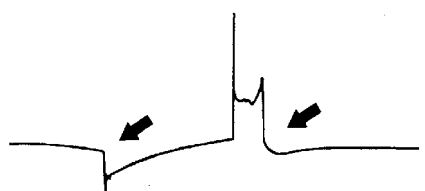
Abnormal waveform	Wave characteristics	Cause of problem
<p>Example 1</p>  <p>01P0215</p>	<p>Spark line is high and short.</p>	<p>Spark plug gap is too large.</p>
<p>Example 2</p>  <p>01P0216</p>	<p>Spark line is low and long, and is sloping. Also, the second half of the spark line is distorted. This could be a result of misfiring.</p>	<p>Spark plug gap is too small.</p>
<p>Example 3</p>  <p>01P0217</p>	<p>Spark line is low and long, and is sloping. However, there is almost no spark line distortion.</p>	<p>Spark plug gap is fouled.</p>
<p>Example 4</p>  <p>01P0218</p>	<p>Spark line is high and short. Difficult to distinguish between this and abnormal waveform example 1.</p>	<p>Spark plug cable is nearly falling off. (Causing a dual ignition)</p>
<p>Example 5</p>  <p>01P0219</p>	<p>No waves in wave damping section.</p>	<p>Layer short in ignition coil</p>

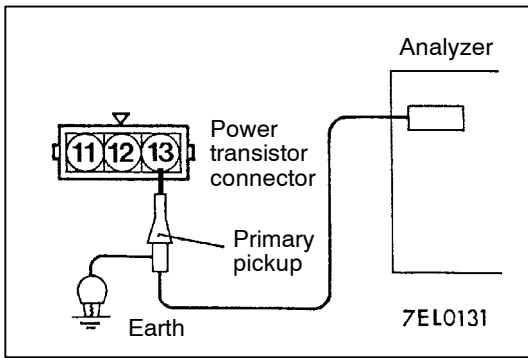

Ignition Primary Voltage Waveform Check

MEASUREMENT METHOD

1. Disconnect the power transistor connector and connect the special tool (harness connector: MB991348) in between.
2. Connect the analyzer primary pickup to the power transistor connector terminal 13 when observing the No. 1 – No. 4 cylinder group, terminal 12 for the No. 2 – No. 5 cylinder group, and terminal 11 for the No. 3 – No. 6 cylinder group.
3. Connect the primary pickup earth terminal.
4. Clamp the spark plug cable with the trigger pickup.

NOTE

- (1) Clamp the spark plug cable for No. 1, No. 3 and No. 5 cylinders of the same group with the cylinder that is connected to the primary pickup.
- (2) The wave-form of either cylinder in the same group will appear at the left edge of the screen.

STANDARD WAVE-FORM Observation Conditions

FUNCTION	SECONDARY
PATTERN HEIGHT	HIGH (or LOW)
PATTERN SELECTOR	RASTER
Engine Speed	Curb idle speed

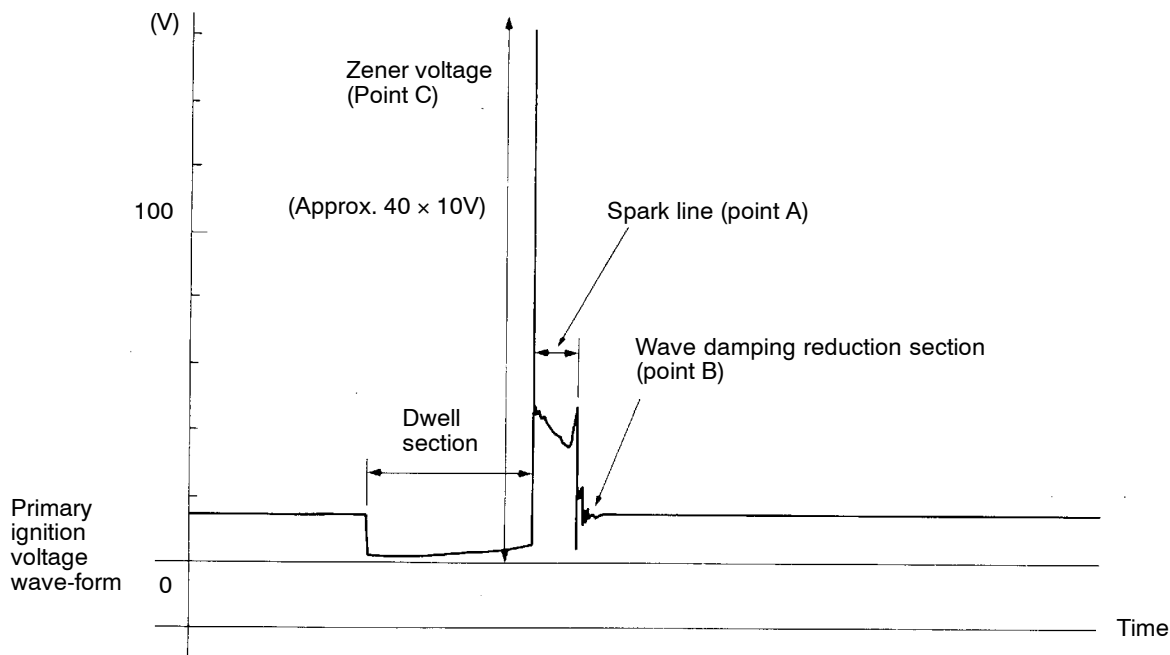

Observation Conditions (Only pattern selector below changes from the above conditions.)

PATTERN SELECTOR	DISPLAY
------------------	---------

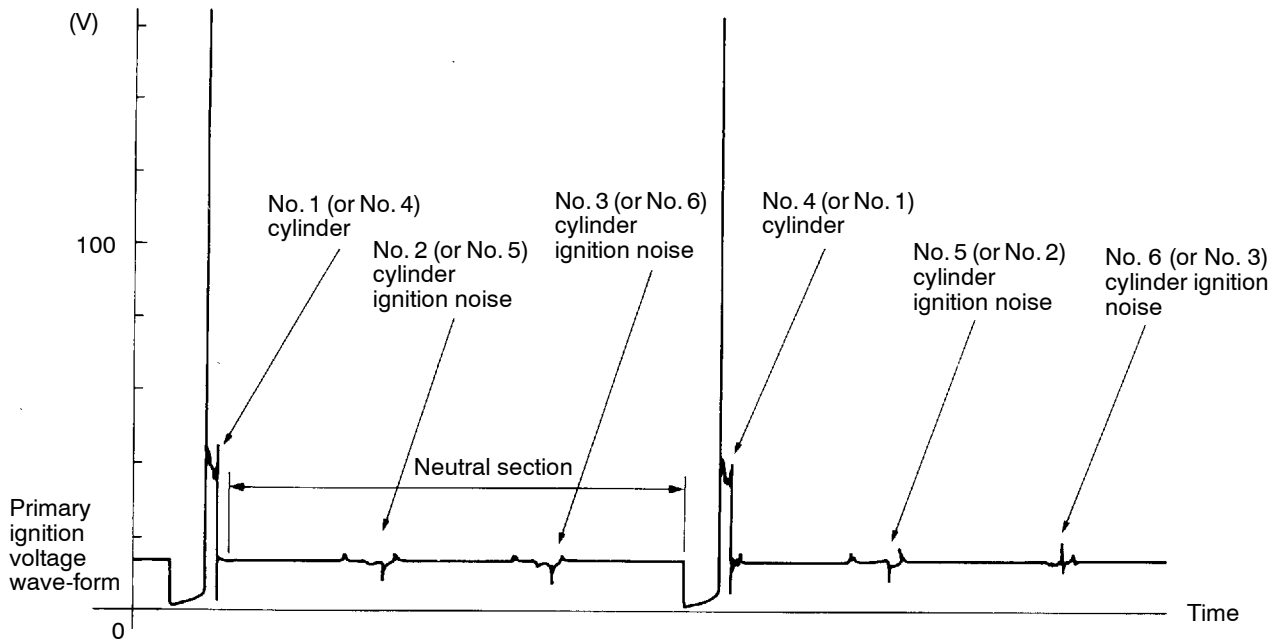

7EL0151

WAVEFORM OBSERVATION POINTS

Point A: The height, length and slope of the spark line (refer to abnormal waveform examples 1, 2, 3 and 4) show the following trends.

Spark line		Plug gap	Condition of electrode	Compression force	Concentration of air mixture	Ignition timing	High tension cable
Length	Long	Small	Normal	Low	Rich	Advanced	Leak
	Short	Large	Large wear	High	Lean	Retarded	High resistance
Height	High	Large	Large wear	High	Lean	Retarded	High resistance
	Low	Small	Normal	Low	Rich	Advanced	Leak
Slope		Large	Plug is fouled	-	-	-	-



Point B: Number of vibration in reduction vibration section (Refer to abnormal waveform example 5)

Number of vibrations	Coil, condenser
3 or higher	Normal
Except above	Abnormal

Point C: Height of Zener voltage

Height of Zener voltage	Probable cause
High	Problem in Zener diode
Low	Abnormal resistance in primary coil circuit

EXAMPLES OF ABNORMAL WAVEFORMS

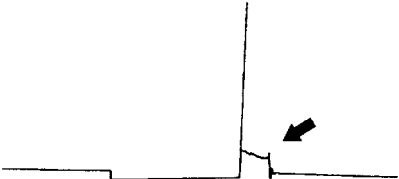
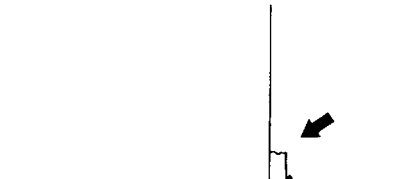
Abnormal waveform	Wave characteristics	Cause of problem
<p>Example 1</p>  <p>01P0210</p>	<p>Spark line is high and short.</p>	<p>Spark plug gap is too large.</p>
<p>Example 2</p>  <p>01P0211</p>	<p>Spark line is low and long, and is sloping. Also, the second half of the spark line is distorted. This could be a result of misfiring.</p>	<p>Spark plug gap is too small.</p>
<p>Example 3</p>  <p>01P0212</p>	<p>Spark line is low and long, and is sloping. However, there is almost no spark line distortion.</p>	<p>Spark plug gap is fouled.</p>
<p>Example 4</p>  <p>01P0213</p>	<p>Spark line is high and short.</p>	<p>Spark plug cable is nearly falling off. (Causing a dual ignition)</p>

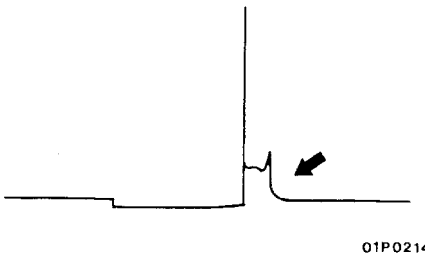
Abnormal waveform	Wave characteristics	Cause of problem
<p>Example 5</p>  <p>01P0214</p>	<p>No waves in wave damping section</p>	<p>Layer short in ignition coil</p>

CAMSHAFT POSITION SENSOR AND CRANKSHAFT ANGLE SENSOR <6G7>

16300250381

REMOVAL AND INSTALLATION

Pre-removal and Post-installation Operation
 Removal and Installation of Timing Belt Cover
 (Refer to GROUP 11A – Timing Belt.)

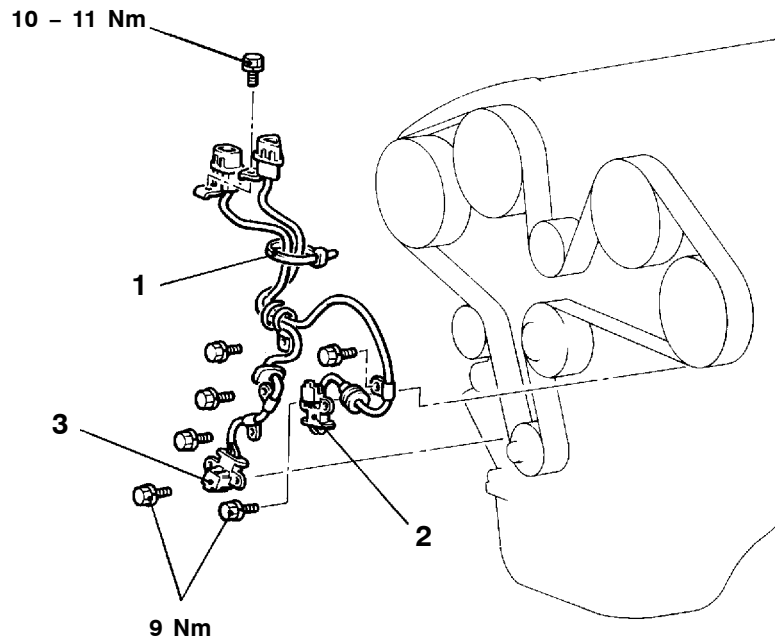

A16W0056

Removal steps

1. Clip
2. Camshaft position sensor
3. Crankshaft angle sensor

GLOW SYSTEM

16400010029

GENERAL INFORMATION

SELF-REGULATING GLOW SYSTEM

The self-regulating glow system reduces the time required for starting at low temperatures to provide a degree of starting and operation that is identical to petrol-engine vehicles by preheating the glow plugs at super-quick speed.

The glow control unit controls both the time during which current is supplied to the glow plugs after the ignition switch is turned to the ON position and

also the glow indicator lamp illumination time in accordance with the engine coolant temperature. The resistances of the heating coils which are built into the glow plugs increase as the glow plug temperatures become higher. As a result of this, the flow of current gradually decreases, thus stabilizing the glow plug temperature at the specified temperature.

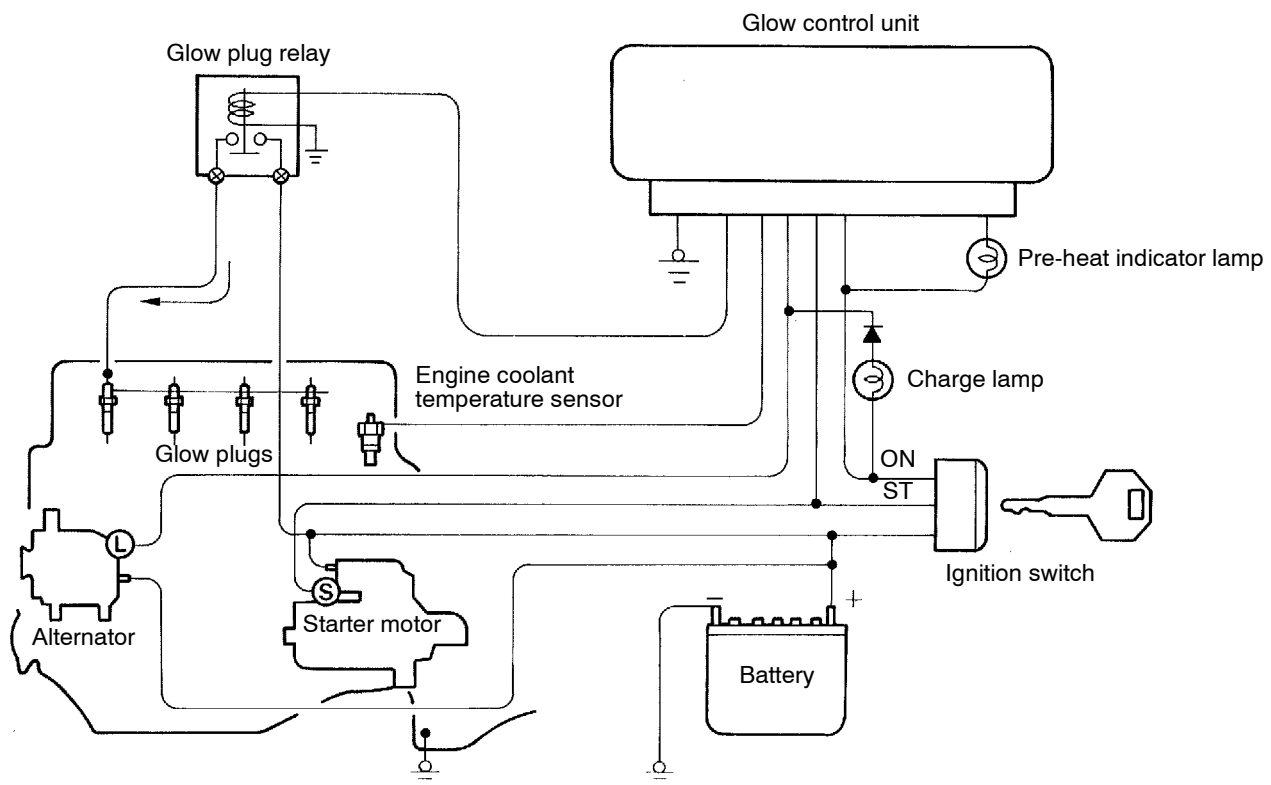

DEN0062

SERVICE SPECIFICATIONS

16400030070

Item		Standard value
Resistance between glow plug plate and glow plug body (parallel resistance for 4 glow plugs) (at 20 °C) Ω		0.15 – 0.25
Voltage between glow plug plate and glow plug body V	Immediately after ignition switch is turned to ON (without starting the engine)	9 – 11 (Drops to 0 V after 4 – 8 seconds have passed)
	While engine is cranking	6 or more
	While engine is warming up	12 – 15 (Drops to 0 V when the engine coolant temperature increases to 60 °C or more or if 180 seconds have passed since the engine was started)
Glow plug resistance (at 20 °C) Ω		0.6 – 1.0

SEALANT

16400050021

Item	Specified sealant	Remark
Engine coolant temperature sensor	3M Nut Locking Part No.4171 or equivalent	Drying sealant

ON-VEHICLE SERVICE

16400100061

SELF-REGULATING GLOW SYSTEM CHECK

1. Check that the battery voltage is 11 – 13 V.
2. Check that the engine coolant temperature is 40 °C or less.

NOTE

If the engine coolant temperature is too high, disconnect the engine coolant temperature sensor connector.

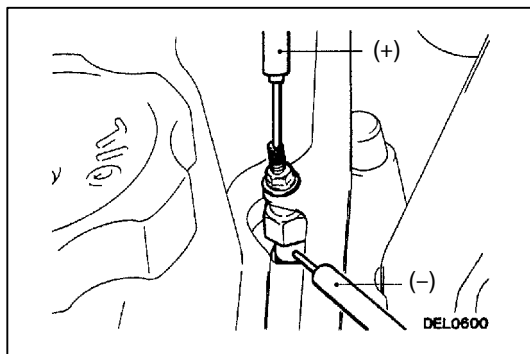

3. Measure the resistance between the glow plug plate and the glow plug body (earth).

Standard value: 0.15 – 0.25 Ω (at 20 °C)

NOTE

The resistance value is the parallel resistance value for the four glow plugs.

4. Connect a voltmeter between the glow plug plate and the glow plug body (earth).
5. Measure the voltage immediately after the ignition switch is turned to ON (without starting the engine).

Standard value:

9 – 11 V (Drops to 0 V after 4 – 8 seconds have passed)

In addition, check to be sure that the glow indicator lamp (red) illuminates immediately after the ignition switch is turned to ON.

NOTE

The time during which the voltage appears (energizing time) will depend on the engine coolant temperature.

6. Measure the voltage while the engine is cranking.

Standard value: 6 V or more

7. Start the engine and measure the voltage while the engine is warming up.

However, if the engine coolant temperature rises above 60 °C or when 180 seconds have passed since the engine was started, the voltage will always return to 0 V. (Refer to the Glow Plug Energization Timing Chart.)

Standard value: 12 – 15 V

<Reference>

Glow Plug Energization Timing Chart

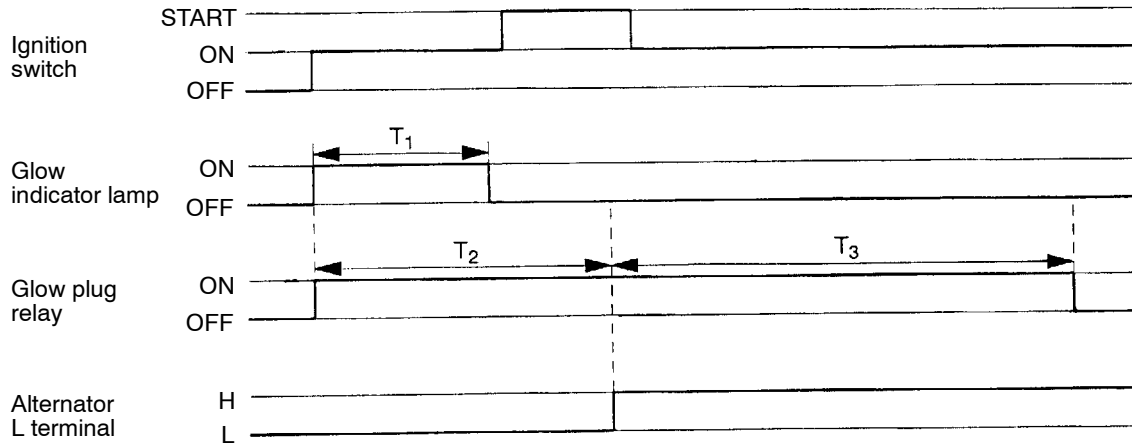

T_1 : Glow indicator lamp
 T_2 : Glow plug relay drive time after ignition switch is turned ON
 T_3 : Glow plug relay drive time after engine starts (after glow)

DEN0063

NOTE

After glow time T_3 becomes longer as the engine coolant temperature drops.

GLOW & EGR CONTROL UNIT CHECK

16400220064

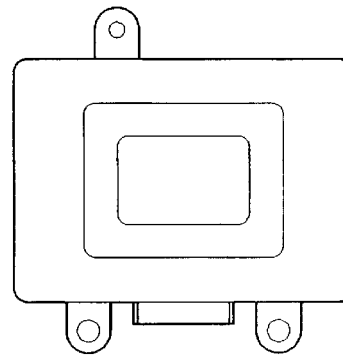
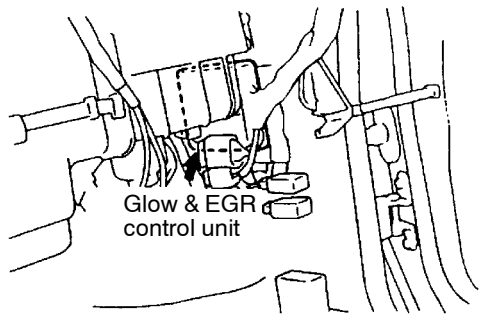

Glow & EGR control unit

↓

1	2	3	4	5	6	7	8	9	10	11	12	13
14	15	16	17	18	19	20	21	22	23	24	25	26

DEN0294

1. Measure the voltage at the control unit terminals.

NOTE

- (1) Inspect with the control unit connector connected.
- (2) When measuring the voltage, connect the control unit terminal (26) to the earth.

Terminal Voltage Reference Table

Inspection terminal	Inspection item	Inspection condition	Standard value	
5	Engine coolant temperature sensor (Engine coolant temperature detection)	Ignition switch "ON" → "OFF"	Engine coolant temperature: -20 °C	4.3 – 4.5 V
			Engine coolant temperature: 0 °C	3.7 – 3.9 V
			Engine coolant temperature: 20 °C	2.8 – 3.0 V
			Engine coolant temperature: 40 °C	1.9 – 2.1 V
			Engine coolant temperature: 80 °C	0.5 – 0.7 V
12	Ignition switch (power supply)	Ignition switch "OFF" → "START"	8 V or more	
14	Glow plug relay (glow time control)	Ignition switch "OFF" → "ON" Engine coolant temperature: 40 °C or less (Pre-glow function inspection)	9 – 12 V 0 – 0.5 V after approx. 8 sec. (when engine coolant temperature is 20 °C)	
17	Glow indicator lamp	Ignition switch "OFF" → "ON" Engine coolant temperature: 40 °C or less	0 – 1 V 11 – 13 V after approx. 1 sec. (when engine coolant temperature is 20 °C)	
23	Alternator charging signal ("L" terminal)	Ignition switch "OFF" → "ON"	1 – 4 V	
		Engine is idling	11 V or more	
26	Earth	-	-	

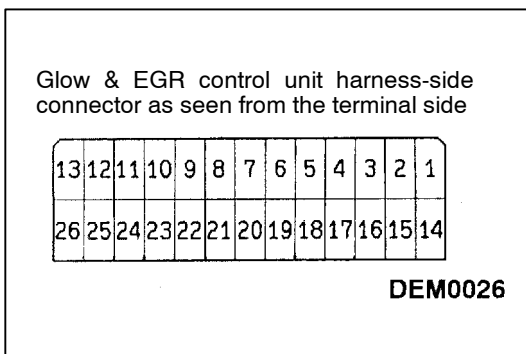

2. Remove the control unit connector and check the continuity between the harness-side connector terminals.

Inspection terminal	Inspection item	Continuity (resistance value)
14 – 26	Glow plug relay	Continuity (approx. 20Ω)

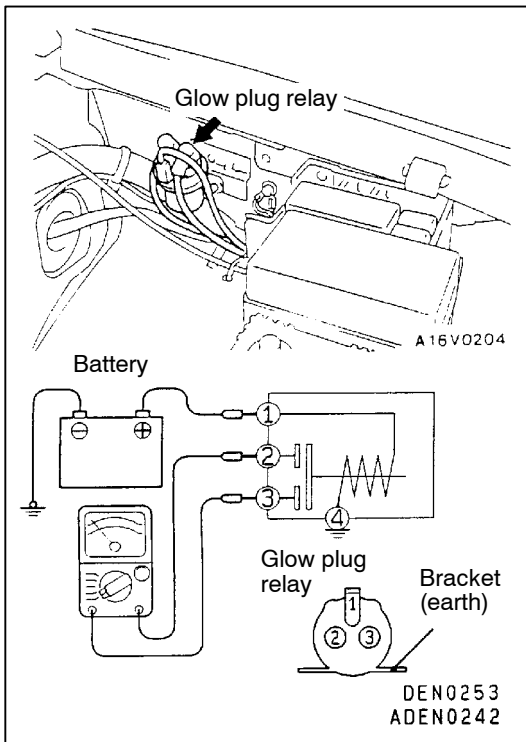

GLOW PLUG RELAY CHECK

16400250032

1. Check to be sure that there is continuity (approx. 20 Ω) between glow plug relay terminal (1) and the bracket (earth).
2. Use jumper cables to connect terminal (1) of the glow plug relay to the battery (+) terminal and the bracket to the battery (-) terminal

Caution

- (1) Always be sure to disconnect the harnesses connected to glow plug relay terminals (2) and (3) before using the jumper cables.
 - (2) The terminals of the disconnected harnesses must not be shorted to earth.
 - (3) When connecting the jumper cables, be very careful not to make a mistake in connecting the terminals, as this will cause damage to the relay.
3. Check the continuity between glow plug relay terminals (2) and (3) while disconnecting and connecting the jumper cable at the battery (+) terminal

Jumper cable at battery (+) terminal	Continuity between terminals (2) – (3)
Connected	Continuity (0.01 Ω or less)
Disconnected	No continuity (infinite resistance)

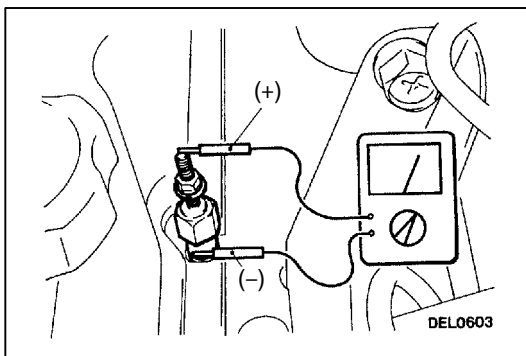

GLOW PLUG CHECK

16400190082

1. Remove the glow plug plate.
2. Measure the resistance between the glow plug terminals and the body.

Standard value: 0.6 – 1.0 Ω (at 20 °C)

Engine coolant temperature gauge unit
(engine coolant temperature sensor)

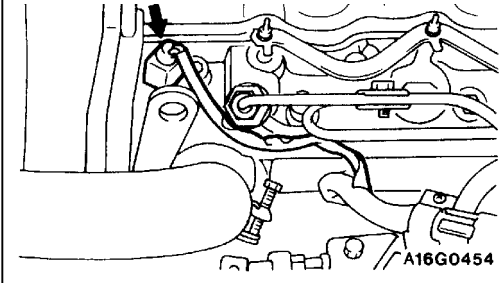

ENGINE COOLANT TEMPERATURE SENSOR CHECK

16400280031

1. Remove the engine coolant temperature sensor.

2. While the sensor section of the engine coolant temperature sensor is immersed, measure the resistance between (B) terminal and the body.

Temperature (°C)	Resistance value (kΩ)
0	8.6
20	3.25 ± 0.33
40	1.5
80	0.3

3. After applying specified sealant to the threaded portion, tighten to the specified torque.

Specified sealant:

3M Nut Locking Part No. 4171 or equivalent

Tightening torque: 35 Nm

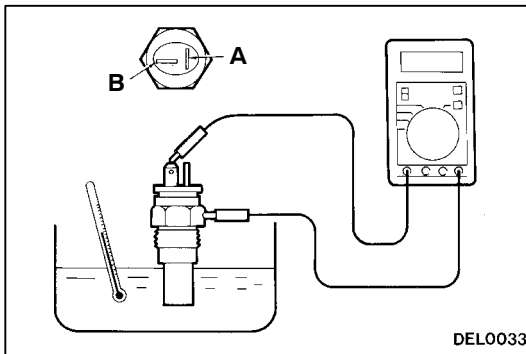

GLOW PLUG

16400180027

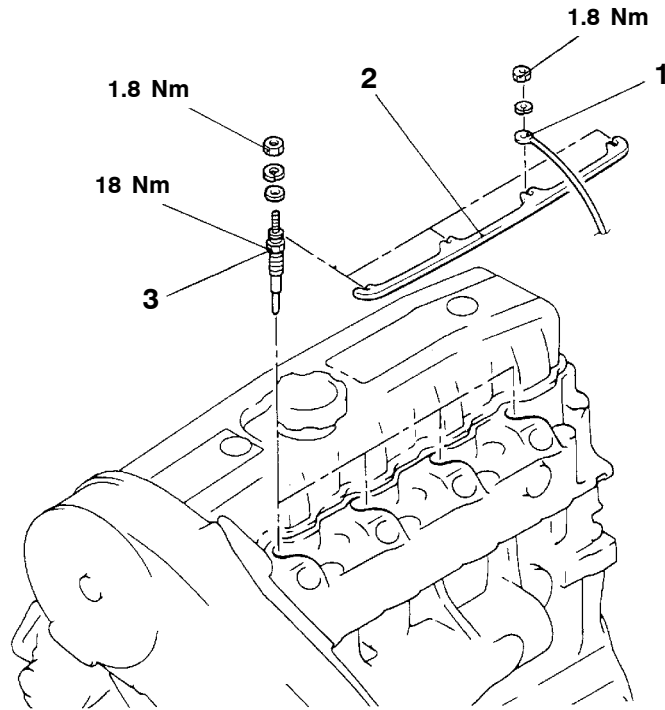
REMOVAL AND INSTALLATION

A01V0001

Removal steps

1. Connector connection
2. Glow plug plate
3. Glow plug

**REMOVAL SERVICE POINT****◀A▶ GLOW PLUG REMOVAL**

Remove glow plug by hand after loosening with tool as its ceramic part is fragile.

INSPECTION

16400190044

- Check for rust on glow plug plate.
- Check glow plug for damage.

Caution

Do not use a plug that has been dropped from a height of 10 cm or more.

ENGINE AND EMISSION CONTROL

CONTENTS

17109000308

ENGINE CONTROL SYSTEM	3	AUTO-CRUISE CONTROL SYSTEM	6
GENERAL INFORMATION	3	6
SERVICE SPECIFICATIONS	3	GENERAL INFORMATION	6
SEALANT	3	SPECIAL TOOL	6
ON-VEHICLE SERVICE	3		
Accelerator Cable Check and Adjustment	3		
ACCELERATOR CABLE AND PEDAL	4		

CONTINUED ON NEXT PAGE

WARNINGS REGARDING SERVICING OF SUPPLEMENTAL RESTRAINT SYSTEM (SRS) EQUIPPED VEHICLES

WARNING!

- (1) Improper service or maintenance of any component of the SRS, or any SRS-related component, can lead to personal injury or death to service personnel (from inadvertent firing of the air bag) or to the driver and passenger (from rendering the SRS inoperative).
- (2) Service or maintenance of any SRS component or SRS-related component must be performed only at an authorized MITSUBISHI dealer.
- (3) MITSUBISHI dealer personnel must thoroughly review this manual, and especially its GROUP 52B – Supplemental Restraint System (SRS) before beginning any service or maintenance of any component of the SRS or any SRS-related component.

NOTE

The SRS includes the following components: Front impact sensors, SRS-ECU, SRS warning lamp, air bag module, clock spring, and interconnecting wiring. Other SRS-related components (that may have to be removed/installed in connection with SRS service or maintenance) are indicated in the table of contents by an asterisk (*).

TROUBLESHOOTING	7	EXHAUST GAS RECIRCULATION (EGR) SYSTEM	36
ON-VEHICLE SERVICE	23	General Information	36
Auto-cruise Control Main Switch Check	23	Operation	36
Auto-cruise Control Switch Check	23	System Diagram	36
Auto-cruise Control Component Check	24	Component Location	36
AUTO-CRUISE CONTROL*	26	Exhaust Gas Recirculation (EGR) Control System Check	37
EMISSION CONTROL SYSTEM <6G7>	28	EGR Valve Check	37
GENERAL INFORMATION	28	EGR Port Vacuum Check	38
Emission Control Device Reference Table	28	EGR Control Solenoid Valve Check	38
SERVICE SPECIFICATIONS	29	CATALYTIC CONVERTER	39
VACUUM HOSE	29	General Information	39
Vacuum Hose Piping Diagram	29	CANISTER AND TWO-WAY VALVE	40
Vacuum Circuit Diagram	30	EMISSION CONTROL SYSTEM <4D5>	41
Vacuum Hose Check	31	GENERAL INFORMATION	41
Vacuum Hose Installation	31	SERVICE SPECIFICATIONS	41
CRANKCASE EMISSION CONTROL SYSTEM	31	SEALANT	41
General Information	31	SPECIAL TOOL	41
System Diagram	31	EXHAUST GAS RECIRCULATION (EGR) SYSTEM	42
Component Location	32	General Information	42
Positive Crankcase Ventilation System Check	32	System Diagram	42
PCV Valve Check	32	Component Location	42
EVAPORATIVE EMISSION CONTROL SYSTEM	33	Function Check	43
General Information	33	EGR Solenoid Valve Operation Check	43
System Diagram	33	EGR Solenoid Valve Resistance Check	44
Component Location	33	Lever Position Sensor (LPS) Adjustment ...	44
Purge Control System Check	34	Engine Speed Sensor Check	45
Purge Port Vacuum Check	34	Engine Coolant Temperature Sensor Check	45
Purge Control Solenoid Valve Check	35	Check at the Glow & EGR Control Unit	46
		Two-way Valve	47

ENGINE CONTROL SYSTEM

17100010126

GENERAL INFORMATION

A Cable-type accelerator mechanism and a suspended-type pedal have been adopted.

SERVICE SPECIFICATIONS

17100020037

Items		Standard value
Accelerator cable play mm		1 – 2
Engine idle speed r/min	4D5	750 ± 100
	6G7	700 ± 100

SEALANT

17300050032

Items	Specified sealant	Remarks
Accelerator arm bracket mounting bolt	3M Nut Locking Part No. 4171 or equivalent	Drying sealant

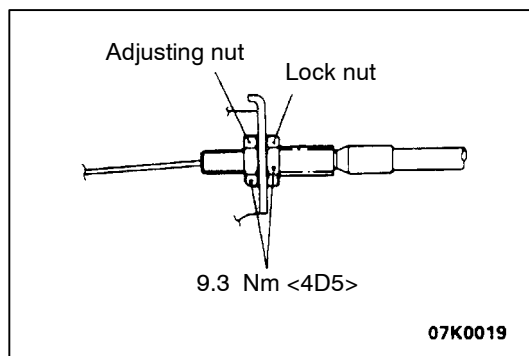

ON-VEHICLE SERVICE

17100090311

ACCELERATOR CABLE CHECK AND ADJUSTMENT

1. Turn A/C and lamps OFF.
Inspect and adjust at no load.
2. Warm engine until stabilized at idle.
3. Confirm idle speed is at prescribed value.

Standard value:

<4D5> 750 ± 100 r/min

<6G7> 700 ± 100 r/min

4. Stop engine (ignition switch OFF).
5. Confirm there are no sharp bends in accelerator cable.
6. Check inner cable for correct slack.

Standard value: 1 – 2 mm

7. If there is too much slack or no slack, adjust play by the following procedures.
 - (1) Loosen the lock nut and fully close the throttle lever.
 - (2) Tighten the adjusting nut until immediately before the throttle lever starts to move.
 - (3) By loosening the adjusting nut one turn, the accelerator cable play will be brought to the standard value.
 - (4) Fix the adjusting nut with the lock nut.
 - (5) After adjusting, check that the throttle lever is touching the stopper.

ACCELERATOR CABLE AND PEDAL

17100120348

REMOVAL AND INSTALLATION

Post-installation Operation

- Adjusting the Accelerator Cable (Refer to P. 17-3.)

<L.H. drive vehicles>

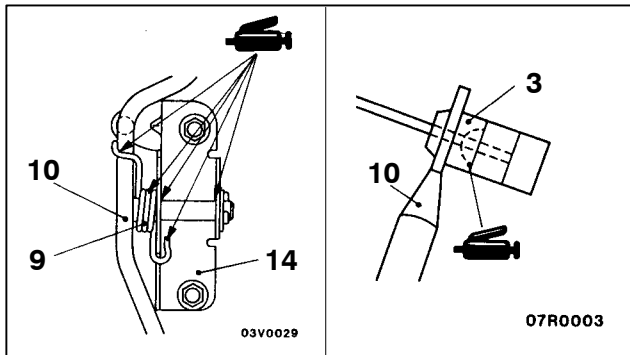
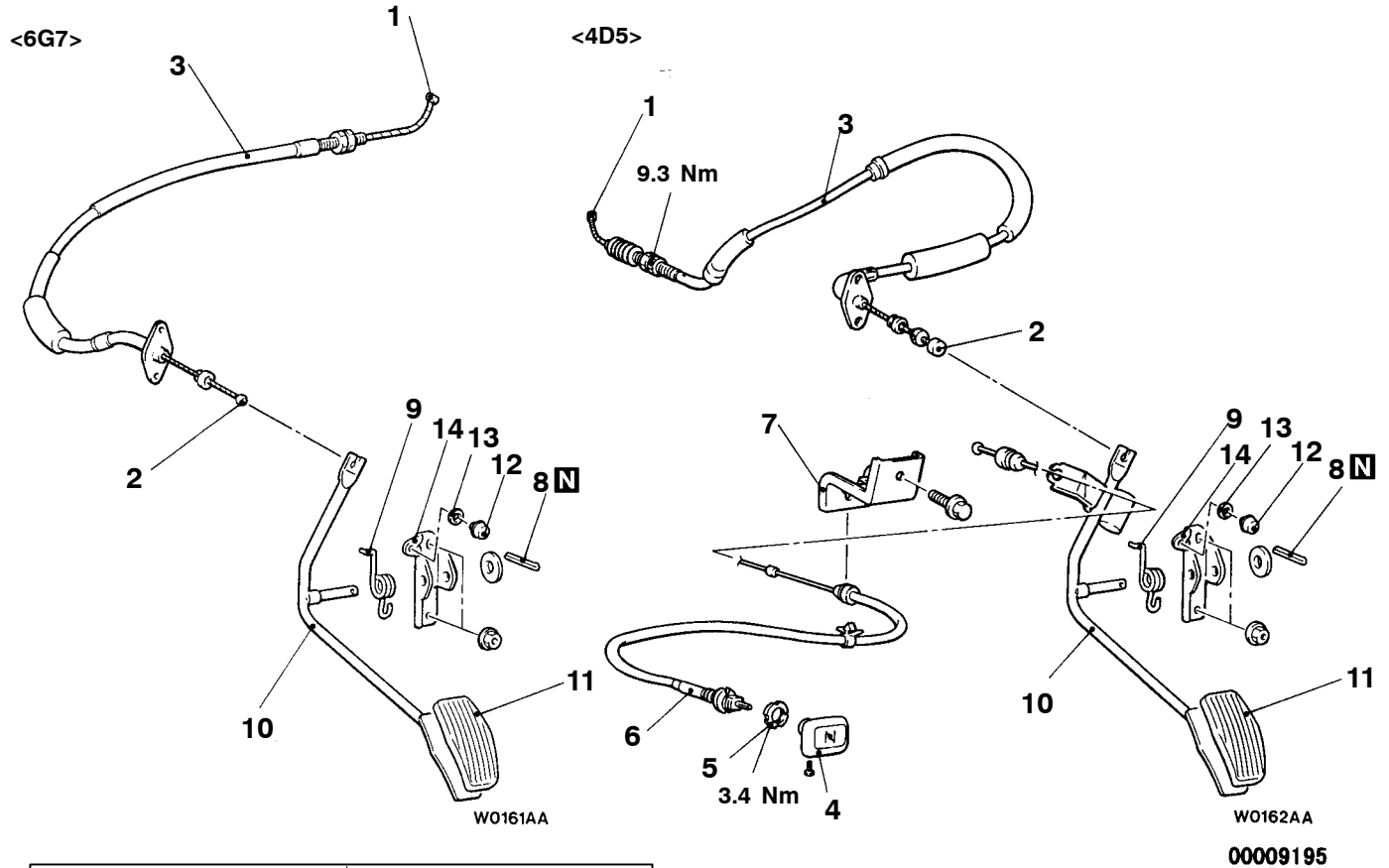

Accelerator cable removal steps

1. Inner cable connection (Injection pump side or throttle body side)
2. Inner cable connection (Accelerator pedal side)
3. Accelerator cable

Throttle control cable removal steps

4. Knob
5. Nut
6. Throttle cable
7. Cable bracket

Accelerator pedal removal steps

2. Inner cable connection (Accelerator pedal side)
4. Knob
5. Nut
6. Throttle cable
8. Split pin
9. Spring
10. Accelerator arm
11. Pedal pad
12. Stopper
13. Washer
14. Bracket

<R.H. drive vehicles>

<6G7>

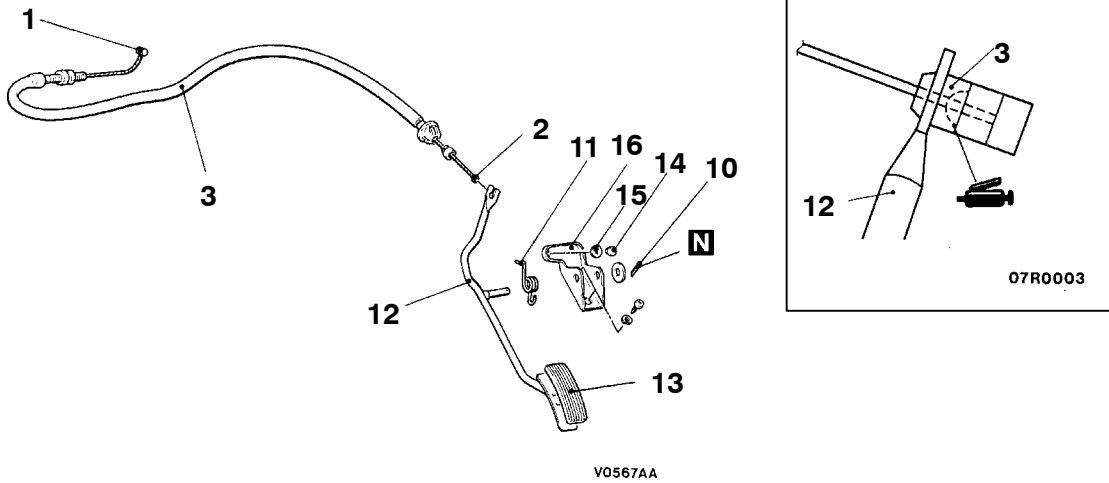

<4D5>

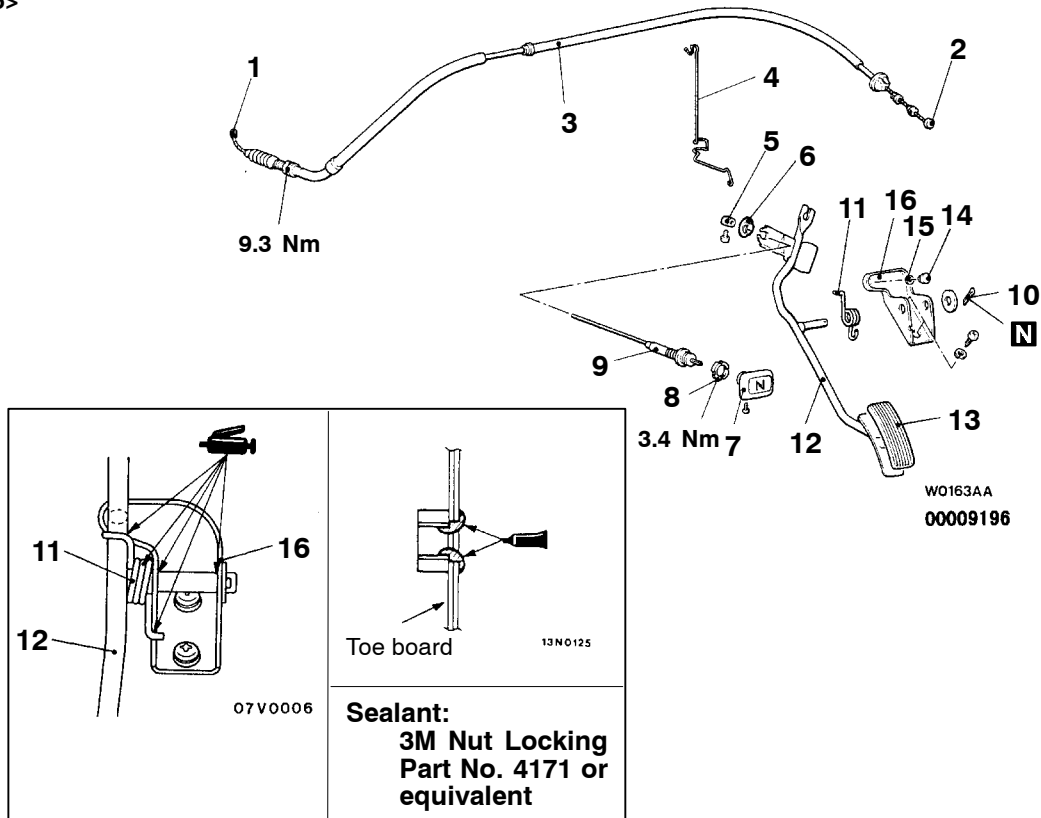

Accelerator cable removal steps

1. Inner cable connection (Injection pump side)
2. Inner cable connection (Accelerator pedal side)
3. Accelerator cable
4. Spring

Throttle control cable removal steps

5. Wire stopper
6. Bush
7. Knob
8. Nut
9. Throttle control cable

Accelerator pedal removal steps

2. Inner cable connection (Accelerator pedal side)
5. Wire stopper
10. Split pin
11. Spring
12. Accelerator arm
13. Pedal pad
14. Stopper
15. Washer
16. Bracket

AUTO-CRUISE CONTROL SYSTEM

17200010211

GENERAL INFORMATION

By using the auto-cruise control, the driver can drive at the speed he/she likes (in a range of

approximately 40–200 km/h) without depressing the accelerator pedal.

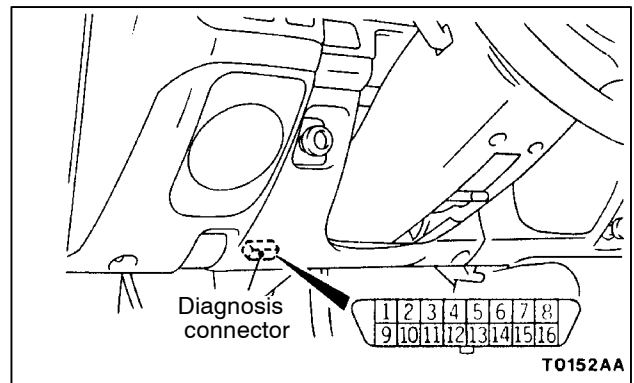
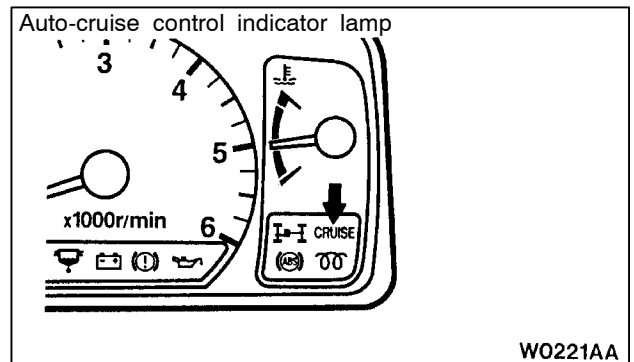
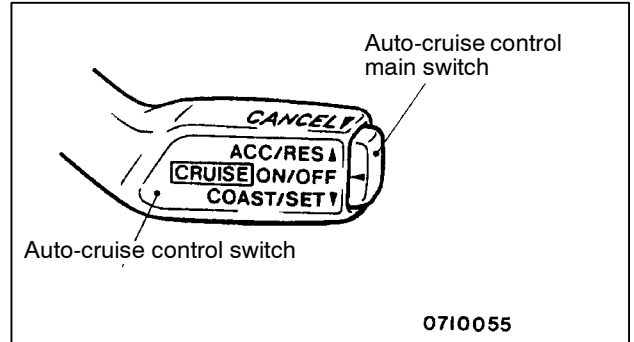
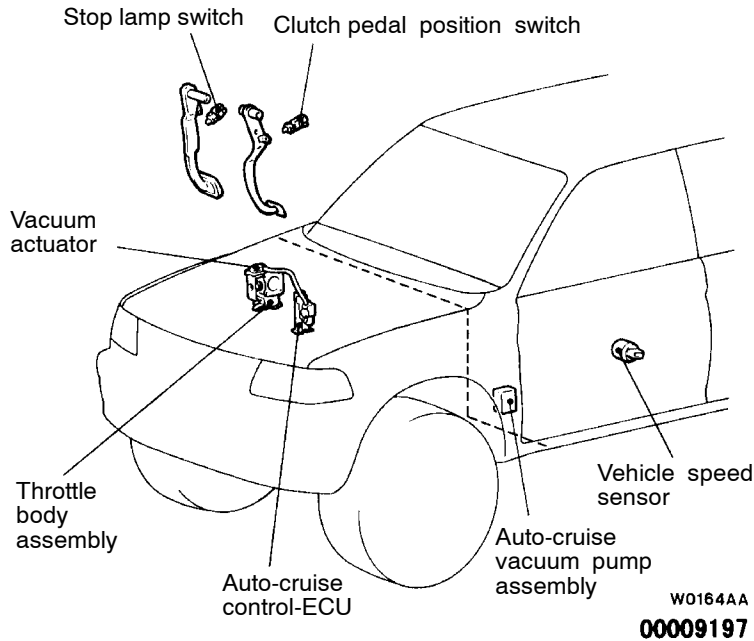

17200060209

SPECIAL TOOL

Tool	Number	Name	Use
<p>B991502</p>	MB991502	MUT-II sub assembly	<ul style="list-style-type: none"> Reading diagnosis codes Auto-cruise control system check

TROUBLESHOOTING

17200200410

STANDARD FLOW OF DIAGNOSIS TROUBLESHOOTING

Refer to GROUP 00 – How to Use Troubleshooting/Inspection Service Points.

NOTE

Check that the vacuum hose is connected correctly and is not damaged, and then carry out the diagnosis.

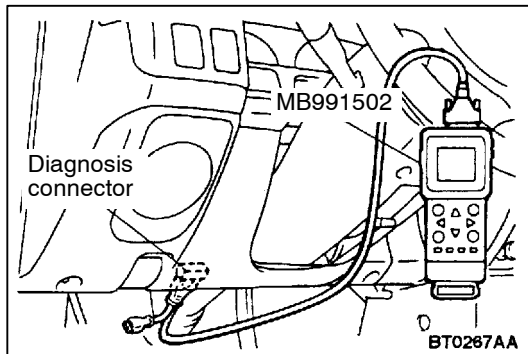

DIAGNOSIS FUNCTION

17200210277

METHOD OF READING THE DIAGNOSIS CODES

Using the MUT-II

1. Connect the MUT-II to the diagnosis connector (16-pin) under the instrument under cover.
2. With the ignition switch in the ON position, take a reading of the diagnosis codes.

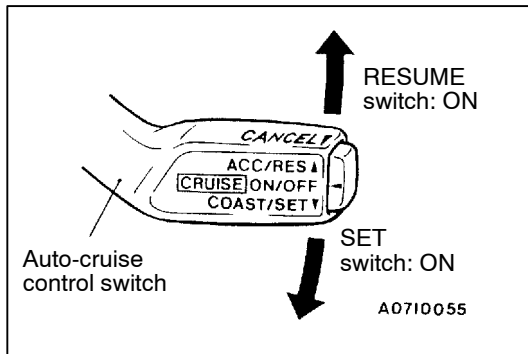

Using a Auto-cruise Control Indicator Lamp

1. Turn the ignition switch ON with the SET switch on. Then, turn the RESUME switch ON within 1 second.
2. Read a diagnosis code by observing the flash display pattern of the auto-cruise control indicator lamp in the combination meter.

Indication of diagnosis code by auto-cruise control indicator lamp

When the diagnosis code No.24 is output	When no diagnosis code is output
<p>14N0173</p>	<p>14N0174</p>

NOTE

Other on-board diagnostic items are also output as voltage waveforms corresponding to diagnosis code numbers.

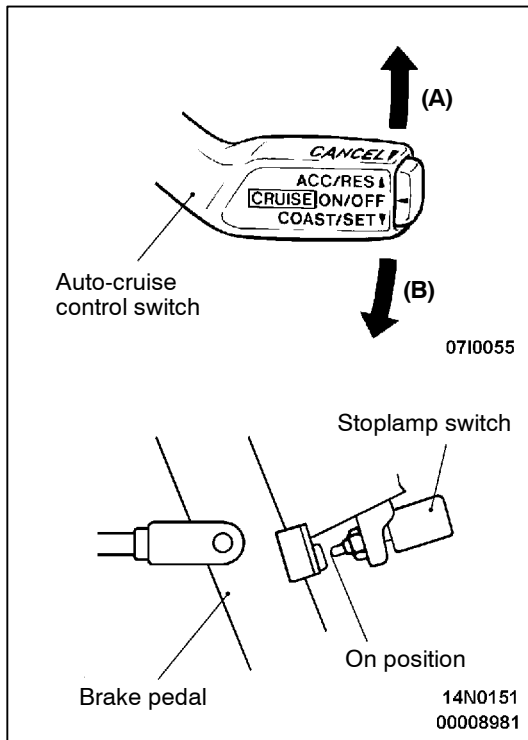

METHOD OF ERASING THE DIAGNOSIS CODES

The diagnosis codes can be erased by the following procedure.

NOTE

The diagnosis code will not be erased even if the battery (-) terminal is disconnected.

Using the MUT-II

1. Connect the MUT-II to the diagnosis connector (16-pin) under the instrument under cover.
2. With the ignition switch in the ON position, take a erasing of the diagnosis codes.

Without using the MUT-II

1. Turn the ignition switch ON.
2. Push the auto-cruise control swith in the direction of arrow (B) in the illustration. Then press the auto-cruise control main switch to the ON position, and within 1 second push the auto-cruise control switch back in the direction of arrow (A).
3. Push the auto-cruise conteol switch again in the direction of arrow (B) in the illustration. While holding the switch in this position, press the stoplamp switch to the ON position, for 5 seconds or more.

INPUT SWITCH CODE CHECK METHOD

1. Connect the MUT-II to the diagnosis connector (16-pin) under the instrument under cover.
2. With the ignition switch in the ON position, take a erasing of the input switch codes.

Service Data Output

Items No.	Service data item		Unit
01	Auto-cruise control switch	Main	ON/OFF
02		Set	ON/OFF
03		Resume	ON/OFF
04		Cancel	ON/OFF
05	Stoplamp switch		ON/OFF
10	Vehicle speed sensor		km/h
13	TPS		mV
14	Clutch pedal position switch		ON/OFF
15	Over drive detective		ON/OFF

INSPECTION CHART FOR DIAGNOSIS CODES

17200220478

Code No.	Diagnosis item	Reference page
11	Auto-cruise vacuum pump drive system	17-10
12	Vehicle speed signal system	17-10
14	Auto-cruise vacuum pump power supply system	17-11
15	Auto-cruise control switch	17-11
16	Auto-cruise control-ECU	17-11
17	Throttle position sensor system	17-12

INSPECTION PROCEDURE FOR DIAGNOSIS CODES

Code No. 11 Auto-cruise vacuum pump drive system	Probable cause
This diagnosis code is output if the release valve, control valve or motor drive signals from the auto-cruise vacuum pump are not input to the auto-cruise control-ECU.	<ul style="list-style-type: none"> ● Malfunction of the auto-cruise vacuum pump ● Malfunction of the connector ● Malfunction of the harness ● Malfunction of the auto-cruise control-ECU

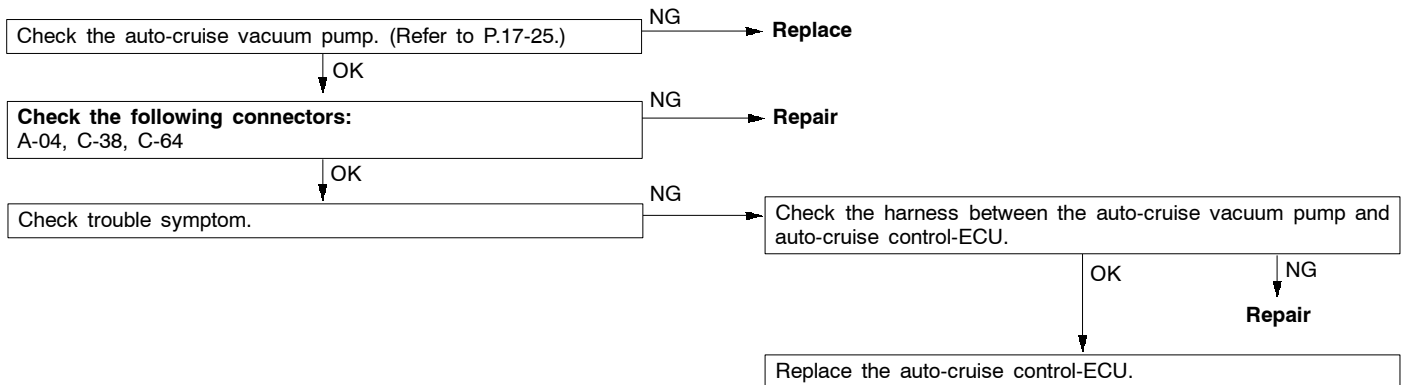

Code No. 12 Vehicle speed signal system	Probable cause
This diagnosis code is output if the vehicle speed signals from the vehicle speed sensor are not input to the auto-cruise control-ECU when the vehicle speed is 40 km/h or more.	<ul style="list-style-type: none"> ● Malfunction of the vehicle speed sensor ● Malfunction of the connector ● Malfunction of the harness ● Malfunction of the auto-cruise control-ECU

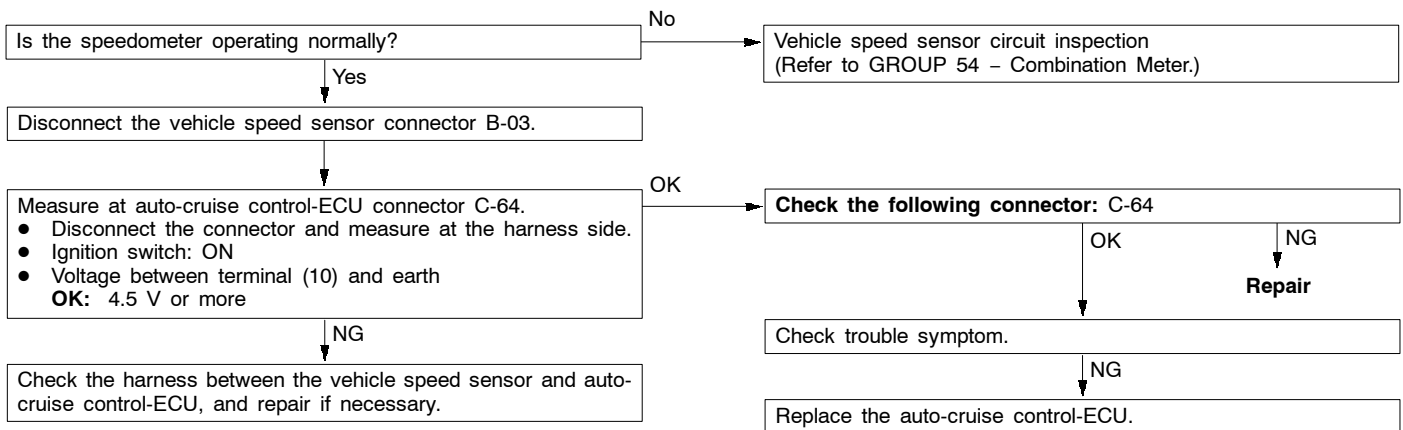

Code No. 14 Auto-cruise vacuum pump power supply system	Probable cause
This diagnosis code is output when none of the drive signals from the release valve, control valve and motor of the auto-cruise vacuum pump are input to the auto-cruise control-ECU.	<ul style="list-style-type: none"> ● Malfunction of the stop lamp switch ● Malfunction of the connector ● Malfunction of the harness ● Malfunction of the auto-cruise control-ECU ● Malfunction of the auto-cruise vacuum pump

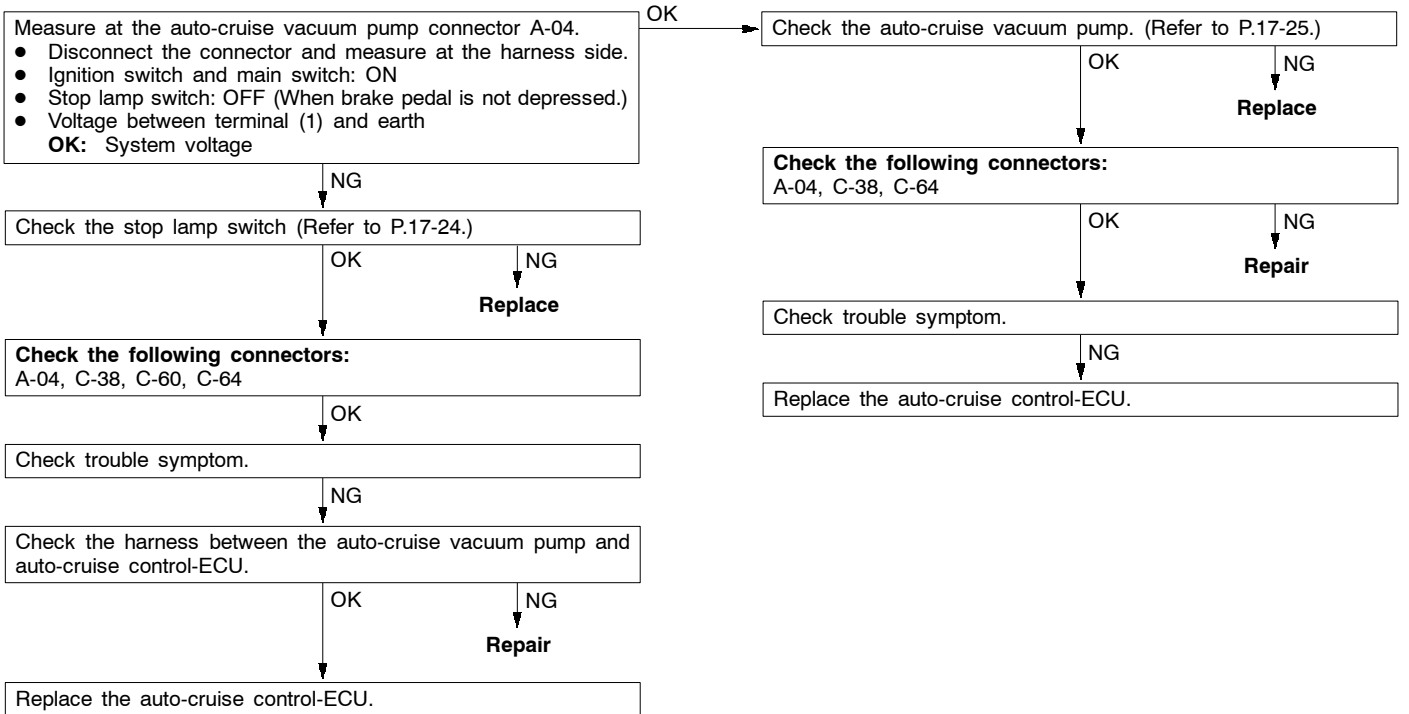

Code No. 15 Auto-cruise control switch	Probable cause
This diagnosis code is output if the cruise control RESUME switch or SET switch remains ON.	<ul style="list-style-type: none"> ● Malfunction of the auto-cruise control switch

Replace the auto-cruise control switch.

Code No. 16 Auto-cruise control-ECU	Probable cause
This diagnosis code is output if there is an abnormality in the CANCEL hold circuit or the microprocessor monitor circuit in the auto-cruise control-ECU.	<ul style="list-style-type: none"> ● Malfunction of the auto-cruise control-ECU

Replace the auto-cruise control-ECU.

17-12 ENGINE AND EMISSION CONTROL – Auto-cruise Control System

Code No. 17 Throttle position sensor system	Probable cause
This diagnosis code is output if a voltage of 2.5 V or more when the idle switch is ON or 0.2 V or less when the idle switch is OFF is output for a continuous period of 4 seconds or more.	<ul style="list-style-type: none"> • Malfunction of the throttle position sensor • Malfunction of the connector • Malfunction of the harness • Malfunction of the auto-cruise control-ECU

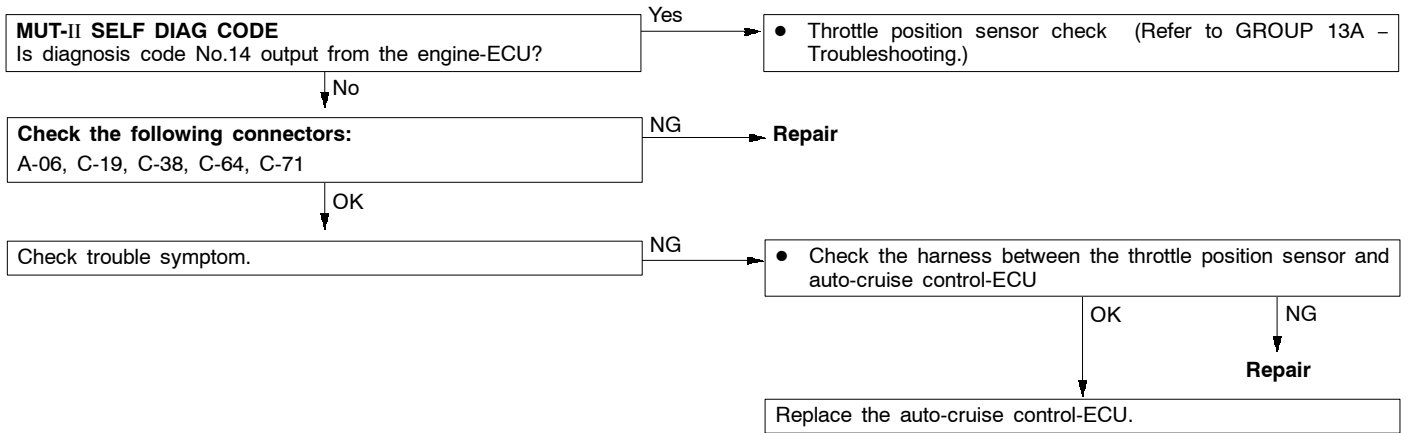

INSPECTION CHART FOR TROUBLE SYMPTOMS

17200230440

Trouble symptom		Inspection procedure No.	Reference page
Communication with MUT-II is not possible.	Communication with all systems is not possible.	1	17-13
	Communication with auto-cruise control-ECU only is not possible.	2	17-14
Input switch inspection using the MUT-II is not possible. (However, diagnosis inspection is possible.)		3	17-15
Auto-cruise control is not cancelled.	Even if brake pedal is depressed	4	17-16
	Even if clutch pedal is depressed	5	17-17
	Even if CANCEL switch is set to ON	6	17-18
Auto-cruise control cannot be set.		7	17-18
Hunting (repeated acceleration and deceleration) occurs at the set vehicle speed.		8	17-19
Auto-cruise control indicator lamp inside combination meter does not illuminate. (However, auto-cruise control is normal.)		9	17-19

INSPECTION PROCEDURE FOR TROUBLE SYMPTOMS

Inspection Procedure 1

Communication with MUT-II is not possible. (Communication with all system is not possible.)	Probable cause
The reason is probably a defect in the power supply system (including earth) for the diagnosis line.	<ul style="list-style-type: none"> ● Malfunction of the connector ● Malfunction of the harness

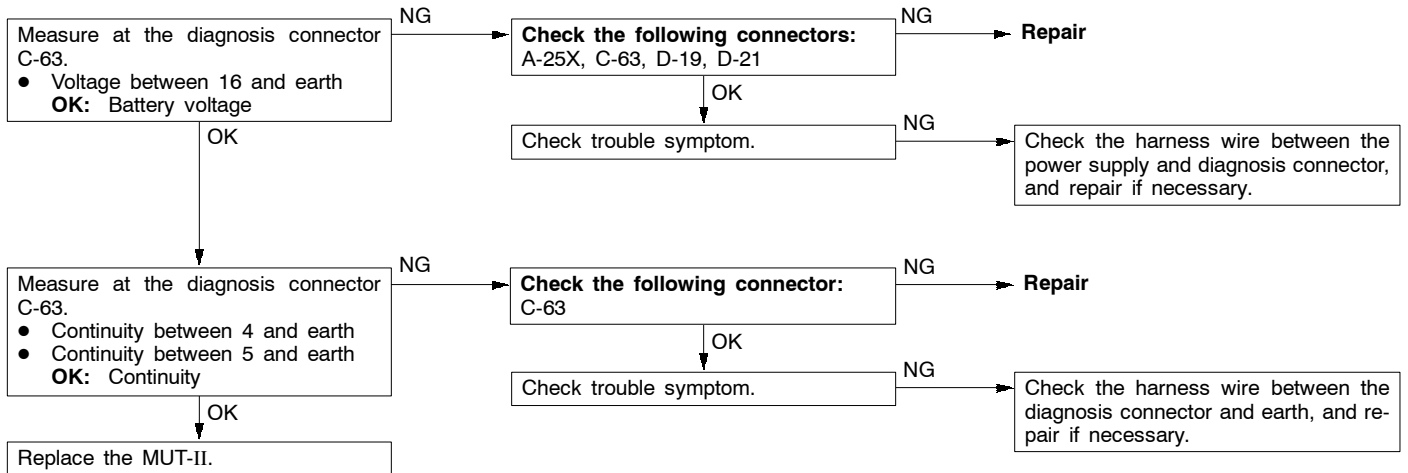

17-14 ENGINE AND EMISSION CONTROL – Auto-cruise Control System

Inspection Procedure 2

Communication with MUT-II is not possible. (Communication with auto-cruise control-ECU only is not possible.)	Probable cause
The cause is probably a malfunction of auto-cruise control-ECU earth circuit.	<ul style="list-style-type: none"> ● Malfunction of the connector ● Malfunction of the harness ● Malfunction of the auto-cruise control-ECU

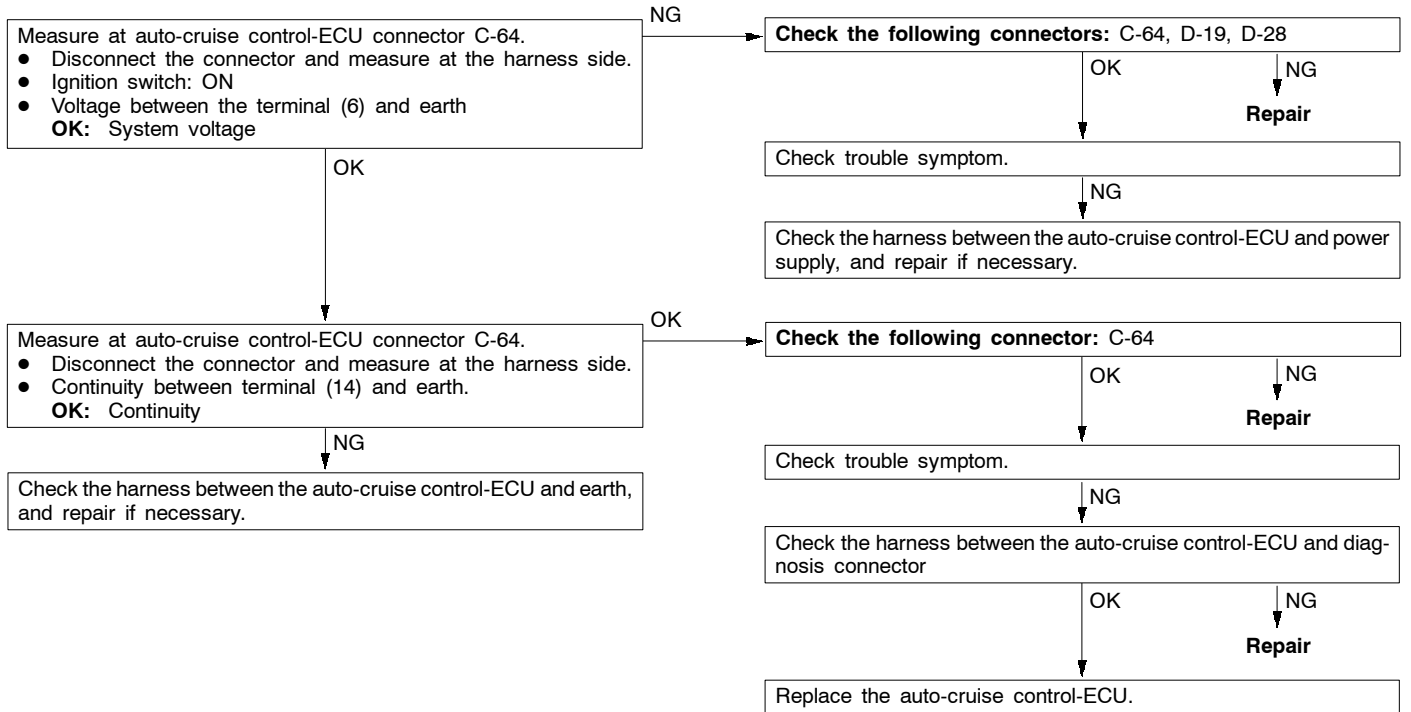

Inspection Procedure 3

Input switch inspection using the MUT-II is not possible. (However, diagnosis inspection is possible.)	Probable cause
The cause is probably a malfunction of auto-cruise control switch circuit system.	<ul style="list-style-type: none"> ● Malfunction of the auto-cruise control switch ● Malfunction of the clock spring ● Malfunction of the connector ● Malfunction of the harness

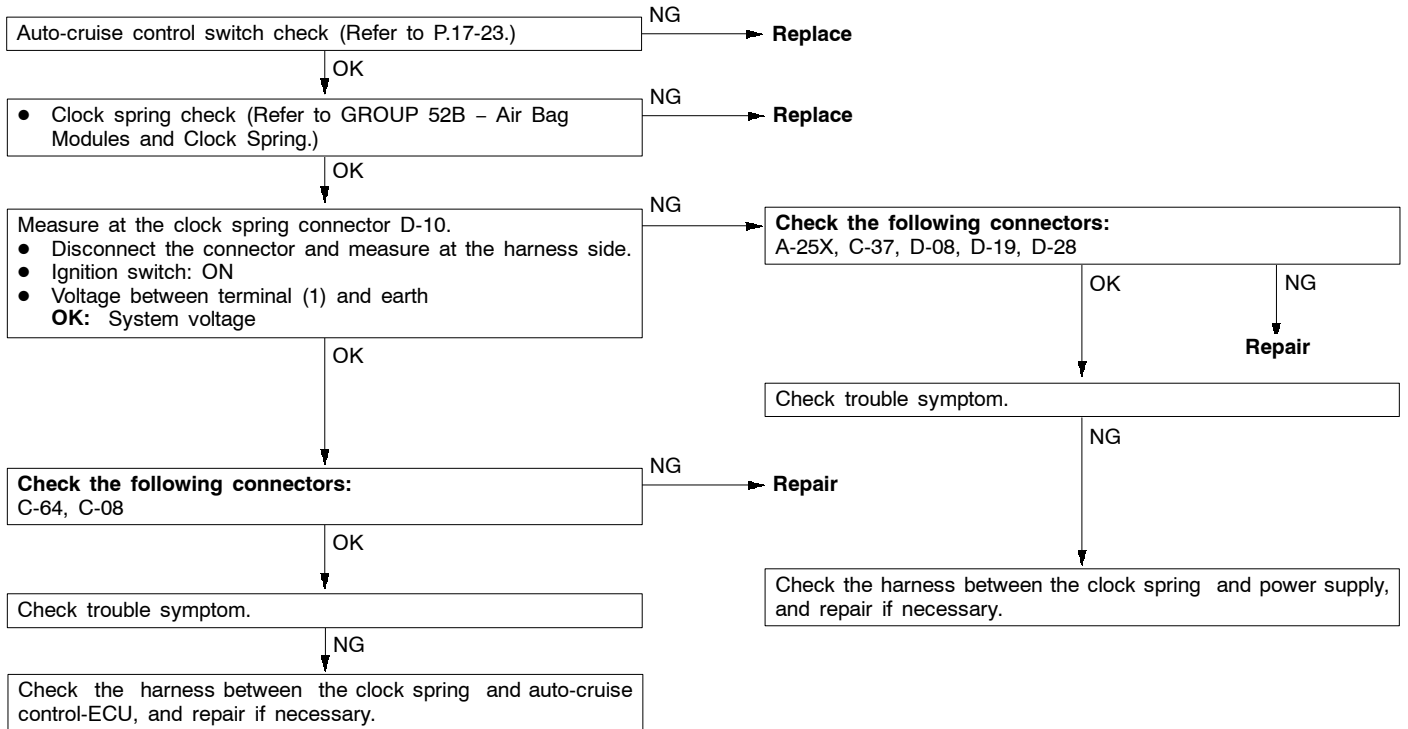

17-16 ENGINE AND EMISSION CONTROL – Auto-cruise Control System

Inspection Procedure 4

Even if brake pedal is depressed, auto-cruise control is not cancelled.	Probable cause
The cause is probably a malfunction of stop lamp switch or a malfunction of stop lamp circuit.	<ul style="list-style-type: none"> ● Malfunction of the stop lamp switch ● Malfunction of the connector ● Malfunction of the harness ● Malfunction of the auto-cruise control-ECU

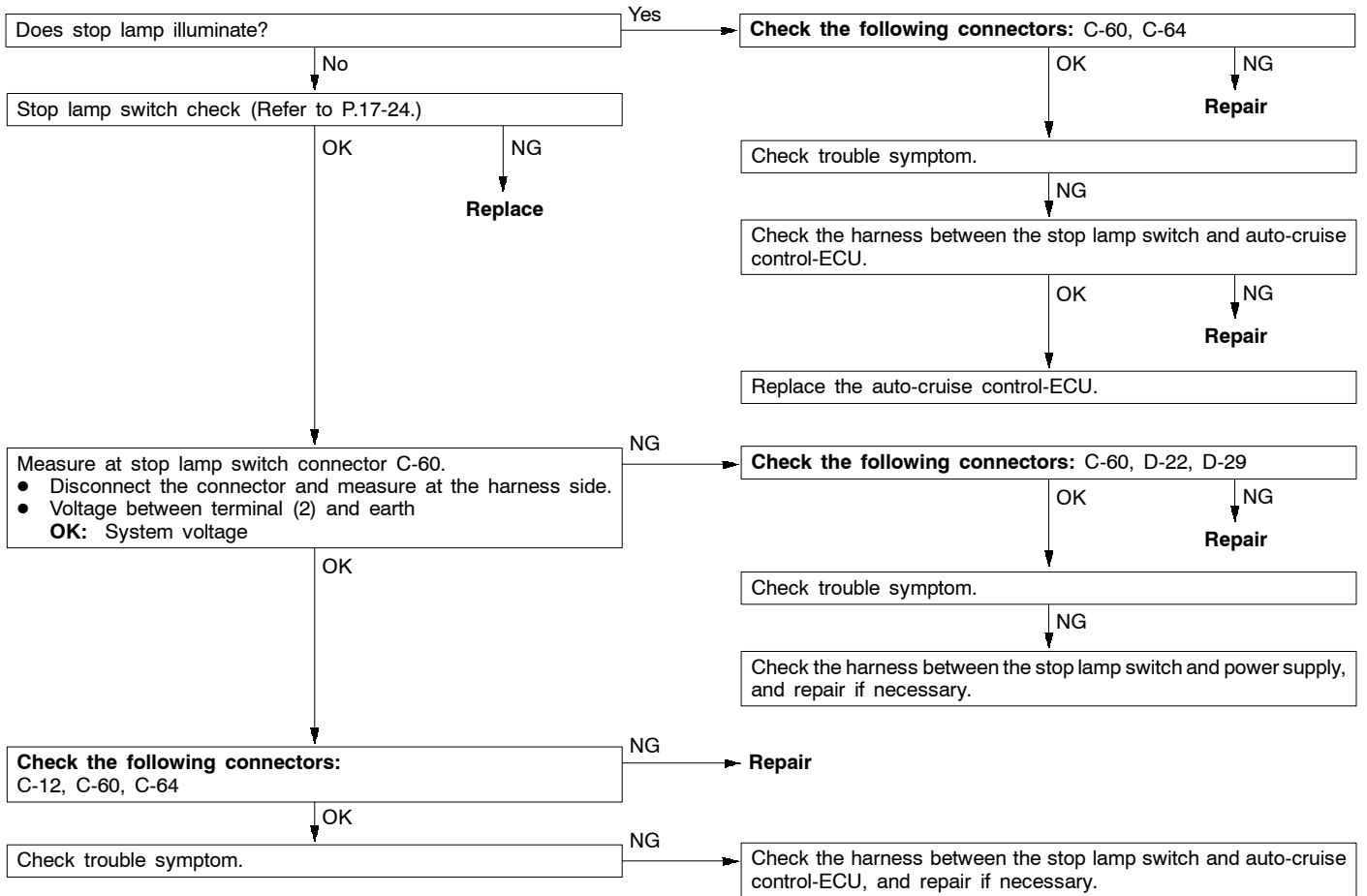

Inspection Procedure 5

Even if clutch pedal is depressed, auto-cruise control is not cancelled.	Probable cause
The cause is probably a malfunction of clutch pedal position switch or clutch circuit.	<ul style="list-style-type: none"> ● Malfunction of the clutch pedal position switch ● Malfunction of the connector ● Malfunction of the harness ● Malfunction of the auto-cruise control-ECU

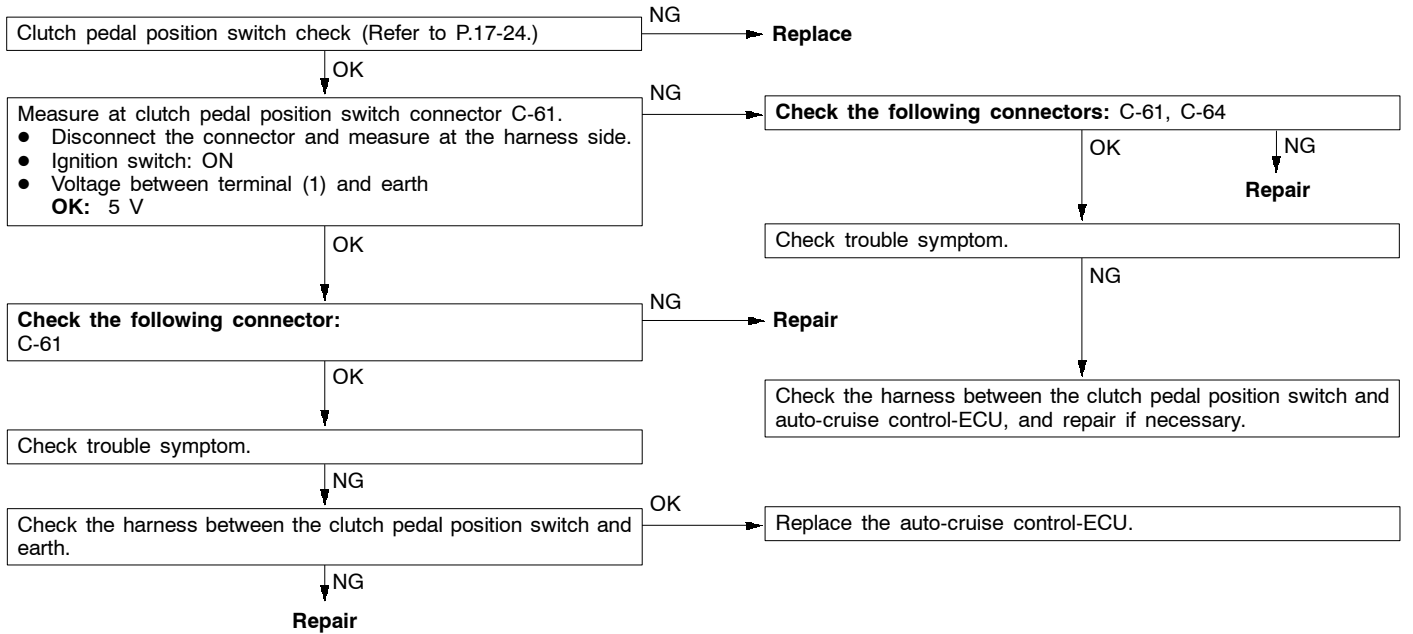

17-18 ENGINE AND EMISSION CONTROL – Auto-cruise Control System

Inspection Procedure 6

Even if auto-cruise control CANCEL switch is set to ON, auto-cruise control is not cancelled.	Probable cause
The cause is probably an open-circuit in the circuit inside the CANCEL switch.	<ul style="list-style-type: none"> Malfunction of the auto-cruise control-ECU

Replace the auto-cruise control switch.

Inspection Procedure 7

Auto-cruise control cannot be set.	Probable cause
The cause is probably that the fail-safe function is cancelling auto-cruise control. In this case, the MUT-II can be used to check the trouble symptoms in each system by inspecting the diagnosis codes. The MUT-II can also be used to check if the circuits of each input switch are normal or not by inspecting the input switch codes.	<ul style="list-style-type: none"> Malfunction of the auto-cruise control main switch Malfunction of the auto-cruise control switch Malfunction of the clock spring Malfunction of the harnesses or connectors Malfunction of the clutch pedal position switch Malfunction of the auto-cruise control-ECU

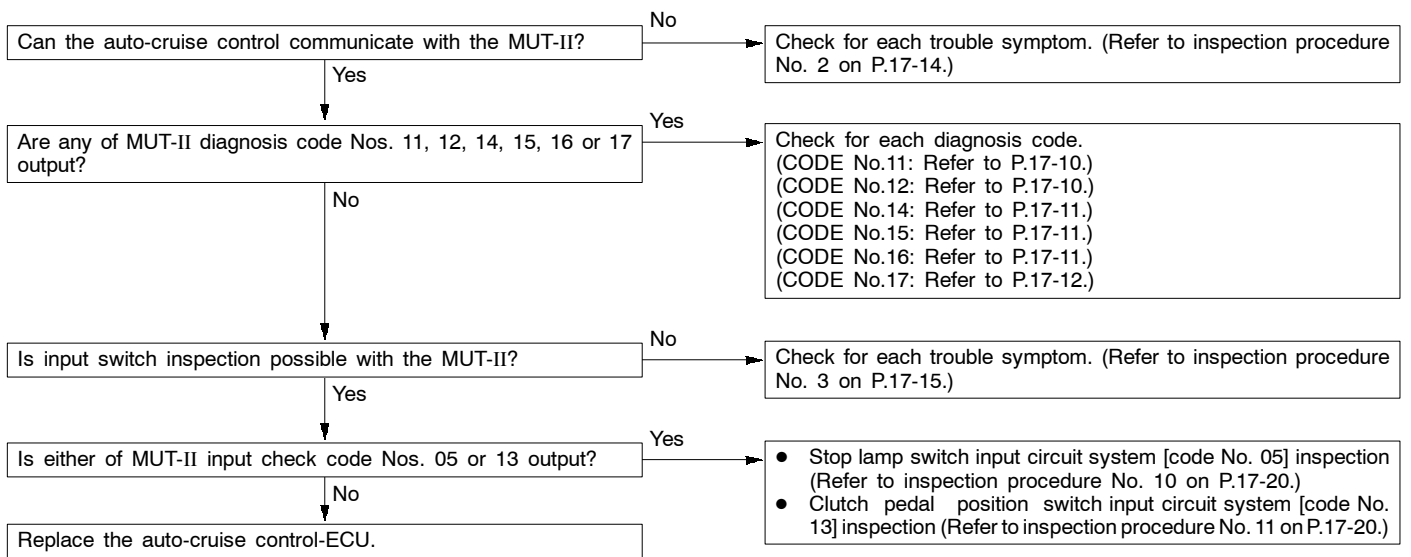

Inspection Procedure 8

Hunting (repeated acceleration and deceleration) occurs at the set vehicle speed.	Probable cause
The cause is probably a malfunction of vehicle speed sensor or incorrect vacuum in the auto-cruise vacuum pump or vacuum actuator.	<ul style="list-style-type: none"> ● Malfunction of the vehicle speed sensor ● Malfunction of the auto-cruise vacuum pump ● Malfunction of the vacuum actuator ● Malfunction of the auto-cruise control-ECU

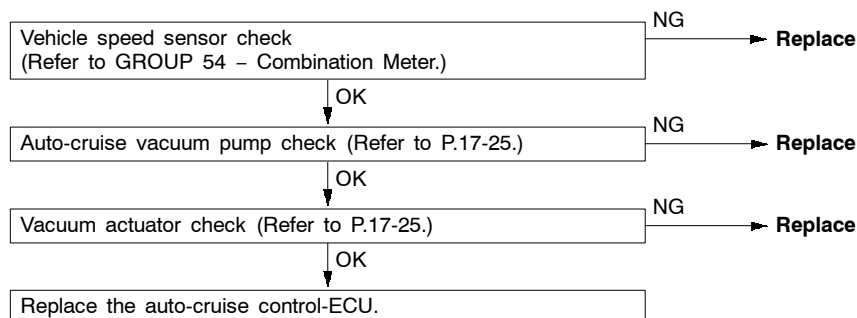

Inspection Procedure 9

Auto-cruise control indicator lamp inside combination meter does not illuminate. (However, auto-cruise control is normal.)	Probable cause
The cause is probably a malfunction of bulb or a malfunction of connector or harness.	<ul style="list-style-type: none"> ● Malfunction of the bulb ● Malfunction of the harness ● Malfunction of the connector ● Malfunction of the auto-cruise control-ECU

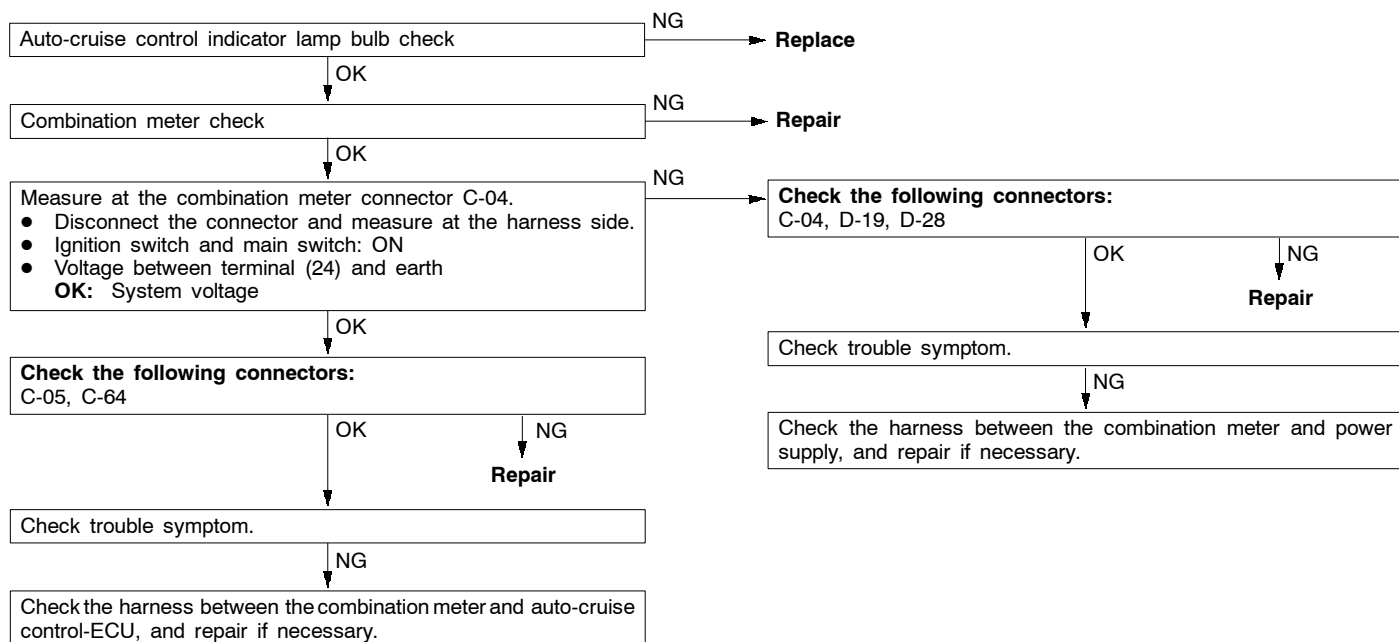

17-20 ENGINE AND EMISSION CONTROL – Auto-cruise Control System

Inspection Procedure 10

Stop lamp switch input circuit system inspection (Code No. 05)

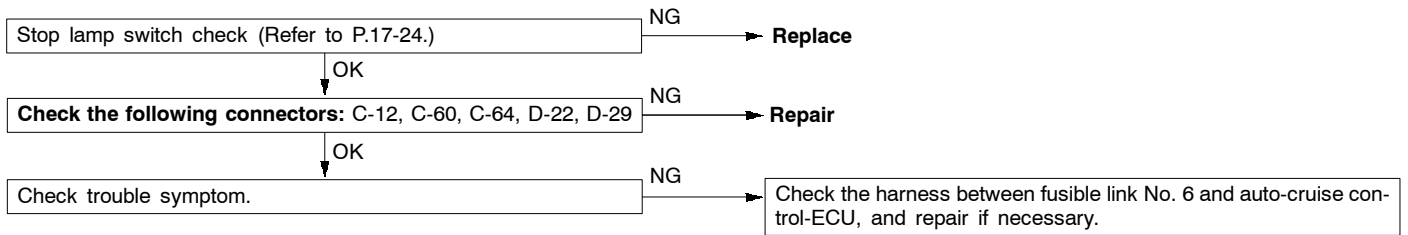

Inspection Procedure 11

Clutch pedal position switch input circuit system inspection (Code No. 13)

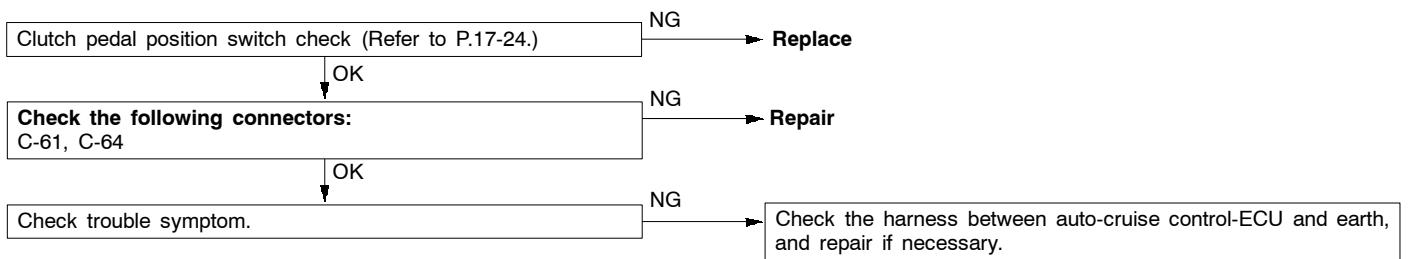

CHECK AT ECU TERMINALS

17200270213

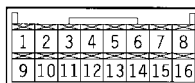

07K0059

Terminal No.	Check item	Check conditions		Normal condition
1	Throttle position sensor input	When accelerator pedal is fully depressed		4.5–5.5 V
		When accelerator pedal is released		0.3 –1.0 V
2	Engine-ECU output	When accelerator pedal is depressed		4.5–5.5 V
		When accelerator pedal is not released		0 V
4	Stoplamp switch input	When brake pedal is depressed	When stop lamp switch is ON	System voltage
		When brake pedal is not depressed	When stop lamp switch is OFF	0 V
5	Pump power supply	Ignition switch: ON Stoplamp switch: OFF		System voltage
6	ECU power supply	Ignition switch: ON		System voltage
7	Auto-cruise vacuum pump release valve and control valve input	When decelerating with the SET switch while driving at constant speed	Release valve closed	System voltage
8			Control valve open/closed	System voltage
7		When cancelling constant speed driving with the CANCEL switch	Release valve open	System voltage
8			Control valve open	System voltage
9	Auto-cruise control switch input	When main switch is ON		Approx. 9.0 V
		When input switch has not been operated	When all switches are OFF	Approx. 4.5 V
		When input switch is pushed down	When SET switch is ON	Approx. 1.5 V
		When input switch is pushed up	When RESUMRE switch is ON	Approx. 3.0 V
		When input switch is pulled forward	When CANCEL switch is ON	Approx. 0 V
10	Vehicle speed sensor input	When vehicle is moved forwards and backwards, sensor turns ON and OFF repeatedly	When sensor is ON	0 V
			When sensor is OFF	4.5 V or more
11	Diagnosis control input	When ignition switch is ON		4 V or more
12	ACC power supply	When ignition switch is in ACC position Main switch: ON		System voltage

17-22 ENGINE AND EMISSION CONTROL – Auto-cruise Control System

Terminal No.	Check item	Check conditions		Normal condition
13	Clutch pedal position switch input	When pedal is not depressed	When clutch pedal position switch is OFF	System voltage
		When pedal is depressed	When clutch pedal position switch is ON	0 V
14	Earth	At any time		Continuity
15	Indicator lamp input (inside combination meter)	When indicator lamp is illuminated		0 V
		When indicator lamp is switch off		System voltage
16	Auto-cruise vacuum pump motor input	When driving at constant speed using the SET switch	Motor stopped/running	System voltage/0 V
		When accelerating with the RESUME switch while driving at constant speed	Motor stopped/running	System voltage/0 V
		When decelerating with the SET switch while driving at constant speed	Motor stopped	System voltage
		When cancelling constant speed driving with the CANCEL switch	Motor stopped	System voltage

ON-VEHICLE SERVICE

17200120198

AUTO-CRUISE CONTROL MAIN SWITCH CHECK

1. Turn the ignition key to ON.
2. Check to be sure that the indicator lamp within the combination meter illuminates when the main switch is switched ON.

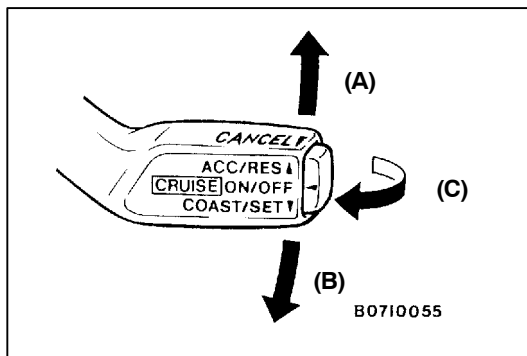
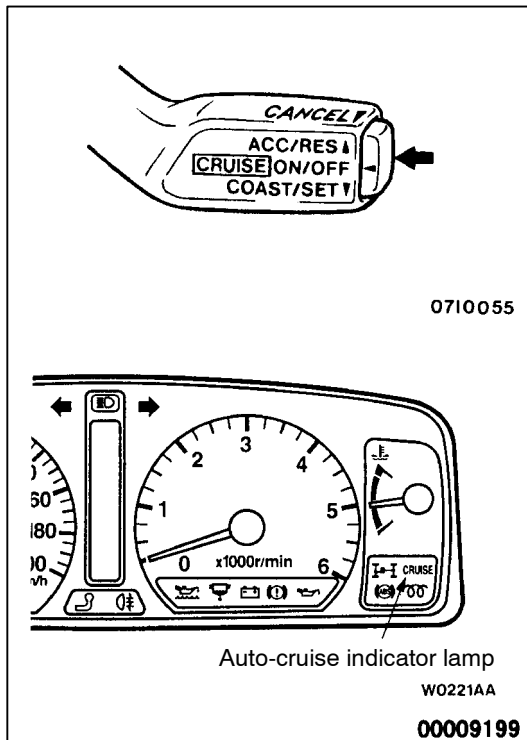
**AUTO-CRUISE CONTROL SWITCH CHECK****AUTO-CRUISE CONTROL SETTING**

1. Switch ON the main switch.
2. Drive at the desired speed within the range of approximately 40–200 km/h.
3. Push the auto-cruise control switch in the direction of arrow (B).
4. Check to be sure that when the switch is released the speed is the desired constant speed.

NOTE

If the vehicle's speed decreases to approximately 15 km/h below the set speed because of climbing a hill for example, the auto-cruise control will be cancelled.

SPEED-INCREASE SETTING

1. Set to the desired speed.
2. Push the auto-cruise control switch in the direction of arrow (A).
3. Check to be sure that acceleration continues while the switch is held, and that when it is released the constant speed at the time when it was released becomes the driving speed.

NOTE

Acceleration can be continued even if the vehicle speed has passed the high-speed limit (approx. 200 km/h). But the speed when the auto-cruise control switch is released will be recorded as the high-speed limit.

SPEED-REDUCTION SETTING

1. Set to the desired speed.
2. Push the auto-cruise control switch in the direction of arrow (B).
3. Check to be sure that deceleration continues while the switch is pressed, and that when it is released the constant speed at the time when it was released becomes the driving speed.

NOTE

When the vehicle speed reaches the low limit (approximately 40 km/h) during deceleration, the auto-cruise control will be cancelled.

RETURN TO THE SET SPEED BEFORE CANCELLATION AND AUTO-CRUISE CONTROL CANCELLATION

1. Set the auto-cruise speed control.
2. When any of the following operations are performed while at constant speed during auto-cruise control, check if normal driving is resumed and deceleration occurs.
 - a. The auto-cruise control switch is pushed in the direction of arrow (C).
 - b. The brake pedal is depressed.
 - c. The clutch pedal is depressed.
3. When the auto-cruise control switch is pushed in the direction of arrow (A) at a vehicle speed of 40 km/h or higher, check if the vehicle speed returns to the speed before auto-cruise control driving was cancelled, and constant speed driving occurs.
4. When the main switch is turned to OFF while driving at constant speed, check if normal driving is resumed and deceleration occurs.

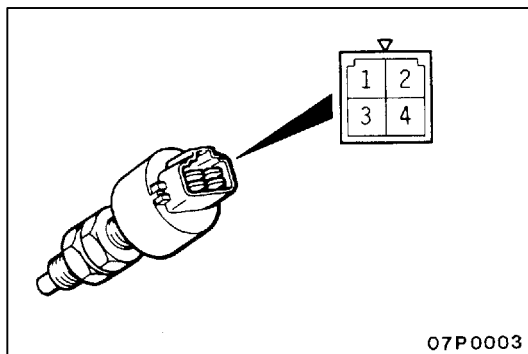

AUTO-CRUISE CONTROL COMPONENT CHECK

STOP LAMP SWITCH

1. Disconnect the connector.
2. Check for continuity between the terminals of the switch.

Measurement conditions	Terminal No.			
	1	3	4	5
When brake pedal is depressed. (for stop lamp circuit)		○—○		
When brake pedal is depressed. (for auto-cruise control circuit)	○—○			

CLUTCH PEDAL POSITION SWITCH

Refer to GROUP 21 – On-vehicle Service.

THROTTLE POSITION SENSOR

Refer to GROUP 13A – On-vehicle Service.

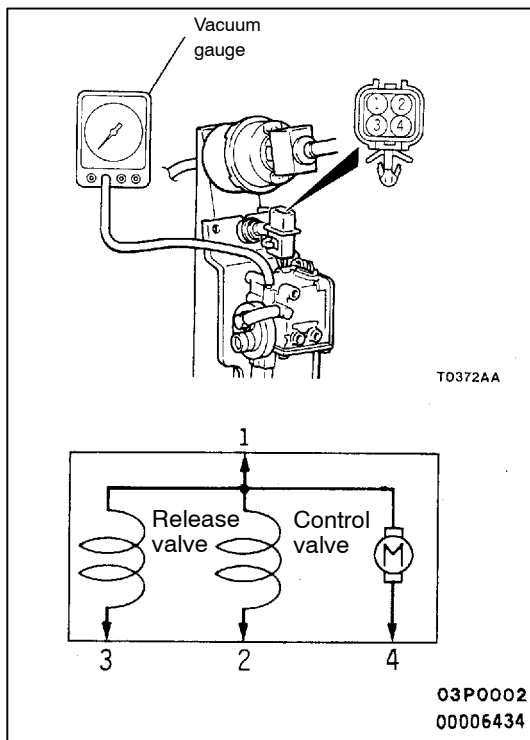

AUTO-CRUISE VACUUM PUMP

1. Disconnect the vacuum hose from the auto-cruise vacuum pump and connect a vacuum gauge to the vacuum pump.
2. Disconnect the vacuum pump connector.
3. Check that the reading on the vacuum gauge matches the values in the table below when the battery is connected to each connector terminal.

Terminal No.				Valve condition	Vacuum gauge kPa
1	2	3	4		
⊕	⊖	⊖	⊖	Release valve closed Control valve closed	53 or more
⊕		⊖	⊖	Release valve open	20 or less
⊕	⊖		⊖	Control valve open	

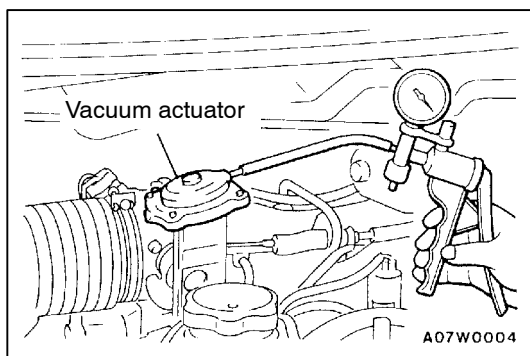

VACUUM ACTUATOR

1. Disconnect the vacuum hose from the vacuum actuator, and connect a hand vacuum pump to the actuator.
2. Check that the throttle lever operates when applying vacuum, and the vacuum is kept.

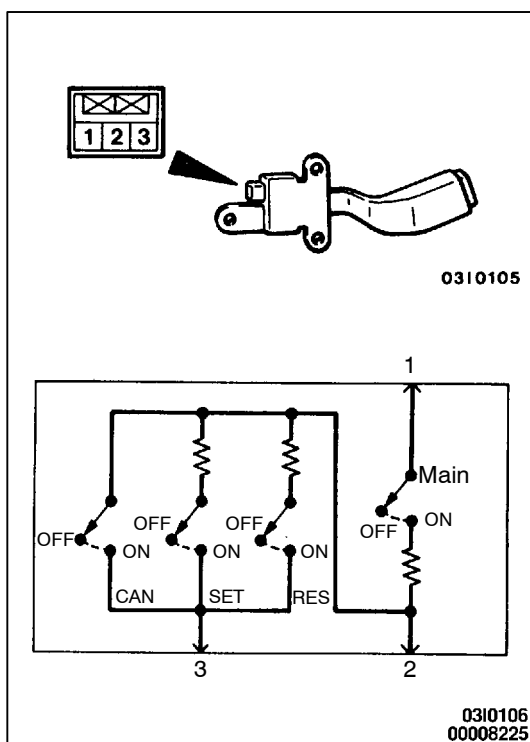

AUTO-CRUISE CONTROL SWITCH CHECK

Measure the resistance between the terminals when each of the SET, RESUME, CANCEL and MAIN switches is pressed. If the values measured at this time correspond to those in the table below, then there is no problem.

Switch position	Resistance between terminals	
Switch OFF	No continuity	
CANSEL switch ON	Terminals 1 and 3	Approx. 3.9 kΩ
	Terminals 2 and 3	Approx. 0 Ω
RESUME switch ON	Terminals 1 and 3	Approx. 4.8 kΩ
	Terminals 2 and 3	Approx. 910 Ω
SET switch ON	Terminals 1 and 3	Approx. 4.1 kΩ
	Terminals 2 and 3	Approx. 220 Ω
MAIN switch ON	Terminals 1 and 2	Approx. 3.9 kΩ

VEHICLE SPEED SENSOR CHECK

Refer to GROUP54 – Combination meters.

AUTO-CRUISE CONTROL REMOVAL AND INSTALLATION

17200140477

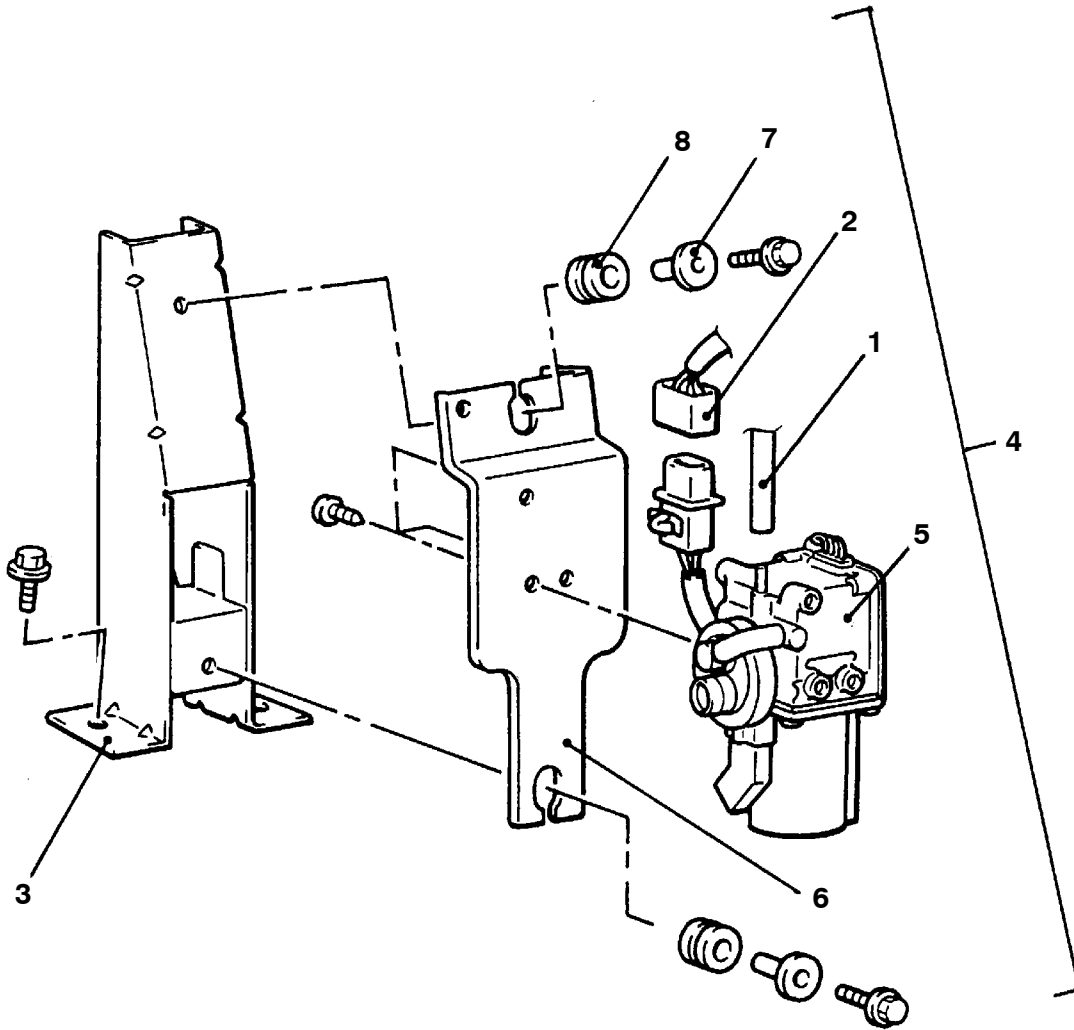

BV0162AA

Removal steps

1. Vacuum hose
2. Wiring connector
3. Actuator bracket
4. Auto-cruise vacuum pump and pump bracket assembly
5. Auto-cruise vacuum pump
6. Pump bracket
7. Distance piece
8. Rubber mount

CAUTION: SRS
 Before removal of air bag module, refer to
 GROUP 52B – SRS Service Precautions and Air
 Bag Modules and Clock Spring.

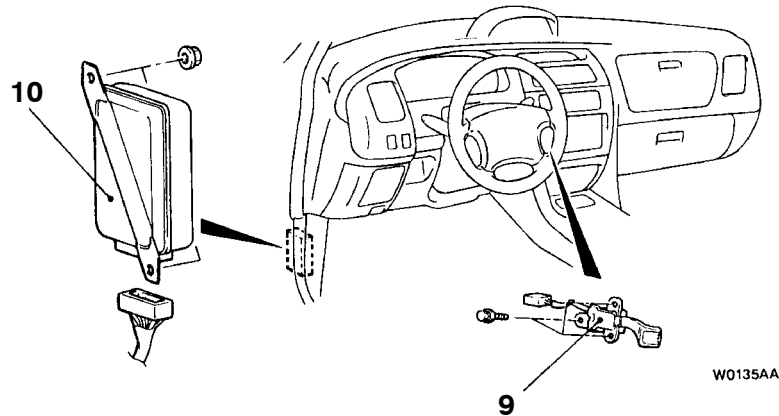
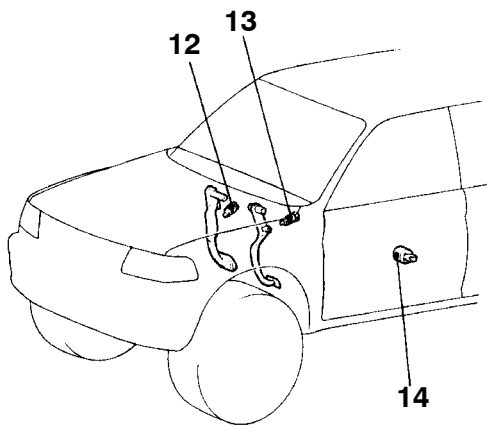
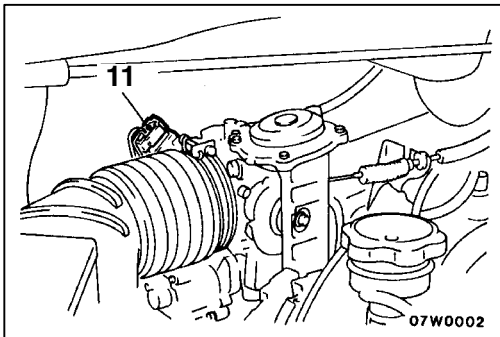

00009198

Auto-cruise control switch removal steps

- Air bag module (Refer to GROUP 52B – Air Bag Module and Clock Spring.)
9. Auto-cruise control switch

Auto-cruise control-ECU removal steps

- Cowl side trim (Refer to GROUP 52A – Trims.)
10. Auto-cruise control-ECU

Sensor removal

- 11. Throttle position sensor
- 12. Stop lamp switch
- 13. Clutch pedal position switch
- 14. Vehicle speed sensor

EMISSION CONTROL SYSTEM <6G7>

17300010283

GENERAL INFORMATION

The emission control system consists of the following subsystems:

- Crankcase emission control system
- Evaporative emission control system
- Exhaust emission control system

Items	Name	Specification
Crankcase emission control system	Positive crankcase ventilation (PCV) valve	Variable flow type (Purpose: HC reduction)
Evaporative emission control system	Canister Purge control solenoid valve	Equipped ON/OFF type solenoid valve (Purpose: HC reduction)
Exhaust emission control system	Air-fuel ratio control device – MPI system	Oxygen sensor feedback type (Purpose: CO, HC, NOx reduction)
	Exhaust gas recirculation system <ul style="list-style-type: none"> ● EGR valve ● EGR control solenoid valve 	Equipped Single type Duty cycle type solenoid valve (Purpose: NOx reduction)
	Catalytic converter	Monolith type (Purpose: CO, HC, NOx reduction)

EMISSION CONTROL DEVICE REFERENCE TABLE

Related parts	Crankcase emission control system	Evaporative emission control system	Air/fuel ratio control system	Catalytic converter	Exhaust gas recirculation system	Reference page
PCV valve	×					17-32
Purge control solenoid valve		×				17-35
MPI system component		×	×			GROUP 13A
Catalytic converter				×		17-39
EGR valve					×	17-37
EGR control solenoid valve					×	17-38

SERVICE SPECIFICATIONS

17300030371

Items	Standard value
Purge control solenoid valve coil resistance (at 20°C) Ω	28–36
EGR control solenoid valve coil resistance (at 20°C) Ω	28–36

VACUUM HOSE

VACUUM HOSE PIPING DIAGRAM

17300090508

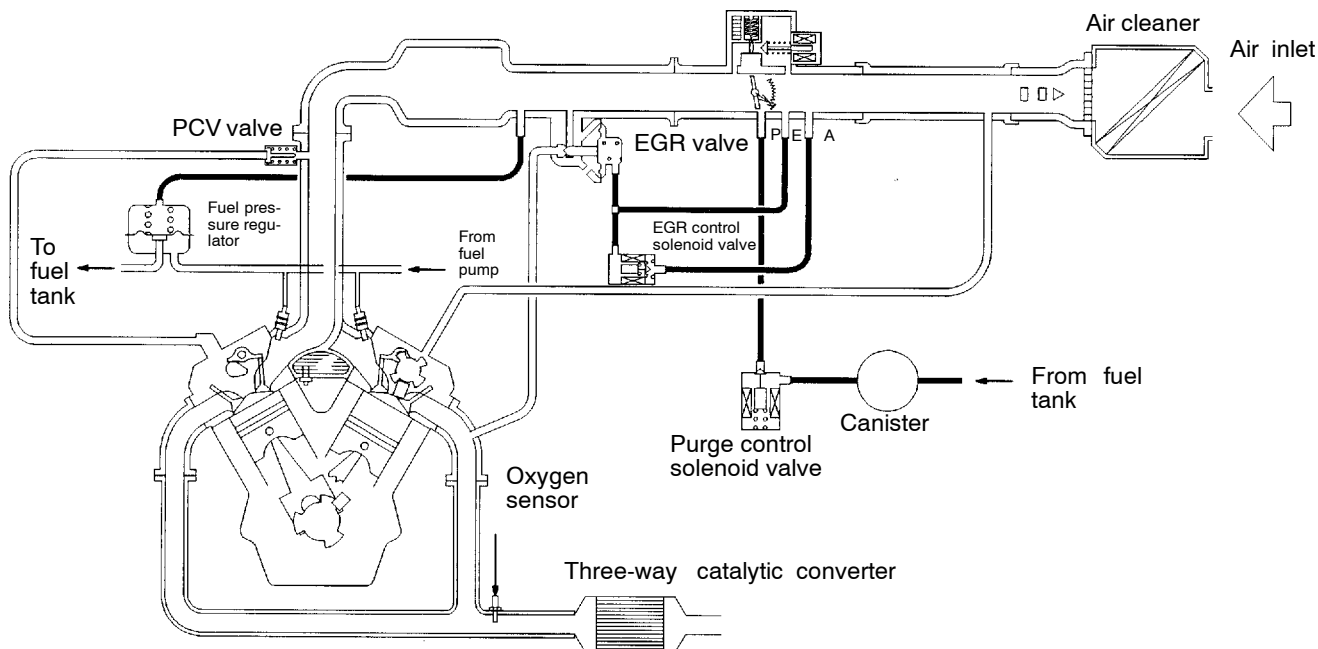

7EM0528

VACUUM CIRCUIT DIAGRAM

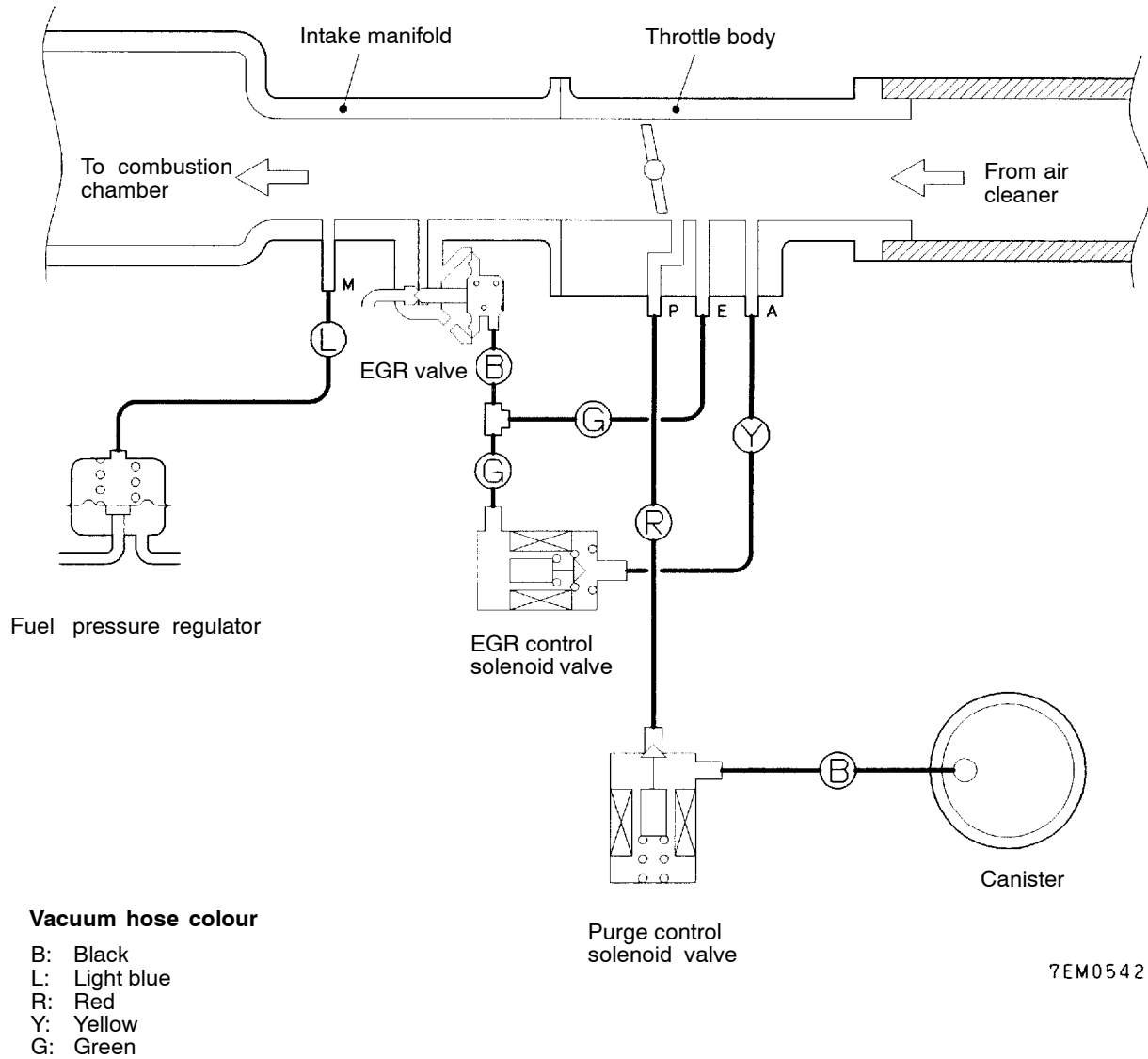

VACUUM HOSE CHECK

1. Using the piping diagram as a guide, check to be sure that the vacuum hoses are correctly connected.
2. Check the connection condition of the vacuum hoses, (removed, loose, etc.) and check to be sure that there are no bends or damage.

VACUUM HOSE INSTALLATION

1. When connecting the vacuum hoses, they should be securely inserted onto the nipples.
2. Connect the hoses correctly, using the vacuum hose piping diagram as a guide.

CRANKCASE EMISSION CONTROL SYSTEM

17300500308

GENERAL INFORMATION

The crankcase emission control system prevents blow-by gases from escaping inside the crankcase into the atmosphere.

Fresh air is sent from the air cleaner into the crankcase through the breather hose. The air becomes mixed with the blow-by gases inside the crankcase.

The blow-by gas inside the crankcase is drawn into the intake manifold through the positive

crankcase ventilation (PCV) valve.

The PCV valve lifts the plunger according to the intake manifold vacuum so as to regulate the flow of blow-by gas properly. In other words, the blow-by gas flow is regulated during low load engine operation to maintain engine stability, while the flow is increased during high load operation to improve the ventilation performance.

SYSTEM DIAGRAM

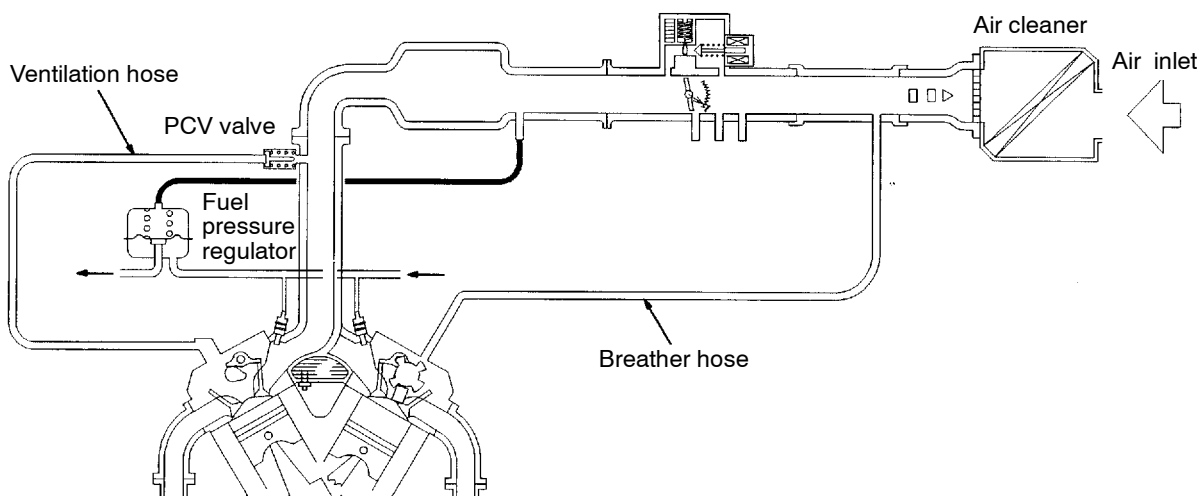

7EM0530

COMPONENT LOCATION

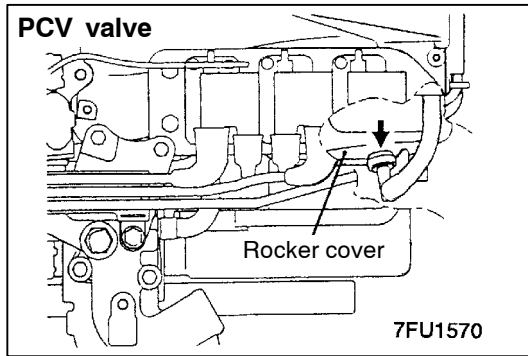

POSITIVE CRANKCASE VENTILATION SYSTEM CHECK

17300110266

1. Remove the ventilation hose from the PCV valve.
2. Remove the PCV valve from the rocker cover.
3. Reinstall the PCV valve at the ventilation hose.
4. Start the engine and run at idle.

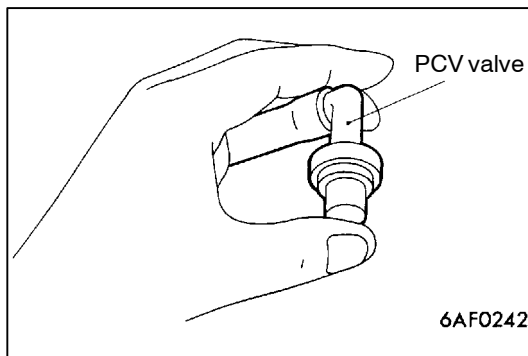

5. Place a finger at the opening of the PCV valve and check that vacuum of the intake manifold is felt.

NOTE

At this moment, the plunger in the PCV valve moves back and forth.

6. If vacuum is not felt, clean the PCV valve or replace it.

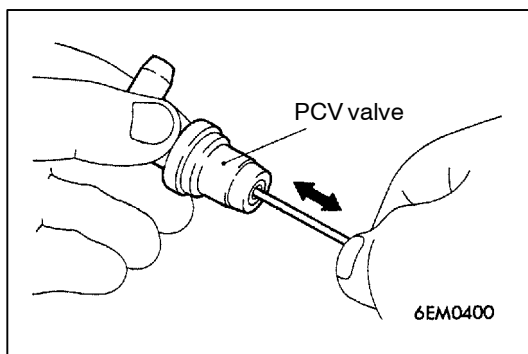

PCV VALVE CHECK

17300120238

1. Insert a thin rod into the PCV valve from the side shown in the illustration (rocker cover installation side), and move the rod back and forth to check that the plunger moves.
2. If the plunger does not move, there is a clogging in the PCV valve. In this case, clean or replace the PCV valve.

EVAPORATIVE EMISSION CONTROL SYSTEM

17300510561

GENERAL INFORMATION

The evaporative emission control system prevents fuel vapours generated in the fuel tank from escaping into the atmosphere.

Fuel vapours from the fuel tank flow through the fuel tank pressure control valve and vapour pipe/hose to be stored temporarily in the canister. When driving the vehicle, fuel vapours stored in the canister flow through the purge solenoid and purge port and go into the intake manifold to be

sent to the combustion chamber.

When the engine coolant temperature is low or when the intake air quantity is small (when the engine is at idle, for example), the engine control unit turns the purge solenoid off to shut off the fuel vapour flow to the intake manifold.

This does not only insure the driveability when the engine is cold or running under low load but also stabilize the emission level.

SYSTEM DIAGRAM

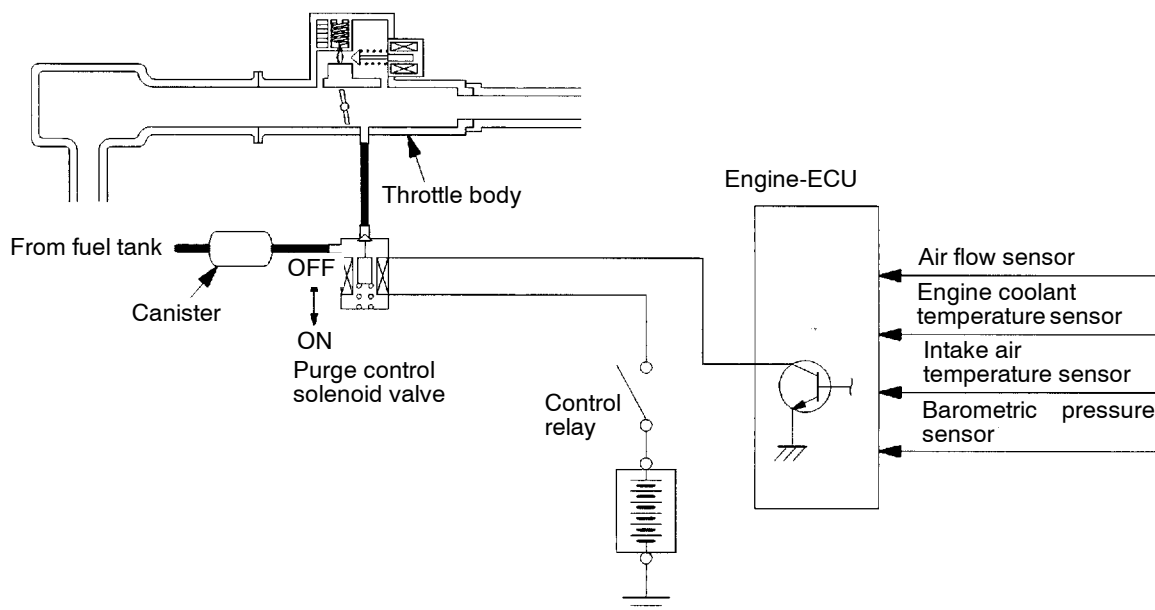

6EM0596

COMPONENT LOCATION

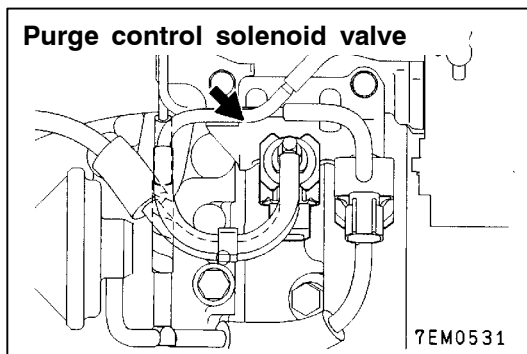

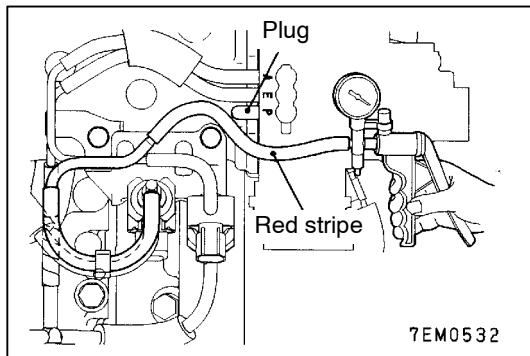

PURGE CONTROL SYSTEM CHECK

17300140531

1. Disconnect the vacuum hose (red stripe) from the throttle body and connect it to a hand vacuum pump.
2. Plug the nipple from which the vacuum hose was removed.
3. When the engine is cold or hot, apply a vacuum while the engine is idling, and check the condition of the engine and the vacuum.

When engine is cold

(Engine coolant temperature: 40°C or less)

Vacuum	Engine condition	Normal condition
53 kPa	3,000 r/min	Vacuum is maintained

When engine is hot

(Engine coolant temperature: 80°C or higher)

Vacuum	Engine condition	Normal condition
53 kPa	At idle	Vacuum is maintained
	3,000 r/min	Vacuum will leak for approximately 3 minutes after the engine is started. After 3 minutes have passed, the vacuum will be maintained momentarily, after which it will again leak.*

NOTE

*: The vacuum will leak continuously if the atmospheric pressure is approximately 77 kPa or less, or the temperature of the intake air is approximately 50°C or higher.

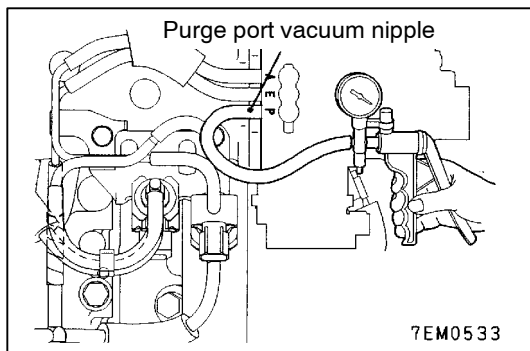

PURGE PORT VACUUM CHECK

17300150411

1. Disconnect the vacuum hose (red stripe) from the throttle body purge vacuum nipple and connect a hand vacuum pump to the nipple.

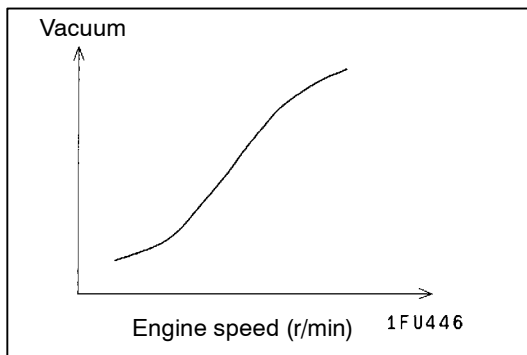

2. Start the engine and check that, after raising the engine speed by racing the engine, purge vacuum raises according to engine speed.

NOTE

If there is a problem with the change in vacuum, the throttle body purge port may be clogged and require cleaning.

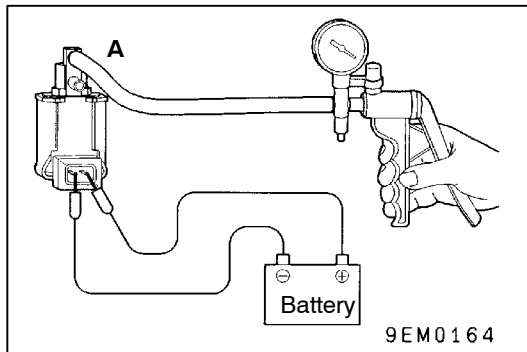
**PURGE CONTROL SOLENOID VALVE CHECK**

17300170370

NOTE

When disconnecting the vacuum hose, always make a mark so that it can be reconnected at original position.

1. Disconnect the vacuum hose (black stripe, red stripe) from the solenoid valve.
2. Disconnect the harness connector.
3. Connect a hand vacuum pump to nipple (A) of the solenoid valve (refer to the illustration at left).
4. Check airtightness by applying a vacuum with voltage applied directly from the battery to the purge control solenoid valve and without applying voltage.

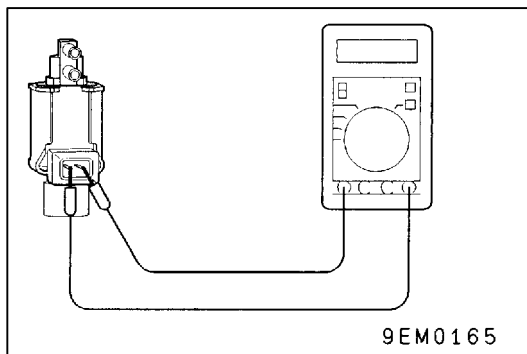

Battery voltage	Normal condition
Applied	Vacuum leaks
Not applied	Vacuum maintained

5. Measure the resistance between the terminals of the solenoid valve.

Standard value: 28 – 36 Ω (at 20°C)

EXHAUST GAS RECIRCULATION (EGR) SYSTEM

17300520434

GENERAL INFORMATION

The exhaust gas recirculation (EGR) system lowers the nitrogen oxide (NOx) emission level. When the air/fuel mixture combustion temperature is high, a large quantity of nitrogen oxides (NOx) is generated in the combustion chamber. Therefore, this system recirculates part of emission gas from

the exhaust port of the cylinder head to the combustion chamber through the intake manifold to decrease the air/fuel mixture combustion temperature, resulting in reduction of NOx. The EGR flow rate is controlled by the EGR valve so as not to decrease the driveability.

OPERATION

The EGR valve is being closed and does not recirculate exhaust gases under one of the following conditions. Otherwise, the EGR valve is opened and recirculates exhaust gases.

- The engine coolant temperature is low.
- The engine is at idle.
- The throttle valve is widely opened.

SYSTEM DIAGRAM

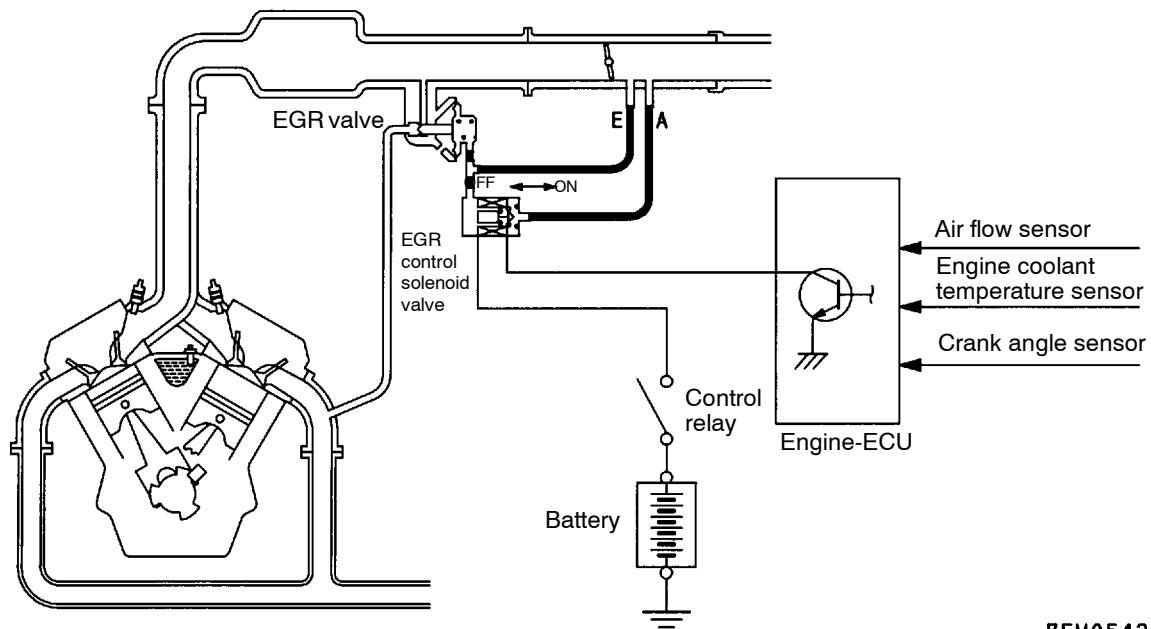

7EM0543

COMPONENT LOCATION

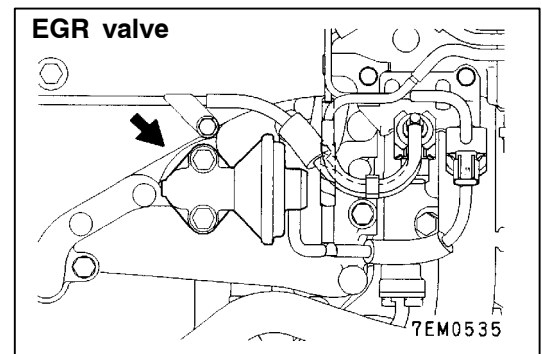
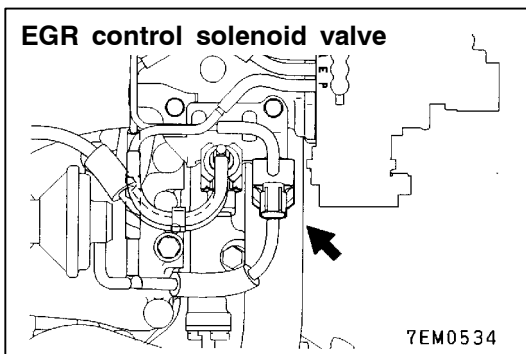

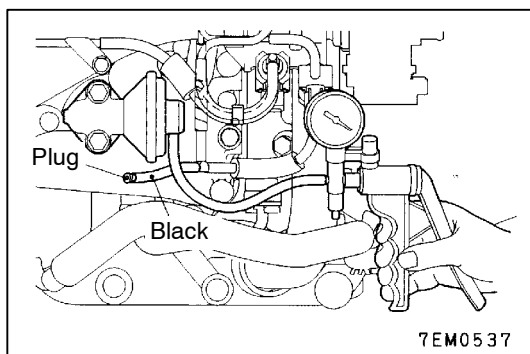
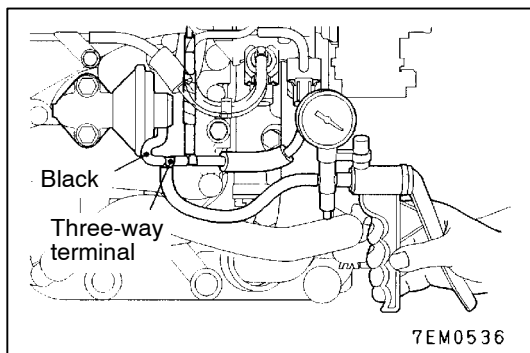

EXHAUST GAS RECIRCULATION (EGR) CONTROL SYSTEM CHECK

17300260398

1. Disconnect the vacuum hose (black) from the EGR valve, and then connect a hand vacuum pump via the three-way terminal.
2. When the engine is hot or cold, check the condition of vacuum by racing the engine.

When engine is cold (Engine coolant temperature: 20°C or less)

Throttle valve	Normal vacuum condition
Open quickly	No vacuum will generate (the same as barometric pressure.)

When engine is hot (Engine coolant temperature: 80°C or higher)

Throttle valve	Normal vacuum condition
Open quickly	It will momentarily rise over 13 kPa

3. Disconnect the three-way terminal.
4. Connect the hand vacuum pump to the EGR valve nipple (Black).
5. Check whether the engine stalls or the idling is unstable when a vacuum of 30 kPa or higher is applied during idling.

EGR VALVE CHECK

17300280257

1. Remove the EGR valve and inspect for sticking, carbon deposits, etc. If found, clean with a suitable solvent so that the valve seats correctly.
2. Connect a hand vacuum pump to the EGR valve.
3. Apply 67 kPa of vacuum, and check that the vacuum is maintained.

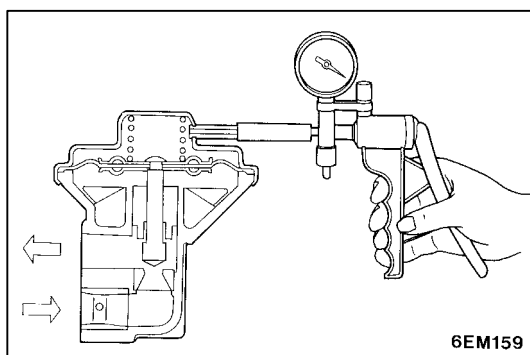

4. Apply a vacuum and check the passage of air by blowing through one side of the EGR passage.

Vacuum	Passage of air
2.7 kPa or less	Air is not blown out
29 kPa or more	Air is blown out

5. Replace the gasket, and tighten to the specified torque.

Tightening torque: 22 Nm

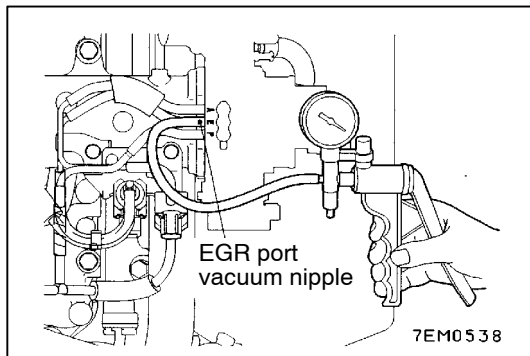

EGR PORT VACUUM CHECK

17300290304

1. Disconnect the vacuum hose (green stripe) from the throttle body EGR vacuum nipple and connect a hand vacuum pump to the nipple.

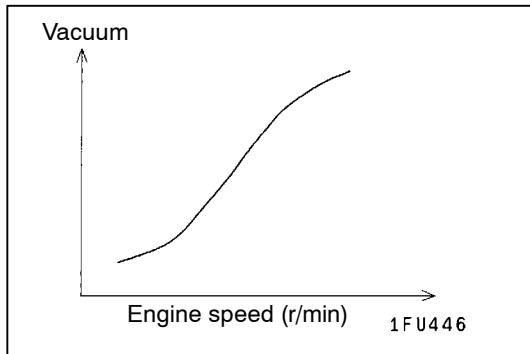

2. Start the engine and check vacuum remains fairly constant after racing the engine.

NOTE

If the vacuum fluctuates, the throttle body EGR port may be clogged and need cleaning.

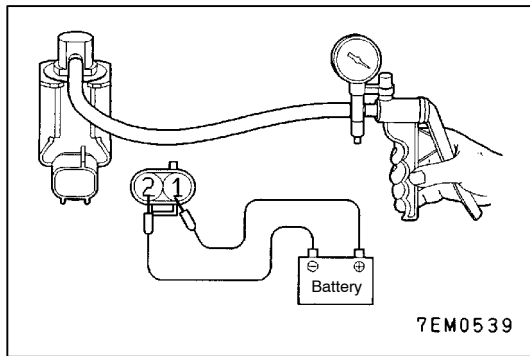

EGR CONTROL SOLENOID VALVE CHECK

17300310352

NOTE

When disconnecting the vacuum hose, always make a mark so that it can be reconnected at original position.

1. Disconnect the vacuum hose (yellow stripe, green stripe) from the solenoid valve.
2. Disconnect the harness connector.
3. Connect a hand vacuum pump to the nipple to which the green-striped vacuum hose was connected.
4. Check airtightness by applying a vacuum with voltage applied directly from the battery to the EGR control solenoid valve and without applying voltage.

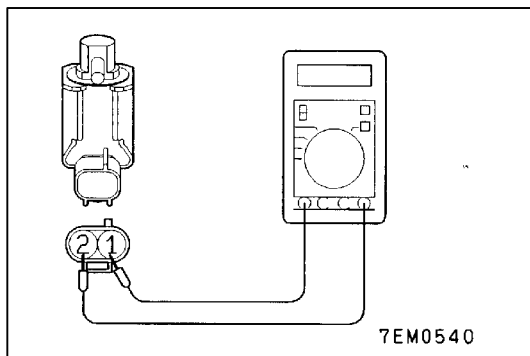

Battery voltage	Normal condition
Not applied	Vacuum leaks
Applied	Vacuum maintained

5. Measure the resistance between the terminals of the solenoid valve.

Standard value: 28 – 36Ω (at 20°C)

CATALYTIC CONVERTER

17300530154

GENERAL INFORMATION

The three-way catalytic converter, together with the closed loop air-fuel ratio control based on the oxygen sensor signal, oxidizes carbon monoxides (CO) and hydrocarbons (HC) and reduces nitrogen oxides (NOx).

When the mixture is controlled at stoichiometric air-fuel ratio, the three-way catalytic converter provides the highest purification against the three constituents, namely, CO, HC and Nox.

REMOVAL AND INSTALLATION

17300390325

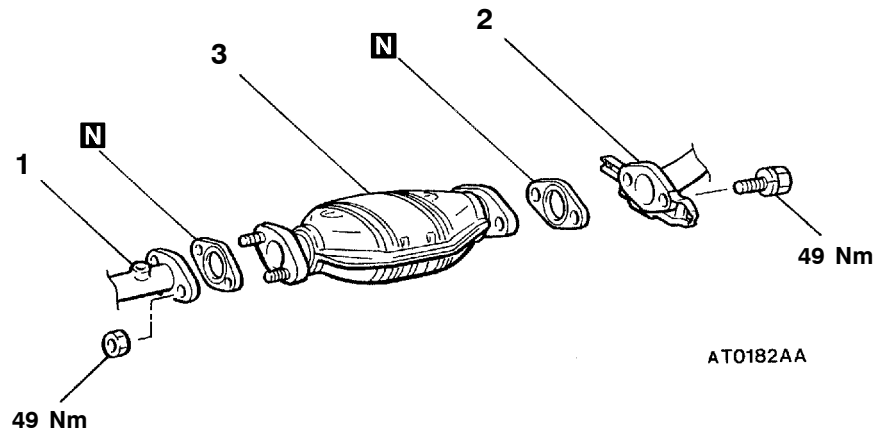

Removal steps

1. Front exhaust pipe
2. Center exhaust pipe
3. Catalytic converter

CANISTER AND TWO-WAY VALVE

REMOVAL AND INSTALLATION

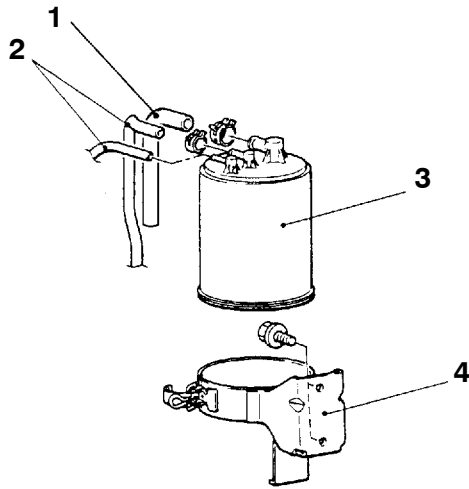

07V0012

Canister removal steps

1. Breather hose connection
2. Vapour hose connection
3. Canister
4. Canister holder

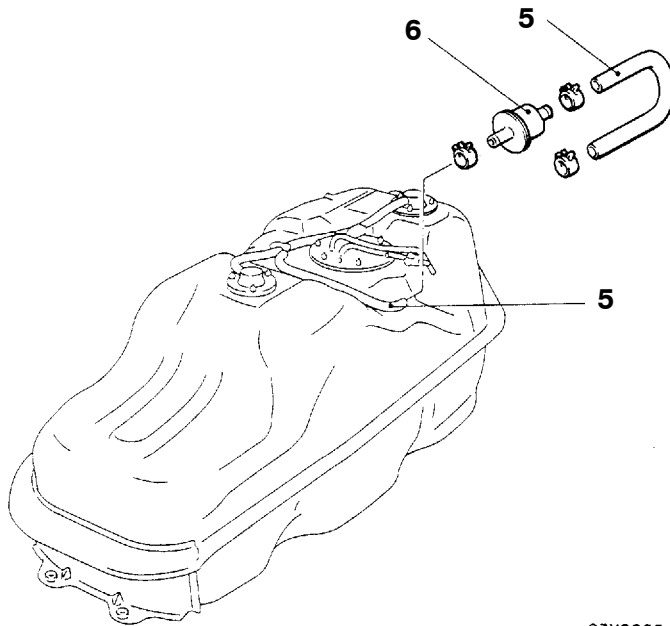

07V0008

00007746

Two-way valve removal steps

5. Vapour hose connection
 6. Two-way valve
- ▶◀

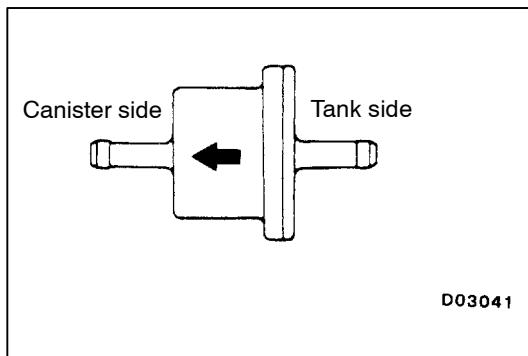

D03041

INSTALLATION SERVICE POINT

▶◀ TWO-WAY VALVE INSTALLATION

Be careful about the installation direction of the two-way valve.

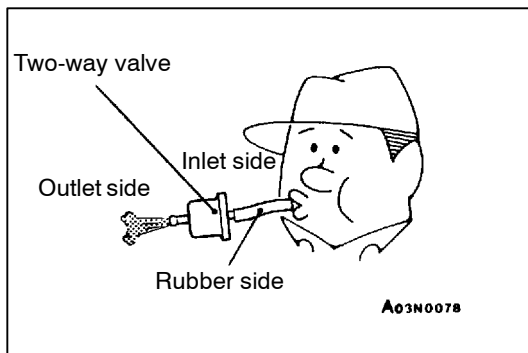

A03N0078

INSPECTION

TWO-WAY VALVE SIMPLE CHECK

Attach a clean hose and check the operation of the two-way valve.

Lightly blow from inlet side (fuel tank side)	Air passes through with a slight feeling of resistance.
Lightly blow from outlet side.	Air passes through.

EMISSION CONTROL SYSTEM <4D5>

17500010043

GENERAL INFORMATION

The electronically-controlled EGR system and the fuel injection timing control system (load timer) reduce the level of exhaust gases (NOx).

Item	Name	Specification
Exhaust emission control system	Exhaust gas recirculation system <ul style="list-style-type: none"> • EGR valve • EGR solenoid valve No.1 • EGR solenoid valve No.2 	Electronically-controlled EGR system Single type Duty cycle solenoid valve ON-OFF solenoid valve

SERVICE SPECIFICATIONS

17500030049

Item	Standard value	
EGR solenoid valve No.1/No.2 resistance (at 20 °C) Ω	36 – 44	
Lever position sensor output voltage V	Idle position	0.8 – 1.0
	Fully open	3.7 – 5.0
Engine speed sensor resistance kΩ	1.3 – 1.9	
Engine coolant temperature sensor resistance kΩ	At 20 °C	2.9 – 3.6
	At 80 °C	0.26 – 0.35

SEALANT

17500050021

Item	Specified sealant	Remark
Engine coolant temperature sensor threaded portion	3M Nut Locking Part No.4171 or equivalent	Drying sealant

SPECIAL TOOL

17500060024

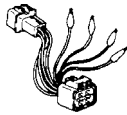
Tool	Number	Name	Use
	MD998464	Test harness (4P, square)	Inspection of lever position sensor

EXHAUST GAS RECIRCULATION (EGR) SYSTEM

17500090023

GENERAL INFORMATION

The electronically-controlled EGR system consists of an EGR valve, vacuum pump, EGR solenoid valves No.1 and No.2, glow & EGR control unit and various sensors.

The EGR valve is controlled by the negative pressure inside the valve, which is controlled by EGR solenoid valves No.1 and No.2.

The EGR solenoid valves No.1 and No.2 are optimally controlled by the glow & EGR control unit in response to the engine operation conditions, based on data input from each of the sensors. In this way, the EGR is controlled to reduce NOx emissions while maintaining good engine performance.

SYSTEM DIAGRAM

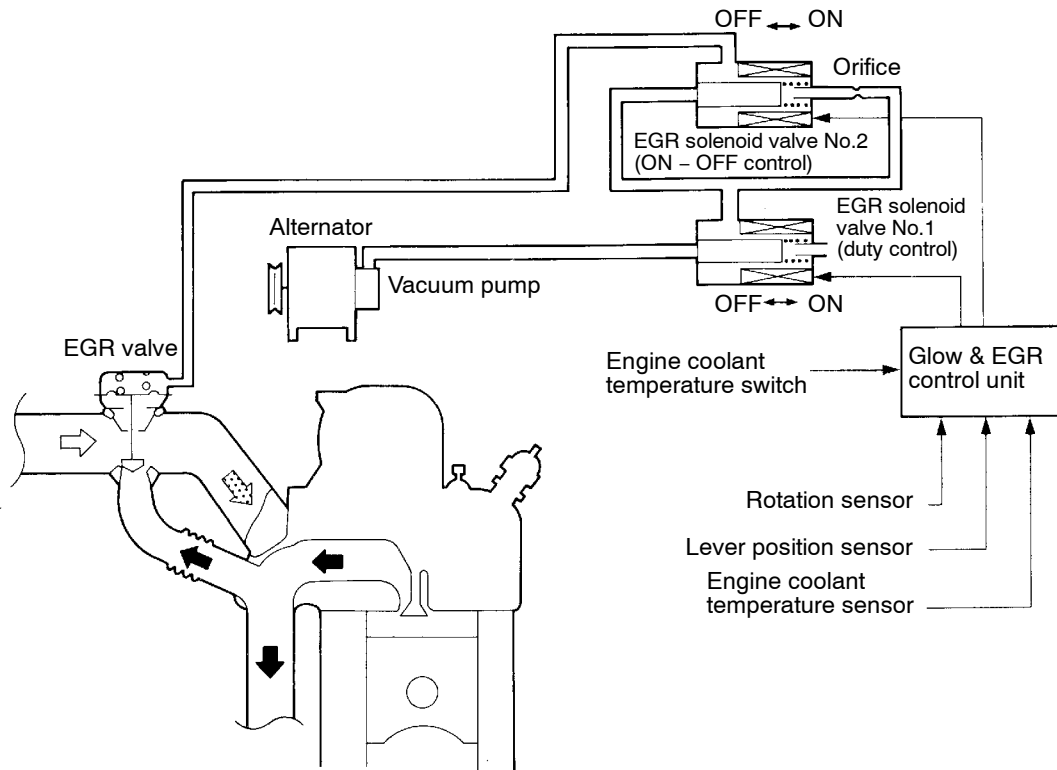

DEM0662

COMPONENT LOCATION

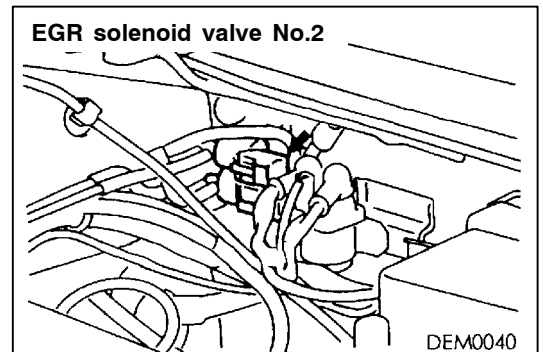
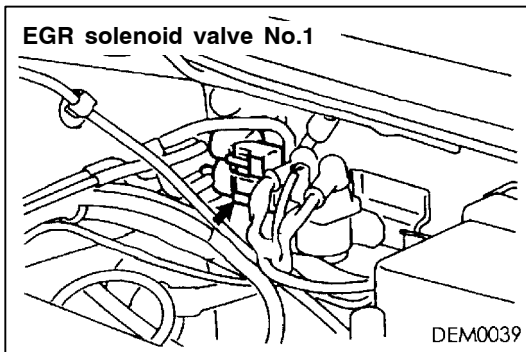

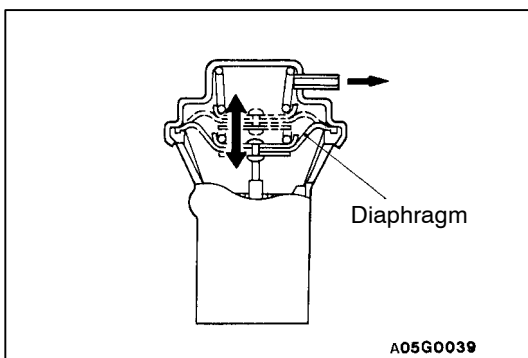
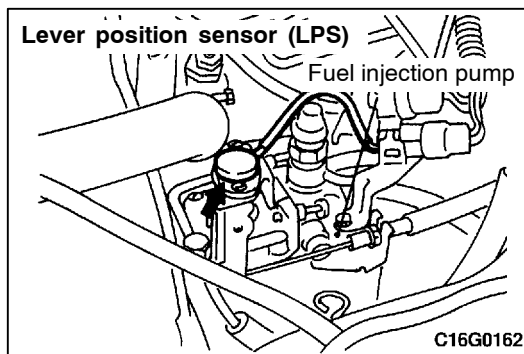
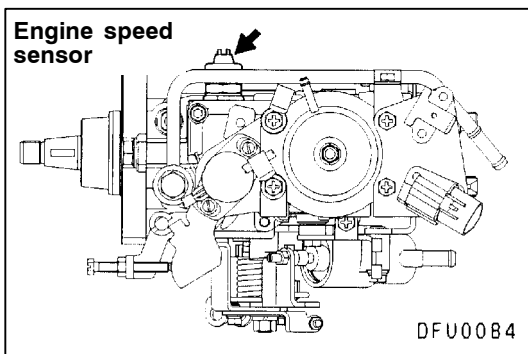
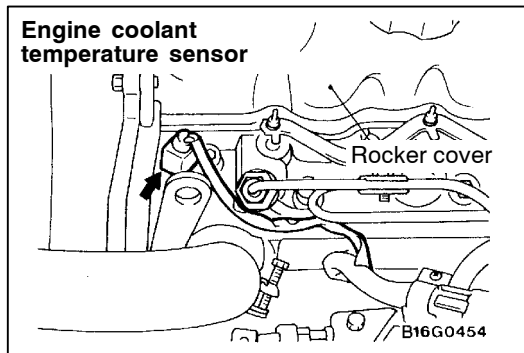
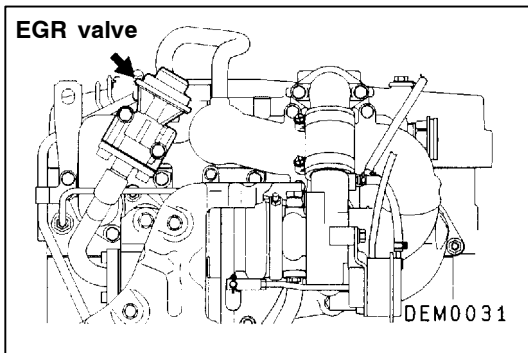

FUNCTION CHECK

17500100047

1. Start the engine and let it warm up until the engine coolant temperature is 65°C or above.
2. When the engine is raced by suddenly depressing the accelerator pedal, check to be sure that the diaphragm of the EGR valve lifts.

EGR SOLENOID VALVE OPERATION CHECK

17500290034

1. Remove the EGR solenoid valve No.1/No.2 connectors and vacuum hoses.
2. Attach a vacuum pump to each nipple of the EGR solenoid valve No.1/No.2 and apply negative pressure. Check that the valves are airtight both when voltage is applied to each terminal of the EGR solenoid valves and when it is not applied.

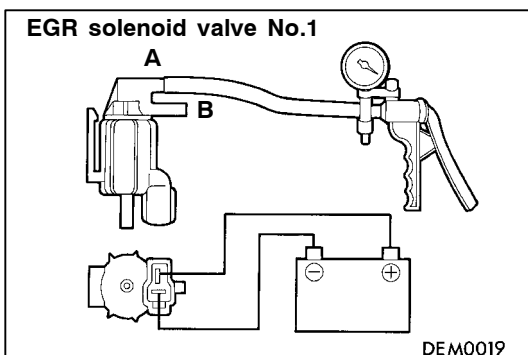

EGR solenoid valve No.1

Battery voltage	Normal condition
When current is flowing	Vacuum leaks (Vacuum is maintained when nipple B is covered)
When current is not flowing	Vacuum is maintained

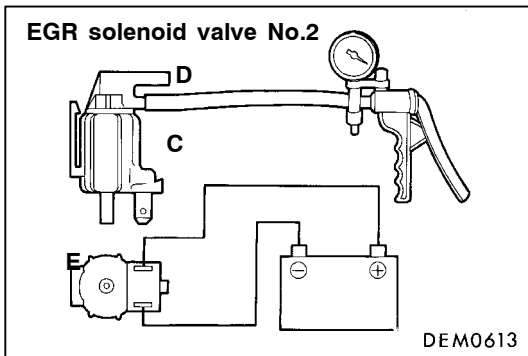

EGR solenoid valve No.2

Battery voltage	Normal condition
When current is flowing	Vacuum leaks (Vacuum is maintained when nipple D is covered)
When current is not flowing	Vacuum leaks (Vacuum is maintained when nipple E is covered)

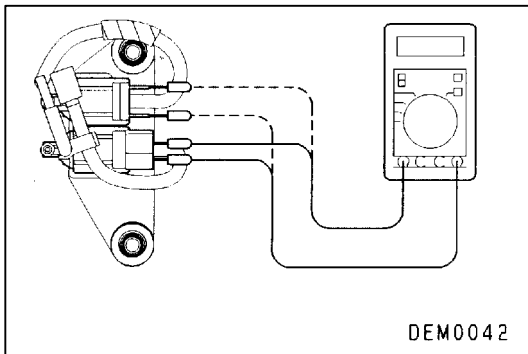

EGR SOLENOID VALVE RESISTANCE CHECK

17500120029

Measure resistances between the terminal of the EGR solenoid valve No.1/No.2 with a circuit tester.

	Solenoid valve No.1/No.2 resistance Ω
Standard value (at 20°C)	36 – 44

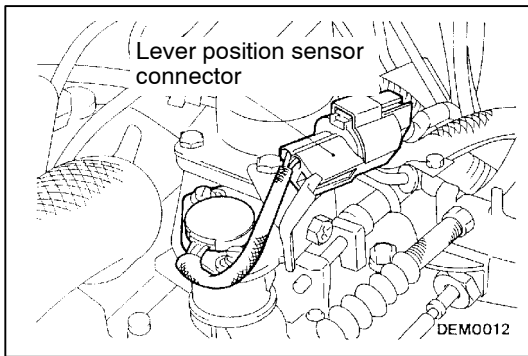

LEVER POSITION SENSOR (LPS) ADJUSTMENT

17500130022

1. Run the engine until the engine coolant temperature rises to 80°C or above, and then release the fast idle.
2. Loosen the accelerator cable tension sufficiently.
3. Connect the special tool (test harness) to the lever position sensor connector shown in the illustration.

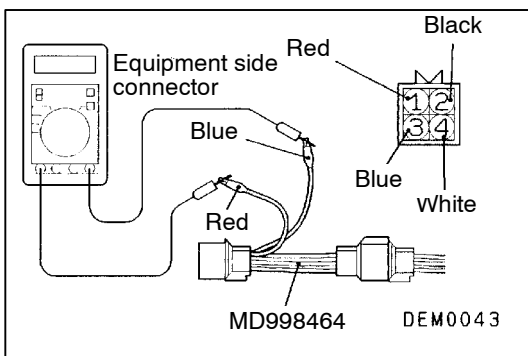

4. Connect a digital-type voltmeter between terminal 1 (red clip) and terminal 3 (blue clip) of the lever position sensor.
5. Turn the ignition switch to ON. (Do not start the engine.)
6. Measure the output voltage of the lever position sensor.

Standard value:

Lever condition	Voltage V
Idle position	0.8 – 1.0
Fully open	3.7 – 5.0

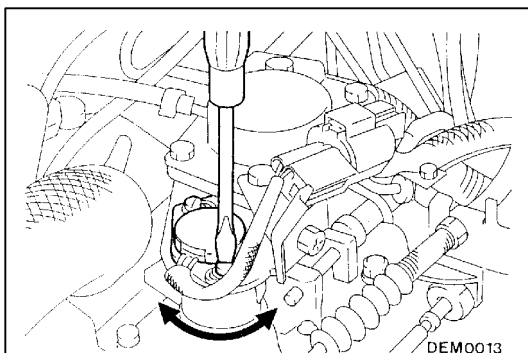

7. If the voltage is outside the standard value, adjust by loosening the lever position sensor mounting screw and turning the lever position sensor body. After adjustment, securely tighten the screw.

NOTE

The output voltage will increase if the lever position sensor body is turned in a clockwise direction.

8. Turn the ignition switch to OFF.
9. Adjust the accelerator cable play.

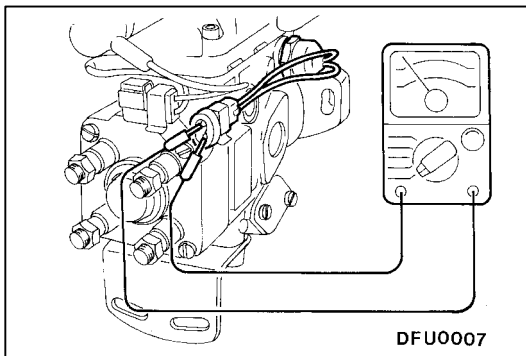
**ENGINE SPEED SENSOR CHECK**

17500140025

1. Disconnect the engine speed sensor connector.
2. Measure the resistance between the engine speed sensor terminals.

Standard value: 1.3 – 1.9 k Ω

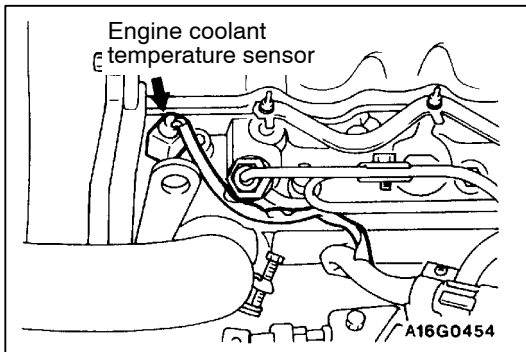
**ENGINE COOLANT TEMPERATURE SENSOR CHECK**

17500150035

1. Remove the engine coolant temperature sensor.

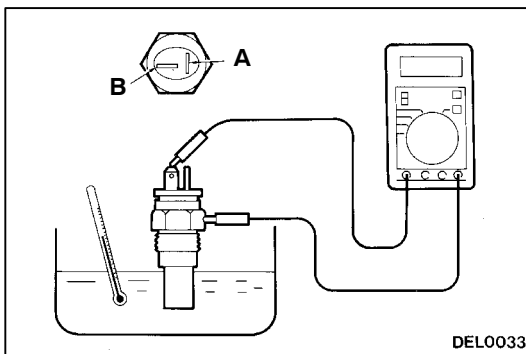

2. Measure the resistance between terminal (B) and the body earth when the temperature sensing portion of the engine coolant temperature sensor is immersed in hot water.

Temperature ($^{\circ}\text{C}$)	Resistance (k Ω)
0	7.7 – 9.5
20	2.9 – 3.6
40	1.3 – 1.7
80	0.26 – 0.35

3. If the resistance deviates from the standard value greatly, replace the sensor.
4. Apply sealant threaded portion.

Specified sealant:

3M NUT Locking Part No. 4171 or equivalent

5. Install engine coolant temperature sensor and tighten it to specified torque.

Sensor tightening torque: 35 Nm

6. Fasten harness connectors securely.

CHECK AT THE GLOW & EGR CONTROL UNIT

17500180041

TERMINAL VOLTAGE CHECK CHART

Glow & EGR Control Unit Connector Terminal Arrangement

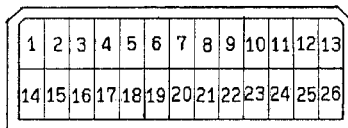

DEM0029

Terminal No.	Check item	Check condition (Engine condition)	Normal condition
3	EGR solenoid valve No.1	Ignition switch: ON	System voltage
		While engine is idle after having warmed up, suddenly depress the accelerator pedal.	Momentarily increases
6	Lever position sensor	Ignition switch: ON	Set throttle lever to idle position
			Fully open throttle lever
			0.8 – 1.0 V
			3.7 – 5.0 V
7	Sensor impressed voltage	Ignition switch: ON	4.5 – 5.5 V
16	EGR solenoid valve No.2	Ignition switch: ON	System voltage
		While engine is idle after having warmed up, suddenly depress the accelerator pedal.	Momentarily decreases

HARNESS-SIDE CONNECTOR TERMINAL RESISTANCE AND CONTINUITY CHECK CHART

Glow & EGR Control Unit Harness Side Connector Terminal Arrangement

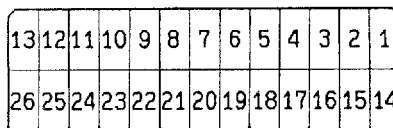

DEM0026

Terminal No.	Check item	Normal condition (Check condition)
3 – 1	EGR solenoid valve No.1	36 – 44 Ω (At 20°C)
5 – Body earth	Engine coolant temperature sensor	7.7 – 9.5 kΩ (When coolant temperature is 0°C)
		2.9 – 3.6 kΩ (When coolant temperature is 20°C)
		1.3 – 1.7 kΩ (When coolant temperature is 40°C)
		0.26 – 0.35 kΩ (When coolant temperature is 80°C)
11 – 24	Engine speed sensor	1.3 – 1.9 kΩ
16 – 1	EGR solenoid valve No.2	36 – 44 Ω (At 20°C)

TWO-WAY VALVE

REMOVAL AND INSTALLATION

17500240022

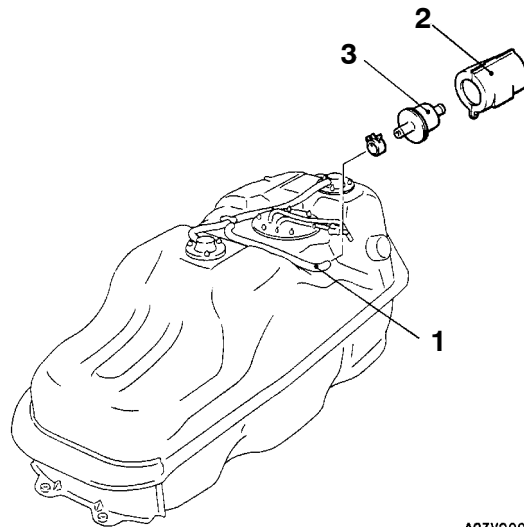

A07V0009

Removal steps

1. Vapour hose connection

- ▶A◀ 2. Breather case
3. Two-way valve

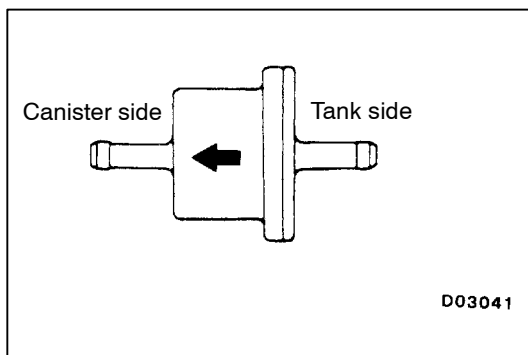

D03041

INSTALLATION SERVICE POINT

▶A◀ TWO-WAY VALVE INSTALLATION

Be careful about the installation direction of the two-way valve.

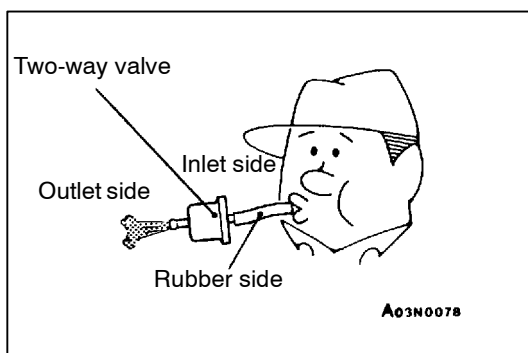

A03N0078

INSPECTION

17500250025

TWO-WAY VALVE SIMPLE CHECK

Attach a clean hose and check the operation of the two-way valve.

Lightly blow from inlet side (fuel tank side)	Air passes through with a slight feeling of resistance.
Lightly blow from outlet side.	Air passes through.

NOTES

CLUTCH

CONTENTS

21109000251

GENERAL INFORMATION	2	CLUTCH PEDAL	4
SERVICE SPECIFICATIONS	2	CLUTCH CONTROL	5
LUBRICANTS	2	Clutch Master Cylinder	7
ON-VEHICLE SERVICE	2		
Clutch Pedal Inspection and Adjustment	2		
Clutch Pedal Position Switch Continuity Check	3		
Bleeding	3		

GENERAL INFORMATION

21100010093

The clutch is a dry single-disc, diaphragm type; hydraulic pressure is used for the clutch control.

SERVICE SPECIFICATIONS

21100030136

Items	Standard value
Clutch pedal height mm	176 – 181
Clutch pedal clevis pin play mm	1 – 3
Clutch pedal free play mm	6 – 13
Distance between the clutch pedal and the toeboard when the clutch is disengaged mm	56 or more

LUBRICANTS

21100040078

Items	Specified lubricants	Quantity
Clutch fluid	Brake fluid DOT 3 or DOT 4	As required
Push rod assembly	Rubber grease	
Boot		
Release cylinder push rod	MITSUBISHI genuine grease Part No. 0101011	

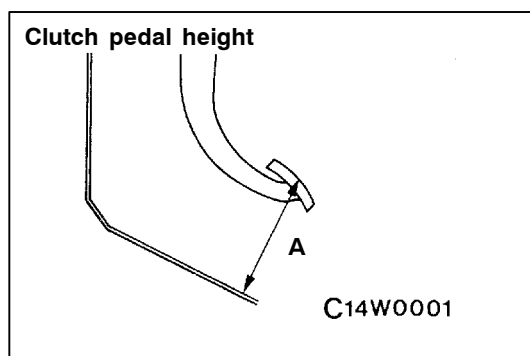
**ON-VEHICLE SERVICE**

21100090127

CLUTCH PEDAL INSPECTION AND ADJUSTMENT

1. Turn up the carpet, etc. under the clutch pedal.
2. Measure the clutch pedal height.

Standard value (A): 176 – 181 mm

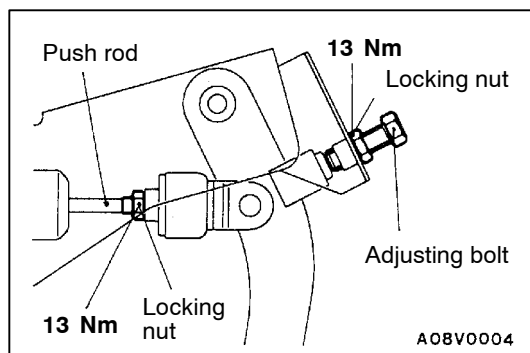

3. If the height of the clutch pedal is outside the standard value, loosen the lock nut and adjust the pedal height to the standard value using the adjusting bolt or push rod.

Clutch pedal clevis pin play

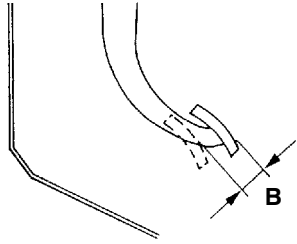

A14W0002

Clutch pedal free play

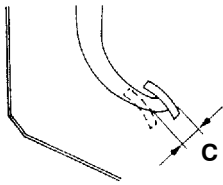

14W0002

Distance between the clutch pedal and the toeboard when the clutch is disengaged

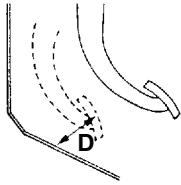

14W0003
00003373

4. Measure the clutch pedal play.
Standard value (B): 1 – 3 mm
5. If the clutch pedal play is not within the standard value, loosen the locking nut and move the push rod to adjust.

Caution

Do not push in the master cylinder push rod at this time.

6. After completing the adjustments, confirm that the clutch pedal free play (measured at the face of the pedal pad) and the distance between the clutch pedal (the face of the pedal pad) and the toeboard when the clutch is disengaged are within the standard value ranges.

Standard value (C): 6 – 13 mm

Standard value (D): 56 mm or more

7. If the clutch pedal free play and the distance between the clutch pedal and the toeboard when the clutch is disengaged do not agree with the standard values, it is probably the result of either air in the hydraulic system or a faulty master cylinder or clutch. Bleed the air, or disassembly and inspect the master cylinder or clutch.
8. Turn back the carpet, etc.

CLUTCH PEDAL POSITION SWITCH CONTINUITY CHECK

21100310049

1. Adjust the clutch pedal. (Refer to P.21-2.)
2. Depress the clutch pedal, and check the continuity between the terminals.

Measurement Conditions	Terminal No.	
	1	2
Clutch pedal depressed	○—○	○—○
Clutch pedal not depressed		

BLEEDING

21100140099

Specified fluid: Brake fluid DOT 3 or DOT 4

Caution

Use the specified brake fluid. Avoid using a mixture of the specified fluid and other fluid.

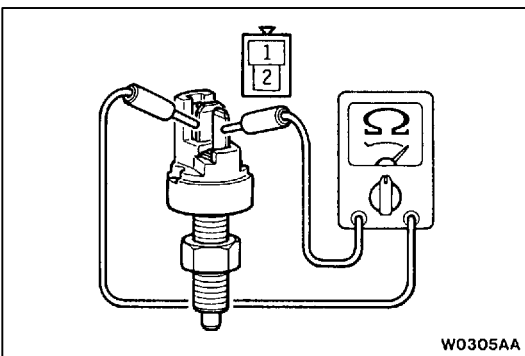

W0305AA

CLUTCH CONTROL

21100190278

REMOVAL AND INSTALLATION

Pre-removal Operation

- Clutch Fluid Draining

Post-installation Operation

- Clutch Fluid Supplying
- Clutch Fluid Bleeding (Refer to P. 21-3.)
- Clutch Pedal Adjustment (Refer to P. 21-2.)

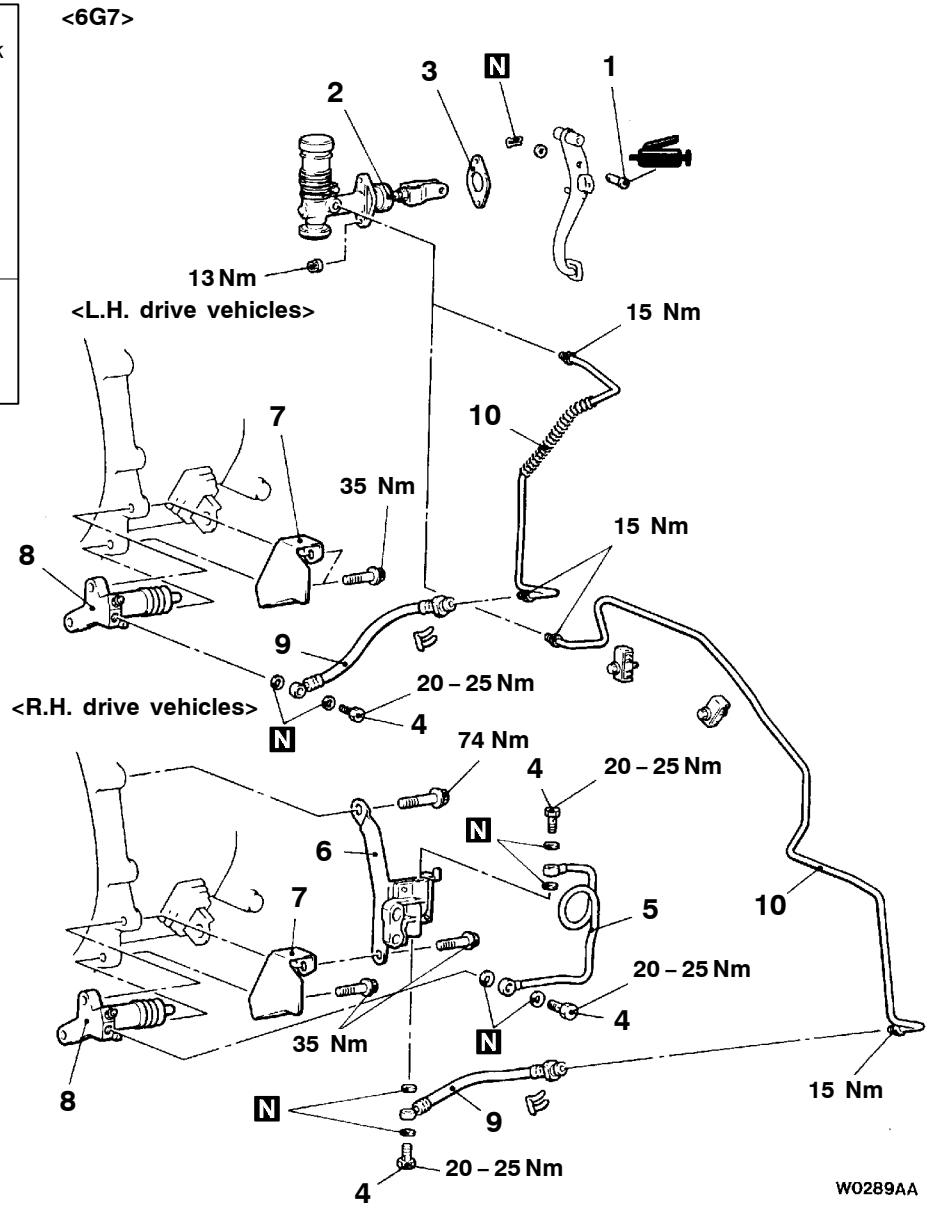
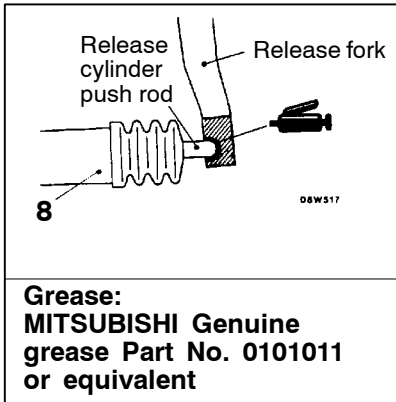

W0289AA

00009290

Clutch master cylinder removal steps

1. Clevis pin
2. Clutch master cylinder
3. Sealer

Clutch release cylinder removal steps

4. Eye bolt
5. Pipe assembly
<R.H. drive vehicles>

6. Clutch damper assembly
<R.H. drive vehicles>

7. Heat protector
8. Clutch release cylinder

Clutch line removal steps

4. Eye bolt
9. Clutch hose
10. Clutch tube

DISASSEMBLY AND REASSEMBLY
CLUTCH MASTER CYLINDER

Caution
Do not disassemble piston assembly.

<6G7 – L.H. drive vehicles, 4D5>

<6G7 – R.H. drive vehicles>

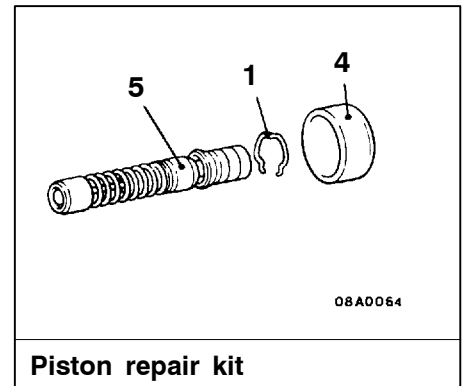
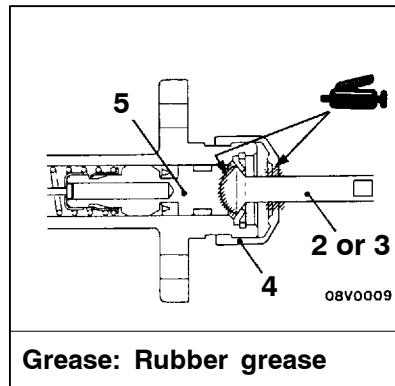
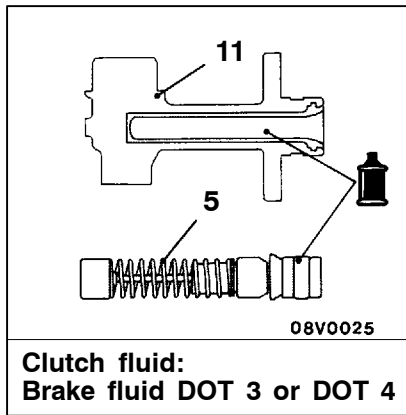
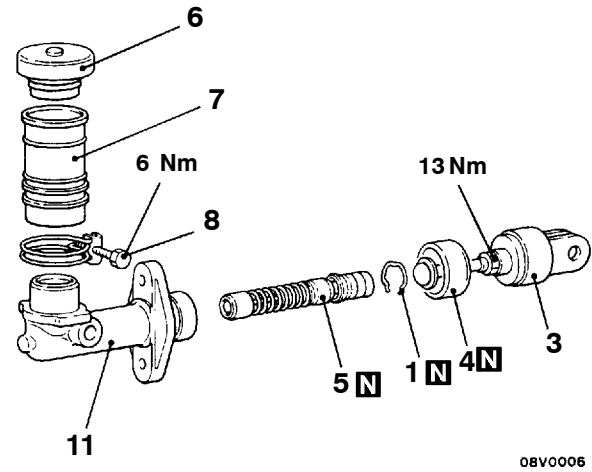
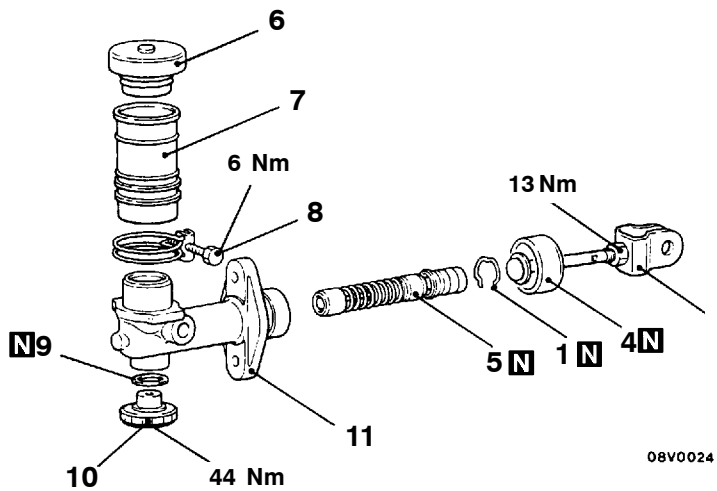

00009292

Disassembly steps

1. Piston stop ring
2. Push rod
3. Damper and push rod
4. Boot
5. Piston assembly
6. Reservoir cap
7. Reservoir
8. Reservoir band
9. Gasket
10. Damper assembly
11. Master cylinder body

NOTES

MANUAL TRANSMISSION

CONTENTS

22109000388

GENERAL INFORMATION	2	4WD Detection Switch Continuity Check	4
LUBRICANTS	2	High/Low Detection Switch Continuity Check ...	4
SEALANTS	2	TRANSMISSION CONTROL	5
ON-VEHICLE SERVICE	3	TRANSMISSION ASSEMBLY	7
Transmission Oil Check	3	4WD INDICATOR-ECU	11
Oil Replacement	3		

GENERAL INFORMATION

22100010236

Items		Specifications	
Transmission model		V5MT1-4-BFG	V5MT1-4-AEG
Engine model		4D5	6G7
Type		5-speed, floor-shift	
Gear ratio	1st	3.918	
	2nd	2.261	
	3rd	1.395	
	4th	1.000	
	5th	0.829	
	Reverse	3.925	
Transfer type		2-speed	
Gear ratio	High	1.000	
	Low	1.925	
Speedometer gear ratio (driven/drive)		26/8	25/8

LUBRICANTS

22100040303

Items	Specified lubricants	Quantity L
Transmission oil	Hypoid gear oil SAE 75W-90 or 75W-85W conforming to API GL-4	2.5
Transfer oil	Hypoid gear oil SAE 75W-90 or 75W-85W conforming to API GL-4	2.3

SEALANTS

22100050108

Items	Specified sealant	Remarks
Oil filler plug	3M ATD Part No. 8660 or equivalent	Semi-drying sealant
Oil drain plug	3M ATD Part No. 8660 or equivalent	Semi-drying sealant
Control lever gasket	3M ATD Part No. 8661 or equivalent	Semi-drying sealant
Control lever assembly mounting bolt	3M Stud Locking No. 4170 or equivalent	Anaerobic sealant

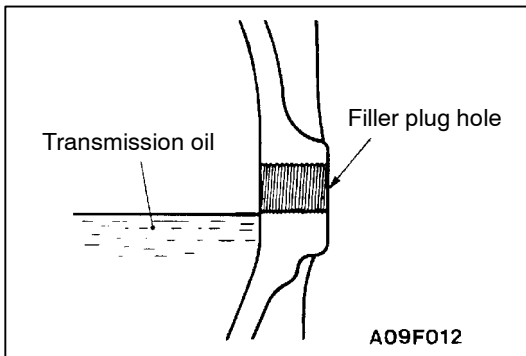

ON-VEHICLE SERVICE

22100090292

TRANSMISSION OIL CHECK

1. Remove the oil filler plug.
2. Oil level should be at the lower portion of the filler plug hole.
3. Check that the transmission oil is not noticeably dirty, and that it has a suitable viscosity.
4. Tighten the filler plug to the specified torque.

Tightening torque: 70 Nm

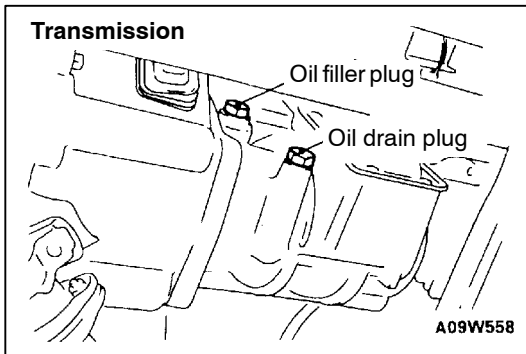

OIL REPLACEMENT

22100100308

1. Remove oil filler plug and oil drain plug.
2. Drain oil.
3. Tighten the oil drain plug to the specified torque.

Tightening torque: 70 Nm

NOTE

Apply sealant to the oil drain plug threads.

Specified sealant:

3M ATD Part No. 8660 or equivalent

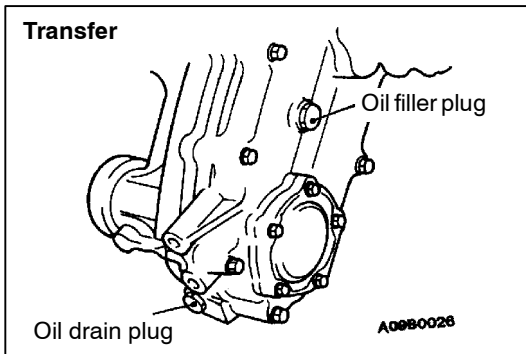

4. Fill with specified oil till the level comes to the lower portion of oil filler plug hole.

Specified transmission oil:

Hypoid gear oil SAE 75W-90 or 75W-85W conforming to API GL-4

Quantity:

Transmission 2.5 L

Transfer 2.3 L

5. Tighten the oil filler plug to the specified torque.

Tightening torque: 70 Nm

NOTE

Apply sealant to the oil filler plug threads.

Specified sealant:

3M ATD Part No. 8660 or equivalent

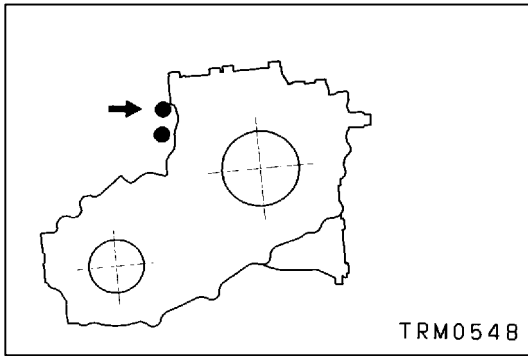

4WD DETECTION SWITCH CONTINUITY CHECK

22100170040

Check the continuity between terminals of the black connector indicated in the illustration.

Transfer lever position	Terminal No.	
	1	2
2H		
4H	○ — ○	○ — ○

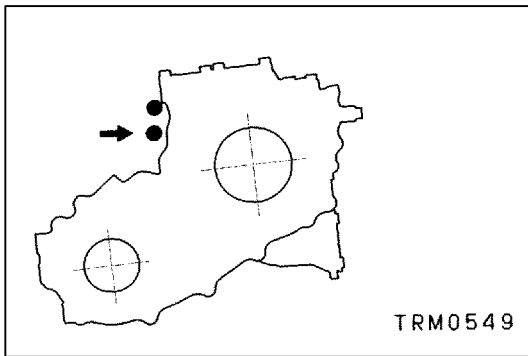

HIGH/LOW DETECTION SWITCH CONTINUITY CHECK

22100210063

Check the continuity between terminals of the gray connector indicated in the illustration.

Transfer lever position	Terminal No.	
	1	2
4H	○ — ○	○ — ○
4L	○ — ○	○ — ○
4H-4L		

TRANSMISSION CONTROL

22100380306

REMOVAL AND INSTALLATION

Pre-removal Operation

- Shift the Transmission Control Lever to the N Position.
- Shift the Transfer Control Lever to the 4H Position.
- Floor Consol Removal (Refer to GROUP 52A – Floor Consol.)

Post-installation Operation

- Floor Consol Installation (Refer to GROUP 52A – Floor Consol.)
- Check the Operation of the Transmission and Transfer Control Levers and the Movement in Each Lever Position.

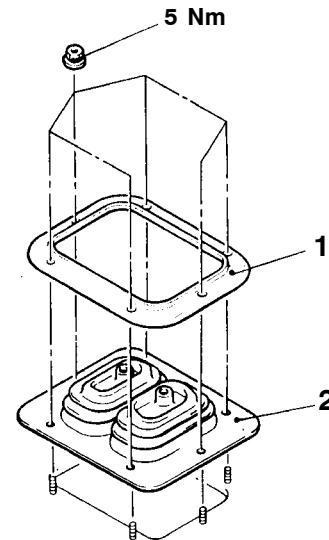
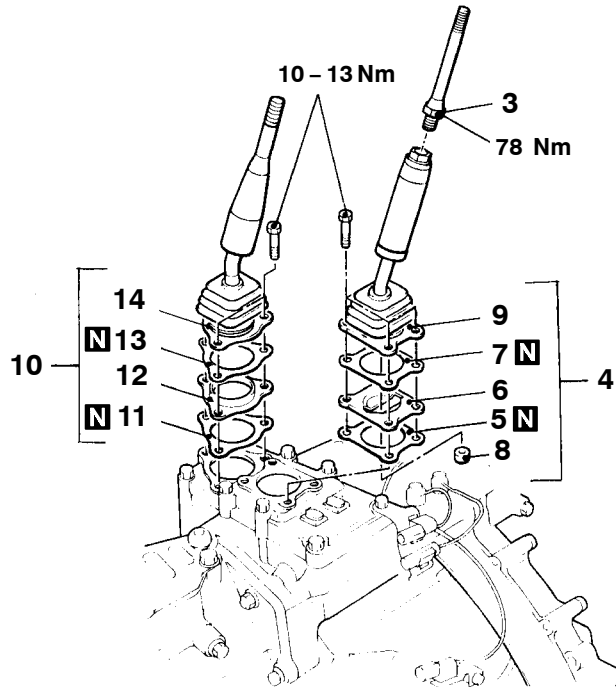

W0314AA
00009330

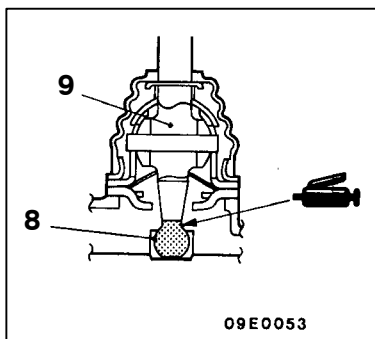

<p>11, 13</p> <p>09W0020</p> <p>Apply the sealant to both sides of the gasket</p>	<p>5, 7</p> <p>09W0021</p> <p>Apply the sealant to both sides of the gasket</p>
<p>Sealant: 3M ATD Part No. 8661 or equivalent</p>	

<p>Control lever assembly mounting bolt</p> <p>09E0031</p>
<p>Adhesive: 3M Stud Locking No. 4170 or equivalent</p>

Transmission control lever assembly removal steps

- 1. Retainer plate
- 2. Dust cover
- 3. Shift lever shaft
- 4. Transmission control lever assembly
- 5. Gasket
- 6. Stopper plate
- 7. Gasket
- 8. Control lever bushing
- 9. Transmission control lever

Transfer control lever assembly removal steps

- 1. Retainer plate
- 2. Dust cover
- 10. Transfer control lever assembly
- 11. Gasket
- 12. Stopper plate
- 13. Gasket
- 14. Transfer control lever

REMOVAL SERVICE POINT

◀A▶ SHIFT LEVER SHAFT REMOVAL

Caution

Hold the transmission control lever with the spanner and loosen the shift lever shaft.

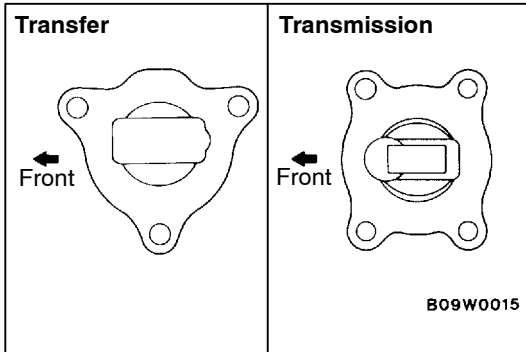

INSTALLATION SERVICE POINTS

▶A◀ STOPPER PLATE INSTALLATION

Install the stopper plates so that they face as shown in the illustration.

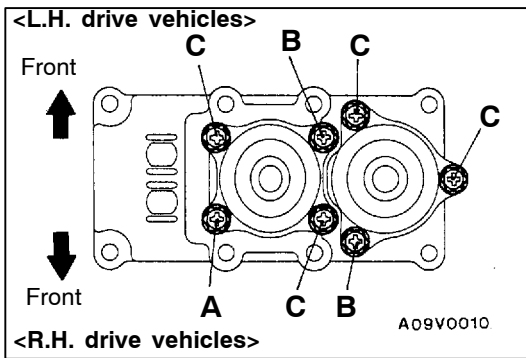

**▶B◀ TRANSFER CONTROL LEVER ASSEMBLY/
TRANSMISSION CONTROL LEVER ASSEMBLY**

1. Remove the adhesive sticking to the control lever assembly mounting bolts.
2. Use a tap (M8 x 1.25) to remove the adhesive sticking to the bolt holes in the control housing, and clean it by blowing in air.
3. Apply specified adhesive to the threads of the control lever assembly mounting bolts.

Specified adhesive:

3M Stud Locking No. 4170 or equivalent

4. The dimensions of the mounting bolts vary according to their mounting locations, so do not confuse them when installing.

Bolt	Diameter x Length mm
A	8 x 18
B	8 x 22
C	8 x 23

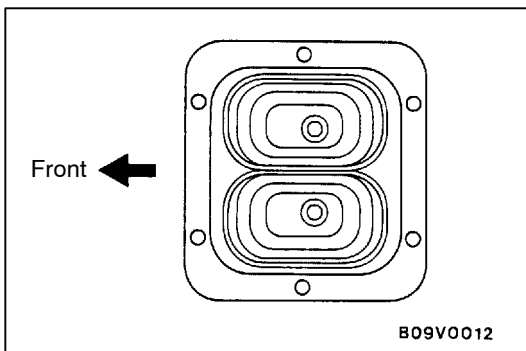

▶C◀ SHIFT LEVER SHAFT INSTALLATION

Caution

Hold the transmission control lever with the spanner and tighten the shift lever shaft.

▶D◀ DUST COVER INSTALLATION

Install the dust cover so that they face as shown in the illustration.

TRANSMISSION ASSEMBLY

22100350086

REMOVAL AND INSTALLATION

Caution

*: Indicates parts which should be initially tightened, and then fully tightened after placing the vehicle horizontally and loading the full weight of the engine on the vehicle body.

Pre-removal Operation

- Transmission and Transfer Control Lever Removal (Refer to P.22-5.)
- Transfer Case Protector Removal
- Transmission and Transfer Oil Draining (Refer to P.22-3.)
- Front and Rear Propeller Shaft Removal (Refer to GROUP 25 – Propeller Shaft.)
- Front and Center Exhaust Pipe Removal <4D5> (Refer to GROUP 15 – Exhaust Pipe and Main Muffler)

Post-installation Operation

- Front and Center Exhaust Pipe Installation <4D5> (Refer to GROUP 15 – Exhaust Pipe and Main Muffler)
- Front and Rear Propeller Shaft Installation (Refer to GROUP 25 – Propeller Shaft.)
- Transmission and Transfer Oil Filling (Refer to P.22-3.)
- Transfer Case Protector Installation
- Transmission and Transfer Control Lever Installation (Refer to P.22-5.)
- Transmission and Transfer Control Lever Operation Check

<6G7>

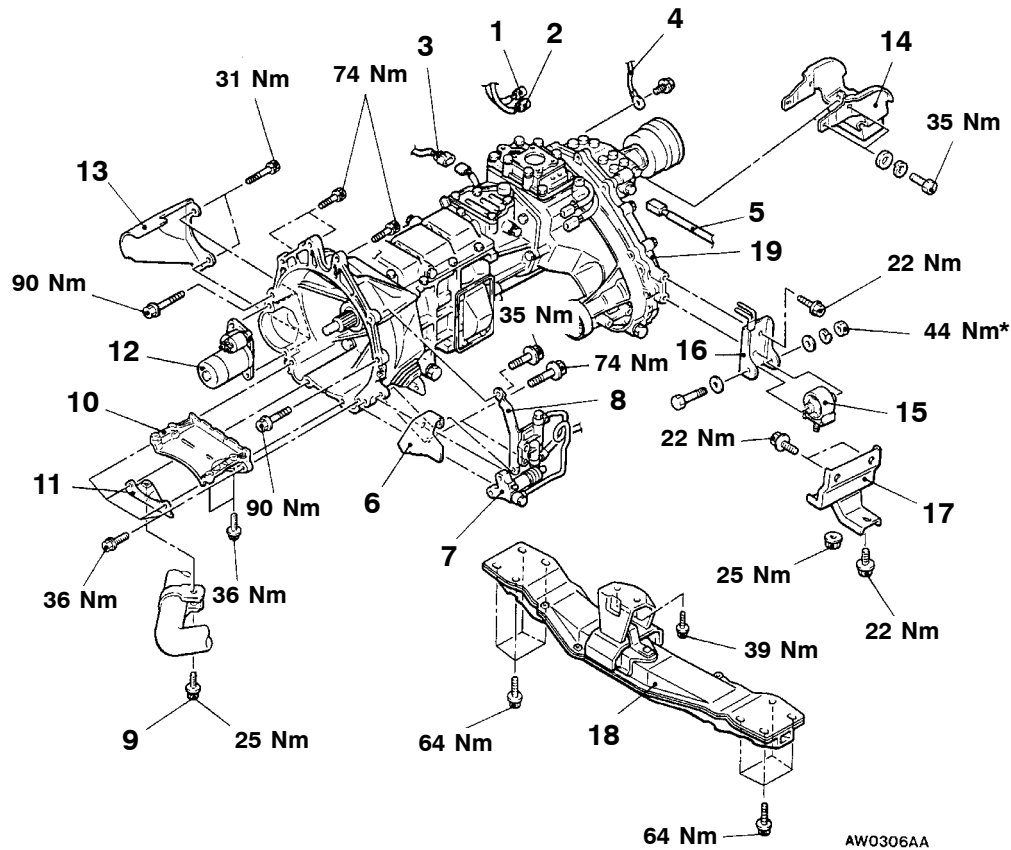

Removal steps

- | | | |
|---|--------------------------------------|--|
| <p>1. High/low detection switch connector</p> <p>2. 4WD detection switch connector</p> <p>3. Back-up lamp switch connector</p> <p>4. Earth cable</p> <p>5. Speed sensor connector</p> <p>6. Heat protector</p> <p>7. Clutch release cylinder</p> <p>8. Clutch damper assembly <R.H. drive vehicles></p> <p>9. Exhaust pipe clamp mounting bolt</p> <p>10. Transmission stay</p> | <p>◀B▶</p> <p>▶B▶</p> <p>◀C▶ ▶A▶</p> | <p>11. Exhaust clamp bracket</p> <p>12. Starter motor</p> <p>13. Starter motor cover</p> <p>14. Dynamic damper assembly</p> <ul style="list-style-type: none"> • Support the transmission with a transmission jack <p>15. Transfer roll stopper</p> <p>16. Transfer mount bracket</p> <p>17. Transfer support bracket</p> <p>18. No. 2 crossmember</p> <p>19. Transmission assembly</p> |
|---|--------------------------------------|--|

◀A▶

<4D5>

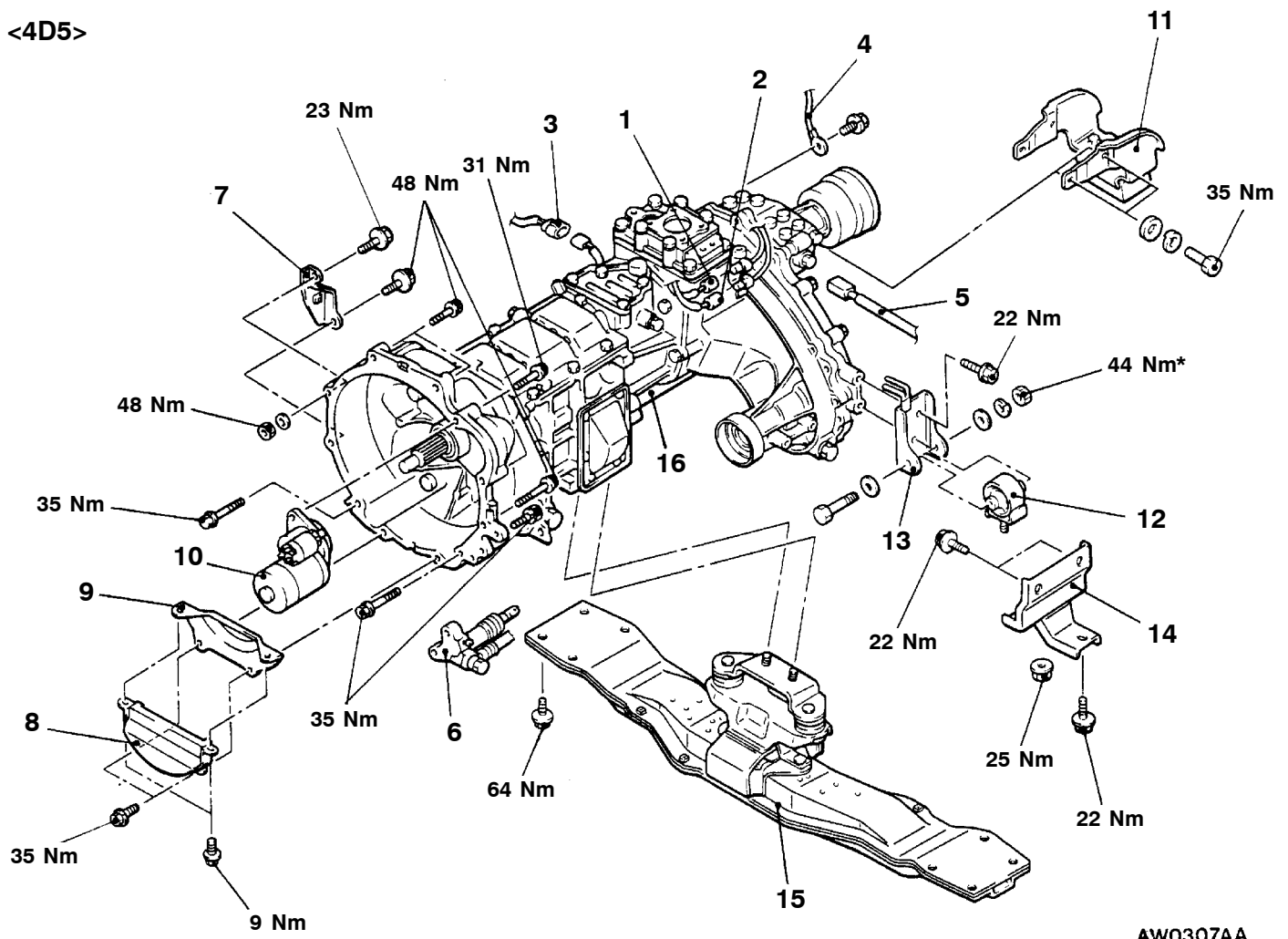

AW0307AA

Removal steps

1. High/low detection switch connector
2. 4WD detection switch connector
3. Back-up lamp switch connector
4. Earth cable
5. Speed sensor connector
6. Clutch release cylinder
7. Exhaust pipe support bracket
8. Space rubber
9. Bell housing cover

- | | |
|--------------------------------------|--|
| <p>◀B▶</p> <p>▶B▶</p> <p>◀C▶ ▶A▶</p> | <p>10. Starter motor</p> <p>11. Dynamic damper assembly
● Support the transmission with a transmission jack</p> <p>12. Transfer roll stopper</p> <p>13. Transfer mount bracket</p> <p>14. Transfer support bracket</p> <p>15. No. 2 crossmember</p> <p>16. Transmission assembly</p> |
|--------------------------------------|--|

◀A▶

REMOVAL SERVICE POINTS

◀A▶ CLUTCH RELEASE CYLINDER REMOVAL

Remove the clutch release cylinder without disconnecting fluid line. Then suspend them with a cord.

◀B▶ STARTER MOTOR REMOVAL

Remove the starter motor with the starter motor harnesses still connected, and secure it inside the engine compartment.

◀C▶ TRANSMISSION ASSEMBLY REMOVAL

Caution

When removing the transmission assembly from the engine, care must be taken not to shake or rock with force, because to do so might cause damage to the end of the main drive gear, the pilot bearing, or the clutch disc, etc.

INSTALLATION SERVICE POINTS

▶A◀ TRANSMISSION ASSEMBLY INSTALLATION

The sizes of the mounting bolts are different. So be sure not to confuse them.

<6G7>

Bolt		Diameter x Length mm
A		12 x 40
B	L.H. drive vehicles	12 x 40
	R.H. drive vehicles	12 x 45
C		12 x 55

<4D5>

Bolt		Diameter x Length mm
A		10 x 45
B		8 x 30
C		10 x 80
D		10 x 25

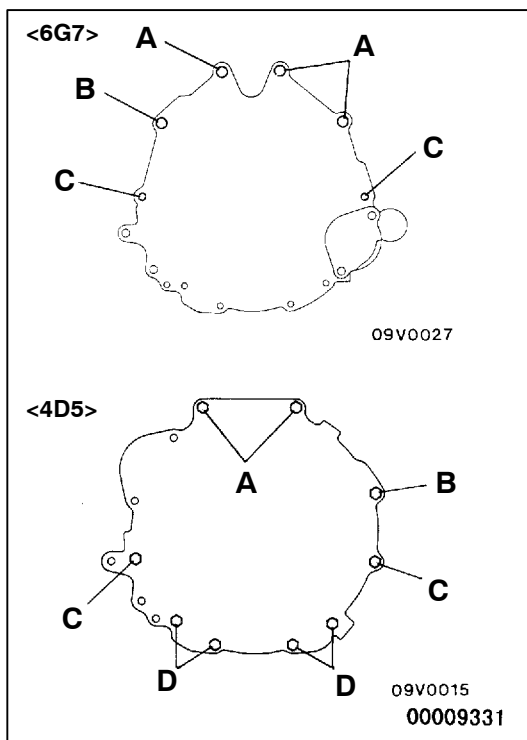

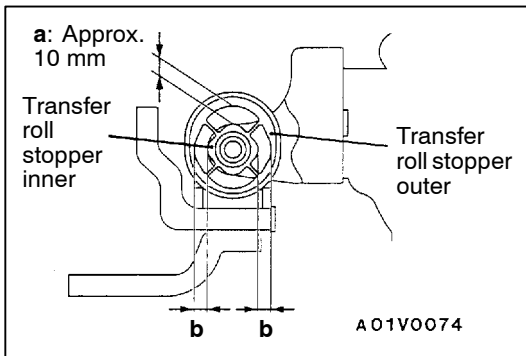

►B◄ TRANSFER ROLL STOPPER INSTALLATION

1. Tighten the transfer roll stopper provisionally.
2. Make the engine and transmission assembly rest on the engine mount.
3. Tighten the transfer roll stoppers inner and outer finally so that the clearance (a) between the two are at the shown dimension.
4. Check that the right and left clearances (b) between the stoppers are equal.

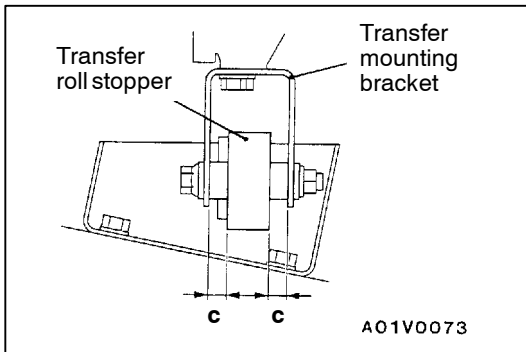

5. Check that the clearances (c) between the transfer roll stopper and transfer mounting bracket are equal.

NOTE

When new, a transfer roll stopper consists of one part, but will separate into outer and inner part during use. This is normal.

**4WD INDICATOR-ECU
REMOVAL AND INSTALLATION**

22100620040

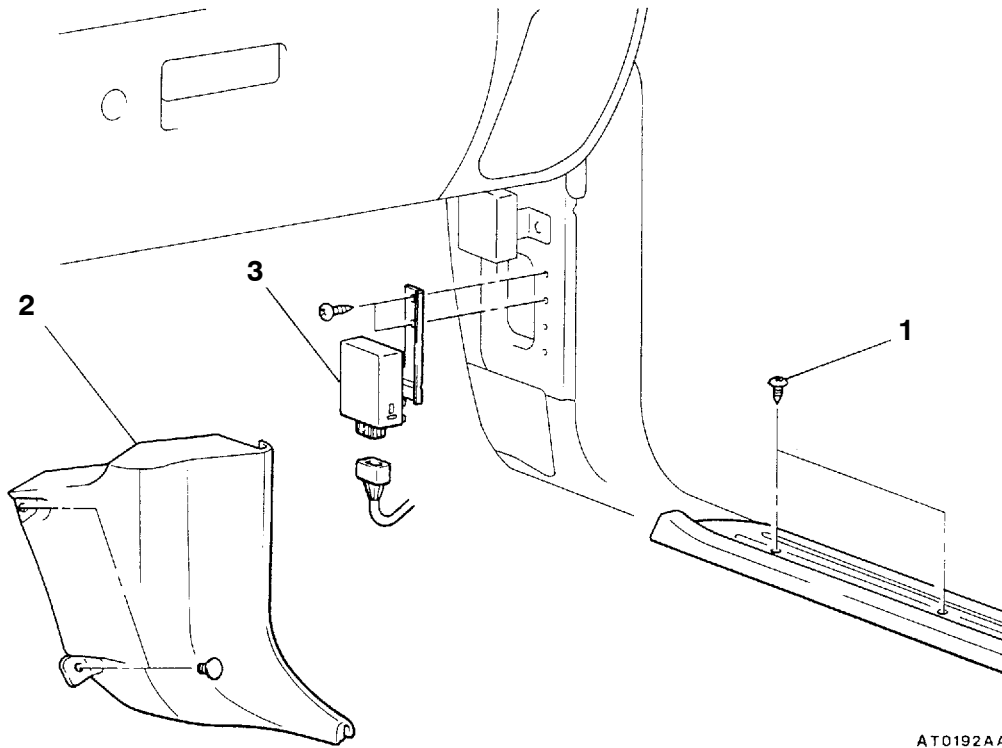

AT0192AA

Removal steps

1. Front scuff plate attaching screw
2. Cowl side trim
3. 4WD indicator-ECU

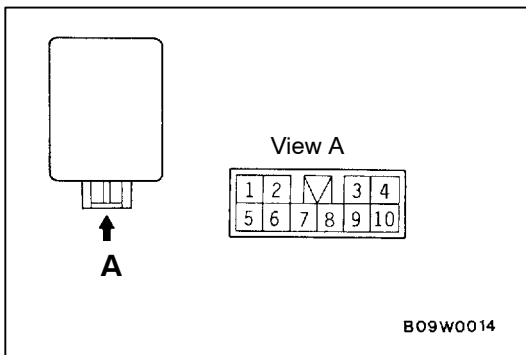

B09W0014

INSPECTION

22100640039

4WD INDICATOR-ECU

1. Measure the voltage with the control unit and harness still connected.
2. Earth terminal (8) and then measure terminal voltage.

Terminal No.	Inspection item	Inspection condition 1: Ignition switch	Inspection condition 2: Transfer lever position	Terminal voltage
1	Free wheel engage switch	ON	2H	System voltage
			4H*1	0 V
2	4WD detection switch	ON	2H	System voltage
			4H, 4L	0 V
3	Ignition switch (IG1)	OFF	–	0 V
		ON	–	System voltage
6	HI/LOW detection switch	ON	Shifting from 4H to 4L or vice versa	System voltage
			2H, 4H, 4L	0 V
7	Free wheel clutch changeover solenoid valve	ON	4H, 4L	0 V
			2H*2	System voltage
10	4WD Indicator lamp	ON	2H	0 V
			4H, 4L	System voltage

NOTE

*1: When vehicle has been moved once.

*2: Shift the lever from 4H to 2H, and then turn the ignition switch to OFF and then back to ON.

PROPELLER SHAFT

CONTENTS

25109000112

GENERAL INFORMATION	2	SPECIAL TOOLS	2
SERVICE SPECIFICATIONS	2	PROPELLER SHAFT	3
LUBRICANT	2		



GENERAL INFORMATION

25100010084

A two-joint propeller shaft was used for both the front and rear. The front propeller shaft has a

B.J.-type joint on the transfer side.

CONSTRUCTION DIAGRAM

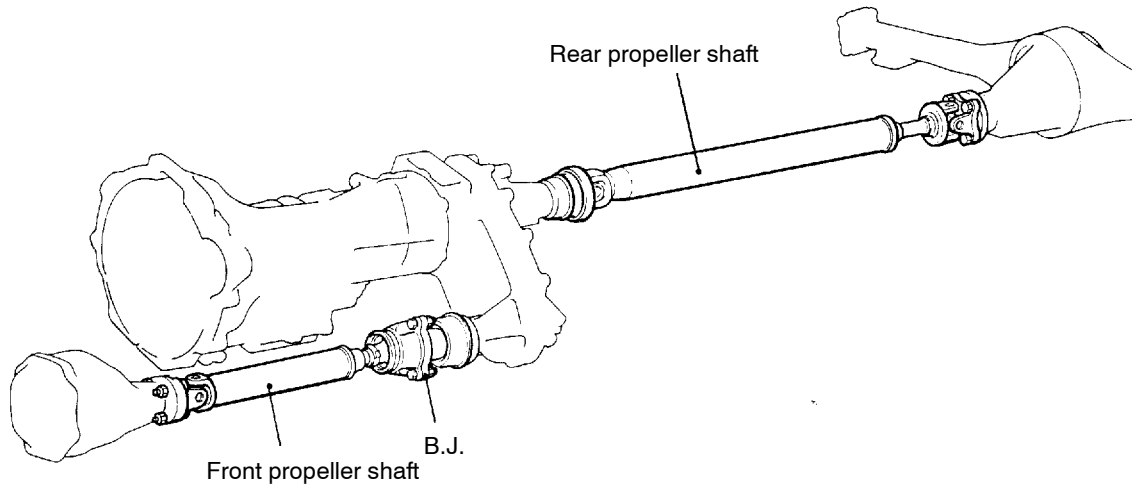

AV0596AA

SERVICE SPECIFICATIONS

25100030080

Items	Standard value	Limit
Front propeller shaft runout mm	–	0.6
Rear propeller shaft runout mm	–	0.6
Clearance between snap ring and groove wall of yoke mm	0.03 or less	–

LUBRICANT

25100040106

Item	Specified lubricant	Quantity
Sleeve yoke	Hypoid gear oil SAE 75W-90 or 75W-85W conforming to API GL-4	As required

SPECIAL TOOLS

25100060096

Tool	Number	Name	Use
	MB990840	Universal joint remover and installer	Disassembly and reassembly of the universal joint
	MB991410	Collar	

PROPELLER SHAFT

25100100163

REMOVAL AND INSTALLATION

Pre-removal Operation

- Set the Transfer Shift Lever to “2H”
- Front Under Cover, Middle Under Cover and Transfer Protector Removal
- Transfer Gear Oil Draining (Refer to GROUP 22 – On-vehicle Service.)

Post-installation Operation

- Transfer Gear Oil Supplying (Refer to GROUP 22 – On-vehicle Service.)
- Front Under Cover, Middle Under Cover and Transfer Protector Installation

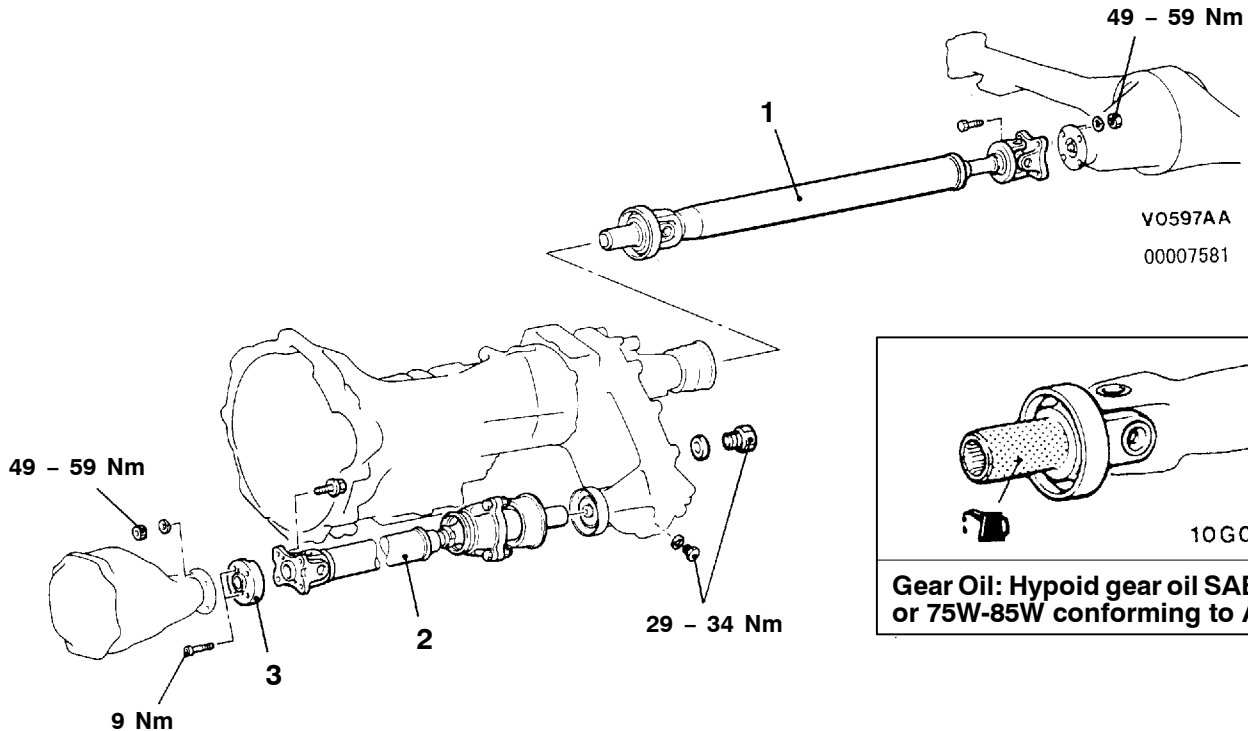

10G0001

Gear Oil: Hypoid gear oil SAE 75W-90 or 75W-85W conforming to API GL-4

Removal steps



1. Rear propeller shaft assembly
2. Front propeller shaft assembly

3. Spacer <6G7>

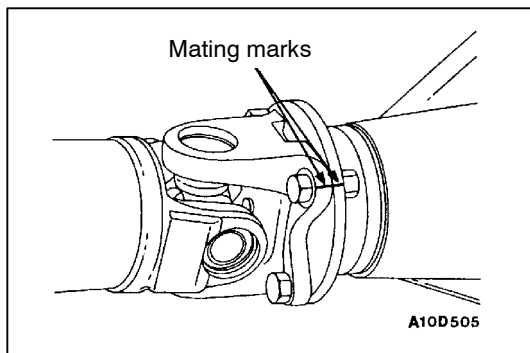

REMOVAL SERVICE POINT

◀A▶ REAR PROPELLER SHAFT ASSEMBLY/FRONT PROPELLER SHAFT ASSEMBLY REMOVAL

1. Make mating marks on the differential companion flange and flange yoke and remove the propeller shaft.
2. Use the plug as a cover so that no foreign material gets into the transmission or transfer.

INSTALLATION SERVICE POINT**▶◀ FRONT PROPELLER SHAFT ASSEMBLY/REAR PROPELLER SHAFT ASSEMBLY INSTALLATION**

Align the mating marks that were made during removal, and then install the propeller shaft assembly to the companion flange.

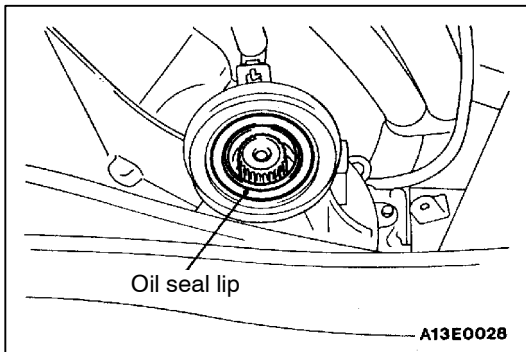
**Caution**

1. Tighten installation bolts after removing oil and grease from threads to prevent them from loosening due to lubrication.
2. Be careful not to damage the lip section of the transfer case oil seal when installing the propeller shaft.

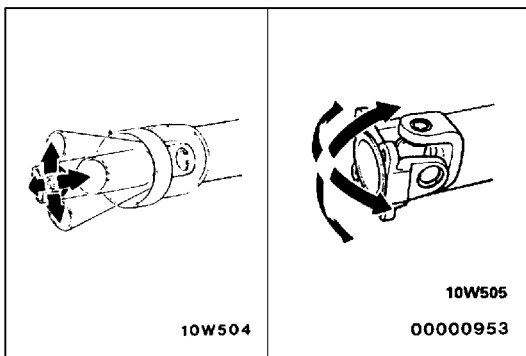
**INSPECTION**

25100110043

- Check the sleeve yoke, center yoke and flange yoke for wear, damage or cracks.
- Check the propeller shaft yokes for wear, damage or cracks.
- Check the propeller shaft for bends twisting or damage.
- Check the universal joints for smooth operation in all directions.
- Check the center bearing for smooth movement.
- Check the center bearing mounting rubber for damage or deterioration.

PROPELLER SHAFT RUNOUT

Limit: 0.6 mm

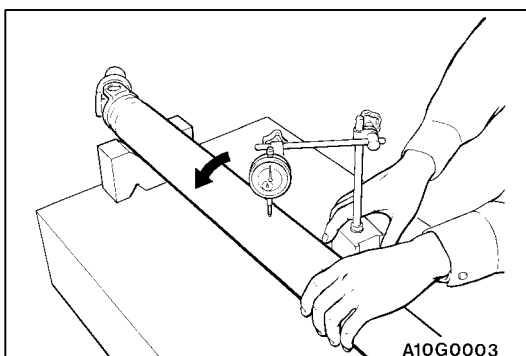

DISASSEMBLY AND REASSEMBLY

25100120114

Front propeller shaft
<Type 1 (External snap ring type)>

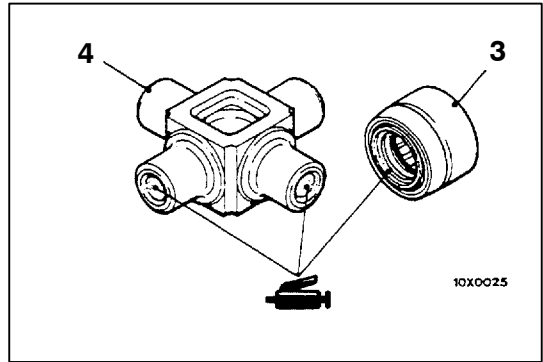
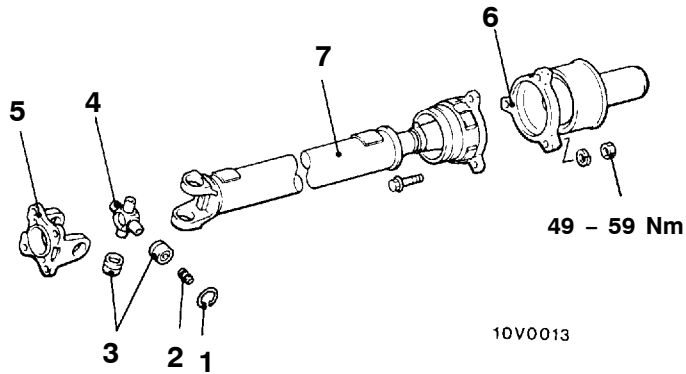

Rear propeller shaft
<Type 2 (Internal snap ring type)>

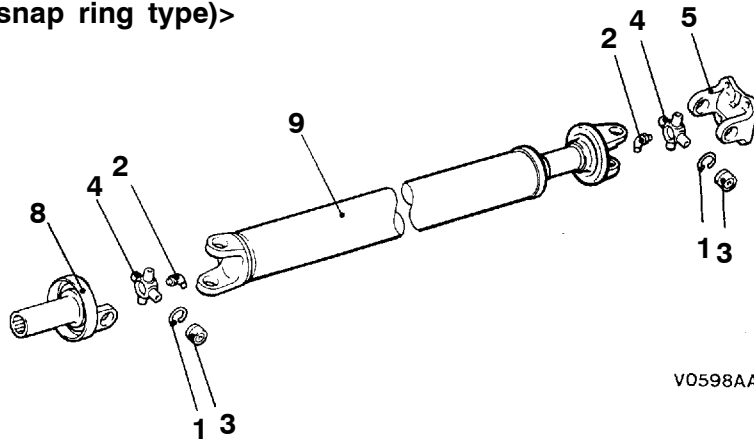

Disassembly steps

- | | | | |
|-------------------------------|---|------------|--|
| <p>◀A▶ ▶B▶</p> <p>◀B▶ ▶A▶</p> | <ol style="list-style-type: none"> 1. Snap ring 2. Grease fitting 3. Journal bearing 4. Journal 5. Flange yoke | <p>◀C▶</p> | <ol style="list-style-type: none"> 6. Sleeve flange 7. Front propeller shaft assembly 8. Sleeve yoke 9. Rear propeller shaft |
|-------------------------------|---|------------|--|

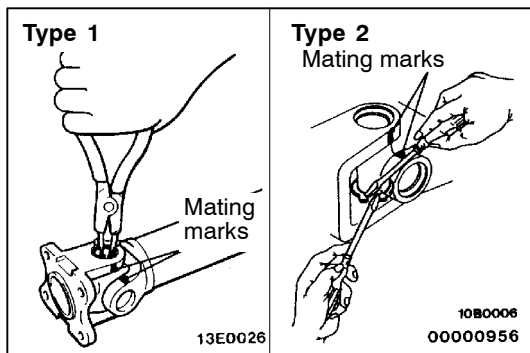

DISASSEMBLY SERVICE POINTS

◀A▶ SNAP RING REMOVAL

Place a mating mark on the yokes of the universal joint that is to be disassembled.

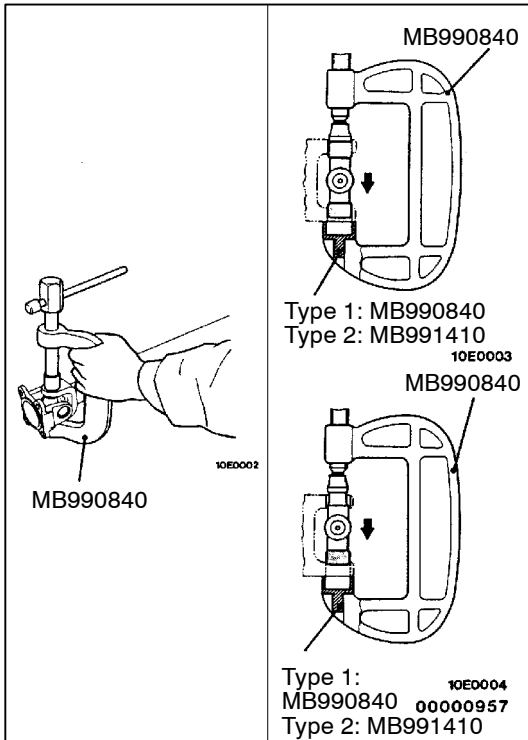

◀B▶ JOURNAL BEARING REMOVAL

1. Use special tool to press in the journal bearing on one side, and take out the journal bearing on the opposite side.
2. Insert special tool into the other side and press the journal to remove the first journal bearing that was pushed.

Caution

Do not tap the journal bearings to remove them, as this will upset the balance of the propeller shaft.

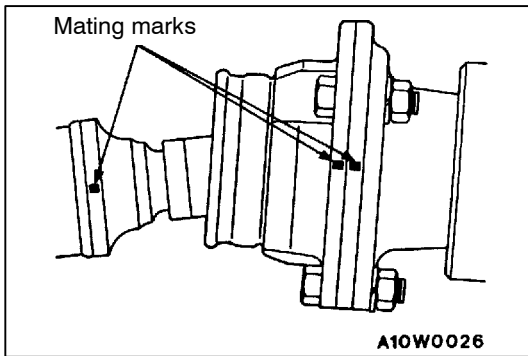

◀C▶ SLEEVE FLANGE REMOVAL

Place a mating mark on the sleeve flange and front propeller shaft assembly, and then remove the sleeve flange.

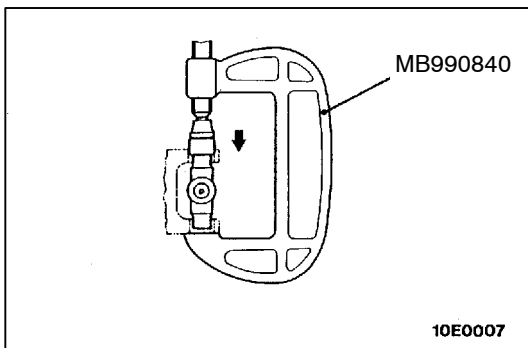

REASSEMBLY SERVICE POINTS

▶A◀ JOURNAL BEARING INSTALLATION

1. Use the special tool to press the journal bearing into the yoke until the snap ring groove is fully visible.

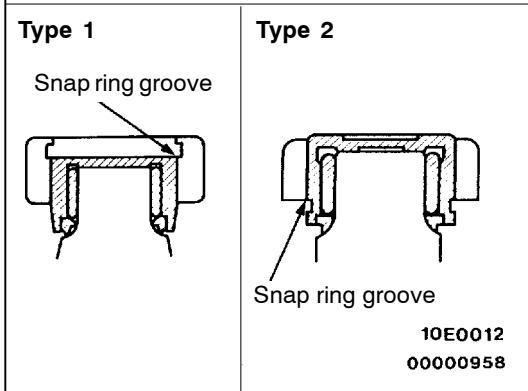

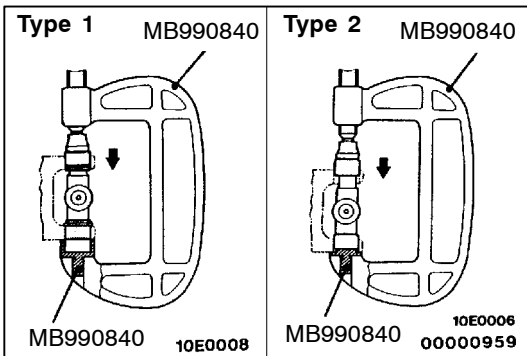

- Use the special tool to press the opposite side journal bearing into the yoke.

Caution

Be careful when pressing the journal bearings, as if they are pressed at an angle, the inside of the journal bearings will be damaged by the journal.

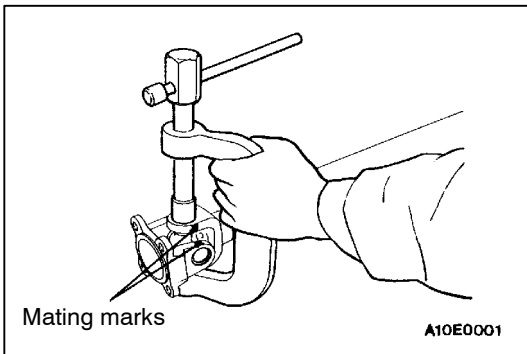

- Align the mating marks on the yoke and propeller shaft, and install the propeller shaft journal bearings in the method described in (1) and (2) above.

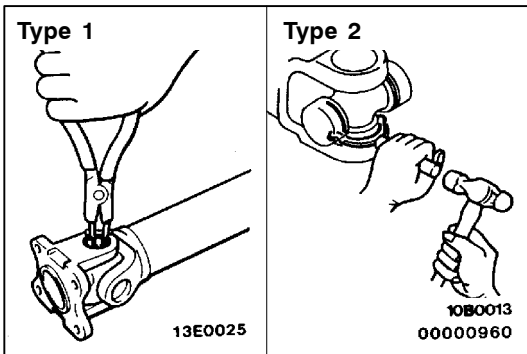

▶B◀SNAP RING INSTALLATION

- Install a snap ring to one side of the journal.

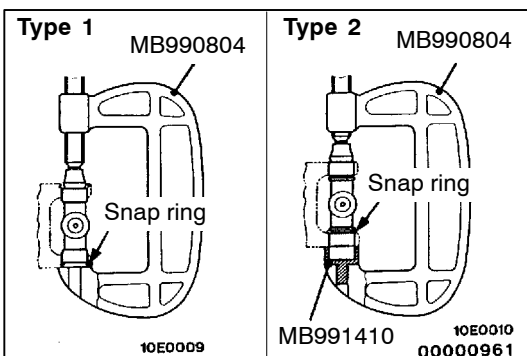

- Use the special tool at the opposite side of the installed snap ring to press in the journal bearing towards the snap ring.

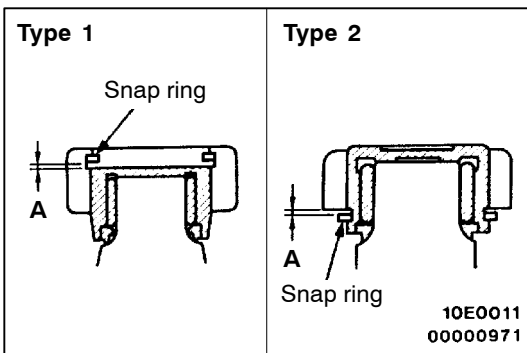

- Install the snap ring on the opposite side, and measure the clearance of the snap ring groove with a thickness gauge.

Standard value (A): 0.03 mm or less

Caution

Always use snap rings of equal thicknesses on both sides.

4. If the clearance exceeds the standard value, adjust by changing the thickness of the snap ring.

Thickness mm Type 1	Thickness mm Type 2	Identification colour
1.28	1.50	–
1.31	1.55	Yellow
1.34	1.60	Blue
1.37	1.65	Purple

FRONT AXLE

CONTENTS

26109000218

GENERAL INFORMATION	2	Drive Shaft Axial Play Check	10
SERVICE SPECIFICATIONS	4	Solenoid Valve Operation Check	10
LUBRICANTS	4	FRONT HUB ASSEMBLY	12
SEALANTS	5	KNUCKLE	17
SPECIAL TOOLS	5	DRIVE SHAFT	21
ON-VEHICLE SERVICE	9	INNER SHAFT	31
Front Axle Total Backlash Check	9	DIFFERENTIAL CARRIER	35
Front Axle Gear Oil Level Check	10	FREEWHEEL CLUTCH	54

GENERAL INFORMATION

26100010241

The front axle consists of the hub assembly, drive shaft, inner shaft, front differential, freewheel clutch assembly and actuator. The features are:

- The wheel bearing uses a double taper roller bearing. For vehicles with ABS, a rotor for detecting the wheel speed is bolted to the brake disc.
- Drive shafts of almost identical length reduce torque steer. In addition, a D.O.J.-B.J.-type constant velocity ball joint has high power transmission efficiency and reduces vibration and noise.
- A vacuum-type freewheel clutch has been adopted in the freewheel mechanism. Its solenoid valve and actuator switch powertrain between 2WD and 4WD.

Item		6G7, 4D5 <Vehicles with-out wide fender>	4D5 <Vehicles with wide fender>	
Wheel bearing	Type	Double taper roller bearing		
	Inner bearing (O.D. x I.D.) mm	73 x 45		
	Outer bearing (O.D. x I.D.) mm	73 x 45		
Drive shaft	Joint type	Outer: B.J. Inner: D.O.J.		
	Shaft length (joint to joint) mm	Right: 316 Left: 288	Right: 318 Left: 291	
Inner shaft	O.D. x length mm	31.5 x 304.2		
	Bearing (O.D. x I.D.) mm	62 x 35		
Differential	Drive gear	Hypoid gear		
	Reduction ratio	4.636	4.900	
	Differential gear type (type x quantity)	Side gear	Straight bevel gear x 2	
		Pinion gear	Straight bevel gear x 2	
	Number of teeth	Drive gear	51	49
		Drive pinion	11	10
		Side gear	14	
		Pinion gear	10	
	Bearing (O.D. x I.D.) mm	Side	80 x 45	
		Front	68 x 30	
Rear		76 x 37		

CONSTRUCTION DIAGRAM

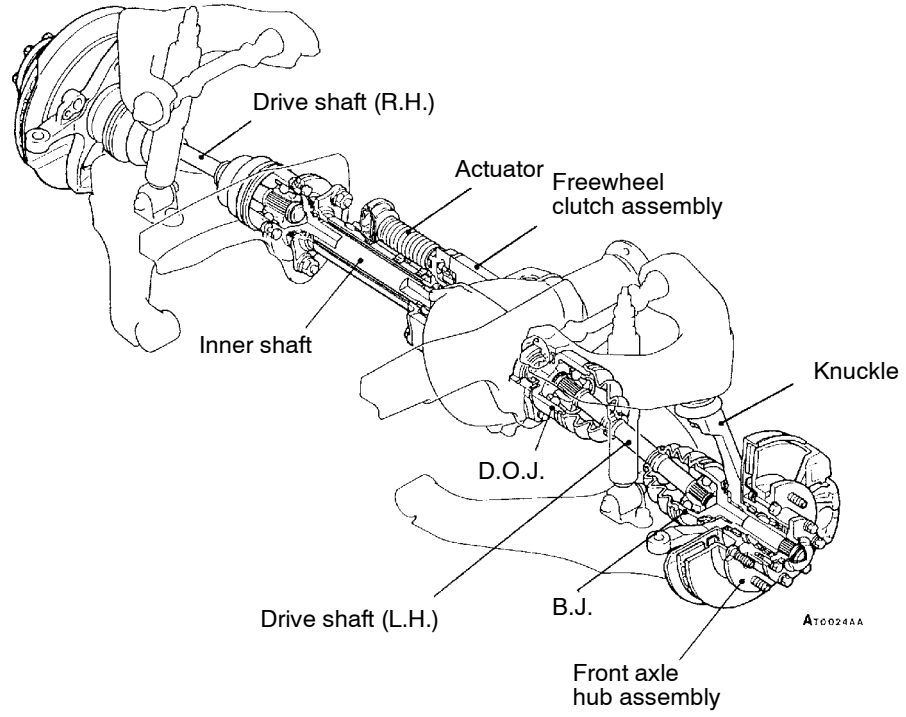

SERVICE SPECIFICATIONS

26100030261

Item	Standard value	Limit	
Front axle total backlash mm	–	11	
Drive shaft axial play mm	0.4 – 0.7	–	
Solenoid valve resistance Ω	36 – 46	–	
Hub rotary sliding resistance N (Hub rotation starting torque) Nm	4 – 19 (0.3 – 1.3)	–	
Amount of movement of far the wheel bearing in an axial direction mm	0.05 or less	–	
Setting of D.O.J. boot length mm	80 \pm 3	–	
Opening dimension of the special tool (MB991561) mm	When the B.J.boot band (small) is crimped.	2.9	–
	When the B.J.boot band (big) is crimped.	3.2	–
Crimped width of the B.J.boot band mm	2.4 – 2.8	–	
Clearance between the B.J.boot (larger diameter side) and the stepped phase of the B.J.housing mm	0.1 – 1.55	–	
Clutch gear play (bearing axial play) mm	0.05 – 0.30	–	
Final drive gear backlash mm	0.11 – 0.16	–	
Differential gear backlash mm	0 – 0.076	0.2	
Drive pinion turning torque Nm	Without oil seal	When replacing (with anti-rust agent) 0.29 – 0.49	–
		When replacing or reusing (with gear oil applied) 0.15 – 0.25	–
	With oil seal	When replacing (with anti-rust agent) 0.49 – 0.69	–
		When replacing or reusing (with gear oil applied) 0.34 – 0.44	–
Drive gear runout mm	–	0.05	

LUBRICANTS

26100040288

Items	Specified lubricants	Quantity
Front differential gear oil	Hypoid gear oil API classification GL-5 or higher SAE viscosity No. 90, 80W	0.9 L
D.O.J. boot grease	Repair kit grease	140 g
B.J.boot grease	Repair kit grease	120 g



SEALANTS



26100050069

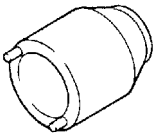
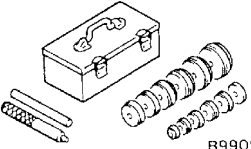
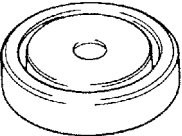
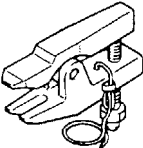

Items	Specified sealants	Remarks
Contact surface of drive flange and front hub assembly	3M ATD Part No. 8663 or equivalent	Semi-drying sealant
Contact surface of hub cap and drive flange		
Contact surface of differential cover and differential carrier		
Vent plug		
Freewheel clutch assembly		
Drive gear threaded hole	3M Stud Locking 4170 or equivalent	Anaerobic sealant

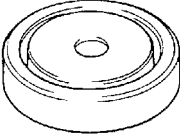
SPECIAL TOOLS

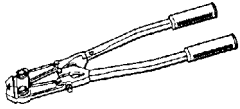
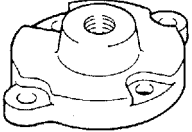
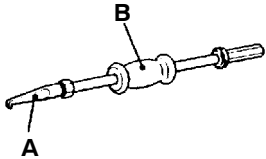
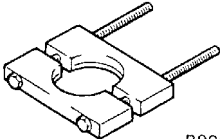
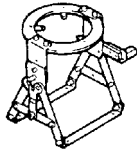
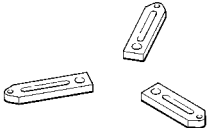
26100060253

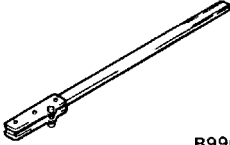
Tool	Number	Name	Use
 B990954	MB990954	Lock nut wrench	Removal and adjustment of lock nut
 B990925	MB990925	Bearing and oil seal installer set	<ul style="list-style-type: none"> ● Press-out and press-fitting of bearing ● Press-fitting of oil seal ● Press-fitting of drive shaft ● Tapping in of side bearing outer race ● Checking of drive gear tooth contact
 B990955	MB990955	Oil seal installer	<ul style="list-style-type: none"> ● Press-fitting of housing tube dust seal ● Press-fitting of front axle hub oil seal (Used together with MB990938)
 B991113	MB991113 or MB990635	Steering linkage puller	<ul style="list-style-type: none"> ● Disconnection of tie rod ● Disconnection of upper ball joint ● Disconnection of lower ball joint
 B990956	MB990956	Needle bearing installer	Press-fitting of knuckle needle bearing (Used together with MB990938)
 B990985	MB990985	Oil seal installer	Press-fitting of knuckle oil seal (Used together with MB990938)

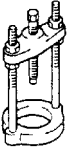
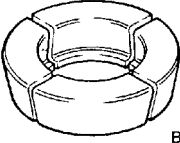
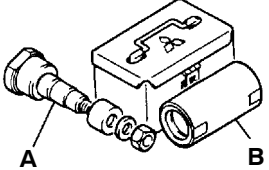
Tool	Number	Name	Use
	MB991561	Boot band clipping tool	Resin boot band installation
 <p style="text-align: center;">B990906</p>	MB990906	Drive shaft attachment	Removal and installation of inner shaft (Used together with MB990211)
 <p style="text-align: center;">A B</p>	MB990590 A: MB990212 B: MB990211	Rear axle shaft oil seal remover A: Adapter B: Sliding hammer	<ul style="list-style-type: none"> ● Removal of differential carrier oil seal ● Removal and installation of inner shaft (Used together with MB990906)
 <p style="text-align: center;">B990560</p>	MB990560	Bearing remover	Removal and press-fitting of inner shaft bearing
 <p style="text-align: center;">B990909</p>	MB990909	Working base	Support of front differential carrier assembly
	MB991116	Adapter	Support of front differential carrier assembly
 <p style="text-align: center;">B990810</p>	MB990810	Side bearing puller	Removal of side bearing inner race
	MB990811	Differential side bearing cap	
 <p style="text-align: center;">B990850</p>	MB990850	End yoke holder	Removal and installation of companion flange

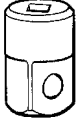
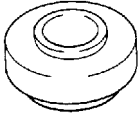
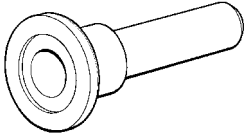
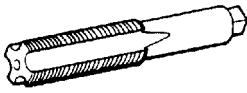
Tool	Number	Name	Use
 <p>B990339</p>	MB990339	Bearing puller	Removal of drive pinion front bearing inner race
 <p>B990374</p>	MB990648	Bearing remover	
 <p>AB990835</p>	MB991171 A: MB990819 B: MB991170	Pinion height gauge set A: Drive pinion gauge assembly B: Cylinder gauge	<ul style="list-style-type: none"> ● Inspection of drive pinion rotation starting torque ● Measurement of drive pinion height
	MB990685	Torque wrench	Measurement of drive pinion preload
	MB990326	Preload socket	
 <p>B990802</p>	MB990802	Bearing installer	<ul style="list-style-type: none"> ● Press-fitting of drive pinion front bearing inner race ● Press-fitting of side bearing inner race
	MB990031 or MB990699	Drive pinion oil seal installer	Press-fitting of drive pinion oil seal
	MB990813	Tap	Removal of adhesive

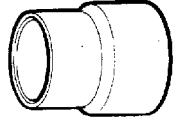
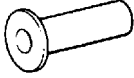
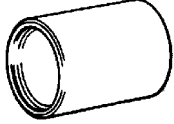
Tool	Number	Name	Use
	MB990799	Ball joint remover and installer	Installation of freewheel clutch bearing
	MB991168	Differential oil seal installer	Installation of freewheel clutch oil seal
	MB990890 or MB990891	Rear suspension bushing base	Installation of freewheel clutch bearing

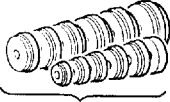
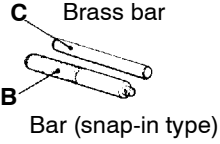
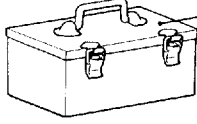
<p>MB990925</p> <div style="display: flex; justify-content: space-around; align-items: flex-start;"> <div style="text-align: center;">  <p>A Installer adapter</p> </div> <div style="text-align: center;">  <p>C Brass bar B Bar (snap-in type)</p> </div> <div style="text-align: center;">  <p>Tool box</p> </div> </div> <p style="text-align: right;">A11W0113</p>					
	Contents of tool (MB990925)	O.D. mm		Contents of tool (MB990925)	O.D. mm
A	MB990926	39	A	MB990933	63.5
	MB990927	45		MB990934	67.5
	MB990928	49.5		MB990935	71.5
	MB990929	51		MB990936	75.5
	MB990930	54		MB990937	79
	MB990931	57	B	MB990938	–
	MB990932	61	C	MB990939	–

ON-VEHICLE SERVICE

26100130046

FRONT AXLE TOTAL BACKLASH CHECK

Observe the following procedure in order to switch powertrain to 4WD.

1. Turn the ignition switch off, and then put the transfer shift lever to the 2H position.

Caution

Do not jack up the vehicle.

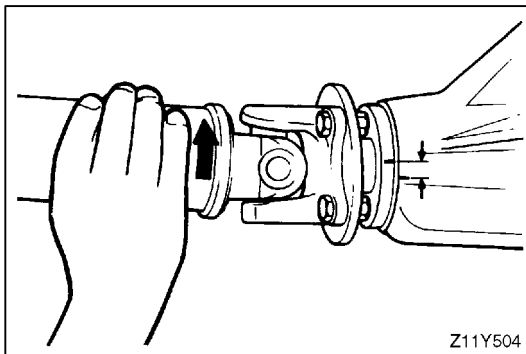
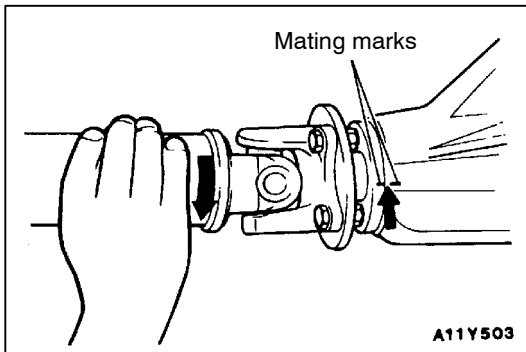

2. Turn the propeller shaft until a click is heard.
3. Turn the companion flange clockwise until all play is removed. Make mating marks on the dust cover of the companion flange with that on the differential carrier.

4. Turn the companion flange anti-clockwise until all play is removed and measure the amount of distance through which the mating marks moved.

Limit: 11 mm

5. If the amount of movement exceeds the limit value, check the following.
 - (1) Final drive gear backlash
 - (2) Differential gear backlash
 - (3) Play in the serrations and splines of the side gears, drive shaft, inner shaft and drive flange

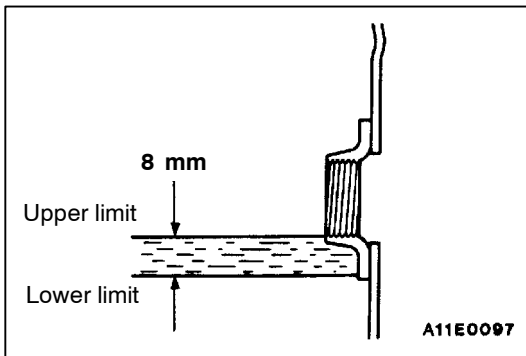

FRONT AXLE GEAR OIL LEVEL CHECK

26200090040

Remove the filler plug, and check the gear oil level. Check that gear oil level is not 8 mm below the bottom of filler plug hole.

Specified gear oil:

Hypoid gear oil API classification GL-5 or higher, SAE viscosity No. 90, 80W [Quantity: 0.9 L]

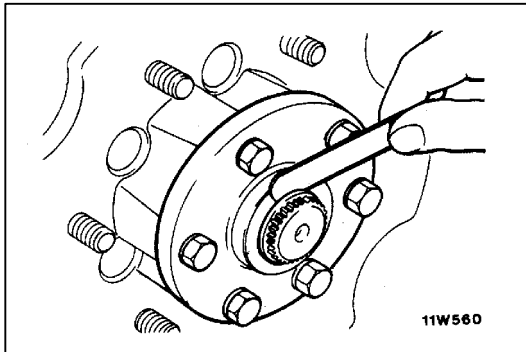

DRIVE SHAFT AXIAL PLAY CHECK

26100140056

1. Jack the vehicle up and remove the front wheels.
2. Remove the hub cap.
3. Manually push the drive shaft in the direction in which it will closely contact the knuckle.
4. As shown in the figure, use a thickness gauge to measure the clearance between the drive flange and snap ring.

Standard value: 0.4 – 0.7 mm

5. If the play is out of standard value, adjust by adding or removing shims.

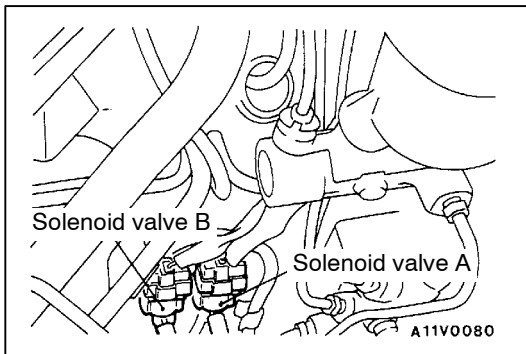

SOLENOID VALVE OPERATION CHECK

261000150028

1. Remove the vacuum hoses (blue stripe, yellow stripe) from the solenoid valves.
2. Disconnect the harness connectors.

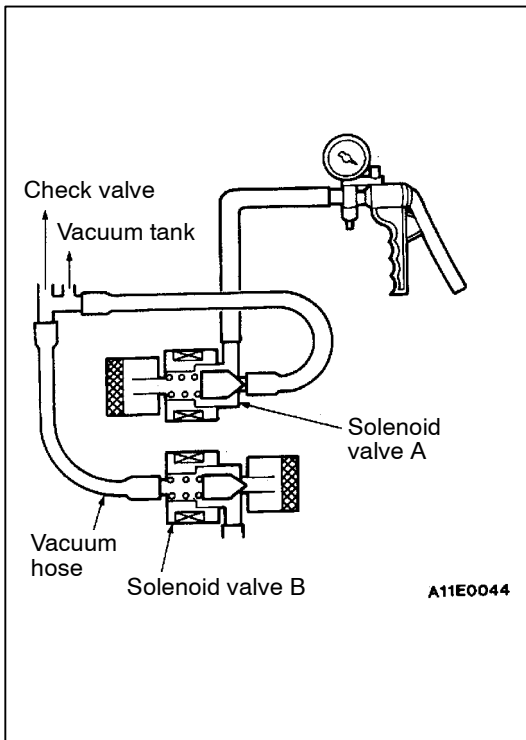

3. Connect a hand vacuum pump to solenoid valve A and carry out the following inspections.
 - (1) Even if the hand pump is operated with no other operation, no negative pressure develops.
 - (2) Negative pressure does not develop when battery voltage is applied to solenoid valve A. Meanwhile, negative pressure is maintained when the vacuum hose of solenoid valve B is blocked by bending.
 - (3) When battery voltage is applied to solenoid valves A and B, negative pressure is maintained.

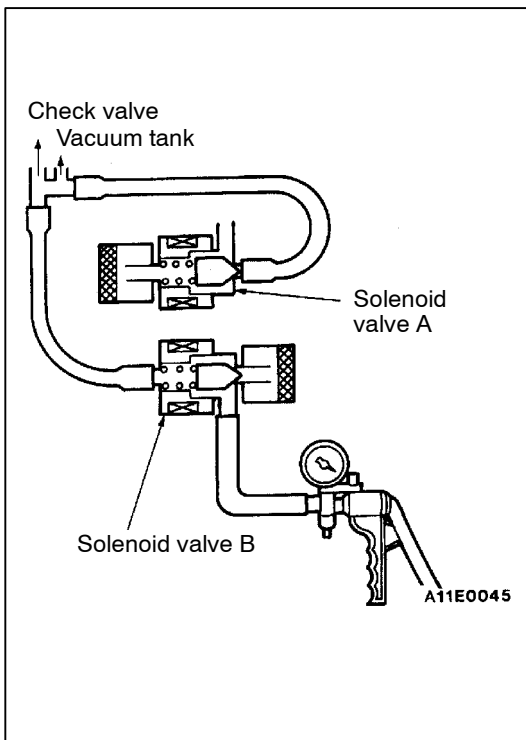

4. Connect the hand vacuum pump to solenoid valve B. Apply negative pressure and carry out the following inspections.
 - (1) With no other operation, negative pressure is maintained.
 - (2) When battery voltage is applied to solenoid valve B, negative pressure disappears.
 - (3) When battery voltage is applied to solenoid valve A, negative pressure disappears.
5. Measure the resistance of the solenoid valves.

Standard value: 36 – 46 Ω

FRONT HUB ASSEMBLY REMOVAL AND INSTALLATION

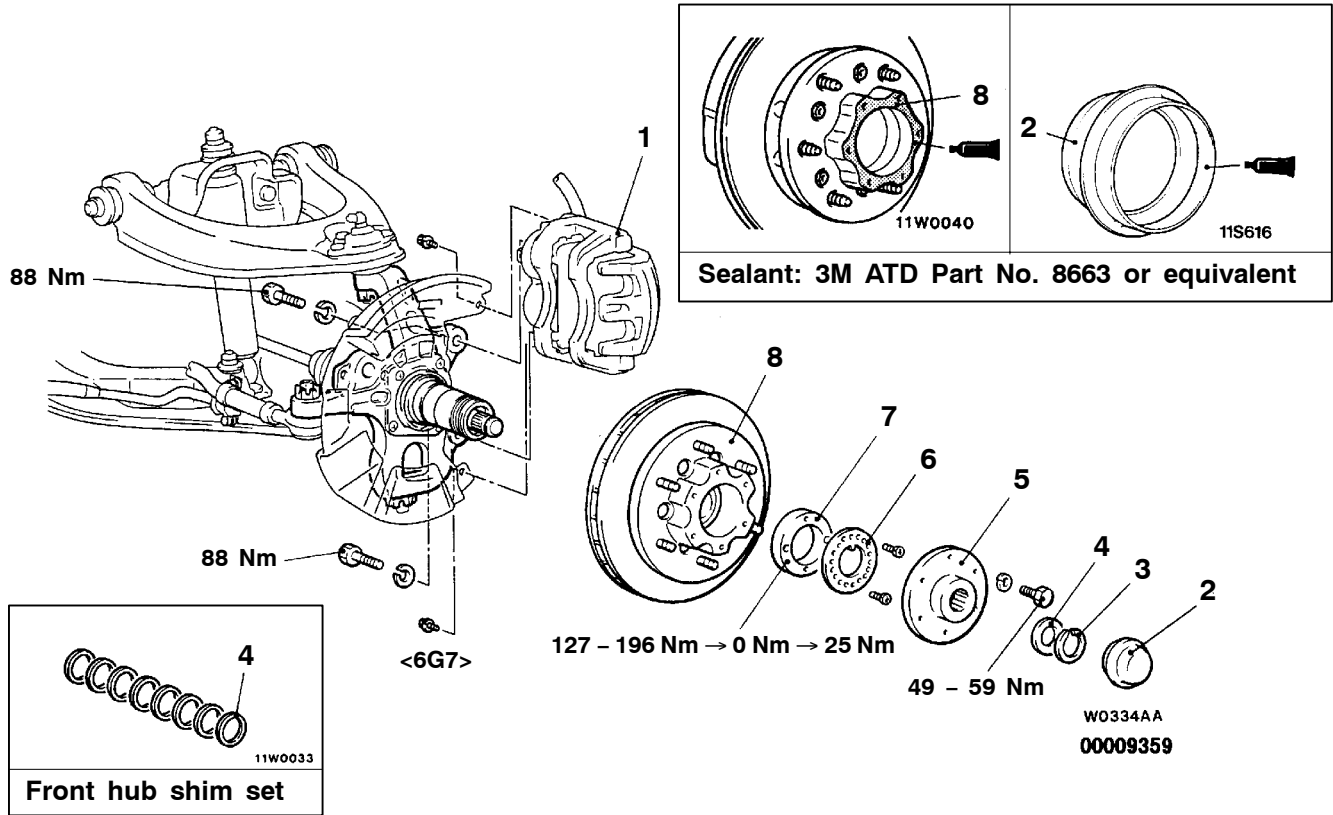

Removal steps

◀A▶

1. Caliper assembly

▶D▶

- 2. Hub cap
- Drive shaft axial play adjustment
- 3. Snap ring
- 4. Shim
- 5. Drive flange

▶C▶

• Hub rotary sliding resistance and wheel bearing axial movement adjustment

▶B▶
▶A▶
▶C▶

- 6. Lock washer
- 7. Lock nut
- 8. Front hub assembly

REMOVAL SERVICE POINTS

◀A▶ CALIPER ASSEMBLY REMOVAL

Secure the removed caliper assembly with wire to prevent it from falling off.

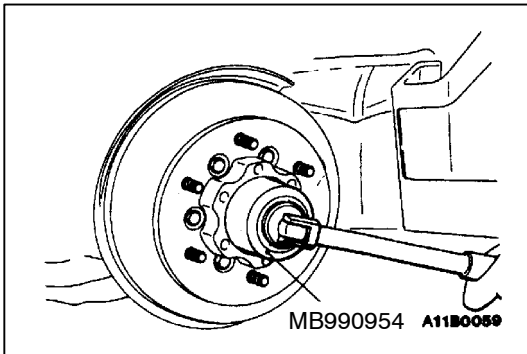

◀B▶ LOCK NUT REMOVAL

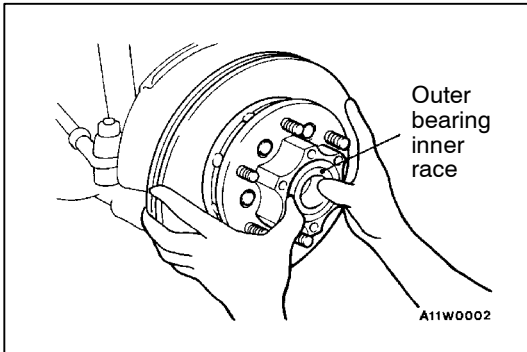

◀C▶ FRONT HUB ASSEMBLY REMOVAL

Do not drop the outer bearing inner race.

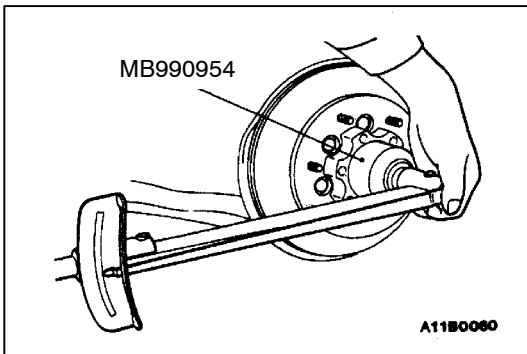

INSTALLATION SERVICE POINTS

▶A▶ LOCK NUT INSTALLATION

Using the special tool, tighten the lock nut by the following procedures.

1. Tighten the lock nut to 127 – 196 Nm, and then turn the front hub assembly to run in the bearings.
2. Loosen the nuts to 0 Nm.
3. After re-tightening to 25 Nm, loosen the lock nuts by approximately 30°.

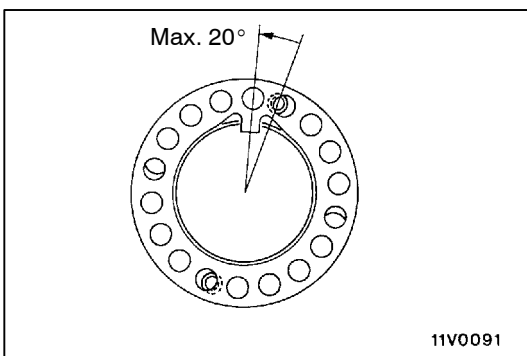

▶B▶ LOCK WASHER INSTALLATION

Install the lock washer. If the hole position is not aligned with the lock nut, move it within a range of not more than 20° until the holes are aligned.

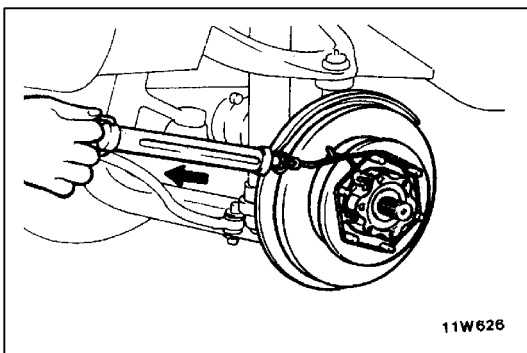

▶C▶ HUB ROTARY SLIDING RESISTANCE AND WHEEL BEARING AXIAL MOVEMENT ADJUSTMENT

1. Use a spring balance to measure the hub rotary sliding resistance (hub rotation starting torque) as shown in the illustration.

Standard value: 4 – 19 N (0.3 – 1.3 Nm)

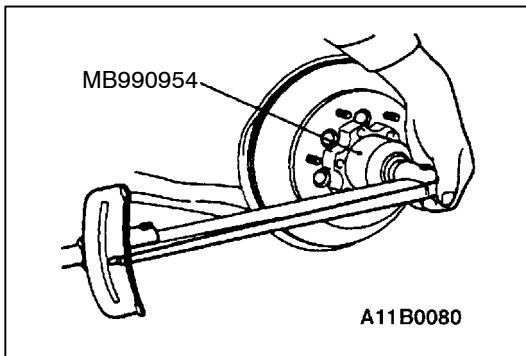

2. If the rotary sliding resistance is not within the standard value, remove the lock washer and adjust by the following procedure.

- (1) If the rotary sliding resistance is lower than the standard value, use the special tool to tighten the lock nut.
- (2) If the rotary sliding resistance is higher than the standard value, use the special tool to loosen the lock nut.

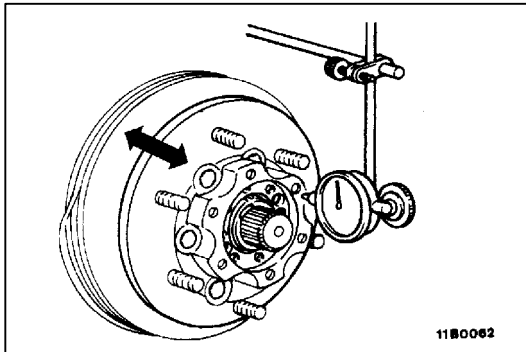

3. Install a dial gauge as shown in the illustration, and then move the hub in the axial direction and measure how far the front wheel bearing moves.

Standard value: 0.05 mm or less

4. If the distance exceeds the standard value, remove the lock washer and use the special tool (MB990954) to tighten the lock nut.
5. If adjustment is not possible, disassemble the hub and inspect each part.

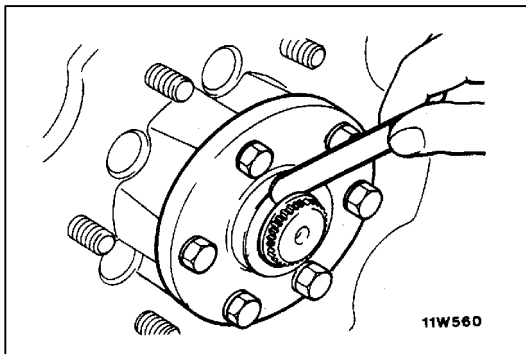

►D◄ DRIVE SHAFT AXIAL PLAY ADJUSTMENT

1. Push the drive shaft in by hand towards the knuckle until they touch.
2. Measure the clearance between the drive flange and the spacer with a thickness gauge as shown in the illustration.

Standard value: 0.4 – 0.7 mm

3. If the amount of play is outside the standard value, adjust by selecting a shim that will bring the play to the standard value.

DISASSEMBLY AND REASSEMBLY

26100190143

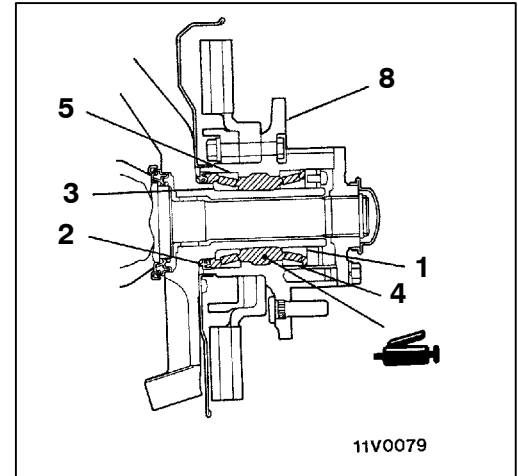
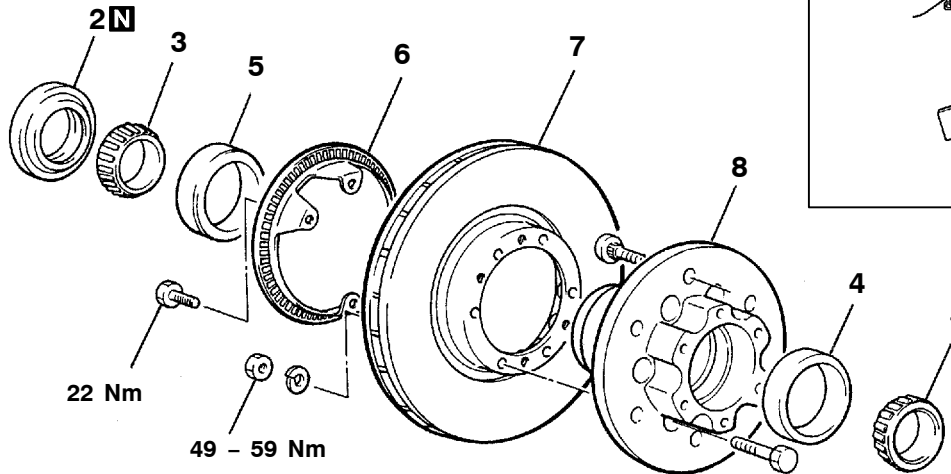

T0014AA
00006229

Disassembly steps

- 1. Outer bearing inner race
- 2. Oil seal
- 3. Inner bearing inner race
- 4. Outer bearing outer race

- 5. Inner bearing outer race
- 6. Rotor <vehicles with ABS>
- 7. Brake disc
- 8. Front hub assembly

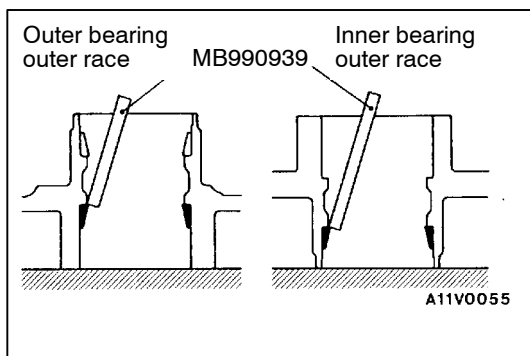

REMOVAL SERVICE POINTS

◀A▶ OUTER BEARING OUTER RACE/INNER BEARING OUTER RACE REMOVAL

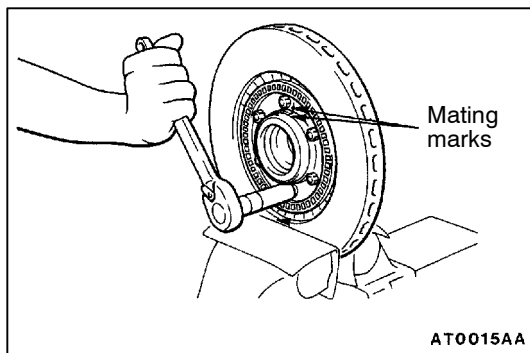

◀B▶ BRAKE DISC REMOVAL

Make the mating marks on the brake disc and front hub, and then separate the front hub and brake disc, if necessary.

Caution

Lock disc in vise and grip with copper or aluminium board.

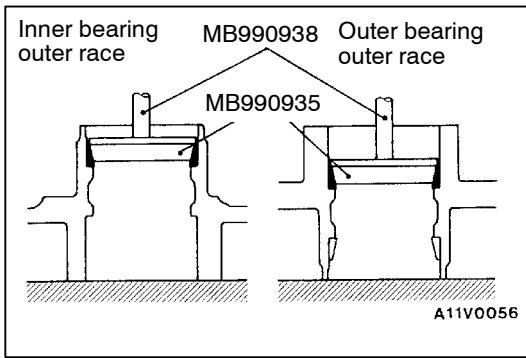

REASSEMBLY SERVICE POINTS

▶A◀ INNER BEARING OUTER RACE/OUTER BEARING OUTER RACE INSTALLATION

NOTE

Replace the inner race and outer race assembly as a set.

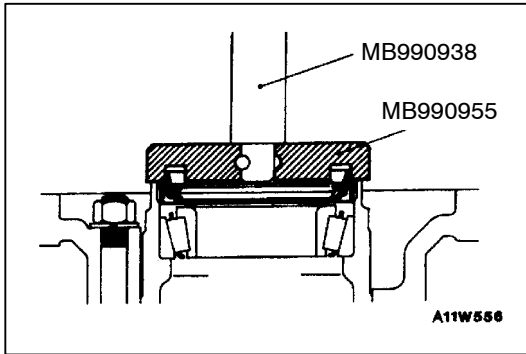

▶B◀ OIL SEAL INSTALLATION

KNUCKLE

26100240220

REMOVAL AND INSTALLATION

Caution

*: Indicates parts which should be temporarily tightened, and then fully tightened with the vehicle on the ground in the unladen condition.

Pre-removal Operation

- Front Hub Assembly Removal. (Refer to P.26-12.)

Post-installation Operation

- Press the dust cover with a finger to check whether the dust cover is cracked or damaged.
- Front Hub Assembly Installation. (Refer to P.26-12.)
- Wheel Alignment Check and Adjustment. (Refer to GROUP 33A – On-vehicle Service.)

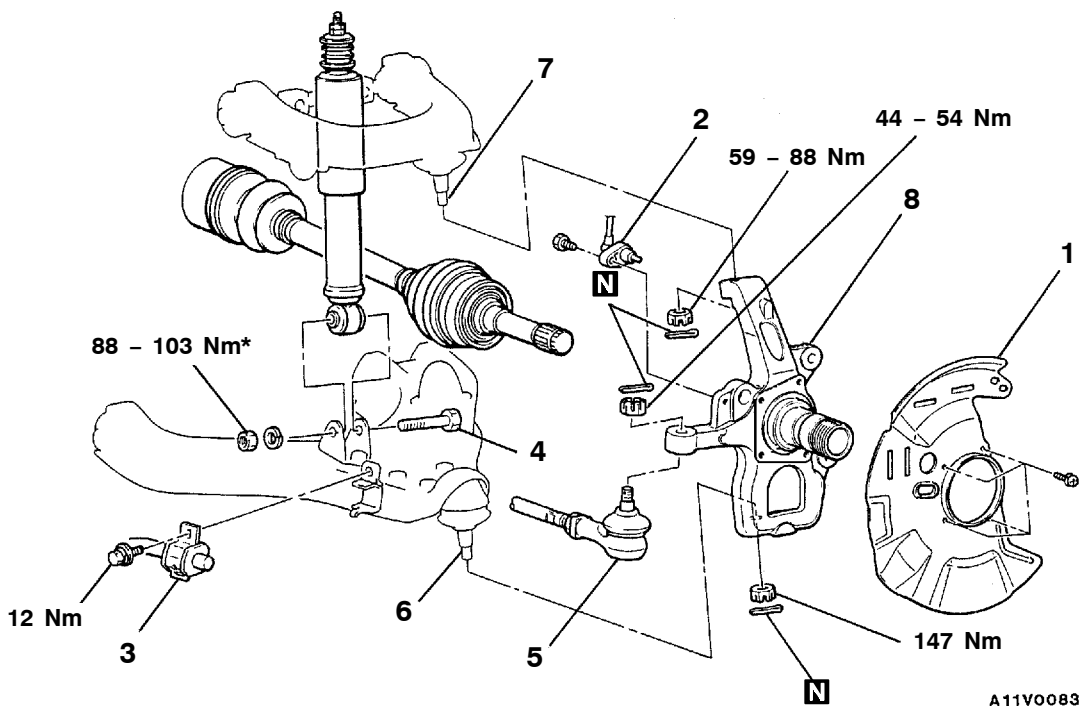

A11V0083

Removal steps

1. Dust cover
2. Front speed sensor <vehicles with ABS> (Refer to Group 35B – Wheel Speed Sensor.)
3. Stabilizer bar connection
4. Shock absorber lower mounting bolt



5. Tie rod end connection
6. Lower arm ball joint connection
7. Upper arm ball joint connection
8. Knuckle

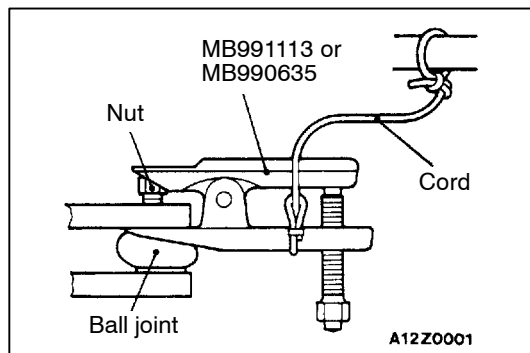

REMOVAL SERVICE POINT

◀▶ TIE ROD END /UPPER ARM BALL JOINT/UPPER ARM BALL JOINT DISCONNECTION

Use special tool to disconnect the tie rod from the knuckle.

Caution

1. Support special tool with a cord, etc to prevent it from coming off.
2. Only loosen mounting nut, do not remove it from the ball joint.

INSPECTION

26100250056

- Check the knuckle for wear or cracks.

DISASSEMBLY AND REASSEMBLY

26100320061

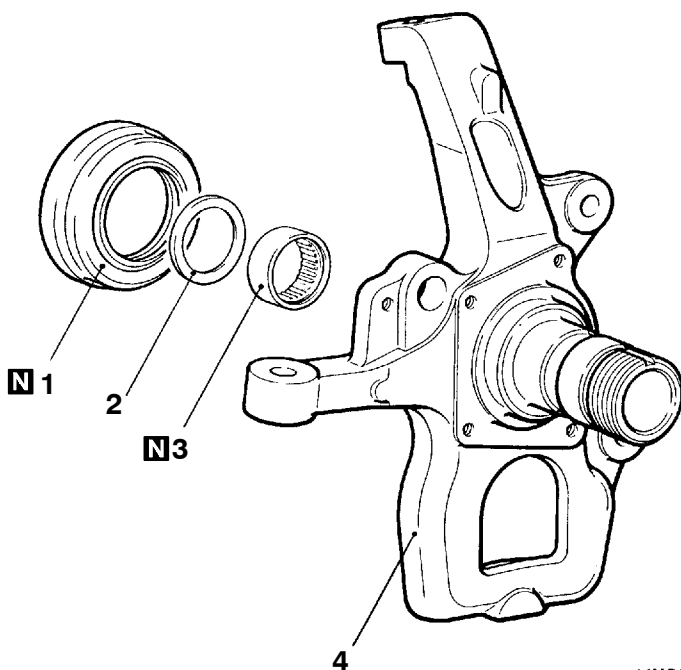
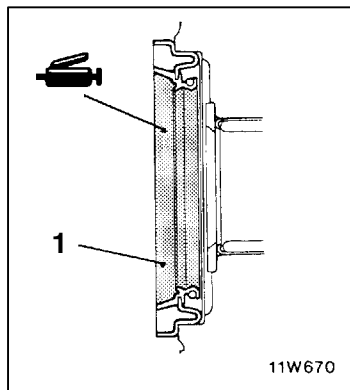
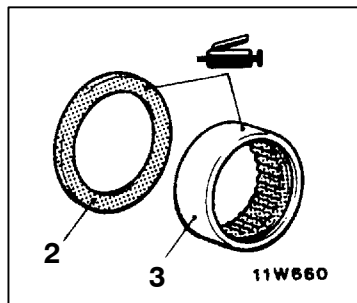

11V0069
00004930

Disassembly steps

- ▶C◀ 1. Oil seal
- ▶B◀ 2. Spacer
- ▶A◀ 3. Needle bearing
- ▶A◀ 4. Knuckle

DISASSEMBLY SERVICE POINT

▶A◀ NEEDLE BEARING REMOVAL

1. Remove the oil seal and take out the spacer.
2. Drive out the needle bearing by tapping the needles uniformly.

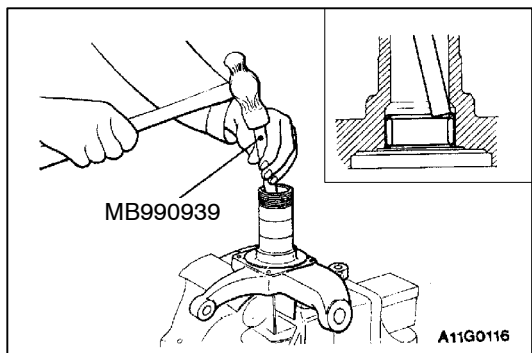

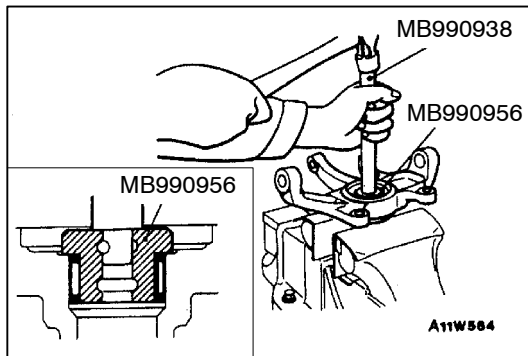
**REASSEMBLY SERVICE POINTS****►A◄ NEEDLE BEARING INSTALLATION****Caution**

Use care to prevent driving the needle bearing too far in.

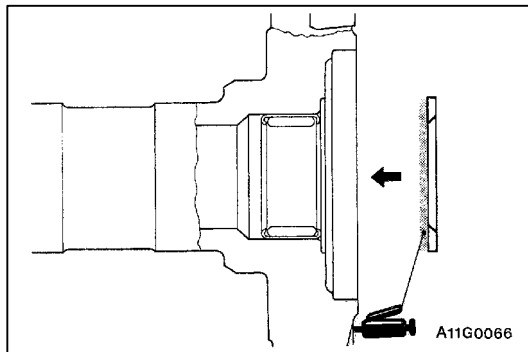
**►B◄ SPACER INSTALLATION**

Install the spacer to the knuckle with the chamfered side toward the center of vehicle.

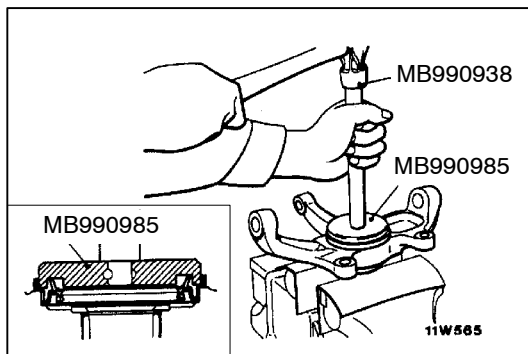
**►C◄ OIL SEAL INSTALLATION**

DRIVE SHAFT

26100350343

REMOVAL AND INSTALLATION

Caution

*: Indicates parts which should be temporarily tightened, and then fully tightened with the vehicle on the ground in the unladen condition.

Pre-removal Operation

- Under Cover Removal
- Gear Oil Draining (Refer to P.26-10.)

Post-installation Operation

- Press the dust cover with a finger to check whether the dust cover is cracked or damaged.
- Gear Oil Supplying (Refer to P.26-10.)
- Under Cover installation
- Wheel Alignment Check and Adjustment. (Refer to GROUP 33A – On-vehicle Service.)

Left-side drive shaft

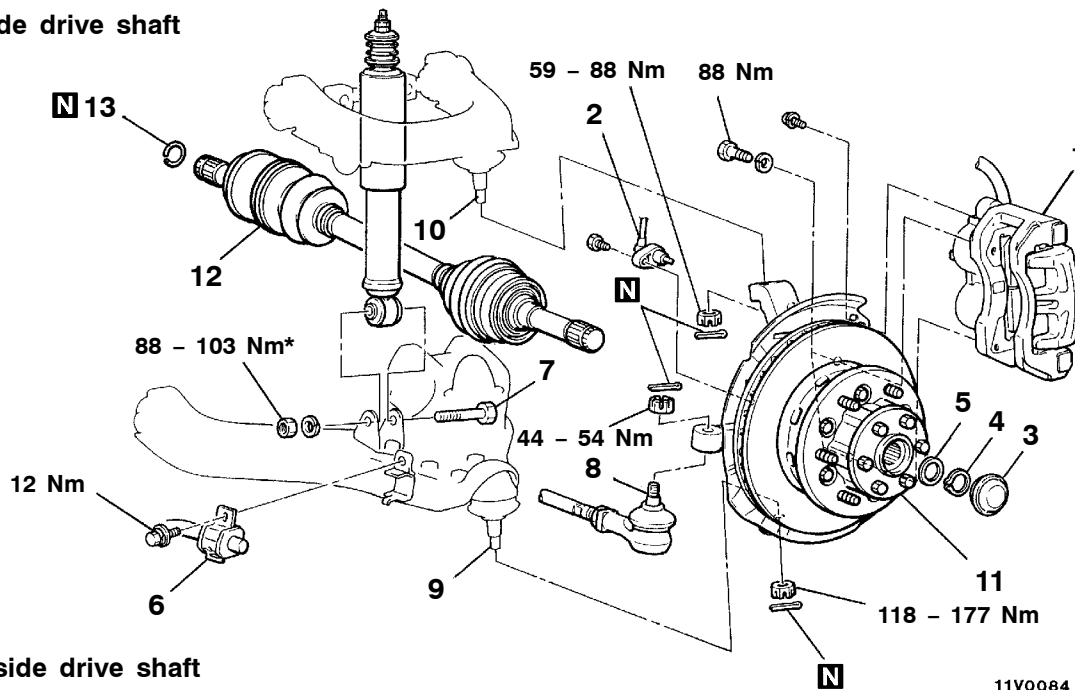

Right-side drive shaft

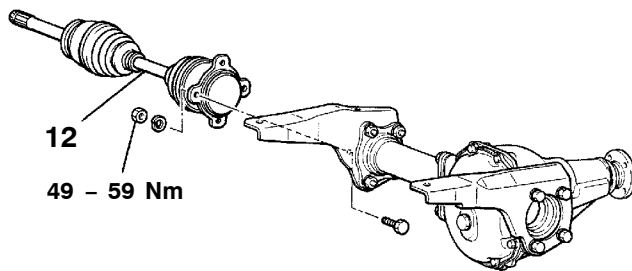

11V0064

11V0084 00006231	
 11W0033	 11S616
Front hub shim set	Sealant: 3M ATD Part No. 8663 or equivalent

Removal steps



1. Caliper assembly
2. Front speed sensor <vehicles with ABS> (Refer to Group 35B – Wheel Speed Sensor.)



3. Hub cap
- Drive shaft axial play adjustment
4. Snap ring
5. Shim
6. Stabilizer bar connection



7. Shock absorber lower mounting bolt
8. Tie rod end connection
9. Lower arm ball joint connection
10. Upper arm ball joint connection
11. Knuckle and front hub assembly
12. Drive shaft assembly
13. Circlip

REMOVAL SERVICE POINTS**◀A▶ CALIPER ASSEMBLY REMOVAL**

Secure the removed caliper assembly with wire so that it does not fall.

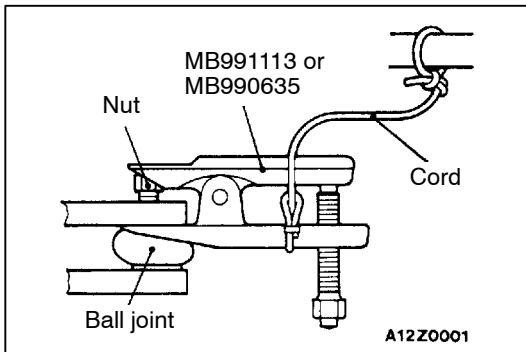
**◀B▶ TIE ROD END /LOWER ARM BALL JOINT /UPPER ARM BALL JOINT DISCONNECTION****Caution**

1. Support special tool with a cord, etc. to prevent it from coming off.
2. Only loosen the mounting nut, do not remove it from the ball joint.

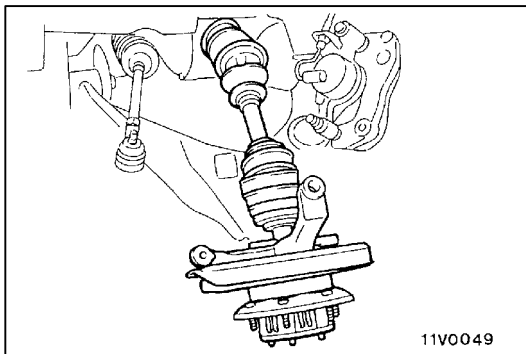
**◀C▶ KNUCKLE AND FRONT HUB ASSEMBLY REMOVAL**

1. Press down lower arm and remove upper knuckle towards you.

NOTE

Pull the D.O.J. side of the drive shaft assembly out slightly from the front differential carrier.

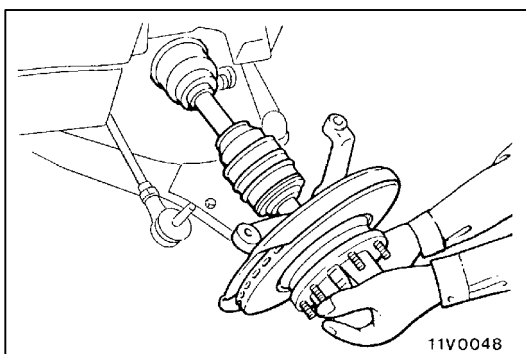

2. Slightly back off drive shaft from knuckle. Remove lower knuckle holding nut from the lower arm ball joint.
3. Disconnect knuckle and lower ball joint.
4. Remove knuckle and front hub assembly from drive shaft assembly.

Caution

Do not damage knuckle oil seals with drive shaft spline.

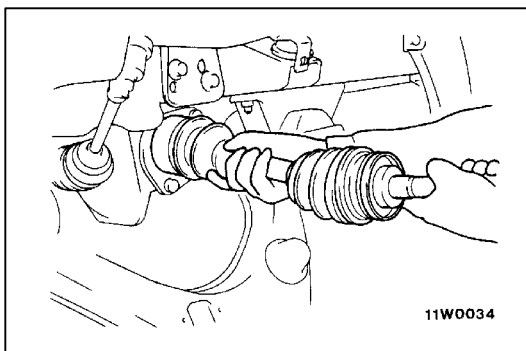
**◀D▶ DRIVE SHAFT (LEFT SIDE) REMOVAL****Caution**

When pulling the drive shaft out from the differential carrier, be careful that the spline part of the drive shaft does not damage the oil seal.

INSTALLATION SERVICE POINTS**►A◄ DRIVE SHAFT (LEFT SIDE) INSTALLATION****Caution**

Do not damage the oil seal of the differential carrier by the drive shaft splines.

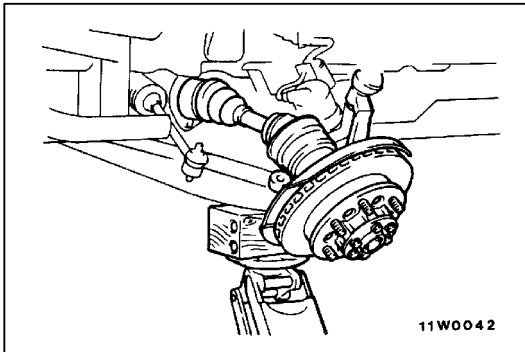
**►B◄ KNUCKLE AND FRONT HUB ASSEMBLY INSTALLATION**

1. Insert knuckle and front hub assembly to drive shaft.

Caution

Do not damage knuckle oil seal with drive shaft spline.

2. Assemble knuckle and lower arm ball joint and temporarily tighten slotted nut.
3. Press up lower arm and lock upper ball joint onto upper arm.
4. Tighten lower, upper arm ball joint mounting nuts to specified torque.

Tightening torque:

Lower arm ball joint: 118 – 177 Nm

Upper arm ball joint: 59 – 88 Nm

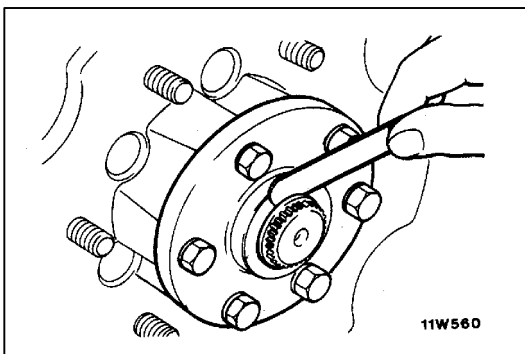
**►C◄ DRIVE SHAFT AXIAL PLAY ADJUSTMENT**

1. Push the drive shaft in by hand towards the knuckle until they touch.
2. Measure the clearance between the drive flange and the spacer with a thickness gauge as shown in the illustration.

Standard value: 0.4 – 0.7 mm

3. If the amount of play is outside the standard value, adjust by selecting a shim that will bring the play to the standard value.

NOTE

The shims available range from 0.3 mm thick to 0.6 mm thick in steps of 0.1 mm, and from 0.9 mm thick to 1.8 mm thick in steps of 0.3 mm.

INSPECTION

26100360087

- Check the boot for damage or deterioration.
- Check the ball joint for operating condition and excessive looseness.
- Check the splines for wear or damage.
- Check the differential carrier oil seal (L.H.) for damage.

DISASSEMBLY AND REASSEMBLY

26100370332

Caution

Never disassemble the B.J. assembly except when replacing the B.J. boot.

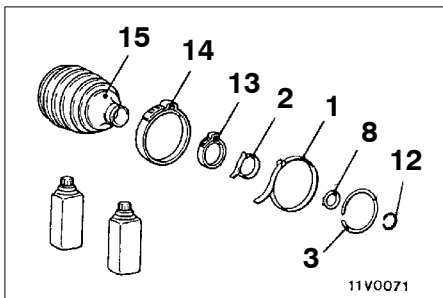
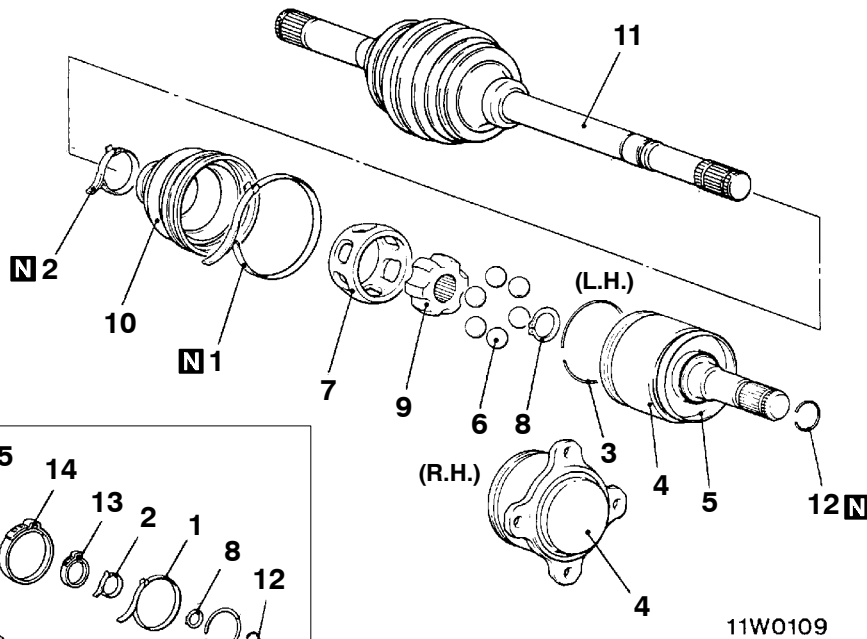

B.J. Repair Kit (B.J.)

00004932

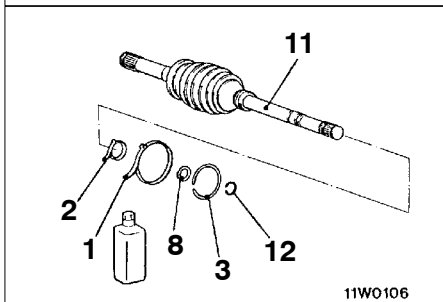

B.J. Repair kit L.H.

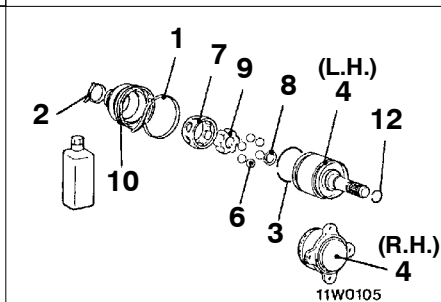

D.O.J. Repair kit

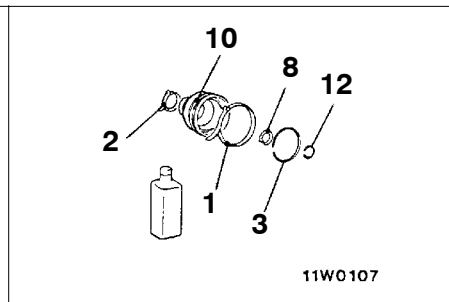

Boot repair kit (D.O.J.)

Disassembly steps

1. D.O.J. boot band (large)
2. D.O.J. boot band (small)
3. Circlip
4. D.O.J. outer race
5. Dust cover
6. Balls
7. D.O.J. cage
8. Snap ring
9. D.O.J. inner race
10. D.O.J. boot
11. B.J. assembly
12. Circlip
13. B.J. boot band (small)
14. B.J. boot band (large)
15. B.J. boot

Reassembly steps

12. Circlip
11. B.J. assembly
9. D.O.J. inner race
8. Snap ring
7. D.O.J. cage
6. Balls
4. D.O.J. outer race
5. Dust cover
3. Circlip
10. D.O.J. boot
2. D.O.J. boot band (small)
1. D.O.J. boot band (large)



Lubrication Points

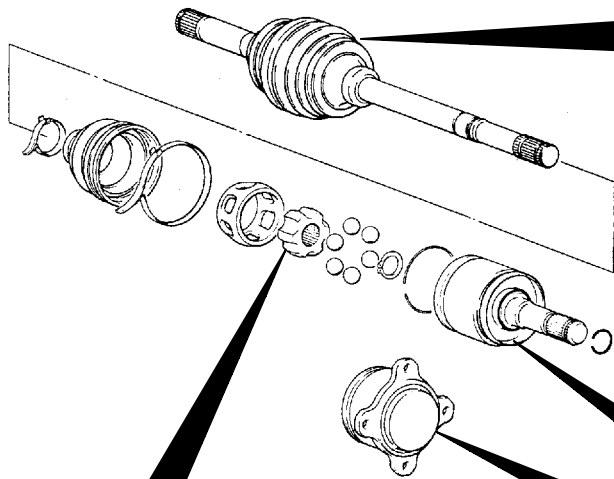

11W0109
00006232

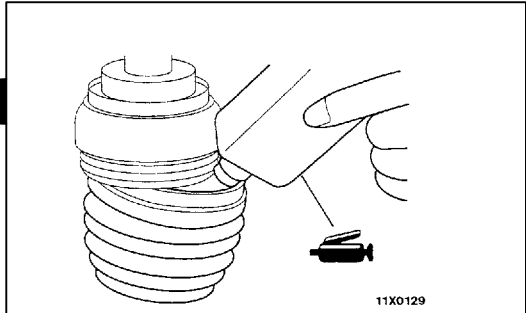

11X0129

Grease
Repair kit grease 120 g

Note
The grease in the repair kit should be divided in half for use, respectively, at the joint and inside the boot.

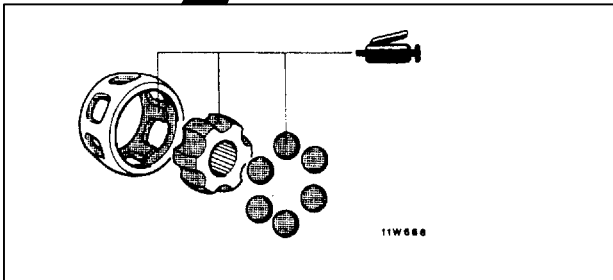

11W666

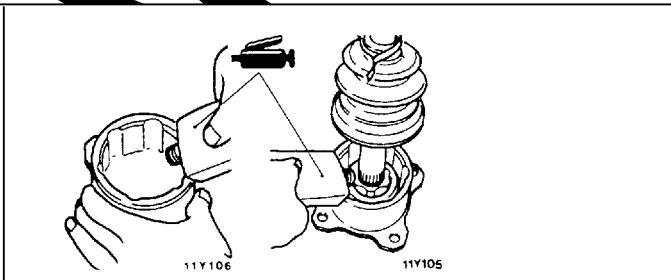

11Y106

11Y105

Grease: repair kit grease

Grease:
Repair kit grease 140 g (90 g inside joint, 50 g inside boot)

Caution
Do not mix old and new or different types of grease, as a special grease is used in the joint.

DISASSEMBLY SERVICE POINTS

◀A▶ BALLS REMOVAL

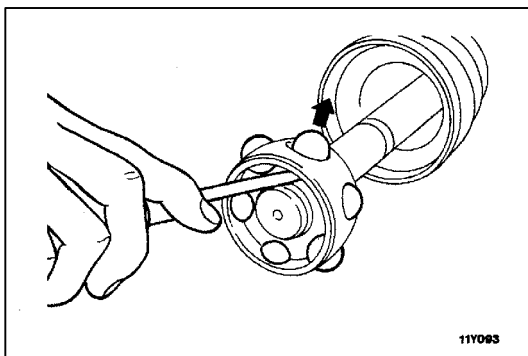

11Y063

◀B▶ D.O.J. CAGE REMOVAL

Remove the D.O.J. cage from the D.O.J. inner race in the direction of the B.J.

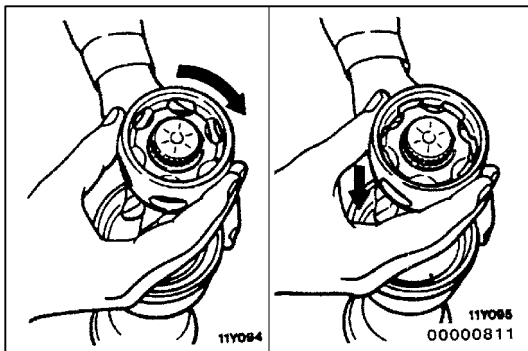

11Y064

11Y065
00000811

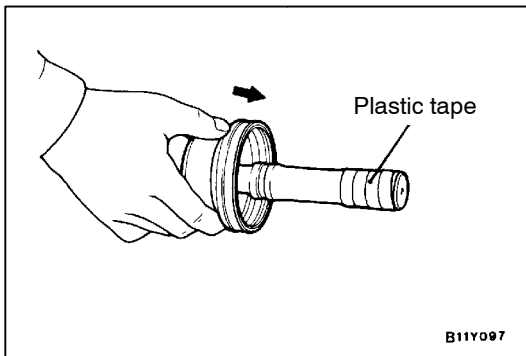

◀C▶ D.O.J. BOOT REMOVAL

Wrap plastic tape around the spline part on the D.O.J. side of the drive shaft so that D.O.J. boot is not damaged when they are removed.

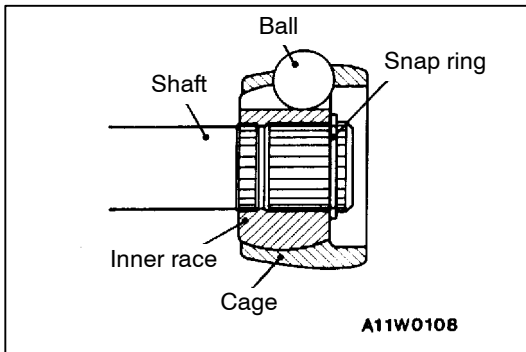

REASSEMBLY SERVICE POINTS

▶A◀ D.O.J. INNER RACE/SNAP RING/D.O.J. CAGE/BALLS INSTALLATION

Install the cage, balls and inner race to the drive shaft, and fit the snap ring securely to the groove in the drive shaft.

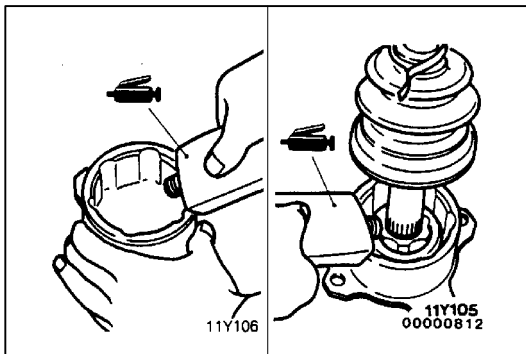

▶B◀ D.O.J. OUTER RACE INSTALLATION

Fill the inside of the D.O.J. outer race and D.O.J. boot with the specified grease.

Specified grease:

Repair kit grease 140 g (90 g inside joint, 50 g inside boot)

Caution

The drive shaft joint use special grease. Do not mix old and new or different types of grease.

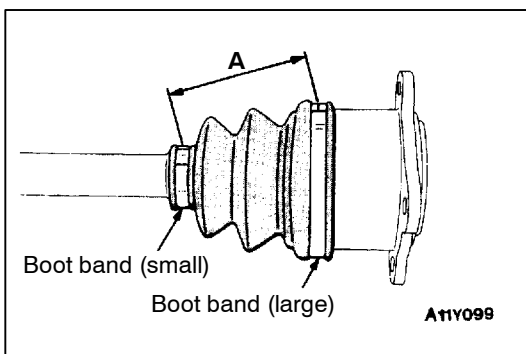

▶C◀ D.O.J. BOOT/D.O.J. BOOT BAND INSTALLATION

1. Position the D.O.J. outer race so that the distance between the boot bands is at the standard value.

Standard value (A): 80 ± 3 mm

2. Remove part of the D.O.J. boot from the D.O.J. outer race to release the air pressure inside the boot.

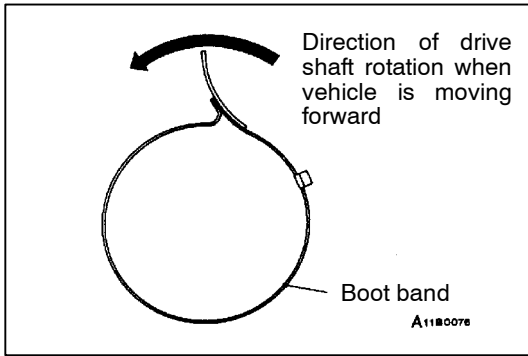

- Secure the boot band (large) on D.O.J. boot.

Caution

Be sure that the installation direction of the boot bands is correct.

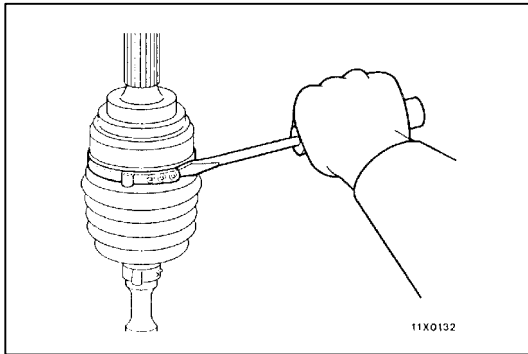

B.J. BOOT (RESIN BOOT) REPLACEMENT

26100520164

- Remove the boot bands (large and small).

NOTE

The B.J. boot bands cannot be re-used.

- Remove the B.J. boot.

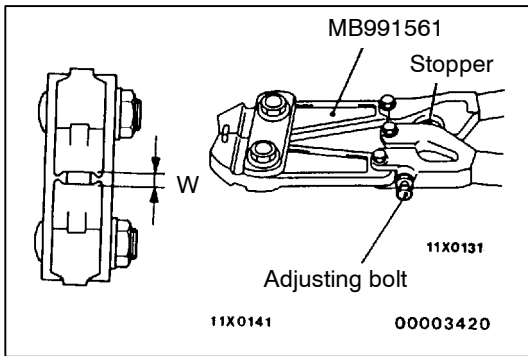

- Turn the adjusting bolt on the special tool so that the size of the opening (W) is at the standard value.

Standard value (W): 2.9 mm

<If it is larger than 2.9 mm>

Tighten the adjusting bolt.

<If it is smaller than 2.9 mm>

Loosen the adjusting bolt.

NOTE

- The value of W will change by approximately 0.7 mm for each turn of the adjusting bolt.
- The adjusting bolt should not be turned more than once.

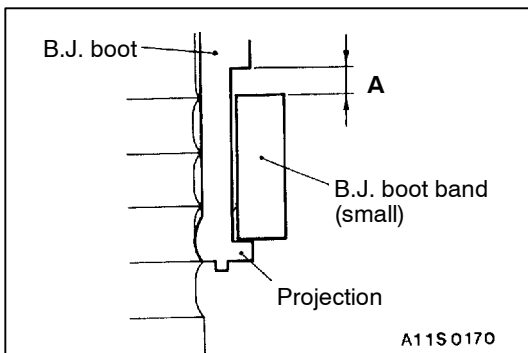

- Place the B.J. boot band (small) against the projection at the edge of the boot, and then secure it so that there is a clearance left as shown by (A) in the illustration.

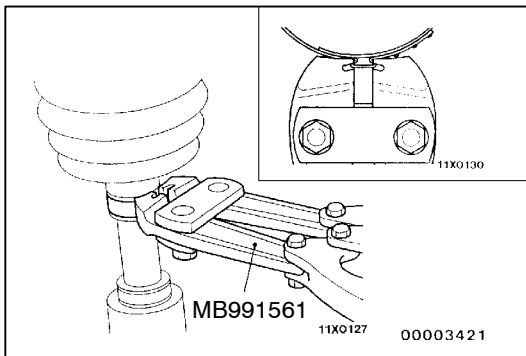

5. Use the special tool to crimp the B.J. boot band (small).

Caution

- (1) **Secure the drive shaft in an upright position and clamp the part of the B.J. boot band to be crimped securely in the jaws of the special tool.**
- (2) **Crimp the B.J. boot band until the special tool touches the stopper.**

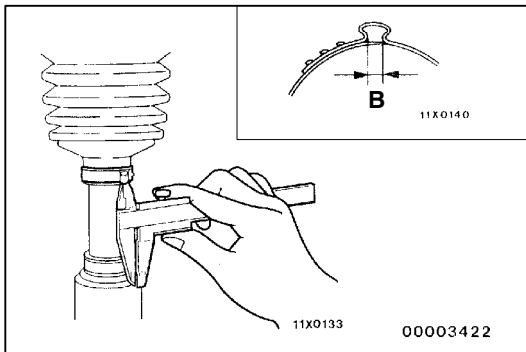

6. Check that crimping amount (B) of the B.J. boot band is at the standard value.

Standard value (B): 2.4 – 2.8 mm

**<If the crimping amount is larger than 2.8 mm>
Readjust the value of (W) in step (3) according to the following formula, and then repeat the operation in step (5).**

$$W = 5.5 \text{ mm} - B$$

Example: If B = 2.9 mm, then W = 2.6 mm.

**<If the crimping amount is smaller than 2.4 mm>
Remove the B.J. boot band, readjust the value of (W) in step (3) according to the following formula, and then repeat the operations in steps (4) and (5) using a new B.J. boot band.**

$$W = 5.5 \text{ mm} - B$$

Example: If B = 2.3, then W = 3.2 mm.

7. Check that the B.J. boot band is not sticking out past the place where it has been installed.
If the B.J. boot band is sticking out, remove it and then repeat the operations in steps (4) to (6) using a new B.J. boot band.
8. Fill the inside of the B.J. boot with the specified amount of the specified grease.

Specified grease: Repair kit grease

Amount to use: 120 g

(60 g inside joint, 60 g inside boot)

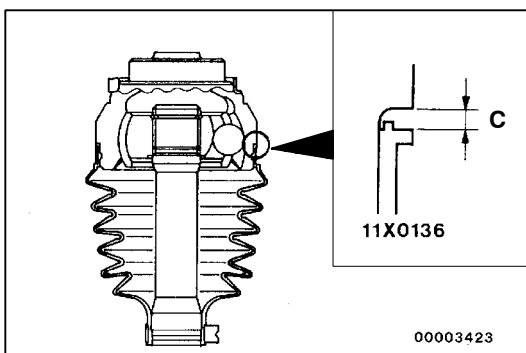

9. Install the B.J. boot band (large) so that the clearance (C) between it and the B.J. housing is at the standard value.

Standard value (C): 0.1 – 1.55 mm

10. Follow the same procedure as in step (4) to adjust the size of the opening (W) on the special tool so that it is at the standard value.

Standard value (W): 3.2 mm

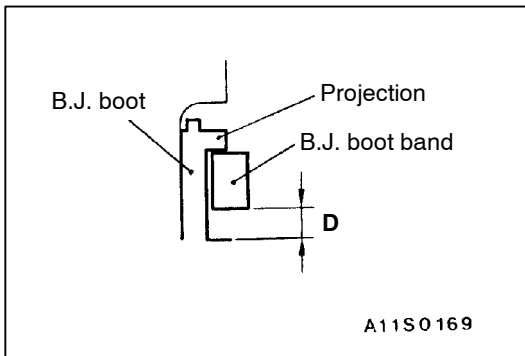

11. Place the B.J. boot band (large) against the projection at the edge of the boot, and then secure it so that there is a clearance left as shown by (D) in the illustration.
12. Use the special tool to crimp the B.J. boot band (large) in the same way as in step (5).

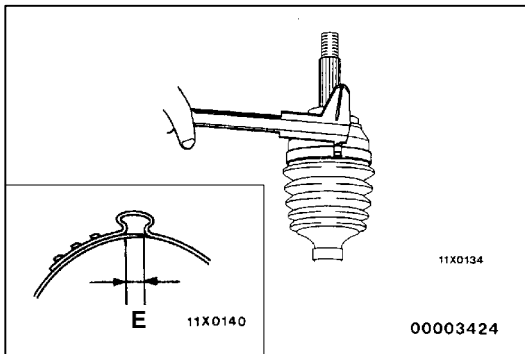

13. Check that the crimping amount (E) of the B.J. boot band is at the standard value.

Standard value (E): 2.4 – 2.8 mm

<If the crimping amount is larger than 2.8 mm>
Readjust the value of (W) in step (10) according to the following formula, and then repeat the operation in step (12).

$$W = 5.8 \text{ mm} - E$$

Example: If E = 2.9 mm, then W = 2.9 mm.

<If the crimping amount is smaller than 2.4 mm>
Remove the B.J. boot band, readjust the value of (W) in step (10) according to the following formula, and then repeat the operations in steps (11) and (12) using a new B.J. boot band.

$$W = 5.8 \text{ mm} - E$$

Example: If E = 2.3 mm, then W = 3.5mm.

14. Check that the B.J. boot band is not sticking out past the place where it has been installed.
 If the B.J. boot band is sticking out, remove it and then repeat the operations in steps (11) to (13) using a new B.J. boot band.

INNER SHAFT

26100400109

REMOVAL AND INSTALLATION

Pre-removal and Post-installation Operation

- Under Cover Removal and Installation
- Gear Oil Draining and Supplying (Refer to P.26-10.)
- Caliper Assembly Removal and Installation
- Hub Assembly, Knuckle Removal and Installation (Refer to P.26-12, 17.)
- Drive Shaft <R.H.> Removal and Installation

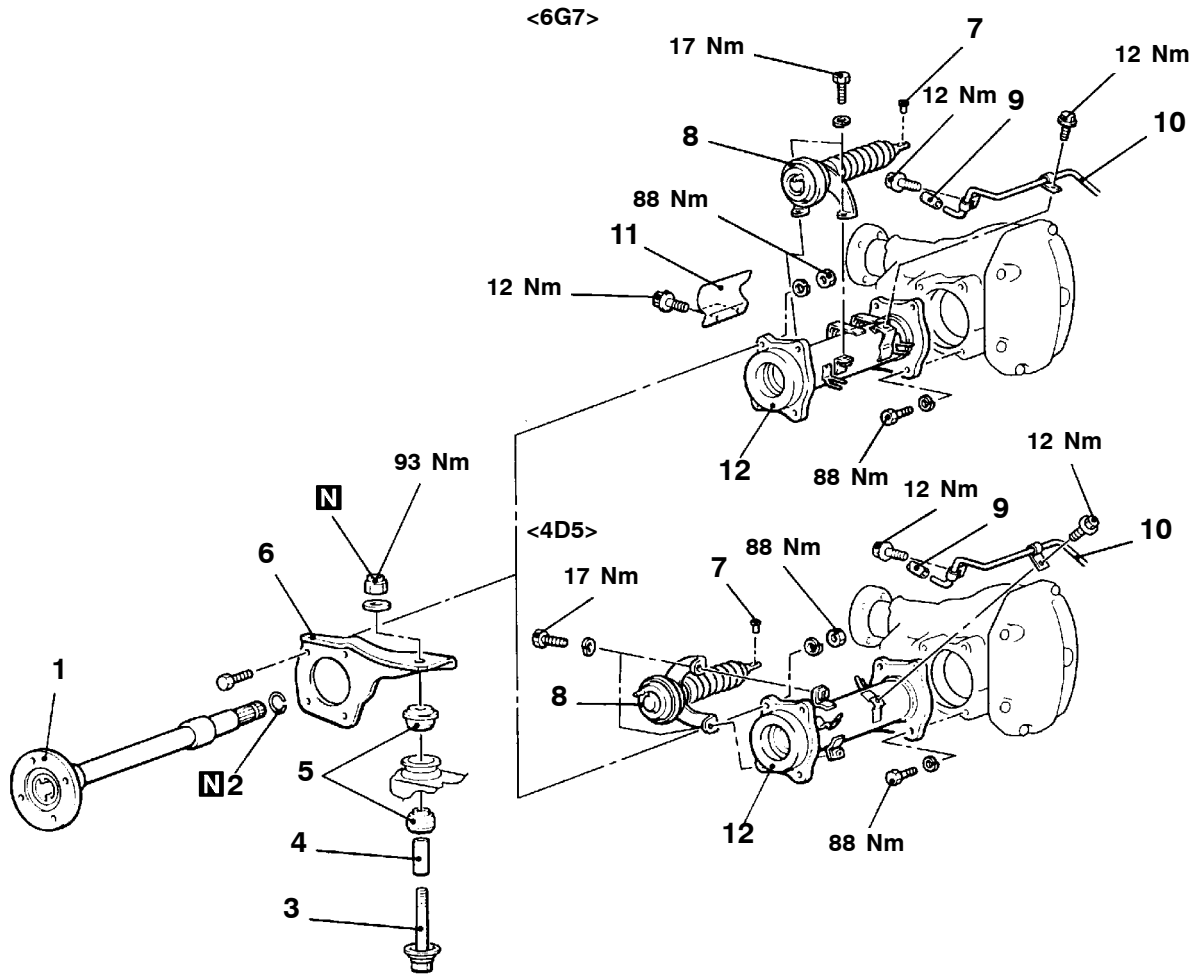

AW0232AA

Removal steps



1. Inner shaft
2. Circlip
3. Pin
4. Spacer
5. Differential mounting cushion
6. Differential mounting bracket <R.H.>

7. Pin
8. Actuator assembly
9. Breather hose
10. Breather pipe
11. Heat protector <6G7>
12. Housing tube assembly

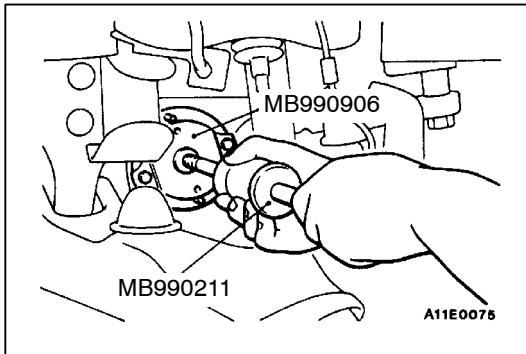
**REMOVAL SERVICE POINT****◀A▶ INNER SHAFT REMOVAL****Caution**

When pulling the inner shaft out from the front differential carrier, be careful that the spline part of the inner shaft does not damage the oil seal.

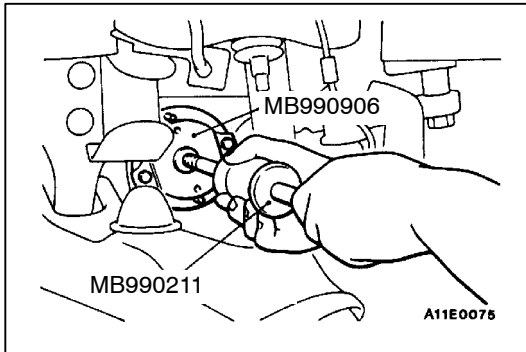
**INSTALLATION SERVICE POINT****▶A◀ INNER SHAFT INSTALLATION****Caution**

Be careful not to damage the lip of the dust seal and oil seal.

DISASSEMBLY AND REASSEMBLY

26100420044

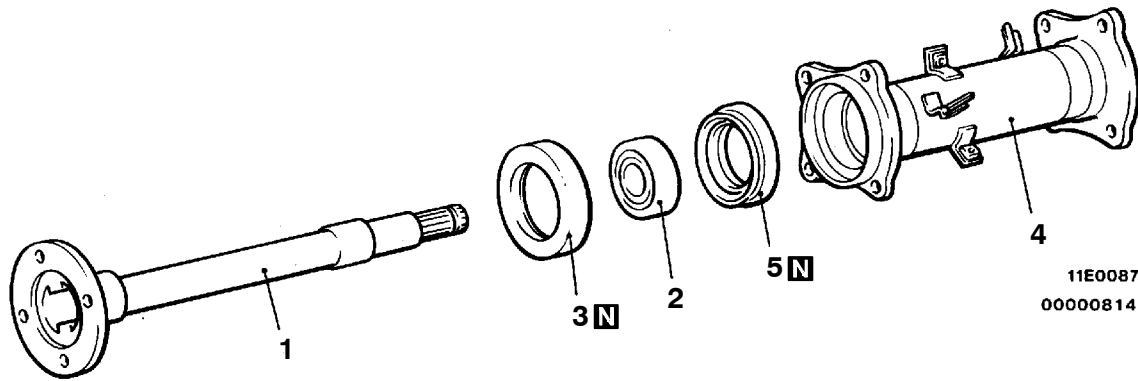
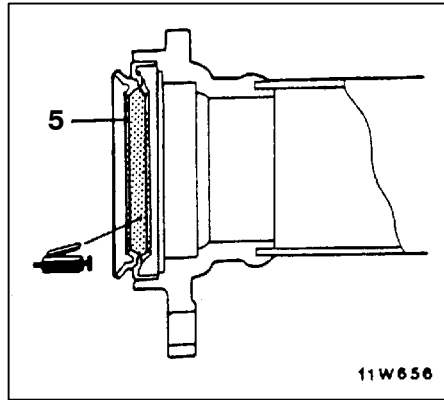
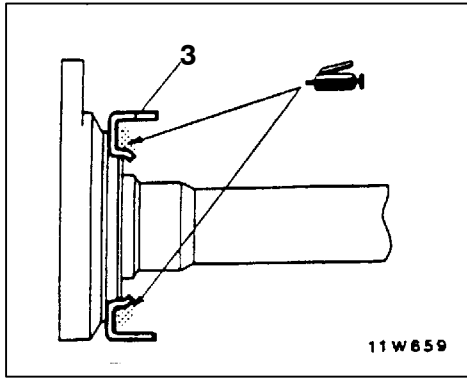

Disassembly steps

- | | | | |
|----------------------------------|--|------------|--|
| <p>◀A▶</p> <p>▶C▶</p> <p>▶B▶</p> | <p>1. Inner shaft</p> <p>2. Bearing</p> <p>3. Dust cover</p> | <p>▶A▶</p> | <p>4. Housing tube</p> <p>5. Dust seal</p> |
|----------------------------------|--|------------|--|

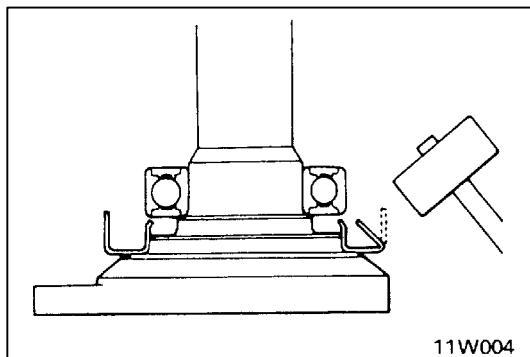

DISASSEMBLY SERVICE POINT

◀A▶ BEARING REMOVAL

1. Bend the outside periphery of dust cover inward with a hammer.
2. After the special tool has been installed as shown, tighten the nut of the special tool until the portion "A" of the special tool touches the bearing outer race.

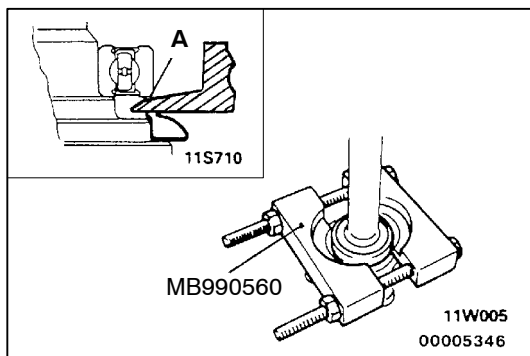

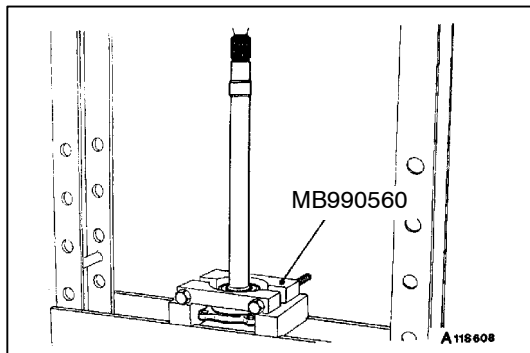

3. Press out the inner shaft from the bearing.

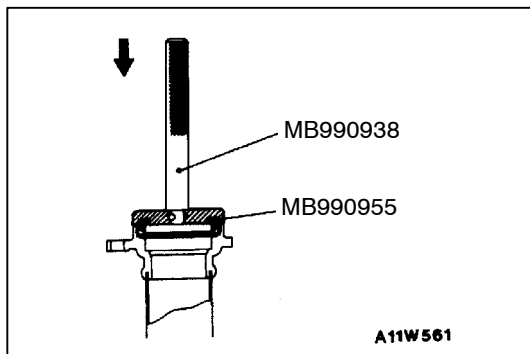

REASSEMBLY SERVICE POINTS

▶A◀ DUST SEAL INSTALLATION

Press-fit the new dust seal into the housing tube by using the special tools, until it is flush with the housing tube end face.

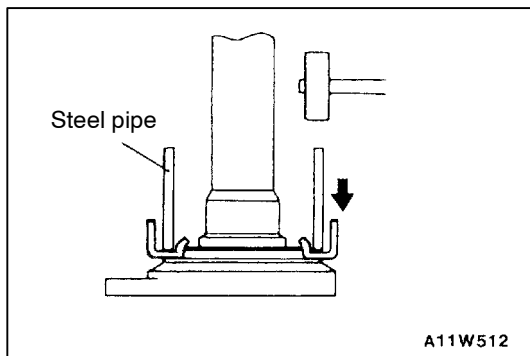

▶B◀ DUST COVER INSTALLATION

Using a steel pipe, force a new dust cover onto the inner shaft.

Steel pipe	mm
Overall length	50
Outside diameter	75
Wall thickness	4

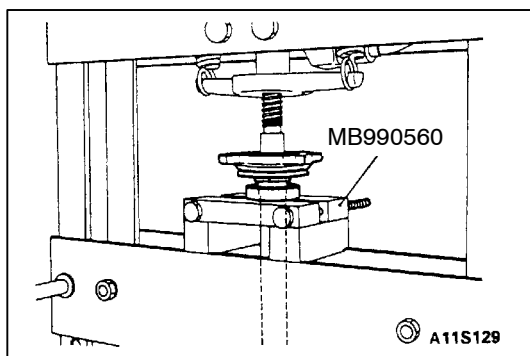

▶C◀ BEARING INSTALLATION

DIFFERENTIAL CARRIER

26200210064

REMOVAL AND INSTALLATION

Pre-removal and Post-installation

- Under Cover Removal and Installation
- Front Axle Gear Oil Level Check (Refer to P.26-10.)
- Drive shaft Removal and Installation (Refer to P.26-21.)
- Inner Shaft Removal and Installation (Refer to P.26-31.)

<6G7>

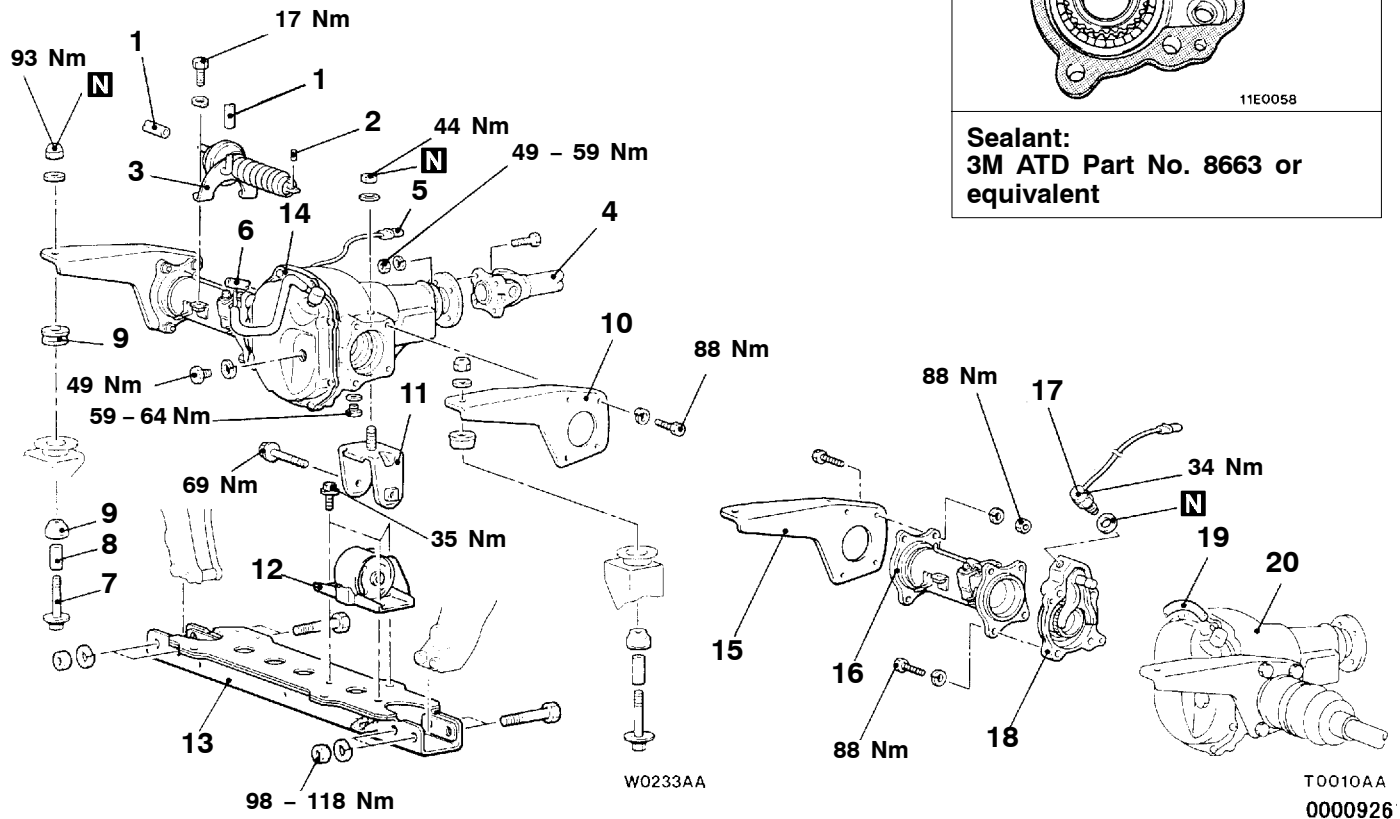

Removal steps

- | | | |
|---------------------------|---|---|
| <p>▶C◀</p> <p>◀A▶ ▶B◀</p> | <ol style="list-style-type: none"> 1. Vacuum hose connection 2. Pin 3. Actuator assembly 4. Front propeller shaft connection 5. Freewheel engage switch connection 6. Vacuum hose connection <ul style="list-style-type: none"> • Support the differential by a transmission jack. 7. Pin 8. Spacer 9. Differential mounting cushion 10. Differential mounting bracket <L.H.> 11. Differential support bracket | <ol style="list-style-type: none"> 12. Differential mount insulator assembly 13. Front suspension crossmember 14. Front differential, housing tube and differential mounting bracket <R.H.> 15. Differential mounting bracket <R.H.> 16. Housing tube 17. Freewheel engage switch 18. Freewheel clutch assembly <ul style="list-style-type: none"> ▶A◀ • Clutch gear bearing axial play inspection. 19. Vacuum hose connection 20. Front differential carrier assembly |
|---------------------------|---|---|

<4D5>

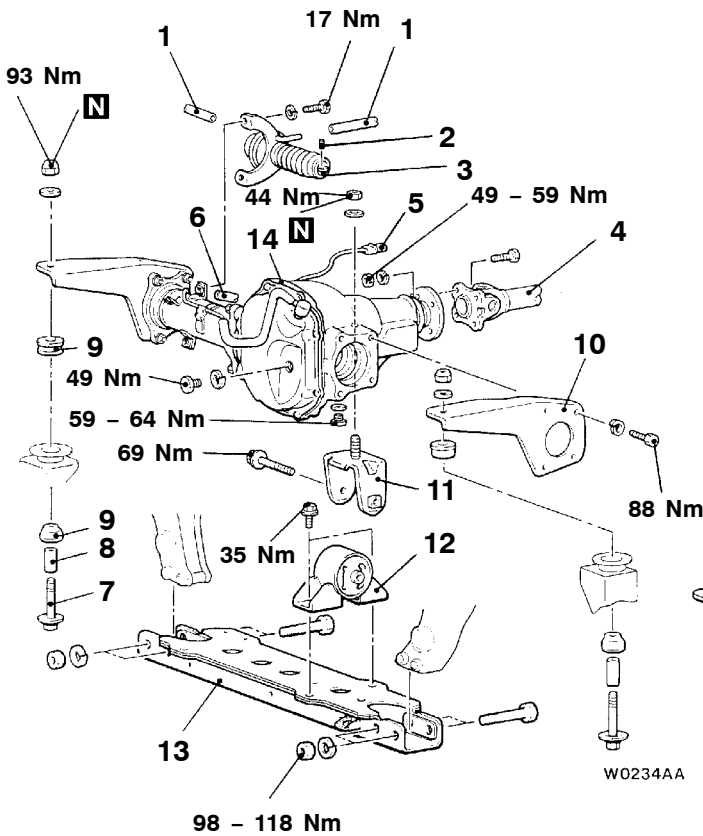

11E0058

Sealant:
3M ATD Part No. 8663 or equivalent

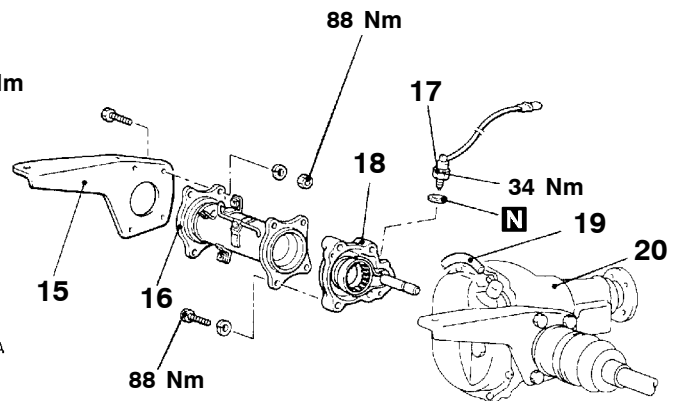

11V0088
00009262

Removal steps

- ▶C◀ 1. Vacuum hose connection
- 2. Pin
- 3. Actuator assembly
- ◀A▶ ▶B◀ 4. Front propeller shaft connection
- 5. Freewheel engage switch connection
- 6. Vacuum hose connection
 - Support the differential by a transmission jack.
- 7. Pin
- 8. Spacer
- 9. Differential mounting cushion
- 10. Differential mounting bracket <L.H.>
- 11. Differential support bracket
- 12. Differential mount insulator assembly
- 13. Front suspension crossmember
- 14. Front differential, housing tube and differential mounting bracket <R.H.>
- 15. Differential mounting bracket <R.H.>
- 16. Housing tube
- 17. Freewheel engage switch
- 18. Freewheel clutch assembly
 - ▶A◀ • Clutch gear bearing axial play inspection.
- 19. Vacuum hose connection
- 20. Front differential carrier assembly

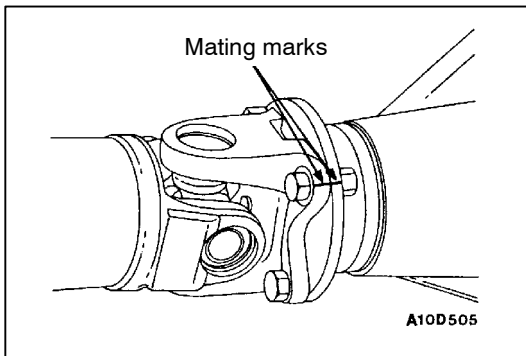

REMOVAL SERVICE POINT

◀A▶ FRONT PROPELLER SHAFT REMOVAL

Make the mating marks on the flange yoke and the differential carrier companion flange and then remove the front propeller shaft.

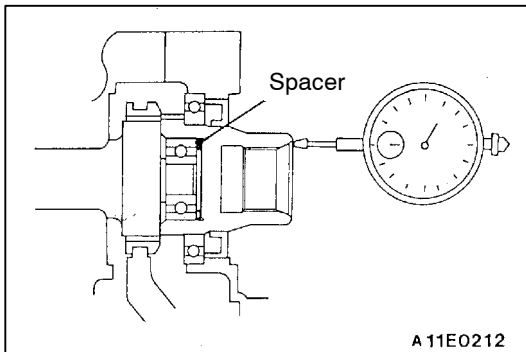

INSTALLATION SERVICE POINTS

▶A◀ CLUTCH GEAR BEARING AXIAL PLAY INSPECTION

Check the axial play of the clutch gear bearing by the following procedure before installing the freewheel clutch assembly.

1. Insert flat washers of the same thickness as the housing tube (9.0 mm) onto the bolt, and then temporarily install the freewheel clutch assembly to the front differential.

2. Place a micrometer against the end of the clutch gear and check the axial play of the clutch gear bearing.

Standard value: 0.05 – 0.30 mm

3. If the play is not within the standard value, disassemble the bearing and insert a spacer of the appropriate thickness.

NOTE

The thicknesses of the spacers vary in steps of 0.25 mm.

▶B◀ FRONT PROPELLER SHAFT INSTALLATION

Install the front propeller shaft so that the mating marks of the flange yoke and the differential carrier companion flange are aligned.

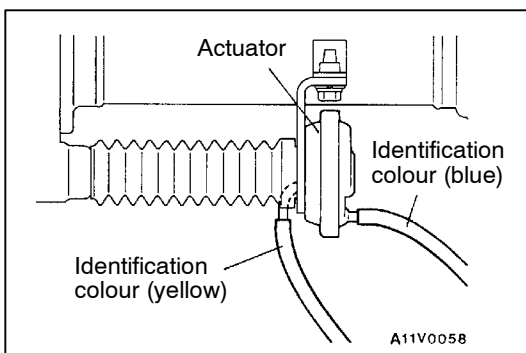

▶C◀ VACUUM HOSE INSTALLATION

Install the vacuum hoses so that they match the identification colours of the actuator assembly nipple.

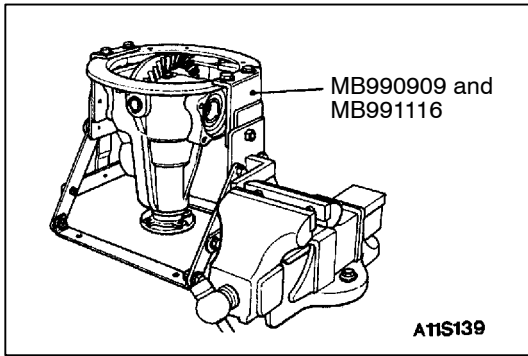

INSPECTION BEFORE DISASSEMBLY

26200430040

1. Remove the cover and gasket.
2. Hold the special tool in a vise, and install the differential carrier assembly to the special tool.

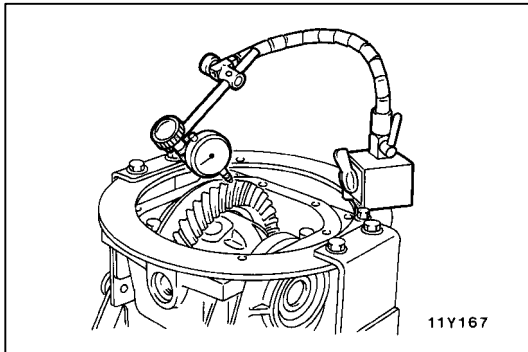

DRIVE GEAR BACKLASH

1. With the drive pinion locked in place, use a dial gauge to measure the drive gear backlash in four or more places on the drive gear.

Standard value: 0.11 – 0.16 mm

2. If the backlash is not within the standard value, insert side bearing adjustment spacers, and then inspect the drive gear tooth contact.

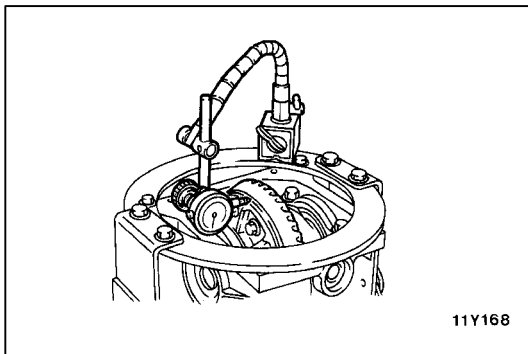

DRIVE GEAR RUNOUT

1. Measure the drive gear runout at the shoulder on the reverse side of the drive gear.

Limit: 0.05 mm

2. When runout exceeds the limit value, check for foreign object between drive gear rear side and differential case, or for loose drive gear installation bolts.
3. When check (2) gives normal results, reposition drive gear and differential case and remeasure.
4. If adjustment is impossible, replace differential case, or replace drive gear and pinion as a set.

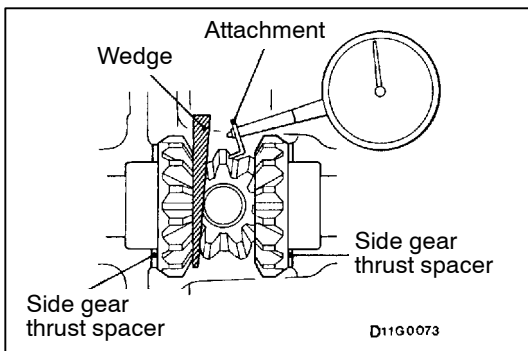

DIFFERENTIAL GEAR BACKLASH

1. While locking the side gear with the wedge, measure the differential gear backlash with a dial indicator on the pinion gear.

Standard value: 0 – 0.076 mm

Limit: 0.2 mm

Repeat the same procedure for both pinion gears.

2. If the backlash exceeds the limit, adjust by using the side gear thrust spacers.
3. If adjustment is impossible, replace the side gear and pinion gear as a set.

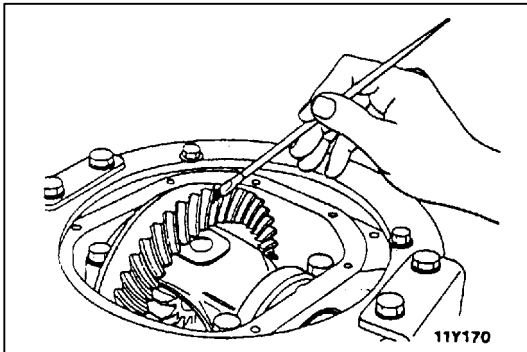

DRIVE GEAR TOOTH CONTACT

Check the tooth contact of drive gear by following the steps below.

1. Apply a thin, uniform coat of machine blue to both surfaces of the drive gear teeth.

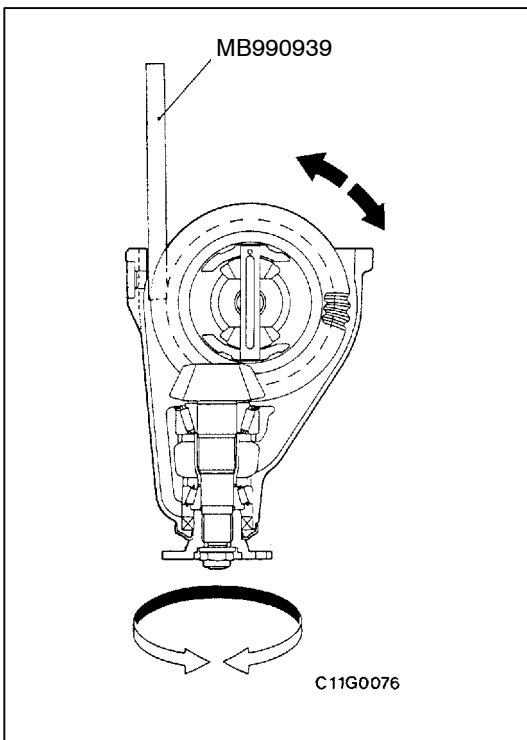

2. Insert the brass between the differential carrier and the differential case, and then rotate the companion flange by hand (once in the normal direction, and then once in the reverse direction) while applying a load to the drive gear so that the revolution torque (approximate 2.5 – 3.0 Nm) is applied to the drive pinion.

Caution

If the drive gear is rotated too much, the tooth contact pattern will become unclear and difficult to check.

3. Check the tooth contact condition of the drive gear and drive pinion.

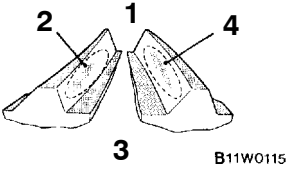
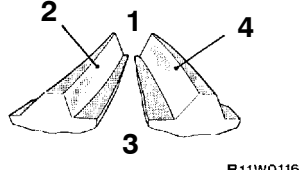
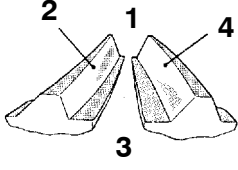
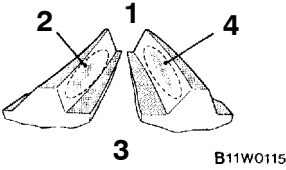
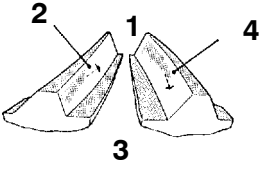
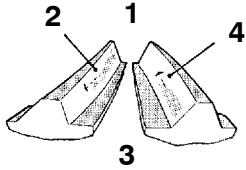
Standard tooth contact pattern	Problem	Solution
<p>1 Narrow tooth side 2 Drive-side tooth surface (the side applying power during forward movement) 3 Wide tooth side 4 Coast-side tooth surface (the side applying power during reverse movement)</p>  <p>B11W0115</p>	<p>Tooth contact pattern resulting from excessive pinion height</p>  <p>B11W0116</p> <p>The drive pinion is positioned too far from the centre of the drive gear.</p>	 <p>B11W0118</p> <p>Increase the thickness of the drive pinion rear shim, and position the drive pinion closer to the centre of the drive gear. Also, for backlash adjustment, position the drive gear farther from the drive pinion.</p>
<p>Standard tooth contact pattern</p>  <p>B11W0115</p>	<p>Tooth contact pattern resulting from insufficient pinion height</p>  <p>B11W0117</p> <p>The drive pinion is positioned too close to the centre of the drive gear.</p>	 <p>B11W0119</p> <p>Decrease the thickness of the drive pinion rear shim, and position the drive pinion farther from the centre of the drive gear. Also, for backlash adjustment, position the drive gear closer to the drive pinion.</p>

NOTE

Checking the tooth contact pattern is the way to confirm that the adjustments of the pinion height and backlash have been done properly. Continue to adjust the pinion height and backlash until the tooth contact pattern resembles the standard pattern.

If, even after adjustments have been made, the correct tooth contact pattern cannot be obtained, it means that the drive gear and the drive pinion have become worn beyond the allowable limit. Replace the gear set.

DISASSEMBLY

26200230053

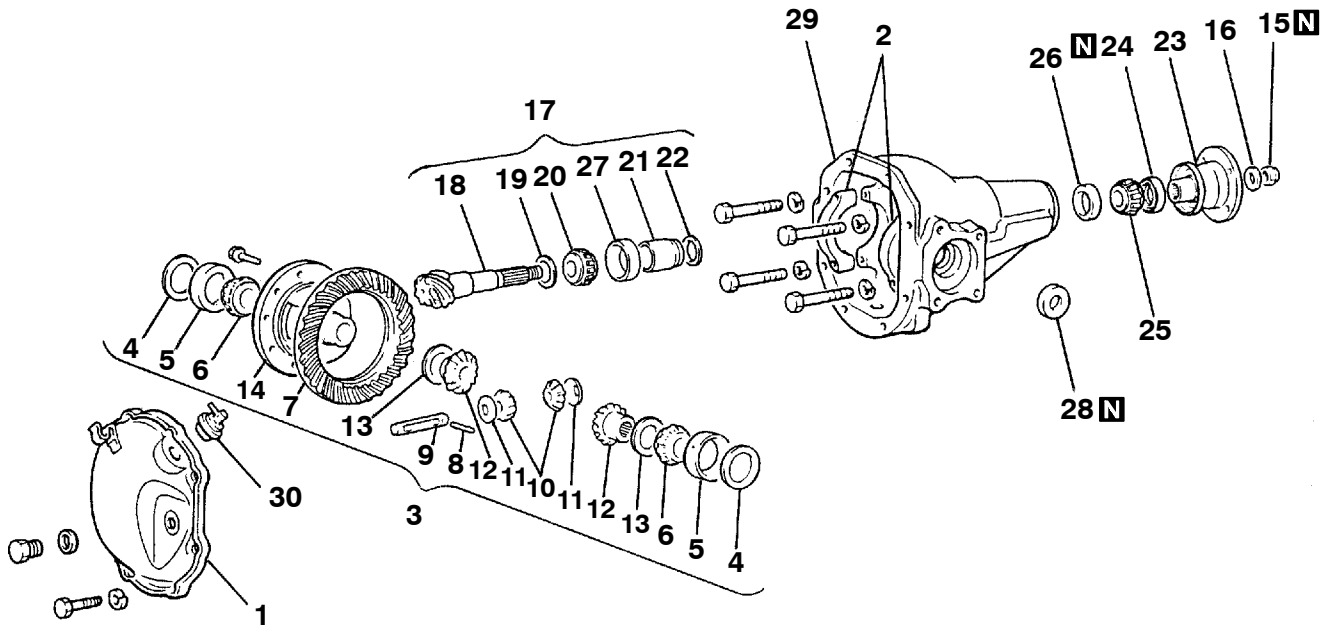

AT0016AA

Disassembly steps

- Inspection before disassembly (Refer to P. 26-38.)

◀A▶

1. Cover
2. Bearing cap
3. Differential case assembly

◀B▶

◀C▶

◀D▶

4. Side bearing spacer
5. Side bearing outer race
6. Side bearing inner race
7. Drive gear
8. Lock pin
9. Pinion shaft
10. Pinion gear
11. Pinion washer
12. Side gear
13. Side gear spacer

◀E▶

◀F▶

14. Differential case
15. Self-locking nut
16. Washer
17. Drive pinion assembly

◀G▶

◀H▶

◀I▶

◀J▶

18. Drive pinion
19. Drive pinion front shim (for pinion height adjustment)
20. Drive pinion front bearing inner race
21. Drive pinion spacer
22. Drive pinion rear shim (for turning torque adjustment)
23. Companion flange
24. Oil seal
25. Drive pinion rear bearing inner race
26. Drive pinion rear bearing outer race
27. Drive pinion front bearing outer race
28. Oil seal
29. Gear carrier
30. Vent plug

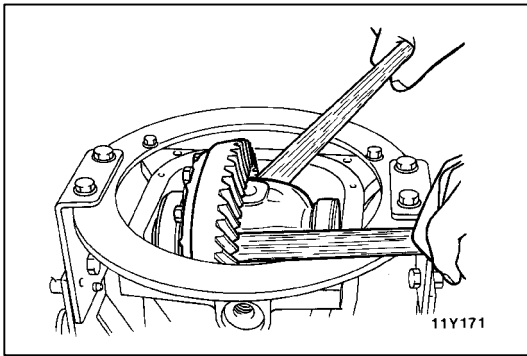

DISASSEMBLY SERVICE POINTS

◀A▶ DIFFERENTIAL CASE ASSEMBLY REMOVAL

Caution

When taking out the differential case assembly, be careful not to drop and damage the side bearing outer races.

NOTE

Keep the right and left side bearings and side bearing adjusting spacers separate, so that they do not become mixed at the time of reassembly.

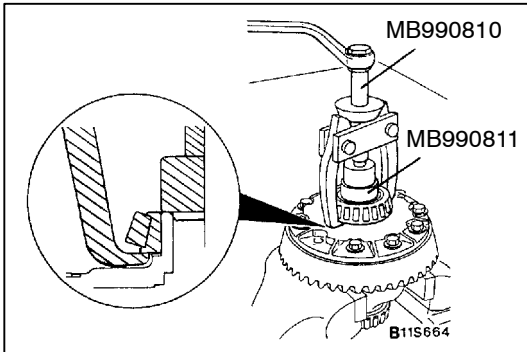

◀B▶ SIDE BEARING INNER RACE REMOVAL

NOTE

There are two notches provided (at the differential case side) for the claw part of the special tool; use the special tool at that position.

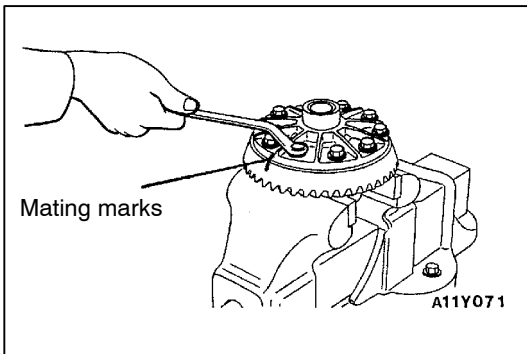

◀C▶ DRIVE GEAR REMOVAL

1. Make the mating marks to the differential case and the drive gear.
2. Loosen the drive gear attaching bolts in diagonal sequence to remove the drive gear.

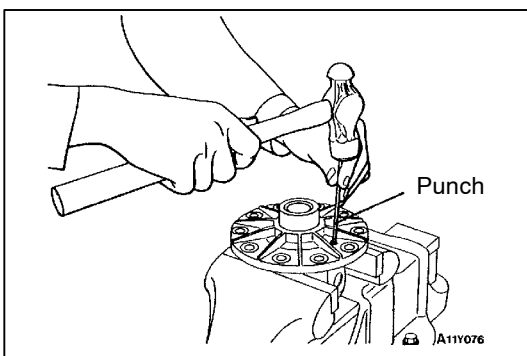

◀D▶ LOCK PIN REMOVAL

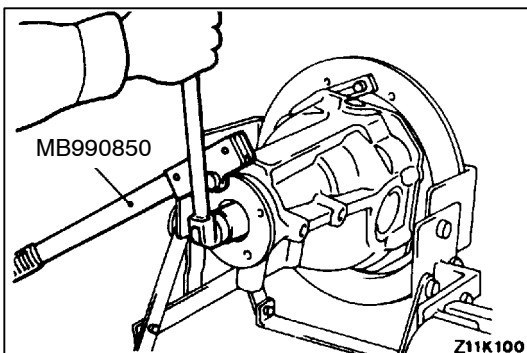

◀E▶ SELF-LOCKING NUT REMOVAL

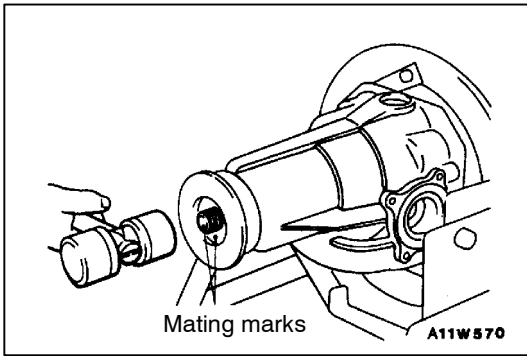

◀F▶ DRIVE PINION ASSEMBLY REMOVAL

1. Make mating marks on the drive pinion and companion flange.

Caution

The mating mark made on the companion flange must not be on the coupling surface of the flange yoke and the front propeller shaft.

2. Drive out the drive pinion together with the drive pinion spacer and drive pinion shims.

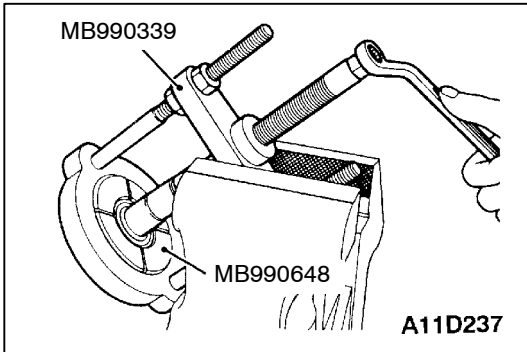

◀G▶ DRIVE PINION FRONT BEARING INNER RACE REMOVAL

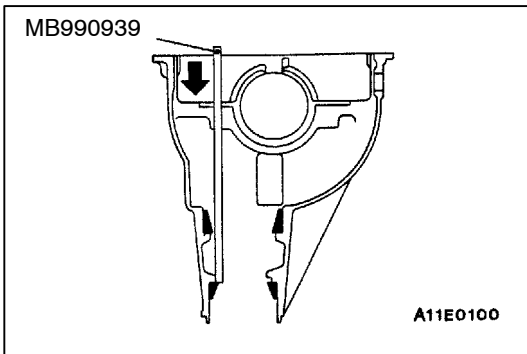

◀H▶ DRIVE PINION REAR BEARING OUTER RACE REMOVAL

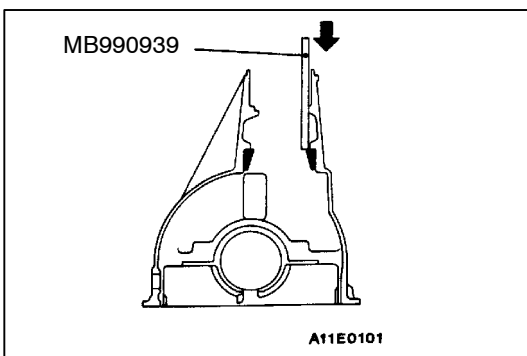

◀I▶ DRIVE PINION FRONT BEARING OUTER RACE REMOVAL

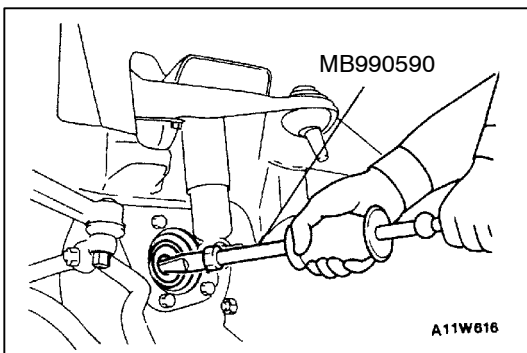

◀J▶ OIL SEAL REMOVAL

REASSEMBLY

26200250080

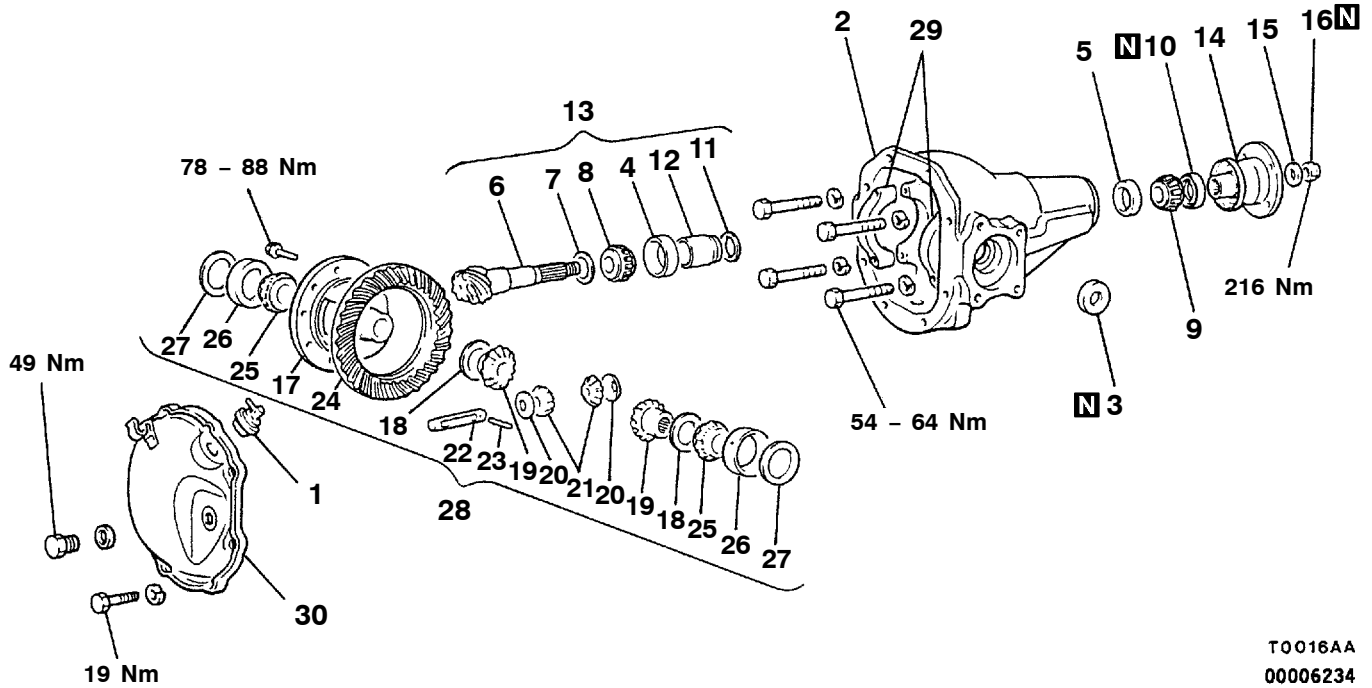

T0016AA
00006234

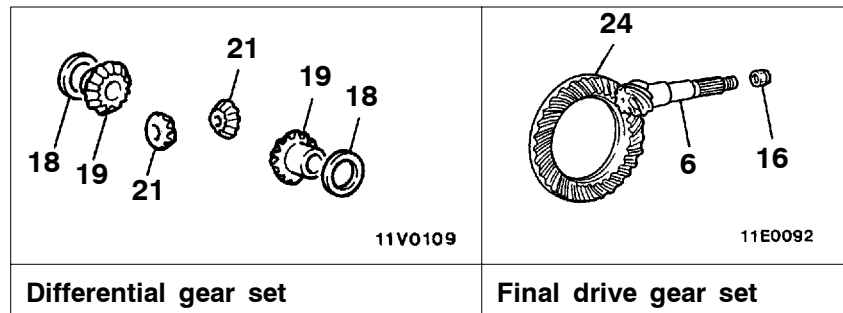

Reassembly steps

- | | |
|---|---|
| <p>1. Vent plug</p> <p>2. Gear carrier</p> <p>▶A◀ 3. Oil seal</p> <p>▶B◀ 4. Drive pinion front bearing outer race</p> <p>▶C◀ 5. Drive pinion rear bearing outer race</p> <p>▶D◀ ● Pinion height adjustment</p> <p>6. Drive pinion</p> <p>7. Drive pinion front shim (for pinion height adjustment)</p> <p>8. Drive pinion front bearing inner race</p> <p>▶E◀ ● Drive pinion turning torque adjustment</p> <p>9. Drive pinion rear bearing inner race</p> <p>10. Oil seal</p> <p>11. Drive pinion rear shim (for turning torque adjustment)</p> <p>12. Drive pinion spacer</p> <p>13. Drive pinion assembly</p> | <p>14. Companion flange</p> <p>15. Washer</p> <p>16. Self-locking nut</p> <p>17. Differential case</p> <p>18. Side gear spacer</p> <p>19. Side gear</p> <p>20. Pinion washer</p> <p>21. Pinion gear</p> <p>▶F◀ ● Differential gear backlash adjustment</p> <p>22. Pinion shaft</p> <p>▶G◀ 23. Lock pin</p> <p>▶H◀ 24. Drive gear</p> <p>▶I◀ 25. Side bearing inner race</p> <p>26. Side bearing outer race</p> <p>27. Side bearing adjusting spacer</p> <p>▶J◀ ● Drive gear backlash adjustment</p> <p>28. Differential case assembly</p> <p>29. Bearing cap</p> <p>30. Cover</p> |
|---|---|

Lubrication, Sealing and Adhesive Points

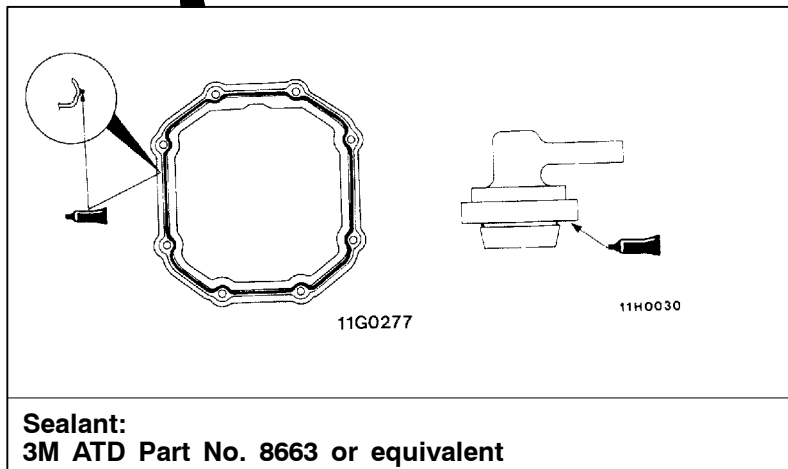
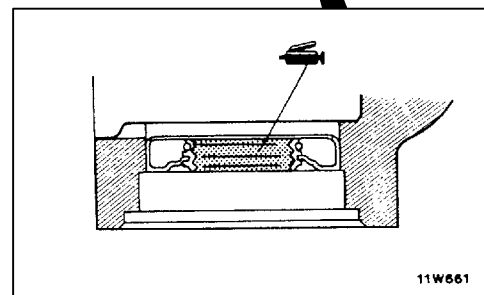
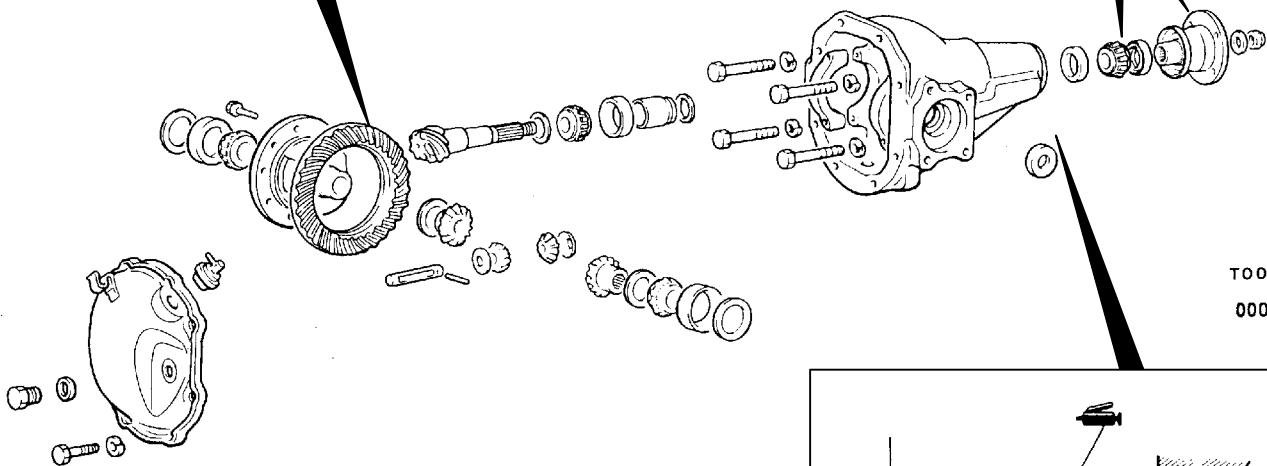
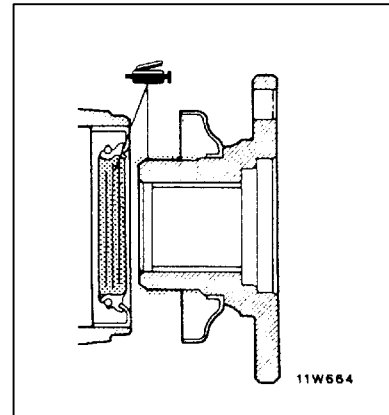
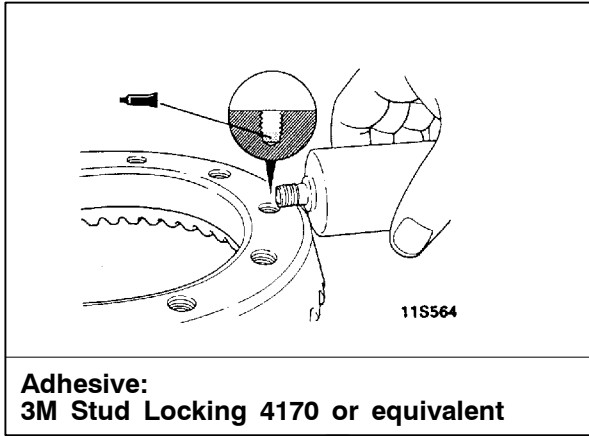

REASSEMBLY SERVICE POINTS

▶A◀ OIL SEAL INSTALLATION

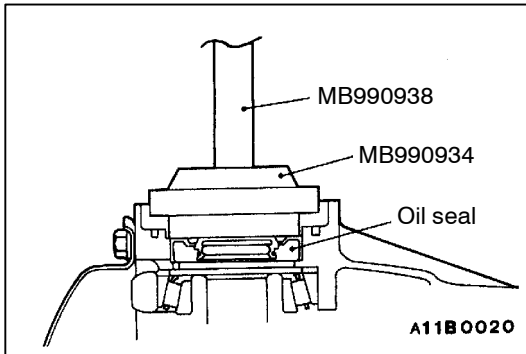

▶B◀ DRIVE PINION FRONT BEARING OUTER RACE INSTALLATION

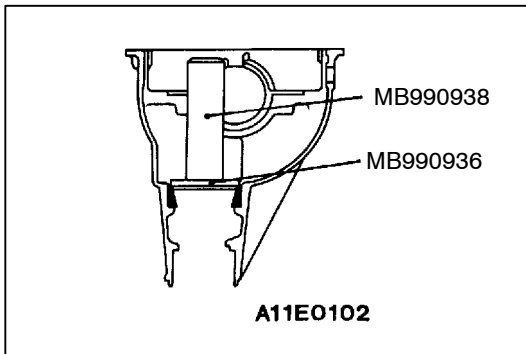

▶C◀ DRIVE PINION REAR BEARING OUTER RACE INSTALLATION

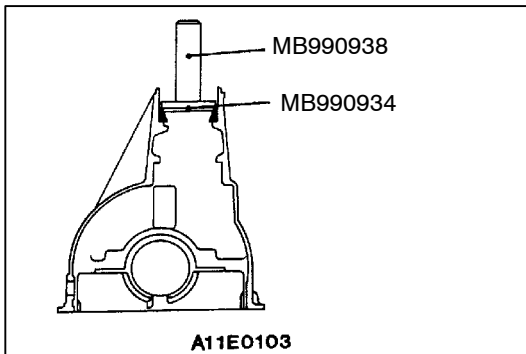

▶D◀ PINION HEIGHT ADJUSTMENT

Adjust the drive pinion height by the following procedure.

1. Apply multipurpose grease to the washer of the special tool.
2. Install the special tool, drive pinion front and rear bearing inner races to the gear carrier.

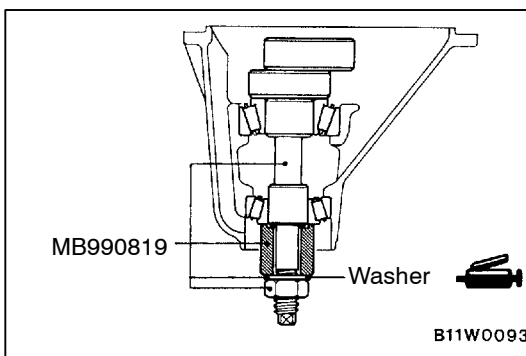

3. Tighten the nut of the special tool while measuring the turning torque of the drive pinion. Gradually keep tightening the nut of the special tool until the turning torque of the drive pinion (without oil seal) is at the standard value.

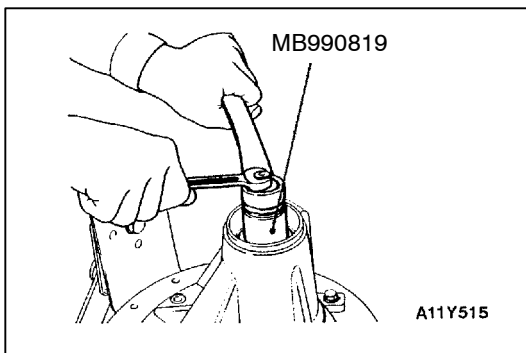

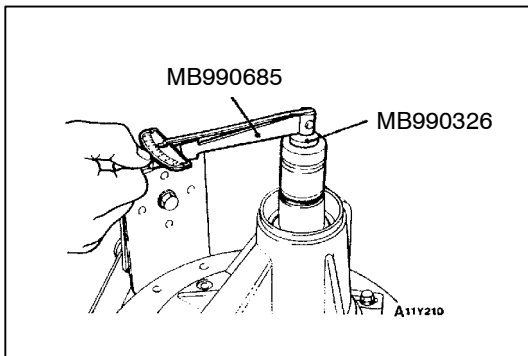

**Standard value:
(Without oil seal)**

Bearing division	Bearing lubrication	Turning torque
New	None (With anti-rust agent)	0.29 – 0.49 Nm
New or reusing	Gear oil applied	0.15 – 0.25 Nm

NOTE

The special tool cannot be turned a full revolution, so turn it several times within the range of movement to run in the bearing, and then measure the turning torque.

- Clean the side bearing hub.

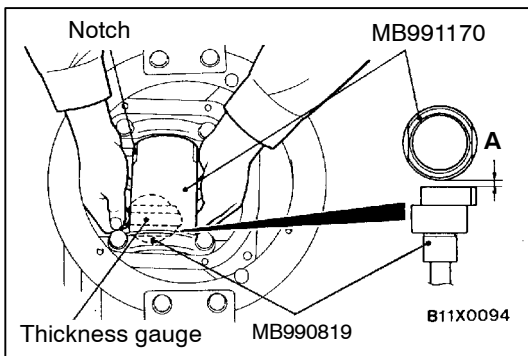

- Install the special tools to the side bearing hub of the gear carrier, and then install the bearing cap.

NOTE

Always check that the notch is in the shown position and that the special tools are touching firmly against the side bearing hub.

- Use a thickness gauge to measure the clearance (A) between the special tools.

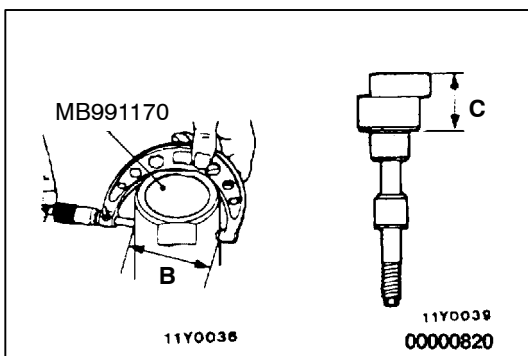

- Remove the special tools (MB991170, MB990819).
- Use a micrometer to measure the special tool in the places (B, C) shown in the illustration.

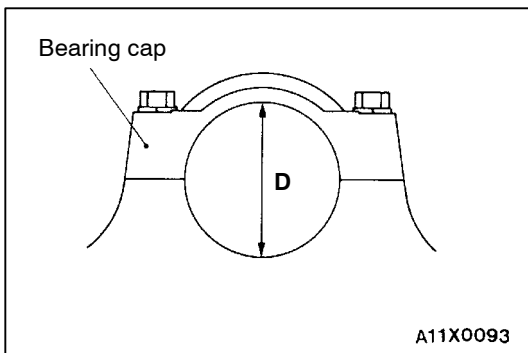

- Install the bearing cap, and then use a cylinder gauge and micrometer to measure the inside diameter (D) of the bearing cap as shown in the illustration.
- Calculate the thickness (E) of the required drive pinion front shim by the following formula, and then select a shim which most closely matches this thickness.

$$E = A + B + C - 1/2D - 100.0$$

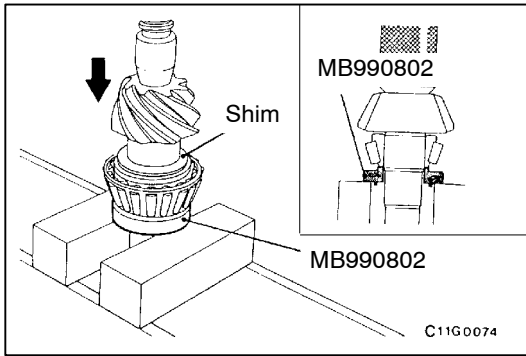

11. Fit the selected drive pinion front shim(s) to the drive pinion, and press-fit the drive pinion front bearing inner race by using the special tool.

▶◀ DRIVE PINION TURNING TORQUE ADJUSTMENT

Adjust the drive pinion rotation torque by using the following procedure:

1. Insert the drive pinion into the gear carrier, and then install the drive pinion spacer, the drive pinion rear shim, the drive pinion rear bearing inner race, and the companion flange in that order.

NOTE

Do not install the oil seal.

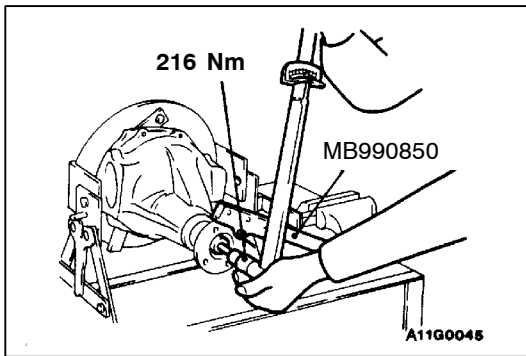

2. Tighten the companion flange to the specified torque by using the special tool.

Tightening torque: 216 Nm

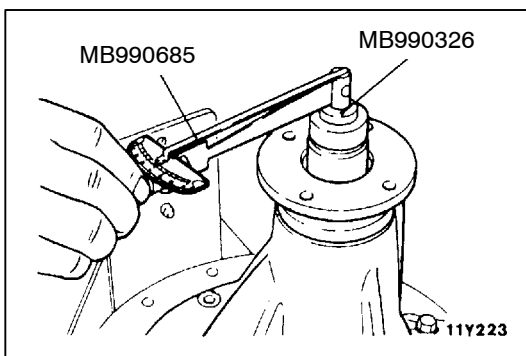

3. Measure the drive pinion turning torque (without the oil seal) by using the special tools.

**Standard value:
(Without oil seal)**

Bearing division	Bearing lubrication	Turning torque
New	None (With anti-rust agent)	0.29 – 0.49 Nm
New/reusing	Gear oil applied	0.15 – 0.25 Nm

4. If the drive pinion turning torque is not within the range of the standard value, adjust the preload by replacing the drive pinion rear shim (s) or the drive pinion spacer.

NOTE

When selecting the drive pinion rear shims, if the number of shims is large, reduce the number of shims to a minimum by selecting the drive pinion spacers. Also, select the drive pinion spacer from the following two types.

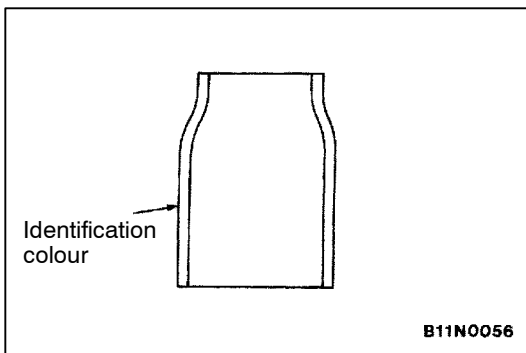

Drive pinion spacer height (mm)	Identification colour
56.67	White
57.01	–

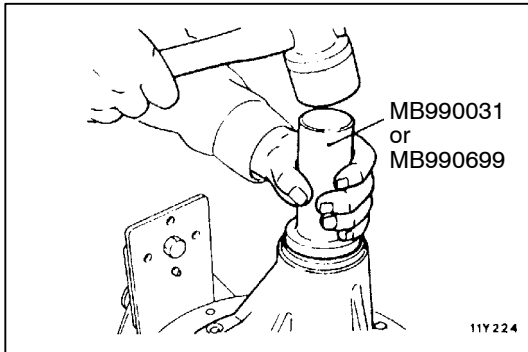

- Remove the companion flange and drive pinion again. Then, after inserting the drive pinion rear bearing inner race into the gear carrier, use the special tool to press-fit the oil seal.

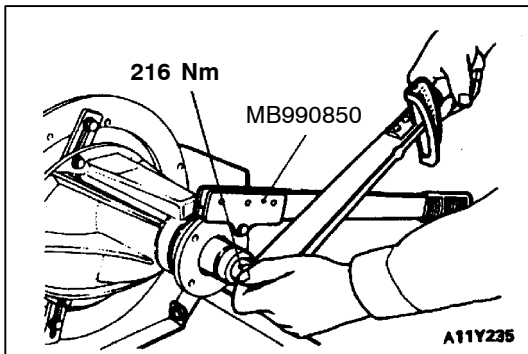

- Install the drive pinion assembly and companion flange with mating marks properly aligned, and tighten the companion flange self-locking nut to the specified torque by using the special tools.

Tightening torque: 216 Nm

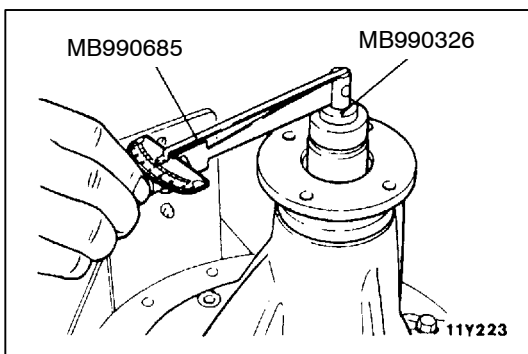

- Measure the drive pinion turning torque (with the oil seal) by using the special tools.

**Standard value:
(With oil seal)**

Bearing division	Bearing lubrication	Turning torque
New	None (With anti-rust agent)	0.49 – 0.69 Nm
New/reusing	Gear oil applied	0.34 – 0.44 Nm

- If the drive pinion turning torque is not within the standard value, check the tightening torque of the companion flange self-locking nut and the oil seal.

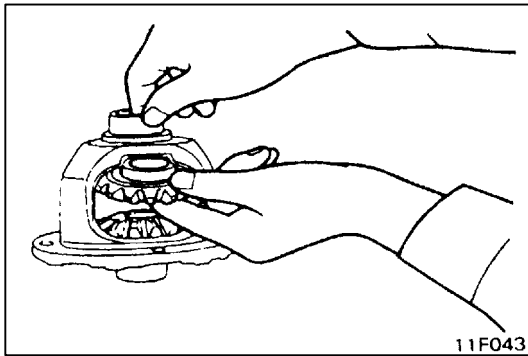

►F◄ DIFFERENTIAL GEAR BACKLASH ADJUSTMENT

1. Assemble the side gears, side gear spacers, pinion gears and pinion washers into the differential case.
2. Temporarily install the pinion shaft.

NOTE

Do not drive in the lock pin yet.

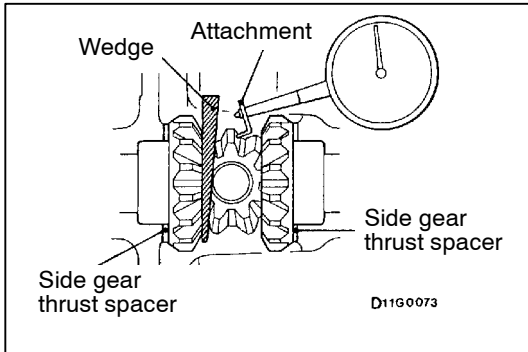

3. Insert a wedge between the side gear and the pinion shaft to lock the side gear.
4. Measure the differential gear backlash with a dial indicator on the pinion gear.

Standard value: 0 – 0.076 mm

Limit: 0.2 mm

5. If the differential gear backlash exceeds the limit, adjust the backlash by installing thicker side gear spacers.
6. If adjustment is not possible, replace the side gears and pinion gears as a set.
7. Measure the differential gear backlash once again, and confirm that it is within the limit.

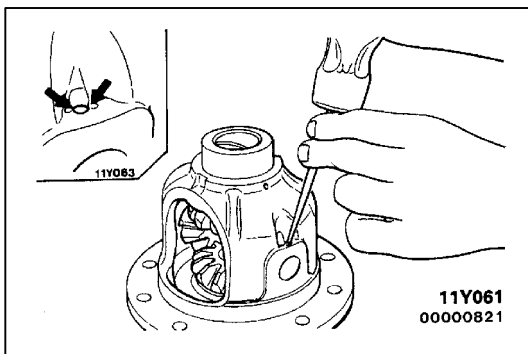

►G◄ LOCK PIN INSTALLATION

1. Align the pinion shaft lock pin hole with the differential case lock pin hole, and drive in the lock pin.
2. Stake the lock pin with a punch at two points.

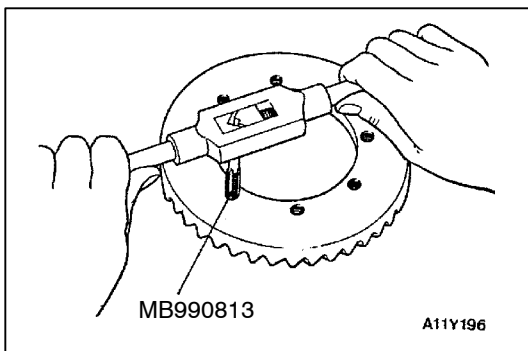

►H◄ DRIVE GEAR INSTALLATION

1. Clean the drive gear attaching bolts.
2. Remove the adhesive adhered to the threaded holes of the drive gear by turning the special tool (tap M10 x 1.25), and then clean the threaded holes by applying compressed air.

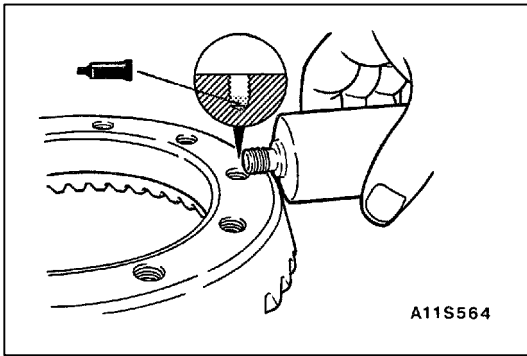

3. Apply the specified adhesive to the threaded holes of the drive gear.

Specified adhesive:
3M Stud Locking 4170 or equivalent

4. Install the drive gear onto the differential case with the mating marks properly aligned. Tighten the bolts to the specified torque in a diagonal sequence.

Tightening torque: 78 – 88 Nm

▶◀ **SIDE BEARING INNER RACE INSTALLATION**

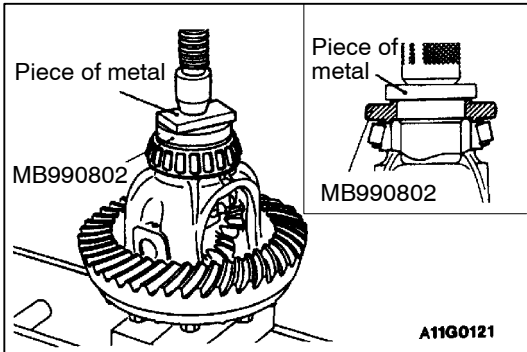

▶◀ **DRIVE GEAR BACKLASH ADJUSTMENT**

Adjust the drive gear backlash by the following procedures:

1. Install the side bearing spacers, which are thinner than those removed, to the side bearing outer races, and then mount the differential case assembly into the gear carrier.

NOTE

Select side bearing spacers with the same thickness for both the drive pinion side and the drive gear side.

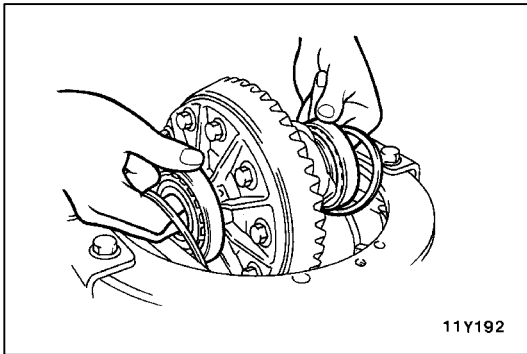

2. Push the differential case assembly to one side, and measure the clearance between the gear carrier and the side bearing adjusting spacer with a thickness gauge.

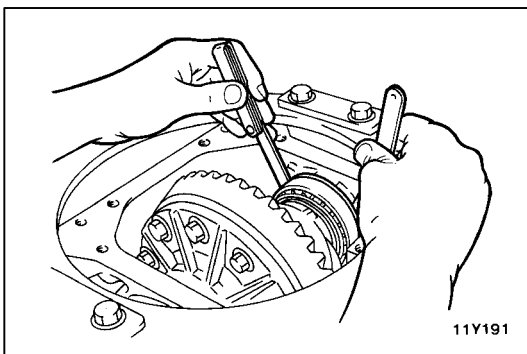

3. Measure the thickness of the side bearing adjusting spacers on one side, select two pairs of spacers which correspond to that thickness plus one half of the clearance plus 0.05 mm, and then install one pair each to the drive pinion side and the drive gear side.

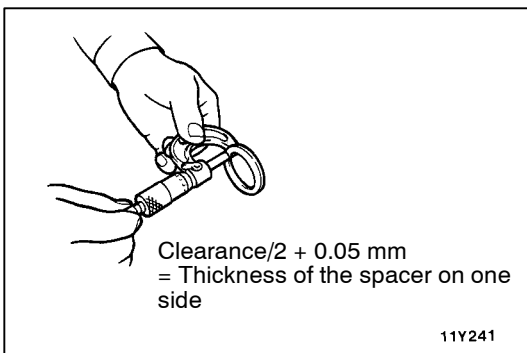

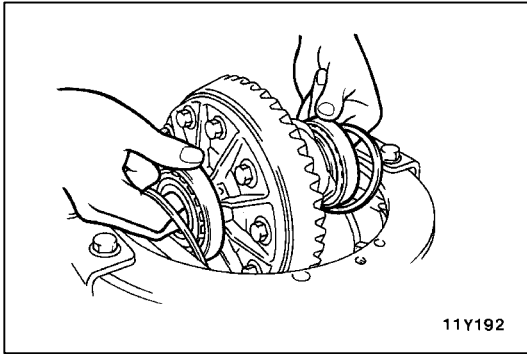

- 4. Install the side bearing adjusting spacers and differential case assembly, as shown in the illustration, to the gear carrier.

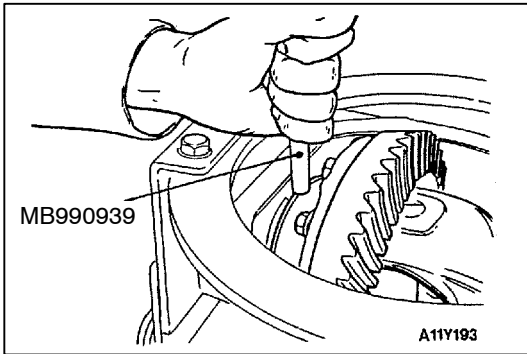

- 5. Tap the side bearing adjusting spacers with the special tool to fit them to the side bearing outer race.

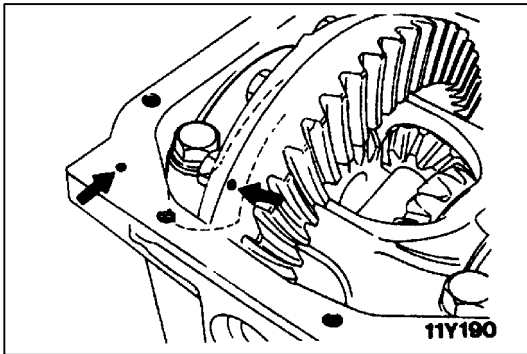

- 6. Align the mating marks on the gear carrier and the bearing cap, and then tighten the bearing cap.

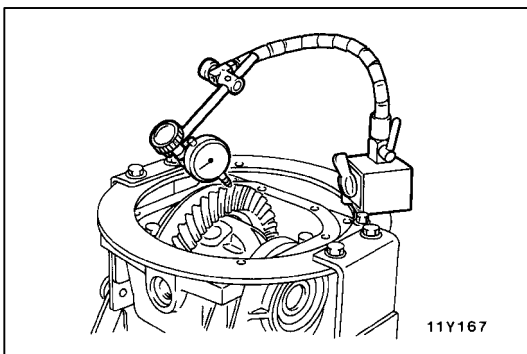

- 7. With the drive pinion locked in place, measure the drive gear backlash with a dial indicator on the drive gear.

NOTE

Measure at four points or more on the circumference of the drive gear.

Standard value: 0.11 – 0.16 mm

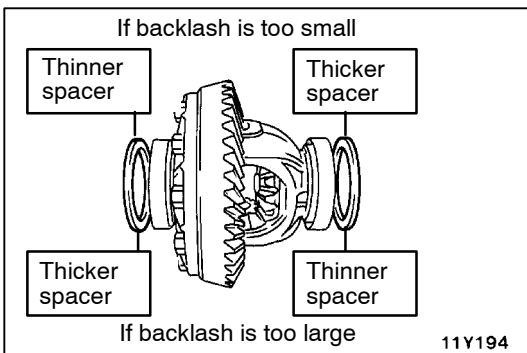

- 8. Change the side bearing adjusting spacers as illustrated, and then adjust the drive gear backlash between the drive gear and the drive pinion.

NOTE

When increasing the number of side bearing adjusting spacers, use the same number for each, and as few as possible.

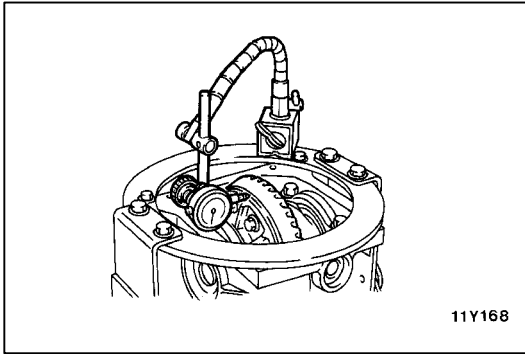

9. Check the drive gear and drive pinion for tooth contact. If poor contact is evident, make adjustment. (Refer to P. 26-39.)
10. Measure the drive gear runout at the shoulder on the reverse side of the drive gear.

Limit: 0.05 mm

11. If the drive gear runout exceeds the limit, reinstall by changing the phase of the drive gear and differential case, and remeasure.
12. If adjustment is not possible, replace the differential case or replace the drive gear and drive pinion as a set.

FREEWHEEL CLUTCH

REMOVAL AND INSTALLATION

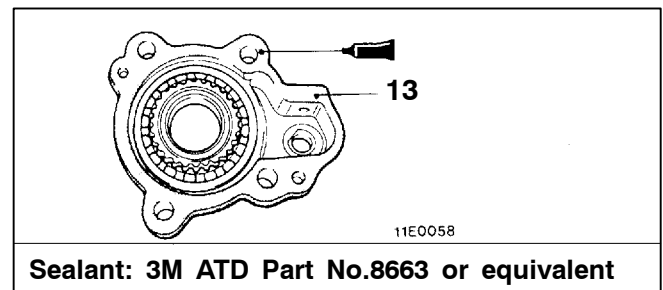
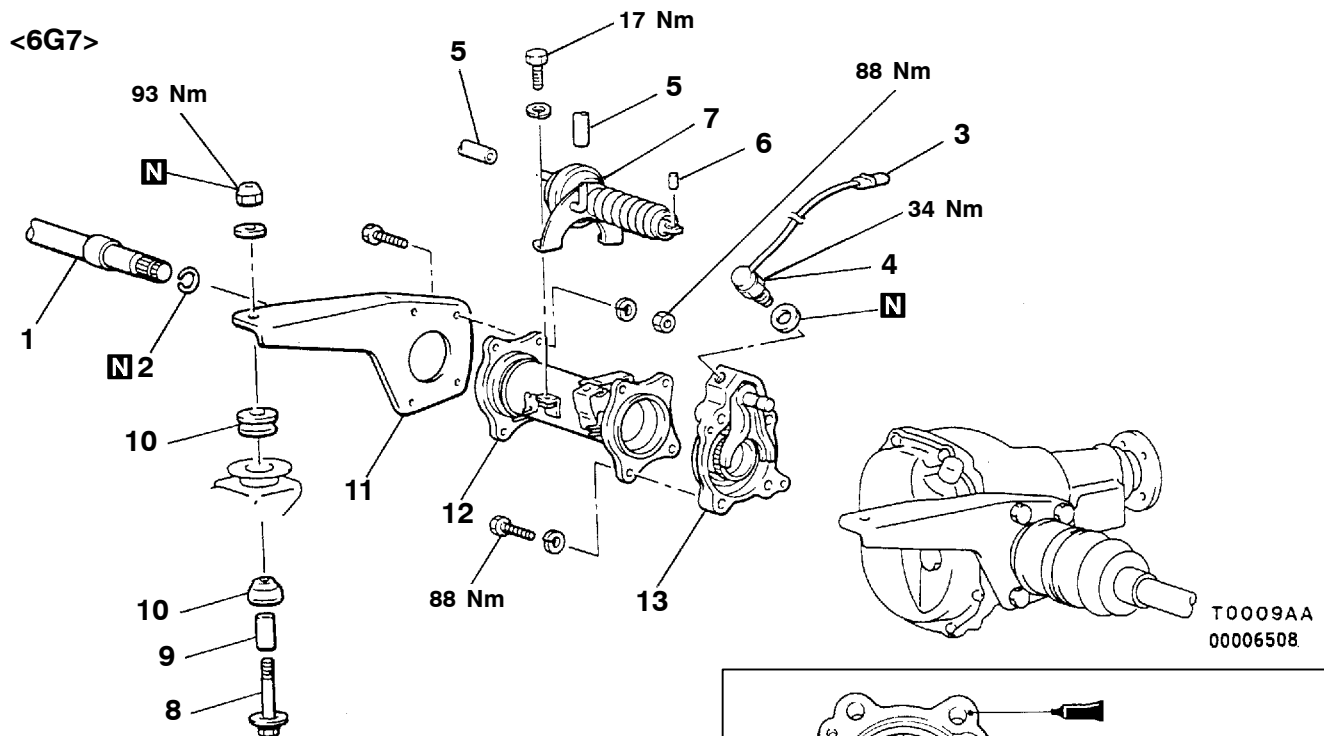

Freewheel clutch removal steps

- ▶E◀
1. Inner shaft (Refer to P. 26-31.)
 2. Circlip
 3. Freewheel engage switch connector
 4. Freewheel engage switch
 5. Vacuum hose
 6. Pin
 7. Actuator assembly
 - Support the differential by a transmission jack.
 8. Pin
 9. Spacer
 10. Differential mounting cushion
 11. Differential mounting bracket (R.H.)
 12. Housing tube assembly
 13. Freewheel clutch assembly
 - ▶D◀ • Clutch gear bearing axial play inspection.

<4D5>

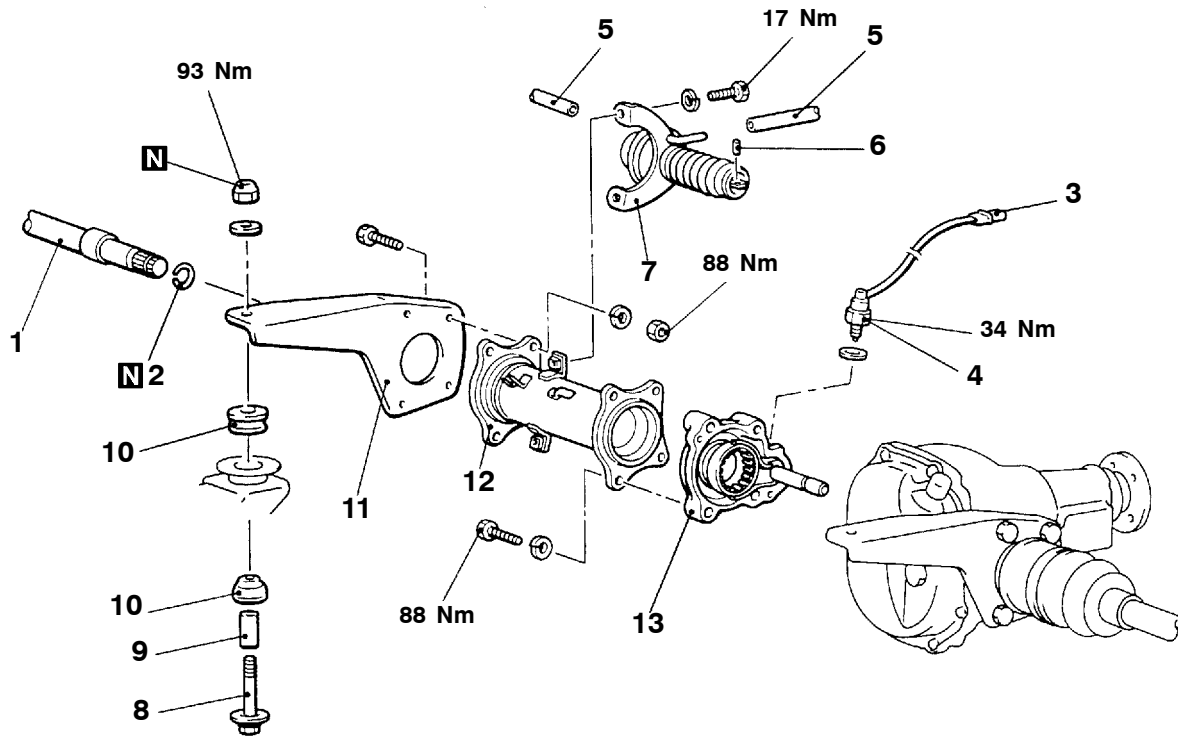
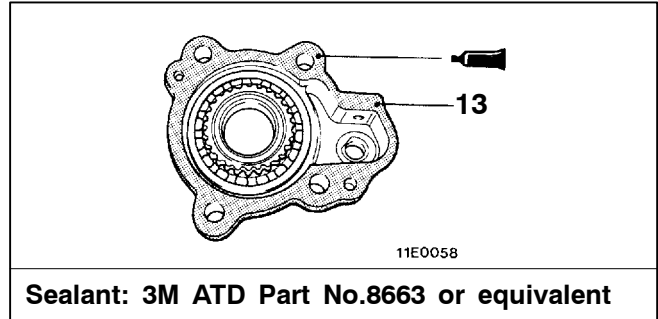

11V0047
00009263

Freewheel clutch removal steps

1. Inner shaft (Refer to P. 26-31.)
2. Circlip
3. Freewheel engage switch connector
4. Freewheel engage switch
5. Vacuum hose
6. Pin
7. Actuator assembly
- Support the differential by a transmission jack.



8. Pin
9. Spacer
10. Differential mounting cushion
11. Differential mounting bracket (R.H.)
12. Housing tube assembly
13. Freewheel clutch assembly
- Clutch gear bearing axial play inspection.



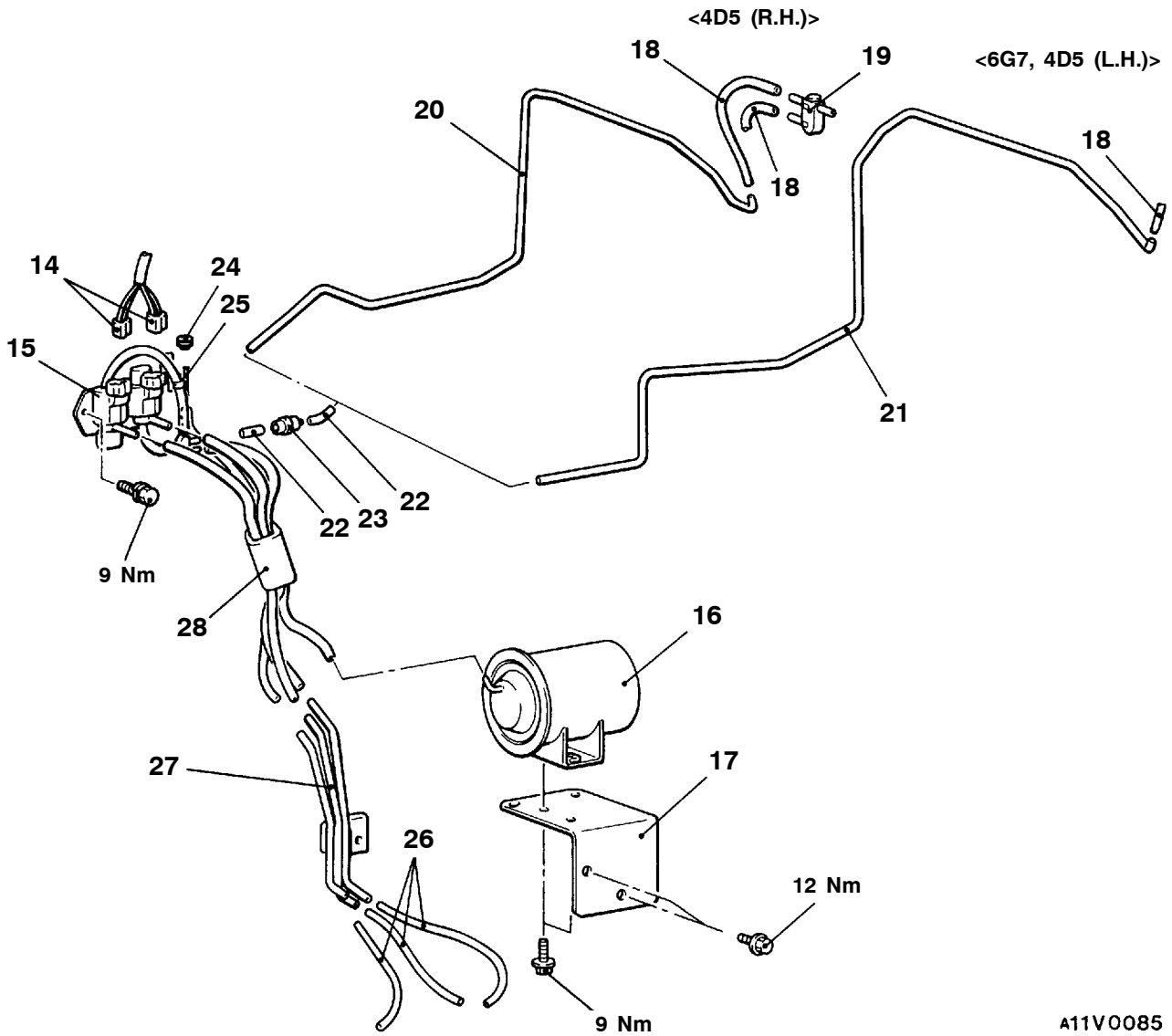

A11V0085

Solenoid valve assembly removal steps

- ▶C◀ 14. Solenoid valve connector
- ▶C◀ 15. Solenoid valve assembly

Vacuum tank and vacuum hose assembly and vacuum pipe assembly removal steps

- ▶A◀ 16. Vacuum tank
- ▶A◀ 17. Vacuum tank bracket

- ▶B◀ 18. Vacuum hose
- ▶B◀ 19. Vacuum terminal
- ▶B◀ 20. Vacuum pipe
- ▶B◀ 21. Vacuum pipe
- ▶B◀ 22. Vacuum hose
- ▶B◀ 23. Check valve
- ▶B◀ 24. Breather cap
- ▶B◀ 25. Breather pipe assembly
- ▶A◀ 26. Vacuum hose
- ▶A◀ 27. Vacuum pipe assembly
- ▶A◀ 28. Vacuum hose assembly

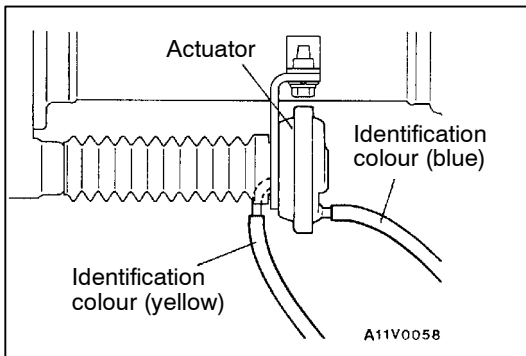

INSTALLATION SERVICE POINTS

▶A◀ VACUUM HOSE ASSEMBLY/VACUUM PIPE ASSEMBLY/VACUUM HOSE INSTALLATION

Install the vacuum hoses so that the identification colours of the vacuum pipe assembly match those of the actuators. Note that there is no identification colour for the vacuum hose which will be connected to the vacuum tank.

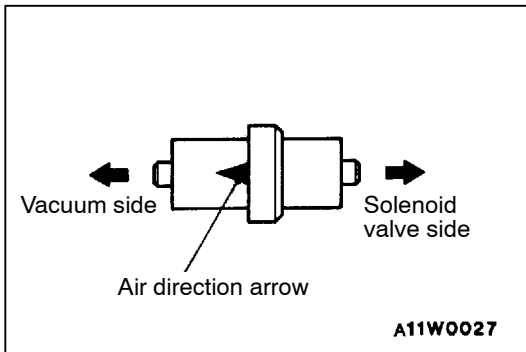

▶B◀ CHECK VALVE INSTALLATION

Install so that air direction arrow points to the vacuum side.

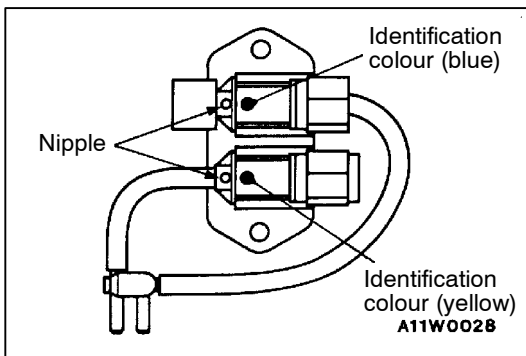

▶C◀ SOLENOID VALVE ASSEMBLY INSTALLATION

Install so that the identification colours of the vacuum hoses match those of the solenoid valve assembly.

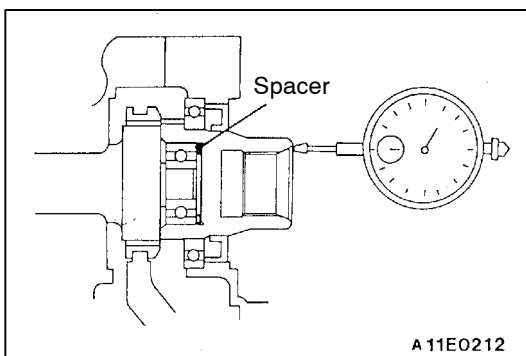

▶D◀ CLUTCH GEAR BEARING AXIAL PLAY INSPECTION

Check the axial play of the clutch gear bearing by the following procedure before installing the freewheel clutch assembly.

1. Insert flat washers of the same thickness as the housing tube (9.0 mm) onto the bolt, and then provisionally install the freewheel clutch assembly to the front differential.
2. Place a micrometer against the end of the clutch gear and check the axial play of the clutch gear bearing.

Standard value: 0.05 – 0.30 mm

3. If the axial play of the clutch gear bearing is not within the standard value, disassemble the bearing and insert a spacer of the appropriate thickness.

NOTE

The thickness of the spacers vary in steps of 0.25 mm.

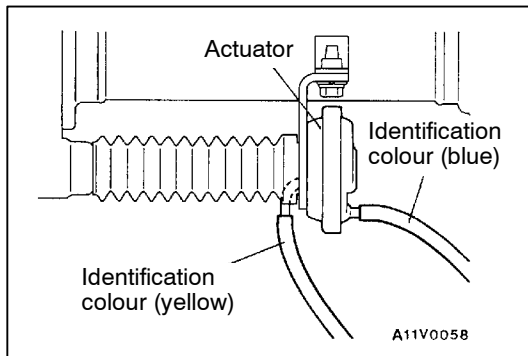

VACUUM HOSE INSTALLATION

Connect the vacuum hoses so that the identification colours match those of the actuator assembly nipples.

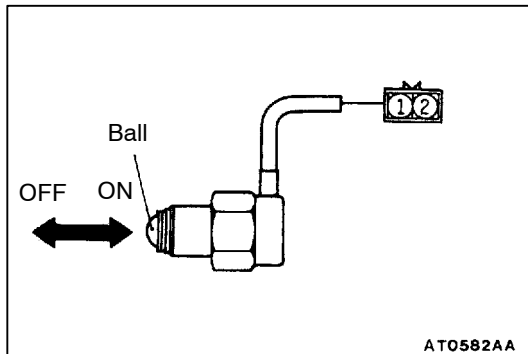

INSPECTION

26200280034

FREEWHEEL ENGAGE SWITCH

Shaft (switch) position	Terminal No. 1	Terminal No. 2
Pressed (ON)	○ ———	——— ○
Released (OFF)		

DISASSEMBLY AND REASSEMBLY

26200290068

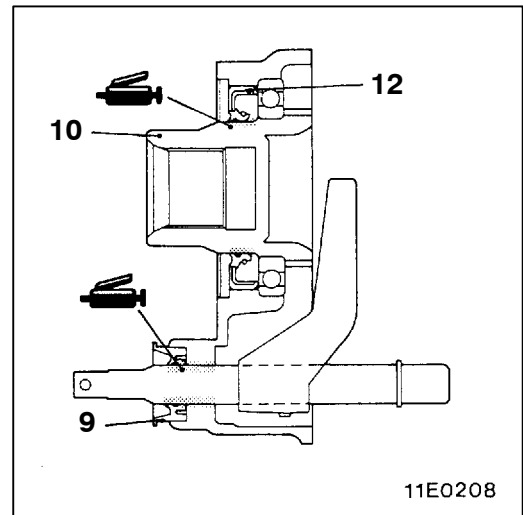
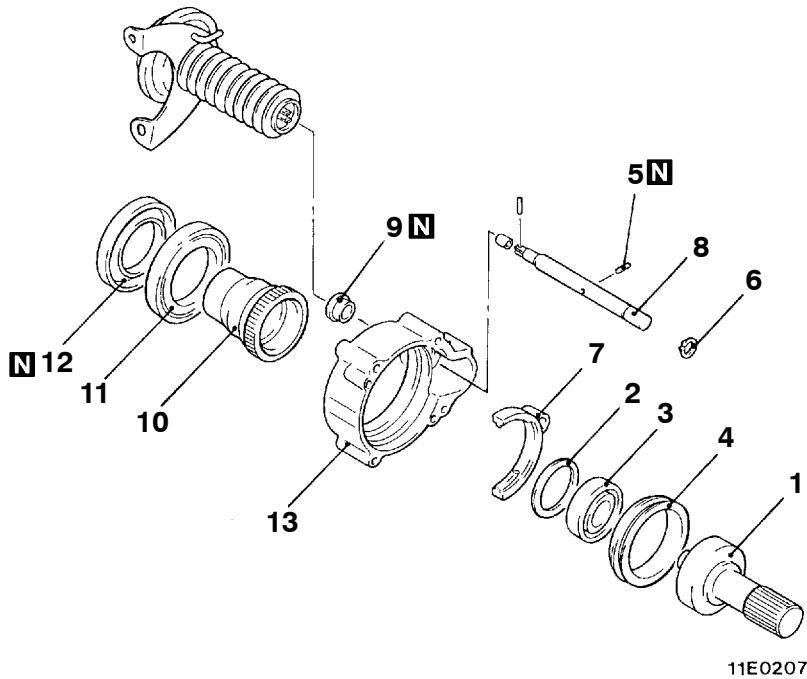

11E0207

11E0208

00004936

Removal steps

- ◀A▶ 1. Main shaft
- ▶F▶ 2. Spacer
- ▶E▶ 3. Bearing
- ▶D▶ 4. Clutch sleeve
- ▶D▶ 5. Spring pin
- ▶D▶ 6. Snap ring
- ▶D▶ 7. Shift fork

- ▶C▶ 8. Shift rod
- ▶B▶ 9. Oil seal
- ▶B▶ 10. Clutch gear
- ▶B▶ 11. Bearing
- ▶A▶ 12. Oil seal
- ▶A▶ 13. Clutch housing

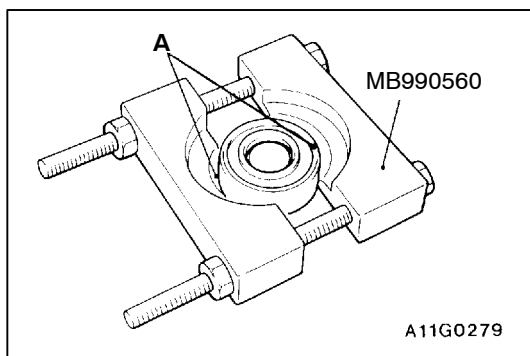

A11G0279

DISASSEMBLY SERVICE POINTS

◀A▶ MAINSHAFT/BEARING REMOVAL

1. After the special tool has been installed as shown, tighten the nut of the special tool until the portion "A" of the special tool touches the bearing outer race.

2. Press out the mainshaft from the bearing.

Caution

Do not allow the mainshaft to drop.

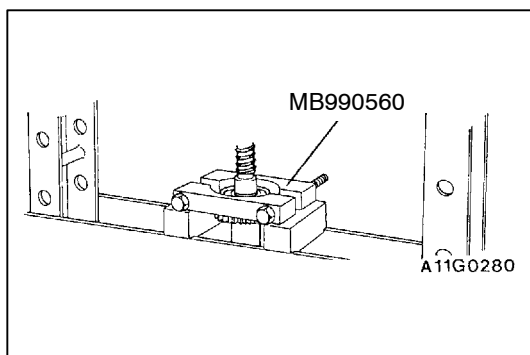

A11G0280

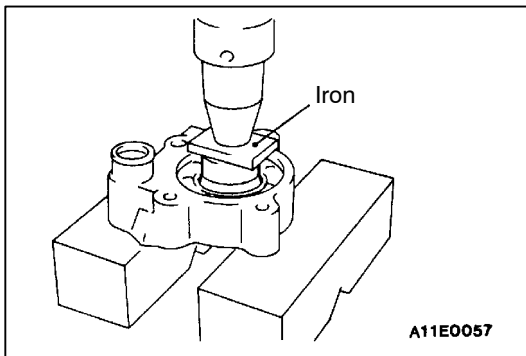

◀B▶ CLUTCH GEAR/BEARING REMOVAL

1. Use a press and steel plate to remove the clutch gear and bearing together.

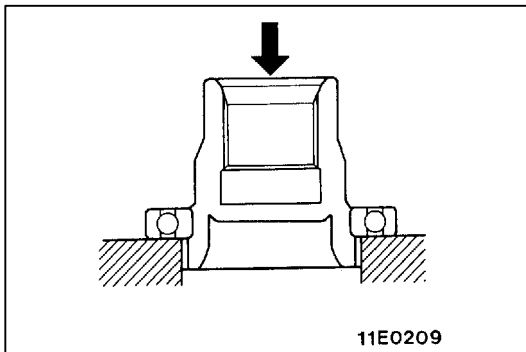

2. Use a press to hold the supports against the bearing inner race, and separate the clutch gear and bearing.

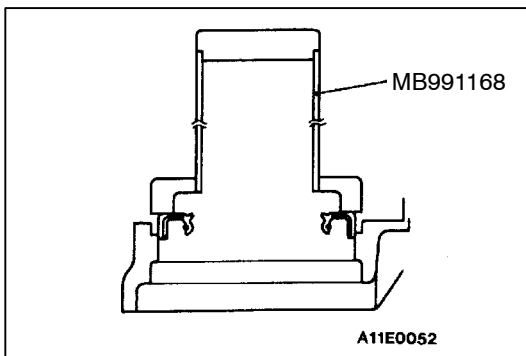

REASSEMBLY SERVICE POINTS

▶A◀ OIL SEAL INSTALLATION

Use the special tool to tap the oil seal until it is flush with the clutch housing.

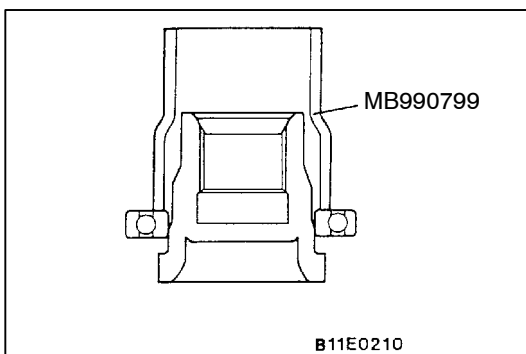

▶B◀ BEARING /CLUTCH GEAR INSTALLATION

1. Use the special tool to press-fit the bearing to the shoulder of the clutch gear.

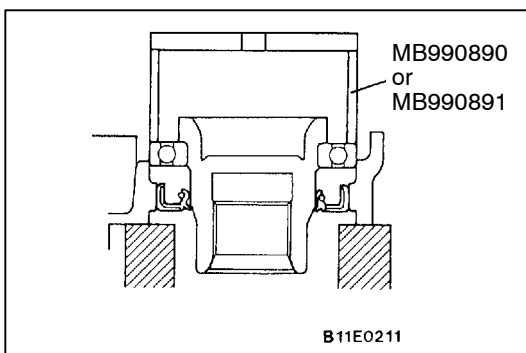

2. Use the special tool to press-fit the bearing to the side of the clutch housing.

Caution

Place the special tool against the outer race of the bearing.

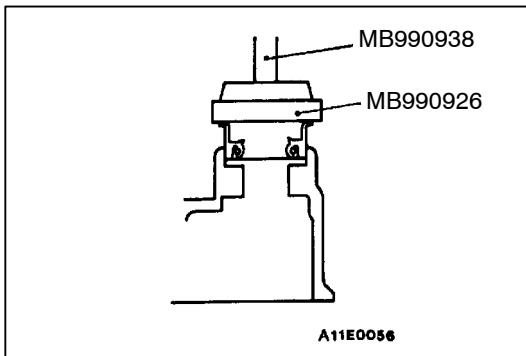

►C◄ OIL SEAL INSTALLATION

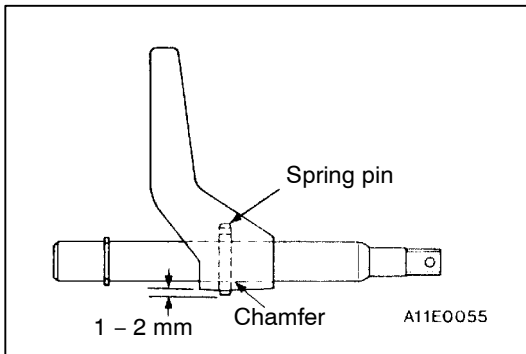

►D◄ SPRING PIN INSTALLATION

Tap the spring pin from the chamfered side of the shift rod until the projection length becomes length shown in the illustration.

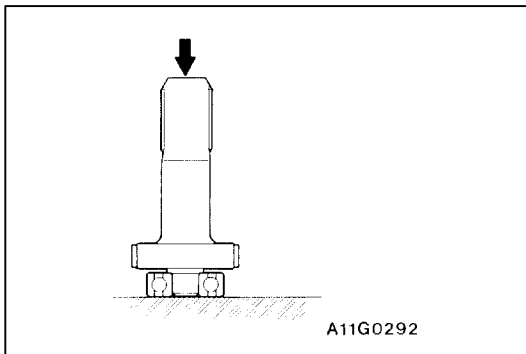

►E◄ BEARING INSTALLATION

Press-fit the bearing to the shoulder of the mainshaft.

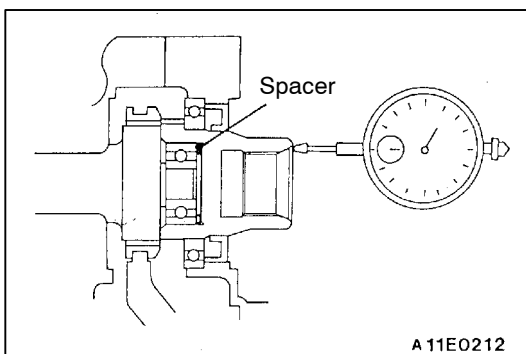

►F◄ SPACER INSTALLATION

1. After installing the freewheel clutch assembly, select a spacer so that the clutch gear axial play (bearing looseness) is within the standard value.

Standard value: 0.05 – 0.30 mm

2. If it is outside the standard value, disassemble and select the appropriate spacer again.

NOTE

The thickness of the gauge is different 0.25 mm each.

NOTES

REAR AXLE

CONTENTS

27109000277

GENERAL INFORMATION	2	Rear Axle Total Backlash Check	7
SERVICE SPECIFICATIONS	3	Axle Shaft Axial Play Check	7
LUBRICANTS	3	Axle Shaft Axial Play Adjustment	7
SEALANTS	4	Gear Oil Level Check	8
SPECIAL TOOLS	4	AXLE ASSEMBLY	9
ON-VEHICLE SERVICE	7	AXLE SHAFT	11
		DIFFERENTIAL CARRIER	18



GENERAL INFORMATION

27100010248

- The rear axle is a banjo-type semi-floating type. As the axle shaft bearings, double taper roller bearings are used. ABS rotor is press-fitted to the axle shaft.
- A hybrid type LSD has a high performance against driving on unstable surfaces such as muddy roads.

REAR AXLE

Item	Specifications	
Axle housing type	Banjo type	
Axle shaft	Support method	Semi-floating type
	Shaft O.D. (Bearing part x Centre x Length) mm	40.0 x 34.5 x 744.5
	Bearing type	Double taper
	Bearing (O.D. x I.D.) mm	80.0 x 40.0

DIFFERENTIAL

Item	6G7, 4D5 <Vehicles with-out wide fender>	4D5 <Vehicles with wide fender>	
Drive gear type	Hypoid gear		
Reduction ratio	4.636	4.900	
Limited slip differential type	Torque sensitivity type and rpm sensitivity type		
Differential gear type (type x quantity)	Side gear	Straight bevel gear x 2 Helical bevel gear x 2*	
	Pinion gear	Straight bevel gear x 2 Helical bevel gear (short), helical bevel gear (long) x 4*	
Number of teeth	Drive gear	51	49
	Drive pinion	11	10
	Side gear	19, 22*	
	Pinion gear	10, 7*	
Bearing (O.D. x I.D.) mm	Side	80 x 45	
	Front	68 x 30	
	Rear	79 x 37	

NOTE

*: Vehicles with hybrid type LSD

CONSTRUCTION DIAGRAM

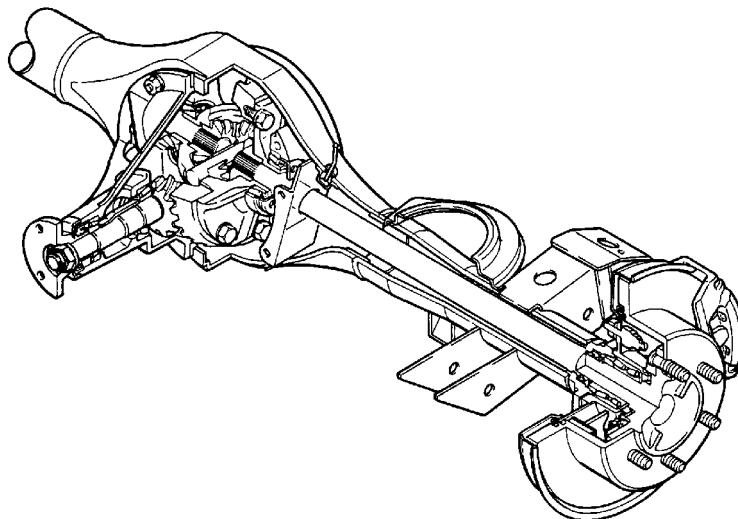

SERVICE SPECIFICATIONS

27100030350

Item	Standard value		Limit	
Rear axle total backlash mm	–		5	
Axle shaft axial play mm	0 – 0.25		–	
Protruding length of stabilizer bar mounting bolt mm	15 – 17		–	
Axle shaft retainer press-fitting force N	Initial press-fitting force 49,000 or more		–	
	Final press-fitting force 9,800 – 108,000		–	
Clearance between axle shaft retainer and snap ring mm	0 – 0.166		–	
Distance between bearing case and ABS rotor mm	19.4 – 20.0		–	
Drive gear backlash mm	0.13 – 0.18		–	
Drive gear runout mm	–		0.05	
Differential gear backlash mm	0 – 0.076		0.2	
Drive pinion turning torque Nm	Without oil seal	When replacing (with anti-rust agent)	0.59 – 0.88	–
		When replacing or reusing (with gear oil applied)	0.39 – 0.49	–
	With oil seal	When replacing (with anti-rust agent)	0.83 – 1.13	–
		When replacing or reusing (with gear oil applied)	0.64 – 0.74	–

LUBRICANTS

27100040148

Item	Specified lubricants	Quantity
Rear differential gear oil	<ul style="list-style-type: none"> ● Conventional differential: Hypoid gear oil API classification GL-5 or higher SAE viscosity No. 90, 80 W ● Limited slip differential: Hypoid gear oil MITSUBISHI Genuine Gear Oil Part No. 8149630 EX, CASTROL HYPOY LS (GL-5, SAE 90), SHELL-LSD (GL-5, SAE 80W-90) or equivalent 	2.6 L

SEALANTS





27100050110



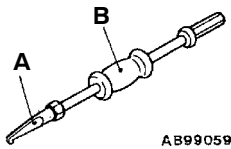
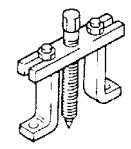
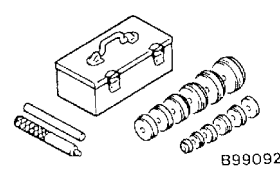
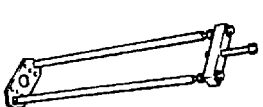
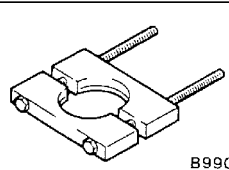
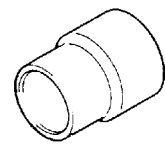
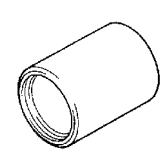

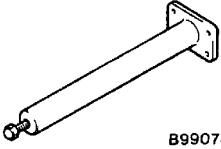
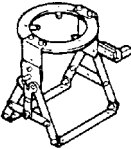
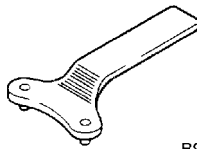
Items	Specified sealants	Remarks
Bearing case	3M ATD Part No. 8663 or equivalent	Semi-drying sealant
Axle housing (differential carrier mounting part)		
Drive gear and differential case mounting part	3M Stud Locking 4170 or equivalent	Anaerobic sealant

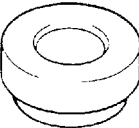
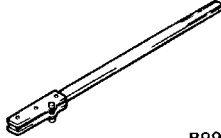
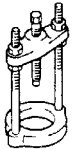
SPECIAL TOOLS

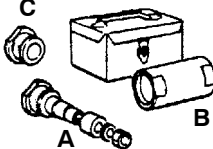
27100060298

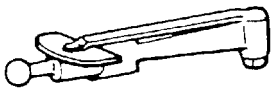
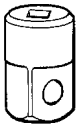
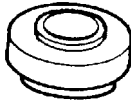
Tool	Number	Name	Use
 <p>MB990590</p>	MB990590 A: MB990212 B: MB990211	Rear axle shaft oil seal remover A: Adapter B: Sliding hammer	<ul style="list-style-type: none"> Removal of axle shaft (Use together with MB990241, MB990211) Removal of axle housing oil seal
 <p>B990241</p>	MB990241	Rear axle shaft puller	Removal of axle shaft (Use together with MB990211)
 <p>B990925</p>	MB990925	Bearing and oil seal installer set	<ul style="list-style-type: none"> Press-fitting of oil seal Inspection of drive gear tooth contact Removal of bearing outer race For details of each installer, refer to GROUP 26 – Special Tools.
	MB991552	Axle shaft bearing and case remover	Removal of the axle shaft bearing and bearing case
 <p>B990560</p>	MB990560	Bearing remover	Removal of bearing inner race
 <p>B990799</p>	MB990799	Bearing inner race installer	<ul style="list-style-type: none"> Removal of axle shaft bearing inner race Press-fitting of the axle shaft bearing inner race Press-fitting of the axle shaft retainer
 <p>B990890</p>	MB990890 or MB990891	Rear suspension bushing base	Press-fitting of bearing outer race

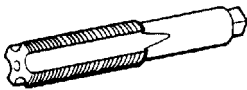
Tool	Number	Name	Use
 <p>B990787</p>	MB990787	Axle shaft bearing remover	Installation of ABS rotor
 <p>B990909</p>	MB990909	Working base	Supporting of the differential carrier
 <p>B990201</p>	MB990201	Side bearing adjusting special spanner	Removal and adjustment of the side bearing nut
 <p>B990810</p>	MB990810	Side bearing puller	Removal of the side bearing inner race
 <p>B990811</p>	MB990811	Side bearing cup	
 <p>B990850</p>	MB990850	End yoke holder	Removal of the companion flange
 <p>B990339</p>	MB990339	Bearing puller	Removal of the drive pinion rear bearing inner race
	MB990648	Bearing remover	
	MB991171 A: MB990819 B: MB991170 C: MB991169	Pinion height gauge set A: Drive pinion gauge B: Cylinder gauge C: Drive pinion gauge attachment	Measurement of the pinion height

Tool	Number	Name	Use
	MB990685	Torque wrench	Measurement of the starting torque of drive pinion
	MB990326	Preload socket	
	MB990728	Bearing installer	Press-fitting of the drive pinion rear bearing inner race
	MB990727	Drive pinion oil seal installer	Press-fitting of the drive pinion oil seal
	MB990813	Tap	Removal of adhesive
	MB990802	Bearing installer	Press-fitting of the side bearing inner race

ON-VEHICLE SERVICE

27100120200

REAR AXLE TOTAL BACKLASH CHECK

1. Park the vehicle on a flat, level surface.
2. Move the transmission control lever to the neutral position. Move the transfer control lever to the neutral position. Apply the parking brake. Raise the vehicle on a jack.

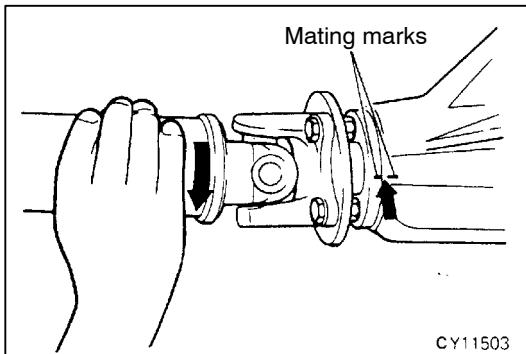

3. Turn the companion flange clockwise as far as it will go. Make the mating mark on the dust cover of the companion flange and on the differential carrier.
4. Turn the companion flange anti-clockwise as far as it will go, and measure the amount of distance the mating marks moved.

Limit: 5 mm

5. If the backlash exceeds the limit value, remove the differential carrier assembly and check the following.
 - Final drive gear backlash (Refer to P.27-19.)
 - Differential gear backlash (Refer to P.27-20.)

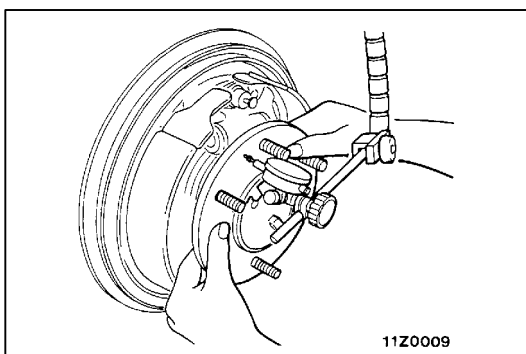
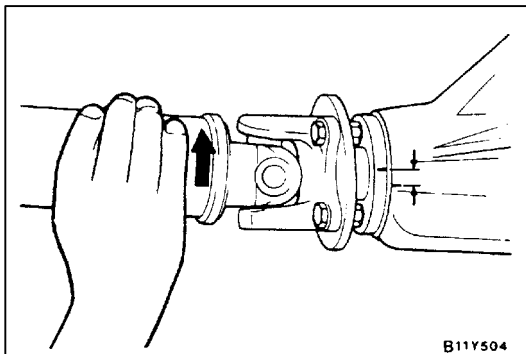
**AXLE SHAFT AXIAL PLAY CHECK**

27100130081

1. Measure the axle shaft axial play by using a dial indicator.
Standard value: 0 – 0.25 mm
2. If within specifications, return vehicles to original condition.

AXLE SHAFT AXIAL PLAY ADJUSTMENT

27100140077

The axle shaft axial play is preset at factory. It can not be adjusted.

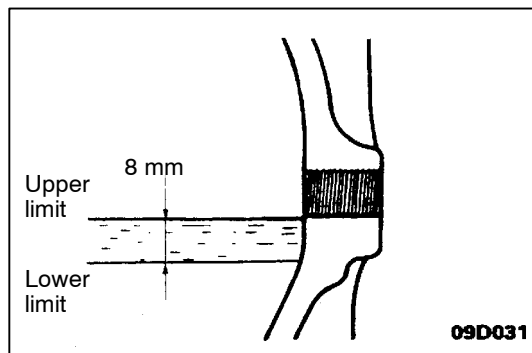

GEAR OIL LEVEL CHECK

27200120142

Check that gear oil level is not 8 mm below the bottom of filler plug hole.

Specified gear oil:

<Conventional differential>

Hypoid gear oil API classification GL-5 or higher
SAE viscosity Number 90, 80W

<Limited slip differential>

Hypoid gear oil MITSUBISHI Genuine Gear oil Part No. 8149630 EX, CASTROL HYPOY LS (GL-5, SAE90), SHELL-LSD (GL-5, SAE 80W-90) or equivalent [Quantity: 2.6 L]

AXLE ASSEMBLY

27100170120

REMOVAL AND INSTALLATION

Caution

*: Indicates parts which should be temporarily tightened, and then fully tightened with the vehicle on the ground in an unladen condition.

Pre-removal Operation

- Brake Fluid Draining

Post-installation Operation

- Brake Fluid Filling and Air Bleeding (Refer to GROUP 35A – On-vehicle Service.)
- Parking Brake Lever Stroke Adjustment (Refer to GROUP 36 – On-vehicle Service.)

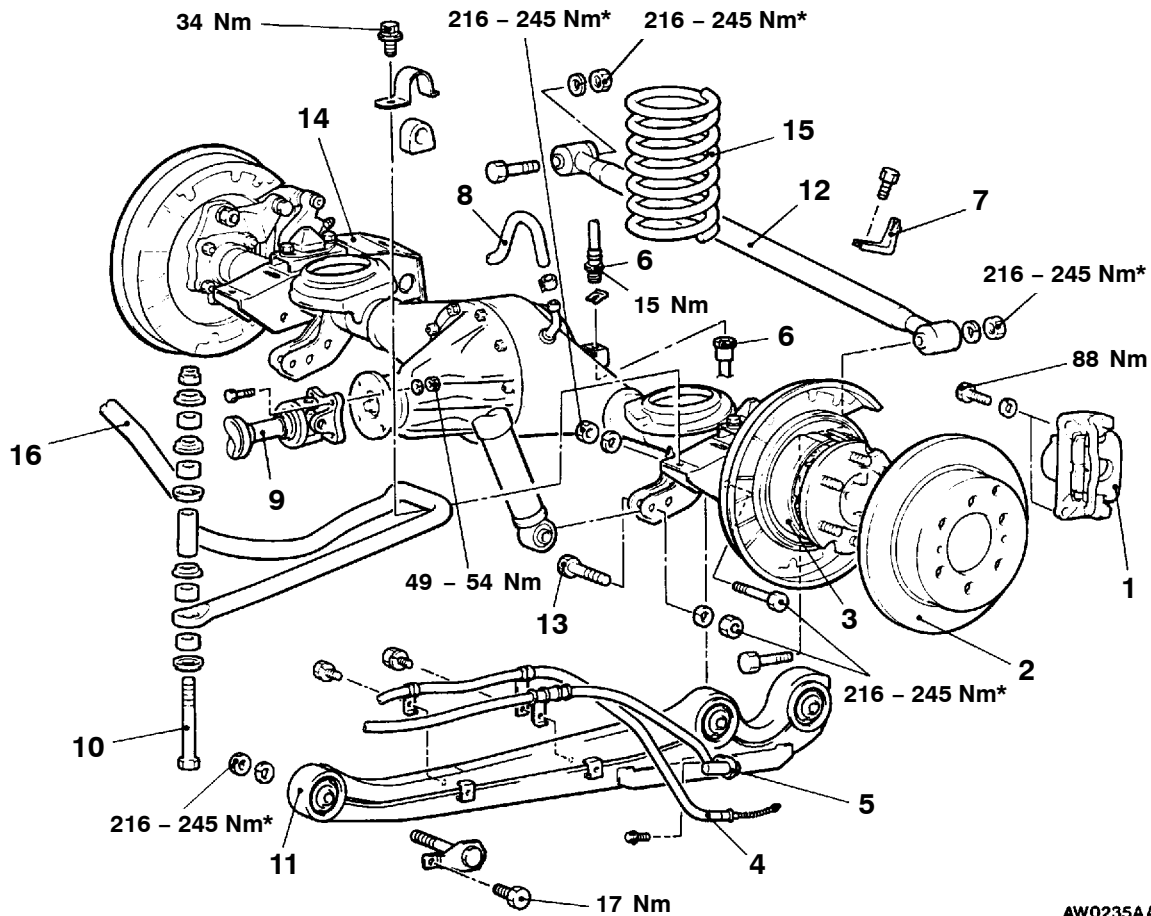

AW0235AA



Removal steps

1. Caliper assembly
2. Break disc
3. Parking brake shoe assembly
(Refer to GROUP 36 – Parking Brake Drum)
4. Parking brake cable connection
5. Speed sensor connection
<Vehicles with ABS>
6. Brake hose and tube connection
7. Spring support
8. Breather hose



9. Propeller shaft
10. Stabilizer bar mounting bolt
• Support the axle assembly by a transmission jack.
11. Lower arm
12. Lateral rod
13. Shock absorber mounting bolt
(lower side only)
14. Axle assembly
15. Coil spring
16. Stabilizer bar



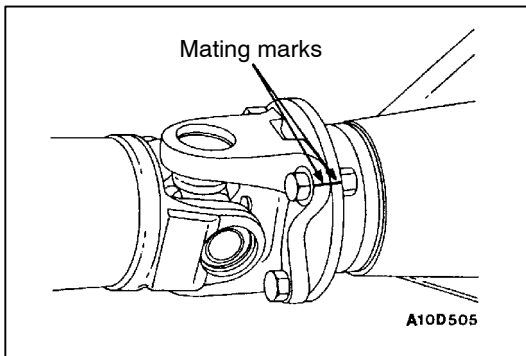

REMOVAL SERVICE POINTS

◀A▶ CALIPER ASSEMBLY REMOVAL

Secure the removed caliper assembly with wire to prevent it from falling off.

◀B▶ PROPELLER SHAFT REMOVAL

Place mating marks on the companion flange and flange yoke. Disconnect the propeller shaft from the companion flange.

Caution

Suspend the propeller shaft from the body with wire, etc. to prevent it from falling.

◀C▶ AXLE ASSEMBLY REMOVAL

Take out the axle assembly from the rear of the vehicle.

Caution

Secure the axle assembly to the jack or equivalent. The axle assembly is heavy and unstable and may fall causing damage to the assembly, surrounding equipment, or injuring the installer.

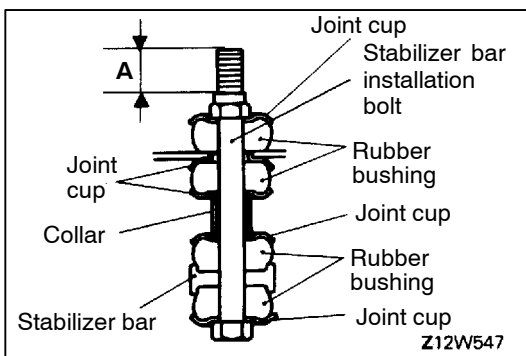

INSTALLATION SERVICE POINTS

▶A◀ STABILIZER BAR MOUNTING BOLT INSTALLATION

When installing the stabilizer bar to the stabilizer bar bracket, check that the amount of projection of the stabilizer bar installation bolt is within the standard value range.

Standard value (A): 15–17 mm

▶B◀ PROPELLER SHAFT INSTALLATION

Align the mating marks on the flange yoke and the companion flange to install the propeller shaft.

AXLE SHAFT

27100250152

REMOVAL AND INSTALLATION

Pre-removal Operation

- Brake Fluid Draining

Post-installation Operation

- Brake Fluid Supplying and Air Bleeding (Refer to GROUP 35A – On-vehicle Service.)
- Parking Brake Lever Stroke Adjustment (Refer to GROUP 36 – On-vehicle Service.)

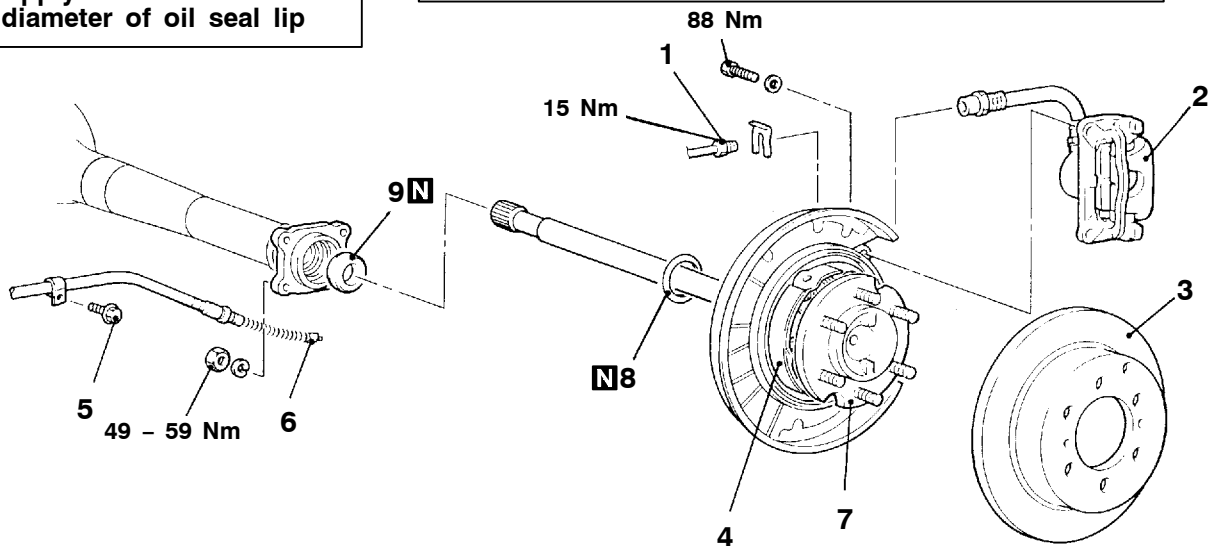
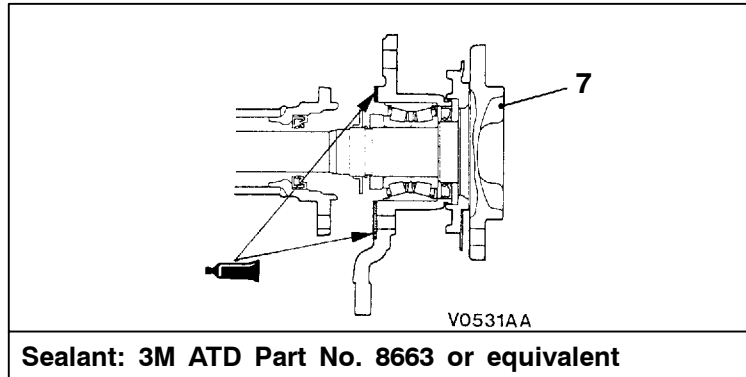
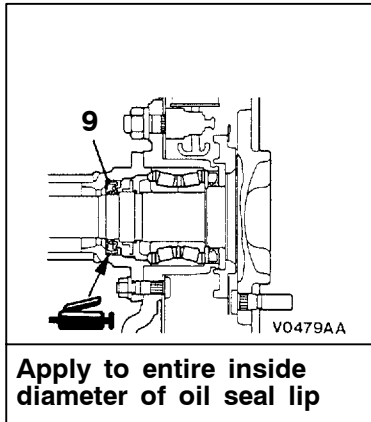

T0122AA
00007608

Removal steps



1. Brake tube
2. Caliper assembly
3. Brake disc
4. Parking brake shoe (Refer to Group 36 – Parking brake drum.)
5. Parking brake cable and speed sensor <vehicles with ABS> attaching bolt



6. Parking brake cable
7. Axle shaft assembly

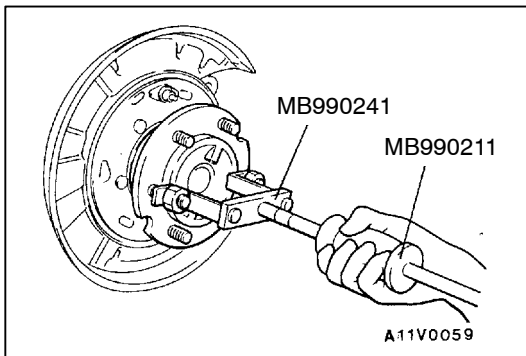

8. O-ring
9. Oil seal

**REMOVAL SERVICE POINTS****◀A▶ CALIPER ASSEMBLY REMOVAL**

Secure the removed caliper assembly with wire to prevent it from falling off.

◀B▶ AXLE SHAFT ASSEMBLY REMOVAL**Caution**

Be careful not to damage the oil seal when pulling axle shaft.

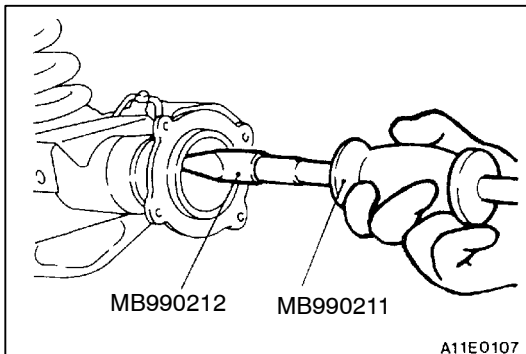
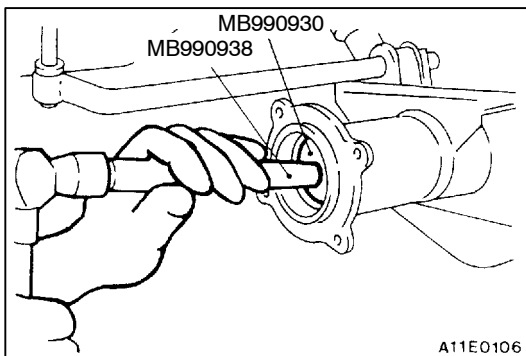
**◀C▶ OIL SEAL REMOVAL****INSTALLATION SERVICE POINT****▶A◀ OIL SEAL INSTALLATION**

DISASSEMBLY AND REASSEMBLY

27100270110

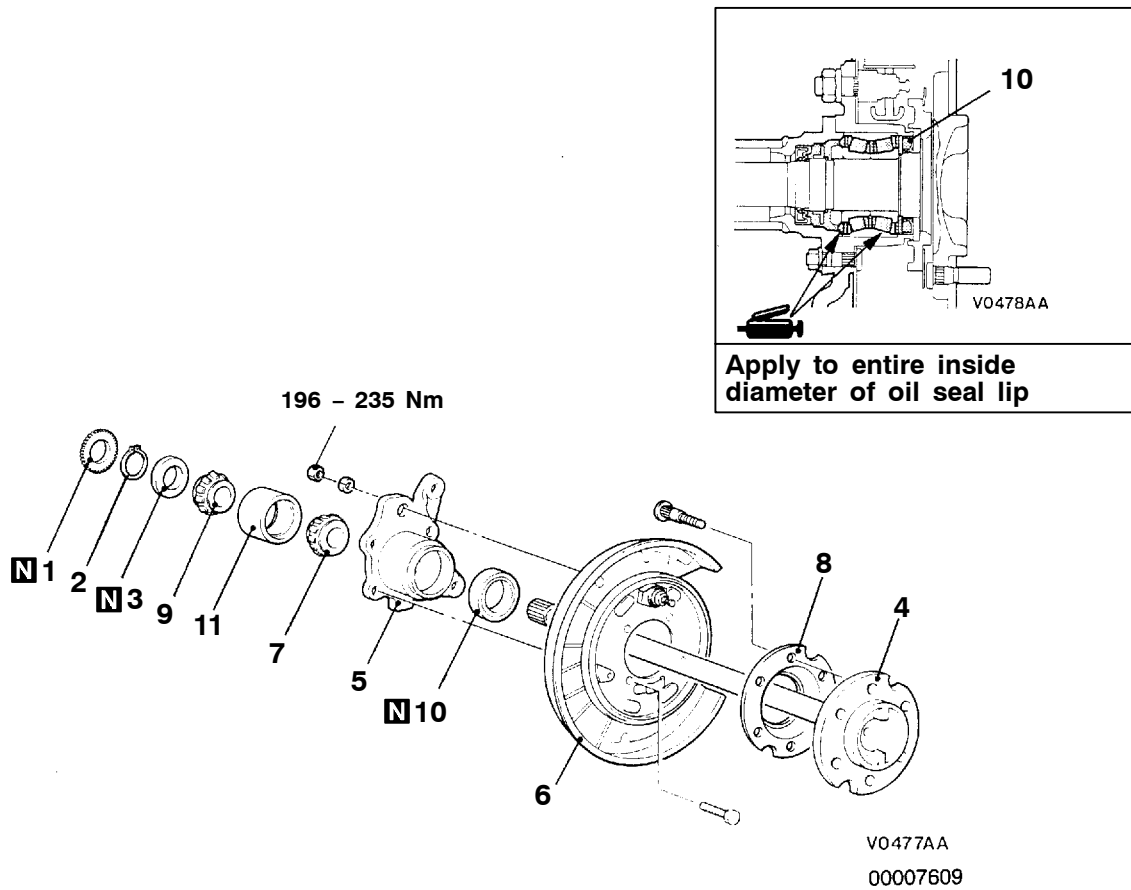

Disassembly steps

1. ABS rotor <vehicles with ABS>
2. Snap ring
3. Retainer ring
4. Axle shaft
5. Bearing case
6. Backing plate
7. Outer bearing inner race
8. Dust cover
9. Inner bearing inner race
10. Oil seal
11. Bearing outer race



Reassembly steps

11. Bearing outer race
9. Inner bearing inner race
7. Outer bearing inner race
10. Oil seal
8. Dust cover
6. Backing plate
5. Bearing case
4. Axle shaft
3. Retainer ring
2. Snap ring
1. ABS rotor <vehicles with ABS>



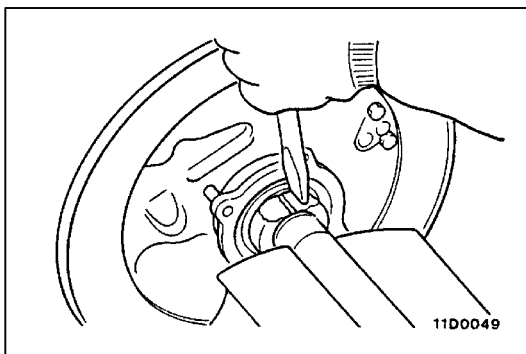
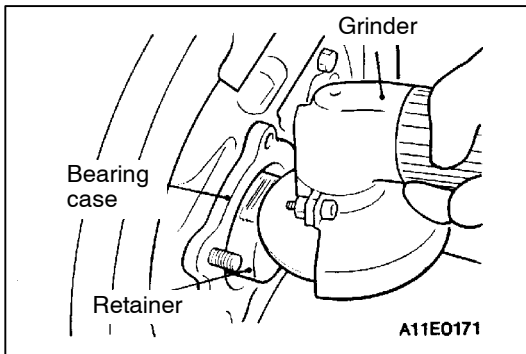
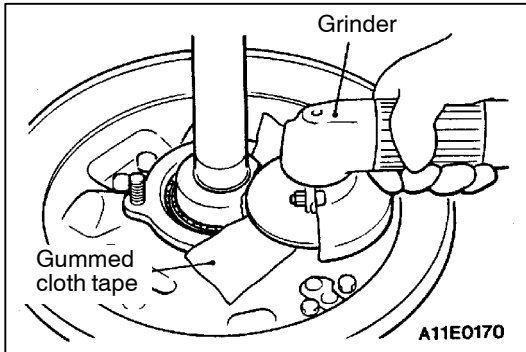
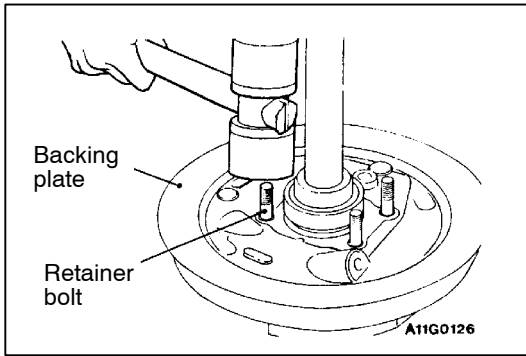

DISASSEMBLY SERVICE POINTS

◀A▶ RETAINER RING REMOVAL

1. Remove one retainer bolt from the backing plate.

2. Apply gummed cloth tape around the edge of the bearing case for protection.

3. As shown in the figure, hold the axle shaft. Using a grinder, shave off a point of its circumference locally until the wall thickness becomes as follows:

- 1.0 – 1.5 mm for axle shaft side
- 2.0 mm for bearing side

Caution

Be careful not to damage the bearing case and the axle shaft.

4. Fix the axle shaft and shave off the remaining 2.0 mm on the side of the retainer bearing.

Caution

Be careful not to damage the bearing case and the axle shaft.

5. Cut in with a chisel the place where the retainer ring has been shaven and remove the retainer ring.

Caution

Be careful not to damage the axle shaft.

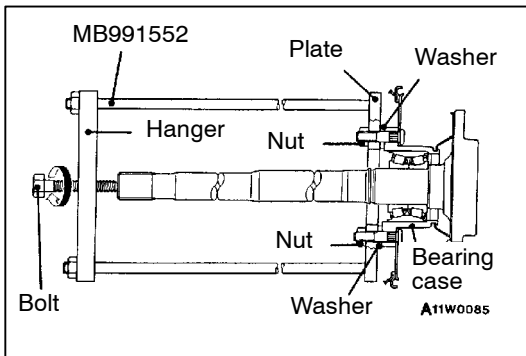

◀B▶ AXLE SHAFT REMOVAL

1. Secure special tool to the bearing case bolts with the nuts and adjust the height of the hanger. Then install the washers, plate and nuts in that order.

NOTE

The washers are used to eliminate the difference in height of the bearing case so that the plate and the bearing case are parallel.

2. Place the end of the bolt against the center of the axle shaft, and then tighten the nut to remove the axle shaft from the bearing case assembly.

Caution

The hanger and plate should be placed so that they are parallel.

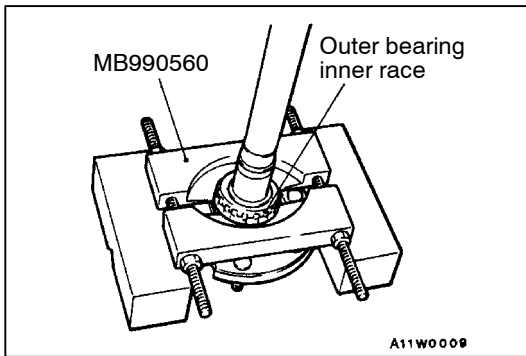

◀C▶ OUTER BEARING INNER RACE REMOVAL

Install special tool as shown in the illustration, and then use a press to remove the outer bearing inner race from the axle shaft.

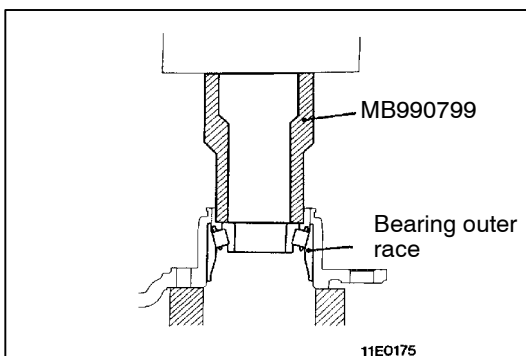

◀D▶ BEARING OUTER RACE REMOVAL

Reinstall the outer bearing inner race that was removed previously, and then use special tool and a press to remove the outer bearing outer race.

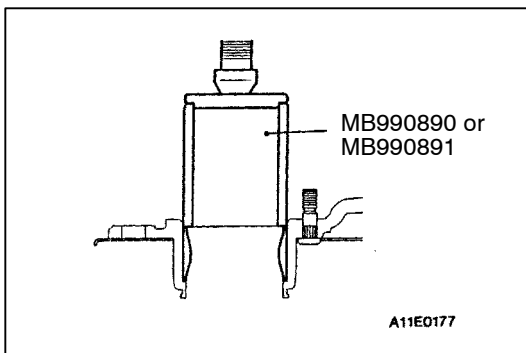

REASSEMBLY SERVICE POINTS

▶A◀ BEARING OUTER RACE INSTALLATION

Use special tool to press-fit the bearing outer race to the bearing case.

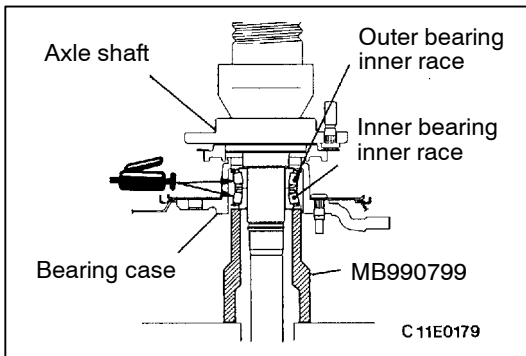

►B◄ INNER BEARING INNER RACE/OUTER BEARING INNER RACE INSTALLATION

1. Apply multipurpose grease to the roller surface and ends of the bearing.
2. Pass the axle shaft through the bearing case and the inner bearing inner race and outer bearing inner race.
3. Use special tool to press-fit the inner bearing inner race and outer bearing inner race to the axle shaft.

Caution

Both bearing inner race, outer race sets should be press-fitted together.

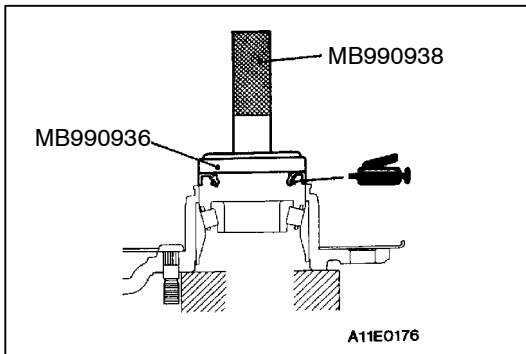

►C◄ OIL SEAL INSTALLATION

1. Apply multipurpose grease to the outside of the oil seal.
2. Use special tools to press-fit the oil seal into the bearing case until it is flush with the face of the bearing case.
3. Apply multipurpose grease to the lips of the oil seal.

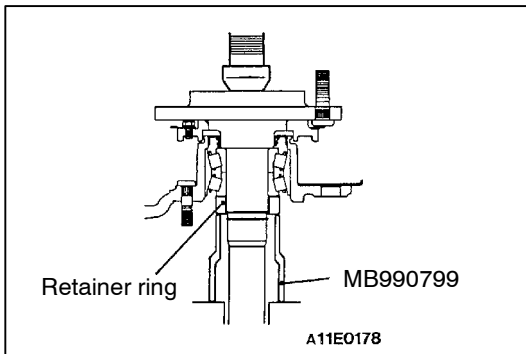

►D◄ RETAINER RING INSTALLATION

Use special tool to press-fit the retainer ring to the axle shaft. Check that the press-fitting force is at the standard value. If the initial press-fitting force is less than the standard value, replace the axle shaft.

Standard value:

Initial press-fitting force N	49,000 or more
Final press-fitting force N	98,000 – 108,000

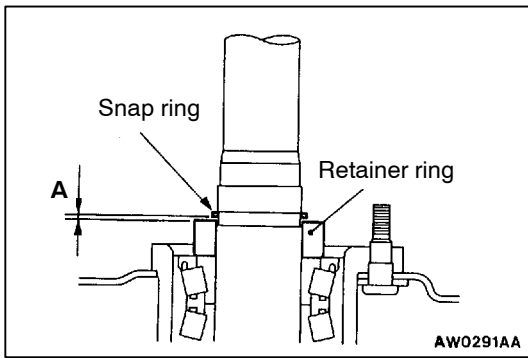

►E◄ SNAP RING INSTALLATION

1. After installing the snap ring, measure clearance (A) between the snap ring and the retainer ring with a thickness gauge, and check that it is within the standard value.

Standard value (A): 0 – 0.166 mm

2. If the clearance exceeds the standard value, change the snap ring so that the clearance is at the standard value.

Thickness of snap ring mm	Identification color
2.17	–
2.01	Yellow
1.85	Blue
1.69	Purple
1.53	Red

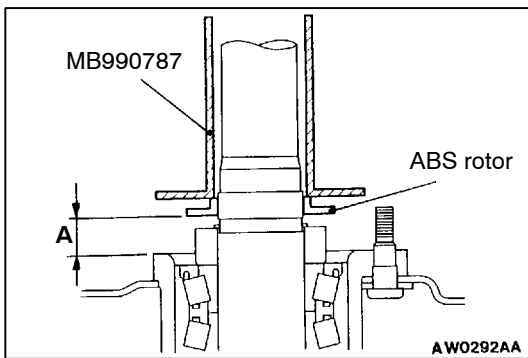

►F◄ ABS ROTOR INSTALLATION

Use special tool to press-fit the ABS rotor so that the distance (A) to the bearing case is at the standard value.

Standard value (A): 19.4 – 20.0 mm

INSPECTION

27100280038

- Check the dust cover for deformation and damage.
- Check the inner and outer bearings for seizure, discoloration and rough raceway surface.
- Check the axle shaft for cracks, wear and damage.

DIFFERENTIAL CARRIER

REMOVAL AND INSTALLATION

Pre-removal Operation

- Differential Gear Oil Draining
- Axle Shaft Assembly Removal (Refer to P.27-11.)

Post-installation Operation

- Axle Shaft Assembly Installation (Refer to P.27-11.)
- Differential Gear Oil Filling (Refer to P.27-8.)

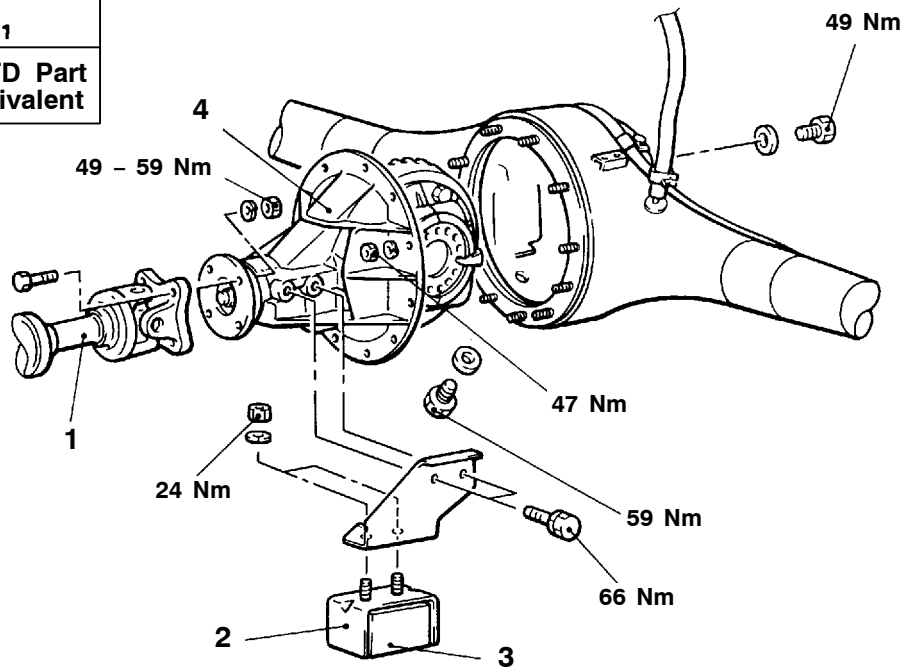
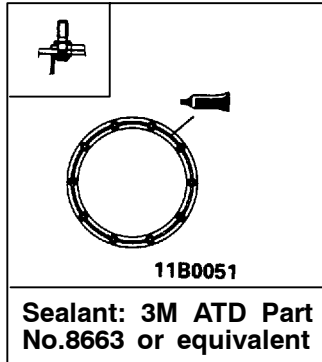

W0118AA
00009264

Removal steps

- ◀A▶ ▶A◀ 1. Propeller shaft connection
- 2. Bracket <4D5>
- 3. Dynamic damper <4D5>
- ◀B▶ 4. Differential carrier assembly

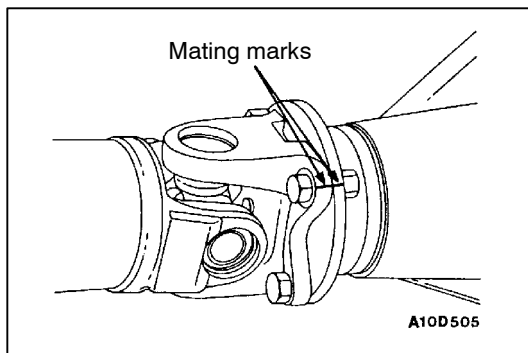

REMOVAL SERVICE POINTS

◀A▶ PROPELLER SHAFT REMOVAL

Make the mating marks on the flange yoke of the propeller shaft and the companion flange of the differential case.

Caution

Suspend the propeller shaft from the body with wire, etc.

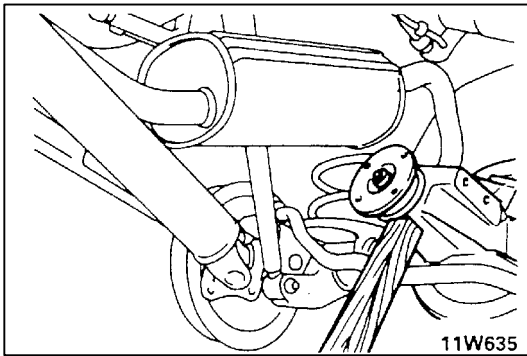

◀B▶ DIFFERENTIAL CARRIER REMOVAL

Remove the attaching nuts and strike the lower part of differential carrier assembly with a piece of timber several times to loosen, then remove the assembly.

Caution

Use care not to strike the companion flange.

INSTALLATION SERVICE POINT

▶A◀ PROPELLER SHAFT INSTALLATION

Align the mating marks on the flange yoke and the companion flange to install the propeller shaft.

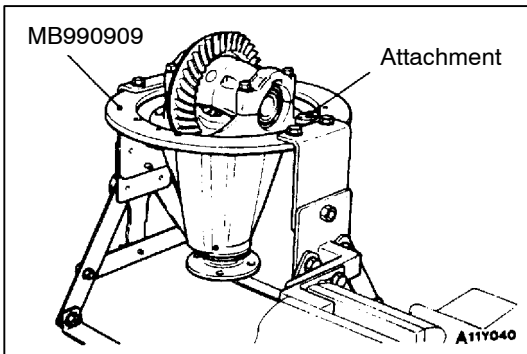

INSPECTION BEFORE DISASSEMBLY

27200290133

Secure the special tool with a vice and install the differential carrier assembly with the attachment. Then carry out the following inspection.

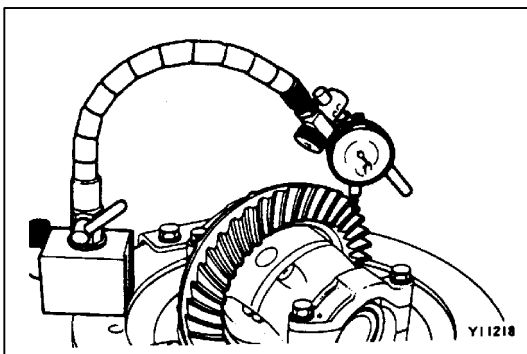

DRIVE GEAR BACKLASH

1. Place a dial gauge against the end of a drive gear tooth and secure the drive pinion. Then turn the drive gear and take measurements at four places or more to check the backlash.

Standard value: 0.13 – 0.18 mm

2. If the backlash is not within the standard value, replace the side bearing spacer, and then check the drive gear tooth contact.

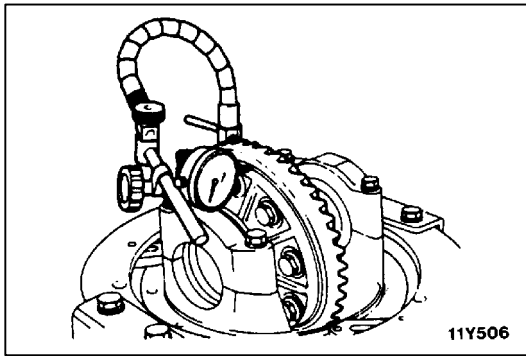

DRIVE GEAR RUNOUT

1. Measure the drive gear runout at the shoulder on the reverse side of the drive gear.

Limit: 0.05 mm

2. If the runout exceeds the limit value, check that there is no foreign material between the reverse side of the drive gear and the differential case, or that there is no looseness in the drive gear mounting bolt.
3. If step (2) is normal, change the assembly position of the drive gear and differential case, and then take another measurement.
4. If adjustment is impossible, replace the differential case or the drive gear and drive pinion as a set.

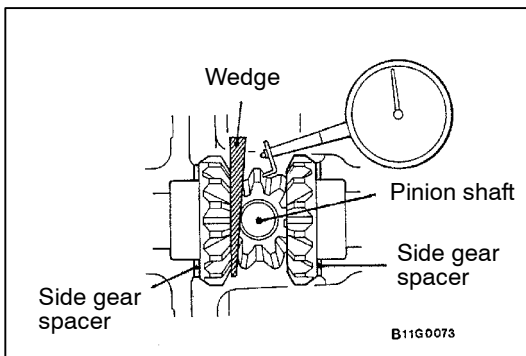

DIFFERENTIAL GEAR BACKLASH

1. Tap in a wooden wedge between the side gear and the pinion shaft and secure one side gear. Then place a dial gauge (with the measuring probe extended) against the pinion gear and measure the backlash.

Standard value: 0 – 0.076 mm

NOTE

Check the other pinion gear by the same procedure.

Limit: 0.2 mm

2. If the backlash exceeds the limit, replace the side gear spacers. (Refer to P.27-30.)
3. If adjustment is not possible, replace the side gears and pinion gears as a set.

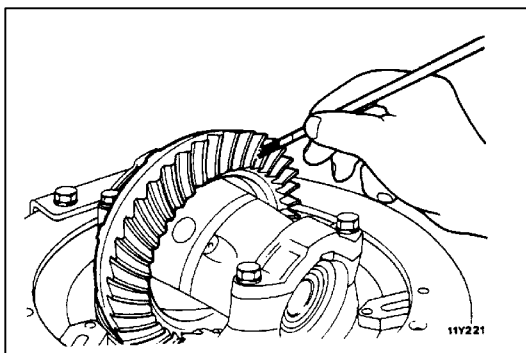

DRIVE GEAR TOOTH CONTACT

Check the drive gear tooth contact by the following steps.

1. Apply a thin, uniform coat of machine blue to both surfaces of the drive gear teeth.

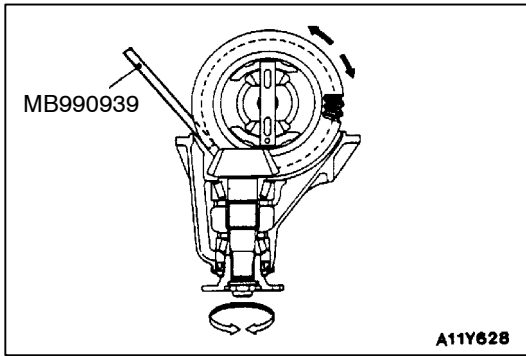

2. Insert a brass rod between the differential carrier and the differential case, and then rotate the companion flange by hand (once in the normal direction, and then once in the reverse direction) while applying a load to the drive gear, so that the revolution torque (approximately 2.5 – 3.0 Nm) is applied to the drive pinion.

Caution

If the drive gear is rotated too much, the tooth contact pattern will become unclear and difficult to check.

3. Check the tooth-contact condition of the drive gear and drive pinion.

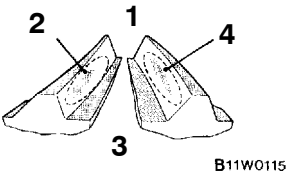
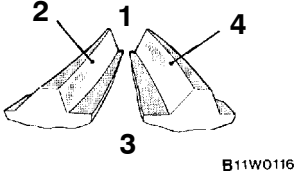
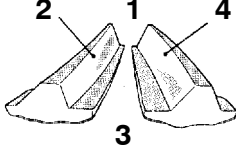
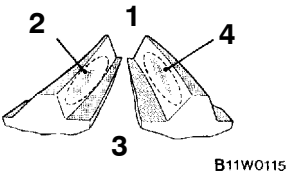
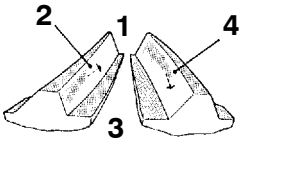
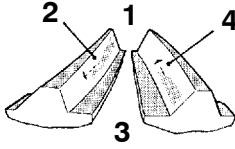
Standard tooth contact pattern	Problem	Solution
<p>1 Narrow tooth side 2 Drive-side tooth surface (the side applying power during forward movement) 3 Wide tooth side 4 Coast-side tooth surface (the side applying power during reverse movement)</p> 	<p>Tooth contact pattern resulting from excessive pinion height</p>  <p>The drive pinion is positioned too far from the centre of the drive gear.</p>	 <p>Increase the thickness of the pinion height adjusting shim, and position the drive pinion closer to the centre of the drive gear. Also, for backlash adjustment, position the drive gear farther from the drive pinion.</p>
	<p>Tooth contact pattern resulting from insufficient pinion height</p>  <p>The drive pinion is positioned too close to the centre of the drive gear.</p>	 <p>Decrease the thickness of the pinion height adjusting shim, and position the drive pinion farther from the centre of the drive gear. Also, for backlash adjustment, position the drive gear closer to the drive pinion.</p>

NOTE

Checking the tooth contact pattern is the way to confirm that the adjustments of the pinion height and backlash have been done properly. Continue to adjust the pinion height and backlash until the tooth contact pattern resembles the standard pattern.

If, even after adjustments have been made, the correct tooth contact pattern cannot be obtained, it means that the drive gear and the drive pinion have become worn beyond the allowable limit. Replace the gear set.

DISASSEMBLY

Caution

*: Do not disassemble the limited slip differential case assembly.

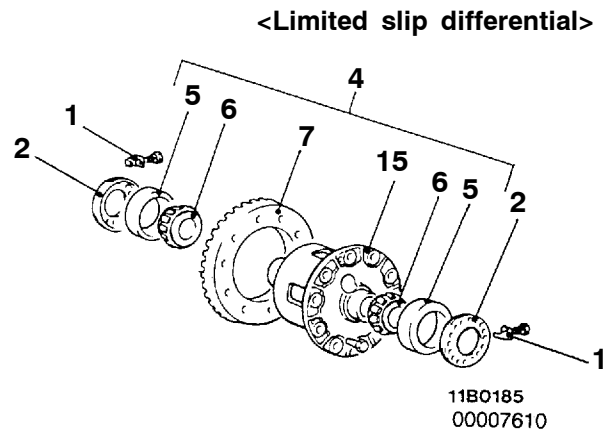
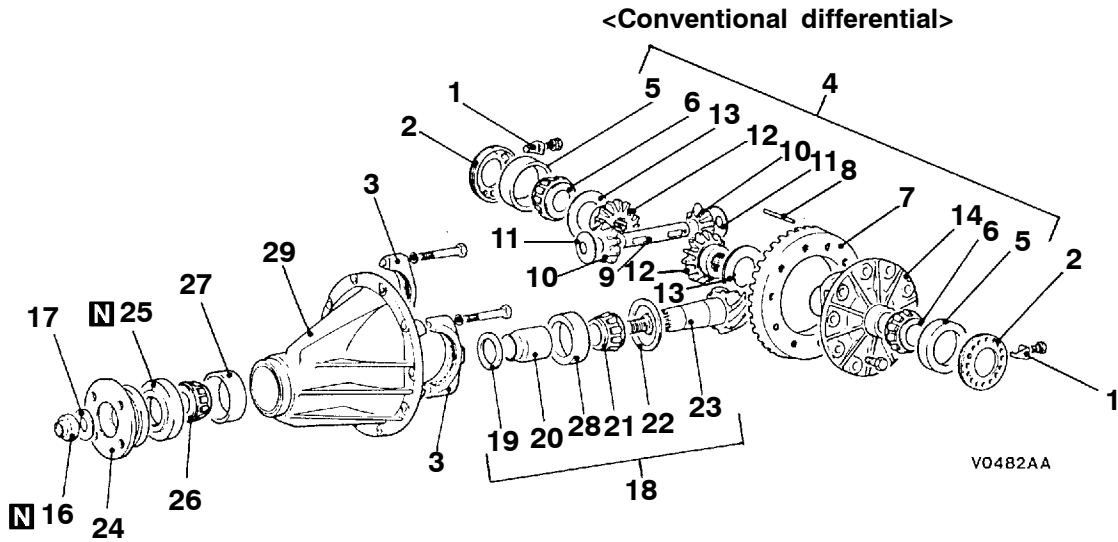

Disassembly steps

- Inspection before disassembly (P.27-20.)

- | | | | |
|--|--|--|--|
| <p>◀A▶</p> <p>◀B▶</p> <p>◀C▶</p> <p>◀D▶</p> <p>◀E▶</p> | <p>1. Lock plate</p> <p>2. Side bearing nut</p> <p>3. Bearing cap</p> <p>4. Differential case assembly</p> <p>5. Side bearing outer race</p> <p>6. Side bearing inner race</p> <p>7. Drive gear</p> <p>8. Lock pin</p> <p>9. Pinion shaft</p> <p>10. Pinion gear</p> <p>11. Pinion washer</p> <p>12. Side gear</p> <p>13. Side gear thrust spacer</p> <p>14. Differential case</p> <p>15. Limited slip differential case assembly*</p> | <p>◀F▶</p> <p>◀G▶</p> <p>◀H▶</p> <p>◀I▶</p> <p>◀J▶</p> | <p>16. Self-locking nut</p> <p>17. Washer</p> <p>18. Drive pinion assembly</p> <p>19. Drive pinion front shim (For adjusting preload of drive pinion)</p> <p>20. Drive pinion spacer</p> <p>21. Drive pinion rear bearing inner race</p> <p>22. Drive pinion rear shim (For adjusting drive pinion height)</p> <p>23. Drive pinion</p> <p>24. Companion flange</p> <p>25. Oil seal</p> <p>26. Drive pinion front bearing inner race</p> <p>27. Drive pinion front bearing outer race</p> <p>28. Drive pinion rear bearing outer race</p> <p>29. Differential carrier</p> |
|--|--|--|--|

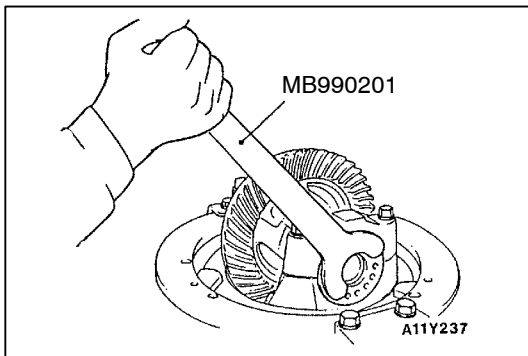

DISASSEMBLY SERVICE POINTS

◀A▶ SIDE BEARING NUT REMOVAL

Use special tool to remove the side bearing nut.

NOTE

Keep the right and left side bearings and side bearing nuts separate, so that they do not become mixed at the time of assembly.

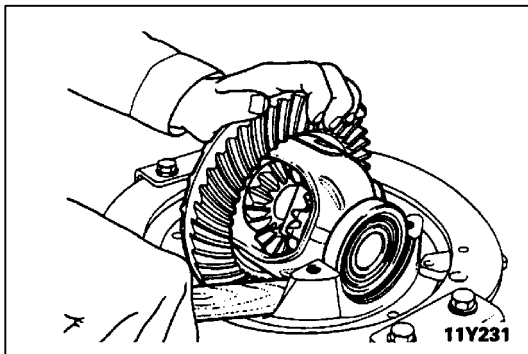

◀B▶ DIFFERENTIAL CASE ASSEMBLY REMOVAL

Use the handle of a hammer to remove the differential case assembly.

Caution

When taking out the differential case assembly, be careful not to drop and damage the side bearing outer races.

NOTE

Keep the right and left side bearings and side bearing outer race separate, so that they do not become mixed at the time of assembly.

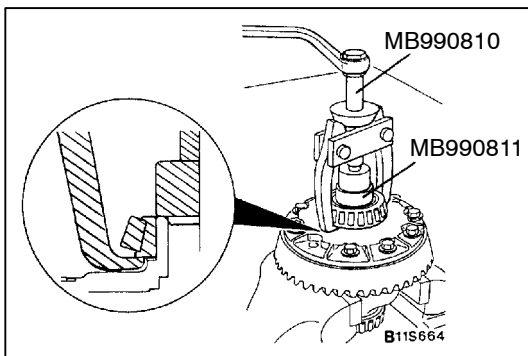

◀C▶ SIDE BEARING INNER RACE REMOVAL

Use special tools to pull out the side bearing inner race.

NOTE

Attach the prongs of special tools to the inner race of the side bearing through the openings in the differential case.

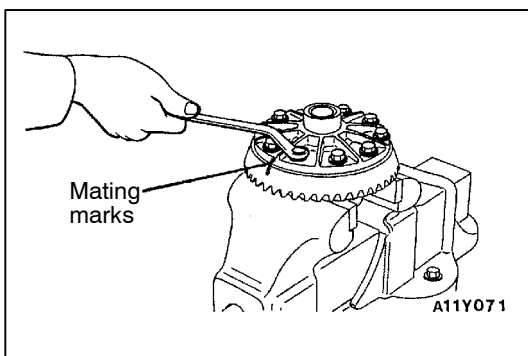

◀D▶ DRIVE GEAR REMOVAL

1. Make mating marks to the differential case and the drive gear.
2. Loosen the drive gear attaching bolts in diagonal sequence to remove the drive gear.

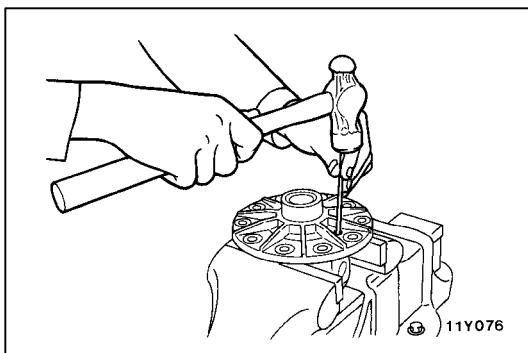

◀E▶ LOCK PIN REMOVAL

Drive out the lock pin with a punch.

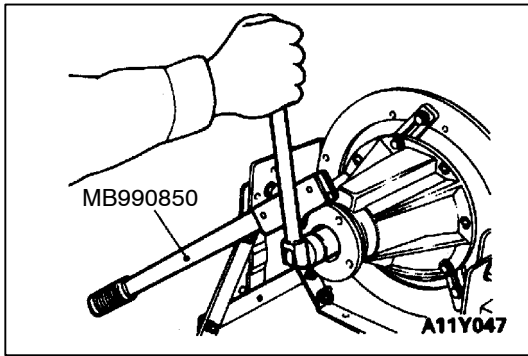

◀F▶ SELF-LOCKING NUT REMOVAL

Use special tool to hold the companion flange, and then remove the companion flange self-locking nut.

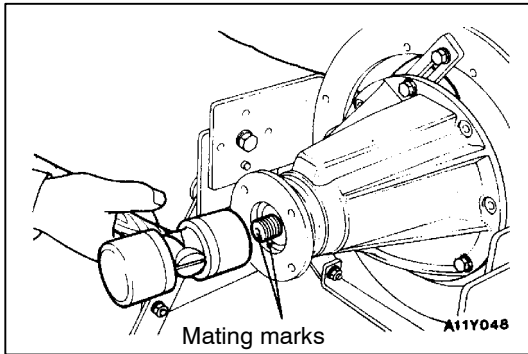

◀G▶ DRIVE PINION ASSEMBLY REMOVAL

1. Make the mating marks to the drive pinion and companion flange.

Caution

Do not make mating marks on the contact surfaces of the companion flange and propeller shaft.

2. Drive out the drive pinion together with the drive pinion spacer and drive pinion front shims.

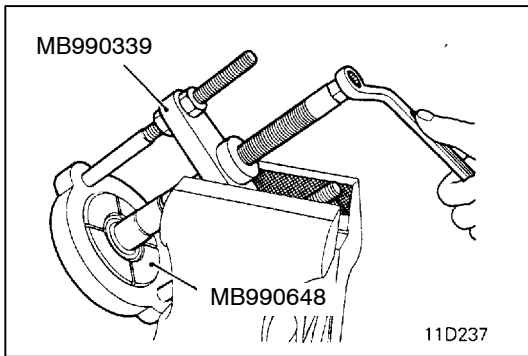

◀H▶ DRIVE PINION REAR BEARING INNER RACE REMOVAL

Use special tools to pull out the front bearing inner race.

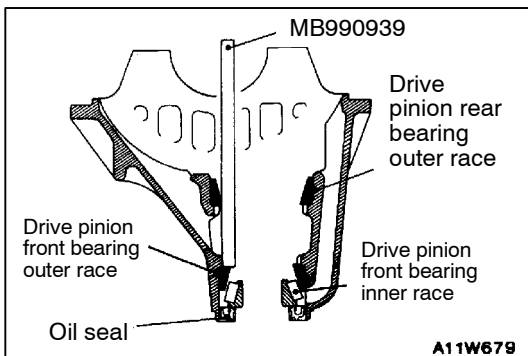

◀I▶ OIL SEAL/DRIVE PINION FRONT BEARING INNER RACE/DRIVE PINION FRONT BEARING OUTER RACE REMOVAL

Use special tool to remove drive pinion front bearing outer race.

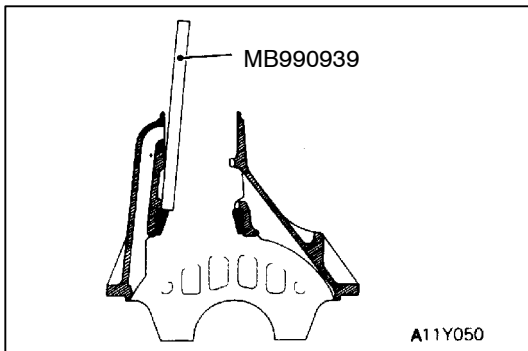

◀J▶ DRIVE PINION REAR BEARING OUTER RACE REMOVAL

Use special tool to remove the drive pinion rear bearing outer race.

REASSEMBLY

27200230173

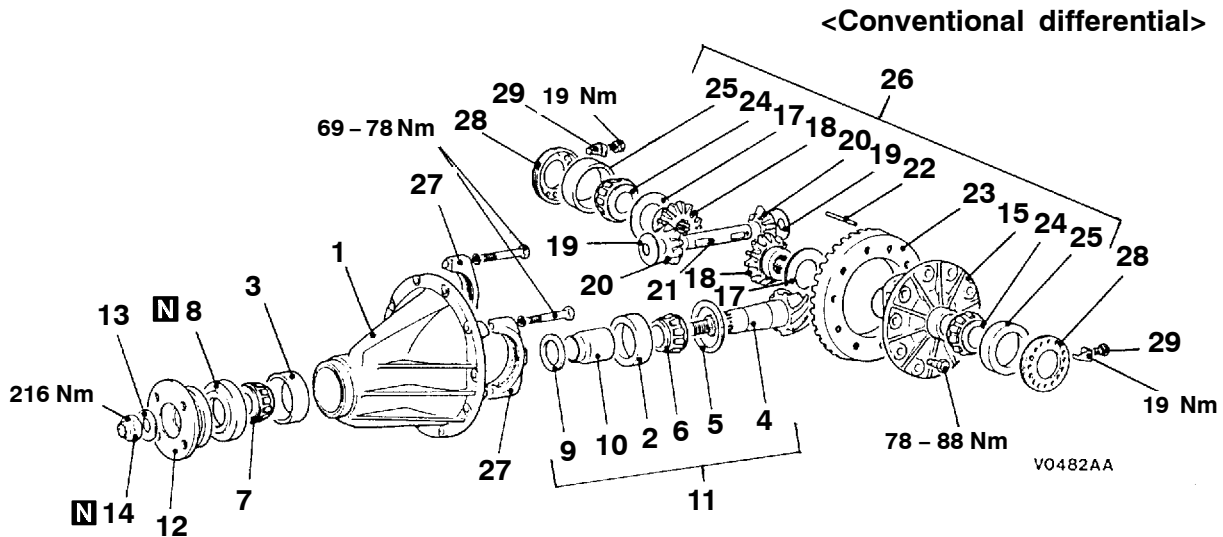

<Limited slip differential>

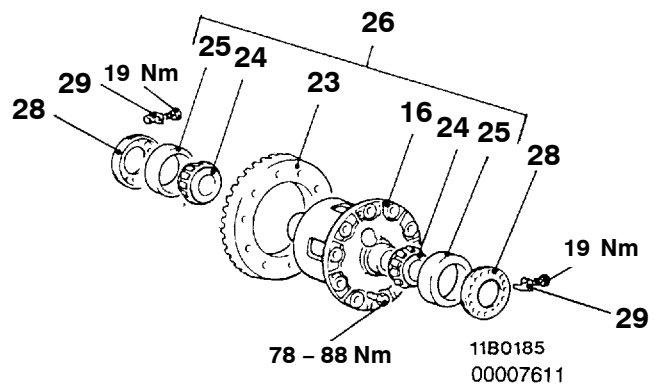
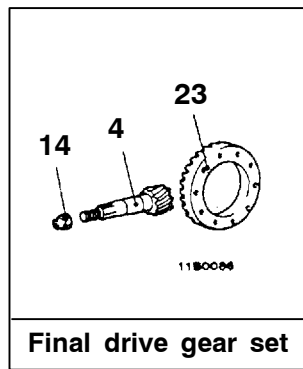
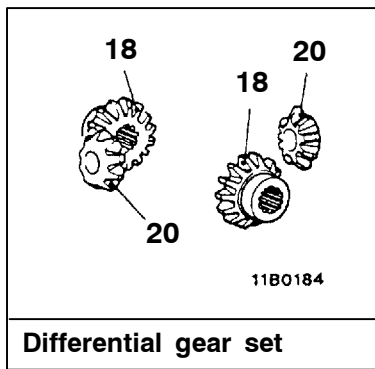

Reassembly steps

- ▶A◀ 1. Differential carrier
- ▶B◀ 2. Drive pinion rear bearing outer race
- ▶B◀ 3. Drive pinion front bearing outer race
- ▶C◀
 - Drive pinion height adjustment
- 4. Drive pinion
- 5. Drive pinion rear shim (For adjusting drive pinion height)
- ▶D◀ 6. Drive pinion rear bearing inner race
- ▶D◀
 - Drive pinion turning torque adjustment
- 7. Drive pinion front bearing inner race
- 8. Oil seal
- 9. Drive pinion front shim (For adjusting drive pinion preload)
- 10. Drive pinion spacer
- 11. Drive pinion assembly
- 12. Companion flange
- 13. Washer
- 14. Self-locking nut
- 15. Differential case
- 16. Limited slip differential case assembly
- 17. Side gear thrust spacer
- 18. Side gear
- 19. Pinion washer
- 20. Pinion gear
- ▶E◀
 - Differential gear backlash adjustment
- 21. Pinion shaft
- ▶F◀ 22. Lock pin
- ▶G◀ 23. Drive gear
- ▶H◀ 24. Side bearing inner race
- ▶H◀ 25. Side bearing outer race
- 26. Differential case assembly
- 27. Bearing cap
- ▶I◀
 - Final drive gear backlash adjustment
- ▶J◀ 28. Side bearing nut
- 29. Lock plate

Lubrication and Adhesive Points

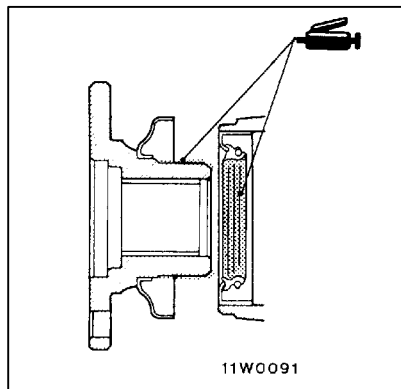

<Conventional differential>

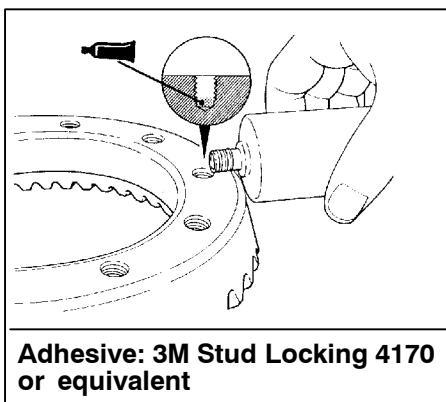
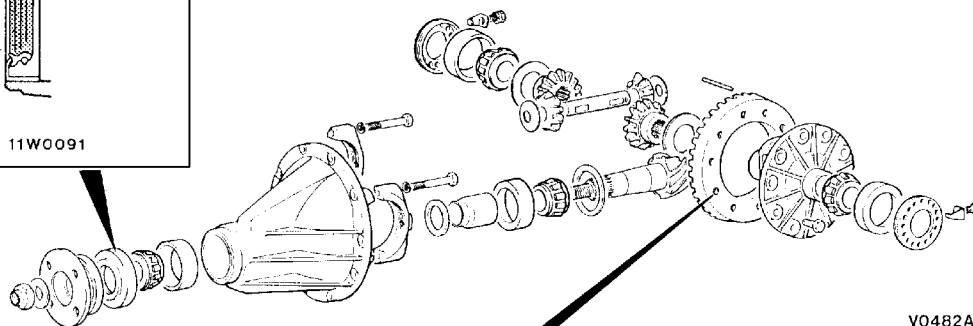

<Limited slip differential>

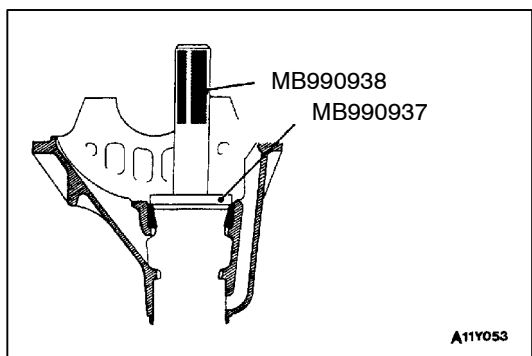
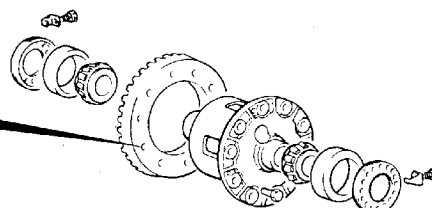

REASSEMBLY SERVICE POINTS

▶A◀ DRIVE PINION REAR BEARING OUTER RACE PRESS-FITTING

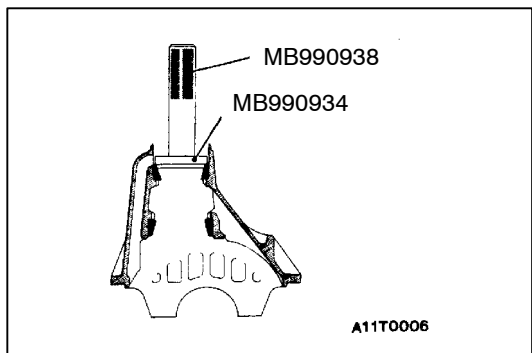

▶B◀ DRIVE PINION FRONT BEARING OUTER RACE PRESS-FITTING

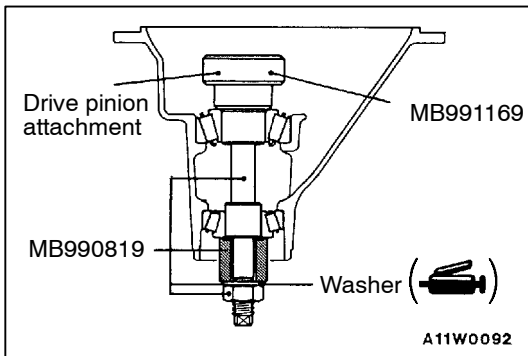

►C◄ DRIVE PINION HEIGHT ADJUSTMENT

Adjust the drive pinion height by the following procedures:

1. Apply multipurpose grease to the washer of special tool.
2. Install special tool and drive pinion front and rear bearing inner races to the gear carrier in the sequence shown in the illustration.

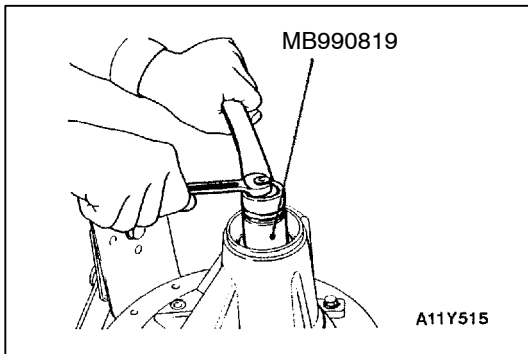

3. Tighten the nut of special tool a little at a time while measuring the turning torque of the drive pinion. Then confirm the turning torque is at the standard value.

Standard value:

Bearing type	Bearing lubrication	Turning torque
New	None (with anti-rust agent)	0.59 – 0.88 Nm
New or reuse	Gear oil applied	0.39 – 0.49 Nm

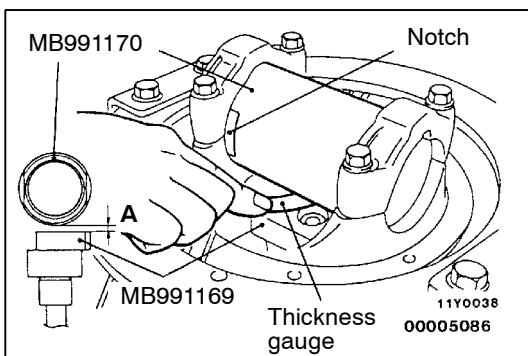
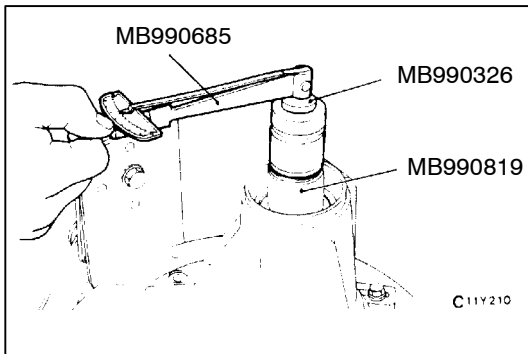

4. Clean the side bearing hub.
5. Place special tool between the side bearing hub of the gear carrier, and position the notch as shown in the illustration. Then tighten side bearing mounting bolt.
6. Use a thickness gauge to measure the clearance (A) between special tools.

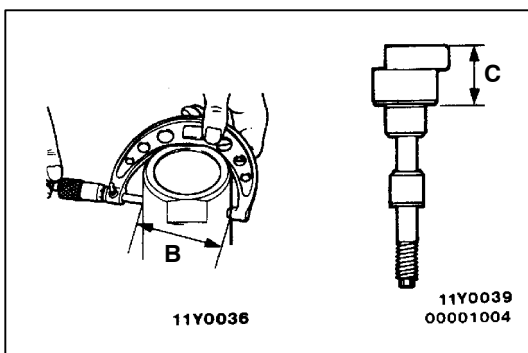

7. Remove special tools (MB991170, MB991169).
8. Use a micrometer to measure the shown dimensions (B, C) of special tools.

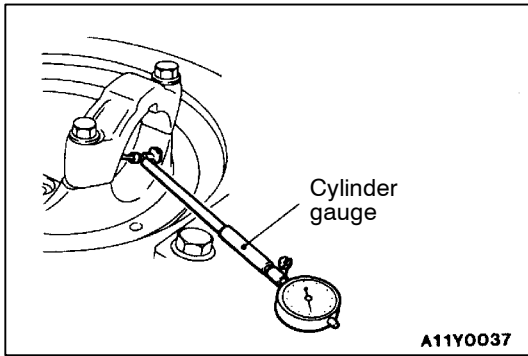

9. Install the bearing cap, and then use a cylinder gauge to measure inside diameter (D) of the bearing cap.
10. Calculate thickness (F) of the required drive pinion rear shim twice by the following formula. Select a shim which most closely matches this thickness.

$$F = A + B + C - 1/2D - E$$

E: 115.00 mm

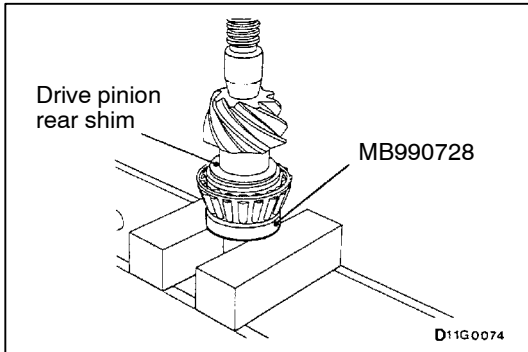

11. Fit the selected drive pinion rear shim(s) to the drive pinion, and press-fit the drive pinion rear bearing inner race by using special tool.

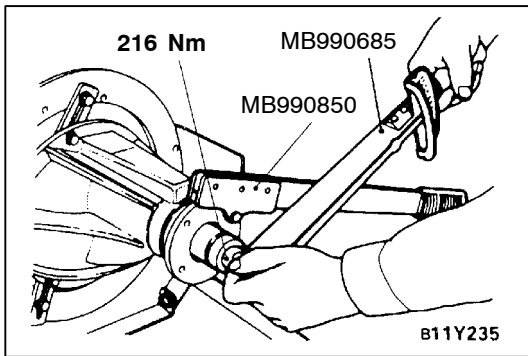

►D◄ DRIVE PINION TURNING TORQUE ADJUSTMENT

1. Insert the drive pinion into the gear carrier, and then install the following parts in sequence from the carrier rear side. Drive pinion spacer, drive pinion front shim and drive pinion front bearing inner race, companion flange.

NOTE

Do not install the oil seal.

2. Tighten the companion flange to the specified torque by using special tool.

Tightening torque: 216 Nm

3. Measure the drive pinion turning torque (without the oil seal).

Standard value:

Bearing division	Bearing lubrication	Turning torque
New	None (with anti-rust agent)	0.59 – 0.88 Nm
New or reuse	Gear oil applied	0.39 – 0.49 Nm

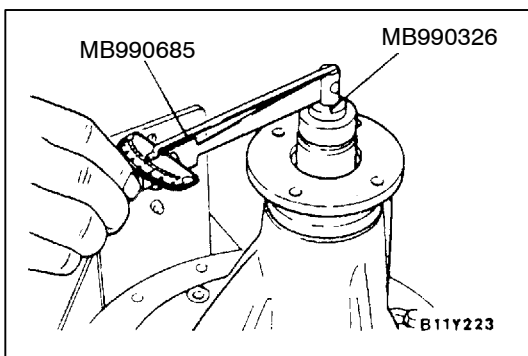

4. If the drive pinion turning torque is not within the standard value, adjust the turning torque by replacing the drive pinion front shim(s) or the drive pinion spacer.

NOTE

When selecting the drive pinion front shims, if the number of shims is large, reduce the number of shims to a minimum by selecting the drive pinion spacers.

Also, select the drive pinion spacer from the following two types.

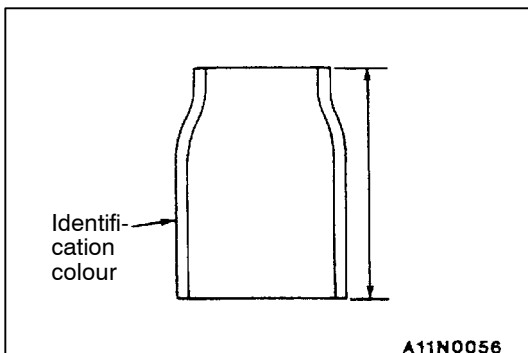

Height of drive pinion spacer mm	Identification colour
56.67	–
57.01	White

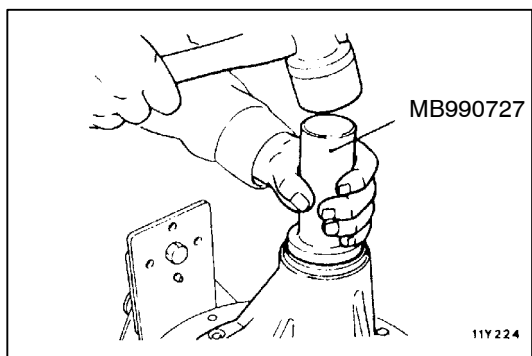

- Remove the companion flange and drive pinion again. Then insert the drive pinion front bearing inner race into the gear carrier. Use special tool to press-fit the oil seal.

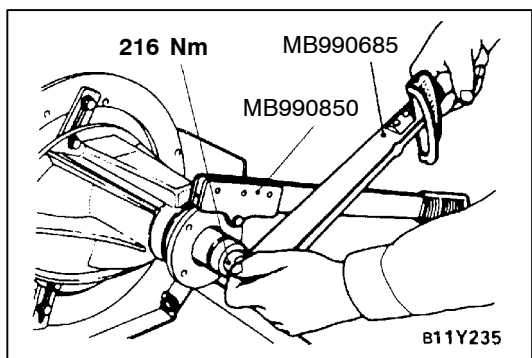

- Install the drive pinion assembly and companion flange with mating marks properly aligned. Tighten the companion flange self-locking nut to the specified torque using special tool.

Tightening torque: 216 Nm

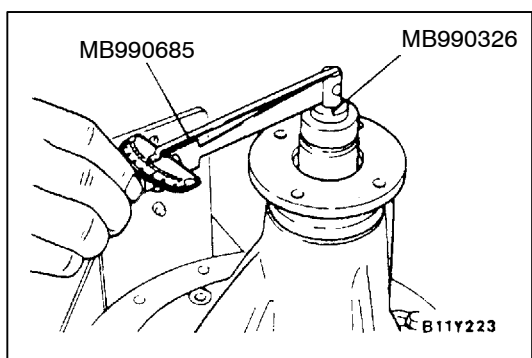

- Measure the drive pinion turning torque (with oil seal) to verify that the drive pinion turning torque complies with the standard value.

Standard value:

Bearing division	Bearing lubrication	Turning torque
New	None (with anti-rust agent)	0.83 – 1.13 Nm
New or reusing	Gear oil applied	0.64 – 0.74 Nm

- If the turning torque is not within the standard value, check the tightening torque of the companion flange self-locking nut, and the installation of the oil seal.

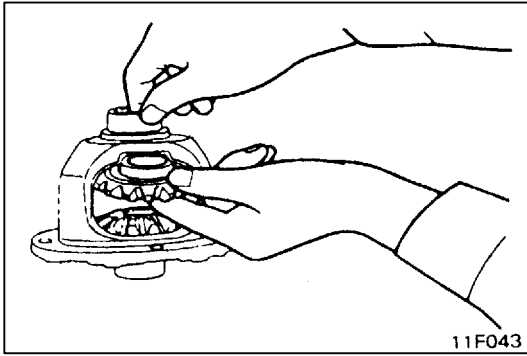

►E◄ DIFFERENTIAL GEAR BACKLASH ADJUSTMENT

Adjust the differential gear backlash by the following procedure.

1. Assemble the side gears, side gear thrust spacers, pinion gears, and pinion washers into the differential case.
2. Temporarily install the pinion shaft.

NOTE

Do not assemble the thrust block and lock pin yet.

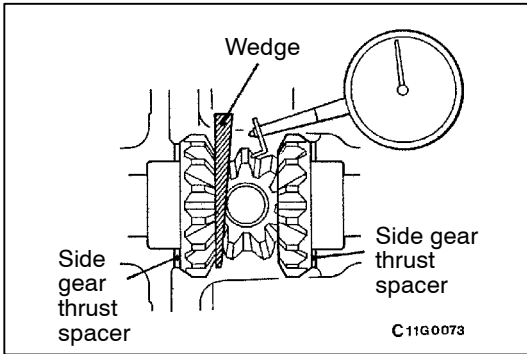

3. Insert a wedge between the side gear and the pinion shaft to lock the side gear.
4. While locking the side gear with the wedge, measure the differential gear backlash with a dial indicator on the pinion gear.

Standard value: 0 – 0.076 mm

Measure by the same procedure for the other pinion gear.

Limit: 0.2 mm

5. If the backlash exceeds the limit value, replace side bearing adjustment spacers.
6. If adjustment is not possible, replace the side gears and pinion gears as a set.
7. Check that the backlash is within the limit value and that the differential gear turns smoothly.

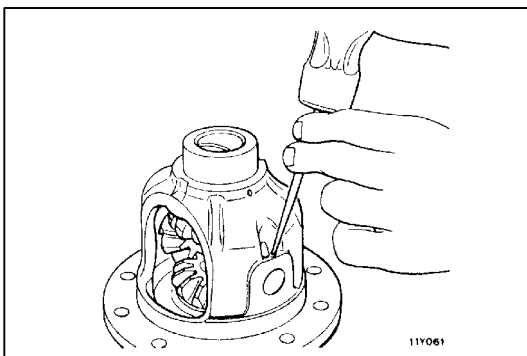

►F◄ LOCK PIN INSTALLATION

1. Align the pinion shaft lock pin hole with the differential case lock pin hole, and drive in the lock pin.
2. Stake the lock pin with a punch on both sides.

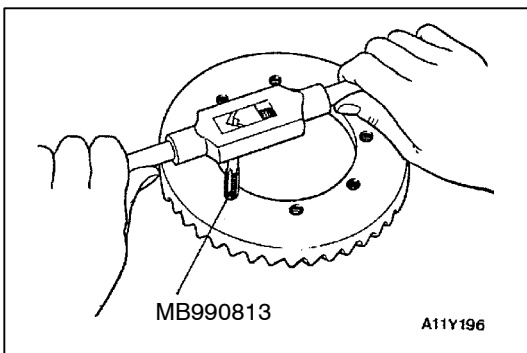

►G◄ DRIVE GEAR INSTALLATION

1. Clean the drive gear attaching bolts.
2. Remove the adhesive adhered to the threaded holes of the drive gear by turning the special tap (tap M10 x 1.25), and then clean the threaded holes by applying compressed air.

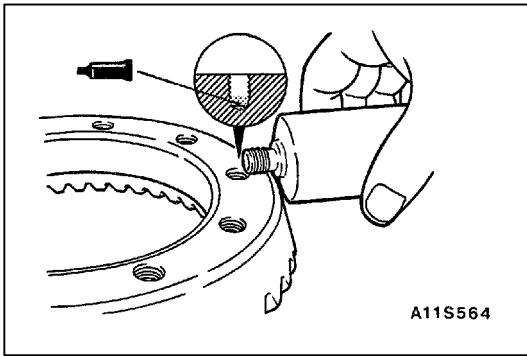

3. Apply the specified adhesive to the threaded holes of the drive gear.

Specified adhesive:
3M Stud Locking 4170 or equivalent

4. Install the drive gear onto the differential case with the mating marks properly aligned. Tighten the bolts to the specified torque in a diagonal sequence.

Tightening torque: 78 – 88 Nm

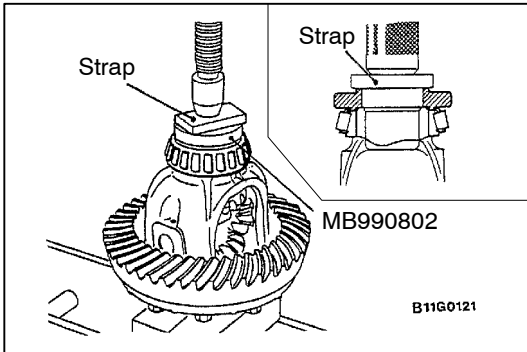

►H◄ SIDE BEARING INNER RACE INSTALLATION

Use special tool to press-fit the side bearing inner races into the differential case.

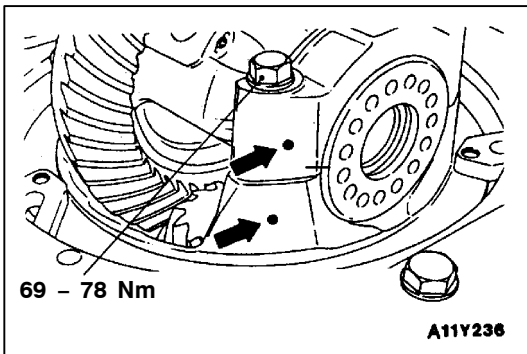

►I◄ BEARING CAP INSTALLATION

Align the mating marks on the gear carrier and the bearing cap, and then tighten the bearing cap.

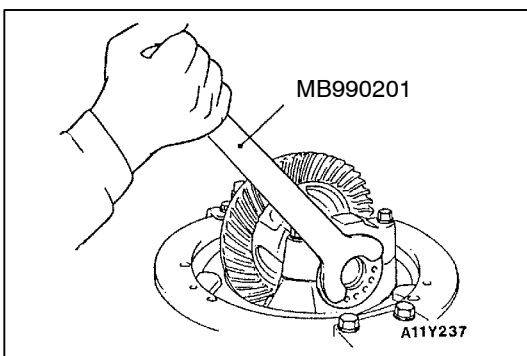

►J◄ FINAL DRIVE GEAR BACKLASH ADJUSTMENT

Adjust drive gear backlash as follows:

1. Using special tool, temporarily tighten the side bearing nut to just before preloading of the side bearing.

2. Measure the drive gear backlash.

NOTE

Measure at four points or more on the circumference of the drive gear.

Standard value: 0.13 – 0.18 mm

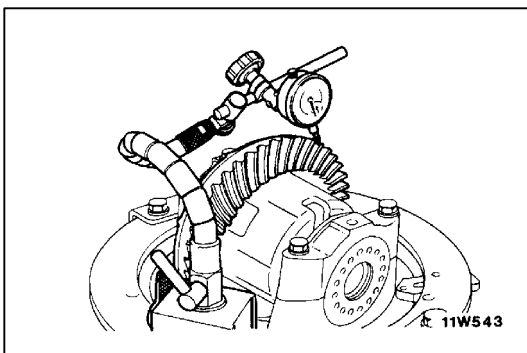

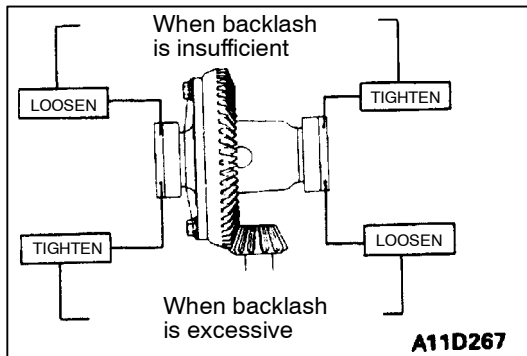

- Using special tool (MB990201), adjust the backlash to standard value by moving the side bearing nut as shown.

NOTE

First loosen the side bearing nut then tighten the side bearing nut the same amount as when it was loosened.

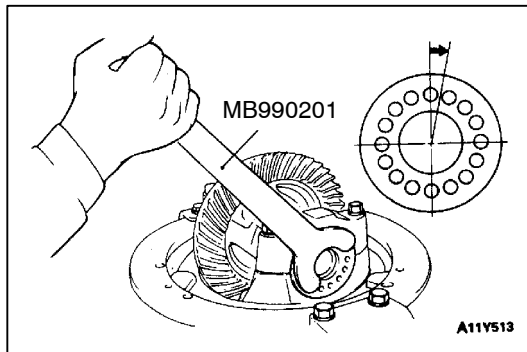

- Using special tool, to apply the preload, turn down both right and left side bearing nuts on half the distance between centers of two neighboring holes.

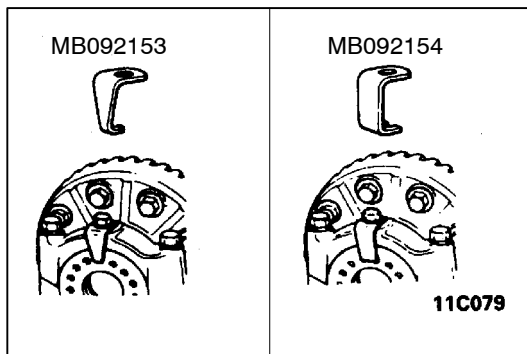

- Choose and install the lock plate (two kinds).
- Check the final drive gear tooth contact. If poor contact is evident, make adjustment. (Refer to P.27-20.)

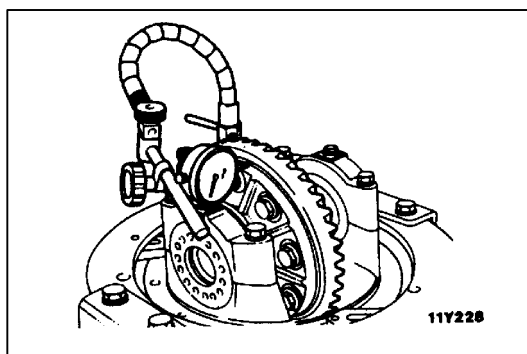

- Measure the drive gear runout.
Limit: 0.05 mm
- When drive gear runout exceeds the limit, remove the differential case and then the drive gears, moving them to different positions and reinstall them.
- If adjustment is not possible, replace the differential case or drive gear and drive pinion as a set.

WHEEL AND TYRE

CONTENTS

31109000168

GENERAL INFORMATION	2	ON-VEHICLE SERVICE	4
SERVICE SPECIFICATIONS	2	Tyre Inflation Pressure Check	4
TROUBLESHOOTING	3	Tyre Wear Check	4
		Wheel Runout Check	4
		WHEEL AND TYRE	4
		UNDERFLOOR SPARE TYRE CARRIER	5



GENERAL INFORMATION

31100010269

Both steel type and aluminium type wheels have been adopted. The type of wheel used depends on the vehicle model.

Items		Vehicles without wide fender	Vehicles with wide fender
Wheel	Type	Steel type	Aluminium type
	Size	15 x 6JJ	16 x 7JJ
	Amount of wheel offset	33	10 ± 1
	Pitch circle diameter (P.C.D.) mm	139.7	139.7
Tyre	Size	235/75 R15	245/70 R16





SERVICE SPECIFICATIONS

31100030036

Items		Limit
Tread depth of tyre mm		1.6
Wheel runout (Radial runout) mm	Steel wheel	1.2 or less
	Aluminium wheel	1.0 or less
Wheel runout (Lateral runout) mm	Steel wheel	1.2 or less
	Aluminium wheel	1.0 or less

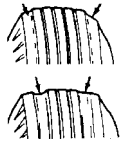
TROUBLESHOOTING

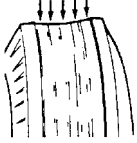
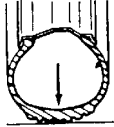
31100070083

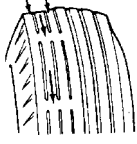
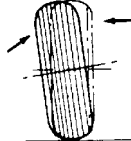
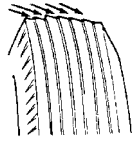
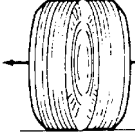
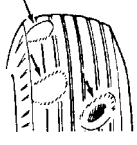
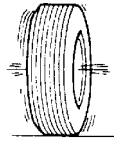
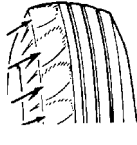
Symptom		Probable cause		Remedy	Reference page
Rapid wear at shoulders	 11X0109	Under-inflation or lack of rotation	 11X0116	Adjust the tyre pressure.	31-4.
Rapid wear at centre	 11X0110	Over-inflation or lack of rotation	 11X0117		
Cracked treads	 11X0111	Under-inflation		Adjust the tyre pressure.	31-4.
Wear on one side	 11X0112	Excessive camber	 11X0118	Inspect the camber.	Refer to GROUP 33A – On-vehicle Service.
Feathered edge	 11X0113	Incorrect toe-in	 11X0119	Adjust the toe-in.	
Bald spots	 11X0114	Unbalanced wheel	 11X0120	Adjust the imbalanced wheels.	–
Scalloped wear	 11X0115	Lack of rotation of tyres or worn or out-of-alignment suspension		Rotate the tyres and check the front suspension alignment.	Refer to GROUP 33A – On-vehicle Service.

ON-VEHICLE SERVICE

31100090034

TYRE INFLATION PRESSURE CHECK

Check the inflation pressure of the tyres. If it is not within the standard value, make the necessary adjustment.

TYRE WEAR CHECK

31100100034

Measure the tread depth of tyres.

Limit: 1.6 mm

If the remaining tread depth is less than the limit, replace the tyre.

NOTE

When the tread depth of tyres is reduced to 1.6 mm or less, wear indicators will appear.

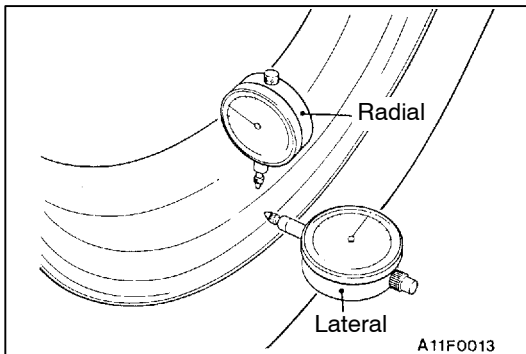
**WHEEL RUNOUT CHECK**

31100110143

Jack up the vehicle so that the wheels are clear of the floor. While slowly turning the wheel, measure wheel runout with a dial indicator.

Limit:

Item	Steel wheel	Aluminium wheel
Radial runout mm	1.2	1.0
Lateral runout mm	1.2	1.0

If wheel runout exceeds the limit, replace the wheel.

WHEEL AND TYRE

31100130156

INSTALLATION SERVICE POINT

Tighten the wheel nut to the specified torque.

Tightening torque:

Steel wheel 118 – 137 Nm

Aluminium wheel 98 – 118 Nm

UNDERFLOOR SPARE TYRE CARRIER

31100180014

REMOVAL AND INSTALLATION

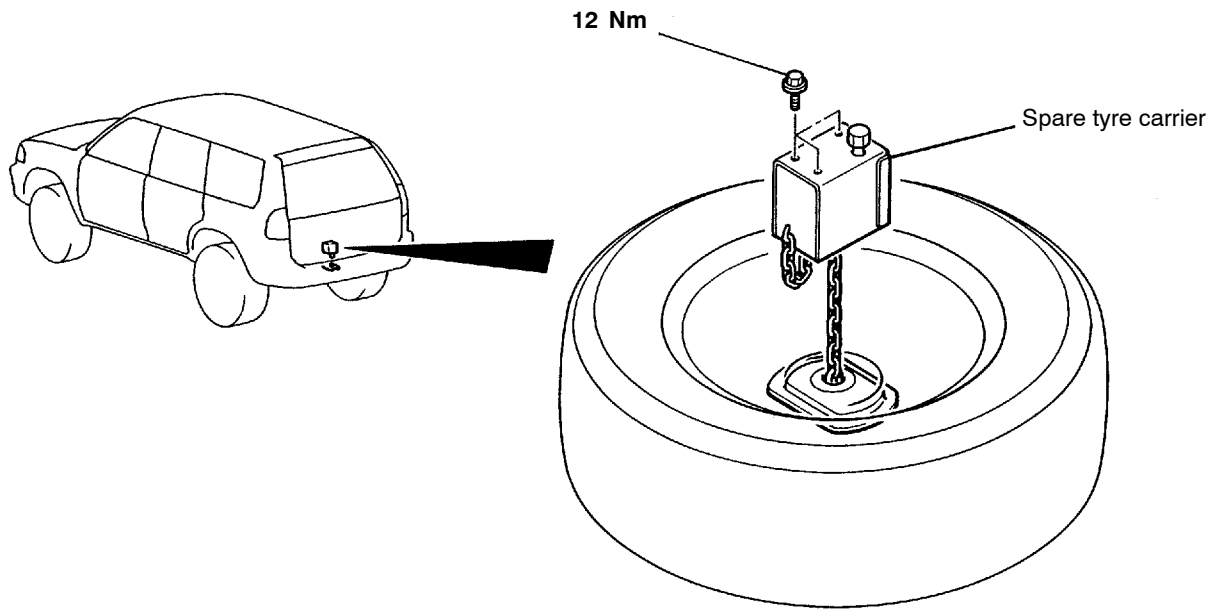

AT0028AA

NOTES

POWER PLANT MOUNT

CONTENTS

32109000226

GENERAL INFORMATION	2	REAR ENGINE MOUNTING	5
SPECIAL TOOL	3	FRONT DIFFERENTIAL MOUNTING	7
FRONT ENGINE MOUNTING	4	FRONT SUSPENSION CROSSMEMBER	9



GENERAL INFORMATION

32100010204

The engine and transmission assembly is supported at four points, where insulators are used. (Two points for the engine, one point for the transmission, and one point for the transfer.)

The differential assembly is supported at three points, where mounting brackets and mounting rubber pieces are used.

The front suspension crossmember is bolted to the frame and supports the front differential.

The number 2 crossmember is bolted to the frame and supports the transmission and transfer.

CONSTRUCTION DIAGRAM

Engine mount

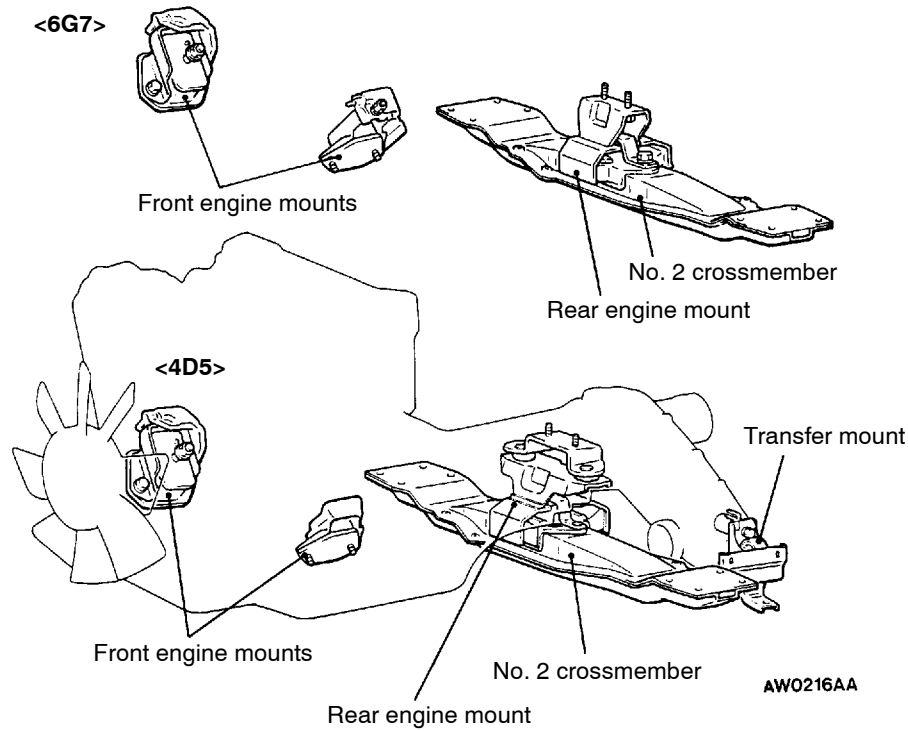

Front differential mount

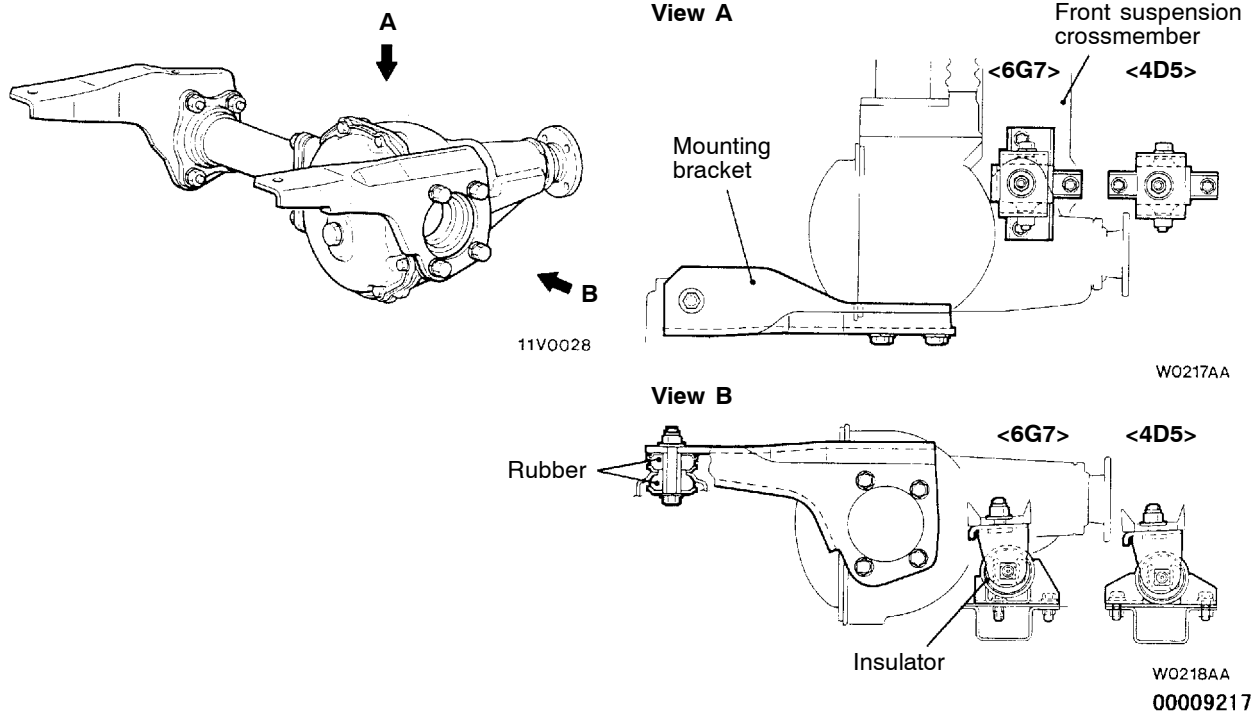

SPECIAL TOOL

32100060193

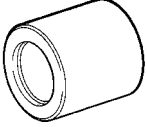
Tool	Number	Name	Use
	MB991118	Inner arm bush remover & installer	Front differential mounting insulator replacement

FRONT ENGINE MOUNTING

REMOVAL AND INSTALLATION

Caution

*: Indicates parts which should be initially tightened, and then fully tightened after placing the vehicle horizontally and loading the full weight of the engine on the vehicle body.

Pre-removal and Post-installation Operation

- Air Cleaner Assembly Removal and Installation (Refer to GROUP 15 – Air Cleaner.)
- Under Skid Plate and Under Cover Removal and Installation

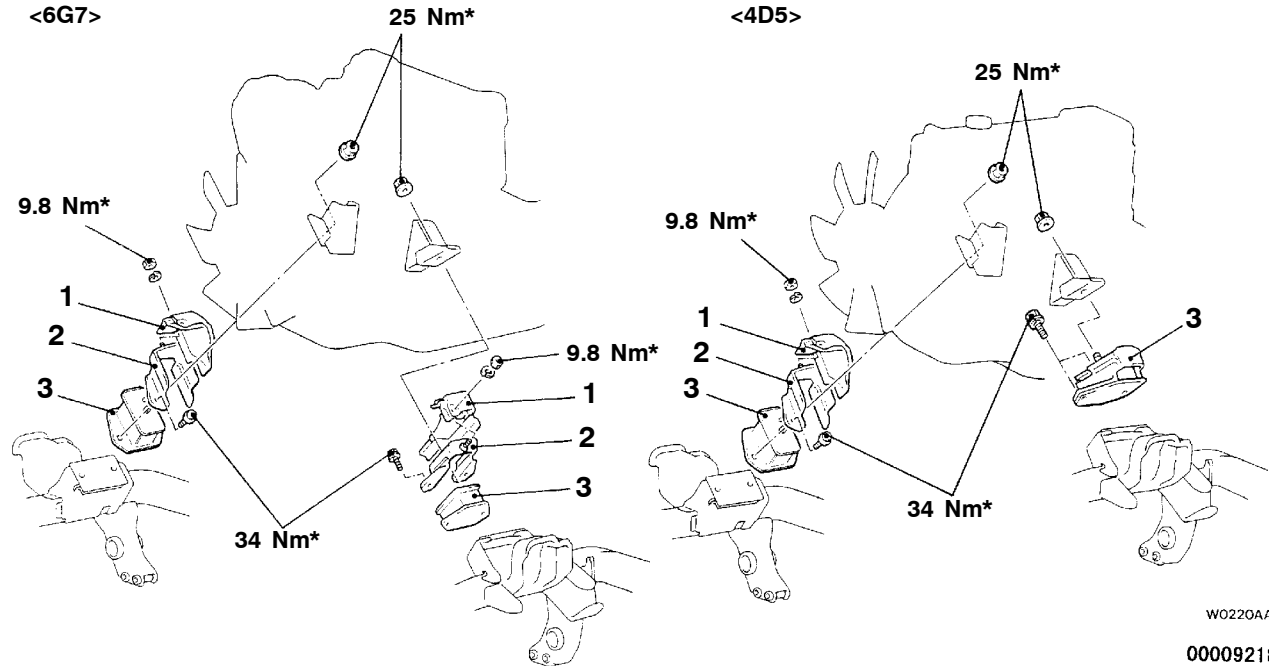

W0219AA

W0220AA

00009218

Removal steps

- Engine assembly removal (Refer to Group 11 – engine assembly.)
- 1. Heat protector

- ▶A◀ 2. Front insulator stopper
- ▶A◀ 3. Front engine support insulator

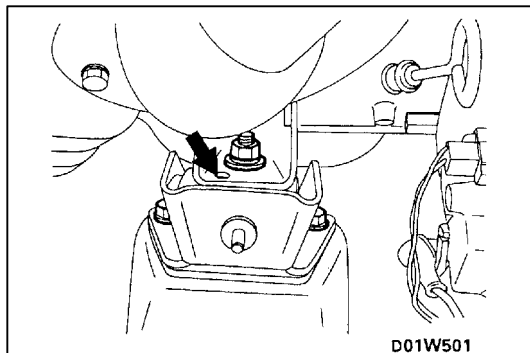

INSTALLATION SERVICE POINT

▶A◀ FRONT ENGINE SUPPORT INSULATOR INSTALLATION

Make sure that the locating boss and hole are in alignment.

Caution

Do not distort rubber portions, and never stain rubber portions with fuel or oil.

INSPECTION

32100120075

- Check the insulators for cracks, separation or deformation.
- Check the front insulator stoppers for deformation.

REAR ENGINE MOUNTING

32100110409

REMOVAL AND INSTALLATION

Caution

*: Indicates parts which should be initially tightened, and then fully tightened after placing the vehicle horizontally and loading the full weight of the engine on the vehicle body.

- Pre-removal and Post-installation Operation**
- Transfer Case Protector Removal and Installation

<6G7>

<4D5>

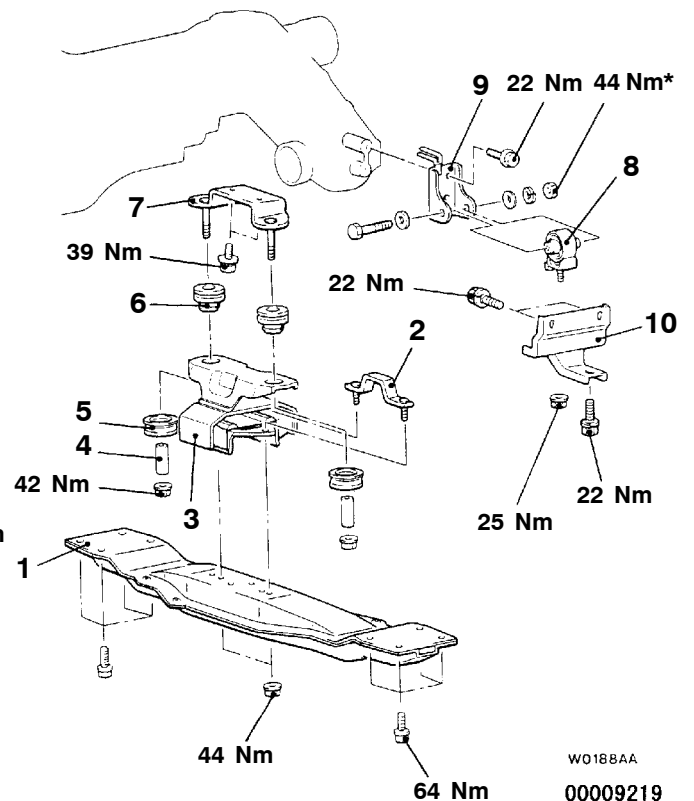
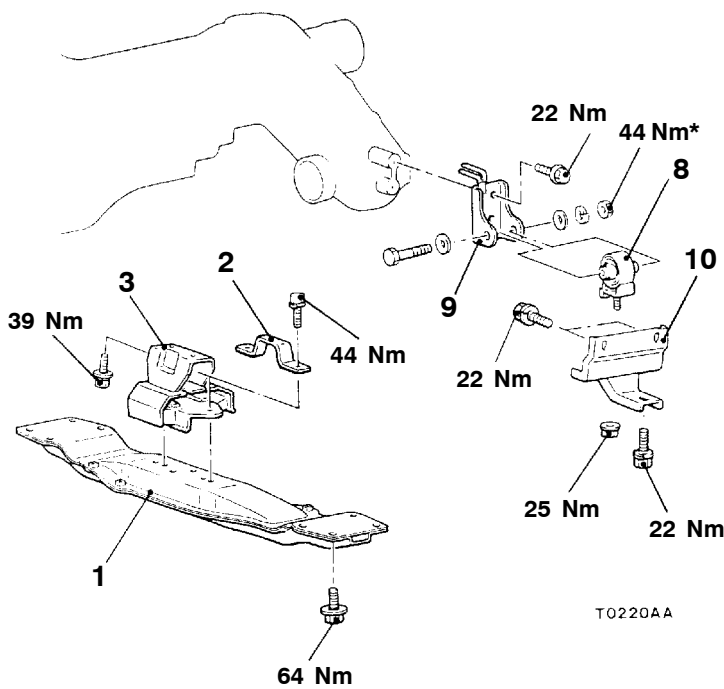

Removal steps

- Hold the transmission with a transmission jack.
1. No.2 crossmember
 2. Stopper
 3. Rear engine support insulator
 4. Collar <4D5>



5. Lower bush <4D5>
6. Upper bush <4D5>
7. Transmission mounting plate <4D5>
8. Transfer roll stopper
9. Transfer mounting bracket
10. Transfer support bracket

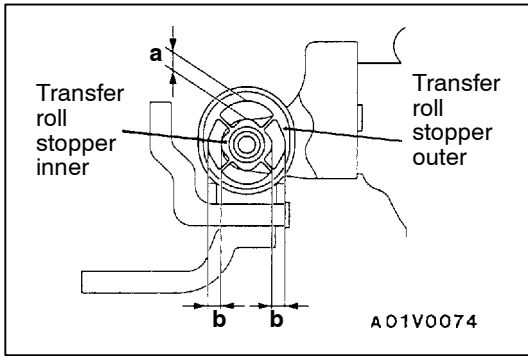

INSTALLATION SERVICE POINT

▶A◀ TRANSFER ROLL STOPPER INSTALLATION

1. Tighten the transfer roll stopper provisionally.
2. Make the engine and transmission assembly rest on the engine mount.
3. Tighten the transfer roll stoppers inner and outer finally so that the clearance (a) between the two are at approx. 10 mm
4. Check that the right and left clearances (b) between the stoppers are equal.
5. Check that the clearances (c) between the transfer roll stopper and transfer mounting bracket are equal.

NOTE

A new transfer roll stopper consists of one part, but will separate into outer and inner part during use. This is normal.

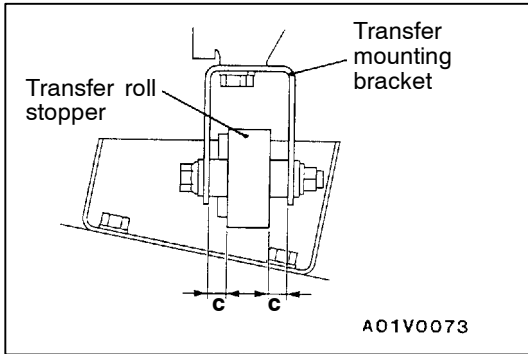

INSPECTION

32100120167

- Check the insulators for cracks, separation or deformation.
- Check the transfer mounting bracket for deformation or corrosion.
- Check the transfer support bracket for deformation or corrosion.
- Check the No. 2 crossmember for deformation or corrosion.

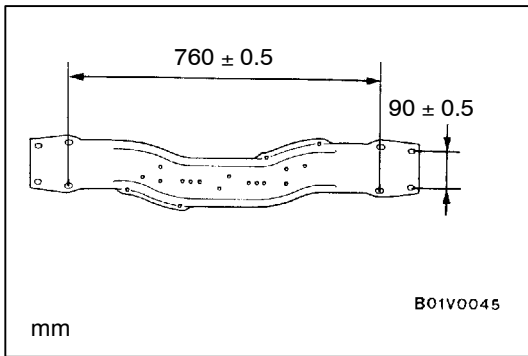

FRONT DIFFERENTIAL MOUNTING

32100170100

REMOVAL AND INSTALLATION

Pre-removal and Post-installation Operation

- Under Skid Plate and Under Cover Removal and Installation

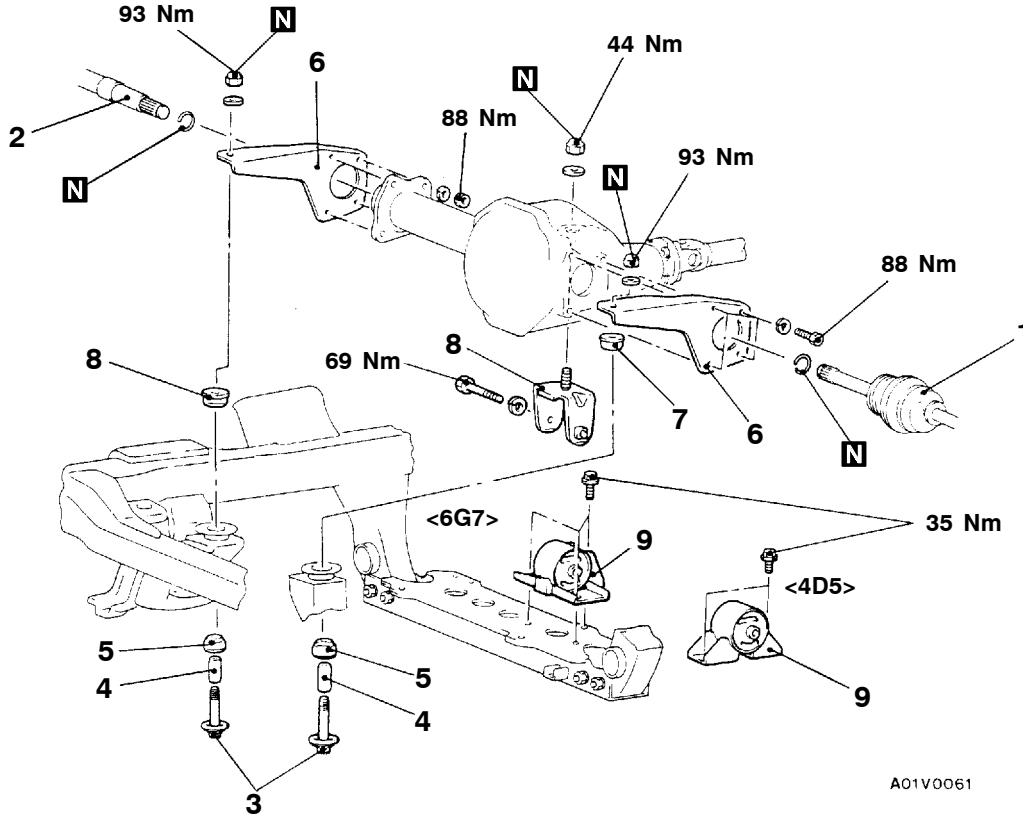

A01V0061

Removal steps

- Hold the front differential with a transmission jack.
1. Drive shaft (Refer to Group 26 – drive shaft.)
 2. Inner shaft (Refer to Group 26 – inner shaft.)
 3. Pin

4. Spacer
5. Differential mounting rubber B
6. Differential mounting bracket
7. Differential mounting rubber A
8. Differential support bracket
9. Differential mounting bracket

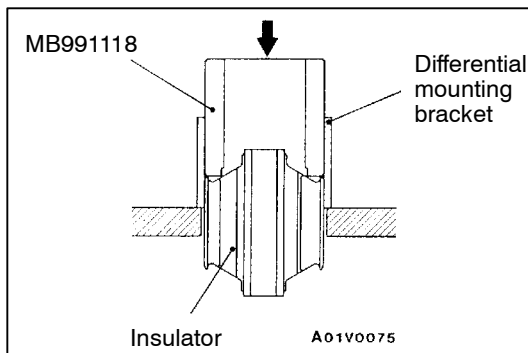

FRONT DIFFERENTIAL MOUNTING INSULATOR REPLACEMENT

1. Use special tool to press-fit and remove the insulator.

A01V0075

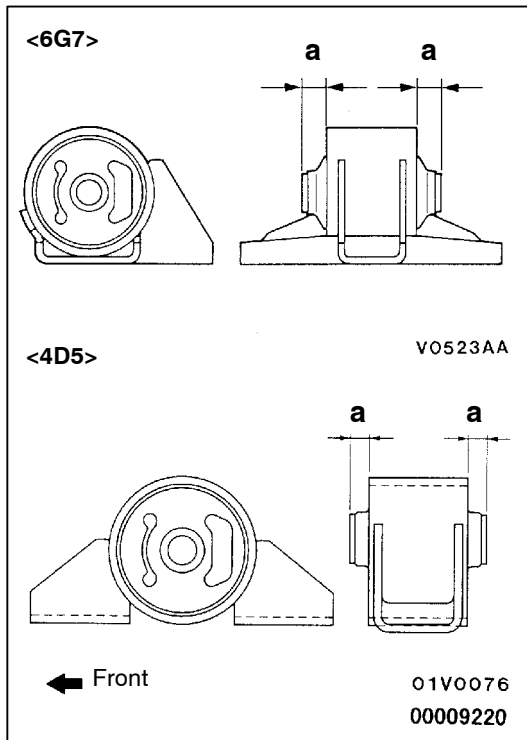

2. Install the insulator in the direction shown in the figure so that the projection lengths (a) are equal.

INSPECTION

32100180028

- Check the differential mounting brackets for deformation and damage.
- Check the differential support bracket for deformation and damage.
- Check the insulators for cracks, separation or deformation.
- Check the differential mounting rubber for cracks and damage.

FRONT SUSPENSION CROSSMEMBER

32100350030

REMOVAL AND INSTALLATION

Pre-removal and Post-installation Operation

- Under Cover Removal and Installation

<6G7>

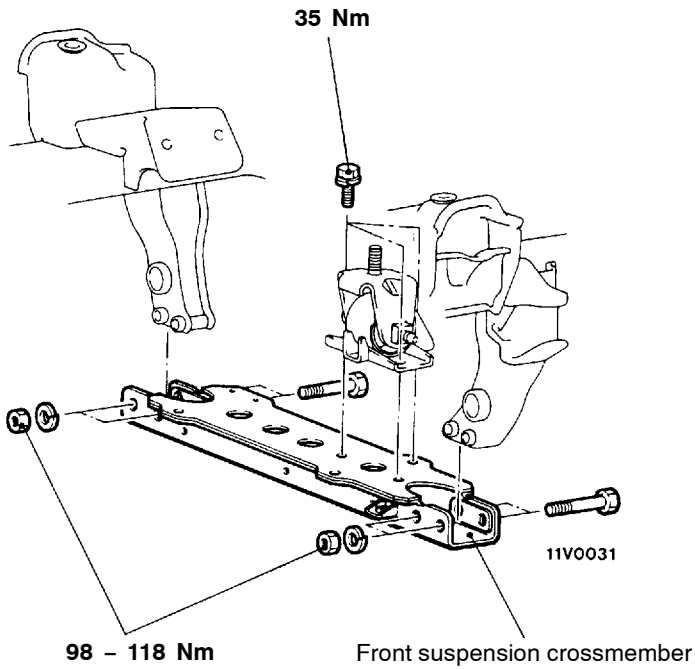

<4D5>

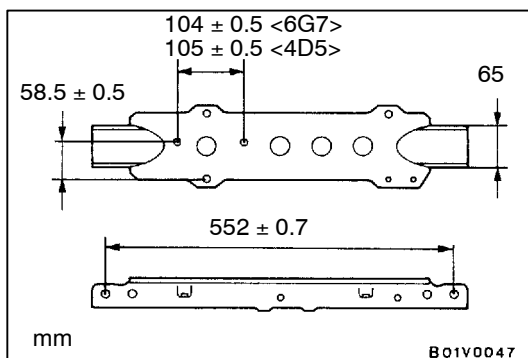
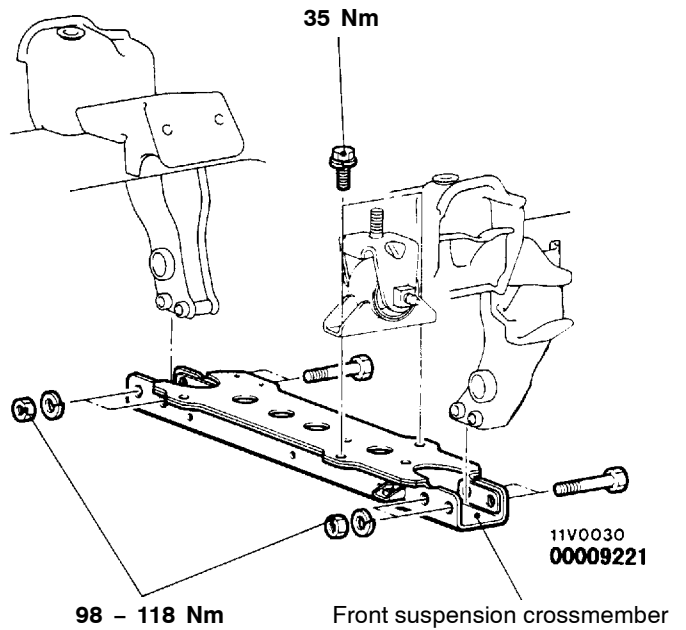

INSPECTION

32100360026

- Check the crossmembers for cracks or damage.
- Check that the crossmembers measure as illustrated.

NOTES

FRONT SUSPENSION

CONTENTS

33209000202

GENERAL INFORMATION	2	ON-VEHICLE SERVICE	4
SERVICE SPECIFICATIONS	2	Front Wheel Alignment Check and Adjustment	4
SEALANTS	3	Ball Joint Dust Cover Check	6
SPECIAL TOOLS	3	SHOCK ABSORBER AND UPPER ARM	7
		LOWER ARM AND TORSION BAR	11
		STABILIZER BAR	15



GENERAL INFORMATION

33200010259

The front suspension is an independent suspension having the double wishbone combined with the torsion bar spring.

TORSION BAR

Items	Specifications
Length x O.D. mm	1,308 x 27

CONSTRUCTION DIAGRAM

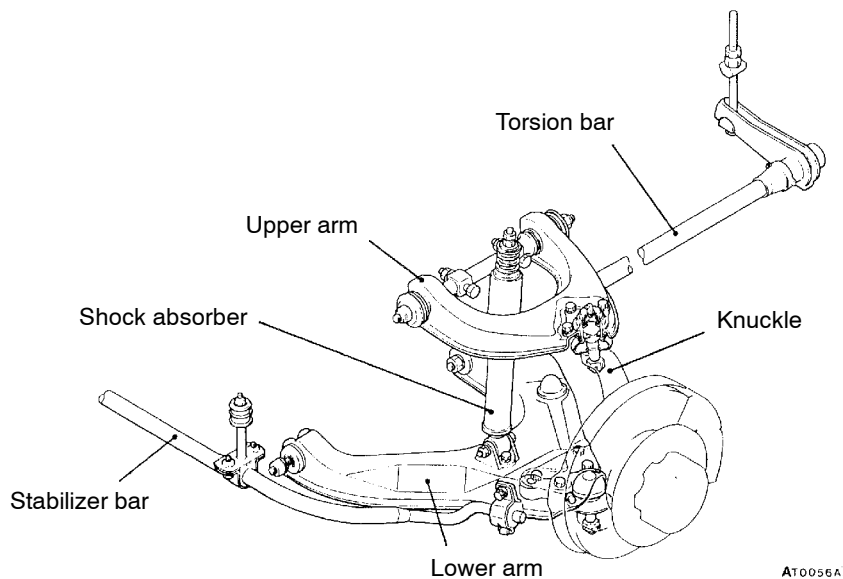

SERVICE SPECIFICATIONS

33200030156

Items	Standard value	Limit
Toe-in	At the centre of tyre thread mm	0 – 7
	Toe-angle (per wheel)	0° – 0°16'
Toe-out angle on turns (inner wheel when outer wheel at 20°)	21°18'	–
Camber	0°40' ± 30' (Difference between right and left within 30')	–
Caster	2°40' ± 1°00' (Difference between right and left within 30')	–
Kingpin angle	14°50'	–
Shock absorber attaching dimension mm	1 – 2	–
Upper arm ball joint starting torque Nm	0.8 – 3.4	–
Lower arm ball joint end play mm	–	0.3
Stabilizer link assembly attaching dimension mm	6 – 8	–

SEALANTS

33200050022

Item	Specified sealant
Upper ball joint dust cover to upper ball joint groove	3M ATD Part No.8661 or equivalent
Stopper bolt	3M Stud Locking Part No.4170 or equivalent

SPECIAL TOOLS

33200060148

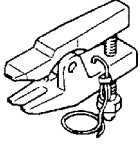
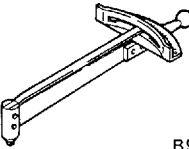
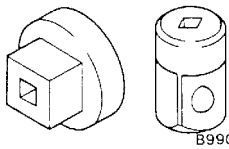
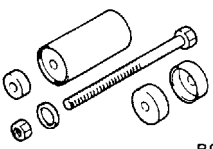
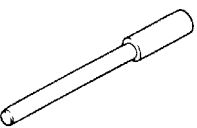
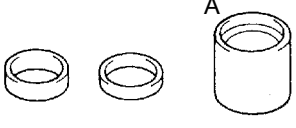
Tool	Number	Name	Use
 B991113	MB991113 or MB990635	Steering linkage puller	Upper or lower arm ball joint disconnection
 B990968	MB990968	Torque wrench	Upper arm ball joint rotation torque measurement
 B990326	MB990326	Preload socket	
 B991522	MB991522	Torsion bar bushing remover and installer	Lower arm bushing (A) removal and press-fitting
 B990883	MB990883	Rear suspension bushing arbor	Lower arm bushing (B) removal and press-fitting
 B990957	MB990957 A: MB990971	Lower arm bushing remover and installer A: Base	

ON-VEHICLE SERVICE

33100090274

FRONT WHEEL ALIGNMENT CHECK AND ADJUSTMENT

Measure the wheel alignment with the vehicle parked on a level surface.

The front suspension, steering system, and wheels should be serviced to normal condition prior to measurement of wheel alignment.

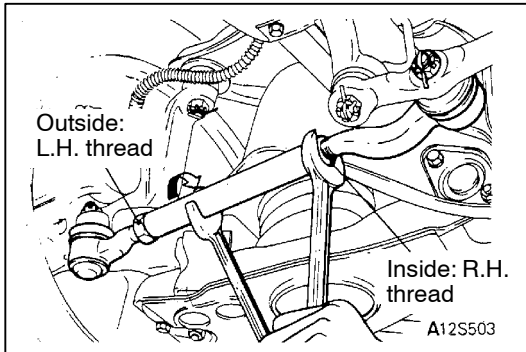
**TOE-IN****Standard value:**

At the centre of tyre tread 0 – 7 mm

Toe angle (per wheel) 0° – 0°16'

1. If the toe-in is not within the standard value, adjust the toe-in by turning the left and right tie rod turnbuckles by the same amount (in opposite directions).

Caution

- (1) **Take care when turning the tie rod end's outer side, as the threads are reversed.**
- (2) **Make sure that the left/right difference of the tie rod does not exceed 5 mm.**

NOTE

The toe will move out as the left turnbuckle is turned toward the front of the vehicle and the right turnbuckle is turned toward the rear of the vehicle.

2. Use a turning radius gauge to check that the steering angle is at the standard value. (Refer to GROUP 37A – On-vehicle Service.)

TOE-OUT ANGLE ON TURNS

To check the steering linkage, especially after the vehicle has been involved in an accident or if an accident is presumed, it is advisable to check the toe-out angle on turns in addition to the wheel alignment.

Conduct this test on the left turn as well as on the right turn.

Standard value:

21°18' (inner wheel when outer wheel at 20°)

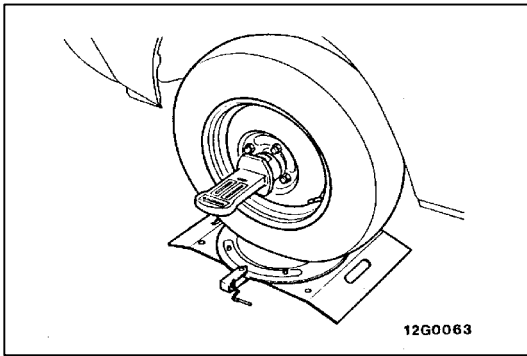

CAMBER AND CASTER

Standard value:

Camber $0^{\circ}40' \pm 30'$ (Difference between right and left within 30')

Caster $2^{\circ}40' \pm 1^{\circ}00'$ (Difference between right and left within 30')

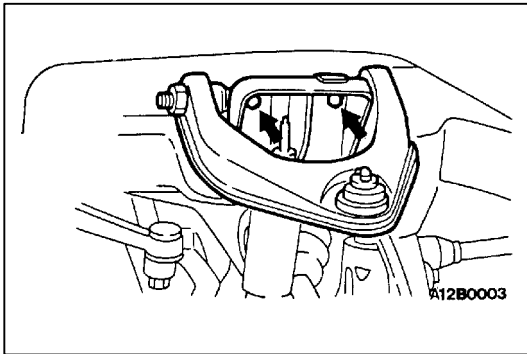

If the standard value is not obtained, make adjustment by the following procedure.

1. Loosen the upper arm mounting bolts and nuts.

NOTE

Remove the shock absorber mounting nut and lock nut, compress the shock absorber and loosen the upper arm mounting bolts and nuts.

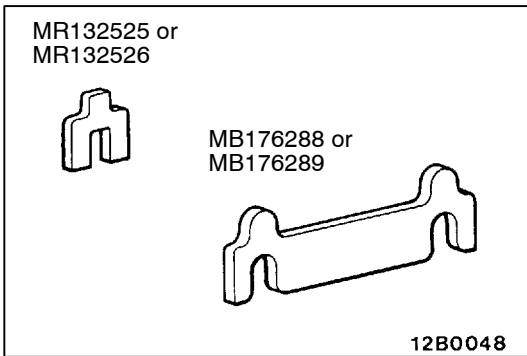

2. Increase or decrease shims between upper arm shaft and crossmember to adjust the camber and caster. (Refer to Charts for Shim Increase or Decrease.)

Caution

(1) Difference in shim thickness between front and rear must be 4 mm or less.

(2) Do not use 4 or more shims at one location.

Adjustment of shim	
Part number	Thickness mm
MR132525	1
MR132526	2
MB176288 (Front shim integral with rear shim)	1
MB176289 (Front shim integral with rear shim)	2

Charts for Shim Increase or Decrease

HOW TO USE CHARTS

These charts show how shims are added to or removed from existing shims.

EXAMPLE

To decrease camber by 30' and caster by 40', increase combined front side shim thickness by 3 mm and increase combined rear side shim thickness by 2 mm.

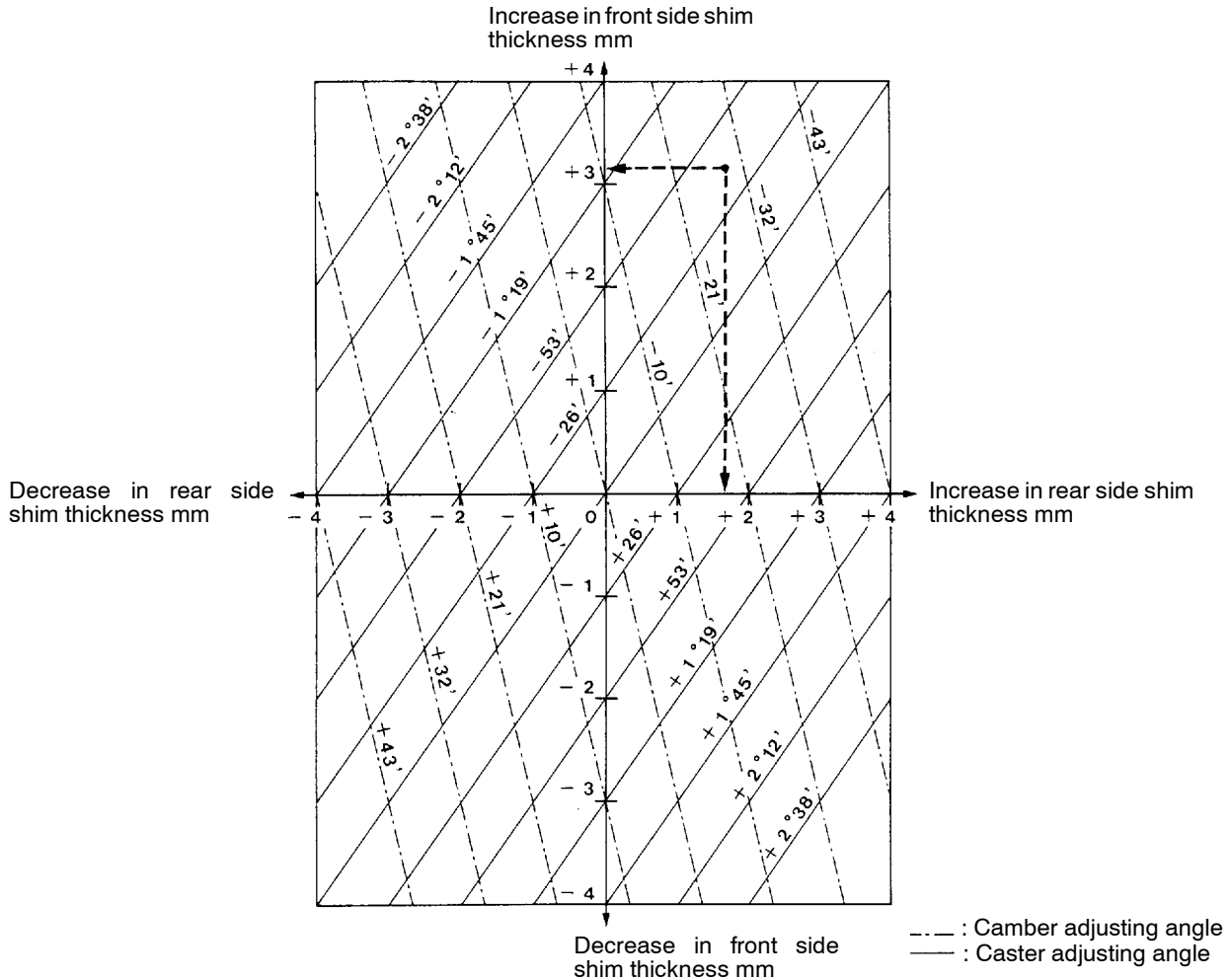

12V0034

KINGPIN INCLINATION

33200860106

Standard value: 14°50'

BALL JOINT DUST COVER CHECK

1. Check the dust cover for cracks or damage by pushing it with finger.
2. If the dust cover is cracked or damaged, replace lower arm ball joint assembly or upper arm ball joint assembly.

NOTE

Cracks or damage of the dust cover may cause damage of the ball joint.

SHOCK ABSORBER AND UPPER ARM

33200250118

REMOVAL AND INSTALLATION

Caution

*: Indicates parts which should be temporarily tightened, and then fully tightened with the vehicle on the ground in an unladen condition.

Pre-removal Operation

- Brake Fluid Draining

Post-installation Operation

- Press the dust cover with a finger to check whether the dust cover is cracked or damaged.
- Brake Fluid Supplying
- Brake Line Bleeding (Refer to GROUP 35A – On-vehicle Service.)
- Front Wheel Alignment Check and Adjustment (Refer to P.33A-4.)

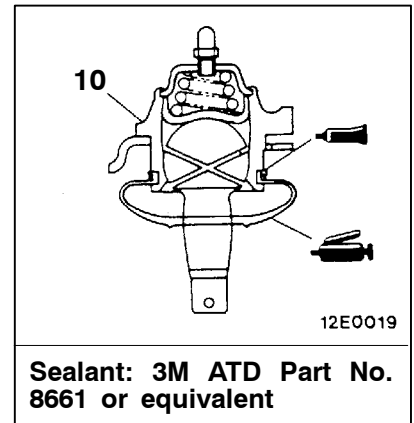
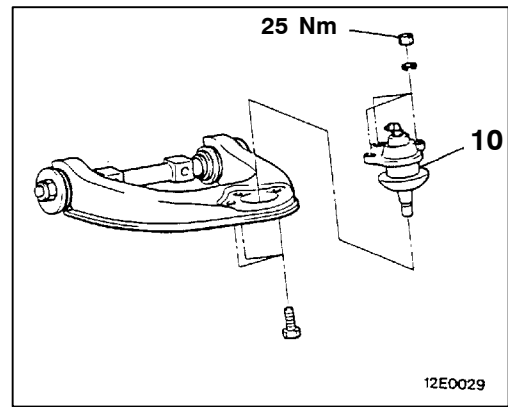
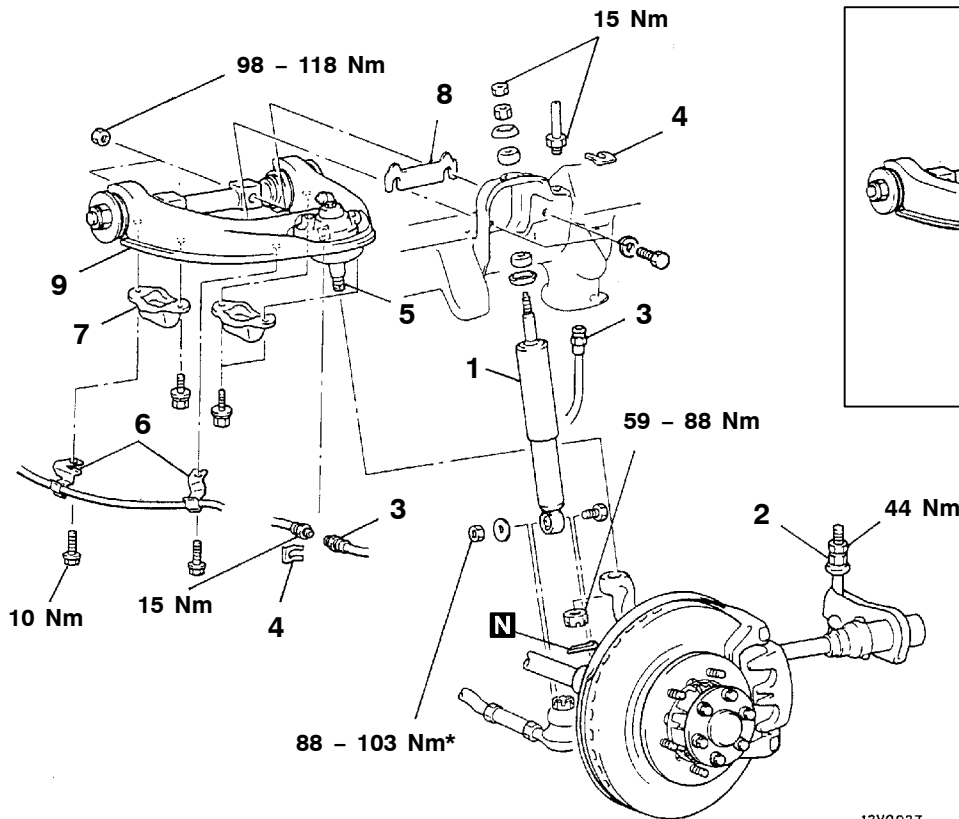

12V0027
00006196

Removal steps

- ▶D◀ 1. Shock absorber
- ▶C◀ • Bump stopper and bump stopper bracket clearance adjustment
- ◀A▶ 2. Rear anchor arm adjusting nut
- 3. Brake hose connection
- ◀B▶ 4. Hose clip
- 5. Upper arm ball joint connection

- ▶B◀ 6. Speed sensor bracket <vehicles with ABS>
- ▶A▶ 7. Rebound stopper
- 8. Shims
- 9. Upper arm
- 10. Upper arm ball joint assembly

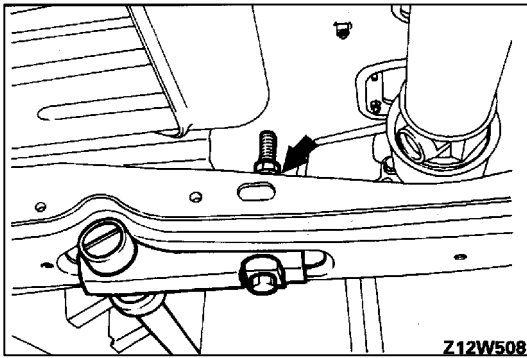

REMOVAL SERVICE POINTS

◀A▶ REAR ANCHOR ARM ADJUSTING NUT LOOSENING

Loosen the anchor arm bolt of the torsion bar all the way.

Caution

When the rear anchor arm adjusting nut is loosened, use a jack to support the lower arm of the side to be loosened.

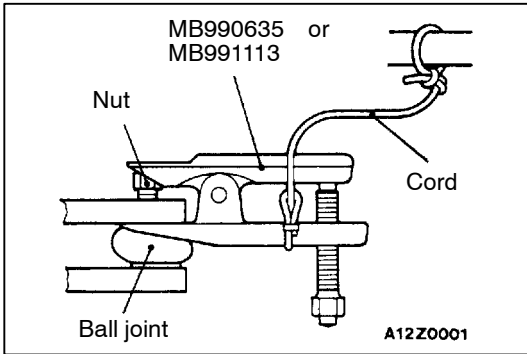

◀B▶ UPPER ARM BALL JOINT DISCONNECTION

Use special tools to disconnect the upper arm ball joint from the knuckle.

Caution

1. Support special tool with a cord, etc. to prevent it from coming off.
2. Only loosen the mounting nut, do not remove it from the ball joint.

◀C▶ SHIMS REMOVAL

NOTE

The camber and caster adjustment shims should be kept for use during assembly.

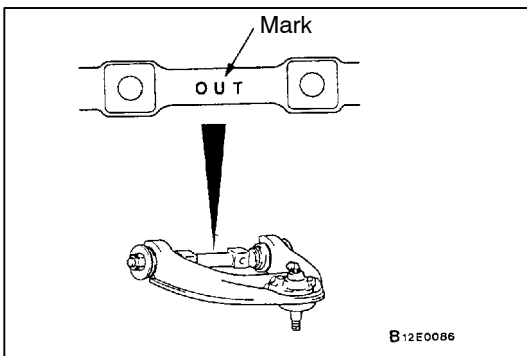

INSTALLATION SERVICE POINTS

▶A▶ UPPER ARM INSTALLATION

Install the upper arm so that the "OUT" mark on the upper arm shaft is facing toward the outside of the vehicle.

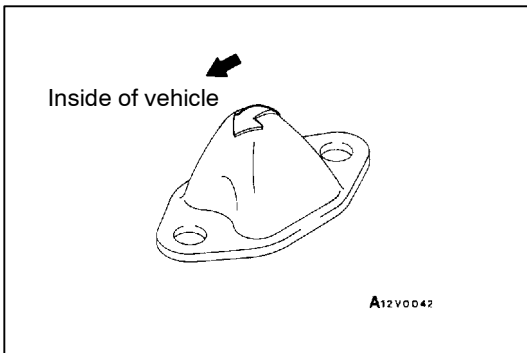

▶B▶ REBOUND STOPPER INSTALLATION

Install the rebound stopper so that its arrow faces inside of the vehicle.

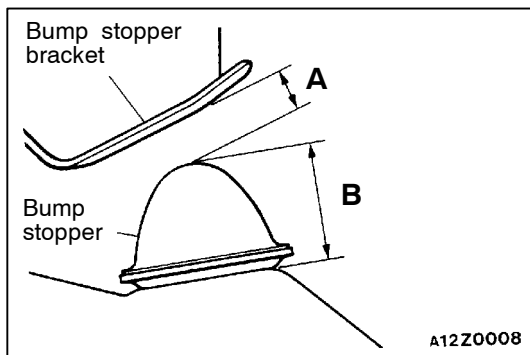

►C◄ **BUMP STOPPER AND BUMP STOPPER BRACKET CLEARANCE ADJUSTMENT**

1. With the vehicle in an unladen condition, dimension A from the bump stopper to the bump stopper bracket should be 18 mm.

NOTE

Dimension A will be (B = 50 mm) when the bump stopper is a new part. When the bump stopper is worn and becomes less than 50 mm, dimension A will increase by the decreased amount.

2. If dimension A is not 18 mm, adjust the rear anchor arm adjusting nut.

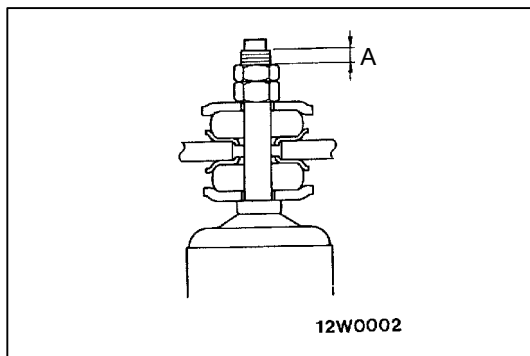

►D◄ **SHOCK ABSORBER INSTALLATION**

Install the shock absorber so that the distance (A) shown in the illustration is at the standard value.

Standard value (A): 1 – 2 mm

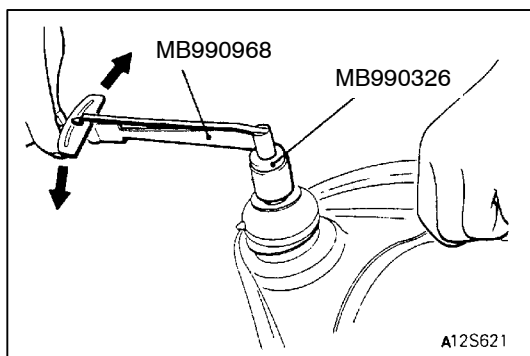

INSPECTION

33200260074

UPPER ARM BALL JOINT BREAKAWAY TORQUE CHECK

1. After shaking the upper arm ball joint assembly stud several times, install the nut to the stud and use the special tool to measure the breakaway torque of the upper arm ball joint assembly.

Standard value: 0.8 – 3.4 Nm

2. When the measured value exceeds the standard value, replace the upper arm ball joint.
3. When the measured value is lower than the standard value, check that the ball joint turns smoothly without excessive play. If not, it is possible to use that upper arm ball joint.

UPPER ARM BALL JOINT DUST COVER CHECK

1. Press the dust cover with a finger to check whether the dust cover is cracked or damaged.
2. If dust cover is cracked or damaged, replace the upper arm ball joint. Cracked or damaged dust cover may cause damage to the ball joint. In addition, if the dust cover is damaged during service work, replace the dust cover.

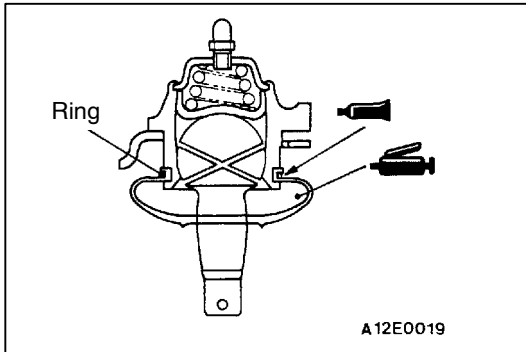
**UPPER ARM BALL JOINT DUST COVER REPLACEMENT**

33200800092

Only when dust cover is damaged accidentally during service work, replace the dust cover as follows:

1. Apply multipurpose grease to the interior of the dust cover and the upper arm ball joint.
2. Apply the specified sealant to the ball joint groove and secure the dust cover to the upper arm ball joint with ring.

Specified sealant:**3M ATD Part No. 8661 or equivalent**

3. Press the dust cover with a finger to check whether the dust cover is cracked or damaged.

LOWER ARM AND TORSION BAR

33200280117

REMOVAL AND INSTALLATION

Caution

*: Indicates parts which should be temporarily tightened, and then fully tightened with the vehicle on the ground in an unladen condition.

Pre-removal Operation

- Under Cover and Skid Plate Removal

Post-installation Operation

- Press the dust cover with a finger to check whether the dust cover is cracked or damaged.
- Front Wheel Alignment Check and Adjustment (Refer to P.33A-4.)
- Under Cover and Skid Plate Installation

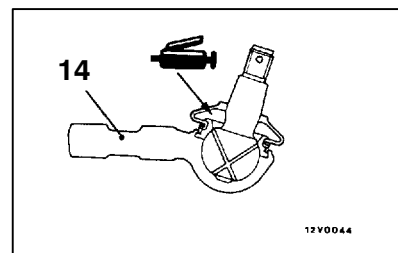
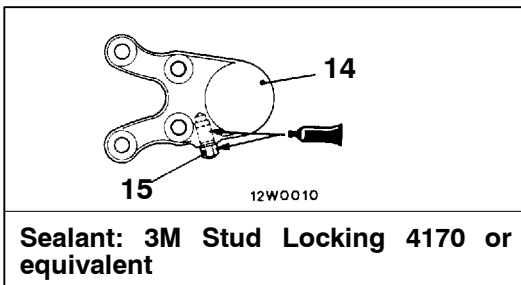
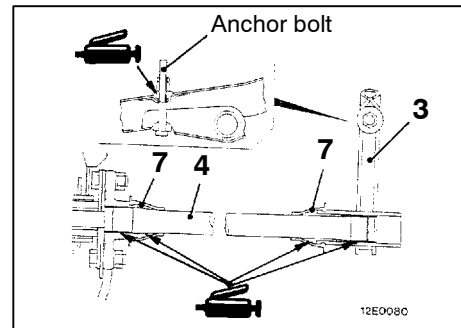
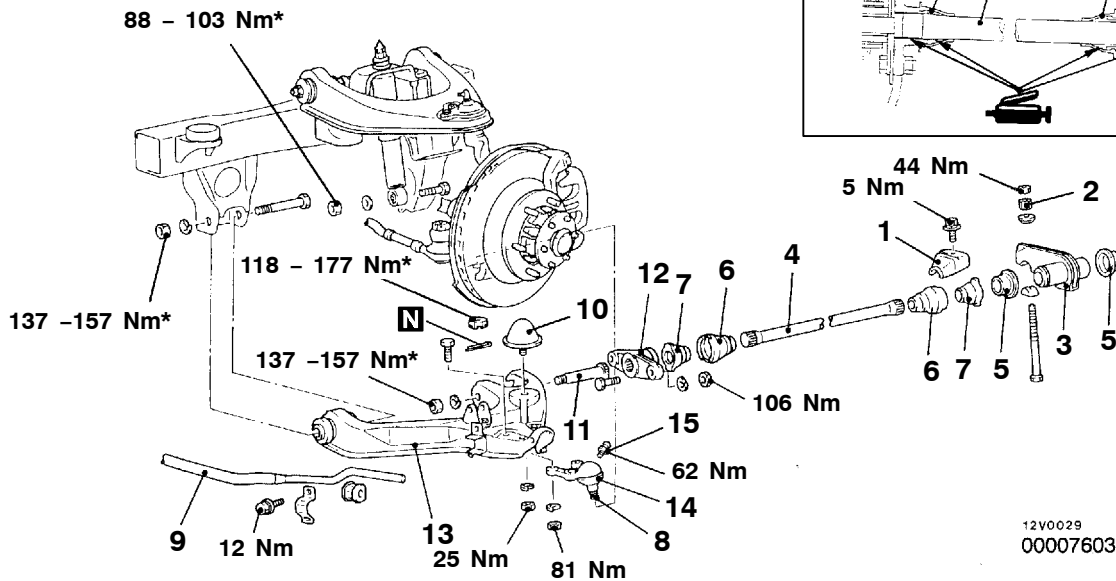

Removal steps

- ▶B◀ • Bump stopper and bump stopper bracket clearance adjustment
- 1. Heat protector (right side only)
- ▶A◀ 2. Anchor arm assembly adjusting nut
- ▶A◀ 3. Rear anchor arm assembly
- ▶A◀ 4. Torsion bar
- 5. Anchor collar
- 6. Heat cover (right side only)
- 7. Dust covers
- ▶A◀ 8. Lower arm ball joint connection
- 9. Stabilizer bar connection
- 10. Bump stopper
- ▶A◀ 11. Lower arm shaft
- ▶A◀ 12. Front anchor arm
- ▶A◀ 13. Lower arm
- ▶A◀ 14. Lower arm ball joint assembly
- ▶A◀ 15. Stopper bolt

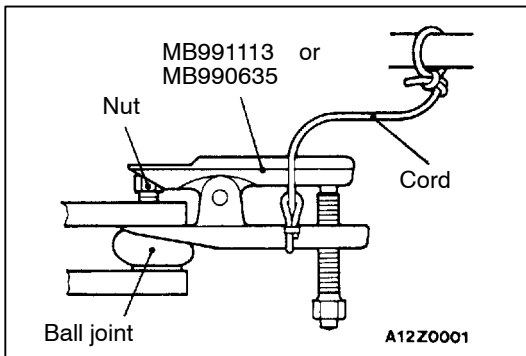

REMOVAL SERVICE POINT

◀A▶ LOWER ARM BALL JOINT DISCONNECTION

Use special tools to disconnect the lower arm ball joint from the knuckle.

Caution

1. Support special tool with a cord, etc. to prevent it from coming off.
2. Only loosen the mounting nut, do not remove it from the ball joint.

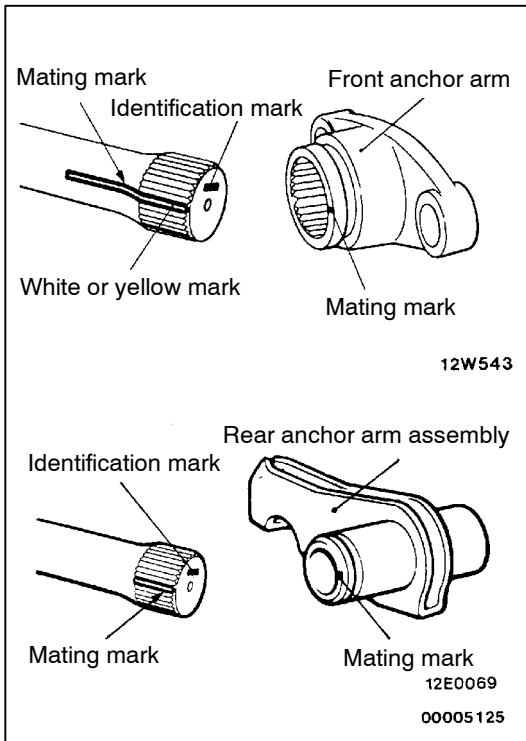

INSTALLATION SERVICE POINTS

▶A◀ FRONT ANCHOR ARM/TORSION BAR/REAR ANCHOR ARM INSTALLATION

1. Check the identification marks at the end of the left and right torsion bars.
 R → for right side
 L → for left side
2. When installing the torsion bar, align the white mark on the serrated section of the torsion bar with the mating mark on the anchor arm.

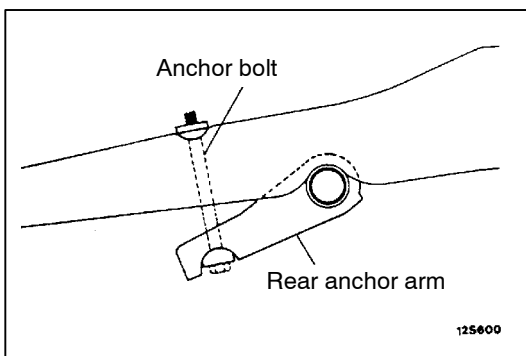

3. Mount the anchor bolt as shown in the illustration, and install the rear anchor arm adjusting nut.

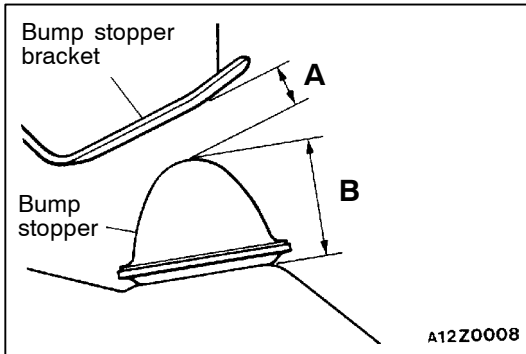

►B◄ BUMP STOPPER AND BUMP STOPPER BRACKET CLEARANCE ADJUSTMENT

1. With the vehicle in an unladen condition, dimension A from the bump stopper to the bump stopper bracket should be 18 mm.

NOTE

Dimension A will be 18 mm (B = 50 mm) when the bump stopper is a new part. When the bump stopper is worn and becomes less than 50 mm, dimension A will increase by the decreased amount.

2. If dimension A is not 18 mm, adjust the anchor arm assembly adjusting nut.

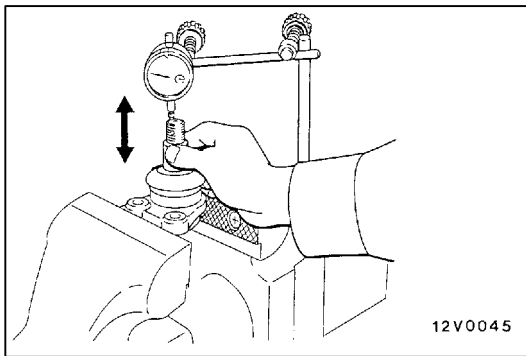

INSPECTION

33200290080

LOWER ARM BALL JOINT END PLAY

Check the lower arm ball joint assembly end play by following the steps below.

1. Measure the lower arm ball joint assembly end play with a dial indicator.

Limit: 0.3 mm

2. If the lower arm ball joint assembly end play exceeds the limit, replace the lower arm ball joint assembly.

LOWER ARM BALL JOINT DUST COVER CHECK

1. Press the dust cover with a finger to check whether the dust cover is cracked or damaged.
2. When dust cover is cracked or damaged, replace the lower arm ball joint assembly.

NOTE

If the dust cover is cracked, the ball joint could be damaged, so if the dust cover is damaged during maintenance work, replace it.

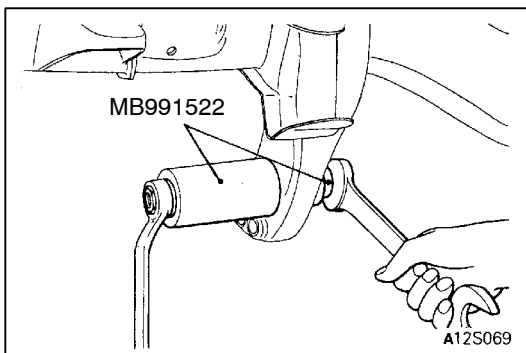

REAR LOWER ARM BUSHING REPLACEMENT

33200810149

1. Using the special tool, remove the lower arm bushing (A) from the bracket.

NOTE

When removing the left hand rear lower arm bushing, detach the differential carrier. (Refer to GROUP 26 – Differential carrier.)

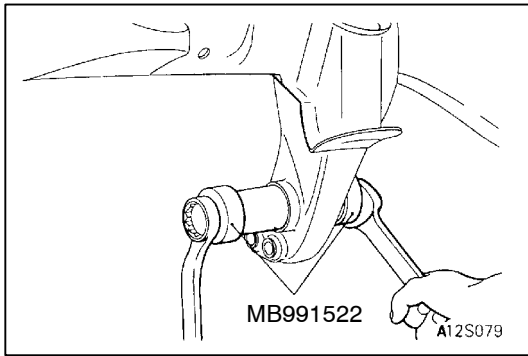

- Using the special tool, press-fit the lower arm bushing (A) into the bracket.

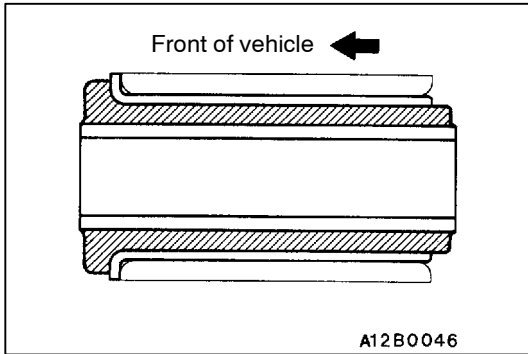

NOTE
Install the rear lower arm bushing in the direction shown in the illustration.

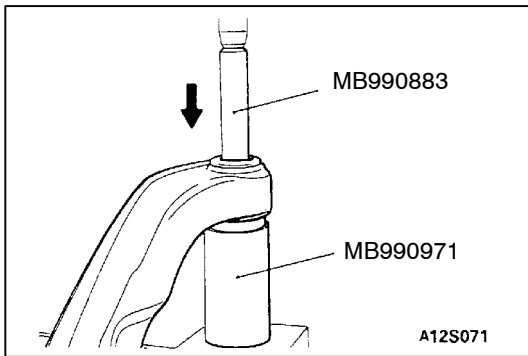

FRONT LOWER ARM BUSHING REPLACEMENT

33200810156

- Remove the front lower arm bushing from the lower arm by using special tools.

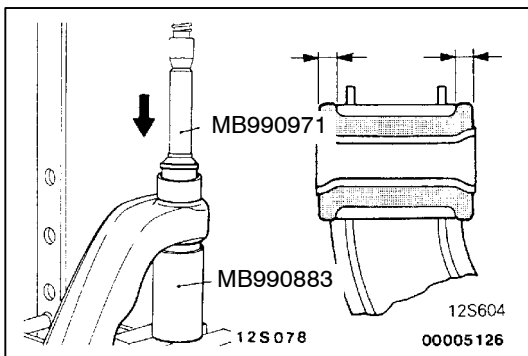

- Coat the front lower arm bushing and the lower arm with soap solution and press-fit the front lower arm bushing into the lower arm by using special tools and taking care not to twist or tilt the front lower arm bushing.

NOTE
Press-fit the front lower arm bushing again from the opposite side to equalize bushing projections at both ends.

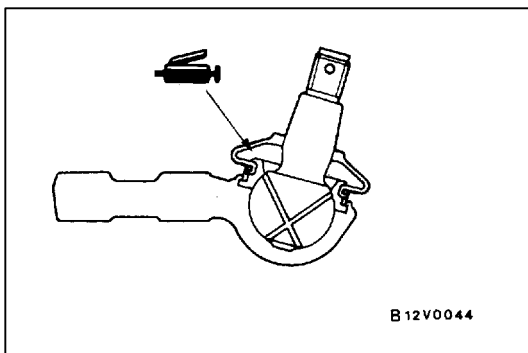

LOWER ARM BALL JOINT DUST COVER REPLACEMENT

33200820104

Only when dust cover is damaged accidentally during service work, replace the dust cover as follows:

- Apply multipurpose grease to the interior of the dust cover and the lower arm ball joint.
- Secure the dust cover to the lower arm ball joint with ring.
- Press the dust cover with a finger to check whether the dust cover is cracked or damaged.

STABILIZER BAR

33200400063

REMOVAL AND INSTALLATION

Pre-removal and Post-installation Operation

- Under Cover and Skid Plate Removal and Installation

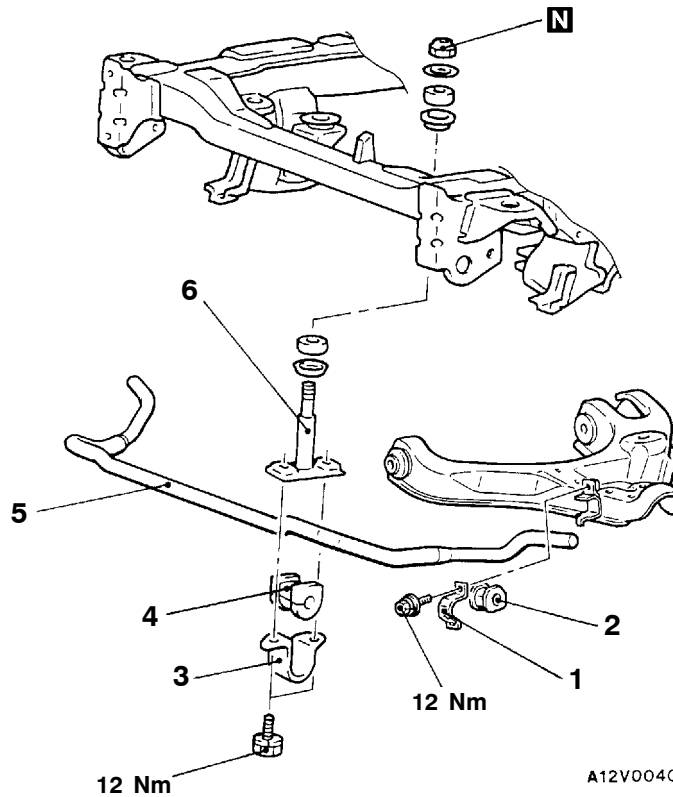

Removal steps

- ▶A◀ • Stabilizer link assembly mounting nut adjustment
- 1. Stabilizer bracket (A)
- 2. Bushing

- 3. Stabilizer bracket
- 4. Bushing
- 5. Stabilizer bar
- 6. Stabilizer link assembly

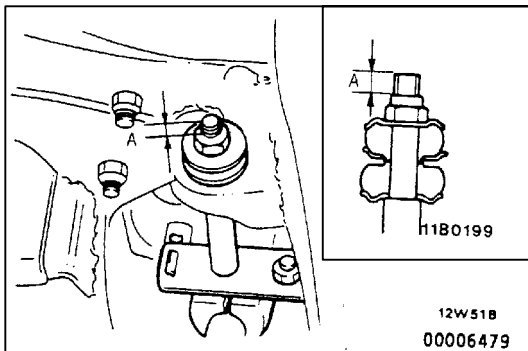

INSTALLATION SERVICE POINT

▶A◀ **STABILIZER LINK ASSEMBLY MOUNTING NUT ADJUSTMENT**

Tighten the nut so that the dimension A shown in the figure is at the standard value.

Standard value (A): 6 – 8 mm

NOTES

REAR SUSPENSION

CONTENTS

34109000213

GENERAL INFORMATION	2	LOWER ARM	4
SERVICE SPECIFICATIONS	2	Lower Arm Rear Bushing Replacement	5
SPECIAL TOOLS	3	SHOCK ABSORBER AND LATERAL ROD ...	6
ON-VEHICLE SERVICE	3	Lateral Rod Bushing Replacement	6
Rear Wheel Alignment	3	COIL SPRING AND AXLE BUMPER	7
		STABILIZER BAR	8



GENERAL INFORMATION

34100010284

The rear suspension is the 3 link coil spring type axle suspension, which assures comfortable ride and outstanding steering stability.

COIL SPRING

Items	Specifications
Wire dia. x O.D. free length mm	13 x 159 x 366

CONSTRUCTION DIAGRAM

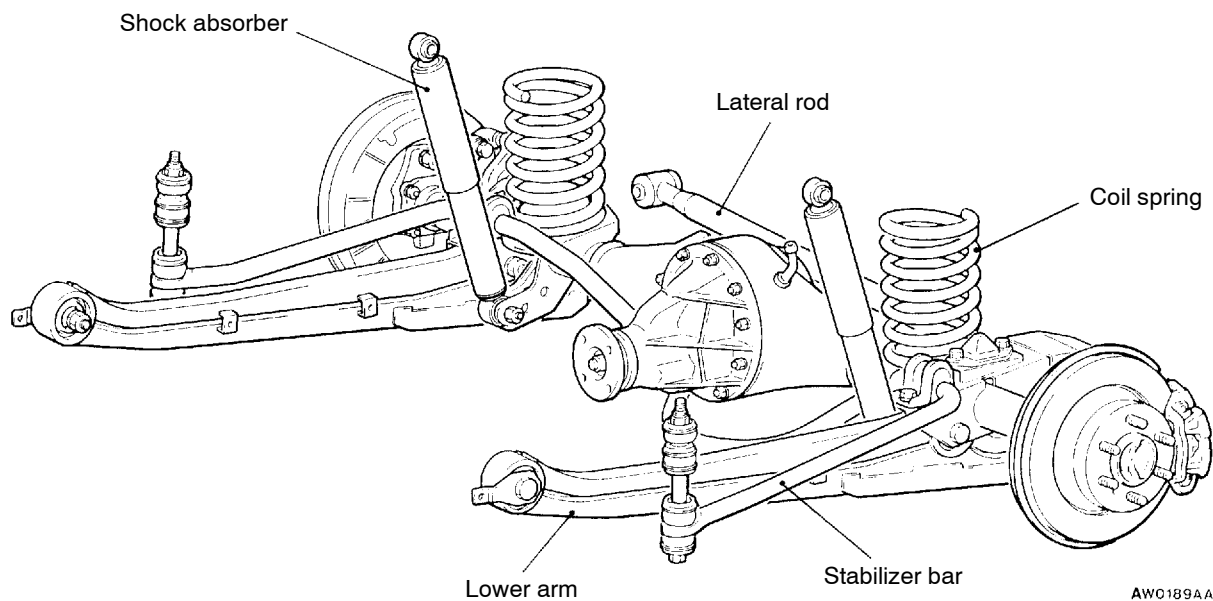

AW0189AA

SERVICE SPECIFICATIONS

34100030242

Items	Standard value
Toe-in mm	0 (Non adjustable)
Camber	0° (Non adjustable)
Protrusion amount of stabilizer bar mounting bolt mm	15 – 17

SPECIAL TOOLS

34100060197

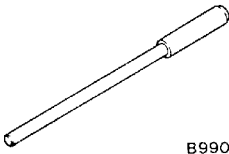
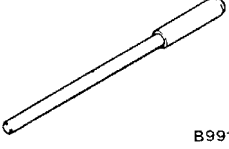
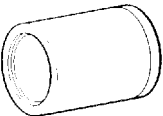
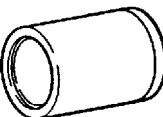
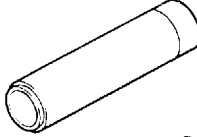
Tool	Number	Name	Use
 B990650	MB990650	Lower arm bushing arbor	<ul style="list-style-type: none"> • Lateral rod bushing removal and installation • Lateral rod removal and press fitting
 B991318	MB991318	Lower arm bushing arbor	<ul style="list-style-type: none"> • Lower arm rear bushing removal and press fitting • Lower arm bushing removal and press fitting
	MB990971	Rear wheel bearing and installer joint	
	MB990891	Bushing remover and installer base	
 B991411	MB991411	Rear wheel bearing and hub installer joint	

ON-VEHICLE SERVICE

34101100034

REAR WHEEL ALIGNMENT

The rear suspension assembly must be free of worn, loose or damaged parts prior to measurement of rear wheel alignment.

Standard value:

Toe-in 0 mm

Camber 0°

NOTE

Toe-in and camber are set at the factory and cannot be adjusted. If toe-in or camber is not within the standard value, check or replace bent or damaged parts.

LOWER ARM

REMOVAL AND INSTALLATION

Caution

*: Indicates parts which should be temporarily tightened, and then fully tightened with the vehicles on the ground in the unladen condition.

Pre-removal Operation

- Support the axle housing with a jack

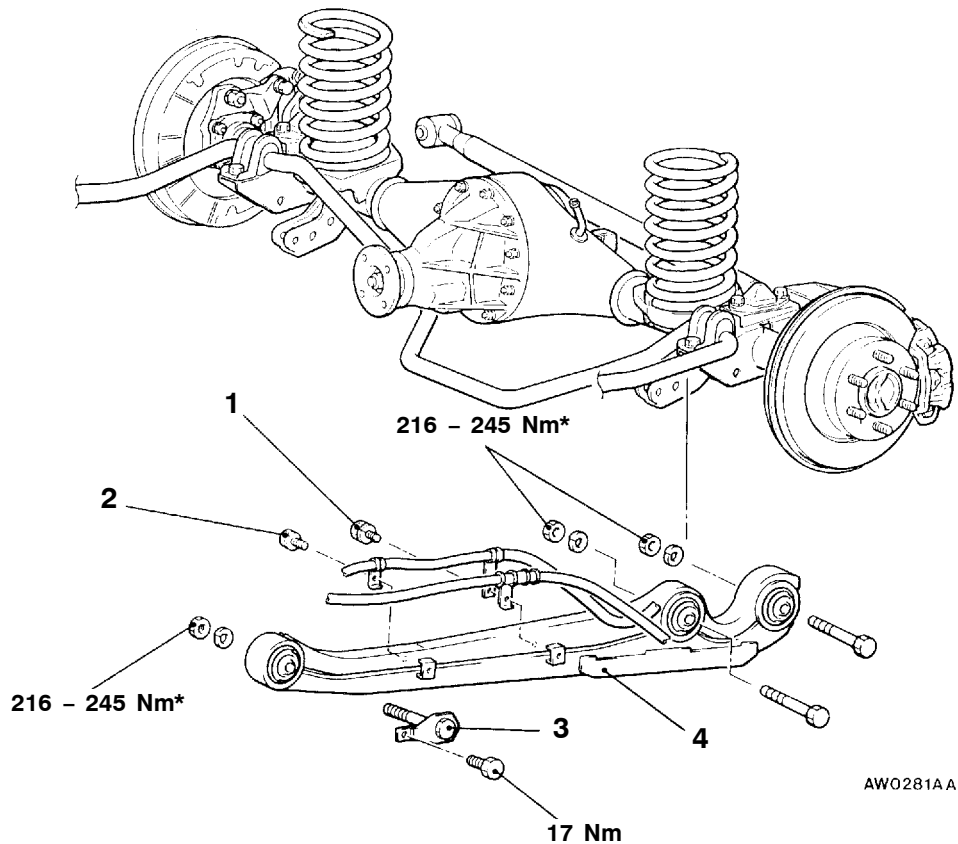

Removal steps

- | | |
|--|------------------|
| 1. Parking brake attaching bolt | 3. Bolt assembly |
| 2. Speed sensor attaching bolt
<Vehicle with ABS> | 4. Lower arm |

LOWER ARM BUSHING REPLACEMENT

34101110051

1. Use the special tools and the press to drive out and press fit the lower arm bushing.

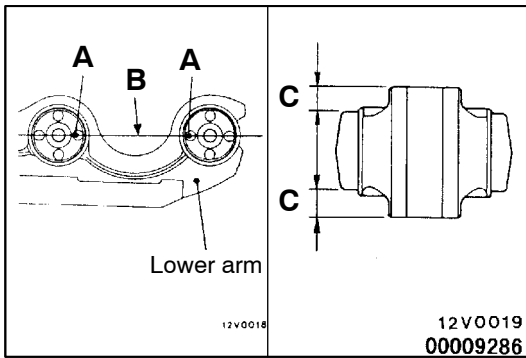
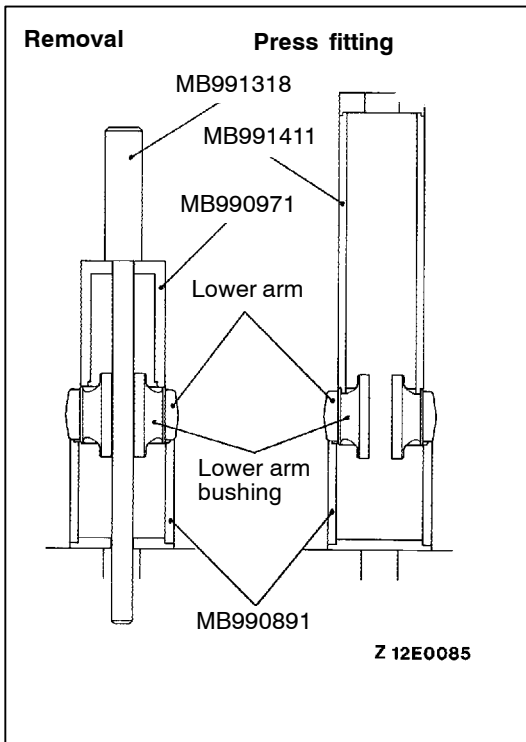

2. Position the lower arm rear bushing holes A as shown in the illustration to align the holes A and line B, and then use the special tools to press the lower arm rear bushings into the lower arm. Equalize the protrusion amounts (dimensions C) of lower arm rear bushing.

COIL SPRING AND AXLE BUMPER

34100940033

REMOVAL AND INSTALLATION

Caution

*: Indicates parts which should be temporarily tightened, and then fully tightened with the vehicles on the ground in the unladen condition.

Pre-removal Operation

- Support the axle housing with a jack

Post-installation Operation

- Brake Fluid Filling and air bleeding (Refer to GROUP 35A – On-vehicle Service.)

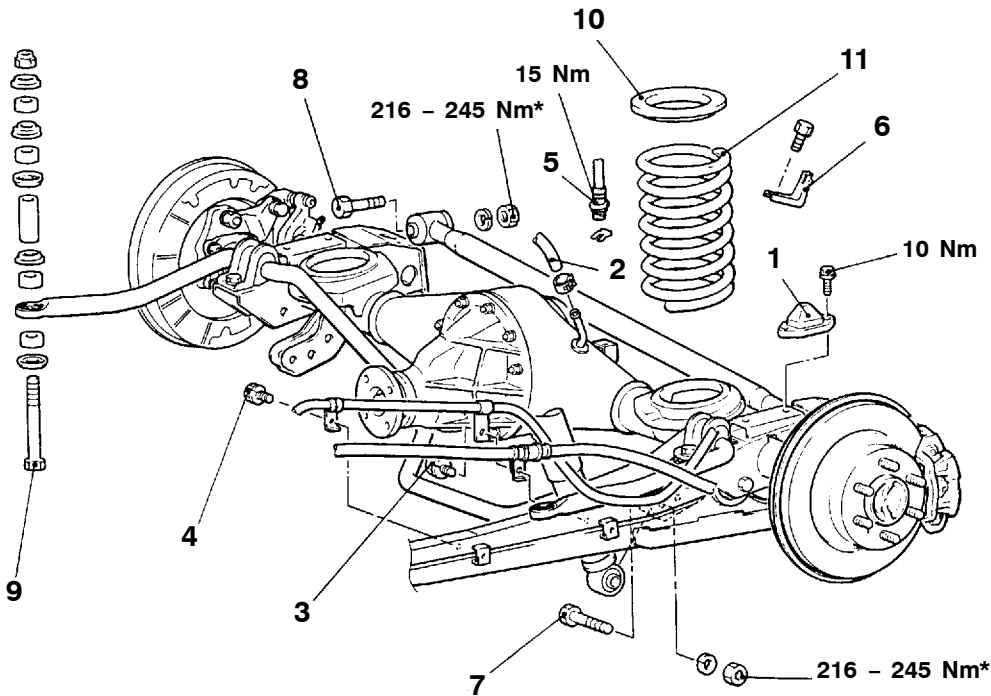

AW0120AA

1. Rear axle bumper

Coil spring removal steps

2. Breather hose
3. Parking brake cable attaching bolt
4. Speed sensor attaching bolt <Vehicle with ABS>
5. Brake hose connection
6. Spring support

7. Shock absorber mounting bolt (lower side only)
8. Lateral rod mounting bolt (vehicle side only)
9. Stabilizer bar mounting bolt
10. Rear spring pad
11. Coil spring

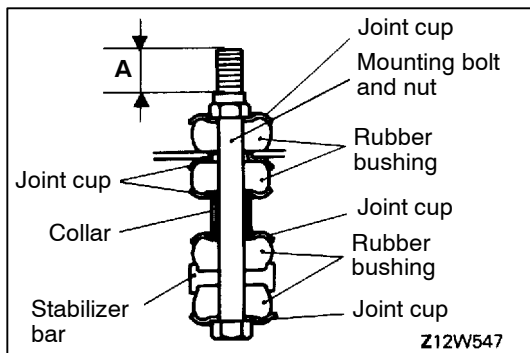

INSTALLATION SERVICE POINT

▶A◀ STABILIZER BAR MOUNTING BOLT INSTALLATION

1. To install the stabilizer, assemble the joint cups and rubber bushings by the order and the specified direction as shown in the figure.
2. Install the nut on the stabilizer bar mounting bolt to the specified dimensions.

Standard value (A): 15 – 17 mm

STABILIZER BAR

REMOVAL AND INSTALLATION

Caution

*: Indicates parts which should be temporarily tightened, and then fully tightened with the vehicles on the ground in the unladen condition.

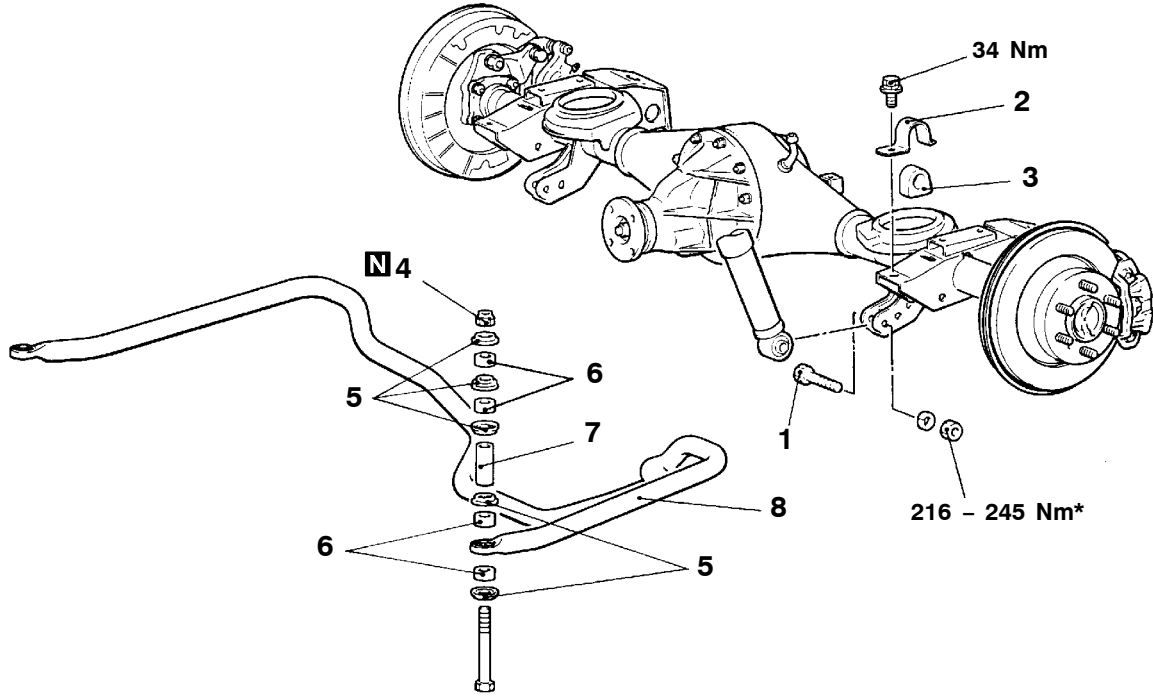

AW0191AA

Removal steps

1. Shock absorber mounting bolt (lower side only)
2. Bracket
3. Bushing
- ▶◀ 4. Stabilizer bar mounting bolt and nut

5. Joint cup
6. Rubber bushing
7. Collar
8. Stabilizer bar

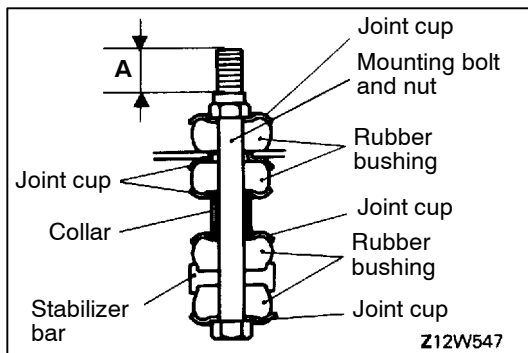

INSTALLATION SERVICE POINT

▶◀ STABILIZER BAR MOUNTING BOLT AND NUT INSTALLATION

1. To install the stabilizer bar, assembly the joint cups and rubber bushings by the order and specified direction as shown in the figure.
2. Install the nut on the stabilizer bar mounting bolt to the specified dimensions.

Standard value (A): 15 – 17 mm

SERVICE BRAKES

CONTENTS

35109000487

BASIC BRAKE SYSTEM	35A
ANTI-SKID BRAKING SYSTEM (ABS) <4WD>	35B



BASIC BRAKE SYSTEM

CONTENTS

35109000494

GENERAL INFORMATION	3	Load Sensing Proportioning Valve Function Test	14
SERVICE SPECIFICATIONS	5	Disc Brake Pad Check and Replacement	15
LUBRICANTS	6	Disc Brake Rotor Check	17
SEALANT	6	Thickness check	20
SPECIAL TOOL	6	Brake Lining Thickness Check	20
TROUBLESHOOTING	7	Brake Disk Inside Diameter Check	21
ON-VEHICLE SERVICE	9	Brake Lining and Brake Disc Connection Check	21
Brake Pedal Check and Adjustment	9	BRAKE PEDAL	22
Stop Lamp Switch Check	11	MASTER CYLINDER AND BRAKE BOOSTER	23
Brake Booster Operating Test	11	Master Cylinder	25
Check Valve Operation Check	12	LOAD SENSING PROPORTIONING VALVE	26
Brake Booster Vacuum Switch Check <4D5>	12	FRONT DISC BRAKE	27
Bleeding	13	REAR DISC BRAKE	33
Brake Fluid Level Sensor Check	14		
Load Sensing Spring Length Check and Adjustment	14		

GENERAL INFORMATION

35100010304

The brake system has high reliability and durability which maintains excellent braking performance and braking feeling. The main features are as follows.

- A dual type master cylinder is equipped in all models.
- A tandem type brake booster has been adopted.
- The following type of brake have been adopted.
 Front: Floating caliper, 2-piston, ventilated disc brakes (V5-W43, V6-W43)
 Rear: Floating caliper, 1-piston, solid disc brakes (S5-S43P)

Items	6G7	4D5 <Vehicles without wide fender>	4D5 <Vehicles with wide fender>
Master cylinder I.D. mm	23.8		
Brake booster effective dia. of power cylinder mm	205 + 230	180 + 205	
Brake booster boosting ratio	5.0	6.0	5.0
Front brake disc effective dia. mm	265	227	265
Front brake wheel cylinder I.D. mm	42.86		
Rear brake disc effective dia. mm	272		
Rear brake wheel cylinder I.D. mm	42.85		

CONFIGURATION DIAGRAM

<L.H. drive vehicles>

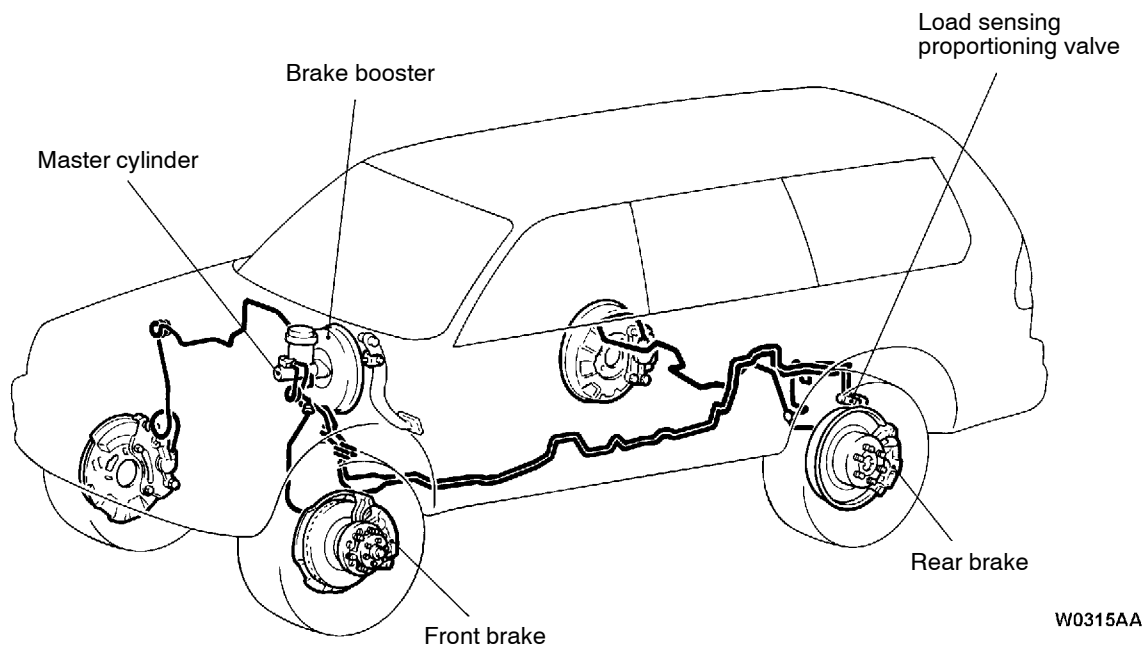

<R.H. drive vehicles>

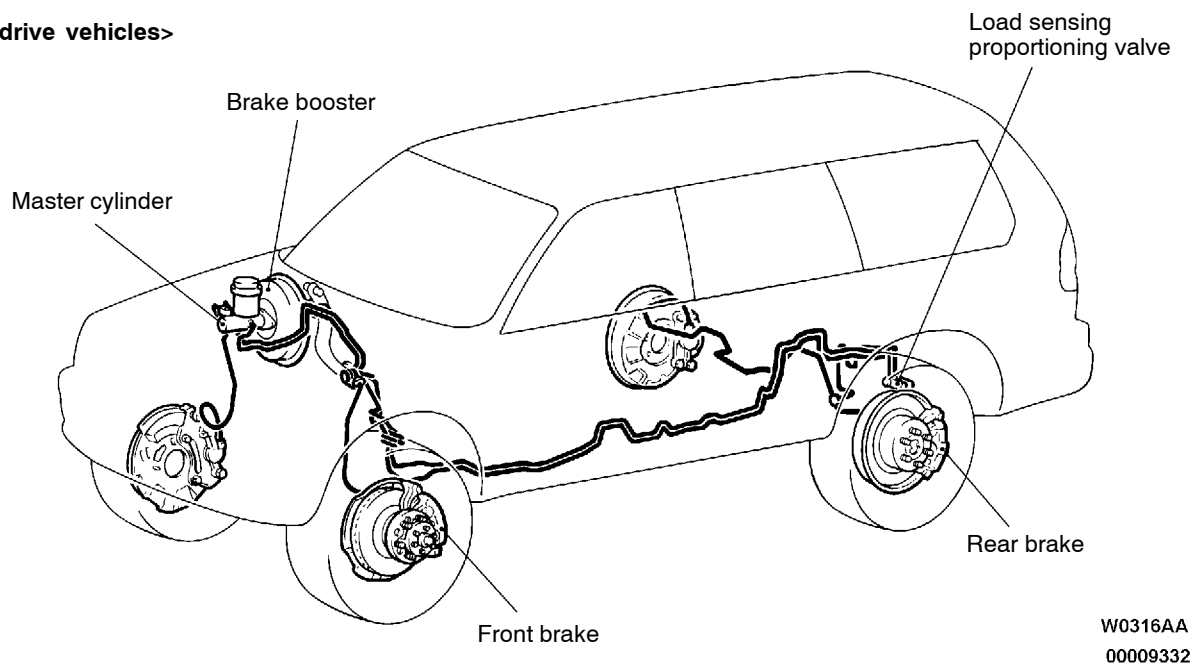

SERVICE SPECIFICATIONS

35100030386

Items		Standard value	Limit
Brake pedal height mm		176 – 181	–
Brake pedal free play mm		3 – 8	–
Brake pedal to floor board clearance mm		95 or more	–
Load sensing spring length mm		164 – 168	–
Load sensing proportioning valve output pressure kPa (Input pressure kPa)	When load sensing spring length is 144 mm (when unladen)	3,633 (5,884)	–
		5,610 (13,730)	–
	When load sensing spring length is 208 mm (when laden)	11,160 (13,730)	–
Disc brake pad thickness mm		10	2.0
Brake disc run-out mm	Front	–	0.06
	Rear	–	0.08
Front hub end play mm		0.05	–
Rear axle shaft end play mm		0 – 0.25	–
Brake disc thickness mm	Front	24	22.4
	Rear	18	16.4
Brake lining thickness mm		–	4.5
Brake drum inside diameter mm		197.0	198.0
Booster push rod to master cylinder piston clearance mm	Vehicle which brake booster of power cylinder is 180 mm and 205 mm in effective diameter	0.90 – 1.30	–
	Vehicle which brake booster of power cylinder is 205 mm and 230 mm in effective diameter	0.70 – 1.10	–
Disc brake drag force (tangential force of wheel mounting bolts) N	Front	106 or less	–
	Rear	56 or less	–

LUBRICANTS

35100040174

Items	Specified lubricant
Brake fluid	DOT3 or DOT4
Brake piston seal	Repair kit grease
Guide pin boot inner surface	
Lock pin boot inner surface	
Piston boot mounting grooves	
Sleeve inner surface	
Bushing inner surface	
Pin boot inner surface	

SEALANT

35100050214

Item	Specified sealant	Remark
Vacuum switch	3M ATD Part No.8661 or equivalent	Semi-drying sealant
Fitting		

SPECIAL TOOL

35100060194

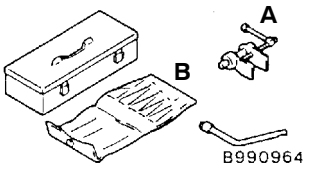
Tool	Number	Name	Use
	MB990964 A: MB990520 B: MB990623	Brake tool set	Pushing-in of the disc brake piston Installation of drum brake wheel cylinder piston cup

TROUBLESHOOTING

35100070128

Symptom	Probable cause	Remedy
Vehicle pulls to one side when brakes are applied	Grease or oil on pad or lining surface	Replace
	Inadequate contact of pad or lining	Correct
Insufficient braking power	Low or deteriorated brake fluid	Refill or change
	Air in brake system	Bleed air
	Overheated brake rotor due to dragging of pad or lining	Correct
	Inadequate contact of pad	
	Brake booster malfunction	
	Clogged brake line	
	Grease or oil on pad surface	Replace
	Load sensing proportioning valve malfunction	
Increased pedal stroke (Reduced pedal to floor board clearance)	Air in brake system	Bleed air
	Worn pad	Replace
	Broken vacuum hose	
	Faulty master cylinder	
	Brake fluid leaks	Correct
	Excessive push rod to master cylinder clearance	Adjust
Brake drag	Incomplete release of parking brake	Correct
	Clogged master cylinder return port	
	Incorrect parking brake adjustment	Adjust
	Improper push rod to master cylinder clearance	
	Faulty master cylinder piston return spring	Replace
	Worn brake pedal return spring	
	Lack of lubrication in sliding parts	Lubricate

Symptom	Probable cause	Remedy
Insufficient parking brake function	Worn brake lining or pad	Replace
	Grease or oil on lining or pad surface	
	Parking brake cable sticking	
	Stuck wheel cylinder or caliper piston	
	Excessive parking brake lever stroke	Adjust the parking brake lever stroke or check the parking brake cable routing
	Auto adjuster malfunction	Adjust
Scraping or grinding noise when brakes are applied	Worn brake pad	Replace
	Caliper to wheel interference	Correct or replace
	Dust cover to disc interference	
	Bent brake backing plate	
	Cracked brake disc	
Squealing, groaning or chattering noise when brakes are applied	Missing or damaged brake pad anti-squeak shim	Replace
	Brake discs and pads worn or scored	Correct or replace
	Burred or rusted calipers	Correct or deburr
	Dirty, greased, contaminated or glazed pad	Clean or replace
	Incorrect brake pedal or booster push rod	Adjust
Squealing noise when brakes are not applied	Bent or warped backing plate causing interference with drum	Replace
	Poor return of brake booster, master cylinder	
	Loose or extra parts in brakes	Retighten
	Improper positioning of pads in caliper	Correct
	Improper installation of support mounting to caliper body	
	Worn, damaged or insufficiently lubricated wheel bearings	Lubricate or replace
	Incorrect brake pedal or booster push rod	Adjust

Symptom	Probable cause	Remedy
Groaning, clicking or rattling noise when brakes are not applied	Loose wheel nuts	Retighten
	Loose installation bolts	
	Worn, damaged or dry wheel bearings	Lubricate or replace
	Failure of shim	Replace
	Wear on sleeve	
	Incorrect brake pedal or booster push rod	Adjust

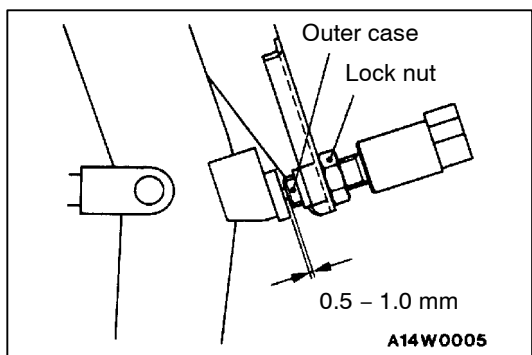
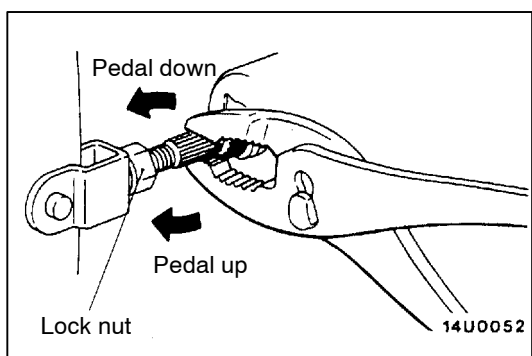
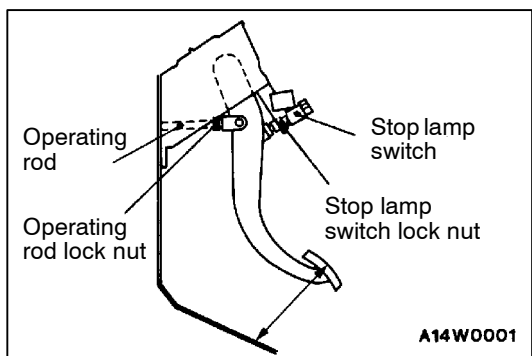

ON-VEHICLE SERVICE

35100090292

BRAKE PEDAL CHECK AND ADJUSTMENT

BRAKE PEDAL HEIGHT

1. Turn back the carpet etc. under the brake pedal.
2. Measure the brake pedal height as illustrated. If it is not within the standard value, adjust as follows.

Standard value: 176 – 181 mm (From the surface of melting seat to the face of pedal pad)

- (1) Disconnect the stop lamp switch connector, loosen the lock nut, and move the stop lamp switch to a position where it does not contact the brake pedal arm.
 - (2) Adjust the brake pedal height by turning the operating rod with pliers (with the operating rod lock nut loosened).
 - (3) Screw in the stop lamp switch until it contacts the brake pedal stopper (just before brake pedal is caused to move), return the stop lamp switch 1/2 to 1 turn and secure with the lock nut.
 - (4) Connect the connector of the stop lamp switch.
 - (5) Check to be sure that the stop lamp is not illuminated with the brake pedal released.
3. Return the carpet etc.

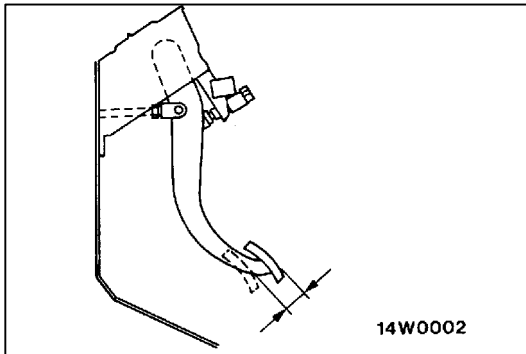

BRAKE PEDAL FREE PLAY

With the engine stopped, depress the brake pedal two or three times. After eliminating the vacuum in the brake booster, press the pedal down by hand, and confirm that the amount of movement before resistance is met (free play) is within the standard value range.

Standard value: 3 – 8 mm

If the free play exceeds the standard value, it is probably due to excessive play between the clevis pin and brake pedal arm.

Check for excessive clearance and replace faulty parts as required.

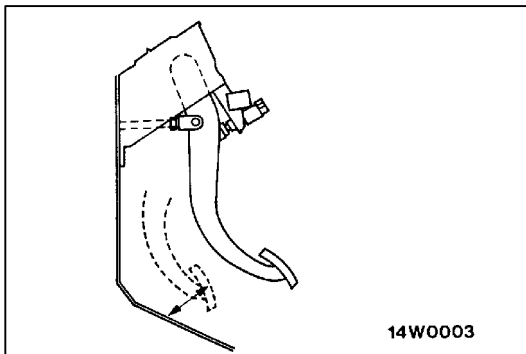

CREARANCE BETWEEN BRAKE PEDAL AND FLOOR BOARD

1. Turn back the carpet etc. under the brake pedal.
2. Start the engine, depress the brake pedal with approximately 490 N of force, and measure the clearance between the brake pedal and the floorboard.

Standard value:

95 mm or more (From the surface of melting seat to the face of pedal pad)

3. If the clearance is outside the standard value, check for air trapped in the brake line, clearance between the lining and the drum and dragging in the parking brake. Adjust and replace defective parts as required.
4. Return the carpet etc.

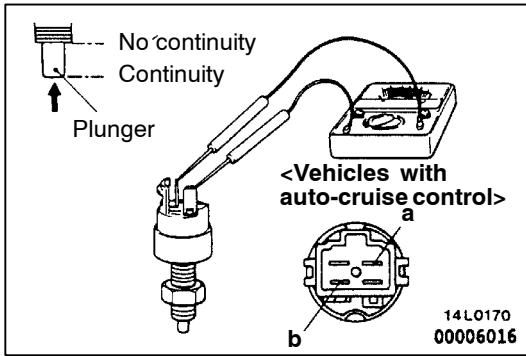

STOP LAMP SWITCH CHECK

35100890168

Connect a circuit tester to the stop lamp switch, and check whether or not there is continuity when the plunger of the stop lamp switch is pushed in and when it is released. The stop lamp switch is in good condition if there is no continuity when the plunger is pushed in to a depth of within 4 mm from the outer case edge surface, and if there is continuity when it is released.

For vehicles with auto-cruise control system, check the continuity between the terminals “a” and “b” of the stop lamp switch.

BRAKE BOOSTER OPERATING TEST

35100100162

For simple checking of the brake booster operation, carry out the following tests:

1. Run the engine for one or two minutes, and then stop it.

If the pedal depresses fully the first time but gradually becomes higher when depressed succeeding times, the booster is operating properly, if the pedal height remains unchanged, the booster is defective.

2. With the engine stopped, step on the brake pedal several times.

Then step on the brake pedal and start the engine. If the pedal moves downward slightly, the booster is in good condition. If there is no change, the booster is defective.

3. With the engine running, step on the brake pedal and then stop the engine.

Hold the pedal depressed for 30 seconds. If the pedal height does not change, the booster is in good condition, if the pedal rises, the booster is defective.

If the above three tests are okay, the booster performance can be determined as good.

If one of the above three tests is not okay at last, the check valve, vacuum hose, or booster will be defective.

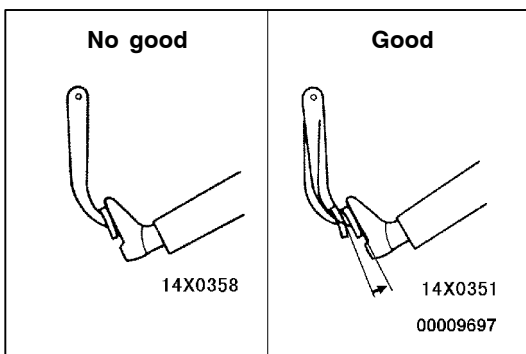
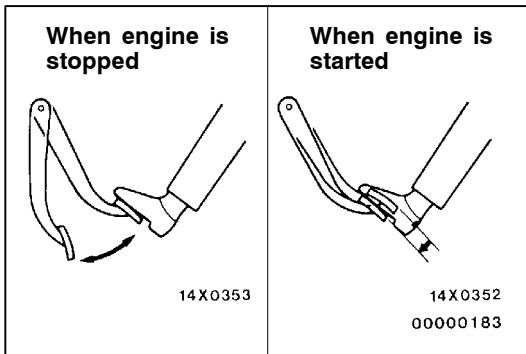
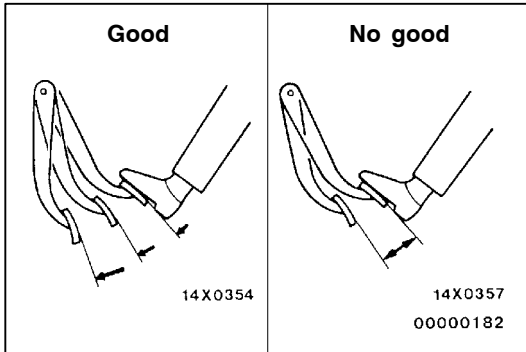

CHECK VALVE OPERATION CHECK

35100900243

1. Remove the vacuum hose. (Refer to P.35A-23.)

Caution

The check valve should not be removed from the vacuum hose.

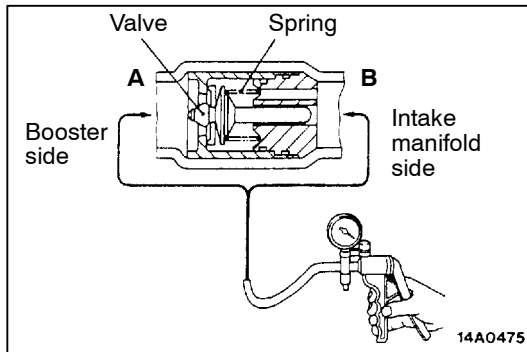

2. Check the operation of the check valve by using a vacuum pump.

Vacuum pump connection	Accept/reject criteria
Connection at the brake booster side (A)	A negative pressure (vacuum) is created and held.
Connection at the intake manifold side (B)	A negative pressure (vacuum) is not created.

Caution

If the check valve is defective, replace it as an assembly unit together with the vacuum hose.

BRAKE BOOSTER VACUUM SWITCH CHECK**<4D5>**

35100920041

1. Connect an ohmmeter to the connector of the vacuum switch.
2. Start the engine and check for continuity when the vacuum hose is connected, and when it is disconnected. The vacuum switch is in good condition if there is no continuity when the vacuum hose is connected, and if there is continuity when it is disconnected.

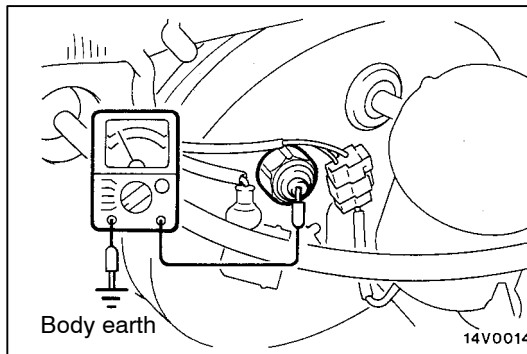

BLEEDING

35100140201

Caution

Use the specified brake fluid. Avoid using a mixture of the specified brake fluid and other fluid.

Specified brake fluid: DOT3 or DOT4

MASTER CYLINDER BLEEDING

The master cylinder used has no check valve, so if bleeding is carried out by the following procedure, bleeding of air from the brake pipeline will become easier. (When brake fluid is not contained in the master cylinder.)

1. Fill the reserve tank with brake fluid.
2. Keep the brake pedal depressed.
3. Have another person cover the master cylinder outlet with a finger.
4. With the outlet still closed, release the brake pedal.
5. Repeat steps 2 – 4 three or four times to fill the inside of the master cylinder with brake fluid.

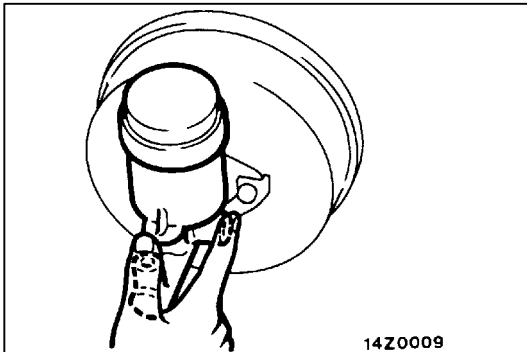

BRAKE PIPE LINE BLEEDING

Start the engine and bleed the air in the sequence shown in the figure.

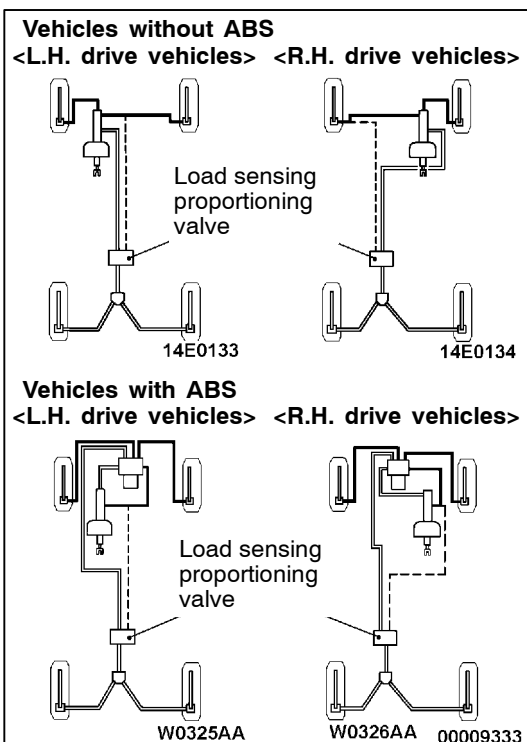

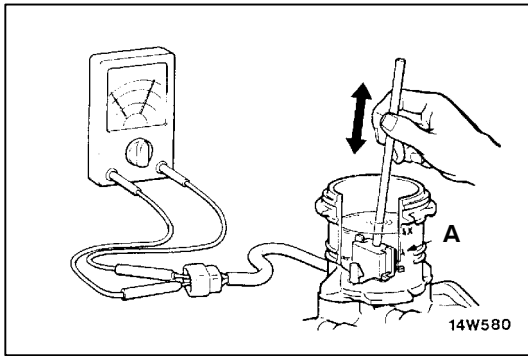

BRAKE FLUID LEVEL SENSOR CHECK

35100910086

The brake fluid level sensor is in good condition if there is no continuity when the float surface is above “A” and if there is continuity when the float surface is below “A”.

LOAD SENSING SPRING LENGTH CHECK AND ADJUSTMENT

35100120045

1. Park the vehicle on a level ground. The vehicle should be unloaded and supported only by wheels.

Caution

Never support the vehicle with jacks or other similar means.

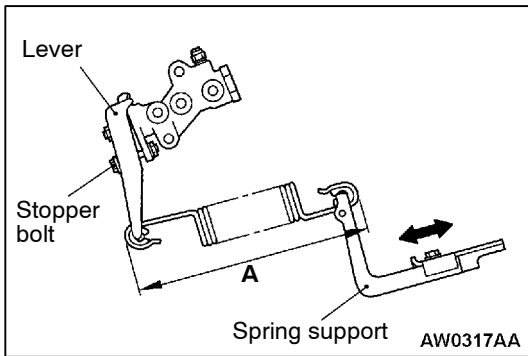

2. While the lever of the load sensing proportioning valve is touching the stopper bolt, install the spring support so that the distance (A) is at the standard value.

Standard value (A): 164 – 168 mm

3. If the spring length is not within the standard value, loosen the bolt attaching the spring support and adjust the distance by moving the spring support.

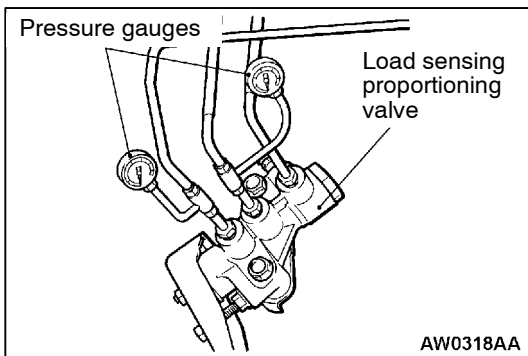

LOAD SENSING PROPORTIONING VALVE FUNCTION TEST

35100130055

1. Connect pressure gauges to the input and output ports of the load sensing proportioning valve.
2. Bleed the system. (Refer to P.35-13.)

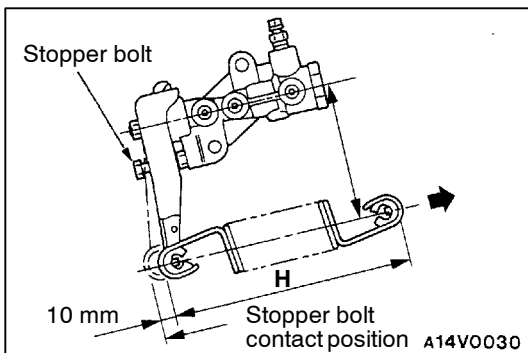

3. Disconnect the spring at the support side.
4. Place the spring so that it is in parallel with the load sensing proportioning valve, and pull in the direction indicated by the arrow so that its length H shown in the figure (the length between its ends) is as noted below.

NOTE

At this time the lever is pressed all the way to the load sensing proportioning valve.

Standard value:

Spring length H mm	Input fluid pressure kPa	Output fluid pressure kPa
144* ¹	5,884	3,633
	13,730	5,610
208* ²	13,730	11,160

NOTE

*¹ and *² indicate the applicable lengths for unladen and laden vehicles respectively.

- After making the check, install the spring. Disconnect the pressure gauges from the load sensing proportioning valve and bleed the air. (Refer to P.35A-13.)

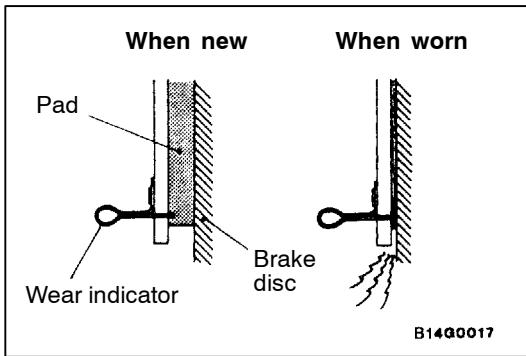

DISC BRAKE PAD CHECK AND REPLACEMENT

35100150242

NOTE

The brake pads have indicators that contact the brake disc when the brake pad thickness becomes 2 mm, and emit a squealing sound to warn the driver.

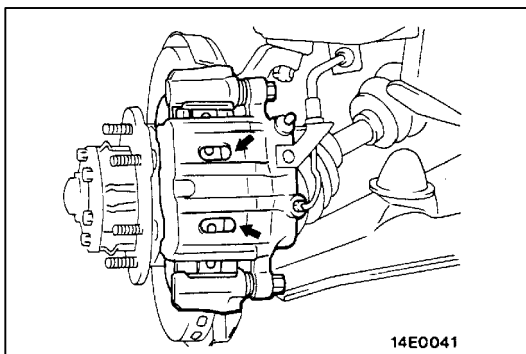

<Front>

- Check the brake pad thickness through the caliper body check port.

Standard value: 10 mm

Limit: 2.0 mm

Caution

- When the limit is exceeded, replace the pads at both sides, and also the brake pads for the wheels on the opposite side at the same time.
- If there is a significant difference in the thicknesses of the pads on the left and right sides, check the sliding condition of the piston, lock pin and guide pin.

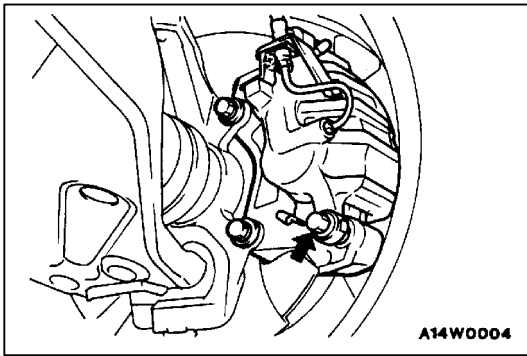

- Remove the lock pin. Lift the caliper assembly and retain with wire.

Caution

**Do not wipe the special grease from the lock pin.
Do not contaminate the lock pin.**

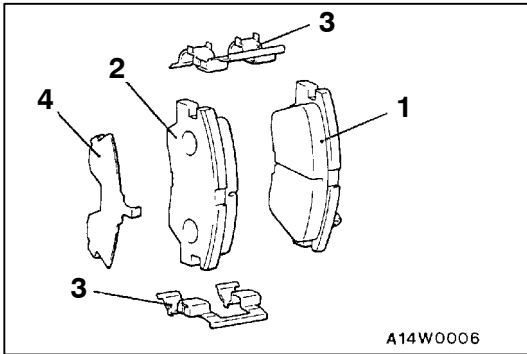

- Remove the following parts from caliper support.
 - Pad and wear indicator assembly
 - Pad assembly
 - Clip
 - Outer shim
- Measure the hub torque with the pad removed to measure the brake drag force after pad installation. (Refer to P.35A-28.)
- Install the pad and caliper assembly, and check the brake drag force. (Refer to P.35A-28.)

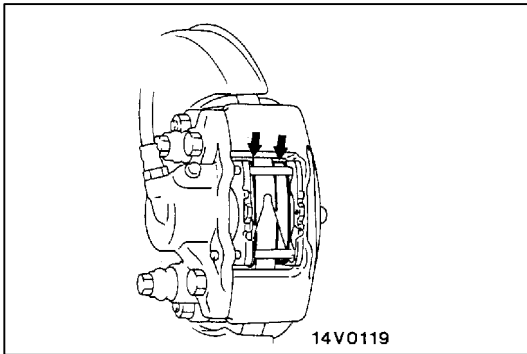

<Rear>

- Check the brake pad thickness through the caliper body check port.

**Standard Value: 10 mm
Limit: 2.0 mm**

Caution

- (1) When the limit is exceeded, replace the pads at both sides, and also the brake pads for the wheels on the opposite side at the same time.**
- (2) If there is a significant difference in the thicknesses of the pads on the left and right sides, check the sliding condition of the piston and pad pin.**

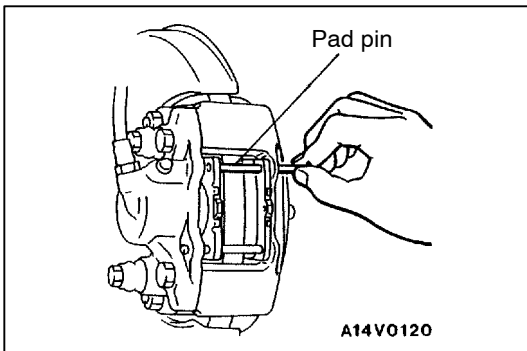

- Remove the clip and pad pin.

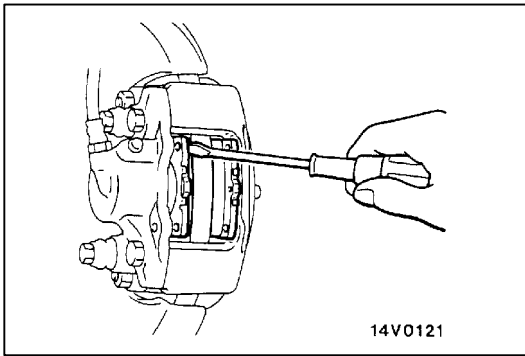

3. Remove the pad and shim with a flat-tipped screwdriver.
 - (1) Pad and wear indicator assembly
 - (2) Pad assembly
 - (3) Inner shim
 - (4) Outer shim
4. Measure the hub torque with the pads removed to measure the brake drag force. (Refer to P.35A-33.)
5. Install the pad and caliper assembly, and check the brake drag force. (Refer to P.35A-33.)

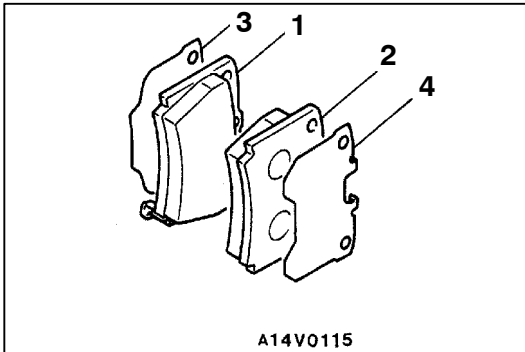

DISC BRAKE ROTOR CHECK

35100270092

CAUTION

When servicing disc brakes, it is necessary to exercise caution to keep the disc brakes within the allowable service values in order to maintain normal brake operation.

Before re-finishing or re-processing the brake disc surface, the following conditions should be checked.

Inspection items	Remarks
Scratches, rust, saturated lining materials and wear	<ul style="list-style-type: none"> ● If the vehicle is not driven for a certain period, the sections of the discs that are not in contact with lining will become rusty, causing noise and shuddering. ● If grooves resulting from excessive disc wear and scratches are not removed prior to installing a new pad assembly, there will momentarily be inappropriate contact between the disc and the lining (pad).
Run-out or drift	Excessive run-out or drift of the discs will increase the pedal depression resistance due to piston knock-back.
Change in thickness (parallelism)	If the thickness of the disc changes, this will cause pedal pulsation, shuddering and surging.
Inset or warping (flatness)	Overheating and improper handling while servicing will cause inset or warping.

FRONT DISC BRAKE RUN-OUT CHECK AND CORRECTION

35100940078

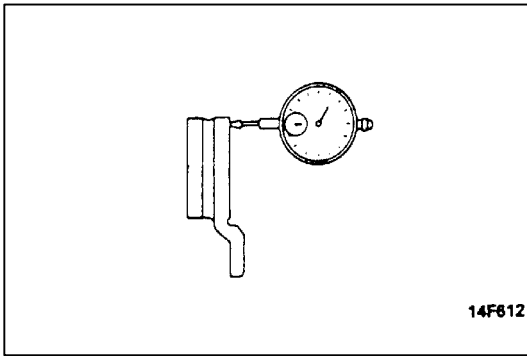

1. Remove the caliper support; then raise the caliper assembly upward and secure by using wire.
2. Inspect the disc surface for grooves, cracks and rust. Clean the disc thoroughly and remove all rust.
3. Place a dial gauge approximately 5 mm from the outer circumference of the brake disc, and measure the run-out of the disc.

Limit: 0.06 mm

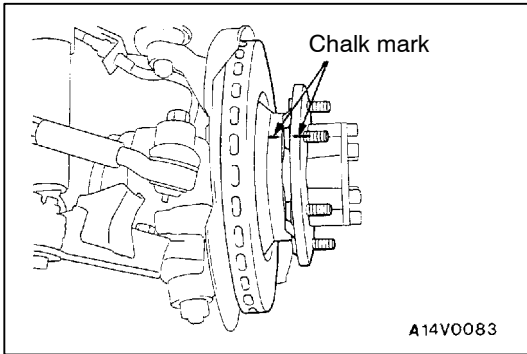

4. If the run-out of the brake disc is equivalent to or exceeds the limit specification, change the phase of the disc and hub, and then measure the run-out again.
 - (1) Before removing the brake disc, chalk both sides of the wheel stud on the side at which run-out is greatest.

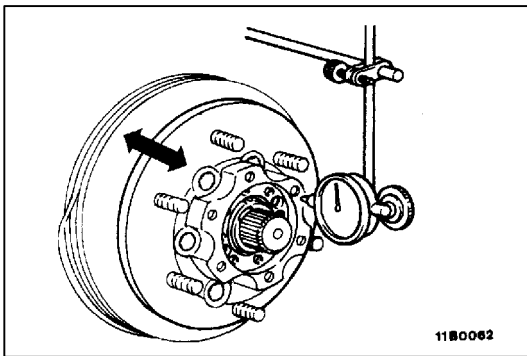

- (2) Place a dial gauge as show in the illustration, and then move the hub in the axial direction and measure the play.

Standard value: 0.05 mm

If the play is equal to or exceeds the standard value, adjust the wheel bearing preload. (Refer to GROUP 26 – Front Hub Assembly.)

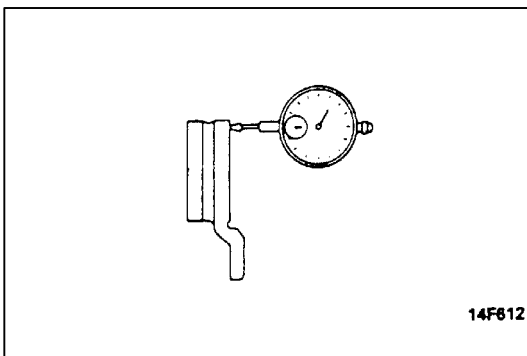

- (3) If the play does not exceed the standard value specification, install the brake disc at a position 180° away from the chalk mark, and then check the run-out of the brake disc one again.
5. If the run-out cannot be corrected by changing the phase of the brake disc, replace the disc or turn rotor with on the car type brake lathe (“MAD, DL-8700PF” or equivalent).

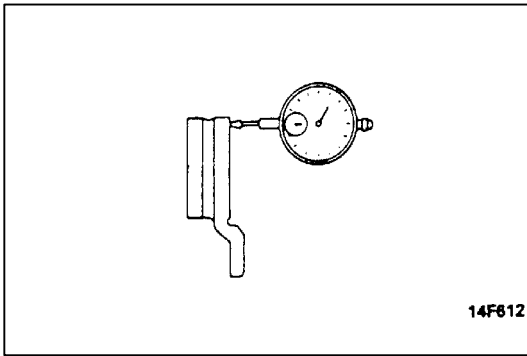

REAR DISC BRAKE RUN-OUT CHECK AND CORRECTION

35100210100

1. Remove the caliper support; then raise the caliper assembly upward and secure with a wire.
2. Check the disc surface for grooves, cracks and rust. Clean the disc thoroughly and remove all rust.
3. Place a dial gauge approximately 5 mm from the outer circumference of the brake disc, and measure the run-out of the disc.

Limit: 0.08 mm

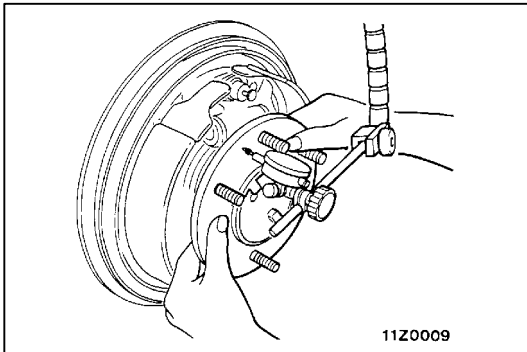

4. If the runout of the brake disc is the limit value or more, change the phase of the disc and hub, and then measure the run-out again.
 - (1) Before removing the brake disc, place a mating mark on both the wheel stud and disc with chalk on the point at which the run-out is greatest.
 - (2) Place a dial gauge as shown in the illustration, and then move the hub in the axial direction and measure the play.

Standard value: 0 – 0.25 mm

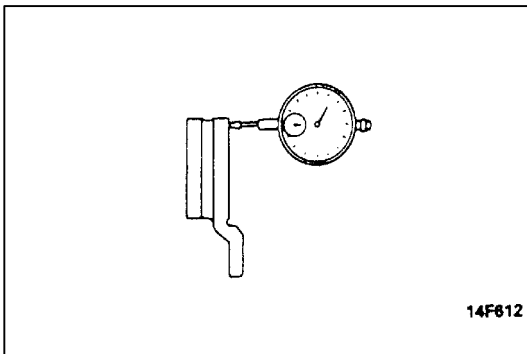

- (3) If the play does not exceed the standard value install the brake disc at a different phase, and then check the run-out of the brake disc again.
5. If the run-out cannot be corrected by changing the phase of the brake disc, replace the disc.

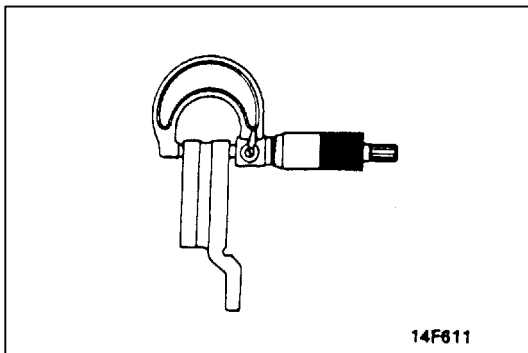
**THICKNESS CHECK**

35100160221

<Front>

1. Using a micrometer, measure disc thickness at eight positions, approximately 45° apart and 10 mm in from the outer edge of the disc.

Brake disc thickness**Standard value: 24 mm****Limit: 22.4 mm**

Thickness variation (at least 8 positions)

The difference between any thickness measurements should not be more than 0.015 mm.

2. If the disc is beyond the limits for thickness, remove it and install a new one. If thickness variation exceeds the specification, replace the brake disc or turn rotor with on the car type brake lathe ("MAD, DL-8700PF" or equivalent).

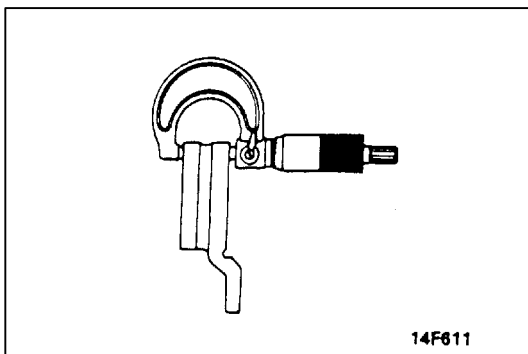
**<Rear>**

1. Remove dirt and rust from the brake disc surface.
2. Measure the disc thickness at four locations or more.

Standard value: 18 mm**Limit: 16.4 mm**

Replace the discs and pad assembly for both left and right sides of the vehicle if they are worn beyond the specified limit.

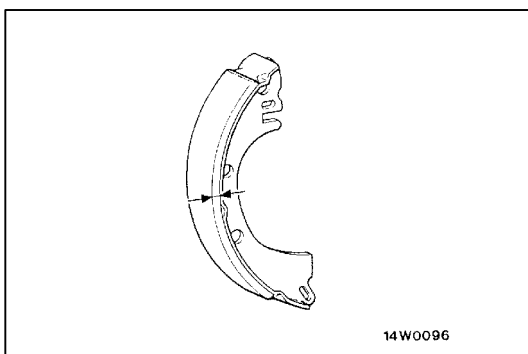
**BRAKE LINING THICKNESS CHECK**

35100300272

1. Remove the rear brake assembly, raise the rear brake assembly and secure it by using a wire, etc.
2. Remove the brake disc.
3. Measure the wear of the brake lining at the place worn the most.

Limit: 4.5 mm

4. Replace the shoe and lining assembly if brake lining thickness is less than the limit if it is not worn evenly.

Caution**Whenever the shoe and lining assembly is replaced, replace both R.H. and L.H. assemblies as a set to prevent car from pulling to one side when braking.**

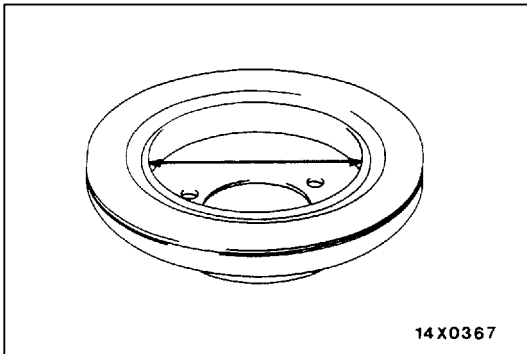

BRAKE DISC INSIDE DIAMETER CHECK

35100320216

1. Remove the rear brake assembly, raise the rear brake assembly and secure it by using a wire, etc.
2. Remove the brake disc.
3. Measure the inside diameter of the brake disc at two or more locations.

Standard value: 197.0 mm

Limit: 198.0 mm

Replace brake disc, shoe and lining assembly when wear exceeds the limit value or is badly imbalanced.

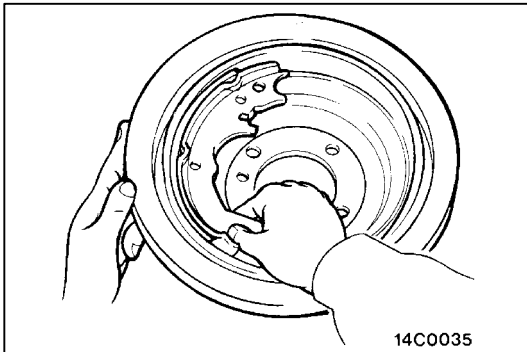

BRAKE LINING AND BRAKE DISC CONNECTION CHECK

35100310275

1. Remove the rear brake assembly, raise the rear brake assembly and secure it by using a wire, etc.
2. Remove the brake disc.
3. Remove the shoe and lining assembly.
4. Chalk inner surface of brake disc and rub with shoe and lining assembly.
5. Replace shoe and lining assembly or brake disc if very irregular contact area.

NOTE

Clean off chalk after check.

BRAKE PEDAL

REMOVAL AND INSTALLATION

Post-installation Operation

- Brake Pedal Adjustment (Refer to P.35A-9.)

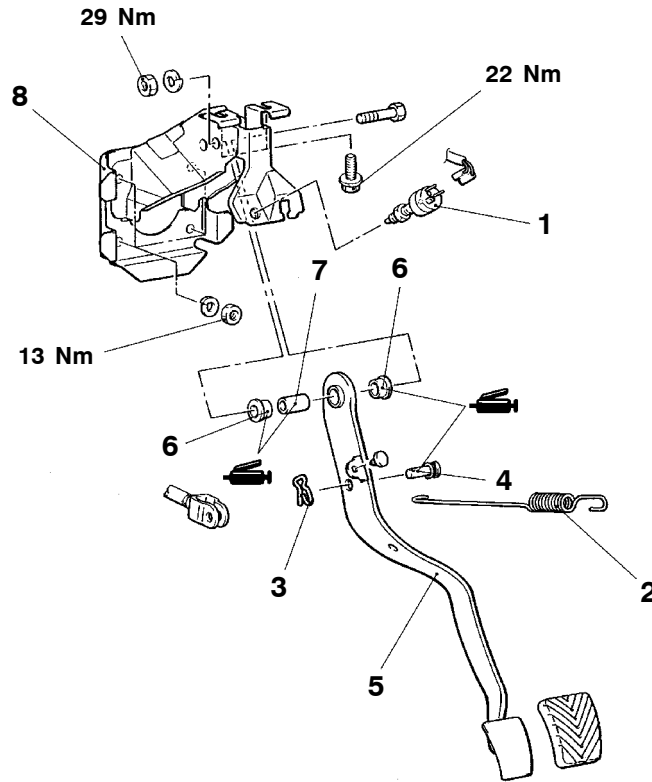

BT0108AA

Removal steps

- | | |
|--|--|
| <p>▶A◀</p> <ol style="list-style-type: none"> 1. Stop lamp switch 2. Brake pedal return spring 3. Snap pin 4. Pin assembly | <ol style="list-style-type: none"> 5. Brake pedal 6. Bushing 7. Spacer 8. Pedal support member |
|--|--|

INSTALLATION SERVICE POINT**▶A◀ BRAKE PEDAL RETURN SPRING INSTALLATION**

For L.H. drive vehicles, face the coil of brake pedal return spring toward the steering column side.

For R.H. drive vehicles, face it toward the brake pedal side.

MASTER CYLINDER AND BRAKE BOOSTER

35100370419

REMOVAL AND INSTALLATION

Pre-removal Operation

- Brake Fluid Draining

Post-installation Operation

- Brake Fluid Supplying
- Brake Line Bleeding (Refer to P.35A-13.)
- Brake Pedal Adjustment (Refer to P.35A-9.)

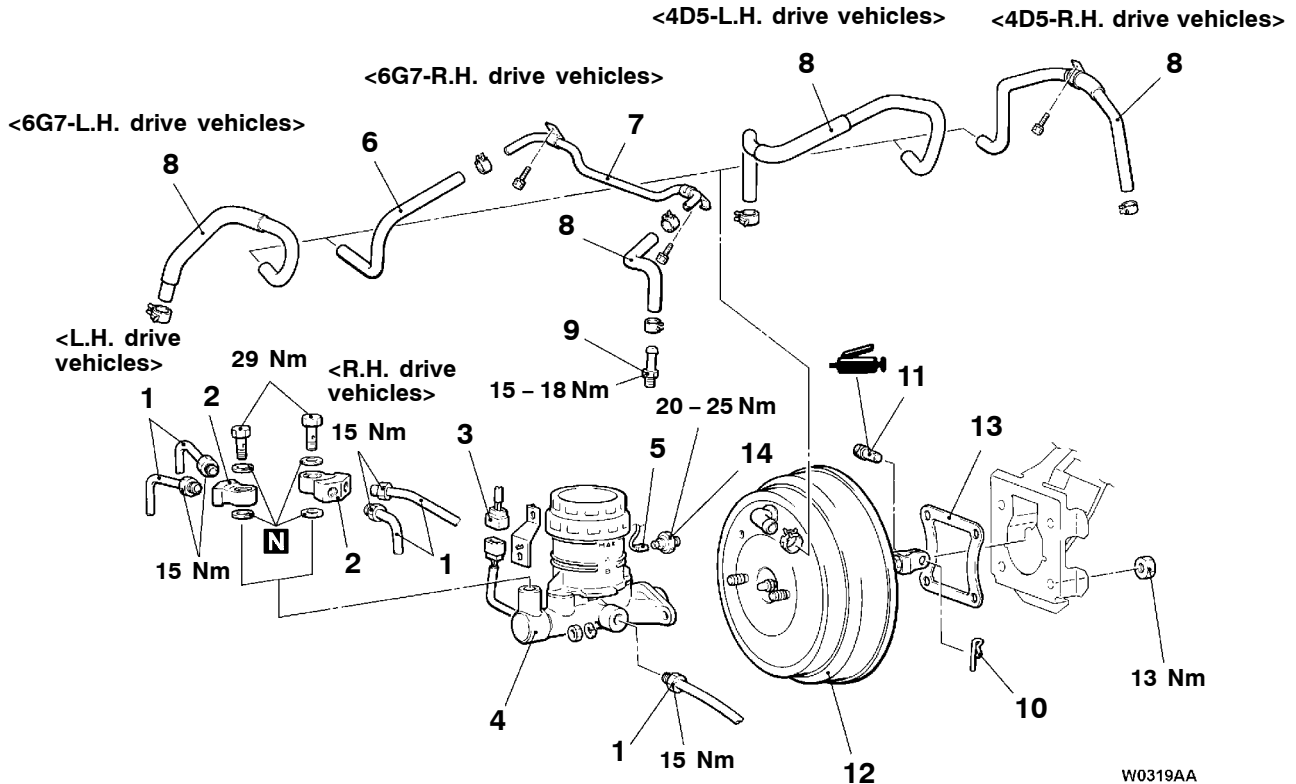

W0319AA
00009334

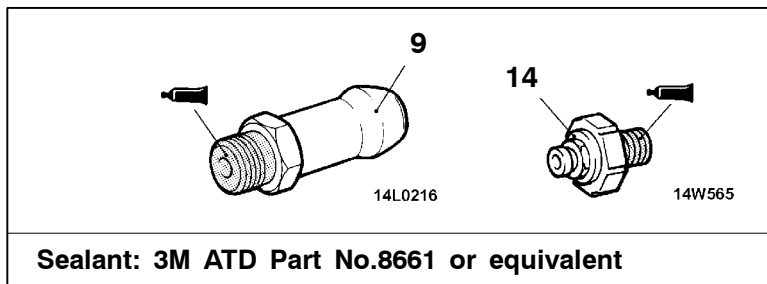

Sealant: 3M ATD Part No.8661 or equivalent

Removal steps

1. Brake tube connection
2. Connector
3. Brake fluid level sensor connector
4. Master cylinder assembly
- ▶B◀ • Adjustment of clearance between brake booster push rod and primary piston
5. Vacuum switch connector <4D5>
6. Vacuum hose
7. Vacuum pipe
- ▶A◀ 8. Vacuum hose (with built-in check valve)

9. Fitting
10. Snap pin
11. Pin assembly
12. Brake booster
13. Sealer
14. Vacuum switch <4D5>

Caution

Do not remove the check valve from the vacuum hose. If the check valve is defective, replace it together with the vacuum hose.

INSTALLATION SERVICE POINTS

►A◄ VACUUM HOSE CONNECTION

Insert securely and completely until the vacuum hose at the engine side contacts the edge of the hexagonal part of the fitting, and then secure by using the hose clip.

►B◄ CLEARANCE ADJUSTMENT BETWEEN BRAKE BOOSTER PUSH ROD AND PRIMARY PISTON

Calculate clearance A from the B, C and D measurements.
 $A = B - C - D$

Standard value:

Brake booster size	Clearance A standard valve mm
Vehicle which brake booster of power cylinder is 180 mm and 205 mm in effective diameter	0.90 – 1.30
Vehicle which brake booster of power cylinder is 205 mm and 230 mm in effective diameter	0.70 – 1.10

NOTE

When brake booster negative pressure (6G7: -66.7 kPa, 4D5: -93.3 kPa) is applied, clearance value will become 0.10 – 0.50 mm.

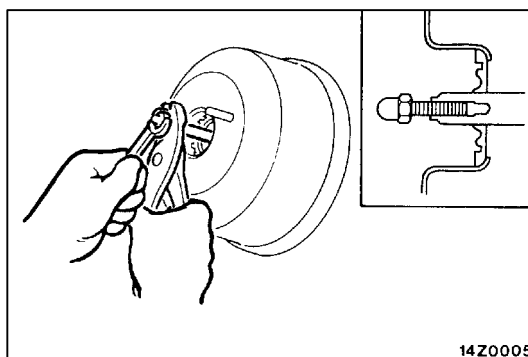
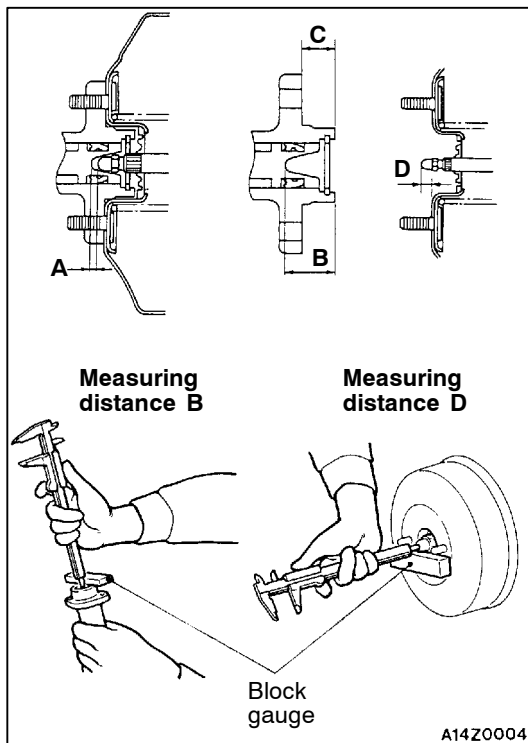

If the clearance is not within the standard value range, adjust by changing the push rod length by turning the screw of the push rod.

**MASTER CYLINDER
DISASSEMBLY AND REASSEMBLY**

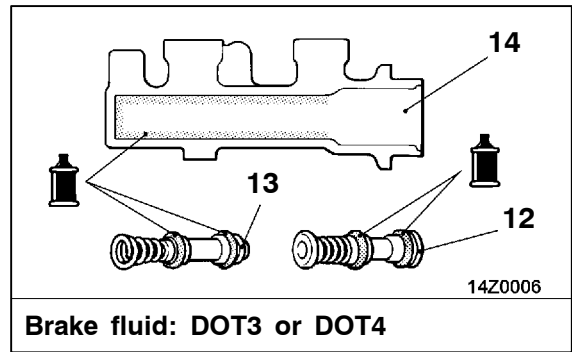
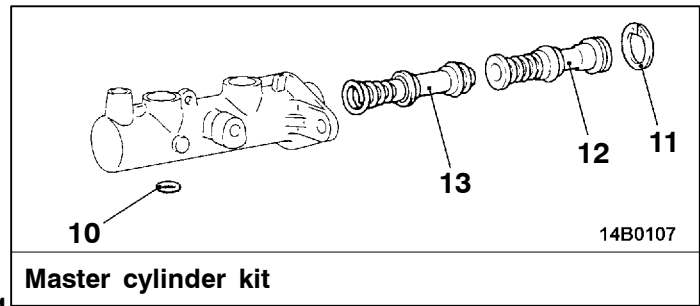
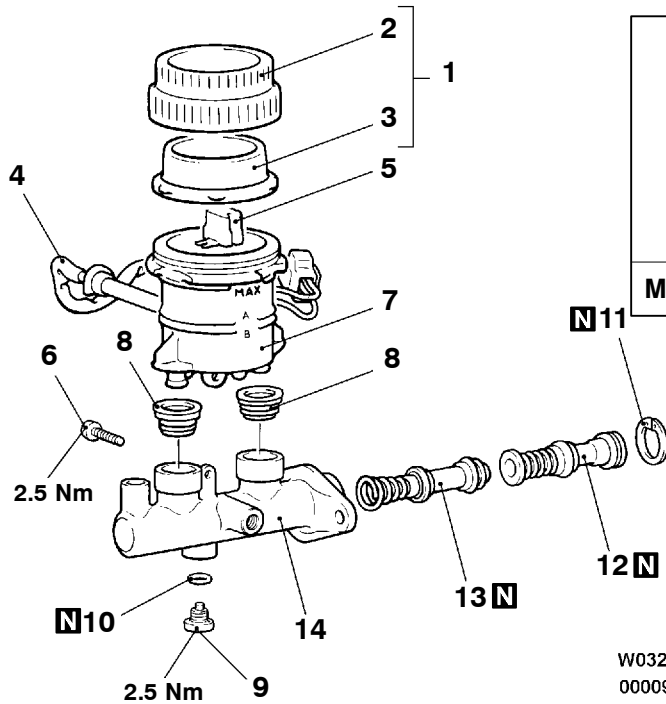

W0320AA
00009335

Disassembly steps

1. Reservoir cap assembly
2. Reservoir cap
3. Diaphragm
4. Brake fluid level sensor
5. Float
6. Reservoir stopper bolt
7. Reservoir tank
8. Reservoir seal
9. Piston stopper bolt

10. Gasket
11. Piston stopper ring
12. Primary piston assembly
13. Secondary piston assembly
14. Master cylinder body



Caution
Do not disassemble the primary piston and secondary piston assembly.

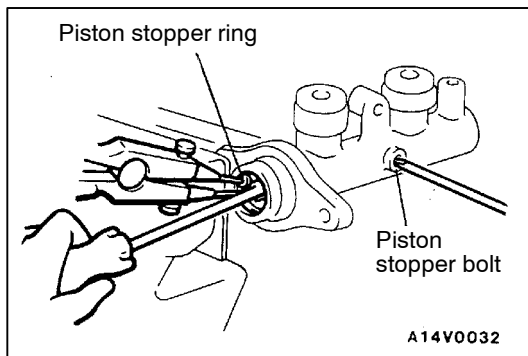

DISASSEMBLY SERVICE POINT

◀A▶ PISTON STOPPER BOLT/PISTON STOPPER RING DISASSEMBLY

Remove the piston stopper bolt and piston stopper ring while depressing the piston.

INSPECTION

- Check the inner surface of master cylinder body for rust or pitting.
- Check the primary and secondary pistons for rust, scoring, wear or damage.
- Check the diaphragm for cracks and wear.

LOAD SENSING PROPORTIONING VALVE

REMOVAL AND INSTALLATION

Caution

Do not disassemble the load sensing proportioning valve.

Pre-removal Operation

- Brake Fluid Draining

Post-installation Operation

- Brake Fluid Supplying
- Brake Line Bleeding (Refer to P.35A-12.)

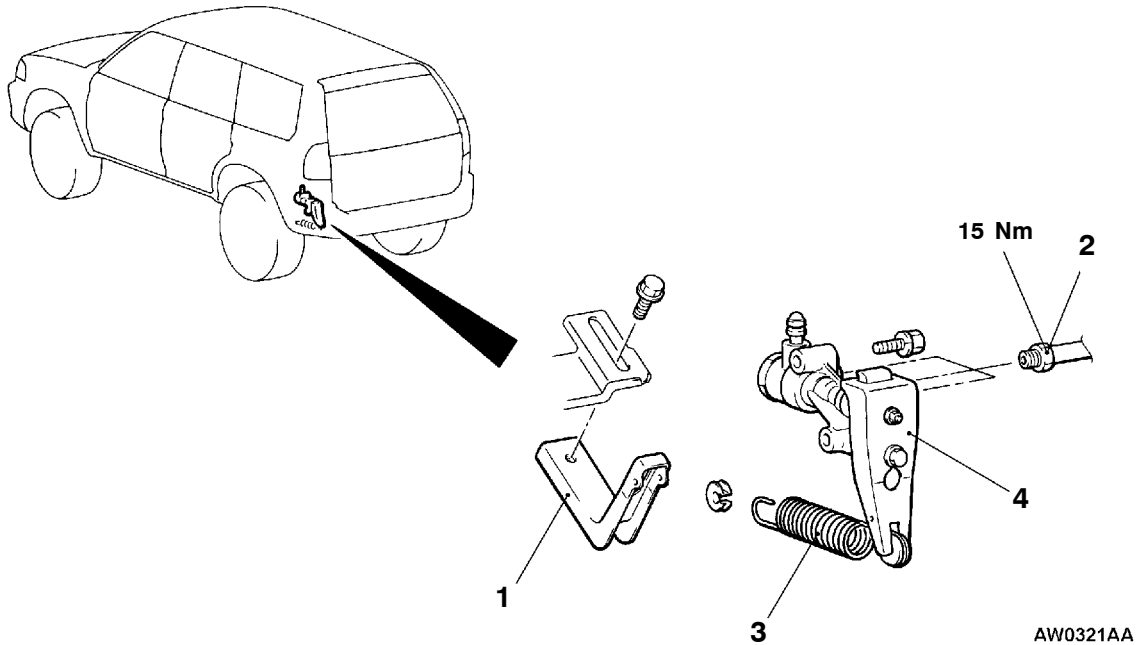

Removal steps

- ▶A◀ 1. Spring support
2. Brake tube connection

3. Load sensing spring
4. Load sensing proportioning valve

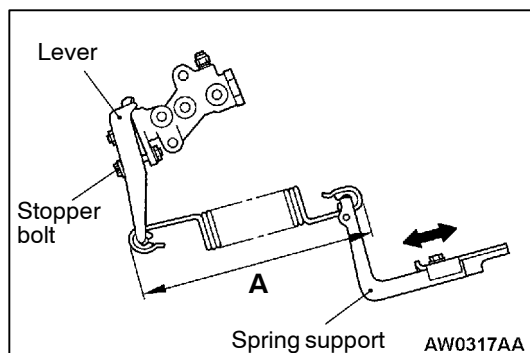

INSTALLATION SERVICE POINT

▶A◀ SPRING SUPPORT INSTALLATION

While the lever of the load sensing proportioning valve is touching the stopper bolt, install the spring support so that the distance (A) is within the standard value.

Standard value (A): 164 – 168 mm

FRONT DISC BRAKE

35100600259

REMOVAL AND INSTALLATION

Pre-removal Operation

- Brake Fluid Draining

Post-installation Operation

- Brake Fluid Supplying
- Brake Line Bleeding (Refer to P.35A-13.)

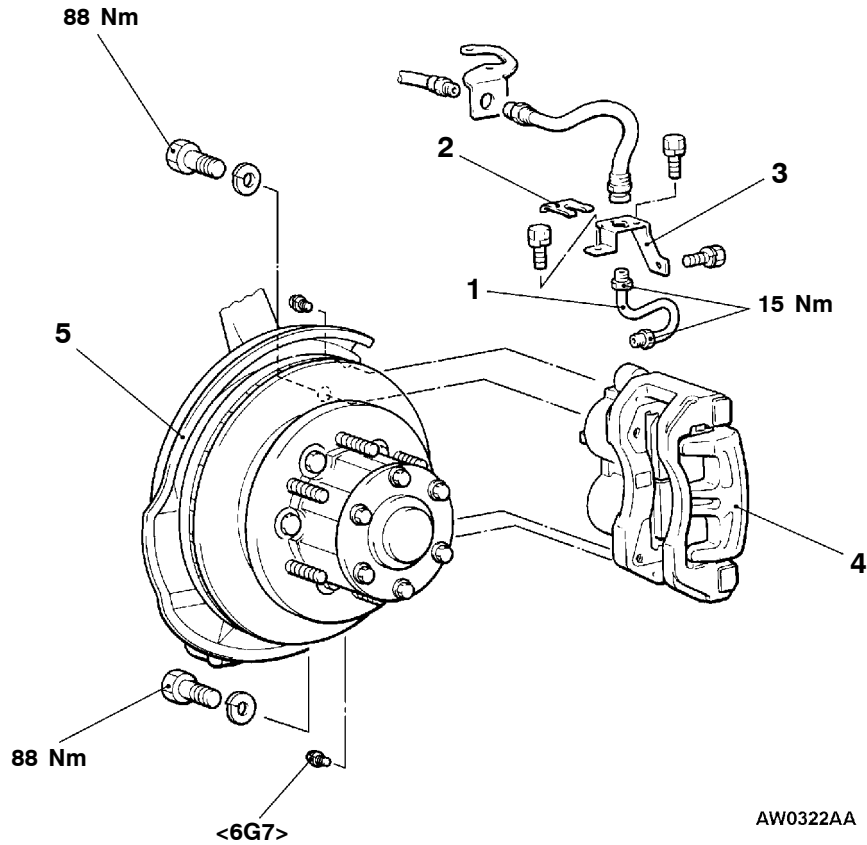

Removal steps

- ▶A◀
1. Brake tube
 2. Clip
 3. Brake hose bracket
 4. Front brake assembly
 5. Brake disc (Refer to GROUP 26 – Front Hub Assembly)

INSTALLATION SERVICE POINT

▶A◀ FRONT BRAKE ASSEMBLY INSTALLATION

1. Measure hub torque (A) with the pad removed to measure the brake drag force after pad installation.

Caution

Engage 2WD before measurement.

2. Securely attach the pad clip to the caliper support.

3. Clean the piston and insert into cylinder with special tool.
4. Be careful that the piston boot does not become caught, when lowering the caliper assembly and installing the lock pin.
5. Check the brake drag force as follows.
 - (1) Start the engine and hold the brake pedal down for 5 seconds. (Pedal depression force: approx. 196 N)
 - (2) Stop the engine.
 - (3) Turn the brake disc forward 10 times.

- (4) Check the hub torque (B) with a spring balance.
- (5) Calculate the drag force of the disc brake [difference between hub torque (B) and hub torque (A)].

Standard value: 106 N or less

6. If the brake drag force exceeds the standard value, disassemble and clean the piston. Check for corrosion or worn piston seal, and check the sliding condition of the lock pin and guide pin.

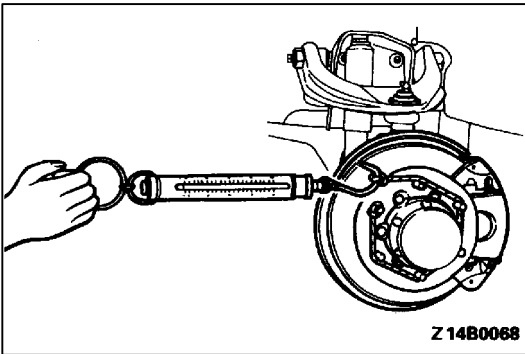
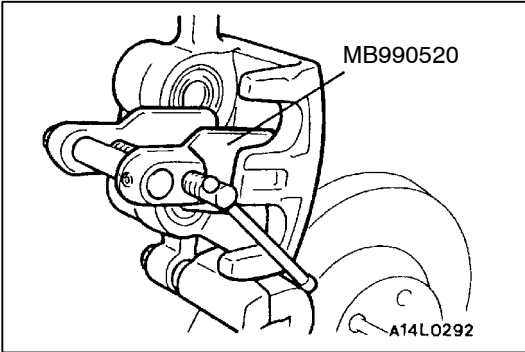
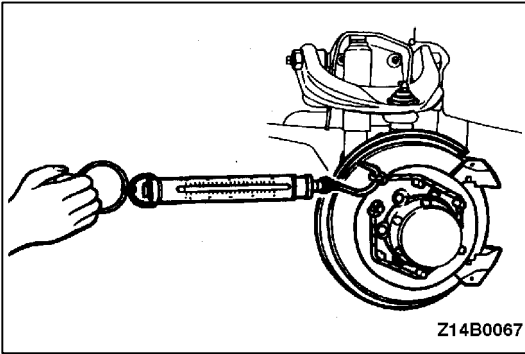

DISASSEMBLY AND REASSEMBLY

35100620293

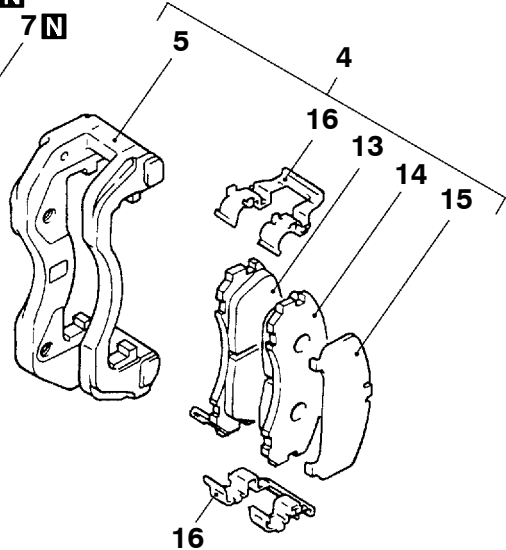
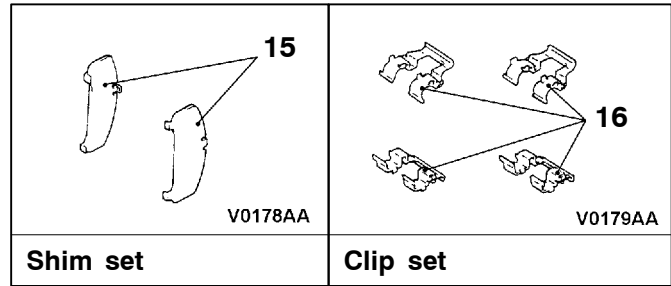
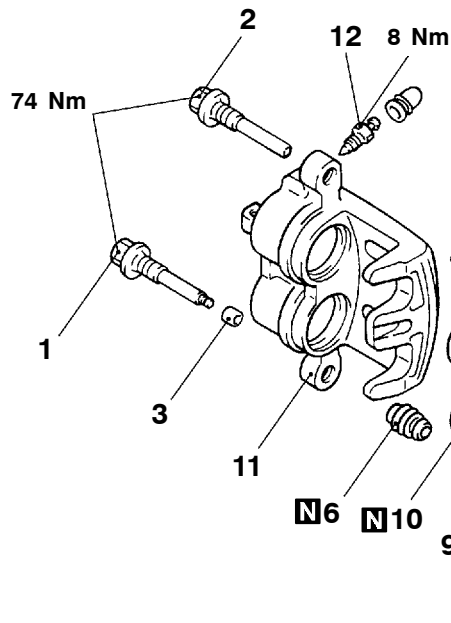

V0180AA
00009336

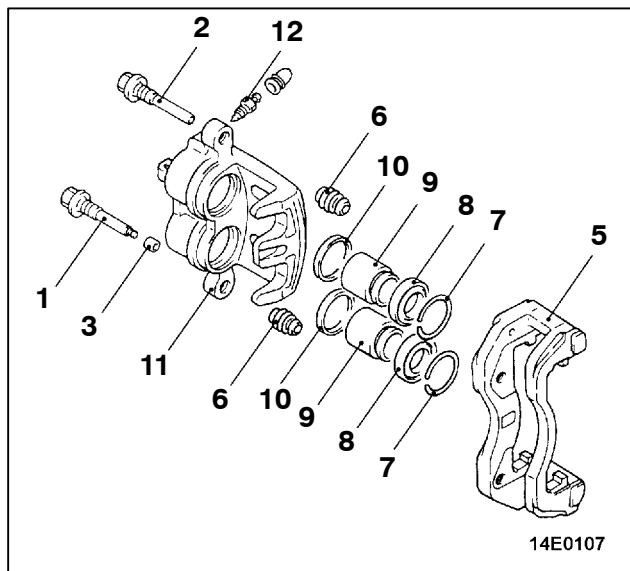

14E0107

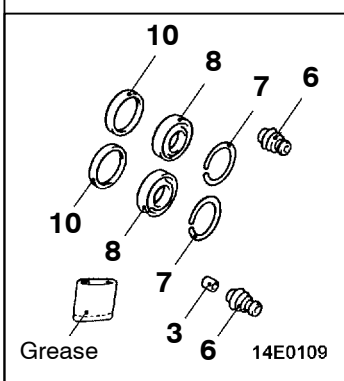

Grease 14E0109

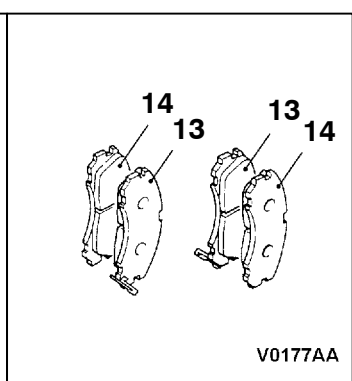

V0177AA

Brake caliper kit	Seal and boots kit	Pad set
-------------------	--------------------	---------

Caliper assembly disassembly steps

- 1. Lock pin
- 2. Guide pin
- 3. Bushing
- 4. Caliper support, pad, clip and shim assembly
- 5. Caliper support
- 6. Pin boot
- 7. Boot ring
- 8. Piston boot
- 9. Piston
- 10. Piston seal
- 11. Caliper body
- 12. Bleeder screw

Pad assembly disassembly steps

- 1. Lock pin
- 2. Guide pin
- 3. Bushing
- 4. Caliper support, pad, clip and shim assembly
- 13. Pad and wear indicator assembly
- 14. Pad assembly
- 15. Outer shim
- 16. Clip



LUBRICATION POINTS

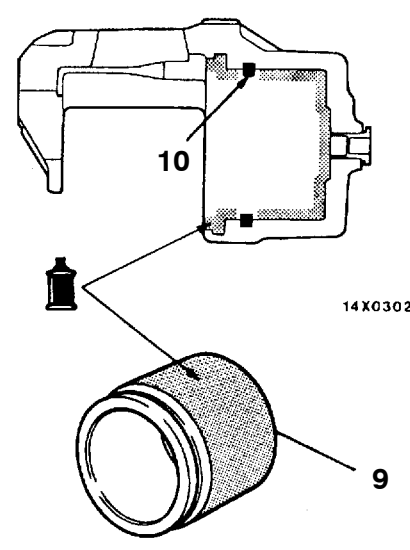

10

14X0302

9

14X0301

Caution
The piston seal inside the seal and boot kit is coated with a special grease, so do not wipe this grease off.

Brake fluid: DOT3 or DOT4

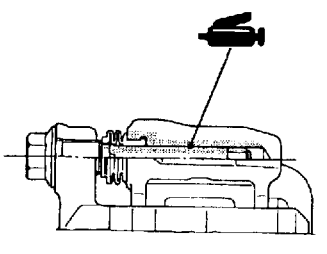

14W0046

Grease: Repair kit grease

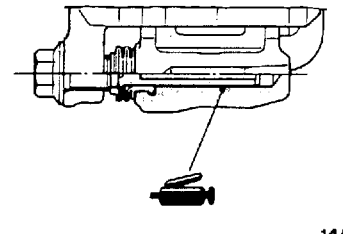
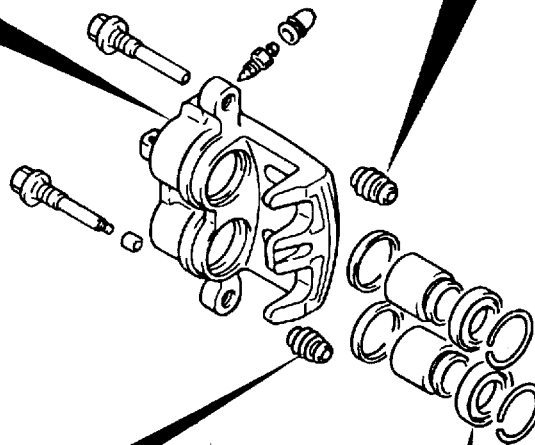

14A0541

Grease: Repair kit grease

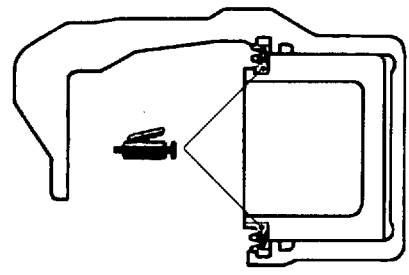

14L0128

Grease: Repair kit grease

DISASSEMBLY SERVICE POINTS

When disassembling the front disc brakes, disassemble both sides (left and right) as a set.

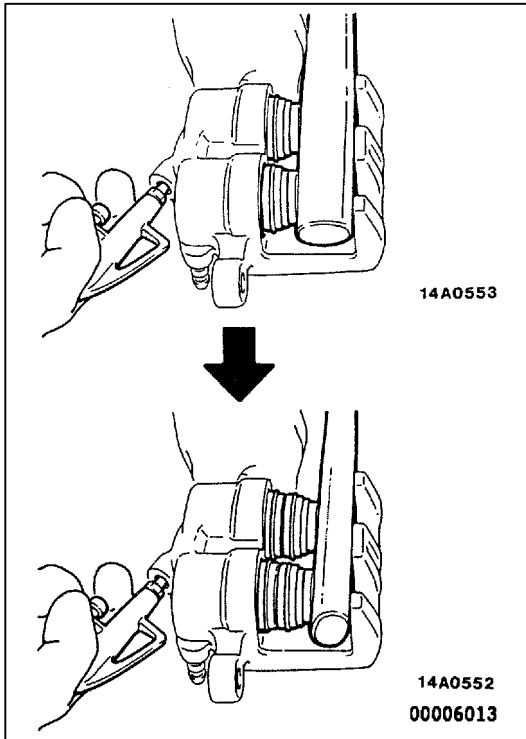

◀A▶ PISTON BOOT/PISTON REMOVAL

Protect caliper body with cloth. Blow compressed air through brake hose to remove piston boot and piston.

Caution

When removing the pistons, be sure to use the handle of a plastic hammer and adjust the height of the two pistons while pumping in air slowly so that the pistons protrude evenly.

Do not remove one piston completely before trying to remove the other piston, because it will become impossible to remove the second piston.

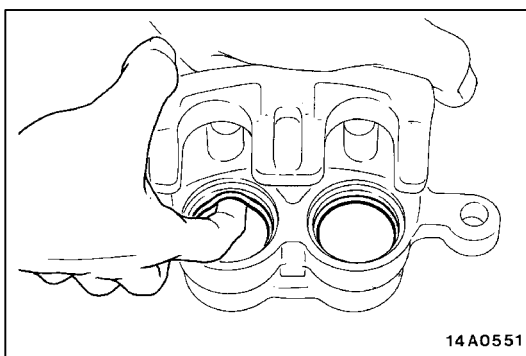

◀B▶ PISTON SEAL REMOVAL

- (1) Remove piston seal with finger tip.

Caution

Do not use a flat-tipped screwdriver or other tool to prevent damage to inner cylinder.

- (2) Clean piston surface and inner cylinder with trichloroethylene, alcohol or specified brake fluid.

Specified brake fluid: DOT3 or DOT4

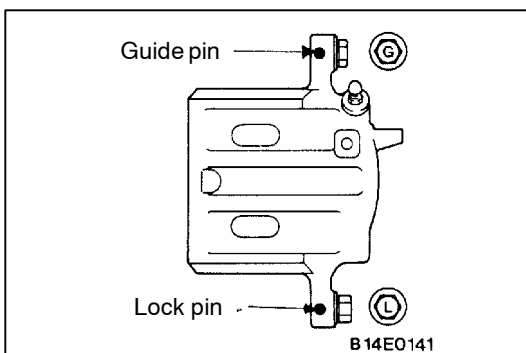

REASSEMBLY SERVICE POINT

▶A◀ LOCK PIN/GUIDE PIN INSTALLATION

Install the lock pin and guide pin to the caliper body as shown in the illustration.

INSPECTION

35100630104

- Check cylinder for wear, damage or rust.
- Check piston surface for wear, damage or rust.
- Check caliper body or sleeve for wear.
- Check pad for damage or adhesion of grease, check backing metal for damage.

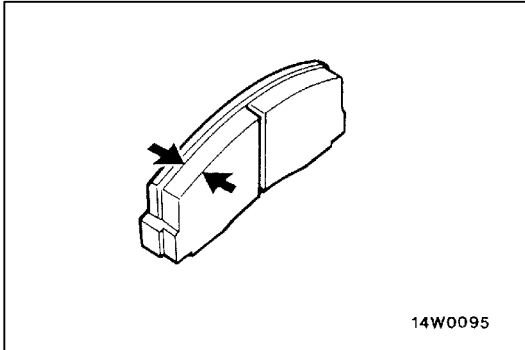
**PAD WEAR CHECK**

Measure the thickness at the thinnest and worn area of the pad.

Replace the pad assembly if pad thickness is less than the limit value.

Standard value: 10 mm

Limit: 2.0 mm

Caution

1. **Replace the pads always at both sides, and also the brake pads for the wheels on the opposite side at the same time.**
2. **If there is significant difference in the thicknesses of the pads on the left and right sides, check the sliding condition of the piston, lock pin and guide pin.**

REAR DISC BRAKE

35100700140

REMOVAL AND INSTALLATION

Pre-removal Operation

- Brake Fluid Draining

Post-installation Operation

- Brake Fluid Supplying
- Brake Line Bleeding (Refer to P.35A-13.)

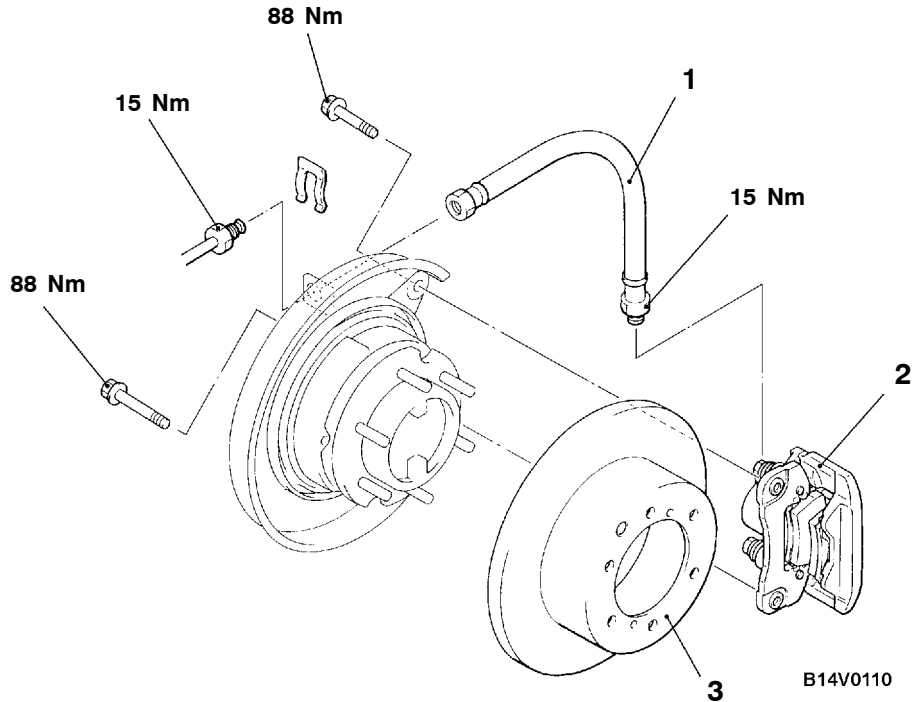

Removal steps

- ▶A◀
1. Brake hose connection
 2. Rear brake assembly
 3. Brake disc

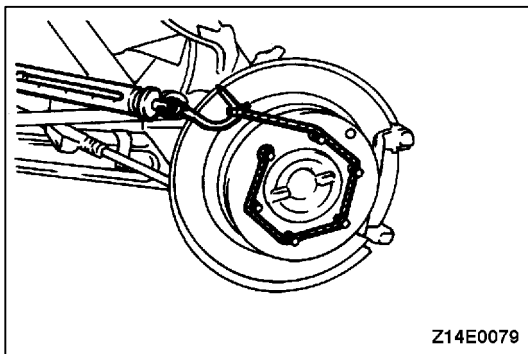

INSTALLATION SERVICE POINT

▶A◀ **REAR BRAKE ASSEMBLY INSTALLATION**

1. Measure hub torque (1) with the pad removed to measure the brake drag force after pad installation.

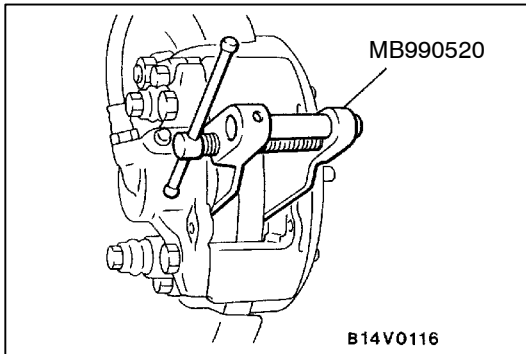

2. Clean the piston and insert into the cylinder with special tool.
3. Install the pad assembly to the caliper.
4. Start the engine. Depress the brake pedal fully a few times, and then stop the engine.
5. Turn the brake disc forward 10 times.

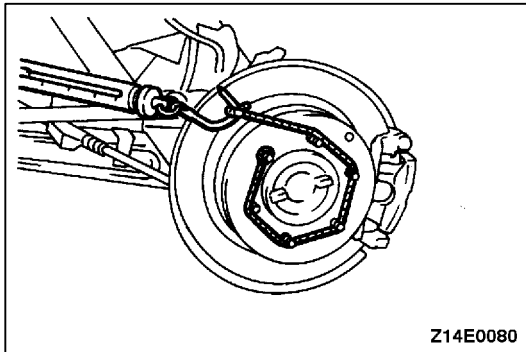

6. Check the hub torque (6) with a spring balance.
7. Calculate the drag force of the disc brake [difference between hub torque (1) and hub torque (6)].

Standard value: 56 N

8. If the brake drag torque exceeds the standard value, disassemble and clean the piston. Check for corrosion or worn piston seal, and check the sliding condition of the lock pin and guide pin.

DISASSEMBLY AND REASSEMBLY

35100720184

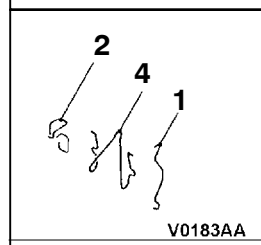
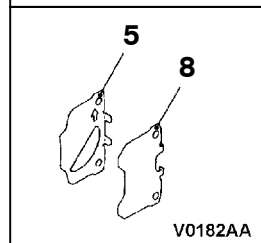
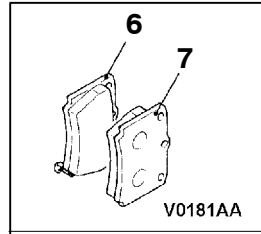
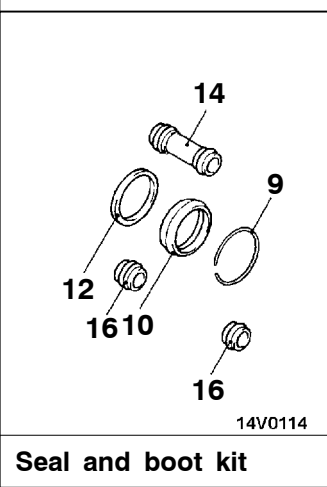
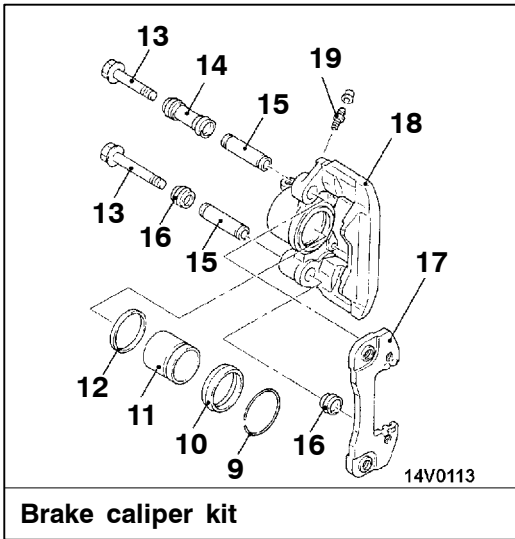
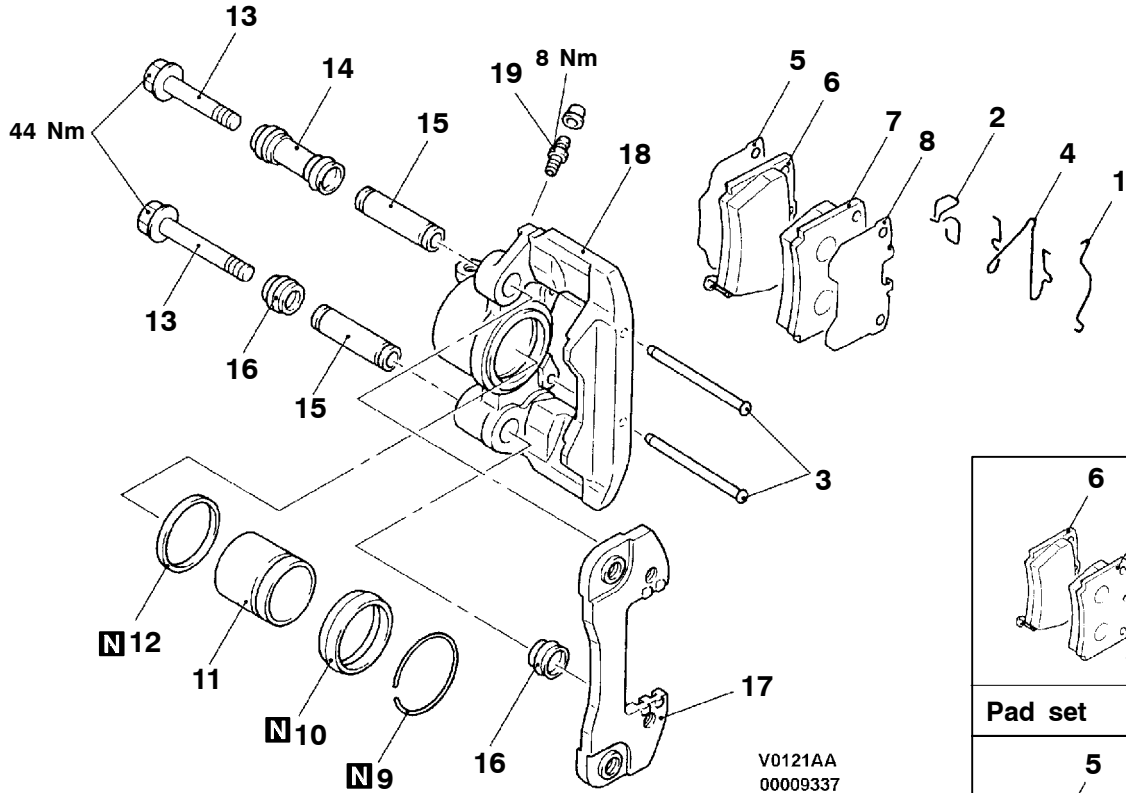

Caliper assembly disassembly steps

1. Clip
2. K-spring
3. Pad pin
4. Spring
5. Inner shim
6. Pad and wear indicator assembly
7. Pad assembly
8. Outer shim
9. Retaining ring
10. Piston boot
11. Piston
12. Piston seal
13. Sleeve bolt
14. Bushing
15. Sleeve
16. Pin boot
17. Inner caliper
18. Torque plate
19. Bleeder screw



Pad assembly disassembly steps

1. Clip
2. K-spring
3. Pad pin
4. Spring
5. Inner shim
6. Pad and wear indicator assembly
7. Pad assembly
8. Outer shim

LUBRICATION POINTS

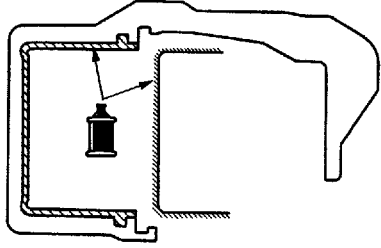

14V0132

Caution
The piston seal inside the seal and boot kit is coated with special grease, so do not wipe this grease off.

Brake fluid: DOT3 or DOT4

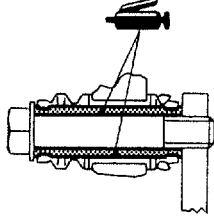

14V0122

Grease: Repair kit grease

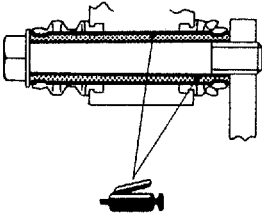

14V0123

Grease: Repair kit grease

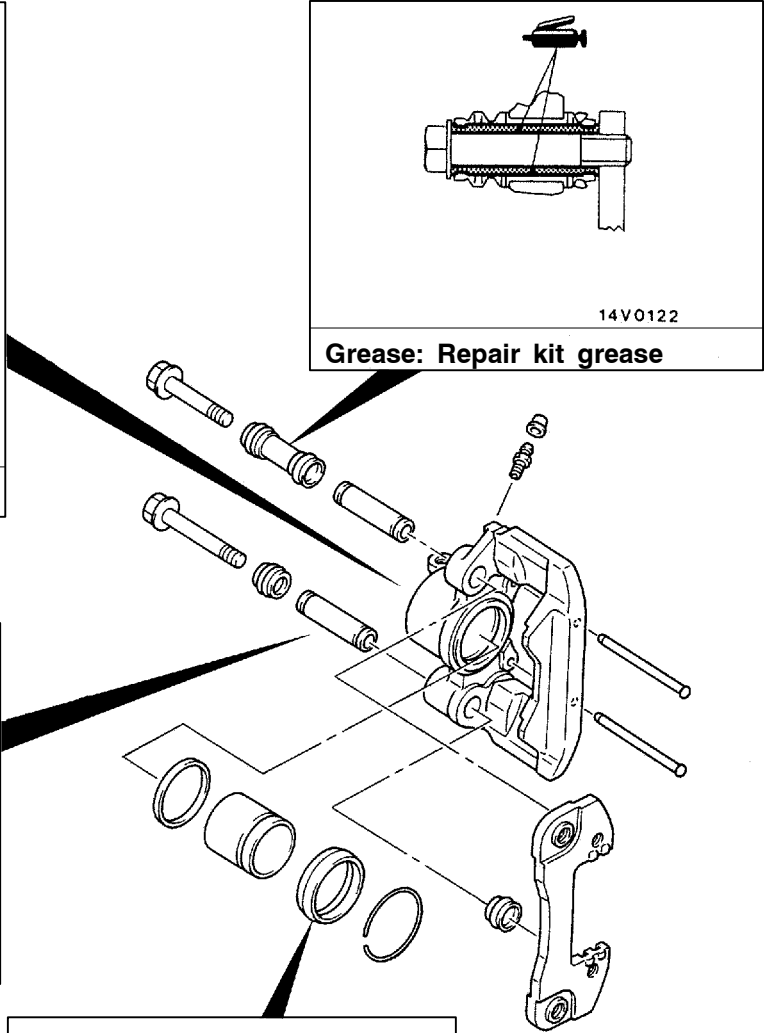
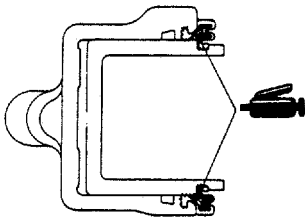
14M0083

Grease: Repair kit grease

14V0113

00006015

DISASSEMBLY SERVICE POINTS

When disassembling the rear disc brakes, disassemble both sides (left and right) as a set.

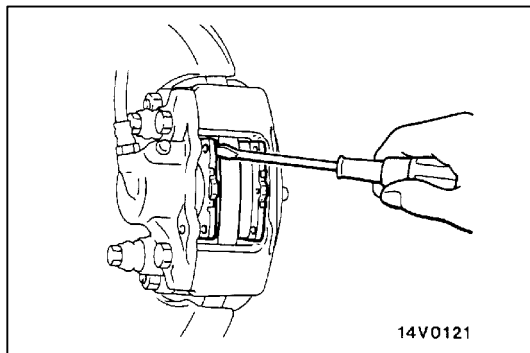

◀A▶ **PAD AND WEAR INDICATOR ASSEMBLY/PAD ASSEMBLY REMOVAL**

Use a flat-tipped screwdriver to remove the pad and wear indicator assembly and the pad assembly.

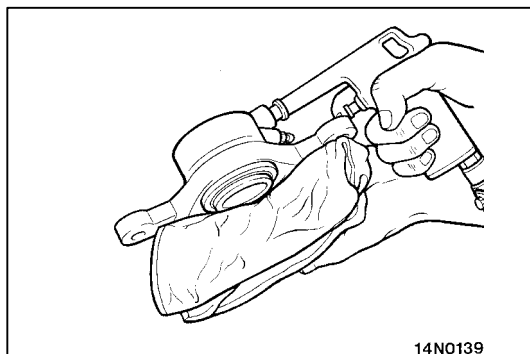

◀B▶ **PISTON BOOT/PISTON REMOVAL**

Protect the caliper body with a shop towel. Blow compressed air through the brake hose to remove the piston boot and piston.

Caution
Blow compressed air gently.

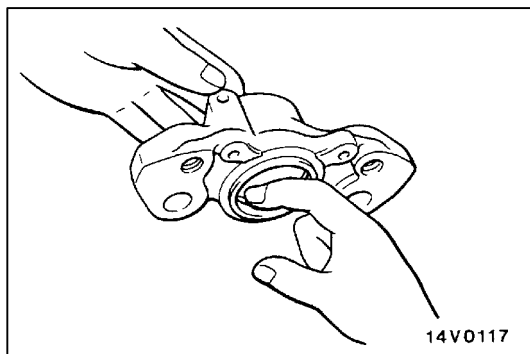

◀C▶ **PISTON SEAL REMOVAL**

1. Remove the piston seal with your finger tip.

Caution
Do not use a flat-tipped screwdriver or other tool to prevent damage to inner cylinder.

2. Clean the piston surface and inner cylinder with trichloroethylene, alcohol or specified brake fluid.

Specified break fluid: DOT3 or DOT4

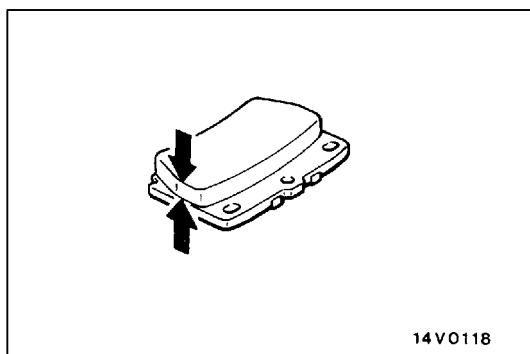

INSPECTION

35100730118

PAD WEAR CHECK

Measure the thickness at the thinnest and worn area of the pad.

Replace the pad assembly if pad thickness is less than the limit value.

Standard value: 10 mm

Limit: 2.0 mm

Caution

1. Always replace both pads on each wheel as a set (both front wheels or both rear wheels). Failure to do so will result in un-even braking which may cause an unpredictable vehicle condition.
2. If there is significant difference in the thicknesses of the pads on the left and right sides, check the sliding condition of the piston, lock pin and guide pin.

NOTES

ANTI-SKID BRAKING SYSTEM (ABS) <4WD>

CONTENTS

35209000282

GENERAL INFORMATION	2	Brake Drum Inside Diameter Check Refer to GROUP 35A	
SERVICE SPECIFICATIONS	3	Brake Lining and Brake Drum Connection Check Refer to GROUP 35A	
LUBRICANT	3	Wheel Speed Sensor Output Voltage Check	22
SPECIAL TOOLS	3	Hydraulic Unit Check	24
TROUBLESHOOTING	4	ABS Warning Lamp Relay Continuity Check	25
ON-VEHICLE SERVICE	22	Remedy for a Flat Battery	25
Brake Pedal Check and Adjustment Refer to GROUP 35A		BRAKE PEDAL	Refer to GROUP 35A
Stop Lamp Switch Check Refer to GROUP 35A		MASTER CYLINDER AND BRAKE BOOSTER	26
Brake Booster Operating Test Refer to GROUP 35A		Master Cylinder	27
Check Valve Operation Check Refer to GROUP 35A		LOAD SENSING PROPORTIONING VALVE	Refer to GROUP 35A
Proportioning Valve Function Test Refer to GROUP 35A		FRONT DISC BRAKE ..	Refer to GROUP 35A
Bleeding	Refer to GROUP 35A	REAR DISC BRAKE	Refer to GROUP 35A
Brake Fluid Level Sensor Check Refer to GROUP 35A		HYDRAULIC UNIT	28
Disc Brake Pad Check and Replacement Refer to GROUP 35A		WHEEL SPEED SENSOR	30
Disc Brake Rotor Check Refer to GROUP 35A		G-SENSOR	32
Thickness Check	Refer to GROUP 35A		
Brake Lining Thickness Check Refer to GROUP 35A			

GENERAL INFORMATION

35200010307

The ABS consists of components such as the wheel speed sensors, stop lamp switch, hydraulic unit assembly (integrated in ABS-ECU) and the ABS warning lamp. If a problem occurs in the system, the malfunctioning components can be identified and the trouble symptoms will be memorized by the diagnosis function.

In addition, reading of diagnosis codes and service data and actuator testing are possible by using the MUT-II.

Items	Specifications
ABS type	4-sensor, 3-channel type
Speed sensor	Magnet coil type on 4-wheels
Front ABS rotor teeth	47
Rear ABS rotor teeth	47

CONSTRUCTION DIAGRAM

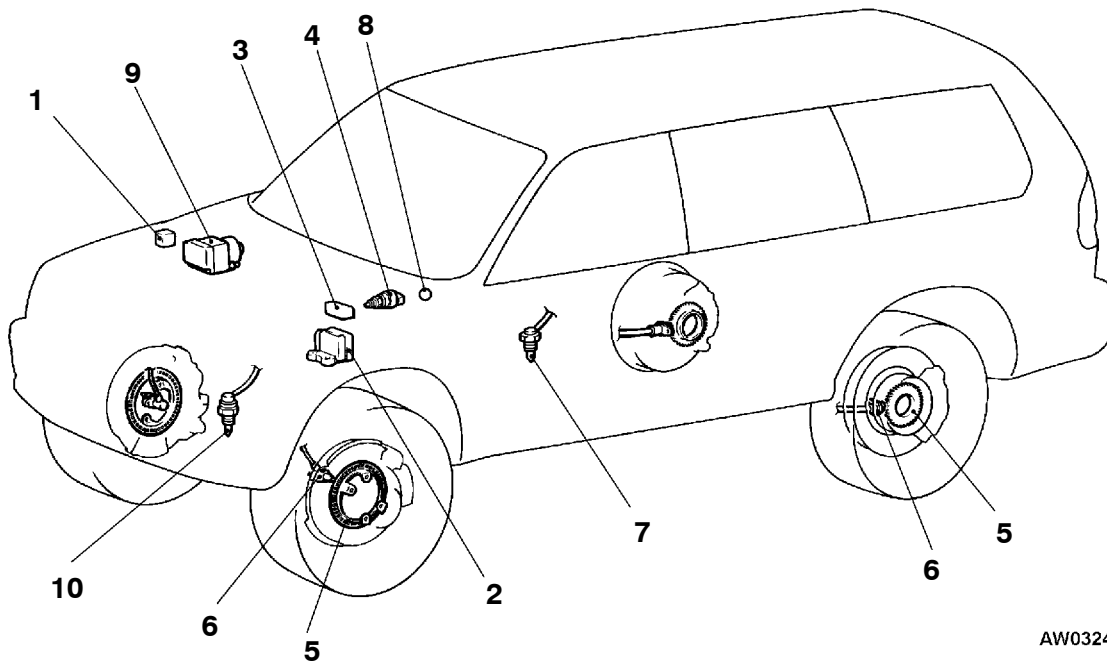

AW0324AA

- | | |
|--|-----------------------------|
| 1. ABS Warning lamp relay | 6. Wheel speed sensor |
| 2. Hydraulic unit assembly (integrated in ABS-ECU) | 7. 4WD detection switch |
| 3. Diagnosis connector | 8. ABS warning lamp |
| 4. Stop lamp switch | 9. G-Sensor |
| 5. ABS rotor | 10. Freewheel engage switch |

SERVICE SPECIFICATIONS

35200030327

Items		Standard value
Wheel speed sensor internal resistance k Ω		1.3 – 1.5
Wheel speed sensor insulation resistance k Ω		100 or more
G-sensor output voltage V	Stationary vehicle	2.4 – 2.6
	Arrow facing downward	3.4 – 3.6

LUBRICANT

35200040061

Item	Specified lubricant
Brake fluid	DOT3 or DOT4

SPECIAL TOOLS

35200060296

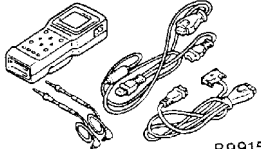
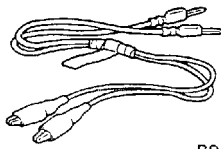
Tool	Number	Name	Use
 B991502	MB991502	MUT-II sub assembly	For checking of ABS (Diagnosis code display when using the MUT-II)
 B991529	MB991529	Diagnosis code check harness	For checking of ABS (Diagnosis code display when using the ABS warning lamp)

TROUBLESHOOTING

35201110501

STANDARD FLOW OF DIAGNOSTIC TROUBLESHOOTING

Refer to GROUP 00 – How to Use Troubleshooting/Inspection Service Points.

NOTES WITH REGARD TO DIAGNOSIS

The phenomena listed in the following table are not abnormal.

Phenomenon	Explanation of phenomenon
System check sound	When starting the engine, a thudding sound can sometimes be heard coming from inside the engine compartment, but this is because the system operation check is being performed, and is not an abnormality.
ABS operation sound	<ol style="list-style-type: none"> 1. Sound of the motor inside the ABS hydraulic unit operation (whine). 2. Sound is generated along with vibration of the brake pedal (scraping). 3. When ABS operates, sound is generated from the vehicle chassis due to repeated brake application and release. (Thump: suspension: squeak: tyres)
ABS operation (Long braking distance)	For road surfaces such as snow-covered roads and gravel roads, the braking distance for vehicles with ABS can sometimes be longer than that for other vehicles. Accordingly, advise the customer to drive safely on such roads by lowering the vehicle speed and not being too overconfident.

Diagnosis detection condition can vary depending on the diagnosis code.

Make sure that checking requirements listed in the “Comment” are satisfied when checking the trouble symptom again.

DIAGNOSIS FUNCTION

35201120351

DIAGNOSIS CODES CHECK

Read a diagnosis code by the MUT-II or ABS warning lamp.
(Refer to GROUP 00 – How to Use Troubleshooting/Inspection Service Points.)

ERASING DIAGNOSIS CODES**With the MUT-II**

Refer to GROUP 00 – How to Use Troubleshooting/Inspection Service Points.

Without the MUT-II

1. Use the special tool to earth terminal (1) (diagnosis control terminal) of the diagnosis connector. (Refer to GROUP 00 – How to Use Troubleshooting/Inspection Service Points.)
2. Stop the engine.
3. Turn on the stop lamp switch. (Depress the brake.)
4. After carrying out steps 1. to 3., turn the ignition switch to ON. Within 3 seconds after turning the ignition switch to ON, turn off the stop lamp switch (release the brake). Then, turn the stop lamp switch on and off a total of 10 times.

NOTE

If the ABS-ECU function has been stopped because of fail-safe operation, it will not be possible to erase the diagnosis codes.

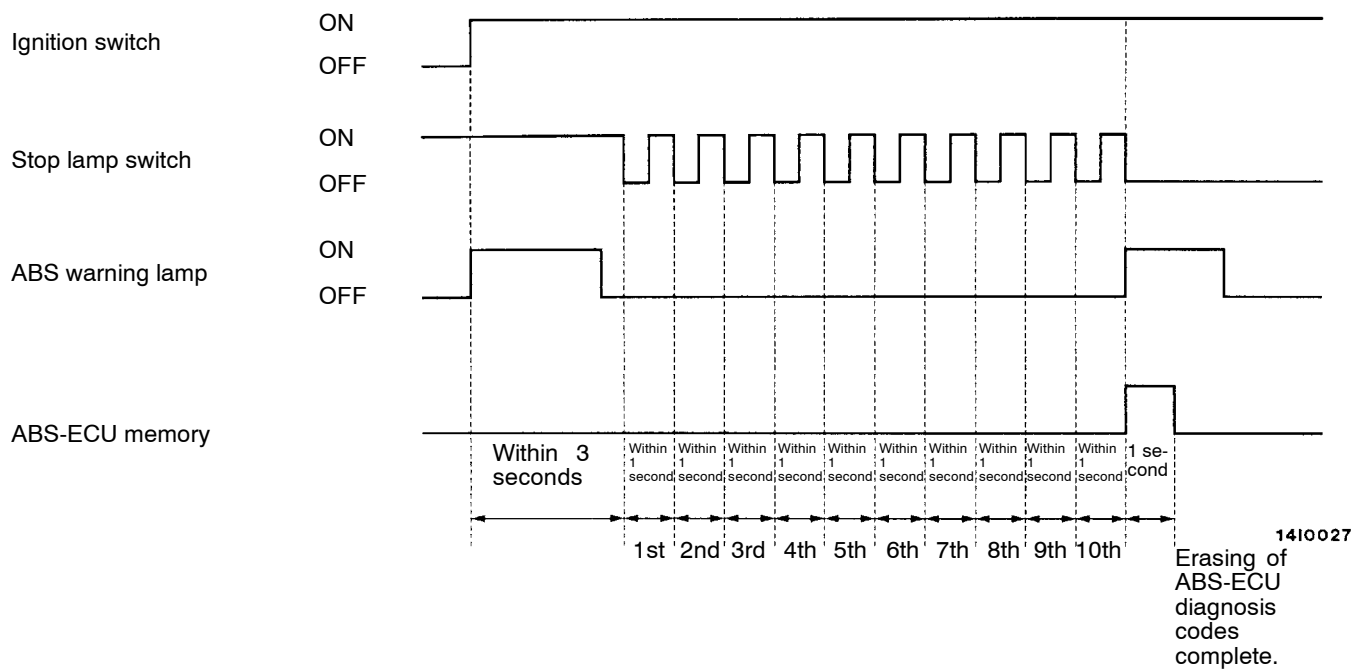

INSPECTION CHART FOR DIAGNOSIS CODES

Inspect according to the inspection chart that is appropriate for the malfunction code.

Diagnosis code No.	Inspection item	Diagnosis content	Reference page
11	Front right wheel speed sensor	Open or short circuit	35B-7
12	Front left wheel speed sensor		
13	Rear right wheel speed sensor		
14	Rear left wheel speed sensor		
15	Wheel speed sensor	Abnormal output signal	35B-8
16	Power supply system		35B-8
21	Front right wheel speed sensor	Abnormal	35B-7
22	Front left wheel speed sensor		
23	Rear right wheel speed sensor		
24	Rear left wheel speed sensor		
25	4WD position detection switch		35B-9
26	Freewheel engage switch		35B-10
32	G-sensor system		35B-11
33	Stop lamp switch system		35B-11
41	Front right solenoid valve		35B-12
42	Front left solenoid valve		
43	Rear solenoid valve		
51	Valve relay		
53	Motor relay, motor		
63	ABS-ECU		Refer to P. 35B-28 (Replace the hydraulic unit assembly)

INSPECTION PROCEDURE FOR DIAGNOSIS CODES

Code No. 11, 12, 13, 14 Wheel speed sensor open circuit or short circuit	Probable cause
Code No. 21, 22, 23, 24 Wheel speed sensor abnormal	
The ABS-ECU determines that an open circuit or short circuit occurs in more than one line of wheel speed sensors.	<ul style="list-style-type: none"> • Malfunction of wheel speed sensor • Malfunction of wiring harness or connector • Malfunction of hydraulic unit assembly
These codes are output at the following times: <ul style="list-style-type: none"> • When an open circuit cannot be found, but more than one wheel speed sensor does not output any signal during driving at 8 km/h or higher. • When a chipped or plugged-up rotor tooth, etc. is detected. • When the sensor output drops and anti-lock control is continuously carried out due to a defective sensor or a warped rotor. 	<ul style="list-style-type: none"> • Malfunction of wheel speed sensor • Malfunction of ABS rotor • Malfunction of wheel bearing • Malfunction of wiring harness or connector • Malfunction of hydraulic unit assembly

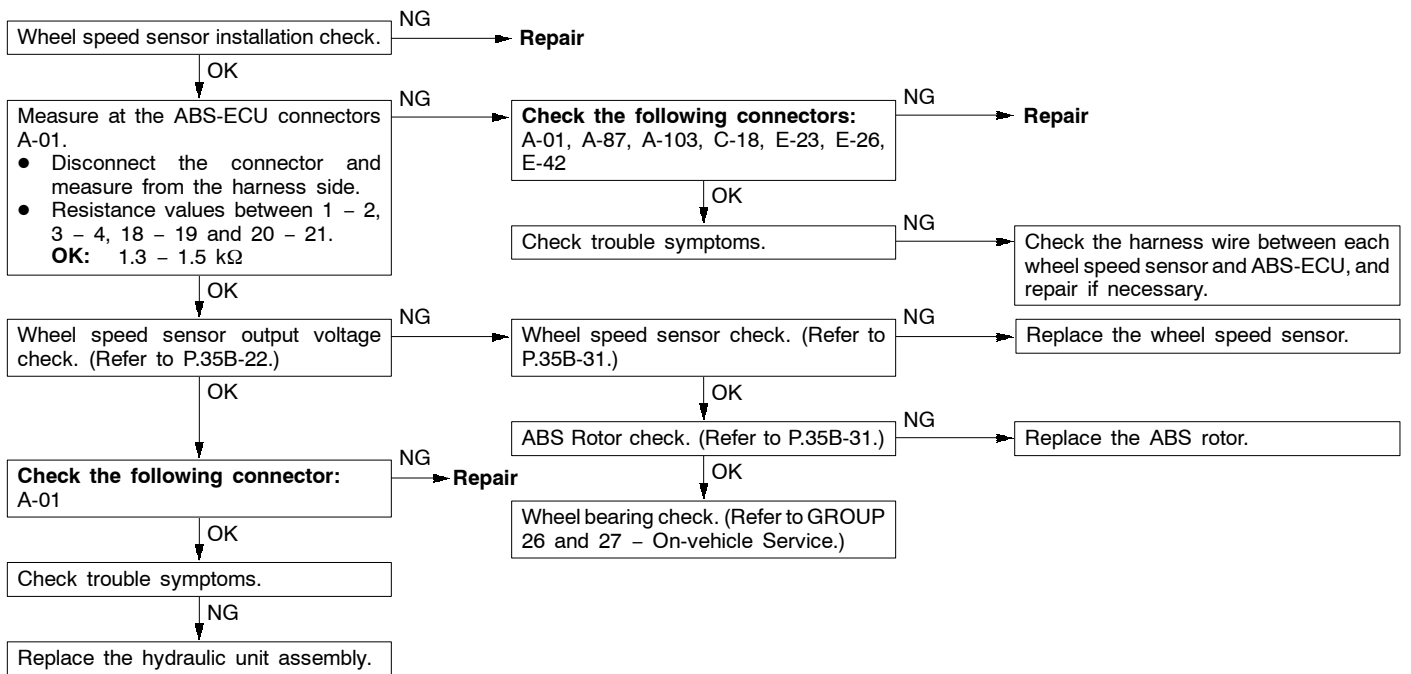

Code No. 15 Wheel speed sensor (Abnormal output signal)	Probable cause
A wheel speed sensor outputs an abnormal signal (other than an open or short-circuit).	<ul style="list-style-type: none"> ● Improper installation of wheel speed sensor ● Malfunction of wheel speed sensor ● Malfunction of ABS rotor ● Malfunction of wheel bearing ● Malfunction of wiring harness or connector ● Malfunction of hydraulic unit assembly

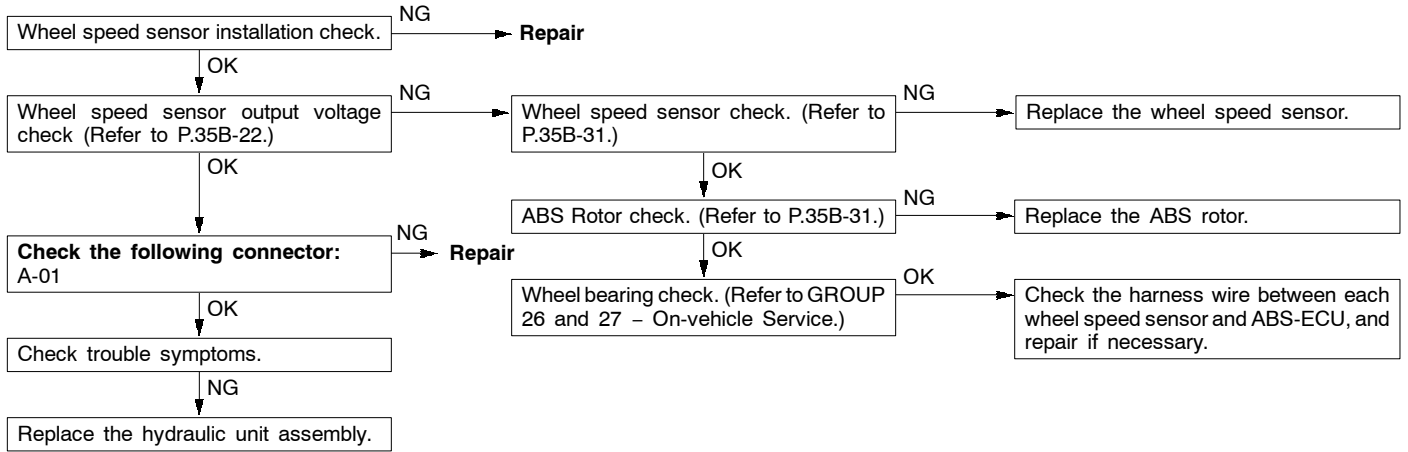

Code No. 16 Power supply system	Probable cause
The voltage of the ABS-ECU power supply drops lower or rises higher than the specified value. If the voltage returns to the specified value, this code is no longer output.	<ul style="list-style-type: none"> ● Malfunction of wiring harness or connector. ● Malfunction of hydraulic unit assembly

Caution

If battery voltage drops or rises during inspection, this code will be output as well. If the voltage returns to standard value, this code is no longer output. Before carrying out the following inspection, check the battery level, and refill distilled water if necessary.

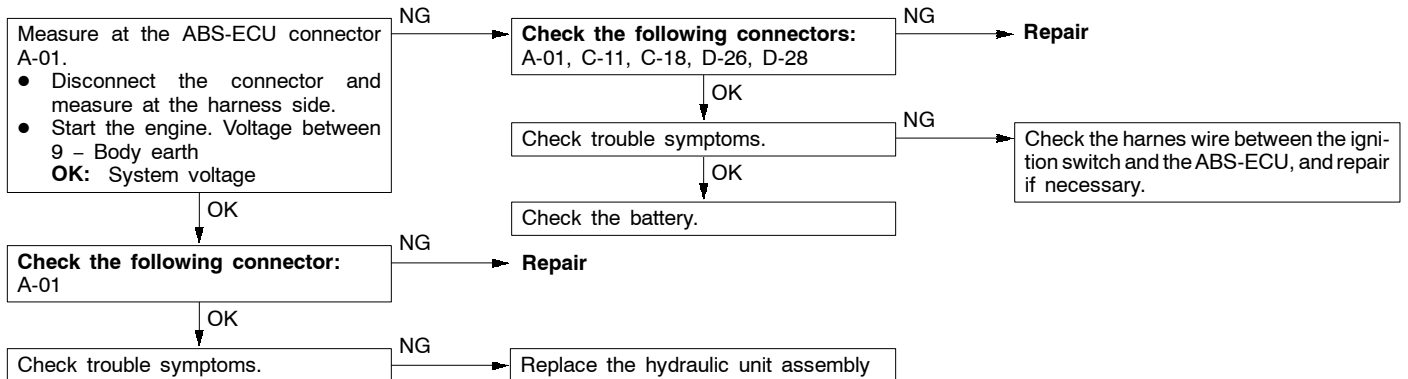

Code No. 25 4WD position detection switch	Probable cause
ABS-ECU determines that an open circuit exists in the 4WD position detection switch system.	<ul style="list-style-type: none"> ● Malfunction of wiring harness or connector ● Malfunction of 4WD indicator-ECU ● Malfunction of 4WD position detection switch ● Malfunction of hydraulic unit assembly

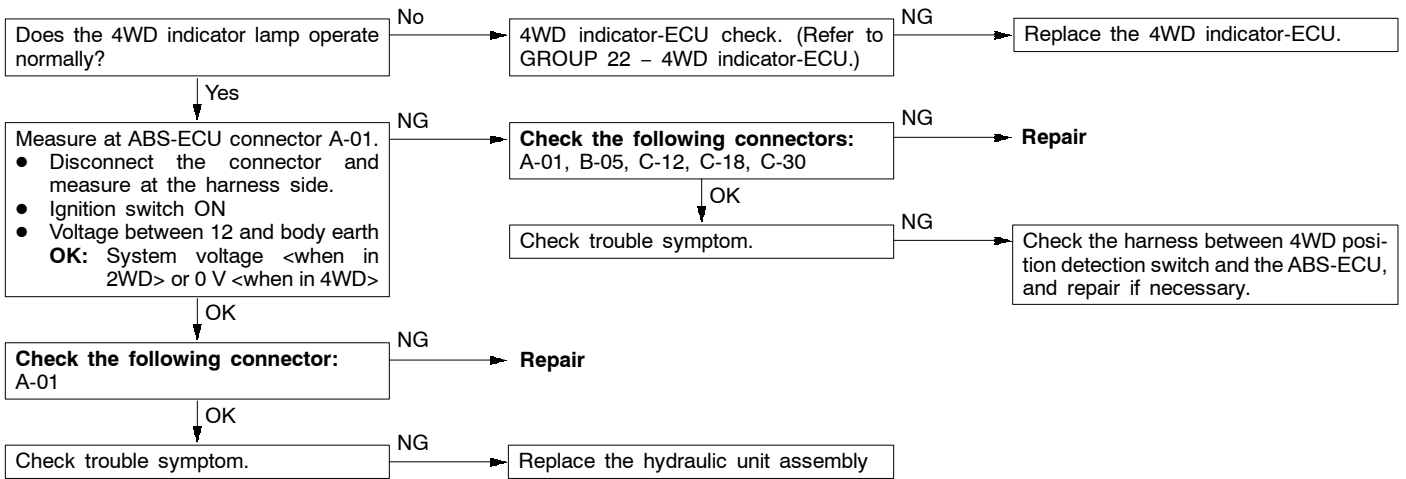

Code No. 26 Freewheel engage switch	Probable cause
<p>This code is output at the following times:</p> <ul style="list-style-type: none"> • ABS-ECU determines that an open circuit exists in the freewheel engage switch system. • When the 4WD detection switch is off and the freewheel engage switch is on, the vehicle will continue running at 20 km/h or more for approximately 5 min. or more and then will continue running until a speed of 0 km/h is reached. (Code Nos. 25 and 26 are output.) 	<ul style="list-style-type: none"> • Malfunction of wiring harness or connector • Malfunction of freewheel engage switch • Malfunction of 4WD indicator-ECU • Malfunction of 4WD position detection switch • Malfunction of hydraulic unit assembly

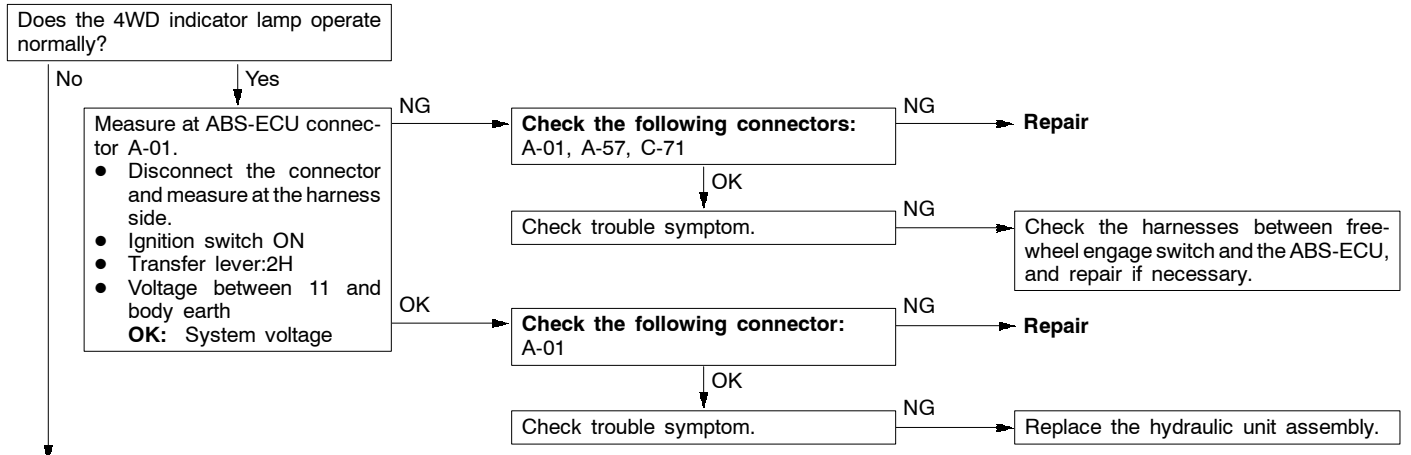

Trouble symptom	Main cause	Remedy
Even when the transfer shift lever is in the "4H" position, the 4WD indicator lamp does not illuminate.	Broken harness wire between the 4WD indicator-ECU and the freewheel engage switch, or broken earth wire from the freewheel engage switch	Repair the harness.
	Freewheel engage switch or 4WD position detection switch is defective.	Replace the switch.
	Broken harness wire between the 4WD indicator-ECU and the 4WD position detection switch	Repair the harness.
	Broken wire in the 4WD indicator-ECU circuit	4WD indicator-ECU inspection (Refer to GROUP 22 – 4WD indicator-ECU.)
4WD indicator lamp illuminates regardless of the position of the transfer shift lever.	Short in the harness wire in the 4WD position detection switch circuit	Repair the harness.
	4WD position detection switch is defective.	Replace the switch.
	Short in the ABS-ECU circuit	Replace the ABS-ECU.
	Short in the 4WD indicator-ECU circuit	4WD indicator-ECU inspection (Refer to GROUP 22 – 4WD indicator-ECU.)
No indicator is illuminated	Power circuit in the 4WD indicator-ECU is defective.	Repair the harness.
	4WD indicator-ECU is defective.	4WD indicator-ECU inspection (Refer to GROUP 22 – 4WD indicator-ECU.)

NOTE

When checking a short in the ABS-ECU circuit, remove the ABS-ECU connector and check if the 4WD indicator returns to normal. If it returns to normal, the ABS-ECU is defective. Furthermore, if the ABS-ECU is normal, then the 4WD indicator-ECU will be defective.

Code No. 32 G-sensor system	Probable cause
This code is output at the following times: ● The G-sensor output is less than 0.5 V or more than 4.5 V. ● An open or short circuit is present in the G-sensor system.	<ul style="list-style-type: none"> ● Malfunction of G-sensor ● Malfunction of wiring harness or connector ● Malfunction of hydraulic unit assembly

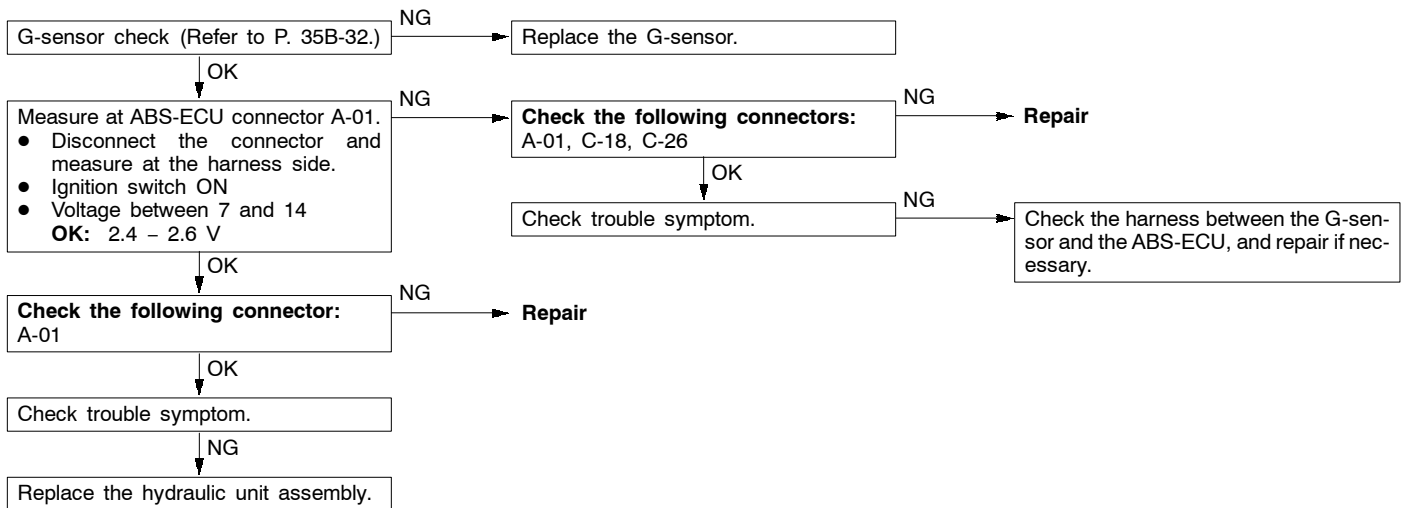

Code No. 33 Stop lamp switch system	Probable cause
These codes are output at the following times: ● When the stop lamp switch is not be turned off (when the stop lamp switch stays on for 15 minutes or more although the ABS is not operating) ● When the ABS-ECU determines that there is an open circuit in harness of the stop lamp switch system.	<ul style="list-style-type: none"> ● Malfunction of stop lamp switch ● Malfunction of harness or connector ● Malfunction of hydraulic unit assembly

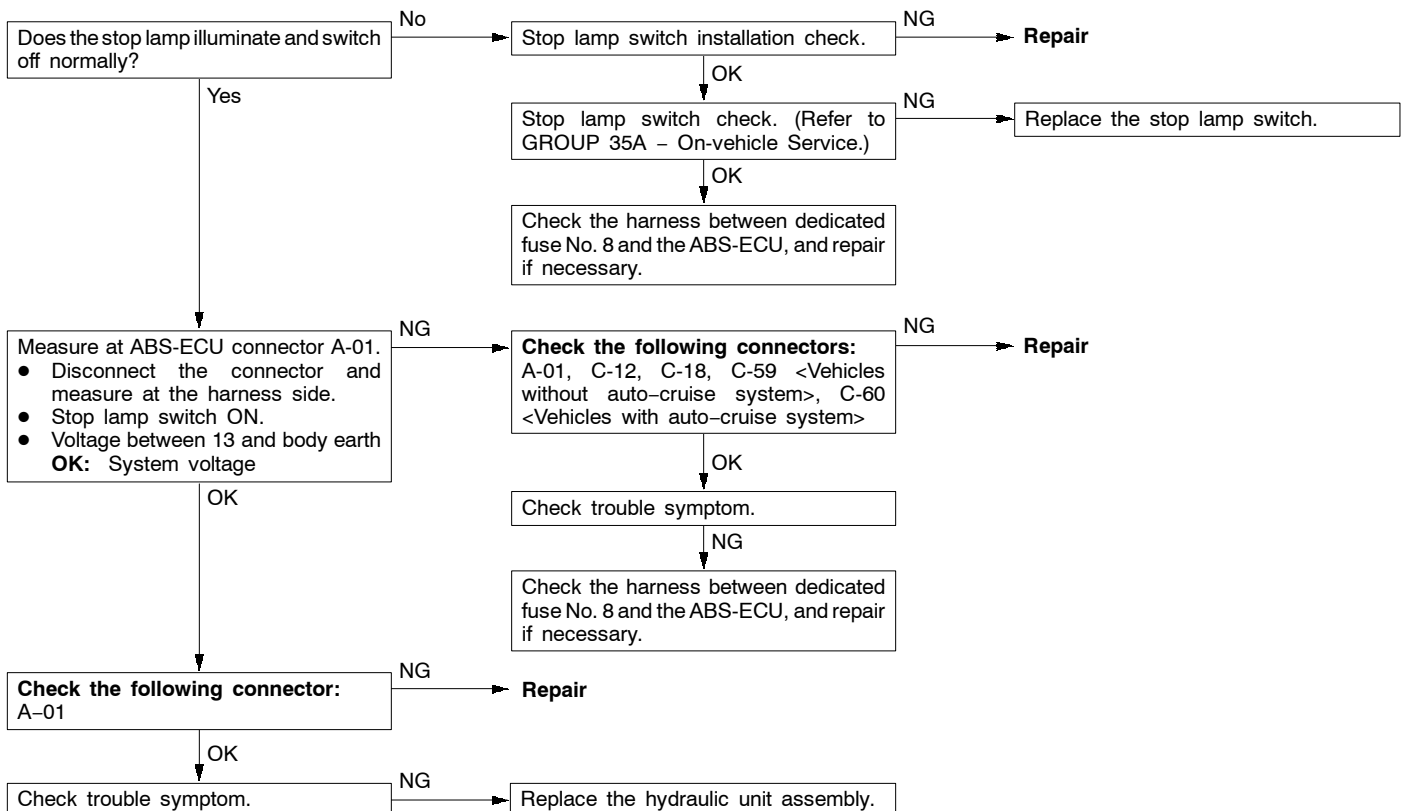

Code No. 41, 42, 43 Solenoid valve system	Probable cause
Code No. 51 Valve relay system	
Code No. 53 Motor relay, Motor system	
These codes are output in the following cases: <ul style="list-style-type: none"> • If there is an open or short circuit in the ABS-ECU power circuit (solenoid valve, motor). • If there is a malfunction in the hydraulic unit inner circuit. 	<ul style="list-style-type: none"> • Malfunction of harness or connector • Malfunction of hydraulic unit assembly

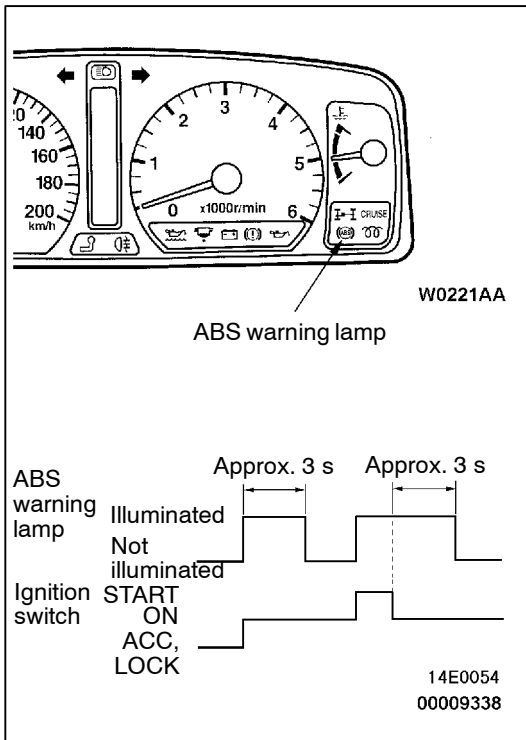
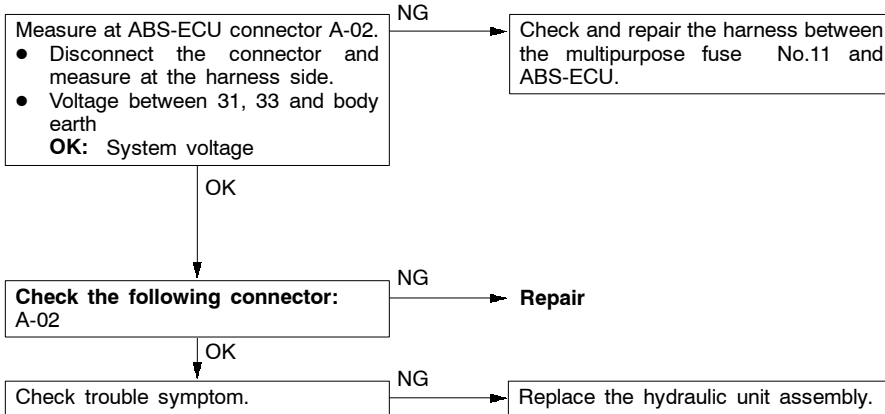

ABS WARNING LAMP INSPECTION

35201200161

Check that the ABS warning lamp illuminates as follows.

1. When the ignition key is turned to "ON", the ABS warning lamp illuminates for approximately 3 seconds and then switches off.
2. When the ignition key is turned to "START", the ABS warning lamp remains illuminated.
3. When the ignition key is turned from "START" back to "ON", the ABS warning lamp illuminates for approximately 3 seconds and then switches off.

NOTE

The ABS warning lamp may remain on until the vehicle reaches a speed of several km/h. This is limited to cases where diagnosis code Nos.21 – 24 and 55 have been recorded because of a previous problem occurring. In this case, the ABS-ECU keeps the warning lamp illuminated until the problem corresponding to that diagnosis code can be detected.

4. If the illumination is other than the above, check the diagnosis codes.

INSPECTION CHART FOR TROUBLE SYMPTOMS

35201140555

Get an understanding of the trouble symptoms and check according to the inspection procedure chart.

Trouble symptoms		Inspection procedure No.	Reference page
Communication with MUT-II is not possible.	Communication with all systems is not possible.	1	35B-14
	Communication with ABS only is not possible.	2	35B-14
When the ignition key is turned to “ON” (engine stopped), the ABS warning lamp does not illuminate.		3	35B-15
The ABS warning lamp remains illuminated after the engine is started.		4	35B-16
Faulty ABS operation	Unequal braking power on both sides	5	35B-17
	Insufficient braking power		
	ABS operates under normal braking conditions		
	ABS operates before vehicle stops under normal braking conditions		
	Large brake pedal vibration (Caution 2.)	–	–

Caution

1. If steering movements are made when driving at high speed, or when driving on road surfaces with low frictional resistance, or when passing over bumps, the ABS may operate even though sudden braking is not being applied. Because of this, when getting information from the customer, check if the problem occurred while driving under such conditions as these.
2. During ABS operation, the brake pedal may vibrate or may not be able to be depressed. Such phenomena are due to intermittent changes in hydraulic pressure inside the brake line to prevent the wheels from locking and is not an abnormality.

INSPECTION PROCEDURE FOR TROUBLE SYMPTOMS

Inspection Procedure 1

Communication with MUT-II is not possible. (Communication with all systems is not possible.)	Probable cause
The reason is probably a defect in the power supply system (including earth) for the diagnosis line.	<ul style="list-style-type: none"> ● Malfunction of connector ● Malfunction of harness

Refer to GROUP 13A – Troubleshooting.

Inspection Procedure 2

Communication with MUT-II is not possible. (Communication with ABS only is not possible.)	Probable cause
When communication with the MUT-II is not possible, the cause is probably an open circuit in the ABS-ECU power circuit or an open circuit in the diagnosis output circuit.	<ul style="list-style-type: none"> ● Blown fuse ● Malfunction of wiring harness or connector ● Malfunction of hydraulic unit assembly

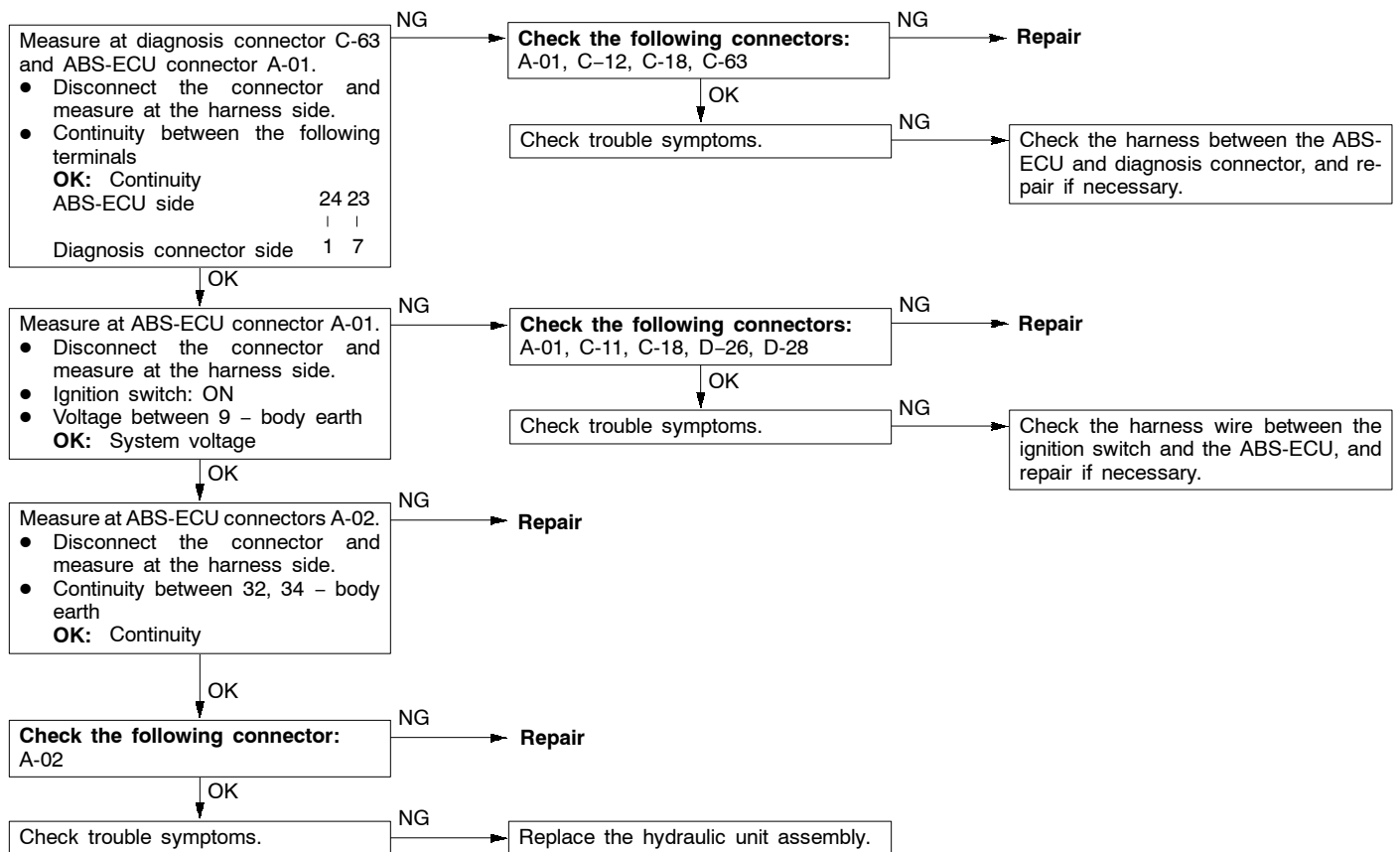

Inspection Procedure 3

When ignition key is turned to “ON” (engine stopped), ABS warning lamp does not illuminate.	Probable cause
Lamp power supply circuit disconnections, lamp bulb burnouts, ABS warning lamp relay faults, or circuit breaks between the ABS warning lamp and the ground are possible causes.	<ul style="list-style-type: none"> ● Blown fuse ● Burnt out ABS warning lamp bulb ● Malfunction of the ABS warning lamp relay ● Malfunction of wiring harness or connector ● Malfunction of hydraulic unit assembly

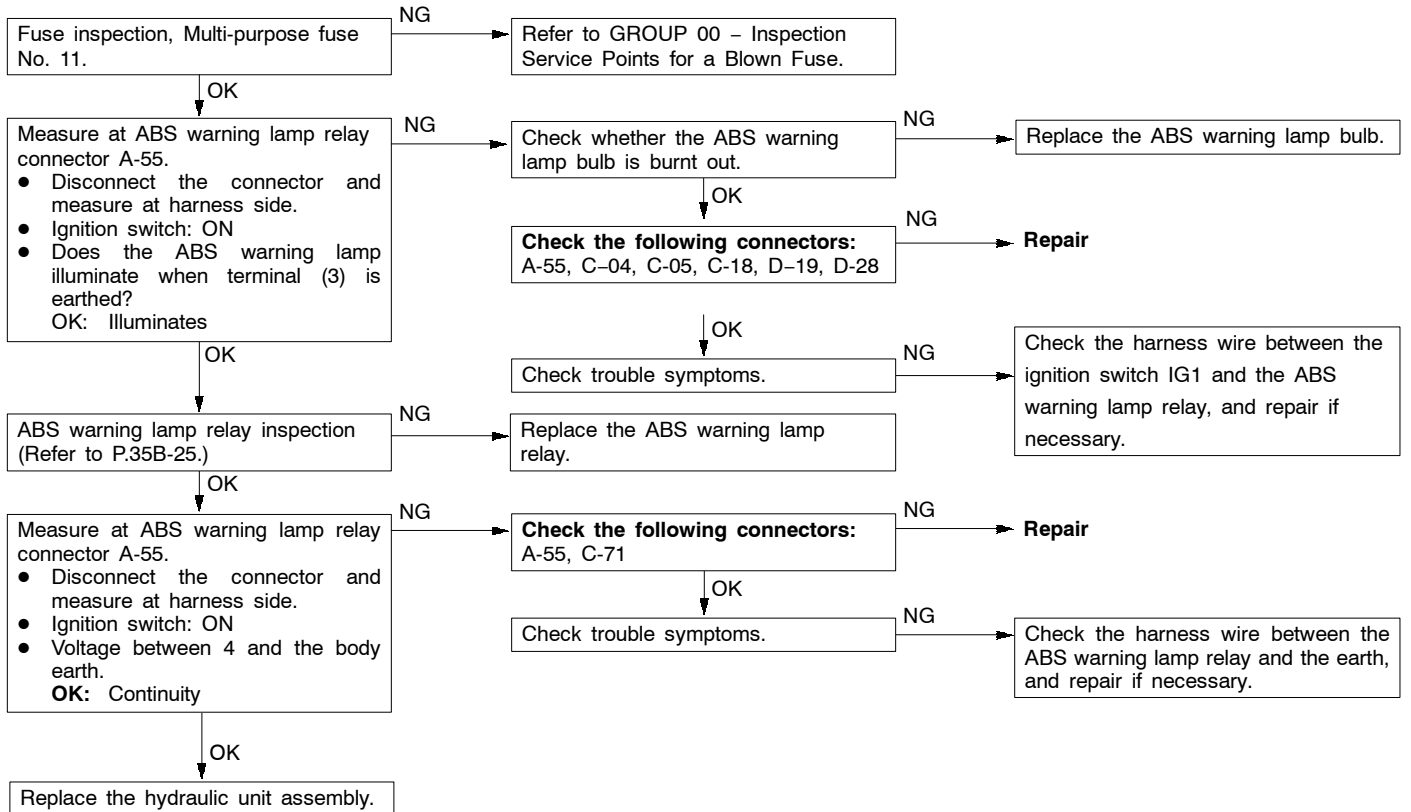

Inspection Procedure 4

The ABS warning lamp remains illuminated after the engine is started.	Probable cause
It is probably a short circuit in the ABS warning lamp circuit.	<ul style="list-style-type: none"> ● Defective combination meter ● Defective ABS warning lamp relay ● Malfunction of wiring or connector ● Defective hydraulic unit assembly

NOTE

This trouble symptom is limited to cases where communication with the MUT-II is possible (ABS-ECU power supply is normal) and the diagnosis code is a normal diagnosis code.

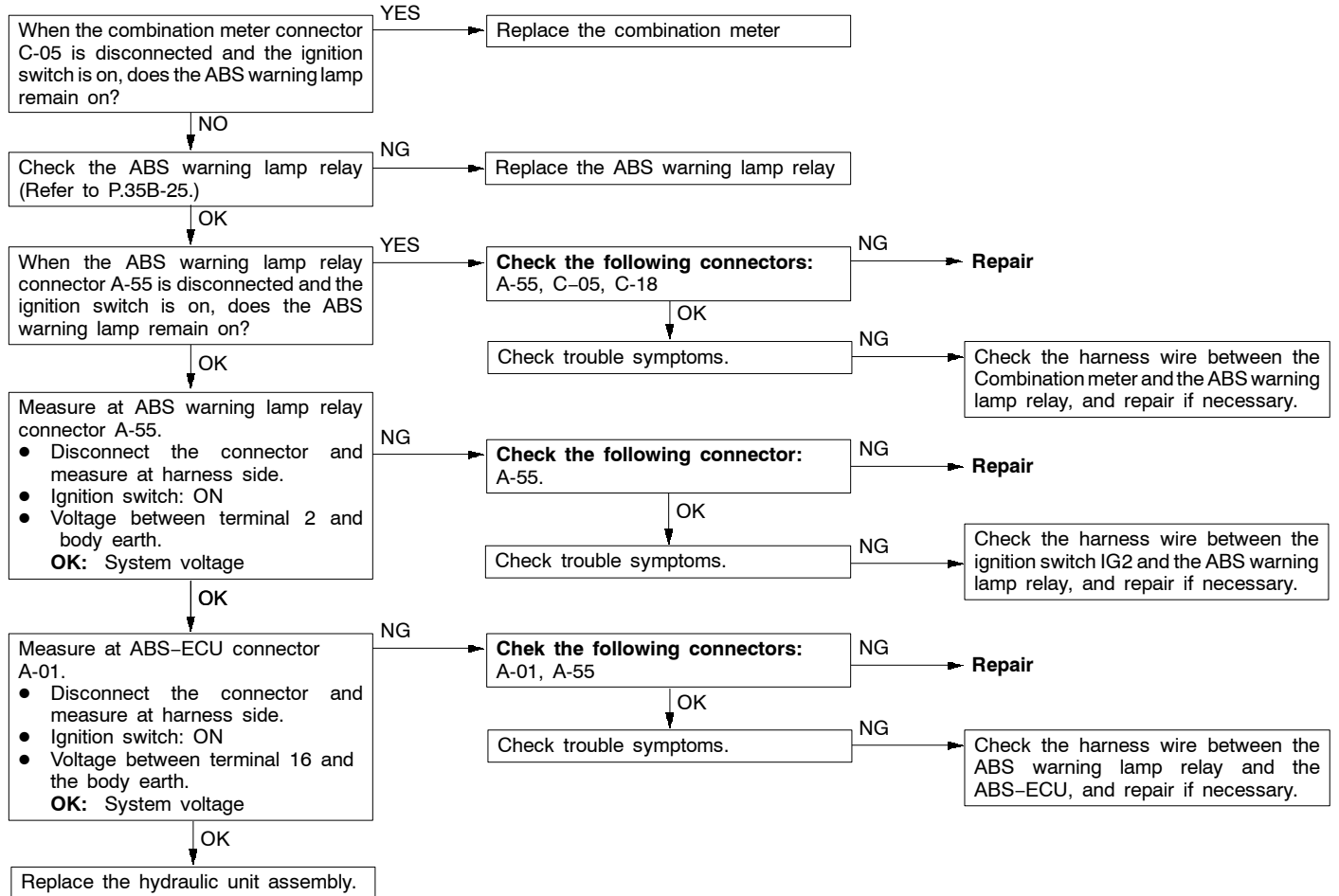

Inspection Procedure 5

Brake operation is abnormal.	Probable cause
This varies depending on the driving conditions and the road surface conditions, so problem diagnosis is difficult. However, if a normal diagnosis code is displayed, carry out the following inspection.	<ul style="list-style-type: none"> ● Improper installation of wheel speed sensor ● Incorrect sensor harness contact ● Foreign material adhering to wheel speed sensor ● Malfunction of wheel speed sensor ● Malfunction of ABS rotor ● Malfunction of wheel bearing ● Malfunction of hydraulic unit assembly

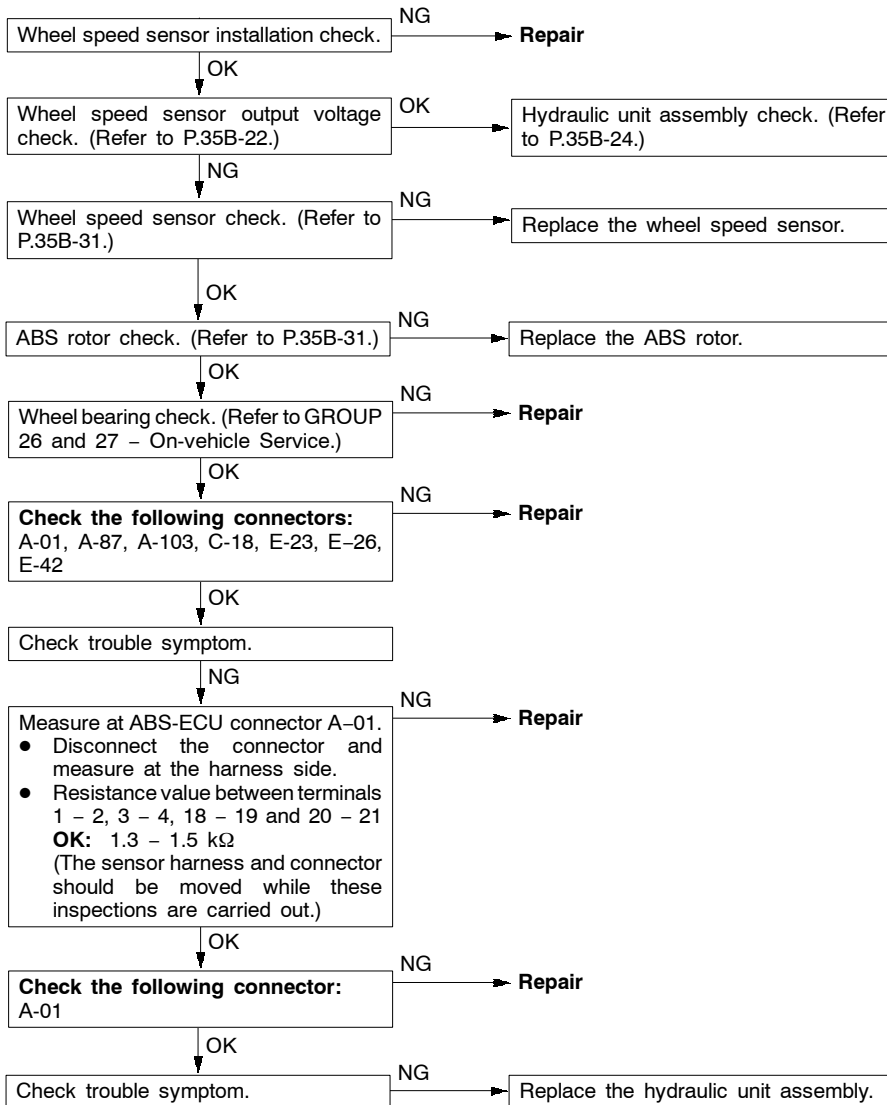

DATA LIST REFERENCE TABLE

35201150299

The following items can be read by the MUT-II from the ABS-ECU input data.

1. When the system is normal

Item No.	Check item	Checking requirements	Normal value
11	Front-right wheel speed sensor	Perform a test run	Vehicle speeds displayed on the speedometer and MUT-II are identical.
12	Front-left wheel speed sensor		
13	Rear-right wheel speed sensor		
14	Rear-left wheel speed sensor		
16	ABS-ECU power supply voltage	Ignition switch power supply voltage and valve monitor voltage	9 – 16 V
25	4WD position detection switch	Place the transfer lever at 4H.	ON
		Place the transfer lever at 2H.	OFF
26	Free wheel engage switch	Engage 4WD	ON
		Engage 2WD	OFF
32	G-sensor output voltage	Stop the vehicle.	2.4 – 2.6 V
		Perform a test run.	Display value fluctuates with a mean value of 2.5 V.
33	Stop lamp switch	Depress the brake pedal.	ON
		Release the brake pedal.	OFF

2. When the ABS-ECU shut off ABS operation.

When the diagnosis system stops the ABS-ECU, the MUT-II display data will be unreliable.

ACTUATOR TEST REFERENCE TABLE

35201160209

The MUT-II activates the following actuators for testing.

NOTE

1. If the ABS-ECU runs down, actuator testing cannot be carried out.
2. Actuator testing is only possible when the vehicle is stationary. If the vehicle speed during actuator testing exceeds 10 km/h, forced actuation will be cancelled.
3. During the actuator test, the ABS warning lamp will illuminate and the anti-skid control will be cancelled.

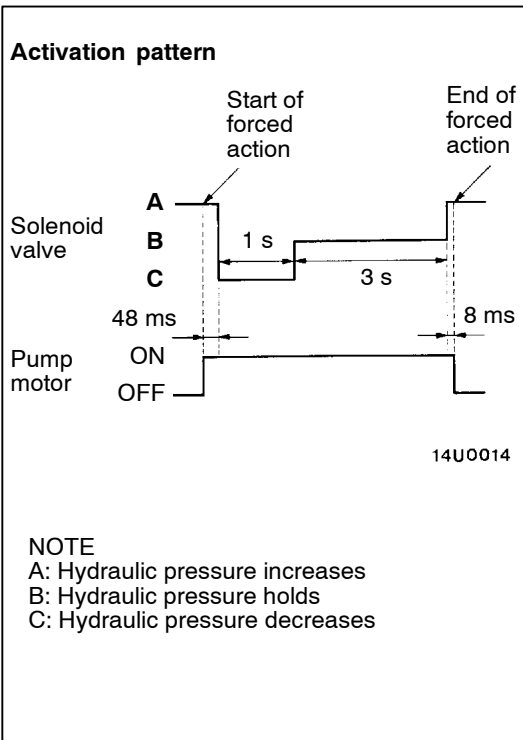

ACTUATOR TEST SPECIFICATIONS

No.	Item	
01	Solenoid valve for front-left wheel	Solenoid valves and pump motors in the hydraulic unit (simple inspection mode)
02	Solenoid valve for front-right wheel	
03	Solenoid valve for rear wheel	

CHECK AT ABS-ECU

35201180359

TERMINAL VOLTAGE CHECK CHART

1. Measure the voltages between terminals (32) and (34) (ground terminals) and each respective terminal.

NOTE

Do not measure terminal voltage for approximately three seconds after the ignition switch is turned on. The ABS-ECU performs the initial check during that period.

2. The terminal layouts are shown in the illustrations below.

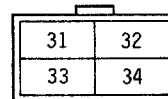
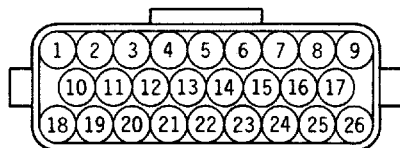

14V0127

Connector terminal No.	Signal	Checking requirement	Normal condition	
6	Engine control module	Ignition switch: "ON" (The motor is on approx.1 second after engine is started)	2 V or less	
7	G-sensor signal	Ignition switch: "ON"	2.38 – 2.62 V	
9	ABS-ECU power supply	Ignition switch: "ON"	System voltage	
		Ignition switch: "START"	0 V	
11	Input from freewheel engage switch	Ignition switch: "ON"	Transfer lever position: "2H"	System voltage
			Transfer lever position: "4H"	0 V

Connector terminal No.	Signal	Checking requirement		Normal condition
12	Input from 4WD detection switch	Ignition switch: ON	Transfer lever position: "2H"	System voltage
			Transfer lever position: "4H"	0 V
13	Input from stop lamp switch	Ignition switch: ON	Stop lamp switch: "ON"	System voltage
			Stop lamp switch: "OFF"	0 V
14	G-sensor	Always		0V
16	Control output to ABS warning lamp relay.	Ignition switch: ON	The lamp is switch off.	2 V or less
			The lamp is illuminated.	System voltage
23	MUT-II	Connect the MUT-II		Serial communication with MUT-II
		Do not connect the MUT-II		1 V or less
24	Input from diagnosis indication selection	Connect the MUT-II		0 V
		Do not connect the MUT-II		Approximately 12 V
31	Solenoid valve power supply	Always		System voltage
33	Motor power supply			

RESISTANCE AND CONTINUITY BETWEEN HARNESS-SIDE CONNECTOR TERMINALS

1. Turn the ignition switch off and disconnect the ABS-ECU connectors before checking resistance and continuity.
2. Check between the terminals indicated in the table below.
3. The terminal layouts are shown in the illustration below.

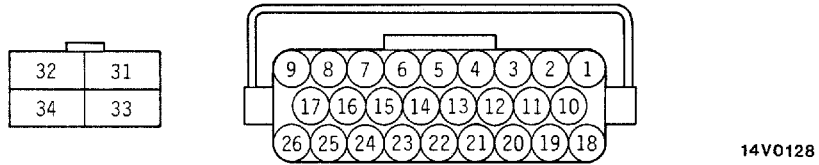

Connector terminal No.	Signal	Normal condition
20 – 21	Front-left wheel speed sensor	1.3 – 1.5 kΩ
1 – 2	Rear-right wheel speed sensor	1.3 – 1.5 kΩ
18 – 19	Front-right wheel speed sensor	1.3 – 1.5 kΩ
3 – 4	Rear-left wheel speed sensor	1.3 – 1.5 kΩ
32 – body earth	Solenoid valve earth	Continuity
34 – body earth	Motor earth	Continuity

ON-VEHICLE SERVICE

WHEEL SPEED SENSOR OUTPUT VOLTAGE CHECK

1. Lift up the vehicle and release the parking brake.
2. Disconnect the ABS-ECU connector, and then use the special tool (inspection harness for connector pin contact pressure) to measure the output voltage at the harness-side connector.
3. Rotate the wheel to be measured at approximately 1/2–1 rotation per second, and check the output voltage using a circuit tester or an oscilloscope.

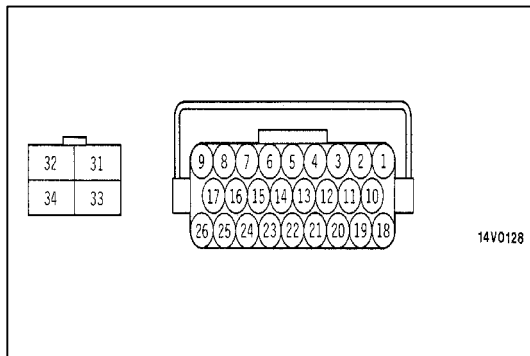

Wheel speed sensor	Front left	Front right	Rear left	Rear right
Terminal No.	20	18	3	1
	21	19	4	2

Output voltage

**When measuring with a circuit tester:
70 mV or more**

**When measuring with an oscilloscope:
200 mV p-p or more**

4. If the output voltage is lower than the above values, the reason could be as follow:
 - Faulty wheel speed sensor.
 So replace the wheel speed sensor.

Inspecting Waveforms With An Oscilloscope

Use the following method to observe the output voltage waveform from each wheel sensor with an oscilloscope.

- Start the engine, and rotate the rear wheels by engaging 1st gear (vehicles with manual transmission) or D range (vehicles with automatic transmission). Turn the front wheels manually so that they rotate at a constant speed.

NOTE

1. Check the connection of the sensor harness and connector before using the oscilloscope.
2. The waveform measurements can also be taken while the vehicle is actually moving.
3. The output voltage will be small when the wheel speed is low, and similarly it will be large when the wheel speed is high.

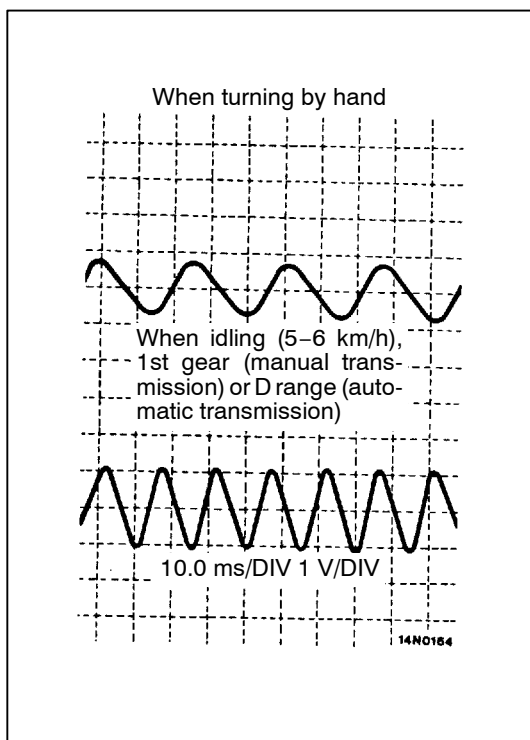

Points In Waveform Measurement

Symptom	Probable causes	Remedy
Too small or zero waveform amplitude	Faulty wheel speed sensor	Replace sensor
Waveform amplitude fluctuates excessively (this is no problem if the minimum amplitude is 100 mV or more)	Axle hub eccentric or with large runout	Replace hub
Noisy or disturbed waveform	Open circuit in sensor	Replace sensor
	Open circuit in harness	Correct harness
	Incorrectly mounted wheel speed sensor	Mount correctly
	ABS rotor with missing or damaged teeth	Replace ABS rotor

NOTE

The wheel speed sensor cable moves following motion of the front or rear suspension. Therefore, it is likely that it has an open circuit only when driving on rough roads and it functions normally on ordinary roads. It is, therefore, recommended to observe sensor output voltage waveform also under special conditions, such as rough road driving.

HYDRAULIC UNIT CHECK

35200170302

Caution

Turn the ignition switch off before connecting or disconnecting the MUT-II.

1. Jack up the vehicle and support the vehicle with rigid racks placed at the specified jack-up points or place the wheels which are checked on the rollers of the braking force tester.

Caution

- (1) The roller of the braking force tester and the tyre should be dry during testing.
- (2) When testing the front brakes, apply the parking brake, and when testing the rear brakes, stop the front wheels by chocking them.

2. Release the parking brake, and feel the drag force (drag torque) on each road wheel. When using the braking force tester, take a reading of the brake drag force.
3. Turn the ignition key to the OFF position and set the MUT-II.
4. After checking that the shift lever is in neutral, start the engine.
5. Use the MUT-II to force-drive the actuator.

NOTE

- (1) During the actuator test, the ABS warning lamp will illuminate and the anti-skid control will be cancelled.
 - (2) When the ABS has been interrupted by the fail-safe function, the MUT-II actuator testing cannot be used.
6. Turn the wheel by hand and check the change in braking force when the brake pedal is depressed. When using the braking force tester, depress the brake pedal until the braking force is at the following values, and check that the braking force decreases when the actuator is force-driven.

Front wheel	785 – 981 N
Rear wheel	294 – 490 N

The result should be as shown in the following diagram.

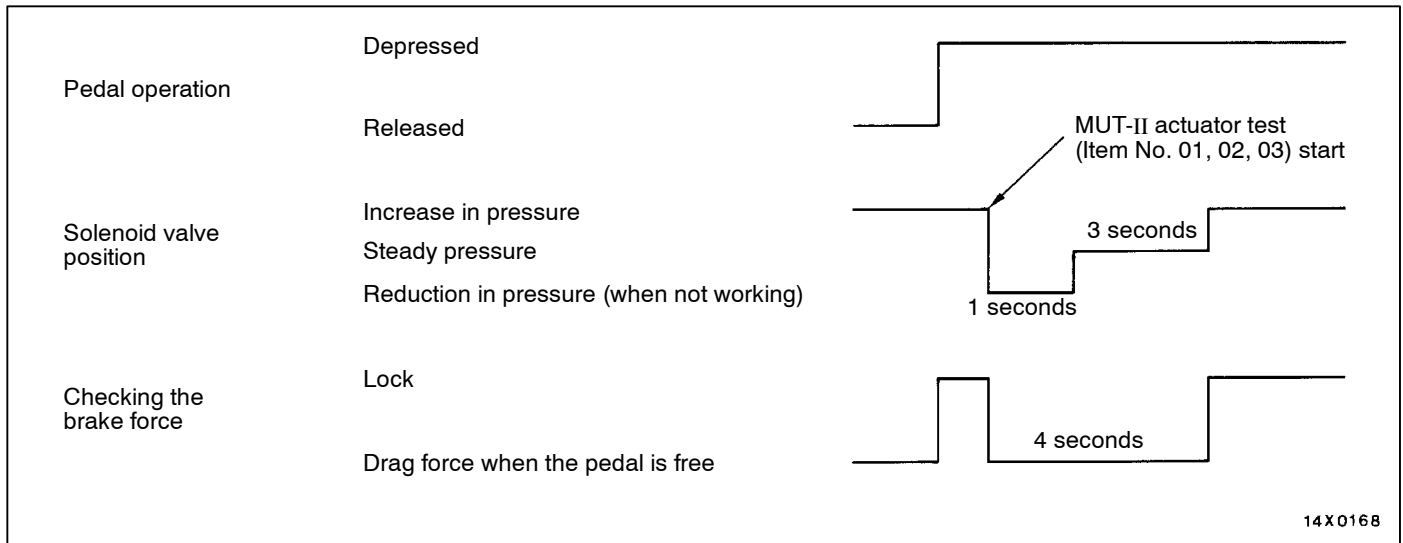

7. If the result of inspection is abnormal, correct according to the “Diagnosis Table” (Refer to P.35B-25).
8. After inspection, disconnect the MUT-II immediately after turning the ignition switch to OFF.

Diagnosis Table

No.	Operation	Judgement – Normal	Judgement – Abnormal	Probable cause	Remedy
01	(1) Depress brake pedal to lock wheel. (2) Using the MUT-II, select the wheel to be checked and force the actuator to operate. (3) Turn the selected wheel manually to check the change of brake force.	Brake force released for 4 seconds after locking.	Wheel does not lock when brake pedal is depressed.	Clogged brake line other than hydraulic unit	Check and clean brake line
02				Clogged hydraulic circuit in hydraulic unit	Replace hydraulic unit assembly
03			Brake force is not released	Incorrect hydraulic unit brake tube connection	Connect correctly
				Hydraulic unit solenoid valve not functioning correctly	Replace hydraulic unit assembly

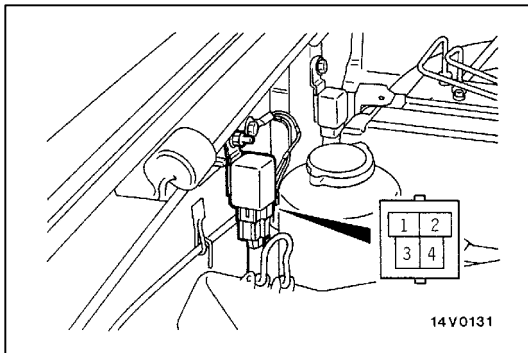

ABS WARNING LAMP RELAY CONTINUITY CHECK

35201090263

Battery voltage	Terminal No.			
	1	2	3	4
Not applied			○	○
Applied	⊖	⊕		

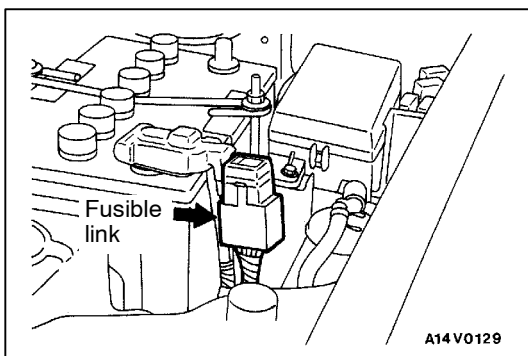

REMEDY FOR A FLAT BATTERY

35200350232

When booster cables are used to start the engine when the battery is completely flat and then the vehicle is immediately driven without waiting for the battery to recharge itself to some extent, the engine may misfire, and driving might not be possible.

This happens because ABS consumes a great amount of current for its self-check function; the remedy is to either allow the battery to recharge sufficiently, or to remove the fusible link for ABS circuit, thus disabling the anti-skid brake system. The ABS warning lamp will illuminate when the fusible link (for ABS) is removed.

After the battery has sufficiently recharged, install the fusible link (for ABS) and restart the engine; then check to be sure the ABS warning lamp is not illuminated.

MASTER CYLINDER AND BRAKE BOOSTER

Caution

Do not remove the check valve from the vacuum hose. If the check valve is defective, replace it together with the vacuum hose.

REMOVAL AND INSTALLATION

Pre-removal Operation

- Brake Fluid Draining

Post-installation Operation

- Brake Fluid Supplying
- Brake Line Bleeding (Refer to GROUP 35A – On-vehicle Service.)
- Brake Pedal Adjustment (Refer to GROUP 35A – On-vehicle Service.)

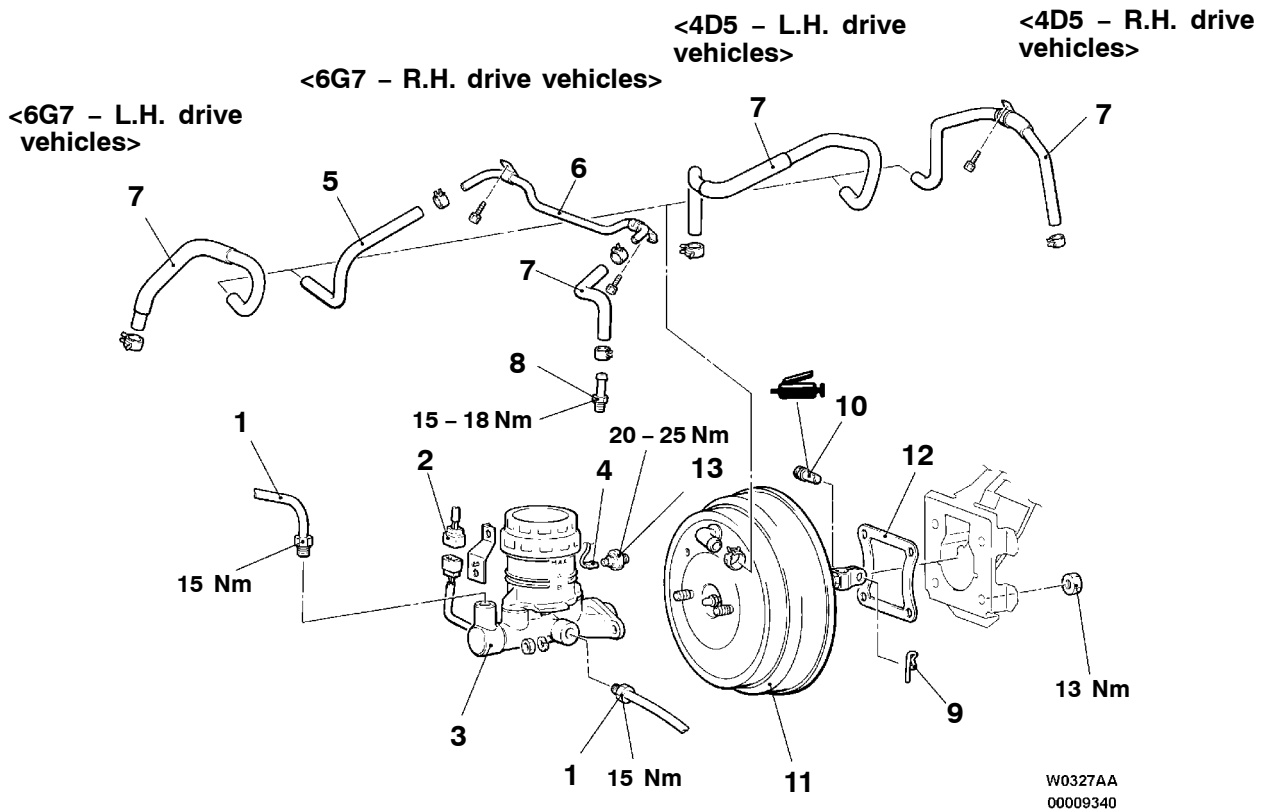

W0327AA
00009340

Sealant: 3M ATD Part No. 8661 or equivalent

Removal steps

- | | |
|--|--|
| <p>1. Brake tube connection</p> <p>2. Brake fluid level sensor connector</p> <p>3. Master cylinder assembly</p> <p>►B◀ • Adjustment of clearance between brake booster push rod and primary piston</p> <p>4. Vacuum switch connector <4D5></p> <p>5. Vacuum hose</p> <p>6. Vacuum pipe</p> | <p>►A◀ 7. Vacuum hose (with built-in check valve)</p> <p>8. Fitting</p> <p>9. Snap pin</p> <p>10. Pin assembly</p> <p>11. Brake booster</p> <p>12. Sealer</p> <p>13. Vacuum switch <4D5></p> |
|--|--|

INSTALLATION SERVICE POINTS

Refer to GROUP 35A – Master Cylinder and Brake Booster.

**MASTER CYLINDER
DISASSEMBLY AND REASSEMBLY**

35200450178

Caution

Do not disassemble the primary piston and secondary piston assembly.

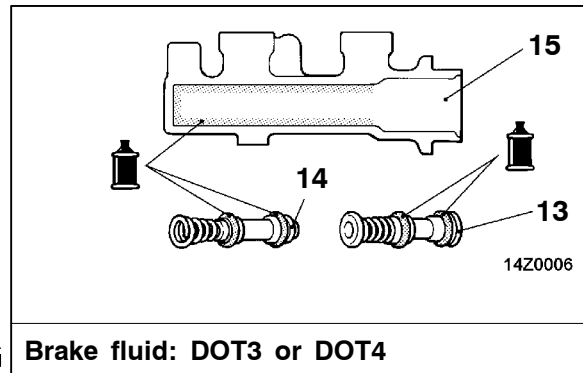
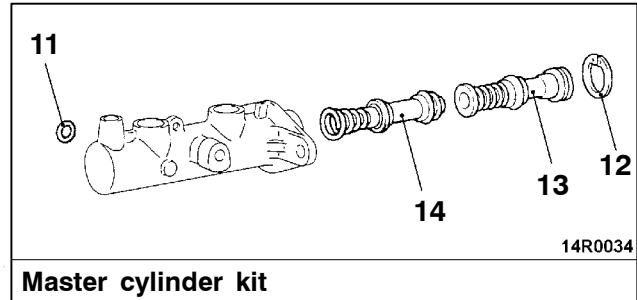
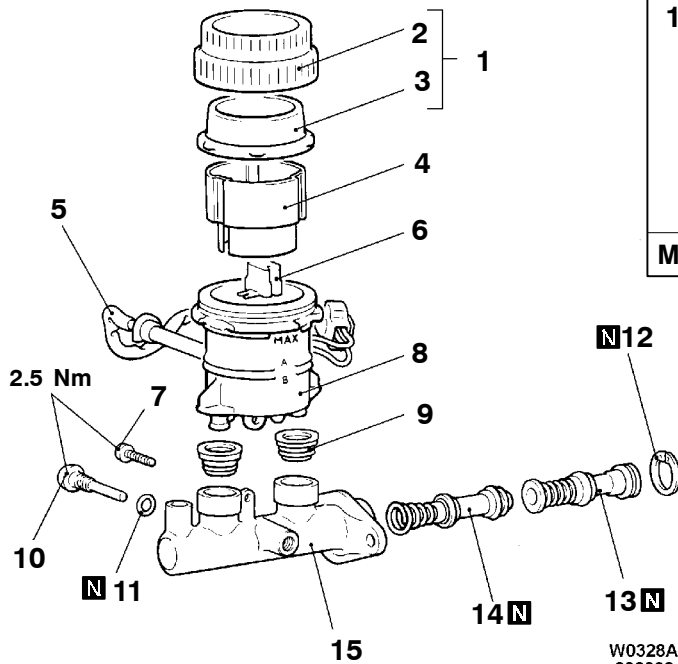

W0328AA
00009341

Disassembly steps

1. Reservoir cap assembly
2. Reservoir cap
3. Diaphragm
4. Filter
5. Brake fluid level sensor
6. Float
7. Reservoir stopper bolt
8. Reservoir tank



9. Reservoir seal
10. Piston stopper bolt
11. Gasket
12. Piston stopper ring
13. Primary piston assembly
14. Secondary piston assembly
15. Master cylinder body

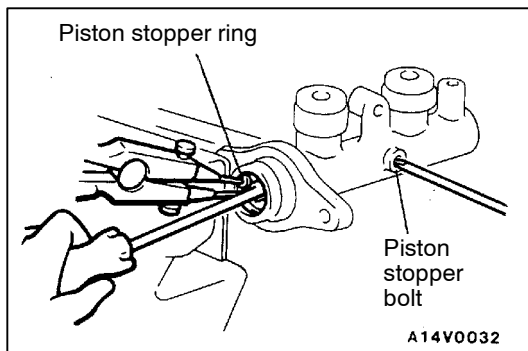

DISASSEMBLY SERVICE POINT

◀A▶ PISTON STOPPER BOLT/PISTON STOPPER RING DISASSEMBLY

Remove the piston stopper bolt and piston stopper ring while depressing the piston.

INSPECTION

35200460027

- Check the inner surface of master cylinder body for rust or pitting.
- Check the primary and secondary pistons for rust, scoring, wear, damage or wear.
- Check the diaphragm for cracks and wear.

HYDRAULIC UNIT

35200860391

REMOVAL AND INSTALLATION

Pre-removal Operation

- Brake Fluid Draining

Post-installation Operation

- Brake Fluid Filling
- Brake Line Bleeding (Refer to GROUP 35A – On-vehicle Service.)

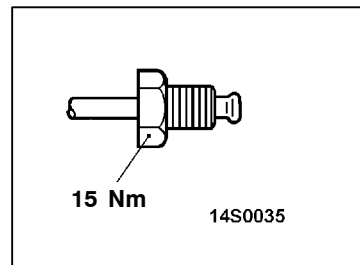
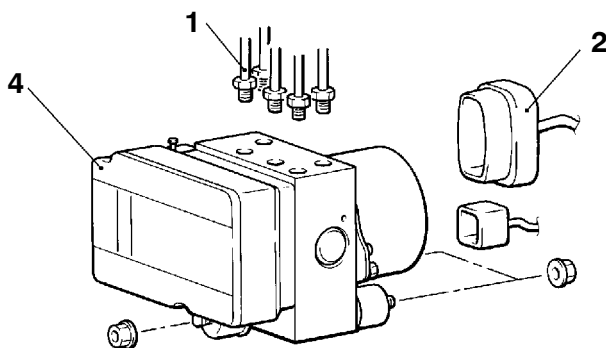

<6G7, 4D5 – R.H. drive vehicles>

<4D5 – L.H. drive vehicles>

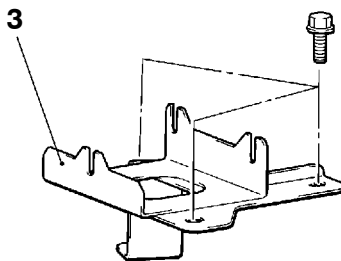
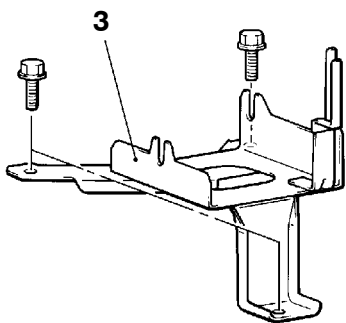

W0329AA

00009342

Removal steps

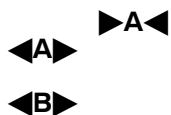

1. Brake tube
2. Harness connector
3. Bracket assembly
4. Hydraulic unit assembly

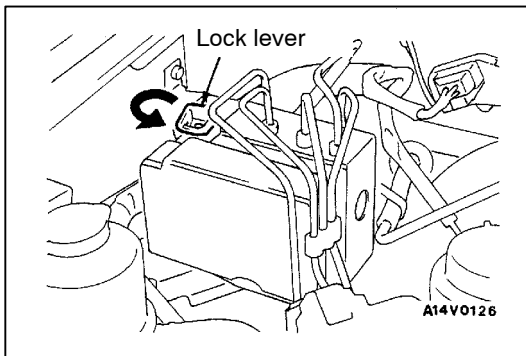

REMOVAL SERVICE POINTS

◀A▶ HARNESS CONNECTOR REMOVAL

Turn the lock lever in the direction shown in the illustration, and remove the harness.

◀B▶ HYDRAULIC UNIT REMOVAL

Caution

1. The hydraulic unit assembly is heavy. Use care when removing it.
2. The hydraulic unit assembly cannot be disassembled. Never loosen its nuts or bolts.
3. Do not drop or shock the hydraulic unit assembly.
4. Do not turn the hydraulic unit assembly upside down or lay it on its side.

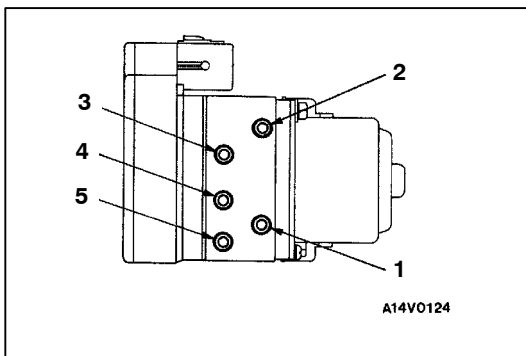

INSTALLATION SERVICE POINT

▶A◀ BRAKE TUBE INSTALLATION

Connect the tubes to the hydraulic unit assembly as shown in the illustration.

1. Master cylinder and load sensing proportioning valve <Front system>
2. Master cylinder <Rear system>
3. Load sensing proportioning valve <Rear system>
4. Front brake <R.H.>
5. Front brake <L.H.>

WHEEL SPEED SENSOR

REMOVAL AND INSTALLATION

Post-installation Operation

- Wheel Speed Sensor Output Voltage Measurement (Refer to P.35B-22.)

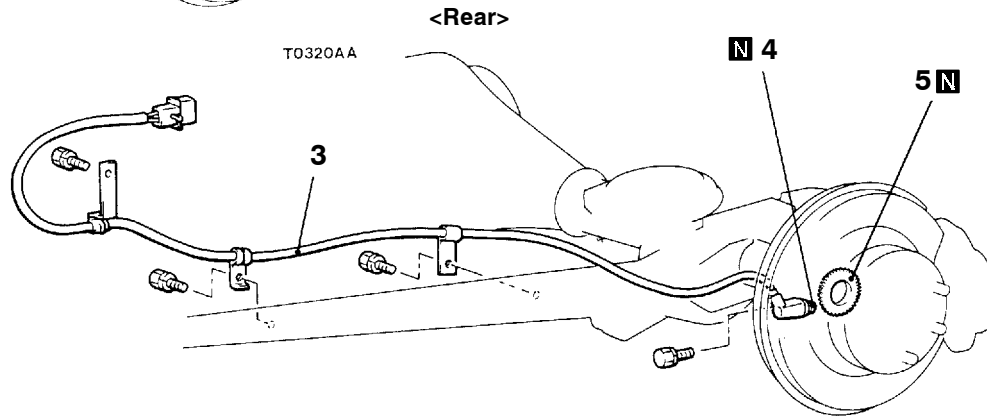
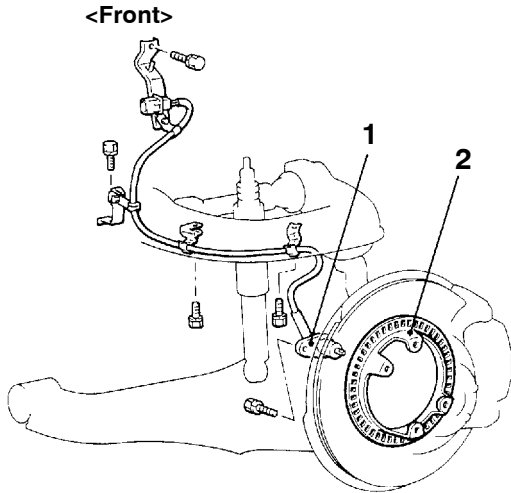

V0448AA
00007720

Rear speed sensor removal steps



1. Front speed sensor
2. Front ABS rotor (Refer to Group 26 - Front Hub Assembly.)
5. Rear ABS rotor (Refer to Group 27 - Axle Shaft.)



3. Rear speed sensor
4. O-ring

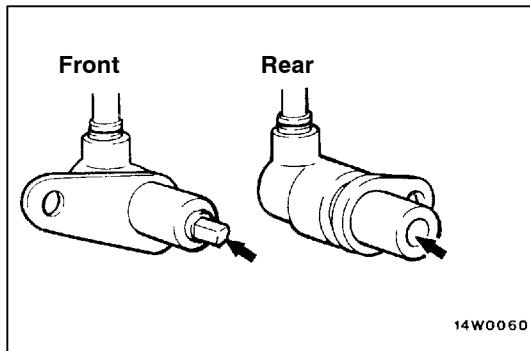

REMOVAL SERVICE POINT

FRONT SPEED SENSOR/REAR SPEED SENSOR REMOVAL

Caution

Be careful when handling the pole piece at the tip of the speed sensor and the toothed edge of the rotor so as not to damage them by contacting other parts.

35200840289

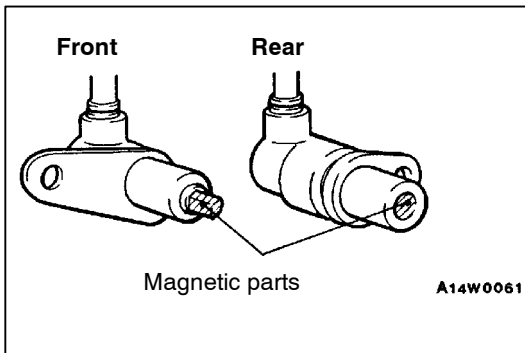
**INSPECTION****SPEED SENSOR CHECK**

1. Check whether any metallic foreign material has adhered to the pole piece at the speed sensor tip. Remove any foreign material.
Also check whether the pole piece is damaged. Replace it with a new one if it is damaged.

NOTE

The pole piece can become magnetized due to the magnet inside the speed sensor, causing foreign material to easily adhere to it. The pole piece may not be able to correctly sense the wheel rotation speed if foreign matter is on it or if it is damaged.

2. Measure the resistance between the speed sensor terminals.

Standard value: 1.3 – 1.5 kΩ

If the internal resistance of the speed sensor is not within the standard value, replace it with a new speed sensor.

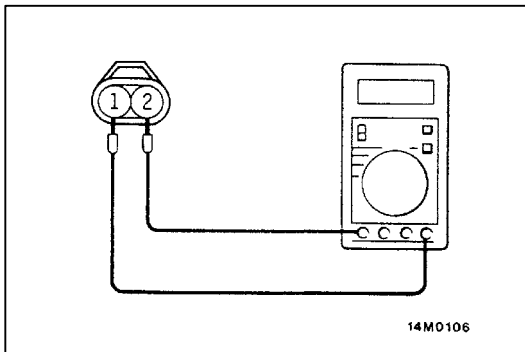

3. Remove all connections from the speed sensor, and then measure the resistance between terminals (1) and (2) and the body of the speed sensor.

Standard value: 100 kΩ or more

If the speed sensor insulation resistance is not within the standard value range, replace with a new speed sensor.

4. Check the speed sensor cable for breakage, damage or disconnection. Replace with a new one if a problem is found.

NOTE

When checking for cable damage, remove the cable clamp part from the body and then gently bend and pull the cable near the clamp.

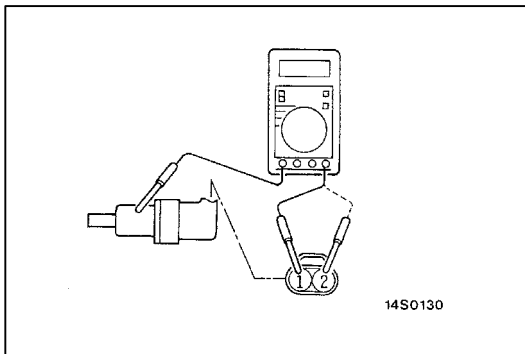
**TOOTHED ABS ROTOR CHECK**

Inspect to see if the ABS rotor is deformed or broken, and if faulty replace it with a new one.

G-SENSOR

35201010160

REMOVAL AND INSTALLATION

Caution

Do not drop or apply a shock on the G-sensor.

Pre-removal and Post-installation Operation

- Front and Rear Console Assembly Removal and Installation (Refer to GROUP 52A – Floor Console.)

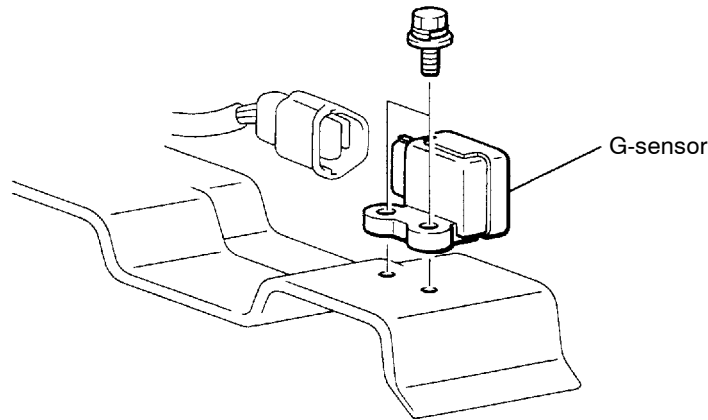

A14V0100

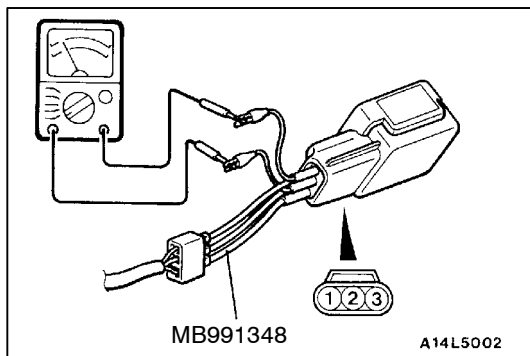

INSPECTION

35201020149

G-SENSOR CHECK

1. Disconnect the G-sensor connector and connect special tool, between terminals of the disconnected connector.
2. With the ignition switch turned ON, read the voltage between terminals No. 2 and 3.

Standard value: 2.4 – 2.6 V

3. With special tool connected, rotate the sensor so that the arrow faces straight down. Read output voltage between terminals No. 2 and 3.

Standard value: 3.4 – 3.6 V

4. If the voltage deviates from the standard value, make sure that nothing is wrong with the power supply wire and ground wire and then replace the G-sensor.

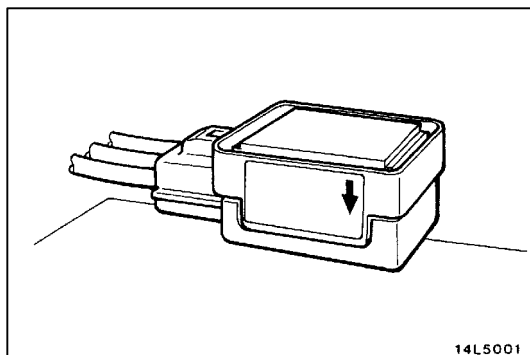

14L5001

PARKING BRAKES

CONTENTS

36109000262

GENERAL INFORMATION	2	Parking Brake Lever Stroke Check	3
SERVICE SPECIFICATIONS	2	Parking Brake Switch Check	4
LUBRICANTS	2	PARKING BRAKE LEVER	5
SEALANT	2	PARKING BRAKE CABLE	6
ON-VEHICLE SERVICE	3	PARKING BRAKE DRUM	7



GENERAL INFORMATION

36100010233

The parking brake is lever type of a mechanical rear-wheel brake construction in all vehicles.

CONSTRUCTION DIAGRAM

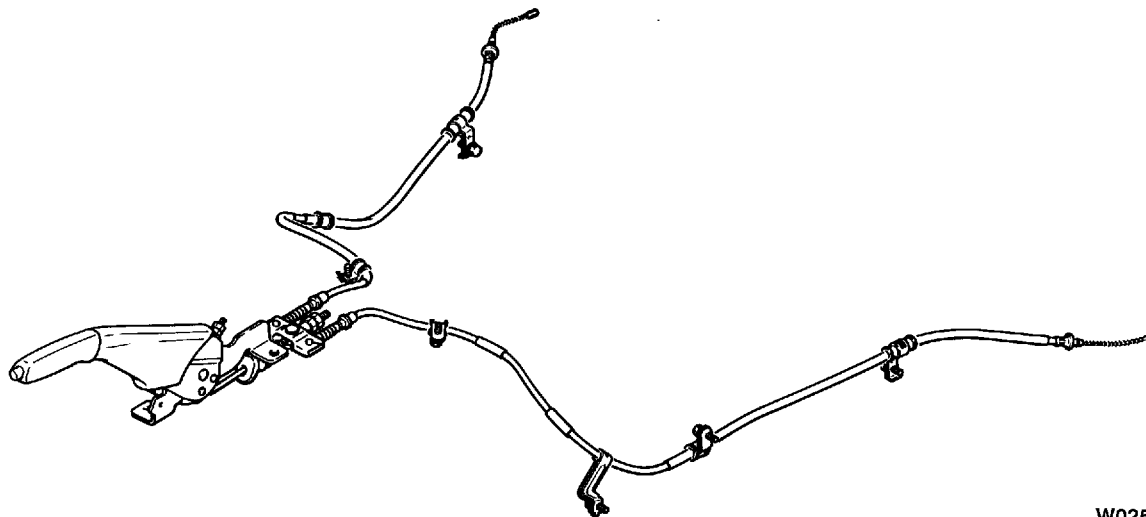

SERVICE SPECIFICATIONS

36100030215

Item	Standard value	Limit
Parking brake stroke	6 – 7 notches	–
Lining thickness mm	–	4.5
Brake drum inside diameter mm	197	198

LUBRICANTS

36100040133

Item	Specifications
Backing plate	Brake grease SAE J310, NLGI No.1
Adjuster assembly	
Shoe and lining assembly	

SEALANT

36100050044

Item	Specifications	Remarks
Shoe hold-down pin	3M ATD Part No.8513 or equivalent	Drying sealant

ON-VEHICLE SERVICE

36100090220

PARKING BRAKE LEVER STROKE CHECK

1. Pull the parking lever with a force of approximately 196 N and count the number of notches.

Caution

The 196 N force of the parking brake lever must be strictly observed.

Standard value: 6 – 7 notches

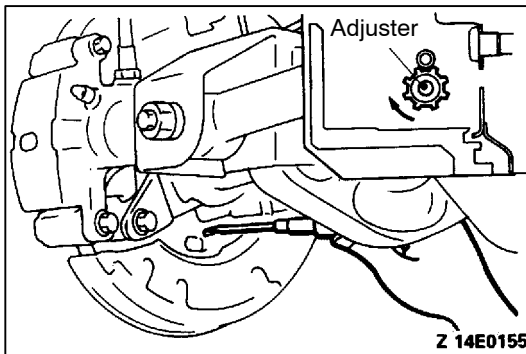
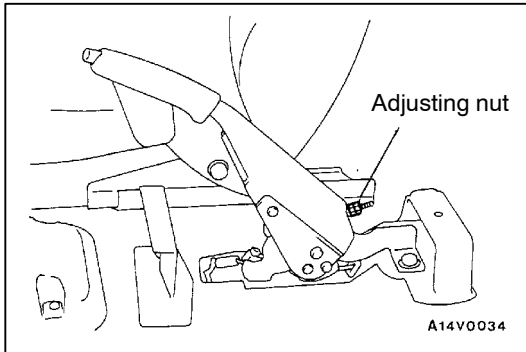

2. Lever Stroke Adjustment
<Adjustment procedure (from passenger compartment)>
If the parking brake lever stroke is not the standard value, adjust as described below.

- (1) Jack up the rear of the vehicle and support on jack stands and remove the rear wheels.
- (2) Loosen the parking brake cable adjusting nut to the end of the cable rod, to allow slack in the cables.

- (3) Remove the adjustment hole plug and then use a flat-tipped screwdriver to turn the adjuster as shown in the illustration until the disc will not rotate. Return the adjuster 3 or 4 notches in the opposite direction to the direction of the arrow.

- (4) Turn the adjusting nut to adjust the parking brake lever stroke to within the standard value range.

Caution

If the number of the brake lever notches engaged is less than the standard value, the cable has been pulled excessively. Be sure to adjust it to the standard value.

- (5) Check that there is no play between the adjusting nut and the parking brake lever.
- (6) Turn the rear wheel to confirm that the rear brakes are not dragging.
- (7) Remove the jack stands and lower the vehicle to the floor. Retorque the wheel nuts to the specified torque.

<Adjustment procedure (from under the vehicle)>
If the parking brake lever stroke is not the standard value, adjust as described below.

- (1) Jack up the rear of the vehicle and support on jack stands and remove the rear wheels.
- (2) Loosen the parking brake cable adjusting nut to the end of the cable rod, to allow slack in the cables.

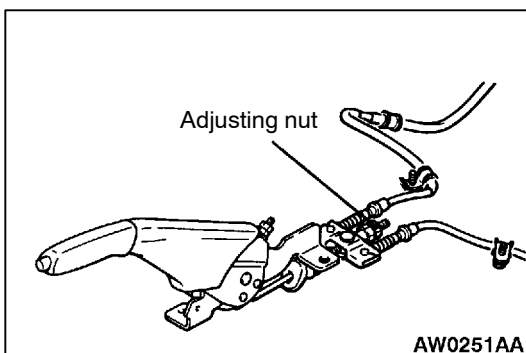

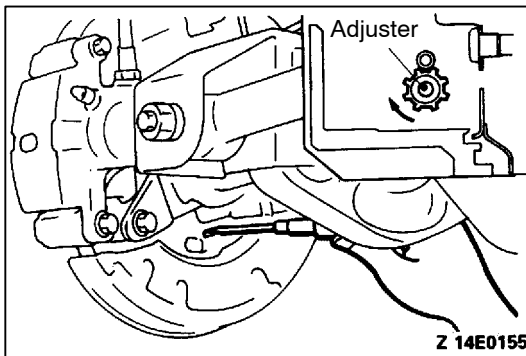

- (3) Remove the adjustment hole plug and then use a flat-tipped screwdriver to turn the adjuster as shown in the illustration until the disc will not rotate. Return the adjuster 3 or 4 notches in the opposite direction to the direction of the arrow.
- (4) Turn the adjusting nut to adjust the parking brake lever stroke to within the standard value range.

Caution

If the number of the brake lever notches engaged is less than the standard value, the cable has been pulled excessively. Be sure to adjust it to the standard value.

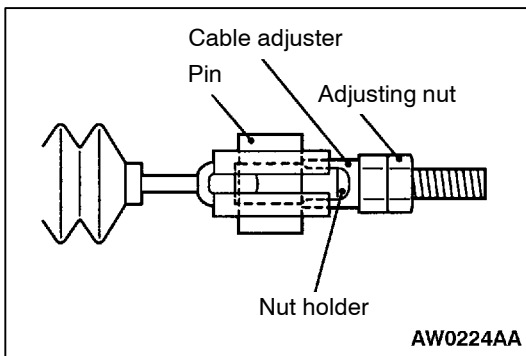

- (5) After completing the adjustment, check to be sure that there is no play between the adjusting nut and the pin. Also check that the adjusting nut is securely held by the nut holder.
- (6) With the parking brake lever in the released position, turn the rear wheels to confirm that the rear brakes are not dragging.
- (7) Remove the jack stands and lower the vehicle to the floor. Retorque the wheel nuts to the specified torque.

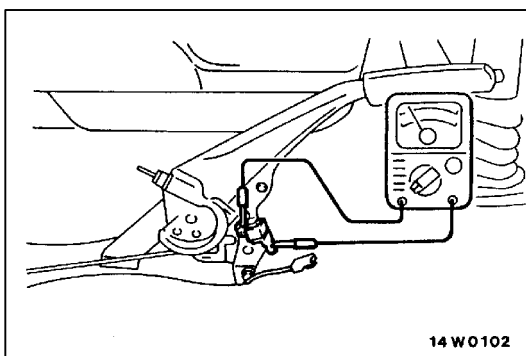

PARKING BRAKE SWITCH CHECK

36100330131

1. Disconnect the connector of the parking brake switch, and connect an ohmmeter between the parking brake switch and the switch installation bolt.
2. The parking brake switch is good if there is continuity when the parking brake lever or parking brake pull rod is pulled, and there is no continuity when it is released.

PARKING BRAKE LEVER

36100130298

REMOVAL AND INSTALLATION

Pre-removal Operation

- Floor Console Removal
(Refer to GROUP 52A – Floor Console.)

Post-installation Operation

- Floor Console Installation
(Refer to GROUP 52A – Floor Console.)
- Parking Brake Lever Stroke Adjustment
(Refer to P.36-3.)

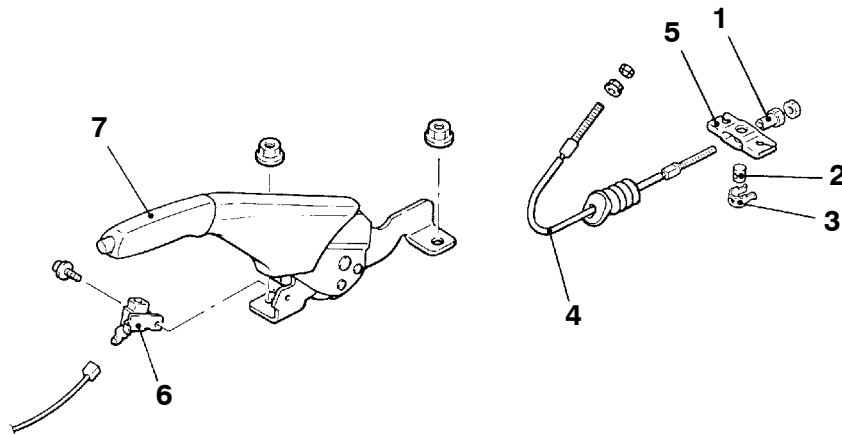
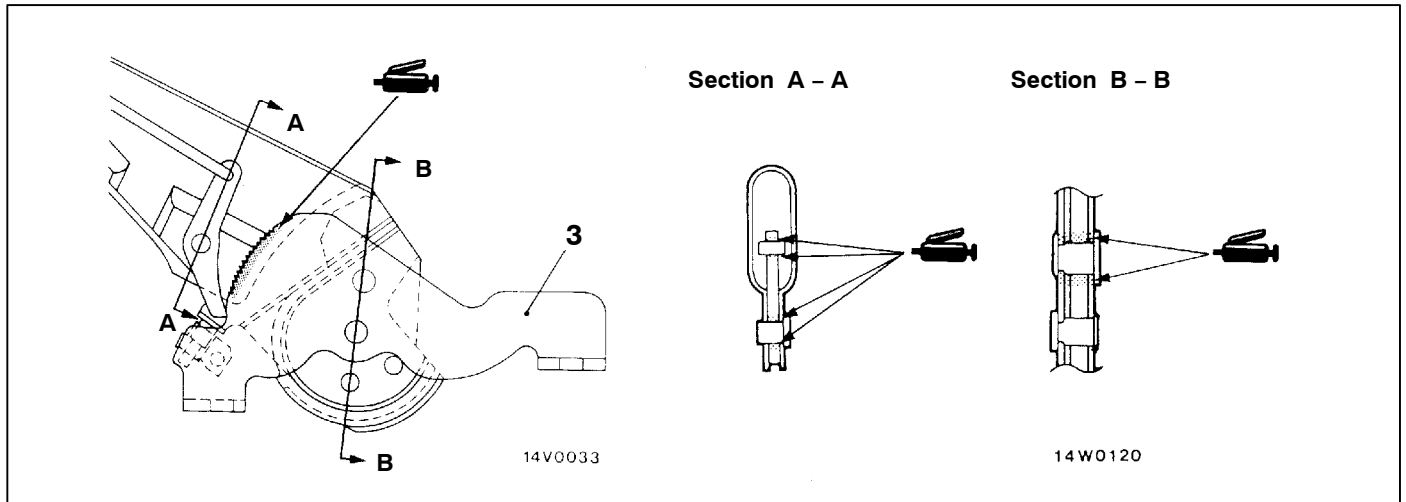

W0252AA

00009227

Removal steps

1. Cable adjuster
2. Pin
3. Nut holder
4. Front parking brake cable
5. Cable equalizer
6. Parking brake switch
7. Parking brake lever

PARKING BRAKE CABLE

REMOVAL AND INSTALLATION

Pre-removal Operation

- Floor Console Removal
(Refer to GROUP 52A – Floor Console.)

Post-installation Operation

- Floor Console Installation
(Refer to GROUP 52A – Floor Console.)
- Parking Brake Lever Stroke Adjustment
(Refer to P.36-3.)

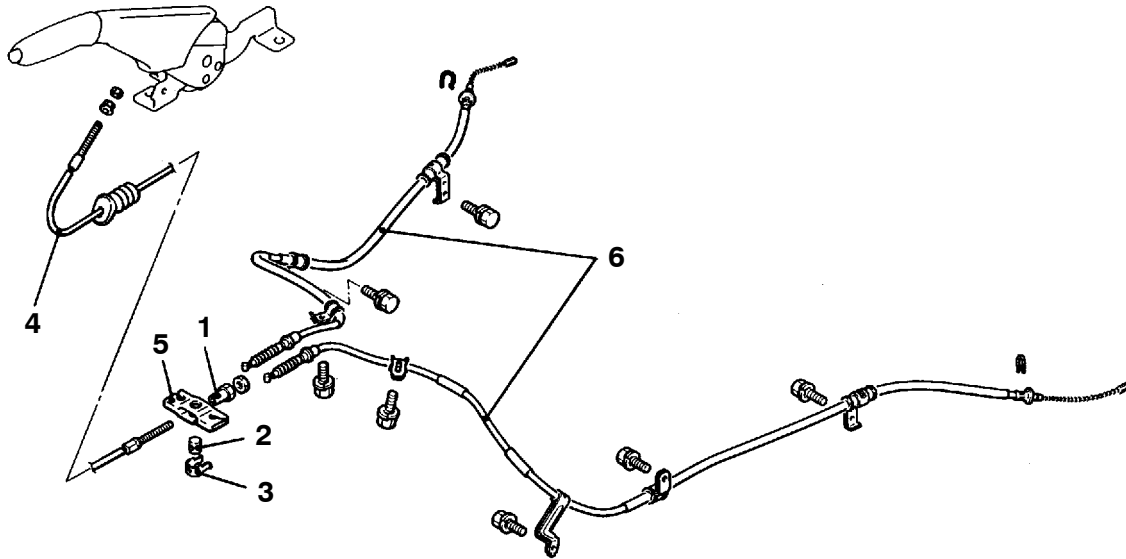

AW0253AA

Removal steps

- Shoe and lining assembly (Refer to P.36-7.)
- 1. Cable adjuster
- 2. Pin

- 3. Nut holder
- 4. Front parking brake cable
- 5. Cable equalizer
- 6. Parking brake cable

**PARKING BRAKE DRUM
REMOVAL AND INSTALLATION**

36100250178

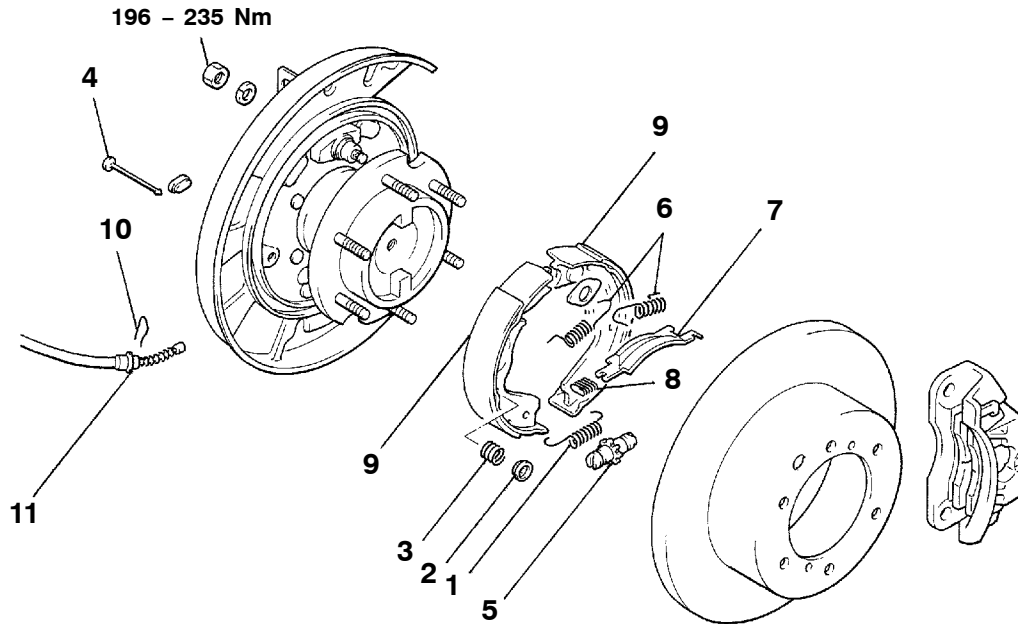

14W0103

<p>14E0031</p>	<p>14E0026</p> <p>Parking lever pin</p> <p>14E0027</p>
<p>Sealant: 3M ATD Part No. 8513 or equivalent</p>	<p>Brake grease: Brake grease SAE J310, NLGI No. 1</p>

00005993

Removal steps

- Rear brake disc assembly (Refer to GROUP 35A – Rear Disc Brake.)

1. Adjusting wheel spring
2. Shoe hold-down cup
3. Shoe hold-down spring
4. Shoe hold-down pin



5. Adjuster assembly
6. Anchor-to-shoe spring
7. Strut
8. Strut-to-shoe spring
9. Shoe and lining assembly
10. Clip
11. Parking brake cable connection

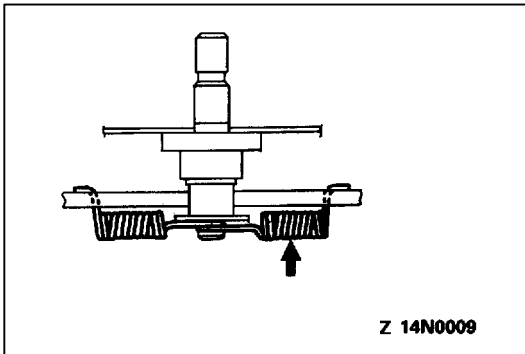

INSTALLATION SERVICE POINTS

▶A◀ ANCHOR-TO-SHOE SPRING INSTALLATION

The loads on the anchor shoe springs are all different, so the spring indicated by the arrow has been painted for identification.

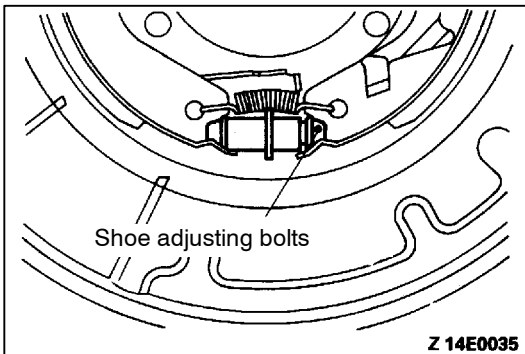

▶B◀ ADJUSTER ASSEMBLY INSTALLATION

Install the adjuster so that the shoe adjusting bolt for the left-hand wheel is toward the rear of the vehicle, and the shoe adjusting bolt for the right-hand wheel is toward the front of the vehicle.

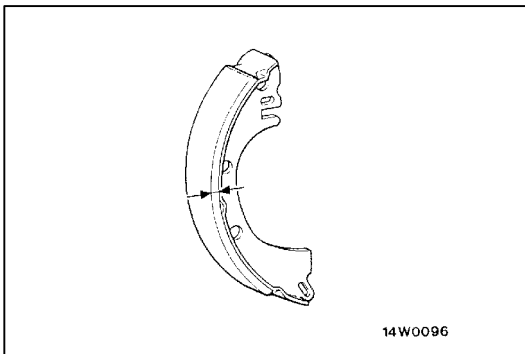

INSPECTION

36100260157

UNUSUAL WEAR OF THE BRAKE LINING AND BRAKE DRUM

1. Measure the thickness of the brake lining at several places.

Limit: 4.5 mm

Caution

Replace the brake shoes if the thickness of the brake lining is limit value or less.

2. Measure the brake disc drum inner diameter at several places.

Standard value: 197 mm

Limit: 198 mm

Caution

Replace if the brake disc drum inner diameter is the limit value or more.

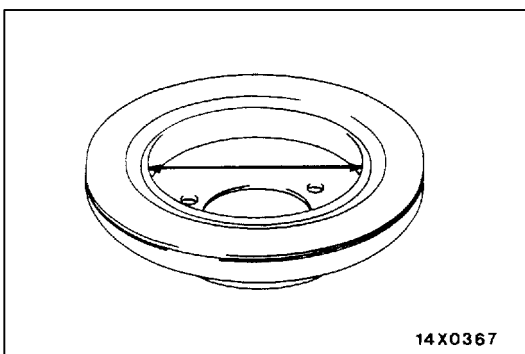

STEERING

CONTENTS

3710900061

GENERAL INFORMATION	2	Checking Steering Wheel Return to Centre	10
SERVICE SPECIFICATIONS	3	Drive Belt Tension Check	10
LUBRICANTS	4	Fluid Level Check	10
SEALANTS	4	Fluid Replacement	11
SPECIAL TOOLS	4	Bleeding	12
ON-VEHICLE SERVICE	7	Oil Pump Pressure Test	13
Steering Wheel Free Play Check	7	Power Steering Oil Pressure Switch Check	14
Steering Angle Check	7	Ball Joint Dust Cover Check	14
Steering Gear Backlash Check	8	STEERING WHEEL AND SHAFT*	15
Tie Rod End Ball Joint Variation Check (Shaft Direction)	8	POWER STEERING GEAR BOX*	18
Tie Rod End Ball Joint Starting Torque Check	9	POWER STEERING OIL PUMP	26
Stationary Steering Effort Check	9	POWER STEERING HOSES	34
		STEERING LINKAGE	38

WARNINGS REGARDING SERVICING OF SUPPLEMENTAL RESTRAINT SYSTEM (SRS) EQUIPPED VEHICLES

WARNING!

- (1) Improper service or maintenance of any component of the SRS, or any SRS-related component, can lead to personal injury or death to service personnel (from inadvertent firing of the air bag) or to the driver and passenger (from rendering the SRS inoperative).
- (2) Service or maintenance of any SRS component or SRS-related component must be performed only at an authorized MITSUBISHI dealer.
- (3) MITSUBISHI dealer personnel must thoroughly review this manual, and especially its GROUP 52B – Supplemental Restraint System (SRS) before beginning any service or maintenance of any component of the SRS or any SRS-related component.

NOTE

The SRS includes the following components: front impact sensors, SRS-ECU, SRS warning lamp, air bag module, clock spring and interconnecting wiring. Other SRS-related components (that may have to be removed/installed in connection with SRS service or maintenance) are indicated in the table of contents by an asterisk (*).

GENERAL INFORMATION

37100010056

Engine speed-responsive hydraulic power steering has been used. The main features are as follows. The steering wheel has four spokes. In addition, SRS (Supplemental Restraint System) is equipped in all vehicles.

The steering column in all vehicles has a shock absorber mechanism and a tilt steering mechanism. A vane-type oil pump with a fluid flow control system has been included. The steering gear and linkage is ball and nut type.

Items		Specifications
Power steering gear box	Type	Ball and nut type
	Gear ratio	14.2 – 15.6
Oil pump	Type	Vane type
	Displacement mL/rev.	9.6
	Relief set pressure MPa	8.3 – 9.0

CONSTRUCTION DIAGRAM

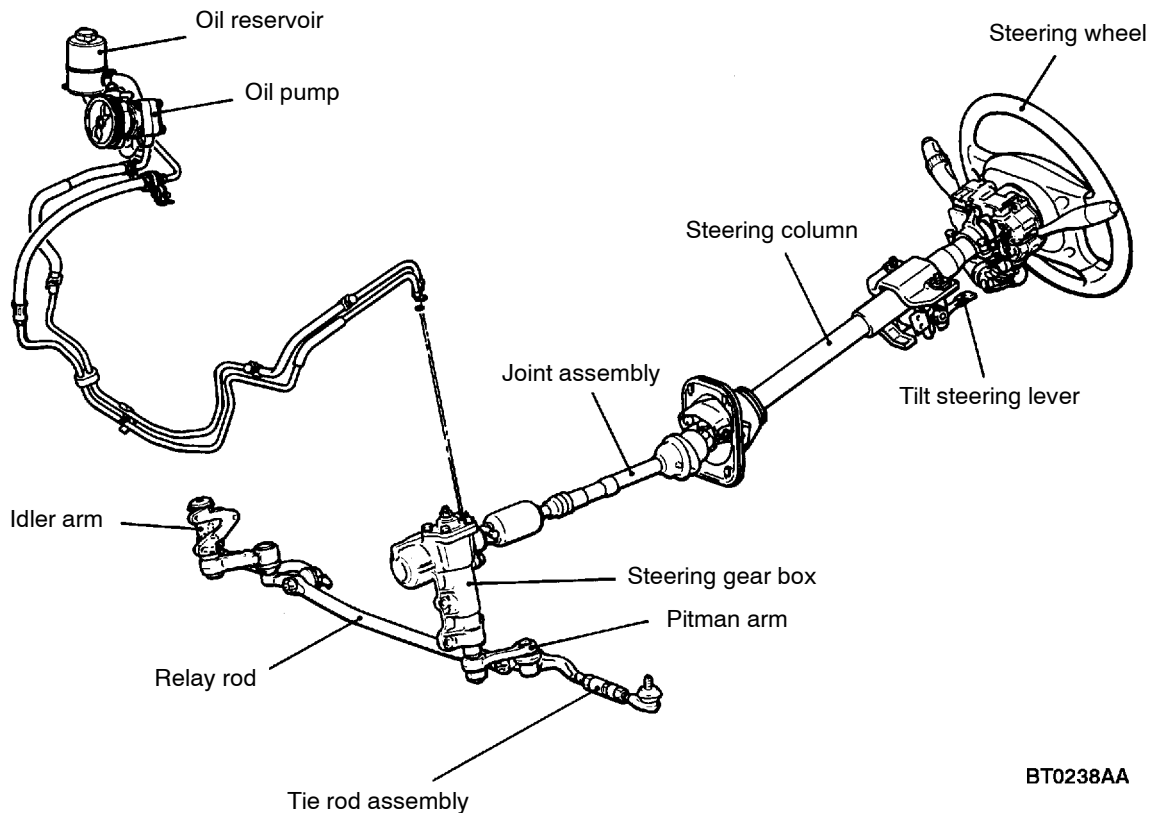

BT0238AA

SERVICE SPECIFICATIONS

37100030052

Items		Standard value	Limit
Steering wheel free play mm	With engine running	–	50
	With engine stopped	10 or less	–
Steering angle	Inner wheel	29° 20' – 32° 20'	–
	Outer wheel	29° 30'	–
Steering gear backlash mm		–	0.5
Variation of tie rod end ball joint shaft direction mm		–	1.5
Tie rod end ball joint starting torque Nm		3.0	–
Engine idle speed r/min	6G7	700 ± 100	–
	4D5	750 ± 100	–
Stationary steering effort N		39.2 or less	–
Oil pump pressure MPa	Oil pump relief pressure	8.3 – 9.0	–
	Pressure under no-load conditions	0.8 – 1.0	–
	Steering gear retention hydraulic pressure	8.3 – 9.0	–
Oil pressure switch operating pressure MPa	OFF → ON	1.5 – 2.0	–
	ON → OFF	0.7 – 1.2	–
Cross-shaft axial play mm		0.05 or less	–
Mainshaft total starting torque Nm		0.69 – 1.28	–
Backlash between ball groove of rack piston and balls mm		–	0.05
Pitman arm ball joint starting torque Nm		0.98 – 2.94	–
Idler arm sliding resistance N		2.4 – 16	–

LUBRICANTS

37100040024

Items	Specified lubricants	Quantity L
Power steering fluid	Automatic transmission fluid DEXRON or DEXRON II	1.0
Cross-shaft, O-ring, oil seal, vane	Automatic transmission fluid DEXRON or DEXRON II	As required



SEALANTS

37100050034

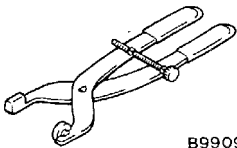
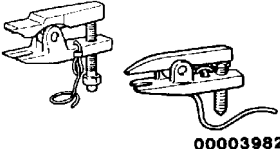

Items	Specified sealants	Remarks
Cover assembly installation hole Adjusting bolt, seal bolt, packing, adjusting shim, dust cover lip for ball joint	3M ATD Part No.8663 or equivalent	Semi-drying sealant

SPECIAL TOOLS

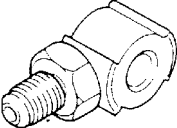
37100060037

Tool	Number	Name	Use
 B990948	MB990948	Linkage joint gauge	Ball joint variation check for shaft direction
 00003982	MB991113 or MB990635	Steering linkage puller	Disconnection of ball joint
	MB990685 MB991151	Torque wrench	<ul style="list-style-type: none"> • Measurement of the ball joint starting torque • Measurement of the pinion shaft preload • Measurement of the mainshaft starting torque
	MB990326	Preload socket	Measurement of the ball joint starting torque
 B990993	MB990993 or MB991217	Power steering oil pressure gauge adapter (pump side)	Measurement of oil pressure

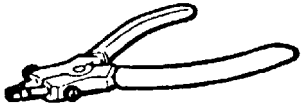
Tool	Number	Name	Use
<p>B990994</p>	MB990994	Power steering oil pressure gauge adapter (hose side)	Measurement of oil pressure
<p>B990662</p>	MB990662	Oil pressure gauge assembly	
<p>B990803</p>	MB990803	Steering wheel puller	Disconnection of the steering wheel
<p>B990915</p>	MB990915	Pitman arm puller	Removal of the pitman arm
<p>B990925</p>	MB990925	Bearing and oil seal installer set	Installation of the oil seal and bearing (Refer to GROUP 26 – Special Tools.)
<p>B991203</p>	MB991203	Oil seal & bearing installer	To press in the valve housing oil seal
<p>B991006</p>	MB991006 or MB990228	Preload socket	Measurement of the mainshaft total starting torque
<p>B990776</p>	MB990776	Front axle base	Installation of dust cover for tie rod end ball joint

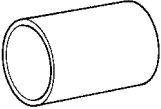
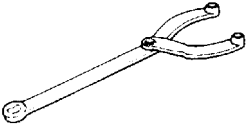
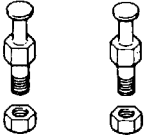
Tool	Number	Name	Use
	MB990628	Snap ring pliers	To remove and install the snap ring of the pulley assembly
 <p>B990956</p>	MB990956	Needle bearing installer	To press in the drive shaft assembly
	MB991172	Adapter	
	MB990767	End yolk holder	Securing the drive pulley
	MD998719 or MD998754	Crankshaft pulley holder pin	

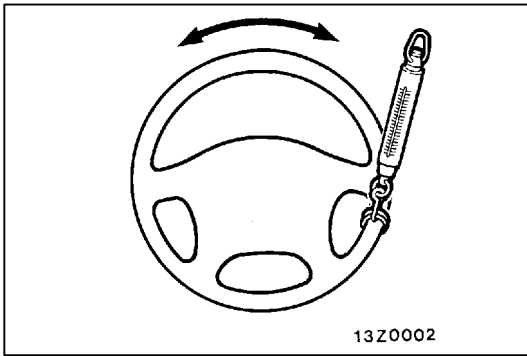

ON-VEHICLE SERVICE

37100090043

STEERING WHEEL FREE PLAY CHECK

1. With engine running (hydraulic operation), set front wheels straight ahead.
2. Measure the play on steering wheel circumference before wheels start to move when slightly moving steering wheel in both directions.

Limit: 50 mm

3. When play exceeds the limit, check for play on steering shaft connection and steering linkage. Correct or replace.
4. If the free play still exceeds the limit value, set steering wheel straight ahead with engine stopped. Load 5 N towards steering wheel circumference and check play.

Standard value (steering wheel play with engine stopped): 10 mm or less

If the play exceeds the standard value, check the steering gear backlash and ball joint axial play.

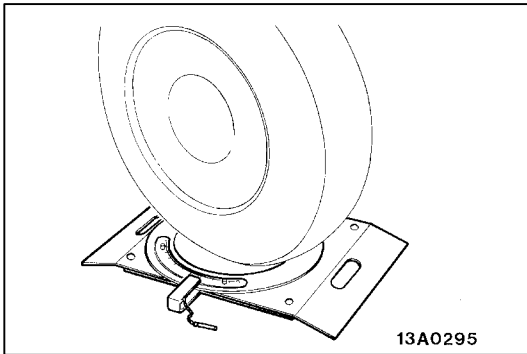

STEERING ANGLE CHECK

37100100029

1. Place the front wheel on a turning radius gauge and measure the steering angle.

Standard value:

Items	Specifications
Inside wheel	29° 40' – 32° 40'
Outside wheel	29° 30'

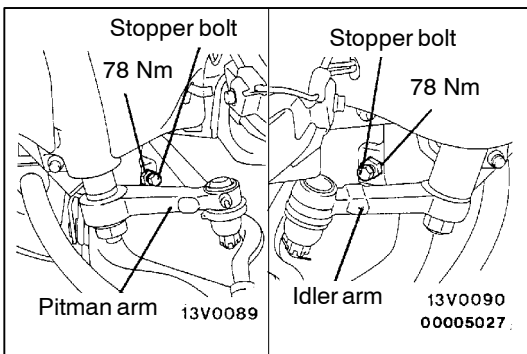

2. If the steering angle is outside the standard value after checking the toe-in (refer to GROUP 33A – On-vehicle Service), adjust the steering angle with the stopper bolt.

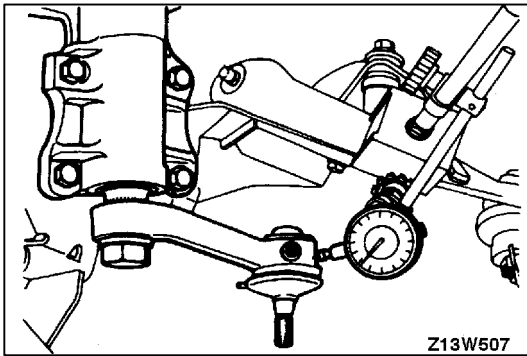

STEERING GEAR BACKLASH CHECK 37100120032

1. Jack up the vehicle front and hold the steering wheel in the straight ahead position.
2. Apart the pitman arm and the relay rod. (Refer to P.37A-41.)
3. Measure the steering gear backlash at the pitman arm top end with a dial indicator.

Limit: 0.5 mm

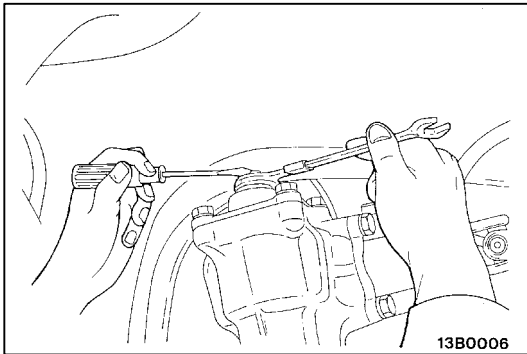

4. If the measured value exceeds the limit, screw in the steering gear box adjusting bolt until steering wheel free play is within the standard value.

Caution

- (1) Be sure to make the adjustment with the steering wheel in the straight ahead position.
- (2) If the adjusting bolt is overtightened, more steering effort will be required, and return of the wheel will be adversely affected.

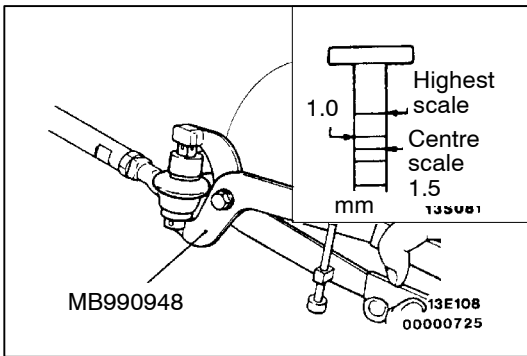

TIE ROD END BALL JOINT VARIATION CHECK (SHAFT DIRECTION)

37100130011

1. Hold the ball joint with the special tool.
2. Set the special tool scale at its highest and measure variation with ball stud compressed. The variation should locate between the highest and centre scales.

Limit: 1.5 mm

3. When the variation exceeds the centre scale, replace the tie rod end.

Caution

Even if the variation is within the limit, check ball joint starting torque.

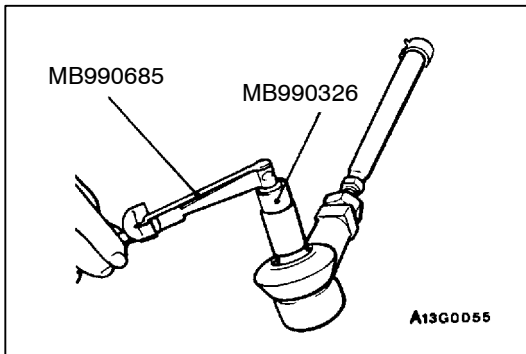
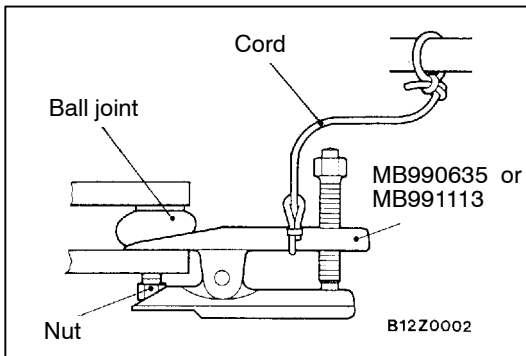

TIE ROD END BALL JOINT STARTING TORQUE CHECK

37100140021

1. Use the special tool to disconnect the ball joint.

Caution

- (1) Only loosen tie rod end mounting nut; but do not remove it from the ball joint.
- (2) Support the special tool with a cord, etc. to prevent it from coming off.

2. Move the ball joint stud several times and install the nut on stud. Measure ball joint starting torque with special tools.

Standard value: 3.0 Nm

3. When the starting torque exceeds the standard value, replace the tie rod end.
4. When the starting torque is under the standard value, check ball joint for end play or ratcheting. If none of these, the ball joint is still serviceable.
5. Tighten the nut to the specified torque and install a new split pin.

Tightening torque: 40 Nm

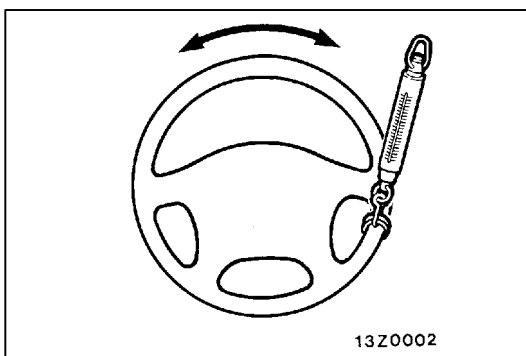

STATIONARY STEERING EFFORT CHECK

37200170221

1. With the vehicle stopped on a flat and paved surface, and turn the steering wheel to the straight ahead position.
2. Start the engine and check the engine idle speed.

Standard value:

Engine idle speed r/min	Remarks
700 ± 100	6G7
750 ± 100	4D5

3. Attach a spring balance to the outer circumference of the steering wheel and measure the steering force required to turn the steering wheel from the straight ahead position to the left and right (within a range of 1.5 turns). Also check to be sure that there is no significant fluctuation of the required steering force.

Standard value:

Steering effort: 39.2 N or less

Fluctuation allowance: 5 N or less

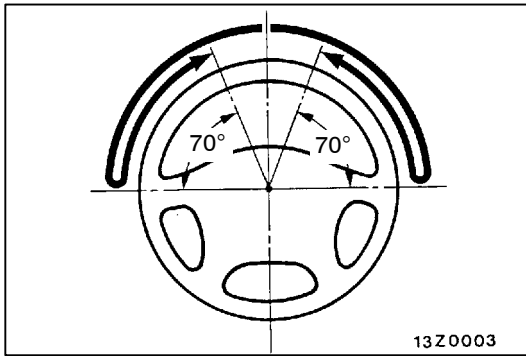

CHECKING STEERING WHEEL RETURN TO CENTRE

37200180170

Conduct a road test before this test.

1. Make both gradual and sudden turns and check the steering “feeling” to be sure that there is no difference in the steering force required and the wheel return between left and right turns.
2. At a speed of 35 km/h, turn the steering wheel 90° and release the steering wheel after 1 or 2 seconds. If the steering wheel then returns 70° or more, the return can be judged to be satisfactory.

NOTE

There will be a momentary feeling or “heaviness” when the wheel is turned quickly, but this is not abnormal. (this is because the oil pump discharge amount is especially apt to be insufficient during idling.)

DRIVE BELT TENSION CHECK

37200190227

Refer to GROUP 11 – On-vehicle Service.

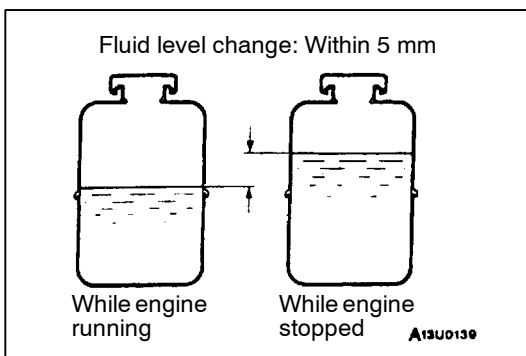

FLUID LEVEL CHECK

37200200142

1. Park the vehicle on a flat, level surface, start the engine, and then turn the steering wheel several times to raise the temperature of the fluid to approximately 50–60°C.
2. With the engine running, turn the wheel all the way to the left and right several times.
3. Check the fluid in the oil reservoir for foaming or milkiness. Check the difference of the fluid level when the engine is stopped, and while it is running. If the change of the fluid level is 5 mm or more, air bleeding should be done.

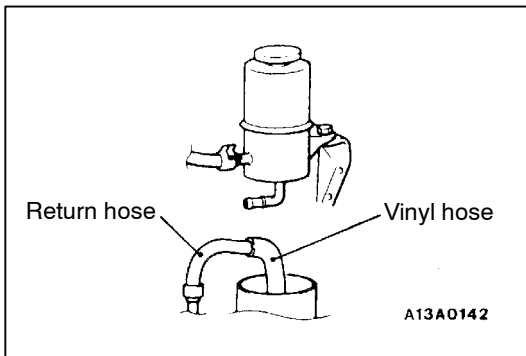

FLUID REPLACEMENT

37200210152

1. Raise the front wheels on a jack, and then support them with rigid racks.
2. Disconnect the return hose connection.
3. Connect a vinyl hose to the return hose, and drain the oil into a container.
4. On vehicles with a petrol engine, disconnect the high-tension cable. On vehicles with a diesel engine, remove the fuel cut valve connector attached to the injection pump.

Caution

Be careful not to position the high-tension cable near the delivery pipe.

5. While operating the starting motor intermittently, turn the steering wheel all the way to the left and right several times to drain all of the fluid.
6. Connect the return hoses securely, and then secure it with the clip.
7. Fill the oil reservoir with the specified fluid up to the lower position of the filter, and then bleed the air.

Specified fluid:

Automatic transmission fluid DEXRON or DEXRON II

BLEEDING

1. Jack up the front wheels and support them by using a rigid rack.
2. Manually turn the oil pump pulley a few times.
3. Turn the steering wheel all the way to the left and to the right five or six times.
4. On vehicles with a petrol engine, disconnect the high-tension cable. On vehicles with a diesel engine, remove the fuel cut valve connector attached to the injection pump.

Caution

Be careful not to place the high-tension cable near the delivery pipe.

5. While operating the starting motor intermittently, turn the steering wheel all the way to the left and right five or six times (for 15 to 20 seconds).

Caution

- (1) **During air bleeding, refill the fluid so that the level never falls below the lower position of the filter.**
- (2) **If air bleeding is done while engine is running, the air will be broken up and absorbed into the fluid; be sure to do the bleeding only while cranking.**

6. On vehicles with a petrol engine, connect the high-tension cable. On vehicles with a diesel engine, connect the fuel cut valve connector attached to the injection pump. Start the engine (idling).
7. Turn the steering wheel to the left and right until there are no air bubbles in the oil reservoir.
8. Confirm that the fluid is not milky, and that the level is up to the specified position on the level gauge.
9. Confirm that there is very little change in the fluid level when the steering wheel is turned left and right.

10. Check whether or not the change in the fluid level is within 5 mm when the engine is stopped and when it is running.
11. If the change of the fluid level is 5 mm or more, the air has not been completely bled from the system, and thus must be bled completely.

Caution

- (1) **If the fluid level rises suddenly after the engine is stopped, the air has not been completely bled.**
- (2) **If air bleeding is not complete, there will be abnormal noises from the pump and the flow-control valve, and this condition could cause a lessening of the life of the pump, etc.**

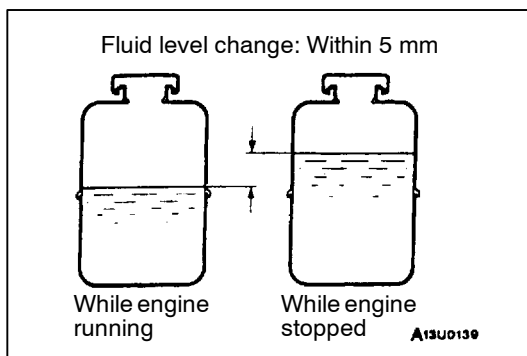

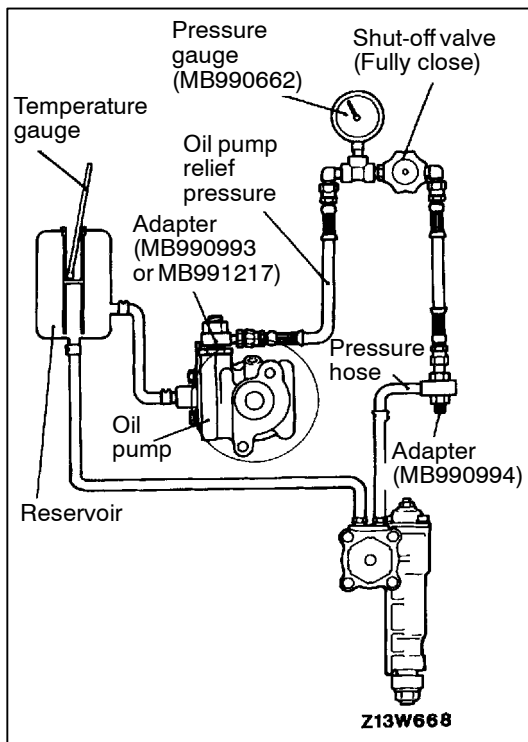

OIL PUMP PRESSURE TEST

37200230233

1. Disconnect the pressure hose from the oil pump, and then connect the special tools.
2. Bleed the air, and then turn the steering wheel several times while the vehicle is not moving so that the temperature of the fluid rises to approximately 50–60°C.
3. Start the engine and idle it at 1,000±100 r/min.
4. Fully close the shut-off valve of the pressure gauge and measure the oil pump relief pressure to confirm that it is within the standard value range.

Standard value: 8.3 – 9.0 MPa

Caution

Pressure gauge shut off valve must not remain closed for more than 10 seconds.

5. If it is not within the standard value, replace the oil pump.
6. Check whether or not the hydraulic pressure is the standard value when no-load conditions are created by fully opening the shut-off valve of the pressure gauge.

Standard value: 0.8 – 1.0 Mpa

7. If it is not within the standard value, the probable cause is a malfunction of the oil line or steering gear box, so check these parts and repair as necessary.
8. Turn the steering wheel all the way to the left or right; then check whether or not the retention hydraulic pressure is the standard value.

Standard value: 8.3 – 9.0 MPa

9. When not within the standard value, overhaul the steering gear box.
Remeasure fluid pressure.
10. Remove the special tools, and then tighten the pressure hose to the specified torque.

Tightening torque: 18 Nm

11. Bleed the system.

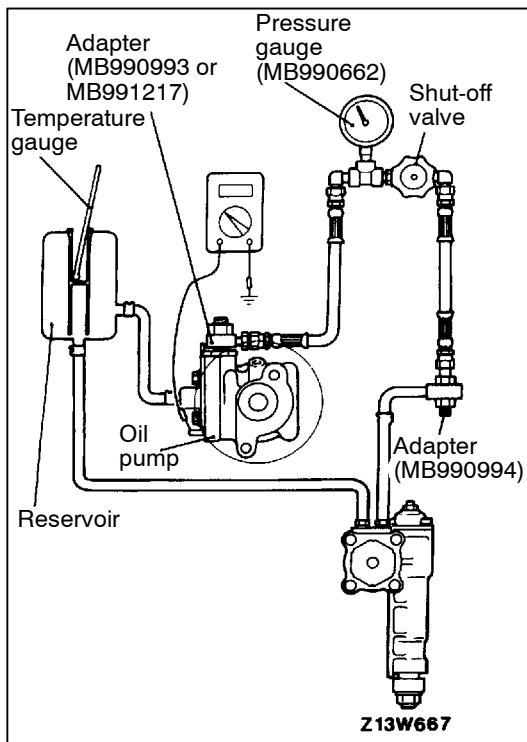

POWER STEERING OIL PRESSURE SWITCH CHECK <Petrol-powered vehicle>

37200720211

1. Disconnect the pressure hose from the oil pump, and then connect the special tools.
2. Bleed the air, and then turn the steering wheel several times while the vehicle is not moving so that the temperature of the fluid rises to approximately 50–60°C.
3. The engine should be idling.
4. Disconnect the connection of the connector for the oil pressure switch, and place an ohmmeter in position.
5. Gradually close the shut-off valve of the pressure gauge and increase the hydraulic pressure, then check whether or not the hydraulic pressure that activates the switch is the standard value.

Standard value: 1.5 – 2.0 MPa

6. Gradually open the shut-off valve and reduce the hydraulic pressure; then check whether or not the hydraulic pressure that deactivates the switch is the standard value.

Standard value: 0.7 – 1.2 MPa

7. Remove the special tools, and then tighten the pressure hose to the specified torque.

Tightening torque: 18 Nm

8. Bleed the system

BALL JOINT DUST COVER CHECK

37200860098

1. Press the dust cover with a finger to check whether the dust cover is cracked or damaged.
2. If the dust cover is cracked or damaged, replace the pitman arm, idler arm or tie rod end ball joint.

NOTE

If the dust cover is cracked or damaged, the ball joint could be damaged.

STEERING WHEEL AND SHAFT

37100170044

REMOVAL AND INSTALLATION

Caution: SRS

- Before removal of the air bag module, refer to GROUP 52B – Service Precautions and Air Bag Module and Clock Spring.
- When removing and installing the steering wheel, do not let it bump against the air bag module.

Post-installation Operation

- Checking Steering Wheel Position with Wheels Straight Ahead

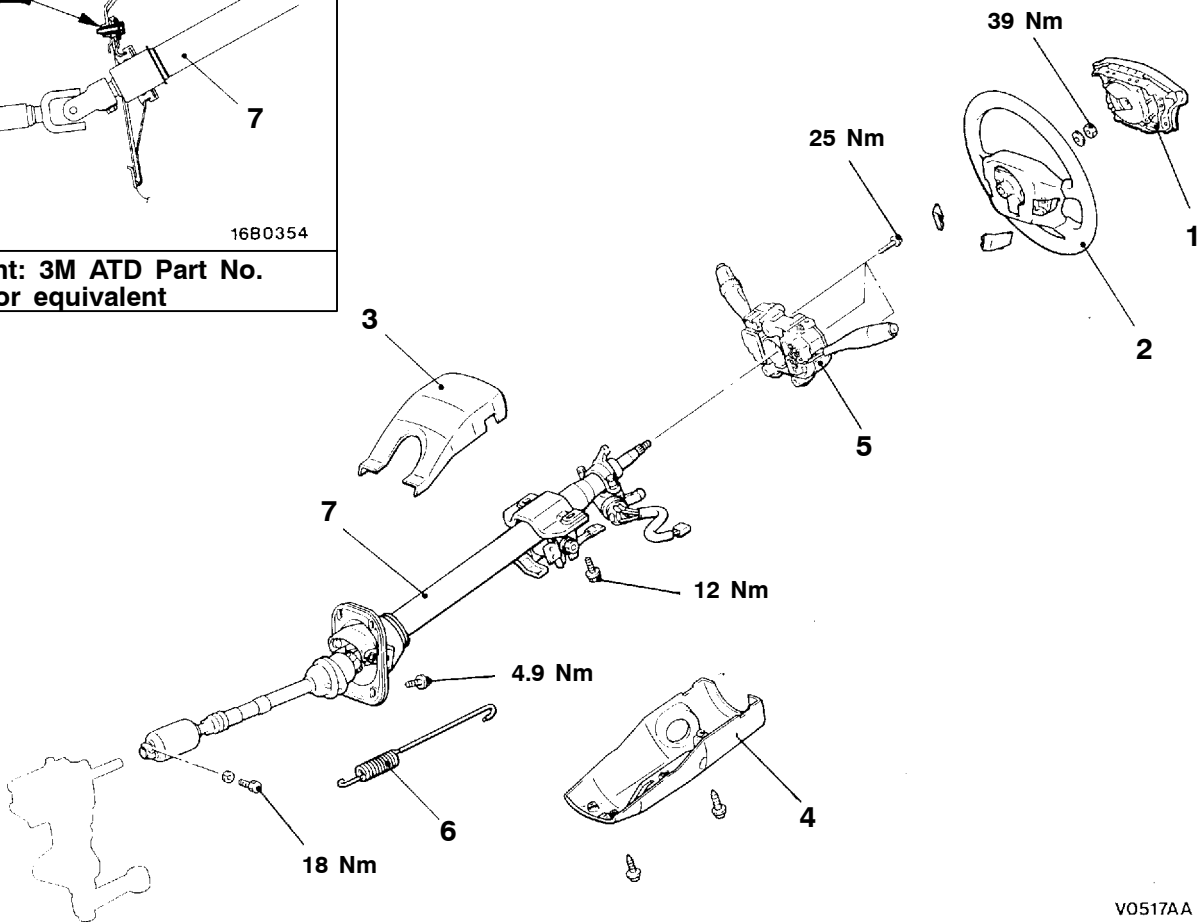
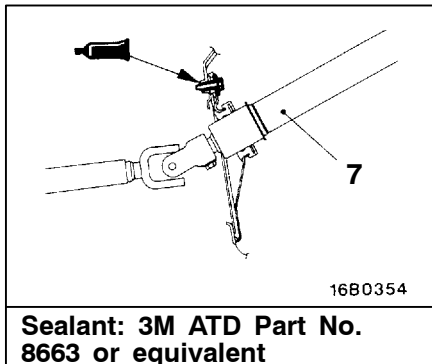

V0517AA

00007672

Removal steps

1. Air bag module (Refer to Group 52B – Air Bag Module and Clock Spring.)
2. Steering wheel
 - Driver under cover (Refer to GROUP 52A – Instrument Panel.)

3. Upper column cover assembly
4. Lower column cover assembly
5. Clock spring and column switch
6. Brake pedal return spring
7. Steering column assembly



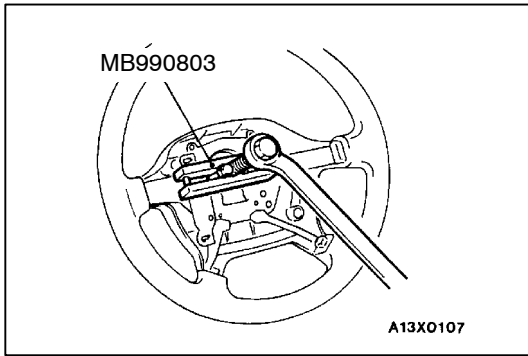

REMOVAL SERVICE POINT

◀A▶ STEERING WHEEL REMOVAL

Use special tool to remove the steering wheel.

Caution

Do not hammer on the steering wheel to remove it; doing so may damage the collapsible mechanism.

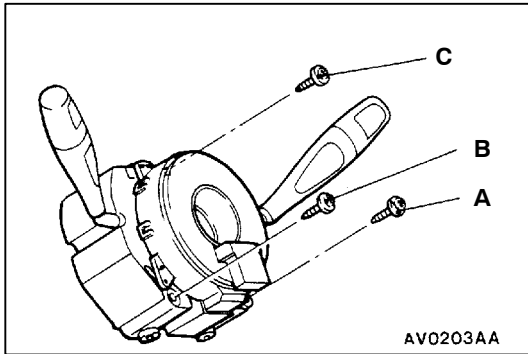

INSTALLATION SERVICE POINT

▶A◀ CLOCK SPRING AND COLUMN SWITCH INSTALLATION

1. Align the mating mark of clock spring. (Refer to GROUP 52B – Air Bag Modules and Clock Spring.)
2. Tighten the screws in the alphabetical order.

DISASSEMBLY AND REASSEMBLY

37100190040

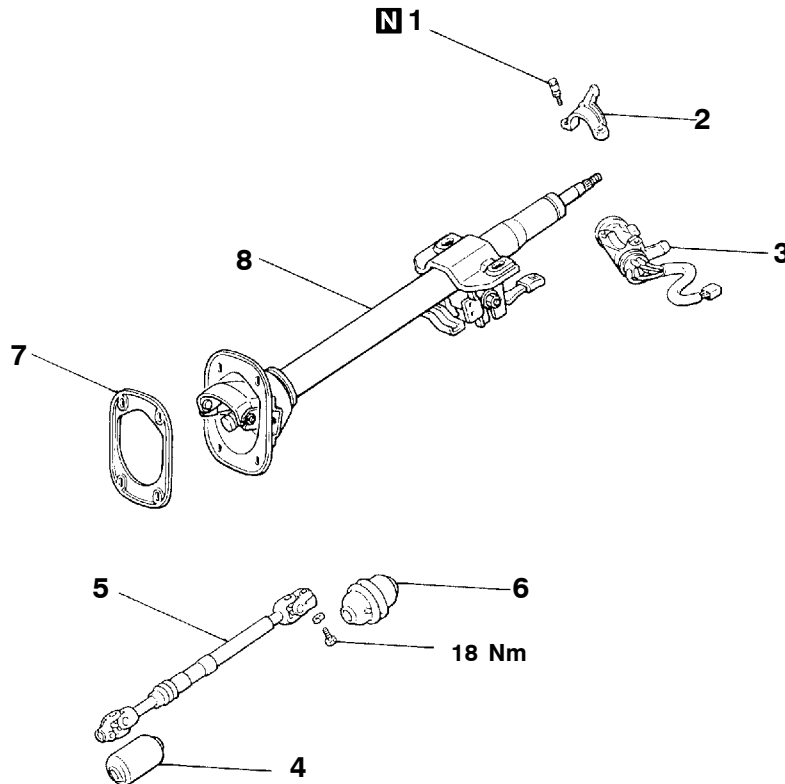

A13V0093

Disassembly steps

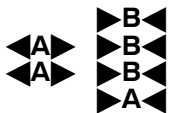

1. Special bolt
2. Steering lock bracket
3. Steering lock cylinder
4. Lower boot



5. Joint assembly
6. Upper boot
7. Packing
8. Column sub assembly

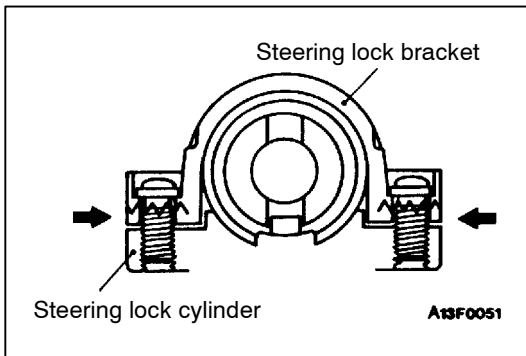

DISASSEMBLY SERVICE POINT

◀A▶ STEERING LOCK BRACKET/STEERING LOCK CYLINDER REMOVAL

If it is necessary to remove the steering lock cylinder, use a hacksaw to cut the special bolts at the steering lock bracket side.

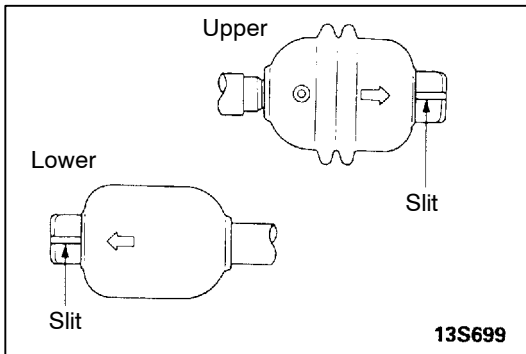

REASSEMBLY SERVICE POINT

▶A◀ UPPER BOOT/LOWER BOOT INSTALLATION

Assemble the upper and lower boots and the dust cover.

NOTE

Align the arrows on the upper and lower boots to the slit on the yokes in order to assemble.

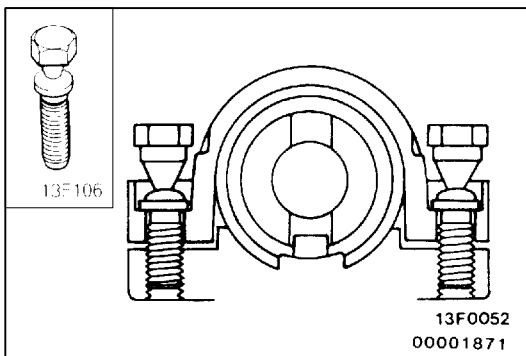

▶B◀ STEERING LOCK CYLINDER/STEERING LOCK BRACKET/SPECIAL BOLT INSTALLATION

1. When installing the steering lock cylinder and steering lock bracket to the column tube, temporarily install the steering lock in alignment with the column boss.
2. After checking that the lock works properly, tighten the special bolts until the head twists off.

Caution

The steering lock bracket and bolts must be replaced with new ones when the steering lock is installed.

POWER STEERING GEAR BOX

37200390375

REMOVAL AND INSTALLATION

Caution: SRS

For vehicles with SRS, before removal of the steering gear box refer to GROUP 52B – Supplemental Restraint System (SRS), center the front wheels and remove the ignition key. Failure to do so may damage the SRS clock spring and render the SRS system inoperative, risking serious driver injury.

Pre-removal Operation

- Power Steering Fluid Draining (Refer to P.37A-11.)

Post-installation Operation

- Power Steering Fluid Supplying (Refer to P.37A-11.)
- Power Steering Fluid Line Bleeding (Refer to P.37A-12.)
- Checking Steering Wheel Position with Wheels Straight Ahead
- Front Wheel Alignment Adjustment (Refer to GROUP 33A – On-vehicle Service.)
- Press the dust cover with a finger to check whether the dust cover is cracked or damaged.

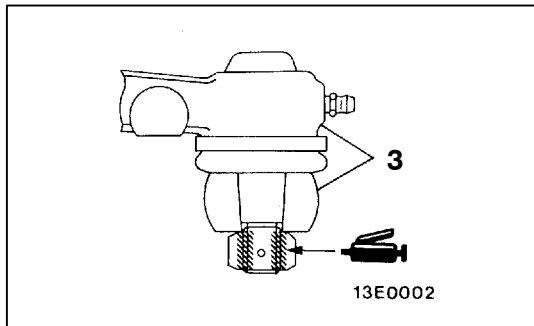
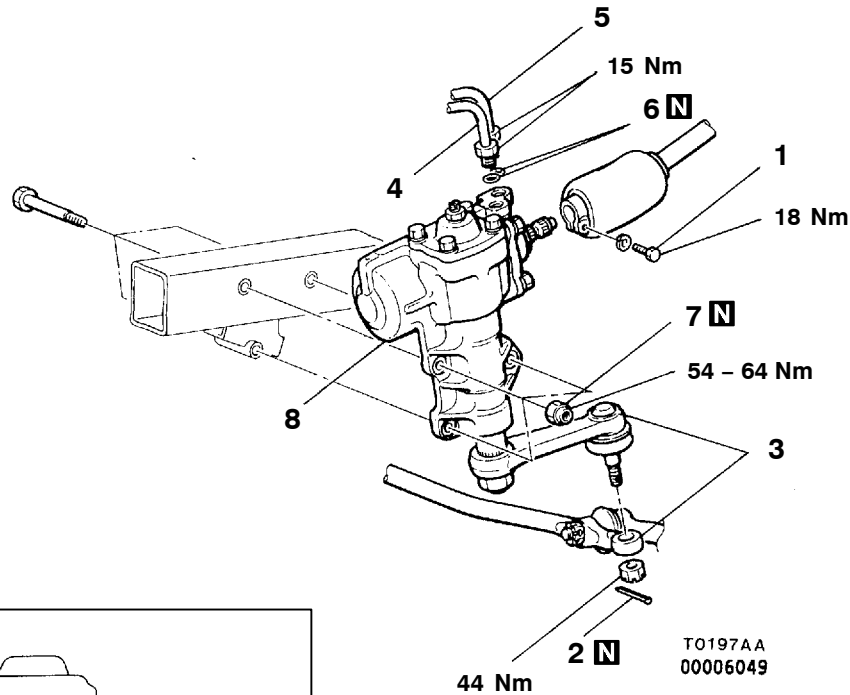

Removal steps

1. Connecting bolt for steering gear box and steering shaft
2. Split pin
3. Connection for pitman arm and relay rod

4. Pressure tube
5. Return tube
6. O-ring
7. Self-locking nut
8. Power steering gear box

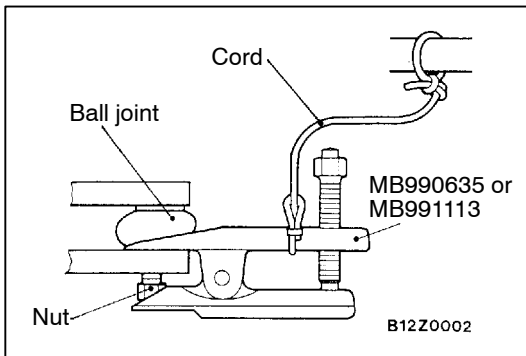

**REMOVAL SERVICE POINT****◀A▶ PITMAN ARM AND RELAY ROD DISCONNECTION**

Use the special tool to disconnect the ball joint.

Caution

1. **Using the special tool, loosen the tie rod end mounting nut. Only loosen the nut; do not remove it from the ball joint.**
2. **Support the special tool with a cord, etc. to prevent it from coming off.**

INSPECTION

37200400184

PITMAN ARM DUST COVER CHECK

1. Press the dust cover with a finger to check whether the dust cover is cracked or damaged.
2. If there are any cracks in or damage to the dust cover, replace the pitman arm. (Refer to P.37A-20.)

NOTE

Cranked or damaged dust cover may cause damage to the ball joint. In addition, if the dust cover is damaged during service work, replace the dust cover. (Refer to P.37A-25.)

DISASSEMBLY

37200420029

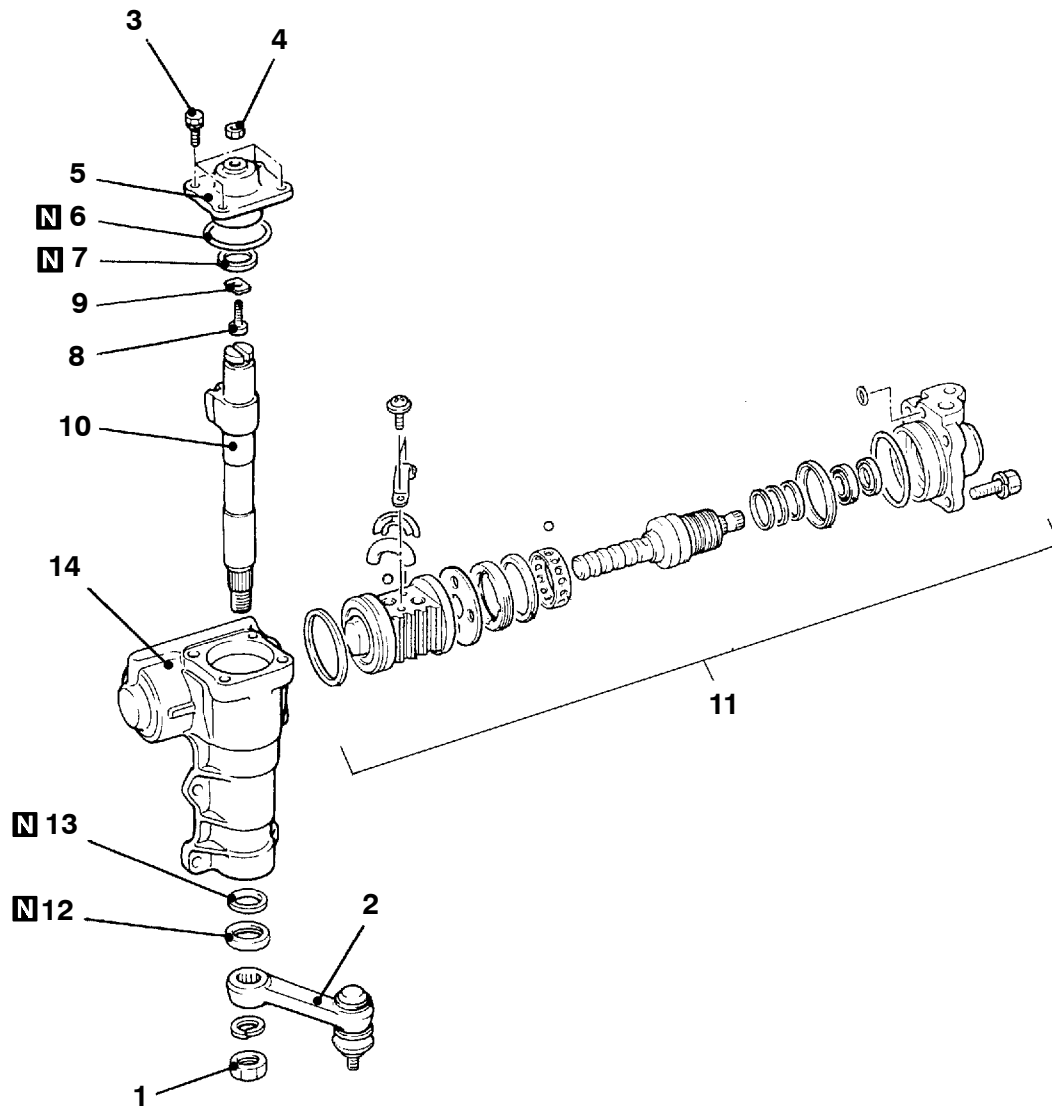

B13V0108

Disassembly steps

◀A▶

- 1. Jam nut
- 2. Pitman arm
- 3. Bolts
- 4. Adjusting bolt locking nut
- 5. Side cover
- 6. O-ring
- 7. Y-packing

◀C▶

- 8. Adjusting bolt
- 9. Adjusting plate
- 10. Cross-shaft
- 11. Mainshaft and valve assembly
- 12. Oil seal
- 13. Y-packing
- 14. Gear box housing

◀B▶

DISASSEMBLY SERVICE POINTS

◀A▶ PITMAN ARM REMOVAL

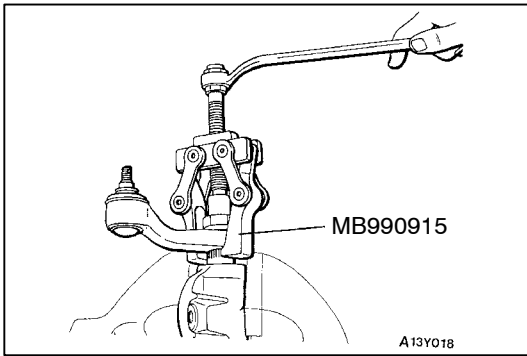

◀B▶ SIDE COVER REMOVAL

1. Loosen the lock nut and then turn the adjusting bolt anti-clockwise slightly.
2. Screw in the adjusting bolt without turning the side cover, and then remove the side cover.

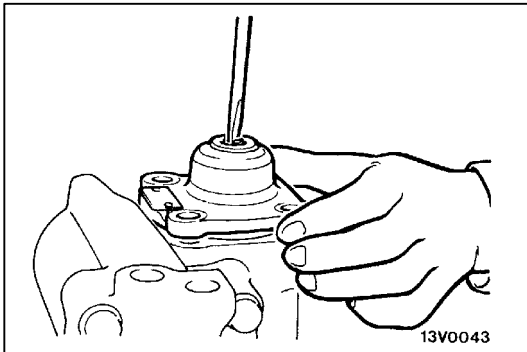

◀C▶ CROSS-SHAFT REMOVAL

With the mainshaft and cross-shaft placed in the straight ahead position, tap the bottom of the cross-shaft with a plastic hammer to take out the cross-shaft together with the side cover.

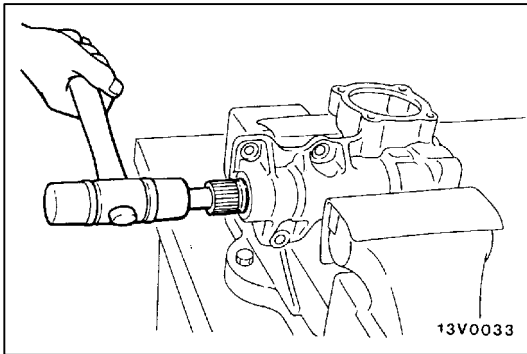

REASSEMBLY

37200430060

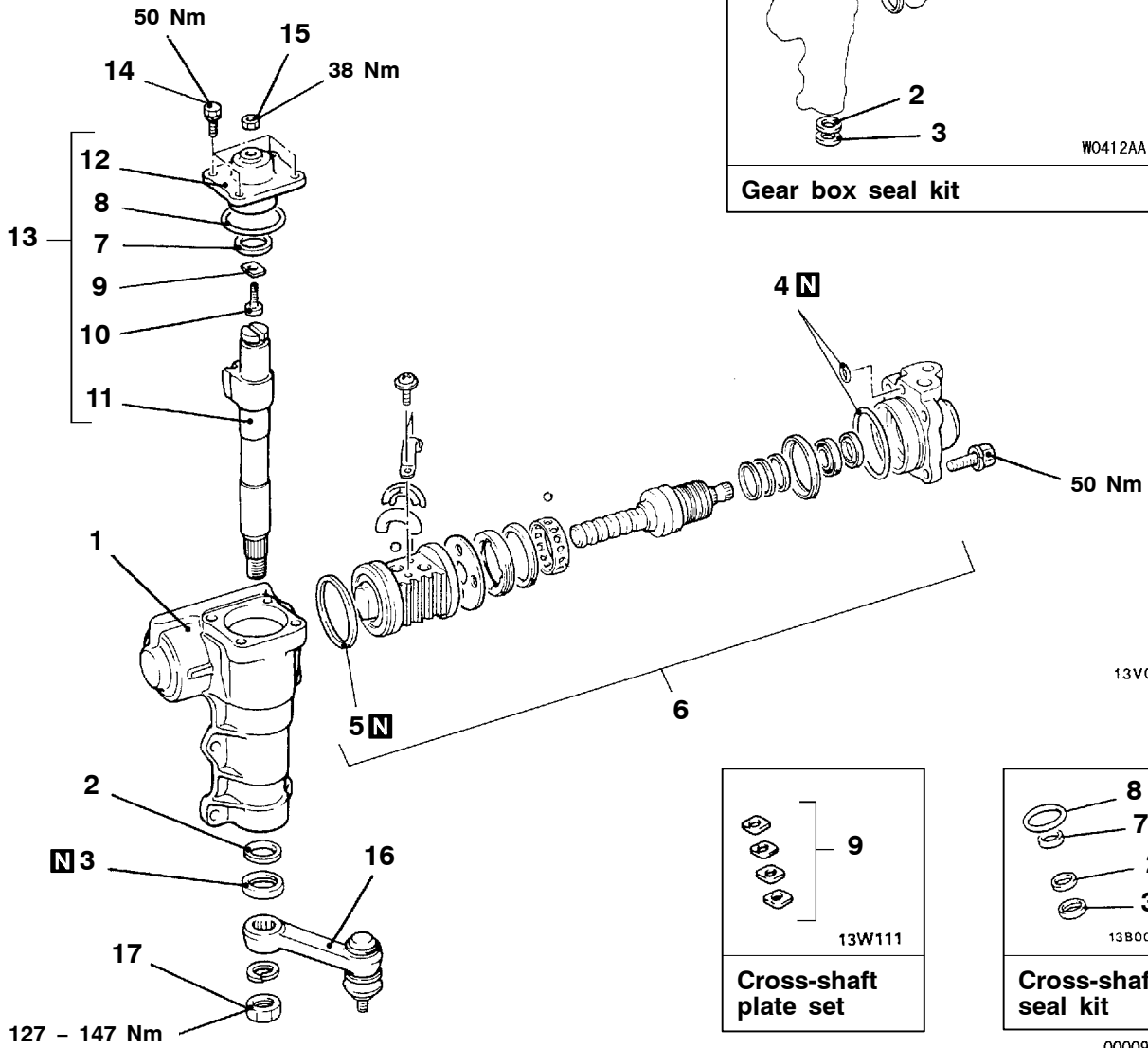

13V0108

00009701

Reassembly steps

- 1. Gear box housing
- ▶A◀ 2. Y-packing
- 3. Oil seal
- 4. O-ring
- 5. Seal ring
- 6. Mainshaft and valve assembly
- 7. Y-packing
- 8. O-ring
- ▶B◀ ● Cross-shaft axial play adjustment
- 9. Adjusting plate
- 10. Adjusting bolt

- ▶C◀ 11. Cross-shaft
- 12. Side cover
- 13. Side cover and cross-shaft assembly
- 14. Bolt
- ▶D◀ ● Mainshaft total starting torque adjustment
- 15. Adjusting bolt lock nut
- ▶E◀ 16. Pitman arm
- 17. Jam nut

LUBRICATION AND SEALING POINTS

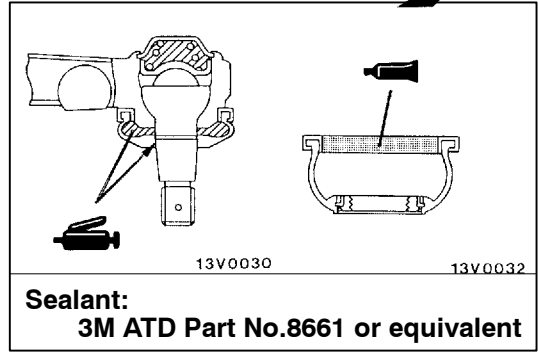
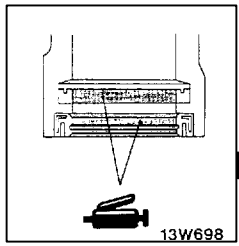
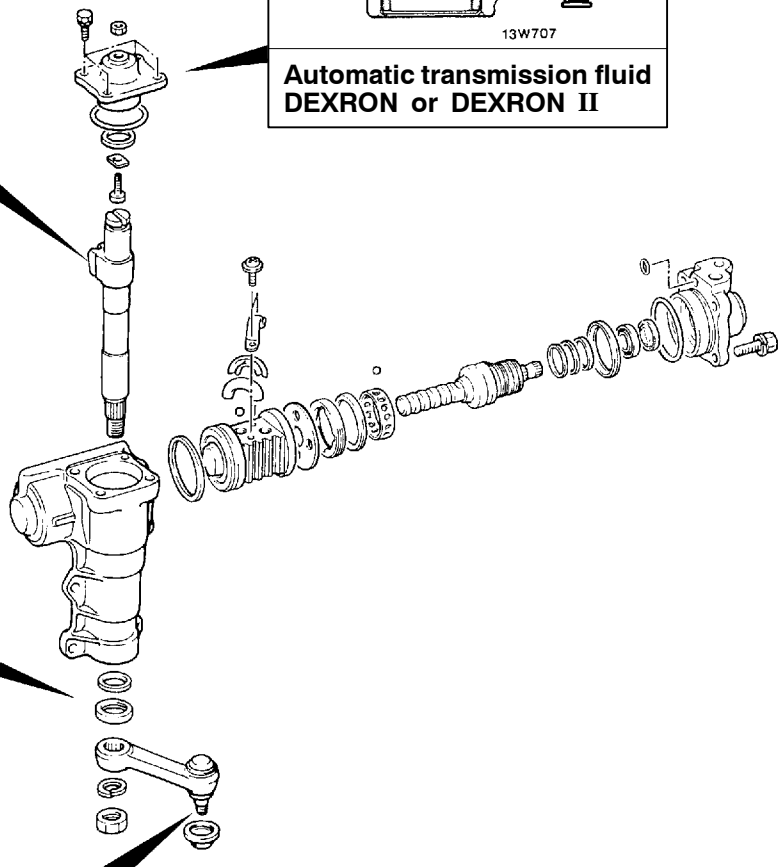
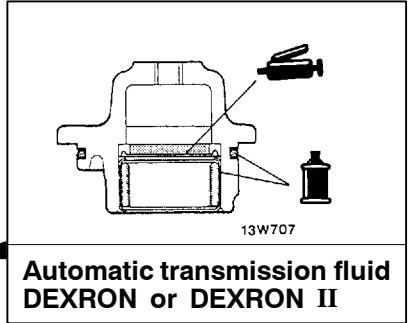
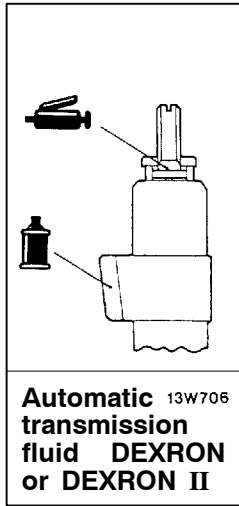

00009702

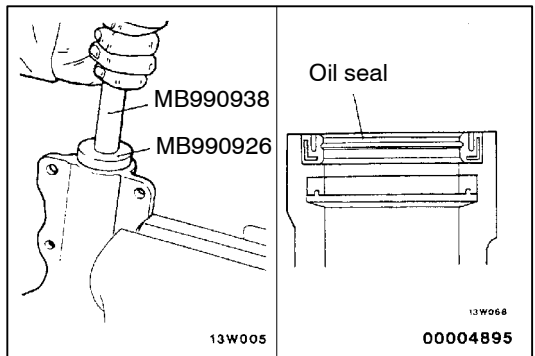

REASSEMBLY SERVICE POINTS

▶◀ OIL SEAL INSTALLATION

Apply a coating of the specified fluid to the outside of the oil seal. Using the special tools, press the oil seal into the valve housing.

Specified fluid:
Automatic transmission fluid DEXRON or DEXRON II

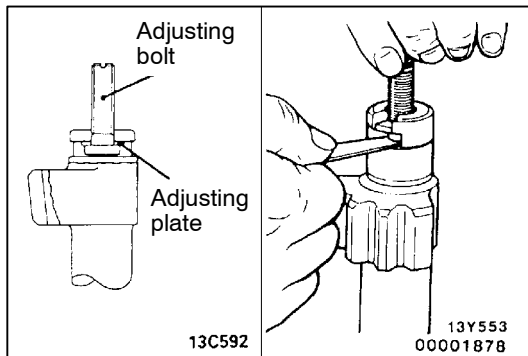

►B◄ CROSS-SHAFT AXIAL PLAY ADJUSTMENT

1. Install the adjusting plate so that the beveled part is facing downward.
2. Using a thickness gauge, measure the clearance between the adjusting bolt and cross-shaft.

Standard value: 0.05 mm or less

3. If the clearance exceeds the standard value, replace with a suitable adjusting plate.

►C◄ CROSS-SHAFT INSTALLATION

Set the rack piston in the neutral position and install the cross-shaft.

Caution

Do not rotate the side cover during installation. Take care not to damage the cross-shaft oil seal.

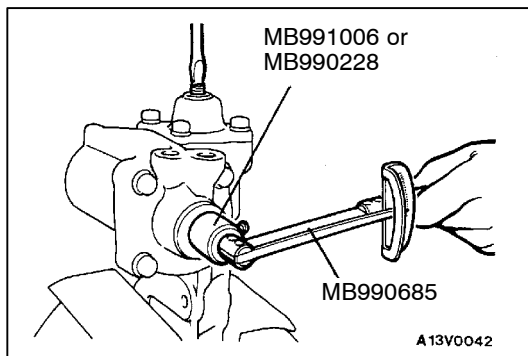

►D◄ MAINSHAFT TOTAL STARTING TORQUE ADJUSTMENT

1. While turning the adjusting bolt, measure the mainshaft total starting torque by using the special tools.

Standard value: 0.69 – 1.28 Nm

Caution

Adjust by turning adjusting bolt so that the starting torque at the centre position of the rack piston is approximately 0.2 Nm higher than the values at the both ends of the rack piston.

2. Tighten the adjusting bolt lock nut to the specified torque.

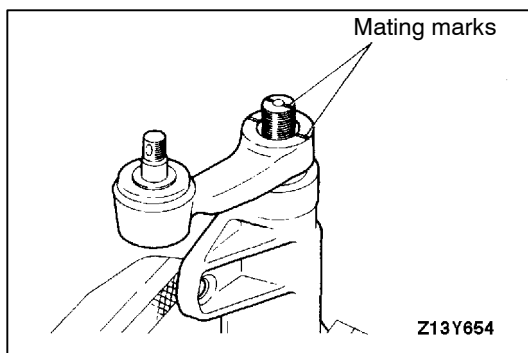

►E◄ PITMAN ARM INSTALLATION

Install the pitman arm to the gear box with the mating marks aligned.

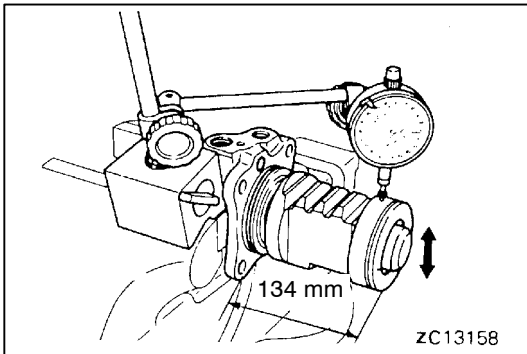

INSPECTION

37200440155

BACKLASH BETWEEN BALL GROOVE OF RACK PISTON AND BALLS

Set the rack piston to the position shown in the figure, and then measure the backlash by using a dial gauge.

Limit: 0.05 mm

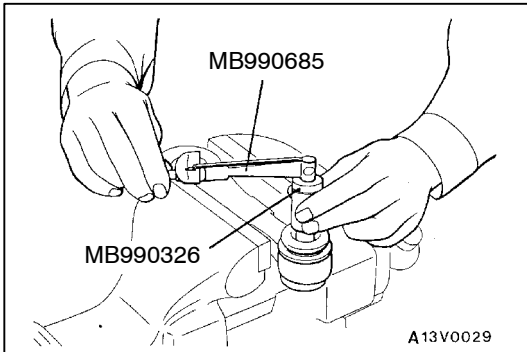

PITMAN ARM BALL JOINT STARTING TORQUE

After shaking the ball joint stud several times, install the nut to the stud and use the special tool to measure the starting torque of the ball joint.

Standard value: 0.98 – 2.94 Nm

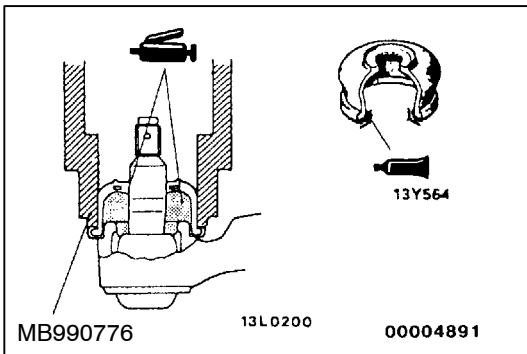

DUST COVER REPLACEMENT

Only when the dust cover is damaged accidentally during service work, replace the dust cover only as follows:

1. Fill inside the dust cover with multipurpose grease.
2. Apply specified sealant to the mounting surface of the dust cover at the pitman arm.

Specified sealant:

3M ATD Part No.8661 or equivalent

3. Using the special tool, install the dust cover to the pitman arm.

POWER STEERING OIL PUMP

37200520422

REMOVAL AND INSTALLATION

Pre-removal Operation

- Power Steering Fluid Draining (Refer to P.37A-11.)

Post-installation Operation

- Power Steering Fluid Supplying (Refer to P.37A-11.)
- Drive Belt Tension Check (Refer to P.37A-10.)
- Power Steering Fluid Line Bleeding (Refer to P.37A-12.)
- Oil Pump Pressure Check (Refer to P.37A-13.)

<6G7>

<4D5>

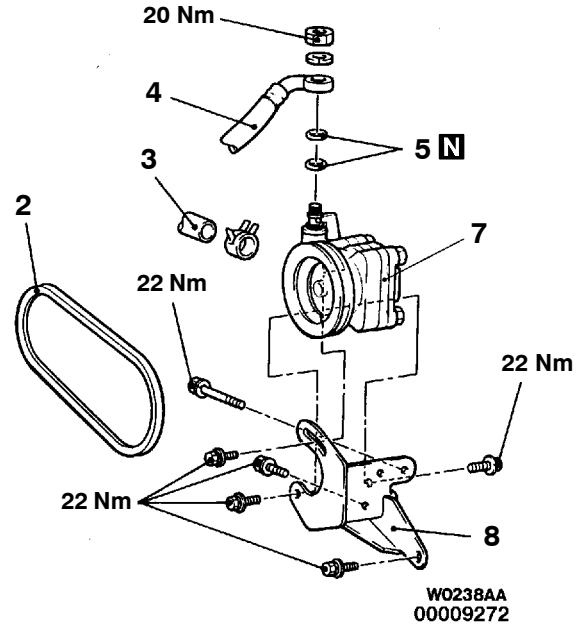
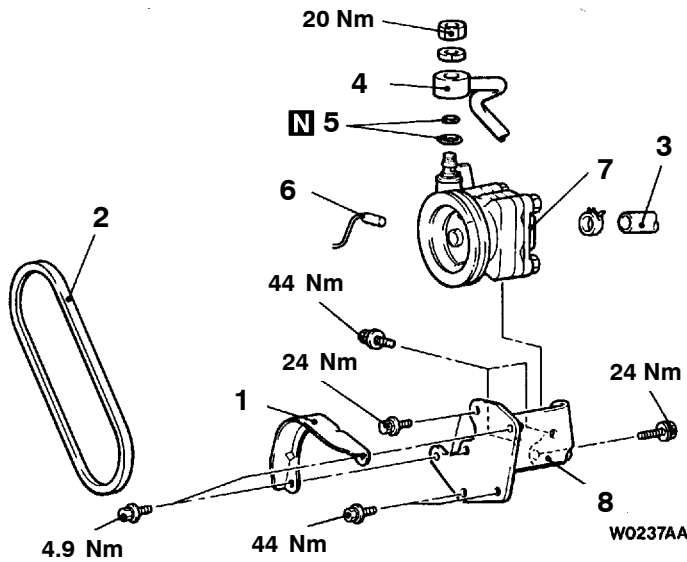

Removal steps

1. Pulley cover <6G7>
2. Drive belt
3. Suction hose
4. Pressure tube



5. O-ring
6. Pressure switch connector <6G7>
7. Oil pump
8. Oil pump bracket

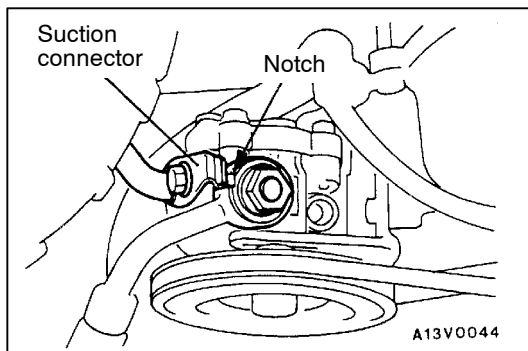

INSTALLATION SERVICE POINT

▶A◀ PRESSURE HOSE INSTALLATION

Connect the pressure hose so that the notched part contacts the suction connector.

INSPECTION

Check the drive belt for cracks.
Check the pulley assembly for uneven rotation.

37200530067

DISASSEMBLY AND REASSEMBLY <6G7>

37200540299

Caution

Do not disassemble the flow control valve.

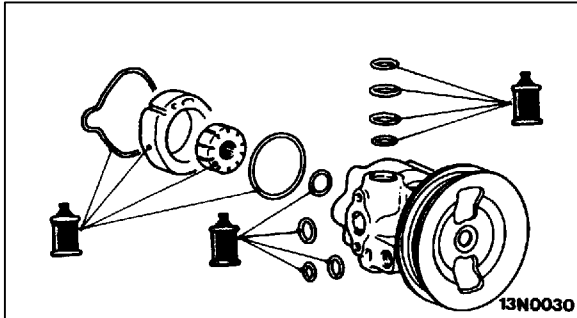

Fluid:

Automatic transmission fluid
DEXRON or DEXRON II

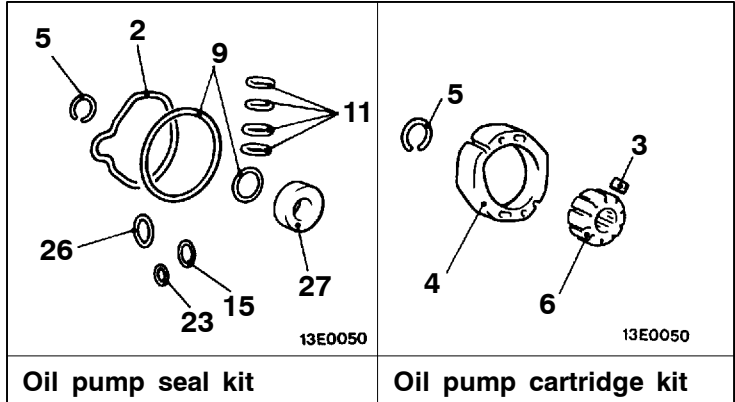

Oil pump seal kit

Oil pump cartridge kit

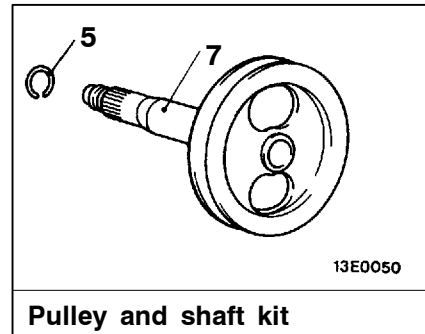
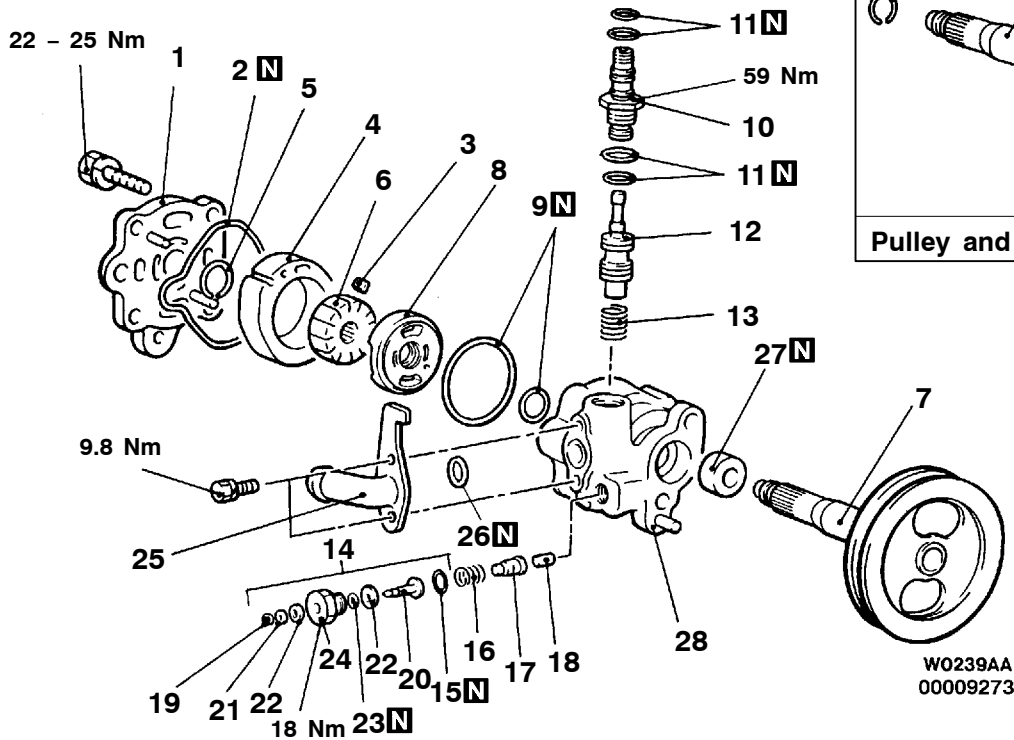

Pulley and shaft kit

Disassembly steps

- | | | | |
|-----|-------------------------|-----|-----------------------|
| | 1. Pump cover | | 16. Spring |
| | 2. O-ring | | 17. Plunger |
| | 3. Vanes | | 18. Piston rod |
| | 4. Cam ring | | 19. Snap ring |
| ◀A▶ | 5. Snap ring | | 20. Terminal |
| ▶H▶ | 6. Rotor | | 21. Washer |
| ▶G▶ | 7. Pulley assembly | | 22. Insulator |
| ▶F▶ | 8. Side plate | | 23. O-ring |
| ▶E▶ | 9. O-ring | ▶B▶ | 24. Plug |
| | 10. Connector | | 25. Suction connector |
| ▶D▶ | 11. O-ring | | 26. O-ring |
| ▶B▶ | 12. Flow control valve | ▶B▶ | 27. Oil seal |
| | 13. Flow control spring | ▶A▶ | 28. Oil pump body |
| | 14. Terminal assembly | | |
| ▶B▶ | 15. O-ring | | |

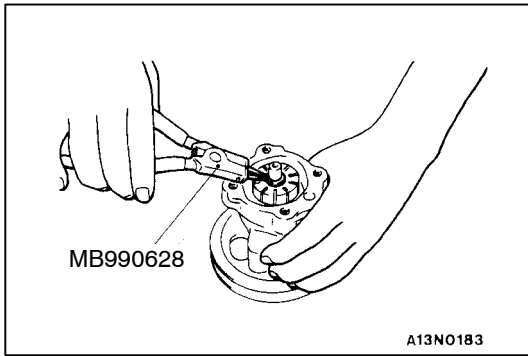

DISASSEMBLY SERVICE POINT

◀A▶ SNAP RING REMOVAL

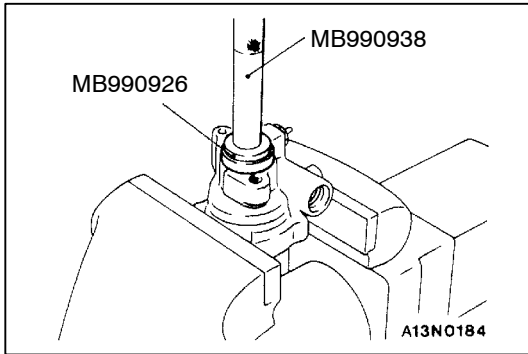

REASSEMBLY SERVICE POINTS

▶A◀ OIL SEAL INSTALLATION

Use special tool to install the oil seal.

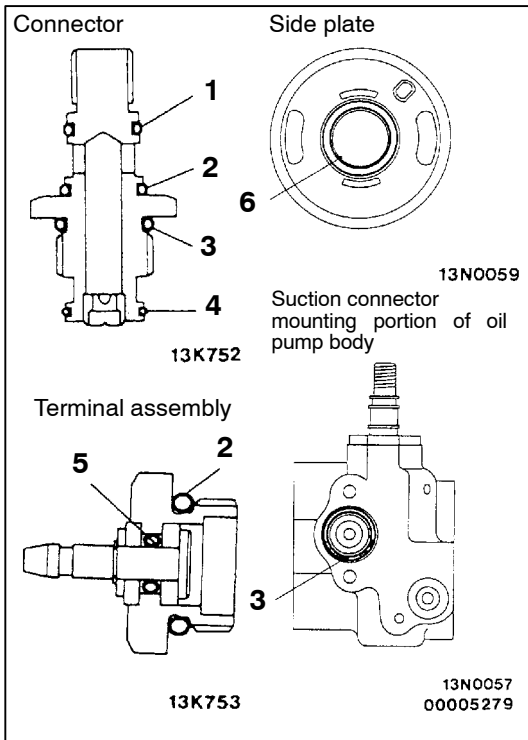

▶B◀ O-RINGS INSTALLATION

No.	I.D. X Width mm
1	11 × 1.9
2	13 × 1.9
3	17.8 × 2.4
4	13.5 × 1.5
5	3.8 × 1.9
6	16.8 × 2.4

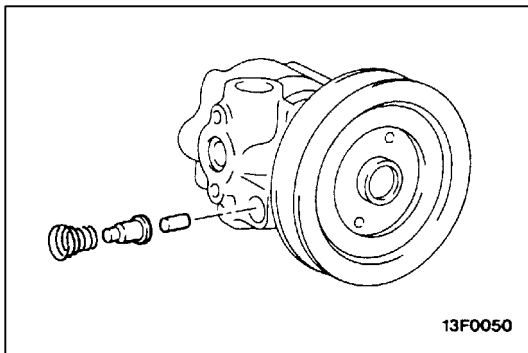

▶C◀ SPRING INSTALLATION

Fit the spring to the oil pump body with the larger-diameter end at the terminal assembly side.

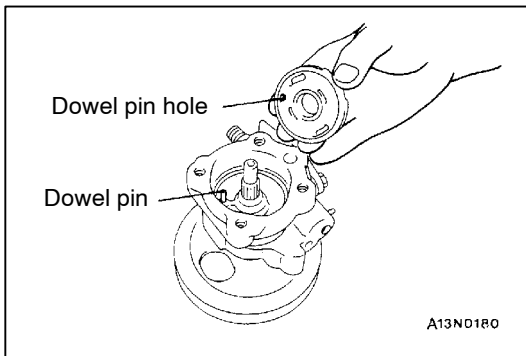

►D◄ SIDE PLATE INSTALLATION

Line up the dowel pin hole of the side plate with the dowel pin of the pump body when installing the side plate.

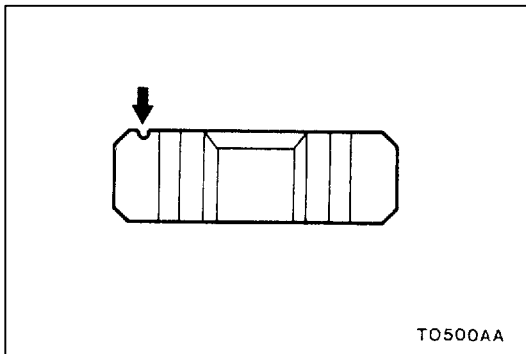

►E◄ ROTOR INSTALLATION

Install the rotor to the pulley assembly so that the rotor's punch mark is at the pump cover side.

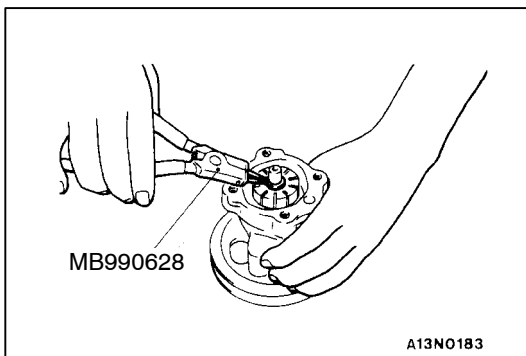

►F◄ SNAP RING INSTALLATION

After installation of the snap ring, lift the rotor and check that the snap ring has entered the countersunk part.

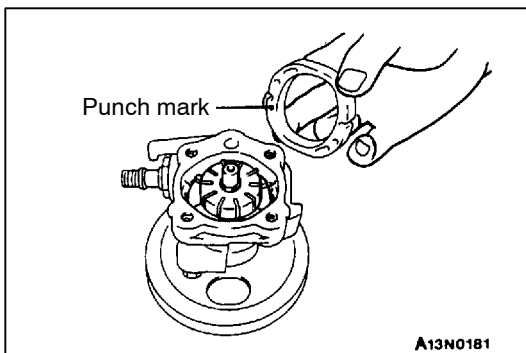
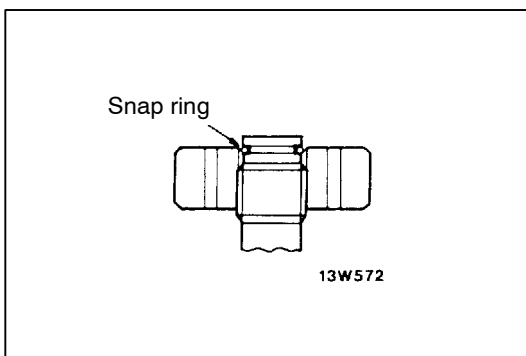

►G◄ CAM RING INSTALLATION

Install the cam ring with the punch mark facing the side plate.

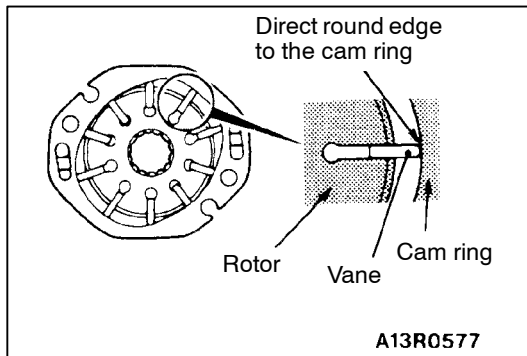

▶◀ VANES INSTALLATION

Install the vanes on the rotor, paying close attention to the installation direction.

INSPECTION

37200550087

- Check the flow control valve for clogging.
- Check the pulley assembly for wear or damage.
- Check the rotor and vane groove for “stepped” wear.
- Check the contact surface of cam ring and vanes for “stepped” wear.
- Check the vanes for damage.

DISASSEMBLY AND REASSEMBLY <4D5>

37200540305

Caution

Do not disassemble the flow control valve.

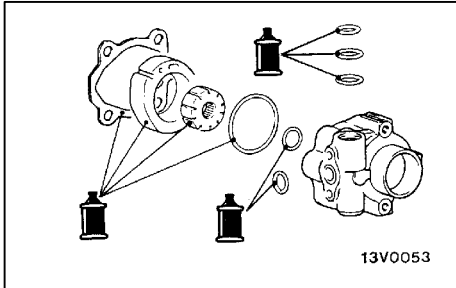

Fluid:
Automatic transmission fluid
DEXRON or DEXRON II

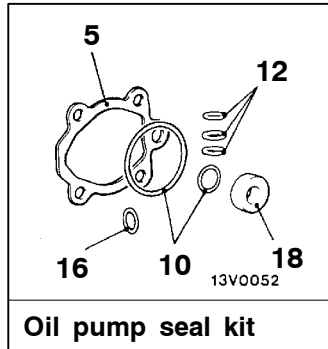

Oil pump seal kit

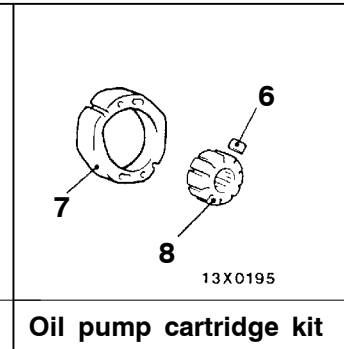

Oil pump cartridge kit

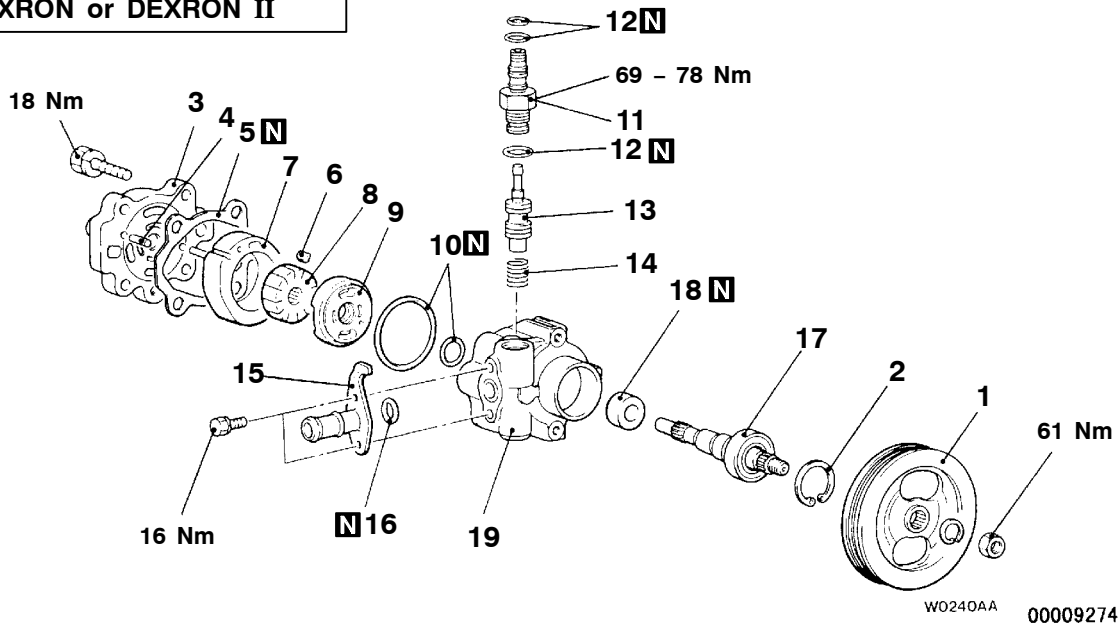

Disassembly steps

- ◀A▶ ▶G▶ 1. Drive pulley
- ▶F▶ ▶E▶ ▶D▶ 2. Snap ring
- ▶E▶ ▶D▶ 3. Pump cover
- ▶D▶ 4. Lock pin
- ▶F▶ ▶E▶ ▶D▶ 5. Seal washer
- ▶E▶ ▶D▶ 6. Vanes
- ▶D▶ 7. Cam ring
- ▶D▶ 8. Rotor
- ▶D▶ 9. Side plate
- ▶C▶ 10. O-ring

- ▶C▶ 11. Connector
- ▶C▶ 12. O-ring
- ▶C▶ 13. Flow control valve
- ▶C▶ 14. Flow control spring
- ▶C▶ 15. Suction connector
- ▶B▶ ▶A▶ 16. O-ring
- ▶B▶ ▶A▶ 17. Drive shaft assembly
- ▶A▶ 18. Oil seal
- ▶A▶ 19. Oil pump body

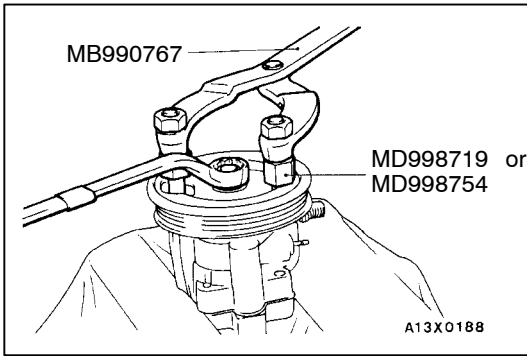

DISASSEMBLY SERVICE POINT

◀A▶ DRIVE PULLEY REMOVAL

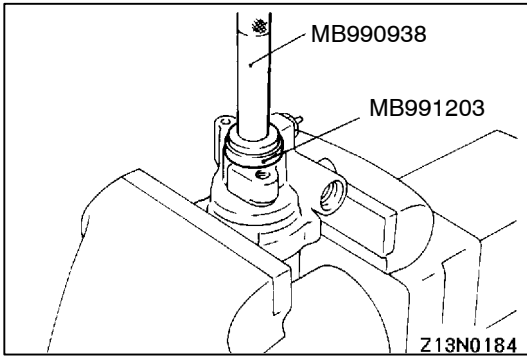

REASSEMBLY SERVICE POINTS

▶A◀ OIL SEAL INSTALLATION

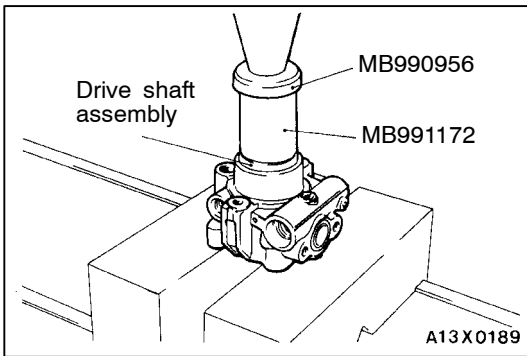

▶B◀ DRIVE SHAFT ASSEMBLY INSTALLATION

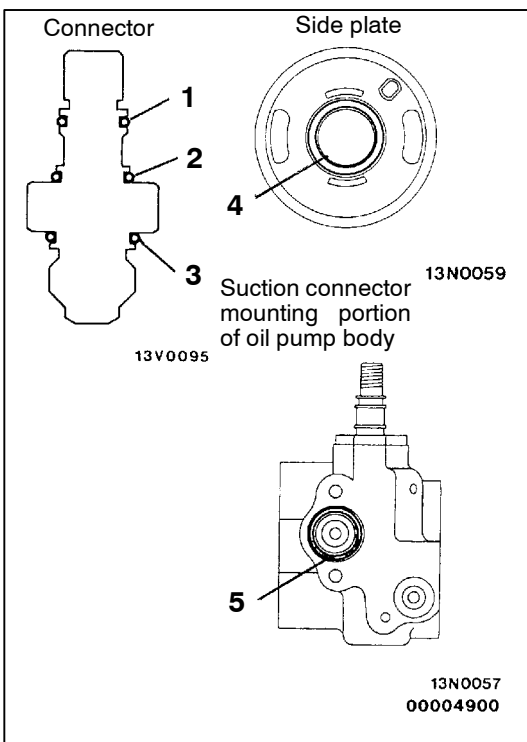

▶C◀ O-RINGS INSTALLATION

No.	I.D. x Width mm
1	11 × 1.9
2	13 × 1.9
3	15.5 × 2.4
4	14.6 × 2.4
5	19.4 × 1.9

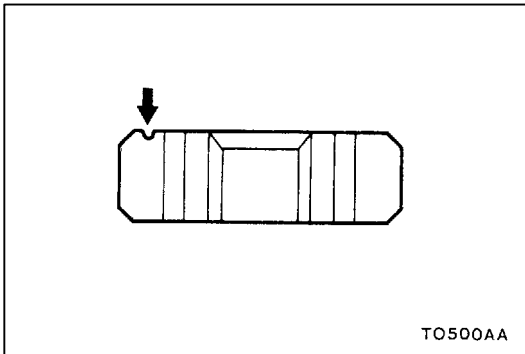

►D◄ ROTOR INSTALLATION

Install the rotor to the pulley assembly so that the rotor’s punch mark is at the pump cover side.

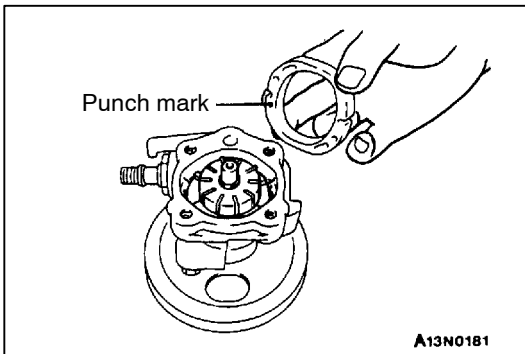

►E◄ CAM RING INSTALLATION

Install the cam ring with the punch mark facing the side plate.

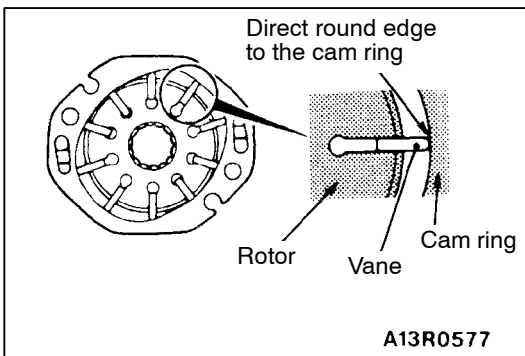

►F◄ VANE INSTALLATION

Install the vanes on the rotor, paying close attention to the installation direction.

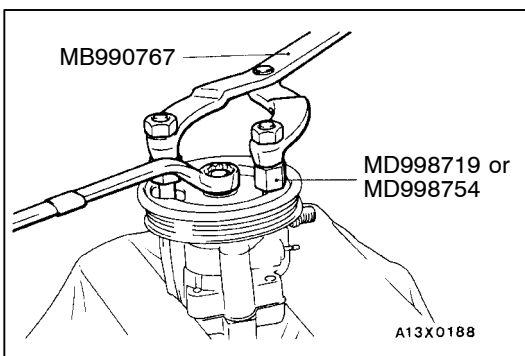

►G◄ DRIVE PULLEY INSTALLATION

INSPECTION

37200550087

- Check the flow control valve for clogging.
- Check the pulley assembly for wear or damage.
- Check the groove of rotor and vane for “stepped” wear.
- Check the contact surface of cam ring and vanes for “stepped” wear.
- Check the vanes for damage.

POWER STEERING HOSES

37200570403

REMOVAL AND INSTALLATION

Pre-removal Installation

- Power Steering Fluid Draining (Refer to P.37A-11.)
- Radiator Grille Removal

Post-installation Operation

- Radiator Grille Installation
- Power Steering Fluid Supplying (Refer to P.37A-11.)
- Power Steering Fluid Line Bleeding (Refer to P.37A-12.)

<6G7>

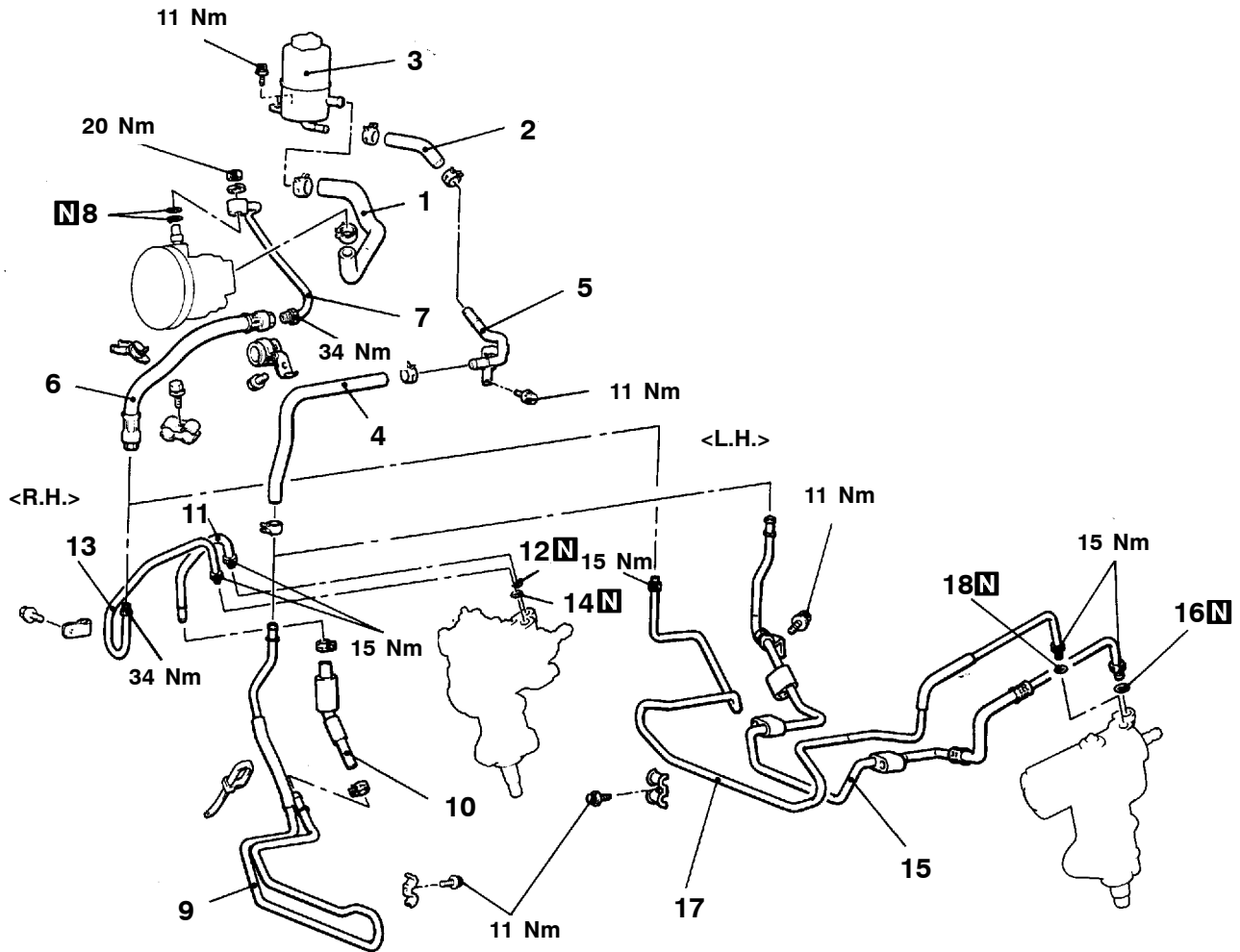

AW0241AA

Removal steps

- ▶E◀
- ▶E◀
- ▶D◀
- ▶C◀
- ▶C◀
- ▶B◀

1. Suction hose
2. Return hose
3. Oil reservoir
4. Return hose
5. Return tube
6. Pressure hose
7. Pressure tube
8. O-ring
9. Return tube

10. Return hose
11. Return tube
12. O-ring
- ▶A◀ 13. Pressure tube
- ▶B◀ 14. O-ring
- ▶B◀ 15. Return tube
- ▶A◀ 16. O-ring
- ▶A◀ 17. Pressure tube
18. O-ring

<4D5>

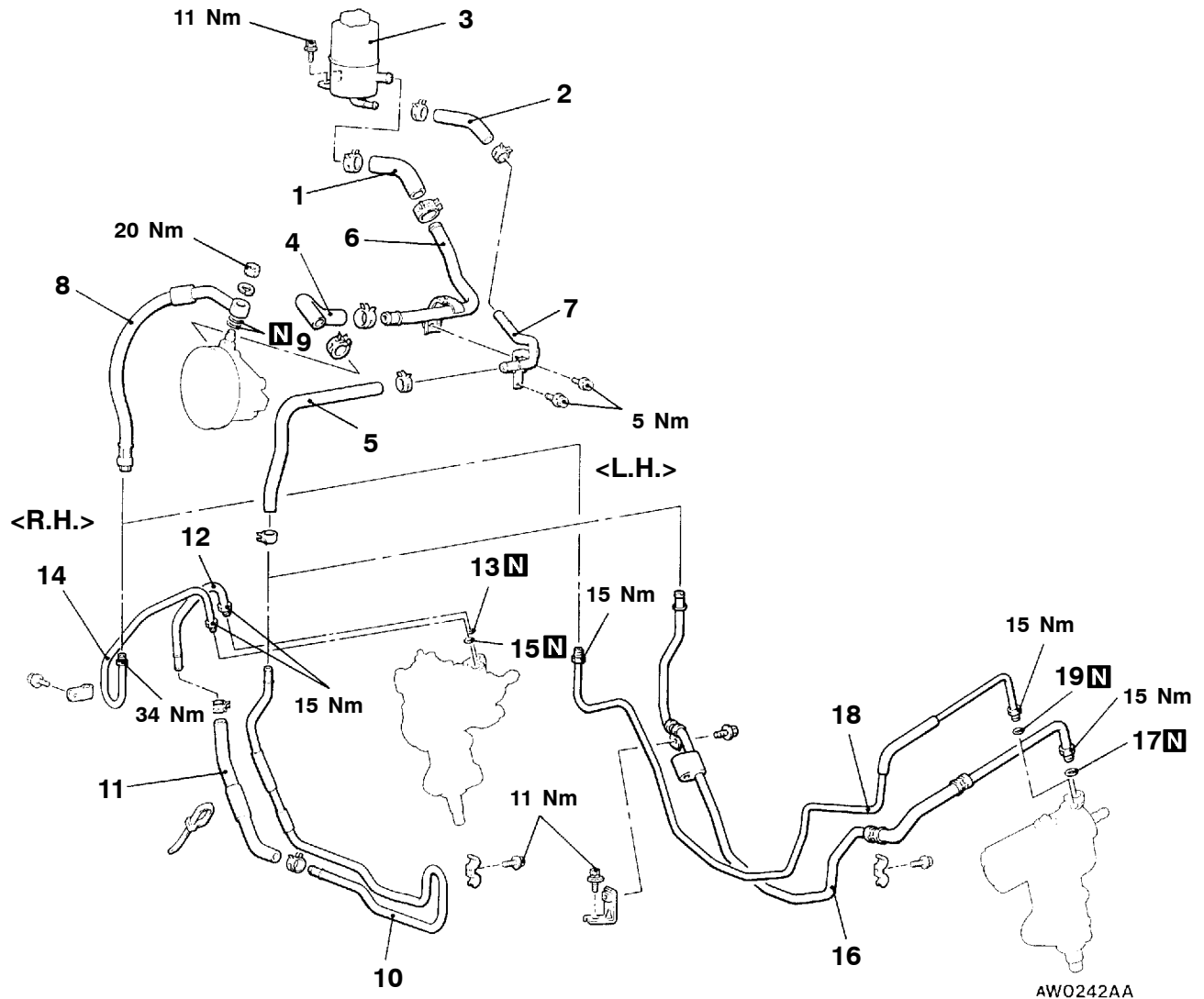

Removal steps

- ▶E◀ 1. Suction hose
- ▶E◀ 2. Return hose
- 3. Oil reservoir
- ▶E◀ 4. Suction hose
- ▶D◀ 5. Return hose
- 6. Suction tube
- 7. Return tube
- ▶C◀ 8. Pressure tube
- 9. O-ring
- ▶B◀ 10. Return tube

- 11. Return hose
- 12. Return tube
- 13. O-ring
- ▶A◀ 14. Pressure tube
- ▶B◀ 15. O-ring
- ▶B◀ 16. Return tube
- ▶A◀ 17. O-ring
- ▶A◀ 18. Pressure tube
- 19. O-ring

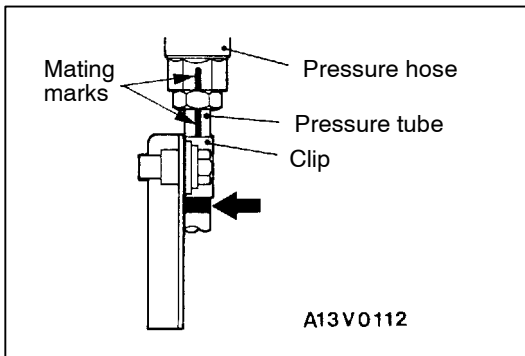
**INSTALLATION SERVICE POINTS****►A◄ PRESSURE TUBE INSTALLATION**

1. Connect the pressure tube so that the marking is positioned as shown in the illustration.
2. Align the pressure tube and pressure hose alignment marks and install.

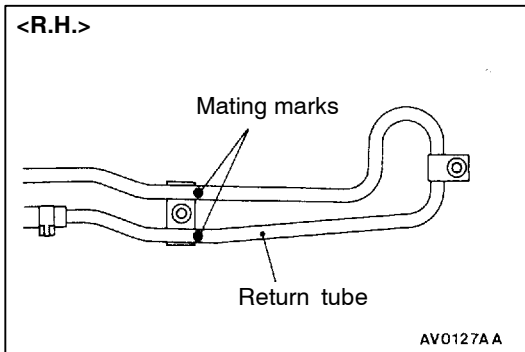
**►B◄ RETURN TUBE INSTALLATION**

Connect the return tube so that the marking is positioned as shown in the illustration.

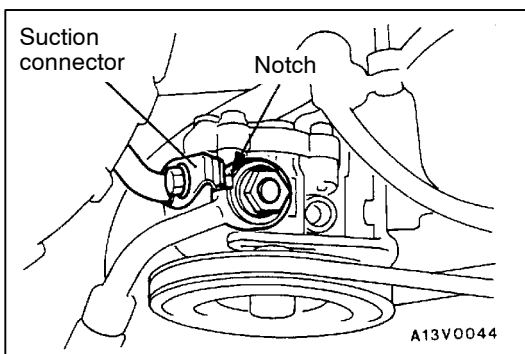
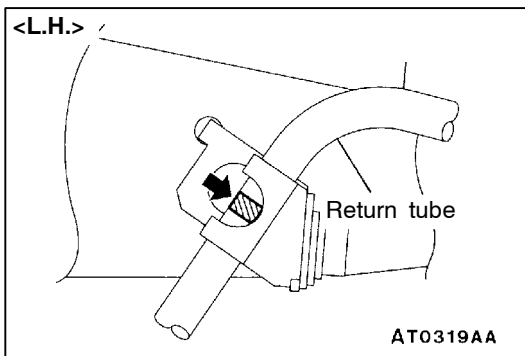
**►C◄ PRESSURE TUBE/PRESSURE HOSE/PRESSURE TUBE INSTALLATION**

1. Connect the pressure tube so that its notched part contacts the suction connector.
2. Align the mating marks on the pressure hose and pressure tube, and install the pressure hose.

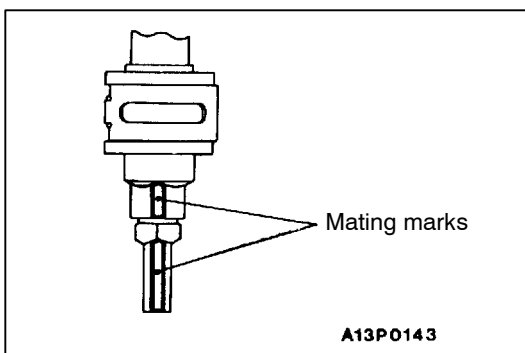

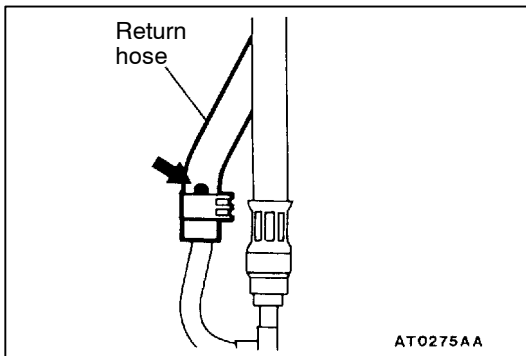

►D◄ RETURN HOSE INSTALLATION

Install the return hose so that the marking faces towards front of the vehicle.

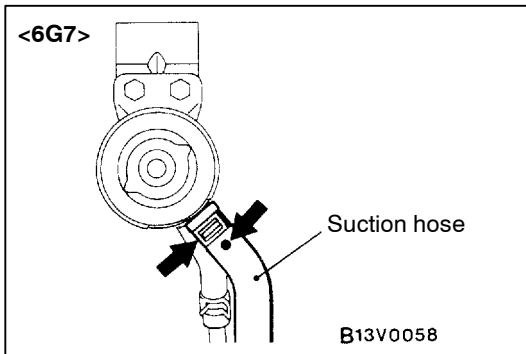

►E◄ RETURN HOSE/SUCTION HOSE INSTALLATION

Connect the return hose and suction hose so that the marking is positioned as shown in the illustration.

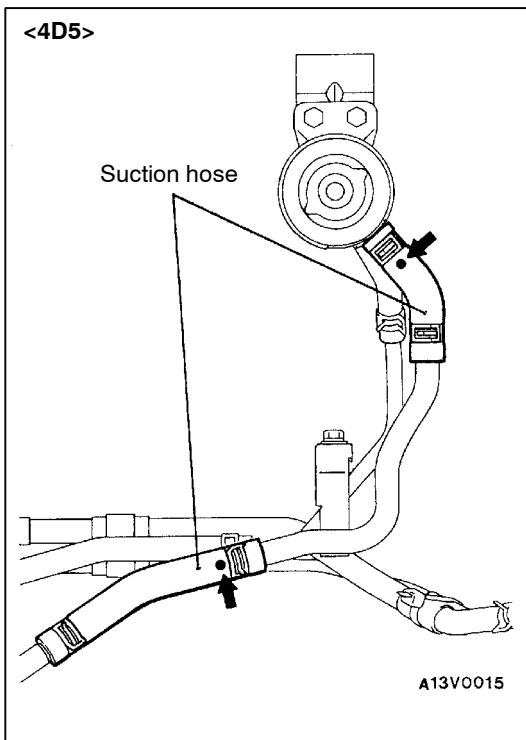

STEERING LINKAGE

REMOVAL AND INSTALLATION

Post-installation Operation

- Checking Steering Wheel Position with the Wheels Straight Ahead
- Front Wheel Alignment (Refer to GROUP 33A – On-vehicle Service.)
- Press the dust cover with a finger to check whether the dust cover is cracked or damaged.

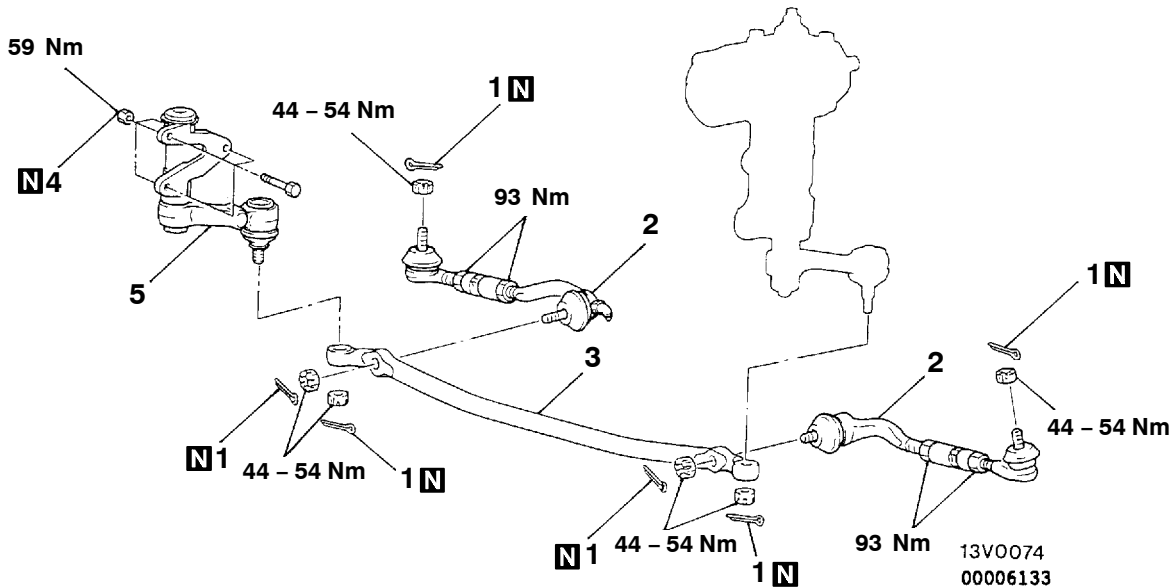
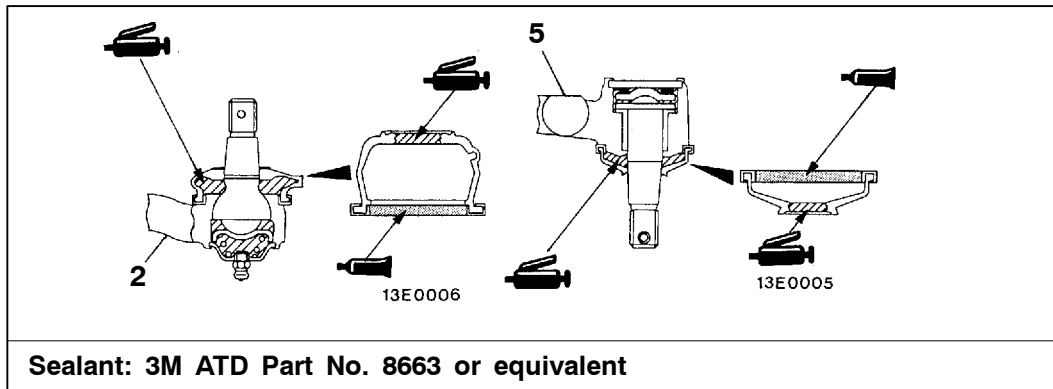

Removal steps



1. Cotter pin
2. Tie rod assembly
3. Relay rod



4. Self-locking nut
5. Idler arm assembly

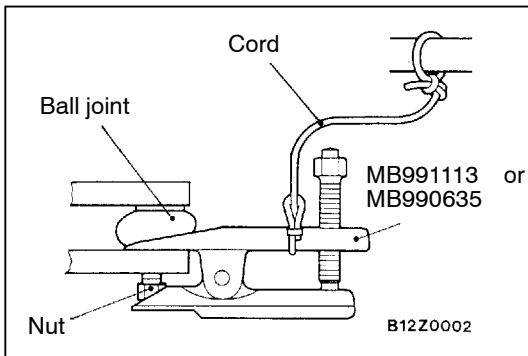

REMOVAL SERVICE POINT

◀A▶ TIE ROD ASSEMBLY/RELAY ROD/IDLER ARM ASSEMBLY REMOVAL

Use special tool to disconnect the ball joint.

Caution

1. Support special tool with a cord, etc. to prevent it from coming off.
2. Only loosen mounting nut, do not remove it from the ball joint.

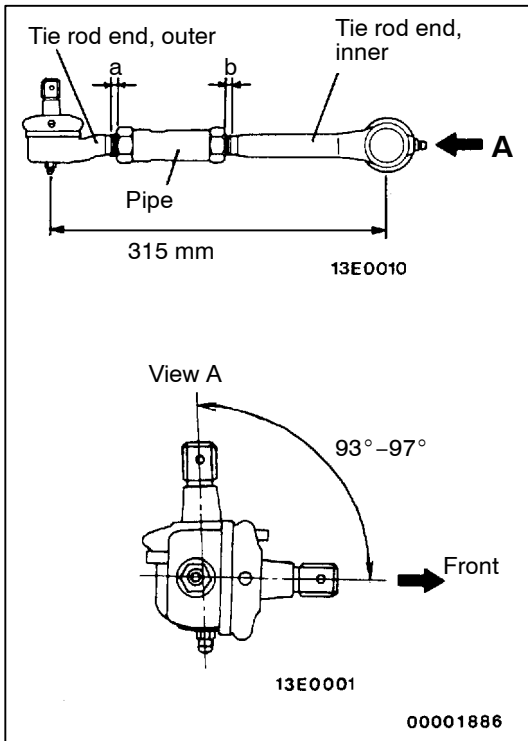

INSTALLATION SERVICE POINT

▶A◀ TIE ROD ASSEMBLY INSTALLATION

1. Install the tie rod assembly so that the dimension is as shown in the illustration.

Caution

The outer end of the tie rod end has a left thread.

NOTE

The illustration at left shows the left side tie rod assembly. The right side tie rod assembly is symmetrical to the left side assembly.

2. Adjust the pipe so that the difference between dimensions (a) and (b) is 1.5 mm or less, and then temporarily tighten the lock nut.

NOTE

Fully tighten the lock nut after the tie rod assembly is installed to the body and the toe-in has been adjusted.

INSPECTION

37100310040

Check the rubber parts for cracks and break.

DUST COVER CHECK

1. Press the dust cover with a finger to check whether the dust cover is cracked or damaged.
2. If there are any cracks in or damage to the dust cover, replace the tie rod end assembly or idler arm. (Refer to P.37A-38.)

NOTE

Cracked or damaged dust cover may cause damage to the ball joint. In addition, if the dust cover is damaged during service work, replace the dust cover. (Refer to P.37A-41.)

DISASSEMBLY AND REASSEMBLY

37100340063

Idler arm

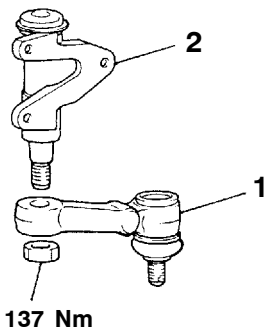

13V0104

Tie rod assembly

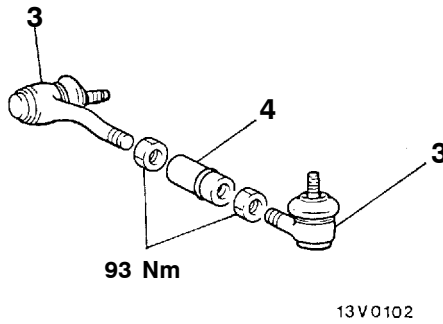

13V0102

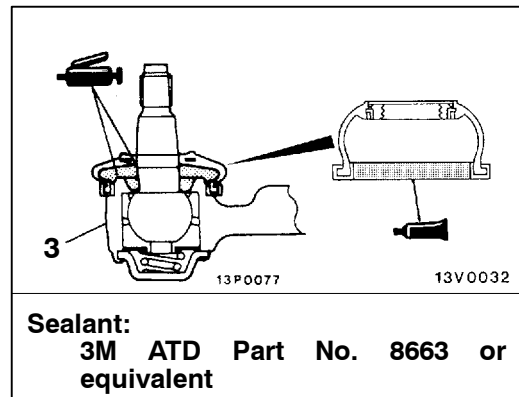

Sealant:
3M ATD Part No. 8663 or equivalent

00006103

Idler arm disassembly steps

1. Idler arm
2. Idler arm support

Tie rod disassembly steps

- ▶A◀
3. Tie rod end assembly
 4. Pipe

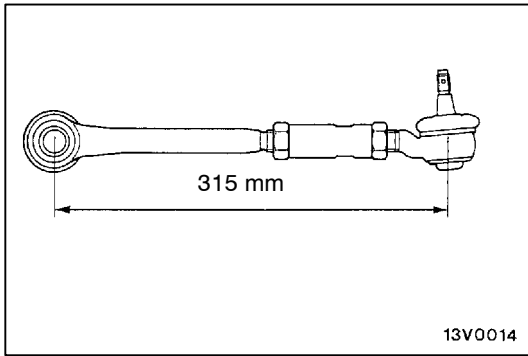

REASSEMBLY SERVICE POINT

▶◀TIE ROD END ASSEMBLY INSTALLATION

1. Apply multipurpose grease to the threaded section of the tie rod end.
2. Screw in the right and left tie rod ends to the pipe by the same amount, and then and provisionally tighten the tie rod end fixing nut.

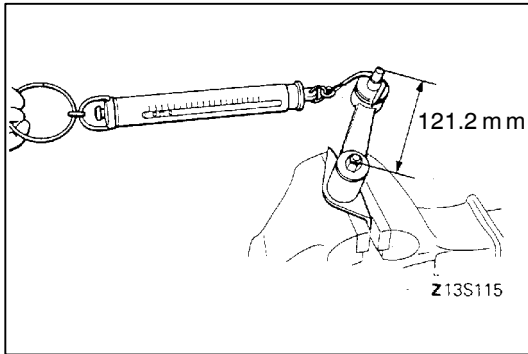

INSPECTION

37100350042

IDLER ARM SLIDING RESISTANCE

Standard value: 2.4 – 16 N
[Starting torque 0.3 – 2.0 Nm]

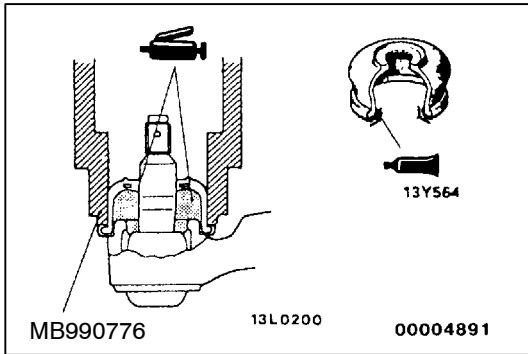

DUST COVER REPLACEMENT

When the dust cover is damaged accidentally during service work, replace the dust cover only as follows:

1. Fill inside the dust cover with multipurpose grease.
2. Apply the specified sealant to the dust cover lip.

Specified sealant:

3M ATD Part No. 8663 or equivalent

3. Using special tool, install the dust cover to the tie rod end ball joint.
4. Press the dust cover with a finger to check whether the dust cover is cracked or damaged.

NOTES

BODY

CONTENTS

42109000317

BODY MOUNTING	3	ON-VEHICLE SERVICE	27
HOOD	4	Door Fit Adjustment	27
FENDER	5	Door Window Glass Adjustment	27
SEALANT	5	Adjustment and Replacement When There is a Malfunction of The Power Windows	27
FENDER	5	Power Window Safety Mechanism Check ..	28
FUEL FILLER DOOR	6	Door Outside Handle Play Check	28
WINDOW GLASS	7	Power Window Operation Current Check	29
ADHESIVES	7	Circuit Breaker (Incorporated in the Power Window Motor) Check	29
SPECIAL TOOL	7	Door Inside Handle Play Check and Adjustment	29
WINDOW REPAIR	7	DOOR ASSEMBLY	30
WINDSHIELD	9	DOOR TRIM AND WATERPROOF FILM	32
QUARTER WINDOW GLASS	12	DOOR GLASS AND REGULATOR	35
TAILGATE WINDOW GLASS	14	DOOR HANDLE AND LATCH	39
DOOR	16	WINDOW GLASS RUNCHANNEL AND DOOR OPENING WEATHERSTRIP	42
SERVICE SPECIFICATIONS	16	TAILGATE	43
SEALANT	16	SEALANT	43
SPECIAL TOOLS	16	SPECIAL TOOL	43
TROUBLESHOOTING	18	TROUBLESHOOTING	43

CONTINUED ON NEXT PAGE

ON-VEHICLE SERVICE 43
Tailgate Fit Adjustment 43
Tailgate Handle Play Inspection 44

TAILGATE ASSEMBLY 45

TAILGATE TRIM AND WATERPROOF FILM
..... 47

TAILGATE HANDLE AND LATCH 48

SUNROOF 49

SEALANT AND ADHESIVE 49

ON-VEHICLE SERVICE 49
Water Test 49
Sunroof Fit Adjustment 49
Operation Check 50

SUNROOF 52



BODY MOUNTING

42100370066

REMOVAL AND INSTALLATION

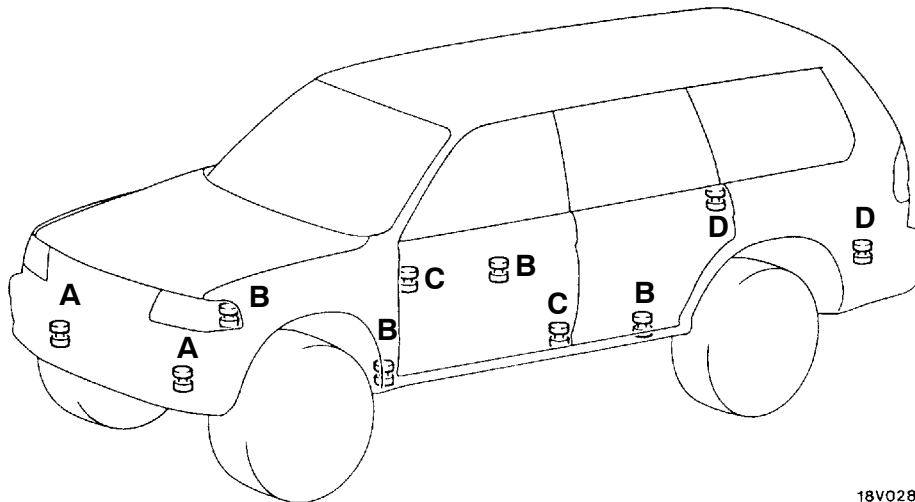

18V0280 00007515

<p>A</p> <p>1 2 4 5 6 7 2 9 N</p> <p>T0125AA</p> <p>27 - 31 Nm</p> <p>V0096AA</p>	<p>B</p> <p>1 2 4 5 6 8 2 9 N</p> <p>18V0121</p> <p>27 - 31 Nm</p> <p>18V0116</p>	<p>C</p> <p>1 2 4 5 6 7 2 9 N</p> <p>T0126AA</p> <p>27 - 31 Nm</p> <p>T0124AA</p>	<p>D</p> <p>1 4 5 6 8 2 9 N</p> <p>18V0122</p> <p>27 - 31 Nm</p> <p>18V0117</p>
---	---	---	---

1. Mounting bolt
2. Plain washer
3. Body mounting rubber
4. Body mounting rubber A
5. Spacer

6. Body mounting rubber B
7. Body mount washer
8. Body mount stopper
9. Self locking nut

HOOD

REMOVAL AND INSTALLATION

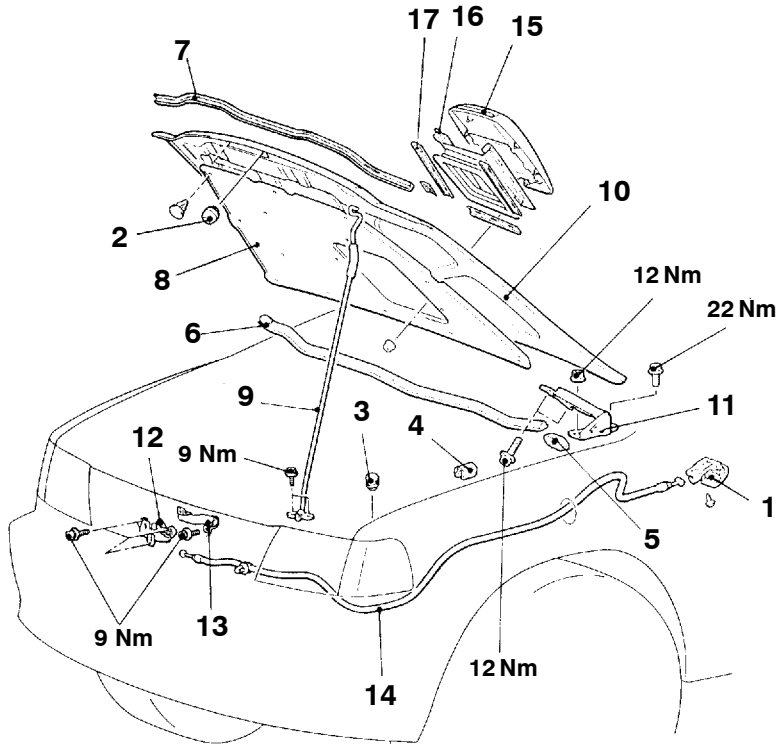

W0155AA

00009075

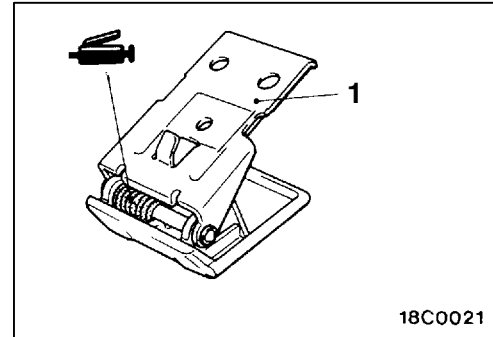

18C0021

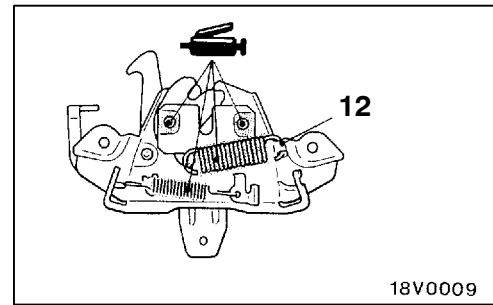

18V0009

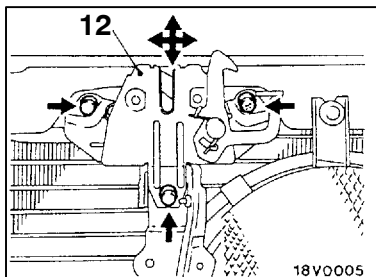

18V0005

Adjustment of hood step and hood striker linkage

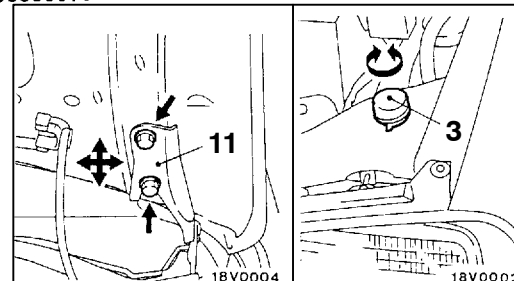

18V0004

18V0002

Adjustment of clearance and height around hood

1. Hood lock release handle
2. Hood bumper
3. Hood bumper
4. Hood damper
5. Hood side weatherstrip
6. Hood weatherstrip
7. Hood weatherstrip
8. Hood silencer
9. Hood support rod

Hood and hood hinge removal steps

- Washer hose connection
- 10. Hood
- Front deck garnish (Refer to GROUP 51 – Windshield Wiper and Washer.)
- 11. Hood hinge

Hood latch and hood lock release cable removal steps

- Radiator grille
- 12. Hood latch
- 13. Cable protector
- Junction block
- 14. Hood lock release cable

Hood garnish removal steps

- 15. Hood garnish
- 16. Hood intercooler weatherstrip
- 17. Hood intercooler weatherstrip plate

FENDER

42100050175

SEALANT

Item	Specified sealant	Remark
Splash shield	3M ATD Part No. 8625 or equivalent	Ribbon sealer

FENDER

42100190273

REMOVAL AND INSTALLATION

Pre-removal and Post-installation Operation

- Front Bumper Removal and Installation (Refer to GROUP 51 – Front Bumper.)
- Front Deck Garnish Removal and Installation (Refer to GROUP 51 – Windshield Wiper and Washer.)
- Headlamp Removal and Installation (Refer to GROUP 54 – Headlamp and Front Combination Lamp.)
- Wide Fender Removal and Installation (Refer to GROUP 51 – Wide Fender.)

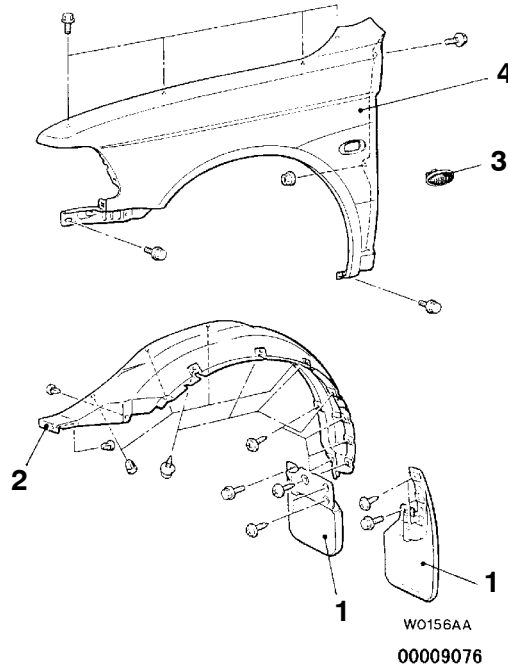
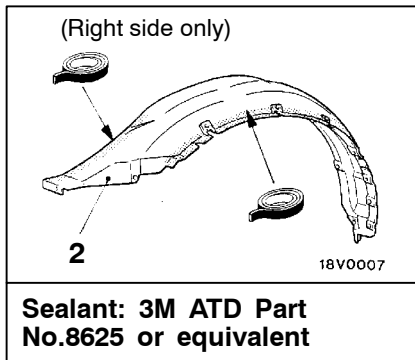

Removal steps

1. Mud guard
2. Splash shield
3. Side turn-signal lamp
4. Fender

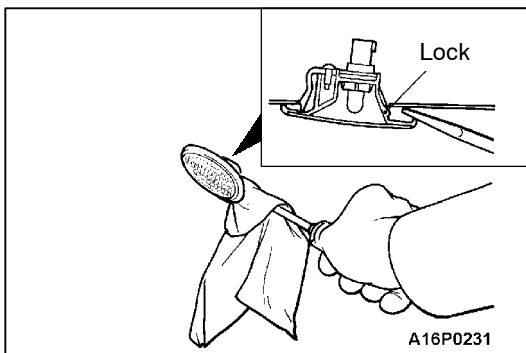

REMOVAL SERVICE POINT

◀▶ SIDE TURN-SIGNAL LAMP REMOVAL

Use a flat-tipped (-) screwdriver or similar tool to remove the lock from the fender panel, and remove the side turn-signal lamp.

FUEL FILLER DOOR

REMOVAL AND INSTALLATION

Pre-removal and Post-installation Operation

- Driver's Side Front Seat Removal and Installation (Refer to GROUP 52A – Front Seat.)
- Rear Seat Removal and Installation (Refer to GROUP 52A – Rear Seat.)
- Quarter Trim Lower (L.H.) Removal and Installation (Refer to GROUP 52A – Trims.)

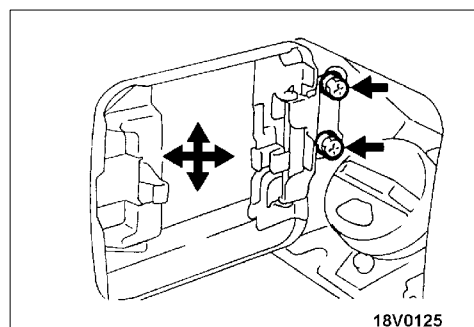
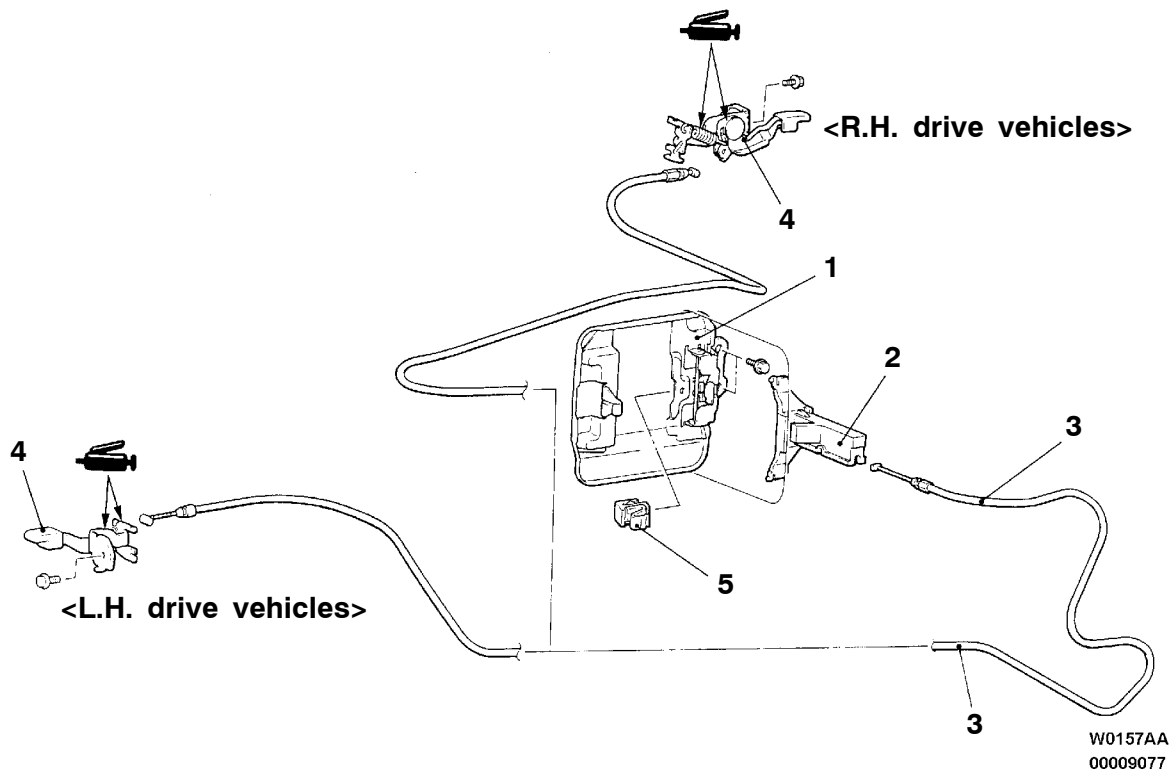

Fuel filler door height and clearance adjustment

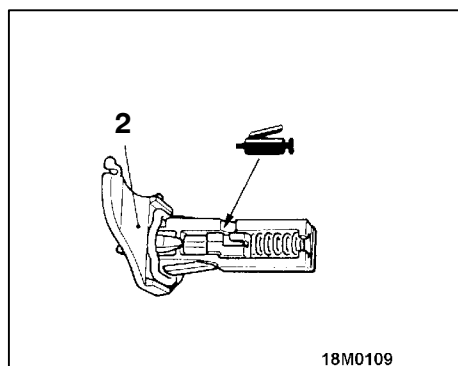

Removal steps

1. Fuel filler door panel
2. Fuel filler door hook
3. Fuel filler door lock release cable
4. Lid lock release handle
5. Clip

WINDOW GLASS

42200050154

ADHESIVES

Items	Specified adhesives
<ul style="list-style-type: none"> • Windshield • Quarter window glass • Tailgate window glass 	3M ATD Part No. 8609 Super Fast Urethane Auto Glass Sealants or equivalent
Windshield moulding	Double-sided tape (6 mm wide and 0.125 mm thick)

SPECIAL TOOL

42200060089

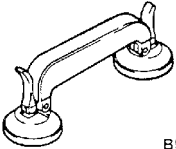
Tool	Number	Name	Use
 <p>B990480</p>	MB990480	Glass holder	Removal and installation of windshield

WINDOW REPAIR

42200560107

The following glass sections are installed by means of a liquid urethane adhesive method.

- Windshield
- Quarter window glass
- Tailgate window glass

ITEMS NEEDED

Name	Remarks
Adhesive	3M ATD Part No. 8609 Super Fast Urethane Auto Glass Sealant or equivalent
Primer	3M ATD Part No. 8608 Super Fast Urethane Primer or equivalent
Spacers	Available as service part
Dam	Available as service part
Anti-rust solvent (or Tectyl 506T...Valvoline Oil Company)	For rust prevention
Isopropyl alcohol	For grease removal from bonded surface
Steel piano wire	Dia. × length...0.6mm × 1m for cutting adhesive
Adhesive gun	For pressing-out adhesive

NOTE

The TEROSON 127.37V auto window sealer kit can also be used. If using the TEROSON 127.37V auto window sealer kit, follow the instructions in the manual included with the kit.

HANDLING OF AUTO WINDOW SEALER

Keep the sealant in a cool place, not exposed to the direct rays of the sun. Do not place any heavy article on the sealant nor press it, otherwise it will become deformed. Avoid storing the sealant for more than 6 months, because it will lose its sealing effect.

BODY PINCH-WELD FLANGE SERVICING.

Before servicing the body pinch-weld flange, remove old adhesive completely. If the flange requires painting, bake it after painting is completed.

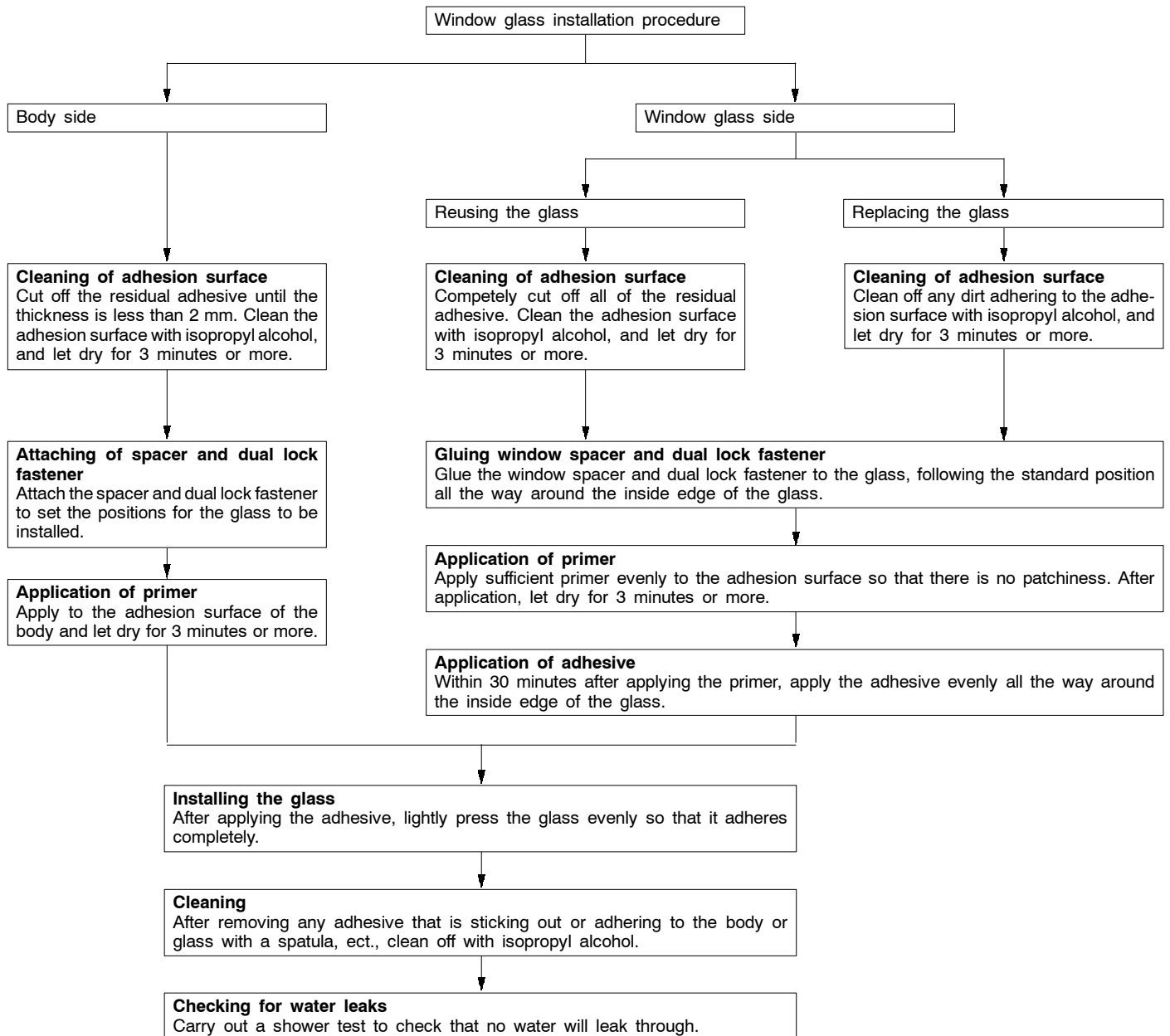
WORKING PROCESS

WINDSHIELD

42200100316

REMOVAL AND INSTALLATION

Pre-removal and Post-installation Operation

- Front Deck Garnish Removal and Installation (Refer to GROUP 51 – Windshield Wiper and Washer.)
- Front Pillar Trim Removal and Installation (Refer to GROUP 52A – Trims.)
- Headlining Removal and Installation

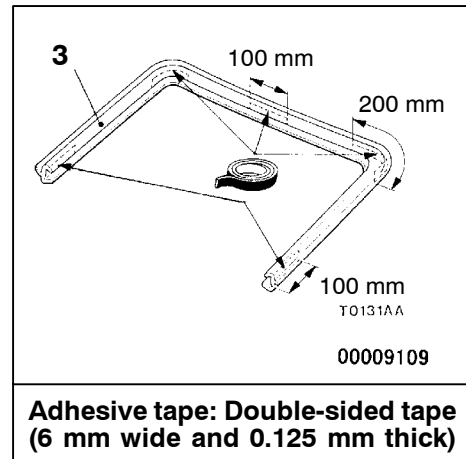
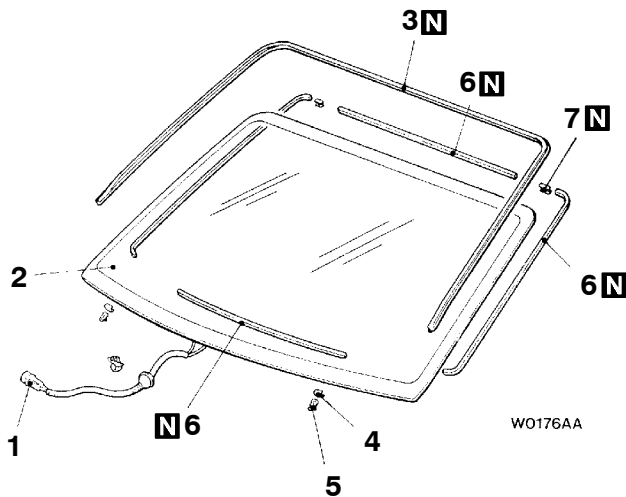
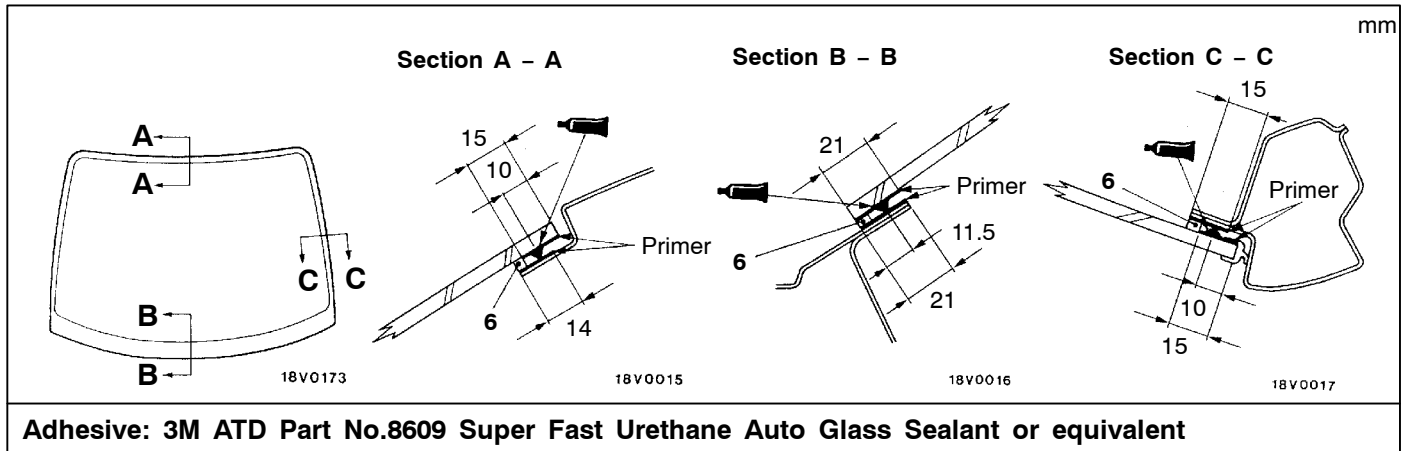

Removal steps

- ◀A▶ ▶A▶
1. Wiper deicer connector
 2. Windshield
 3. Windshield moulding
 4. Windshield protector

- ▶A▶
5. Window spacer
 6. Window spacer
 7. Dual lock fastener

REMOVAL SERVICE POINT**◀A▶ WINDSHIELD REMOVAL**

1. In order to protect the body (paint surface), apply cloth tape to all body areas around the installed windshield.
2. Cut the moulding with a cutter knife.

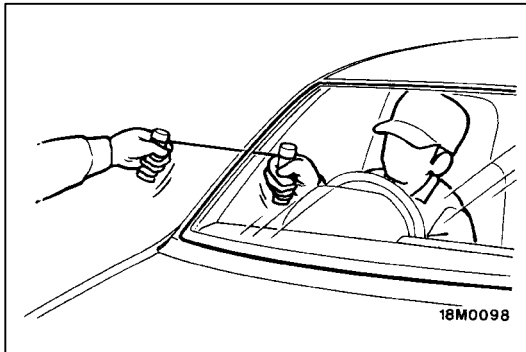

3. Using a sharp-point drill, make hole in the windshield adhesive.
4. Pass the piano wire from the inside of the vehicle through the hole.
5. Pull the piano wire alternately from the inside and outside along the windshield to cut the adhesive.

Caution

Do not let the piano wire touch the edge of the windshield.

6. Make mating marks on the windshield and body.
7. Use the special tool to remove the windshield.

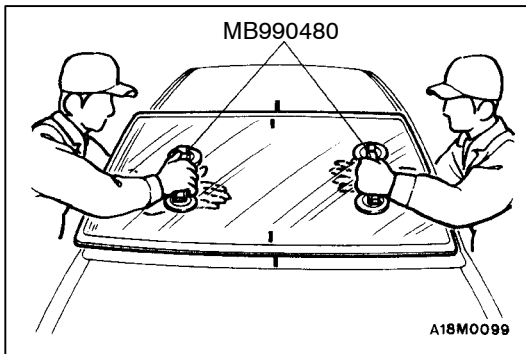

8. Use a knife to cut away the remaining adhesive so that the thickness is within 2 mm around the entire circumference of the body flange.
9. Finish the flange surfaces so that they are smooth

Caution

(1) Be careful not to remove more adhesive than is necessary.

(2) Be careful also not to damage the paintwork on the body surface with the knife. If the paintwork is damaged, repair the damaged area with repair paint or anti-rust agent.

10. When reusing the windshield, remove the adhesive still adhering to the windshield, and clean with isopropyl alcohol.
11. Clean the body side in the same way.

Caution

Let the cleaned places stand for 3 minutes or more, and carry out the next procedures after they have dried. Also, do not touch any surface that has been cleaned.

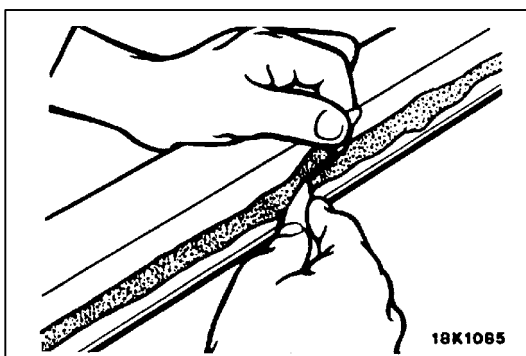

Dual lock fastener installation position

Glass side

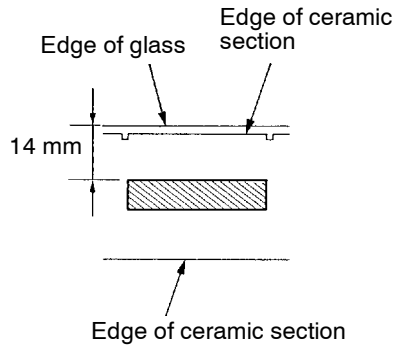

Body side

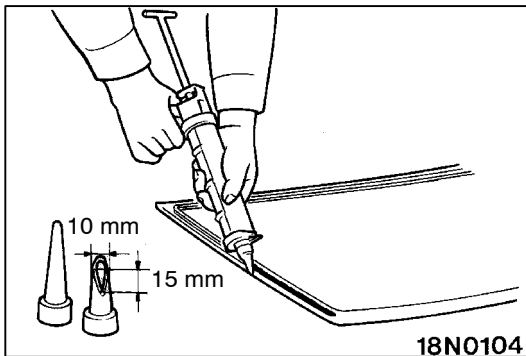
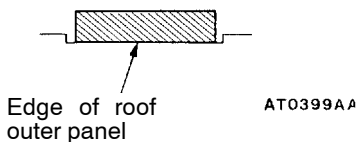

INSTALLATION SERVICE POINT

▶◀ DUAL LOCK FASTENER/WINDSHIELD INSTALLATION

1. When replacing the windshield, temporarily set the windshield against the body, and place a mating mark on the windshield and body.
2. Use isopropyl alcohol to degrease the inside and outside of the windshield and the body flanges.
3. Soak a sponge in the primer, and apply evenly to the windshield and the body in the specified places.
4. Apply the primer, and then let it dry for 3 to 30 minutes.

Caution

- (1) **The primer strengthens the adhesive, so be sure to apply it evenly around the entire circumference. However, a too thick application will weaken the adhesive.**
- (2) **Do not touch the coated surface.**

5. Install the dual lock fasteners to the windshield in the position shown in the illustration.
6. Install the dual lock fasteners to the body flange in the positions that are corresponding to those on the windshield.
7. Fill a sealant gun with adhesive. Then apply the adhesive evenly around the windshield within 30 minutes after applying the primer.

NOTE

Cut the tip of the sealant gun nozzle into a V shape to simplify adhesive application.

8. Align the mating marks on the windshield and the body, and lightly press the windshield evenly so that it adheres completely.
9. Use a spatula or the like to remove any excessive adhesive. Then clean the surface with isopropyl alcohol. Try not to move the vehicle until the adhesive sets.
10. Wait 30 minutes or more, and then test for water leakage.

Caution

- (1) **Do not move the vehicle unless absolutely necessary.**
- (2) **When testing for water leakage, do not pinch the end of the hose to spray the water.**

QUARTER WINDOW GLASS

REMOVAL AND INSTALLATION

Pre-removal and Post-installation Operation

- Quarter Trim Upper Removal and Installation (Refer to GROUP 52A – Trims.)

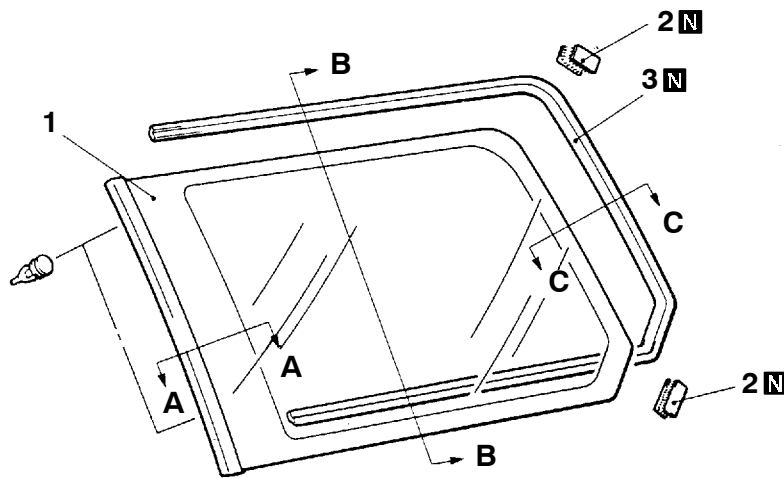
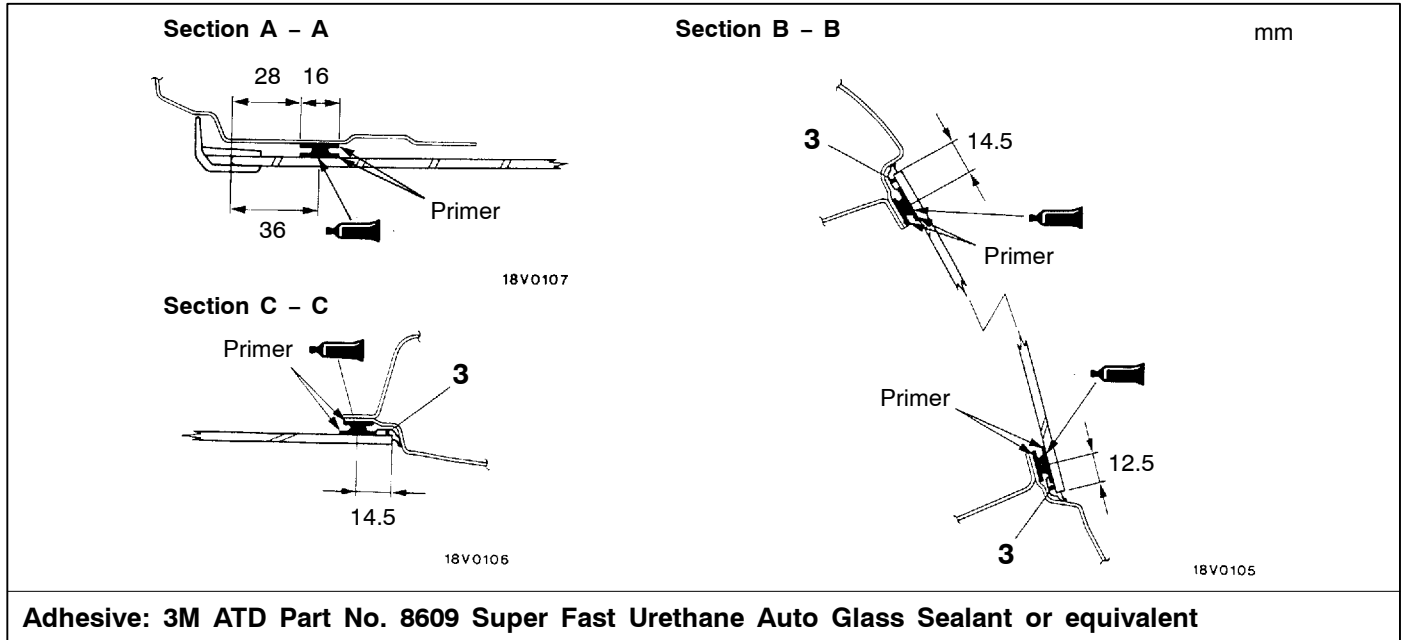

18V0126
 00007520

Removal steps

- ◀A▶ ▶A◀ 1. Quarter window glass assembly
 ▶A◀ ▶A◀ 2. Dual lock fastener
 ▶A◀ ▶A◀ 3. Window dam

REMOVAL SERVICE POINT

◀A▶ QUARTER WINDOW GLASS REMOVAL

Remove the quarter window glass by the same procedure as for the windshield. (Refer to P.42-10.)

INSTALLATION SERVICE POINTS

▶A◀ WINDOW DAM/DUAL LOCK FASTENER/QUARTER WINDOW GLASS INSTALLATION

1. Use isopropyl alcohol to degrease the window dam and dual lock fastener mounting surface on both the glass and the body.
2. Attach the window dam.
3. Install the dual lock fastener to the shown position.
4. Apply primer and adhesive. (Refer to P.42-12.)
5. Install the glass in the same way as for the windshield. (Refer to P.42-11.)

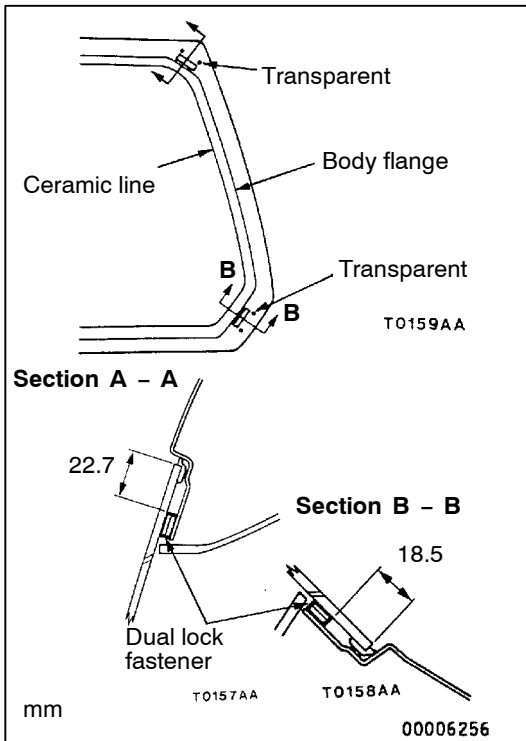

TAILGATE WINDOW GLASS

REMOVAL AND INSTALLATION

Pre-removal and Post-installation Operation

- Tailgate Garnish Removal and Installation (Refer to GROUP 51 – Grill, Moulding and Garnish.)
- High-mounted Stop lamp Removal and Installation <Vehicles without roof spoiler> (Refer to GROUP 54 – High-mounted Stop lamp.)
- Tailgate Trim Removal and Installation (Refer to P.42-47.)

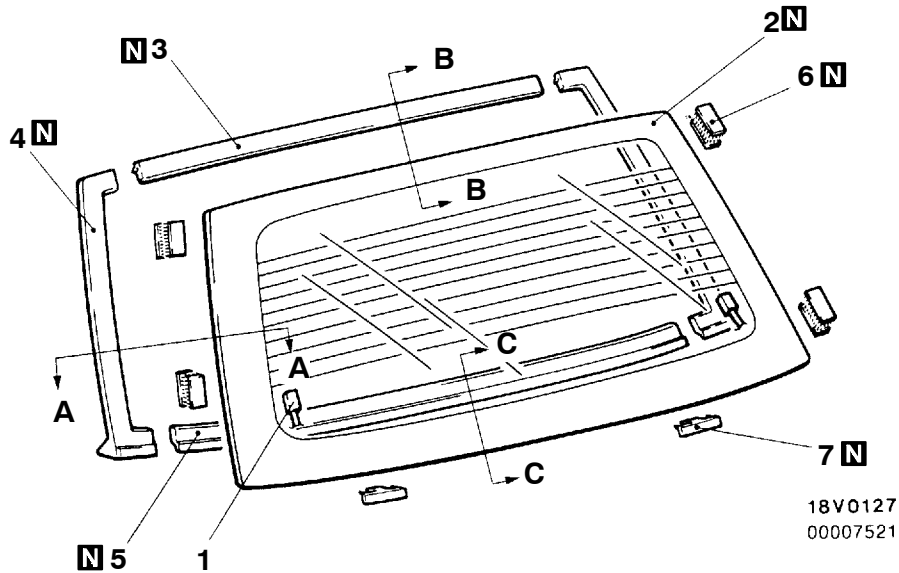
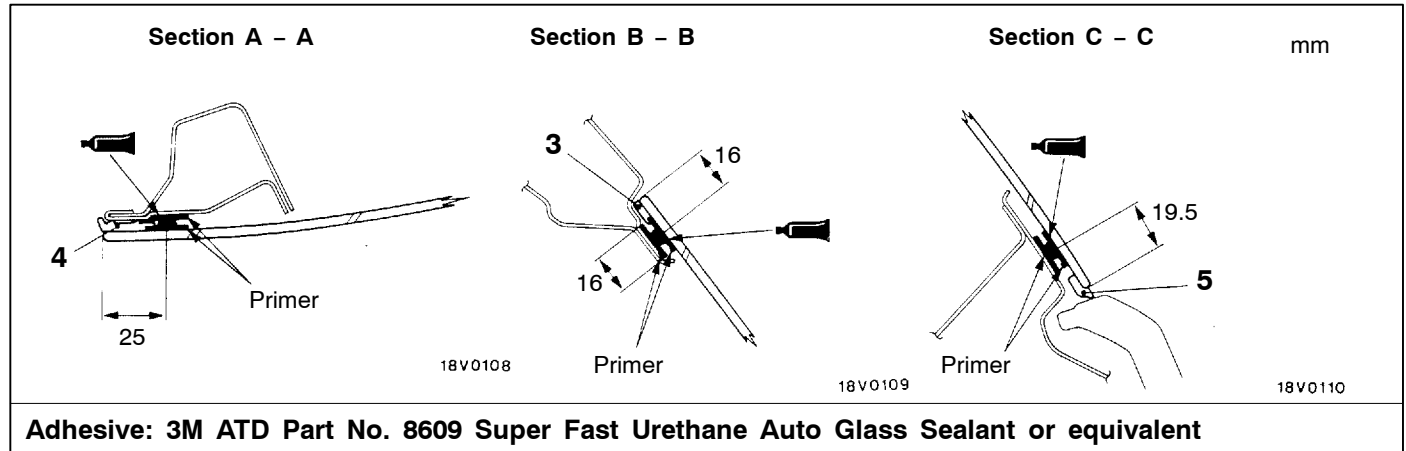

Removal steps

- | | | | | |
|-----|-----|------------------------------------|-----|------------------------------------|
| ◀A▶ | ▶A▶ | 1. Harness connector | ▶A▶ | 5. Tailgate window glass lower dam |
| | ▶A▶ | 2. Tailgate window glass | ▶A▶ | 6. Dual lock fastener |
| | ▶A▶ | 3. Tailgate window glass upper dam | ▶A▶ | 7. Clip |
| | ▶A▶ | 4. Tailgate window glass side dam | | |

REMOVAL SERVICE POINT

◀A▶ TAILGATE WINDOW GLASS REMOVAL

Remove the tailgate window glass by the same procedure as for the windshield. (Refer to P.42-10.)

INSTALLATION SERVICE POINT

▶A◀ CLIP/DUAL LOCK FASTENER/TAILGATE WINDOW GLASS LOWER DAM/TAILGATE WINDOW GLASS SIDE DAM/TAILGATE WINDOW GLASS UPPER DAM/TAILGATE WINDOW GLASS

1. Use isopropyl alcohol to degrease the inside and outside edges of the tailgate window glass and the surface of the body flange.
2. Face the clip's claws downward, and attach to the inner side of the tailgate window glass as shown in the illustration.
3. Align the dual lock fastener to the markings on the glass, and install. Then, install the tailgate outer panel so that it is aligned.
4. Attach the tailgate glass dam from the dam attachment reference mark to the edge of the glass.
5. Apply primer and adhesive (Refer to P.42-14.)
6. Install the glass in the same way as for the windshield. (Refer to P.42-11.)

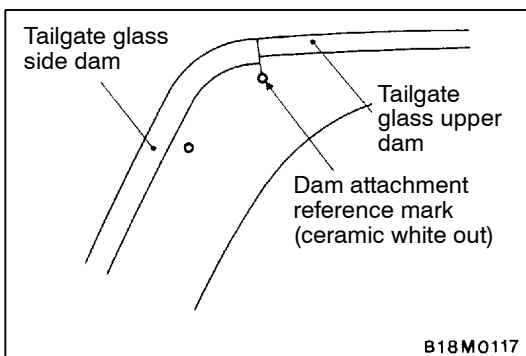
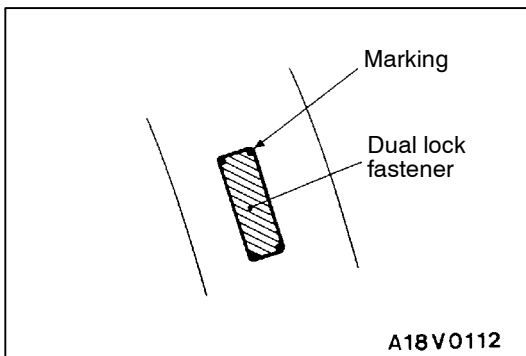
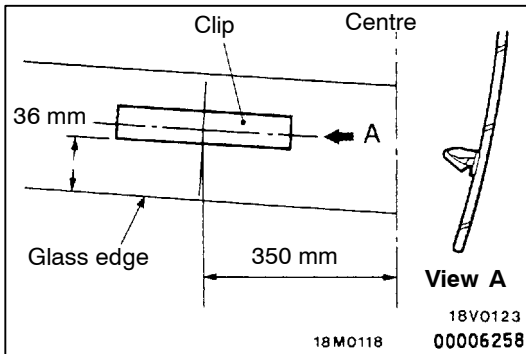

DOOR

42300030151

SERVICE SPECIFICATIONS

Items		Standard value
Door outside handle play mm		2.8 or more
Power window operation current A		7 or more (at 20°C)
Door inside handle play mm		7.3 or more
Glass pad and glass holder installation position mm	Distance (A) between glass holder and rear edge of glass	106.7 – 108.2
	Distance (B) between glass holders	417.5 – 420.5
	Distance (C) between glass holder and rear edge of glass	127 – 131

SEALANT



42300050034

Items	Specified sealant	Remark
Waterproof film	3M ATD Part No. 8625 or equivalent	Ribbon sealer

SPECIAL TOOLS

42300060136

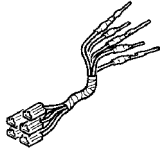
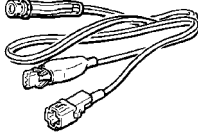
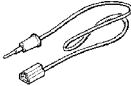
Tool	Number	Name	Use
B991502	MB991502	MUT-II sub assembly	ETACS-ECU input signal checking
B990784	MB990784	Ornament remover	Removal of door trim

Tool	Number	Name	Use
<p>A</p>  <p>B</p>  <p>C</p>  <p>D</p>  <p>C991223</p>	<p>MB991223</p> <p>A: MB991219 B: MB991220 C: MB991221 D: MB991222</p>	<p>Harness set</p> <p>A: Test harness B: LED harness C: LED harness adapter D: probe</p>	<p>Measurement of terminal voltage</p> <p>A: Connector pin contact pressure inspection B: Power circuit inspection C: Power circuit inspection D: Commercial tester connection</p>

TROUBLESHOOTING

42300070207

DIAGNOSIS FUNCTION**INPUT SIGNAL INSPECTION POINTS**

1. Connect the MUT-II to the diagnosis connector.
2. If buzzer of the MUT-II sounds once when door lock actuator switch is operated (LOCK/UNLOCK), the ETACS-ECU input signal for that switch circuit system is normal.

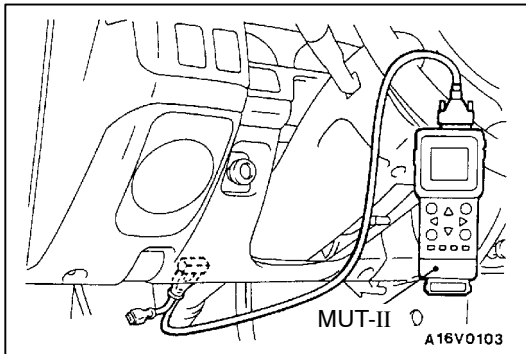
**INSPECTION CHART FOR TROUBLE SYMPTOMS**

Trouble symptom		Inspection procedure	Reference page
Power windows	The power windows cannot be operated by any of the power window switches.	1	42-19
	Driver's side power window cannot be operated by the power window main switch.	2	42-20
	Passenger's side and rear power windows cannot be operated by the power window main switch. (However, they can be operated by the power window sub-switches.)	3	42-21
	Passenger's side and rear power windows cannot be operated by the power window sub-switches. (However, they can be operated by the power window main switch.)	4	42-21
	Passenger's side and rear power windows cannot be operated by both the power window sub-switches and by the power window main switch.	5	42-22
	When the glass is raised, it then lowers automatically.	6	42-24
	The glass is not lowered when something is jammed in the window.	7	42-24
	When the glass is fully raised, it then lowers automatically.	8	42-25
Door locking mechanism	None of the door lock functions operate.	9	42-25
	None of the doors lock or unlock when the driver's side inside door locking knob is operated (including by means of the door key).	10	42-26
	Some doors do not lock or unlock.	11	42-26

INSPECTION PROCEDURE FOR TROUBLE SYMPTOMS

Inspection Procedure 1

The power windows cannot be operated by any of the power window switches.	Probable cause
The cause may be a malfunction of the power window relay and of the power window relay drive circuit.	<ul style="list-style-type: none"> ● Malfunction of power window relay ● Malfunction of wiring harness or connector

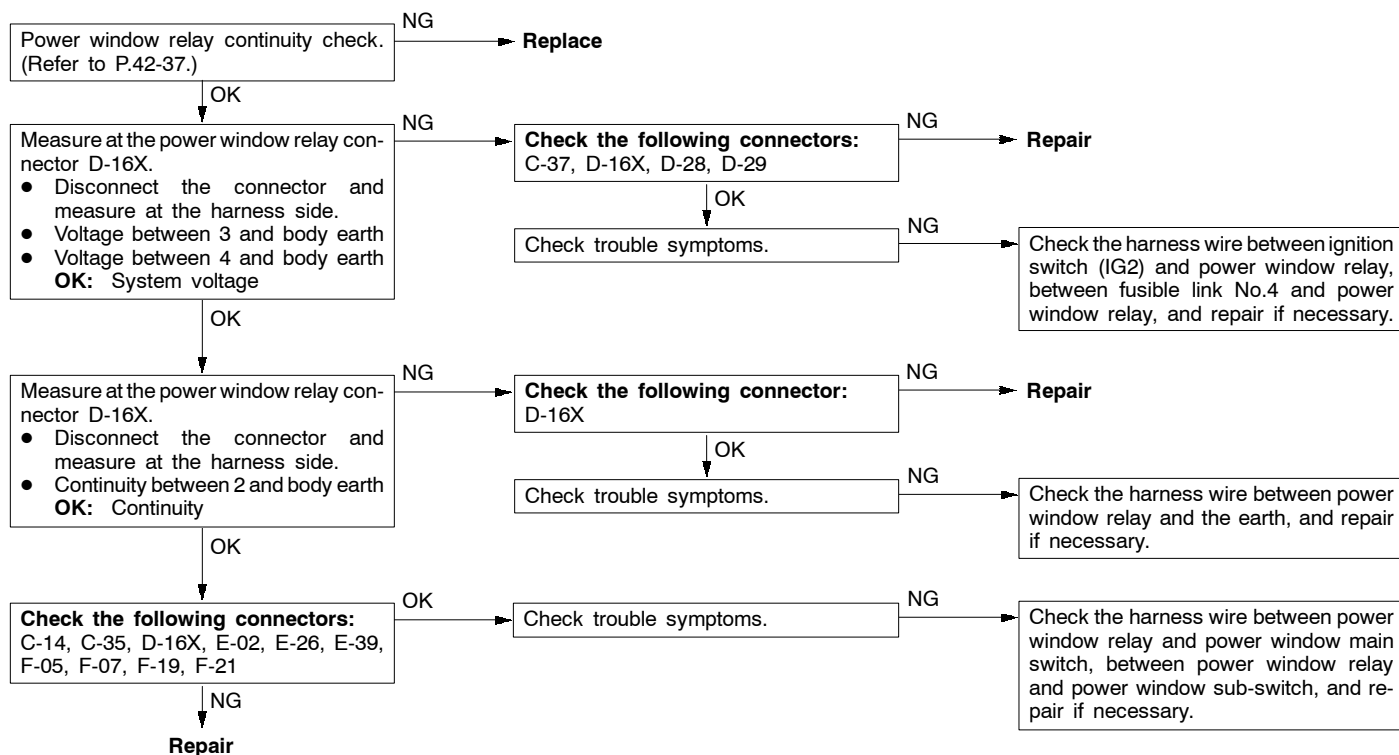

Inspection Procedure 2

Driver's side power window cannot be operated by the power window main switch.	Probable cause
The cause may be a malfunction of the earth circuit in the power window main switch or of the power supply circuit for the power window motor. The cause may also be a malfunction of the control circuit inside the power window main switch.	<ul style="list-style-type: none"> ● Malfunction of power window motor ● Malfunction of power window main switch ● Malfunction of wiring harness or connector

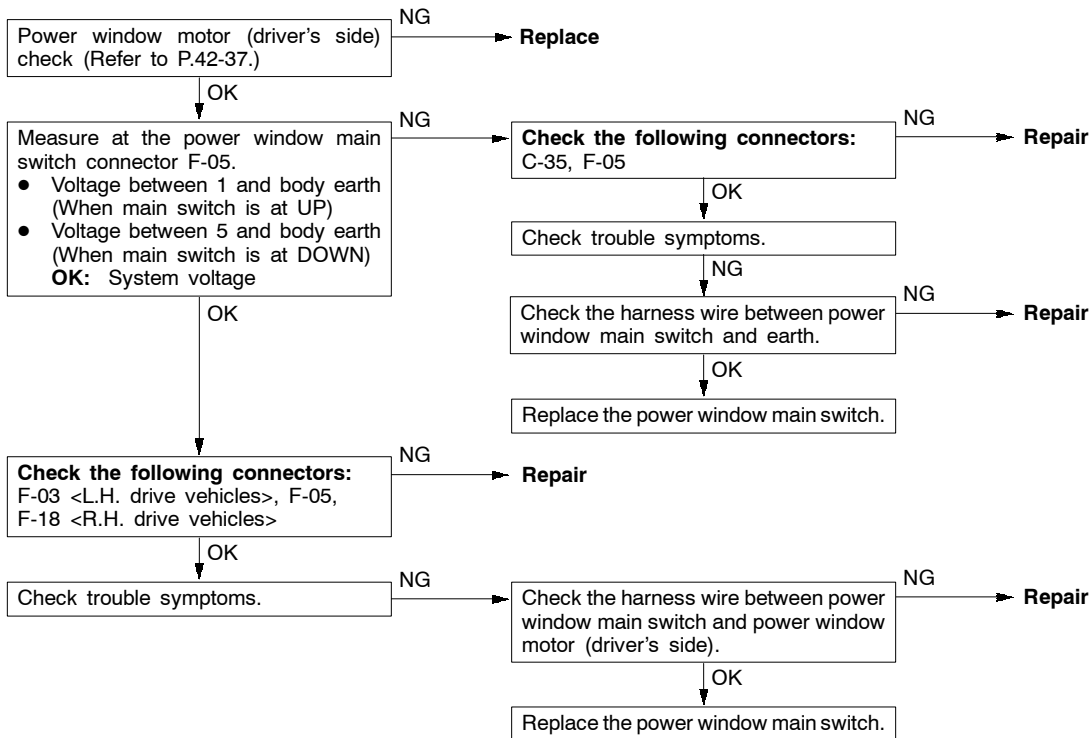

Inspection Procedure 3

<p>Passenger's side and rear power windows cannot be operated by the power window main switch. (However, they can be operated by the power window sub-switches.)</p>	<p>Probable cause</p>
<p>The cause may be a malfunction of the power window main switch, or an open circuit or short-circuit in the communication line.</p>	<ul style="list-style-type: none"> ● Malfunction of power window main switch ● Malfunction of wiring harness or connector

<If passenger's side power window does not operate>

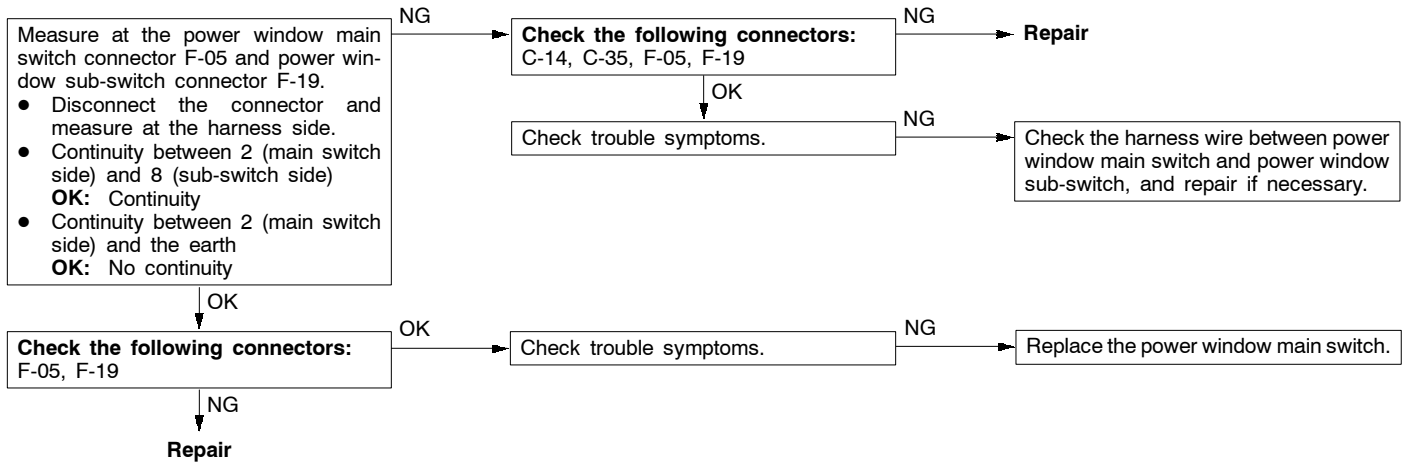

<If a rear power window does not operate>

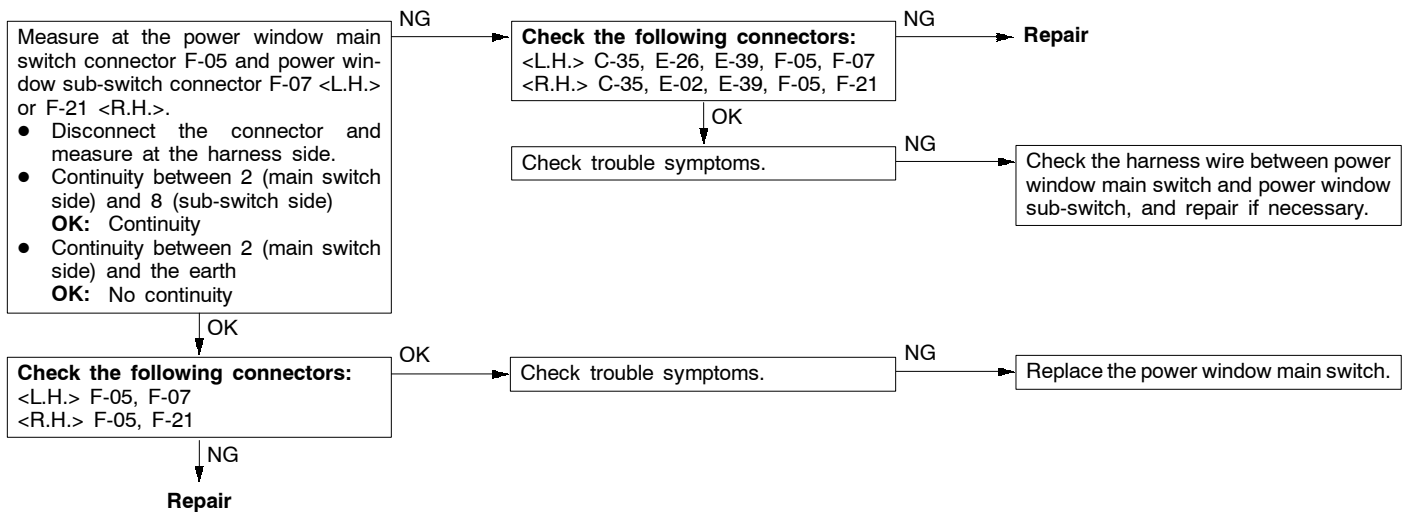

Inspection Procedure 4

<p>Passenger's side and rear power windows cannot be operated by the power window sub-switches. (However, they can be operated by the power window main switch.)</p>	<p>Probable cause</p>
<p>The cause may be a malfunction of the power window sub-switch.</p>	<ul style="list-style-type: none"> ● Malfunction of power window sub-switch

Replace the power window sub-switch

Inspection Procedure 5

<p>Passenger's side and rear power windows cannot be operated by both the power window sub-switches and by the power window main switch.</p>	<p>Probable cause</p>
<p>One of the following items can be defective:</p> <ul style="list-style-type: none"> ● Power supply circuit of the power window sub-switch ● Earth circuit ● Power window motor ● Lock switch ● Power window main switch ● Power window sub-switch 	<ul style="list-style-type: none"> ● Malfunction of power window main switch ● Malfunction of power window sub-switch ● Malfunction of power window motor ● Malfunction of wiring harness or connector

<If passenger's side power window does not operate>

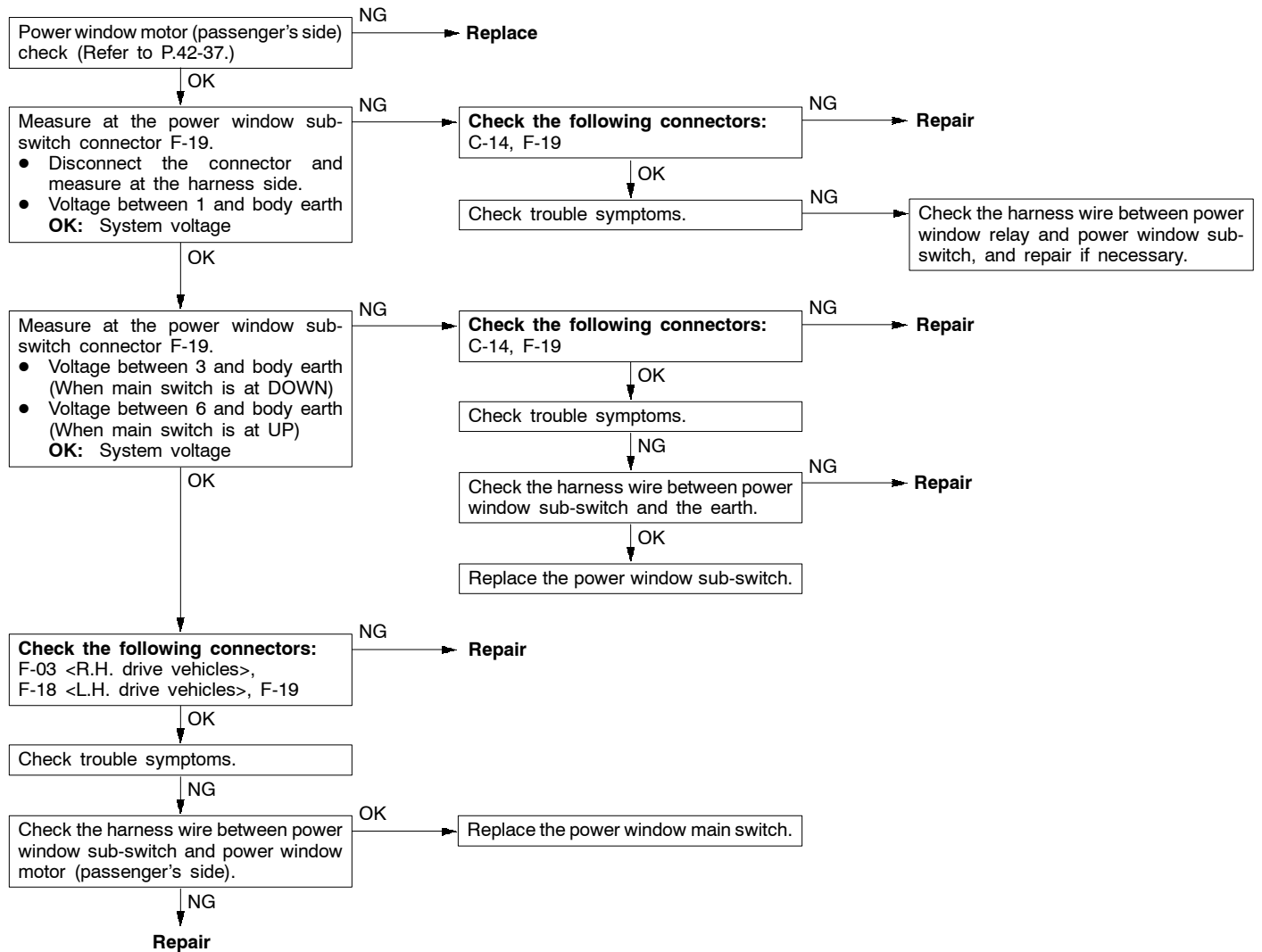

<If a rear power window does not operate>

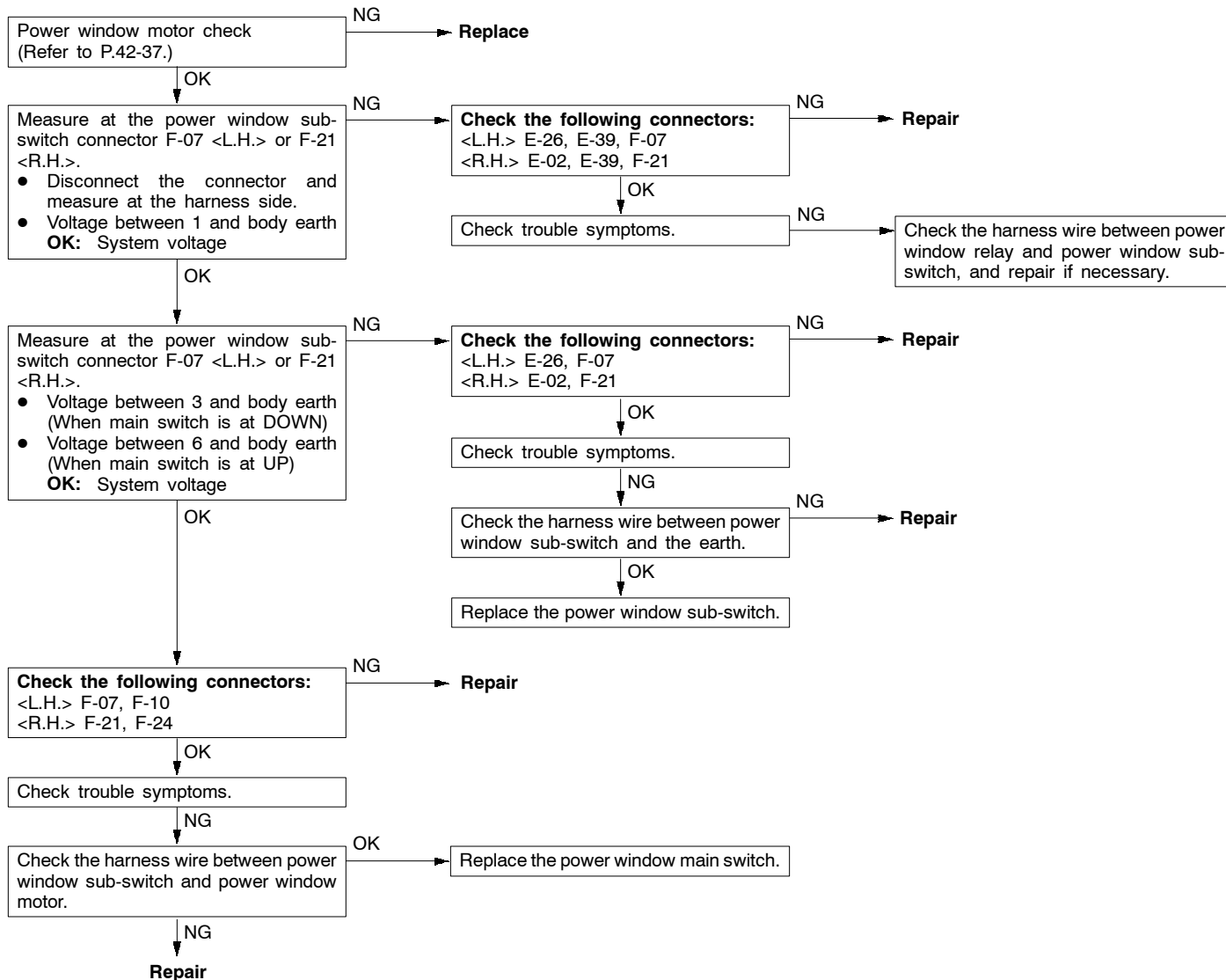

Inspection Procedure 6

When the glass is raised, it then lowers automatically.	Probable cause
If the sliding resistance is too large when the glass is being raised, it is judged that something is jammed in the window, and the window is lowered by approximately 150 mm.	<ul style="list-style-type: none"> • Incorrect window glass adjustment • Glass slider is incorrectly installed or warped • Malfunction of power window main switch or sub-switch

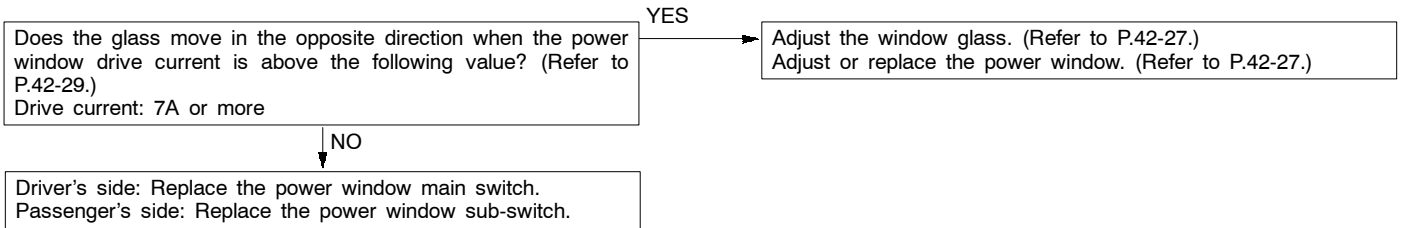

Inspection Procedure 7

The glass is not lowered when something is jammed in the window.	Probable cause
The safety mechanism is released under the following conditions, and the window will not be lowered even if something becomes jammed in it. <ul style="list-style-type: none"> • If the limit switch is always off • If there is an open circuit in the harness between the limit switch and the power window main switch or the power window sub-switch • If the limit switch turns off before the set value is reached • If the window is within 10 mm of being fully closed (normal setting to prevent the window from being lowered) 	<ul style="list-style-type: none"> • Malfunction of limit switch • Malfunction of wiring harness • Malfunction of power window main switch or sub-switch • Incorrect limit switch operation position

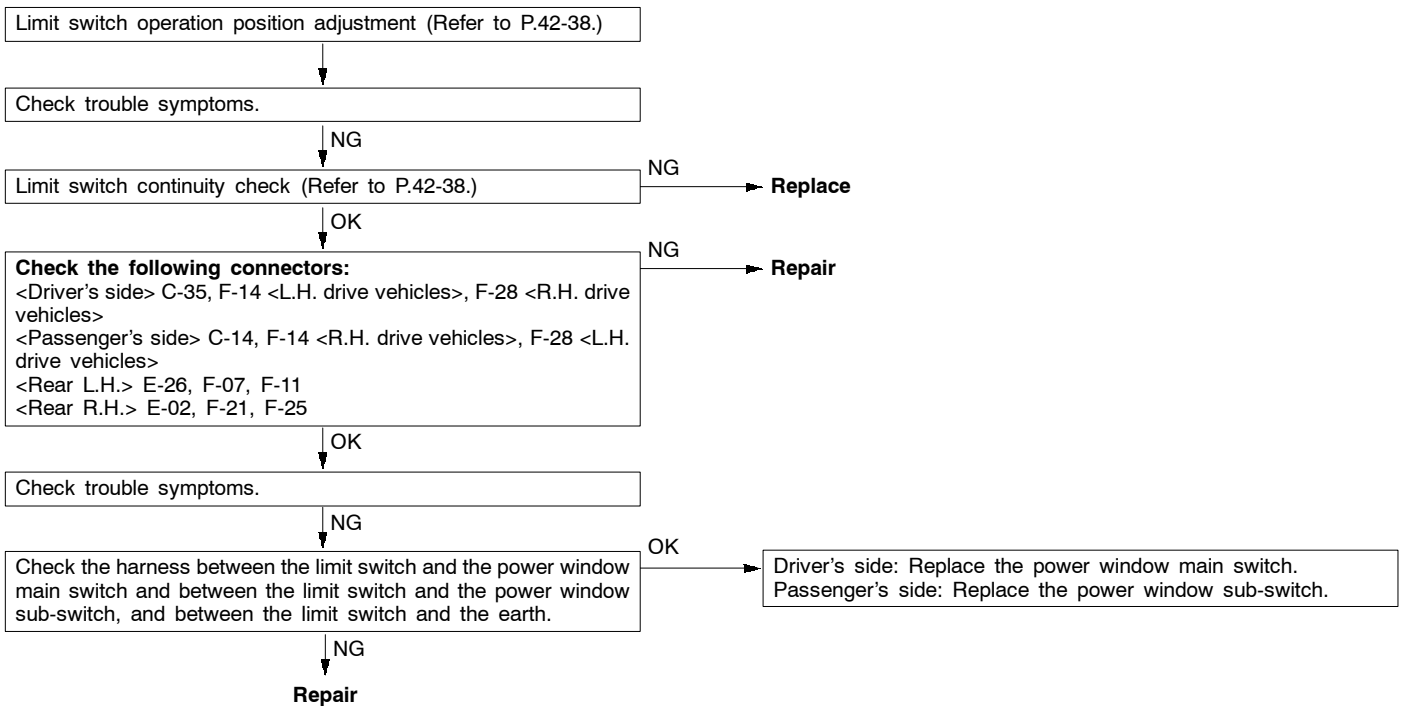

Inspection Procedure 8

When the glass is fully raised, it then lowers automatically.	Probable cause
When the window is within 10 mm of being fully closed, the limit switch turns off to prevent the window from being lowered. However, the above problem can occur if there is a malfunction of the limit switch or a short-circuit in a harness.	<ul style="list-style-type: none"> ● Malfunction of limit switch ● Malfunction of wiring harness or connector ● Malfunction of power window main switch or sub-switch ● Incorrect limit switch operation position

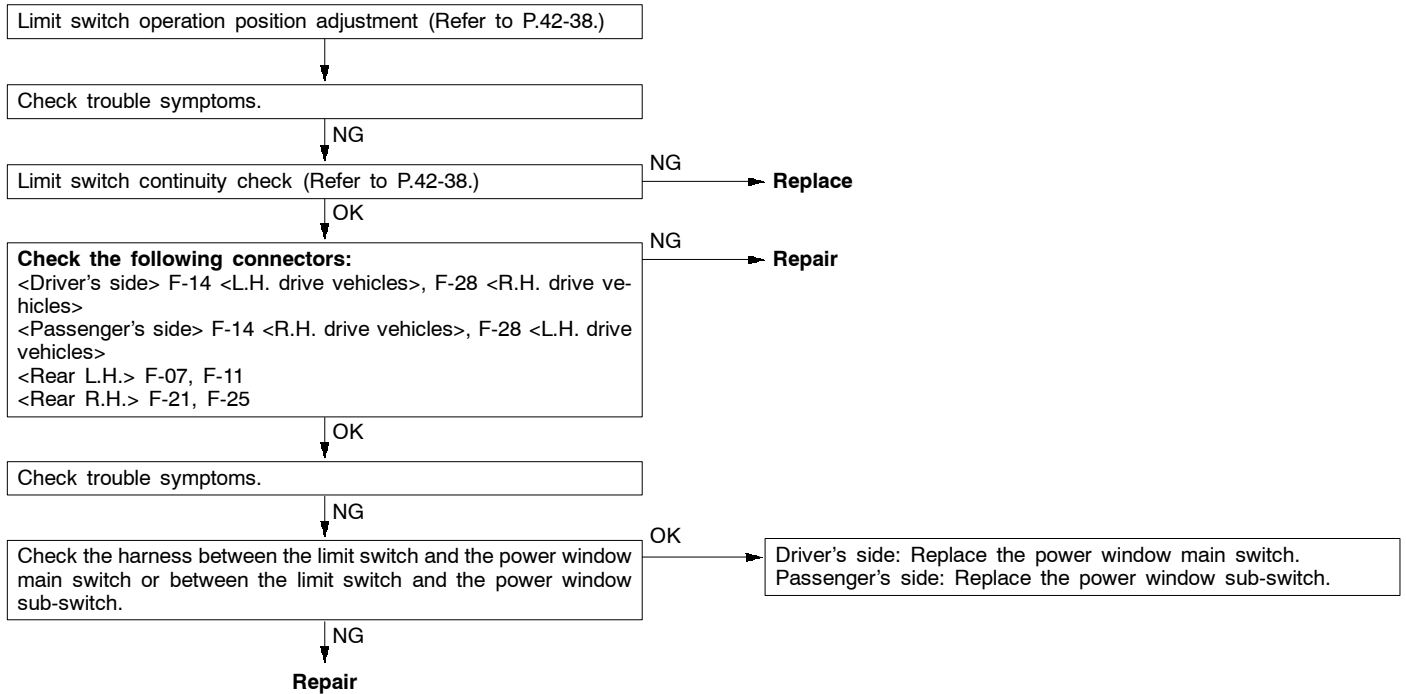

Inspection Procedure 9

None of the door lock functions operate.	Probable cause
The cause may be a malfunction of the ETACS-ECU power supply circuit system or of the earth circuit system.	<ul style="list-style-type: none"> ● Malfunction of ETACS-ECU ● Malfunction of wiring harness or connector

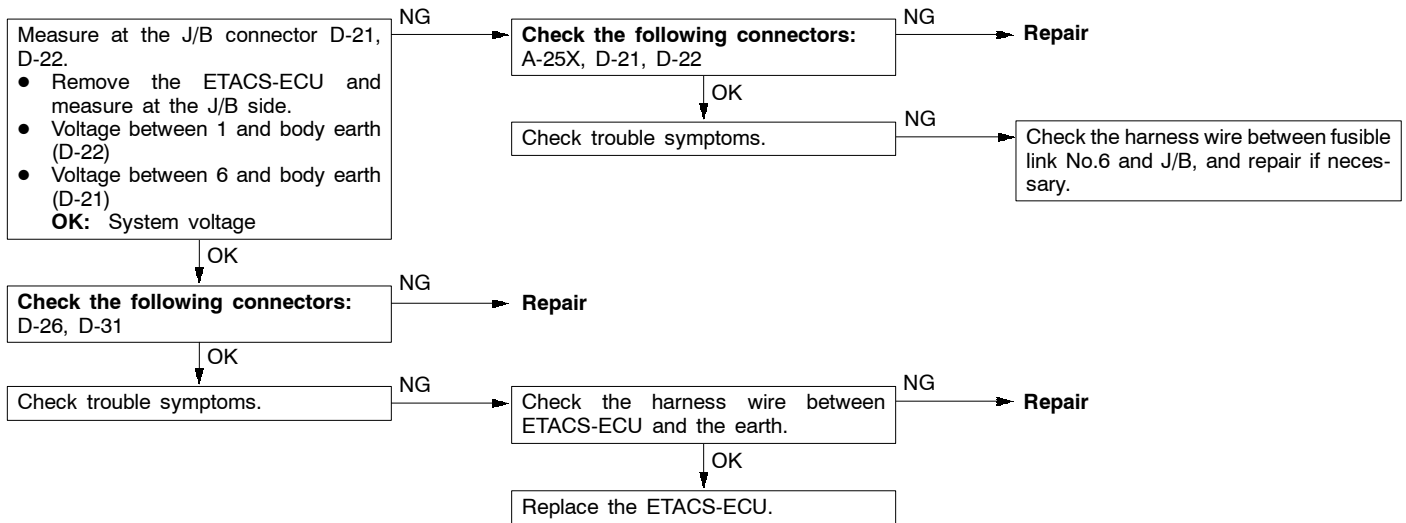

Inspection Procedure 10

<p>None of the doors lock or unlock when the driver's-side inside door locking knob is operated (including by means of the door key).</p>	<p>Probable cause</p>
<p>The cause may be a malfunction of the door lock actuator switch, the ETACS-ECU or of a wiring harness or connector.</p>	<ul style="list-style-type: none"> ● Malfunction of front door lock actuator (driver's side) ● Malfunction of ETACS-ECU ● Malfunction of wiring harness or connector

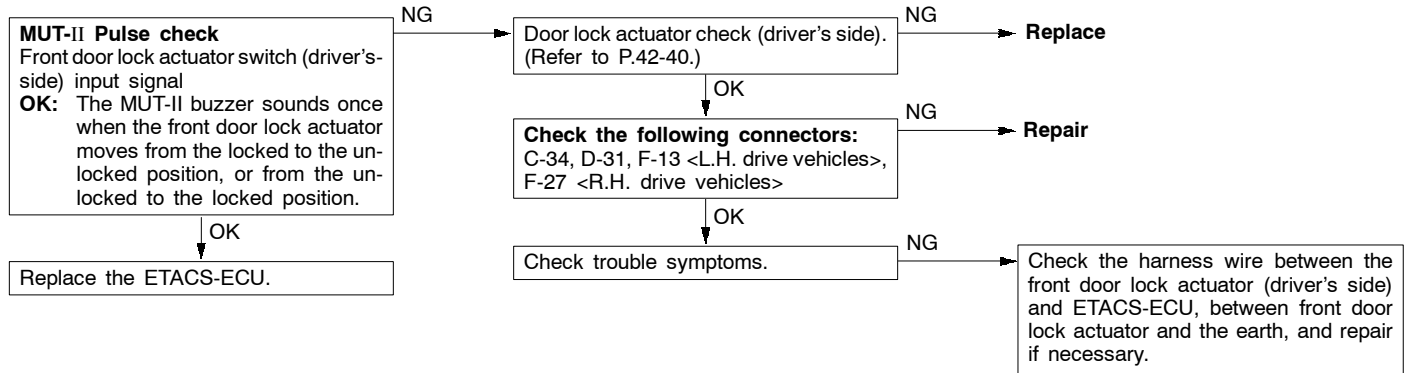

Inspection Procedure 11

<p>Some doors do not lock or unlock.</p>	<p>Probable cause</p>
<p>The cause may be a malfunction of the door lock actuator or of a wiring harness or connector.</p>	<ul style="list-style-type: none"> ● Malfunction of door lock actuator ● Malfunction of wiring harness or connector

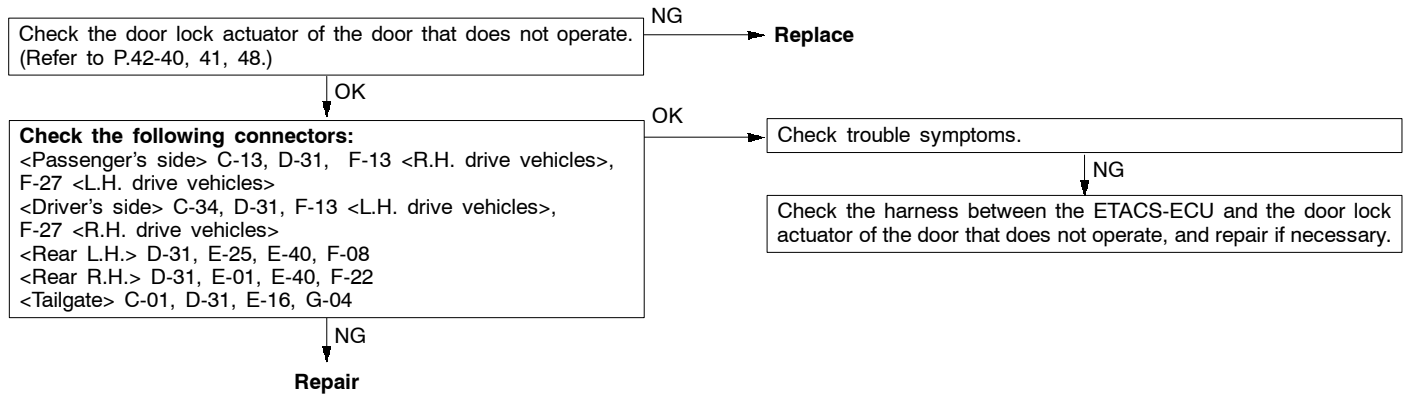

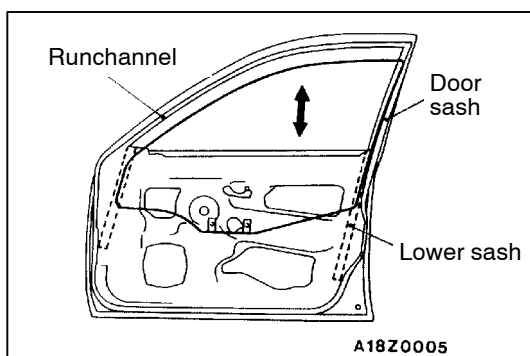
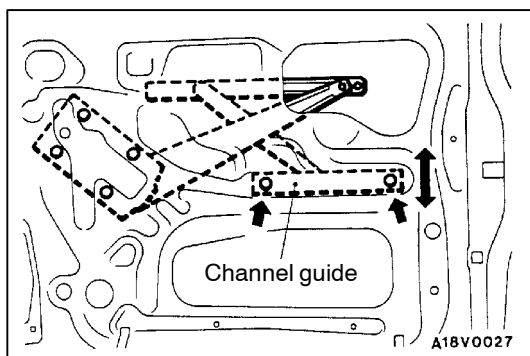
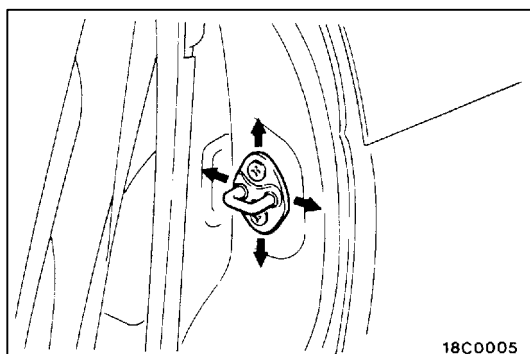
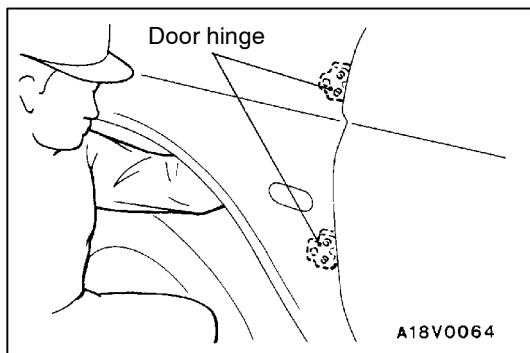

ON-VEHICLE SERVICE

42300090159

DOOR FIT ADJUSTMENT

1. If the clearance between the door and body is uneven, remove the splash shield, loosen the mounting bolt of the body side door hinges from inside the fender, and then move the door to adjust so that the clearance is even.
2. If there is a step between the door and body, loosen the mounting bolts and nuts of the door hinges, and adjust the door alignment.
3. If the striker and latch do not engage properly, move the striker up and down or to the left and right.

DOOR WINDOW GLASS ADJUSTMENT

42300100272

Check that the window glass moves smoothly and touches the glass runchannel firmly when it is fully raised and fully lowered. If the window glass doesn't move properly, adjust by the following procedure.

1. Remove the door trim and waterproof film. (Refer to P.42-32.)
2. Raise the window glass, loosen the channel guide mounting bolts and adjust the vertical tilt of the glass.

ADJUSTMENT AND REPLACEMENT WHEN THERE IS A MALFUNCTION OF THE POWER WINDOWS

42900190093

If the window glass automatically starts moving downwards at the wrong time while it is being raised, carry out the following adjustment or replacement procedures.

1. Remove the door trim and waterproof film. (Refer to P.42-32.)
2. Remove the window regulator assembly from the door window glass, and then raise and lower the door window glass by hand to check the operation force.

NOTE

Insert a cushion or similar object to prevent damage to the glass if it should happen to fall down.

3. If the door window glass does not move up and down smoothly, check or repair the following points.
 - Check the installation condition of the runchannel.
 - Repair the twisting in the door sash.
 - Check the installation condition of the lower sash or the center sash.

NOTE

The lower sash cannot normally be adjusted, but it may be possible to adjust the sash span slightly within the range allowed by manufacturing tolerances by pushing the lower sash outwards while re-installing it.

4. If repair or adjustment is not possible, replace the door assembly.

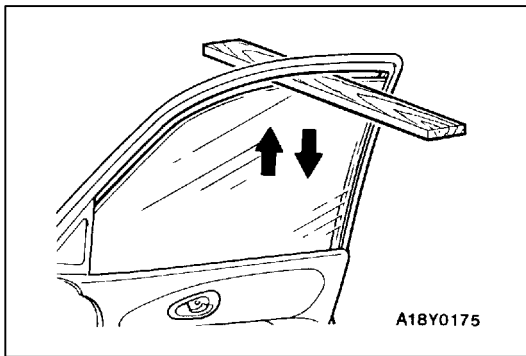

POWER WINDOW SAFETY MECHANISM CHECK

42900100096

1. Place a wooden board with a thickness of approximately 15 mm as shown in the illustration, and then raise the window glass.
2. Check that the window lowers by a distance of approximately 150 mm when the window clamps the wooden board. If this doesn't happen, refer to "Troubleshooting" (P.42-24).

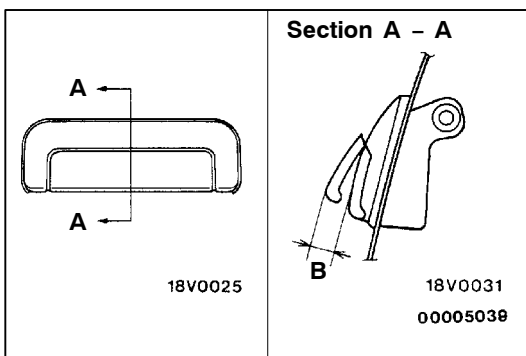

DOOR OUTSIDE HANDLE PLAY CHECK

42300160157

1. Check that the door outside handle play is within the standard value range.

Standard value (B): 2.8 mm or more

2. If the door outside handle play is not within the standard value range, check the door outside handle or the door latch assembly. Replace, if necessary.

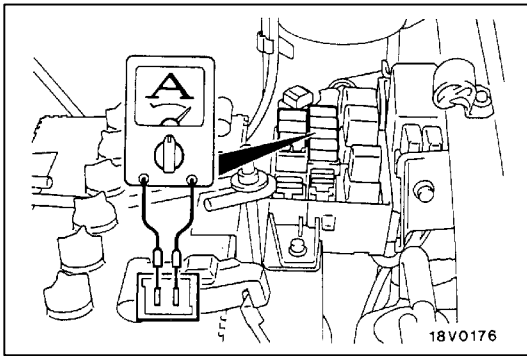

POWER WINDOW OPERATION CURRENT CHECK

42900110099

1. Remove the power window fuse and connect a circuit analyzer as shown in the illustration.
2. When the power window switch is pulled to the UP position, a large amount of current flows at the time the window starts to close and when it is fully closed, so measure the operation current in the interval between these two points.

Standard value: 7A or more (at 20°C)

3. If the operation current is outside the standard value, refer to “Troubleshooting” (P.42-18).

CIRCUIT BREAKER (INCORPORATED IN THE POWER WINDOW MOTOR) CHECK

42900170127

1. Pull the power window switch to the UP position to fully close the window glass, and keep pulling the switch for a further 10 seconds.
2. Release the power window switch from the UP position and immediately press it to the DOWN position. The condition of the circuit breaker is good if the power window glass starts to move downwards within 60 seconds.

DOOR INSIDE HANDLE PLAY CHECK AND ADJUSTMENT

42300150253

1. Check that the door inside handle play is within the standard value range.

Standard value (A): 7.3 mm or more

2. If the door inside handle play is outside the standard value range, remove the door trim. (Refer to P.42-32.)
3. Loosen the inside handle mounting screws, and then move the inside handle back and forth to adjust the play.

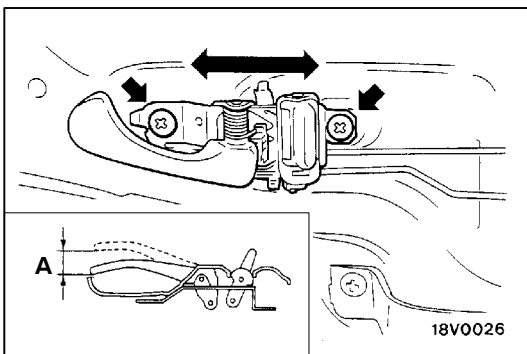

DOOR ASSEMBLY

REMOVAL AND INSTALLATION

Post-installation Operation

- Door Fit Adjustment (Refer to P.42-27.)

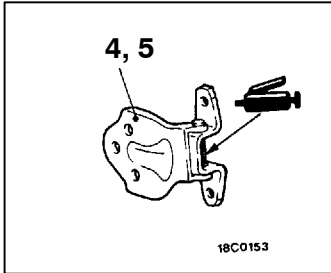

Front door

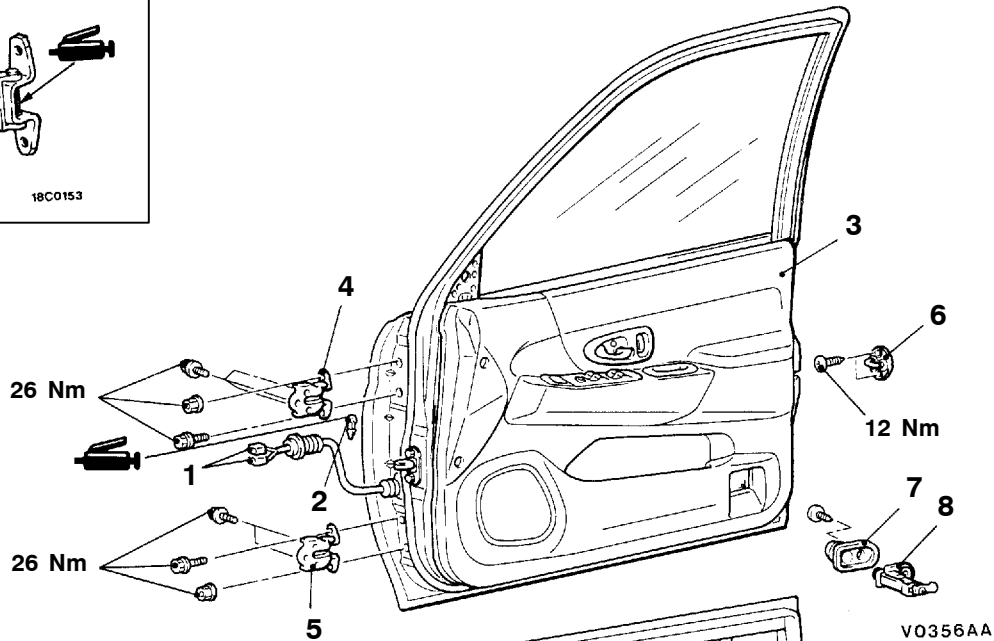

Rear door

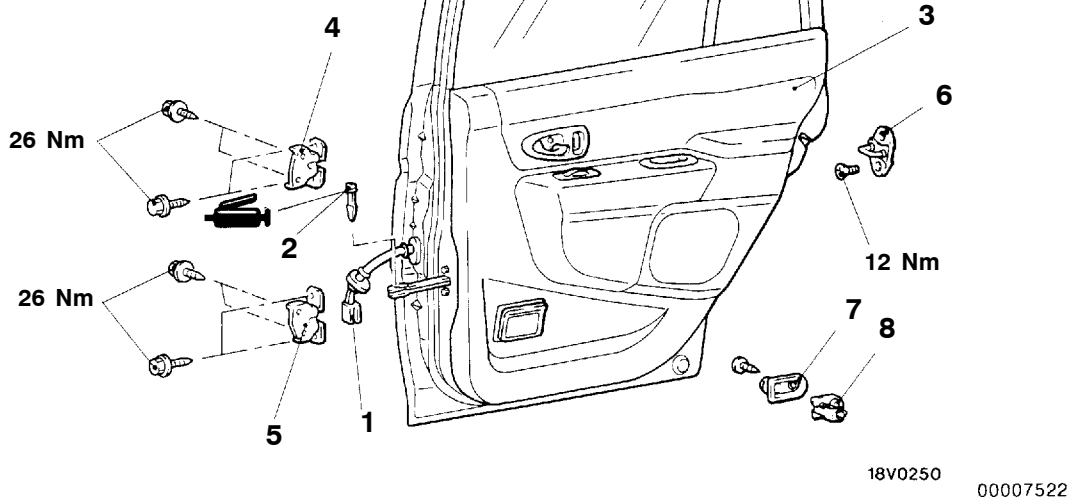

Door assembly removal steps

1. Harness connector
2. Spring pin
3. Door assembly
4. Door upper hinge
5. Door lower hinge



Striker removal

6. Striker

Door switch removal steps

7. Door switch cap
8. Door switch

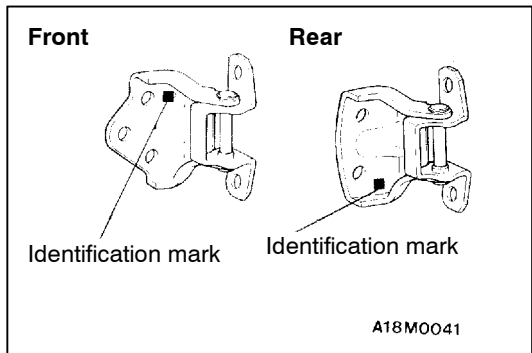

INSTALLATION SERVICE POINT

▶◀ DOOR LOWER HINGE/DOOR UPPER HINGE INSTALLATION

The door hinges differ according to where they are used, so check the identification marks before installation.

Applicable location		Identification mark
Front left side door	Upper hinge	F1
	Lower hinge	E1
Front right side door	Upper hinge	E1
	Lower hinge	F1
Rear left side door	Upper hinge	A1
	Lower hinge	B1
Rear right side door	Upper hinge	B1
	Lower hinge	A1

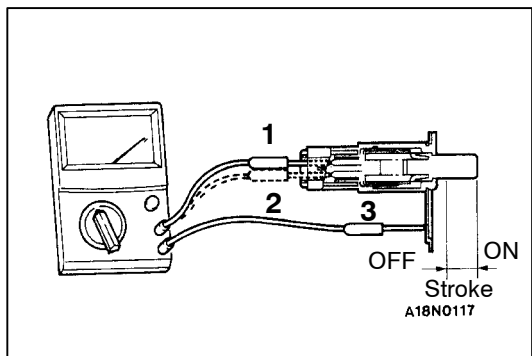

INSPECTION

42300600031

DOOR SWITCH CONTINUITY CHECK

Driver's door switch

Switch position	Terminal No.		
	1	2	3
Open (ON)	○	○	○
Depressed (OFF)			

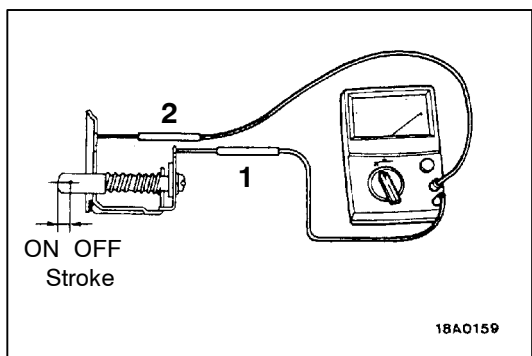

Passenger's door and rear door switch

Switch position	Terminal No.	
	1	2
Open (ON)	○	○
Depressed (OFF)		

DOOR TRIM AND WATERPROOF FILM

REMOVAL AND INSTALLATION

Front door

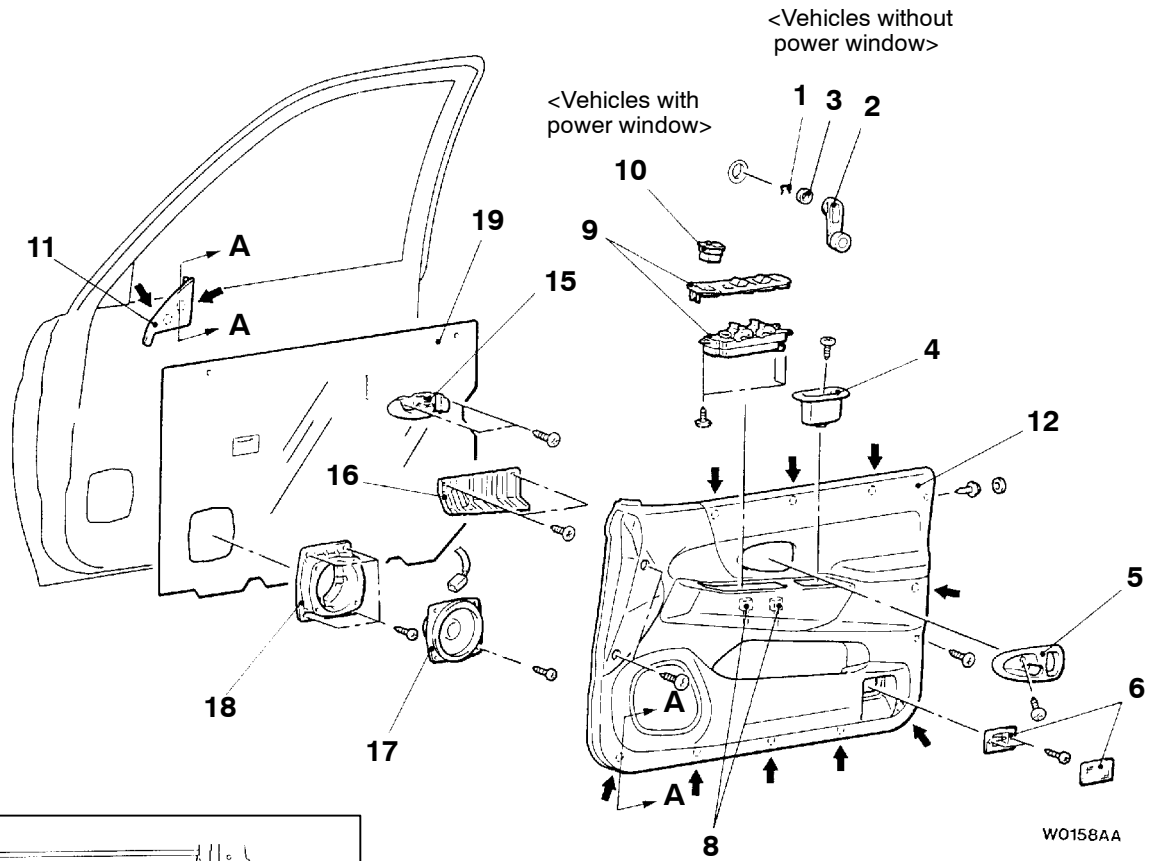

<Vehicles without power window>

<Vehicles with power window>

W0158AA
00009078

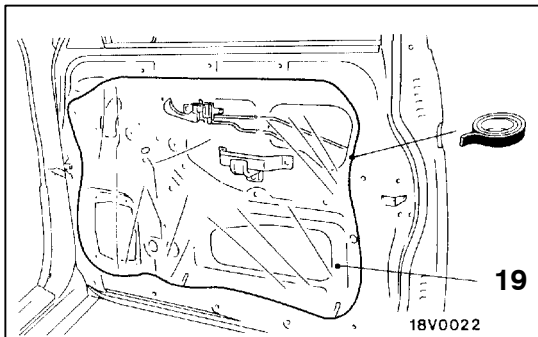

Sealant:
3M ATD Part No. 8625 or equivalent

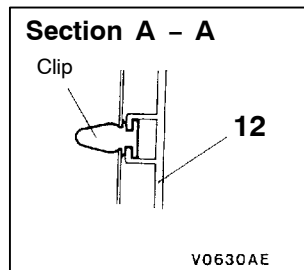

NOTE
← : Resin clip position

Removal steps

- | | | |
|---|--|---|
| <p>◀A▶ ▶A▶
▶A▶▶A▶
▶A▶▶A▶</p> <p>◀B▶</p> | <ol style="list-style-type: none"> 1. Clip 2. Regulator handle 3. Escutcheon 4. Pull handle box 5. Cover 6. Door lamp 8. Harness connector 9. Power window switch assembly | <ol style="list-style-type: none"> 10. Remote controlled mirror switch 11. Inner delta cover 12. Door trim 15. Door inside handle 16. Pull handle bracket 17. Speaker 18. Speaker cover 19. Waterproof film |
|---|--|---|

Rear door

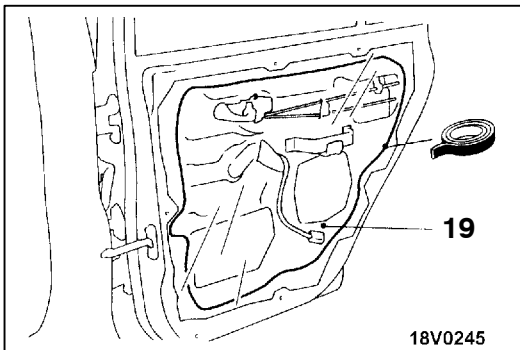
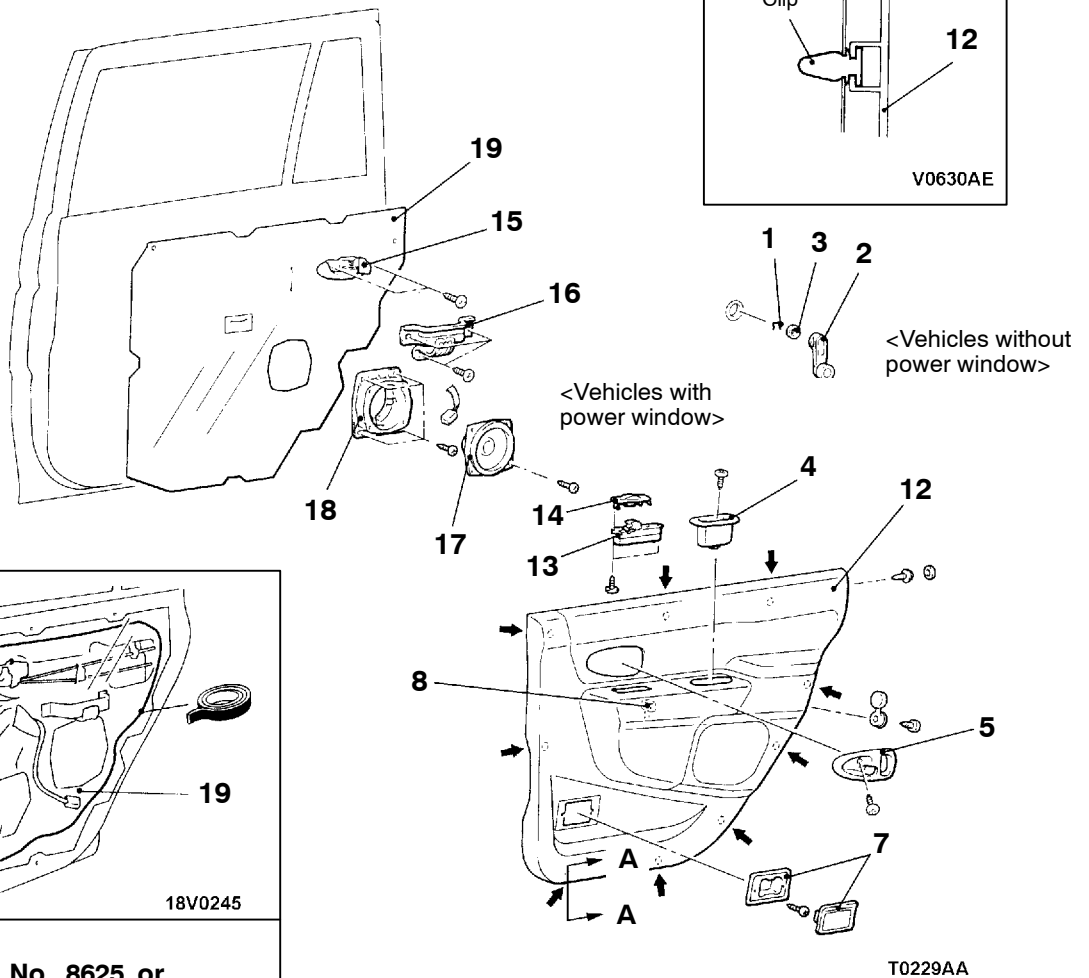
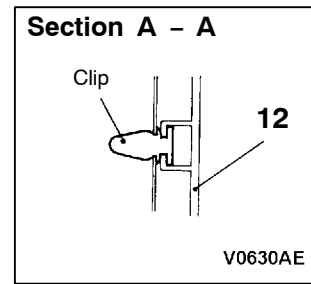

Sealant:
3M ATD Part No. 8625 or
equivalent

00009079

Removal steps

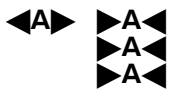

1. Clip
2. Regulator handle
3. Escutcheon
4. Pull handle box
5. Cover
7. Ashtray
8. Harness connector
12. Door trim

13. Power window switch
14. Power window switch cover
15. Door inside handle
16. Pull handle bracket
17. Speaker
18. Speaker cover
19. Waterproof film

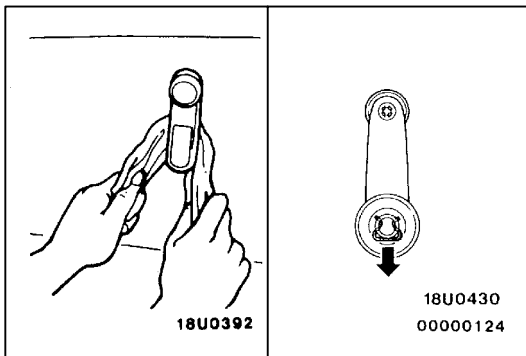
**REMOVAL SERVICE POINTS****◀A▶ CLIP REMOVAL**

Remove the clip by using a rag, and then remove the regulator handle.

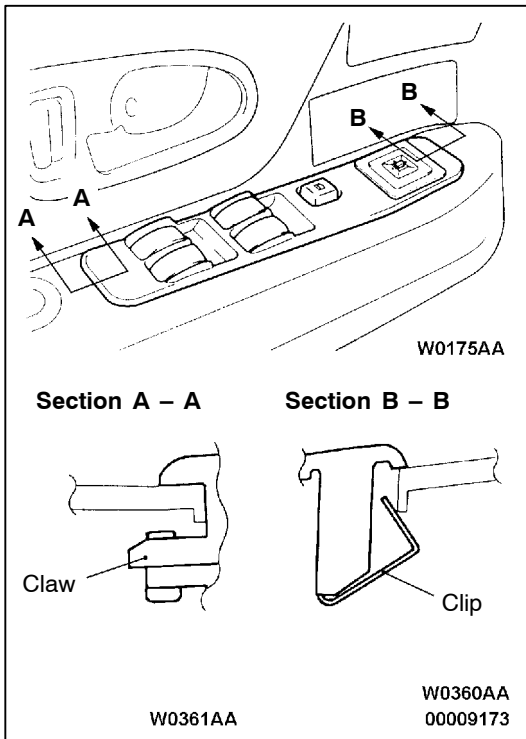
**◀B▶ POWER WINDOW SWITCH ASSEMBLY**

1. Use the special tool to remove the front area clip engagement.
2. Remove the back claw engagement.

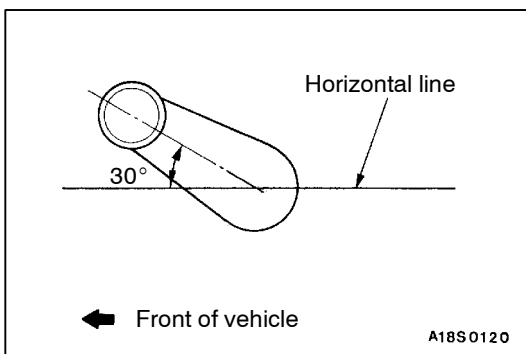
**INSTALLATION SERVICE POINT****▶A◀ ESCUTCHEON/REGULATOR HANDLE/CLIP INSTALLATION**

1. Install the escutcheon and the clip to the regulator handle.
2. Fully close the front door glass, and install the regulator handle so that it faces as shown in the illustration.

DOOR GLASS AND REGULATOR

42900130316

REMOVAL AND INSTALLATION

Front door

Pre-removal Operation

- Door Trim and Waterproof Film Removal (Refer to P.42-32.)
- Door Mirror Removal (Refer to GROUP 51 – Door Mirror.)

Post-installation Operation

- Door Trim and Waterproof Film Installation (Refer to P.42-32.)
- Door Mirror Installation (Refer to GROUP 51 – Door Mirror.)
- Door Window Glass Adjustment (Refer to P.42-27.)

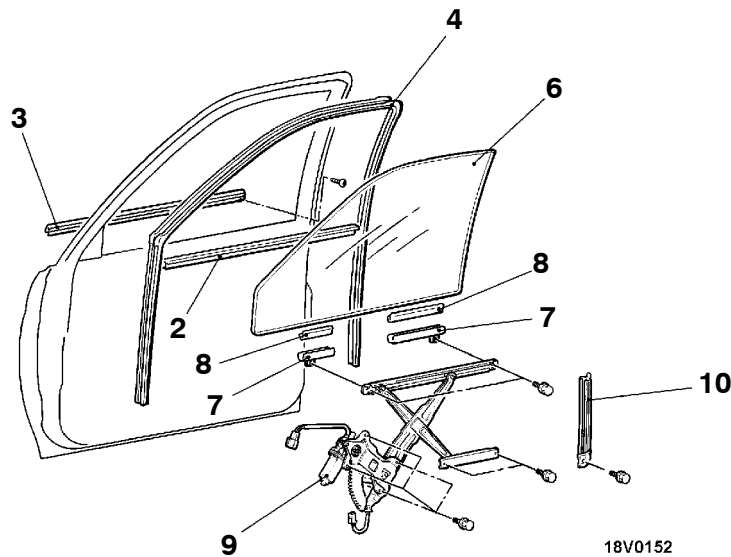
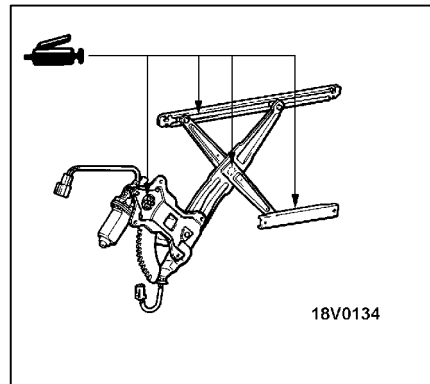
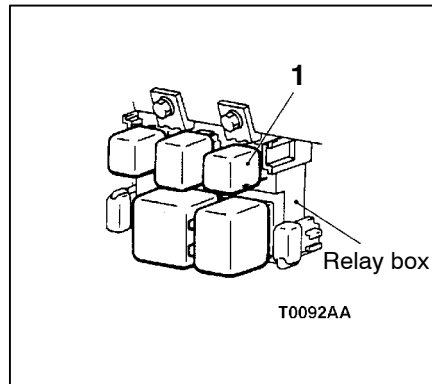

Power window relay removal steps

- Driver's side under cover (Refer to GROUP 52A – Instrument Panel.)
- 1. Power window relay

Front window regulator assembly removal steps

- 2. Door beltline inner weatherstrip
 - 3. Door beltline moulding assembly
 - 4. Door window glass runchannel
 - 6. Door window glass
 - 7. Door glass holder
 - 8. Door glass pad
 - 9. Window regulator assembly
 - 10. Rear lower sash
- ▶B◀
- ▶A◀

18V0152

00009080

Rear door

Pre-removal Operation

- Door Trim and Waterproof Film Removal (Refer to P.42-33.)

Post-installation Operation

- Door Trim and Waterproof Film Installation (Refer to P.42-33.)
- Door Window Glass Adjustment (Refer to P.42-27.)

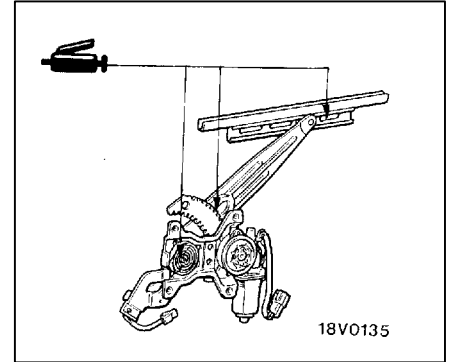
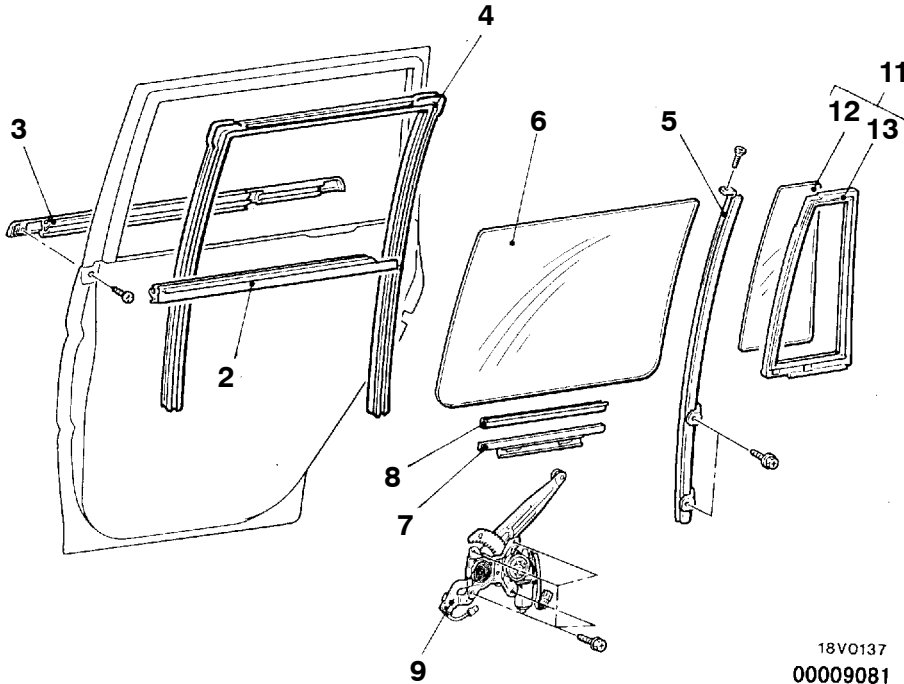

18V0137
00009081

Removal steps

2. Door beltline inner weatherstrip
3. Door beltline moulding assembly
4. Door window glass runchannel
5. Door center sash
6. Door window glass
7. Door window glass

8. Door glass pad
9. Window regulator assembly
11. Stationary window glass and weatherstrip assembly
12. Stationary window glass
13. Stationary window weatherstrip

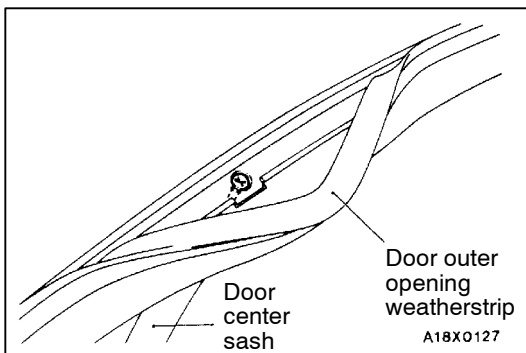

REMOVAL SERVICE POINT

◀A▶ **DOOR CENTER SASH REMOVAL (REAR DOOR)**

1. Remove the door outer opening weatherstrip from the door center sash section only.
2. Remove the mounting screw for the door center sash, and remove the door center sash from the door panel.

INSTALLATION SERVICE POINTS

►A◄ REAR LOWER SASH INSTALLATION

Securely insert the rear lower sash into the window rear sash.

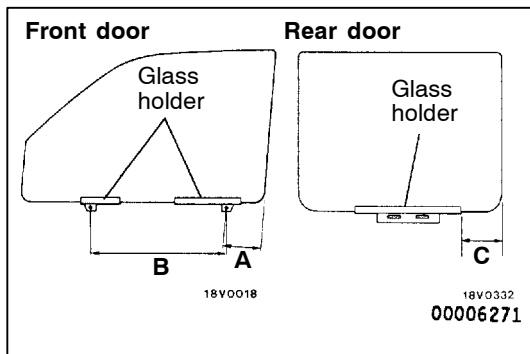

►B◄ DOOR GLASS HOLDER INSTALLATION

Install the glass pad and the glass holders to the window glass as shown in the illustration.

Standard value:

- (A) 106.7 – 108.2 mm
- (B) 417.5 – 420.5 mm
- (C) 127 – 131 mm

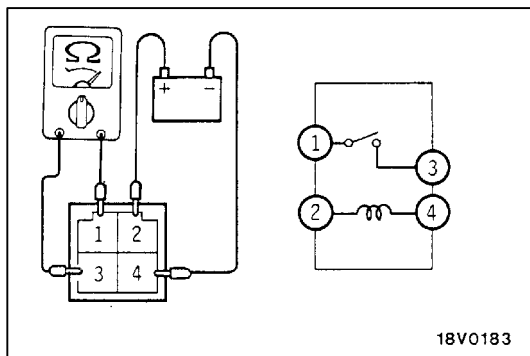

INSPECTION

42900180069

POWER WINDOW RELAY CONTINUITY CHECK

System voltage	Terminal No.			
	1	2	3	4
Not applied		○	○	○
Applied	○	+	○	-

POWER WINDOW MOTOR CHECK

42900150053

1. Connect a battery directly to the motor terminals and check that the motor runs smoothly.
2. Check that the motor runs in the opposite direction when the battery is connected with the polarity reversed.

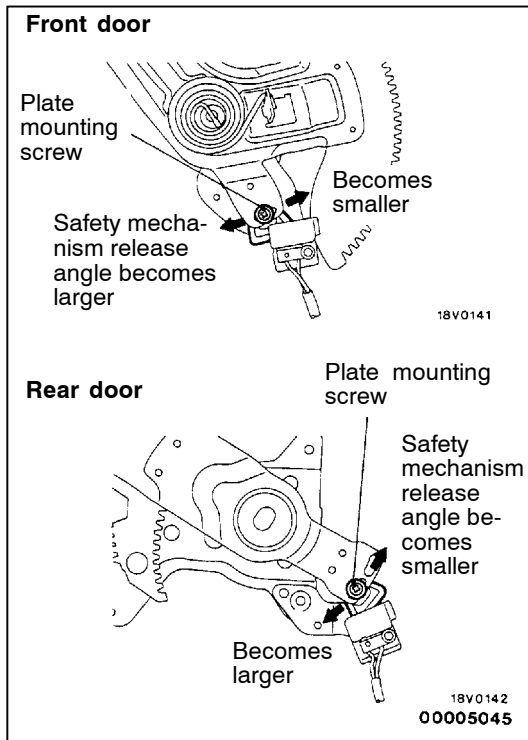

LIMIT SWITCH OPERATION POSITION ADJUSTMENT

42900230023

Loosen the plate mounting screw and move the plate to the left or right to adjust where the limit switch starts working (safety mechanism stops working).

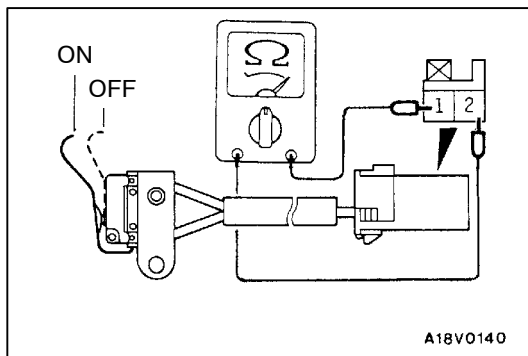

LIMIT SWITCH CONTINUITY CHECK

42900220020

Switch position	Terminal No.	
	1	2
ON	○ — ○	○ — ○
OFF		

DOOR HANDLE AND LATCH

42300460301

REMOVAL AND INSTALLATION

Pre-removal Operation

- Door Trim Removal (Refer to P.42-32.)

Post-installation Operation

- Door Inside Handle Play Check (Refer to P.42-29.)
- Door Outside Handle Play Check (Refer to P.42-28.)
- Door Trim Installation (Refer to P.42-32.)
- Door Fit Adjustment (Refer to P.42-27.)

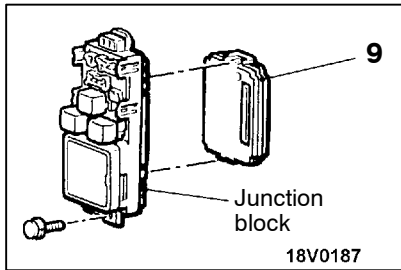

Front door

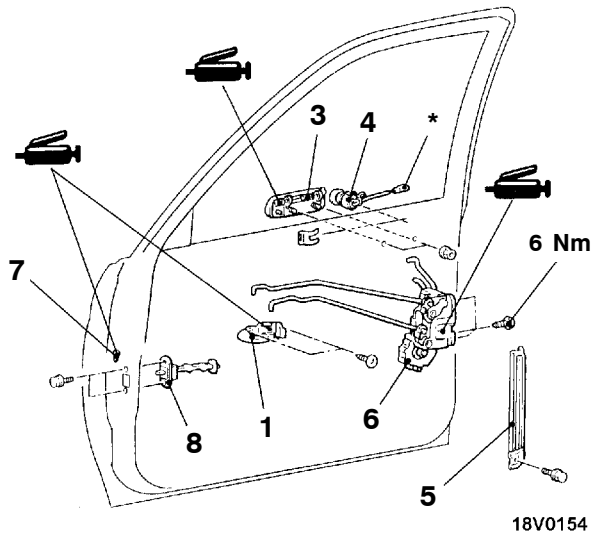

Front door handle and door latch assembly removal steps

1. Door inside handle
 - Waterproof film (Refer to P.42-32.)
 3. Door outside handle
 4. Door lock key cylinder
- B◀ 5. Rear lower sash
6. Door latch assembly

Rear door handle and door latch assembly removal steps

1. Door inside handle
 - Waterproof film (Refer to P.42-32.)

Rear door

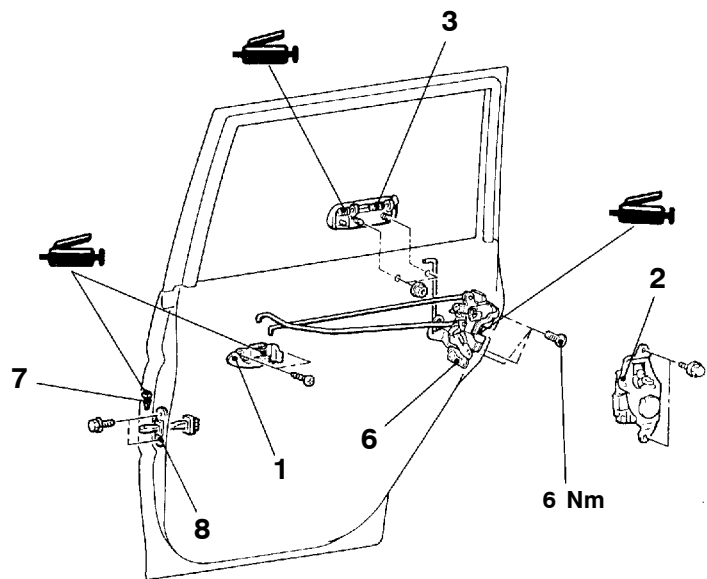

18V0139

00009082

- C◀ 2. Rear door lock actuator assembly
3. Door outside handle
6. Door latch assembly

Door check removal steps

- A◀ 7. Spring pin
8. Door check

ETACS-ECU removal

9. ETACS-ECU

NOTE

*: This is equipped on passenger's side door lock key cylinder of vehicles with central door locking system.

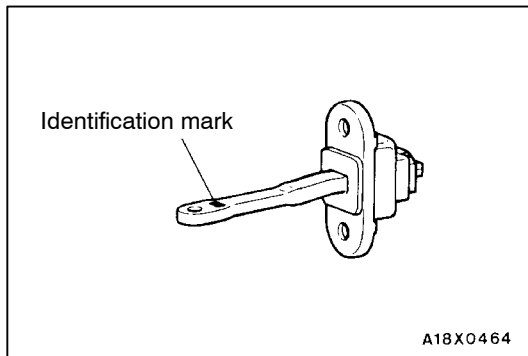

INSTALLATION SERVICE POINTS

▶A◀ DOOR CHECK INSTALLATION

Install the door check so that the identification mark faces upwards.

Applicable location		Identification mark
L.H.	Front door	19L
	Rear door	25L
R.H.	Front door	19R
	Rear door	25R

▶B◀ REAR LOWER SASH INSTALLATION

Securely insert the rear lower sash into the window rear sash.

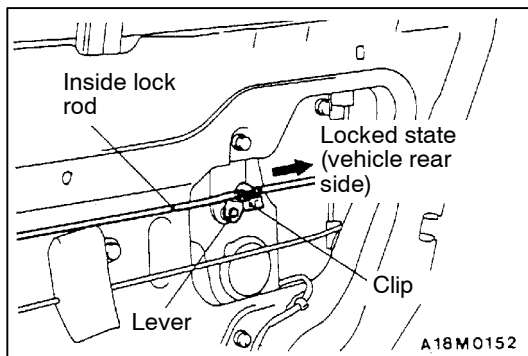

▶C◀ REAR DOOR LOCK ACTUATOR ASSEMBLY

1. Lock the inside lock knob.
2. Lock the actuator lever and install.
3. Fit the clip into the inside lock rod.

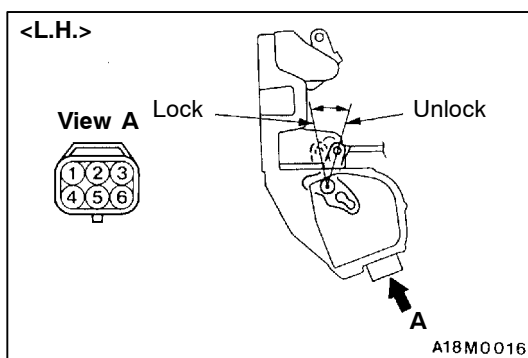

INSPECTION

42300610133

FRONT DOOR LOCK ACTUATOR CHECK <Vehicles with central door locking system>

<L.H.>

Rod position	Terminal No.					Rod operation
	1	2	3	4	6	
LOCK				⊕	⊖	LOCK position → UNLOCK position
UNLOCK				⊕	⊖	UNLOCK position → LOCK position
LOCK*	○	—	○			
UNLOCK*	○	○				

NOTE

*: Driver's side only

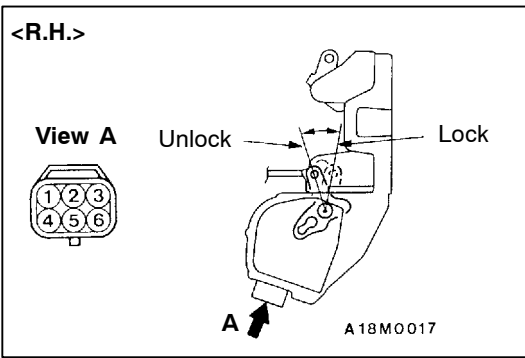

<R.H.>

Rod position	Terminal No.					Rod operation
	1	2	3	4	6	
LOCK				⊖	⊕	LOCK position → UNLOCK position
UNLOCK				⊕	⊖	UNLOCK position → LOCK position
LOCK*	○	—	○			
UNLOCK*		○	○			

NOTE

*: Driver's side only

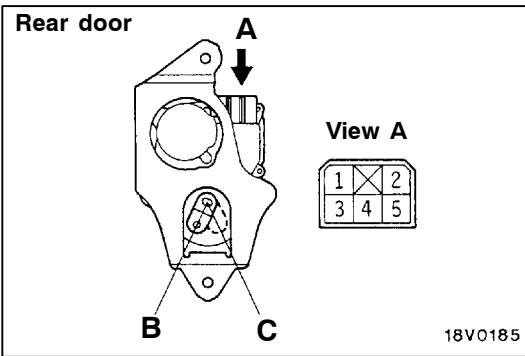

REAR DOOR LOCK ACTUATOR CHECK <Vehicles with central door locking system>

42300620112

Rod position	Terminal No.		Rod operation
	1	2	
B	⊕	⊖	B position → C position
C	⊖	⊕	C position → B position

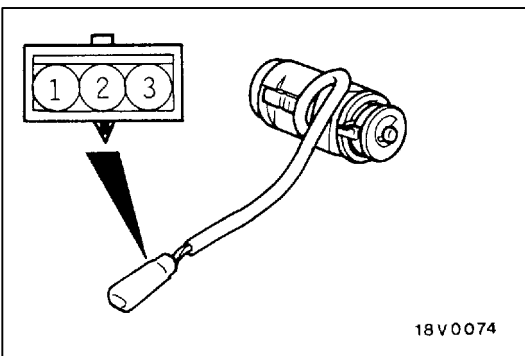

DOOR LOCK KEY CYLINDER SWITCH CONTINUITY CHECK <Vehicles with central door locking system>

42300630160

Passenger's side only

Switch position	Terminal No.		
	1	2	3
LOCK		○	○
Neutral (OFF)			
UNLOCK	○	○	

WINDOW GLASS RUNCHANNEL AND DOOR OPENING WEATHERSTRIP

42300310231

REMOVAL AND INSTALLATION

Front door

Rear door

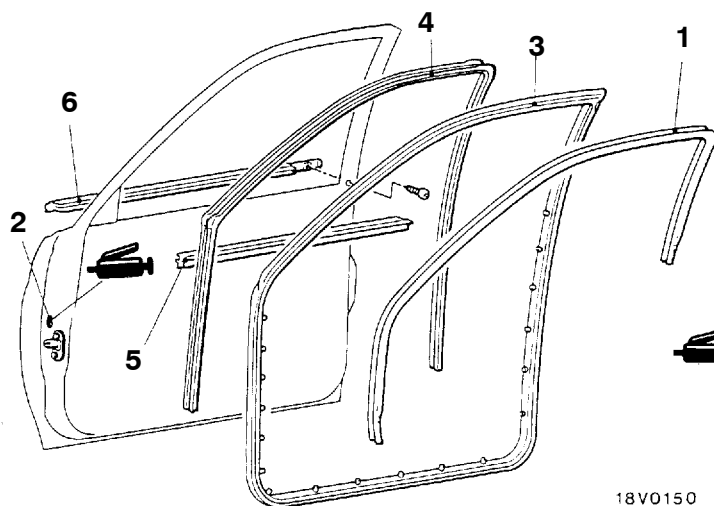

18V0150

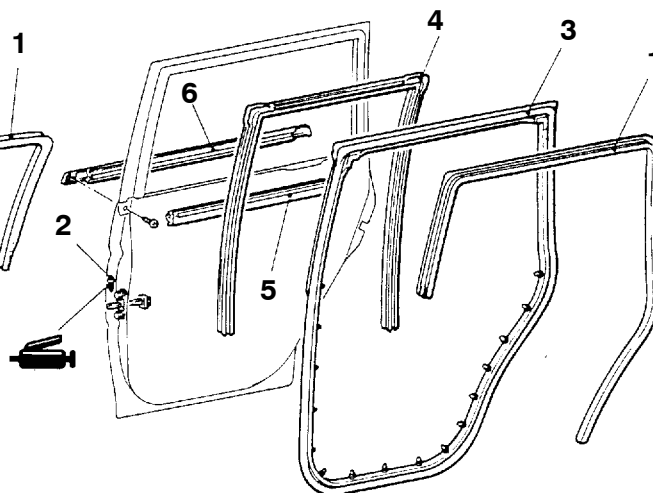

18V0138

00007529

Door inner opening weatherstrip removal steps

- Front scuff plate, rear scuff plate, centre pillar lower trim and cowl side trim (Refer to Group 52A – Trims.)

1. Door inner opening weatherstrip

Door outer opening weatherstrip removal steps

2. Spring pin

3. Door outer opening weatherstrip



Window glass runchannel removal

4. Window glass runchannel

Door beltline inner weatherstrip removal steps

- Door trim (Refer to P.42-32.)
- 5. Door beltline inner weatherstrip

Door beltline outer weatherstrip removal steps

- Door mirror (Refer to Group 51 – Door Mirror.)
- 6. Door beltline outer weatherstrip

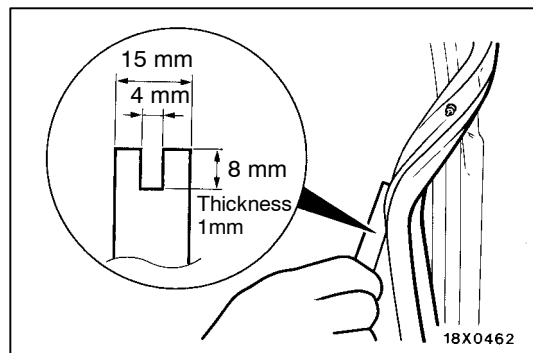

18X0462

REMOVAL SERVICE POINT

◀A▶ DOOR OUTER OPENING WEATHERSTRIP REMOVAL

Make a tool as shown in the illustration to remove the door opening weatherstrip.

INSTALLATION SERVICE POINT

▶◀ DOOR OUTER OPENING WEATHERSTRIP INSTALLATION

The clip colour identifies the left and right weatherstrips, so be sure to use the colours so as to install correctly.

Applicable side	Identification colour
Left door	Natural (white)
Right door	Brown or yellow

TAILGATE

42400050068

SEALANT

Item	Specified sealant	Remark
Waterproof film	3M ATD Part No. 8625 or equivalent	Ribbon sealer

SPECIAL TOOL

42400060061

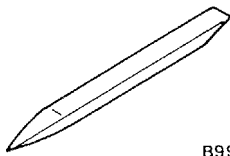
Tool	Number	Name	Use
 B990784	MB990784	Ornament remover	Removal of the tailgate trim

TROUBLESHOOTING

42400070101

INSPECTION CHART FOR TROUBLE SYMPTOMS

Trouble symptom	Reference page
Door lock mechanism does operate.	42-18.

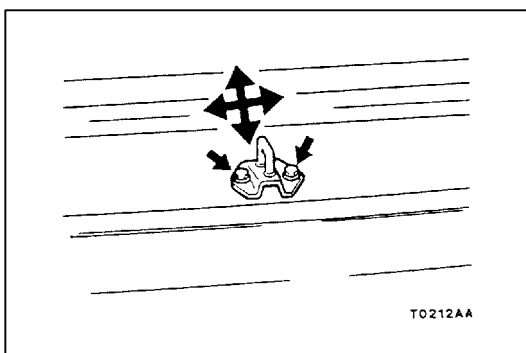

ON-VEHICLE SERVICE

42400090053

TAILGATE FIT ADJUSTMENT

1. If the striker and latch do not mesh properly, move the striker up and down and to the left and right.

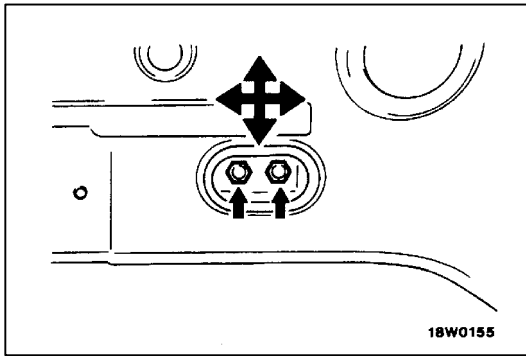

- If the clearance around the tailgate is not even when the tailgate is closed, move the tailgate hinge forward and back or to the left and right.

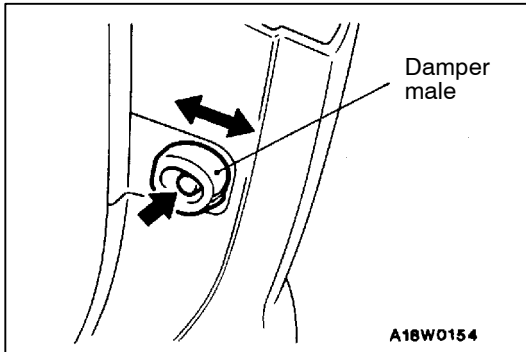

- Check the fitting of the damper male when the tailgate is closed. If the position is not correct, move the damper male forward and back.

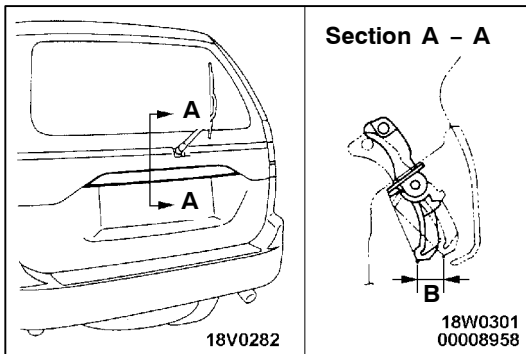

TAILGATE HANDLE PLAY INSPECTION 42400180057

- Check the tailgate handle play.
Standard value (B): 1.5 – 5.5 mm
- If the play is not within the standard value range, check and replace the tailgate handle or the tailgate latch assembly.

TAILGATE ASSEMBLY

42400110179

REMOVAL AND INSTALLATION

Pre-removal Operation

- Rear Headlining Removal

Post-installation Operation

- Rear Headlining Installation
- Tailgate Fit Adjustment (Refer to P.42-43.)

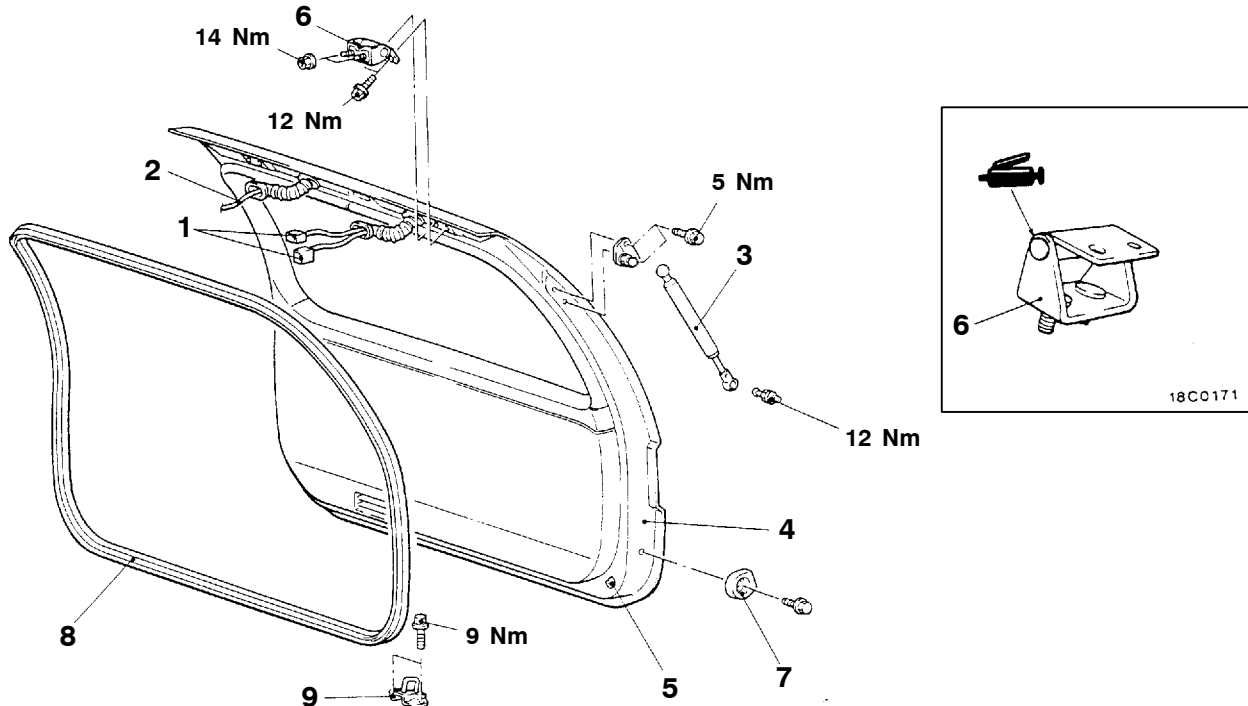

18V0242

00007530

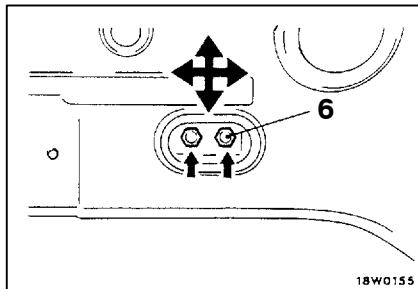

18W0155

Tailgate clearance adjustment

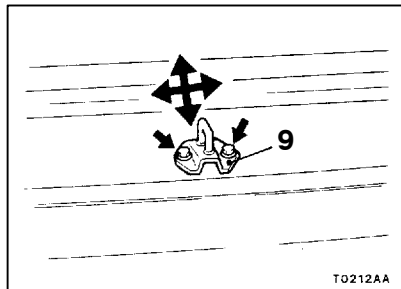

T0212AA

Tailgate height and tailgate striker meshing adjustment

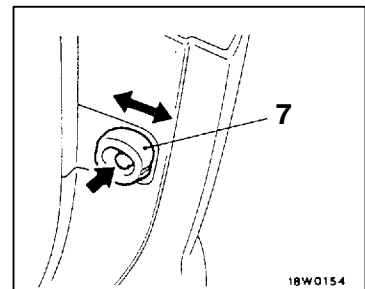

18W0154

Tailgate fit adjustment

Removal steps

1. Harness connector
2. Rear window washer tube connection
3. Tailgate gas spring
4. Tailgate assembly
5. Tailgate bumper
6. Tailgate hinge
7. Damper male

- ▶◀ 8. Tailgate opening weatherstrip

Striker removal

9. Striker

Caution

1. Do not disassemble or throw the tailgate gas spring into fire.
2. Punch a hole in the gas spring before disposal to release the gas inside.

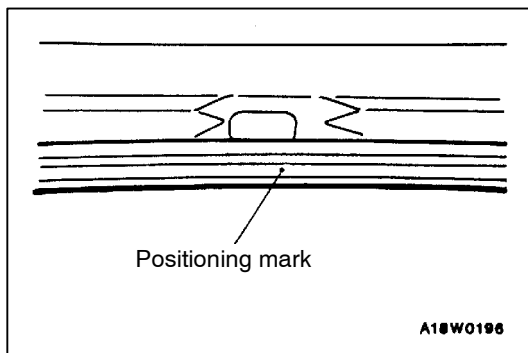
**INSTALLATION SERVICE POINT****►A◄ TAILGATE OPENING WEATHERSTRIP
INSTALLATION**

1. Check the identification colour, and then align the positioning mark with the top center of the tailgate to install the weatherstrip.
2. Check that the tailgate opening weatherstrip joint is centred.

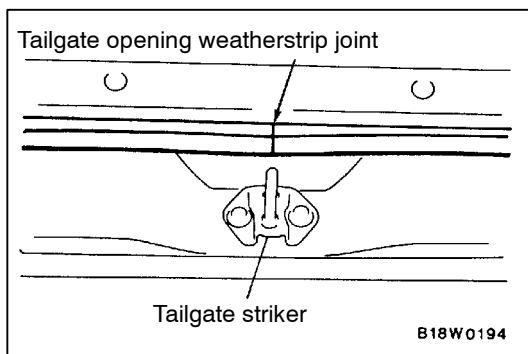

TAILGATE TRIM AND WATERPROOF FILM

42400140062

REMOVAL AND INSTALLATION

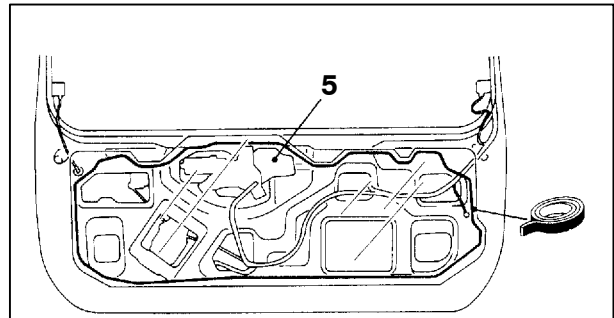

18V0243

Sealant:
3M ATD Part No. 8625 or equivalent

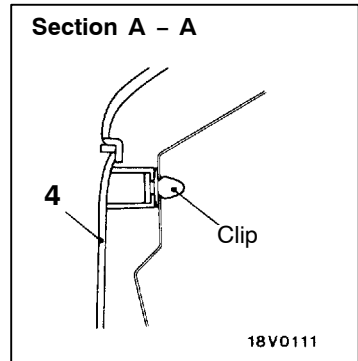
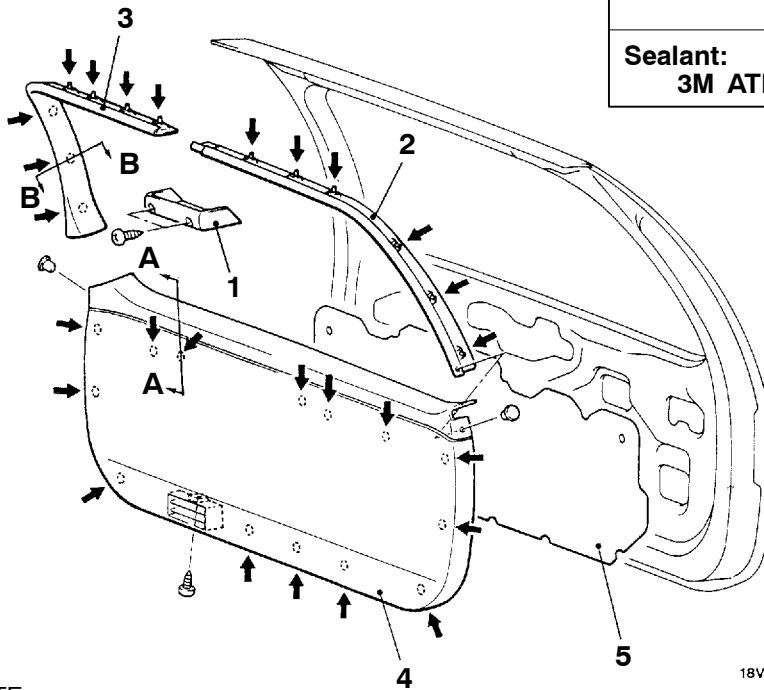

18V0111

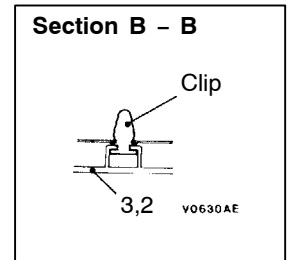

3,2 V0630AE

18V0244
00007531

NOTE
← : Resin clip position

Removal steps

- 1. Cover <vehicles without roof spoiler>
- 2. Tailgate upper trim <L.H.>
- 3. Tailgate upper trim <R.H.>
- 4. Tailgate lower trim
- 5. Waterproof film

TAILGATE HANDLE AND LATCH

42400170078

REMOVAL AND INSTALLATION

Pre-removal Operation

- Tailgate Garnish Removal (Refer to GROUP 51 – Grill, Moulding and Garnish.)
- Tailgate Trim and Waterproof Film Removal (Refer to P.42-47.)

Post-installation Operation

- Tailgate Handle Play Inspection (Refer to P.42-44.)
- Tailgate Trim and Waterproof Film Installation (Refer to P.42-47.)
- Tailgate Garnish Installation (Refer to GROUP 51 – Grill, Moulding and Garnish.)

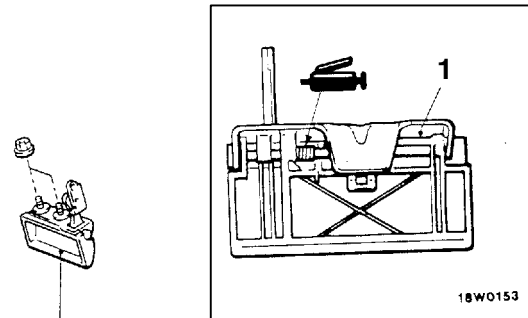
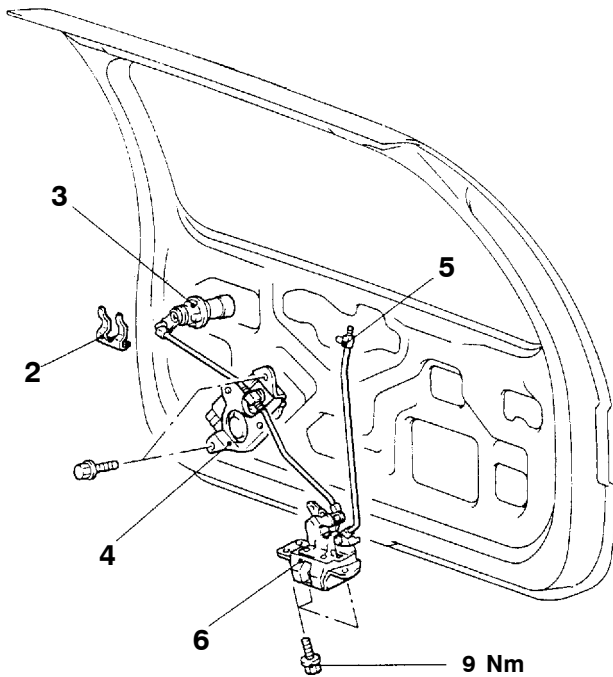

18V0241
00007532

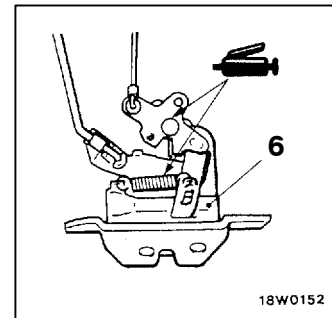

Tailgate lock key cylinder removal steps

1. Tailgate handle
2. Cylinder lock retainer
3. Tailgate lock key cylinder

Tailgate latch removal steps

4. Tailgate lock actuator
5. Holder
6. Tailgate latch assembly

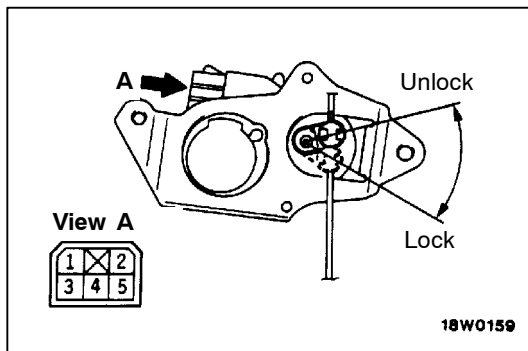

INSPECTION

42400210039

TAILGATE LOCK ACTUATOR INSPECTION

Rod position	Terminal No.		Rod movement
	1	2	
LOCK	⊕	⊖	LOCK → UNLOCK
UNLOCK	⊖	⊕	UNLOCK → LOCK

SUNROOF

42600050071

SEALANT AND ADHESIVE

Items	Specified sealant and adhesive	Remarks
Sunroof glass attaching screws	3M Stud locking Part No. 4170 or equivalent	Anaerobic sealant
Sunroof glass sealing	3M Part No. 8155 or equivalent	Quick fix adhesive

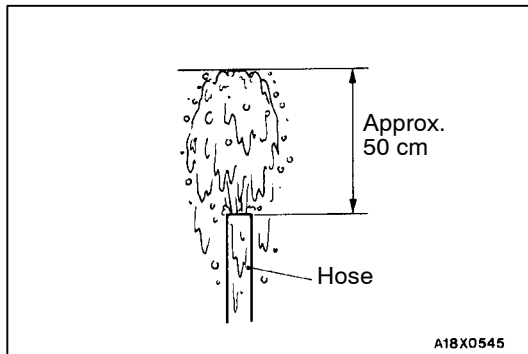

ON-VEHICLE SERVICE

42600090141

WATER TEST

1. Close the roof lid tightly.
2. Hold the hose upward and adjust water fountain to approx. 50 cm high.

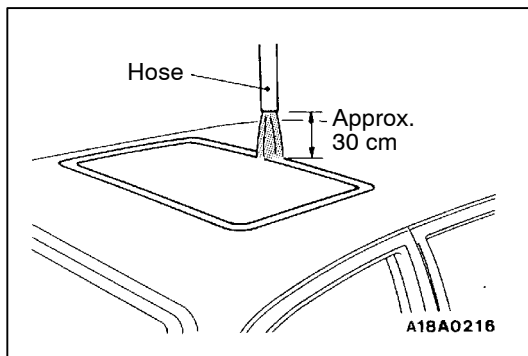

3. Pour water over the roof from approx. 30 cm above roof for more than 5 minutes.
4. While pouring water, check for leak around the roof lid.
5. In the event of leakage, check the drain pipe, weatherstrip contact and others.

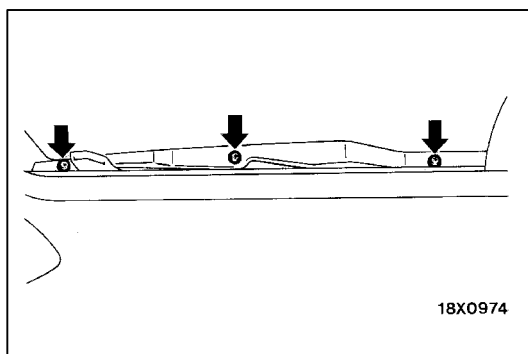

SUNROOF FIT ADJUSTMENT

42600100165

With the sunroof in the closed position, adjust the sunroof glass to 1 mm below roof surface at front of the glass and 1 mm above roof surface at rear of the glass and tighten the sunroof glass attaching screws.

OPERATION CHECK

Check the following items. If defective, replace the sunroof control unit.

Caution

Check that the following items are normal before carrying out this operation check.

- (1) Installation condition of the sunroof assembly
- (2) Installation condition, deforms and foreign material of the sunroof drive cable
- (3) Unfitted sunroof lid glass
- (4) Sunroof switch and sunroof motor

No.	Sunroof initial position	Switch operation	Judgment (normal)
01	Fully closed	Ignition switch: ON 1. Sunroof switch: Open 2. Sunroof switch: Release the open button	1. Sunroof tilts up. 2. Sunroof stops before tilt-up finishes.
02	From fully closed position to tilted position	Ignition switch: ON ● Sunroof switch: Close	● Sunroof closes fully and stops
03	Fully closed	Ignition switch: ON ● Sunroof switch: Open	● Sunroof tilts up and stops.
04	Fully closed	Ignition switch: ON ● Sunroof switch: Open Block the sunroof between fully closed position and tilted position	● Sunroof moves until the blocking force reaches 98N. At this time check the current to the sunroof motor. If the motor stops at more than 15 A, the motor is normal. [approx. 15 A at 98 N]
05	Tilt	Ignition switch: ON ● Sunroof switch: Open Block the sunroof between fully tilted position* and fully open position.	● Sunroof moves until the blocking force reaches 98 N. Sunroof stops when the force has reached 98 N.
06	Fully open	Ignition switch: ON ● Sunroof switch: Close Block the sunroof at 200 mm before the sunroof is fully closed.	● Sunroof moves until the blocking force reaches 98 N. Sunroof stops in one seconds after the blocking force has reached 98 N.
07	Fully open	Ignition switch: ON ● Sunroof switch: Close Block the sunroof at 5 mm before the sunroof is fully closed.	● Sunroof moves toward close until the blocking force reaches 98 N. Then the sunroof moves back toward open when the blocking force reaches 98 N and stops after second.

NOTE

*: "Fully tilted position" is the position where the sunroof has tilted up and begins sliding.

No.	Sunroof initial position	Switch operation	Judgment (normal)
08	Fully open	Ignition switch: ON ● Sunroof switch: Close Block the sunroof at 3 mm before the sunroof is fully closed.	● Sunroof moves toward close until the blocking force reaches 98 N. Then the sunroof stops when the blocking force reaches 98 N. (The sunroof does not move back toward open.)
09	Fully open	Ignition switch: ON ● Sunroof switch: Close Block the sunroof at 18 mm before the sunroof is fully closed.	● Sunroof moves toward close before the blocking force reaches 98 N. Then the sunroof moves back toward open when the blocking force reaches 98 N and stops after one second.
10	Fully open	Ignition switch: ON ● Sunroof switch: Close Block the sunroof at 16 mm before the sunroof is fully closed.	● Sunroof moves toward close until the blocking force reaches 98 N. Then the sunroof stops when the blocking force reaches 98 N. (The sunroof does not move back toward open.)
11	Fully closed	Ignition switch: ON 1. Sunroof switch: Open 2. Sunroof switch: Release the open button	1. Sunroof tilts up. 2. Sunroof stops before tilt-up finishes.
12	Tilt up	Ignition switch: ON 1. Sunroof switch: Open 2. Ignition switch: OFF (before the sunroof is fully open)	1. Sunroof moves toward open. 2. Sunroof stops.
13	Fully open	Ignition switch: ON 1. Sunroof switch: Close 2. Ignition switch: OFF (before tilt-up finishes)	1. Sunroof tilts up. 2. Sunroof stops
14	Tilt up	Ignition switch: ON ● Sunroof switch: Open Block the sunroof between fully tilted position and fully open position.	● Sunroof moves toward close until the blocking force reaches 98 N. Then the sunroof stops when the blocking force reaches 98 N.

SUNROOF

REMOVAL AND INSTALLATION

Post-installation Operation

- Sunroof Fit Adjustment (Refer to P.42-49.)
- Water Test (Refer to P.42-49.)

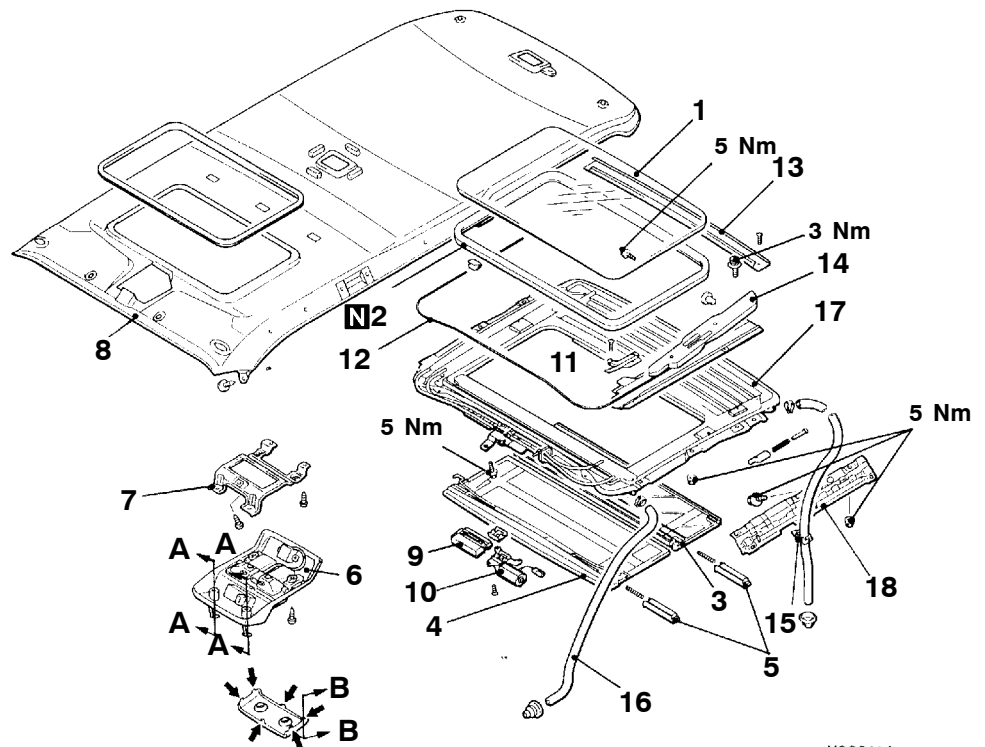
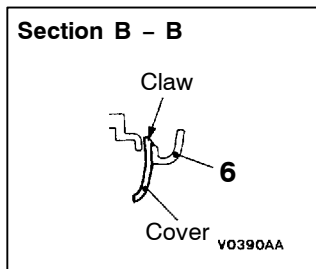
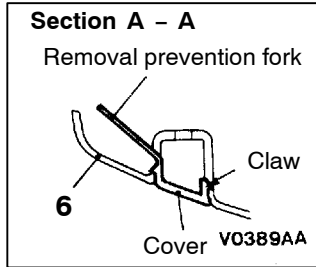

NOTE

← : Shows the claw position

V0391AA
00007533

6. Sunroof switch map lamp assembly

8. Headlining
10. Sunroof motor

Sunroof glass seal removal steps



1. Sunroof glass
2. Sunroof glass seal

Sunroof guide assembly removal steps



1. Sunroof glass
3. Rear sunroof sunshade
4. Front sunroof sunshade
11. Locator
12. Sunroof drive cable connection
13. Drain channel
14. Sunroof guide assembly

Sunroof sunshade removal steps



1. Sunroof glass
3. Rear sunroof sunshade
4. Front sunroof sunshade
5. Sunshade slide block

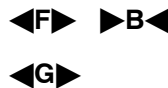

Sunroof assembly

6. Sunroof switch map lamp assembly
7. Bracket
8. Headlining
15. Clip
16. Drain hose
17. Sunroof assembly
18. Set bracket

Sunroof-ECU

6. Sunroof switch map lamp assembly
7. Bracket
8. Headlining
9. Sunroof-ECU



Sunroof motor removal steps

6. Sunroof switch map lamp assembly
7. Bracket



ADHESION POINTS

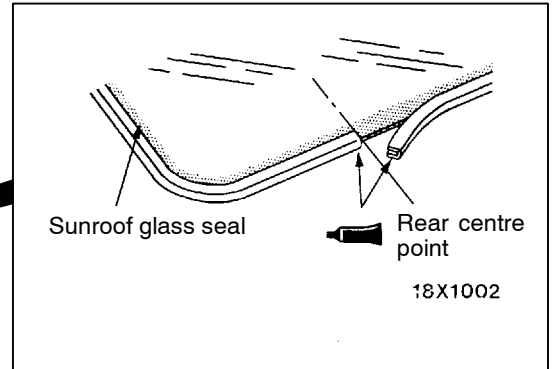
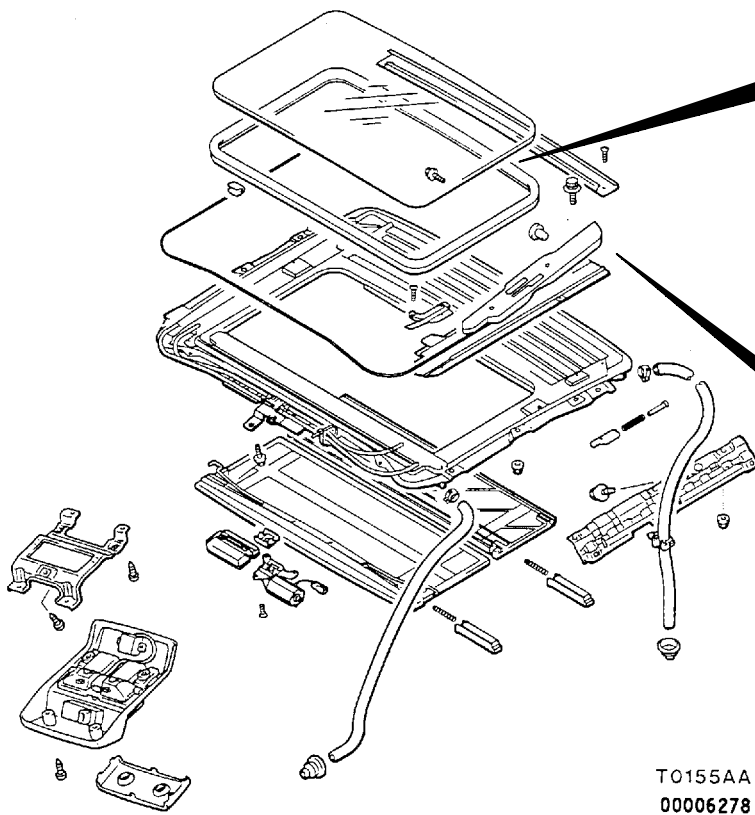

Adhesive:
3M Part No. 8155 or equivalent

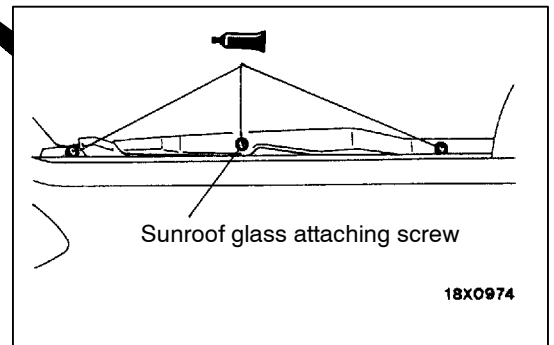

Sealant:
3M Stud locking Part No. 4170 or equivalent

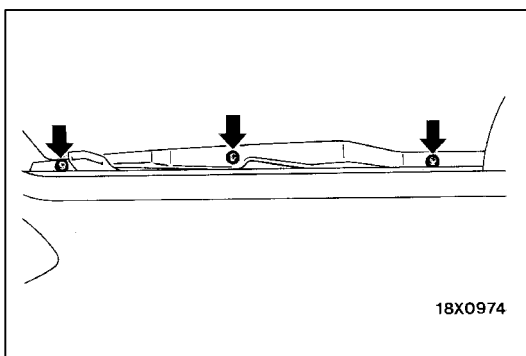

REMOVAL SERVICE POINTS

◀A▶ SUNROOF GLASS REMOVAL

1. Tilt the sunroof.
2. Remove the screws attaching sunroof glass to the guide assemblies, and then lift the glass out of roof opening.

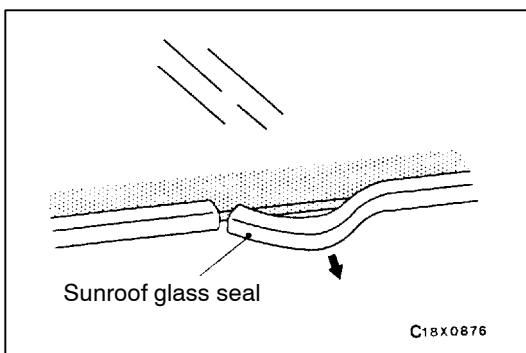

◀B▶ SUNROOF GLASS SEAL REMOVAL

Remove the seal by pulling it off of glass starting at the splice joint.

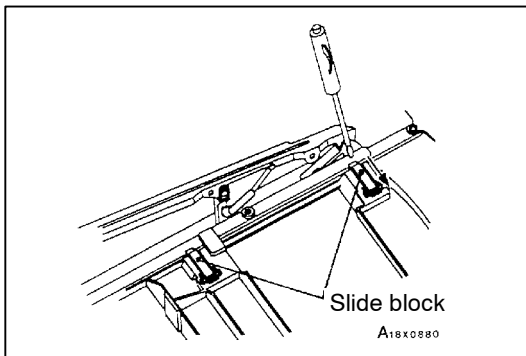

◀C▶ REAR SUNROOF SUNSHADE/FRONT SUNROOF SUNSHADE REMOVAL

1. Remove the rear sunroof sunshade first by pushing in the slide blocks to release them from the sunroof guide assembly on one side of the sunshade. Remove the rear sunroof sunshade out of roof opening.
2. Repeat the step 1 for the front sunroof sunshade.

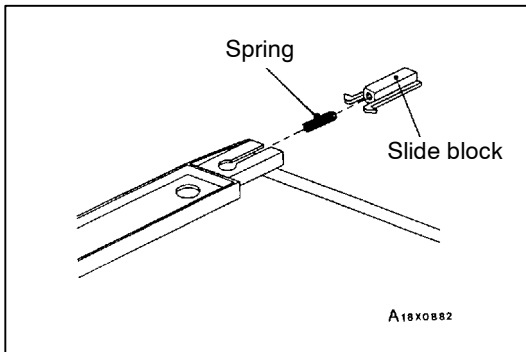

◀D▶ SUNSHADE SLIDE BLOCK REMOVAL

Squeeze together your fingers on inboard end of the slide block to allow the slide block to slide out of it's channel, and then remove the slide block and spring.

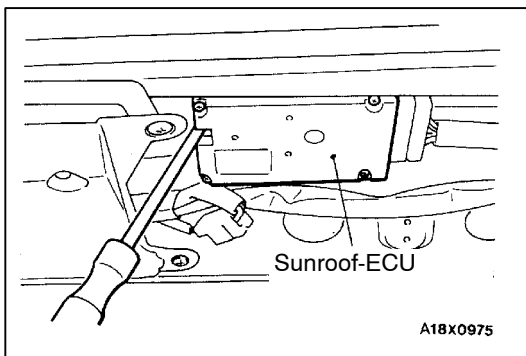

◀E▶ SUNROOF-ECU REMOVAL

1. Close the sunroof glass fully.
2. Insert a flat-tipped screwdriver, place it on the tab, and then press it to the right.
3. Lower sunroof-ECU and slide to left.

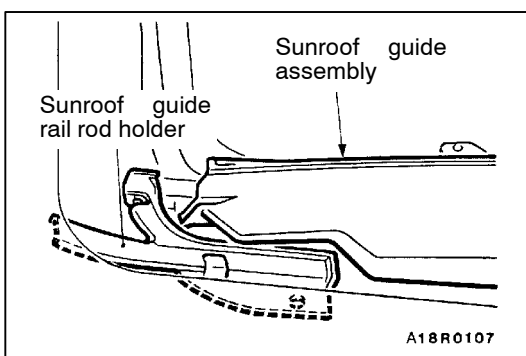

◀F▶ SUNROOF DRIVE CABLES REMOVAL

1. Tilt the sunroof guide assembly and then remove the sunroof guide rail rod holder.
2. Close the sunroof guide assembly and disconnect the sunroof drive cable end from the sunroof guide assembly.

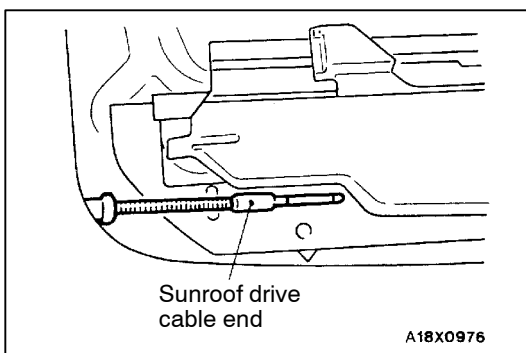

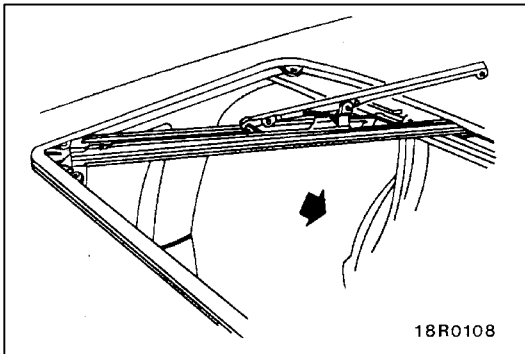

◀G▶ SUNROOF GUIDE ASSEMBLY REMOVAL

1. Slide the roof drip rear channel backward, and then remove the guide assembly screws, the rear screw and spacer.
2. Slide the rear of the guide assembly toward center of the vehicle and remove the guide assembly.

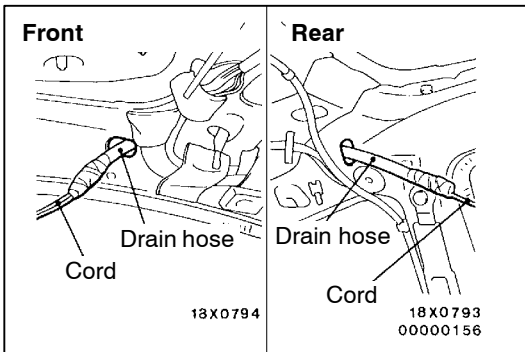

◀H▶ DRAIN HOSE REMOVAL

Remove the grommet. Tie a cord to the end of the drain hose, wind plastic tape around it so that there is no unevenness, and pull the drain hose out into the wheel house.

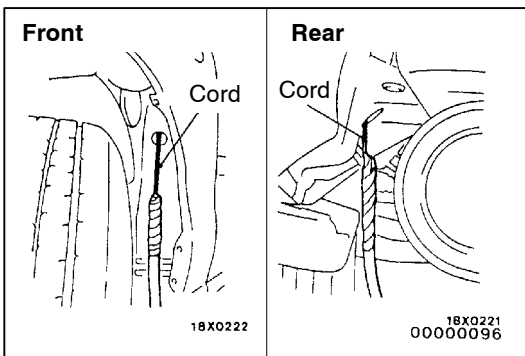

INSTALLATION SERVICE POINTS

▶A◀ DRAIN HOSE INSTALLATION

1. Tie the cord that was used during removal to the end of the drain hose, and wind the plastic tape around it so that there is no unevenness.
2. Pull the cord to pull through the drain hose.

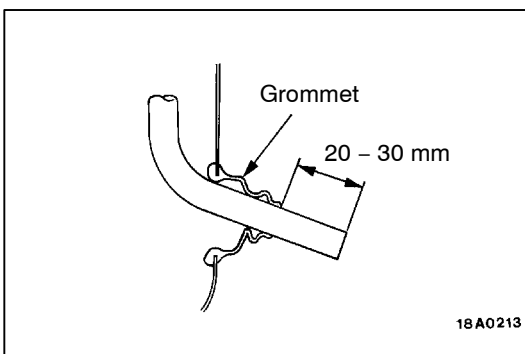

3. Make the protrusion from the drain hose grommet as shown in the illustration.

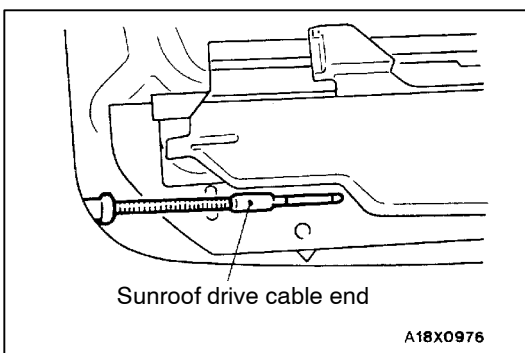

▶B◀ SUNROOF DRIVE CABLES INSTALLATION

Caution

If cables are kinked, replace them. Always replace the cables in pair and grease them before installation.

Close the sunroof guide assembly and install the sunroof drive cable end to the sunroof guide assembly.

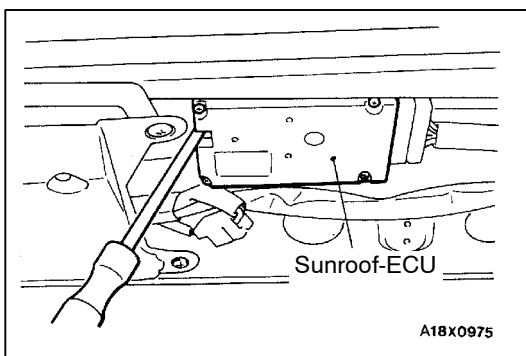
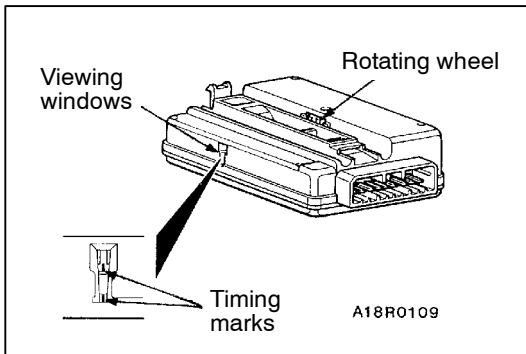
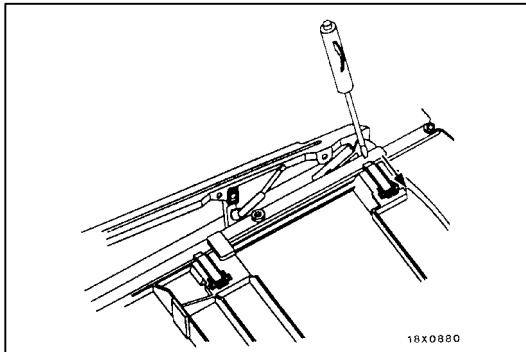
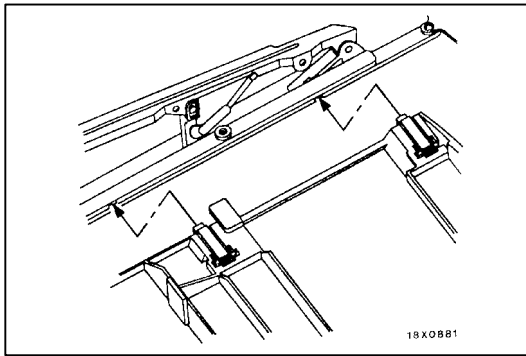

►◄ FRONT SUNROOF SUNSHADE/REAR SUNROOF SUNSHADE INSTALLATION

1. Install the front sunroof sunshade first by inserting the slide blocks on the right side of the sunshade into the lower slide position of the right guide assembly.
2. Push the sunshade slide blocks on the left side of the sunshade into the sunshade to allow the front sunroof sunshade to drop into position. Once in position, engage the slide blocks into the lower channel of the left guide assembly.
3. Push the front sunroof sunshade to full forward position.
4. Position the rear sunroof sunshade so that the stop tabs are against the stop bumpers on the guide assembly. Engage the right side slide blocks of the upper half of the sunshade into the upper channel on the right guide assembly. Engage the slide blocks on the left side of the sunshade into the upper channel in the left guide assembly.
5. Slide the sunshade back and forth to check that it functions smoothly.

►◄ SUNROOF-ECU INSTALLATION

1. Look into the “viewing windows” while turning the rotating wheel. Turn the rotating wheel until the white timing marks appear. When the white timing marks appear in the “viewing windows” at the same time, stop turning the rotating wheel.
2. Close the sunroof fully. Install the timed sunroof-ECU. Make sure that the sunroof cable is properly inserted into the sunroof-ECU.
3. Insert a flat-tipped screwdriver, place it on the tab, and press it to the right, being careful not to pinch wiring.

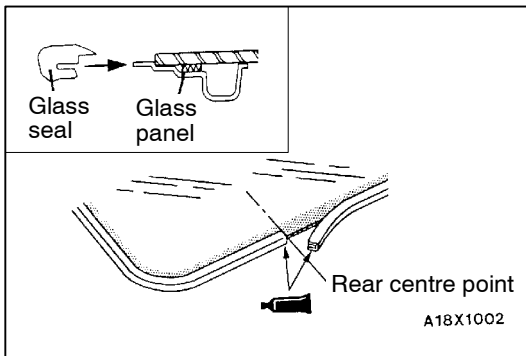

►E◄ SUNROOF GLASS SEAL INSTALLATION

1. Starting at the rear centre of the sunroof glass, begin installing the seal by pushing it onto the edge of the glass panel and gently pulling on it while installing.
2. Approximately 102 mm before completing installation, lay the end of the seal over top of the beginning of the seal. Cut the seal so there is an extra 3.18 mm of the seal past the point where the seal lines up with the beginning of the seal.
3. Apply the specified adhesive to the splice joint area where two ends of the seal meet.

Specified adhesive:

3M Part No. 8155 or equivalent

4. With the approximately 102 mm of the seal unattached, push two ends of the seal together at glue joint.
5. Install remainder of the seal by pushing the seal onto the edge of the glass panel. The 3.18 mm of extra seal material should strengthen the seal at the splice joint.

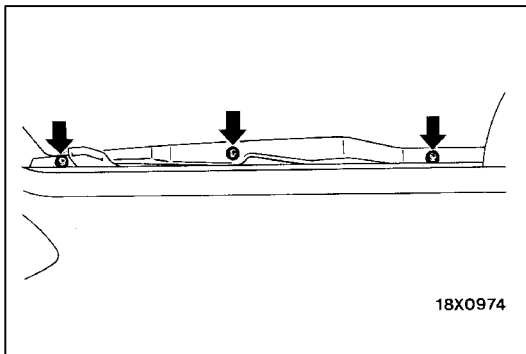

►F◄ SUNROOF GLASS INSTALLATION

1. Position the sunroof glass onto the guide assemblies and align the mounting holes.
2. Apply the specified sealant to the sunroof glass attaching screws and install them, going to the next step before tightening.

Specified sealant:

3M Stud locking Part No. 4170 or equivalent

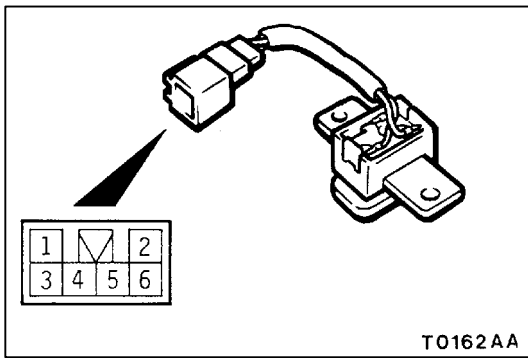

INSPECTION

42600160132

SUNROOF SWITCH CHECK

Operate the sunroof switch and check the continuity between each of the terminals.

Switch position	Terminal No.		
	1	3	4
OPEN		○	○
OFF			
CLOSE	○		○

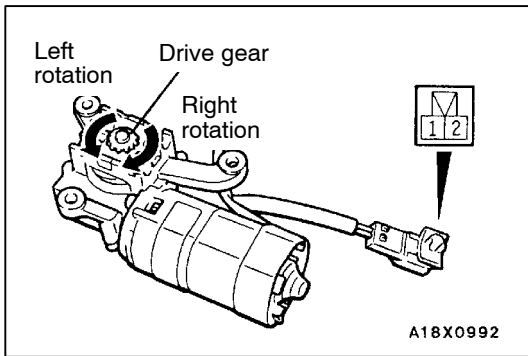

SUNROOF MOTOR CHECK

42600250105

Check the rotation direction of the drive gear when the battery is connected to the connector.

Terminal No.		Drive gear rotation direction
1	2	
⊖	⊕	Right
⊕	⊖	Left

EXTERIOR

CONTENTS

51109000296

FRONT BUMPER	2	WINDSHIELD WIPER AND WASHER	16
REAR BUMPER	4	SERVICE SPECIFICATION	16
BUMPER GUARD	6	WINDSHIELD WIPER AND WASHER ...	16
GRILLE, MOULDING AND GARNISH	7	REAR WIPER AND WASHER	19
SPECIAL TOOL	7	SERVICE SPECIFICATION	19
GRILLE, MOULDING AND GARNISH	7	REAR WIPER AND WASHER	19
EXTERIOR PARTS	9	HEADLAMP WASHER	22
WIDE FENDER	10	MARKS	24
SIDE STEP <VEHICLES WITHOUT WIDE FENDER>	12	DOOR MIRROR	28
SIDE STEP <VEHICLES WITH WIDE FENDER>	13	SPECIAL TOOL	28
		DOOR MIRROR	28

FRONT BUMPER

REMOVAL AND INSTALLATION

51100140263

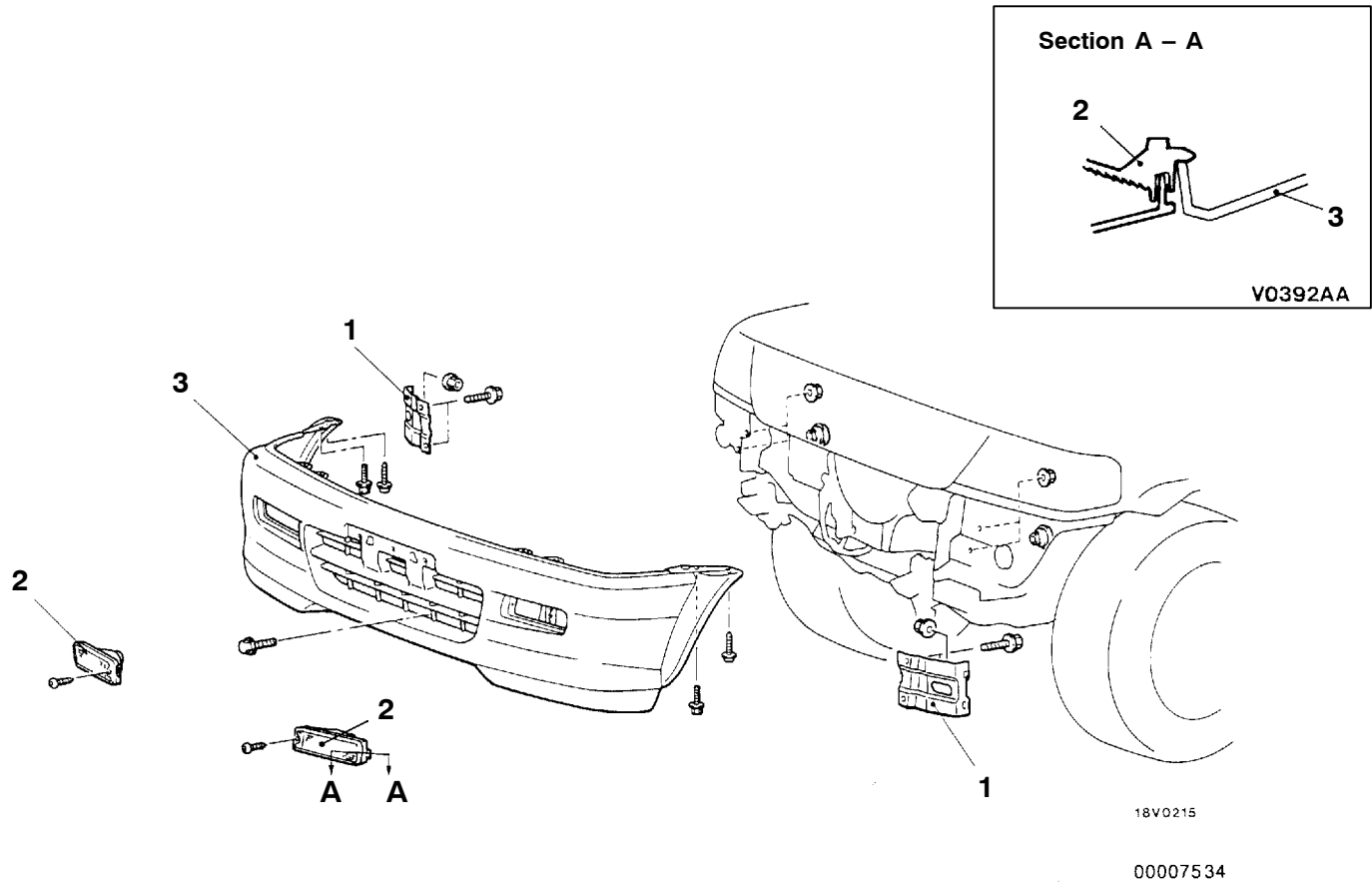

Removal steps

1. Front bumper side stay
2. Front turn signal lamp
3. Front bumper assembly

DISASSEMBLY AND REASSEMBLY

51100160306

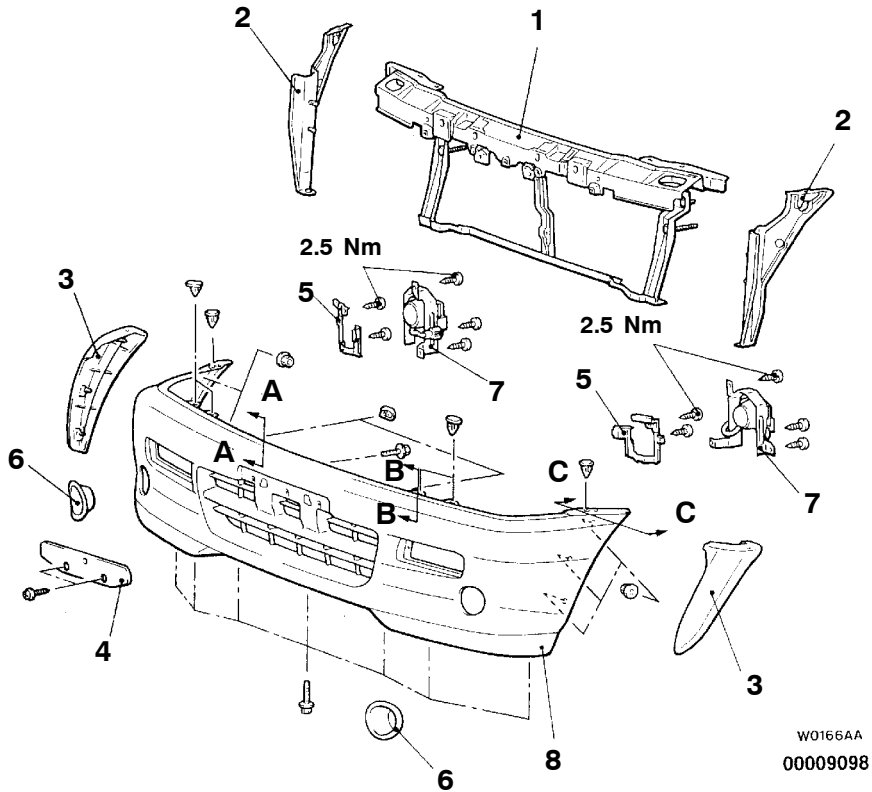

W0166AA
00009098

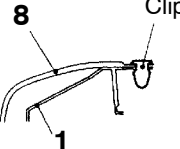
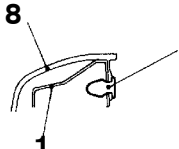
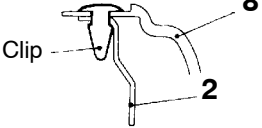
Section A – A	Section B – B	Section C – C
 <p data-bbox="479 1260 568 1281">V0394AA</p>	 <p data-bbox="852 1260 941 1281">V0393AA</p>	 <p data-bbox="1242 1260 1315 1281">V0395AA</p>

Disassembly steps

- | | |
|---|--|
| <ol style="list-style-type: none"> 1. Front bumper beam assembly 2. Front bumper side reinforcement 3. Front bumper side extension 4. Licence plate bracket
<Vehicles without bumper guard> 5. Fog lamp bracket
<Vehicles with fog lamp> | <ol style="list-style-type: none"> 6. Fog lamp bezel
<Vehicles with fog lamp> 7. Fog lamp <Vehicles with fog lamp> 8. Front bumper face |
|---|--|

REAR BUMPER

51100190282

REMOVAL AND INSTALLATION**Pre-removal and Post-installation Operation**

- Luggage Floor Box, Rear Removal and Installation

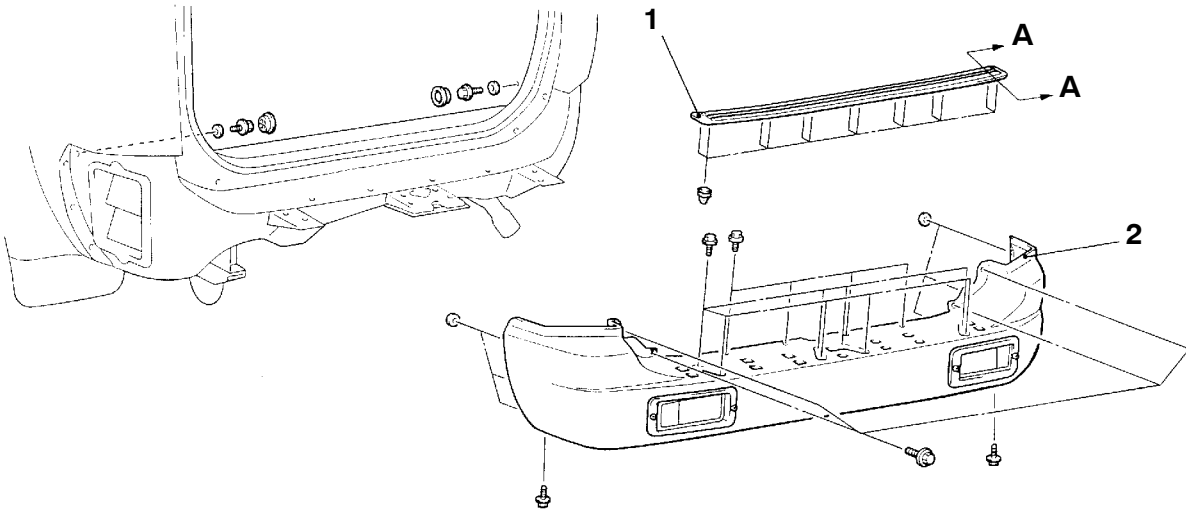
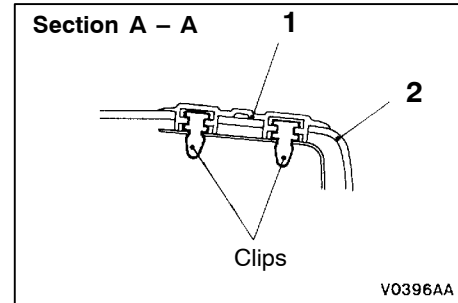
W0167AA
00009099**Removal steps**

1. Rear bumper step
2. Rear bumper assembly

DISASSEMBLY AND REASSEMBLY

51100210247

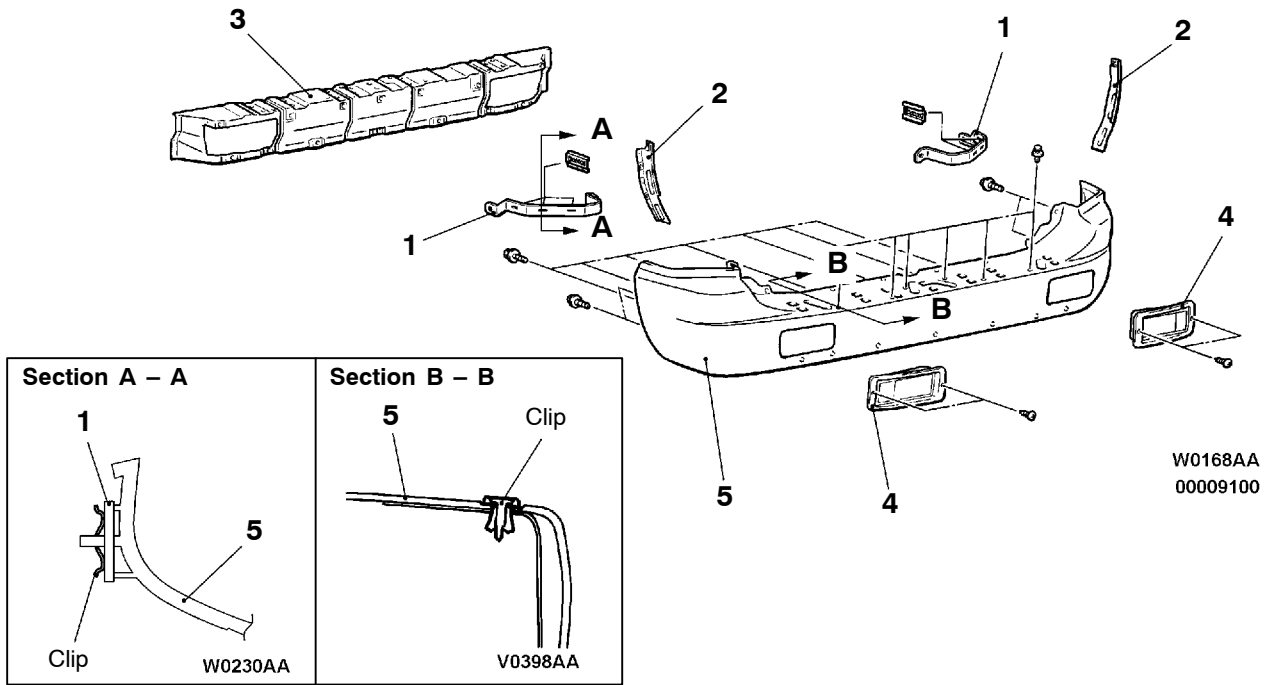

Disassembly steps

1. Rear bumper side reinforcement
2. Rear bumper side bracket
3. Rear bumper reinforcement assembly

4. Rear fog lamp
5. Rear bumper face

BUMPER GUARD

51101090017

REMOVAL AND INSTALLATION**Pre-removal and Post-installation Operation**

- Front Bumper Removal and Installation
(Refer to P.51-2.)

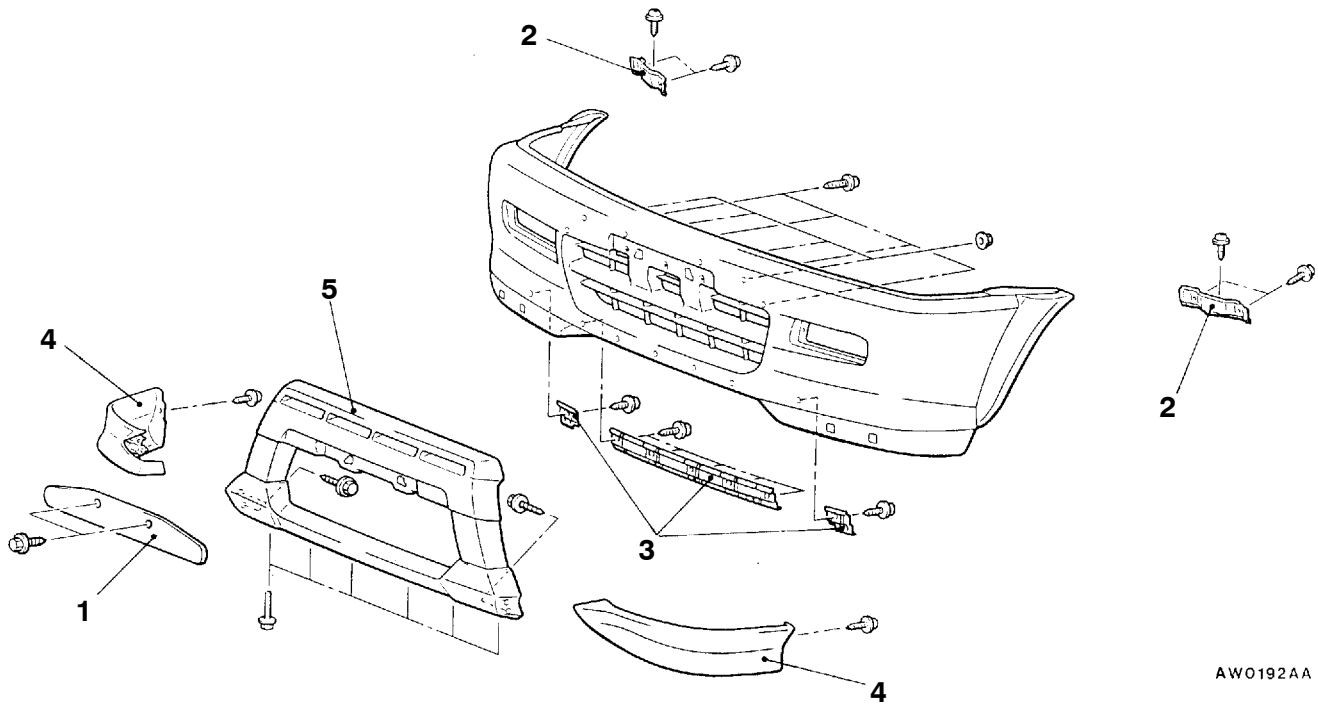

AW0192AA

Removal steps

1. Licence plate
2. Bumper guard side plate
3. Bumper guard lower plate
4. Bumper guard side
5. Bumper guard center

**GRILLE, MOULDING AND GARNISH
SPECIAL TOOL**

51100060248

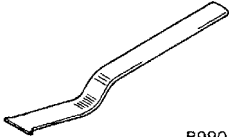
Tool	Number	Name	Use
 B990449	MB990449	Window moulding remover	Roof drip moulding removal

**GRILLE, MOULDING AND GARNISH
REMOVAL AND INSTALLATION**

51100350109

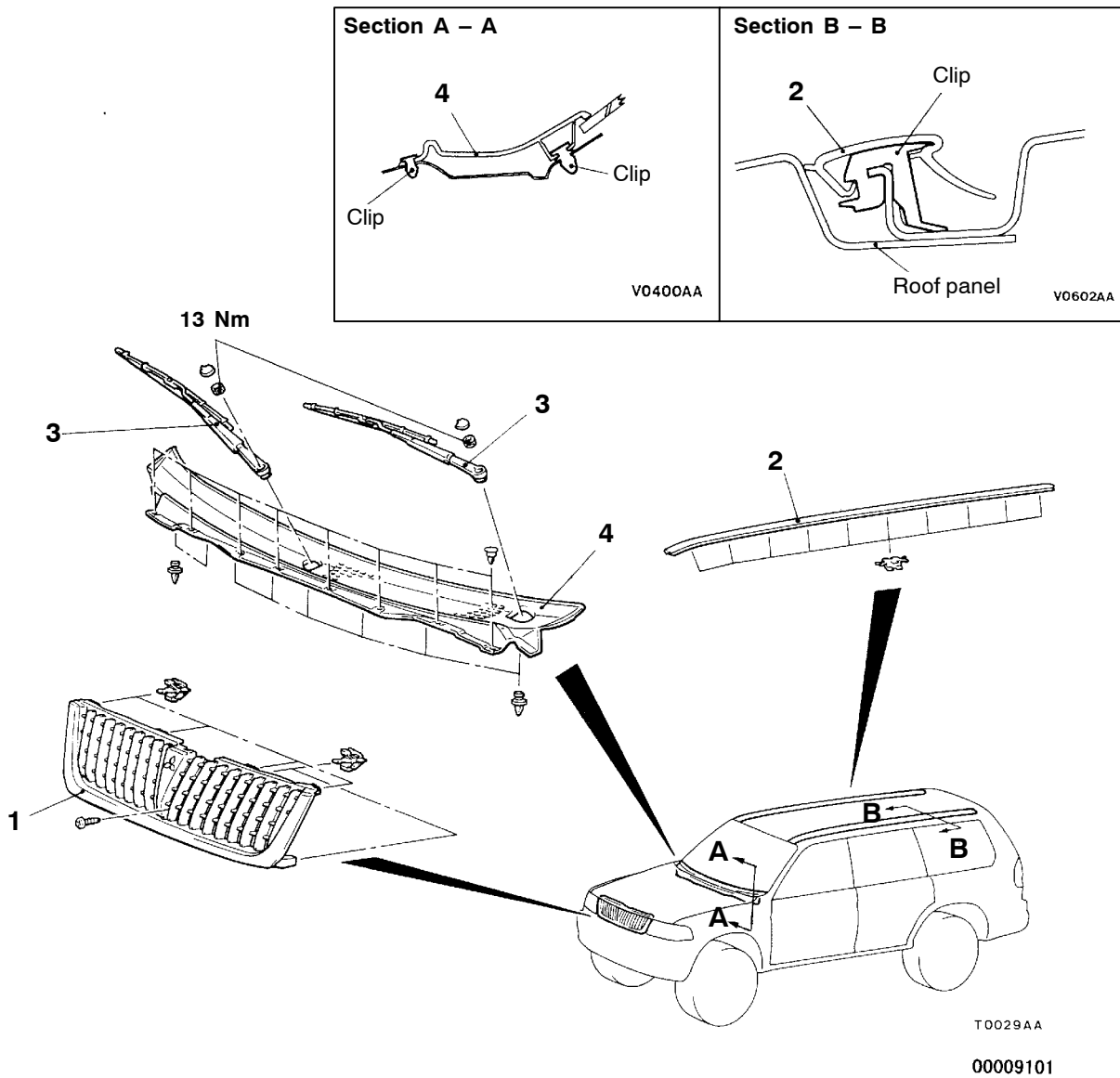

- 1. Radiator grille
- 2. Roof drip moulding

Front deck garnish removal steps

- 3. Wiper arm and blade assembly
(Refer to P.51-16.)
- 4. Front deck garnish

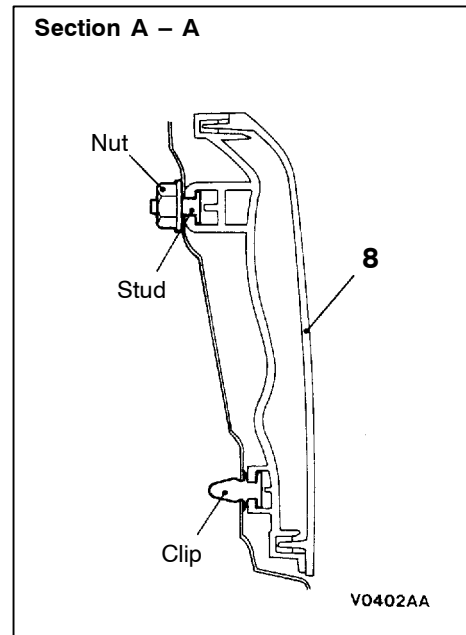
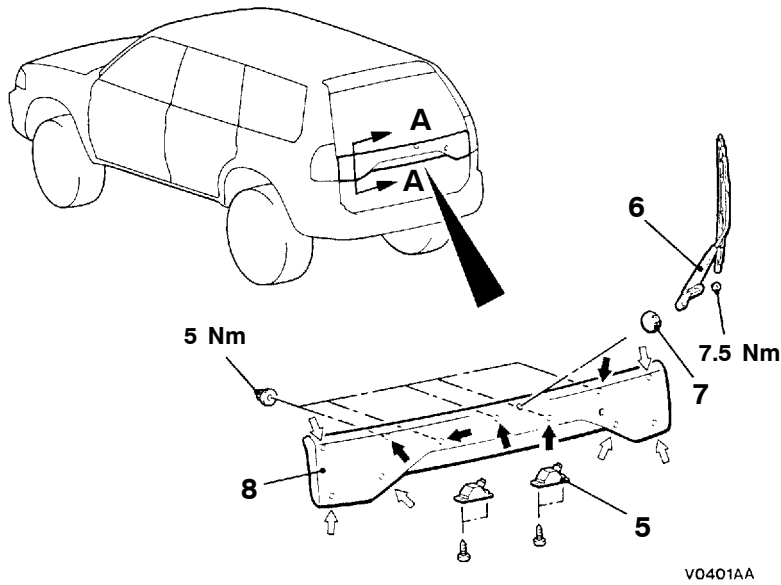

NOTE

- ← : Resin clip position
- ➡ : Stud position

00007539

Tailgate garnish removal steps

- 5. Licence plate lamp
- 6. Rear wiper arm and blade assembly (Refer to P.51-19.)
- 7. Grommet (Refer to P.51-19.)
- 8. Tailgate garnish

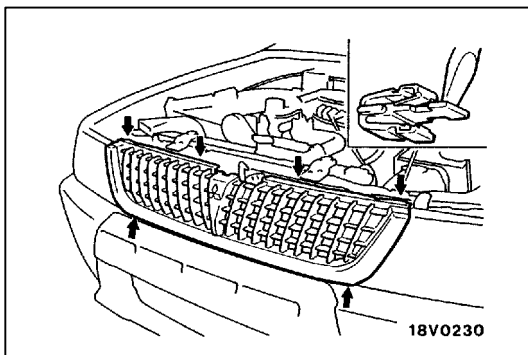

REMOVAL SERVICE POINTS

◀A▶ RADIATOR GRILLE REMOVAL

1. Remove the screw at the centre of the radiator grille.
2. Remove the radiator grille by pushing the tab of the radiator grille clips in the direction of the arrows with a flat-tipped screwdriver, while lightly pulling the radiator grille toward you.

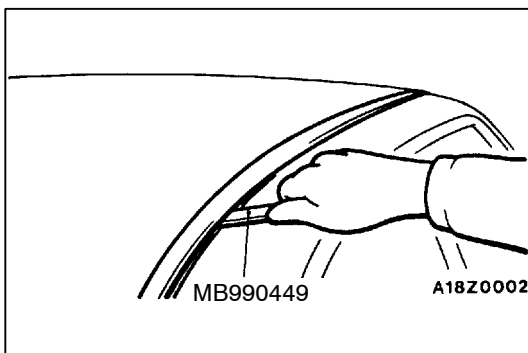

◀B▶ ROOF DRIP MOULDING REMOVAL

Use the special tool to lever out the moulding.

Caution

Do not reuse the warped moulding.

EXTERIOR PARTS

51101750014

REMOVAL AND INSTALLATION

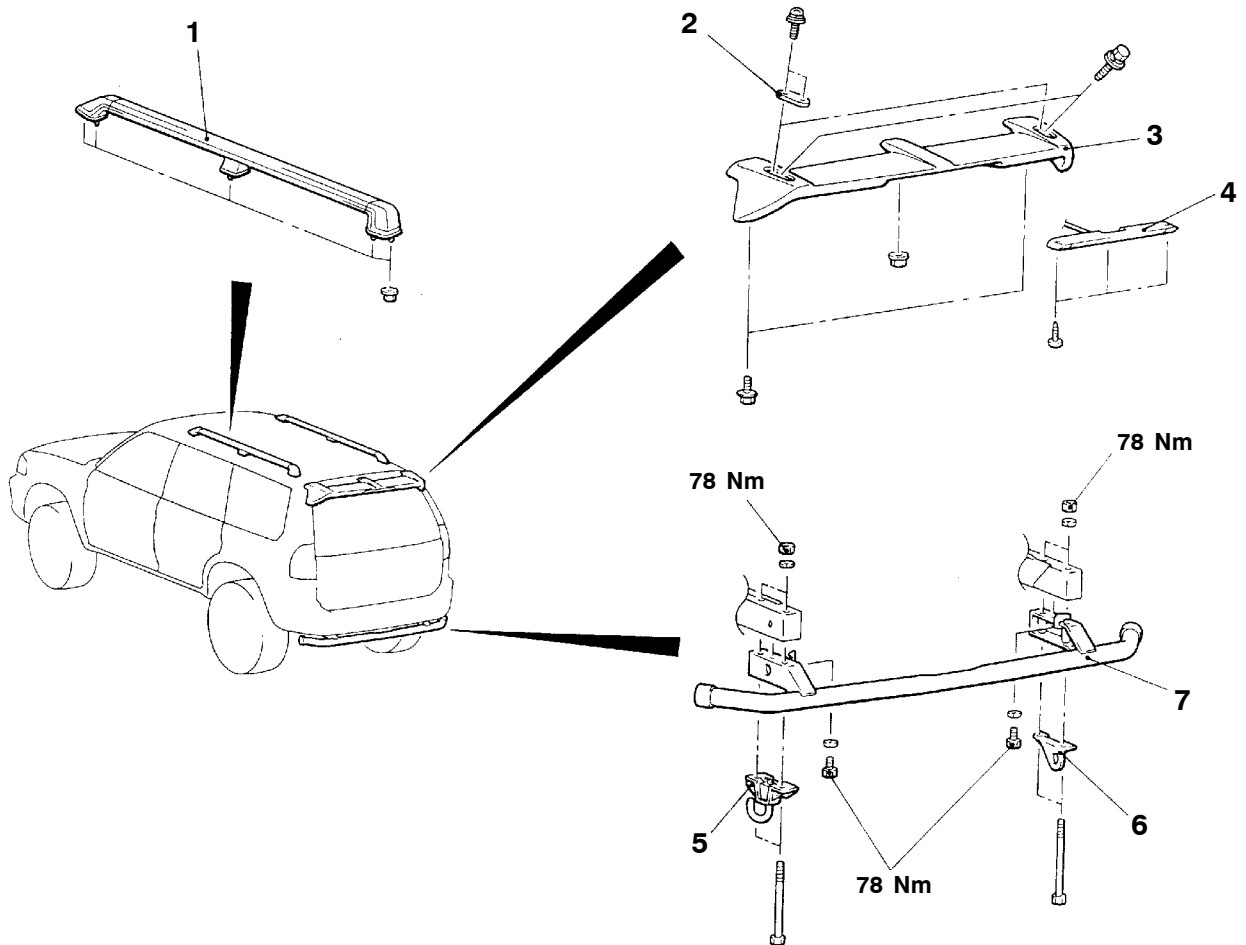

AW0169AA

Roof rail removal steps

- Headlining
- 1. Roof rail

Roof spoiler removal steps

- ▶A◀ 2. Spoiler cover
- 3. Roof spoiler
- 4. High-mounted stop lamp

Rear under guard bar removal steps

- 5. Towing hook
- 6. Tie down bracket
- 7. Rear under guard bar

INSTALLATION SERVICE POINT

▶A◀ **SPOILER COVER INSTALLATION**

Install with the arrow shown on the rear surface facing forward.

WIDE FENDER

REMOVAL AND INSTALLATION

Pre-removal and Post-installation Operation

- Mud Guard Removal and Installation

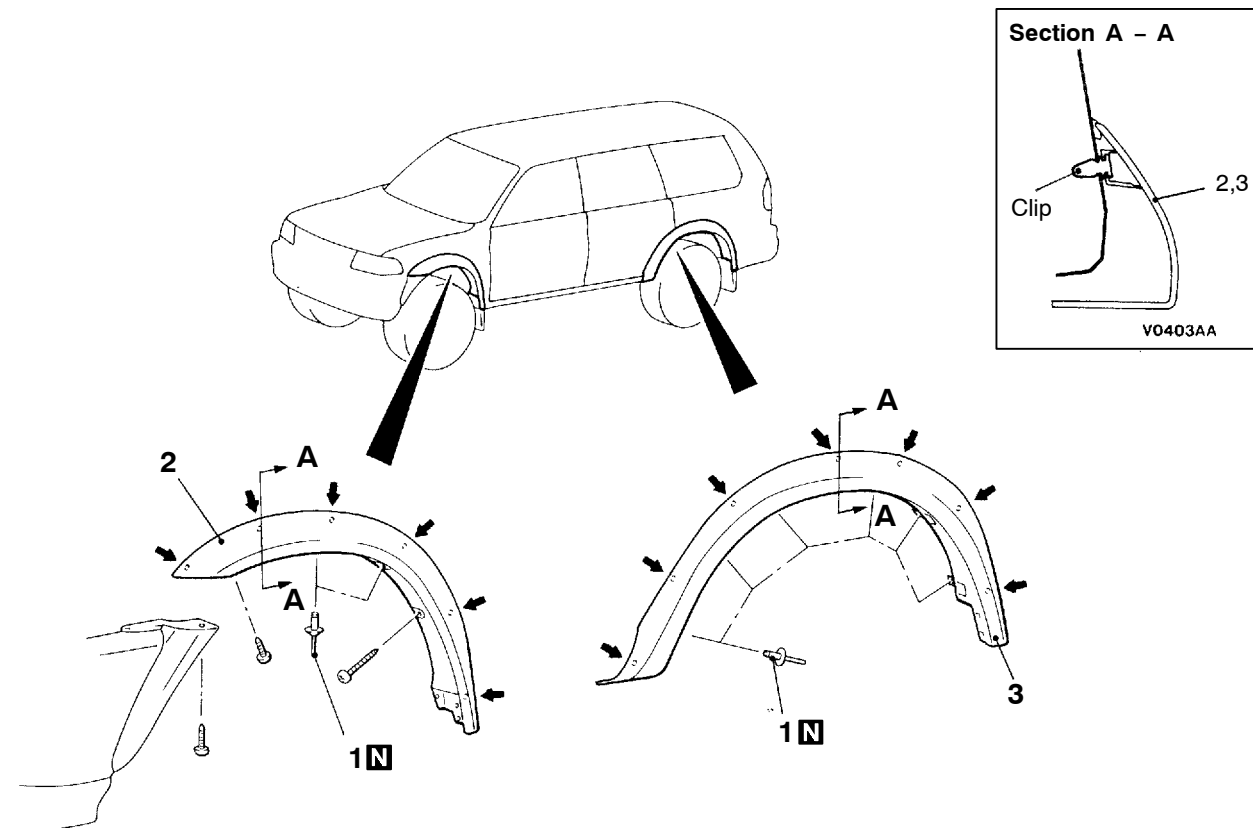

18V0238
00007540

NOTE
◀▶ : Resin clip position

Removal steps



1. Rivet
2. Front flare
3. Rear flare

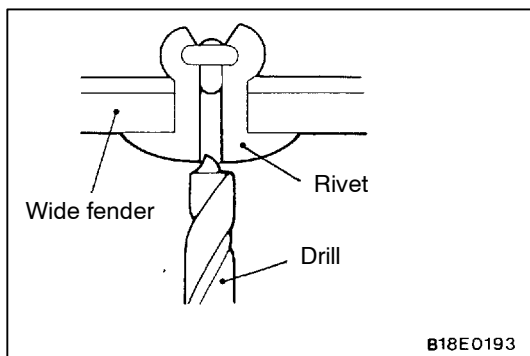

REMOVAL SERVICE POINT

◀▶ RIVET REMOVAL

Use a drill ($\phi 4.0 - 5.5$ mm) to break the rivet by drilling a hole, and remove the rivet.

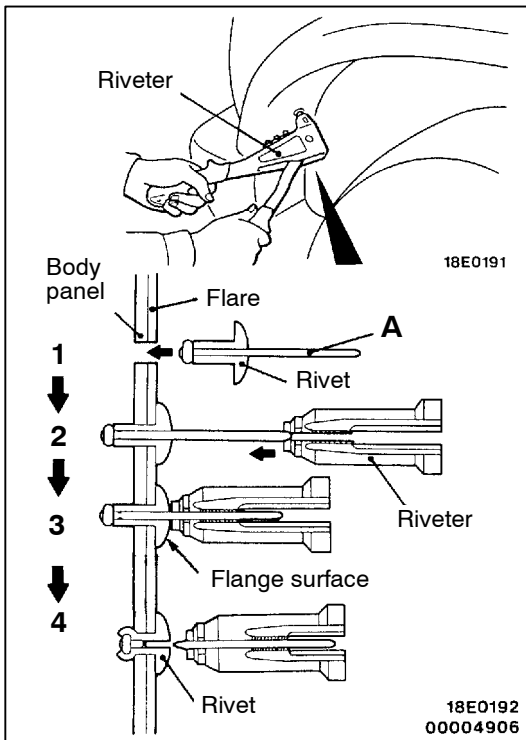
**INSTALLATION SERVICE POINT****▶A◀ RIVET INSTALLATION**

1. Insert the rivet into the body panel and flare.
2. Insert A of the rivet into the riveter.
3. Pressing the flange surface of the rivet, move the handle of the riveter.
4. The thinnest point of A is cut and the rivet is held in the position.

SIDE STEP <VEHICLES WITHOUT WIDE FENDER>

51101150050

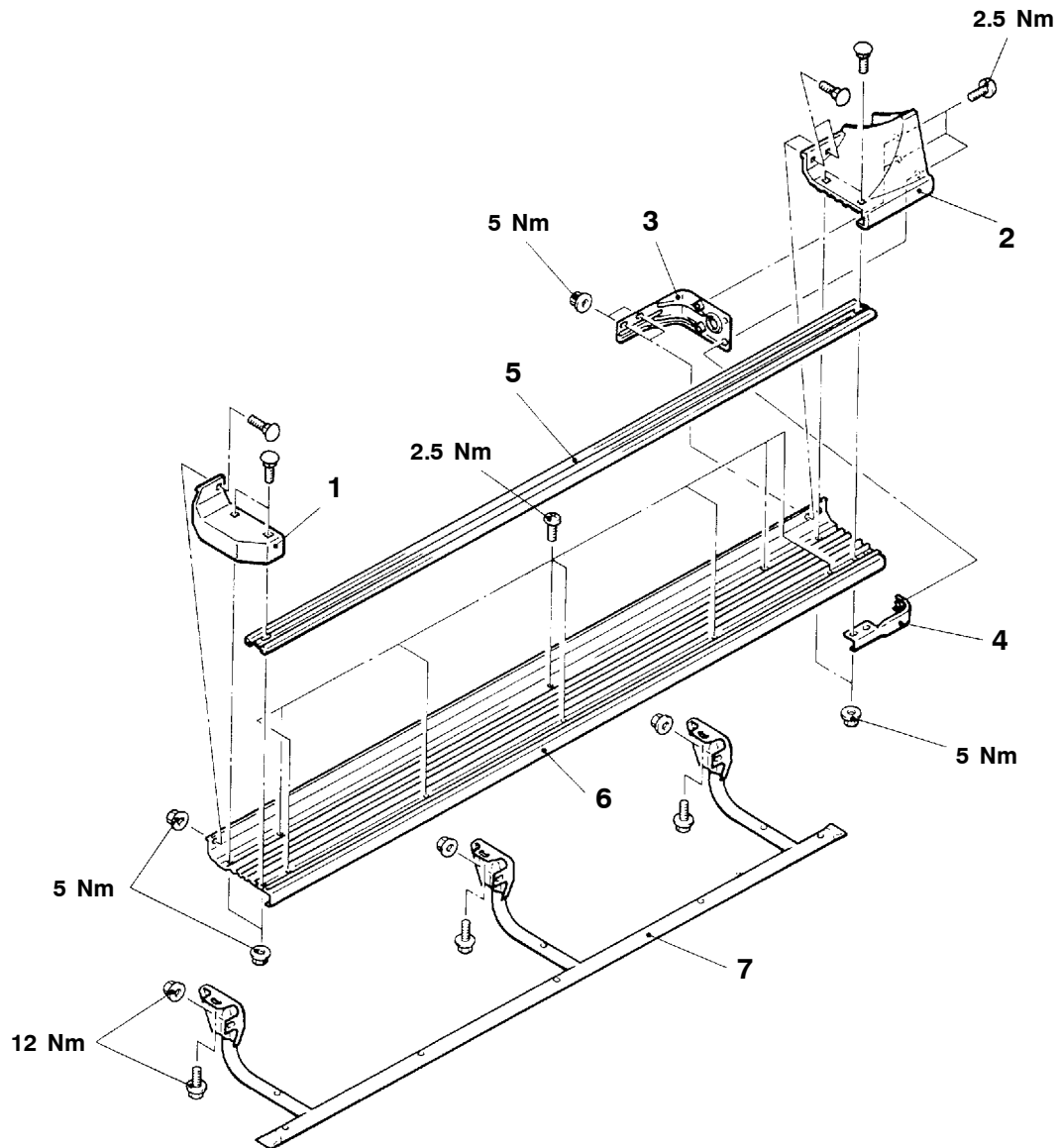
REMOVAL AND INSTALLATION

B18V0132

Removal steps

1. Front step cover
2. Rear step cover
3. Rear step cover stay
4. Rear step cover reinforcement
5. Non-slip cover
6. Step plate
7. Side step pipe assembly

SIDE STEP <VEHICLES WITH WIDE FENDER>

51101150067

REMOVAL AND INSTALLATION

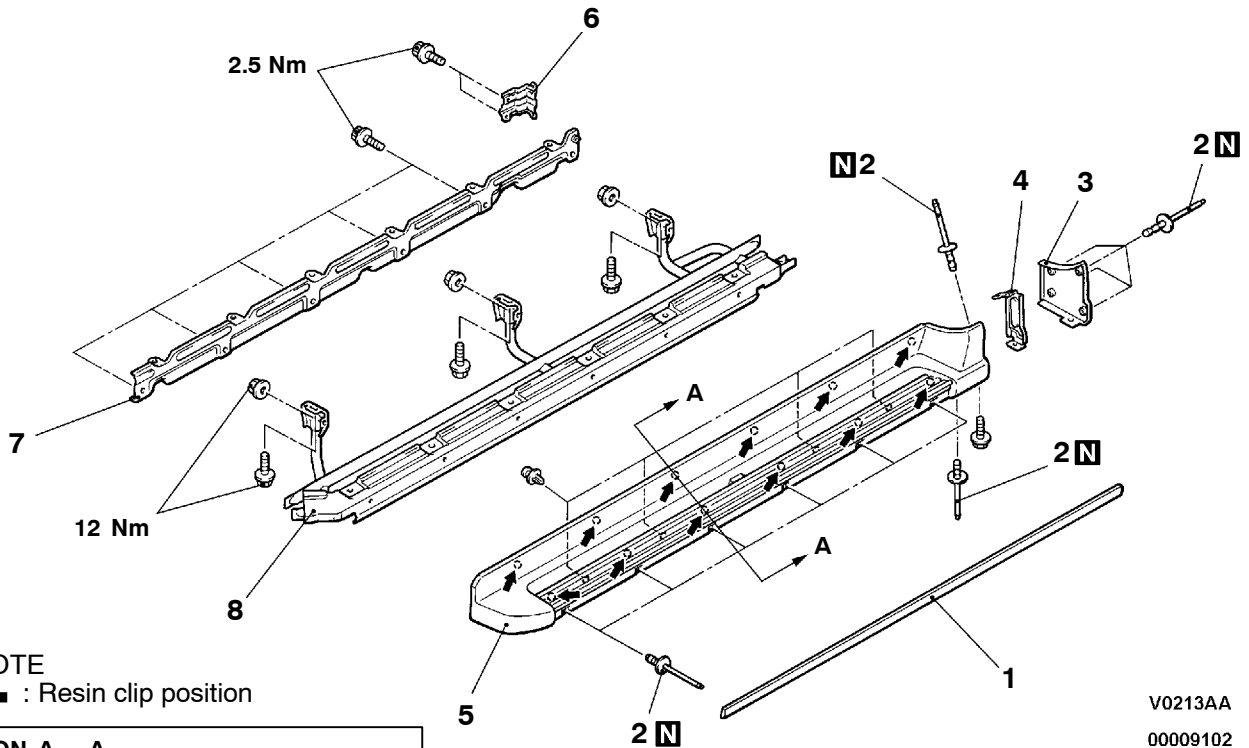

NOTE
 ← : Resin clip position

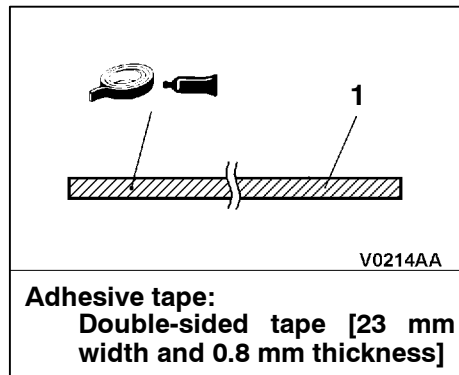
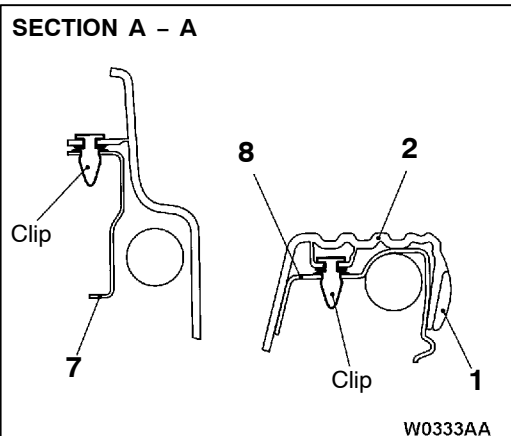

Removal steps



1. Side step moulding
2. Rivet
3. Side step rear cover
4. Side step rear reinforcement (B)

5. Side step cover
6. Side step rear reinforcement (A)
7. Side step inner plate
8. Side step pipe assembly

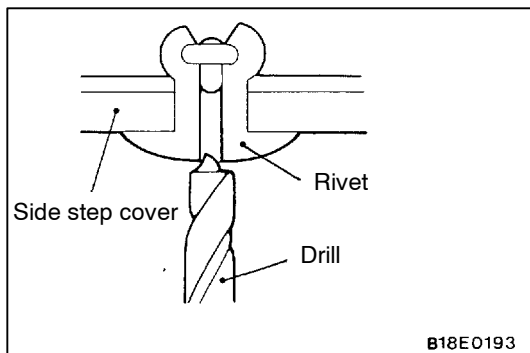

REMOVAL SERVICE POINT

◀A▶ RIVET REMOVAL

Use a drill (φ3.0 – 3.2 mm) to break the rivet by drilling a hole, and remove the rivet.

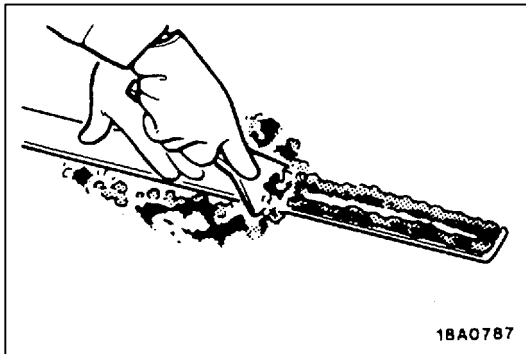

INSTALLATION SERVICE POINTS

▶A◀ SIDE STEP MOULDING INSTALLATION

Double-sided tape affixing to the side step moulding (when reusing)

1. Scrape off the double-sided tape with a resin spatula or gasket scraper.

2. Wipe off the side step moulding adhesion surface and clean it with a shop towel moistened with isopropyl alcohol.
3. Affix the specified double-sided tape to the side step moulding.

Specified adhesive tape:

Double-sided tape 23 mm width and 0.8 mm thickness

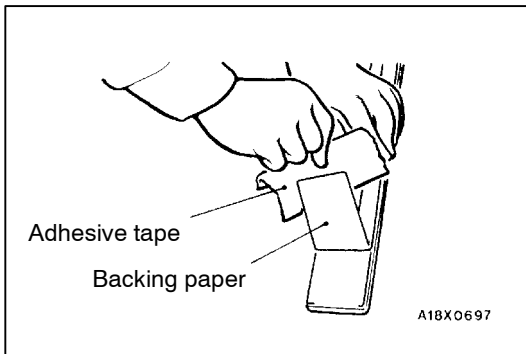

4. Remove strip paper from the pressure sensitive double-sided tape.

NOTE

Affix double-sided tape to the end of strip paper for ease of strip paper removal.

5. Install the side step moulding.

NOTE

If it is hard to affix the double-sided tape in winter, heat the application surfaces at both the side step cover and the side step moulding.

Side step cover 40 – 60 °C

Side step moulding 20 – 30 °C

Apply pressure fully to the side step moulding.

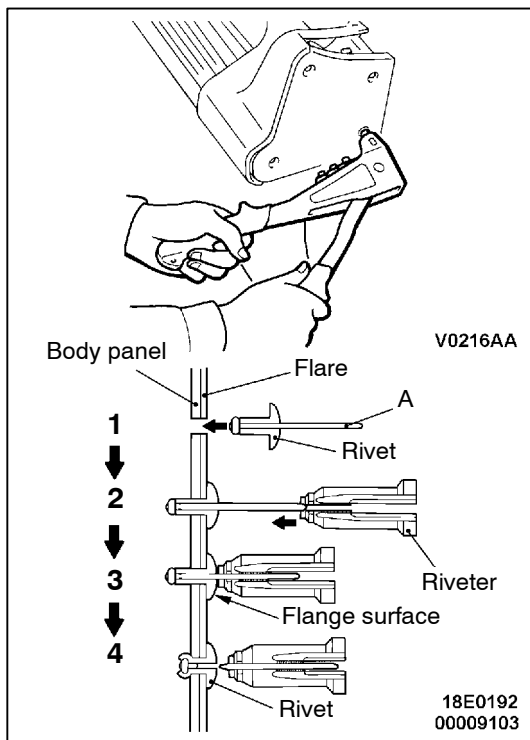
**►B◄ RIVET INSTALLATION**

1. Insert the rivet into the body panel and flare.
2. Insert A of the rivet into the riveter.
3. Pressing the flange surface of the rivet, move the handle of the riveter.
4. The thinnest point of A is cut and the rivet is held in the position.

WINDSHIELD WIPER AND WASHER SERVICE SPECIFICATION

51100030232

Item	Standard value	
Windshield wiper blade installation position mm	Driver's side	21 – 31
	Passenger's side	30 – 40

WINDSHIELD WIPER AND WASHER REMOVAL AND INSTALLATION

51100760377

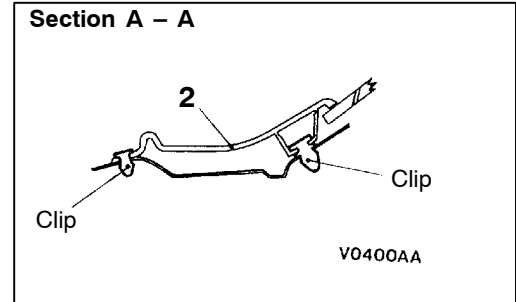
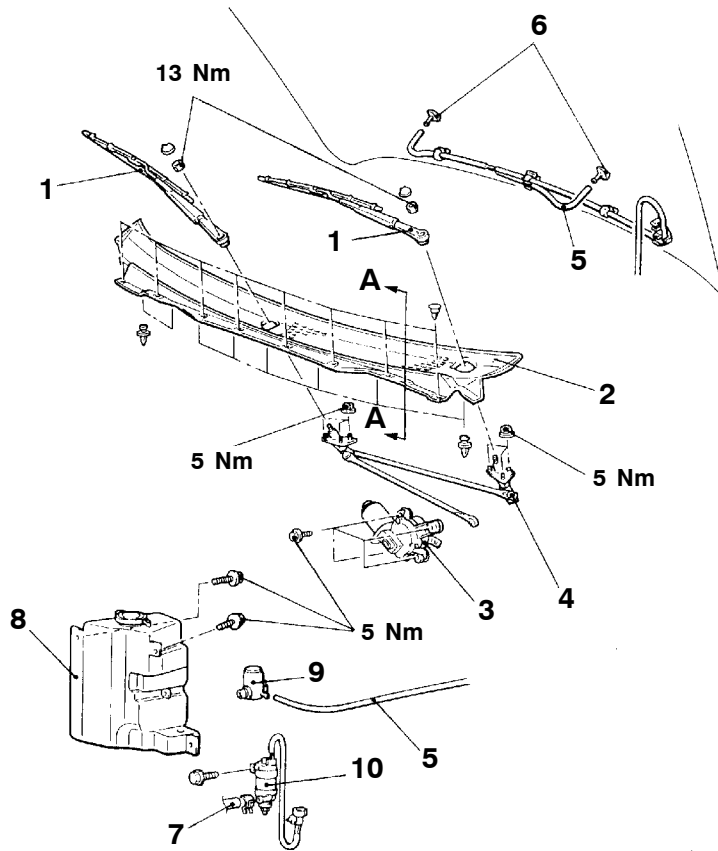

W0170AA

00009104

Wiper motor and link assembly removal steps

1. Wiper arm and blade assembly
2. Front deck garnish
3. Wiper motor
4. Wiper link assembly

Washer nozzle removal

5. Washer hose
6. Washer nozzle

Washer tank removal steps

- Washer fluid draining and supplying
- 5. Washer hose
- 7. Headlamp washer hose connection <Vehicles with headlamp washer>
- 8. Washer tank assembly
- 9. Washer motor
- 10. Headlamp washer motor <Vehicles with headlamp washer>

NOTE

For removal and installation of the column switch assembly (windshield wiper and washer switch), refer to GROUP 37A – Steering Wheel and Shaft.

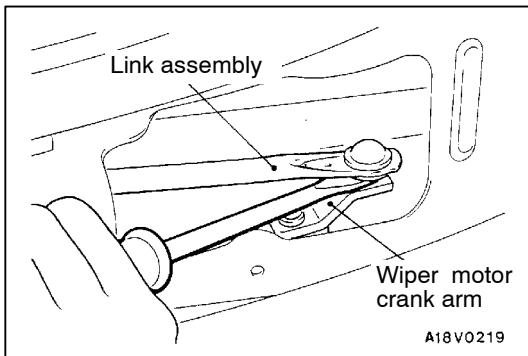

REMOVAL SERVICE POINT

◀A▶ WIPER MOTOR REMOVAL

Use a flat-tipped screwdriver to remove the connection between the wiper motor crank arm and the link assembly.

Caution

Auto-stop angle is controlled so do not remove crank arm from wiper motor unless necessary.

When removing, mark crank arm and wiper motor.

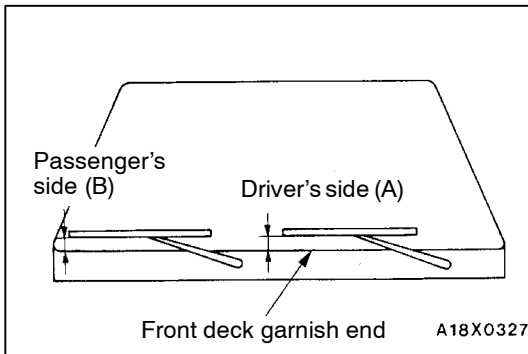

INSTALLATION SERVICE POINT

▶A◀ WIPER ARM AND BLADE ASSEMBLY INSTALLATION

Install the wiper blade in the specified position (standard value).

Standard value:

Driver's side (A) 21 – 31 mm

Passenger's side (B) 30 – 40 mm

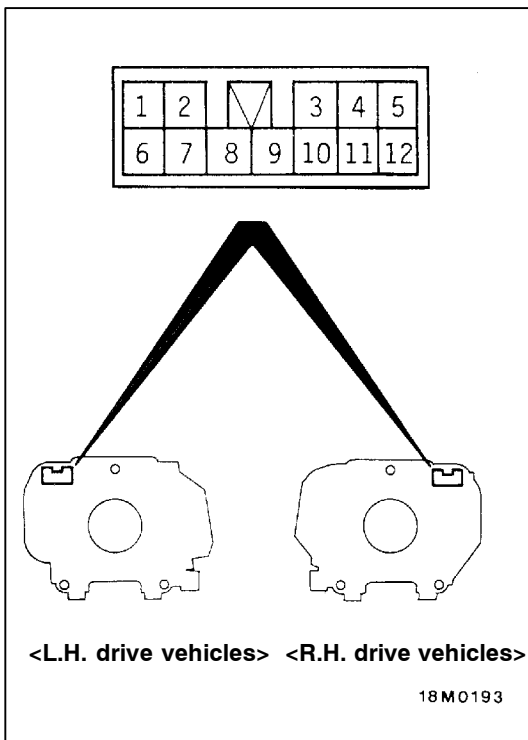

INSPECTION

51101450068

COLUMN SWITCH CHECK

Wiper and Washer Switch

<L.H. drive vehicles>

Switch position		Terminal No.				
		6	7	8	9	10
Wiper switch	OFF		○	○		
	INT		○	○		
	1 (LO)			○		○
	2 (HI)				○	○
Washer switch	ON	○				○

<R.H. drive vehicles>

Switch position		Terminal No.				
		8	9	10	11	12
Wiper switch	OFF			○	○	
	INT			○	○	
	1 (LO)	○		○		
	2 (HI)	○	○			
Washer switch	ON	○				○

Intermittent Wiper Relay (Intermittent Operation Inspection)

1. Connect the column switch connector.
2. Turn the ignition switch to ACC.
3. Inspect the intermittent operation time when the wiper switch is turned to INT.

Vehicles with variable intermittent control

FAST: Approx. 2 seconds

SLOW: Approx. 15 seconds

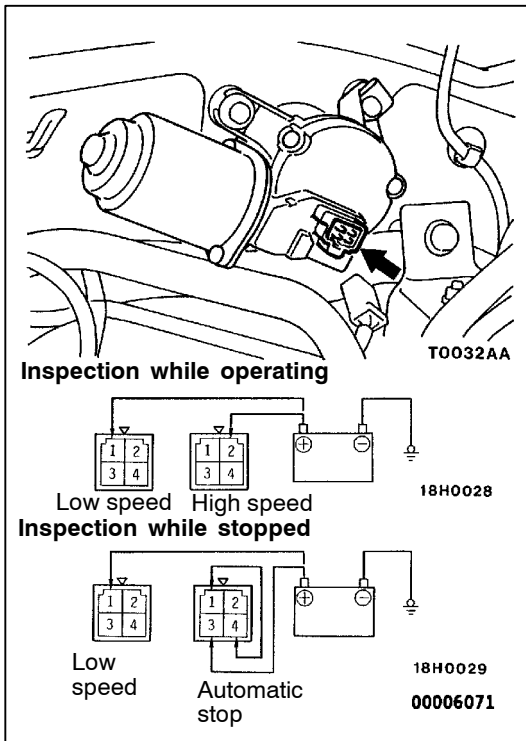

WIPER MOTOR CHECK

51101260142

Check the wiper motor after disconnecting the wiring harness connector, and with the wiper motor remaining installed to the body.

Wiper Motor at Low Speed and High Speed Operation

Connect a battery to the wiper motor as shown in the illustration and inspect motor operation at low speed and high speed.

Wiper Motor at Stop Position Operation

1. Run the wiper motor at low speed, disconnect the battery, and stop the motor.
2. Reconnect the battery as shown in the illustration, and confirm that after the motor starts turning at low speed, it stops at the automatic stop position.

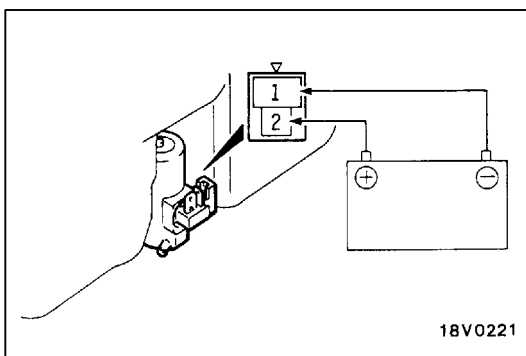

WASHER MOTOR CHECK

51101270060

1. With the washer motor installed to the washer tank, fill the washer tank with water.
2. Check that the water squirts out strongly when battery voltage is applied to terminals (1) and (2).

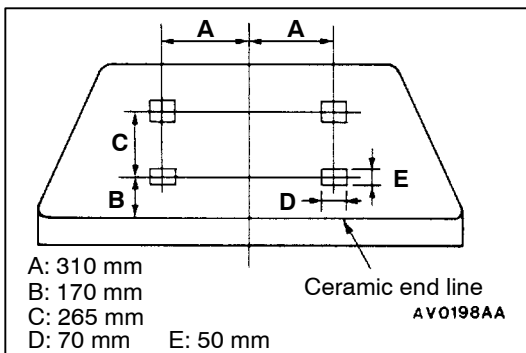

WASHER FLUID EJECTION POINTS CHECK

51100770202

Adjust the ejection angle by moving a ball in the nozzle.

**REAR WIPER AND WASHER
SERVICE SPECIFICATION**

51100030249

Item	Standard value
Rear wiper blade installation position mm	65 – 75

**REAR WIPER AND WASHER
REMOVAL AND INSTALLATION**

51100850210

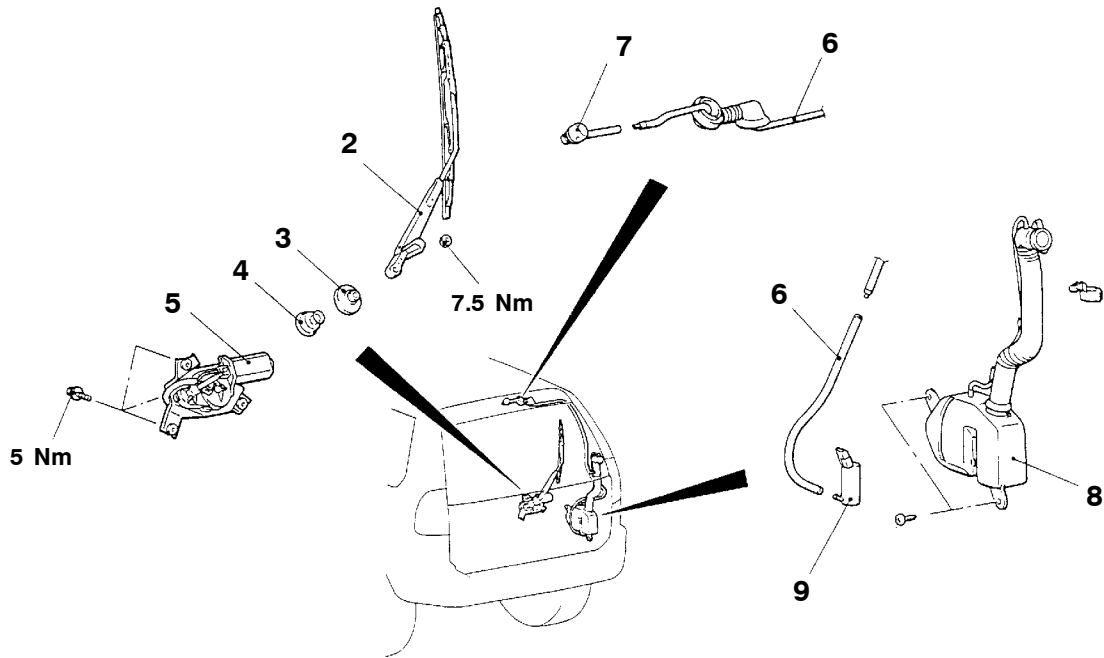

18V0235
00007542

NOTE
For removal and installation of the column switch assembly (rear wiper and washer switch), refer to GROUP 37A – Steering Wheel and Shaft.

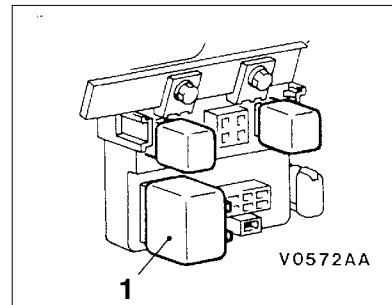

1. Rear intermittent wiper relay

Wiper motor removal steps

- ▶B◀▶A▶ 2. Wiper arm and blade assembly
- 3. Grommet
- Tailgate garnish (Refer to P.51-8.)
- 4. Grommet
- 5. Wiper motor

Washer hose removal steps

- Quarter trim, lower <R.H.> (Refer to GROUP 52A – Trims.)
- 6. Washer hose
- 7. Washer nozzle

Washer tank and motor removal steps

- Quarter trim lower <R.H.> (Refer to GROUP 52A – Trims.)
- Washer fluid draining
- 6. Washer hose
- 8. Washer tank
- 9. Washer motor

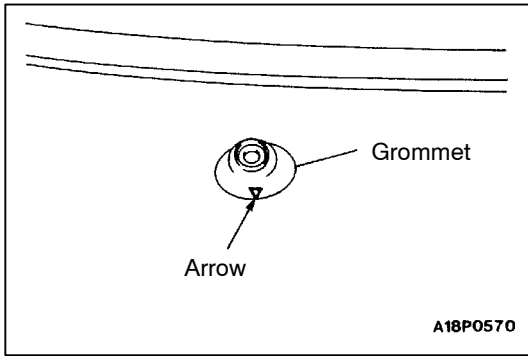

INSTALLATION SERVICE POINTS

▶A◀ GROMMET INSTALLATION

Install the grommet so that the arrow points downwards.

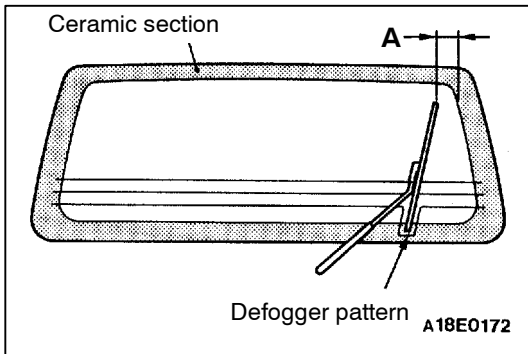

▶B◀ WIPER ARM AND BLADE ASSEMBLY INSTALLATION

Install the wiper blade so that the tip stops at the standard position (standard value), and also so that the lower section of the wiper blade enters the middle of the defogger pattern.

Standard value (A): 65 – 75 mm

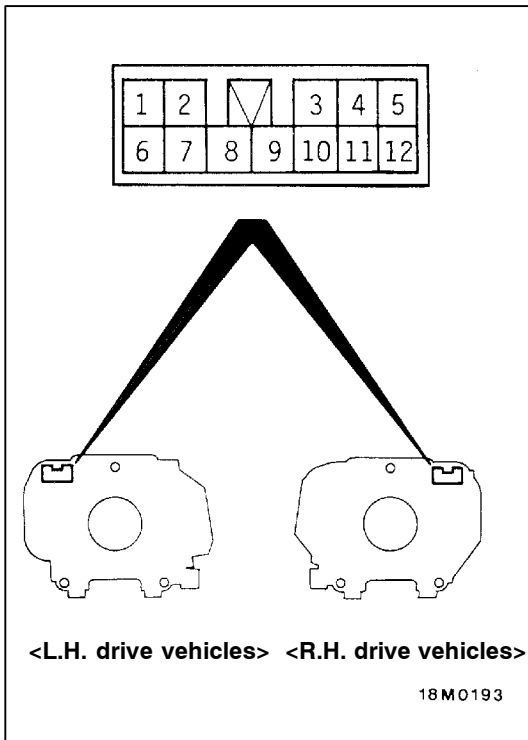

INSPECTION

51100950118

COLUMN SWITCH CHECK

Rear Wiper and Washer Switch

<L.H. drive vehicles>

Switch position		Terminal No.			
		2	3	4	10
Wiper switch	INT		○	—	○
	ON			○	○
Washer switch	ON	○	—	○	○

<R.H. drive vehicles>

Switch position		Terminal No.			
		2	3	4	8
Wiper switch	INT		○	—	○
	ON			○	○
Washer switch	ON	○	—	○	○

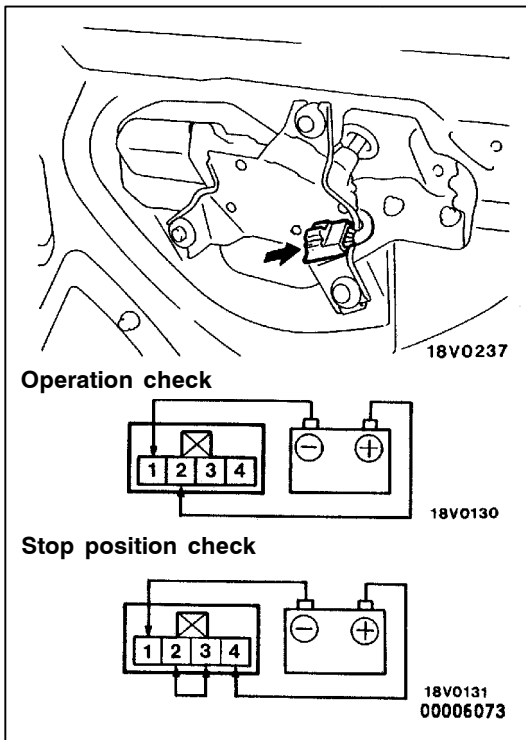

WIPER MOTOR CHECK

51101290110

Check the wiper motor after first disconnecting the wiring harness connector, and with the wiper motor remaining installed to the body.

Wiper Motor Operation

Connect a battery to the wiper motor as shown in the illustration and inspect the motor operation.

Wiper Motor at Stop Position Operation

1. Run the wiper motor, disconnect the battery, and stop the motor.
2. Reconnect the battery as shown in the illustration, and confirm that after the motor starts turning it stops at the automatic stop position.

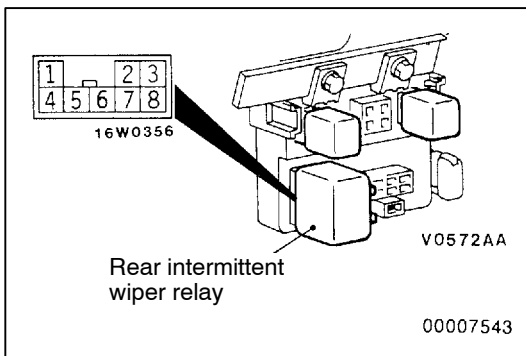

INTERMITTENT WIPER RELAY CHECK

51101300097

1. Check that there is continuity between terminals (1) and (2).
2. Connect terminals (4), (5) to the battery (+) terminal.
3. Check that there is battery voltage at terminal (2) for intermittent periods of eight seconds when terminal (7) is connected to the battery (-) terminal.

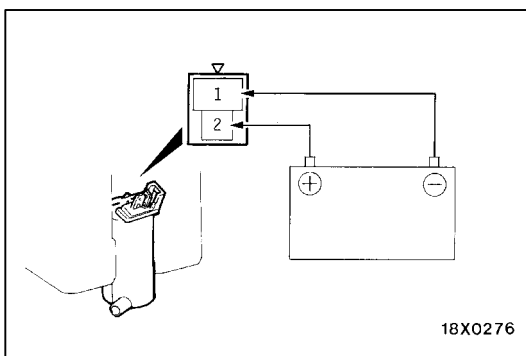

WASHER MOTOR CHECK

51101310106

1. With the washer motor installed to the washer tank, fill the washer tank with water.
2. When the battery is connected as shown in the figure, check that the washer squirts out strongly.

HEADLAMP WASHER REMOVAL AND INSTALLATION

51100970138

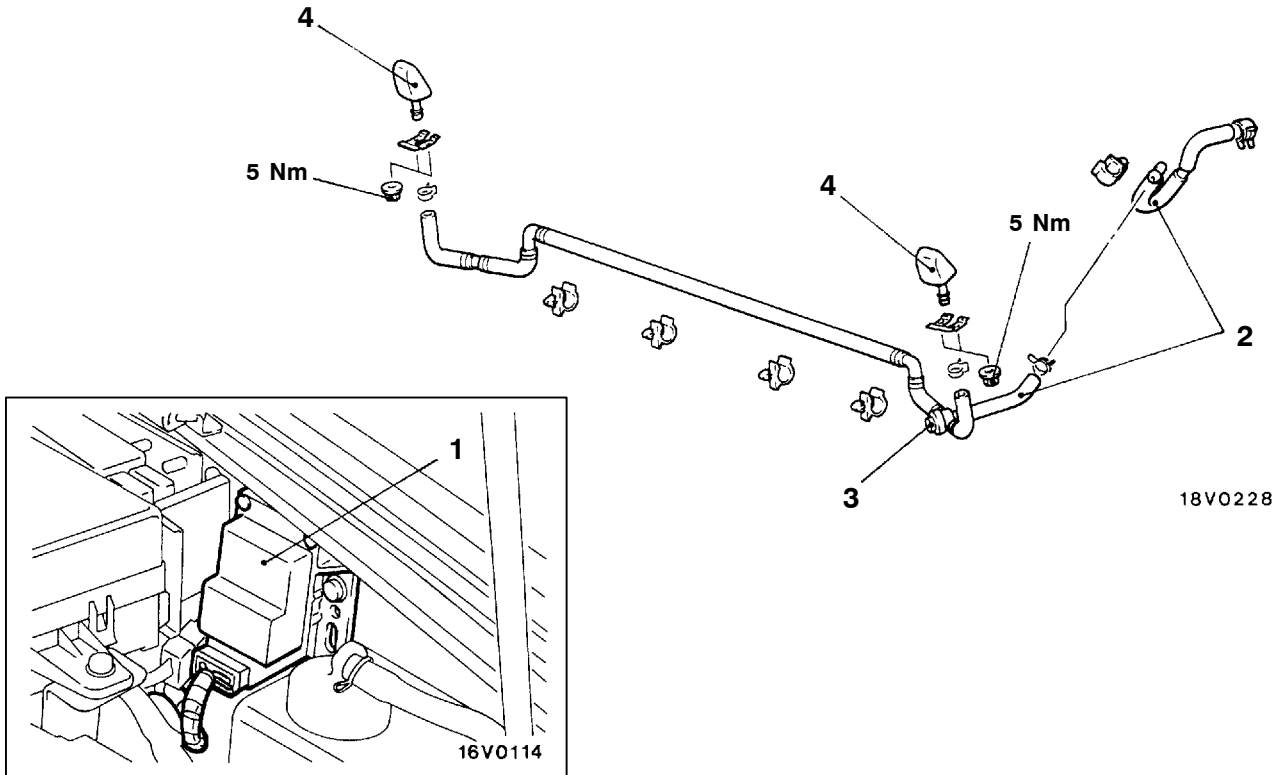

18V0228

00004908

1. Headlamp washer relay

Washer nozzle and check valve removal steps

- Washer fluid draining
 - Front bumper (Refer to P.51-2.)
2. Washer hose
 3. Check valve
 4. Washer nozzle

NOTE

1. For removal and installation of the column switch assembly (built-in headlamp washer switch), refer to GROUP 37A – Steering Wheel and Shaft.
2. For removal and installation of the washer tank, refer to P.51-16.

INSPECTION

51100980070

COLUMN SWITCH (HEADLAMP WASHER SWITCH) CHECK

Check the continuity between terminal (2) of connector A and terminal (1) of connector B with headlamp washer switch in ON position.

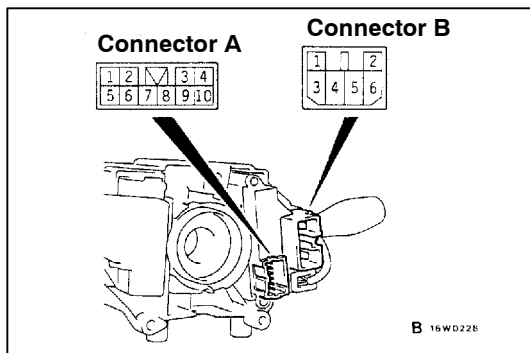

B 16W0228

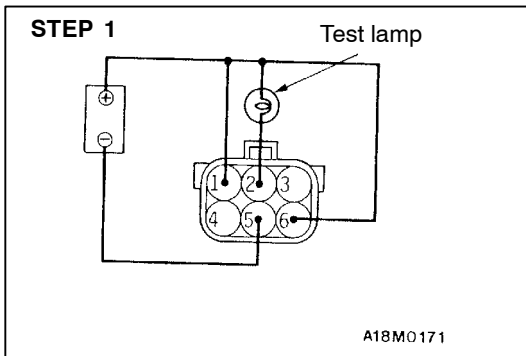

HEADLAMP WASHER RELAY CHECK

51101320062

1. Connect battery and test lamp to the relay as illustrated.

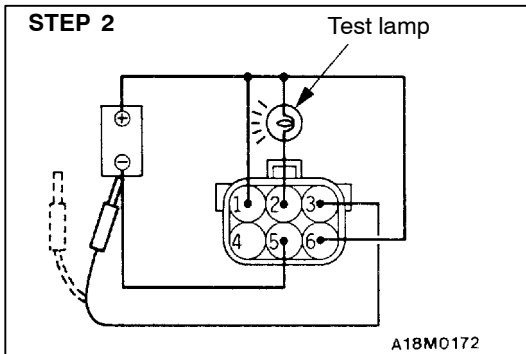

2. The relay is normal if the lamp lights for approximately 0.5 second upon connection of terminal (3) to battery (-).

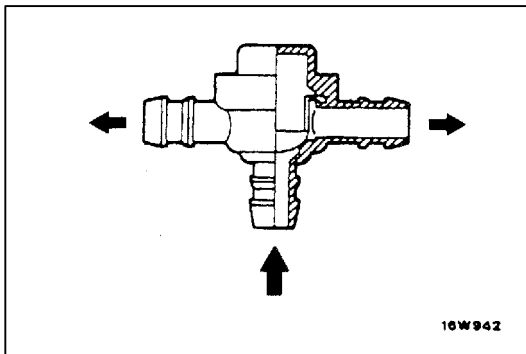

CHECK VALVE CHECK

51101330041

Apply pressure to the inlet of the check valve to check its opening pressure.

Opening pressure: 78 kPa

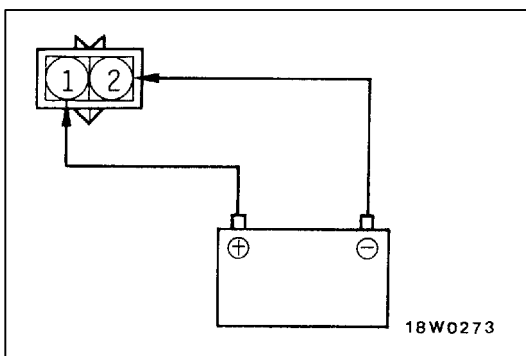

HEADLAMP WASHER MOTOR CHECK

51101340044

1. With the headlamp washer motor installed to the washer tank, fill the washer tank with water.
2. Check that the water squirts out strongly when battery voltage is applied to terminals (1) and (2).

MARKS

51101180189

REMOVAL AND INSTALLATION

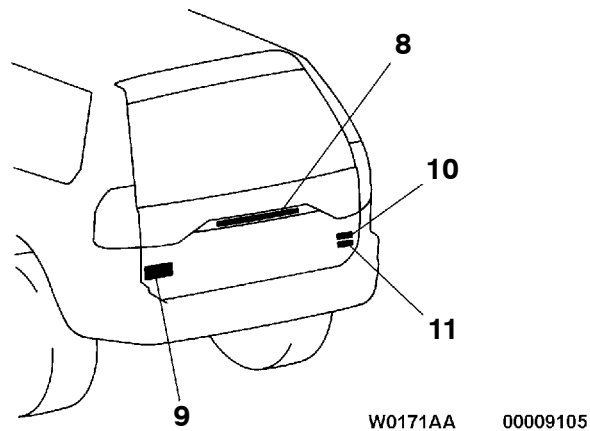
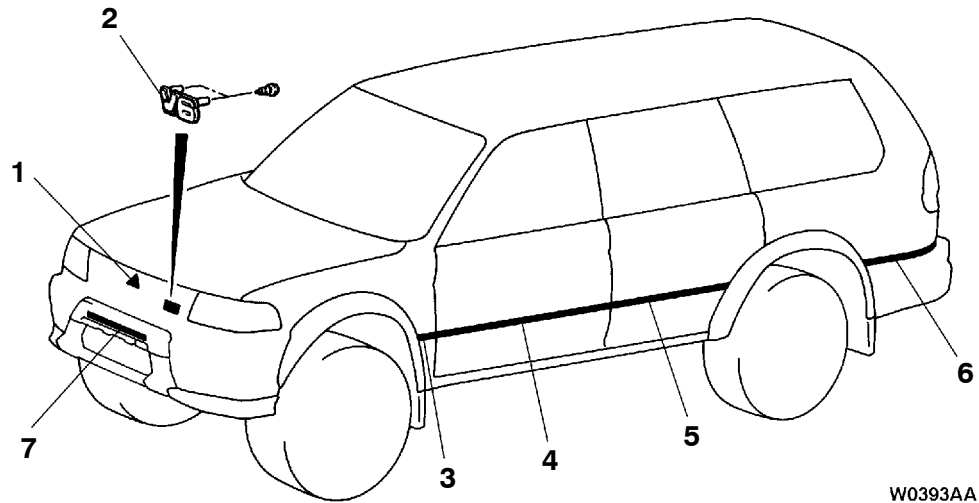

- 1. Top mark
- 2. V6 mark
- ▶◀A▶◀ 3. Fender pin stripe tape
- ▶◀A▶◀ 4. Front door pin stripe tape
- ▶◀A▶◀ 5. Rear door pin stripe tape
- ▶◀A▶◀ 6. Side pin stripe tape
- ▶◀A▶◀ 7. MITSUBISHI mark
<Vehicles with bumper guard>
- ▶◀A▶◀ 8. MITSUBISHI mark
- ▶◀A▶◀ 9. PAJERO SPORT mark (rear)
- ▶◀A▶◀ 10. 4WD decal
- ▶◀A▶◀ 11. GLX or GLS mark

INSTALLATION SERVICE POINT

▶A◀ MARKS INSTALLATION

1. INSTALLATION POSITION

Attach to the position shown in the illustration.

PIN STRIPE TAPE

- Align the notch at the section “a” with the end of the door panel.
- Fold the sections of protruding from the end of the fender panel and door panel inward.

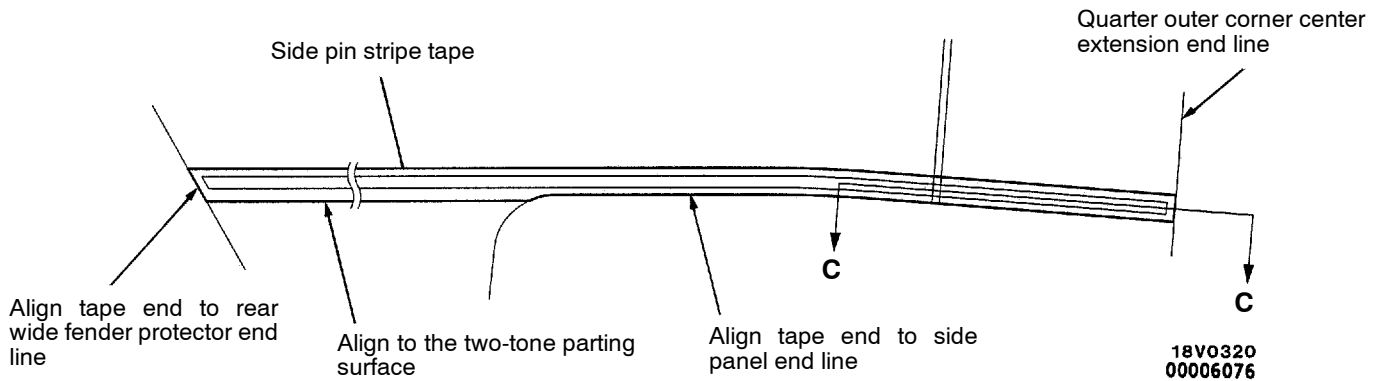
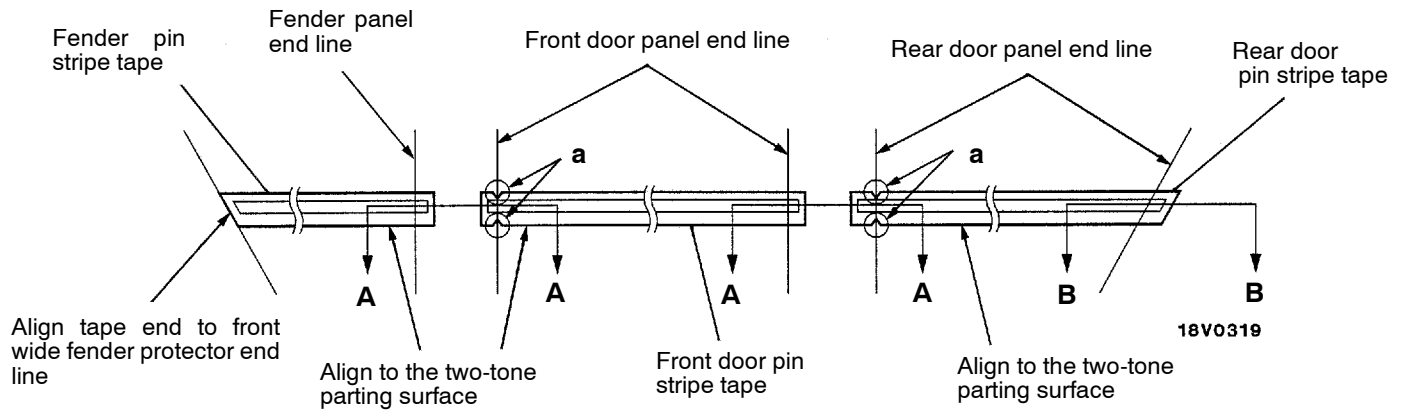

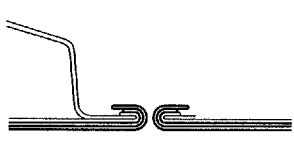
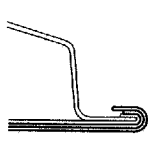
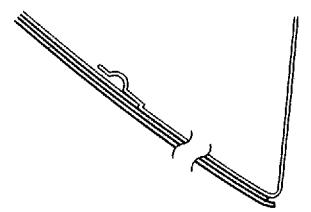
Section A - A	Section B - B	Section C - C
 <p>18V0321</p>	 <p>18V0331</p>	 <p>18V0322</p>

MITSUBISHI mark <Vehicle with bumper guard>

Each dimension from the edge to the notch (V shape) of the mark should be equal to each installation dimension. (i.e. $D = D'$)

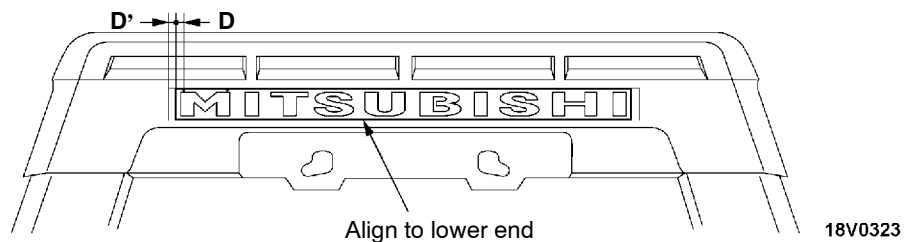

MITSUBISHI mark

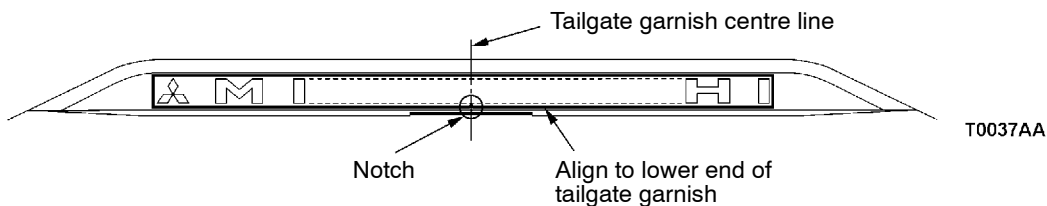

PAJERO SPORT mark (rear)

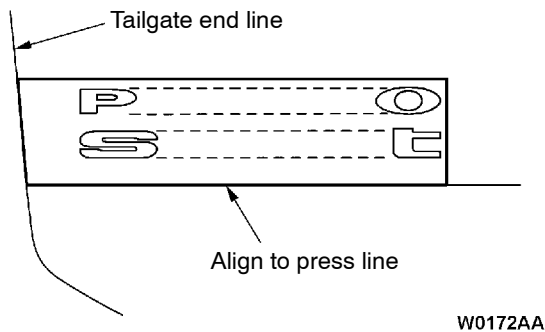

4WD decal, GLX or GLS mark

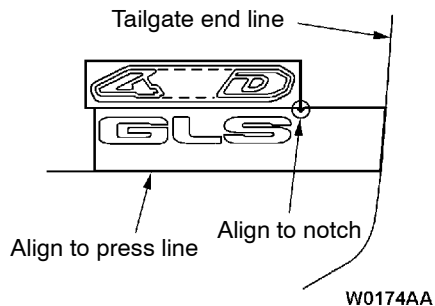

2. INSTALLATION PROCEDURE

- (1) Clean the mark installation surfaces on the body with unleaded petrol.
- (2) Peel off the backing paper from the reverse side of the marks, and then attach the marks to the vehicle body so that they fit properly into position.

Caution

When attaching the marks, the surrounding temperature should be 20 – 38 °C and the air should be completely free from dust.

If the surrounding temperature is lower than 20 °C, the marks and the places on the body where the marks are to be attached should be heated to 20 – 38 °C.

**DOOR MIRROR
SPECIAL TOOL**

5110060255

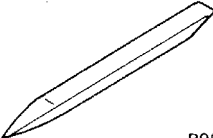
Tool	Number	Name	Use
 B990784	MB990784	Ornament remover	Remote controlled mirror switch removal

**DOOR MIRROR
REMOVAL AND INSTALLATION**

51100640152

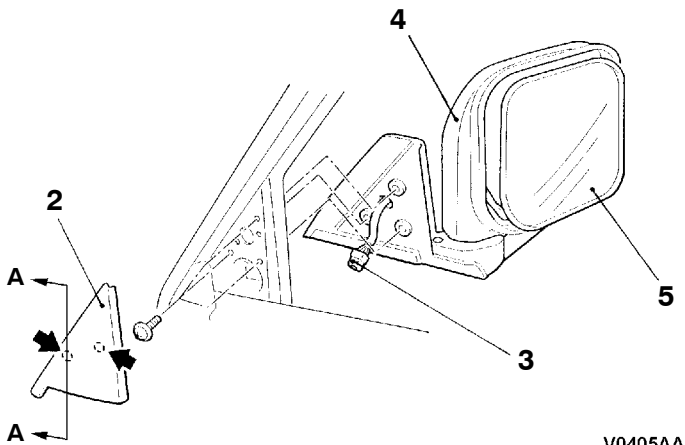
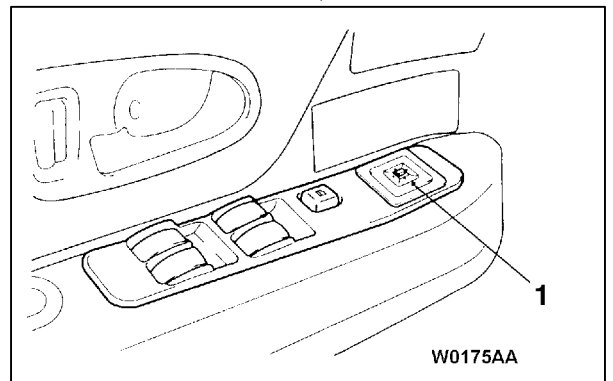
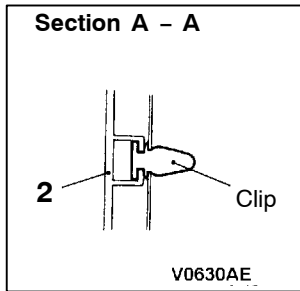

V0405AA
00009108

NOTE
← : Resin clip position

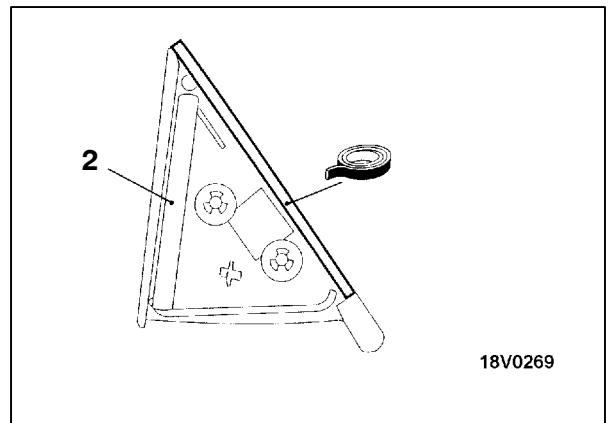

18V0269

Adhesive tape:
Double-sided tape [5 mm width and 0.4 mm thickness]

1. Remote controlled mirror switch
- Door mirror removal steps**
2. Delta cover, inner
3. Harness connector <Vehicle with remote controlled mirror>
4. Door mirror assembly
5. Mirror



REMOVAL SERVICE POINT

◀A▶ MIRROR REMOVAL

1. Tilt the mirror upward by hand, insert a flat-tipped screwdriver onto which protective tape has been wound, and then pry the claws off of the actuator.

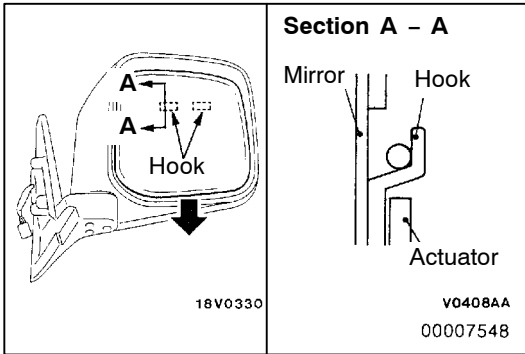
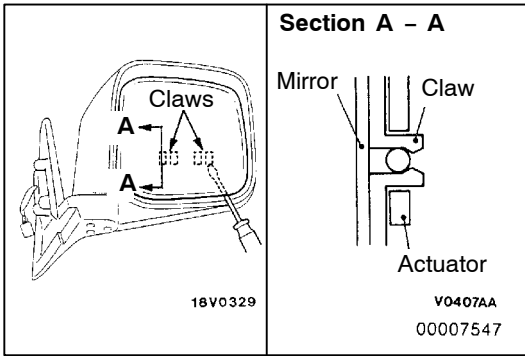

2. Pull the mirror downward to release the hooks.

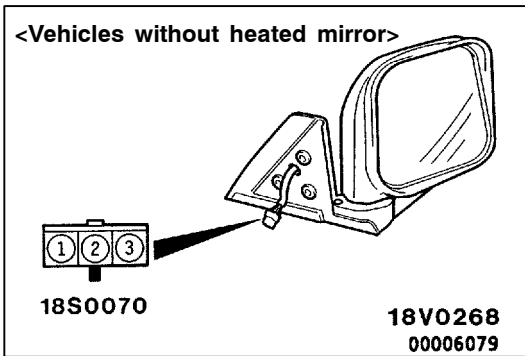

INSPECTION

51100650162

REMOTE CONTROLLED MIRROR ASSEMBLY CHECK

<Vehicles without heated mirror>

Check to be sure that the mirror moves as described in the table when each terminal is connected to the battery.

Battery connection terminal			Direction operation
1	2	3	
⊖		⊕	UP
⊕		⊖	DOWN
⊖	⊕		RIGHT
⊕	⊖		LEFT

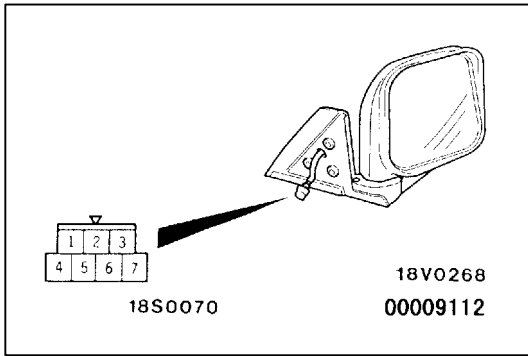

<Vehicles with heated mirror>

1. Check to be sure that the mirror moves as described in the table when each terminal is connected to the battery.
2. Check if there is continuity between terminals (1) and (2).

Battery connection terminal					Direction operation
5	6	7	1	4	
⊖	—	⊕	Printed heating wire		UP
⊕	—	⊖			DOWN
⊖	⊕	—			RIGHT
⊕	⊖	—			LEFT

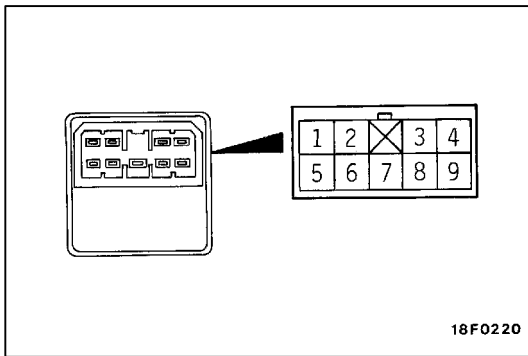

REMOTE CONTROLLED MIRROR SWITCH CONTINUITY CHECK

51101350108

Switch position		Terminal No.						
		2	3	4	6	7	8	9
Left side	UP			○	○	○	○	
	DOWN			○	○	○	○	
	LEFT		○	○	○	○		
	RIGHT		○	○	○	○		
Right side	UP	○		○	○	○		
	DOWN	○		○	○	○		
	LEFT			○	○	○		○
	RIGHT			○	○	○		○

**SWITCH AND RELAY OF DOOR MIRROR PRINTED
HEATING WIRE CHECK**

51101360033

The printed heating wire of the door mirror operates in conjunction with the rear window defogger.

The switch and relay are used for the rear window defogger also, so refer to GROUP 54 for inspection service points.

NOTES

INTERIOR AND SUPPLEMENTAL RESTRAINT SYSTEM (SRS)

CONTENTS

52109000187

INTERIOR	52A
SUPPLEMENTAL RESTRAINT SYSTEM (SRS)	52B



INTERIOR

CONTENTS

52109000453

SERVICE SPECIFICATIONS	3	TRIMS	13
SPECIAL TOOL	3	INSIDE REAR VIEW MIRROR	14
INSTRUMENT PANEL <L.H. DRIVE VEHICLES>*	4	FRONT SEAT	15
INSTRUMENT PANEL <R.H. DRIVE VEHICLES>*	8	REAR SEAT	18
FLOOR CONSOLE	12	FRONT SEAT BELT	21
		REAR SEAT BELT	22

WARNINGS REGARDING SERVICING OF SUPPLEMENTAL RESTRAINT SYSTEM (SRS) EQUIPPED VEHICLES

WARNING!

- (1) Improper service or maintenance of any component of the SRS, or any SRS-related component, can lead to personal injury or death to service personnel (from inadvertent firing of the air bag) or to the driver (from rendering the SRS inoperative).
- (2) Service or maintenance of any SRS component or SRS-related component must be performed only at an authorized MITSUBISHI dealer.
- (3) MITSUBISHI dealer personnel must thoroughly review this manual, and especially its GROUP 52B – Supplemental Restraint System (SRS) before beginning any service or maintenance of any component of the SRS or any SRS-related component.

NOTE

The SRS includes the following components: front impact sensors, SRS-ECU, SRS warning lamp, air bag module, clock spring and interconnecting wiring. Other SRS-related components (that may have to be removed/installed in connection with SRS service or maintenance) are indicated in the table of contents by an asterisk (*).

SERVICE SPECIFICATIONS

52100030062

Items		Standard value
Seatback heater resistance (between terminals) Ω		Approx. 10
Seat cushion heater resistance (between terminals) Ω	Between terminals 2 and 3	Approx. 11
	Between terminals 1 and 3	Approx. 9

SPECIAL TOOL

52100060146

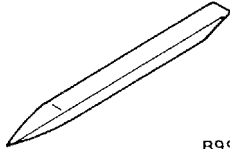
Tool	Number	Name	Use
 <p>B990784</p>	MB990784	Ornament remover	Removal of switch, trim, etc.

INSTRUMENT PANEL <L.H. DRIVE VEHICLES>







52100170351

Caution

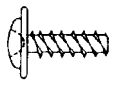
For removal and installation of the passenger's side air bag module, always observe the service procedures described in GROUP 52B – Air Bag Module and Clock Spring.

REMOVAL AND INSTALLATION

The bolts and screws described below are used, for installation of the instrument panel. They are indicated by symbols in the illustration.

Name	Symbol	Size (D x L) mm	Colour	Shape	
Tapping screw	a	5 x 12	–	 19Z0004	
	b	5 x 14			
	c	5 x 16			
	d	5 x 20			
	e	5 x 12	Black		
	f	5 x 16			
	g	5 x 20			
	h	5 x 12	–		 19Z0022
	i	5 x 16			
Washer assembled screw	j	5 x 12	–	 19Z0007	
	k	5 x 16	–	 19Z0006	
	l	5 x 20	Black		
	m	5 x 20	Black	 19Z0030	
Washer assembled bolt	n	6 x 16	–	 19Z0012	
	o	8 x 20	–	 19Z0019	
	p	6 x 16	–		
	q	8 x 20	–	 19Z0010	
	r	5 x 16	Black		

D = Thread diameter

L = Effective thread length

Pre-removal and Post-installation Operation

- Floor Console Assembly Removal and Installation (Refer to P.52A-12.)
- Steering Wheel and Column Cover Removal and Installation (Refer to GROUP 37A – Steering Column and Shaft.)

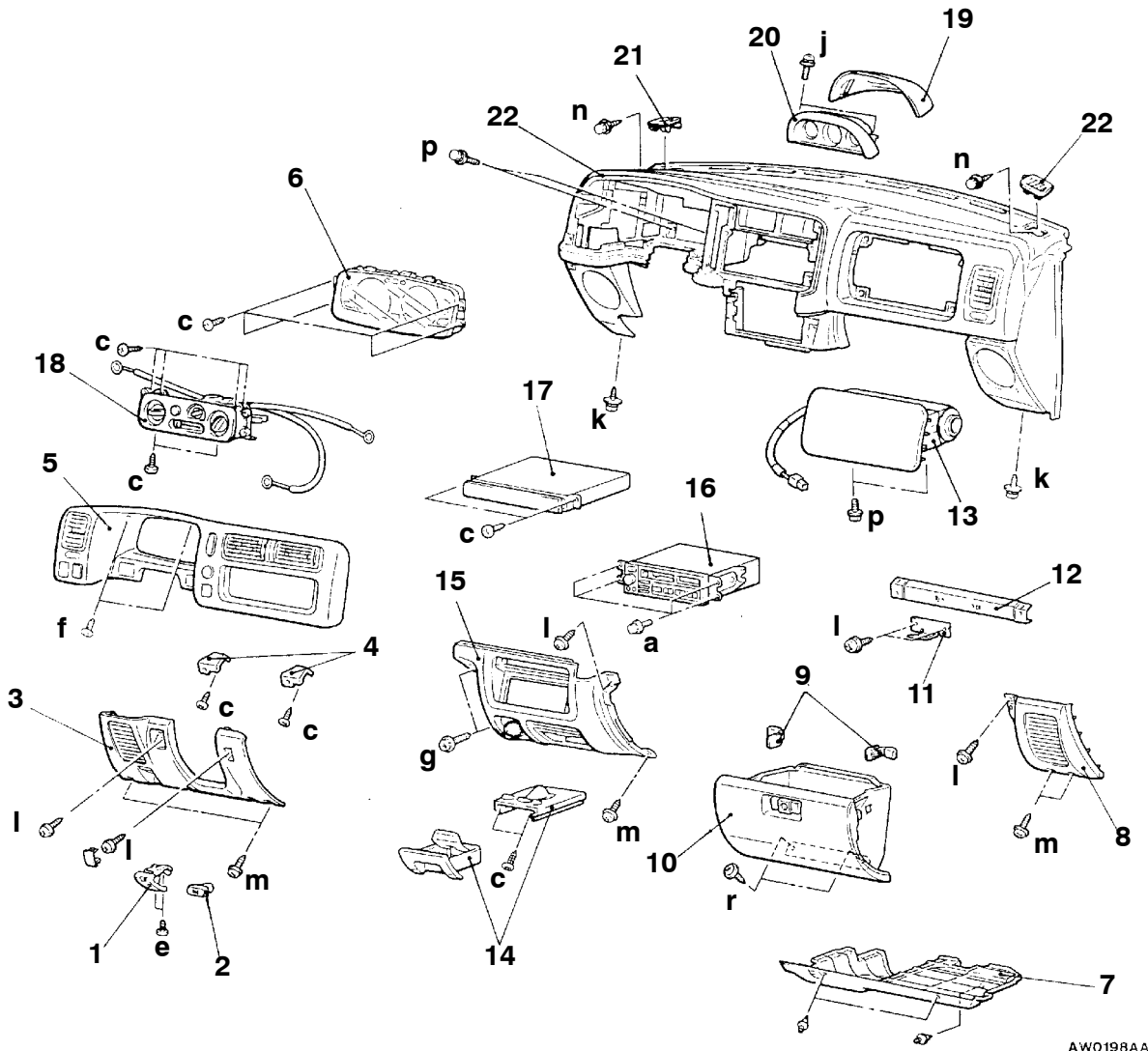

AW0198AA

Removal steps

1. Hood lock release handle
2. Throttle knob
3. Knee protector assembly
4. Knee protector bracket
5. Meter bezel assembly
6. Combination meter
7. Under cover
8. Corner cover
9. Stopper
10. Glove box assembly
11. Glove box striker
12. Glove box upper frame
13. Front passenger's side air bag module (Refer to GROUP 52B – Air Bag Module and Clock Spring.)
14. Ashtray assembly
15. Center under cover assembly
16. Radio and tape player
17. Cup holder assembly
18. Heater control assembly (Refer to GROUP 55 – Heater Control Assembly and A/C Switch.)
19. Multi-meter panel
20. Multi-meter assembly
21. Side defroster grill
22. Instrument panel assembly

CLIP AND CLAW POSITION

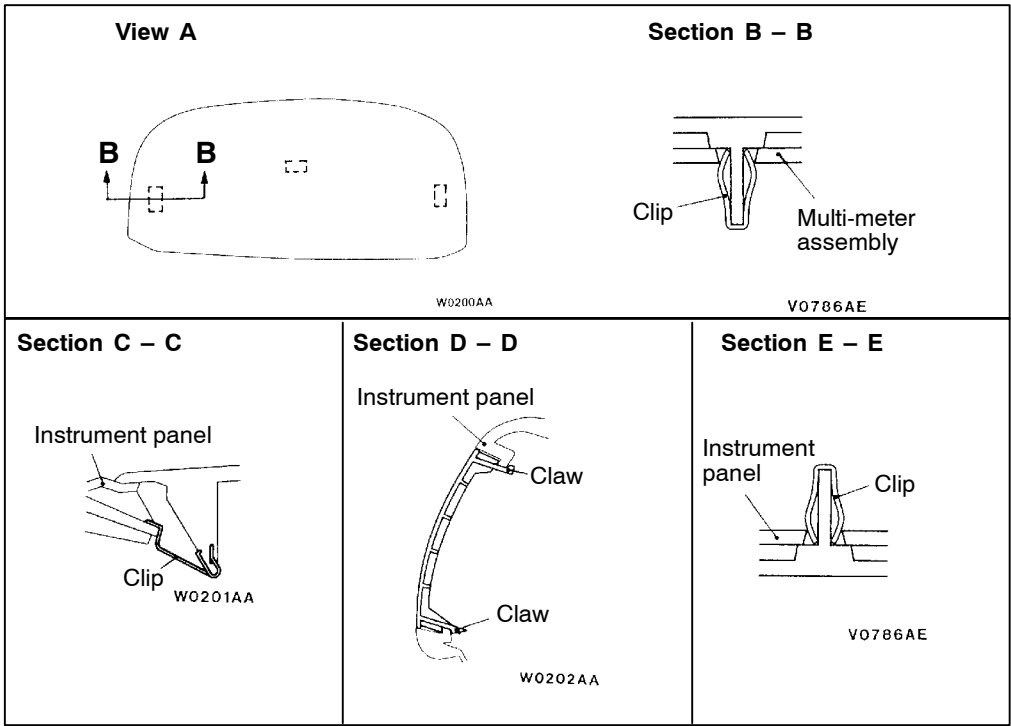
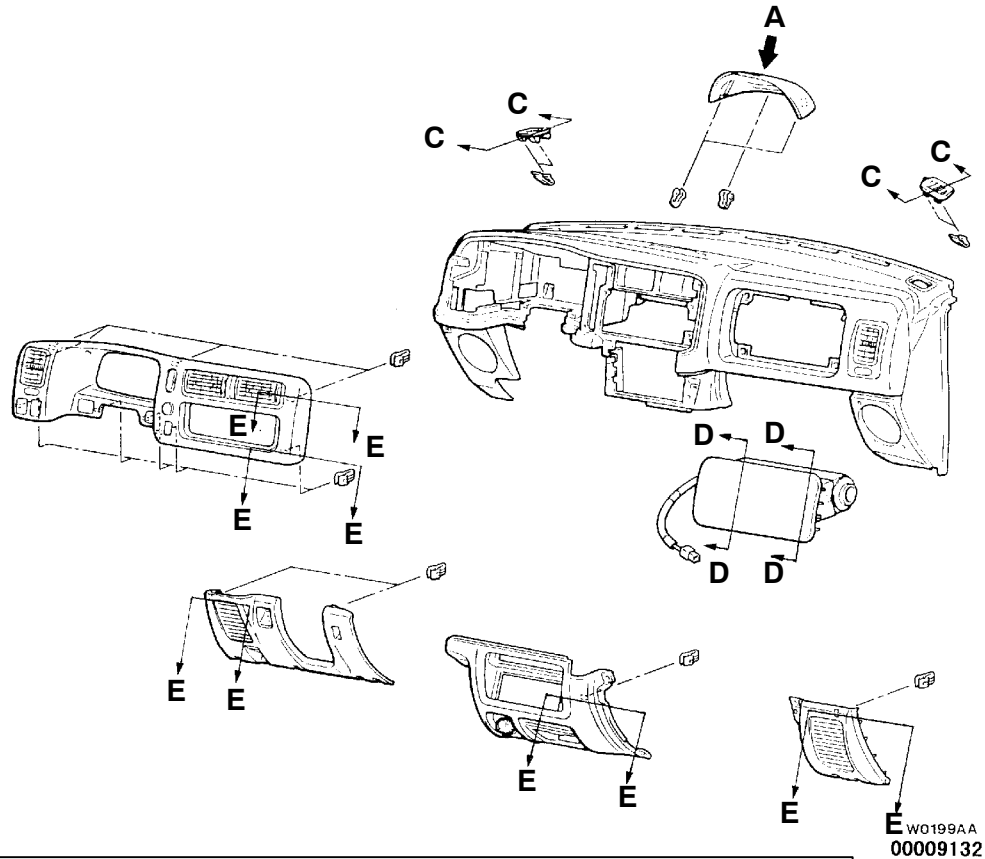

DISASSEMBLY AND REASSEMBLY

52100190265

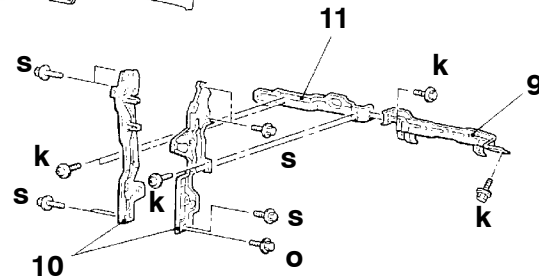
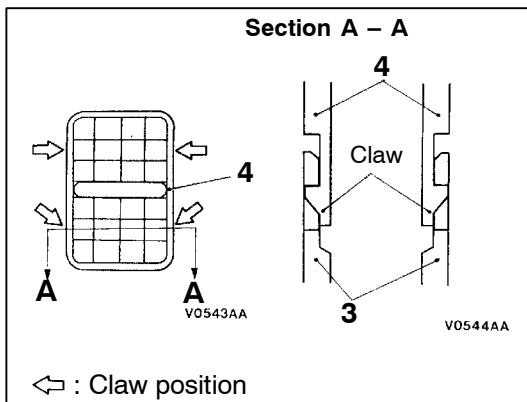
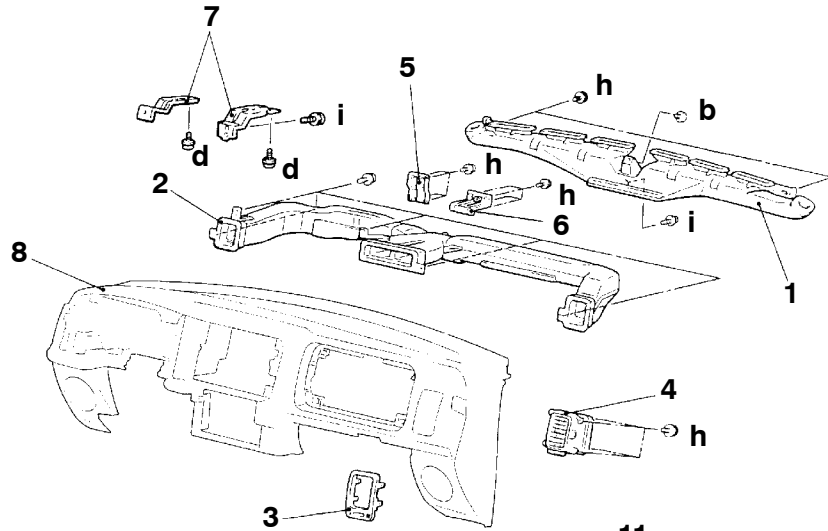

W0203AA

00009133

Disassembly steps

1. Defroster nozzle assembly
2. Distribution duct
3. Air outlet grille
4. Air outlet assembly
5. Combination meter reinforcement
6. Instrument panel reinforcement

7. Multi-meter bracket
8. Instrument panel
9. Glove box frame
10. Center reinforcement
11. Center frame A

INSTRUMENT PANEL <R.H. DRIVE VEHICLES>







52100170368

Caution

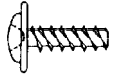
For removal and installation of the passenger's side air bag module, always observe the service procedures described in GROUP 52B – Air Bag Module and Clock Spring.

REMOVAL AND INSTALLATION

The bolts and screws described below are used, for installation of the instrument panel. They are indicated by symbols in the illustration.

Name	Symbol	Size (D x L) mm	Colour	Shape
Tapping screw	a	5 x 12	–	 19Z0004
	b	5 x 14		
	c	5 x 16		
	d	5 x 20		
	e	5 x 25		
	f	5 x 12	Black	
	g	5 x 16		
	h	5 x 20		
	i	5 x 20	Black	
	j	5 x 12	–	 19Z0022
	k	5 x 16		
Washer assembled screw	l	5 x 12	–	 19Z0007
	m	5 x 16	–	 19Z0006
	n	5 x 20	Black	 19Z0030
Washer assembled bolt	o	6 x 16	–	 19Z0012
	p	8 x 20	–	 19Z0019
	q	6 x 16	–	 19Z0010
	r	8 x 20		

D = Thread diameter

L = Effective thread length

Pre-removal and Post-installation Operation

- Floor Console Assembly Removal and Installation (Refer to P.52A-12.)
- Steering Wheel and Column Cover Removal and Installation (Refer to GROUP 37A – Steering Column and Shaft.)

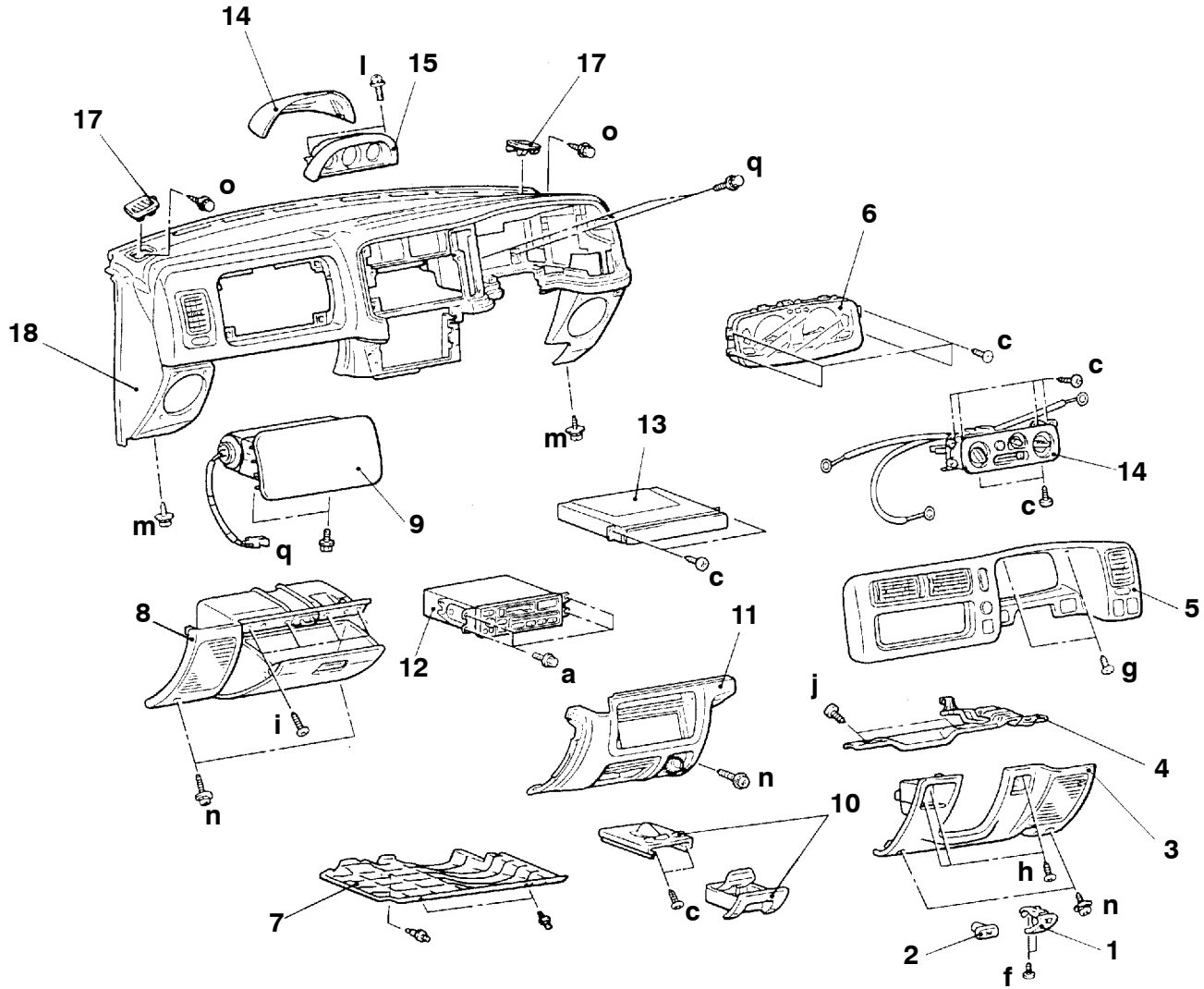

AW0204AA

Removal steps

- | | |
|--|--|
| <ol style="list-style-type: none"> 1. Hood lock release handle 2. Throttle knob 3. Driver side under cover assembly 4. Driver side frame 5. Meter bezel assembly 6. Combination meter 7. Under cover 8. Glove box assembly 9. Front passenger's side air bag module (Refer to GROUP 52B – Air Bag Module and Clock Spring.) | <ol style="list-style-type: none"> 10. Ashtray assembly 11. Center under cover assembly 12. Radio and tape player 13. Cup holder assembly 14. Heater control assembly (Refer to GROUP 55 – Heater Control Assembly and A/C Switch.) 15. Multi-meter panel 16. Multi-meter assembly 17. Side defroster grill 18. Instrument panel assembly |
|--|--|

CLIP AND CLAW POSITION

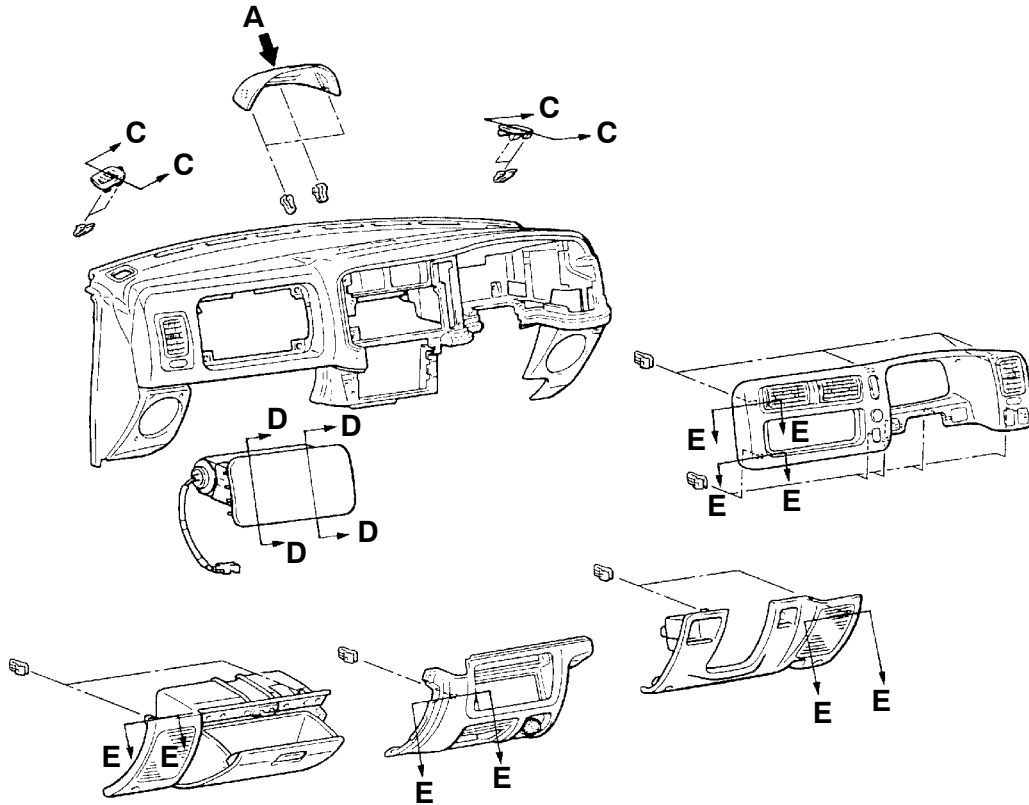

W0205AA

00009134

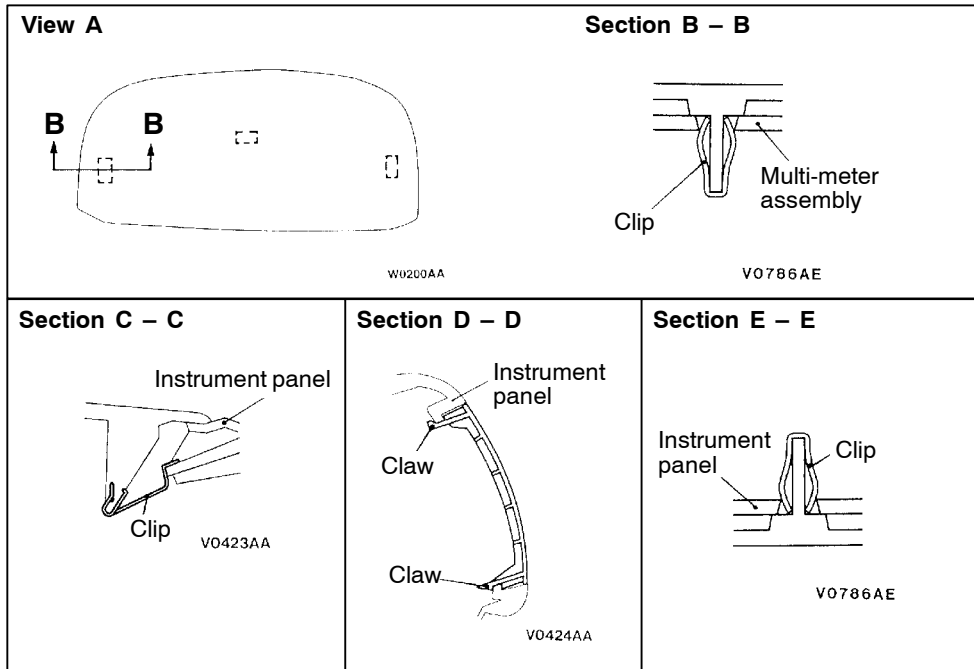

DISASSEMBLY AND REASSEMBLY

52100190272

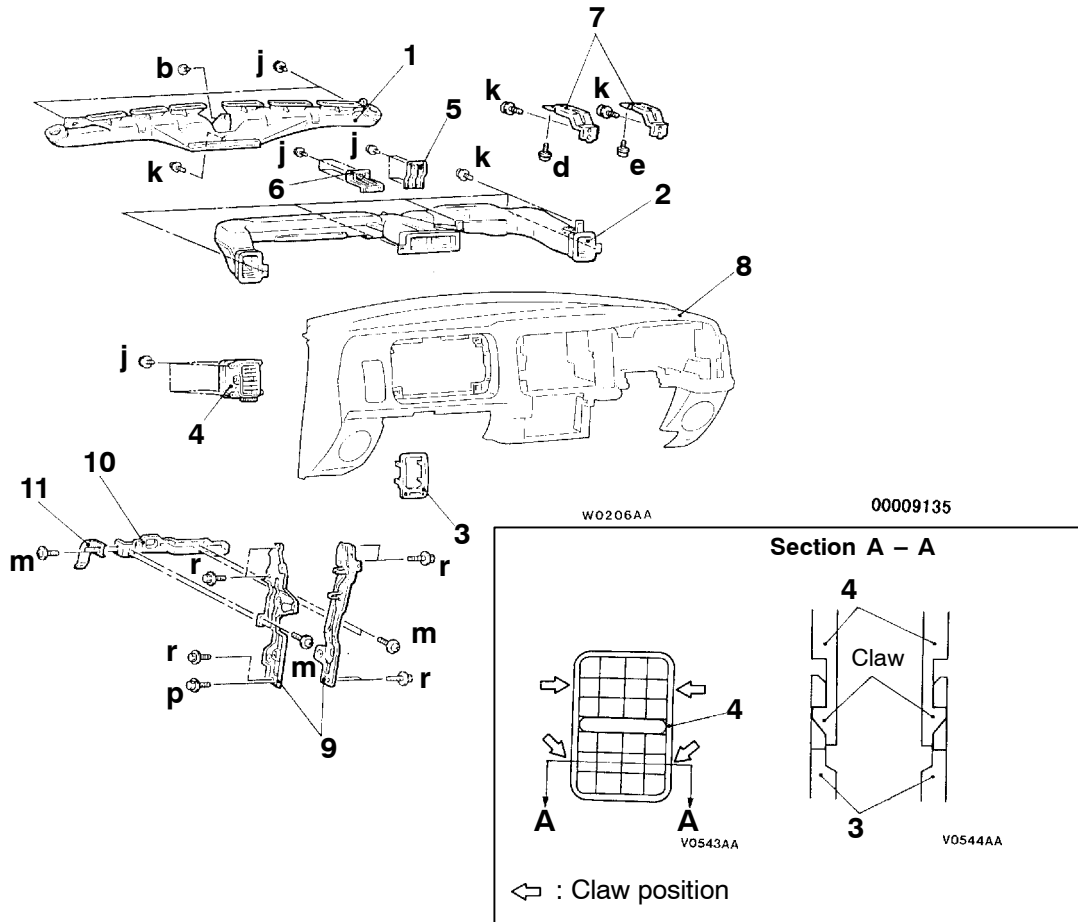

Disassembly steps

- | | |
|------------------------------------|-------------------------|
| 1. Defroster nozzle assembly | 7. Multi-meter bracket |
| 2. Distribution duct | 8. Instrument panel |
| 3. Air outlet grille | 9. Center reinforcement |
| 4. Air outlet assembly | 10. Center frame A |
| 5. Combination meter reinforcement | 11. Center frame B |
| 6. Instrument panel reinforcement | |

TRIMS

52100110360

REMOVAL AND INSTALLATION

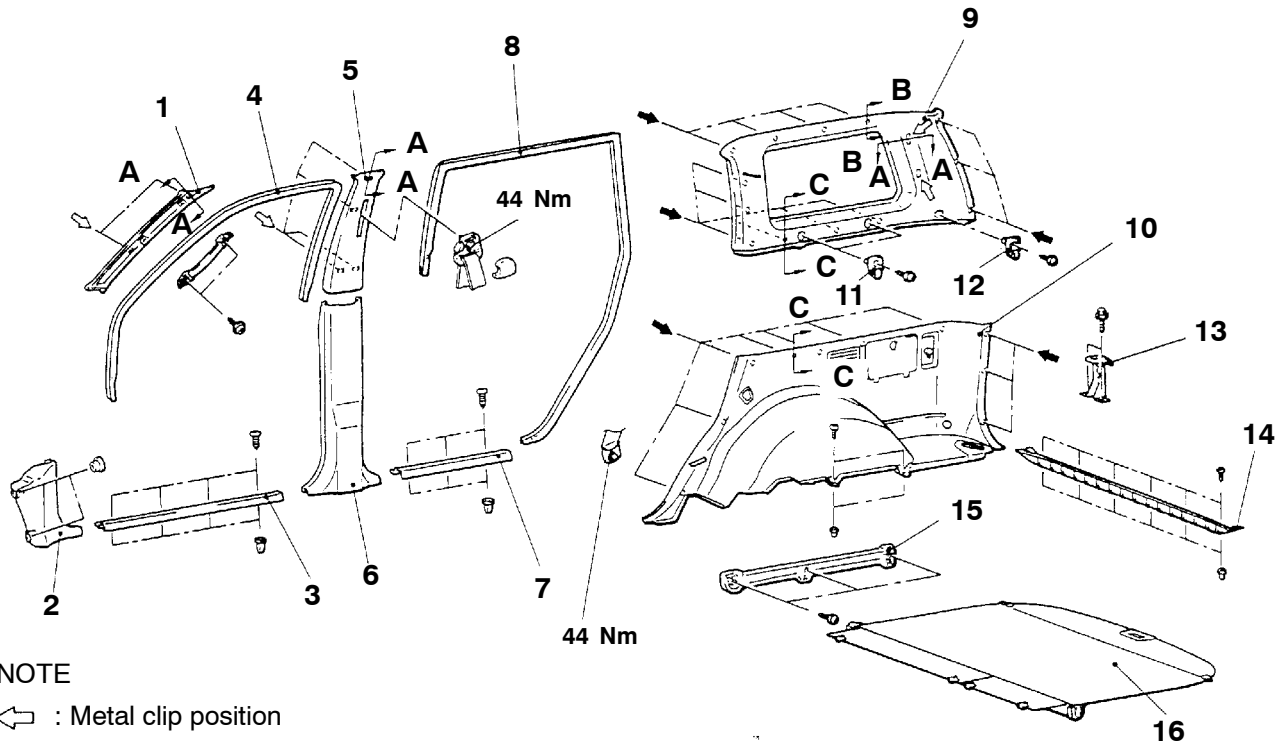

NOTE

← : Metal clip position

→ : Resin clip position

19V0157

00007552

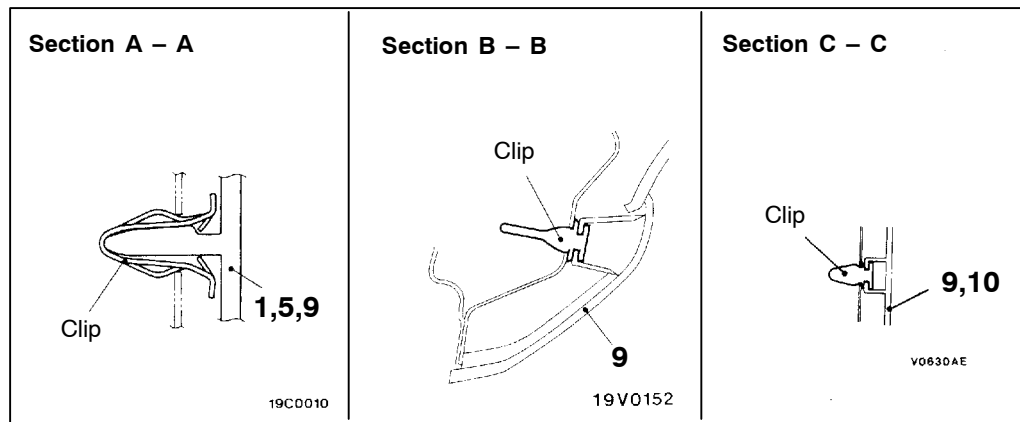

1. Front pillar trim
2. Cowl side trim
3. Front scuff plate
4. Front door opening weatherstrip, inner
5. Center pillar trim, upper
6. Center pillar trim, lower
7. Rear scuff plate
8. Rear door opening weatherstrip, inner
9. Quarter trim, upper

10. Quarter trim, lower
11. Side hook, center <vehicles without tonneau cover>
12. Side hook, rear <vehicles without tonneau cover>
13. Parcel hook
14. Rear end trim
15. Shelf holder <vehicles with tonneau cover>
16. Tonneau cover <vehicles with tonneau cover>

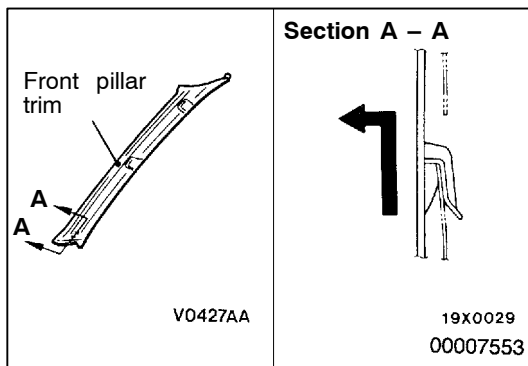
**REMOVAL SERVICE POINT****◀A▶ FRONT PILLAR TRIM REMOVAL**

After pulling upward, pull forward and remove as shown in the illustration.

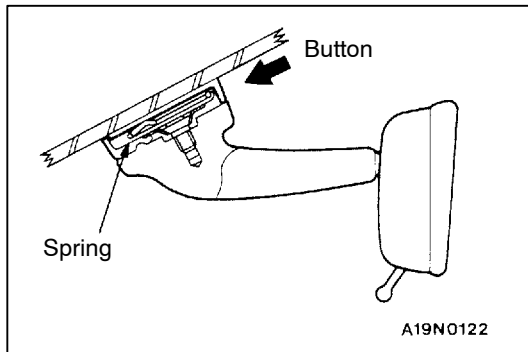
**INSIDE REAR VIEW MIRROR**

52100270105

REMOVAL SERVICE POINT

Remove by pushing in the direction of the arrow in the illustration.

NOTE

1. The mirror spring fits firmly in the groove of the button that is attached to the glass.
2. The mirror breaking load is within 450 N.

FRONT SEAT

REMOVAL AND INSTALLATION

Pre-removal and Post-installation Operation

- Rear Floor Console Assembly Removal and Installation (Refer to P.52A-12.)

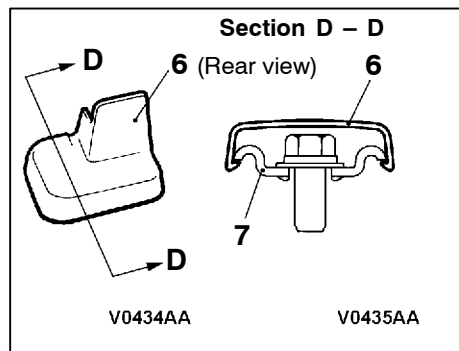
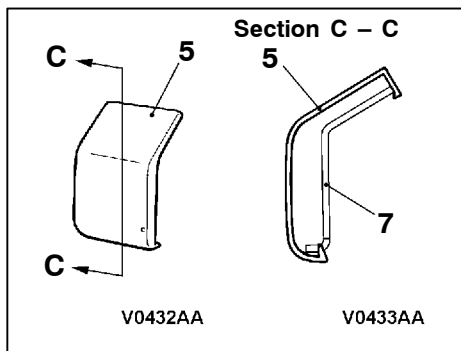
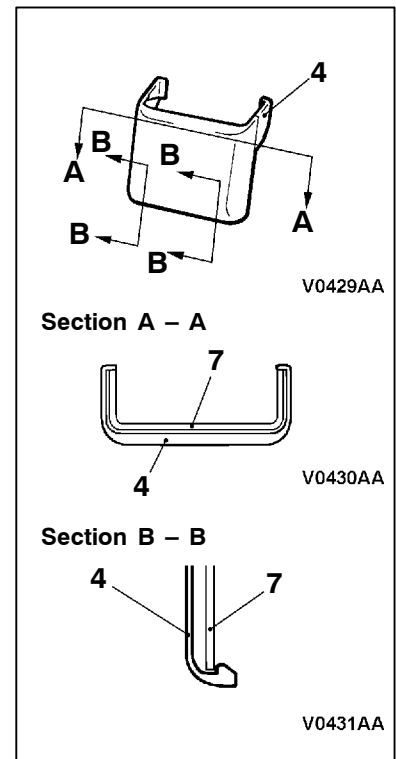
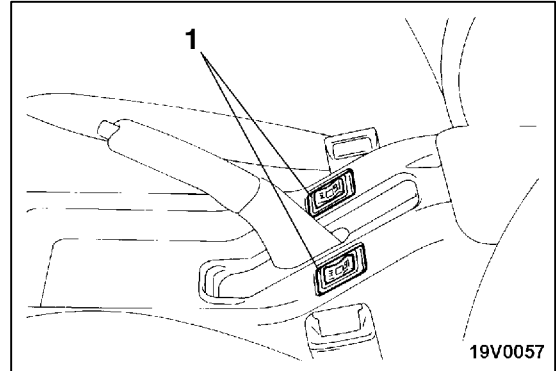
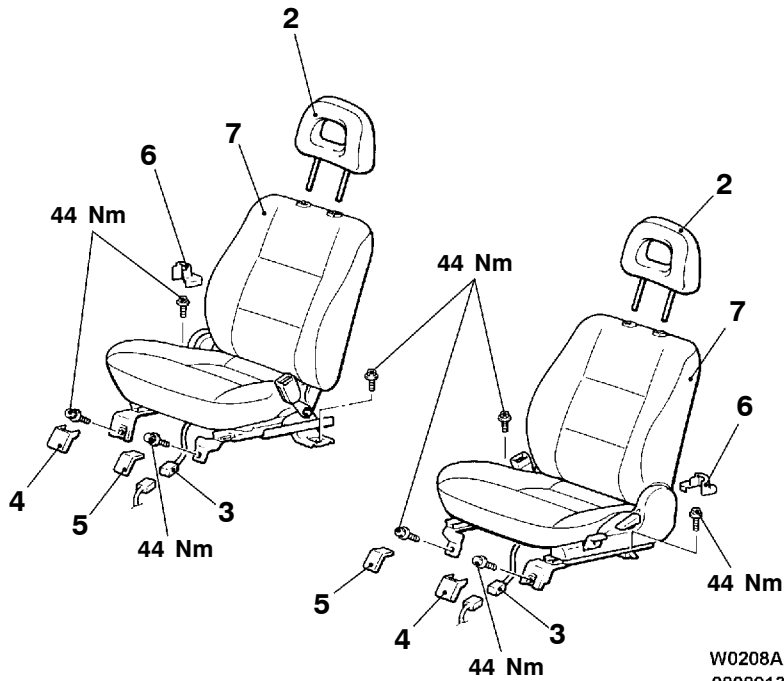

1. Head seat switch
<Vehicles with heated seat>
2. Head restraint

Front seat assembly removal steps

3. Harness connector
<Vehicles with heated seat>
4. Seat anchor cover, outer

5. Seat anchor cover, inner
6. Seat anchor cover, rear
7. Front seat assembly

NOTE

Install each seat assembly mounting bolt in every installation location, then tighten to the specified torque.

INSPECTION

HEATED SEAT SWITCH CONTINUITY CHECK

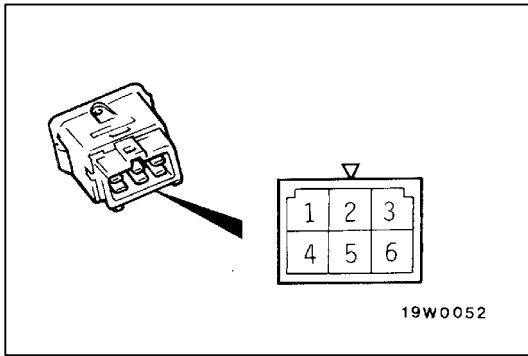

Switch position	Terminal No.							
	1	2	IND	5	6	3	ILL	4
HI	○	○	⚡	○	○	○	⚡	○
OFF						○	⚡	○
LO		○	⚡	○	○	○	⚡	○

NOTE

To inspect the diode, match the polarity of the circuit tester with the (+) (-) polarities in the table.

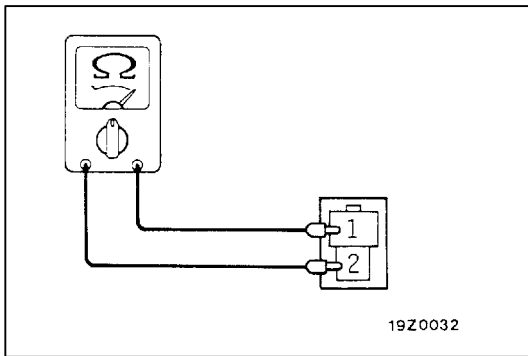

SEATBACK HEATER CHECK

Measure the resistance between terminals.

Standard value: Approx. 10 Ω

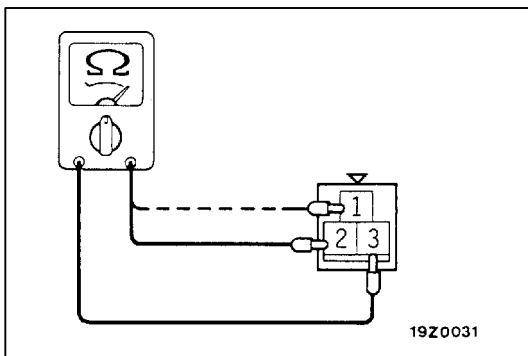

SEAT CUSHION HEATER CHECK

Measure the resistance between terminals.

Standard value:

Between terminals 2 and 3: Approx. 11 Ω

Between terminals 1 and 3: Approx. 9 Ω

DISASSEMBLY AND REASSEMBLY

52200150365

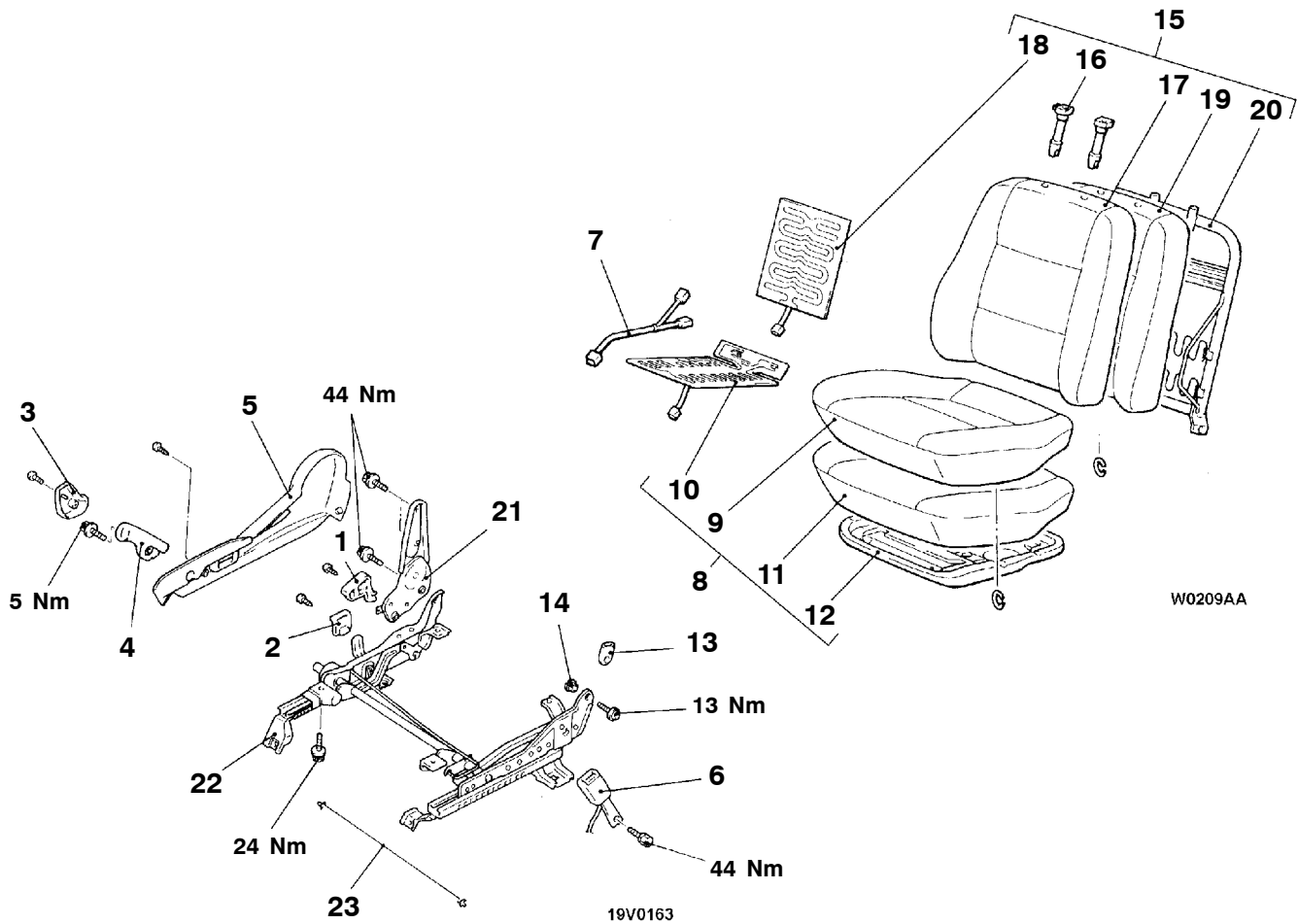

W0209AA

00009138

Disassembly steps

- | | | |
|--|------------|--|
| <ol style="list-style-type: none"> 1. Reclining adjusting knob 2. Slide adjusting knob 3. Front seat height adjuster inner lever 4. Front seat height adjuster lever 5. Front seat shield cover 6. Inner seat belt 7. Heated seat harness
<Vehicles with heated seat> 8. Front seat cushion assembly 9. Front seat cushion cover 10. Front seat cushion heater
<Vehicles with heated seat> 11. Front seat cushion pad | <p>◀A▶</p> | <ol style="list-style-type: none"> 12. Front seat cushion frame 13. Protector 14. Bush 15. Front seatback assembly 16. Head restraint guide 17. Front seatback cover 18. Front seatback heater
<Vehicles with heated seat> 19. Front seatback pad 20. Front seatback frame 21. Reclining adjuster 22. Seat adjuster assembly 23. Pull wire |
|--|------------|--|

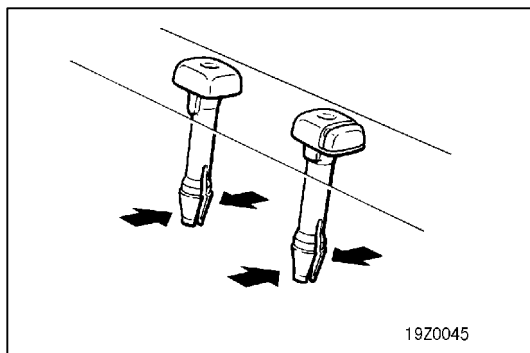

19Z0045

DISASSEMBLY SERVICE POINT

◀A▶ HEAD RESTRAINT GUIDE REMOVAL

REAR SEAT

REMOVAL AND INSTALLATION

<Bench seat>

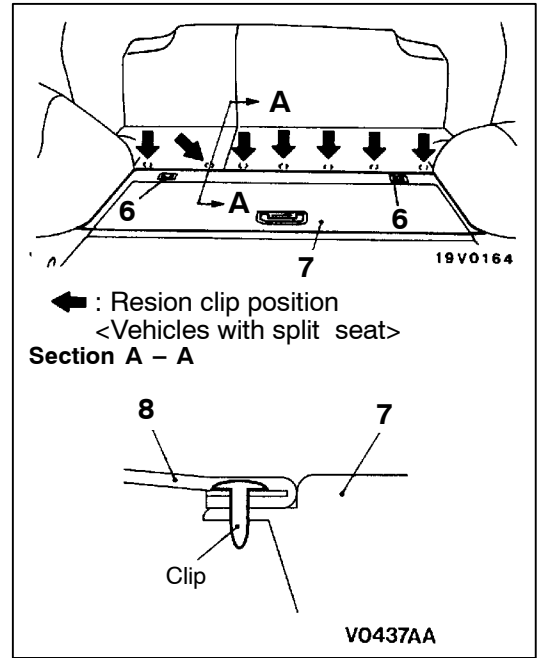
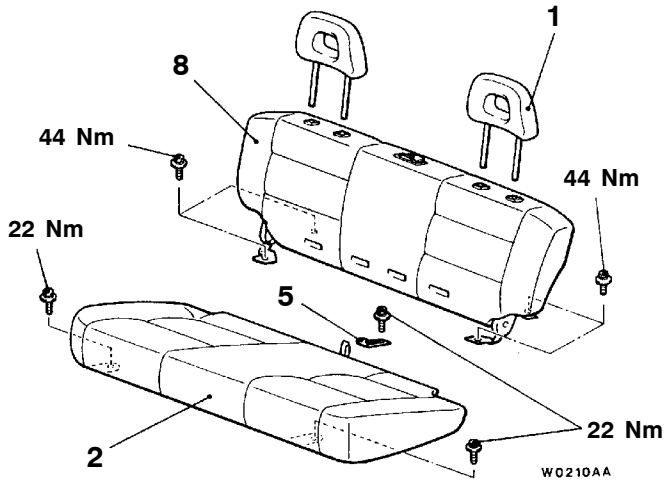

<Split seat>

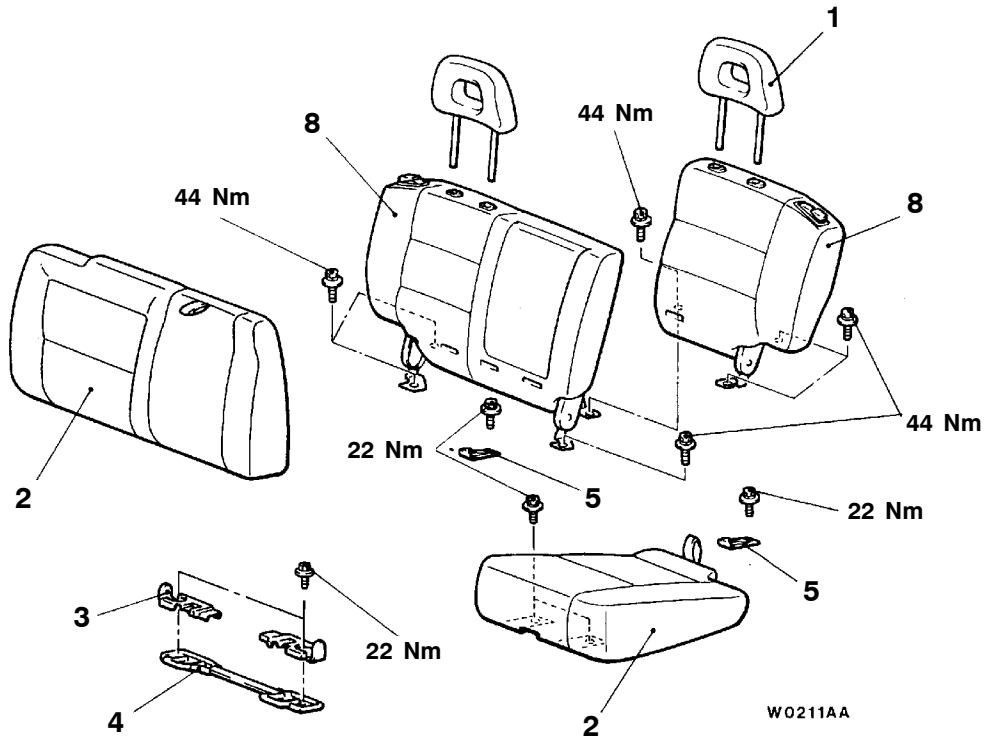

1. Head restraint

Rear seat removal steps

- 2. Rear seat cushion assembly
- 3. Striker cover

4. Striker assembly

- 5. Catch
- 6. Parcel hook
- 7. Luggage floor box, front
- 8. Rear seatback assembly

00009139

DISASSEMBLY AND REASSEMBLY

52200200121

<Bench seat>

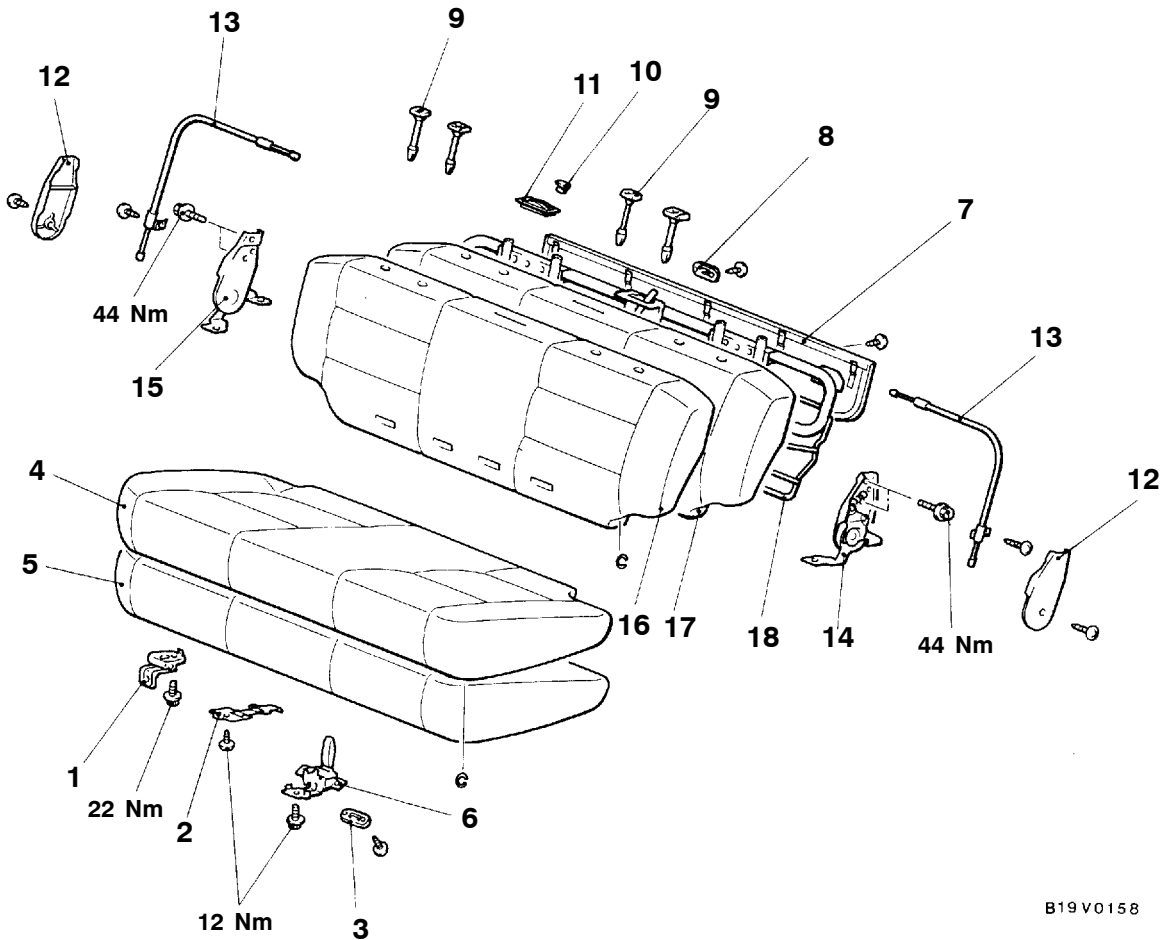

B19V0158

Rear seat cushion disassembly steps

1. Hinge
2. Band
3. Lock cover
4. Rear seat cushion cover
5. Rear seat cushion pad
6. Lock bracket

Rear seatback disassembly steps

7. Panel

8. Shelf clip
9. Head restraint guide
10. Knob
11. Garnish
12. Reclining cover
13. Control cable
14. Reclining adjuster <L.H.>
15. Reclining adjuster, outer <R.H.>
16. Rear seatback cover
17. Rear seatback pad
18. Rear seatback frame

<Split seat>

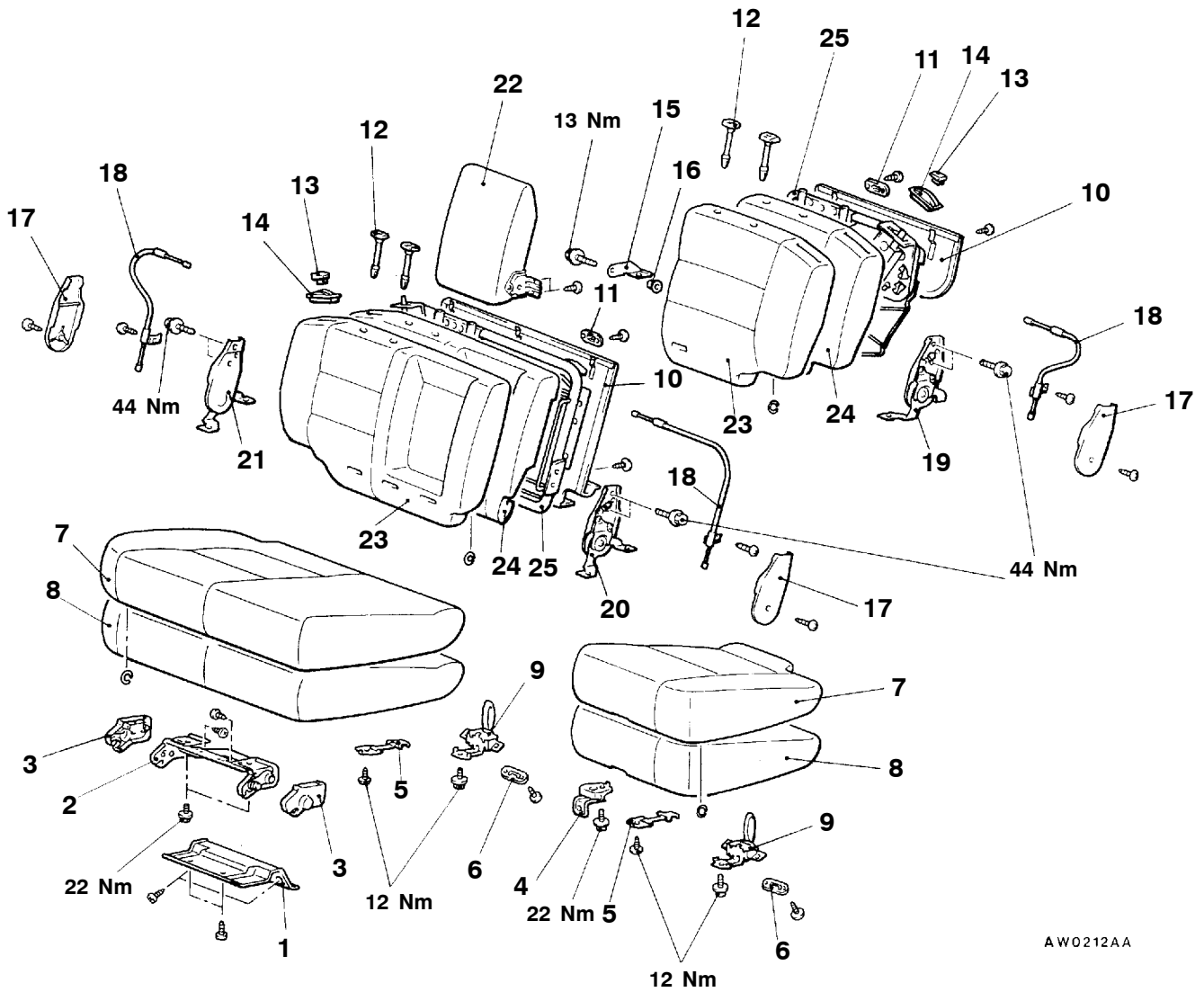

AW0212AA

Rear seat cushion disassembly steps ◀▶

1. Bottom cover
2. Lever assembly
3. Bracket cover
4. Hinge
5. Band
6. Lock cover
7. Rear seat cushion cover
8. Rear seat cushion pad
9. Lock bracket

Rear seatback disassembly steps

10. Panel
11. Shelf clip

12. Head restraint guide
13. Knob
14. Garnish
15. Hinge bracket
16. Bush
17. Reclining cover
18. Control cable
19. Reclining adjuster <L.H.>
20. Reclining adjuster, inner <L.H.>
21. Reclining adjuster, outer <R.H.>
22. Armrest
23. Rear seatback cover
24. Rear seatback pad
25. Rear seatback frame

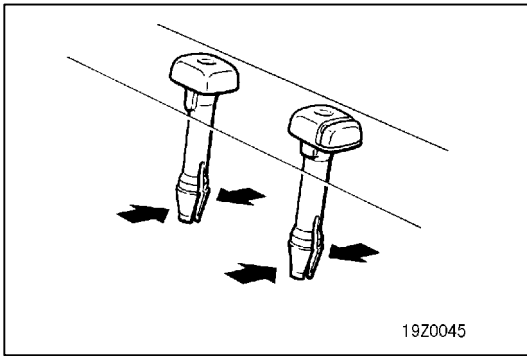

DISASSEMBLY SERVICE POINT

◀A▶ HEAD RESTRAINT GUIDE REMOVAL

**FRONT SEAT BELT
REMOVAL AND INSTALLATION**

52300130317

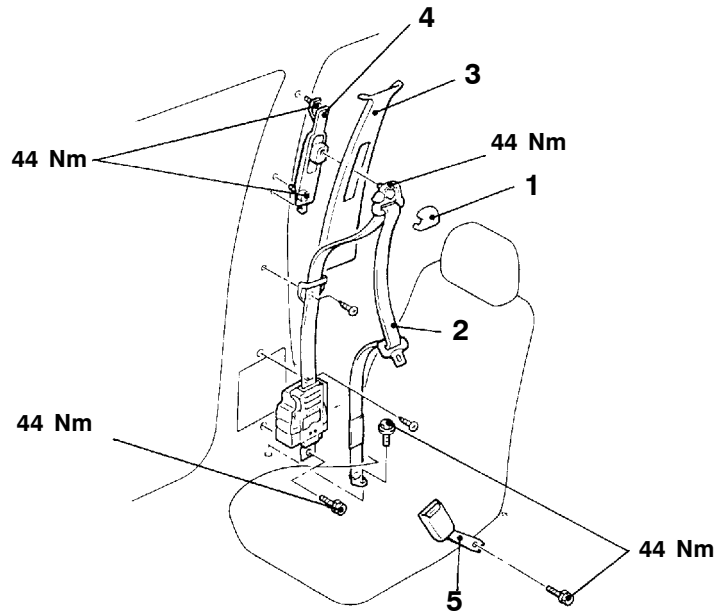

BT0141AA

Outer seat belt removal steps

- Center pillar trim, lower (refer to P.52A-13.)
- 1. Sash guide cover
- 2. Outer seat belt
- 3. Center pillar trim, upper (refer to P.52A-13.)
- 4. Adjustable seat belt anchor

Inner seat belt removal steps

- Front seat (refer to P.52A-15.)
- 5. Inner seat belt

REAR SEAT BELT REMOVAL AND INSTALLATION

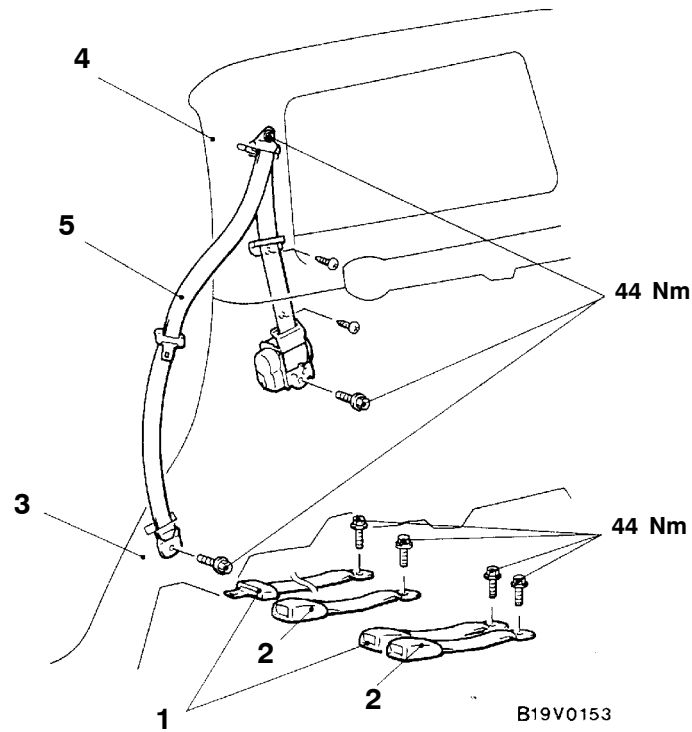

1. Center seat belt
2. Inner seat belt

Outer seat belt removal step

3. Quarter trim, lower (refer to P.52A-13.)
4. Quarter trim, upper (refer to P.52A-13.)
5. Outer seat belt

SUPPLEMENTAL RESTRAINT SYSTEM (SRS)

CONTENTS

52409000285

GENERAL INFORMATION	2	WARNING/CAUTION LABELS	21
SRS SERVICE PRECAUTIONS	3	FRONT IMPACT SENSORS	22
SERVICE SPECIFICATION	5	SRS AIR BAG CONTROL UNIT (SRS-ECU)	24
SEALANT	5	AIR BAG MODULES AND CLOCK SPRING	25
SPECIAL TOOLS	5	AIR BAG MODULE DISPOSAL PROCEDURES	33
TEST EQUIPMENT	5	Undeployed Air Bag Module Disposal	33
TROUBLESHOOTING	6	Deployed Air Bag Module Disposal Procedures	38
SRS MAINTENANCE	14	SENSOR CABLE INSTALLATION PROCEDURES	39
POST-COLLISION DIAGNOSIS	18		
INDIVIDUAL COMPONENT SERVICE	20		

CAUTION

- Carefully read and observe the information in the SRS SERVICE PRECAUTIONS (P.52B-3.) prior to any service.
- For information concerning troubleshooting or maintenance, always observe the procedures in the Troubleshooting (P.52B-6.) section.
- If any SRS components are removed or replaced in connection with any service procedures, be sure to follow the procedures in the INDIVIDUAL COMPONENT SERVICE section (P.52-20.) for the components involved.
- If you have any questions about the SRS, please contact your local distributor.

GENERAL INFORMATION

To improve safety, the SRS is available as optional part. The SRS consists of two air bag modules, SRS air bag control unit (SRS-ECU), front impact sensors, SRS warning lamp and clock spring. One air bag is located in the centre of the steering wheel and another above the glove box. Each air bag has a folded air bag and an inflator unit. The control unit under the floor console monitors the system and has a safing G-sensor and an analog G-sensor. The front impact sensors are installed in the fender

shield panel. The warning lamp on the instrument panel indicates the operational status of the SRS. The clock spring is installed in the steering column. Only authorized service personnel should do work on or around the SRS components. Those service personnel should read this manual carefully before starting any such work. Extreme care must be used when servicing the SRS to avoid injury to the service personnel (by inadvertent deployment of the air bags) or the driver (by rendering the SRS inoperative).

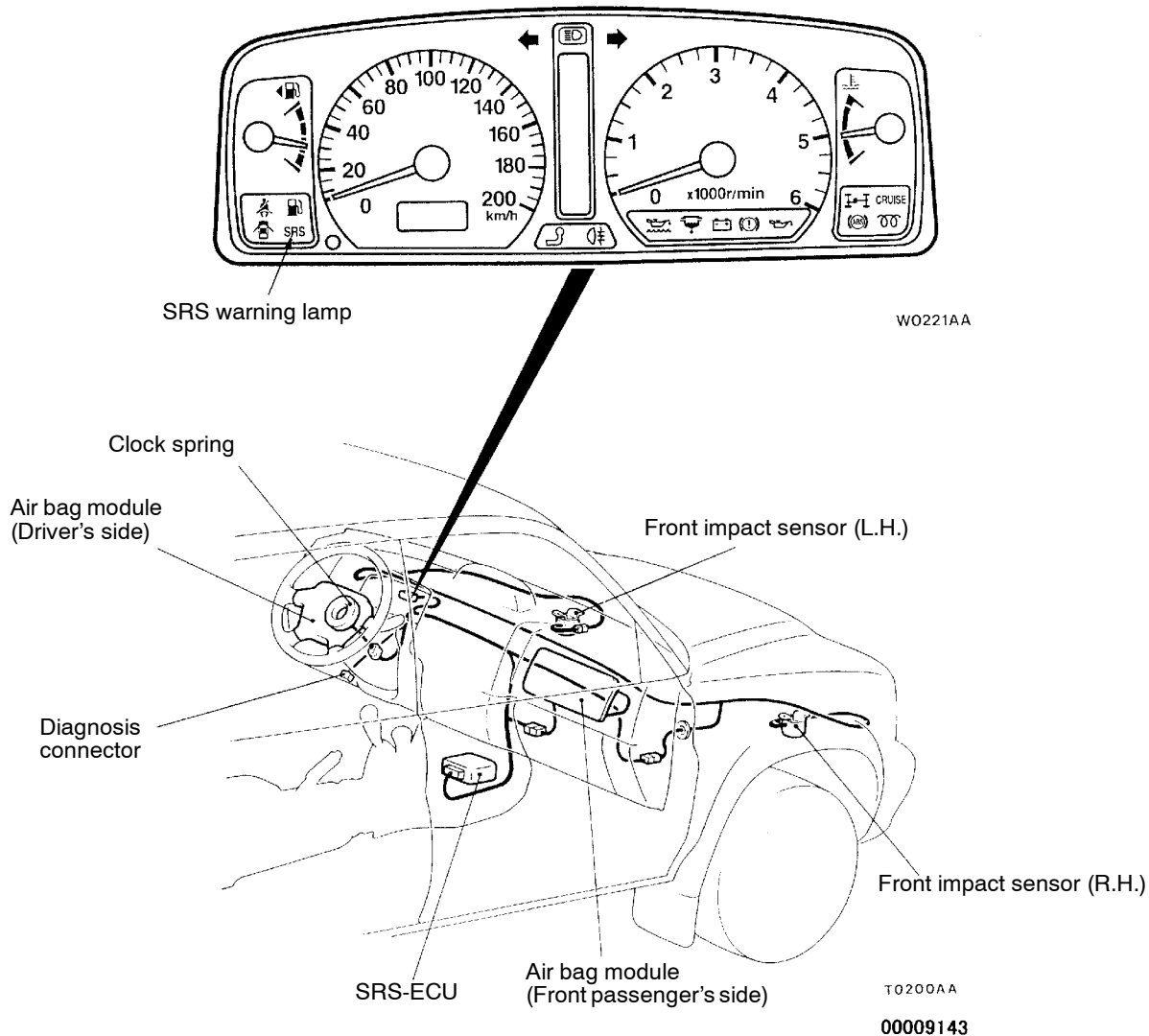

SRS SERVICE PRECAUTIONS

52400030375

1. In order to avoid injury to yourself or others from accidental deployment of the air bag during servicing, read and carefully follow all the precautions and procedures described in this manual.
2. Do not use any electrical test equipment on or near SRS components, except those specified on P.52B-6.
3. **Never Attempt to Repair the Following Components:**
 - SRS air bag control unit (SRS-ECU)
 - Front impact sensor
 - Clock Spring
 - Air Bag Module

If any of these components are diagnosed as faulty, they should only be replaced, in accordance with the INDIVIDUAL COMPONENTS SERVICE procedures in this manual, starting at page 52B-20.

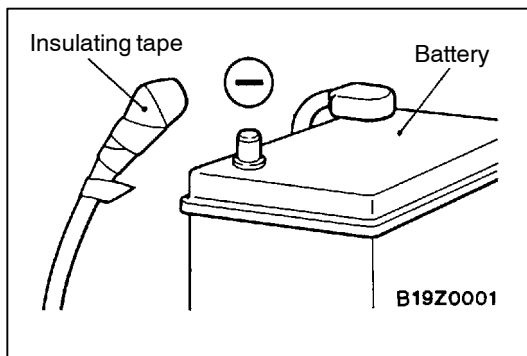

4. **After disconnecting the battery cable, wait 60 seconds or more before proceeding with the following work. The SRS system is designed to retain enough voltage to deploy the air bag for a short time even after the battery has been disconnected, so serious injury may result from unintended air bag deployment if work is done on the SRS system immediately after the battery cables are disconnected.**

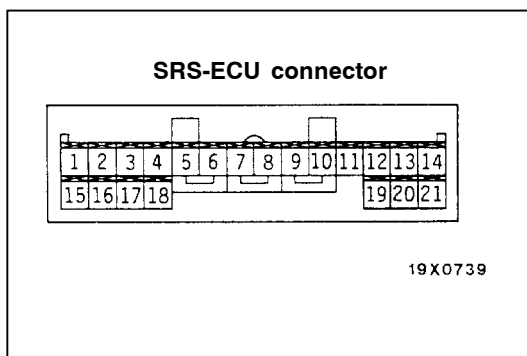

5. Do not attempt to repair the wiring harness connectors of the SRS. If any of the connectors are diagnosed as faulty, replace the wiring harness. If the wires are diagnosed as faulty, replace or repair the wiring harness according to the following table.

SRS-ECU terminal No.	Harness connector (No. of terminals, colour)	Destination of harness	Corrective action
1 to 4	21 pins, yellow	–	–
5, 6		Body wiring harness → Clock spring → Air bag module (Driver's side)	Correct or replace each wiring harness. Replace clock spring.
7, 8		Body wiring harness → Air bag module (Front passenger's side)	Correct or replace each wiring harness.
9,10		–	–
11		Body wiring harness → Diagnosis connector	Correct or replace each wiring harness.
12, 17		Body wiring harness → Front wiring harness→Front impact sensor (L.H.)	Sensor cable* installation procedures (Refer to P.52B-39.)
13		Body wiring harness → Junction block (fuse No.11)	Correct or replace each wiring harness.
14		Body wiring harness → Junction block (fuse No.10)	
15		Body wiring harness → SRS warning lamp	
16		–	–
18, 19		Body wiring harness → Front wiring harness→Front impact sensor (R.H.)	Sensor cable* installation procedures (Refer to P.52B-39.)
20		Body wiring harness → Earth	Correct or replace body wiring harness.
21		–	–

NOTE

*: The sensor cable is available as service part.

6. SRS components should not be subjected to heat over 93°C, so remove the SRS-ECU, air bag module, clock spring and front impact sensors before drying or baking the vehicle after painting.
7. Whenever you finish servicing the SRS, check warning lamp operation to make sure that the system functions properly. (Refer to P.52B-13.)
8. Make certain that the ignition switch is OFF when the MUT-II is connected or disconnected.
9. If you have any questions about the SRS, please contact your local distributor.

NOTE

SERIOUS INJURY CAN RESULT FROM UNINTENDED AIR BAG DEPLOYMENT, SO USE ONLY THE PROCEDURES AND EQUIPMENT SPECIFIED IN THIS MANUAL.

SERVICE SPECIFICATION

52400040132

Item	Standard value
Front impact sensor resistance Ω	2,000 \pm 40

SEALANT

52400060015

Item	Specified sealant	Remark
Sensor cable	3M ATD Part No. 8625 or equivalent	Ribbon sealer

SPECIAL TOOLS

52400070261

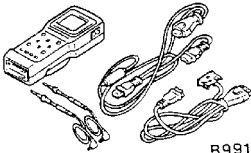
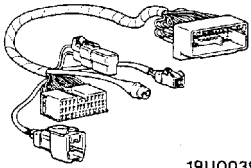
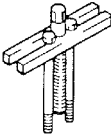
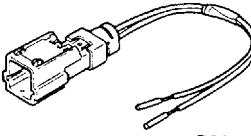
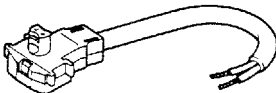
Tool	Number	Name	Use
 B991502	MB991502	MUT-II sub assembly	<ul style="list-style-type: none"> ● Reading diagnosis codes ● Erasing diagnosis code ● Reading trouble period ● Reading erase times
 19U0039	MB991613	SRS check harness	Checking the SRS electrical circuitry
 B990803	MB990803	Steering wheel puller	Steering wheel removal
 B686560	MB686560	SRS air bag adapter harness A	<ul style="list-style-type: none"> ● Deployment of air bag modules inside the vehicle ● Deployment of air bag module (front passenger's side) outside the vehicle
 B628919	MR203491 MB628919	SRS air bag adapter harness B	Deployment of air bag module (driver's side) outside the vehicle

TEST EQUIPMENT

52400080035

Tool	Name	Use
 13R0745	Digital multi-meter	Checking the SRS electrical circuitry Use a multi-meter for which the maximum test current is 2 mA or less at the minimum range of resistance measurement

TROUBLESHOOTING

52400310257

STANDARD FLOW OF DIAGNOSTIC TROUBLESHOOTING

Refer to GROUP 00 – How to Use Troubleshooting/Inspection Service Points.

DIAGNOSIS FUNCTION

52400320205

DIAGNOSIS CODES CHECK

Connect the MUT-II to the diagnosis connector (16-pin) under the instrument cover, then check diagnosis codes.

(Refer to GROUP 00 – How to Use Troubleshooting/Inspection Service Points.)

ERASING DIAGNOSIS CODES**WHEN USING THE MUT-II**

Connect the MUT-II to the diagnosis connector and erase the diagnosis code.

Caution

Turn off the ignition switch before connecting or disconnecting the MUT-II.

INSPECTION CHART FOR DIAGNOSIS CODES

52400330369

Inspect according to the inspection chart that is appropriate for the malfunction code.

Code No.	Diagnosis item	Reference page	
11, 12, 13	Front impact sensor system	52B-7	
14	Analog G-sensor system in the SRS-ECU	52B-8	
15,16	Safing G-sensor system in the SRS-ECU	52B-8	
21, 22, 61, 62	Driver's side air bag module (squib) system	52B-9	
24, 25, 64, 65	Front passenger's side air bag module (squib) system	52B-10	
31, 32	SRS-ECU capacitor system	52B-8	
34*	Connector lock system	52B-10	
35	SRS-ECU (deployed air bag) system	52B-11	
41*	Power circuit system (fuse No.10 circuit)	52B-11	
42*	Power circuit system (fuse No.11 circuit)	52B-11	
43	SRS warning lamp drive circuit system	Lamp does not illuminate.*	52B-12
		Lamp does not switch off.	52B-12
44	SRS warning lamp drive circuit system	52B-13	
45	SRS-ECU non-volatile memory (EEPROM) and A/D converter system	52B-8	
51, 52	Driver's side air bag module (squib ignition drive circuit) system	52B-8	
54, 55	Front passenger's side air bag module (squib ignition drive circuit) system	52B-8	

NOTE

- *: If the vehicle condition returns to normal, the diagnosis code will be automatically erased, and the SRS warning lamp will return to normal.
- If the vehicle has a discharged battery it will store the fault codes 41 or 42. When these diagnosis codes are displayed, check the battery.

INSPECTION PROCEDURE CLASSIFIED BY DIAGNOSIS CODE

Code No.11, 12 or 13 Front impact sensor system	Probable cause
These diagnostic trouble codes are output if there is abnormal resistance between the input terminals of the front impact sensors. The trouble causes for each diagnosis code No. are as follows.	<ul style="list-style-type: none"> ● Malfunction of front impact sensor ● Malfunction of wiring harness of connectors ● Malfunction of SRS-ECU

Code No.	Trouble Symptom
11	<ul style="list-style-type: none"> ● Short circuit in front impact sensor or harness ● Short circuit in front impact sensor harness leading to the vehicle body ground ● Short circuit in front impact sensor harness leading to the power supply
12	<ul style="list-style-type: none"> ● Open circuit in either left or right front impact sensor or harness ● Short circuit in front impact sensor harness leading to the power supply
13	<ul style="list-style-type: none"> ● Open circuit in both left and right front impact sensor or harness ● Short circuit in front impact sensor harness leading to the power supply

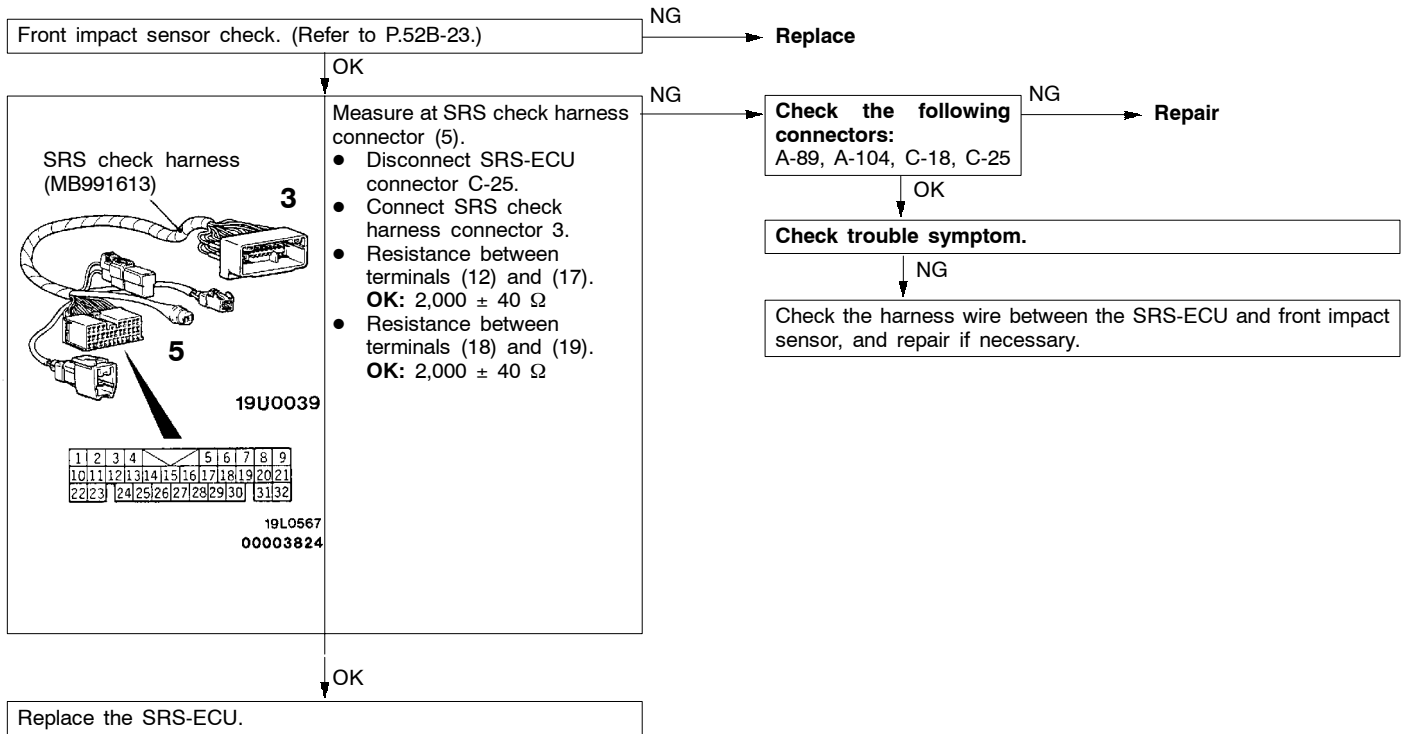

Code No. 14, 15, 16, 31, 32, 45, 51, 52, 54, 55 System inside SRS-ECU	Probable cause
These diagnostic trouble codes are output when a fault is detected in the SRS-ECU. The trouble causes for each diagnosis code No. are as follows.	<ul style="list-style-type: none"> ● Malfunction of SRS-ECU

Code No.	Defective part	Trouble Symptom
14	Analog G-sensor	<ul style="list-style-type: none"> ● When the analog G-sensor is not operating ● When the characteristics of the analog G-sensor are abnormal ● When the output from the analog G-sensor is abnormal
15	Safing G-sensor	<ul style="list-style-type: none"> ● Short circuit in the safing G-sensor
16		<ul style="list-style-type: none"> ● Open circuit in the safing G-sensor
31	Capacitor	<ul style="list-style-type: none"> ● Voltage at the capacitor terminal is higher than the specified value for five seconds or more
32		<ul style="list-style-type: none"> ● Voltage at the capacitor terminal is lower than the specified value for five seconds or more (this is not detected if diagnostic trouble code No.41 or 42 indicating battery voltage drop has been output.)
45	Non-volatile memory (EEPROM) and A/D converter	<ul style="list-style-type: none"> ● When the non-volatile memory (EEPROM) and A/D converter system are abnormal
51	Driver's side air bag module (squib ignition drive circuit)	<ul style="list-style-type: none"> ● Short circuit in the squib ignition drive circuit
52		<ul style="list-style-type: none"> ● Open circuit in the squib ignition drive circuit
54	Front passenger's side air bag module (squib ignition drive circuit)	<ul style="list-style-type: none"> ● Short circuit in the squib ignition drive circuit
55		<ul style="list-style-type: none"> ● Open circuit in the squib ignition drive circuit

Replace the SRS-ECU.

Code No.21, 22, 61 or 62 Driver's side air bag module (squib) system	Probable cause
These diagnosis codes are output if there is abnormal resistance between the input terminals of the driver's side air bag module (squib). The trouble causes for each diagnosis code No. are as follows.	<ul style="list-style-type: none"> ● Malfunction of clock spring ● Malfunction of wiring harnesses or connectors ● Malfunction of driver's side air bag module (squib) ● Malfunction of SRS-ECU

Code No.	Trouble symptom
21	<ul style="list-style-type: none"> ● Short in driver's side air bag module (squib) or harness short ● Short in clock spring
22	<ul style="list-style-type: none"> ● Open circuit in driver's side air bag module (squib) or open harness ● Open circuit in clock spring ● Malfunction of connector contact
61	<ul style="list-style-type: none"> ● Short in driver's side air bag module (squib) harness leading to the power supply
62	<ul style="list-style-type: none"> ● Short in driver's side air bag module (squib) harness leading to the earth

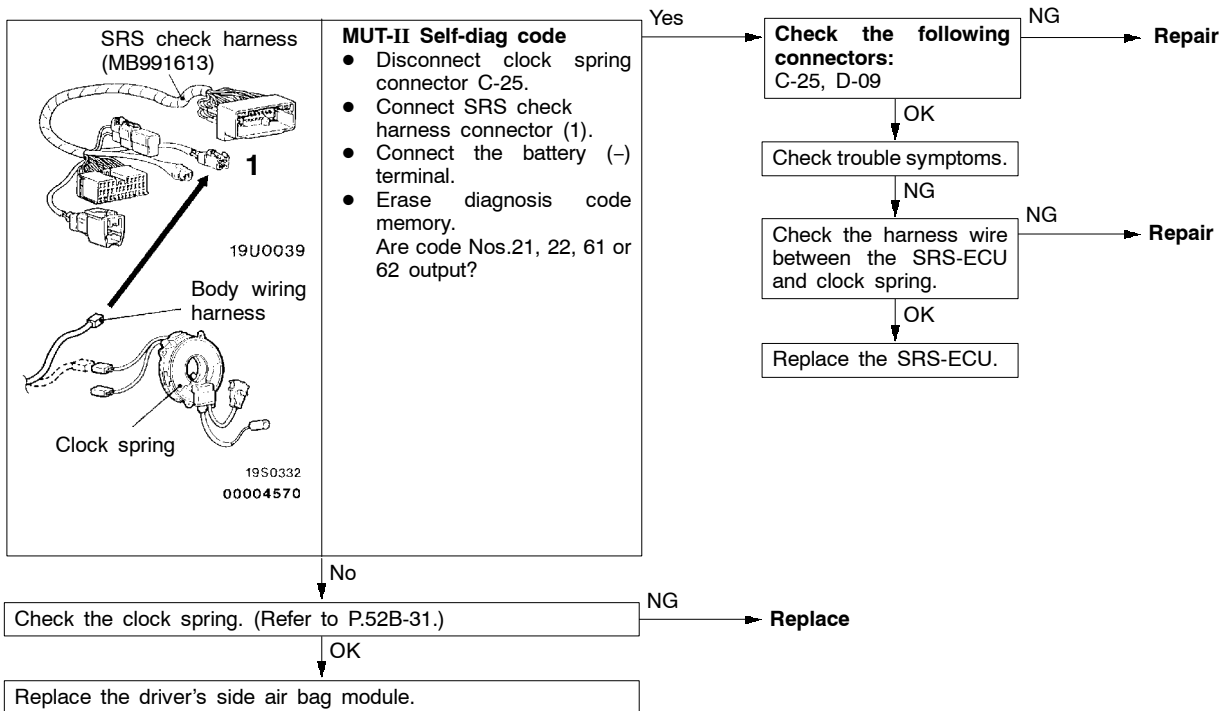

Code No.24, 25, 64 or 65 Front passenger’s side air bag module (squib) system	Probable cause
These diagnosis codes are output if there is abnormal resistance between the input terminals of the driver’s side air bag module (squib). The trouble causes for each diagnosis code No. are as follows.	<ul style="list-style-type: none"> • Malfunction of wiring harnesses or connectors • Malfunction of front passenger’s side air bag module (squib) • Malfunction of SRS-ECU

Code No.	Trouble symptom
24	<ul style="list-style-type: none"> • Short in front passenger’s side air bag module (squib) or harness short
25	<ul style="list-style-type: none"> • Open circuit in front passenger’s side air bag module (squib) or open harness • Malfunction of connector contact
64	<ul style="list-style-type: none"> • Short in front passenger’s side air bag module (squib) harness leading to the power supply
65	<ul style="list-style-type: none"> • Short in front passenger’s side air bag module (squib) harness leading to the earth

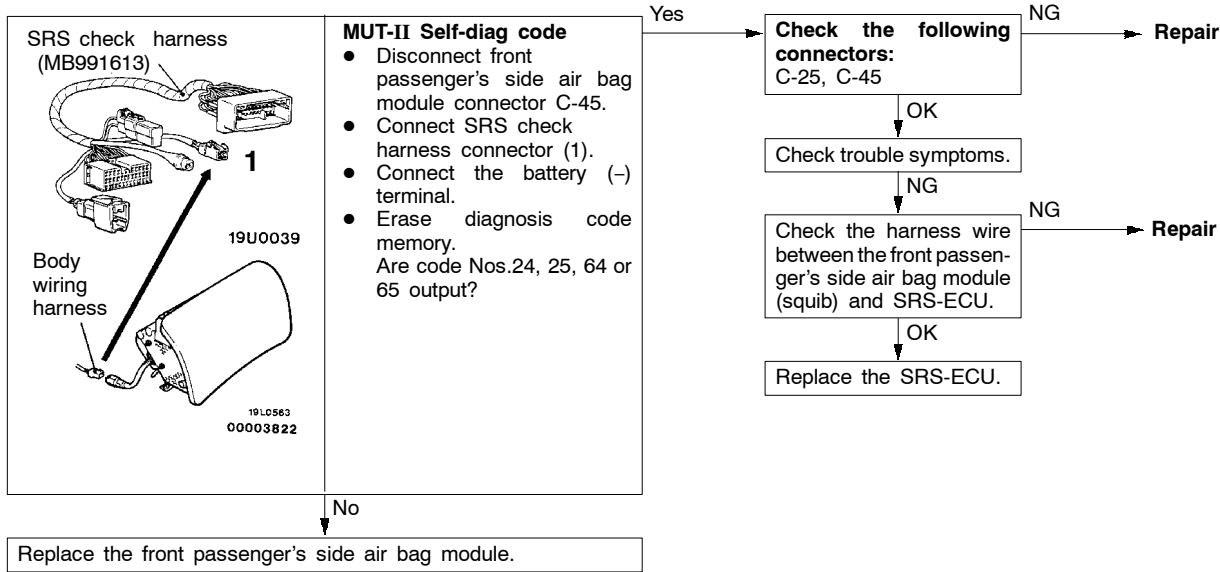

Code No.34 Connector lock system	Probable cause
This diagnosis code is output if a poor connection of the SRS-ECU is detected. However, if the vehicle condition returns to normal, diagnosis code No.34 will be automatically erased, and the SRS warning lamp will switch off.	<ul style="list-style-type: none"> • Malfunction of connectors • Malfunction of SRS-ECU

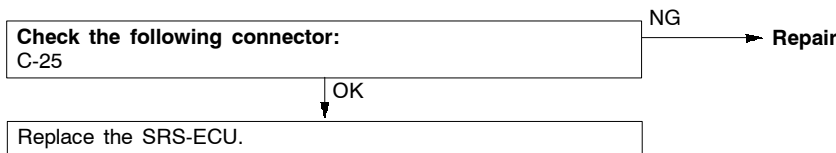

Code No.35 SRS-ECU (deployed air bag) system	Probable cause
This diagnosis code is output after the air bag deploys. If this code is output before the air bag has deployed, the cause is probably a malfunction inside the SRS-ECU.	<ul style="list-style-type: none"> Malfunction of SRS-ECU

Replace the SRS-ECU.

Code No.41 Power circuit system (fuse No.10 circuit)	Probable cause
Code No.42 Power circuit system (fuse No.11 circuit)	
<p>Code No.41 is output if the voltage between the IG₁ terminal (SRS-ECU, terminal 14) and the earth is lower than the specified value for a continuous period of five seconds or more.</p> <p>Code No.42 is output if the voltage between the IG₁ terminal (SRS-ECU, terminal 13) and the earth is lower than the specified value for a continuous period of five seconds or more.</p> <p>Automatically erased, and the SRS warning lamp will switch off.</p> <p>If the vehicle has a discharged battery it will store the fault codes 41 and 42. When these diagnosis codes are displayed, check the battery.</p>	<ul style="list-style-type: none"> Malfunction of wiring harness or connectors Malfunction of SRS-ECU

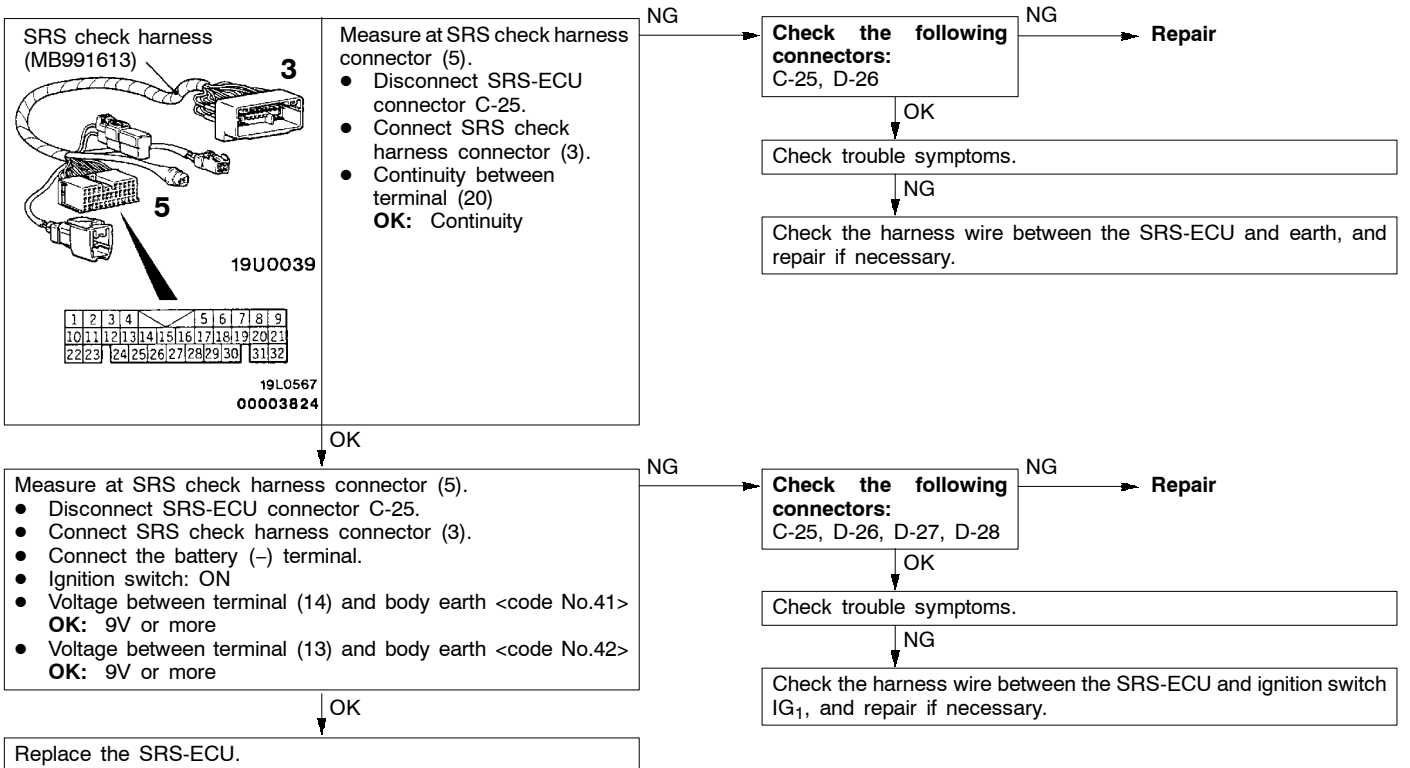

Code No.43 SRS warning lamp drive circuit system (Lamp does not illuminate.)	Probable cause
<p>This diagnosis code is output when an open circuit occurs for a continuous period of 5 seconds while the SRS-ECU in monitoring the SRS warning lamp and the lamp is OFF (transistor OFF). However, if this code is output due to an open circuit, if the vehicle condition returns to normal, this diagnosis code No.43 will be automatically erased, and the SRS warning lamp will return to normal.</p>	<ul style="list-style-type: none"> Malfunction of wiring harnesses or connectors Blown bulb Malfunction of SRS-ECU Malfunction of combination meter

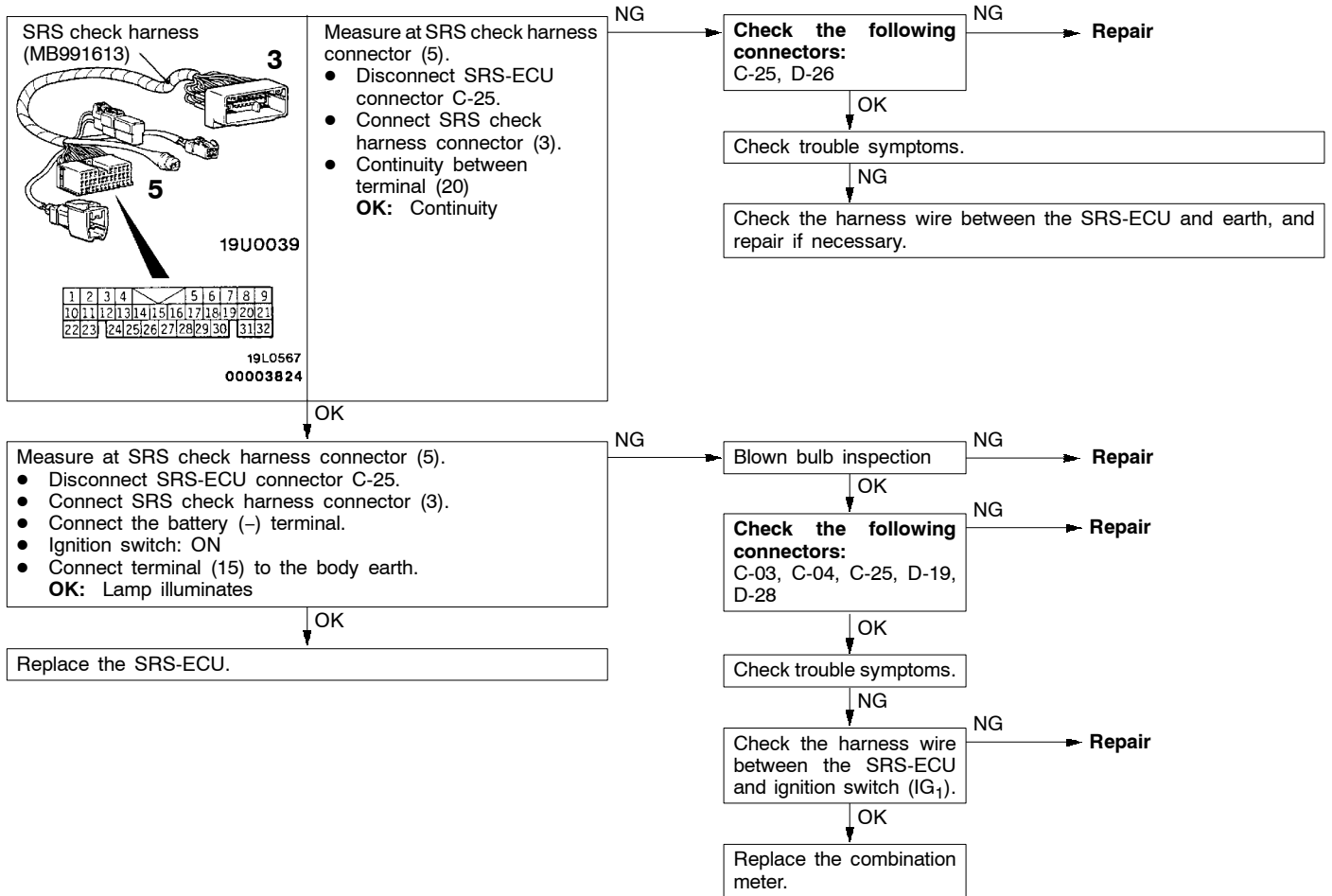

Code No.43 SRS warning lamp drive circuit system (Lamp does not switch off.)	Probable cause
<p>This diagnosis code is output when a short to earth occurs in the harness between the lamp and the SRS-ECU while SRS-ECU is monitoring the SRS warning lamp and the lamp is ON.</p>	<ul style="list-style-type: none"> Malfunction of wiring harnesses or connectors Malfunction of SRS-ECU Malfunction of combination meter

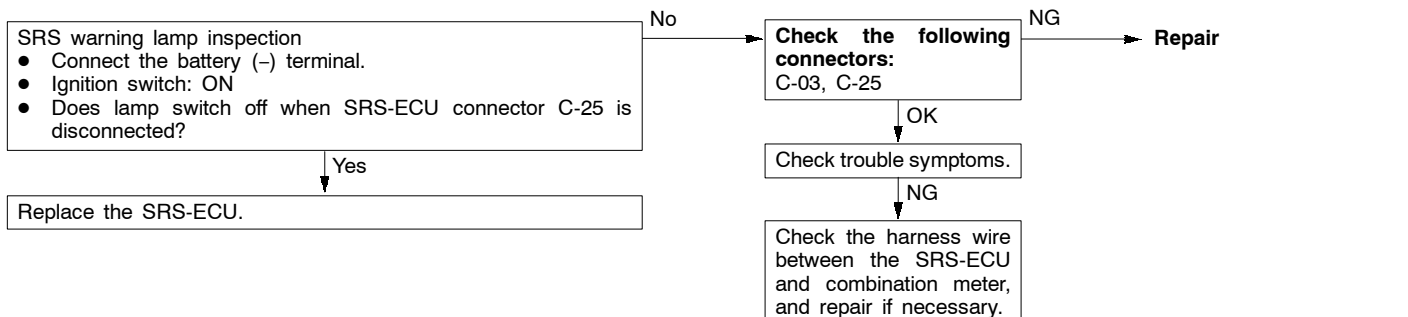

Code No.44 SRS warning lamp drive circuit system	Probable cause
This diagnosis code is output when a short occurs in the lamp drive circuit or a malfunction of the output transistor inside the SRS-ECU is detected while the SRS-ECU is monitoring the SRS warning lamp drive circuit.	<ul style="list-style-type: none"> • Malfunction of wiring harnesses or connectors • Malfunction of SRS-ECU

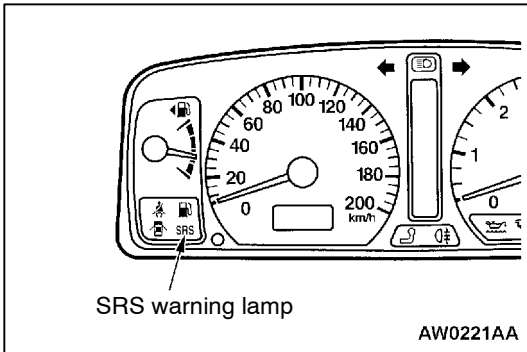
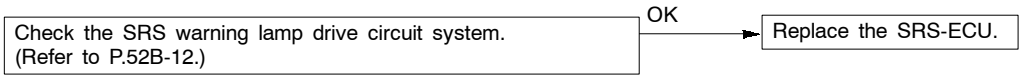

SRS WARNING LAMP INSPECTION

52400430106

1. Check to be sure that the SRS warning lamp illuminates when the ignition switch is in the ON position.
2. Check to be sure that it illuminates for approximately 7 seconds and then switches off.
3. If the above is not the cause, inspect the diagnosis codes.

INSPECTION CHART FOR TROUBLE SYMPTOMS

52400340379

Get an understanding of the trouble symptoms and check according to the inspection procedure chart.

Trouble symptom		Inspection procedure No.	Reference page
Communication with MUT-II is not possible.	Communication with all systems is not possible.	1	52B-13
	Communication is not possible with SRS only.	2	52B-14
When the ignition key is turned to ON (engine stopped), the SRS warning lamp does not illuminate.		Refer to diagnosis code No.43.	52B-12
After the ignition switch is turned to ON, the SRS warning lamp is still on after approximately 7 seconds have passed.		Refer to diagnosis code No.43.	52B-12

INSPECTION PROCEDURE FOR TROUBLE SYMPTOMS

Inspection Procedure 1

Communication with MUT-II is not possible. (Communication with all systems is not possible.)	Probable cause
The cause is probably a power supply system (including earth circuit) of the diagnosis line.	<ul style="list-style-type: none"> • Malfunction of connectors • Malfunction of wiring harness

Refer to GROUP 13A – Troubleshooting.

Inspection Procedure 2

Communication with MUT-II is not possible. (Communication is not possible with SRS only.)	Probable cause
If communication is not possible with the SRS only, the cause is probably an open circuit in the diagnosis output circuit of the SRS or in the power circuit (including earth circuit).	<ul style="list-style-type: none"> ● Malfunction of wiring harnesses or connectors ● Malfunction of SRS-ECU

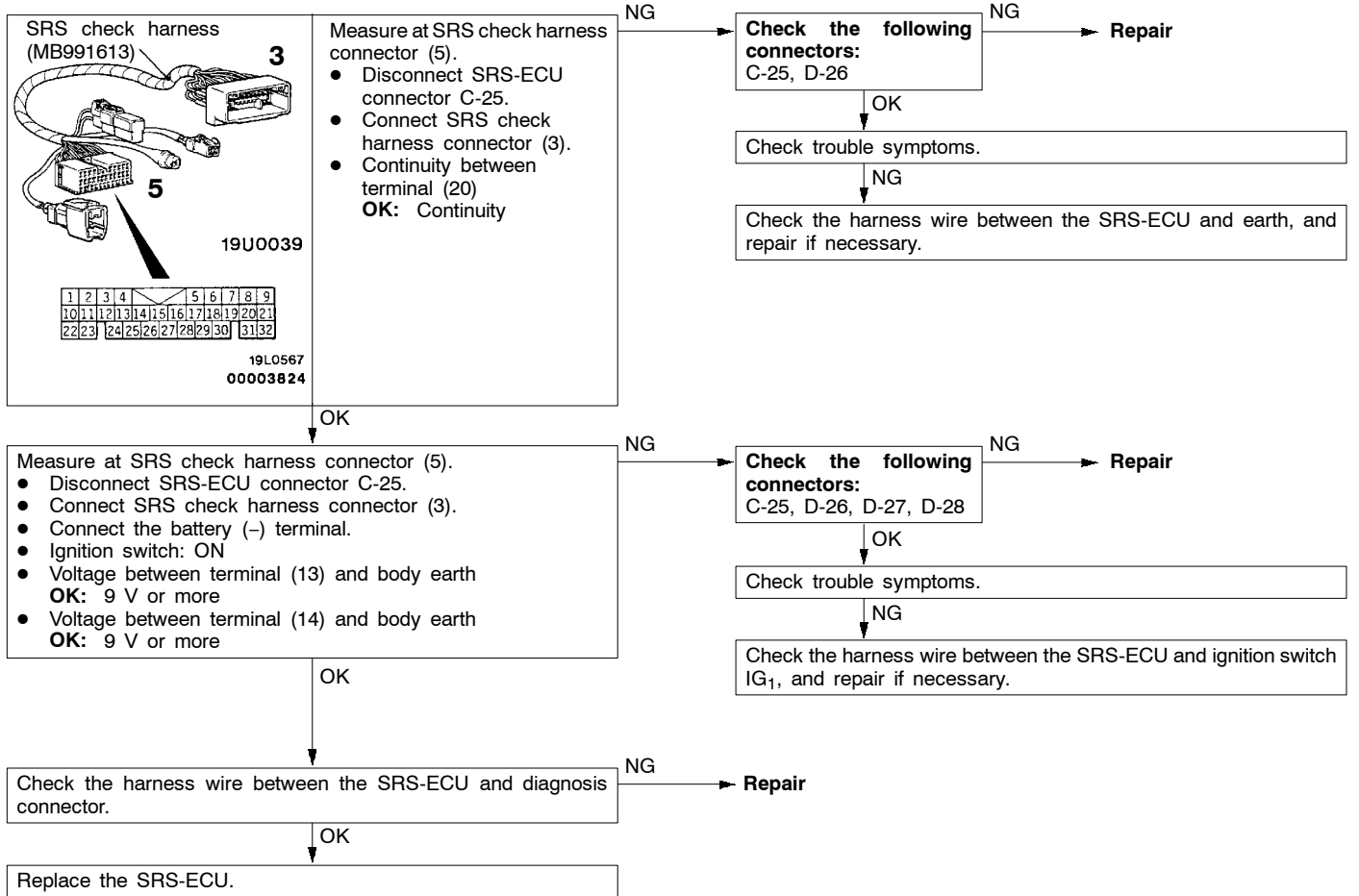

SRS MAINTENANCE

52400390299

The SRS must be inspected by an authorized dealer 10 years after the date of vehicle registration.

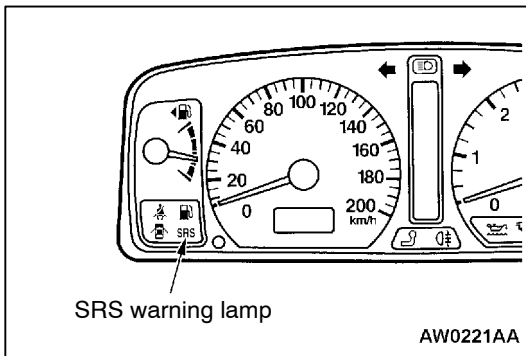

SRS WARNING LAMP CHECK

Turn the ignition key to the ON position. Does the SRS warning lamp illuminate for about 7 seconds, turn off and then remain extinguished for at least 5 seconds? If yes, SRS system is functioning properly. If no, consult page 52B-6.

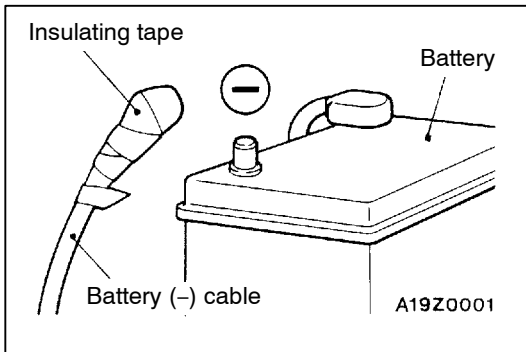

SRS COMPONENT VISUAL CHECK

Turn the ignition key to the LOCK position, disconnect the negative battery cable and tape the terminal.

Caution

Wait at least 60 seconds after disconnecting the battery cable before doing any further work. (Refer to P.52B-3.)

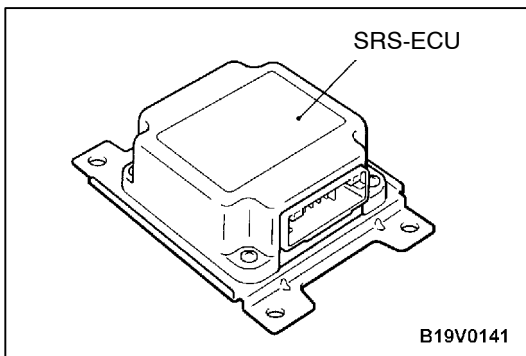

SRS CONTROL UNIT (SRS-ECU)

1. Check SRS-ECU case and brackets for dents, cracks, deformation or rust.

Caution

The SRS may not activate if the SRS-ECU is not installed properly, which could result in serious injury or death to the vehicle's driver or front passenger.

2. Check connector for damage, and terminals for deformation or rust.
Replace SRS-ECU if it fails visual check.
(Refer to P.52B-24.)

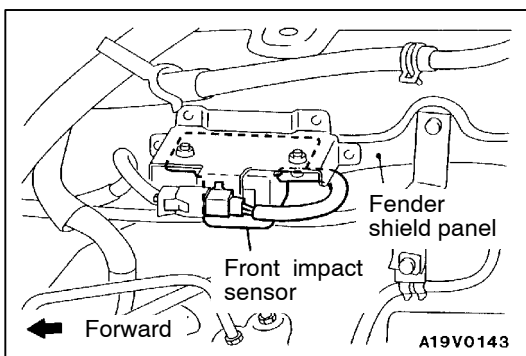

FRONT IMPACT SENSORS

1. Check the fender shield panel for deformation or rust.
2. Check the front impact sensor for dents, cracks, deformation or rust.
3. Check the sensor harnesses for binding, the connectors for damage, and the terminals for deformation.

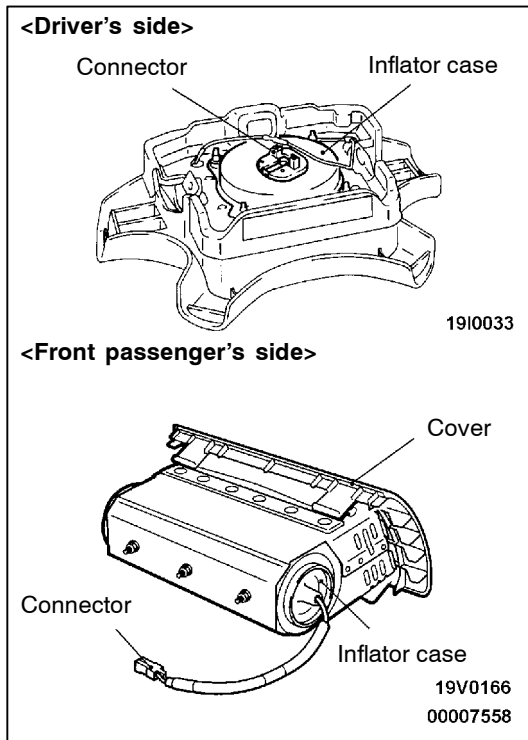

AIR BAG MODULES, STEERING WHEEL AND CLOCK SPRING

1. Remove the air bag modules, steering wheel and clock spring. (Refer to P.52B-25.)

Caution

The removed air bag modules should be stored in a clean, dry place with the pad cover face up.

2. Check pad cover for dents, cracks or deformation.
3. Check connector for damage, terminals deformities, and harness for binds.
4. Check air bag inflator case for dents, cracks or deformities.
5. Check harness and connectors for damage, and terminals for deformation.

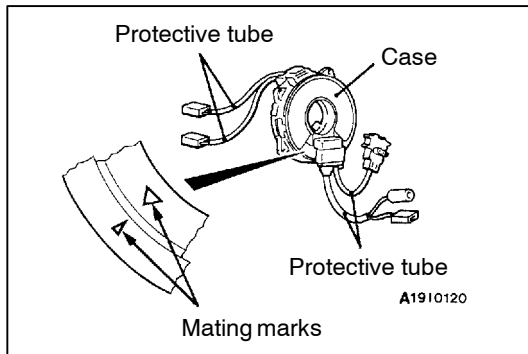

6. Check clock spring connectors and protective tube for damage, and terminals for deformation.
7. Visually check the clock spring case for damage.
8. Align the mating marks of the clock spring and, after turning the vehicle's front wheels to straight-ahead position, install the clock spring to the column switch.

Mating Mark Alignment

Turn the clock spring clockwise fully, and then turn back it approx. 3 4/5 turns counterclockwise to align the mating marks.

Caution

If the clock spring's mating mark is not properly aligned, the steering wheel may not be completely rotational during a turn, or the flat cable within the clock spring may be severed, obstructing normal operation of the SRS and possibly leading to serious injury to the vehicle's driver or front passenger.

9. Install the steering column covers, steering wheel and the air bag module.
10. Check steering wheel for noise, binds or difficult operation.
11. Check steering wheel for excessive free play.
REPLACE ANY VISUALLY INSPECTED PART IF IT FAILS THAT INSPECTION. (Refer to P.52B-25.)

Caution

The SRS may not activate if any of the above components is not installed properly, which could result in serious injury or death to the vehicle's driver or front passenger.

BODY WIRING HARNESS/FRONT WIRING HARNESS

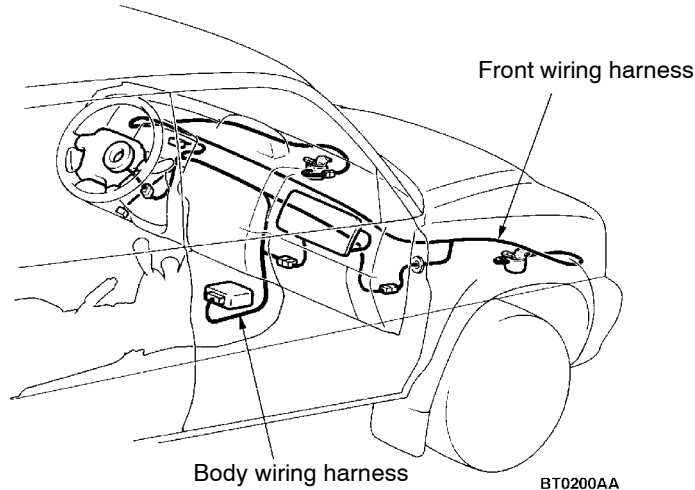

1. Check connector for poor connection.
2. Check harnesses for binds, connectors for damage, and terminals for deformation.
REPLACE ANY CONNECTORS OR HARNESS THAT FAIL THE VISUAL INSPECTION. (Refer to P.52B-3.)

Caution

The SRS may not activate if SRS harnesses or connectors are damaged or improperly connected, which could result in serious injury or death to the vehicle's driver or front passenger.

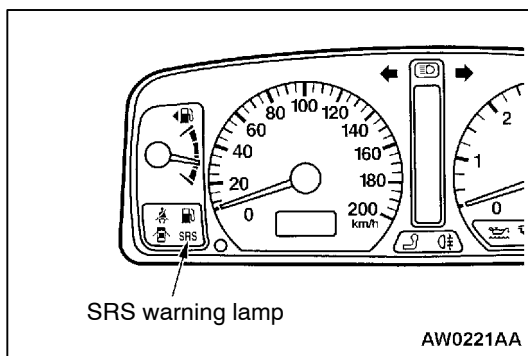

POST-INSTALLATION INSPECTION

Reconnect the negative battery terminal. Turn the ignition key to the ON position. Does the SRS warning lamp illuminate for about 7 seconds, turn off and then remain extinguished for at least 5 seconds? If yes, SRS system is functioning properly. If no, consult page 52B-6.

POST-COLLISION DIAGNOSIS

52400110390

To inspect and service the SRS after a collision (whether or not the air bags have deployed), perform the following steps.

SRS-ECU MEMORY CHECK

1. Connect the MUT-II to the diagnosis connector (16-pin).

Caution

Make certain that the ignition switch is OFF when the MUT-II is connected or disconnected.

2. Read (and write down) all displayed diagnosis codes. (Refer to P.52B-6.)

NOTE

If the battery power supply has been disconnected or disrupted by the collision, the MUT-II cannot communicate with the SRS-ECU. Inspect and, if necessary, repair the body wiring harness before proceeding further.

3. Read the data list (fault duration and how many times memories are erased) using the MUT-II.

Data list

No	Service Data Item	Applicability
91	How long a problem has lasted (how long it takes from the occurrence of the problem till the first air bag squib igniting signal or from the first air bag squib ignition signal till now.)	Maximum time to be stored: 9,999 minutes (approximately seven days)
92	Number indicating how often the memory is cleared	Maximum time to be stored: 250

4. Erase the diagnosis codes and after waiting 5 seconds or more read (and write down) all displayed diagnosis codes. (Refer to P.52B-6.)

REPAIR PROCEDURE

WHEN AIR BAG DEPLOYS IN A COLLISION.

1. Replace the following parts with new ones.
 - SRS-ECU (Refer to P.52B-24.)
 - Air bag module (Refer to P.52B-25.)
 - Front impact sensors (Refer to P.52B-22.)

2. Check the following parts and replace if there are any malfunctions.
 - Clock spring (Refer to P.52B-25.)
 - Steering wheel, steering column and intermediate joint
 - (1) Check wiring harness (built into steering wheel) and connectors for damage, and terminals for deformation.
 - (2) Install air bag module to check fit or alignment with steering wheel.
 - (3) Check steering wheel for noise, binds or difficult operation and excessive free play.
3. Check harnesses for binding, connectors for damage, poor connections, and terminals for deformation. (Refer to P.52B-17.)

WHEN AIR BAG DOES NOT DEPLOY IN LOW-SPEED COLLISION.

Check the SRS components. If the SRS components are showing any visible damage such as dents, cracks, or deformation, replace them with new ones. Concerning parts removed for inspection, replacement with new parts and cautionary points for working, refer to appropriate INDIVIDUAL COMPONENT SERVICE, P.52B-20.

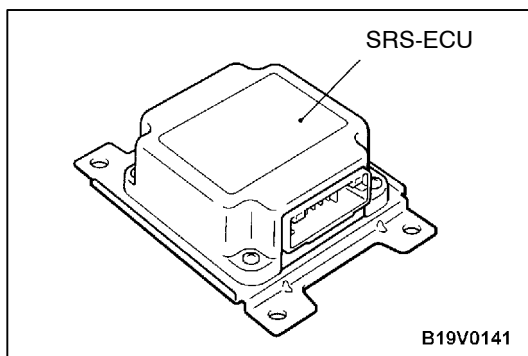

SRS-ECU

1. Check SRS-ECU case and brackets for dents, cracks or deformation.
2. Check connector for damage, and terminals for deformation.

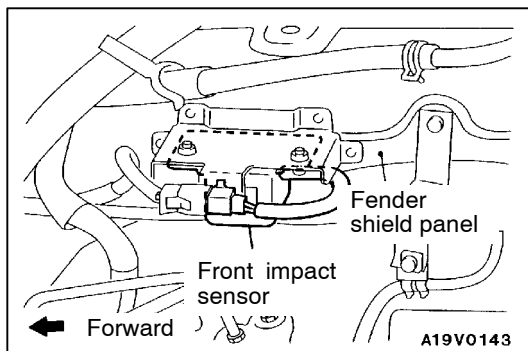

Front impact sensors

1. Check the fender shield panel for deformation or rust.
2. Check the front impact sensor for dents, cracks, deformation or rust.
3. Check the sensor harnesses for binding, the connectors for damage, and the terminals for deformation.

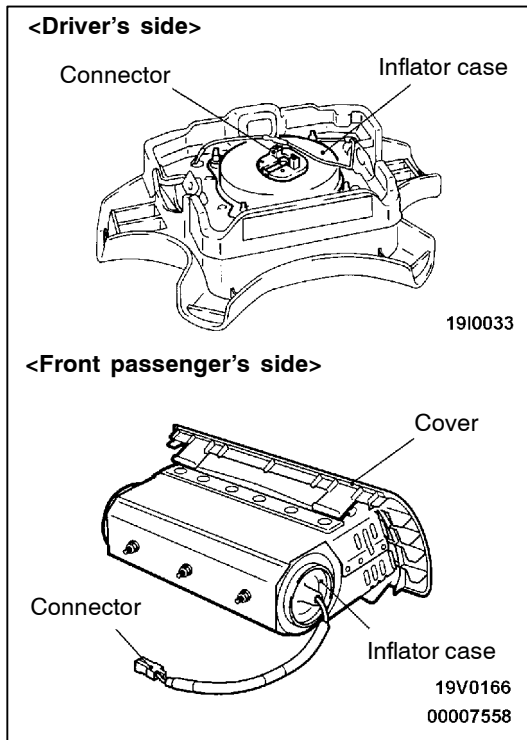

Air bag modules

1. Check pad cover for dents, cracks or deformation.
2. Check connector for damage, terminals deformities, and harness for binds.
3. Check air bag inflator case for dents, cracks or deformities.
4. Install air bag module (driver's side) to steering wheel to check fit or alignment with the wheel.
5. Install the air bag module (front passenger's side) to the instrument panel and crossmember to check fit or alignment.
6. Install the air bag module cover (front passenger's side) to the instrument panel to check fit or alignment.

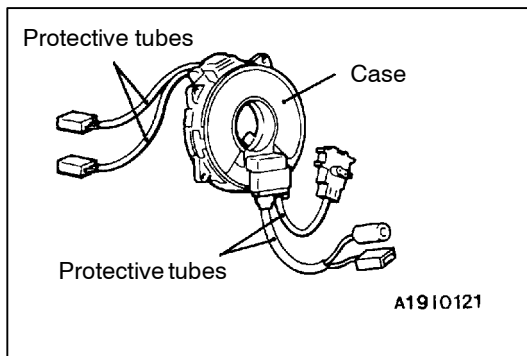

Clock spring

1. Check clock spring connectors and protective tube for damage, and terminals for deformation.
2. Visually check the case for damage.

Steering wheel, steering column and intermediate joint

1. Check wiring harness (built into steering wheel) and connectors for damage, and terminals for deformation.
2. Install air bag module to check fit or alignment with steering wheel.
3. Check steering wheel for noise, binds or difficult operation and excessive free play.

Harness connector (front wiring harness, body wiring harness)

Check harnesses for binding, connectors for damage, poor connection, and terminals for deformation. (Refer to P.52B-17.)

INDIVIDUAL COMPONENT SERVICE

52400290377

If the SRS components are to be removed or replaced as a result of maintenance, troubleshooting, etc., follow each procedure (P.52B-22 – P.52B-32.)

Caution

1. SRS components should not be subjected to heat over 93°C, so remove the SRS-ECU, air bag module and clock spring before drying or baking the vehicle after painting. Recheck SRS system operability after re-installing them.
2. If the SRS components are removed for the purpose of check, sheet metal repair, painting, etc., they should be stored in a clean, dry place until they are reinstalled.

WARNING/CAUTION LABELS

52400300117

A number of caution labels related to the SRS are found in the vehicle, as shown in the following

illustration. Follow label instructions when servicing SRS. If labels are dirty or damaged, replace them.

Steering wheel

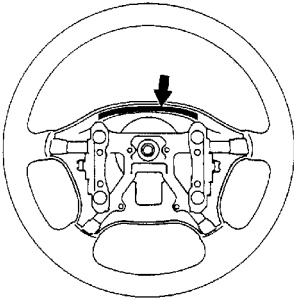

19I0042

Air bag module (Driver's side)

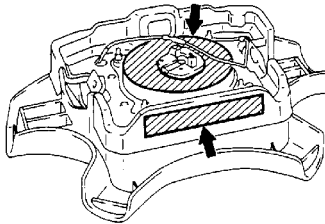

19I0034

Clock spring

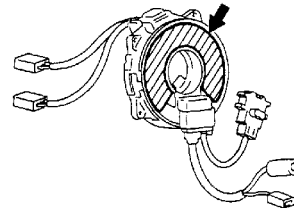

19I0122

Air bag module (Front passenger's side)

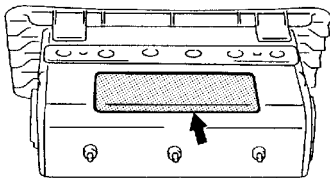

19V0127

SRS-ECU

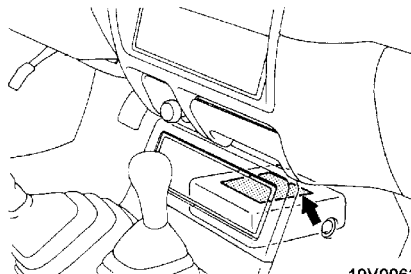

19V0062

Sun visor

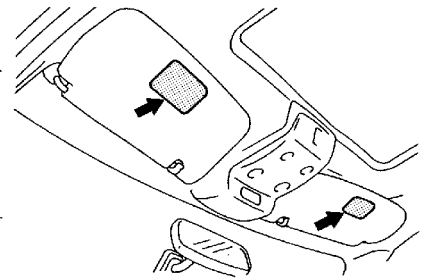

19V0128

Glove box

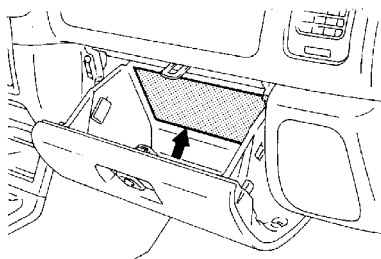

T0235AA

Instrument panel

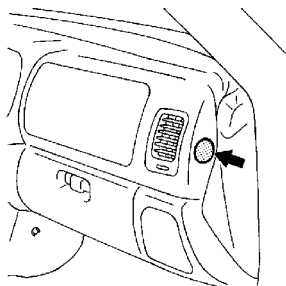

V0656AA

Hood

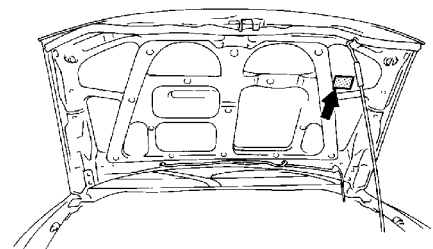

T0236AA

Frame*

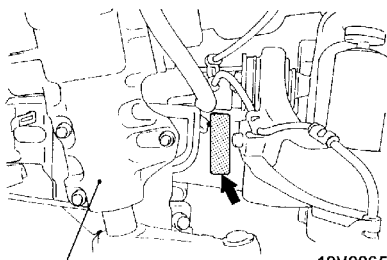

19V0065

Steering gear box

Frame*

Front bumper

Tyre

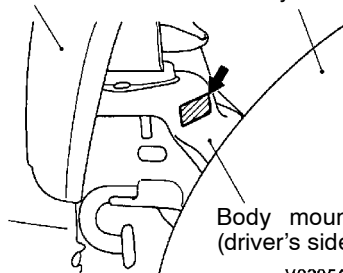

V0205AA

Body mounting bracket (driver's side)

00009144

NOTE

*:The frame label is affixed to one of the positions.

FRONT IMPACT SENSORS

Caution

1. Disconnect the battery (-) terminal and wait for 60 seconds or more before starting work. Furthermore, the disconnected battery terminal should be covered with tape to insulate it. (Refer to P.52B-3.)
2. Never attempt to disassemble or repair the front impact sensor. If faulty, replace it.

3. Do not drop or subject the front impact sensor to impact or vibration. If denting, cracking, deformation, or rust are discovered in the front impact sensor, replace it with a new front impact sensor. Discard the old one.
4. After deployment of an air bag, replace the front impact sensor with a new one.

REMOVAL AND INSTALLATION

Pre-removal Operation

- Turn the ignition key to the LOCK position.

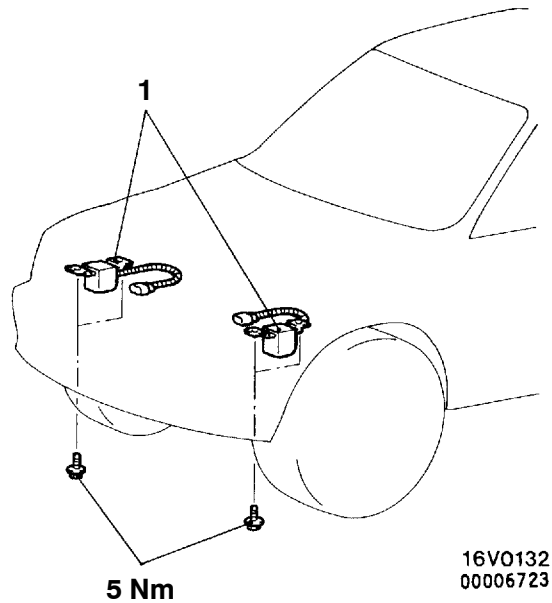
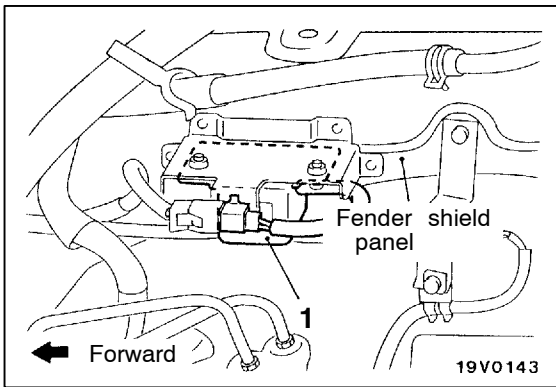

Removal steps

- ▶◀C▶ • Post-installation inspection
- Negative (-) battery cable connection

- ▶◀B▶ 1. Front impact sensor
- ▶◀A▶ • Pre-installation inspection

INSTALLATION SERVICE POINTS

▶◀A▶ PRE-INSTALLATION INSPECTION

To mount the new front impact sensor, visually check it and measure the resistance between the terminals. (Refer to the previous item "INSPECTION")

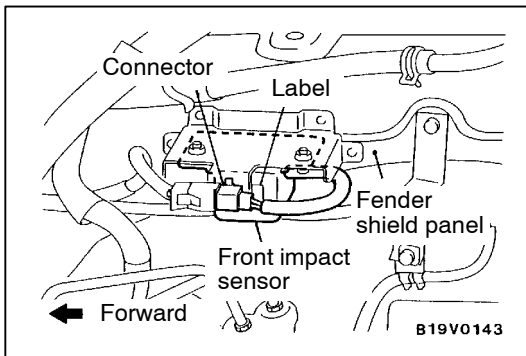

►B◄ FRONT IMPACT SENSOR INSTALLATION

1. Securely connect the connector.
2. Position the front impact sensor facing toward the front of the vehicle as shown by the arrow on the label, and install it securely.

Caution

The SRS may not activate properly if a front impact sensor is not installed properly, which could result in serious injury or death to the vehicle's driver.

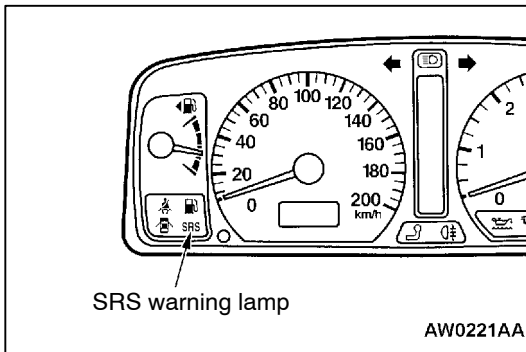

►C◄ POST-INSTALLATION INSPECTION

1. Reconnect the negative battery terminal.
2. Turn the ignition key to the ON position.
3. Does the SRS warning lamp illuminate for about 7 seconds, and then remain extinguished for at least 5 seconds after turning OFF?
4. If yes, SRS system is functioning properly. If no, consult page 52B-6.

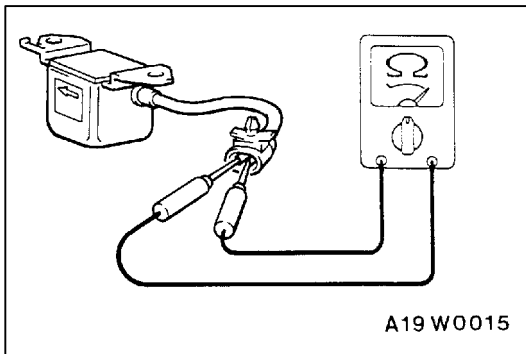

INSPECTION

52400160104

1. Check the front impact sensor for dents, cracks, deformation or rust.

Caution

If a dent, crack, deformation or rust is detected, replace with a new sensor.

2. Measure the resistance between terminals and check whether it is within the standard value.

Standard value: $2,000 \pm 40\Omega$

Caution

Always replace the sensor with a new one if the resistance is not within the standard value.

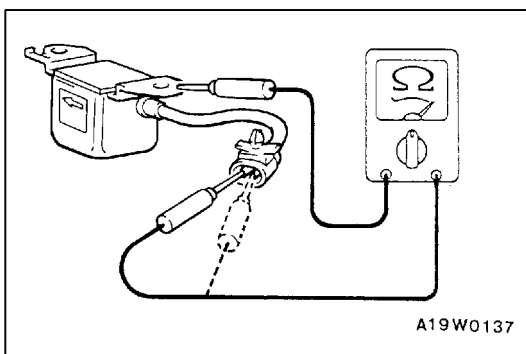

3. Check fender shield panel for deformation or rust.
4. Check the continuity between the terminal and bracket. If there is a continuity, the insulation is malfunctioned, and replace the sensor with a new one.

SRS AIR BAG CONTROL UNIT (SRS-ECU)

52400210281

Caution

1. Disconnect the battery (-) terminal and wait for 60 seconds or more before starting work. Furthermore, the disconnected battery terminal should be covered with tape to insulate it. (Refer to P.52B-3.)
2. Never attempt to disassemble or repair the SRS-ECU. If faulty, replace it.
3. Do not drop or subject the SRS-ECU to impact or vibration.

If denting, cracking, deformation, or rust are discovered in the SRS-ECU, replace it with a new SRS-ECU. Discard the old one.

4. After deployment of an air bag, replace the SRS-ECU with a new one.
5. Never use an ohmmeter on or near the SRS-ECU, and use only the special test equipment described on P.52B-5.

REMOVAL AND INSTALLATION

Pre-removal Operation

- Turn the ignition key to the LOCK position.
- Floor Console Removal (Refer to GROUP 52A – Floor Console.)

Post-installation Operation

- Floor Console Installation (Refer to GROUP 52A – Floor Console.)

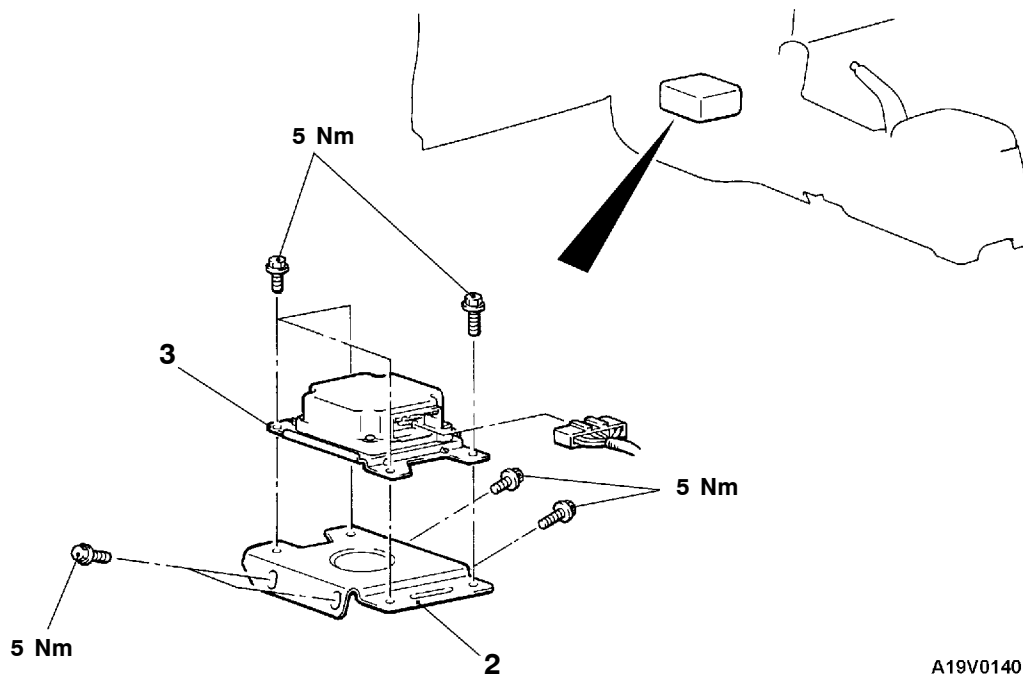

Removal steps

- B◄
- Post-installation inspection
 - Negative (-) battery cable connection
1. SRS-ECU bracket

- A◄ 2. SRS-ECU

INSTALLATION SERVICE POINTS

▶A◀ SRS-ECU INSTALLATION

Caution

The SRS may not activate if SRS-ECU is not installed properly, which could result in serious injury or death to the vehicle's driver or front passenger.

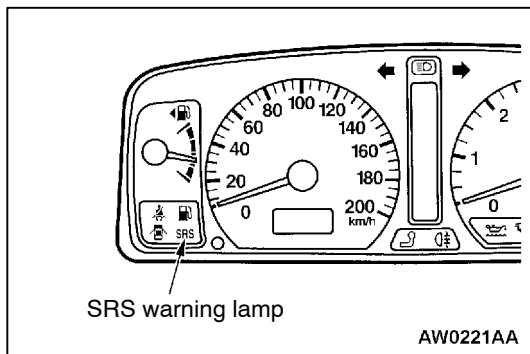

▶B◀ POST-INSTALLATION INSPECTION

1. Reconnect the negative battery terminal.
2. Turn the ignition key to the ON position.
3. Does the SRS warning lamp illuminate for about 7 seconds, and then remain extinguished for at least 5 seconds after turning OFF?
4. If yes, SRS system is functioning properly. If no, consult page 52B-6.

INSPECTION

52400220246

- Check the SRS-ECU and brackets for dents, cracks or deformation.
- Check connector for damage, and terminals for deformation.

Caution

If a dent, crack, deformation or rust is discovered, replace the SRS-ECU with a new one.

NOTE

For checking of the SRS-ECU other than described above, refer to the section concerning troubleshooting. (Refer to P.52B-6.)

AIR BAG MODULES AND CLOCK SPRING

52400240358

Caution

1. Disconnect the battery (-) terminal and wait for 60 seconds or more before starting work. Furthermore, the disconnected battery terminal should be covered with tape to insulate it. (Refer to P.52B-3.)
2. Never attempt to disassemble or repair the air bag modules or clock spring. If faulty, replace it.
3. Do not drop the air bag modules or clock spring or allow contact with water, grease or oil. Replace it if a dent, crack, deformation or rust is detected.
4. The air bag modules should be stored on a flat surface and placed so that the pad surface is facing upward. Do not place anything on top of it.

5. Do not expose the air bag modules to temperatures over 93°C.
6. After deployment of an air bag, replace the air bag modules. Check the clock spring, and if faulty, replace it with a new part.
7. Wear gloves and safety glasses when handling air bags that have already deployed.
8. An undeployed air bag module should only be disposed of in accordance with the procedures (Refer to P.52B-33.)

REMOVAL AND INSTALLATION

<Air bag module (driver’s side), clock spring>

Pre-removal Operation

- After setting the steering wheel and the front wheels to the straight ahead position, remove the ignition key.

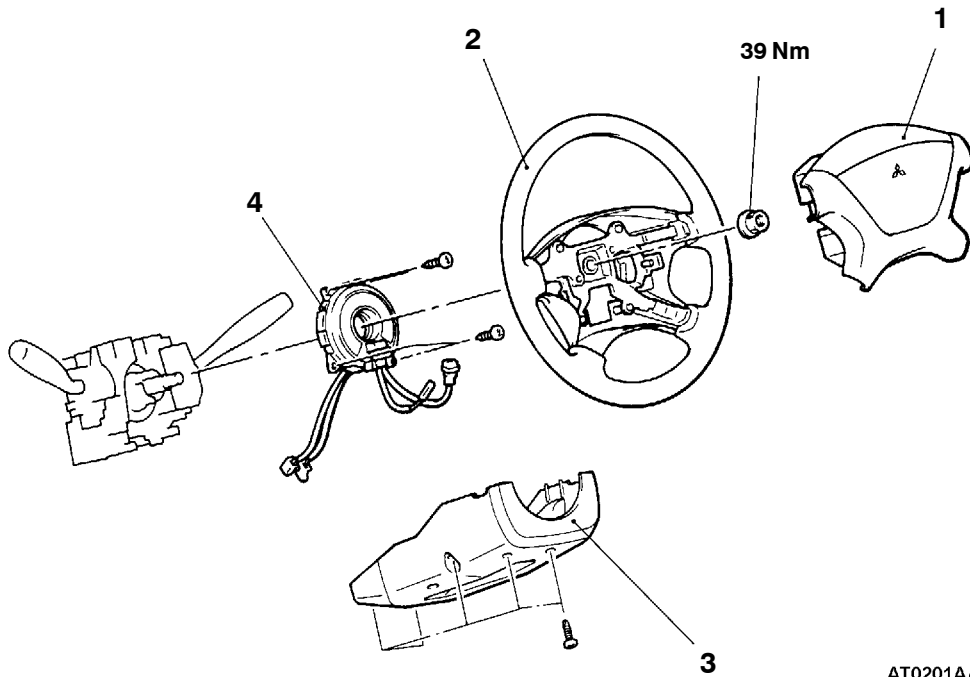

AT0201AA

Air bag module removal steps

- ▶F◀ ● Post-installation inspection
- Negative (-) battery cable connection
- ◀A▶ ▶E◀ 1. Air bag module
- ▶A◀ ● Pre-installation inspection

Clock spring removal steps

- ▶F◀ ● Post-installation inspection
- Negative (-) battery cable connection
- ◀A▶ ▶E◀ 1. Air bag module
- ◀B▶ ▶D◀ 2. Steering wheel
- 3. Column cover lower
- ◀C▶ ▶C◀ 4. Clock spring
- ▶A◀ ● Pre-installation inspection

<Air bag module (front passenger’s side)>

<L.H. drive vehicles>

<R.H. drive vehicles>

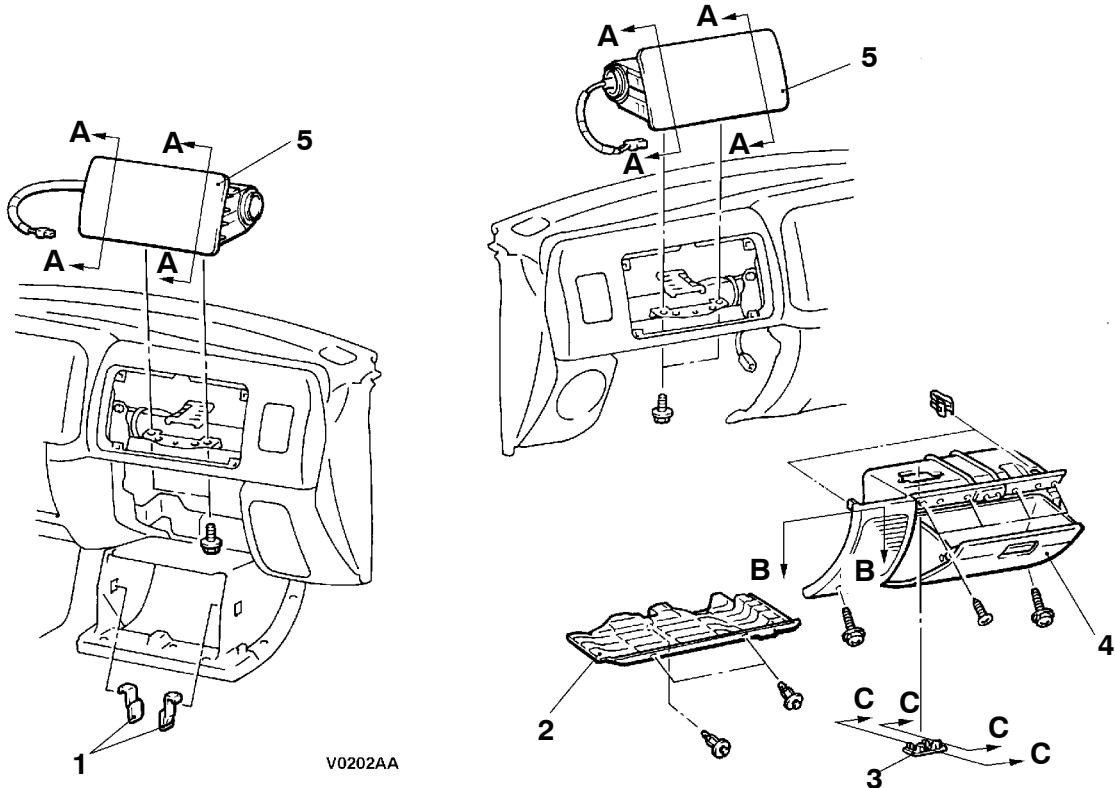

V0202AA

V0444AA
00009145

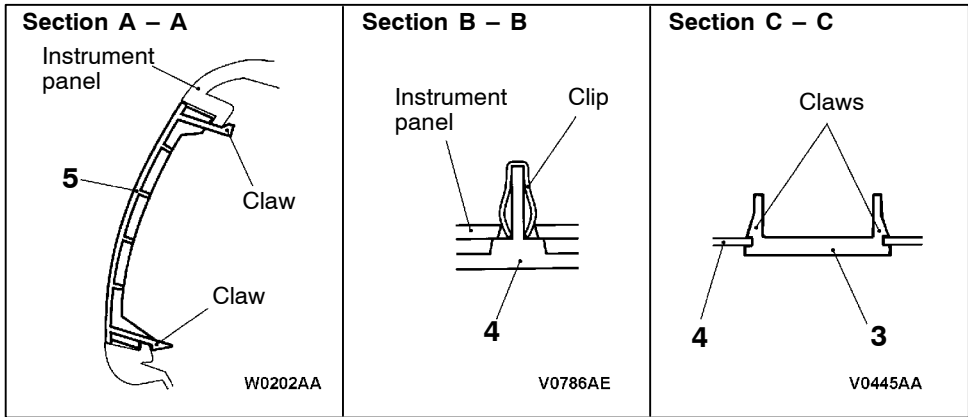

Air bag module removal steps



- Post-installation inspection
- Negative (-) battery cable connection
- 1. Stopper
- 2. Under cover



- 3. Connector plug
- 4. Glove box assembly
- 5. Air bag module



- Pre-installation inspection

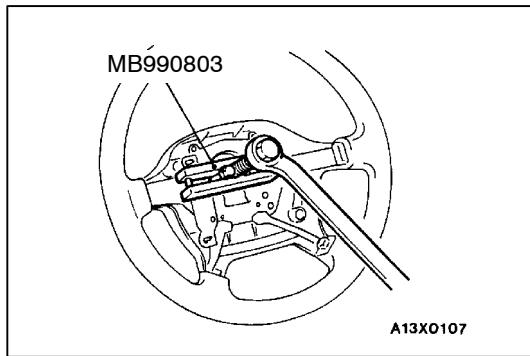
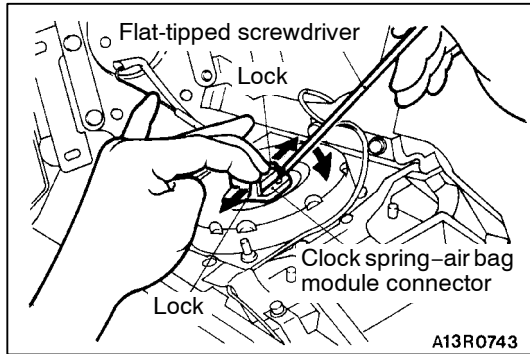
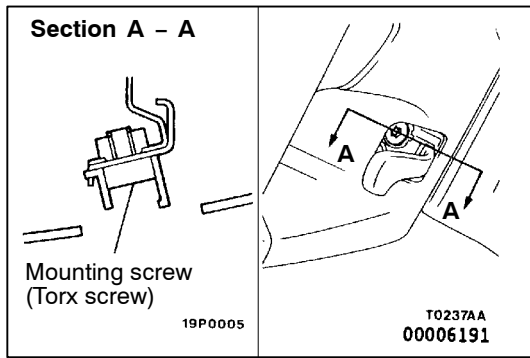

REMOVAL SERVICE POINTS

◀A▶ AIR BAG MODULE REMOVAL (DRIVER’S SIDE)

1. Remove the air bag module mounting screws (Torx screws) at the sides of the steering wheel.

NOTE

Do not remove the screws from the holders.

2. When disconnecting the connector of the clock spring from the air bag module, press the air bag’s lock towards the outer side to spread it open. Use a flat-tipped screwdriver, as shown in the figure at the left, to pry so as to remove the connector gently.

Caution

- (1) When disconnecting the air bag module-clock spring connector, take care not to apply excessive force to it.
- (2) The removed air bag module should be stored in a clean, dry place with the pad cover face up.

◀B▶ STEERING WHEEL REMOVAL

Caution

Do not hammer on the steering wheel. Doing so may damage the collapsible column mechanism.

◀C▶ CLOCK SPRING REMOVAL

Caution

The removed clock spring should be stored in a clean, dry place.

◀D▶ AIR BAG MODULE REMOVAL (FRONT PASSENGER’S SIDE)

Caution

The removed air bag module should be stored in a clean, dry place with the pad cover face up.

INSTALLATION SERVICE POINTS**►A◄ PRE-INSTALLATION INSPECTION**

1. When installing the new air bag modules and clock spring, refer to “INSPECTION”.

Caution

Dispose of air bag modules only according to the specified procedure. (Refer to P.52B-33.)

2. Connect the battery (-) terminal.
3. Connect the MUT-II to the diagnosis connector.

Caution

Make certain that the ignition switch is OFF when the MUT-II is connected or disconnected.

4. Turn the ignition key to the ON position.
5. Conduct self-diagnosis using the MUT-II to ensure entire SRS operates properly, except open circuit of air bag modules.
6. Turn the ignition key to the LOCK position, disconnect the negative battery cable and tape the terminal.

Caution

Wait at least 60 seconds after disconnecting the battery cable before doing any further work. (Refer to P.52B-3.)

►B◄ CONNECTOR PLUG INSTALLATION

Install the connector plug to the glove box assembly after installing the connection between the passenger's side air bag module connector and the body harness connector at the back of the plug.

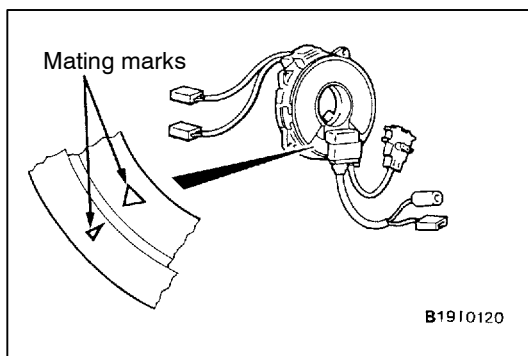
**►C◄ CLOCK SPRING INSTALLATION**

Align the mating marks of the clock spring and, after turning the front wheels to the straight-ahead position, install the clock spring to the column switch.

Mating Mark Alignment

Turn the clock spring clockwise fully, and then turn back it approx. 3 4/5 turns counterclockwise to align the mating marks.

Caution

If the clock spring's mating marks are not properly aligned, the steering wheel may not be completely rotational during a turn, or the flat cable within the clock spring may be severed, obstructing normal operation of the SRS and possibly leading to serious injury to the vehicle's driver.

►D◄ STEERING WHEEL INSTALLATION

1. Before installation the steering wheel, be sure to first turn the vehicle's front wheels to the straight-ahead position and align the mating marks of the clock spring.

Caution

Be sure when installing the steering wheel, that the harness of the clock spring does not become caught or tangled.

2. After clamping, turn the steering wheel all the way in both directions to confirm that steering is normal.

►E◄ AIR BAG MODULE INSTALLATION (DRIVER'S SIDE)

1. Connect the air bag module connector securely.
2. Tighten the air bag module mounting screws.

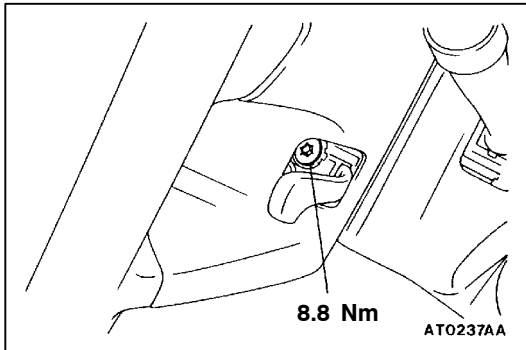
**►F◄ POST-INSTALLATION INSPECTION**

1. Reconnect the negative battery terminal.
2. Turn the ignition key to the ON position.
3. Does the SRS warning lamp illuminate for about 7 seconds, and then remain extinguished for at least 5 seconds after turning OFF?
4. If yes, SRS system is functioning properly. If no, consult page 52B-6.

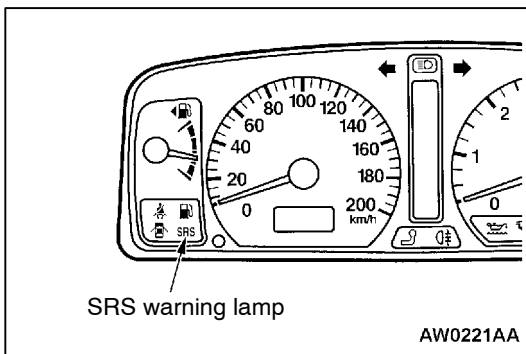

52400250351

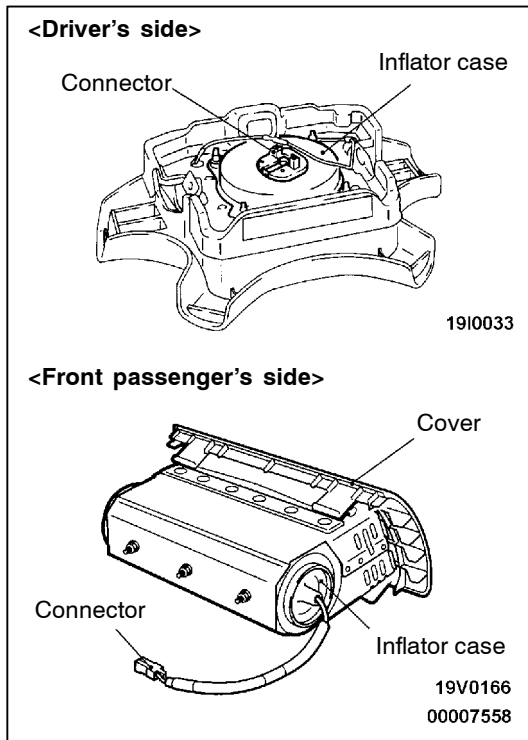
**INSPECTION****AIR BAG MODULE CHECK**

If any improper part is found during the following inspection, replace the air bag modules with a new one. Dispose the old one according to the specified procedure. (Refer to P.52B-33.)

Caution

Never attempt to measure the circuit resistance of the air bag modules (squib) even if you are using the specified tester. If the circuit resistance is measured with a tester, accidental air bags deployment will result in serious personal injury.

1. Check pad cover for dents, cracks or deformation.
2. Check connectors for damage, terminals for deformation, and harness for binds.
3. Check air bag inflator case for dents, cracks or deformation.
4. Install the air bag module (driver's side) to steering wheel to check fit or alignment with the wheel.
5. Install the air bag module (front passenger's side) to the instrument panel and crossmember and check fit and alignment.
6. Install the air bag module cover (front passenger's side) to the instrument panel to check fit and alignment.

Caution

If dents, cracks, deformation, or rust are discovered in the air bag module, replace it with a new one. Dispose of the old one according to the specified procedures. (Refer to P.52B-33.)

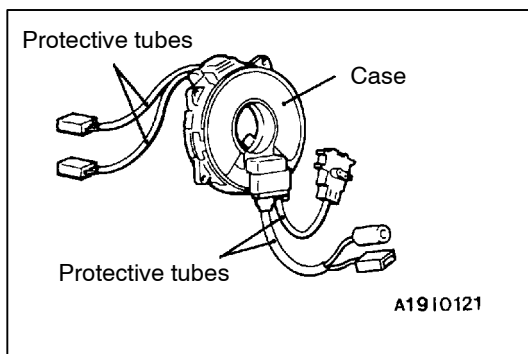
**CLOCK SPRING CHECK**

If, as result of following checks, even one abnormal point is discovered, replace the clock spring with a new one.

1. Check connectors and protective tube for damage, and terminals for deformation.
2. Visually check the case for damage.

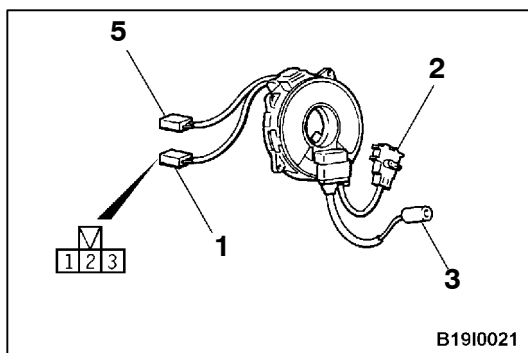

3. Check continuity.

<Vehicles without auto-cruise control>

Check the continuity between the number 1 connector terminal 3 and number 3 connector.

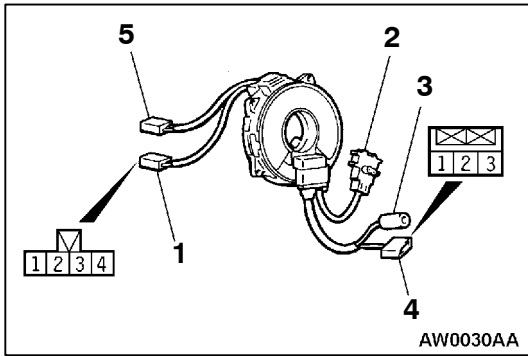

<Vehicles with auto-cruise control>

No.1 connector terminal				No.3 con- nector	No.4 connector terminal		
1	2	3	4		1	2	3
○						○	
	○			○			○
		○		○	○		
			○		○		
To auto-cruise control unit	To ACC power	To horn relay	To ground	To horn switch	To auto-cruise control switch		

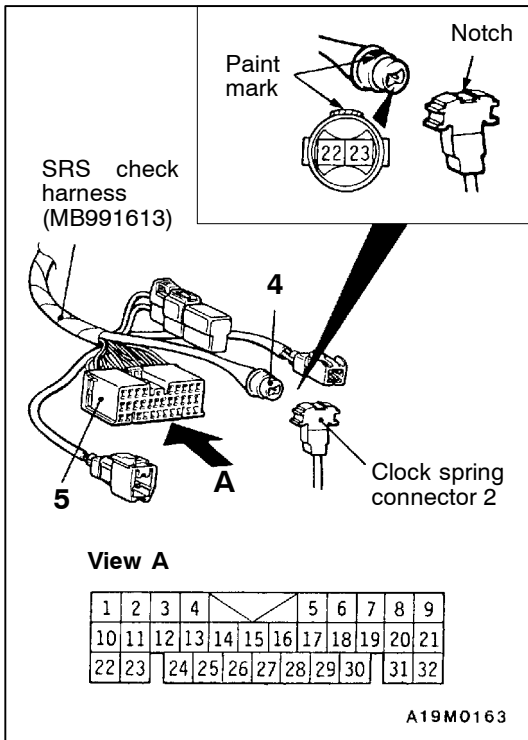

4. Align the paint mark of the SRS check harness connector No.4 with the notch in clock spring connector No.2 to connect the connectors Nos.2 and 4.
5. Check continuity between the terminals 22 and 23 of the SRS check harness connector No.5.

AIR BAG MODULE DISPOSAL PROCEDURES

52400120379

Before disposing of an air bag or a vehicle which is equipped with it, the procedures below are to be followed to deploy them.

UNDEPLOYED AIR BAG MODULE DISPOSAL

Caution

1. If the vehicle is to be scrapped or otherwise disposed of, deploy the air bags inside the vehicle. If the vehicle will continue to be used and only the air bag modules are to be disposed of, deploy the air bags outside the vehicle.
2. Since a large amount of smoke is produced when the air bag is deployed, avoid residential areas whenever possible.
3. Since there is loud noise when the air bags are deployed, avoid residential areas whenever possible. If anyone is nearby, give warning of the impending noise.
4. Suitable ear protection should be worn by personnel performing these procedures or by people in the immediate area.

DEPLOYMENT INSIDE THE VEHICLE

(when disposing of a vehicle)

1. Open all windows and doors of the vehicle. Move the vehicle to an isolated spot.
2. Disconnect the negative (-) and positive (+) battery cables from the battery terminals, and then remove the battery from the vehicle.

Caution

Wait at least 60 seconds after disconnecting the battery cables before doing any further work.
(Refer to P.52B-3.)

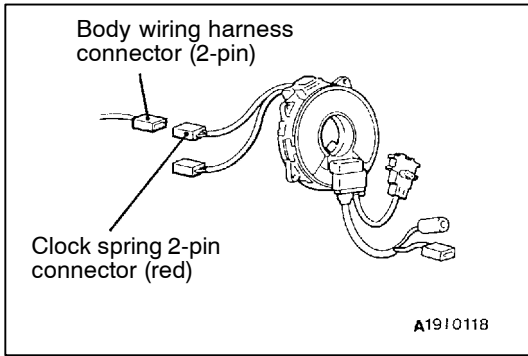

3. To deploy the air bag module (driver's side):
 - (1) Remove the steering column cover lower.
 - (2) Remove the connection between the clock spring 2-pin connector (red) and the body wiring harness connector.

NOTE

If the clock spring connector is disconnected from the body wiring harness, both electrodes of the clock spring connector will be automatically shorted to prevent unintended deployment of the air bag due to static electricity, etc.

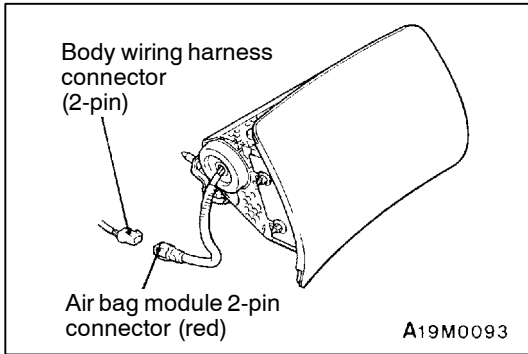

4. To deploy the air bag module (front passenger's side):
 - (1) Remove the glove box. (Refer to P.52B-27.)
 - (2) Remove the connection between the air bag module (front passenger's side) connector (red 2-pin) and the body wiring harness connector.

NOTE

If the air bag module connector is disconnected from the body wiring harness, both electrodes of the air bag module connector will be automatically shorted to prevent unintended deployment of the air bag due to static electricity, etc.

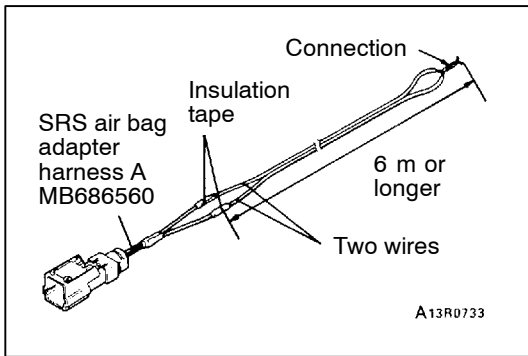

5. Connect two wires, each six meters or longer, to the two leads of SRS air bag adapter harness A and cover the connections with insulation tape. The other ends of the two wires should be connected to each other (short-circuited), to prevent sudden unexpected deployment of the air bag.

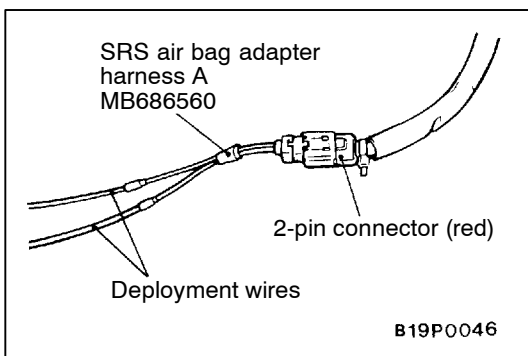

6. Connect the clock spring or air bag module (front passenger's side) 2-pin connector (red) to SRS air bag adapter harness A and pass the deployment wires out of the vehicle.

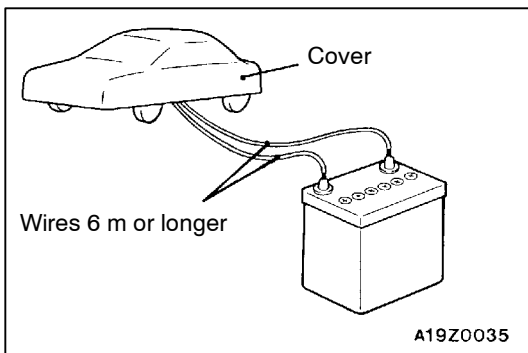

7. Fully close all door windows, close the doors and place a cover over the vehicle to minimize the amount of noise.

Caution

If the glass is damaged, it may break, so the car must be covered.

8. At a location as far away from the vehicle as possible, disconnect the two connected wires from each other, and connect them to the two terminals of the battery (which has been removed from the vehicle) to deploy the air bag.

Caution

- (1) Before deploying the air bag in this manner, first check to be sure that there is no one in or near the vehicle. Wear safety glasses.
 - (2) The inflator will be quite hot immediately following the deployment, so wait at least 30 minutes to allow it to cool before attempting to handle it. Although not poisonous, do not inhale gas from air bag deployment. See Deployed Air Bag Module Disposal Procedures (P.52B-38) for post-deployment handling instructions.
 - (3) If the air bag module fails to deploy when the procedures above are followed, do not go near the module. Contact your local distributor.
9. After deployment, dispose of the air bag module according to the Deployed Air Bag Module Disposal Procedures. (Refer to P.52B-38.)

DEPLOYMENT OUTSIDE THE VEHICLE**Caution**

1. This should be carried out in a wide, flat area at least 6 m away from obstacles and other people.
 2. Do not perform deployment outside, if a strong wind is blowing, and if there is even a slight breeze, the air bag module should be placed and deployed downwind from the battery.
1. Disconnect the negative (-) and positive (+) battery cables from the battery terminals, and then remove the battery from the vehicle.

Caution

Wait at least 60 seconds after disconnecting the battery cables before doing any further work. (Refer to P.52B-3.)

2. Remove the air bag module from the vehicle. (Refer to P.52B-25.)

Caution

The air bag module should be stored on a flat surface and placed so that the pad cover face up. Do not place anything on top of it.

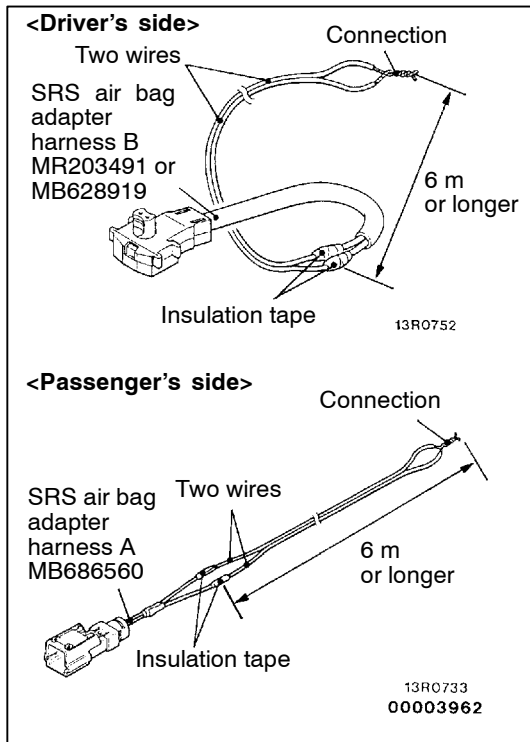

3. Connect two wires, each six meters or longer, to the two leads of SRS air bag adapter harness B <driver's side> or SRS air bag adapter harness A <front passenger's side>, and cover the connections with insulation tape. The other ends of the two wires should be connected to each other (short-circuited), to prevent sudden unexpected deployment of the air bag module.

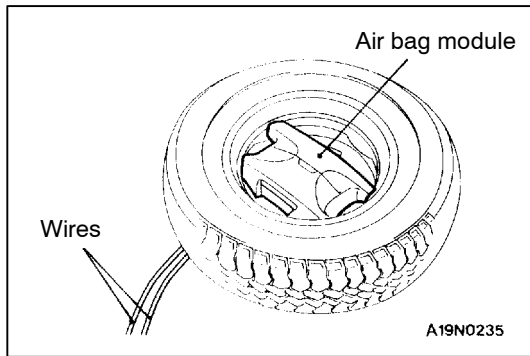

4. Set the air bag modules as follows:

<Air bag module (driver's side)>

- (1) Take the SRS air bag adapter harness B that is connected to the wires, pass it beneath the old tyre wheel assembly, and connect it to the air bag module.
- (2) Pass the thick wire through the air bag module mounting hole, and then secure the air bag module to an old tyre with a wheel in it so that the pad on the module is facing upwards.

Caution

Leave some space below the wheel for the adaptor harness. If there is no space, the reaction when the air bag deploys could damage the adaptor harness.

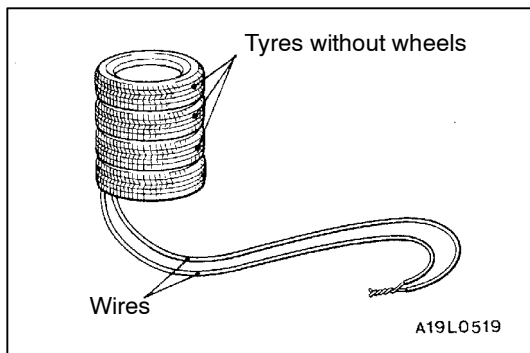

- (3) Place three old tyres with no wheels on top of the tyre secured to the air bag module.

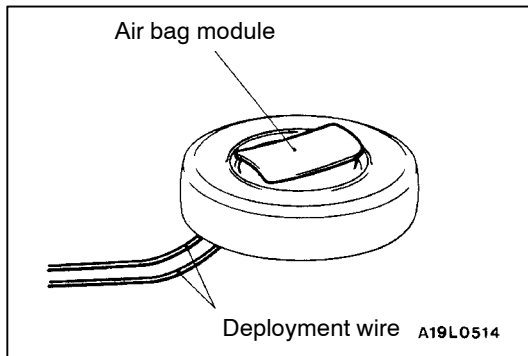

<Air bag module (front passenger's side)>

- (1) Connect the deployment wires to the SRS air bag adaptor harness A, pass it beneath the tyre, and wheel assembly, and connect it to the air bag module.
- (2) Pass the thick wires into the hole of the air bag module bracket, and secure it to the wheel of the old tyre with wheel (4 locations), with the air bag facing upwards.

Caution

- 1) **Leave some space below the wheel for the deployment wires.**
If there is no space, the reaction of the air bag deployment could result in damage of the adaptor harness.
- 2) **While deployment takes place, do not have the connector of the SRS air bag adaptor harness A inserted between the tyres.**

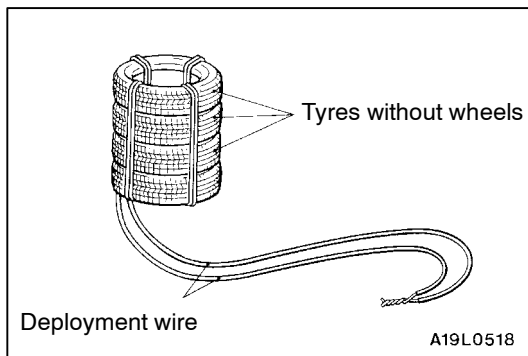

- (3) Place three old tyres, without wheels, on top of the tyre secured to the air bag module, and secure all tyres with ropes (4 locations).

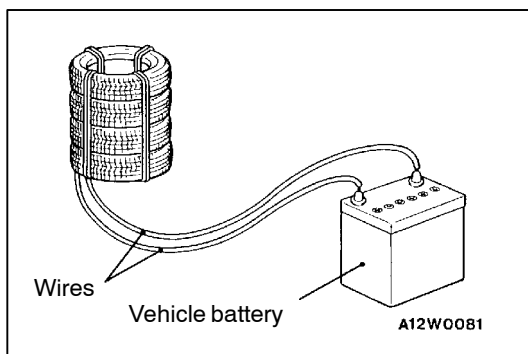

5. At a location as far away from the air bag module as possible, and from a shielded position, disconnect the two connected wires from each other, and connect them to the two terminals of the battery (which has been removed from the vehicle) to deploy the air bag.

Caution

- (1) **Before deployment, check carefully to be sure that no one is nearby.**
- (2) **The inflator will be quite hot immediately following the deployment, so wait at least 30 minutes to allow it to cool before attempting to handle it. Although not poisonous, do not inhale gas from air bag deployment. See Deployed Air Bag Module Disposal Procedures (P.52B-38.) for post-deployment handling instructions.**

- (3) If the air bag fails to deploy when the procedures above are followed, do not go near the module. Contact your local distributor.
6. After deployment, dispose of the air bag module according to the Deployed Air Bag Module Disposal Procedures.

DEPLOYED AIR BAG MODULE DISPOSAL PROCEDURES

After deployment, the air bag module should be disposed of in the same manner as any other scrap parts, adhering to local laws and/or legislation that may be in force except that the following points should be carefully noted during disposal.

1. The inflator will be quite hot immediately following deployment, so wait at least 30 minutes to allow it cool before attempting to handle it.
2. Do not put water or oil on the air bag after deployment.
3. There may be, adhered to the deployed air bag module, material that could irritate the eye and/or skin, so wear gloves and safety glasses when handling a deployed air bag module. IF AFTER FOLLOWING THESE PRECAUTIONS, ANY MATERIAL DOES GET INTO THE EYES OR ON THE SKIN, IMMEDIATELY RINSE THE AFFECTED AREA WITH A LARGE AMOUNT OF CLEAN WATER. IF ANY IRRITATION DEVELOPS, SEEK MEDICAL ATTENTION.
4. Tightly seal the air bag module in a strong vinyl bag for disposal.
5. Be sure to always wash your hands after completing this operation.

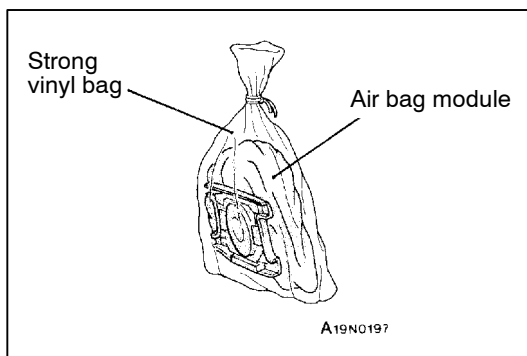

SENSOR CABLE INSTALLATION PROCEDURES

52400130068

If there is a malfunction in the front wiring harness between the front impact sensor and body wiring

harness, install and route a new sensor cable. (Refer to P.52B-4.)

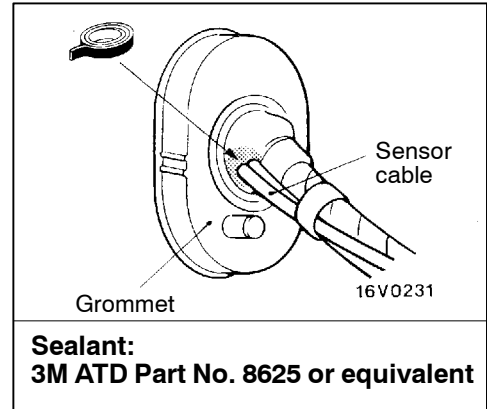
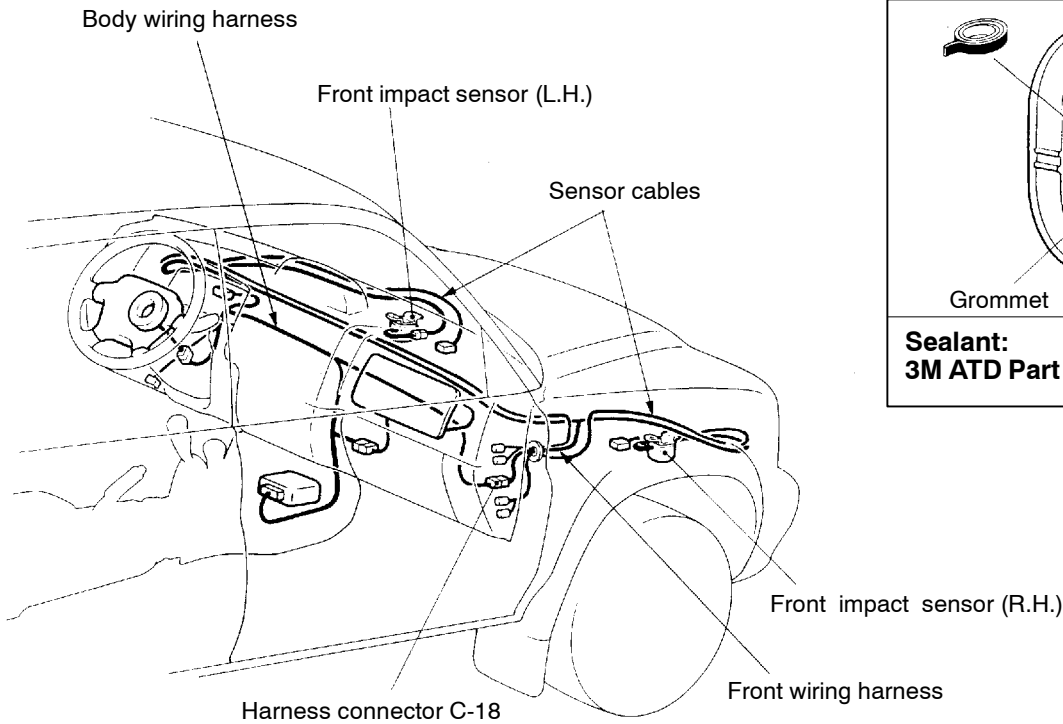

T0203AA

00009146

NOTE

Connector C-18 for R.H. drive vehicles is also installed at right side of vehicle. Carry out the installation by the same procedure as for L.H. drive vehicles.

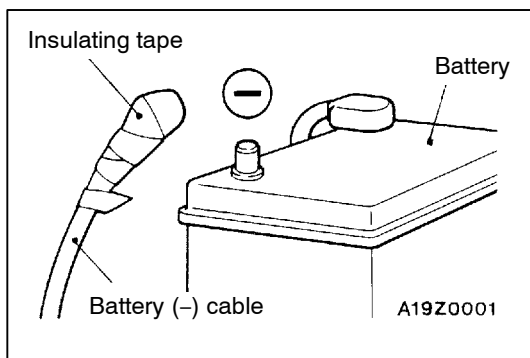

1. Turn the ignition key to the LOCK position, disconnect the negative battery cable and tape the terminal.

Caution

Wait at least 60 seconds after disconnecting the battery cable before doing any further work. (Refer to P.52B-3.)

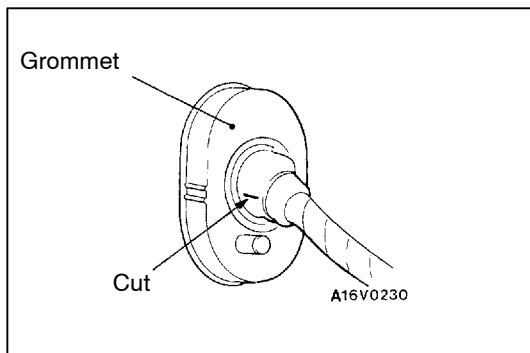

2. Make a cut in the grommet in the place shown in the illustration, and pass the sensor cable through the cut.

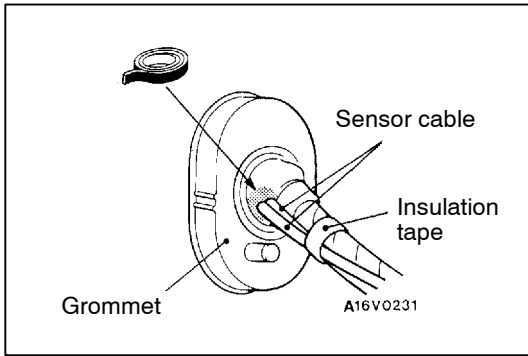

3. Run the sensor cable along the front wiring harness, and the secure the cable to the harness with insulation tape.
4. Apply the specified sealant to the grommet cut portion.

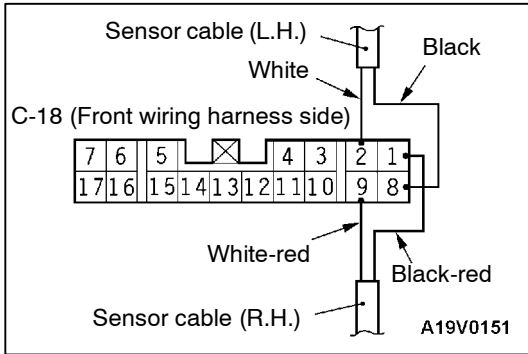

5. Exchange the terminal of the front wiring harness connector C-18 shown in the illustration with the terminal of the sensor cable shown in the illustration.

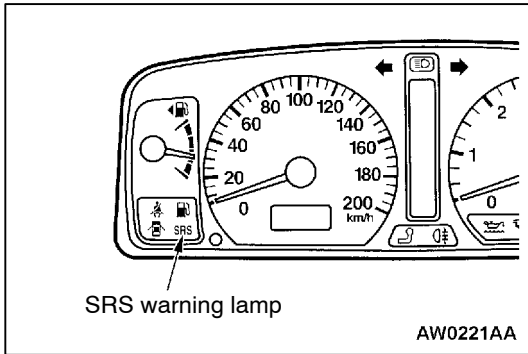

POST-INSTALLATION INSPECTION

1. Reconnect the negative battery terminal.
2. Turn the ignition key to the ON position.
3. Does the SRS warning lamp illuminate for about 7 seconds, and then remain extinguished for at least 5 seconds after turning OFF?
4. If yes, SRS system is functioning properly. If no, consult page 52B-6.

CHASSIS ELECTRICAL

CONTENTS

54109000297

BATTERY	4	COMBINATION METERS	32
SERVICE SPECIFICATION	4	MULTI-METER	34
ON-VEHICLE SERVICE	4	TROUBLESHOOTING	34
Fluid Level and Specific Gravity Check	4	ON-VEHICLE SERVICE	38
Charging	5	Vehicle Magnetic Compensation	38
Battery Testing Procedure	6	MULTI-METER	39
IGNITION SWITCH AND IMMOBILIZER SYSTEM	7	OUTSIDE THERMO SENSOR	40
SPECIAL TOOL	7	SERVICE SPECIFICATIONS	40
TROUBLESHOOTING	7	OUTSIDE THERMO SENSOR	40
IGNITION SWITCH AND IMMOBILIZER SYSTEM	19	HEADLAMP AND FRONT COMBINATION LAMP	41
COMBINATION METERS	24	SERVICE SPECIFICATIONS	41
SERVICE SPECIFICATIONS	24	SPECIAL TOOLS	41
SEALANT	24	TROUBLESHOOTING	42
SPECIAL TOOLS	25	ON-VEHICLE SERVICE	48
TROUBLESHOOTING	25	Headlamp Aiming	48
ON-VEHICLE SERVICE	29	Intensity Measurement	49
Speedometer Check	29	Bulb Replacement	49
Tachometer Check	30	HEADLAMP AND FRONT COMBINATION LAMP	50
Fuel Gauge Unit Check	30		
Engine Coolant Temperature Gauge Unit Check	31		

CONTINUED ON NEXT PAGE

FRONT FOG LAMP	53	Chart	68
SERVICE SPECIFICATIONS	53	Radio and Tape Player with Anti-theft System	82
SPECIAL TOOL	53	RADIO AND TAPE PLAYER	85
ON-VEHICLE SERVICE	53	SPEAKER	85
Front Fog Lamp Aiming	53	ANTENNA	86
Bulb Replacement	54	SPECIAL TOOL	86
FRONT FOG LAMP	55	ANTENNA	86
TURN-SIGNAL LAMP	56	REAR WINDOW DEFOGGER	87
REAR COMBINATION LAMP	57	SPECIAL TOOL	87
REAR FOG LAMP	59	ON-VEHICLE SERVICE	87
SPECIAL TOOL	59	Printed-heater Line Check	87
REAR FOG LAMP	59	REAR WINDOW DEFOGGER SWITCH ..	88
HIGH-MOUNTED STOP LAMP	61	RADIATOR FAN MOTOR	Refer to GROUP 14
RHEOSTAT	62	INTERCOOLER (INTERCOOLER FAN MOTOR)	Refer to GROUP 15
SPECIAL TOOL	62	SERVICE BRAKES (ABS)	Refer to GROUP 35B
RHEOSTAT	62	DOOR GLASS AND REGULATOR (POWER WINDOWS)	Refer to GROUP 42
HAZARD WARNING LAMP SWITCH	63	DOOR HANDLE AND LATCH (DOOR LOCKING)	Refer to GROUP 42
SPECIAL TOOL	63	SUN ROOF	Refer to GROUP 42
HAZARD WARNING LAMP SWITCH	63	WINDSHIELD WIPER AND WASHER	Refer to GROUP 51
HORN	64	REAR WIPER AND WASHER	Refer to GROUP 51
CIGARETTE LIGHTER	65		
ACCESSORY SOCKET	66		
RADIO AND TAPE PLAYER	67		
SPECIAL TOOL	67		
TROUBLESHOOTING	67		
Quick-reference Troubleshooting Chart	67		

CONTINUED ON NEXT PAGE

HEADLAMP WASHER
..... Refer to GROUP 51

**DOOR MIRROR (ELECTRONIC
CONTROLLED DOOR MIRROR)**
..... Refer to GROUP 51

FRONT SEAT (HEATED SEAT)
..... Refer to GROUP 52A

SRS AIR BAG
..... Refer to GROUP 52B

HEATER Refer to GROUP 55

AIR CONDITIONER
..... Refer to GROUP 55

BATTERY

54100030028

SERVICE SPECIFICATION

Item	Specification
Specific gravity of the battery fluid	1.220 – 1.290 [20°C]

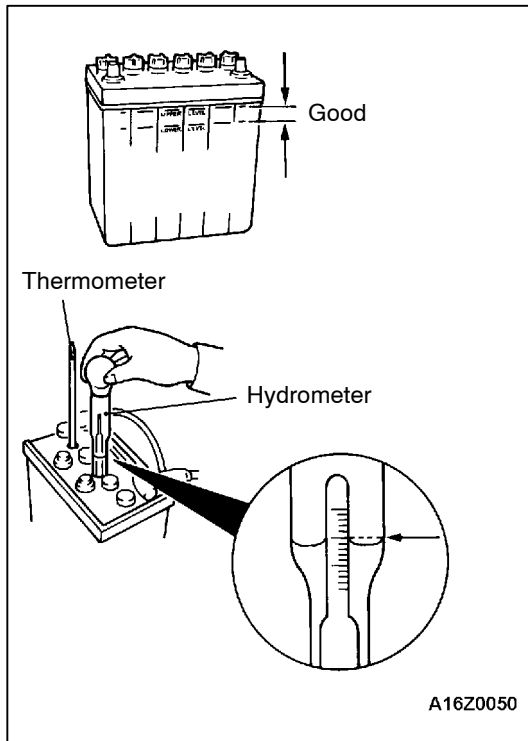

ON-VEHICLE SERVICE

54100090064

FLUID LEVEL AND SPECIFIC GRAVITY CHECK

1. Inspect whether or not the battery fluid is between the UPPER LEVEL and LOWER LEVEL marks.
2. Use a hydrometer and thermometer to check the specific gravity of the battery fluid.

Standard value: 1.220 – 1.290 [20°C]

The specific gravity of the battery fluid varies with the temperature, so use the following formula to calculate the specific gravity for 20°C. Use the calculated value to determine whether or not the specific gravity is satisfactory.

$$D_{20} = D_t + 0.0007 (t - 20)$$

D₂₀: Specific gravity of the battery fluid calculated for 20°C.

D_t: Actually measured specific gravity

t: Actually measured temperature

CHARGING

54100110029

1. When charging a battery while still installed in the vehicle, disconnect the battery cables to prevent damage to electrical parts.
2. The current normally used for charging a battery should be approximately 1/10th of the battery capacity.
3. When performing a quick-charging due to lack of time, etc., the charging current should never exceed the battery capacity as indicated in amperes.
4. Determining if charging is completed.
 - (1) If the specific gravity of the battery fluid reaches 1.250–1.290 and remains constant for at least one hour.
 - (2) If the voltage of each cell reaches 2.5–2.8 V and remains constant for at least one hour.

Caution

- (1) **Be careful since the battery fluid level may rise during charging.**
- (2) **Keep all sources of fire away while charging because there is a danger of explosion.**
- (3) **Be careful not to do anything that could generate sparks while charging.**
- (4) **When charging is completed, replace the battery caps, pour clean water over the battery to remove any sulfuric acid and dry.**

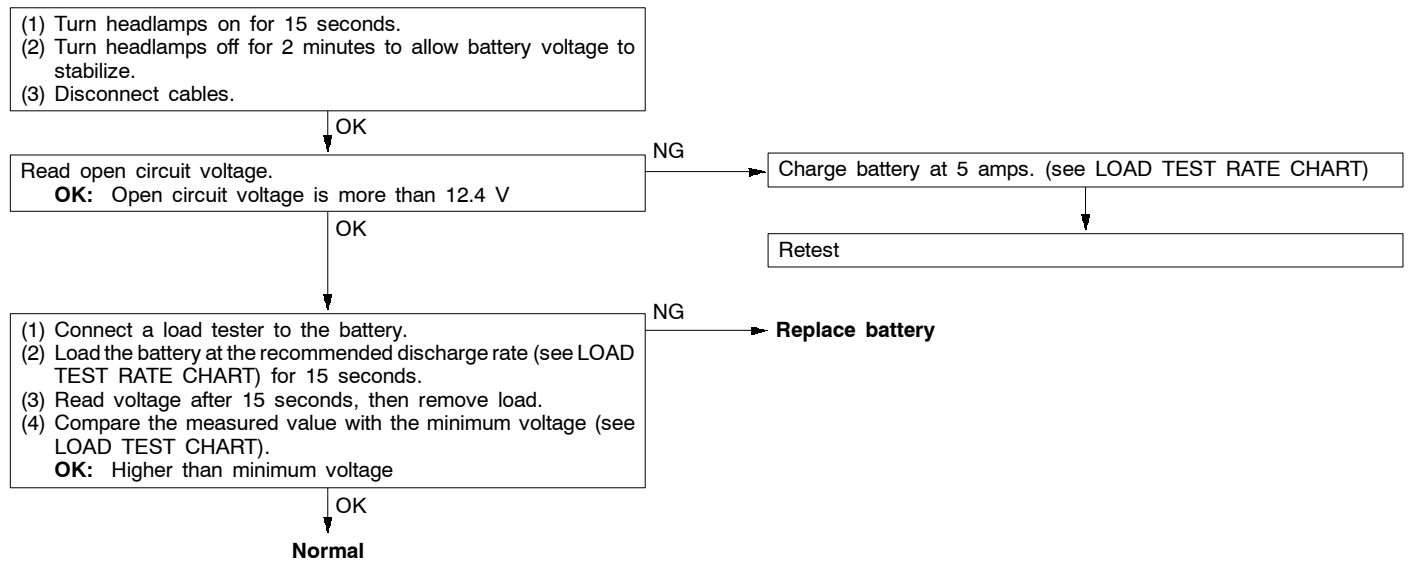
BATTERY TESTING PROCEDURE**TEST STEP****LOAD TEST RATE CHART**

Battery type	75D26R	80D26R	95D31R
Charging time when fully discharged h [5-amp rated current charging]	12	12	14
Load test (Amps)	240	290	310

LOAD TEST CHART

Temperature °C	21 and above	16	10	4	-1	-7	-12	-18
Minimum voltage V	9.6	9.5	9.4	9.3	9.1	8.9	8.7	8.5

IGNITION SWITCH AND IMMOBILIZER SYSTEM

54300060528

SPECIAL TOOL

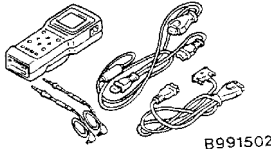
Tool	Number	Name	Use
	MB991502	MUT-II sub assembly	<ul style="list-style-type: none"> • ETACS-ECU input signal checking • Immobilizer system check (Diagnosis display using the MUT-II) • Registration of the ID code • Resetting the code to the factory setting <4D5> • Change of the password

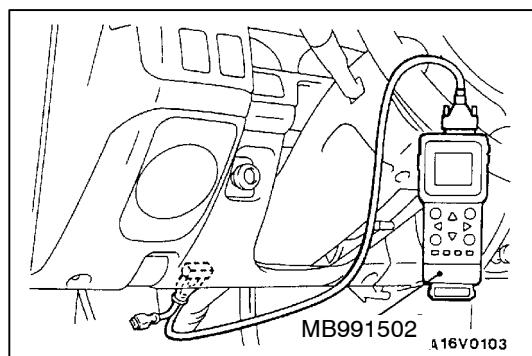
**TROUBLESHOOTING**
Ignition Switch

54300700185

DIAGNOSIS FUNCTION**INPUT SIGNAL INSPECTION POINTS**

1. Connect the MUT-II to the diagnosis connector.
2. If buzzer of the MUT-II sounds once when a switch is operated (ON/OFF), the ETACS-ECU input signal for that switch circuit system is normal.

INSPECTION CHART FOR TROUBLE SYMPTOMS

54300720747

Trouble symptoms		Inspection procedure	Reference page
Communication with MUT-II is impossible.	Communication with all systems is impossible.	1	54-8
	Communication with one-shot pulse input signal only is impossible.	2	54-8
Ignition key hole illumination lamp system	Even if the driver's side door is opened, the key hole illumination lamp does not illuminate.	3	54-9
	The key hole illumination lamp remains illuminated.	4	54-9

INSPECTION PROCEDURE FOR TROUBLE SYMPTOMS

Inspection Procedure 1

Communication with MUT-II is impossible. (Communication with all systems is impossible.)	Probable cause
The cause is probably a defective power supply system (including earth) for the diagnosis line.	<ul style="list-style-type: none"> ● Malfunction of connector ● Malfunction of harness wire

Refer to GROUP 13A – Troubleshooting.

Inspection Procedure 2

Communication with MUT-II is impossible. (Communication with the one-shot pulse input signal only is impossible.)	Probable cause
The cause is probably a defective one-shot pulse input circuit system of the diagnosis line.	<ul style="list-style-type: none"> ● Malfunction of connector ● Malfunction of harness wire ● Malfunction of ETACS-ECU

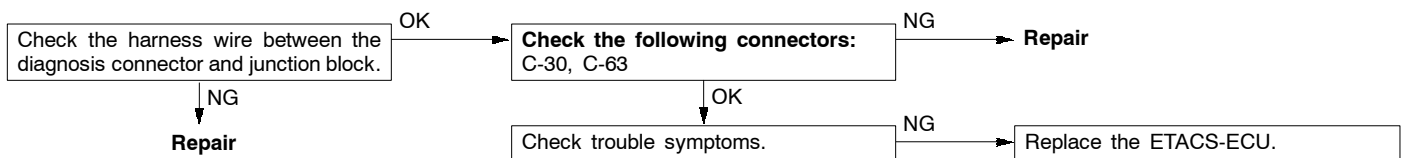

Inspection Procedure 3

Even if the driver's side door is opened, the key hole illumination lamp does not illuminate.	Probable cause
The cause is probably a defective key hole illumination lamp circuit system or a defective driver's side door switch input circuit system.	<ul style="list-style-type: none"> ● Malfunction of driver's side door switch ● Malfunction of key hole illumination lamp ● Malfunction of harness or connector ● Malfunction of ETACS-ECU

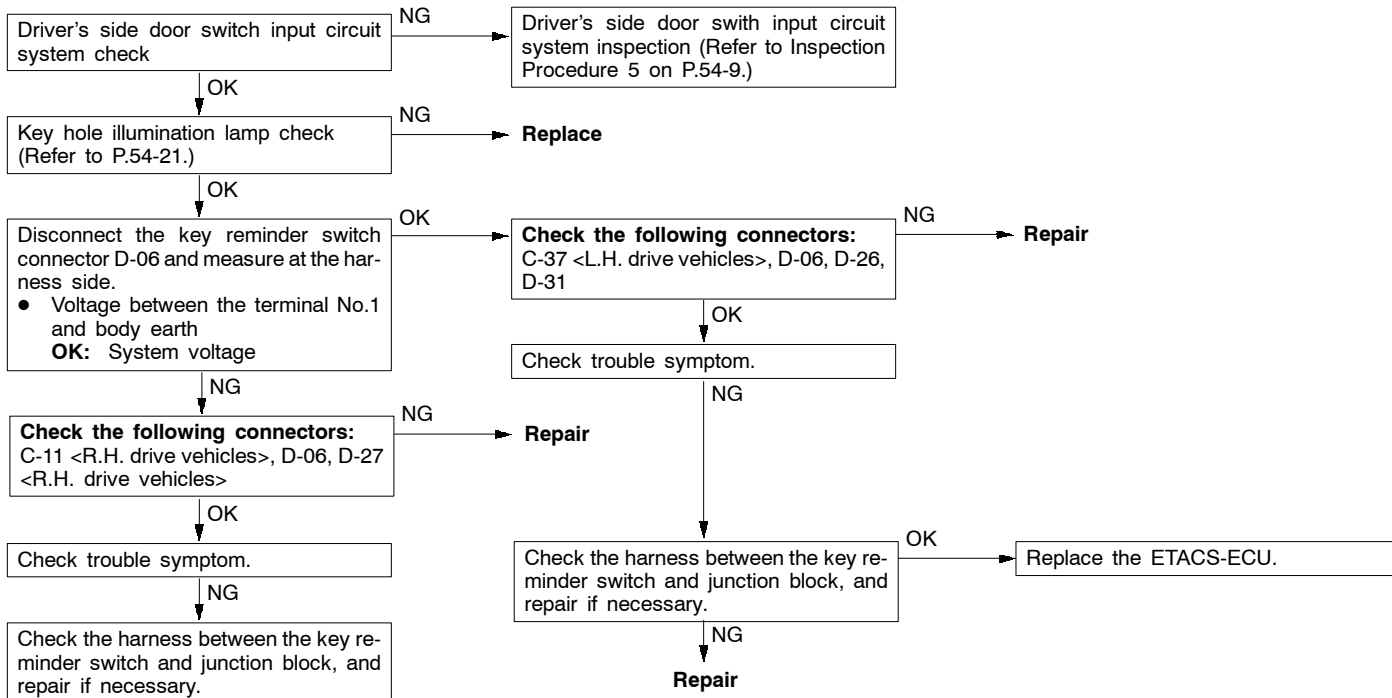

Inspection Procedure 4

Key hole illumination lamp remains illuminated.	Probable cause
The cause is probably a short harness or a defective ETACS-ECU.	<ul style="list-style-type: none"> ● Malfunction of harness ● Malfunction of ETACS-ECU

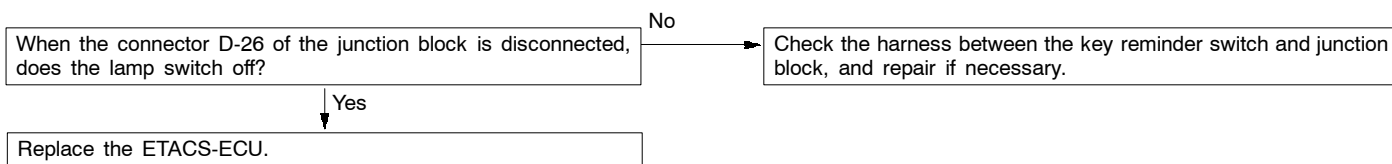

Inspection Procedure 5

Driver's side door switch input circuit system check

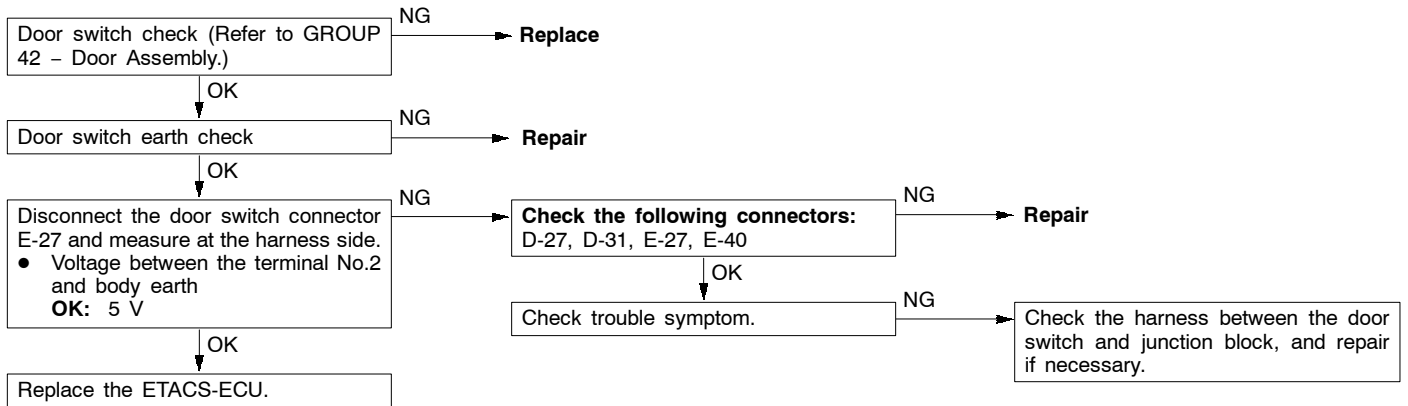

Immobilizer System

54300690130

Caution

1. The encrypted code should always be re-registered when replacing the immobilizer-ECU. <6G7>
2. If the immobilizer-ECU has been replaced, you will need to re-register the ignition key encrypted codes and to reset the code for the fuel cut valve controller to the factory setting. <4D5>
3. If the immobilizer-ECU has been replaced with a new part, the password (vehicle secret code) which has been stored in the immobilizer-ECU for each vehicle will be replaced by the password (secret code) specified by the customer.

STANDARD FLOW OF DIAGNOSIS TROUBLESHOOTING

Refer to GROUP 00 – How To Use Troubleshooting/Inspection Service Points.

DIAGNOSIS FUNCTION

54300700192

DIAGNOSIS CODES CHECK

Refer to GROUP 00 – How To Use Troubleshooting/Inspection Service Points.

ERASING DIAGNOSIS CODES

Refer to GROUP 00 – How To Use Troubleshooting/Inspection Service Points.

Caution

The diagnosis codes which result from disconnecting the battery cables cannot be erased.

INSPECTION CHART FOR DIAGNOSIS CODES <6G7>

54300710119

Diagnosis code No.	Inspection items	Reference page
11	Transponder communication system or radio interference of encrypted code	54-11
12	Encrypted code are not the same or are not registered	54-11

NOTE

Diagnosis code is not recorded.

INSPECTION PROCEDURE FOR DIAGNOSIS CODES <6G7>

Code No.11 Transponder communication system or radio interference of encrypted code	Probable cause
<ul style="list-style-type: none"> • The encrypted code of the transponder is not sent to the immobilizer-ECU immediately after the ignition switch is turned to ON position. • If the engine is started while several ignition keys are in the vicinity, then interference between the different keys may occur, which will cause this code to be generated. 	<ul style="list-style-type: none"> • Radio interference of encrypted code • Malfunction of transponder • Malfunction of ignition key ring antenna • Malfunction of harness or connector • Malfunction of immobilizer-ECU

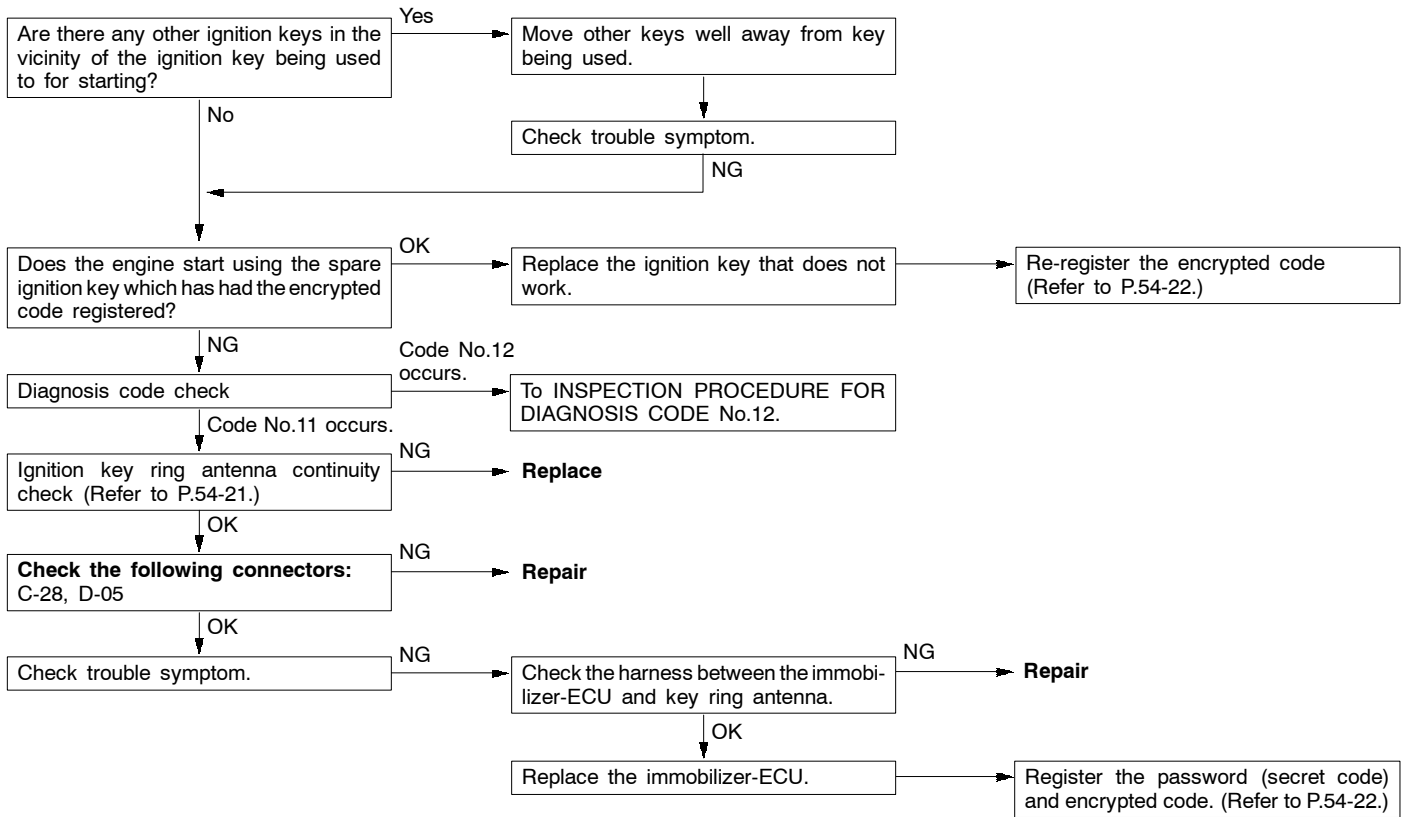

Code No.12 Encrypted codes are not the same or not registered.	Probable cause
<p>The encrypted code which is sent from the transponder is not the same as the encrypted code which is registered in the immobilizer-ECU.</p>	<ul style="list-style-type: none"> • The encrypted code in the ignition key being used has not been properly registered. • Malfunction of immobilizer-ECU

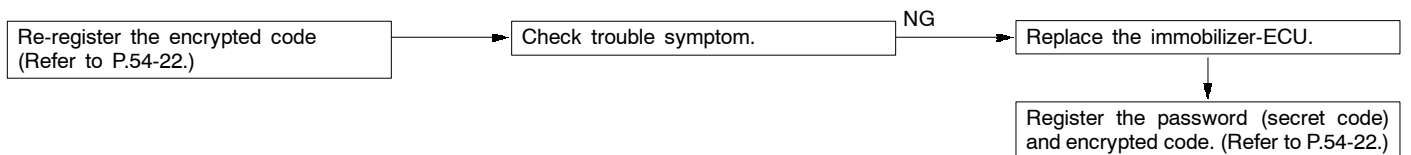

INSPECTION CHART FOR DIAGNOSIS CODES <4D5>

54300710126

Diagnosis code No.	Inspection items	Reference page
11*	Transponder communication system or radio interference of encrypted code	54-11
12*	Encrypted codes are not the same or not registered	54-11
21	Communication system between fuel cut valve controller and immobilizer-ECU	54-12
22	Malfunction of fuel cut valve controller system	54-13
23*	Identification codes are not identical	54-13

NOTE

*: diagnosis code Nos. 11, 12, 23 are recorded.

INSPECTION PROCEDURE FOR DIAGNOSIS CODES <4D5>

For diagnosis code numbers other than those listed below, refer to “INSPECTION PROCEDURE FOR DIAGNOSIS CODES <6G7>”.

Code No.21 Communication system between fuel cut valve controller and immobilizer-ECU	Probable cause
The confirmation code is not sent from the fuel cut valve controller within the specified time after the ignition key is turned to ON or, an incorrect code is sent.	<ul style="list-style-type: none"> ● Malfunction of harness or connector ● Malfunction of fuel cut valve controller ● Malfunction of immobilizer-ECU

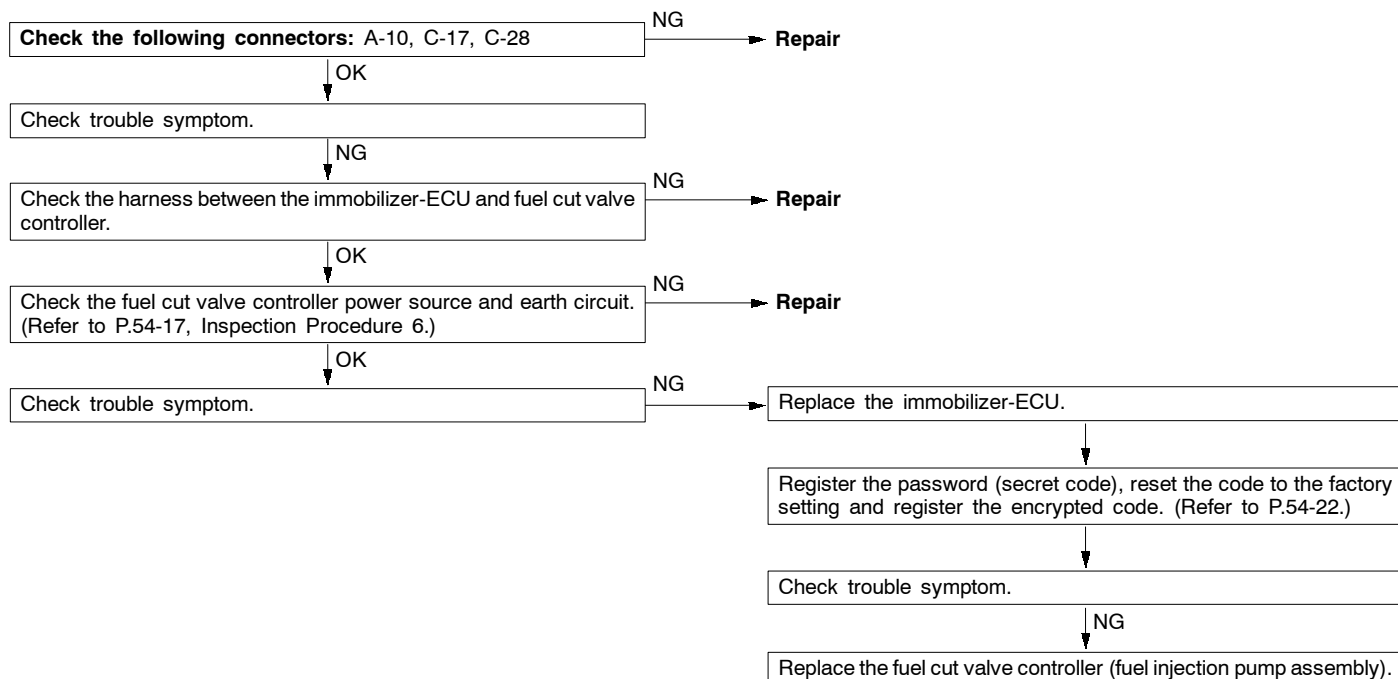

Code No.22 Malfunction of fuel cut valve controller system	Probable cause
The cause is probably a malfunction of the fuel cut valve controller.	<ul style="list-style-type: none"> Malfunction of fuel cut valve controller

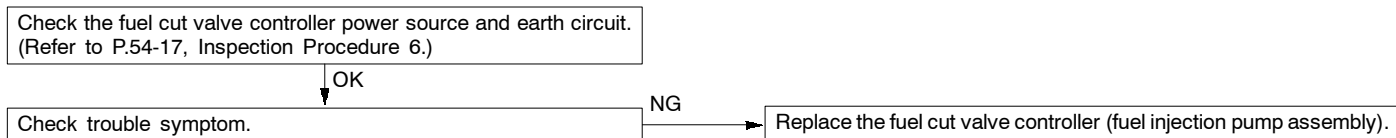

Code No.23 Identification codes are not identical	Probable cause
The identification code received from the immobilizer-ECU is not identical to the identification code that has been recorded in the fuel cut valve controller.	<ul style="list-style-type: none"> Resetting the code to the factory setting is not made using the MUT-II Malfunction of fuel cut valve controller

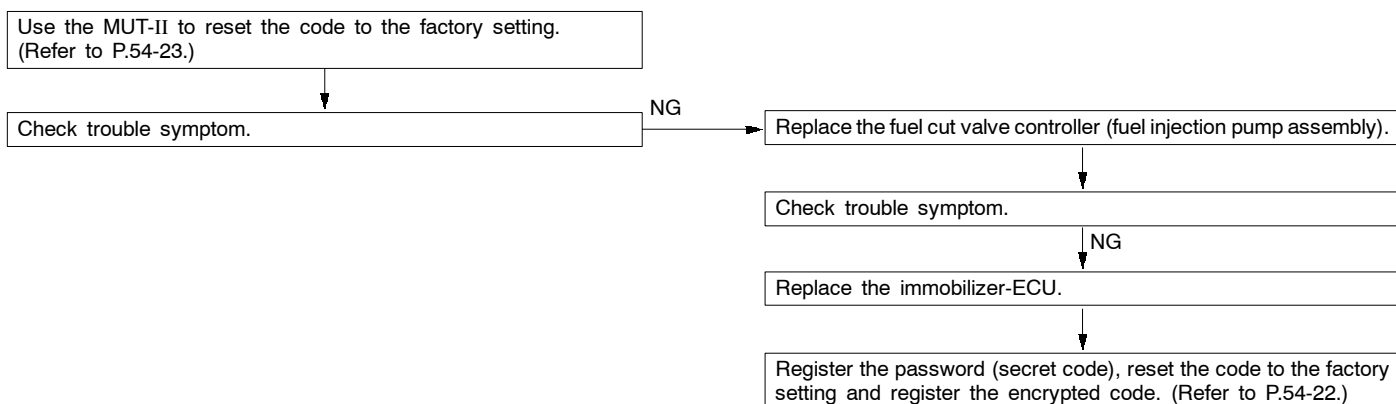

INSPECTION CHART FOR TROUBLE SYMPTOMS

54300720754

Trouble symptom	Inspection procedure No.	Reference page
Communication with MUT-II is impossible	1	54-14
Encrypted code cannot be registered using the MUT-II	2	54-15
Engine does not start (Cranking but no initial combustion). <6G7>	3	54-15
Engine does not start (Cranking but no initial combustion). <4D5>	4	54-16
Malfunction of the immobilizer-ECU power source and earth circuit	5	54-17
Malfunction of the fuel cut valve controller power source and earth circuit <4D5>	6	54-17

INSPECTION PROCEDURE FOR TROUBLE SYMPTOMS

Inspection Procedure 1

Communication with MUT-II is impossible	Probable cause
The cause is probably that a malfunction of the diagnosis line or the immobilizer-ECU is not functioning.	<ul style="list-style-type: none"> Malfunction of diagnosis line Malfunction of harness or connector Malfunction of immobilizer-ECU

<6G7>

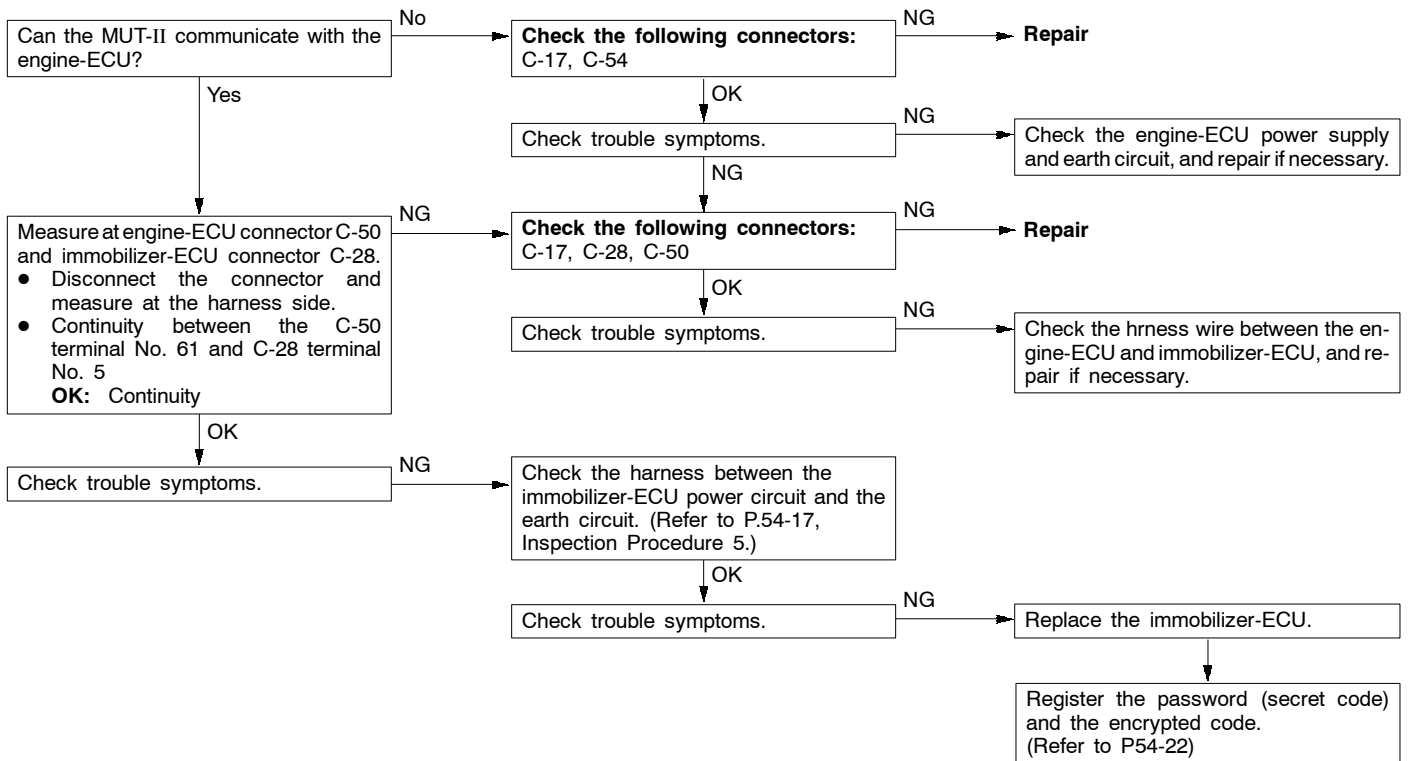

<4D5>

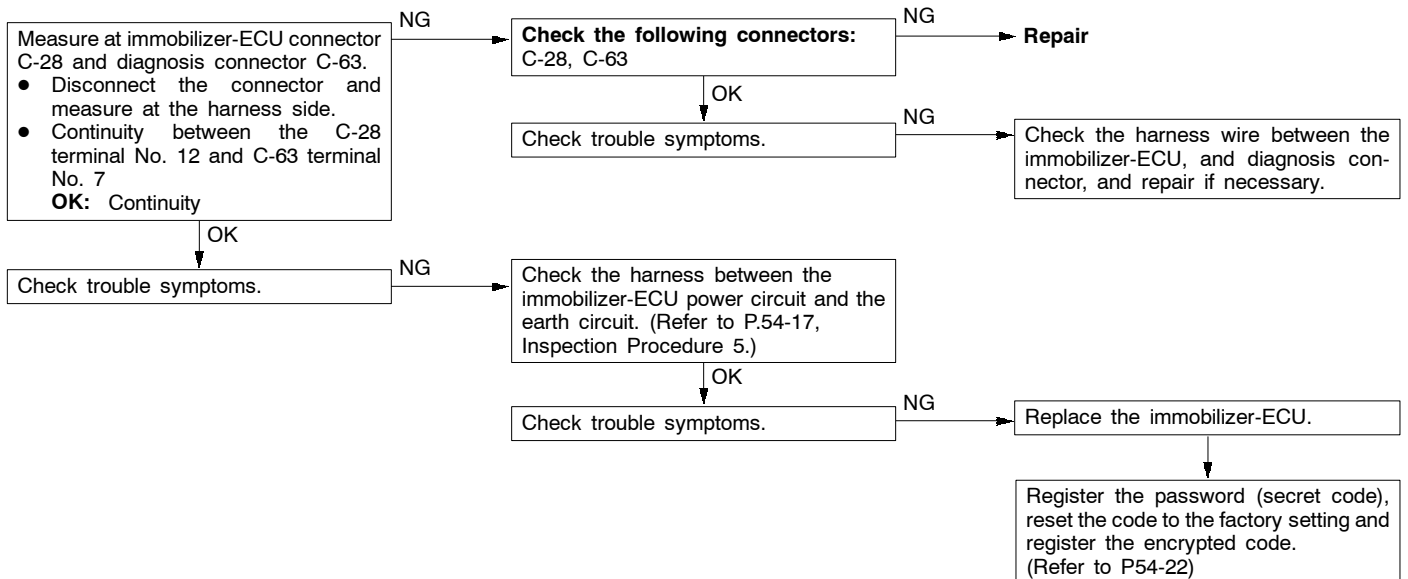

Inspection Procedure 2

Encrypted code cannot be registered using the MUT-II	Probable cause
The cause is probably that there is no encrypted code registered in the immobilizer-ECU or there is a malfunction of the immobilizer-ECU.	<ul style="list-style-type: none"> ● Malfunction of transponder ● Malfunction of ignition key ring antenna ● Malfunction of harness or connector ● Malfunction of immobilizer-ECU

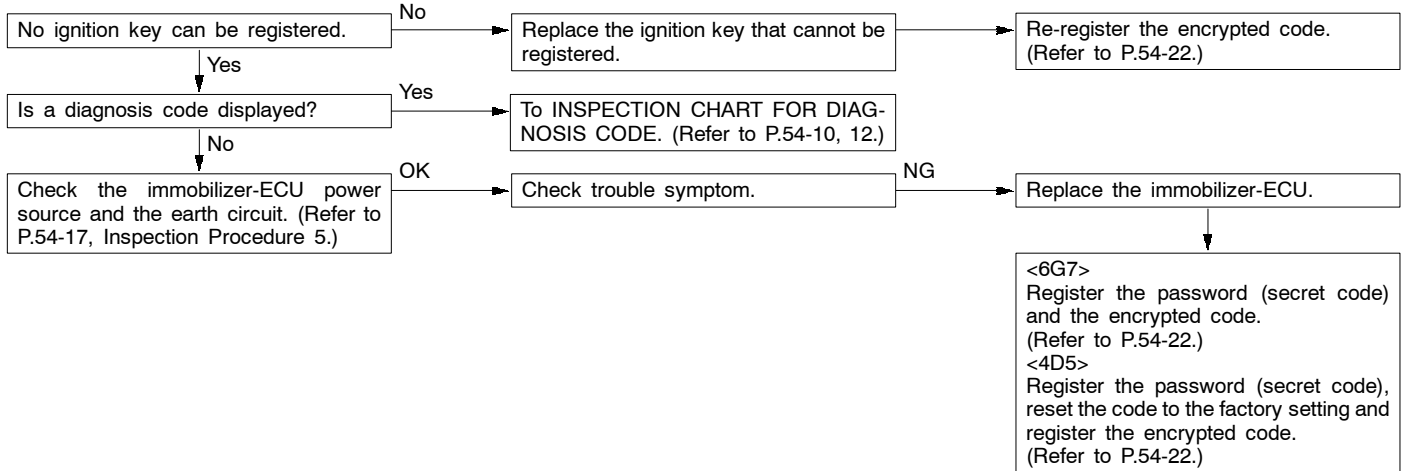

Inspection Procedure 3

Engine does not start (Cranking but no initial combustion). <6G7>	Probable cause
If the fuel injectors are not operating, there might be a problem with the MPI system in addition to a malfunction of the immobilizer system. It is normal for this to occur if an attempt is made to start the engine using a key that has not been properly registered.	<ul style="list-style-type: none"> ● Malfunction of MPI system ● Malfunction of immobilizer-ECU

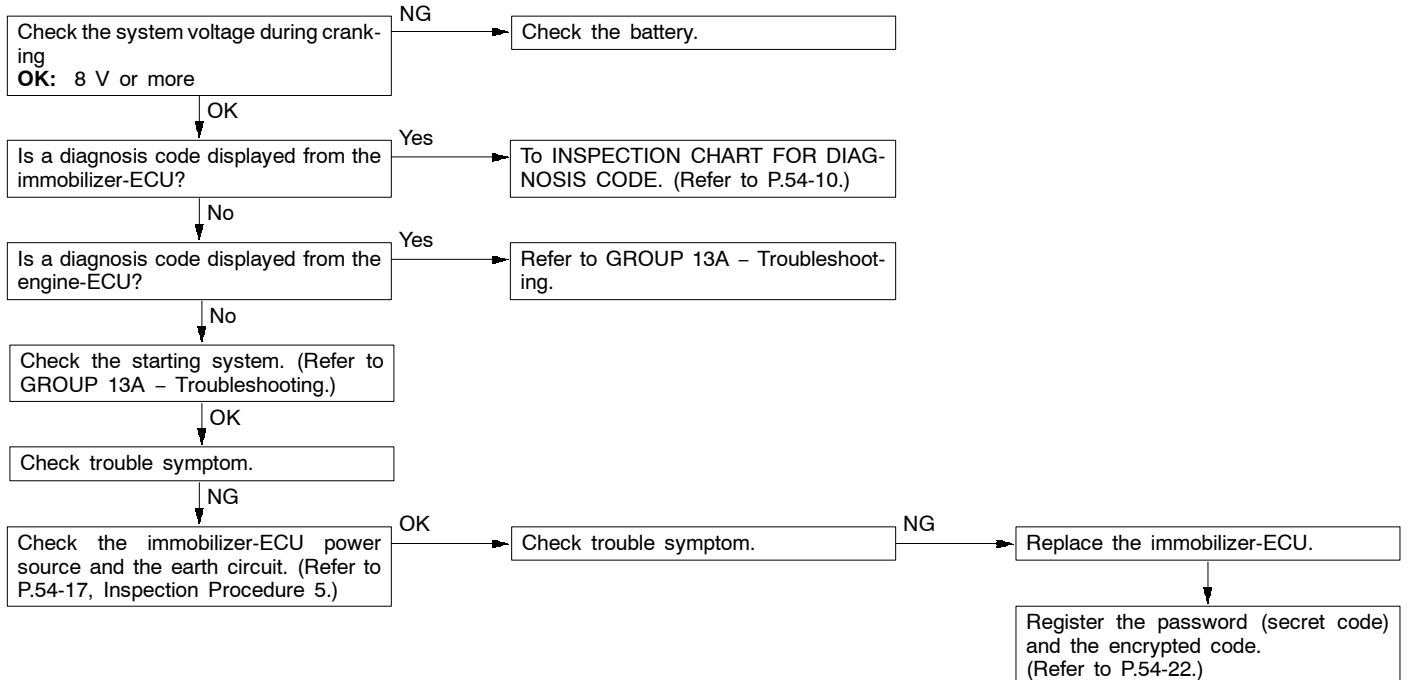

54-16 CHASSIS ELECTRICAL – Ignition Switch and Immobilizer System

Inspection Procedure 4

Engine does not start (Cranking but no initial combustion). <4D5>	Probable cause
<p>If no fuel injection, there might be a problem with the fuel injection system in addition to a malfunction of the immobilizer system. It is normal for this to occur if an attempt is made to start the engine using a key that has not been properly registered.</p>	<ul style="list-style-type: none"> • Malfunction of diesel fuel injection system • Malfunction of immobilizer-ECU

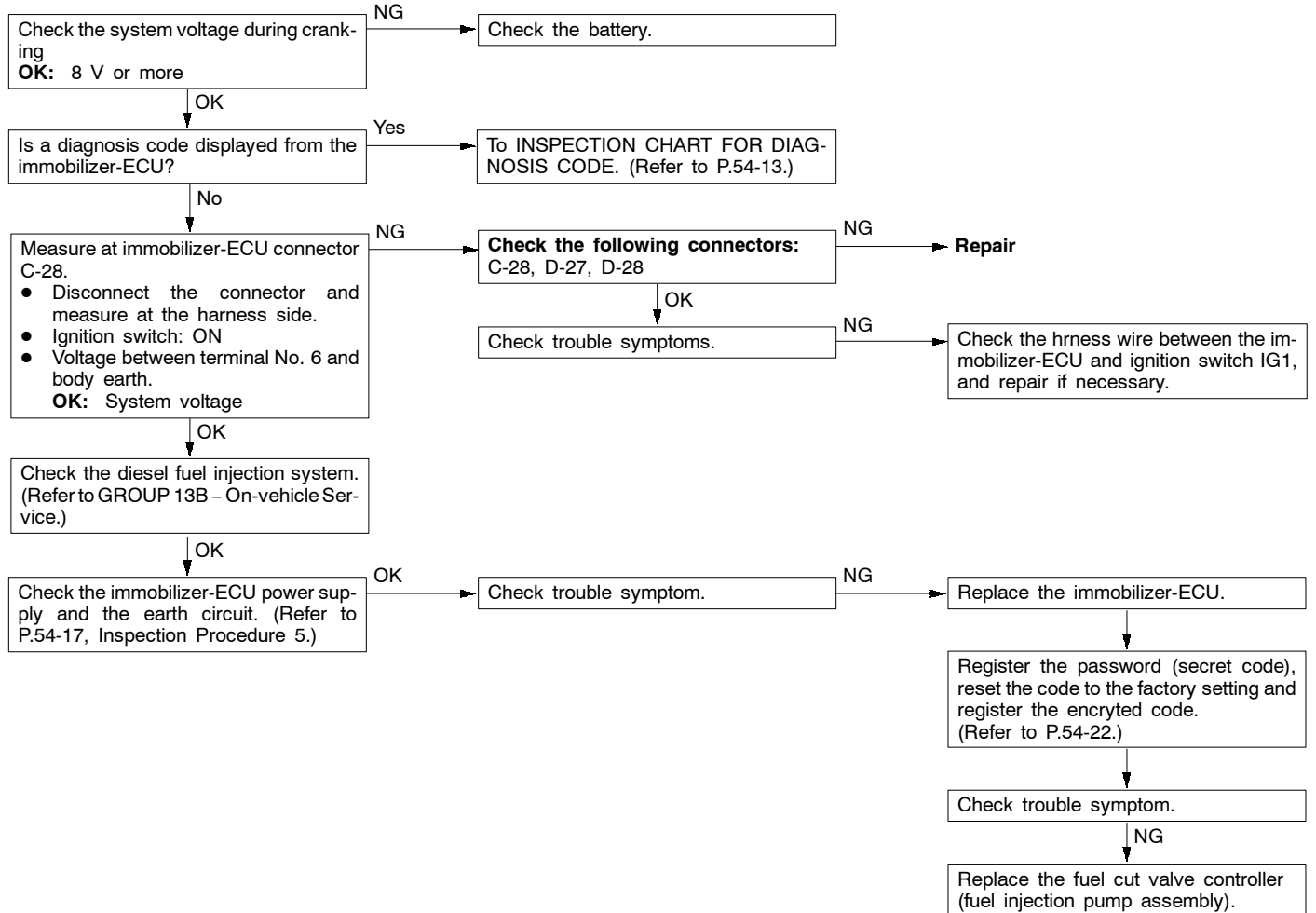

Inspection Procedure 5

Malfunction of the immobilizer-ECU power source and earth circuit

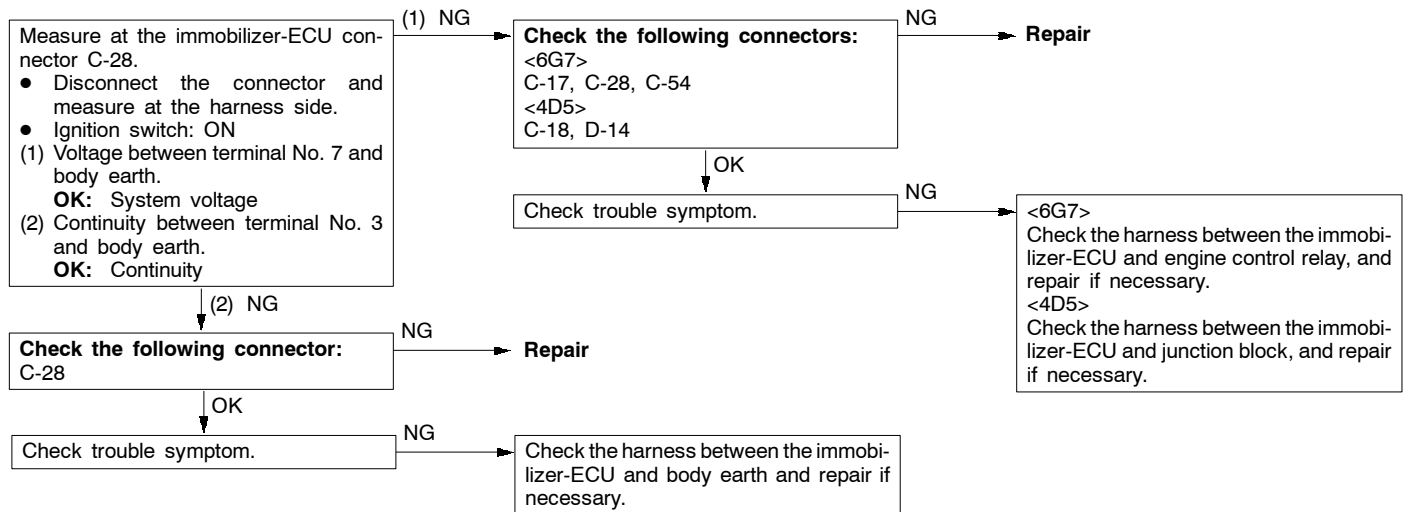

Inspection Procedure 6

Malfunction of the fuel cut valve controller power source and earth circuit <4D5>

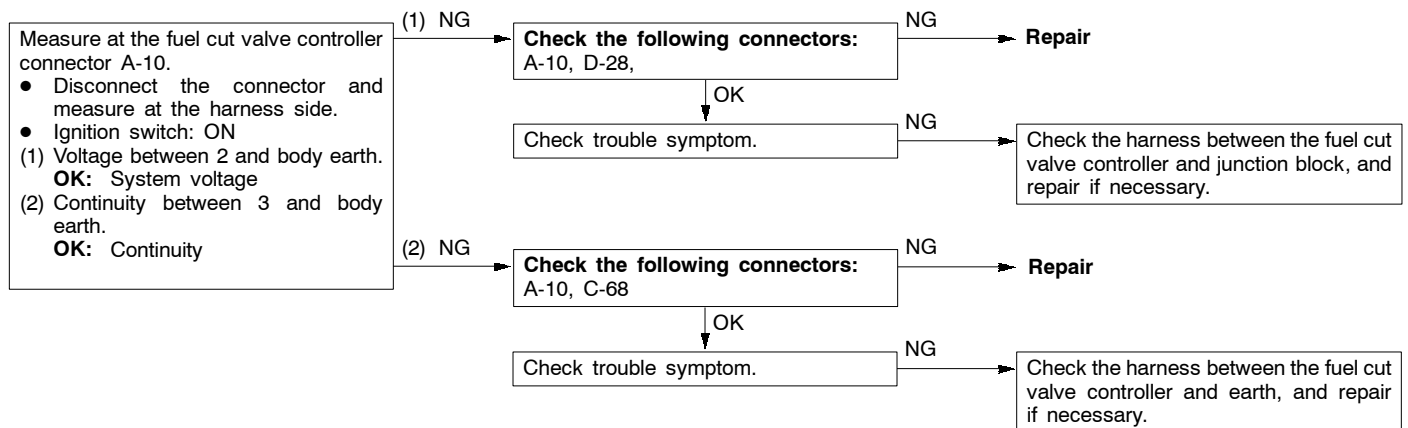

54-18 CHASSIS ELECTRICAL – Ignition Switch and Immobilizer System

CHECK AT IMMOBILIZER-ECU

54300760053

Terminal Voltage Check Chart

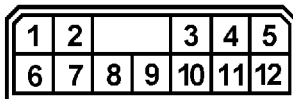

20F0191

Terminal No.	Signal	Checking requirements	Terminal voltage
3	Immobilizer-ECU earth	Always	0 V
6	Ignition switch-IG <4D5>	Ignition switch: OFF	0 V
		Ignition switch: ON	System voltage
7	Immobilizer-ECU power supply <6G7>	Always	System voltage
	Immobilizer-ECU power supply <4D5>	Ignition switch: OFF or approx. 5 or more seconds after switch has been turned from ON to OFF.	0 V
		Ignition switch: ON or within approx. 5 seconds after switch has been turned from ON to OFF.	System voltage

IGNITION SWITCH AND IMMOBILIZER SYSTEM

54300210367

REMOVAL AND INSTALLATION

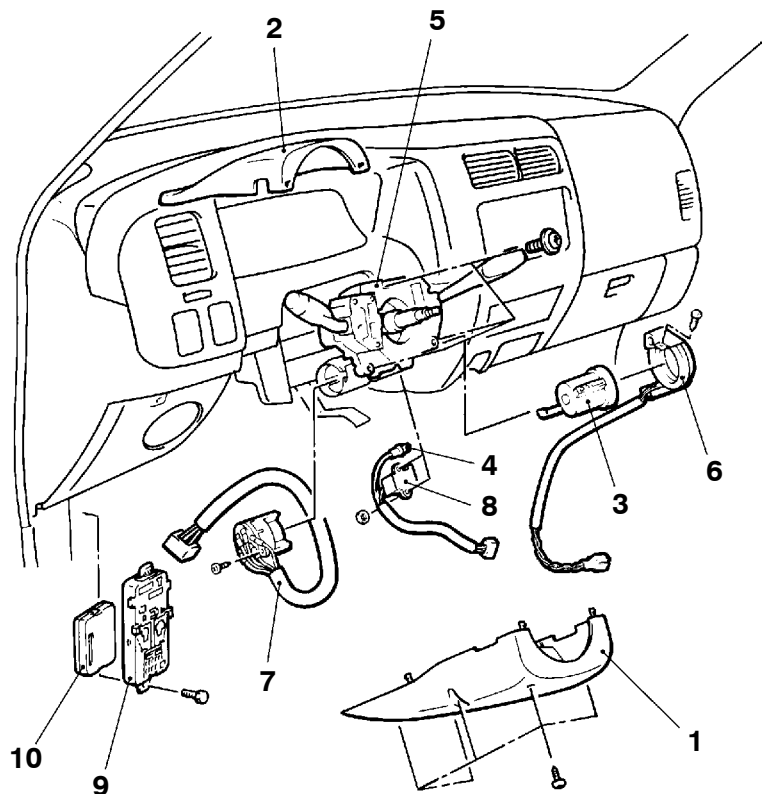

W0228AA
00009158

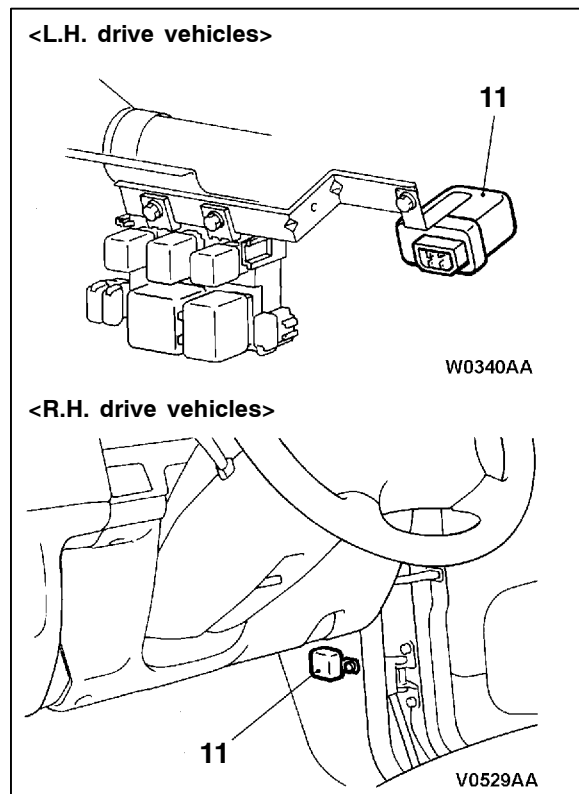

Steering lock cylinder and key hole illumination lamp removal steps

- Driver's side under cover or knee protector assembly (Refer to GROUP 52A – Instrument Panel.)

1. Column cover, lower
2. Column cover, upper
3. Steering lock cylinder
4. Key hole illumination lamp

Ignition switch, key reminder switch and ignition key ring antenna removal steps

- Steering wheel (Refer to GROUP 37A – Steering Wheel and Shaft.)
- Clock spring (Refer to GROUP 52B – Air Bag Module and Clock Spring.)
- Driver's side under cover or knee protector assembly (Refer to GROUP 52A – Instrument Panel.)



1. Column cover, lower
2. Column cover, upper
5. Column switch assembly
6. Ignition key ring antenna
7. Ignition switch
8. Key reminder switch

ETACS-ECU removal steps

- Driver's side under cover or knee protector assembly (Refer to GROUP 52A – Instrument Panel.)

9. Junction block
10. ETACS-ECU

Immobilizer-ECU removal steps

- Front scuff plate and cowl side trim <driver's side> (Refer to GROUP 52A – Trims.)

11. Immobilizer-ECU

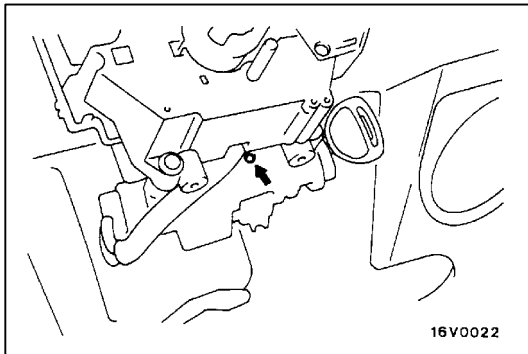

REMOVAL SERVICE POINT

◀A▶ STEERING LOCK CYLINDER REMOVAL

1. Insert the key in the steering lock cylinder and turn it to the “ACC” position.
2. Using a cross-tip (+) screwdriver (small) or a similar tool, push the lock pin of the steering lock cylinder inward and then pull the steering lock cylinder toward you.

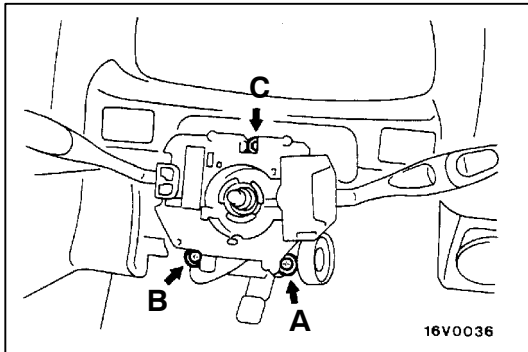

INSTALLATION SERVICE POINT

▶A◀ COLUMN SWITCH ASSEMBLY INSTALLATION

Tighten the column switch assembly mounting screws to the specified torque in the order of A, B and C.

Tightening torque: 25 Nm

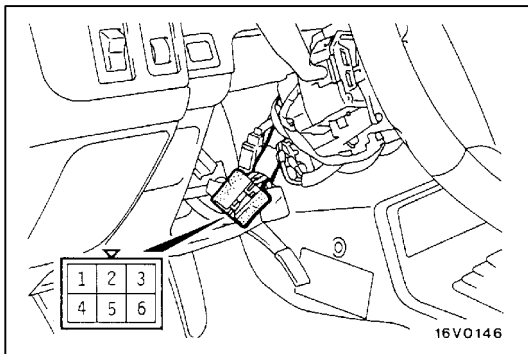

INSPECTION

54300220285

IGNITION SWITCH CONTINUITY CHECK

1. Remove the driver’s side under cover or knee protector assembly.
2. Remove the column cover lower and upper.
3. Disconnect the wiring connector from the ignition switch.
4. Operate the switch and check the continuity between the terminals.

Ignition key position	Terminal No.				
	1	2	4	5	6
LOCK					
ACC	○				○
ON	○	○	○		○
START	○	○		○	

KEY REMINDER SWITCH CONTINUITY CHECK

54300770094

1. Remove the driver’s side under cover or knee protector assembly.
2. Remove the column cover lower and upper.
3. Disconnect the wiring connector from the key reminder switch.
4. Check the continuity between the terminal when the ignition key is pulled out of and inserted into the steering lock cylinder.

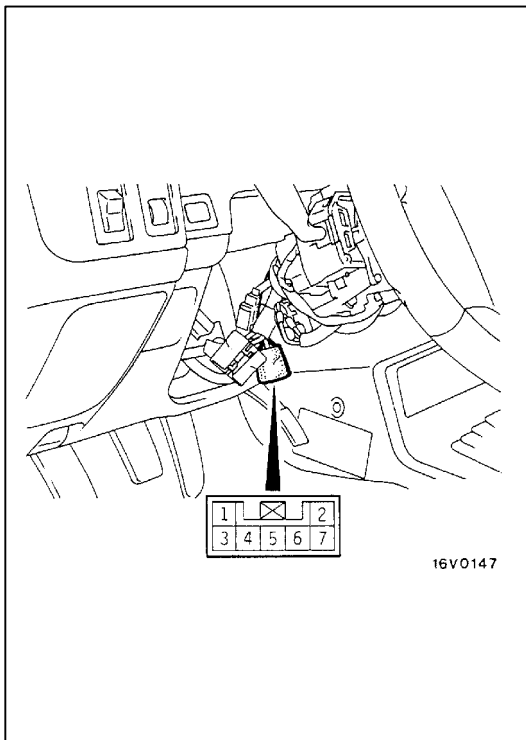

Ignition key position	Terminal No.				
	1	ILL	2	4	6
Pulled out	○	⊕	○	○	○
Inserted	○	⊕	○		

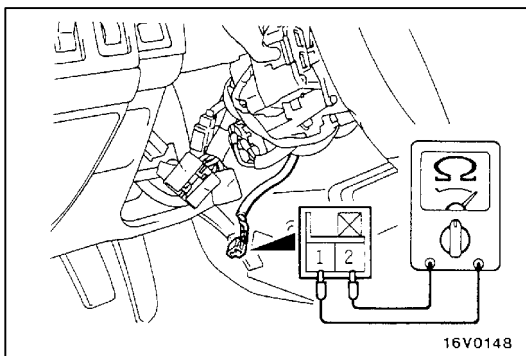

IGNITION KEY RING ANTENNA CONTINUITY CHECK

54300930027

Use a circuit tester to check the continuity between the terminals.

**ENCRYPTED CODE REGISTRATION METHOD
AND RESETTING THE CODE TO THE
FACTORY SETTING**

54300810086

Register the encrypted code in the immobilizer-ECU and then reset the code to the factory setting after parts have been replaced.

Replacement part	6G7	4D5	
	Encrypted registration code	Encrypted registration code	Resetting the code to the factory setting
Ignition key	Necessary	Necessary	Not necessary
Ignition key ring antenna	Not necessary	Not necessary	Not necessary
Immobilizer-ECU	Necessary	Necessary	Necessary
Engine-ECU <6G7>*	Necessary	–	–
Fuel cut valve controller (fuel injection pump) <4D5>	–	Not necessary	Not necessary (New part) Necessary (Used part)

NOTE

- *: If the engine-ECU is replaced, the immobilizer-ECU and ignition key should be replaced together with it.
Each engine-ECU has encrypted code for immobilizer-ECU, and the encrypted code is registered in the immobilizer-ECU.

Encrypted Code Registration Method

If using an ignition key that has just been newly purchased, or if the immobilizer-ECU has been replaced, you will need to register the encrypted codes for each ignition key being used into the immobilizer-ECU. (A maximum of eight different encrypted codes can be registered.)

Moreover, when the immobilizer-ECU has been replaced, you will need to use the MUT-II to input the vehicle secret code and to register the password (secret code) that the user specifies into the immobilizer-ECU. (Refer to the “MUT-II REFERENCE MANUAL” or “MUT-II OPERATING INSTRUCTIONS”)

Caution

Because registering of the encrypted codes is carried out after all previously-registered codes have been erased, you should have ready all of the ignition keys that have already been registered.

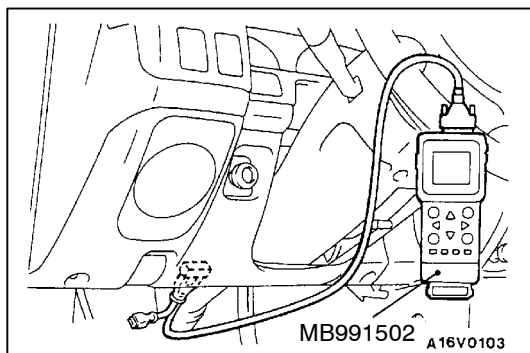

1. Connect the MUT-II to the diagnosis connector.

Caution

Turn off the ignition switch before connecting or disconnecting of the MUT-II.

2. Check that the diagnosis code No.54 is not being generated by the engine-ECU. If it is being generated check according to the Troubleshooting Procedures.

3. Use the ignition key that is to be registered to turn on the ignition switch.
4. Use the MUT-II to register the encrypted code. To register the second or subsequent key, leave the MUT-II connected and remove the first registered key. Within 5 seconds insert the key to be registered and turn on the ignition switch.

NOTE

After 5 seconds have elapsed, the key registration must be repeated from the beginning because the key registration mode terminates.

5. This complete the registration operation. Turn the ignition switch OFF and leave it for approx. 10 seconds.
6. Check that the engine can be started with each of the ignition keys.
7. Check the diagnosis output from the engine-ECU, and erase code No.54 if it appears.

Resetting the code to the factory setting <4D5>

Refer to the “MUT-II REFERENCE MANUAL” or “MUT-II OPERATING INSTRUCTIONS” on handling the MUT-II.

NOTE

Resetting the code to the factory setting refers to the process of clearing the identification code which has been recorded in the fuel cut valve controller and switching the controller to learning mode. After this resetting is carried out, the identification code in the immobilizer-ECU will be recorded in the controller the next time the ignition switch is turned to the ON.

1. Connect the MUT-II to the diagnosis connector.

Caution

Turn off the ignition switch before connecting or disconnecting of the MUT-II.

2. Turn on the ignition switch.
3. Use the MUT-II to reset the code to the factory setting.

NOTE

Approximately 16 minutes are required to complete resetting the code to the factory setting.

4. Disconnect the MUT-II

COMBINATION METERS

54300030260

SERVICE SPECIFICATIONS

Items		Standard value	
Speedometer indication error km/h (mph)	40 (20)	40 – 48 (20 – 25)	
	80 (40)	80 – 92 (40 – 47)	
	120 (60)	120 – 136 (60 – 69)	
	160 (80)	160 – 180 (80 – 91)	
	– (100)	– (100 – 114)	
Tachometer indication error r/min	6G7	700	±100
		3,000	±150
		5,000	±250
		6,000	±300
	4D5	700	±100
		3,000	±150
		4,750	±160
		5,000	±250
Fuel gauge unit resistance Ω	Float point F	1 – 5	
	Float point E	103 – 117	
Fuel gauge unit float height mm	A (Float point F)	16	
	B (Float point E)	219.5	
Engine coolant temperature gauge unit resistance (at 70 °C) Ω		104 ± 13.5	
Fuel gauge resistance Ω	Power supply and earth	250 ± 25	
	Power supply and fuel gauge	91 ± 9.1	
	Fuel gauge and earth	159 ± 15.9	
Engine coolant temperature gauge resistance Ω	Power supply and earth	179 ± 17.9	
	Power supply and engine coolant temperature gauge	54 ± 5.4	
	Engine coolant temperature gauge and earth	233 ± 23.3	



SEALANT

54300050075

Items	Specified sealant	Remark
Engine coolant temperature gauge unit threaded portion	3M Adhesive nut locking No. 4171 or equivalent	Drying sealant

SPECIAL TOOLS

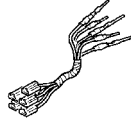
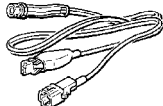
54300060504

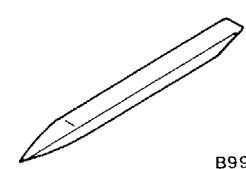
Tool	Number	Name	Use
<p>A</p>  <p>B</p>  <p>C</p>  <p>D</p>  <p>C991223</p>	<p>MB991223</p> <p>A: MB991219</p> <p>B: MB991220</p> <p>C: MB991221</p> <p>D: MB991222</p>	<p>Harness set</p> <p>A: Test harness</p> <p>B: LED harness</p> <p>C: LED harness adapter</p> <p>D: Probe</p>	<ul style="list-style-type: none"> ● Fuel gauge check ● Engine coolant temperature gauge check <4D5> <p>A: Connector pin contact pressure check</p> <p>B: Power circuit check</p> <p>C: Power circuit check</p> <p>D: Commercial tester connection</p>
 <p>B990784</p>	<p>MB990784</p>	<p>Ornament remover</p>	<p>Removal of meter bezel assembly</p>

TROUBLESHOOTING

54300720761

INSPECTION CHART FOR TROUBLE SYMPTOMS

Trouble symptom	Inspection procedure	Reference page
Speedometer does not work.	1	54-26
Tachometer does not work.	2	54-26
Fuel gauge does not work.	3	54-27
Engine coolant temperature gauge does not work.	4	54-27

INSPECTION PROCEDURE FOR TROUBLE SYMPTOMS

Inspection Procedure 1

Speedometer does not work.	Probable cause
The cause may be a defective vehicle speed sensor circuit system or a defective speedometer. Vehicle speed sensor is co-used among the engine-ECU and A/T-ECU.	<ul style="list-style-type: none"> • Malfunction of vehicle speed sensor • Malfunction of speedometer • Malfunction of harness or connector

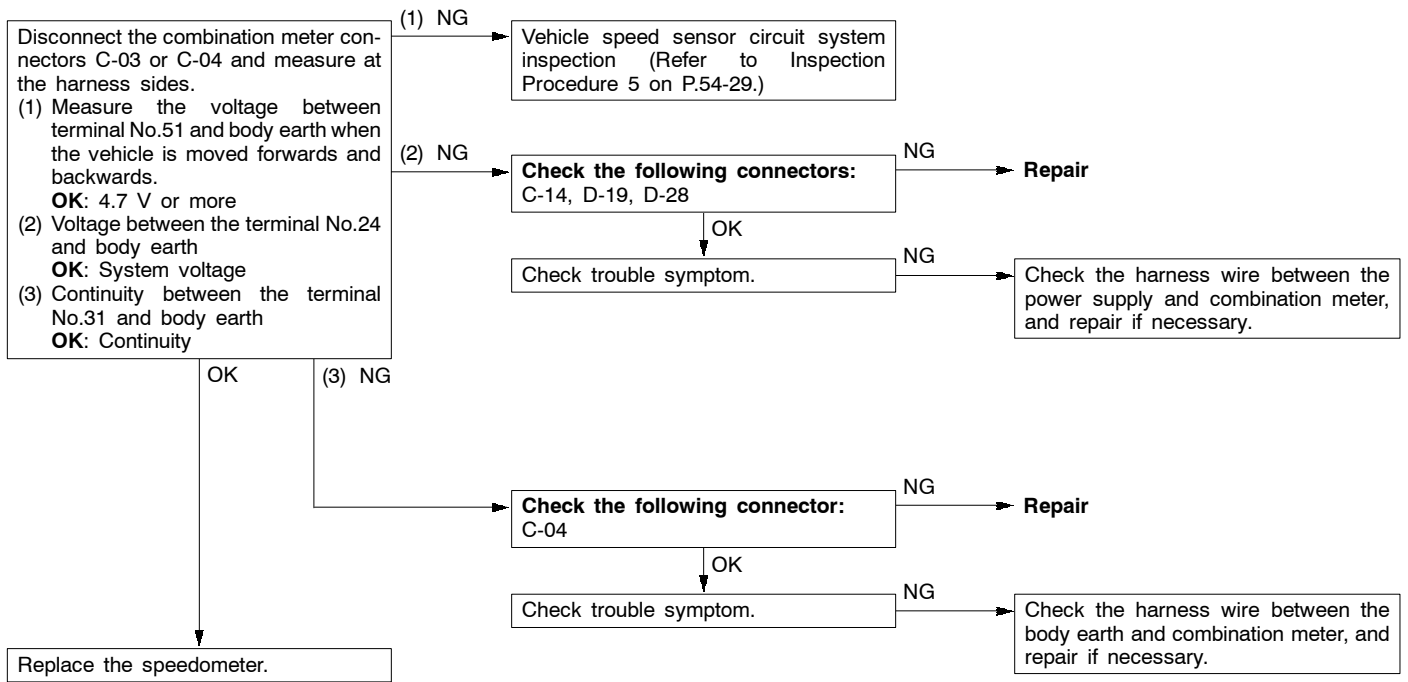

Inspection Procedure 2

Tachometer does not work.	Probable cause
The ignition signal may not be input from the engine, or there may be a malfunction in the power supply or earth circuit.	<ul style="list-style-type: none"> • Malfunction of tachometer • Malfunction of harness or connector

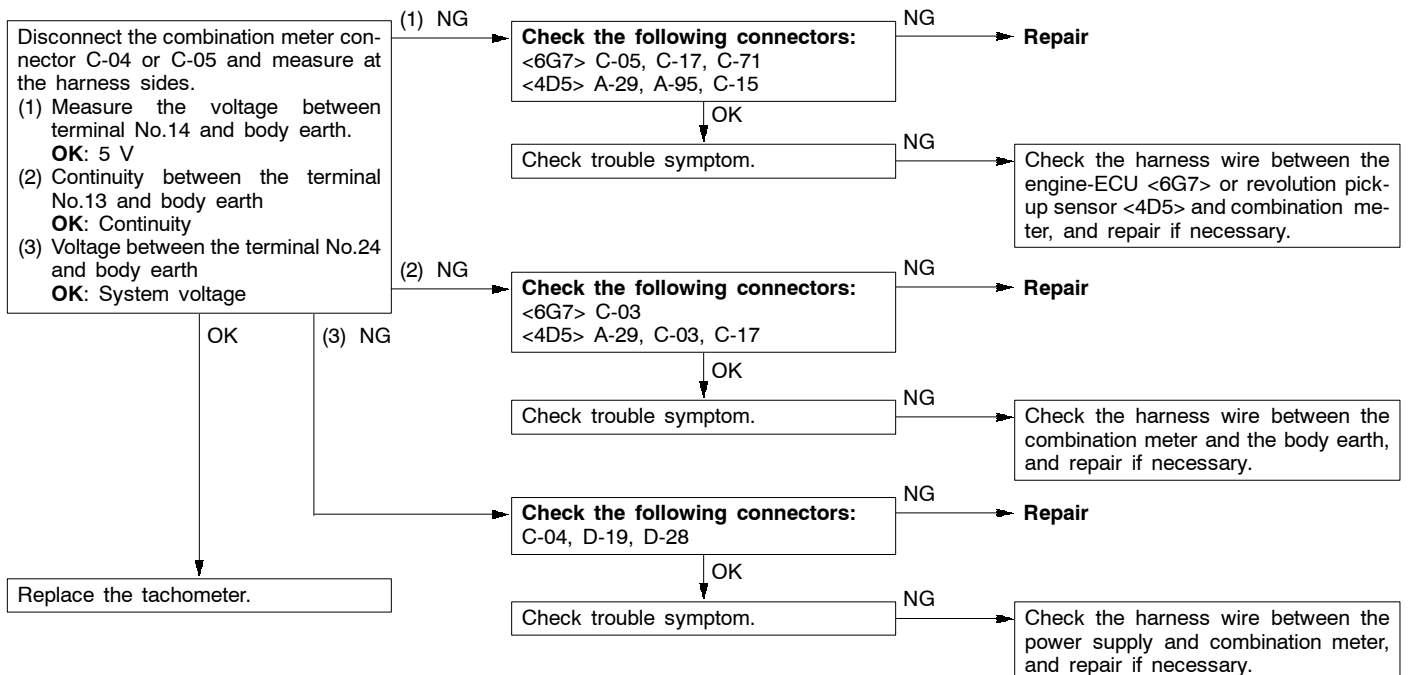

Inspection Procedure 3

Fuel gauge does not work.	Probable cause
If the speedometer and tachometer are normal, the circuit from the ignition switch (IG ₁) to the combination meter is normal.	<ul style="list-style-type: none"> ● Malfunction of the fuel gauge unit ● Malfunction of the fuel gauge ● Malfunction of the harness wire or connector

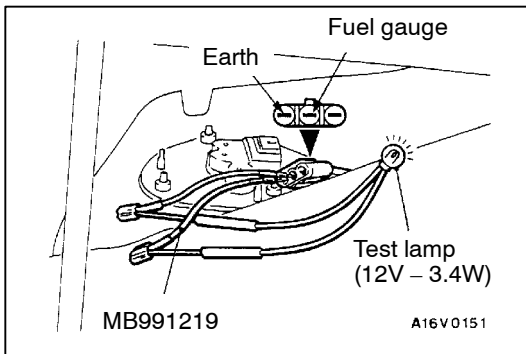
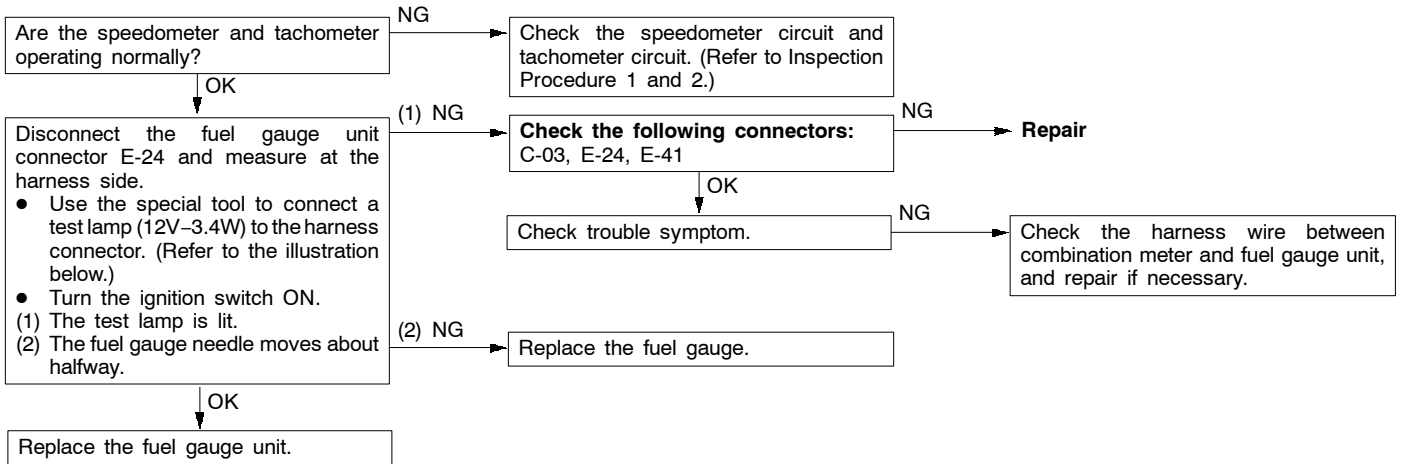

Inspection Procedure 4

Engine coolant temperature gauge does not work.	Probable cause
If the speedometer and tachometer are normal, the circuit from the ignition switch (IG ₁) to the combination meter is normal.	<ul style="list-style-type: none"> • Malfunction of the engine coolant temperature gauge unit • Malfunction of the engine coolant temperature gauge • Malfunction of the harness wire or connector

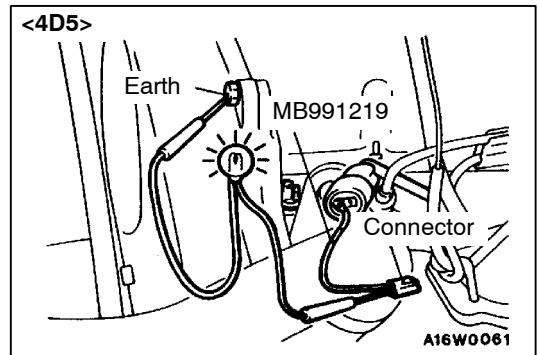
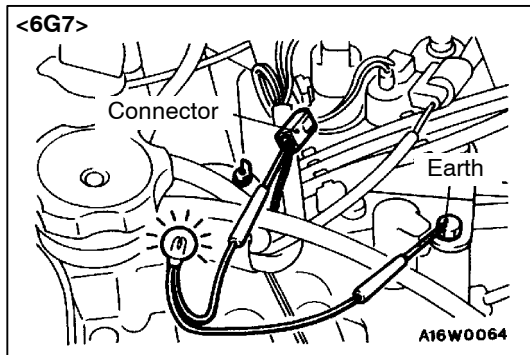
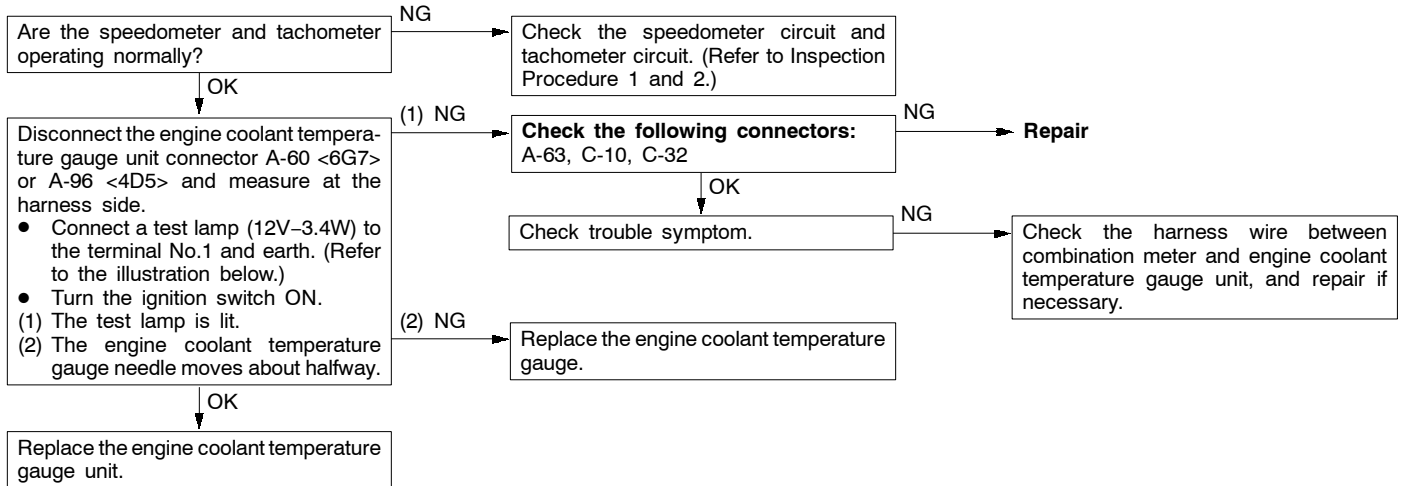

Inspection Procedure 5

Vehicle speed sensor circuit system inspection

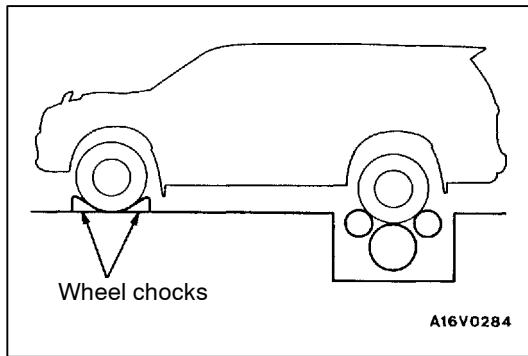
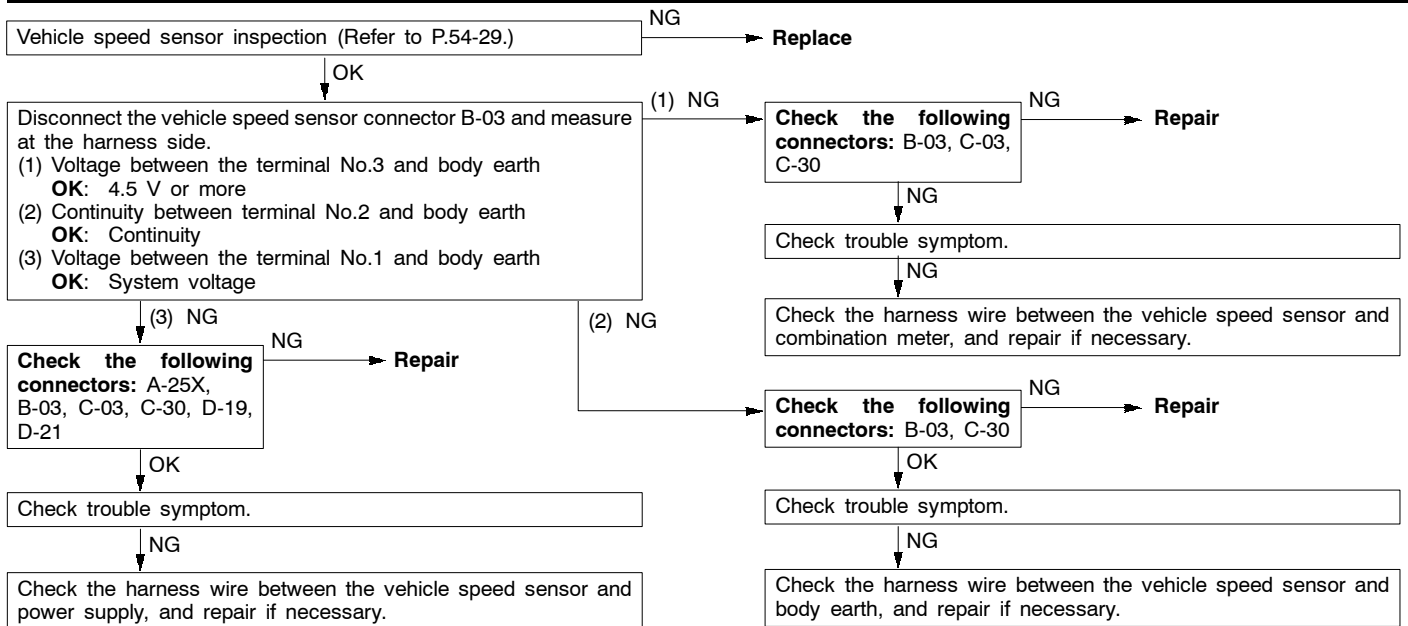

ON-VEHICLE SERVICE

54300090213

SPEEDOMETER CHECK

1. Adjust the pressure of tyres to the specified level. (Refer to GROUP 31 – On-vehicle Service.)
2. Set the vehicle onto a speedometer tester and use wheel chocks to hold the front wheels.

Caution

Place the transfer shift lever to 2H position.

3. Check if the speedometer indicator range is within the standard values.

Caution

Do not operate the clutch suddenly. Do not increase/decrease speed rapidly while testing.

Standard value:

Standard indication (mph)	km/h	Allowance range km/h (mph)
40 (20)		40 – 48 (20 – 25)
80 (40)		80 – 92 (40 – 47)
120 (60)		120 – 136 (60 – 69)
160 (80)		160 – 180 (80 – 91)
– (100)		– (100 – 114)

TACHOMETER CHECK

54300100220

<6G7>

1. Connect the MUT-II to the diagnosis connector (16-pin).

Caution

Make certain that the ignition switch is OFF when the MUT-II is connected or disconnected.

2. Start the engine and run.
3. Select the item No.22 of the MUT-II Service Data.
4. Compare the readings of the engine speedometer and the tachometer at every engine speed, and check if the variations are within the standard value.

Standard value:

700 r/min: ±100 r/min

3,000 r/min: ±150 r/min

5,000 r/min: ±250 r/min

6,000 r/min: ±300 r/min

NOTE

For tachometer inspection, use of a fluxmeter-type engine speedometer is recommended. (Because a fluxmeter only needs to be clipped to the high tension cable.)

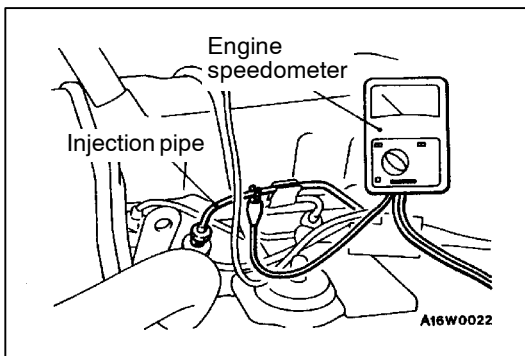
**<4D5>**

1. Connect the engine speedometer to the injection pipe.
2. Compare the readings of the engine speedometer and the tachometer at every engine speed, and check if the variation are within the standard values.

Standard value:

700 r/min: ±100 r/min

3,000 r/min: ±150 r/min

4,750 r/min: ±160 r/min

5,000 r/min: ±250 r/min

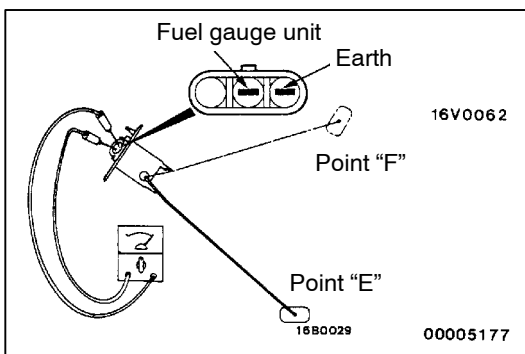
**FUEL GAUGE UNIT CHECK**

54300120363

Remove the fuel gauge unit from the fuel tank.

FUEL GAUGE UNIT RESISTANCE

1. Check that resistance value between the fuel gauge terminal and earth terminal is at standard value when fuel gauge unit float is at point F (highest) and point E (lowest).

Standard value:

Point F: 1 – 5 Ω

Point E: 103 – 117 Ω

2. Check that resistance value changes smoothly when float moves slowly between point F (highest) and point E (lowest).

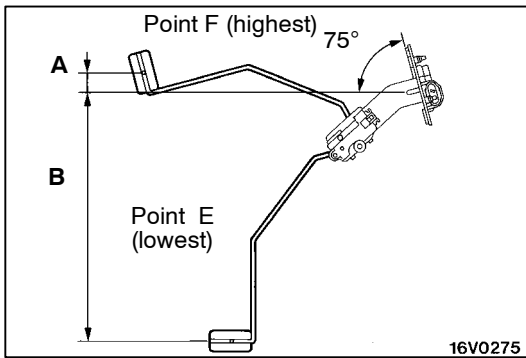

FUEL GAUGE UNIT FLOAT HEIGHT

Move float and measure the height A at point F (highest) and B at point E (lowest) with float arm touching stopper.

Standard value:
A: 16 mm
B: 219.5 mm

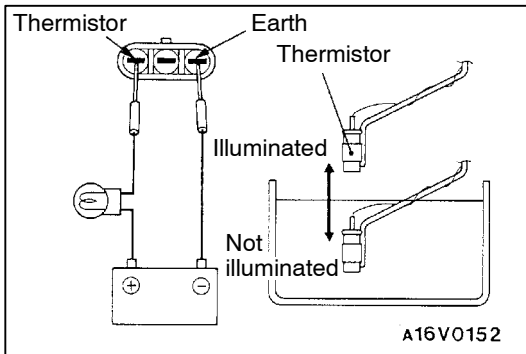

THERMISTOR

1. Connect fuel gauge unit (thermistor) to battery via test lamp (12 V – 3.4 W). Immerse in water.
2. Condition is good if lamp goes off when the thermistor is immersed in water and goes on when it is taken out of water.

Caution
After finishing this test, wipe the unit, dry and install it in the fuel tank.

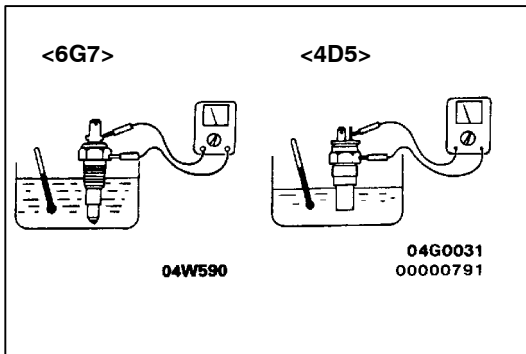

ENGINE COOLANT TEMPERATURE GAUGE UNIT CHECK

54300150287

1. Bleed the engine coolant.
(Refer to GROUP 14 – On-vehicle Service.)
2. Remove the engine coolant temperature gauge unit.
3. Immerse the unit in 70°C water to measure the resistance.

Standard value: 104 ± 13.5 Ω

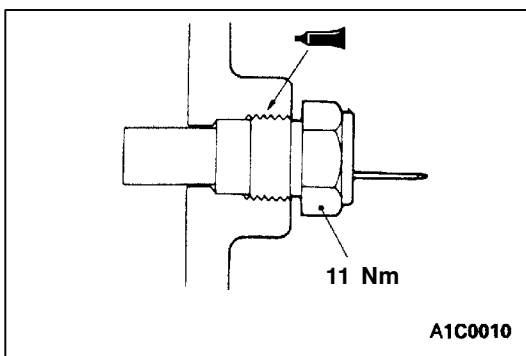

4. After checking, apply the specified adhesive around the thread of engine coolant temperature gauge unit.

Specified sealant:
3M Adhesive Nut Locking No. 4171 or equivalent

5. Add engine coolant.
(Refer to GROUP 14 – On-vehicle Service.)

COMBINATION METERS

54300290248

REMOVAL AND INSTALLATION

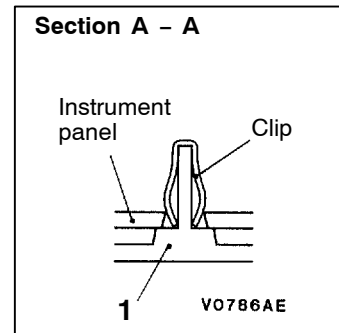
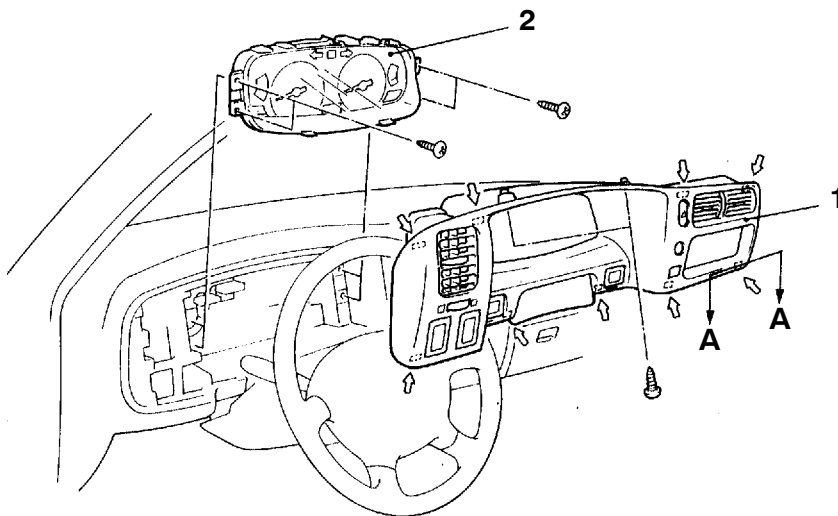

NOTE

← : metal clip position

T0280AA

00009159

Removal steps

1. Meter bezel assembly
2. Combination meter

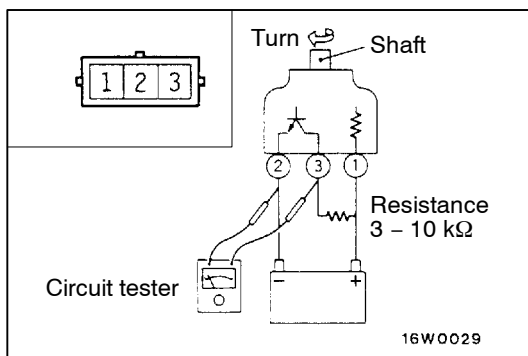

INSPECTION

54300640173

VEHICLE SPEED SENSOR CHECK

1. Remove the vehicle speed sensor and connect a 3 – 10 kΩ resistance as shown in the illustration.
2. Turn the shaft of the vehicle speed sensor and check that there is voltage between terminals 2 – 3. (1 turn = 4 pulses)

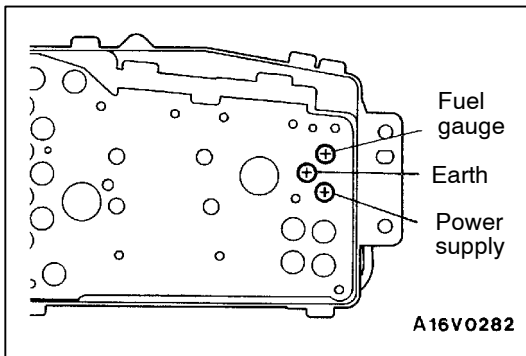
**FUEL GAUGE RESISTANCE CHECK**

54300300187

1. Remove the power supply tightening screw.
2. Use a circuit tester to measure the resistance value between the terminals.

Standard value:

Power supply – Earth: $250 \pm 25 \Omega$

Power supply – Fuel gauge: $91 \pm 9.1 \Omega$

Fuel gauge – Earth: $159 \pm 15.9 \Omega$

Caution

When inserting the testing probe into the power supply terminal, be careful not to touch the printed board.

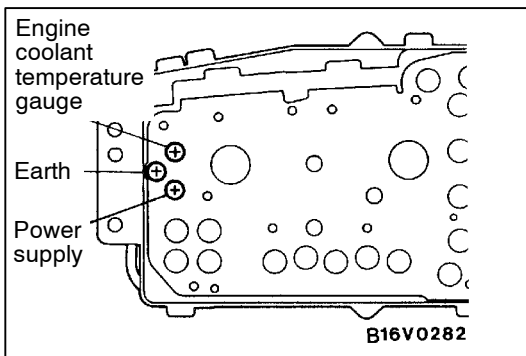
**ENGINE COOLANT TEMPERATURE GAUGE RESISTANCE CHECK**

1. Remove the power supply tightening screw.
2. Use a circuit tester to measure the resistance value between the terminals.

Standard value:

Power supply – Earth: $179 \pm 17.9 \Omega$

Power supply – Engine coolant temperature gauge: $54 \pm 5.4 \Omega$

Engine coolant temperature gauge – Earth: $233 \pm 23.3 \Omega$

Caution

When inserting the testing probe into the power supply terminal, be careful not to touch the printed board.

MULTI-METER

54300720778

TROUBLESHOOTING

INSPECTION CHART FOR TROUBLE SYMPTOMS

Trouble symptom	Inspection procedure	Reference page
Voltmeter does not work.	1	54-34
Oil pressure gauge does not work.	2	54-35
Bearing indicator is off when moving forward. (for electronic compass)	3	54-36
Vehicle magnetic compensation cannot be made. (for electronic compass)	4	54-36
Discrepancy between the actual outside temperature and displayed temperature.	5	54-36
Display is hard to see or no display appears.	6	54-37

INSPECTION PROCEDURE FOR TROUBLE SYMPTOMS

Inspection Procedure 1

Voltmeter does not work.	Probable cause
The ignition switch circuit system, the body earth circuit system, the power circuit system or the voltmeter may be defective.	<ul style="list-style-type: none"> Malfunction of the voltmeter Malfunction of the harness wire or connector

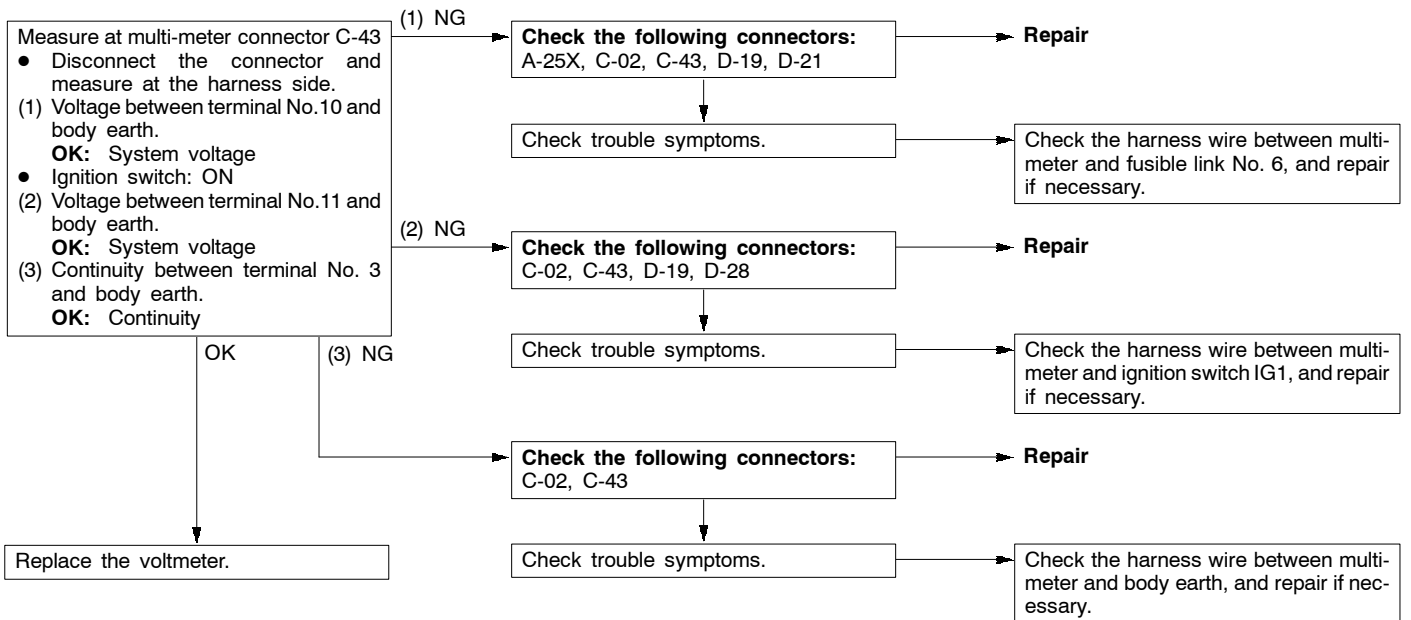

Inspection Procedure 2

Oil pressure gauge does not work.	Probable cause
The oil pressure gauge unit, the oil pressure unit circuit system. The ignition switch circuit system, the body earth circuit system, the multi-meter power circuit system or the oil pressure gauge may be defective.	<ul style="list-style-type: none"> • Malfunction of the oil pressure gauge unit • Malfunction of the oil pressure gauge • Malfunction of the harness wire or connector

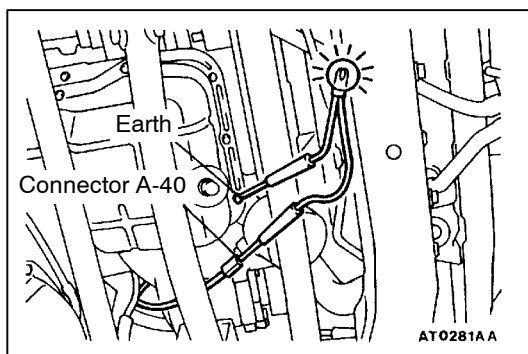
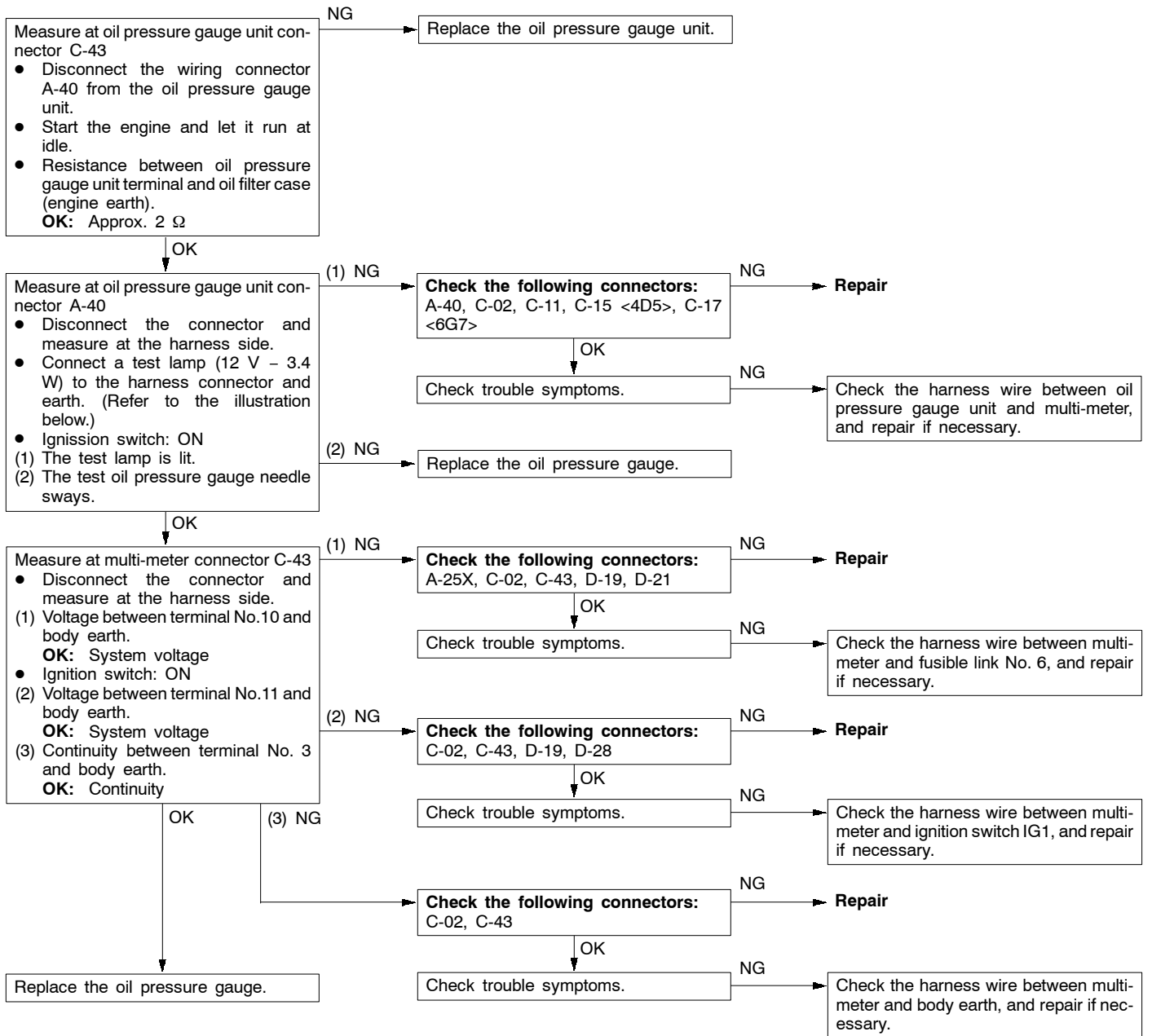

Inspection Procedure 3

Bearing indicator is off when moving forward. (for electric compass)	Probable cause
The vehicle magnetism tends to be disturbed particularly at such places as tunnel, railway crossing, area along railway, elevated road, urban above subway, etc. if disturbed, the driving direction marker will fluctuate.	<ul style="list-style-type: none"> • The vehicle magnetic compensation failed

Vehicle magnetic compensation. (Refer to P.54-38)

Inspection Procedure 4

Vehicle magnetic compensation cannot be made. (for electronic compass)	Probable cause
The multi-meter (outside temperature meter of the electronic compass) may be defective.	<ul style="list-style-type: none"> • Malfunction of the multi-meter (outside temperature meter and electronic compass)

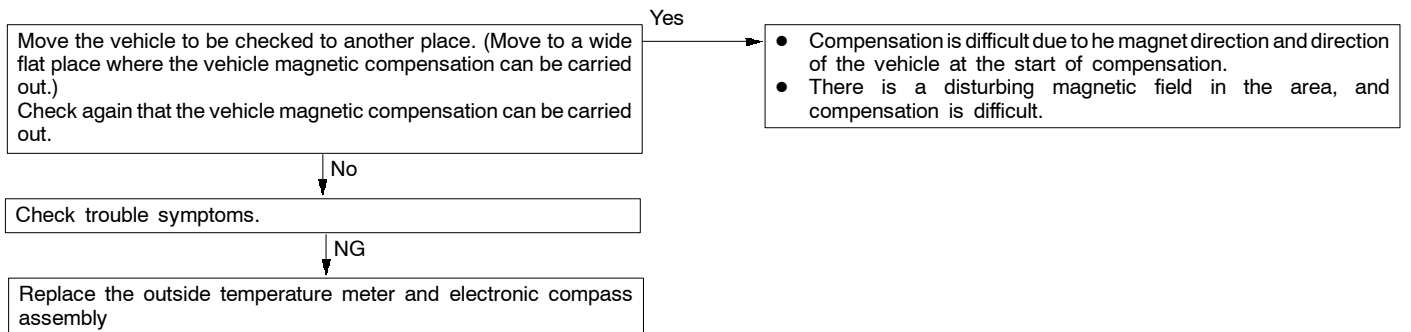

Inspection Procedure 5

Discrepancy between the actual outside temperature and displayed temperature.	Probable cause
The outside thermo sensor, multi-meter (outside temperature meter and electronic compass), harness, or connector may be defective.	<ul style="list-style-type: none"> • Malfunction of the outside thermo sensor • Malfunction of the multi-meter (outside temperature meter and electronic compass) • Malfunction of the harness or connector

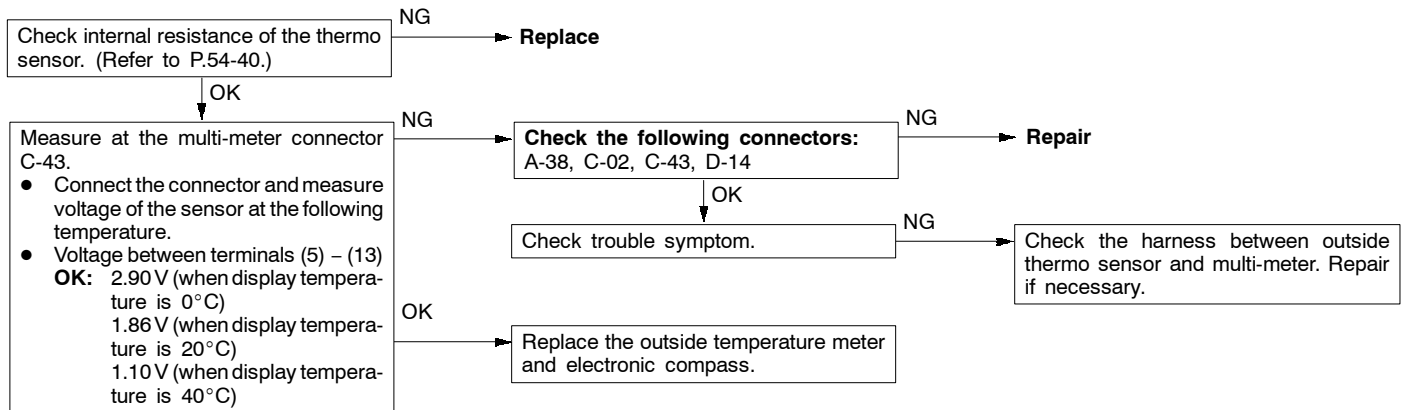

Inspection Procedure 6

Display is hard to see or no display appears.	Probable cause
The The multi-meter (outside temperature meter of the electronic compass), harness, or connector may be defective.	<ul style="list-style-type: none"> ● Malfunction of the multi-meter (outside temperature meter and electronic compass) ● Blown back-lamp ● Malfunction of the harness wire and connector

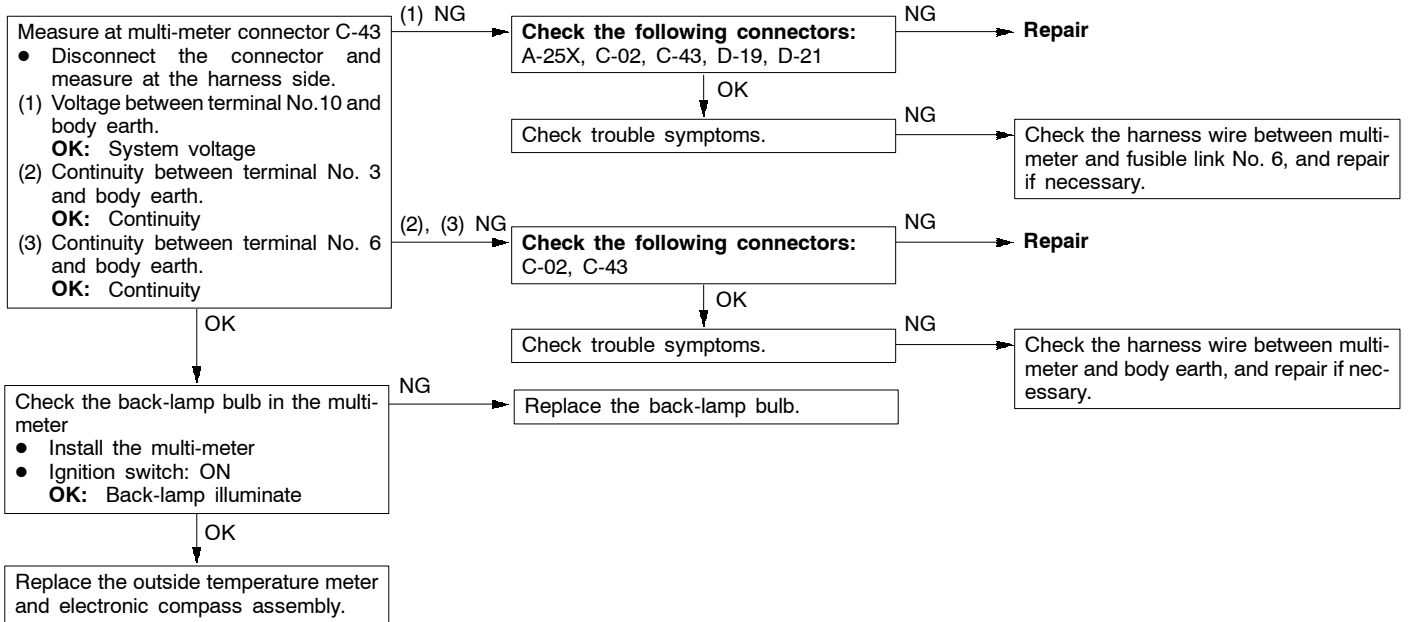

ON-VEHICLE SERVICE

54300970029

VEHICLE MAGNETIC COMPENSATION

1. When the vehicle magnetic compensation switch (S) is pressed, "S" will display on the full scale. When pressed down longer (0.5 second or more), the "S" display will move to the right turn or left turn, and the magnetic compensation mode will be entered.

2. The compensation will be completed automatically when the vehicle is slowly steered 360° or more.

NOTE

- The compensation can be carried out by steering to the right or to the left.
- The "S" display speed will increase as the compensation degree advances.

3. If there is not enough space to steer the vehicle, rotate the vehicle once without turning the handle.
4. After compensation is completed, the forward direction will be displayed.

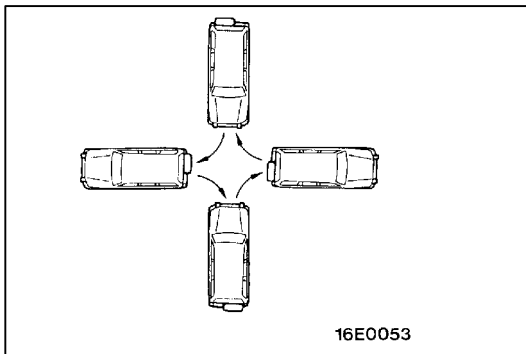
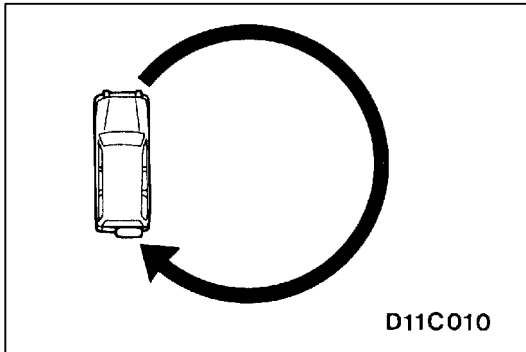
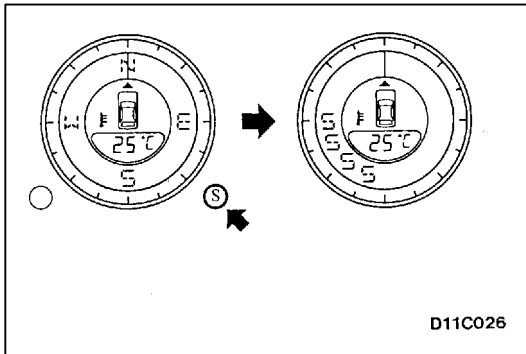

MULTI-METER

54300390054

REMOVAL AND INSTALLATION

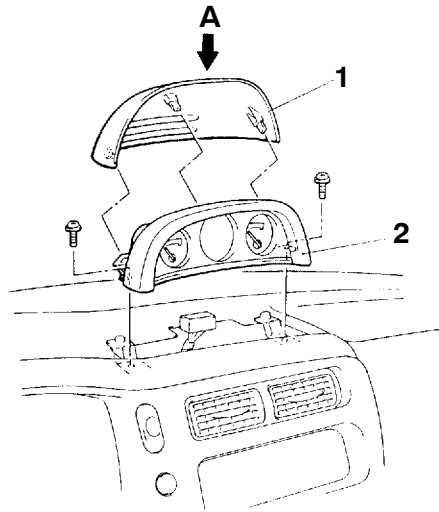

T0282AA
00009160

View A

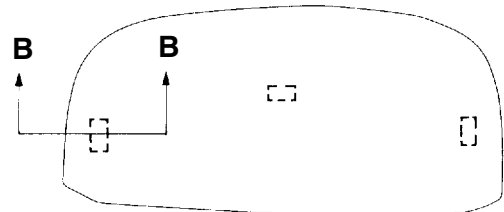

W0200AA

Section B - B

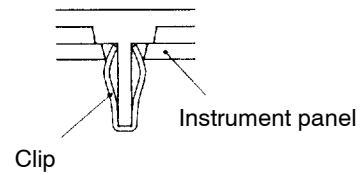

V0786AE

Removal steps

1. Multi-meter panel
2. Multi-meter

DISASSEMBLY AND REASSEMBLY

54300410064

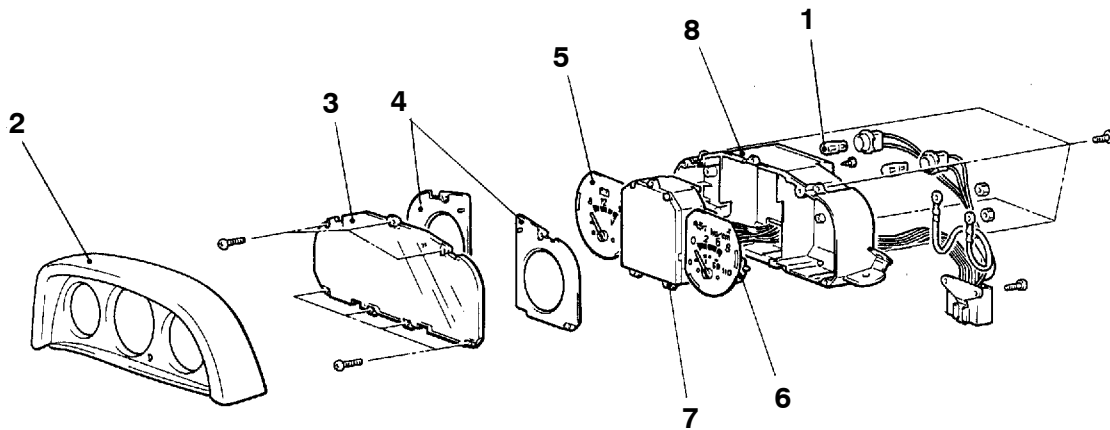

BT0283AA

Disassembly steps

- | | |
|--|---|
| <ol style="list-style-type: none"> 1. Bulb 2. Meter garnish 3. Meter glass 4. Window plate | <ol style="list-style-type: none"> 5. Oil pressure gauge 6. Voltmeter 7. Electronic compass 8. Meter case |
|--|---|

OUTSIDE THERMO SENSOR

54300030123

SERVICE SPECIFICATIONS

Items	Standard value	
Internal resistance of outside thermo sensor Ω	At 20°C	Approx. 1,200
	At 40°C	Approx. 500

OUTSIDE THERMO SENSOR

54300950030

REMOVAL AND INSTALLATION

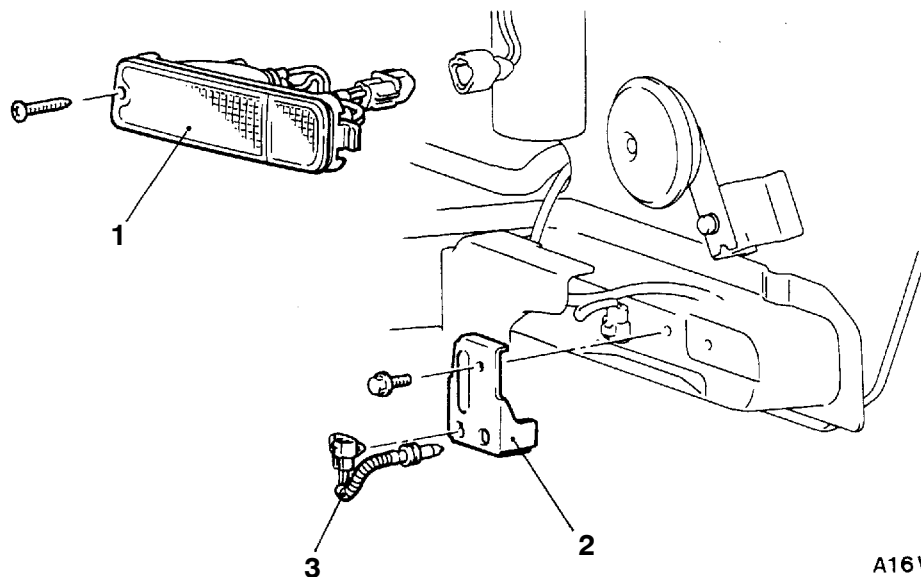

A16V0130

1. Front turn-signal lamp (L.H.)
2. Bracket
3. Outside thermo sensor

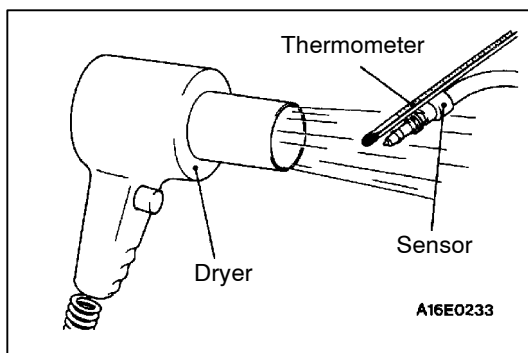

INSPECTION

54300960019

OUTSIDE THERMO SENSOR INTERNAL RESISTANCE CHECK

Check the internal resistance of the outside thermo sensor are at the standard values at temperatures of 20°C and 40°C.

Standard value:

Approx. 1,200 Ω (at 20°C)

Approx. 500 Ω (at 40°C)

HEADLAMP AND FRONT COMBINATION LAMP



54200030267

SERVICE SPECIFICATIONS

Items		Standard value	Limit
Headlamp aiming for low beam	Vertical direction	60 mm below horizontal (H)	–
	Horizontal direction	Position where the 15° sloping section intersects the vertical line (V)	–
Headlamp intensity cd		–	30,000 or more

SPECIAL TOOLS

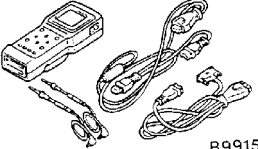
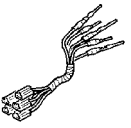
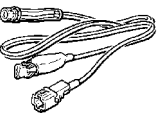
54200060570

Tool	Number	Name	Use
 <p>B991502</p>	MB991502	MUT-II sub assembly	ETACS-ECU input signal checking
<p>A</p>  <p>B</p>  <p>C</p>  <p>D</p>  <p>C991223</p>	MB991223 A: MB991219 B: MB991220 C: MB991221 D: MB991222	Harness set A: Test harness B: LED harness C: LED harness adapter D: Probe	Making voltage and resistance measurements during troubleshooting A: Connector pin contact pressure inspection B: Power circuit inspection C: Power circuit inspection D: Commercial tester connection

TROUBLESHOOTING

54200900100

The special tool (MB991223) should always be used to measure voltages and resistances when carrying out troubleshooting.

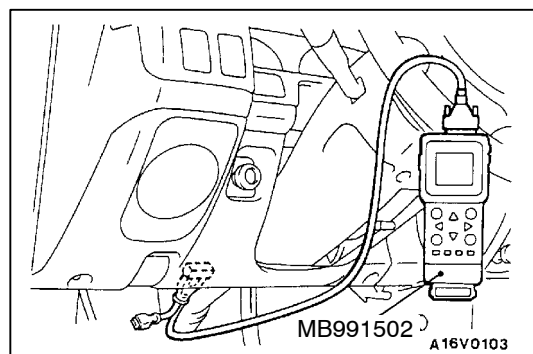

DIAGNOSIS FUNCTION

INPUT SIGNAL INSPECTION POINTS

1. Connect the MUT-II to the diagnosis connector.
2. If buzzer of the MUT-II sounds once when a switch is operated (ON/OFF), the ETACS-ECU input signal for that switch circuit system is normal.

INSPECTION CHART FOR TROUBLE SYMPTOMS

54200910226

Trouble symptoms	Inspection procedure	Reference page
Communication with MUT-II is impossible.	Communication with all systems is impossible.	1 54-43
	Communication with one-shot pulse input signal only is impossible.	2 54-43
The lighting monitor buzzer doesn't sound under the following conditions while tail lamps or headlamps illuminate. <ul style="list-style-type: none"> ● When the ignition switch is turned to OFF and the driver's side door is open. 	3	54-43
Headlamp leveling does not occur when the headlamp leveling switch is operated.	5	54-44
The headlamps do not illuminate when the vehicle is in the following condition and the ignition switch is at the ON position. However, the headlamps illuminate when the lighting switch is moved to the HEAD position. <Vehicles with daytime running lamp system> <ul style="list-style-type: none"> ● Lighting switch: OFF ● Passing switch: OFF 	6	54-45
The headlamps do not switch off when the vehicle is in the following condition and the lighting switch is moved to the TAIL position. <Vehicles with daytime running lamp system> <ul style="list-style-type: none"> ● Ignition switch: OFF ● Passing switch: OFF 	7	54-46

INSPECTION PROCEDURE FOR TROUBLE SYMPTOMS

Inspection Procedure 1

Communication with MUT-II is impossible. (Communication with all systems is impossible.)	Probable cause
The cause is probably a defective power supply system (including earth) for the diagnosis line.	<ul style="list-style-type: none"> ● Malfunction of connector ● Malfunction of harness wire

Refer to GROUP 13A – Troubleshooting.

Inspection Procedure 2

Communication with MUT-II is impossible. (Communication with the one-shot pulse input signal only is impossible.)	Probable cause
The cause is probably a defective one-shot pulse input circuit system of the diagnosis line.	<ul style="list-style-type: none"> ● Malfunction of connector ● Malfunction of harness wire ● Malfunction of ETACS-ECU

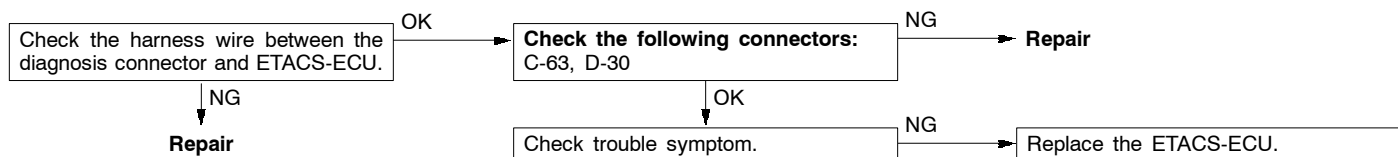

Inspection Procedure 3

The ignition switch is turned to the OFF position and the driver's side door is opened while the tail lamps or headlamps are operating, but the light reminder warning buzzer does not sound.	Probable cause
The cause is probably a defective lighting switch input circuit system or a defective driver's side door switch input circuit system.	<ul style="list-style-type: none"> ● Malfunction of driver's side door switch ● Malfunction of harness or connector ● Malfunction of ETACS-ECU

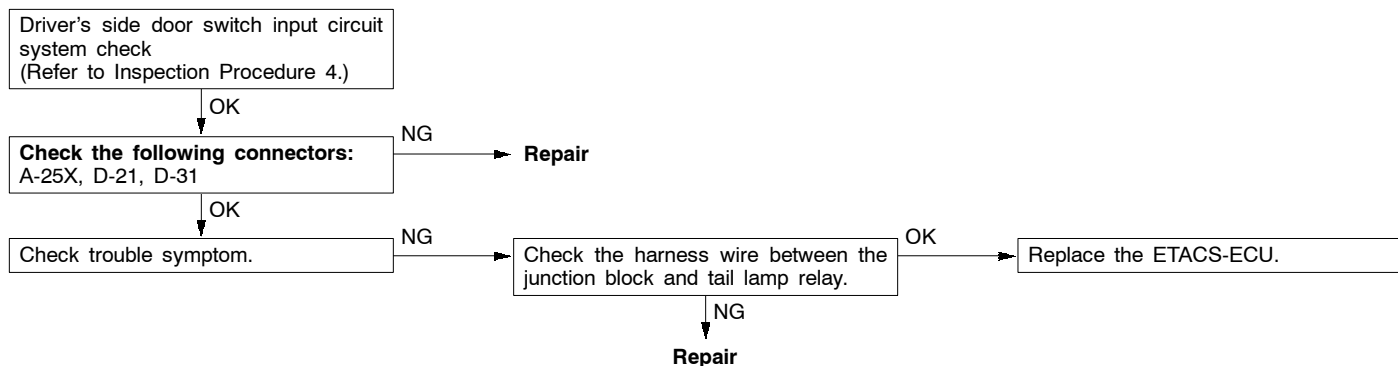

54-44 CHASSIS ELECTRICAL – Headlamp and Front Combination Lamp

Inspection Procedure 4

Driver's side door switch input circuit system check

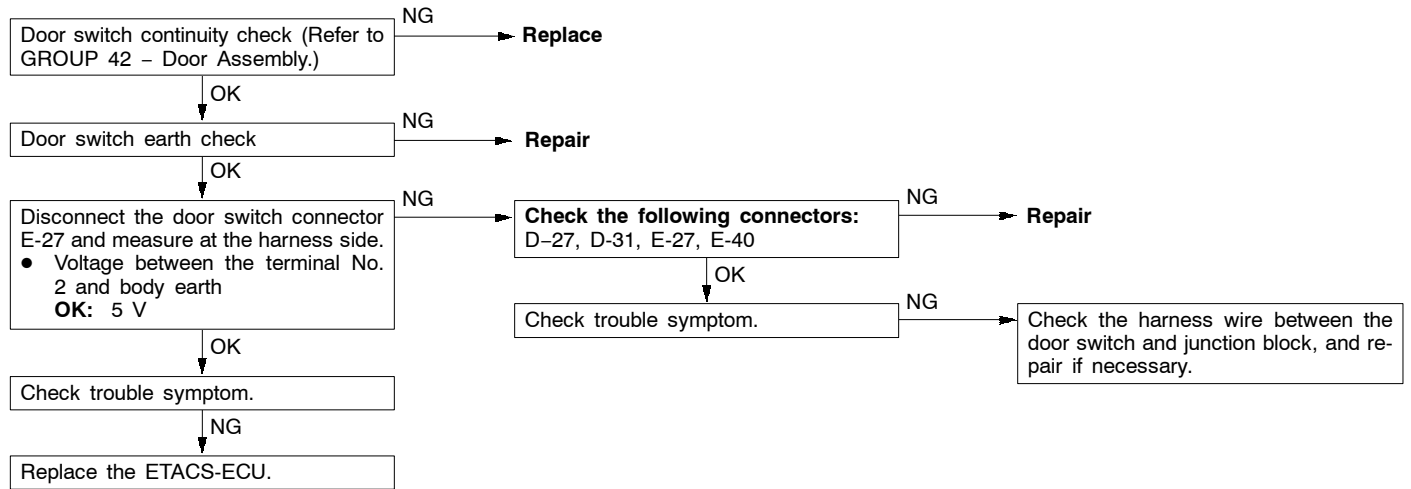

Inspection procedure 5

Headlamp leveling does not occur when the headlamp leveling switch is operated.	Probable cause
The cause is probably a malfunction of the headlamp leveling switch circuit system or a malfunction of the headlamp leveling unit circuit system. If there is a blown fuse, there may also be a short-circuit in a harness.	<ul style="list-style-type: none"> ● Malfunction of fuse ● Malfunction the headlamp leveling switch ● Malfunction of connector ● Malfunction of harness wire ● Malfunction of the headlamp leveling unit

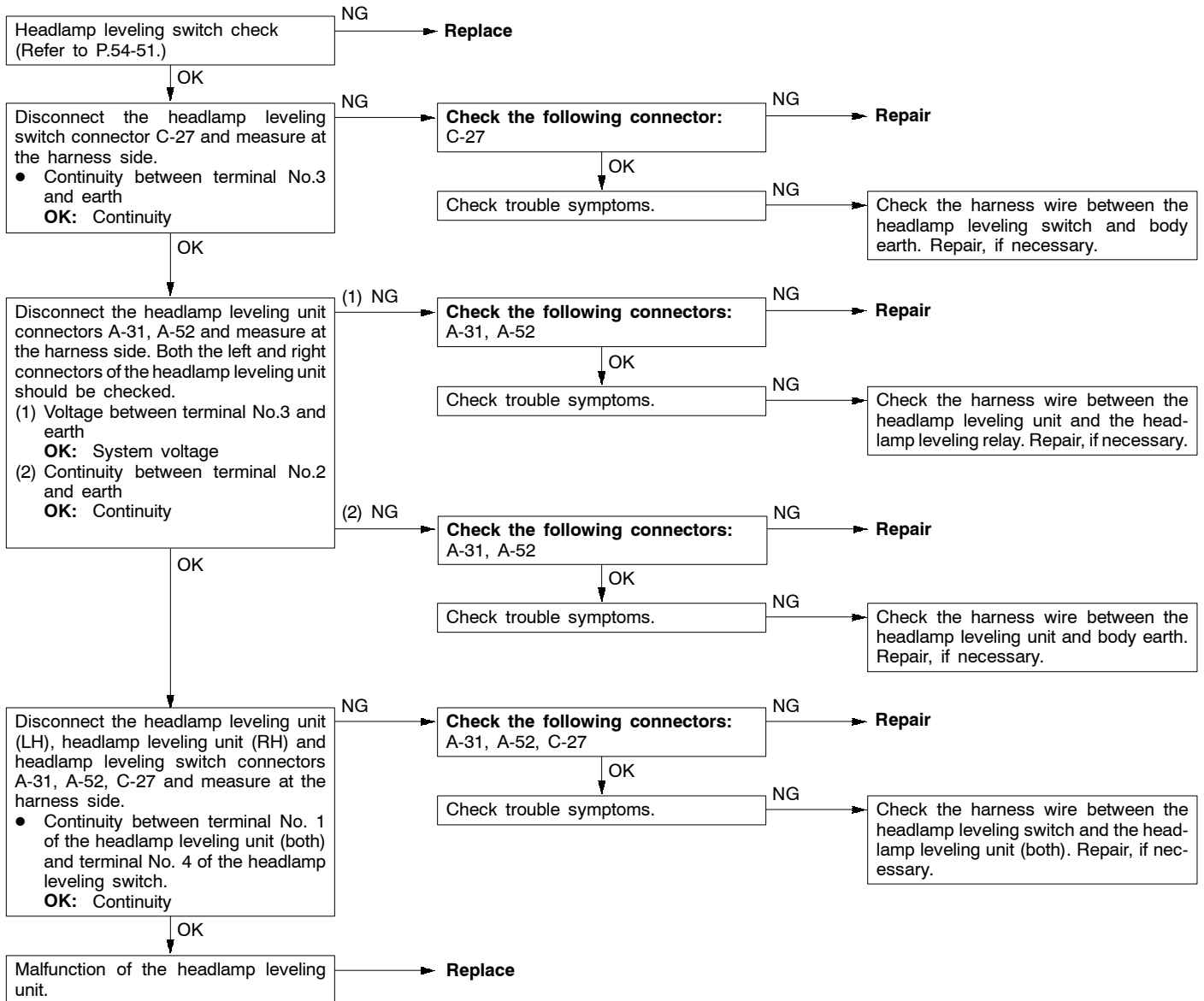

Inspection procedure 6

<p>The headlamps do not illuminate when the vehicle is in the following condition and the ignition switch is moved to the ON position. However, they illuminate when the lighting switch is moved to the HEAD position. <Vehicles with daytime running lamp></p> <ul style="list-style-type: none"> ● Lighting switch: OFF ● Passing switch: OFF 	<p>Probable cause</p>
<p>The cause is probably a malfunction of the daytime running lamp control unit (DRL-ECU) circuit system. If there is a blown fuse, there may also be a short-circuit in a harness.</p>	<ul style="list-style-type: none"> ● Malfunction of fuse ● Malfunction of connector ● Malfunction of harness wire ● Malfunction of the DRL relay (1) ● Malfunction of the DRL-ECU

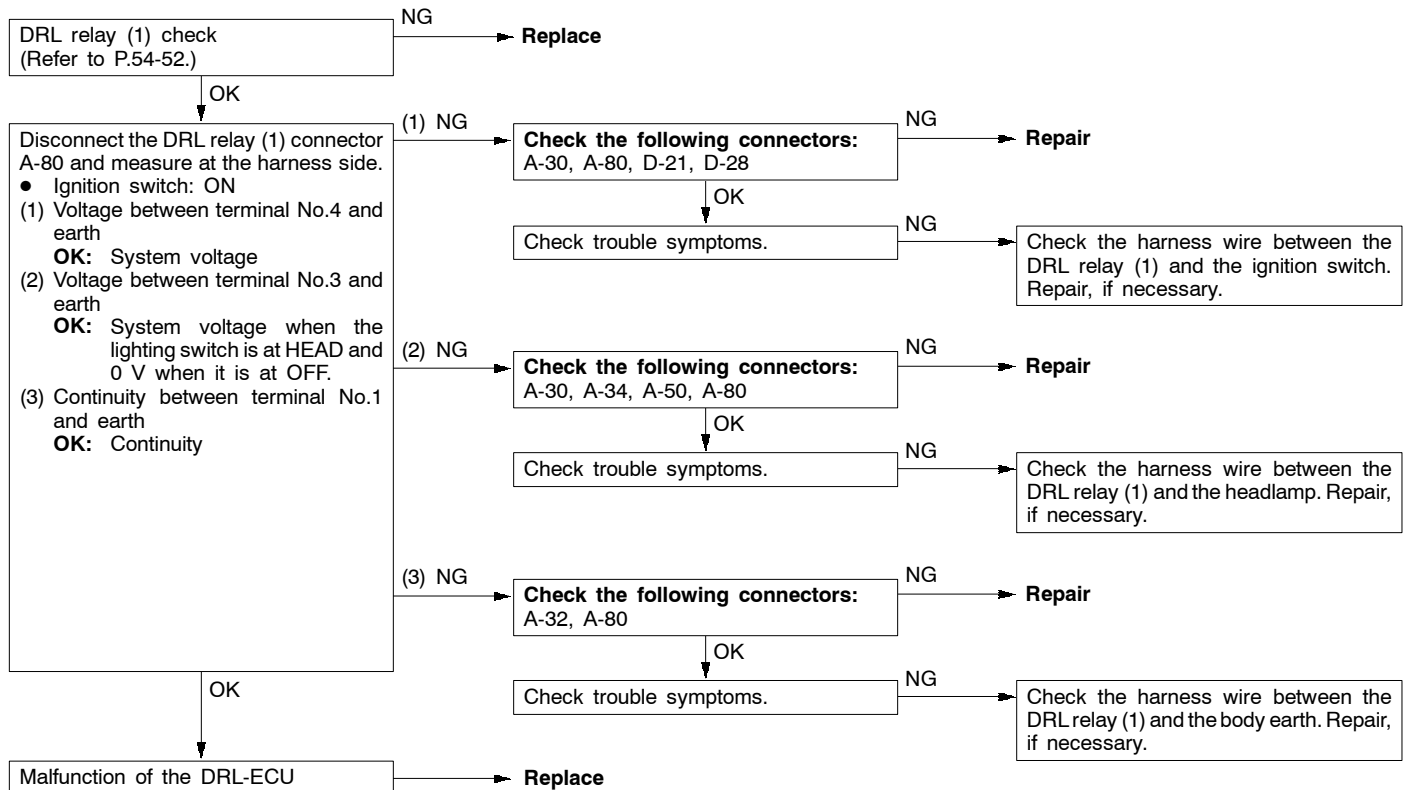

Inspection procedure 7

<p>The headlamps do not switch off when the vehicle is in the following condition and the lighting switch is moved to the TAIL position. <Vehicles with daytime running lamp></p> <ul style="list-style-type: none"> ● Ignition switch: OFF ● Passing switch: OFF 	<p>Probable cause</p>
<p>The cause is probably a malfunction of the daytime running lamp control unit (DRL-ECU) circuit system. If there is a blown fuse, there may also be a short-circuit in a harness.</p>	<ul style="list-style-type: none"> ● Malfunction of fuse ● Malfunction of connector ● Malfunction of harness wire ● Malfunction of the tail lamp relay ● Malfunction of the DRL-ECU

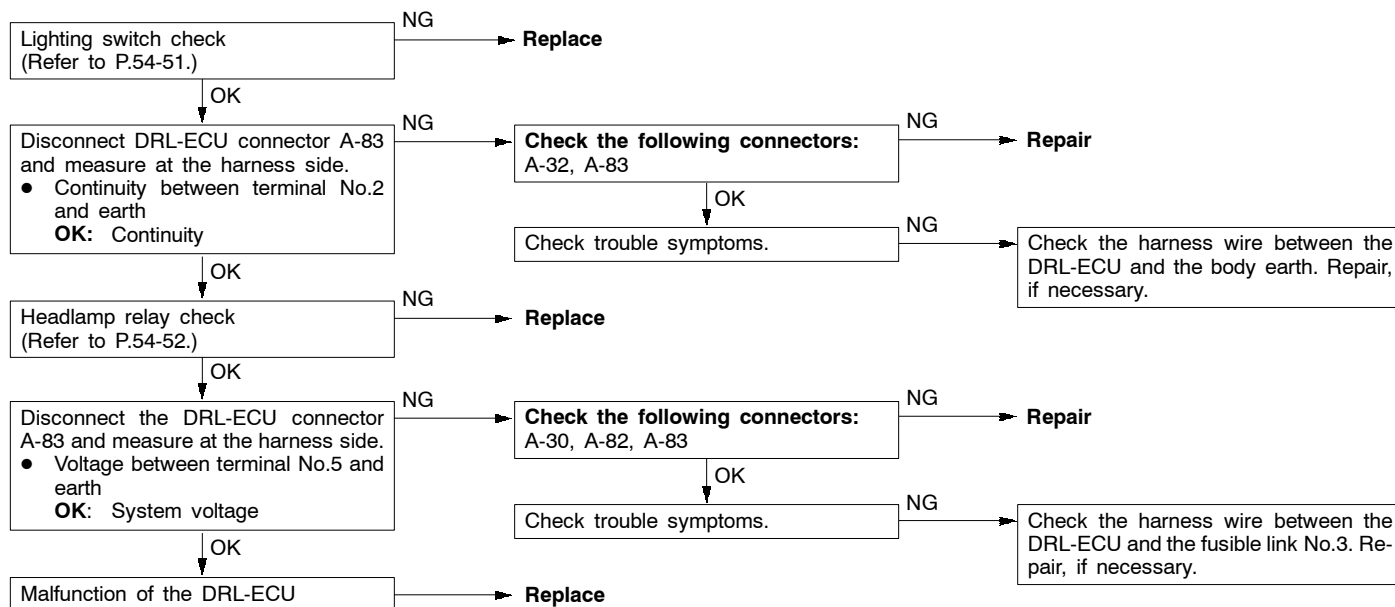

ON-VEHICLE SERVICE

HEADLAMP AIMING

<USING A BEAMSETTING EQUIPMENT>

1. The headlamps should be aimed with the proper beamsetting equipment, and in accordance with the equipment manufacturer's instructions.

NOTE

If there are any regulations pertinent to the aiming of headlamps in the area where the vehicle is to be used, adjust so as to meet those requirements.

2. Alternately turn the adjusting screw to adjust the headlamp aiming.

<USING A SCREEN>

1. Inflate the tyres to the specified pressures and there should be no other load in the vehicles other than driver or substituted weight of approximately 75 kg placed in driver's position.
2. Put the headlamp leveling switch in "0" position.
3. Set the distance between the screen and the centre of the headlamps as shown in the illustration.

4. Check if the beam shining onto the screen is at the standard value.

Standard value:

(Vertical direction)

60 mm below horizontal (H)

(Horizontal direction)

Position where the 15° sloping section intersects the vertical line (V)

NOTE

Illustration is for L.H. drive vehicles. For R.H. drive vehicles, beam pattern is symmetrical.

5. Alternately turn the adjusting screw to adjust the headlamp aiming.

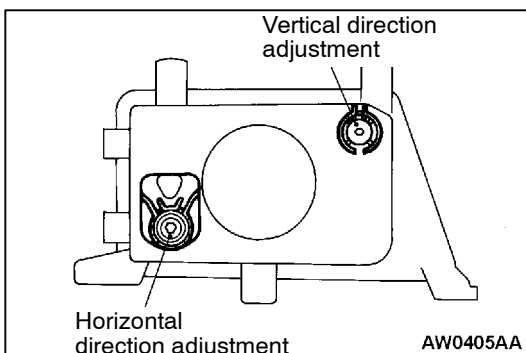
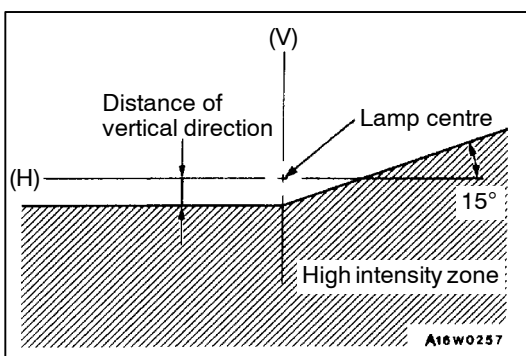
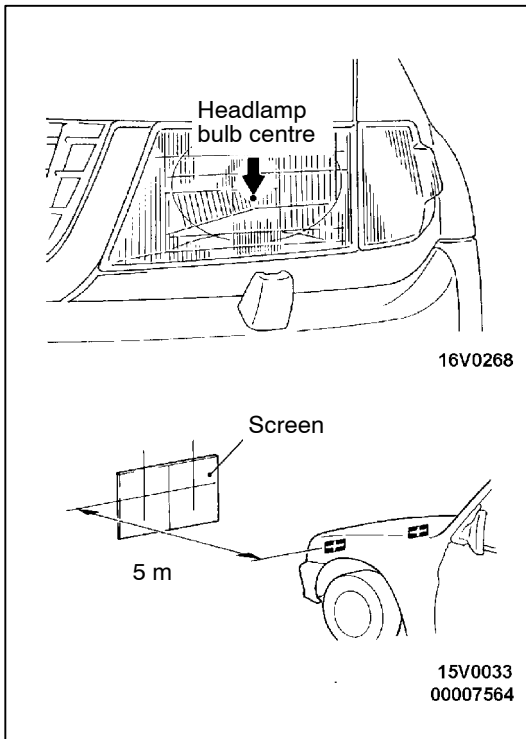
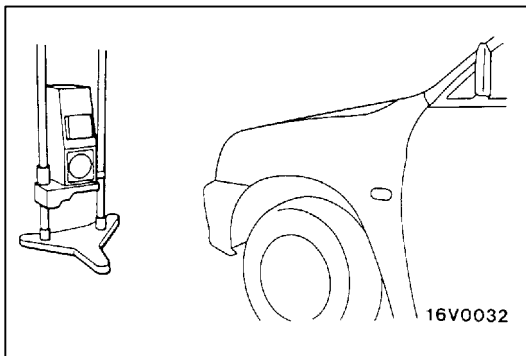

INTENSITY MEASUREMENT

54200100074

Using a photometer, and following its manufacture's instruction manual, measure the headlamp intensity and check to be sure that the limit value is satisfied.

Limit: 30,000 cd or more

NOTE

1. When measuring the intensity, maintain an engine speed of 2,000 r/min, with the battery in the charging condition.
2. There may be special local regulations pertaining to headlamp intensity, be sure to make any adjustments necessary to satisfy such regulations.
3. If an illuminometer is used to make the measurements, convert its values to photometer values by using the following formula.

$I = Er^2$ Where:

I = intensity (cd)

E = illumination (lux)

r = distance (m) from headlamps to illuminometer

BULB REPLACEMENT

54200130264

<Headlamp Bulb>

1. Disconnect the connector.
2. Remove the socket cover.

3. Unhook the spring which secures the bulb, and then remove the bulb.

Caution

Do not touch the surface of the bulb with hands or dirty gloves. If the surface does become dirty, clean it with alcohol or thinner, and let it dry thoroughly before installing.

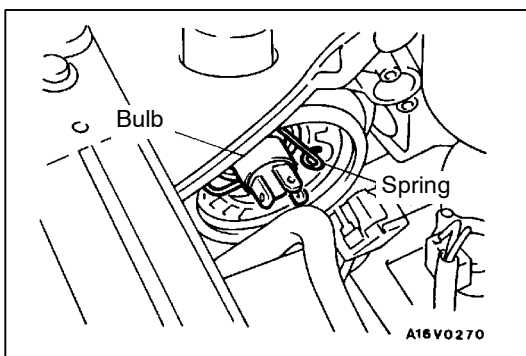

HEADLAMP AND FRONT COMBINATION LAMP

REMOVAL AND INSTALLATION

Post-installation operation

- Headlamp aiming adjustment (Refer to P.54-48.)

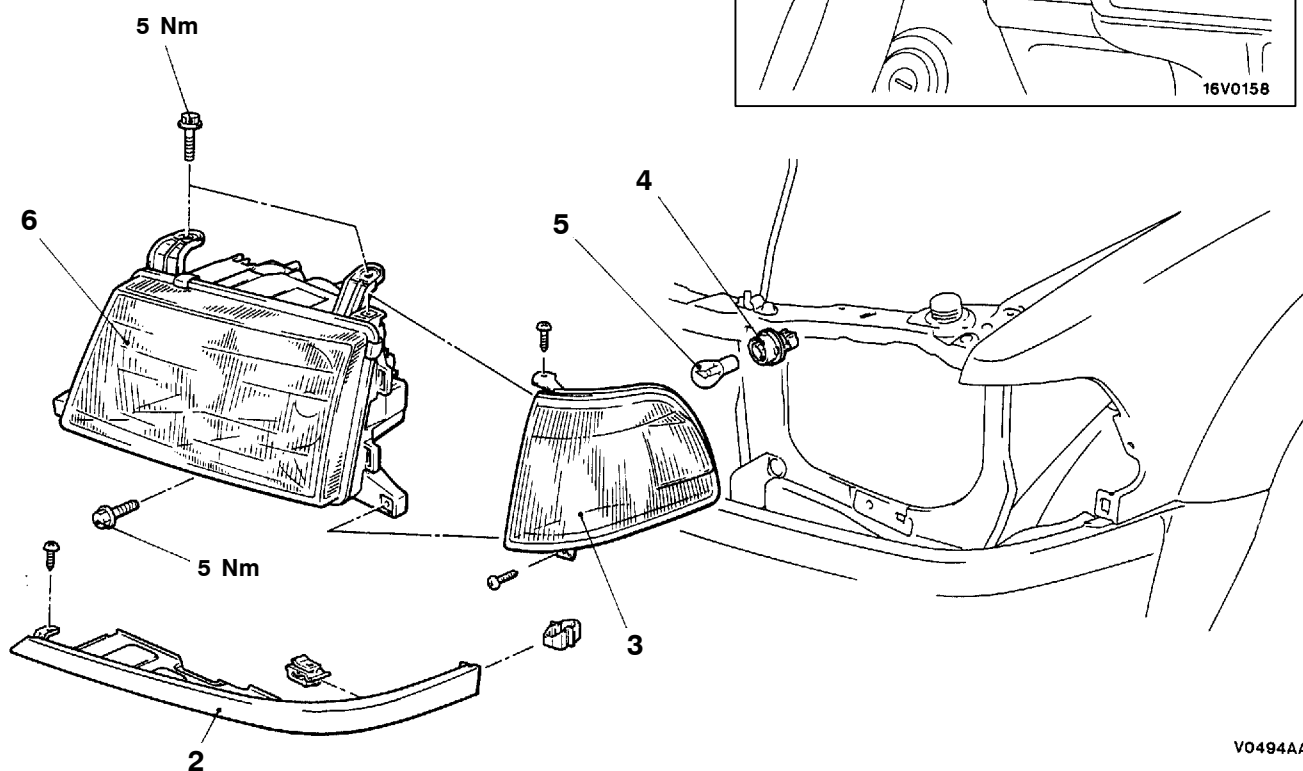
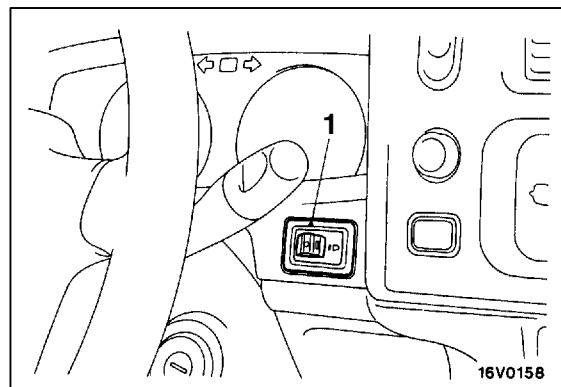

VO494AA
00009161

NOTE

For removal and installation of the column switch assembly (lighting switch, dimmer/passing switch), refer to GROUP 37A – Steering Wheel and Shaft.

- 1. Headlamp leveling switch
- Headlamp and front combination lamp removal steps**

- Radiator grille (Refer to GROUP 51 – Grille, Moulding and Garnish)

- 2. Grille filler panel
- 3. Front combination lamp
- 4. Bulb socket
- 5. Bulb
- 6. Headlamp



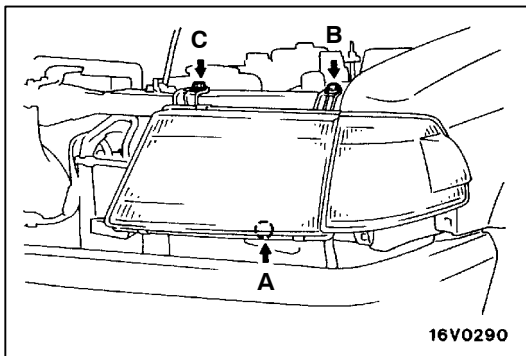

INSTALLATION SERVICE POINT

►A◄ HEADLAMP INSTALLATION

Tighten the mounting bolts in A, B, C order.

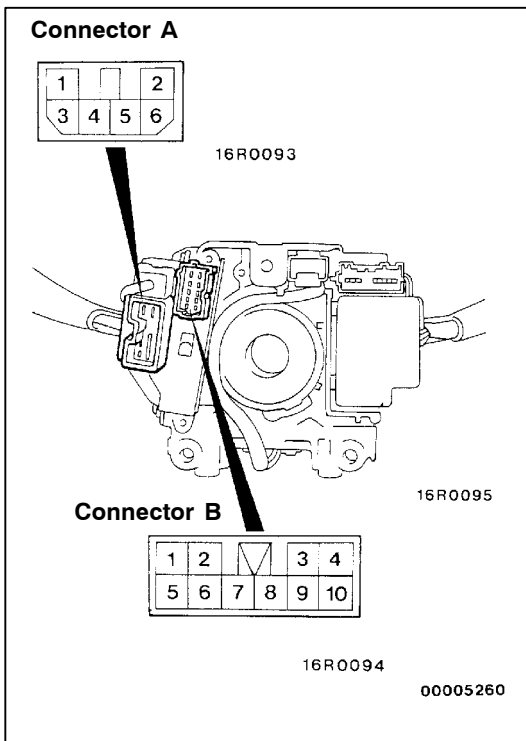

INSPECTION

54200800127

LIGHTING SWITCH AND DIMMER/PASSING SWITCH CONTINUITY CHECK

Switch position		Connector A– terminal No.				Connector B– terminal No.		
		1	2	3	4	5	6	7
LIGHTING SWITCH	OFF							
	TAIL					○	—	○
	HEAD	○				○	—	○
DIMMER/PASSING SWITCH	LOWER			○	○			
	UPPER				○	○		
	PASSING	○	○					
				○	○			

NOTE

- *1 indicates continuity when the dimmer switch is in the lower position.
- *2 indicates continuity when the dimmer switch is in the upper position.

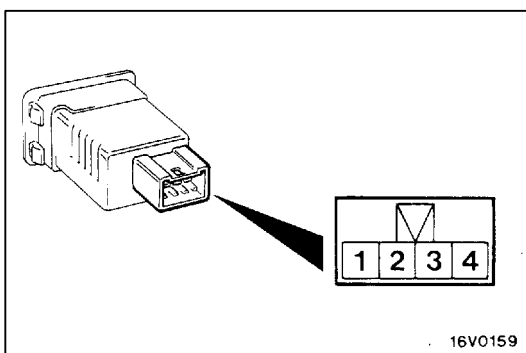

HEADLAMP LEVELING SWITCH CHECK

54200810038

Check the resistance between the terminals when the headlamp leveling switch is operated.

Switch position	0	1	2	3	4
Resistance measurement between terminal No.3 and 4 Ω	120	300	620	1,100	2,000

HEADLAMP RELAY

54200820161

Battery voltage	Terminal No.			
	1	3	4	5
Supplied	⊕	⊖	○	○
Not supplied	○	○		

Headlamp relay

16V0187

04Z0001

00009162

DAYTIME RUNNING LAMP RELAY (1) AND (2) CONTINUITY CHECK

54200830041

Battery voltage	Terminal No.			
	1	2	3	4
Supplied	○		○	⊖
Not supplied		○		○

Daytime running lamp relay (1), (2)

16V0210

20Z0001

00009163

FRONT FOG LAMP

54200030069

SERVICE SPECIFICATIONS

Items		Standard value
Front fog lamp aiming	Vertical direction	100 mm below horizontal (H)
	Horizontal direction	Parallel to direction of vehicle travel

SPECIAL TOOL

54200060464

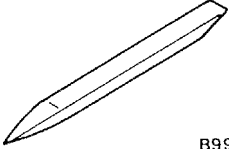
Tool	Number	Name	Use
 B990784	MB990784	Ornament remover	Removal of switch garnish

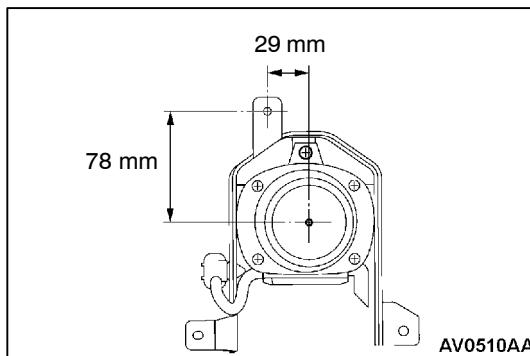

ON-VEHICLE SERVICE

54200110190

FRONT FOG LAMP AIMING

1. Measure the centre of the fog lamps, shown in the illustration.
2. Set the distance between the screen and the centre of the fog lamps as shown in the illustration.
3. Inflate the tyres to the specified pressures and there should be no other load in the vehicles other than driver or substituted weight of approximately 75 kg placed in the driver's position.
4. With the engine running at 2,000 r/min, aim the fog lamp.

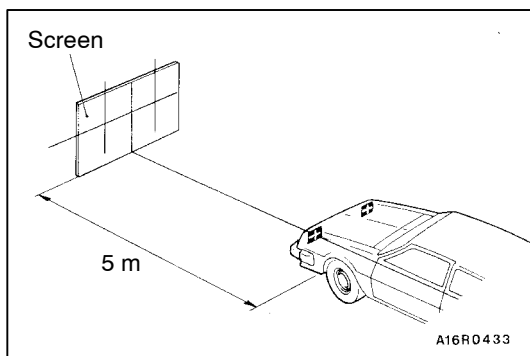

5. Check if the beam shining onto the screen is at the standard value.

Standard value:

(Vertical direction)

100 mm below horizontal (H)

(Horizontal direction)

Parallel to direction of vehicle travel

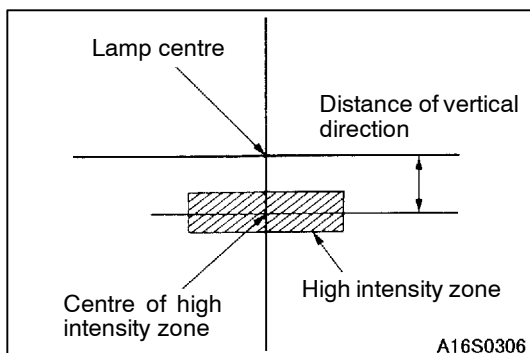

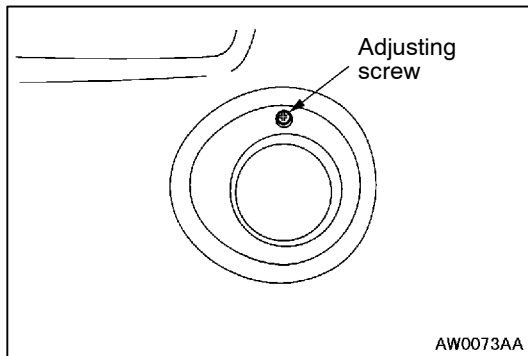
**NOTE**

The horizontal direction is non-adjustable. If deviation of the light beam axis exceeds the standard value, check to be sure that the mounting location or some other point is not defective.

Caution

When making the aiming adjustment, be sure to mask those lamps which are not being adjusted.

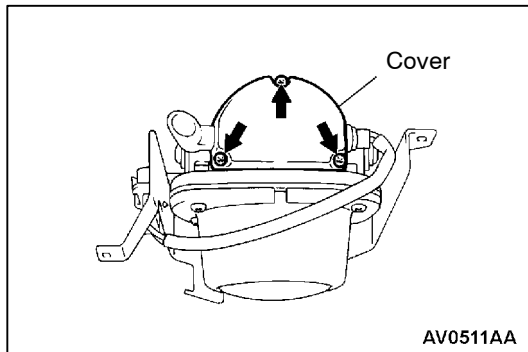
**BULB REPLACEMENT**

54200130271

1. Remove the fog lamp.
2. Remove the screws shown in the illustration, then remove the under cover.

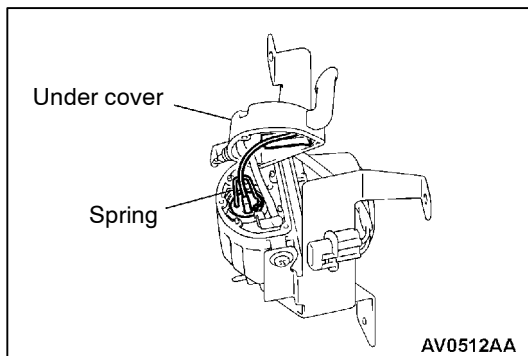

3. Unhook the spring which secures the bulb and then remove the bulb.

Caution

- Do not touch the surface of the bulb with hands or dirty gloves. If the surface does become dirty, clean it with alcohol or thinner, and let it dry thoroughly before installing.
- If the under cover is not attached properly, the lens might become cloudy or water might penetrate inside the lamp unit. Always be sure to install the under cover securely.

FRONT FOG LAMP

54200150246

REMOVAL AND INSTALLATION

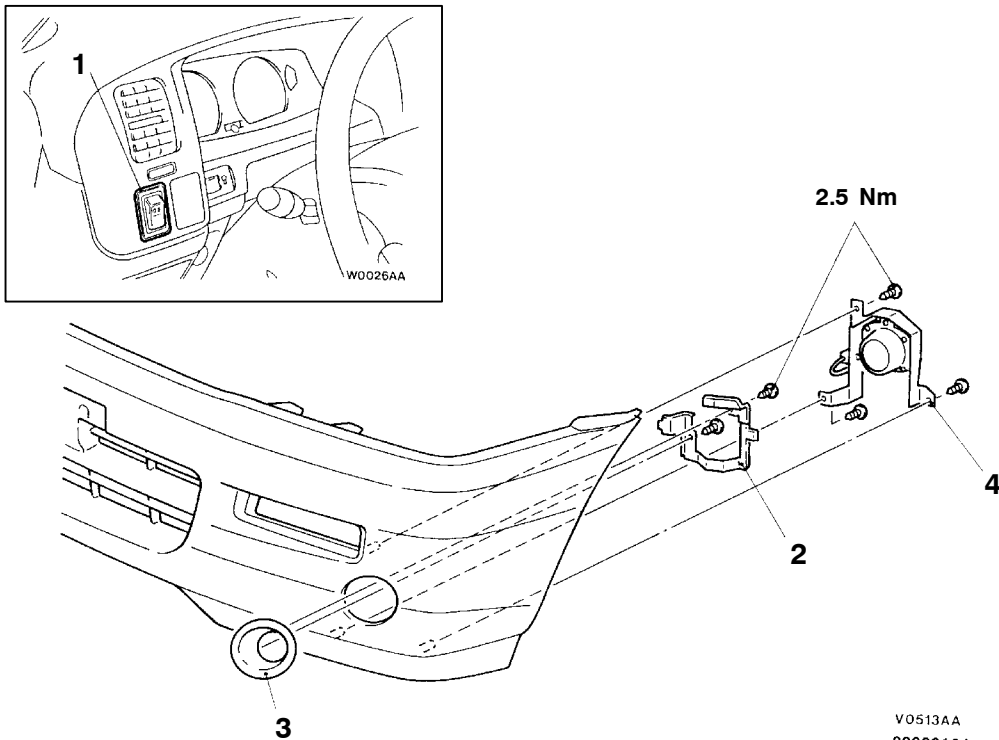

1. Fog lamp switch

Fog lamp removal steps

- Front bumper (Refer to GROUP 51.)

2. Fog lamp bracket

3. Fog lamp bezel

4. Fog lamp

V0513AA
00009164

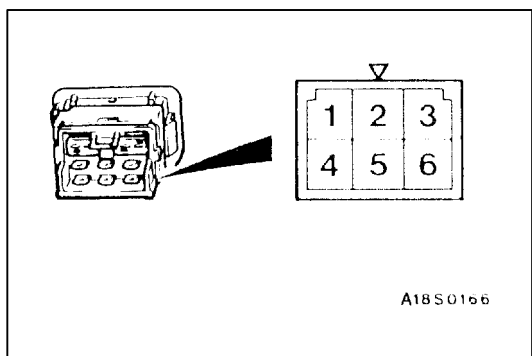

INSPECTION

54200740115

FOG LAMP SWITCH CONTINUITY CHECK

Switch position	Terminal No.						
	1	2	3	IND	4	5	6
OFF			○	⊕			○
ON	○	○	○	⊕	○	○	○

TURN-SIGNAL LAMP

REMOVAL AND INSTALLATION

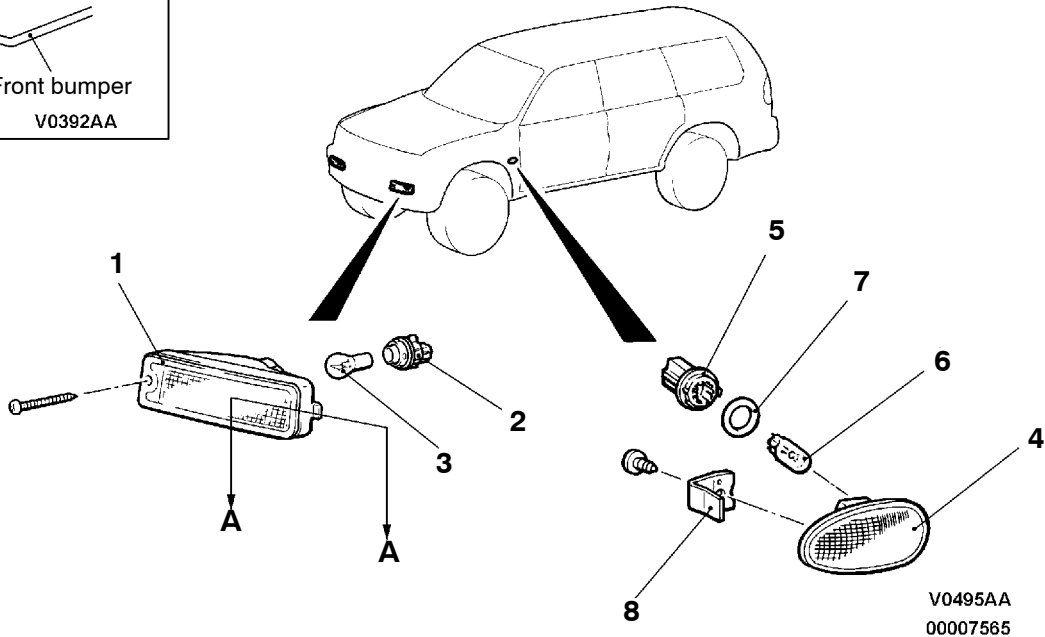
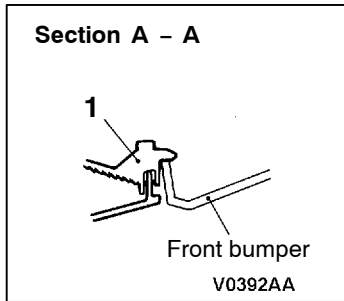

NOTE

For removal and installation of the column switch assembly (turn-signal switch), refer to GROUP 37A – Steering Wheel and Shaft.

Front turn-signal lamp removal steps

1. Front turn-signal lamp
2. Bulb socket
3. Bulb



Side turn-signal lamp removal steps

4. Side turn-signal lamp
5. Bulb socket
6. Bulb
7. Packing
8. Hook

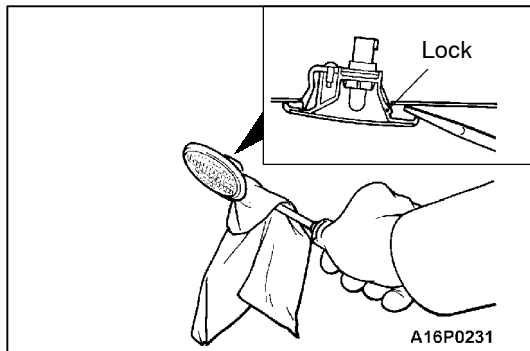

REMOVAL SERVICE POINT

◀A▶ SIDE TURN-SIGNAL LAMP REMOVAL

Use a flat-tipped screw driver or similar tool to remove the lock from the fender panel, and then remove the side turn-signal lamp.

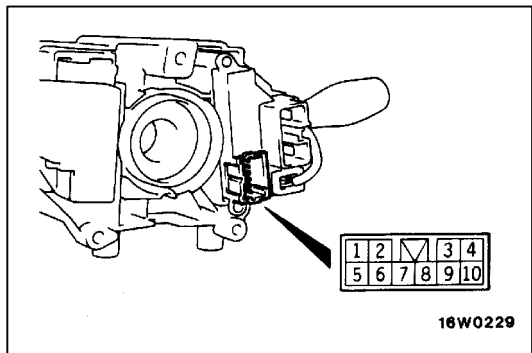

INSPECTION

54200760173

TURN-SIGNAL LAMP SWITCH CONTINUITY CHECK

Switch position	Terminal No.		
	3	8	9
L.H.	○—	○—	
OFF			
R.H.		○—	○—

REAR COMBINATION LAMP

54200070566

TROUBLESHOOTING

Refer to P.54-42.

REAR COMBINATION LAMP

54200390204

REMOVAL AND INSTALLATION

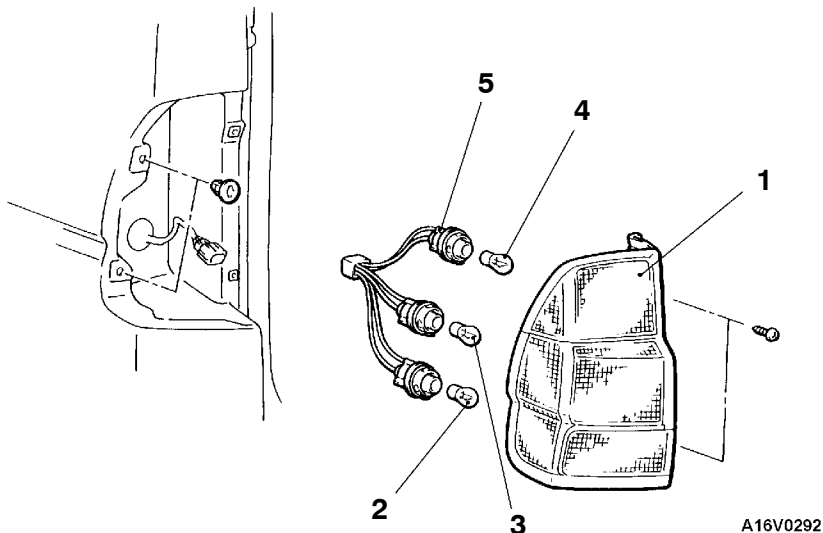

A16V0292

NOTE

For removal and installation of the column switch assembly lighting switch, dimmer/passing switch and turn-signal switch, refer to GROUP 37A – Steering Wheel and Shaft.

Removal steps

1. Rear combination lamp
2. Bulb (For back-up lamp)
3. Bulb (For tail and stop lamp)
4. Bulb (For turn-signal lamp)
5. Bulb socket assembly

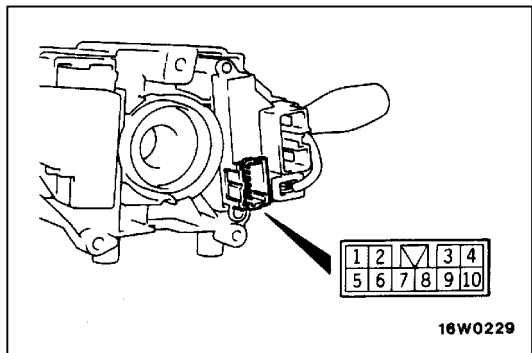

INSPECTION

LIGHTING SWITCH AND TURN-SIGNAL LAMP SWITCH CONTINUITY CHECK

Switch position		Terminal No.				
		3	5	7	8	9
LIGHTING SWITCH	OFF					
	TAIL		○	○		
TURN-SIGNAL LAMP SWITCH	R.H.				○	○
	OFF					
	L.H.	○	○	○	○	

REAR FOG LAMP

54200060334

SPECIAL TOOL

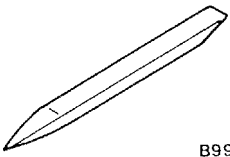
Tool	Number	Name	Use
 B990784	MB990784	Ornament remover	Fog lamp switch removal

REAR FOG LAMP

54200980029

REMOVAL AND INSTALLATION

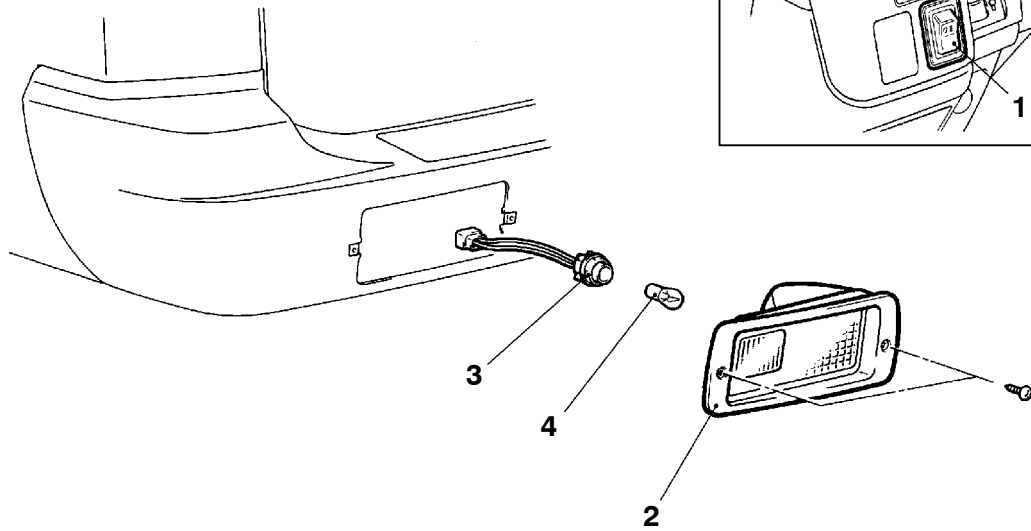

- 1. Rear fog lamp switch
 - 2. Rear fog lamp
- Rear fog lamp removal steps**

- 3. Bulb
- 4. Bulb socket

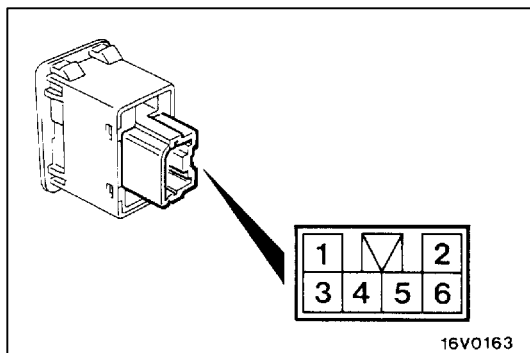

INSPECTION

54200920021

REAR FOG LAMP SWITCH CONTINUITY CHECK

Switch position	Terminal No.				
	1	2	ILL	3	6
OFF		○	⊕		○
ON	○	○	⊕	○	○

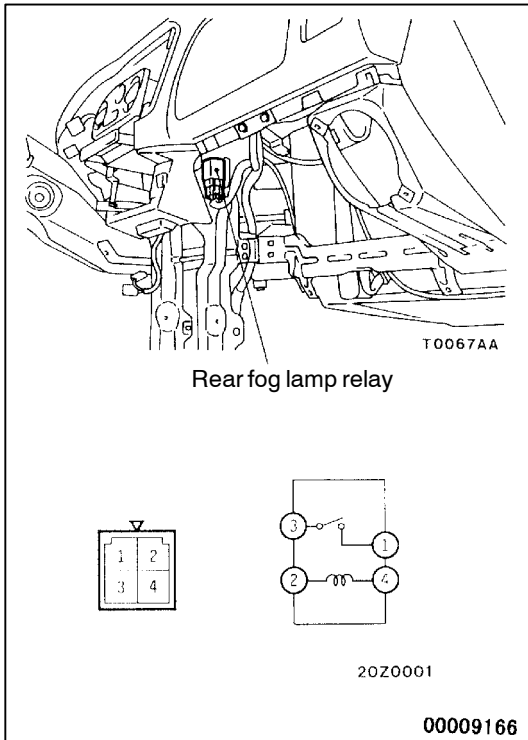

REAR FOG LAMP RELAY CONTINUITY CHECK

54200930024

Battery voltage	Terminal No.			
	1	2	3	4
Supplied	○	⊕	○	⊖
Not supplied		○		○

HIGH-MOUNTED STOP LAMP

54200510297

REMOVAL AND INSTALLATION

<Tailgate mounted type>

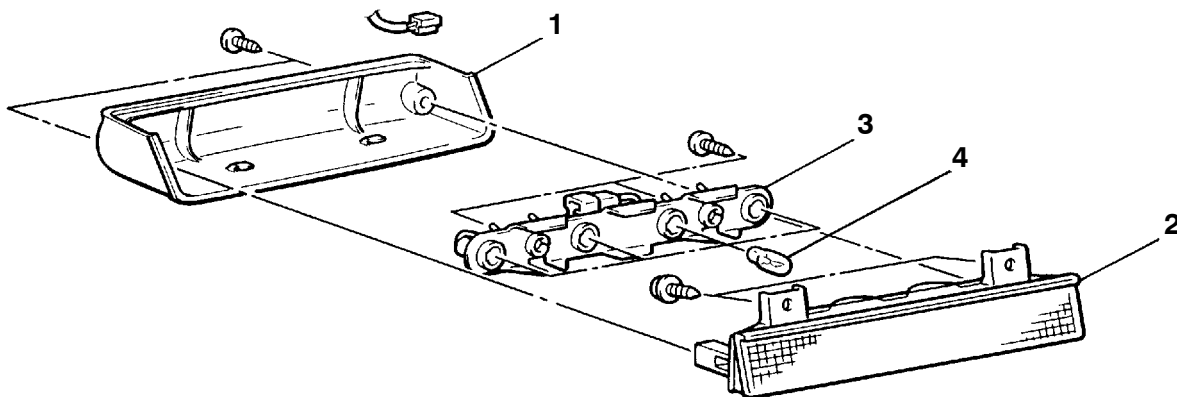

A16V0288

Removal steps

1. Cover
2. Light unit

3. Bulb socket
4. Bulb

<Roof spoiler mounted type>

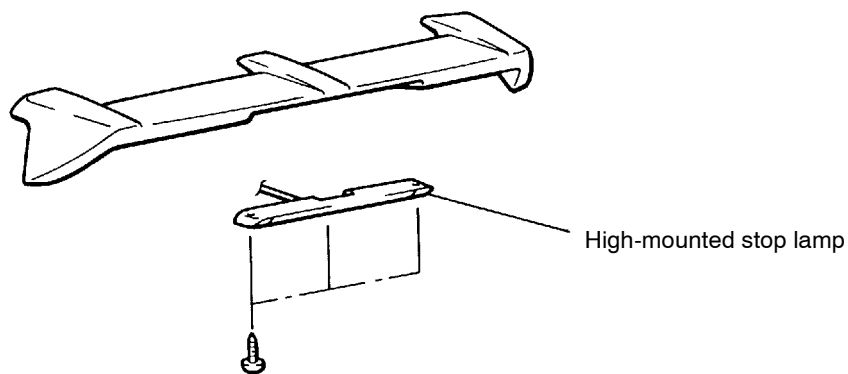

A18V0240

RHEOSTAT

54200060341

SPECIAL TOOL

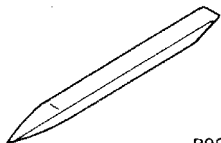
Tool	Number	Name	Use
 <p>B990784</p>	MB990784	Ornament remover	Rheostat removal

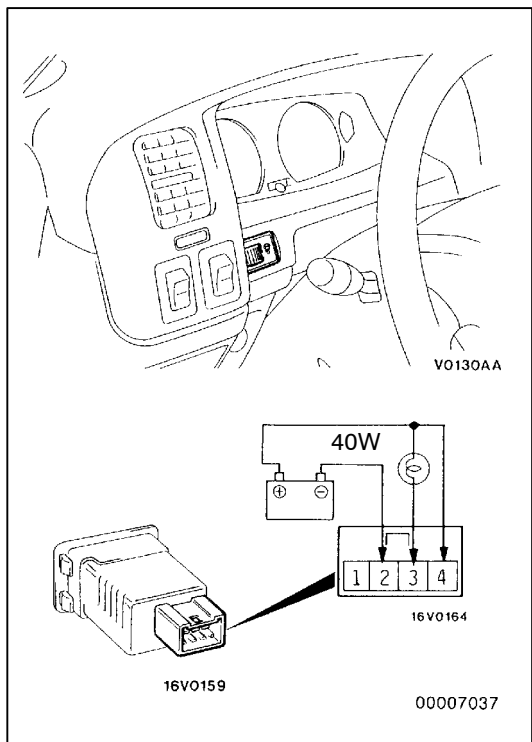

RHEOSTAT

54200610201

INSPECTION

1. Connect the battery and the test lamp (40 W) as shown in the illustration.
2. Operate the rheostat and if the brightness changes smoothly without switching off, then the rheostat function is normal.

HAZARD WARNING LAMP SWITCH

54200060358

SPECIAL TOOL

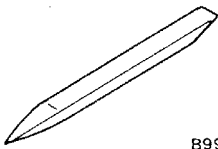
Tool	Number	Name	Use
 B990784	MB990784	Ornament remover	Meter bezel assembly removal

HAZARD WARNING LAMP SWITCH

54200660183

REMOVAL AND INSTALLATION

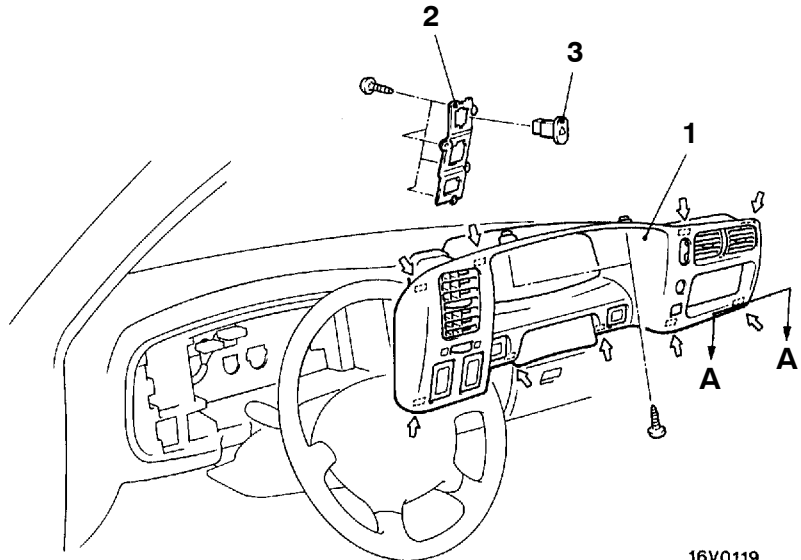
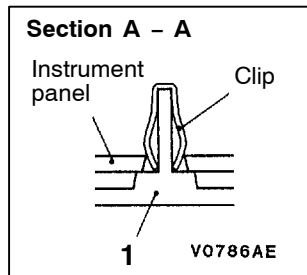

NOTE

↔ : metal clip position

16V0119
00009167

Removal steps

1. Meter bezel assembly
2. Switch holder
3. Hazard warning lamp switch

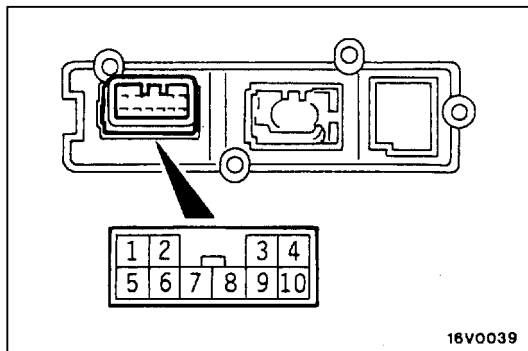

INSPECTION

54200670209

HAZARD WARNING LAMP SWITCH CONTINUITY CHECK

Switch position	Terminal No.									
	1	2	4	5	6	7	9	ILL	10	
OFF				○	—	○	○	⊕	○	
ON	○	○	○	○	○		○	⊕	○	

HORN

54300790069

REMOVAL AND INSTALLATION

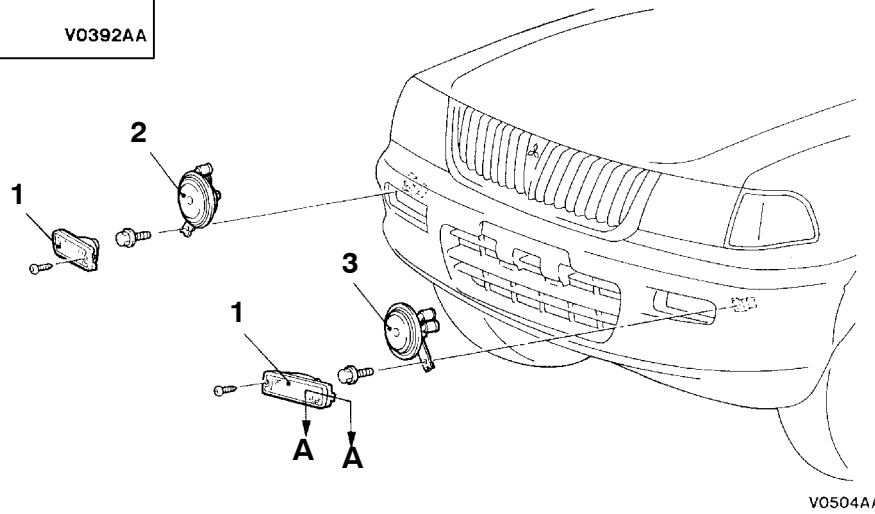
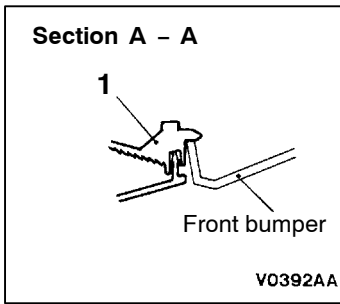

V0504AA

00007568

Removal steps

1. Front turn-signal lamp
2. Horn (high sound)
3. Horn (low sound)

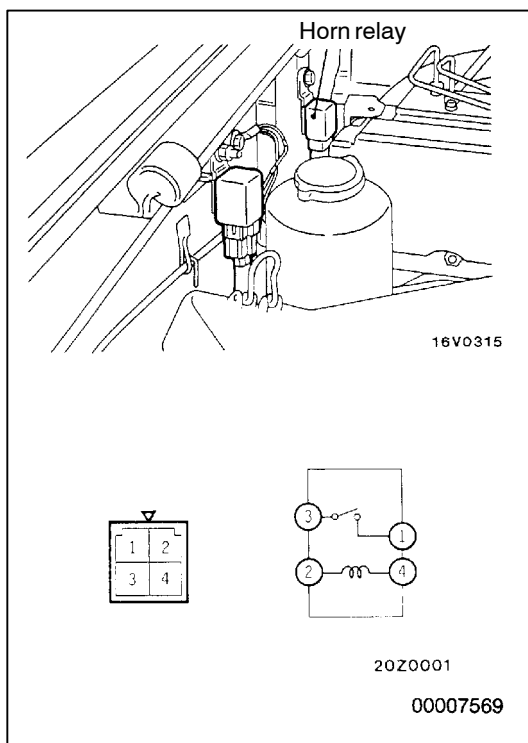

INSPECTION

54200650036

HORN RELAY CONTINUITY CHECK

Battery voltage	Terminal No.			
	1	2	3	4
Supplied	○	+	○	○
Not supplied		○		○

CIGARETTE LIGHTER

54300560189

REMOVAL AND INSTALLATION

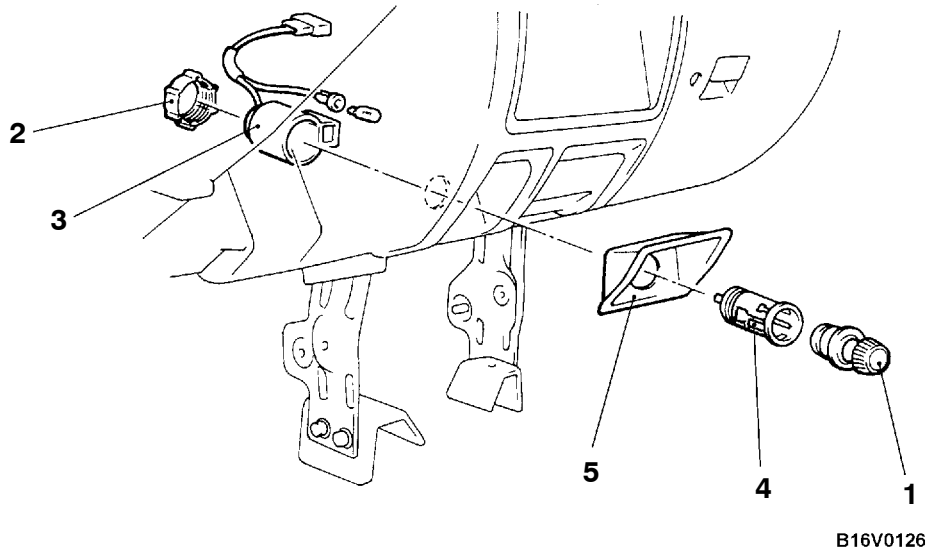

Removal steps

- Front floor console assembly (Refer to GROUP 52A.)
- 1. Plug
- 2. Fixing ring

- 3. Socket case
- 4. Socket
- 5. Protector

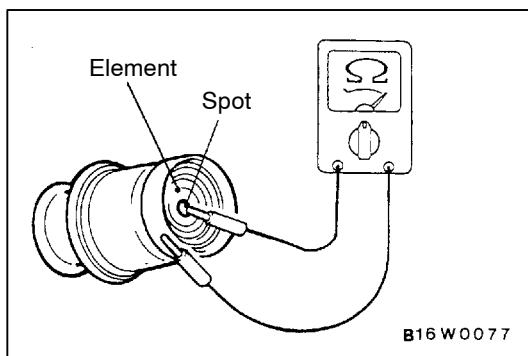

INSPECTION

54300570113

- Take out the plug, and check for a worn edge on the element spot connection, and for shreds of tobacco or other material on the element.
- Using a circuit tester, check the continuity of the element.

ACCESSORY SOCKET

54300890059

REMOVAL AND INSTALLATION

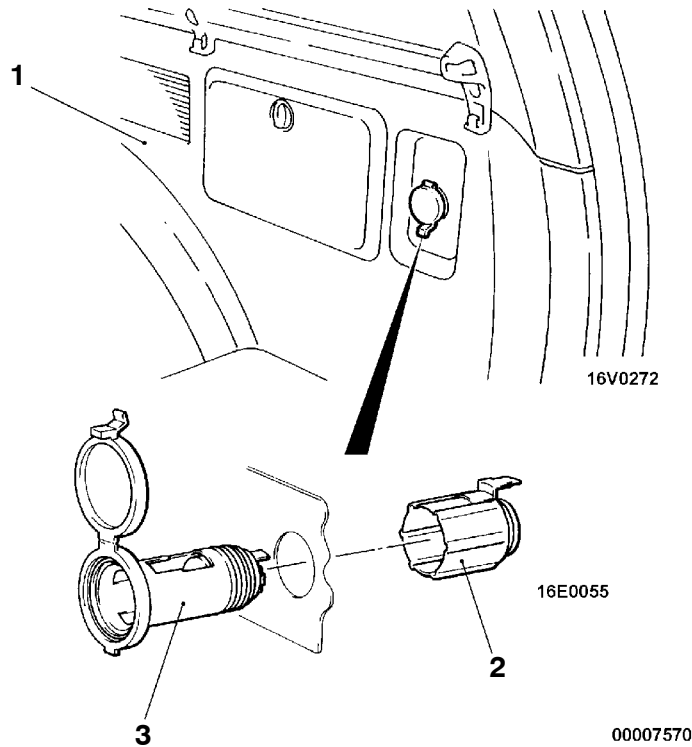

Removal steps

1. Quarter trim, lower <R.H.> (Refer to GROUP 52A – Trims.)
2. Outer case
3. Socket

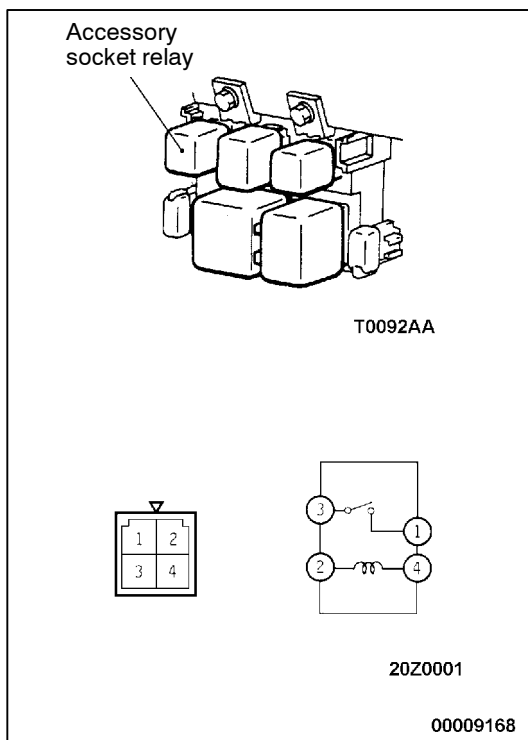

INSPECTION

54300900042

Accessory socket relay continuity check

Battery voltage	Terminal No.			
	1	2	3	4
Not supplied		○	—	○
Supplied	○	+	—	—

RADIO AND TAPE PLAYER

54400060057

SPECIAL TOOL

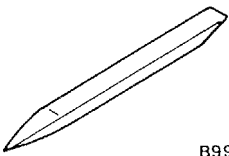
Tool	Number	Name	Use
 B990784	MB990784	Ornament remover	Meter bezel assembly removal

TROUBLESHOOTING

54400070265

QUICK-REFERENCE TROUBLESHOOTING CHART

Items	Problem symptom	Relevant chart
Noise	Noise appears at certain places when travelling (AM).	A-1
	Noise appears at certain places when travelling (FM).	A-2
	Mixed with noise, only at night (AM).	A-3
	Broadcasts can be heard but both AM and FM have a lot of noise.	A-4
	There is more noise either on AM or on FM.	A-5
	There is noise when starting the engine.	A-6
	Some noise appears when there is vibration or shocks during travelling.	A-7
	Noise sometimes appears on FM during travelling.	A-8
	Ever-present noise.	A-9
Radio	When switch is set to ON, no power is available.	B-1
	No sound from one speaker.	B-2
	There is noise but no reception for both AM and FM or no sound from AM, or no sound from FM.	B-3
	Insufficient sensitivity.	B-4
	Distortion on AM or on both AM and FM.	B-5
	Distortion on FM only.	B-6
	Too few automatic select stations.	B-7
	Insufficient memory (preset stations are erased).	B-8

NOTE

Refer to problem symptoms of AM radio for MW radio.

Items	Problem symptom	Relevant chart
Tape player	Cassette tape will not be inserted.	C-1
	No sound.	C-2
	No sound from one speaker.	C-3
	Sound quality is poor, or sound is weak.	C-4
	Cassette tape will not be ejected.	C-5
	Uneven revolution. Tape speed is fast or slow.	C-6
	Faulty auto reverse.	C-7
	Tape gets caught in mechanism.	C-8

CHART

A. NOISE

A-1 Noise appears at certain places when travelling (AM).

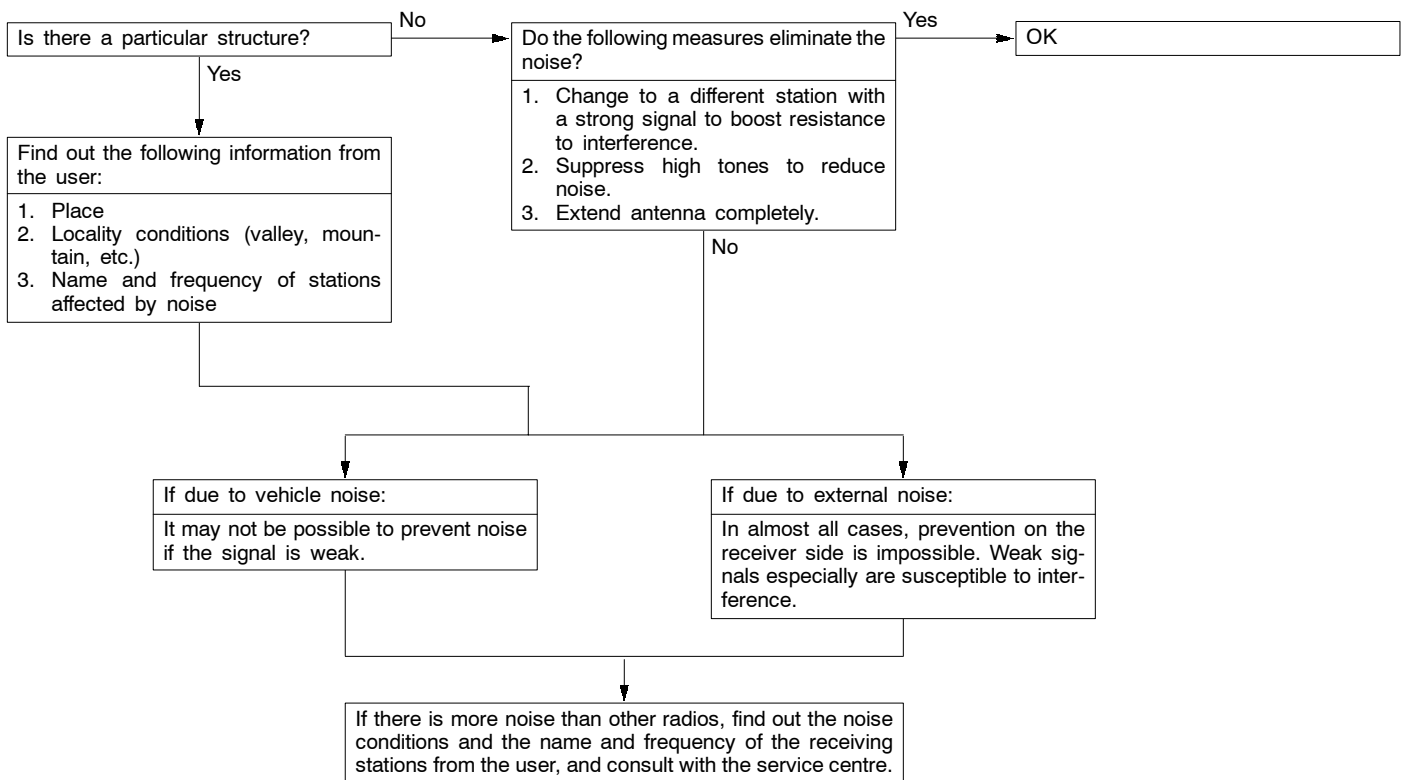

A-2 Noise appears at certain places when travelling (FM).

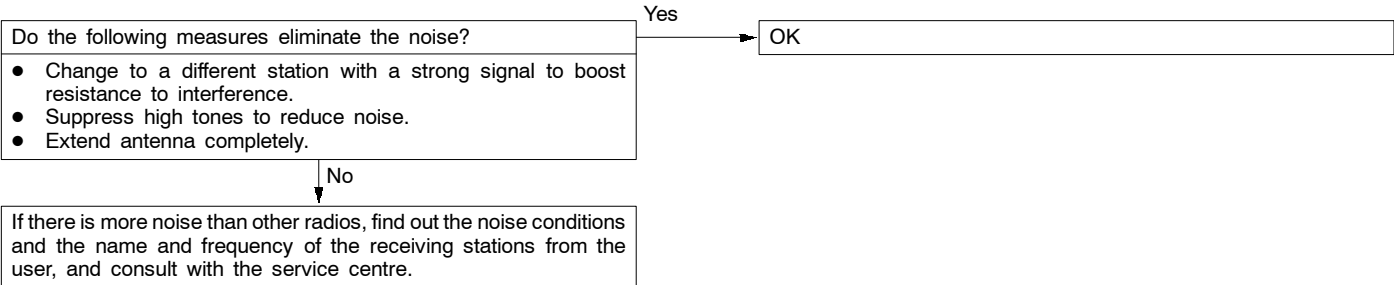

NOTE

About FM waves:

FM waves have the same properties as light, and can be deflected and blocked. Wave reception is not possible in the shadow of obstructions such as buildings or mountains.

1. The signal becomes weak as the distance from the station's transmission antenna increases. Although this may vary according to the signal strength of the transmitting station and intervening geographical formation or buildings, the area of good reception is approx. 20–25 km for stereo reception, and 30–40 km for monaural reception.
2. The signal becomes weak when an area of shadow from the transmitting antenna (places where there are obstructions such as mountains or buildings between the antenna and the car), and noise will appear. <This is called first fading, and gives a steady buzzing noise.>

3. If a direct signal hits the antenna at the same time as a signal reflected by obstructions such as mountains or buildings, interference of the two signals will generate noise. During travelling, noise will appear each time the vehicle's antenna passes through this kind of obstructed area. The strength and interval of the noise varies according to the signal strength and the conditions of deflection. <This is called multipath noise, and is a repetitious buzzing.>
4. Since FM stereo transmission and reception has a weaker field than monaural, it is often accompanied by a hissing noise.

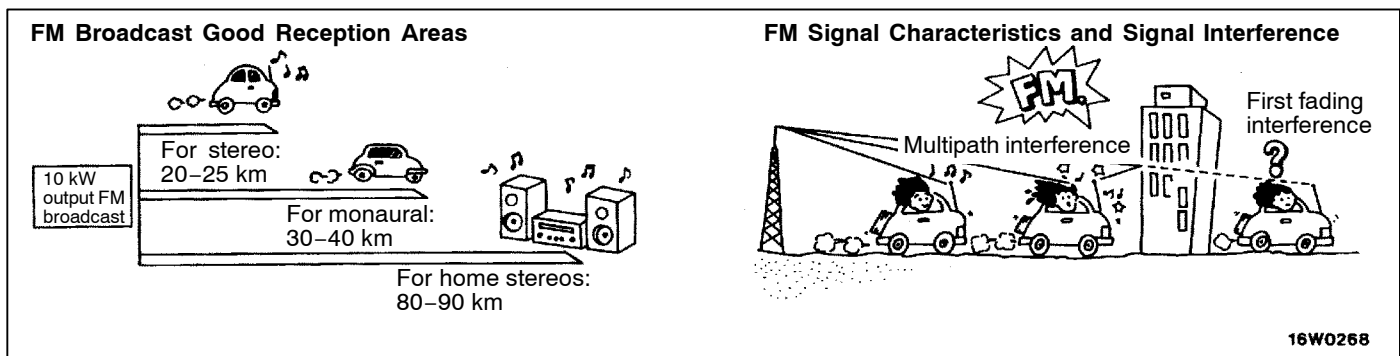

A-3 Mixed with noise, only at night (AM).

The following factors can be considered as possible causes of noise appearing at night.

1. Factors due to signal conditions: Due to the fact that long-distance signals are more easily received at night, even stations that are received without problem during the day may experience interference in a general worsening of reception conditions. The weaker a station is the more susceptible it is to interference,

and a change to a different station or the appearance of a beating sound* may occur. Beat sound*: Two signals close in frequency interfere with each other, creating a repetitious high-pitched sound. This sound is generated not only by sound signals but by electrical waves as well.

2. Factors due to vehicle noise: Alternator noise may be a cause.

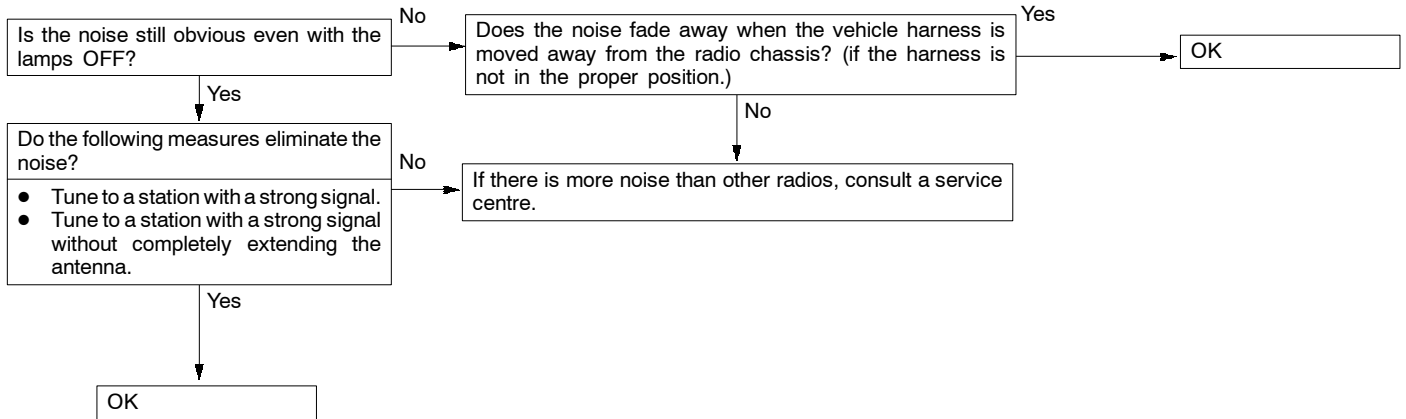

A-4 Broadcasts can be heard but both AM and FM have a lot of noise.

(1)

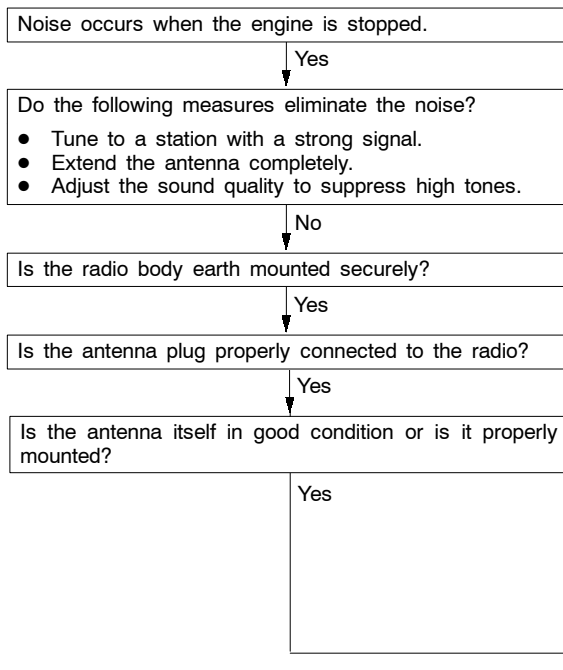

(2)

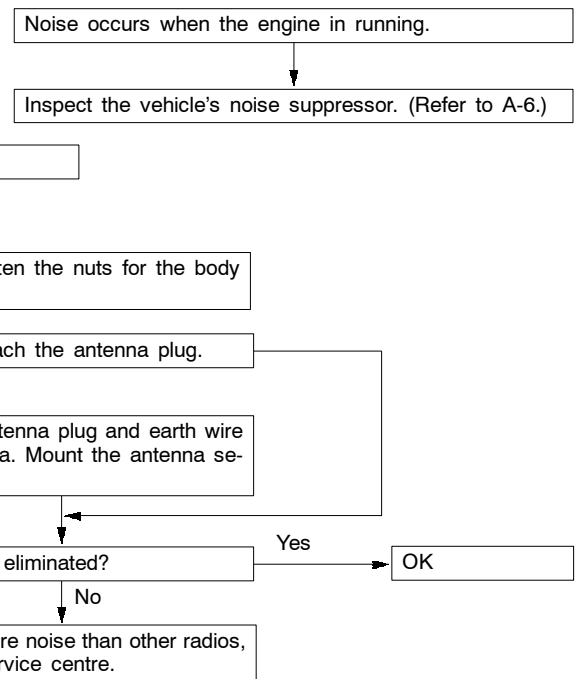

NOTE

About noise encountered during FM reception only. Due to differences in FM and AM systems, FM is not as susceptible as AM to interference from engines, power lines, lightning, etc. On the other hand, there are cases due to the characteristics

of FM waves of noise or distortion generated by typical noise interference (first fading and multipath). (Refer to A-2.)

<Noise (hissing) occurs in weak signal areas such as mountainous regions, but this is not due to a problem with the radio.>

A-5 There is more noise either on AM or on FM.

1. There is much noise only on AM.
Due to differences in AM and FM systems, AM is more susceptible to noise interference.

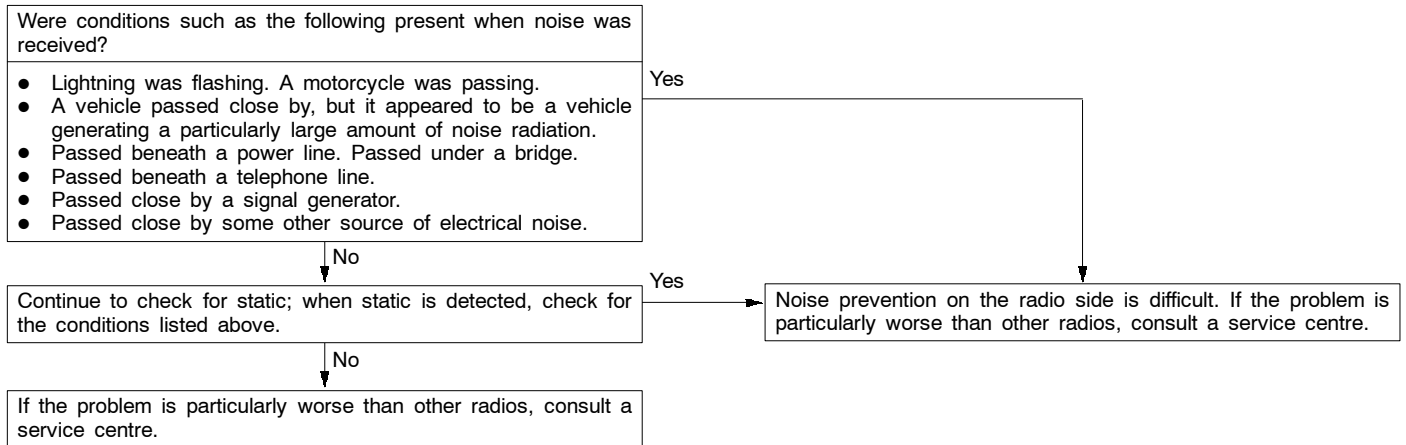

2. There is much noise only on FM.
Due to differences in FM and AM systems, FM is not as susceptible as AM to interference from engines, power lines, lightning, etc. On the other hand, there are cases due to the characteristics of FM waves of noise or

distortion generated by typical noise interference (first fading and multipath). (Refer to A-2) <Noise (hissing) occurs in weak signal areas such as mountainous regions, but this is not due to a problem with the radio.>

A-6 There is noise when starting the engine.

Noise type Sounds are in parentheses ().	Conditions	Cause	Remedy
AM, FM: Ignition noise (Popping, snapping, cracking, buzzing)	<ul style="list-style-type: none"> Increasing the engine speed causing the popping sound to speed up, and volume decreases. Disappears when the ignition switch is turned to ACC. 	<ul style="list-style-type: none"> Mainly due to the spark plugs. Due to the engine noise. 	<ul style="list-style-type: none"> Check or replace the earth cable. (Refer to Fig. 1, 2 and 3 on P.54-72, 73.) Check or replace the noise capacitor. <6G7> (Refer to 4 on P.54-73.)
Other electrical components	–	Noise may appear as electrical components become older.	Repair or replace electrical components.
Static electricity (Cracking, crinkling)	<ul style="list-style-type: none"> Disappears when the vehicle is completely stopped. Severe when the clutch is engaged. 	Occurs when parts or wiring move for some reason and contact metal parts of the body.	Return parts or wiring to their proper position.
	<ul style="list-style-type: none"> Various noises are produced depending on the body part of the vehicle. 	Due to detachment from the body of the front hood, bumpers, exhaust pipe and muffler, suspension, etc.	Tighten the mounting bolts securely. Cases where the problem is not eliminated by a single response to one area are common, due to several body parts being imperfectly earthed.

Caution

1. **Connecting a high tension cable to the noise filter may destroy the noise filter and should never be done.**
2. **Check that there is no external noise. Since failure caused by this may result in misdiagnosis due to inability to identify the noise source, this operation must be performed.**
3. **Noise prevention should be performed by suppressing strong sources of noise step by step.**

NOTE

1. Capacitor
The capacitor does not pass D.C. current, but as the number of waves increases when it

passes A.C. current, impedance (resistance against A.C.) decreases, and current flow is facilitated. A noise suppressing condenser which takes advantage of this property is inserted between the power line for the noise source and the earth. This suppresses noise by earthing the noise component (A.C. or pulse signal) to the body of the vehicle.

2. Coil
The coil passes D.C. current, but impedance rises as the number of waves increases relative to the A.C. current. A noise suppressing coil which takes advantage of this property is inserted into the power line for the noise source, and works by preventing the noise component from flowing or radiating out of the line.

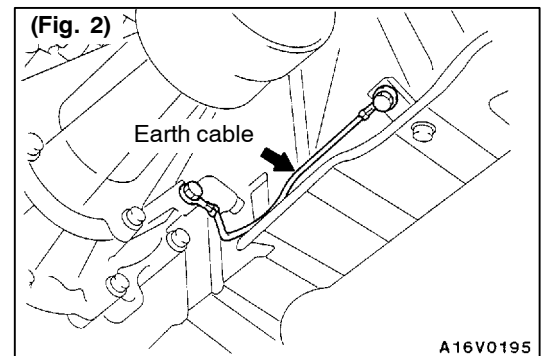
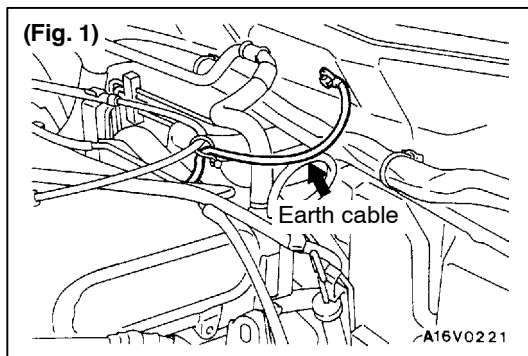

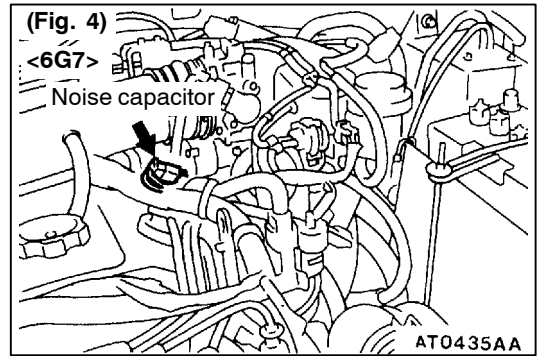
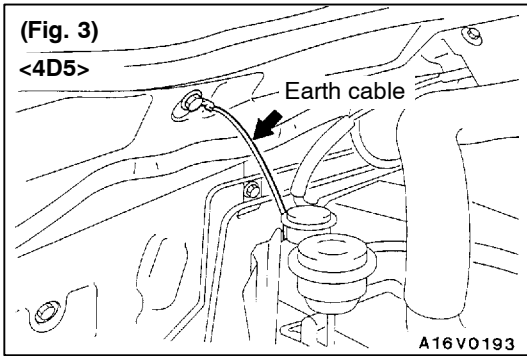

A-7 Some noise appears when there is vibration or shocks during travelling.

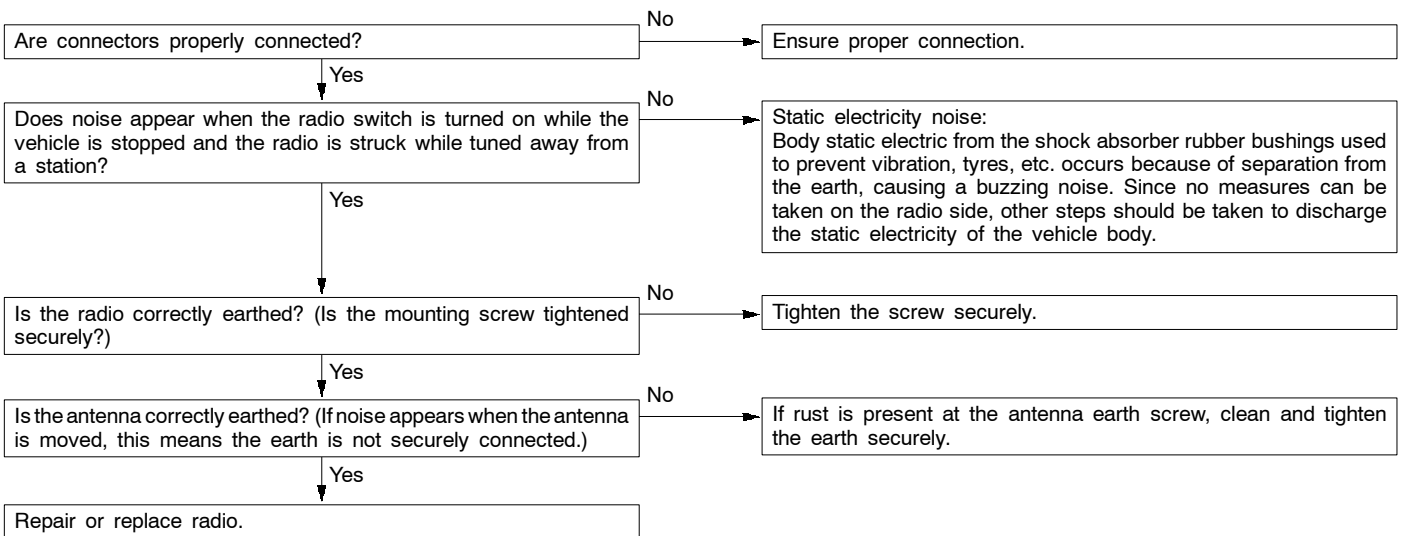

A-8 Noise sometimes appears on FM during travelling.

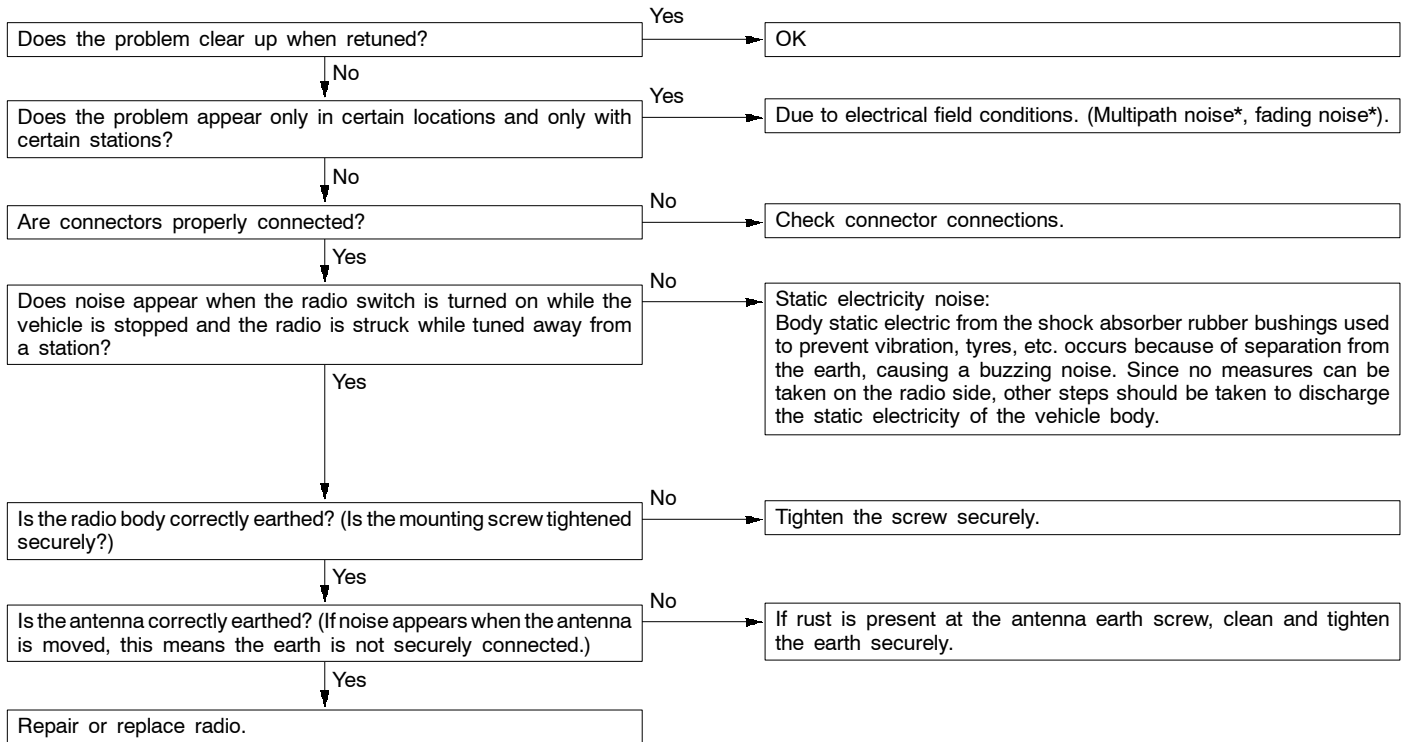

* About multipath noise and fading noise
 Because the frequency of FM waves is extremely high, it is highly susceptible to effects from geological formations and buildings. These effects disrupt the broadcast signal and obstruct reception in several ways.

- Multipath noise
 This describes the echo that occurs when the broadcast signal is reflected by a large

- obstruction and enters the receiver with a slight time delay relative to the direct signal (repetitious buzzing).
- Fading noise
 This is a buzzing noise that occurs when the broadcast beam is disrupted by obstructing objects and the signal strength fluctuates intricately within a narrow range.

A-9 Ever-present noise.

Noise is often created by the following factors, and often the radio is OK when it is checked individually.

- Travelling conditions of the vehicle
- Terrain of area travelled through
- Surrounding buildings
- Signal conditions
- Time period

For this reason, if there are still problems with noise even after the measures described in steps A-1 to A-8 have been taken, get information on the factors listed above as well as determining whether the problem occurs with AM or FM, the station names, frequencies, etc., and contact a service centre.

B. RADIO

B-1 No power is supplied when the switch is set to ON.

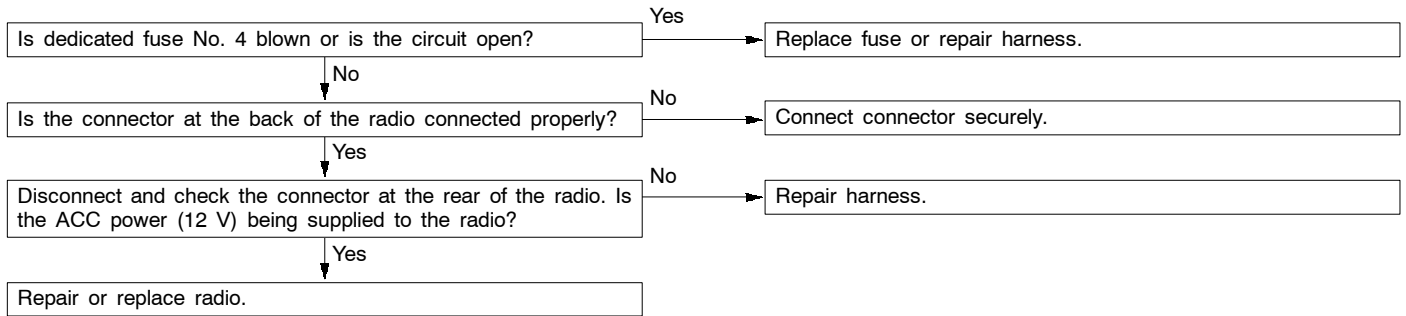

B-2 No sound from one speaker.

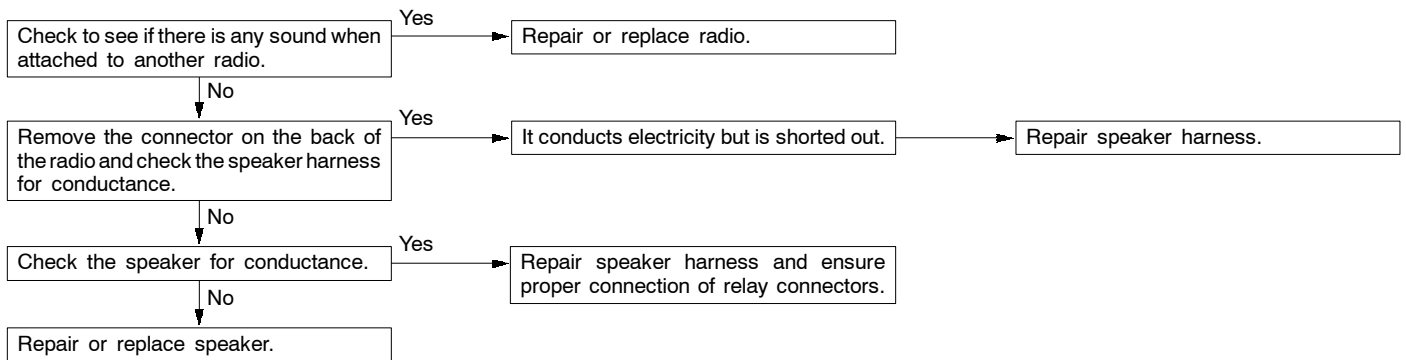

B-3 There is noise but no reception for both AM and FM or no sound from AM, or no sound from FM.

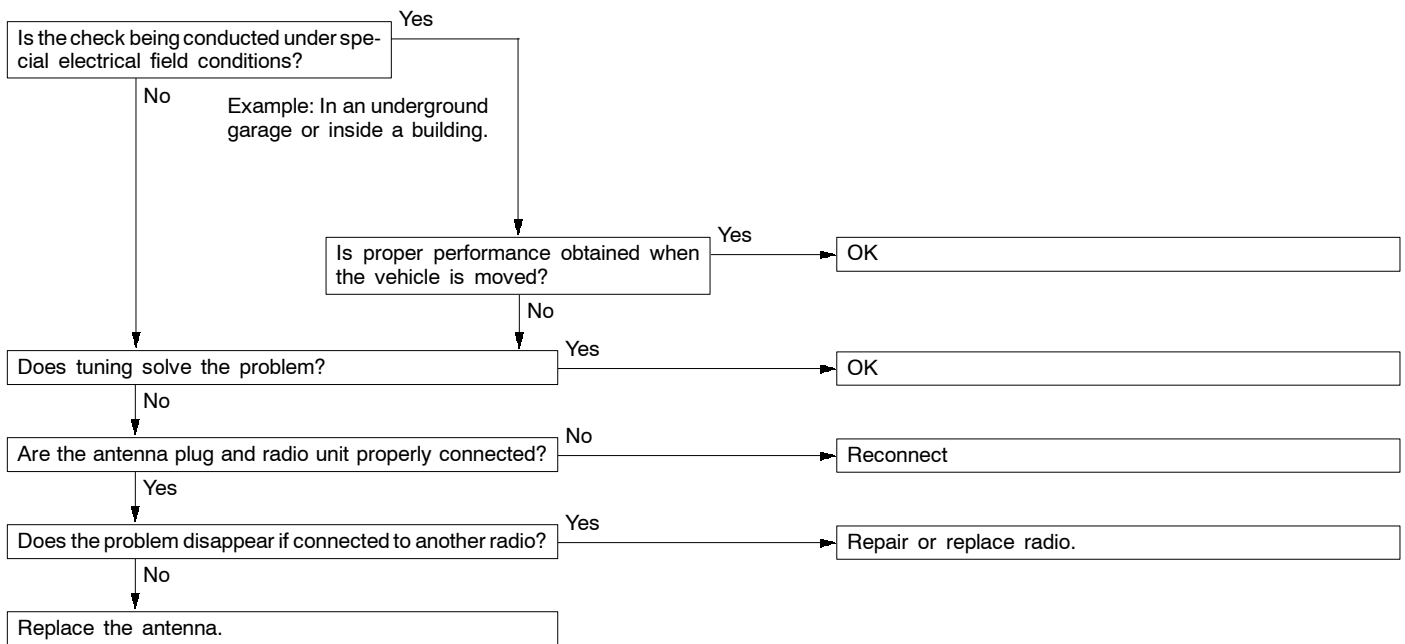

B-4 Insufficient sensitivity.

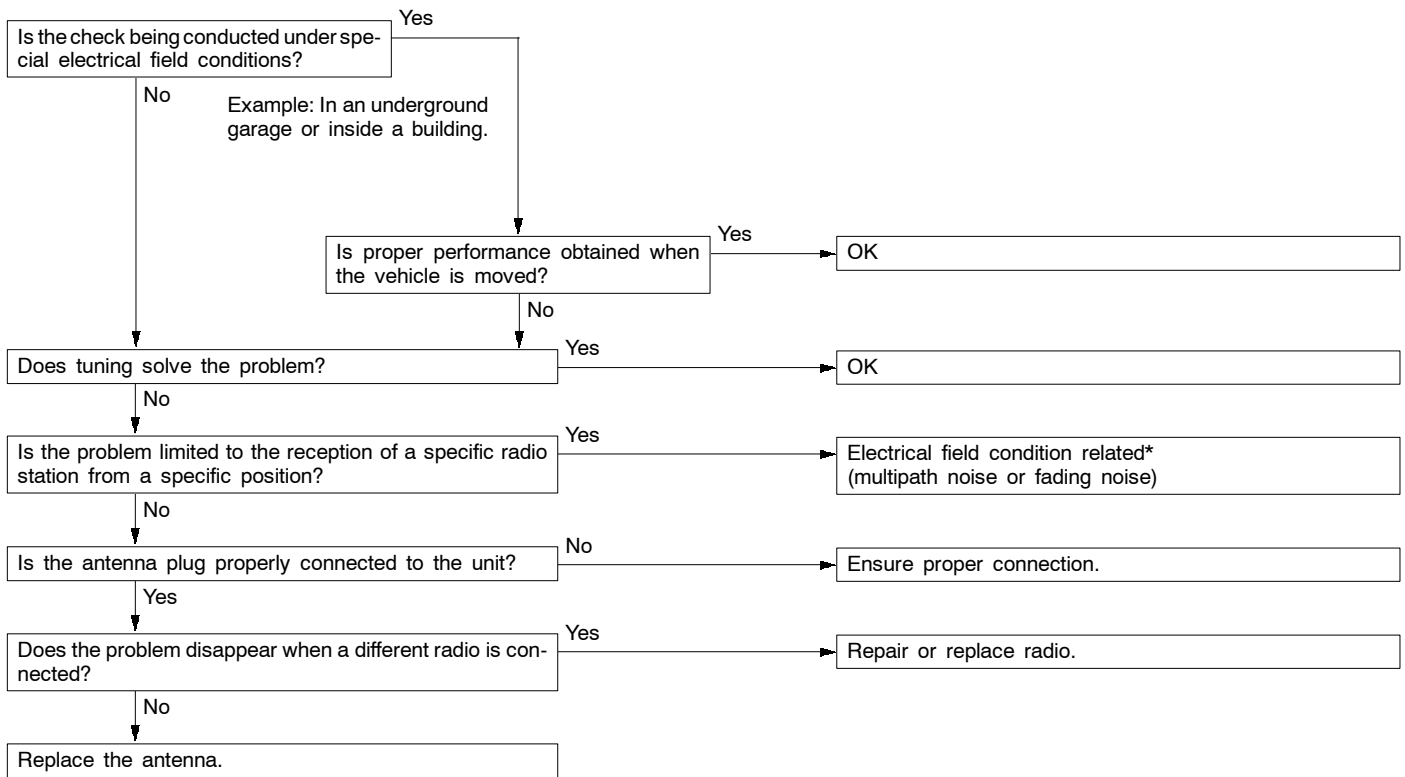

* For multipath noise and fading noise problems, refer to P. 54-72.

B-5 Distortion on AM or on both AM and FM.

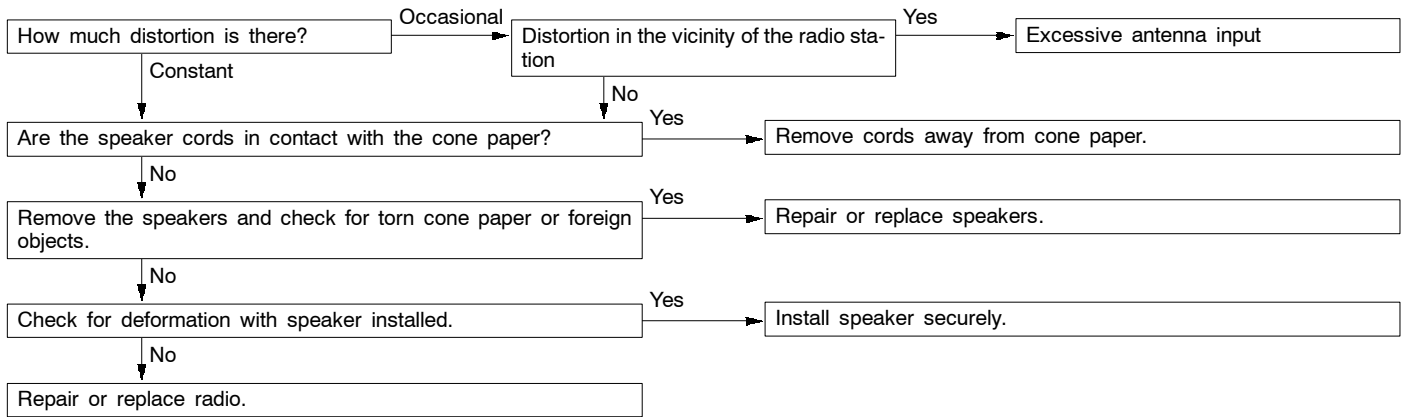

B-6 Distortion on FM only

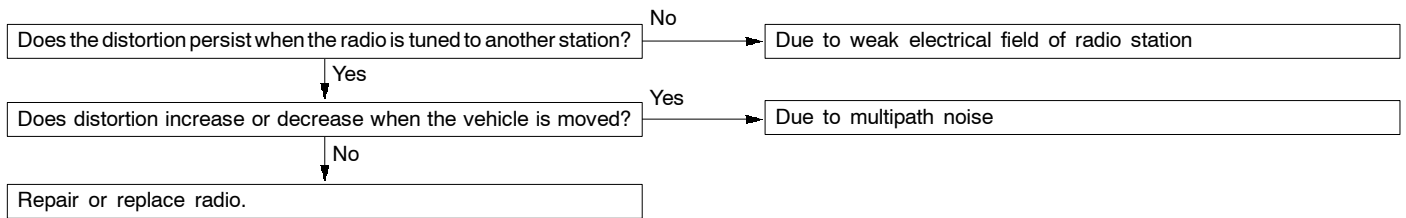

B-7 Too few automatic select stations.

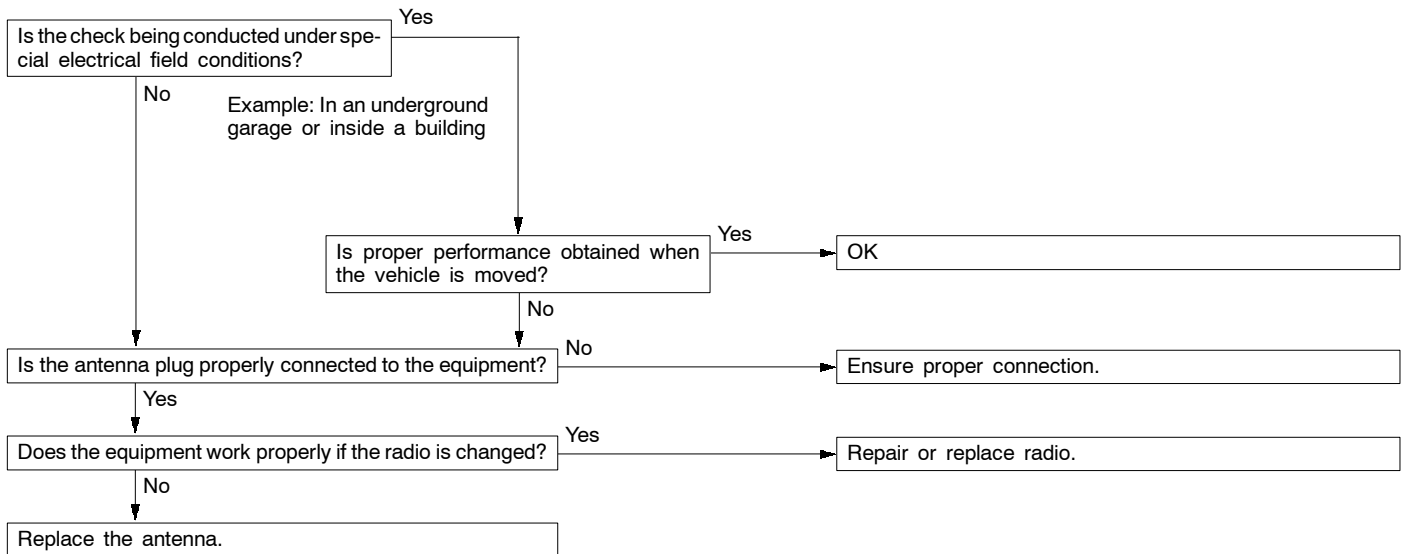

B-8 Insufficient memory (preset stations are erased).

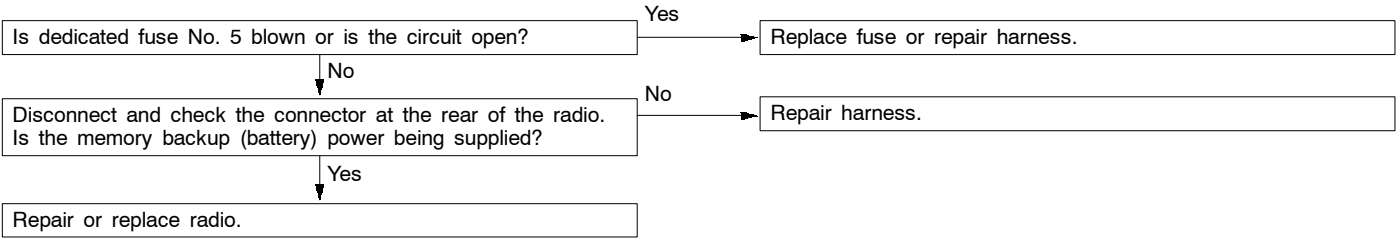

C. TAPE PLAYER

C-1 Cassette tape will not be inserted.

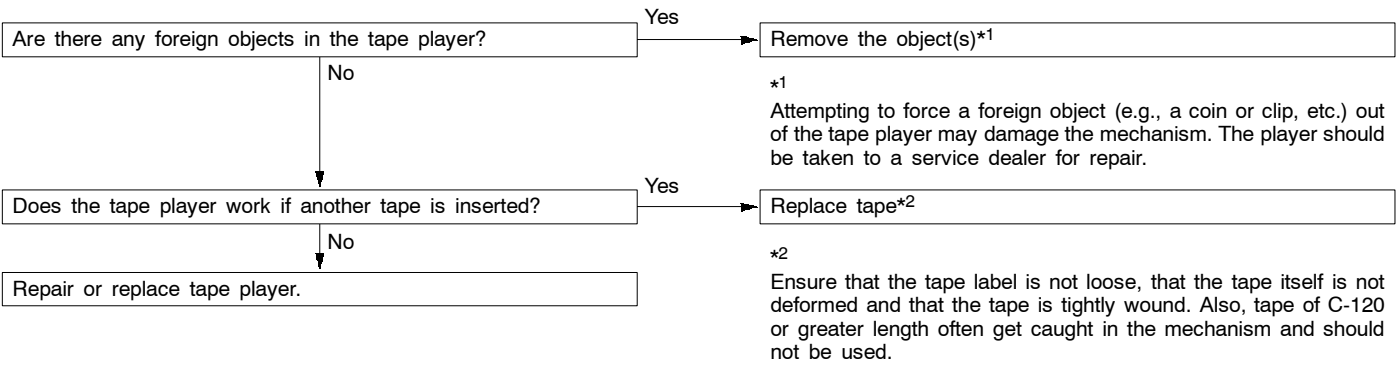

C-2 No sound (even after a tape has been inserted).

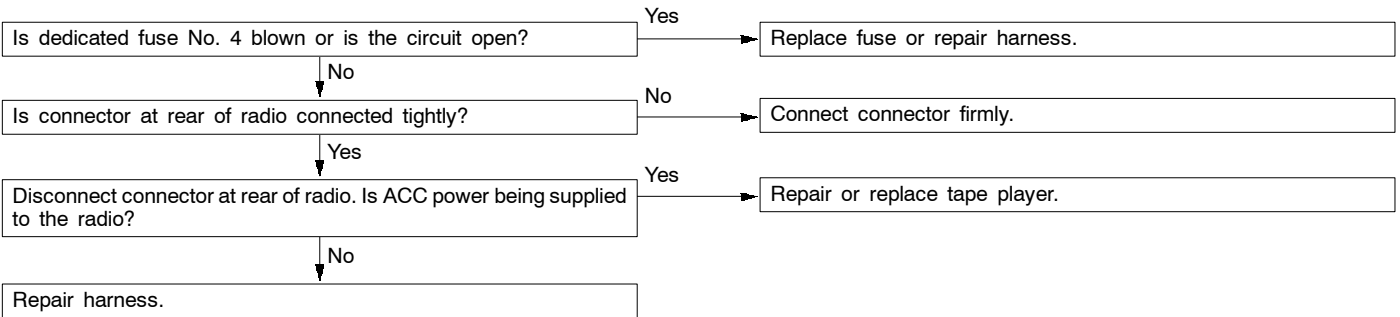

C-3 No sound from one speaker.

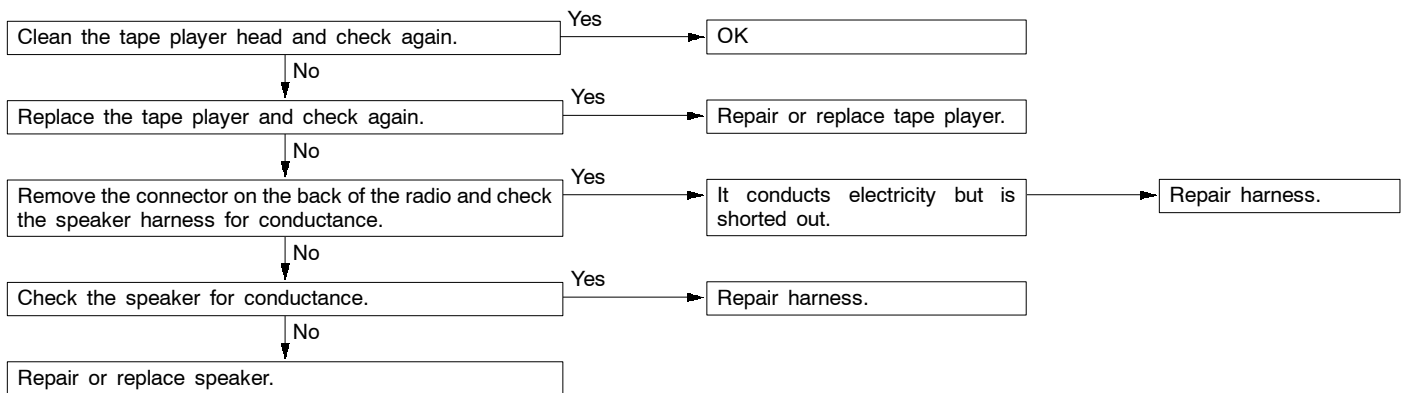

C-4 Sound quality is poor, or sound is weak.

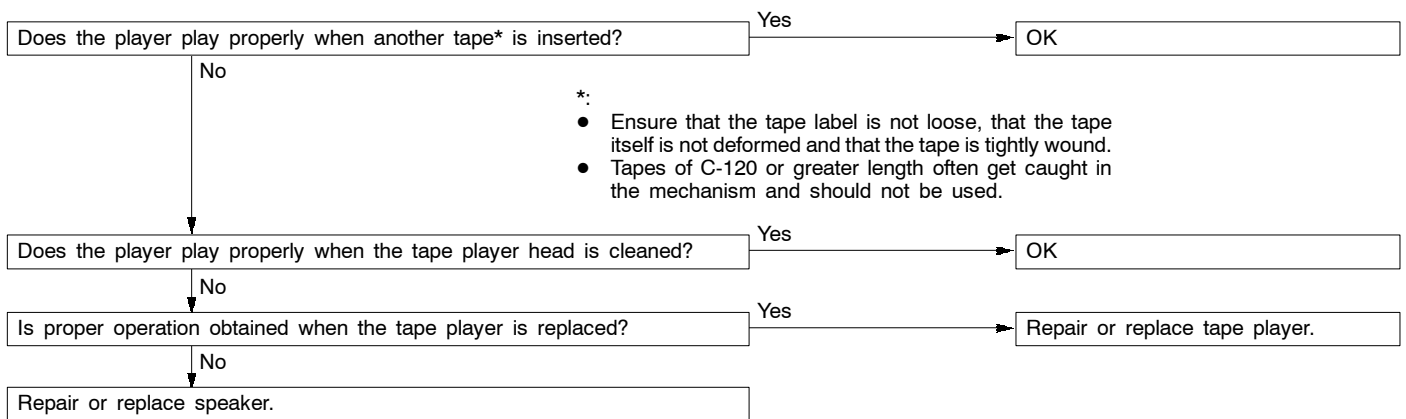

C-5 Cassette tape will not be ejected.

The problems covered here are all the result of the use of a bad tape (deformed or not properly tightened) or of a malfunction of the tape player itself. Malfunctions involving the tape becoming caught in the mechanism and ruining the case are

also possible, and attempting to force the tape out of the player can cause damage to the mechanism. The player should be taken to a service dealer for repair.

C-6 Uneven revolution. Tape speed is fast or slow.

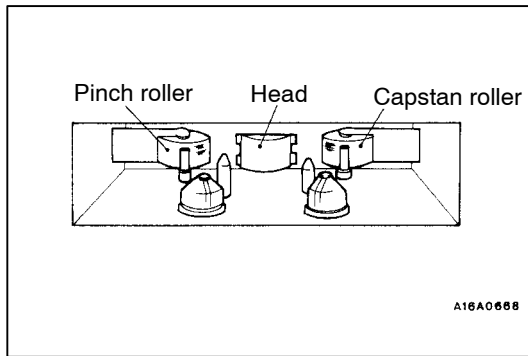
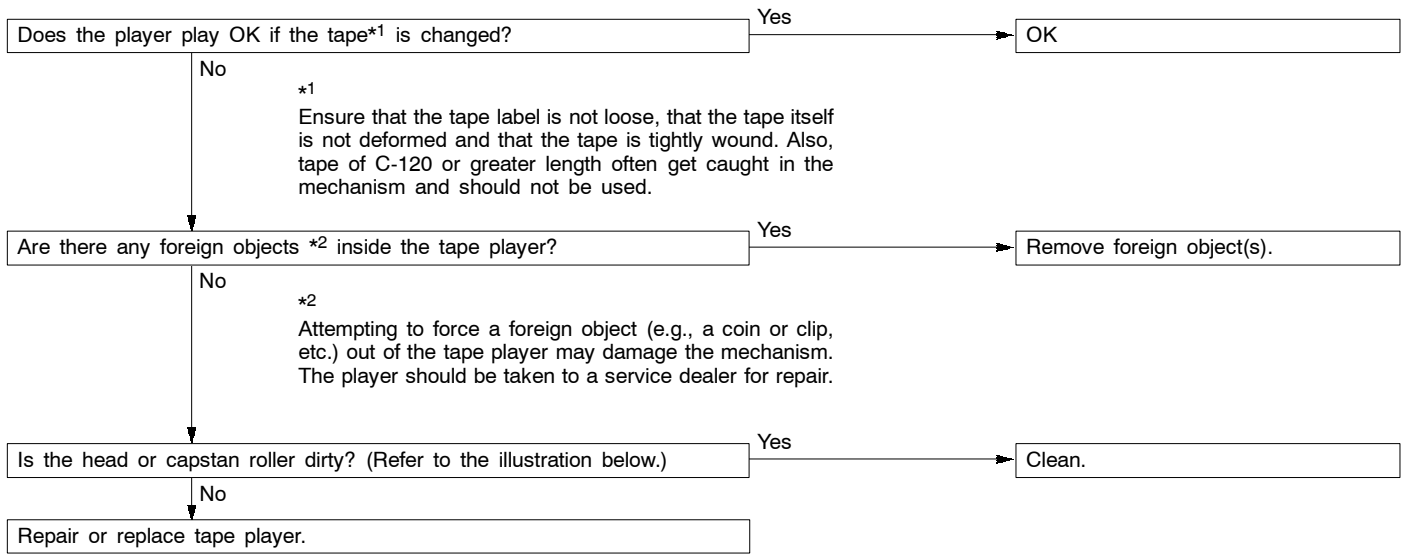

C-7 Faulty auto reverse.

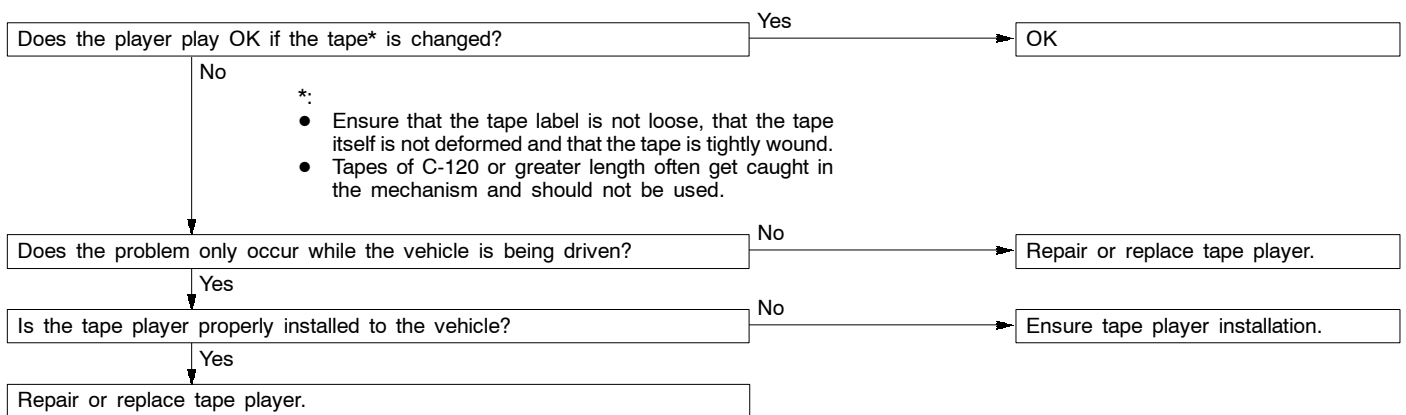

C-8 Tape gets caught in mechanism*1.

*1
When the tape is caught in the mechanism, the case may not eject. When this occurs, do not try to force the tape out as this may damage the tape player mechanism. Take the cassette to a service dealer for repair.

Does the player play OK if the tape*2 is changed?

Yes

Tape used is bad.

No

*2
Ensure that the tape label is not loose, that the tape itself is not deformed and that the tape is tightly wound. Also, tapes of C-120 or greater length often get caught in the mechanism and should not be used.

Repair or replace tape player.

RADIO AND TAPE PLAYER WITH ANTI-THEFT SYSTEM

- After the power supply to the radio and tape player has been interrupted for an hour or more, the anti-theft system will prevent the radio and tape player from working, even if the power

supply is restored. Problem with the anti-theft system can be found using the flow chart below.

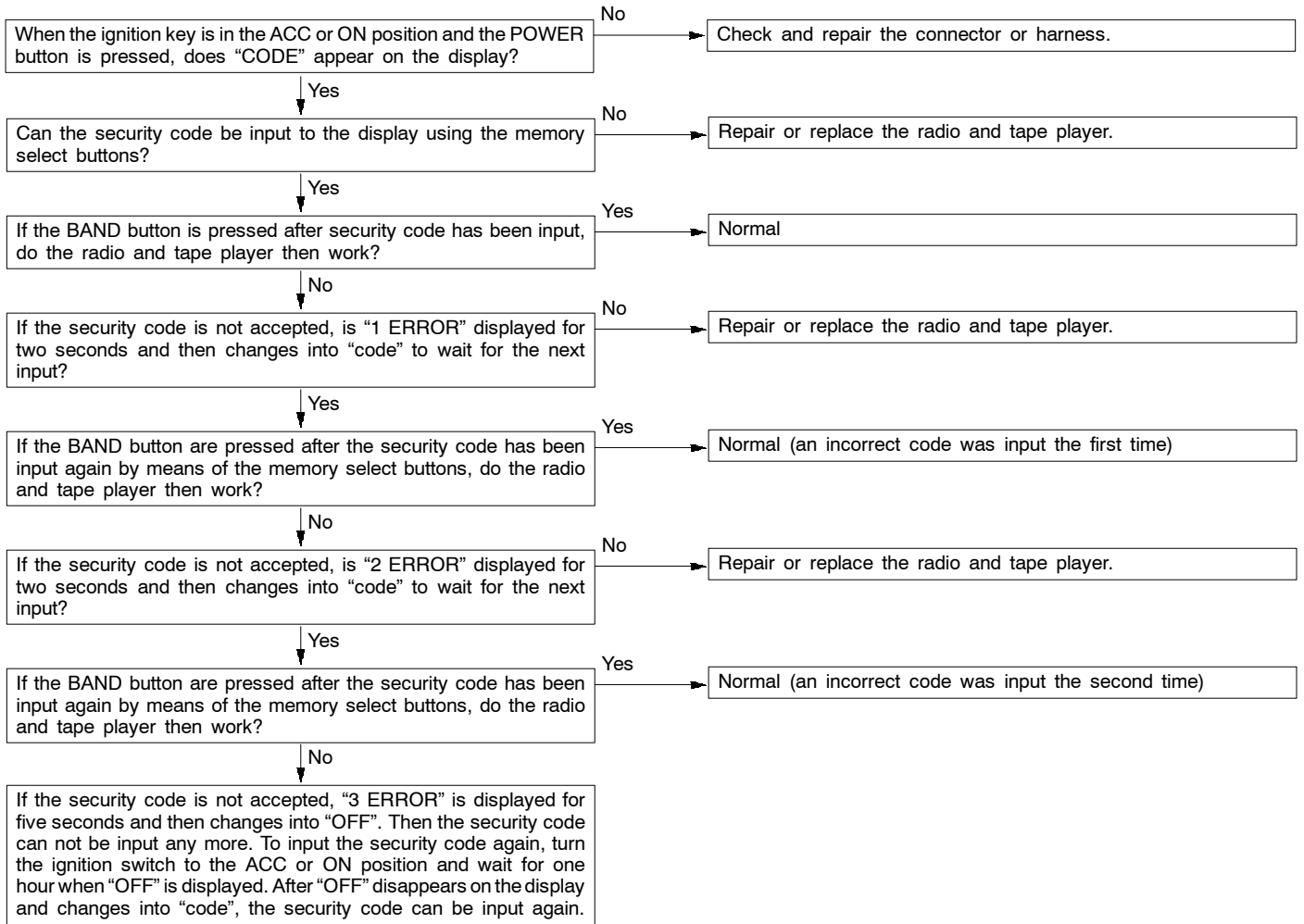

PROCEDURE FOR INPUT OF SECURITY CODE FOR RADIO AND TAPE PLAYER WITH ANTI-THEFT SYSTEM

54400440158

The radio and tape player does not work in the following states.

- Power supply to the radio and tape player has been suspended for more than an hour continuously by removing the cable from the battery terminal for disconnecting the harness connectors.
- The power supply to the radio and tape player has been suspended for more than an hour owing to blown fuse or discharged battery.
- The radio and tape player has been replaced.

If the radio and tape player does not work for these causes, input the security code by the following procedure.

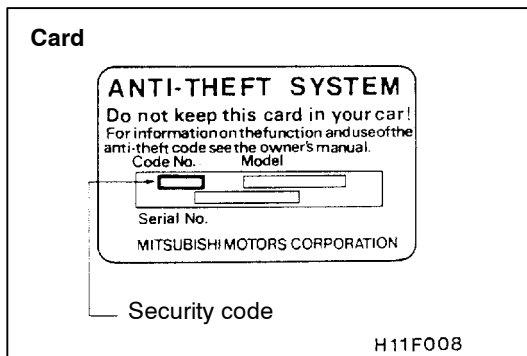

1. Using any of the following methods, confirm the security code.

- (1) Read the security code indicated on the cards retained by the car.

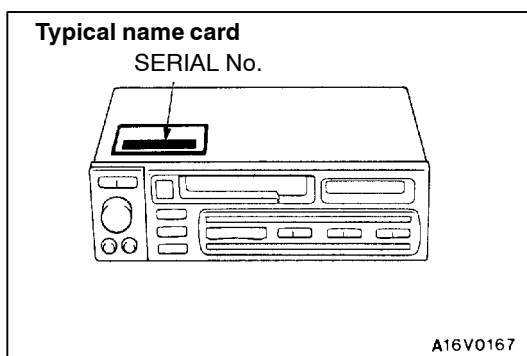

- (2) If the security code is unknown owing to the user's loss of the card:
 - a. Remove the radio and tape player, referring to P.54-85.
 - b. Read the serial No. stamped on the radio and tape player.
 - c. Look up the security code (anti-theft code table) corresponding to the serial number, or ask the authorized Mitsubishi dealer.

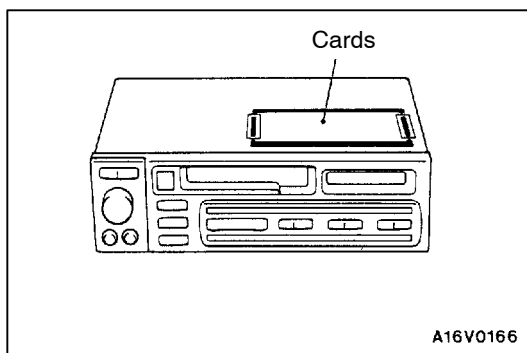

- (3) When the radio and tape player is replaced:
Read the security code on the cards attached to the upper surface of the replacement radio and tape player.

NOTE

Deliver the two cards to the user.

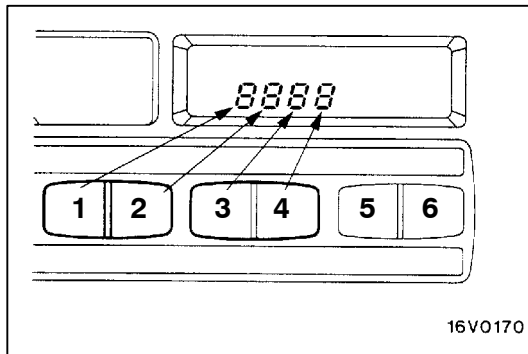
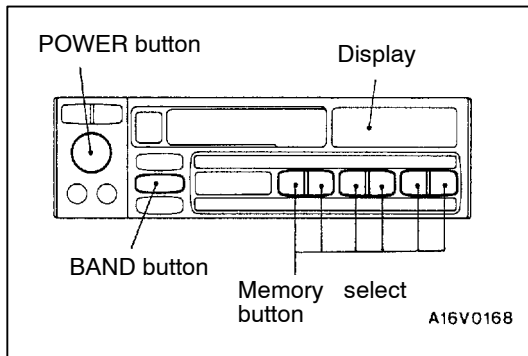

2. Return the power supply from the battery to the normal condition.
3. Turn the ignition key to the "ACC" or "ON" position.
4. Press the POWER button, and "CODE" will be displayed.

5. Press No.1 through No.4 memory select button to set the four-digit security code shown on the card. Every time each digit key is pressed, the figure changes as follows: 0→1→2.....9→0
6. Press the BAND button, and a beep will be heard and the radio and tape player will work.
7. If the security code is not accepted, "1 ERROR" is displayed. In a few minutes, it will change to "CODE". Then repeat the steps 5 and 6.

NOTE

- (1) If an incorrect security code is input, the anti-theft system will allow three attempts at most to input the correct code.
- (2) The second error is displayed as "2 ERROR". When the third error is made, "3 ERROR" is displayed and then the display changes to "OFF". If this should occur, the unit will not work any more.
- (3) To input the security code again, turn the ignition switch to the ACC or ON position and wait for one hour when "OFF" is displayed. After "OFF" disappears on the display and changes into "CODE", the security code can be input again.

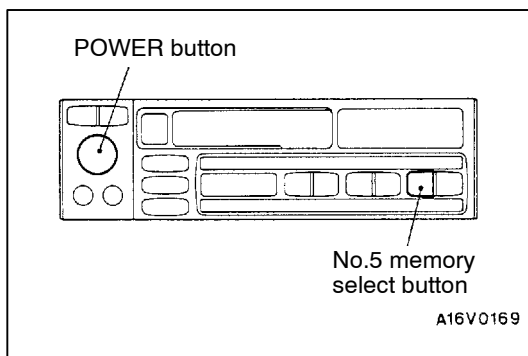

5-minute operation mode

To facilitate replacement or check, the radio and tape player can be operated for five minutes without inputting the security code.

1. Press the POWER button and No.5 memory select button together to operate the radio and tape player.
2. In five minutes the unit will not be able to work, and "CODE" will be displayed to indicate that the security code can be input again.

RADIO AND TAPE PLAYER

54400140164

REMOVAL AND INSTALLATION

Pre-removal and Post-installation Operation

- Front Floor Console Assembly Removal and Installation (Refer to GROUP 52A.)
- Driver's Side Under Cover or Knee Protector Assembly, Meter Bezel Assembly, Glove Box

Assembly, Center Under Cover Removal and Installation (Refer to GROUP 52A – Instrument Panel.)

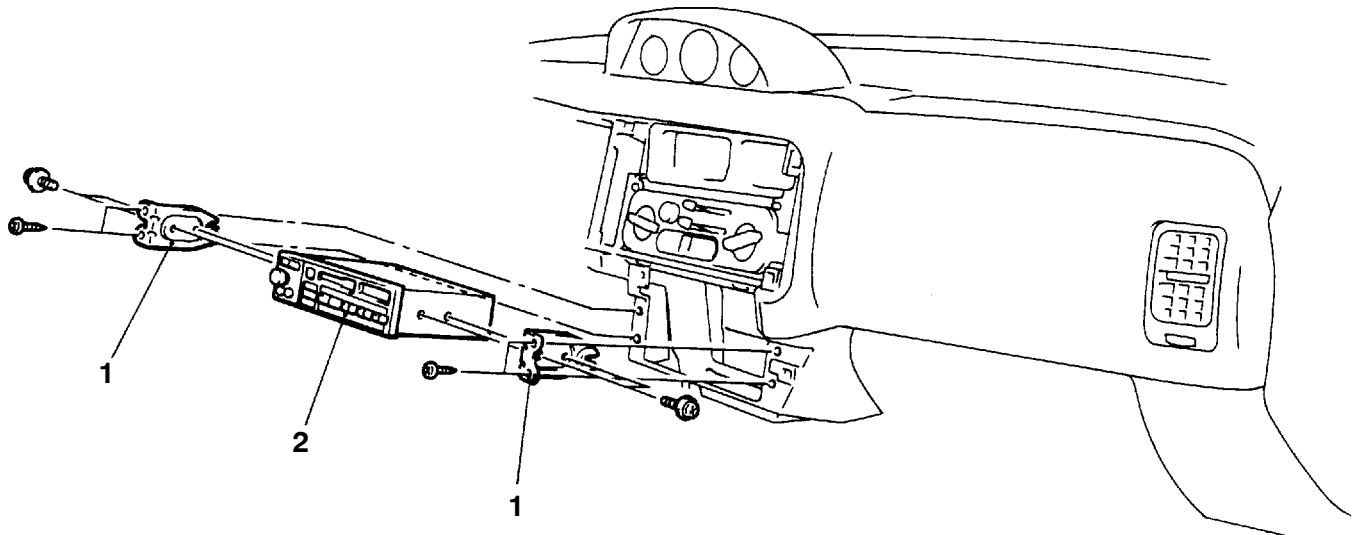

A16V0134

Removal steps

1. Radio bracket
2. Radio and tape player

SPEAKER

54400260358

REMOVAL AND INSTALLATION

Refer to GROUP 42 – Door.

ANTENNA

54400060064

SPECIAL TOOL

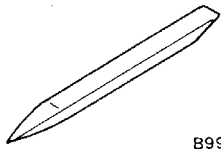
Tool	Number	Name	Use
 B990784	MB990784	Ornament remover	Meter bezel assembly removal

ANTENNA

54400290340

REMOVAL AND INSTALLATION

Pre-removal and Post-installation Operation

- Front Floor Console Assembly Removal and Installation (Refer to GROUP 52A.)
- Driver's Side Under Cover, Meter Bezel Assembly, Glove Box Assembly, Center Under Cover Removal

and Installation (Refer to GROUP 52A – Instrument Panel.)

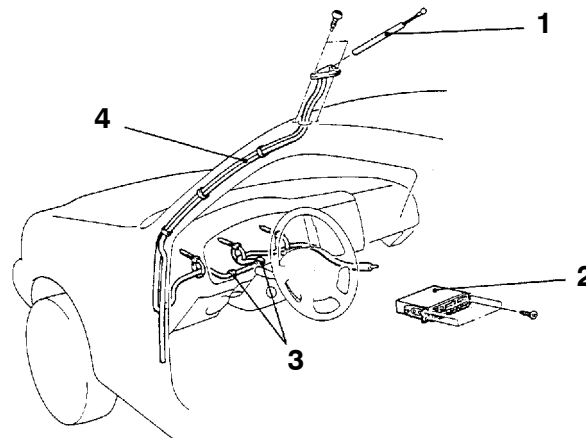

B16V0133

Removal steps

1. Pole
2. Radio and tape player
 - Front scuff plate (driver's side), cowl side trim (driver's side) (Refer to GROUP 52A – Trim.)



3. Cable clipped portion
4. Antenna base

REMOVAL SERVICE POINT

◀A▶ ANTENNA BASE REMOVAL

1. Tie a cord to the end of the feeder cable.

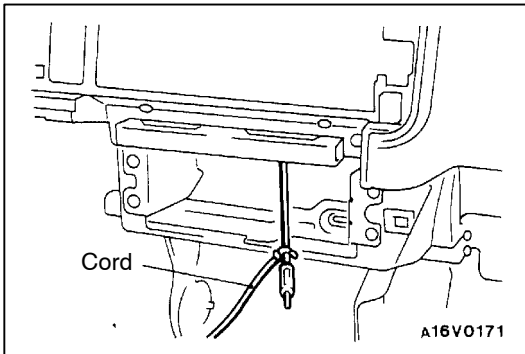

2. Pull out the antenna base until the end of the drain pipe can be seen.

3. Pass the cord through the hole in the end of the drain pipe and wrap it with vinyl tape.

Caution

Wrap it securely so that the cord will not come off.

4. Pull out the antenna base little by little to remove it.

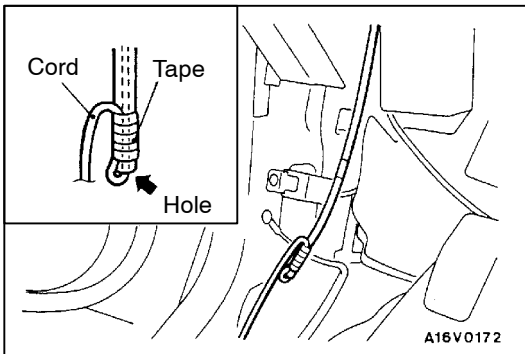

REAR WINDOW DEFOGGER

54300060269

SPECIAL TOOL

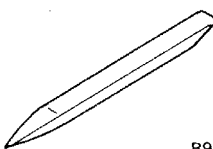
Tool	Number	Name	Use
 B990784	MB990784	Ornament remover	Meter bezel assembly removal

ON-VEHICLE SERVICE

54300180033

PRINTED-HEATER LINE CHECK

1. Run engine at 2,000 r/min. Check heater element with battery at full.
2. Turn ON rear window defogger switch. Measure heater element voltage with circuit tester at rear window glass centre A.

Condition is good if it indicates about 6V.

3. If 12 V is indicated at A, there is a break in the negative terminals from A.

Move test bar slowly to negative terminal to detect where voltage changes suddenly (0V).

4. If 0 V is indicated at A, there is a break in the positive terminals from A. Defect where the voltage changes suddenly (12 V) in the same method described above.

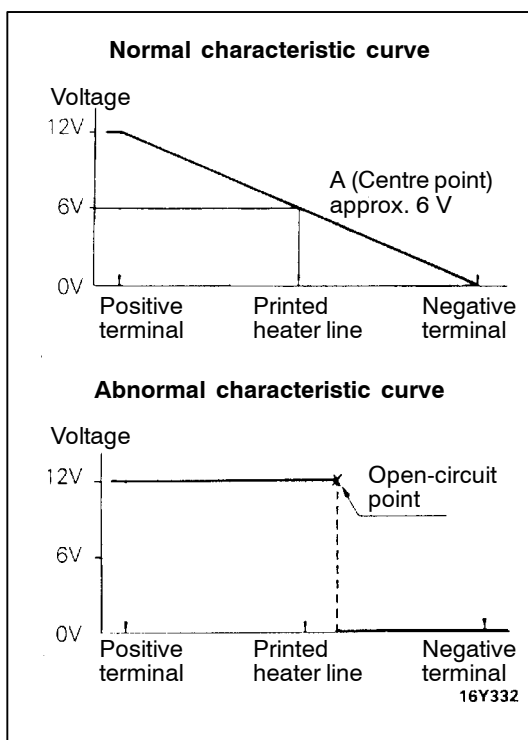

REAR WINDOW DEFOGGER SWITCH

54300620191

REMOVAL AND INSTALLATION

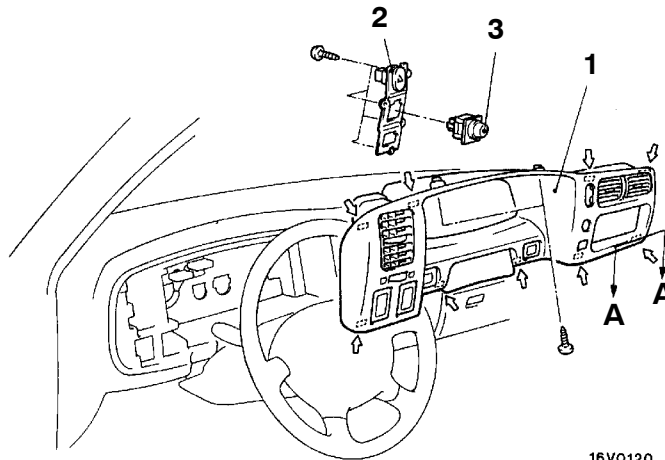
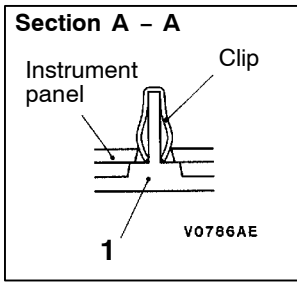

16V0120
00009189

NOTE

↔ : metal clip position

Removal steps

1. Meter bezel assembly
2. Switch holder
3. Rear window defogger switch

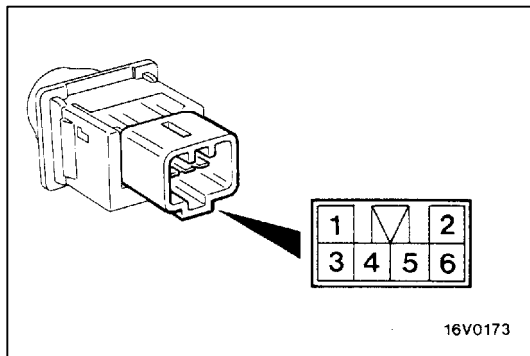

INSPECTION

54300630033

DEFOGGER SWITCH CONTINUITY CHECK

Switch position	Terminal No.							
	1	ILL	5	2	IND	6	3	4
OFF	○	⊕	○	○	⊕	○		
ON	○	⊕	○	○	⊕	○	○	○

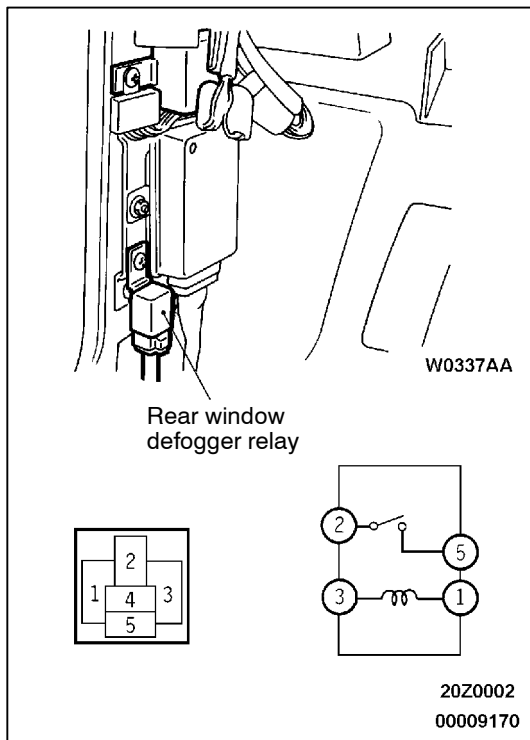

REAR WINDOW DEFOGGER RELAY CONTINUITY CHECK

54300680205

Battery voltage	Terminal No.			
	1	2	3	5
Power is not supplied	○	○	○	
Power is supplied	⊕	○	○	○

HEATER, AIR CONDITIONER AND VENTILATION

CONTENTS

55109000157

GENERAL INFORMATION	3	Magnetic Clutch Test	8
Safety Precautions	3	Receiver Drier Test	8
SERVICE SPECIFICATIONS	4	Dual Pressure Switch Check	9
LUBRICANTS	4	Compressor Drive Belt Adjustment	9
SEALANT	5	Charging	10
SPECIAL TOOL	5	Performance Test	15
TROUBLESHOOTING	5	Refrigerant Leak Repair	16
ON-VEHICLE SERVICE	8	Compressor Noise	17
Sight Glass Refrigerant Level Test	8	Power Relay Continuity Check	17
		Idle-up Operation Check	19

CONTINUED ON NEXT PAGE

WARNINGS REGARDING SERVICING OF SUPPLEMENTAL RESTRAINT SYSTEM (SRS) EQUIPPED VEHICLES

WARNING!

- (1) Improper service or maintenance of any component of the SRS, or any SRS-related component, can lead to personal injury or death to service personnel (from inadvertent firing of the air bag) or to the driver (from rendering the SRS inoperative).
- (2) Service or maintenance of any SRS component or SRS-related component must be performed only at an authorized MITSUBISHI dealer.
- (3) MITSUBISHI dealer personnel must thoroughly review this manual, and especially its GROUP 52B – Supplemental Restraint System (SRS) before beginning any service or maintenance of any component of the SRS or any SRS-related component.

NOTE

The SRS includes the following components: impact sensors, SRS-ECU unit, SRS warning lamp, air bag module, clock spring and interconnecting wiring. Other SRS-related components (that may have to be removed/installed in connection with SRS service or maintenance) are indicated in the table of contents by an asterisk (*).

Vacuum Actuator Check <4D5>	21	CONDENSER AND CONDENSER FAN MOTOR	39
Idle-up Solenoid Valve Check <4D5>	22	REFRIGERANT LINE	41
HEATER CONTROL ASSEMBLY AND A/C SWITCH	23	ENGINE COOLANT TEMPERATURE SWITCH <4D5>	43
HEATER UNIT AND HEATER CORE* ...	26	IDLE-UP SYSTEM <4D5>	45
BLOWER ASSEMBLY AND RESISTOR	28	OUTSIDE AIR TEMPERATURE SENSOR <6G7>	46
EVAPORATOR <VEHICLES WITH A/C>	30	VENTILATORS	47
REAR HEATER UNIT	32		
COMPRESSOR AND TENSION PULLEY*	34		

GENERAL INFORMATION

55200010305

The heater system uses a two-way-flow full-air-mix system that features high performance and low operating noise, and includes an independent side face air blowing function. The A/C system is

basically the same as the conventional system, but a new refrigerant system has been adopted as a response to restrictions on the use of chlorofluorocarbons.

Items		Specifications
Heater unit	Type	Two-way-flow full-air-mix system
Heater control assembly		Dial type
Compressor	Model	Scroll type <MSC 105C>
Dual pressure switch kPa	High-pressure switch	ON → OFF: 2,942, OFF → ON: 2,354
	Low-pressure switch	ON → OFF: 196, OFF → ON: 221
Refrigerant and quantity g		R-134a (HFC-134a), Approx. 600 – 650

SAFETY PRECAUTIONS

Because R-134a refrigerant is a hydrofluorocarbon (HFC) which contains hydrogen atoms in place of chlorine atoms, it will not cause damage to the ozone layer.

Refrigerant R-134a is transparent and colourless in both the liquid and vapour state. Since it has a boiling point of -29.8°C , at atmospheric pressure, it will be a vapour at all normal temperatures and pressures. The vapour is heavier than air, non-flammable, and nonexplosive. The following precautions must be observed when handling R-134a.

Caution

Wear safety goggles when servicing the refrigeration system.

R-134a evaporates so rapidly at normal atmospheric pressures and temperatures that it tends to freeze anything it contacts. For this reason, extreme care must be taken to prevent any liquid refrigerant from contacting the skin and especially the eyes. Always wear safety goggles when servicing the refrigeration part of the A/C system. Keep a bottle of sterile mineral oil handy when working on the refrigeration system. Should any liquid refrigerant get into the eyes, use a few drops of mineral oil to wash them out. R-134a is rapidly absorbed by the oil. Next splash the eyes with plenty of cold water. Call your doctor immediately even though irritation has ceased after treatment.

Caution

Do not heat R-134a above 40°C

In most instances, moderate heat is required to bring the pressure of the refrigerant in its container above the pressure of the system when charging or adding refrigerant.

A bucket or large pan of hot water not over 40°C is all the heat required for this purpose. Do not heat the refrigerant container with a blow torch or any other means that would raise temperature and pressure above this temperature. Do not weld or steam clean on or near the system components or refrigerant lines.

Caution

Keep R-134a containers upright when charging the system.

When metering R-134a into the refrigeration system keep the supply tank or cans in an upright position. If the refrigerant container is on its side or upside down, liquid refrigerant will enter the system and damage the compressor.

Caution

1. **The leak detector for R-134a should be used to check for refrigerant gas leaks.**
2. **Do not allow liquid refrigerant to touch bright metal.**

Refrigerant will tarnish bright metal and chrome surfaces, and in combination with moisture can severely corrode all metal surfaces.

SERVICE SPECIFICATIONS

55200030325

Items		Standard value	
Idle speed r/min	6G7	700±100	
	4D5	750±50	
Idle up speed r/min	6G7	When low load on A/C (Outside air temperature sensor: ON)	750±100
		When high load on A/C (Outside air temperature sensor: OFF)	900±100
	4D5		950±50
Resistor <L.H. drive vehicles> Ω		LO: 2.00, ML: 1.10, MH: 0.68	
Resistor <R.H. drive vehicles> Ω		LO: 2.48, ML: 1.17, MH: 0.28	
Rear heater resistor Ω		3.9	
Air gap (Magnetic clutch) mm		0.3 – 0.5	
Engine coolant temperature switch (for A/C cut-off) <4D5> C°	ON (continuity)	108 or less	
	OFF (no continuity)	115 or more	
Engine coolant temperature switch (for condenser fan) <4D5> C°	ON (continuity)	102 or more	
	OFF (no continuity)	97 or less	

LUBRICANTS

55200040229

Items	Specified lubricants	Quantity
Each connection of refrigerant line	SUN PAG 56	As required
Compressor refrigerant unit lubricant mL	SUN PAG 56	170

SEALANT

55200050048

Item	Specified sealant	Remark
Engine coolant temperature switch threaded part	3M Nut Locking Part No. 4171 or equivalent	Drying sealant

SPECIAL TOOL

55100060017

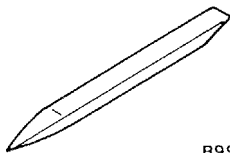
Tool	Number	Name	Use
 B990784	MB990784	Ornament remover	Meter bezel assembly removal

TROUBLESHOOTING

55200070372

TROUBLESHOOTING PROCEDURES

Caution

For vehicles with 6G7 engine, when the A/C is working under low loads (when outside temperature is low), condenser fan may not operate due to the A/C condenser control function. Disconnect the battery (-) cable and reconnect it, and then check the trouble symptom during the initial check that is performed for five minutes after the battery (-) cable has been reconnected.

Trouble symptom	Problem cause	Remedy	Reference page
When the ignition switch is "ON", the A/C does not operate.	A/C compressor relay is defective	Replace A/C compressor relay	55-18
	Magnetic clutch is defective	Replace the A/C compressor	55-8, 36
	Refrigerant leak or overfilling of refrigerant	Replenish the refrigerant, repair the leak or take out some of the refrigerant	55-8, 16
	Dual pressure switch is defective	Replace the dual pressure switch	55-9, 41
	A/C switch is defective	Replace the A/C switch	55-23, 25
	Blower switch is defective	Replace the blower switch	55-23, 25
	Thermostat is defective	Replace the Thermostat	55-31
	Automatic compressor controller is defective	Replace the automatic compressor controller	55-31
	Engine coolant temperature switch (for A/C cut-off) is defective <4D5>	Replace the engine coolant temperature switch	55-43, 44
Engine-ECU is defective <4D5>	Replace the engine-ECU	-	

Trouble symptom	Problem cause	Remedy	Reference page
When the A/C is operating, temperature inside the passenger compartment doesn't decrease (cool air is not emitted).	Refrigerant leak	Replenish the refrigerant and repair the leak	55-16
	Dual pressure switch is defective	Replace the dual pressure switch	55-9, 41
	Thermostat is defective	Replace the Thermostat	55-31
	Automatic compressor controller is defective	Replace the automatic compressor controller	55-31
Blower fan and motor doesn't turn	Blower relay is defective	Replace the blower relay	55-17
	Blower fan and motor is defective	Replace the blower fan and motor	55-28, 29
	Blower resistor is defective	Replace the blower resistor	55-28, 29
	Blower switch is defective	Replace the blower switch	55-23, 25
Blower fan and motor doesn't stop turning.	Short circuit of the harness between the blower fan and motor and the blower switch	Repair the harness	-
	Blower switch is defective	Replace the blower switch	55-23, 25
	Blower relay is defective	Replace the blower relay	55-1
When the A/C is operating condenser fan does not turn.	Condenser fan motor is defective	Replace the condenser fan motor	55-39, 40
	Condenser fan relay is defective	Replace the condenser fan relay	55-18
	Automatic compressor controller is defective <6G7>	Replace the automatic compressor controller	55-31

INSPECTION AT THE AUTOMATIC COMPRESSOR-CONTROLLER TERMINAL

55201030089

<6G7>

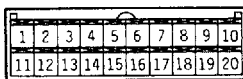

V0224AA

Terminal No.	Name of signal	Condition	Terminal voltage
1	IG2 power supply	Ignition switch ON	System voltage
2	A/C switch input	A/C switch OFF or Blower switch OFF	0V
		A/C switch ON Ignition switch ON Blower switch ON	System voltage
4	Air conditioning output	A/C compressor relay OFF	0V
		A/C compressor relay ON	System voltage
8	Earth	At all time	Continuity

Terminal No.	Name of signal	Condition	Terminal voltage
9	Earth	At all time	Continuity
14	Air thermo sensor power supply	At all time	4.8 – 5.2V
15	Air thermo sensor input	Sensor temperature 25°C (4kΩ)	2.3 – 2.9V
16	Outside air temperature sensor power supply	At all time	4.8 – 5.2V
17	Outside air temperature sensor input	Sensor temperature 25°C (4kΩ)	2.3 – 2.9V
18	Backup power supply	At all time	System voltage
19	Outside air temperature output	Sensor temperature 15°C or more	System voltage
		Sensor temperature 18°C or less	2V or more

<4D5>

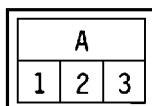

16V0297

Terminal No.	Name of signal	Condition	Terminal voltage
1	Air conditioning output	A/C compressor relay OFF	0V
		A/C compressor relay ON	System voltage
2	A/C switch input	A/C switch OFF or Blower switch OFF	0V
		A/C switch ON Ignition switch ON Blower switch ON	System voltage
3	Earth	At all time	0V

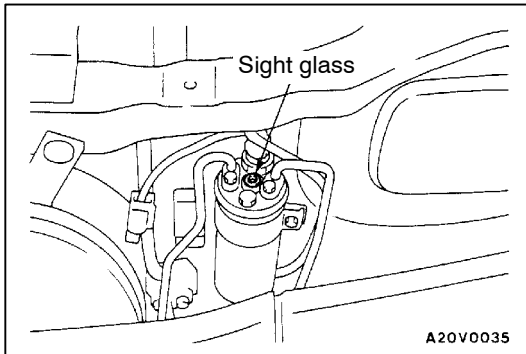

ON-VEHICLE SERVICE

55200840096

SIGHT GLASS REFRIGERANT LEVEL TEST

The sight glass is a refrigerant level indicator. To check the refrigerant level, clean the sight glass and start the vehicle engine. Push the A/C button to operate the compressor, place the blower switch to high and move the temperature control lever to max cool. After operating for a few minutes in this manner, check the sight glass.

1. If the sight glass is clear, the magnetic clutch is engaged, the compressor discharge line is warm and the compressor inlet line is cool; the system has a full charge.
2. If the sight glass is clear, the magnetic clutch is engaged and there is no significant temperature difference between compressor inlet and discharge lines; the system has lost some refrigerant.
3. If the sight glass shows foam or bubbles, the system could be low on charge. The system has to be recharged with refrigerant.

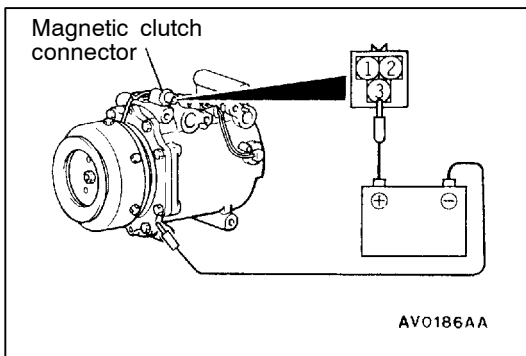

MAGNETIC CLUTCH TEST

55200850280

1. Disconnect the magnetic clutch connector to the magnetic clutch.
2. Connect battery (+) voltage directly to the connector for the magnetic clutch.
3. If the magnetic clutch is normal, there will be "click". If the pulley and armature do not make contact ('click'), there is a malfunction.

RECEIVER DRIER TEST

55200860139

Operate the unit and check the piping temperature by touching the receiver drier outlet and inlet.

If there is a difference in the temperatures, the receiver assembly is restricted.

Replace the receiver assembly.

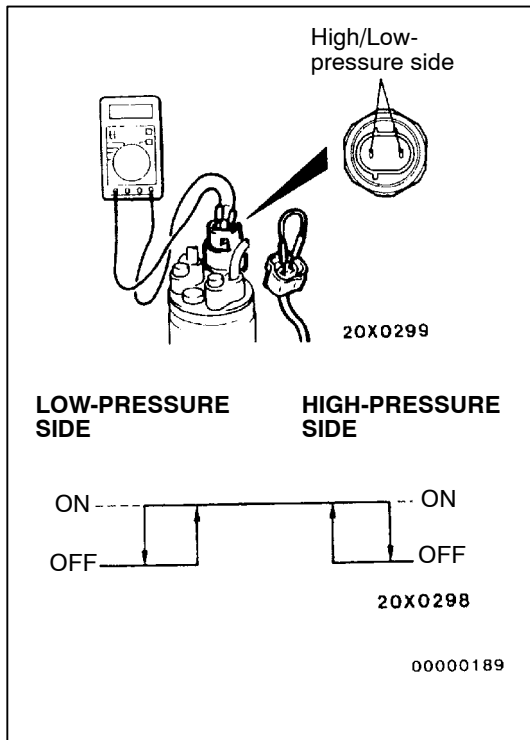

DUAL PRESSURE SWITCH CHECK

55201040228

1. Remove the dual pressure switch connector and connect the high/low-pressure side terminals located on the harness side as shown in the illustration.
2. Install a gauge manifold to the high-pressure side service valve of the refrigerant line. (Refer to Performance Test.)
3. When the high/low-pressure sides of the dual pressure switch are at operation pressure (ON) and there is continuity between the respective terminals, then the condition is normal. If there is no continuity, replace the switch.

Items	Switch position	
	OFF → ON	ON → OFF
Low-pressure side kPa	221	196
High-pressure side kPa	2,354	2,942

COMPRESSOR DRIVE BELT ADJUSTMENT

55200100255

Refer to GROUP 11 - On-vehicle Service.

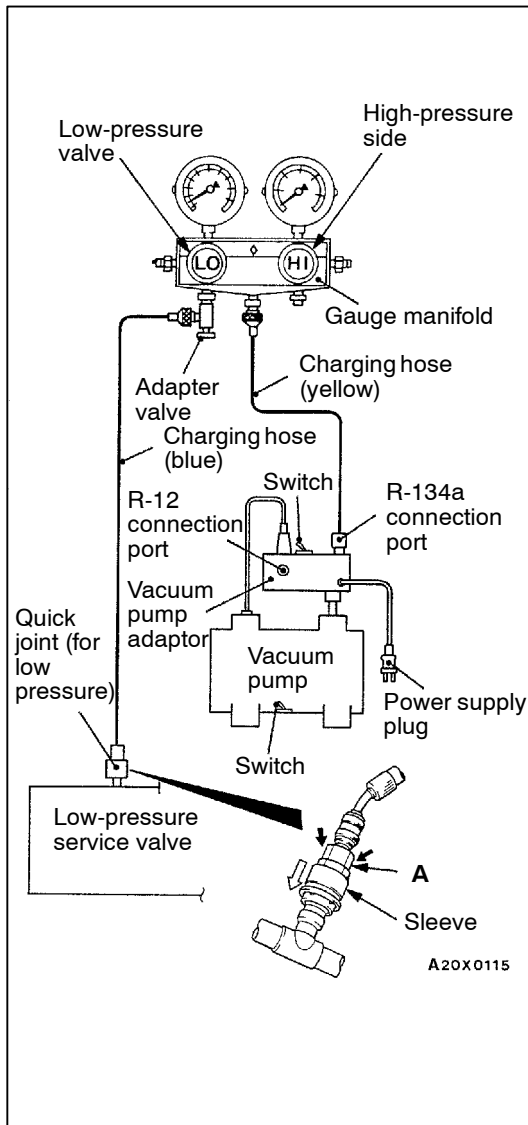

CHARGING

55200120268

1. With the handles turned back all the way (valve closed), install the adaptor valve to the low-pressure side of the gauge manifold.
2. Connect the charging hose (blue) to the adaptor valve.
3. Connect the quick joint (for low-pressure) to the charging hose (blue).
4. Connect the quick joint (for low-pressure) to the low-pressure service valve.

NOTE

The low-pressure service valve should be connected to the suction hose.

Caution

- (1) Use tools that are suited to R-134a.
- (2) To install the quick joint, press section "A" firmly against the service valve until a click is heard. When connecting, run your hand along the hose while pressing to ensure that there are no bends in the hose.

5. Close the high and low-pressure valves of the gauge manifold.
6. Install the vacuum pump adaptor to the vacuum pump.
7. Connect the vacuum pump plug to the vacuum pump adaptor.
8. Connect the charging hose (yellow) to the R-134a connection port of the vacuum pump adaptor.
9. Tighten the adaptor valve handle (valve open).
10. Open the low-pressure valve of the gauge manifold.
11. Turn the power switch of the vacuum pump to the ON position.

NOTE

Even if the vacuum pump power switch is turned ON, the vacuum pump will not operate because of the power supply connection in step (7).

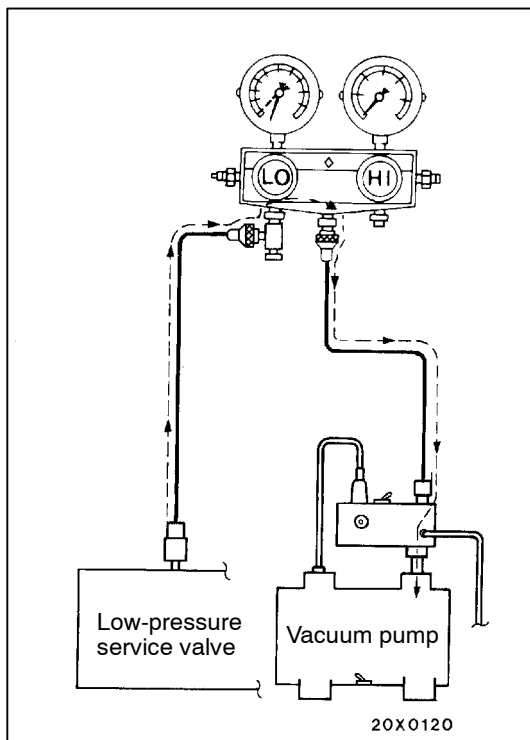

12. Turn the vacuum pump adaptor switch to the R-134a side to start the vacuum pump.

Caution

Do not operate the compressor for evacuation.

13. Evacuate to a vacuum reading of 100 kPa or higher (takes approx. 10 minutes).
14. Turn the vacuum pump adaptor switch OFF and allow to stand it for 5 minutes.

Caution

Do not operate the compressor in the vacuum condition; damage may occur.

15. Carry out a leak test. (Good if the negative pressure does not drop.)

Caution

If the negative pressure drops, increase the tightness of the connections, and then repeat the evacuation procedure from step (12).

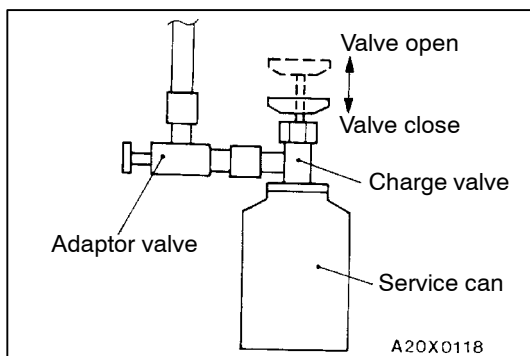

16. With the handle turned back all the way (valve open), install the charging valve to the service van.

17. Turn the handle of the adaptor valve back all the way (valve closed), remove it from the gauge manifold and install the service can.

18. Tighten the handle of the charging valve (valve closed) to puncture the service can.

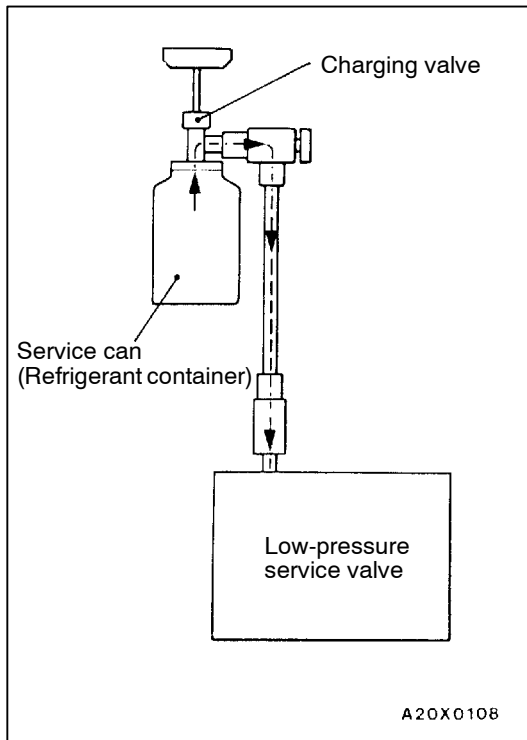

19. Turn the handle of the charging valve back (valve open) and tighten the handle of the adaptor valve (valve open) to charge the system with refrigerant.

Caution

If the service can is inverted, liquid refrigerant may be drawn into the compressor damaging it by liquid compression. Keep the service can upright to ensure that refrigerant is charged in gas state.

20. If the refrigerant is not drawn in, turn the handle of the adaptor valve back all the way (valve closed).
21. Check for gas leaks using a leak detector. If a gas leak is detected, re-tighten the connections, and then repeat the charging procedure from evacuation in step (12).

Caution

The leak detector for R-134a should be used.

22. Start the engine.
23. Operate the A/C and set to the lowest temperature (MAX. COOL).
24. Fix the engine speed at 1,500 r/min.
25. Tighten the handle of the adaptor valve (valve open) to charge the required volume of refrigerant.

Caution

If the service can is inverted, liquid refrigerant may be drawn into the compressor damaging it by liquid compression. Keep the service can upright to ensure that refrigerant is charged in gas state.

26. After charging with refrigerant, turn the handle of the adaptor valve back all the way (valve closed).
27. Tighten the charging valve handle (valve closed). Remove the quick joint (for low-pressure) from the low-pressure service valve.

NOTE

If the service can is not emptied completely, keep the handles of the charging valve and adaptor valve closed for the next charging.

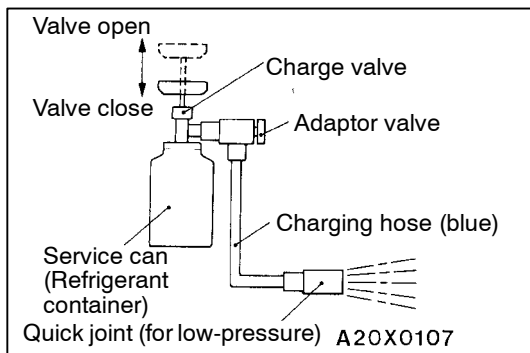

CORRECTING LOW REFRIGERANT LEVEL IN CASE THE SERVICE CAN IS USED.

1. Install the charge valve with the handle turned all the way back (valve open) to the service can.
2. Install the adaptor valve with the handle turned all the way back (valve close) to the charging valve.
3. Connect the charging hose (blue) to the adaptor valve.
4. Connect the charging hose (blue) to the quick joint (for low-pressure).
5. Tighten the handle of the charge valve (valve close), and pierce the service can.
6. Turn the handle of the adaptor valve to bleed the air.

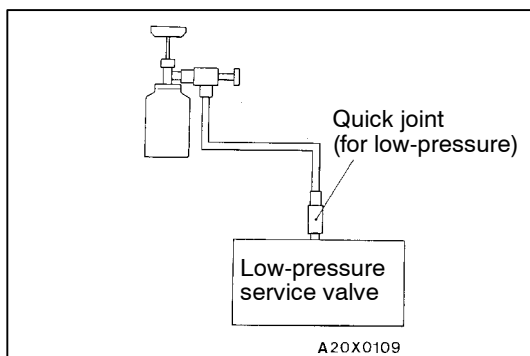

7. Install the quick joint (for low-pressure) to the low-pressure service valve.

NOTE

The low-pressure service valve should be connected to the suction hose.

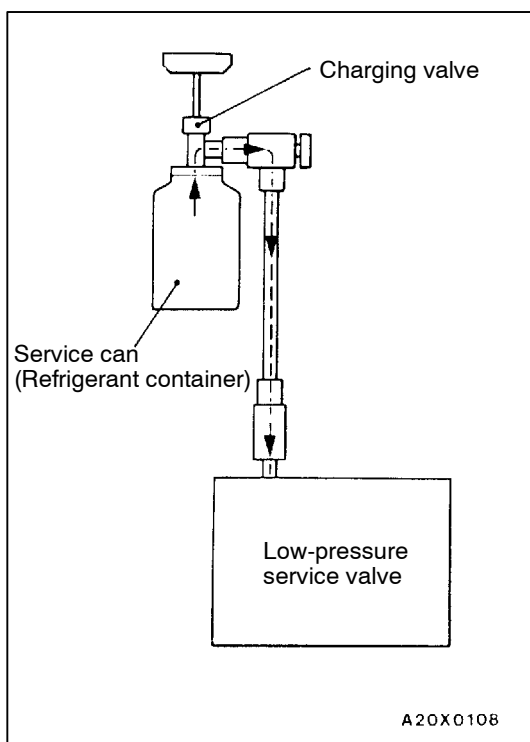

8. Start the engine.
9. Operate the air conditioner and set at the lowest temperature (MAX. COOL).
10. Fix the engine speed at 1,500 r/min.
11. Tighten the handle of the adaptor valve (valve open), and replenish refrigerant while checking the quantity through the sight glass.

Caution

If the service can is inverted, liquid refrigerant may be drawn into the compressor damaging it by liquid compression. Keep the service can upright to ensure that refrigerant is changed in gas state.

12. After replenishing is completed, turn the handle of the adaptor valve all the way back (valve close), and remove the quick joint.

NOTE

When there is remainder of refrigerant in the service can, keep it for next use with the charge valve and the valve of the adaptor valve being closed.

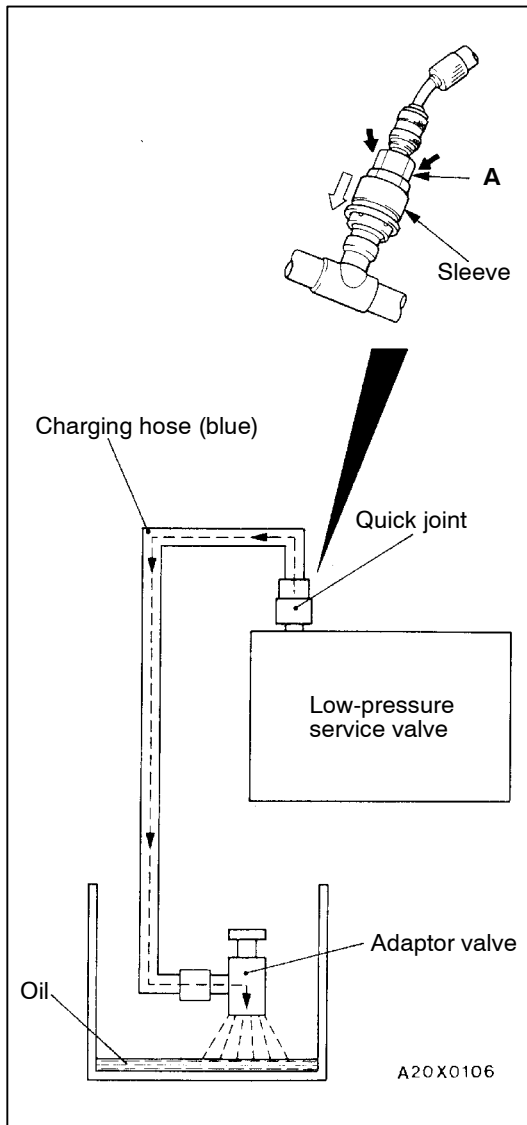

DISCHARGING SYSTEM

1. Run the engine at an engine speed of 1,200–1,500 r/min for approximately 5 minutes with the A/C operating to return to the oil.

NOTE

Returning the oil will be more effective if it is done while driving.

2. Stop the engine.
3. Connect the charging hose (blue) to the adaptor valve with its handle turned back all the way (valve closed).
4. Connect the quick joint to the charging hose (blue).
5. Install the quick joint to the low-pressure service valve.

NOTE

The low-pressure service valve should be connected to the suction hose.

Caution

To connect the quick joint, press section “A” firmly against the service valve until a click is heard. When connecting, run your hand along the hose while pressing to ensure that there are no bends in the hose.

6. Place the adaptor valve inside the container and discharge the refrigerant by opening the handle gradually so that oil does not gush out.

NOTE

Any oil remaining in the container should be returned to the A/C system.

REFILLING OF OIL IN THE A/C SYSTEM

Too little oil will provide inadequate compressor lubrication and cause a compressor failure. Too much oil will increase discharge air temperature.

When a compressor is installed at the factory, it contains 180 mL of refrigerant oil. While the A/C system is in operation, the oil is carried through the entire system by the refrigerant. Some of this oil will be trapped and retained in various parts of the system.

When the following system components are changed, it is necessary to add oil to the system to replace the oil being removed with the component.

Compressor oil: SUN PAG 56

Quantity

Condenser: 20 mL

Evaporator: 70 mL

Suction hose: 10 mL

Receiver: 10 mL

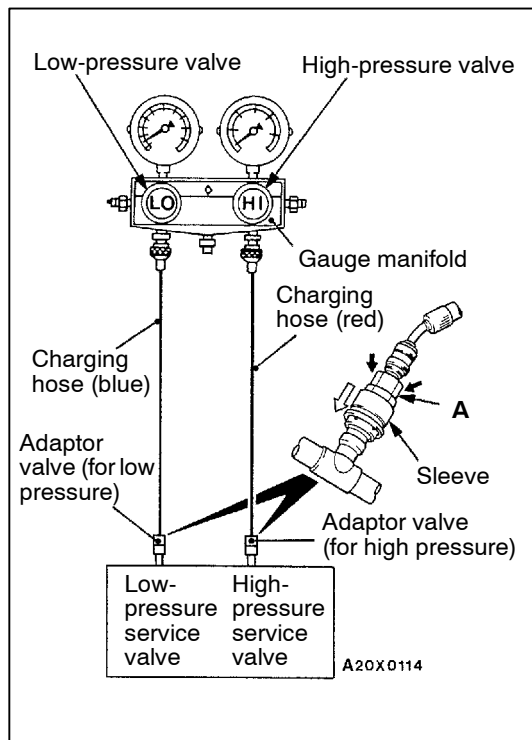

PERFORMANCE TEST

55200140240

1. The vehicles to be tested should be in a place that is not in direct sunlight.
2. Close the high and low-pressure valve of the gauge manifold.
3. Connect the charging hose (blue) to the low-pressure valve and connect the charging hose (red) to the high-pressure valve of the gauge manifold.
4. Install the quick joint (for low-pressure) to the charging hose (blue), and connect the quick joint (for high-pressure) to the charging hose (red).
5. Connect the quick joint (for low-pressure) to the low-pressure service valve and connect the quick joint (for high-pressure) to the high-pressure service valve.

NOTE

The high-pressure service valve is on discharge hose and the low-pressure service valve is on the suction hose.

Caution

To connect the quick joint, press section "A" firmly against the service valve until a click is heard. When connecting, run your hand along the hose while pressing to ensure that there are no bends in the hose.

6. Start the engine.
7. Set the controls to the A/C as follows:
A/C switch: A/C - ON position
Mode selection: Face position
Temperature control: Max. cooling position
Air selection: Recirculation position
Blower switch: HI (Fast) position
8. Adjust engine speed to 1,000 r/min with A/C clutch engaged.
9. Engine should be warmed up with doors and windows closed.
10. Insert a thermometer in the center air outlet and operate the engine for 20 minutes.
11. Note the discharge air temperature.

NOTE

If the clutch cycles, take the reading before the clutch disengages.

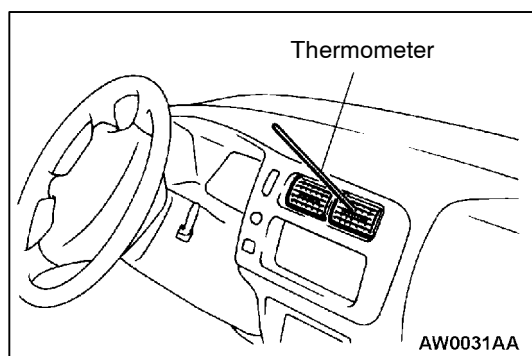

Performance Temperature Chart

Garage ambient temperature °C	20	25	35	40
Discharge air temperature °C	4.5 – 6.5	5.0 – 7.0	7.2 – 9.2	8.5 – 10.5
Compressor high pressure kPa	830 – 1,130	1,000 – 1,300	1,200 – 1,500	1,550 – 1,850
Compressor low pressure kPa	95 – 195	105 – 205	125 – 225	145 – 245

REFRIGERANT LEAK REPAIR

55200150120

LOST CHARGE

If the system has lost all charge due to a leak:

1. Evacuate the system. (See procedure.)
2. Charge the system with approximately one pound of refrigerant.
3. Check for leaks.
4. Discharge the system.
5. Repair leaks.
6. Replace receiver drier.

Caution

Replacement filter-drier units must be sealed while in storage. The drier used in these units will saturate water quickly upon exposure to the atmosphere. When installing a drier, have all tools and supplies ready for quick reassembly to avoid keeping the system open any longer than necessary.

7. Evacuate and charge system.

LOW CHARGE

If the system has not lost all of its refrigerant charge; locate and repair all leaks. If it is necessary to increase the system pressure to find the leak (because of an especially low charge) add refrigerant. If it is possible to repair the leak without discharging the refrigerant system, use the procedure for correcting low refrigerant level.

HANDLING TUBING AND FITTINGS

Kinks in the refrigerant tubing or sharp bends in the refrigerant hose lines will greatly reduce the capacity of the entire system. High pressures are produced in the system when it is operating. Extreme care must be exercised to make sure that all connections are pressure tight. Dirt and moisture can enter the system when it is opened for repair or replacement of lines or components. The following precautions must be observed. The system must be completely discharged before opening any fitting or connection in the refrigeration system. Open fittings with caution even after the system has been discharged. If any pressure is noticed as a fitting is loosened, allow trapped pressure to bleed off very slowly.

Never attempt to rebend formed lines to fit. Use the correct line for the installation you are servicing. A good rule for the flexible hose lines is keep the radius of all bends at least 10 times the diameter of the hose.

Sharper bends will reduce the flow of refrigerant. The flexible hose lines should be routed so that they are at least 80 mm from the exhaust manifold. It is good practice to inspect all flexible hose lines at least once a year to make sure they are in good condition and properly routed.

Unified plumbing connections with O-rings, these O-rings are not reusable.

COMPRESSOR NOISE

55200870156

You must first know the conditions when the noise occurs. These conditions are: weather, vehicle speed, in gear or neutral, engine temperature or any other special conditions.

Noises that develop during A/C operation can often be misleading. For example: what sounds like a failed front bearing or connecting rod, may be caused by loose bolts, nuts, mounting brackets, or a loose clutch assembly. Verify accessory drive belt tension (power steering or alternator).

Improper accessory drive belt tension can cause a misleading noise when the compressor is engaged and little or no noise when the compressor is disengaged.

Drive belts are speed-sensitive. That is, at different engine speeds, and depending upon belt tension, belts can develop unusual noises that are often mistaken for mechanical problems within the compressor.

ADJUSTMENT

1. Select a quiet area for testing. Duplicate conditions as much as possible. Switch compressor on and off several times to clearly identify compressor noise. To duplicate high ambient conditions (high head pressure), restrict air flow through condenser. Install manifold gauge set to make sure discharge pressure doesn't exceed 2,070 kPa.
2. Tighten all compressor mounting bolts, clutch mounting bolt, and compressor drive belt. Check to assure clutch coil is tight (no rotation or wobble).
3. Check refrigerant hoses for rubbing or interference that can cause unusual noises.
4. Check refrigerant charge. (See "Charging System".)
5. Recheck compressor noise as in Step 1.
6. If noise still exists, loosen compressor mounting bolts and retorque. Repeat Step 1.
7. If noise continues, replace compressor and repeat Step 1.

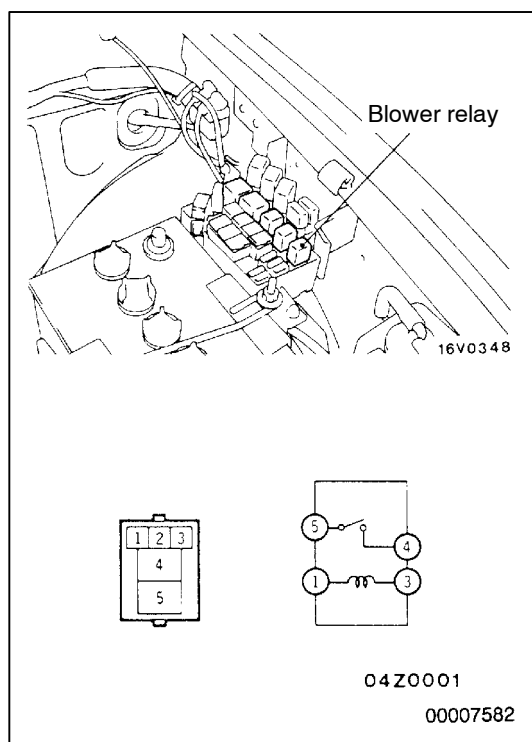

POWER RELAY CONTINUITY CHECK BLOWER RELAY

55200880289

Battery voltage	Terminal No.			
	1	3	4	5
Power is not supplied	○	○		
Power is supplied	⊕	⊖	○	○

REAR HEATER RELAY

Battery voltage	Terminal No.			
	1	2	3	4
Power is not supplied		○	—	○
Power is supplied	○	⊖	○	⊕

Rear heater relay

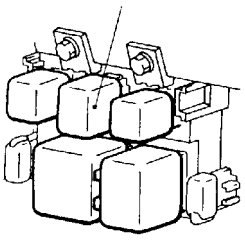

T0092AA

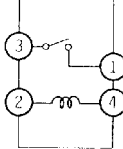
20Z0001

00009186

**A/C COMPRESSOR RELAY, CONDENSER FAN RELAY,
CONDENSER FAN CONTROL RELAY**

Battery voltage	Terminal No.			
	1	2	3	4
Power is not supplied		○	—	○
Power is supplied	○	⊖	○	⊕

Condenser fan control relay

Condenser fan relay

A/C compressor relay

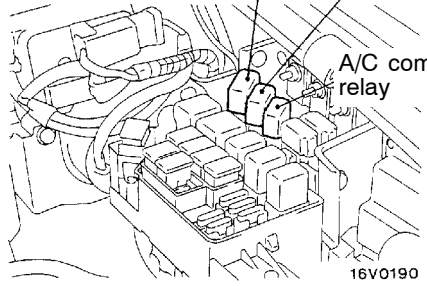

16V0190

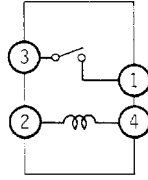
20Z0001

00005069

IDLE-UP OPERATION CHECK

55200160321

<6G7>

1. Before inspection and adjustment, set vehicle in the following condition:
 - Engine coolant temperature: 80 – 90°C
 - Lights, electric cooling fan and accessories: Set to OFF
 - Transmission: Neutral
 - Steering wheel: Straight forward
2. Check whether or not the idling speed is the standard value.

Standard value: 700 ± 100 r/min

NOTE

There is no necessity to make an adjustment, because the idling speed is automatically adjusted by the ISC system. If, however, there occurs a deviation from the standard value for some reason, check the ISC system. (Refer to GROUP 13A – On-vehicle Service.)

3. When the A/C is running after turning the A/C switch to ON, and the blower switch to the MH or HI position, check to be sure that the idle speed is at the standard value.

Standard value:

When low load on air conditioner (Outside air temperature sensor: ON): 750 ± 100 r/min

When high load on air conditioner (Outside air temperature sensor: OFF): 900 ± 100 r/min

NOTE

Whether a low load or a high load is applied to the air conditioner is determined by the outside air temperature signal that is sent to the engine-ECU from the automatic compressor-ECU.

<4D5>

1. Before inspection and adjustment, set vehicle in the following condition:
 - Engine coolant temperature: 80 – 90 °C
 - Lamps, electric cooling fan and accessories: Set to OFF
 - Transmission: Neutral
 - Steering wheel: Straight forward
2. Check whether or not the idling speed is the standard value.

Standard value: 750 ± 50 r/min

3. If there is a deviation of the idling speed from the standard value, adjust the idling speed. (Refer to GROUP 11B – On-vehicle Service.)
4. Check to be sure that the idling speed becomes the standard value when the A/C switch is switched ON and the A/C is activated.

Standard value: 950 ± 50 r/min

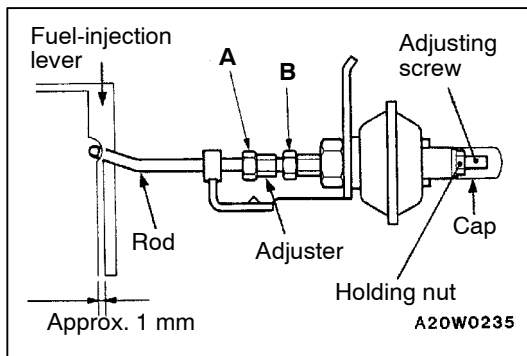

5. If there is a deviation of the idling speed from the standard value, adjust the idling speed by the following the procedures.
 - (1) Loosen nuts (A) and (B).
 - (2) Adjust, by using the adjuster, so that the end of the vacuum actuator's rod is at the position indicated in the illustration.
 - (3) Securely tighten nuts (A) and (B).
 - (4) After activating the vacuum actuator, check to be sure that the rod and the lever do not contact when the activation is cancelled.
 - (5) Remove the cap and loosen the nut for holding.
 - (6) Adjust to the specified r/min by turning the adjusting screw.
 - (7) Securely tighten the holding nut, and then attach the cap.

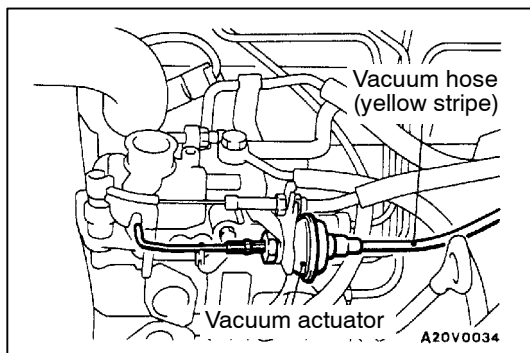

VACUUM ACTUATOR CHECK <4D5>

55200890060

1. Pull off the vacuum hose (yellow stripe) connected to the vacuum actuator.
2. Connect a manual vacuum pump to the nipple of the vacuum actuator.
3. Check to be sure that the vacuum actuator rod starts to contact when 8 kPa of negative pressure is applied, and that the rod contracts to its full stroke when 12 kPa of negative pressure is applied.
4. Disconnect the manual vacuum pump from the vacuum actuator, and connect the vacuum hose (yellow stripe) to the vacuum actuator.
5. Start the engine and let it run at idle. Then cover the end of the vacuum hose (yellow stripe) with a finger and check the negative pressure when the A/C switch is turned on and off.

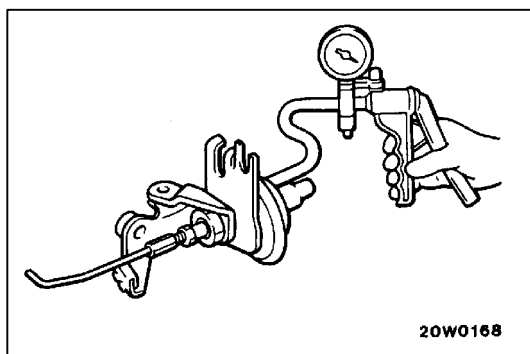

A/C switch	Negative pressure at hose end
OFF	No
ON	Yes

Caution

Be careful, when connecting the vacuum hose not to damage it.

IDLE-UP SOLENOID VALVE CHECK <4D5>

55201120038

1. Disconnect the vacuum hoses (white stripes, yellow stripes) from the solenoid valve.
2. Disconnect the harness connector.

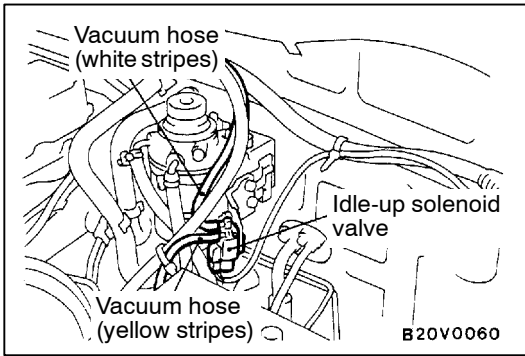

3. Connect a manual vacuum pump to the nipple A.

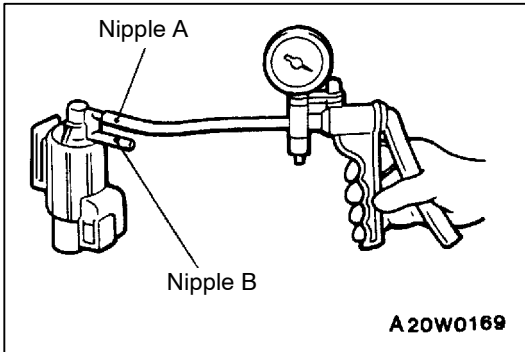

4. Check air-tightness by applying a vacuum with voltage applied directly from the battery to the solenoid valve terminal and without applying voltage.

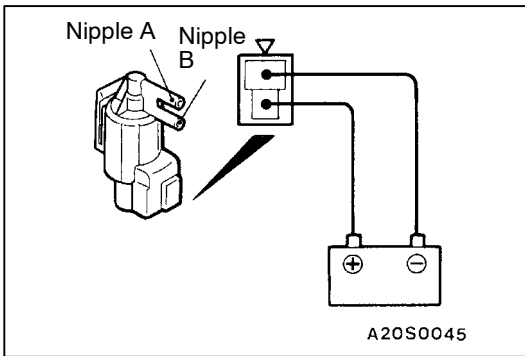

Battery voltage	Nipple B	Vacuum condition
Applied	Open	Vacuum leaks from nipple B
	Blocked with finger *1	Vacuum is maintained
Not applied	Open	Vacuum is maintained
	Blocked with finger *2	

NOTE

In case of mark *1, a vacuum can be felt but in case of mark *2, a vacuum can not be felt.

5. Measure the resistance of the solenoid valve.

Standard value: Approx. 40 Ω

6. When disconnecting the vacuum hose, always make a mark so that the hose can be reconnected at original position.

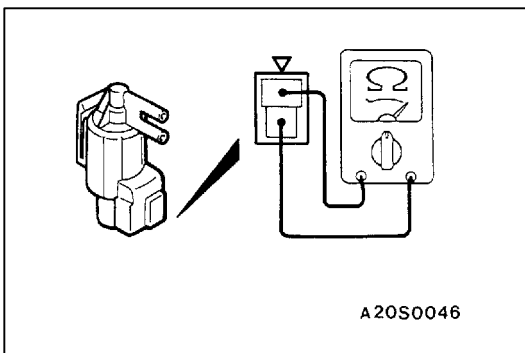

HEATER CONTROL ASSEMBLY AND A/C SWITCH

55200240131

REMOVAL AND INSTALLATION

Pre-removal and Post-installation Operation

- Foot Duct Removal and Installation (Refer to P.55-47.)
- Driver Side Under Cover or Knee Protector, Meter Bezel Assembly, Glove Box Assembly, Center Under Cover Removal and Installation (Refer to GROUP 52A – Instrument Panel.)

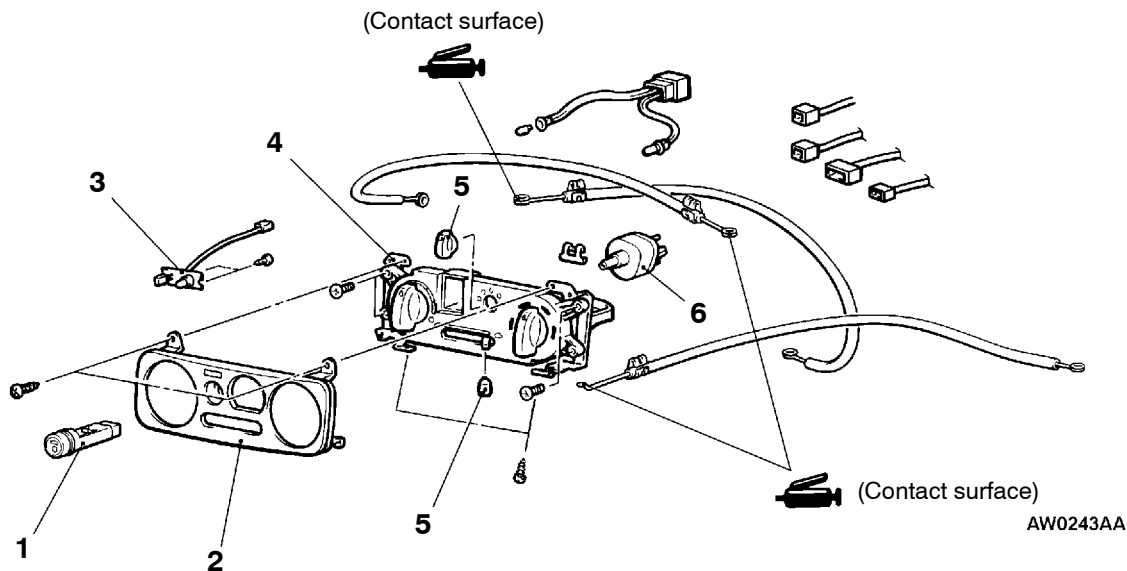

Removal steps

1. A/C switch
2. Heater control bezel
3. Rear heater indicator
<Vehicles with rear heater>

- ▶◀ 4. Heater control assembly
5. Knob
 6. Blower switch

INSTALLATION SERVICE POINT

▶A◀ HEATER CONTROL ASSEMBLY INSTALLATION

1. Follow the steps below to install the air outlet changeover damper link cable.
 - (1) Set the air outlet changeover control knob on the heater control assembly to the defroster position.
 - (2) Set the air outlet changeover damper link of the heater unit to the defroster position as shown in the illustration, and then connect the cable to the link pin.
 - (3) Push the outer cable in the direction of the arrow so that there is no looseness, and then secure it with clip.

2. Follow the steps below to instal the air mix damper lever cable.
 - (1) Set the temperature control knob on the heater control assembly to the max. hot position.
 - (2) Set the air mix damper lever of the heater unit to the max. hot position as shown in the illustration, and then connect the cable to the lever pin.
 - (3) Push the outer cable in the direction of the arrow so that there is no looseness, and then secure it with clip.

3. Follow the steps below to install the inside/outside air changeover damper link cable.
 - (1) Set the inside/outside air changeover control knob on the heater control assembly to the inside recirculation position.
 - (2) Set the inside/outside air changeover damper link of the blower assembly to the inside recirculation position as shown in the illustration, and then connect the cable to the link pin.
 - (3) Push the outer cable in the direction of the arrow so that there is no looseness, and then secure it with clip.

4. After installation, ensure that each damper operates smoothly by operating the heater control assembly knob.

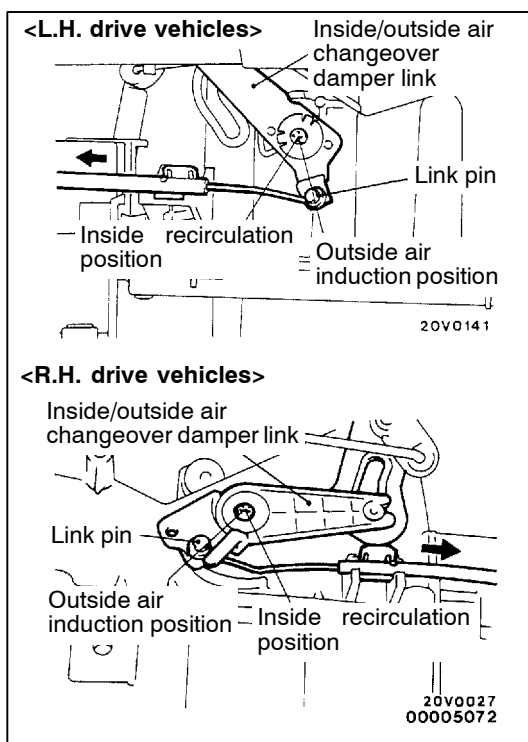
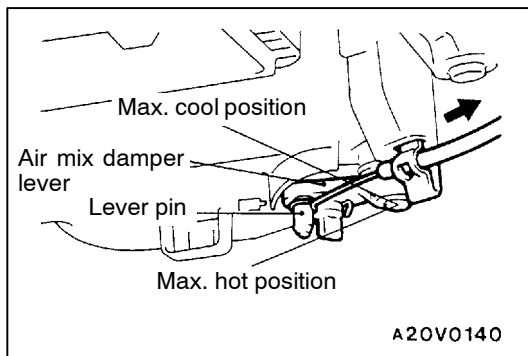
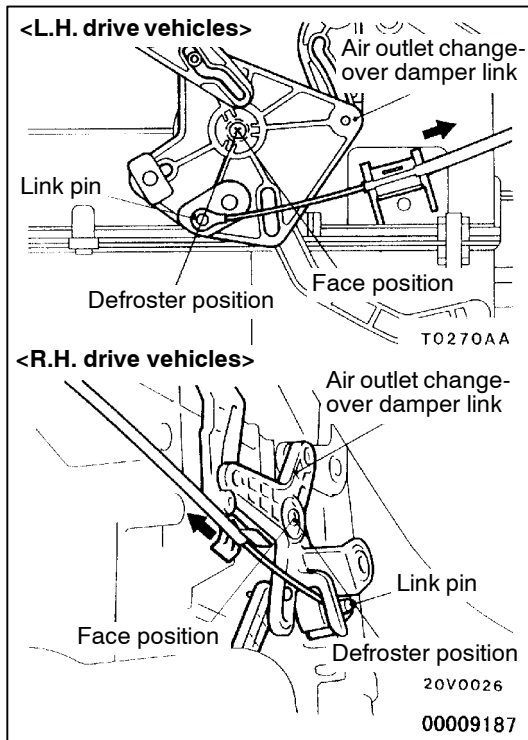

55200220074

INSPECTION

A/C SWITCH CONTINUITY CHECK

Switch position	Terminal No.						
	1	4	IND	5	3	ILL	6
OFF		○	⊞	○	○	⊞	○
ON	○	○	⊞	○	○	⊞	○

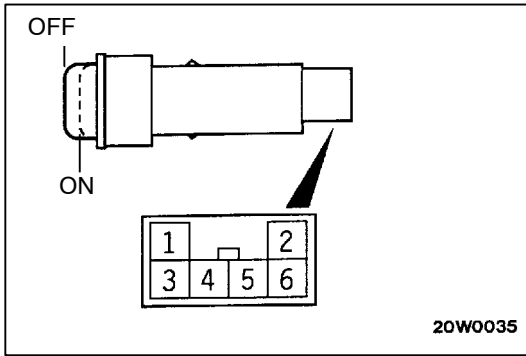

BLOWER SWITCH CONTINUITY CHECK

55200900091

Switch position	Terminal No.							
	1	2	3	5	6	7	8	
OFF								
LO	○		○	○			○	
ML	○			○	○		○	
MH	○	○		○			○	
HI	○			○		○	○	

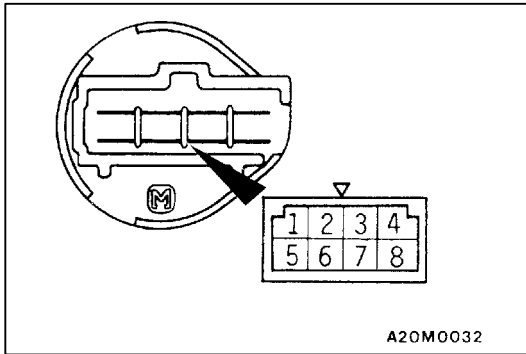

HEATER UNIT AND HEATER CORE

REMOVAL AND INSTALLATION

Caution: SRS

When removing and installing the heater unit from vehicles equipped with SRS, do not let it bump against the SRS-ECU or the components.

Pre-removal and Post-installation Operation

- Refrigerant Discharging and Charging <Vehicles with A/C> (Refer to P. 55-10, 14.)
- Engine Coolant Draining and Refilling (Refer to GROUP 14 - On-vehicle Service.)
- Instrument Panel Removal and Installation (Refer to GROUP 52A.)
- Joint Duct Removal and Installation <Vehicles without A/C> (Refer to P.55-28.)

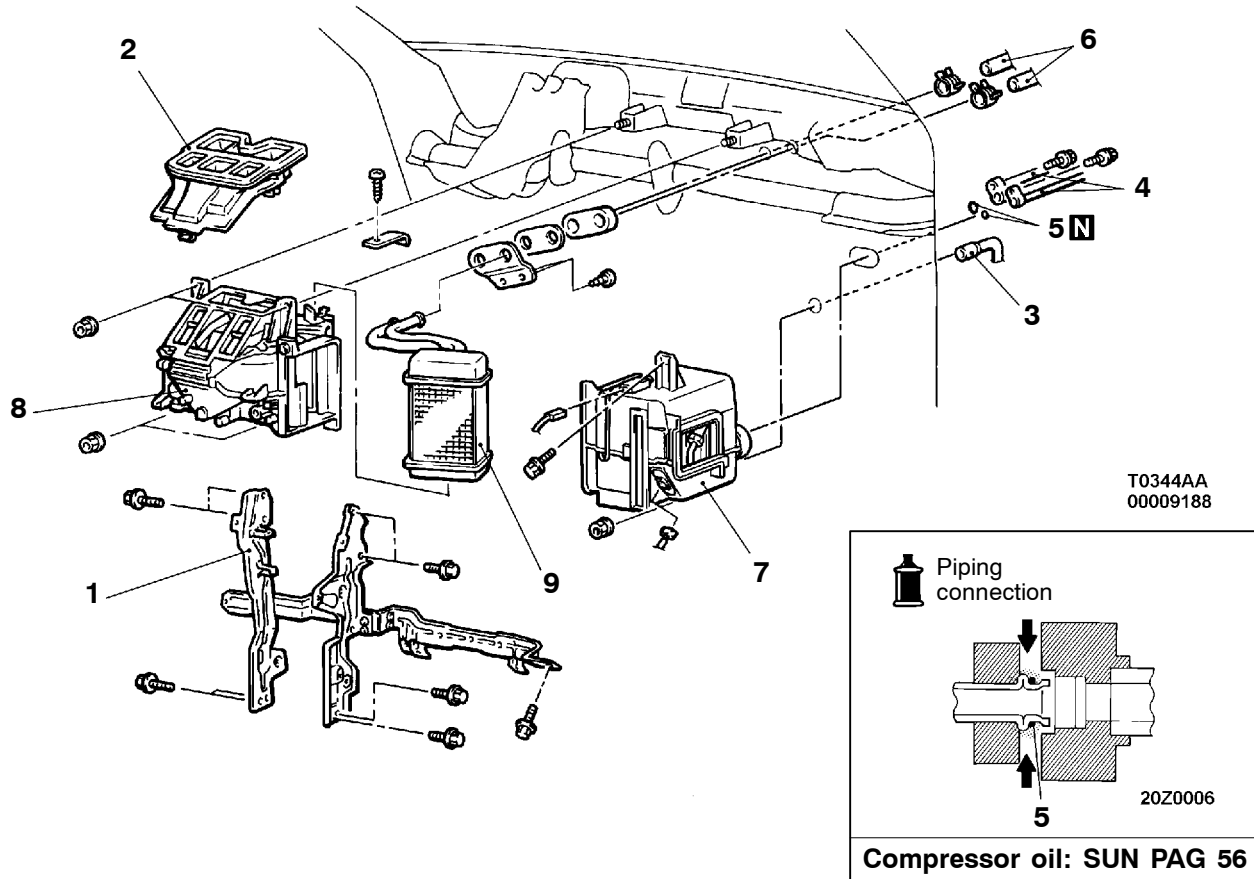

Removal steps

1. Center reinforcement
2. Center ventilation duct
3. Drain hose <Vehicles with A/C>
4. Suction pipe or hose and liquid pipe connection <Vehicles with A/C>

5. O-ring
6. Heater hose connection
7. Evaporator <Vehicles with A/C>
8. Heater unit
9. Heater core



REMOVAL SERVICE POINT

◀A▶ SUCTION PIPE OR HOSE, LIQUID PIPE DISCONNECTION

Plug the disconnected hose and the evaporator nipple not to let foreign matter get into them.

Caution

Seal the hoses completely, otherwise the compressor oil and receiver will absorb water vapour easily.

INSTALLATION SERVICE POINT

▶A◀ EVAPORATOR INSTALLATION

When replacing the evaporator, refill with a specified amount of compressor oil and install it (to the vehicle).

Compressor oil: SUN PAG 56

Quantity: 70 mL

BLOWER ASSEMBLY AND RESISTOR

55100280314

REMOVAL AND INSTALLATION

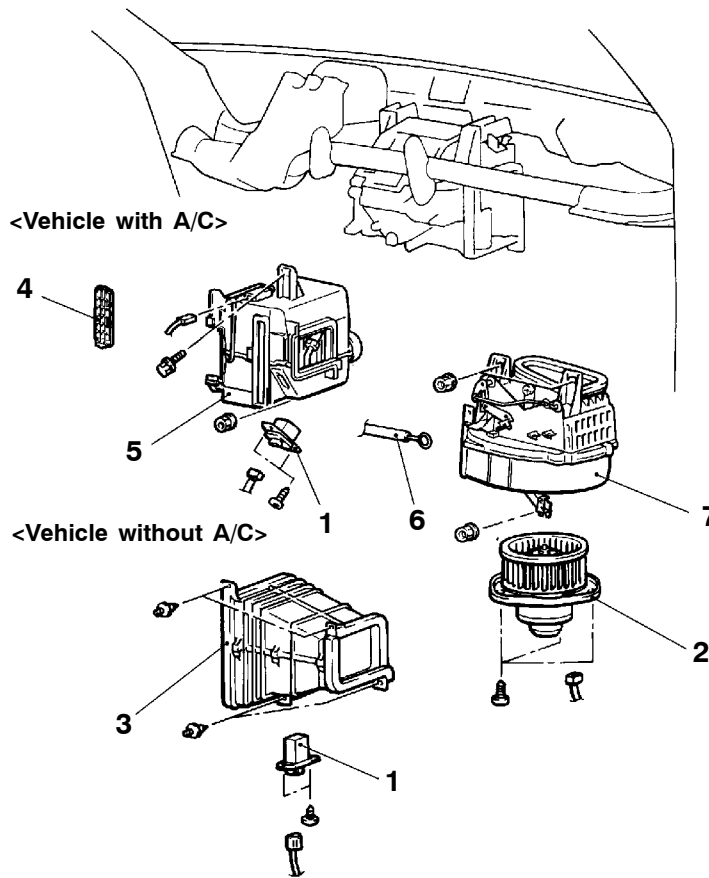

BV0113AA

Resistor, blower fan and motor removal steps

- Under cover and glove box assembly (Refer to GROUP 52A – Instrument Panel.)
- 1. Resistor
- 2. Blower fan and motor

Blower case removal steps

- Instrument panel (Refer to GROUP 52A.)
- Glove box frame or center frame B (Refer to GROUP 52A – Instrument Panel.)
- 3. Joint duct <Vehicles without A/C>
- 4. Cover <L.H. drive vehicles, Vehicles with A/C>
- 5. Evaporator <Vehicles with A/C> (Refer to P.55-30.)
- ▶A◀ 6. Inside/outside air changeover damper cable connection
- 7. Blower case assembly

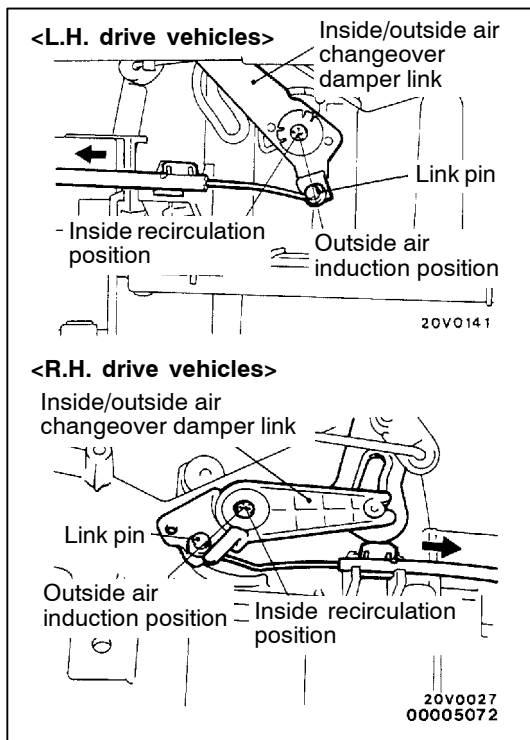

INSTALLATION SERVICE POINT

▶A◀ INSIDE/OUTSIDE AIR CHANGEOVER DAMPER CABLE INSTALLATION

1. Set the inside/outside air changeover control knob on the heater control assembly to the inside recirculation position.
2. Set the inside/outside air changeover damper link of the blower assembly to the inside recirculation position as shown in the illustration, and then connect the cable to the link pin.
3. Push the outer cable in the direction of the arrow so that there is no looseness, and then secure it with clip.

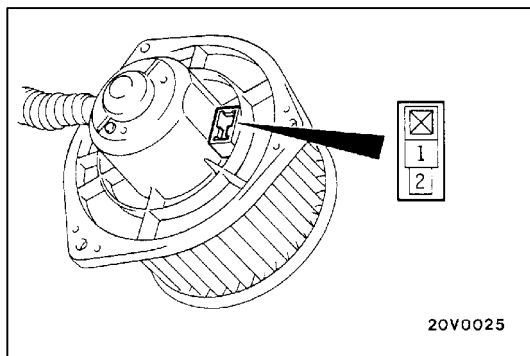

INSPECTION

55100290119

BLOWER FAN AND MOTOR CHECK

When battery voltage is applied between the terminals, check that the motor operates. Also, check that there is no abnormal noise.

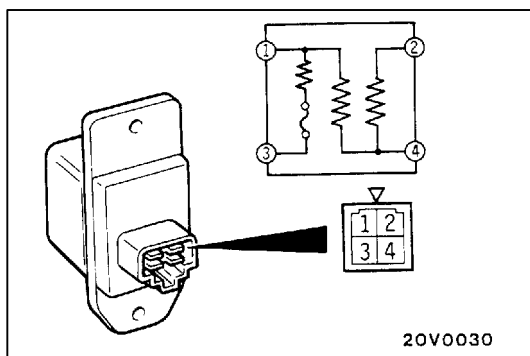

RESISTOR CHECK

Use a circuit tester to measure the resistance between the terminals as indicated below. Check that the measured value is at the standard value.

Standard value:

<L.H. drive vehicles>

Measurement terminal	Standard value Ω
Between terminals 3 and 2 (LO)	2.00
Between terminals 3 and 4 (ML)	1.10
Between terminals 3 and 1 (MH)	0.68

<R.H. drive vehicles>

Measurement terminal	Standard value Ω
Between terminals 3 and 2 (LO)	2.48
Between terminals 3 and 4 (ML)	1.17
Between terminals 3 and 1 (MH)	0.28

EVAPORATOR <VEHICLES WITH A/C>

55200360271

REMOVAL AND INSTALLATION

Pre-removal and Post-installation Operation

- Refrigerant Discharging and Charging (Refer to P. 55-10, 14.)
- Under Cover, Glove Box Assembly Removal and Installation (Refer to GROUP 52A – Instrument Panel.)

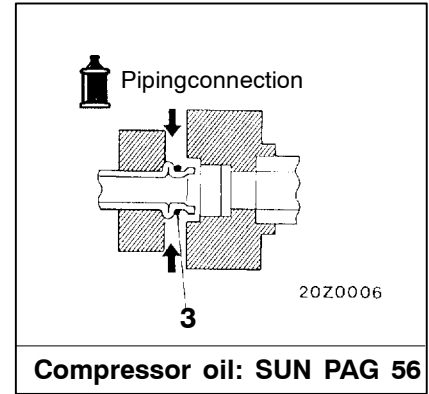
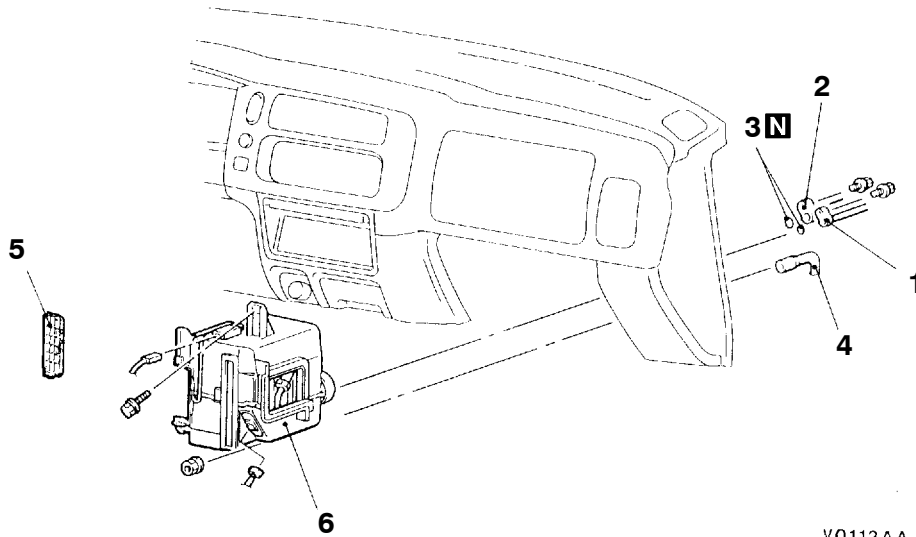

00009189

Removal steps



1. Suction pipe or hose connection
2. Liquid pipe connection
3. O-ring
4. Drain hose

- Glove box frame or center frame B (Refer to GROUP 52A – Instrument Panel.)
- 5. Cover <L.H. drive vehicles>
- 6. Evaporator



REMOVAL SERVICE POINT

◀A▶ SUCTION PIPE OR HOSE, LIQUID PIPE DISCONNECTION

Plug the disconnected hose and the evaporator nipple not to let foreign matter get into them.

Caution

Seal the hoses completely, otherwise the compressor oil and receiver will absorb water vapour easily.

INSTALLATION SERVICE POINT

►A◄ EVAPORATOR INSTALLATION

When replacing the evaporator, refill it with a specified amount of compressor oil and install it (to the vehicle).

Compressor oil: SUN PAG 56

Quantity: 70 mL

DISASSEMBLY AND REASSEMBLY

55200380215

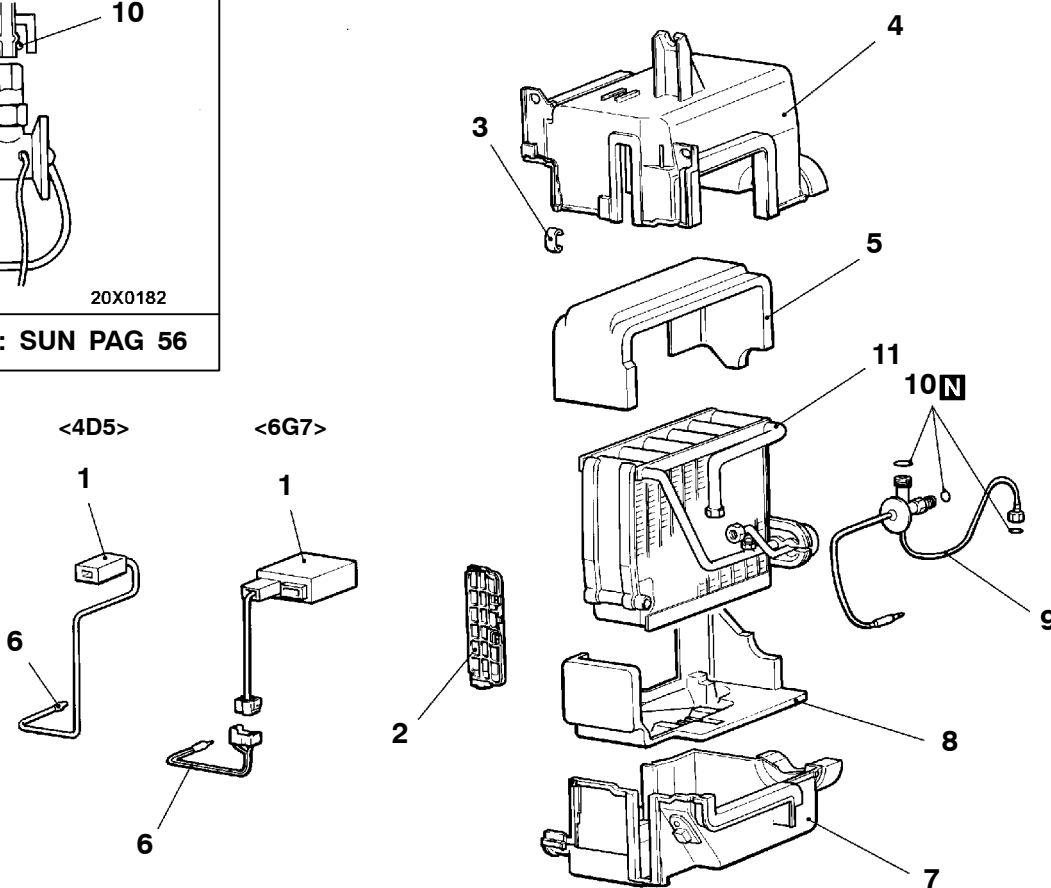
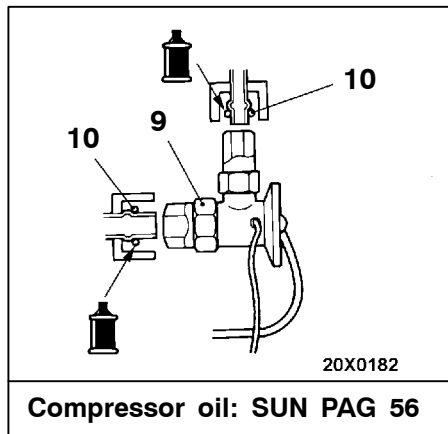

W0244AA
00009190

Disassembly steps

- | | |
|---|---|
| <ol style="list-style-type: none"> 1. Automatic compressor controller 2. Cover <L.H. drive vehicles> 3. Clip 4. Evaporator cover (upper) 5. Lining, upper 6. Thermostat | <ol style="list-style-type: none"> 7. Evaporator cover (lower) 8. Lining, lower 9. Expansion valve 10. O-ring 11. Evaporator |
|---|---|

REAR HEATHER UNIT

55100470025

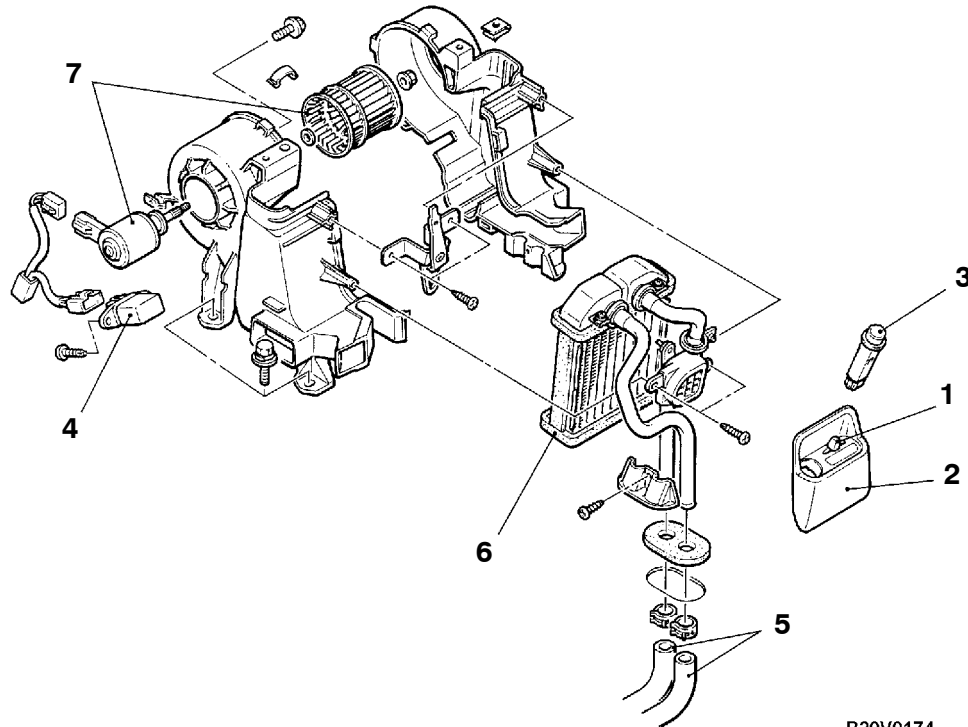
REMOVAL AND INSTALLATION

B20V0174

Rear heater unit switch removal steps

1. Knob
2. Rear heater control panel assembly
3. Rear heater switch

Fan motor assembly removal steps

- Rear floor console (Refer to GROUP 52A - Floor Console.)

4. Resistor

- Draining and supplying of coolant (Refer to GROUP 14 - On-vehicle Service.)
5. Rear heater hose connection
 6. Rear heater core assembly
 7. Rear blower motor assembly

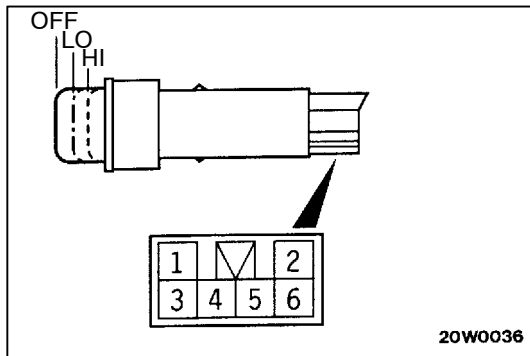

INSPECTION

55100480028

REAR HEATER SWITCH CONTINUITY CHECK

Level position	Terminal No.							
	1	2	4	IND	5	3	ILL	6
OFF						○	⊕	○
LO		○	○	yellow ▶	○	○	⊕	○
HI	○	○	○	orange ▶	○	○	⊕	○

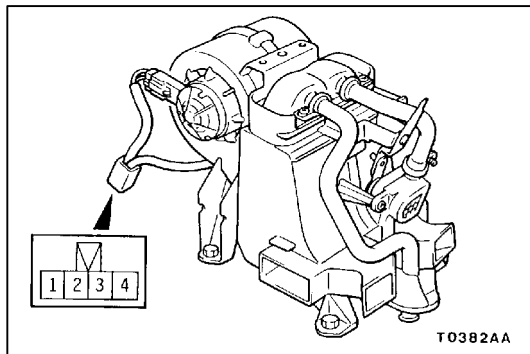

REAR BLOWER MOTOR INSPECTION

Check that the motor rotates when the battery voltage is applied between the terminals. Make sure that there is no abnormal noise from the motor at this time.

Battery connection terminal				Motor operation (HI)
1	2	3	4	
⊕		⊖		Rotates (HI)
⊕			⊖	Rotates (LO)

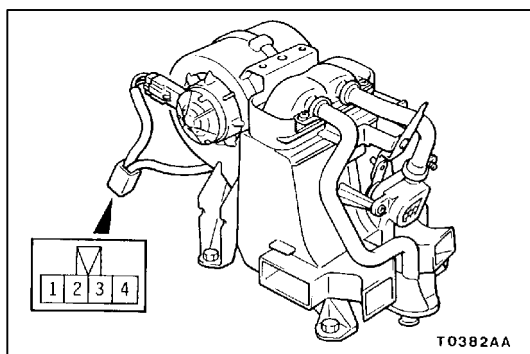

RESISTOR CHECK

Use an ohmmeter to check the resistance between terminals number 3 and number 4. Check that the measured value is at the standard value.

Standard value: 3.9 Ω

COMPRESSOR AND TENSION PULLEY

55200410440

REMOVAL AND INSTALLATION

Caution: SRS

When removing and installing the compressor from vehicles equipped with SRS, do not let it bump against the front impact sensor (L.H.).

Pre-removal Operation

- Refrigerant Discharging (Refer to P. 55-14.)
- Battery Removal

Post-installation Operation

- Drive Belt Tension Adjustment (Refer to GROUP 11 - On-vehicle Service.)
- Battery Installation
- Refrigerant Charging (Refer to P. 55-10.)

<6G7>

<4D5>

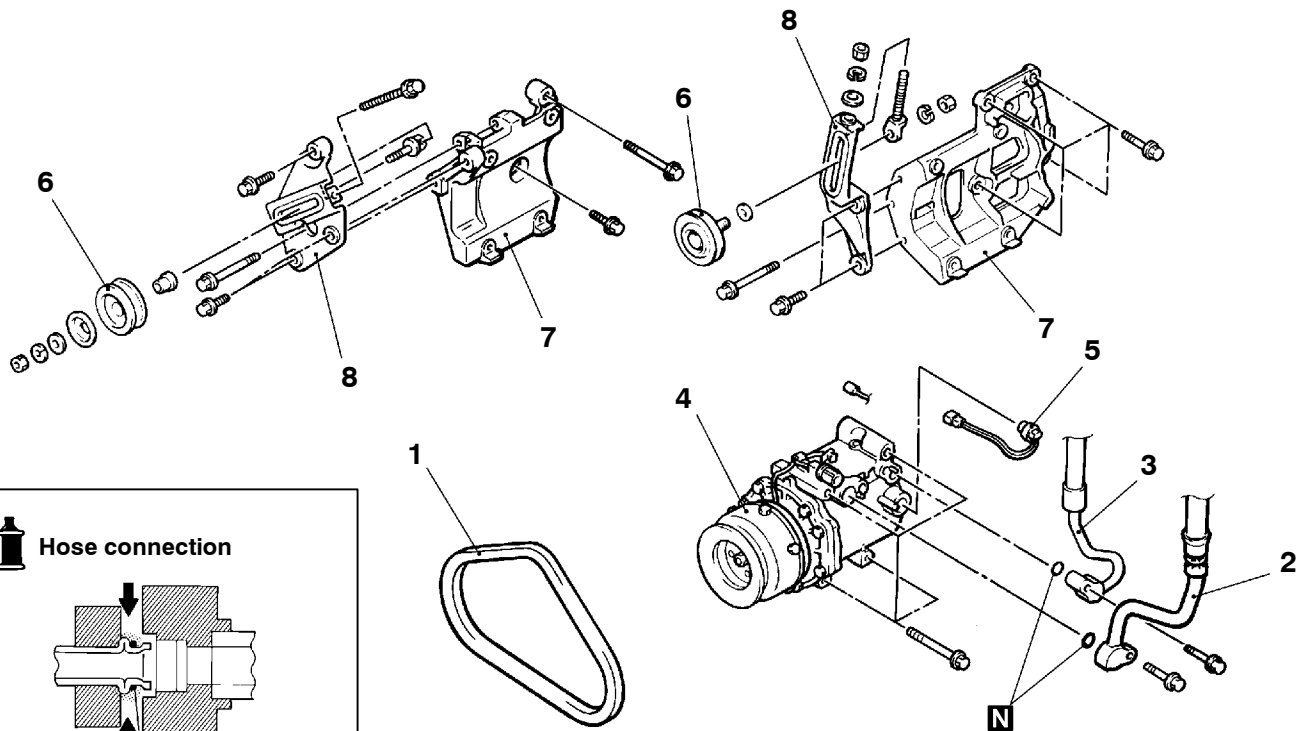

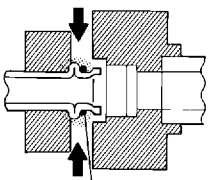

Hose connection

O-ring 20Z0006

Compressor oil: SUN PAG 56

W0245AA
00009191

Removal steps

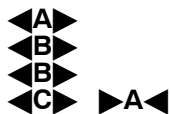

1. Drive belt
2. Suction hose connection
3. Discharge hose connection
4. Compressor

5. Refrigerant-temperature switch
6. Tension pulley
7. Compressor bracket
8. Tension pulley bracket assembly

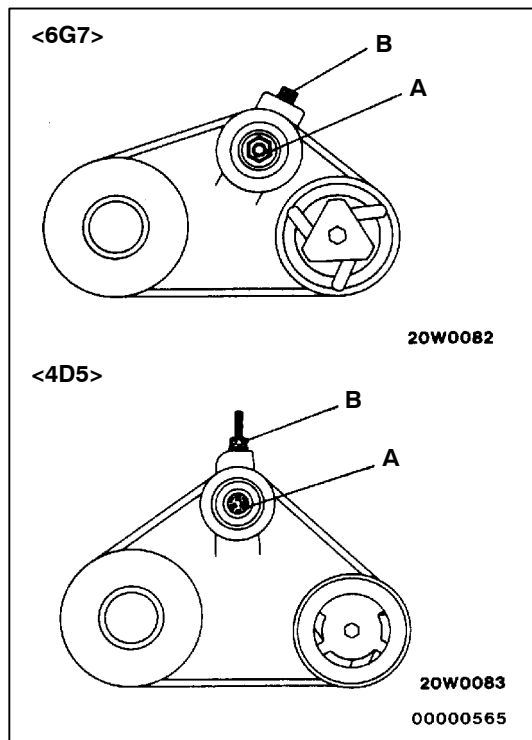

REMOVAL SERVICE POINTS

◀A▶ DRIVE BELT REMOVAL

1. Loosen the nut "A" for holding.
2. Loosen the bolt "B" for adjustment.
3. Remove the drive belt.

◀B▶ SUCTION HOSE, DISCHARGE HOSE DISCONNECTION

Plug the disconnected hose and the compressor nipple not to let foreign matter get into them.

Caution

Seal the hoses completely, otherwise the compressor oil and receiver will absorb water vapour easily.

◀C▶ COMPRESSOR REMOVAL

When doing this work, be careful not to spill the compressor oil.

INSTALLATION SERVICE POINT

▶A◀ COMPRESSOR INSTALLATION

If a new compressor is installed, first adjust the amount of oil according to the procedures described below, and then install the compressor.

1. Measure the amount (X mL) of oil within the removed compressor.
2. Drain (from the new compressor) the amount of oil calculated according to the following formula, and then install the new compressor.

New compressor oil amount

$$170 \text{ mL} - X \text{ mL} = Y \text{ mL}$$

NOTE

- (1) Y mL indicates the amount of oil in the refrigerant line, the condenser, the evaporator etc.
- (2) When replacing the following parts at the same times as the compressor, subtract the rated oil amount of the each part from Y mL and discharge from the new compressor.

Quantity

Evaporator: 70 mL

Condenser: 20 mL

Suction hose: 10 mL

Receiver: 10 mL

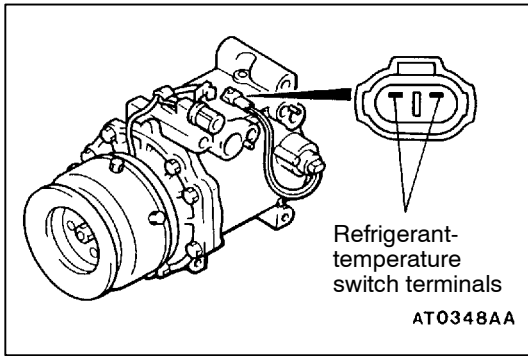

INSPECTION

55200930137

REFRIGERANT-TEMPERATURE SWITCH SIMPLE CHECK

When the A/C is off, check that there is continuity between the refrigerant-temperature switch terminals. If no, replace the compressor assembly.

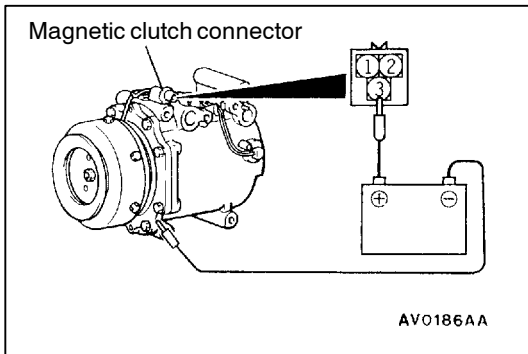

COMPRESSOR MAGNETIC CLUTCH OPERATION INSPECTION

55200850297

Connect the battery (+) terminal to the compressor magnetic clutch connector terminal 3, and ground the battery (-) terminal to the body of the compressor. The condition is normal if the sound of the magnetic clutch (click) can be heard.

**MAGNETIC CLUTCH
DISASSEMBLY AND REASSEMBLY**

55200460339

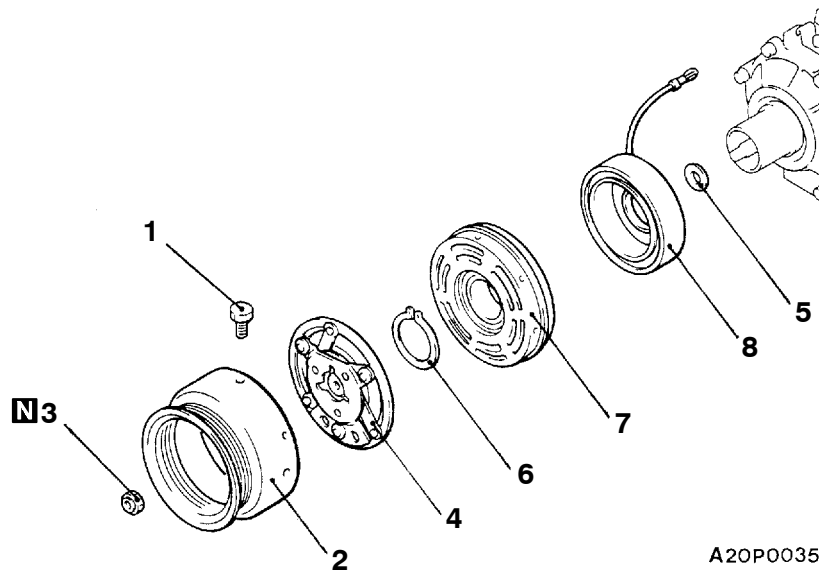

A20P0035

Disassembly steps

- 1. Bolt
- 2. Pulley
- Air gap adjustment
- 3. Nut
- 4. Armature plate



- 5. Shims
- 6. Snap ring
- 7. Rotor
- 8. Clutch coil

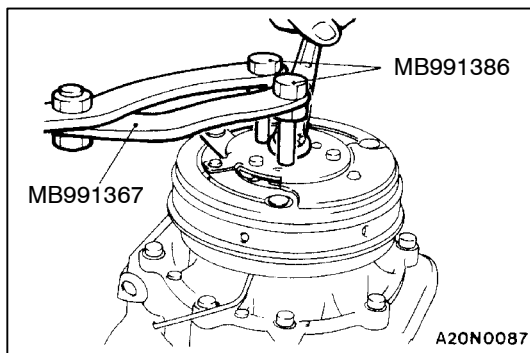

DISASSEMBLY SERVICE POINT

◀A▶ NUT REMOVAL

Use special tools to hold the magnetic clutch, and remove the nut.

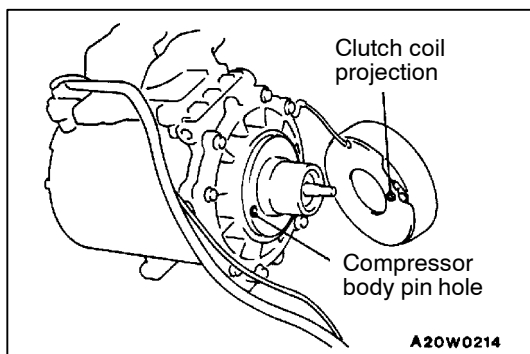

REASSEMBLY SERVICE POINTS

▶A◀ CLUTCH COIL INSTALLATION

When installing the clutch coil to the A/C compressor body, install so that the pin hole of the A/C compressor body and the clutch coil projection are aligned.

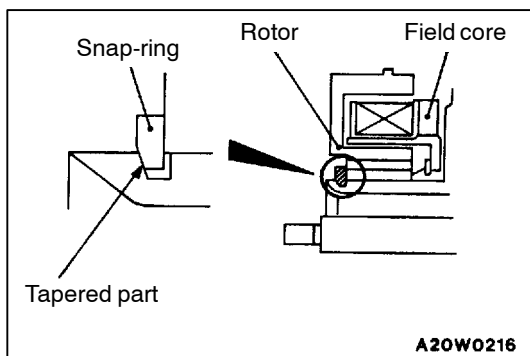

▶B◀ SNAP RING INSTALLATION

Install the snap ring so that the tapered surface is to the outside.

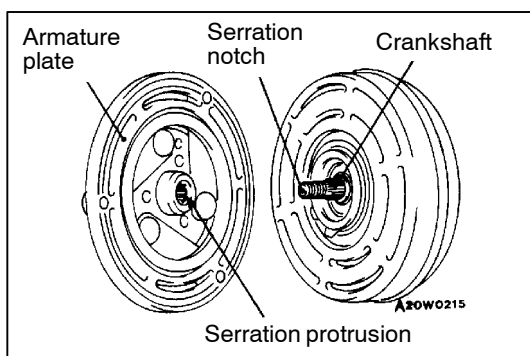

▶C◀ ARMATURE PLATE INSTALLATION

Align the serration protrusion on the crankshaft with the notch on the armature and install.

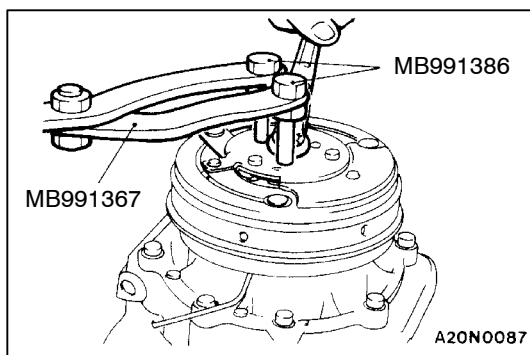

▶D◀ NUT INSTALLATION

Use special tools to hold the magnetic clutch, and tighten the nut in the same manner as for removal.

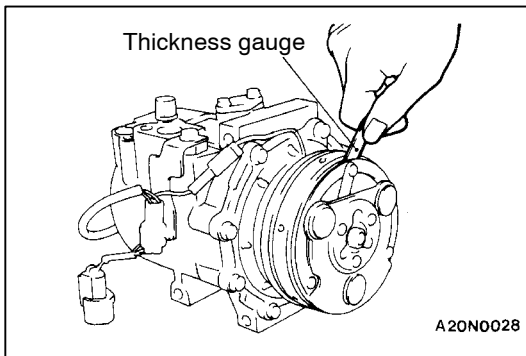
**►E◄ AIR GAP ADJUSTMENT**

Check whether or not the air gap of the clutch is within the standard value.

Standard value: 0.3 – 0.5 mm

NOTE

If there is a deviation of the air gap from the standard value, make the necessary adjustment by adjusting the number of shims.

CONDENSER AND CONDENSER FAN MOTOR

55200670350

REMOVAL AND INSTALLATION

Pre-removal and Post-installation Operation

- Radiator Grille Removal and Installation (Refer to GROUP 51 – Grille, Moulding and Garnish.)
- Front Bumper Removal and Installation (Refer to GROUP 51 – Front Bumper.)
- Hood Latch Removal and Installation (Refer to GROUP 42 – Hood.)
- Engine Oil Cooler Removal and Installation <4D5> (Refer to GROUP 12.)

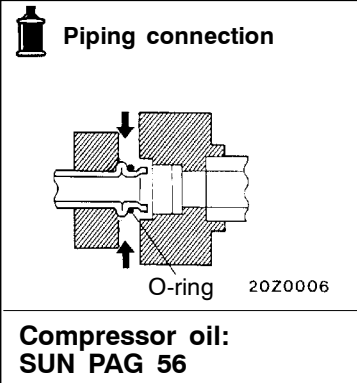
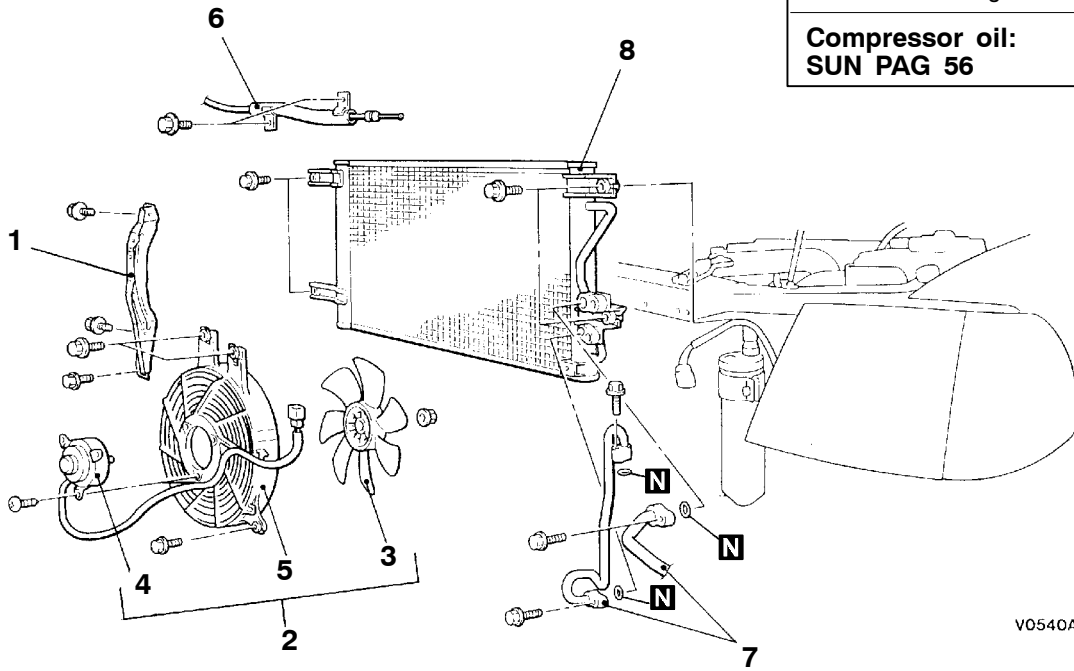

Condenser fan motor removal steps

1. Hood lock stay
2. Condenser fan motor and shroud assembly
3. Condenser fan
4. Condenser fan motor
5. Shroud

Condenser removal steps

- Refrigerant Discharging and Charging (Refer to P.55-10.)
- 1. Hood lock stay
- 2. Condenser fan motor and shroud assembly
- 6. Cable protector
- 7. Discharge hose, liquid pipe A and condenser connection
- 8. Condenser



REMOVAL SERVICE POINTS**◀A▶ LIQUID PIPE A/DISCHARGE HOSE
DISCONNECTION**

Plug the disconnected pipe, hose and the condenser nipple not to let foreign matter get into them.

Caution

Seal the hoses completely, otherwise the compressor oil and receiver will absorb water vapour easily.

INSTALLATION SERVICE POINT**▶A◀ CONDENSER INSTALLATION**

When replacing the condenser, refill it with a specified amount of compressor oil and install it. (to the vehicle).

Compressor oil: SUN PAG 56

Quantity: 20 mL

INSPECTION

55200680193

CONDENSER FAN MOTOR CHECK

Check to be sure that the condenser fan motor operates when battery voltage is applied to terminal 1 and terminal 2 earthed.

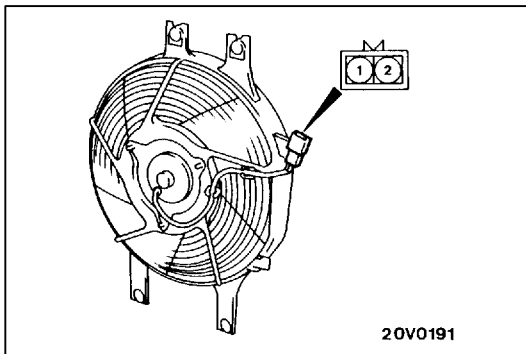

20V0191

REFRIGERANT LINE

REMOVAL AND INSTALLATION

Pre-removal and Post-installation Operation

- Refrigerant Discharging and Charging (Refer to P. 55-10, 14.)
- Radiator Grill Removal and Installation (Refer to GROUP 51 - Grille, Moulding and Garnish.)
- Front Bumper Removal and Installation (Refer to GROUP 51 - Front Bumper.)
- Battery Removal and Installation
- Windshield Washer Tank Removal and Installation (Refer to GROUP 51 - Windshield Wiper and Washer.)

<L.H. drive vehicles>

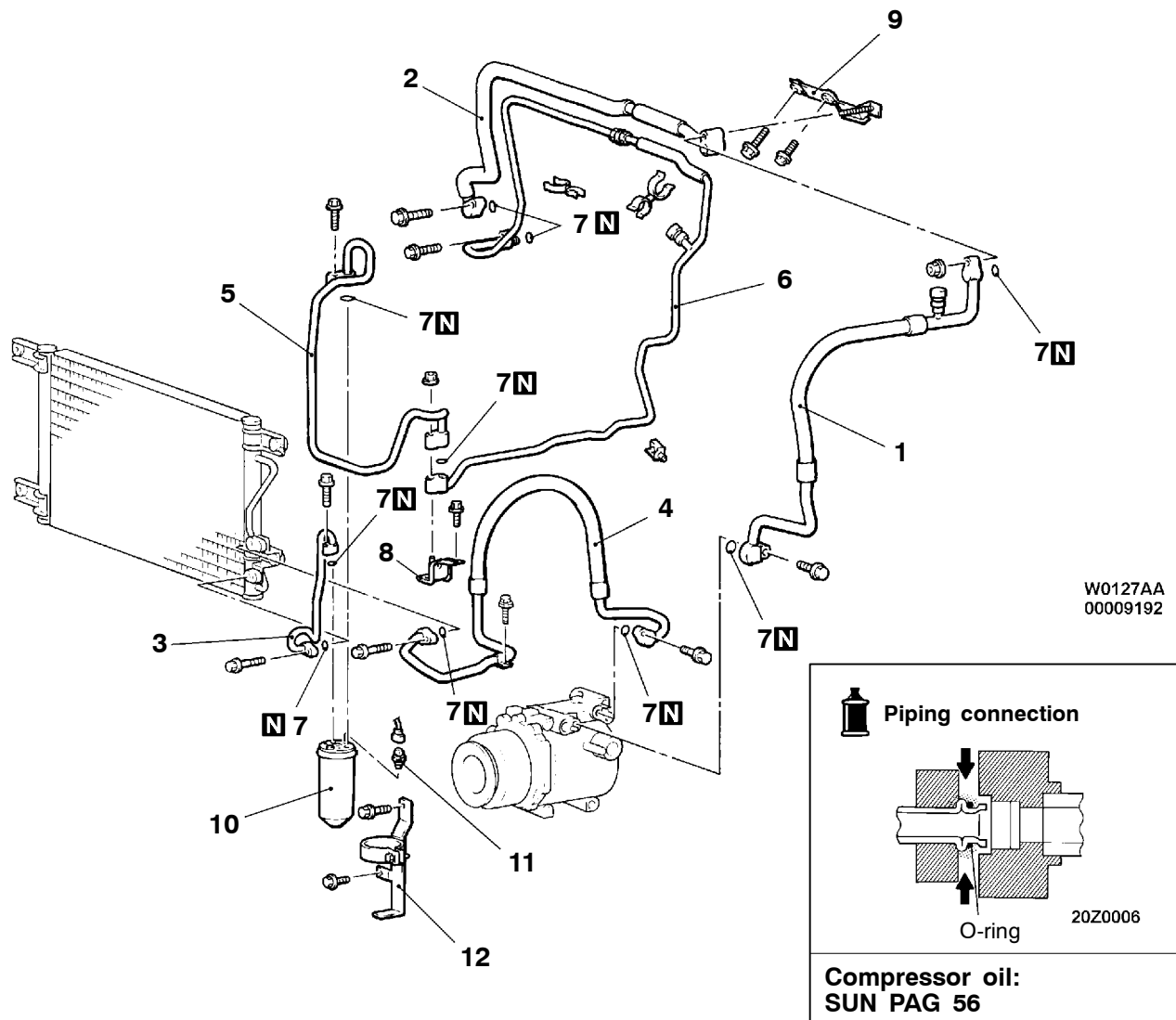

Removal steps

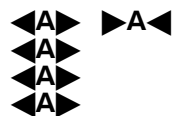

1. Suction hose
2. Suction pipe A
3. Liquid pipe A
4. Discharge hose
5. Liquid pipe B
6. Liquid pipe C



7. O-ring
8. Cramp bracket
9. Suction pipe bracket
10. Receiver assembly
11. Dual pressure switch
12. Receiver bracket

<R.H. drive vehicles>

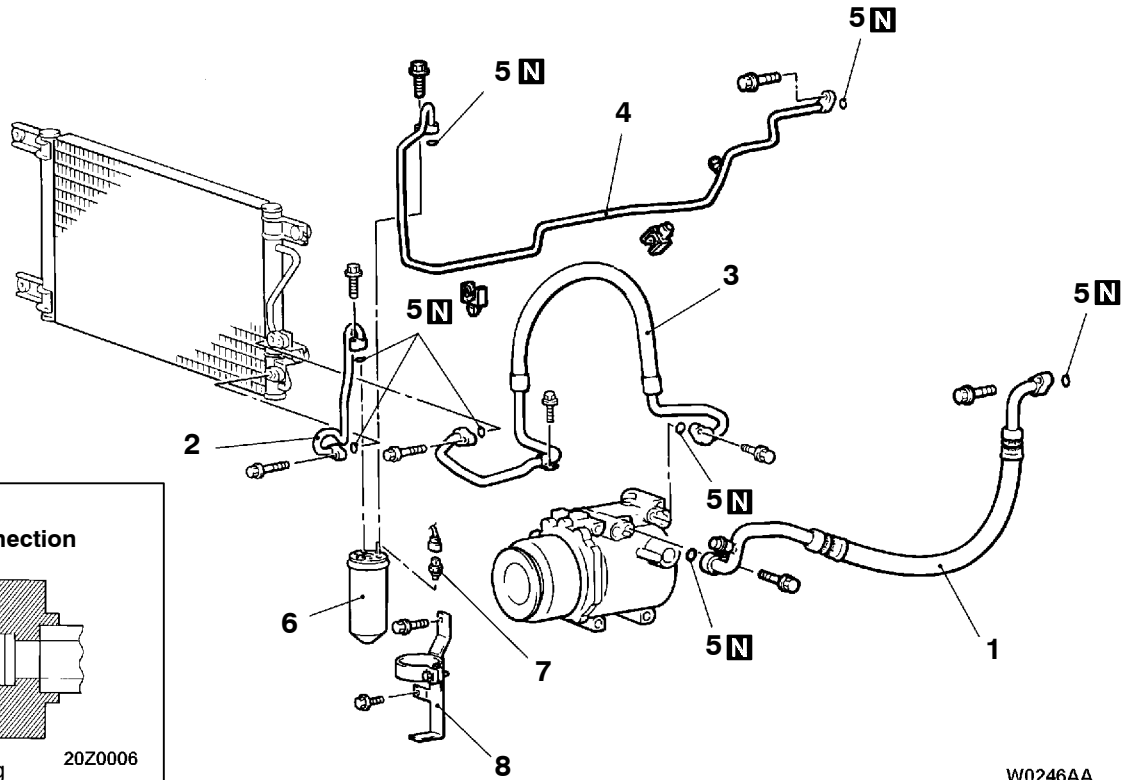

W0246AA
00009193

Piping connection

O-ring 20Z0006

**Compressor oil:
SUN PAG 56**

Removal steps

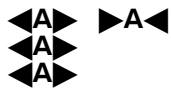

1. Suction hose
2. Liquid pipe A
3. Discharge hose
4. Liquid pipe B



5. O-ring
6. Receiver assembly
7. Dual pressure switch
8. Receiver bracket

REMOVAL SERVICE POINT

**◀▶ HOSE/PIPE/RECEIVER ASSEMBLY
DISCONNECTION**

Plug the disconnected hose, the receiver, the evaporator and the compressor nipple not to let foreign matter get into them.

Caution

Seal the hoses completely, otherwise the compressor oil and receiver will absorb water vapour easily.

INSTALLATION SERVICE POINT

▶◀ SUCTION HOSE/RECEIVER ASSEMBLY INSTALLATION

When replacing the suction hose or receiver assembly, refill them with a specified amount of compressor oil, and then install them.

Compressor oil: SUN PAG 56

Quantity:

Suction hose: 10 mL

Receiver assembly: 10 mL

ENGINE COOLANT TEMPERATURE SWITCH <4D5>

55200730096

REMOVAL AND INSTALLATION

Pre-removal and Post-installation Operation

- Coolant Refilling (Refer to GROUP 14 – On-vehicle Service.)
- Intercooler Removal and Installation (Refer to GROUP 15.)

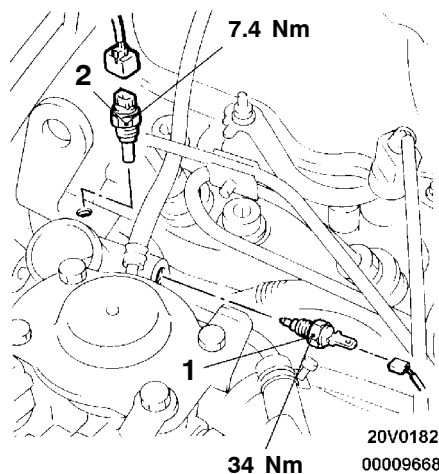

1. Engine coolant temperature switch (for A/C cut-off)
2. Engine coolant temperature switch (for condenser fan)

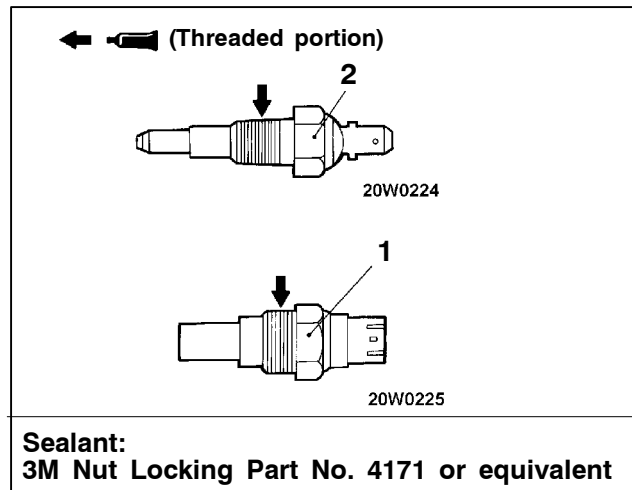

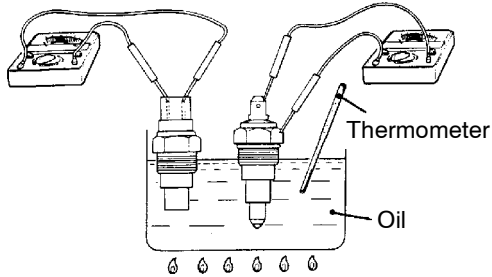

<For A/C cut-off>

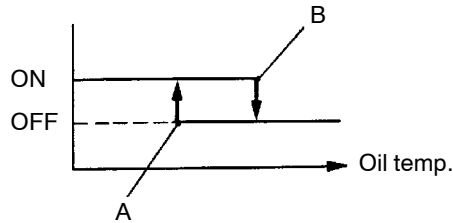

20W0237

<For condenser fan>

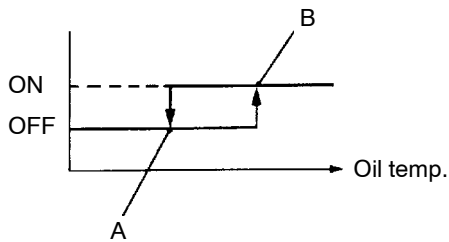

20W0204
00000585

INSPECTION

ENGINE COOLANT TEMPERATURE SWITCH CONTINUITY CHECK

1. Dip the engine coolant temperature switch in oil and heat the oil with a gas burner or similar item.

Caution

Do not heat any more than is necessary.

2. Check the continuity with a circuit tester as the temperature of the oil changes, and the condition is normal if the continuity is within the following ranges.

Standard value:

Engine coolant temperature switch	Temperature	Continuity
For A/C cut-off	Less than 108 °C (Temperature at point A)	ON (Continuity)
	More than 115 °C (Temperature at point B)	OFF (No continuity)
For condenser fan	Less than 97 °C (Temperature at point A)	OFF (No continuity)
	More than 102 °C (Temperature at point B)	ON (Continuity)

IDLE-UP SYSTEM <4D5>

55200810035

REMOVAL AND INSTALLATION

Pre-removal Operation

- Intercooler Removal (Refer to GROUP 15.)

Post-installation Operation

- Accelerator Cable Adjustment (Refer to GROUP 17 - On-vehicle Service.)
- Intercooler Installation (Refer to GROUP 15.)
- Idle-up Operation Check (Refer to P. 55-20.)

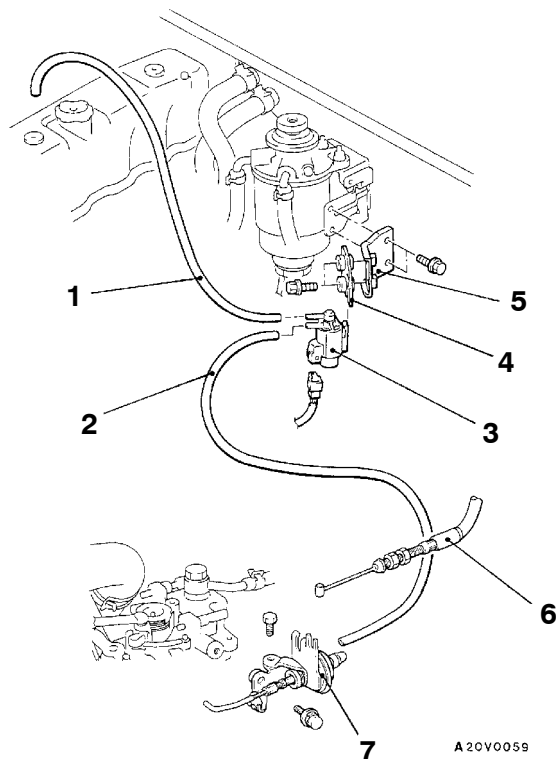

Idle-up solenoid valve removal steps

1. Vacuum hose (white stripe) connection
2. Vacuum hose (yellow stripe) connection
3. Idle-up solenoid valve
4. Solenoid valve bracket B
5. Solenoid valve bracket A

Vacuum actuator assembly removal steps

2. Vacuum hose (yellow stripe) connection
6. Accelerator cable connection
7. Vacuum actuator assembly

OUTSIDE AIR TEMPERATURE SENSOR <6G7>

55400340080

REMOVAL AND INSTALLATION**Pre-removal and Post-installation Operation**

- Front Bumper Removal and Installation
(Refer to GROUP 51 – Front Bumper.)

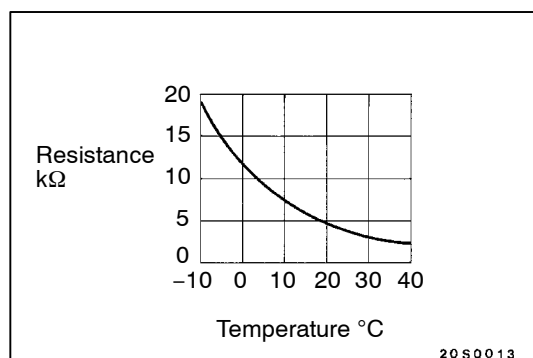
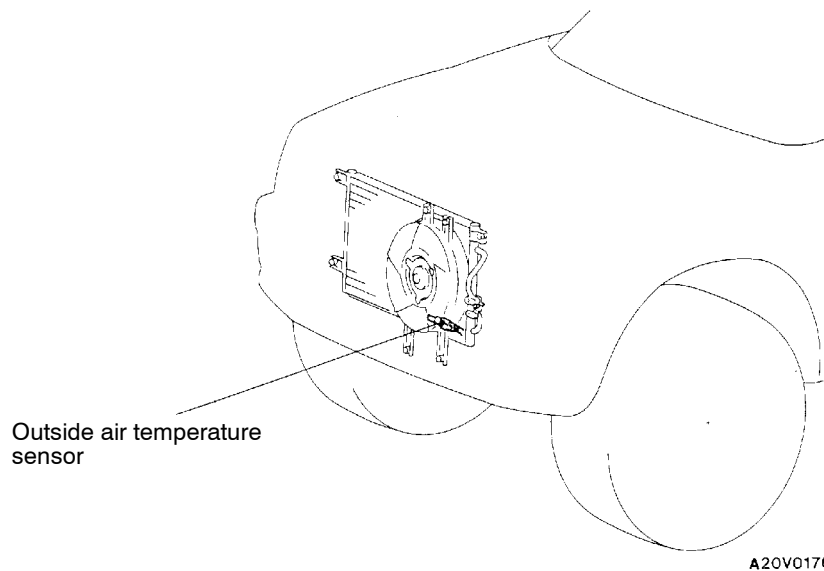
**INSPECTION**

55400350076

When the resistance between the sensor terminals is measured under two or more temperature conditions, the resistance should approximately satisfy the illustrated values.

NOTE

The temperature conditions when checking should not exceed the range shown in the diagram.

VENTILATORS

55300160225

REMOVAL AND INSTALLATION

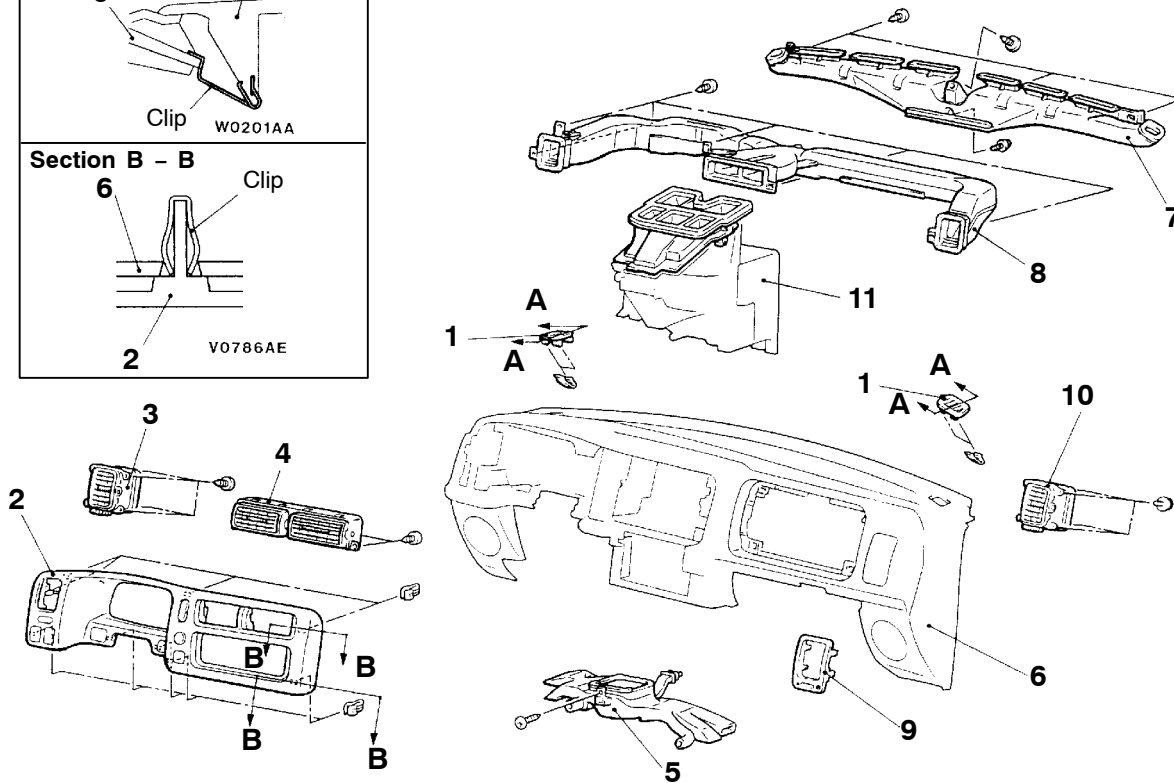
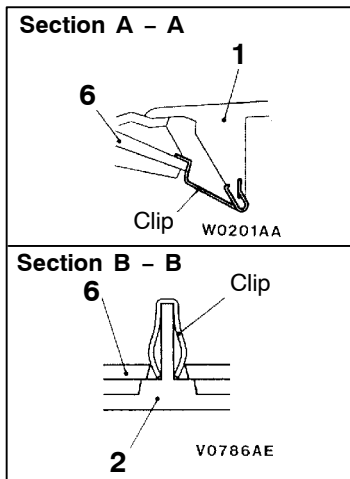

W0247AA
00009194

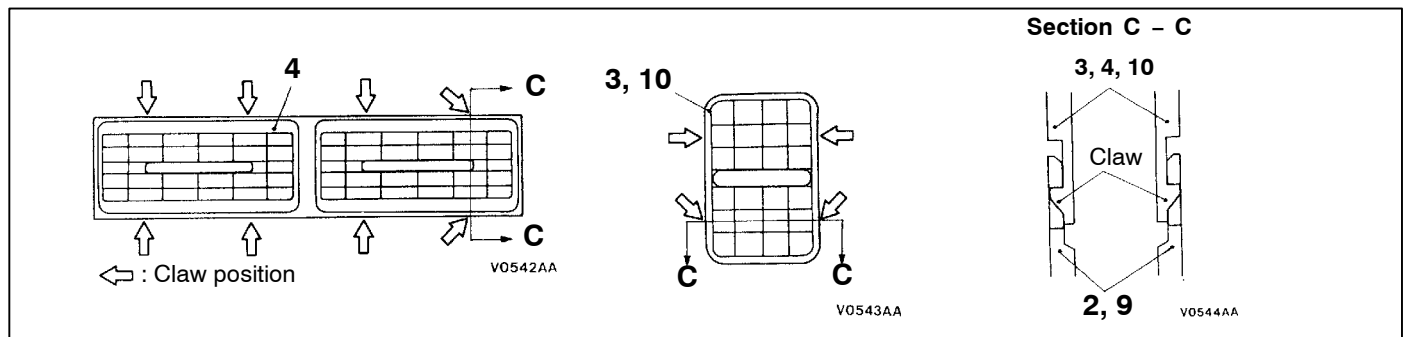

1. Side defroster grille
**Air outlet assembly (Driver's side)
and center outlet assembly removal
steps**

2. Meter bezel assembly
3. Air outlet assembly (Driver's side)
4. Center outlet assembly

Foot duct removal steps

- Floor console assembly (Refer to GROUP 52A – Floor Console.)
- 5. Foot duct

**Defroster nozzle, distribution duct,
air outlet assembly (Passenger's
side) and center ventilation duct
removal steps**

6. Instrument panel (Refer to GROUP 52A – Instrument Panel.)
7. Defroster nozzle
8. Distribution duct
9. Air outlet grille
10. Air outlet assembly (Passenger's side)
11. Center ventilation duct

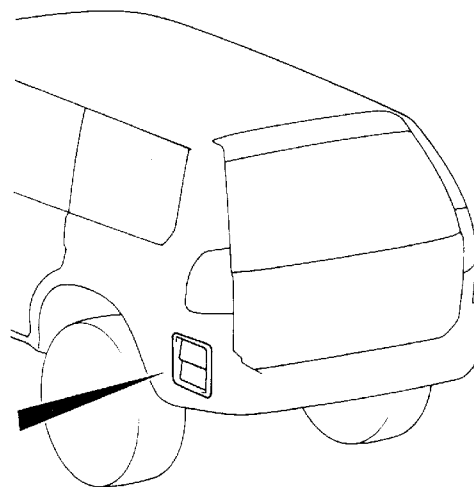
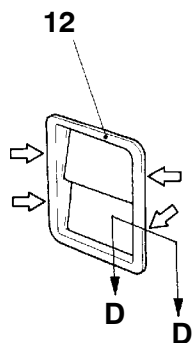
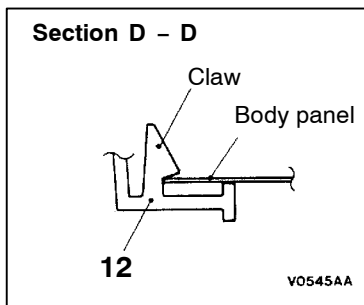

NOTE

↔ : Claw position

20V0165

00007589

Rear ventilation duct removal steps

- Rear bumper assembly (Refer to GROUP 51 – Rear Bumper.)
12. Rear ventilation duct