INTRODUCTION

HOW TO USE THIS MANUAL	IN-1
GENERAL INFORMATION	IN-1
IDENTIFICATION INFORMATION	IN-3
ENGINE SERIAL NUMBER	IN-3
REPAIR INSTRUCTIONS	IN-4
GENERAL INFORMATION	IN-4
FOR ALL OF VEHICLES	IN-8
PRECAUTION	IN-8
HOW TO TROUBLESHOOT	
ECU CONTROLLED SYSTEMS	IN-9
GENERAL INFORMATION	IN-9
HOW TO PROCEED	
WITH TROUBLESHOOTING	IN-10
HOW TO USE THE DIAGNOSTIC CHART	
AND INSPECTION PROCEDURE	IN-20
TERMS	IN-25
ABBREVIATIONS USED IN THIS MANUAL	IN-25

HOW TO USE THIS MANUAL

GENERAL INFORMATION

IN04V-03

1. INDEX

An INDEX is provided on the first page of each section to guide you to the item to be repaired. To assist you in finding your way through the manual, the section title and major heading are given at the top of every page.

2. PRECAUTION

At the beginning of each section, a PRECAUTION is given that pertains to all repair operations contained in that section.

Read these precautions before starting any repair task.

3. TROUBLESHOOTING

TROUBLESHOOTING tables are included for each system to help you diagnose the problem and find the cause. The fundamentals of how to proceed with troubleshooting are described on page IN-9.

Be sure to read this before performing troubleshooting.

4. PREPARATION

Preparation lists the SST (Special Service Tools), recommended tools, equipment, lubricant and SSM (Special Service Materials) which should be prepared before beginning the operation and explains the purpose of each one.

5. REPAIR PROCEDURES

Most repair operations begin with an overview illustration. It identifies the components and shows how the parts fit together.

Example:

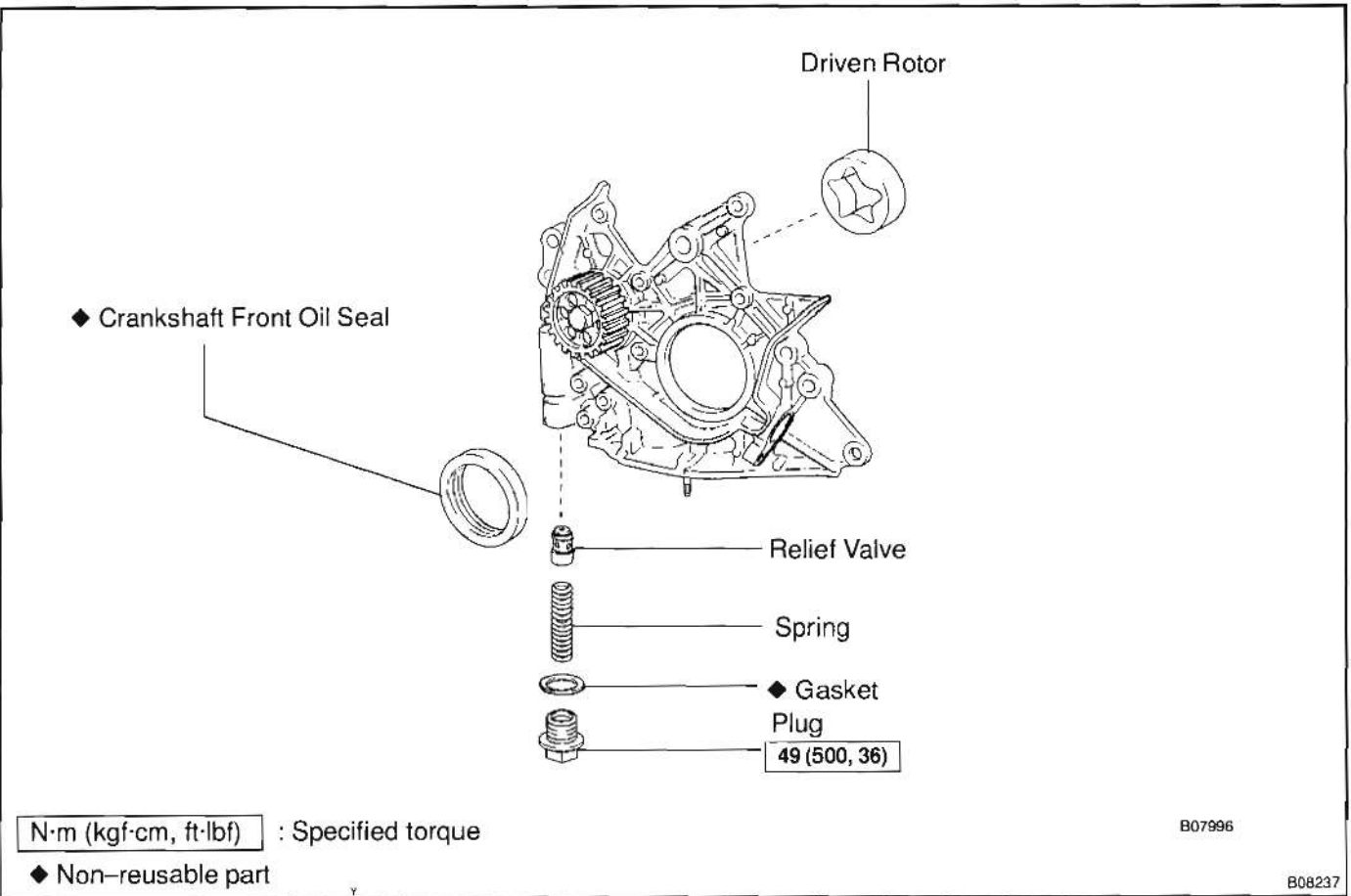

IN

B07996

B08237

The procedures are presented in a step-by-step format:

- The illustration shows what to do and where to do it.
- The task heading tells what to do.
- The detailed text tells how to perform the task and gives other information such as specifications and warnings.

Example:

IN

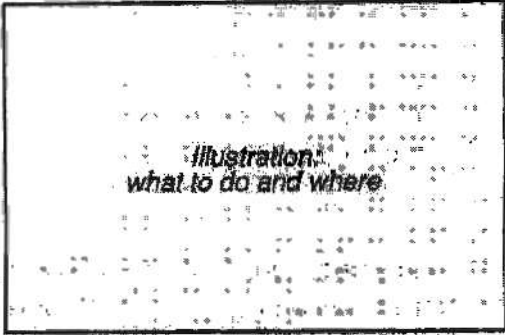

Task heading: what to do

21. CHECK PISTON STROKE OF OVERDRIVE BRAKE

(a) Place SST and a dial indicator onto the overdrive brake piston as shown in the illustration.
SST 09350-30020 (09350-06120)
Set part No. Component part No.

Detailed text: how to do task

(b) Measure the stroke applying and releasing the compressed air (392 — 786 kPa, 4 — 8 kgf/cm² or 57 — 114 psi) as shown in the illustration.

Piston stroke: 1.40 — 1.70 mm (0.0551 — 0.0669 in.)
Specification

This format provides the experienced technician with a FAST TRACK to the information needed. The upper case task heading can be read at a glance when necessary, and the text below it provides detailed information. Important specifications and warnings always stand out in bold type.

6. REFERENCES

References have been kept to a minimum. However, when they are required you are given the page to refer to.

7. SPECIFICATIONS

Specifications are presented in bold type throughout the text where needed. You never have to leave the procedure to look up your specifications. They are also found in Service Specifications section for quick reference.

8. CAUTIONS, NOTICES, HINTS:

- CAUTIONS are presented in bold type, and indicate there is a possibility of injury to you or other people.
- NOTICES are also presented in bold type, and indicate the possibility of damage to the components being repaired.
- HINTS are separated from the text but do not appear in bold. They provide additional information to help you perform the repair efficiently.

9. SI UNIT

The UNITS given in this manual are primarily expressed according to the SI UNIT (International System of Unit), and alternately expressed in the metric system and in the English System.

Example:

Torque: 30 N·m (310 kgf·cm, 22 ft·lbf)

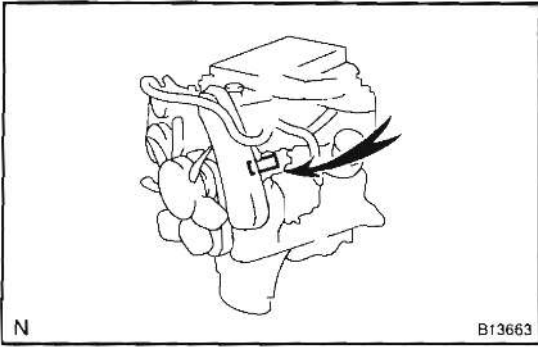

N

B13663

IDENTIFICATION INFORMATION

ENGINE SERIAL NUMBER

IN066-04

The engine serial number is stamped on the engine block, as shown in the illustration.

IN

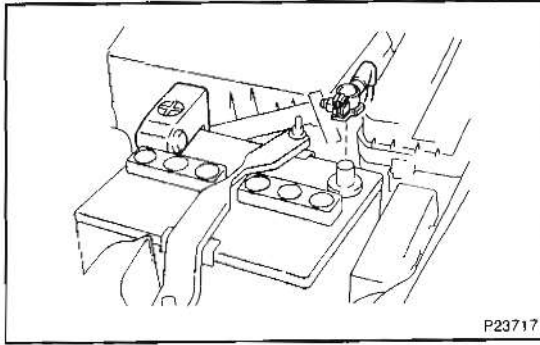

IN

REPAIR INSTRUCTIONS

GENERAL INFORMATION

IN07-01

BASIC REPAIR HINT

- (a) Use fender, seat and floor covers to keep the vehicle clean and prevent damage.
- (b) During disassembly, keep parts in the appropriate order to facilitate reassembly.
- (c) Observe the following operations:
 - (1) Before performing electrical work, disconnect the negative (-) terminal cable from the battery.
 - (2) If it is necessary to disconnect the battery for inspection or repair, always disconnect the negative (-) terminal cable which is grounded to the vehicle body.
 - (3) To prevent damage to the battery terminal, loosen the cable nut and raise the cable straight up without twisting or prying it.
 - (4) Clean the battery terminals and cable ends with a clean shop rag. Do not scrape them with a file or other abrasive objects.
 - (5) Install the cable ends to the battery terminals with the nut loose, and tighten the nut after installation. Do not use a hammer to tap the cable ends onto the terminals.
 - (6) Be sure the cover for the positive (+) terminal is properly in place.
- (d) Check hose and wiring connectors to make sure that they are secure and correct.
- (e) Non-reusable parts
 - (1) Always replace cotter pins, gaskets, O-rings and oil seals etc. with new ones.
 - (2) Non-reusable parts are indicated in the component illustrations by the "◆" symbol.
- (f) Precoated parts

Precoated parts are bolts and nuts, etc. that are coated with a seal lock adhesive at the factory.







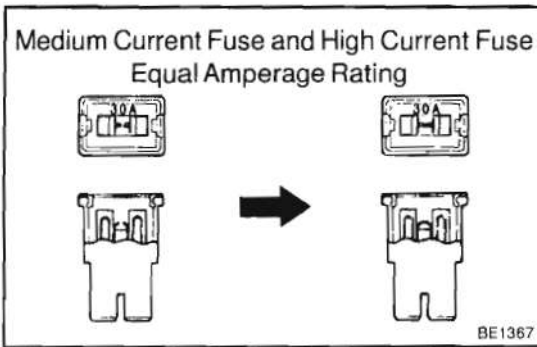

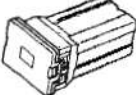

 - (1) If a precoated part is retightened, loosened or caused to move in any way, it must be recoated with the specified adhesive.
 - (2) When reusing precoated parts, clean off the old adhesive and dry with compressed air. Then apply the specified seal lock adhesive to the bolt, nut or threads.
 - (3) Precoated parts are indicated in the component illustrations by the "★" symbol.
- (g) When necessary, use a sealer on gaskets to prevent leaks.

- (h) Carefully observe all specifications for bolt tightening torques. Always use a torque wrench.
- (i) Use of special service tools (SST) and special service materials (SSM) may be required, depending on the nature of the repair. Be sure to use SST and SSM where specified and follow the proper work procedure. A list of SST and SSM can be found in section PP (Preparation) in this manual.

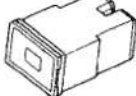
IN

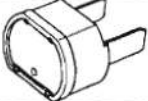

- (j) When replacing fuses, be sure the new fuse has the correct amperage rating. DO NOT exceed the rating or use one with a lower rating.

Illustration	Symbol	Part Name	Abbreviation
 BE5594	 IN0365	FUSE	FUSE
 BE5595	 IN0366	MEDIUM CURRENT FUSE	M-FUSE
 BE5596	 IN0367	HIGH CURRENT FUSE	H-FUSE
 BE5597	 IN0367	FUSIBLE LINK	FL
 BE5598	 IN0368	CIRCUIT BREAKER	CB

V00076

- (k) Care must be taken when jacking up and supporting the vehicle. Be sure to lift and support the vehicle at the proper locations.
 - Cancel the parking brake on the level place and shift the transmission in Neutral (or N position).
 - When jacking up the front wheels of the vehicle at first place stoppers behind the rear wheels.
 - When jacking up the rear wheels of the vehicle at first place stoppers behind the rear wheels.

- When either the front or rear wheels only should be jacked up, set rigid racks and place stoppers in front and behind the other wheels on the ground.
- After the vehicle is jacked up, be sure to support it on rigid racks. It is extremely dangerous to do any work on a vehicle raised on a jack alone, even for a small job that can be finished quickly.

(l) Observe the following precautions to avoid damage to the following parts:

- (1) Do not open the cover or case of the ECU unless absolutely necessary. (If the IC terminals are touched, the IC may be destroyed by static electricity.)

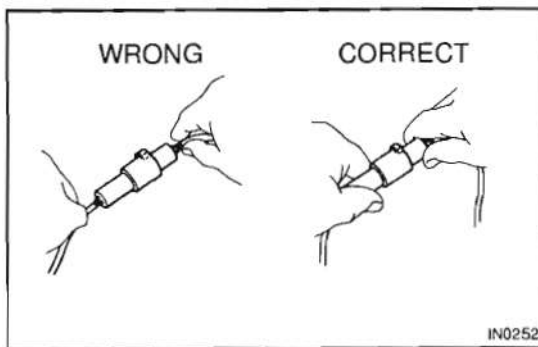
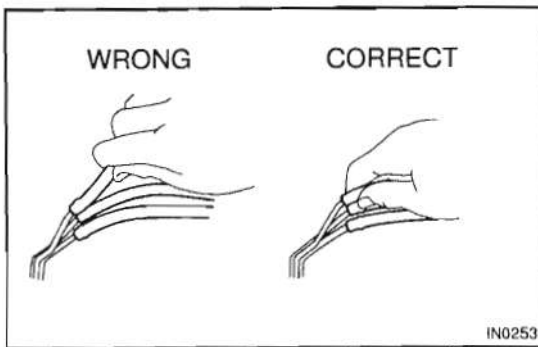

- (2) To disconnect vacuum hoses, pull off the end, not the middle of the hose.
- (3) To pull apart electrical connectors, pull on the connector itself, not the wires.
- (4) Be careful not to drop electrical components, such as sensors or relays. If they are dropped on a hard floor, they should be replaced and not reused.
- (5) When steam cleaning an engine, protect the electronic components, air filter and emission-related components from water.
- (6) Never use an impact wrench to remove or install temperature switches or temperature sensors.
- (7) When checking continuity at the wire connector, insert the tester probe carefully to prevent terminals from bending.
- (8) When using a vacuum gauge, never force the hose onto a connector that is too large. Use a step-down adapter for adjustment. Once the hose has been stretched, it may leak.

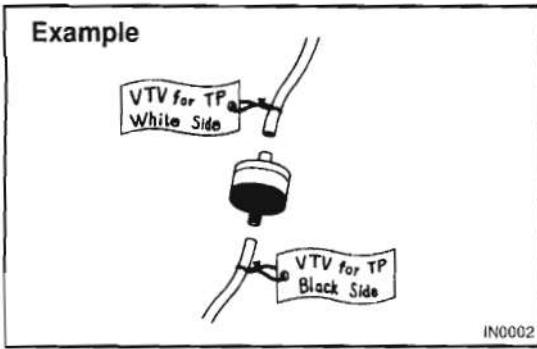

- (m) Tag hoses before disconnecting them:
- (1) When disconnecting vacuum hoses, *use* tags to identify how they should be reconnected.
 - (2) After completing a job, double check that the vacuum hoses are properly connected. A label under the hood shows the proper layout.
- (n) Unless otherwise stated, all resistance is measured at an ambient temperature of 20°C (68°F). Because the resistance may be outside specifications if measured at high temperatures immediately after the vehicle has been running, measurement should be made when the engine has cooled down.

FOR ALL OF VEHICLES

INCEB-01

PRECAUTION

1. FOR VEHICLES EQUIPPED WITH A CATALYTIC CONVERTER

CAUTION:

If large amount of unburned gasoline flows into the converter, it may overheat and create a fire hazard. To prevent this, observe the following precautions and explain them to your customer.

- (a) Use only unleaded gasoline.
- (b) Avoid prolonged idling.
Avoid running the engine at idle speed for more than 20 minutes.
- (c) Avoid spark jump test.
 - (1) Perform spark jump test only when absolutely necessary. Perform this test as rapidly as possible.
 - (2) While testing, never race the engine.
- (d) Avoid prolonged engine compression measurement.
Engine compression tests must be done as rapidly as possible.
- (e) Do not run engine when fuel tank is nearly empty.
This may cause the engine to misfire and create an extra load on the converter.
- (f) Avoid coasting with ignition turned off and prolonged braking.
- (g) Do not dispose of used catalyst along with parts contaminated with gasoline or oil.

2. IF VEHICLE IS EQUIPPED WITH MOBILE COMMUNICATION SYSTEM

For vehicles with mobile communication systems such as two-way radios and cellular telephones, observe the following precautions.

- (1) Install the antenna as far as possible away from the ECU and sensors of the vehicle's electronic system.
- (2) Install the antenna feeder at least 20 cm (7.87 in.) away from the ECU and sensors of the vehicle's electronic systems. For details about ECU and sensors locations, refer to the section on the applicable component.
- (3) Avoid winding the antenna feeder together with the other wiring as much as possible, and also avoid running the antenna feeder parallel with other wire harnesses.
- (4) Check that the antenna and feeder are correctly adjusted.
- (5) Do not install powerful mobile communications system.

3. FOR USING HAND-HELD TESTER

CAUTION:

Observe the following items for safety reasons:

- Before using the hand-held tester, the hand-held tester's operator manual should be read thoroughly.
- Be sure to route all cables securely when driving with the hand-held tester connected to the vehicle. (i.e. Keep cables away from feet, pedals, steering wheel and shift lever.)
- Two persons are required when test driving with the hand-held tester, one person to drive the vehicle and one person to operate the hand-held tester.

HOW TO TROUBLESHOOT ECU CONTROLLED SYSTEMS

GENERAL INFORMATION

IN050-06

A large number of ECU controlled systems are used in the LAND CRUISER/LAND CRUISER PRADO. In general, the ECU controlled system is considered to be a very intricate system requiring a high level of technical knowledge and expert skill to troubleshoot. However, the fact is that if you proceed to inspect the circuits one by one, troubleshooting of these systems is not complex. If you have adequate understanding of the system and a basic knowledge of electricity, accurate diagnosis and necessary repair can be performed to locate and fix the problem. This manual is designed through emphasis of the above standpoint to help service technicians perform accurate and effective troubleshooting, and is compiled for the following major ECU controlled systems:

System	Page
Engine	DI-1

The troubleshooting procedure and how to make use of it are described on the above pages.

FOR USING HAND-HELD TESTER

- Before using the hand-held tester, the hand held-tester's operator manual should be read thoroughly.
- If the hand-held tester cannot communicate with ECU controlled systems when you have connected the cable of the hand-held tester to DLC3, turned the ignition switch ON and operated the scan tool, there is a problem on the vehicle side or tool side.
 - (1) If communication is normal when the tool is connected to another vehicle, inspect the diagnosis data link line (Bus \oplus line) or ECU power circuit of the vehicle.
 - (2) If communication is still not possible when the tool is connected to another vehicle, the problem is probably in the tool itself, so perform the Self Test procedures outlined in the Tester Operator's Manual.

HOW TO PROCEED WITH TROUBLESHOOTING

Carry out troubleshooting in accordance with the procedure on the following page. Here, only the basic procedure is shown. Details are provided in each section, showing the most effective methods for each circuit. Confirm the troubleshooting procedures first for the relevant circuit before beginning troubleshooting of that circuit.

IN

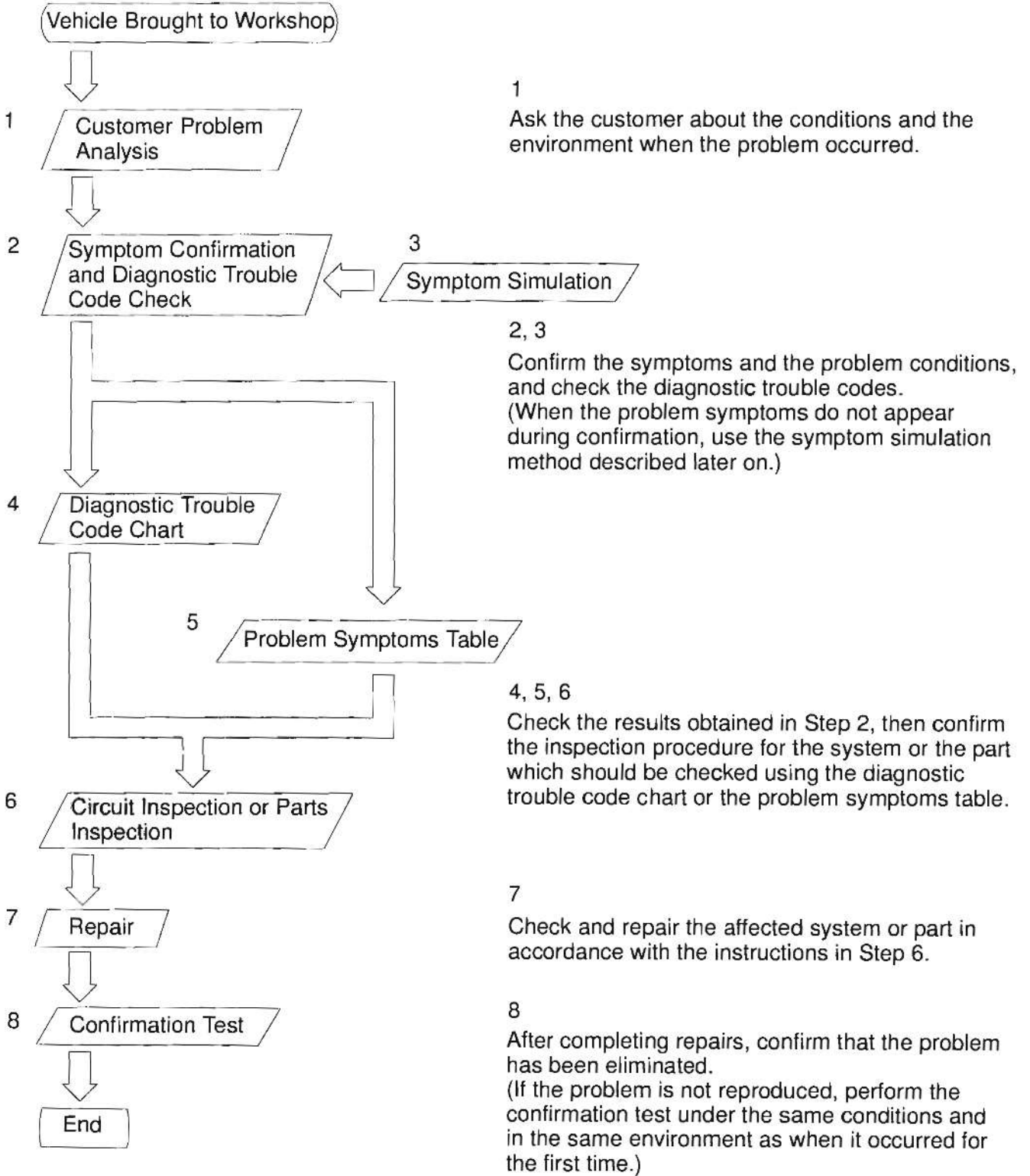

1. CUSTOMER PROBLEM ANALYSIS

In troubleshooting, the problem symptoms must be confirmed accurately and all preconceptions must be cleared away in order to give an accurate judgement. To ascertain just what the problem symptoms are, it is extremely important to ask the customer about the problem and the conditions at the time it occurred.

Important Point in the Problem Analysis:

The following 5 items are important points in the problem analysis. Past problems which are thought to be unrelated and the repair history, etc. may also help in some cases, so as much information as possible should be gathered and its relationship with the problem symptoms should be correctly ascertained for reference in troubleshooting. A customer problem analysis table is provided in the troubleshooting section for each system for your use.

Important Points in the Customer Problem Analysis

- What ——— Vehicle model, system name
- When ——— Date, time, occurrence frequency
- Where ——— Road conditions
- Under what conditions? ——— Running conditions, driving conditions, weather conditions
- How did it happen? ——— Problem symptoms

(Sample) Engine control system check sheet.

CUSTOMER PROBLEM ANALYSIS CHECK				
ENGINE CONTROL SYSTEM Check Sheet		Inspector's Name _____		
Customer's Name		Model and Model Year		
Driver's Name		Frame No.		
Data Vehicle Brought in		Engine Model		
License No.		Odometer Reading	km miles	
Problem Symptoms	<input type="checkbox"/> Engine does not Start	<input type="checkbox"/> Engine does not crank	<input type="checkbox"/> No initial combustion	
	<input type="checkbox"/> Engine does not Start	<input type="checkbox"/> No complete combustion		
	<input type="checkbox"/> Difficult to Start	<input type="checkbox"/> Engine cranks slowly <input type="checkbox"/> Other _____		
	<input type="checkbox"/> Poor Idling	<input type="checkbox"/> Incorrect first idle <input type="checkbox"/> Idling rpm is abnormal <input type="checkbox"/> High (rpm) <input type="checkbox"/> Low (rpm) <input type="checkbox"/> Rough idling <input type="checkbox"/> Other _____		
	<input type="checkbox"/> Poor Drive ability	<input type="checkbox"/> Hesitation <input type="checkbox"/> Back fire <input type="checkbox"/> Muffler explosion (after-fire) <input type="checkbox"/> Surging <input type="checkbox"/> Knocking <input type="checkbox"/> Other _____		
	<input type="checkbox"/> Engine Stall	<input type="checkbox"/> Soon after starting <input type="checkbox"/> After accelerator pedal depressed <input type="checkbox"/> After accelerator pedal released <input type="checkbox"/> During A/C operation <input type="checkbox"/> Shifting from N to D <input type="checkbox"/> Other _____		
<input type="checkbox"/> Others	_____			
<input type="checkbox"/> Constant <input type="checkbox"/> Sometimes (times per day/month)				

2. SYMPTOM CONFIRMATION AND DIAGNOSTIC TROUBLE CODE CHECK

The diagnostic system in the LAND CRUISE/LAND CRUISER PRADO fulfills various functions. The first function is the Diagnostic Trouble Code Check in which a malfunction in the signal circuits to the ECU is stored in code in the ECU memory at the time of occurrence, to be output by the technician during troubleshooting. Another function is the Input Signal Check which checks if the signals from various switches are sent to the ECU correctly.

By using these check functions, the problem areas can be narrowed down quickly and troubleshooting can be performed effectively. Diagnostic functions are incorporated in the following systems in the LAND CRUISER/LAND CRUISER PRADO.

System	Diagnostic Trouble Code Check	Input Signal Check (Sensor Check)	Other Diagnosis Function
Engine	○ (with Test Mode)	○	Diagnostic Test Mode

In diagnostic trouble code check, it is very important to determine whether the problem indicated by the diagnostic trouble code is still occurring or occurred in the past but returned to normal at present. In addition, it must be checked in the problem symptom check whether the malfunction indicated by the diagnostic trouble code is directly related to the problem symptom or not. For this reason, the diagnostic trouble codes should be checked before and after the symptom confirmation to determine the current conditions, as shown in the table below. If this is not done, it may, depending on the case, result in unnecessary troubleshooting for normally operating systems, thus making it more difficult to locate the problem, or in repairs not pertinent to the problem. Therefore, always follow the procedure in correct order and perform the diagnostic trouble code check.

DIAGNOSTIC TROUBLE CODE CHECK PROCEDURE

Diagnostic Trouble Code Check (Make a note of and then clear)	Confirmation of Symptoms	Diagnostic Trouble Code Check	Problem Condition
Diagnostic Trouble Code Display	Problem symptoms exist	Same diagnostic trouble code is displayed	Problem is still occurring in the diagnostic circuit
		Normal code is displayed	The problem is still occurring in a place other than in the diagnostic circuit (The diagnostic trouble code displayed first is either for a past problem or it is a secondary problem)
	No problem symptoms exist		The problem occurred in the diagnostic circuit in the past
Normal Code Display	Problem symptoms exist	Normal code is displayed	The problem is still occurring in a place other than in the diagnostic circuit
	No problem symptoms exist	Normal code is displayed	The problem occurred in a place other than in the diagnostic circuit in the past

Taking into account the above points, a flow chart showing how to proceed with troubleshooting using the diagnostic trouble code check is shown below. This flow chart shows how to utilize the diagnostic trouble code check effectively, then by carefully checking the results, indicates how to proceed either to diagnostic trouble code troubleshooting or to troubleshooting of problem symptoms.

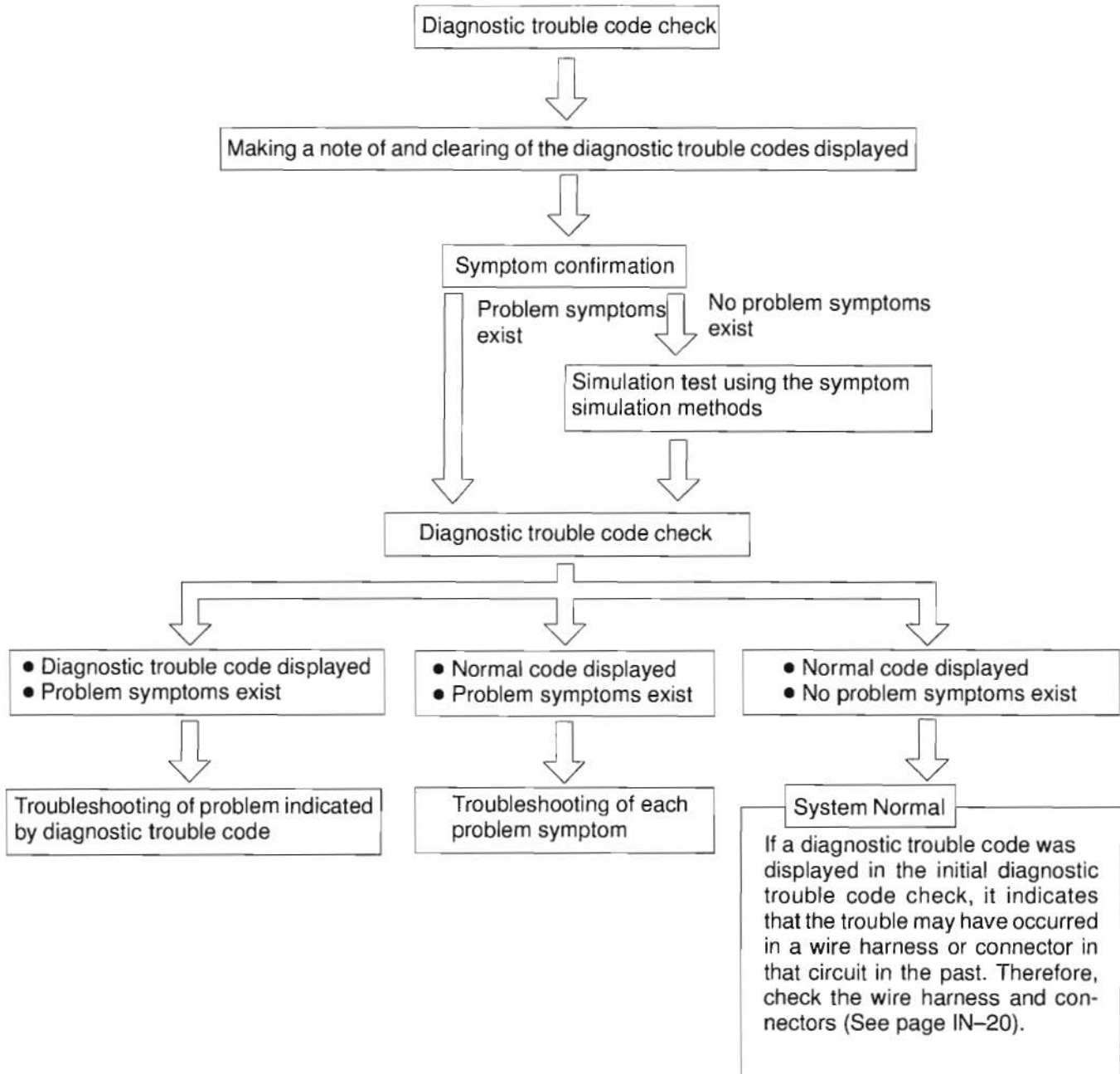



3. SYMPTOM SIMULATION

The most difficult case in troubleshooting is when there are no problem symptoms occurring. In such cases, a thorough customer problem analysis must be carried out, then simulate the same or similar conditions and environment in which the problem occurred in the customer's vehicle. No matter how much experience a technician has, or how skilled he may be, if he proceeds to troubleshoot without confirming the problem symptoms he will tend to overlook something important in the repair operation and make a wrong guess somewhere, which will only lead to a standstill. For example, for a problem which only occurs when the engine is cold, or for a problem which occurs due to vibration caused by the road during driving, etc., the problem can never be determined so long as the symptoms are confirmed with the engine hot condition or the vehicle at a standstill. Since vibration, heat or water penetration (moisture) is likely cause for problem which is difficult to reproduce, the symptom simulation tests introduced here are effective measures in that the external causes are applied to the vehicle in a stopped condition.

Important Points in the Symptom Simulation Test:

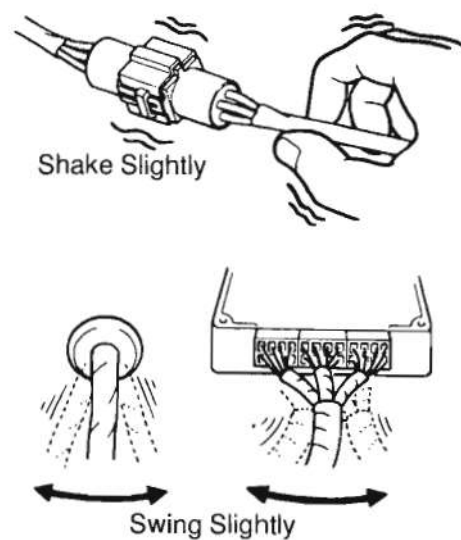
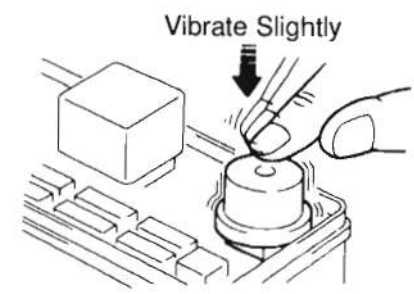
In the symptom simulation test, the problem symptoms should of course be confirmed, but the problem area or parts must also be found out. To do this, narrow down the possible problem circuits according to the symptoms before starting this test and connect a tester beforehand. After that, carry out the symptom simulation test, judging whether the circuit being tested is defective or normal and also confirming the problem symptoms at the same time. Refer to the problem symptoms table for each system to narrow down the possible causes of the symptom.

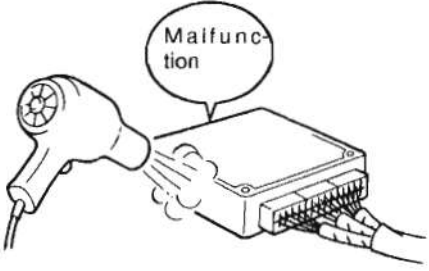
<p>1</p>	<p>VIBRATION METHOD: When vibration seems to be the major cause.</p>
<p>CONNECTORS Slightly shake the connector vertically and horizontally.</p> <p>WIRE HARNESS Slightly shake the wire harness vertically and horizontally. The connector joint, fulcrum of the vibration, and body through portion are the major areas to be checked thoroughly.</p>	 <p>The diagrams illustrate two vibration methods. The top diagram shows a hand holding a connector with the text 'Shake Slightly' and wavy lines indicating movement. The bottom diagram shows a hand holding a wire harness with the text 'Swing Slightly' and arrows indicating a swinging motion.</p> <p>F12331 F12332</p>
<p>PARTS AND SENSOR Apply slight vibration with a finger to the part of the sensor considered to be the problem cause and check that the malfunction occurs.</p> <p>HINT: Applying strong vibration to relays may result in open relays.</p>	 <p>The diagram shows a hand applying vibration to a sensor component on a circuit board with the text 'Vibrate Slightly' and a downward arrow.</p> <p>F12330</p>

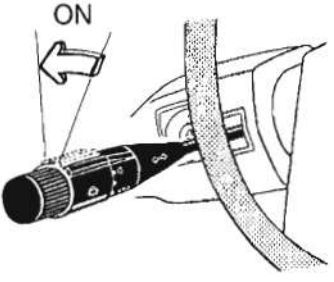
<p>2</p>	<p>HEAT METHOD: When the problem seems to occur when the suspect area is heated.</p>
<p>Heat the component that is the likely cause of the malfunction with a hair dryer or similar object. Check to see if the malfunction occurs.</p> <p>NOTICE:</p> <p>(1) Do not heat to more than 60°C (140°F). (Temperature is limited not to damage the components.)</p> <p>(2) Do not apply heat directly to parts in the ECU.</p>	 <p>F12334</p>
<p>3</p>	<p>WATER SPRINKLING METHOD: When the malfunction seems to occur on a rainy day or in a high-humidity condition.</p>
<p>Sprinkle water onto the vehicle and check to see if the malfunction occurs.</p> <p>NOTICE:</p> <p>(1) Never sprinkle water directly into the engine compartment, but indirectly change the temperature and humidity by applying water spray onto the radiator front surface.</p> <p>(2) Never apply water directly onto the electronic components.</p> <p>HINT:</p> <p>If a vehicle is subject to water leakage, the leaked water may contaminate the ECU. When testing a vehicle with a water leakage problem, special caution must be taken.</p>	 <p>F16649</p>
<p>4</p>	<p>OTHER: When a malfunction seems to occur when electrical load is excessive.</p>
<p>Turn on all electrical loads including the heater blower, head lights, rear window defogger, etc. and check to see if the malfunction occurs.</p>	 <p>F12336</p>

4. DIAGNOSTIC TROUBLE CODE CHART

The inspection procedure is shown in the table below. This table permits efficient and accurate troubleshooting using the diagnostic trouble codes displayed in the diagnostic trouble code check. Proceed with troubleshooting in accordance with the inspection procedure given in the diagnostic chart corresponding to the diagnostic trouble codes displayed. The engine diagnostic trouble code chart is shown below as an example.

- DTC No.
Indicates the diagnostic trouble code.
- Page or Instructions
Indicates the page where the inspection procedure for each circuit is to be found, or gives instructions for checking and repairs.
- Detection Item
Indicates the system of the problem or contents of the problem.
- Trouble Area
Indicates the suspect area of the problem.

DIAGNOSTIC TROUBLE CODE CHART

HINT:

Parameters listed in the chart may not be exactly the same as your reading due to the type of instrument or other factors.

If a malfunction code is displayed during the DTC check in check (test) mode, check the circuit for that code listed in the table below. For details of each code, turn to the page referred to under the "See page" for the respective "DTC No." in the DTC chart.

DTC No. (See page)	Detection Item	Trouble Area	*1 Check Engine Warning Light Normal Mode Test Mode	*2 Memory
12 (DI - 12)	Crankshaft Position Sensor Circuit Malfunction	<ul style="list-style-type: none"> ● Open or short in crankshaft position sensor circuit ● Crankshaft position sensor ● Engine ECU 	ON / N.A	○
13 (DI - 28)	Engine Speed Sensor Circuit Malfunction	<ul style="list-style-type: none"> ● Open or short in engine speed sensor circuit ● Engine speed sensor ● Engine ECU 	ON / N.A	○
15 (DI - 32)	Diesel Throttle Control Circuit Malfunction	<ul style="list-style-type: none"> ● Open or short in E-VRV for main actuator circuit ● E-VRV for main actuator ● Diesel throttle position sensor circuit ● Diesel throttle position sensor ● Main actuator ● Vacuum hose disconnected or blocked ● Engine ECU 	ON / N.A	○
	Interior IC Malfunction	<ul style="list-style-type: none"> ● Engine ECU 		

5. PROBLEM SYMPTOMS TABLE

The suspect circuits or parts for each problem symptom are shown in the table below. Use this table to troubleshoot the problem when a "Normal" code is displayed in the diagnostic trouble code check but the problem is still occurring. Numbers in the table indicate the inspection order in which the circuits or parts should be checked.

HINT:

When the problem is not detected by the diagnostic system even though the problem symptom is present, it is considered that the problem is occurring outside the detection range of the diagnostic system, or that the problem is occurring in a system other than the diagnostic system.

● Page
Indicates the page where the flow chart for each circuit is located.

● Circuit Inspection, Inspection Order
Indicates the circuit which needs to be checked for each problem symptom. Check in the order indicated by the numbers.

● Problem Symptom

● Circuit or Part Name
Indicates the circuit or part which needs to be checked.

PROBLEM SYMPTOMS TABLE		
Symptom	Suspect Area	See page
Engine does not crank (Does not start)	1. Starter 2. Starter relay	ST-5 ST-20
No initial combustion (Does not start)	1. ECU power source circuit 2. Pre-heating system 3. Compression 4. Engine ECU	DI-93 ST-2 EM-2 IN-20
Cold engine (Difficult to start)	1. Pre-heating system 2. Starter signal circuit 3. Water temperature sensor 4. Injector 5. Fuel filter 6. Diesel throttle body 7. Engine ECU	ST-2 DI-116 ED-11 FU-1 DI-26 IN-20
Excessive idling	1. Starter signal circuit 2. Injector 3. Fuel filter 4. Diesel throttle body 5. Engine ECU	DI-116
Excessive idling	1. Fuel filter 2. Diesel throttle body 3. Engine ECU	

6. CIRCUIT INSPECTION

How to read and use each page is shown below.

• Diagnostic Trouble Code No. and Detection Item

• Circuit Description
The major role and operation, etc. of the circuit and its component parts are explained.

DTC	12	Crankshaft Position Sensor Circuit Malfunction
-----	----	--

CIRCUIT DESCRIPTION
The crankshaft position sensor in the Engine Control System contains signal plate and a pickup coil for TDC signal. The TDC signal plate has 1 tooth on its outer circumference. The TDC signal sensor generates 1 signal for every engine revolution. The engine ECU detects the top dead center by the TDC signals. The NE signal plate has 52 teeth and is mounted in the supply pump. The NE signal sensor generates 52 signals of engine 2 revolutions. The engine ECU detects the engine speed and cam lift position of the supply pump. The engine ECU uses TDC signal and NE signals for injection control. And NE signal is used for injection volume control, also.



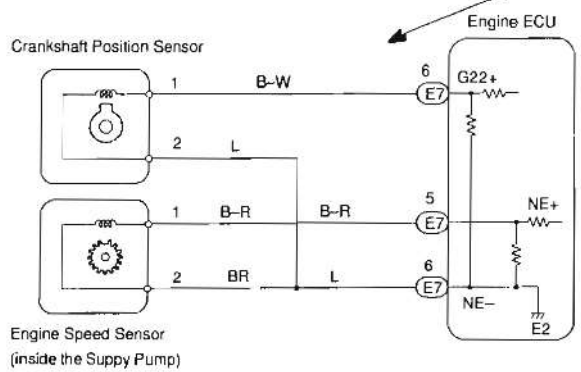

DTC No.	DTC Detecting Condition	Trouble Area
12	No TDC signal to engine ECU at 500 rpm or more	<ul style="list-style-type: none"> • Open or short in crankshaft position sensor circuit • Crankshaft position sensor • Engine ECU

• Indicates the diagnostic trouble code, diagnostic trouble code set parameter and suspect area of the problem.

WIRING DIAGRAM



• Wiring Diagram
This shows a wiring diagram of the circuit. Use this diagram together with ELECTRICAL WIRING DIAGRAM to thoroughly understand the circuit. Wire colors are indicated by an alphabetical code. B = Black, L = Blue, R = Red, BR = Brown, LG = Light Green, V = Violet, G = Green, O = Orange, W = White, GR = Gray, P = Pink, Y = Yellow. The first letter indicates the basic wire color and the second letter indicates the color of the stripe.

- Indicates the position of the ignition switch during the check.
- | | |
|--|---|
| LOCK | ON |
|  Ignition Switch LOCK (OFF) |  Ignition Switch ON |
| START | ACC |
|  Ignition Switch START |  Ignition Switch ACC |

- Inspection Procedure
- Use the inspection procedure to determine if the circuit is normal or abnormal, and if it is abnormal, use it to determine whether the problem is located in the sensors, actuators, wire harness or ECU.

INSPECTION PROCEDURE

1 Check continuity between terminal THW of ECU connector and body ground.

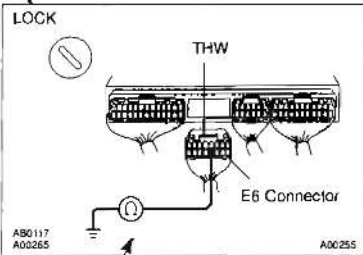

PREPARATION:

- (a) Remove the glove compartment.
- (b) Disconnect the E6 connector of ECU.

CHECK:

Measure resistance between terminal THW of ECU connector and body ground.

OK:

Resistance: 1 MΩ or higher

OK

Go to step 3.

NG

2 Check water temp. sensor (See page ED-10).

OK

Replace water temp. sensor.

- Indicates the place to check the voltage or resistance.
- Indicates the connector position to be checked, from the front or back side.

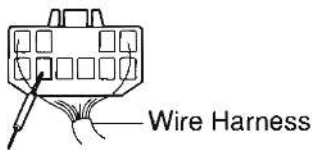

Check from the connector back side. (with harness)



Check from the connector front side. (without harness)
In this case, care must be taken not to bend the terminals.

- Indicates the condition of the connector of ECU during the check.

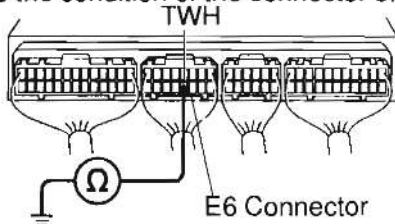

Connector being checked is connected.

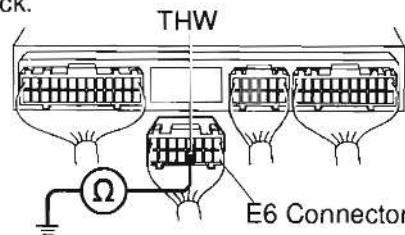

Connector being checked is disconnected.

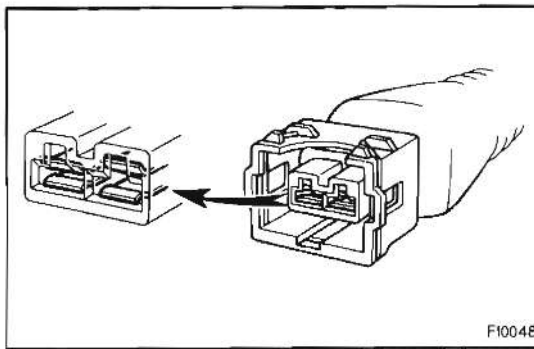
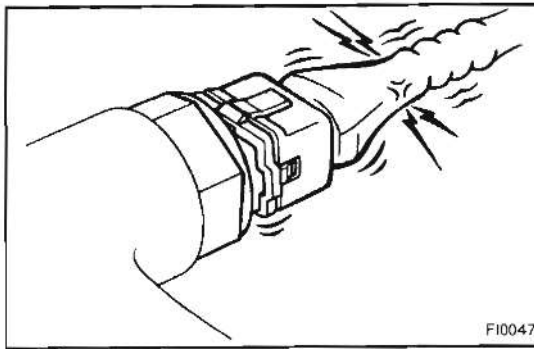
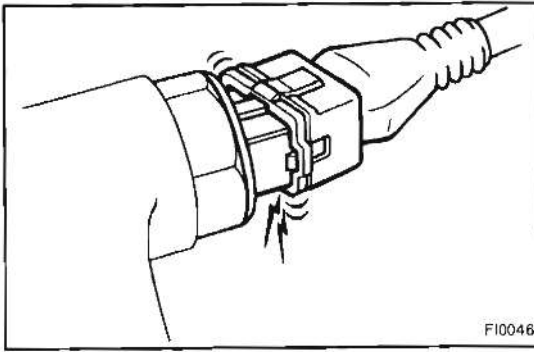

HOW TO USE THE DIAGNOSTIC CHART AND INSPECTION PROCEDURE

1. CONNECTOR CONNECTION AND TERMINAL INSPECTION

- For troubleshooting, diagnostic trouble code charts or problem symptom charts are provided for each circuit with detailed inspection procedures on the following pages.
- When all the component parts, wire harnesses and connectors of each circuit except the ECU are found to be normal in troubleshooting, then it is determined that the problem is in the ECU. Accordingly, if diagnosis is performed without the problem symptoms occurring, refer to step 8 to replace the ECU, even if the problem is not in the ECU. So always confirm that the problem symptoms are occurring, or proceed with inspection while using the symptom simulation method.
- The instructions "Check wire harness and connector" and "Check and replace ECU" which appear in the inspection procedure, are common and applicable to all diagnostic trouble codes. Follow the procedure outlined below whenever these instructions appear.

OPEN CIRCUIT:

This could be due to a disconnected wire harness, faulty contact in the connector, and a connector terminal pulled out, etc.

HINT:

- It is rarely the case that a wire is broken in the middle of it. Most cases occur at the connector. In particular, carefully check the connectors of sensors and actuators.
- Faulty contact could be due to rusting of the connector terminals, to foreign materials entering terminals or a deformation of connector terminals. Simply disconnecting and reconnecting the connectors once changes the condition of the connection and may result in a return to normal operation. Therefore, in troubleshooting, if no abnormality is found in the wire harness and connector check, but the problem disappears after the check, then the cause is considered to be in the wire harness or connectors.

SHORT CIRCUIT:

This could be due to a contact between wire harness and the body ground or to a short circuit occurred inside the switch, etc.

HINT:

When there is a short circuit between the wire harness and body ground, check thoroughly whether the wire harness is caught in the body or is clamped properly.

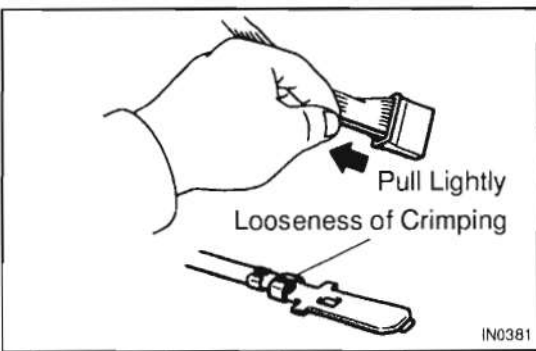
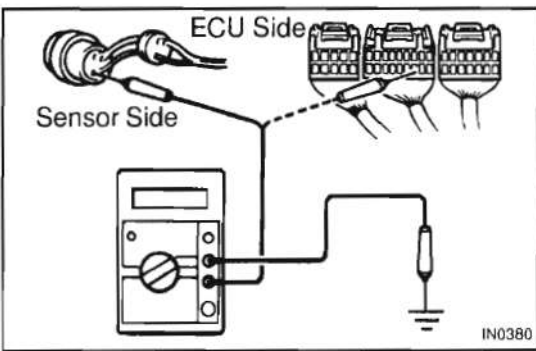
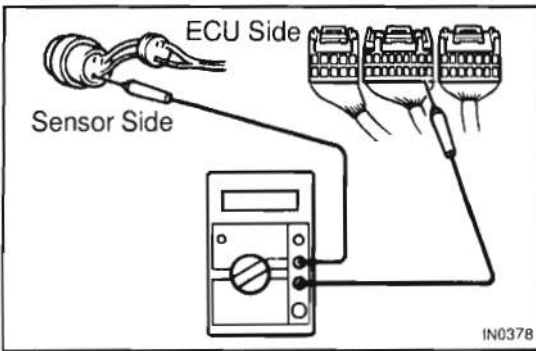
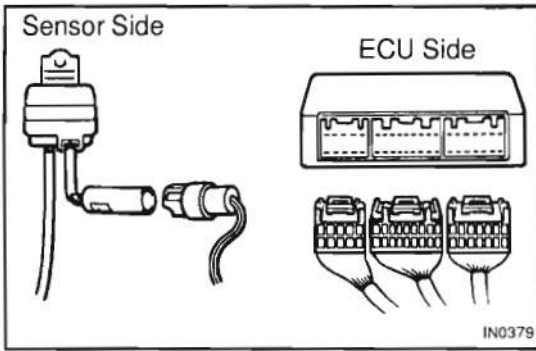

2. CONTINUITY CHECK (OPEN CIRCUIT CHECK)

- (a) Disconnect the connectors at both ECU and sensor sides.
- (b) Measure the resistance between the applicable terminals of the connectors.

Resistance: 1Ω or less

HINT:

- Measure the resistance while lightly shaking the wire harness vertically and horizontally.
- When tester probes are inserted into a connector, insert the probes from the back. For waterproof connectors in which the probes cannot be inserted from the back, be careful not to bend the terminals when inserting the tester probes.

3. RESISTANCE CHECK (SHORT CIRCUIT CHECK)

- (a) Disconnect the connectors on both ends.
- (b) Measure the resistance between the applicable terminals of the connectors and body ground. Be sure to carry out this check on the connectors on both ends.

Resistance: 1 MΩ or higher

HINT:

Measure the resistance while lightly shaking the wire harness vertically and horizontally.

4. VISUAL CHECK AND CONTACT PRESSURE CHECK

- (a) Disconnect the connectors at both ends.
- (b) Check for rust or foreign material, etc. in the terminals of the connectors.
- (c) Check crimped portions for looseness or damage and check that the terminals are secured in lock portion.

HINT:

The terminals should not come out when pulled lightly.

- (d) Prepare a test male terminal and insert it in the female terminal, then pull it out.

NOTICE:

When testing a gold-plated female terminal, always use a gold-plated male terminal.

HINT:

When the test terminal is pulled out more easily than others, there may be poor contact in that section.

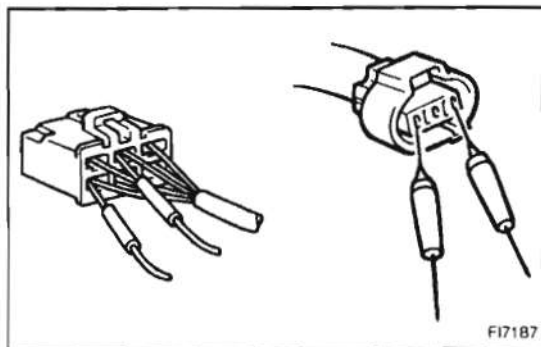

5. CONNECTOR HANDLING

When inserting tester probes into a connector, insert them from the rear of the connector. When necessary, use mini test leads. For water resistant connectors which cannot be accessed from behind, take good care not to deform the connector terminals.

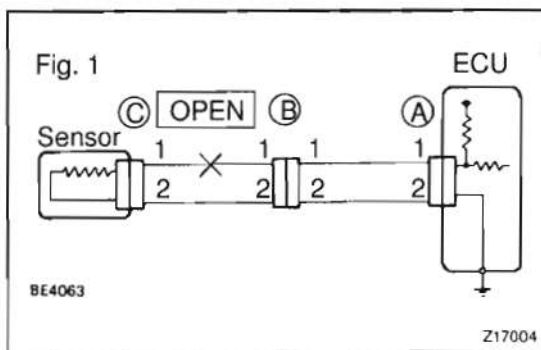

6. CHECK OPEN CIRCUIT

For the open circuit in the wire harness in Fig. 1, perform "(a) Continuity Check" or "(b) Voltage Check" to locate the section.

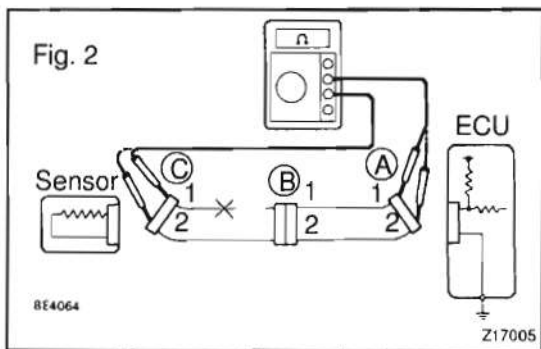

(a) Check the continuity.

- (1) Disconnect connectors "A" and "C" and measure the resistance between them.

In the case of Fig. 2,
 Between terminal 1 of connector "A" and terminal 1 of connector "C" → No continuity (open)
 Between terminal 2 of connector "A" and terminal 2 of connector "C" → Continuity

Therefore, it is found out that there is an open circuit between terminal 1 of connector "A" and terminal 1 of connector "C".

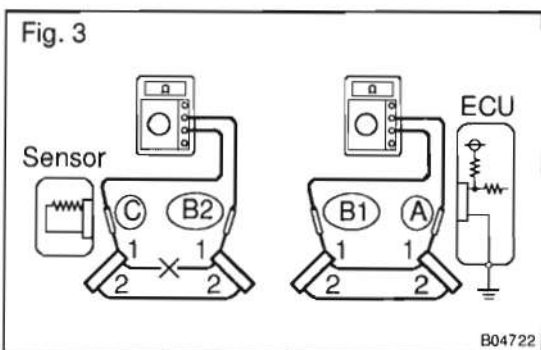

- (2) Disconnect connector "B" and measure the resistance between the connectors.

In the case of Fig. 3,
 Between terminal 1 of connector "A" and terminal 1 of connector "B1" → Continuity
 Between terminal 1 of connector "B2" and terminal 1 of connector "C" → No continuity (open)

Therefore, it is found out that there is an open circuit between terminal 1 of connector "B2" and terminal 1 of connector "C".

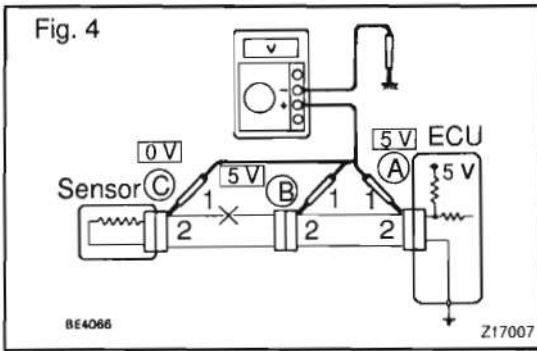

(b) Check the voltage.

In a circuit in which voltage is applied (to the ECU connector terminal), an open circuit can be checked for by conducting a voltage check.

As shown in Fig. 4, with each connector still connected, measure the voltage between body ground and terminal 1 of connector "A" at the ECU 5V output terminal, terminal 1 of connector "B", and terminal 1 of connector "C", in that order.

If the results are:

5V: Between Terminal 1 of connector "A" and Body Ground

5V: Between Terminal 1 of connector "B" and Body Ground

0V: Between Terminal 1 of connector "C" and Body Ground

Then it is found out that there is an open circuit in the wire harness between terminal 1 of "B" and terminal 1 of "C".

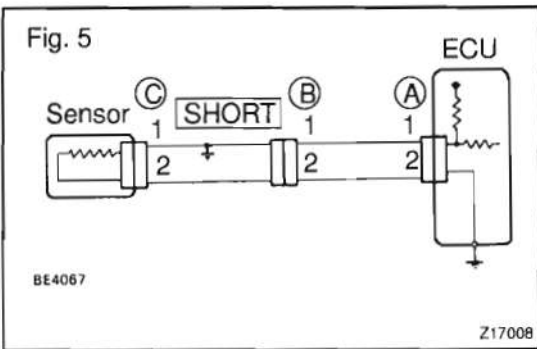

7. CHECK SHORT CIRCUIT

If the wire harness is ground shorted as in Fig. 5, locate the section by conducting a "continuity check with ground".

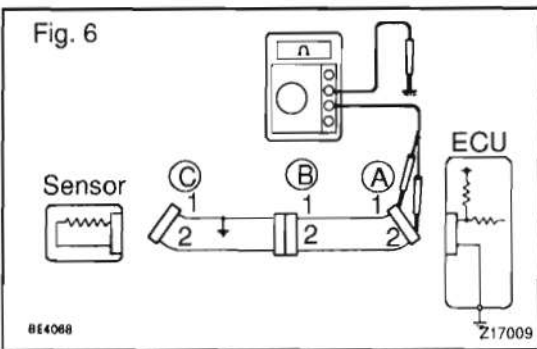

Check the continuity with ground.

- (1) Disconnect connectors "A" and "C" and measure the resistance between terminal 1 and 2 of connector "A" and body ground.

In the case of Fig. 6

Between terminal 1 of connector "A" and body ground → Continuity (short)

Between terminal 2 of connector "A" and body ground → No continuity

Therefore, it is found out that there is a short circuit between terminal 1 of connector "A" and terminal 1 of connector "C".

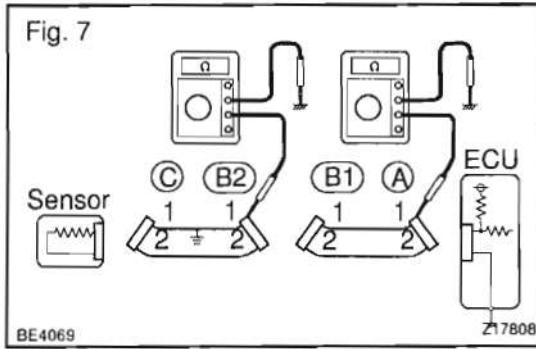

- (2) Disconnect connector "B" and measure the resistance between terminal 1 of connector "A" and body ground, and terminal 1 of connector "B2" and body ground.
 Between terminal 1 of connector "A" and body ground → No continuity
 Between terminal 1 of connector "B2" and body ground → Continuity (short)
 Therefore, it is found out that there is a short circuit between terminal 1 of connector "B2" and terminal 1 of connector "C".

8. CHECK AND REPLACE ECU

First check the ECU ground circuit. If it is faulty, repair it. If it is normal, the ECU could be faulty, so replace the ECU with a normal functioning one and check that the symptoms appear.

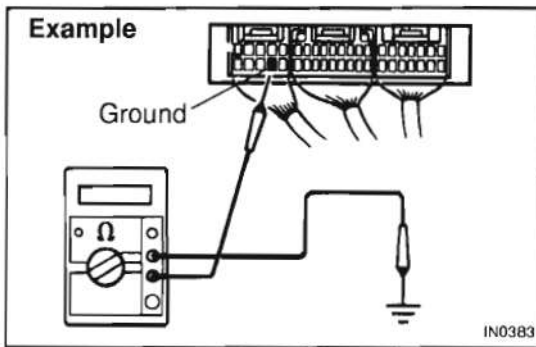

- (1) Measure the resistance between the ECU ground terminal and the body ground.
Resistance: 1 Ω or less

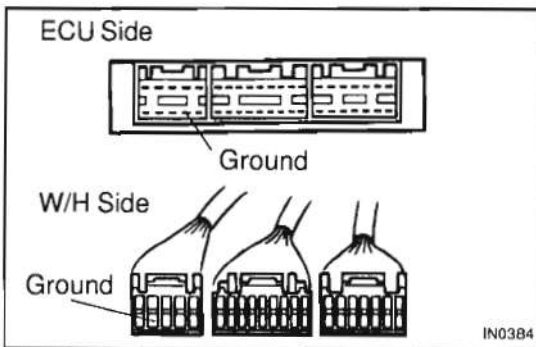

- (2) Disconnect the ECU connector, check the ground terminals on the ECU side and the wire harness side for bend and check the contact pressure.

TERMS**ABBREVIATIONS USED IN THIS MANUAL**

IN06-13

Abbreviations	Meaning
A/C	Air Conditioning
AC	Alternating Current
ACC	Accessory
ACIS	Acoustic Control Induction System
ACSD	Automatic Cold Start Device
ALT	Alternator
AMP	Amplifier
APPROX.	Approximately
A/T	Automatic Transmission (Transaxle)
BACS	Boost Altitude Compensation System
BAT	Battery
BTDC	Before Top Dead Center
BVSV	Bimetallic Vacuum Switching Valve
CB	Circuit Breaker
CCO	Catalytic Converter for Oxidation
DC	Direct Current
DLC	Data Link Connector
DTC	Diagnostic Trouble Code
ECD	Electronic Control Diesel
ECT	Electronic Control Transmission
ECU	Electronic Control Unit
EDU	Electronic Driving Unit
EFI	Electronic Fuel Injection
E/G	Engine
EGR	Exhaust Gas Recirculation
EVAP	Evaporative Emission Control
E-VRV	Electronic Vacuum Regulating Valve
EX	Exhaust
FIPG	Formed in Place Gasket
FL	Fusible Link
Fr	Front
GND	Ground
HAC	High Altitude Compensator
IG	Ignition
IIA	Integrated Ignition Assembly
IN	Intake
ISC	Idle Speed Control
J/B	Junction Block
J/C	Junction Connector
LCD	Liquid Crystal Display
LED	Light Emitting Diode
LH	Left-Hand

LHD	Left-Hand Drive
LO	Low
MAP	Manifold Absolute Pressure
MAX.	Maximum
MIL	Malfunction Indicator Lamp
MIN.	Minimum
MP	Multipurpose
M/T	Manual Transmission
N	Neutral
O ₂ S	Oxygen Sensor
O/D	Overdrive
O/S	Oversize
PKB	Parking Brake
PS	Power Steering
RAM	Random Access Memory
R/B	Relay Block
RH	Right-Hand
RHD	Right-Hand Drive
ROM	Read Only Memory
Rr	Rear
SICS	Starting Injection Control System
SPEC	Specification
SSM	Special Service Materials
SST	Special Service Tools
STD	Standard
SW	Switch
TACH	Tachometer
TDC	Top Dead Center
TEMP.	Temperature
TM	Transmission
TMC	TOYOTA Motor Corporation
TWC	Three-Way Catalyst
U/D	Underdrive
VCV	Vacuum Control Valve
VIN	Vehicle Identification Number
VSV	Vacuum Switching Valve
w/	With
W/H	Wire Harness
w/o	Without
WU-TWC	Warm Up Three-Way Catalytic Converter
2WD	Two Wheel Drive Vehicle (4x2)
4WD	Four Wheel Drive Vehicle (4x4)

