

---

# STARTING SYSTEM

DESCRIPTION .....	ST- 2
SYSTEM CIRCUIT .....	ST- 3
OPERATION.....	ST- 3
PREPARATION .....	ST- 4
STARTER (2.2 kW) .....	ST- 5
STARTER (2.7 kW) .....	ST- 16
STARTER RELAY .....	ST- 27
PRE-HEATING SYSTEM .....	ST- 28
GLOW PLUG .....	ST- 33
SERVICE SPECIFICATIONS .....	ST- 37

ST

DESCRIPTION

The starter is a reduction type with a small, high-speed motor used to drive the pinion gear. ST055-01

ST

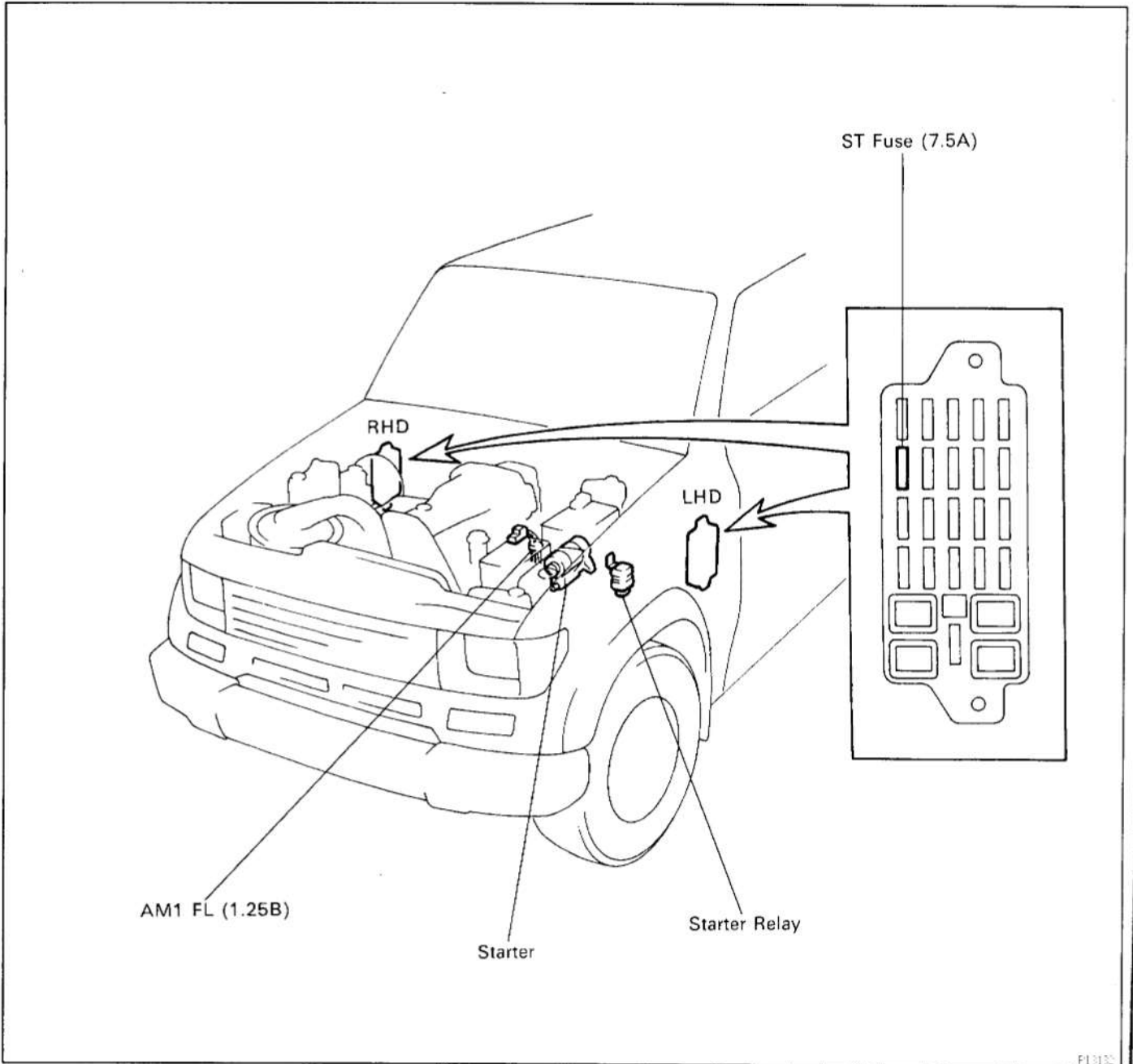

## SYSTEM CIRCUIT

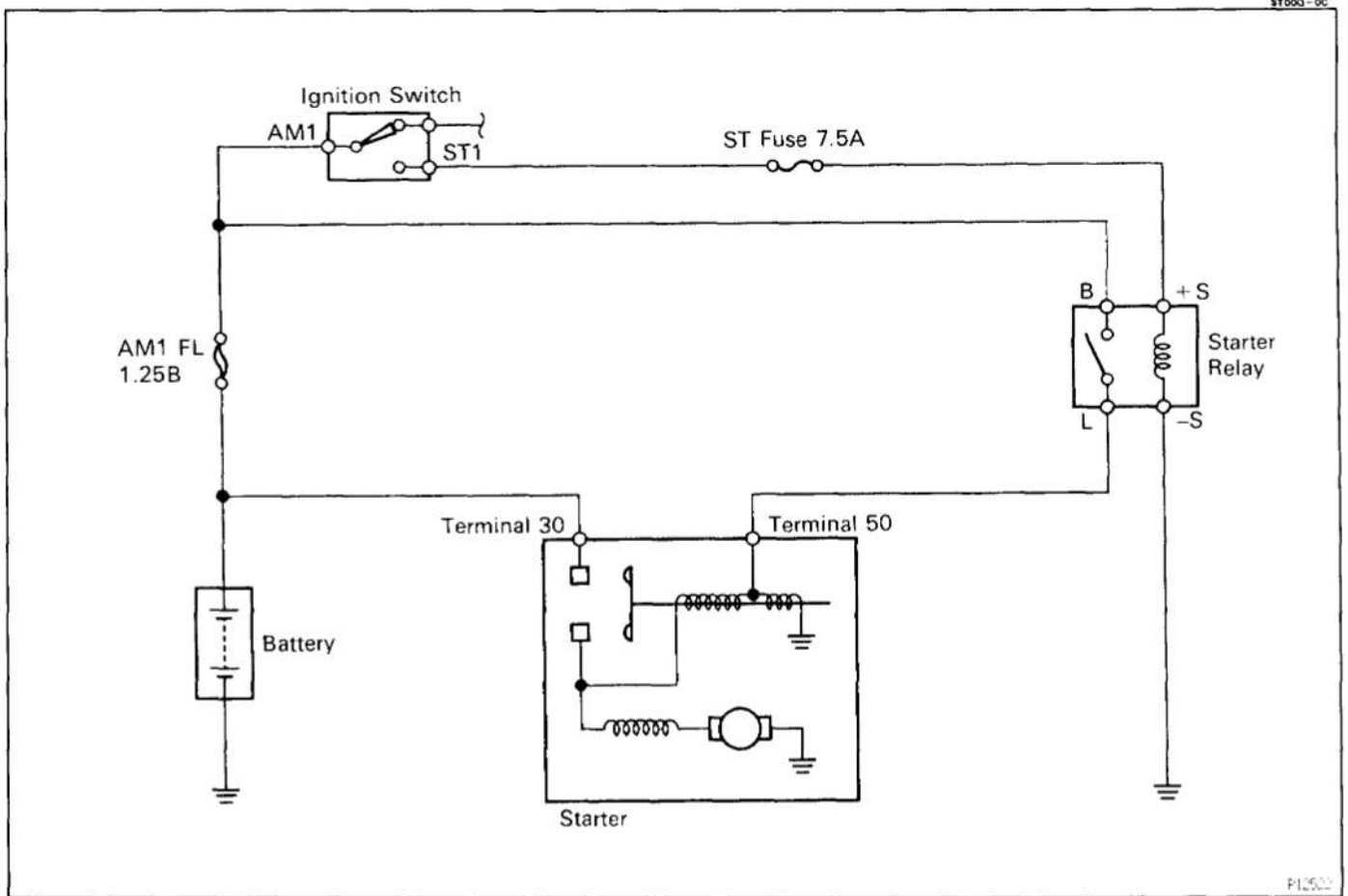

## OPERATION



When the ignition switch is turned to START position, current flows from terminal 50 to the coil of the solenoid and the plunger is pulled by the magnetic force of the coil. When the plunger is pulled to the left as shown above, the contact plate of the plunger allows current from the battery to flow directly from terminal 30 to the motor, and the starter rotates.

When the engine is running and the ignition switch is returned to ON, the magnetic force of the coil disappears and the contact plate of the plunger is returned to its original position by the return spring. Battery voltage no longer flows from terminal 30, so the motor stops.

## PREPARATION

## SST (SPECIAL SERVICE TOOLS)

ST005-08

	09286-46011	Injection Pump Spline Shaft Puller	
	09820-00030	Alternator Rear Bearing Replacer	Armature rear bearing for 2.7 kW type
	09950-00020	Bearing Remover	Armature rear bearing for 2.2 kW type

## RECOMMENDED TOOLS

ST007-01

	09082-00015	TOYOTA Electrical Tester	
--	-------------	--------------------------	--

## EQUIPMENT

ST00U-01

Dial indicator	Commutator
Magnetic finger	
Pull scale	Brush spring
Sandpaper	Commutator
Torque wrench	
V-block	
Vernier calipers	Commutator, Brush

# STARTER (2.2 kW) COMPONENTS FOR DISASSEMBLY AND ASSEMBLY

ST00W-00

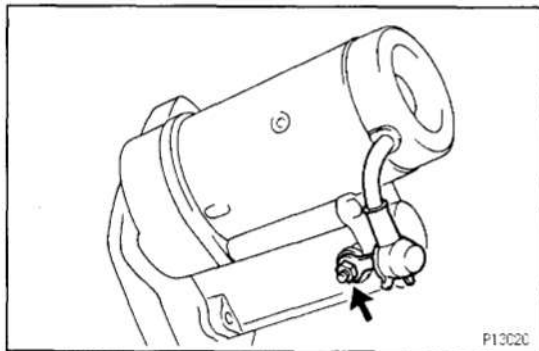
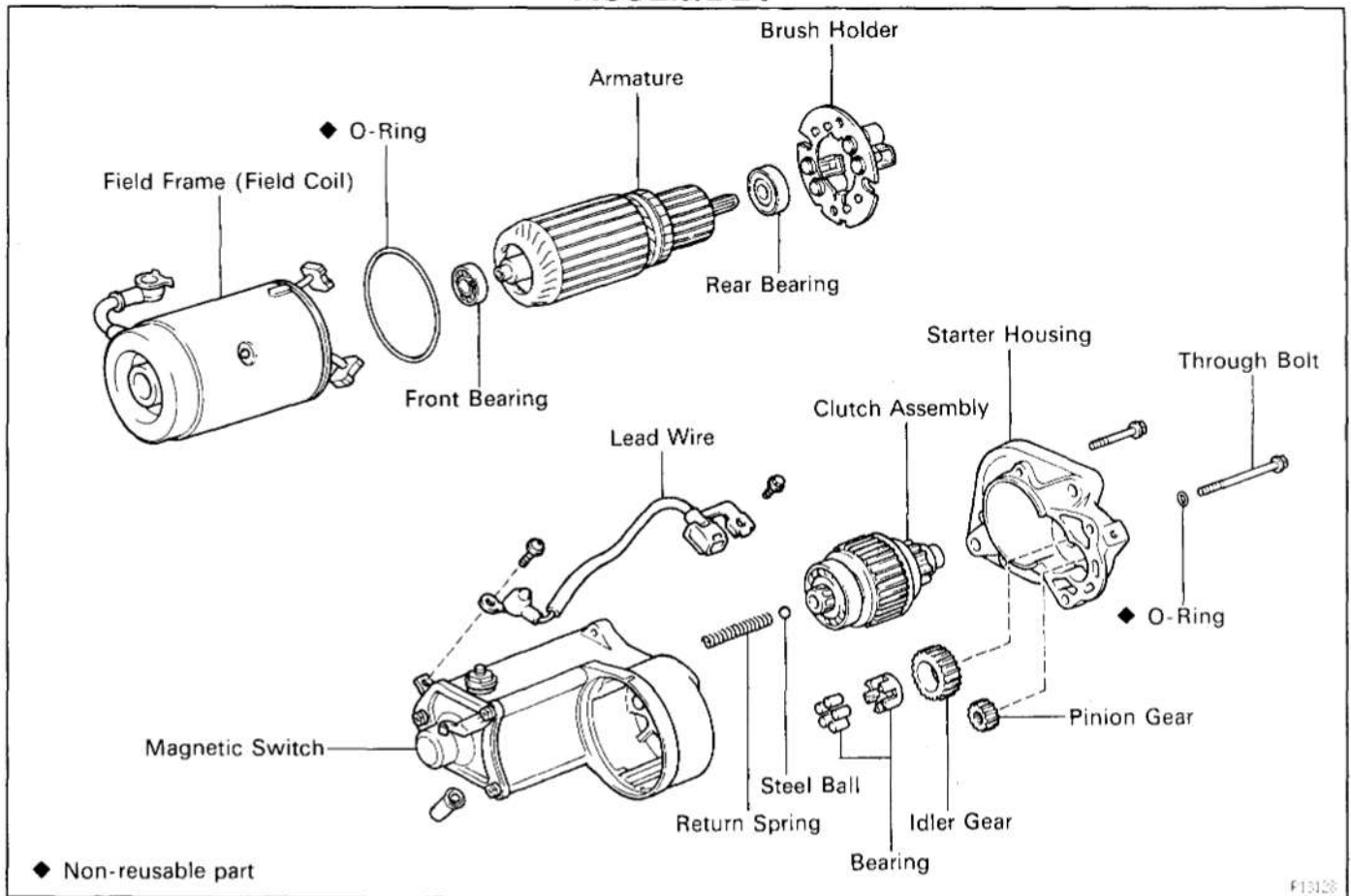

## STARTER DISASSEMBLY

ST05T-01

### 1. REMOVE FIELD FRAME AND ARMATURE

- (a) Remove the nut, and disconnect the lead wire from the magnetic switch terminal.

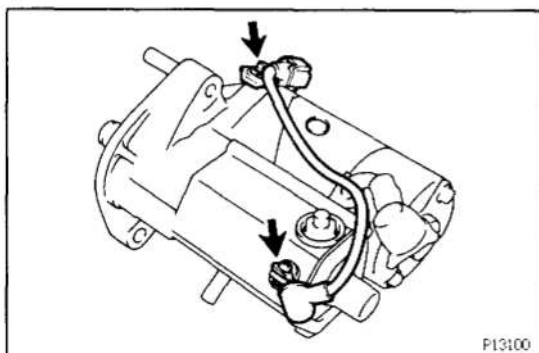

- (b) Remove the bolt, screw and the lead wire from the terminal 50 and starter housing.

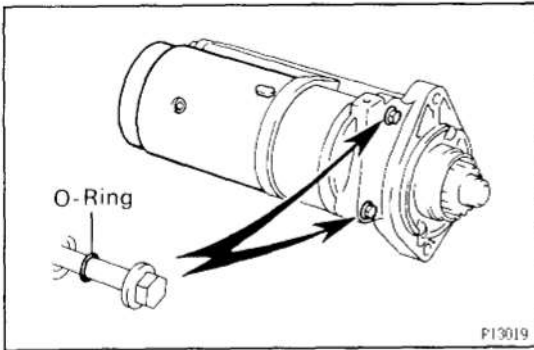

- (c) Remove the 2 through bolts and O-rings.
- (d) Pull out the field frame with the armature from the magnetic switch assembly.
- (e) Remove the O-ring from the field frame.

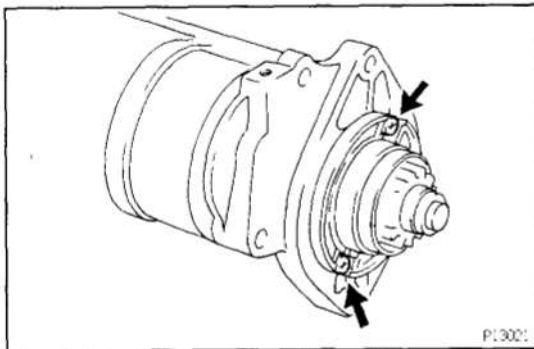

## 2. REMOVE STARTER HOUSING, CLUTCH ASSEMBLY AND GEARS

- (a) Remove the 2 screws.

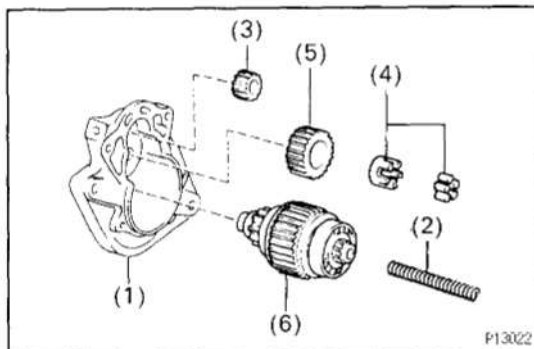

- (b) Remove the following parts from the magnetic switch assembly:
  - (1) Starter housing
  - (2) Return spring
  - (3) Pinion gear
  - (4) Bearing
  - (5) Idler gear
  - (6) Clutch assembly

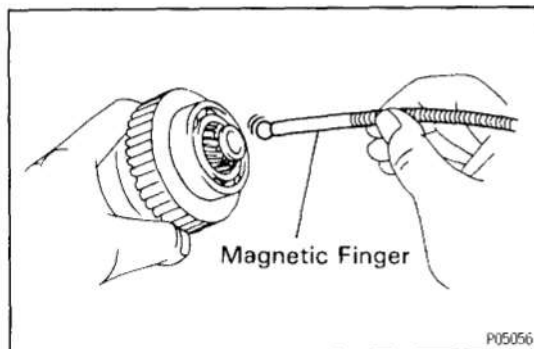

## 3. REMOVE STEEL BALL

Using a magnetic finger, remove the steel ball from the clutch shaft hole.

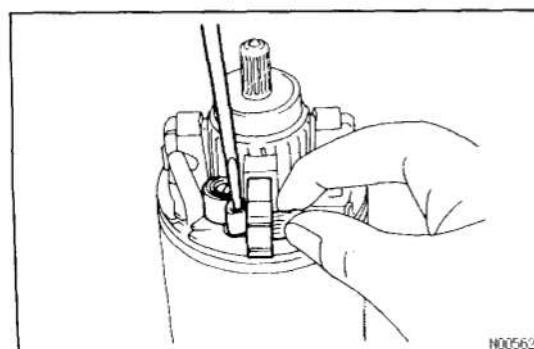

## 4. REMOVE BRUSH HOLDER

Using a screwdriver, hold the spring back and disconnect the brush from the brush holder. Disconnect the 4 brushes and remove the brush holder.

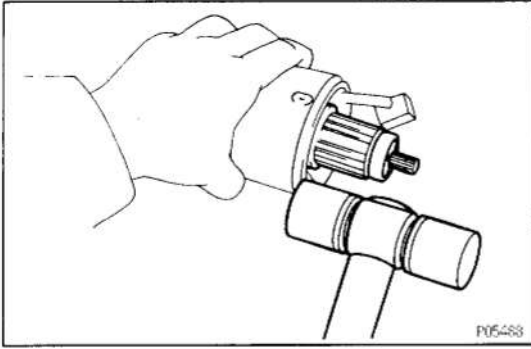

### 5. REMOVE ARMATURE FROM FIELD FRAME

Using a plastic hammer, tap the frame end to remove the armature from the field frame.

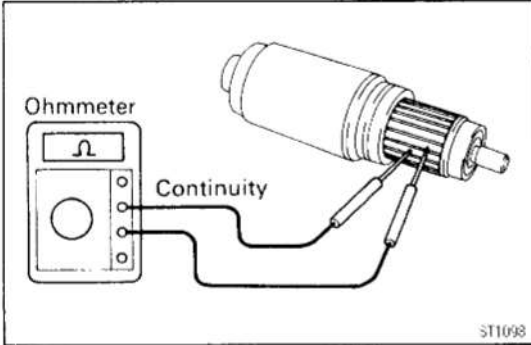

## STARTER INSPECTION AND REPAIR

### Armature Coil

#### 1. INSPECT COMMUTATOR FOR OPEN CIRCUIT

Using an ohmmeter, check that there is continuity between the segments of the commutator. If there is no continuity between any segment, replace the armature.

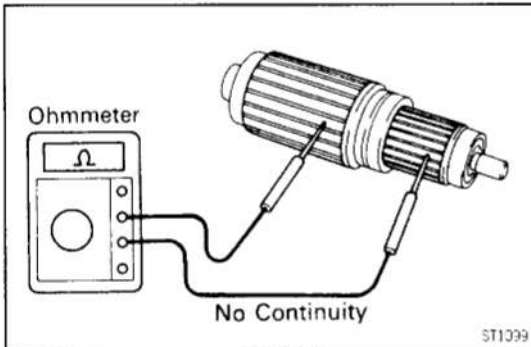

#### 2. INSPECT COMMUTATOR FOR GROUND

Using an ohmmeter, check that there is no continuity between the commutator and armature coil core. If there is continuity, replace the armature.

### Commutator

#### 1. INSPECT COMMUTATOR FOR DIRTY AND BURNT SURFACES

If the surface is dirty or burnt, correct it with sandpaper (No. 400) or on a lathe.

#### 2. INSPECT COMMUTATOR CIRCLE RUNOUT

- (a) Place the commutator on V-blocks.
- (b) Using a dial gauge, measure the circle runout.

**Maximum circle runout:**

**0.05 mm (0.0020 in.)**

If the circle runout is greater than maximum, correct it on a lathe.

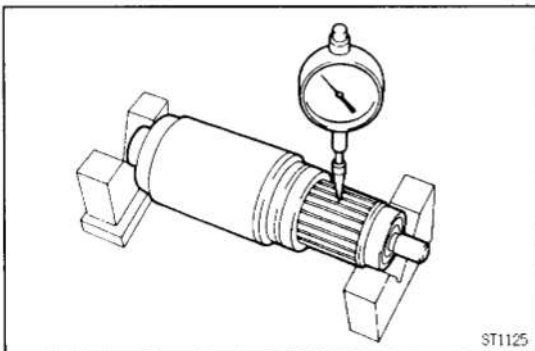

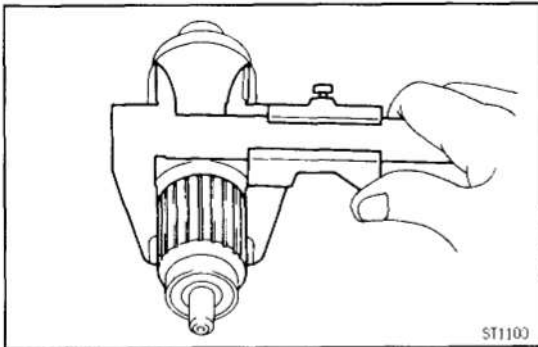

### 3. INSPECT COMMUTATOR DIAMETER

Using a vernier caliper, measure the commutator diameter.

**Standard diameter:**

35 mm (1.38 in.)

**Minimum diameter:**

34 mm (1.34 in.)

If the diameter is less than minimum, replace the armature.

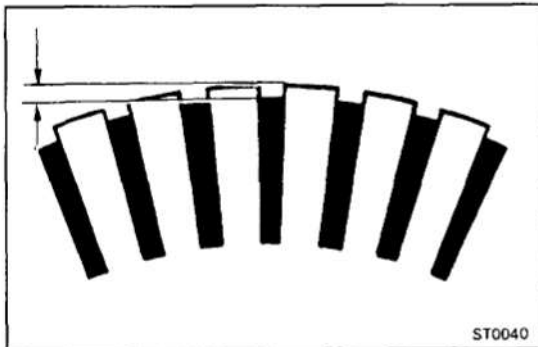

### 4. INSPECT UNDERCUT DEPTH

Check that the undercut depth is clean and free of foreign materials. Smooth out the edge.

**Standard undercut depth:**

0.6 mm (0.025 in.)

**Minimum undercut depth:**

0.2 mm (0.008 in.)

If the undercut depth is less than minimum, correct it with a hacksaw blade.

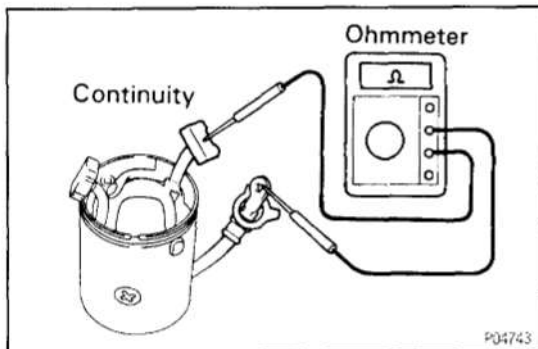

## Field Frame (Field Coil)

### 1. INSPECT FIELD COIL FOR OPEN CIRCUIT

Using an ohmmeter, check that there is continuity between the lead wire and field coil brush lead.

If there is no continuity, replace the field frame.

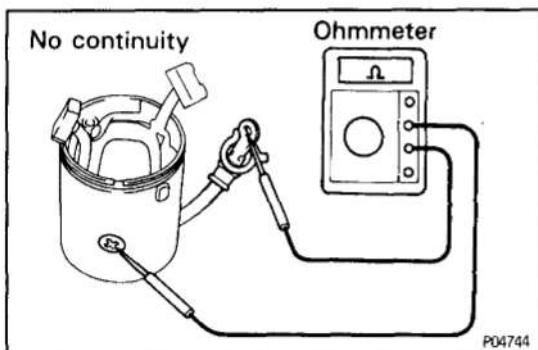

### 2. INSPECT FIELD COIL FOR GROUND

Using an ohmmeter, check that there is no continuity between the field coil end and field frame.

If there is continuity, repair or replace the field frame.



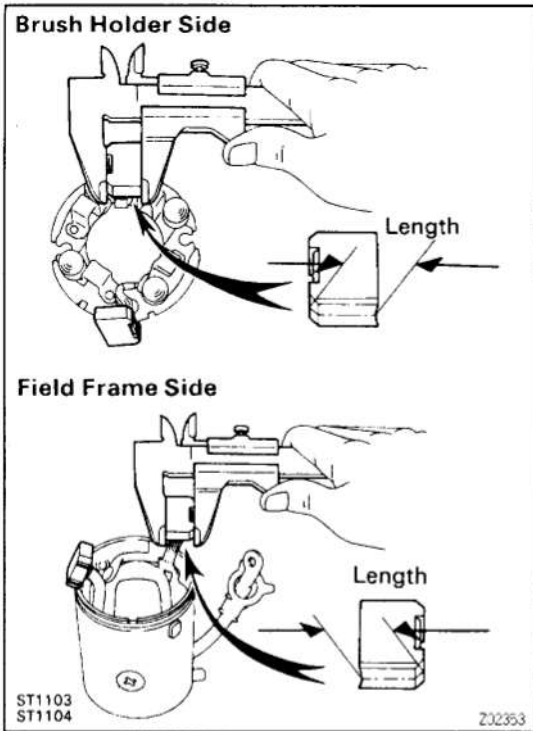

## Brushes

### INSPECT BRUSH LENGTH

Using a vernier caliper, measure the brush length.

**Standard length:**

**16.5 – 17.0 mm (0.650 – 0.669 in.)**

**Minimum length:**

**9.0 mm (0.354 in.)**

If the length is less than minimum, replace the brush holder and field frame.

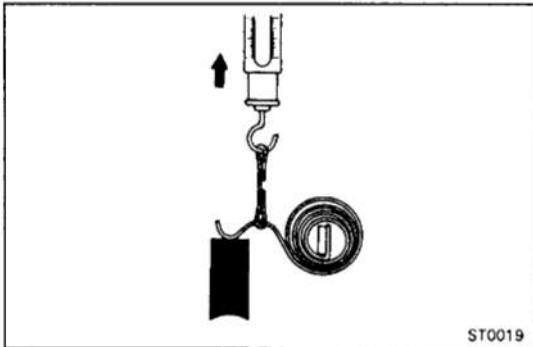

## Brush Springs

### INSPECT BRUSH SPRING LOAD

Take the pull scale reading the instant the brush spring separates from the brush.

**Spring installed load:**

**26 – 32 N (2.7 – 3.3 kgf, 6.0 – 7.3 lbf)**

If the installed load is not within specification, replace the brush springs.

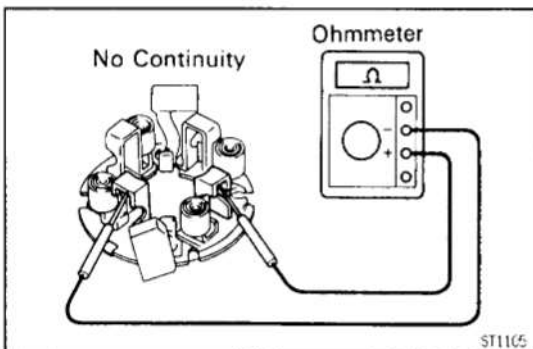

## Brush Holder

### INSPECT BRUSH HOLDER INSULATION

Using an ohmmeter, check that there is no continuity between the positive (+) and negative (-) brush holders.

If there is continuity, repair or replace the brush holder.

## Clutch and Gears

### 1. INSPECT GEAR TEETH

Check the gear teeth on the pinion gear, idle gear and clutch assembly for wear or damage.

If damaged, replace the gear or clutch assembly.

If damaged, also check the drive plate ring gear for wear or damage.

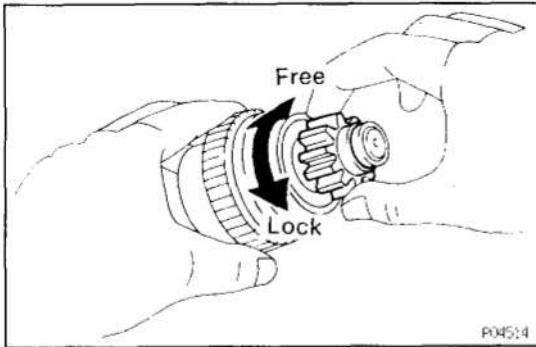

## 2. INSPECT CLUTCH PINION GEAR

Hold the starter clutch and rotate the pinion gear clockwise, and check that it turns freely. Try to rotate the pinion gear counterclockwise and check that it locks.

If necessary, replace the clutch assembly.

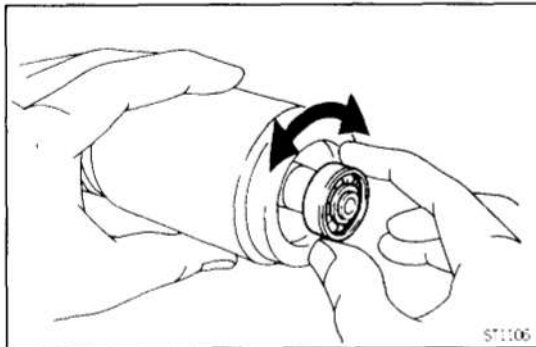

## Bearings

### 1. INSPECT FRONT BEARING

Turn the bearing by hand while applying inward force. If resistance is felt or the bearing sticks, replace the bearing.

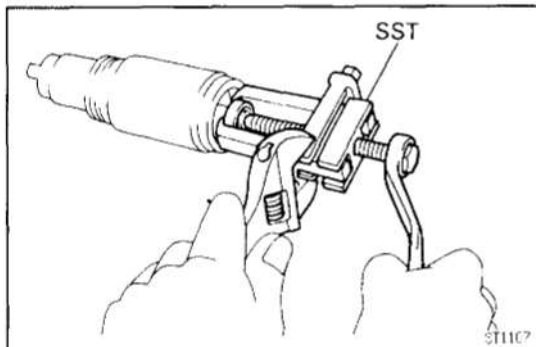

### 2. IF NECESSARY, REPLACE FRONT BEARING

- (a) Using SST, remove the bearing.  
SST 09286-46011

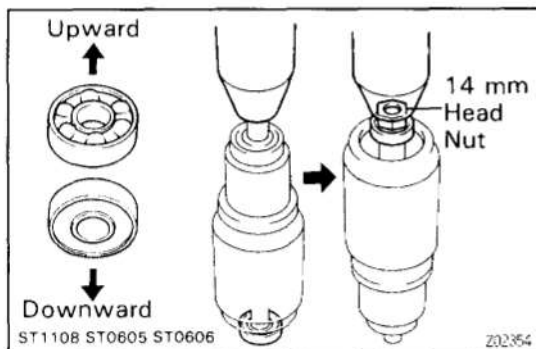

- (b) Using a 14 mm head nut and press, press in a new bearing.

**NOTICE:** Be careful of the bearing installation direction.

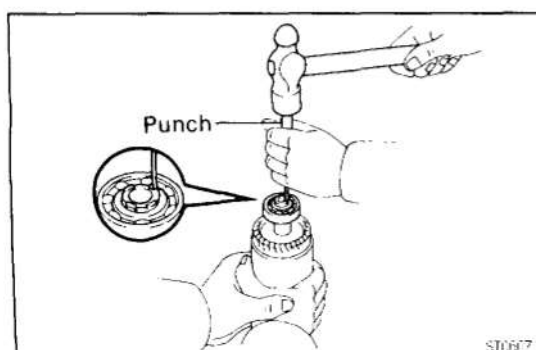

- (c) Using a punch, stake the armature shaft.

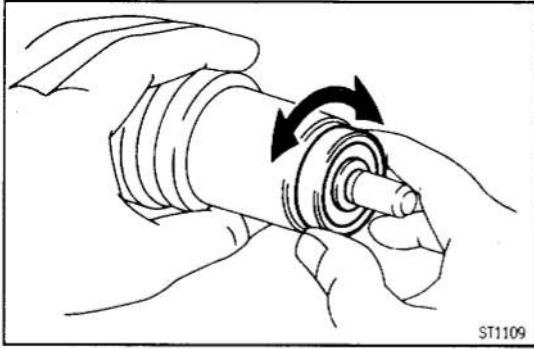
**3. INSPECT REAR BEARING**

Turn the bearing by hand while applying inward force. If resistance is felt or the bearing sticks, replace the bearing.

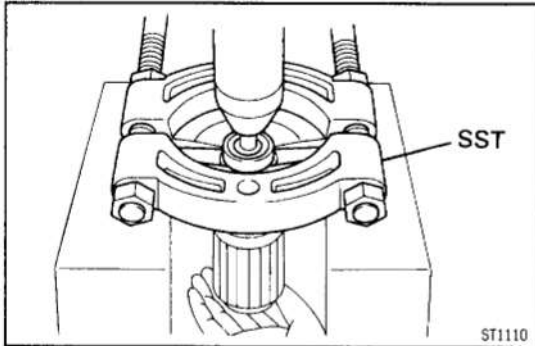
**4. IF NECESSARY, REPLACE REAR BEARING**

- (a) Using SST and a press, press out the bearing.  
SST 09950-00020

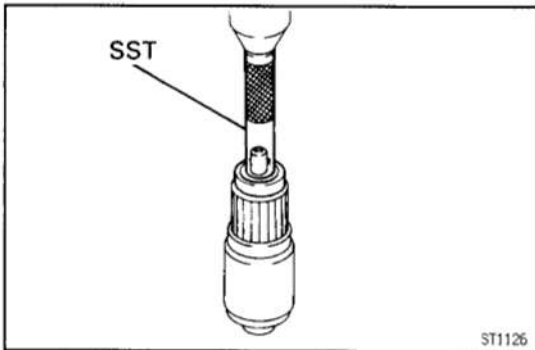

- (b) Using SST and a press, press in a new bearing.  
SST 09201-41020

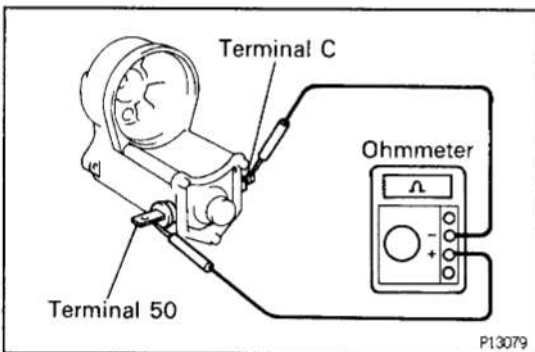
**Magnetic Switch**

- 1. PERFORM PULL-IN COIL OPEN CIRCUIT TEST**  
Using an ohmmeter, check that there is continuity between terminals 50 and C.  
If there is no continuity, replace the magnetic switch.

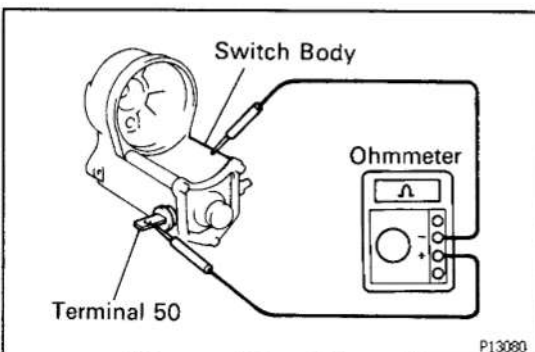

- 2. PERFORM HOLD-IN COIL OPEN CIRCUIT TEST**  
Using an ohmmeter, check that there is continuity between terminal 50 and the switch body.  
If there is no continuity, replace the magnetic switch.

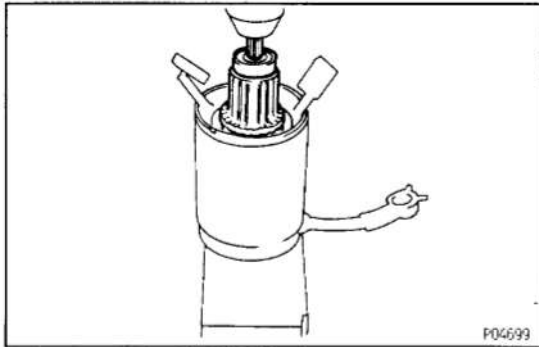

## STARTER ASSEMBLY

(See Components for Disassembly and Assembly)

HINT: Use high-temperature grease to lubricate the bearings and gears when assembling the starter.

### 1. PLACE ARMATURE INTO FIELD FRAME

- (a) Apply grease to the armature bearings.
- (b) Using a press, press the armature into the field frame.

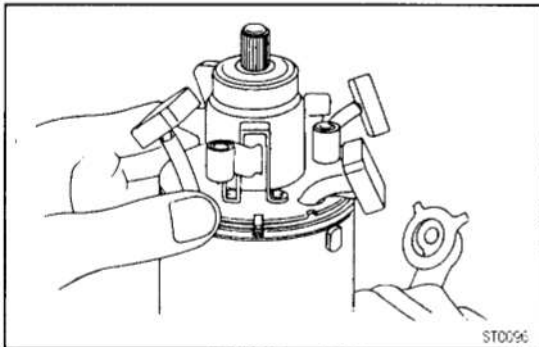

### 2. INSTALL BRUSH HOLDER

- (a) Align the claw of the brush holder with the claw groove of the field frame.
- (b) Place the brush holder on the field frame.

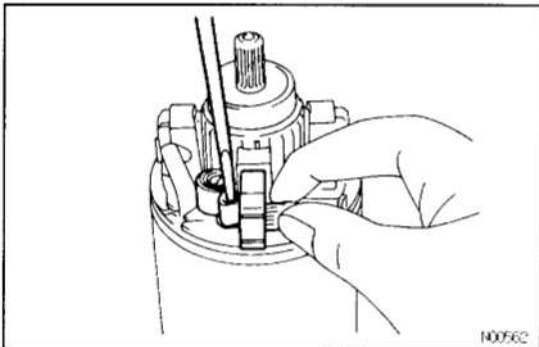

- (c) Using a screwdriver, hold the brush spring back, and connect the brush into the brush holder. Connect the 4 brushes.

**NOTICE:** Check that the positive (+) lead wires are not grounded.

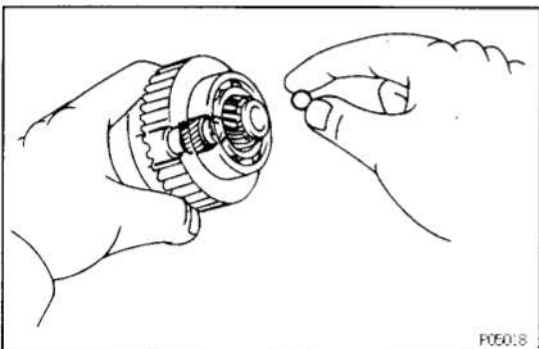

### 3. INSERT STEEL BALL INTO CLUTCH SHAFT HOLE

- (a) Apply grease to the steel ball.
- (b) Insert the steel ball into the clutch shaft hole.

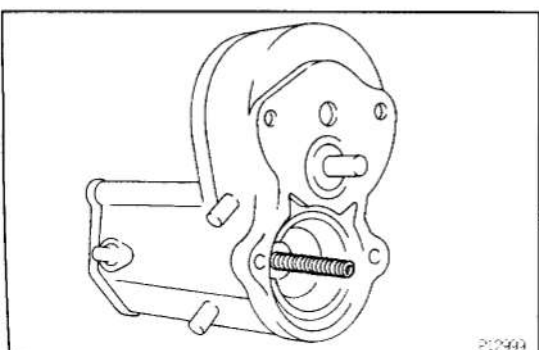

### 4. INSTALL STARTER HOUSING, CLUTCH ASSEMBLY AND GEARS

- (a) Apply grease to the return spring.
- (b) Insert the return spring into the magnetic switch hole.

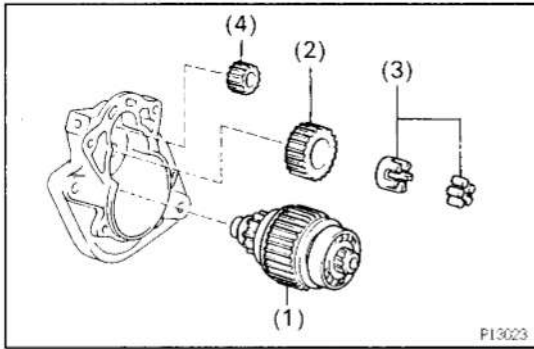

(c) Place the following parts in position on the starter housing:

- (1) Clutch assembly
- (2) Idler gear
- (3) Bearing
- (4) Pinion gear

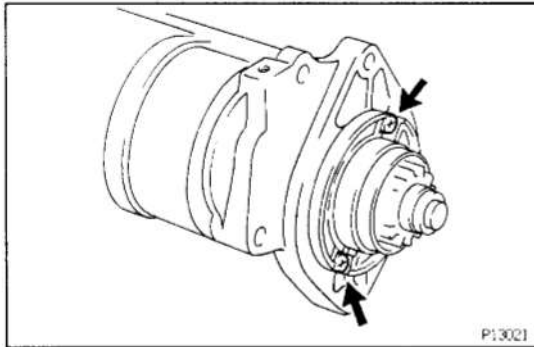

(d) Assemble the starter housing and magnetic switch assembly and install the 2 screws.

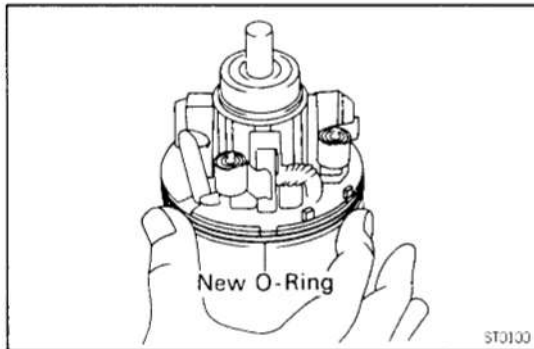

**5. INSTALL FIELD FRAME AND ARMATURE ASSEMBLY**

(a) Place a new O-ring in position on the field frame.

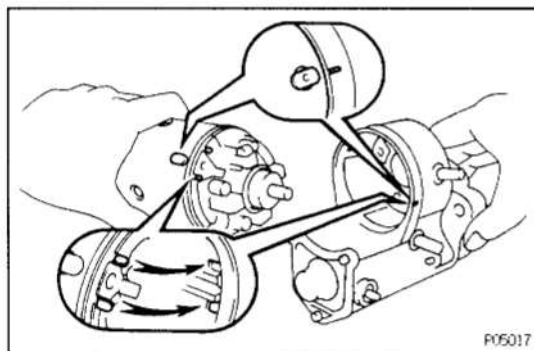

(b) Align the claws of the brush holder with the grooves of the magnetic switch, and install the field frame and armature shaft assembly.

(c) Align the punch mark of the field frame with the line of the magnet switch.

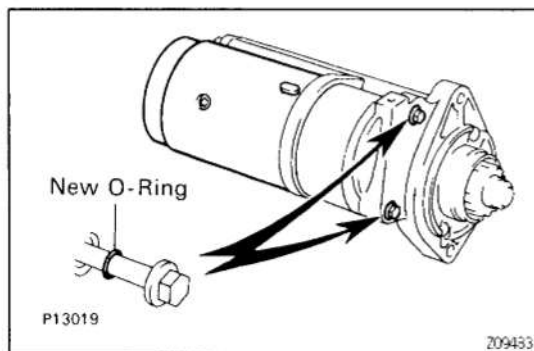

(d) Install a new O-rings to the through bolts.

(e) Install the field frame and armature assembly with the 2 through bolts.

**Torque: 12.7 N·m (130 kgf·cm, 9 ft·lbf)**

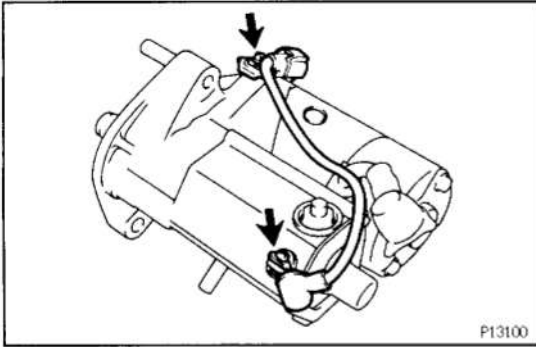

- (f) Install the lead wire to terminal 50 and starter housing with the bolt and screw.

**Torque: 3.6 N·m (41 kgf·cm, 35 in.-lbf)**

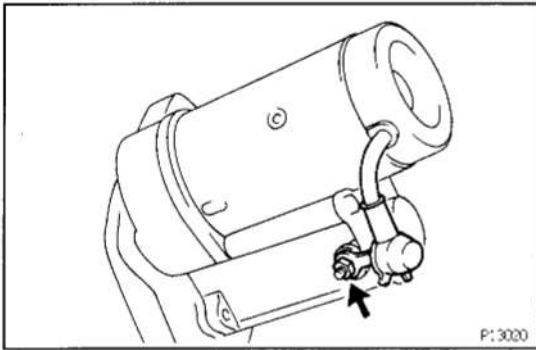

- (g) Connect the lead wire to terminal C, and install the nut.

**Torque: 5.4 N·m (51 kgf·cm, 44 in.-lbf)**

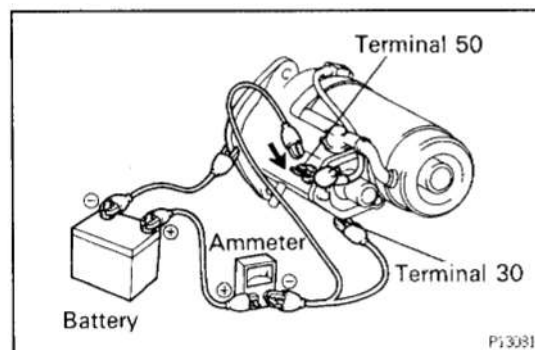
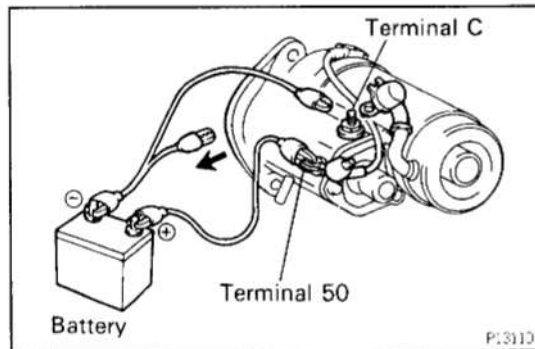
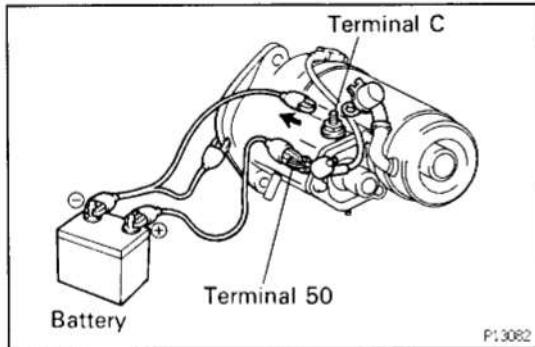
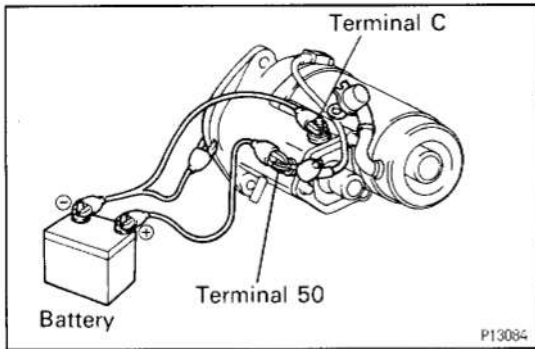

## STARTER PERFORMANCE TEST

**NOTICE:** These tests must be performed within 3 to 5 seconds to avoid burning out the coil.

### 1. PERFORM PULL-IN TEST

- Disconnect the field coil lead wire from terminal C.
- Connect the battery to the magnetic switch as shown. Check that the clutch pinion gear moves outward. If the clutch pinion gear does not move, replace the magnetic switch assembly.

### 2. PERFORM HOLD-IN TEST

With battery connected as above with the clutch pinion gear out, disconnect the negative (–) lead from terminal C. Check that the pinion gear remains out. If the clutch pinion gear returns inward, replace the magnetic switch assembly.

### 3. INSPECT CLUTCH PINION GEAR RETURN

Disconnect the negative (–) lead from the switch body.

Check that the clutch pinion gear returns inward. If the clutch pinion gear does not return, replace the magnetic switch assembly.

### 4. PERFORM NO-LOAD PERFORMANCE TEST

- Connect the battery and ammeter to the starter as shown.
- Check that the starter rotates smoothly and steadily with the pinion gear moving out. Check that the ammeter shows the specified current.

**Specified current:**

**120 A or less at 11.5 V**

# STARTER (2.7 kW) COMPONENTS FOR DISASSEMBLY AND ASSEMBLY

ST00W-0E

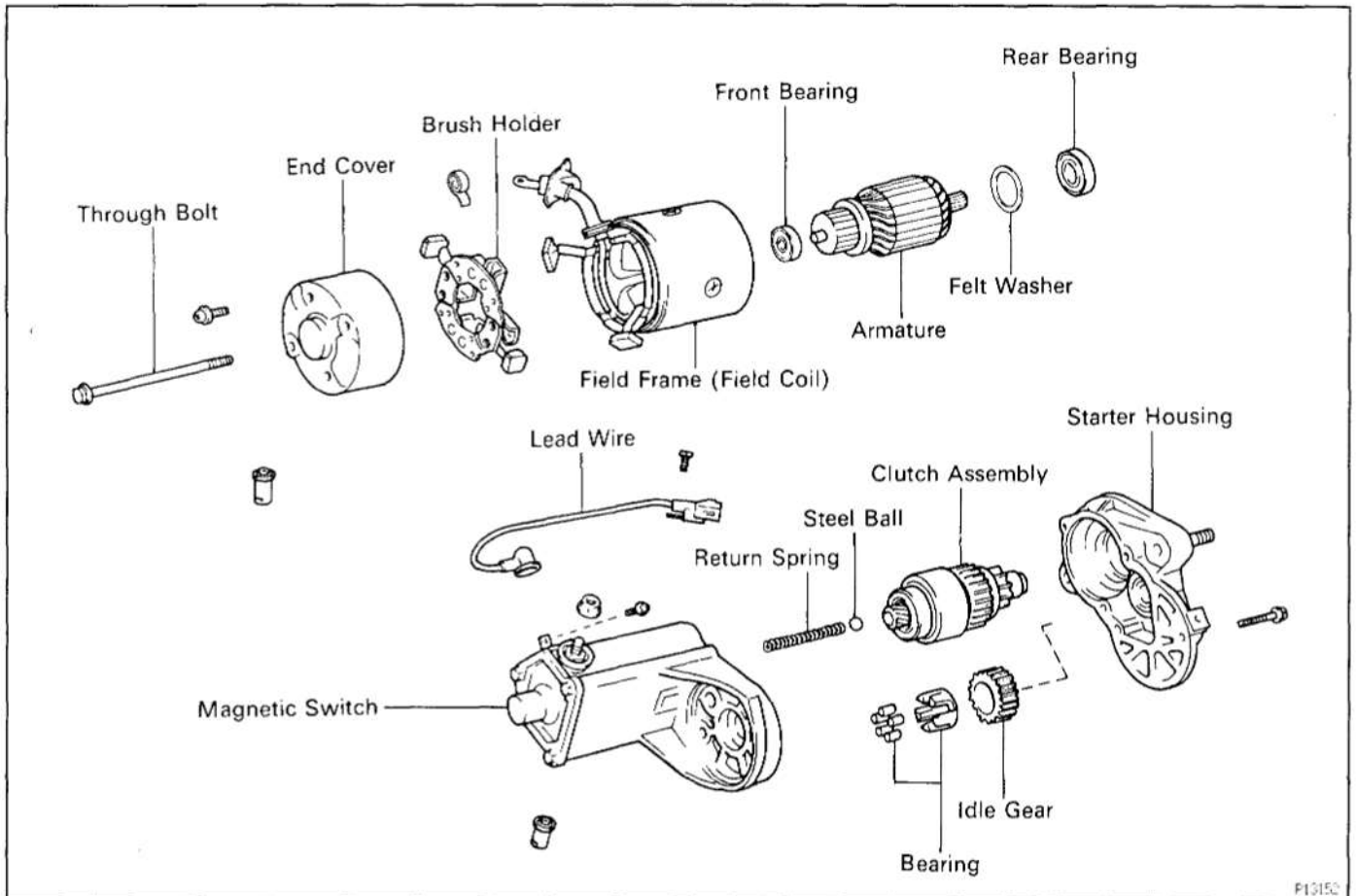

F13152

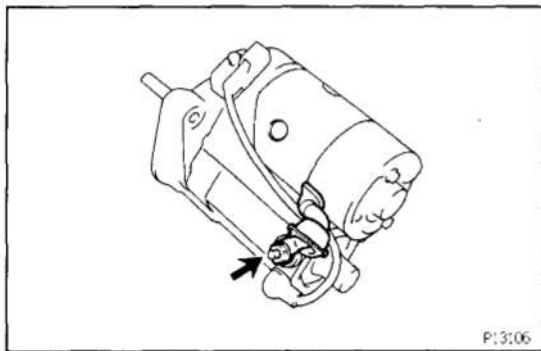

P13106

## STARTER DISASSEMBLY

8T06V-01

### 1. REMOVE FIELD FRAME WITH ARMATURE FROM MAGNETIC SWITCH ASSEMBLY

(a) Remove the nut, and disconnect the lead wire from the magnetic switch terminal.

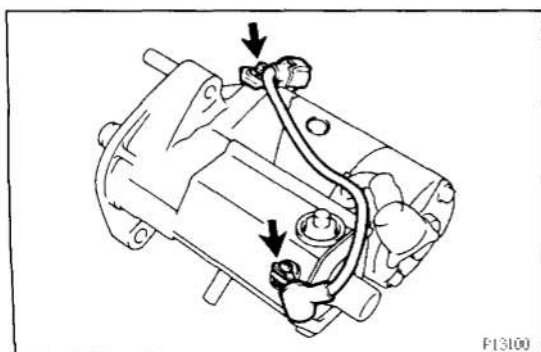

F13100

(b) Remove the bolt, screw and the lead wire from the terminal 50 and starter housing.



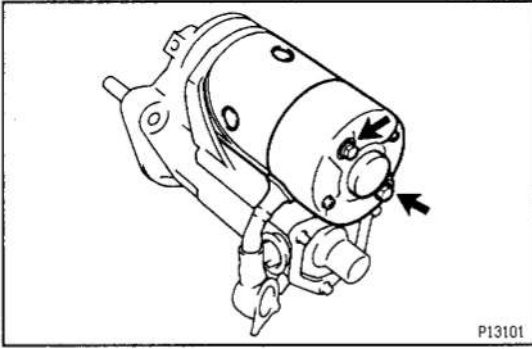

- (c) Remove the 2 through bolts.
- (d) Pull out the field frame with the armature from the magnetic switch assembly.

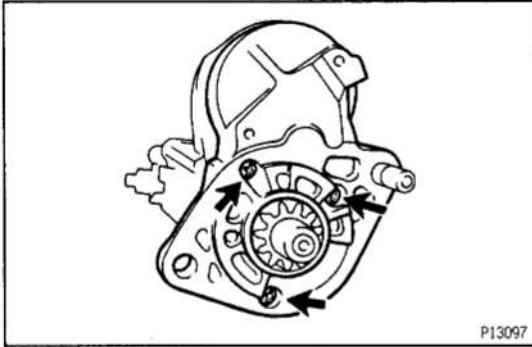

## 2. REMOVE STARTER HOUSING, CLUTCH ASSEMBLY AND GEARS

- (a) Remove the 3 screws.

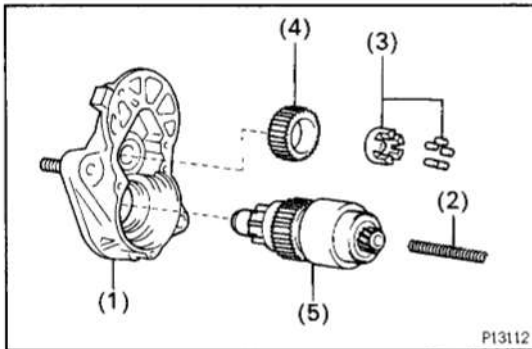

- (b) Remove the following parts from the magnetic switch assembly:

- (1) Starter housing
- (2) Return spring
- (3) Bearing
- (4) Idler gear
- (5) Clutch assembly

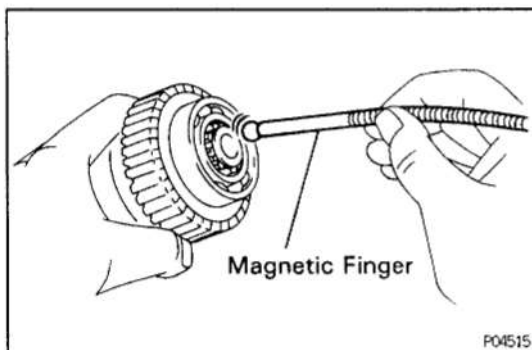

## 3. REMOVE STEEL BALL

Using a magnetic finger, remove the steel ball from the clutch shaft hole.

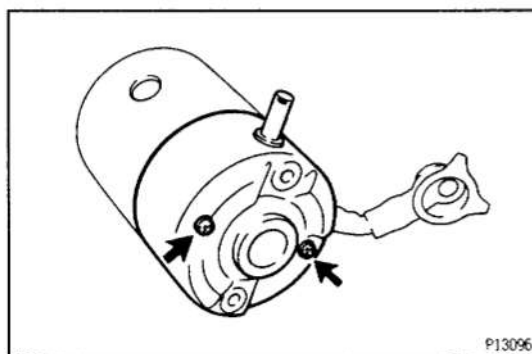

## 4. REMOVE BRUSH HOLDER

- (a) Remove the 2 screws and end cover from the field frame.

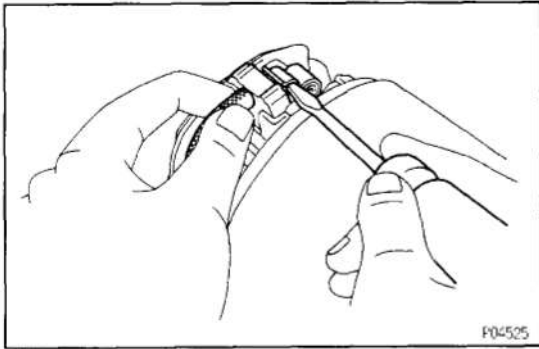

- (b) Using a screwdriver, hold the spring tank back and disconnect the brush from the brush holder.
- (c) Disconnect the 4 brushes and remove the brush holder.

## 5. REMOVE ARMATURE FROM FIELD FRAME

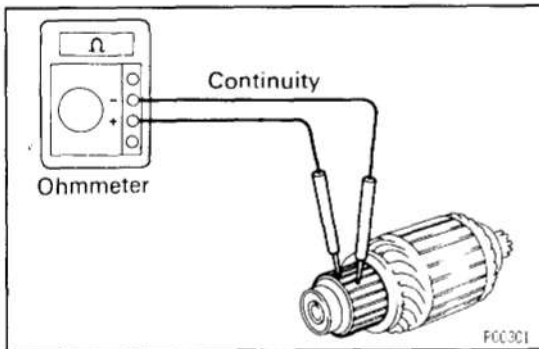

## STARTER INSPECTION AND REPAIR

### Armature Coil

#### 1. INSPECT COMMUTATOR FOR OPEN CIRCUIT

Using an ohmmeter, check that there is continuity between the segments of the commutator. If there is no continuity between any segment, replace the armature.

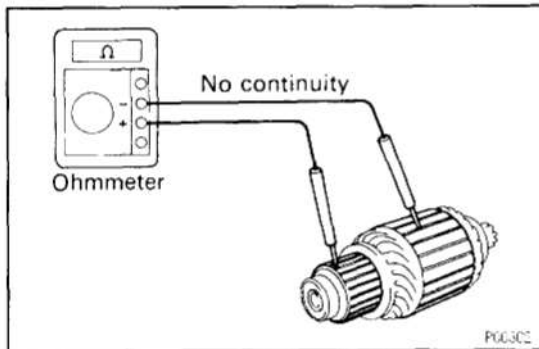

#### 2. INSPECT COMMUTATOR FOR GROUND

Using an ohmmeter, check that there is no continuity between the commutator and armature coil core. If there is continuity, replace the armature.

## Commutator

#### 1. INSPECT COMMUTATOR FOR DIRTY AND BURNT SURFACES

If the surface is dirty or burnt, correct it with sandpaper (No. 400) or on a lathe.

#### 2. INSPECT COMMUTATOR CIRCLE RUNOUT

- (a) Place the commutator on V-blocks.
- (b) Using a dial gauge, measure the circle runout.

**Maximum circle runout:**

**0.05 mm (0.0020 in.)**

If the circle runout is greater than maximum, correct it on a lathe.

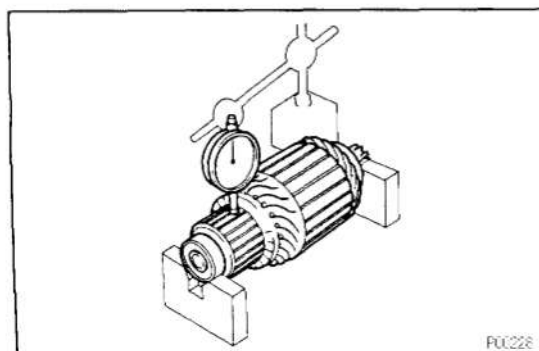

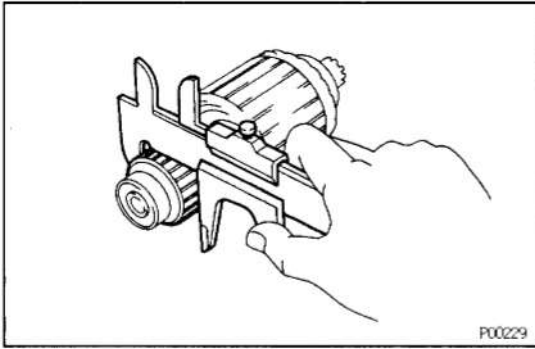

### 3. INSPECT COMMUTATOR DIAMETER

Using a vernier caliper, measure the commutator diameter.

**Standard diameter:**

36 mm (1.42 in.)

**Minimum diameter:**

35 mm (1.38 in.)

If the diameter is less than minimum, replace the armature.

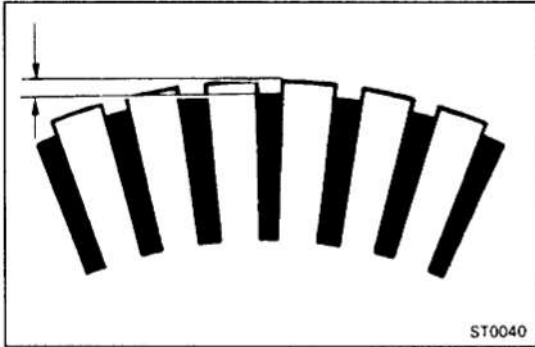

### 4. INSPECT UNDERCUT DEPTH

Check that the undercut depth is clean and free of foreign materials. Smooth out the edge.

**Standard undercut depth:**

0.7 – 0.9 mm (0.028 – 0.035 in.)

**Minimum undercut depth:**

0.2 mm (0.008 in.)

If the undercut depth is less than minimum, correct it with a hacksaw blade.

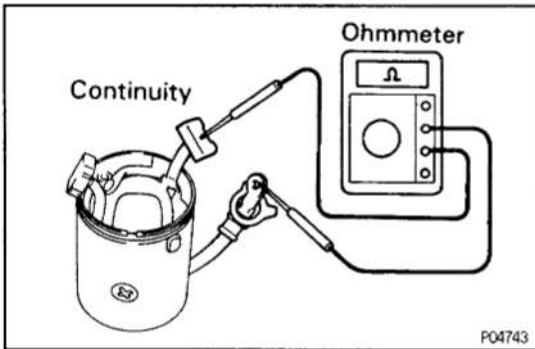

## Field Frame (Field Coil)

### 1. INSPECT FIELD COIL FOR OPEN CIRCUIT

Using an ohmmeter, check that there is continuity between the lead wire and field coil brush lead.

If there is no continuity, replace the field frame.

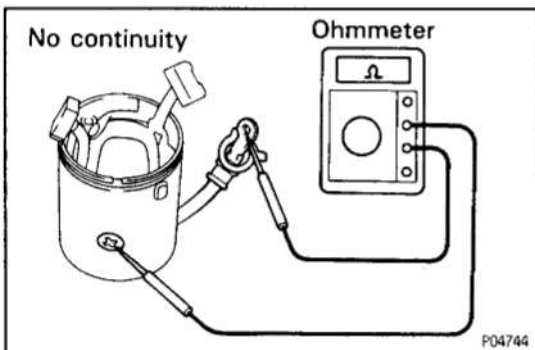

### 2. INSPECT FIELD COIL FOR GROUND

Using an ohmmeter, check that there is no continuity between the field coil end and field frame.

If there is continuity, repair or replace the field frame.

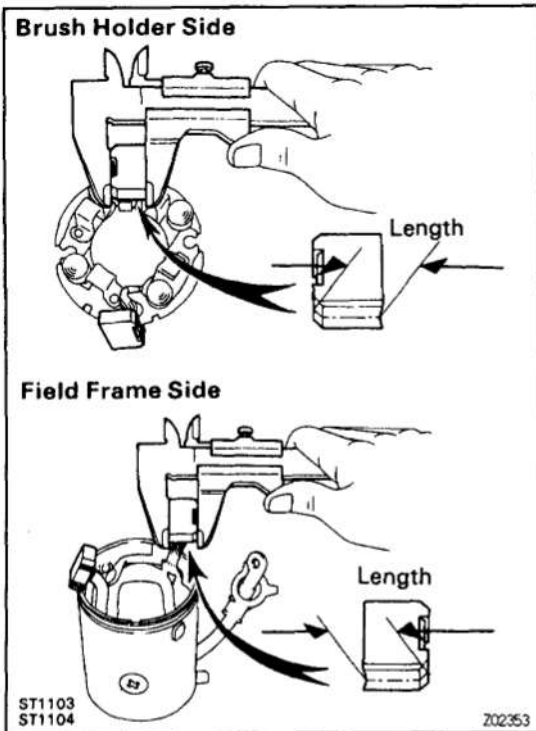

## Brushes

### INSPECT BRUSH LENGTH

Using a vernier caliper, measure the brush length.

**Standard length:**

20.5 – 21.0 mm (0.807 – 0.827 in.)

**Minimum length:**

13.5 mm (0.531 in.)

If the length is less than minimum, replace the brush holder and field frame.

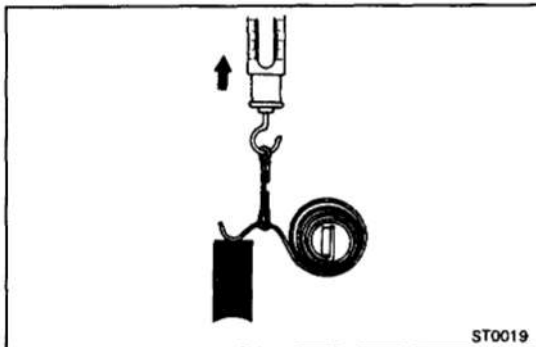

## Brush Springs

### INSPECT BRUSH SPRING LOAD

Take the pull scale reading the instant the brush spring separates from the brush.

**Spring installed load:**

32 – 38 N (3.3 – 3.9 kgf, 7.3 – 8.5 lbf)

If the installed load is not within specification, replace the brush springs.

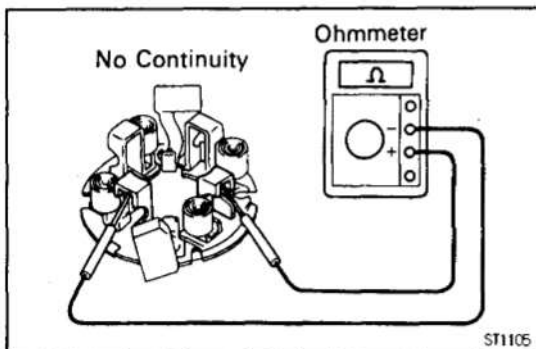

## Brush Holder

### INSPECT BRUSH HOLDER INSULATION

Using an ohmmeter, check that there is no continuity between the positive (+) and negative (-) brush holders.

If there is continuity, repair or replace the brush holder.

## Clutch and Gears

### 1. INSPECT GEAR TEETH

Check the gear teeth on the pinion gear, idle gear and clutch assembly for wear or damage.

If damaged, replace the gear or clutch assembly.

If damaged, also check the drive plate ring gear for wear or damage.

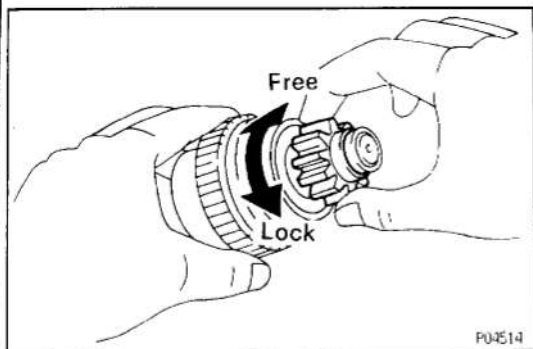

## 2. INSPECT CLUTCH PINION GEAR

Hold the starter clutch and rotate the pinion gear clockwise, and check that it turns freely. Try to rotate the pinion gear counterclockwise and check that it locks.

If necessary, replace the clutch assembly.

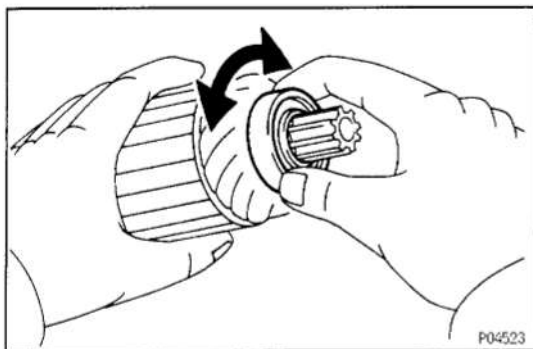

## Bearings

### 1. INSPECT BEARINGS

Turn the bearing by hand while applying inward force. If resistance is felt or the bearing sticks, replace the bearing.

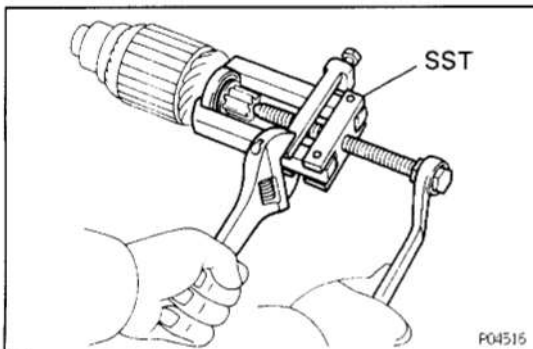

### 2. IF NECESSARY, REPLACE BEARINGS

- (a) Using SST, remove the bearing.  
SST 09286-46011

- (b) Using a press, press in a new front bearing.  
(c) Using SST and a press, press in a new rear bearing.  
SST 09820-00030

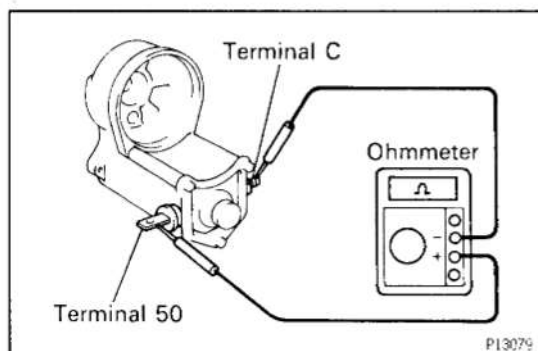
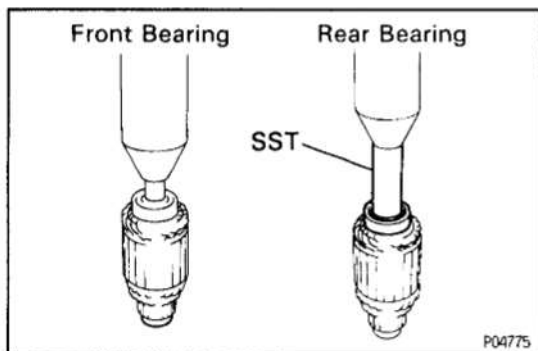

## Magnetic Switch

### 1. PERFORM PULL-IN COIL OPEN CIRCUIT TEST

Using an ohmmeter, check that there is continuity between terminals 50 and C.

If there is no continuity, replace the magnetic switch.

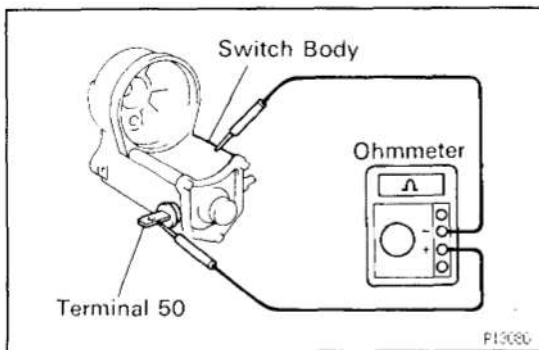

- 2. PERFORM HOLD-IN COIL OPEN CIRCUIT TEST**  
Using an ohmmeter, check that there is continuity between terminal 50 and the switch body.  
If there is no continuity, replace the magnetic switch.

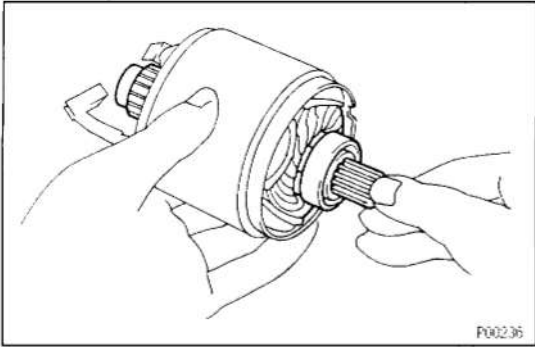

## STARTER ASSEMBLY

(See Components for Disassembly and Assembly)

**HINT:** Use high-temperature grease to lubricate the bearings and gears when assembling the starter.

### 1. PLACE ARMATURE INTO FIELD FRAME

Apply grease to the armature bearings, and insert the armature into the field frame.

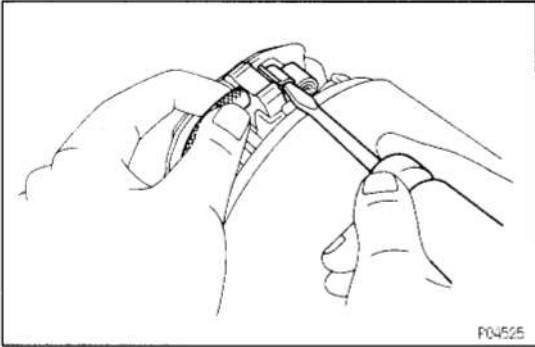

### 2. INSTALL BRUSH HOLDER

(a) Place the brush holder on the armature.

(b) Using a screwdriver, hold the brush spring back, and connect the brush into the brush holder. Connect the four brushes.

**NOTICE:** Check that the positive (+) lead wires are not grounded.

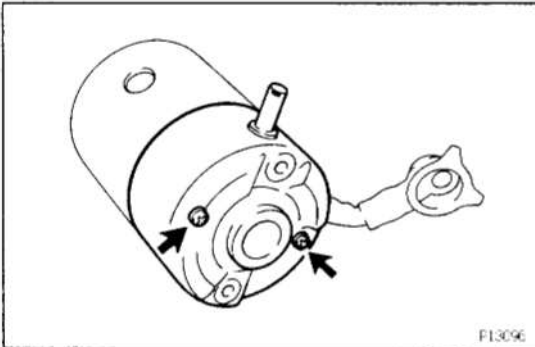

(c) Install the end cover to the field frame with the 2 screws.

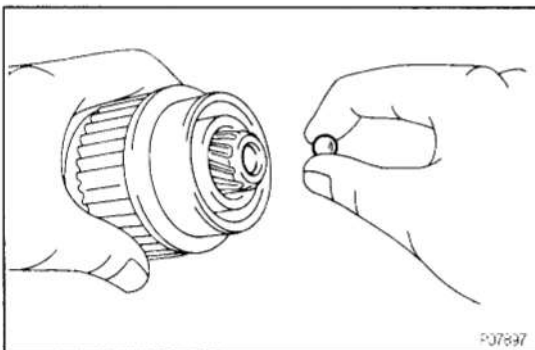

### 3. INSERT STEEL BALL INTO CLUTCH SHAFT HOLE

(a) Apply grease to the steel ball.

(b) Insert the steel ball into the clutch shaft hole.

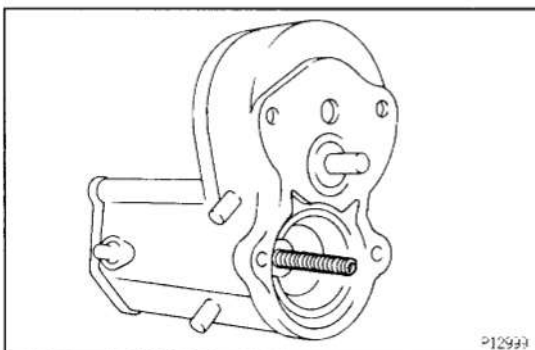

### 4. INSTALL STARTER HOUSING, CLUTCH ASSEMBLY AND GEAR

(a) Apply grease to the return spring.

(b) Insert the return spring into the magnetic switch hole.

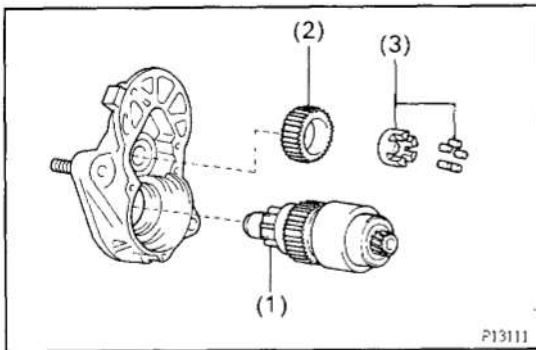

(c) Place the following parts in position on the starter housing:

- (1) Clutch assembly
- (2) Idler gear
- (3) Bearing

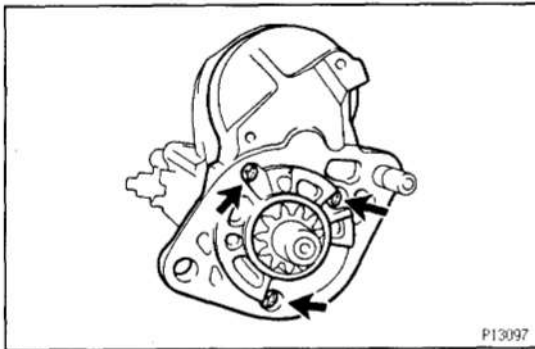

(d) Assemble the starter housing and magnetic switch assembly and install the 2 screws.

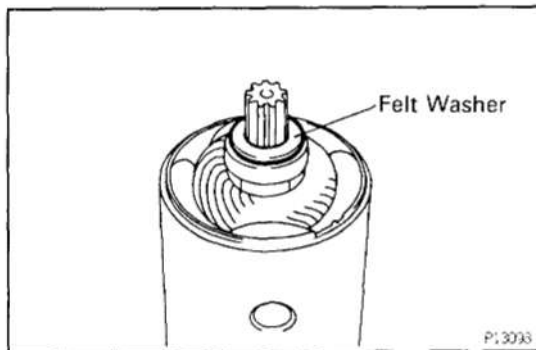

## 5. INSTALL FIELD FRAME WITH ARMATURE TO MAGNETIC SWITCH ASSEMBLY

(a) Install a new felt washer to the armature.

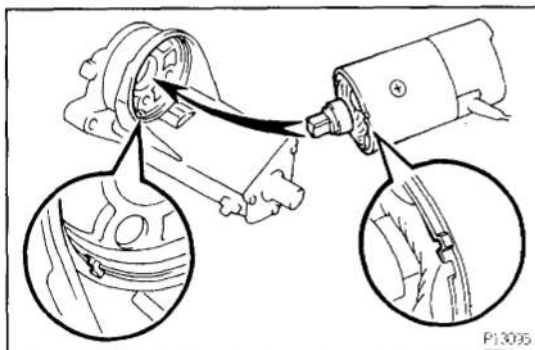

(b) Align the protrusion of the field frame with the cutout of the magnetic switch.

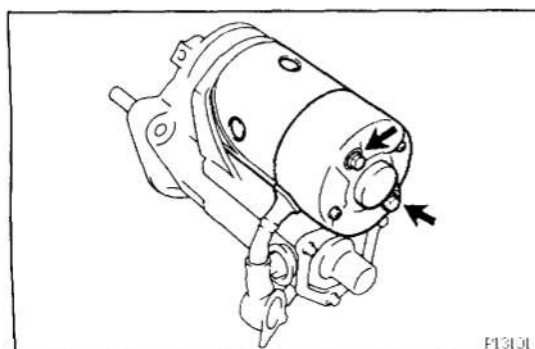

(c) Install the field frame and armature assembly with the 2 through bolts.

Torque: 9.3 N·m (95 kgf·cm, 82 in·lbf)



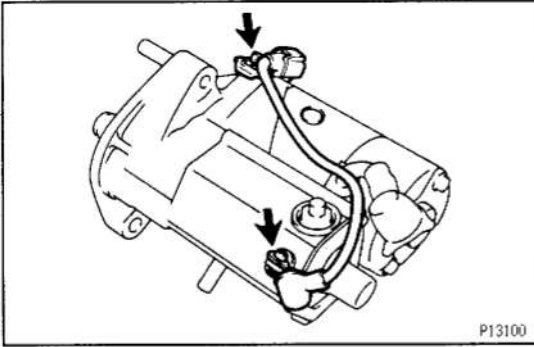

- (d) Install the lead wire to terminal 50 and starter housing with the bolt and screw.

**Torque: 3.6 N·m (41 kgf·cm, 32 in.-lbf)**

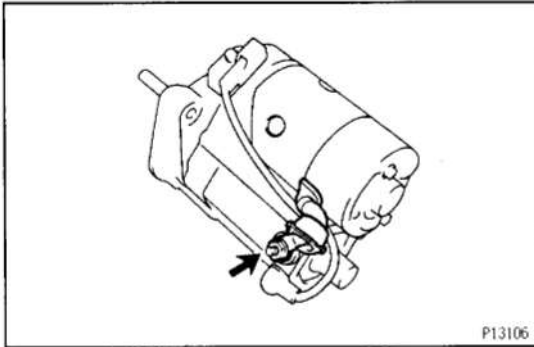

- (e) Connect the lead wire to terminal C, and install the nut.

**Torque: 21.1 N·m (215 kgf·cm, 16 ft·lbf)**

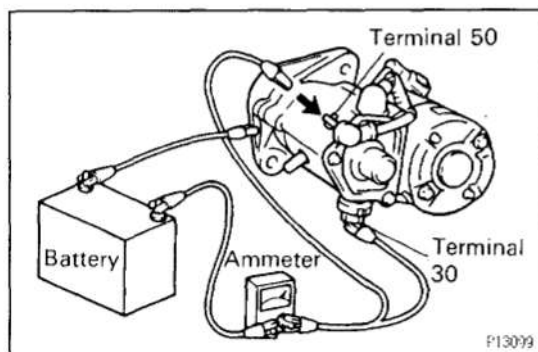
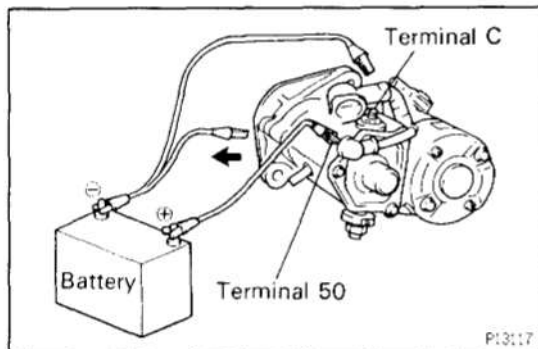
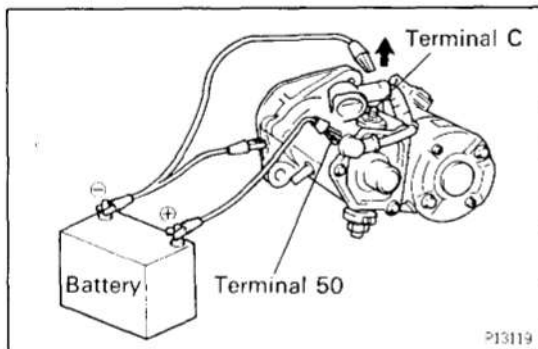
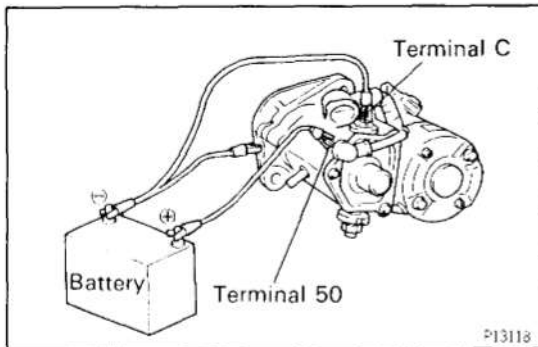

## STARTER PERFORMANCE TEST

**NOTICE:** These tests must be performed within 3 to 5 seconds to avoid burning out the coil.

### 1. PERFORM PULL-IN TEST

- (a) Disconnect the field coil lead wire from terminal C.
- (b) Connect the battery to the magnetic switch as shown. Check that the clutch pinion gear moves outward. If the clutch pinion gear does not move, replace the magnetic switch assembly.

### 2. PERFORM HOLD-IN TEST

With battery connected as above with the clutch pinion gear out, disconnect the negative (–) lead from terminal C. Check that the pinion gear remains out. If the clutch pinion gear returns inward, replace the magnetic switch assembly.

### 3. INSPECT CLUTCH PINION GEAR RETURN

Disconnect the negative (–) lead from the switch body.

Check that the clutch pinion gear returns inward. If the clutch pinion gear does not return, replace the magnetic switch assembly.

### 4. PERFORM NO-LOAD PERFORMANCE TEST

- (a) Connect the battery and ammeter to the starter as shown.
- (b) Check that the starter rotates smoothly and steadily with the pinion gear moving out. Check that the ammeter shows the specified current.

**Specified current:**

**180 A or less at 11.0 V**

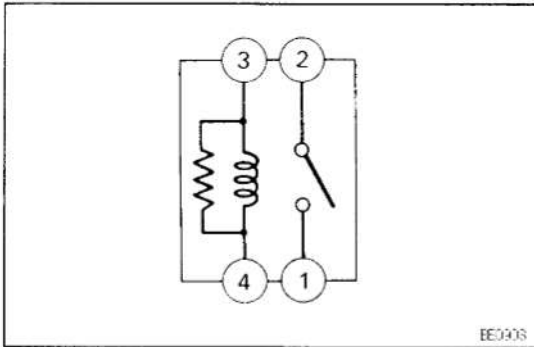

## STARTER RELAY

### STARTER RELAY INSPECTION

ST05Y-01

1. REMOVE STARTER RELAY
2. INSPECT STARTER RELAY

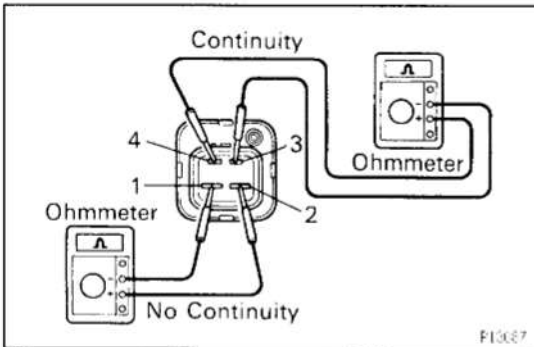

### 3. INSPECT RELAY CONTINUITY

- (a) Using an ohmmeter, check that there is continuity between terminals 3 and 4.
- (b) Check that there is no continuity between terminals 1 and 2.

If continuity is not as specified, replace the relay.

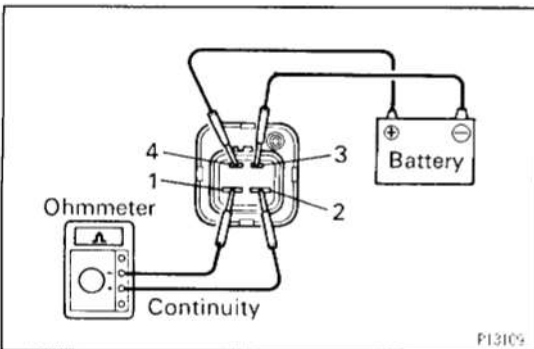

### 4. INSPECT RELAY OPERATION

- (a) Apply battery voltage across terminals 3 and 4.
- (b) Using an ohmmeter, check that there is continuity between terminals 1 and 2.

If operation is not as specified, replace the relay.

### 5. REINSTALL STARTER RELAY

# PRE-HEATING SYSTEM DESCRIPTION

ST05N-01

## PRE-HEATING TIMER

Newly developed ceramic glow plugs are used to greatly reduce pre-heating time and simplify the system. The glow plugs are computer controlled for optimum efficiency.

## GLOW PLUG

This engine uses ceramic glow plugs. The heater element consists of a glow filament made from conductive ceramic, an insulator made from insulating ceramic, and a tungsten wire.

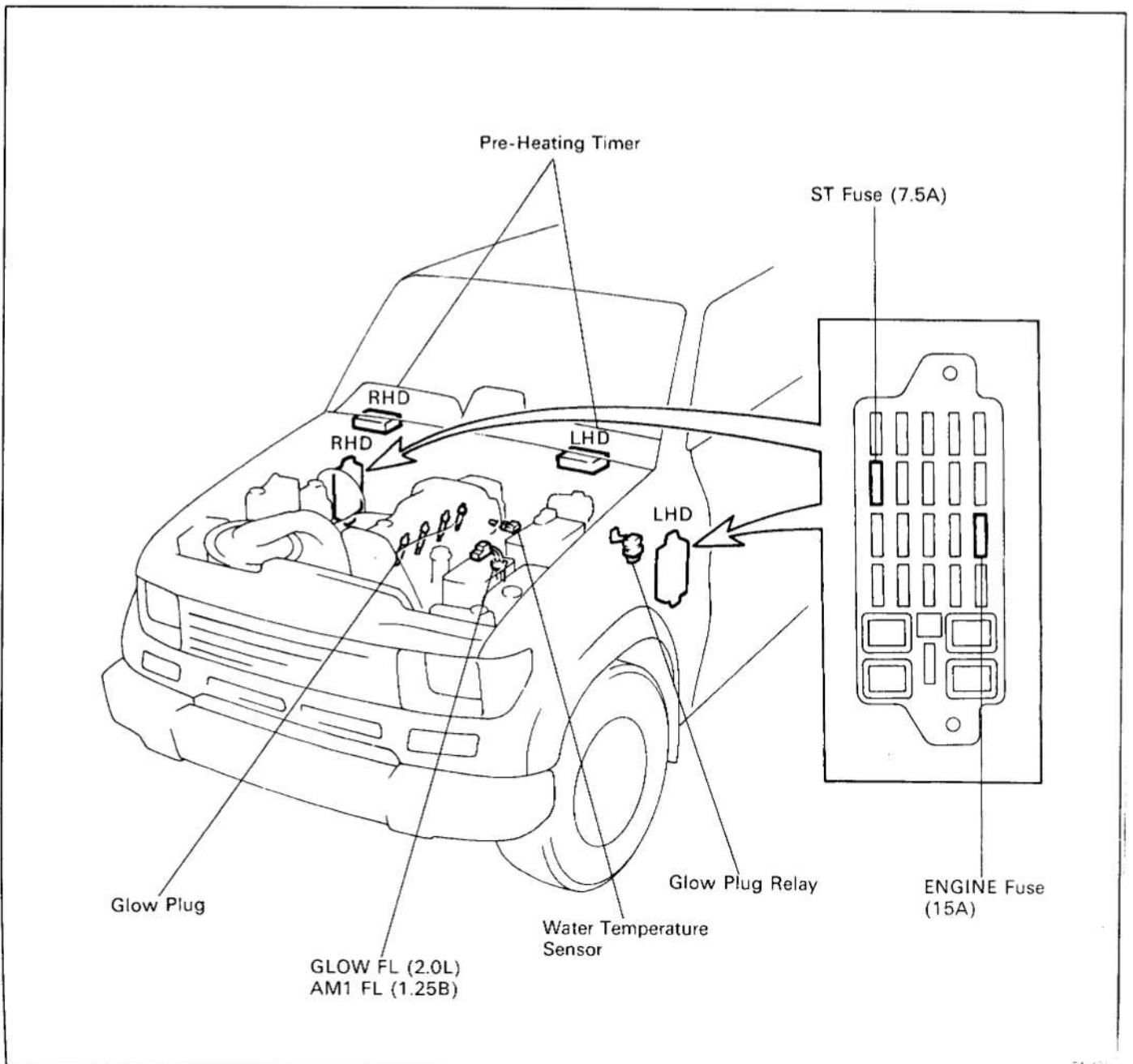

P1300

## SYSTEM CIRCUIT

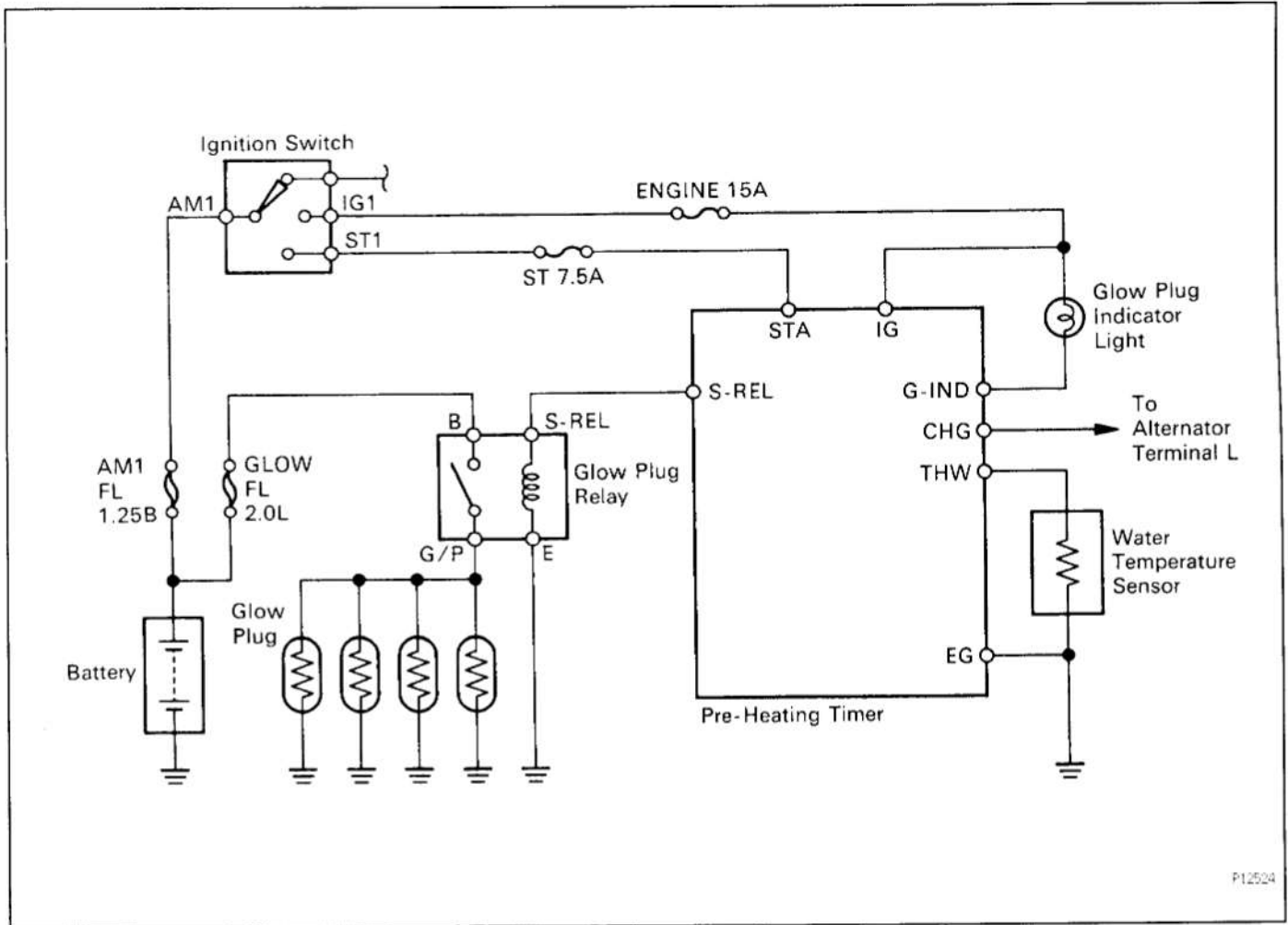

P12524

## ON – VEHICLE INSPECTION

ST05Q-01

HINT: Refer to Diesel Electrical System Diagnosis for inspection procedures. (See page EG-11)

1. **INSPECT LIGHTING TIME OF GLOW INDICATOR LIGHT**

Turn the ignition switch "ON", measure the lighting time.

Light lighting time:

Refer to the chart graph

2. **INSPECT AFTER GLOW TIME**

Turn the ignition switch "ON", measure the time battery voltage is applied to terminal S-REL of the pre-heating timer.

After glow time:

Refer to the chart graph

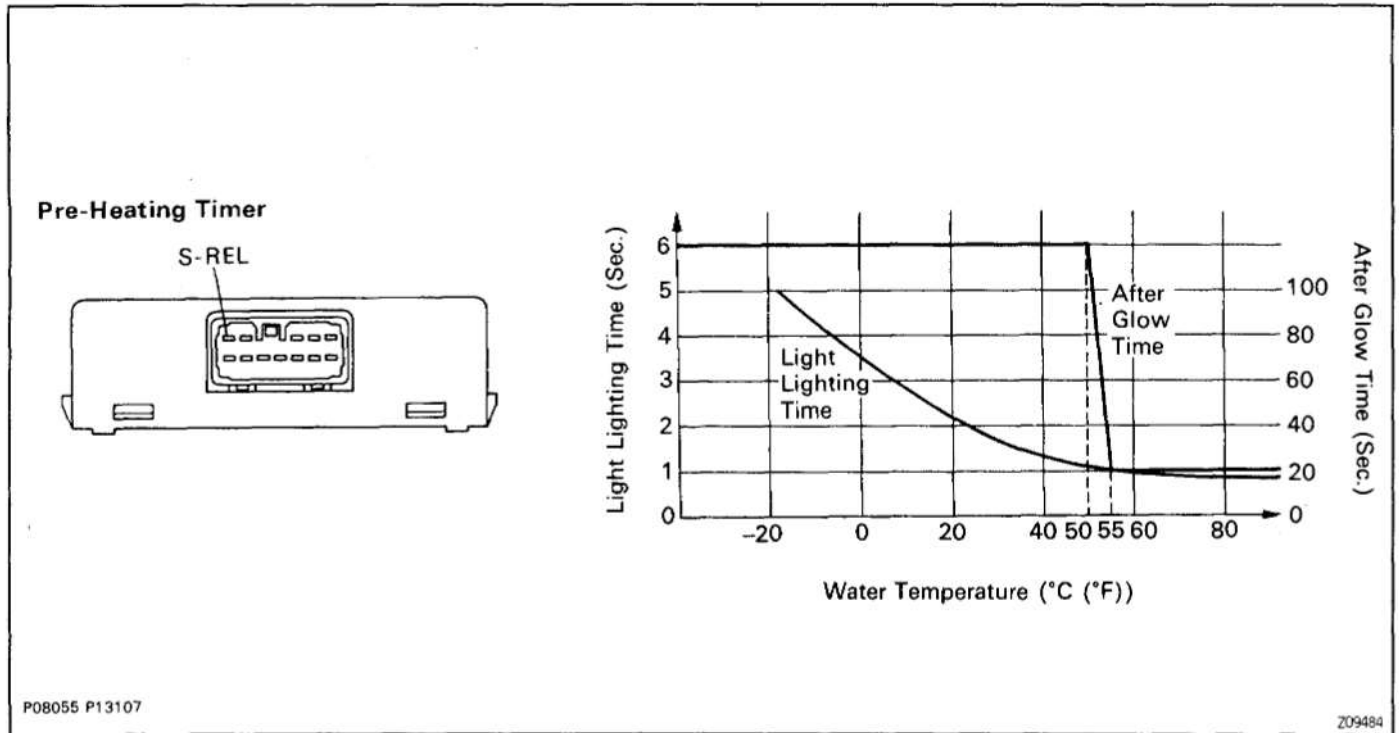

**PRE-HEATING TIMER INSPECTION**

ST06R-01

**INSPECT PRE-HEATING TIMER CIRCUIT**

Disconnect the connector(s) from the pre-heating timer, and check the connector on the wire harness side as shown in the following chart:

Check for	Tester connection	Condition	Specified value
Voltage	G-IND – Ground	Ignition switch OFF	No voltage
		Ignition switch ON	Battery voltage
Voltage	IG – Ground	Ignition switch OFF	No voltage
		Ignition switch ON	Battery voltage
Voltage	STA – Ground	Ignition switch OFF	No voltage
		Ignition switch START	Battery voltage
Continuity	S-REL – Ground	-	Continuity
Continuity	THW – EG	-	Continuity

Wire Harness Side of Pre-Heating Timer

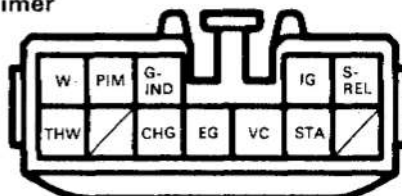

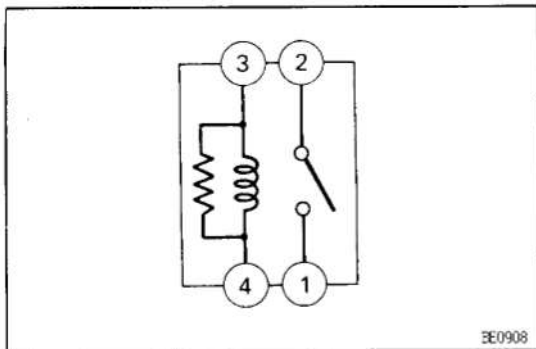

EE0908

## GLOW PLUG RELAY INSPECTION

1. REMOVE GLOW PLUG RELAY
2. INSPECT GLOW PLUG RELAY

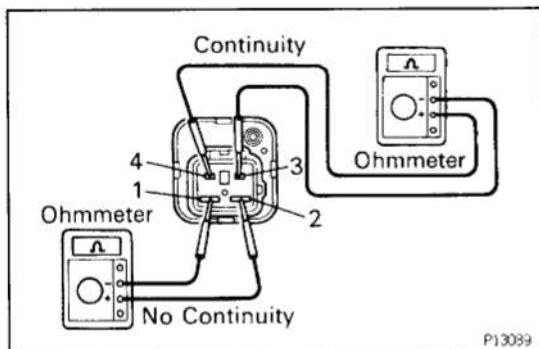

P13089

### 3. INSPECT RELAY CONTINUITY

- (a) Using an ohmmeter, check that there is continuity between terminals 3 and 4.
- (b) Check that there is no continuity between terminals 1 and 2.

If continuity is not as specified, replace the relay.

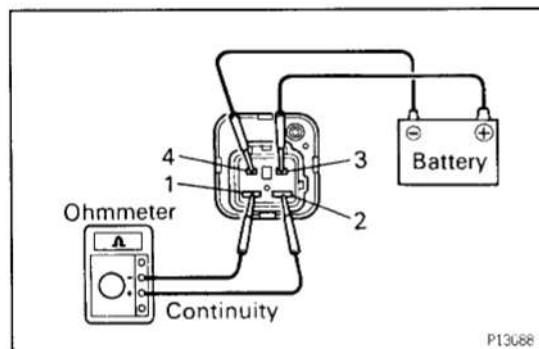

P13088

### 4. INSPECT RELAY OPERATION

- (a) Apply battery voltage across terminals 3 and 4.
- (b) Using an ohmmeter, check that there is continuity between terminals 1 and 2.

If operation is not as specified, replace the relay.

### 5. REINSTALL GLOW PLUG RELAY

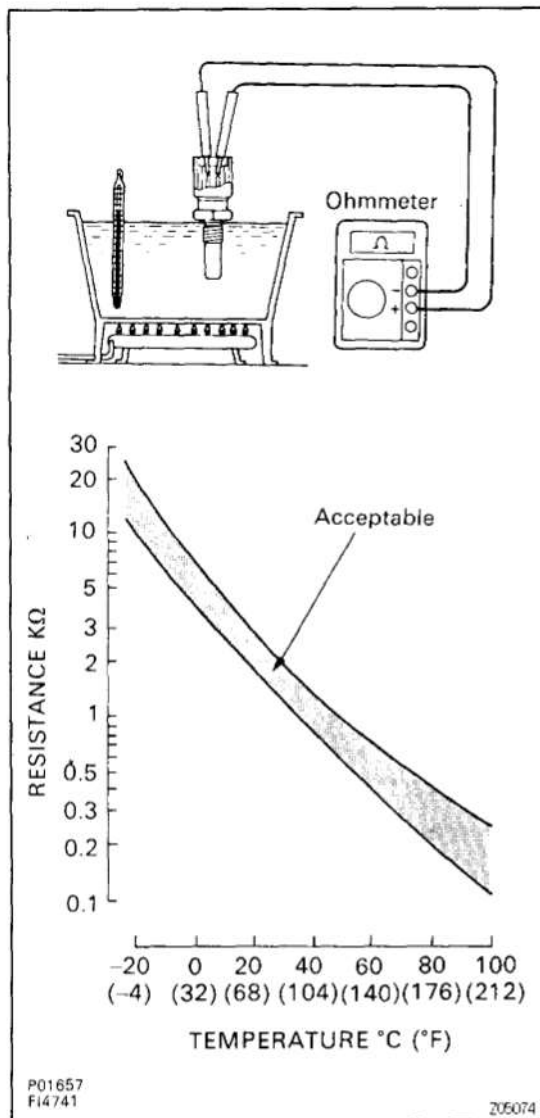

## WATER TEMPERATURE SENSOR INSPECTION

1. REMOVE WATER TEMPERATURE SENSOR
2. INSPECT WATER TEMPERATURE SENSOR

Using an ohmmeter, measure the resistance between the terminals.

**Resistance:**

**Refer to the chart graph**

If the resistance is not as specified, replace the water temperature sensor.

3. REINSTALL WATER TEMPERATURE SENSOR



# GLOW PLUG COMPONENTS FOR REMOVAL AND INSTALLATION

ST05Z-01

**NOTICE:**

- The cylinder head and glow plug hole can seize up with carbon deposits. And if the glow plug is forcefully twisted when you remove it, the torsion can crack the ceramic. So keep removal of the glow plugs to a minimum.
- The heater element is ceramic. So if you drop or knock a glow plug even once, replace the glow plug. Replace it regardless of it being new or used, having a normal resistance value and no sign of external damage.

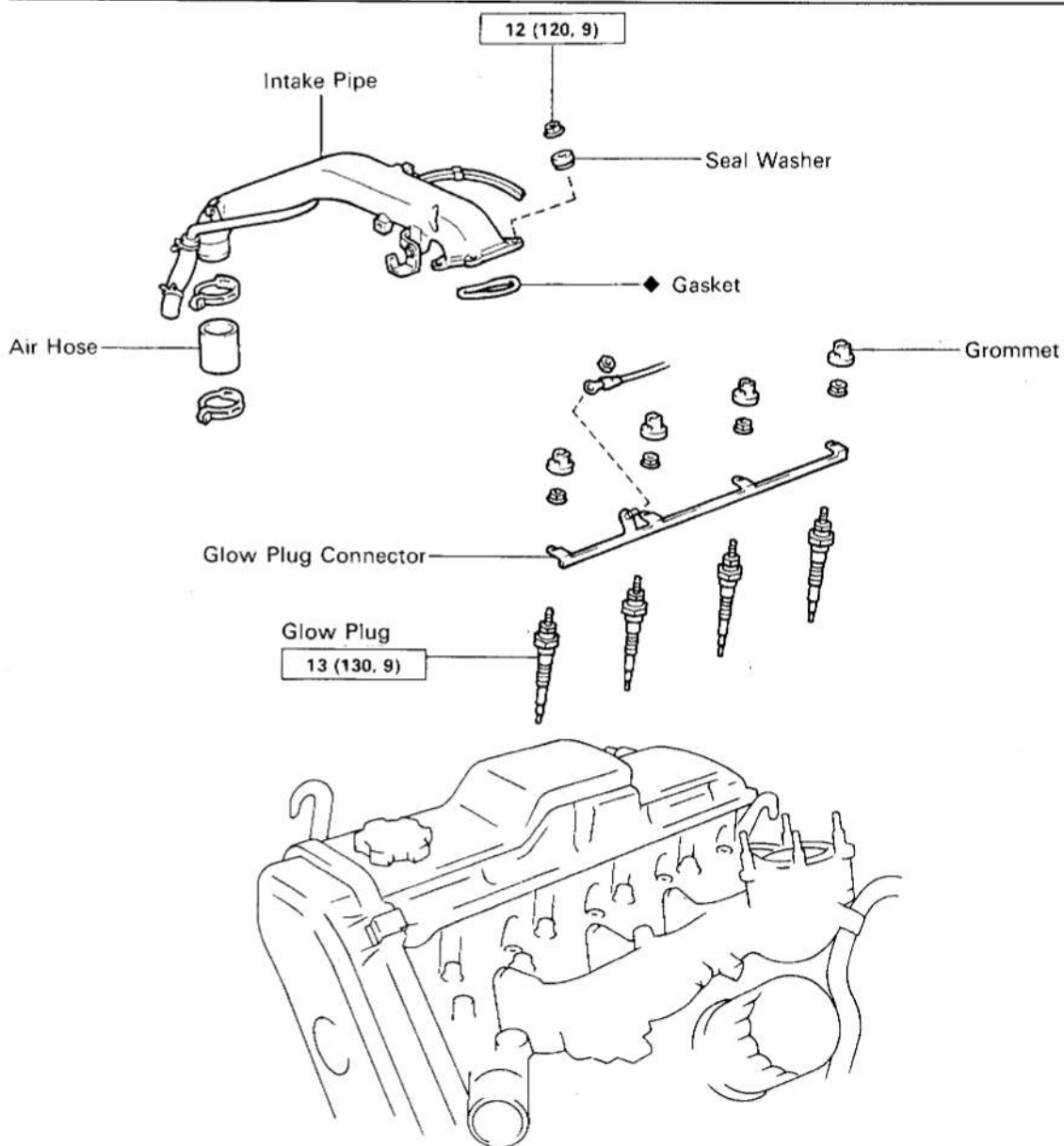

N·m (kgf·cm, ft·lbf) : Specified torque

◆ Non-reusable part

## ON – VEHICLE INSPECTION

**NOTICE:** When checking the resistance of the glow plugs, do it with the engine installed. Keep removal and installation of the glow plugs to a minimum.

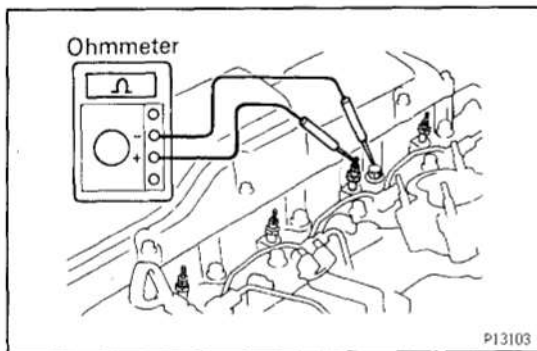

### INSPECT GLOW PLUGS

Using an ohmmeter, that there is continuity between the glow plug terminal and ground.

**Resistance (Cold):**

**Approx. 0.65  $\Omega$**

If the resistance exceeds 1.0  $\Omega$ , replace the glow plug.

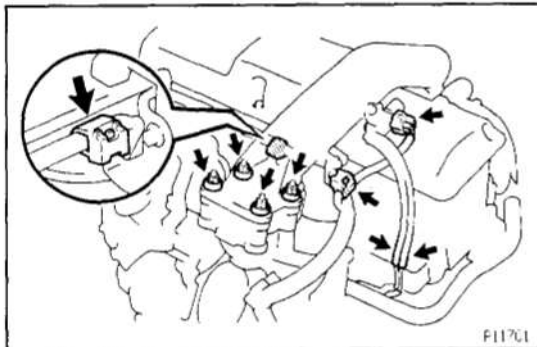

## GLOW PLUGS REMOVAL

(See Components for Removal and Installation)

### 1. REMOVE INTAKE PIPE

- (a) Disconnect the VSV connector and 2 vacuum hoses.
- (b) Disconnect the 2 wire harness clamps.
- (c) Remove the 4 nuts and seal washers.
- (d) Disconnect the 2 PCV hoses.
- (e) Use pliers to pinch the ends of the clamp together until the lock plate engages the catch. Make sure the lock plate and catch are engaged securely.
- (f) Remove the intake pipe and gasket.

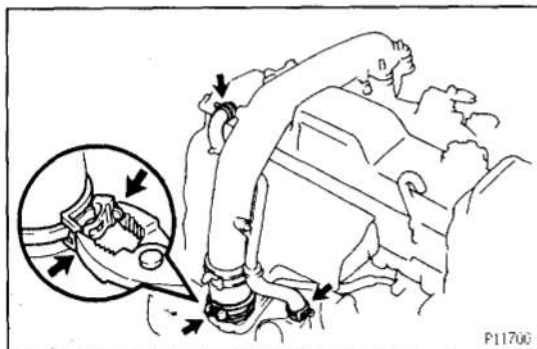

### 2. DISCONNECT ENGINE WIRE

- (a) Disconnect the following connectors:
  - Turbo pressure sensor connector
  - Water temperature sender gauge connector
- (b) Remove the grommet, nut and wire.
- (c) Disconnect the 2 engine wire harness clamps.

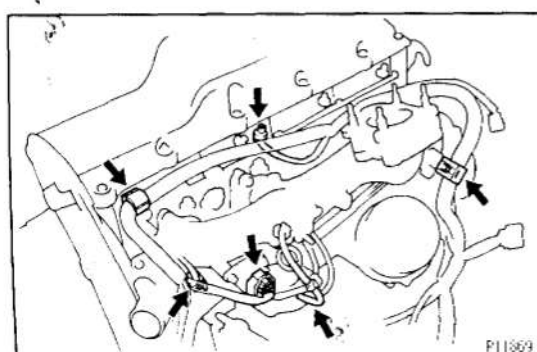

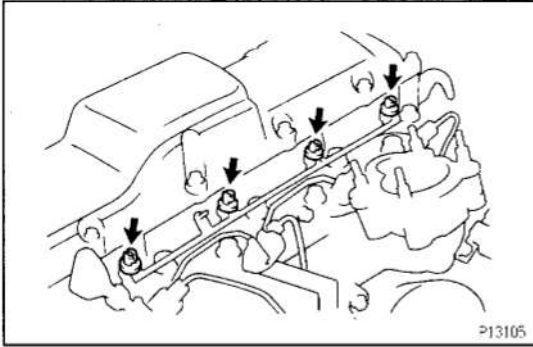

### 3. REMOVE GLOW PLUGS

- (a) Remove the 4 screw grommets.
- (b) Remove the 4 nuts and glow plug connector.

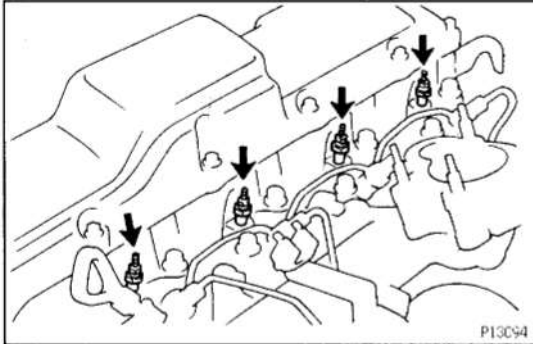

- (c) Using a 12 mm deep socket wrench, remove the 4 glow plugs.

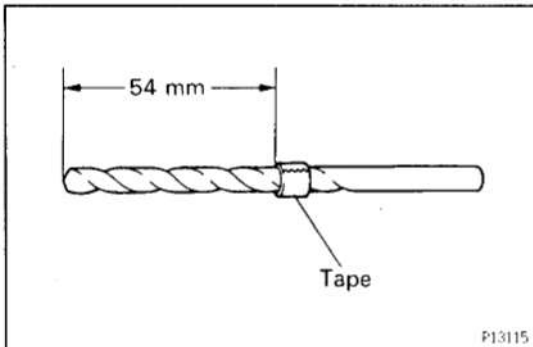

### GLOW PLUGS INSTALLATION

BT042-01

(See Components for Removal and Installation)

**NOTICE:** Before reinstalling glow plugs, always first remove the carbon from the glow plug hole according to the following procedure.

#### 1. INSTALL GLOW PLUGS

- (a) Wind tape back for 54 mm from the tip of a 6 mm drill.
- (b) Insert the taped 54 mm of the drill into the plug hole and turn the drill by hand to remove the carbon.
- (c) Insert a 4 mm drill into the glow plug hole and turn the drill by hand to remove the carbon from the tip of the plug hole.

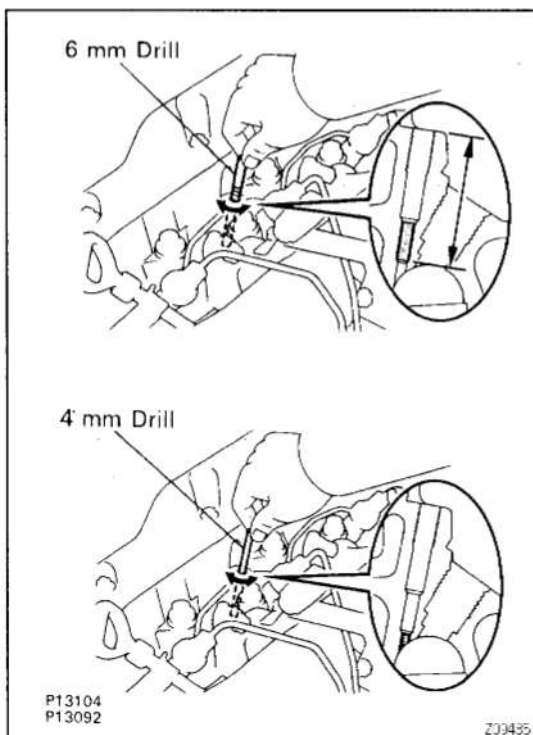

**STARTING SYSTEM – GLOW PLUG**

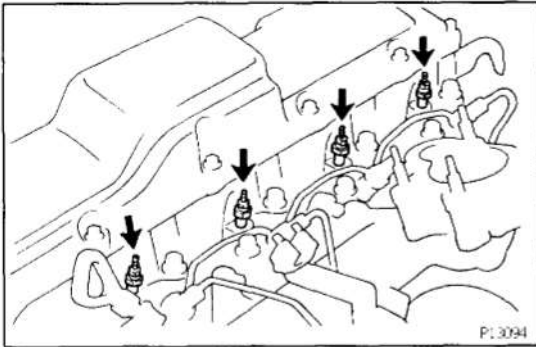

- (d) Using a 12 mm deep socket wrench, install the 4 glow plugs.

**Torque: 13 N·m (130 kgf·cm, 9 ft·lbf)**

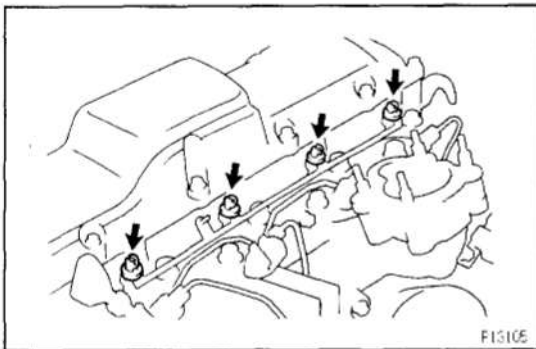

- (e) Install glow plug connector with the 4 nuts.  
 (f) Install the 4 screw grommets.

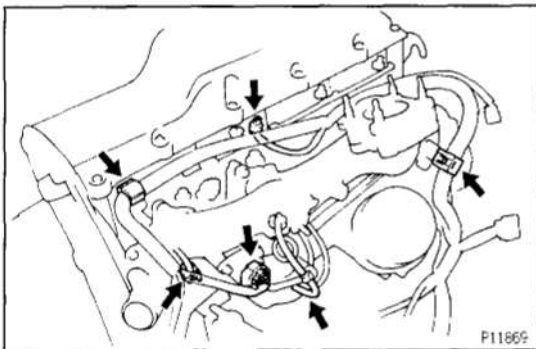

**2. CONNECT ENGINE WIRE**

- (a) Connect the 2 engine wire harness clamps.  
 (b) Install the wire, nut and grommet.  
 (c) Connect the following connectors:
- Turbo pressure sensor connector
  - Water temperature sender gauge connector

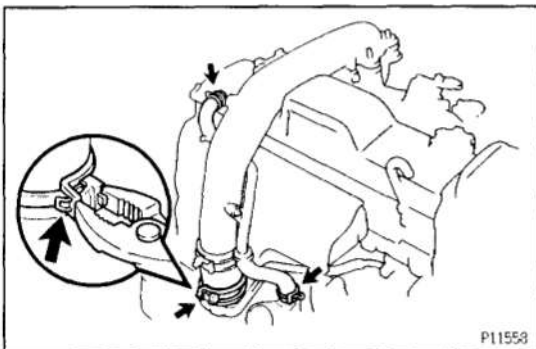

**3. INSTALL INTAKE PIPE**

- (a) Place a new gasket on the intake manifold.  
 (b) Connect the air hose and install the intake pipe.  
 (c) Press the clamp lock together with pliers and press down the tip of the lock plate. Carefully let the lock spread apart.

Take care not to let the pliers slip.

- (d) Connect the 2 PCV hoses.

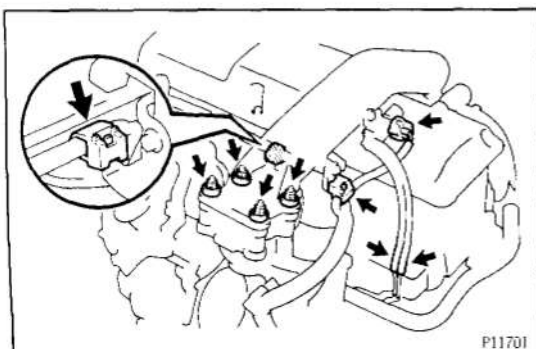

- (e) Install the 4 seal washers and nuts.  
**Torque: 12 N·m (120 kgf·cm, 9 ft·lbf)**  
 (f) Connect the 2 wire harness clamps.  
 (g) Connect the VSV connector and 2 vacuum hoses.

# SERVICE SPECIFICATIONS

## SERVICE DATA

8T018-0A

Starter (2.2 kW type)	Rated voltage and output power	12 V 2.2 kW
	No-load characteristics (Current)	120 A or less at 11.5 V
	No-load characteristics (rpm)	4,000 rpm or more
	Brush length (STD)	16.5 – 17.0 mm (0.650 – 0.669 in.)
	Brush length (Minimum)	9.0 mm (0.354 in.)
	Spring installed load	26 – 32 N (2.7 – 3.3 kgf, 6.0 – 7.3 lbf)
	Commutator	
	Diameter (STD)	35 mm (1.38 in.)
	Diameter (Minimum)	34 mm (1.34 in.)
	Undercut depth (STD)	0.6 mm (0.025 in.)
Undercut depth (Minimum)	0.2 mm (0.008 in.)	
Circle runout (Maximum)	0.05 mm (0.0020 in.)	
Starter (2.7 kW type)	Rated voltage and output power	12 V 2.7 kW
	No-load characteristics (Current)	180 A or less at 11.0 V
	No-load characteristics (rpm)	3,500 rpm or more
	Brush length (STD)	20.5 – 21.0 mm (0.807 – 0.827 in.)
	Brush length (Minimum)	13.5 mm (0.531 in.)
	Spring installed load	32 – 38 N (3.3 – 3.9 kgf, 7.3 – 8.5 lbf)
	Commutator	
	Diameter (STD)	36 mm (1.42 in.)
	Diameter (Minimum)	35 mm (1.38 in.)
	Undercut depth (STD)	0.7 – 0.9 mm (0.028 – 0.035 in.)
Undercut depth (Minimum)	0.2 mm (0.008 in.)	
Circle runout (Maximum)	0.05 mm (0.0020 in.)	
Glow plug	Resistance (Cold)	Approx. 0.65 $\Omega$

8T018-0B

## TORQUE SPECIFICATIONS

Part tightened	N-m	kgf-cm	ft-lbf
Field frame x armature (2.2 kW type)	12.7	130	9
Field frame x armature (2.7 kW type)	9.3	95	82 in.-lbf
Starter x lead wire	3.6	41	35 in.-lbf
Nut for terminal C (2.2 kW type)	5.4	51	44 in.-lbf
Nut for terminal C (2.7 kW type)	21.1	215	16
Glow plug x cylinder head	13	130	9
Intake pipe x intake manifold	12	120	9

