

# HOW TO USE THIS MANUAL

## GENERAL INFORMATION

IN01F-04

### 1. INDEX

An INDEX is provided on the first page of each section to guide you to the item to be repaired. To assist you in finding your way through the manual, the Section Title and major heading are given at the top of every page.

### 2. GENERAL DESCRIPTION

At the beginning of each section, a General Description is given that pertains to all repair operations contained in that section.

Read these precautions before starting any repair task.

### 3. TROUBLESHOOTING

TROUBLESHOOTING tables are included for each system to help you diagnose the problem and find the cause. The fundamentals of how to proceed with troubleshooting are described on [page IN-8](#).

Be sure to read this before performing troubleshooting.

### 4. PREPARATION

Preparation lists the SST (Special Service Tools), recommended tools, equipment, lubricant and SSM (Special Service Materials) which should be prepared before beginning the operation and explains the purpose of each one.

### 5. REPAIR PROCEDURES

Most repair operations begin with an overview illustration. It identifies the components and shows how the parts fit together.

Example:

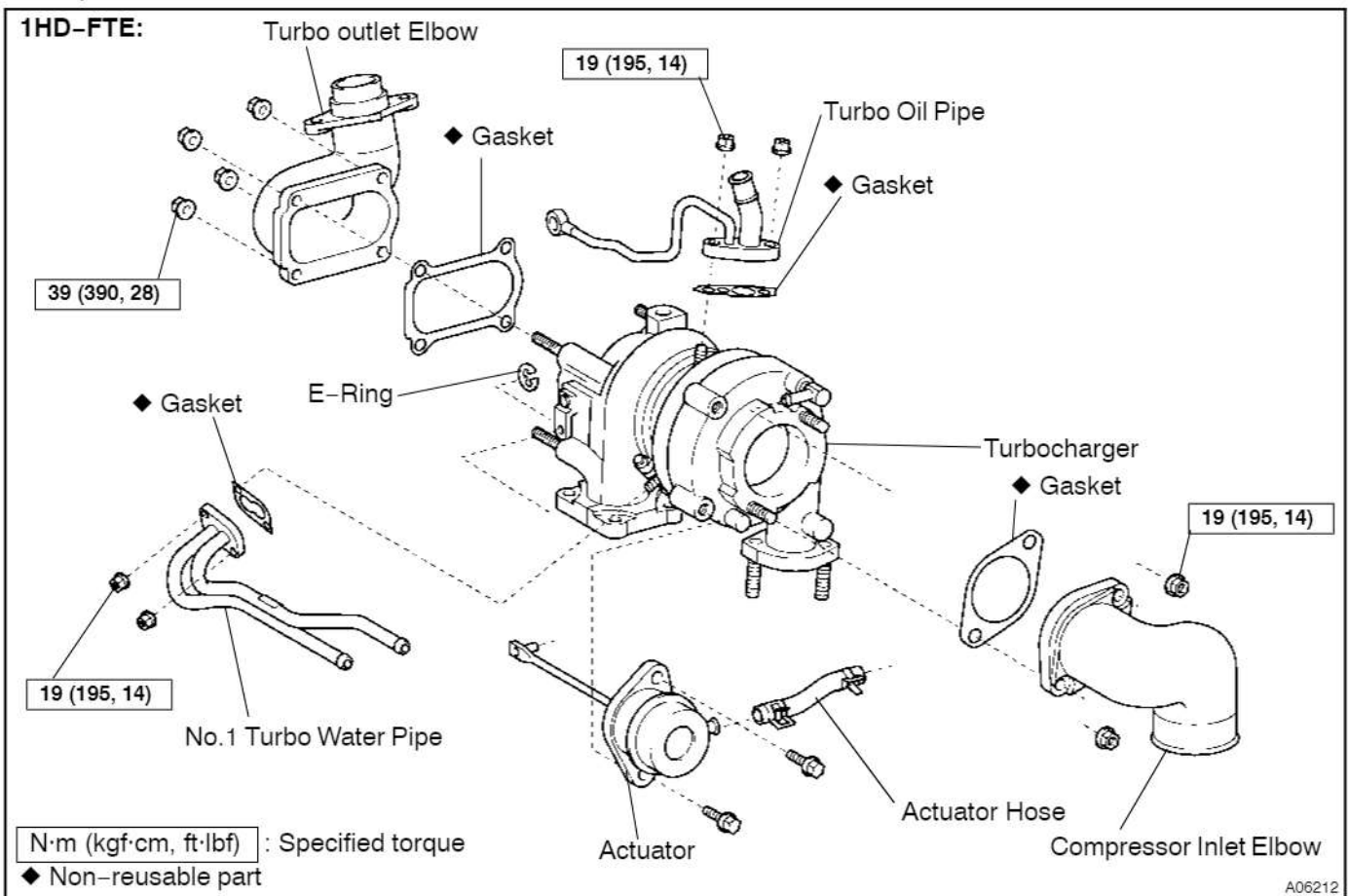

The procedures are presented in a step-by-step format:

- The illustration shows what to do and where to do it.
- The task heading tells what to do.
- The detailed text tells how to perform the task and gives other information such as specifications and warnings.

Example:

*Illustration:  
what to do and where*

*Task heading: what to do*

**21. CHECK PISTON STROKE OF OVERDRIVE BRAKE**

(a) Place SST and a dial indicator onto the overdrive brake Piston as shown in the illustration.

**SST 09350-30020 (09350-06120)**

*Set part No.*

*Component part No.*

*Detailed text: how to do task*

(b) Measure the stroke applying and releasing the compressed air (392 — 785 kPa, 4 — 8 kgf/cm<sup>2</sup> or 57 — 114 psi) as shown in the illustration.

**Piston stroke: 1.40 — 1.70 mm (0.0551 — 0.0669 in.)**

*Specification*

This format provides the experienced technician with a FAST TRACK to the information needed. The upper case task heading can be read at a glance when necessary, and the text below it provides detailed information. Important specifications and warnings always stand out in bold type.

## 6. REFERENCES

References have been kept to a minimum. However, when they are required you are given the page to refer to.

## 7. SPECIFICATIONS

Specifications are presented in bold type throughout the text where needed. You never have to leave the procedure to look up your specifications. They are also found in Service Specifications section for quick reference.

## 8. CAUTIONS, NOTICES, HINTS:

- CAUTIONS are presented in bold type, and indicate there is a possibility of injury to you or other people.
- NOTICES are also presented in bold type, and indicate the possibility of damage to the components being repaired.
- HINTS are separated from the text but do not appear in bold. They provide additional information to help you perform the repair efficiently.

## 9. SI UNIT

The UNITS given in this manual are primarily expressed according to the SI UNIT (International System of Unit), and alternately expressed in the metric system and in the English System.

Example:

**Torque: 30 N·m (310 kgf·cm, 22 ft·lbf)**

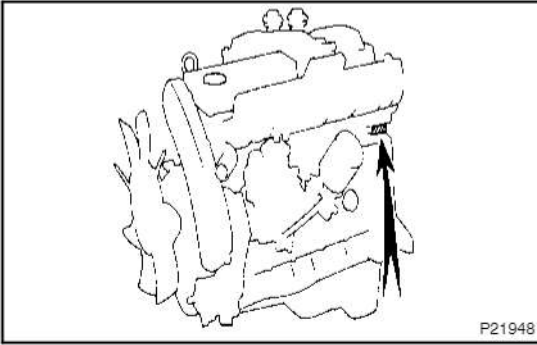

## IDENTIFICATION INFORMATION ENGINE SERIAL NUMBER

IN01G-04

The engine serial number is stamped on the engine block as shown.

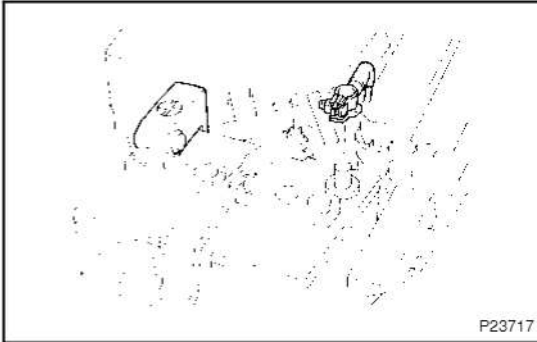

## REPAIR INSTRUCTIONS

### GENERAL INFORMATION

IN01H-04

#### BASIC REPAIR HINT

- (a) Use fender, seat and floor covers to keep the vehicle clean and prevent damage.
- (b) During disassembly, keep parts in the appropriate order to facilitate reassembly.
- (c) Observe the following:
  - (1) Before performing electrical work, disconnect the negative (-) terminal cable from the battery.
  - (2) If it is necessary to disconnect the battery for inspection or repair, always disconnect the negative (-) terminal cable which is grounded to the vehicle body.
  - (3) To prevent damage to the battery terminal, loosen the cable nut and raise the cable straight up without twisting or prying it.
  - (4) Clean the battery terminals and cable ends with a clean shop rag. Do not scrape them with a file or other abrasive objects.
  - (5) Install the cable ends to the battery terminals with the nut loose, and tighten the nut after installation. Do not use a hammer to tap the cable ends onto the terminals.
  - (6) Be sure the cover for the positive (+) terminal is properly in place.
- (d) Check hose and wiring connectors to make sure that they are secure and correct.
- (e) Non-reusable parts
  - (1) Always replace cotter pins, gaskets, O-rings and oil seals etc. with new ones.
  - (2) Non-reusable parts are indicated in the component illustrations by the "◆" symbol.
- (f) Precoated parts
 







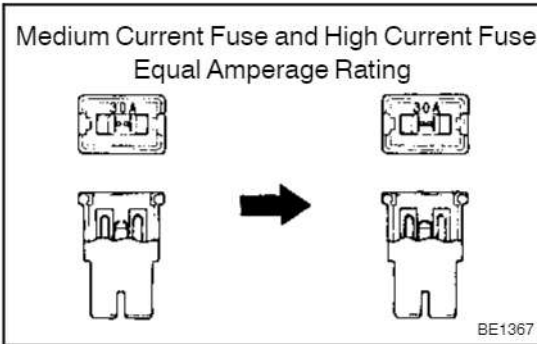

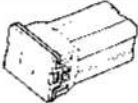

Precoated parts are bolts and nuts, etc. that are coated with a seal lock adhesive at the factory.

  - (1) If a precoated part is retightened, loosened or caused to move in any way, it must be recoated with the specified adhesive.
  - (2) When reusing precoated parts, clean off the old adhesive and dry with compressed air. Then apply the specified seal lock adhesive to the bolt, nut or threads.
  - (3) Precoated parts are indicated in the component illustrations by the "★" symbol.
- (g) When necessary, use a sealer on gaskets to prevent leaks.

- (h) Carefully observe all specifications for bolt tightening torques. Always use a torque wrench.
- (i) Use of special service tools (SST) and special service materials (SSM) may be required, depending on the nature of the repair. Be sure to use SST and SSM where specified and follow the proper work procedure. A list of SST and SSM can be found in section PP (Preparation) in this manual.



- (j) When replacing fuses, be sure the new fuse has the correct amperage rating. DO NOT exceed the rating or use one with a lower rating.

Illustration	Symbol	Part Name	Abbreviation
 BE5594	 IN0365	FUSE	FUSE
 BE5595	 IN0366	MEDIUM CURRENT FUSE	M-FUSE
 BE5596	 IN0367	HIGH CURRENT FUSE	H-FUSE
 BE5597	 IN0367	FUSIBLE LINK	FL
 BE5598	 IN0368	CIRCUIT BREAKER	CB

V00076

- (k) Care must be taken when jacking up and supporting the vehicle. Be sure to lift and support the vehicle at the proper locations.
  - (1) If the vehicle is to be jacked up only at the front or rear end, be sure to block the wheels at the opposite end in order to ensure safety.
  - (2) After the vehicle is jacked up, be sure to support it on stands. It is extremely dangerous to do any work on a vehicle raised on a jack alone, even for a small job that can be finished quickly.

- (l) Observe the following precautions to avoid damage to the following parts:

- (1) Do not open the cover or case of the ECU unless absolutely necessary. (If the IC terminals are touched, the IC may be destroyed by static electricity.)

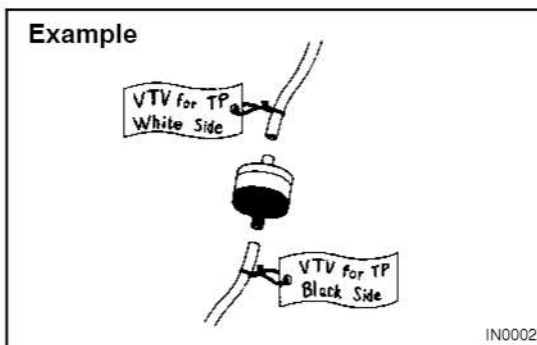
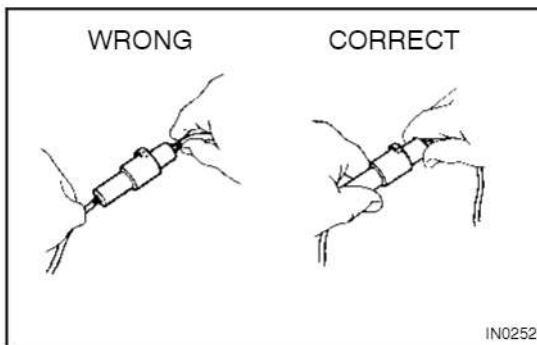
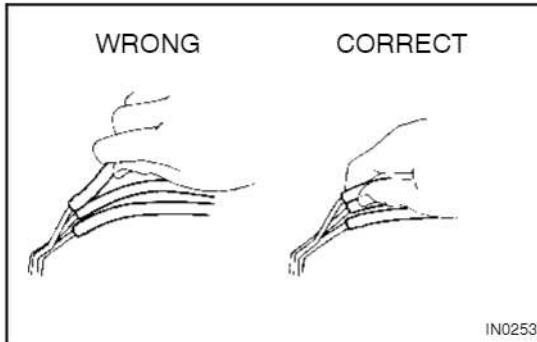

- (2) To disconnect vacuum hoses, pull on the end, not the middle of the hose.
- (3) To pull apart electrical connectors, pull on the connector itself, not the wires.
- (4) Be careful not to drop electrical components, such as sensors or relays. If they are dropped on a hard floor, they should be replaced and not reused.
- (5) When steam cleaning an engine, protect the electronic components, air filter and emissions-related components from water.
- (6) Never use an impact wrench to remove or install temperature switches or temperature sensors.
- (7) When checking continuity at the wire connector, insert the tester probe carefully to prevent terminals from bending.
- (8) When using a vacuum gauge, never force the hose onto a connector that is too large. Use a step-down adapter instead. Once the hose has been stretched, it may leak.

- (m) Tag hoses before disconnecting them:
- (1) When disconnecting vacuum hoses, use tags to identify how they should be reconnected.
- (2) After completing a job, double check that the vacuum hoses are properly connected. A label under the hood shows the proper layout.
- (n) Unless otherwise stated, all resistance is measured at an ambient temperature of 20°C (68°F). Because the resistance may be outside specifications if measured at high temperatures immediately after the vehicle has been running, measurements should be made when the engine has cooled down.

# FOR ALL OF VEHICLES

IN011-02

## PRECAUTION

### 1. FOR VEHICLES EQUIPPED WITH A CATALYTIC CONVERTER

#### CAUTION:

**If large amounts of unburned gasoline flow into the converter, it may overheat and create a fire hazard. To prevent this, observe the following precautions and explain them to your customer.**

- (a) Use only unleaded gasoline
- (b) Avoid prolonged idling  
Avoid running the engine at idle speed for more than 20 minutes.
- (c) Avoid spark jump test
  - (1) Perform spark jump test only when absolutely necessary. Perform this test as rapidly as possible.
  - (2) While testing, never race the engine.
- (d) Avoid prolonged engine compression measurement  
Engine compression tests must be done as rapidly as possible.
- (e) Do not run engine when fuel tank is nearly empty  
This may cause the engine to misfire and create an extra load on the converter.
- (f) Avoid coasting with ignition turned off and prolonged braking
- (g) Do not dispose of used catalyst along with parts contaminated with gasoline or oil

### 2. IF VEHICLE IS EQUIPPED WITH MOBILE COMMUNICATION SYSTEM

For vehicles with mobile communication systems such as two-way radios and cellular telephones, observe the following precautions.

- (1) Install the antenna as far as possible away from the ECU and sensors of the vehicle's electronic system.
- (2) Install the antenna feeder at least 20 cm (7.87 in.) away from the ECU and sensors of the vehicle's electronics systems. For details about ECU and sensors locations, refer to the section on the applicable component.
- (3) Do not wind the antenna feeder together with the other wiring. As much as possible, also avoid running the antenna feeder parallel with other wire harnesses.
- (4) Confirm that the antenna and feeder are correctly adjusted.
- (5) Do not install powerful mobile communications system.

### 3. FOR USING HAND-HELD TESTER

#### CAUTION:

**Observe the following for safety reasons:**

- **Before using the hand-held tester, the hand-held tester's operator manual should be read thoroughly.**
- **Be sure to route all cables securely when driving with the hand-held tester connected to the vehicle. (i.e. Keep cables away from feet, pedals, steering wheel and shift lever.)**
- **Two persons are required when test driving with the hand-held tester, one person to drive the vehicle and one person to operate the hand-held tester.**

# HOW TO TROUBLESHOOT ECU CONTROLLED SYSTEMS

IN01J-03

## GENERAL INFORMATION

A large number of ECU controlled systems are used in the LAND CRUISER. In general, the ECU controlled system is considered to be a very intricate system requiring a high level of technical knowledge and expert skill to troubleshoot. However, the fact is that if you proceed to inspect the circuits one by one, troubleshooting of these systems is not complex. If you have adequate understanding of the system and a basic knowledge of electricity, accurate diagnosis and necessary repair can be performed to locate and fix the problem. This manual is designed through emphasis of the above standpoint to help service technicians perform accurate and effective troubleshooting, and is compiled for the following major ECU controlled systems:

System	Page
Engine	DI-1

The troubleshooting procedure and how to make use of it are described on the following pages.

### FOR USING HAND-HELD TESTER

- Before using the hand-held tester, the hand-held tester's operator manual should be read throughly.
- If the hand-held tester cannot communicate with ECU controlled systems when you have connected the cable of the hand-held tester to DLC3, turned the ignition switch ON and operated the scan tool, there is a problem on the vehicle side or tool side.
  - (1) If communication is normal when the tool is connected to another vehicle, inspect the diagnosis data link line (Bus ⊕ line) or ECU power circuit of the vehicle.
  - (2) If communication is still not possible when the tool is connected to another vehicle, the problem is probably in the tool itself, so perform the Self Test procedures outlined in the Tester Operator's Manual.



## HOW TO PROCEED WITH TROUBLESHOOTING

Carry out troubleshooting in accordance with the procedure on the following page. Here, only the basic procedure is shown. Details are provided in each section, showing the most effective methods for each circuit. Confirm the troubleshooting procedures first for the relevant circuit before beginning troubleshooting of that circuit.

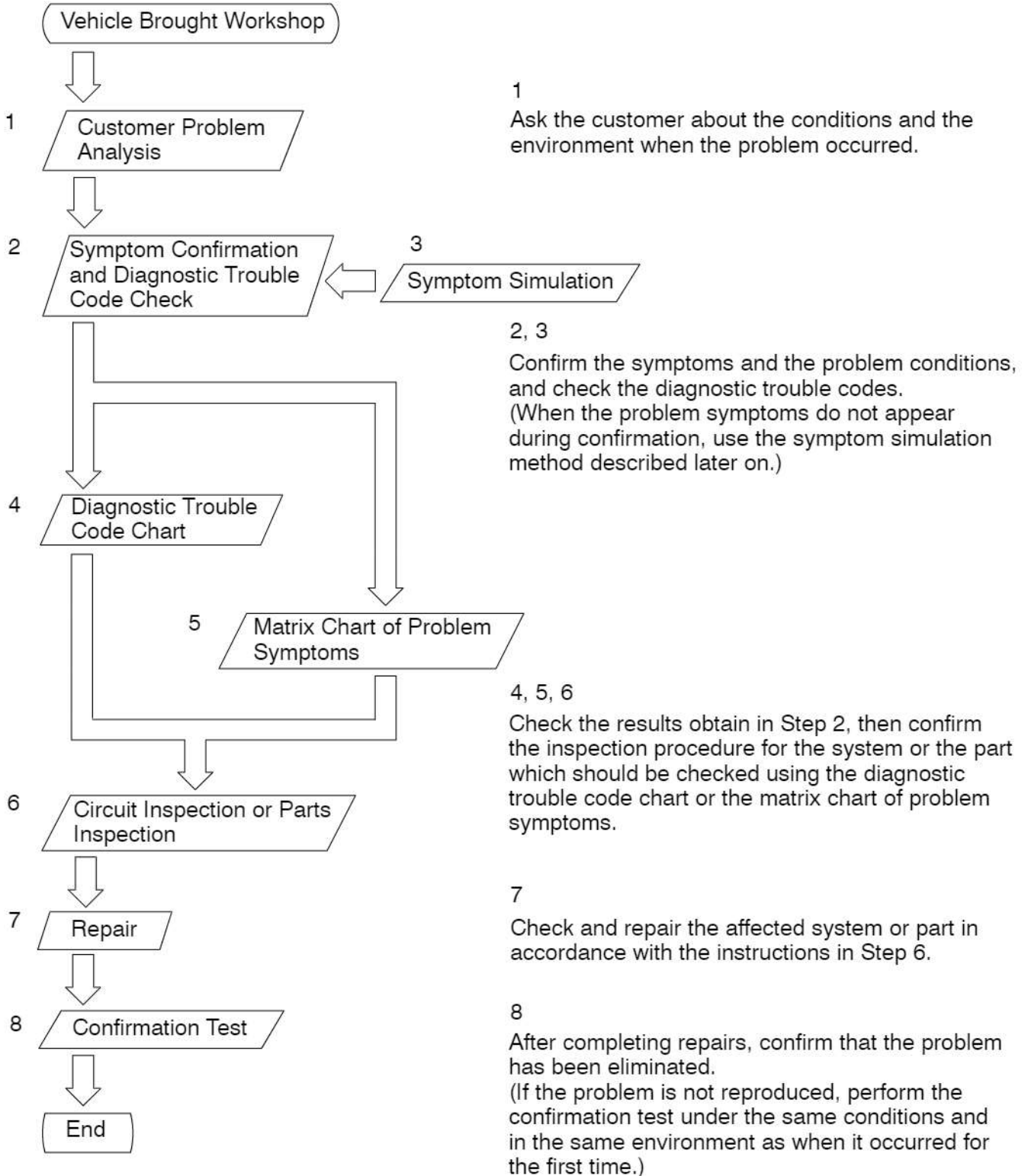

### 1. CUSTOMER PROBLEM ANALYSIS

In troubleshooting, the problem symptoms must be confirmed accurately and all preconceptions must be cleared away in order to give an accurate judgment. To ascertain just what the problem symptoms are, it is extremely important to ask the customer about the problem and the conditions at the time it occurred.

Important Point in the Problem Analysis:

The following 5 items are important points in the problem analysis. Past problems which are thought to be unrelated and the repair history, etc. may also help in some cases, so as much information as possible should be gathered and its relationship with the problem symptoms should be correctly ascertained for reference in troubleshooting. A customer problem analysis table is provided in the troubleshooting section for each system for your use.

**Important Points in the Customer Problem Analysis**

- What ----- Vehicle model, system name
- When ----- Date, time, occurrence frequency
- Where ----- Road conditions
- Under what conditions? ----- Running conditions, driving conditions, weather conditions
- How did it happen? ----- Problem symptoms

(Sample) Engine control system check sheet.

<b>CUSTOMER PROBLEM ANALYSIS CHECK</b>					
<b>ENGINE CONTROL SYSTEM Check Sheet</b>		Inspector's Name _____			
Customer's Name		Model and Model Year			
Driver's Name		Frame No.			
Data Vehicle Brought in		Engine Model			
License No.		Odometer Reading	km miles		
Problem Symptoms	<input type="checkbox"/> Engine does not Start	<input type="checkbox"/> Engine does not crank	<input type="checkbox"/> No initial combustion	<input type="checkbox"/> No complete combustion	
	<input type="checkbox"/> Difficult to Start	<input type="checkbox"/> Engine cranks slowly <input type="checkbox"/> Other _____			
	<input type="checkbox"/> Poor Idling	<input type="checkbox"/> Incorrect first idle	<input type="checkbox"/> Idling rpm is abnormal	<input type="checkbox"/> High (          rpm)	<input type="checkbox"/> Low (          rpm)
	<input type="checkbox"/> Poor Drive ability	<input type="checkbox"/> Hesitation	<input type="checkbox"/> Back fire	<input type="checkbox"/> Muffler explosion (after-fire)	<input type="checkbox"/> Surging
	<input type="checkbox"/> Engine Stall	<input type="checkbox"/> Knocking <input type="checkbox"/> Other _____			
	<input type="checkbox"/> Engine Stall	<input type="checkbox"/> Soon after starting <input type="checkbox"/> After accelerator pedal depressed <input type="checkbox"/> After accelerator pedal released <input type="checkbox"/> During A/C operation <input type="checkbox"/> Shifting from N to D <input type="checkbox"/> Other _____			
<input type="checkbox"/> Others	_____				
<input type="checkbox"/> constant <input type="checkbox"/> Sometimes (          times per          day/month)					

## 2. SYMPTOM CONFIRMATION AND DIAGNOSTIC TROUBLE CODE CHECK

The diagnostic system in the LAND CRUISER (Station Wagon) fulfills various functions. The first function is the Diagnostic Trouble Code Check in which a malfunction in the signal circuits to the ECU is stored in code in the ECU memory at the time of occurrence, to be output by the technician during troubleshooting. Another function is the Input Signal Check which checks if the signals from various switches are sent to the ECU correctly.

By using these check functions, the problem areas can be narrowed down quickly and troubleshooting can be performed effectively. Diagnostic functions are incorporated in the following systems in the LAND CRUISER (Station Wagon).

System	Diagnostic Trouble Code Check	Input Signal Check (Sensor Check)	Other Diagnosis Function
Engine	○ (with Check Mode)	○	Diagnostic Test Mode

In diagnostic trouble code check, it is very important to determine whether the problem indicated by the diagnostic trouble code is still occurring or occurred in the past but returned to normal at present. In addition, it must be checked in the problem symptom check whether the malfunction indicated by the diagnostic trouble code is directly related to the problem symptom or not. For this reason, the diagnostic trouble codes should be checked before and after the symptom confirmation to determine the current conditions, as shown in the table below. If this is not done, it may, depending on the case, result in unnecessary troubleshooting for normally operating systems, thus making it more difficult to locate the problem, or in repairs not pertinent to the problem. Therefore, always follow the procedure in correct order and perform the diagnostic trouble code check.

### DIAGNOSTIC TROUBLE CODE CHECK PROCEDURE

Diagnostic Trouble Code Check (Make a note of and then clear)	Confirmation of Symptoms	Diagnostic Trouble Code Check	Problem Condition
Diagnostic Trouble Code Display	Problem symptoms exist	Same diagnostic trouble code is displayed	Problem is still occurring in the diagnostic circuit
	→ No problem symptoms exist	Normal code is displayed	The problem is still occurring in a place other than in the diagnostic circuit. (The diagnostic trouble code displayed first is either for a past problem or it is a secondary problem.)
Normal Code Display	→ Problem symptoms exist	Normal code is displayed	The problem is still occurring in a place other than in the diagnostic circuit.
	→ No problem symptoms exist	Normal code is displayed	The problem occurred in a place other than in the diagnostic circuit in the past.

Taking into account the above points, a flow chart showing how to proceed with troubleshooting using the diagnostic trouble code check is shown below. This flow chart shows how to utilize the diagnostic trouble code check effectively, then by carefully checking the results, indicates how to proceed either to diagnostic trouble code troubleshooting or to troubleshooting of problem symptoms.

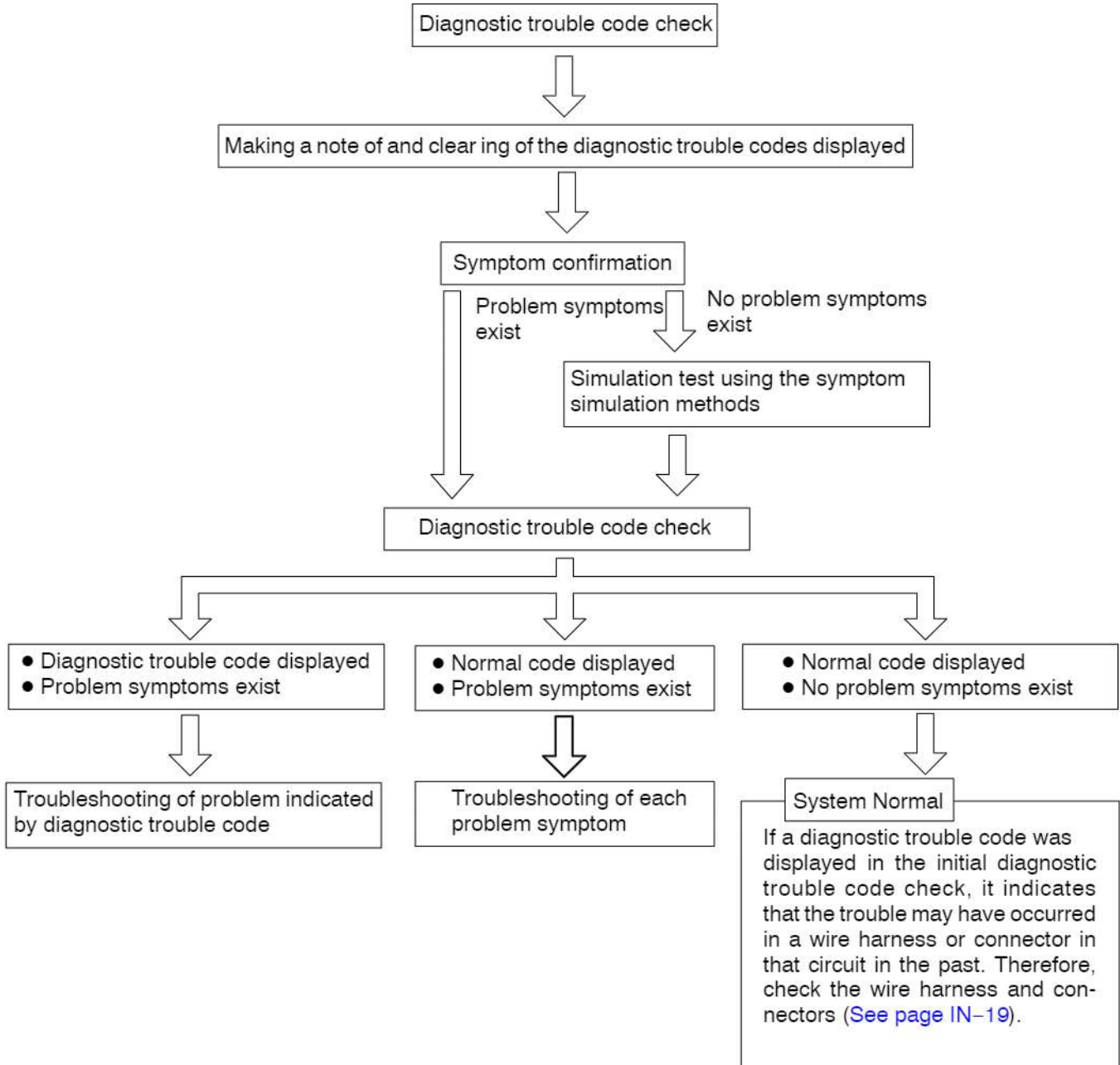

cardiagn.com

### 3. SYMPTOM SIMULATION



The most difficult case in troubleshooting is when there are no problem symptoms occurring. In such cases, a thorough customer problem analysis must be carried out, then simulate the same or similar conditions and environment in which the problem occurred in the customer's vehicle. No matter how much experience a technician has, or how skilled he may be, if he proceeds to troubleshoot without confirming the problem symptoms he will tend to overlook something important in the repair operation and make a wrong guess somewhere, which will only lead to a standstill. For example, for a problem which only occurs when the engine is cold, or for a problem which occurs due to vibration caused by the road during driving, etc., the problem can never be determined so long as the symptoms are confirmed with the engine hot condition or the vehicle at a standstill. Since vibration, heat or water penetration (moisture) are likely causes for problems which are difficult to reproduce, the symptom simulation tests introduced here are effective measures in that the external causes are applied to the vehicle in a stopped condition.

Important Points in the Symptom Simulation Test:

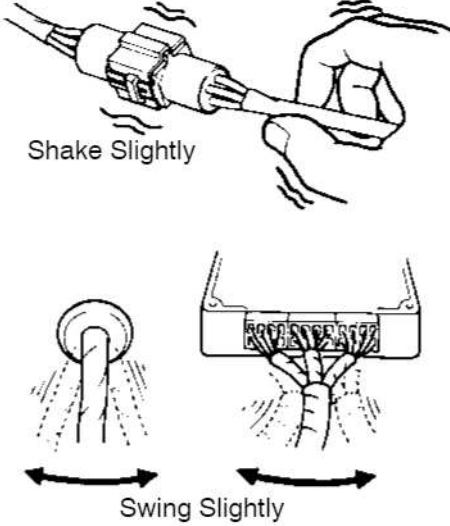
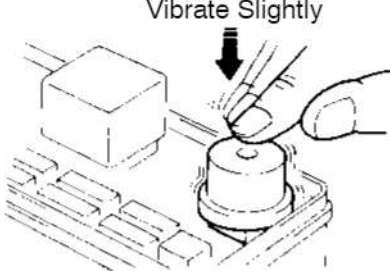
In the symptom simulation test, the problem symptoms should of course be confirmed, but the problem area or parts must also be found out. To do this, narrow down the possible problem circuits according to the symptoms before starting this test and connect a tester beforehand. After that, carry out the symptom simulation test, judging whether the circuit being tested is defective or normal and also confirming the problem symptoms at the same time. Refer to the matrix chart of problem symptoms for each system to narrow down the possible causes of the symptom.

<p>1</p>	<p><b>VIBRATION METHOD: When vibration seems to be the major cause.</b></p>
<p><b>CONNECTORS</b> Slightly shake the connector vertically and horizontally.</p> <p><b>WIRE HARNESS</b> Slightly shake the wire harness vertically and horizontally. The connector joint, fulcrum of the vibration, and body through portion are the major areas to be checked thoroughly.</p>	 <p>The diagrams illustrate two vibration methods. The top diagram shows a hand holding a connector with the label 'Shake Slightly' and wavy lines indicating movement. The bottom diagram shows a hand holding a wire harness with the label 'Swing Slightly' and arrows indicating a swinging motion.</p>
<p><b>PARTS AND SENSOR</b> Apply slight vibration with a finger to the part of the sensor considered to be the problem cause and check if the malfunction occurs.</p> <p>HINT: Applying strong vibration to relays may result in open relays.</p>	 <p>The diagram shows a hand applying vibration to a sensor on a circuit board with the label 'Vibrate Slightly' and a downward arrow.</p>

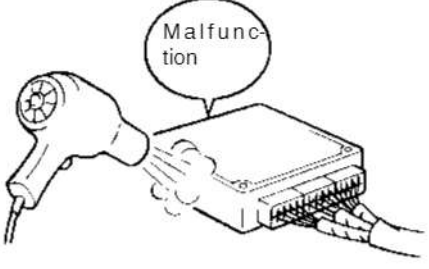
V07268

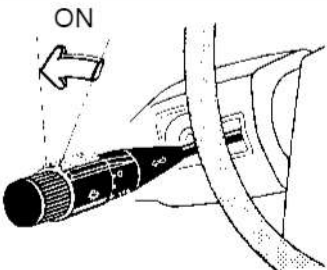
2	<b>HEAT METHOD:</b> When the problem seems to occur when the suspect area is heated.
<p>Heat the component that is the likely cause of the malfunction with a hair dryer or similar object. Check to see if the malfunction occurs.</p> <p><b>NOTICE:</b></p> <p>(1) Do not heat to more than 60 °C (140 °F). (Temperature limit that no damage is done to the component.)</p> <p>(2) Do not apply heat directly to parts in the ECU.</p>	 <p>F12334</p>
3	<b>WATER SPRINKLING METHOD:</b> When the malfunction seems to occur on a rainy day or in a high-humidity condition.
<p>Sprinkle water onto the vehicle and check to see if the malfunction occurs.</p> <p><b>NOTICE:</b></p> <p>(1) Never sprinkle water directly into the engine compartment, but indirectly change the temperature and humidity by applying water spray onto the radiator front surface.</p> <p>(2) Never apply water directly onto the electronic components.</p> <p>(Service hint) If a vehicle is subject to water leakage, the leaked water may contaminate the ECU. When testing a vehicle with a water leakage problem, special caution must be used.</p>	 <p>F16649</p>
4	<b>OTHER:</b> When a malfunction seems to occur when electrical load is excessive.
<p>Turn on all electrical loads including the heater blower, head lights, rear window defogger, etc. and check to see if the malfunction occurs.</p>	 <p>F12336</p>

### 4. DIAGNOSTIC TROUBLE CODE CHART

The inspection procedure is shown in the table below. This table permits efficient and accurate troubleshooting using the diagnostic trouble codes displayed in the diagnostic trouble code check. Proceed with troubleshooting in accordance with the inspection procedure given in the diagnostic chart corresponding to the diagnostic trouble codes displayed. The engine diagnostic trouble code chart is shown below as an example.

- **DTC No.**  
Indicates the diagnostic trouble code.
- **Page or Instructions**  
Indicates the page where the inspection procedure for each circuit is to be found, or gives instructions for checking and repairs.

- **Trouble Area**  
Indicates the suspect area of the problem.

- **Detection Item**  
Indicates the system of the problem or contents of the problem.

**DTC CHART (SAE Controlled)**

HINT: Parameters listed in the chart may not be exactly the same as your reading due to the type of instrument or other factors.

If a malfunction code is displayed during the DTC check in check mode, check the circuit for that code listed in the table below. For details of each code, turn to the page referred to under the "See page" for the respective "DTC No." in the DTC chart.

DTC No. (See page)	Detection Item	Trouble Area	*1 Check Engine Warning Light Normal Mode/ Test Mode	*Memory
12 (DI-25)	Crankshaft Position Sensor Circuit Malfunction	<ul style="list-style-type: none"> <li>● Open or short in crankshaft position sensor circuit</li> <li>● Crankshaft position sensor</li> <li>● Engine ECU</li> </ul>	ON / N.A	○
13 (DI-30)	Engine Speed Sensor Circuit Malfunction	<ul style="list-style-type: none"> <li>● Open or short in engine speed sensor circuit</li> <li>● Engine speed sensor</li> <li>● Open or short in STA circuit</li> <li>● Engine ECU</li> </ul>	ON / ON	○
14 (DI-35)	Timing Control System Malfunction	<ul style="list-style-type: none"> <li>● Open or short in timing control valve circuit</li> <li>● Fuel filter (Clogging)</li> <li>● Engine ECU</li> </ul>	ON / N.A	○
17	Ignition IC Malfunction	<ul style="list-style-type: none"> <li>● Engine ECU</li> </ul>	ON / N.A	○

cardiagn.com

**5. PROBLEM SYMPTOMS TABLE**

The suspect circuits or parts for each problem symptom are shown in the table below. Use this table to troubleshooting the problem when a "Normal" code is displayed in the diagnostic trouble code check but the problem is still occurring. Numbers in the table indicate the inspection order in which the circuits or parts should be checked.

HINT:

When the problem is not detected by the diagnostic system even though the problem symptom is present, it is considered that the problem is occurring outside the detection range of the diagnostic system, or that the problem is occurring in a system other than the diagnostic system.

● Page  
Indicates the page where the flow chart for each circuit is located.

● Circuit Inspection, Inspection Order  
Indicates the circuit which needs to be checked for each problem symptom. Check in the order indicated by the numbers.

● Problem Symptom

● Circuit or Part Name  
Indicates the circuit or part which needs to be checked.

<b>PROBLEM SYMPTOMS TABLE</b>		
Symptom	Suspect Area	See page
Engine not crank (Difficult to start)	1. Starter and starter relay	-
No initial combustion (Difficult start)	1. Engine ECU power source circuit 2. Pre-heating system 3. Compression 4. Engine ECU 5. Injection Pump	DI-124 DI-127 EM-30 DI-128 FU-2
Cold engine (Difficult to start)	1. pre-heating system 2. STA signal circuit 3. Water temperature sensor 4. Injection nozzle 5. Fuel filter 6 Diesel throttle body 7. Engine ECU 8. Injection pump	DI-121 DI-127 DI-85 FU-15 FU-16 ED-5 D-175 FU-2
Hot engine (Difficult to start)	1. STA signal circuit 2. Injection pump 3. Fuel filter 4. Diesel throttle body 5. Engine ECU 6. Injection pump	AC-54 DL-124

cardiagn.com



## 6. CIRCUIT INSPECTION

How to read and use each page is shown below.

• Diagnostic Trouble Code No. and Detection Item

• Circuit Description  
The major role and operation, etc. of the circuit and its component parts are explained.

<b>DTC</b>	<b>14</b>	<b>Timing Control System Malfunction</b>
------------	-----------	--

**CIRCUIT DESCRIPTION**  
The engine ECU control the injection timing by actuating the timing control valve. The timing control valve is mounted on the injection pump and delay one by duty control of pump internal fuel pressure. The engine ECU detects the injection advance angle by TDC and NE signal.

DTC No.	Detection Item	Trouble Area
14	After engine warm up and during, actual injection timing is different from target vaue of engine ECU calculated for several sec.	<ul style="list-style-type: none"> <li>• Open or short in timing control valve circuit</li> <li>• Fuel filter (Clogging)</li> <li>• Fuel (Freezing Airin)</li> <li>• Injection pump (Internal pressure and timing control valve)</li> <li>• Engine ECU</li> </ul>

• Indicates the diagnostic trouble code, diagnostic trouble code set parameter and suspect area of the problem.

### WIRING DIAGRAM

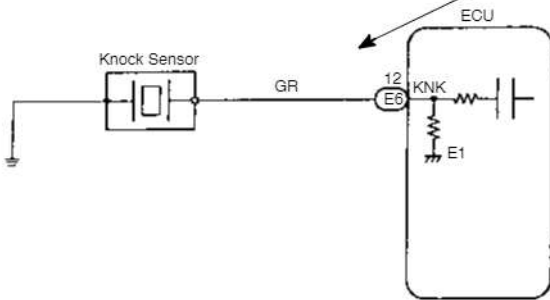

- Wiring Diagram  
This shows a wiring diagram of the circuit. Use this diagram together with ELECTRICAL WIRING DIAGRAM to thoroughly understand the circuit.  
Wire colors are indicated by an alphabetical code.  
B = Black, L = Blue, R = Red, BR = Brown, LG = Light Green, V = Violet, G = Green, O = Orange, W = White, GR = Gray, P = Pink, Y = Yellow  
The first letter indicates the basic wire color and the second letter indicates the color of the stripe.

cardiagn.com

- Indicates the position of the ignition switch during the check.

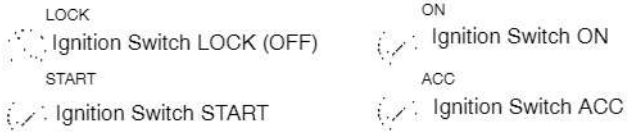

- Inspection Procedure

Use the inspection procedure to determine if the circuit is normal or abnormal, and, if it is abnormal, use it to determine whether the problem is located in the sensors, actuators, wire harness or ECU.

**INSPECTION PROCEDURE**

**1** Check continuity between terminal KNK of ECM connector and body ground.

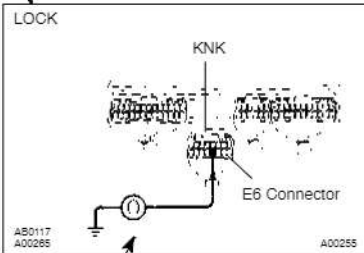

**PREPARATION:**

- (a) Remove the glove compartment (See page FI-37).
- (b) Disconnect the E6 connector of ECM.

**CHECK:**

Measure resistance between terminal KNK of ECU connector and body ground.

**OK:**

Resistance: 1 MΩ or higher

OK → Go to step 3.

NG

**2** Check knock sensor (See page FI-34).

OK → Replace knock sensor.

- Indicates the place to check the voltage or resistance.
- Indicates the connector position to checked, from the front or back side.

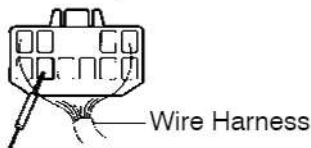

Check from the connector back side. (with harness)



Check from the connector front side. (without harness)  
In this case, care must be taken not to bend the terminals.

- Indicates the condition of the connector of ECU during the check.

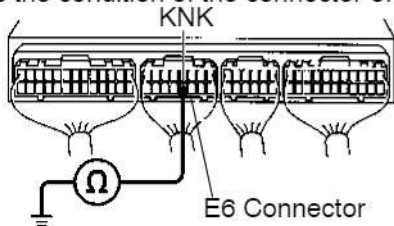

Connector being checked is connected.

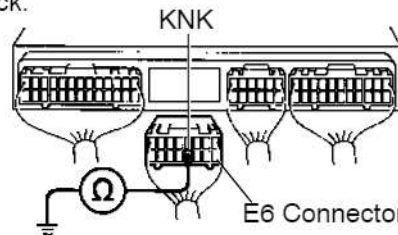

Connector being checked is disconnected.

cardiagn.com

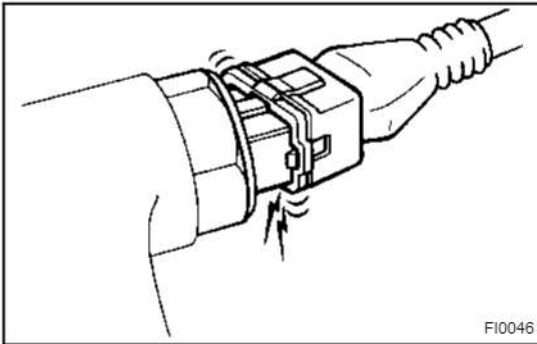

FI0046

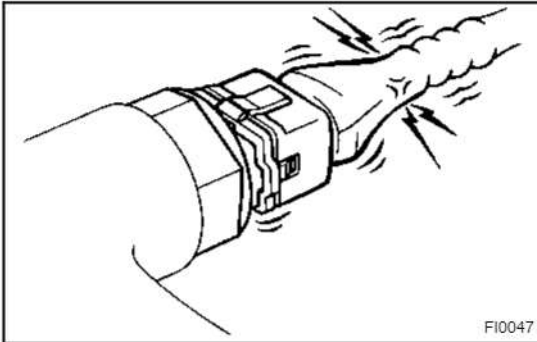

FI0047

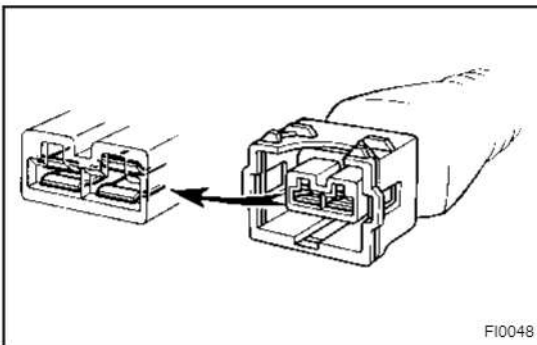

FI0048

## HOW TO USE THE DIAGNOSTIC CHART AND INSPECTION PROCEDURE

### 1. CONNECTOR CONNECTION AND TERMINAL INSPECTION

- For troubleshooting, diagnostic trouble code charts or problem symptom charts are provided for each circuit with detailed inspection procedures on the following pages.
- When all the component parts, wire harnesses and connectors of each circuit except the ECU are found to be normal in troubleshooting, then it is determined that the problem is in the ECU. Accordingly, if diagnosis is performed without the problem symptoms occurring, the instruction will be to check and replace the ECU, even if the problem is not in the ECU. So always confirm that the problem symptoms are occurring, or proceed with inspection while using the symptom simulation method.
- The instructions "Check wire harness and connector" and "Check and replace ECU" which appear in the inspection procedure, are common and applicable to all diagnostic trouble codes. Follow the procedure outlined below whenever these instructions appear.

#### OPEN CIRCUIT:

This could be due to a disconnected wire harness, faulty contact in the connector, a connector terminal pulled out, etc.

#### HINT:

- It is rarely the case that a wire is broken in the middle of it. Most cases occur at the connector. In particular, carefully check the connectors of sensors and actuators.
- Faulty contact could be due to rusting of the connector terminals, to foreign materials entering terminals or a drop in the contact pressure between the male and female terminals of the connector. Simply disconnecting and reconnecting the connectors once changes the condition of the connection and may result in a return to normal operation. Therefore, in troubleshooting, if no abnormality is found in the wire harness and connector check, but the problem disappears after the check, then the cause is considered to be in the wire harness or connectors.

#### SHORT CIRCUIT:

This could be due to a short circuit between the wire harness and the body ground or to a short inside the switch etc.

#### HINT:

When there is a short between the wire harness and body ground, check thoroughly whether the wire harness is caught in the body or is clamped properly.

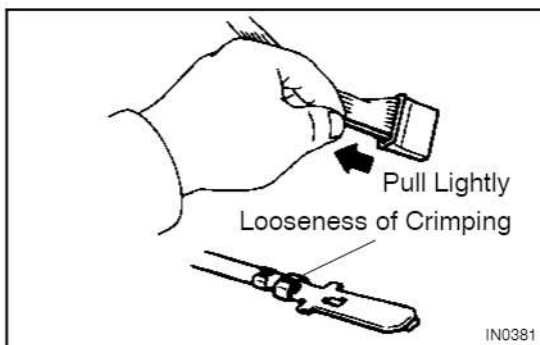
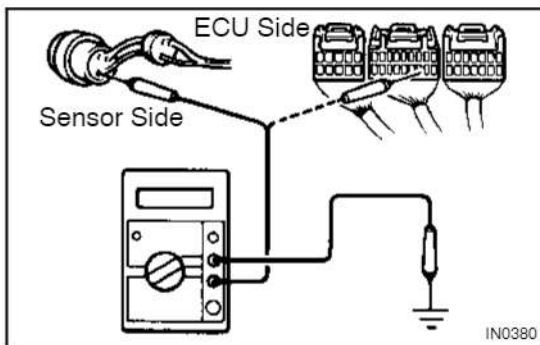
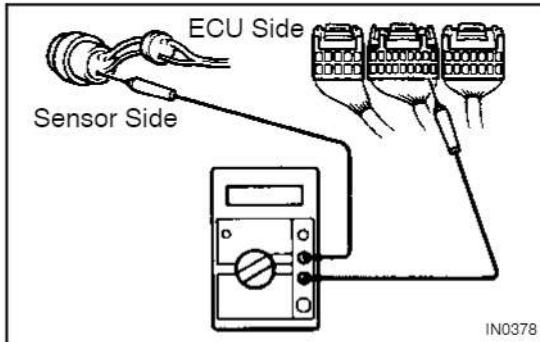
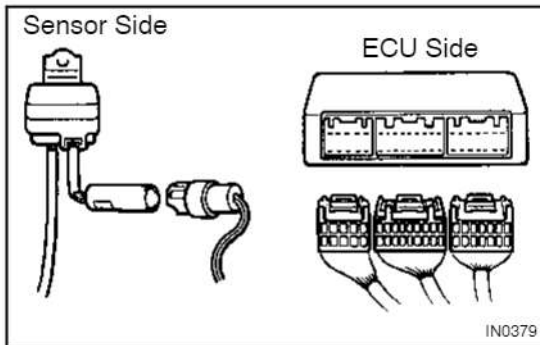

## 2. CONTINUITY CHECK (OPEN CIRCUIT CHECK)

- Disconnect the connectors at both ECU and sensor sides.
- Measure the resistance between the applicable terminals of the connectors.

**Resistance: 1  $\Omega$  or less**

### HINT:

- Measure the resistance while lightly shaking the wire harness vertically and horizontally.
- When tester probes are inserted into a connector, insert the probes from the back. For waterproof connectors in which the probes cannot be inserted from the back, be careful not to bend the terminals when inserting the tester probes.

## 3. RESISTANCE CHECK (SHORT CIRCUIT CHECK)

- Disconnect the connectors at both ends.
- Measure the resistance between the applicable terminals of the connectors and body ground. Be sure to carry out this check on the connectors on both ends.

**Resistance: 1 M $\Omega$  or higher**

### HINT:

Measure the resistance while lightly shaking the wire harness vertically and horizontally.

## 4. VISUAL CHECK AND CONTACT PRESSURE CHECK

- Disconnect the connectors at both ends.
- Check for rust or foreign material, etc. in the terminals of the connectors.
- Check crimped portions for looseness or damage and check if the terminals are secured in lock portion.

### HINT:

The terminals should not come out when pulled lightly.

- Prepare a test male terminal and insert it in the female terminal, then pull it out.

### NOTICE:

**When testing a gold-plated female terminal, always use a gold-plated male terminal.**

### HINT:

When the test terminal is pulled out more easily than others, there may be poor contact in that section.

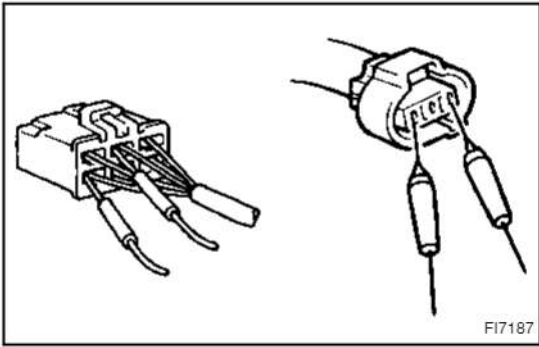

**5. CONNECTOR HANDLING**

When inserting tester probes into a connector, insert them from the rear of the connector. When necessary, use mini test leads. For water resistant connectors which cannot be accessed from behind, take good care not to deform the connector terminals.

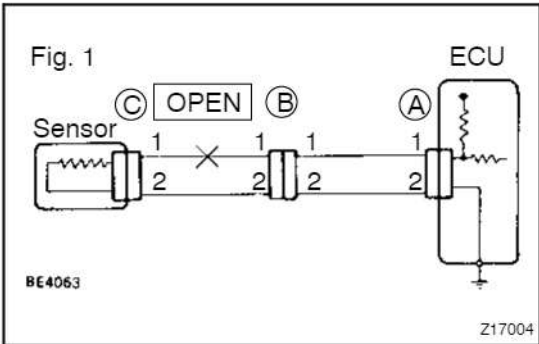

**6. CHECK OPEN CIRCUIT**

For the open circuit in the wire harness in Fig.1, perform "(a) Continuity Check" or "(b) Voltage Check" to locate the section.

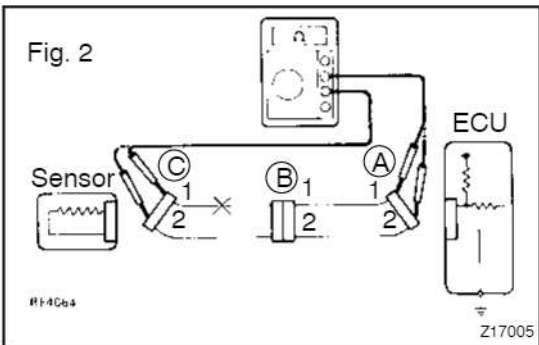

(a) Check the continuity.

(1) Disconnect connectors "A" and "C" and measure the resistance between them.

In the case of Fig.2,

Between terminal 1 of connector "A" and terminal 1 of connector "C" → No continuity (open)

Between terminal 2 of connector "A" and terminal 2 of connector "C" → Continuity

Therefore, it is found out that there is an open circuit between terminal 1 of connector "A" and terminal 1 of connector "C".

(2) Disconnect connector "B" and measure the resistance between them.

In the case of Fig.3,

Between terminal 1 of connector "A" and terminal 1 of connector "B1" → Continuity

Between terminal 1 of connector "B2" and terminal 1 of connector "C" → No continuity (open)

Therefore, it is found out that there is an open circuit between terminal 1 of connector "B2" and terminal 1 of connector "C".

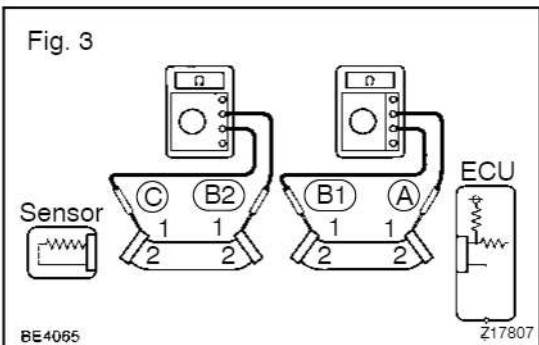

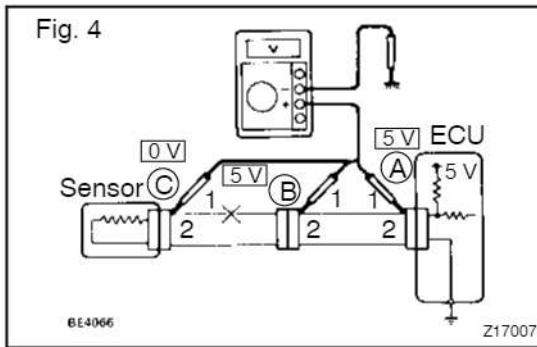

## (b) Check the voltage.

In a circuit in which voltage is applied (to the ECU connector terminal), an open circuit can be checked for by conducting a voltage check.

As shown in Fig.4, with each connector still connected, measure the voltage between body ground and terminal 1 of connector "A" at the ECU 5V output terminal, terminal 1 of connector "B", and terminal 1 of connector "C", in that order.

If the results are:

5V: Between Terminal 1 of connector "A" and Body Ground

5V: Between Terminal 1 of connector "B" and Body Ground

0V: Between Terminal 1 of connector "C" and Body Ground

Then it is found out that there is an open circuit in the wire harness between terminal 1 of "B" and terminal 1 of "C".

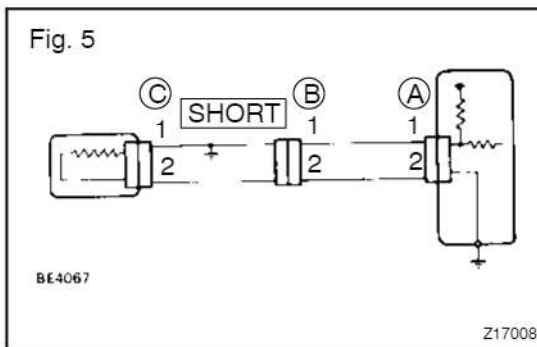
**7. CHECK SHORT CIRCUIT**

If the wire harness is ground shorted as in Fig.5, locate the section by conducting a "continuity check with ground".

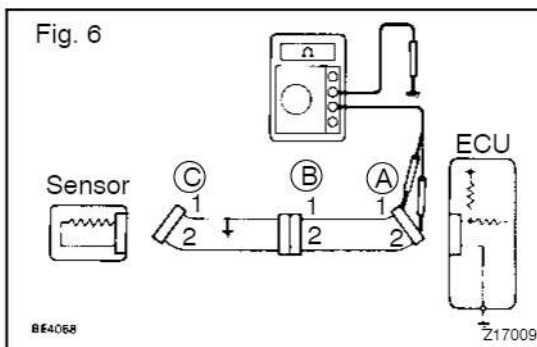

Check the continuity with ground.

- (1) Disconnect connectors "A" and "C" and measure the resistance between terminal 1 and 2 of connector "A" and body ground.

In the case of Fig.6

Between terminal 1 of connector "A" and body ground → Continuity (short)

Between terminal 2 of connector "A" and body ground → No continuity

Therefore, it is found out that there is a short circuit between terminal 1 of connector "A" and terminal 1 of connector "C".

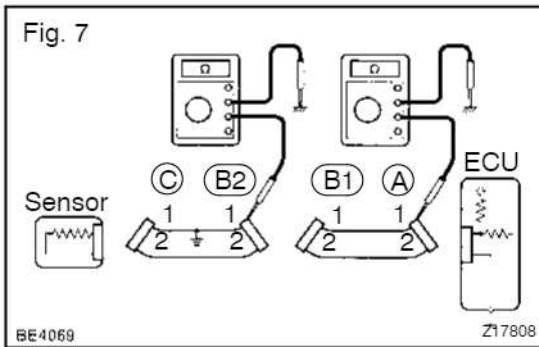

- (2) Disconnect connector "B" and measure the resistance between terminal 1 of connector "A" and body ground, and terminal 1 of connector "B2" and body ground.
- Between terminal 1 of connector "A" and body ground → No continuity
- Between terminal 1 of connector "B2" and body ground → Continuity (short)
- therefore, it is found out that there is a short circuit between terminal 1 of connector "B2" and terminal 1 of connector "C".

**8. CHECK AND REPLACE ECU**

First check the ECU ground circuit. If it is faulty, repair it. If it is normal, the ECU could be faulty, so replace the ECU with a known good one and check if the symptoms appear.

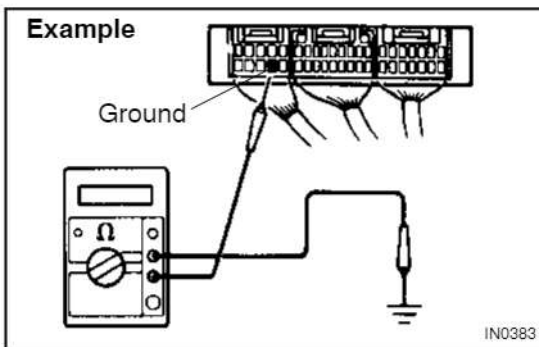

- (1) Measure the resistance between the ECU ground terminal and the body ground.

**Resistance: 1 Ω or less**

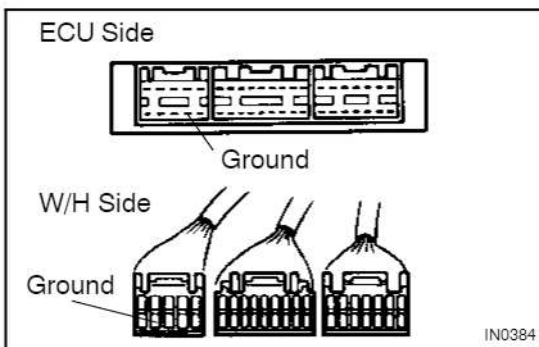

- (2) Disconnect the ECU connector, check the ground terminals on the ECU side and the wire harness side for bend and check the contact pressure.

**TERMS****ABBREVIATIONS USED IN THIS MANUAL**

IN01M-04







Abbreviations	Meaning
ACSD	Automatic Cold Start Device
A/C	Air Conditioner
Approx.	Approximately
A/T	Automatic Transmission
BTDC	Before Top Dead Center
BACS	Boost and Altitude Compensation Stopper
CCo	Catalytic Converter for Oxidation
ECD	Electronic Control Diesel
ECU	Electronic Control Unit
EGR	Exhaust Gas Recirculation
E-VRV	Electronic Vacuum Regulating Valve
EX	Exhaust
EDU	Electronic Drive Unit
FIPG	Formed In Place Gasket
FL	Fusible Link
HAC	High Altitude Compensator
IG	Ignition
IN	Intake
J/C	Junction Connector
LH	Left-Hand
M/T	Manual Transmission
MP	Multipurpose
LHD	Left-Hand Drive
O/S	Oversized
PCV	Positive Crankcase Ventilation
RH	Right-Hand
RHD	Right-Hand Drive
SSM	Special Service Materials
SST	Special Service Tools
STD	Standard
SW	Switch
TDC	Top Dead Center
U/S	Undersized
VSV	Vacuum Switching Valve
w/	With
w/ o	Without



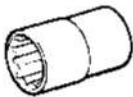

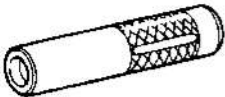
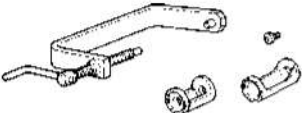
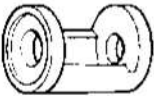
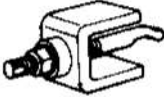
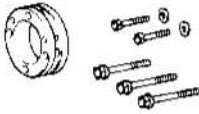





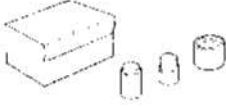

# ENGINE MECHANICAL

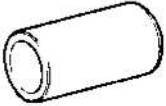

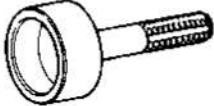

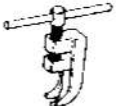
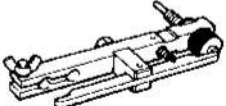



## SST (Special Service Tools)

PF1TM-01

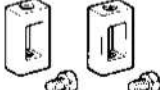
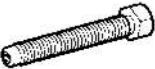
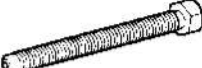

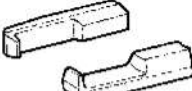

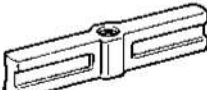
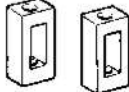

	09011-38121	12 mm Socket Wrench for 12 Pointed Head	Cylinder head
	09201-10000	Valve Guide Bushing Remover & Replacer Set	
	(09201-01060)	Valve Guide Bushing Remover & Replacer 6	
	09201-41020	Valve Stem Oil Seal Replacer	
	09202-70020	Valve Spring Compressor	
	(09202-00010)	Attachment	
	09208-48010	Combustion Chamber Remover	
	09213-58012	Crankshaft Pulley Holding Tool	
	(90201-08131)	Washer	
	(91111-50845)	Bolt	
	09214-60010	Crankshaft Pulley & Gear Replacer	Crankshaft pulley
	09214-76011	Crankshaft Pulley Replacer	Injection pump drive gear oil seal Crankshaft front oil seal

	09222-17011	Connecting Rod Bushing Remover & Replacer	
	(09222-05021)	Remover & Replacer	
	(09222-05031)	Guide	
	(09222-05041)	Base	
	09223-00010	Cover & Seal Replacer	Crankshaft timing gear Oil pump drive shaft gear
	09223-15020	Oil Seal & Bearing Replacer	Drive gear bearing
	09223-46011	Crankshaft Front Oil Seal Replacer	Camshaft oil seal
	09223-56010	Crankshaft Rear Oil Seal Replacer	Crankshaft front oil seal
	09223-78010	Crankshaft Oil Seal Replacer	Crankshaft front oil seal
	09248-64011	Valve Clearance Adjusting Tool	Drive gear bearing
	09275-54011	Plunger Stroke Measuring Tool	
	09308-10010	Oil Seal Puller	Crankshaft front oil seal
	09330-00021	Companion Flange Holding Tool	Crankshaft pulley

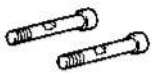
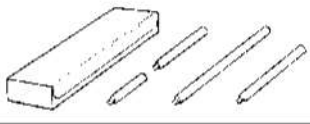

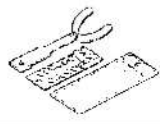
PREPARATION - ENGINE MECHANICAL

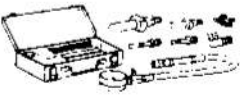
	<p>09502-12010 Differential Bearing Replacer</p>	
	<p>09950-40011 Puller B Set</p>	
	<p>(09951-04010) Hanger 150</p>	<p>No.1 camshaft timing pulley Oil pump drive shaft gear Crankshaft timing gear Injection pump drive gear bearing</p>
	<p>(09952-04010) Slide Arm</p>	<p>No.1 camshaft timing pulley Oil pump drive shaft gear Crankshaft timing gear Injection pump drive gear bearing</p>
	<p>(09953-04010) Center Bolt 100</p>	<p>Oil pump drive shaft gear Crankshaft timing gear</p>
	<p>(09953-04020) Center Bolt 150</p>	<p>No.1 camshaft timing pulley Oil pump drive shaft gear Crankshaft timing gear Injection pump drive gear bearing</p>
	<p>(09954-04010) Arm 25</p>	<p>No.1 camshaft timing pulley Oil pump drive shaft gear Crankshaft timing gear Injection pump drive gear bearing</p>
	<p>(09955-04040) Claw No.4</p>	
	<p>(09955-04060) Claw No.6</p>	<p>No.1 camshaft timing pulley Oil pump drive shaft gear Crankshaft timing gear Injection pump drive gear bearing</p>
	<p>09950-50010 Puller C Set</p>	
	<p>(09951-05010) Hanger 150</p>	<p>Crankshaft pulley Injection pump drive gear</p>
	<p>(09952-05010) Slide Arm</p>	<p>Crankshaft pulley Injection pump drive gear</p>
	<p>(09953-05010) Center Bolt 100</p>	<p>Crankshaft pulley Injection pump drive gear Crankshaft front oil seal</p>

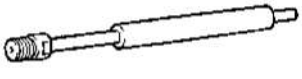
cardiagn.com

	(09953-05020) Center Bolt 150	Crankshaft pulley
	(09954-05020) Claw No.2	Crankshaft pulley Injection pump drive gear
	09950-70010 Handle Set	
	(09951-07100) Handle 100	Valve guide bushing Injection pump drive gear
	09960-10010 Variable Pin Wrench Set	
	(09962-01000) Variable Pin Wrench Arm Assy	Injection pump drive gear
	(09963-00700) Pin 7	Injection pump drive gear
	09992-00025 Cylinder Compression Check Gauge Set	
	(09992-00160) No. 5 Attachment	
	09992-00400 Attachment No.7	Cylinder compression check

# RECOMMENDED TOOLS

	<p>09040-00010 Hexagon Wrench Set .</p>	
	<p>09200-00010 Engine Adjust Kit .</p>	
	<p>09904-00010 Expander Set .</p>	

cardiagn.com

**EQUIPMENT**

Carbide cutter	
Caliper gauge	
Connecting rod aligner	
Cylinder gauge	
Dial indicator	
Dye penetrant	
Engine tune-up tester	
Gasket scraper	
Heater	
Micrometer	
Magnetic finger	
Piston ring compressor	
Piston ring expander	
Plastigage	
Precision straight edge	
Soft brush	
Spring tester	Valve spring
Steel square	Valve spring
Tachometer	
Thermometer	
Torque wrench	
Valve seat cutter	
V-block	
Vernier calipers	

**SSM (Special Service Materials)**

08826-00080	Seal Packing Black or equivalent (FIPG)	Timing belt cover Timing gear cover Camshaft oil seal retainer Cylinder head semi-circular plug
08826-00080	Seal Packing Black or equivalent (FIPG)	Cylinder head cover Main bearing cover Rear oil seal retainer
08826-00100	Seal Packing 1282B, THREE BOND 1282B or equivalent (FIPG)	Water sender gauge
08833-00080	Adhesive 1344 THREE BOND 1344 LOCTITE 242 or equivalent	Idler pulley



# TURBOCHARGING

## SST (Special Service Tools)

PF1TQ-01

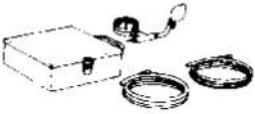
	09992-00242 Turbocharger Pressure Gauge	
---	---	--

cardiagn.com



**EQUIPMENT**

Dial indicator	Impeller wheel
Torque wrench	



# EMISSION CONTROL RECOMMENDED TOOLS

PF15X-01

	09082-00040 TOYOTA Electrical Tester.	
---	---------------------------------------	--

cardiagn.com

**EQUIPMENT**

MITYVAC (Hand-held vacuum tester)	
Tachometer	
Torque wrench	
Vacuum gauge	

# ELECTRONIC CONTROL DIESEL

## SST (Special Service Tools)

PF1TS-01

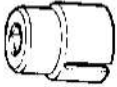
	09817-16011 Back-up Light Switch Tool	Shift position switch
---	---------------------------------------	-----------------------

**RECOMMENDED TOOLS**

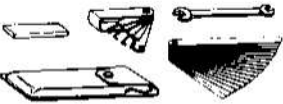







	09082-00040 TOYOTA Electrical Tester.	
	09200-00010 Engine Adjust Kit .	

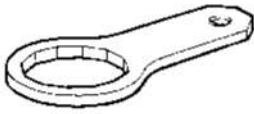



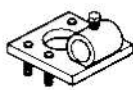

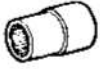

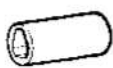
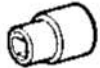

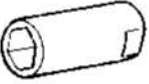

**EQUIPMENT**

19 mm deep socket wrench	
21 mm deep socket wrench	
Torque wrench	

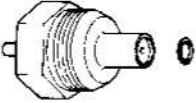
**ENGINE FUEL****SST (Special Service Tools)**

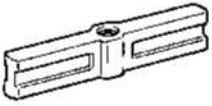
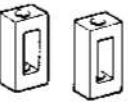

PF1US-01

	09228-64040	Fuel Filter Wrench	
	09236-00101	Water Pump Overhaul Tool Set	
	(09237-00070)	Shaft "C"	1HZ, 1HD-T Governor sleeve plug
	09241-76022	Injection Pump Stand Set	
	09245-54010	Injection Pump Stand Arm	1HZ, 1HD-T
	09245-68010	Injection Pump Stand Arm	1HD-FTE
	09260-54012	Injection Pump Tool Set	
	(09262-54010)	Distributor Head Plug Wrench	1HZ, 1HD-T
	(09269-54020)	Socket 14 mm	1HZ, 1HD-T
	(09269-54030)	Tweezers	1HZ, 1HD-T
	(09269-54040)	Governor Lever Support Bolt Wrench	1HZ, 1HD-T
	(09262-54020)	Regulator Valve Wrench	1HZ, 1HD-T



	09263-00010	Boring Guide	1HZ, 1HD-T
	09268-17010	2 Spring Nozzle Tool set	1HZ
	09268-17020	Master Spring Seat	1HD-FTE
	09268-64010	Injection Nozzle Wrench Set	
	(09268-64020)	Injection Nozzle Holder Retaining Nut Wrench	1HZ
	(09268-64030)	Injection Nozzle Holder Wrench	1HZ
	09275-17010	Pre-stroke Measuring Adapter	1HZ, 1HD-T
	09950-40011	Puller B Set	
	(09957-04010)	Attachment	Injection pump
	09950-50010	Puller C Set	
	(09951-05010)	Hanger 150	Injection pump
	(09952-05010)	Slide Arm	Injection pump
	(09953-05020)	Center Bolt 150	Injection pump



## PREPARATION - ENGINE FUEL

	(09954-05020) O-ring No.2	Injection pump
	09992-00242 Turbocharger Pressure Gauge	1HD-T

## RECOMMENDED TOOLS

	09082-00040 TOYOTA Electrical Tester.	
	09200-00010 Engine Adjust Kit .	
	09258-00030 Hose Plug Set .	Plug for fuel hose

**EQUIPMENT**

Angle gauge	
Brass brush	
Dial indicator with magnetic base	
Graduated cylinder	
Injection nozzle tester	
Injection pump tester	
Inner pressure gauge	
Micrometer	
Steel square	
Timer measuring device	
Torque wrench	
Vernier calipers	
Wooden stick	

**SSM (Special Service Materials)**

08833-00080 Adhesive 1344 THREE BOND 1344 LOCTITE 242 or equivalent	1HD-T Injection pump
---	----------------------

# COOLING EQUIPMENT

PF1TU-01

Heater	Thermostat
Radiator cap tester	
Thermometer	Thermostat
Torque wrench	

**COOLANT**

Item		Capacity	Classification
Engine coolant			Ethylene-glycol base
1HZ			
G.C.C. countries		12.4 liters (13.1 US qts, 10.9 Imp. qts)	
w/ Rear heater		12.9 liters (13.6 US qts, 11.3 Imp. qts)	
Australia	M/T	12.4 liters (13.1 US qts, 10.9 Imp. qts)	
	A/T	12.0 liters (12.7 US qts, 10.6 Imp. qts)	
w/ Rear heater	M/T	12.9 liters (13.6 US qts, 11.3 Imp. qts)	
	A/T	12.5 liters (13.2 US qts, 11.0 Imp. qts)	
Others	M/T	12.4 liters (13.1 US qts, 10.9 Imp. qts)	
	A/T	12.0 liters (12.7 US qts, 10.6 Imp. qts)	
w/ Rear heater	M/T	12.9 liters (13.6 US qts, 11.3 Imp. qts)	
	A/T	12.5 liters (13.2 US qts, 11.0 Imp. qts)	
1HD-T			
	M/T	12.5 liters (13.2 US qts, 11.0 Imp. qts)	
	A/T	12.1 liters (12.8 US qts, 10.6 Imp. qts)	
w/ Rear heater	M/T	13.0 liters (13.7 US qts, 11.4 Imp. qts)	
	A/T	12.6 liters (13.3 US qts, 11.1 Imp. qts)	
1HD-FTE			
	M/T	13.2 liters (13.9 US qts, 11.6 Imp. qts)	
	A/T	12.8 liters (13.5 US qts, 11.7 Imp. qts)	
w/ Viscous heater	M/T	13.7 liters (14.5 US qts, 12.1 Imp. qts)	
	A/T	13.3 liters (14.1 US qts, 11.7 Imp. qts)	

**SSM (Special Service Materials)**

	08826-00100 Seal Packing 1282B, THREE BOND 1282B or equivalent (FIPG)	Engine drain plug on oil cooler cover
--	---	---------------------------------------

# LUBRICATION

## SST (Special Service Tools)

PF16Z-01

	09032-00100 Oil Pan Seal Cutter	
	09228-10002 Oil Filter Wrench	

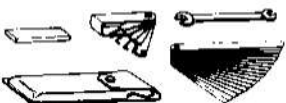

**RECOMMENDED TOOLS**

	09200-00010 Engine Adjust Kit .	
---	---------------------------------	--

**EQUIPMENT**

Oil pressure gauge	
Precision straight edge	
Torque wrench	

**LUBRICANT**





Item	Capacity	Classification
Engine oil		API grade CD or better
1HZ		
Dry fill	10.4 liters (11.0 US qts, 9.2 Imp. qts)	
Drain and refill		
w/ Oil filter change	9.3 liters (9.9 US qts, 8.2 Imp. qts)	
w/o Oil filter change	8.0 liters (8.5 US qts, 7.0 Imp. qts)	
1HD-T		
Dry fill	11.7 liters (12.3 US qts, 10.3 Imp. qts)	
Drain and refill		
w/ Oil filter change	11.4 liters (12.0 US qts, 10.0 Imp. qts)	
w/o Oil filter change	10.1 liters (10.7 US qts, 8.9 Imp. qts)	
1HD-FTE		
Dry fill	12.1 liters (12.8 US qts, 10.6 Imp. qts)	
Drain and refill		
w/ Oil filter change	11.4 liters (12.0 US qts, 10.0 Imp. qts)	
w/o Oil filter change	10.1 liters (10.7 US qts, 8.9 Imp. qts)	

**SSM (Special Service Materials)**

08826-00080	Seal Packing Black or equivalent (FIPG)	Oil pump Oil pan
08833-00080	Adhesive 1344 THREE BOND 1344 LOCTITE 242 or equivalent	Oil pressure sender gauge Taper screw plug on timing gear case

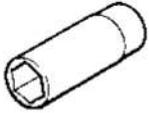
**STARTING****SST (Special Service Tools)**

PF1TD-01

	09286-46011	Injection Pump Spline Shaft Puller	Armature front and rear bearing for 2.5 kW Armature rear bearing for 3.0 kW
	09810-38140	Starter Magnet Switch Nut Wrench 14	
	09810-38170	Starter Magnet Switch Nut Wrench 17	
	09820-00030	Alternator Rear Bearing Replacer	
	09950-00020	Bearing Remover	Armature front bearing for 3.0 kW

**RECOMMENDED TOOLS**









	09082-00040 TOYOTA Electrical Tester.	
	09905-00013 Snap Ring Pliers .	

**EQUIPMENT**

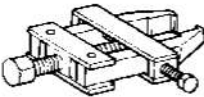
Dial indicator	Commutator
Magnetic finger	Steel ball
Pull scale	Brush spring
Sandpaper	Commutator
Torque wrench	
V-block	Commutator
Vernier calipers	Commutator, Brush
Plastic hammer	

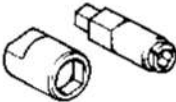
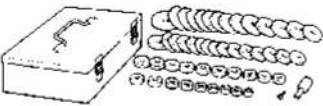
**CHARGING****SST (Special Service Tools)**

PF1TG-01

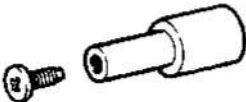
	09285-76010	Injection Pump Camshaft Bearing Cone Replacer	Rotor rear bearing cover
	09286-46011	Injection Pump Spline Shaft Puller	Rectifier end frame
	09820-00021	Alternator Rear Bearing Puller	
	09820-00030	Alternator Rear Bearing Replacer	
	09820-63010	Alternator Pulley Set Nut Wrench Set	
	09950-60010	Replacer Set	Rotor front bearing
	(09951-00230)	Replacer 23	
	(09951-00260)	Replacer 26	
	(09951-00450)	Replacer 45	
	(09951-00500)	Replacer 50	
	(09952-06010)	Adapter	



## RECOMMENDED TOOLS

	09082-00040 TOYOTA Electrical Tester.	
---	---------------------------------------	--











**EQUIPMENT**

Ammeter(A)	
Battery specific gravity gauge	Except maintenance-free battery
Torque wrench	
Vernier calipers	Rotor (Slip ring)
Plastic hammer	

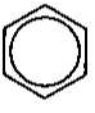
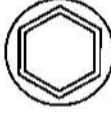
# STANDARD BOLT

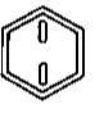
## HOW TO DETERMINE BOLT STRENGTH

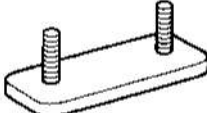
SS0LD-01

	Mark	Class		Mark	Class		
Hexagon head bolt	 <p>Bolt head No.</p>	4-	4T	Hexagon flange bolt w/ washer hexagon bolt	 <p>4 Protruding lines</p>	9T	
		5-	5T				
		6-	6T	Hexagon flange bolt w/ washer hexagon bolt	 <p>5 Protruding lines</p>	10T	
		7-	7T				
		8-	8T	Hexagon flange bolt w/ washer hexagon bolt	 <p>6 Protruding lines</p>	11T	
		9-	9T				
		10-	10T	Hexagon flange bolt w/ washer hexagon bolt	 <p>6 Protruding lines</p>	11T	
		11-	11T				
			 <p>No mark</p>	4T			
		Hexagon flange bolt w/ washer hexagon bolt	 <p>No mark</p>	4T	Stud bolt	 <p>No mark</p>	4T
Hexagon head bolt	 <p>2 Protruding lines</p>	5T	 <p>Grooved</p>	6T			
Hexagon flange bolt w/ washer hexagon bolt	 <p>2 Protruding lines</p>	6T	Welded bolt		4T		
Hexagon head bolt	 <p>3 Protruding lines</p>	7T					
Hexagon head bolt	 <p>4 Protruding lines</p>	8T					

cardiagn.com

V06821

## SPECIFIED TORQUE FOR STANDARD BOLTS

Class	Diameter mm	Pitch mm	Specified torque					
			Hexagon head bolt			Hexagon flange bolt		
			N·m	kgf·cm	ft·lbf	N·m	kgf·cm	ft·lbf
4T	6	1	5	55	48 in·lbf	6	60	52 in·lbf
	8	1.25	12.5	130	9	14	145	10
	10	1.25	26	260	19	29	290	21
	12	1.25	47	480	35	53	540	39
	14	1.5	74	760	55	84	850	61
	16	1.5	115	1,150	83	—	—	—
5T	6	1	6.5	65	56 in·lbf	7.5	75	65 in·lbf
	8	1.25	15.5	160	12	17.5	175	13
	10	1.25	32	330	24	36	360	26
	12	1.25	59	600	43	65	670	48
	14	1.5	91	930	67	100	1,050	76
	16	1.5	140	1,400	101	—	—	—
6T	6	1	8	80	69 in·lbf	9	90	78 in·lbf
	8	1.25	19	195	14	21	210	15
	10	1.25	39	400	29	44	440	32
	12	1.25	71	730	53	80	810	59
	14	1.5	110	1,100	80	125	1,250	90
	16	1.5	170	1,750	127	—	—	—
7T	6	1	10.5	110	8	12	120	9
	8	1.25	25	260	19	28	290	21
	10	1.25	52	530	38	58	590	43
	12	1.25	95	970	70	105	1,050	76
	14	1.5	145	1,500	108	165	1,700	123
	16	1.5	230	2,300	166	—	—	—
8T	8	1.25	29	300	22	33	330	24
	10	1.25	61	620	45	68	690	50
	12	1.25	110	1,100	80	120	1,250	90
9T	8	1.25	34	340	25	37	380	27
	10	1.25	70	710	51	78	790	57
	12	1.25	125	1,300	94	140	1,450	105
10T	8	1.25	38	390	28	42	430	31
	10	1.25	78	800	58	88	890	64
	12	1.25	140	1,450	105	155	1,600	116
11T	8	1.25	42	430	31	47	480	35
	10	1.25	87	890	64	97	990	72
	12	1.25	155	1,600	116	175	1,800	130

cardiagn.com

## ENGINE MECHANICAL

## SERVICE DATA

SS02E-01

Compression pressure	STD 1HZ 1HD-T, 1HD-FTE Minimum 1HZ 1HD-T, 1HD-FTE Difference between each cylinder	3,628 kPa (37.0 kgf/cm <sup>2</sup> , 526 psi) or more 3,432 kPa (35.0 kgf/cm <sup>2</sup> , 498 psi) or more 2,648 kPa (27.0 kgf/cm <sup>2</sup> , 384 psi) 2,452 kPa (25.0 kgf/cm <sup>2</sup> , 356 psi) 490 kPa (5.0 kgf/cm <sup>2</sup> , 71 psi) or less
Valve clearance (1HZ, 1HD-T)	at cold Intake Exhaust Adjust shim thickness No. 709 No. 704 No. 710 No. 01 No. 42 No. 06 No. 43 No. 11 No. 44 No. 16 No. 45 No. 21 No. 46 No. 26 No. 47 No. 31 No. 48 No. 36 No. 49 No. 41	0.15 - 0.25 mm (0.006 - 0.010 in.) 0.35 - 0.45 mm (0.014 - 0.018 in.) 2.35mm (0.0925 in.) 2.40 mm (0.0945 in.) 2.45 mm (0.0965 in.) 2.50 mm (0.0984 in.) 2.55 mm (0.1004 in.) 2.60 mm (0.1024 in.) 2.65 mm (0.1043 in.) 2.70 mm (0.1063 in.) 2.75 mm (0.1083 in.) 2.80 mm (0.1102 in.) 2.85 mm (0.1122 in.) 2.90 mm (0.1142 in.) 2.95 mm (0.1161 in.) 3.00 mm (0.1181 in.) 3.05 mm (0.1201 in.) 3.10 mm (0.1220 in.) 3.15 mm (0.1240 in.) 3.20 mm (0.1260 in.) 3.25 mm (0.1280 in.) 3.30 mm (0.1299 in.)
Valve clearance (1HD-FTE)	at cold Intake Exhaust	0.17 - 0.23 mm (0.007 - 0.009 in.) 0.47 - 0.53 mm (0.099 - 0.021 in.)
Injection timing (1HZ, 1HD-T)	Plunger stroke 1HZ w/ ACSD w/o ACSD 1HD-T	0.65 - 0.71 mm (0.0256 - 0.0280 in.) 0.85 - 0.91 mm (0.0335 - 0.0358 in.) 1.18 - 1.24 mm (0.0465 - 0.0488 in.)
Idle speed (1HZ, 1HD-T)	1HZ M/T A/T 1HD-T M/T A/T	650 ± 50 rpm 710 ± 50 rpm 650 ± 50 rpm 700 - 800 rpm
Idle speed (1HD-FTE)		550 - 650 rpm
Maximum speed (1HZ, 1HD-T)	1HZ 1HD-T	4600 ± 100 rpm 4400 ± 100 rpm
Maximum speed (1HD-FTE)		4300 - 4500 rpm
A/C idle-up speed (1HZ, 1HD-T)		725 - 850 rpm
A/C idle-up speed (1HD-FTE)		725 - 850 rpm
VSV for intake shutter (1HD-FTE)	Resistance at 20 °C (68°F)	33 - 39 Ω
Timing belt tensioner	Protrusion from husing end	9.0 - 9.8 mm (0.354 - 0.386 in.)

1HZ, 1HD-T, 1HD-FTE ENGINE (RM617E)

Timing gear	Idler gear thrust clearance	STD	0.05 – 0.15 mm (0.0020 – 0.0059 in.)
		Maximum	0.030 mm (0.0118 in.)
	Idler gear inside diameter		45.000 – 45.025 mm (1.7717 – 1.7726 in.)
			44.950 – 44.975 mm (1.7697 – 1.7707 in.)
	Idler gear oil clearance	STD	0.025 – 0.075 mm (0.0010 – 0.0030 in.)
		Maximum	0.20 mm (0.0079 in.)
Gear backlash	STD	0.05 – 0.15 mm (0.0020 – 0.0059 in.)	
	Maximum	0.30 mm (0.0118 in.)	
Cylinder head (1HZ, 1HD-T)	Warpage	Maximum	0.20 mm (0.0079 in.)
	Valve seat Refacing angle	Intake	25° 45° 70°
		Exhaust	25° 45° 60°
	Contacting angle		45°
	Contacting width	Intake	1.5 – 1.9 mm (0.059 – 0.075 in.)
		Exhaust	1.8 – 2.2 mm (0.071 – 0.087 in.)
	Cylinder head bolt outer diameter	STD	10.800 – 11.000 mm (0.4252 – 0.4331 in.)
Minimum		10.55 mm (0.4154 in.)	
New cylinder head gasket thickness	Cut number "1"	1.15 – 1.25 mm (0.0453 – 0.0492 in.)	
	Cut number "3"	1.25 – 1.35 mm (0.0492 – 0.0531 in.)	
	Cut number "5"	1.35 – 1.45 mm (0.0531 – 0.0571 in.)	
Cylinder head (1HD-FTE)	Warpage	Maximum	0.20 mm (0.079 in.)
	Valve seat Refacing angle	Intake	25° 45° 70°
		Exhaust	25° 45° 65°
	Contacting angle		45°
	Contacting width	Intake	1.4 – 1.8 mm (0.055 – 0.071 in.)
		Exhaust	1.6 – 2.0 mm (0.063 – 0.079 in.)
	Cylinder head bolt outer diameter	STD	10.800 – 11.000 mm (0.4252 – 0.4331 in.)
Minimum		10.550 mm (0.4154 in.)	
New cylinder head gasket thickness	Cut number "1"	0.85 – 0.95 mm (0.0335 – 0.0374 in.)	
	Cut number "3"	0.95 – 1.05 mm (0.0374 – 0.0414 in.)	
	Cut number "5"	1.05 – 1.15 mm (0.0414 – 0.0453 in.)	
Valve guide bushing	Inside diameter	1HZ, 1HD-T	8.010 – 8.030 mm (0.3154 – 0.3164 in.)
		1HD-FTE	7.010 – 7.030 mm (0.2760 – 0.2768 in.)
Valve (1HZ, 1HD-T)	Valve overall length	STD Intake	103.49 mm (4.0744 in.)
		Exhaust	103.34 mm (4.0685 in.)
		Minimum Intake	102.79 mm (4.0468 in.)
		Exhaust	102.64 mm (4.0409 in.)
	Valve face angle		44.5°
	Stem diameter	Intake	7.975 – 7.990 mm (0.3140 – 0.3146 in.)
		Exhaust	7.960 – 7.975 mm (0.3134 – 0.3140 in.)
	Stem oil clearance	STD Intake	0.020 – 0.055 mm (0.0008 – 0.0022 in.)
		Exhaust	0.035 – 0.070 mm (0.0014 – 0.0028 in.)
		Maximum Intake	0.08 mm (0.0031 in.)
Exhaust		0.10 mm (0.0394 in.)	
Margin thickness	STD	1.00 mm (0.0394 in.)	
	Minimum	0.83 mm (0.0327 in.)	

## SERVICE SPECIFICATIONS - ENGINE MECHANICAL

Valve (1HD-FTE)	Valve overall length	STD Intake	126.85 – 127.45 mm (4.9941 – 5.0177 in.)	
		Exhaust	126.83 – 127.43 mm (4.9933 – 5.0169 in.)	
	Stem diameter	Minimum Intake	126.85 mm (4.9941 in.)	
		Exhaust	126.83 mm (4.9933 in.)	
	Stem oil clearance	Intake	6.970 – 6.985 mm (0.2744 – 0.2750 in.)	
Exhaust		6.960 – 6.975 mm (0.2740 – 0.2746 in.)		
Margin thickness	STD Intake	STD Intake	0.025 – 0.060 mm (0.0010 – 0.0024 in.)	
		Exhaust	0.035 – 0.070 mm (0.0014 – 0.0028 in.)	
	Maximum Intake	Maximum Intake	0.08 mm (0.0031 in.)	
		Exhaust	0.10 mm (0.0039 in.)	
Valve spring (1HZ, 1HD-T)	Free length		46.20 mm (1.8189 in.)	
	Install tension	at 37.0 mm (1.457 in.)	301 – 322 N (30.7 – 33.9 kgf, 67.7 – 74.7 lbf)	
	Deviation	Maximum	2.0 mm (0.079 in.)	
Valve spring (1HD-FTE)	Free length		49.60 mm (1.9527 in.)	
	Install tension	at 39.5 mm (1.555 in.)	237 – 263 N (24.2 – 26.8 kgf, 53.4 – 59.1 lbf)	
	Deviation	Maximum	2.0 mm (0.079 in.)	
Valve rocker arm and shaft (1HD-FTE)	Valve rocker arm inside diameter		20.012 – 20.033 mm (0.7879 – 0.7887 in.)	
	Valve rocker shaft diameter		19.972 – 19.993 mm (0.7879 – 0.7887 in.)	
	Oil clearance	STD Maximum	0.019 – 0.061 mm (0.0007 – 0.0024 in.) 0.10 mm (0.0039 in.)	
Camshaft (1HZ, 1HD-T)	Thrust clearance	STD	0.10 – 0.20 mm (0.0039 – 0.0079 in.)	
		Maximum	0.30 mm (0.0118 in.)	
	Standard oil clearance	STD No.1	0.022 – 0.074 mm (0.0009 – 0.0029 in.)	
		Other	0.030 – 0.066 mm (0.0012 – 0.0026 in.)	
		Maximum	0.100 mm (0.0039 in.)	
	Journal diameter	No.1	34.969 – 34.985 mm (1.3767 – 1.3774 in.)	
		Other	27.986 – 28.002 mm (1.1018 – 1.1024 in.)	
	Cam lobe height	STD Intake	1HZ	55.090 – 55.110 mm (2.1689 – 2.1697 in.)
			1HD-T	54.440 – 54.460 mm (2.1433 – 2.1441 in.)
			Exhaust	55.940 – 55.960 mm (2.2024 – 2.2031 in.)
Minimum Intake		1HZ	54.59 mm (2.1492 in.)	
		1HD-T	53.94 mm (2.1236 in.)	
Circle runout	Exhaust	55.44 mm (2.1827 in.)		
Camshaft (1HD-FTE)	Thrust clearance	STD	0.10 – 0.20 mm (0.0039 – 0.00 in.)	
		Maximum	0.30 mm (0.0118 in.)	
	Standard oil clearance	STD No.1	0.022 – 0.074 mm (0.0009 – 0.0029 in.)	
		Other	0.023 – 0.075 mm (0.0009 – 0.0030 in.)	
		Maximum	0.10 mm (0.0039 in.)	
	Journal diameter	No.1	34.969 – 34.985 mm (1.3767 – 1.3774 in.)	
		Other	27.986 – 28.002 mm (1.1018 – 1.1024 in.)	
	Cam lobe height	STD Intake	Intake	48.203 – 48.303 mm (1.8978 – 1.9017 in.)
			Exhaust	50.734 – 50.834 mm (1.9974 – 2.0013 in.)
		Minimum Intake	Exhaust	47.998 mm (1.8897 in.) 50.234 mm (1.9777 in.)
Circle runout		0.10 mm (0.0039 in.)		
Valve lifter (1HZ, 1HD-T)	Lifter diameter		40.892 – 40.902 mm (1.6099 – 1.6103 in.)	
	Cylinder head lifter bore diameter		40.960 – 40.980 mm (1.6126 – 1.6134 in.)	
	Oil clearance	STD Maximum	0.058 – 0.083 mm (0.0023 – 0.0033 in.) 0.10 mm (0.0039 in.)	
Manifold	Warpage	Maximum	0.40 mm (0.0157 in.)	
Combustion chamber (1HZ)	Protrusion		Minus 0.04 – Plus 0.04 mm (Minus 0.0016 – Plus 0.0016 in.)	
	Shim thickness		0.03 mm (0.0012 in.)	

Cylinder block	Cylinder head surface warpage	Maximum	0.20 mm (0.0079 in.)
	Cylinder bore diameter	STD Mark "1"	94.000 – 94.010 mm (3.7001 – 3.7012 in.)
		Mark "2"	94.010 – 94.020 mm (3.7012 – 3.7016 in.)
		Mark "3"	94.020 – 94.030 mm (0.37016 – 3.7020 in.)
	Main bearing cap stud bolt Tension portion diameter	Maximum STD	94.23 mm (3.7098 in.)
O/S 0.50		94.73 mm (3.7295 in.)	
Piston and piston ring	Piston diameter	STD Mark "1" 1HZ	93.885 – 93.895 mm (3.69625 – 3.69665 in.)
		1HD-T	93.950 – 93.951 mm (3.69881 – 3.69885 in.)
1HD-FTE		93.870 – 93.880 mm (3.69566 – 3.69606 in.)	
Mark "2" 1HZ		93.895 – 93.905 mm (3.69665 – 3.69704 in.)	
1HD-T		93.960 – 93.961 mm (3.69921 – 3.69924 in.)	
1HD-FTE		93.880 – 93.890 mm (3.69606 – 3.69645 in.)	
Mark "3" 1HZ		93.905 – 93.915 mm (3.69704 – 3.69743 in.)	
1HD-T		93.970 – 93.971 mm (3.69960 – 3.69964 in.)	
1HD-FTE		93.890 – 93.900 mm (3.69645 – 3.69684 in.)	
O/S 0.50 1HZ		94.385 – 94.415 mm (3.71594 – 3.71712 in.)	
1HD-T		94.450 – 94.471 mm (3.71850 – 3.71932 in.)	
1HD-FTE		94.370 – 94.400 mm (3.71535 – 3.71653 in.)	
Piston oil clearance		STD 1HZ	0.105 – 0.125 mm (0.0041 – 0.0049 in.)
		1HD-T	0.040 – 0.060 mm (0.0016 – 0.0024 in.)
		1HD-FTE	0.070 – 0.090 mm (0.0028 – 0.0035 in.)
Piston ring groove clearance	Maximum 1HZ	0.125 mm (0.0049 in.)	
	1HD-T	0.060 mm (0.0024 in.)	
	1HD-FTE	0.090 mm (0.0035 in.)	
Piston ring end gap	No.1 STD 1HZ, 1HD-T	1HD-T	0.054 – 0.095 mm (0.0021 – 0.0037 in.)
		1HD-FTE	0.070 – 0.110 mm (0.0028 – 0.0043 in.)
	Maximum	0.20 mm (0.0079 in.)	
	No.2 STD 1HZ, 1HD-T	1HD-T	0.060 – 0.100 mm (0.0024 – 0.0039 in.)
		1HD-FTE	0.040 – 0.080 mm (0.0016 – 0.0031 in.)
	Maximum	0.20 mm (0.0079 in.)	
Oil ring STD	Maximum	0.030 – 0.070 mm (0.0012 – 0.0028 in.)	
	Maximum	0.20 mm (0.0079 in.)	
Piston ring end gap	No.1 STD 1HZ, 1HD-T	1HD-T	0.270 – 0.370 mm (0.0106 – 0.0146 in.)
		1HD-FTE	0.270 – 0.330 mm (0.0106 – 0.0130 in.)
	Maximum	0.850 mm (0.0335 in.)	
	No.2 STD	Maximum	0.400 – 0.550 mm (0.0157 – 0.0119 in.)
		Maximum	0.900 mm (0.0354 in.)
	Oil ring STD	Maximum	0.200 – 0.500 mm (0.0079 – 0.0157 in.)
Maximum	0.880 mm (0.0346 in.)		



## SERVICE SPECIFICATIONS - ENGINE MECHANICAL

Connecting rod	Thrust clearance	STD	0.100 – 0.200 mm (0.0039 – 0.0079 in.)
		Maximum	0.300 mm (0.0118 in.)
	Connecting rod oil clearance	STD	0.036 – 0.054 mm (0.0014 – 0.0021 in.)
		U/S 0.25 and U/S 0.50	0.037 – 0.077 mm (0.0015 – 0.0030 in.)
		Maximum	0.100 mm (0.0039 in.)
	Connecting rod bearing center wall thickness (Reference)	STD Mark "2"	1.486 – 1.489 mm (0.0585 – 0.0586 in.)
		Mark "3"	1.489 – 1.492 mm (0.0586 – 0.0587 in.)
		Mark "4"	1.492 – 1.495 mm (0.0587 – 0.0589 in.)
		Mark "5"	1.495 – 1.498 mm (0.0589 – 0.0590 in.)
		Mark "6"	1.498 – 1.501 mm (0.0590 – 0.0591 in.)
		Rod bend maximum per 100 mm (3.94 in.)	
	Rod twist maximum per 100 mm (3.94 in.)		0.15 mm (0.0059 in.)
	Busing inside diameter		33.008 – 33.020 mm (1.2995 – 1.3000 in.)
	Piston pin diameter		33.000 – 33.012 mm (1.2992 – 1.2997 in.)
	Bushing oil clearance	STD	0.004 – 0.012 mm (0.0002 – 0.0005 in.)
Maximum		0.030 mm (0.0012 in.)	
Connecting rod bolt tension portion diameter	STD	8.300 – 8.400 mm (0.3268 – 0.3307 in.)	
	Maximum	7.950 mm (0.3130 in.)	
Crankshaft	Thrust clearance	STD	0.040 – 0.240 mm (0.0016 – 0.0094 in.)
		Maximum	0.300 mm (0.0118 in.)
	Thrust washer thickness		2.930 – 2.980 mm (0.1154 – 0.1173 in.)
	Main journal oil clearance	STD	0.030 – 0.042 mm (0.00118 – 0.00165 in.)
		U/S 0.25 and U/S 0.50	0.031 – 0.053 mm (0.00122 – 0.00208 in.)
		Maximum	0.100 mm (0.0039 in.)
	Main journal diameter	STD	66.982 – 67.000 mm (2.6371 – 2.6378 in.)
		U/S 0.25	66.745 – 66.755 mm (2.6278 – 2.6281 in.)
		U/S 0.50	66.495 – 66.505 mm (2.6179 – 2.6183 in.)
		Main bearing center wall thickness (Reference)	Mark "3"
		Mark "4"	1.985 – 1.988 mm (0.07815 – 0.07827 in.)
		Mark "5"	1.988 – 1.991 mm (0.07827 – 0.07839 in.)
		Mark "6"	1.991 – 1.994 mm (0.07839 – 0.07850 in.)
		Mark "7"	1.994 – 1.997 mm (0.07850 – 0.07862 in.)
		Mark "8"	1.997 – 2.000 mm (0.07862 – 0.07874 in.)
Crank pin diameter	STD	58.982 – 59.000 mm (2.3221 – 2.3228 in.)	
	U/S 0.25	58.745 – 58.755 mm (2.3128 – 2.3132 in.)	
	U/S 0.50	58.495 – 58.505 mm (2.3029 – 2.3033 in.)	
Circle runout		0.06 mm (0.0024 in.)	
Main journal taper and out-of-round		0.02 mm (0.0008 in.)	

## TORQUE SPECIFICATION

Part tightened		N·m	kgf·cm	ft·lbf
Timing gear case x Injection pump		18	185	13
Injection pump x Injection pipe union nuts		24.5	250	18
Injection pipe x Injection pump	1HZ	14.7	150	11
	1HD-T	24.5	250	18
Injection pump x Distributive head plug	1HZ	16.7	170	12
	1HD-T	25.5	260	19
Injection pump x Injection pump stay bracket	1HD-FTE	39	398	29
Injection pump x Injection pump stay		69	700	51
Intake heater x Intake shutter		19.6	200	14
Camshaft x No.1 camshaft timing pulley		98	1,000	72
Timing gear cover x timing belt tensioner		13	130	10
Timing gear cover x Idler pulley		34.5	350	25
Injection pump drive gear x Injection pump	1HZ, 1HD-T	103	1,050	76
	1HD-FTE	137	1,397	101
Idler gear x Timing belt tensioner		68	694	50
Timing gear cover x Cylinder block		19.6	200	14
Oil pipe x Cylinder block, Vacuum pump		18	185	13
Vacuum pump x Timing belt cover		39	400	29
Crankshaft x Crankshaft pulley		430	4,400	317
Cylinder head x Cylinder block	1st	68.6	700	51
	2nd	Turn 90°	Turn 90°	Turn 90°
	3rd	Turn 90°	Turn 90°	Turn 90°
Cylinder head x bearing cap	No.1 journal 1HZ, 1HD-T	25	250	18
	Other journal 1HZ, 1HD-T	18	185	13
Cylinder head x bearing cap	1HD-FTE	25	250	18
Camshaft oil seal retainer x Cylinder head		19.6	200	14
Cylinder head cover x Cylinder head		6.4	65	57 in.·lbf
Water outlet x Cylinder head		19.6	200	14
Nozzle leakage pipe x Injection nozzle	1HD-T	12.3	125	9
Nozzle leakage pipe x Injection nozzle	1HZ	29	300	22
Glow plug x Cylinder head		12.7	130	9
Intake manifold assembly x Cylinder head		19.6	200	14
Intake pipe x Intake manifold		19.6	200	14
Cylinder head x bearing cap		25	250	18
EGR pipe x Intake pipe	1HD-FTE	19.6	200	14
EGR pipe x Exhaust manifold	1HD-FTE	39.2	400	29
Exhaust manifold x Cylinder head		41.7	425	31
Main bearing cap x Cylinder block	12 pointed head 1st	103	1,050	76
	2nd	Turn 90°	Turn 90°	Turn 90°
	6 pointed head	18	185	13
Connecting rod cap x Connecting rod	1st	36.8	375	27
	2nd	Turn 90°	Turn 90°	Turn 90°
Cylinder head x Cylinder head cover	1HZ, 1HD-T	6.4	65	57
	1HD-FTE	8	8	71
Engine mounting brackets x Cylinder block		68.6	700	51

1HZ, 1HD-T, 1HD-FTE ENGINE (RM617E)

## SERVICE SPECIFICATIONS - ENGINE MECHANICAL

Injection pump stay x Cylinder block	68.6	700	51
Alternator bracket x Cylinder block	68.6	700	51
Rear end plate x Cylinder block	18	185	13
Flywheel (M/T), Drive plate (A/T) x Crankshaft	127.4	1,300	94
Oil pan x Cylinder block	15.7	160	12
Oil strainer x Main bearing cap	8.8	90	78 in.·lbf
Check valve x Cylinder block	27	275	20
Oil cooler assembly x Cylinder block	19.6	200	14

**TURBOCHARGING****SERVICE DATA**

SS02G-01

Turbocharger	Turbocharging pressure	1HD-T	38.6 – 50.0 kPa (0.38 – 0.49 kgf/cm <sup>2</sup> , 5.4 – 7.0 psi)
		1HD-FTE	50.0 – 70.0 kPa (0.49 – 0.69 kgf/cm <sup>2</sup> , 7.0 – 9.8 psi)
	Turbine wheel axial play	Maximum	0.11 mm (0.0043 in.) or less
	Turbine wheel radial play	Maximum 1HD-T	0.16 mm (0.0063 in.)
		1HD-FTE	0.14 mm (0.0055 in.)
	Actuator push rod stroke	1HD-T	1.20 – 1.70 mm (0.0472 – 0.0669 in.)
		1HD-FTE	0.72 – 1.22 mm (0.0283 – 0.0480 in.)
Turbo pressure sensor	Voltage		4.75 – 5.5 V
VSV for turbocharging pressure control	Resistance	At 20°C (68°F)	37 – 44 Ω

**TORQUE SPECIFICATION**

Part tightened		N·m	kgf·cm	ft·lbf
EGR pipe x Exhaust manifold	1HD-FTE	39.2	400	29
Exhaust manifold x Cylinder head		41.7	425	31
EGR pipe x Intake pipe assembly	1HD-FTE	19.6	200	14
Turbocharger x Exhaust manifold		52	530	38
Turbo oil pipe x Turbocharger		18.1	185	13
No.1 turbo water pipe x Turbocharger		7.8	8	69 in.·lbf
Turbo outlet elbow x Turbocharger		52	530	38
Compressor inlet elbow x Turbocharger	1HD-FTE	19.6	200	14

# EMISSION CONTROL

## SERVICE DATA

SS01M-01

E-VRV for EGR (1HD-FTE)	at 20°C (68°F)	11 - 13 Ω
EGR cut VSV (1HD-FTE)	at 20°C (68°F)	37 - 44 Ω

**TORQUE SPECIFICATION**

Part tightened		N·m	kgf·cm	ft·lbf
No.1 intake pipe x No.2 intake pipe	1HD-FTE	19.6	200	14
No.1 intake pipe x Intake pipe stay	1HD-FTE	19.6	200	14
EGR valve x EGR pipe	1HD-FTE	19.6	200	14
EGR pipe x Exhaust manifold	1HD-FTE	39.2	400	29
Front exhaust pipe x Turbo outlet elbow	1HD-FTE	62	632	46
Front exhaust pipe x Center exhaust pipe	1HD-FTE	40	408	30

**ELECTRONIC CONTROL DIESEL**

SS02-02

**SERVICE DATA**

Water temperature sensor, Fuel temperature sensor, Intake air temperature sensor	Resistance	At -20°C (-4°F) At 0°C (0°F) At 20°C (68°F) At 40°C (104°F) At 60°C (140°F) At 80°C (176°F)	10 - 20 KΩ 4 - 7 KΩ 2 - 3 KW 0.9 - 1.3 KW 0.4 - 0.7 KW 0.2 - 0.4 KW
Crankshaft position sensor	Resistance	At Cold At Hot	19 - 32 Ω 24 - 37 Ω
ECU	Resistance		
	Intake air temp. 20°C (68°F)	THA - E2	2.0 - 3.0 kΩ
	Fuel temp. 20°C (68°F)	THF - E2	2.0 - 3.0 kΩ
	Coolant temp. 80°C (176°F)	THW - E2	0.2 - 0.4 kΩ
	Cold (-10°C (14°F) to 50°C (122°F)	TDC+ - TDC-	19 - 37 Ω
	Hot (-50°C (122°F) to 100°C (212°F)	TDC+ - TDC-	24 - 37 Ω
		NE+ - NE-	205 - 255 Ω
		TCV - +B	10 - 16 Ω
		EGR - +B	11 - 18 Ω
	25°C (77°F)	EGRC - +B	30 - 40 Ω
	25°C (77°F)	S/TH- - +B	30 - 40 Ω
	25°C (77°F)	PA - +B	30 - 40 Ω
		SVR - +B	60 - 80 Ω
		IREL - E01	4 - 8 Ω
		MREL - E01	60 - 80 Ω

cardiagn.com



**TORQUE SPECIFICATION**

Part tightened	N·m	kgf·cm	ft·lbf
Water temperature sensor x Cylinder block	20.4	200	15
Fuel temperature sensor x Fuel pump	21.6	220	16.5
Intake air temperature sensor x Intake pipe	29	300	21
Crankshaft position sensor x Cylinder block	5	50	44 in.·lbf
Shift position switch x Transmission	44.1	450	33

# ENGINE FUEL

## SERVICE DATA

SS00X-03

Fuel heater	Resistance	at 20°C (68°F)	0.5 - 2.0 Ω		
Injection nozzles (1HZ)	Nozzle opening pressure	New nozzle	M/T, A/T (White indication ring)	14,710 - 15,690 kPa (150 - 160 kgf/cm <sup>2</sup> , 2,133 - 2,276 psi)	
			A/T (Brown indication ring)	15,690 - 16,671 kPa (160 - 170 kgf/cm <sup>2</sup> , 2,276 - 2,418 psi)	
	Reused nozzle	M/T, A/T (White indication ring)	A/T (Brown indication ring)	14,220 - 15,220 kPa (145 - 155 kgf/cm <sup>2</sup> , 2,062 - 2,205 psi)	
			A/T (Brown indication ring)	15,200 - 16,181 kPa (155 - 165 kgf/cm <sup>2</sup> , 2,205 - 2,347 psi)	
	Adjusting shim thickness			0.900 mm (0.0354 in.)	0.925 mm (0.0364 in.)
				0.950 mm (0.0374 in.)	0.975 mm (0.0384 in.)
				1.000 mm (0.0394 in.)	1.025 mm (0.0404 in.)
				1.050 mm (0.0413 in.)	1.075 mm (0.0423 in.)
				1.100 mm (0.0433 in.)	1.125 mm (0.0443 in.)
				1.150 mm (0.0453 in.)	1.175 mm (0.0463 in.)
				1.200 mm (0.0472 in.)	1.225 mm (0.0482 in.)
				1.250 mm (0.0492 in.)	1.275 mm (0.0502 in.)
				1.300 mm (0.0512 in.)	1.325 mm (0.0522 in.)
				1.350 mm (0.0531 in.)	1.375 mm (0.0541 in.)
				1.400 mm (0.0551 in.)	1.425 mm (0.0561 in.)
				1.450 mm (0.0571 in.)	1.475 mm (0.0581 in.)
				1.500 mm (0.0591 in.)	1.525 mm (0.0600 in.)
				1.550 mm (0.0610 in.)	1.575 mm (0.0620 in.)
				1.600 mm (0.0630 in.)	1.625 mm (0.0640 in.)
				1.650 mm (0.0650 in.)	1.675 mm (0.0659 in.)
				1.700 mm (0.0669 in.)	1.725 mm (0.0679 in.)
			1.750 mm (0.0689 in.)	1.775 mm (0.0699 in.)	
			1.800 mm (0.0709 in.)	1.825 mm (0.0719 in.)	
		1.850 mm (0.0728 in.)	1.875 mm (0.0738 in.)		
		1.900 mm (0.0748 in.)	1.925 mm (0.0758 in.)		
		1.950 mm (0.0768 in.)			
Injection nozzles (1HD-T)	Pre-lift			0.06 - 0.08 mm (0.00236 - 0.00315 in.)	
		Nozzle opening pressure	No.1	17,652 - 18,633 kPa (180 - 190 kgf/cm <sup>2</sup> , 2,560 - 2,702 psi)	
	No.2 (Inspection pressure)		13,239 - 14,220 kPa (135 - 145 kgf/cm <sup>2</sup> , 1,920 - 2,062 psi)		
	Pre-lift and nozzle opening pressure adjusting shim thickness			0.700 mm (0.0276 in.)	0.750 mm (0.0295 in.)
				0.800 mm (0.0315 in.)	0.850 mm (0.0335 in.)
				0.900 mm (0.0354 in.)	0.950 mm (0.0374 in.)
				0.975 mm (0.0384 in.)	1.000 mm (0.0394 in.)
				1.025 mm (0.0404 in.)	1.050 mm (0.0413 in.)
				1.075 mm (0.0423 in.)	1.100 mm (0.0433 in.)
				1.125 mm (0.0443 in.)	1.150 mm (0.0453 in.)
				1.175 mm (0.0463 in.)	1.200 mm (0.0472 in.)
				1.225 mm (0.0482 in.)	1.250 mm (0.0492 in.)
				1.280 mm (0.0504 in.)	1.290 mm (0.0508 in.)
				1.300 mm (0.0512 in.)	1.310 mm (0.0516 in.)
				1.320 mm (0.0520 in.)	1.330 mm (0.0524 in.)
				1.340 mm (0.0528 in.)	1.350 mm (0.0531 in.)
				1.360 mm (0.0535 in.)	1.370 mm (0.0539 in.)
				1.380 mm (0.0543 in.)	1.390 mm (0.0547 in.)
				1.400 mm (0.0551 in.)	1.410 mm (0.0555 in.)
				1.420 mm (0.0559 in.)	1.430 mm (0.0563 in.)
			1.440 mm (0.0567 in.)	1.450 mm (0.0571 in.)	
			1.460 mm (0.0575 in.)	1.470 mm (0.0579 in.)	
			1.480 mm (0.0583 in.)	1.490 mm (0.0587 in.)	
		1.500 mm (0.0591 in.)	1.510 mm (0.0594 in.)		
		1.520 mm (0.0598 in.)	1.530 mm (0.0602 in.)		
		1.540 mm (0.0606 in.)	1.550 mm (0.0610 in.)		
		1.560 mm (0.0614 in.)	1.570 mm (0.0618 in.)		

## SERVICE SPECIFICATIONS - ENGINE FUEL

Injection nozzles (1HD-T) (Cont'd)	Pre-lift and nozzle opening pressure adjusting shim thickness (Cont'd)	1.580 mm (0.0622 in.)	1.590 mm (0.0626 in.)
		1.600 mm (0.0630 in.)	1.610 mm (0.0634 in.)
		1.620 mm (0.0638 in.)	1.630 mm (0.0641 in.)
		1.640 mm (0.0646 in.)	1.650 mm (0.0650 in.)
		1.660 mm (0.0654 in.)	1.670 mm (0.0657 in.)
		1.680 mm (0.0661 in.)	1.690 mm (0.0665 in.)
		1.700 mm (0.0669 in.)	1.750 mm (0.0689 in.)
		1.800 mm (0.0709 in.)	
		Injection nozzles (1HD-FTE)	Nozzle opening pressure
No.2 (Inspection pressure)	33,539 – 35,500 kPa (342 – 362 kgf/cm <sup>2</sup> , 4,864 – 5,149 psi)		
No.2 pressure spring washer (No.1 nozzle opening pressure adjusting shim) thickness	0.800 mm (0.0315 in.)		0.825 mm (0.0325 in.)
	0.850 mm (0.0335 in.)		0.875 mm (0.0344 in.)
	0.900 mm (0.0354 in.)		0.925 mm (0.0364 in.)
	0.950 mm (0.0374 in.)		0.975 mm (0.0384 in.)
	1.000 mm (0.0394 in.)		1.025 mm (0.0404 in.)
	1.050 mm (0.0413 in.)		1.075 mm (0.0423 in.)
	1.100 mm (0.0433 in.)		1.125 mm (0.0443 in.)
	1.150 mm (0.0453 in.)		1.175 mm (0.0463 in.)
	1.200 mm (0.0472 in.)		1.225 mm (0.0482 in.)
	1.250 mm (0.0492 in.)		1.275 mm (0.0502 in.)
	1.300 mm (0.0512 in.)		1.325 mm (0.0521 in.)
	1.350 mm (0.0531 in.)		1.375 mm (0.0541 in.)
	1.400 mm (0.0551 in.)		1.425 mm (0.0561 in.)
	1.450 mm (0.0571 in.)		1.475 mm (0.0581 in.)
	1.500 mm (0.0591 in.)		1.525 mm (0.0600 in.)
	1.550 mm (0.0610 in.)		1.575 mm (0.0620 in.)
	1.600 mm (0.0630 in.)		1.625 mm (0.0640 in.)
	1.650 mm (0.0650 in.)		1.675 mm (0.0659 in.)
	1.700 mm (0.0669 in.)		1.725 mm (0.0679 in.)
	1.750 mm (0.0689 in.)		1.775 mm (0.0699 in.)
	1.800 mm (0.0709 in.)		1.825 mm (0.0719 in.)
	1.850 mm (0.0728 in.)		1.875 mm (0.0738 in.)
	1.900 mm (0.0748 in.)		1.925 mm (0.0758 in.)
	1.950 mm (0.0768 in.)		1.975 mm (0.0778 in.)
	2.000 mm (0.0787 in.)		2.025 mm (0.0797 in.)
	2.050 mm (0.0807 in.)		2.075 mm (0.0817 in.)
	2.100 mm (0.0827 in.)		2.125 mm (0.0837 in.)
2.150 mm (0.0846 in.)	2.175 mm (0.0856 in.)		
2.200 mm (0.0866 in.)			
No.1 pressure spring washer (No.2 nozzle opening pressure adjusting shim) thickness	0.700 mm (0.0276 in.)		0.750 mm (0.0295 in.)
	0.800 mm (0.0315 in.)		0.850 mm (0.0335 in.)
	0.900 mm (0.0354 in.)	0.950 mm (0.0374 in.)	
	0.975 mm (0.0384 in.)	1.000 mm (0.0394 in.)	
	1.025 mm (0.0404 in.)	1.050 mm (0.0413 in.)	
	1.075 mm (0.0423 in.)	1.100 mm (0.0433 in.)	
	1.125 mm (0.0443 in.)	1.150 mm (0.0453 in.)	
	1.175 mm (0.0463 in.)	1.200 mm (0.0472 in.)	
	1.225 mm (0.0482 in.)	1.250 mm (0.0492 in.)	
	1.275 mm (0.0502 in.)	1.300 mm (0.0512 in.)	
	1.325 mm (0.0521 in.)	1.350 mm (0.0531 in.)	
	1.375 mm (0.0541 in.)	1.400 mm (0.0551 in.)	
	1.425 mm (0.0561 in.)	1.450 mm (0.0571 in.)	
	1.475 mm (0.0581 in.)	1.500 mm (0.0591 in.)	
	1.525 mm (0.0600 in.)	1.550 mm (0.0610 in.)	
1.575 mm (0.0620 in.)	1.600 mm (0.0630 in.)		
1.625 mm (0.0640 in.)	1.650 mm (0.0650 in.)		
1.675 mm (0.0659 in.)	1.700 mm (0.0669 in.)		
1.725 mm (0.0679 in.)	1.750 mm (0.0689 in.)		
1.775 mm (0.0699 in.)	1.800 mm (0.0709 in.)		

Injection nozzles (1HD-FTE) (Cont'd)	No.1 pressure spring washer (No.2 nozzle opening pressure adjusting shim) thickness (Cont'd)		1.850 mm (0.0728 in.)	1.900 mm (0.0748 in.)	
			1.950 mm (0.0768 in.)	2.000 mm (0.0787 in.)	
			2.050 mm (0.0807 in.)	2.100 mm (0.0827 in.)	
			2.150 mm (0.0846 in.)		
Injection pump (1HZ, 1HD-T)	Direction of rotation		Clockwise as seen from drive side		
	Injection order		1 - 4 - 2 - 6 - 3 - 5 (A - B - C - D - E - F)		
	Delivery valve opening pressure	1HD-T	7,350 - 8,330 kPa (75 - 85 kgf/cm <sup>2</sup> , 1,067 - 1,209 psi)		
	Plunger spring deviation		2.0 mm (0.079 in.)		
	Spring free length				
	Delivery valve spring	1HZ	24.4 mm (0.961 in.)		
		1HD-T	12.6 mm (0.496 in.)		
	Plunger spring	1HZ	30.0 mm (1.181 in.)		
		1HD-T	31.2 mm (1.228 in.)		
	Coupling spring	1HZ	16.6 mm (0.645 in.)		
		1HD-T	15.5 mm (0.610 in.)		
	Pneumatic bellows spring	1HZ w/ HAC	35.0 mm (1.378 in.)		
	Boost compensator spring	1HD-T	19.4 mm (0.764 in.)		
	Roller height variation		0.02 mm (0.0008 in.)		
	Pickup sensor resistance		650 - 970 Ω		
	Timer adjusting screw protrusion pre-setting		7.5 - 8.0 mm (0.295 - 0.315 in.)		
	Plunger spring shim thickness			0.5 mm (0.020 in.)	0.8 mm (0.031 in.)
				1.0 mm (0.039 in.)	1.2 mm (0.047 in.)
				1.5 mm (0.059 in.)	1.8 mm (0.071 in.)
				2.0 mm (0.079 in.)	
	Flyweight holder thrust clearance		0.15 - 0.35 mm (0.0059 - 0.0138 in.)		
	Governor gear adjusting washer thickness			1.05 mm (0.0413 in.)	1.25 mm (0.0492 in.)
				1.45 mm (0.0571 in.)	1.65 mm (0.0650 in.)
				1.85 mm (0.0728 in.)	
	Governor shaft protrusion		0.3 - 2.0 mm (0.012 - 0.079 in.)		
	Plunger pre-strokes	1HZ	0.2 mm (0.0079 in.)		
		1HD-T	0.25 mm (0.0089 in.)		
	Adjusting shim thickness		Shim are available in 131 sized in increments		
			0.01 mm (0.004 in.), from 1.90 mm (0.0748 in.) to 3.20 mm (0.1260 in.)		
	Timer inner spring with coefficient	1HZ		1.57 N/mm (0.16 kgf/mm)	1.67 N/mm (0.17 kgf/mm)
				1.77 N/mm (0.18 kgf/mm)	1.86 N/mm (0.19 kgf/mm)
				1.96 N/mm (0.20 kgf/mm)	
		1HD-T (Philippine)		1.08 N/mm (0.11 kgf/mm)	1.18 N/mm (0.12 kgf/mm)
			1.27 N/mm (0.13 kgf/mm)	1.37 N/mm (0.14 kgf/mm)	
			1.57 N/mm (0.16 kgf/mm)	1.77 N/mm (0.18 kgf/mm)	
1HD-T (Others)		1.57 N/mm (0.16 kgf/mm)	1.77 N/mm (0.18 kgf/mm)		
		1.96 N/mm (0.20 kgf/mm)	2.16 N/mm (0.22 kgf/mm)		
Governor sleeve plug head thickness	1HZ		3.0 mm (0.118 in.)	3.1 mm (0.122 in.)	
			3.2 mm (0.126 in.)	3.3 mm (0.130 in.)	
			3.4 mm (0.134 in.)	3.5 mm (0.138 in.)	
			3.6 mm (0.142 in.)	3.7 mm (0.146 in.)	
			3.8 mm (0.150 in.)	3.9 mm (0.154 in.)	
			4.0 mm (0.158 in.)	4.1 mm (0.161 in.)	
			4.2 mm (0.165 in.)		
Governor sleeve plug head thickness	1HD-T		3.0 mm (0.118 in.)	3.1 mm (0.122 in.)	
			3.2 mm (0.126 in.)	3.3 mm (0.130 in.)	
			3.4 mm (0.134 in.)	3.5 mm (0.138 in.)	
			3.6 mm (0.142 in.)	3.7 mm (0.146 in.)	
			3.8 mm (0.150 in.)	3.9 mm (0.154 in.)	
			4.0 mm (0.158 in.)	4.1 mm (0.161 in.)	
			4.2 mm (0.165 in.)	4.3 mm (0.169 in.)	
			4.4 mm (0.173 in.)	4.5 mm (0.177 in.)	
			4.6 mm (0.181 in.)	4.7 mm (0.185 in.)	
			4.8 mm (0.189 in.)	4.9 mm (0.193 in.)	
			5.0 mm (0.197 in.)	5.1 mm (0.201 in.)	

## SERVICE SPECIFICATIONS - ENGINE FUEL

Injection pump (1HZ, 1HD-T) (Cont'd)	Governor sleeve plug head thickness (Cont'd)	1HD-T	5.2 mm (0.205 in.)	5.3 mm (0.209 in.)
			5.4 mm (0.213 in.)	5.5 mm (0.216 in.)
			5.6 mm (0.220 in.)	5.7 mm (0.224 in.)
			5.8 mm (0.228 in.)	5.9 mm (0.232 in.)
			6.0 mm (0.236 in.)	6.1 mm (0.240 in.)
			6.2 mm (0.244 in.)	6.3 mm (0.248 in.)
			6.4 mm (0.252 in.)	6.5 mm (0.256 in.)
			6.6 mm (0.260 in.)	
Injection pump (1HD-FTE)	Engine speed sensor resistance	at 20°C (68°F)	205 - 255 Ω	
	Spill control valve resistance	at 20°C (68°F)	1 - 2 Ω	
	Timing control valve resistance	at 20°C (68°F)	10 - 14 Ω	

## TORQUE SPECIFICATION

Part tightened		N·m	kgf·cm	ft·lbf
Fuel prefilter upper body x Fuel prefilter lower body		16.7	170	12
Fuel prefilter x Bracket		18	185	13
Fuel damper x Body		7.5	80	66 n.·lbf
Nozzle holder body x Nozzle holder retaining nut	1HZ	46.58	475	34
	1HD-T	34.3	350	25
	1HD-FTE	29.4	300	22
Injection nozzle x Cylinder head	1HZ	63.7	650	47
	1HD-T	39.2	400	29
	1HD-FTE	25	255	18
Injection pipe x Injection nozzle, Injection pump	1HZ	14.7	150	11
	1HD-T, 1HD-FTE	24.5	250	18
Injection pipe clamp x Intake manifold, Injection pipe clamp		6.4	65	56 in.·lbf
No.3 nozzle leakage pipe x Intake manifold	1HD-FTE	19.6	200	14
Nozzle leakage pipe x Injection nozzle	1HZ	29.4	300	22
	1HD-T	12.3	125	9
	1HD-FTE	11.3	115	8
Nozzle leakage pipe x Cylinder head	1HD-FTE	19	186	14
Delivery valve holder x Distributive head	1HZ, 1HD-T	58.85	600	43
Fuel inlet hollow screw x Injection pump body	1HZ, 1HD-T	36.8	375	27
Regulator valve x Injection pump body	1HZ, 1HD-T	8.8	90	78 in.·lbf
Feed pump cover x Injection pump body	1HZ, 1HD-T	2.9	29.5	25 in.·lbf
Timer cover x Injection pump body	1HZ, 1HD-T	8.35	85	74 in.·lbf
Timer adjusting screw x Timer cover	1HZ, 1HD-T	14.2	145	11
Governor link support x Injection pump body	1HZ, 1HD-T	14	140	10
Distributive head x Injection pump body	1HZ, 1HD-T	12	120	9
Governor shaft x Injection pump body	1HZ, 1HD-T	27	275	20
Overflow screw x Governor cover	1HD-T	24.55	250	18
Control lever x Governor cover	1HZ, 1HD-T	6.85	70	61 in.·lbf
Governor cover x Injection pump body	1HZ, 1HD-T	8.3	85	74 in.·lbf
Wire clamp x Governor cover	1HZ, 1HD-T	8.35	85	74 in.·lbf
Idle speed adjusting screw x Governor cover	1HZ, 1HD-T	6.9	70.4	61 in.·lbf
Adjusting lever x Governor cover	1HZ, 1HD-T	8.35	85	74 in.·lbf
Pickup sensor x Injection pump body	1HZ, 1HD-T	20.6	210	15
Distributive head plug x Distributive head	1HZ	69	700	51
	1HD-T	88	900	65
Distributive head plug bolt x Distributive head plug	1HZ, 1HD-T	16.7	170	12
Pneumatic bellows cover x Governor cover	1HZ w/ HAC	7.35	75	65 in.·lbf
Diaphragm x Push rod	1HD-T	7.35	75	65 in.·lbf
Diaphragm cover x Governor cover	1HD-T	7.35	75	65 in.·lbf
Lever control spring x Governor cover	1HZ, 1HD-T	11.3	115	8
Injection pump stay x Injection pump	1HZ, 1HD-T	8.35	85	74 in.·lbf
	1HD-FTE	19.6	200	14
Fuel cut solenoid x Distributive head	1HZ, 1HD-T	22	225	16
Lead wire x Fuel cut solenoid	1HZ, 1HD-T	1.7	17	15 in.·lbf
Cap x Injection pump	1HD-T	11	115	8

1HZ, 1HD-T, 1HD-FTE ENGINE (RM617E)

## SERVICE SPECIFICATIONS - ENGINE FUEL

Thermo wax x Injection pump body	w/ ACSD	8.35	85	74 in.·lbf
Idle-up lever x Injection pump body	1HZ, 1HD-T Short bolt	8.35	85	74 in.·lbf
	Long bolt	11.75	120	9
No.2 nozzle leakage pipe, Fuel inlet pipe x Injection pump	1HZ, 1HD-T	22.1	225	16
Idle-up actuator x Idle-up lever	1HZ, 1HD-T	9.35	95	83 in.·lbf
Fuel temperature sensor x Injection pump	1HD-FTE	22.1	225	16
Fuel inlet pipe x Injection pump	1HD-FTE	24.5	250	18
Fuel outlet pipe x Injection pump	1HD-FTE	22.1	225	16
Injection pump x Timing gear case		18	185	13
Pump stay x Injection pump	1HZ, 1HD-T	69	700	51
Pump stay x Injection pump, Cylinder Block	1HZ, 1HD-T	69	700	51
Pump stay bracket x Injection pump	1HZ, 1HD-T	39	398	29
Injection pump drive gear x Injection pump	1HZ, 1HD-T	103	1,050	76
	1HD-FTE	137	1,400	101

**COOLING****SERVICE DATA**

SS01Y-01

Thermostat	Valve opening temperature	74 - 78°C (165 - 172°F)
	Valve lift at 90°C (194°F)	10 mm (0.39 in.) or more
Radiator cap	Relief valve opening pressure	93 - 123 kPa (0.95 - 1.25 kgf/cm <sup>2</sup> , 13.5 - 17.8 psi)
	STD Minimum	78 kPa (0.8 kgf/cm <sup>2</sup> , 11.4 psi)



## TORQUE SPECIFICATION

Part tightened	N·m	kgf·cm	ft·lbf
Drain plug x Union	12.7	130	9
Water pump x Cylinder block	12 mm head	19.6	14
	14 mm head	39.2	29
Fan x Fluid coupling	6.4	65	57 in.·lbf
Fluid coupling x Water pump pulley	19.6	200	14
Water inlet x Cylinder block	19.6	200	14
Water pump x Alternator bracket	19.6	200	14
Oil cooler x Lower tank	10	100	7
Oil cooler pipe x Oil cooler	15	150	11
Support x Tank on radiator	12.7	130	9

# LUBRICATION

## SERVICE DATA

SS010-01

Oil pressure		at idle speed at 3,000 rpm	29 kPa (0.3 kgf/cm <sup>2</sup> , 43 psi) or more 250 - 600 kpa (2.5 - 6.1 kgf/cm <sup>2</sup> , 36 - 87 psi)
Oil pump	Tip clearance	STD	0.080 - 0.160 mm (0.0031 - 0.0063 in.)
		Maximum	0.21 mm (0.0083 in.)
	Body clearance	STD	0.100 - 0.170 mm(0.0039 - 0.0067 in.)
		Maximum	0.20 mm (0.0079 in.)
	Side clearance	STD	0.030 - 0.090 mm (0.0012 - 0.0035in.)
		Maximum	0.15 mm (0.0059 in.)

**TORQUE SPECIFICATION**

Part tightened	N·m	kgf·cm	ft·lbf
Drain plug x Oil pan	34.3	350	25
Relief valve x Timing gear case	49	500	36
Oil strainer x Main bearing cap	8.8	90	78 in.·lbf
Timing gear case x Cylinder block, Main bearing	19.6	200	14
Injection pump x Timing gear case	18	185	13
Oil pan x Main bearing cap, Timing gear case, Rear oil seal retainer	15.7	160	12
Oil cooler cover x Oil cooler	15.7	160	12
Oil cooler cover, Oil dipstick guide x Cylinder block	19.6	200	14
Relief valve x Oil cooler cover	39	400	29
Check valve x Oil cooler cover	27	275	20
Water temperature sensor x Oil cooler cover	19.6	200	14
Oil nozzle x Cylinder block	27	275	20

# STARTING

## SERVICE DATA

SS0YU-01

Pre-heating system	Light lighting time Super glow type at 20°C (68°F)	Approx. 1.0 seconds	
Glow plug	Resistance	Approx. 0.75 Ω	
Starter (2.5 kW type)	Rated voltage and output power	12V 2.5 kW	
	No-load characteristics	Current	180 A or less at 11.0 V
		rpm	3,500 rpm or less
	Brush length	STD	20.5 mm (0.807 in.)
		Minimum	11.0 mm (0.433 in.)
	Spring installed load	STD	34.3 - 42.1 N (3.4 - 4.1 kgf, 7.7 - 9.5 lbf)
		Minimum	18.6 N (1.8 kgf, 4.2 lbf)
	Commutator Diameter	STD	36.0 mm (1.417 in.)
		Minimum	35.0 mm (1.378 in.)
	Undercut depth	STD	0.7 mm (0.028 in.)
Minimum		0.2 mm (0.008 in.)	
Circle runout	Maximum	0.05 mm (0.0020 in.)	
Magnetic switch			
Contact plate for wear	Maximum	1.6 mm (0.063 in.)	
Starter (3.0 kW type)	Rated voltage and output power	12V 3.0 kW	
	No-load characteristics	Current	220 A or less at 11.0 V
		rpm	4,200 rpm or less
	Brush length	STD	21.0 mm (0.828 in.)
		Minimum	12.0 mm (0.472 in.)
	Spring installed load	STD	27.5 - 37.3 N (2.8 - 3.8 kgf, 6.1 - 8.3 lbf)
		Minimum	14.7 N (1.5 kgf, 3.3 lbf)
	Commutator Diameter	STD	43.0 mm (1.692 in.)
		Minimum	42.0 mm (1.654 in.)
	Undercut depth	STD	0.7 mm (0.028 in.)
Minimum		0.2 mm (0.008 in.)	
Circle runout	Maximum	0.05 mm (0.0020 in.)	
Magnetic switch			
Contact plate for wear	Maximum	1.6 mm (0.063 in.)	

cardiagn.com

## TORQUE SPECIFICATION

Part tightened		N·m	kgf·cm	ft·lbf
Glow plug x Cylinder head		13	130	10
Intake Shutter x Intake pipe No.2		19.6	200	14
Intake Shutter x Intake heater		7.5	75	66 in·lbf
Intake heater relay x Wire		3.5	35	31 in·lbf
Terminal 30 nut, Terminal C nut x Terminal bolt	2.5 kW	36.3	370	27
	3.0 kW	34.3	350	25
End cover x Magnetic switch housing		3.6	37	32 in·lbf
End cover x Brush holder	2.5 kW	3.6	37	32 in·lbf
Brush x Brush holder	3.0 kW	3.6	37	32 in·lbf
Starter hosing x Magnetic switch	2.5 kW	9.3	95	82 in·lbf
	3.0 kW	11.3	115	8.3
End cover with field frame x Magnetic switch	2.5 kW	9.3	95	82 in·lbf
	3.0 kW	14.2	145	10
Lead wire of field coil x Terminal C		24	245	18

# CHARGING

## SERVICE DATA

SS01W-01

Battery	Specific gravity	at 20°C (68°F)	1.25 - 1.29
	Voltage	at 20°C (68°F)	12.5 - 12.9 V
Drive belt	Deflection	New belt	6 - 7 mm (0.24 - 0.28 in.)
		Used belt	8 - 11 mm (0.31 - 0.43 in.)
	Tension	New belt	441 - 539 N (45 - 55 kgf)
		Used belt	196 - 343 N (20 - 35 kgf)
Alternator	Rated output		12 V 70 A, 12 V 80 A, 12 V 120 A
	Rotor coil resistance	at 20°C (68°F)	2.1 - 2.5 Ω
	Slip ring diameter	STD	14.2 - 14.4 mm (0.559 - 0.567 in.)
		Minimum	12.8 mm (0.504 in.)
	Brush exposed length	STD	10.5 mm (0.413 in.)
Minimum		1.5 mm (0.059 in.)	
IC regulator	Regulating voltage		13.2 - 14.8 V

## TORQUE SPECIFICATION

Part tightened		N·m	kgf·cm	ft·lbf
Retainer x Drive end frame		3.0	31	27 in.·lbf
Rectifier end frame x Drive end frame	70 A	4.5	46	40 in.·lbf
Rectifier end frame without cord clip x Drive end frame	80 A, 120 A	4.5	46	40 in.·lbf
Rectifier end frame with cord clip x Drive end frame	80 A, 120A	5.4	55	48 in.·lbf
Alternator pulley x Rotor		110.5	1,125	81
Rectifier holder x Lead wire on rectifier end frame	70 A Screw Bolt	1.96	20	17 in.·lbf
		3.9	40	35 in.·lbf
Rectifier holder x Lead wire on rectifier end frame	80 A, 120 A	2.94	30	26 in.·lbf
IC regulator x Rectifier end frame	70 A	1.96	20	17 in.·lbf
	80 A, 120 A	2.0	20	18 in.·lbf
IC regulator x Rectifier holder	70 A	1.96	20	17 in.·lbf
	80 A, 120 A	2.0	20	18 in.·lbf
Brush holder x Rectifier holder	70 A	1.96	20	17 in.·lbf
	80 A, 120 A	2.0	20	18 in.·lbf
Brush holder x IC regulator	70 A	1.96	20	17 in.·lbf
	80 A, 120 A	2.0	20	18 in.·lbf
Rear end cover x Rectifier holder		4.4	45	39 in.·lbf
Plate terminal x Rectifier holder	80 A, 120 A	3.85	39	34 in.·lbf
Terminal insulator x Rectifier holder		4.1	42	36 in.·lbf

# ENGINE

## HOW TO PROCEED WITH TROUBLESHOOTING

DI31H-02

When using hand-held tester, troubleshoot in accordance with the procedure on the following pages.

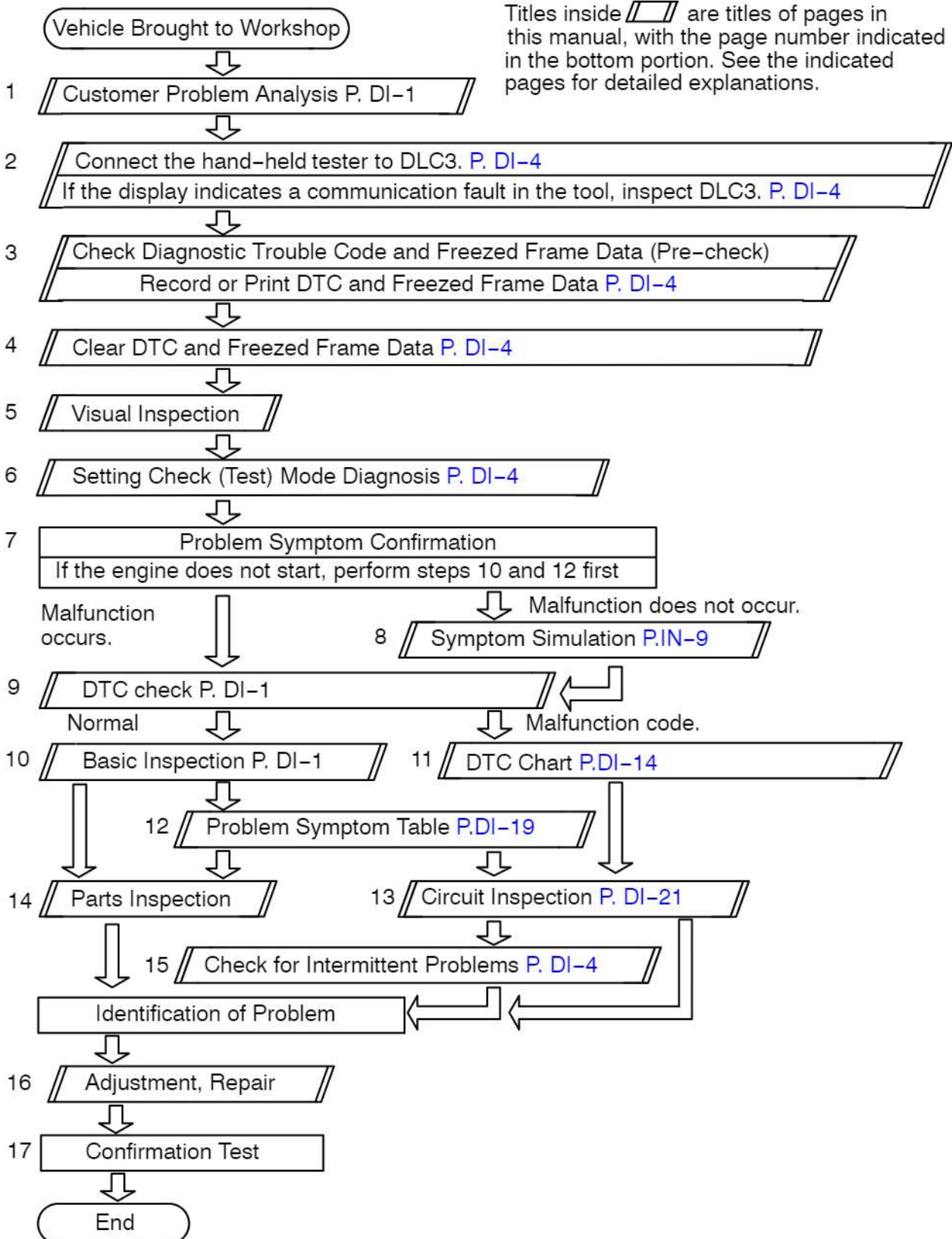



When not using hand-held tester, troubleshoot in accordance with the procedure on the following pages.

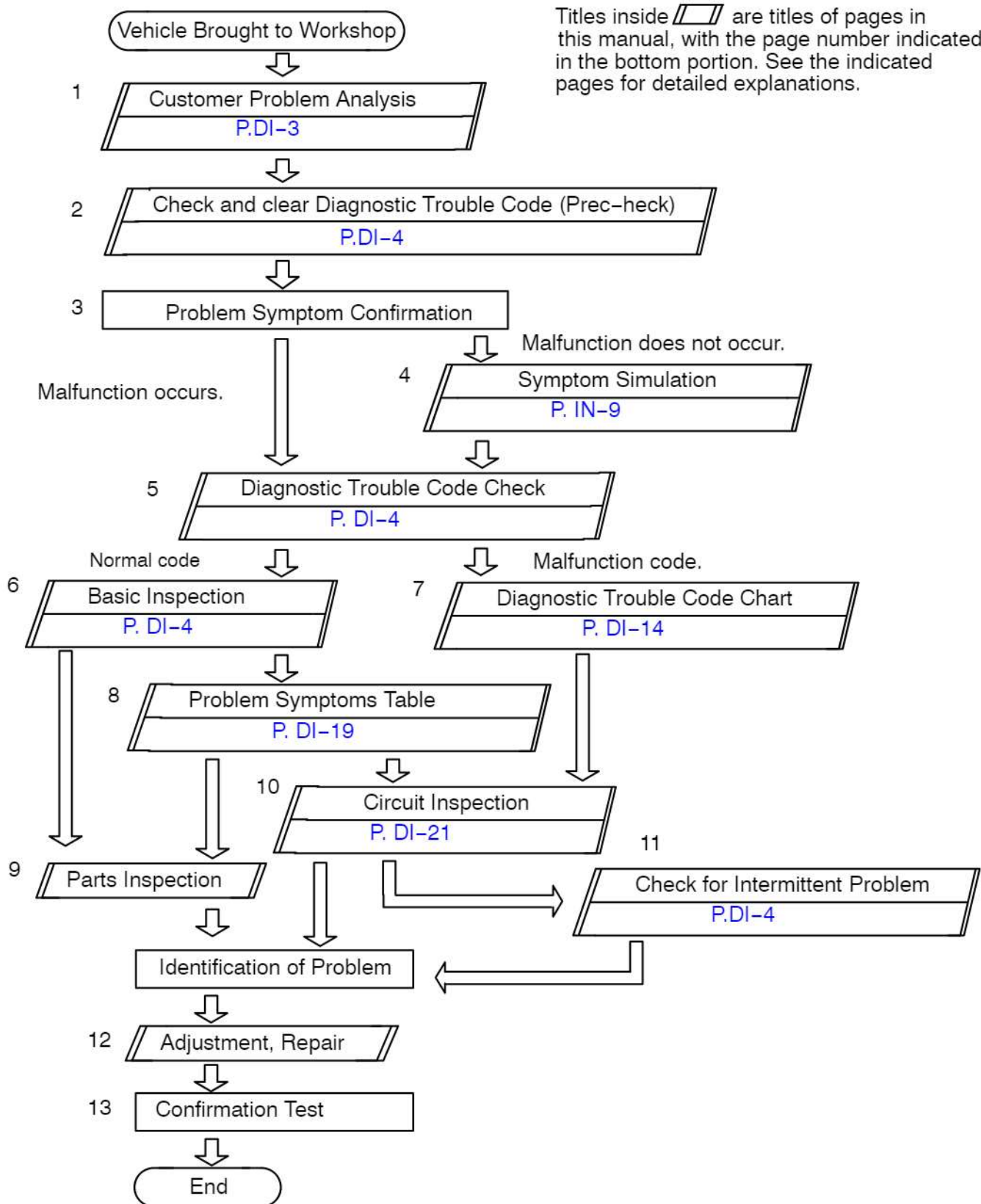

# CUSTOMER PROBLEM ANALYSIS CHECK

## ENGINE CONTROL SYSTEM Check Sheet

 Inspector's  
Name
 

---

Customer's Name		Model and Model Year	
Driver's Name		Frame No.	
Date Vehicle Brought in		Engine Model	
License No.		Odometer Reading	km miles

Problem Symptoms	<input type="checkbox"/> Engine does not Start	<input type="checkbox"/> Engine does not crank	<input type="checkbox"/> No initial combustion	<input type="checkbox"/> No complete combustion
	<input type="checkbox"/> Difficult to Start	<input type="checkbox"/> Engine cranks slowly <input type="checkbox"/> Other _____		
	<input type="checkbox"/> Poor Idling	<input type="checkbox"/> Incorrect first idle <input type="checkbox"/> Idling rpm is abnormal <input type="checkbox"/> High (          rpm) <input type="checkbox"/> Low (          rpm) <input type="checkbox"/> Rough idling <input type="checkbox"/> Other _____		
	<input type="checkbox"/> Poor Driveability	<input type="checkbox"/> Hesitation <input type="checkbox"/> Back fire <input type="checkbox"/> Muffler explosion (after-fire) <input type="checkbox"/> Surging <input type="checkbox"/> Knocking <input type="checkbox"/> Other _____		
	<input type="checkbox"/> Engine Stall	<input type="checkbox"/> Soon after starting <input type="checkbox"/> After accelerator pedal depressed <input type="checkbox"/> After accelerator pedal released <input type="checkbox"/> During A/C operation <input type="checkbox"/> Shifting from N to D <input type="checkbox"/> Other _____		
	<input type="checkbox"/> Others	_____		

Dates Problem Occurred		_____		
Problem Frequency		<input type="checkbox"/> Constant <input type="checkbox"/> Sometimes (          times per          day/month) <input type="checkbox"/> Once only <input type="checkbox"/> Other _____		
Condition When Problem Occurs	Weather	<input type="checkbox"/> Fine <input type="checkbox"/> Cloudy <input type="checkbox"/> Rainy <input type="checkbox"/> Snowy <input type="checkbox"/> Various/Other _____		
	Outdoor Temperature	<input type="checkbox"/> Hot <input type="checkbox"/> Warm <input type="checkbox"/> Cool <input type="checkbox"/> Cold (approx. ____ °F/ ____ °C)		
	Place	<input type="checkbox"/> Highway <input type="checkbox"/> Suburbs <input type="checkbox"/> Inner City <input type="checkbox"/> Uphill <input type="checkbox"/> Downhill <input type="checkbox"/> Rough road <input type="checkbox"/> Other _____		
	Engine Temp.	<input type="checkbox"/> Cold <input type="checkbox"/> Warming up <input type="checkbox"/> After Warming up <input type="checkbox"/> Any temp. <input type="checkbox"/> Other _____		
	Engine Operation	<input type="checkbox"/> Starting <input type="checkbox"/> Just after starting (          min.) <input type="checkbox"/> Idling <input type="checkbox"/> Racing <input type="checkbox"/> Driving <input type="checkbox"/> Constant speed <input type="checkbox"/> Acceleration <input type="checkbox"/> Deceleration <input type="checkbox"/> A/C switch ON/OFF <input type="checkbox"/> Other _____		

Condition of Malfunction indicator Lamp		<input type="checkbox"/> Remains on <input type="checkbox"/> Sometimes light up <input type="checkbox"/> Does not light up		
Diagnostic Trouble Code Inspection	Normal mode (Precheck)	<input type="checkbox"/> Normal <input type="checkbox"/> Malfunction code(s) (code          ) <input type="checkbox"/> Freezed frame data (          )		
	Check Mode	<input type="checkbox"/> Normal <input type="checkbox"/> Malfunction code(s) (code          ) <input type="checkbox"/> Freezed frame data (          )		

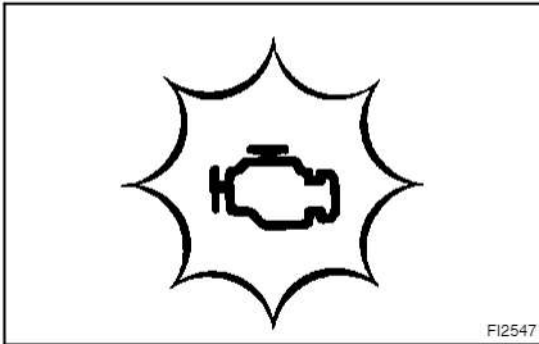

F12547

## PRE-CHECK

### 1. DIAGNOSIS SYSTEM

#### (a) Description

When troubleshooting Multiplex OBD (M-OBD) vehicles, the only difference from the usual troubleshooting procedure is that you connect to the vehicle the hand-held tester, and read off various data output from the vehicle's engine ECU.

The vehicle's on-board computer lights up the check engine warning light on the instrument panel when the computer detects a malfunction in the computer itself or in drive system components. In addition to the check engine warning light lighting up when a malfunction is detected, the applicable diagnostic trouble codes are recorded in the engine ECU memory. (See page DI-14)

If the malfunction has been repaired, the check engine warning light goes off automatically but the diagnostic trouble codes remain recorded in the engine ECU memory.

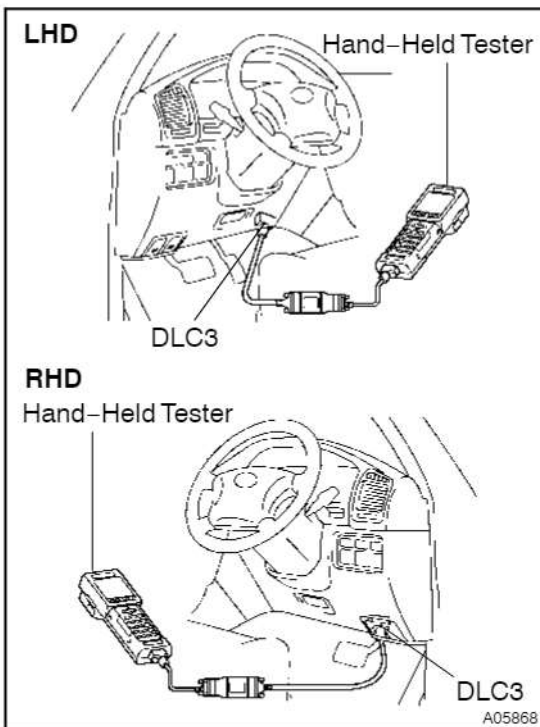

To check the diagnostic trouble codes, connect the hand-held tester to Data Link Connector 3 (DLC3) on the vehicle or read the number of blinks of the check engine warning light when TC and CG terminals on the DLC3 are connected. The hand-held tester also enables you to erase the diagnostic trouble codes and activate the several actuators and check freeze frame date and various forms of engine data. (For operating instructions, see the hand-held tester instruction book.)

The diagnosis system operates in normal mode during normal vehicle use. It also has a check (test) mode for technicians to simulate malfunction symptoms and troubleshoot. Some diagnostic trouble codes use 2 trip detection logic\* to prevent erroneous detection and ensure thorough malfunction detection. By switching the engine ECU to check (test) mode using hand-held tester when troubleshooting, the technician can cause the check engine warning light to light up for a malfunction that is only detected once or momentarily. (hand-held tester only)

(See page DI-14)

\*2 trip detection logic

When a logic malfunction is first detected, the malfunction is temporarily stored in the engine ECU memory. If the same malfunction is detected again during the second drive test, this second detection causes the check engine warning light to light up.

The 2 trip repeats the same mode a 2nd time. (However, the IG switch must be turned OFF between the 1st trip and 2nd trip).

**Freeze frame data:**

Freeze frame data records the engine condition when malfunction is detected.

Because freeze frame data records the engine conditions (fuel system, calculator load, engine coolant temperature, fuel trim, engine speed, vehicle speed, etc.) when the malfunction is detected, when troubleshooting it is useful for determining whether the vehicle was running or stopped, the engine warmed up or not, the air-fuel ratio lean or rich, etc. at the time of the malfunction.

**(b) Check the DLC3.**

The vehicle's engine ECU uses ISO 14230 for communication. The terminal arrangement of DLC3 complies with SAE J1962 and matches the ISO 14230 format.

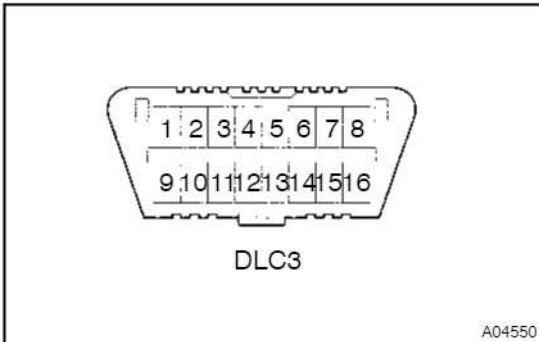

Terminal No.	Connection/Voltage or Resistance	Condition
7	Bus ⊕ Line / Pulse generation	During transmission
4	Chassis Ground / ↔ Body Ground 1 Ω or less	Always
16	Battery Positive / ↔ Body Ground 9 ~ 14 V	Always

**HINT:**

If your display shows "UNABLE TO CONNECT TO VEHICLE" when you have connected the cable of the hand-held tester to DLC3, turned the ignition switch ON and operated the hand-held tester, there is a problem on the vehicle side or tool side.

- (1) If communication is normal when the tool is connected to another vehicle, inspect DLC3 on the original vehicle.
- (2) If communication is still not possible when the tool is connected to another vehicle, the problem is probably in the tool itself, so consult the Service Department listed in the tool's instruction manual.

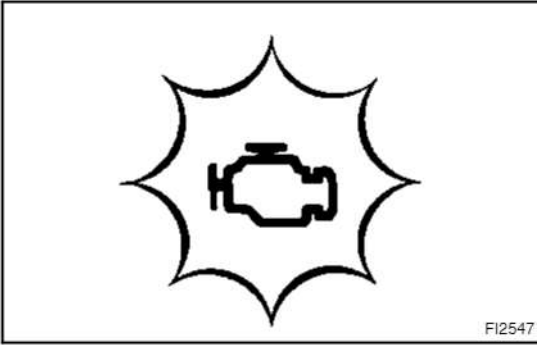

## 2. INSPECT DIAGNOSIS (Normal Mode)

(a) Check the check engine warning light.

- (1) The check engine warning light comes on when the ignition switch is turned ON and the engine is not running.

HINT:

If the check engine warning light does not light up, troubleshoot the combination meter.

- (2) when the engine is started, the check engine warning light should go off. If the lamp remains on, the diagnosis system has detected a malfunction or abnormality in the system.

(b) Check the DTC using hand-held tester.

**NOTICE:**

**When the diagnosis system is switched from normal mode to check test mode, it erases all DTCs and frozen frame data recorded in normal mode. So before switching modes, always check the DTCs and frozen frame data, and note them down.**

- (1) Prepare the hand-held tester.
- (2) Connect the hand-held tester to the DLC3.
- (3) Turn the ignition switch ON and switch the hand-held tester main switch ON.
- (4) Use the hand-held tester to check the DTCs and frozen frame data, note them down. (for operating instructions, see the hand-held tester's instruction book.)
- (5) Confirm the details of the DTCs.

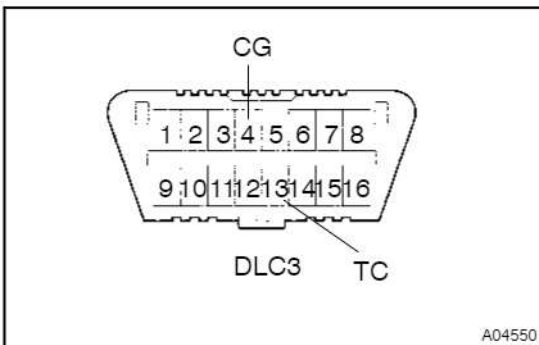

(c) Check the DTC not using hand-held tester.

- (1) Turn the ignition switch ON.
- (2) Using SST, connect between terminals 13 (TC) and 4 (CG) of DLC3.  
SST 09843-18040

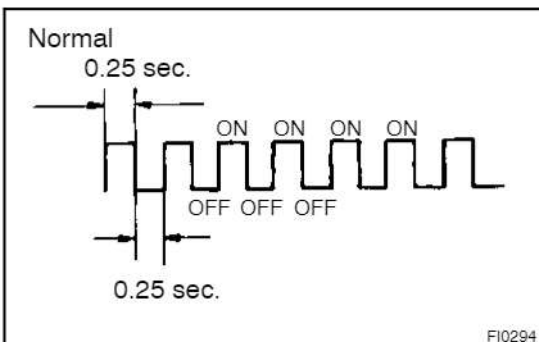

- (3) Read the diagnostic trouble code from check engine warning light.

HINT:

If a diagnostic trouble code is not output, check the diagnostic connector (DLC3) circuit ([See page DI-100](#)).

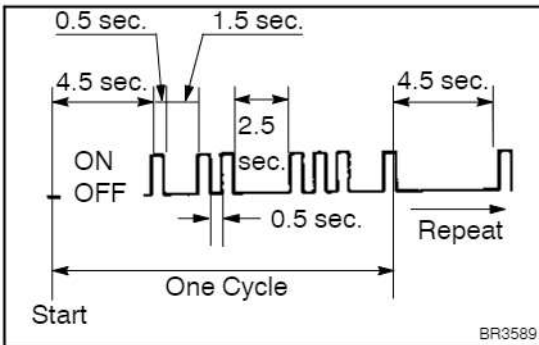

As an example, the blinking patterns for codes; normal, 12 and 31 are as shown on the illustration.

- (1) Check the details of the malfunction using the diagnostic trouble code chart on [page DI-14](#).
- (2) After completing the check, disconnect terminals 13 (TC) and 4 (CG) and turn off the display.

**HINT:**

In the event of 2 or more malfunction codes, indication will begin from the smaller numbered code and continue in order to the larger.

**NOTICE:**

**When simulating symptoms without a hand-held tester to check the DTCs, use normal mode. For code on the DTCs chart subject to "2 trip detection logic", turn the ignition switch OFF after the symptom is simulated the first time. Then repeat the simulation process again. When the problem has been simulated twice, the check engine warning light lights up and the DTCs are recorded in the engine ECU.**

### 3. INSPECT DIAGNOSIS (Check (Test) Mode)

HAND-HELD TESTER only:

Compared to the normal mode, the check mode has an increased sensitivity to detect malfunctions.

Furthermore, the same diagnostic items which are detected in the normal mode can also be detected in the check (test) mode.

- (a) Check the DTC.
  - (1) Initial conditions.
    - Battery positive voltage 11 V or more
    - Throttle valve fully closed.
    - Transmission in neutral position
    - Air conditioning switched OFF.
  - (2) Turn the ignition switch OFF.
  - (3) Prepare the hand-held tester.
  - (4) Connect the hand-held tester to the DLC3.
  - (5) Turn the ignition switch ON and push the hand-held tester main switch ON.
  - (6) Switch the hand-held tester normal mode to check (test) mode. (Check that the check engine warning light flashes.).
  - (7) Start the engine. (The check engine warning light goes out after the engine start.).
  - (8) Simulate the conditions of the malfunction described by the customer.

**NOTICE:**

**Leave the ignition switch ON until you have checked the DTCs, etc.**

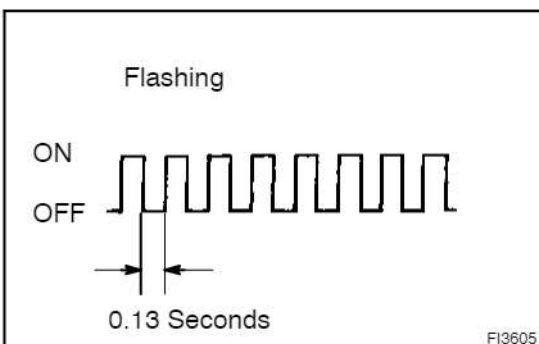

- (9) After simulating the malfunction conditions, use the hand-held tester diagnosis selector to check the DTCs and frozen frame data, etc.

**HINT:**

Take care not to turn the ignition switch OFF. Turning the ignition switch OFF switches the diagnosis system from check (test) mode to normal mode, so all diagnostic codes, etc. are erased.

- (10) After checking the DTCs, inspect the applicable circuit.

- (b) Clear the DTC.

The following actions will erase the DTCs and frozen frame data.

- (1) Operating the hand-held tester to erase the codes. (See the hand-held tester's instruction book for operating instructions.)
- (2) Disconnecting the battery terminals or ECD fuse.

**NOTICE:**

**If the hand-held tester switches the engine ECU from normal mode to check (test) mode or vice-versa, or if the ignition switch is turned from ON to ACC or OFF during check (test) mode, the DTCs and frozen frame data will be erased.**

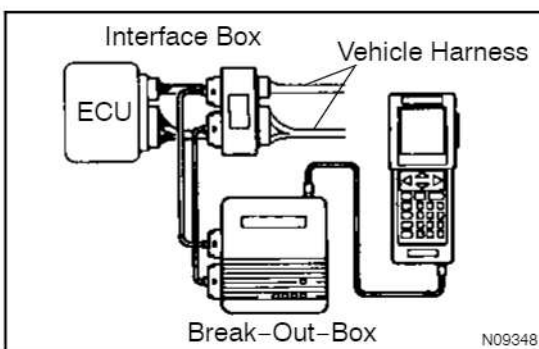

- (c) Measure the engine ECU terminal values using break-out box and hand-held tester.

- (1) Hook up the break-out-box and hand-held tester to the vehicle.
- (2) Read the engine ECU input/output values by following the prompts on the tester screen.

**HINT:**

Hand-held tester has a "Snapshot" function.

This records the measured values and is effective in the diagnosis of intermittent problems.

Please refer to the hand-held tester/break-out-box operator's manual for further details.

#### 4. FAIL-SAFE CHART

If any of the following codes is recorded, the engine ECU enters fail-safe mode.

DTC No.	Fail-Safe Operation	Fail-Safe Deactivation Conditions
12	TCV duty is fixed at 30.0 %	2 of more TDC signals are detected for 4 engine revolution
13	<ul style="list-style-type: none"> <li>•Fuel cut</li> <li>•TCV duty is fixed at 1.0 %</li> <li>•Close diesel throttle valve</li> </ul>	2 of more NE signals are detected for 0.5 sec.
19(1)	Accelerator pedal closed position SW ON : Accelerator pedal position is fixed at 0 % Accelerator pedal closed position SW OFF : Accelerator pedal position is fixed at 8 %	+B OFF
19(2)	Accelerator pedal closed position SW ON : Accelerator pedal position is fixed at 0 % Accelerator pedal closed position SW OFF : Accelerator pedal position is fixed at 8 %	+B OFF
	Accelerator pedal position below 10 %	+B OFF
19(3)	When the idle SW is faulty. Accelerator pedal closed position SW ON: Accelerator pedal position is fixed at 0 % Accelerator pedal closed position SW OFF: Accelerator pedal position is fixed at 8 %	+B OFF
	When the idle SW is okay. Idle SW ON : Accelerator pedal position is fixed at 0 % Idle SW OFF : Accelerator pedal position below 10 %	+B OFF
19(4)	Accelerator pedal position below 10 %	+B OFF
22	Engine coolant temp. is fixed at 100°C (212°F)	Return to normal condition
24	Intake air temp. is fixed at 20°C (68°F)	Return to normal condition
35	Intake air pressure is fixed at 101.3 kPa (760 mmHg, 30 in.Hg)	Return to normal condition
39	Fuel temp. is fixed at 60°C (140°F)	Return to normal condition
42	Vehicle speed is fixed at 0 km/h (0 mph)	Vehicle speed > 0 km/h (0 mph)

#### 5. CHECK FOR INTERMITTENT PROBLEMS

HAND-HELD TESTER only:

By putting the vehicle's engine ECU in check (test) mode, 1 trip detection logic is possible instead of 2 trip detection logic and sensitivity to detect open circuits is increased. This makes it easier to detect intermittent problems.

- (a) Clear the DTC (See page DI-4).
- (b) Set the check (test) mode (See page DI-4).
- (c) Perform a simulation test (See page IN-9).
- (d) Check the connector and terminal (See page IN-19).
- (e) Handle the connector (See page IN-19).



## 6. BASIC INSPECTION

When the malfunction code is not confirmed in the DTC check, troubleshooting should be carried out in the order for all possible circuits to be considered as the cases of the problems.

In many cases, by carrying out the basic engine check shown in the following flow chart, the location causing the problem can be found quickly and efficiently. Therefore, use of this check is essential in engine troubleshooting.

<b>1</b>	<b>Is battery positive voltage 11 V or more when engine is stopped ?</b>
----------	--

**NO**

**Charge or replace battery.**

**YES**

<b>2</b>	<b>Is engine cranked ?</b>
----------	----------------------------

**NO**

**Proceed to problem symptoms table on [page DI-19](#).**

**YES**

<b>3</b>	<b>Check air filter (<a href="#">See page EM-1</a>).</b>
----------	--

**NG**

**Repair or replace.**

**OK**

<b>4</b>	<b>Check fuel quality.</b>
----------	----------------------------

### **CHECK:**

- Check that use only diesel fuel.
- Check that the fuel does not contain any impurity.

**NG**

**Replace fuel.**

**OK**

5 Check engine oil (See page LU-1).

NG

Add or replace.

OK

6 Check coolant (See page CO-1).

NG

Replace coolant.

OK

7 Check injection timing (See page EM-14).

NG

Adjusting injection timing.

OK

8 Check idle speed and maximum speed (See page EM-17).

NG

Repair or replace injection pump.

OK

9 Check diagnostic connector (DLC3) circuit (See page DI-100).

NG

Repair or replace.

OK

10 Check vacuum pump (See page EC-3).

NG

Repair or replace.

OK

Proceed to problem symptoms table on page DI-19.

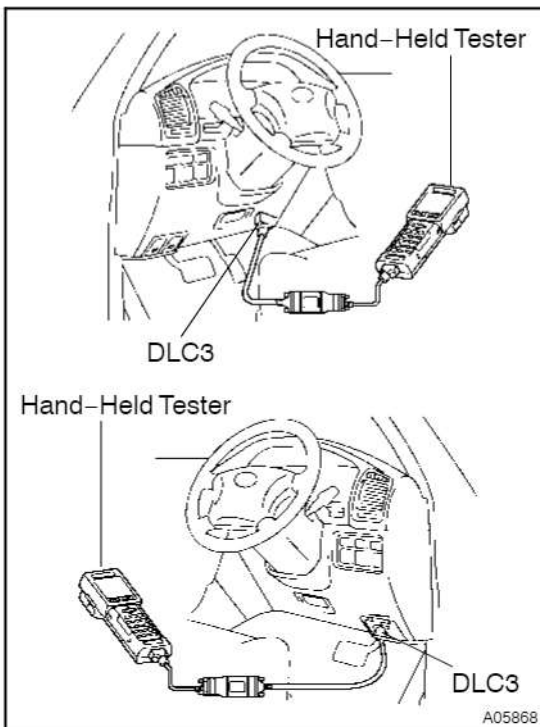

### 7. REFERENCE VALUE OF ENGINE ECU DATA NOTICE:

The values given below for "Normal Condition" are representative values, so a vehicle may still be normal even if its values from those listed here. So do not decide whether a part is faulty or not solely according to the "Normal Condition" here.

#### HINT:

Engine engine ECU data can be monitored by hand-held tester.

- (a) Connect the hand-held tester to the DLC3.
- (b) Monitor engine ECU data by following the prompts on the tester screen.

Please refer to the hand-held tester operator's manual for further detail.

## (c) Reference Value

Item	Inspection Condition	Reference Value
INJECTION VOLUME	Engine at idling *1	4 – 12 mm <sup>3</sup>
	Engine racing at 2,000 rpm *1	4 – 8 mm <sup>3</sup>
	Engine racing at 3,000 rpm *1	5 – 9 mm <sup>3</sup>
INJECTION TIMING	Engine at idling *1	17.0 – 19.0°CA
	Engine racing at 2,000 rpm *1	11.7 – 15.7°CA
	Engine racing at 3,000 rpm *1	17.0 – 23.0°CA
ENGINE SPD	RPM kept stable (Comparison with tachometer)	No great changes
PIM	Engine at idling *1	91 – 111 kPa (683–833 mmHg, 26.9–32.8 in.Hg)
	Engine racing at 2,000 rpm *1	97 – 117 kPa
	Engine racing at 3,000 rpm *1	110 – 130 kPa
COOLANT TEMP	Engine at normal operating temp.	75 – 95°C (167 – 203°F) *2
INTAKE AIR	Engine at normal operating temp.	Ambient temp. – 140°C
FUEL TEMP	Engine at normal operating temp.	Ambient temp. – 65°C
ACCELE POSITION	Accelerator pedal fully closed	0 – 20 %
	Accelerator pedal fully opened	59 – 100 %
	From closed position to wide open accelerator pedal	Gradually increases
VEHICLE SPD	During driving (Comparison with speed meter)	No large differences
A/C SIG	A/C switch ON	ON
IDL SIG	Accelerator pedal full closed	ON
STARTER SIG	During cranking	ON
A/C CUT SIG	A/C switch OFF	ON
EGR SYSTEM	Idling	ON
NSW *3	Neutral start switch signal	P or N position : ON
PS OIL PRESS SW	Power steering oil pressure switch signal	Turn steering wheel : ON
ACCEL CLOSE SW	Accelerator pedal fully closed	ON

## HINT:

\*1: All accessories and A/C are switched OFF.

\*2: If the water temp. sensor circuit is open or shorted, the engine ECU.

\*3: A/T only

## DIAGNOSTIC TROUBLE CODE CHART

### HINT:

Parameters listed in the chart may not be exactly the same as you reading due to the type of instrument or other factors.

If a malfunction code is displayed during the DTC check in check(test) mode, check the circuit for that code listed in the table below. For details of each code, turn to the page referred to under the "See Page" for the respective "DTC No." in the DTC chart.

DTC No. (See Page)	Detection Item	Trouble Area	*1 Check Engine Warning Light (Normal Mode/ Test Mode)	*2 Memory
12 (DI-21)	Crankshaft Position Sensor Circuit Malfunction	<ul style="list-style-type: none"> <li>• Open or short in crankshaft position sensor circuit</li> <li>• Crankshaft position sensor</li> <li>• Engine ECU</li> </ul>	ON/ON	○
13 (DI-23)	Engine Speed Sensor Circuit Malfunction	<ul style="list-style-type: none"> <li>• Open or short in engine speed sensor circuit</li> <li>• Engine speed sensor</li> <li>• Open or short in STA circuit</li> <li>• Engine ECU</li> </ul>	ON/ON	○
14 (DI-24)	Timing Control System Malfunction	<ul style="list-style-type: none"> <li>• Open or short in timing control valve circuit</li> <li>• Fuel filter (Clogging)</li> <li>• Fuel (Freezing, Air in)</li> <li>• Injection pump (Internal pressure and timing control valve)</li> <li>• Engine ECU</li> </ul>	ON/N.A.	○
17	Interior IC Malfunction	<ul style="list-style-type: none"> <li>• Engine ECU</li> </ul>	ON/N.A.	○
19(1) (DI-27)	Accelerator Pedal Position Sensor Circuit Malfunction (Open/Short)	<ul style="list-style-type: none"> <li>• Open or short in accelerator pedal position sensor circuit</li> <li>• Accelerator pedal position sensor</li> <li>• Engine ECU</li> </ul>	ON/ON	○
19(2) (DI-34)	Accelerator Pedal Position Sensor Circuit Malfunction (IDL Switch / Range)	<ul style="list-style-type: none"> <li>• Open or short in accelerator pedal position sensor circuit</li> <li>• Accelerator pedal position sensor</li> <li>• Engine ECU</li> </ul>	ON/N.A.	○
19(3) (DI-39)	Accelerator Pedal Closed Posi- tion Switch Circuit Malfunction (Short)	<ul style="list-style-type: none"> <li>• Short in accelerator pedal closed position switch circuit</li> <li>• Accelerator pedal closed position switch</li> <li>• Engine ECU</li> </ul>	ON/N.A.	○
19(4) (DI-39)	Accelerator Pedal Closed Posi- tion Switch Circuit Malfunction (Open)	<ul style="list-style-type: none"> <li>• Open in accelerator pedal closed position switch circuit</li> <li>• Accelerator pedal closed position switch</li> <li>• Engine ECU</li> </ul>	ON/N.A.	○
22 (DI-41)	Water Temp. Sensor Circuit Malfunction	<ul style="list-style-type: none"> <li>• Open or short in water temp. sensor circuit</li> <li>• Water temp. sensor</li> <li>• Engine ECU</li> </ul>	ON/ON	○

\*1: "ON" displayed in the diagnosis mode column indicates that the check engine warning light is lighted up when a malfunction is detected. "N.A." indicates that the item is not included in malfunction diagnosis.

\*2: "○" in the memory column indicates that a diagnostic trouble code is recorded in the engine ECU memory when a malfunction occurs. Accordingly, output of diagnostic results in normal or test mode is done with the IG switch ON.

## DIAGNOSTICS - ENGINE

DTC No. (See Page)	Detection Item	Trouble Area	*1 Check Engine Warning Light (Normal Mode/ Test Mode)	*2 Memory
24 (DI-46)	Intake Air Temp. Sensor Circuit Malfunction	<ul style="list-style-type: none"> <li>• Open or short in intake air temp. sensor circuit</li> <li>• Intake air temp. sensor</li> <li>• Engine ECU</li> </ul>	OFF/ON	○
32 (DI-52)	Injection Pump System Malfunction	<ul style="list-style-type: none"> <li>• Open or short in injection pump correction unit circuit</li> <li>• Injection pump correction unit</li> <li>• Engine ECU</li> </ul>	OFF/N.A.	○
33 (DI-54)	Intake Shutter Control Circuit Malfunction	<ul style="list-style-type: none"> <li>• Open or short in VSV for intake shutter circuit</li> <li>• VSV for intake shutter</li> <li>• Engine ECU</li> </ul>	ON/N.A.	○
35 (DI-56)	Turbo Pressure Sensor Circuit Malfunction	<ul style="list-style-type: none"> <li>• Open or short in turbo pressure sensor circuit</li> <li>• Turbo pressure sensor</li> <li>• Engine ECU</li> </ul>	ON/ON	○
39 (DI-64)	Fuel Temp. Sensor Circuit Malfunction	<ul style="list-style-type: none"> <li>• Open or short in fuel temp. sensor circuit</li> <li>• Fuel pressure sensor</li> <li>• Engine ECU</li> </ul>	ON/ON	○
42 (DI-69)	Vehicle Speed Sensor Signal Circuit Malfunction	<ul style="list-style-type: none"> <li>• Open or short in vehicle speed sensor circuit</li> <li>• Vehicle speed sensor</li> <li>• Combination meter</li> <li>• Engine ECU</li> </ul>	ON/ON	○
89	Interior IC Malfunction	<ul style="list-style-type: none"> <li>• Engine ECU</li> </ul>	ON/N.A.	○
97 (DI-71)	EDU Circuit Malfunction	<ul style="list-style-type: none"> <li>• Open or short in EDU circuit</li> <li>• Spill control valve</li> <li>• EDU</li> </ul>	ON/N.A.	○
*3 99	Engine Immobilizer System Malfunction	<ul style="list-style-type: none"> <li>• Open or short in engine immobilizer system circuit</li> <li>• Transponder key amplifier</li> <li>• Transponder key computer</li> <li>• Transponder key coil</li> <li>• Engine ECU</li> </ul>	OFF/N.A.	○

\*1: "ON" displayed in the diagnosis mode column indicates that the check engine warning light is lighted up when a malfunction is detected. "OFF" indicates that the "CHECK ENGINE" does not light up during malfunction diagnosis, even if a malfunction is detected. "N.A." indicates that the item is not included in malfunction diagnosis.

\*2: "○" in the memory column indicates that a diagnostic trouble code is recorded in the engine ECU memory when a malfunction occurs. Accordingly, output of diagnostic results in normal or test mode is done with the IG switch ON.

\*3: See Pub. No. RM616E1 BE section.

# PARTS LOCATION

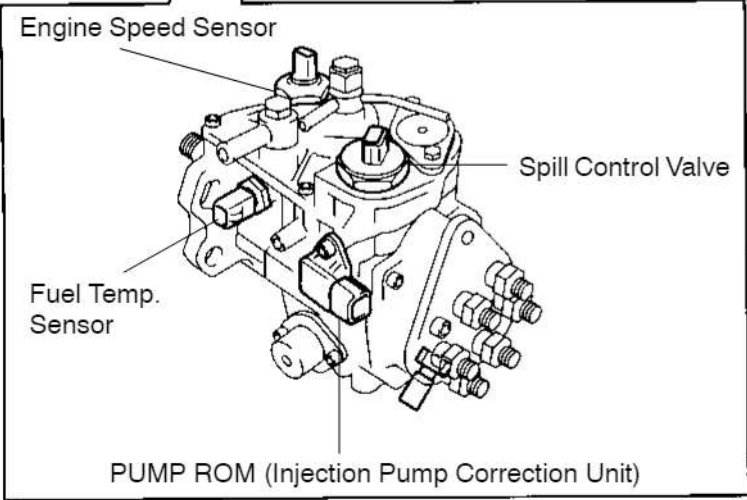
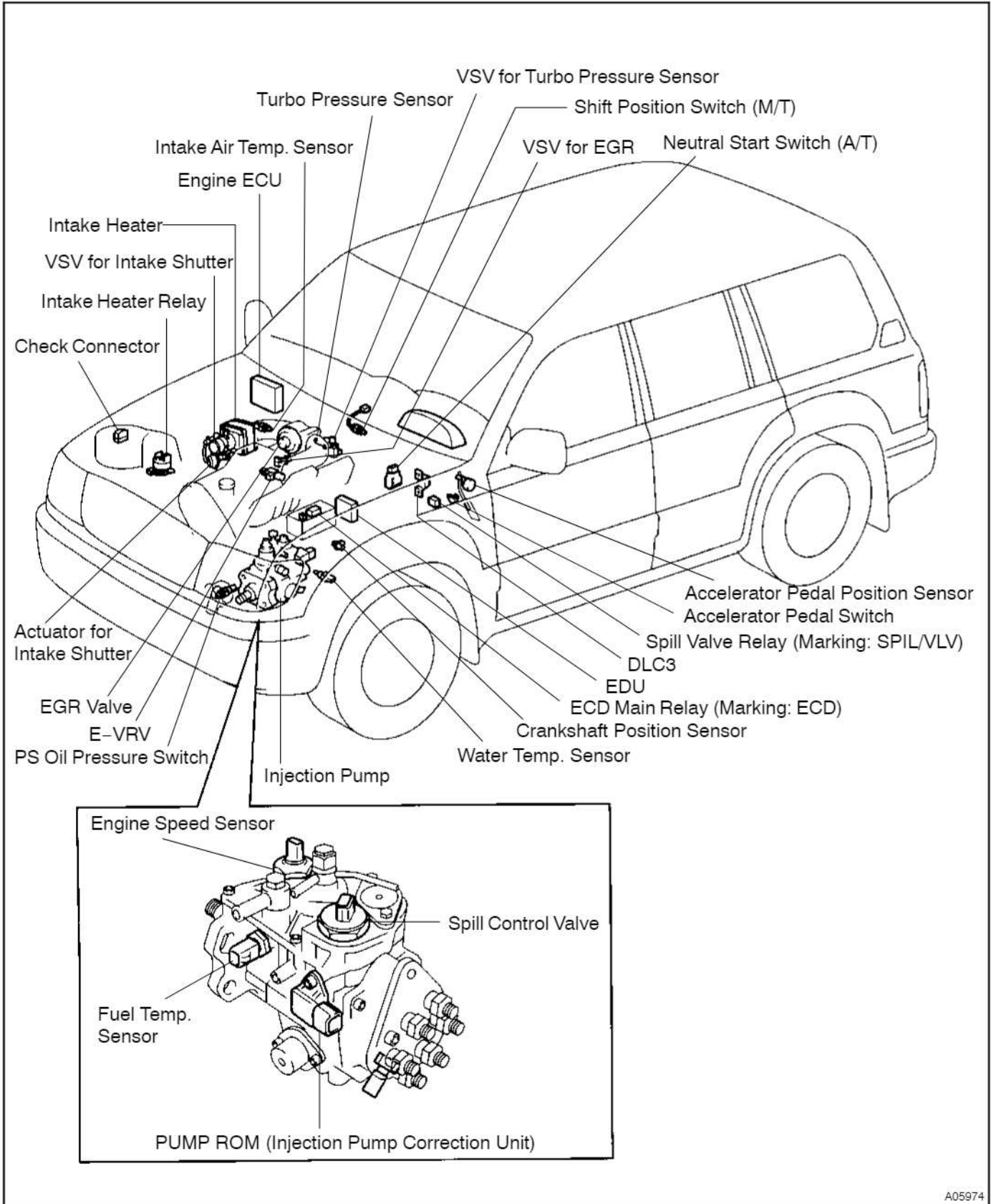

cardiagn.com

## TERMINALS OF ECU

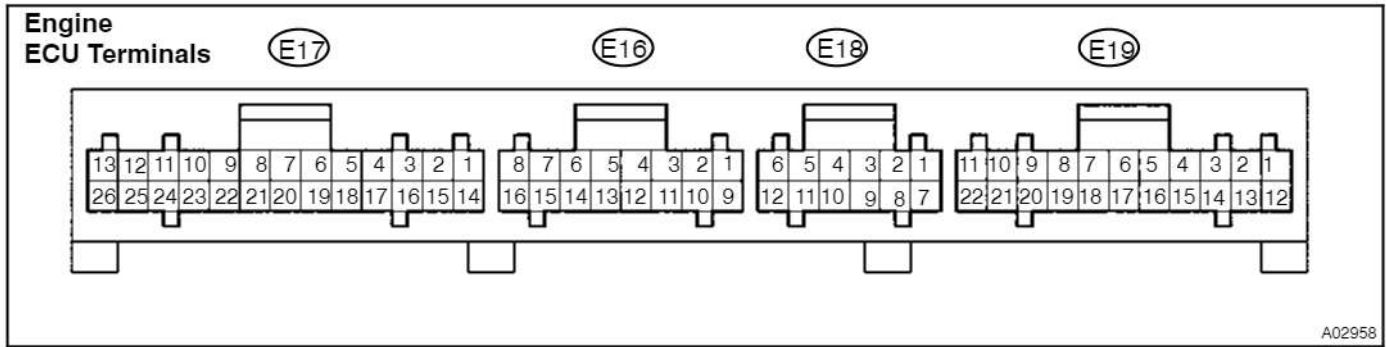

Symbols (Terminals No.)	Wiring Color	Condition	STD Voltage (V)
BATT (E19-1) - E1 (E17-14)	B-R - BR	Always	9 ~ 14
+ B (E19-12) - E1 (E17-14)	B-Y - BR	IG switch ON	9 ~ 14
VC (E16-1) - E2 (E16-9)	L-R - BR-W	IG switch ON	4.5 ~ 5.5
VCC (E18-6) - E2C (E18-4)	L-R - BR-W	IG switch ON	4.5 ~ 5.5
VA (E18-5) - E2C (E18-4)	R-Y - BR-W	Accelerator pedal fully closed	0.6 ~ 1.3
		Accelerator pedal fully opened	2.8 ~ 4.5
VAS (E18-12) - E2C (E18-4)	P-L - BR-W	Accelerator pedal fully closed	0.6 ~ 1.3
		Accelerator pedal fully opened	2.8 ~ 4.5
IDL (E18-9) - E2C (E18-4)	LG-B - BR-W	Accelerator pedal fully closed	9 ~ 14
		Accelerator pedal fully opened	0 ~ 3
PIM (E16-2) - E2 (E16-9)	P-L - BR-W	Apply vacuum 40 kPa (300 mmHg, 11.8 in.Hg)	1.0 ~ 1.8
		Apply vacuum 135 kPa (1,000 mmHg, 39.4 in.Hg)	2.3 ~ 4.2
THA (E16-3) - E2 (E16-9)	W-G - BR-W	Idling, air intake temp. 0°C (32°F) to 60°C (140°F)	0.2 ~ 3.8
THW (E16-4) - E2 (E16-9)	G-B - BR-W	Idling, engine coolant temp. 60°C (140°F) to 120°C (248°F)	0.1 ~ 1.5
THF (E16-5) - E2 (E16-9)	B-R - BR-W *1	IG switch ON (at engine cold)	0.5 ~ 3.8
	G-R - BR-W *2		
STA (E19-11) - E1 (E17-14)	B-W - BR	Cranking	6.0 or more
TDC+ (E17-17) - TDC- (E17-16)	B - W	Idling	Pulse generation (See page DI-21)
NE+ (E17-19) - NE- (E17-18)	L - G	Idling	Pulse generation (See page DI-21)
SP1 (E19-9) - E1 (E17-14)	V - BR	IG switch ON Rotate driving wheel slowly	Pulse generation
TCV (E17-11) - E01 (E17-13)	R-Y - W-B	IG switch ON	9 ~ 14
		Idling	Pulse generation (See page DI-24)
SPVD (E17-12) - E1 (E17-14)	L-Y - BR	IG switch ON	9 ~ 14
SPVF (E17-25) - E1 (E17-14)	L-R - BR	Idling	Pulse generation (See page DI-71)
EGR (E17 - 24) - E01 (E17-13)	R-G - W-B	IG switch ON	9 ~ 14
		EGR ON	Pulse generation (See page DI-85)

\*1: LHD

\*2: RHD



Symbols (Terminals No.)	Wiring Color	Condition	STD Voltage (V)
S/TH (E17-10) - E01 (E17-13)	W-L - W-B	VSV OFF (idling)	9 ~ 14
		VSV ON (after IG switch OFF for 2 sec.)	0 ~ 3
PA (E17-9) - E01 (E17-13)	W-R - W-B	VSV for atmospheric pressure leaning OFF	9 ~ 14
		VSV for atmospheric pressure leaning ON	0 ~ 3
MREL (E19-3) - E01 (E17-13)	B-W - W-B	IG switch ON	9 ~ 14
IGSW (E19-14) - E1 (E17-14)	B-R - BR	IG switch ON	9 ~ 14
AC1 (E18-2) - E1 (E17-14)	W-G - BR	A/C switch ON (at idling)	0 ~ 1.5
		A/C switch OFF	9 ~ 14
ACT (E18-8) - E1 (E17-14)	L-B - BR	IG switch ON	9 ~ 14
		At A/C cut controlled (Driving below 30 km/h, accelerator pedal fully opened for 5 sec.)	0 ~ 3
PDL (E18-3) - E1 (E17-14)	GR - BR	Accelerator pedal fully closed	9 ~ 14
		Accelerator pedal fully opened	0 ~ 3
TAC (E18-7) - E1 (E17-14)	B - BR	Idling	Pulse generation
TC (E19-4) - E1 (E17-14)	P-B - BR	IG switch ON	9 ~ 14
W (E19-5) - E1 (E17-14)	W - BR	Check engine warning light lights up	0 ~ 3
		Except check engine warning light lights up	9 ~ 14
G-IND (E18-1) - E1 (E17-14)	Y-R - BR	Glow indicator light lights up	0 ~ 3
		Except glow indicator light lights up	9 ~ 14
DATA (E16-6) - E1 (E17-14)	G-B - BR	For 0.5 sec. after IG switch ON	Pulse generation
CLK (E16-14) - E1 (E17-14)	G-W - BR	For 0.5 sec. after IG switch ON	Pulse generation
THWO (E19-8) - E1 (E17-14)	Y-B - BR	IG switch ON	Pulse generation (See page DI-96)
EGRC (E17-3) - E1 (E17-14)	R - BR	IG switch ON	0 ~ 3
		Maintain engine speed at 1500 rpm after warming up	9 ~ 14
IREL (E19-2) - E1 (E17-14)	G-Y - BR	IG switch ON	0 ~ 3
		At intake heater ON	9 ~ 14
SPVD (E17-12) - E1 (E17-14)	L-Y - BR	Idling	Pulse generation (See page DI-71)
VCH (E17-23) - E1 (E17-14)	Y-R - BR	Heater blower switch ON	0 ~ 3
		Heater blower switch OFF	9 ~ 14
SVR (E19-13) - E1 (E17-14)	L-W - BR	IG switch ON	0 ~ 1.5
VCT (E16-7) - E1 (E17-14)	L-B - BR	Heater blower switch ON	0 ~ 3
		Heater blower switch OFF	9 ~ 14
HSW (E19-20) - E1 (E17-14)	B-L - BR	Push on power heater switch	0 ~ 3
		Push off power heater switch	9 ~ 14
FSW (E17-7) - E1 (E17-14)	R-L - BR	At shift position in first position	9 ~ 14
		At other shift position in first position	0 ~ 3
PS (E16-8) - E1 (E17-14)	P - BR	Idling, Turn steering wheel	0 ~ 3
		IG switch ON	9 ~ 14
SIL (E19-15) - E1 (E17-14)	V-W - BR	Connect hand-held tester to DLC3	Pulse generation
IMI (E19-17) - E1 (E17-14)	L-B - BR	Idling	Pulse generation
IMO (E19-6) - E1 (E17-14)	L-R - BR	A few sec. after engine starting	Pulse generation

## PROBLEM SYMPTOMS TABLE

When the malfunction code is not confirmed the DTC check and the problem still can not be confirmed in the basic inspection, then proceed to this step and perform troubleshooting according to the numbered order given in the table below.

Symptom	Suspect Area	See page
Does not crank (Difficult to start)	<ol style="list-style-type: none"> <li>1. Starter</li> <li>2. Starter relay</li> <li>3. Neutral start switch circuit (A/T)</li> </ol>	<a href="#">ST-20</a> <a href="#">ST-35</a> <a href="#">DI-108</a>
Cold engine (Difficult to start)	<ol style="list-style-type: none"> <li>1. Intake heater control circuit</li> <li>2. STA signal circuit</li> <li>3. Heater idle-up switch circuit</li> <li>4. Injection nozzle</li> <li>5. Fuel filter</li> <li>6. Engine ECU</li> <li>7. Injection pump</li> </ol>	<a href="#">DI-80</a> <a href="#">DI-105</a> <a href="#">DI-115</a> <a href="#">FU-43</a> <a href="#">FU-1</a> <a href="#">ED-17</a> <a href="#">FU-113</a>
Hot engine (Difficult to start)	<ol style="list-style-type: none"> <li>1. STA signal circuit</li> <li>2. Injection nozzle</li> <li>3. Fuel filter</li> <li>4. Compression</li> <li>5. Engine ECU</li> <li>6. Injection pump</li> </ol>	<a href="#">DI-105</a> <a href="#">FU-43</a> <a href="#">FU-1</a> <a href="#">EM-2</a> <a href="#">ED-17</a> <a href="#">FU-113</a>
Soon after starting (Engine stall)	<ol style="list-style-type: none"> <li>1. Fuel filter</li> <li>2. ECU power source circuit</li> <li>3. Engine ECU</li> <li>4. Injection pump</li> </ol>	<a href="#">FU-1</a> <a href="#">DI-76</a> <a href="#">ED-17</a> <a href="#">FU-113</a>
Others (Engine stall)	<ol style="list-style-type: none"> <li>1. ECU power source circuit</li> <li>2. Spill valve relay circuit</li> <li>3. Engine ECU</li> <li>4. Injection pump</li> </ol>	<a href="#">DI-76</a> <a href="#">DI-113</a> <a href="#">ED-17</a> <a href="#">FU-113</a>
Incorrect first idle (Poor idling)	<ol style="list-style-type: none"> <li>1. Fuel filter</li> <li>2. Engine ECU</li> <li>3. Injection pump</li> </ol>	<a href="#">FU-1</a> <a href="#">ED-17</a> <a href="#">FU-113</a>
High engine idle speed (Poor idling)	<ol style="list-style-type: none"> <li>1. A/C signal circuit</li> <li>2. STA signal circuit</li> <li>3. Engine ECU</li> <li>4. Injection pump</li> </ol>	<a href="#">DI-93</a> <a href="#">ED-5</a> <a href="#">ED-17</a> <a href="#">FU-113</a>
Lower engine idle speed (Poor idling)	<ol style="list-style-type: none"> <li>1. A/C signal circuit</li> <li>2. Injection nozzle</li> <li>3. EGR control circuit</li> <li>4. Compression</li> <li>5. Valve clearance</li> <li>6. Fuel line (Air bead)</li> <li>7. Engine ECU</li> <li>8. Injection pump</li> </ol>	<a href="#">DI-93</a> <a href="#">FU-43</a> <a href="#">DI-85</a> <a href="#">EM-2</a> <a href="#">EM-9</a> - <a href="#">ED-17</a> <a href="#">FU-113</a>
Rough idling (Poor idling)	<ol style="list-style-type: none"> <li>1. Injection nozzle</li> <li>2. Fuel line (Air bead)</li> <li>3. Intake heater control circuit</li> <li>4. EGR control circuit</li> <li>5. Compression</li> <li>6. Valve clearance</li> <li>7. Engine ECU</li> <li>8. Injection pump</li> </ol>	<a href="#">FU-43</a> - <a href="#">DI-80</a> <a href="#">DI-85</a> <a href="#">EM-2</a> <a href="#">EM-9</a> <a href="#">ED-17</a> <a href="#">FU-113</a>

Symptom	Suspect Area	See page
Hunting at hot engine (Poor idling)	<ol style="list-style-type: none"> <li>1. Injection nozzle</li> <li>2. ECU power source circuit</li> <li>3. Compression</li> <li>4. Fuel line (Air bead)</li> <li>5. Valve clearance</li> <li>6. Engine ECU</li> <li>7. Injection pump</li> </ol>	<p>FU-43 DI-76 EM-2 - EM-9 ED-17 FU-113</p>
Hunting at cold engine (Poor idling)	<ol style="list-style-type: none"> <li>1. Injection nozzle</li> <li>2. ECU power source circuit</li> <li>3. Intake heater control circuit</li> <li>4. Compression</li> <li>5. Fuel line (Air bead)</li> <li>6. Valve clearance</li> <li>7. Engine ECU</li> <li>8. Injection pump</li> </ol>	<p>FU-43 DI-76 DI-80 EM-2 - EM-9 ED-17 FU-113</p>
Hesitation/ Poor acceleration (Poor driveability)	<ol style="list-style-type: none"> <li>1. Injection nozzle</li> <li>2. Fuel filter</li> <li>3. EGR control circuit</li> <li>4. Compression</li> <li>5. Engine ECU</li> <li>6. Injection pump</li> </ol>	<p>FU-36 FU-1 DI-85 EM-2 ED-17 FU-113</p>
Knocking (Poor driveability)	<ol style="list-style-type: none"> <li>1. Injection nozzle</li> <li>2. EGR control circuit</li> <li>3. Engine ECU</li> </ol>	<p>FU-36 DI-85 ED-17</p>
Black smoke (Poor driveability)	<ol style="list-style-type: none"> <li>1. Injection nozzle</li> <li>2. EGR control circuit</li> <li>3. Engine ECU</li> <li>4. Injection pump</li> </ol>	<p>FU-36 DI-85 ED-17 FU-113</p>
White smoke (Poor driveability)	<ol style="list-style-type: none"> <li>1. EGR control circuit</li> <li>2. Intake heater control circuit</li> <li>3. Injection nozzle</li> <li>4. Fuel filter</li> <li>5. Engine ECU</li> <li>6. Injection pump</li> </ol>	<p>DI-85 DI-80 FU-36 FU-1 ED-17 FU-113</p>
Surging/ Hunting (Poor driveability)	<ol style="list-style-type: none"> <li>1. Injection nozzle</li> <li>2. Engine ECU</li> <li>3. Injection pump</li> </ol>	<p>FU-43 ED-17 FU-113</p>

# CIRCUIT INSPECTION

<b>DTC</b>	<b>12</b>	<b>Crankshaft Position Sensor Circuit Malfunction</b>
------------	-----------	---

## CIRCUIT DESCRIPTION

The crankshaft position sensor in the Engine Control System contains signal plate and a pickup coil for TDC signal. The TDC signal plate has 1 tooth on its outer circumference. The TDC signal sensor generates 1 signal for every engine revolution. The engine ECU detects the top dead center by the TDC signals. The engine speed sensor in the Engine Control System contains signal plate and a pickup coil for NE signal. The NE signal plate has 78 teeth and is mounted in the injection pump. The NE signal sensor generates 78 signals of engine 2 revolutions. The engine ECU detects the engine speed and cam lift position of the injection pump. The engine ECU uses TDC signal and NE signals for injection timing control. And NE signal is used for injection volume control, also.

DTC No.	DTC Detecting Condition	Trouble Area
12	No TDC signal to engine ECU at 400 rpm or more	<ul style="list-style-type: none"> <li>• Open or short in crankshaft position sensor circuit</li> <li>• Crankshaft position sensor</li> <li>• Engine ECU</li> </ul>

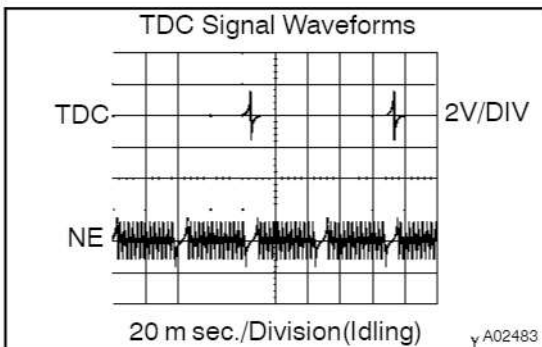

### Reference: INSPECTION USING OSCILLOSCOPE

During cranking or idling, check between terminals TDC+ and TDC- of engine ECU.

HINT:

The correct waveforms are as shown.

## WIRING DIAGRAM

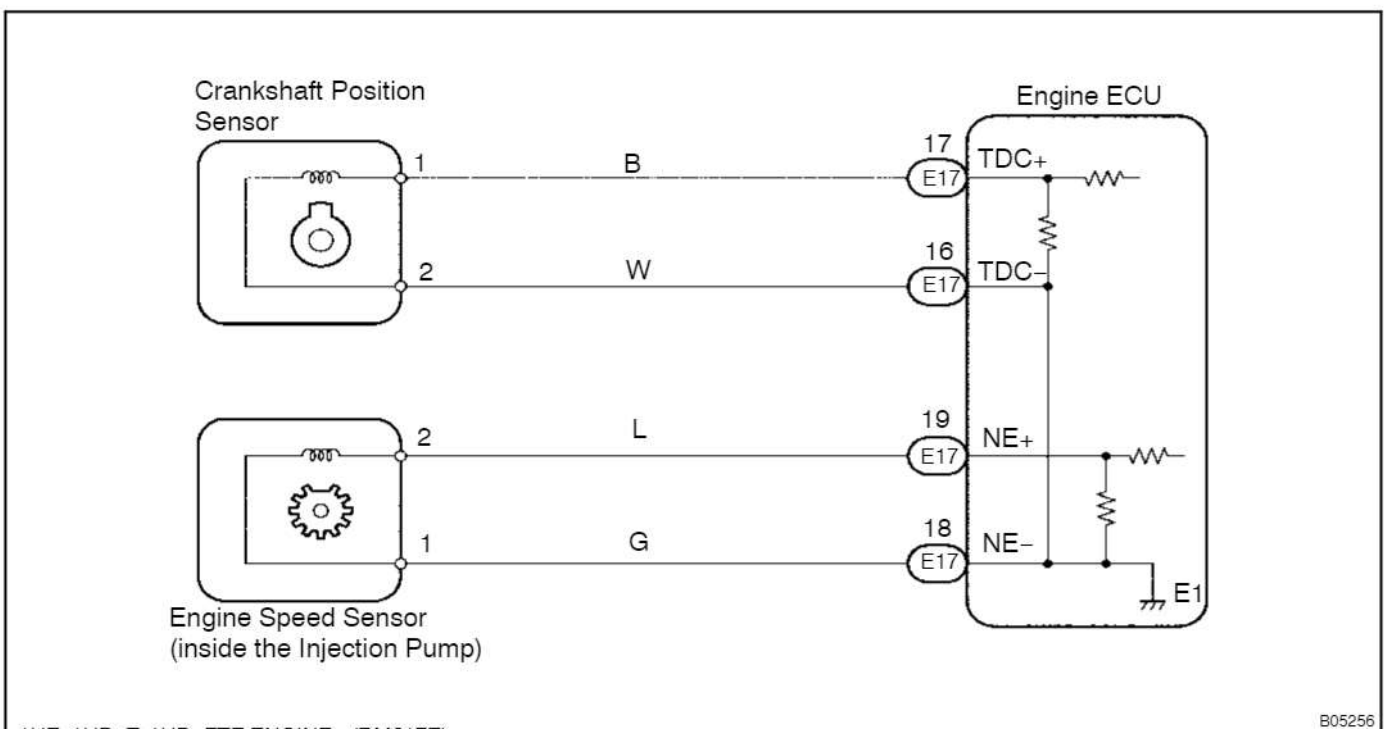

**INSPECTION PROCEDURE**

1 Check resistance of crankshaft position sensor (TDC) ([See page ED-8](#)).

NG

Replace crankshaft position sensor.

OK

2 Check for open and short in harness and connector between engine ECU and crankshaft position sensor ([See page IN-19](#)).

NG

Repair or replace harness or connector.

OK

3 Inspection sensor installation.

NG

Tighten sensor.

OK

Check and replace engine ECU ([See page IN-19](#)).

<b>DTC</b>	<b>13</b>	<b>Engine Speed Sensor Circuit Malfunction</b>
------------	-----------	--

## CIRCUIT DESCRIPTION

Refer to DTC12 (Crankshaft Position Sensor Circuit Malfunction) on [page DI-21](#).

DTC No.	DTC Detecting Condition	Trouble Area
13	No NE signal to engine ECU for 0.5 sec. or more at 580 rpm or more	<ul style="list-style-type: none"> <li>• Open or short in engine speed sensor circuit</li> <li>• Engine speed sensor</li> <li>• Engine ECU</li> </ul>
	No NE signal to engine ECU for 2.0 sec. or more during cranking	

## WIRING DIAGRAM

Refer to DTC12 (Crankshaft Position Sensor Circuit Malfunction) on [page DI-21](#).

## INSPECTION PROCEDURE

<b>1</b>	<b>Check resistance of engine speed sensor (See page FU-113).</b>
----------	---

NG

Check and replace injection pump (See page FU-113).

OK

<b>2</b>	<b>Check for open and short in harness and connector between engine ECU and engine speed sensor (See page IN-19).</b>
----------	---

NG

Repair or replace harness or connector.

OK

<b>3</b>	<b>Inspection sensor installation.</b>
----------	--

NG

Tighten sensor.

OK

<b>Check and replace engine ECU (See page IN-19).</b>
---

<b>DTC</b>	<b>14</b>	<b>Timing Control System Malfunction</b>
------------	-----------	--

## CIRCUIT DESCRIPTION

The engine ECU control the injection timing by actuating the timing control valve. The timing control valve is mounted on the injection pump and delay one by duty control of pump internal fuel pressure. The engine ECU detects the injection advance angle by TDC and NE signals.

DTC No.	DTC Detecting Condition	Trouble Area
14	After engine warm up and during, actual injection timing is different from target value of engine ECU calculated for several sec.	<ul style="list-style-type: none"> <li>• Open or short in timing control valve circuit</li> <li>• Timing control valve</li> <li>• Fuel filter (Clogging)</li> <li>• Fuel (Freezing, Air in)</li> <li>• Injection pump (Internal pressure and timing control valve)</li> <li>• Engine ECU</li> </ul>

## WIRING DIAGRAM

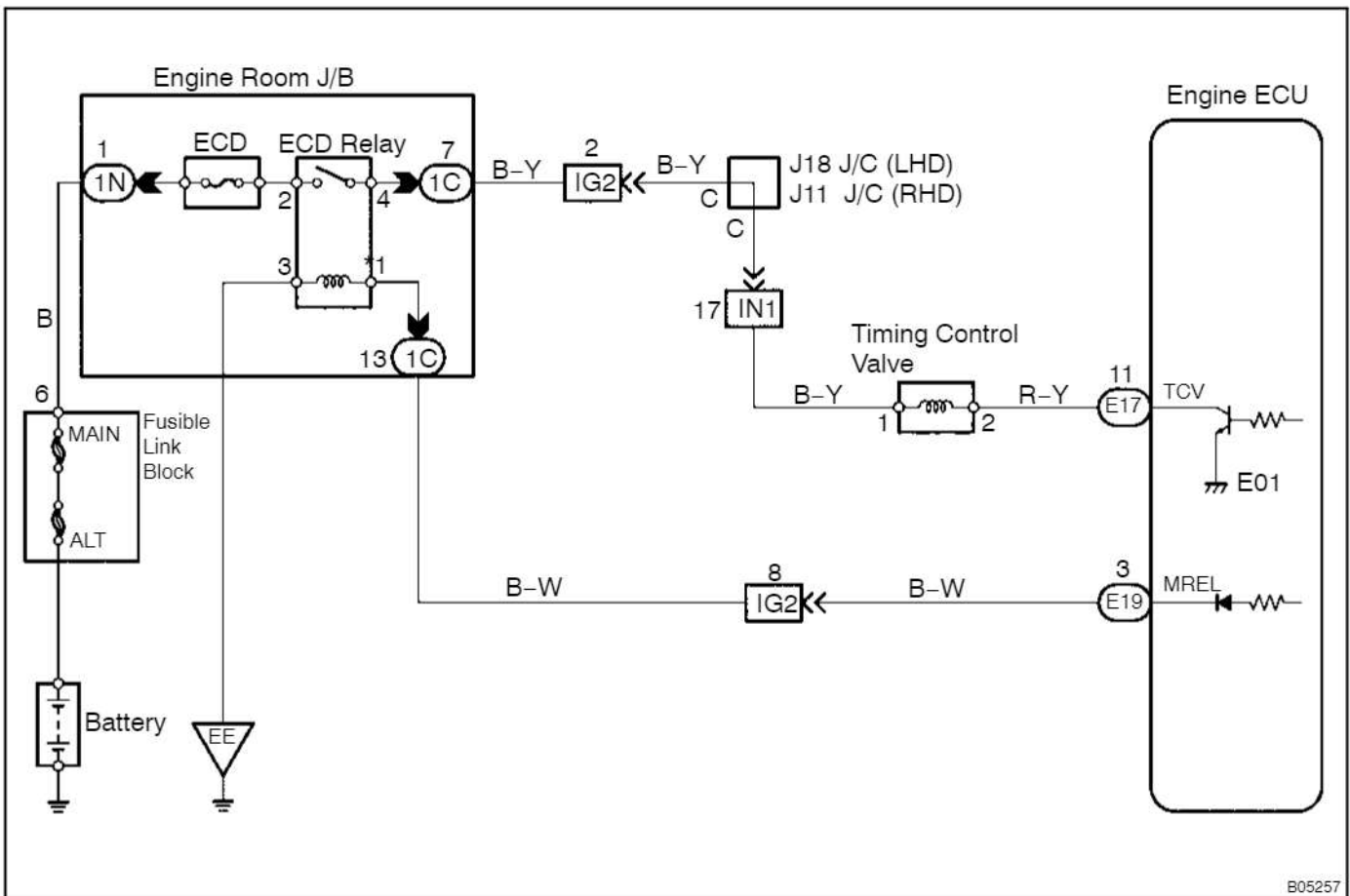

B05257

## INSPECTION PROCEDURE

1 Check timing control valve (See page FU-113).

NG

Check and replace injection pump (See page FU-113).

OK

2 Check voltage between terminal TCV of engine ECU connector and body ground.

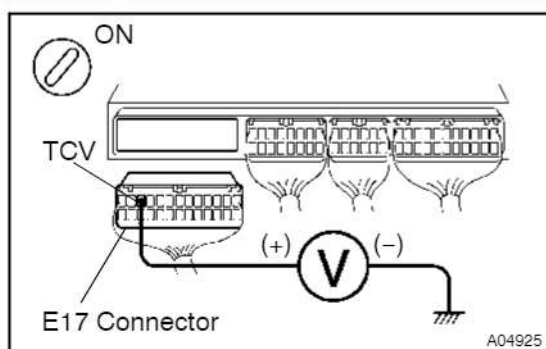
**PREPARATION:**

- Remove the glove compartment door.
- Disconnect the "E17" connector of engine ECU.
- Turn the ignition switch ON.

**CHECK:**

Measure voltage between terminal TCV of engine ECU connector and body ground.

**OK:**

**Voltage: 9 - 14 V**

OK

Go to step 3.

NG

Check for open or short in harness and connector between timing control valve and engine ECU, timing control valve and ECD main relay (Marking: ECD) (See page IN-19).



### 3 Check voltage between terminal TCV of engine ECU and body ground.

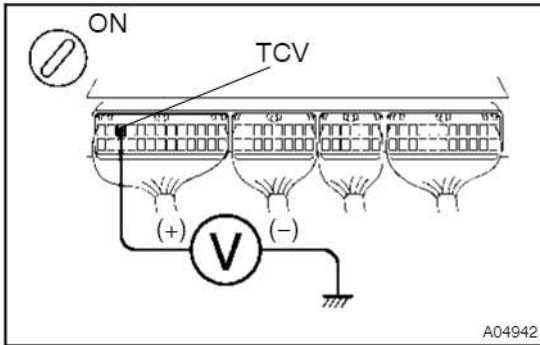

#### PREPARATION:

- Remove the glove compartment door.
- Turn the ignition switch ON.

#### CHECK:

Measure voltage between terminal TCV of engine ECU and body ground.

#### OK:

**Voltage: 9 - 14 V**

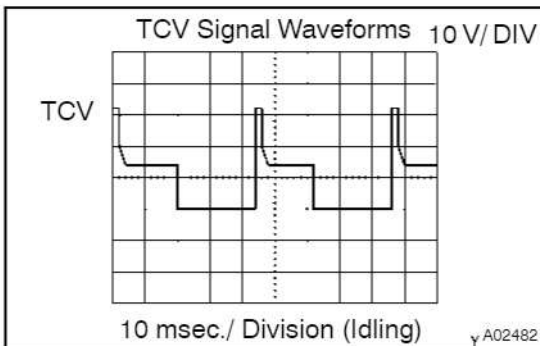

#### Reference: INSPECTION USING OSCILLOSCOPE

During idling, check waveform between terminals TCV and E1 of engine ECU.

#### HINT:

The correct waveform is as shown.

NG

Check and replace engine ECU  
(See page IN-19).

OK

### 4 Check fuel filter clogging, fuel freezing and fuel air in.

NG

Replace or repair.

OK

Check and replace injection pump (See page FU-113).

<b>DTC</b>	<b>19 (1)</b>	<b>Accelerator Pedal Position Sensor circuit Malfunction (Open /Short)</b>
------------	---------------	--

## CIRCUIT DESCRIPTION

The accelerator pedal position sensor is mounted at the accelerator pedal and detects the accelerator pedal opening angle. When the accelerator pedal is fully closed, a voltage of approximately 1.0 V is applied to terminals VA, VAS of the engine ECU. The voltage applied to the terminals VA, VAS of the engine ECU increases in proportion to the opening angle of the accelerator pedal and becomes approximately 3.8 V when the accelerator pedal is fully opened. The engine ECU judges the vehicle driving conditions from these signals input from terminals VA, VAS and uses them as one of the conditions to control the injection volume and diesel throttle valve position. The idle switch is mounted in the accelerator pedal position sensor and sends the IDL signal to the engine ECU when accelerator pedal is fully closed.

This system has 2 way accelerator pedal position sensor and accelerator pedal closed position switch for fail safe.

DTC No.	DTC Detecting Condition	Trouble Area
19 (1)	Open or short in accelerator pedal position sensor circuit for 0.05 sec. or more	<ul style="list-style-type: none"> <li>• Open or short in accelerator pedal position sensor circuit</li> <li>• Accelerator pedal position sensor</li> <li>• Engine ECU</li> </ul>

### HINT:

After confirming DTC 19 (1) use the hand-held tester to confirm the accelerator pedal opening percentage and accelerator pedal close position switch condition.

Accelerator pedal opening position expressed as percentage		Trouble area
Accelerator pedal fully closed	Accelerator pedal fully open	
0 %	0 %	VCC line open VA, VAS line open or short
Approx. 100 %	Approx. 100 %	E2C line open

WIRING DIAGRAM

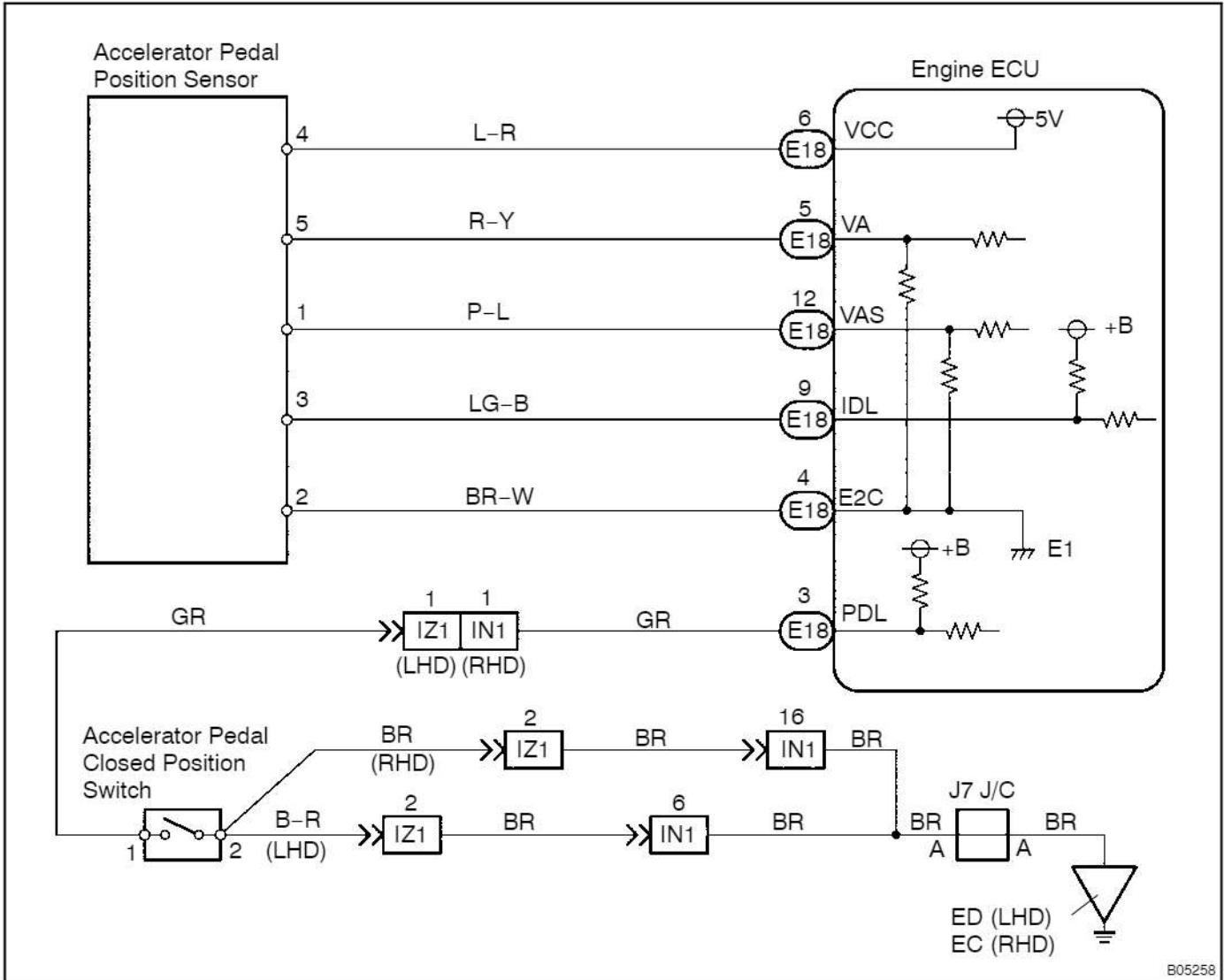

cardiagn.com

**INSPECTION PROCEDURE****When using hand-held tester**

- |          |   |
|----------|---|
| <b>1</b> | <b>Connect the hand-held tester, read the accelerator pedal opening percentage.</b> |
|----------|---|

**PREPARATION:**

- (a) Connect the hand-held tester to the DLC3.  
 (b) Turn the ignition switch ON and push the hand-held tester main switch ON.

**CHECK:**

Read the accelerator pedal opening percentage.

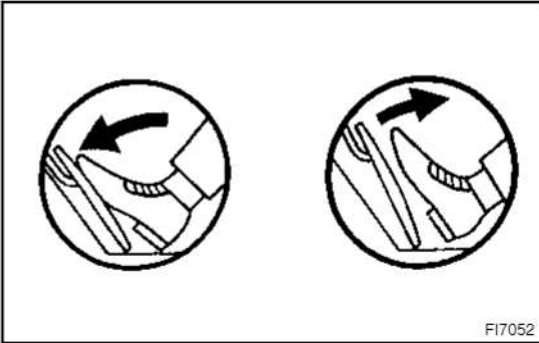

F17052

**OK:**

Accelerator pedal	Accelerator pedal opening position expressed as percentage
Fully open	Approx. 65 %
Fully closed	Approx. 18 %

**OK**

**Check for intermittent problems**  
 (See page DI-4).

**NG**

- |          |   |
|----------|---|
| <b>2</b> | <b>Check voltage between terminal 4 of wire harness side connector and body ground.</b> |
|----------|---|

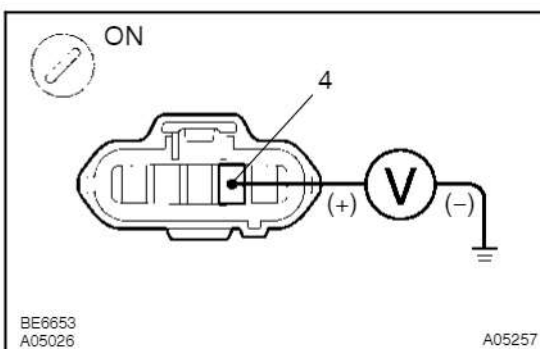
**PREPARATION:**

- (a) Disconnect the accelerator pedal position sensor connector.  
 (b) Turn the ignition switch ON.

**CHECK:**

Measure voltage between terminal 4 of wire harness side connector and body ground.

**OK:**

**Voltage: 4.5 – 5.5 V**

**NG**

**Go to step 5.**

**OK**

### 3 Check voltage between terminals VA, VAS and E2C of engine ECU.

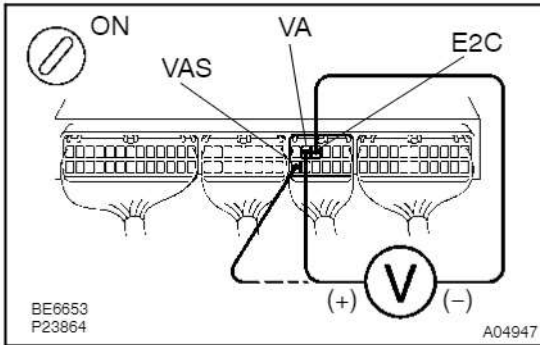

#### PREPARATION:

- Remove the glove compartment door.
- Turn the ignition switch ON.

#### CHECK:

Measure voltage between terminals VA, VAS and E2C of engine ECU.

#### OK:

Accelerator pedal	Voltage
Fully closed	0.6 – 1.3 V
Fully open	2.8 – 4.5 V

OK

Check and replace engine ECU  
(See page IN-19).

NG

### 4 Check for open and short in harness and connector between engine ECU and accelerator pedal position sensor (VA, VAS line) (See page IN-19).

NG

Repair harness or connector.

OK

Replace accelerator pedal position sensor.

### 5 Check voltage between terminals VCC and E2C of engine ECU.

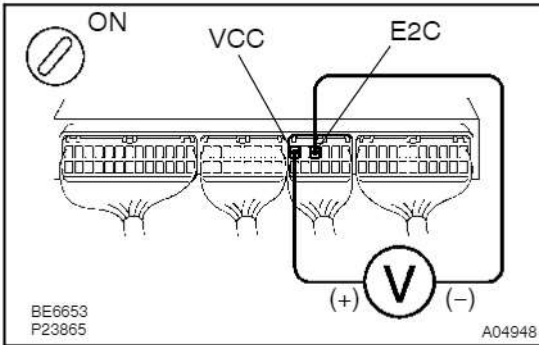

#### PREPARATION:

- Remove the glove compartment door.
- Turn the ignition switch ON.

#### CHECK:

Measure voltage between terminals VCC and E2C of engine ECU connector.

#### OK:

**Voltage: 4.5 – 5.5 V**

NG

Check and replace engine ECU  
(See page IN-19).

OK

Check for open in harness and connector between engine ECU and accelerator pedal position sensor (VCC line) (See page IN-19).

### When not using hand-held tester

### 1 Check voltage between terminal 4 of wire harness side connector and body ground.

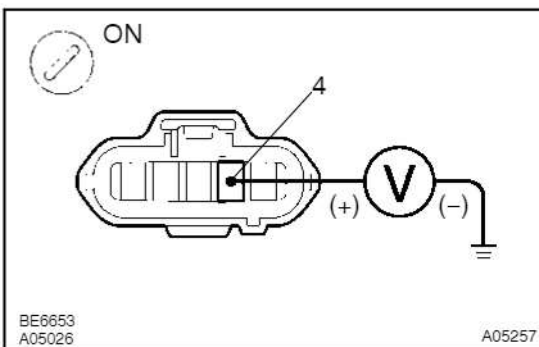

#### PREPARATION:

- Disconnect the accelerator pedal position sensor connector.
- Turn the ignition switch ON.

#### CHECK:

Measure voltage between terminal 4 of wire harness side connector and body ground.

#### OK:

**Voltage: 4.5 – 5.5 V**

NG

Go to step 4.

OK

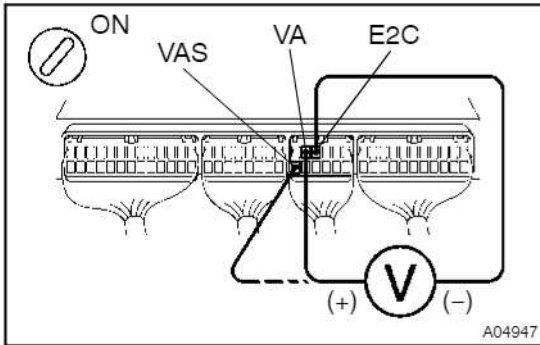
**2 Check voltage between terminals VA, VAS and E2C of engine ECU.**

**PREPARATION:**

- (a) Remove the glove compartment door.
- (b) Turn the ignition switch ON.

**CHECK:**

Measure voltage between terminals VA, VAS and E2C of engine ECU.

**OK:**

Accelerator pedal	Voltage
Fully closed	0.6 - 1.3 V
Fully open	2.8 - 4.5 V

**OK**

**Check and replace engine ECU**  
(See page IN-19).

**NG**
**3 Check for open and short in harness and connector between engine ECU and accelerator pedal position sensor (VA, VAS line) (See page IN-19).**
**NG**

**Repair harness or connector.**

**OK**

**Replace accelerator pedal position sensor.**

**4 Check voltage between terminals VCC and E2C of engine ECU.**

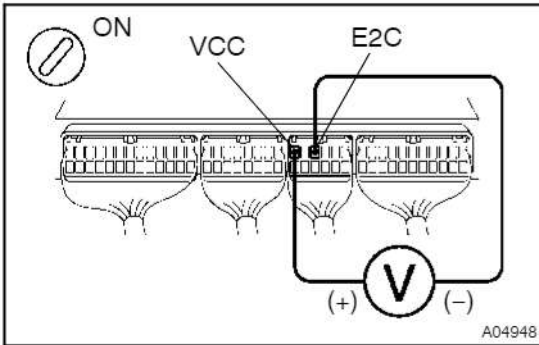

**PREPARATION:**

- Remove the glove compartment door.
- Turn ignition switch ON.

**CHECK:**

Measure voltage between terminals VCC and E2C of engine ECU connector.

**OK:**

**Voltage: 4.5 – 5.5 V**

**NG**

**Check and replace engine ECU  
(See page IN-19).**

**OK**

**Check for open in harness and connector between engine ECU and accelerator pedal position sensor (VCC line) (See page IN-19).**



<b>DTC</b>	<b>19 (2)</b>	<b>Accelerator Pedal Position Sensor Circuit Malfunction (IDL Switch/Range Malfunction)</b>
------------	---------------	---

## CIRCUIT DESCRIPTION

Refer to DTC 19 (1) (Accelerator Pedal Position Sensor Circuit Malfunction (Open/Short)) on [page DI-27](#).

DTC No.	DTC Detecting Condition	Trouble Area
19(2)	Condition (a) or (b) continue 0.5 sec. or more: (a) IDL ON and VA > 1.4 V (b) IDL ON and VAS > 1.4 V	<ul style="list-style-type: none"> <li>• Open or short in accelerator pedal position sensor circuit</li> <li>• Accelerator pedal position sensor</li> <li>• Engine ECU</li> </ul>
	Condition (a) or (b) continue 0.5 sec. or more: (a) IDL OFF and VA < 0.6 V (b) IDL OFF and VAS < 0.6 V	
	Conditions (a) and (b) continue 0.05 sec. or more: (a) 0.6 V < VA < 4.4 V and 0.6 V < VAS < 4.4 V (b) VA – VAS > 0.5 V	

## WIRING DIAGRAM

Refer to DTC 19 (1) (Accelerator Pedal Position Sensor Circuit Malfunction (Open/Short)) on [page DI-27](#).

## INSPECTION PROCEDURE

### When using hand-held tester

<b>1</b>	<b>Connect the hand-held tester, read the IDL signal.</b>
----------	---

#### PREPARATION:

- Connect the hand-held tester to the DLC3.
- Turn the ignition switch ON and push the hand-held tester main switch ON.

#### CHECK:

Read the IDL signal.

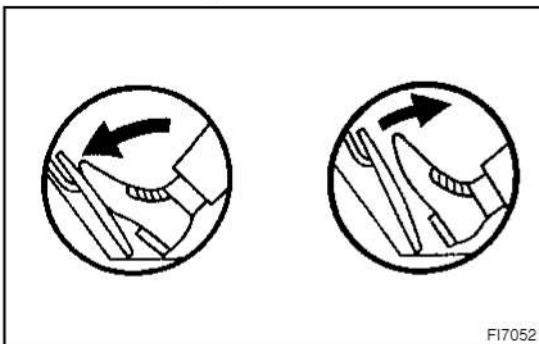

#### OK:

Accelerator pedal	IDL signal
Fully open	OFF
Fully closed	ON

OK

Go to step 4.

NG

## 2 Check voltage between terminals IDL and E2C of engine ECU.

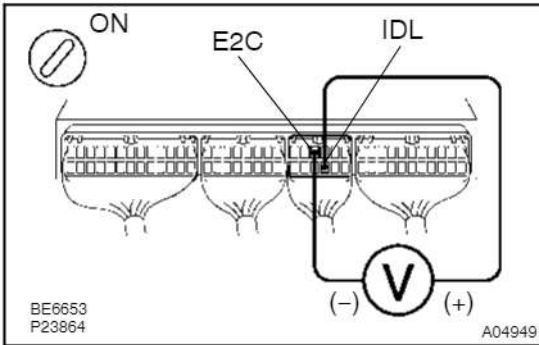

### PREPARATION:

- Remove the glove compartment door.
- Turn the ignition switch ON.

### CHECK:

Measure voltage between terminals IDL and E2C of engine ECU.

### OK:

Accelerator pedal	Voltage
Fully closed	9 - 14 V
Fully open	0 - 3 V

OK

Check and replace engine ECU  
(See page IN-19).

NG

## 3 Check for open and short in harness and connector between engine ECU and accelerator pedal position sensor (IDL line) (See page IN-19).

NG

Repair harness or connector.

OK

Replace accelerator pedal position sensor.

## 4 Connect the hand-held tester, read the accelerator pedal operating percentage (See page DI-27 , Step 1).

OK

Check for intermittent problems  
(See page DI-4).

OK

5 Check voltage between terminal VCC of wire harness side connector and body ground (See page DI-27, Step 2).

NG

Go to step 8.

OK

6 Check voltage between terminals VA, VAS and E2C of engine ECU (See page DI-27, Step 3).

OK

Check and replace engine ECU (See page IN-19).

NG

7 Check for open and short in harness and connector between engine ECU and accelerator pedal position sensor (VA, VAS line) (See page IN-19).

NG

Repair harness or connector.

OK

Replace accelerator pedal position sensor.

8 Check voltage between terminals VCC and E2C of engine ECU (See page DI-27, Step 5).

NG

Check and replace engine ECU (See page IN-19).

OK

Check for open in harness and connector between engine ECU and accelerator pedal position sensor (VCC line) (See page IN-19).

## When not using hand-held tester

**1 Check voltage between terminals IDL and E2C of engine ECU.**

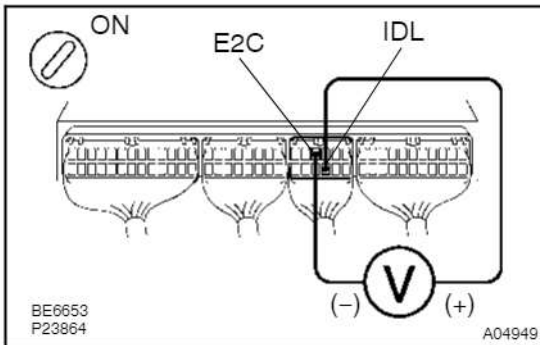

### PREPARATION:

- (a) Remove the glove compartment door.
- (b) Turn the ignition switch ON.

### CHECK:

Measure voltage between terminals IDL and E2C of engine ECU.

### OK:

Accelerator pedal	Voltage
Fully closed	9 - 14 V
Fully open	0 - 3 V

OK

Go to step 3.

NG

**2 Check for open and short in harness and connector between engine ECU and accelerator pedal position sensor (IDL line) (See page IN-19).**

NG

Repair harness or connector.

OK

Replace accelerator pedal position sensor.

**3 Check voltage between terminal 4 of wire harness side connector and body-ground (See page DI-27, Step 2).**

NG

Go to step 6.

OK

- 4 Check voltage between terminals VA, VAS and E2C of engine ECU  
(See page DI-27, Step 3).

OK

Check and replace engine ECU  
(See page IN-19).

NG

- 5 Check for open and short in harness and connector between engine ECU and accelerator pedal position sensor (VA, VAS line) (See page IN-19).

NG

Repair harness or connector.

OK

Replace accelerator pedal position sensor.

- 6 Check voltage between terminals VCC and E2C of engine ECU  
(See page DI-27, Step 5).

NG

Check and replace engine ECU  
(See page IN-19).

OK

Check for open in harness and connector between engine ECU and accelerator pedal position sensor (VCC line) (See page IN-19).

<b>DTC</b>	<b>19 (3)</b>	<b>Accelerator Pedal Closed Position Switch Circuit Malfunction (Short)</b>
------------	---------------	---

<b>DTC</b>	<b>19 (4)</b>	<b>Accelerator Pedal Closed Position Switch Circuit Malfunction (Open)</b>
------------	---------------	--

## CIRCUIT DESCRIPTION

Refer to DTC 19 (1) (Accelerator Pedal Position Sensor Circuit Malfunction (Open/Short)) on [page DI-27](#).

DTC No.	DTC Detecting Condition	Trouble Area
19(3)	Conditions (a), (b) and (c) continue 0.5 sec. or more: (a) PDL ON (b) VA > Fully closed study voltage +0.41 V (c) VAS > Fully closed study voltage +0.41 V	<ul style="list-style-type: none"> <li>• Short in accelerator pedal closed position switch circuit</li> <li>• Accelerator pedal closed position switch</li> <li>• Engine ECU</li> </ul>
19(4)	PDL does not turn ON even once while driving vehicle (2 trip detection logic) Conditions (a) and (b) continue 5 sec. or more: (a) PDL OFF (b) IDL ON	<ul style="list-style-type: none"> <li>• Open in accelerator pedal closed position switch circuit</li> <li>• Accelerator pedal closed position switch</li> <li>• Engine ECU</li> </ul>

## WIRING DIAGRAM

Refer to DTC 19 (1) (Accelerator Pedal Position Sensor Circuit Malfunction (Open/Short)) on [page DI-27](#).

## INSPECTION PROCEDURE

## 1 Check accelerator pedal closed position switch.

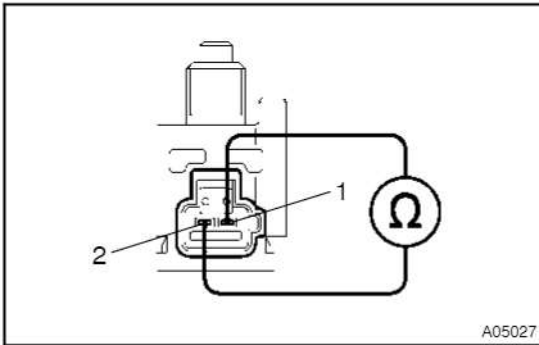
**PREPARATION:**

Disconnect the accelerator pedal closed position switch connector.

**CHECK:**

Measure resistance between terminals of accelerator pedal closed position switch.

**OK:**

Terminals	Accelerator pedal	Resistance
1 - 2	Fully closed	$\infty$
1 - 2	Fully open	0 - 20 $\Omega$

NG

Replace accelerator pedal closed position switch (See page ED-9).

OK

## 2 Check voltage between terminal PDL of engine ECU and body ground.

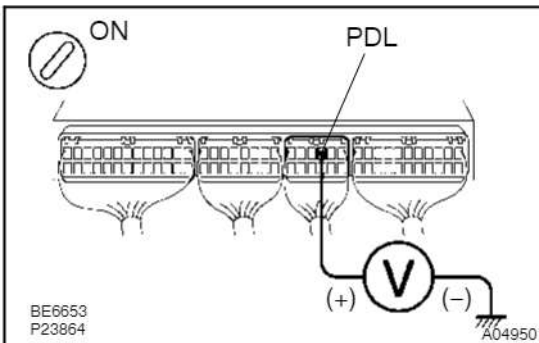
**PREPARATION:**

- Remove the glove compartment door.
- Turn the ignition switch ON.

**CHECK:**

Measure voltage between terminal PDL of engine ECU and body ground.

**OK:**

Accelerator pedal	Voltage
Fully closed	9 - 14 V
Fully open	0 - 3 V

OK

Check and replace engine ECU (See page IN-19).

NG

Check for open and short in harness and connector between engine ECU and accelerator pedal closed position switch and body ground (See page IN-19).

<b>DTC</b>	<b>22</b>	<b>Water Temp. Sensor Circuit Malfunction</b>
------------	-----------	---

**CIRCUIT DESCRIPTION**

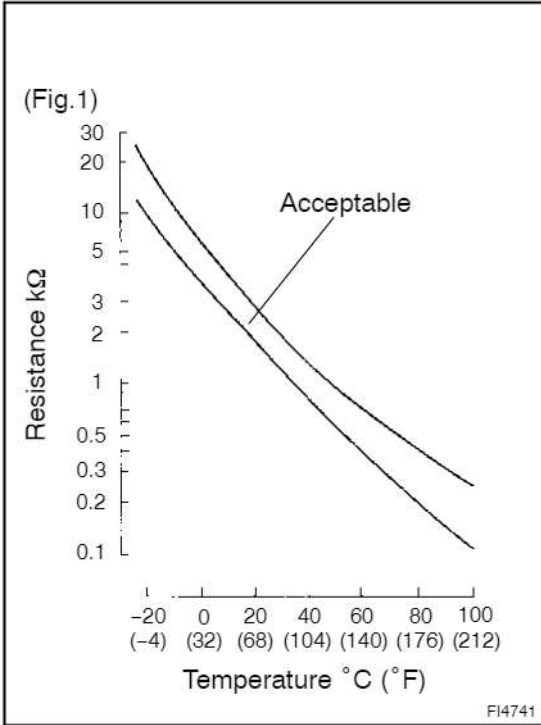

The water temperature sensor senses the coolant temperature. A thermistor built into the sensor changes the resistance value according to the coolant temperature. The lower the coolant temperature, the greater the thermistor resistance value, and the higher the coolant temperature, the lower the thermistor resistance value (See Fig.1).

The water temperature sensor is connected to the engine ECU (See below). The 5 V power source voltage in the engine ECU is applied to the water temperature sensor from the terminal THW via a resistor R. That is, the resistor R and the water temperature sensor are connected in series. When the resistance value of the water temperature sensor changes in accordance with changes in the coolant temperature, the potential at the terminal THW also changes. Based on this signal, the engine ECU increases the fuel injection volume to improve driveability during cold engine operation.

DTC No.	DTC Detecting Condition	Trouble Area
22	Open or short in water temp. sensor circuit for 0.5 sec. or more	<ul style="list-style-type: none"> <li>• Open or short in water temp. sensor circuit</li> <li>• Water temp. sensor</li> <li>• Engine ECU</li> </ul>

**HINT:**

After confirming DTC22 use the hand-held tester to confirm the water temperature from, "CURRENT DATA".

Temperature displayed	Malfunction
-40°C (-40°F)	Open circuit
140°C (284°F) or more	Short circuit

**WIRING DIAGRAM**

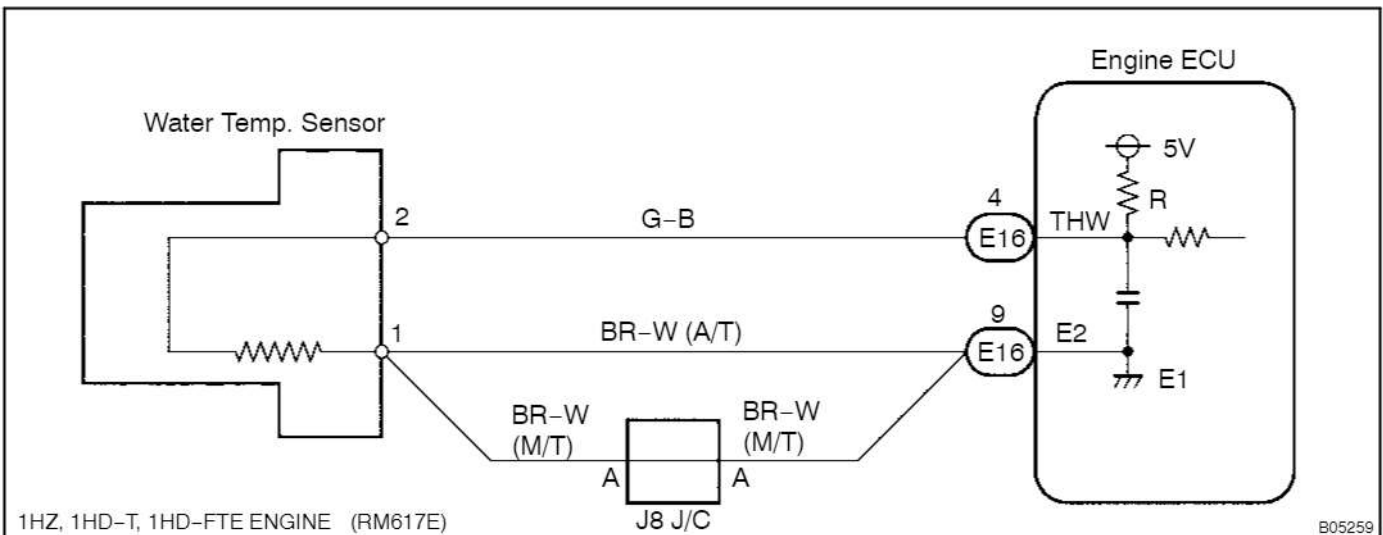



## INSPECTION PROCEDURE

### HINT:

If DTC "22" (Water Temp. Sensor Circuit Malfunction), "24" (Intake Air Temp. Sensor Circuit Malfunction) and "39" (Fuel Temp. Sensor Circuit Malfunction) are output simultaneously, E2 (sensor ground) may be open.

### When using hand-held tester

<b>1</b>	<b>Connect the hand-held tester, and read value of water temperature.</b>
----------	---

### PREPARATION:

- (a) Connect the hand-held tester to the DLC 3.
- (b) Turn the ignition switch ON and push the hand-held tester main switch ON.

### CHECK:

Read temperature value on the hand-held tester.

### OK:

**Same as actual water temperature.**

### HINT:

- If there is open circuit, hand-held tester indicates  $-40^{\circ}\text{C}$  ( $-40^{\circ}\text{F}$ ).
- If there is short circuit, hand-held tester indicates  $140^{\circ}\text{C}$  ( $284^{\circ}\text{F}$ ) or more.

<b>NG</b>	$-40^{\circ}\text{C}$ ( $-40^{\circ}\text{F}$ ) ... Go to step 2. $140^{\circ}\text{C}$ ( $284^{\circ}\text{F}$ ) or more ... Go to step 4.
-----------	--



<b>Check for intermittent problems (See page DI-4).</b>
---

## 2 Check for open in harness or engine ECU.

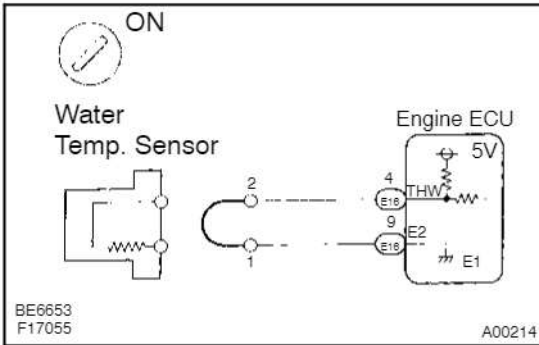

### PREPARATION:

- Disconnect the water temp. sensor connector.
- Connect sensor wire harness terminals together.
- Turn the ignition switch ON.

### CHECK:

Read temperature value on the hand-held tester.

### OK:

Temperature value: 140°C (284°F) or more

OK

Confirm good connection at sensor.  
If OK, replace water temp. sensor.

NG

## 3 Check for open in harness or engine ECU.

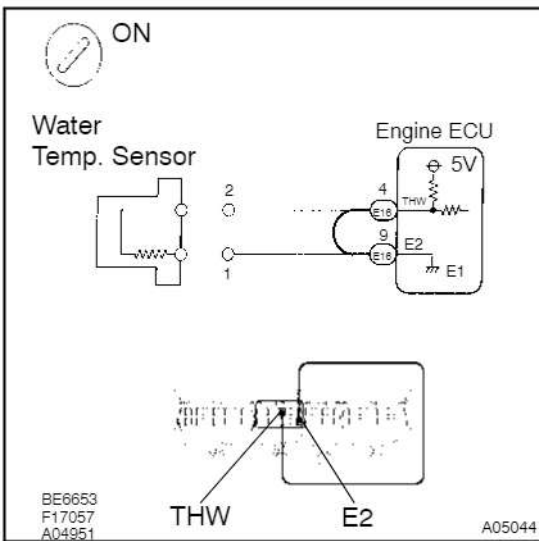

### PREPARATION:

- Remove the glove compartment door.
- Connect between terminals THW and E2 of engine ECU connector.

### HINT:

Water temp. sensor connector is disconnected.

Before checking, do a visual and contact pressure check for the engine ECU connector (See page IN-19).

- Turn the ignition switch ON.

### CHECK:

Read temperature value on the hand-held tester.

### OK:

Temperature value: 140°C (284°F) or more

OK

Open in harness between terminal E2 or THW,  
repair or replace harness.

NG

Confirm good connection at engine ECU. If OK, replace engine ECU.

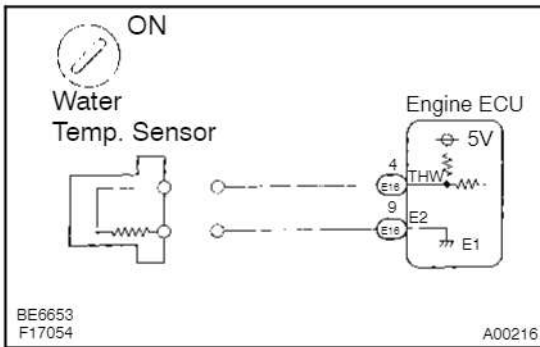
**4 Check for short in harness and engine ECU.****PREPARATION:**

- Disconnect the water temp. sensor connector.
- Turn the ignition switch ON.

**CHECK:**

Read temperature value on the hand-held tester.

**OK:**

Temperature value:  $-40^{\circ}\text{C}$  ( $-40^{\circ}\text{F}$ )

OK

Replace water temp. sensor.

NG

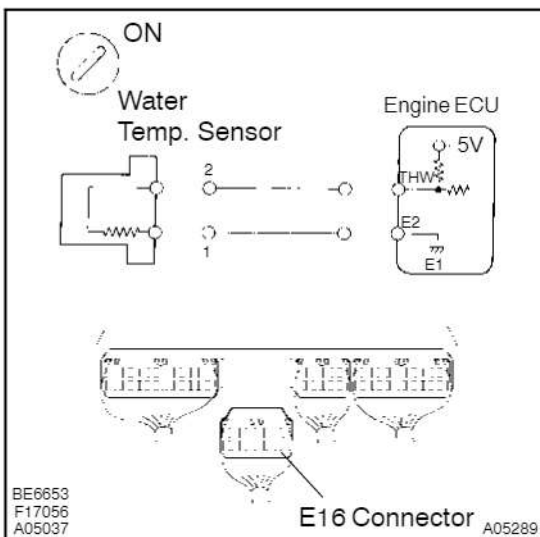
**5 Check for short in harness or engine ECU.****PREPARATION:**

- Remove the glove compartment door.
- Disconnect the "E16" connector of engine ECU.

**HINT:**

Water temp. sensor connector is disconnected.

- Turn the ignition switch ON.

**CHECK:**

Read temperature value on the hand-held tester.

**OK:**

Temperature value:  $-40^{\circ}\text{C}$  ( $-40^{\circ}\text{F}$ )

OK

Repair or replace harness or connector.

NG

Check and replace engine ECU (See page IN-19).

## When not using hand-held tester

**1 Check voltage between terminals THW and E2 engine ECU connector.**

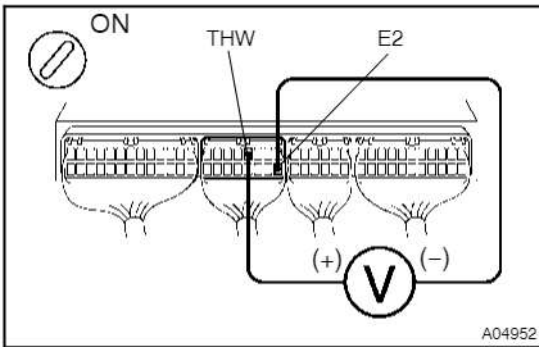

### PREPARATION:

- Remove the glove compartment door.
- Turn the ignition switch ON.

### CHECK:

Measure voltage between terminals THW and E2 of engine ECU connector.

### OK:

Water temp. °C (°F)	Voltage
20 (68) (Engine is cool)	0.2 – 3.8 V
80 (176) (Engine is hot)	0.1 – 1.5 V

OK

**Check for intermittent problems  
(See page DI-4).**

NG

**2 Check water temp. sensor (See page ED-5).**

NG

**Replace water temp. sensor.**

OK

**3 Check for open and short in harness and connector between engine ECU and water temp. sensor (See page IN-19).**

NG

**Repair or replace harness or connector.**

OK

**Check and replace engine ECU (See page IN-19).**

<b>DTC</b>	<b>24</b>	<b>Intake Air Temp. Sensor Circuit Malfunction</b>
------------	-----------	--

## CIRCUIT DESCRIPTION

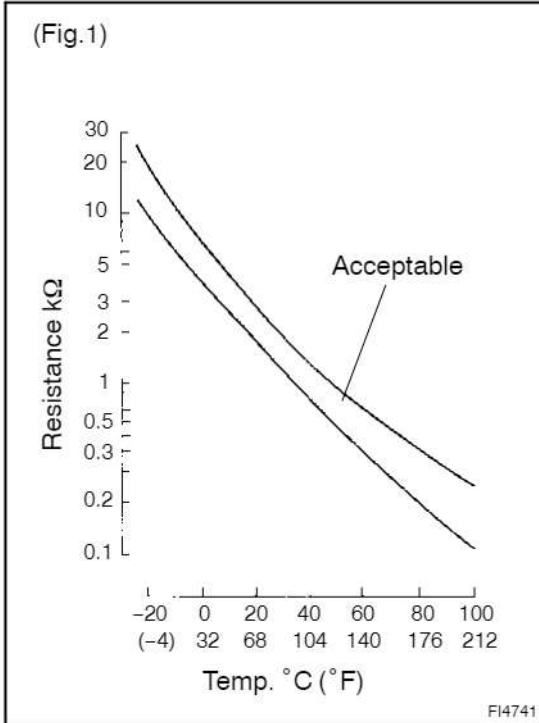

The intake air temp. sensor is built into the intake manifold and senses the intake air temperature. A thermistor built in the sensor changes the resistance value according to the intake air temperature. The lower the intake air temperature, the greater the thermistor, the lower the thermistor resistance value (See Fig.1). The intake air temperature sensor is connected to the engine ECU. The 5 V power source voltage in the engine ECU is applied to the intake air temperature sensor from the terminal THA via a resistor R. That is the resistor R and the intake air temperature sensor are connected in series. When the resistance value of the intake air temperature sensor changes. Based on this signal, the engine ECU increases the fuel injection volume to improve drivability during cold engine operation.

DTC No.	DTC Detecting Condition	Trouble Area
24	Open or short in intake air temp. sensor circuit for 0.5 sec. or more	<ul style="list-style-type: none"> <li>• Open or short in intake air temp. sensor circuit</li> <li>• Intake air temp. sensor</li> <li>• Engine ECU</li> </ul>

### HINT:

After confirming DTC 24 use the hand-held tester to confirm the water temperature from "CURRENT DATA".

Temperature displayed	Malfunction
-40°C (-40°F)	Open circuit
140°C (284°F) or more	Short circuit

## WIRING DIAGRAM

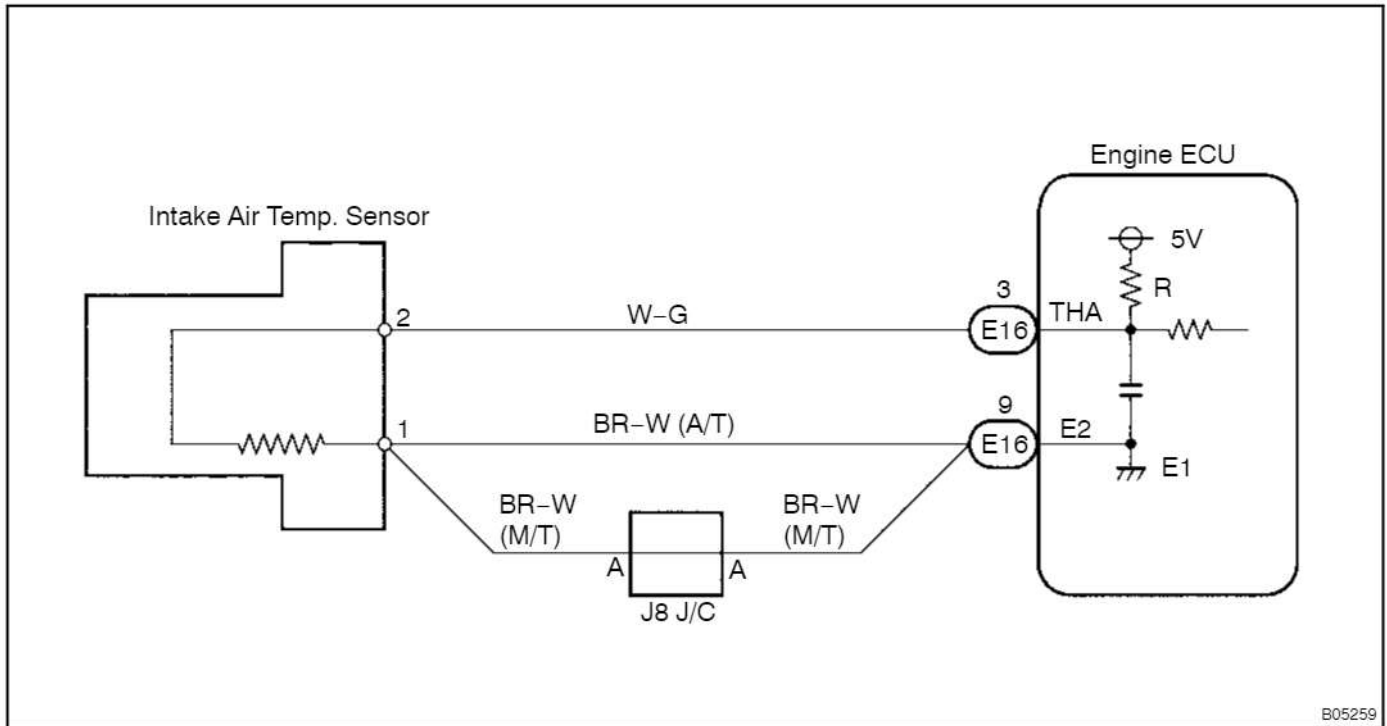

B05259

## INSPECTION PROCEDURE

## HINT:

If DTC "22" (Water Temp. Sensor Circuit Malfunction), "24" (Intake Air Temp. Sensor Circuit Malfunction), "35" (Turbo Pressure Sensor Circuit Malfunction) and "39" (Fuel Temp. Sensor Circuit Malfunction) are output simultaneously, E2 (sensor ground) may be open.

## When using hand-held tester

**1** Connect the hand-held tester, and read value of water temperature.

### PREPARATION:

- Connect the hand-held tester to the DLC3.
- Turn the ignition switch ON and push the hand-held tester main switch ON.

### CHECK:

Read temperature value on the hand-held tester.

### OK:

**Same as actual intake air temperature.**

### HINT:

- If there is open circuit, hand-held tester indicates  $-40^{\circ}\text{C}$  ( $-40^{\circ}\text{F}$ ).
- If there is short circuit, hand-held tester indicates  $140^{\circ}\text{C}$  ( $284^{\circ}\text{F}$ ) or more.

**NG**

$-40^{\circ}\text{C}$  ( $-40^{\circ}\text{F}$ ) ... Go to step 2.  
 $140^{\circ}\text{C}$  ( $284^{\circ}\text{F}$ ) or more ... Go to step 4.

**OK**

Check for intermittent problems (See page DI-4).

**2** Check for open in harness or engine ECU.

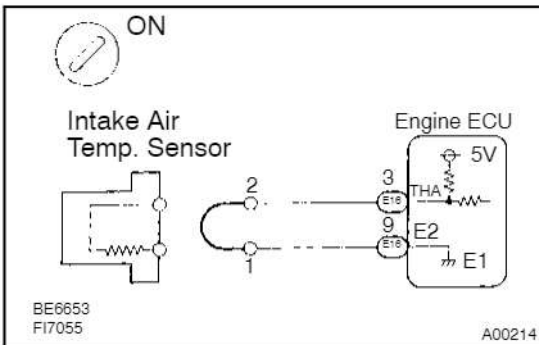

### PREPARATION:

- Disconnect the intake air temp. sensor connector.
- Connect sensor wire harness terminals together.
- Turn the ignition switch ON.

### CHECK:

Read temperature value on the hand-held tester.

### OK:

**Temperature value:  $140^{\circ}\text{C}$  ( $284^{\circ}\text{F}$ ) or more**

**OK**

**Confirm good connection at sensor.  
 If OK, replace intake air temp. sensor.**

**NG**

### 3 Check for open in harness or engine ECU.

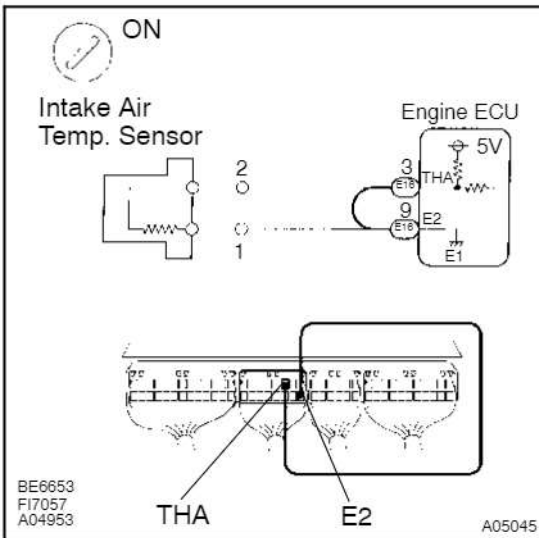

#### PREPARATION:

- Remove the glove compartment door.
- Connect between terminals THA and E2 of engine ECU connector.

#### HINT:

Intake air temp. sensor connector is disconnected.  
Before checking, do a visual and contact pressure check for the engine ECU connector (See page IN-19).

- Turn the ignition switch ON.

#### CHECK:

Read temperature value on the hand-held tester.

#### OK:

Temperature value: 140°C (284°F) or more

OK

Open in harness between terminal E2 or THA, repair or replace harness.

NG

Confirm good connection at engine ECU. If OK, replace engine ECU.

### 4 Check for short in harness and engine ECU.

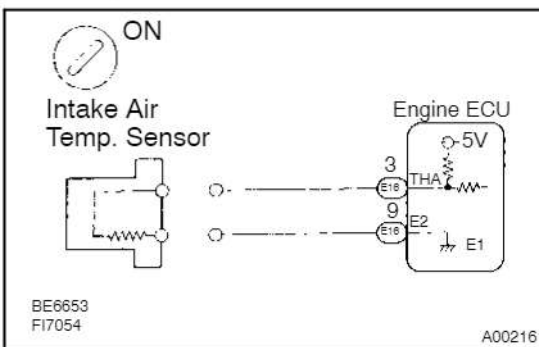

#### PREPARATION:

- Disconnect the intake air temp. sensor connector.
- Turn the ignition switch ON.

#### CHECK:

Read temperature value on the hand-held tester.

#### OK:

Temperature value: -40°C (-40°F)

OK

Replace intake air temp. sensor.

NG



## 5 Check for short in harness or engine ECU.

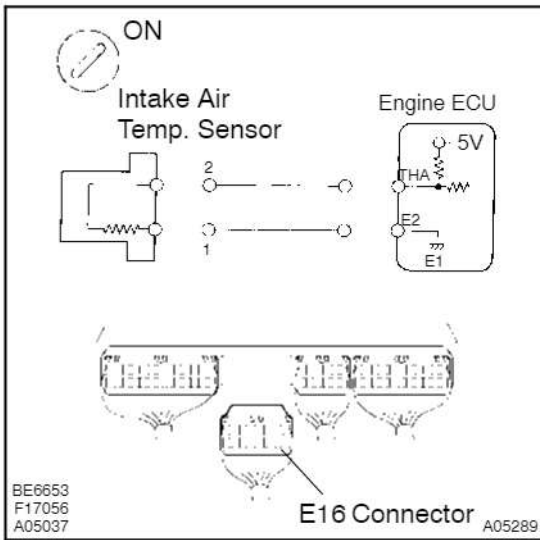

### PREPARATION:

- Remove the glove compartment door.
- Disconnect the "E16" connector of engine ECU.

### HINT:

Intake air temp. sensor connector is disconnected.

- Turn the ignition switch ON.

### CHECK:

Read temperature value on the hand-held tester.

### OK:

Temperature value:  $-40^{\circ}\text{C}$  ( $-40^{\circ}\text{F}$ )

OK

Repair or replace harness or connector.

NG

Check and replace engine ECU (See page IN-19).

## When not using hand-held tester

1 Check voltage between terminals THA and E2 engine ECU connector.

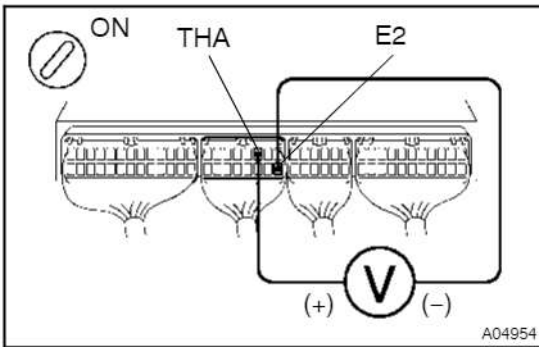

### PREPARATION:

- Remove the glove compartment door.
- Turn the ignition switch ON.

### CHECK:

Measure voltage between terminals THA and E2 of engine ECU connector.

### OK:

Intake air temp. °C (°F)	Voltage
20 (68) (Engine is cool)	0.2 - 3.8 V
80 (176) (Engine is hot)	0.1 - 1.5 V

OK

Check for intermittent problems  
(See page DI-4).

NG

2 Check intake air temp. sensor (See page ED-7).

NG

Replace intake air temp. sensor.

OK

3 Check for open and short in harness and connector between engine ECU and intake air temp. sensor (See page IN-19).

NG

Repair or replace harness or connector.

OK

Check and replace engine ECU (See page IN-19).

<b>DTC</b>	<b>32</b>	<b>Injection Pump Correction System Malfunction</b>
------------	-----------	---

## CIRCUIT DESCRIPTION

The correction system is correcting a few vary between each injection pumps.

DTC No.	DTC Detecting Condition	Trouble Area
32	Open or short in injection pump correction unit circuit	<ul style="list-style-type: none"> <li>• Injection pump correction unit circuit</li> <li>• Injection pump correction unit</li> <li>• Engine ECU</li> </ul>

## WIRING DIAGRAM

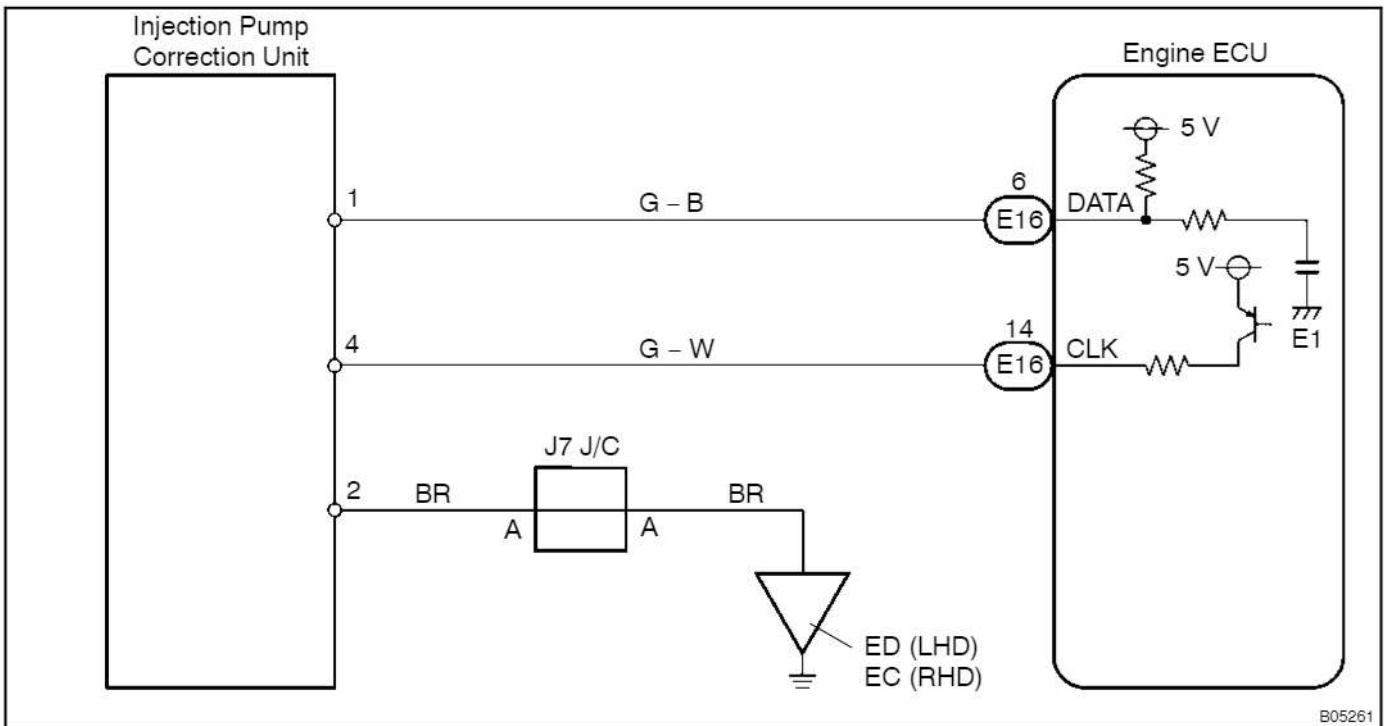

## INSPECTION PROCEDURE

1	Check for open and short in harness and connector between the engine ECU and injection pump correction unit (See page IN-19).
---	---

NG

Repair harness or connector.

OK

**2** Try to change the injection pump correction unit to another one.

**PREPARATION:**

- (a) Remove the injection pump correction unit from injection pump.
- (b) Install the another injection pump correction unit.
- (c) Clear DTC.
- (d) Turn the ignition switch ON.

**CHECK:**

Read DTC again.

**OK:**

Does not output DTC "32" (Injection Pump Correction System Malfunction).

OK

Check and replace injection pump  
(See page [FU-113](#)).

NG

Check and replace engine ECU (See page [IN-19](#)).

<b>DTC</b>	<b>33</b>	<b>Intake Shutter Control Circuit Malfunction</b>
------------	-----------	---

## CIRCUIT DESCRIPTION

When the ignition switch turned OFF, the intake shutter control system shuts off the air intake by closing the intake shutter for the engine stopping smoothly. The actuator shuts the intake shutter by the engine ECU controlling the VSV.

DTC No.	DTC Detecting Condition	Trouble Area
33	Open or short in VSV for intake shutter circuit for 0.5 sec. or more	<ul style="list-style-type: none"> <li>• Open or short in VSV for intake shutter circuit</li> <li>• VSV for intake shutter</li> <li>• Intake shutter</li> <li>• Vacuum hose disconnected or blocked</li> <li>• Engine ECU</li> </ul>

## WIRING DIAGRAM

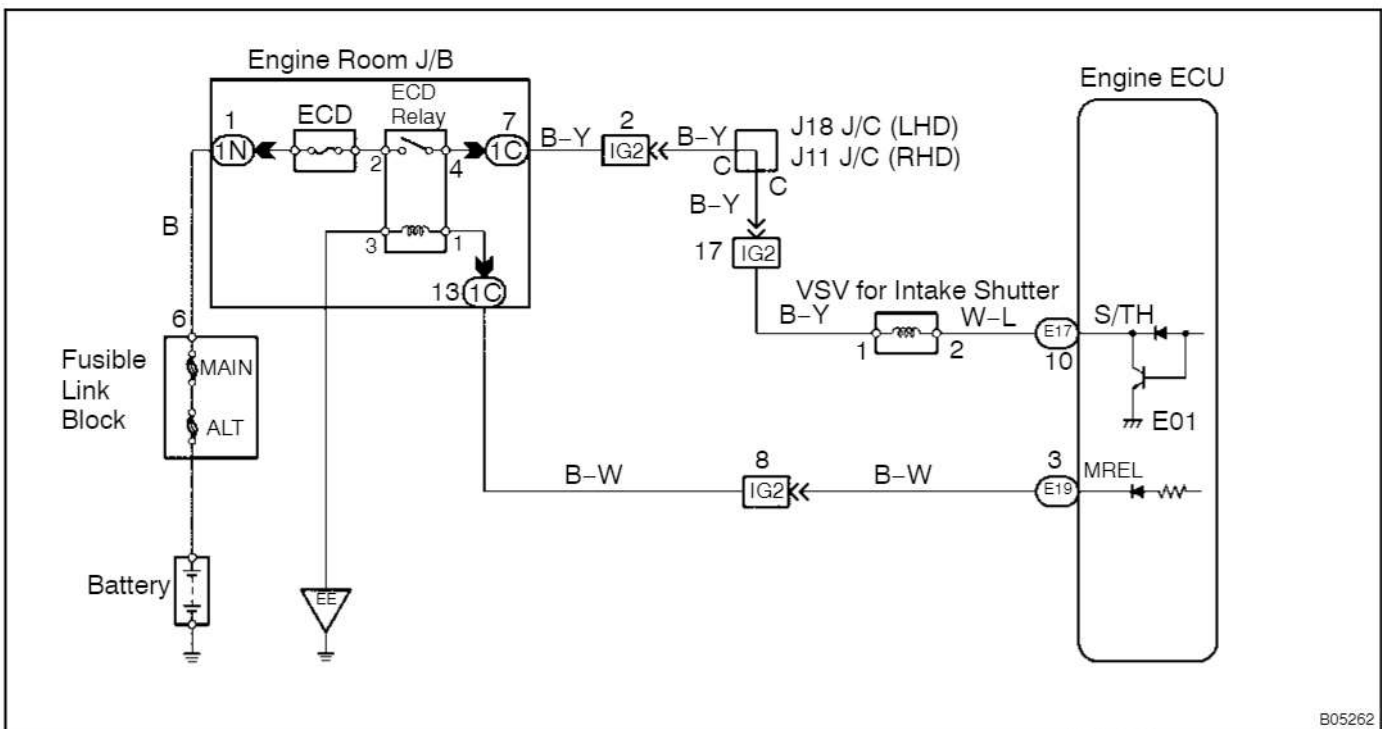

## INSPECTION PROCEDURE

1	Check resistance of VSV for intake shutter (See page EM-20).
---	--

NG

Replace the VSV for intake shutter.

OK

## 2 Check the VSV for intake shutter.

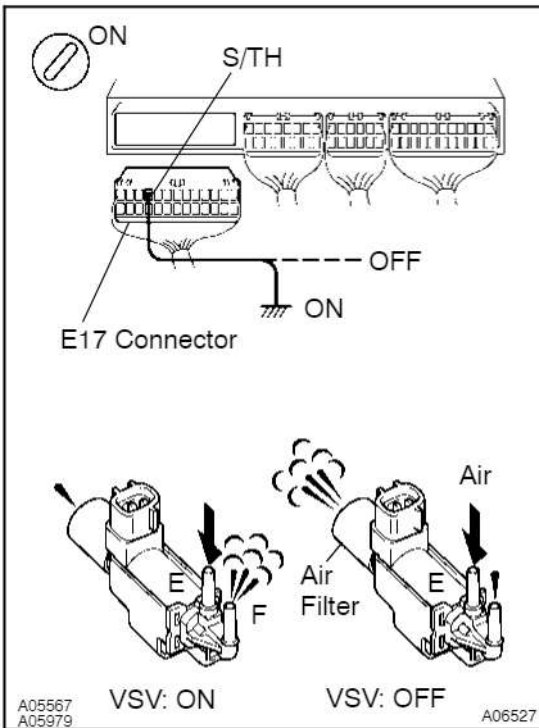

### PREPARATION:

- Remove the glove compartment door.
- Disconnect the "E17" connector of engine ECU.
- Turn the ignition switch ON.

### CHECK:

Check VSV function

- Connect between terminal S/TH of engine ECU and body ground (VSV is ON).
- Disconnect between terminal S/TH of engine ECU and body ground (VSV is OFF).

### OK:

**VSV is ON:**

**Air from pipe E flows out through pipe F.**

**VSV is OFF:**

**Air from pipe E flows out through the air filter.**

OK

Check and replace engine ECU  
(See page IN-19).

NG

## 3 Check for open and short in harness and connector between engine ECU and VSV for intake shutter, VSV for intake shutter and ECD main relay (Marking: ECD) (See page IN-19).

NG

Repair harness or connector.

OK

Replace VSV for intake shutter.

<b>DTC</b>	<b>35</b>	<b>Turbo Pressure Sensor Circuit Malfunction</b>
------------	-----------	--

### CIRCUIT DESCRIPTION

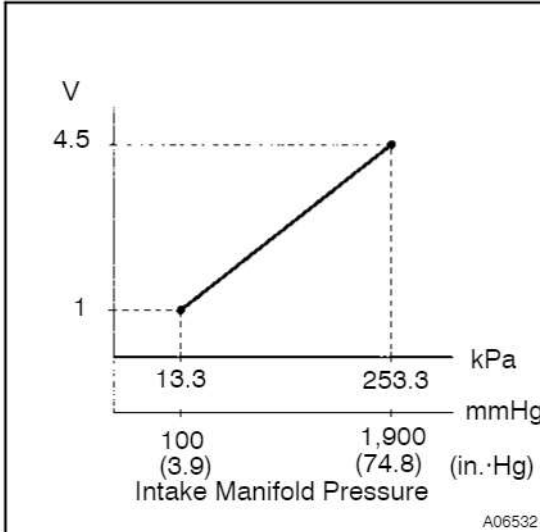

The turbo pressure sensor is connected to the intake manifold. The engine ECU detects the intake manifold pressure as a voltage by the sensor. The engine ECU uses the intake manifold pressure signal for correction of injection volume control and injection timing control.

The VSV for turbo pressure sensor switches the atmosphere applied to the turbo pressure sensor to the intake manifold pressure. The turbo pressure sensor monitors both the atmospheric pressure and intake manifold pressure and transmits the output voltage to the engine ECU, and the engine ECU uses this atmospheric pressure value for correcting the injection volume.

DTC No.	DTC Detecting Condition	Trouble Area
35	Open or short in turbo pressure sensor circuit for 2 sec. or more	<ul style="list-style-type: none"> <li>• Open or short in turbo pressure sensor circuit</li> <li>• Turbo pressure sensor</li> <li>• Open or short in VSV for turbo pressure sensor circuit</li> <li>• VSV for turbo pressure sensor</li> <li>• Vacuum hose disconnected or blocked</li> <li>• Engine ECU</li> </ul>

#### HINT:

After confirming DTC 35, use the hand-held tester to confirm the intake manifold pressure from "CURRENT DATA".

Intake manifold pressure (kPa)	Malfunction
Approx. 0	<ul style="list-style-type: none"> <li>• PIM circuit short</li> </ul>
130 or more	<ul style="list-style-type: none"> <li>• VC circuit open or short</li> <li>• PIM circuit open</li> <li>• E2 circuit open</li> </ul>

## WIRING DIAGRAM

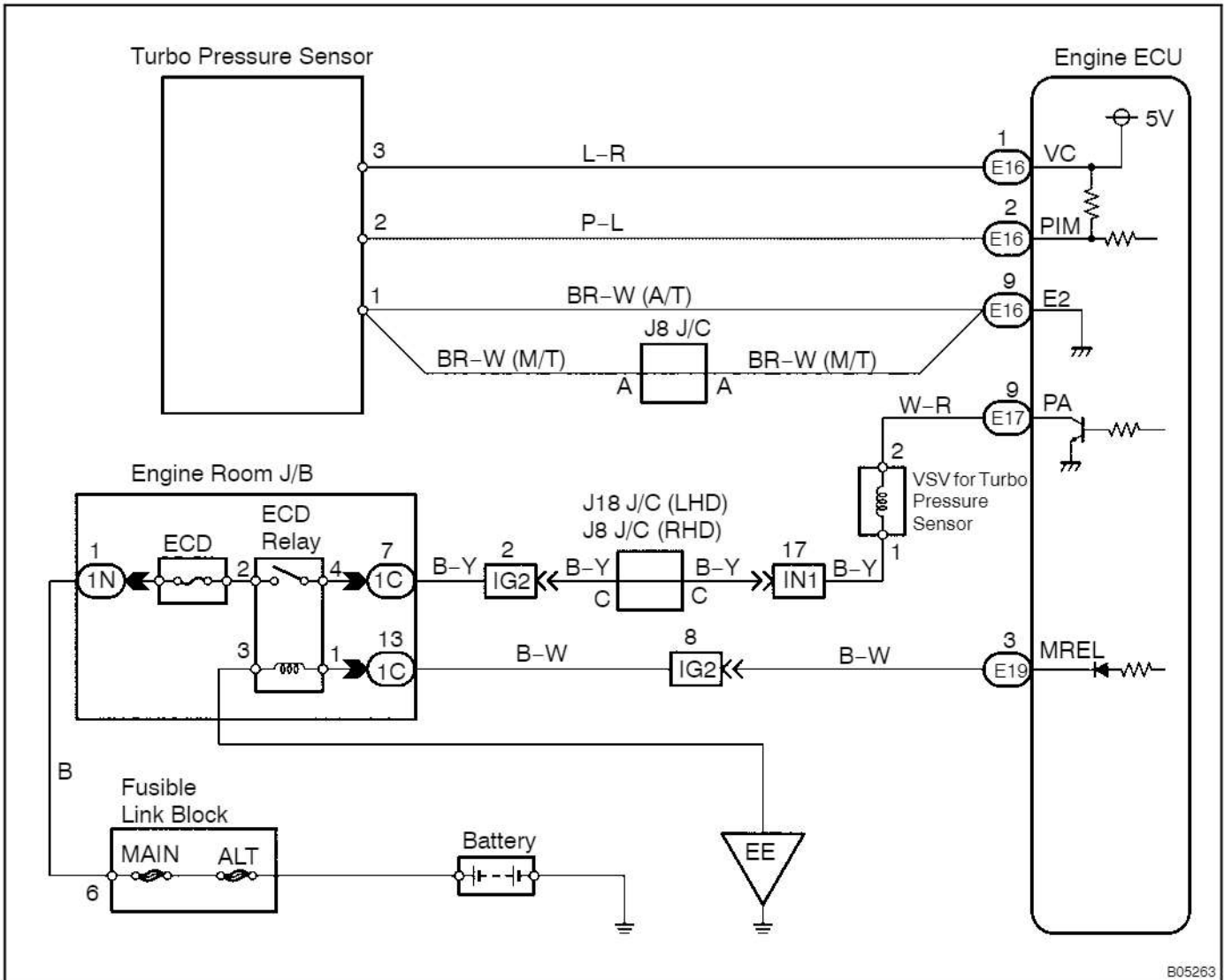

## INSPECTION PROCEDURE

## HINT:

If DTC "22" (Water Temp. Sensor Circuit Malfunction), "24" (Intake Air Temp. Sensor Circuit Malfunction), "35" (Turbo Pressure Sensor Circuit Malfunction) and "39" (Fuel Temp. Sensor Circuit Malfunction) are output simultaneously, E2 (sensor ground) may be open.



## When using hand-held tester

1 Connect the hand-held tester, and read value of intake manifold pressure.

### PREPARATION:

- (a) Connect the hand-held tester to the DLC3.
- (b) Turn the ignition switch ON and push the hand-held tester main switch ON.

### CHECK:

Read value of intake manifold pressure on the hand-held tester.

### OK:

Same as atmospheric pressure.

OK

Go to step 5.

NG

2 Check turbo pressure sensor (See page TC-17).

NG

Replace turbo pressure sensor.

OK

3 Check voltage between terminals VC and E2 of engine ECU.

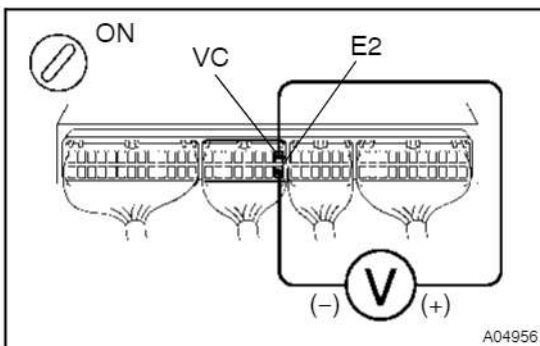

### PREPARATION:

- (a) Remove the glove compartment door.
- (b) Turn the ignition switch ON.

### CHECK:

Measure voltage between terminals VC and E2 of engine ECU.

### OK:

Voltage: 4.5 – 5.5 V

NG

Check and replace engine ECU (See page IN-19).

OK

#### 4 Check voltage between terminals PIM and E2 of engine ECU.

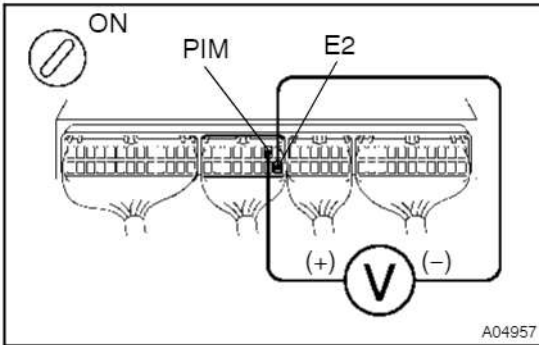

#### PREPARATION:

- Remove the glove compartment door.
- Turn the ignition switch ON.

#### CHECK:

Measure voltage between terminals PIM and E2 of engine ECU.

#### OK:

Voltage: 1.7 - 2.9 V

OK

Check and replace engine ECU  
(See page IN-19).

NG

Check for open and short in harness and connector between engine ECU and turbo pressure sensor (See page IN-19).

#### 5 Check the connection of vacuum hose between turbo pressure sensor and VSV for turbo pressure sensor, VSV for turbo pressure sensor and intake manifold.

NG

Repair or replace.

OK

#### 6 Check resistance of VSV for turbo pressure sensor (See page TC-19).

NG

Replace VSV for turbo pressure sensor.

OK

## 7 Check the VSV for turbo pressure sensor.

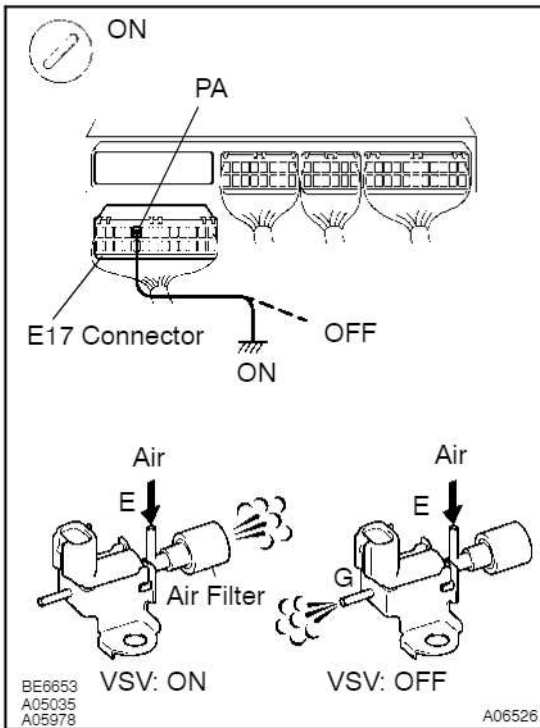

### PREPARATION:

- Remove the glove compartment door.
- Disconnect the "E17" connector of engine ECU.
- Turn the ignition switch ON.

### CHECK:

Check VSV function

- Connect between terminal PA of engine ECU and body ground (VSV is ON).
- Disconnect between terminal PA of engine ECU and body ground (VSV is OFF).

### OK:

**VSV is ON:**

Air from pipe E flows out through the air filter.

**VSV is OFF:**

Air from pipe E flows out through pipe G.

OK

Check and replace engine ECU  
(See page IN-19).

NG

## 8 Check for open and short in harness and connector between engine ECU and VSV for turbo pressure sensor, VSV for turbo pressure sensor and ECD main relay (Marking: ECD) (See page IN-19).

NG

Repair harness or connector.

OK

Replace VSV for turbo pressure sensor.

## When not using hand-held tester

1 Check turbo pressure sensor (See page TC-17).

NG

Replace turbo pressure sensor.

OK

2 Check voltage between terminals VC and E2 of engine ECU.

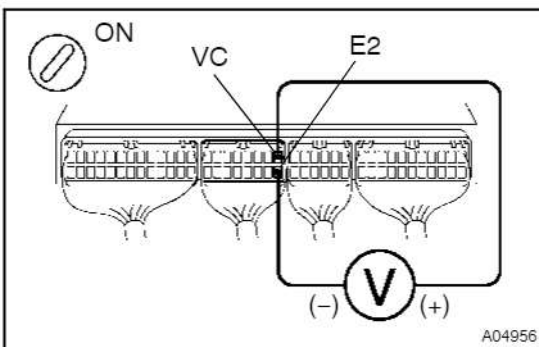

### PREPARATION:

- Remove the glove compartment door.
- Turn the ignition switch ON.

### CHECK:

Measure voltage between terminals VC and E2 of engine ECU.

### OK:

Voltage: 4.5 - 5.5 V

NG

Check and replace engine ECU (See page IN-19).

OK

3 Check voltage between terminals PIM and E2 of engine ECU.

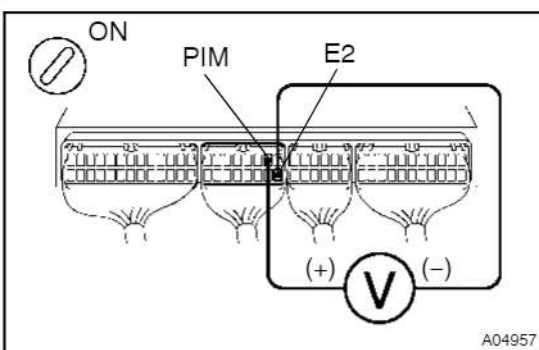

### PREPARATION:

- Remove the glove compartment door.
- Turn the ignition switch ON.

### CHECK:

Measure voltage between terminals PIM and E2 of engine ECU.

### OK:

Voltage: 1.7 - 2.9 V

OK

Check and replace engine ECU (See page IN-19).

NG

- |          |   |
|----------|---|
| <b>4</b> | <b>Check for open and short in harness and connector between engine ECU and turbo pressure sensor (See page IN-19).</b> |
|----------|---|

NG

Repair or replace harness or connector.

OK

- |          |  |
|----------|--|
| <b>5</b> | <b>Check the connection of vacuum hose between turbo pressure sensor and VSV for turbo pressure sensor, VSV for turbo pressure sensor and intake manifold.</b> |
|----------|--|

NG

Repair or replace.

OK

- |          |  |
|----------|--|
| <b>6</b> | <b>Check resistance of VSV for turbo pressure sensor (See page TC-19).</b> |
|----------|--|

NG

Replace VSV for turbo pressure sensor.

OK

## 7 Check the VSV for turbo pressure sensor.

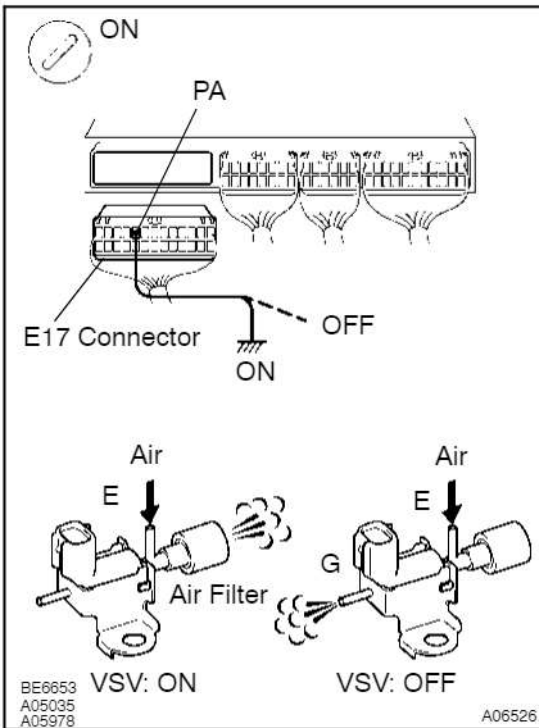

### PREPARATION:

- Remove the glove compartment door.
- Disconnect the "E17" connector of engine ECU.
- Turn the ignition switch ON.

### CHECK:

Check VSV function

- Connect between terminal PA of engine ECU and body ground (VSV is ON).
- Disconnect between terminal PA of engine ECU and body ground (VSV is OFF).

### OK:

**VSV is ON:**

Air from pipe E flows out through the air filter.

**VSV is OFF:**

Air from pipe E flows out through pipe G.

OK

Check and replace engine ECU  
(See page IN-19).

NG

## 8 Check for open and short in harness and connector between engine ECU and VSV for turbo pressure sensor and ECD main relay (Marking: ECD) (See page IN-19).

NG

Repair harness or connector.

OK

Replace VSV for turbo pressure sensor.

<b>DTC</b>	<b>39</b>	<b>Fuel Temp. Sensor Circuit Malfunction</b>
------------	-----------	--

**CIRCUIT DESCRIPTION**

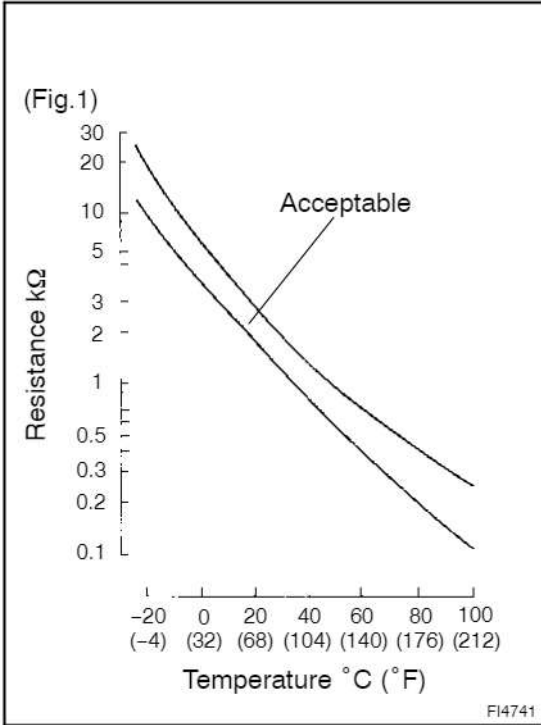

The fuel temperature sensor senses the fuel temperature. A thermistor built into the sensor changes the resistance value according to the fuel temperature. The lower the fuel temperature, the greater the thermistor resistance value, and the higher the fuel temperature, the lower the thermistor resistance value (See Fig.1).

The fuel temperature sensor is connected to the engine ECU (See below). The 5 V power source voltage in the engine ECU is applied to the fuel temperature sensor from the terminal THF via a resistor R. That is, the resistor R and the fuel temperature sensor are connected in series. When the resistance value of the fuel temperature sensor changes in accordance with changes in the fuel temperature, the potential at the terminal THF also changes. Based on this signal, the engine ECU increases the fuel injection volume to improve driveability during low engine revolution and high fuel temperature.

DTC No.	DTC Detecting Condition	Trouble Area
39	Open or short in fuel temp. sensor circuit for 0.5 sec. or more	<ul style="list-style-type: none"> <li>• Open or short in fuel temp. sensor circuit</li> <li>• Fuel temp. sensor</li> <li>• Engine ECU</li> </ul>

**HINT:**

After confirming DTC 39, use the hand-held tester to confirm the water temperature from "CURRENT DATA".

Temperature displayed	Malfunction
-40°C (-40°F)	Open circuit
140°C (284°F) or more	Short circuit

**WIRING DIAGRAM**

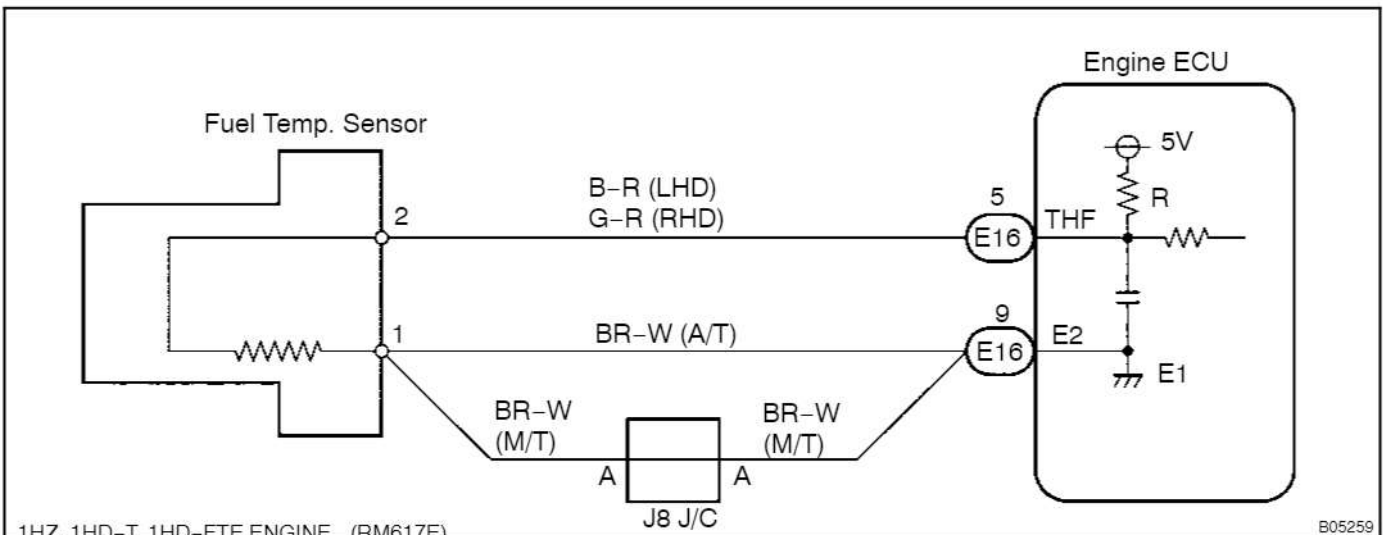

## INSPECTION PROCEDURE

HINT:

If DTC "22" (Water Temp. Sensor Circuit Malfunction), "24" (Intake Air Temp. Sensor Circuit Malfunction), "35" (Turbo Pressure Sensor Circuit Malfunction) and "39" (Fuel Temp. Sensor Malfunction) are output simultaneously, E2 (sensor ground) may be open.

### When using hand-held tester

<b>1</b>	<b>Connect the hand-held tester, and read value of fuel temperature.</b>
----------	--

#### PREPARATION:

- (a) Connect the hand-held tester to the DLC3.
- (b) Turn the ignition switch ON and push the hand-held tester main switch ON.

#### CHECK:

Read temperature value on the hand-held tester.

#### OK:

**Same as actual fuel temperature.**

HINT:

- If there is open circuit, hand-held tester indicates  $-40^{\circ}\text{C}$  ( $-40^{\circ}\text{F}$ ).
- If there is short circuit, hand-held tester indicates  $140^{\circ}\text{C}$  ( $284^{\circ}\text{F}$ ) or more.

**NG**

$-40^{\circ}\text{C}$  ( $-40^{\circ}\text{F}$ ) ... Go to step 2.  
 $140^{\circ}\text{C}$  ( $284^{\circ}\text{F}$ ) or more ... Go to step 4.

**OK**

**Check for intermittent problems (See page DI-4).**



## 2 Check for open in harness or engine ECU.

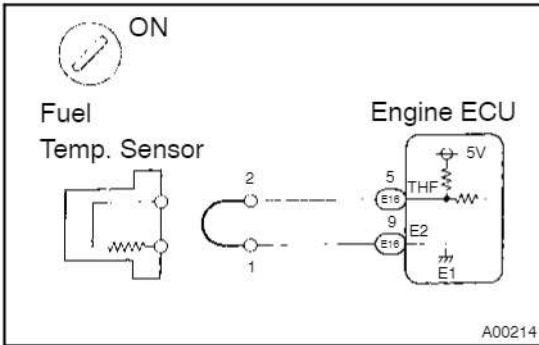

### PREPARATION:

- Disconnect the fuel temp. sensor connector.
- Connect sensor wire harness terminals together.
- Turn the ignition switch ON.

### CHECK:

Read temperature value on the hand-held tester.

### OK:

Temperature value: 140°C (284°F) or more

OK

Confirm good connection at sensor.  
If OK, replace fuel temp. sensor.

NG

## 3 Check for open in harness or engine ECU.

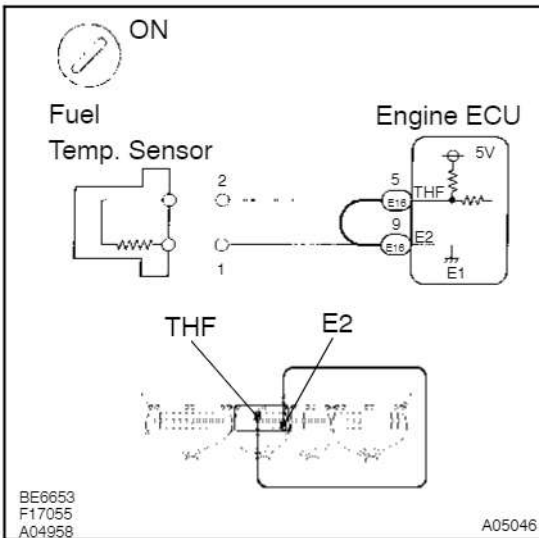

### PREPARATION:

- Remove the glove compartment door.
- Connect between terminals THF and E2 of engine ECU connector.

### HINT:

Fuel temp. sensor connector is disconnected. Before checking, do a visual and contact pressure check for the engine ECU connector (See page IN-19).

- Turn the ignition switch ON.

### CHECK:

Read temperature value on the hand-held tester.

### OK:

Temperature value: 140°C (284°F) or more

OK

Open in harness between terminal E2 or THF, repair or replace harness.

NG

Confirm good connection at engine ECU. If OK, replace engine ECU.

#### 4 Check for short in harness or engine ECU.

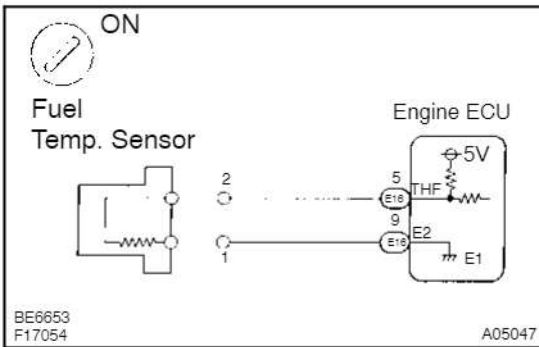

#### PREPARATION:

- Disconnect the fuel temp. sensor connector.
- Turn the ignition switch ON.

#### CHECK:

Read temperature value on the hand-held tester.

#### OK:

Temperature value:  $-40^{\circ}\text{C}$  ( $-40^{\circ}\text{F}$ )

OK

Replace fuel temp. sensor.

NG

#### 5 Check for short in harness or engine ECU.

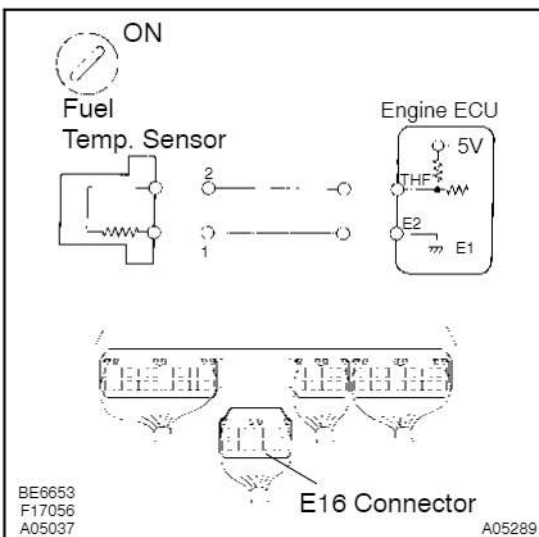

#### PREPARATION:

- Remove the glove compartment door.
- Disconnect the "E16" connector of engine ECU.

#### HINT:

Fuel temp. sensor connector is disconnected.

- Turn the ignition switch ON.

#### CHECK:

Read temperature value on the hand-held tester.

#### OK:

Temperature value:  $-40^{\circ}\text{C}$  ( $-40^{\circ}\text{F}$ )

OK

Repair or replace harness or connector.

NG

Check and replace engine ECU (See page IN-19).

## When not using hand-held tester

1 Check voltage between terminals THF and E2 engine ECU connector.

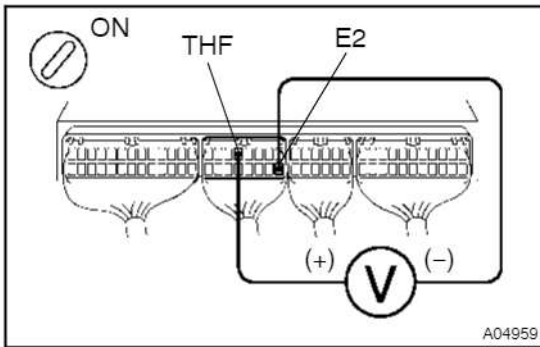

### PREPARATION:

- (a) Remove the glove compartment door.
- (b) Turn the ignition switch ON.

### CHECK:

Measure voltage between terminals THF and E2 of engine ECU connector.

### OK:

Fuel temp. °C (°F)	Voltage
20 (68) (Engine is cool)	0.2 – 3.8 V
80 (176) (Engine is hot)	0.1 – 1.5 V

OK

Check for intermittent problems  
(See page DI-4).

NG

2 Check fuel temp. sensor (See page ED-6).

NG

Replace fuel temp. sensor.

OK

3 Check for open and short in harness and connector between engine ECU and fuel temp. sensor (See page IN-19).

NG

Repair or replace harness or connector.

OK

Check and replace engine ECU (See page IN-19).

<b>DTC</b>	<b>42</b>	<b>Vehicle Speed Sensor Signal Circuit Malfunction</b>
------------	-----------	--

**CIRCUIT DESCRIPTION**

The vehicle speed sensor outputs a 4-pulse signal for every revolution of the rotor shaft, which is rotated by the transmission output shaft via the driven gear. After this signal is converted into a more precise rectangular waveform by the waveform shaping circuit inside the combination meter, it is then transmitted to the engine ECU. The engine ECU determines the vehicle speed based on the frequency of these pulse signals.

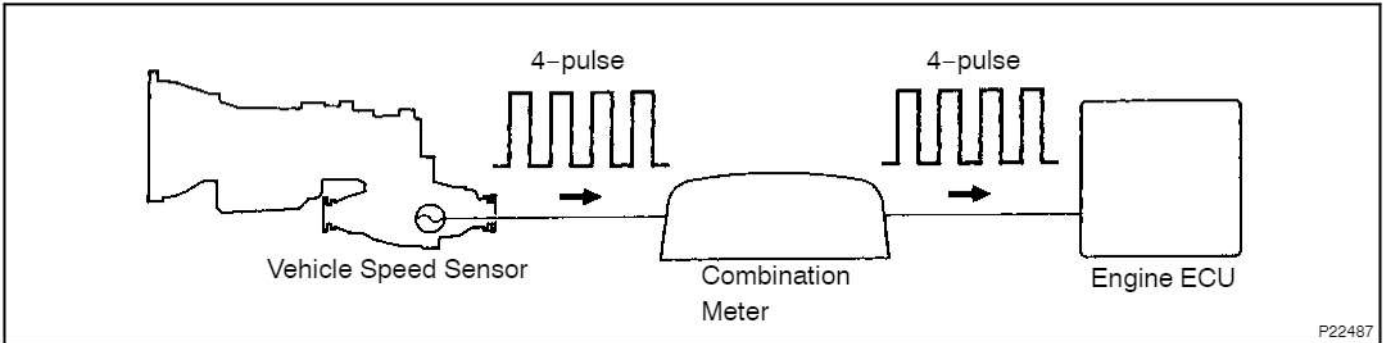

DTC No.	DTC Detecting Condition	Trouble Area
42	All conditions below are detected continuously for 8 sec. or more: (a) Vehicle speed signal: 0 km/h (0 mph) (b) Engine speed: 2,400 ~ 4,000 rpm (c) Engine coolant temp.: 60°C (176°F) or more (d) Accelerator pedal opening angle : 60 % or more	<ul style="list-style-type: none"> <li>• Open or short in vehicle speed sensor circuit</li> <li>• Vehicle speed sensor</li> <li>• Combination meter</li> <li>• Engine ECU</li> </ul>

**WIRING DIAGRAM**

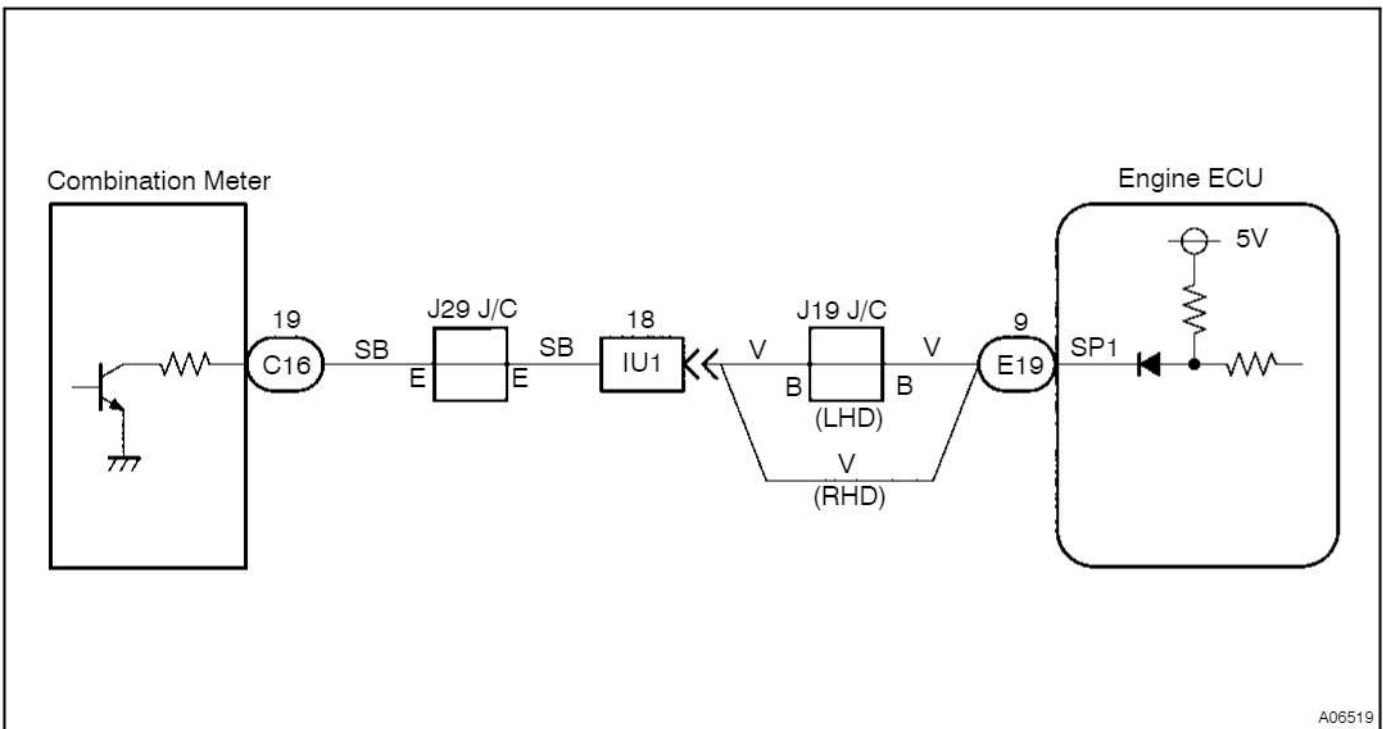

## INSPECTION PROCEDURE

## 1 Check operation of speedometer.

**CHECK:**

Drive the vehicle and check if the operation of the speedometer in the combination meter is normal.

**HINT:**

The vehicle speed sensor is operating normally if the speedometer display is normal.

NG

Check speedometer.

OK

## 2 Check voltage between terminal SP1 of engine ECU and body ground.

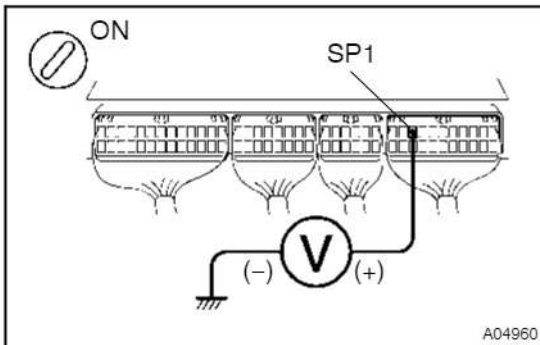
**PREPARATION:**

- Remove the glove compartment door.
- Shift the shift lever to neutral.
- Jack up one of the front wheels.
- Turn the ignition switch ON.

**CHECK:**

Measure voltage between terminal SP1 of engine ECU and body ground when the wheel is turned slowly.

**OK:**

**Voltage is generated intermittently.**

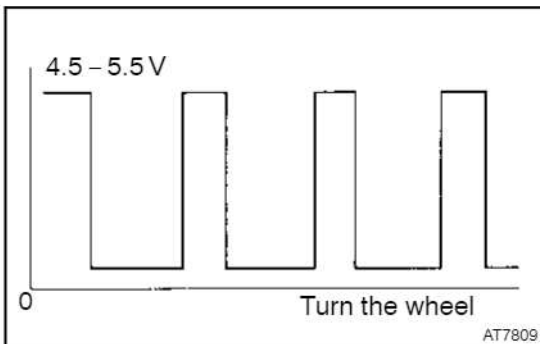

NG

**Check and repair harness and connector between combination meter and engine ECU (See page IN-19).**

OK

**Check and replace engine ECU (See page IN-19).**

<b>DTC</b>	<b>97</b>	<b>EDU Circuit Malfunction</b>
------------	-----------	--------------------------------

## CIRCUIT DESCRIPTION

The EDU has been adopted to drive the spill control valve at high speeds. The EDU has realized high-speed driving under high fuel pressure conditions through the use of a DC/DC converter that provides a high-voltage, quick-charging system.

The engine ECU constantly monitors the EDU and stops the engine in case an abnormal condition is detected.

The battery voltage is increased by the DC/DC converter. A voltage of approximately 150 V is applied to the spill control valve in accordance with the IJ+ signal received from the engine ECU. Also at this time, the injection verification signal (IJf) is sent to the engine ECU.

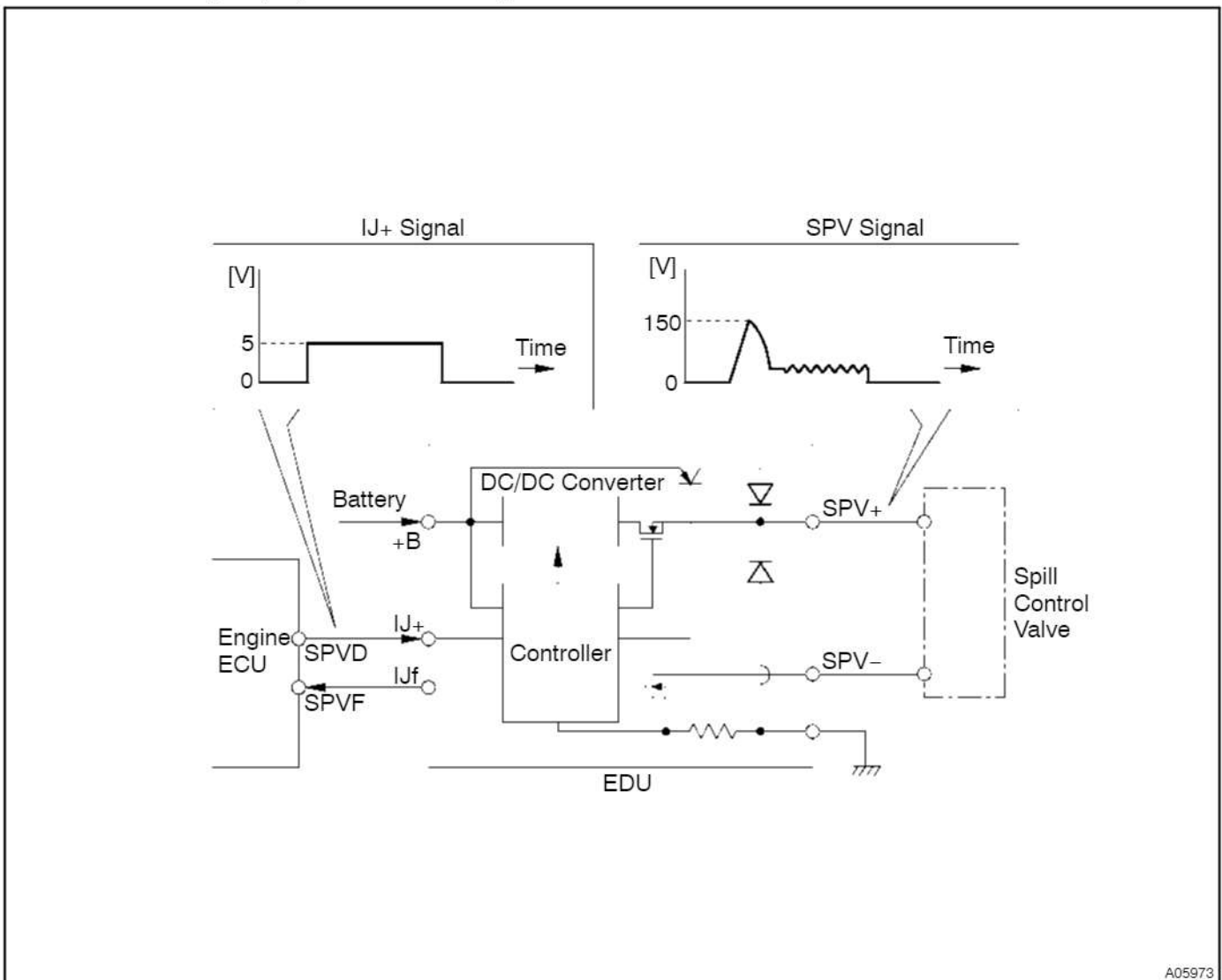

A05973

DTC No.	DTC Detecting condition	Trouble Area
97	Although the SPVD is output to EDU with the engine speed at 500 rpm or more, the SPVF is not input continuously 5 times or more	<ul style="list-style-type: none"> <li>• Open or short in EDU circuit</li> <li>• EDU</li> <li>• Spill control valve</li> </ul>

## WIRING DIAGRAM

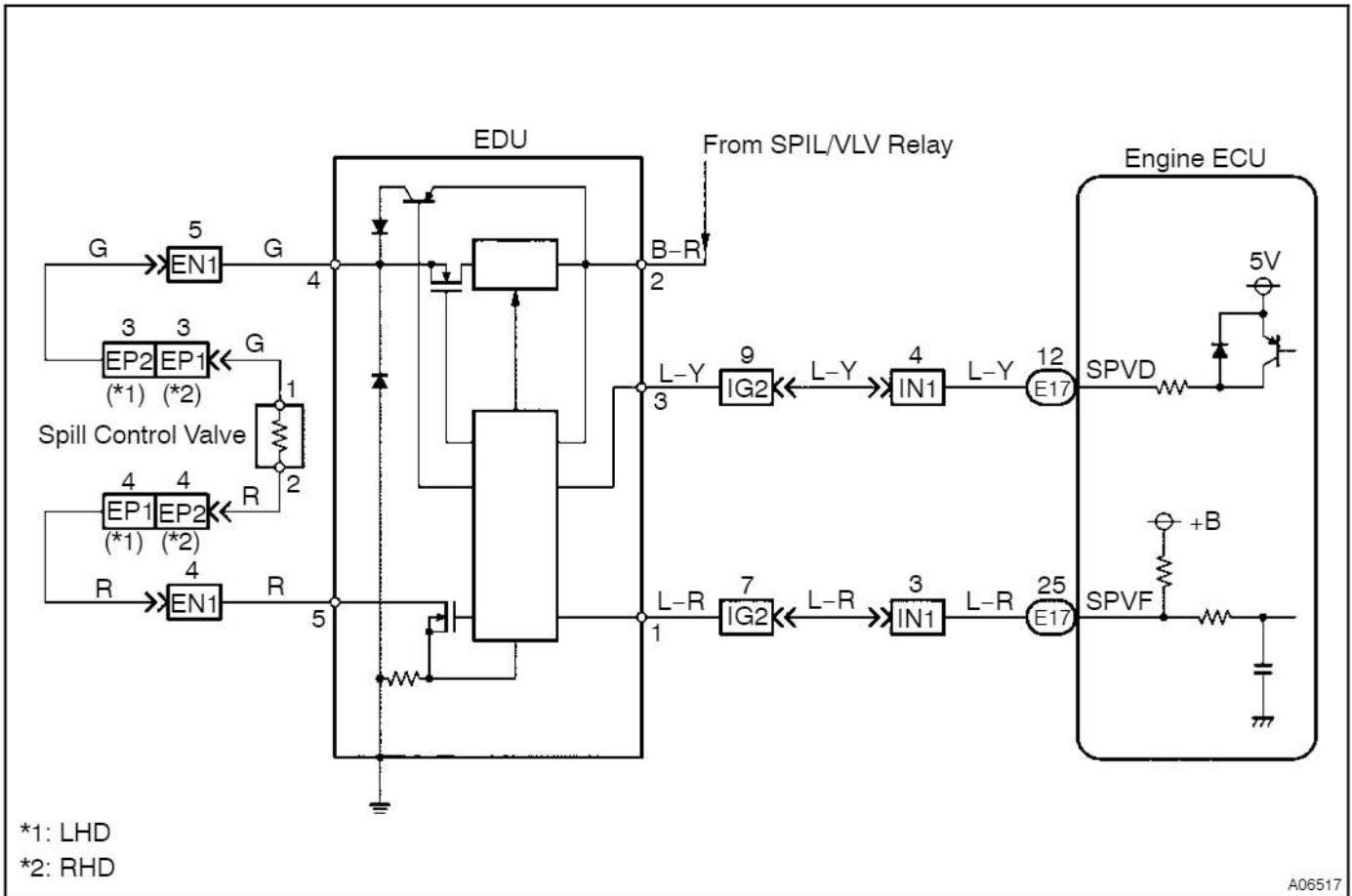

## INSPECTION PROCEDURE

- 1 Check voltage between terminal 2 of wire harness side connector and body ground.

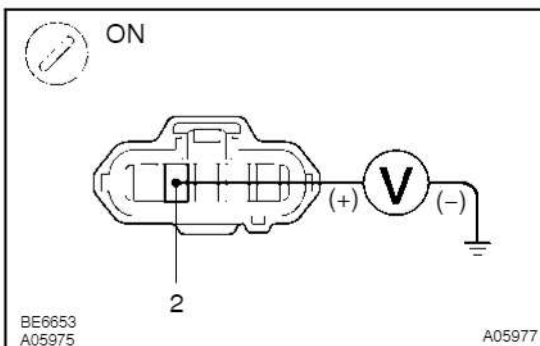
**PREPARATION:**

- Disconnect the EDU connector.
- Turn the ignition switch ON.

**CHECK:**

Measure voltage between terminal 2 of wire harness side connector and body ground.

**OK:**

**Voltage: 10 - 14 V**

**NG**

**Check ECU power source circuit  
(See page DI-76).**

**OK**

2 Check continuity EDU ground bolt and body ground.

NG

Tighten EDU ground bolt.

OK

3 Check resistance between terminals 4 and 5 of wire harness side connector.

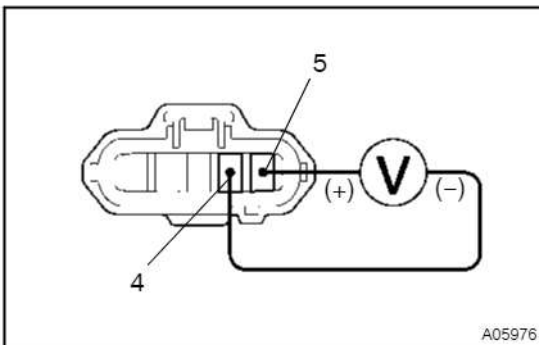

**CHECK:**

Measure resistance between terminals 4 and 5 of wire harness side connector.

**OK:**

Resistance: Approx. 1.7  $\Omega$

OK

Go to step 6.

NG

4 Check spill control valve (See page FU-113).

NG

Check and replace injection pump (See page FU-113).

OK

5 Check for open and short in harness and connector between spill control valve and EDU. (See page IN-19).

NG

Repair or replace harness or connector.

OK



- 6 Check for open and short in harness and connector between engine ECU and EDU (See page IN-19).

NG

Repair or replace harness or connector.

OK

- 7 Check voltage between terminal SPVD of engine ECU connector and body ground.

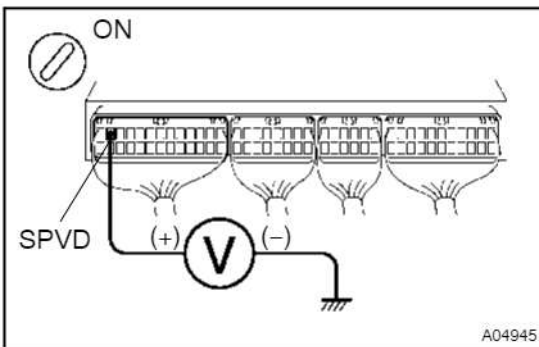
**PREPARATION:**

- (a) Remove the glove compartment door.  
 (b) Turn the ignition switch ON.

**CHECK:**

Measure voltage between terminal SPVD of engine ECU connector and body ground.

**OK:**

**Voltage: Approx. 0 V**

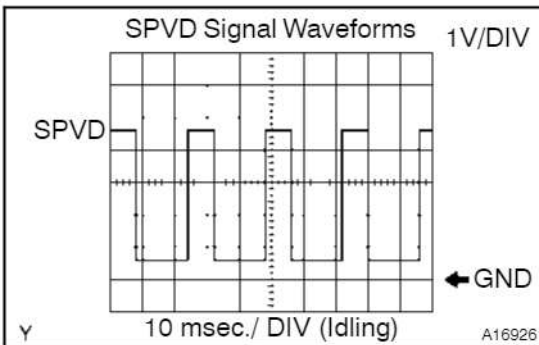
**Reference: INSPECTION USING OSCILLOSCOPE**

During idling, check waveform between terminals SPVD and E1 of engine ECU.

**HINT:**

The correct waveform is as shown.

NG

Check and replace engine ECU (See page IN-19).

OK

## 8 Check voltage between terminal SPVF of engine ECU and body ground.

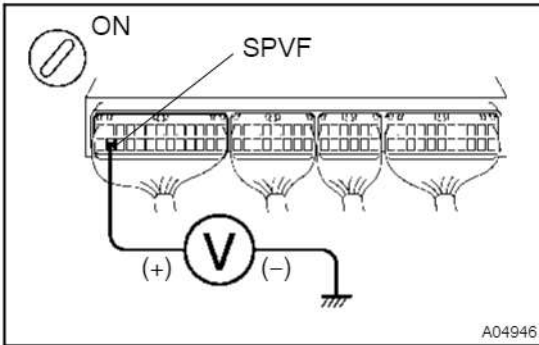

### PREPARATION:

- Remove the glove compartment door.
- Turn the ignition switch ON.

### CHECK:

Measure voltage between terminals SPVF of engine ECU and body ground.

### OK:

**Voltage: 9 - 14 V**

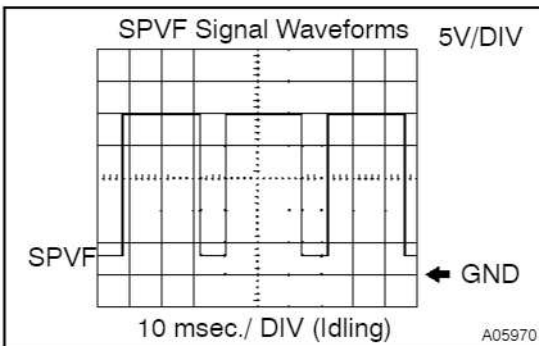

### Reference: INSPECTION USING OSCILLOSCOPE

During idling, check waveform between terminals SPVF and E1 of engine ECU.

### HINT:

The correct waveform is as shown.

NG

Check and replace engine ECU  
(See page IN-19).

OK

Check and replace EDU (See page ED-15).

## ECU Power Source Circuit

### CIRCUIT DESCRIPTION

When the ignition switch is turned ON, battery positive voltage is applied to the coil, closing the contacts of the ECD main relay (Marking: ECD) and supplying power to the terminal +B of the engine ECU.

### WIRING DIAGRAM

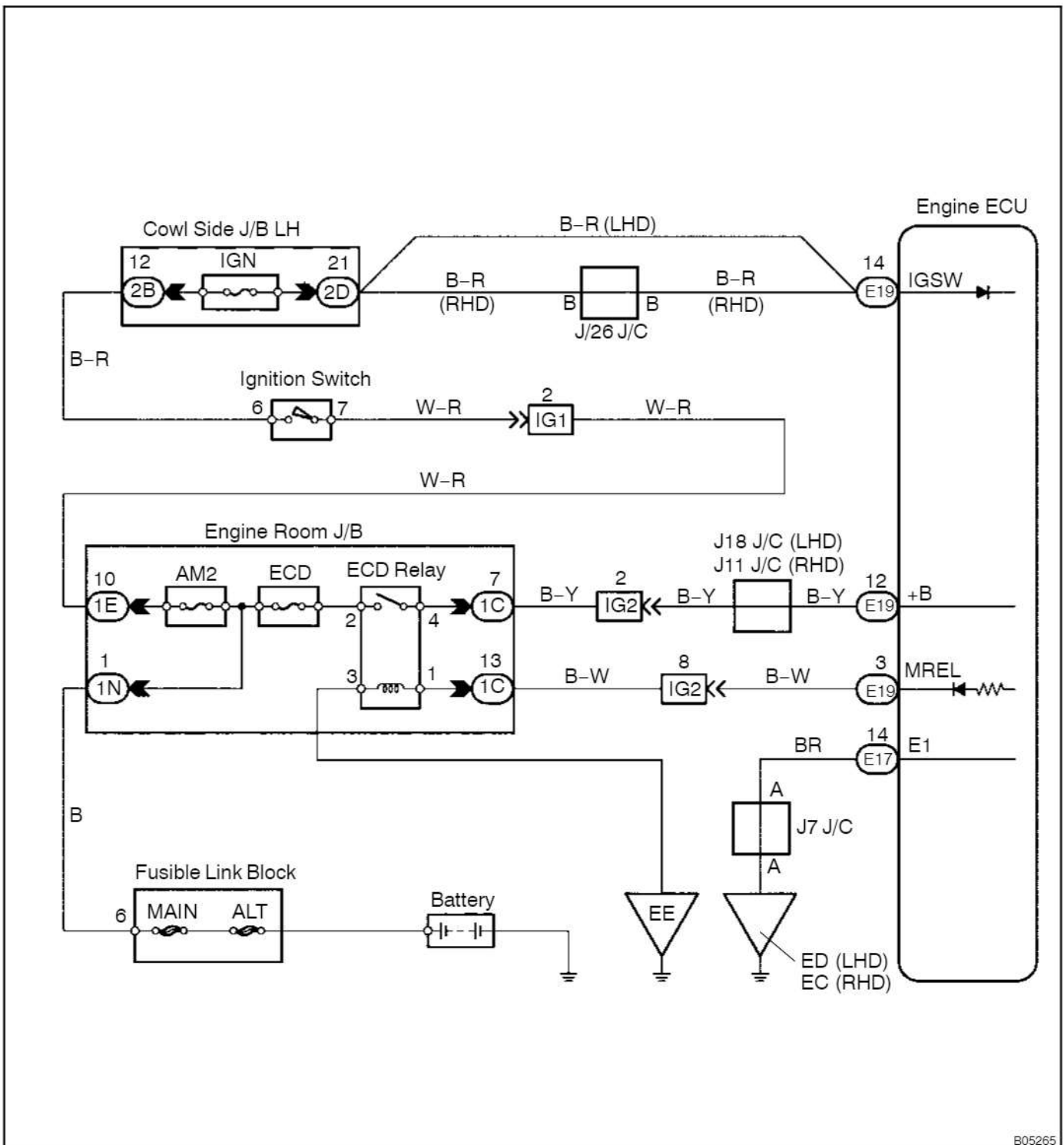

B05265

## INSPECTION PROCEDURE

1 Check voltage between terminals +B and E1 of engine ECU.

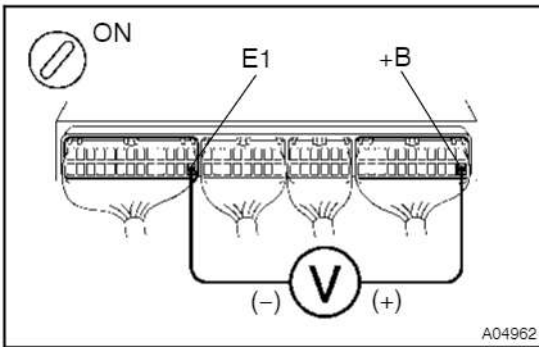
**PREPARATION:**

- (a) Remove the glove compartment door.
- (b) Turn the ignition switch ON.

**CHECK:**

Measure voltage between terminals +B and E1 of engine ECU.

**OK:**

**Voltage: 9 – 14 V**

OK

Proceed to next circuit inspection shown on problem symptoms table (See page DI-19).

NG

2 Check for open in harness and connector between terminal E1 of engine ECU and body ground (See page IN-19).

NG

Repair or replace harness or connector.

OK

3 Check ECD main relay (Marking: ECD) (See page ED-3).

NG

Replace ECD main relay.

OK

#### 4 Check ECD fuse.

##### **PREPARATION:**

Remove the ECD fuse from the engine room J/B.

##### **CHECK:**

Check continuity of ECD fuse.

##### **OK:**

Continuity

NG

Check for short in all the harness and components connected to ECD fuse.

OK

#### 5 Check for open in harness and connector between engine ECU and ECD main relay (Marking: ECD), ECD main relay and battery (See page IN-19).

NG

Repair harness or connector.

OK

#### 6 Check voltage between terminals IGSW and E1 of engine ECU.

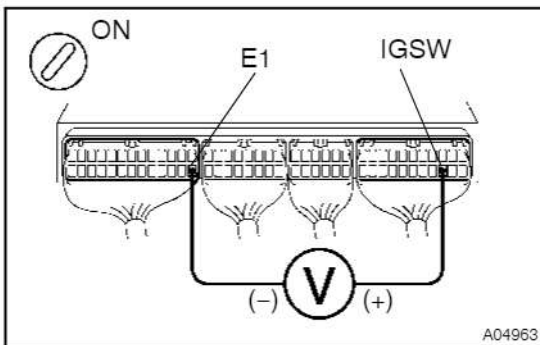

##### **PREPARATION:**

- Remove the glove compartment door.
- Turn the ignition switch ON.

##### **CHECK:**

Measure voltage between terminals IGSW and E1 of engine ECU.

##### **OK:**

Voltage : 9 - 14 V

OK

Go to step 9.

NG

7 Check ignition switch (See Pub. No. RM616E2 BE section).

NG

Replace ignition switch.

OK

8 Check for open in harness and connector between ignition switch and engine ECU (See page IN-19).

NG

Repair or replace harness or connector.

OK

9 Check voltage between terminal MREL of engine ECU and body ground.

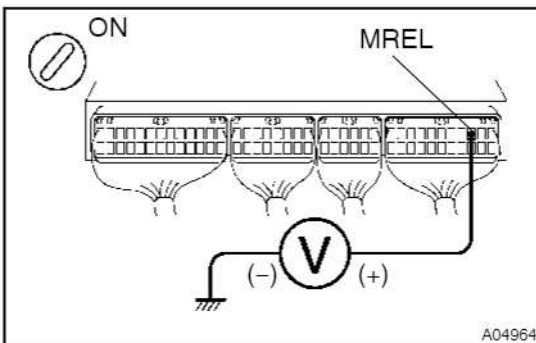

**PREPARATION:**

- Remove the glove compartment door.
- Turn the ignition switch ON.

**CHECK:**

Measure voltage between terminal MREL of engine ECU and body ground.

**OK:**

**Voltage: 9 - 14 V**

OK

Check and replace engine ECU (See page IN-19).

NG

Check for open in harness and connector between engine ECU and ECD main relay (Marking: ECD), ECD main relay and body ground (See page IN-19).

# Intake Heater Control Circuit

## CIRCUIT DESCRIPTION

When the engine coolant temperature is below 40°C (104°F), turning the ignition switch ON causes the intake heater relay to turn ON, allowing the intake heater to operate. The intake heater operates until the engine coolant temperature becomes higher than 40°C (104°F), or the maximum of 90 seconds.

At the same time, the glow indicator lamp is illuminated in accordance with the engine coolant temperature (maximum 10 seconds).

## WIRING DIAGRAM

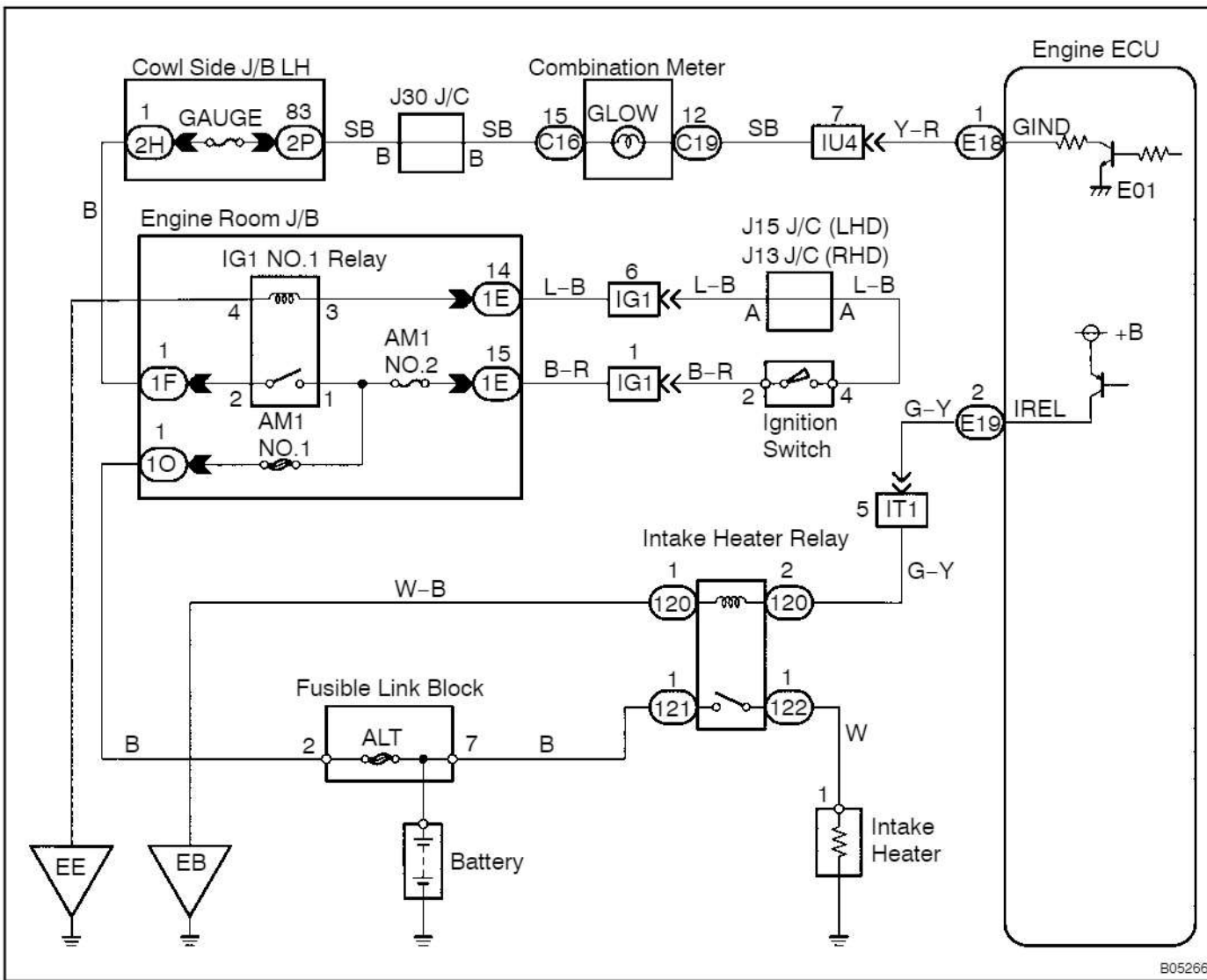

cardiagn.com

**INSPECTION PROCEDURE**

<b>1</b>	<b>Does glow indicator light up?</b>
----------	--------------------------------------

**PREPARATION:**

Turn the ignition switch ON.

**CHECK:**

Does the glow indicator light up?

**OK:**

The glow indicator lights up for 0.5 sec. or more.

OK

Go to step 5.

NG

<b>2</b>	<b>Check voltage between terminal GIND of engine ECU connector and body ground.</b>
----------	---

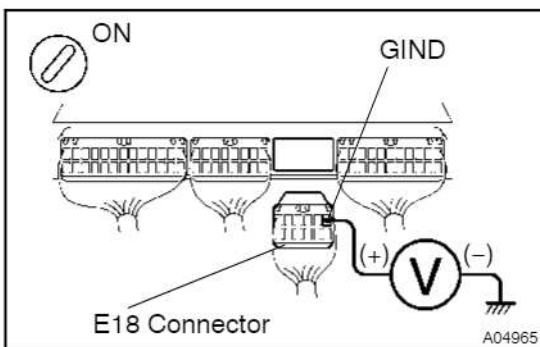
**PREPARATION:**

- Remove the glove compartment door.
- Disconnect the "E18" connector of engine ECU.
- Turn the ignition switch ON.

**CHECK:**

Measure voltage between terminal GIND of engine ECU connector and body ground.

**OK:**

**Voltage: 9 - 14 V**

OK

Check and replace engine ECU  
(See page IN-19).

NG



**3 Check GAUGE fuse.****PREPARATION:**

Remove the GAUGE fuse from the cowl side J/B LH.

**CHECK:**

Measure continuity of GAUGE fuse.

**OK:**

Continuity

**NG**

Check for short in all the harness and components connected to GAUGE fuse.

**OK****4 Check glow indicator light bulb.****NG**

Replace bulb.

**OK**

Check for open in harness and connector between combination meter and engine ECU, combination meter and GAUGE fuse ([See page IN-19](#)).

**5 Check glow indicator lighting time ([See page ST-1](#)).****NG**

Check and replace engine ECU ([See page IN-19](#)).

**OK**

6 Are there any DTC being output?

YES

Go to relevant DTC chart (See page DI-14).

NO

7 Check intake heater relay (See page ST-7).

NG

Replace intake heater relay.

OK

8 Check voltage between terminal IREL of engine ECU and body ground at cranking.

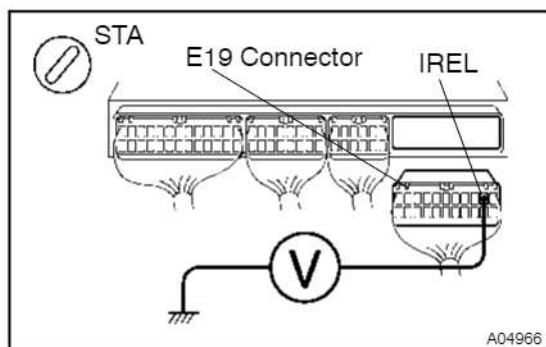

**PREPARATION:**

- Remove the glove compartment door.
- Disconnect the "E19" connector of engine ECU.
- Start the engine.

**CHECK:**

Measure voltage between terminal IREL of engine ECU and body ground at cranking.

**OK:**

**Voltage: 9 - 14 V**

NG

Check and replace engine ECU (See page IN-19).

OK

9 Check for open and short in harness and connector between intake heater relay and engine ECU, intake heater relay and body ground (See page IN-19).

NG

Repair harness or connector.

OK

10 Check resistance of intake heater (See page ST-5).

NG

Replace intake heater.

OK

11 Inspect intake heater installation.

NG

Tighten intake heater.

OK

12 Check for open in harness and connector between intake heater relay and intake heater (See page IN-19).

NG

Repair harness or connector.

OK

Proceed to next circuit inspection shown on problem symptoms table (See page DI-19).

## EGR Control Circuit

### CIRCUIT DESCRIPTION

The EGR system recirculates exhaust gas, which is controlled to the proper quantity to suit the driving conditions into the intake air mixture to slow down combustion, reduce the combustion temperature and reduce NOx emissions,

The lift amount of EGR valve is controlled by the vacuum which is regulated by the E-VRV operated by the engine ECU.

If even one of the following conditions is fulfilled, the VSV is turned ON by a signal from the ECU. This results in atmospheric air acting on the EGR valve, closing the EGR valve and shutting off the exhaust gas (EGR cut-off).

Under the following conditions, EGR is cut to maintain driveability.

- Before the engine is warmed up
- During deceleration (Diesel throttle valve closed)
- Light engine load (amount of intake air very small)
- Engine speed over 3,000 rpm

### WIRING DIAGRAM

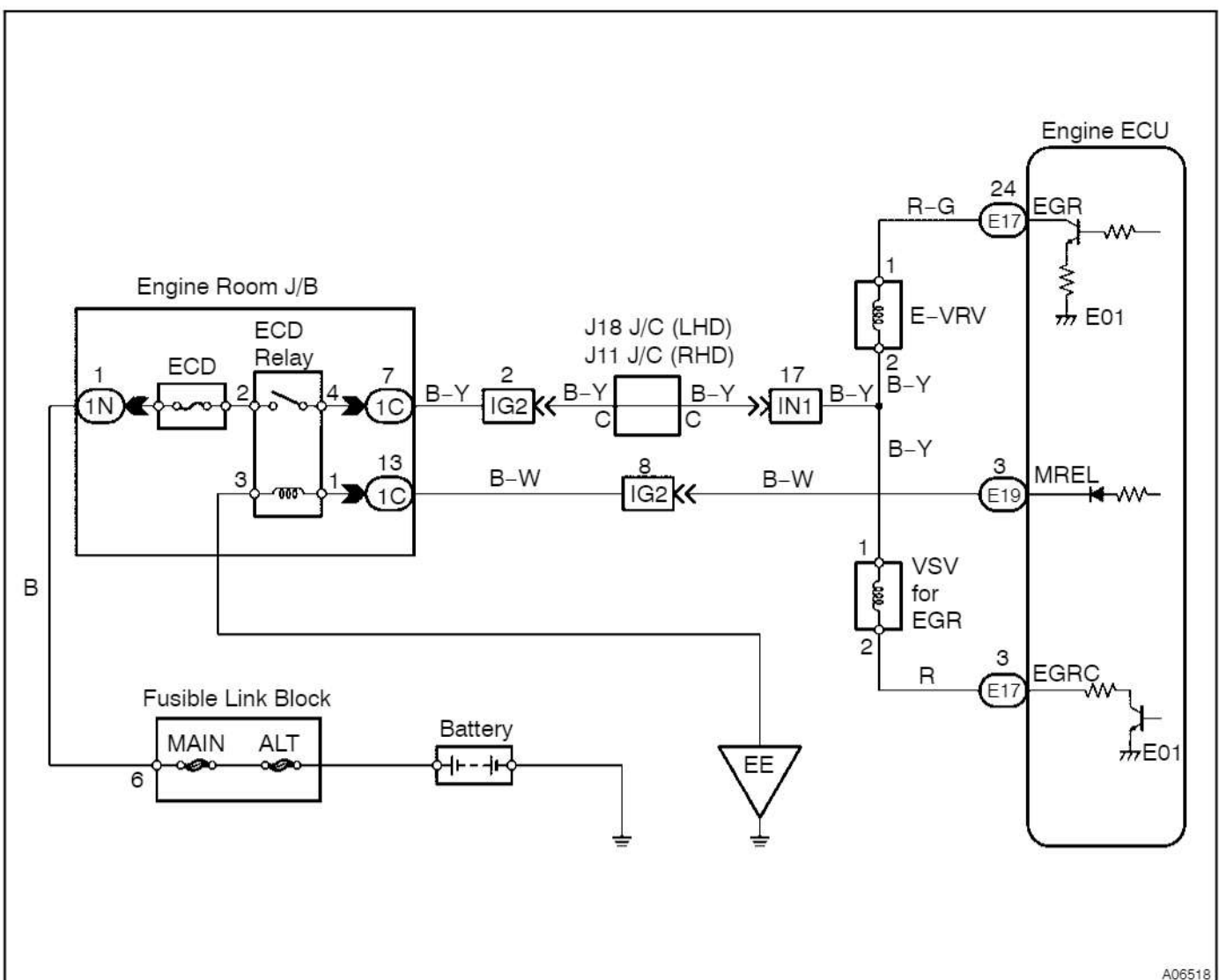

**INSPECTION PROCEDURE****When using hand-held tester**

1 Check the connection of vacuum hose.

NG

Repair or replace.

OK

2 Check the vacuum between EGR valve and VSV for EGR at 1,500 rpm.

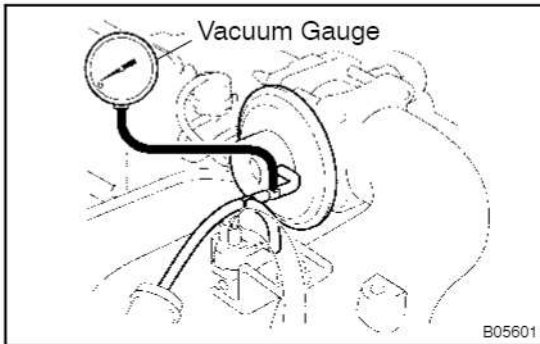
**PREPARATION:**

- (a) Using a 3-way connector, connect a vacuum gauge to the hose between the VSV and EGR valve.  
 (b) Warm up the engine to above 80°C (176°F).

**CHECK:**

Check the vacuum at 1,500 rpm.

**RESULT:**

Type	Vacuum
I	0 kPa (0 mmHg, 0 in. Hg)
II	0 kPa (0 mmHg, in. Hg) ~ 28 kPa (210 mmHg, 8.3 in. Hg)
III	Above 28 kPa (210 mmHg, 8.3 in. Hg)

Type I

Go to step 7.

Type III

Go to step 10

Type II

### 3 Check the VSV circuit for EGR.

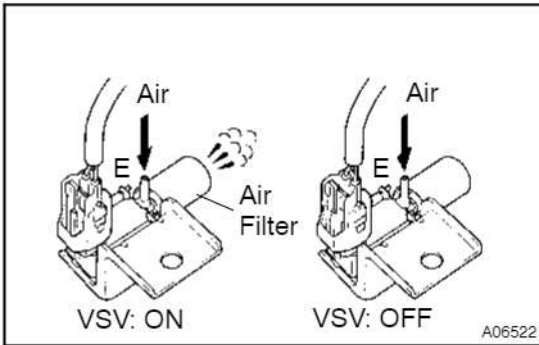

#### PREPARATION:

- Disconnect the vacuum hose from the VSV for EGR.
- Connect the hand-held tester to the DLC3.
- Turn the ignition switch ON and push the hand-held tester main switch ON.
- Select the ACTIVE TEST mode on the hand-held tester.

#### CHECK:

Check operation of VSV for EGR, when it is operated by the hand-held tester.

#### OK:

**VSV is ON:**

**Air from pipe E flows out through air filter.**

**VSV is OFF:**

**Air does not flow from pipe E to air filter.**

OK

Check the connection, damage and blockage of vacuum hose.

NG

### 4 Check VSV for EGR (See page EC-9).

NG

Replace VSV for EGR.

OK

**5 Check voltage between terminal EGR of engine ECU and body ground.**

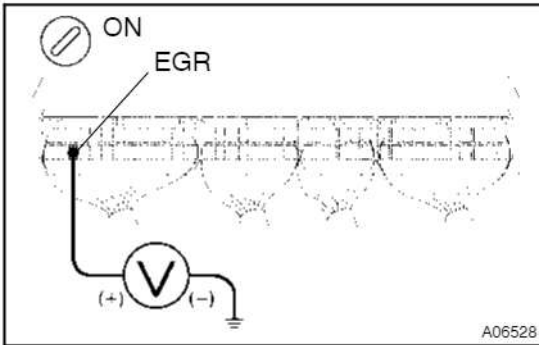

**PREPARATION:**

- Remove the glove compartment door.
- Turn the ignition switch ON.

**CHECK:**

Measure voltage between terminal EGR of engine ECU and body ground.

**OK:**

**Voltage: 9 - 14 V**

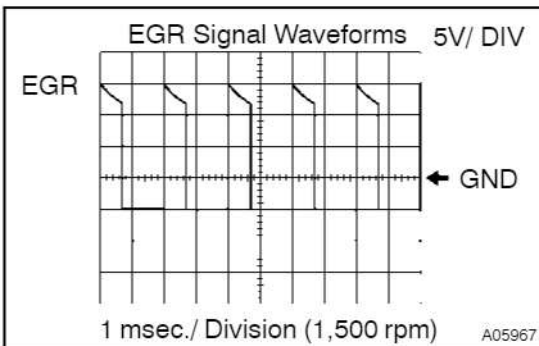

**Reference: INSPECTION USING OSCILLOSCOPE**

During EGR system is ON (engine speed 1,500 rpm), check waveform between terminals EGR and E1 of engine ECU.

**HINT:**

The correct waveform is as shown.

**NG**

**Check and replace engine ECU**  
(See page IN-19).

**OK**

**6 Check for open and short in harness and connector between VSV for EGR and engine ECU (See page IN-19).**

**NG**

**Repair or replace harness or connector.**

**OK**

## 7 Check operation of E-VRV.

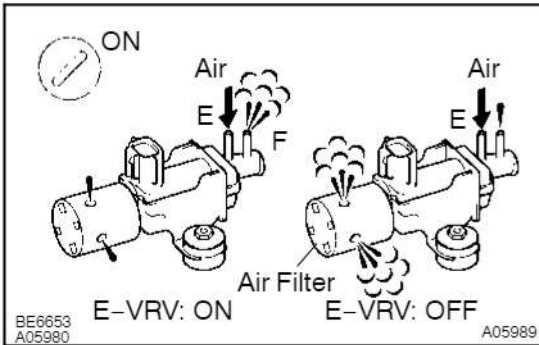

### PREPARATION:

- Disconnect the vacuum hoses from the E-VRV.
- Connect the hand-held tester to the DLC3.
- Turn the ignition switch ON and the push hand-held tester main switch ON.
- Select the ACTIVE TEST mode on the hand-held tester.

### CHECK:

Check operation of E-VRV, when it is operated by the hand-held tester.

### OK:

**E-VRV ON:**

Air from pipe E is flowing out through pipe F.

**E-VRV OFF:**

Air from pipe E is flowing out through air filter.

OK

Go to step 10.

NG

## 8 Check E-VRV for EGR (See page EC-9).

NG

Replace E-VRV.

OK

## 9 Check for open and short in harness and connector between E-VRV and engine ECU, E-VRV and ECD main relay (Marking : ECD) (See page IN-19).

NG

Repair or replace harness or connector.

OK



10 Check EGR valve (See page EC-9).

NG

Replace the EGR valve.

OK

Check and replace engine ECU (See page IN-19).

### When not using hand-held tester

1 Check the connection of vacuum hose.

NG

Repair or replace.

OK

2 Check the vacuum between EGR valve and VSV for EGR at 1,500 rpm (See page DI-85, Step 2).

Type I

Go to step 6.

Type III

Go to step 9.

Type II

3 Check VSV for EGR (See page EC-9).

NG

Replace VSV for EGR.

OK

- 4 Check voltage between terminal EGR of engine ECU and body ground  
(See page DI-85, Step 5).

NG

Check and replace engine ECU  
(See page IN-19).

OK

- 5 Check for open and short in harness and connector between VSV for EGR and engine ECU (See page IN-19).

NG

Repair or replace harness or connector.

OK

- 6 Check operation of E-VRV.

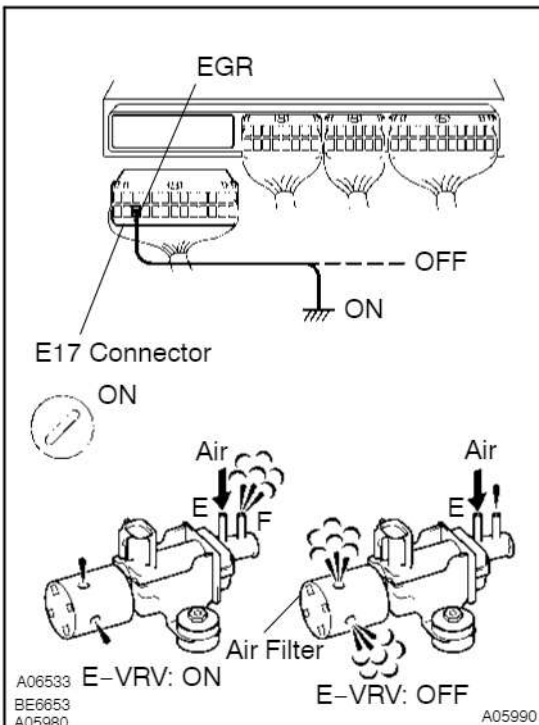
**PREPARATION:**

- Remove the glove compartment door.
- Disconnect the "E17" connector of engine ECU.
- Turn the ignition switch ON.

**CHECK:**

Check E-VRV operation.

- Connect between terminal EGR of engine ECU connector and body ground (ON).
- Disconnect between terminal EGR of engine ECU connector and body ground (OFF).

**OK:****E-VRV ON:**

Air from pipe E is flowing out through pipe F.

**E-VRV OFF:**

Air from pipe E is flowing out through air filter.

OK

Go to step 9.

NG

7 Check E-VRV (See page EC-9).

NG

Replace E-VRV.

OK

8 Check for open and short in harness and connector between E-VRV and engine ECU, E-VRV and ECD main relay (Marking : ECD) (See page IN-19).

NG

Repair or replace harness or connector.

OK

9 Check EGR valve (See page EC-9).

NG

Replace EGR valve.

OK

Check and replace engine ECU (See page IN-19).

## A/C Signal Circuit

### CIRCUIT DESCRIPTION

When the A/C compressor is ON, the A/C amplifier sends the A/C signal to the engine ECU, then engine ECU increases the fuel injection volume to improve driveability during engine idling.

### WIRING DIAGRAM

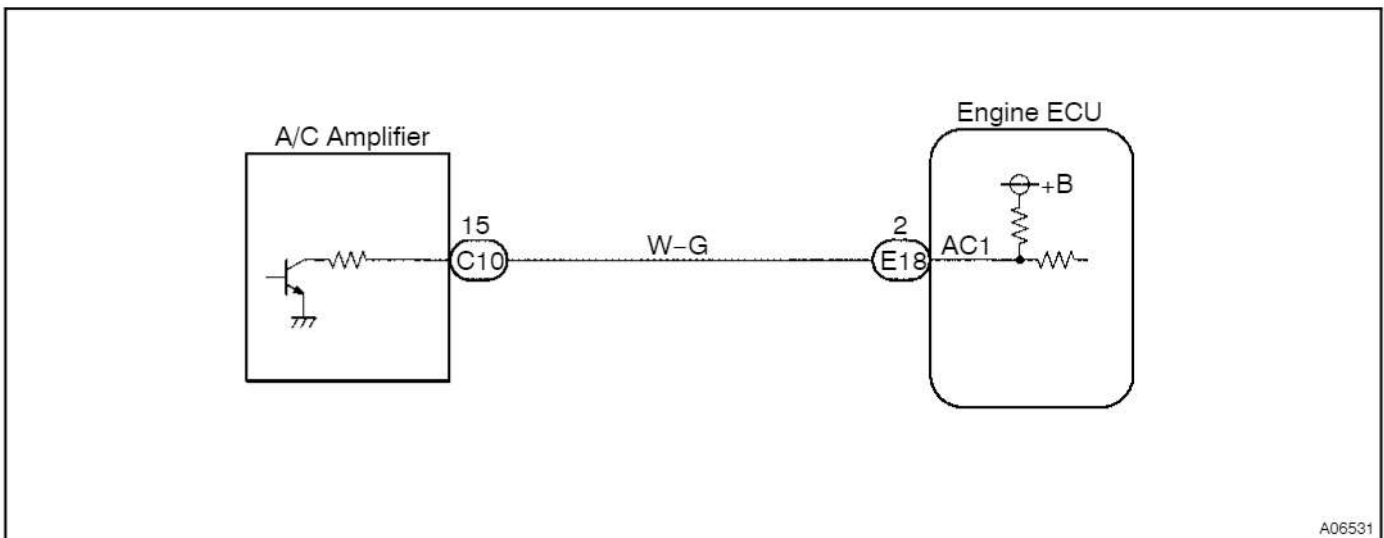

### INSPECTION PROCEDURE

#### When using hand-held tester

- 1 Connect the hand-held tester and check A/C signal.

#### PREPARATION:

- (a) Connect the hand-held tester to the DLC3.
- (b) Turn the ignition switch ON and push the hand-held tester main switch ON.

#### CHECK:

Read A/C signal on the hand-held tester while A/C compressor is ON.

#### OK:

A/C switch condition	OFF	ON
A/C signal	OFF	ON

OK

Proceed to next circuit inspection shown on problem symptoms table (See page DI-19).

NG

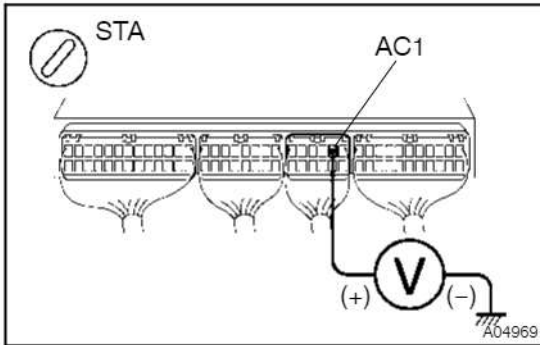
**2 Check voltage between terminal AC1 of engine ECU and body ground.**

**PREPARATION:**

- (a) Remove the glove compartment door.
- (b) Start the engine.

**CHECK:**

Measure voltage between terminal AC1 of engine ECU and body ground when A/C switch is turned to ON and OFF.

**OK:**

A/C switch condition	Voltage
ON	Below 1.5 V
OFF	9 - 14 V

**OK**

**Check and replace engine ECU**  
(See page IN-19).

**NG**
**3 Check for open and short in harness and connector between engine ECU and A/C amplifier (See page IN-19).**
**NG**

**Repair or replace harness or connector.**

**OK**

**Check and replace A/C amplifier.**

## When not using hand-held tester

1 Check voltage between terminal AC1 of engine ECU and body ground.

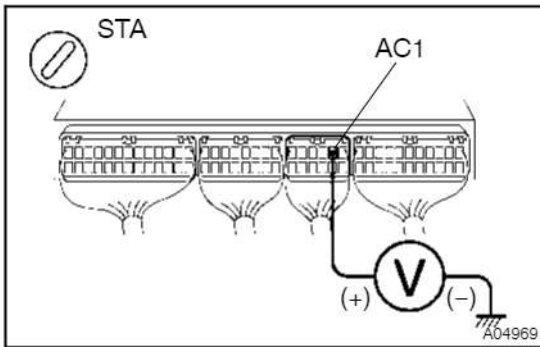

### PREPARATION:

- (a) Remove the glove compartment door.
- (b) Start the engine.

### CHECK:

Measure voltage between terminal AC1 of engine ECU and body ground when A/C switch is turned to ON and OFF.

### OK:

A/C switch condition	Voltage
ON	Below 1.5 V
OFF	9 - 14 V

OK

Proceed to next circuit inspection shown on problem symptoms table (See page DI-19).

NG

2 Check for open and short in harness and connector between engine ECU and A/C amplifier (See page IN-19).

NG

Repair or replace harness or connector.

OK

Check and replace A/C amplifier.

## A/C Cut Control Circuit

### CIRCUIT DESCRIPTION

This circuit cuts air conditioning operation during vehicle acceleration in order to increase acceleration performance. During acceleration with the vehicle speed at 30 km/h (19 mph) or less and accelerator pedal opening angle at 45° or more, the A/C magnetic switch is turned OFF for several seconds.

The air conditioning is also controlled by the ECU out putting the engine coolant temperature to A/C amplifier.

### WIRING DIAGRAM

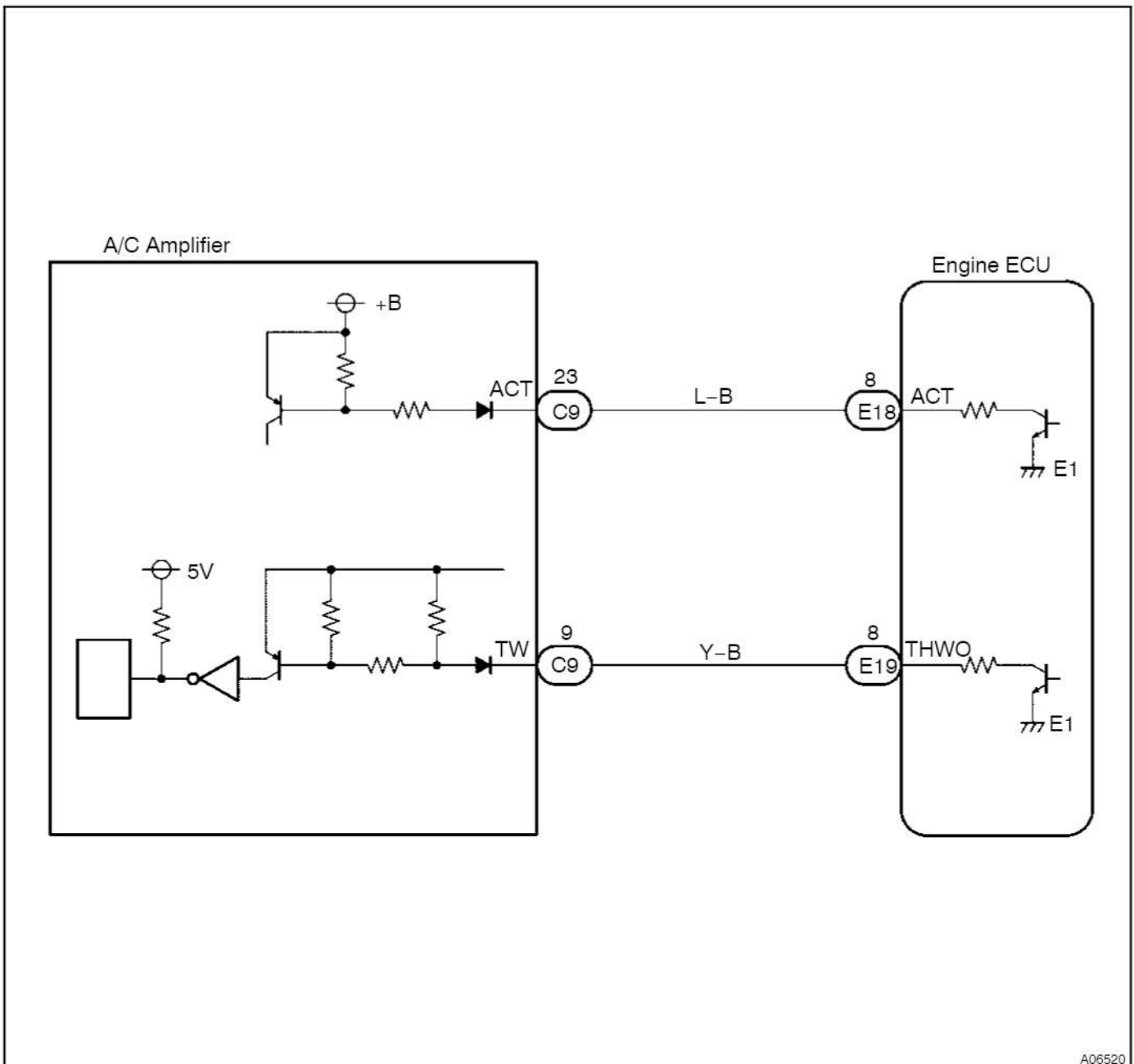

## INSPECTION PROCEDURE

### When using hand-held tester

<b>1</b>	<b>Connect the hand-held tester and check operation of air conditioning cut control.</b>
----------	--

#### PREPARATION:

- (a) Connect the hand held tester to the DLC3.
- (b) Turn the ignition switch ON and push the hand-held tester main switch ON.
- (c) Start the engine and air conditioning switch ON.

HINT:

A/C magnetic clutch is turned ON.

- (d) Select the ACTIVE TEST mode on the hand-held tester.

#### CHECK:

Check operation of A/C magnetic clutch cut when air conditioning cut control is operated by the hand-held tester.

#### OK:

A/C magnet clutch is turned OFF.

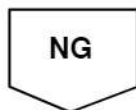
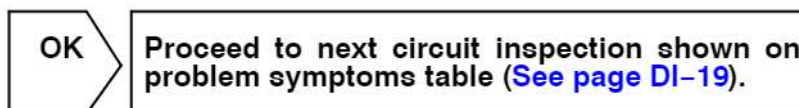

<b>2</b>	<b>Check for open and short in harness and connector between engine ECU and A/C amplifier (See page IN-19).</b>
----------	---





**3 Check voltage between terminal ACT of engine ECU and body ground.**

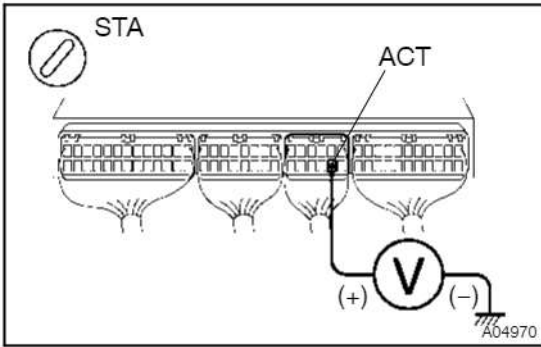

**PREPARATION:**

- (a) Remove the glove compartment door.
- (b) Start the engine.

**CHECK:**

Measure voltage between terminal ACT of engine ECU connector and body ground when A/C switch is turned to ON and OFF.

**OK:**

A/C switch condition	Voltage
ON	9 - 14 V
OFF	0 - 3 V

**NG** Check and replace A/C amplifier.

**OK**

**4 Check voltage between terminal THWO of engine ECU and body ground.**

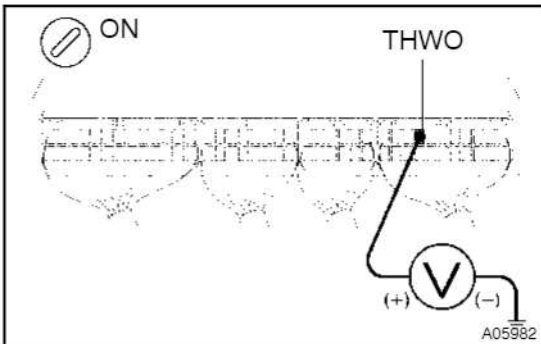

**PREPARATION:**

- (a) Remove the glove compartment door.
- (b) Turn the ignition switch ON.

**CHECK:**

Measure voltage between terminal THWO of engine ECU and body ground.

**OK:**

**Voltage is generated intermittently.**

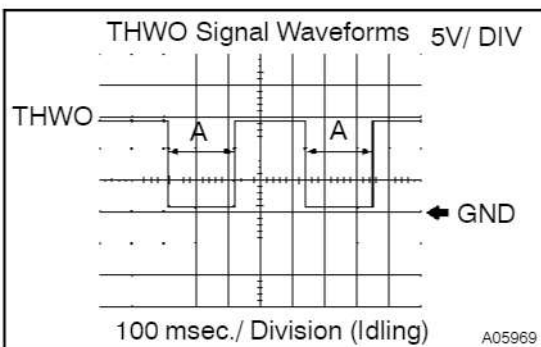

**Reference: INSPECTION USING OSCILLOSCOPE**

During idling, check waveform between terminals THWO and E1 of engine ECU.

**HINT:**

The correct waveform is as shown.

Water temp.	30°C or less	Approx. 75°C	90°C or more
A	65 msec.	335.8 msec.	393 msec.

**NG** Check and replace A/C amplifier.

**OK**

Check and replace engine ECU (See page IN-19).

### When not using hand-held tester

- 1 Check voltage between terminal ACT of engine ECU and body ground (See page DI-96, Step 3).

OK

Check and replace engine ECU (See page IN-19).

NG

- 2 Check voltage between terminal THWO of engine ECU and body ground (See page DI-96, Step 4).

OK

Check and replace engine ECU (See page IN-19).

NG

- 3 Check for open and short in harness and connector between engine ECU and A/C amplifier (See page IN-19).

NG

Repair or replace harness or connector.

OK

Check and replace A/C amplifier.

## Diagnostic Connector (DLC3) Circuit

### CIRCUIT DESCRIPTION

Terminals TC and CG are located in the DLC3.

The DLC3 is located under the finish lower panel. When terminals TC and CG are connected, DTC in normal mode or test mode can be read from the check engine warning light in the combination meter.

Also, terminal SIL is located in the DLC3. This terminal is used by the M-OBD communication with hand-held tester.

### WIRING DIAGRAM

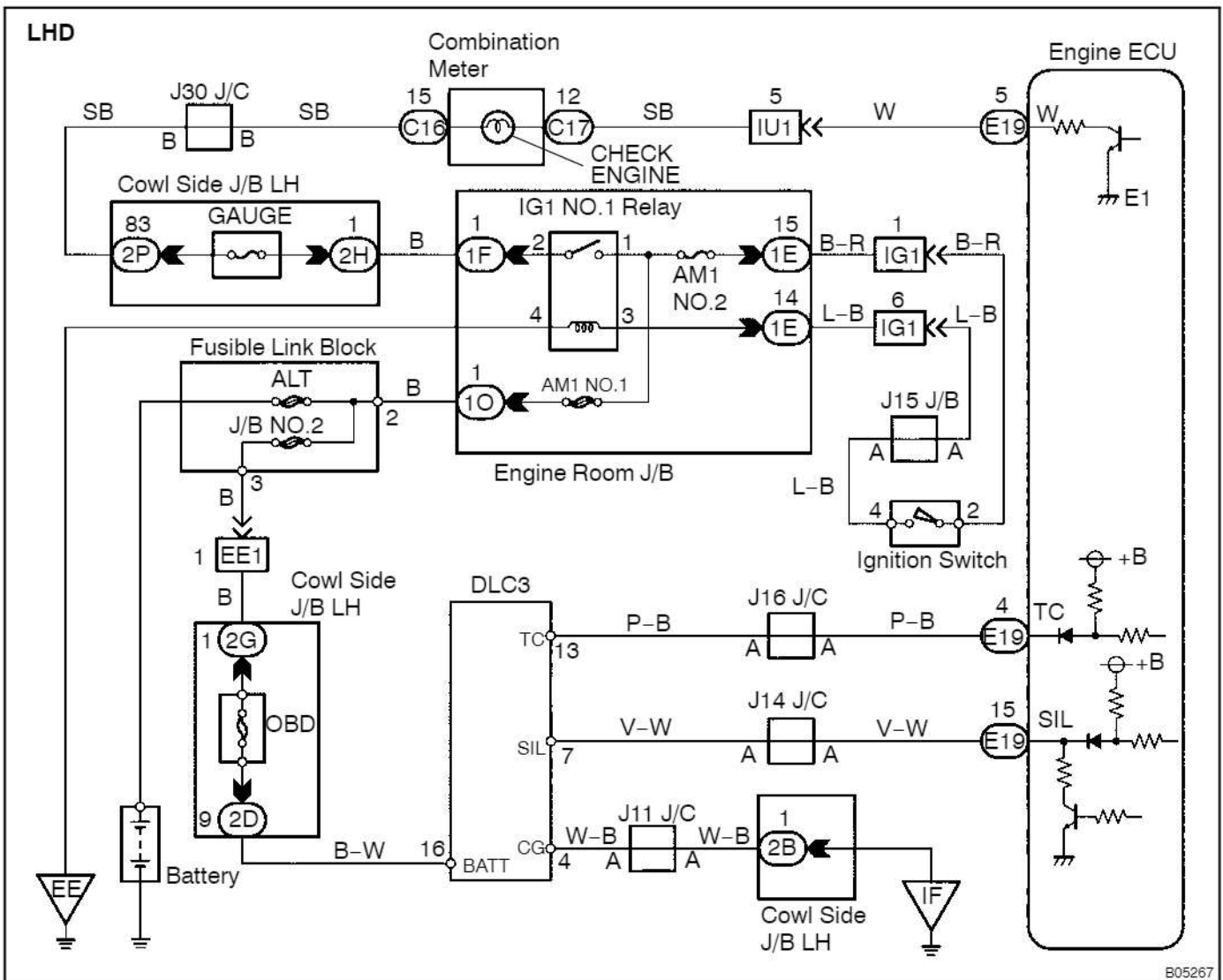

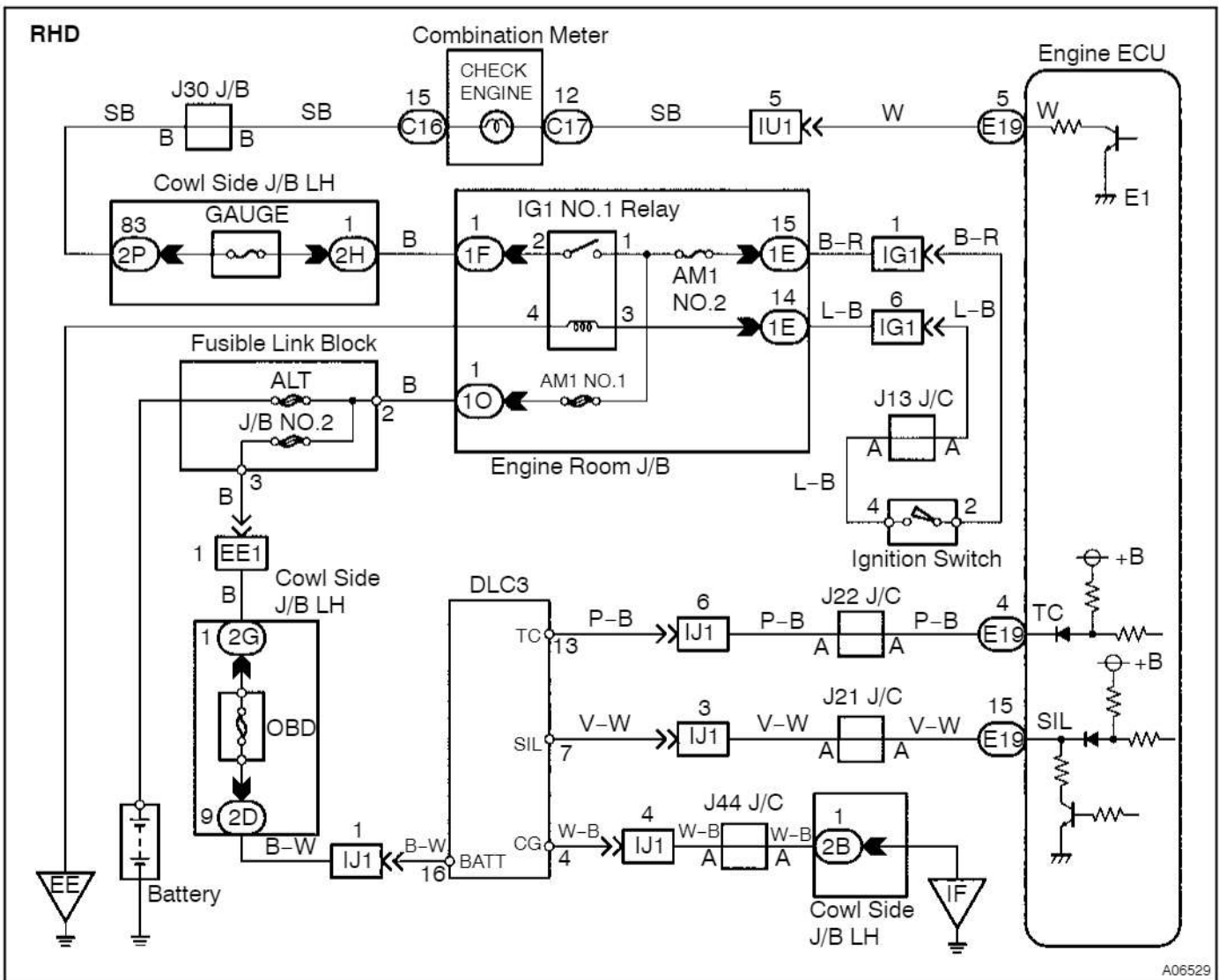

A06529

## INSPECTION PROCEDURE

## 1 Check the check engine warning light condition.

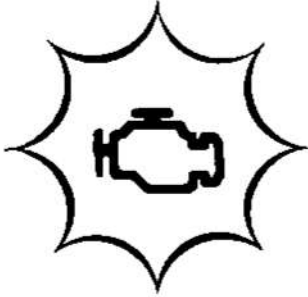

F12547

**PREPARATION:**

- (a) Turn the ignition switch ON.
- (b) Using SST, connect the terminals TC and CG of DLC3.  
SST 09843-18040

**CHECK:**

Check the check engine warning light condition.

**OK:**

**Check engine warning light : Blinking**

**HINT:**

If this inspection OK and there is no hand-held tester, do not need to do the following steps and this circuit is OK. Proceed to next circuit inspection shown on problem symptom table (See page DI-19).

OK

Go to step 7.

NG

## 2 Check voltage between terminals TC and CG of DLC3.

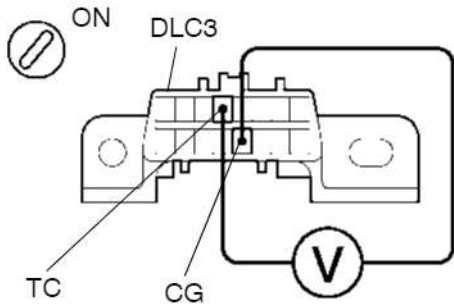

A04971

**PREPARATION:**

Turn the ignition switch ON.

**CHECK:**

Measure the voltage between terminals TC and CG of DLC3.

**OK:**

**Voltage : 9 - 14 V**

OK

Go to step 5.

NG

**3 Check continuity terminal CG of DLC3 and body ground.**

NG

Repair or replace harness or connector.

OK

**4 Check for open and short in harness and connector between terminal TC of DLC3 and terminal TC of engine ECU (See page IN-19).**

NG

Repair or replace harness or connector.

OK

Check and replace engine ECU (See page IN-19).

**5 Check voltage between terminal W of engine ECU connector and body ground.**

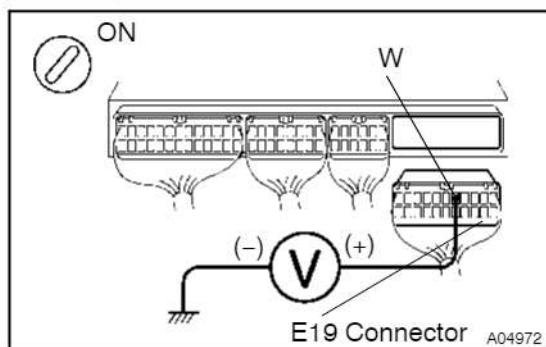

**PREPARATION:**

- Remove the glove compartment door.
- Disconnect the "E19" connector of engine ECU.
- Turn the ignition switch ON.

**CHECK:**

Measure voltage between terminal W of engine ECU connector and body ground.

**OK:**

**Voltage : 9 - 14 V**

OK

Check and replace engine ECU (See page IN-19).

NG

6 Check the bulb of check engine warning light.

NG

Replace bulb.

OK

Check for open in harness and connector between terminal W of engine ECU and combination meter (See page IN-19).

7 Can you read the DTC (including normal DTC) using hand-held tester?

YES

Proceed to next circuit inspection shown on problem symptom table (See page DI-19).

NO

8 Check voltage between terminal BATT of DLC3 and body ground.

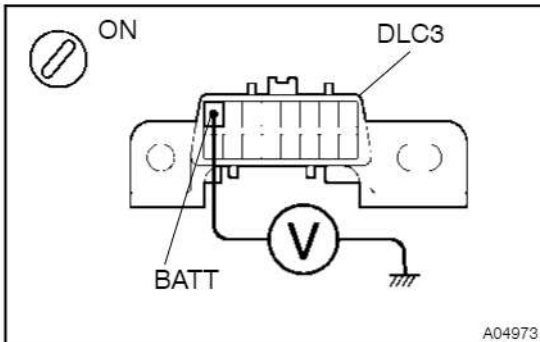

**CHECK:**

Measure voltage between terminal BATT of DLC3 and body ground.

**OK:**

Voltage : 9 - 14 V

NG

Check for open and short in harness and connector between terminal BATT of DLC3 and fusible link block (See page IN-19).

OK

Check for open and short in harness and connector between terminal SIL of DLC3 and terminal SIL of engine ECU (See page IN-19).

## Starter Signal Circuit

### CIRCUIT DESCRIPTION

When the engine is being cranked, the intake air flow is slow, so fuel vaporization is poor. A rich mixture is therefore necessary in order to achieve good start ability. While the engine is being cranked, the battery positive voltage is applied to terminal STA of the engine ECU. The starter signal is mainly used to increase the fuel injection volume for the starting injection control and after-start injection control.

### WIRING DIAGRAM

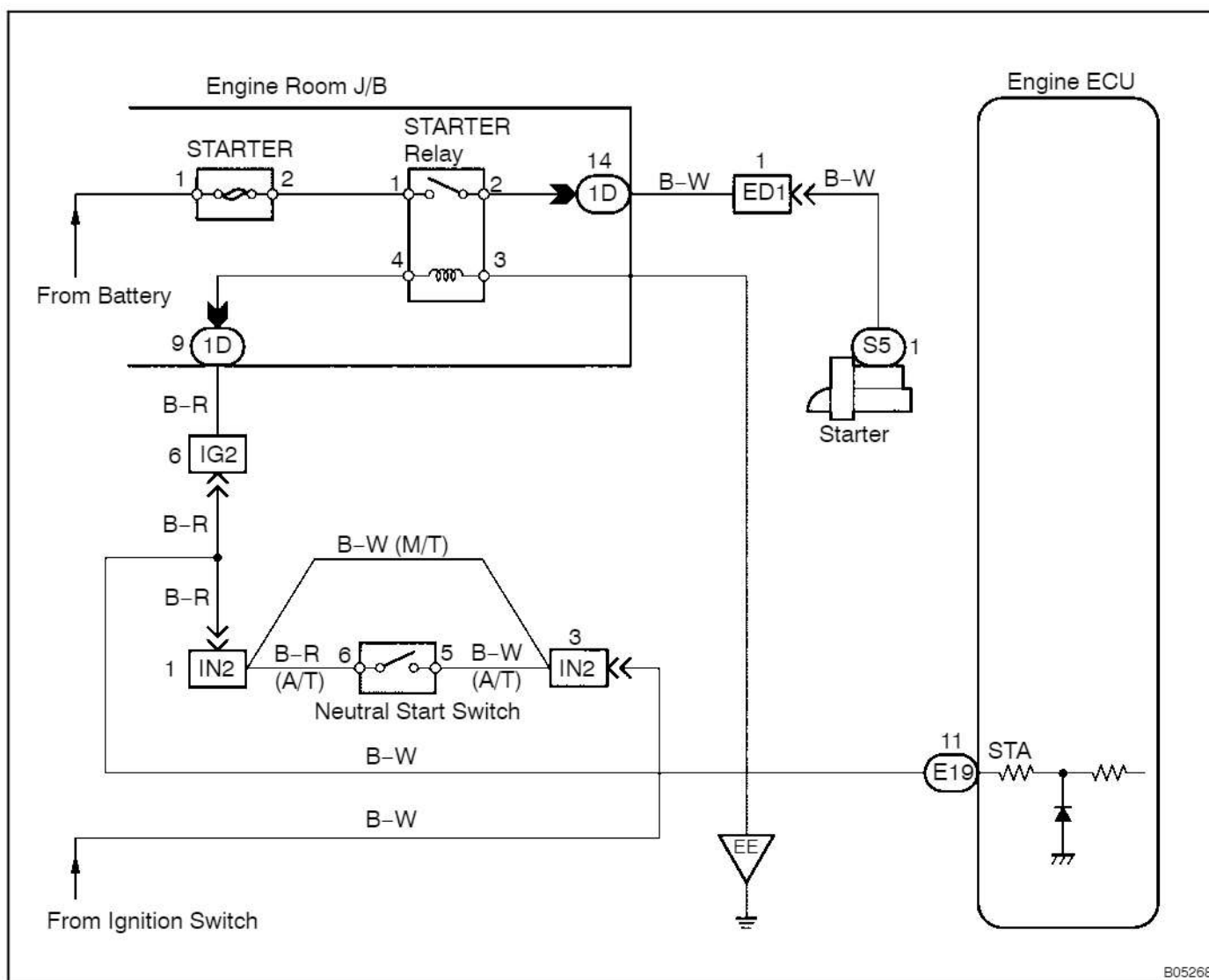

B05268



## INSPECTION PROCEDURE

### When using hand-held tester

#### HINT:

This diagnostic chart is based on the premise that the engine is being cranked under normal conditions. If the engine does not crank, proceed to the problem symptoms table on [page DI-19](#).

<b>1</b>	<b>Connect the hand-held tester and check STA signal.</b>
----------	---

#### PREPARATION:

- (a) Connect the hand-held tester to the DLC3.
- (b) Turn the ignition switch ON and push the hand-held tester main switch ON.

#### CHECK:

Read STA signal on the hand-held tester while starter operates.

#### OK:

Ignition switch position	ON	STA
STA signal	OFF	ON

OK

Proceed to next circuit inspection shown on problem symptoms table ([See page DI-19](#)).

NG

<b>2</b>	<b>Check for open in harness and connector between engine ECU and starter relay (Marking : STARTER) (<a href="#">See page IN-19</a>).</b>
----------	---

NG

Repair or replace harness or connector.

OK

Check and replace engine ECU ([See page IN-19](#)).

## When not using hand-held tester

HINT:

This diagnostic chart is based on the premise that the engine is being cranked under normal conditions. If the engine does not crank, proceed to the problem symptoms table on [page DI-19](#).

### 1 Check the starter signal.

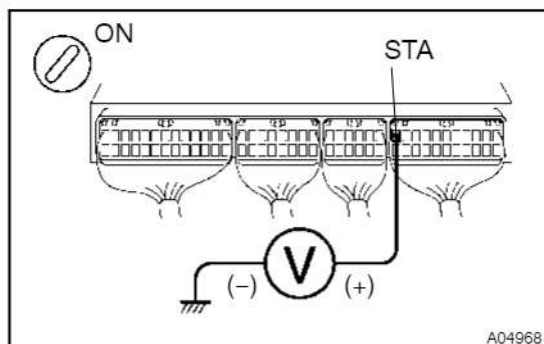

#### PREPARATION:

- (a) Remove the glove compartment door.
- (b) Turn the ignition switch ON.

#### CHECK:

Measure voltage between terminal STA of engine ECU connector and body ground during cranking.

#### OK:

**Voltage: 6.0 V or more**

OK

Proceed to next circuit inspection shown on problem symptoms table ([See page DI-19](#)).

NG

### 2 Check for open in harness and connector between engine ECU and starter relay (Marking : STARTER) ([See page IN-19](#)).

NG

Repair or replace harness or connector.

OK

Check and replace engine ECU ([See page IN-19](#)).

## Neutral Start Switch Circuit (only for vehicles with A/T)

### CIRCUIT DESCRIPTION

The neutral start switch goes on when the shift lever is in the N or P shift position. When it goes on the terminal NSW of the engine ECU is grounded to body ground via the starter relay thus the terminal NSW voltage becomes 0 V. When the shift lever is in the D, 2, L or R position, the neutral start switch goes off, so the voltage of the engine ECU terminal NSW becomes battery positive voltage, the voltage of the engine ECU internal power source.

If the shift lever is moved from the N position to the D position, this signal is used for air-fuel ratio correction, for idle speed control (estimated control), etc.

### WIRING DIAGRAM

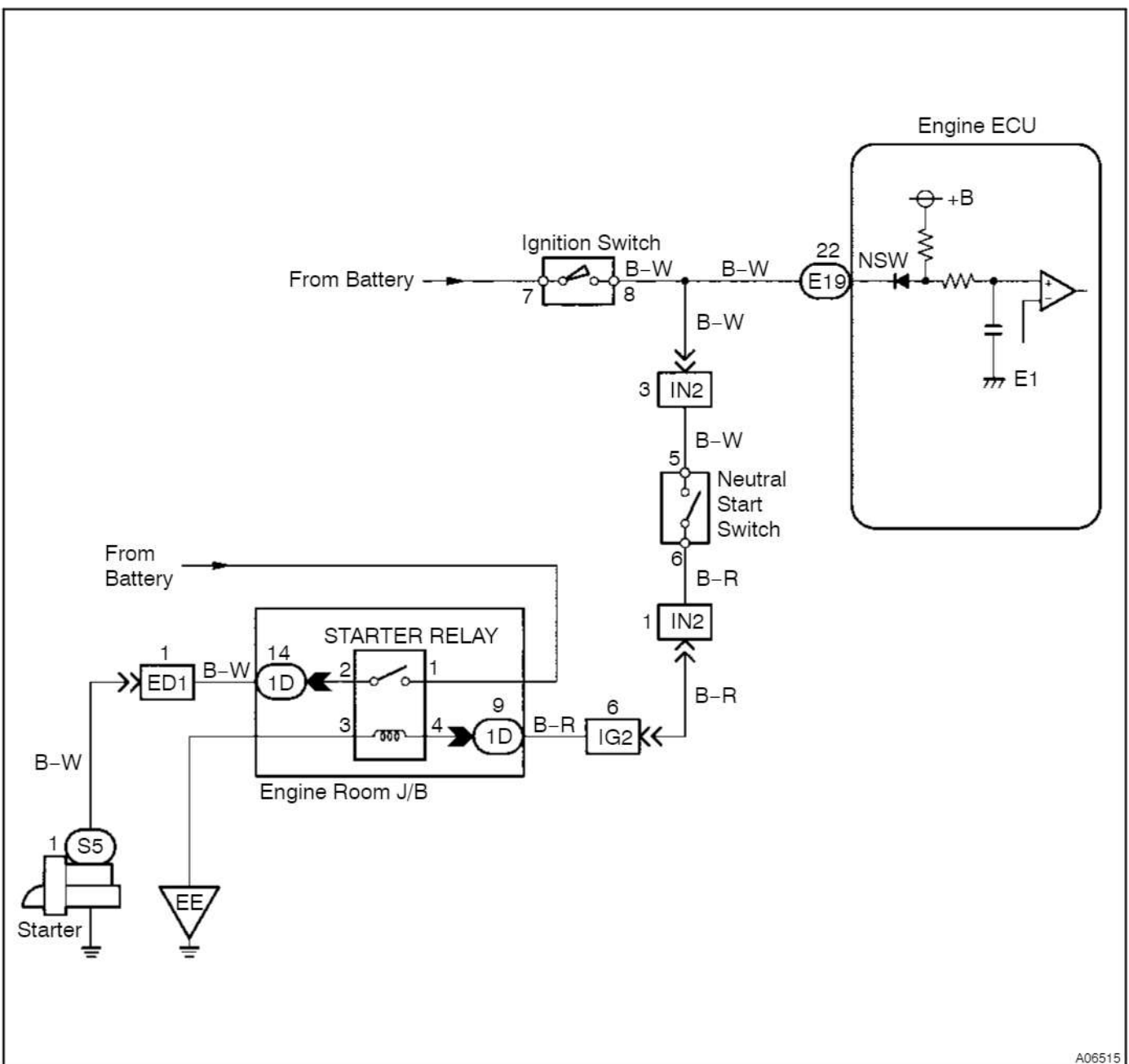

A06515

## INSPECTION PROCEDURE

HINT:

This diagnosis chart is based on the premise that the engine is being cranked under normal conditions. If the engine does not crank, proceed to the problem symptoms table on [page DI-19](#).

**1 Check neutral start switch.**

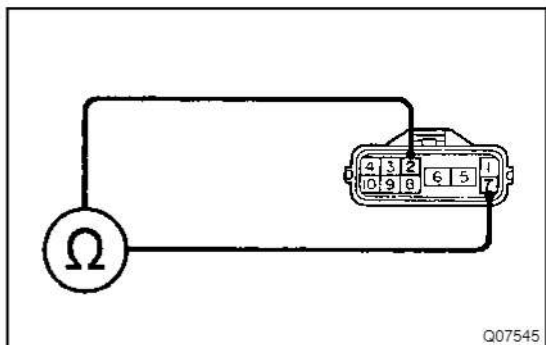

### PREPARATION:

Disconnect the neutral start switch connector.

### CHECK:

Check continuity between each terminal shown below when the shift lever is shifted to each position.

### OK:

Shift position	Terminal No. to continuity	
P	5 - 6	2 - 7
R	2 - 8	-
N	5 - 6	2 - 9
D	2 - 10	-
2	2 - 3	-
L	2 - 4	-

**NG**

**Replace neutral start switch.**

**OK**

**2 Check voltage between terminal NSW of engine ECU connector and body ground.**

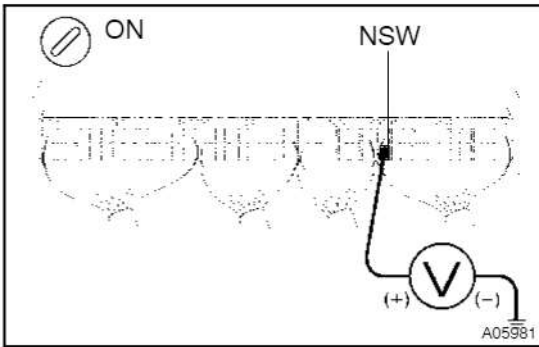
**PREPARATION:**

- (a) Remove the glove compartment door.
- (b) Turn the ignition switch ON.

**CHECK:**

Measure voltage between terminal NSW of engine ECU connector and body ground after the shift lever is moved to the following positions.

**OK:**

Shift lever position	P or N	L, 2, D or R
Voltage	0 - 3 V	9 - 14 V

**OK**

**Check and replace engine ECU**  
(See page IN-19).

**NG**

**Check for open and short in harness and connector between neutral start switch and engine ECU (See page IN-19).**

## 1st Gear Position Switch Circuit (only for vehicles with M/T)

### CIRCUIT DESCRIPTION

The shift position switch on the side of transmission detects the 1st gear and limits the engine output when the high load is applied during running in the 1st gear.

### WIRING DIAGRAM

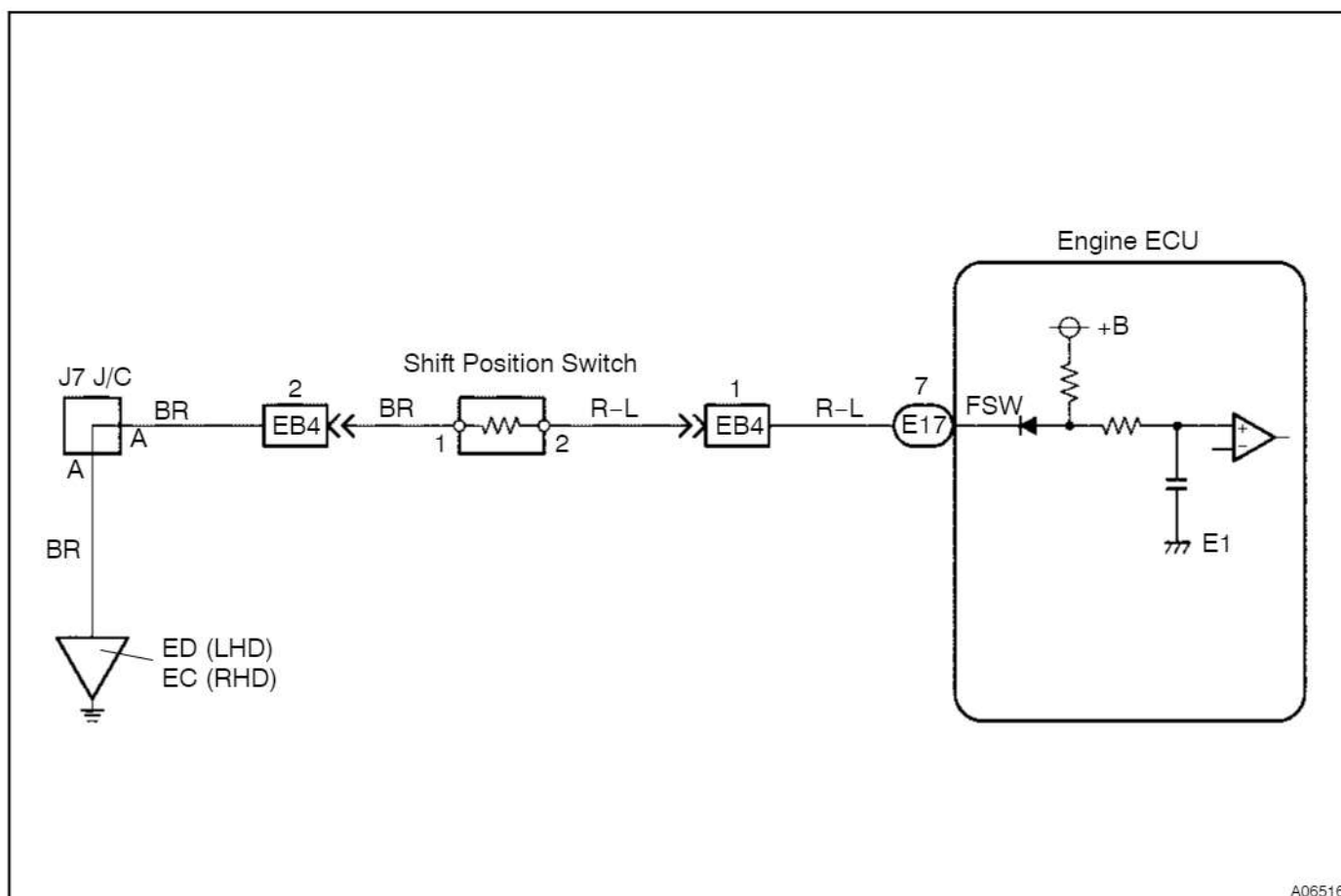

A06516

## INSPECTION PROCEDURE

1 Check shift position switch (See page ED-12).

NG

Replace shift position switch.

OK

2 Check voltage between terminal FSW of engine ECU connector and body ground.

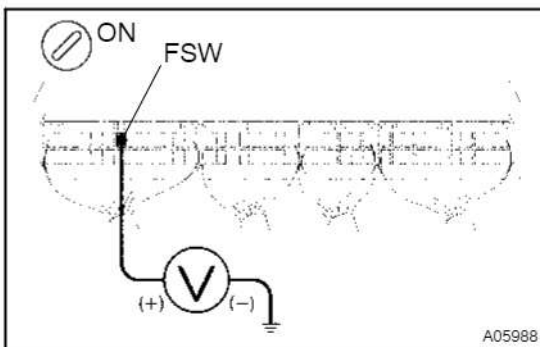
**PREPARATION:**

- Remove the glove compartment door.
- Turn the ignition switch ON.

**CHECK:**

Measure voltage between terminal FSW of engine ECU connector and body ground after the shift lever is moved to the following positions.

**OK:**

Shift lever position	1st gear	Except 1st gear
Voltage	9 - 14 V	0 - 3 V

OK

Check and replace engine ECU (See page IN-19).

NG

Check for open and short in harness and connector between shift position switch and engine ECU (See page IN-19).

## Spill Valve Relay Circuit

### CIRCUIT DESCRIPTION

When the ignition switch is turned ON, battery positive voltage is applied to the coil, closing the contacts of the spill valve relay (Marking : SPIL/VLV) and supplying power to the terminal +B of the EDU.

### WIRING DIAGRAM

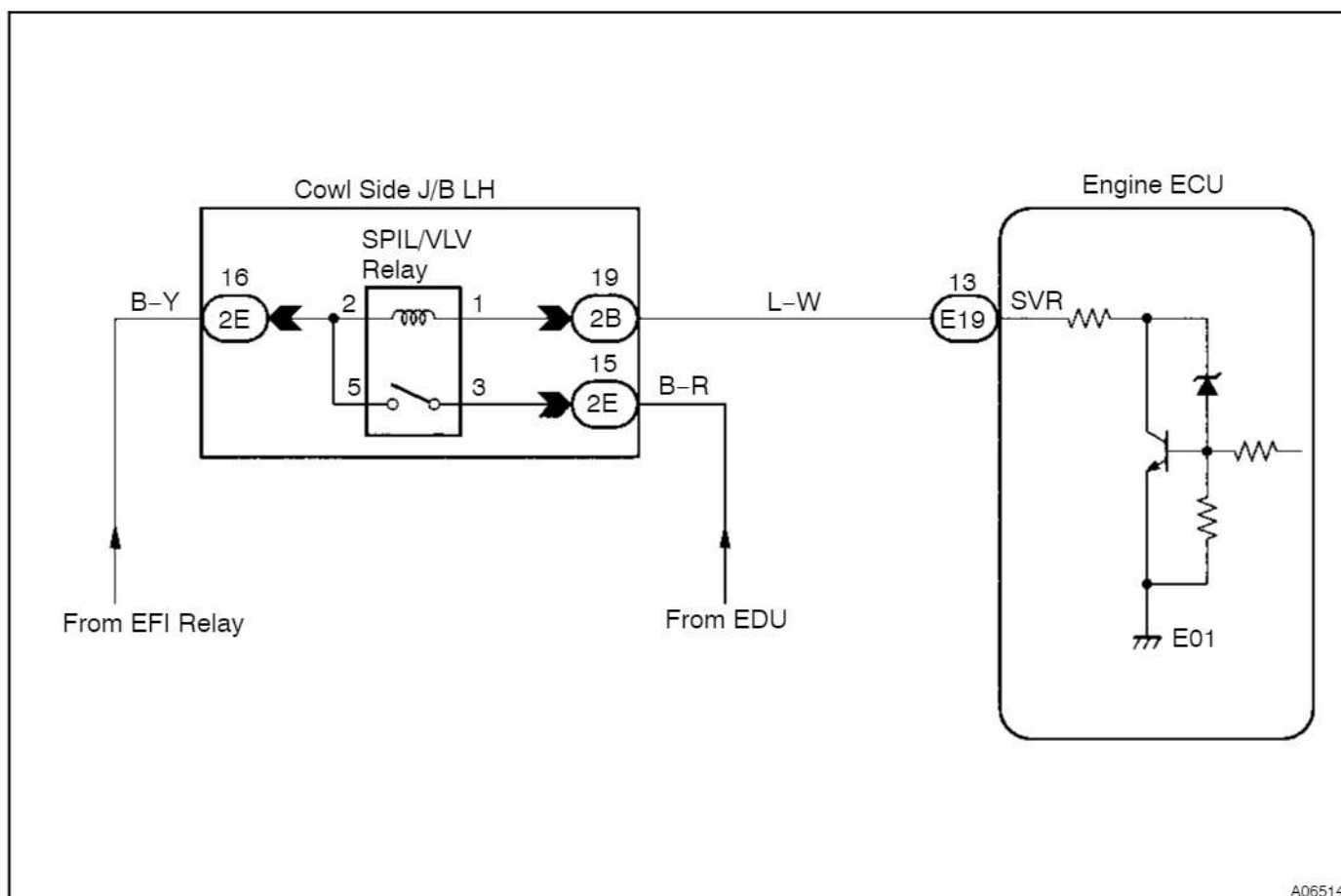

A06514



## INSPECTION PROCEDURE

1 Check spill valve relay (Marking : SPIL/VLV) (See page ED-4).

NG

Replace spill valve relay.

OK

2 Check voltage between terminal SVR of engine ECU connector and body ground.

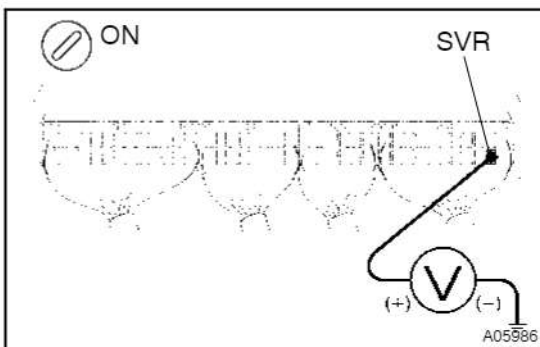
**PREPARATION:**

- Remove the glove compartment door.
- Turn the ignition switch ON.

**CHECK:**

Measure voltage between terminal SVR of engine ECU connector and body ground.

**OK:**

Voltage: 0 - 1.5 V

OK

Check and replace engine ECU (See page IN-19).

NG

Check for open in harness and connector between engine ECU and spill valve relay (Marking : SPIL/VLV) and spill valve relay and EDU (See page IN-19).

## Heater Idle-Up Switch Circuit

### CIRCUIT DESCRIPTION

When the vehicle is stopped with the power heater switch on the left side (LHD) or right side (RHD) of the ignition switch ON, the engine ECU controls the spill control valve to idle-up. However, it is OFF during engine starting, A/C operating and acceleration (with the vehicle speed at less than 30 km/h (19 mph) and accelerator pedal opening at 45 % or more for 5 seconds).

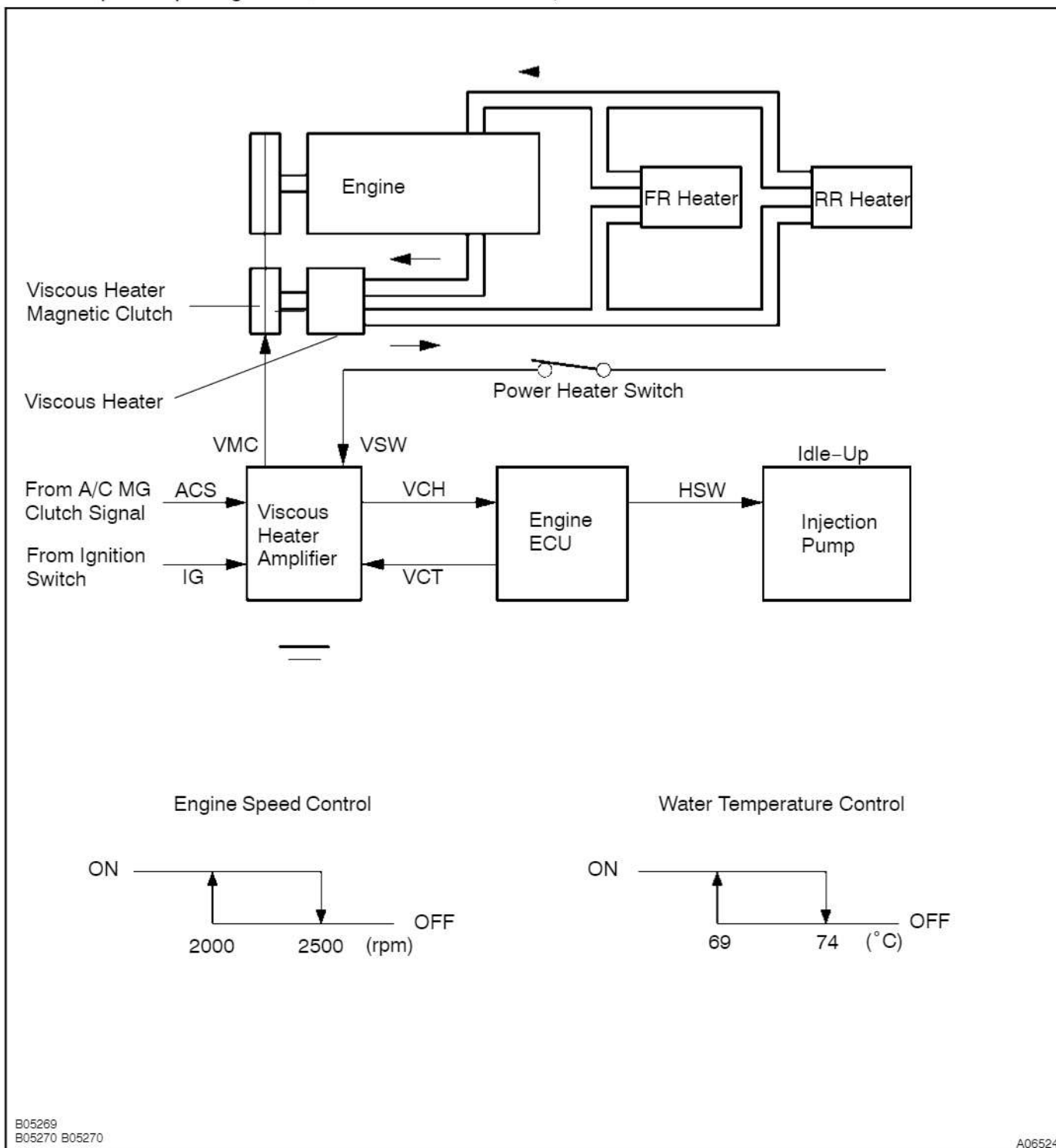

# WIRING DIAGRAM

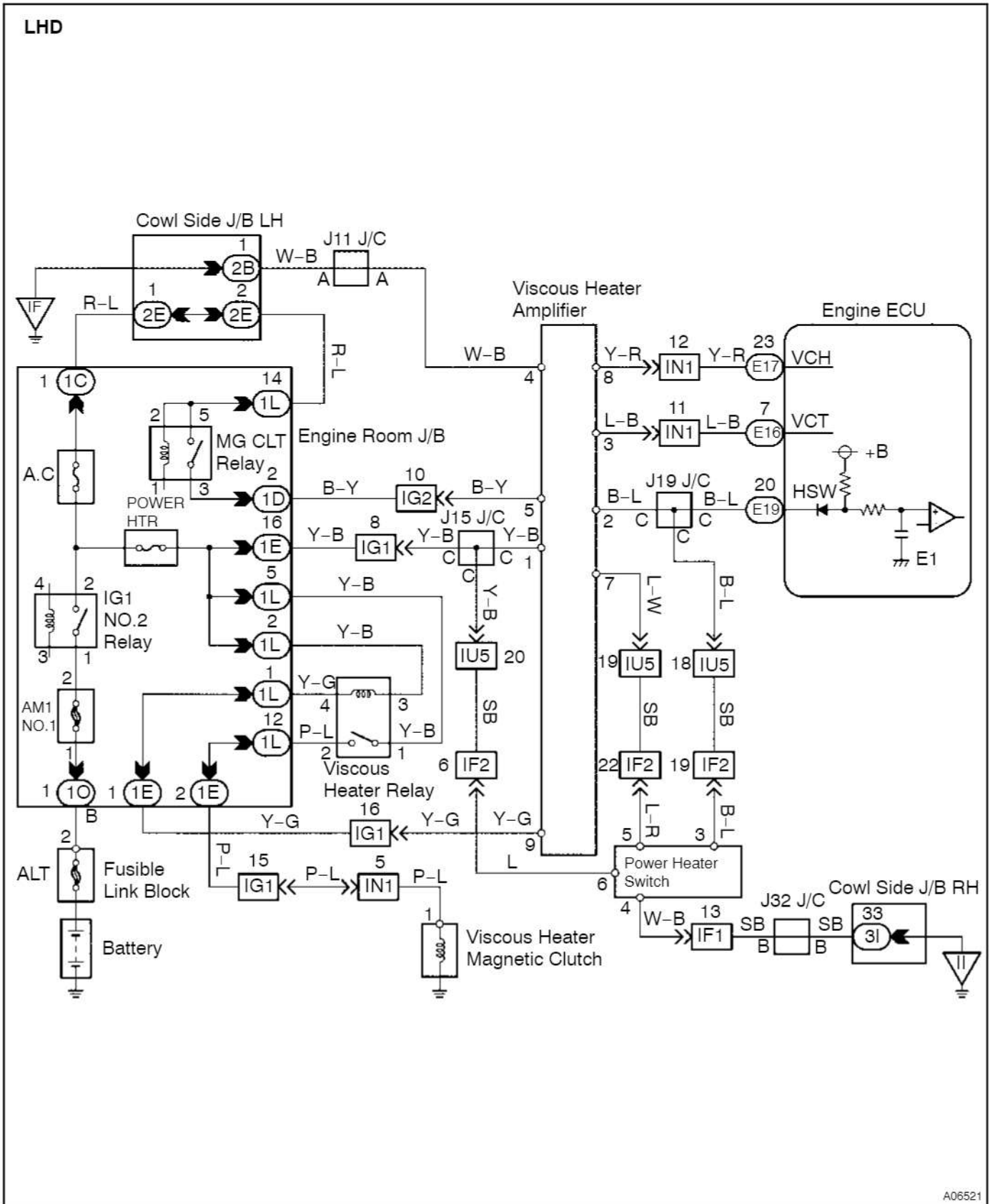

cardiagn.com

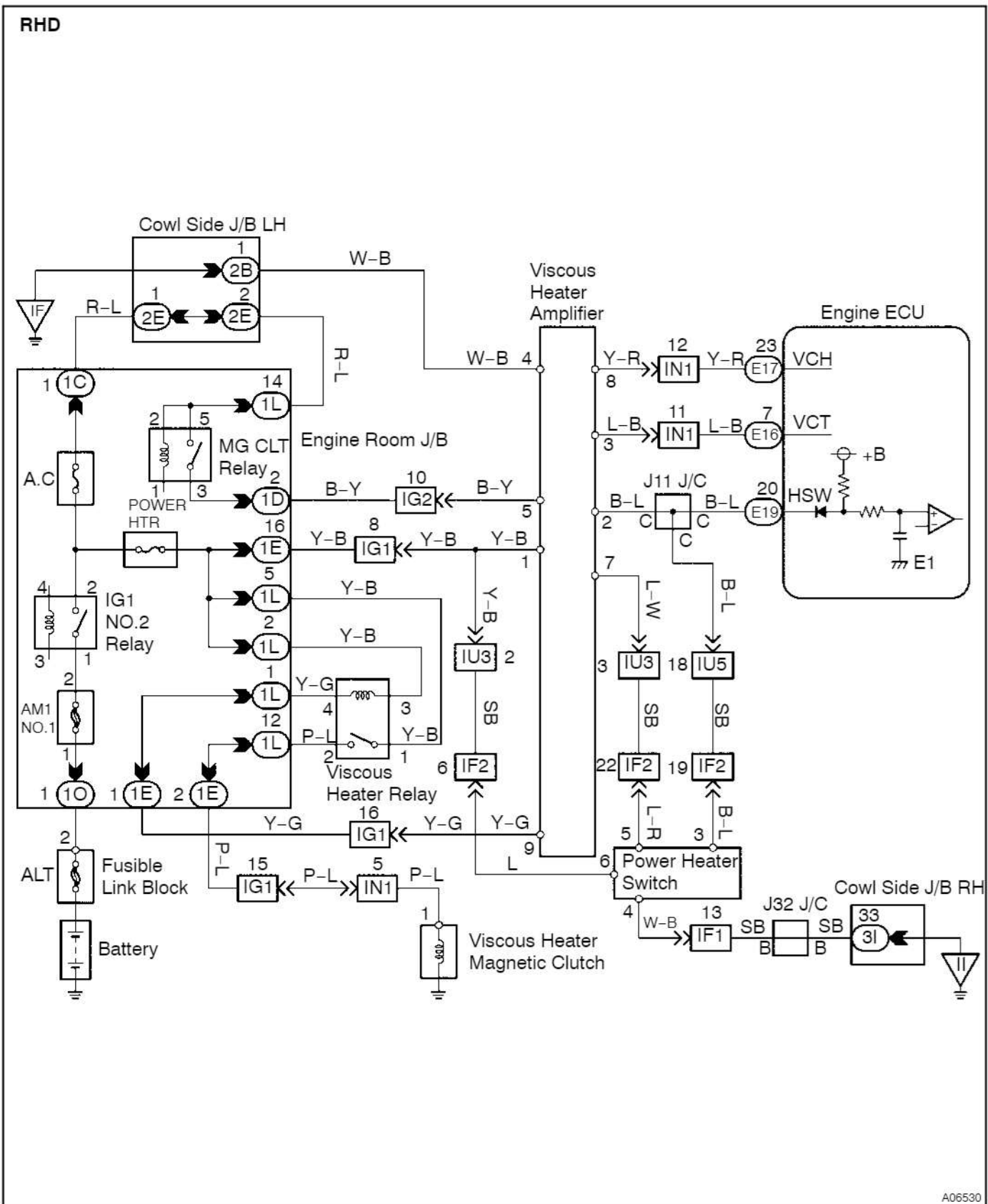

cardiagn.com

## INSPECTION PROCEDURE

## 1 Check power heater switch.

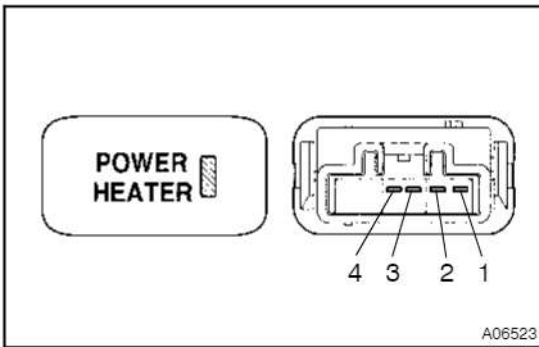
**PREPARATION:**

- (a) Remove the lower finish panel.
- (b) Remove the power heater switch.

**CHECK:**

Check continuity between each terminal.

Switch position	Tester connection	Specified condition
OFF	3 - 4	No continuity
ON	3 - 4	Continuity
Illumination circuit	1 - 2	Continuity

NG

Replace power heater switch.

OK

## 2 A/C Cut Control Circuit (See page DI-96).

NG

Check and replace A/C amplifier.

OK

## 3 Check voltage between terminal VCH of engine ECU and body ground.

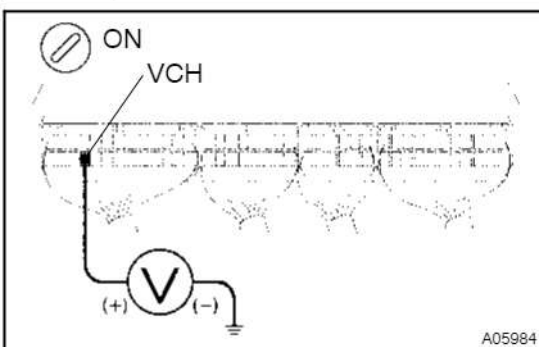
**PREPARATION:**

- (a) Remove the glove compartment door.
- (b) Turn the ignition switch ON.

**CHECK:**

Measure voltage between terminal VCH of engine ECU connector and body ground when heater blower switch is turned to OFF and ON.

**OK:**

Heater blower switch condition	Voltage
OFF	9 - 14 V
ON	0 - 3 V

OK

Go to step 5.

NG

- 4 Check for open and short in harness and connector between engine ECU and viscous heater amplifier (See page IN-19)

NG

Repair or replace harness or connector.

OK

Check and replace viscous heater amplifier.

- 5 Check voltage between terminal VCT of engine ECU and body ground.

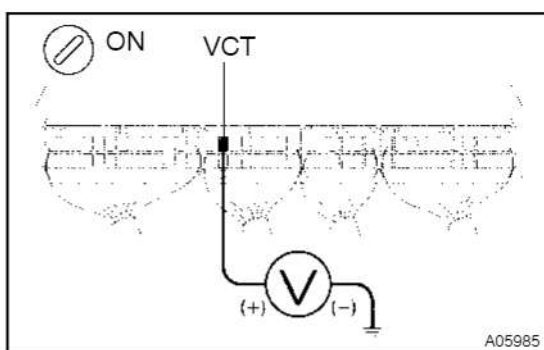
**PREPARATION:**

- (a) Remove the glove compartment door.  
 (b) Turn the ignition switch ON.

**CHECK:**

Measure voltage between terminal VCT of engine ECU connector and body ground when heater blower switch is turned to OFF and ON.

**OK:**

Heater blower switch condition	Voltage
OFF	9 - 14 V
ON	0 - 3 V

OK

Check and replace engine ECU (See page IN-19).

NG

- 6 Check for open and short in harness and connector between engine ECU and viscous heater amplifier (See page IN-19).

NG

Repair or replace harness or connector.

OK

**7 Check voltage between terminal HSW of engine ECU and body ground.**

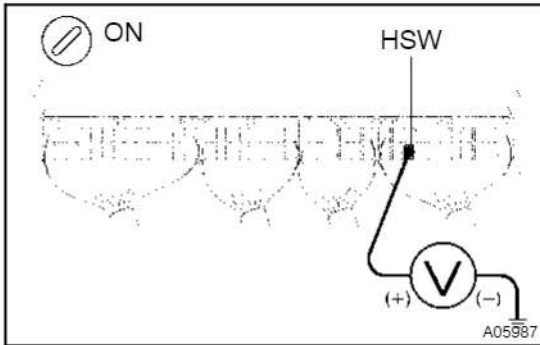

**PREPARATION:**

- Remove the glove compartment door.
- Turn the ignition switch ON.

**CHECK:**

Measure voltage between terminal HSW of engine ECU connector and body ground when power heater switch is pushed to OFF and ON.

**OK:**

Power heater switch condition	Voltage
OFF	9 - 14 V
ON	0 - 3 V

OK

Check and replace engine ECU  
(See page IN-19).

NG

**8 Check for open and short in harness and connector between injection pump and viscous heater amplifier (See page IN-19).**

NG

Repair or replace harness or connector.

OK

Check and replace injection pump (See page FU-113).

## AIR FILTER ON-VEHICLE CLEANING

EM0VY-01

### 1. PAPER FILTER TYPE:

- (a) Remove air filter

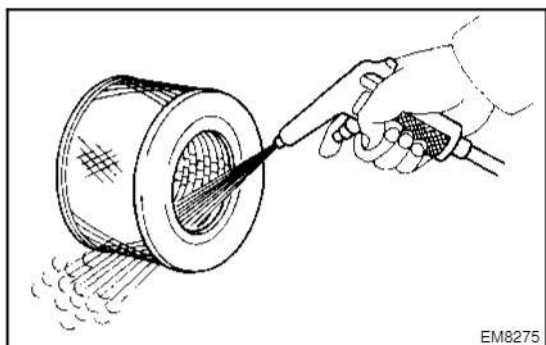

EM8275

- (b) Inspect air filter  
Visually check that the filter element is not excessively dirty, damaged or oily.
- (c) Clean air filter  
Clean the filter element with compressed air. First blow from the inside thoroughly. Then blow off the outside of the filter element.
- (d) Reinstall air filter

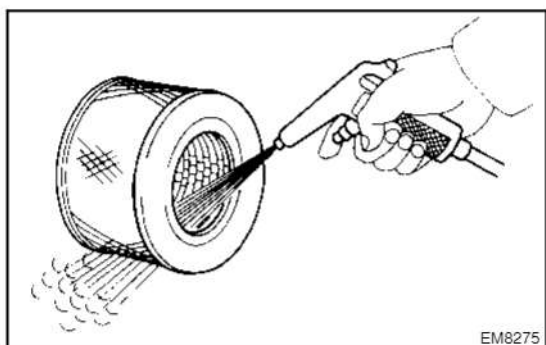

EM8275

### 2. WASHABLE TYPE:

- (a) Remove air filter
- (b) Inspect air filter  
Visually check that the filter element is not excessively dirty, damaged or oily.
- (c) Clean air filter
- (1) Blow dirt off in the filter element with compressed air.
  - (2) Submerge the filter element in the water and agitate it up and down more than 10 times.
  - (3) Repeat ringing in clean water until rinsing water is clear.

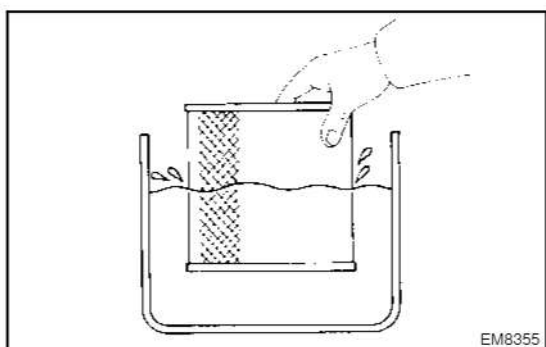

EM8355

- (4) Remove excess water by shaking the filter element or blowing with compressed air.

### NOTICE:

**Do not beat or drop filter element.**

- (5) Wipe off dust on the air cleaner case interior.
- (d) Reinstall air filter

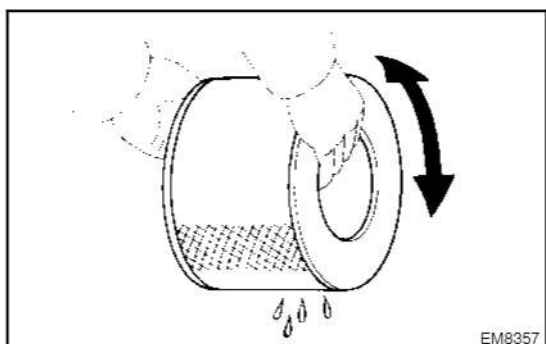

EM8357



# COMPRESSION INSPECTION

## HINT:

If there is lack of power, excessive oil consumption or poor fuel economy, measure the compression pressure.

### 1. WARM UP AND STOP ENGINE

Allow the engine to warm up to normal operating temperature.

### 2. REMOVE INTAKE PIPE ASSEMBLY

1HZ, 1HD-T: (See page EM-48)

1HD-FTE: (See page EM-77)

### 3. 1HD-FTE:

REMOVE NO.2 CYLINDER HEAD COVER

(See page EM-77)

### 4. 1HD-FTE:

REMOVE NO.1 CYLINDER HEAD COVER

(See page EM-77)

### 5. 1HZ, 1HD-T:

REMOVE CYLINDER HEAD COVER

(See page EM-48)

### 6. REMOVE INJECTION PIPES

1HZ, 1HD-T: (See page FU-7)

1HD-FTE: (See page FU-33)

### 7. REMOVE NOZZLE LEAKAGE PIPE

1HZ, 1HD-T: (See page EM-48)

1HD-FTE: (See page EM-48)

### 8. DISCONNECT INJECTION PUMP (FUEL CUT SOLENOID) CONNECTOR

### 9. CHECK CYLINDER COMPRESSION PRESSURE

#### NOTICE:

When measuring the compression pressure of each, the other 5 injection nozzles must be installed in the cylinder head.

#### (a) Remove the injection nozzle.

1HZ: (See page FU-7)

1HD-T: (See page FU-17)

1HD FTE: (See page FU-33)

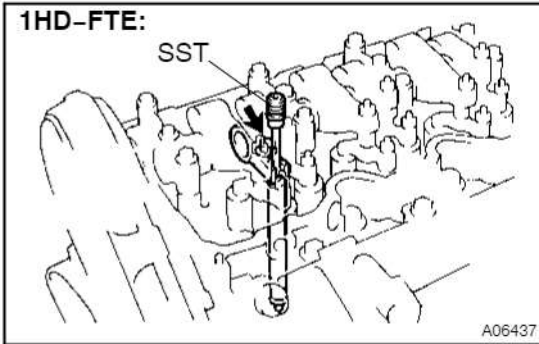

- (b) Install the gasket and SST (attachment) to the injection nozzle hole with the nozzle holder clamp and bolt.  
SST 09992-00400  
**Torque: 25 N·m (255 kgf·cm, 18 ft·lbf)**

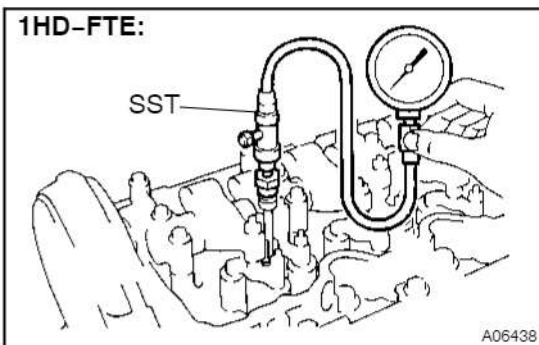
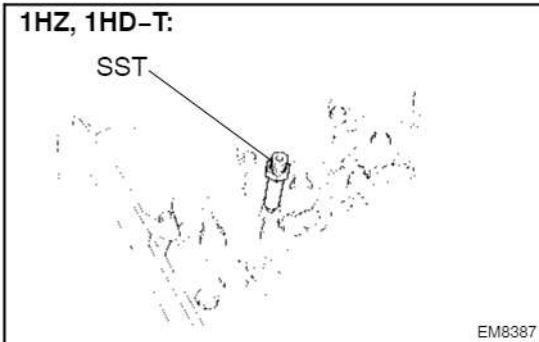

- (c) Connect SST (compression gauge) to the SST (attachment).  
SST 09992-00025 (09992-00160)
- (d) While cranking the engine, measure the compression pressure.

**HINT:**

Always use a fully charged battery to obtain engine revolution of 250 rpm or more.

- (e) Repeat steps (b) through (d) for each cylinder.

**NOTICE:**

**This measurement must be done in as short a time as possible.**

**Compression pressure:****STD:****1HZ:**

**3,628 kPa (37.0 kgf/cm<sup>2</sup>, 526 psi) or more**

**1HD-T, 1HD-FTE:**

**3,432 kPa (35.0 kgf/cm<sup>2</sup>, 498 psi) or more**

**Minimum pressure:****1HZ:**

**2,648 kPa (27.0 kgf/cm<sup>2</sup>, 384 psi)**

**1HD-T, 1HD-FTE:**

**2,452 kPa (25.0 kgf/cm<sup>2</sup>, 356 psi)**

**Difference between each cylinder:**

**490 kPa (5.0 kgf/cm<sup>2</sup>, 71 psi) or less**

- (f) If the cylinder compression in one or more cylinders is low, pour a small amount of engine oil into the cylinder through the injection nozzle hole and repeat steps (b) through (d) for the cylinder with low compression.

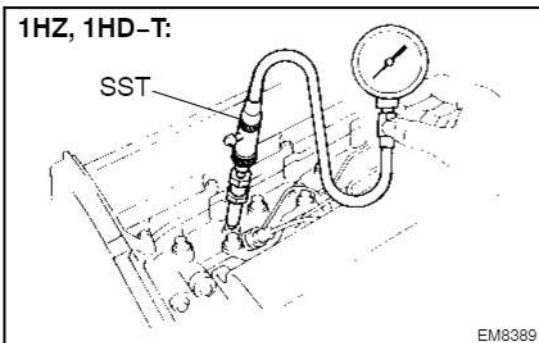

- If adding oil helps the compression, chances are that the piston rings and or cylinder bore are worn or damaged.
  - If pressure stays low, a valve may be sticking or seating improperly, or there may be leakage past the gasket.
- (g) Remove the SST.  
SST 09992-00400, 09992-00025 (09992-00160)
- (h) Reinstall the injection nozzle.  
1HZ: (See page FU-13)  
1HD-T: (See page FU-30)  
1HD-FTE: (See page FU-44)
10. **RECONNECT INJECTION PUMP (FUEL CUT SOLENOID) CONNECTOR**
11. **REINSTALL NOZZLE LEAKAGE PIPE**  
1HZ, 1HD-T: (See page EM-66)  
1HD-FTE: (See page EM-94)
12. **REINSTALL INJECTION PIPES**  
1HZ, 1HD-T: (See page FU-13)  
1HD-FTE: (See page FU-44)
13. 1HZ, 1HD-T:  
**REINSTALL CYLINDER HEAD COVER**  
(See page EM-66)
14. 1HD-FTE:  
**REINSTALL NO.1 CYLINDER HEAD COVER**  
(See page EM-94)
15. 1HD-FTE:  
**REINSTALL NO.2 CYLINDER HEAD COVER**  
(See page EM-94)
16. **REINSTALL INTAKE PIPE ASSEMBLY**  
1HZ, 1HD-T: (See page EM-66)  
1HD-FTE: (See page EM-94)
17. **START ENGINE AND CHECK FOR LEAKS**

## VALVE CLEARANCE (1HZ, 1HD-T) INSPECTION

EMOW-01

1. REMOVE INTAKE PIPE ASSEMBLY  
(See page EM-48)
2. REMOVE CYLINDER HEAD COVER  
(See page EM-77)

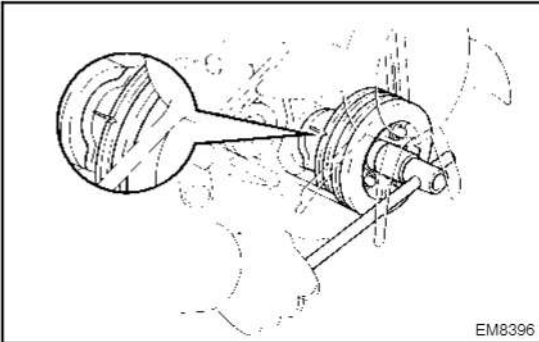

EM8396

### 3. SET NO.1 CYLINDER TO TDC/COMPRESSION

- (a) Turn crankshaft pulley clockwise, and align its groove with the timing gear cover groove.
- (b) Check that the valve lifters on the No.1 cylinder are loose and valve lifters on the No.6 cylinder are tight.

If not, turn the crankshaft one revolution (360°) and align the mark as above.

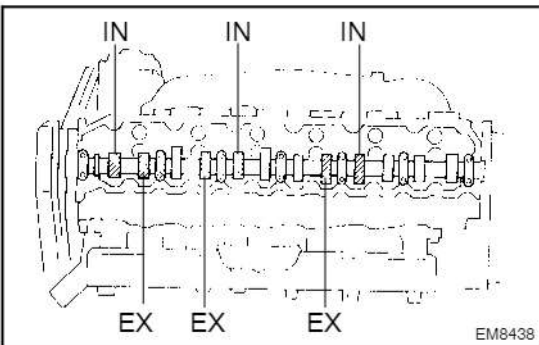

EM8438

### 4. INSPECT VALVE CLEARANCE

- (a) Check only those valves indicated in the illustration.
  - Using a feeler gauge, measure the clearance between the valve lifter and camshaft.
  - Record the out of specification valve clearance measurements. They will be used later to determine the required replacement adjusting shim.

#### Valve clearance (Cold):

##### Intake

0.15 – 0.25 mm (0.006 – 0.010 in.)

##### Exhaust

0.35 – 0.45 mm (0.014 – 0.018 in.)

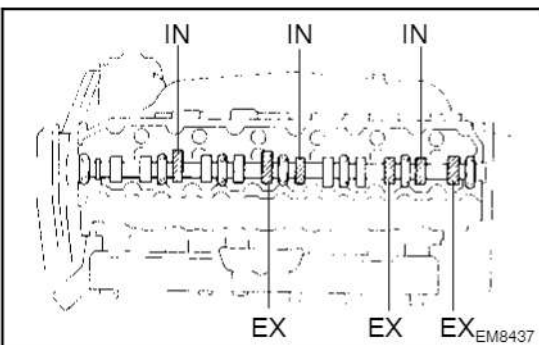

EM8437

- (b) Turn the crankshaft one revolution (360°) and align the mark as above (See step 3).
- (c) Check only the valves indicated in the illustration. Measure the valve clearance (See step 3).

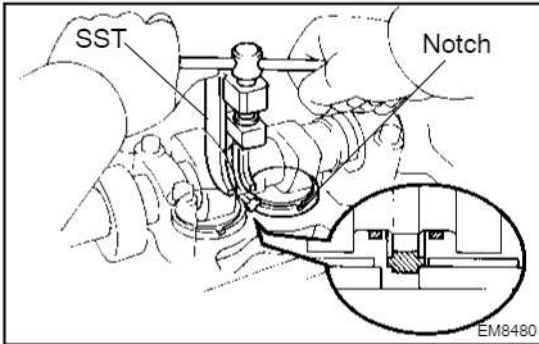

- (d) Remove the adjusting shim.
- Turn the crankshaft to position the cam lobe of the camshaft on the adjusting valve upward.
  - Using SST press down the valve lifter.

SST 09248-64011

HINT:

Before pressing down the valve lifter position the notch on the exhaust manifold side.

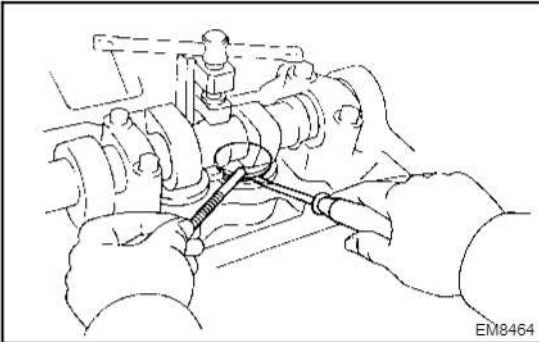

- Remove the adjusting shim with a small screwdriver and magnetic finger.
- (e) Determine the replacement adjusting shim size by using following (Formula or Charts).

- Using a micrometer measure the thickness of the removed shim.
- Calculate the thickness of the new shim so the valve clearance comes within specified valve.

T..... Thickness of used shim

A..... Measured valve clearance

N..... Thickness of new shim

**Intake  $N = T + (A - 0.20 \text{ mm (0.008 in.)})$**

**Exhaust  $N = T + (A - 0.40 \text{ mm (0.016 in.)})$**

- Select a new shim with a thickness as close as possible to the calculated values.

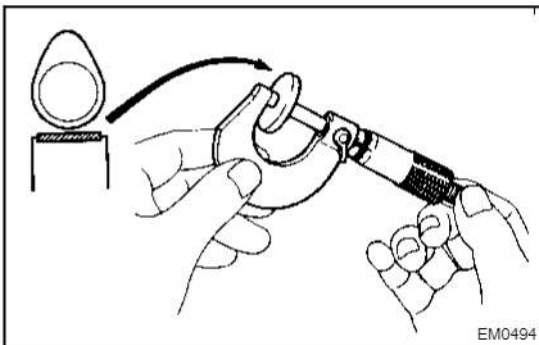

HINT:

Shims are available in twenty sizes in increments of 0.05 mm (0.0020 in.) from 2.35 mm (0.0925 in.) to 3.30 mm (0.1299 in.)

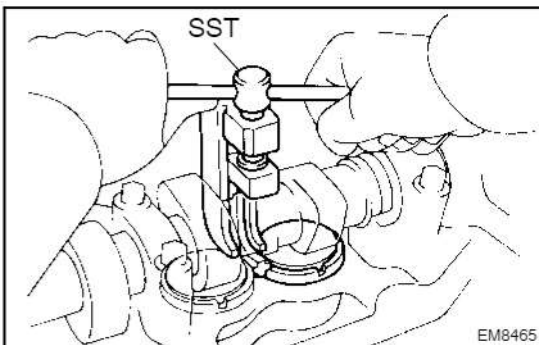

- (f) Install a new adjusting shim.
- Place a new adjusting shim on the valve lifter.
  - Remove SST.

SST 09248-64011

- (g) Recheck the valve clearance.

## 5. REINSTALL CYLINDER HEAD COVER

(See page EM-66)

## 6. REINSTALL INTAKE PIPE ASSEMBLY

(See page EM-66)

Adjusting Shim Selection Using Chart (Intake)

Measured clearance mm (in.)	Installed shim thickness mm (in.)																
	2.340 (0.0921)	2.350 (0.0925)	2.360 (0.0929)	2.380 (0.0937)	2.400 (0.0945)	2.420 (0.0953)	2.440 (0.0961)	2.450 (0.0965)	2.460 (0.0969)	2.480 (0.0976)	2.500 (0.0984)	2.520 (0.0992)	2.540 (0.1000)	2.550 (0.1004)	2.560 (0.1008)	2.580 (0.1016)	
0.000 - 0.020 (0.0000 - 0.0008)																	
0.021 - 0.040 (0.0008 - 0.0016)																	
0.041 - 0.060 (0.0016 - 0.0024)																	
0.061 - 0.080 (0.0024 - 0.0032)																	
0.081 - 0.100 (0.0032 - 0.0040)																	
0.101 - 0.120 (0.0040 - 0.0048)																	
0.121 - 0.140 (0.0048 - 0.0056)																	
0.141 - 0.160 (0.0056 - 0.0064)																	
0.161 - 0.180 (0.0064 - 0.0072)																	
0.181 - 0.200 (0.0072 - 0.0080)																	
0.201 - 0.220 (0.0080 - 0.0088)																	
0.221 - 0.240 (0.0088 - 0.0096)																	
0.241 - 0.260 (0.0096 - 0.0104)																	
0.261 - 0.280 (0.0104 - 0.0112)																	
0.281 - 0.300 (0.0112 - 0.0120)																	
0.301 - 0.320 (0.0120 - 0.0128)																	
0.321 - 0.340 (0.0128 - 0.0136)																	
0.341 - 0.360 (0.0136 - 0.0144)																	
0.361 - 0.380 (0.0144 - 0.0152)																	
0.381 - 0.400 (0.0152 - 0.0160)																	
0.401 - 0.420 (0.0160 - 0.0168)																	
0.421 - 0.440 (0.0168 - 0.0176)																	
0.441 - 0.460 (0.0176 - 0.0184)																	
0.461 - 0.480 (0.0184 - 0.0192)																	
0.481 - 0.500 (0.0192 - 0.0200)																	
0.501 - 0.520 (0.0200 - 0.0208)																	
0.521 - 0.540 (0.0208 - 0.0216)																	
0.541 - 0.560 (0.0216 - 0.0224)																	
0.561 - 0.580 (0.0224 - 0.0232)																	
0.581 - 0.600 (0.0232 - 0.0240)																	
0.601 - 0.620 (0.0240 - 0.0248)																	
0.621 - 0.640 (0.0248 - 0.0256)																	
0.641 - 0.660 (0.0256 - 0.0264)																	
0.661 - 0.680 (0.0264 - 0.0272)																	
0.681 - 0.700 (0.0272 - 0.0280)																	
0.701 - 0.720 (0.0280 - 0.0288)																	
0.721 - 0.740 (0.0288 - 0.0296)																	
0.741 - 0.760 (0.0296 - 0.0304)																	
0.761 - 0.780 (0.0304 - 0.0312)																	
0.781 - 0.800 (0.0312 - 0.0320)																	
0.801 - 0.820 (0.0320 - 0.0328)																	
0.821 - 0.840 (0.0328 - 0.0336)																	
0.841 - 0.860 (0.0336 - 0.0344)																	
0.861 - 0.880 (0.0344 - 0.0352)																	
0.881 - 0.900 (0.0352 - 0.0360)																	
0.901 - 0.920 (0.0360 - 0.0368)																	
0.921 - 0.940 (0.0368 - 0.0376)																	
0.941 - 0.960 (0.0376 - 0.0384)																	
0.961 - 0.980 (0.0384 - 0.0392)																	
0.981 - 1.000 (0.0392 - 0.0400)																	
1.001 - 1.020 (0.0400 - 0.0408)																	
1.021 - 1.040 (0.0408 - 0.0416)																	
1.041 - 1.060 (0.0416 - 0.0424)																	
1.061 - 1.080 (0.0424 - 0.0432)																	
1.081 - 1.100 (0.0432 - 0.0440)																	
1.101 - 1.120 (0.0440 - 0.0448)																	
1.121 - 1.140 (0.0448 - 0.0456)																	
1.141 - 1.160 (0.0456 - 0.0464)																	
1.161 - 1.180 (0.0464 - 0.0472)																	
1.181 - 1.200 (0.0472 - 0.0480)																	
1.201 - 1.210 (0.0472 - 0.0478)																	

New shim thickness mm (in.)			
Shim No.	Thickness	Shim No.	Thickness
709	2.35 (0.0925)	45	2.85 (0.1122)
704	2.40 (0.0945)	21	2.90 (0.1142)
710	2.45 (0.0965)	46	2.95 (0.1161)
01	2.50 (0.0984)	26	3.00 (0.1181)
42	2.55 (0.1004)	47	3.05 (0.1201)
06	2.60 (0.1024)	31	3.10 (0.1220)
43	2.65 (0.1043)	48	3.15 (0.1240)
11	2.70 (0.1063)	36	3.20 (0.1260)
44	2.75 (0.1083)	49	3.25 (0.1280)
16	2.80 (0.1102)	41	3.30 (0.1299)

**Intake valve clearance (Cold):**  
0.15 - 0.25 mm (0.006 - 0.010 in.)

EXAMPLE: The 2.800 mm (0.1102 in.) shim is installed and the measured clearance is 0.300 mm (0.0118 in.). Replace the 2.800 mm (0.1102 in.) shim with a No. 21 shim.



## VALVE CLEARANCE (1HD-FTE) INSPECTION

EMOW1-01

### HINT:

Inspect and adjust the valve clearance when the engine is cold.

### 1. REMOVE CYLINDER HEAD COVER

(See page EM-77)

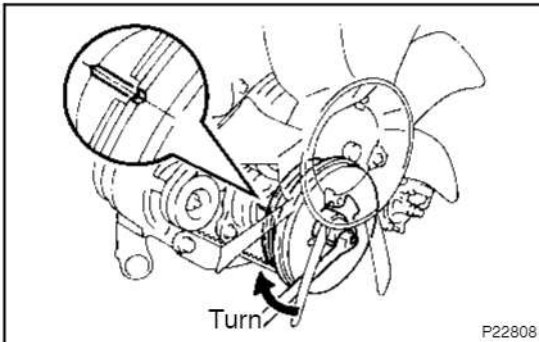

### 2. SET NO.1 CYLINDER TO TDC/COMPRESSION

- Turn the crankshaft pulley clockwise, and align its groove with the groove of the timing gear cover.
- Check that the valve rocker arm on the No.1 cylinder are loose and valve rocker arm on the No.6 cylinder are tight. If not, turn the crankshaft 1 revolution (360°) and align the mark as above.

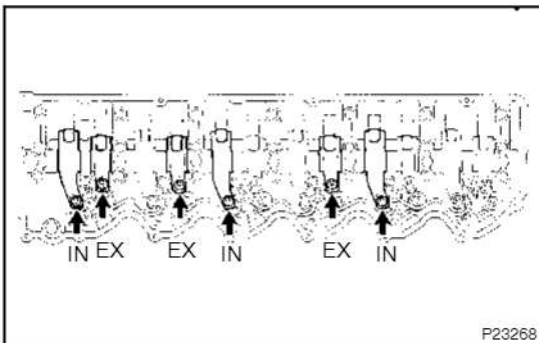

### 3. INSPECT VALVE CLEARANCE

- Check only the valves indicated in the illustration.
  - Using a feller gauge, measure the clearance between the adjusting screw on the valve rocker arm and the valve bridge.
  - Record the out-of-specification valve clearance measurements.

#### Valve clearance (Cold):

##### Intake

0.17 – 0.23 mm (0.007 – 0.009 in.)

##### Exhaust

0.47 – 0.53 mm (0.019 – 0.021 in.)

- Turn the crankshaft pulley 1 revolution (360°) and align the mark as above. (See procedure step 2)
- Check only the valves indicated as shown. Measure the valve clearance. (See procedure in step (a))

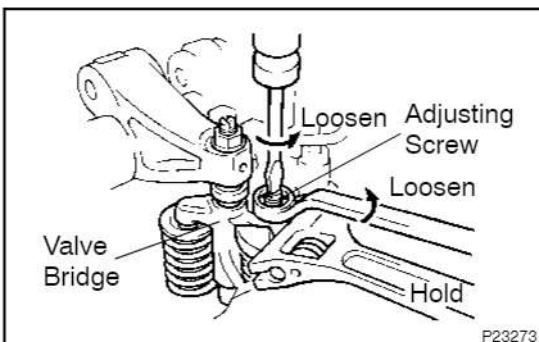
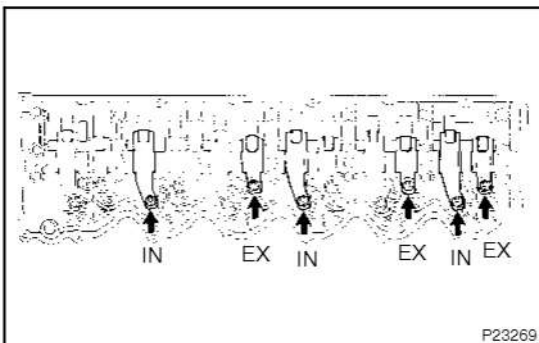

### 4. ADJUST VALVE CLEARANCE

- Loosen the lock nut on the valve bridge, and loosen the adjusting screw until the adjusting screw and valve stem are completely separated.

### NOTICE:

Hold the valve bridge with a wrench, and loosen the lock nut. Do not apply torque to the valve bridge.



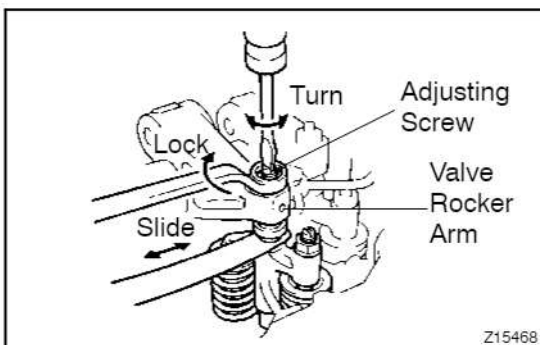
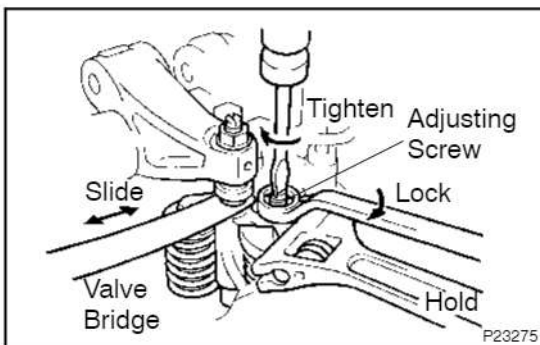
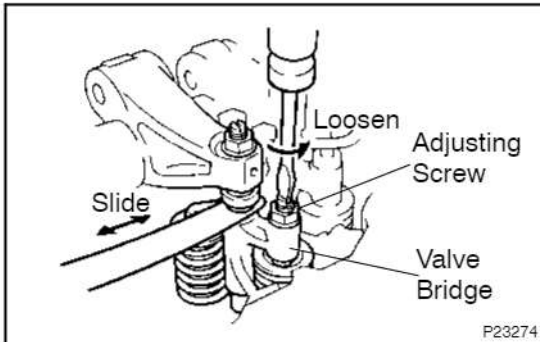
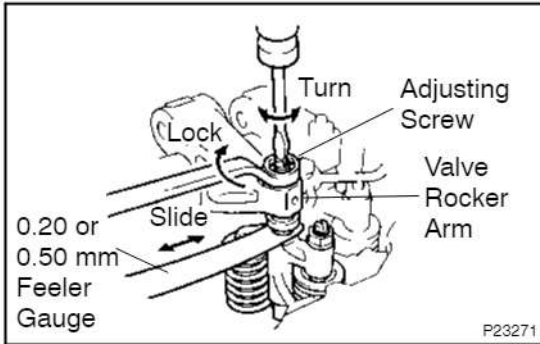

- (b) Loosen the lock nut on the valve rocker arm, and loosen the adjusting screw.
- (c) Insert a 0.20 mm (0.008 in.) feeler gage for intake or 0.50 mm (0.020 in.) feeler gage for exhaust between the adjusting screw on the valve rocker arm and the valve bridge.
- (d) Turn the adjusting screw on the valve rocker arm until the feeler gauge slides with a very slight drag, and lock the adjusting screw with the lock nut.
- (e) With the feeler gauge inserted, check that the resistance of the feeler gauge remains the same when the adjusting screw on the valve bridge is loosened. If the resistance of the feeler gauge changes, repeat from step (b).
- (f) Tighten the adjusting screw on the valve bridge, and lock the adjusting screw with the lock nut when the resistance of the feeler gauge begins to get stronger.

**NOTICE:**

**Hold the valve bridge with a wrench, and lock the adjusting screw with the lock nut. Do not apply torque to the valve bridge.**

- (g) Loosen the lock nut on the valve rocker arm.
- (h) Turn the adjusting screw on the valve rocker arm until the feeler gauge slides with a very slight drag, and lock the adjusting screw with the lock nut.

## 5. REINSTALL CYLINDER HEAD COVER (See page EM-94)

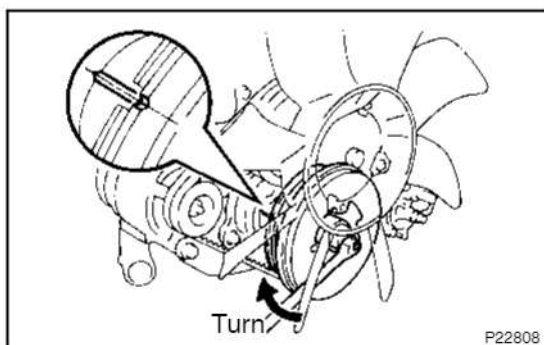

## INJECTION TIMING (1HZ, 1HD-T) INSPECTION

EM0W2-01

### 1. SET NO.1 OR NO.6 CYLINDER TO TDC/COMPRESSION

Turn the crankshaft pulley clockwise, and align its groove with the groove of the timing gear cover.

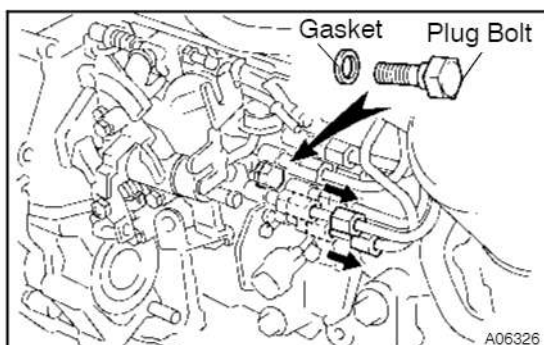

### 2. INSTALL SST AND DIAL INDICATOR

- Remove the plug bolt and gasket from the distributive head plug of the injection pump.
- Loosen the 2 union nuts holding the injection pump to the 2 injection pipes, and slide the union nut rearward.

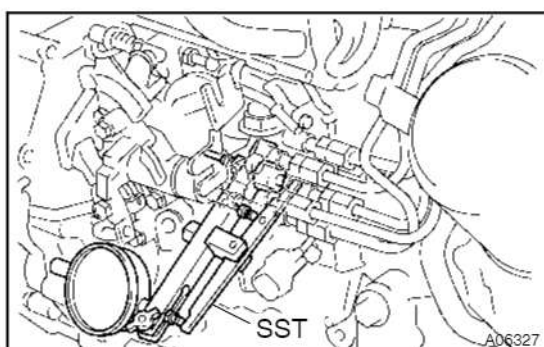

- Install SST (plunger stroke measuring tool) and a dial indicator to the plug bolt hole of distributive head plug.  
SST 09275-54011

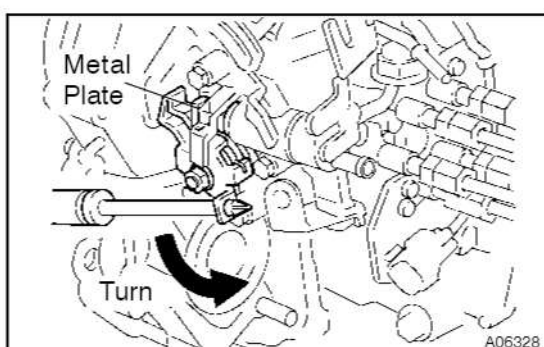

### 3. RELEASE ACSD ADVANCE

- Using a screwdriver, turn the cold starting lever counterclockwise approx.  $20^\circ$ .
- Put a metal plate (thickness of 9.0 - 10.0 mm (0.354 - 0.394 in.)) between the cold starting lever and thermo wax plunger.

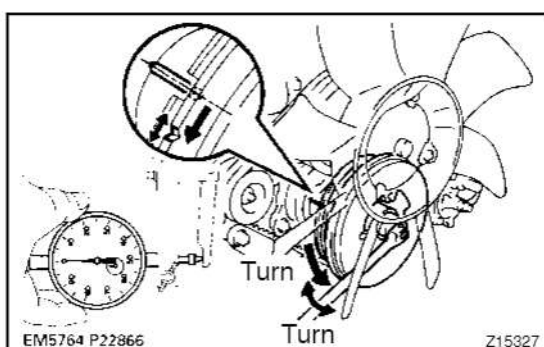

### 4. INSPECT AND ADJUST INJECTION TIMING

- Slowly rotate the crankshaft pulley counterclockwise and set the dial indicator at 0 mm (0 in.) when the dial indicator reaches the minimum value.
- Turn the crankshaft to the left and right and check that the dial indicator shows the minimum value.

#### NOTICE:

**Check that the minimum value is set at 0 mm (0 in.)**

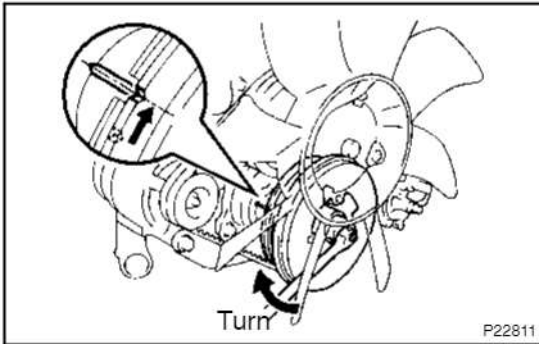

- (c) Slowly rotate the crankshaft pulley clockwise until its groove is aligned with the groove of the timing gear cover.  
 (d) Measure the plunger stroke.

**Plunger stroke:****1HZ:**

w/ ACSD: 0.65 – 0.71 mm (0.0256 – 0.0280 in.)

w/o ACSD: 0.85 – 0.91 mm (0.0335 – 0.0358 in.)

**1HD-T:**

1.18 – 1.24 mm (0.0465 – 0.0488 in.)

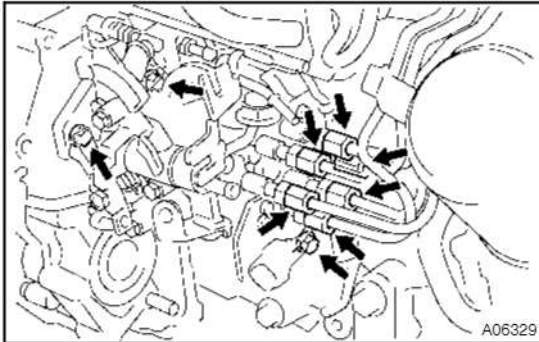

- (e) Loosen these nuts and bolts:  
 (1) 6 remaining union nuts holding injection pipes to injection pump  
 (2) Bolt holding injection pump to injection pump stay  
 (3) 2 nuts holding injection pump to timing gear case

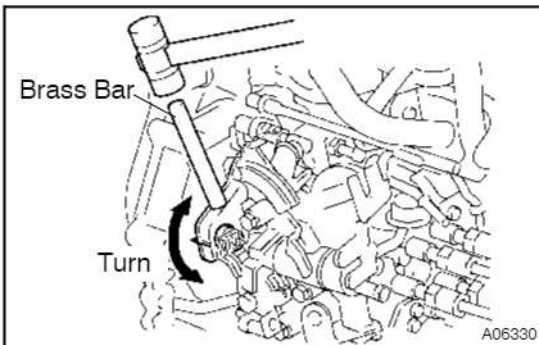
**NOTICE:****Do not turn the nuts more than 90°.**

- (f) Adjust plunger stroke by slightly tilting the injection pump body.  
 If the stroke is less than specification, tilt the pump toward the engine.  
 If the stroke is greater than specification, tilt the pump away from the engine.

**HINT:**

- If the stroke is less than specification, move the injection pump toward the engine.
  - Using a brass bar and plastic-faced hammer, gradually tap the pump flange away from the engine.
- (g) Tighten these nuts and bolts:

- 2 nuts holding injection pump to timing gear case

**Torque: 18 N·m (185 kgf·cm, 13 ft·lbf)**

- Bolts holding injection pump to injection pump stay

**Torque: 69 N·m (700 kgf·cm, 51 ft·lbf)**

- (h) Recheck the plunger stroke.

**5. REMOVE METAL PLATE****6. REMOVE SST AND DIAL INDICATOR**

- (a) Remove the SST and dial indicator.

SST 09275-54011

- (b) Install a new gasket and the plug bolt of the distributive head plug.

**Torque:****1HZ: 16.7 N·m (170 kgf·cm, 12 ft·lbf)****1HD-T: 25.5 N·m (260 kgf·cm, 19 ft·lbf)**

7. **TIGHTEN INJECTION PIPE UNION NUTS**  
Torque:  
1HZ: 14.7 N·m (150 kgf·cm, 11 ft·lbf)  
1HD-T: 24.5 N·m (250 kgf·cm, 18 ft·lbf)
8. **START ENGINE AND CHECK FOR FUEL LEAKS**

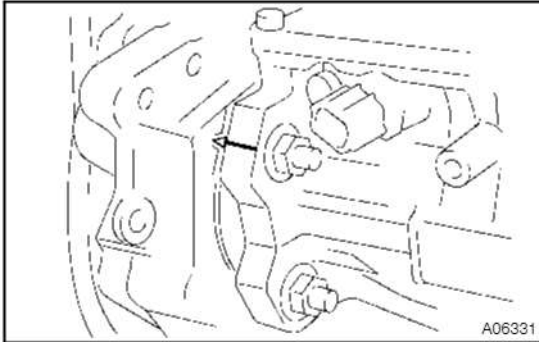

## INJECTION TIMING (1HD-FTE) INSPECTION

EMOW3-01

### 1. INSPECT INJECTION TIMING

Using mirror, check that the punching line of the injection pump flange and the punching line of the water pump aligned.

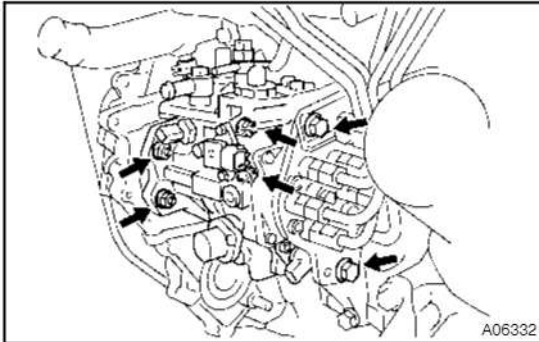

### 2. ADJUST INJECTION TIMING

- (a) Loosen these nuts and bolt:
    - 2 Bolts holding injection pump to injection pump stay.
    - 4 nuts holding injection pump to timing belt case.
  - (b) Align the punching line by slightly tilting the injection pump.
  - (c) Tighten these nuts and bolt:
    - 4 nuts holding injection pump to timing belt cover.
- Torque: 18 N·m (185 kgf·cm, 13 ft·lbf)**
- 2 Bolts holding injection pump to injection pump stay.

#### Torque:

**Injection pump stay bracket**  
39 N·m (398 kgf·cm, 29 ft·lbf)

**Injection pump stay**  
69 N·m (700 kgf·cm, 51 ft·lbf)

## IDLE SPEED AND MAXIMUM SPEED (1HZ, 1HD-T) INSPECTION

EM0W4-01

### 1. INITIAL CONDITIONS

- (a) Engine at normal operating temperature
- (b) Air cleaner installed
- (c) All accessories switched OFF
- (d) All vacuum lines properly connected
- (e) Valve clearance set correctly

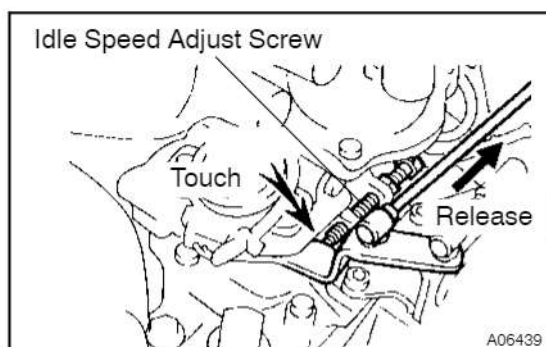

- (f) Injection timing set correctly
- (g) A/T:  
Transmission in neutral position
- (h) w/ PS:  
Steering wheel at straight-ahead position

### 2. CONNECT TACHOMETER

### 3. CHECK AND ADJUST IDLE SPEED

- (a) Check that the adjusting lever touches the idle speed adjusting screw when the accelerator pedal is released.

If not, adjust the accelerator linkage.

- (b) Start the engine.
- (c) Check the idle speed.

#### Idle speed:

##### 1HZ:

**M/T: 650 ± 50 rpm**

**A/T: 710 ± 50 rpm**

##### 1HD-T:

**M/T: 650 ± 50 rpm**

**A/T: 700 – 800 rpm**

- (d) Adjust the idle speed.
  - Disconnect the accelerator linkage.
  - Loosen the lock nut of the idle speed adjusting screw.
  - Adjust the idle speed by turning the idle speed adjusting screw.
  - Securely tighten the lock nut, and recheck the idle speed.
  - Reconnect the accelerator linkage.
  - After adjustment, adjust the accelerator linkage.

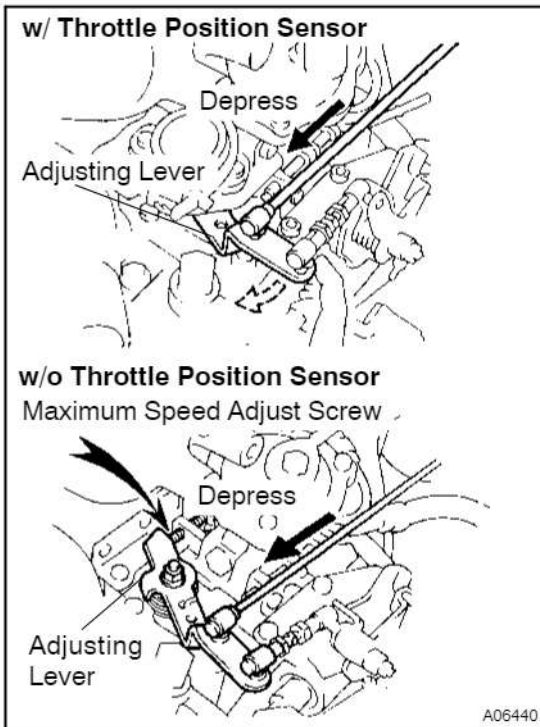

#### 4. CHECK AND ADJUST MAXIMUM SPEED

- (a) w/ Throttle Position Sensor:  
Depress the accelerator pedal all the way. Then check that the adjusting lever does not move when you try to push it to the maximum speed side.

If not, adjust the accelerator linkage.

- (b) w/o Throttle Position Sensor:  
Check that the adjusting lever touches the maximum speed adjusting screw when the accelerator pedal is depressed all the way.

If not, adjust the accelerator linkage.

- (c) Start the engine.  
(d) Depress the accelerator pedal all the way.  
(e) Check the maximum speed.

##### Maximum speed:

**1HZ: 4,600 ± 100 rpm**

**1HD-T: 4400 ± 100 rpm**

If the maximum speed is not as specified, remove the injection pump and adjust the maximum speed.

## IDLE SPEED AND MAXIMUM SPEED (1HD-FTE) INSPECTION

EM0WS-01

### 1. INITIAL CONDITIONS

- (a) Engine at normal operating temperature.
- (b) Air cleaner installed.
- (c) All pipes and hoses of air induction system connected.
- (d) All accessories switched OFF.
- (e) All vacuum lines properly connected.
- (f) ECD system warning connectors fully plugged.
- (g) Valve clearance set correctly.
- (h) Ignition timing check correctly.

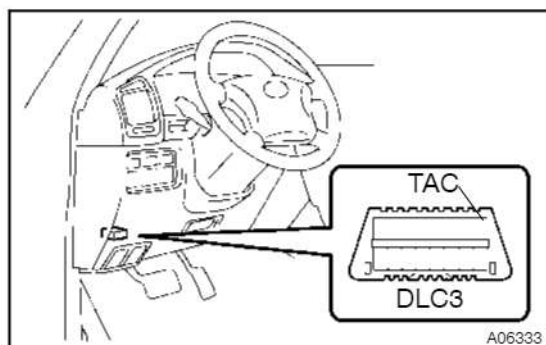

### 2. CONNECT TACHOMETER

Connect the tester probe of a tachometer to terminal TAC of the DLC3.

### 3. INSPECT IDLE SPEED

Start the engine.

Check the idle speed.

**Idle speed: 550 – 650 rpm**

### 4. INSPECT MAXIMUM SPEED

- (a) Start the engine.
- (b) Depress the accelerator pedal all the way.
- (c) Check the maximum speed.

**Maximum speed: 4300 – 4500 rpm**



## AIR CONDITIONER IDLE-UP SPEED (1HZ, 1HD-T) INSPECTION

EM006-01

### 1. INITIAL CONDITIONS

- (a) Engine at normal operating temperature
- (b) Air cleaner installed
- (c) All accessories switched OFF
- (d) All vacuum lines properly connected
- (e) Valve clearance set correctly
- (f) Injection timing set correctly
- (g) Transmission in neutral position
- (h) Idle speed set correctly

### 2. CONNECT TACHOMETER

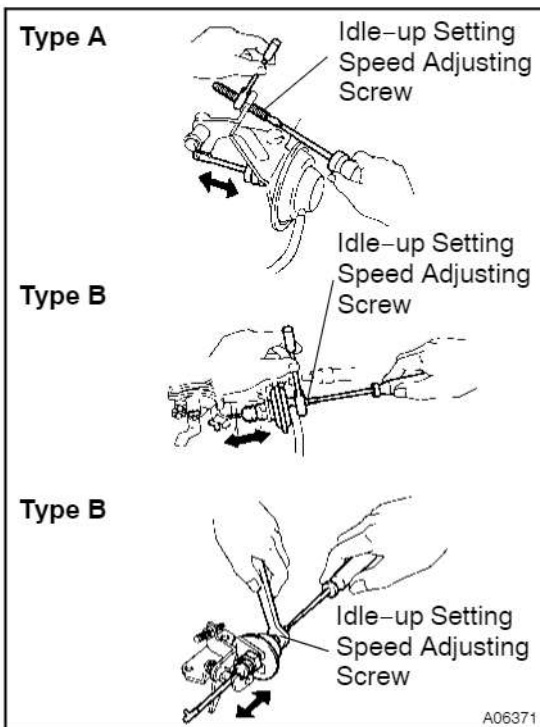

### 3. ADJUST A/C IDLE-UP SPEED

- (a) Start the engine.
- (b) Turn the A/C switch ON, and set these position:
  - Blower switch to HI
  - Air intake control lever to RECIRCULATED AIR
  - Air flow control lever to FACE
  - Temperature control lever to COOL
- (c) Check the idle-up speed.  
**A/C idle-up speed: 725 - 850 rpm**
- (d) Loosen the lock nut, and adjust the idle-up setting speed by turning the idle-up speed adjusting screw. Lock the adjusting screw with the lock nut.
- (e) Turn the A/C switch OFF, then ON again, and recheck the idle-up speed.
- (f) Turn the A/C switch OFF, and check that the rod end of the idle-up actuator is not touching the idle-up lever.

## AIR CONDITIONER IDLE-UP SPEED (1HD-FTE)

EM0W7-01

### INSPECTION

#### 1. INITIAL CONDITIONS

- (a) Engine at normal operating temperature.
- (b) Air cleaner installed.
- (c) All pipes and hoses of air induction system connected.
- (d) All accessories switch OFF.
- (e) All vacuum lines properly connected.
- (f) ECD system wiring connectors fully plugged.
- (g) Valve clearance set correctly.
- (h) Injection timing set correctly.
- (i) Idle speed set correctly.

#### 2. CONNECT TACHOMETER

(See page EM-17)

#### 3. INSPECT A/C IDLE-UP SPEED

- (a) Start the engine.
- (b) Push on the A/C switch.
- (c) Check the A/C idle-up speed.

**A/C idle-up speed: 725 – 850 rpm**

If the A/C idle-up speed is not specified, check the troubleshooting in DI section.

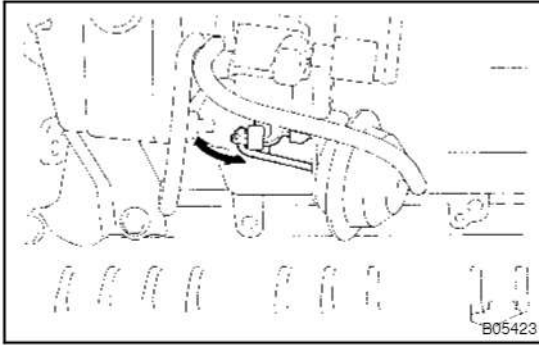

## INTAKE SHUTTER (1HD-FTE) ON-VEHICLE INSPECTION

EMOW8-01

### 1. INSPECT INTAKE SHUTTER

- (a) Check that the intake shutter linkage moves smoothly.

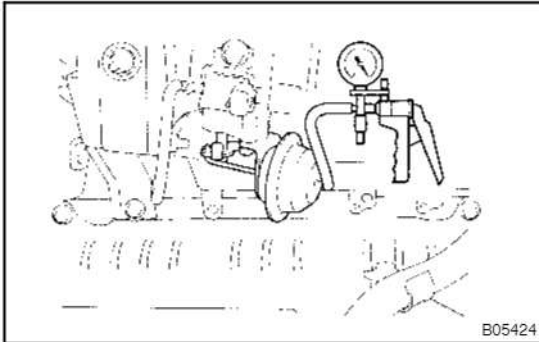

- (b) Check that the diaphragm rod is pulled up when a vacuum of approx. 60 kPa (450 mmHg, 17.72 in.Hg) is applied to the actuator.
- (c) Apply approx. 60 kPa (450 mmHg, 17.72 in.Hg) of vacuum directly to the actuator with the engine idling.
- (d) Check that the engine runs rough or dies.

### NOTICE:

**Connect the actuator vacuum hose.**

- (e) Reconnect the hoses to the proper locations.

### 2. REMOVE VSV FOR INTAKE SHUTTER

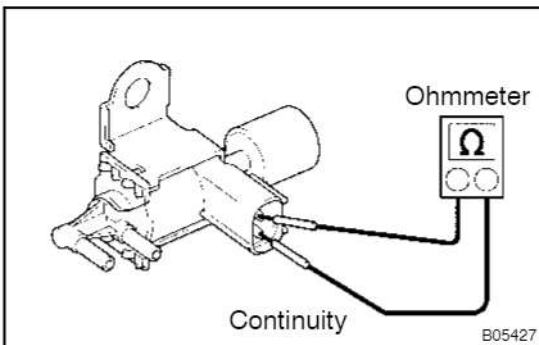

### 3. INSPECT VSV FOR OPEN CIRCUIT

Using an ohmmeter, measure the resistance between the terminals.

**Resistance: 33 – 39  $\Omega$  at 20°C (68°F)**

If the resistance is not within specification, replace the VSV.

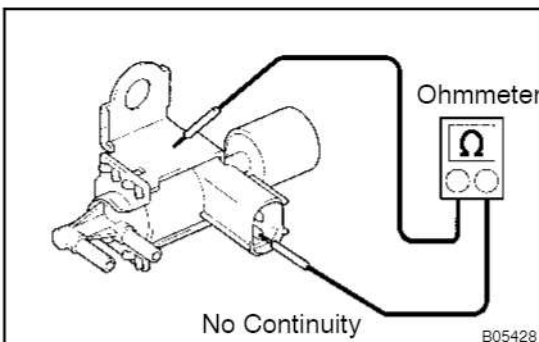

### 4. INSPECT VSV FOR GROUND

Using an ohmmeter, check that there is no continuity between the terminals and VSV body.

If there is continuity, replace the VSV.

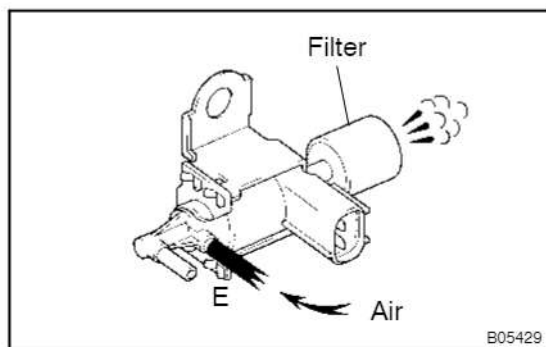

## 5. INSPECT VSV OPERATION

(a) Check that air flows from port E to the filter.

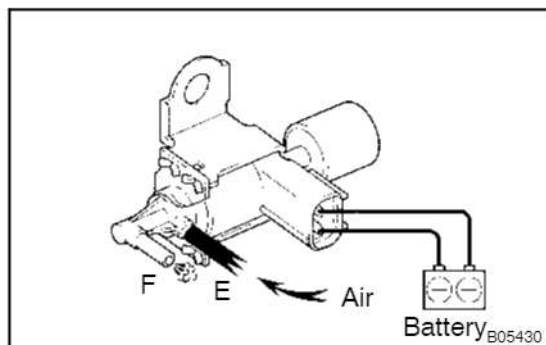

(b) Apply battery voltage across the terminals.

(c) Check that air flows from port E to F.

If operation is not as specified, replace the VSV.

# COMPONENTS

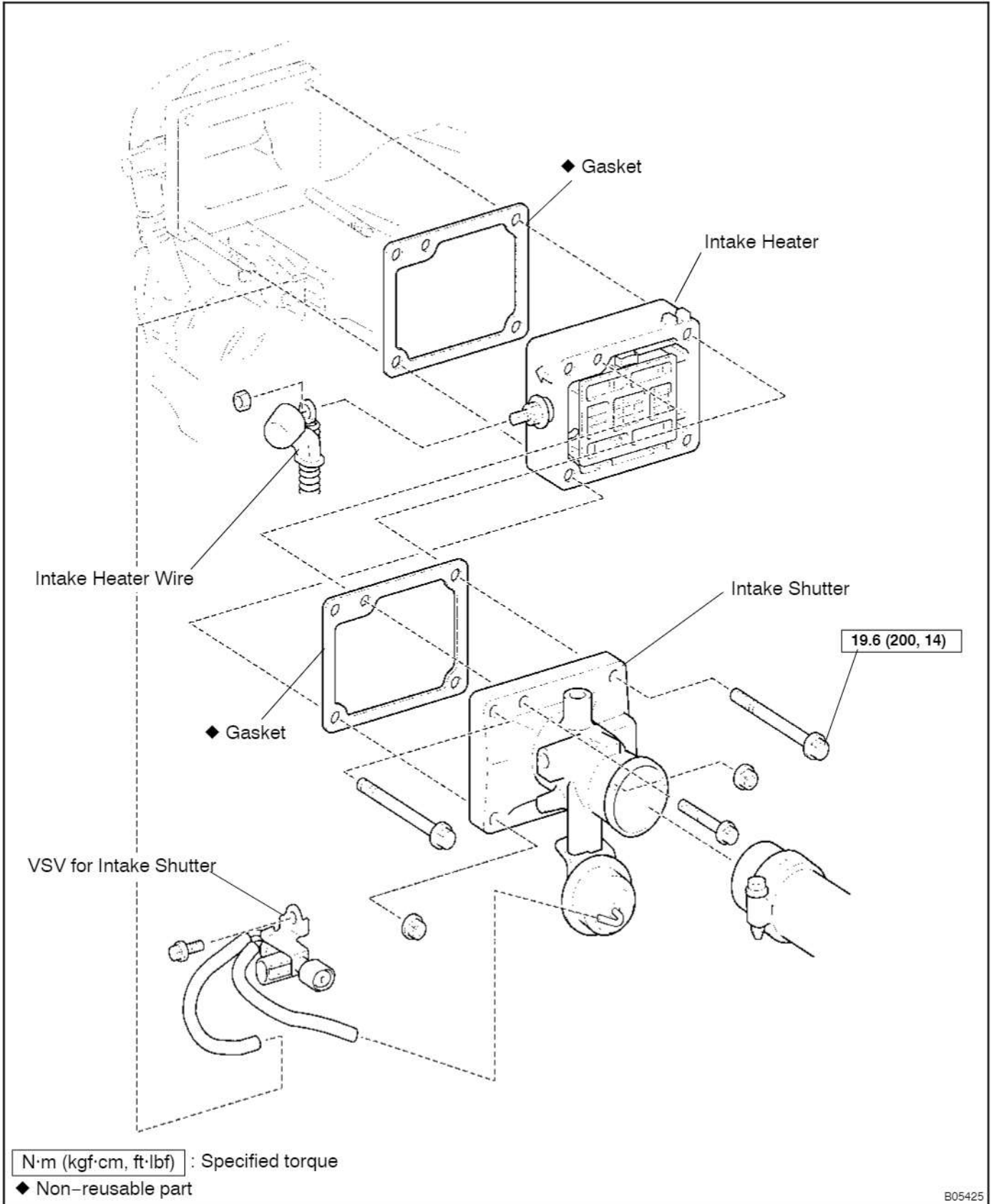

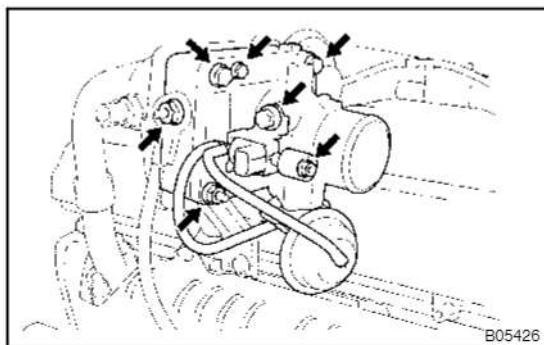

## REMOVAL

1. **DISCONNECT INTAKE HEATER WIRE**
2. **REMOVE VSV FOR INTAKE SHUTTER**
  - (a) Disconnect the 2 vacuum hoses from the cylinder head cover and actuator
  - (b) Remove the bolt and VSV.
3. **REMOVE INTAKE SHUTTER AND INTAKE HEATER**

Remove the 3 bolts , 2 nuts, intake shutter, intake heater and 2 gasket.

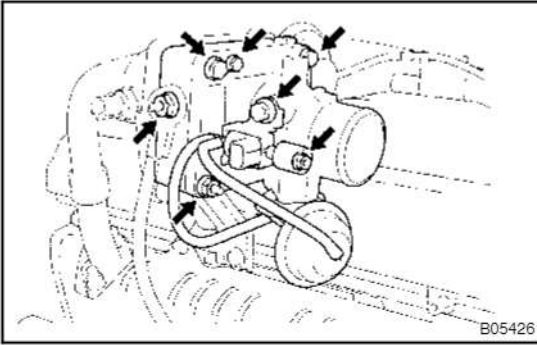

## INSTALLATION

### 1. INSTALL INTAKE HEATER AND INTAKE SHUTTER

- (a) Place 2 new gaskets, the intake heater and intake shutter.
- (b) Install the 2 bolts and 2 nuts.

**Torque: 19.6 N·m (200 kgf·cm, 14 ft·lbf)**

### 2. CONNECT INTAKE HEATER WIRE

### 3. INSTALL VSV FOR INTAKE SHUTTER

- (a) Install the VSV with the bolt.
- (b) Connect the 2 vacuum hoses to the cylinder head cover and actuator

# TIMING BELT COMPONENTS

EM0WC-01

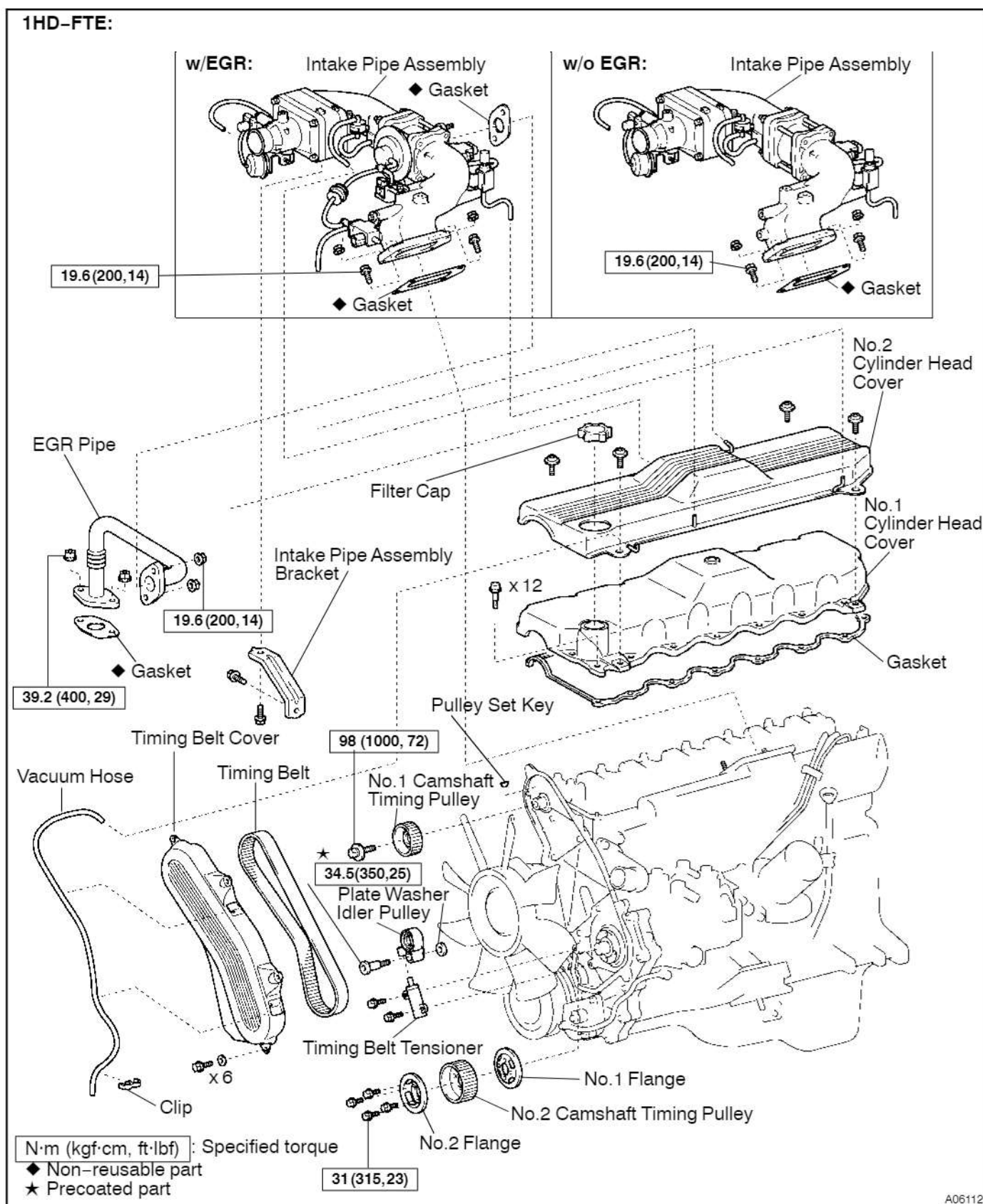

cardiagn.com

A06112



1HZ, 1HD-T:

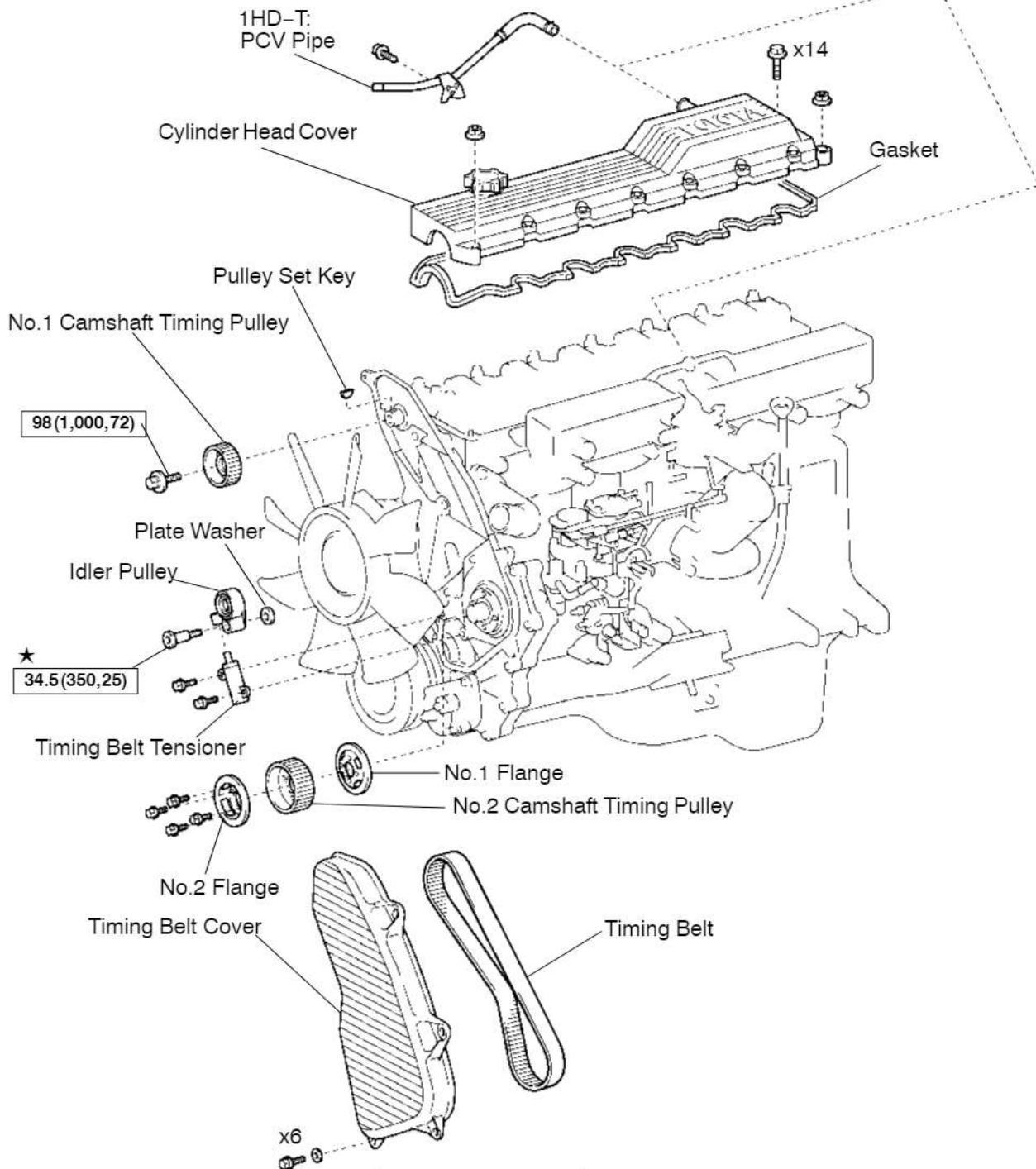
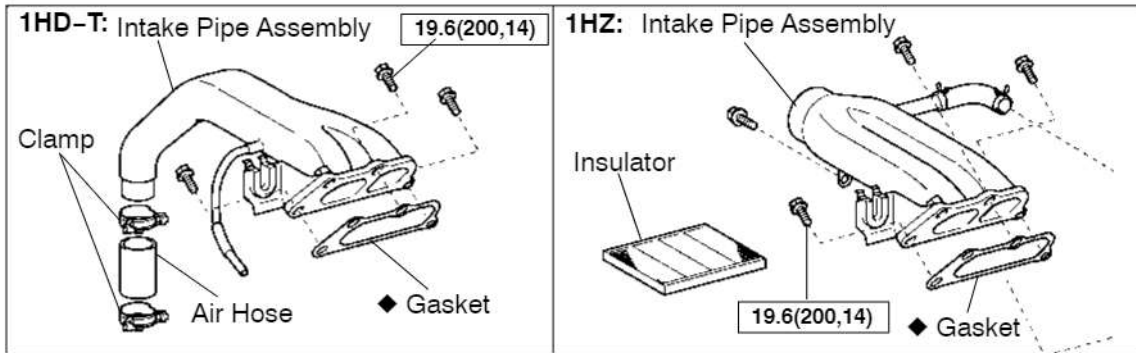

★ Precoated part ◆ Non-reusable part [N·m (kgf·cm, ft·lbf)]: Specified torque

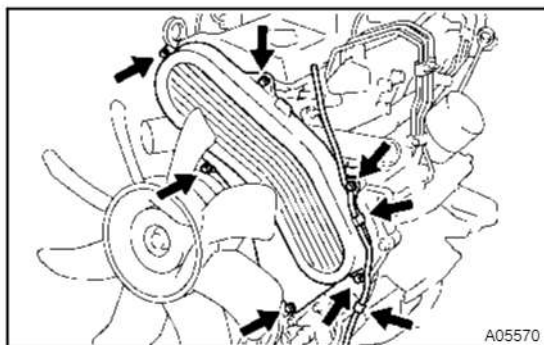

## REMOVAL

### 1. REMOVE INTAKE PIPE ASSEMBLY

1HZ, 1HD-T: (See page EM-48)

1HD-FTE: (See page EM-77)

### 2. REMOVE TIMING BELT COVER

- (a) Disconnect the vacuum hose from the timing belt cover and vacuum hose from the clip.
- (b) Remove the 6 bolts, 6 seal washers and timing belt cover.

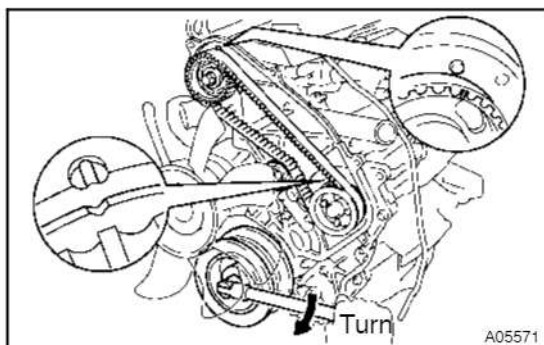

### 3. SET NO.1 CYLINDER TO BDC/COMPRESSION

Turn the crankshaft pulley clockwise, align the timing marks of the No.1 and No.2 camshaft timing pulleys with the BDC marks.

#### NOTICE:

If the timing belt is disengaged, having the crankshaft pulley at the wrong angle can cause the piston head and valve head to come into contact with each other when you remove the camshaft timing pulley (step 8), causing damage. so always set the crankshaft pulley at the correct angle.

### 4. REMOVE TIMING BELT

#### HINT:

- When re-using timing belt:  
Draw a direction arrow on the timing belt (in the direction of engine revolution), and place match-marks on the timing pulleys and timing belt.
- When replacing timing belt tensioner only:  
To avoid meshing of the timing pulley and timing belt, secure one of them with the string.

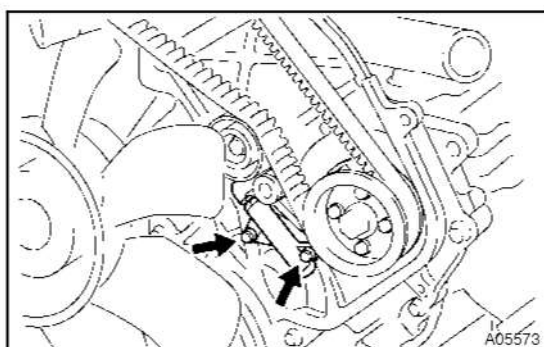
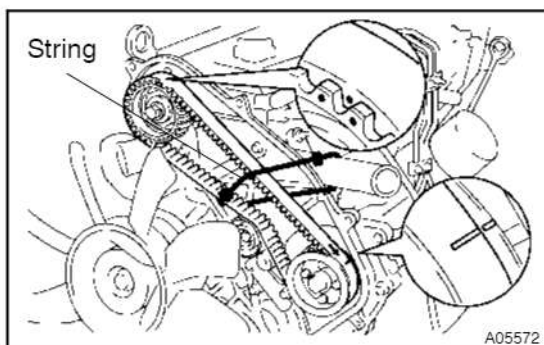

- (a) Alternately loosen the 2 bolts, and remove them and the timing belt tensioner.
- (b) Remove the timing belt.

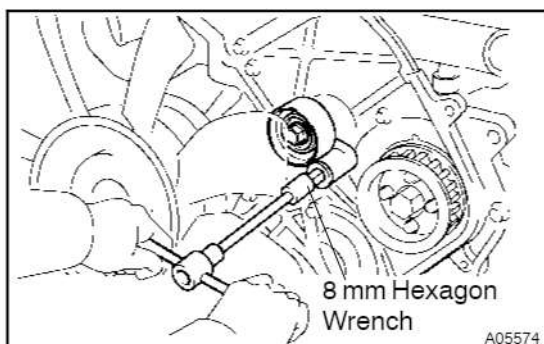

### 5. REMOVE IDLER PULLEY

Using an 8 mm hexagon wrench, remove the pivot bolt, idler pulley and plate washer.

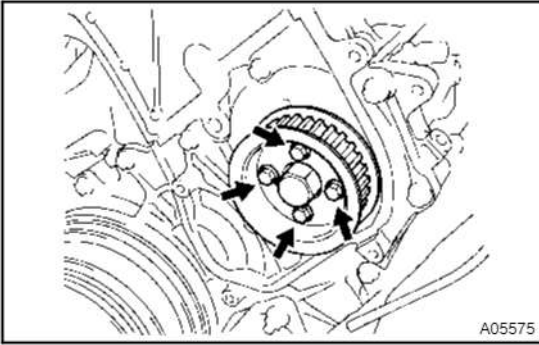

**6. REMOVE NO.2 CAMSHAFT TIMING PULLEY**

Remove the 4 bolts, No.2 flange, timing pulley and No.1 flange.

**7. 1HD-FTE:**

**REMOVE NO.1 AND NO.2 CYLINDER HEAD COVER**

(See page EM-77)

**8. 1HZ, 1HD-T:**

**REMOVE CYLINDER HEAD COVER**

(See page EM-48)

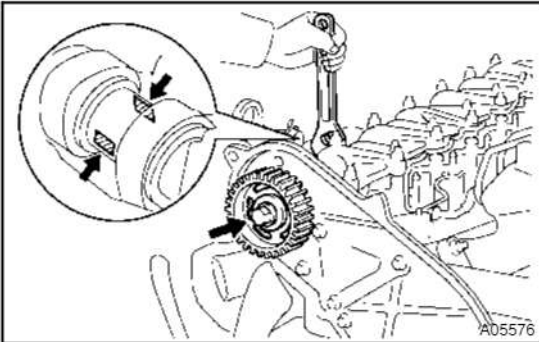

**9. REMOVE NO.1 CAMSHAFT TIMING PULLEY**

- (a) Slightly turn the camshaft timing pulley counterclockwise and hold the hexagon wrench head portion of the camshaft with a wrench, and remove the bolt and timing pulley.

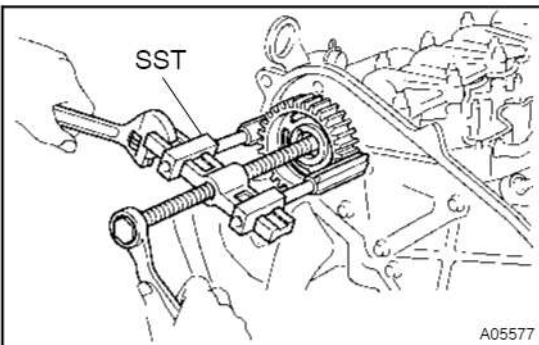

- (b) Using SST, remove the timing pulley.

SST 09950-40010 (09951-04010, 09952-04010, 09953-04020, 09954-04010, 09955-04060)

- (c) Remove the set key.

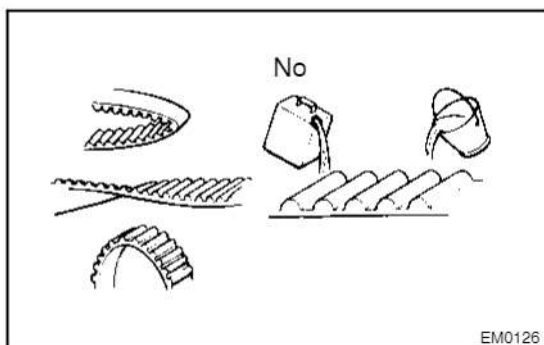

EM0126

## INSPECTION

### 1. INSPECT TIMING BELT

#### NOTICE:

- Do not bend, twist or turn the timing belt inside out.
- Do not allow the timing belt to come into contact with oil, water or steam.
- Do not utilize timing belt tension when installing or removing the mount bolt of the camshaft timing pulley.

If there are any defects, as shown in the illustrations, check these points:

- Premature parting
  - Check for proper installation.
  - Check the timing cover gasket for damage and proper installation.
- If the belt teeth are cracked or damaged, check to see if the camshaft is locked.
- If there is noticeable wear or cracks on the belt face, check to see if there are nicks on the side of the idler pulley lock.
- If there is wear or damage on only one side of the belt, check the belt guide and the alignment of each pulley.
- If there is noticeable wear on the belt teeth, check timing cover for damage and check gasket has been installed correctly and for foreign material on the pulley teeth. If necessary, replace the timing belt.

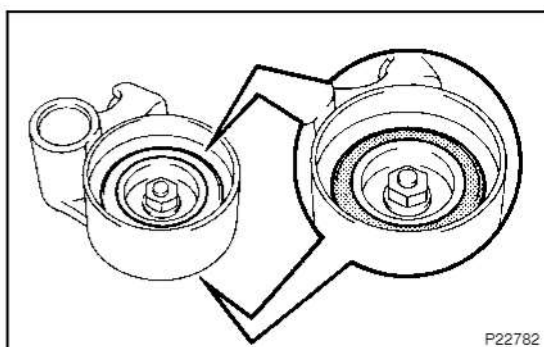

P22782

### 2. INSPECT IDLER PULLEY

- Visually check the seal portion of the idler pulley for oil leakage. If leakage is found, replace the idler pulley.

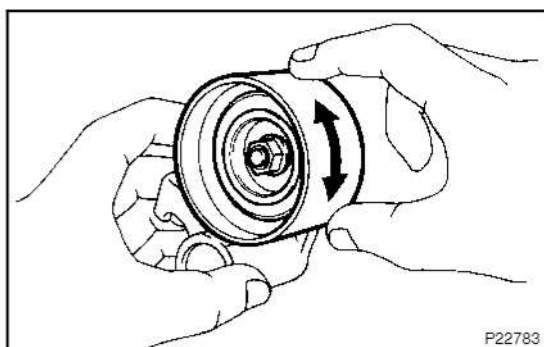

P22783

- Check that the idler pulley turns smoothly. If necessary, replace the idler pulley.

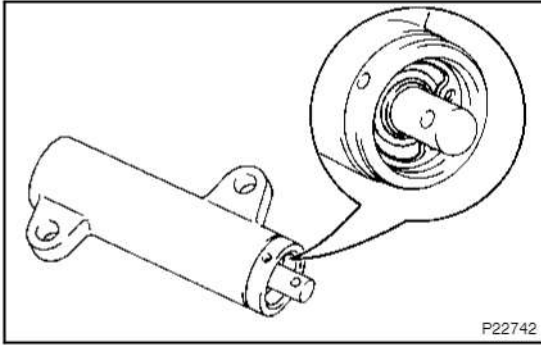

### 3. INSPECT TIMING BELT TENSIONER

- (a) Visually check the seal portion of the tensioner for oil leakage.

**HINT:**

If there is only the faintest trace of oil on the seal on the push rod side, the tensioner is all right.

If leakage is found, replace the tensioner.

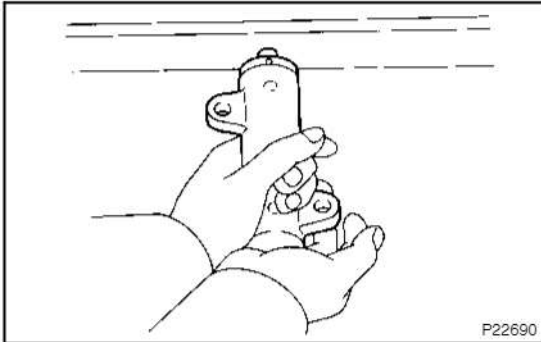

- (b) Hold the tensioner with both hands and push the push rod strongly as shown to check that it doesn't move.

If the push rod moves, replace the tensioner.

**NOTICE:**

**Never hold the tensioner push rod facing downward.**

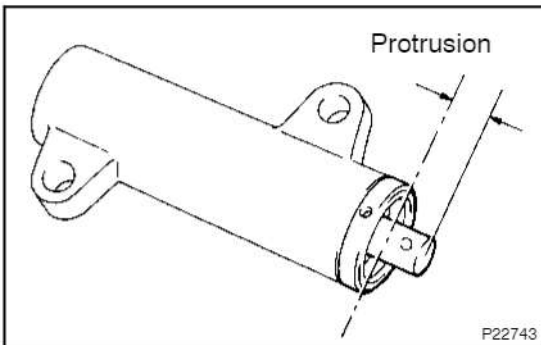

- (c) Measure the protrusion of the push rod from the housing end.

**Protrusion: 9.0 – 9.8 mm (0.354 – 0.386 in.)**

If the protrusion is not as specified, replace the tensioner.

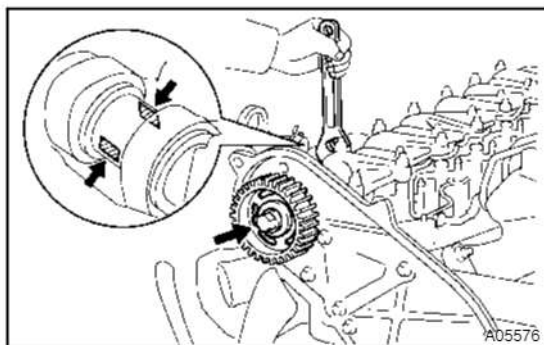

## INSTALLATION

### 1. INSTALL NO.1 CAMSHAFT TIMING PULLEY

- Install the set key to the key groove of the camshaft.
- Align the pulley set key with the key groove of the timing pulley, and slide the timing pulley.
- Temporarily install the pulley bolt.
- Hold the hexagon wrench head portion of the camshaft with a wrench, and tighten the pulley bolt.

**Torque: 98 N·m (1,000 kgf·cm, 72 ft·lbf)**

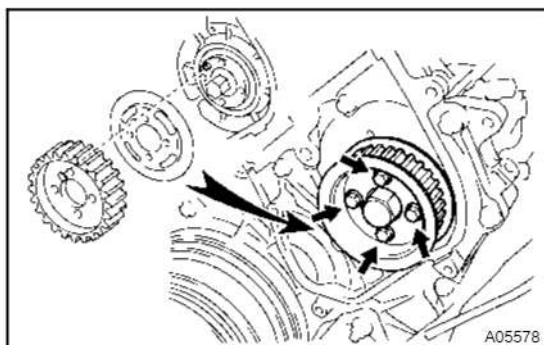

### 2. 1HD-FTE:

#### INSTALL NO.1 AND NO.2 CYLINDER HEAD COVER

(See page EM-94)

### 3. 1HZ, 1HD-T:

#### INSTALL CYLINDER HEAD COVER

(See page EM-66)

### 4. INSTALL NO.2 CAMSHAFT TIMING PULLEY

- Align the knock pin on the injection pump drive gear with the knock pin hole of the No.1 flange and the knock pin groove of the timing pulley.
- Install the No.1 flange, timing pulley and No.2 flange with the 4 bolts.

**Torque: 31 N·m (315 kgf·cm, 23 ft·lbf)**

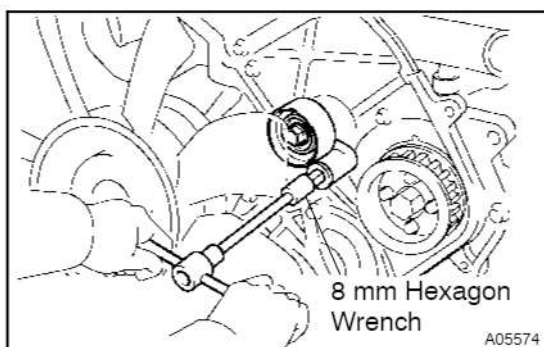

### 5. INSTALL IDLER PULLEY

- Using an 8 mm hexagon wrench, install the plate washer and idler pulley with the pivot bolt.

#### Adhesive:

**Part No. 08833 - 00080, THREE BOND 1344, LOCTITE 242 or equivalent**

**Torque: 34.5 N·m (350 kgf·cm, 25 ft·lbf)**

- Check that the pulley bracket moves smoothly.

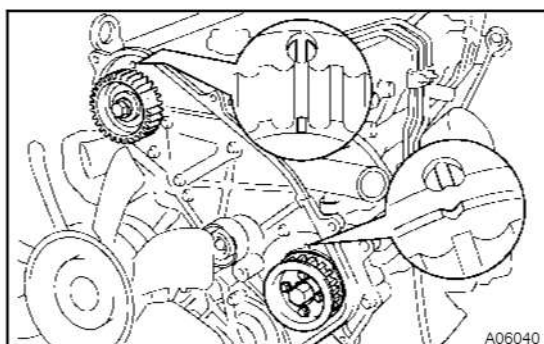

### 6. SET NO.1 CYLINDER TO BDC/COMPRESSION

- Check that the timing mark of the No.2 camshaft timing pulley is aligned with the BDC mark.

#### NOTICE:

**Do not turn the crankshaft pulley. The valve heads will hit against the piston top.**

- Align the timing mark of the No.1 camshaft timing pulley with the BDC mark.

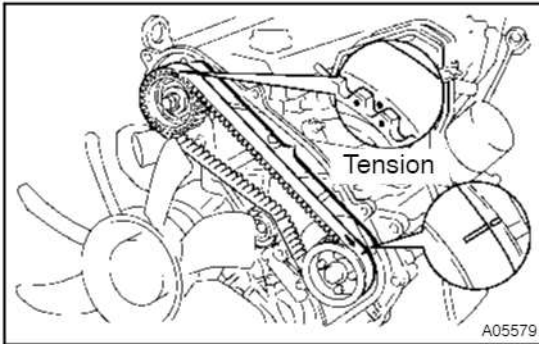

## 7. INSTALL TIMING BELT

### NOTICE:

**The engine should be cold.**

### HINT:

Align the points marked during removal, and install the belt with the arrow pointing in the direction of engine revolution.

- (a) Remove any oil or water on the pulleys, and keep them clean.

### NOTICE:

**Only wipe the pulleys; do not use any cleansing agent.**

- (b) Install the timing belt under tension between the No.1 and No.2 camshaft timing pulleys.

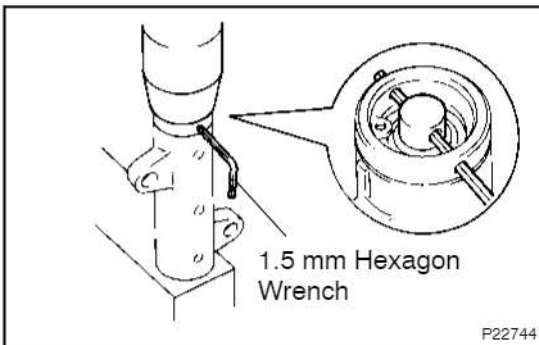

## 8. SET TIMING BELT TENSIONER

- (a) Using a press, slowly press in the push rod using 981 – 9,807 N (100 – 1,000 kgf, 220 – 2,205 lbf) of force.
- (b) Align the holes of the push rod and housing, pass a 1.5 mm hexagon wrench through the holes to keep the setting position of the push rod.
- (c) Release the press.

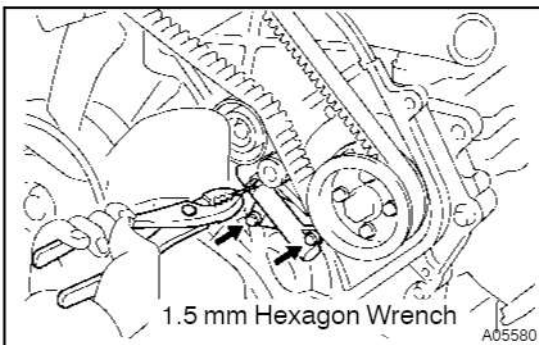

## 9. INSTALL TIMING BELT TENSIONER

- (a) Temporarily install the timing belt tensioner with the 2 bolts while pushing the idler pulley toward the timing belt.
- (b) Alternately tighten the 2 bolts.

**Torque: 13 N·m (130 kgf·cm, 10 ft·lbf)**

- (c) Remove the 1.5 mm hexagon wrench from the tensioner.

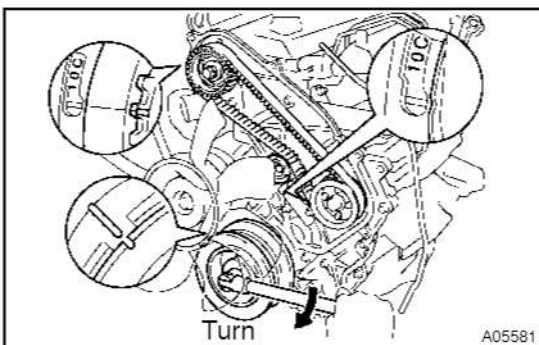

## 10. CHECK VALVE TIMING

Turn the crankshaft pulley clockwise and check that each pulley timing mark aligns with the TDC marks.

If the marks do not align, remove the timing belt and reinstall it.

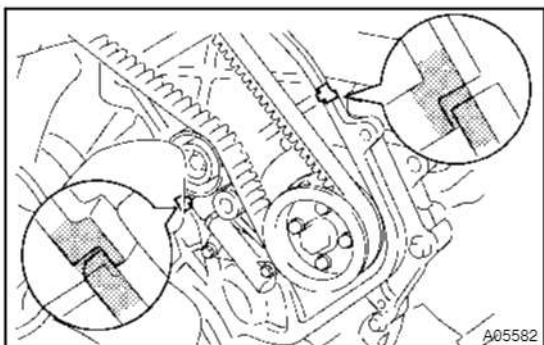
**11. INSTALL TIMING BELT COVER**

- (a) Remove any old packing (FIPG) material.
- (b) Apply seal packing to the camshaft oil seal retainer and timing gear cover as shown in the illustration.

**Seal packing: Par No. 08826-00080 or equivalent**

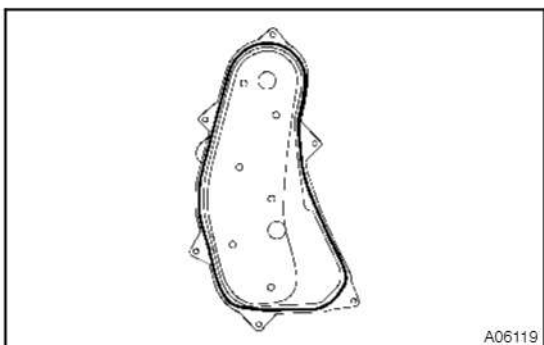

- (c) Check that timing belt cover gaskets have cracks or peeling, etc.

If the gasket has cracks or peeling, etc. replace it using these steps:

- Using a screwdriver and gasket scraper, remove all the oil gasket material.
- Thoroughly clean all components to remove all the loose material.
- Remove the backing paper from a new gasket and install the gasket evenly to the part of the timing belt cover shaded black in the illustration.

**NOTICE:**

**Do not leave a gap between them.**

**Cut off any excess gasket.**

- After installing the gasket, press down on it so that the adhesive firmly sticks to the timing belt cover.

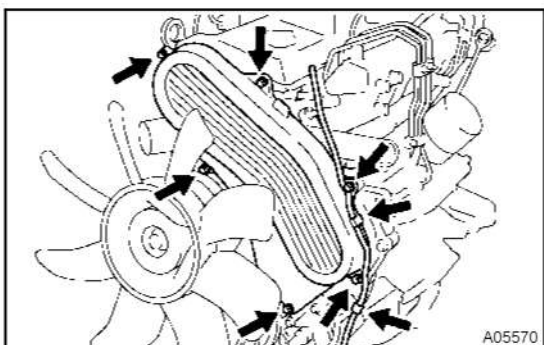

- (d) Install the timing belt cover with the 6 seal washers and 6 bolts.
- (e) Install the vacuum hose to the the timing belt cover and vacuum hose to the clip.

**12. INSTALL INTAKE PIPE ASSEMBLY**

**1HZ, 1HD-T: (See page EM-66)**

**1HD-FTE: (See page EM-94)**



# TIMING GEAR COMPONENTS

EM0WG-01

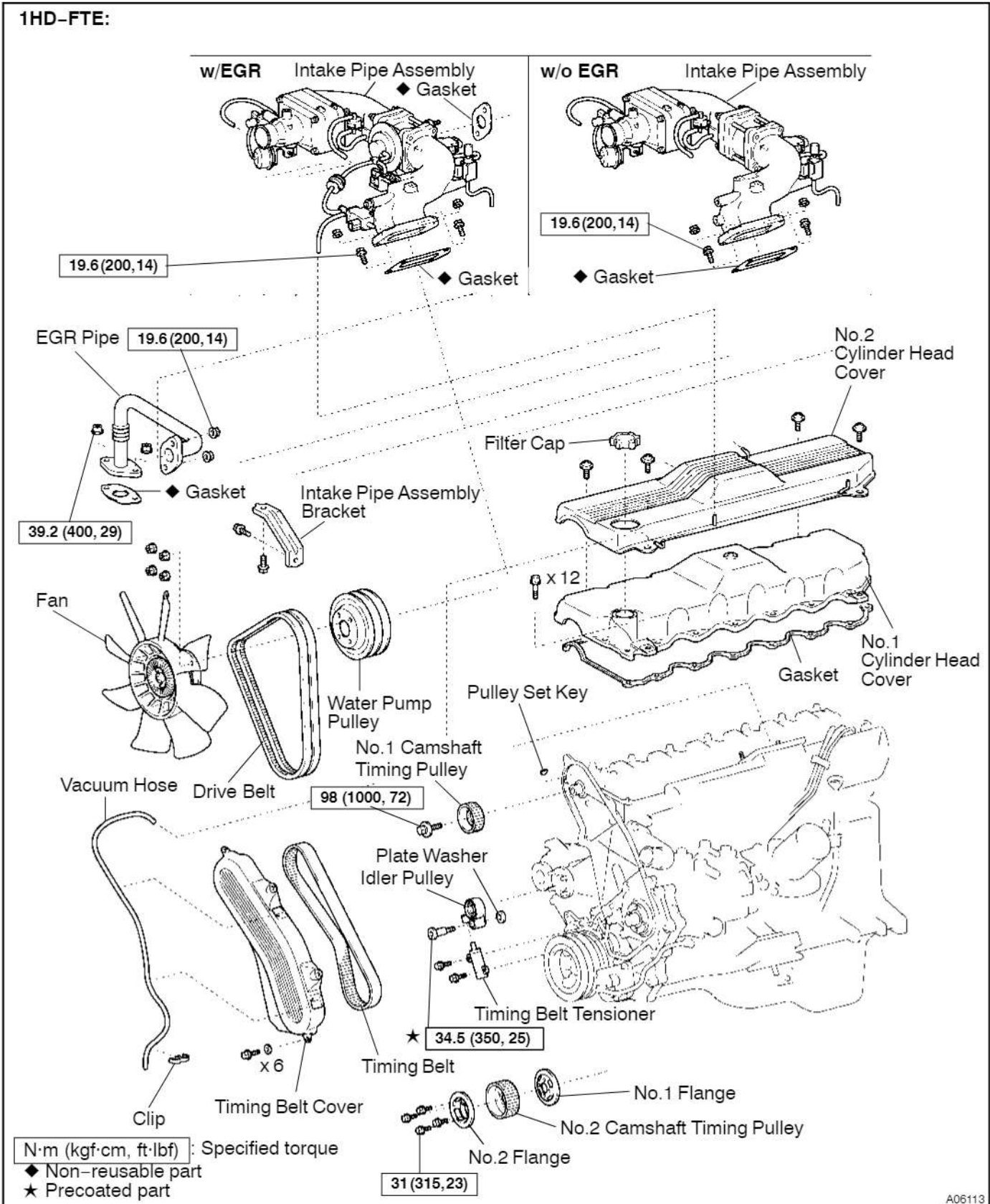

cardiagn.com

1HZ, 1HD-T:

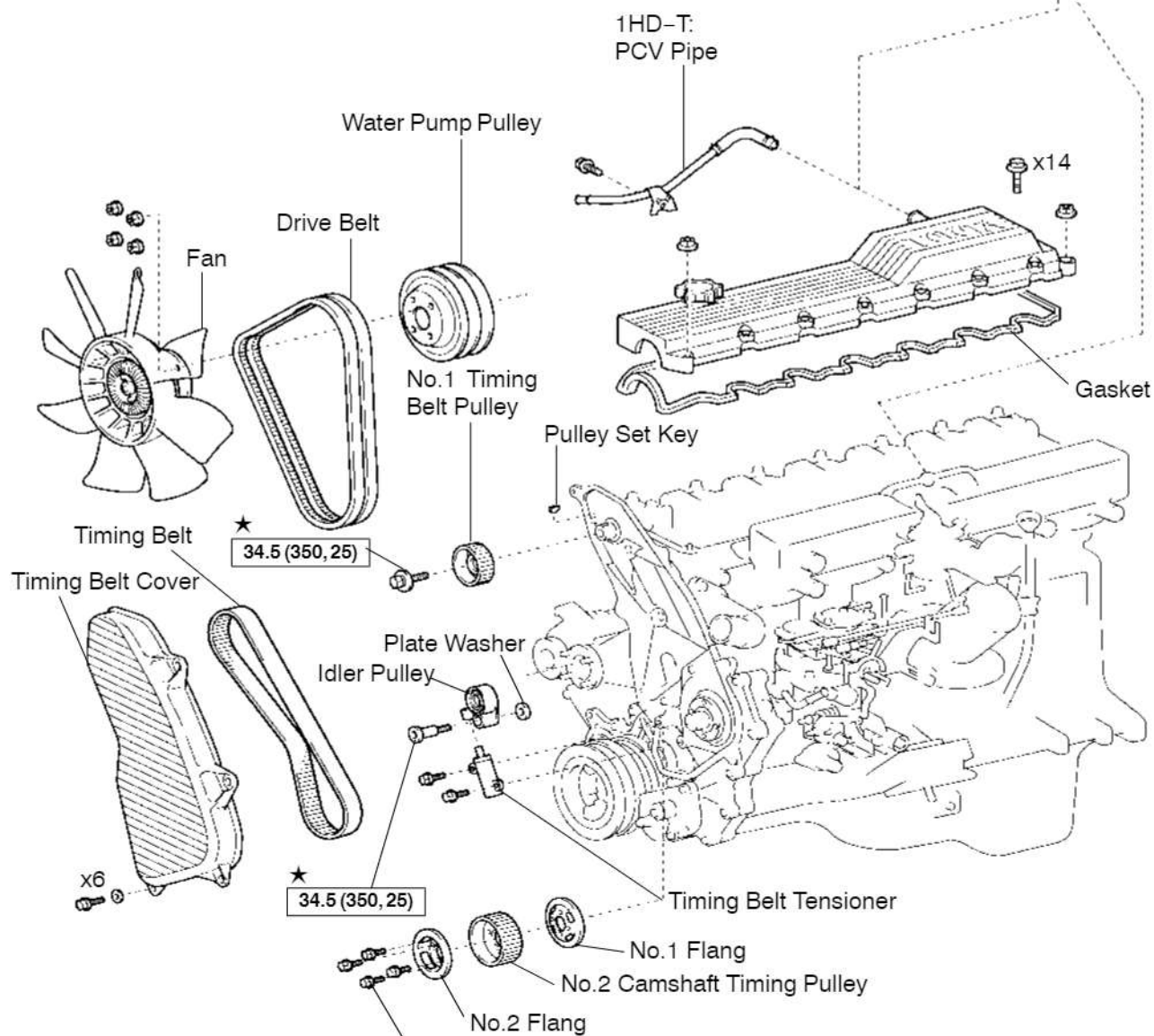
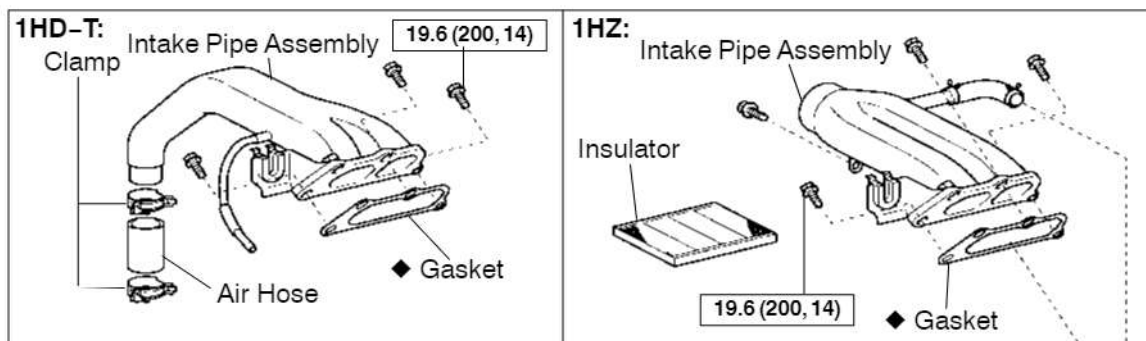

N·m (kgf·cm, ft·lbf) : Specified torque

◆ Non-reusable part

★ Precoated part

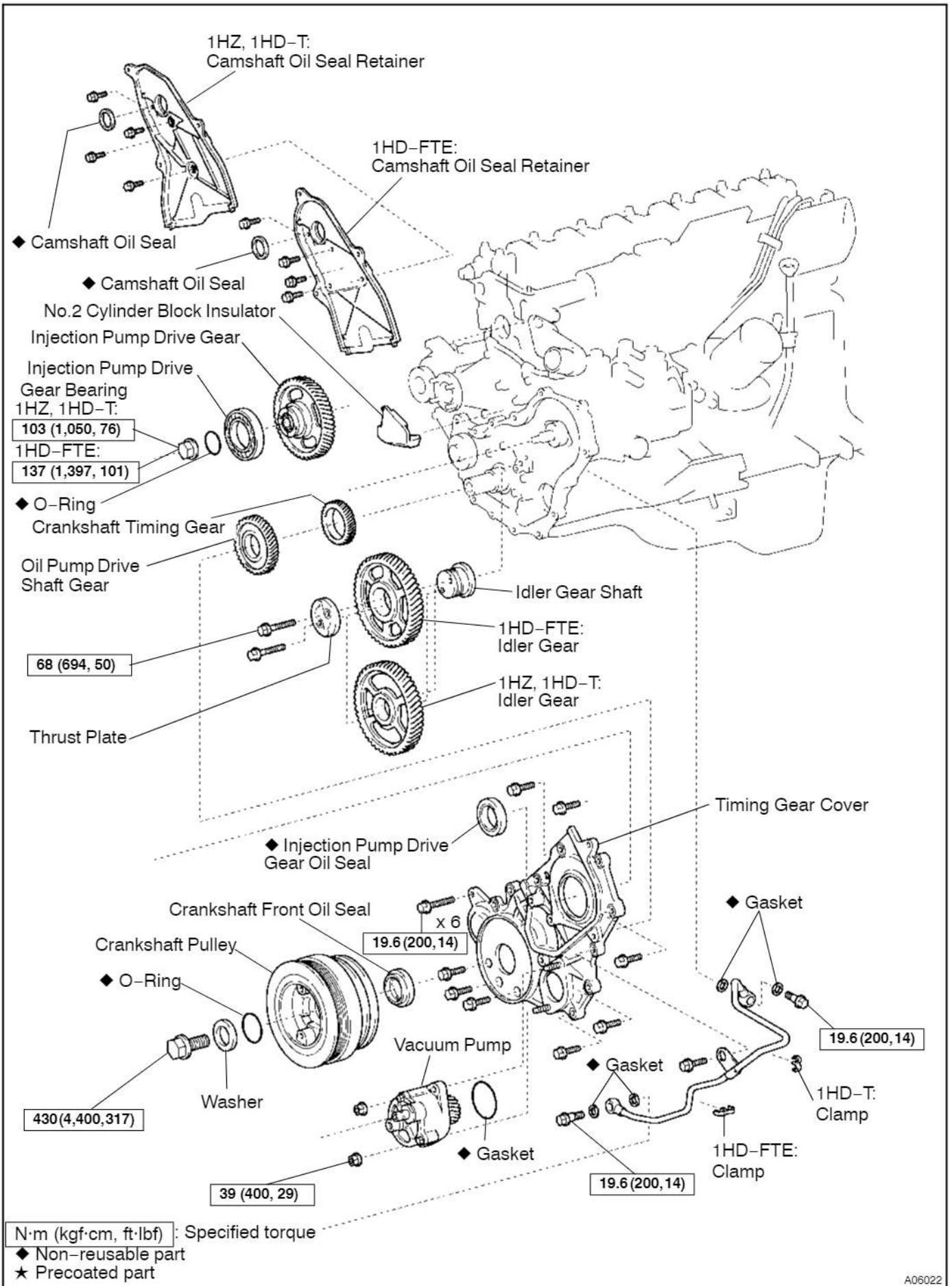

cardiagn.com

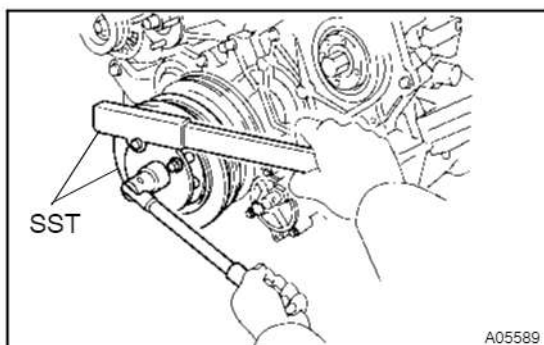

## REMOVAL

1. REMOVE DRIVE BELTS, FLUID COUPLING AND WATER PUMP PULLEY

(See page CO-7)

2. LOOSEN CRANKSHAFT PULLEY

Using SST, loosen the pulley bolt.

SST 09213-58012 (90201-08131, 91111-50845),  
09330-00021

### NOTICE:

If the timing belt is disengaged, having the crankshaft pulley at the wrong angle can cause the piston head and valve head to come into contact with each other when you remove the camshaft timing pulley causing damage.

3. REMOVE TIMING BELT AND TIMING PULLEYS

(See page EM-27)

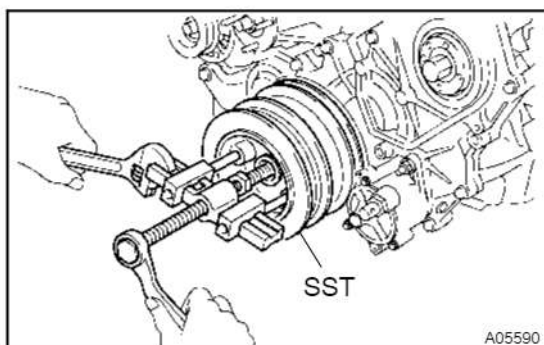

4. REMOVE CRANKSHAFT PULLEY

- (a) Remove the pulley bolt and plate washer.

### NOTICE:

Do not turn the crankshaft pulley. The valve heads will hit against the piston top.

- (b) Using SST, remove the crankshaft pulley. The valve heads will hit against the piston top.

SST 09950-50010 (09951-05010, 09952-05010,  
09953-05010, 09953-05020, 09954-05020)

- (c) Remove the O-ring from the crankshaft pulley.

5. REMOVE OIL PIPE

- (a) Remove the 2 union bolts and 4 gaskets.

- (b) Remove the bolt and oil pipe.

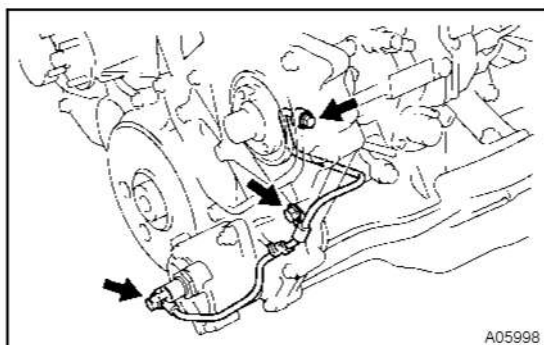

6. REMOVE VACUUM PUMP

- (a) Remove the 2 nuts and vacuum pump.

- (b) Remove the O-ring.

7. REMOVE CAMSHAFT OIL SEAL RETAINER

1HZ, 1HD-T: (See page EM-63)

1HD-FTE: (See page EM-91)

8. REMOVE NO.2 CYLINDER BLOCK INSULATOR

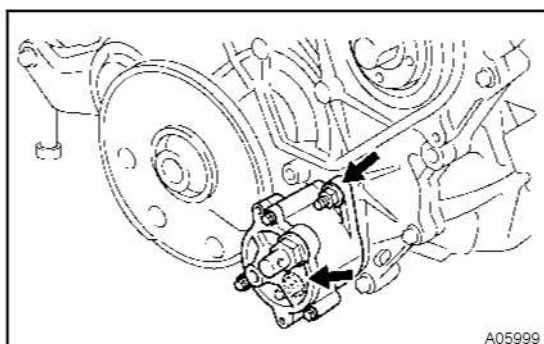

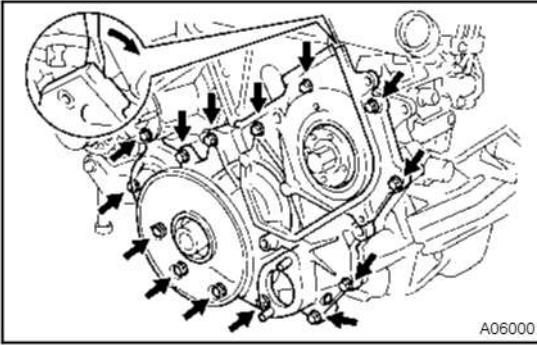
**9. REMOVE TIMING GEAR COVER**

- (a) Remove the 14 bolts.
- (b) Pry out the timing gear cover.

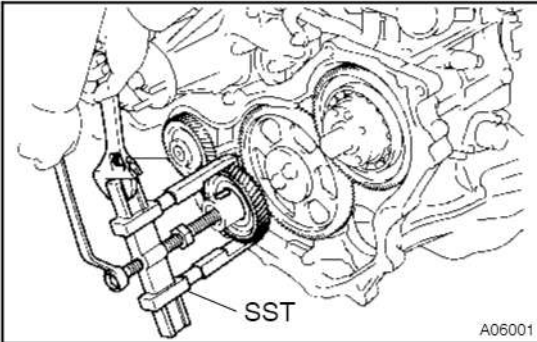
**10. REMOVE OIL PUMP DRIVE SHAFT GEAR**

Using SST, remove the drive shaft gear.

SST 09950-40010 (09951-04010, 09952-04010,  
09953-04010, 09953-04020, 09954-04010,  
09955-04060)

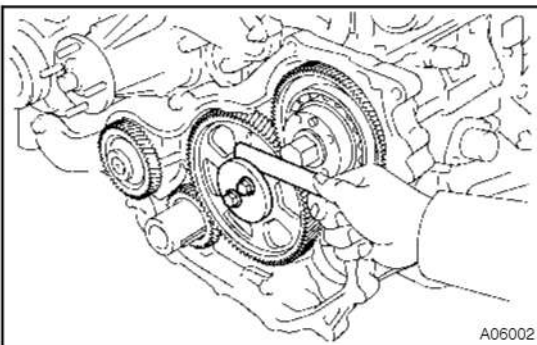
**11. CHECK THRUST CLEARANCE OF IDLER GEAR**

Using a feeler gauge, measure the thrust clearance.

**Standard thrust clearance:**  
**0.05 - 0.15 mm (0.0020 - 0.0059 in.)**

**Maximum thrust clearance:**  
**0.030 mm (0.0118 in.)**

If the thrust clearance is greater than maximum, replace the thrust plate. If necessary, replace the idler gear and/or idler gear shaft.

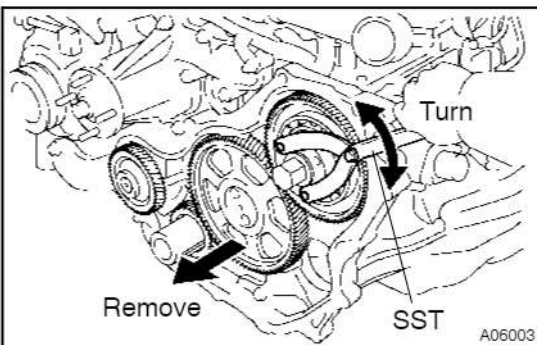
**12. REMOVE IDLER GEAR**

- (a) Remove the 2 bolts and thrust plate.
- (b) Using SST, turn the injection pump drive gear clockwise or counterclockwise and remove the idler gear.  
SST 09960-10010 (09962-01000, 09963-00700)
- (c) Remove the idler gear shaft.

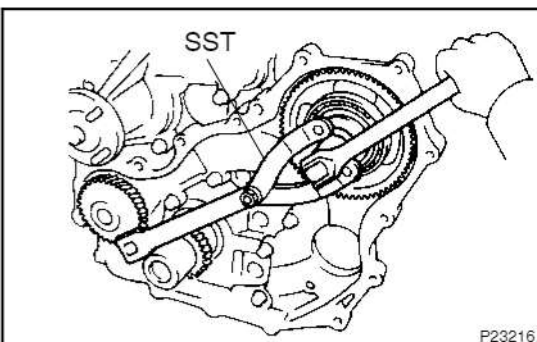
**13. REMOVE INJECTION PUMP DRIVE GEAR**

- (a) Using SST, loosen the gear nut.  
SST 09960-10010 (09962-01000, 0993-00700)
- (b) Remove the gear nut and O-ring.

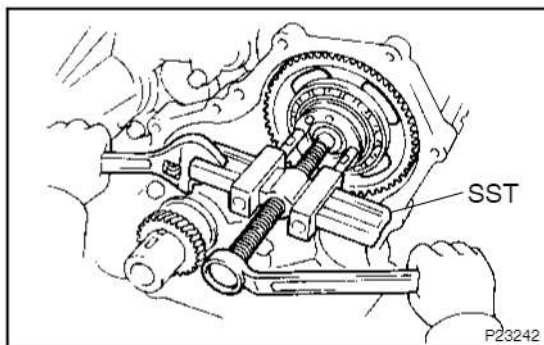

- (c) Using SST, remove the drive gear.  
SST 09950-50010 (09951-05010, 09952-05010,  
09953-05010, 09954-05020)

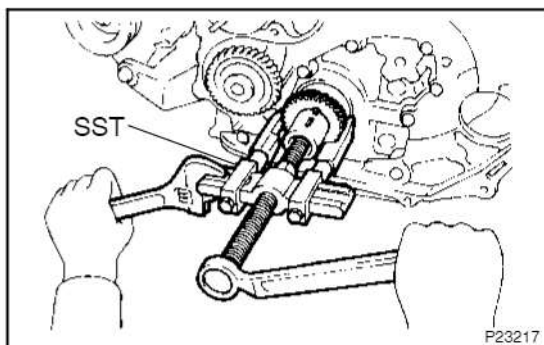

#### 14. REMOVE CRANKSHAFT TIMING GEAR

Using SST, remove the timing gear.

- SST 09950-40010 (09951-04010, 09952-04010,  
09953-04020, 09954-04010, 09955-04060)

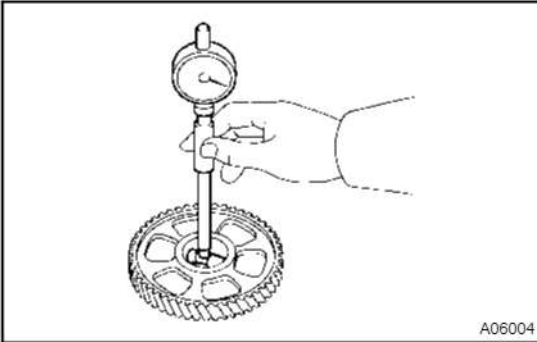

## INSPECTION

### 1. INSPECT IDLER GEAR

- (a) Using a cylinder gauge, measure the inside diameter of the idler gear.

**Idler gear inside diameter:**

**45.000 – 45.025 mm (1.7717 – 1.7726 in.)**

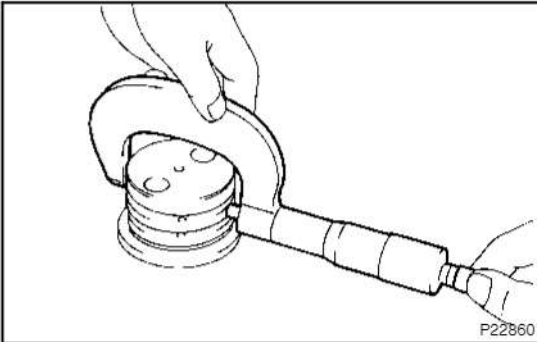

- (b) Using a micrometer, measure the diameter of the idler gear shaft.

**Idler gear shaft diameter:**

**44.950 – 44.975 mm (1.7697 – 1.7707 in.)**

- (c) Subtract the idler gear shaft diameter measurement from the idler gear inside diameter measurement.

**Standard oil clearance:**

**0.025 – 0.075 mm (0.0010 – 0.0030 in.)**

**Maximum oil clearance: 0.20 mm (0.0079 in.)**

If the clearance is greater than maximum, replace the gear and shaft.

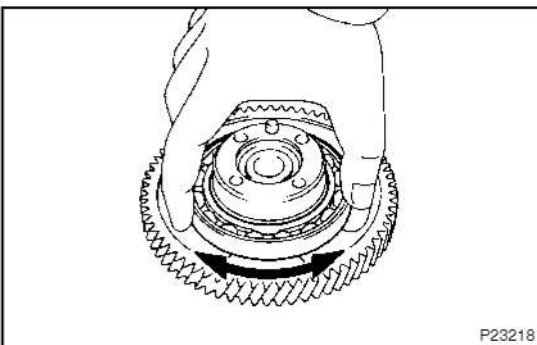

### 2. INSPECT INJECTION PUMP DRIVE GEAR BEARING

Check that bearing is not rough or worn.

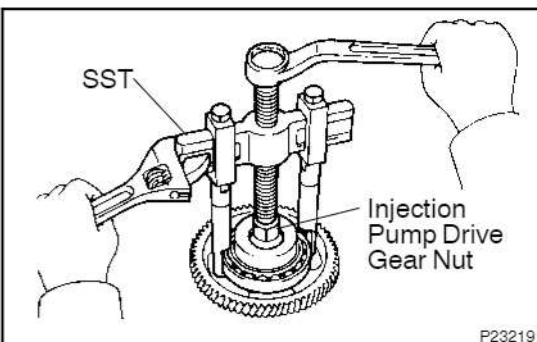

### 3. IF NECESSARY, REPLACE INJECTION PUMP DRIVE GEAR BEARING

- (a) Remove bearing

Using SST, remove the bearing

SST 09950-40010 (09951-04010, 09952-04010, 09953-04020, 09954-04010, 09955-04040)

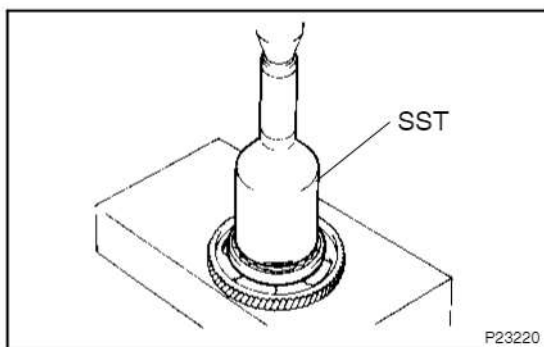

- (b) Install bearing  
Using SST and a press, press in a new bearing.  
SST 09502-12010  
09223-15020  
09950-70010 (09951-07100)

Crankshaft Timing Gear To Idler Gear

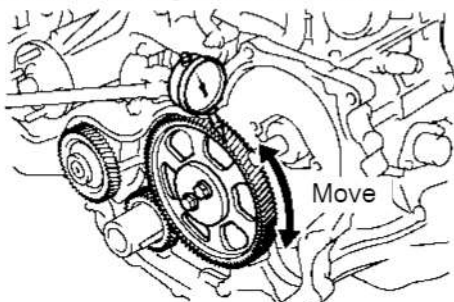

Injection Pump Drive Gear To Idler Gear

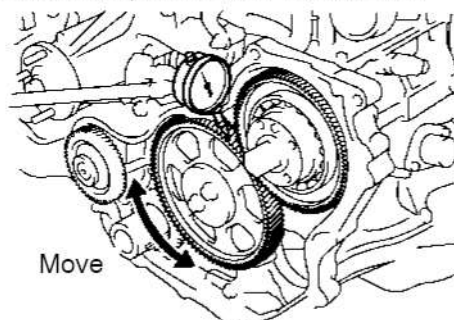

Oil Pump Drive Shaft Gear To Driven Shaft Gear

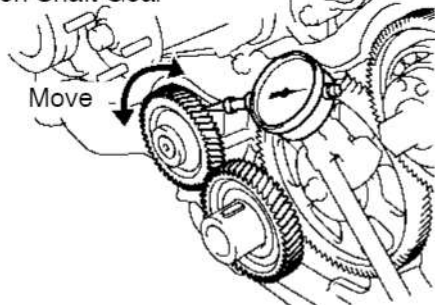

A06005

#### 4. CHECK BACKLASH OF TIMING GEARS

- (a) Install the gears.  
(b) Using a dial indicator, measure the backlash.

**Standard gear backlash:**

**0.05 - 0.15 mm (0.0020 - 0.0059 in.)**

**Maximum gear backlash: 0.30 mm (0.0118 in.)**

If the gear backlash is greater than maximum, replace the gears as a set.

- (c) Remove the gears.



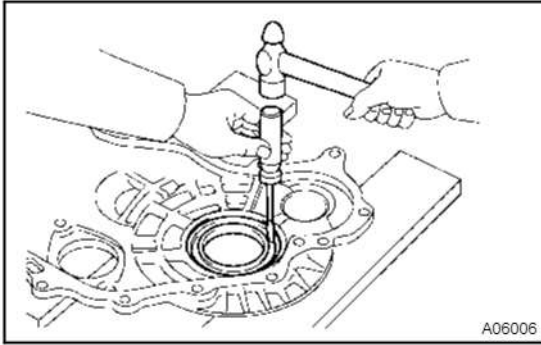

A06006

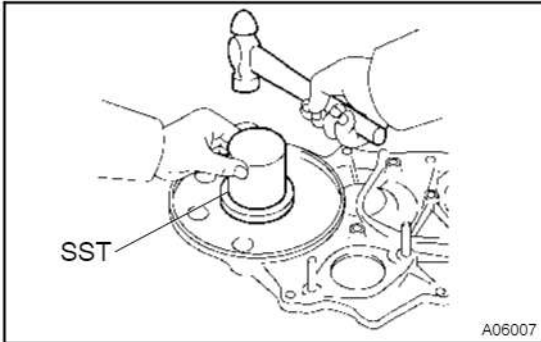

A06007

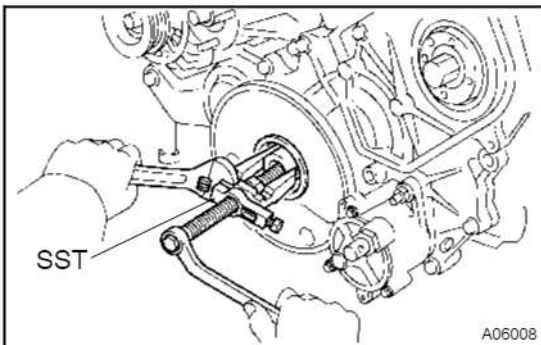

A06008

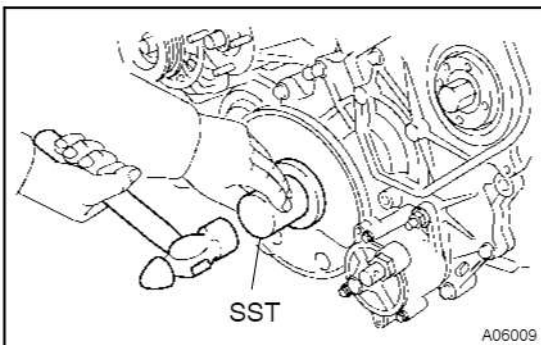

A06009

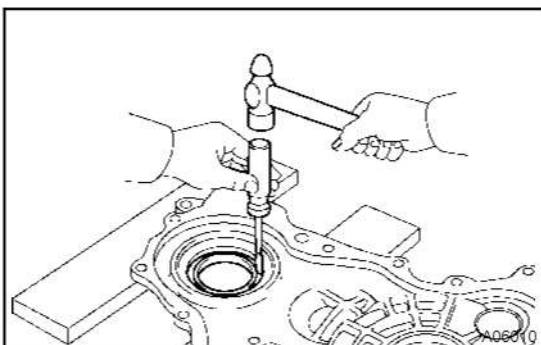

A06010

## REPLACEMENT

### HINT:

There are 2 methods (a and b) to replace the oil seal as follows:

#### 1. REPLACE CRANKSHAFT FRONT OIL SEAL

- (a) If timing gear cover is removed from cylinder block:
- (1) Using a screwdriver and hammer, tap out the oil seal.
  - (2) Using SST and a hammer, tap in a new oil seal until its surface is flush with the timing gear cover edge.
- SST 09223-78010
- (3) Apply MP grease to the oil seal lip.

- (b) If timing gear cover is installed to the cylinder block:

- (1) Using SST, remove the oil seal.
- SST 09308-10010, 09950-50010 (09953-05010)

- (2) Apply MP grease to a new oil seal lip.
  - (3) Using SST and a hammer, tap in the oil seal until its surface is flush with the timing gear cover edge.
- SST 09223-78010

### HINT:

There are 2 methods (a and b) to replace the oil seal as follows:

#### 2. REPLACE INJECTION PUMP DRIVE GEAR OIL SEAL

- (a) If timing gear cover is removed from cylinder block:
- (1) Using a screwdriver and hammer, tap out the oil seal.

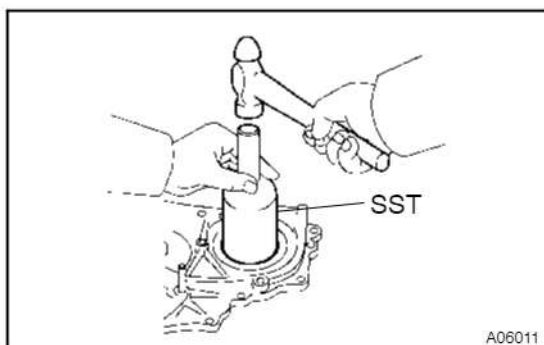

- (2) Using SST and a hammer, tap in a new oil seal until its surface is flush with the timing gear cover edge.
- SST 09214-76011
- (3) Apply MP grease to the oil seal lip.

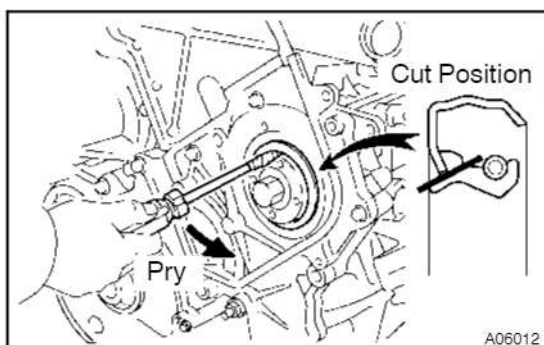

- (b) If timing gear cover is installed to the cylinder block:
  - (1) Using a knife, cut off the oil seal lip.
  - (2) Using a screwdriver, pry out the oil seal.

**NOTICE:**

Be careful not to damage the injection pump drive gear. Tape the screwdriver tip.

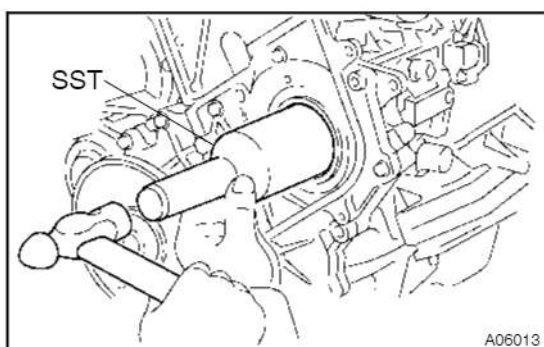

- (3) Apply MP grease to the oil seal lip.
  - (4) Using SST and a hammer, tap in a new oil seal until its surface is flush with the timing gear cover edge.
- SST 09214-76011

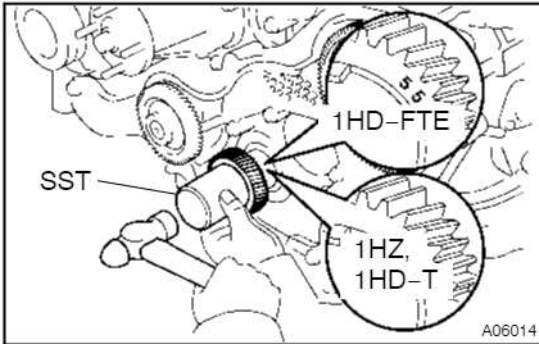

## INSTALLATION

### 1. INSTALL CRANKSHAFT TIMING GEAR

- Put the timing gear with the timing mark facing forward.
- Align the set key on the crankshaft with the key groove of the timing gear.
- Using SST and a hammer, tap in the timing gear.  
SST 09223-00010

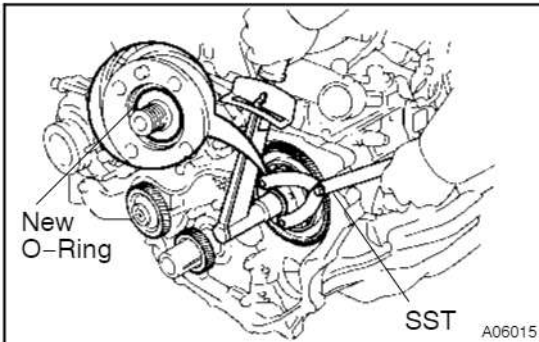

### 2. INSTALL INJECTION PUMP DRIVE GEAR

- Align the set key on the drive shaft with the key groove of the drive gear, and install the drive gear.
- Install a new O-ring to the drive gear groove.
- Install the gear net.
- Using SST, tighten the gear nut.  
SST 09960-10010 (09962-01000, 09963-00700)

#### Torque:

**1HZ, 1HD-T: 103 N·m (1,050 kgf·cm, 76 ft·lbf)**

**1HD-FTE: 137 N·m (1,397 kgf·cm, 101 ft·lbf)**

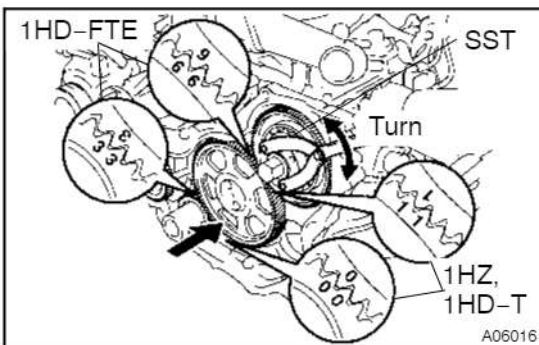

### 3. INSTALL IDLER GEAR

- Align the bolt holes of the idler gear shaft and cylinder block, and install the idler gear shaft.
- Using SST, turn the injection pump drive gear clockwise or counterclockwise, and align timing marks "3" and "4" of the idler gear with timing mark "3" of the crankshaft timing gear and timing mark "4" of the injection pump drive gear respectively, and mesh the gears.  
SST 09960-10010 (09962-01000, 09963-00700)

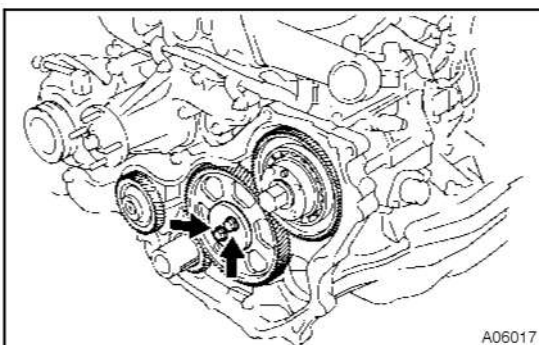

- Install the thrust plate with the 2 bolts.

**Torque: 68 N·m (694 kgf·cm, 50 ft·lbf)**

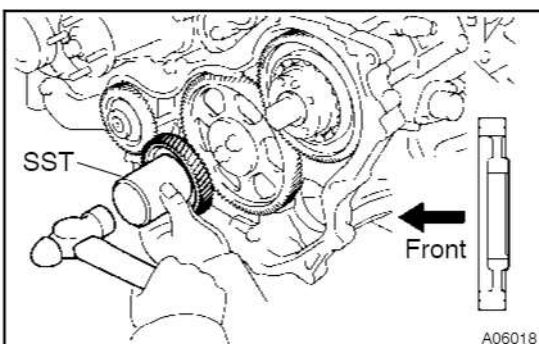

### 4. INSTALL OIL PUMP DRIVE SHAFT GEAR

- Align the set key on the crankshaft with the key groove of the drive shaft gear.
- Using SST and a hammer, tap in the drive shaft gear.  
SST 09223-00010

### 5. INSTALL NO. 2 CYLINDER BLOCK INSULATOR

### 6. INSTALL TIMING GEAR COVER

- Remove and old packing (FIPG) material and be careful not to drop any oil on the contact surface of the timing gear cover and cylinder block.

- Using a razor blade and gasket scraper, remove all the old packing (FIPG) material from the gasket surfaces and sealing groove.
- Thoroughly clean all components to remove all the loose material.
- Using a non-residue solvent, clean both sealing surfaces.

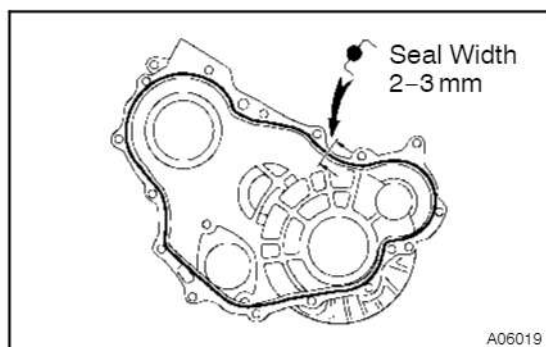

- (b) Apply seal packing to the timing gear cover as shown in the illustration.

**Part No. 08826-00080 or equivalent**

- Install a nozzle that has been cut to a 2 – 3 mm (0.08 – 0.12 in.) opening.
- Parts must be assembled within 5 minutes of application. Otherwise the material must be reapplied. Otherwise the material must be removed and reapplied.
- Immediately remove nozzle from the tube and reinstall cap.

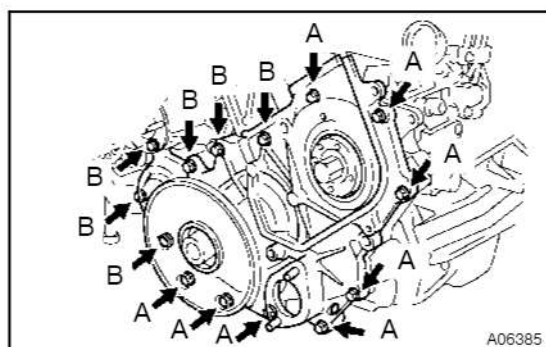

**7. INSTALL CRANKSHAFT PULLEY**

- Install a new O-ring to the crankshaft pulley groove.
- Align the set key on the crankshaft with the key groove of the crankshaft pulley.
- Using SST and a hammer, tap in the crankshaft pulley. SST 09214-60010
- Temporarily install the plate washer and pulley nut.

**NOTICE:**

**Do not turn the crankshaft pulley. The valve heads will hit against the piston top.**

- Install the timing gear cover, clamp and bracket with the 14 bolts.

**Torque: 19.6 N·m (200 kgf·cm, 14 ft·lbf)**

**HINT:**

Each bolt length is indicated in the illustration.

Bolt length:

A 25 mm (0.98 in.)

B 50 mm (1.97 in.)

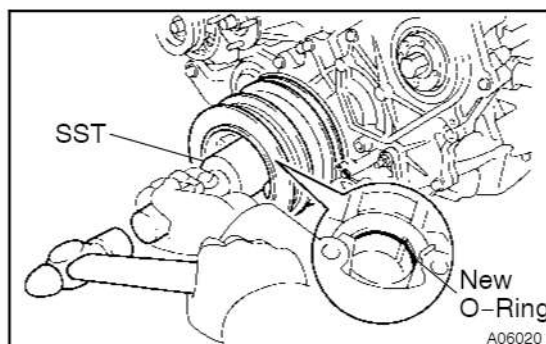

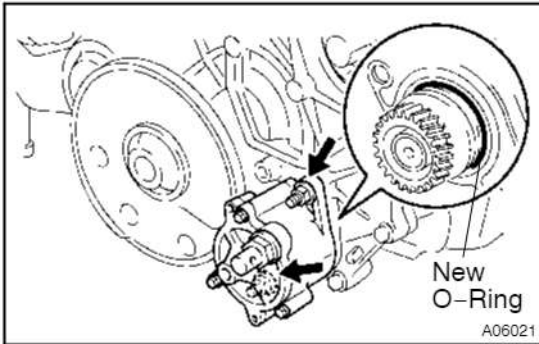
**8. INSTALL VACUUM PUMP**

- (a) Install a new O-ring to the vacuum pump.
- (b) Install the vacuum pump with the 2 nuts.

**Torque: 39 N·m (400 kgf·cm, 29 ft·lbf)**

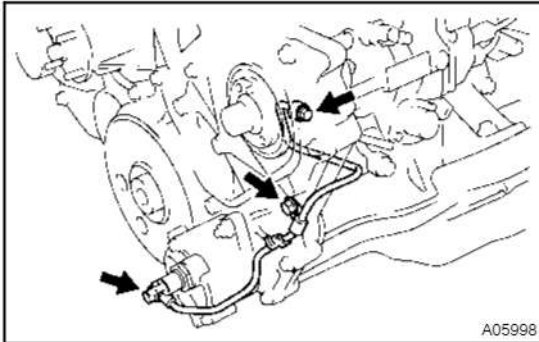
**9. INSTALL OIL PIPE**

Install the oil pipe with the bolt, 2 union bolts and 4 new gaskets.

**Torque:**

**Bolt 19.6 N·m (200 kgf·cm, 14 ft·lbf)**

**Union bolt 18 N·m (185 kgf·cm, 13 ft·lbf)**

**10. INSTALL CAMSHAFT OIL SEAL RETAINER**

1HZ, 1HD-T: (See page EM-63)

1HD-FTE: (See page EM-91)

**11. INSTALL TIMING PULLEYS AND TIMING BELT**

(See page EM-31)

**12. TIGHTEN CRANKSHAFT PULLEY BOLT**

Using SST, tighten the pulley bolt.

SST 09213-58012 (90201-08131, 91111-50845),  
09330-00021

**Torque: 430 N·m (4,400 kgf·cm, 317 ft·lbf)**

**13. INSTALL WATER PUMP PULLEY, FAN, FLUID COUPLING AND DRIVE BELTS**

(See page CO-9)

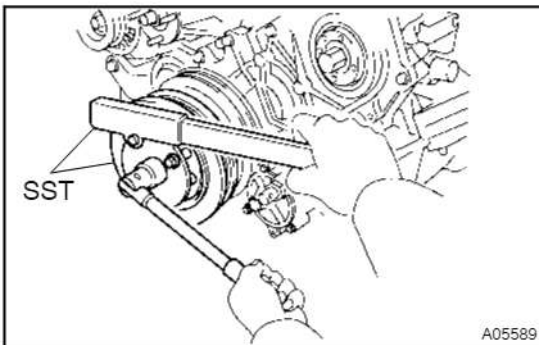

# CYLINDER HEAD (1HZ, 1HD-T) COMPONENTS

EMOVL-01

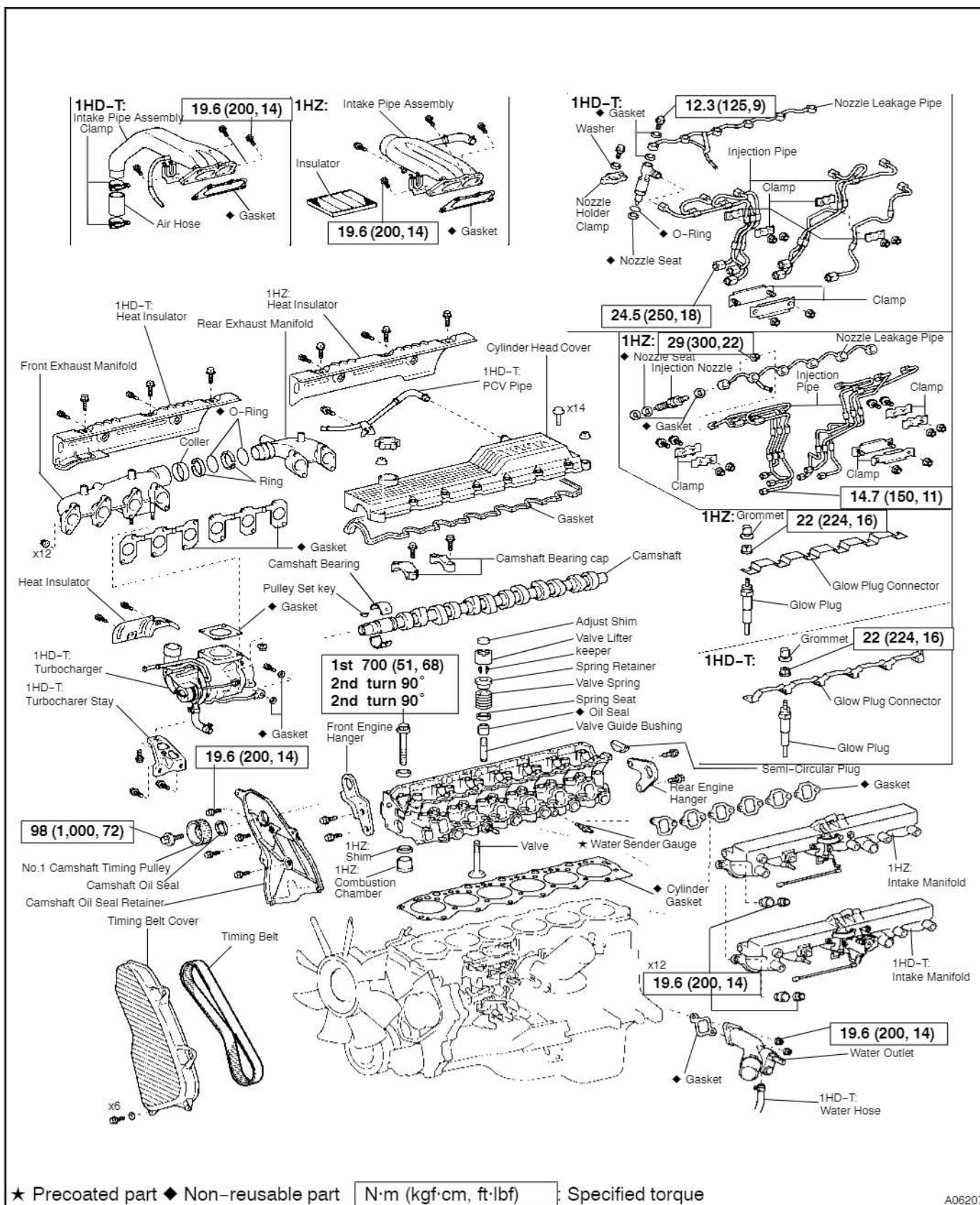

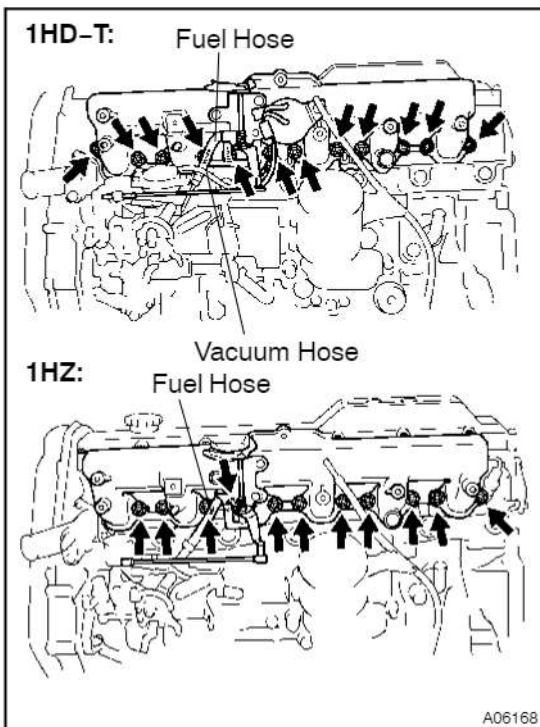
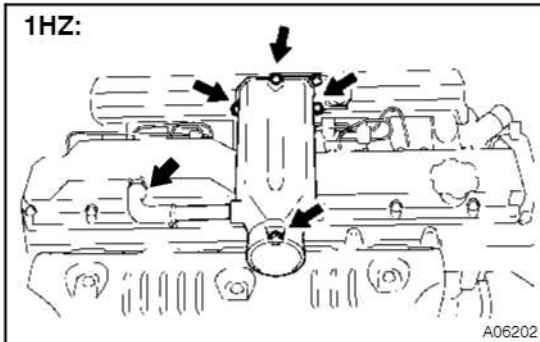
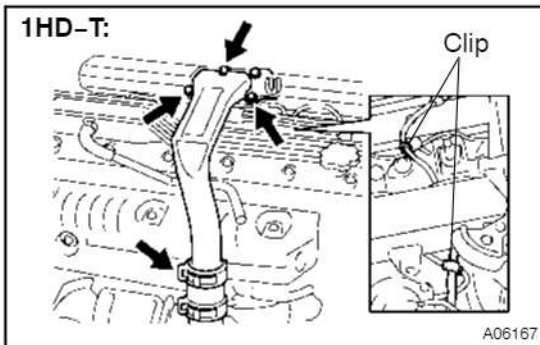

## REMOVAL

### 1. 1HD-T:

#### REMOVE INTAKE PIPE ASSEMBLY

- Remove the vacuum hose and 2 clip.
- Remove the 3 bolts holding the intake pipe to the intake manifold.
- Disconnect the intake pipe assembly to the air hose and remove the intake pipe assembly and gasket.

### 2. 1HZ:

#### REMOVE INTAKE PIPE ASSEMBLY

- Disconnect the PCV hose to the cylinder head cover.
- Remove the 3 bolts holding the intake pipe to the intake manifold, intake pipe assembly and insulator.

### 3. REMOVE INJECTION PIPE

(See page FU-7)

### 4. REMOVE INTAKE MANIFOLD

#### (a) 1HD-T:

Disconnect the fuel hose to the fuel pipe and vacuum hose to the injection pump.

#### (b) 1HZ:

Disconnect the fuel hose to the fuel pipe.

#### (c) Remove the accelerator linkage.

#### (d) Remove the 12 nuts, 12 seals, intake manifold and 6 gaskets.

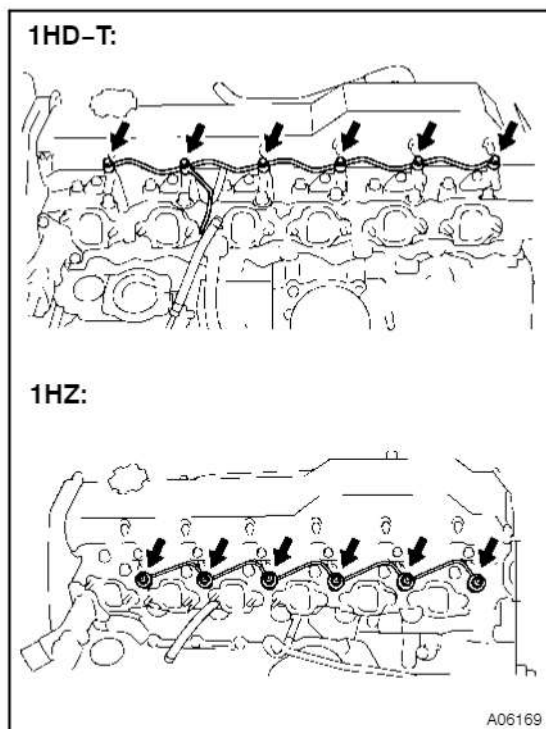
**5. REMOVE NOZZLE LEAKAGE PIPE**

- (a) 1HD-T:  
Remove the 6 bolts, 12 gaskets and nozzle leakage pipe.
- (b) 1HZ:  
Remove the 6 nuts, 6 gaskets and nozzle leakage pipe.

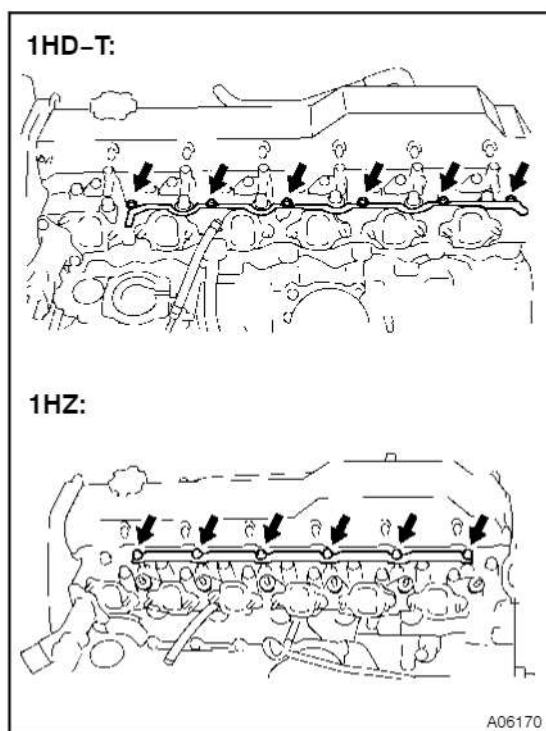
**6. REMOVE GLOW PLUG CONNECTOR AND GLOW PLUG**

- (a) Remove 6 screw grommets, 6 nuts and glow plug connector.
- (b) Remove 6 glow plugs.

**7. REMOVE INJECTION NOZZLES**

1HZ: (See page FU-7)

1HD-T: (See page FU-17)

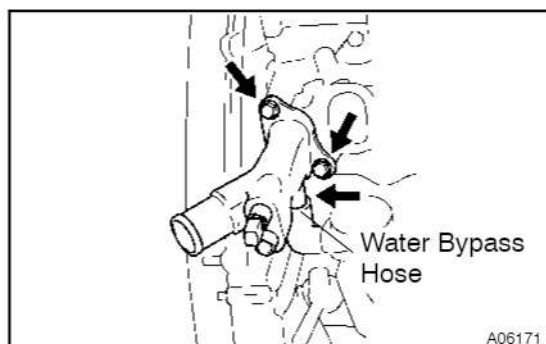
**8. REMOVE WATER OUTLET**

- (a) Remove the 2 nuts.
- (b) 1HD-T:  
Disconnect the water bypass hose from the water outlet, gasket and remove the water outlet.
- (c) 1HZ:  
Remove the water outlet and gasket.



9. **1HD-T:**  
**REMOVE TURBOCHARGER AND EXHAUST MANIFOLDS ASSEMBLY**  
(See page TC-8)
10. **1HD-T:**  
**REMOVE EXHAUST MANIFOLDS FROM TURBOCHARGER**  
(See page TC-8)

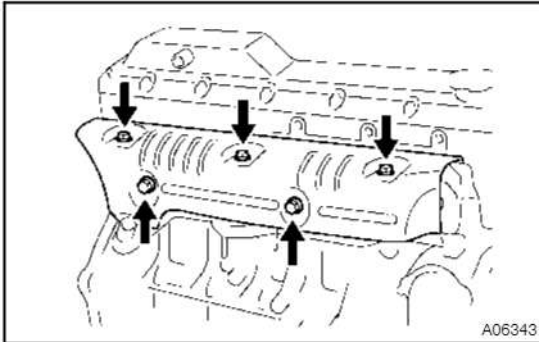

11. **1HZ:**  
**REMOVE HEAT INSULATOR**  
Remove the 5 bolts and heat insulator

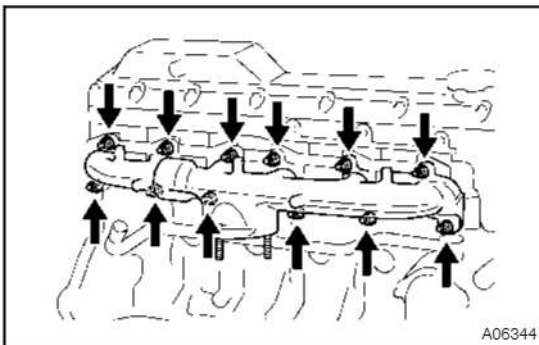

12. **1HZ:**  
**REMOVE EXHAUST MANIFOLDS ASSEMBLY**  
Remove the 12 bolts, exhaust manifold and 2 gaskets.

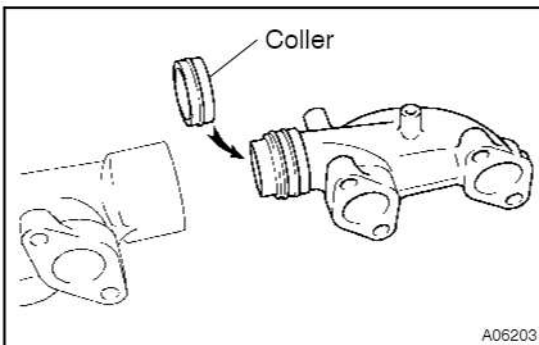

13. **SEPARATE EXHAUST MANIFOLDS**
  - (a) Separate the front and rear exhaust manifolds.
  - (b) Remove the collar.

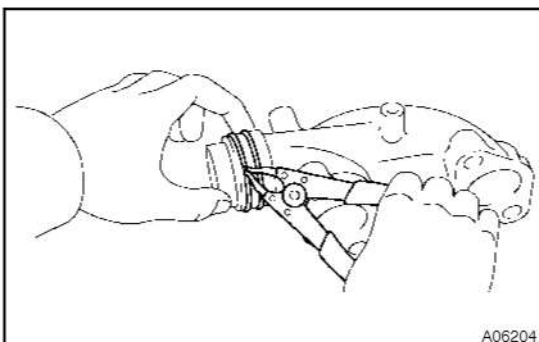

- (c) Using snap ring pliers, remove the 2 rings from the rear exhaust manifold.
- (d) Remove the O-ring materials to the rear exhaust manifold grooves.

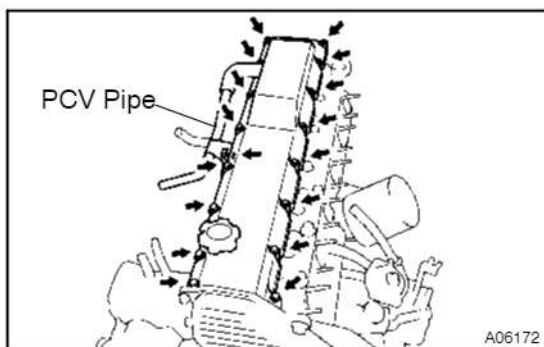
**14. REMOVE CYLINDER HEAD COVER**

- (a) 1HD-T:  
Remove the bolt and PCV pipe.
- (b) Remove the 2 nuts, 14 bolts, cylinder head cover and gasket.

**15. REMOVE 2 ENGINE HANGER****16. REMOVE SEMI-CIRCULAR PLUG****17. REMOVE TIMING BELT AND PULLEYS**

(See page EM-27)

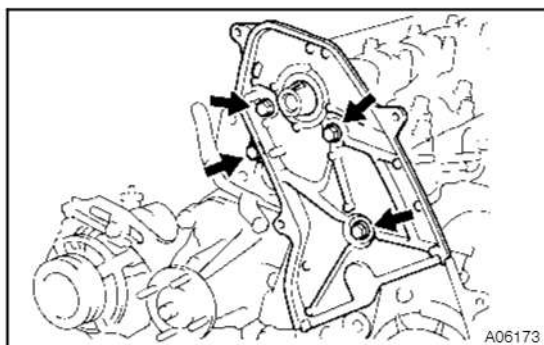
**18. REMOVE CAMSHAFT OIL SEAL RETAINER**

- (a) Remove the 4 bolts.
- (b) Pry out the oil seal retainer.

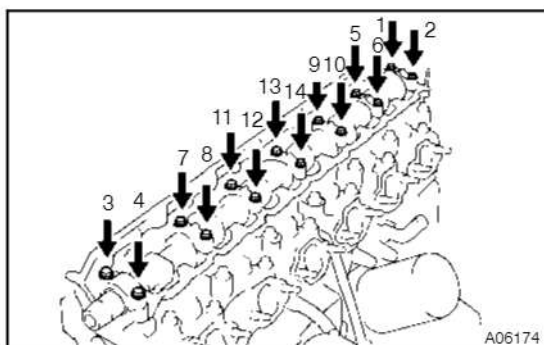
**19. REMOVE CAMSHAFT**

- (a) Uniformly loosen and remove the 14 bearing cap bolts in the sequence shown.
- (b) Remove the 7 bearing caps and camshaft.

**HINT:**

Arrange the bearing caps and bearings in correct order.

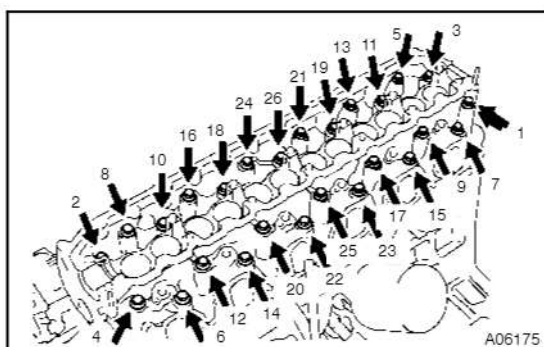
**20. REMOVE CYLINDER HEAD ASSEMBLY**

- (a) Disconnect the water bypass hose (from the injection pump) from the cylinder head.
- (b) Uniformly loosen and remove the 26 cylinder head bolts in several passes, in the sequence shown.

SST 09011-38121

**NOTICE:**

**Head warpage or cracking could result from removing bolts in incorrect order.**

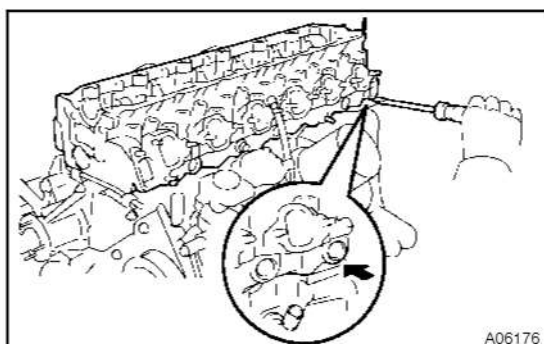

- (c) Lift the cylinder head from the dowels on the cylinder block, and place the cylinder head on wooden blocks on a bench.

**HINT:**

If the cylinder head is difficult to lift off, pry with a screwdriver between the cylinder head and block.

**NOTICE:**

**Be careful not to damage the contact surfaces of the cylinder head and cylinder block.**

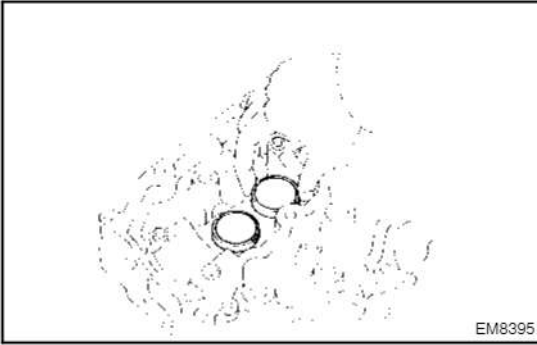

EM8395

## DISASSEMBLY

### 1. REMOVE VALVE BRIDGE

HINT:

Arrange the valve lifters and shims in correct order.

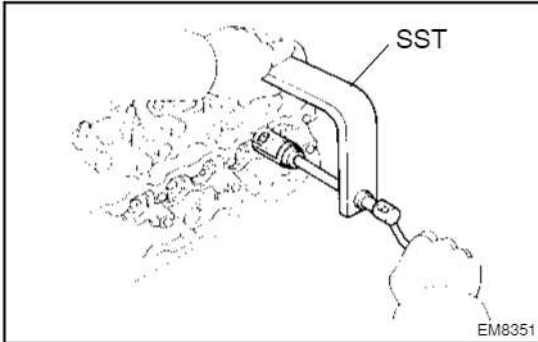

EM8351

### 2. REMOVE VALVES

- (a) Using SST, compress the valve spring and remove the 2 keepers.

SST 09202-70020 (09202-00010)

- (b) Remove the 2 keeper, spring retainer, valve spring, spring seat and valve.

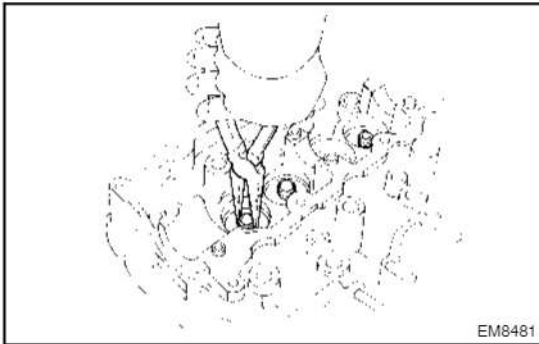

EM8481

- (c) Using needle-nose plies, remove the oil seal.

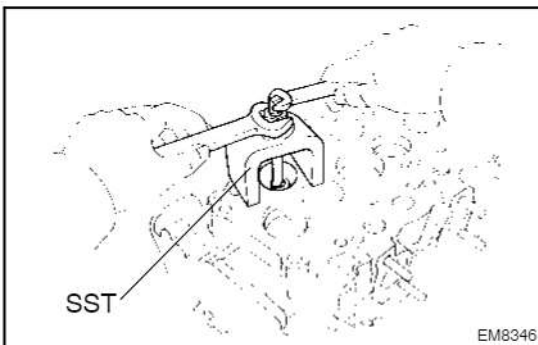

EM8346

### 3. 1HZ:

#### REMOVE COMBUSTION CHAMBERS

Using SST, remove the 6 combustion chambers (and shims).

SST 09208-48010

HINT:

Arrange the combustion chambers (and shims) in correct order.

### 4. REMOVE WATER SENDER GAUGE

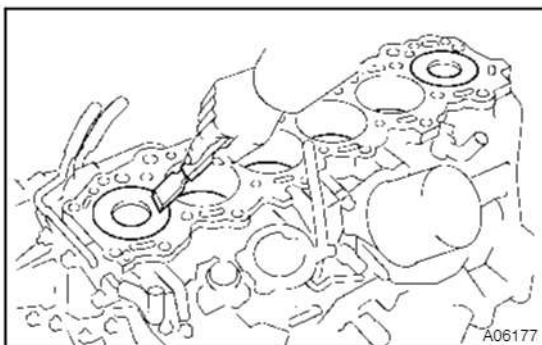

## INSPECTION

### 1. CLEAN TOP SURFACES OF PISTONS AND CYLINDER BLOCK

- (a) Turn the crankshaft, and bring each piston to the top dead center (TDC). Using a gasket scraper, remove all the carbon from the piston top surface.

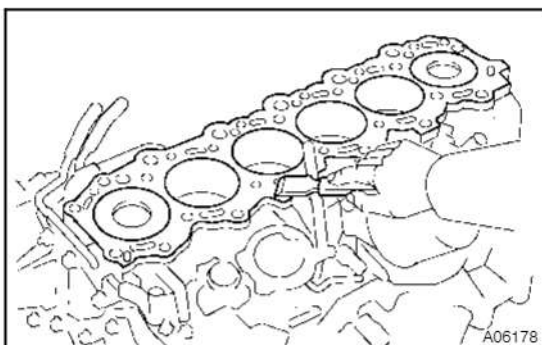

- (b) Remove all the gasket material from the top of the cylinder block.

#### NOTICE:

**Be careful not to scratch the surfaces.**

- (c) Using compressed air, blow carbon and oil from the bolt holes.

#### CAUTION:

**Protect your eyes when using high-compressed air.**

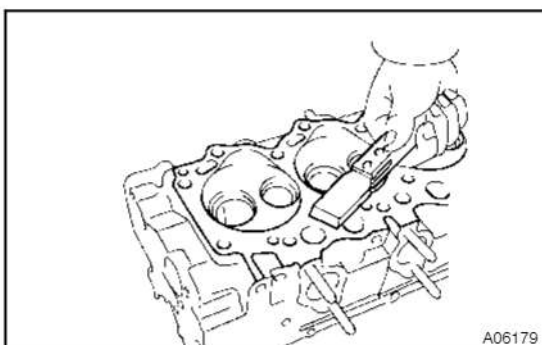

### 2. CLEAN CYLINDER HEAD

- (a) Remove gasket material  
Using a gasket scraper, remove all the gasket material from the cylinder block contact surface.

#### NOTICE:

**Be careful not to scratch the cylinder block contact surface.**

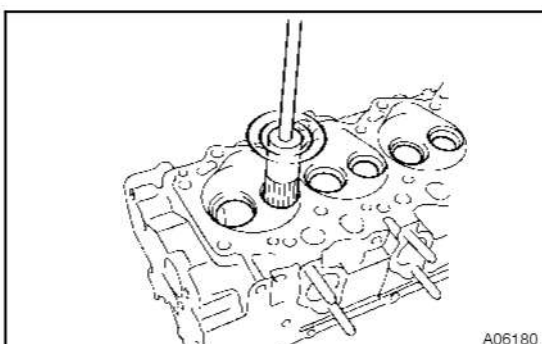

- (b) Clean intake and exhaust ports  
Using a wire brush, remove all the carbon from the intake and exhaust ports.

#### NOTICE:

**Be careful not to scratch the valve contact surface.**

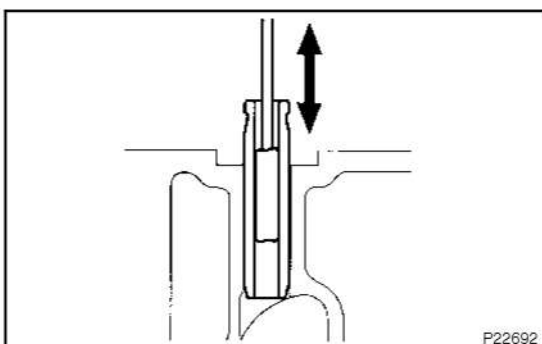

- (c) Clean valve guide bushings  
Using a valve guide bushing brush and solvent, clean all the guide bushings.

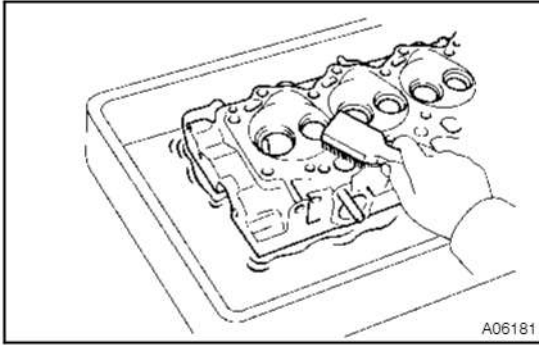

- (d) Clean cylinder head  
Using a soft brush and solvent, thoroughly clean the cylinder head.

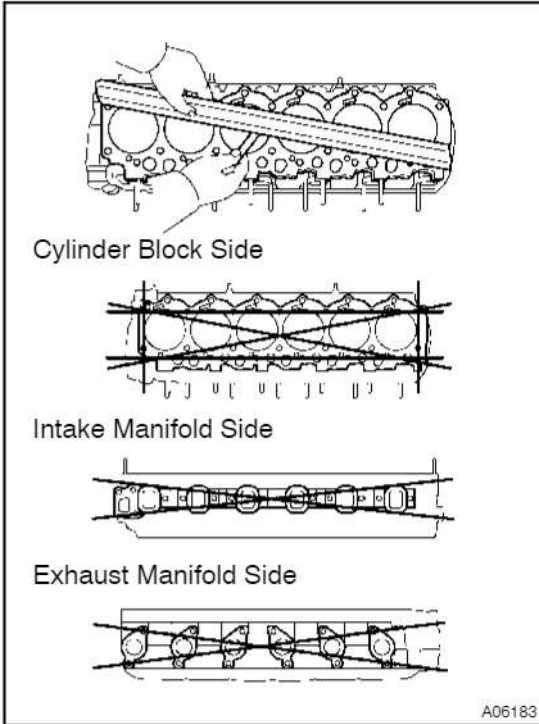

### 3. INSPECT CYLINDER HEAD

- (a) Inspect for flatness  
Using a precision straight edge and thickness gauge, measure the surfaces contacting the cylinder block and the manifolds for warpage.

**Maximum warpage: 0.20 mm (0.0079 in.)**

If warpage is greater than maximum, replace the cylinder head.

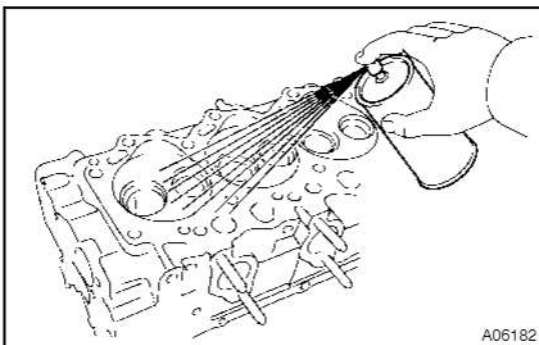

- (b) Inspect for cracks  
Using a dye penetrant, check the intake ports, exhaust ports and surface contacting the cylinder block.  
If cracked, replace the cylinder head.

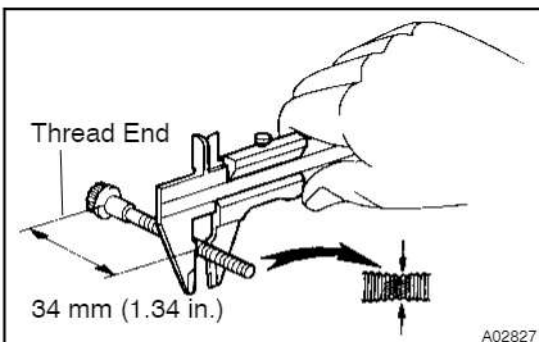

- (c) Inspect cylinder head bolts  
Using vernier calipers, measure the minimum outer diameter of the compressed thread at the measuring point.

**Standard outer diameter:**

**10.800 - 11.000 mm (0.4252 - 0.4331 in.)**

**Minimum outer diameter: 10.55 mm (0.4154 in.)**

If the outer diameter is less than minimum, replace the bolt.

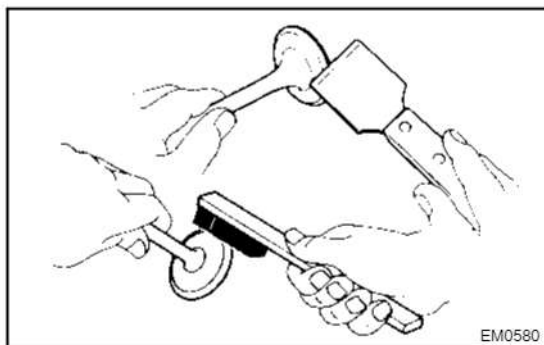
**4. CLEAN VALVES**

- (a) Using a gasket scraper, chip off any carbon from the valve head.
- (b) Using a wire brush, thoroughly clean the valve.

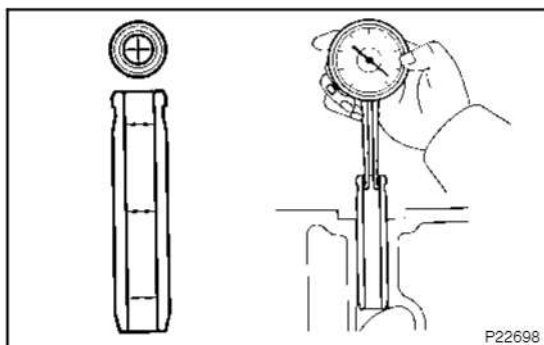
**5. INSPECT VALVE STEMS AND GUIDE BUSHINGS**

- (a) Using a caliper gauge, measure the inside diameter of the guide bushing.

**Busing inside diameter:**

**8.010 - 8.030 mm (0.3154 - 0.3161 in.)**

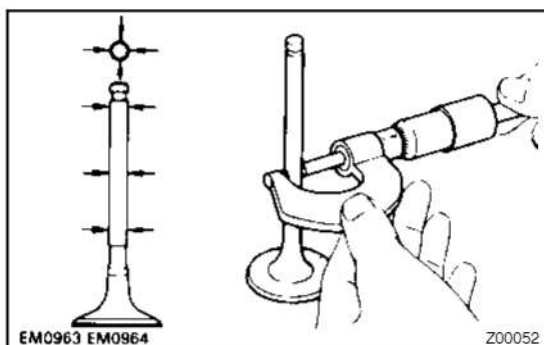

- (b) Using a micrometer, measure the diameter of the valve stem.

**Valve stem diameter:**

**Intake**

**7.975 - 7.990 mm (0.3140 - 0.3146 in.)**

**Exhaust**

**7.960 - 7.975 mm (0.3134 - 0.3140 in.)**

- (c) Subtract the valve stem diameter measurement from the guide bushing inside diameter measurement.

**Standard oil clearance:**

**Intake**

**0.020 - 0.055 mm (0.0008 in.)**

**Exhaust**

**0.035 - 0.070 mm (0.0014 - 0.0028 in.)**

**Maximum oil clearance:**

**Intake**

**0.08 mm (0.0031 in.)**

**Exhaust**

**0.10 mm (0.0039 in.)**

If the clearance is greater than maximum, replace the valve and guide bushings.

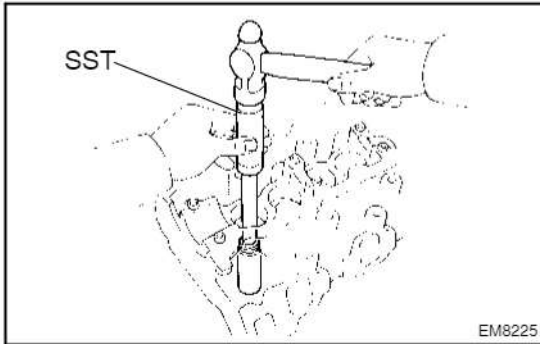

## 6. IF NECESSARY, REPLACE VALVE GUIDE BUSHINGS

- (a) Using SST and a hammer, tap out the guide bushing.  
SST 09201-10000 (09201-01060)

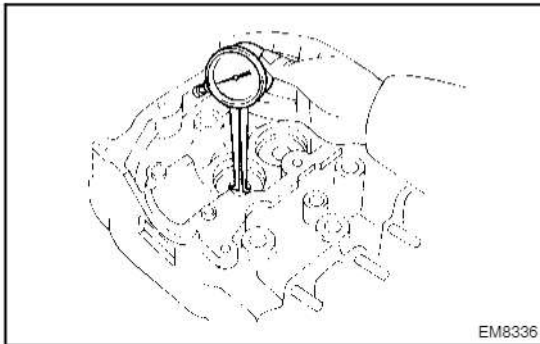

- (b) Using a caliper gauge, measure the bushing bore diameter of the cylinder head.

Bushing bore diameter mm (in.)	Bushing size
13.004 - 13.025 (0.5112 - 0.5128)	Use STD
13.054 - 13.075 (0.5139 - 0.5148)	Use O/S 0.05

- (c) Select a new guide bushing (STD size or O/S 0.05). If the bushing bore diameter of the cylinder head is greater than 13.025 mm (0.5128 in.), machine the bushing bore to the following dimension:

**Rebored cylinder head bushing bore dimension:  
13.054 - 13.075 mm (0.5139-0.5148 in.)**

- If the bushing bore diameter of the cylinder head is greater than 13.075 mm (0.5148 in.), replace the cylinder head.

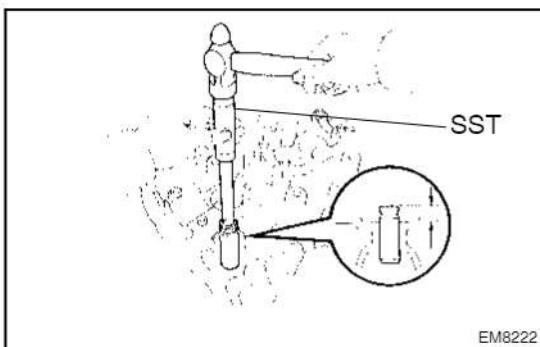

- (d) Using SST and a hammer, tap in a new guide bushing to where there is 11.8 - 12.2 mm (0.465 - 0.480 in.) protruding from the cylinder head.  
SST 09201-10000 (09201-01060)

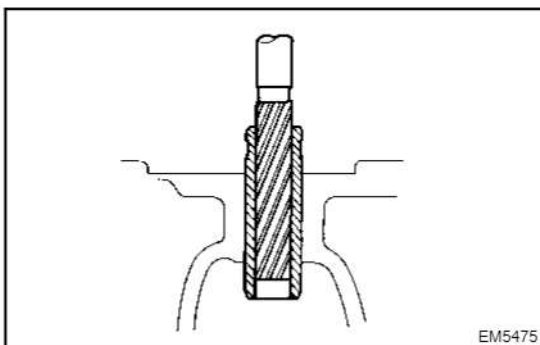

- (e) Using a sharp 8 mm reamer, ream the guide bushing to obtain the standard specified clearance between the guide bushing and valve stem.

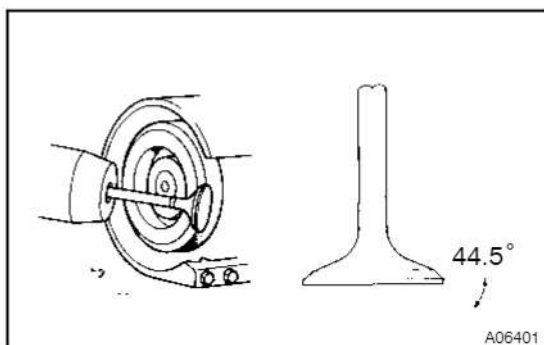
**7. INSPECT AND GRIND VALVES**

- (a) Grind the valve enough to remove pits and carbon.
- (b) Check that the valve is ground to the correct valve face angle.

**Valve face angle: 44.5°**

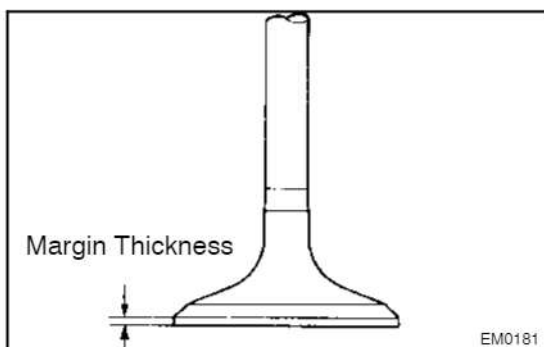

- (c) Check the valve face for wear.  
If the valve face is worn, replace the valve.
- (d) Check the valve head margin thickness.

**Standard margin thickness: 1.00 mm (0.0394 in.)**

**Minimum margin thickness: 0.83 mm (0.0327 in.)**

If the margin thickness is less than minimum, replace the valve

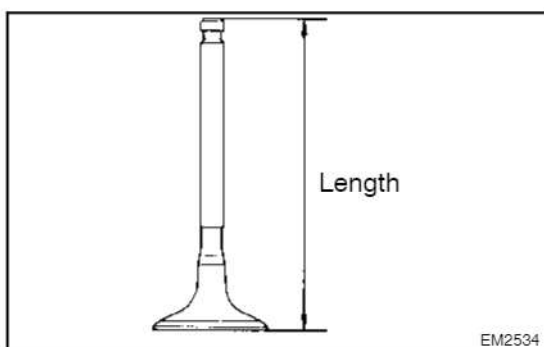

- (e) Check the valve overall length.

**Standard overall length:**

**Intake**

**103.49 mm (4.0744 in.)**

**Exhaust**

**103.34 mm (4.0685 in.)**

**Minimum overall length:**

**Intake**

**102.79 mm (4.0468 in.)**

**Exhaust**

**102.64 mm (4.0409 in.)**

If the overall length is less than minimum, replace the valve.

- (f) Check the valve stem tip for wear.

If the valve stem tip is worn, replace the valve.

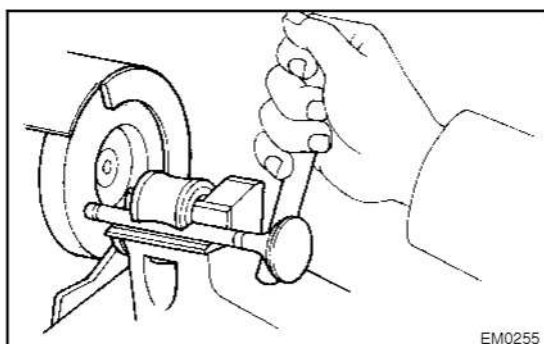

- (g) Check the surface of the valve stem tip for wear.  
If the valve stem tip is worn, resurface the tip with a grinder or replace the valve.

**NOTICE:**

**Do not grind off more than the minimum overall length.**



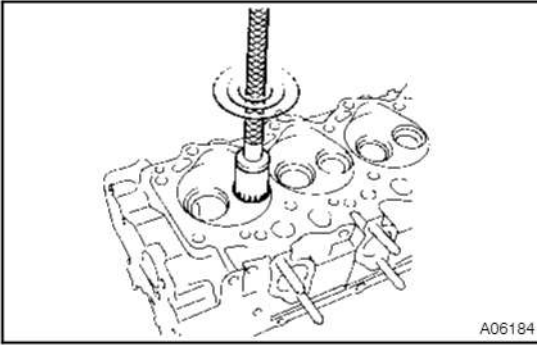

## 8. INSPECT AND CLEAN VALVE SEATS

- (a) Using a 45° carbide cutter, resurface the valve seats. Remove only enough metal to clean the seats.

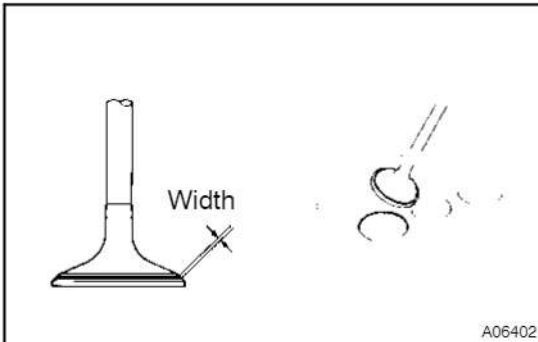

- (b) Check the valve seating position. Apply a light coat of Prussian blue (or white lead) to the valve face. Lightly press the valve against the seat. Do not rotate valve.
- (c) Check the valve face and seat for the following:
- If blue appears 360° around the valve face, the valve is concentric. If not, replace the valve.
  - If blue appears 360° around the valve seat, the guide and face are concentric. If not, resurface the seat.
  - Check that the seat contact is in the middle of the valve face with the following width:

### Intake

1.5 – 1.9 mm (0.059 – 0.075 in.)

### Exhaust

1.8 – 2.2 mm (0.071 – 0.087 in.)

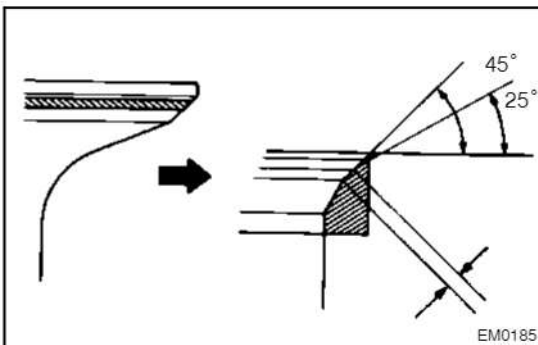

If not, correct the valve seats as follows:

- (1) If the seating is too high on the valve face, use 25° and 45° cutters to correct the seat.

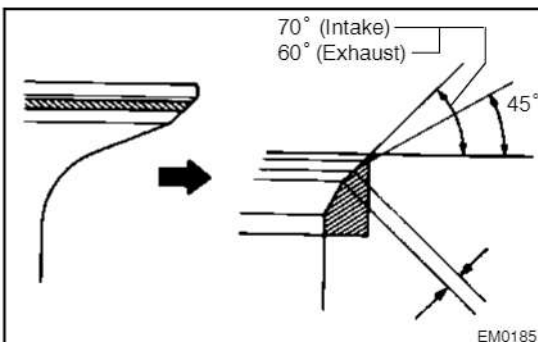

- (2) (Intake)  
If the seating is too low on the valve face, use 70° and 45° cutters to correct the seat.
- (3) (Exhaust)  
If the seating is too low on the valve face, use 60° and 45° cutters to correct the seat.

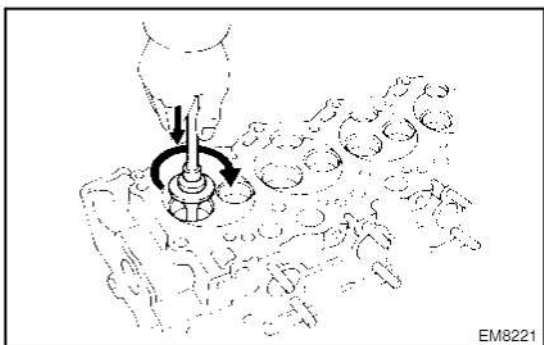

EM8221

- (d) Hand-lap the valve and valve seat with an abrasive compound.
- (e) After hand-lapping, clean the valve and valve seat.

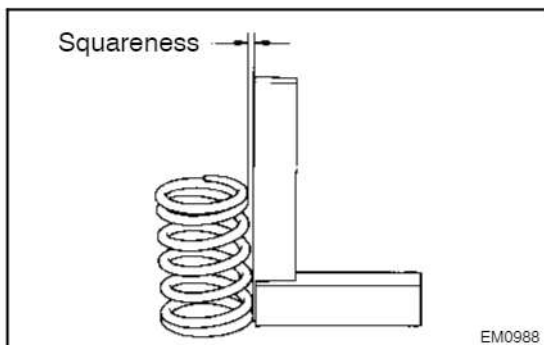

EM0988

## 9. INSPECT VALVE SPRINGS

- (a) Using a steel square, measure the deviation of the valve spring.

**Maximum deviation: 2.0 mm (0.079 in.)**

If the deviation is greater than maximum, replace the valve spring.

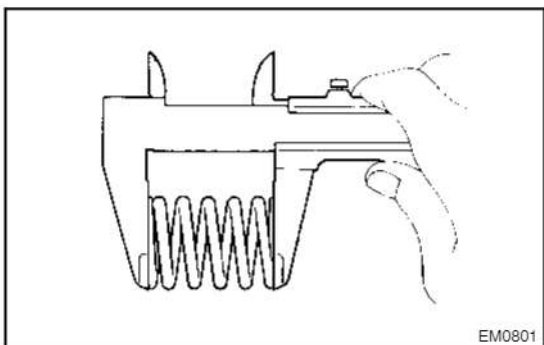

EM0801

- (b) Using vernier calipers, measure the free length of the valve spring.

**Free length: 46.20 mm (1.8189 in.)**

If the free length is not as specified, replace the valve spring.

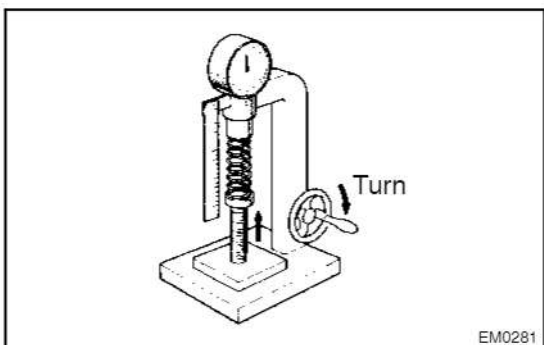

EM0281

- (c) Using a spring tester, measure the tension of the valve spring at the specified installed length.

**Installed tension:**

**301 - 332 N (30.7 - 33.9 kgf, 67.7 - 74.7 lbf)**

**at 37.0 mm (1.457 in.)**

If the installed tension is not as specified, replace the valve spring.

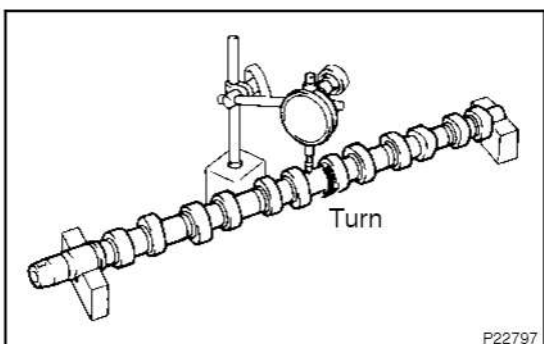

P22797

## 10. INSPECT CAMSHAFTS AND BEARINGS

- (a) Inspect camshaft for runout
  - (1) Place the camshaft on V-blocks.
  - (2) Using a dial indicator, measure the circle runout at the center journal.

**Maximum circle runout: 0.10 mm (0.0039 in.)**

If the circle runout is greater than maximum, replace the camshaft.

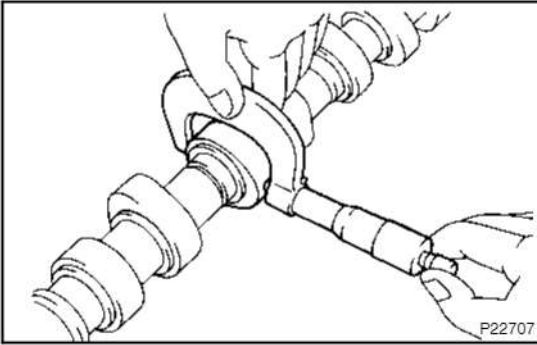

- (b) Inspect cam lobes  
Using a micrometer, measure the cam lobe height.

**Standard cam lobe height:**

**Intake:**

**1HZ:**

55.090 – 55.110 mm (2.1689 – 2.1697 in.)

**1HD-T:**

54.440 – 54.460 mm (2.1433 – 2.1441 in.)

**Exhaust:**

55.940 – 55.960 mm (2.2024 – 2.2031 in.)

**Minimum cam lobe height:**

**Intake**

**1HZ:**

54.59 mm (2.1492 in.)

**1HD-T:**

53.94 mm (2.1236 in.)

**Exhaust**

55.44 mm (2.1827 in.)

If the cam lobe height is less than minimum, replace the camshaft.

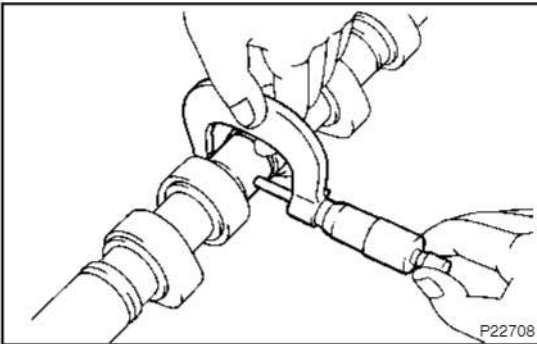

- (c) Inspect camshaft journals  
Using a micrometer, measure the journal diameter.

**Journal diameter:**

**No.1**

34.969 – 34.985 mm (1.3767 – 1.3774 in.)

**others**

27.986 – 28.002 mm (1.1018 – 1.1024 in.)

If the journal diameter is not as specified, check the oil clearance.

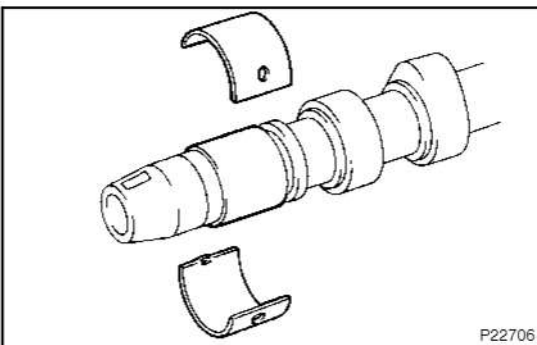

- (d) Inspect camshaft bearings  
Check the bearings for flaking and scoring.

If the bearings are damaged, replace the bearing caps and cylinder head as a set.

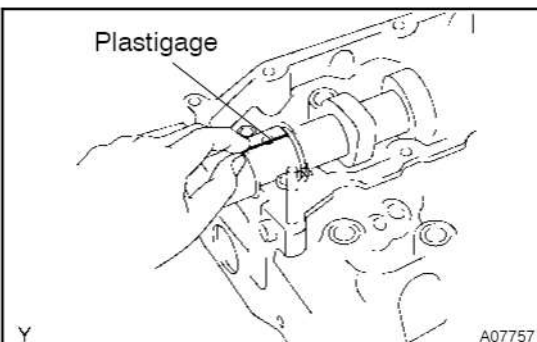

- (e) Inspect camshaft journal oil clearance
- (1) Clean the bearing caps and camshaft journals.
  - (2) Place the camshaft on the cylinder head.
  - (3) Lay a strip of Plastigage across each of the camshaft journals.

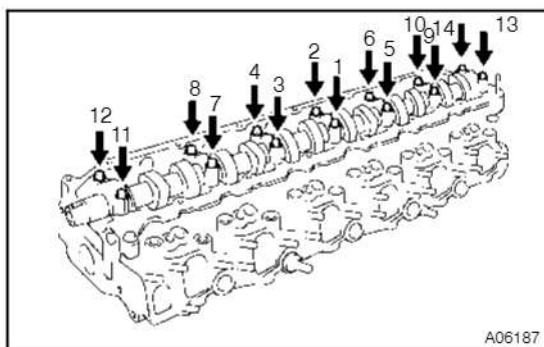

- (4) Install the 7 bearing caps with the 14 bolts. Uniformly tighten the bolts in several passes, in the sequence shown.

**Torque: 25 N·m (250 kgf·cm, 18 ft·lbf)**

**NOTICE:**

**Do not turn the camshaft.**

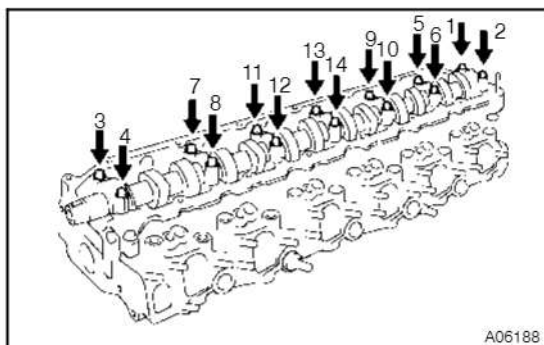

- (5) Uniformly loosen and remove the 14 bolts in several passes, in the sequence shown.  
 (6) Remove the 7 bearing caps.

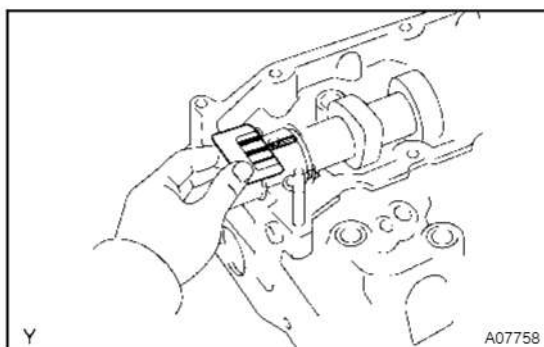

- (7) Measure the Plastigage at its widest point.

**Standard oil clearance:**

**No.1**

**0.022 – 0.074 mm (0.0009 – 0.0029 in.)**

**Others**

**0.030 – 0.066 mm (0.0012 – 0.0026 in.)**

**Maximum oil clearance: 0.10 mm (0.0039 in.)**

If the oil clearance is greater than maximum, replace the camshaft. If necessary, replace the bearing caps and cylinder head as a set.

- (8) Completely remove the Plastigage.

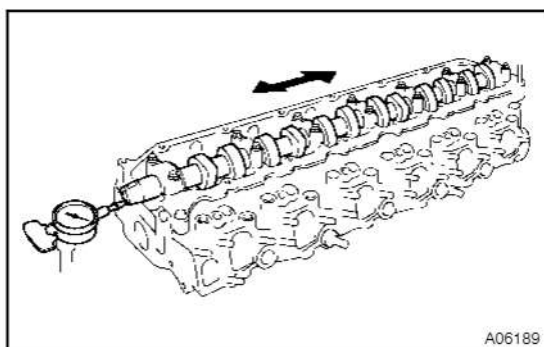

- (f) Inspect camshaft thrust clearance  
 (1) Install the camshaft.  
 (See procedure in item (4) above)  
 (2) Using a dial indicator, measure the thrust clearance while moving the camshaft back and forth.

**Standard thrust clearance:**

**0.10 – 0.20 mm (0.0039 – 0.0079 in.)**

**Maximum thrust clearance: 0.30 mm (0.0118 in.)**

If the thrust clearance is greater than maximum, replace the camshaft. If necessary, replace the bearing caps and cylinder head as a set.

- (3) Remove the camshaft.

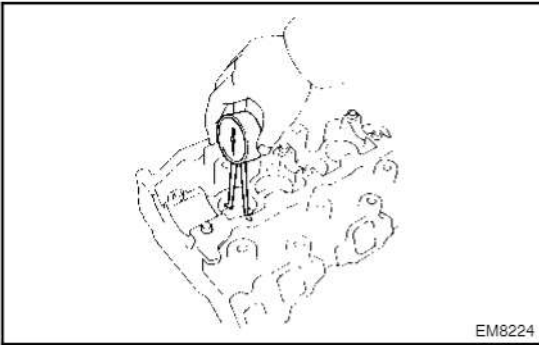

### 11. INSPECT VALVE LIFTERS AND LIFTER BORES

- (a) Using a caliper gauge, measure the lifter bore diameter of the cylinder head.

**Lifter bore diameter:**

**40.960 – 40.980 mm (1.6126 – 1.6134 in.)**

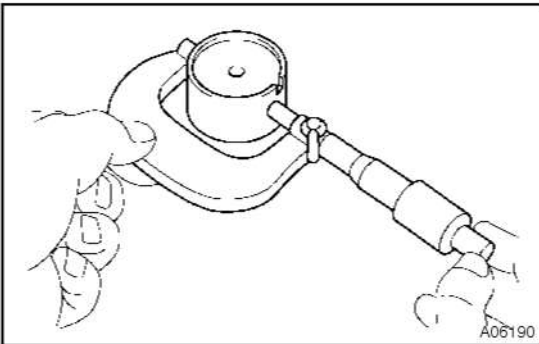

- (b) Using a micrometer, measure the lifter diameter.

**Lifter diameter:**

**40.892 – 40.902 mm (1.6099 – 1.6103 in.)**

- (c) Subtract the lifter diameter measurement from the lifter bore diameter measurement.

**Standard oil clearance:**

**0.058 – 0.083 mm (0.0023 – 0.0033 in.)**

**Maximum oil clearance: 0.10 mm (0.0039 in.)**

If the oil clearance is greater than maximum, replace the lifter. If necessary, replace the cylinder head.

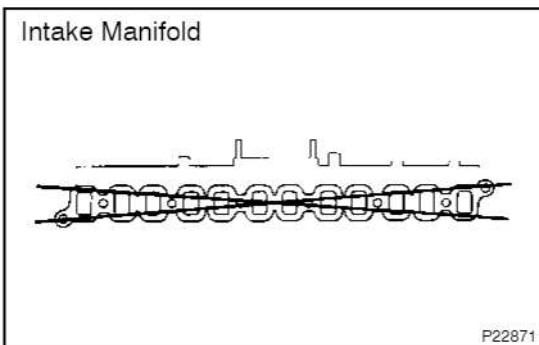

### 12. INSPECT INTAKE MANIFOLD

Using a precision straight edge and feeler gauge, measure the surface contacting the cylinder head for warpage.

**Maximum warpage: 0.40 mm (0.0157 in.)**

If warpage is greater than maximum, replace the manifold.

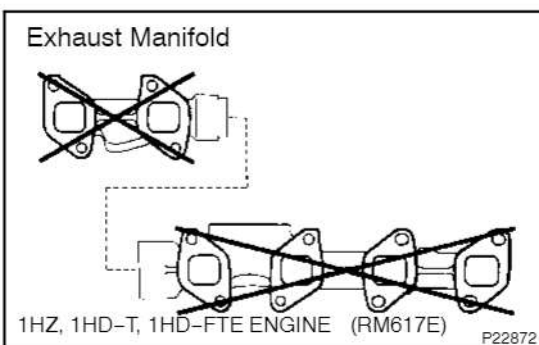

### 13. INSPECT EXHAUST MANIFOLD

Using a precision straight edge and feeler gauge, measure the surface contacting the cylinder head for warpage.

**Maximum warpage: 0.40 mm (0.0157 in.)**

If warpage is greater than maximum, replace the manifold.

## REPLACEMENT

### HINT:

There are 2 methods (a and b) to replace the oil seal which are as follows:

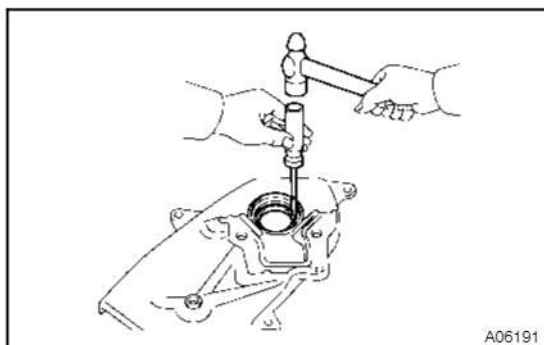

### REPLACE CAMSHAFT OIL SEAL

(a) If camshaft oil seal retainer is removed from cylinder head:

(1) Using a screwdriver, tap out the oil seal.

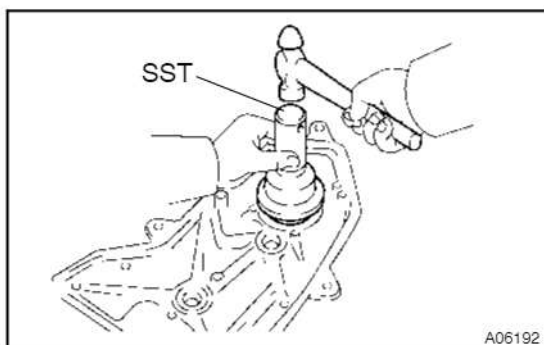

(2) Using SST and a hammer, tap in a new oil seal until its surface is flush with the oil seal retainer edge.

SST 09223 - 46011

(3) Apply MP grease to the oil seal lip.

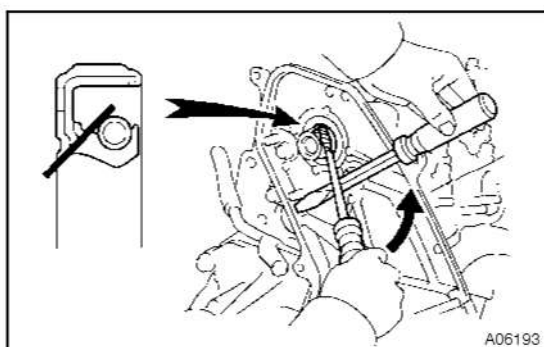

(b) If camshaft oil seal retainer is installed to cylinder head.

(1) Using a knife, cut off the oil seal lip.

(2) Using 2 screwdrivers, pry out the oil seal.

### NOTICE:

**Be careful not to damage the camshaft. Tape the screwdriver tip.**

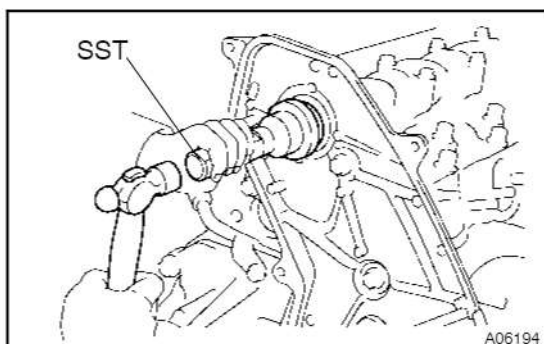

(3) Apply MP grease to a new oil seal lip.

(4) Using SST and a hammer, tap in the oil seal retainer edge.

SST 09223 - 46011

## REASSEMBLY

### HINT:

- Thoroughly clean all parts to be assembled.
- Before installing the parts, apply new engine oil to all sliding and rotating surfaces.
- Replace all gaskets and oil seals with new ones,

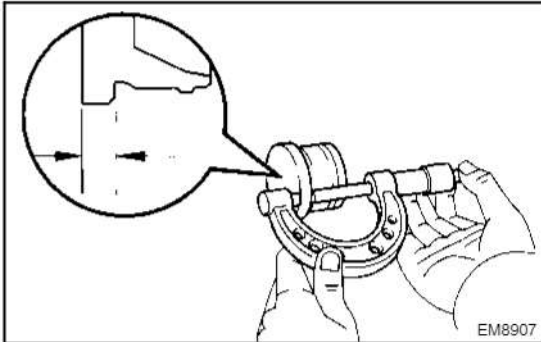

EM8907

### 1. 1HZ: SELECT COMBUSTION CHAMBER SHIM

- (a) If using the new combustion chamber:  
Using a micrometer, measure the thickness of each used combustion chamber at the position shown in the illustration, then select the number of shims to be used.

Combustion chamber thickness mm (in.)	No. of shims to be used
6.02 - 6.05 (0.2370 - 0.2382)	0
6.06 - 6.08 (0.2386 - 0.2394)	1
6.09 - 6.11 (0.2398 - 0.2406)	2

**Shim thickness: 0.03 mm (0.0012 in.)**

### NOTICE:

**If combustion chamber shims were already being used, do not perform the above step, use the same number of shims as were used before.**

- (b) If reusing the combustion chamber.  
Install the combustion chamber back in the same position it was originally at.

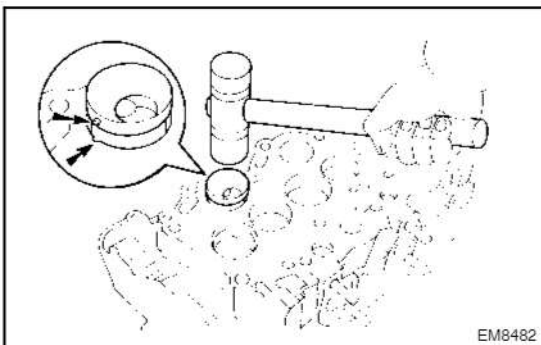

EM8482

### 2. 1HZ: INSTALL COMBUSTION CHAMBERS

- (a) Align the knock pin of the combustion chamber with the notch of the cylinder head.
- (b) Using a plastic - faced hammer, tap in the (shim and) combustion chamber.

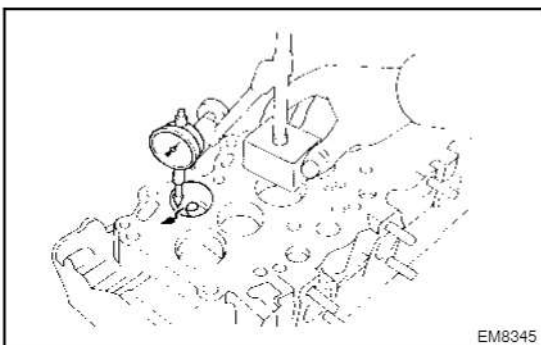

EM8345

- (c) Using a dial indicator, measure the protrusion of the combustion chamber from the cylinder head.

### Protrusion:

**Minus 0.04 - Plus 0.04 mm**

**(Minus 0.0016 - Plus 0.0016 in.)**

If the protrusion is less than specified, adjust with shims.

**Shim thickness: 0.03 mm (0.0012 in.)**

If the protrusion is greater than specification, replace the chamber and recheck the protrusion.

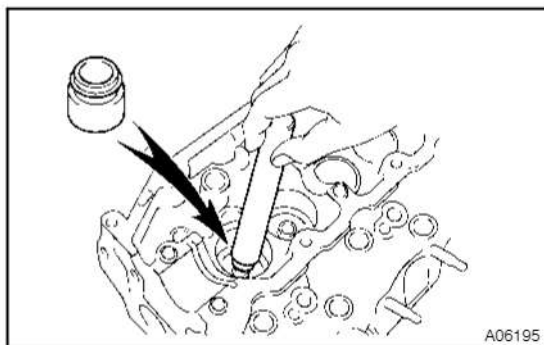

### 3. INSTALL VALVES

- (a) Using SST, push in a new oil seal.  
SST 09201-41020

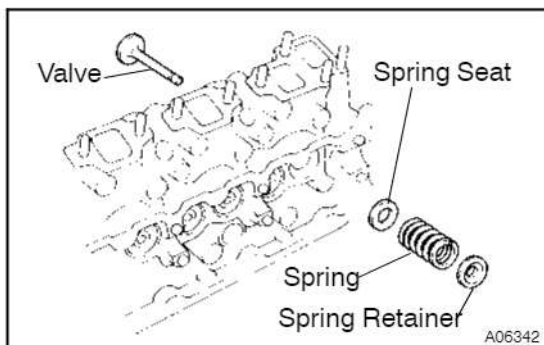

- (b) Install these parts:
- Valve
  - Spring seat
  - Valve spring
  - Spring retainer

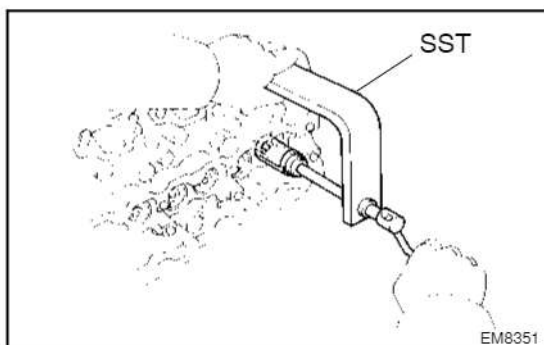

- (c) Using SST, compress the valve spring and place the 2 keepers around the valve stem.  
SST 09202-70020 (09202-00010)

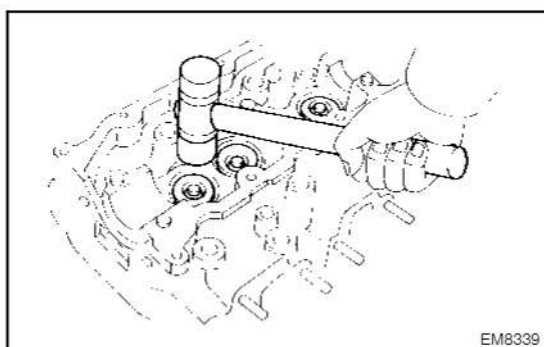

- (d) Using a plastic-faced hammer, lightly tap the valve stem tip to assure a proper fit.

### 4. INSTALL VALVE LIFTERS AND SHIMS

- (a) Install the valve lifter and shim.  
(b) Check the valve lifter rotates smoothly by hand.

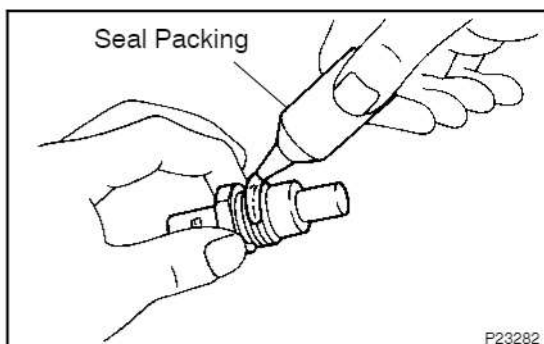

### 5. INSTALL WATER TEMPERATURE SENDER GAUGE

- (a) Apply seal packing to 2 or 3 threads.  
**Seal packing: Part No. 08826-00100 or equivalent**  
(b) Install the sender gauge.



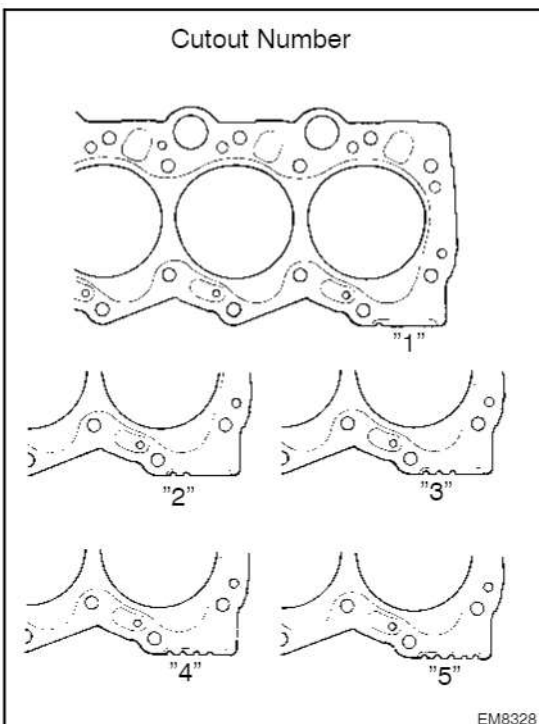
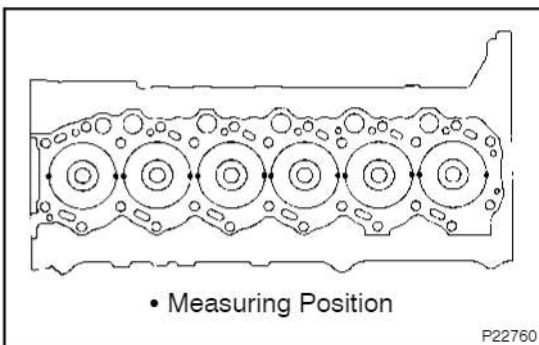
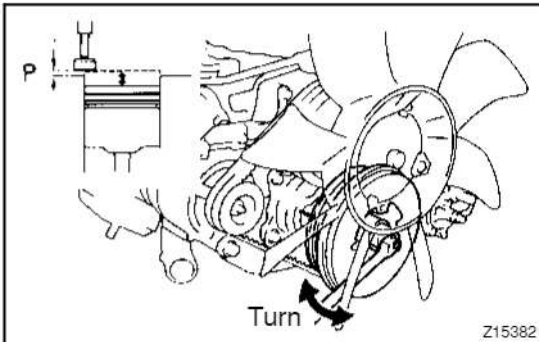
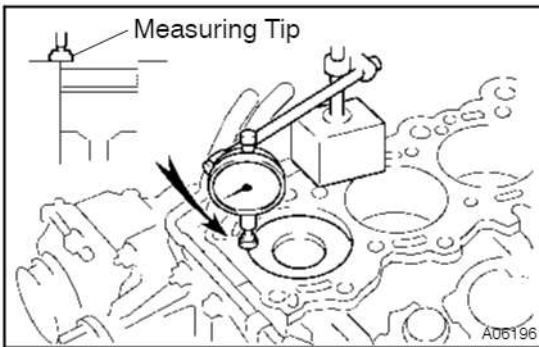

## INSTALLATION

### 1. CHECK PISTON PROTRUSION AND SELECT CYLINDER HEAD GASKET

Check piston protrusions for each cylinder

- (1) Clean the cylinder block with solvent.
- (2) Set the piston of the cylinder to be measured to slightly before TDC.
- (3) Place a dial indicator on the cylinder block, and set the dial indicator at 0 mm (0 in.).

HINT:

- Use a dial indicator measuring tip as shown in the illustration.
- Make sure that the measuring tip is square to the cylinder block gasket surface and piston head when taking the measurements.
- (4) Find where the piston head protrudes most by slowly turning the crankshaft clockwise and counter-clockwise.
- (5) Measure each cylinder at 2 places as shown in the illustration, making a total of 12 measurements.
- (6) For the piston protrusion value of each cylinder, use the average of the 2 measurements of each cylinder.

**Protrusion (P): 0.175 – 0.425 mm (0.0069 – 0.0167 in.)**

When removing piston and connecting rod assembly:

If the protrusion is not as specified, remove the piston and connecting rod assembly and reinstall it.

(See page EM-102)

### 2. SELECT NEW CYLINDER HEAD GASKET

HINT:

There are 5 types of gasket (cutout number 1 to 5) installed at factory, but only 3 types for supply parts (cutout number 1, 3 and 5), so when replacing the gasket select from one of 3 types above.

**New installed cylinder head gasket thickness:**

**Cutout number 1: 1.15 – 1.25 mm (0.0453 – 0.0492 in.)**

**Cutout number 3: 1.25 – 1.35 mm (0.0492 – 0.0531 in.)**

**Cutout number 5: 1.35 – 1.45 mm (0.0531 – 0.0571 in.)**

Select the largest piston protrusion value from the measurements made, then select a new appropriate gasket according to the table below.

**1HZ:**

Piston protrusion	Gasket size
0.455 mm (0.0179 in.) or less	Use 1
0.456 – 0.555 mm (0.0180 – 0.0219 in.)	Use 3
0.556 mm (0.0246 in.) or more	Use 5

**1HD-T:**

Piston protrusion	Gasket size
0.525 mm (0.0207 in.) or less	Use 1
0.526 - 0.625 mm (0.0207 - 0.0246 in.)	Use 3
0.626 mm (0.0246 in.) or more	Use 5

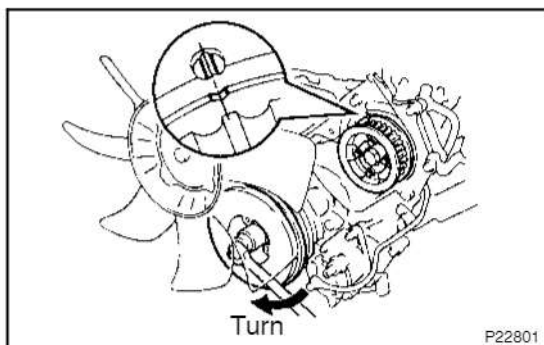
**3. SET NO.1 CYLINDER TO BDC/COMPRESSION**

Turn the crankshaft pulley, and align the timing mark of the No.2 camshaft timing pulley, with the BDC mark of the timing gear cover.

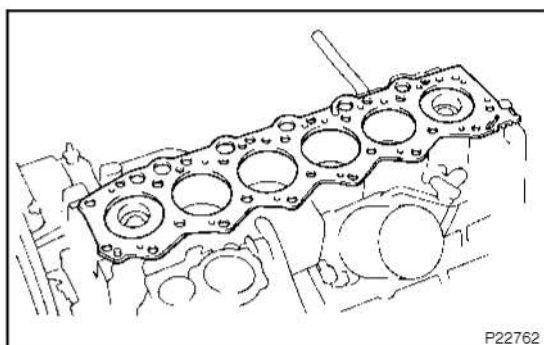
**4. INSTALL CYLINDER HEAD**

(a) Place cylinder on cylinder block

- (1) Place a new cylinder head gasket in position on the cylinder block.

**NOTICE:**

**Be careful of the installation direction.**

- (2) Place the cylinder head in position on the cylinder head gasket.

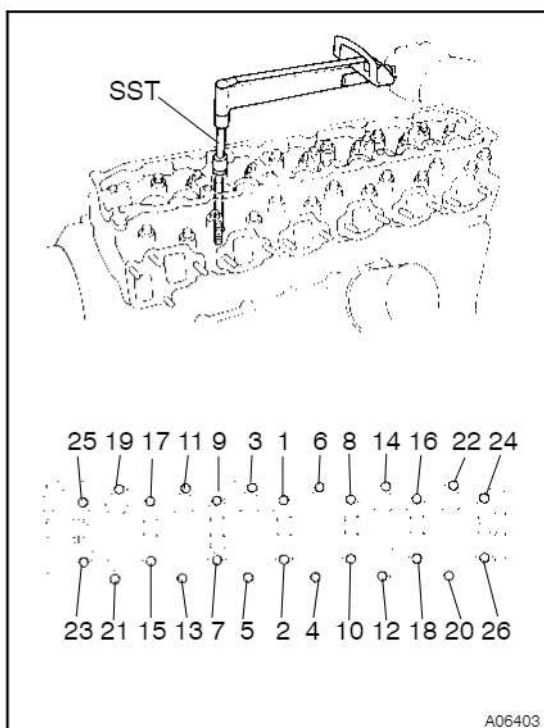

(b) Install cylinder head bolts

**HINT:**

- The cylinder head bolts are tightened in 3 progressive steps (steps (b), (d) and (e)).
- If any bolts is broke or deformed, replace it.
  - (1) Apply a light coat of engine oil on the threads and under the heads of the cylinder head bolts.
  - (2) Install and uniformly tighten the 26 cylinder head bolts in several passes, in the sequence shown.

SST 09011-38121

**Torque: 68.6 N·m (700 kgf·cm, 51 ft·lbf)**

If any one of the cylinder head bolts does not meet the torque specification, replace the cylinder head bolt.

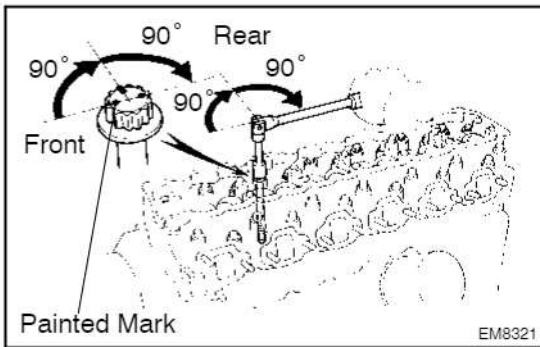

- (c) Mark the front of the cylinder head bolt with paint.
- (d) Retighten the cylinder head bolts 90° in the numerical order shown.
- (e) Retighten cylinder head bolts by an additional 90°.
- (f) Check that the painted mark is now facing rearward.
- (g) Connect the water bypass hose (from the injection pump) to the cylinder head.

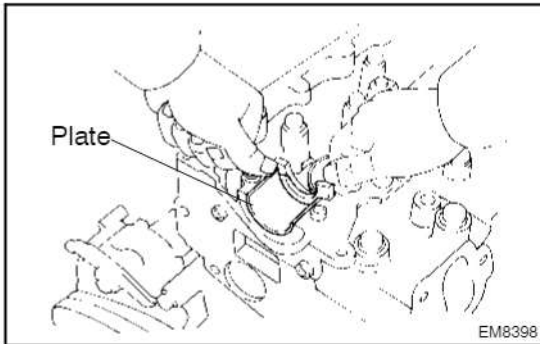

## 5. INSTALL CAMSHAFT

- (a) Install the camshaft thrust plate to the cylinder head.
- (b) Install the camshaft bearings to the No. 1 bearing cap and No.1 journal of the cylinder head.

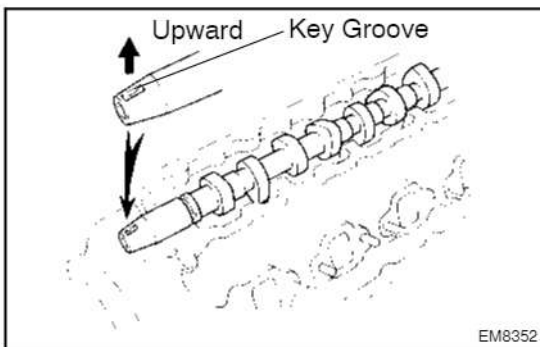

- (c) Place the camshaft on the cylinder head, facing the key groove upward.

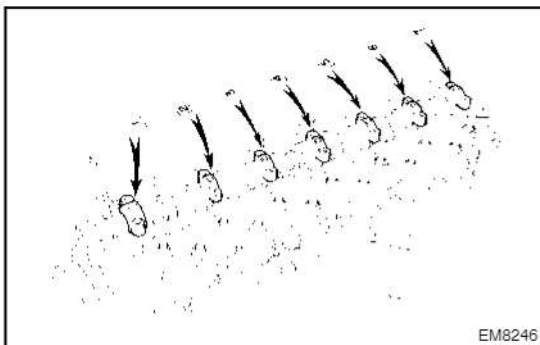

- (d) Install the 7 bearing caps in their proper locations.

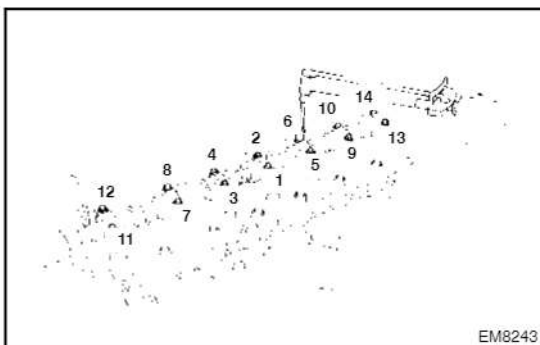

- (e) Install and uniformly tighten the 14 bearing cap bolts in several passes in the sequence shown.

### Torque:

**No.1 Bearing cap 25 N·m (250 kgf·cm, 18 ft·lbf)**

**Other 18 N·m (185 kgf·cm, 13 ft·lbf)**

**6. INSTALL CAMSHAFT OIL SEAL RETAINER**

- (a) Remove any old packing (FIPG) material and be careful not to drop any oil on the contact surfaces of the oil seal retainer and cylinder head.
- Using a razor blade and gasket scraper, remove all the oil packing (FIPG) material from the gasket surfaces and sealing groove.
  - Thoroughly clean all components to remove all the loose material.
  - Using a non-residue solvent, clean both sealing surfaces.
- (b) Apply seal packing to the oil seal retainer as shown in the illustration.

**Seal packing: Part No. 08826-00080 or equivalent**

- Install a nozzle that has been cut to a 2-3 mm (0.08 - 0.12 in.) opening.
- Parts must be assembled within 5 minutes of application. Otherwise the material must be removed and reapplied.
- Immediately remove nozzle from the tube and reinstall cap.

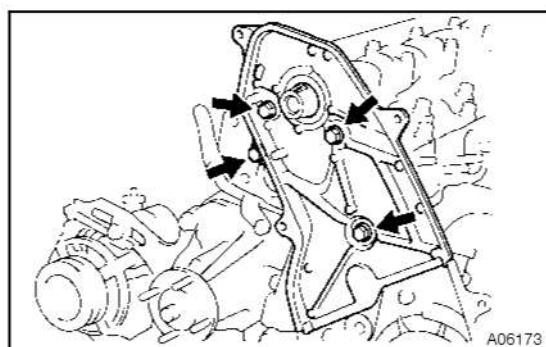
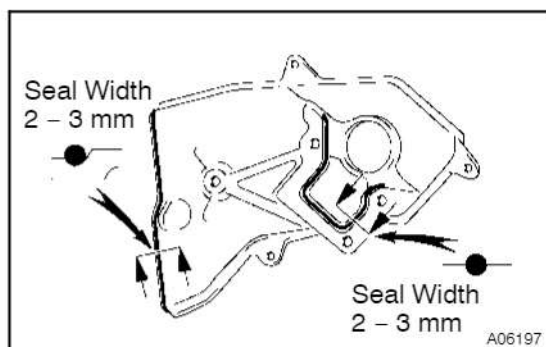

- (c) Install the oil seal retainer with the 4 bolts. Uniformly tighten the bolts in several passes.

**Torque: 19.6 N·m (200 kgf·cm, 14 ft·lbf)**

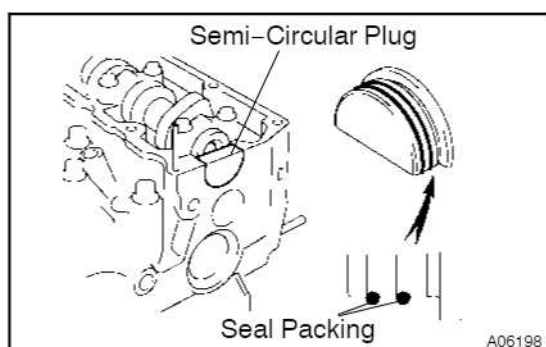
**7. INSTALL TIMING BELT AND PULLEYS**  
(See page EM-31)**8. INSTALL SEMI-CIRCULAR PLUG**

- (a) Remove any old packing (FIPG) material.
- (b) Apply seal packing to the semi-circular plug as shown in the illustration.
- Seal packing: Part No. 08826-00080 or equivalent**
- (c) Install the semi-circular plug to the cylinder head.

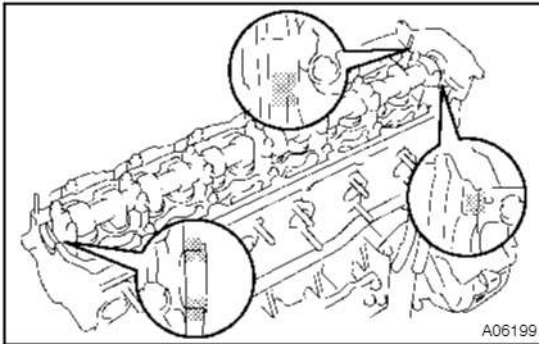
**9. INSTALL CYLINDER HEAD COVER**

- (a) Remove any old packing (FIPG) material.
- (b) Apply seal packing to the cylinder head as shown in the illustration.

**Seal packing: Part No. 08826-00080 or equivalent**

- (c) Install the gasket to the cylinder head cover, 14 bolts and 2 nuts .

**Torque: 6.4 N·m (65 kgf·cm, 57 ft·lbf)**

- (d) 1HD - T:  
Install the PCV pipe.

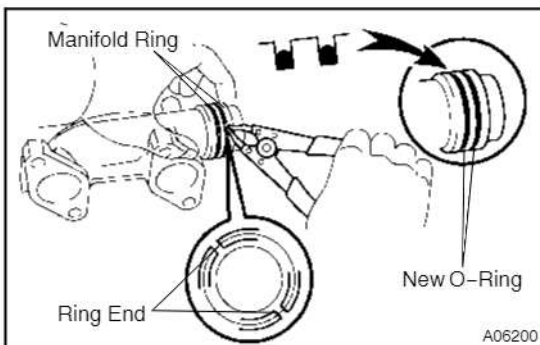
**10. INSTALL 2 ENGINE HANGERS****11. ASSEMBLE EXHAUST MANIFOLDS**

- (a) Install 2 new O-rings to the rear exhaust manifold.
- (b) Using snap ring pliers, install the 2 rings to the rear exhaust manifold.
- (c) Position the rings so that the ring ends are as shown.

**NOTICE:**

**Do not align the ring ends.**

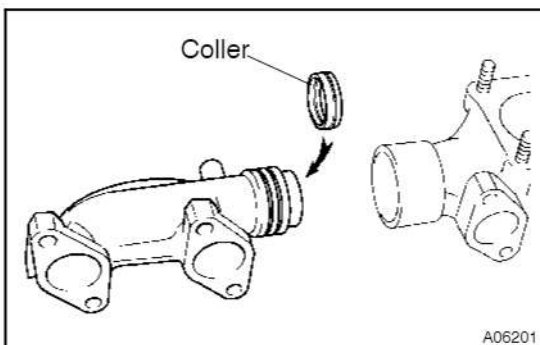

- (d) Install the collar the rear exhaust manifold.
- (e) Assemble the front and rear exhaust manifolds.

**12. 1HD-T:**

**INSTALL EXHAUST MANIFOLD TO TURBOCHARGER**  
(See page TC-15)

**13. 1HD-T:**

**INSTALL TURBOCHARGER AND EXHAUST MANIFOLDS ASSEMBLY**  
(See page TC-15)

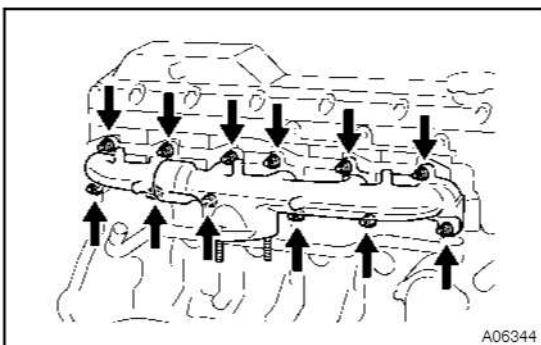
**14. 1HZ:**

**INSTALL EXHAUST MANIFOLDS ASSEMBLY**

Install the 12 bolts, exhaust manifold and 2 gaskets.

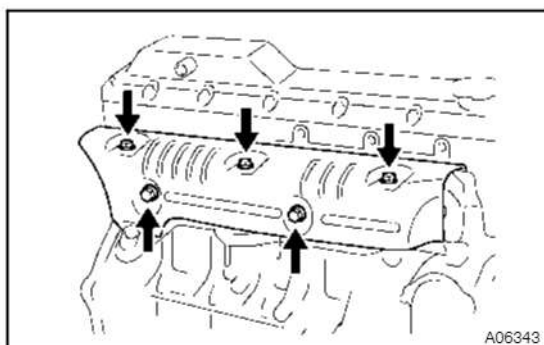

- 15. 1HZ:**  
**INSTALL HEAT INSULATOR**  
 Install the 5 bolts and heat insulator.

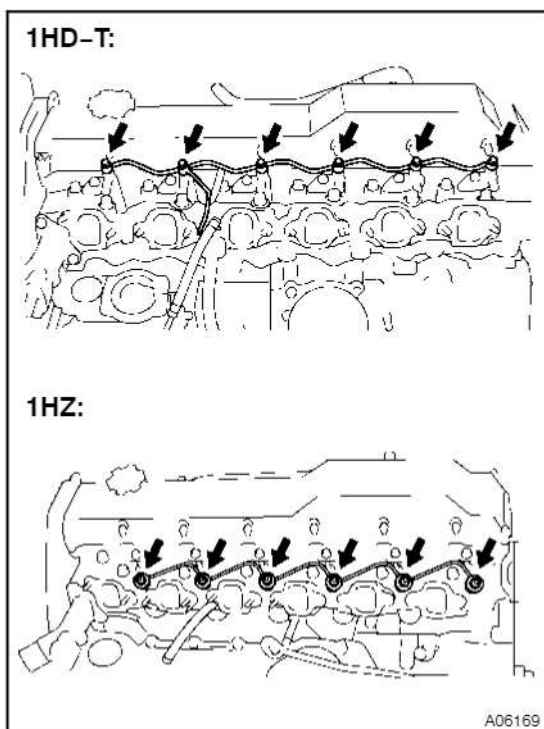

- 16. INSTALL NOZZLE LEAKAGE PIPE**
- (a) 1HZ:  
 Install the 6 nuts, 6 gaskets and nozzle leakage pipe.  
**Torque: 29 N·m (300 kgf·cm, 22 ft·lbf)**
- (b) 1HD - T:  
 Install the 6 bolts, 12 gaskets and nozzle leakage pipe.  
**Torque: 12.3 N·m (125 kgf·cm, 9 ft·lbf)**
- 17. INSTALL INJECTION NOZZLES**  
 1HZ: (See page FU-13)  
 1HD-T: (See page FU-30)

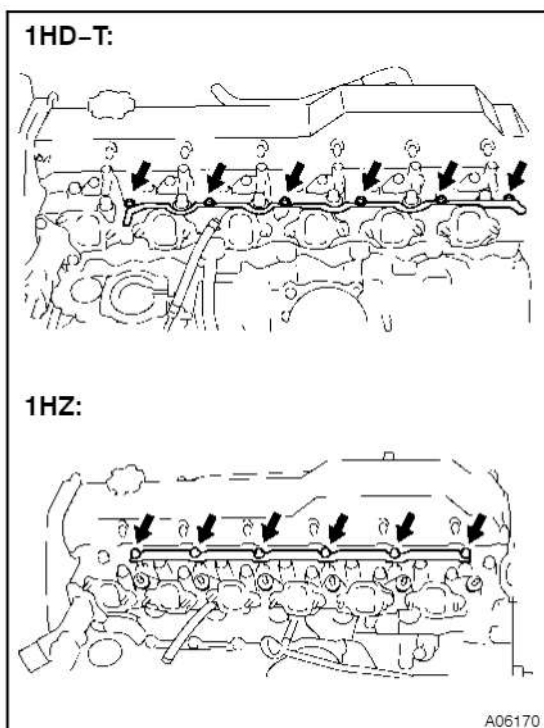

- 18. INSTALL GLOW PLUG AND GLOW PLUG CONNECTOR**
- (a) Install 6 glow plugs.
- (b) Install glow plug connector, 6 nuts and 6 screw grommets.  
**Torque:**  
**6 nuts: 22 N·m (224 kgf·cm, 16 ft·lbf)**  
**Glow plug: 12.7 N·m (130 kgf·cm, 9 ft·lbf)**

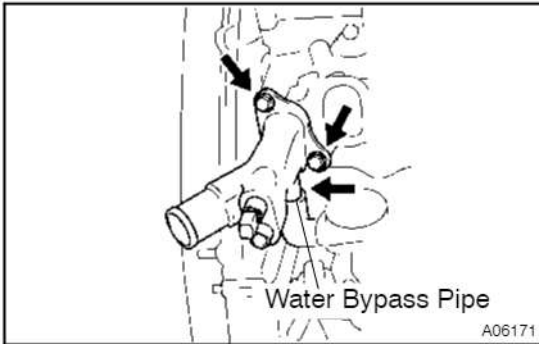
**19. INSTALL WATER OUTLET**

- (a) Install a new gasket to the intake manifold.
- (b) 1HD - T:  
Connect the water bypass hose to the water outlet.
- (c) Install the water outlet with the 2 nuts.

**Torque: 19.6 N·m (200 kgf·cm, 14 ft·lbf)**

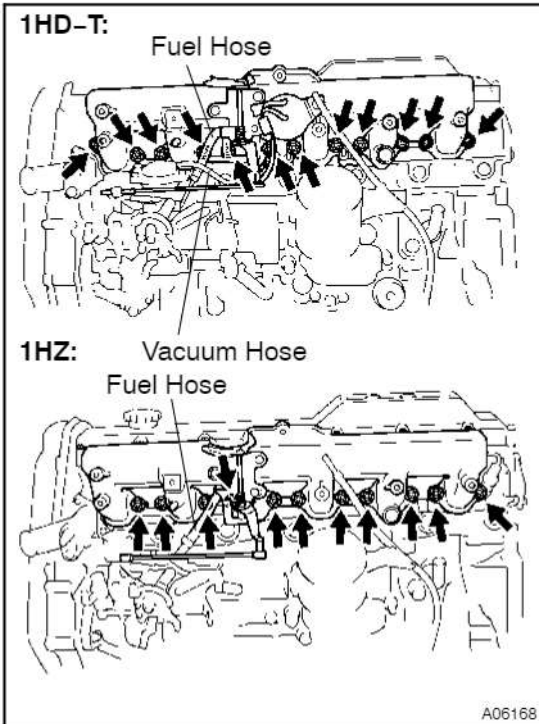
**20. INSTALL INTAKE MANIFOLD**

- (a) Install 6 new gaskets and the intake manifold with the 12 seals and 12 nuts.

**Torque: 19.6 N·m (200 kgf·cm, 15 ft·lbf)**

- (b) Install the accelerator linkage.
- (c) 1HD - T:  
Connect the vacuum hose to the injection pump, and the fuel hose to the fuel pipe, and install the 2 clips.
- (d) 1HZ:  
Connect the fuel hose to the fuel pipe.

**21. INSTALL INJECTION PIPES**

(See page FU-13)

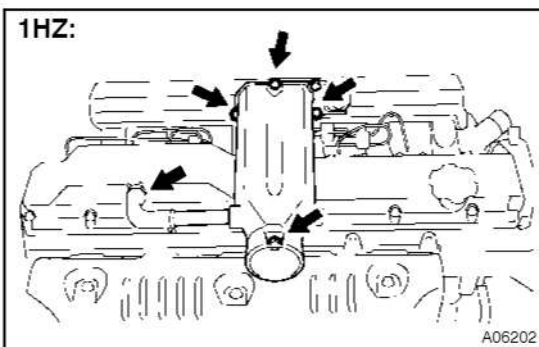
**22. 1HZ: INSTALL INTAKE PIPE ASSEMBLY**

- (a) Install the insulator, gasket and the intake pipe assembly to the intake manifold with the 3 bolts.

**Torque: 19.6 N·m (200 kgf·cm, 15 ft·lbf)**

- (b) Connect the PCV hose to the cylinder head cover.

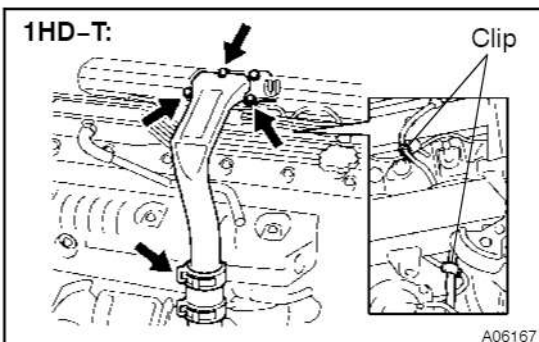
**23. 1HD - T: INSTALL INTAKE PIPE ASSEMBLY**

- (a) Connect the intake pipe assembly to the air hose.
- (b) Install a new gasket and the intake pipe to the intake manifold with the 3 bolts.

**Torque: 19.6 N·m (200 kgf·cm, 15 ft·lbf)**

- (c) Install the 2 clips and vacuum hose.

24. FILL WITH ENGINE COOLANT
25. START ENGINE AND CHECK FOR LEAKS
26. RECHECK ENGINE COOLANT LEVEL AND OIL LEVEL



# CYLINDER HEAD (1HD-FTE) COMPONENTS

EM0WS-01

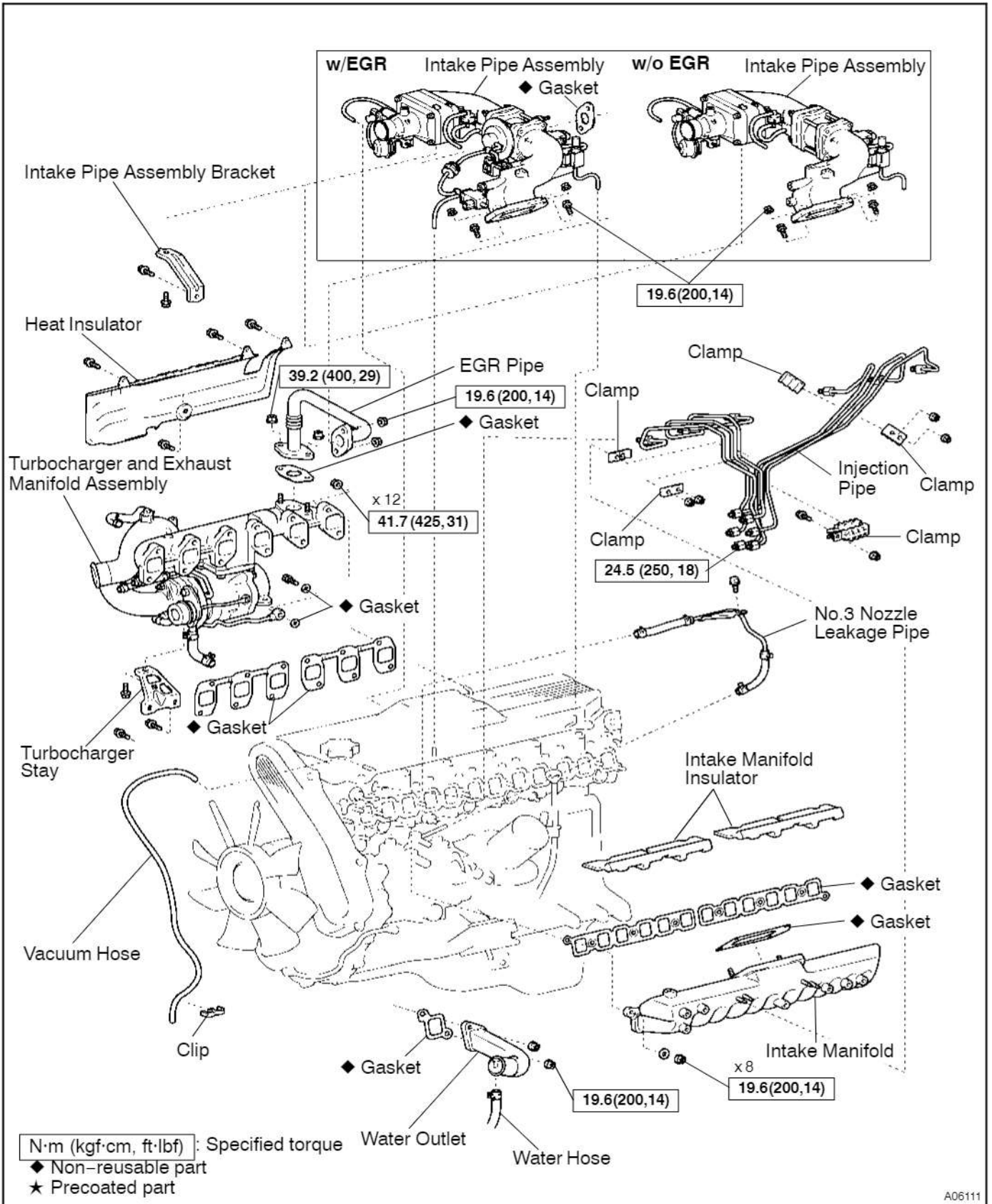

cardiagn.com

A06111

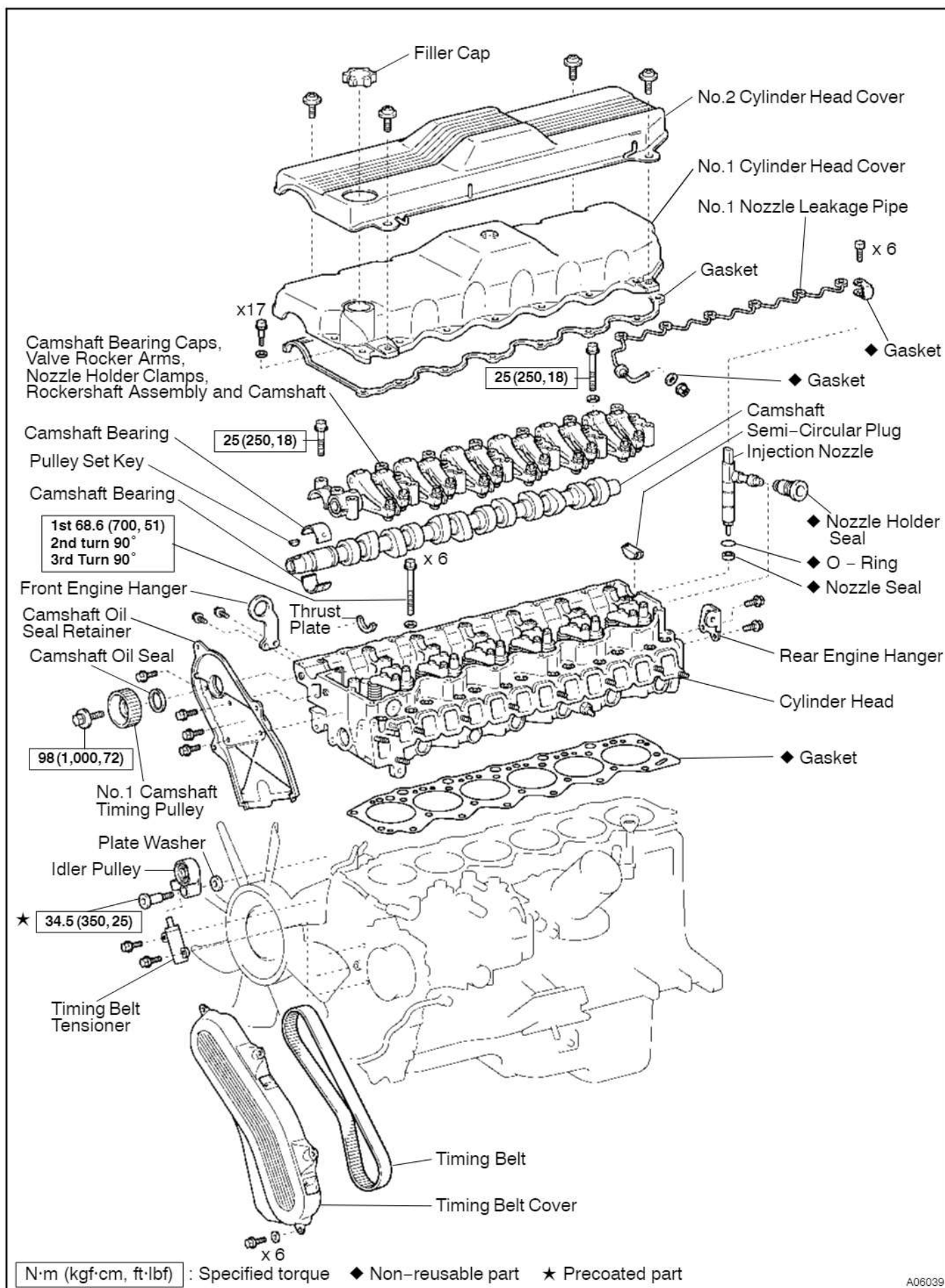

A06039

Camshaft Bearing Cap, Valve Rocker Arm, Nozzle Holder Clamp and Rocker Shaft Assembly

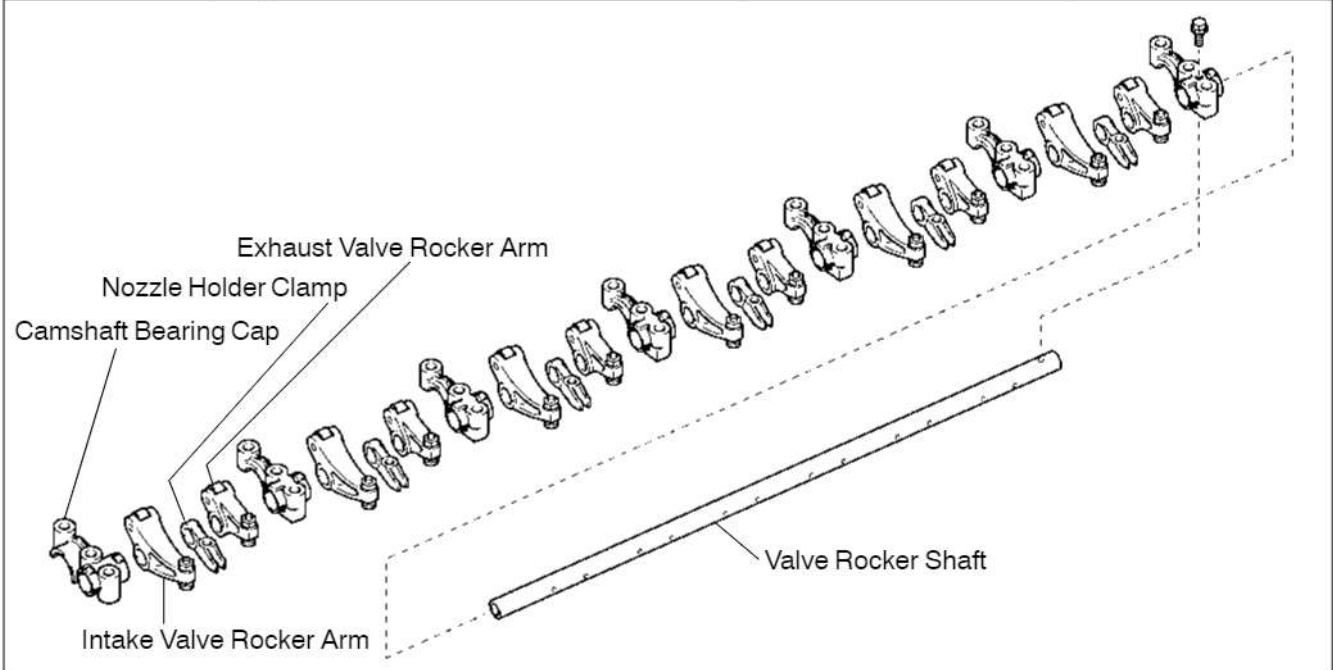

Cylinder Head Assembly

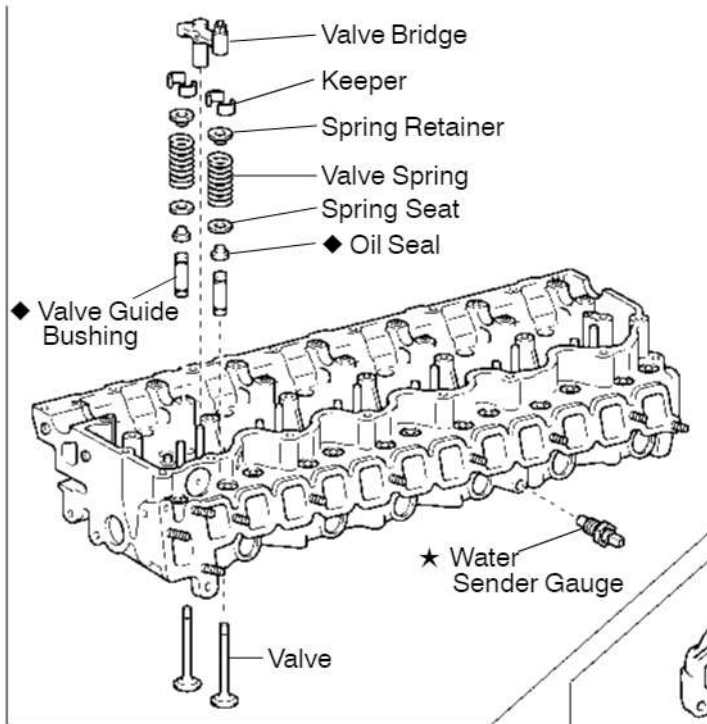

Turbocharger and Exhaust Manifold Assembly

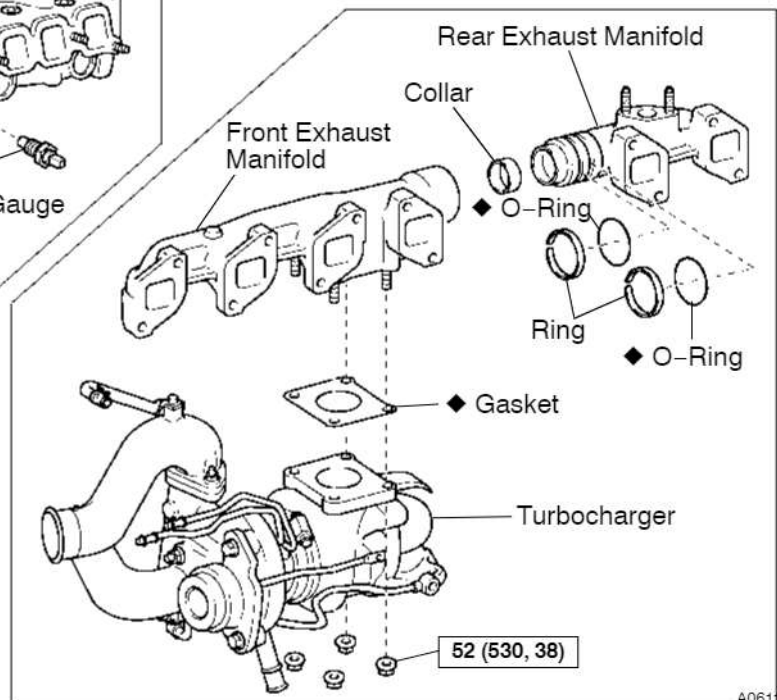

N·m (kgf·cm, ft·lbf) : Specified torque

◆ Non-reusable part

★ Precoated part

A06110

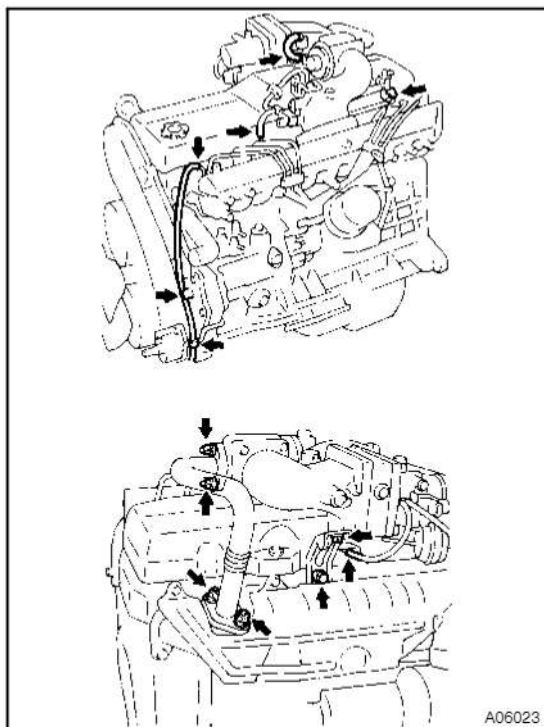

## REMOVAL

### 1. REMOVE INTAKE PIPE ASSEMBLY

- (a) Disconnect the vacuum hose to the clamp and timing belt cover.
- (b) Disconnect the 5 vacuum hose to the No.2 cylinder head cover.
- (c) w/EGR:  
Remove the 4 nuts, 2 gaskets and the EGR pipe.
- (d) Remove the 2 bolts and intake pipe assembly bracket.
- (e) Remove the 2 bolts, 2 nuts, gasket and intake pipe assembly.

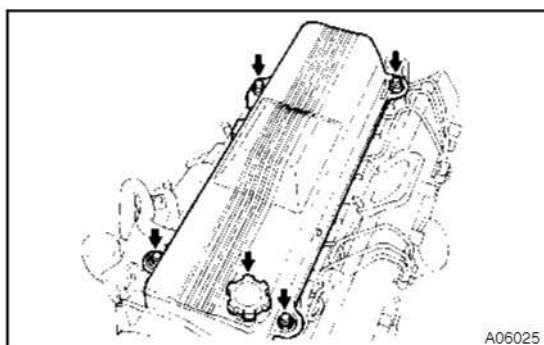

### 2. REMOVE NO.2 CYLINDER HEAD COVER

- (a) Remove the oil filler cap.
- (b) Remove the 4 bolts and cylinder head No.2 cover.

### 3. REMOVE INJECTION PIPE

(See page FU-33)

### 4. REMOVE 2 INTAKE MANIFOLD INSULATOR

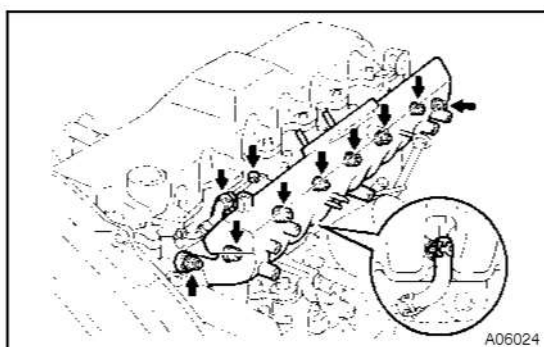

### 5. REMOVE INTAKE MANIFOLD

- (a) Remove the fuel hose from the injection pump.
- (b) Remove the 8 nuts, 8 seal washers, 2 gasket and intake manifold insulator.

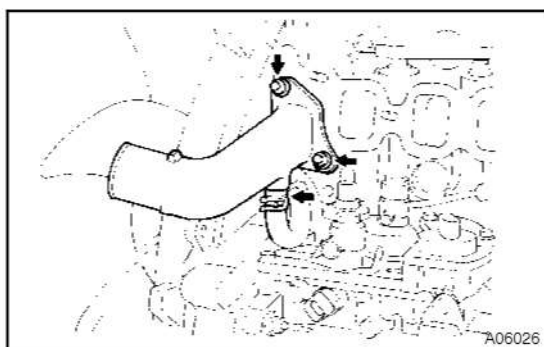

### 6. REMOVE WATER OUTLET

- (a) Disconnect the water bypass hose from the water outlet.
- (b) Remove the 2 bolts, water outlet and gasket.

### 7. REMOVE TURBOCHARGER AND EXHAUST MANIFOLD ASSEMBLY

(See page TC-8)

### 8. REMOVE EXHAUST MANIFOLD FROM TOURBOCHARGER

(See page TC-8)

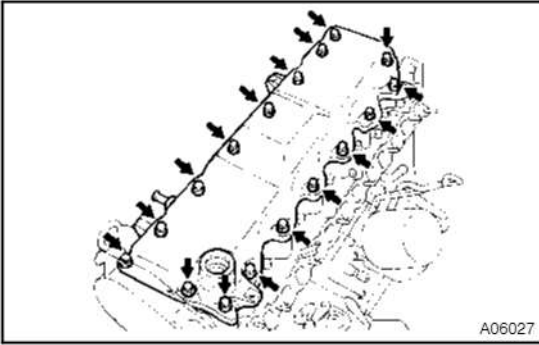
**9. REMOVE NO.1 CYLINDER HEAD COVER**

Remove the 17 bolts, 17 seal washers, No.1 cylinder head cover and gasket.

**10. REMOVE TIMING BELT AND PULLEY**

(See page EM-27)

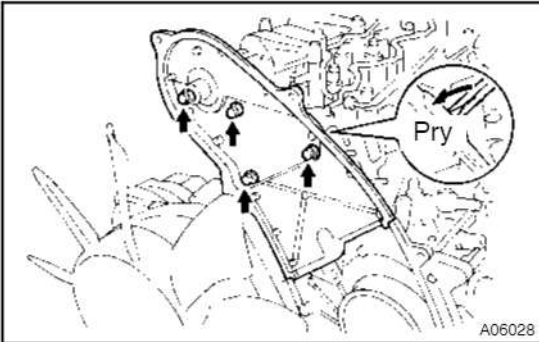
**11. REMOVE CAMSHAFT OIL SEAL RETAINER**

(a) Remove the 4 bolts.

(b) Pry out the oil seal retainer.

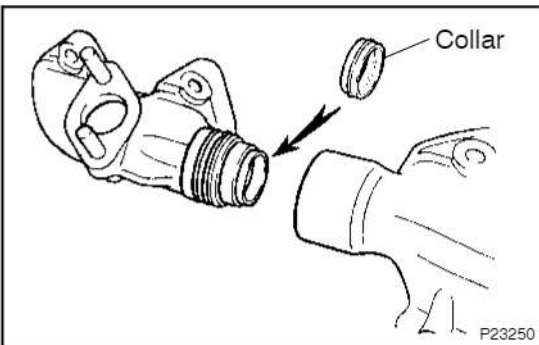
**12. REMOVE 2 ENGINE HANGER****13. SEPARATE EXHAUST MANIFOLDS**

(a) Separate the front and rear exhaust manifolds.

(b) Remove the collar.

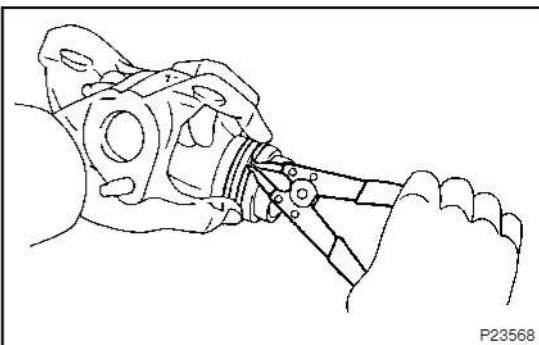

(c) Using snap ring pliers, remove the 2 rings from the rear exhaust manifold.

(d) Remove all the O-ring materials from the rear exhaust manifold grooves.

**14. REMOVE SEMI-CIRCULAR PLUG****15. REMOVE INJECTION NOZZLES**

(See page FU-33)

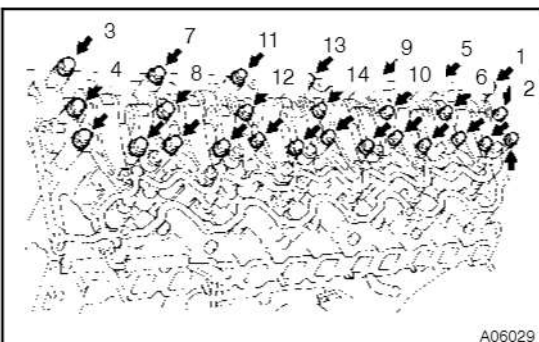
**16. REMOVE CAMSHAFT BEARING CAPS, VALVE ROCKER ARMS, NOZZLE HOLDER CLAMPS, ROCKER SHAFT ASSEMBLY AND CAMSHAFT**

(a) Remove the 13 bolts.

(b) Uniformly loosen and remove the 14 other bolts in several passes, in the sequence shown.

(c) Remove the 7 bearing caps, 12 rocker arms, 6 holder clamps, rocker shaft assembly and 7 upper camshaft bearings.

- Keep the bearing caps, rocker arms and nozzle holder clamps installed with the rocker shaft.
  - Keep the bearings inserted with the bearing cap.
- (d) Remove the camshaft, thrust plate and 7 lower camshaft bearings.

HINT:

Arrange the bearings in correct order.

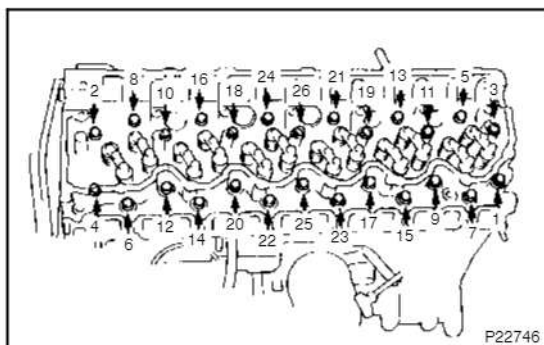

### 17. REMOVE CYLINDER HEAD ASSEMBLY

- (a) Disconnect the water bypass hose (from the injection pump) from the cylinder head.
- (b) Uniformly loosen and remove the 26 cylinder head bolts in several passes, in the sequence shown.

**NOTICE:**

**Head warpage or cracking could result from removing bolts in incorrect order.**

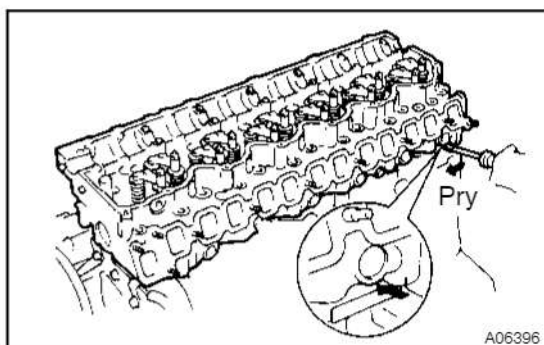

- (c) Lift the cylinder head from the dowels on the cylinder block, and place the cylinder head on wooden blocks on a bench.

HINT:

If the cylinder head is difficult to lift off, pry with a screwdriver between the cylinder head and block.

**NOTICE:**

**Be careful not to damage the contact surfaces of the cylinder head and cylinder block.**

## DISASSEMBLY

### 1. REMOVE WATER SENDER GAUGE

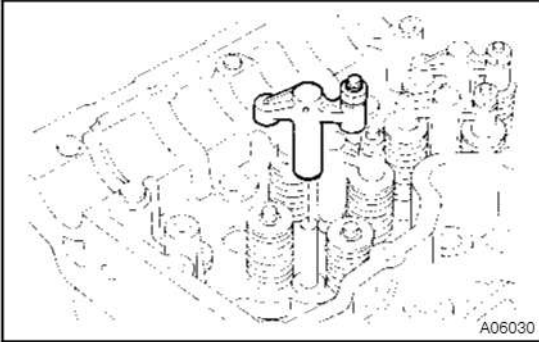

### 2. REMOVE VALVE BRIDGE

HINT:

Arrange the valve bridge in correct order.

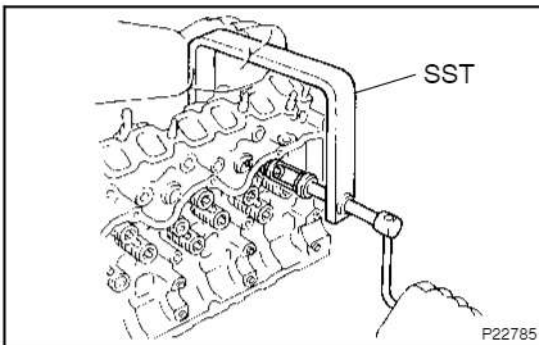

### 3. REMOVE VALVES

- (a) Using SST, compress the valve spring and remove the 2 keepers.

SST 09202-70020 (09202-00010)

- (b) Remove the spring retainer, valve spring, valve and spring seat.

HINT:

Arrange the valves, valve spring, valve springs, spring seats and spring retainers in correct order.

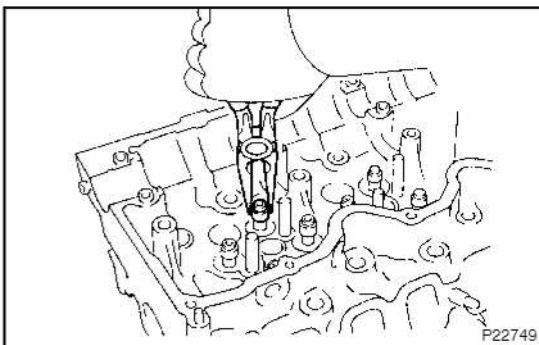

- (c) Using needle-nose pliers, remove the oil seal.

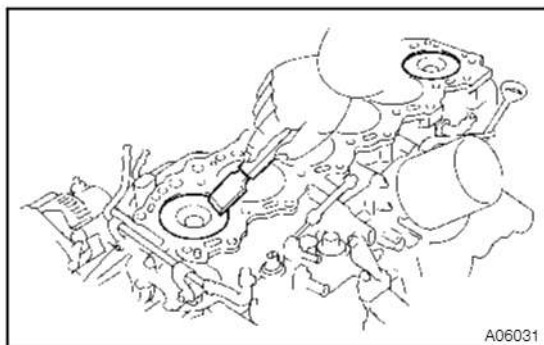

A06031

## INSPECTION

### 1. CLEAN TOP SURFACES OF PISTONS AND CYLINDER BLOCK

- (a) Turn the crankshaft, and bring each piston to the top dead center (TDC). Using a gasket scraper, remove all the carbon from the piston top surface.

- (b) Remove all the gasket material from the top of the cylinder block.

#### NOTICE:

**Be careful not to scratch the surfaces.**

- (c) Using compressed air, blow carbon and oil from the bolt holes.

#### CAUTION:

**Protect your eyes when using high-compressed air.**

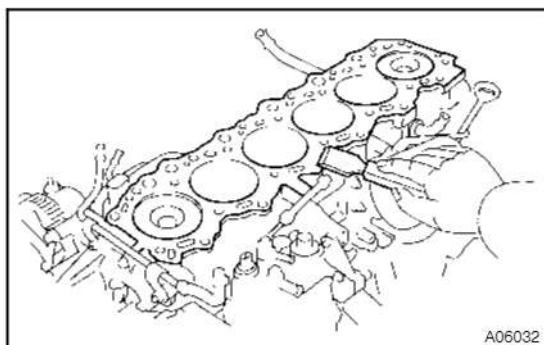

A06032

### 2. CLEAN CYLINDER HEAD

- (a) Remove gasket material  
Using a gasket scraper, remove all the gasket material from the cylinder block contact surface.

#### NOTICE:

**Be careful not to scratch the cylinder block contact surface.**

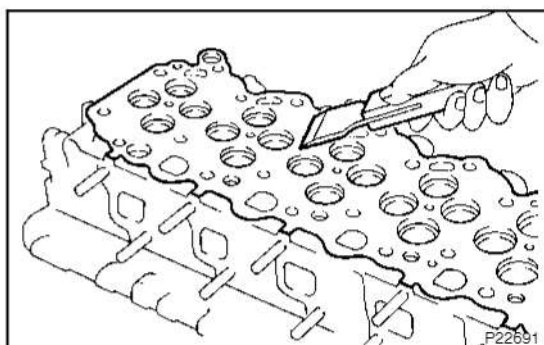

P22691

- (b) Clean intake and exhaust ports  
Using a wire brush, remove all the carbon from the intake and exhaust ports.

#### NOTICE:

**Be careful not to scratch the valve contact surface.**

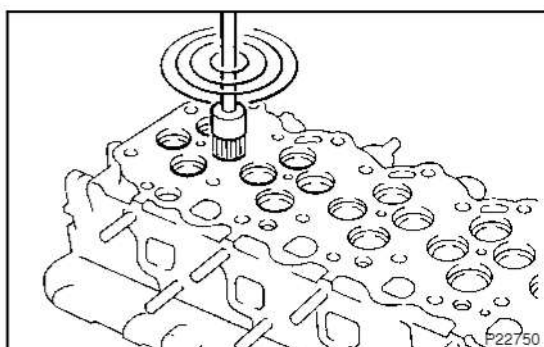

P22750

- (c) Clean valve guide bushings  
Using a valve guide bushing brush and solvent, clean all the guide bushings.

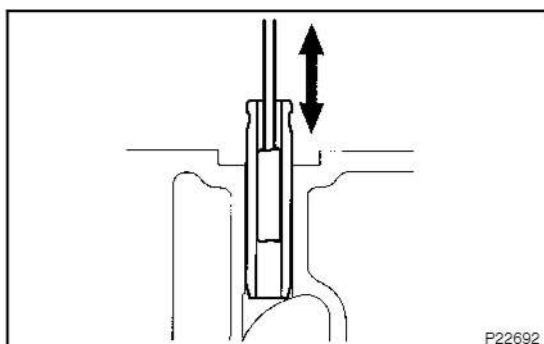

P22692



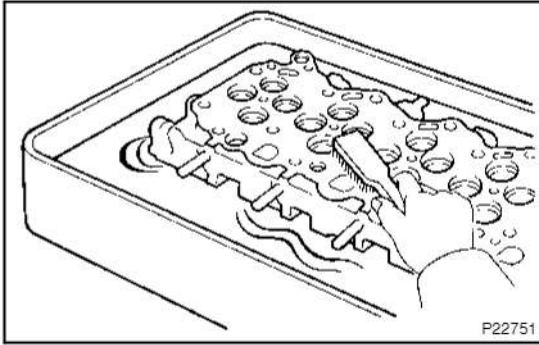

- (d) Clean cylinder head  
Using a soft brush and solvent, thoroughly clean the cylinder head.

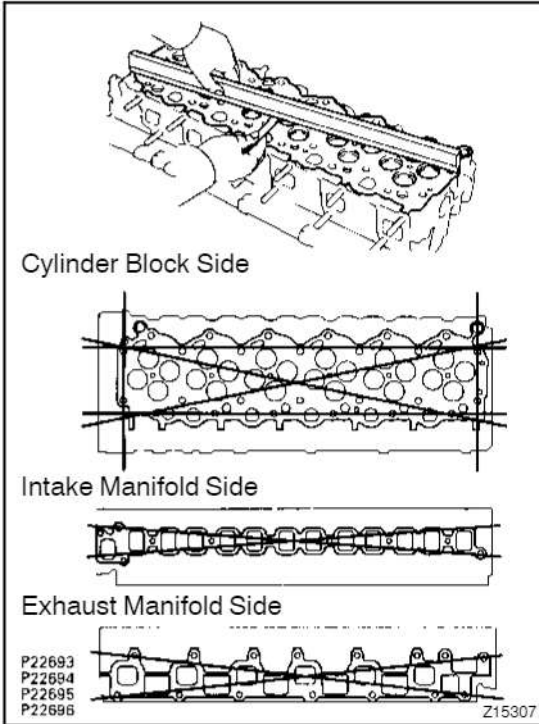

### 3. INSPECT CYLINDER HEAD

- (a) Inspect for flatness  
Using a precision straight edge and thickness gauge, measure the surfaces contacting the cylinder block and the manifolds for warpage.

**Maximum warpage: 0.20 mm (0.0079 in.)**

If warpage is greater than maximum, replace the cylinder head.

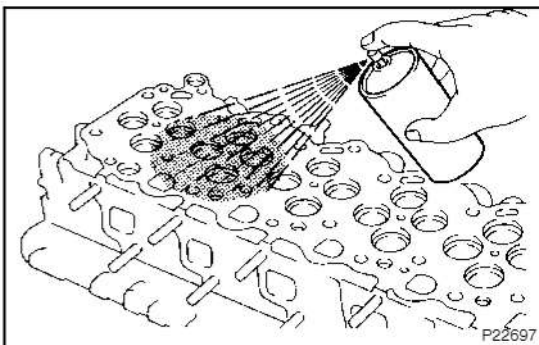

- (b) Inspect for cracks  
Using a dye penetrant, check the intake ports, exhaust ports and surface contacting the cylinder block.  
If cracked, replace the cylinder head.

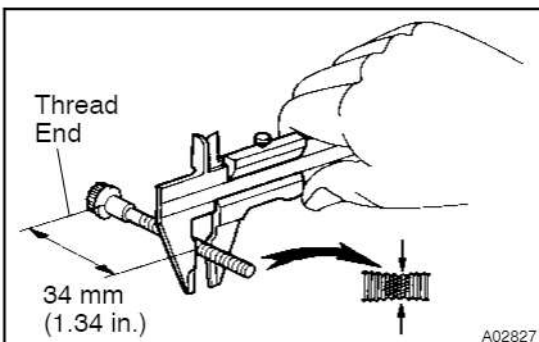

- (c) Inspect cylinder head bolts  
Using vernier calipers, measure the minimum outer diameter of the compressed thread at the measuring point.

**Standard outer diameter:**

**10.800 - 11.000 mm (0.4252 - 0.4331 in.)**

**Minimum outer diameter: 10.55 mm (0.4154 in.)**

If the outer diameter is less than minimum, replace the bolt.

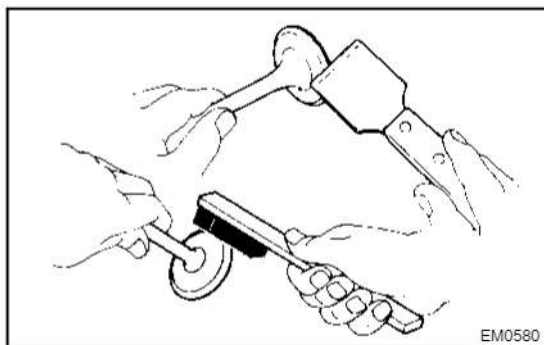
**4. CLEAN VALVES**

- (a) Using a gasket scraper, chip off any carbon from the valve head.
- (b) Using a wire brush, thoroughly clean the valve.

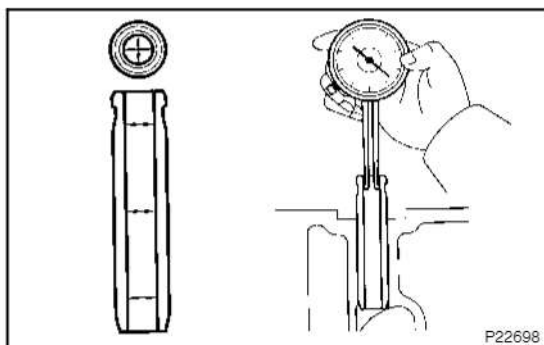
**5. INSPECT VALVE STEMS AND GUIDE BUSHINGS**

- (a) Using a caliper gauge, measure the inside diameter of the guide bushing.

**Busing inside diameter:**

**7.010 – 7.030 mm (0.2760 – 0.2768 in.)**

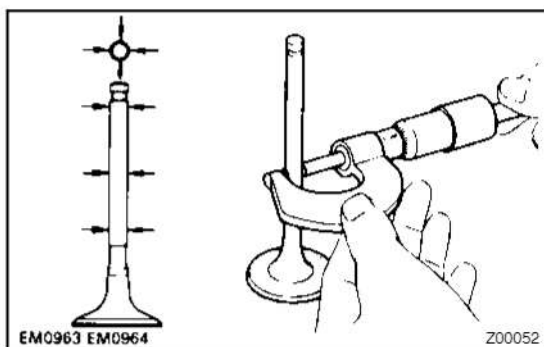

- (b) Using a micrometer, measure the diameter of the valve stem.

**Valve stem diameter:**

**Intake**

**6.970 – 6.985 mm (0.2744 – 0.2750 in.)**

**Exhaust**

**6.960 – 6.975 mm (0.2740 – 0.2746 in.)**

- (c) Subtract the valve stem diameter measurement from the guide bushing inside diameter measurement.

**Standard oil clearance:**

**Intake**

**0.025 – 0.060 mm (0.0010 – 0.0024 in.)**

**Exhaust**

**0.035 – 0.070 mm (0.0014 – 0.0028 in.)**

**Maximum oil clearance:**

**Intake**

**0.08 mm (0.0031 in.)**

**Exhaust**

**0.10 mm (0.0039 in.)**

If the clearance is greater than maximum, replace the valve and cylinder head.

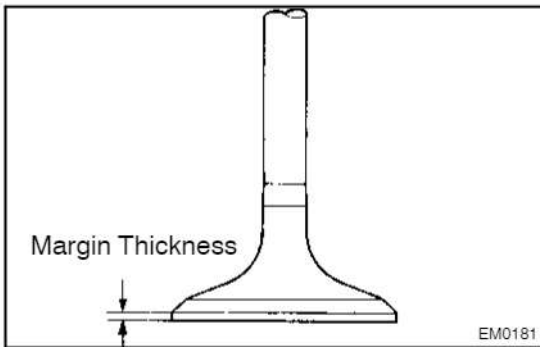

## 6. INSPECT VALVES

- (a) Check the valve face for wear.  
If the valve face is worn, replace the valve.
- (b) Check the valve head margin thickness.

**Standard margin thickness: 1.00 mm (0.0394 in.)**

**Minimum margin thickness: 0.83 mm (0.0327 in.)**

If the margin thickness is less than minimum, replace the valve

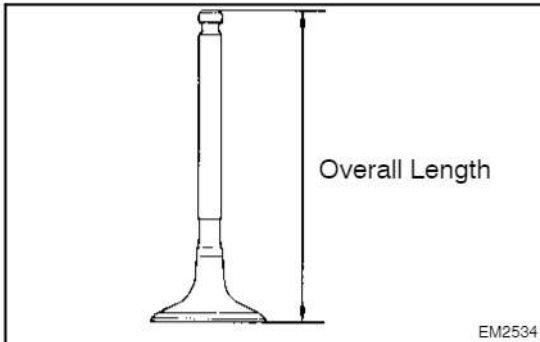

- (c) Check the valve overall length.

**Standard overall length:**

**Intake**

**126.85 - 127.45 mm (4.9941 - 5.0177 in.)**

**Exhaust**

**126.83 - 127.43 mm (4.9933 - 5.0169 in.)**

**Minimum overall length:**

**Intake**

**126.85 mm (4.9941 in.)**

**Exhaust**

**126.83 mm (4.9933 in.)**

If the overall length is less than minimum, replace the valve.

- (d) Check the valve stem tip for wear.

If the valve stem tip is worn, replace the valve.

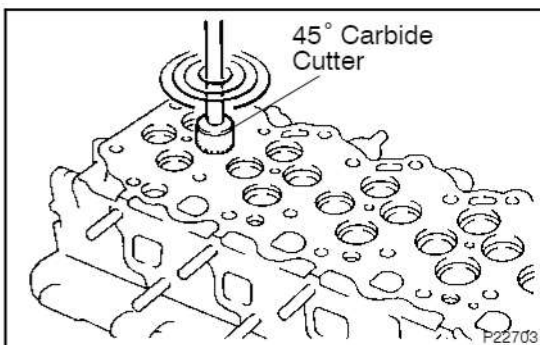

## 7. INSPECT AND CLEAN VALVE SEATS

- (a) Using a 45° carbide cutter, resurface the valve seats.  
Remove only enough metal to clean the seats.

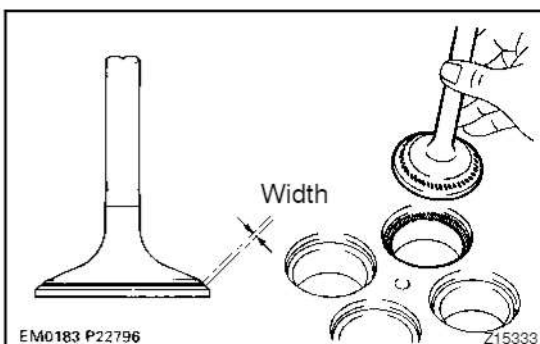

- (b) Check the valve seating position.

Apply a light coat of prussian blue (or white lead) to the valve face. Lightly press the valve against the seat. Do not rotate valve.

- (c) Check the valve face and seat for the following:
- If blue appears 360° around the valve face, the valve is concentric. If not, replace the valve.
  - If blue appears 360° around the valve seat, the guide and face are concentric. If not, resurface the seat.
  - Check that the seat contact is in the middle of the valve face with the following width:

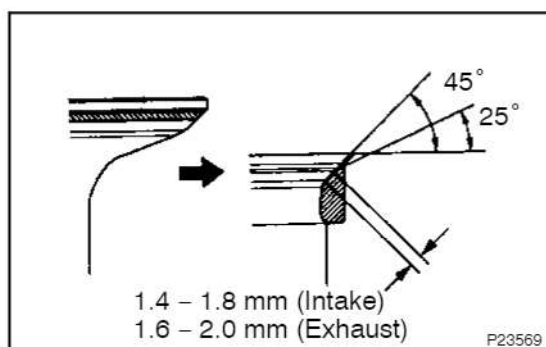
**Intake****1.4 – 1.8 mm (0.055 – 0.071 in.)****Exhaust****1.6 – 2.0 mm (0.063 – 0.079 in.)**

If not, correct the valve seats as follows:

- (1) If the seating is too high on the valve face, use 25° and 45° cutters to correct the seat.

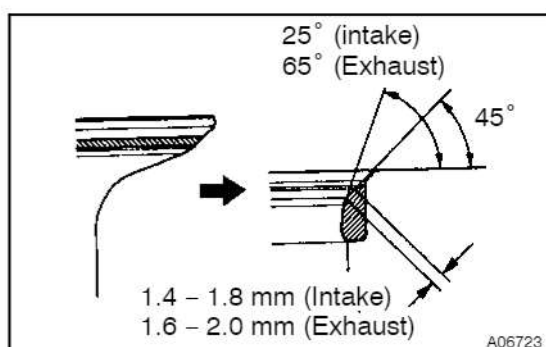

- (2) If the seating is too low on the valve face, use 70° (intake) or 65° (exhaust) and 45° cutters to correct the seat.

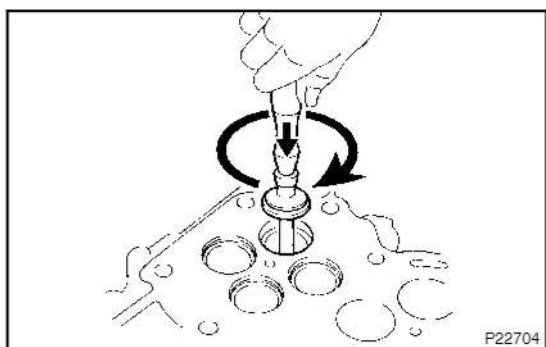

- (d) Hand-lap the valve and valve seat with an abrasive compound.
- (e) After hand-lapping, clean the valve and valve seat.

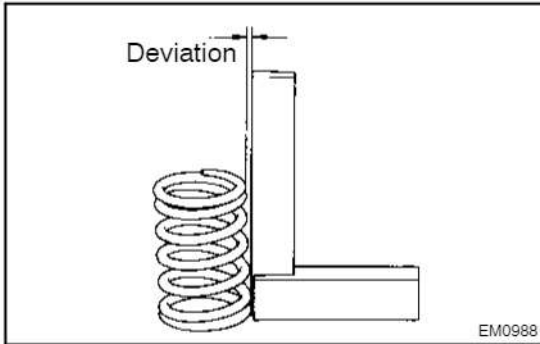

## 8. INSPECT VALVE SPRINGS

- (a) Using a steel square, measure the deviation of the valve spring.

**Maximum deviation: 2.0 mm (0.079 in.)**

If the deviation is greater than maximum, replace the valve spring.

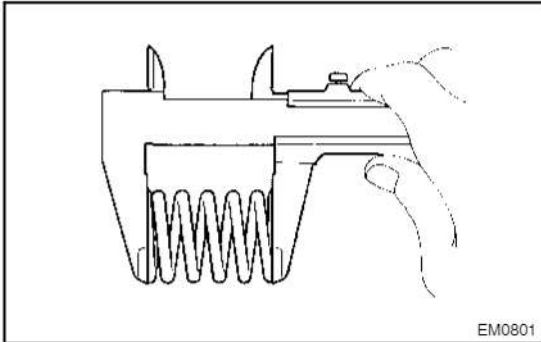

- (b) Using vernier calipers, measure the free length of the valve spring.

**Free length: 49.6 mm (1.9527 in.)**

If the free length is not as specified, replace the valve spring.

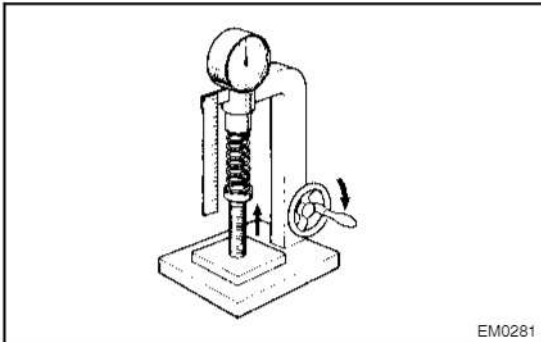

- (c) Using a spring tester, measure the tension of the valve spring at the specified installed length.

**Installed tension:**

**237 - 263 N (24.2 - 26.8 kgf, 53.4 - 59.1 lbf)**

**at 39.5 mm (1.555 in.)**

If the installed tension is not as specified, replace the valve spring.

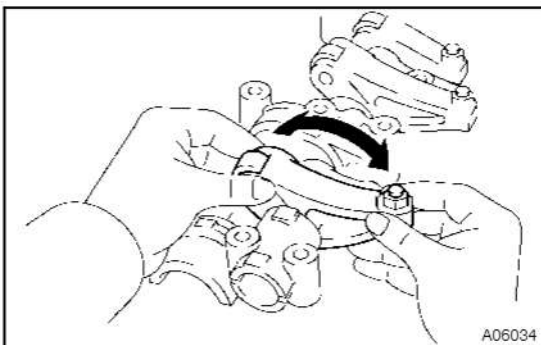

## 9. INSPECT VALVE ROCKER ARM AND SHAFT

- (a) Check that each rocker arm turns smoothly. If movement is felt, disassemble and check.
- (b) Remove the bolt, and disassemble the parts.

**HINT:**

Arrange the disassembled parts in correct order.

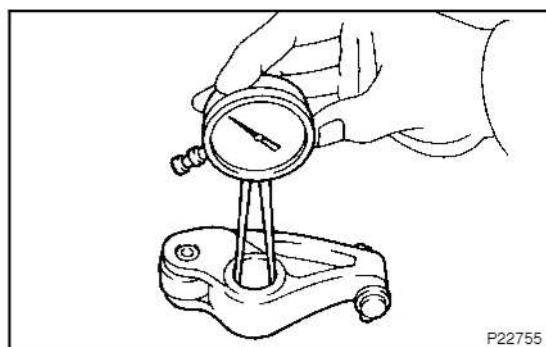
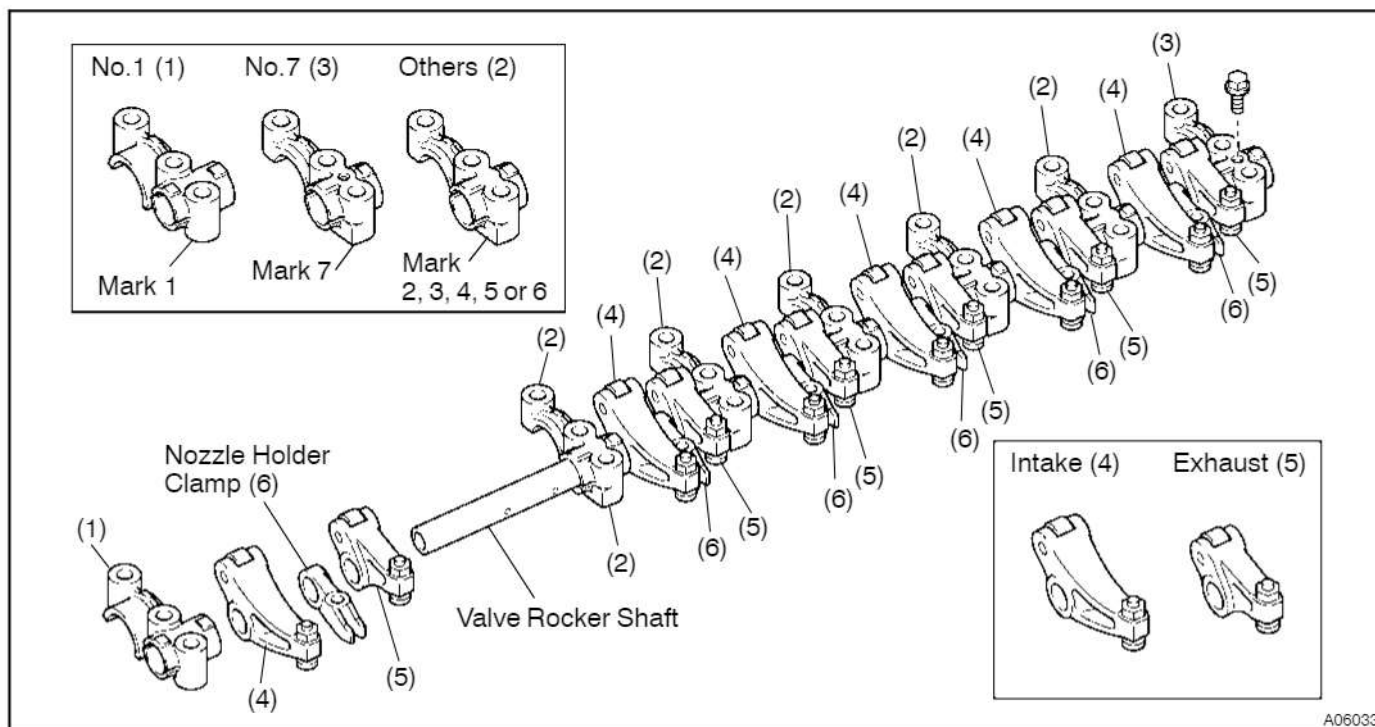

- (c) Using a caliper gauge, measure the inside diameter of the rocker arm.

**Rocker arm inside diameter:**

**20.012 – 20.033 mm (0.7879 – 0.7887 in.)**

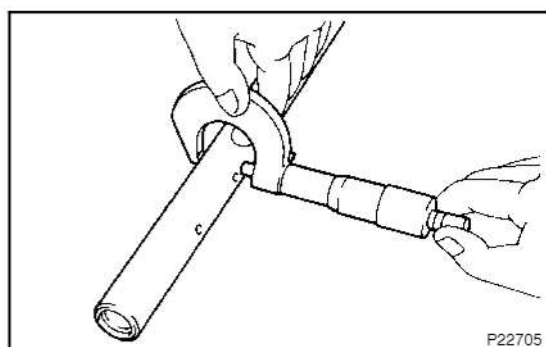

- (d) Using a micrometer, measure the diameter of the rocker arm shaft.

**Shaft diameter:**

**19.972 – 19.993 mm (0.7863 – 0.7871 in.)**

- (e) Subtract the rocker arm shaft measurement from the rocker arm measurement.

**Standard oil clearance:**

**0.019 – 0.061 mm (0.0007 – 0.0024 in.)**

**Maximum oil clearance: 0.10 mm (0.0039 in.)**

If the clearance is greater than maximum, replace the rocker shaft and shaft.

- (f) Assemble the parts as shown in the illustration.  
(See step (b) above)

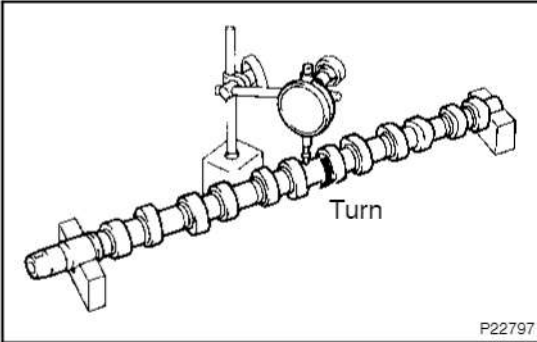

## 10. INSPECT CAMSHAFTS AND BEARINGS

- (a) Inspect camshaft for runout
- (1) Place the camshaft on V-blocks.
  - (2) Using a dial indicator, measure the circle runout at the center journal.

**Maximum circle runout: 0.10 mm (0.0039 in.)**

If the circle runout is greater than maximum, replace the camshaft.

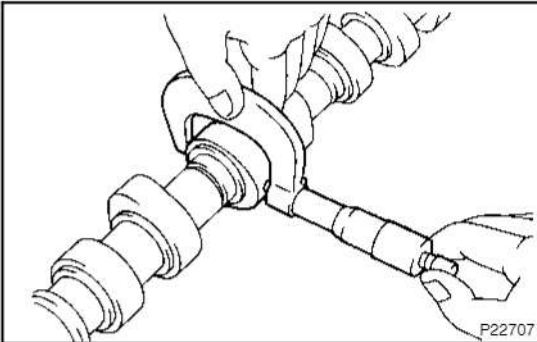

- (b) Inspect cam lobes  
Using a micrometer, measure the cam lobe height.

**Standard cam lobe height:**

**Intake**

**48.203 – 48.303 mm (1.8978 – 1.9017 in.)**

**Exhaust**

**50.734 – 50.834 mm (1.9974 – 2.0013 in.)**

**Minimum cam lobe height:**

**Intake**

**47.998 mm (1.8897 in.)**

**Exhaust**

**50.234 mm (1.9777 in.)**

If the cam lobe height is less than minimum, replace the camshaft.

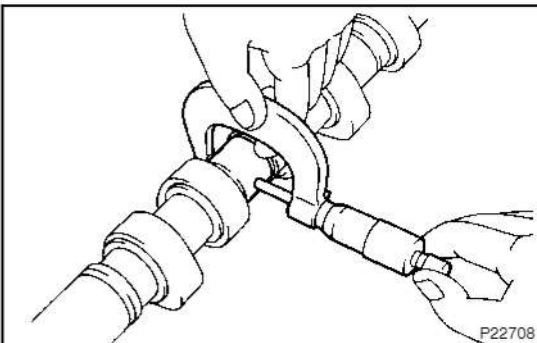

- (c) Inspect camshaft journals  
Using a micrometer, measure the journal diameter.

**Journal diameter:**

**No.1**

**34.969 – 34.985 mm (1.3767 – 1.3774 in.)**

**others**

**27.986 – 28.002 mm (1.1018 – 1.1024 in.)**

If the journal diameter is not as specified, check the oil clearance.

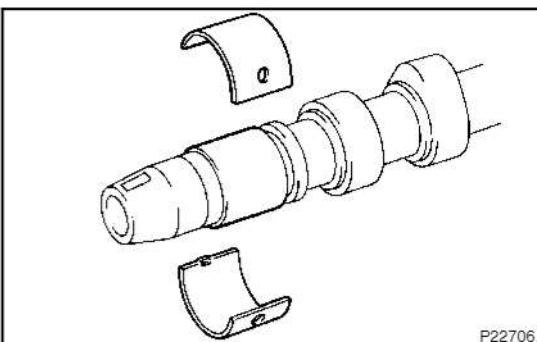

- (d) Inspect camshaft bearings  
Check the bearings for flaking and scoring.

If the bearings are damaged, replace the bearing caps and cylinder head as a set.

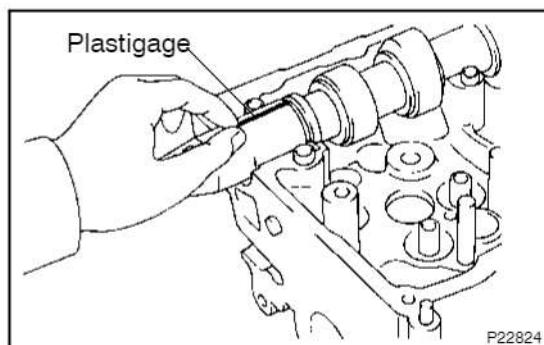

- (e) Inspect camshaft journal oil clearance
- (1) Clean the bearing caps and camshaft journals.
  - (2) Place the camshaft on the cylinder head.
  - (3) Lay a strip of Plastigage across each of the camshaft journals.
  - (4) Remove the 7 bearing caps from the valve rocker shaft. (See step 9)

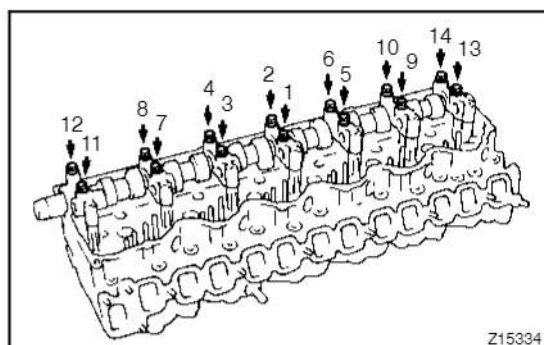

- (5) Install the 7 bearing caps with the 14 bolts. Uniformly tighten the bolts in several passes, in the sequence shown.

**Torque: 25 N·m (250 kgf·cm, 18 ft·lbf)**

**NOTICE:**

**Do not turn the camshaft.**

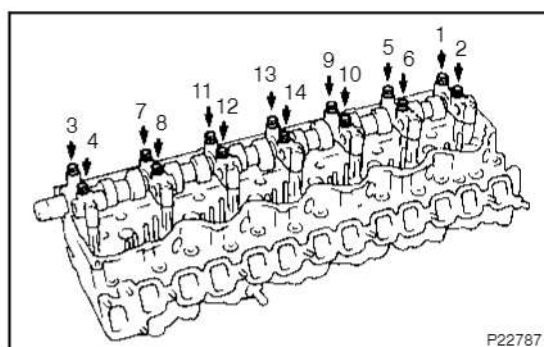

- (6) Uniformly loosen and remove the 14 bolts in several passes, in the sequence shown.
- (7) Remove the 7 bearing caps.

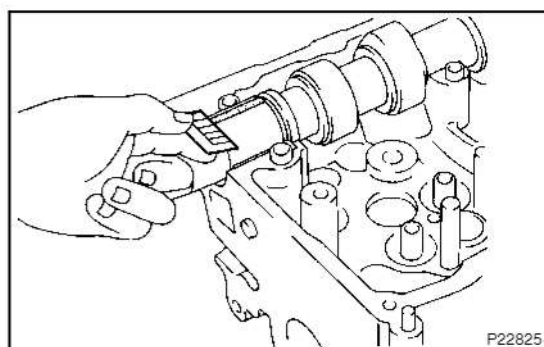

- (8) Measure the Plastigage at its widest point.

**Standard oil clearance:**

**No.1**

**0.022 - 0.074 mm (0.0009 - 0.0029 in.)**

**Others**

**0.023 - 0.075 mm (0.0009 - 0.0030 in.)**

**Maximum oil clearance: 0.10 mm (0.0039 in.)**

If the oil clearance is greater than maximum, replace the camshaft. If necessary, replace the bearing caps and cylinder head as a set.

- (9) Completely remove the Plastigage.
- (10) Install the 7 bearing caps to the valve rocker shaft. (See item 9 (b) above)



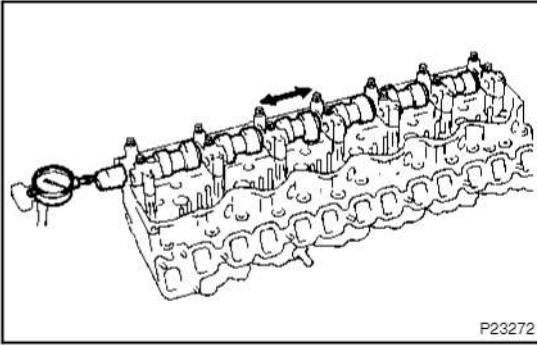

- (f) Inspect camshaft thrust clearance
- (1) Install the camshaft.  
(See procedure in item e above)
  - (2) Using a dial indicator, measure the thrust clearance while moving the camshaft back and forth.

**Standard thrust clearance:**

**0.10 - 0.20 mm (0.0039 - 0.0079 in.)**

**Maximum thrust clearance: 0.30 mm (0.0118 in.)**

If the thrust clearance is greater than maximum, replace the camshaft. If necessary, replace the bearing caps and cylinder head as a set.

- (3) Remove the camshaft.

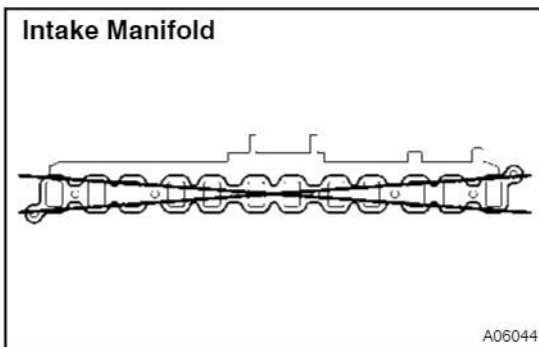

**11. INSPECT INTAKE MANIFOLD**

Using a precision straight edge and feeler gauge, measure the surface contacting the cylinder head for warpage.

**Maximum warpage: 0.40 mm (0.0157 in.)**

If warpage is greater than maximum, replace the manifold.

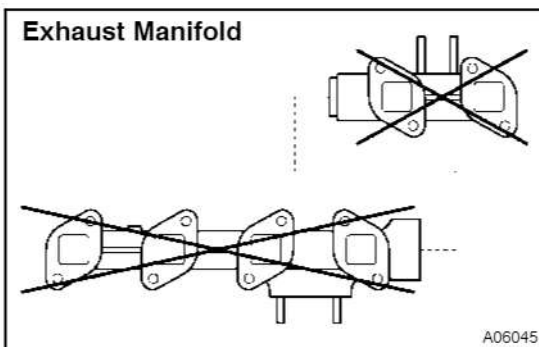

**12. INSPECT EXHAUST MANIFOLD**

Using a precision straight edge and feeler gauge, measure the surface contacting the cylinder head for warpage.

**Maximum warpage: 0.40 mm (0.0157 in.)**

If warpage is greater than maximum, replace the manifold.

## REPLACEMENT

### HINT:

There are 2 methods (a and b) to replace the oil seal which are as follows:

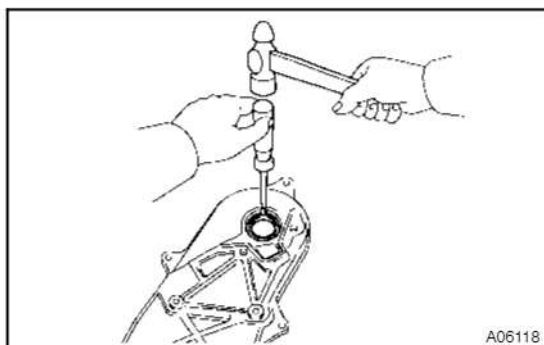

### REPLACE CAMSHAFT OIL SEAL

(a) If the camshaft oil seal retainer is removed from cylinder head.

(1) Using a screwdriver, tap out the oil seal.

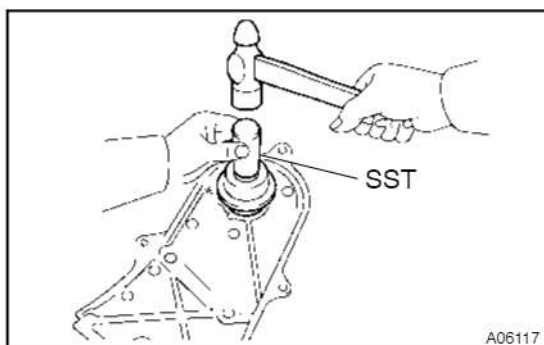

(2) Using SST and a hammer, tap in a new oil seal until its surface is flush with the oil seal retainer edge.

SST 09223 - 46011

(3) Apply MP grease to the oil seal lip.

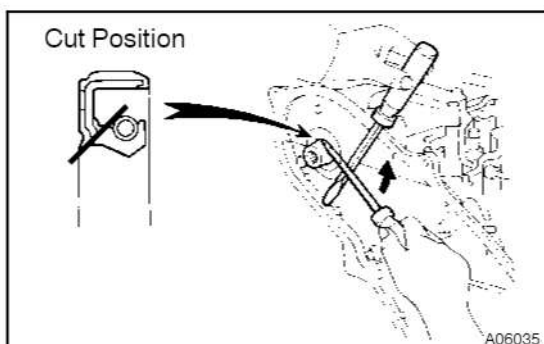

(b) If the camshaft oil seal retainer is installed to cylinder head.

(1) Using a knife, cut off the seal lip.

(2) Using 2 screwdrivers, pry out the oil seal.

### NOTICE:

**Be careful not to damage the camshaft. Tape the screwdriver tip.**

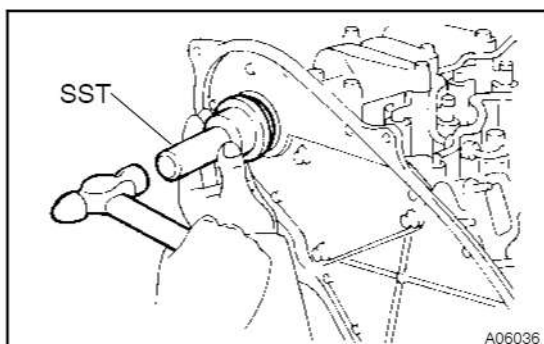

(3) Apply MP grease to a new oil seal lip.

(4) Using SST and a hammer, tap in the oil seal until its surface is flush with the oil seal retainer edge.

SST 09223 - 46011

## REASSEMBLY

### HINT:

- Thoroughly clean all parts to be assembled.
- Before installing the parts, apply new engine oil to all sliding and rotating surfaces.
- Replace all gaskets and oil seals with new ones,

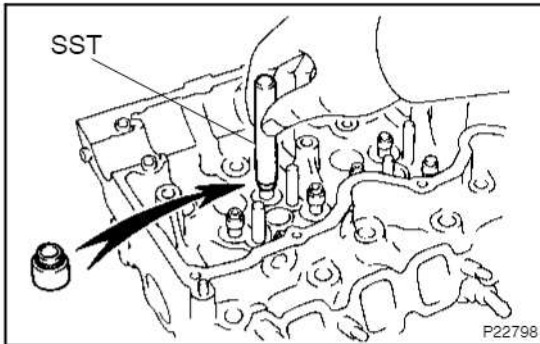

### 1. INSTALL VALVES

- (a) Using SST, push in a new oil seal.

SST 09201-41020

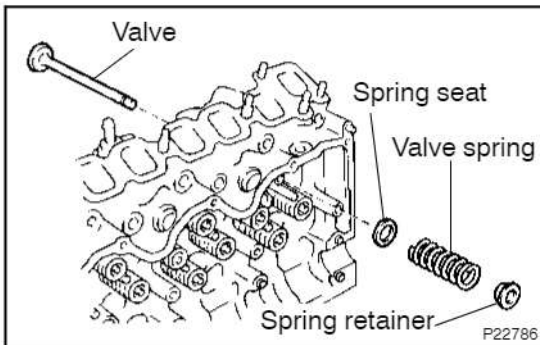

- (b) Install these parts:

- (1) Valve
- (2) Spring seat
- (3) Valve spring
- (4) Spring retainer

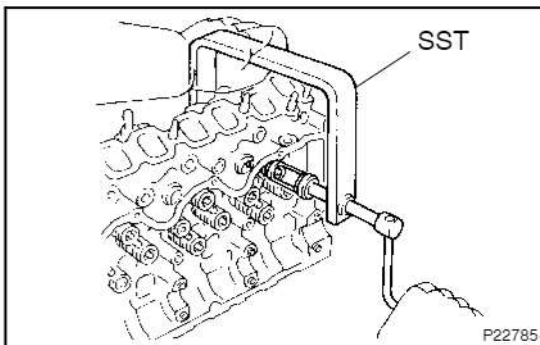

- (c) Using SST, compress the valve spring and place the 2 keepers around the valve stem.

SST 09202-70020 (09202-00010)

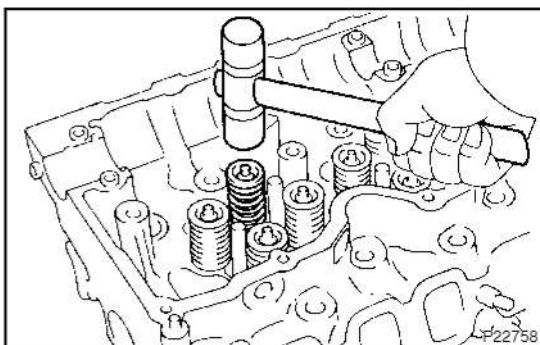

- (d) Using a plastic-faced hammer, lightly tap the valve stem tip to assure a proper fit.

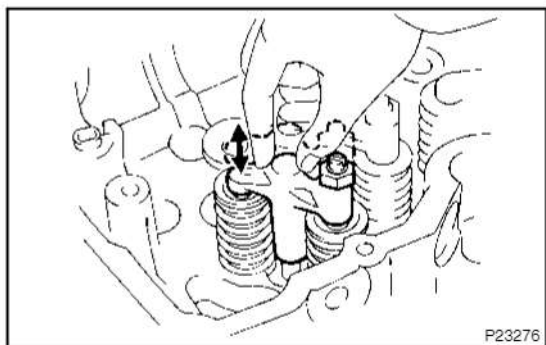
**2. INSTALL VALVE BRIDGES**

- (a) Install the valve bridge.
- (b) Check that the valve bridge rotates smoothly.

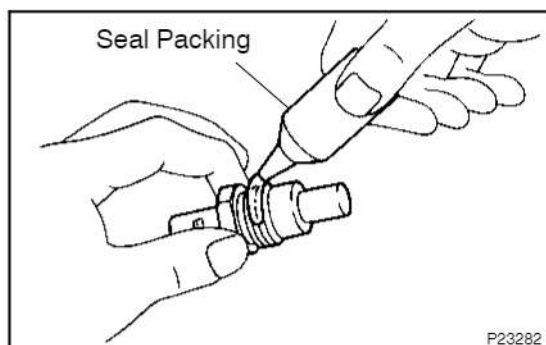
**3. INSTALL WATER SENDER GAUGE**

- (a) Apply seal packing to 2 or 3 threads.  
**Seal packing: Part No. 08826-00100 or equivalent**
- (b) Install the sender gauge.

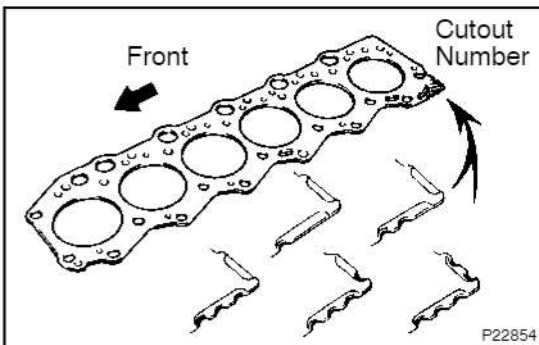
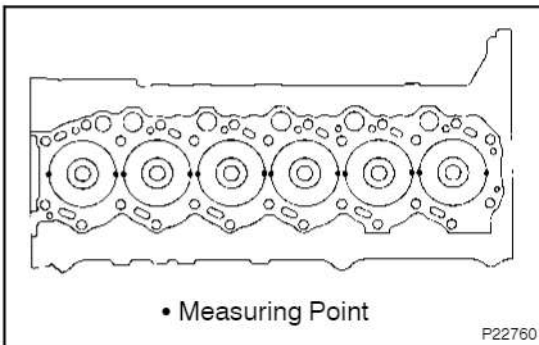
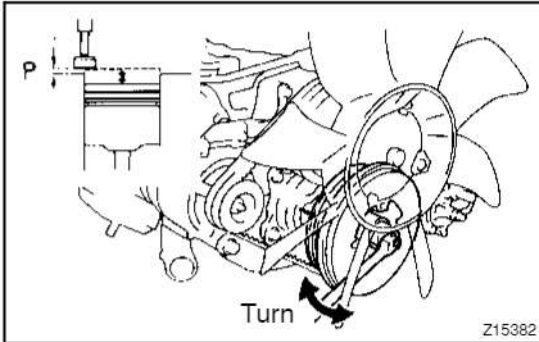
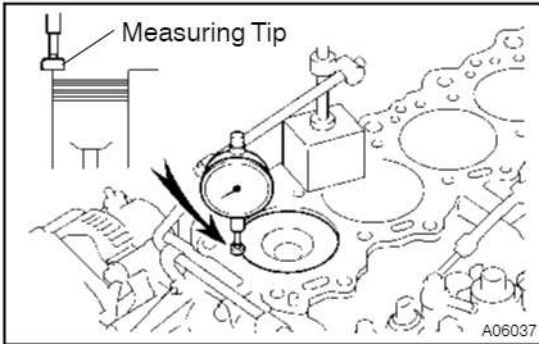

## INSTALLATION

### 1. CHECK PISTON PROTRUSION AND SELECT CYLINDER HEAD GASKET

Check piston protrusions for each cylinder

- (1) Clean the cylinder block with solvent.
- (2) Set the piston of the cylinder to be measured to slightly before TDC.
- (3) Place a dial indicator on the cylinder block, and set the dial indicator at 0 mm (0 in.).

HINT:

- Use a dial indicator measuring tip as shown in the illustration.
- Make sure that the measuring tip is square to the cylinder block gasket surface and piston head when taking the measurements.
- (4) Find where the piston head protrudes most by slowly turning the crankshaft clockwise and counter-clockwise.
- (5) Measure each cylinder at 2 places as shown in the illustration, making a total of 12 measurements.
- (6) For the piston protrusion value of each cylinder, use the average of the 2 measurements of each cylinder.

**Protrusion (P): 0.175 – 0.425 mm (0.0069 – 0.0167 in.)**

When removing piston and connecting rod assembly:

If the protrusion is not as specified, remove the piston and connecting rod assembly and reinstall it.

(See page EM-121)

### 2. SELECT NEW CYLINDER HEAD GASKET

HINT:

There are 5 types of gasket (cutout number 1 to 5) installed at factory, but only 3 types for supply parts (cutout number 1, 3 and 5), so when replacing the gasket select from one of 3 types above.

**New installed cylinder head gasket thickness:**

**Cutout number 1: 0.85 – 0.95 mm (0.0335 – 0.0374 in.)**

**Cutout number 3: 0.95 – 1.05 mm (0.0374 – 0.0414 in.)**

**Cutout number 5: 1.05 – 1.15 mm (0.0414 – 0.0453 in.)**

Select the largest piston protrusion value from the measurements made, then select a new appropriate gasket according to the table below.

Piston protrusion	Gasket size
0.225 mm (0.0089 in.) or less	Use 1
0.226 – 0.325 mm (0.0089 – 0.0128 in.)	Use 3
0.326 mm (0.0128 in.) or more	Use 5

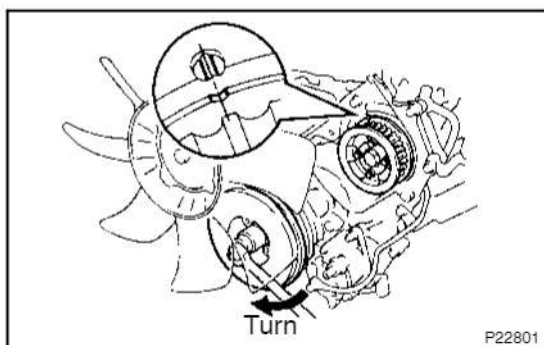

### 3. SET NO.1 CYLINDER TO BDC/COMPRESSION

Turn the crankshaft pulley, and align the timing mark of the No.2 camshaft timing pulley, with the BDC mark of the timing gear cover.

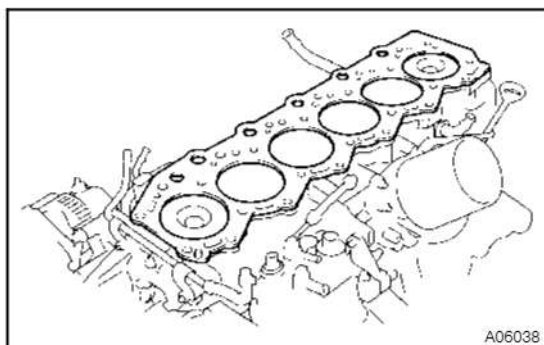

### 4. INSTALL CYLINDER HEAD

(a) Place cylinder on cylinder block

- (1) Place a new cylinder head gasket in position on the cylinder block.

#### NOTICE:

**Be careful of the installation direction.**

- (2) Place the cylinder head in position on the cylinder head gasket.

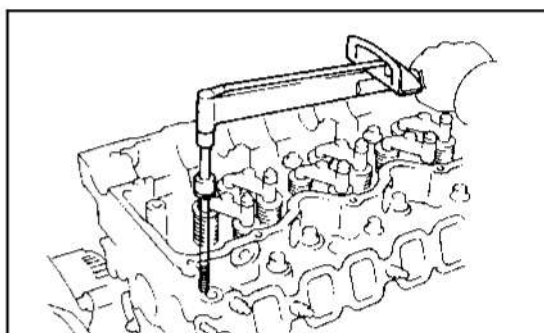

(b) Install cylinder head bolts

#### HINT:

- The cylinder head bolts are tightened in 3 progressive steps (steps (b), (d) and (e)).
- If any bolts is broke or deformed, replace it.
  - (1) Apply a light coat of engine oil on the threads and under the heads of the cylinder head bolts.
  - (2) Install and uniformly tighten the 26 cylinder head bolts in several passes, in the sequence shown.

**Torque: 68.6 N·m (700 kgf·cm, 51 ft·lbf)**

#### HINT:

Each bolt length is indicated in the illustration.

Bolt length:

A 121.5 mm (4.783 in.)

B 133.5 mm (5.256 in.)

If any one of the cylinder head bolts does not meet the torque specification, replace the cylinder head bolt.

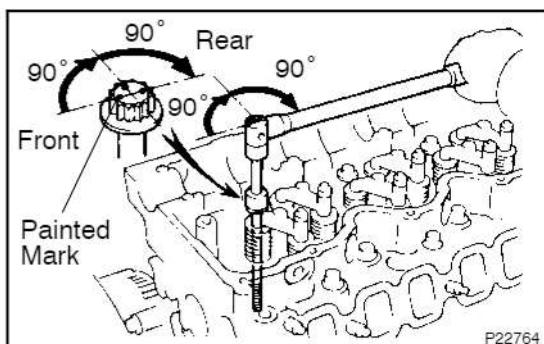
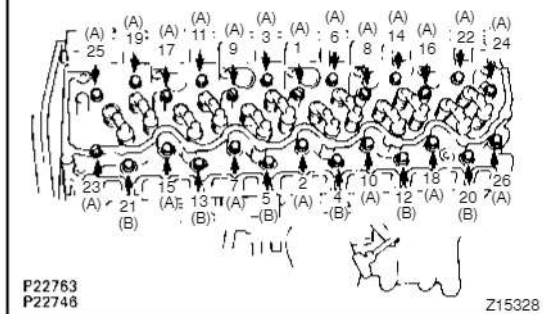

- (c) Mark the front of the cylinder head bolt with paint.
- (d) Retighten the cylinder head bolts 90° in the numerical order shown.
- (e) Retighten cylinder head bolts by an additional 90°.
- (f) Check that the painted mark is now facing rearward.
- (g) Connect the water bypass hose (from the injection pump) to the cylinder head.

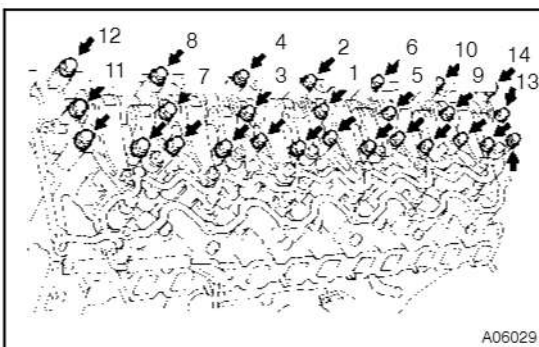
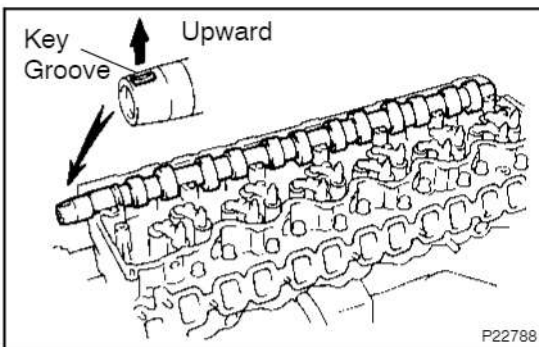
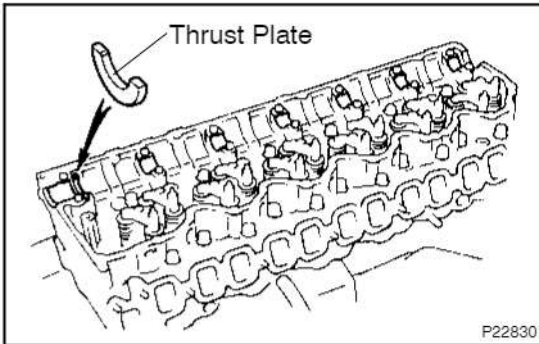
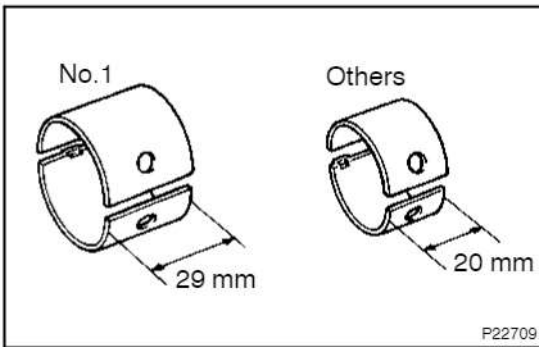

## 5. INSTALL CAMSHAFT, CAMSHAFT BEARING CAPS VALVE ROCKER ARMS NOZZLE HOLDER CLAMPS AND ROCKER SHAFT ASSEMBLY

### HINT:

Camshaft bearings come in widths of 20 mm (0.79 in.) and 29 mm (1.14 in.). Install the 29 mm (0.886 in.) bearings in the No.1 cylinder head journal positions with the camshaft bearing cap. Install the 20 mm (0.79 in.) bearings in the other positions.

- (a) Install the 7 lower camshaft bearings and thrust plate.
- (b) Place the camshaft on the cylinder head, facing the key groove upward.
- (c) Install the 7 upper camshaft bearings to the bearing caps.
- (d) Install the 7 bearing caps, 12 rocker arms, 6 holder clamps and rocker shaft assembly.
- (e) Install and uniformly tighten the 14 bearing cap bolts in several passes, in the sequence shown.  
**Torque: 25 N·m (250 kgf·cm, 18 ft·lbf)**
- (f) Install the 13 others bolts.  
**Torque: 25 N·m (250 kgf·cm, 18 ft·lbf)**

## 6. INSTALL INJECTION NOZZLES

(See page FU-44)

## 7. INSTALL CAMSHAFT OIL SEAL RETAINER

- (a) Remove any old packing (FIPG) material and be careful not to drop any oil on the contact surfaces of the oil seal retainer and cylinder head.
  - Using a razor blade and gasket scraper, remove all the oil pacing (FIPG) material from the gasket surfaces and sealing groove.
  - Thoroughly clean all components to remove all the loose material.

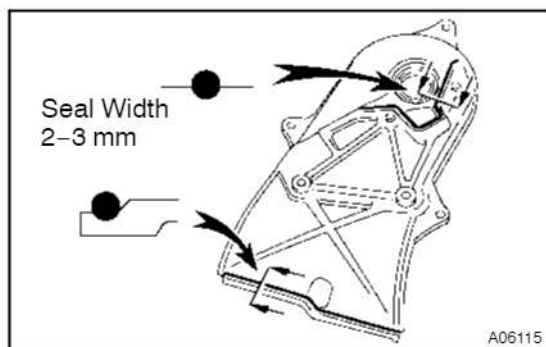

- Using a non-residue solvent, clean both sealing surfaces.
- (b) Apply seal packing to the oil seal retainer as shown in the illustration.

**Seal packing: Part No. 08826-00080 or equivalent**

- Install a nozzle that has been cut to a 2-3 mm (0.08 - 0.12 in.) opening.
- Parts must be assembled within 5 minutes of application. Otherwise the material must be removed and reapplied.
- Immediately remove nozzle from the tube and reinstall cap.

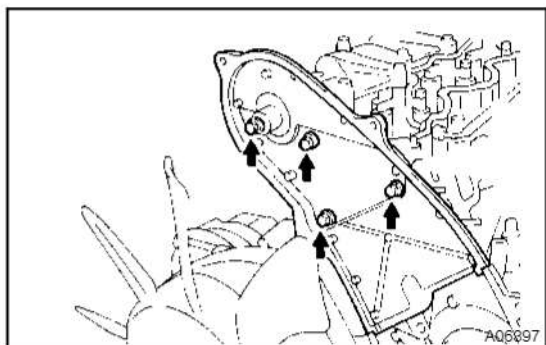

- (c) Install the oil seal retainer with the 4 bolts. Uniformly tighten the bolts in several passes.

**Torque: 19.6 N·m (200 kgf·cm, 14 ft·lbf)**

**8. INSTALL PULLEYS AND TIMING BELT**

(See page EM-31)

**9. CHECK AND ADJUST VALVE CLEARANCE**

(See page EM-9)

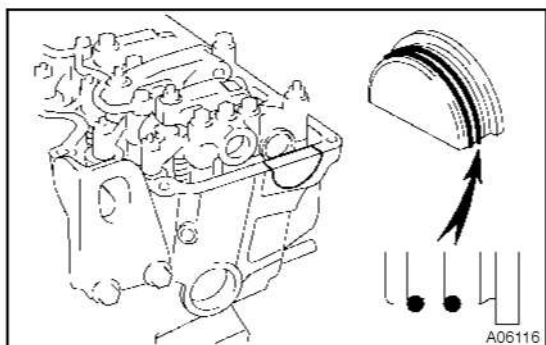

**10. INSTALL SEMI-CIRCULAR PLUG**

- (a) Remove any old packing (FIPG) material.
- (b) Apply seal packing to the semi-circular plug as shown in the illustration.

**Seal packing: Part No. 08826-00080 or equivalent**

- (c) Install the semi-circular plug to the cylinder head.

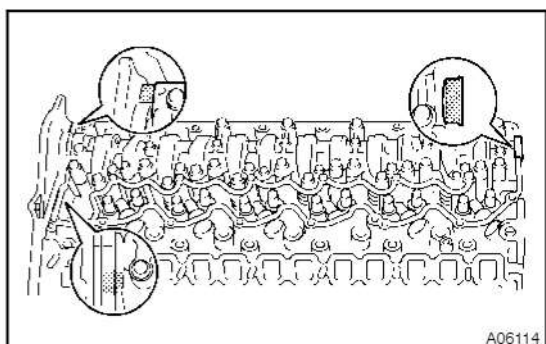

**11. INSTALL NO.1 CYLINDER HEAD COVER**

- (a) Remove any old packing (FIPG) material.
- (b) Apply seal packing to the No.1 cylinder head as shown in the illustration.

**Seal packing: Part No. 08826-00080 or equivalent**

- (c) Install the gasket to the No.1 cylinder head cover.
- (d) Install the No.1 cylinder head cover with 17 new seal washers and 17 bolts. Uniformly tighten the bolts in several passes.

**Torque: 8 N·m (80 kgf·cm, 71 in·lbf)**



**12. INSTALL 2 ENGINE HANGERS**

**Torque: 39.2 N·m (400 kgf·cm, 29 ft·lbf)**

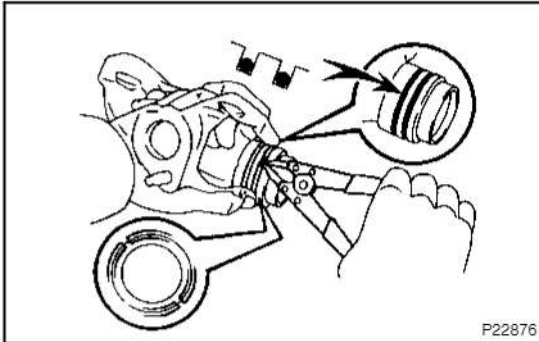

P22876

**13. ASSEMBLE EXHAUST MANIFOLDS**

- (a) Install 2 new O-rings to the rear exhaust manifold.
- (b) Using snap ring pliers, install the 2 rings to the rear exhaust manifold.
- (c) Position the rings so that the ring ends are as shown.

**NOTICE:**

**Do not align the ring ends.**

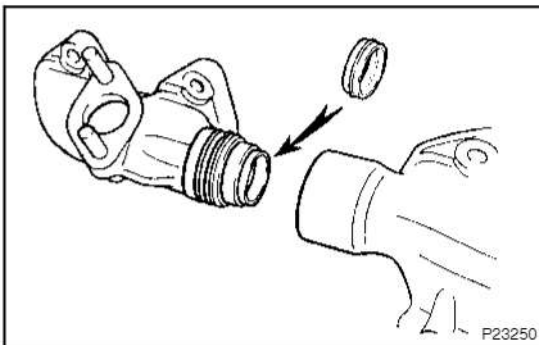

P23250

- (d) Install the collar the rear exhaust manifold.
- (e) Assemble the front and rear exhaust manifolds.

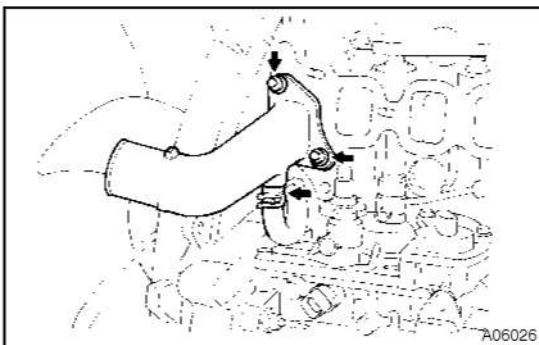
**14. INSTALL EXHAUST MANIFOLD TO TURBOCHARGER**  
(See page TC-15)**15. INSTALL TURBOCHARGER AND EXHAUST MANIFOLDS ASSEMBLY**  
(See page TC-15)

A06026

**16. INSTALL WATER OUTLET**

- (a) Install a new gasket and the water outlet.
- (b) Connect the water bypass hose to the water outlet.
- (c) Install the water outlet with the 2 nuts.

**Torque: 19.6 N·m (200 kgf·cm, 14 ft·lbf)**

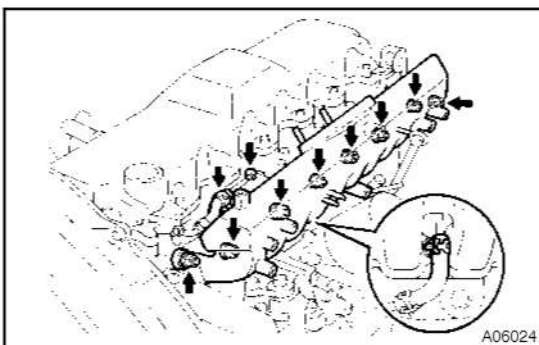

A06024

**17. INSTALL INTAKE MANIFOLD**

- (a) Install the 2 gaskets and intake manifold with the 8 seal washers and 8 nuts.

**Torque: 19.6 N·m (200 kgf·cm, 14 ft·lbf)**

- (b) Connect the fuel hose to the injection pump.

**18. INSTALL 2 INTAKE MANIFOLD INSULATORS****19. INSTALL INJECTION PIPES**

(See page FU-44)

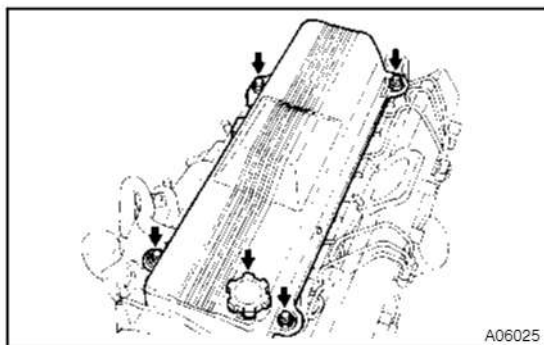
**20. INSTALL NO.2 CYLINDER HEAD COVER**

- (a) Install the No.2 cylinder head cover with the 4 bolts.
- (b) Install the oil filler cap.

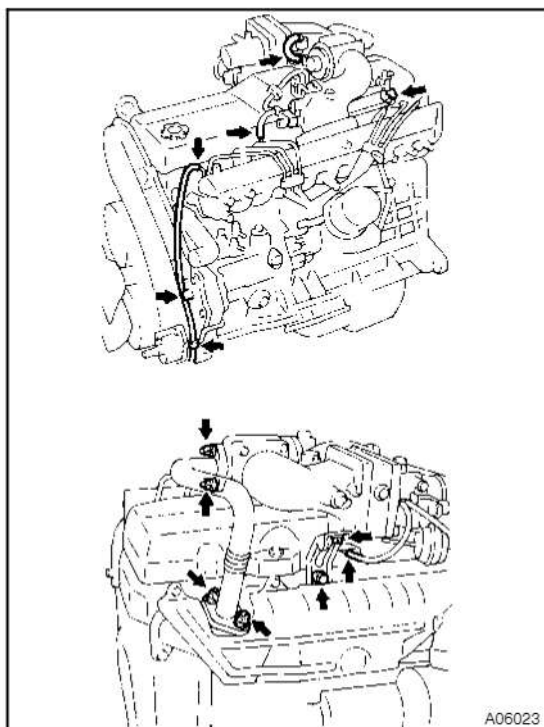
**21. INSTALL INTAKE PIPE ASSEMBLY**

- (a) Install the intake pipe assembly with the 2 bolts and 2 nuts.
- (b) Install the intake pipe assembly bracket with the 2 bolts.
- (c) w/EGR:  
Install 2 new gaskets and EGR pipe with the 4 nuts.
- (d) Connect the 5 vacuum hoses to the No.2 cylinder head cover.
- (e) Connect the vacuum hose to the clamp and timing belt cover.

**22. FILL WITH ENGINE COOLANT****23. START ENGINE AND CHECK FOR LEAKS****24. RECHECK ENGINE COOLANT LEVEL AND OIL LEVEL**



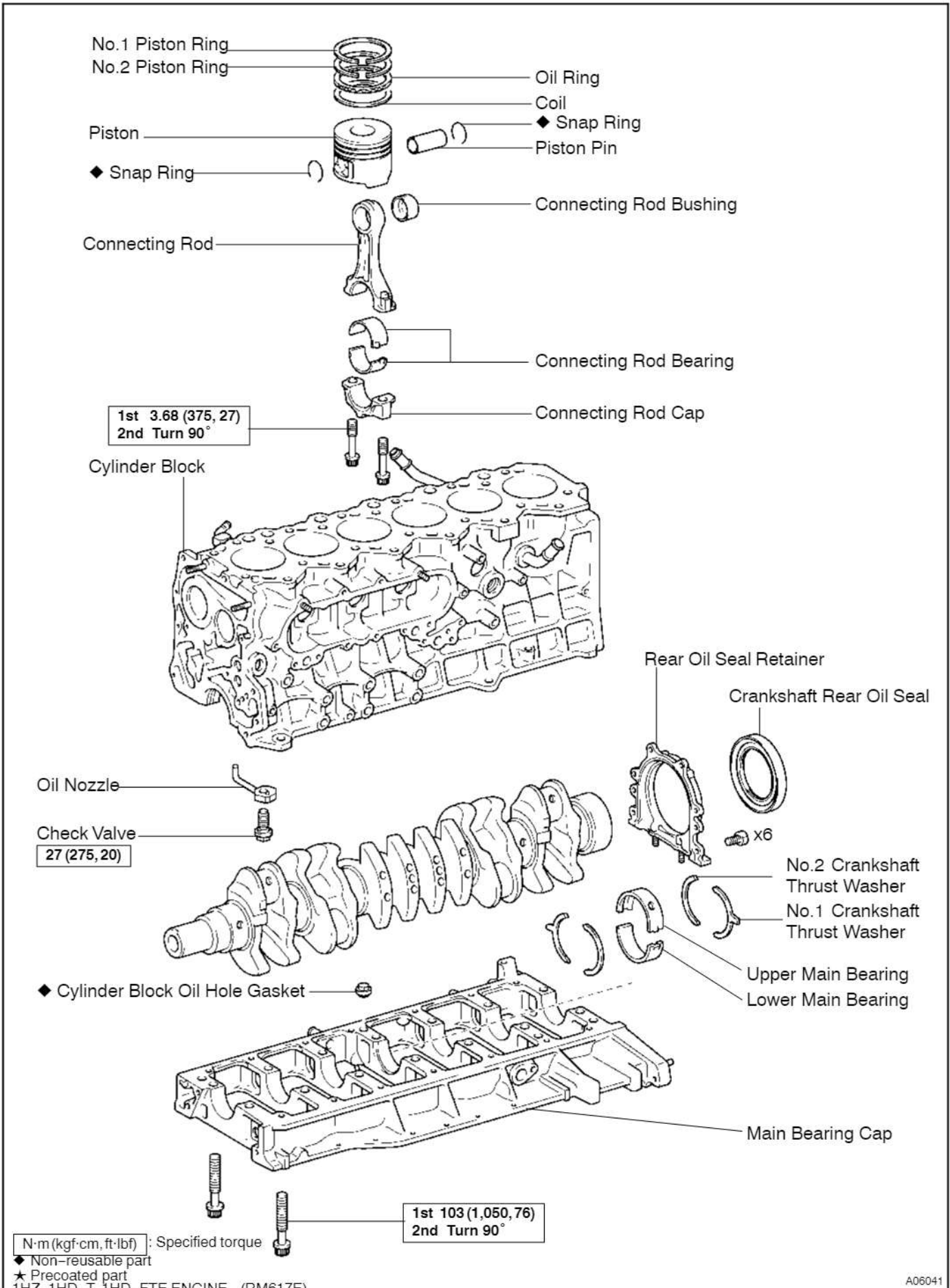

## DISASSEMBLY

1. M/T:  
REMOVE FLYWHEEL
2. A/T:  
REMOVE REAR PLATE, DRIVE PLATE AND FLY-  
WHEEL
3. REMOVE REAR END PLATE
4. INSTALL ENGINE TO ENGINE STAND FOR DIS-  
ASSEMBLY
5. REMOVE TIMING BELT AND PULLEYS  
(See page EM-27)
6. REMOVE CYLINDER HEAD  
1HZ, 1HD-T: (See page EM-48)  
1HD-FTE: (See page EM-77)
7. REMOVE TIMING GEARS  
(See page EM-37)
8. REMOVE ALTERNATOR ADJUSTING BAR, TURBO  
WATER PIPE AND WATER PUMP  
(See page CO-7)
9. REMOVE WATER INLET AND THERMOSTAT  
1HZ, 1HD-T: (See page EM-48)  
1HD-FTE: (See page EM-77)
10. REMOVE ALTERNATOR AND BRACKET ASSEMBLY
11. REMOVE INJECTION PUMP  
1HZ, 1HD-T: (See page FU-51)  
1HD-FTE: (See page FU-117)
12. REMOVE 3 INSULATORS
13. REMOVE INJECTION PUMP STAY
14. REMOVE OIL PAN, OIL PUMP (TIMING GEAR CASE)  
AND OIL STRAINER  
(See page LU-9)
15. REMOVE OIL DIPSTICK, GUIDE, OIL COOLER AS-  
SEMBLY AND NO.1 CYLINDER BLOCK INSULATOR  
(See page LU-20)
16. REMOVE OIL PRESSURE SENDER
17. REMOVE TURBO OIL HOSE
18. REMOVE ENGINE MOUNTING BRACKETS
19. REMOVE TURBO WATER PIPE
20. 1HD-FTE:  
REMOVE CRANKSHAFT POSITION SENSOR
21. REMOVE DRAIN PLUG

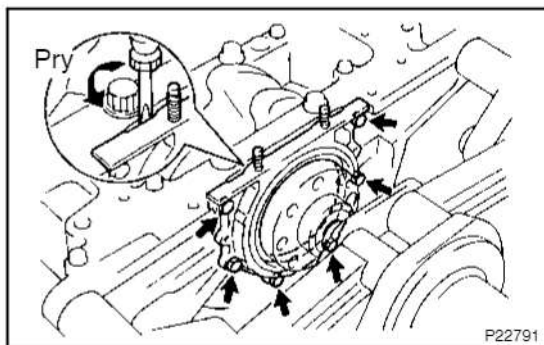
**22. REMOVE REAR OIL SEAL RETAINER**

- (a) Remove the 6 bolts.
- (b) Using a screwdriver, remove the oil seal retainer by prying the portions between the oil seal retainer and main bearing cap.

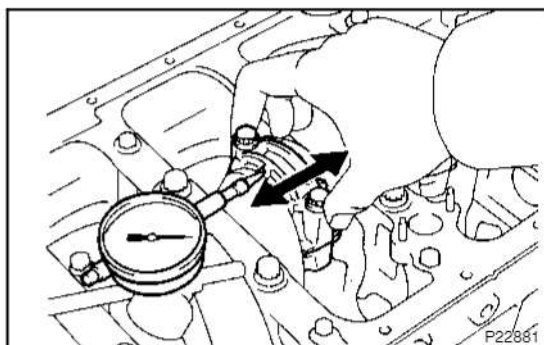
**23. CHECK CONNECTING ROD THRUST CLEARANCE**

Using a dial indicator, measure the thrust clearance while moving the connecting rod back and forth.

**Standard thrust clearance:**

**0.100 - 0.200 mm (0.0039 - 0.0079in.)**

**Maximum thrust clearance: 0.300 mm(0.0118 in.)**

If the thrust clearance is greater than maximum, replace the connecting rod assembly. If necessary, replace the crankshaft.

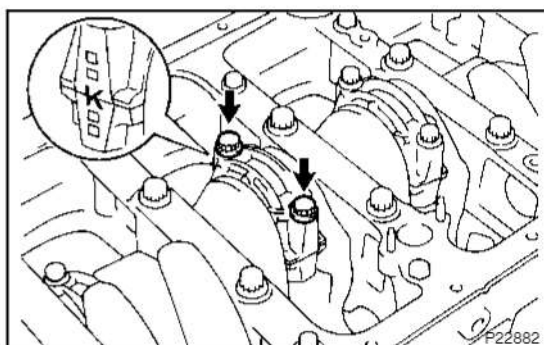
**24. REMOVE CONNECTING ROD CAPS AND CHECK OIL CLEARANCE**

- (a) Check the matchmarks on the connecting rod and cap to ensure correct reassembly.
- (b) Remove the 2 connecting rod cap bolts.

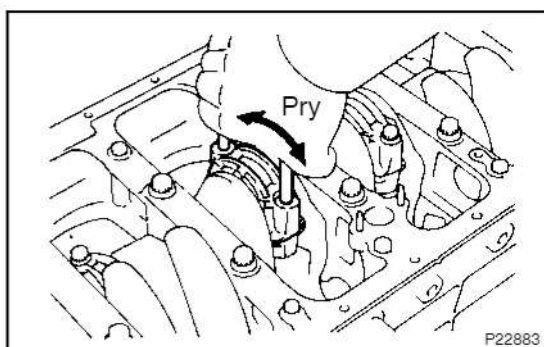

- (c) Using the 2 removed connecting rod cap bolts, and remove the connecting cap by wiggling the connecting rod cap right and left.

**HINT:**

Keep the lower bearing inserted with the connecting rod cap.

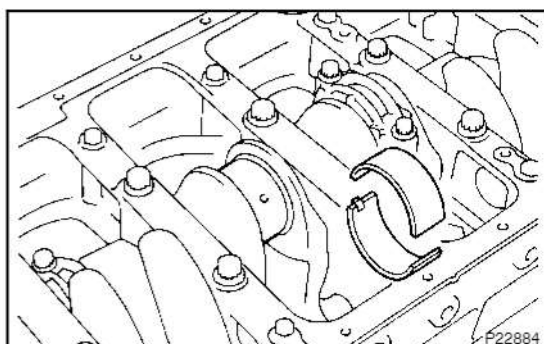

- (d) Clean the crank pin and bearing.
- (e) Check the crank pin and bearing for pitting and scratches. If the crank pin or bearing is damaged, replace the bearings. If necessary, grind or replace the crankshaft.

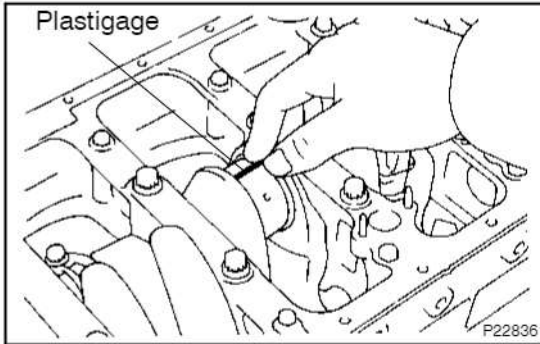

- (f) Lay a strip of Plastigage across the crank pin.

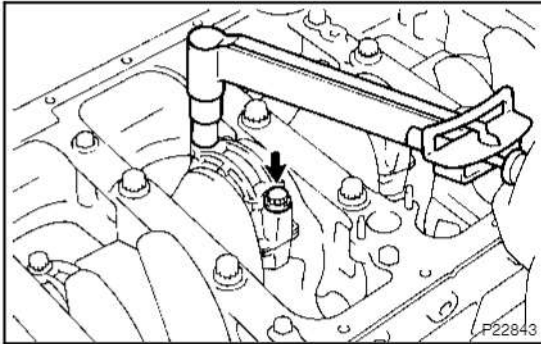

- (g) Install the connecting rod cap with the 2 bolts.

**Torque:**

**1st 36.8 N·m (375 kgf·cm, 27 ft·lbf)**

**2nd Turn 90°**

**NOTICE:**

**Do not turn the crankshaft.**

- (h) Remove the 2 bolts, connecting rod cap and lower bearing. (See procedure (b) and (c) above)

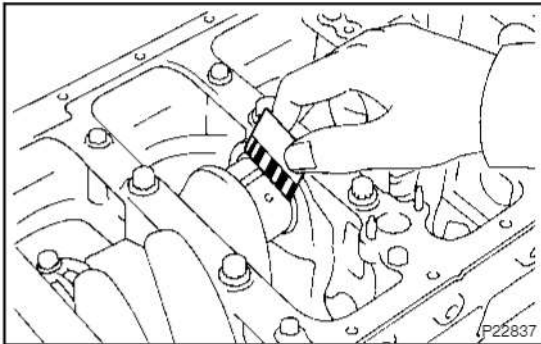

- (i) Measure the Plastigage at its widest point.

**Standard oil clearance:**

**STD**

**0.036 - 0.054 mm (0.0014 - 0.0021 in.)**

**U/S 0.25 and U/S 0.50**

**0.037 - 0.077 mm (0.0015 - 0.0030 in.)**

**Maximum oil clearance: 0.100 mm (0.0039 in.)**

If the oil clearance is greater than maximum, replace the bearings. If necessary, grind or replace the crankshaft.

**HINT:**

If using a standard bearing, replace it with one having the same number. If the number of the bearing cannot be determined, select the correct bearing by adding together the numbers imprinted on the crankshaft and connecting rod, then selecting the bearing with the same number as the total. There are 5 sizes of standard bearings, marked "2", "3", "4", "5" and "6" accordingly.

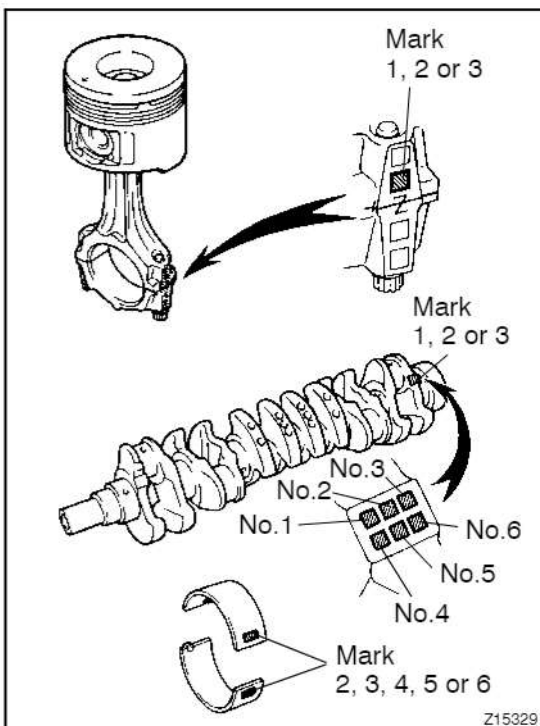

**Reference****Connecting rod big end inside diameter:**

Mark "1"	62.014 – 62.020 mm (2.4415 – 2.4417 in.)
Mark "2"	62.020 – 62.026 mm (2.4417 – 2.4420 in.)
Mark "3"	62.026 – 62.032 mm (2.4420 – 2.4422 in.)

**Crankshaft crank pin diameter:**

Mark "1"	58.994 – 59.000 mm (2.3226 – 2.3228 in.)
Mark "2"	58.988 – 58.994 mm (2.3224 – 2.3226 in.)
Mark "3"	58.982 – 58.988 mm (2.3221 – 2.3224 in.)

**Standard sized bearing center wall thickness:**

Mark "2"	1.486 – 1.489 mm (0.0585 – 0.0586 in.)
Mark "3"	1.489 – 1.492 mm (0.0586 – 0.0587 in.)
Mark "4"	1.492 – 1.495 mm (0.0587 – 0.0589 in.)
Mark "5"	1.495 – 1.498 mm (0.0589 – 0.0590 in.)
Mark "6"	1.498 – 1.501 mm (0.0590 – 0.0591 in.)

- (j) Completely remove the Plastigage.

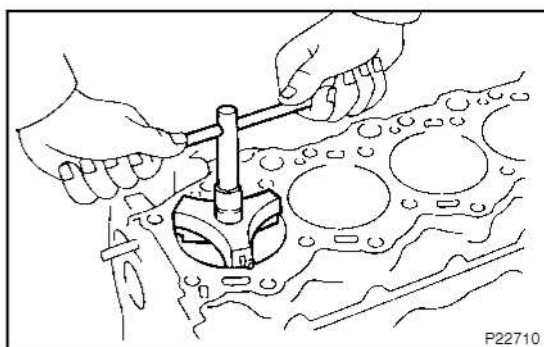
**25. REMOVE PISTON AND CONNECTING ROD ASSEMBLIES**

- (a) Using a ridge reamer, remove all the carbon from the top of the cylinder.
- (b) Push the piston, connecting rod assembly and upper bearing through the top of the cylinder block.

**HINT:**

- Keep the bearings, connecting rod and cap together.
- Arrange the piston and connecting rod assemblies in correct order.

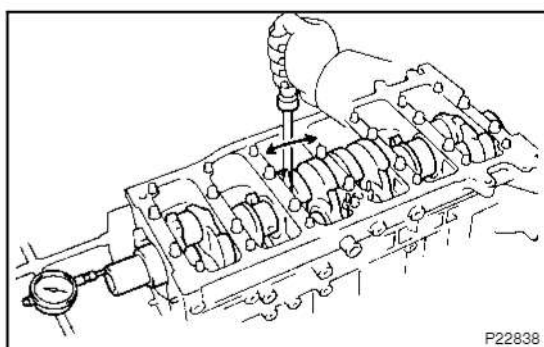
**26. CHECK CRANKSHAFT THRUST CLEARANCE**

Using a dial indicator, measure the thrust clearance while prying the crankshaft back and forth with a screwdriver.

**Standard thrust clearance:**

**0.040 – 0.240mm (0.0016 – 0.0094 in.)**

**Maximum thrust clearance: 0.300 mm (0.0118 in.)**

If the thrust clearance is greater than maximum, replace the thrust washers as a set.

**Thrust washer thickness:**

**2.930–2.980 mm (0.1154–0.1173 in.)**

**27. REMOVE MAIN BEARING CAP AND CHECK OIL CLEARANCE**

- (a) Remove the 15 main bearing cap bolts (6 pointed head).

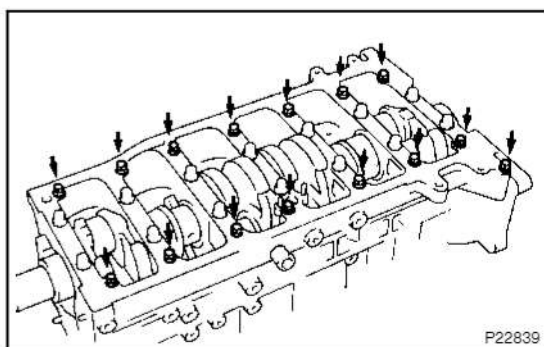



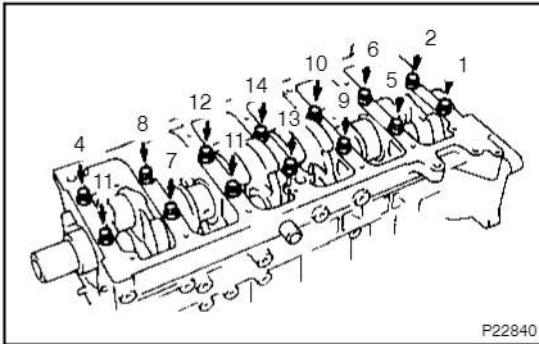

- (b) Uniformly loosen and remove the 14 main bearing cap bolts (12 pointed head) in several passes, in the sequence shown.

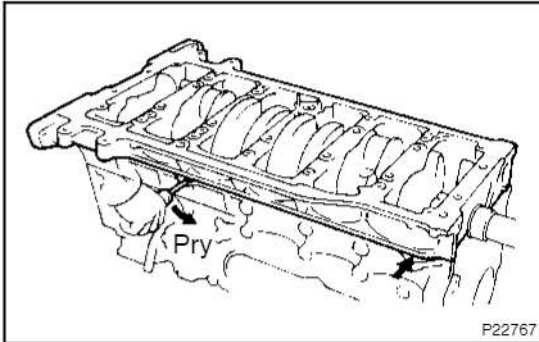

- (c) Using a screwdriver, remove the main bearing cap by prying the portions between the main bearing cap and cylinder block.

**NOTICE:**

**Be careful not to scratch the surfaces contacting the main bearing cap and cylinder block.**

**HINT:**

Keep the lower bearings inserted with the main bearing cap.

- (d) Lift out the crankshaft.

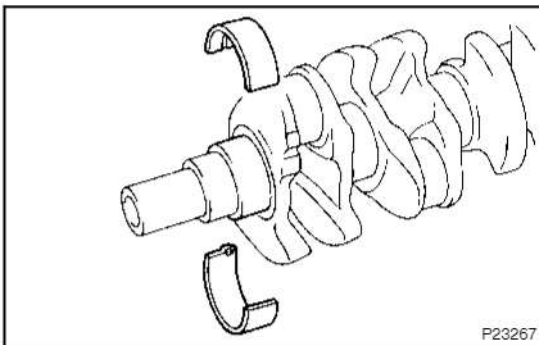
**HINT:**

- Keep the upper bearings inserted with the cylinder block.
- Arrange the thrust washers in correct order.

- (e) Clean each main journal and bearing.

- (f) Check each main journal and bearing for pitting and scratches.

If the journal or bearing is damaged, replace the bearings. If necessary, grind or replace the crankshaft.

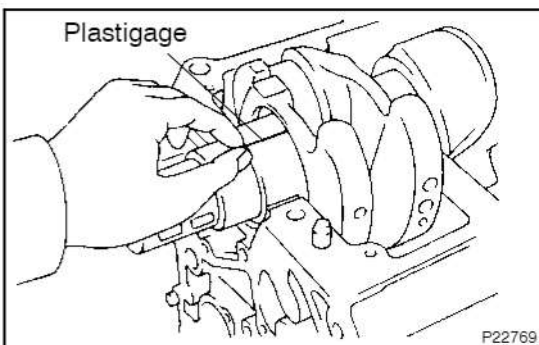

- (g) Place the crankshaft on the cylinder block.  
(h) Lay a strip of Plastigage across each journal.

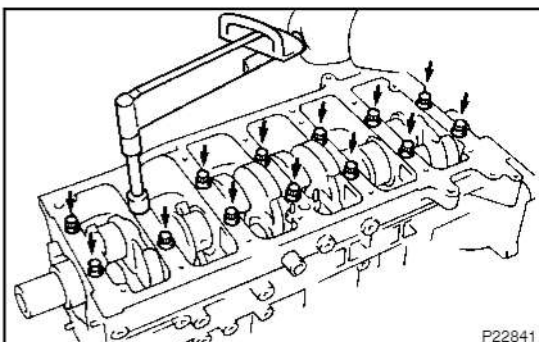

- (i) Install the main bearing cap with the 14 bolts (12 pointed head).

**Torque:**

**1st 103N·m (1,050 kgf·cm, 76 ft·lbf)**

**2nd Turn 90°**

**NOTICE:**

**Do not turn the crankshaft.**

- (j) Remove the 14 bolts (12 pointed head) and main bearing cap. (See procedure (b) and (c) above)

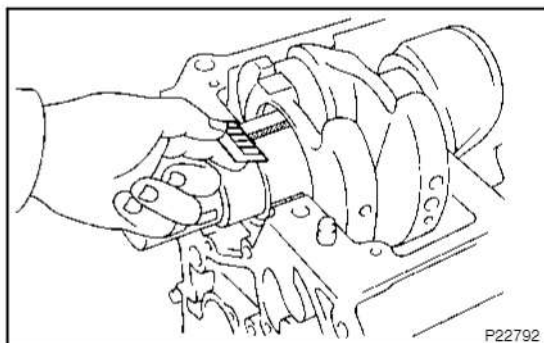

P22792

(k) Measure the Plastigage at its widest point.

**Standard clearance:**

**STD**

**0.030 – 0.042 mm (0.00118 – 0.00165 in.)**

**U/S 0.25 and U/S 0.50**

**0.031 – 0.053 mm (0.00122 – 0.00208 in.)**

**Maximum clearance: 0.100 mm (0.0039 in.)**

If the oil clearance is greater than maximum, replace the bearings. If necessary, grind or replace the crankshaft.

**HINT:**

If using a standard bearing, replace it with one having the same number. If the number of the bearing cannot be determined, select the correct bearing by adding together the numbers imprinted on the main bearing cap and crankshaft, then selecting the bearing with the same number as the total. There are 5 sizes of standard bearings, marked "2", "3", "4", "5", and "6" accordingly.

### Reference

#### Cylinder block main journal bore diameter:

Mark "A"	70.999 – 71.000 mm (2.79523 – 2.79527 in.)
Mark "B"	70.998 – 70.999 mm (2.79519 – 2.79523 in.)
Mark "C"	70.997 – 70.998 mm (2.79515 – 2.79519 in.)
Mark "D"	70.996 – 70.997 mm (2.79511 – 2.79515 in.)
Mark "E"	70.995 – 70.996 mm (2.79507 – 2.79511 in.)
Mark "H"	70.994 – 70.995 mm (2.79503 – 2.79507 in.)
Mark "4"	70.993 – 70.994 mm (2.79499 – 2.79503 in.)
Mark "5"	70.992 – 70.993 mm (2.79496 – 2.79499 in.)
Mark "6"	70.991 – 70.992 mm (2.79492 – 2.79496 in.)
Mark "7"	70.990 – 70.991 mm (2.79488 – 2.79492 in.)
Mark "8"	70.989 – 70.990 mm (2.79484 – 2.79488 in.)
Mark "9"	70.988 – 70.989 mm (2.79480 – 2.79484 in.)
Mark "L"	70.987 – 70.988 mm (2.79476 – 2.79480 in.)
Mark "M"	70.986 – 70.987 mm (2.79472 – 2.79476 in.)
Mark "R"	70.985 – 70.986 mm (2.79468 – 2.79472 in.)
Mark "S"	70.984 – 70.985 mm (2.79464 – 2.79468 in.)
Mark "U"	70.983 – 70.984 mm (2.79460 – 2.79464 in.)
Mark "X"	70.982 – 70.983 mm (2.79456 – 2.79460 in.)

#### Crankshaft main journal diameter:

Mark "A"	66.999 – 67.000 mm (2.63775 – 2.63779 in.)
Mark "B"	66.998 – 66.999 mm (2.63771 – 2.63775 in.)
Mark "C"	66.997 – 66.998 mm (2.63767 – 2.63771 in.)
Mark "D"	66.996 – 66.997 mm (2.63763 – 2.63767 in.)
Mark "E"	66.995 – 66.996 mm (2.63759 – 2.63763 in.)
Mark "H"	66.994 – 66.995 mm (2.63755 – 2.63759 in.)
Mark "4"	66.993 – 66.994 mm (2.63751 – 2.63755 in.)
Mark "5"	66.992 – 66.993 mm (2.63748 – 2.63751 in.)
Mark "6"	66.991 – 66.992 mm (2.63744 – 2.63748 in.)

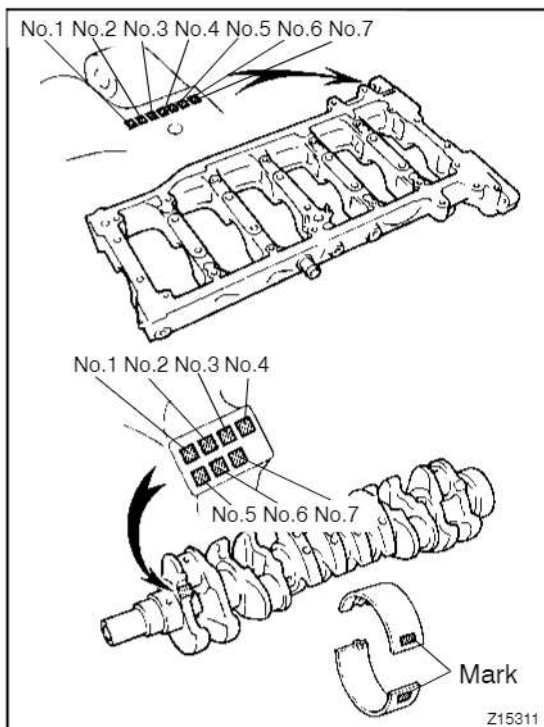

Z15311

Mark "7"	66.990 – 66.991 mm (2.63740 – 2.63744 in.)
Mark "8"	66.989 – 66.990 mm (2.63736 – 2.63740 in.)
Mark "9"	66.988 – 66.989 mm (2.63732 – 2.63736 in.)
Mark "L"	66.987 – 66.988 mm (2.63728 – 2.63732 in.)
Mark "M"	66.986 – 66.987 mm (2.63724 – 2.63728 in.)
Mark "R"	66.985 – 66.986 mm (2.63720 – 2.63724 in.)
Mark "S"	66.984 – 66.985 mm (2.63716 – 2.63720 in.)
Mark "U"	66.983 – 66.984 mm (2.63712 – 2.63716 in.)
Mark "X"	66.982 – 66.983 mm (2.63708 – 2.63712 in.)

**Standard sized bearing center wall thickness:**

Mark "2"	1.982 – 1.985 mm (0.07803 – 0.07815 in.)
Mark "3"	1.985 – 1.988 mm (0.07815 – 0.07827 in.)
Mark "4"	1.988 – 1.991 mm (0.07827 – 0.07839 in.)
Mark "5"	1.991 – 1.994 mm (0.07839 – 0.07850 in.)
Mark "6"	1.994 – 1.997 mm (0.07850 – 0.07862 in.)
Mark "7"	1.997 – 2.000 mm (0.07862 – 0.07874 in.)

**Journal standard bearings selection chart**

Cylinder block number mark	Crankshaft number mark																		
	A	B	C	D	E	H	4	5	6	7	8	9	L	M	R	S	U	X	
A	2	2	2	2	2	2	3	3	3	3	3	3	4	4	4	4	4	4	
B	2	2	2	2	2	3	3	3	3	3	3	4	4	4	4	4	4	5	
C	2	2	2	2	3	3	3	3	3	3	4	4	4	4	4	4	5	5	
D	2	2	2	3	3	3	3	3	3	4	4	4	4	4	4	5	5	5	
E	2	2	3	3	3	3	3	3	4	4	4	4	4	4	5	5	5	5	
H	2	3	3	3	3	3	3	4	4	4	4	4	4	5	5	5	5	5	
4	3	3	3	3	3	3	4	4	4	4	4	4	5	5	5	5	5	5	
5	3	3	3	3	3	4	4	4	4	4	4	5	5	5	5	5	5	6	
6	3	3	3	3	4	4	4	4	4	4	5	5	5	5	5	5	6	6	
7	3	3	3	4	4	4	4	4	4	5	5	5	5	5	5	6	6	6	
8	3	3	4	4	4	4	4	4	5	5	5	5	5	5	6	6	6	6	
9	3	4	4	4	4	4	4	5	5	5	5	5	5	6	6	6	6	6	
L	4	4	4	4	4	4	5	5	5	5	5	5	6	6	6	6	6	6	
M	4	4	4	4	4	5	5	5	5	5	5	6	6	6	6	6	6	7	
R	4	4	4	4	5	5	5	5	5	5	6	6	6	6	6	6	7	7	
S	4	4	4	5	5	5	5	5	5	6	6	6	6	6	6	7	7	7	
U	4	4	5	5	5	5	5	5	6	6	6	6	6	6	7	7	7	7	
X	4	5	5	5	5	5	5	6	6	6	6	6	6	7	7	7	7	7	

EXAMPLE: Cylinder block "B", Crankshaft "D" = Using bearing "2"

- (l) Completely remove the Plastigage.

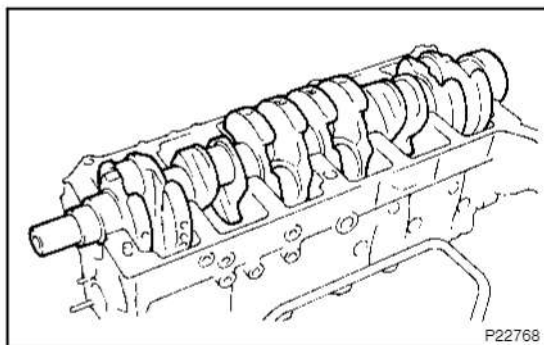
**28. REMOVE CRANKSHAFT**

- (a) Lift out the crankshaft.
- (b) Remove the upper bearings and thrust washers from the cylinder block.

HINT:

Arrange the main bearings and thrust washers in correct order.

**29. REMOVE CHECK VALVES AND OIL NOZZLES**

(See page LU-26)

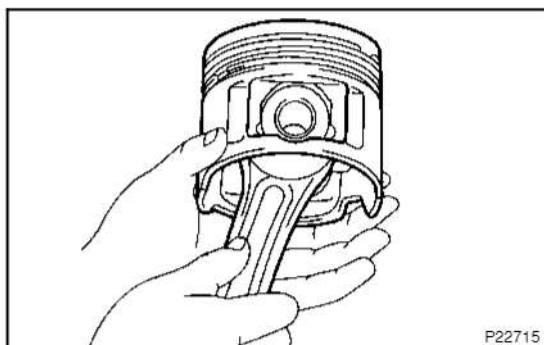
**30. CHECK FIT BETWEEN PISTON AND PISTON PIN**

Try to move the piston back and forth on the piston pin.

If any movement is felt, replace the piston and pin as a set.

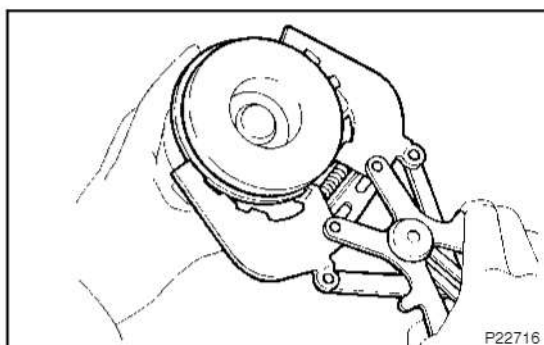
**31. REMOVE PISTON RINGS**

- (a) Using a piston ring expander, remove the No.1, No.2 and oil rings.
- (b) Remove the coil by hand.

HINT:

Arrange the rings in correct order only.

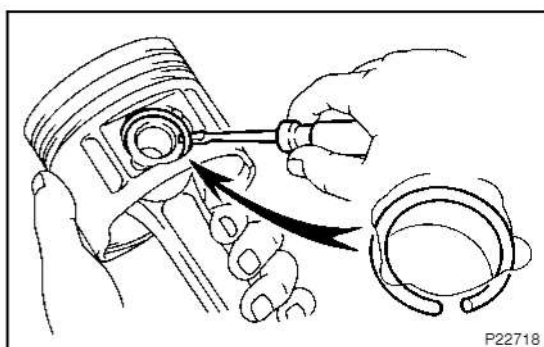
**32. DISCONNECT CONNECTING ROD FROM PISTON**

- (a) Using a small screwdriver, pry off the snap ring from the piston.

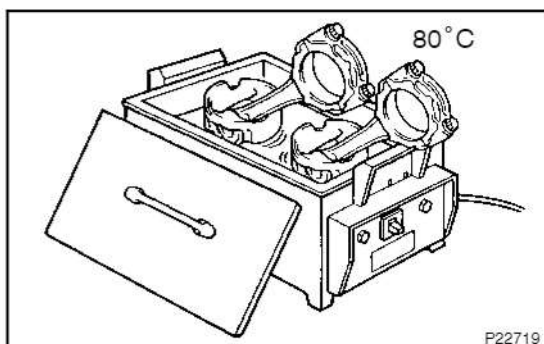

- (b) Gradually heat the piston to approx. 80°C (176°F).

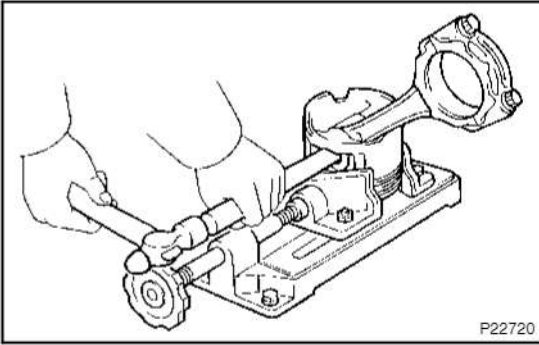

- (c) Using a plastic-faced hammer and brass bar, lightly tap out the piston pin and remove the connecting rod.

HINT:

- The piston and pin are a matched set.
- Arrange the pistons, pins, rings, connecting rods and bearings in correct order.

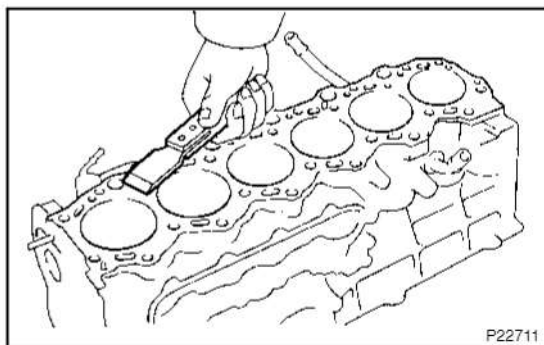

## INSPECTION

### 1. CLEAN CYLINDER BLOCK

- (a) Remove gasket material  
Using a gasket scraper, remove all the gasket material from the top surface of the cylinder block.
- (b) Clean cylinder block  
Using a soft brush and solvent, thoroughly clean the cylinder block.

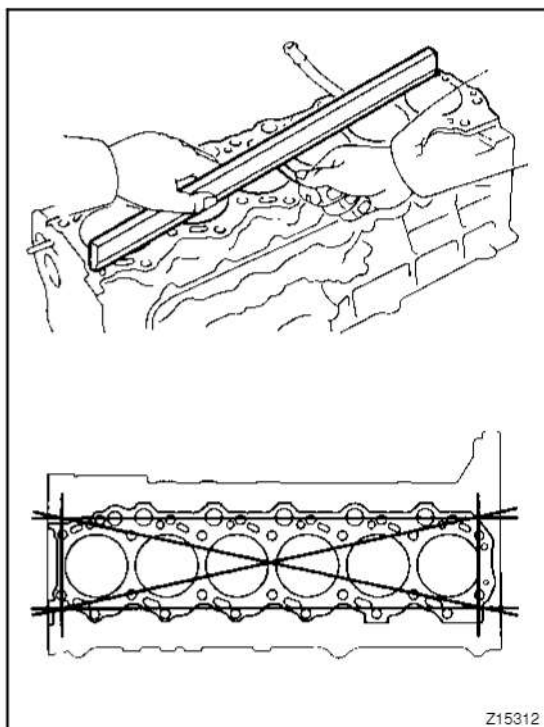

### 2. INSPECT TOP SURFACE OF CYLINDER BLOCK FOR FLATNESS

Using a precision straight edge and feeler gauge, measure the surfaces contacting the cylinder head gasket for warpage.

**Maximum warpage: 0.20 mm (0.0079 in.)**

If warpage is greater than maximum, replace the cylinder block.

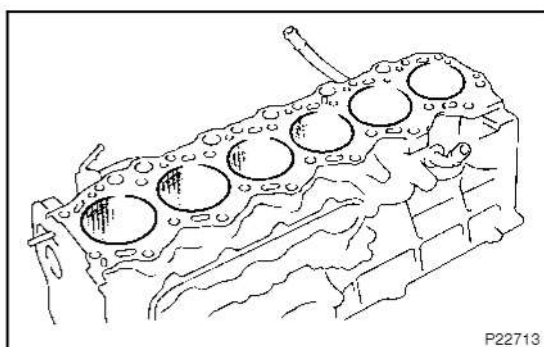

### 3. INSPECT CYLINDER FOR VERTICAL SCRATCHES

Visually check the cylinder for vertical scratches.

If deep scratches are present, rebore all the 6 cylinders. If necessary, replace the cylinder block.

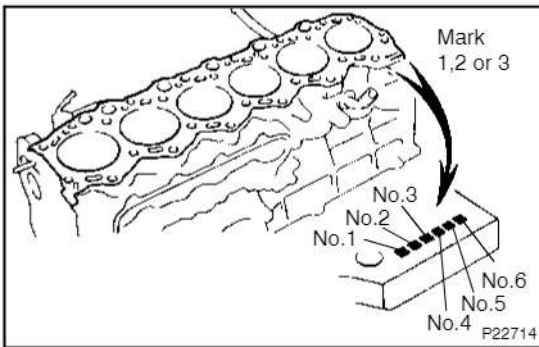

#### 4. INSPECT CYLINDER BORE DIAMETER

##### HINT:

There are 3 sizes of the standard cylinder bore diameter, marked "1", "2" and "3" accordingly. The mark stamped on the top of the cylinder block.

Using a cylinder gauge, measure the cylinder bore diameter at positions A, B and C in the thrust and axial directions.

##### Standard diameter:

##### STD

##### Mark "1"

94.000 – 94.010 mm (3.7001 – 3.7012 in.)

##### Mark "2"

94.010 – 94.020 mm (3.7012 – 3.7016 in.)

##### Mark "3"

94.020 – 94.030 mm (3.7016 – 3.7020 in.)

##### Maximum diameter:

##### STD

94.23 mm (3.7098 in.)

##### O/S 0.50

94.73 mm (3.7295 in.)

If the diameter is greater than maximum, rebore all the 6 cylinders. If necessary, replace the cylinder block.

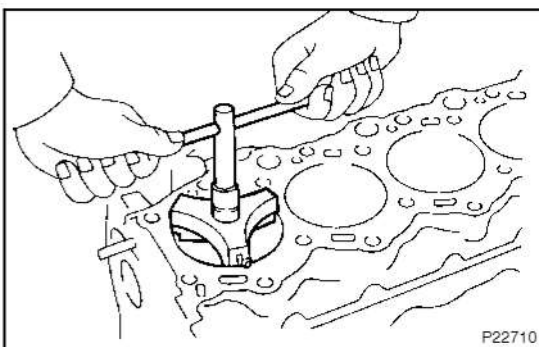
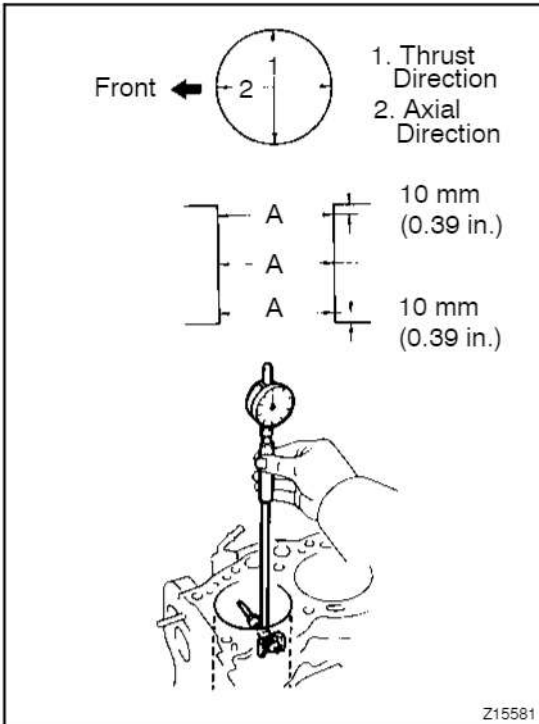

#### 5. REMOVE CYLINDER RIDGE

If the wear is less than 0.2 mm (0.008 in.), using a ridge reamer, grind the top of the cylinder.

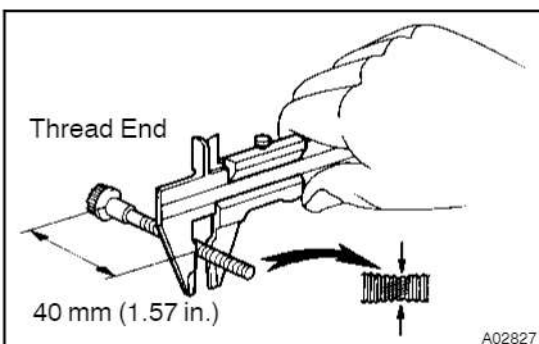

#### 6. INSPECT MAIN BEARING CAP BOLTS

Using vernier calipers, measure the thread outside diameter at the measuring point.

##### Standard diameter:

11.80 – 12.00 mm (0.4646 – 0.4724 in.)

Minimum diameter: 11.50 mm (0.4528 in.)

If the diameter is less than minimum, replace the bolt.

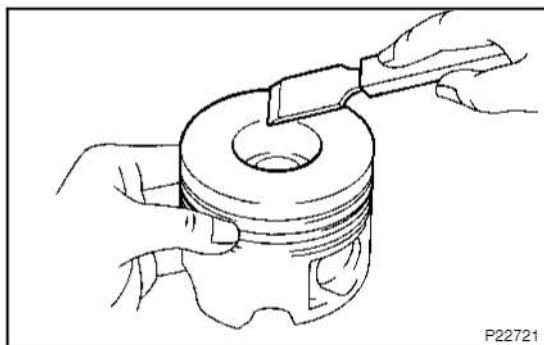
**7. CLEAN PISTON**

- (a) Using a gasket scraper, remove the carbon from the piston top.

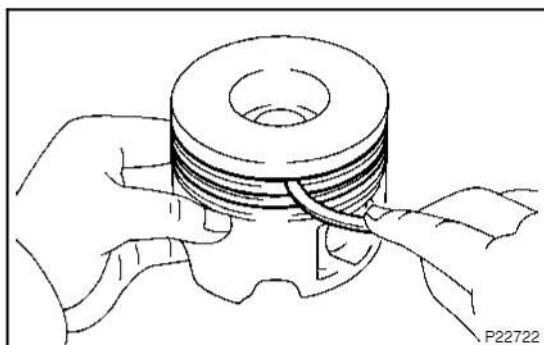

- (b) Using a groove cleaning tool or broken ring, clean the piston ring grooves.

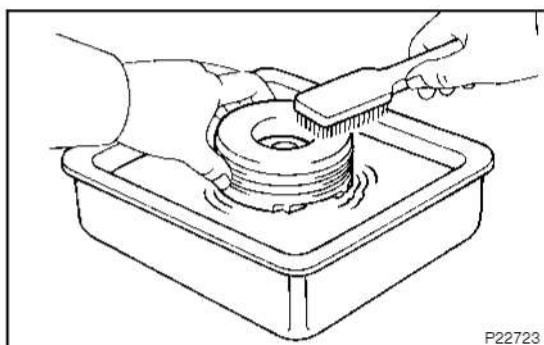

- (c) Using solvent and a brush, thoroughly clean the piston.

**NOTICE:**

**Do not use a wire brush.**

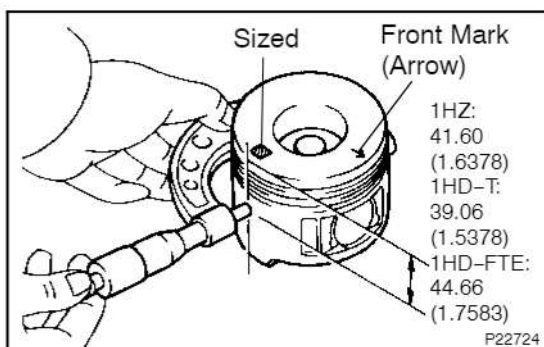
**8. INSPECT PISTON AND PISTON RING**

- (a) Inspect piston diameter and oil clearance

**HINT:**

There are 3 sizes of the standard piston diameter, marked "1", "2" and "3" accordingly. The mark is stamped on the piston top.

- (1) Using a micrometer, measure the piston diameter at right angles to the piston pin center line from the piston head.

**Piston diameter:**

	1HZ	1HD-T	1HD-FTE
Mark1	93.885 – 93.895 mm (3.69625–3.69665 in.)	93.950–93.960 mm (3.69881–3.69921 in.)	93.850–93.860 mm (3.69487–3.69527 in.)
Mark2	93.896–93.905 mm (3.69669–3.69704 in.)	93.961–93.970 mm (3.69924–3.69959 in.)	93.861–93.870 mm (3.69531–3.69566 in.)
Mark3	93.906–93.915 mm (3.69708–3.69743 in.)	93.971–93.980 mm (3.69963–3.69999 in.)	93.871–93.880 mm (3.69570–3.69606 in.)
O/S 0.50	94.385–94.415 mm (3.71594–3.71712 in.)	94.450–94.471 mm (3.71850–3.71932 in.)	94.370–94.100 mm (3.71535–3.71653 in.)



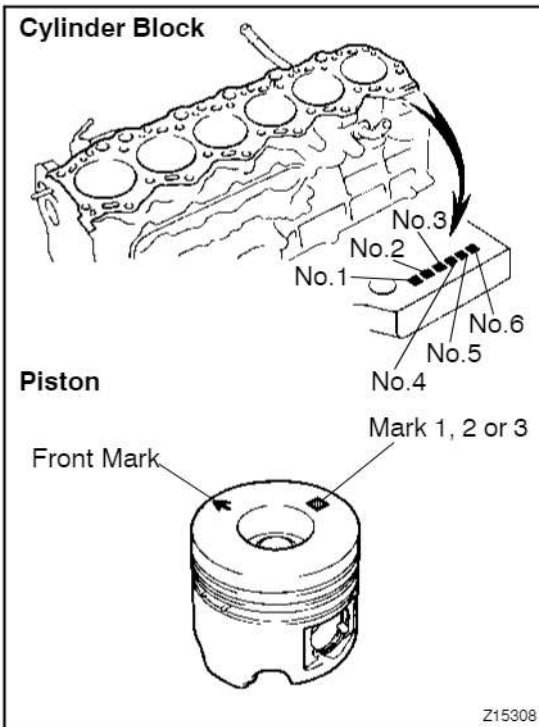

- (2) Measure the cylinder bore diameter in the thrust directions. (See step 4)
- (3) Subtract the piston diameter measurement from the cylinder bore diameter measurement.

**Standard oil clearance:**

**1HZ:** 0.105 – 0.125 mm (0.0041 – 0.0049 in.)

**1HD-T:** 0.040 – 0.060 mm (0.0016 – 0.0024 in.)

**1HD-FTE:** 0.070 – 0.090 mm (0.0028 – 0.0035 in.)

**Maximum oil clearance:**

**1HZ:** 0.125 mm (0.0049 in.)

**1HD-T:** 0.060 mm (0.0024 in.)

**1HD-FTE:** 0.090 mm (0.0035 in.)

If the oil clearance is greater than maximum, replace all the 6 pistons and rebores all the 6 cylinders. If necessary, replace the cylinder block.

**HINT:**

Use a piston with the same number mark as the cylinder bore diameter marked on the cylinder block.

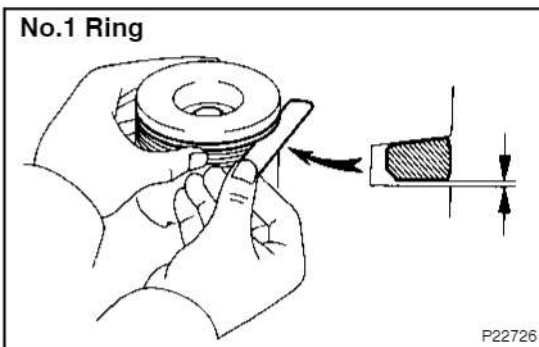

- (b) Inspect piston ring groove clearance

- (1) No.1 Ring:

Install a new piston ring to the piston. Using a feeler gauge, measure the clearance between the piston ring and the wall of the ring groove.

**Standard groove clearance:**

**1HZ, 1HD-T:** 0.054 – 0.095 mm (0.0021 – 0.0037 in.)

**1HD-FTE:** 0.070 – 0.110 mm (0.0028 – 0.0043 in.)

**Maximum groove clearance:** 0.20 mm (0.0079 in.)

If the clearance is greater than maximum, replace the piston.

- (2) No.2 and Oil Rings:

Using a feeler gauge, measure the clearance between a new piston ring and the wall of the ring groove.

**Standard groove clearance:****No.2:**

**1HZ, 1HD-T:** 0.060 – 0.100 mm (0.0024 – 0.0039 in.)

**1HD-FTE:** 0.040 – 0.080 mm (0.0016 – 0.0031 in.)

**Maximum groove clearance:** 0.020 mm (0.0079 in.)

**Standard groove clearance:**

**Oil:** 0.030 – 0.070 mm (0.0012 – 0.0028 in.)

**Maximum groove clearance:** 0.20 mm (0.0079 in.)

If the clearance is greater than maximum, replace the piston.

- (c) Inspect piston ring end gap

- (1) Insert the piston ring into the cylinder bore.

- (2) Using a piston, push the piston ring a little beyond the bottom of the ring travel, 130 mm (5.12 in.) from the top of the cylinder block.

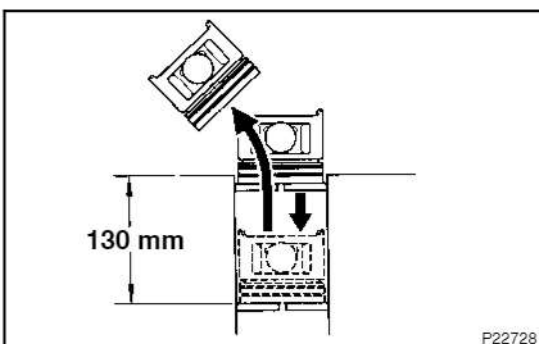
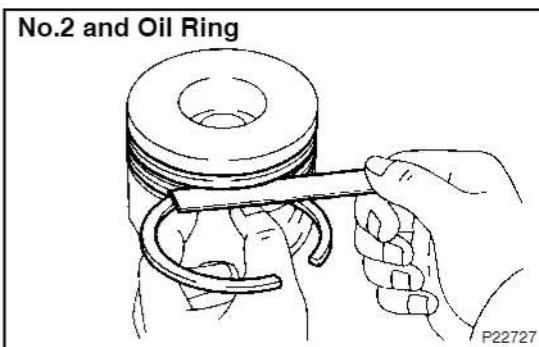

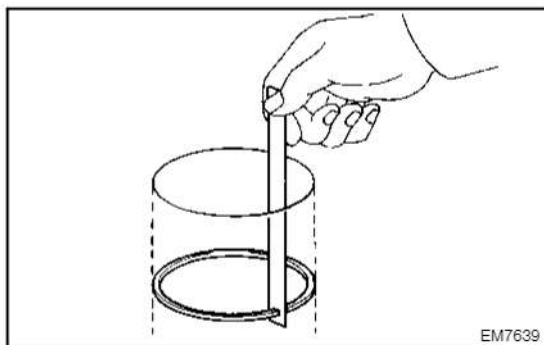

(3) Using a feeler gauge, measure the end gap.

**Standard end gap:**

**No.1:**

**1HZ, 1HD-T: 0.270 – 0.370 mm (0.0106 – 0.0146 in.)**

**1HD-FTE: 0.270 – 0.330 mm (0.0106 – 0.0130 in.)**

**No.2: 0.400 – 0.550 mm (0.0157 – 0.0119 in)**

**Oil: 0.200 – 0.500 mm (0.0079 – 0.0157 in.)**

**Maximum end gap:**

**No.1: 0.850 mm (0.0335 in.)**

**No.2: 0.900 mm (0.0354 in.)**

**Oil: 0.880 mm (0.0346 in.)**

If the end gap is greater than maximum, replace the piston ring.  
If the end gap is greater than maximum, even with a new piston ring, rebore all the 6 cylinders or replace the cylinder block.

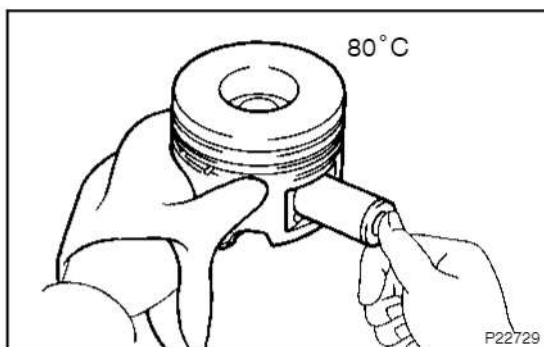

**9. INSPECT PISTON PIN FIT**

At 80°C (176°F), you should be able to push the piston pin into the piston pin hole with your thumb.

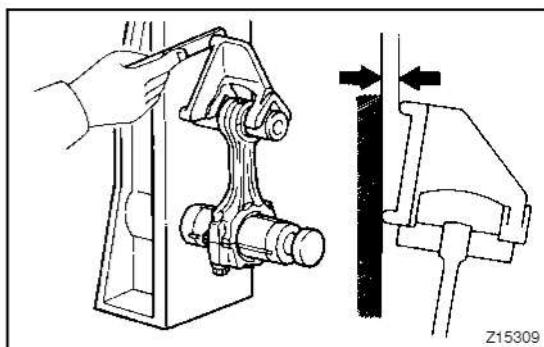

**10. INSPECT CONNECTING ROD**

(a) Inspect connecting rod alignment

Using a rod aligner and feeler gauge, check the connecting rod alignment.

- Check for bend.

**Maximum bend:**

**0.03 mm (0.0012 in.) per 100 mm (3.94 in.)**

If bend is greater than maximum, replace the connecting rod assembly.

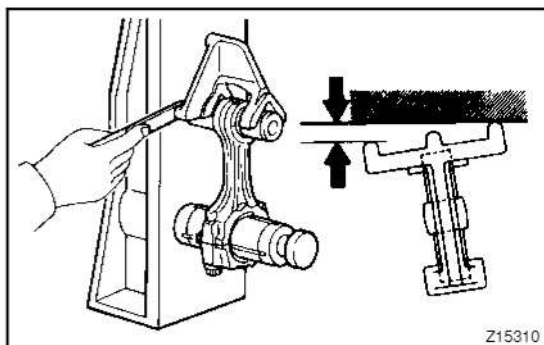

- Check for twist

**Maximum twist:**

**0.15 mm (0.0059 in.) per 100 mm (3.94 in.)**

If twist is greater than maximum, replace the connecting rod assembly.

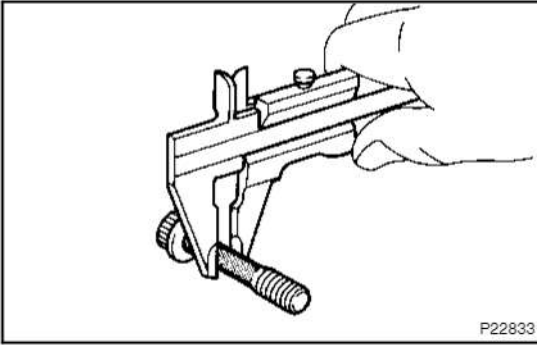

- (b) Inspect connecting rod bolts  
Using vernier calipers, measure the tension portion diameter.

**Standard diameter:**

**8.300 – 8.400 mm (0.3268 – 0.3307 in.)**

**Minimum diameter: 7.95 mm (0.3130 in.)**

If the diameter is less than minimum, replace the connecting rod bolt.

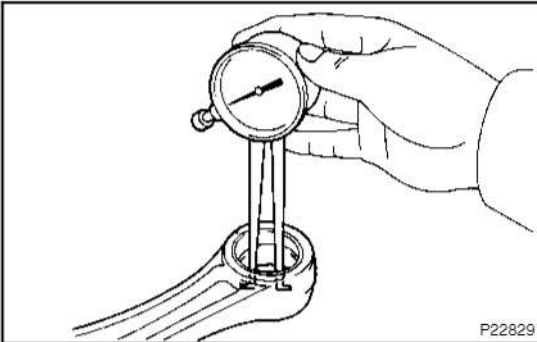

- (c) Inspect piston pin oil clearance  
(1) Using caliper gauge, measure the inside diameter of the connecting rod bushing.

**Bushing inside diameter:**

**33.008 – 33.020 mm (1.2995 – 1.3000 in.)**

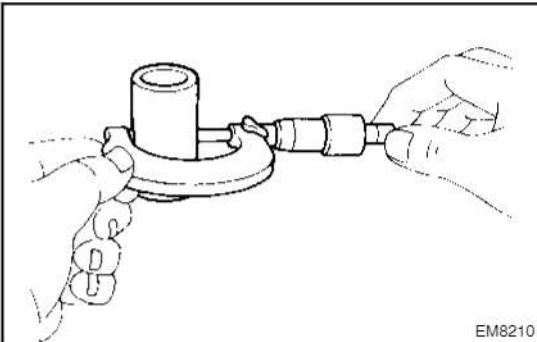

- (2) Using micrometer, measure the piston pin diameter.

**Piston pin diameter:**

**33.000 – 33.012 mm (1.2992 – 1.2997 in.)**

- (3) Subtract the piston pin diameter measurement from the bushing inside diameter measurement.

**Standard oil clearance:**

**0.004 – 0.012 mm (0.0002 – 0.0005 in.)**

**Maximum oil clearance: 0.030 mm (0.0012 in.)**

If the oil clearance is greater than maximum, replace the bushing. If necessary, replace the piston and piston pin as a set.

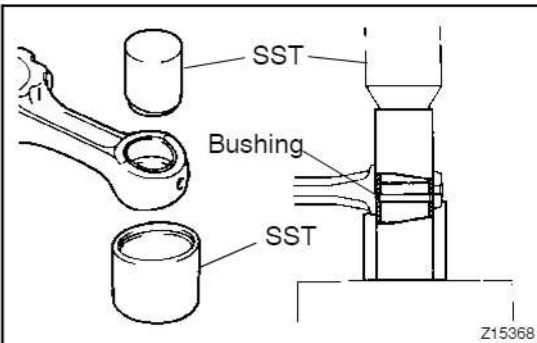

- (d) If necessary, replace connecting rod bushing  
(1) Using SST and a press, press out the bushing.  
SST 09222-17011 (09222-05021, 09222-05041)

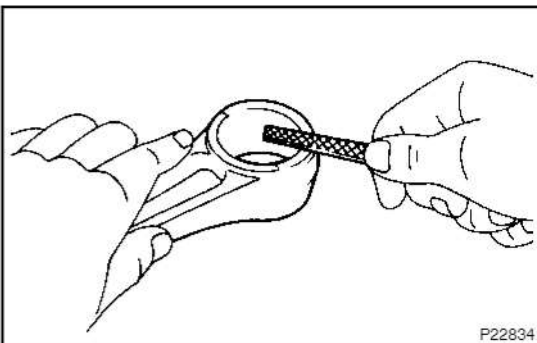

- (2) Using a round file, lightly file off any roughness from the small end of the connecting rod.

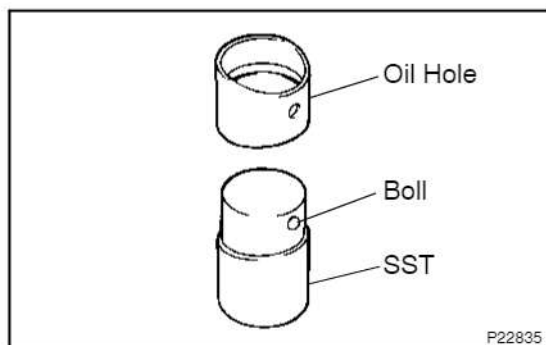

- (3) Attach the bushing to SST with the ball of SST inside the oil hole of the bushing.

SST 09222-17011 (09222-05031)

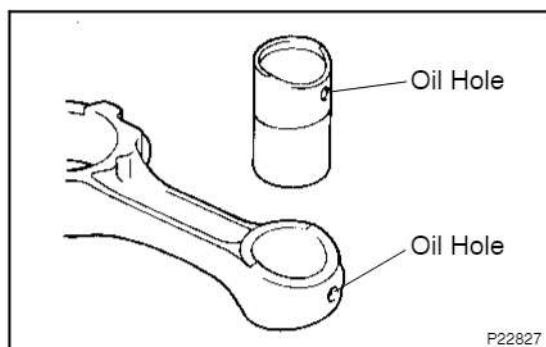

- (4) Align the oil holes of the new bushing and the connecting rod.

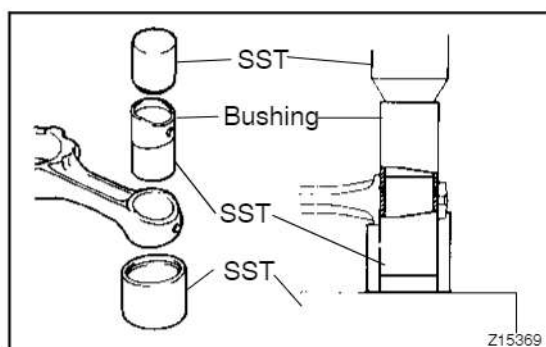

- (5) Using SST and a press, press in the bushing.  
SST 09222-17011 (09222-05021, 09222-05031, 09222-05041)

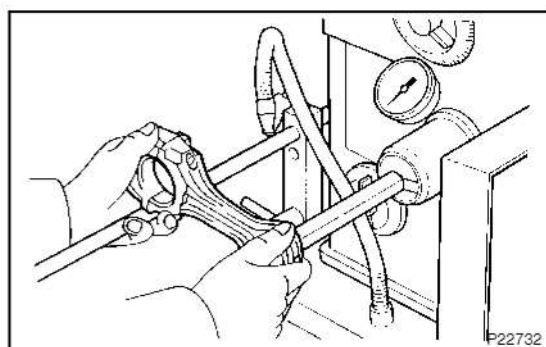

- (6) Using a pin hole grinder, hone the bushing to obtain the standard specified clearance (see item C above) between the bushing and piston pin.

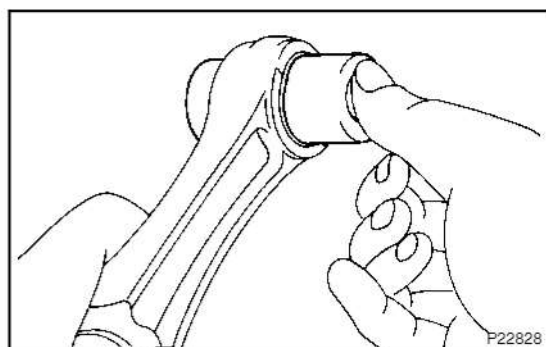

- (7) Check the piston pin fit at normal room temperature. Coat the piston pin with engine oil, and push it into the connecting rod engine oil, and push it into the connecting rod with your thumb.

**11. CYLINDER BORING****HINT:**

- Bore all the 6 cylinders to the oversized piston outside diameter.
- Replace all the piston rings with ones to match the oversized pistons.

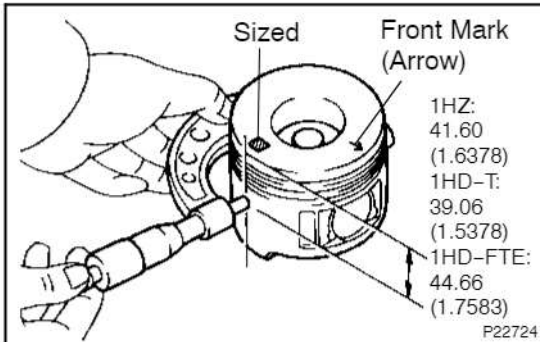
**12. KEEP OVERSIZED PISTONS****Oversized piston diameter:****O/S 0.50****1HZ:** 94.385 – 94.415 mm (3.71594 – 3.71712 in.)**1HD-T:** 94.450 – 94.471 mm (3.71850 – 3.71932 in.)**1HD-FTE:** 94.370 – 94.400 mm (3.71535 – 3.71653 in.)**13. CALCULATE AMOUNT TO BORE CYLINDERS**

- Using a micrometer, measure the piston diameter at right angles to the piston pin center line.
- Calculate the amount each cylinder is to be rebored as follows:

$$\text{Size to be rebored} = P + C - H$$

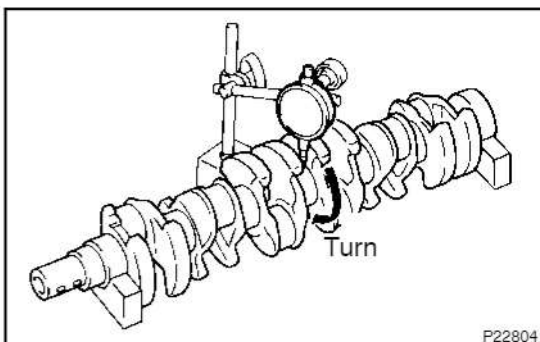
**P = Piston diameter****C = piston clearance****0.145 – 0.165 mm (0.0057 – 0.0065 in.)****H = Allowance for honing****0.02 mm (0.0008 in.) or less****14. BORE AND HONE CYLINDER TO CALCULATED DIMENSIONS****Maximum honing: 0.02 mm (0.0008 in.)****NOTICE:****Excess honing will destroy the finished roundness.****15. INSPECT CRANKSHAFT FOR RUNOUT**

- place the crankshaft on V- blocks.
- Using a dial indicator, measure the circle runout at the center journal.

**Maximum circle runout: 0.06 mm (0.0024 in.)**

If the circle runout is greater than maximum, replace the crankshaft.

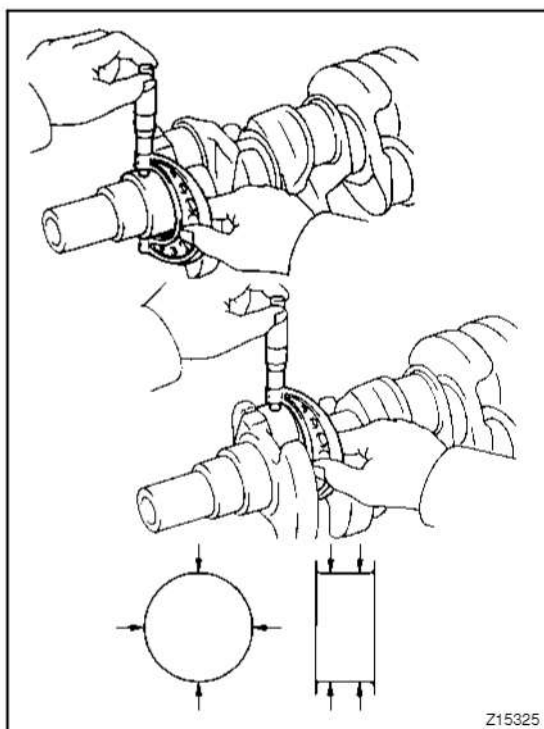

Z15325

## 16. INSPECT MAIN JOURNALS AND CRANK PINS

- (a) Using a micrometer, measure the diameter of each main journal and crank pin.

### Main journal diameter:

#### STD

66.982 – 67.000 mm (2.6371 – 2.6378 in.)

#### U/S 0.25

66.745 – 66.755 mm (2.6278 – 2.6281 in.)

#### U/S 0.50

66.495 – 66.505 mm (2.6179 – 2.6183 in.)

### Crank pin diameter:

#### STD

58.982 – 59.000 mm (2.3221 – 2.3228 in.)

#### U/S 0.25

58.745 – 58.755 mm (2.3128 – 2.3132 in.)

#### U/S 0.50

58.495 – 58.505 mm (2.3029 – 2.3033 in.)

If the diameter is not as specified, check the oil clearance. (See page EM-121) If necessary, grind or replace the crankshaft.

- (b) Check each main journal and crank pin for taper and out-of-round as shown.

### Maximum taper and out-of-round:

0.020 mm (0.0008 in.)

If the taper and out-of-round is greater than maximum, replace the crankshaft.

## 17. IF NECESSARY, GRIND AND HONE MAIN JOURNALS AND/OR CRANK PINS

Grind and hone the main journals and/or crank pins to the finished undersized diameter.

Install new main journal and/or crankshaft pin undersized bearing.

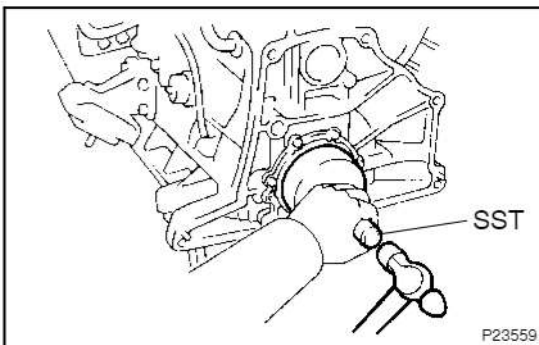
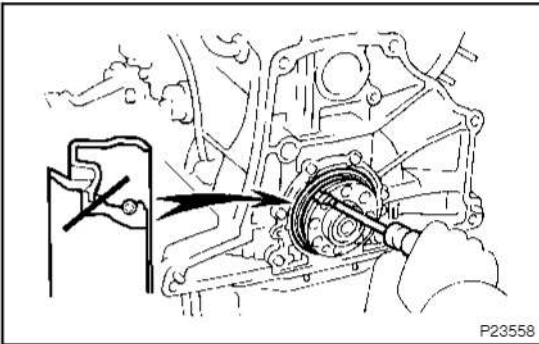
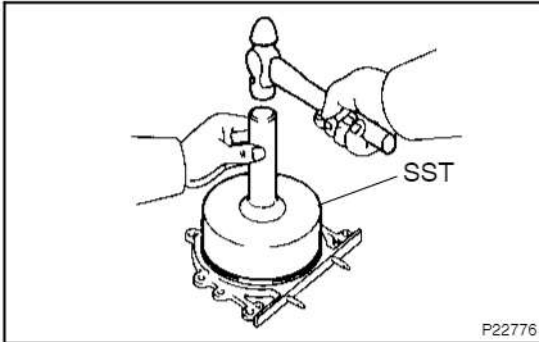
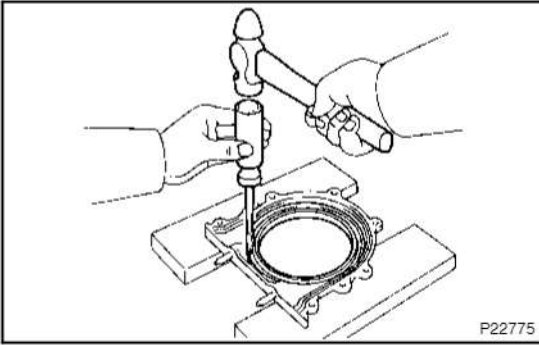

## REPLACEMENT

### HINT:

There are 2 methods (a and b) to replace the oil seal which are as follows:

### REPLACE CRANKSHAFT REAR OIL SEAL

- (a) If rear oil seal retainer is removed from cylinder block:
- (1) Using a screwdriver and hammer, tap out the oil seal.
  - (2) Using SST and a hammer, tap in a new oil seal until its surface is flush with the rear oil seal retainer edge.
- SST 09223-56010
- (3) Apply MP grease to the oil seal lip.

- (b) If rear oil seal retainer is installed to cylinder block:

- (1) Using a knife, cut off the oil seal lip.
- (2) Using a screwdriver, pry out the oil seal.

### NOTICE:

**Be careful not to damage the crankshaft. Tape the screwdriver tip.**

- (3) Apply MP grease to a new oil seal lip.
- (4) Using SST and a hammer, tap in the oil seal until its surface is flush with the rear oil seal retainer edge.

SST 09223-56010

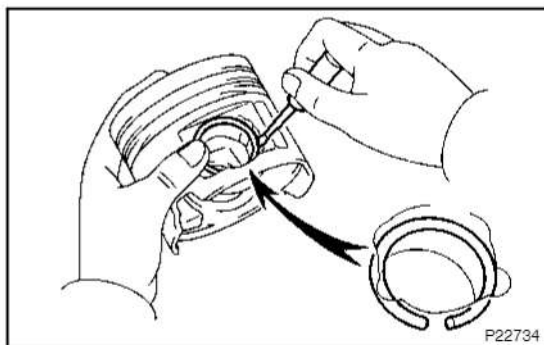

P22734

## REASSEMBLY

### 1. ASSEMBLE PISTON AND CONNECTING ROD

- (a) Install a new snap ring on one side of the piston pin hole.

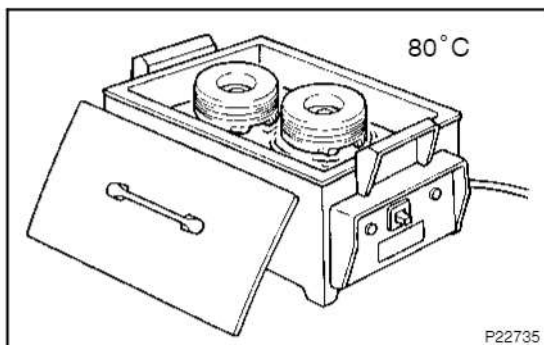

P22735

- (b) Gradually heat the piston to 80°C (176°F).

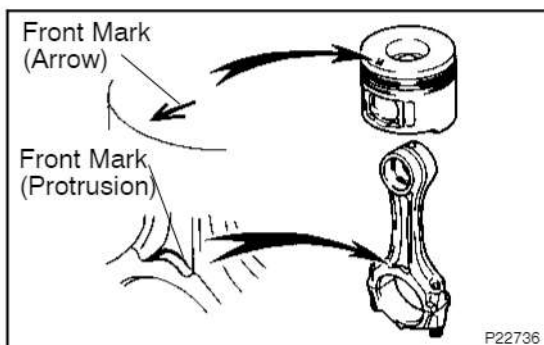

P22736

- (c) Coat the piston pin with engine oil.  
 (d) Align the front marks of the piston and connecting rod, and push in the piston pin with your thumb.

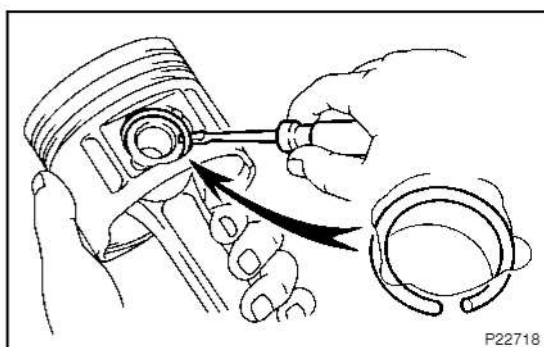

P22718

- (e) Install a new snap ring on the other side of the piston pin hole.

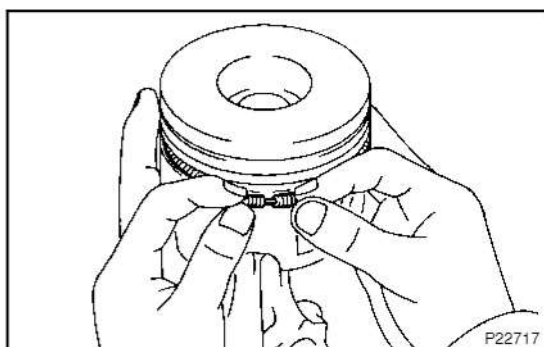

P22717

### 2. INSTALL PISTON RINGS

- (a) Install the coil by hand.  
 (b) Install a piston ring expander, install the oil ring.



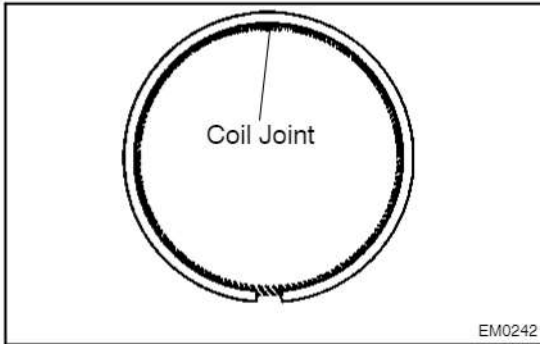

HINT:

Face the end gap of the oil ring in the opposite direction of coil joint.

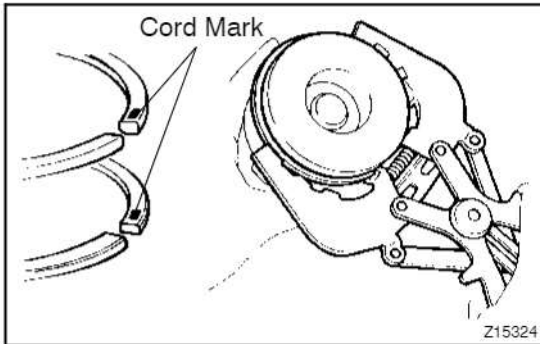

- (c) Using a piston ring expander, install the No.1 and No.2 piston rings with the code mark facing upward.

**Code mark:**

**No.1:**

**1HZ, 1HD-T: T1**

**1HD-FTE: 1T**

**No.2: 2T**

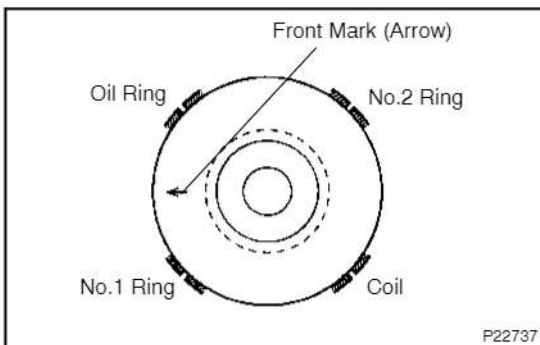

- (d) Position the piston rings so that the ring ends are as shown.

**NOTICE:**

**Do not align the ring ends.**

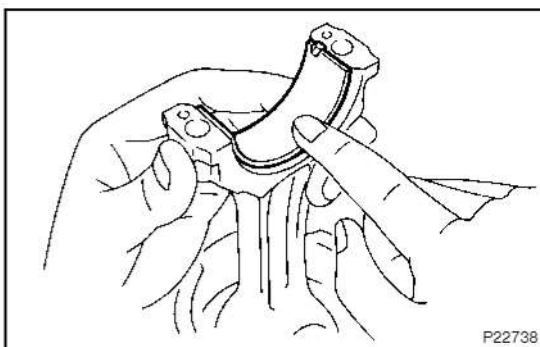

### 3. INSTALL CONNECTING ROD BEARINGS

- Align the bearing claw with the groove of the connecting rod or connecting rod cap.
- Install the bearings in the connecting rod and connecting rod cap.

### 4. CYLINDER BLOCK ASSEMBLY

HINT:

- Thoroughly clean all parts to be assembled.
- Before installing the parts, apply new engine oil to all sliding and rotating surfaces.
- Replace all gaskets, O-rings and oil seals with new parts.

### 5. INSTALL OIL NOZZLES AND CHECK VALVES

(See page LU-28)

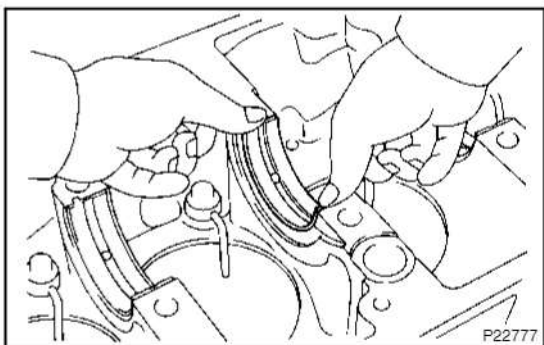

## 6. INSTALL MAIN BEARINGS

### HINT:

Upper bearings have an oil groove and oil hole; lower bearings do not.

- (a) Align the bearing claw with the claw groove of the cylinder block, and push in the 7 upper bearings.
- (b) Align the bearing claw with the claw groove of the main bearing cap, and push in the 7 lower bearings.

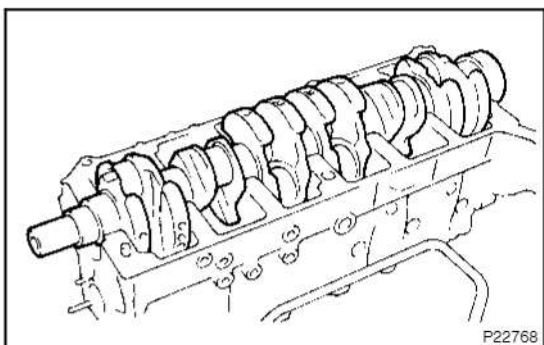

## 7. PLACE CRANKSHAFT ON CYLINDER BLOCK

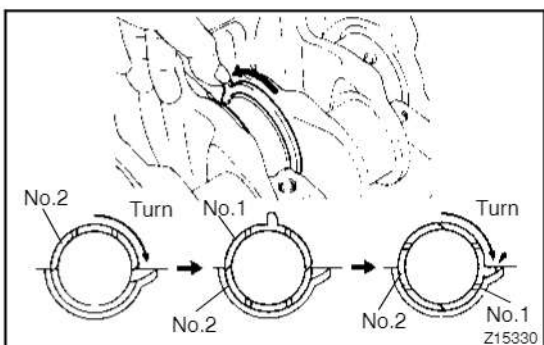

## 8. INSTALL THRUST WASHERS

- (a) Push the crankshaft toward the front (rear) side.
- (b) Install the 4 thrust washers to the No.4 journal position of the cylinder block with the oil grooves facing outward.

## 9. INSTALL MAIN BEARING CAPS

- (a) Place main bearing cap on cylinder block
  - (1) Remove any old packing (FIPG) material and be careful not to drop any oil the contact surfaces of the main bearing cap and cylinder block.
    - Thoroughly clean all components to remove all the loose material.
    - Using a non-residue solvent, clean both sealing surfaces.

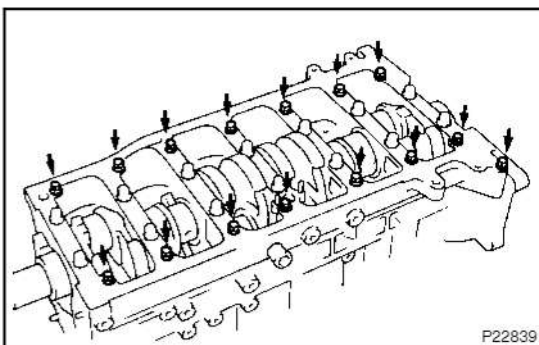
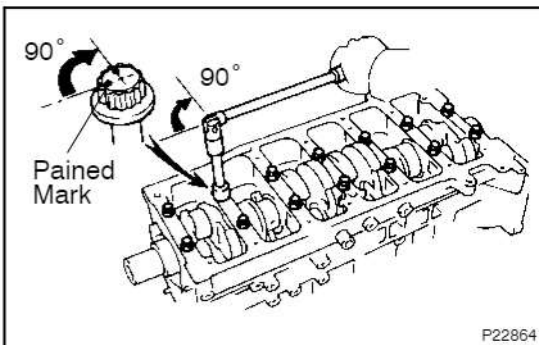
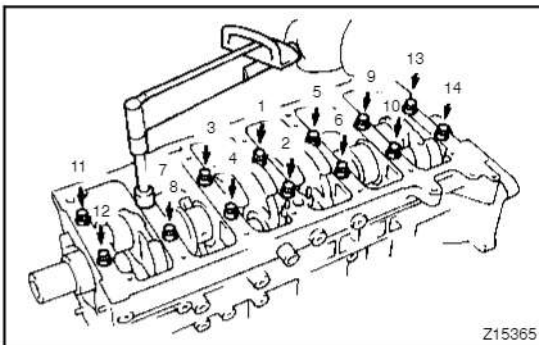
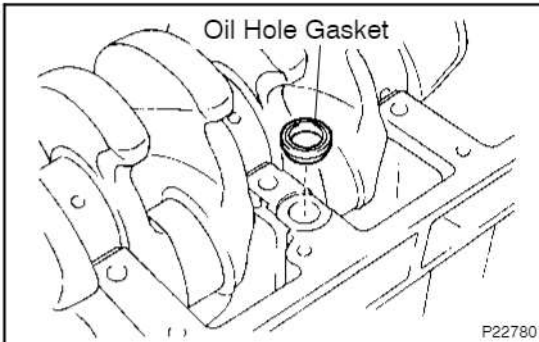
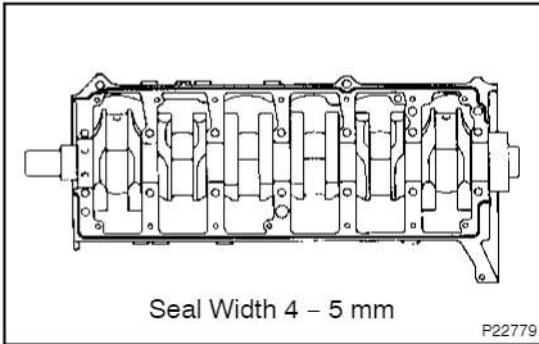

- (2) Apply seal packing to the cylinder block as shown in the illustration.

**Seal packing: Part No. 08826-00080 or equivalent**

- Install a nozzle that has been cut to a 4 - 5 mm (0.16 - 0.20 in.) opening.
- Parts must be assembled within 5 minutes of application. Otherwise the material must be removed and reapplied.
- Immediately remove nozzle from the tube and reinstall cap.

- (3) Install a new cylinder block hole gasket.

- (4) Place the main bearing cap on the cylinder block.

- (b) Install main bearing cap bolts (12 pointed head)

**HINT:**

- The main bearing cap bolts are tightened in 2 progressive steps (steps (b) and (c)).
- If any one of the main bearing cap bolts is broken or deformed, replace it.

- (1) Apply a light coat of engine oil on the threads and under the heads of the main bearing cap bolts.

- (2) Install and uniformly tighten the 14 main bearing cap bolts in several passes, in the sequence shown.

**Torque: 103 N·m (1,050 kgf·cm, 76 ft·lbf)**

If any one of the main bearing cap bolts does not meet the torque specification, replace the main bearing cap bolt.

- (3) Mark the front of the main bearing cap bolt with paint.

- (4) Retighten the main bearing cap bolts 90° in the numerical order shown above.

- (5) Check that the painted mark is now at a 90° angle to the front.

- (6) Check that the crankshaft turns smoothly.

- (c) Install main bearing cap bolts (6 pointed head)  
Install the 15 main bearing bolts.

**Torque: 18 N·m (185 kgf·cm, 13 ft·lbf)**

**10. CHECK CRANKSHAFT THRUST CLEARANCE**

(See page EM-102)

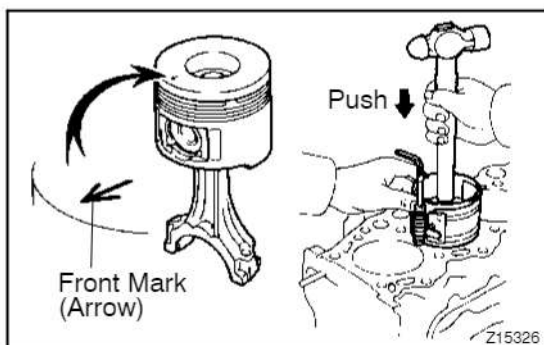

## 11. INSTALL PISTON AND CONNECTING ROD ASSEMBLES

Using a piston ring compressor, push the correctly numbered piston and connecting rod assemblies into each cylinder with the front mark of the piston facing forward.

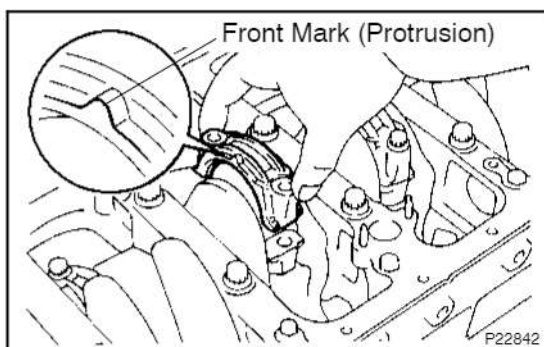

## 12. INSTALL CONNECTING ROD CAPS

- (a) Place connecting rod cap on connecting rod
  - (1) Match the numbered connecting rod cap with the connecting rod.
  - (2) Install the connecting rod cap with the front mark facing forward.

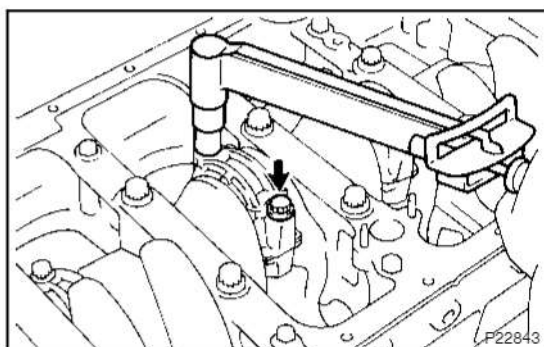

- (b) Install connecting rod cap bolts

### HINT:

- The connecting rod cap nuts are tightened in 2 progressive steps (steps (b) and (d)).
- If any connecting rod bolt is broken or deformed, replace it.
  - (1) Apply a light of engine oil on the threads and under the heads of the connecting rod cap bolts.
  - (2) Install and alternately tighten the bolts of the connecting rod cap in several passes.

**Torque: 36.8 N·m (375 kgf·cm, 27 ft·lbf)**

If any one of the connecting rod cap bolts does not meet the torque specification, replace the cap bolts.

- (3) Mark the front of the connecting rod cap bolt with paint.
- (4) Retighten the connecting rod cap bolts 90° as shown.
- (5) Check that the painted mark is now at a 90° angle to the front.
- (6) Check that the crankshaft turns smoothly.

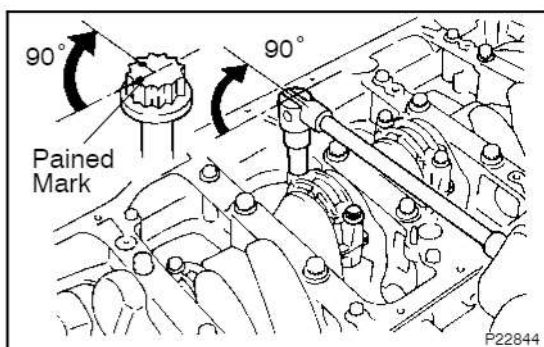

## 13. CHECK CONNECTING ROD THRUST CLEARANCE (See page EM-102)

## 14. INSTALL REAR OIL SEAL RETAINER

- (a) Remove any old packing (FIPG) material and be careful not to drop any oil on the contact surfaces of the retainer and cylinder block.
  - Using a razor blade and gasket scraper, remove all the old packing (FIPG) material from the gasket surfaces and sealing groove.

- Thoroughly clean all components to remove all the loose material.
- Using a non-residue solvent, clean both sealing surfaces.

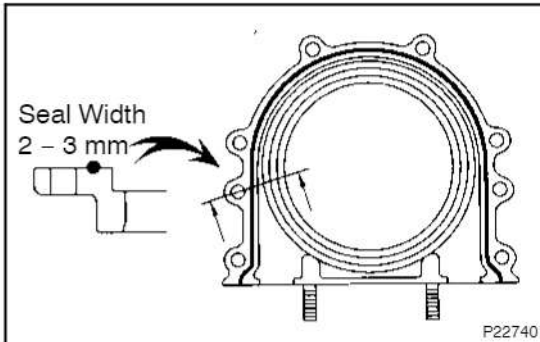

- (b) Apply seal packing to the retainer as shown in the illustration.

**Seal packing: Part No. 08826-00080 or equivalent**

- Install a nozzle that has been cut to a 2 – 3 mm (0.08 – 0.12 in.) opening.

**HINT:**

Avoid applying an excessive amount to the surface.

- Parts must be assembled within 5 minutes of application. Otherwise the material must be removed and reapplied.
- Immediately remove nozzle from the tube and reinstall

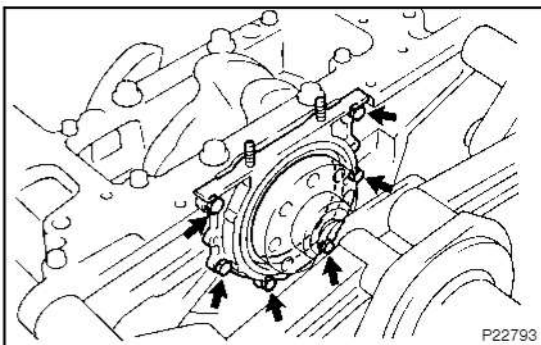

- (c) Install the retainer with the 6 bolts.

**Torque: 6.4 N·m (65 kgf·cm, 57 in·lbf)**

**15. INSTALL TURBO WATER PIPE**

**16. 1HD-FTE:**

**INSTALL CRANKSHAFT POSITION SENSOR**

**17. INSTALL DRAIN PLUG**

**18. INSTALL ENGINE MOUNTING BRACKETS**

**Torque: 68.6 N·m (700 kgf·cm, 51 ft·lbf)**

**19. INSTALL TURBO OIL HOSE**

**20. INSTALL OIL PRESSURE SENDER**

**21. INSTALL OIL COOLER ASSEMBLY, OIL DIPSTICK, GUIDE AND NO.1 CYLINDER BLOCK INSULATOR**  
(See page LU-23)

**22. INSTALL OIL STRAINER, TIMING GEAR CASE (OIL PUMP) AND OIL PAN**

**23. INSTALL INJECTION PUMP STAY**

**Torque: 68.6 N·m (700 kgf·cm, 51 ft·lbf)**

**24. INSTALL 3 INSULATORS**

25. **INSTALL INJECTION PUMP**  
1HZ, 1HD-T: (See page FU-111)  
1HD-FTE: (See page FU-121)
26. **INSTALL ALTERNATOR AND BRACKET**  
Torque: 68.6 N·m (700 kgf·cm, 51 ft·lbf)
27. **INSTALL WATER INLET AND THERMOSTAT**  
1HZ, 1HD-T: (See page EM-66)  
1HD-FTE: (See page EM-94)
28. **INSTALL WATER PUMP, TURBO WATER PIPE AND ALTERNATOR ADJUSTING BAR**  
(See page CO-9)
29. **INSTALL TIMING GEARS**  
(See page EM-44)
30. **INSTALL CYLINDER HEAD**  
1HZ, 1HD-T: (See page EM-66)  
1HD-FTE: (See page EM-94)
31. **INSTALL TIMING BELT AND PULLEYS**  
(See page EM-31)
32. **DISCONNECT ENGINE FROM ENGINE STAND**
33. **INSTALL REAR END PLATE**  
Install the rear end plate with the bolt.  
Torque: 18 N·m (185 kgf·cm, 13 ft·lbf)

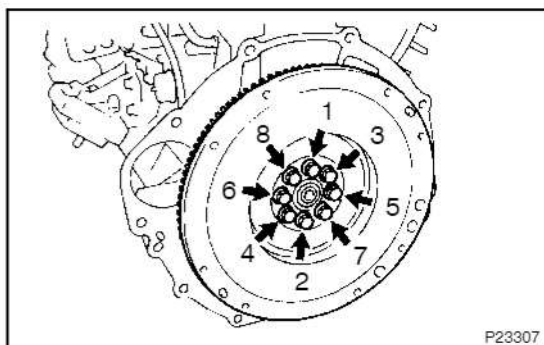

34. **M/T:**  
**INSTALL FLYWHEEL**  
(a) Install the flywheel on the crankshaft.  
(b) Install and uniformly tighten the bolt in several passes, in the sequence shown.  
Torque: 127.4 N·m (1,300 kgf·cm, 94 ft·lbf)
35. **A/T:**  
**INSTALL FLYWHEEL, DRIVE PLATE AND REAR PLATE**

# TROUBLESHOOTING

## PROBLEM SYMPTOMS TABLE

TC025-01

### HINT:

Before troubleshooting the turbocharger, first check the engine itself. (valve clearance, engine compression, injection timing etc.)

### INSUFFICIENT ACCELERATION, LACK OF POWER OR EXCESSIVE FUEL CONSUMPTION

Possible Cause	Check Procedure and Correction Method	See page
1. Turbocharging pressure too low	Check turbocharging pressure.	TC-4
2. Restricted intake system	Check intake air system, and repair or replace parts as necessary.	EM-1 EM-48 EM-77
3. Leak in intake air system	Check intake air system, and repair or replace parts as necessary.	EM-1 EM-48 EM-77
4. Restricted exhaust system	Check exhaust system, and repair or replace parts as necessary.	EM-48 EM-77 EC-12
5. Leak in exhaust system	Check exhaust system, and repair or replace parts as necessary.	EM-48 EM-77 EC-12
6. Erratic turbocharger operation	Check exhaust system, and repair or replace parts as necessary.	EM-48 EM-77 EC-12

### ABNORMAL NOISE

Possible Cause	Check Procedure and Correction Method	See page
1. Turbocharging heat insulator resonance	Check for loose, improperly installed or deformed insulator nuts and bolt, and repair or replace as necessary.	TC-2
2. Exhaust pipe leaking or vibrating	Check for deformed exhaust pipe, loose bolts or damaged gasket, and repair or replace as necessary.	EC-12
3. Erratic turbocharger operation	Insufficient acceleration, lack of power or excessive fuel consumption.	TC-2

### EXCESSIVE OIL CONSUMPTION OR WHITE EXHAUST

#### NOTICE:

**Some oil mist in blowby from PCV is normal. Do not mistake it for oil leak from turbocharger.**

Possible Cause	Check Procedure and Correction Method	See page
Faulty turbocharger oil seal	<p>Check for oil leakage in exhaust system.</p> <ul style="list-style-type: none"> <li>Remove exhaust manifold converter or turbine elbow from turbocharger, and check for excessive carbon deposits on turbine wheel. Excessive carbon deposits indicate a faulty turbocharger.</li> </ul> <p>Check for oil leakage in intake air system.</p> <ul style="list-style-type: none"> <li>Check for axial and radial plays of turbine shaft, and replace turbocharger if necessary.</li> </ul>	TC-8

# TURBOCHARGER PRECAUTION

TC028-01

## MAINTENANCE PRECAUTION

- (a) Do not stop the engine immediately after pulling a trailer or after high speed or uphill driving. Idle the engine for 20 – 120 seconds, depending on how hard the vehicle has been driven.
- (b) Avoid sudden acceleration or racing immediately after starting a cold engine.
- (c) Do not run the engine with air cleaner removed, as this may cause foreign material to enter and damage the impeller wheel operating at high speed.
- (d) If the turbocharger is found to be defective and must be replaced, check for the cause, and repair or replace these items as necessary:
  - Engine oil level and quality
  - Conditions under which the turbocharger was used
  - Oil lines leading to the turbocharger

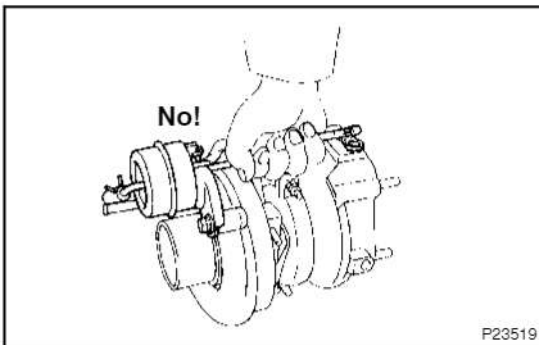

- (e) Use caution when removing and reinstalling the turbocharger assembly. Do not drop it or bang it against anything or grasp it by easily-deformed parts, such as the actuator or rod, when moving it.
- (f) Before removing the turbocharger, plug the intake and exhaust ports and oil inlet to prevent entry of dirt or other foreign material.

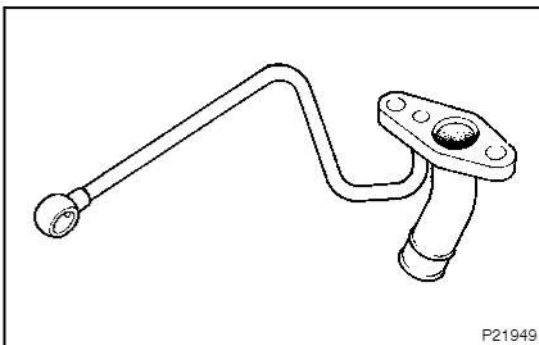

- (g) If replacing the turbocharger, check for accumulation of sludge particles in the oil pipes, and if necessary, replace the oil pipes.
- (h) Completely remove the gasket adhered to the lubrication oil pipe flange and turbocharger oil flange.
- (i) When replacing bolt or nuts, use only authorized replacement parts to prevent breakage or deformation.

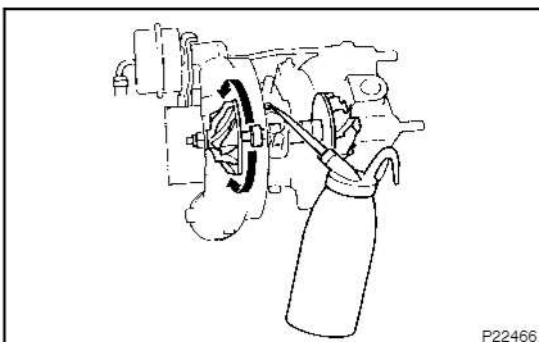

- (j) If replacing the turbocharger, put 20 cm<sup>3</sup> (1.2 cu in.) of oil into the turbocharger oil inlet and turn the impeller wheel by hand to spread oil to the bearing.
- (k) If overhauling or replacing the engine, cut the fuel supply after reassembly and crank the engine for 30 seconds to distribute oil throughout the engine. Then allow the engine to idle for 60 seconds.



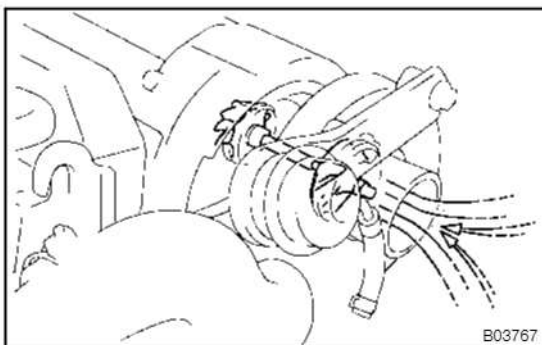

- (l) If the engine is running with out the air cleaner, case cover and hose, entry of foreign particles will damage the wheel which run at extremely high speed.



## ON-VEHICLE INSPECTION

### 1. INSPECT INTAKE AIR SYSTEM

Check for leakage or clogging between the air cleaner housing and turbocharger inlet and between the turbocharger outlet and cylinder head.

- Clogged air cleaner .... Clean or replace element
- Hoses collapsed or deformed .... Repair or replace
- Leakage from connections .... Check each connection and repair
- Cracks in components .... Check and replace

### 2. INSPECT EXHAUST SYSTEM

Check for leakage or clogging between the cylinder head and turbocharger inlet and between the turbocharger outlet and exhaust pipe.

- Deformed components .... Repair or replace
- Foreign material in passages .... Remove
- Leakage from components .... Repair or replace
- Cracks in components .... Check and replace

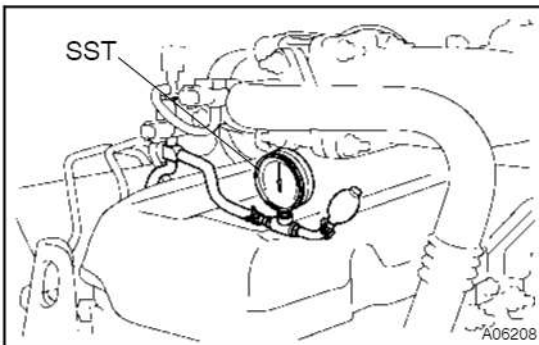

### 3. CHECK TURBOCHARGING PRESSURE

- Warm up engine.
- Using a 3 - way connector, connect SST (turbocharger pressure gauge) to the hose leading to the VSV for turbo pressure sensor..  
SST 09992-00241
- Press in the clutch pedal, then press the accelerator pedal down as far as it will go. Measure the turbocharging pressure at maximum speed 1HD-T: 4400 rpm 1HD-FTE: 4300 rpm.

**Standard pressure:**

**1HD-T:**

**38.6 - 50.0 kPa (0.38 - 0.49 kgf/cm<sup>2</sup>, 5.4 - 7.0 psi)**

**1HD-FTE:**

**50.0 - 70.0 kPa (0.49 - 0.69 kgf/cm<sup>2</sup>, 7.0 - 9.8 psi)**

If the pressure is less than that specification, check the intake air and exhaust systems for leakage.

If there is no leakage, replace the turbocharger assembly.

If the pressure is above specification, check if the actuator hose is disconnected or cracked. If not, replace the turbocharger assembly.

### 4. INSPECT IMPELLER WHEEL ROTATION

(See page TC-10)

### 5. INSPECT ACTUATOR OPERATION

(See page TC-10)

### 6. INSPECT TURBO PRESSURE SENSOR

(See page TC-17)

### 7. INSPECT VSV FOR TURBOCHARGING PRESSURE CONTROL

(See page TC-19)

# COMPONENTS

1HD-T:

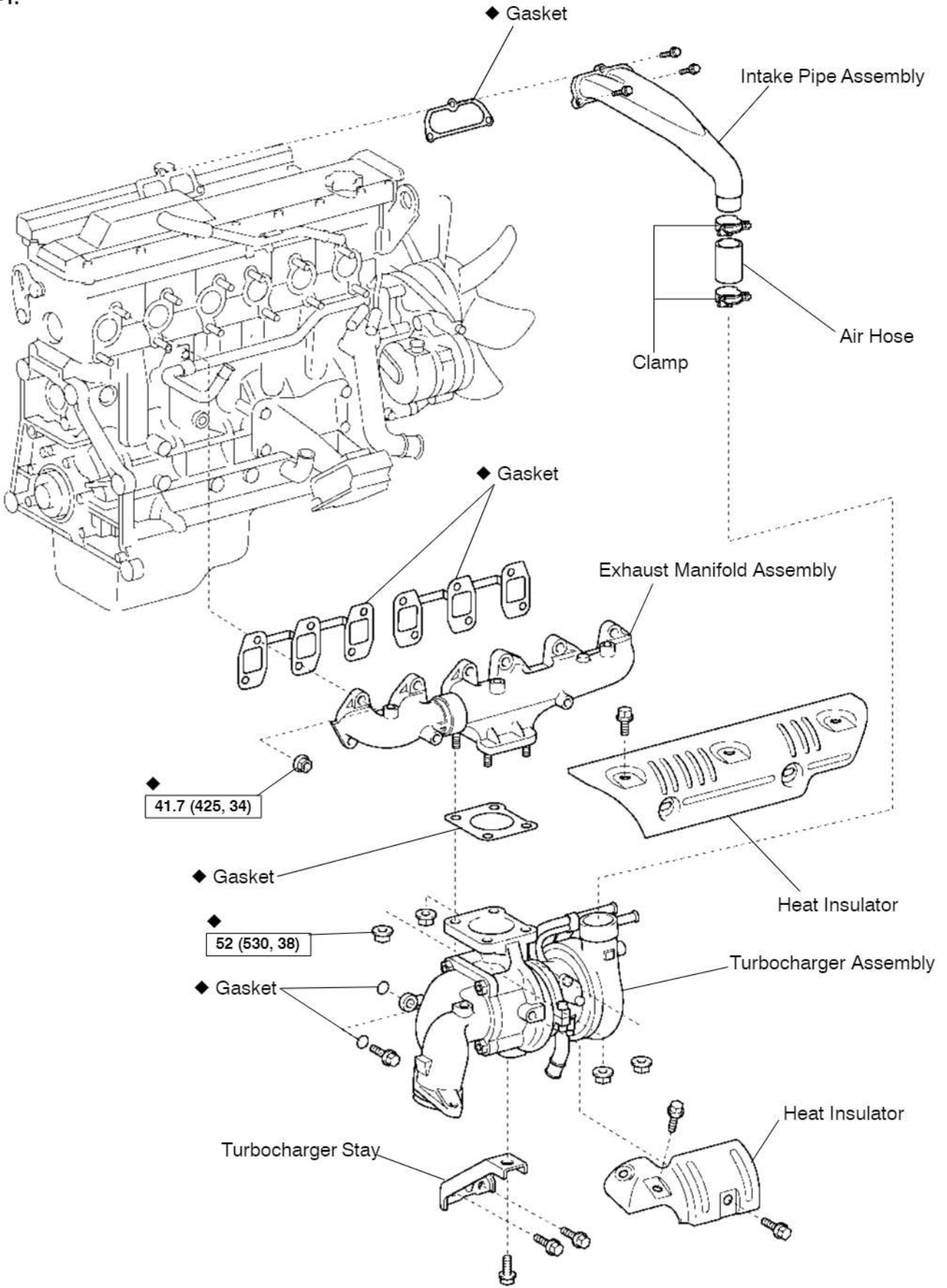

N·m (kgf·cm, ft·lbf) : Specified torque

◆ Non-reusable part

1HZ, 1HD-T, 1HD-FTE ENGINE (RM617E)

1HD-FTE:

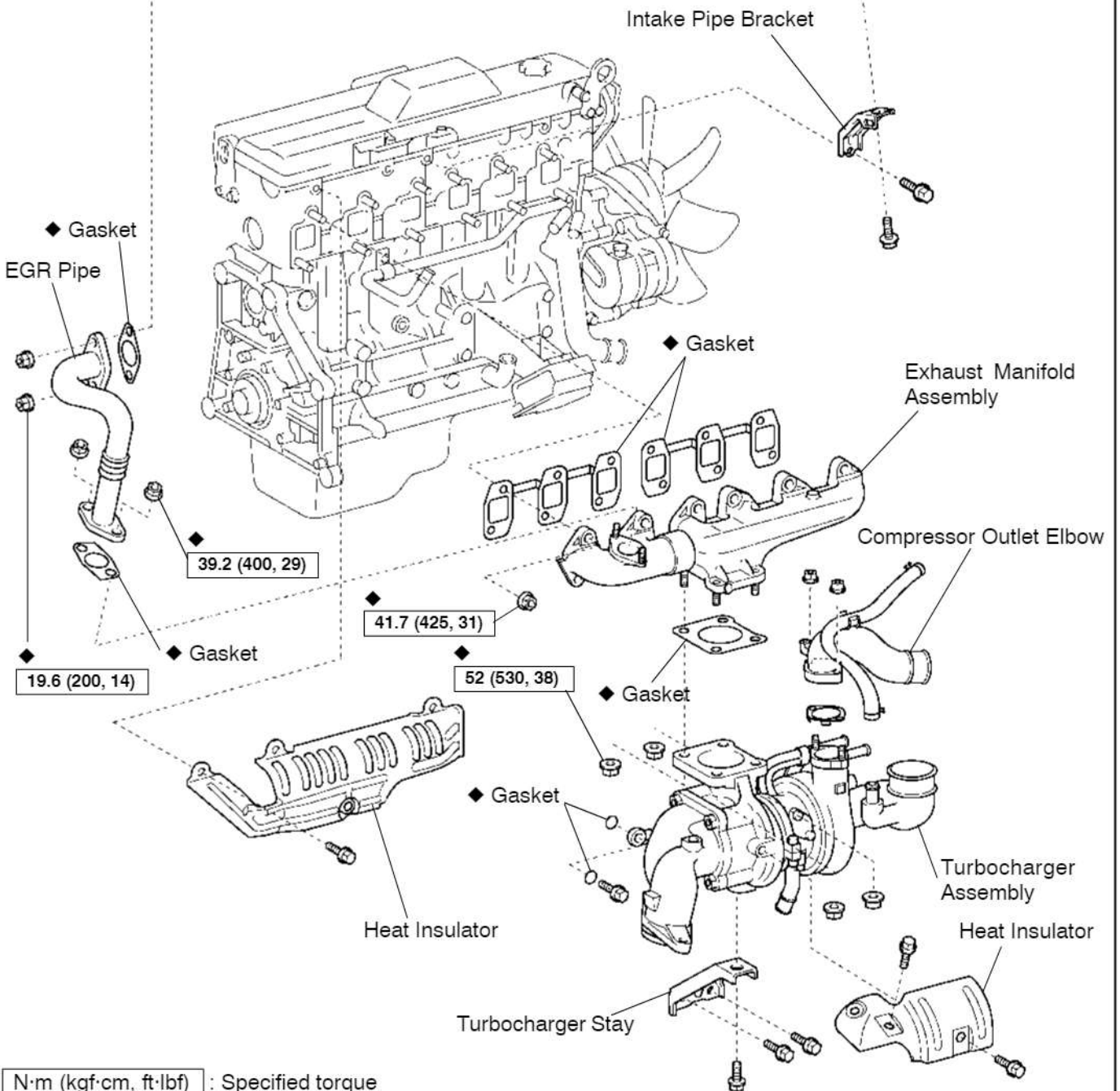
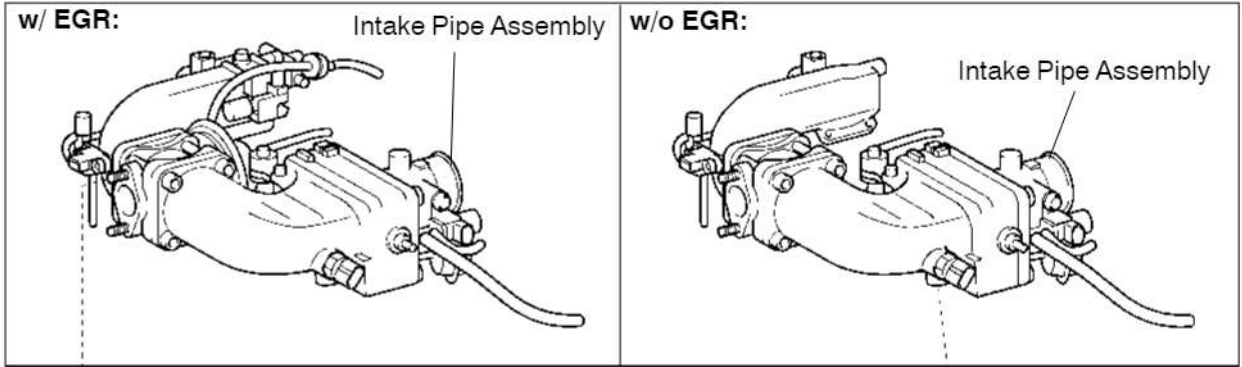

N·m (kgf·cm, ft·lbf) : Specified torque  
 ◆ Non-reusable part

A06209

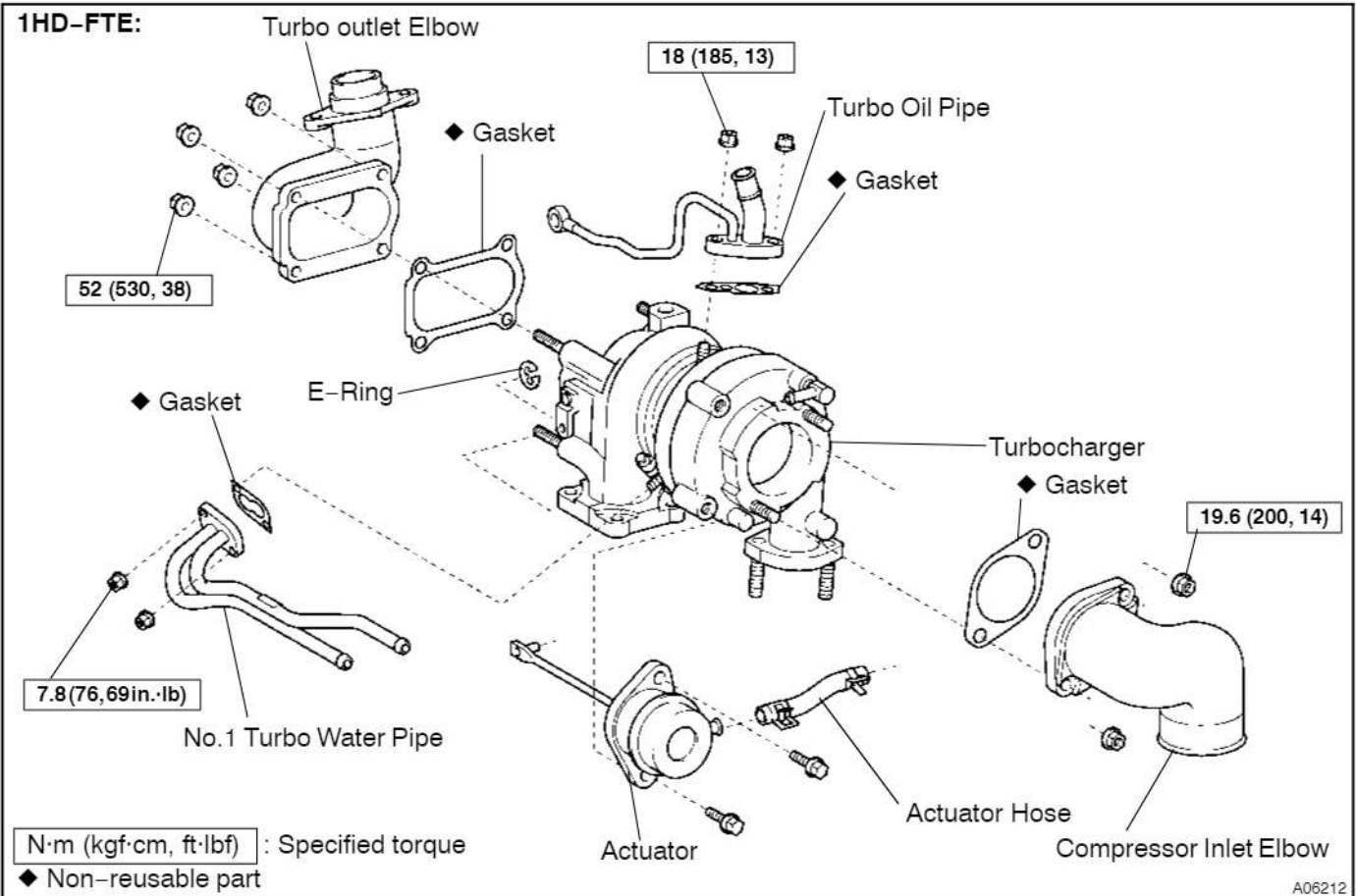
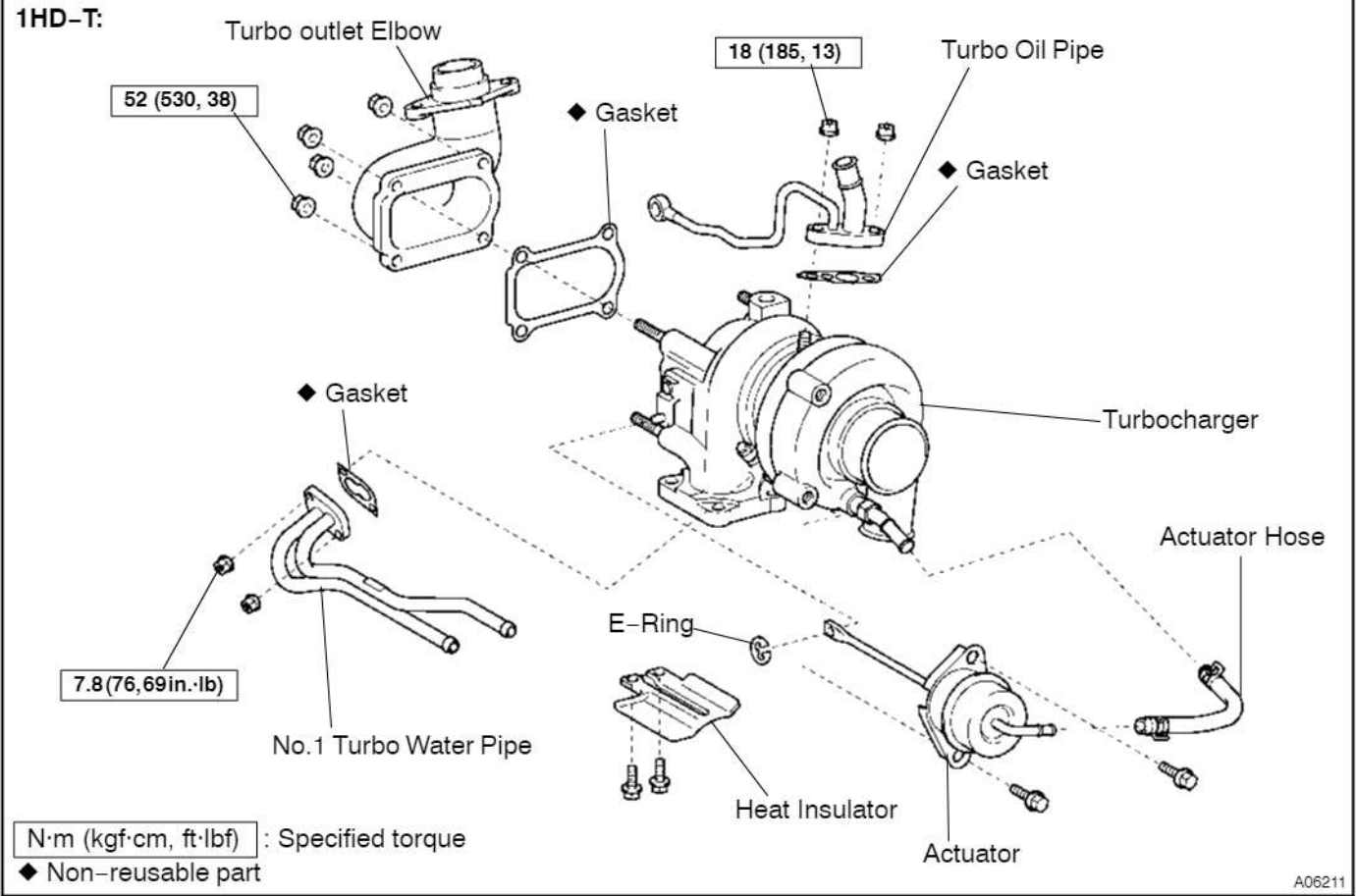

## REMOVAL

1. DRAIN ENGINE COOLANT
2. REMOVE INTAKE PIPE ASSEMBLY

1HD-T: (See page EM-48)

1HD-FTE: (See page EM-77)

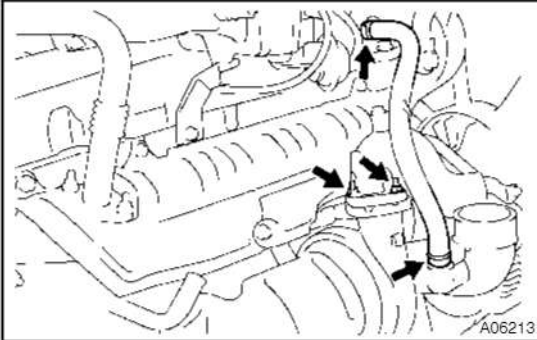

3. 1HD-FTE:  
REMOVE PCV HOSE AND COMPRESSOR OUTLET ELBOW

- (a) Disconnect the PCV hose.
- (b) Remove the 2 nuts compressor outlet elbow and gasket.

4. REMOVE HEAT INSULATOR

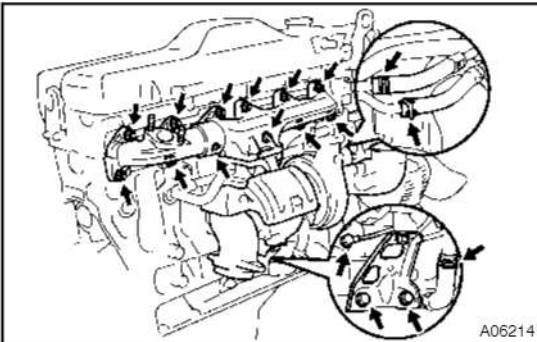

5. REMOVE TURBOCHARGER AND EXHAUST MANIFOLDS ASSEMBLY

- (a) Remove the 3 bolts and turbocharger stay.
- (b) Disconnect the turbo oil hose.
- (c) Remove the union bolt and 2 gaskets holding the turbo oil pipe to the cylinder block.
- (d) Disconnect the 2 water hose to the turbocharger.
- (e) Remove the 12 nuts turbocharger and exhaust manifolds assembly and 2 gaskets.

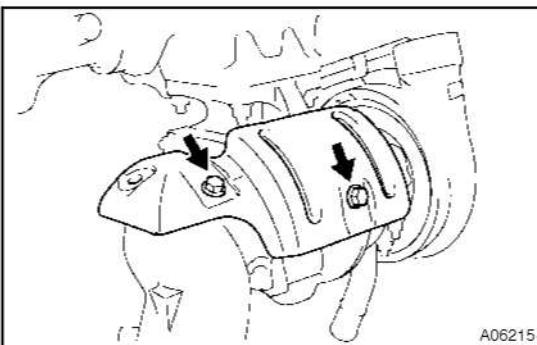

6. REMOVE HEAT INSULATOR

- (a) Remove the 2 bolts and the heat insulator.

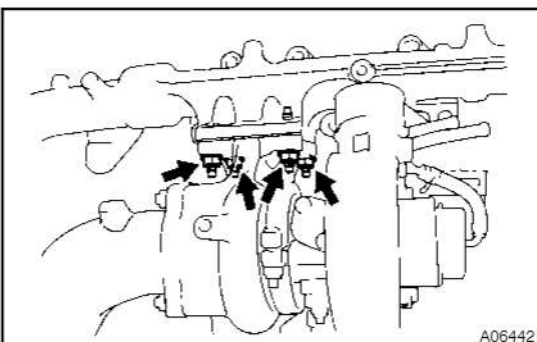

7. REMOVE TURBOCHARGER FROM EXHAUST MANIFOLDS

Remove the 4 nuts turbocharger and the gasket.

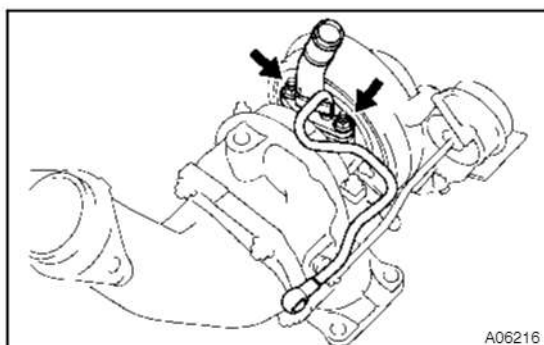
**8. REMOVE OIL PIPE**

Remove the 2 nuts turbo oil pipe and the gasket.

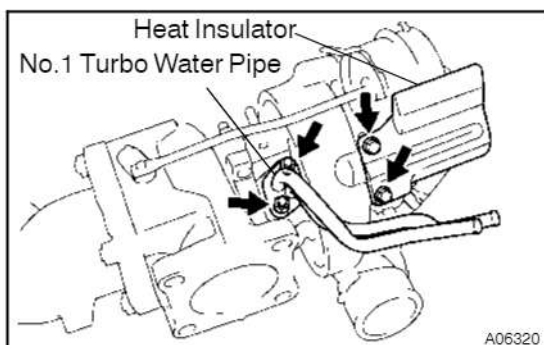
**9. REMOVE NO.1 TURBO WATER PIPE**

Remove the 2 nuts No.1 turbo water pipe and the gasket.

**10. 1HD-T:****REMOVE HEAT INSULATOR**

Remove the 2 bolts and the heat insulator.

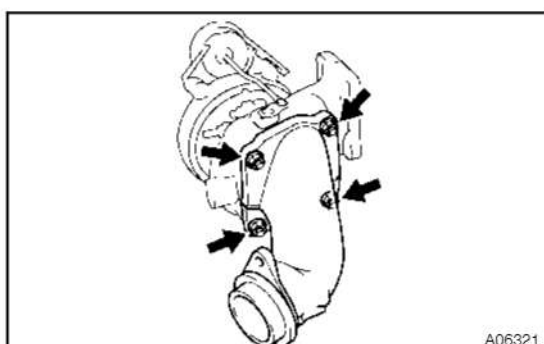
**11. REMOVE TURBO OUTLET ELBOW**

Remove the 4 nuts turbo outlet elbow and gasket.

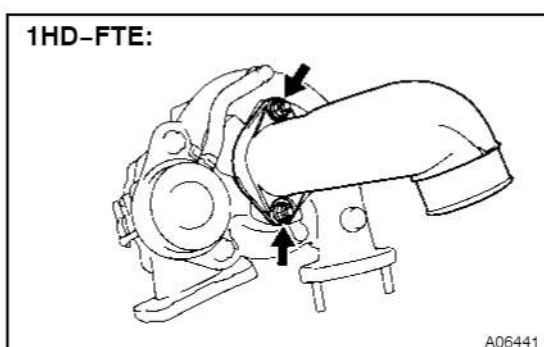
**12. 1HD-FTE:****REMOVE COMPRESSOR INLET ELBOW**

Remove the 2 nuts compressor inlet elbow and gasket.



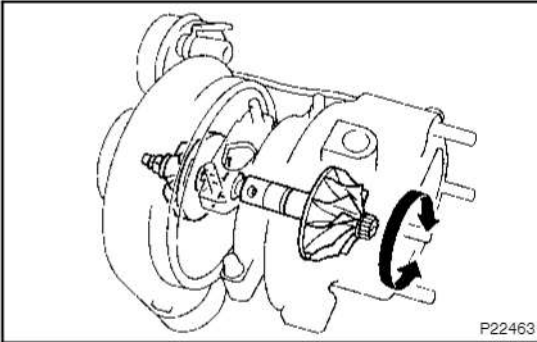

## INSPECTION

### 1. INSPECT IMPELLER WHEEL ROTATION

Grasp the edge of the turbine wheel and turn it. Check that the impeller wheel turns smoothly.

If the impeller wheel does not turn or if it turns with a heavy drag, replace the turbocharger assembly.

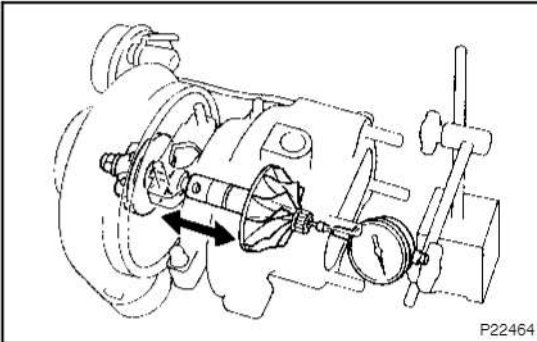

### 2. INSPECT AXIAL PLAY OF TURBINE SHAFT

Insert a dial indicator into the exhaust side hold the turbine wheel edge by hand, and check the axial play.

**Maximum oil clearance: 0.11 mm (0.0043 in.) or less**

If the axial play is not as specified, replace the turbocharger assembly.

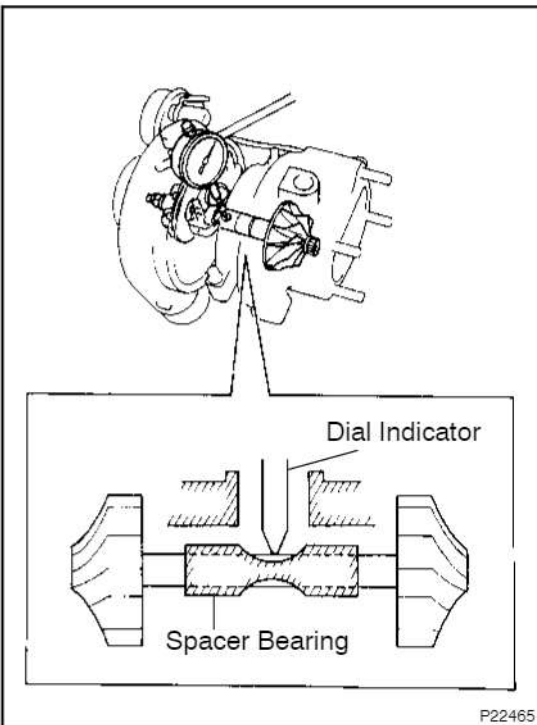

### 3. INSPECT RADIAL PLAY OF TURBINE SHAFT

(a) From oil outlet hole, insert a dial indicator through the hole in the spacer bearing and set it in the center of the turbine shaft.

(b) Move the impeller shaft in a radial direction, measure the radial play of the turbine shaft.

**Maximum oil clearance:**

**1HD-T: 0.16 mm (0.0063 in.) or less**

**1HD-FTE: 0.14 mm (0.0055 in.) or less**

If the radial play is not as specified, replace the turbocharger assembly.



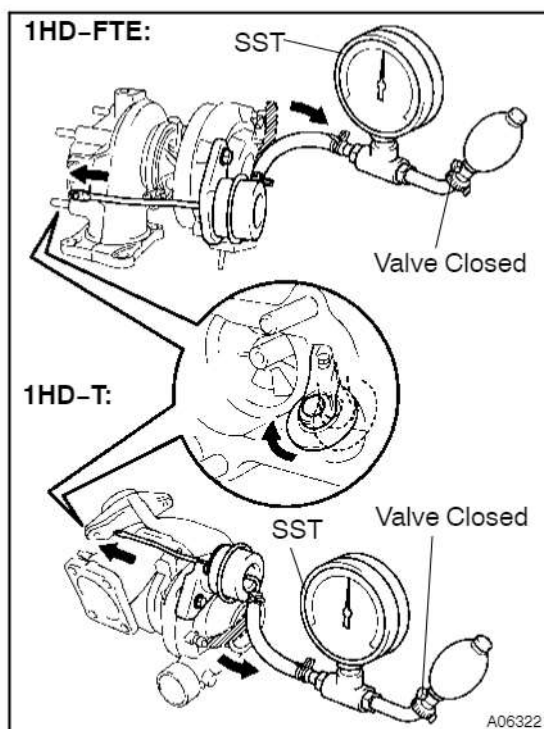

#### 4. INSPECT ACTUATOR OPERATION

- (a) Disconnect the actuator hose.
- (b) Using SST (turbocharger pressure gauge), 1HD-T: 92.7 kpa (0.94 kgf/cm<sup>2</sup>, 13.4 psi) 1HD-FTE: 114.0 kpa (1.16 kgf/cm<sup>2</sup>, 16.5 psi) of pressure to the actuator and check that the rod moves.

If the rod does not move, replace the turbocharger assembly.

SST 09992-00241

#### NOTICE:

Never apply more than 1HD-T: 111.0 kPa (1.13 kgf/cm<sup>2</sup>, 16.1 psi) 1HD-FTE: 148.5 kPa (1.51 kgf/cm<sup>2</sup>, 21.5 psi) of pressure to the actuator.

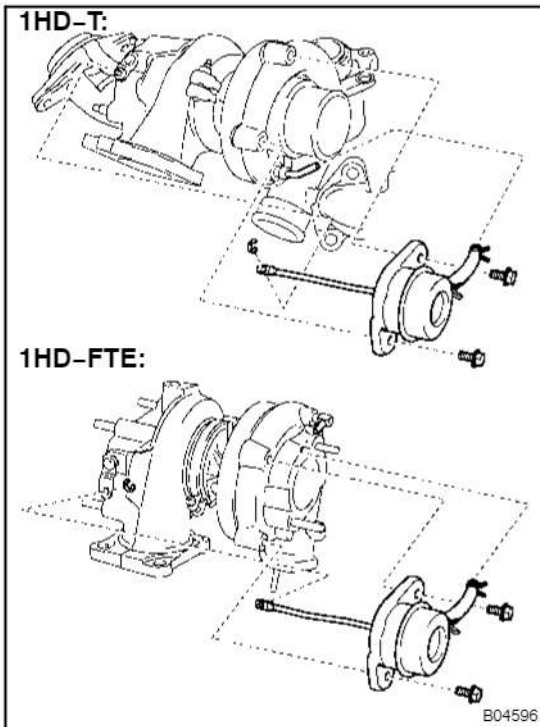

## REPLACEMENT

### 1. REMOVE ACTUATOR

- (a) Remove the actuator hose.
- (b) Remove the 2 bolts holding the actuator to the compressor housing.
- (c) Remove the E-ring holding the actuator push rod to the waste gate valve link, and remove the actuator.

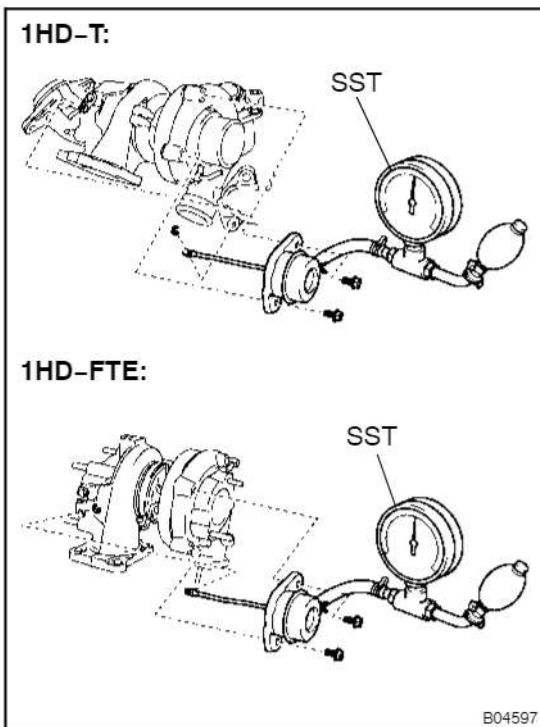

### 2. INSTALL ACTUATOR

- (a) Using SST, apply approx. 1HD-T: 92.7 kPa (0.94 kgf/cm<sup>2</sup>, 13.4 psi) 1HD-FTE: 114.0 kPa (1.16 kgf/cm<sup>2</sup>, 16.5 psi) of pressure to a new actuator.  
SST 09992-00242
- (b) Connect the actuator push rod to the waste gate valve link with a new E-ring.
- (c) Install the actuator to the compressor housing with the 2 bolts.

**Torque: 19 N·m (195 kgf·cm, 14 ft·lbf)**

- (d) Remove SST

#### NOTICE:

- **Never apply more than 1HD-T: 111.0 kPa (1.13 kgf/cm<sup>2</sup>, 16.1 psi) 1HD-FTE: 145.5 kPa (1.48 kgf/cm<sup>2</sup>, 21.1 psi) of pressure to the actuator.**
- **Do not use a hammer, etc. to force the actuator push rod on to the waste gate valve link.**

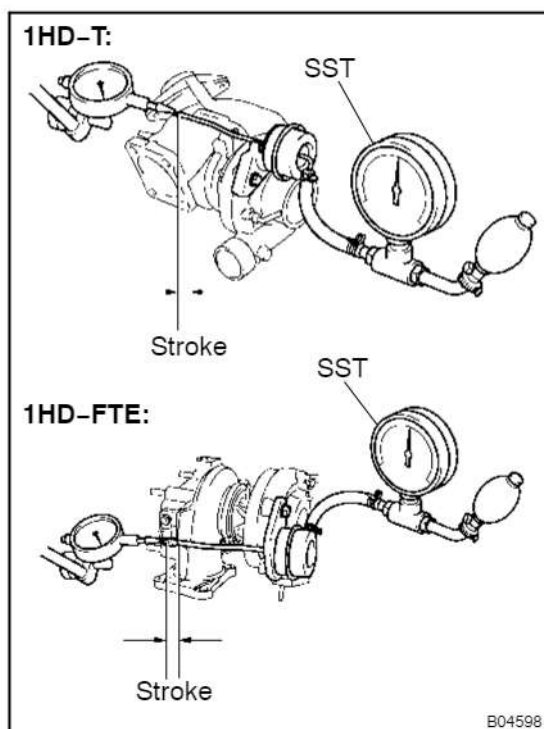

### 3. ADJUST ACTUATOR ROD STROKE

#### NOTICE:

Never apply more than 1HD-T: 111.0 kPa (1.13 kgf/cm<sup>2</sup>, 16.1 psi) 1HD-FTE: 145.5 kPa (1.48 kgf/cm<sup>2</sup>, 21.1 psi) of pressure to the actuator.

- Using a dial indicator, set the dial indicator in a straight line with the actuator push rod.
- Using SST, apply 1HD-T: 92.7 kPa (0.94 kgf/cm<sup>2</sup>, 13.4 psi) 1HD-FTE: 114.0 kPa (1.16 kgf/cm<sup>2</sup>, 16.5 psi) of pressure to the actuator, and measure the actuator push rod stroke.

SST 09992-00242

- From the table below select the plate washer thickness to match the stroke measured in (b) above.

1HD-T:	Stroke measurement mm (in.)	1HD-FTE:	Stroke measurement mm (in.)	Required plate washer thickness mm (in.)
	1.20 - 1.70 (0.0472 - 0.0670)		0.72 - 1.22 (0.0283 - 0.0480)	None required
	1.71 - 2.20 (0.0671 - 0.866)		1.23 - 1.72 (0.0481 - 0.0677)	0.5 (0.020)
	2.21 - 2.70 (0.867 - 0.1063)		1.73 - 2.22 (0.0678 - 0.0874)	1.0 (0.039)
	2.71 - 3.20 (0.1064 - 0.1260)		2.23 - 2.72 (0.0875 - 0.1071)	1.5 (0.059)
	3.21 - 3.70 (0.1261 - 0.1457)		2.73 - 3.22 (0.1072 - 0.1268)	2.0 (0.079)
	3.71 - 4.20 (0.1458 - 0.1654)		3.23 - 3.72 (0.1269 - 0.1465)	2.5 (0.098)
	4.21 - 4.70 (0.1655 - 0.1850)		3.73 - 4.22 (0.1466 - 0.1661)	3.0 (0.118)
	4.71 - 5.20 (0.1850 - 0.2047)		4.23 - 4.72 (0.1662 - 0.1858)	3.5 (0.138)
	5.21 - 5.70 (0.2048 - 0.2244)		4.73 - 5.22 (0.1859 - 0.2055)	4.0 (0.157)
	5.71 - 6.20 (0.2245 - 0.2441)		5.23 - 5.72 (0.2056 - 0.2252)	4.5 (0.177)
	6.21 - 6.70 (0.2442 - 0.2638)		5.73 - 6.22 (0.2253 - 0.2449)	5.0 (0.197)
	6.71 - 7.20 (0.2639 - 0.2827)		6.23 - 6.72 (0.2450 - 0.2646)	5.5 (0.217)
	7.21 - 7.70 (0.2828 - 0.3031)		6.73 - 7.22 (0.2647 - 0.2843)	6.0 (0.236)
	7.71 - 8.20 (0.3032 - 0.3228)		7.23 - 7.72 (0.2844 - 0.3039)	6.5 (0.256)

#### NOTICE:

- Use a combination of plate washers of 0.5 mm (0.020 in.), 1.0 mm (0.039 in.), 2.0 mm (0.079 in.) and 3.0 mm (0.118 in.) thickness to achieve the required thickness.
- Use the same thickness of plate washer for the 2 locations between the actuator and compressor housing.
- If the plate washer thickness exceeds 3.5 mm (0.138 in.) replace the actuator installation bolts with the bolts from the kit part.

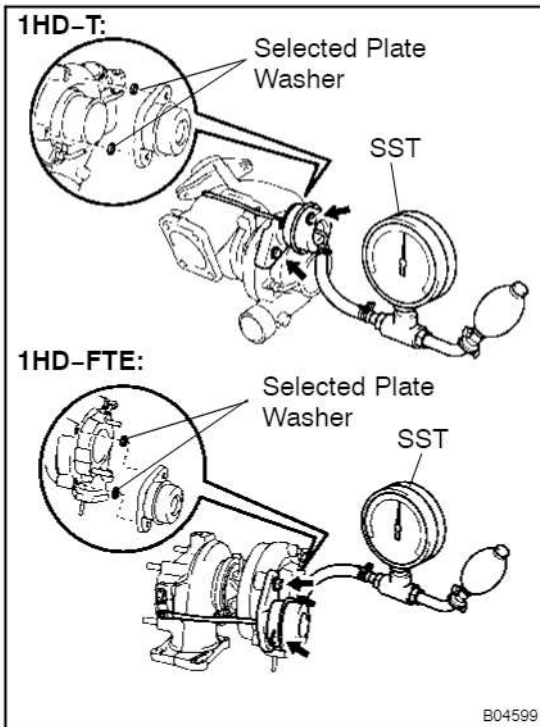

- (d) Using SST, apply approx. 1HD-T: 92.7 kPa (0.94 kgf/cm<sup>2</sup>, 13.4 psi) 1HD-FTE: 114.0 kPa (1.16 kgf/cm<sup>2</sup>, 16.5 psi) of pressure to the actuator and install the selected plate washers between the actuator and compressor housing with the 2 bolts.

**Torque: 19 N·m (195 kgf·cm, 14 ft·lbf)**

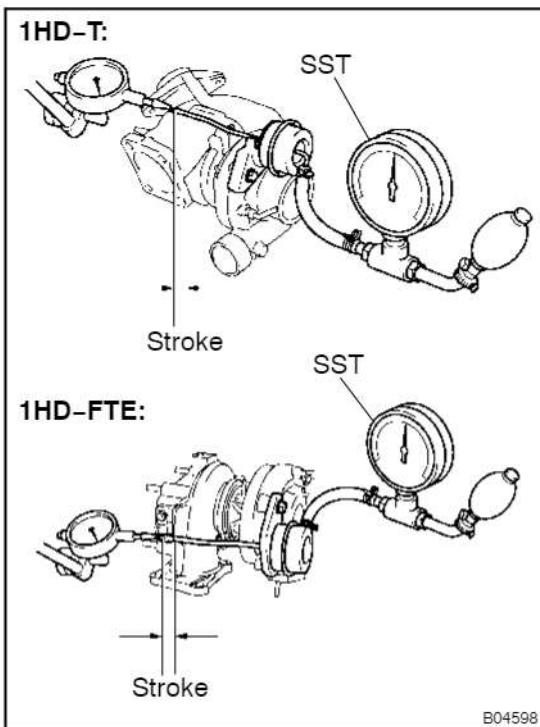

- (e) Using SST, apply 1HD-T: 92.7 kPa (0.94 kgf/cm<sup>2</sup>, 13.4 psi) 1HD-FTE: 114.0 kPa (1.16 kgf/cm<sup>2</sup>, 16.5 psi) of pressure to the actuator, and measure the actuator push rod stroke.

SST 09992-00242

**Standard stroke:**

**1HD-T: 1.20 - 1.70 mm (0.0472 - 0.0669 in.)**

**1HD-FTE: 0.72 - 1.22 mm (0.0283 - 0.0480 in.)**

If the stroke is outside specifications, reselect the plate washers.

**4. INSTALL ACTUATOR HOSE**

**5. APPLY YELLOW PAINT**

Apply yellow paint from the actuator bolts to the actuator bracket to indicate that they have been correctly installed.

**6. CHECK TURBOCHARGING PRESSURE**

**(See page TC-4)**

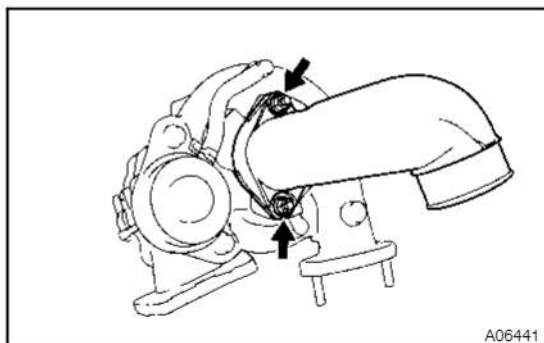

## INSTALLATION

### 1. 1HD-FTE:

#### INSTALL COMPRESSOR INLET ELBOW

Install the gasket, compressor inlet elbow and the 2 new nuts.

**Torque: 19 N·m (195 kgf·cm, 14 ft·lbf)**

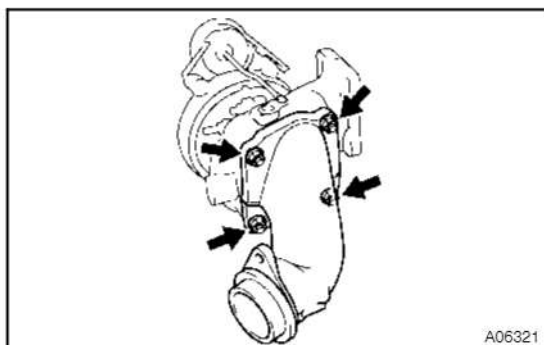

### 2. INSTALL TURBO OUTLET ELBOW

Install the new gasket, turbo outlet and the 4 nuts.

**Torque: 39 N·m (390 kgf·cm, 28 ft·lbf)**

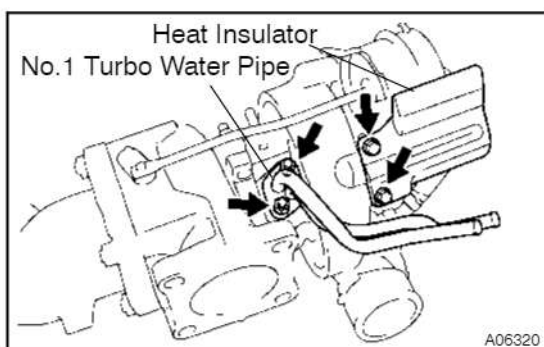

### 3. 1HD-T:

#### INSTALL HEAT INSULATOR

Install the heat insulator and the 2 bolts.

### 4. REMOVE NO.1 TURBO WATER PIPE

Install the new gasket, No.1 turbo water pipe and the 2 nuts.

**Torque: 19 N·m (195 kgf·cm, 14 ft·lbf)**

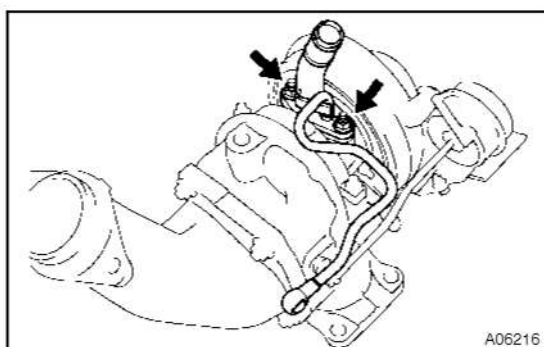

### 5. INSTALL OIL PIPE

Install the new gasket, turbo oil pipe and the 2 nuts.

**Torque: 19 N·m (195 kgf·cm, 14 ft·lbf)**

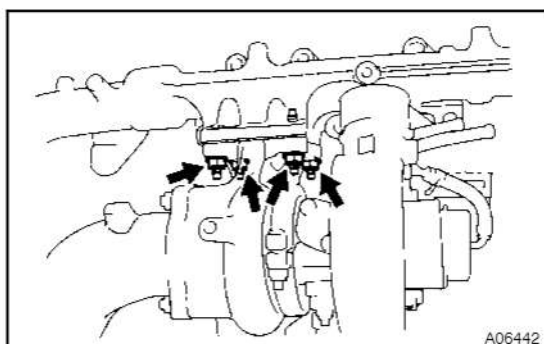

### 6. INSTALL TURBOCHARGER TO EXHAUST MANIFOLDS

Install the new gasket, turbocharger and the 4 nuts.

**Torque: 52 N·m (530 kgf·cm, 38 ft·lbf)**

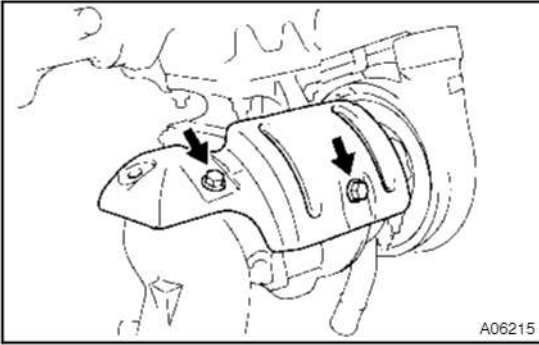
**7. INSTALL HEAT INSULATOR**

Install the heat insulator and the 2 bolts.

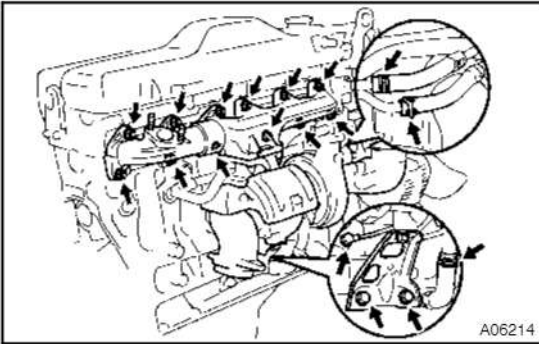
**8. INSTALL TURBOCHARGER AND EXHAUST MANIFOLDS ASSEMBLY**

- (a) Install the 2 new gaskets, turbocharger and exhaust manifolds assembly and the 12 nuts.

**Torque: 41.7 N·m (425 kgf·cm, 31 ft·lbf)**

- (b) Connect the 2 water hose from the turbocharger.  
 (c) Install the 2 new gasket and the union bolt of the turbo oil pipe.  
 (d) Connect the turbo oil hose.  
 (e) Install the turbocharger stay and the 3 bolts.

**9. 1HD-FTE:****INSTALL PCV HOSE AND COMPRESSOR OUTLET ELBOW**

- (a) Install the new gasket, compressor outlet elbow and the 2 nuts.  
 (b) Connect the PCV hose

**10. INSTALL HEAT INSULATOR****11. INSTALL INLET PIPE ASSEMBLY**

**1HD-T:** (See page EM-66)

**1HD-FTE:** (See page EM-94)

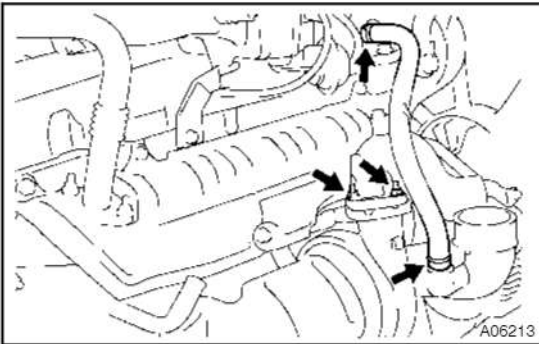
**12. FILL WITH ENGINE COOLANT****13. START ENGINE AND CHECK FOR LEAK****14. CHECK ENGINE OIL LEVEL**

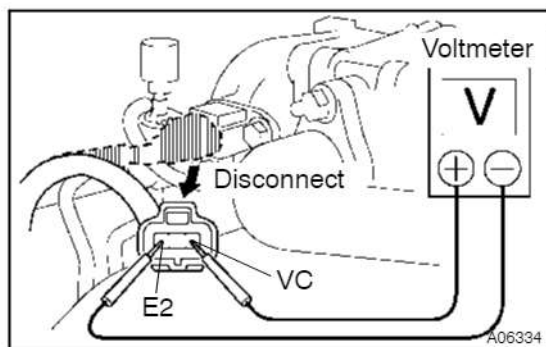

## TURBO PRESSURE SENSOR (1HD-FTE) INSPECTION

TC020-01

1. **INSPECT POWER SOURCE VOLTAGE OF TURBO PRESSURE SENSOR**
  - (a) Disconnect the turbo pressure sensor connector.
  - (b) Turn the ignition switch ON.
  - (c) Using a voltmeter, measure the voltage between connector terminals VC and E2 of the wiring harness side.  
**Voltage:**  
**4.75 - 5.25 V**
  - (d) Turn the ignition switch OFF.
  - (e) Reconnect the turbo pressure sensor connector.

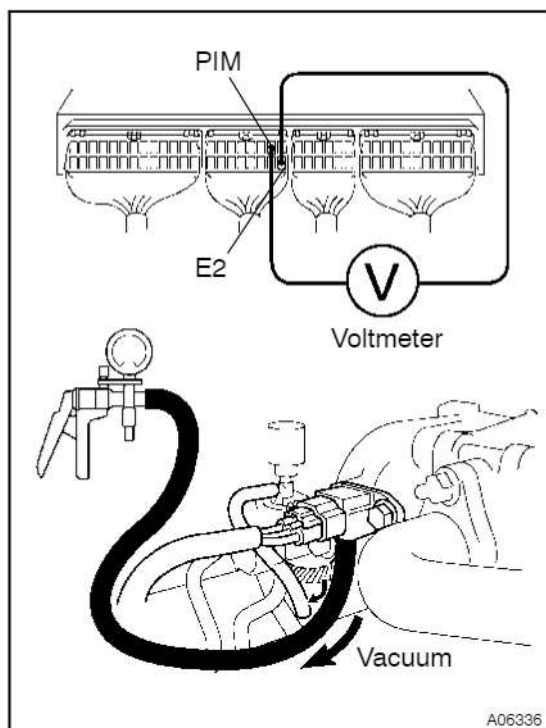

2. **INSPECT SUPPLY POWER OF TURBO PRESSURE SENSOR**
  - (a) Turn the ignition switch ON.
  - (b) Disconnect the vacuum hose from the turbo pressure sensor.
  - (c) Connect a voltmeter to terminals PIM and E2 of the ECU, and measure the output voltage under ambient atmospheric pressure.
  - (d) Apply vacuum to the turbo pressure sensor in 13.3 kPa (100 mmHg, 3.94 in.Hg) segments to 66.7 kPa (500 mmHg, 19.69 in.Hg).
  - (e) Measure the voltage drop from step (c) above for each segment.  
**Voltage drop:**

<b>Applied vacuum kPa ( mmHg in.Hg )</b>	<b>13.3 ( 100 ) ( 3.94 )</b>	<b>26.7 ( 200 ) ( 7.87 )</b>	<b>40.0 ( 300 ) ( 11.81 )</b>
<b>Voltage drop V</b>	<b>0.1 - 0.3</b>	<b>0.3 - 0.5</b>	<b>0.5 - 0.7</b>

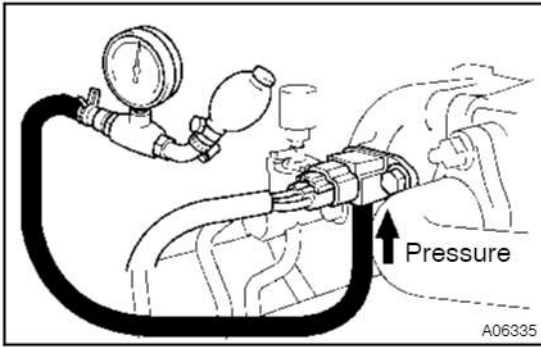

- (f) Using SST (turbocharger pressure gauge), apply pressure to the turbo pressure sensor in 9.8 kPa (0.10 kgf/cm<sup>2</sup>, 1.4 psi) segments to 49.0 kPa (0.50 kgf/cm<sup>2</sup>, 7.1 psi).

SST 09992-00241

- (g) Measure the voltage up from step (c) above for each segment.

**Voltage up:**

<b>Applied pressure</b> kPa (kgf/cm <sup>2</sup> ) (psi)	19.6 (0.20) (2.84)	39.2 (0.40) (5.69)	58.8 (0.60) (8.53)	78.5 (0.80) (11.4)	98.0 (1.00) (14.2)
<b>Voltage up</b> V	0.15 - 0.45	0.4 - 0.7	0.7 - 1.0	1.0 - 1.3	1.3 - 1.6

- (h) Reconnect the vacuum hose to the turbo pressure sensor.



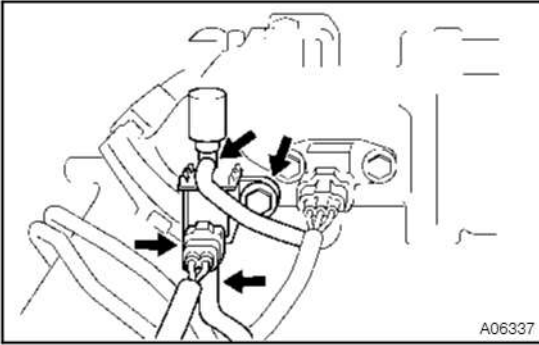

## VSV FOR TURBOCHARGING PRESSURE CONTROL (1HD-FTE) INSPECTION

### 1. REMOVE VSV

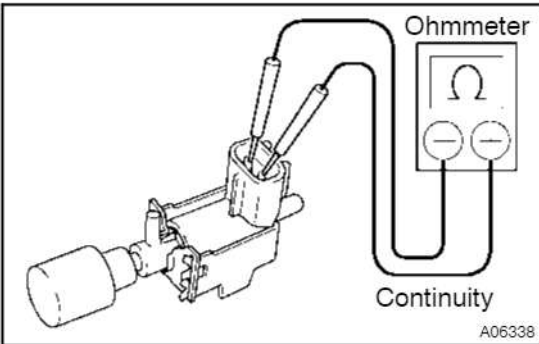

### 2. INSPECT VSV FOR OPEN CIRCUIT

Using an ohmmeter, check that there is continuity between the terminals.

**Resistance:**

**At 20°C (68°F) 37 – 44 Ω**

If there is no continuity, replace the VSV.

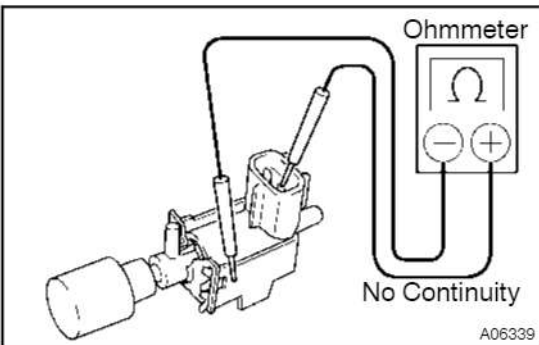

### 3. INSPECT VSV FOR GROUND

Using an ohmmeter, check that there is no continuity between each terminal and the body.

If there is continuity, replace the VSV.

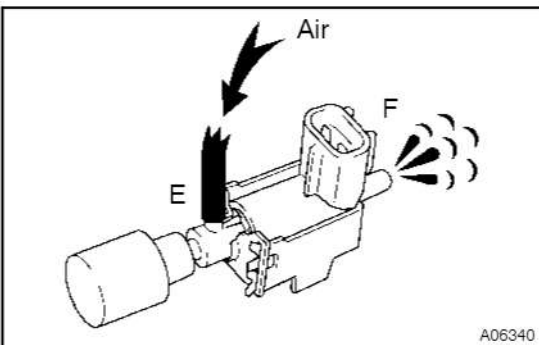

### 4. INSPECT VSV OPERATION

(a) Check that air does not flow from port E to F.

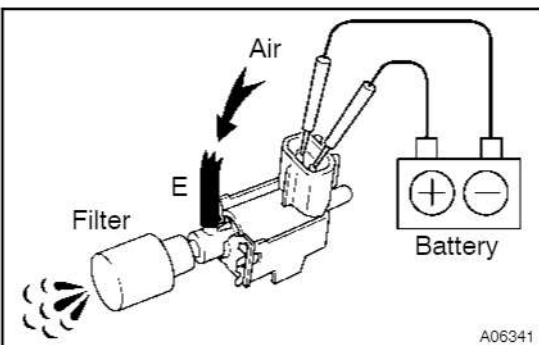

(b) Apply battery voltage across the terminals.

(c) Check that air flows from port E to the filter.

If operation is not as specified, replace the VSV.

### 5. REINSTALL VSV

# PARTS LAYOUT AND SCHEMATIC DRAWING LOCATION

EC09A-01

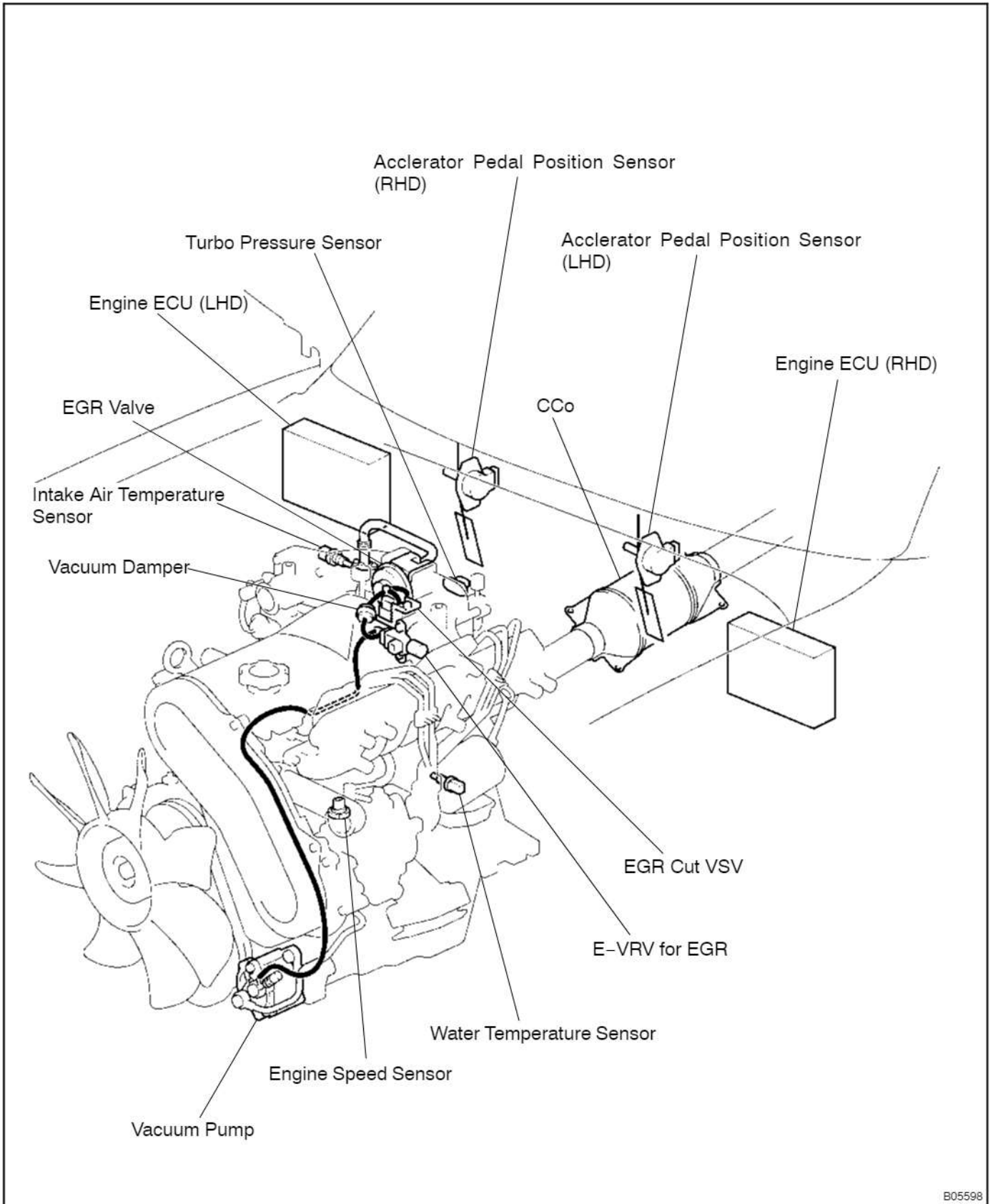

cardiagn.com

# DRAWING

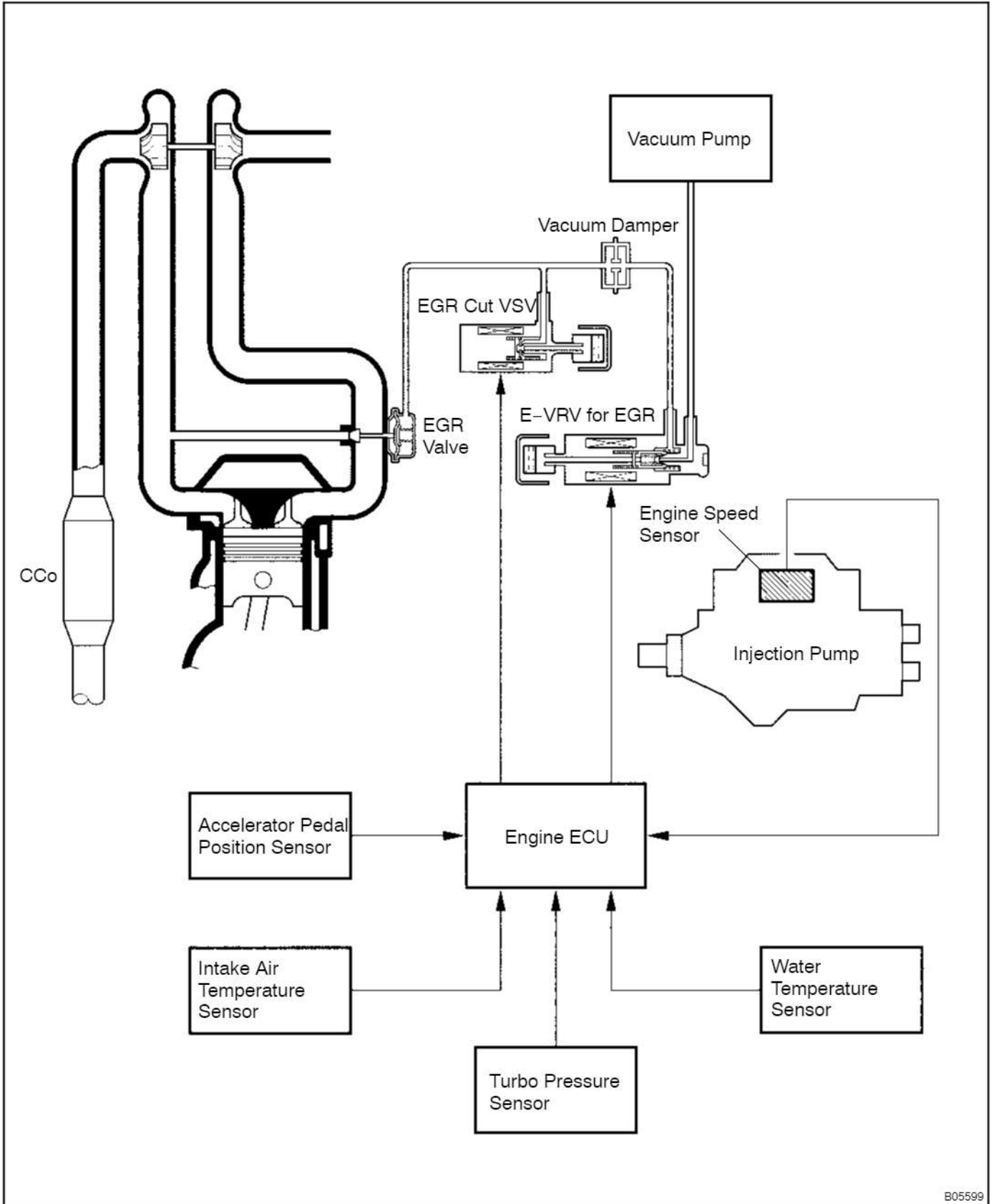

cardiagn.com

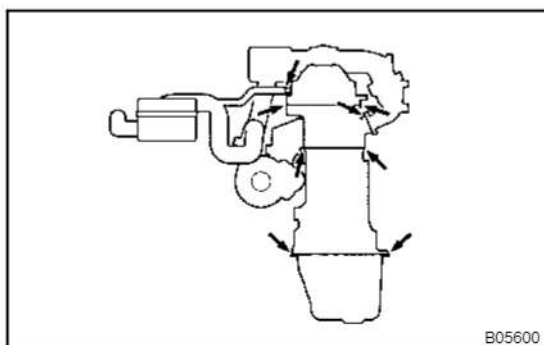

## POSITIVE CRANKCASE VENTILATION (PCV) SYSTEM INSPECTION

EC08C-01

**VISUALLY INSPECT HOSE AND CONNECTION**  
Check for cracks, leaks or damage.

## BOOST ALTITUDE COMPENSATIONAL STOPPER (BACS) SYSTEM (1HD-T) ON-VEHICLE INSPECTION

EC09D-01

### 1. INSPECT EGR SYSTEM (See page EC-6)

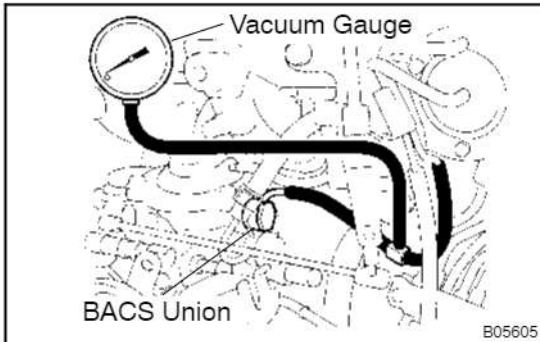

### 2. INSTALL VACUUM GAUGE

Using a 3 way connector, connect a vacuum gauge to the hose between the BACS union and high altitude compensator.

### 3. INSPECT HOT ENGINE CONDITION

- (a) Warm up the engine, the coolant temperature should be above 70°C (104°F).
- (b) When the adjusting lever of the injection pump is quickly pushed to full open, check that the vacuum gauge indicator slowly increases from 0 to 40.0 kPa (300 mmHg, 11.8 in. Hg).

If no problem is found with this inspection, system is normal; Otherwise inspect each port.

### 4. REMOVE VACUUM GAUGE

# LOCATION

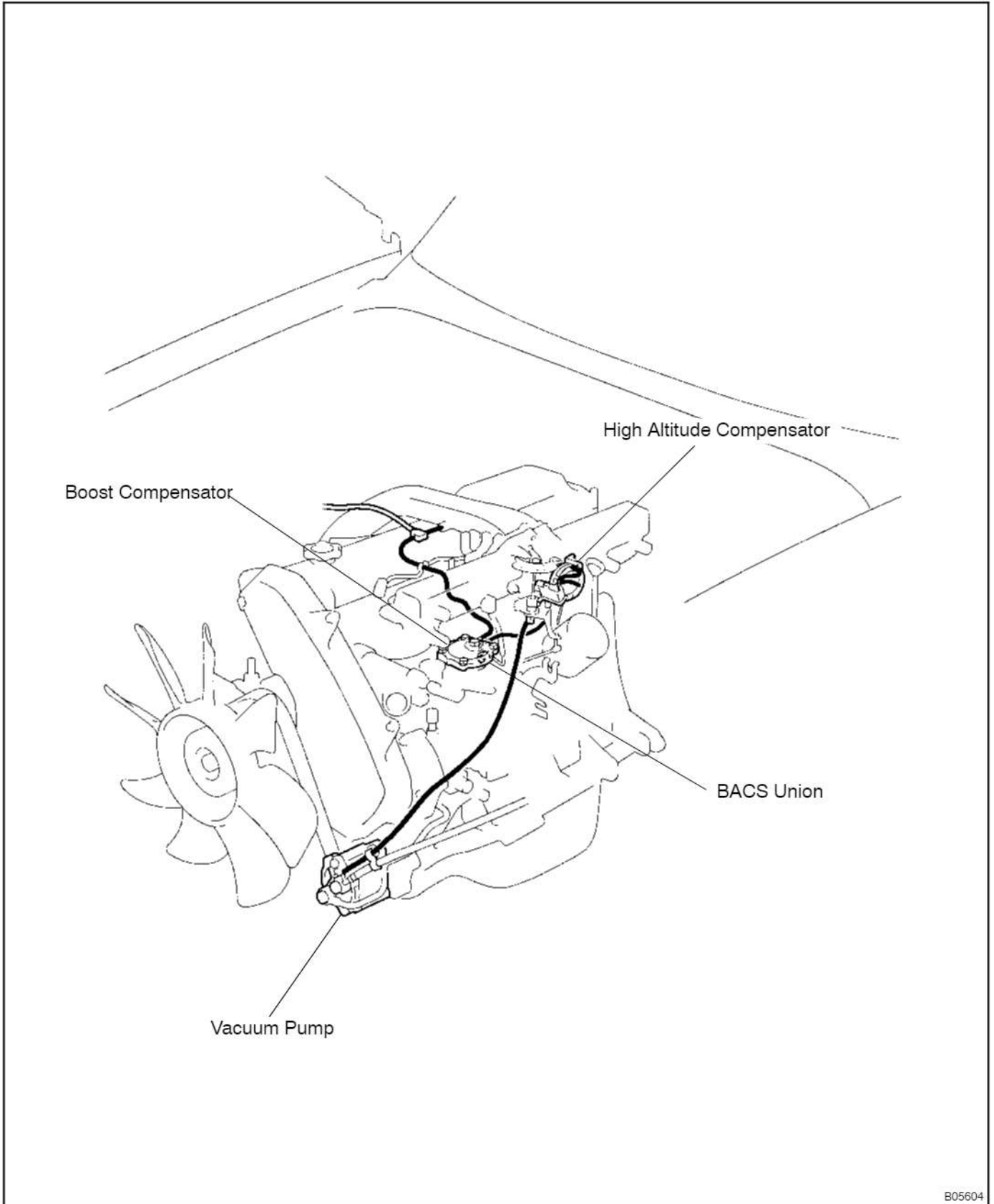

cardiagn.com

## EXHAUST GAS RECIRCULATION (EGR) SYSTEM (Europe) ON-VEHICLE INSPECTION

EC09F-01

### HINT:

In a malfunction where the EGR system is always on, black smoke or white smoke may be output from the exhaust pipe. If this occurs, inspect the EGR system also.

### NOTICE:

**Always stop the engine when installing or removing the vacuum gauges, or removing the vacuum hoses.**

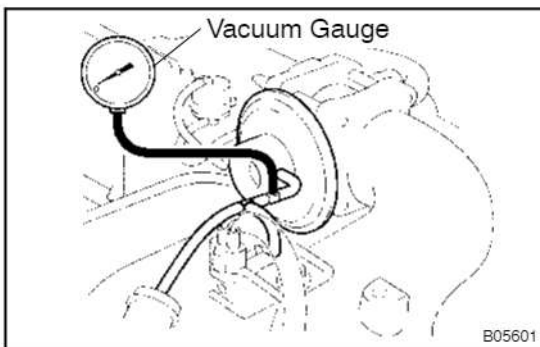

### 1. INSTALL VACUUM GAUGE

Using a 3 way connector, connect a vacuum gauge to the hose between the EGR valve and E-VRV.

### 2. INSPECT SEATING OF EGR VALVE

Start the engine and check that the engine starts and run at idle.

### 3. INSPECT COLD ENGINE CONDITION

- (a) The coolant temperature should be below 20°C (64°F).
- (b) Check that the vacuum gauge indicates 0 at idle.

### 4. INSPECT HOT ENGINE CONDITION

- (a) Warm up the engine, the coolant temperature should be above 70°C (104°F) and below 96°C (205°F).
- (b) Check that the vacuum gauge indicates about more than 28.0 kPa (210 mmHg, 8.3 in.Hg) at idle.
- (c) Check that the vacuum gauge indicator increases about more than 28.0 kPa (210 mm Hg, 8.3 in.Hg) at 1,500 rpm.
- (d) When the accelerator pedal is quickly depress to the full open, check that the vacuum gauge indicator drops momentarily.
- (e) Keep the engine speed at more than 4,000 rpm.
- (f) Check that the vacuum gauge indicates 0.
- (g) When the accelerator pedal is released, check that the vacuum gauge indicator drops momentarily while the engine speed decreases from more than 4,000 rpm to idle.

### 5. REMOVE VACUUM GAUGE

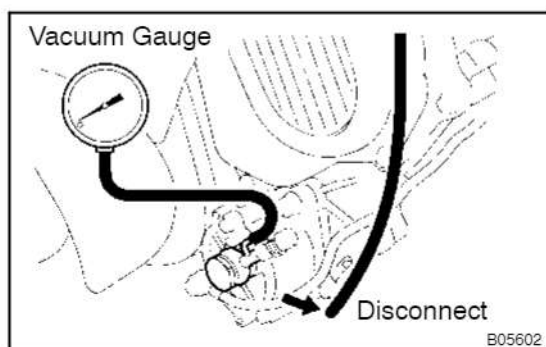

**6. CHECK OUTPUT VACUUM WITH VACUUM GAUGE**

- (a) Connect a vacuum gauge to the output pipe.
- (b) Warm up the engine and check that the vacuum gauge indicates above 86.7 kPa (650 mmHg, 25.59 in.Hg).

If a problem is found, repair the vacuum pump.



# COMPONENTS

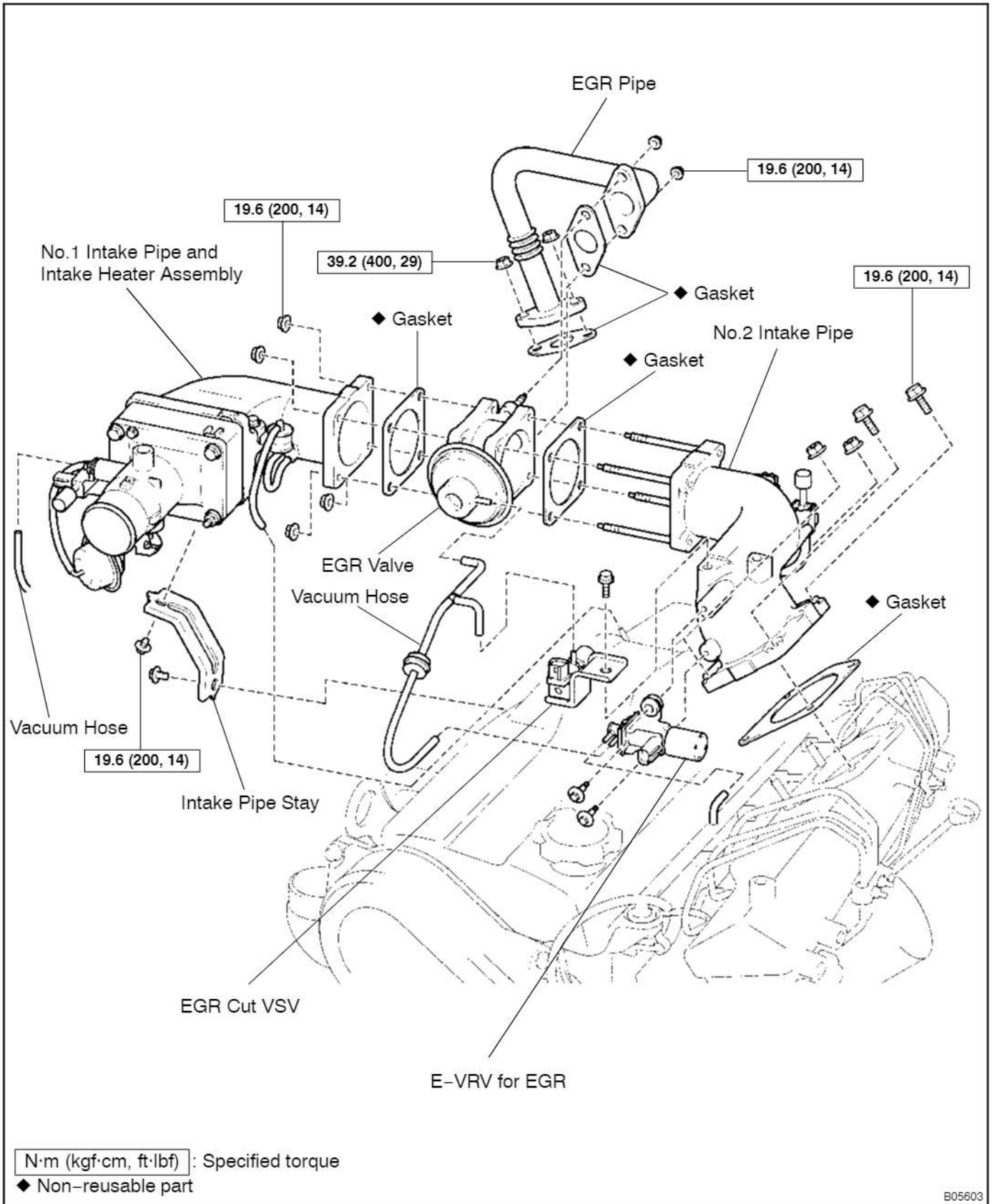

cardiagn.com

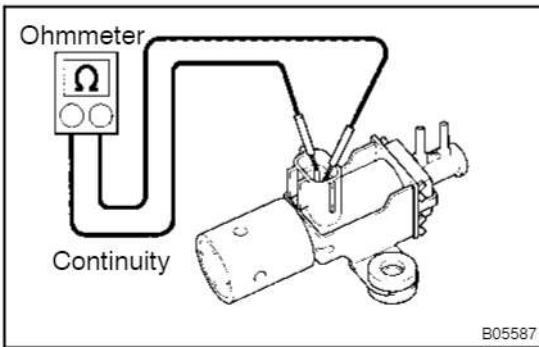

## INSPECTION

### 1. INSPECT E-VRV FOR OPEN CIRCUIT

Using an ohmmeter, measure the resistance between terminals as shown.

**Resistance: 11 – 13  $\Omega$  at 20°C (68°F)**

If the resistance is not specified, replace the E-VRV.

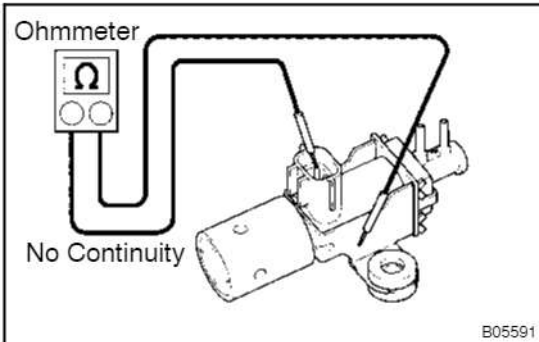

### 2. INSPECT E-VRV FOR GROUND

Using an ohmmeter, check that there is no continuity between terminals and E-VRV body.

If there is continuity, replace the E-VRV.

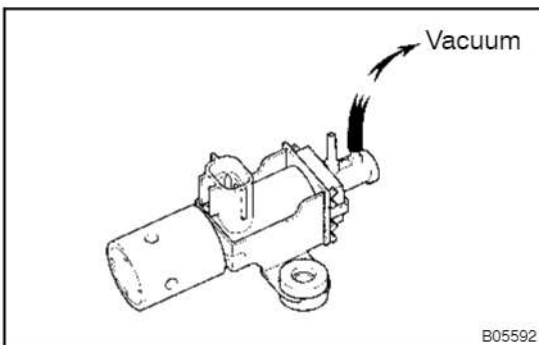

### 3. INSPECT E-VRV FOR AIR TIGHTNESS

Check that when vacuum is applied to the vacuum outlet port shown, the needle of vacuum pump indicates an increase of 66.7 kPa (500 mmHg, 19.7 in. Hg) or more.

If a problem is found, replace the E-VRV

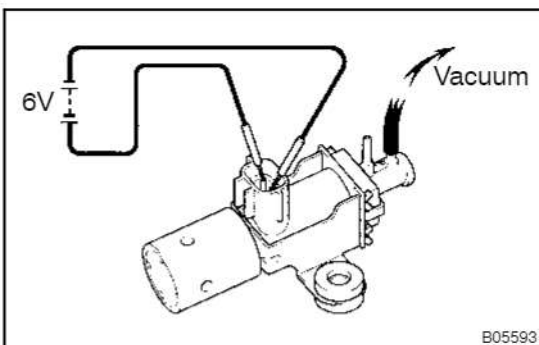

### 4. INSPECT E-VRV OPERATION

- Apply about 6 V of DC power to the terminals.
- Check that when vacuum is applied to the vacuum outlet port shown, the need does not move.

If operation is not as specified, replace the E-VRV.

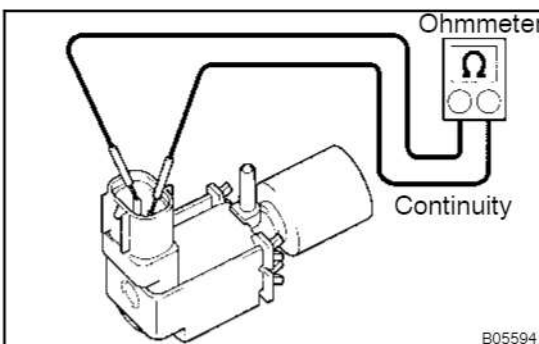

### 5. INSPECT VSV FOR OPEN CIRCUIT

Using an ohmmeter, check that there is continuity between terminals.

**Resistance: 37 – 44  $\Omega$  at 20°C (68°F)**

If there is no continuity, replace the VSV

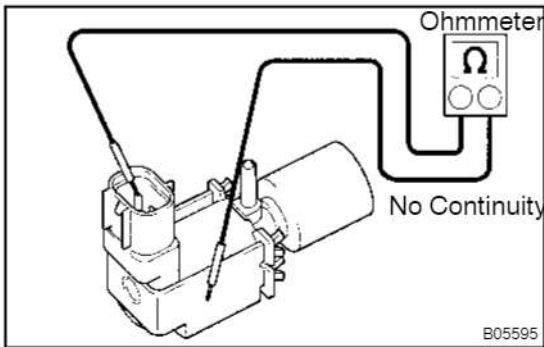

**6. INSPECT VSV FOR GROUND**

Using an ohmmeter, check that there is no continuity between terminals and body.  
If there is continuity, replace the VSV.

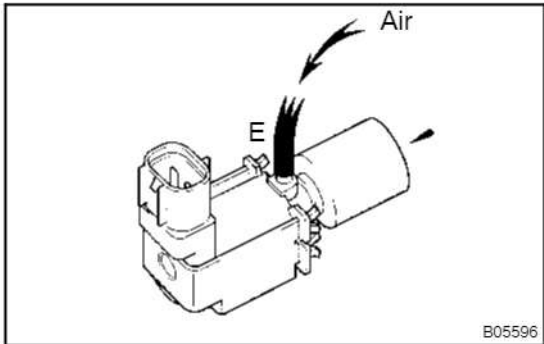

**7. INSPECT VSV OPERATION**

(a) Check that air does not flows from port E to the filter.

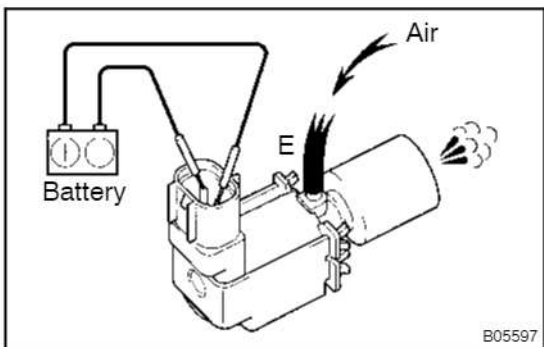

(b) Apply battery voltage across the terminals.

(c) Check that air flows from ports E to filter.

If operation is not as specified, replace the VSV.

**8. INSPECT EGR VALVE**

(a) Remove the EGR valve.

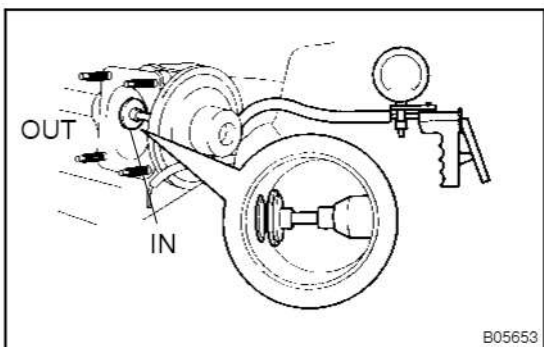

(b) Under the condition of applying the vacuum to the diaphragm chamber, check if there is ventilation between IN and OUT.

**Standard:**

**Less than 13 kPa (100 mmHg, 3.8 in. Hg)**

**No ventilation**

**More than 27 kPa (200 mmHg, 8.0 in. Hg)**

**With ventilation**

(c) When applying more than 67 kPa (500 mmHg, 19 in. Hg) of the vacuum, check if there is any leakage of the vacuum.

(d) Check the valve for sticking and heavy carbon deposits. If a problem is found, replace it.

(e) Reinstall the EGR valve with the new gasket.

**9. INSPECT ACCELERATOR PEDAL POSITION SENSOR (See page DI-27, DI-34 and DI-39)**

**10. INSPECT ENGINE SPEED SENSOR (See page FU-113)**

**11. INSPECT INTAKE AIR TEMPERATURE SENSOR (See page ED-7)**

12. INSPECT WATER TEMPERATURE SENSOR  
(See page ED-5)
13. INSPECT TURBO PRESSURE SENSOR  
(See page TC-17)

# CATALYTIC CONVERTER FOR OXIDATION (CCo) SYSTEM (Europe)

EC09I-01

## ON-VEHICLE INSPECTION

### 1. INSPECT EXHAUST PIPE ASSEMBLY

- (a) Check the connections for looseness or damage.
- (b) Check the clamps for weakness, cracks or damage.

### 2. INSPECT CCo

Check for dents or damage.

If any part of the protector is damaged or dented to the extent that it contacts the CCo, repair or replace it.

# COMPONENTS

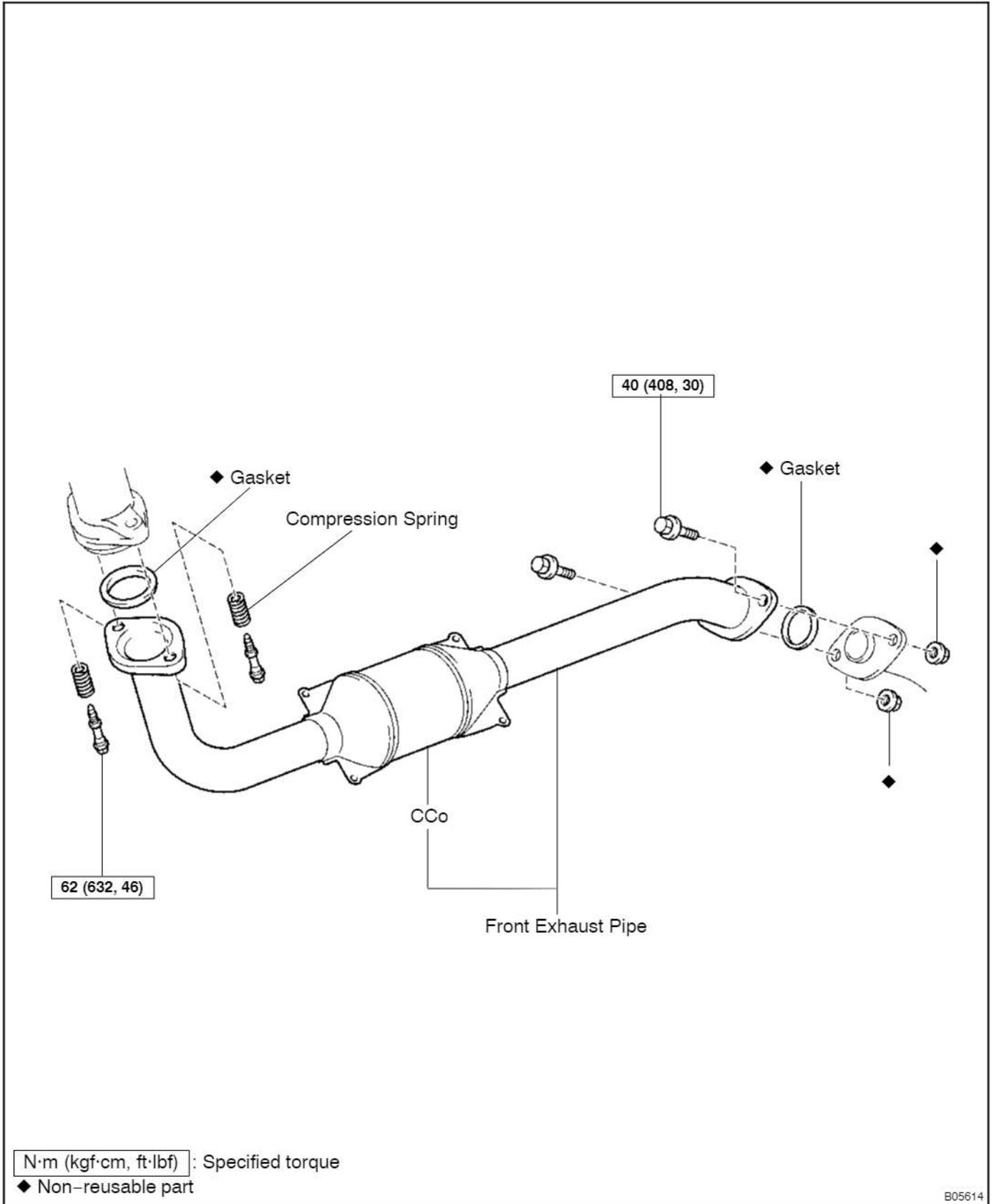

## ECD SYSTEM PRECAUTION

ED001-02

### 1. BEFORE WORKING ON FUEL SYSTEM, DISCONNECT NEGATIVE (-) TERMINAL CABLE FROM BATTERY

#### HINT:

- Any DTC code retained by the computer will be erased when the negative (-) terminal cable is removed from the battery.
- Therefore, if necessary, read the diagnosis before removing the negative (-) terminal cable from the battery.

### 2. DO NOT SMOKE OR WORK NEAR AN OPEN FLAME WHEN WORKING ON FUEL SYSTEM

### 3. KEEP DIESEL FUEL AWAY FROM RUBBER OR LEATHER PARTS

### 4. AIR INDUCTION SYSTEM

- (a) Separation of the engine oil dipstick, oil filler cap, PCV hose, etc. may cause the engine to run out of tune.
- (b) Disconnection, looseness or cracks in the parts of the air induction system between the throttle body and cylinder head will allow air suction and cause the engine to run out of tune.

### 5. ELECTRONIC CONTROL SYSTEM

- (a) Before removing ECD wiring connectors, terminals, etc., first disconnect the power by either turning the ignition switch OFF or disconnecting the negative (-) terminal cable from the battery.

#### HINT:

Always check the DTC before disconnecting the negative (-) terminal cable from the battery.

- (b) When installing the battery, be especially careful not to incorrectly connect the positive (+) and negative (-) cables.
- (c) Do not permit parts to receive a severe impact during removal or installation. Handle all ECD parts carefully, especially the engine ECU.
- (d) Do not be careless during troubleshooting as there are numerous transistor circuits and even slight terminal contact can further troubles.
- (e) Do not open the engine ECU cover.
- (f) When inspecting during rainy weather, take care to prevent entry of water. Also, when washing the engine compartment, prevent water from getting on the ECD parts and wiring connectors.
- (g) Parts should be replaced as an assembly.

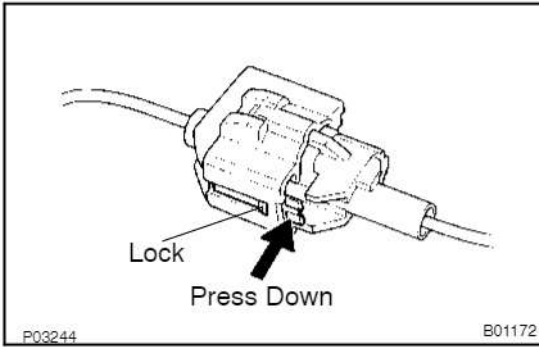

(h) Care is required when pulling out and inserting wiring connectors.

- (1) Release the lock and pull out the connector, pulling on the connectors.

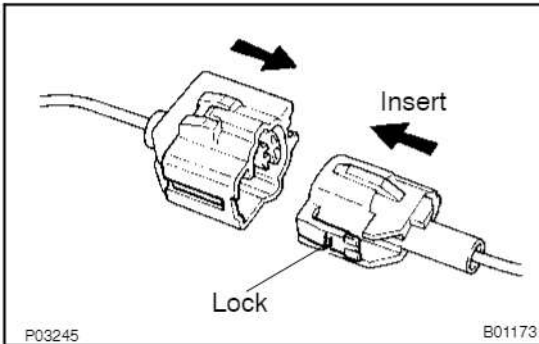

(i) Fully insert the connector and check that it locked. When inspecting a connector with a volt/ohmmeter.

- (1) Carefully take out the water-proofing rubber if it is a water-proof type connector.
- (2) Insert the test probe in to the connector from the wiring side when checking the continuity, amperage or voltage.
- (3) Do not apply unnecessary force to the terminal.
- (4) After checking, install the water-proofing rubber on the connector securely.



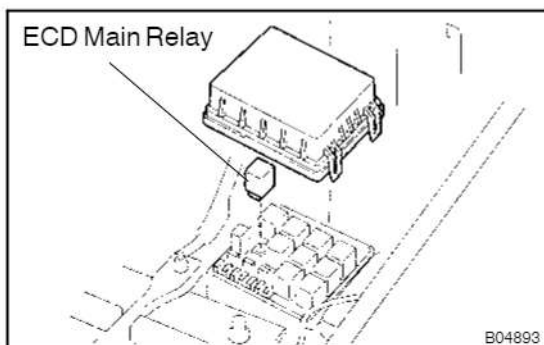

## ECD MAIN RELAY INSPECTION

ED00J-02

1. REMOVE RELAY BOX COVER
2. REMOVE ECD MAIN RELAY (Marking: ECD)

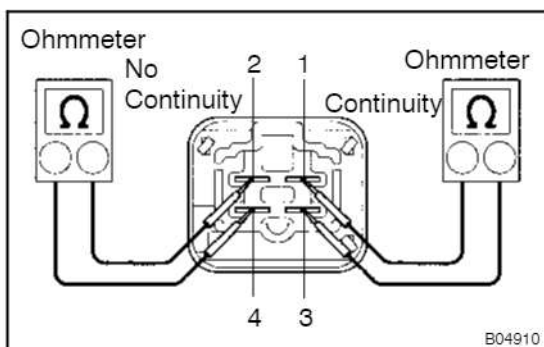

### 3. INSPECT ECD MAIN RELAY

- (a) Inspect the relay continuity.
  - (1) Using an ohmmeter, check that there is continuity between terminals 1 and 3.

If there is no continuity, replace the relay.

- (2) Check that there is no continuity between terminals 2 and 4.

If there is continuity, replace the relay.

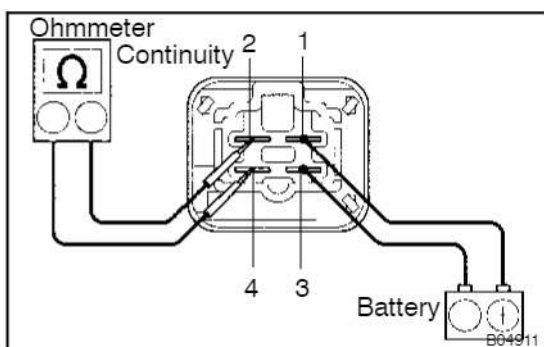

- (b) Inspect the relay operation.

- (1) Apply battery positive voltage across terminals 1 and 3.
- (2) Using an ohmmeter, check that there is continuity between terminals 2 and 4.

If there is no continuity, replace the relay.

4. REINSTALL ECD MAIN RELAY
5. REINSTALL RELAY BOX COVER

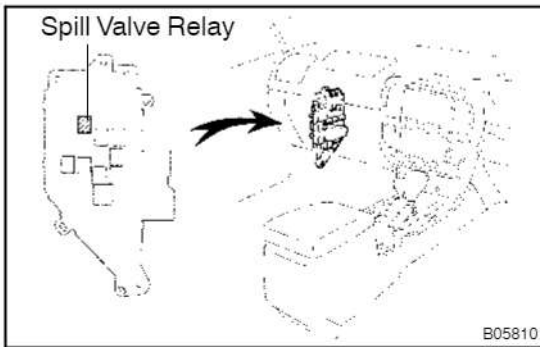

## SPILL VALVE RELAY INSPECTION

ED021-01

1. REMOVE LH COWL SIDE R/B
2. REMOVE SPILL VALVE RELAY

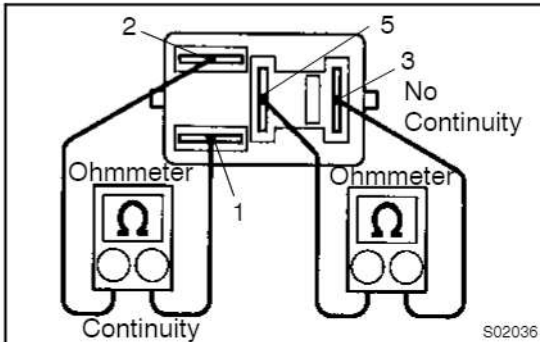

### 3. INSPECT SPILL VALVE RELAY CONTINUITY

- (a) Using an ohmmeter, check that there is continuity between terminals 1 and 2.

If there is no continuity, replace the relay.

- (b) Check that there is no continuity between terminals 3 and 5.

If there is continuity, replace the relay.

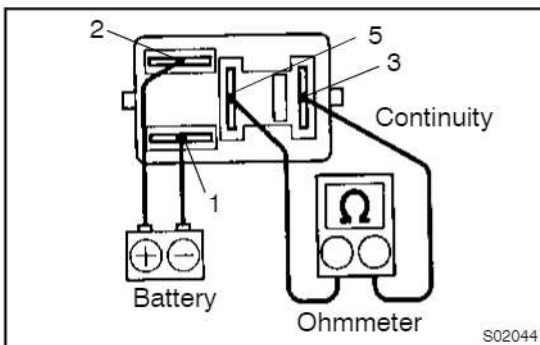

### 4. INSPECT SPILL VALVE RELAY OPERATION

- (a) Apply battery positive voltage across terminals 1 and 2.
- (b) Using an ohmmeter, check that there is continuity between terminals 3 and 5.

If there is no continuity, replace the relay.

5. REINSTALL SPILL VALVE RELAY
6. REINSTALL LH COWL SIDE R/B

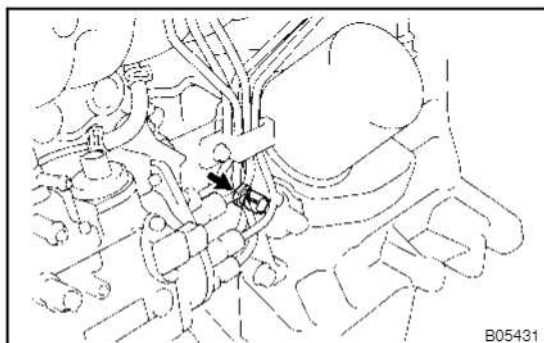

## WATER TEMPERATURE SENSOR INSPECTION

ED00M-02

1. **DRAIN ENGINE COOLANT**
2. **REMOVE WATER TEMPERATURE SENSOR**
  - (a) Disconnect the sensor connector.
  - (b) Using a 19 mm deep socket wrench, remove the sensor and gasket.

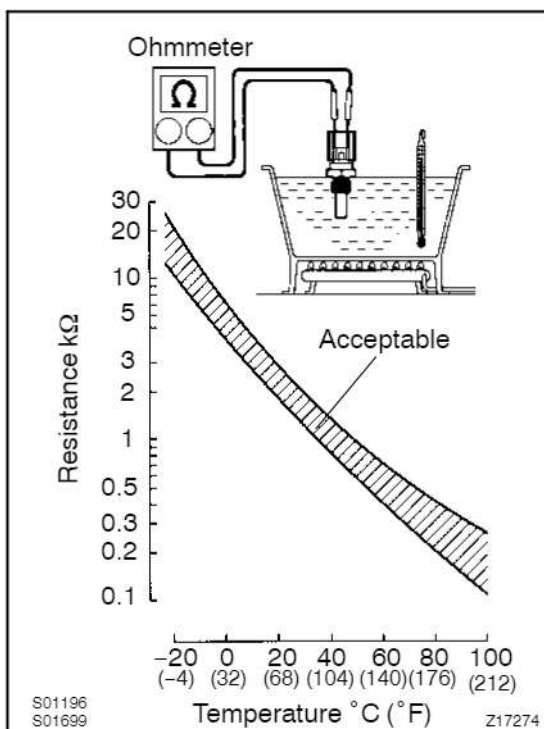

### 3. INSPECT WATER TEMPERATURE SENSOR

Using an ohmmeter, measure the resistance between the terminals.

#### Resistance: Refer to the chart graph

If the resistance is not as specified, replace the water temperature sensor.

### 4. REINSTALL WATER TEMPERATURE SENSOR

- (a) Using a 19 mm deep socket wrench, install a new gasket and the sensor.

**Torque: 20.4 N·m (200 kgf·cm, 15 ft·lbf)**

- (b) Connect the sensor connector.

### 5. REINSTALL WITH ENGINE COOLANT

(See page CO-2)

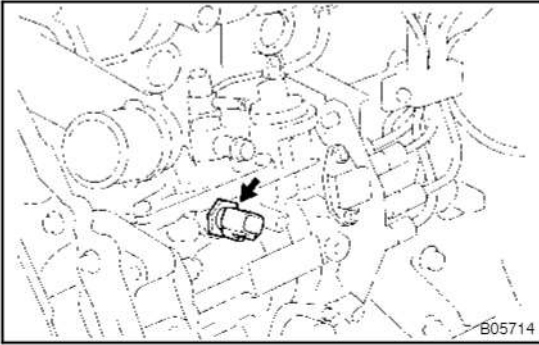

## FUEL TEMPERATURE SENSOR INSPECTION

ED00N-02

### 1. REMOVE FUEL TEMPERATURE SENSOR

- (a) Disconnect the sensor connector.
- (b) Using a 19 mm deep socket wrench, remove the sensor and gasket.

### 2. INSPECT FUEL TEMPERATURE SENSOR

(See page ED-5)

### 3. REINSTALL FUEL TEMPERATURE SENSOR

- (a) Using a 19 mm deep socket wrench, install a new gasket and the sensor.

**Torque: 21.6 N·m (220 kgf·cm, 16.5 ft·lbf)**

- (b) Connect the sensor connector.

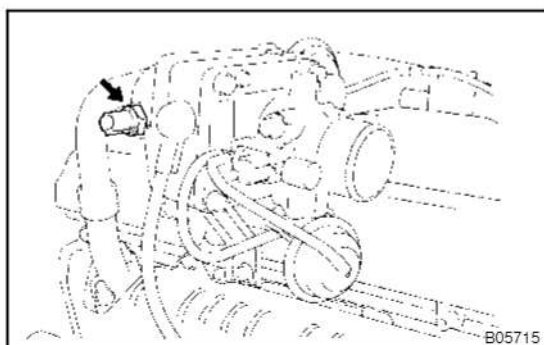

## INTAKE AIR TEMPERATURE SENSOR INSPECTION

ED000-02

1. **REMOVE INTAKE AIR TEMPERATURE SENSOR**
  - (a) Disconnect the sensor connector.
  - (b) Using a 22 mm deep socket wrench, remove the intake air temperature sensor.
2. **INSPECT INTAKE AIR TEMPERATURE SENSOR**  
(See page ED-5)
3. **REINSTALL INTAKE AIR TEMPERATURE SENSOR**
  - (a) Using a 21 mm deep socket wrench, install a new gasket and the sensor.  
**Torque: 29 N·m (300 kgf·cm, 21 ft·lbf)**
  - (b) Connect the sensor connector.

## CRANKSHAFT POSITION SENSOR INSPECTION

ED00P-02

### NOTICE:

"Cold" and "Hot" in the following sentences express the temperature of the sensors themselves. "Cold" is from  $-10^{\circ}\text{C}$  ( $14^{\circ}\text{F}$ ) to  $50^{\circ}\text{C}$  ( $122^{\circ}\text{F}$ ) and "Hot" is from  $50^{\circ}\text{C}$  ( $122^{\circ}\text{F}$ ) to  $100^{\circ}\text{C}$  ( $212^{\circ}\text{F}$ ).

### 1. DISCONNECT CRANKSHAFT POSITION SENSOR CONNECTOR

### 2. INSPECT CRANKSHAFT POSITION SENSOR

Using an ohmmeter, measure the resistance between terminals.

#### Resistance:

Cold	19 - 32 $\Omega$
Hot	24 - 37 $\Omega$

If the resistance is not as specified, replace the crankshaft position sensor.

### NOTICE:

**Be careful not drop and shock the sensor.**

### HINT:

Apply engine oil to the O-ring.

**Torque: 5 N·m, (50 kgf·cm, 44 in·lbf)**

### 3. RECONNECT CRANKSHAFT POSITION SENSOR

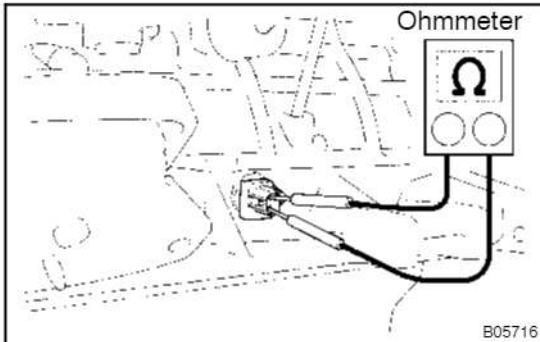

# ACCEL PEDAL COMPONENTS

ED000-02

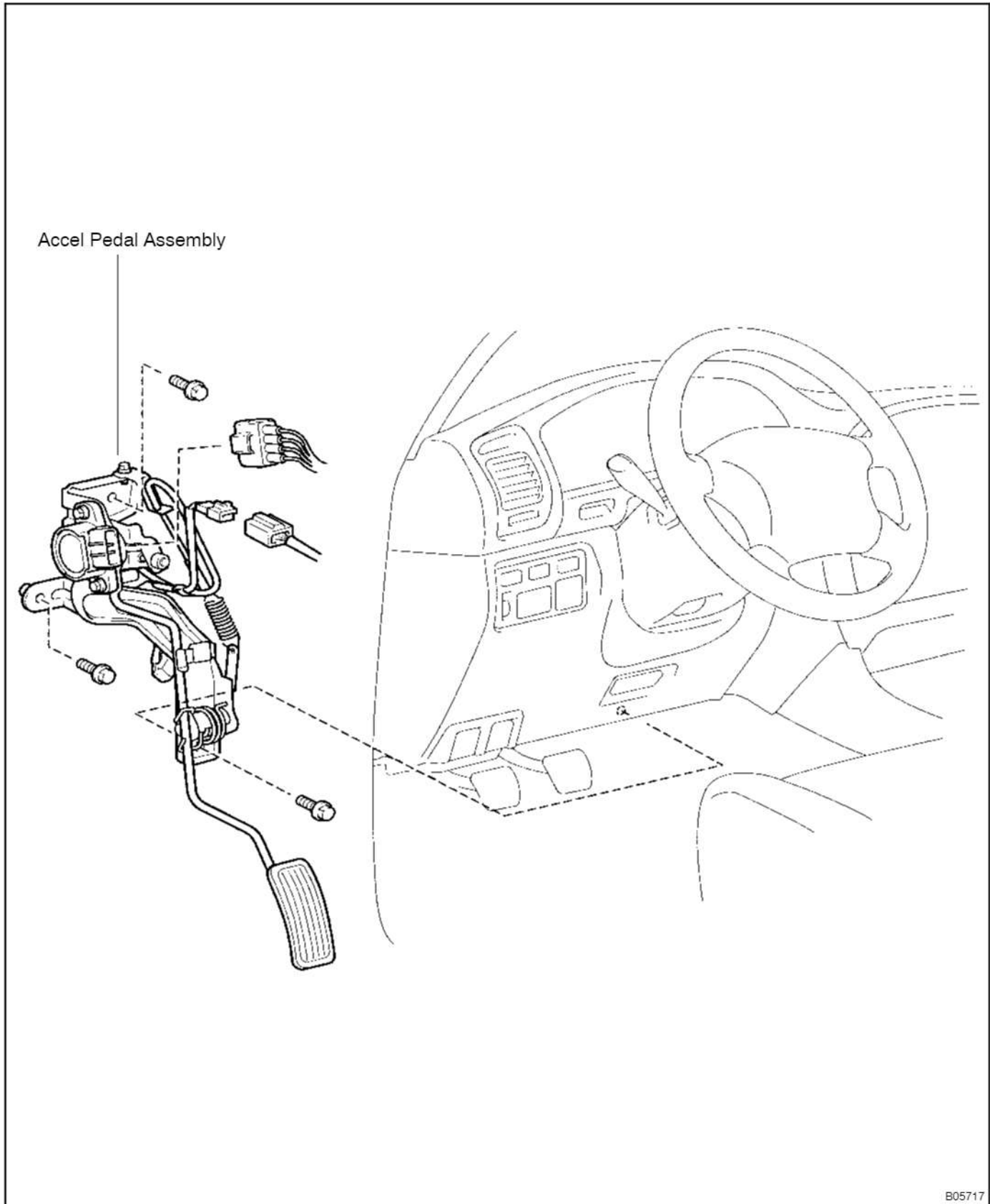

cardiagn.com

B05717



## REMOVAL

### REMOVE ACCELERATOR PEDAL ASSEMBLY

- (a) Disconnect the 2 connectors.
- (b) Remove 3 bolts and accelerator pedal assembly.





## INSTALLATION

### INSTALL ACCELERATOR PEDAL ASSEMBLY

- (a) Install the accelerator pedal assembly with the 3 bolts.
- (b) Connect the 2 connectors.

## SHIFT POSITION SWITCH (M/T) ON-VEHICLE INSPECTION

ED022-01

### INSPECT SHIFT POSITION SWITCH CONTINUITY

- (a) Disconnect the switch connector.

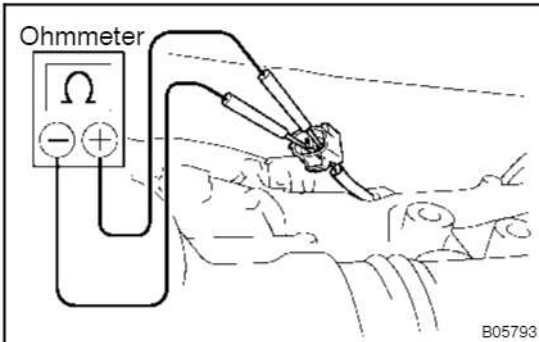

- (b) Using an ohmmeter, check the switch continuity.

#### Continuity:

Transmission position	Specified continuity
1	Continuity
Others	No continuity

If continuity is not as specified, replace the shift position switch.

- (c) Reconnect the switch connector.

## REMOVAL

### 1. REMOVE TRANSMISSION

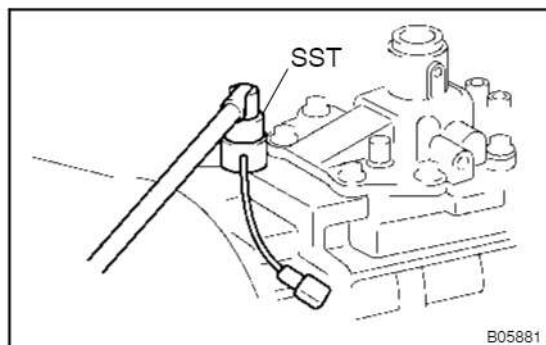

### 2. REMOVE SHIFT POSITION SWITCH

- (a) Using SST, remove the shift position switch.  
SST 09817-16011
- (b) Remove the gasket from the shift position switch.

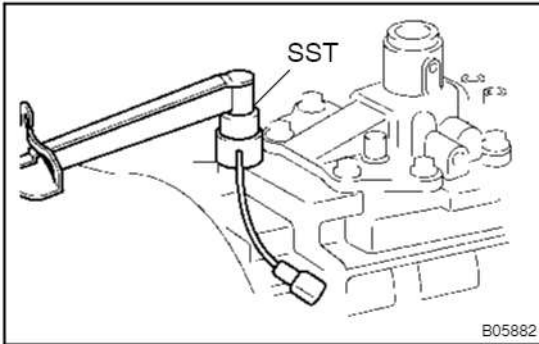

## INSTALLATION

### 1. INSTALL SHIFT POSITION SWITCH

- (a) Install a new gasket to the shift position switch.
- (b) Using SST, install the shift position switch.

**Torque: 44.1 N·m (450 kgf·cm, 33 ft·lbf)**

SST 09817-16011

### 2. INSTAL TRANSMISSION

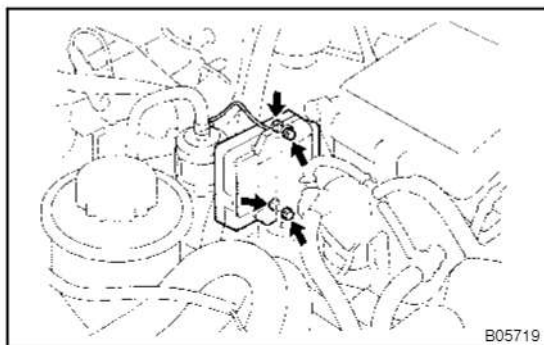

## ELECTRONIC DRIVING UNIT (EDU) INSPECTION

ED025-01

### 1. REMOVE EDU

- (a) Disconnect the connector.
- (b) Remove the 2 bolts, 2 nuts, and EDU.
- (c) Disconnect the ground wire.

### 2. INSPECT EDU (See page DI-71)

### 3. INSTALL EDU

- (a) Install the EDU and ground wire with the 2 bolts and 2 nuts.
- (b) Connect the connector.

# ENGINE ECU COMPONENTS

SF000-04

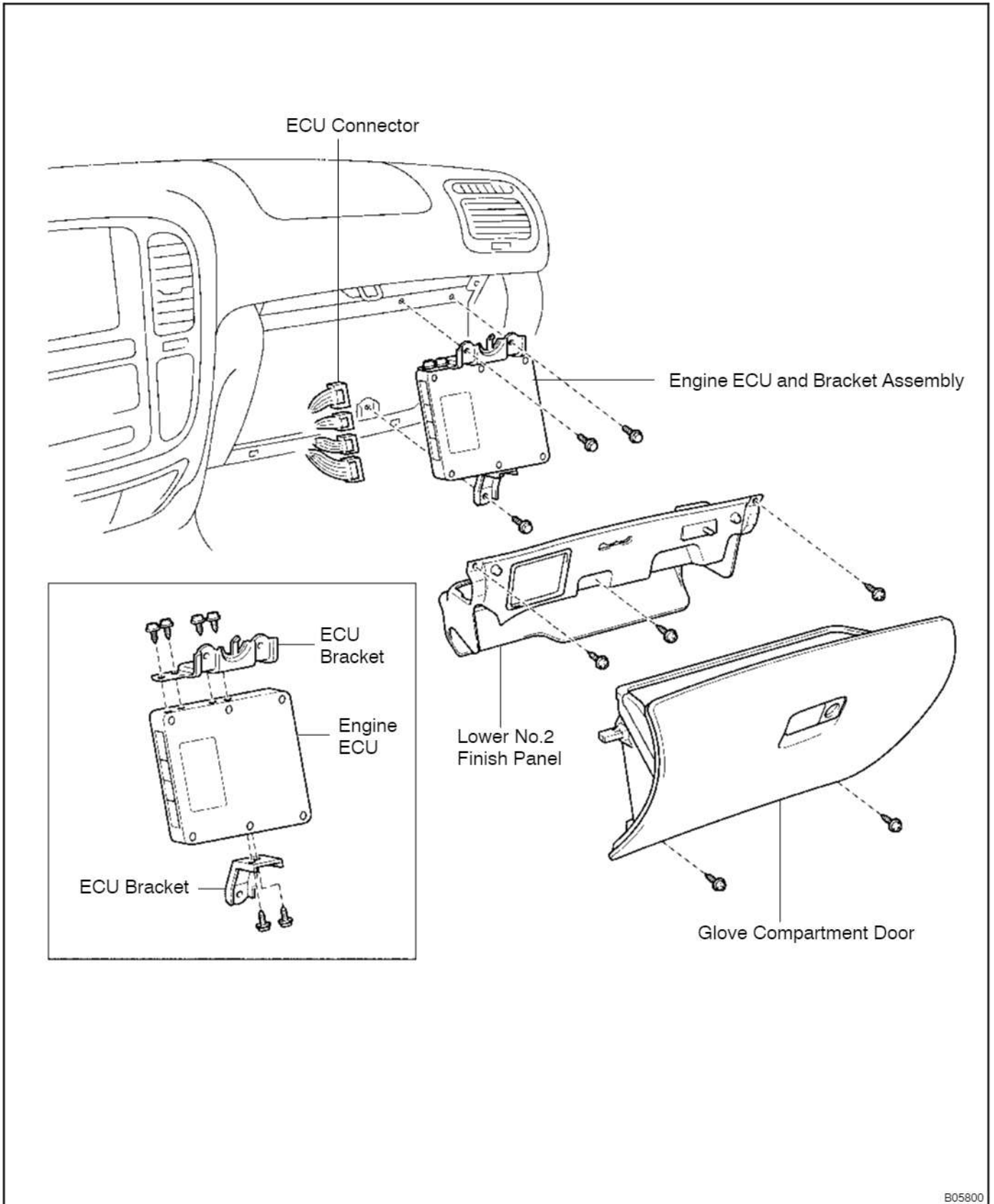

cardiagn.com

B05800

## INSPECTION

### HINT:

The ECD circuit can be checked by measuring the resistance and voltage at the wiring connectors of the engine ECU.

1. REMOVE ENGINE ECU FROM VEHICLE BODY
2. INSPECT VOLTAGE OF ENGINE ECU  
(See page DI-17)
3. INSPECT RESISTANCE OF ECD CIRCUITRY

Terminals	Condition	STD resistance ( $\Omega$ )
THA - E2	Intake air temp. 20°C (68°F)	2.0 - 3.0 k
THF - E2	Fuel temp. 20°C (68°F)	2.0 - 3.0 k
THW - E2	Coolant temp. 80°C (176°F)	0.2 - 0.4 k
TDC+ - TDC-	Cold (-10°C (14°F) to 50°C (122°F))	19 - 32
TDC+ - TDC-	Hot (50°C (122°F) to 100°C (212°F))	24 - 37
NE+ - NE-	-	205 - 255
TCV - +B	-	10 - 16
EGR - +B	-	11 - 18
EGRC - +B	25°C (77°F)	30 - 40
S/TH - +B	25°C (77°F)	30 - 40
PA - +B	25°C (77°F)	30 - 40
SVR - +B	-	60 - 80
IREL - E01	-	4 - 8
MREL - E01	-	60 - 80

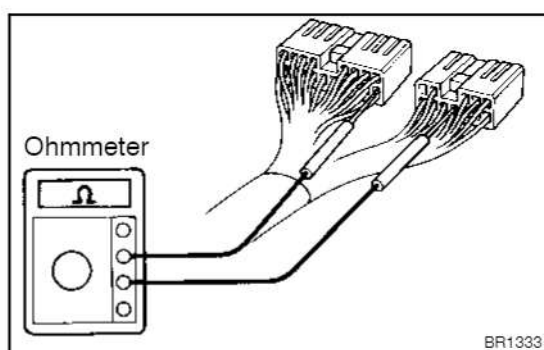

- (a) Turn the ignition switch OFF.
- (b) Disconnect the 4 connectors from the engine ECU.
- (c) Measure the resistance between each terminal of the wiring connectors.

### NOTICE:

- Do not touch the engine ECU terminals.
- The tester probe should be inserted in the wiring connector from the wiring side

## FUEL FILTER REPLACEMENT

FU04W-01

1. **DISCONNECT FUEL FILTER WARNING SWITCH CONNECTOR**
2. **DRAIN FUEL FROM FUEL FILTER**
  - (a) Install a vinyl hose to the drain cock, and insert the other end of the vinyl hose in a container.
  - (b) Loosen the drain plug, and drain the fuel.

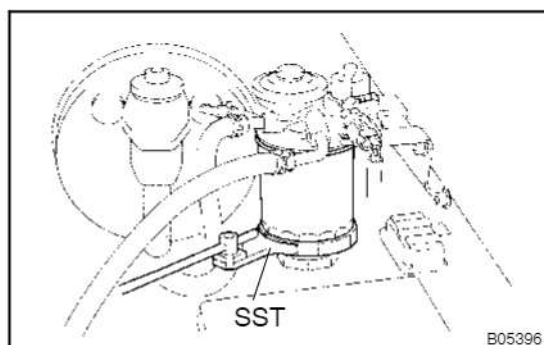

3. **REPLACE FUEL FILTER**
  - (a) Remove the fuel filter.  
Using SST, remove the fuel filter.  
SST 09228-64040

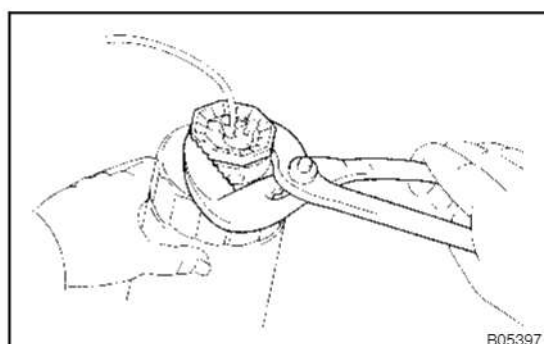

- (b) Remove the fuel filter warning switch from the fuel filter.  
Using pliers, remove the warning switch and O-ring.

### NOTICE:

**Be careful not to damage the warning switch.**

- (c) Install the fuel filter warning switch to new fuel filter.
  - (1) Install a new O-ring to the warning switch.
  - (2) Apply fuel to the O-ring of the warning switch.
  - (3) Install the warning switch to a new fuel filter by hand.
- (d) Install a new fuel filter.
  - (1) Check and clean the fuel filter installation surface.
  - (2) Apply fuel to the gasket of a new fuel filter.
  - (3) Lightly screw the fuel filter into place, and tighten it until the gasket comes into contact with the seat.
  - (4) Tighten it additional 3/4 turn by hand.

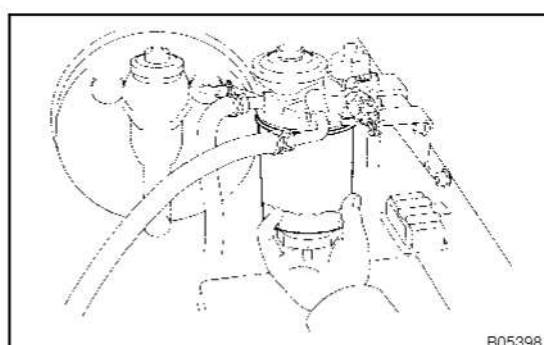

4. **REPLACE FUEL PREFILTER**
  - (a) Remove the fuel prefilter assembly.
    - (1) Disconnect the 2 fuel hoses.
    - (2) Remove the 2 nuts and fuel prefilter assembly from the bracket.



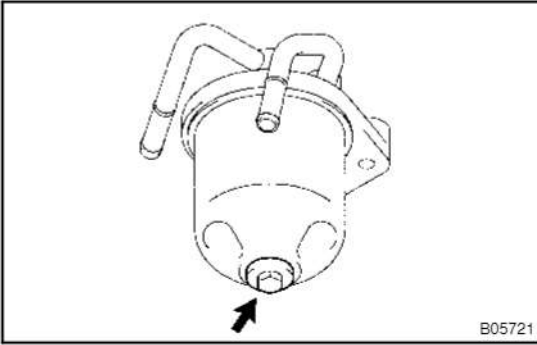

- (b) Remove the fuel prefilter.
  - (1) Remove the bolt and gasket.
  - (2) Remove the upper body from the lower body.
  - (3) Remove the gasket from the upper body.
  - (4) Remove the filter, 2 gaskets, spring plate and spring.
- (c) Install a new prefilter.
  - (1) Install a new gasket to the upper body.
  - (2) Place the spring, spring plate, a new filter, 2 new gaskets and the upper body to the lower body.
  - (3) Install a new gasket and the bolt.

**Torque: 16.7 N·m (170 kgf·cm, 12 ft·lbf)**
- (d) Install the fuel prefilter assembly.
  - (1) Install the fuel prefilter with the 2 nuts.

**Torque: 18 N·m (185 kgf·cm, 13 ft·lbf)**

  - (2) Connect the 2 fuel hoses.

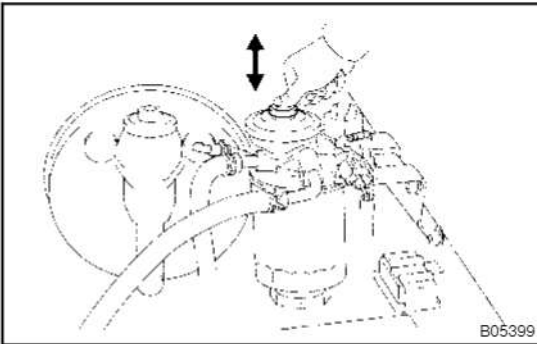

#### 5. FILL FUEL FILTER WITH FUEL

Operate the hand pump until you feel more resistance.

#### 6. CONNECT FUEL FILTER WARNING SWITCH CONNECTOR

#### 7. START ENGINE AND CHECK FOR FUEL LEAKS

## FUEL DAMPER REPLACEMENT

FU04X-01

1. DRAIN FUEL FILTER AND DAMPER  
(See page FU-1)

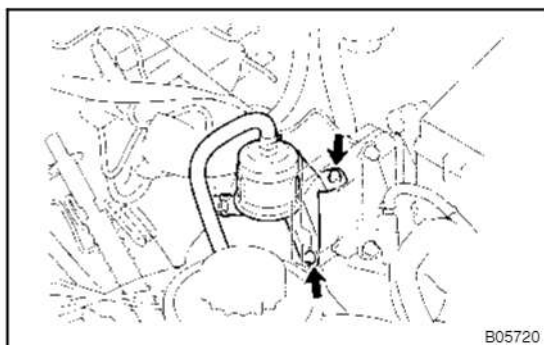

2. REPLACE FUEL DAMPER
  - (a) Remove the fuel damper.
    - (1) Disconnect the 2 fuel hoses.
    - (2) Remove the 2 bolts and fuel damper.
  - (b) Install the fuel damper.
    - (1) Install the fuel damper with the 2 bolts.  
**Torque: 7.5 N·m (80 kgf·cm, 66 in·lbf)**
    - (2) Connect the 2 fuel hoses.
3. FILL FUEL FILTER AND DAMPER WITH FUEL  
(See page FU-1)

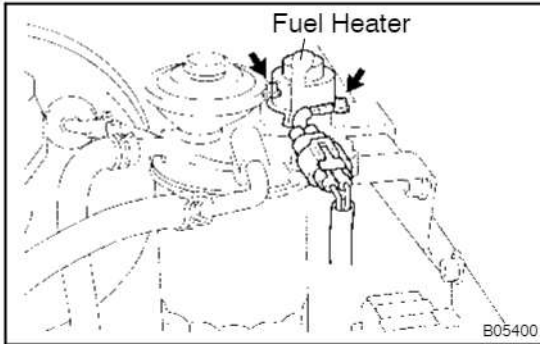

## FUEL HEATER INSPECTION

FU01W-02

### 1. REMOVE FUEL HEATER

- Disconnect the fuel heater connector.
- Remove the screws, cover and fuel heater.
- Remove the O-ring from the fuel heater.

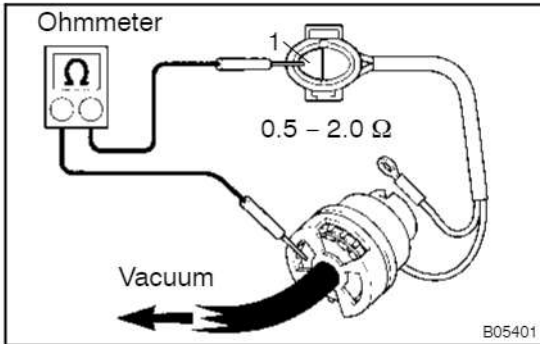

### 2. INSPECT FUEL HEATER

- Apply a vacuum of  $34.7 \pm 5.3$  kPa ( $260 \pm 40$  mmHg,  $10.24 \pm 1.57$  in.Hg) or more to the vacuum switch port.
- Using an ohmmeter, measure the resistance between terminal 1 and the switch body.

**Resistance: 0.5 - 2.0 Ω at 20 °C (68 °F)**

If the resistance is not as specified, replace the fuel heater and vacuum switch assembly.

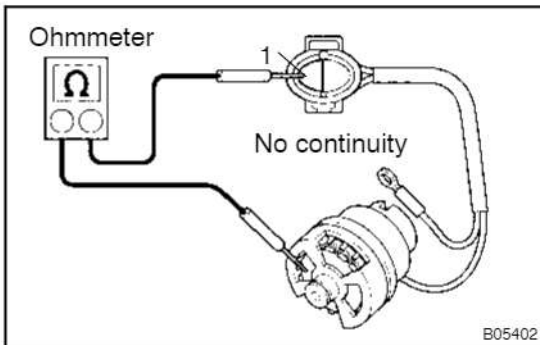

### 3. INSPECT VACUUM SWITCH CONTINUITY

Using an ohmmeter, check that there is no continuity between terminal 1 and the switch body.

If continuity is not as specified, replace the fuel heater and vacuum switch assembly.

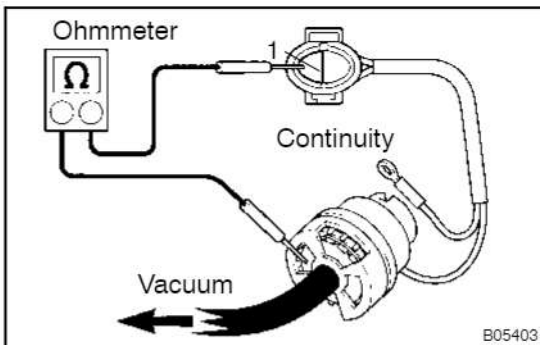

### 4. INSPECT VACUUM SWITCH OPERATION

- Apply a vacuum of  $34.7 \pm 5.3$  kPa ( $260 \pm 40$  mmHg,  $10.24 \pm 1.57$  in.Hg) or more to the vacuum switch port.
- Using an ohmmeter, check that there is continuity between terminal 1 and the switch body.

If operation is not as specified, replace the fuel heater and vacuum switch assembly.

### 5. REINSTALL FUEL HEATER

- Install a new O-ring to the fuel heater.
- Install the fuel heater and cover with the 2 screws.  
**Torque: 1.96 N·m (20 kgf·cm, 17 in·lbf)**
- Connect the fuel heater connector.

# INJECTION NOZZLE (1HZ) COMPONENTS

FU04Y-01

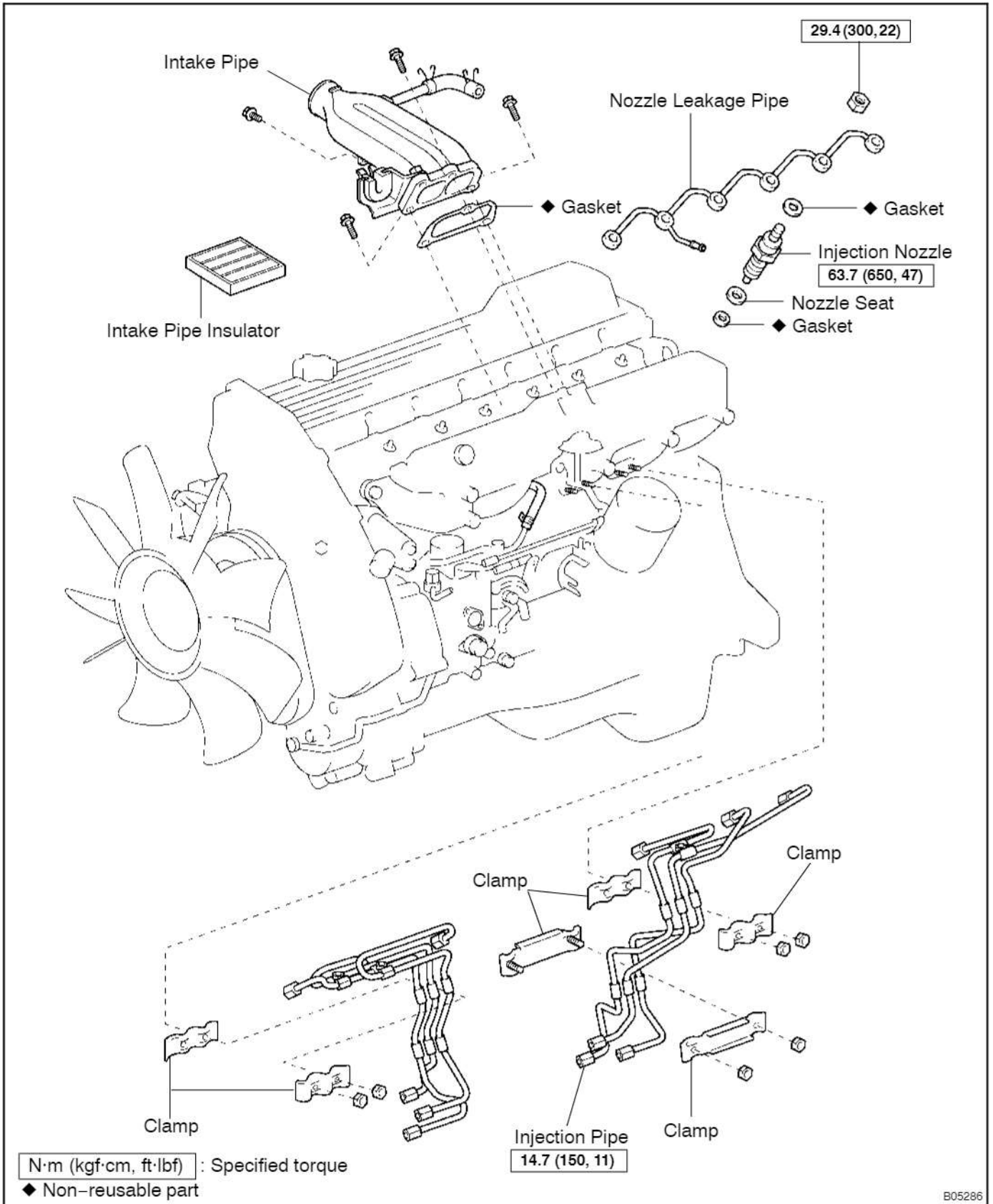

cardiagn.com

B05286

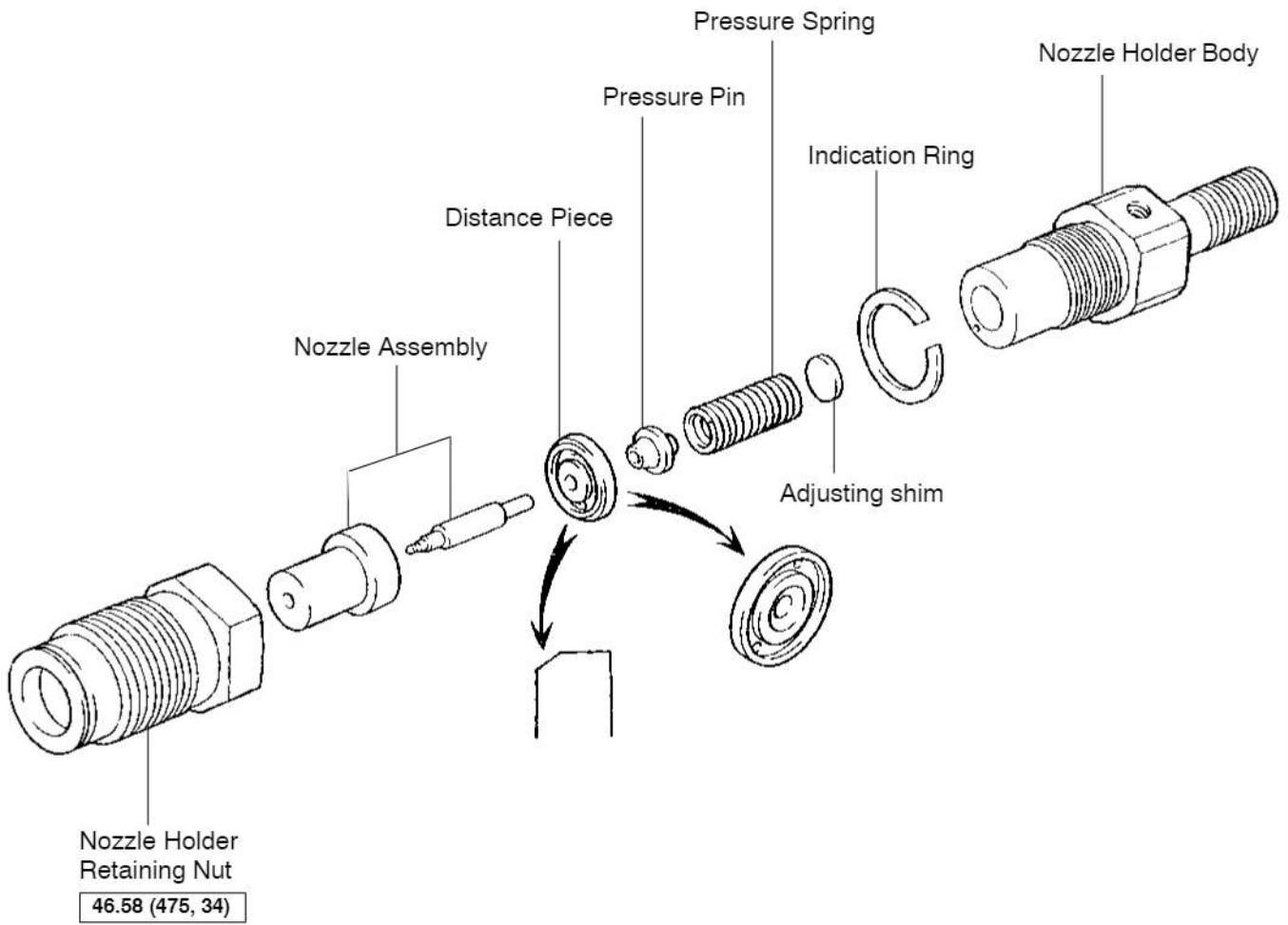

N·m (kgf·cm, ft·lbf) : Specified torque

## REMOVAL

### 1. REMOVE INTAKE PIPE (See page EM-48)

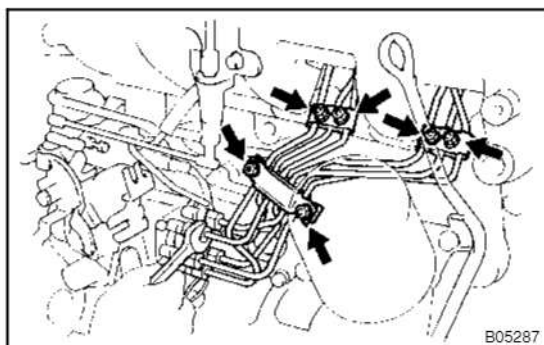

### 2. REMOVE INJECTION PIPES

- (a) Remove the 4 nuts and 2 clamps from the intake manifold.
- (b) Remove the 2 nuts and 2 clamps.
- (c) Loosen the 6 union nuts of the injection pipes from the injection pump.

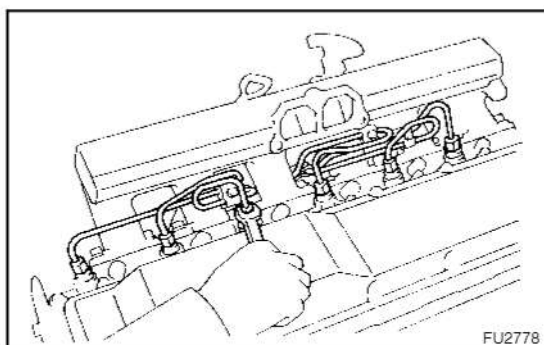

- (d) Loosen the 6 union nuts of the injection pipes from the injection nozzles.
- (e) Remove the 6 injection pipes.
- (f) Remove the 2 injection pipe clamps.

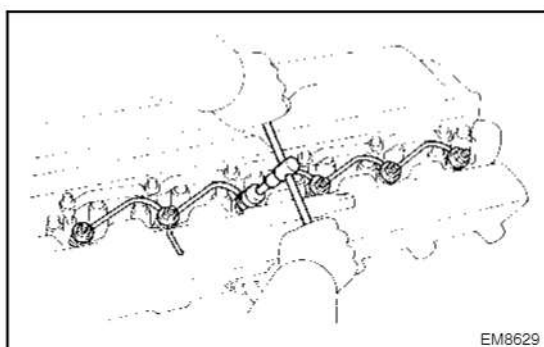

### 3. REMOVE NOZZLE LEAKAGE PIPE

- (a) Disconnect the fuel return hose from the nozzle leakage pipe.
- (b) Remove the 6 nuts, nozzle leakage pipe and 6 gaskets.

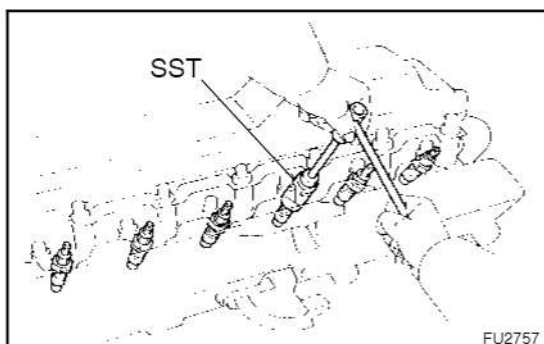

### 4. REMOVE INJECTION NOZZLES

Using SST, remove the 6 injection nozzles, 6 seats and 6 gaskets.

SST 09268-64010 (09268-64020)

HINT:

Arrange the injection nozzles in correct order.

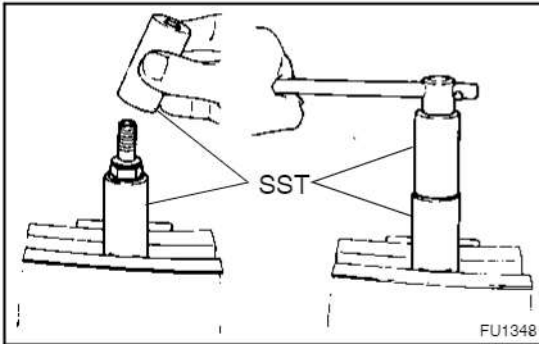

## DISASSEMBLY

### DISASSEMBLE INJECTION NOZZLES

(a) Using SST, remove the nozzle holder body.

SST 09268-64010 (09268-64020, 09268-64030)

### NOTICE:

**When disassembling the nozzle, be careful not to drop the inner parts.**

(b) Remove the pressure spring, shim, pressure pin, distance piece, nozzle assembly and identification ring.

## INSPECTION

### 1. NOZZLE CLEANING

- (a) To wash the nozzles, use a wooden stick and brass brush. Wash them in clean diesel fuel.

HINT:

Do not touch the nozzle mating surface with your fingers.

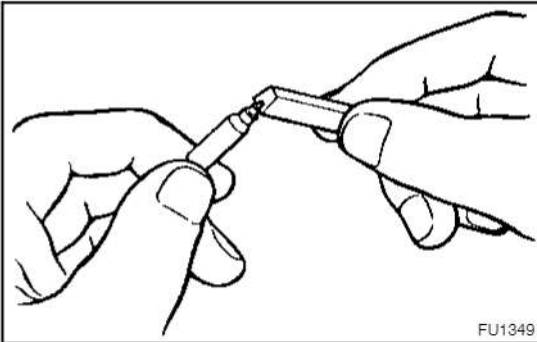

FU1349

- (b) Using a wooden stick, remove the carbon adhering to the nozzle needle tip.

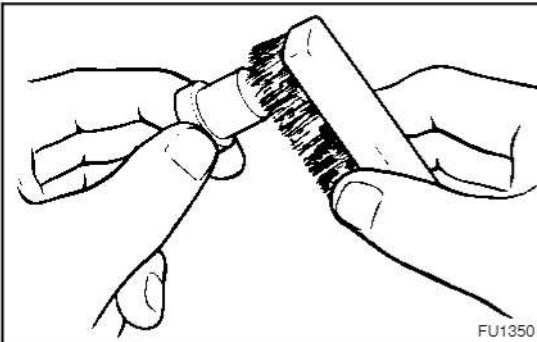

FU1350

- (c) Using a brass brush, remove the carbon from the exterior of the nozzle body (except lapped surface).

- (d) Check the seat of the nozzle body for burns or corrosion.

- (e) Check the nozzle needle tip for damage or corrosion.

If any of these conditions are present, replace the nozzle assembly.

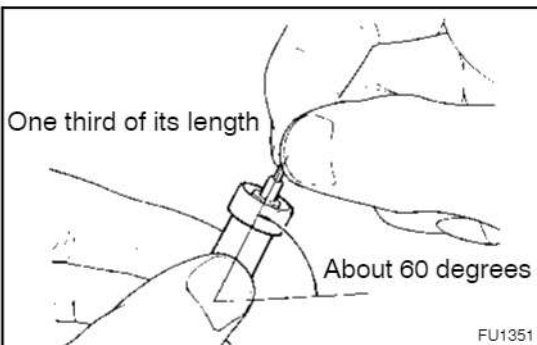

FU1351

### 2. INSPECT NOZZLE ASSEMBLY

- (a) Wash the nozzle in clean diesel fuel.

HINT:

Do not touch the nozzle mating surface with your fingers.

- (b) Tilt the nozzle body about 60 degrees and pull the needle out about one third of its length.

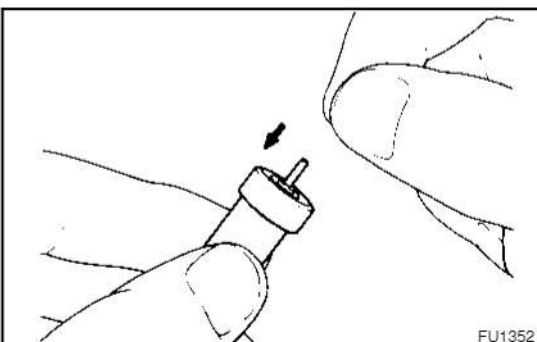

FU1352

- (c) When released, the needle should sink down into the body vent smoothly by its own weight.

- (d) Repeat this test, rotating the needle slightly each time.

If the needle does not sink freely, replace the nozzle assembly.



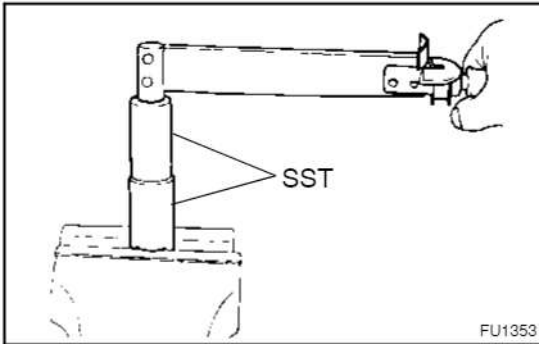

## REASSEMBLY

### 1. ASSEMBLE INJECTION NOZZLE HOLDERS

- (a) Assemble the nozzle holder retaining nut, the nozzle assembly, distance piece, pressure pin, pressure spring, adjusting shim, identification ring and nozzle holder body, and finger tighten the retaining nut.
- (b) Using SST, tighten the nozzle holder body.

SST 09268-64010 (09268-64020, 09268-64030)

**Torque: 46.58 N·m (475 kgf·cm, 34 ft·lbf)**

### NOTICE:

**Over torquing could cause nozzle deformation and needle adhesion or other defects.**

### 2. PERFORM PRESSURE AND SPRAY PATTERN TEST

(See page FU-11)

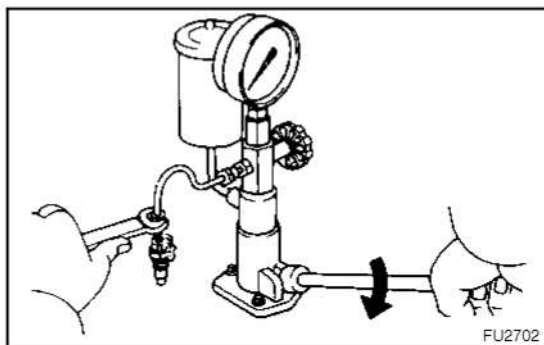

FU2702

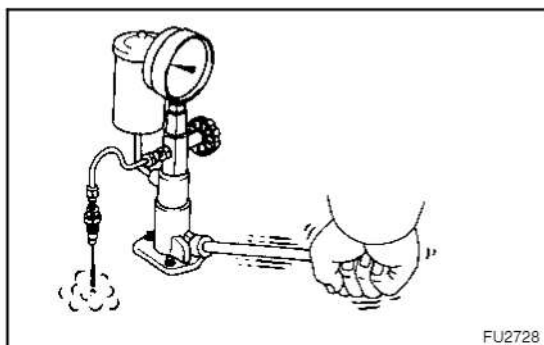

FU2728

## TEST

### 1. INJECTION PRESSURE TEST

- (a) Install the injection nozzle to the injection nozzle hand tester and bleed air from the union nut.

#### CAUTION:

**Do not place your finger over the nozzle injection hole.**

- (b) Pump the tester handle a few times as fast as possible to discharge the carbon from the injection hole.
- (c) Pump the tester handle slowly and observe the pressure gauge.
- (d) Read the pressure gauge just as the injection pressure begins to drop.

#### Opening pressure:

##### New nozzle:

M/T		14,710 - 15,690 kPa
A/T	White indication ring	(150 - 160 kgf/cm <sup>2</sup> , 2,133 - 2,276 psi)
A/T	Brown indication ring	15,690 - 16,671 kPa (160 - 170 kgf/cm <sup>2</sup> , 2,276 - 2,418 psi)

##### Reused nozzle:

M/T		14,220 - 15,200 kPa
A/T	White indication ring	(145 - 155 kgf/cm <sup>2</sup> , 2,062 - 2,205 psi)
A/T	Brown indication ring	15,200 - 16,181 kPa (155 - 165 kgf/cm <sup>2</sup> , 2,205 - 2,347 psi)

#### HINT:

Proper nozzle operation can be determined by a switching sound.

If the opening pressure is not as specified, disassemble the nozzle holder and change the adjusting shim on the top of the pressure spring.

#### Adjusting opening pressure:

M/T		14,220 - 15,200 kPa
A/T	White indication ring	(145 - 155 kgf/cm <sup>2</sup> , 2,062 - 2,205 psi)
A/T	Brown indication ring	15,200 - 16,181 kPa (155 - 165 kgf/cm <sup>2</sup> , 2,205 - 2,347 psi)

**Adjusting shim thickness:**

mm (in.)	mm (in.)	mm (in.)
0.900 (0.0354)	1.275 (0.0502)	1.650 (0.0650)
0.925 (0.0364)	1.300 (0.0512)	1.675 (0.0659)
0.950 (0.0374)	1.325 (0.0522)	1.700 (0.0669)
0.975 (0.0384)	1.350 (0.0531)	1.725 (0.0679)
1.000 (0.0394)	1.375 (0.0541)	1.750 (0.0689)
1.025 (0.0404)	1.400 (0.0551)	1.775 (0.0699)
1.050 (0.0413)	1.425 (0.0561)	1.800 (0.0709)
1.075 (0.0423)	1.450 (0.0571)	1.825 (0.0719)
1.100 (0.0433)	1.475 (0.0581)	1.850 (0.0728)
1.125 (0.0443)	1.500 (0.0591)	1.875 (0.0738)
1.150 (0.0453)	1.525 (0.0600)	1.900 (0.0748)
1.175 (0.0463)	1.550 (0.0610)	1.925 (0.0758)
1.200 (0.0472)	1.575 (0.0620)	1.950 (0.0768)
1.225 (0.0482)	1.600 (0.0630)	-
1.250 (0.0492)	1.625 (0.0640)	-

**HINT:**

- Varying the adjusting shim thickness by 0.025 mm (0.0010 in.) changes the injection pressure by about 470 kPa (4.8 kgf/cm<sup>2</sup>, 68 psi).
- Only one adjusting shim should be used.
- (e) There should be no dripping after injection.

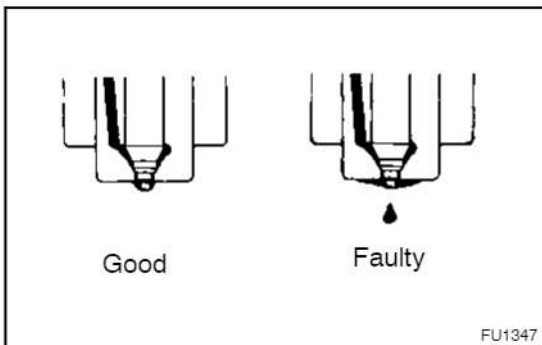

**2. LEAKAGE TEST**

While maintaining pressure at about 981 – 1,961 kPa (10 – 20 kgf/cm<sup>2</sup>, 142 – 284 psi) below opening pressure (adjust by tester handle), check that there is no dripping for 10 seconds from the injection hole or around the retaining nut.

If the nozzle drips within 10 seconds, replace or clean and overhaul the nozzle assembly.

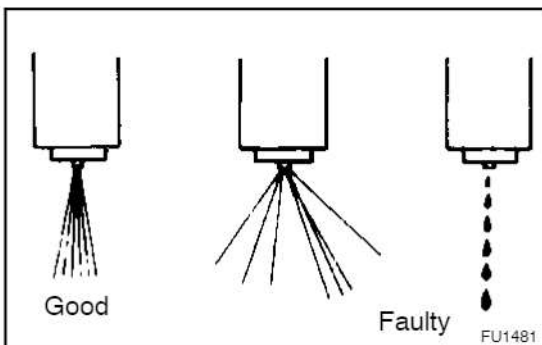

**3. SPRAY PATTERN TEST**

(a) The injection nozzle should shudder at a certain pumping speed between 15 – 60 times (old nozzle) or 30 – 60 times (new nozzle) per minute.

(b) Check the spray pattern during shuddering.

If the spray pattern is not correct during shuddering, the nozzle must be replaced or cleaned.

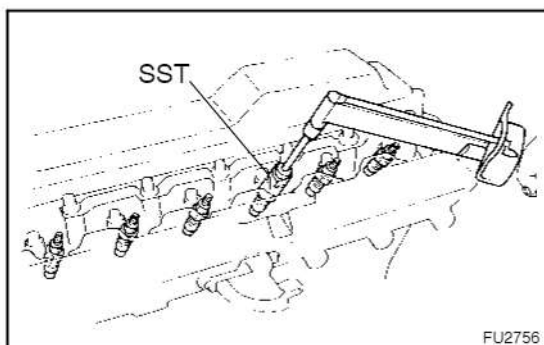

## INSTALLATION

### 1. INSTALL INJECTION NOZZLES

- Place 6 new gaskets and the 6 nozzle seats into the injection nozzle holes of the cylinder head.
- Using SST, install the 6 injection nozzles.  
SST 09268-64010 (09268-64020)

**Torque: 63.7 N·m (650 kgf·cm, 47 ft·lbf)**

HINT:

Australia A/T:

Install the injection nozzle either with the combination (A) or (B).

(A)

Cylinder	Indication ring
1, 2 and 3	White
4, 5 and 6	Brown

(B)

Cylinder	Indication ring
1, 2 and 3	Brown
4, 5 and 6	White

**NOTICE:**

**Over torquing could cause nozzle deformation and needle adhesion or other defects.**

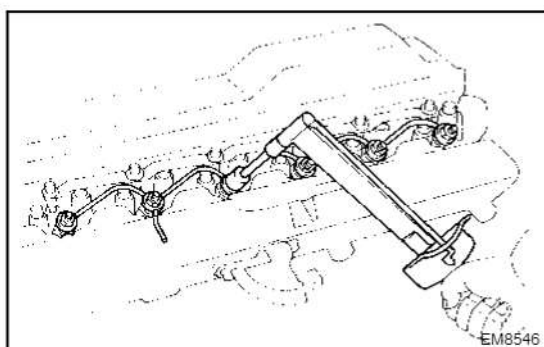

### 2. INSTALL NOZZLE LEAKAGE PIPE

- Install 6 new gaskets and the leakage pipe with the 6 nuts.  
**Torque: 29.4 N·m (300 kgf·cm, 22 ft·lbf)**
- Connect the fuel return hose to the leakage pipe.

### 3. INSTALL INJECTION PIPES

- Place the 2 injection pipe clamps on the intake manifold.
- Attach the 6 injection pipes to the injection nozzles and injection pump.

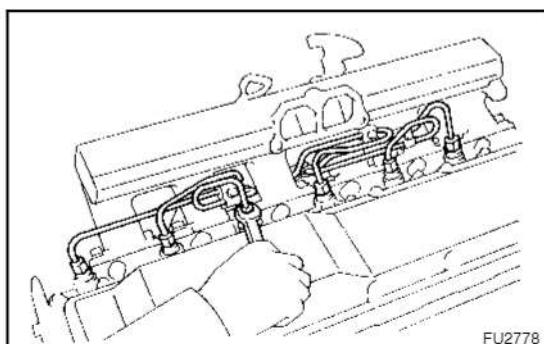

- Tighten the 6 union nuts to the injection nozzle.  
**Torque: 14.7 N·m (150 kgf·cm, 11 ft·lbf)**

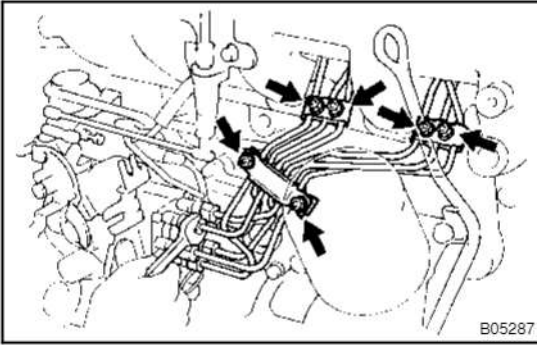

- (d) Tighten the 6 union nuts to the injection pump.  
**Torque: 14.7 N·m (150 kgf·cm, 11 ft·lbf)**
  - (e) install the 2 clamps with the 2 nuts  
**Torque: 6.4 N·m (65 kgf·cm, in·lbf)**
  - (f) install the 2 clamps with the 4 nuts  
**Torque: 6.4 N·m (65 kgf·cm, in·lbf)**
4. **INSTALL INTAKE PIPE (See page EM-66)**
  5. **START ENGINE AND CHECK FOR FUEL LEAKAGE**

# INJECTION NOZZLE (1HD-T) COMPONENTS

FU051-01

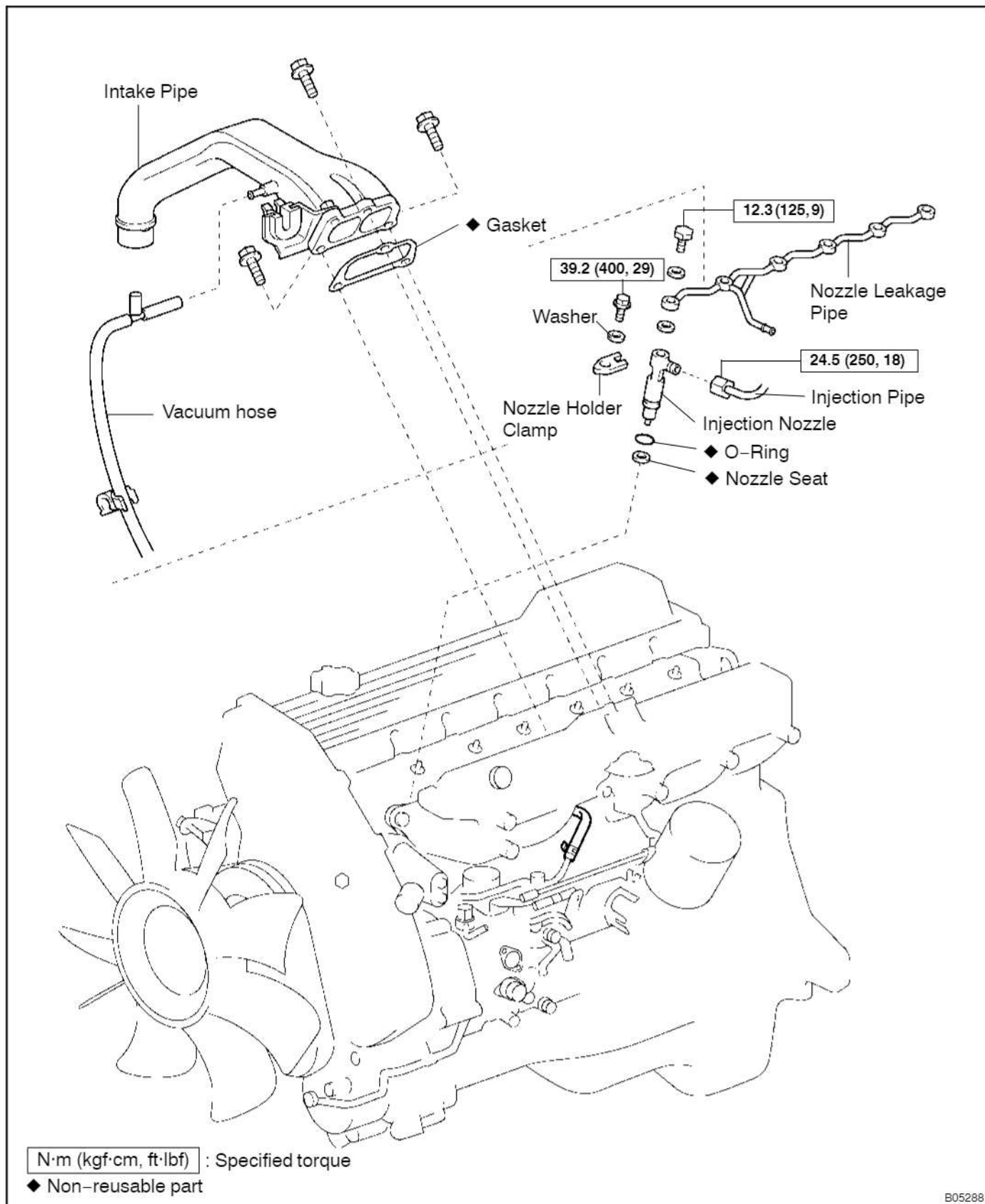

cardiagn.com

B05288

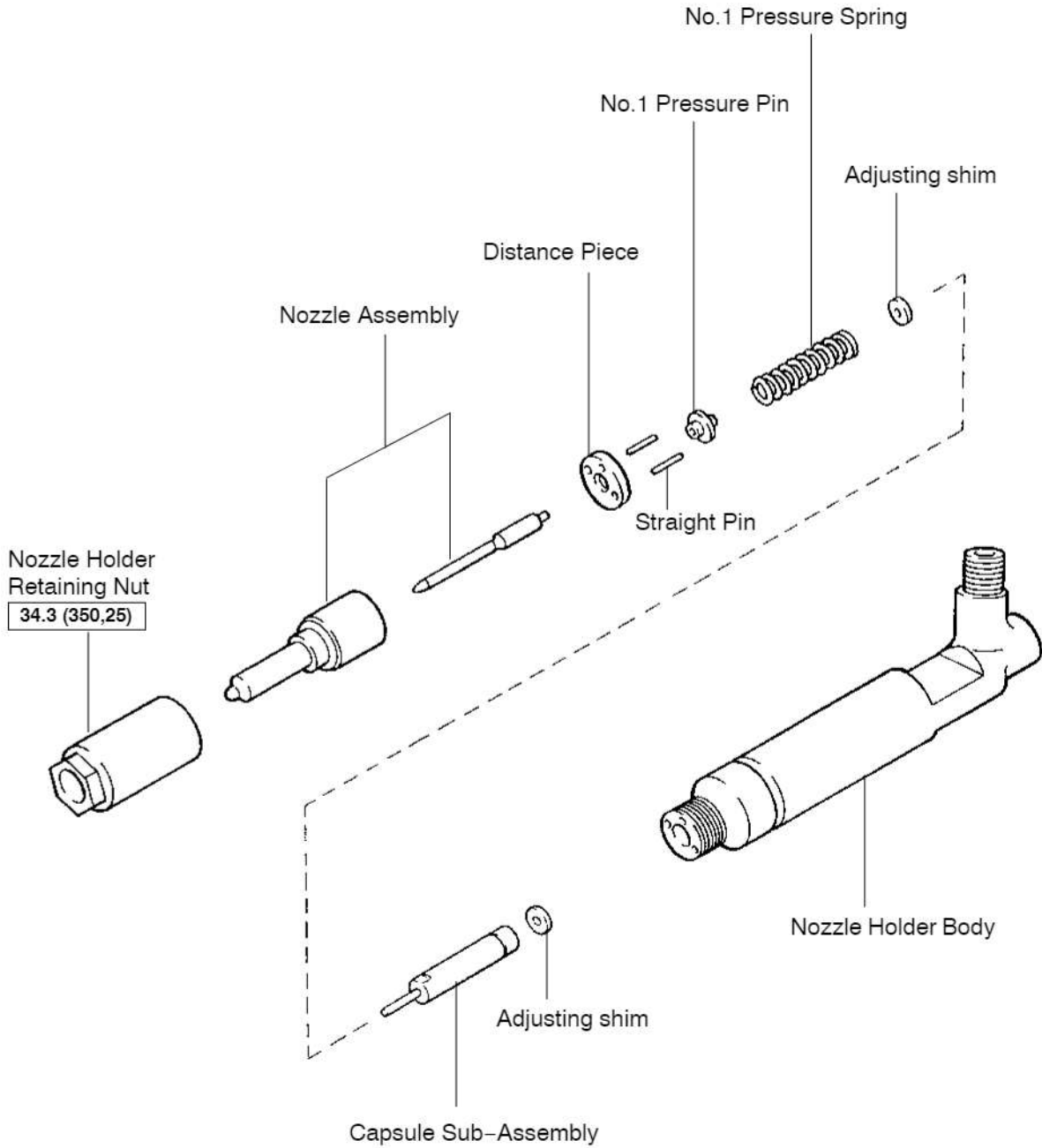

N·m (kgf·cm, ft·lbf) : Specified torque

B05289

## REMOVAL

### 1. REMOVE INTAKE PIPE (See page EM-48)

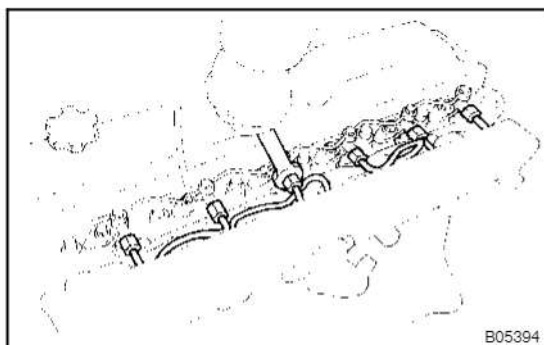

### 2. DISCONNECT INJECTION PIPES

Loosen the 6 union nuts from the 6 injection nozzles.

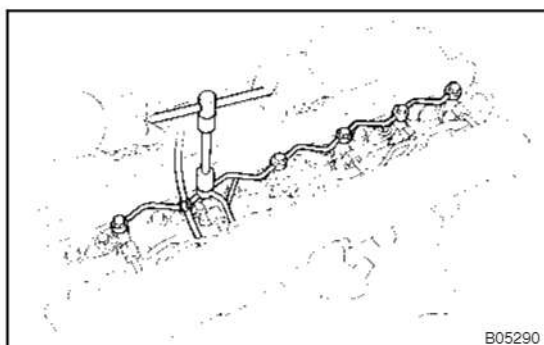

### 3. REMOVE NOZZLE LEAKAGE PIPE

- Disconnect the fuel return hose from the nozzle leakage pipe.
- Disconnect the hose clamp from the nozzle leakage pipe.
- Remove the 6 hollow bolts, nozzle leakage pipe and 12 gaskets.

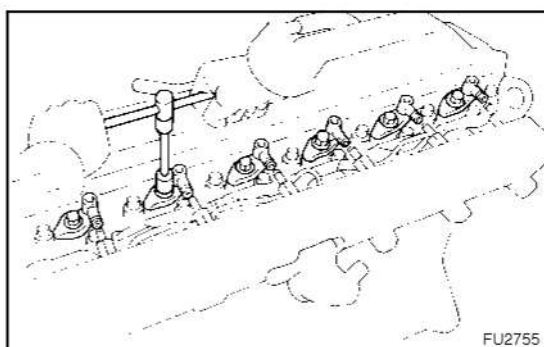

### 4. REMOVE INJECTION NOZZLES

- Remove the 6 bolts, 6 washers, 6 nozzle holder clamps, 6 injection nozzles and 6 seats.
- Remove the O-ring from the injection nozzle.

HINT:

Arrange the injection nozzles in correct order.



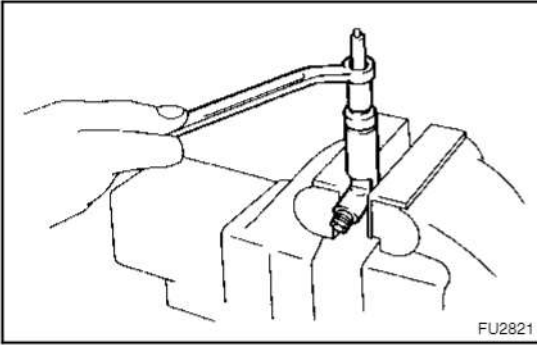

FU2821

## DISASSEMBLY

### DISASSEMBLE INJECTION NOZZLES

(a) Remove the nozzle holder retaining nut.

#### NOTICE:

**When disassembling the nozzle, be careful not to drop the inner parts.**

(b) Disassemble the injection nozzle.

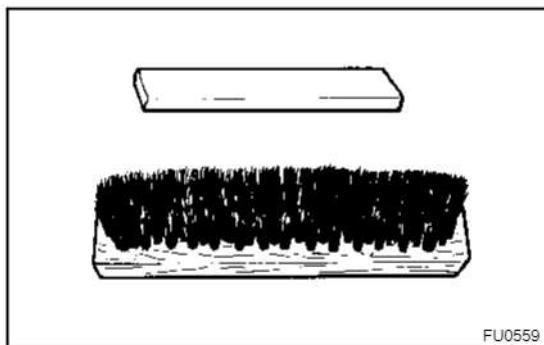

## INSPECTION

### 1. NOZZLE CLEANING

- (a) To wash the nozzles, use a wooden stick and brass brush. Wash them in clean diesel fuel.

HINT:

Do not touch the nozzle mating surfaces with your fingers.

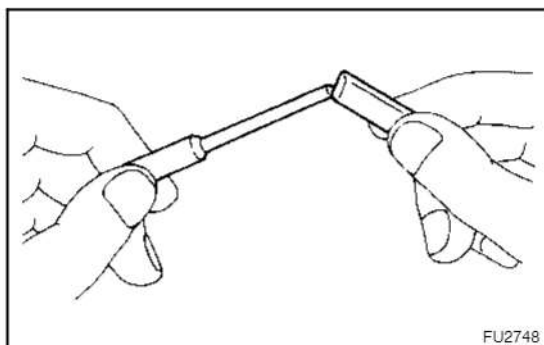

- (b) Using a wooden stick, remove the carbon adhering to the nozzle needle tip.

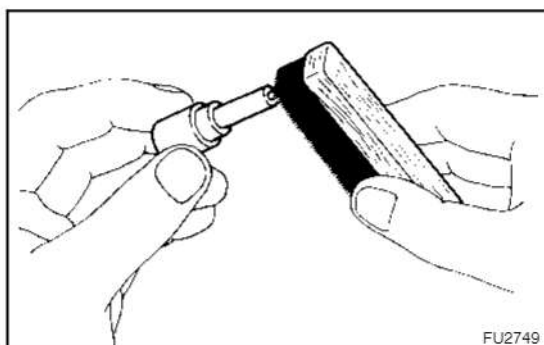

- (c) Using a brass brush, remove the carbon from the exterior of the nozzle body (except lapped surface).

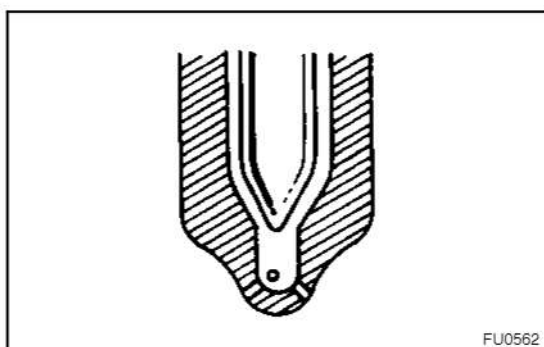

- (d) Check the seat of the nozzle body for burns or corrosion.  
 (e) Check the nozzle needle tip for damage or corrosion.  
 If any of these conditions are present, replace the nozzle assembly.

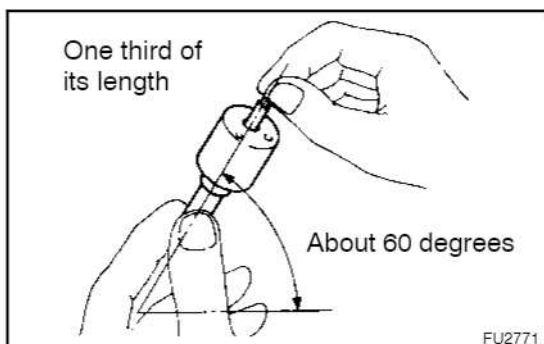

### 2. INSPECT NOZZLE ASSEMBLY

- (a) Wash the nozzle in clean diesel fuel.

HINT:

Do not touch the nozzle mating surfaces with your fingers.

- (b) Tilt the nozzle body about 60 degrees and pull the needle out about one third of its length.

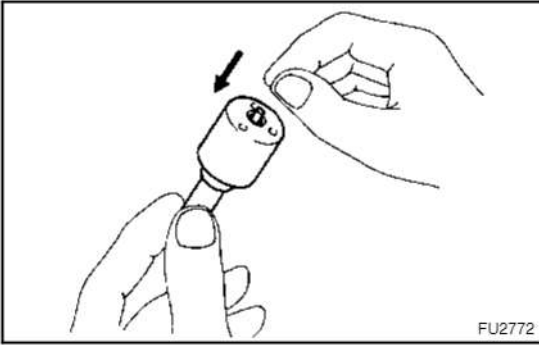

- (c) When released, the needle should stick down into the body vent smoothly by its own weight.
- (d) Repeat this test, rotating the needle slightly each time. If the needle does not sink freely, replace the nozzle assembly.

## ADJUSTMENT

### 1. ADJUST PRE-LIFT

#### NOTICE:

pre-lift adjustment requires great precision, so when doing this operation, make sure everything is clean and that no foreign substances are trapped.

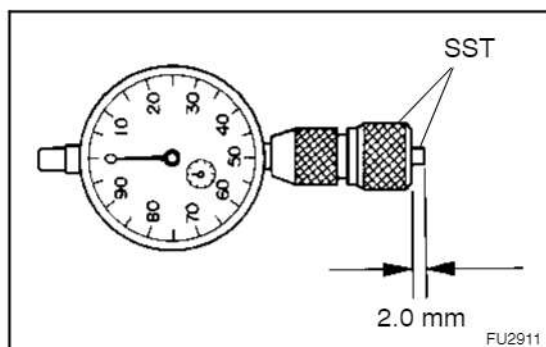

- (a) Install the SST to the dial indicator so that the protrusion shown in the illustration is 2.0 mm (0.079 in.) or less.

SST 09268-17010

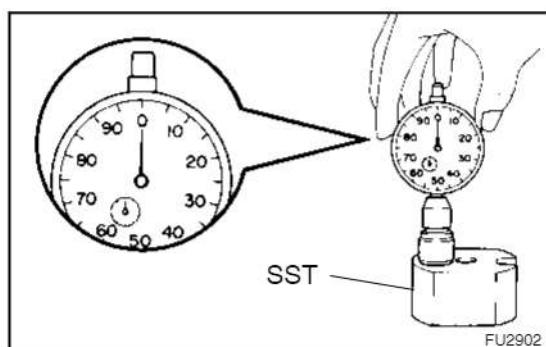

- (b) Set the dial indicator scale to 0 mm (0 in.) on top of the SST or the surface plate.

SST 09268-17010

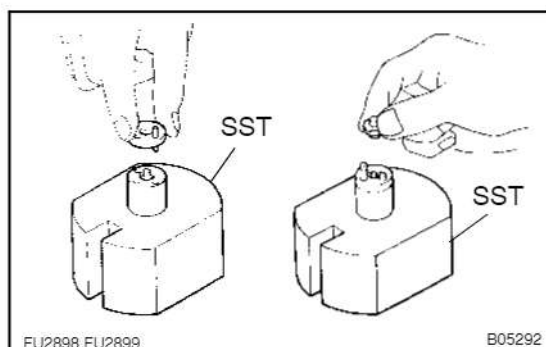

- (c) Place the nozzle sub-assembly, distance piece, 2 straight pins and No.1 pressure pin on the SST as shown in the illustration.

SST 09268-17010

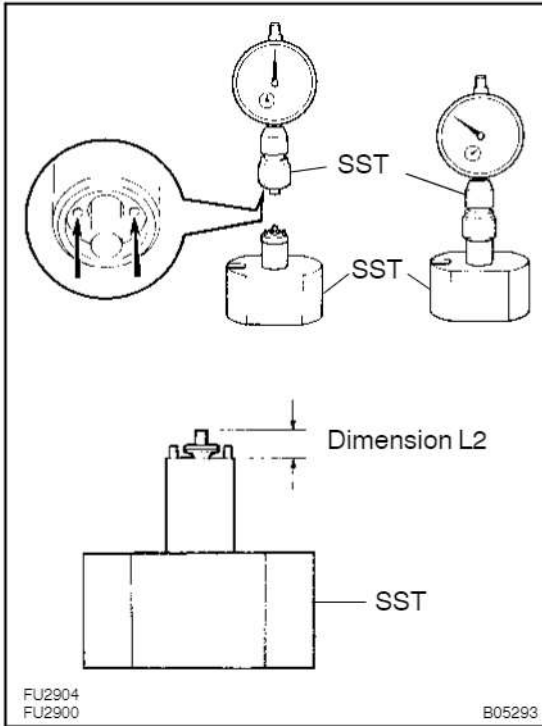

- (d) Install SST holes to the straight pins and measure dimension L2.

SST 09268-17010

**Dimension L2 (Reference) = 4.70 mm (0.1850 in.)**

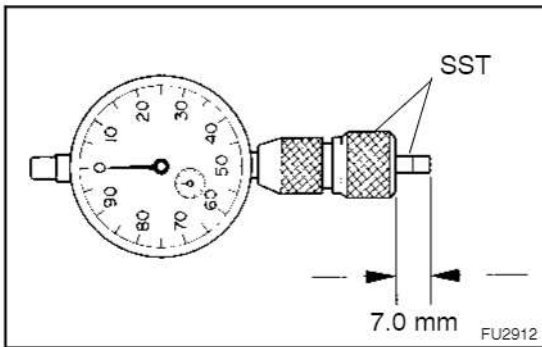

- (e) Install the SST to the dial indicator so that the protrusion shown in the illustration is 7.0 mm (0.276 in.) or less.

SST 09268-17010

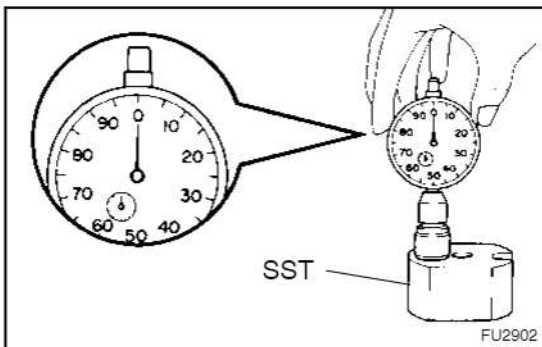

- (f) Set the dial indicator scale to 0 mm (0 in.) on top of the SST or the surface plate.

SST 09268-17010

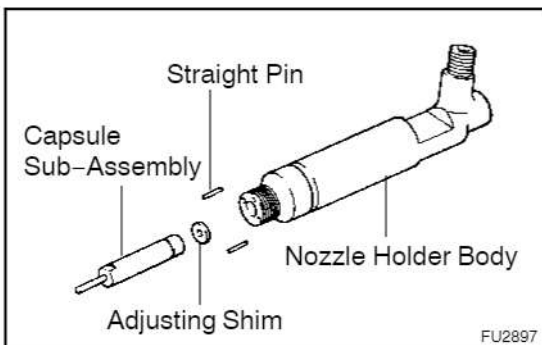

- (g) Place the adjusting shim, the capsule sub-assembly and straight pins on the nozzle holder body.

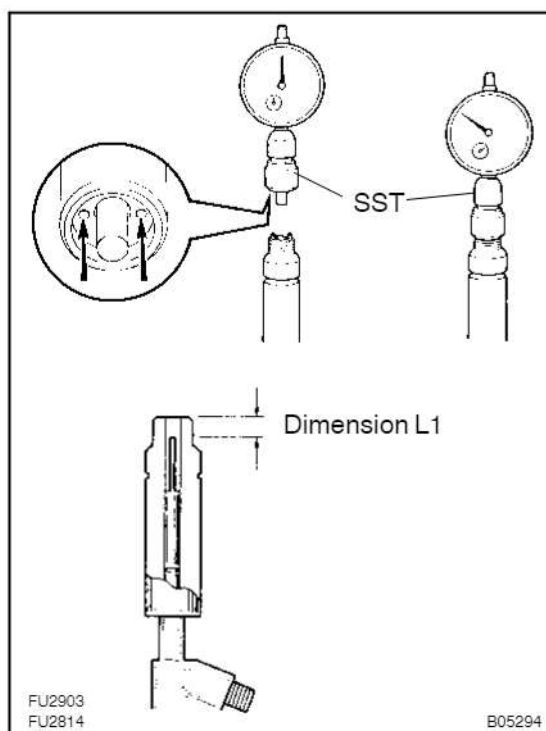

- (h) Install SST holes to the straight pins and measure dimension L1.

SST 09268-17010

**Dimension L1 (Reference) = 4.77 mm (0.1878 in.)**

- (i) Subtract the dimension L2 from the dimension L1 .

**Pre-lift = L1 - L2**

**Pre-lift: 0.06 - 0.08 mm (0.00236 - 0.00315 in.)**

If the pre-lift dimension is not as specified, change the adjusting shim on the top of the capsule sub-assembly.

**Adjusting shim:**

mm (in.)	mm (in.)	mm (in.)
0.700 (0.0276)	1.310 (0.0516)	1.520 (0.0598)
0.750 (0.0295)	1.320 (0.0520)	1.530 (0.0602)
0.800 (0.0315)	1.330 (0.0524)	1.540 (0.0606)
0.850 (0.0335)	1.340 (0.0528)	1.550 (0.0610)
0.900 (0.0354)	1.350 (0.0531)	1.560 (0.0614)
0.950 (0.0374)	1.360 (0.0535)	1.570 (0.0618)
0.975 (0.0384)	1.370 (0.0539)	1.580 (0.0622)
1.000 (0.0394)	1.380 (0.0543)	1.590 (0.0626)
1.025 (0.0404)	1.390 (0.0547)	1.600 (0.0630)
1.050 (0.0413)	1.400 (0.0551)	1.610 (0.0634)
1.075 (0.0423)	1.410 (0.0555)	1.620 (0.0638)
1.100 (0.0433)	1.420 (0.0559)	1.630 (0.0641)
1.125 (0.0443)	1.430 (0.0563)	1.640 (0.0646)
1.150 (0.0453)	1.440 (0.0567)	1.650 (0.0650)
1.175 (0.0463)	1.450 (0.0571)	1.660 (0.0654)
1.200 (0.0472)	1.460 (0.0575)	1.670 (0.0657)
1.225 (0.0482)	1.470 (0.0579)	1.680 (0.0661)
1.250 (0.0492)	1.480 (0.0583)	1.690 (0.0665)
1.280 (0.0504)	1.490 (0.0587)	1.700 (0.0669)
1.290 (0.0508)	1.500 (0.0591)	1.750 (0.0689)
1.300 (0.0512)	1.510 (0.0594)	1.800 (0.0709)

**HINT:**

If the shim is made thicker, the pre-lift is decreased.

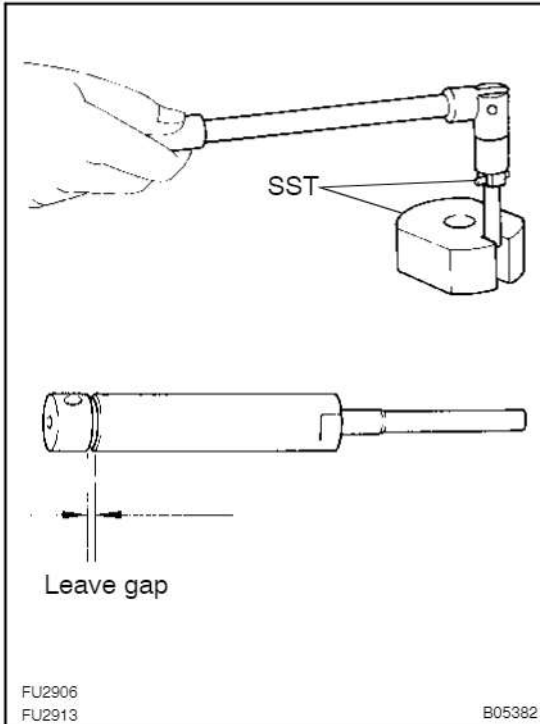

## 2. CHECK NO.2 OPENING PRESSURE

- (a) Loosen by 1 or 2 turns the plug screw of the capsule sub-assembly with SST.  
SST 09268-17010

### HINT:

When the plug screw is loosened by 1 or 2 turns, the pre-lift from installation in the nozzle holder becomes 0 mm (0 in.).

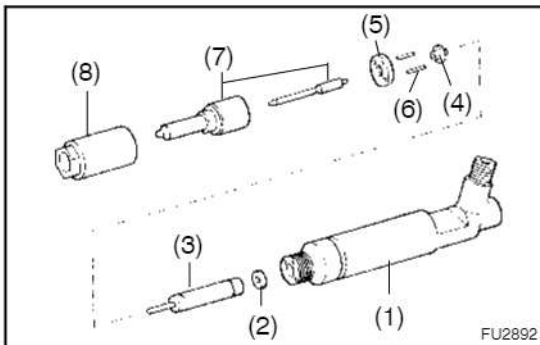

- (b) Assemble these parts:

- (1) Nozzle holder body
- (2) Adjusting shim selected in step 1 above
- (3) Capsule sub-assembly in the condition from step 2 (a)
- (4) No.1 pressure pin
- (5) Distance piece
- (6) Straight pins
- (7) Nozzle sub-assembly
- (8) Retaining nut

### NOTICE:

**Do not assemble the No.1 pressure spring and adjusting shim for adjustment of the No.1 opening pressure.**

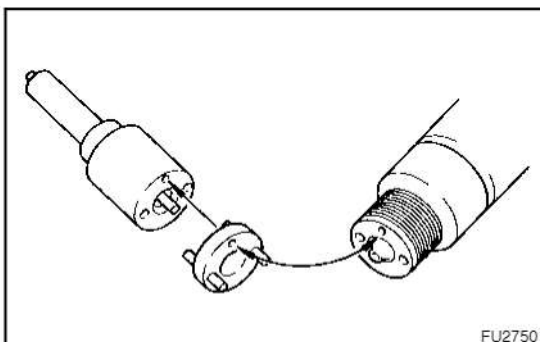

### HINT:

Align the holes of the nozzle body, distance piece and nozzle holder body.

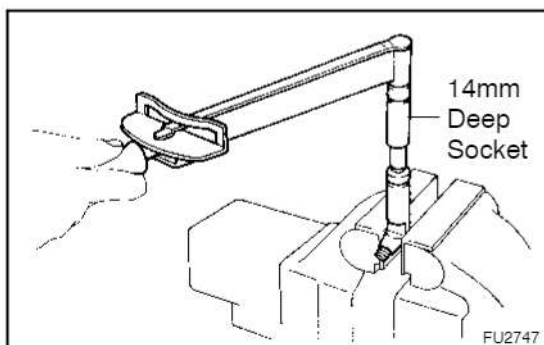

- (c) Using a 14 mm deep socket wrench, torque the retaining nut.

**Torque: 34.3 N·m (350 kgf·cm, 25 ft·lbf)**

**NOTICE:**

**Over torquing could cause the nozzle deformation and the needle adhesion or other defects.**

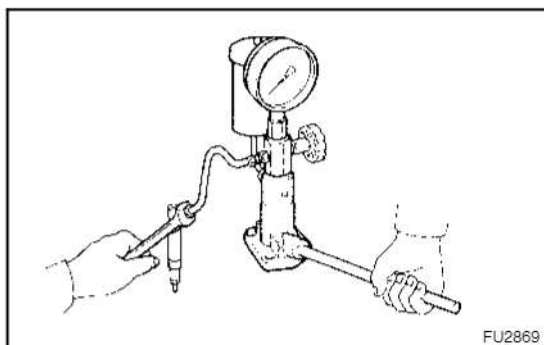

- (d) Install the injection nozzle to the injection nozzle hand tester and bleed air from the union nut.

**CAUTION:**

**Do not place your finger over the nozzle injection hole.**

- (e) Pump the tester handle a few times as fast as possible to discharge the carbon from the injection hole.

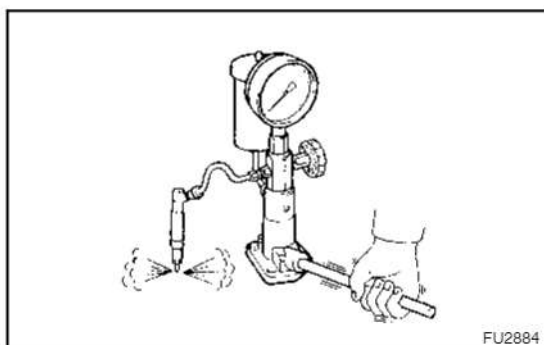

- (f) Pump the tester handle slowly and observe the pressure gauge.  
 (g) Read the pressure gauge just as the injection pressure begins to drop.

**No.2 opening pressure (Inspection pressure):**

**13,239 - 14,220 kPa**

**(135 - 145 kgf/cm<sup>2</sup>, 1,920 - 2,062 psi)**

**HINT:**

Proper nozzle operation can be determined by a swishing sound.

If the opening pressure is not as specified, replace the capsule sub-assembly.

**HINT:**

The No.2 opening pressure is already adjusted for the new capsule sub-assembly.

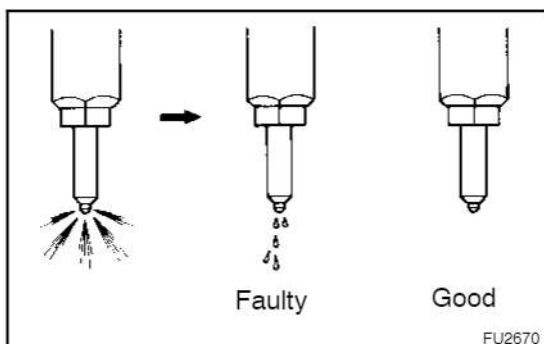

- (h) There should be no dripping after injection.



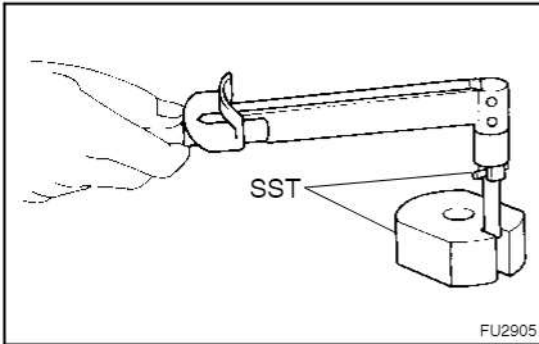

- (i) After checking the No.2 opening pressure, remove the capsule sub-assembly and tighten the plug screw with SST.

SST 09268-17010

**Torque: 2.5 N·m (25 kgf·cm, 21 in·lbf)**

### 3. ADJUST NO.1 OPENING PRESSURE

- (a) Assemble the nozzle holder body, adjusting shim selected in step 1, the capsule sub-assembly, adjusting shim for adjustment of No.1 opening pressure, No.1 pressure spring, No.1 pressure pin, distance piece, 2 straight pins and nozzle sub-assembly, and finger tighten the retainer nut.

#### HINT:

- Align the holes of the nozzle body, distance piece and nozzle holder body.
  - When the thickness of the originally used adjusting shim is not known, use a shim 1.5 mm (0.56 in.) thick instead.
- (b) Read the pressure gauge just as the injection pressure begins to drop. (See Steps (c) to (g) in step 1 above)

#### No.1 opening pressure:

**17,652 – 18,633 kPa**

**(180 – 190 kgf/cm<sup>2</sup>, 2,560 – 2,702 psi)**

#### HINT:

Proper nozzle operation can be determined by a swishing sound.

If the opening pressure is not as specified, disassemble the nozzle and change the adjusting shim on the top of the No.1 pressure spring.

**Adjusting shim thickness:**

mm (in.)	mm (in.)	mm (in.)
0.700 (0.0276)	1.310 (0.0516)	1.520 (0.0598)
0.750 (0.0295)	1.320 (0.0520)	1.530 (0.0602)
0.800 (0.0315)	1.330 (0.0524)	1.540 (0.0606)
0.850 (0.0335)	1.340 (0.0528)	1.550 (0.0610)
0.900 (0.0354)	1.350 (0.0531)	1.560 (0.0614)
0.950 (0.0374)	1.360 (0.0535)	1.570 (0.0618)
0.975 (0.0384)	1.370 (0.0539)	1.580 (0.0622)
1.000 (0.0394)	1.380 (0.0543)	1.590 (0.0626)
1.025 (0.0404)	1.390 (0.0547)	1.600 (0.0630)
1.050 (0.0413)	1.400 (0.0551)	1.610 (0.0634)
1.075 (0.0423)	1.410 (0.0555)	1.620 (0.0638)
1.100 (0.0433)	1.420 (0.0559)	1.630 (0.0641)
1.125 (0.0443)	1.430 (0.0563)	1.640 (0.0646)
1.150 (0.0453)	1.440 (0.0567)	1.650 (0.0650)
1.175 (0.0463)	1.450 (0.0571)	1.660 (0.0654)
1.200 (0.0472)	1.460 (0.0575)	1.670 (0.0657)
1.225 (0.0482)	1.470 (0.0579)	1.680 (0.0661)
1.250 (0.0492)	1.480 (0.0583)	1.690 (0.0665)
1.280 (0.0504)	1.490 (0.0587)	1.700 (0.0669)
1.290 (0.0508)	1.500 (0.0591)	1.750 (0.0689)
1.300 (0.0512)	1.510 (0.0594)	1.800 (0.0709)

**HINT:**

- **Varying the adjusting shim thickness by 0.01 mm (0.0004 in.) changes the injection pressure by about 147 kPa (1.5 kg/cm<sup>2</sup>, 21 psi).**
  - **Only one adjusting shim should be used.**
- (c) There should be no dripping after injection.  
(See step (h) in step 2 above)

## REASSEMBLY

### 1. ASSEMBLE INJECTION NOZZLE HOLDERS

- (a) Assemble the nozzle holder body, adjusting shim, capsule sub-assembly, adjusting shim, No.1 pressure spring, No.1 pressure pin, distance piece, 2 straight pins and nozzle sub-assembly, and finger tighten the retainer nut.

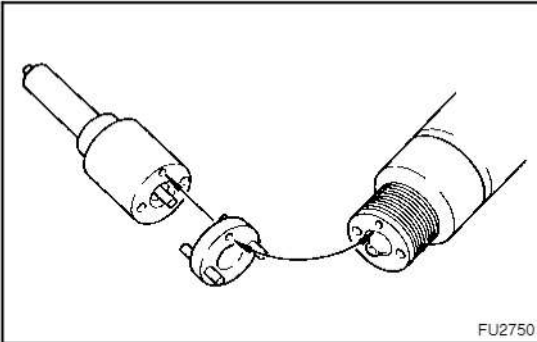

#### HINT:

- Align the holes of the nozzle body, distance piece and nozzle holder body.
- When the thickness of the originally used adjusting shim is not known, use a shim 1.5 mm (0.56 in.) thick instead.

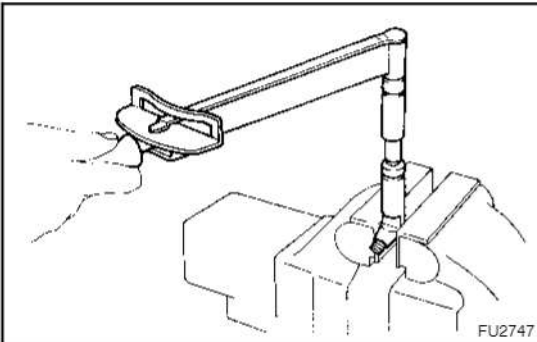

- (b) Using a 14 mm deep socket wrench, torque the retaining nut.

**Torque: 34.3 N·m (350 kgf·cm, 25 ft·lbf)**

#### NOTICE:

**Over torquing could cause the nozzle deformation and the needle adhesion or other defects.**

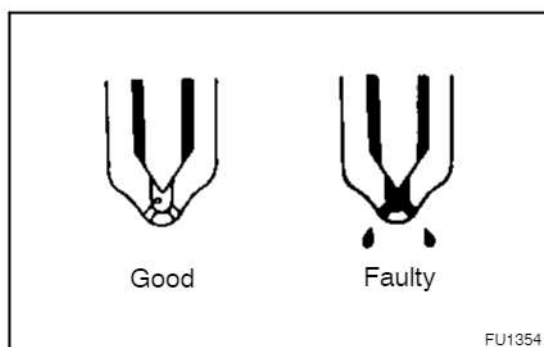

## TEST

### 1. LEAKAGE TEST

While maintaining pressure at about 981 – 1,961 kPa (10 – 20 kgf/cm<sup>2</sup> 142 – 284 psi), below No.1 opening pressure (adjust by tester handle), check that there is not dripping for 10 seconds from the injection hole or around the retaining nut.

If the nozzle drips within 10 seconds, replace or clean and overhaul the nozzle assembly.

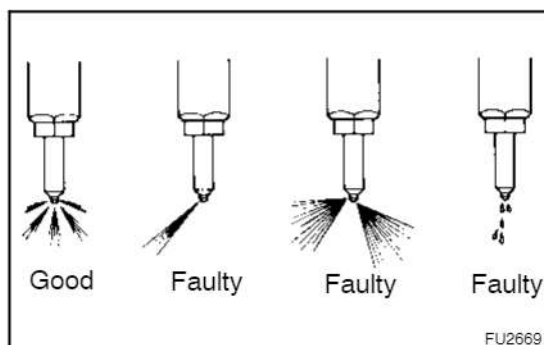

### 2. SPRAY PATTERN TEST

- (a) The injection nozzle should shudder at a certain pumping speed between 15 – 60 times (old nozzle) or 30 – 60 times (new nozzle) per minute.
- (b) Check the spray pattern during shuddering.  
If the spray pattern is not correct during shuddering, the nozzle must be replaced or cleaned.

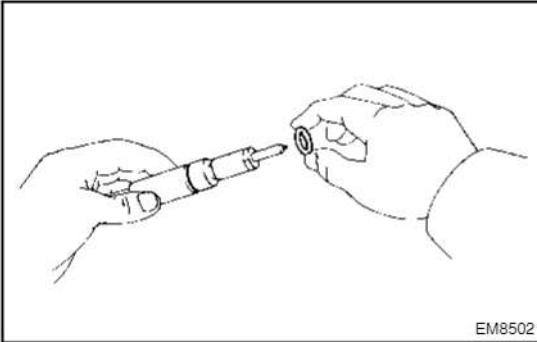

## INSTALLATION

### 1. INSTALL INJECTION NOZZLES

- (a) Install a new O-ring to the injection nozzle.

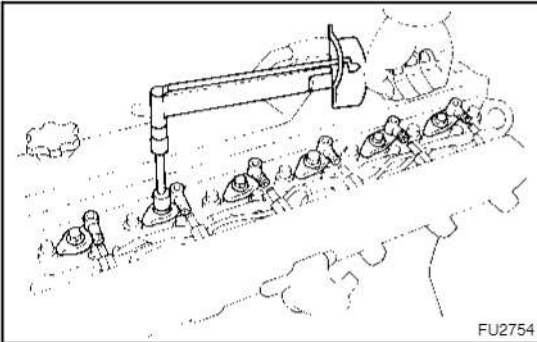

- (b) Install 6 new nozzle seats into the injection nozzle holes of the cylinder head.
- (c) Install the injection nozzles with the washer, nozzle holder clamp and bolt. Install the 6 injection nozzles.

**Torque: 39.2 N·m (400 kgf·cm, 29 ft·lbf)**

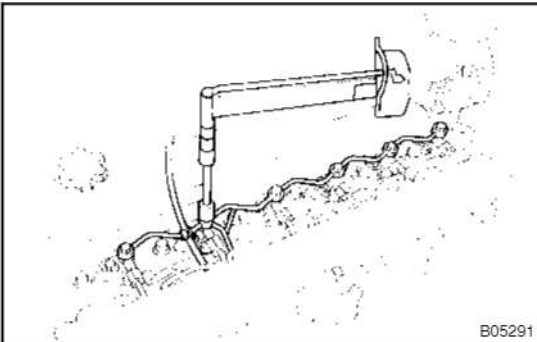

### 2. INSTALL NOZZLE LEAKAGE PIPE

- (a) Install 12 new gaskets and the nozzle leakage pipe with the 6 hollow bolts.

**Torque: 12.3 N·m (125 kgf·cm, 9 ft·lbf)**

- (b) Connect the fuel return hose to the nozzle leakage pipe.
- (c) Connect the hose clamp to the nozzle leakage pipe.

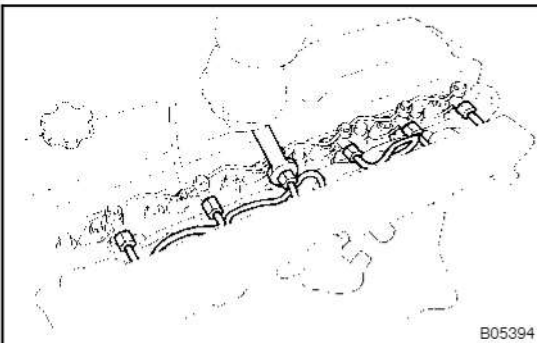

### 3. CONNECT INJECTION PIPES

Tighten the 6 union nuts to the 6 injection nozzles.

**Torque: 24.5 N·m (250 kgf·cm, 18 ft·lbf)**

### 4. INSTALL INTAKE PIPE (See page EM-66)

### 5. START ENGINE AND CHECK FOR FUEL LEAKAGE

# INJECTION NOZZLE (1HD-FTE) COMPONENTS

FU056-01

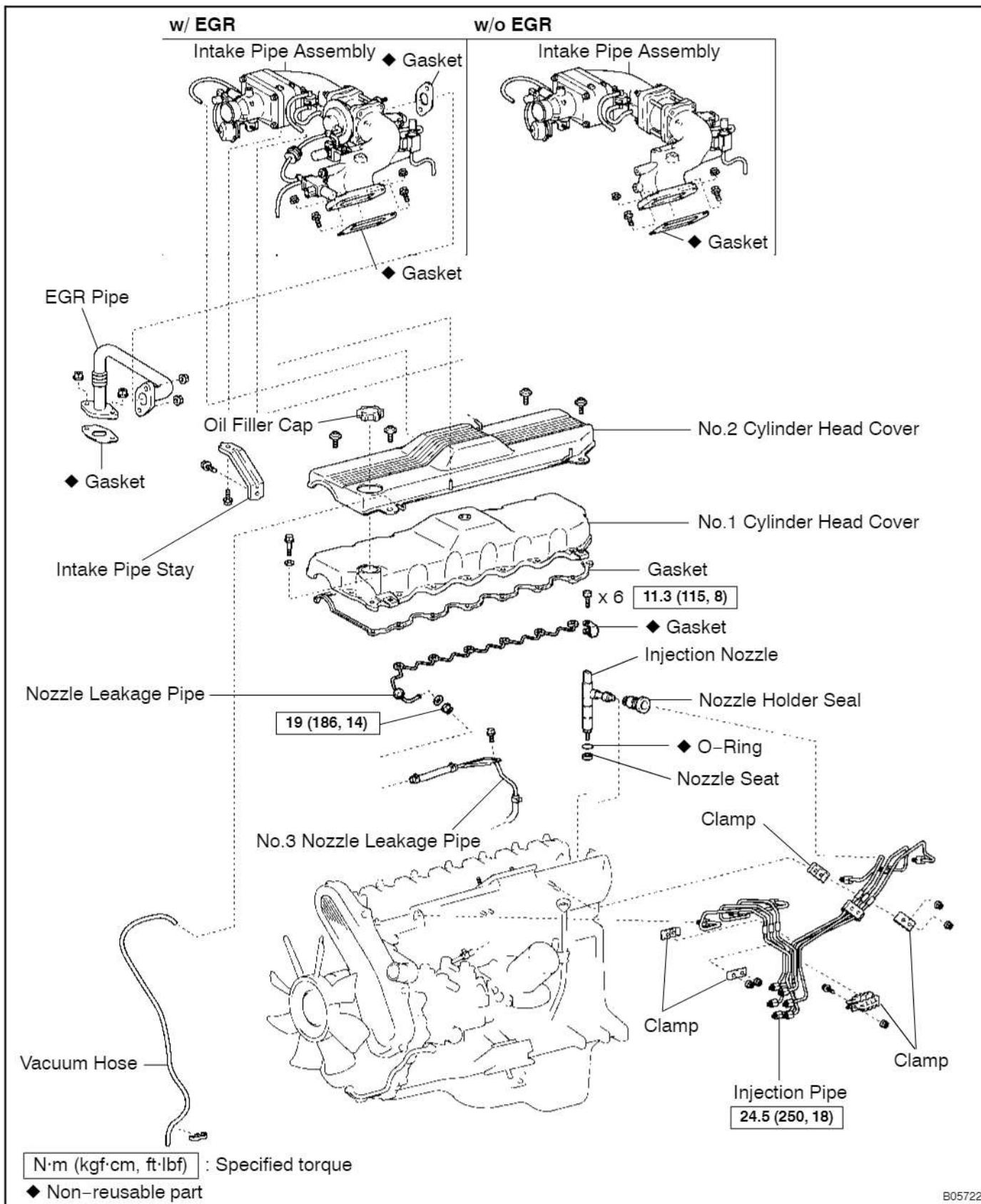

cardiagn.com

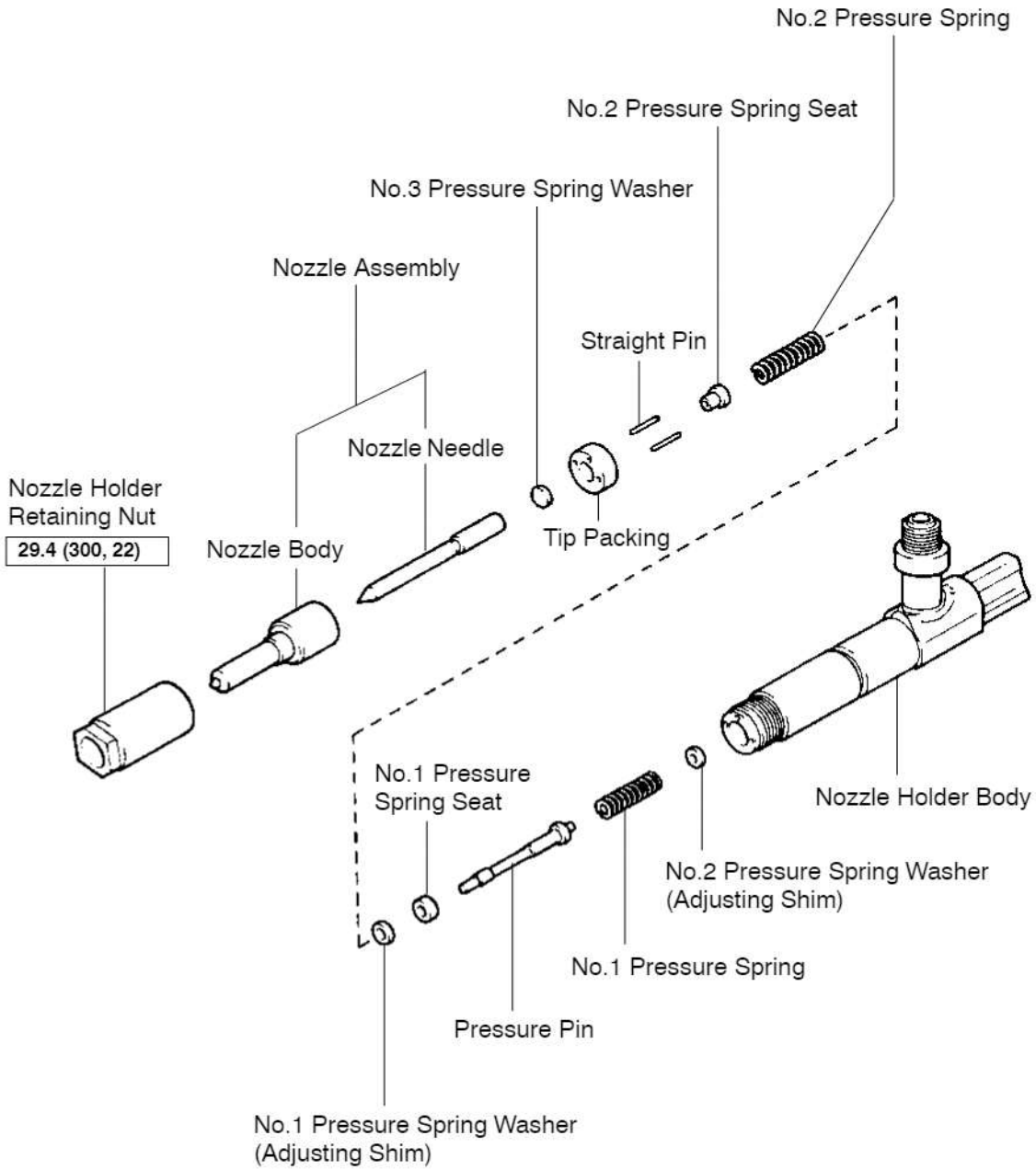

N·m (kgf·cm, ft·lbf) : Specified torque

B05384

## REMOVAL

1. REMOVE INTAKE PIPE (See page EM-77)
2. REMOVE NO.1 AND NO.2 CYLINDER HEAD COVERS (See page EM-77)

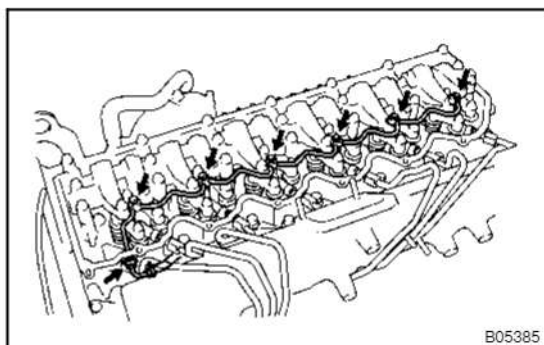

3. REMOVE NO.1 NOZZLE LEAKAGE PIPE
  - (a) Disconnect the fuel return hose from the No.1 nozzle leakage pipe.
  - (b) Remove the nut holding the No.1 nozzle leakage pipe to the cylinder head.
  - (c) Remove the 6 hollow bolts, 7 gaskets and No.1 nozzle leakage pipe.

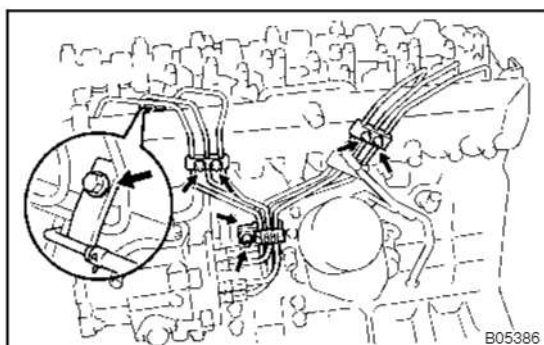

4. REMOVE INJECTION PIPES
  - (a) Remove the bolt holding the No.3 nozzle leakage pipe to the intake manifold.
  - (b) Remove the 4 nuts and 2 clamps from the intake manifold.
  - (c) Remove the bolt, nut and clamp.

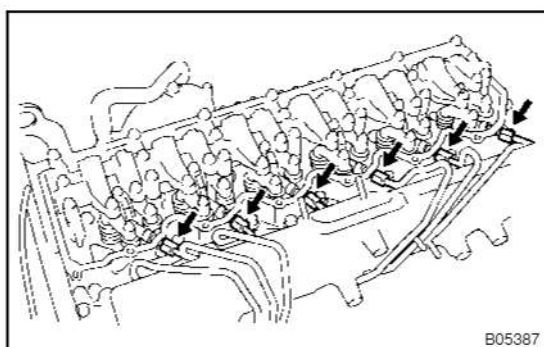

- (d) Loosen the 6 union nuts of the injection pipes from the injection nozzles.

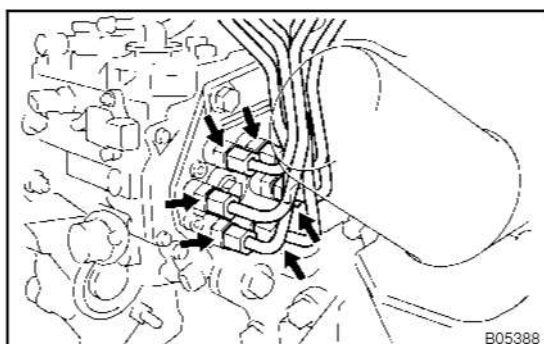

- (e) Loosen the 6 union nuts of the injection pipes from the injection pump.
- (f) Remove the 6 injection pipes.
- (g) Remove the 2 clamps.

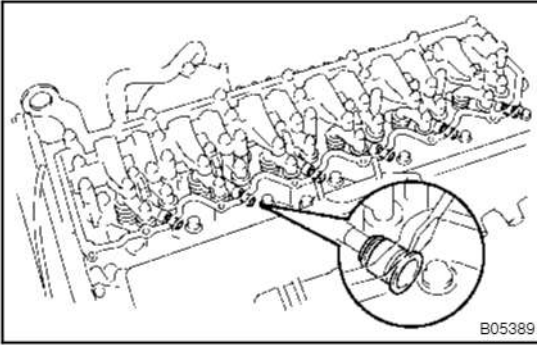

**5. REMOVE NOZZLE HOLDER SEALS**

Using a screwdriver, pry out the nozzle holder seals from the cylinder head.

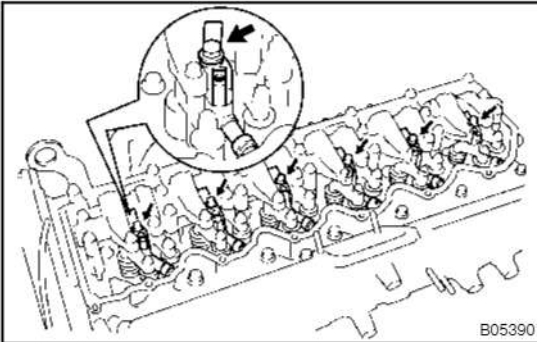
**6. REMOVE INJECTION NOZZLES**

- (a) Remove the bolt and washer holding the nozzle holder clamp to the cylinder head.
- (b) Remove the 6 injection nozzles and seats from the cylinder head.
- (c) Remove the O-ring from the injection nozzle.

HINT:

Arrange the injection nozzles in correct order.

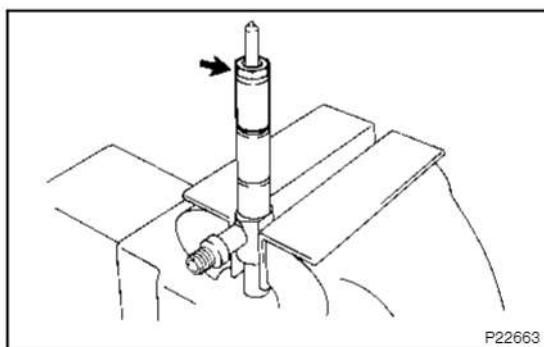

## DISASSEMBLY

### DISASSEMBLE INJECTION NOZZLES

(a) Remove the nozzle holder retaining nut.

#### NOTICE:

**When disassembling the nozzle, careful not to drop the inner parts.**

(b) Disassemble the injection nozzle.

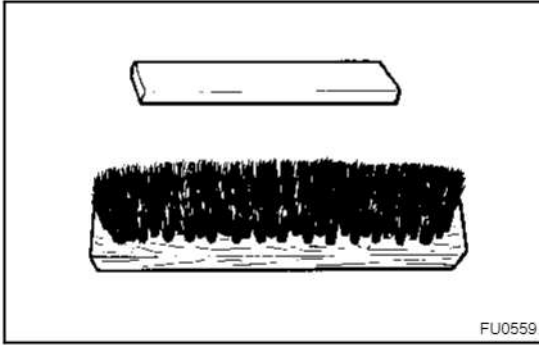

## INSPECTION

### 1. NOZZLE CLEANING

- (a) To wash the nozzles, use a wooden stick and brass brush. Wash them in clean diesel fuel.

HINT:

Do not touch the nozzle mating surfaces with your fingers.

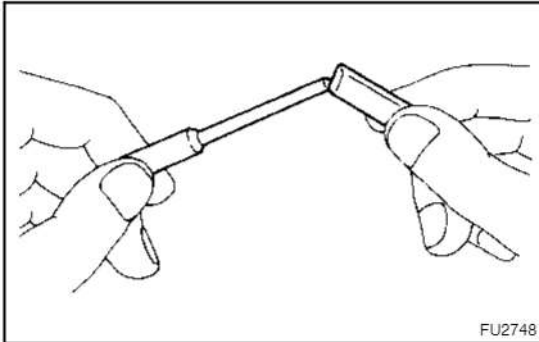

- (b) Using a wooden stick, remove the carbon adhering to the nozzle needle tip.

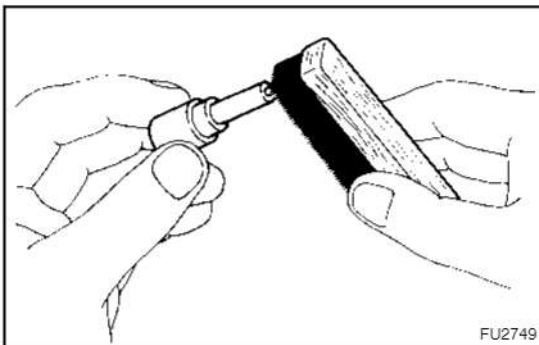

- (c) Using a brass brush, remove the carbon from the exterior of the nozzle body (except lapped surface).

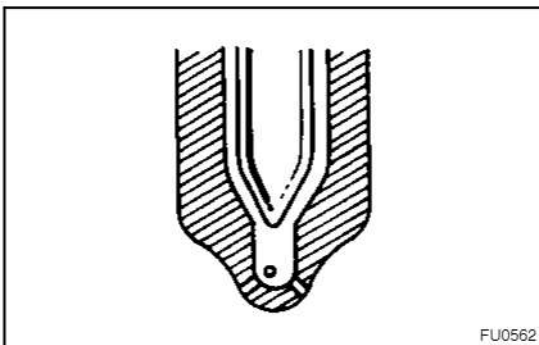

- (d) Check the seat of the nozzle body for burns or corrosion.  
 (e) Check the nozzle needle tip for damage or corrosion. If any of these conditions are present, replace the nozzle assembly.

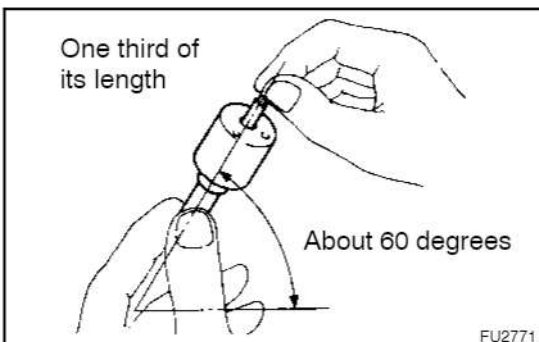

### 2. INSPECT NOZZLE ASSEMBLY

- (a) Wash the nozzle in clean diesel fuel.

HINT:

Do not touch the nozzle mating surfaces with your fingers.

- (b) Tilt the nozzle body about 60 degrees and pull the needle out about one third of its length.

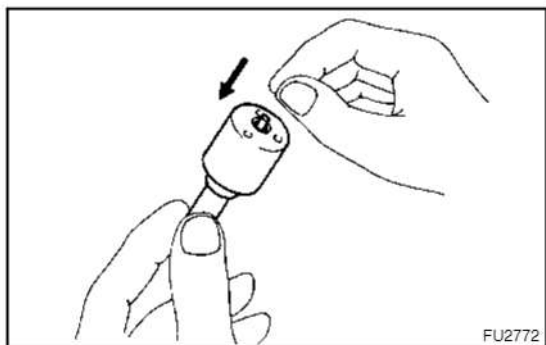

FU2772

- (c) When released, the needle should stick down into the body vent smoothly by its own weight.
- (d) Repeat this test, rotating the needle slightly each time. If the needle does not sink freely, replace the nozzle assembly.

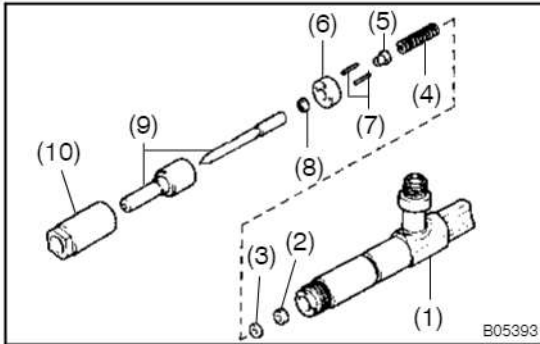

## ADJUSTMENT

### 1. CHECK NO.2 OPENING PRESSURE

- (a) Assemble these parts:
- (1) Nozzle holder body
  - (2) No.1 pressure spring seat
  - (3) No.1 pressure spring washer (Adjusting shim)
  - (4) No.2 pressure spring
  - (5) SST
  - (6) Tip packing
  - (7) Straight pins
  - (8) No.3 pressure spring washer
  - (9) Nozzle assembly
  - (10) Retaining nut
- SST 09268-17020

#### NOTICE:

**Do not assemble the No.1 pressure spring, No.1 pressure pin and adjusting shim for adjustment of the No.1 opening pressure.**

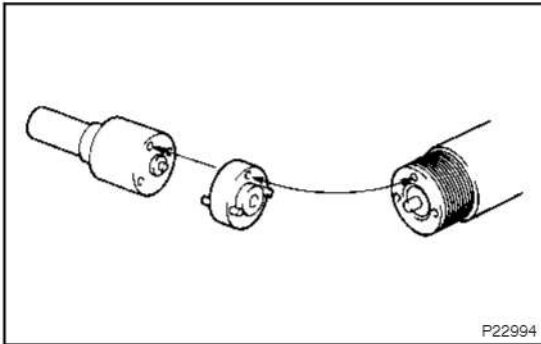

#### HINT:

Align the holes of the nozzle body, tip packing and nozzle holder body.

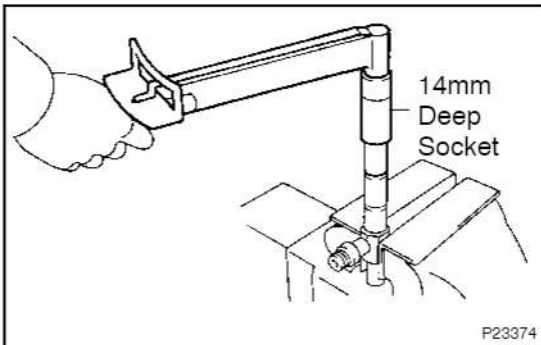

- (b) Using a 14 mm deep socket wrench, torque the retaining nut.

**Torque: 29.4 N·m (300 kgf·cm, 22 ft·lbf)**

#### NOTICE:

**Over torquing could cause the nozzle deformation and the needle adhesion or other defects.**

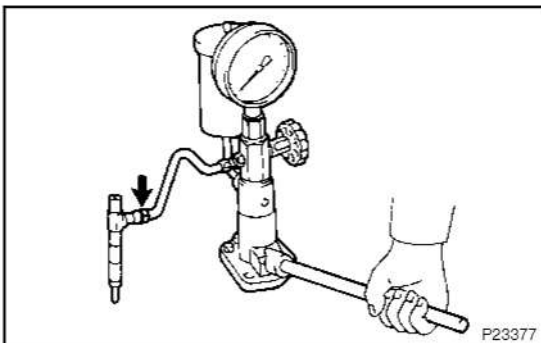

- (c) Install the injection nozzle to the injection nozzle hand tester and bleed air from the union nut.

#### CAUTION:

**Do not place your finger over the nozzle injection hole.**

- (d) Pump the tester handle a few times as fast as possible to discharge the carbon from the injection hole.

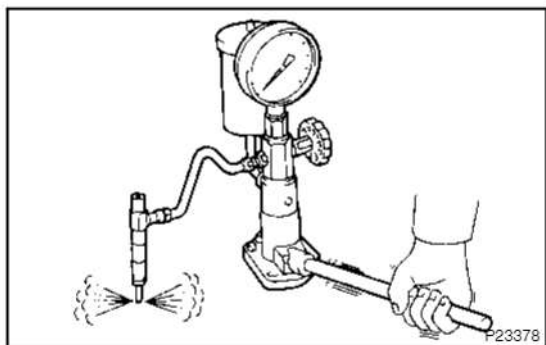

- (e) Pump the tester handle slowly and observe the pressure gauge.
- (f) Read the pressure gauge just as the injection pressure begins to drop.

**No.2 opening pressure (Inspection pressure):**

**33,539 – 35,500 kPa**

**(342 – 362 kgf/cm<sup>2</sup>, 4,864 – 5,149 psi)**

**HINT:**

- Proper nozzle operation can be determined by a swishing sound.
- With the SST installation, the inspection adjusting valve of No.2 opening pressure has become higher than 27,459 kPa (280 kgf/cm<sup>2</sup>, 3,982 psi).

If the opening pressure is not as specified, disassemble the nozzle and change the No.1 pressure spring washer (adjusting shim).

**No.1 pressure spring washer (adjusting shim) thickness:**

mm (in.)	mm (in.)	mm (in.)
0.700 (0.0276)	1.225 (0.0482)	1.625 (0.0640)
0.750 (0.0295)	1.250 (0.0492)	1.650 (0.0650)
0.800 (0.0315)	1.275 (0.0502)	1.675 (0.0659)
0.850 (0.0335)	1.300 (0.0512)	1.700 (0.0669)
0.900 (0.0354)	1.325 (0.0521)	1.725 (0.0679)
0.950 (0.0374)	1.350 (0.0531)	1.750 (0.0689)
0.975 (0.0384)	1.375 (0.0541)	1.775 (0.0699)
1.000 (0.0394)	1.400 (0.0551)	1.800 (0.0709)
1.025 (0.0404)	1.425 (0.0561)	1.850 (0.0728)
1.050 (0.0413)	1.450 (0.0571)	1.900 (0.0748)
1.075 (0.0423)	1.475 (0.0581)	1.950 (0.0768)
1.100 (0.0433)	1.500 (0.0591)	2.000 (0.0787)
1.125 (0.0443)	1.525 (0.0600)	2.050 (0.0807)
1.150 (0.0453)	1.550 (0.0610)	2.100 (0.0827)
1.175 (0.0463)	1.575 (0.0620)	2.150 (0.0846)
1.200 (0.0472)	1.600 (0.0630)	-

**HINT:**

- Varying the adjusting shim thickness by 0.025 mm (0.0010 in.) changes the injection pressure by about 373 kpa (3.8 kgf/cm<sup>2</sup>, 54 psi).
- Only one adjusting shim should be used.

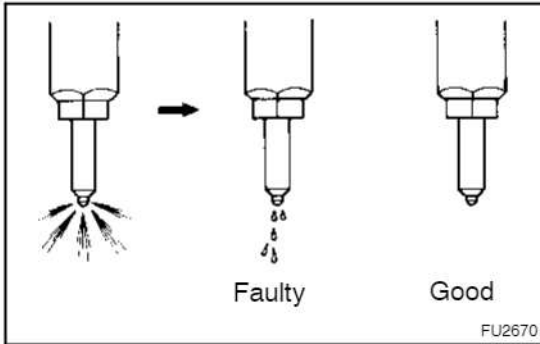

- (g) There should be no dripping after injection.  
 (h) After checking the No.2 opening pressure, disassemble the nozzle.

## 2. ADJUST NO.1 OPENING PRESSURE

- (a) Assemble the nozzle holder body, No.2 pressure spring washer (adjusting shim) for adjustment of No.1 opening pressure, No.1 pressure spring, pressure pin, No.1 pressure spring seat, No.1 pressure spring washer (adjusting shim) selected in step 1 above, No.2 pressure spring, No.2 pressure spring seat, tip packing, straight pins, No.3 pressure spring washer and nozzle assembly, and finger tighten the retaining nut.

### HINT:

- Align the holes of the nozzle body, the distance piece and the nozzle holder body.
  - When the thickness of the original used adjusting shim is not known, use a shim 1.5 mm (0.59 in.) thick instead.
- (b) Read the pressure gauge just as the injection pressure begins to drop. (See steps (b) to (f) in step 1 above)

### No.1 opening pressure:

**17,162 – 18,142 kpa**

**(175 – 185 kgf/cm<sup>2</sup>, 2,489 – 2,631 psi)**

### HINT:

Proper nozzle operation can be determined by a swishing sound.

If the opening pressure is not as specified, disassemble the nozzle and change the No.2 pressure spring washer (adjusting shim).

**No.2 pressure spring washer (adjusting shim) thickness:**

mm (in.)	mm (in.)	mm (in.)
0.800 (0.0315)	1.275 (0.0502)	1.750 (0.0689)
0.825 (0.0325)	1.300 (0.0512)	1.775 (0.0699)
0.850 (0.0335)	1.325 (0.0521)	1.800 (0.0709)
0.875 (0.0344)	1.350 (0.0531)	1.825 (0.0719)
0.900 (0.0354)	1.375 (0.0541)	1.850 (0.0728)
0.925 (0.0364)	1.400 (0.0551)	1.875 (0.0738)
0.950 (0.0374)	1.425 (0.0561)	1.900 (0.0748)
0.975 (0.0384)	1.450 (0.0571)	1.925 (0.0758)
1.000 (0.0394)	1.475 (0.0581)	1.950 (0.0768)
1.025 (0.0404)	1.500 (0.0591)	1.975 (0.0778)
1.050 (0.0413)	1.525 (0.0600)	2.000 (0.0787)
1.075 (0.0423)	1.550 (0.0610)	2.025 (0.0797)
1.100 (0.0433)	1.575 (0.0620)	2.050 (0.0807)
1.125 (0.0443)	1.600 (0.0630)	2.075 (0.0817)
1.150 (0.0453)	1.625 (0.0640)	2.100 (0.0827)
1.175 (0.0463)	1.650 (0.0650)	2.125 (0.0837)
1.200 (0.0472)	1.675 (0.0659)	2.150 (0.0846)
1.225 (0.0482)	1.700 (0.0669)	2.175 (0.0856)
1.250 (0.0492)	1.725 (0.0679)	2.200 (0.0866)

**HINT:**

- Varying the adjusting shim thickness by 0.025 mm (0.0010 in.) changes the injection pressure by about 373 kpa (3.8 kgf/cm<sup>2</sup>, 54 psi).
  - Only one adjusting shim should be used.
- (c) There should be no dripping after injection.  
(See step (g) in step 1 above)



## REASSEMBLY

### ASSEMBLY INJECTION NOZZLE HOLDER

- (a) Assemble the nozzle holder body, No.2 pressure spring washer (adjusting shim), No.1 pressure spring, pressure pin, No.1 pressure spring seat, No.1 pressure spring washer (adjusting shim), No.2 pressure spring, No.2 pressure spring seat, tip packing, straight pins, No.3 pressure spring washer and nozzle assembly, and finger tighten the retaining nut.

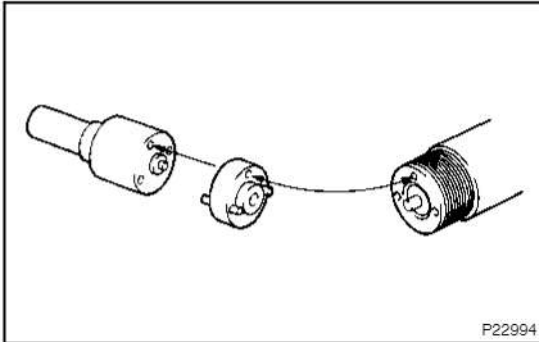

#### HINT:

- Align the holes of the nozzle body, the distance piece and the nozzle holder body.
- When the thickness of the original used adjusting shim is not known, use a shim 1.5 mm (0.59 in.) thick instead.

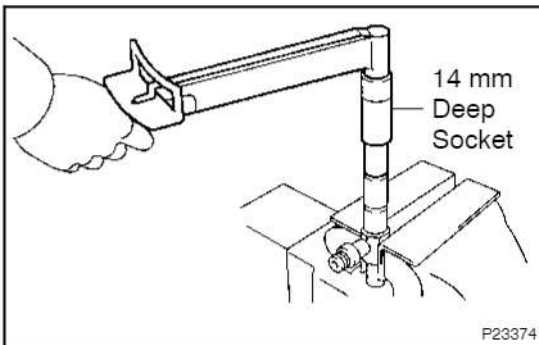

- (b) Using a 14 mm deep socket wrench, torque the retaining nut.

**Torque: 29.4 N·m (300 kgf·cm, 22 ft·lbf)**

#### NOTICE:

**Over torquing could cause the nozzle deformation and the needle adhesion or other defects.**

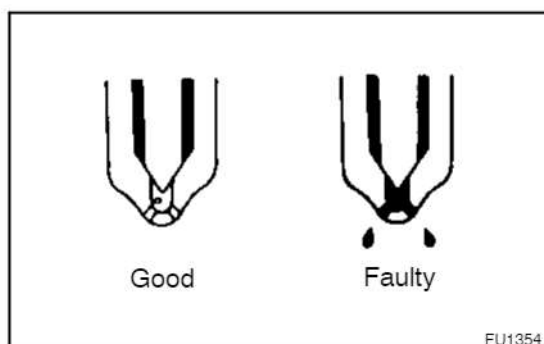

## TEST

### 1. LEAKAGE TEST

While maintaining pressure at about 981 – 1,961 kPa (10 – 20 kgf/cm<sup>2</sup> 142 – 284 psi), below No.1 opening pressure (adjust by tester handle), check that there is not dripping for 10 seconds from the injection hole or around the retaining nut.

If the nozzle drips within 10 seconds, replace or clean and overhaul the nozzle assembly.

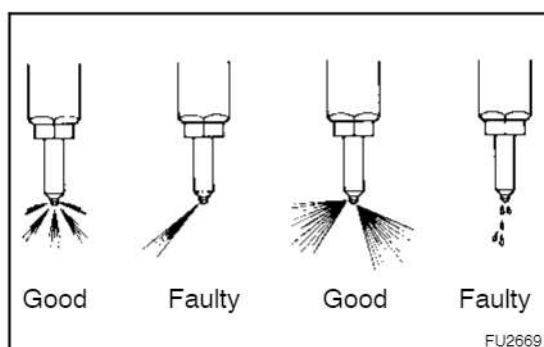

### 2. SPRAY PATTERN TEST

- The injection nozzle should shudder at a certain pumping speed between 15 – 60 times (old nozzle) or 30 – 60 times (new nozzle) per minute.
- Check the spray pattern during shuddering. If the spray pattern is not correct during shuddering, the nozzle must be replaced or cleaned.

## INSTALLATION

### 1. INSTALL INJECTION NOZZLES

- (a) Install a new O-ring to the injection nozzle.
- (b) Place 6 new nozzle seats into the injection nozzle holes of the cylinder head.

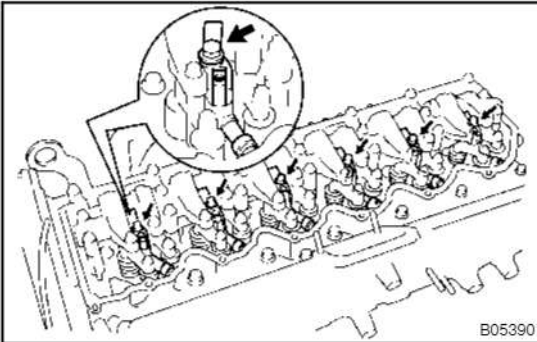

- (c) Install the injection nozzles with the nozzle holder clamp, washer and bolt to the cylinder head.

**Torque: 25 N·m (255 kgf·cm, 18 ft·lbf)**

- (d) Inspect the valve clearance. (See page EM-9)

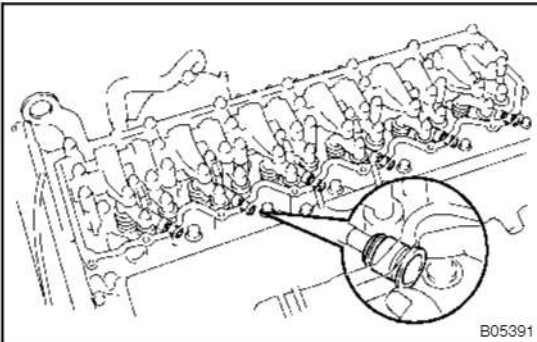

### 2. INSTALL NOZZLE HOLDER SEALS

Install the 6 new nozzle holder seals to the cylinder head with your hand.

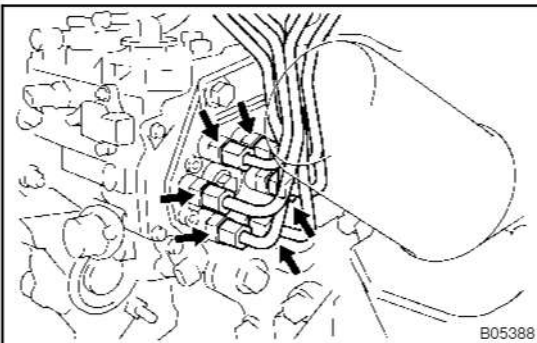

### 3. INSTALL INJECTION PIPES

- (a) Place the 2 clamps on the intake manifold.
- (b) Attach the 6 injection pipes to the injection nozzle and injection pump.
- (c) Tighten the 6 union nuts to the injection pump.

**Torque: 24.5 N·m (250 kgf·cm, 18 ft·lbf)**

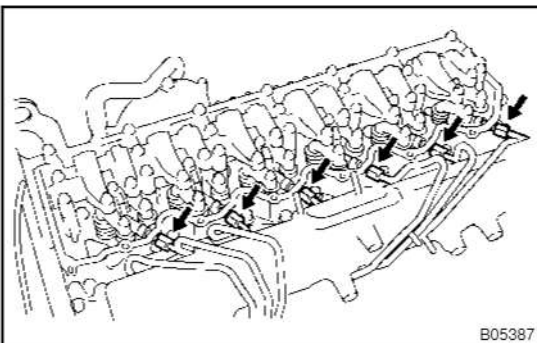

- (d) Tighten the 6 union nuts to the injection nozzle.

**Torque: 24.5 N·m (250 kgf·cm, 18 ft·lbf)**

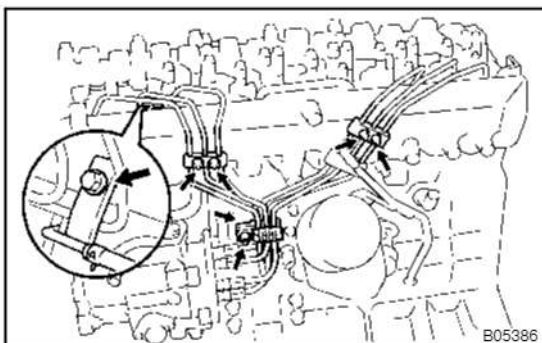

- (e) Install the 2 clamps with the 2 nuts.  
**Torque: 6.4 N·m (65 kgf·cm, 56 in·lbf)**
- (f) Install the clamp with the bolt and nut.  
**Torque: 6.4 N·m (65 kgf·cm, 56 in·lbf)**
- (g) Install the No.3 nozzle leakage pipe with the bolt.  
**Torque: 19.6 N·m (200 kgf·cm, 15 ft·lbf)**

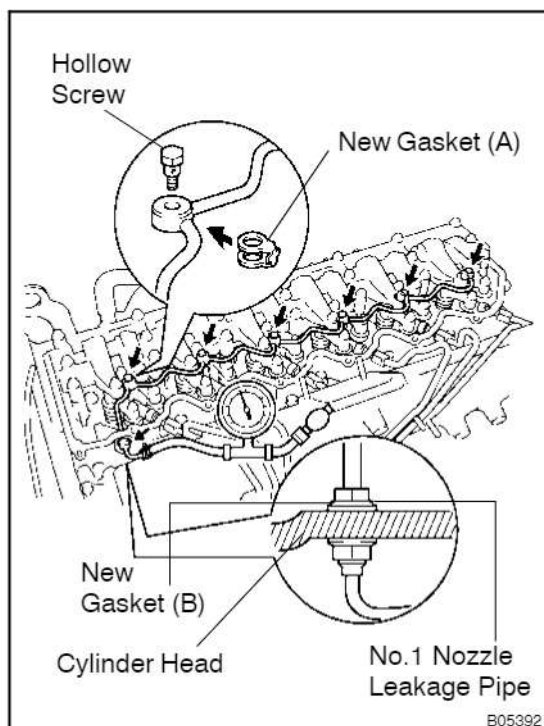

#### 4. INSTALL NO.1 NOZZLE LEAKAGE PIPE

- (a) Install the 7 new gaskets, No.1 nozzle leakage pipe to the cylinder head, injection nozzle with the 6 hollow screw and nut.  
**Torque:**  
**Hollow screw: 11.3 N·m (115 kgf·cm, 8 ft·lbf)**  
**Nut: 19 N·m (186 kgf·cm, 14 ft·lbf)**

#### NOTICE:

**Install the gasket (A) so that its connecting part is between the pipe as shown in the illustration.**

- (b) Using SST (turbocharger pressure gauge), apply the SST to the fuel return side of the No.1 nozzle leakage pipe, and maintain 49 kPa (0.5 kgf/cm<sup>2</sup>, 7.1 psi) of pressure for 10 seconds to check that there are no leaks.  
SST 09992-00241
  - (c) Connect the fuel return hose to the No.1 nozzle leakage pipe.
5. **INSTALL NO.1 AND NO.2 CYLINDER HEAD COVERS (See page EM-94)**
6. **INSTALL INTAKE PIPE (See page EM-94)**
7. **START ENGINE AND CHECK FOR FUEL LEAKAGE**

# INJECTION PUMP (1HZ, 1HD-T) COMPONENTS

FU05A-01

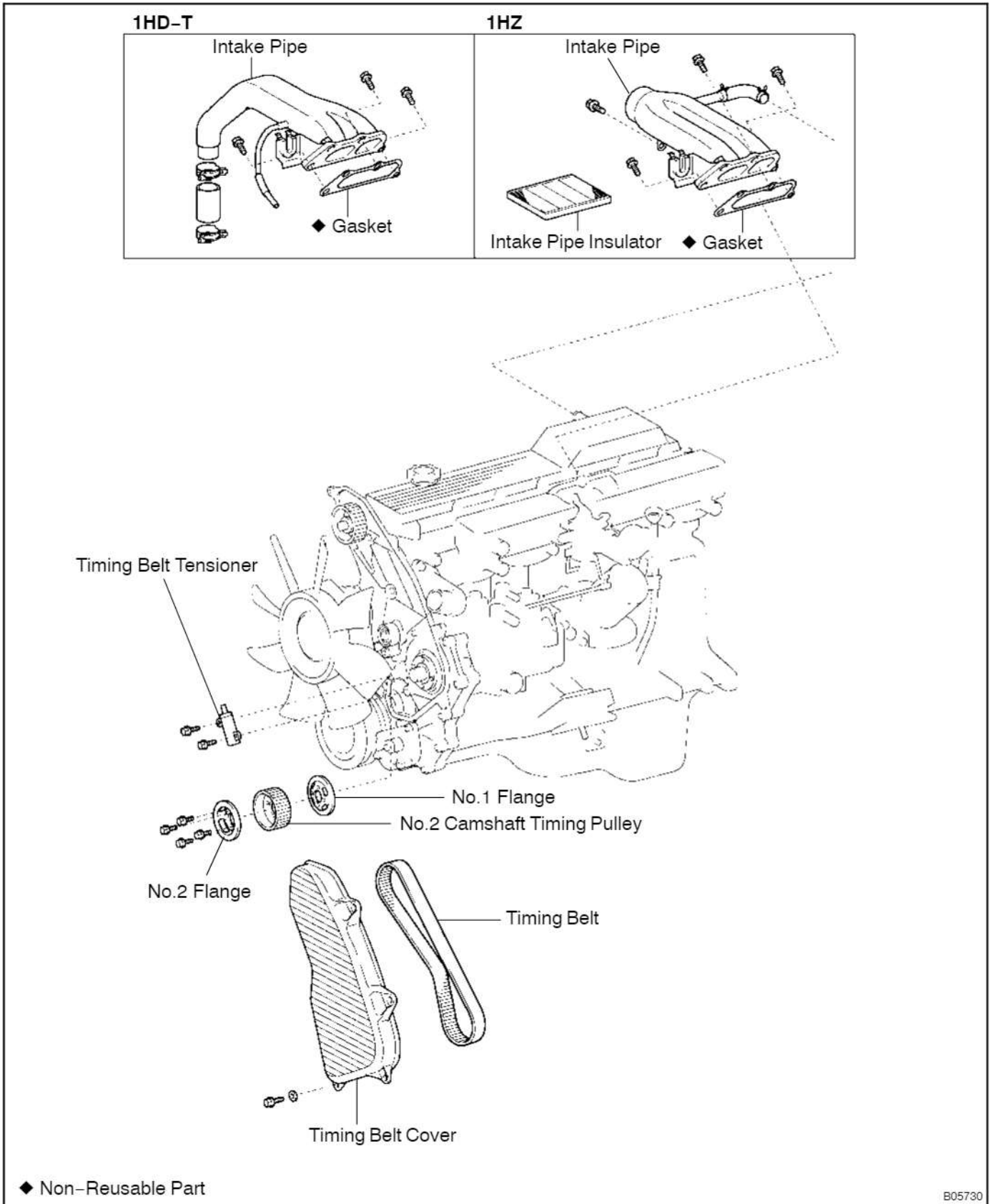

cardiagn.com

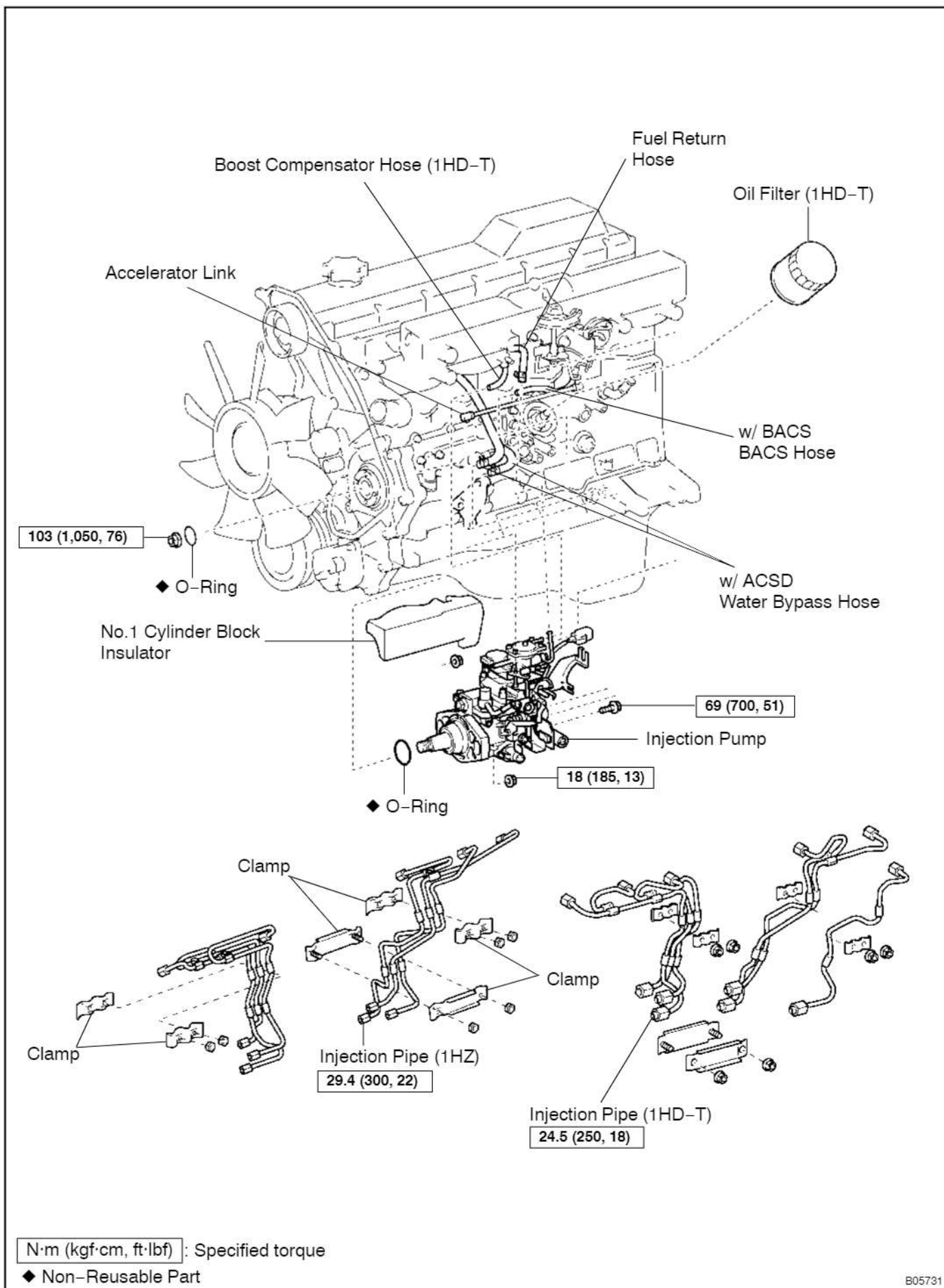

cardiagn.com

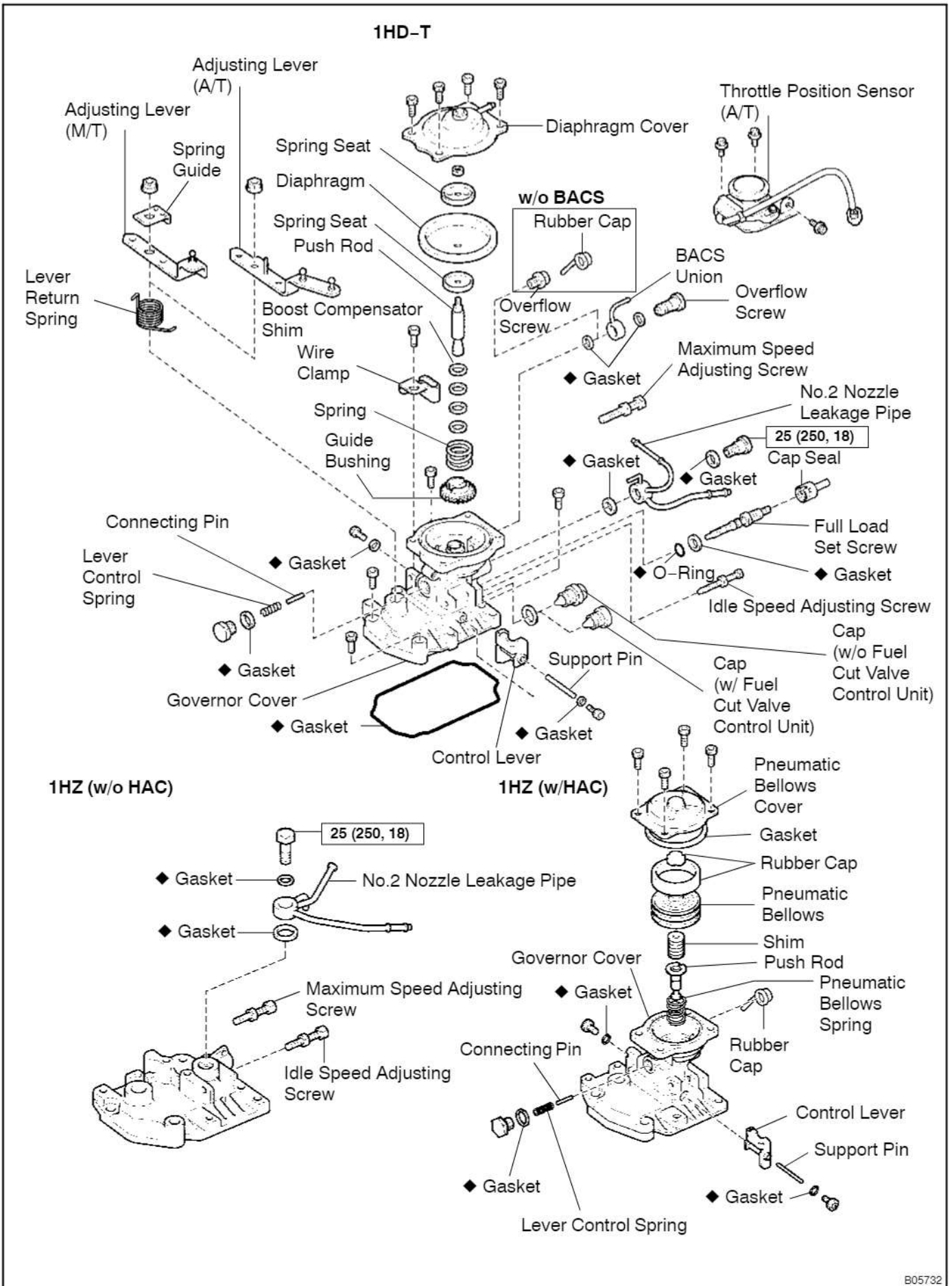

cardiagn.com

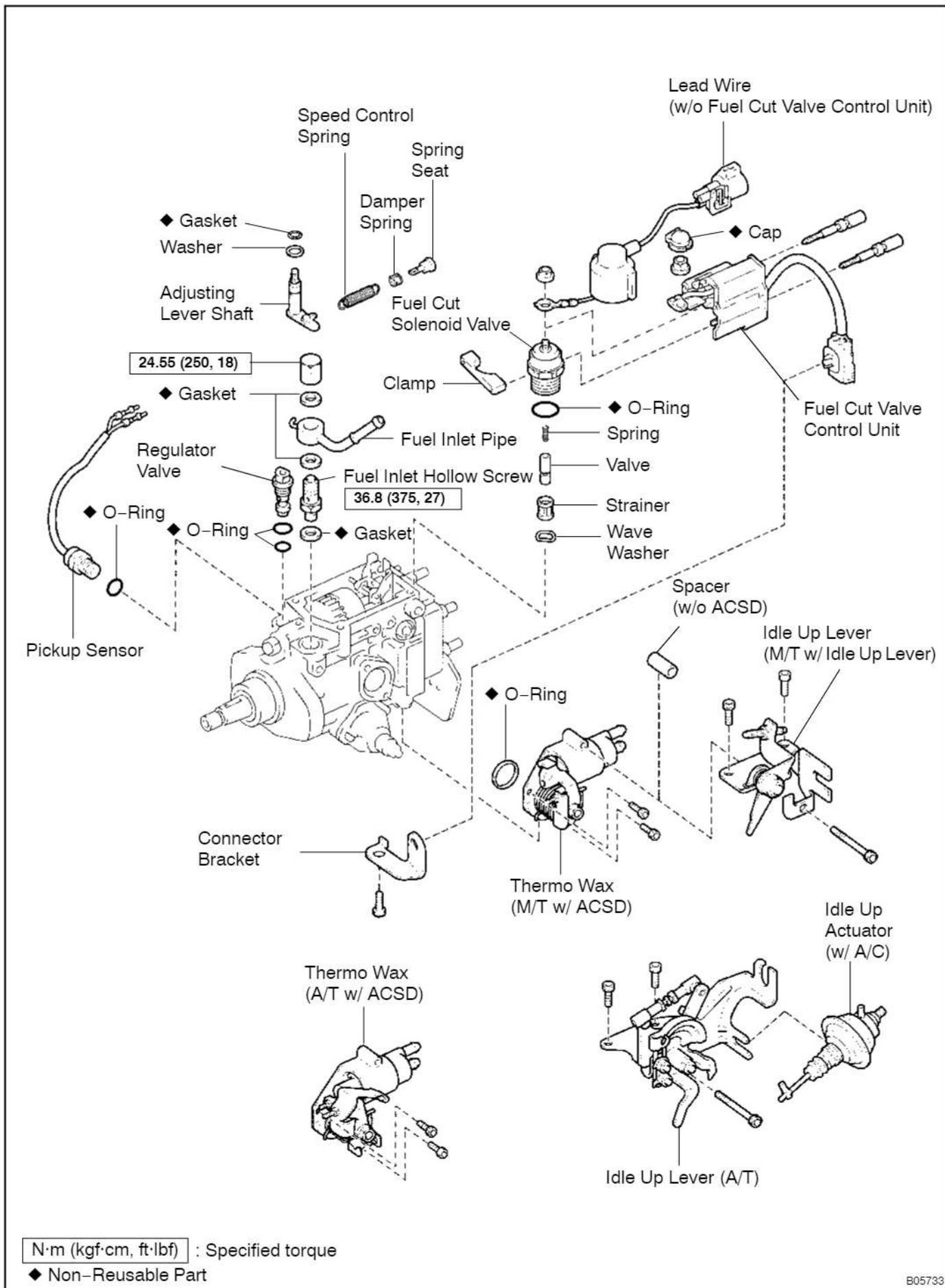

cardiagn.com



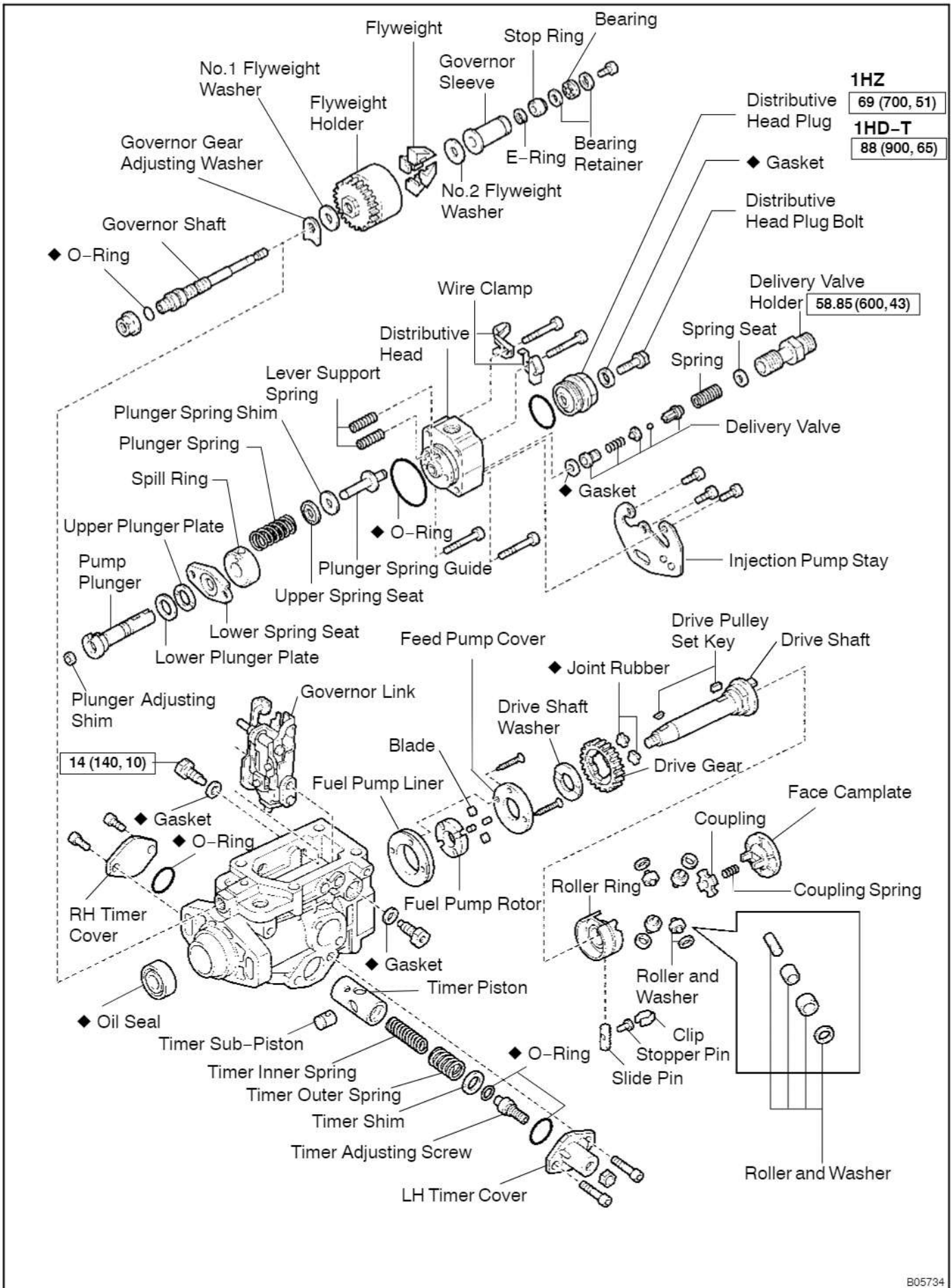

cardiagn.com

## REMOVAL

1. w/ ACSD:  
DRAIN ENGINE COOLANT (See page CO-2)
2. REMOVE TIMING BELT (See page EM-27)
3. REMOVE NO.2 CAMSHAFT TIMING PULLEY (See page EM-27)
4. DISCONNECT ACCELERATOR CONNECTING ROD
5. 1HD-T:  
REMOVE OIL FILTER (See page LU-2)
6. REMOVE INJECTION PIPES (See page FU-7)
7. w/ ACSD:  
DISCONNECT WATER BYPASS HOSES FROM THERMO WAX

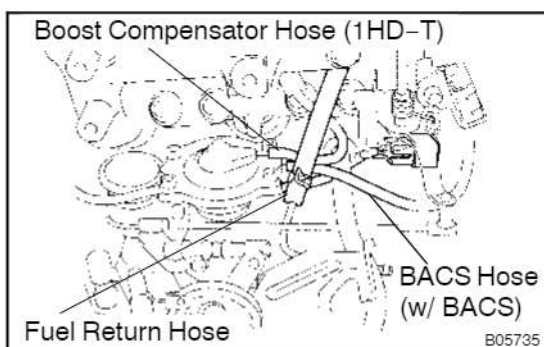

8. DISCONNECT HOSES
  - (a) Disconnect the fuel return hose from the injection pump.
  - (b) 1HD-T:  
Disconnect the boost compensator hose.
  - (c) 1HD-T (w/ BACS):  
Disconnect the BACS hose.
9. A/T:  
DISCONNECT THROTTLE POSITION SENSOR CONNECTOR FROM ACCELERATOR LINK

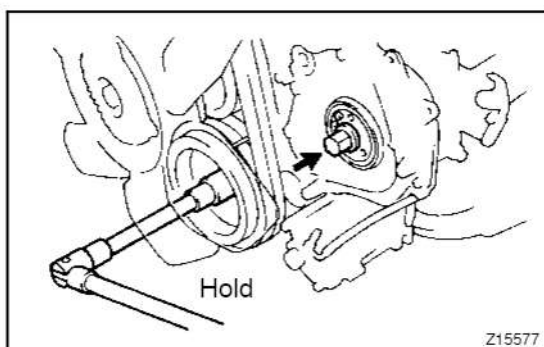

10. REMOVE INJECTION PUMP
  - (a) Hold the crankshaft pulley, and remove the injection pump drive gear set nut.

**NOTICE:**  
Do not turn the crankshaft pulley. The valve heads will hit against the piston top.

- (b) Remove the O-ring from the injection pump drive gear.

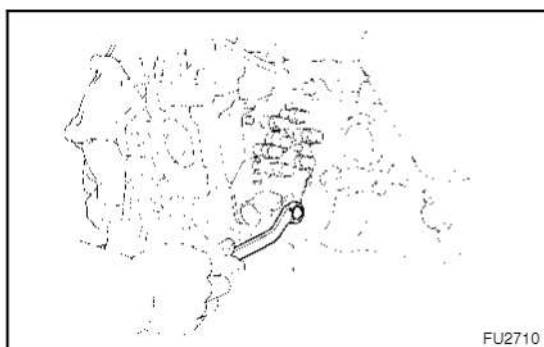

- (c) Remove the bolt holding the injection pump to the injection pump stay.

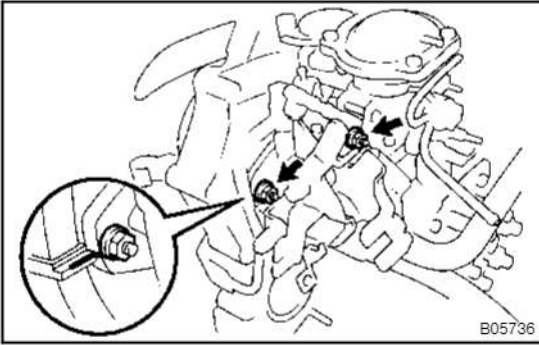

- (d) Before removing the injection pump, check if the matchmarks are aligned.  
If not, place new matchmarks for reinstallation.
- (e) Remove the 2 nuts holding the injection pump to the timing gear case.

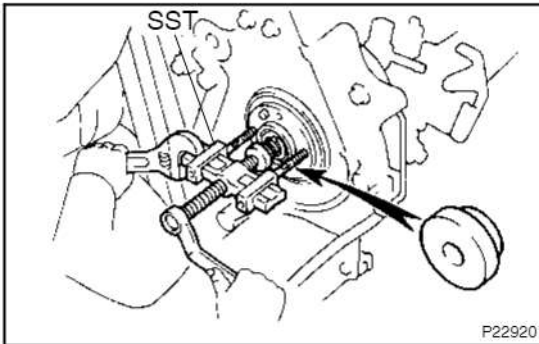

- (f) Using SST, remove the injection pump.  
SST 09950-40011 (09957-04010),  
09950-50010 (09951-05010, 09952-05010,  
09953-05020, 09954-05020)

**NOTICE:**

- **Tighten the 2 bolts more than 8 mm (0.31 in.).**
  - **Set SST so that it is balanced.**
  - **Do not hold or carry the injection pump by the adjusting lever.**
  - **Do not put the injection pump at an angle more than 45° from the horizontal.**
- (g) 1HD-T:  
Remove the No.1 cylinder block insulator.
- (h) Remove the O-ring from the injection pump.

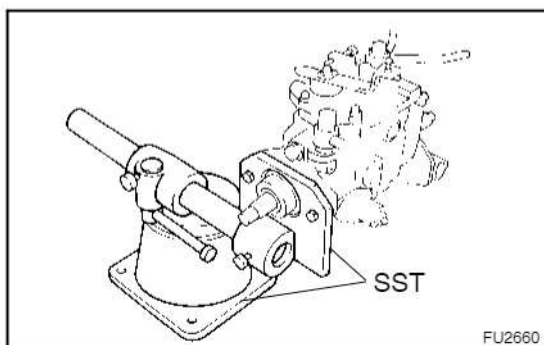

## DISASSEMBLY

1. **MOUNT PUMP ASSEMBLY TO SST (STAND)**  
SST 09241-76022, 09245-54010
2. **REMOVE SET KEY OF DRIVE PULLEY FROM DRIVE SHAFT**
3. **w/ A/C:**  
**REMOVE IDLE-UP ACTUATOR**

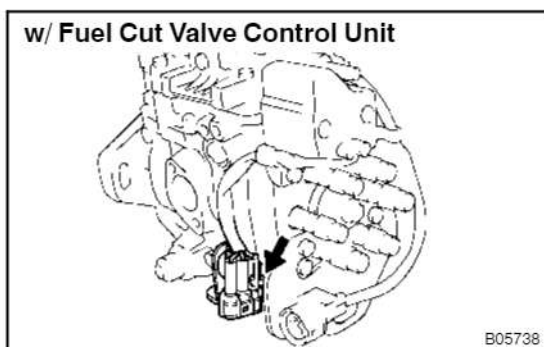

4. **w/ Fuel Cut Valve Control Unit:**  
**REMOVE FUEL CUT VALVE CONTROL UNIT**
  - (a) Disconnect the connector and wire.
  - (b) Using a 8 mm hexagon wrench, remove the bolt and connector bracket.

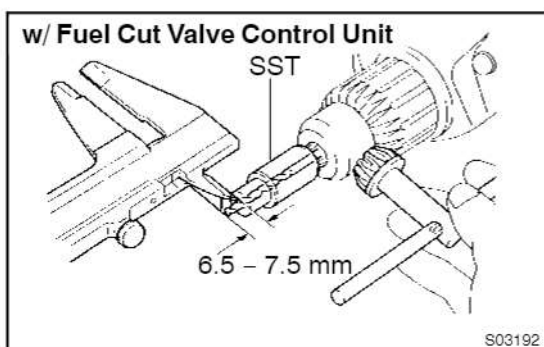

- (c) Attach a drill (diameter: 3.2 mm) and SST to a drill motor.  
SST 09263-00010
- (d) Protrude the drill tip 6.5 – 7.5 mm (0.256 – 0.295 in.) from the SST, and set it.

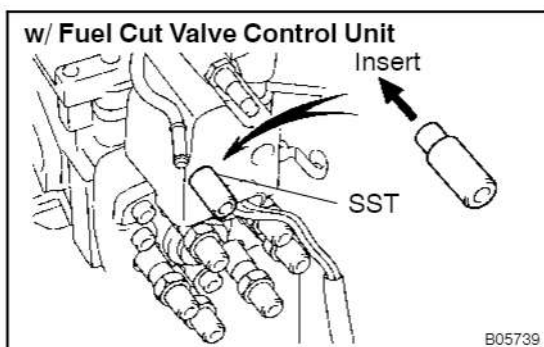

- (e) Attach the SST to the bolt hole of the fuel cut valve control unit as shown in the illustration.

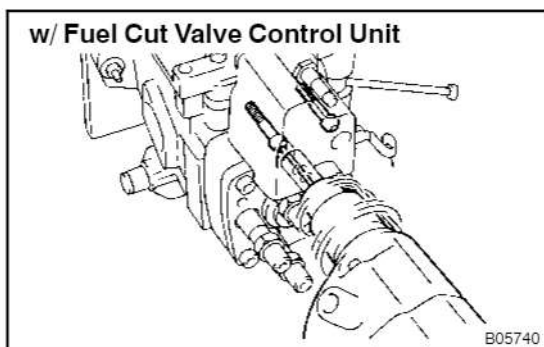

- (f) Drill the heads of the 2 bolts.
- NOTICE:**
- **Advance the drill bit slowly, making sure to drill a hole straight.**
  - **In addition to place a cap over the delivery valve holder, cover the area with a cloth to prevent the cutting chip from coming in contact with the delivery valve holder.**
- (g) Remove the SST from the bolt hole.

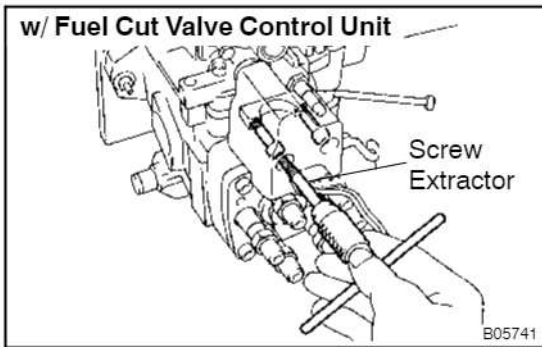

- (h) Using a screw extractor, remove the 2 bolts.
- (i) Disconnect the fuel cut valve control unit from the fuel cut solenoid.

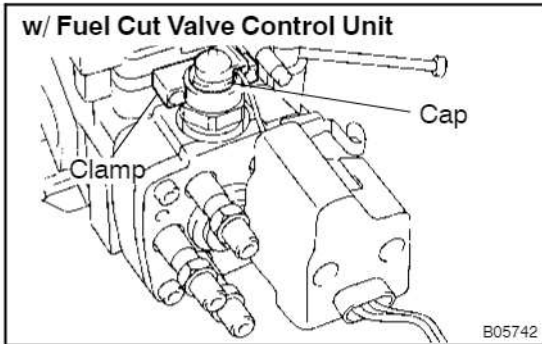

- (j) Remove the cap and clamp.

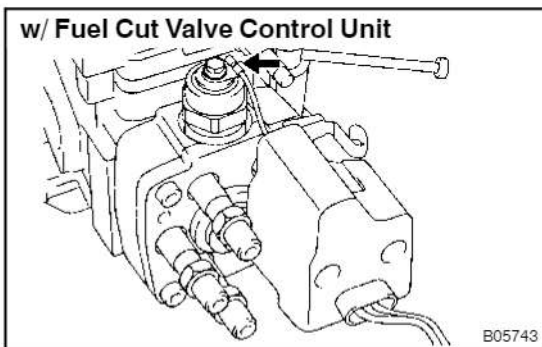

- (k) Remove the nut, and disconnect the lead wire from the fuel cut solenoid terminal. Remove the fuel cut valve control unit.
- (l) Clean the cutting tip from the bolt holes of the fuel cut valve control unit.

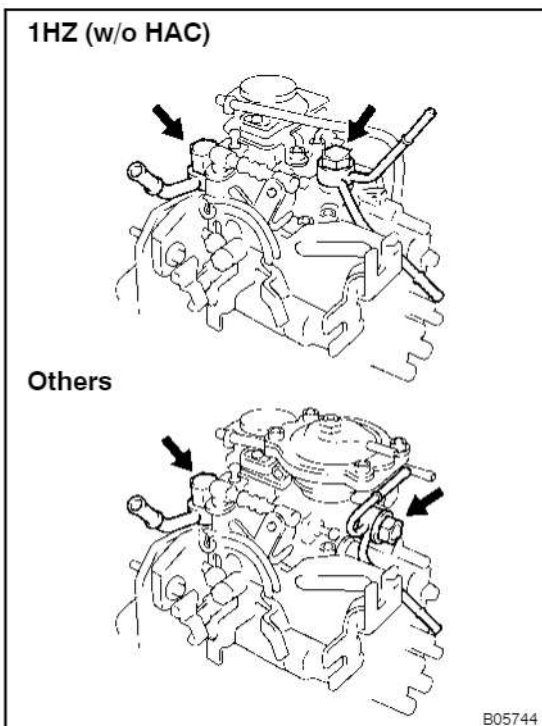

**5. REMOVE FUEL PIPES**

- (a) Remove the cap nut, fuel inlet pipe and 2 gaskets.
- (b) Remove the union bolts, No.2 nozzle leakage pipe and 2 gaskets.

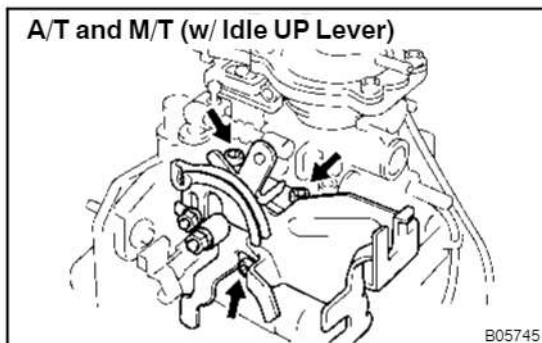
**A/T and M/T (w/ Idle UP Lever)**

B05745

**6. A/T and M/T (w/ Idle Up Lever):  
REMOVE IDLE-UP LEVER**

- (a) A/T:  
Remove the idle-up lever link from the adjusting lever.
- (b) Using a 5 mm hexagon wrench, remove the 3 bolts, idle-up lever and spacer (w/o ACSD).

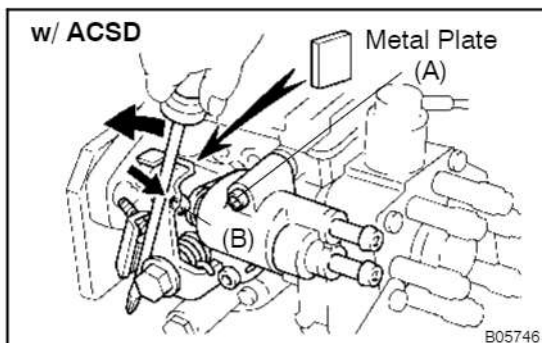
**w/ ACSD**

B05746

**7. w/ ACSD:  
REMOVE THERMO WAX**

- (a) Using a 5 mm hexagon wrench, temporarily install the bolt (A).
- (b) Using a screwdriver, turn the cold starting lever counter-clockwise.
- (c) Using a 5 mm hexagon wrench, remove the bolt (B).
- (d) Put a metal plate (thickness of 3.5 - 7.5 mm (0.138 - 0.295 in.)) between the cold starting lever and thermo wax plunger.
- (e) Using a 5 mm hexagon wrench, remove the 2 bolts, thermo wax and O-ring.

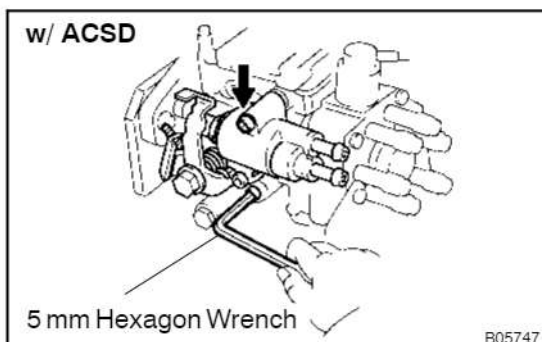
**w/ ACSD**

B05747

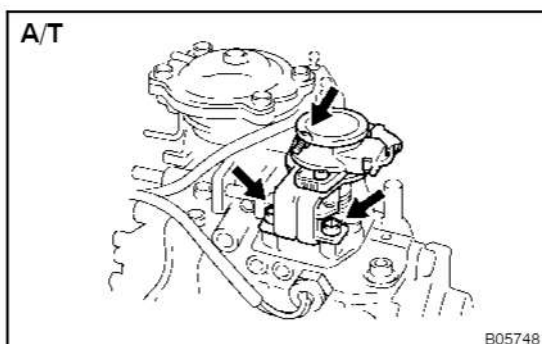
**A/T**

B05748

**8. A/T:  
REMOVE THROTTLE POSITION SENSOR AND  
BRACKET ASSEMBLY**

Using a 5 mm hexagon wrench, remove the 3 bolts, the throttle position sensor and bracket assembly.

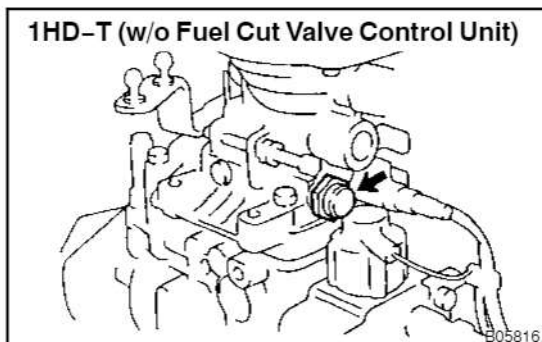
**1HD-T (w/o Fuel Cut Valve Control Unit)**

B05816

**9. 1HD-T:  
REMOVE CAP**

- (a) w/o Fuel cut valve control unit:  
Remove the cap and gasket.

**1HD-T (w/ Fuel Cut Valve Control Unit)**

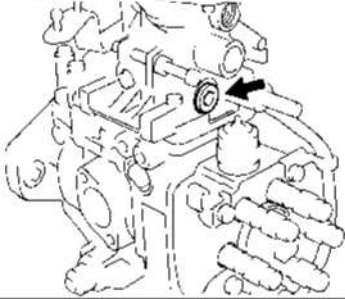

B05749

- (b) w/ Fuel cut valve control unit:  
Using a 6 mm hexagon wrench, remove the cap and gasket.

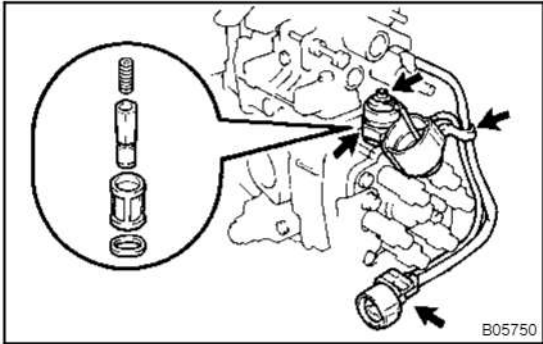

B05750

**10. REMOVE FUEL CUT SOLENOID**

- (a) w/o Fuel Cut Valve Control Unit:  
Disconnect the lead wire connector from the bracket.
- (b) w/o Fuel Cut Valve Control Unit:  
Disconnect the wire harness from the wire clamp.
- (c) w/o Fuel Cut Valve Control Unit:  
Disconnect the dust cover from the fuel cut solenoid.
- (d) w/o Fuel Cut Valve Control Unit:  
Remove the nut, lead wire and dust cover.
- (e) Remove the fuel cut solenoid, O-ring, spring, valve, strainer and wave washer.

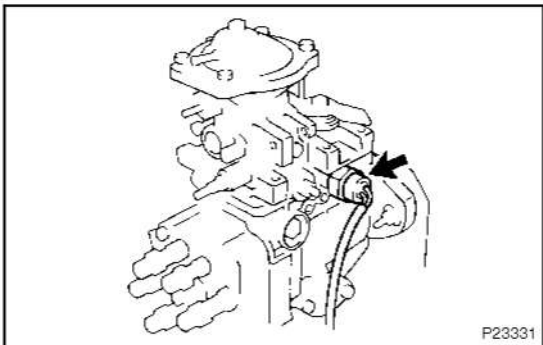

P23331

**11. REMOVE PICKUP SENSOR**

- (a) Remove the pickup sensor and O-ring.
- (b) Disconnect the sensor lead wires from the connector.

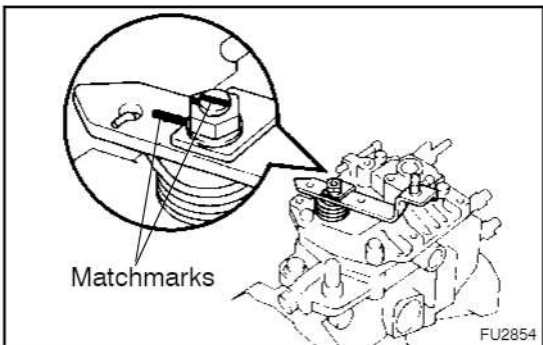

Matchmarks

FU2854

**12. REMOVE ADJUSTING LEVER**

- (a) Place the matchmarks on adjusting lever and shaft.
- (b) Remove the nut, return spring guide (M/T), adjusting lever and return spring.

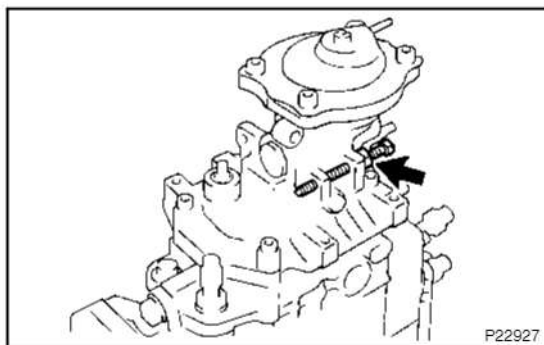
**13. REMOVE GOVERNOR COVER**

- (a) Remove the idle speed adjusting screw.
- (b) Using a 5 mm hexagon wrench, remove the bolt and wire clamp from the governor cover.

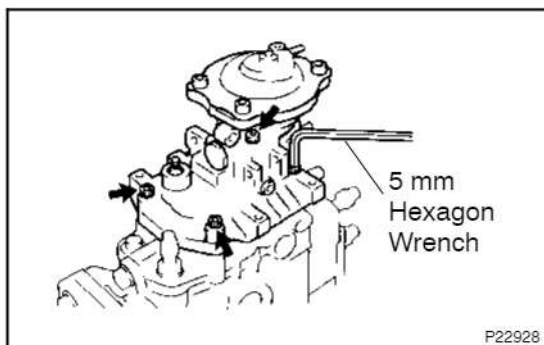

- (c) Using a 5 mm hexagon wrench, remove the 4 bolts.

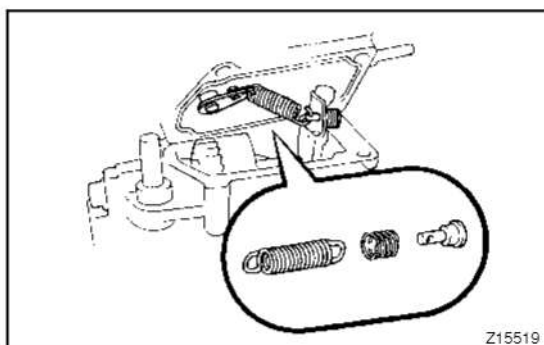

- (d) Disconnect the speed control spring from the spring seat, and remove the spring seat, damper spring, speed control spring, the governor cover, adjusting lever shaft assembly and gasket.

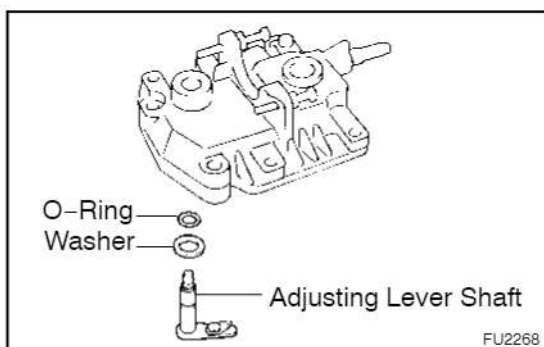
**14. REMOVE GOVERNOR ADJUSTING LEVER SHAFT FROM GOVERNOR COVER**

- (a) Remove the adjusting lever shaft assembly from the governor cover.
- (b) Remove the O-ring and washer from the adjusting lever shaft.

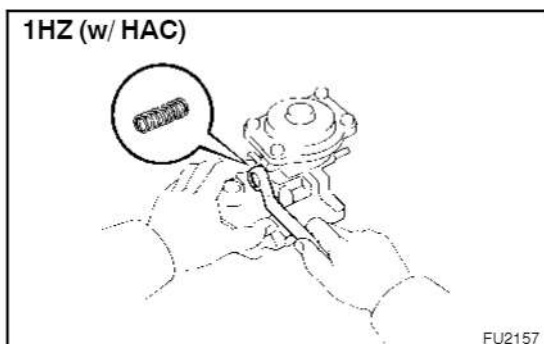
**15. 1HZ (w/ HAC): DISASSEMBLE HIGH ALTITUDE COMPENSATOR**

- (a) Remove the lever control spring.  
Remove the bolt, gasket and lever control spring.



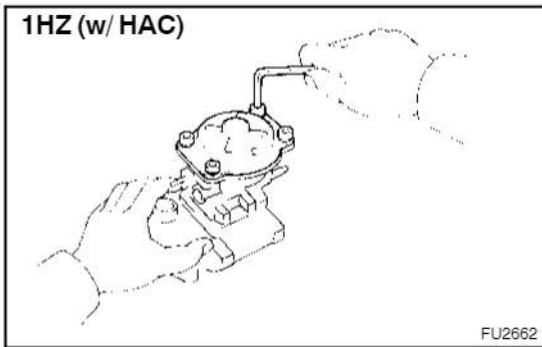

- (b) Remove the pneumatic bellows.
- (1) Using a 5 mm hexagon wrench, remove the four bolts.

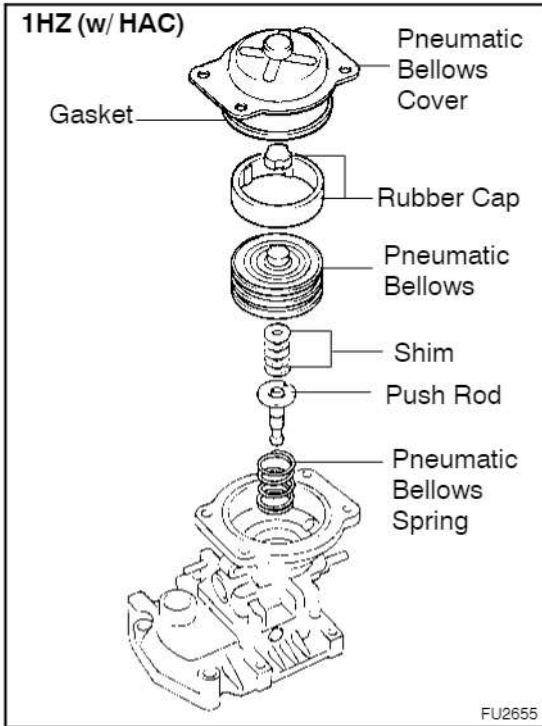

- (2) Remove the pneumatic bellows cover, gasket, shims, pneumatic bellows, 2 rubber caps, push rod and pneumatic bellows spring.

**NOTICE:**  
**Note the number of the shims.**

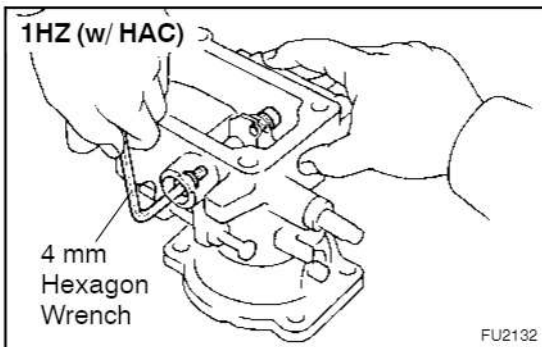

- (c) Remove the control lever.
- (1) Using a 4 mm hexagon wrench, remove the 2 bolts and 2 gaskets.

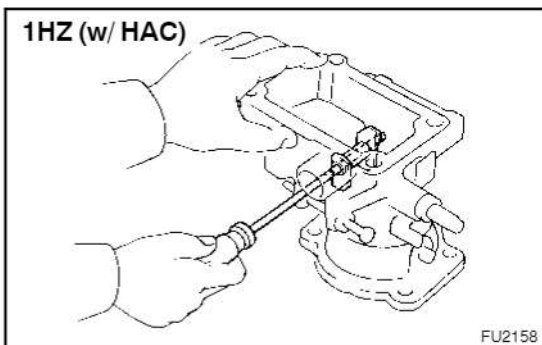

- (2) Using a small screwdriver, push out the support pin and remove the control lever.

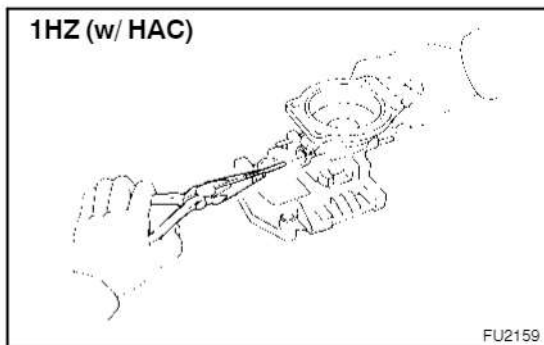

- (3) Using needle nose pliers, remove the connecting pin.

**NOTICE:**

**Be careful not to damage the connecting. Tape the tip of the pliers.**

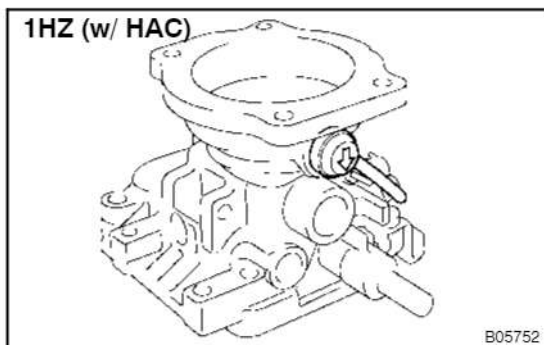

- (d) Remove the rubber cap from the governor cover.

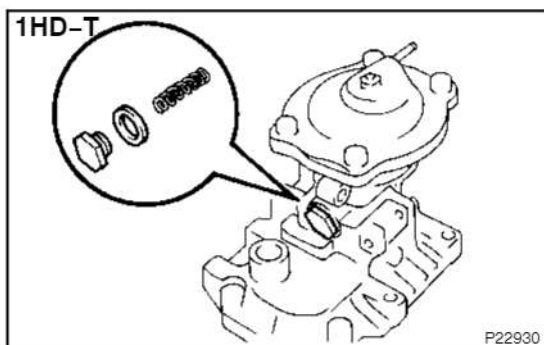

**16. 1HD-T:**

**DISASSEMBLE BOOST COMPENSATOR**

- (a) Remove the lever control spring.  
Remove the bolt, gasket and lever control spring.

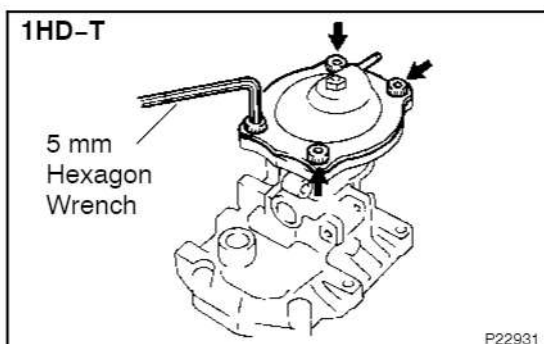

- (b) Remove the boost compensator diaphragm.  
(1) Using a 5 mm hexagon wrench, remove the 4 bolts.

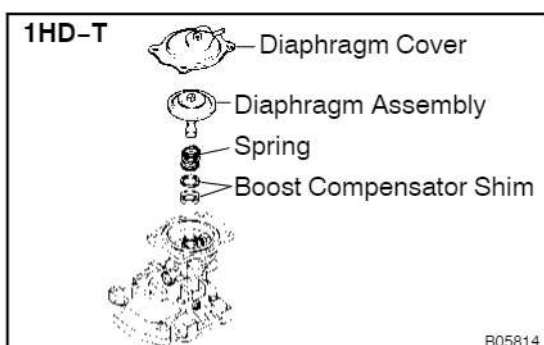

- (2) Remove the diaphragm cover, diaphragm assembly, spring and boost compensator shims.

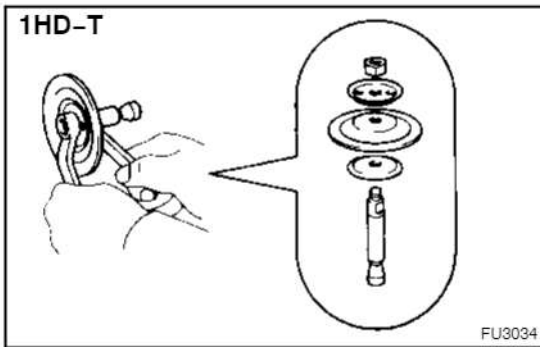

- (3) Remove the nut, 2 spring seats, diaphragm from the push rod.

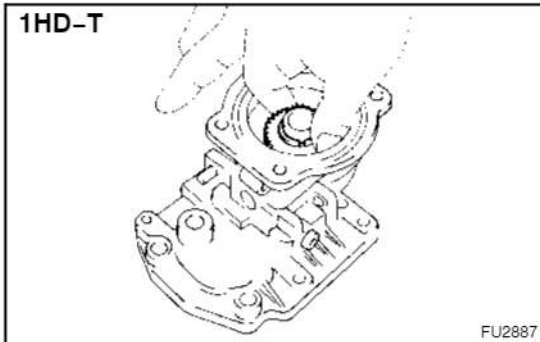

- (c) Remove the guide bushing.

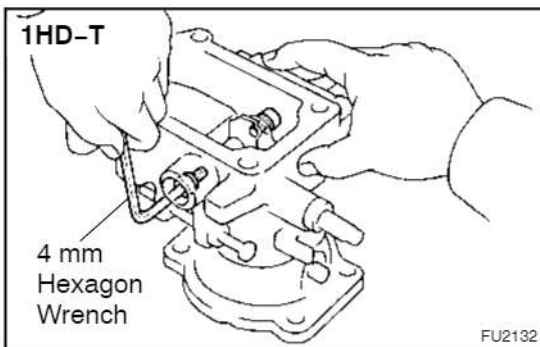

- (d) Remove the control lever.  
 (1) Using a 4 mm hexagon wrench, remove the 2 bolts and 2 gaskets.

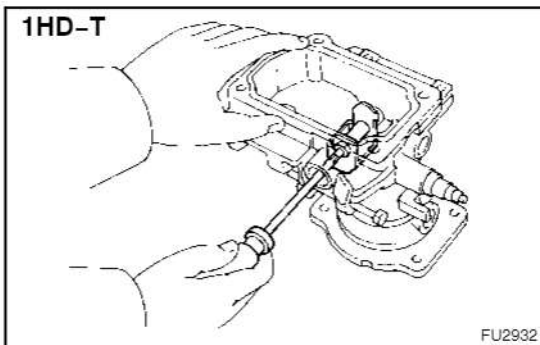

- (2) Using a small screwdriver, push out the support pin and remove the control lever.

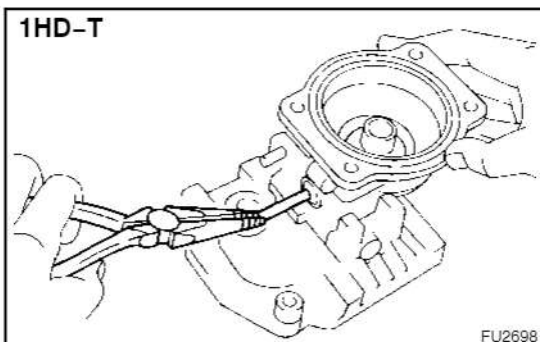

- (3) Using needle nose pliers, remove the connecting pin.

**NOTICE:**  
 Be careful not to damage the connecting pin. Tape the tip of the pliers.

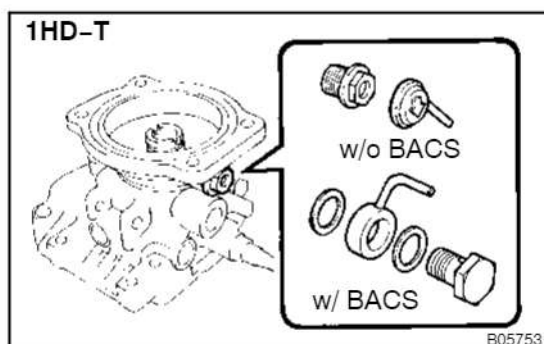

- (e) Remove overflow screw
- (1) w/o BACS:  
Remove the rubber cap and overflow screw.
  - (2) w/ BACS:  
Remove the overflow screw, BACS union and 2 gaskets.

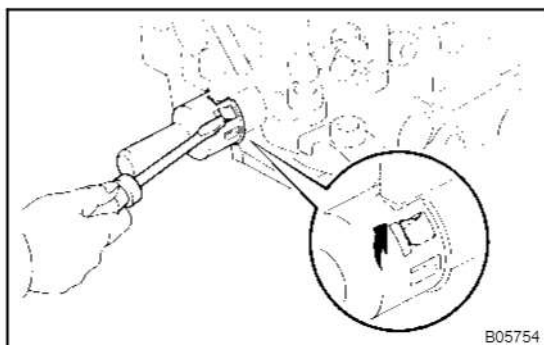

**17. REMOVE FULL LOAD SET SCREW**

- (a) Using a small screwdriver, pry the claws.
- (b) Remove the cap seal.
- (c) Remove the full load set screw.

**18. CHECK FLYWEIGHT HOLDER THRUST CLEARANCE**  
(See page FU-92)

Thrust clearance: 0.15 – 0.35 mm (0.0059 – 0.0138 in.)

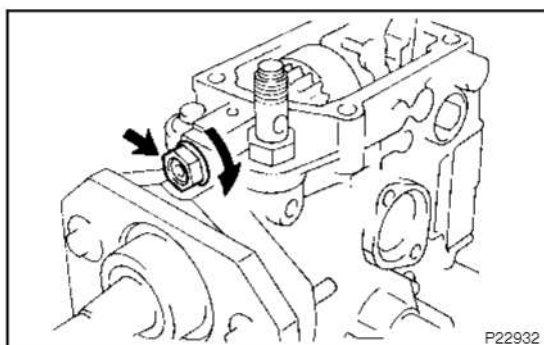

**19. REMOVE GOVERNOR SHAFT AND FLYWEIGHT HOLDER**

- (a) Remove the governor shaft lock nut by turning it clockwise.

**NOTICE:**

The governor shaft and lock nut have LH threads.

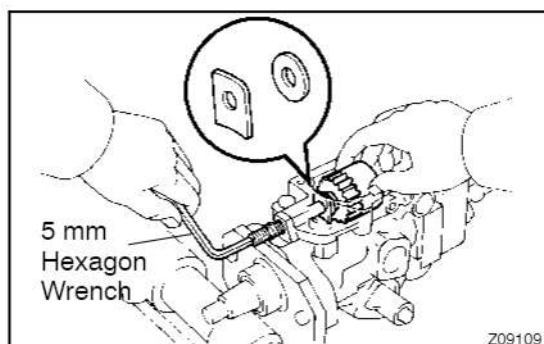

- (b) Using a 5 mm hexagon wrench, remove the governor shaft O-ring clockwise and remove the flyweight holder assembly, No.1 flyweight washer and governor gear adjusting washer.

**HINT:**

Be careful not to drop the 2 washers into the pump housing.

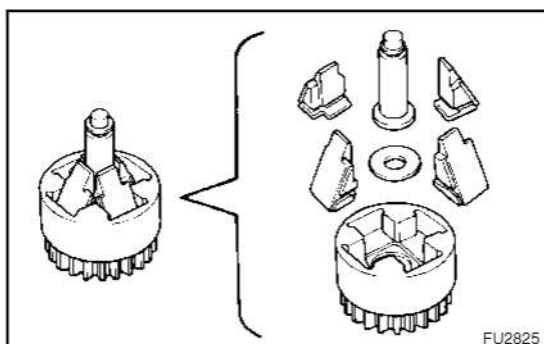

- (c) Remove the governor sleeve, No.2 flyweight washer and 4 flyweights from the flyweight holder.

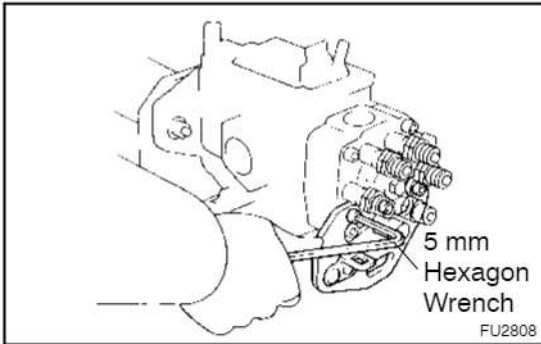

**20. REMOVE INJECTION PUMP STAY**

Using a 5 mm hexagon wrench, remove the 3 bolts and injection pump stay.

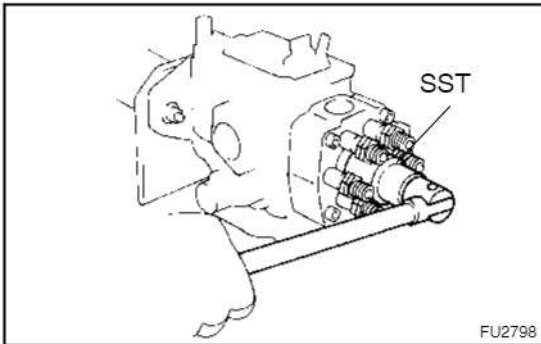

**21. REMOVE DISTRIBUTIVE HEAD PLUG**

Using SST, remove the distributive head plug and O-ring.

SST 09260-54012 (09262-54010)

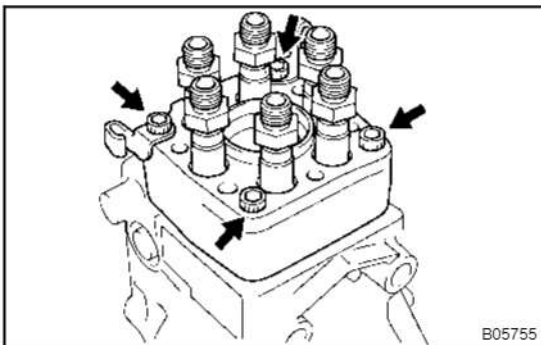

**22. REMOVE DISTRIBUTIVE HEAD**

(a) Using a 5 mm hexagon wrench, remove the 4 bolts and 2 wire clamps.

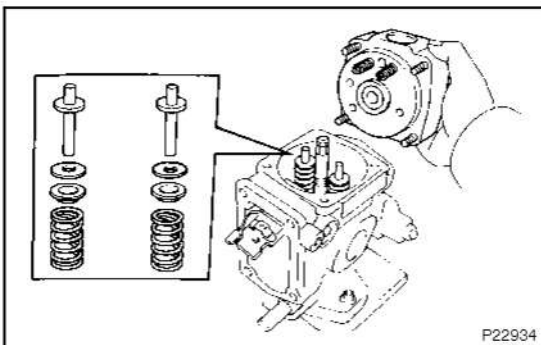

(b) Remove the distributive head, 2 lever support springs, 2 plunger spring guides, 2 plunger spring shims, 2 upper spring seats and 2 plunger springs.

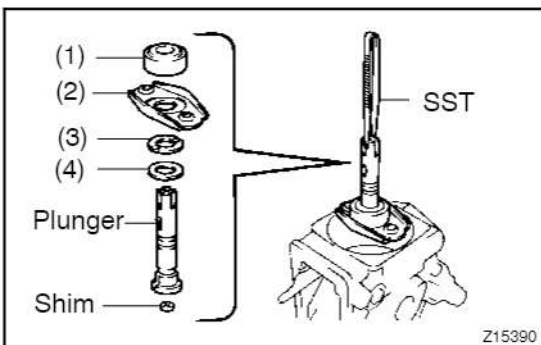

**23. REMOVE PUMP PLUNGER**

Using SST, remove the pump plunger and plunger adjusting shim together with the spill ring, lower spring seat, upper plunger plate and lower plunger plate.

SST 09260-54012 (09269-54030)

**NOTICE:**

**Do not touch the sliding surfaces of the pump plunger with your hand.**

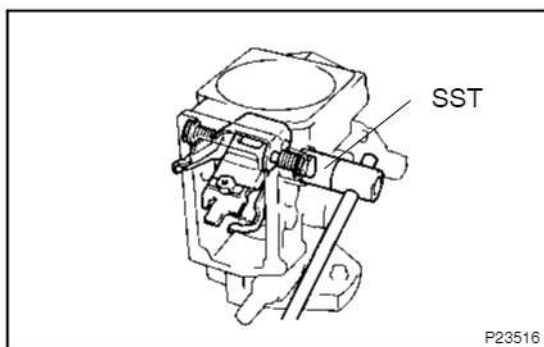
**24. REMOVE GOVERNOR LINK**

Using SST, remove the 2 support bolts, gaskets and governor link.

SST 09260-54012 (09269-54040)

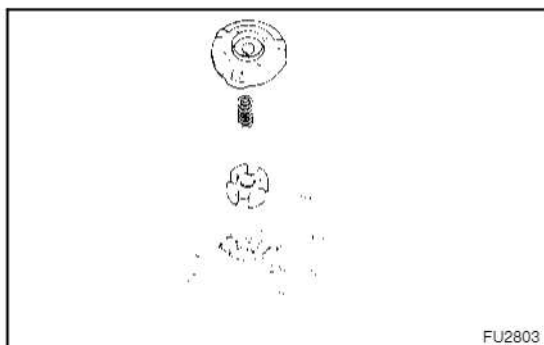
**25. REMOVE FACE CAMPLATE AND COUPLING**

Remove the face camplate, coupling spring and coupling.

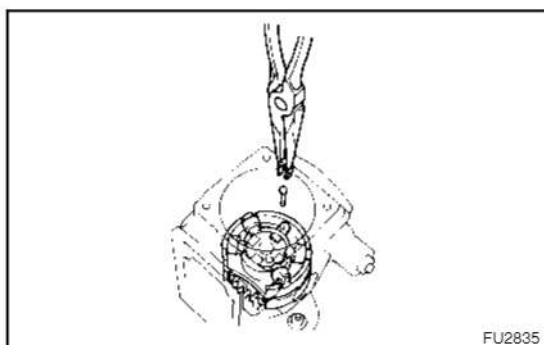
**26. REMOVE ROLLER RING AND DRIVE SHAFT**

(a) Remove the timer clip and stopper pin.

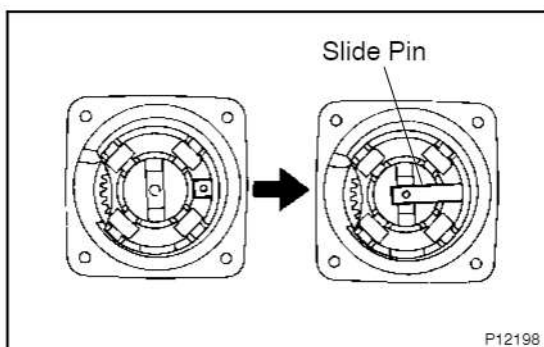

(b) Push the slide pin toward inside.

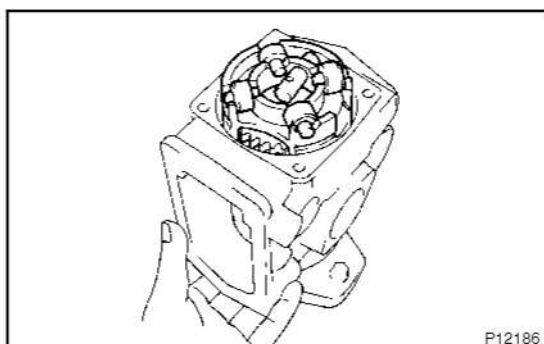

(c) Push the drive shaft, and remove the roller ring, 4 rollers and shims assembly.

**NOTICE:**

- **Be careful not to drop the rollers.**
- **Do not alter the position or assembly of the rollers.**

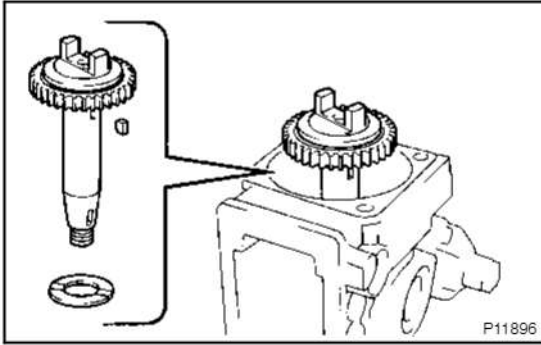

- (d) Remove the drive shaft, governor drive gear, 2 joint rubbers assembly, set key and drive shaft washer.

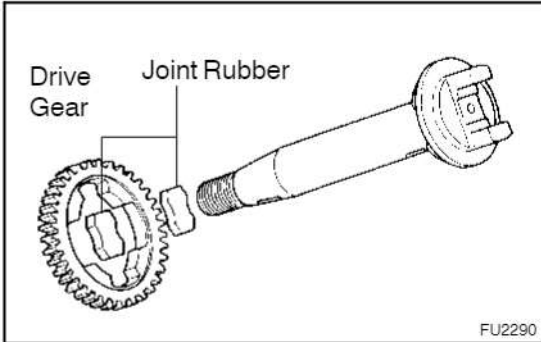

- (e) Remove the drive gear and 2 joint rubbers from the drive shaft assembly.

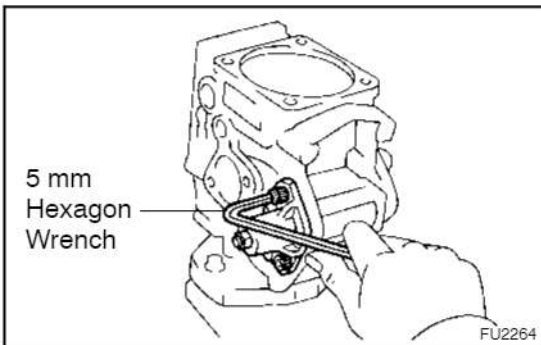

## 27. REMOVE TIMER

- (a) Using a 5 mm hexagon wrench, remove the 4 bolts.

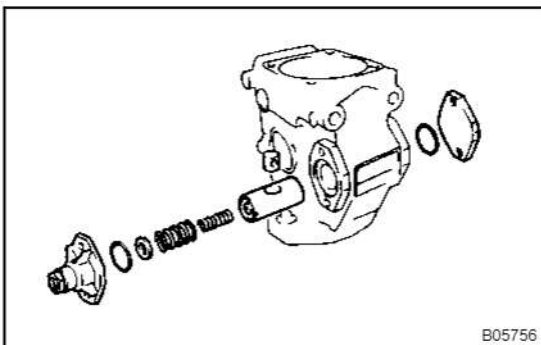

- (b) Remove the LH timer cover, timer adjusting screw and nut assembly, O-ring, shim, outer spring, inner spring, RH timer cover, O-ring, piston and sub-piston.  
 (c) Remove the nut from the LH timer cover.

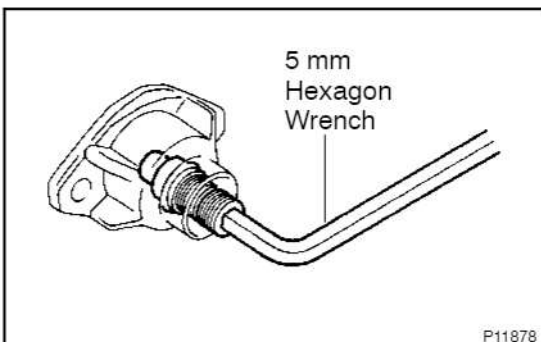

- (d) Using a 5 mm hexagon wrench, remove the timer adjusting screw.  
 (e) Remove the O-ring from the timer adjusting ring.

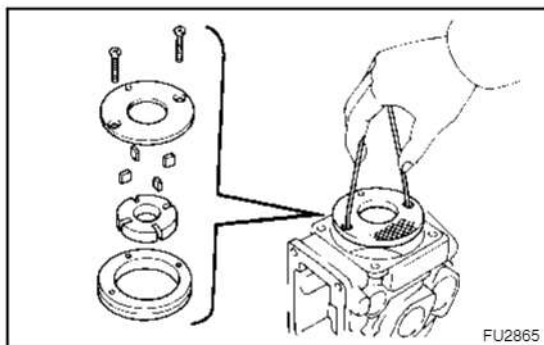
**28. REMOVE FUEL FEED PUMP**

- (a) Remove the 2 screws.
- (b) Using a piece of wire, remove the feed pump cover.
- (c) Remove the feed pump rotor, 4 blades and liner.

**NOTICE:**

- **Be careful not to interchange the blade positions.**
- **Be careful not to damage the pump body.**

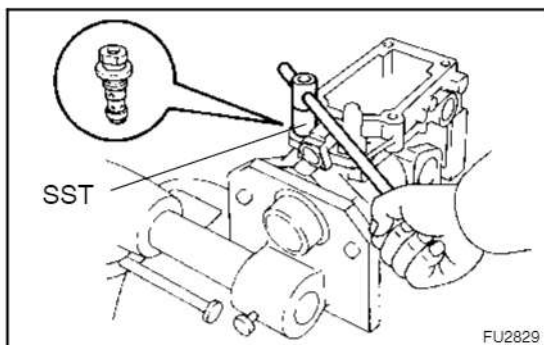
**29. REMOVE REGULATOR VALVE**

Using SST, remove the regulator valve and 2 O-rings.

SST 09260-54012 (09262-54020)

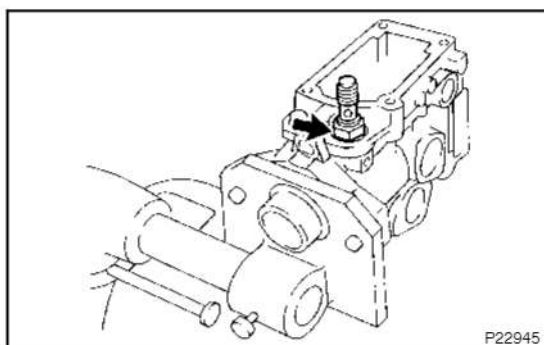
**30. REMOVE FUEL INLET HOLLOW SCREW**

Remove the hollow screw and gasket.



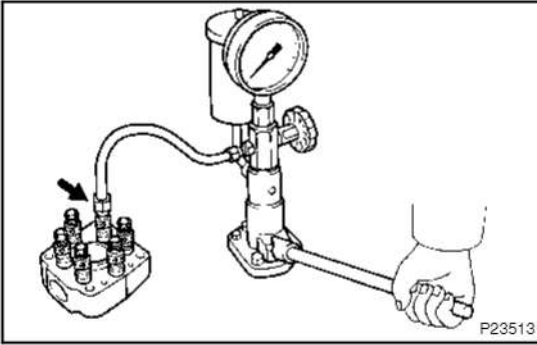

## INSPECTION

### 1. 1HD-T:

#### INSPECT DELIVERY VALVES

- (a) Attach the nozzle tester to the delivery valve holder of the pipe you wish to measure.
- (b) Use the nozzle tester to check the valve opening pressure of the delivery valve.

**Standard valve opening pressure:**

**7,350 – 8,330 kPa**

**(75 – 85kgf/cm<sup>2</sup>, 1,067 – 1,209 psi)**

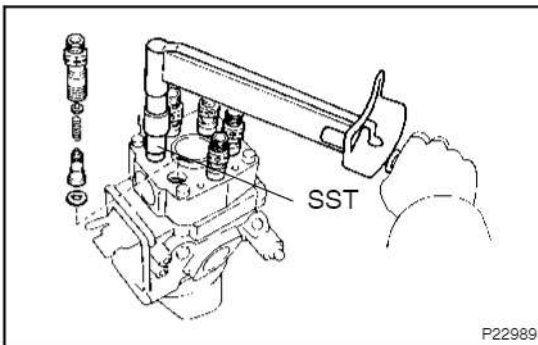

If the valve opening pressure of the delivery valve is not within specification, replace the delivery valve assembly.

SST 09260-54012 (09269-54020)

**Torque: 58.85 N·m (600 kgf·cm, 43 ft·lbf)**

#### NOTICE:

**Do not lose the steel ball when doing an overhaul.**

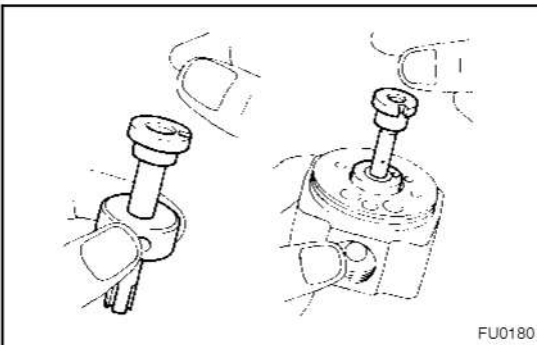

### 2. INSPECT PUMP PLUNGER, SPILL RING AND DISTRIBUTIVE HEAD

- (a) Tilt the spill ring (distributive head) slightly and pull out the plunger.
- (b) When released, the plunger should sink down smoothly into the spill ring (distributive head) by its own weight.
- (c) Rotate the plunger and repeat the test at various positions.

If the plunger sticks at any position, replace the parts as a set.

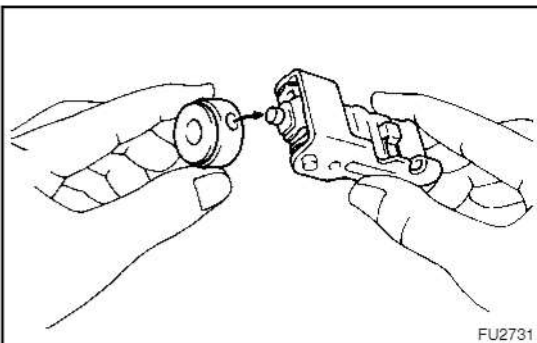

- (d) Insert the governor link ball pin into the spill ring and check that it moves smoothly without any play.

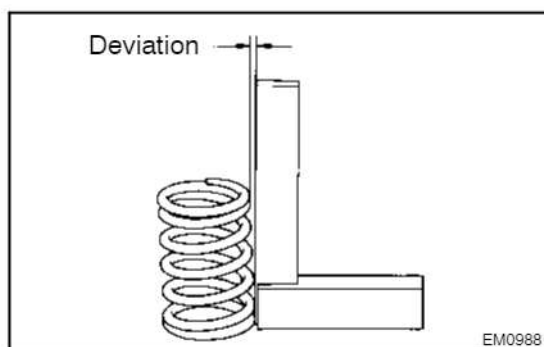

### 3. INSPECT PLUNGER SPRINGS FOR DEVIATION

Using a steel square, check the deviation of the plunger springs.

**Maximum deviation: 2.0 mm (0.079 in.)**

If deviation is greater than maximum, replace the springs.

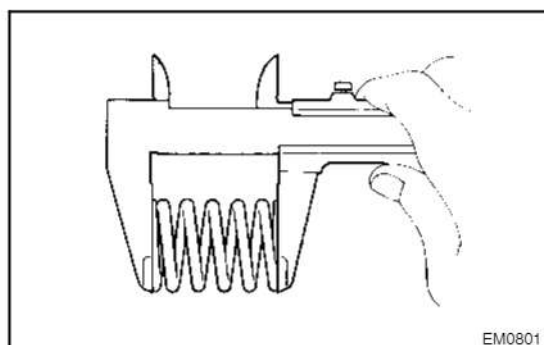

### 4. INSPECT SPRING LENGTH

Using vernier calipers, measure the free length of each spring.

**Spring free length:**

**Delivery valve spring:**

1HZ	24.4 mm (0.961 in.)
1HD-T	12.6 mm (0.496 in.)

**Plunger spring:**

1HZ	30.0 mm (1.181 in.)
1HD-T	31.2 mm (1.228 in.)

**Coupling spring:**

1HZ	16.6 mm (0.654 in.)
1HD-T	15.5 mm (0.610 in.)

**1HZ (w/ HAC):**

**Pneumatic bellows spring: 35.0 mm (1.378 in)**

**1HD-T:**

**Boost compensator spring: 19.4 mm (0.764 in.)**

If the free length is not as specified, replace the spring (s).

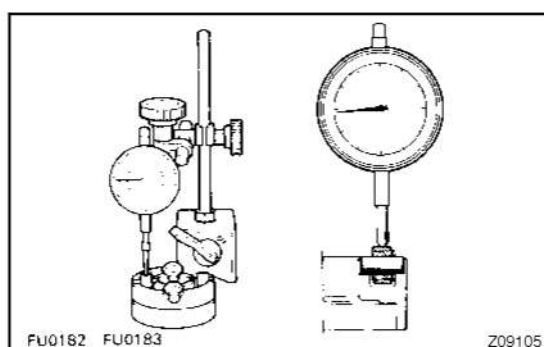

### 5. INSPECT ROLLER RING AND ROLLERS

Using a dial indicator, measure the roller height.

**Maximum roller height variation: 0.02 mm (0.0008 in.)**

If the variation is greater than specification, replace the roller ring and roller as a set.

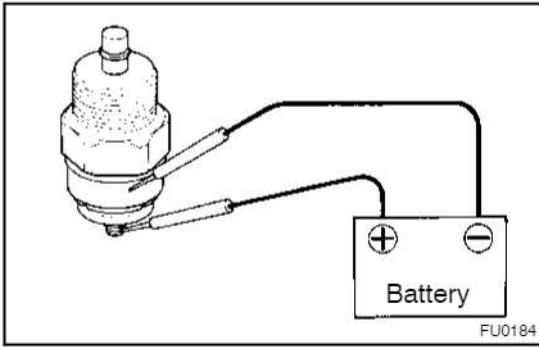

## 6. INSPECT FUEL CUT SOLENOID

- (a) Connect the solenoid valve body and terminal to the battery terminals.
- (b) You should feel the click from the solenoid valve when the battery power is connected and disconnected.  
If the solenoid valve is not operating properly, replace it.

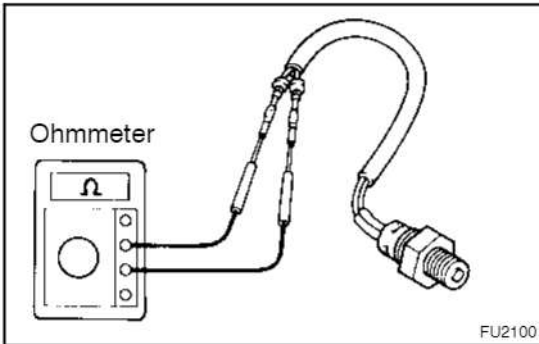

## 7. INSPECT PICKUP SENSOR

Using an ohmmeter, measure the resistance between the terminals.

**Resistance: 650 -970  $\Omega$**

If resistance is not as specified, replace the sensor.

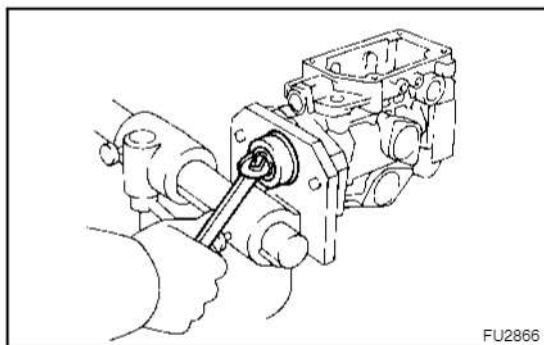

## REPLACEMENT

### REPLACE OIL SEAL

(a) Using a wrench, pry out the oil seal.

#### NOTICE:

**Be careful not to damage to the pump body.**

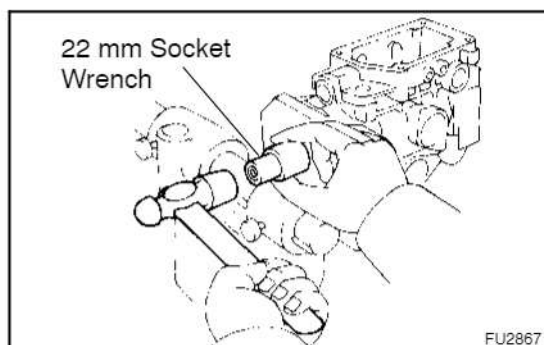

(b) Apply MP grease to the lip of a new oil seal.

(c) Using a 22 mm socket wrench, tap in the oil seal until its surface is flush with the pump housing.

## ADJUSTMENT

1. A/T:  
REMOVE THROTTLE POSITION SENSOR AND BRACKET ASSEMBLY (See page FU-53)
2. REMOVE FUEL CUT VALVE CONTROL UNIT (See page FU-53)
3. REMOVE FUEL PIPES (See page FU-53)
4. w/ A/C:  
REMOVE IDLE UP ACTUATOR

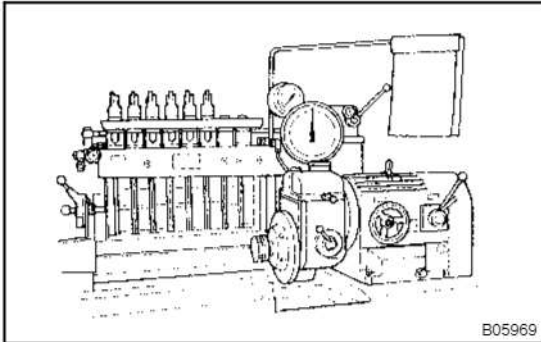

5. PRE-TEST CHECK AND PREPARATION
  - (a) The specifications for test nozzle and nozzle holders are as follows.  
**Test nozzle: DN12SD12 (DENSO)**  
**Test nozzle opening pressure:**  
**14,220 - 15,200 kPa**  
**(145 - 155 kgf/cm<sup>2</sup>, 2,062 - 2,205 psi)**

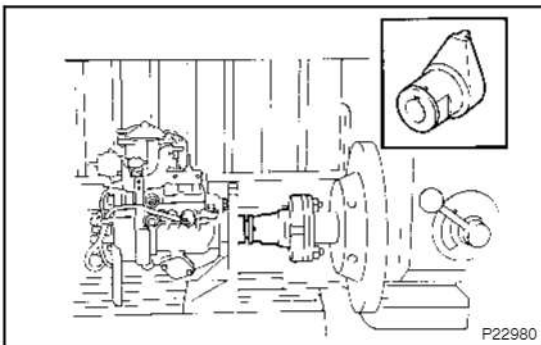

- (b) Check the accuracy of the tachometer.  
**Allowable error: ± 40 rpm**
- (c) Install the angle gauge stand.
- (d) Mount the injection pump body on the pump tester.

HINT:

Place a mark on the key groove portion of the coupling.

**NOTICE:**

**To prevent vibration or dislocation of the injection pump, fix in place the distributive head of the injection pump.**

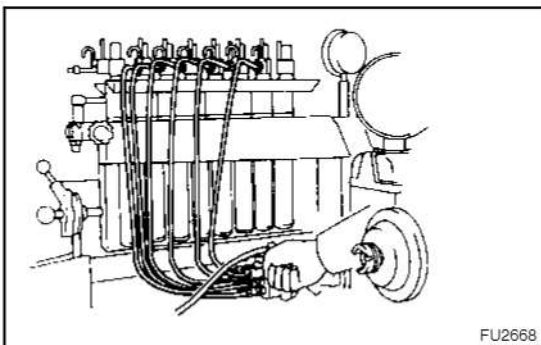

- (e) Install an injection pipe with these specifications.

Outer Diameter	6.0 mm (0.236 in.)
Inner diameter	2.0 mm (0.079 in.)
Length	840 mm (33.07 in.)
Minimum bending radius	25 mm (0.98 in.) or more

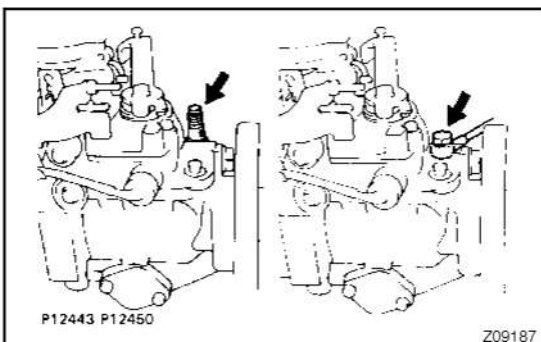

- (f) Remove the fuel inlet hollow screw.
- (g) Connect the fuel inlet pipe with an adapter.

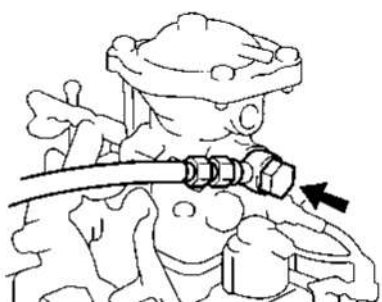
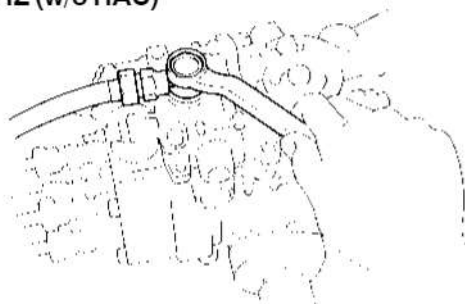
**1HZ (w/ HAC) and 1HD-T****1HZ (w/o HAC)**

B05813

(h) Install an overflow hose with 2 gaskets and union bolts.

HINT:

Always use the overflow screw installed on the pump to be adjusted.

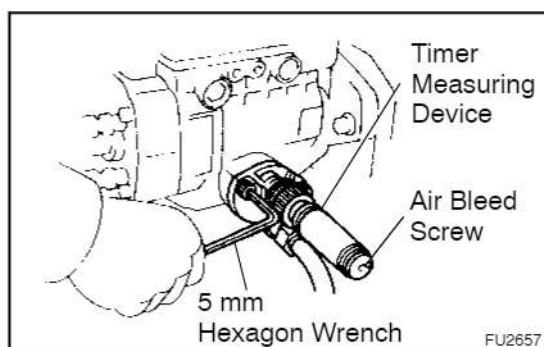

FU2657

(i) Using a 5 mm hexagon wrench, remove the 2 bolts and RH timer cover.

(j) Install the inner pressure gauge with the timer measuring device.

**Part No. 95095-10231 and 95095-10480  
(DENSO)**

HINT:

Bleed the air by the air bleed screw.

(k) 1HD-T:

Connect SST (turbocharger pressure gauge) to the boost compensator.

SST 09992-00242

1HZ

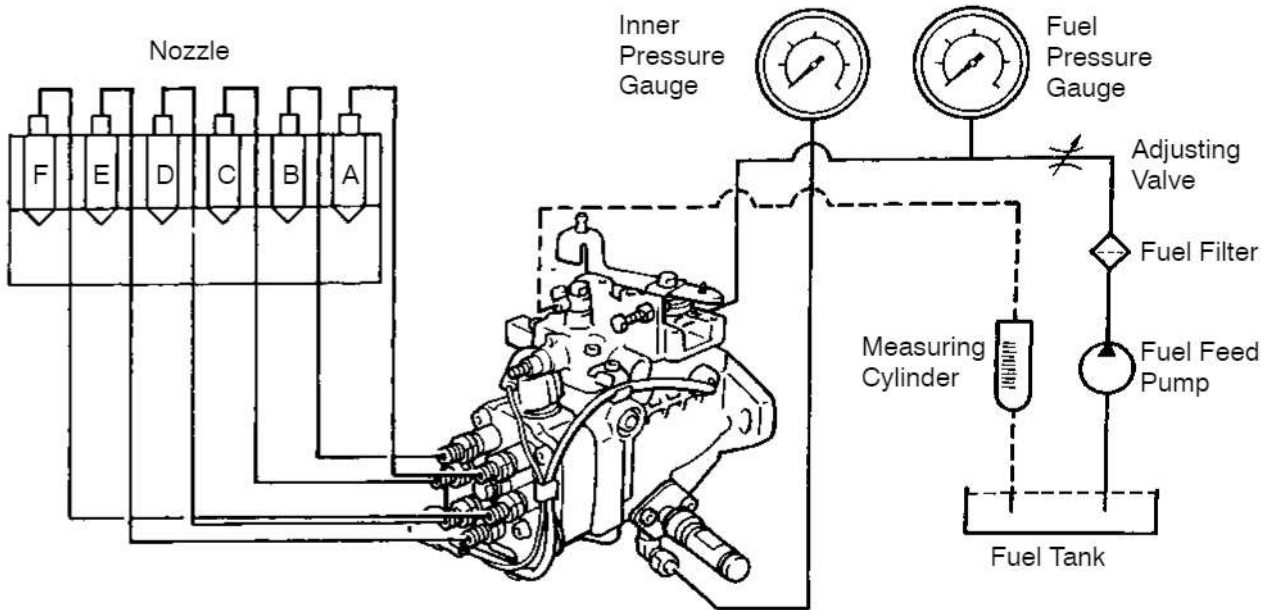

1HD-T

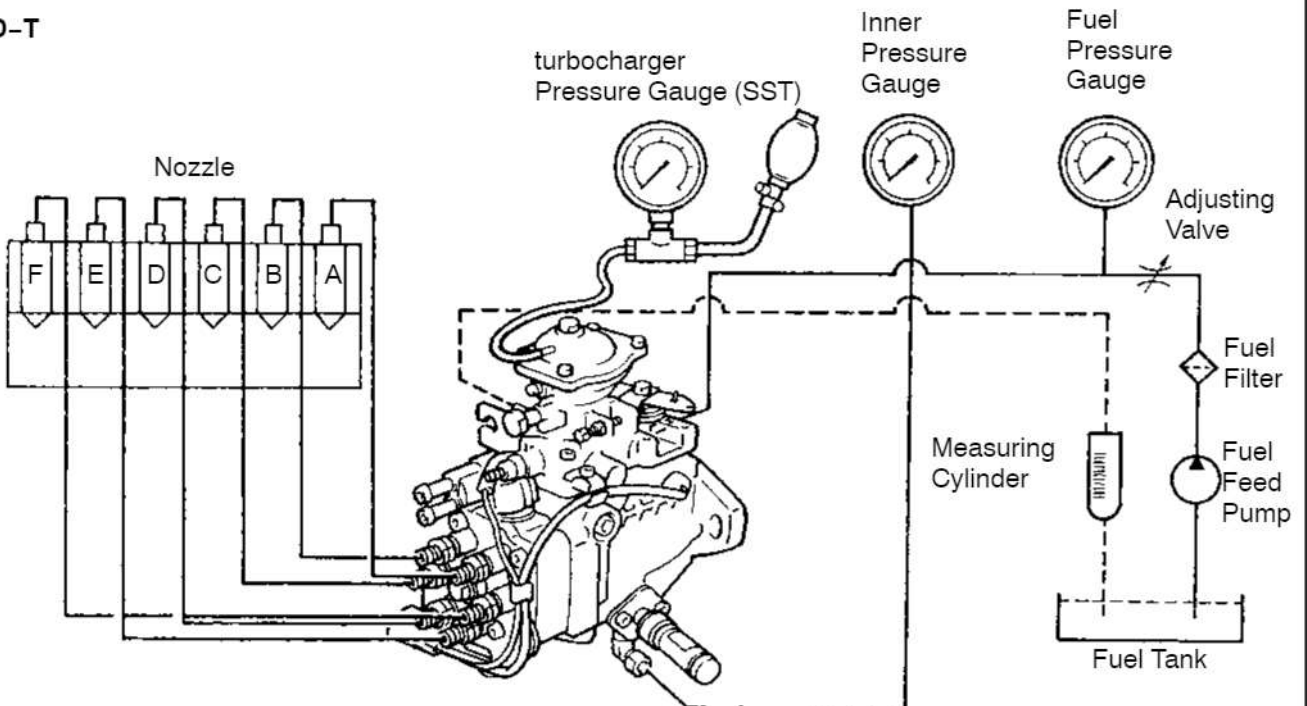

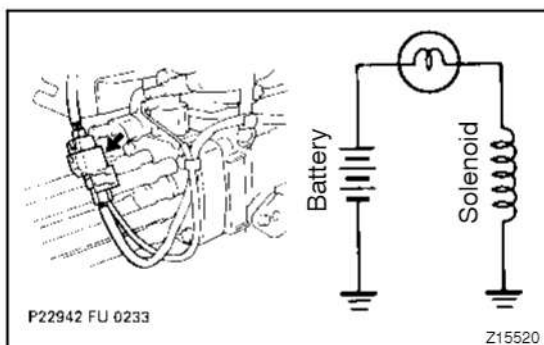

(l) Apply about 6 volts of DC power to the fuel cut solenoid.

**NOTICE:**

- When applying voltage to the solenoid, position the battery as far away from the solenoid as possible so that a spark does not occur.
- when connecting the battery cable, connect the solenoid side first.

(m) The pressure for feeding fuel to the injection pump should be 20 kPa (0.2 kgf/cm<sup>2</sup>, 2.8 psi). The fuel temperature for pump testing should be 40 – 45 °C (104 – 113 °F).

(n) Install an angle gauge to the stand and set it to the adjusting lever.

**Part No. 95095-10360 (Stand w/ angle gauge)**

(o) Secure the adjusting lever fully on the maximum speed side.

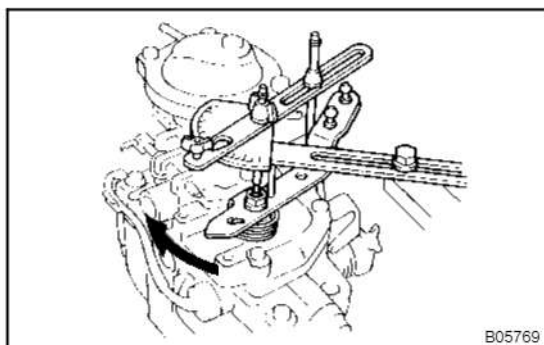

(p) Check the installation direction of the camplate as follows:

- Disconnect the injection pipe from the position marked "C" on the distributive head.
- Using SST, remove the delivery valve holder assembly and gasket.

SST 09260-54012 (09269-54020)

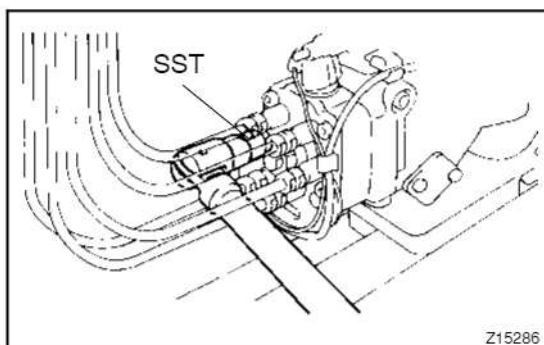

- Check that fuel is flowing out when the mark is in the position shown in the illustration.

If not, it is improperly assembled.

- Disassemble and change the camplate position 180° in the opposite direction.

**HINT:**

At this time, disconnect the fuel cut solenoid wire harness.

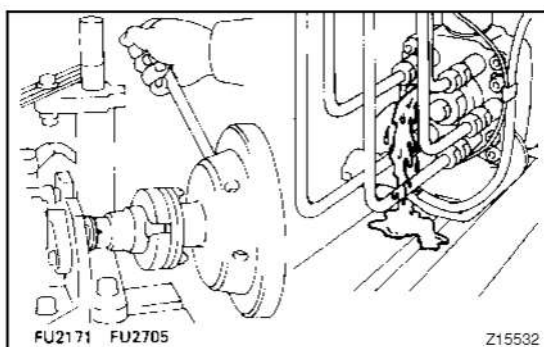

- Using SST, install a new gasket and the delivery valve holder assembly.

SST 09260-54012 (09269-54020)

**Torque: 59 N·m (600 kgf·cm, 43 ft·lbf)**

- Connect the injection pipe.

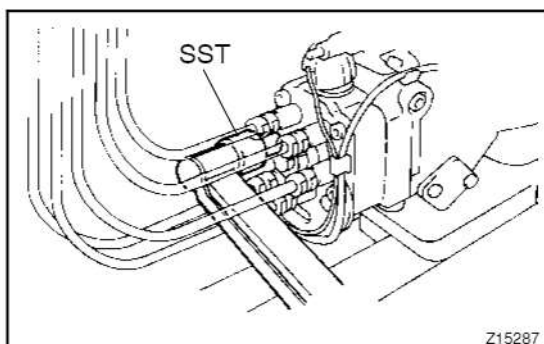



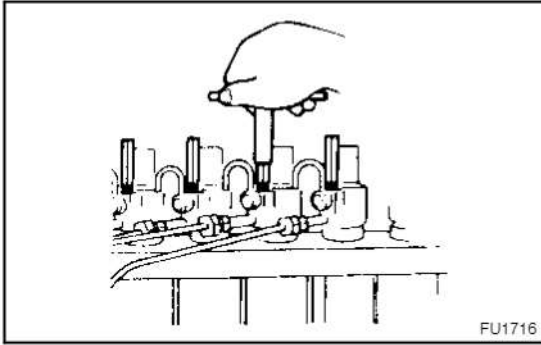

- (q) Bleed the air from the injection pipes.
- (r) Measure the injection volume.

Pump rpm	No. of measuring strokes	Each injection volume cc (cu in.)
1,080	200	14.92 - 16.52 (0.91 - 1.01)

- (s) Race the injection pump for 5 minutes at 1,200 rpm.

**NOTICE:**

**Check that there is no fuel leakage or abnormal noise.**

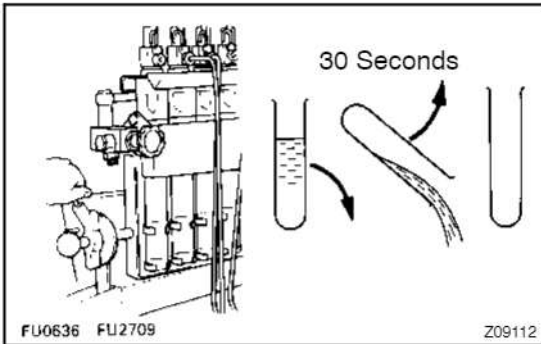

**HINT:**

- Measure the volume of each injection cylinder with a measuring cylinder.
- Before measuring the injection volume, first hold the cylinder tilted for at least 30 seconds to discard all the fuel.

**6. PRE-SET FULL LOAD INJECTION VOLUME**

- (a) Set the adjusting lever to maximum position.
- (b) 1HZ (w/ HAC):  
Apply  $101.3 \pm 0.2$  kPa ( $760 \pm 1.5$  mmHg,  $29.92 \pm 0.06$  in.Hg) absolute pressure.
- (c) 1HD-T (w/o BACS):  
Apply 80 kPa ( $0.81$  kgf/cm<sup>2</sup>, 11.5 psi) of pressure to the boost compensator.
- (d) 1HD-T (w/ BACS):  
Apply 129 kPa ( $1.32$  kgf/cm<sup>2</sup>, 18.7 psi) of pressure to the boost compensator.
- (e) Measure the injection volume.

Item	Pump rpm	No. of measuring strokes	Each injection volume cc (cu in.)
1HZ	1,200	200	11.84 - 12.24 (0.72 - 0.75)
1HD-T (Philippine)	1,100	200	11.74 - 12.94 (0.72 - 0.79)
1HD-T (Others)	1,100	200	12.18 - 13.38 (0.74 - 0.82)

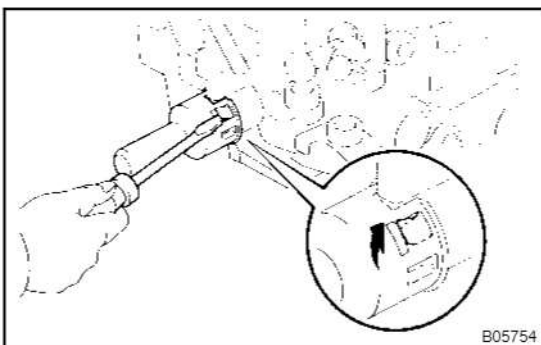

- (f) Remove the cap seal.
  - (1) Using a small screwdriver, pry the claws.
  - (2) Remove the cap seal.

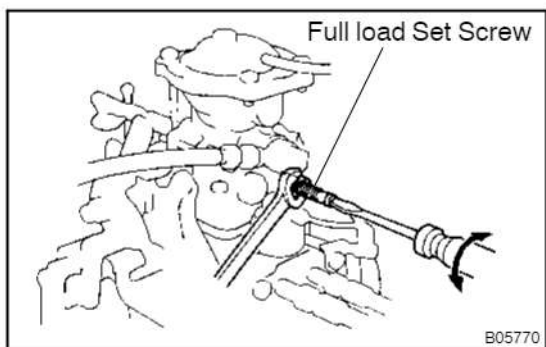

(g) Adjust by turning the full load set screw.  
**HINT:**  
 The injection volume will increase about 3 cc (0.18 cu in.) with each 1/2 turn of the screw.

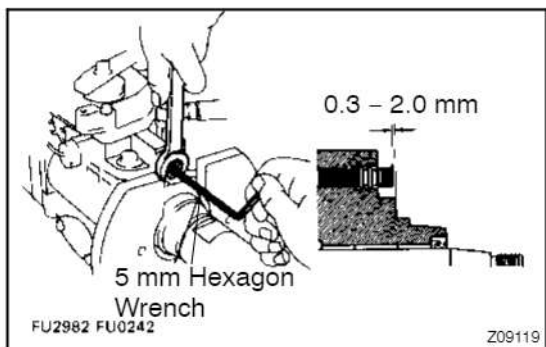

**7. Except 1HD-T (w/BACS):**  
**PRE-SETTING OF LOAD SENSING TIMER**  
 Using a 5 mm hexagon wrench, adjust the protrusion of the governor shaft.

**Protrusion: 0.3 - 2.0 mm (0.012 - 0.079 in.)**

**8. PRE-SET MAXIMUM SPEED**

- (a) Set the adjusting lever to maximum position.
- (b) 1HZ (w/ HAC):  
 Apply  $101.3 \pm 0.2$  kPa ( $760 \pm 1.5$  mmHg,  $29.92 \pm 0.06$  in.Hg) absolute pressure.
- (c) 1HD-T:  
 Apply 80 kPa (0.81 kgf/cm<sup>2</sup>, 11.5 psi) of pressure to the boost compensator.
- (d) Measure the injection volume.

Item	Pump rpm	No. of measuring strokes	Each injection volume cc (cu in.)
1HZ	2,300	200	4.6 - 6.6 (0.28 - 0.40)
1HD-T	2,200	200	1.8 - 4.2 (0.11 - 0.26)

(e) Cut off the seal wire.

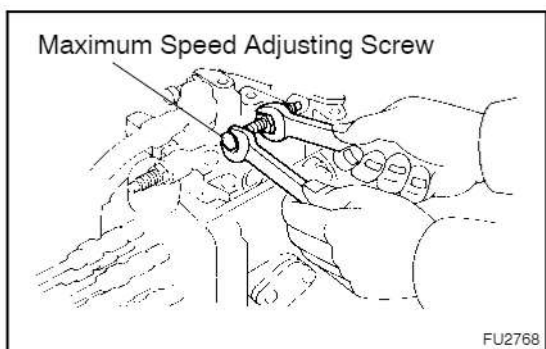

(f) Adjust the injection volume with the maximum speed adjusting screw.

**9. ADJUST PUMP INNER PRESSURE**

(a) Measure the pump inner pressure at the below listed rpm.

Item	Pump rpm	Inner pressure kPa (kgf/cm <sup>2</sup> , psi)
1HZ	500	343 - 402 (3.5 - 4.1, 49 - 58)
	1,900	765 - 824 (7.8 - 8.4, 111 - 119)
1HD-T	500	196 - 294 (2.0 - 3.0, 28 - 43)
	1,800	834 - 932 (8.5 - 9.5, 121 - 135)

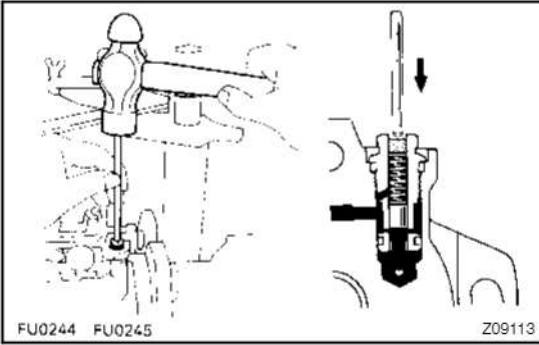

(b) If the pressure is low, adjust by lightly tapping the regulator valve piston while watching the pressure gauge.

HINT:

If the pressure is too high or if the regulator valve was tapped in too far, the regulator valve must be replaced.

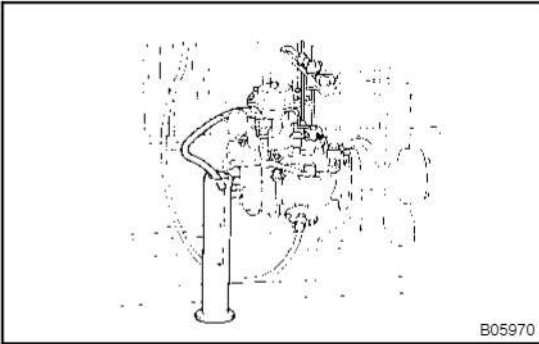

**10. CHECK OVERFLOW VOLUME**

Measure the overflow volume at the below listed rpm.

Item	Pump rpm	Overflow volume cc/min. (cu in./min.)
1HZ	2,000	366 - 800 (22.3 - 48.8)
1HD-T	1,800	666 - 1,167 (40.6 - 71.2)

HINT:

Always use the overflow screw installed on the pump to be adjusted.

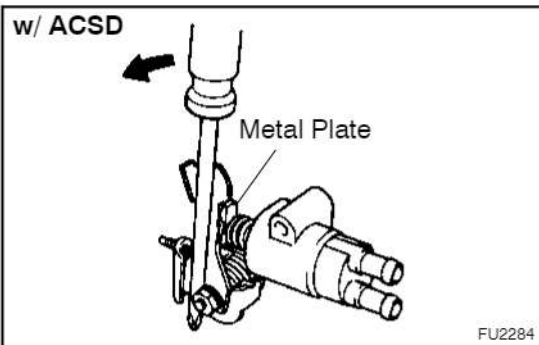

**11. w/ ACSD:**

**RELEASE COLD STARTING SYSTEM FOR NEXT INSPECTIONS**

- (a) Using a screwdriver, turn the cold starting lever counter-clockwise approx. 20°.
- (b) Put a metal plate (thickness of 5.0 - 8.0 mm (0.20 - 0.31 in.)) between the cold starting lever and thermo wax plunger.

HINT:

Keep the cold starting system released until all measurements and adjustments are finished.

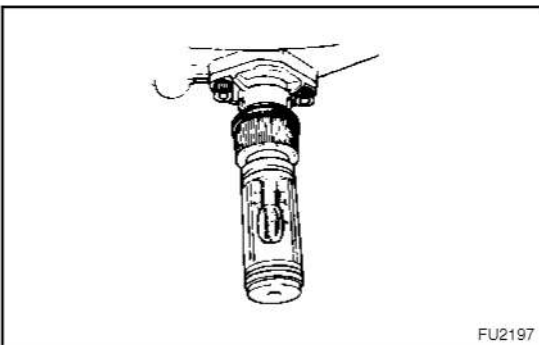

**12. ADJUST TIMER**

- (a) Set the timer measuring device at zero.

(b) Measure the timer piston stroke at the below listed rpm.

Item	Pump rpm	Timer piston stroke mm (in.)
1HZ (w/ACSD)	800	1.84 - 2.84 (0.0724 - 0.1118)
	1,200	3.70 - 4.70 (0.1457 - 0.1850)
	1,520	5.18 - 6.18 (0.2039 - 0.2433)
	1,900	6.95 - 7.65 (0.2736 - 0.3012)
1HZ (w/o ACSD)	800	0.61 - 1.61 (0.0240 - 0.0634)
	1,200	2.47 - 3.47 (0.0972 - 0.1366)
	1,520	3.95 - 4.95 (0.1556 - 0.1949)
	1,900	5.72 - 6.72 (0.2252 - 0.2647)
1HD-T (Philippine)	1,300	0.95 - 1.95 (0.0374 - 0.0768)
	1,440	2.25 - 3.25 (0.0886 - 0.1280)
	1,800	5.50 - 6.50 (0.2165 - 0.2559)
1HD-T (Others)	1,000	0.44 - 1.44 (0.0173 - 0.0567)
	1,440	3.25 - 4.25 (0.1280 - 0.1673)
	1,800	5.55 - 6.55 (0.2185 - 0.2579)
	2,350	7.70 - 8.70 (0.3031 - 0.3425)

HINT:

Check that the hysteresis is within 0.3 mm (0.012 in.).

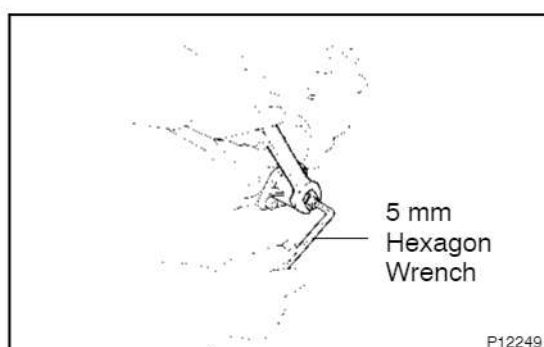

(c) Using a 5 mm hexagon wrench, adjust by turning the timer adjusting screw.

HINT:

Turn clockwise to reduce the stroke, turn counterclockwise to increase the stroke.

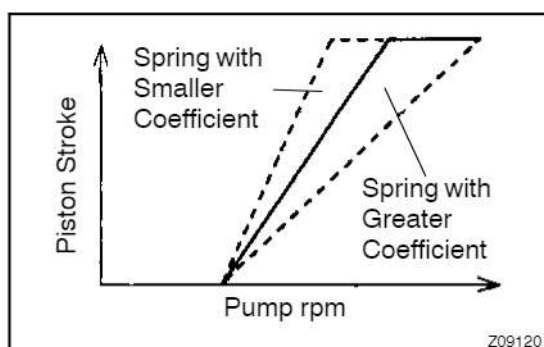

(d) Check the timer stroke for characteristic tendency.

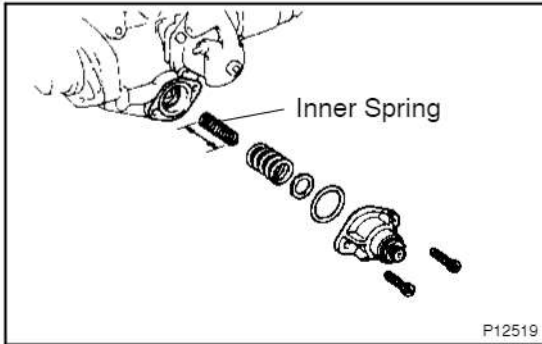

If tendency is not as specified, select and replace the inner spring.

**Timer inner spring with coefficient (k):**

**1HZ:**

**N/mm (kgf/mm)**

1.57 (0.16)	1.67 (0.17)	1.77 (0.18)
1.86 (0.19)	1.96 (0.20)	-

**1HD-T (Philippine):**

**N/mm (kgf/mm)**

1.08 (0.11)	1.18 (0.12)	1.27 (0.13)
1.37 (0.14)	-	-

**1HD-T (Others):**

**N/mm (kgf/mm)**

1.57 (0.16)	1.77 (0.18)	1.96 (0.20)
2.16 (0.22)	-	-

**HINT:**

The timer stroke will increase with a long spring and decrease with a short spring.

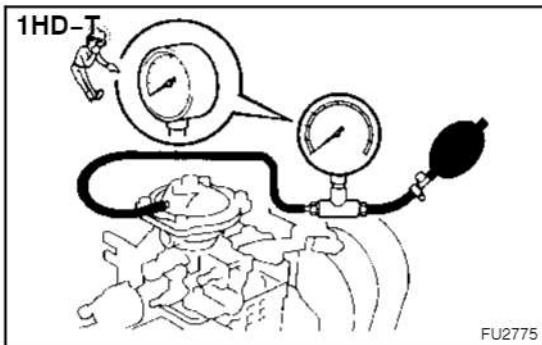

**13. 1HD-T:**

**CHECK BOOST COMPENSATOR FOR AIR TIGHTNESS**

- (a) Apply 98 kPa (1.00 kgf/cm<sup>2</sup>, 14.2 psi) of pressure to the boost compensator.
- (b) Measure the time it takes for pressure to drop to 95 kPa (0.97 kgf/cm<sup>2</sup>, 13.8 psi).

**Pressure drop: 10 seconds or more**

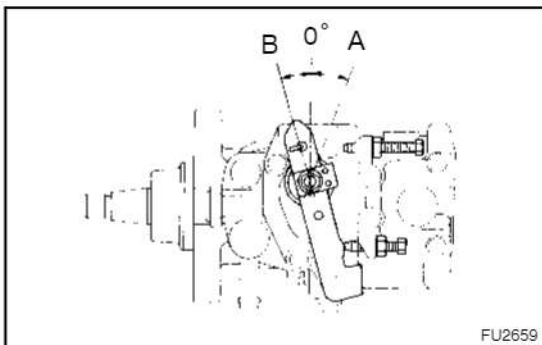

**14. ADJUST FULL LOAD INJECTION VOLUME**

- (a) The adjusting lever angle for the adjustment below should be as shown in the illustration.

**Adjusting lever angle:**

A (Maximum speed side)	B (Idle speed side)
Plus 21 - 31°	Minus 12 - 22°

- (b) 1HZ (w/ HAC):  
Apply 101.3 ± 0.2 kPa (760 ± 1.5 mmHg, 29.92 ± 0.06 in.Hg) absolute pressure.
- (c) 1HD-T (w/o BACS):  
Apply 80 kPa (0.81 kgf/cm<sup>2</sup>, 11.5 psi) of pressure to the boost compensator.
- (d) 1HD-T (w/ BACS):  
Apply 129 kPa (1.32 kgf/cm<sup>2</sup>, 18.7 psi) of pressure to the boost compensator.
- (e) Measure the full load injection volume.

Item	Adjusting lever angle	Pump rpm	No. of measuring strokes	Each injection volume cc (cu in.)
1HZ	Plus 21 – 31°	1,200	200	11.84 – 12.24 (0.72 – 0.75)
1HD-T (Philippine)	Plus 21 – 31°	1,100	200	11.74 – 12.94 (0.72 – 0.79)
1HD-T (Others)	Plus 21 – 31°	1,100	200	12.18 – 13.38 (0.74 – 0.82)

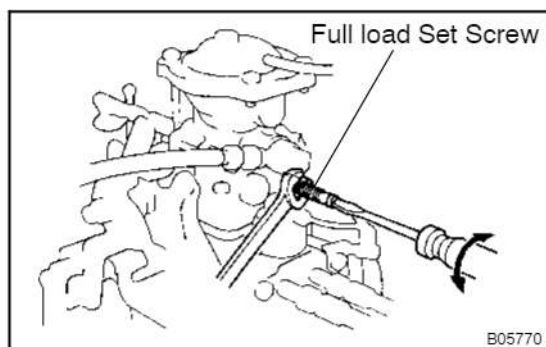

(f) Adjust by turning the full load set screw.

HINT:

The injection volume will increase about 3 cc (0.18 cu in.) with each 1/2 turn of the screw.

#### 15. ADJUST MAXIMUM SPEED

(a) 1HZ (w/ HAC):

Apply  $101.3 \pm 0.2$  kPa ( $760 \pm 1.5$  mmHg,  $29.92 \pm 0.06$  in.Hg) absolute pressure.

(b) 1HD-T (w/o BACS):

Apply 80 kPa (0.81 kgf/cm<sup>2</sup>, 11.5 psi) of pressure to the boost compensator.

(c) 1HD-T (w/ BACS):

Apply 129 kPa (1.32 kgf/cm<sup>2</sup>, 18.7 psi) of pressure to the boost compensator.

(d) Measure the injection volume at each pump rpm.

Item	Adjusting lever angle	Pump rpm	No. of measuring strokes	Each injection volume cc (cu in.)	Remarks
1HZ	Plus 21 – 31°	2,300	200	4.6 – 6.6 (0.28 – 0.40)	Adjust
	Minus 12 – 22°	2,300		2.0 (0.12) or less	–
1HD-T	Plus 21 – 31°	2,200	200	1.8 – 4.2 (0.11 – 0.26)	Adjust
	Minus 12 – 22°	2,200		1.0 (0.06) or less	–

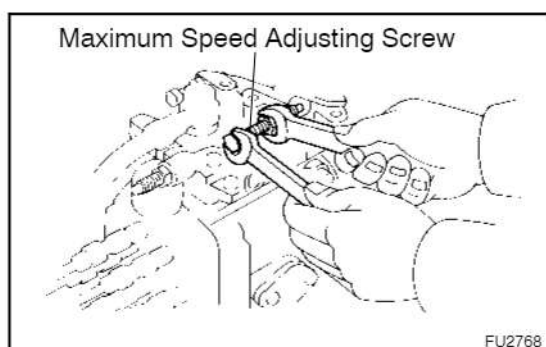

(e) Adjust by turning the maximum speed adjusting screw.

**16. CHECK INJECTION VOLUME**

(a) 1HZ:

Measure the injection volume at each pump rpm and absolute pressure.

Item	Adjusting lever angle	Pump rpm	Absolute pressure kPa (mmHg, in.Hg)	No. of measuring strokes	Each injection volume cc (cu in.)	Variation limit cc (cu in.)	Remarks
1HZ (w/ HAC)	Plus 21 - 31°	1,200	101.3 (760, 29.92)	200	11.84 - 12.24 (0.72 - 0.75)	0.5 (0.03)	Basic full-load injection volume
					10.78 - 11.38 (0.66 - 0.69)	-	-
					9.82 - 10.24 (0.60 - 0.64)	-	-
		100	101.3 (760, 29.92)	200	10.00 - 14.00 (0.61 - 0.86)	1.4 (0.09)	Volume during starting
					10.48 - 11.48 (0.64 - 0.70)	0.6 (0.04)	-
					11.38 - 12.58 (0.69 - 0.77)	-	-
					10.42 - 11.62 (0.64 - 0.71)	0.6 (0.04)	-
		1HZ (w/o HAC)	Plus 21 - 31°	1,200	101.3 (760, 29.92)	200	11.84 - 12.24 (0.72 - 0.75)
100	10.00 - 14.00 (0.61 - 0.86)			1.4 (0.09)			Volume during starting
500	10.48 - 11.48 (0.64 - 0.70)			0.6 (0.04)			-
1,500	11.38 - 12.58 (0.69 - 0.77)			-			-
1,900	10.42 - 11.62 (0.64 - 0.71)			0.6 (0.04)			-

## (b) 1HD-T:

Measure the injection volume at each pump rpm and boost pressure.

Item	Adjusting lever angle	Pump rpm	Boost pressure kPa (kg/cm <sup>2</sup> , psi)	No. of measuring strokes	Each injection volume cc (cu in.)	Variation limit cc (cu in.)	Remarks
1HD-T (Philippine)	Plus 21 – 31°	1,100	80 (0.81, 11.5)	200	11.74 – 12.94 (0.72 – 0.79)	0.7 (0.04)	Basic full-load injection volume
		100	0 (0, 0)		9.50 – 14.30 (0.58 – 0.87)	1.4 (0.09)	Volume during starting
		500	0 (0, 0)		7.30 – 8.10 (0.45 – 0.49)	0.8 (0.05)	–
		900	80 (0.81, 11.5)		11.60 – 12.80 (0.71 – 0.78)	–	–
		1,800	80 (0.81, 11.5)		12.80 – 13.60 (0.78 – 0.83)	1.3 (0.08)	–
1HD-T (Others) (w/o BACS)	Plus 21 – 31°	1,100	80 (0.81, 11.5)	200	12.18 – 13.38 (0.74 – 0.82)	0.7 (0.04)	Basic full-load injection volume
		100	0 (0, 0)		9.50 – 14.30 (0.58 – 0.87)	1.4 (0.09)	Volume during starting
		500	0 (0, 0)		7.30 – 8.10 (0.45 – 0.49)	0.8 (0.05)	–
		900	80 (0.81, 11.5)		12.26 – 13.46 (0.75 – 0.82)	–	–
		1,800	80 (0.81, 11.5)		12.50 – 13.30 (0.76 – 0.81)	1.3 (0.08)	–
1HD-T (Others) (w/ BACS)	Plus 21 – 31°	1,100	129 (1.32, 18.7)	200	12.18 – 13.38 (0.74 – 0.82)	0.7 (0.04)	Basic full-load injection volume
		100	49.3 (0.50, 7.2)		9.50 – 14.30 (0.58 – 0.87)	1.4 (0.09)	Volume during starting
		500	49.3 (0.50, 7.2)		7.30 – 8.10 (0.45 – 0.49)	0.8 (0.05)	–
		900	129 (1.32, 18.7)		12.26 – 13.46 (0.75 – 0.82)	–	–
		1,800	129 (1.32, 18.7)		12.50 – 13.30 (0.76 – 0.81)	1.3 (0.08)	–

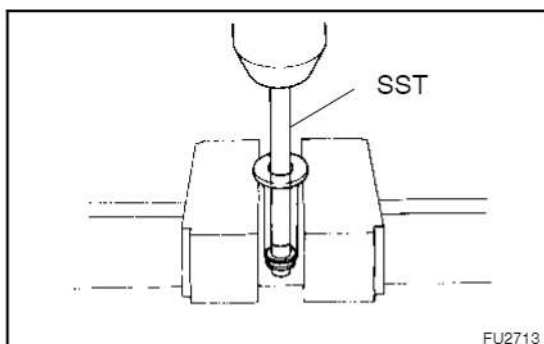

If the injection volume at 100 rpm is not as specified, replace the governor sleeve plug as follows:

- Using SST and a press, press out the sleeve plug assembly from the governor sleeve.

SST 09236-00101 (09237-00070)



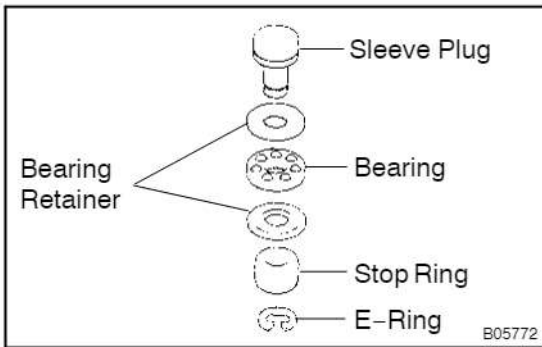

- Remove the E-ring, stop ring, bearing and 2 bearing retainers from the sleeve plug.

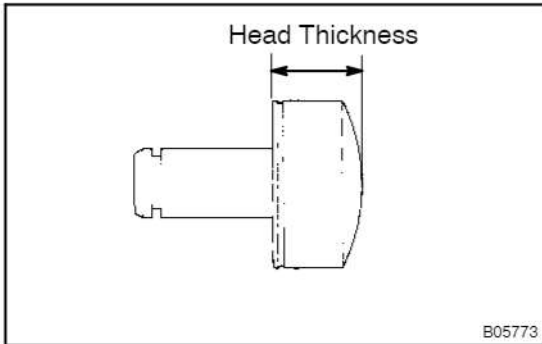

- Measure the head thickness of the sleeve plug, and select a new sleeve plug.

Sleeve plug head thickness for 1HZ		mm (in.)
3.0 (0.118)	3.5 (0.138)	4.0 (0.158)
3.1 (0.122)	3.6 (0.142)	4.1 (0.161)
3.2 (0.126)	3.7 (0.146)	4.2 (0.165)
3.3 (0.130)	3.8 (0.150)	
3.4 (0.134)	3.9 (0.154)	

Sleeve plug head thickness for 1HD-T		mm (in.)
3.0 (0.118)	4.3 (0.169)	5.6 (0.220)
3.1 (0.122)	4.4 (0.173)	5.7 (0.224)
3.2 (0.126)	4.5 (0.177)	5.8 (0.228)
3.3 (0.130)	4.6 (0.181)	5.9 (0.232)
3.4 (0.134)	4.7 (0.185)	6.0 (0.236)
3.5 (0.138)	4.8 (0.189)	6.1 (0.240)
3.6 (0.142)	4.9 (0.193)	6.2 (0.244)
3.7 (0.146)	5.0 (0.197)	6.3 (0.248)
3.8 (0.150)	5.1 (0.201)	6.4 (0.252)
3.9 (0.154)	5.2 (0.205)	6.5 (0.256)
4.0 (0.158)	5.3 (0.209)	6.6 (0.260)
4.1 (0.161)	5.4 (0.213)	
4.2 (0.165)	5.5 (0.216)	

**HINT:**

Lengthening the plug by 0.1 mm (0.004 in.) will decrease injection volume by 0.6 cc (0.04 in.).

If the variation limit is greater than specified, replace the delivery valve.

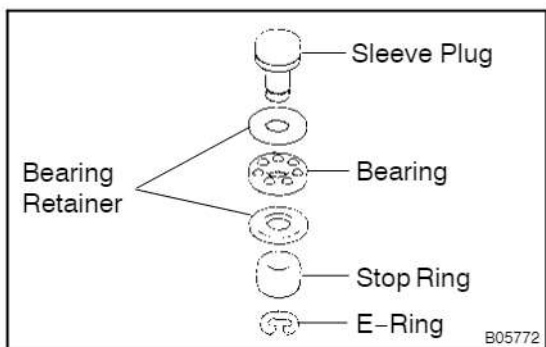

- Install the bearing , 2 bearing retainer and stop ring to the new sleeve plug with a new E-ring:

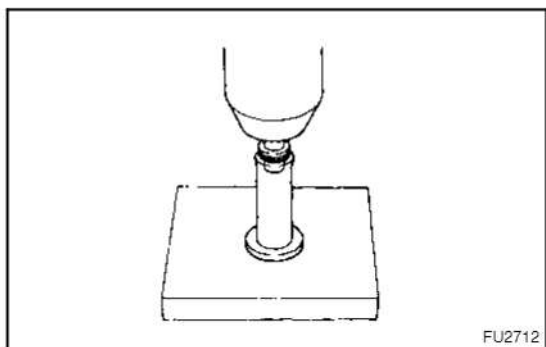

- Using a press, press in the sleeve plug assembly to the governor sleeve.

**17. 1HD-T: ADJUST FULL LOAD MINIMUM INJECTION VOLUME**

- Set the adjusting lever to maximum position.
- Release the pressure from the boost compensator.
- Measure the injection volume.

**w/o BACS:**

Pump rpm	No. of measuring strokes	Each injection volume cc (cu in.)
500	200	7.30 - 8.10 (0.45 - 0.49)

**w/ BACS:**

Pump rpm	No. of measuring strokes	Each injection volume cc (cu in.)
500	200	5.60 - 6.40 (0.34 - 0.39)

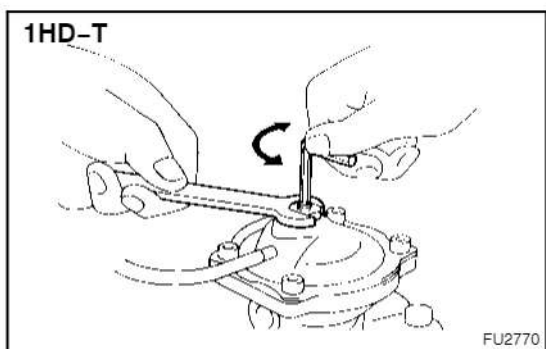

- Using a 5 mm hexagon wrench, adjust by turning the timer slide pin.

**18. 1HD-T: ADJUST BOOST COMPENSATOR CHARACTERISTIC**

- Apply pressure to the boost compensator.
- Measure the injection volume.

Item	Pump rpm	Boost pressure kPa (kg/cm <sup>2</sup> , psi)	No. of measuring strokes	Each injection volume cc (cu in.)
Philippine	1,100	37.4 (0.38, 5.4)	200	10.92 - 12.10 (0.67 - 0.74)
Others (w/o BACS)	1,100	37.4 (0.38, 5.4)	200	10.84 - 12.04 (0.66 - 0.73)
Others (w/ BACS)	500	49.3 (0.50, 7.2)	200	7.30 - 8.10 (0.45 - 0.49)

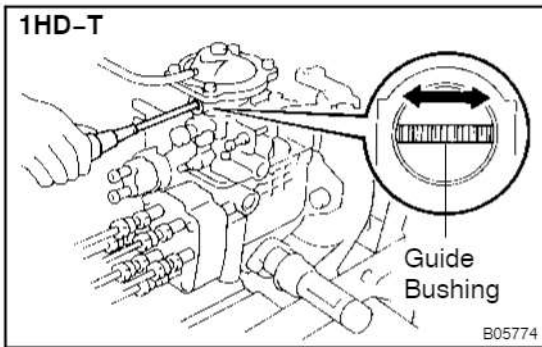

(c) Using a screwdriver, adjust the injection volume by the guide bushing.

HINT:

When the guide bushing is turned clockwise, as seen from above, the injection volume will increase.

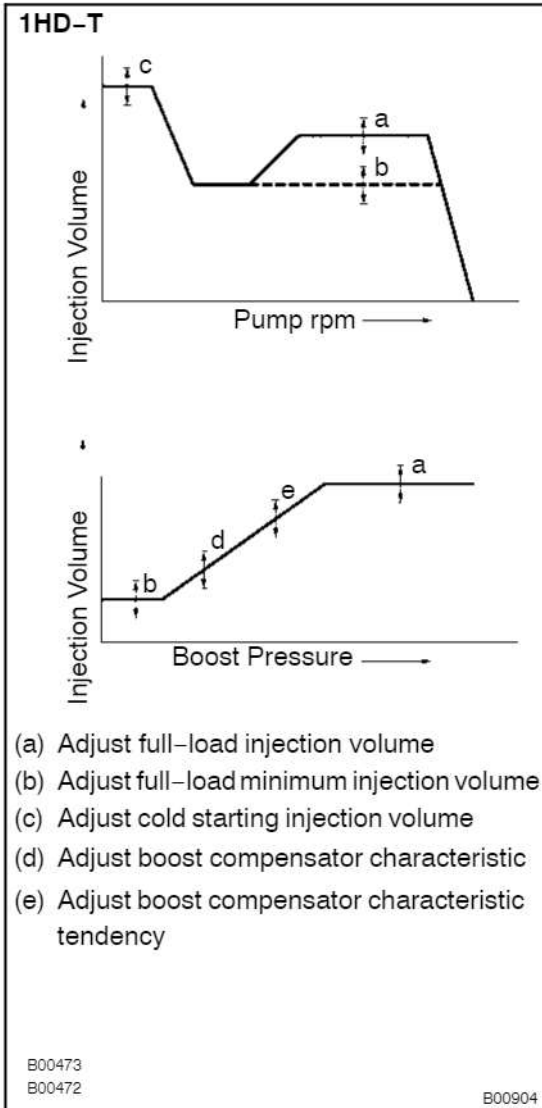

**19. 1HD-T: CHECK FOR CHARACTERISTIC TENDENCY**

- (a) Apply pressure to the boost compensator.
- (b) Measure the injection volume.

Item	Pump rpm	Boost pressure kPa (kg/cm <sup>2</sup> , psi)	No. of measuring strokes	Each injection volume cc (cu in.)
Philippine	1,100	30.7 (0.31, 4.4)	200	9.20 – 10.00 (0.56 – 0.61)
Others (w/o BACS)	1,100	24.0 (0.24, 3.5)	200	9.54 – 10.74 (0.58 – 0.66)
Others (w/ BACS)	500	86.7 (0.88, 12.6)	200	8.64 – 9.84 (0.53 – 0.60)

## 20. 1HD-T: CHECK HYSTERESIS

- (a) w/o BACS:  
Compare the injection volume when the boost compensator pressure is lowered from 80 kPa (0.81 kgf/cm<sup>2</sup>, 11.5 psi) to 0 kPa (0 kgf/cm<sup>2</sup>, 0 psi) and, conversely, when it is raised from zero.
- (b) w/ BACS:  
Compare the injection volume when the boost compensator pressure is lowered from 129 kPa (1.32 kgf/cm<sup>2</sup>, 18.7 psi) to 0 kPa (0 kgf/cm<sup>2</sup>, 0 psi) and, conversely, when it is raised from zero.

### HINT:

Make measurements after moving the adjusting lever between idle and maximum 3 times for each lowering of the pressure.

Item	Pump rpm	Boost pressure kPa (kg/cm <sup>2</sup> , psi)	No. of measuring strokes	Each injection volume cc. (cu in.)	Hysteresis cc. (cu in.)
Philippine	1,100	80.0 (0.81, 11.5)	200	11.74 – 12.94 (0.72 – 0.79)	–
	1,100	37.4 (0.38, 5.4)	200	10.92 – 12.10 (0.67 – 0.74)	–
	1,100	26.7 (0.27, 3.9)	200	9.20 – 10.00 (0.56 – 0.61)	0.3 (0.02) or less
	600	0 (0, 0)	200	8.76 – 10.16 (0.53 – 0.62)	–
Others (w/o BACS)	1,100	80.0 (0.81, 11.5)	200	12.18 – 13.38 (0.74 – 0.82)	–
	1,100	37.4 (0.38, 5.4)	200	10.84 – 12.04 (0.66 – 0.73)	–
	1,100	24.0 (0.24, 3.5)	200	9.54 – 10.74 (0.58 – 0.66)	0.3 (0.02) or less
	1,100	0 (0, 0)	200	8.38 – 9.78 (0.53 – 0.62)	–
(w/ BACS)	1,100	136 (139, 19.7)	200	12.18 – 13.38 (0.74 – 0.82)	–
	500	86.7 (0.88, 12.6)	200	8.64 – 9.84 (0.53 – 0.62)	0.3 (0.02) or less
	500	49.3 (0.50, 7.2)	200	7.30 – 8.10 (0.45 – 0.49)	–
	500	0 (0, 0)	200	5.60 – 6.40 (0.34 – 0.39)	–

If not within standard value, check each sliding part of the boost compensator and check whether or not there is any oil.

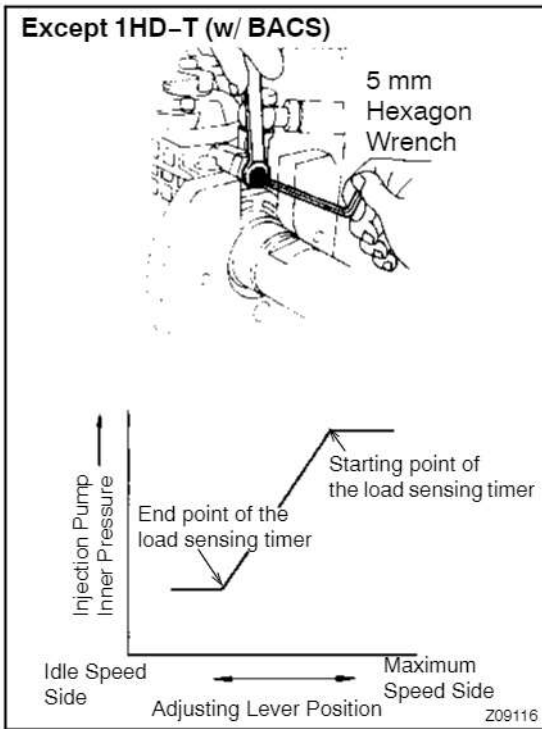

**21. Except 1HD-T (w/BACS):**

**ADJUST LOAD SENSING TIMER**

- (a) Using a 5 mm hexagon wrench, adjust the starting and end points of the load sensing timer by turning the governor shaft.
- (b) Set the adjusting lever to maximum position.
- (c) 1HZ (w/ HAC):  
Apply  $101.3 \pm 0.2$  kPa ( $760 \pm 1.5$  mmHg,  $29.92 \pm 0.06$  in.Hg) absolute pressure.
- (d) 1HD-T:  
Apply 80 kPa (0.81 kgf/cm<sup>2</sup>, 11.5 psi) of pressure to the boost compensator.
- (e) Measure the injection volume.

Item	adjusting lever position	Pump rpm	No. of measuring strokes
1HZ	Maximum speed side	1,520	200
1HD-T	Maximum speed side	1,440	200

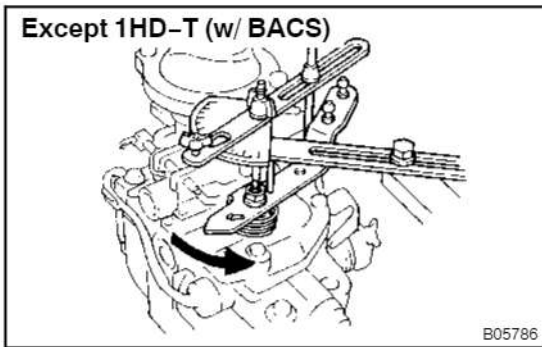

- (f) Slowly move the adjusting lever from the maximum speed side to the idle speed side, and secure it at the point where the pump inner pressure begins to drop.
- (g) Measure the injection volume at the drop point (starting point).

Item	Pump rpm	No. of measuring strokes	Each injection volume cc (cu in.)
1HZ	1,520	200	Measured value at step (f) minus 1.4 (0.09) ± 0.4 (0.02)
1HD-T	1,800	200	Measured value at step (f) minus 1 - 1.6 (0.06 - 0.01)

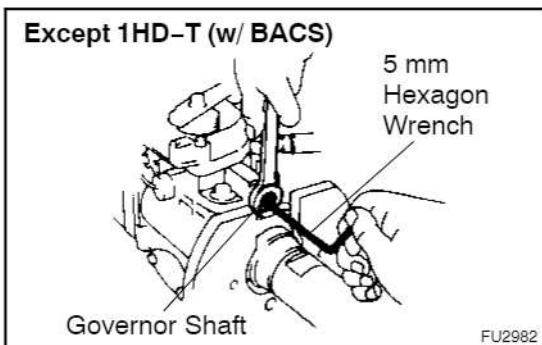

- (h) Using a 5 mm hexagon wrench, adjust the load sensing timer by turning the governor shaft, and to the measurement again as specified.

**HINT:**

The injection volume will increase approx. 3 cc (0.2 cu in.) with each 1/2 turn of the governor shaft.

- (i) 1HZ:  
Check the end point injection volume by slowly moving the adjusting lever from the maximum speed side to the idle speed side, and secure it at the point where the pump inner pressure stops dropping.

Pump rpm	No. of measuring strokes	Each injection volume cc (cu in.)
1,520	200	7.6 (0.46) or more

- (j) 1HD-T (Philippine):  
Check the timer piston stroke when the pump rpm is 1,800 rpm and timer piston stroke is maximum delayed.

**Timer piston stroke: 3.7 mm (0.146 in.) or more**

- (k) 1HD-T (Others):  
Check the injection volume when the pump rpm is 1,440 rpm and injection volume is 7.0 – 7.8 cc (0.43 – 0.48 cu in.).

**Timer piston stroke: 2.5 mm (0.098 in.) or less**

**HINT:**

The end point for 1HD-T engine is hard to identify, so use the methods used in the (j) or (k) above.

- (l) When the adjusting lever is moved slowly from the maximum speed side to the idle speed side.

Item	Pump rpm	Timer piston fluctuation mm (in.)
1HZ (w/ ACSD)	1,520	3.86 – 4.66 (0.1520 – 0.1835)
1HZ (w/o ACSD)	1,520	2.63 – 3.43 (0.1035 – 0.1350)
1HD-T (Philippine)	1,440	0.8 (0.0315)
1HD-T (Others)	1,440	1.5 – 2.5 (0.0591 – 0.0984)

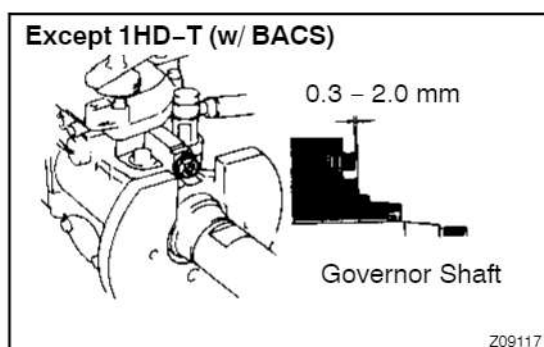

- (m) Check the protrusion of the governor shaft.  
**Protrusion: 0.3 – 2.0 mm (0.012 – 0.079 in.)**

**22. ADJUST IDLE SPEED**

(a) Measure the injection volume for each pump rpm.

Item	Adjusting lever angle	Pump rpm	No. of measuring strokes	Each injection volume cc. (cu in.)	Variation limit cc (cu. in.)	Remarks
1HZ (M/T)	Minus 12 - 22°	375	200	q = 2.30 - 3.30 (0.14 - 0.20)	-	Pre-set
		350		More than q plus 0.5 (0.03)	-	-
		450		q Minus 1.2 - 2.4 (0.07 - 0.15)	-	-
		325		3.36 - 4.36 (0.21 - 0.27)	0.5 (0.03)	Adjust
1HZ (A/T)	Minus 12 - 22°	375	200	q = 2.40 - 3.40 (0.15 - 0.21)	-	Pre-set
		350		More than q plus 0.5 (0.03)	-	-
		450		q Minus 1.2 - 2.4 (0.07 - 0.15)	-	-
		375		2.40 - 3.40 (0.15 - 0.21)	0.5 (0.03)	Adjust
1HD-T (M/T)	Minus 12 - 22°	325	200	0.70 - 1.70 (0.04 - 0.10)	0.5 (0.03)	Adjust
1HD-T (A/T)	Minus 12 - 22°	390	200	0.70 - 1.70 (0.04 - 0.10)	0.5 (0.03)	Adjust

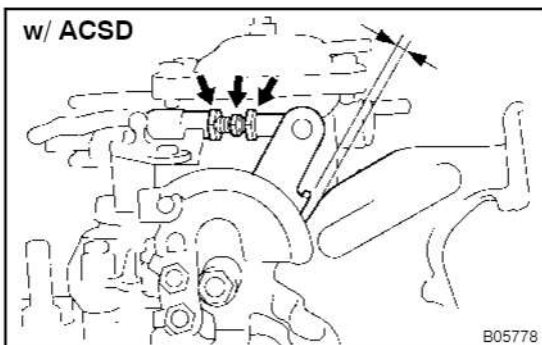
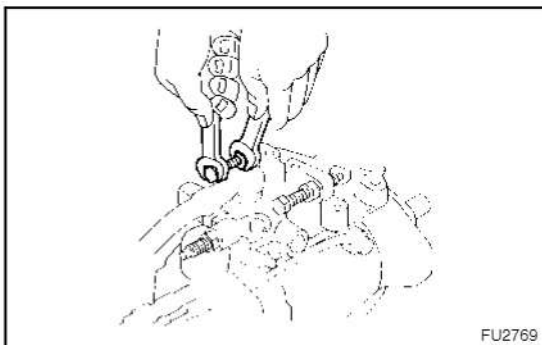

(b) Adjust injection volume by turning the idle speed adjusting screw.

**23. w/ACSD:**

**ADJUST COLD STARTING SYSTEM**

(a) Remove the overflow screw and check the fuel temperature in the fuel pump.

**Fuel temperature: 15 - 35°C (59 - 95°F)**

(b) Check that the cam part of the camplate is not on top of the roller ring.

(c) Set the scale of the timer measuring device to zero.

(d) A/T:

Check the adjusting lever opening angle and consider this angle as zero.

(e) Measure the clearance between the idle-up lever and idle-up lever bracket.

**Clearance: 1.5 - 2.5 mm (0.059 - 0.098 in.)**

(f) Adjust by turning the fast idle adjusting screw.

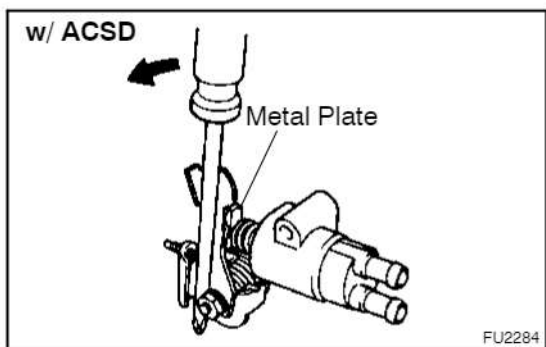

(g) Remove the metal plate between the cold starting lever and thermo wax plunger.

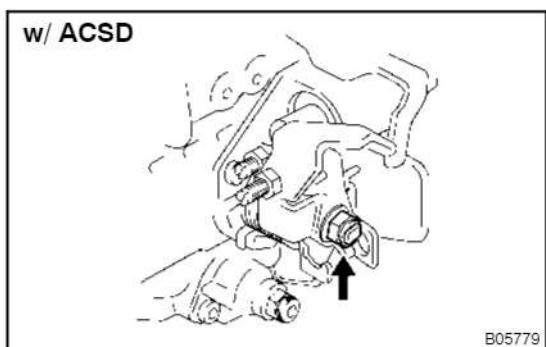

(h) Loosen the nut from the cold starting lever.

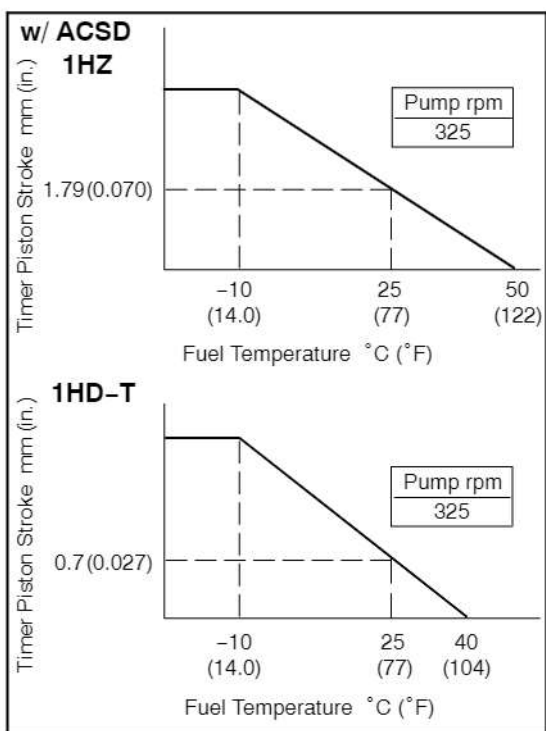

(i) Measure the timer piston stroke.

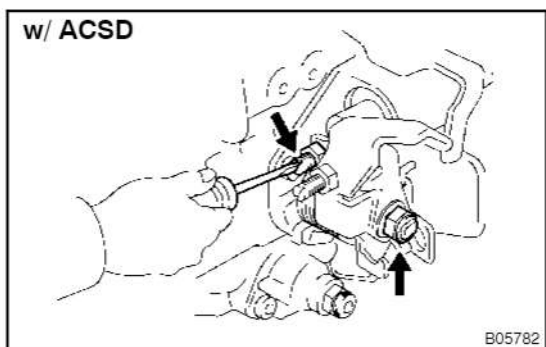

(j) Adjust by turning the timer adjusting screw.  
HINT:  
Screw in for stroke decrease.



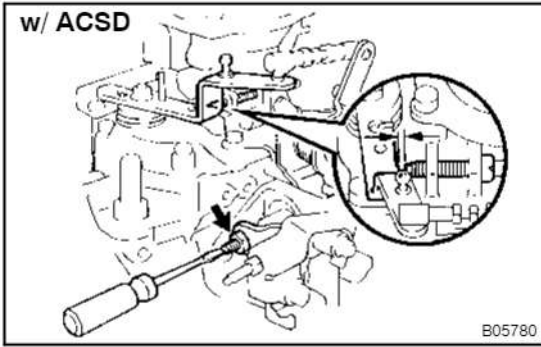

(k) Measure the clearance between the adjusting lever and idle speed adjusting screw.

Item	Fuel temperature	Clearance
1HZ	25°C (77°F)	0.71 mm (0.028 in.)
	40°C (104°F)	0 mm (0 in.)
1HD-T	25°C (77°F)	0.28 mm (0.011 in.)
	40°C (104°F)	0 mm (0 in.)

(l) Adjust by turning the cold starting adjusting screw.

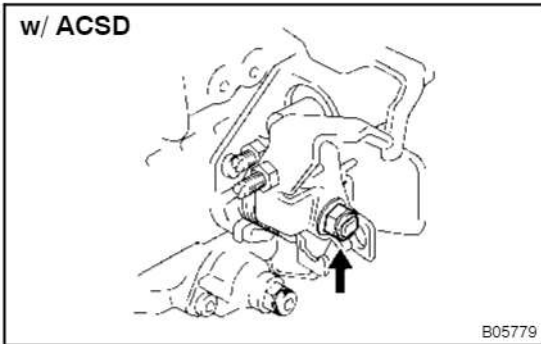

(m) Torque the nut to the cold starting lever.  
**Torque: 13 N·m (137 kgf·cm, 9.5 ft·lbf)**

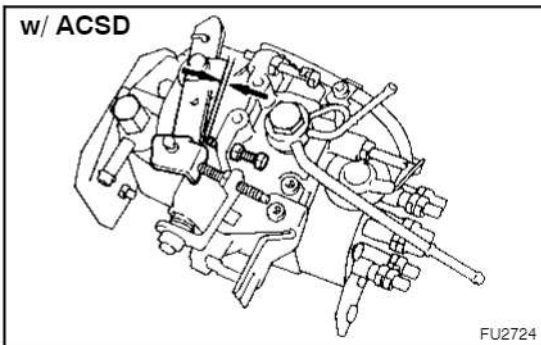

**24. w/ ACSD:  
ADJUST FAST IDLE**

(a) Measure the clearance between the adjusting lever and idle speed adjusting screw.

Item	Fuel temperature	Clearance
1HZ	25°C (77°F)	0.71 mm (0.028 in.)
	40°C (104°F)	0 mm (0 in.)
1HD-T	25°C (77°F)	0.28 mm (0.011 in.)
	40°C (104°F)	0 mm (0 in.)

(b) Adjust by turning the fast idle adjusting screw.

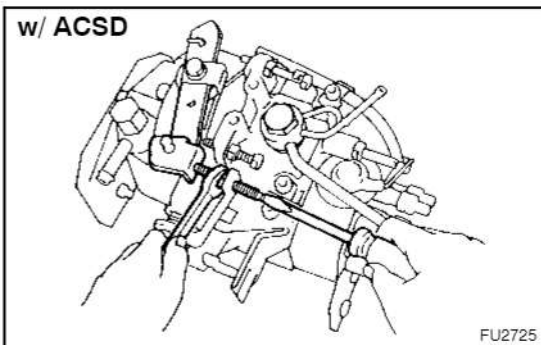

**25. POST ADJUSTMENT CHECK**

(a) Check that injection stops when the fuel cut solenoid harness is removed.

Item	Adjusting lever angle	Pump rpm	Each injection volume cc (cu in.)
1HZ	Minus 12 - 22°	100	0.6 (0.04)
1HD-T		300	
		1,000	

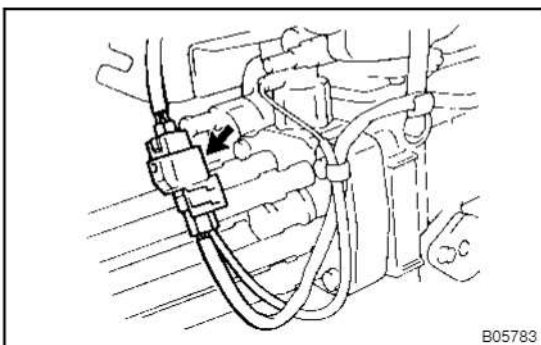

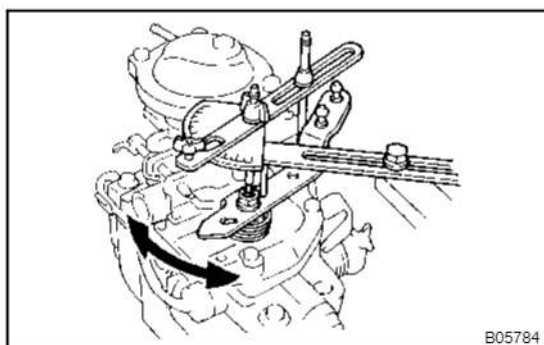

- (b) Check the adjusting lever movement.  
**Adjusting lever angle: 38 - 48°**
- 26. **A/T:**  
**INSTALL THROTTLE POSITION SENSOR AND BRACKET (See page FU-92)**
- 27. **SEAL PARTS**
  - (a) Seal the full load set screw with new cap seal.
  - (b) Seal the maximum speed adjusting screw with new lead seal.
- 28. **w/ Fuel Cut Valve Control Unit:**  
**INSTALL FUEL CUT VALVE CONTROL UNIT (See page FU-92)**
- 29. **INSTALL FUEL PIPES (See page FU-92)**
- 30. **w/ A/C:**  
**INSTALL IDLE-UP ACTUATOR**  
**Torque: 9.35 N·m (95 kgf·cm, 83 in·lbf)**
- 31. **REMOVE INJECTION PUMP FROM SST (STAND)**  
SST 09241-76022, 09245-54010

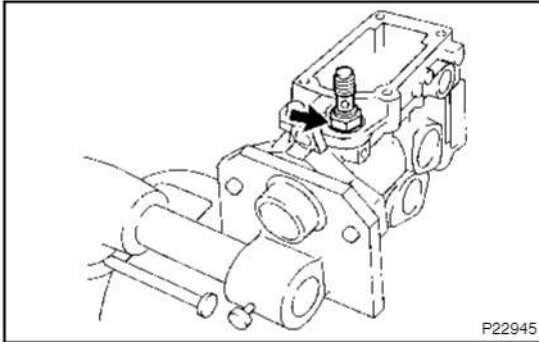

## REASSEMBLY

### 1. INSTALL FUEL INLET HOLLOW SCREW

Install a new gasket and the hollow screw.

**Torque: 36.8 N·m (375 kgf·cm, 27 ft·lbf)**

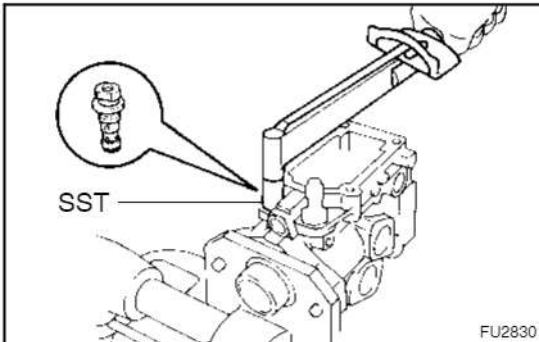

### 2. INSTALL REGULATOR VALVE

(a) Install 2 new O-rings to the regulator valve.

(b) Using SST, install the regulator valve.

SST 09260-54012 (09262 - 54020)

**Torque: 8.8 N·m (90 kgf·cm, 78 in·lbf)**

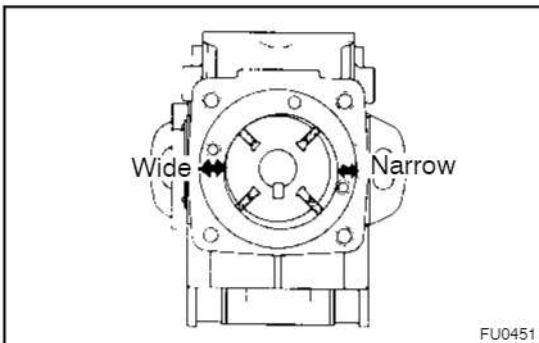

### 3. INSTALL FUEL FEED PUMP

(a) Install the liner, rotor and 4 blades.

(b) Check that the liner and blades are facing in the correct direction, as shown.

(c) Check that the blades move smoothly.

(d) Align the fuel outlet holes of the cover and liner.

(e) Install the pump cover with the 2 screws.

**Torque: 2.9 N·m (29.5 kgf·cm, 25 in·lbf)**

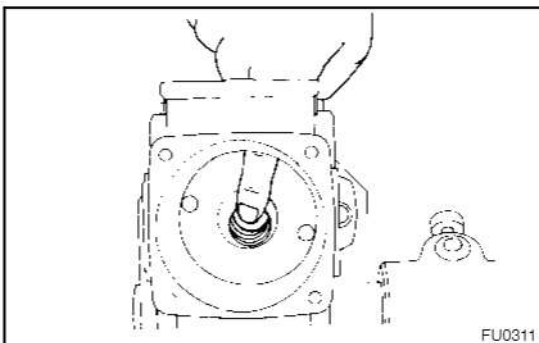

(f) Check that the rotor moves smoothly.

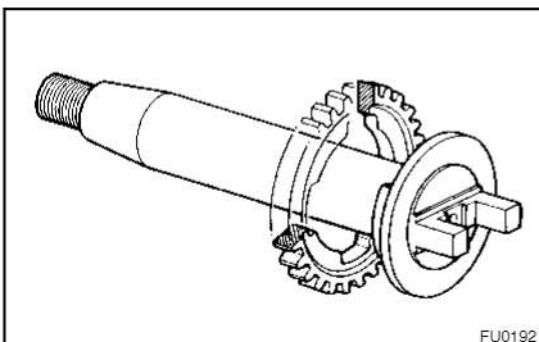

### 4. INSTALL DRIVE SHAFT

(a) Install the drive gear on the drive shaft as shown.

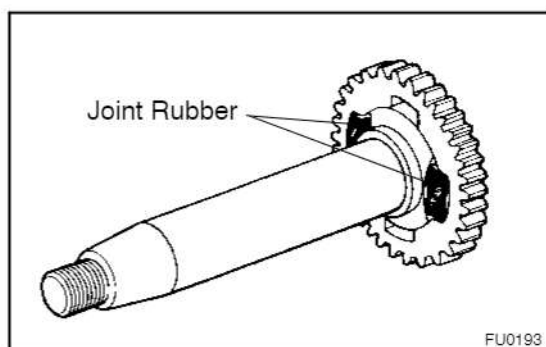

- (b) Install 2 new joint rubbers into the drive gear.

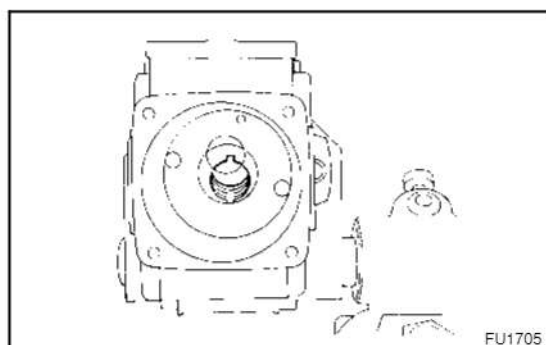

- (c) Position the key groove of the feed pump rotor upward.

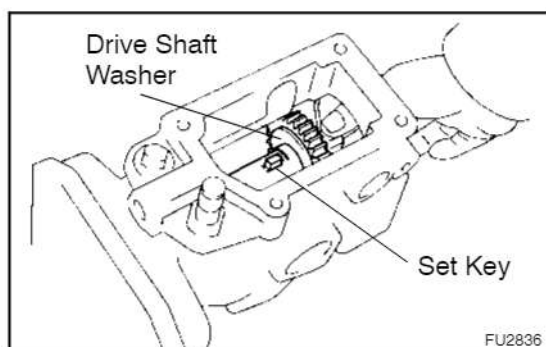

- (d) Install the drive shaft washer and set key on the drive shaft and insert the drive shaft assembly into the pump housing.

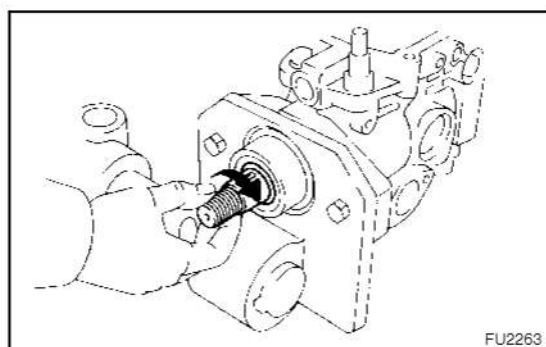

- (e) Check that the drive shaft turns without catching.

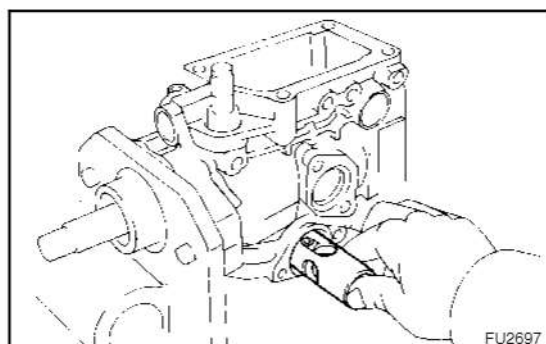

## 5. INSTALL TIMER PISTON

- Apply grease to the timer piston.
- Install the sub-piston into the timer piston.
- Insert the timer piston into the pump housing.

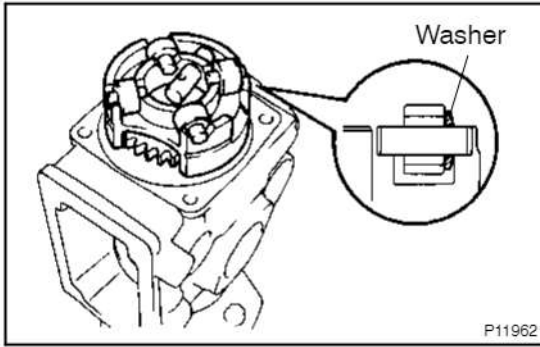

**6. INSTALL ROLLER RING**

- (a) Install the slide pin, 4 rollers and 4 washers on the roller ring.
- (b) Check that the roller is facing the flat surface of the washer.
- (c) Install the roller ring into the pump housing.

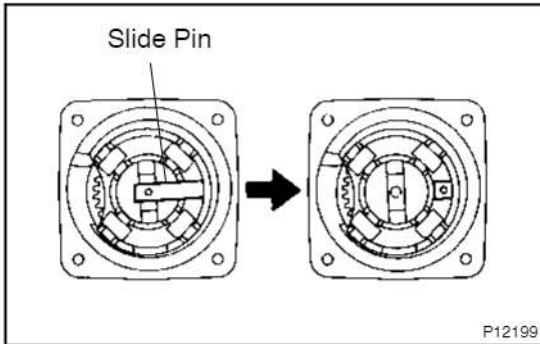

- (d) Carefully install the slide pin into the sub-piston.

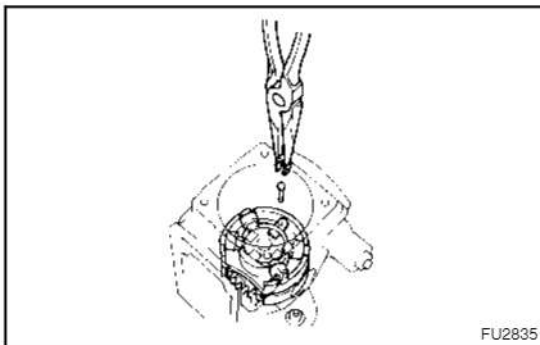

- (e) Install the stopper pin and clip.

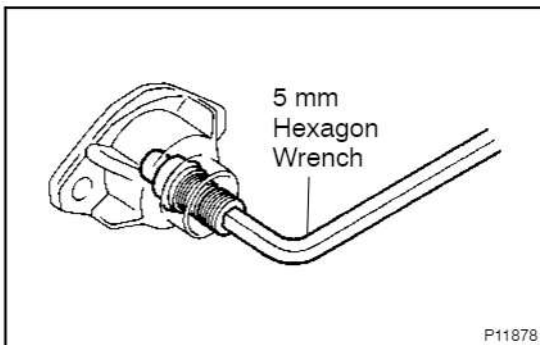

**7. INSTALL TIMER SPRING**

- (a) Install a new O-ring to the timer adjusting screw.
- (b) Using a 5 mm hexagon wrench, install the timer adjusting screw to the LH timer cover and temporarily install the nut.

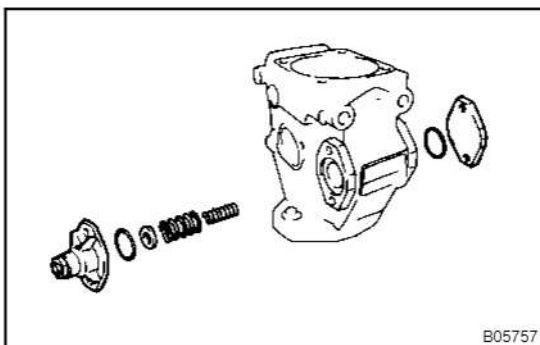

- (c) Install the inner spring, outer spring, shim, 2 new O-rings, the RH timer cover and LH timer cover, timer adjusting screw and nut assembly.

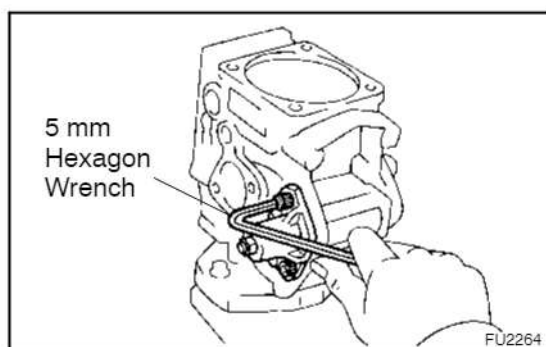

- (d) Using a 5 mm hexagon wrench, install the 4 bolts.  
**Torque: 8.35 N·m (85 kgf·cm, 74 in·lbf)**

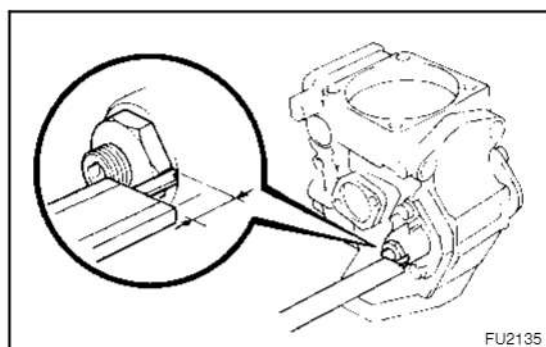

### 8. PRESET TIMER ADJUSTING SCREW

- (a) Using vernier calipers, measure the protrusion of the adjusting screw from the timer cover.  
**Protrusion: 7.5 - 8.0 mm (0.295 - 0.315 in.)**

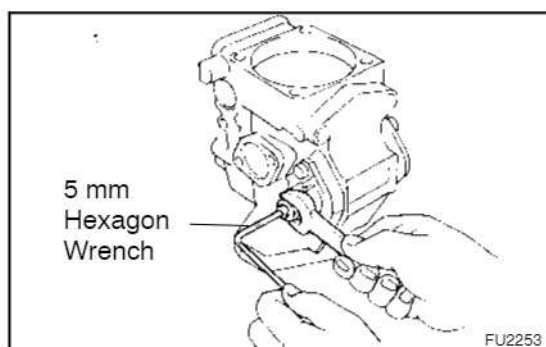

- (b) using a 5 mm hexagon wrench, adjust the protrusion of the adjusting screw from the timer cover.  
(c) Tighten the nut.  
**Torque: 14.2 N·m (145 kgf·cm, 11 ft·lbf)**

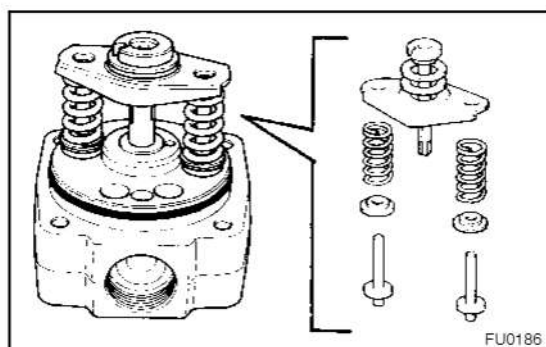

### 9. ADJUST PLUNGER SPRING SHIM

- (a) Install the 2 plunger spring guides, 2 upper spring seats, 2 plunger springs, lower spring seat, upper plunger plate, lower plunger plate and pump plunger to the distributive head:

HINT:

Do not assemble the plunger spring shims at this time

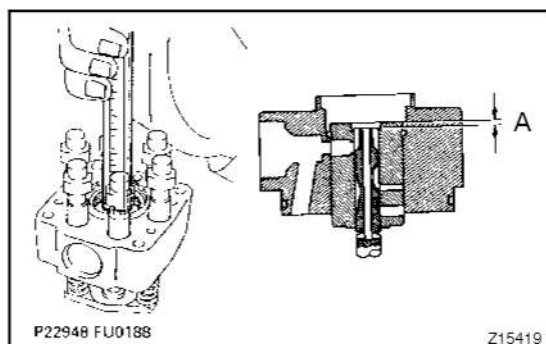

- (b) Using vernier calipers, measure clearance A indicated  
(c) Determine the plunger spring shim size by using these formula and chart.

**1HZ:**

**New plunger spring shim thickness = 5.9 - A**

**A ... Measured plunger position**

**1HD-T:**

**New plunger spring shim thickness = 5.2 - A**

**A ... Measured plunger position**

**Plunger spring shim selection chart:**

**1HZ:**

Measured clearance mm (in.)	Shim thickness mm (in.)
More than 5.4 (0.213)	0.5 (0.020)
5.1 - 5.3 (0.201 - 0.209)	0.8 (0.031)
4.9 - 5.0 (0.193 - 0.197)	1.0 (0.039)
4.7 - 4.8 (0.185 - 0.189)	1.2 (0.047)
4.4 - 4.6 (0.173 - 0.181)	1.5 (0.059)
4.1 - 4.3 (0.161 - 0.169)	1.8 (0.071)
Less than 4.0 (0.157)	2.0 (0.079)

**1HD-T:**

Measured clearance mm (in.)	Shim thickness mm (in.)
More than 4.7 (0.185)	0.5 (0.020)
4.4 - 4.6 (0.173 - 0.181)	0.8 (0.031)
4.2 - 4.3 (0.165 - 0.169)	1.0 (0.039)
4.0 - 4.1 (0.157 - 0.161)	1.2 (0.047)
3.7 - 3.9 (0.146 - 0.154)	1.5 (0.059)
3.4 - 3.6 (0.134 - 0.142)	1.8 (0.071)
Less than 3.3 (0.130)	2.0 (0.079)

**HINT:**

- For a measurement between listed sizes, use the next larger size. For example, if thickness is 1.1 mm (0.043 in.) by calculation, use a 1.2 mm (0.047 in.) shim.
- Select 2 shims which have the same thickness.

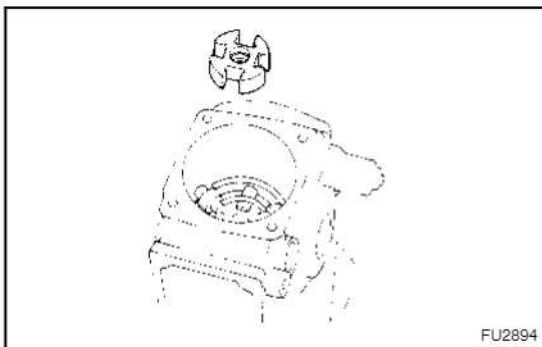

**10. INSTALL COUPLING**

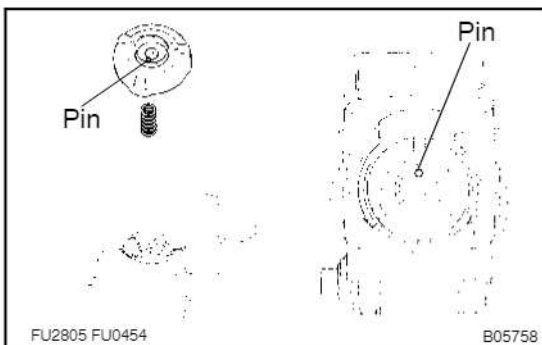

**11. INSTALL FACE CAMPLATE**

- Face the drive shaft with the key groove facing upward.
- Install the coupling spring and camplate with the camplate pin facing the governor cover side.

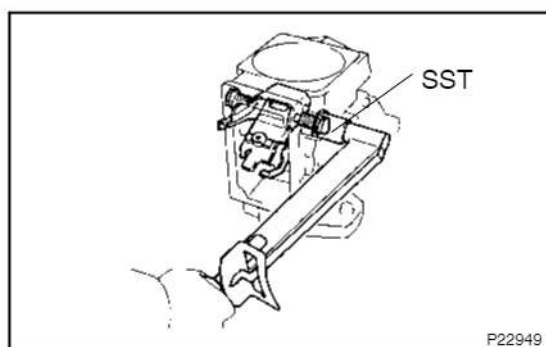
**12. INSTALL GOVERNOR LINK**

- (a) Using SST, install the governor link with 2 new gaskets and the 2 support bolts.

**Torque: 14 N·m (140 kgf·cm, 10 ft·lbf)**

SST 09260-54012 (09269-54040)

- (b) Check that the governor link moves smoothly.

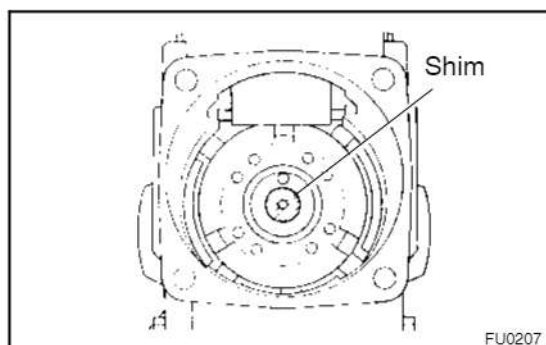
**13. INSTALL PUMP PLUNGER**

- (a) Place the previously used plunger adjusting shim on the center of the camplate.

**NOTICE:**

**Do not apply grease to the shim.**

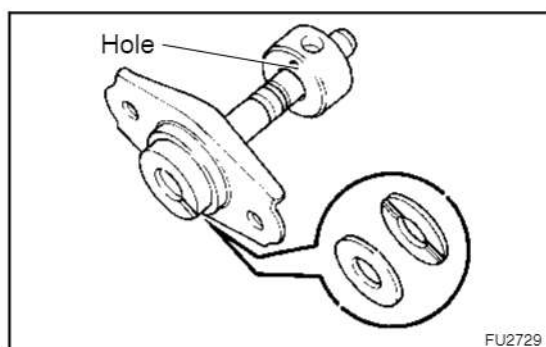

- (b) Install the lower plunger plate, upper plunger plate, lower spring seat and spill ring to the pump plunger.

**HINT:**

Face the spill ring with the hole facing the lower spring seat.

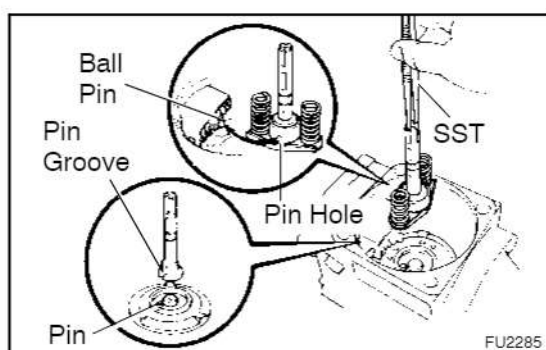

- (c) Align the pin groove of the plunger with the pin of the face camplate.

- (d) align the ball pin of the governor link with the pin hole of the spill ring.

- (e) Using SST, install the pump plunger and 2 plunger springs.

SST 09260-54012 (09269-54030)

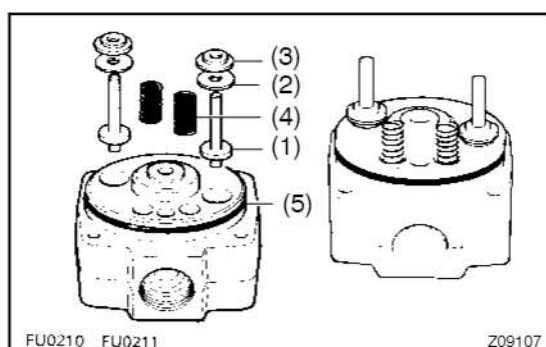
**14. INSTALL DISTRIBUTIVE HEAD**

- (a) Apply grease to these parts and install them to the distributive head.

- (1) 2 plunger spring guides
- (2) 2 new selected plunger spring shims
- (3) 2 upper spring seats
- (4) 2 lever support springs
- (5) New O-ring



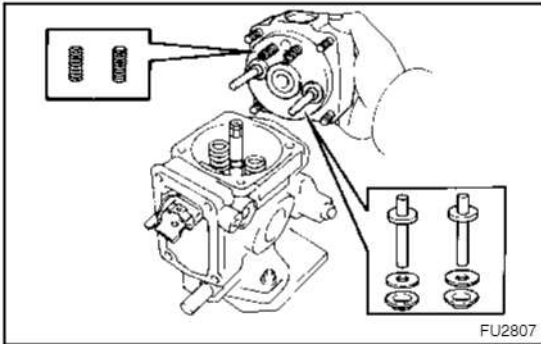

FU2807

(b) Install the distributive head.

**NOTICE:**

**Be careful not to damage the pump plunger.**

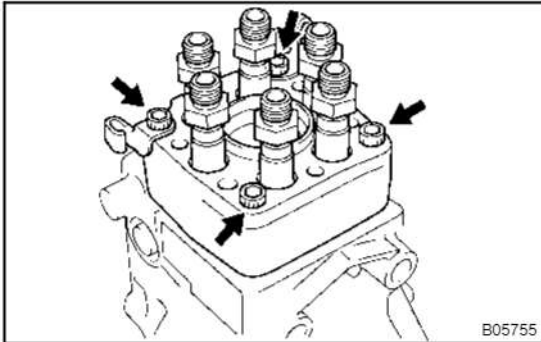

B05755

(c) Using a 5 mm hexagon wrench, install the 2 wire clips and 4 bolts.

**Torque: 12 N·m (120 kgf·cm, 9 ft·lbf)**

**HINT:**

Use the bolt which is 45 mm (1.77 in.) in length.

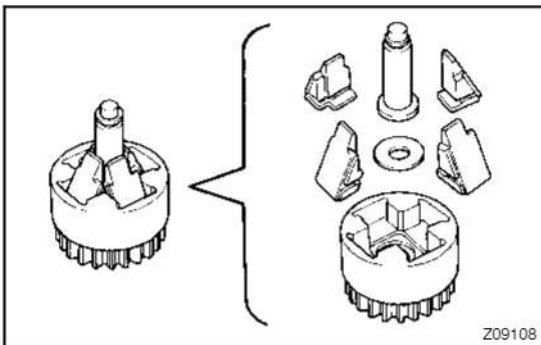

Z09108

**15. INSTALL GOVERNOR SHAFT AND FLYWEIGHT HOLDER**

(a) Install the 4 flyweight, No.2 flyweight washer and governor sleeve to the flyweight holder.

**HINT:**

Replace the 4 flyweights as a set.

(b) Install a new O-ring to the governor shaft.

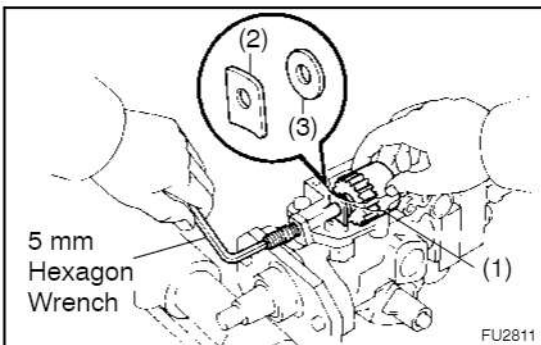

FU2811

(c) Place the flyweight holder assembly (1) in position, and install the governor gear adjusting washer (2) and No.1 flyweight washer (3) between the flyweight holder and pump housing.

(d) Install the governor shaft through the governor gear adjusting washer, No.1 flyweight washer and flyweight holder assembly.

(e) Using a 5 mm hexagon wrench, turn the governor shaft counterclockwise.

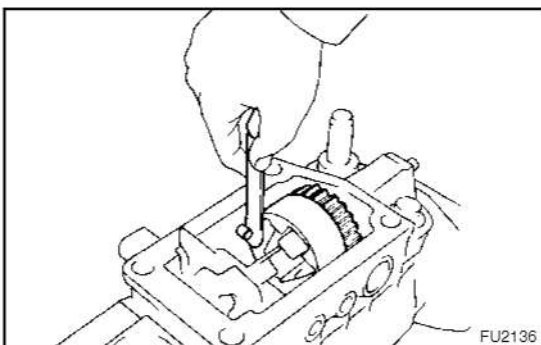

FU2136

**16. CHECK FLYWEIGHT HOLDER THRUST CLEARANCE**

Using a thickness gauge, measure the thrust clearance between the housing pin and flyweight holder.

**Thrust clearance: 0.15 - 0.35 mm (0.0059 - 0.0138 in.)**

If the thrust clearance is not as specified, adjust with a governor gear adjusting washer.

**Governor gear adjusting washer thickness:**

1.05 mm (0.0413 in.)	1.25 mm (0.0492 in.)	1.45 mm (0.0571 in.)
1.65 mm (0.06500 in.)	1.85 mm(0.0728 in.)	-

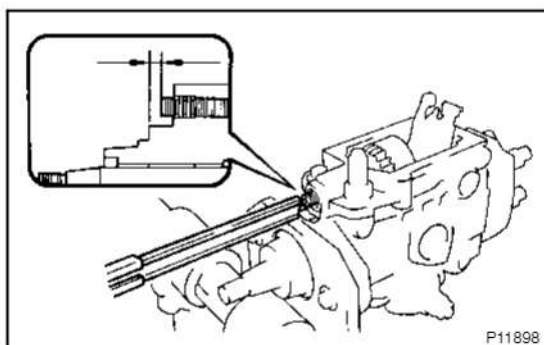
**17. ADJUST PROTRUSION OF GOVERNOR SHAFT**

- (a) Using vernier calipers, measure the protrusion of the governor shaft.

**Protrusion: 0.3 – 2.0 mm (0.012 – 0.079 in.)**

If the protrusion is not as specified, adjust by turning the governor shaft.

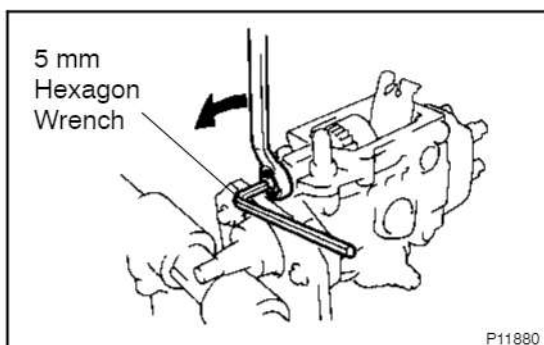

- (b) Using a 5 mm hexagon wrench, install and tighten the nut while holding the governor shaft.

**Torque: 27 N·m (275 kgf·cm, 20 ft·lbf)**

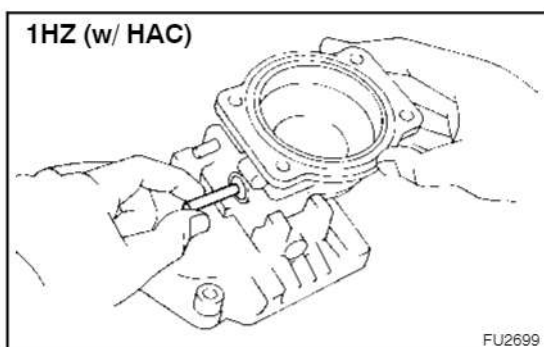
**18. 1HZ (w/ HAC):****ASSEMBLE HIGH ALTITUDE COMPENSATOR**

- (a) Install the control lever.

(1) Insert the connecting pin into the governor cover.

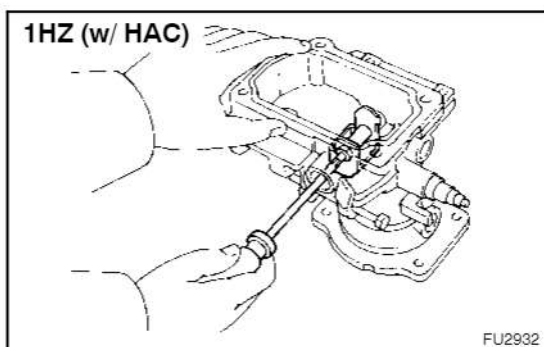

(2) Using a small screwdriver, install the control lever with the support pin.

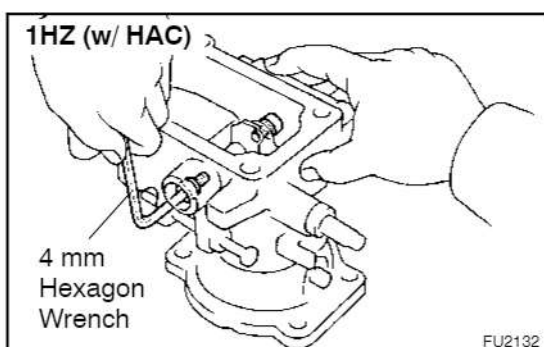

(3) Using a 4 mm hexagon wrench, install 2 new gaskets and the 2 bolts.

**Torque: 6.85 N·m (70 kgf·cm, 61 in·lbf)**

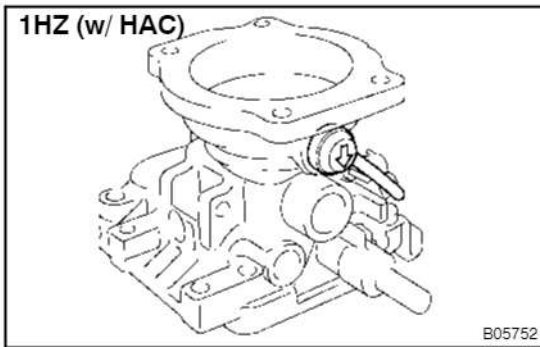

- (b) Install the rubber cap facing the arrow downward.

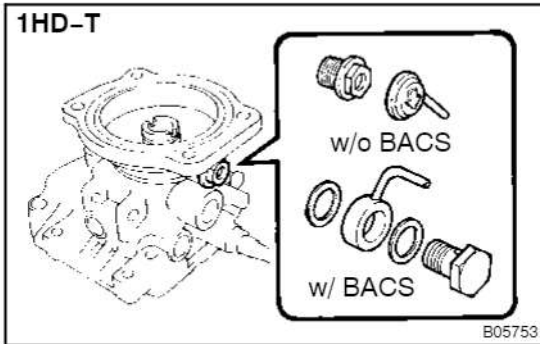

19. 1HD-T:  
**ASSEMBLE BOOST COMPENSATOR**

- (a) Install the overflow screw.
- (1) w/ BACS:  
Install the BACS union and 2 new gaskets with the overflow screw.
- Torque: 24.55 N·m (250 kgf·cm, 18 ft·lbf)**
- (2) w/o BACS:  
Install the overflow screw.
- Torque: 24.55 N·m (250 kgf·cm, 18 ft·lbf)**
- (3) w/o BACS:  
Install the rubber cap facing the arrow downward.

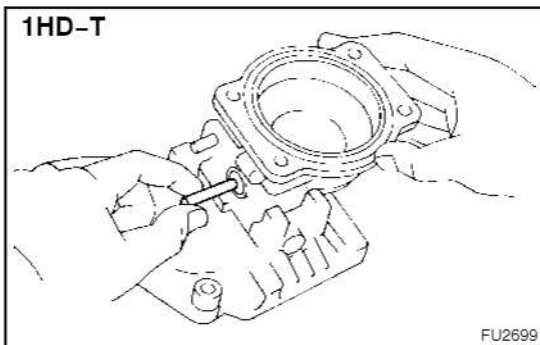

- (b) Install the control lever.
- (1) Insert the connecting pin into the governor cover.

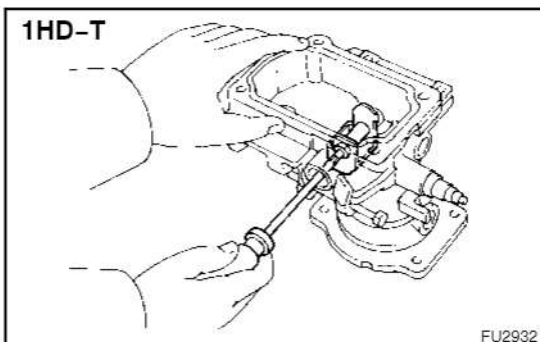

- (2) Using a small screwdriver, install the control lever with the support pin.

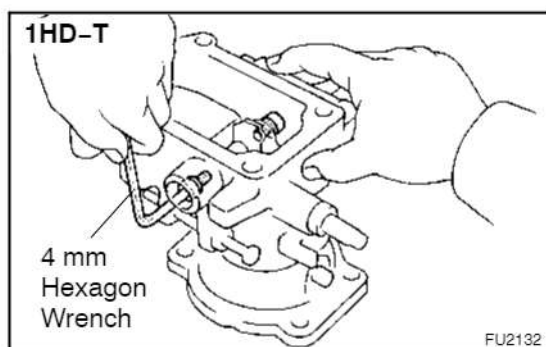

- (3) Using a 4 mm hexagon wrench, install 2 new gaskets and the 2 bolts.

**Torque: 6.85 N·m (70 kgf·cm, 61 in.·lbf)**

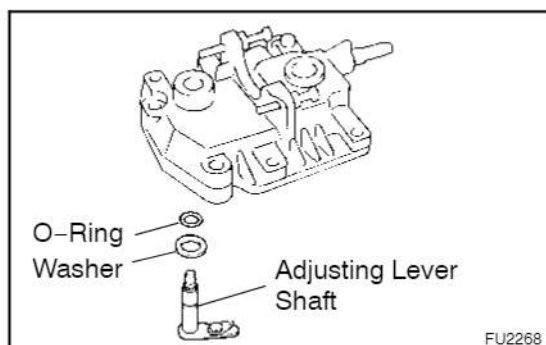

## 20. INSTALL ADJUSTING LEVER SHAFT TO GOVERNOR SHAFT

- (a) Install the washer and a new O-ring to the adjusting lever shaft.
- (b) Install the adjusting lever shaft, washer and O-ring assembly to the governor cover.

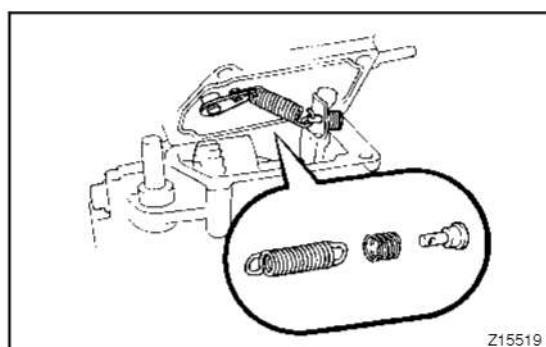

## 21. INSTALL GOVERNOR COVER

- (a) Install the speed control spring to the adjusting shaft.
- (b) Install a new gasket to the groove of the governor cover.
- (c) Install the damper spring and spring seat, and connect the speed control spring to the spring seat.

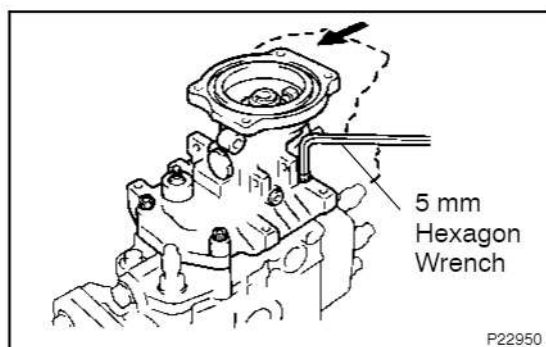

- (d) Using a 5 mm hexagon wrench, install the governor cover with the 4 bolts.

**Torque: 8.3 N·m (85 kgf·cm, 74 in.·lbf)**

### HINT:

Use the bolt which is 35 mm (1.38 in.) length.

- (e) Using a 5 mm hexagon wrench, install the wire clip to the governor cover with the bolt.

**Torque: 8.35 N·m (85 kgf·cm, 74 in.·lbf)**

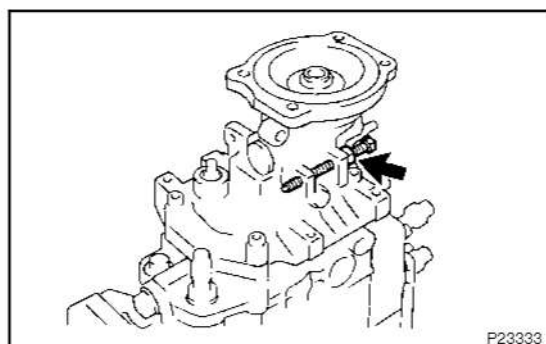

- (f) Install the idle speed adjusting screw and lock nut.

**Torque: 6.9 N·m (70 kgf·cm, 61 in.·lbf)**

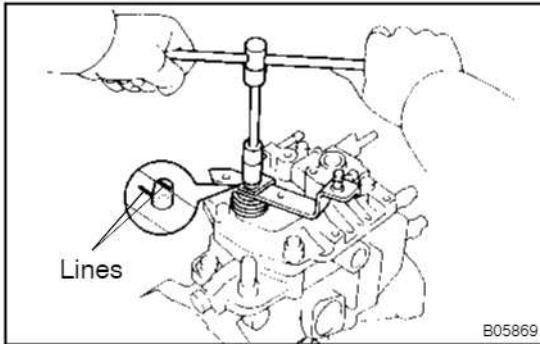
**22. INSTALL ADJUSTING LEVER**

- Place the return spring on the governor cover.
- Hook the return spring to the adjusting lever, and turn and place the adjusting lever on the governor shaft.
- Align the lines of the adjusting lever shaft and adjusting lever.
- Install adjusting lever and spring guide (M/T) with the nut.

**Torque: 8.35 N·m (85 kgf·cm, 74 in·lbf)**

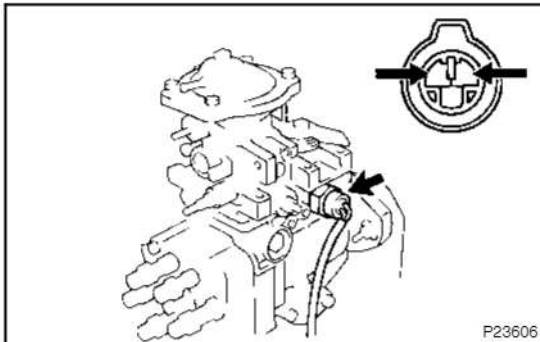
**23. INSTALL PICKUP SENSOR**

- Connect the sensor lead wires to the connector.
- Install a new O-ring and pickup sensor.

**Torque: 20.6 N·m (210 kgf·cm, 15 ft·lbf)**

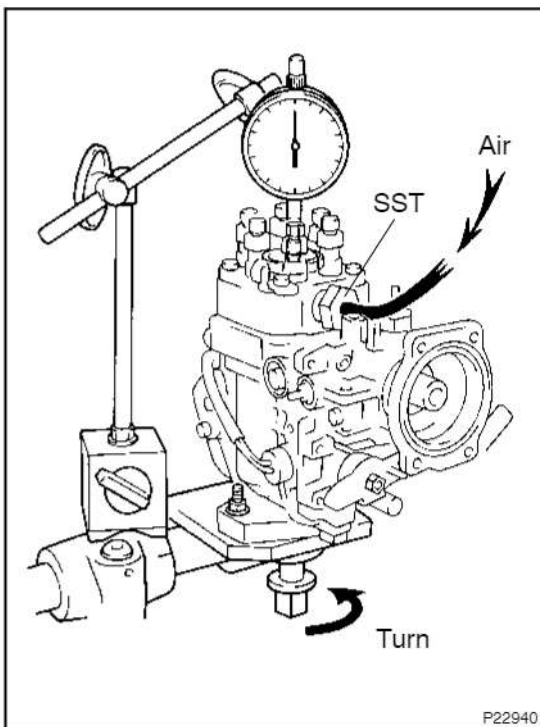
**24. ADJUST PLUNGER PRE-STROKE**

- Install SST to the fuel cut solenoid installation screw section.  
SST 09275-17010
- Set the dial indicator so that the tip of the dial indicator push rod touches the upper surface of the plunger.
- Install the set nut to the drive shaft.
- Rotate the drive shaft, set the plunger to BDC and set the scale on the dial indicator to 0 mm (0 in.).
- Apply a few drops of light oil (diesel fuel) to the top surface of the plunger, and when 49 kpa (0.1 kgf/cm<sup>2</sup>, 1.4 psi) of air is applied to SST, bubbles appear on the upper surface of the plunger.
- Slowly rotate the drive shaft in the pump rotation direction (clockwise) and read the dial indicator when the bubbles on the top of the plunger disappear.

**Pre-stroke:**

**1HZ: 0.2 mm (0.0079 in.)**

**1HD-T: 0.25 mm (0.0098 in.)**

If the pre-stroke is not as specified, replace the plunger adjusting shim under the plunger with a different sized shim.

**HINT:**

- Shims are available in 131 sized in increments 0.01 mm(0.004 in.), from 1.90 mm (0.0748 in.) to 3.20 mm (0.1260 in.).
  - If the shim is made thicker, the pre-stroke is decreased.
- Remove the SST from the fuel cut solenoid installation screw section.
  - Remove the set nut from the drive shaft.

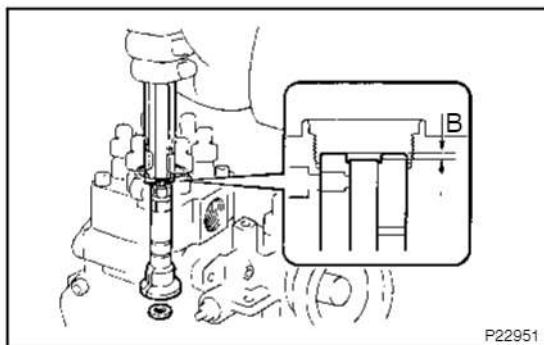

- (i) After completing the pre-stroke adjustment, check that dimension B is within the specifications.

**Dimension B:**

**1HZ: 3.1 – 3.5 mm (0.122 – 0.138 in.)**

**1HD-T: 2.8 – 3.2 mm (0.110 – 0.126 in.)**

If dimension B is not within the specification, replace the distributor head.

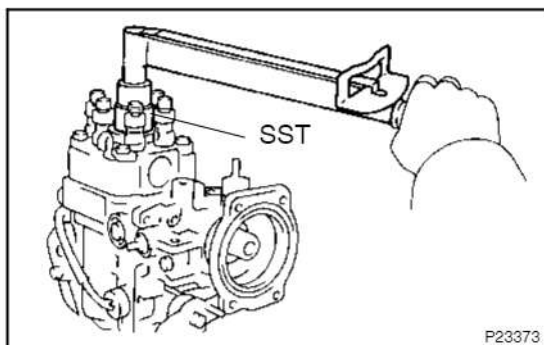

**25. INSTALL DISTRIBUTIVE HEAD PLUG**

- (a) Install a new O-ring to the head plug.

- (b) Using SST, install the head plug.

SST 09260-54012 (09262-54010)

**Torque:**

**1HZ: 69 N·m (700 kgf·cm, 51 ft·lbf)**

**1HD-T: 88 N·m (900 kgf·cm, 65 ft·lbf)**

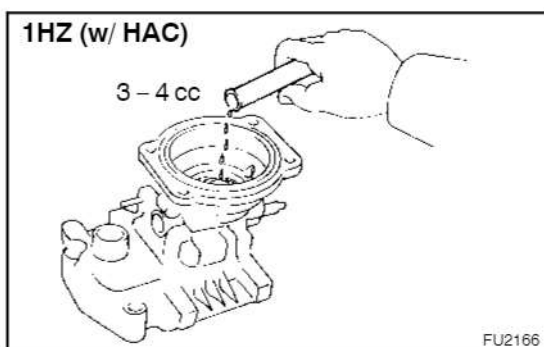

**26. 1HZ (w/ HAC):**

**ASSEMBLE HIGH ALTITUDE COMPENSATOR**

- (a) Install the pneumatic bellows.

- (1) Insert 3 – 4 cc (0.18 – 0.24 cu in.) of engine oil into the bushing hole.

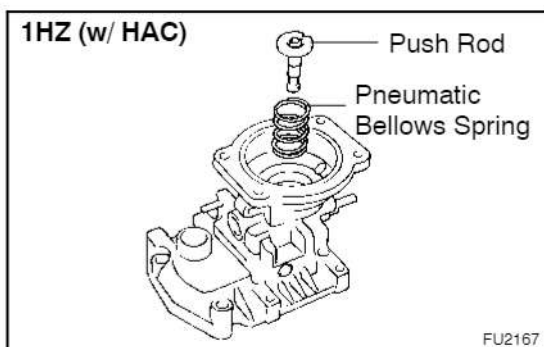

- (2) Place the pneumatic bellows spring and push rod on the governor cover.

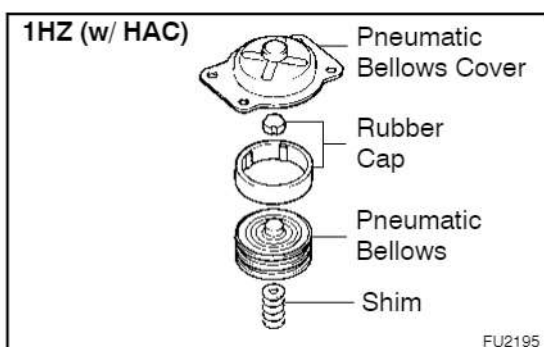

- (3) Install the 2 rubber caps, pneumatic bellows and shims to the pneumatic bellows cover.

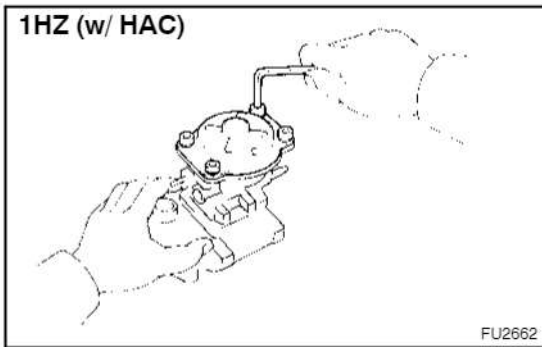

- (4) Install a new gasket and the pneumatic bellows and bellows cover assembly to the governor cover.
  - (5) Using a 5 mm hexagon wrench, install the 4 bolts.
- Torque: 7.35 N·m (75 kgf·cm, 65 in·lbf)**



- (b) Install the lever control spring. Install the lever spring with a new gasket and the bolt.
- Torque: 11.3 N·m (115 kgf·cm, 8 ft·lbf)**

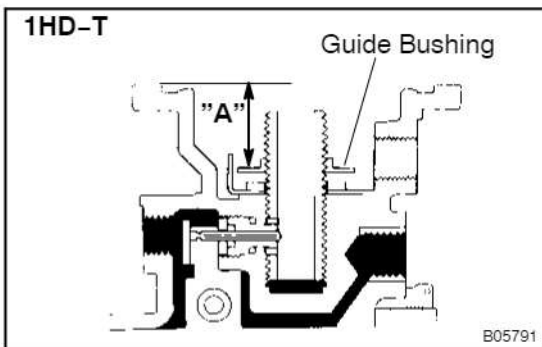

**27. 1HD-T: ASSEMBLE BOOST COMPENSATOR**

- (a) Install the guide bushing. Install and adjust the guide bushing to the dimension "A" as shown in the illustration.

Item	Dimension "A"
Philippine	16.25 – 16.35 mm (0.640 – 0.644 in.)
Others (w/ BACS)	18.65 – 18.75 mm (0.734 – 0.738 in.)
Others (w/o BACS)	17.95 – 18.05 mm (0.707 – 0.711 in.)

- (b) Install the boost compensator diaphragm.
  - (1) Apply sealant to the push rod threads.

**Sealant:**  
**Part No.08833-00080, THREE BOND 1344, LOCTITE 242 or equivalent**

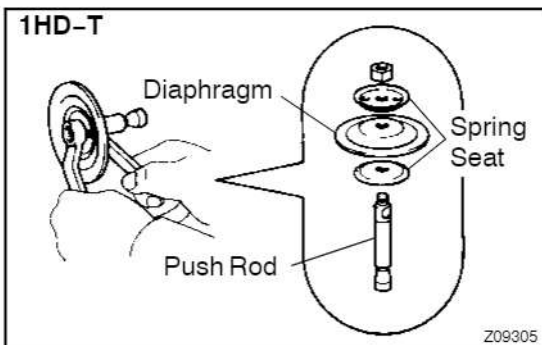

- (2) Install the diaphragm and 2 spring seats to the push rod with the nut.
- Torque: 7.35 N·m (75 kgf·cm, 65 in·lbf)**

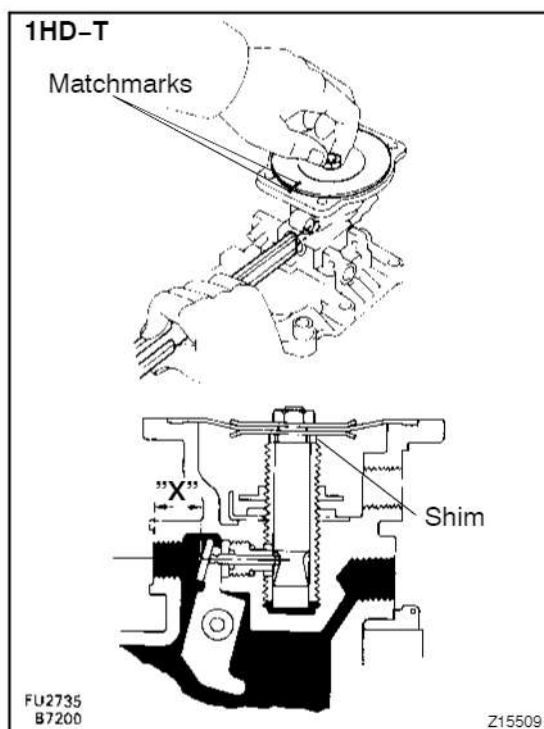

- (3) Adjust the installation direction of boost compensator diaphragm assembly.
- Install the shim and diaphragm assembly.

HINT:

Do not assemble the spring.

- Using vernier calipers, while pushing on the diaphragm assembly dimension "X" with vernier calipers as shown.

Item	Dimension "X"
Philippine	7.9 – 8.1 mm (0.311 – 0.319 in.)
Others (w/ BACS)	8.35 – 8.55 mm (0.329 – 0.337 in.)
Others (w/o BACS)	8.1 – 8.3 mm (0.319 – 0.327 in.)

HINT:

Measure at the center of the hole.

- Place matchmarks on the diaphragm assembly and governor cover.
- Remove the diaphragm assembly.

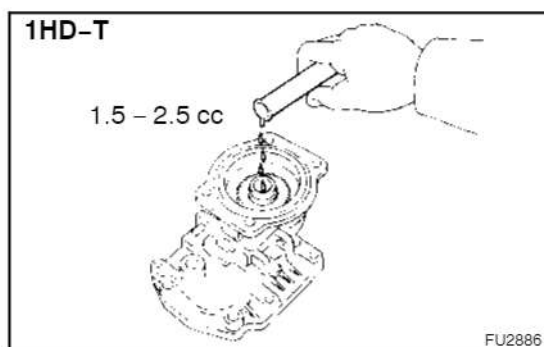

- (4) Insert 1.5 – 2.5 cc (0.09 – 0.15 cu in.) of engine oil into the bushing hole.

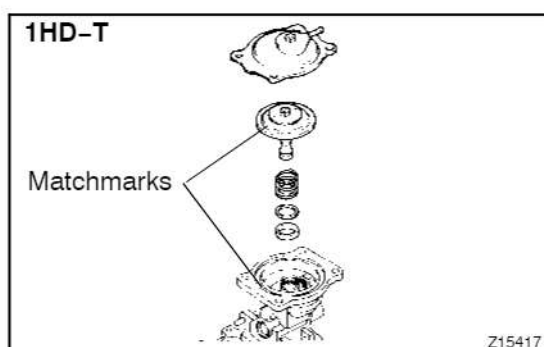

- (5) Install the boost compensator shims, spring, diaphragm assembly and diaphragm cover to the governor cover.

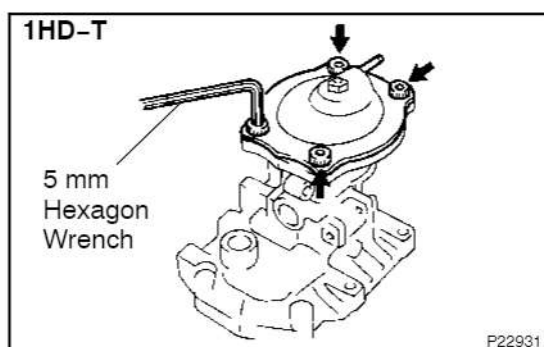

- (6) Using a 5 mm hexagon wrench, install the diaphragm cover with the 4 bolts.

**Torque: 7.35 N·m (75 kgf·cm, 65 in·lbf)**



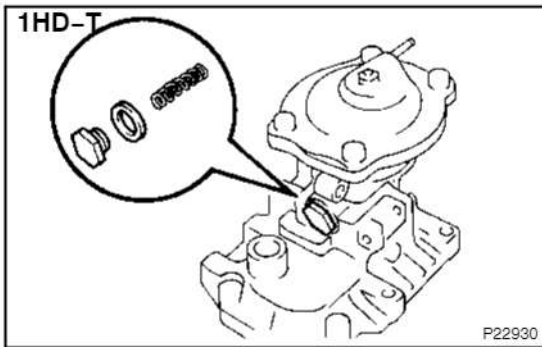

- (c) Install the lever control spring.  
Install the lever control spring with a new gasket and the bolts.

**Torque: 11.3 N·m (115 kgf·cm, 8 ft·lbf)**

**28. INSTALL INJECTION PUMP STAY**

**Torque: 8.35 N·m (85 kgf·cm, 74 in·lbf)**

**29. INSTALL FUEL CUT SOLENOID**

- (a) Install a new O-ring on the fuel cut solenoid.

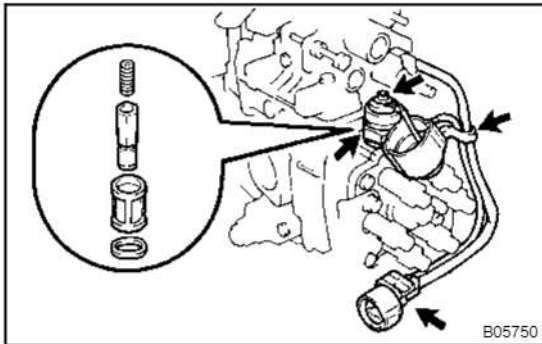

- (b) Install the wave washer, strainer, valve, spring and fuel cut solenoid.

**Torque: 22 N·m (225 kgf·cm, 16 ft·lbf)**

- (c) w/o Fuel Cut Valve Control Unit:  
Install the lead wire to the fuel cut solenoid with the nut.

**Torque: 1.7 N·m (17 kgf·cm, 15 ft·lbf)**

- (d) w/o Fuel Cut Valve Control Unit:  
Install the dust cover to the fuel cut solenoid.

- (e) w/o Fuel Cut Valve Control Unit:  
Install the wire harness to the wire clip.

- (f) w/o Fuel Cut Valve Control Unit:  
Install the lead wire connector to the bracket.

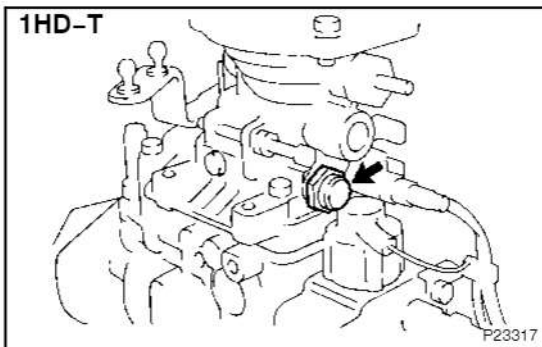

**30. 1HD-T:  
INSTALL CAP**

- (a) w/o Fuel Cut Valve Control Unit:  
Install a new gasket and the cap.

**Torque: 11 N·m (115 kgf·cm, 8 ft·lbf)**

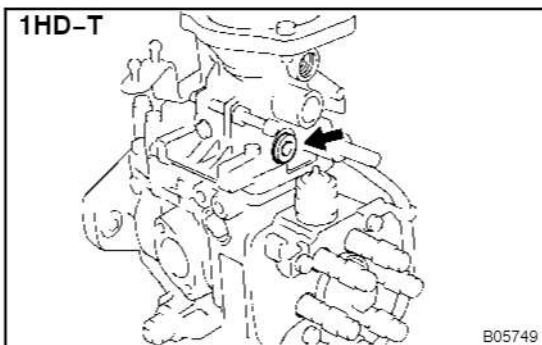

- (b) w/ Fuel Cut Valve Control Unit:  
Using a 6 mm hexagon wrench Install a new gasket and the cap.

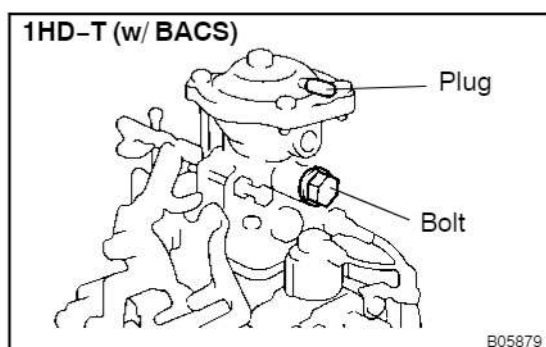
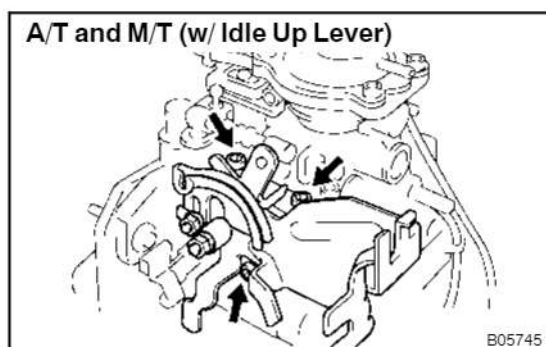
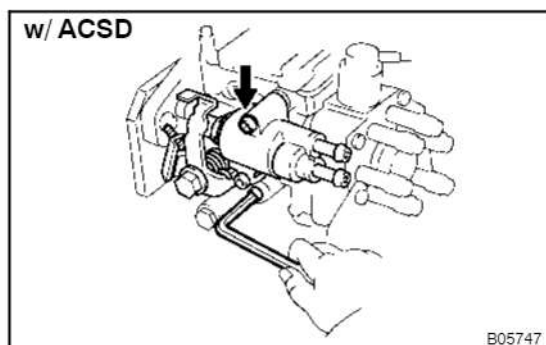
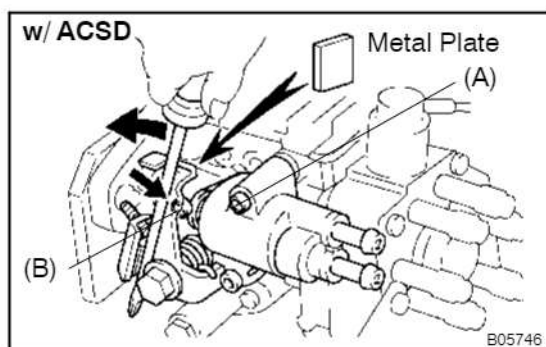
**31. w/ ACSD:****INSTALL THERMO WAX**

- (a) Using a screwdriver, turn the cold starting lever counter-clockwise approx. 20°.
- (b) Put a metal plate (thickness of 3.5 – 7.5 mm (0.183 – 0.295 in.)) between the cold starting lever and thermo wax plunger.
- (c) Install a new O-ring to the pump body.
- (d) Using a 5 mm hexagon wrench, temporarily install the thermo wax with the 2 bolts.
- (e) Using a screwdriver, turn the cold starting lever counter-clockwise.
- (f) Using a 5 mm hexagon wrench, install the bolt (B), and removal the bolts (A).

**Torque: 8.35 N·m (85 kgf·cm, 74 in·lbf)**

- (g) Using a 5 mm hexagon wrench, tighten the bolt.

**Torque: 8.35 N·m (85 kgf·cm, 74 in·lbf)**

**32. A/T and M/T (w/ Idle Up Lever)****INSTALL IDLE-UP LEVER**

- (a) Using a 5 mm hexagon wrench, install the spacer (w/o ACSD) idle-up lever with the 3 bolts.

**Torque:**

**Short bolt: 8.35 N·m (85 kgf·cm, 74 in·lbf)**

**Long bolt: 11.75 N·m (120 kgf·cm, 9 ft·lbf)**

- (b) A/T:  
Connect the idle up link.

**33. REMOVE INJECTION PUMP FROM SST (STAND)**

SST 09241-76022, 09245-54010

**34. PERFORM AIR TIGHT TEST**

- (a) 1HD-T (w/ BACS):  
Install a bolt and gasket to the overflow port.
- (b) 1HD-T:  
Install the plug to the port of the boost compensator.

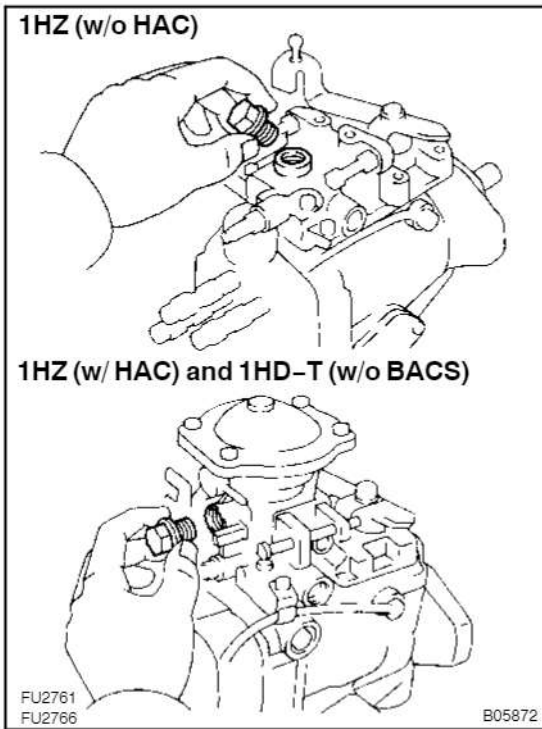

- (c) w/o BACS:  
Install a bolt to the overflow port.

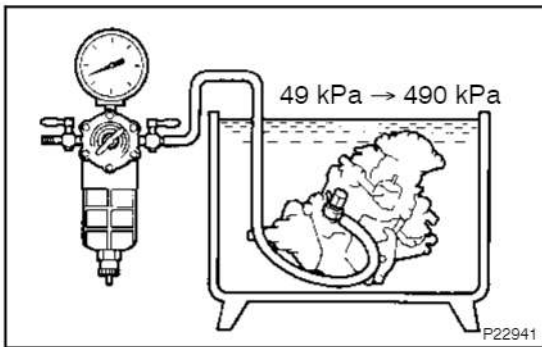

- (d) Connect an air hose to the fuel inlet pipe and place the injection pump into diesel fuel.  
(e) Apply 49 kPa (0.5 kgf/cm<sup>2</sup>, 7 psi) of pressure and confirm that there are no leaks.  
(f) Next check that there are no leaks with 490 kPa (5.0 kgf/cm<sup>2</sup>, 71 psi) of pressure applied.

**35. INSTALL INJECTION PUMP TO SST (STAND)**  
SST 09241-76022, 09245-54011

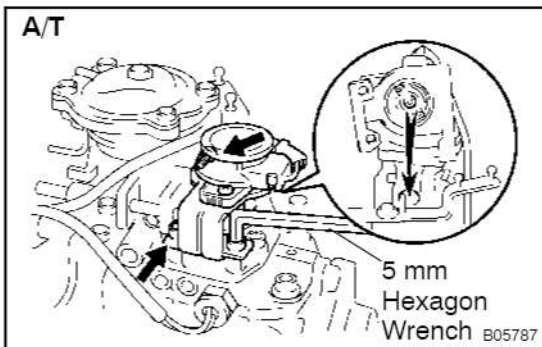

- 36. A/T: INSTALL THROTTLE POSITION SENSOR AND BRACKET**
- (a) Attach the portions of the throttle position sensor and adjusting lever.  
(b) Using a 5 mm hexagon wrench, install the throttle position sensor with the 3 bolts.

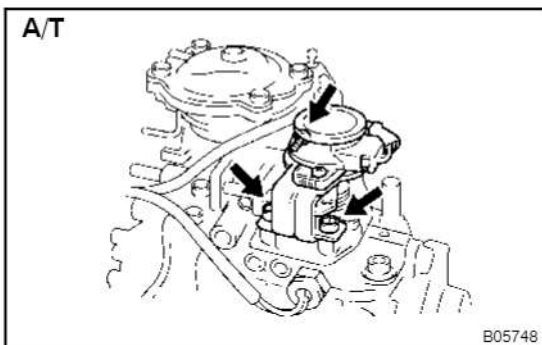

- (c) Loosen the 2 screws holding the throttle position sensor to the bracket.

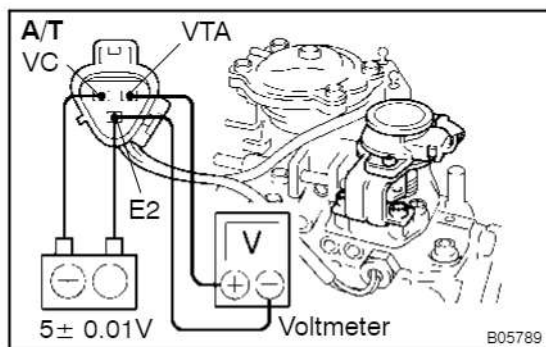

- (d) Apply  $5 \pm 0.01$  V across terminals VC and E2.
- (e) Connect the tester probes of a voltmeter to terminals VTA and E2 of the throttle position sensor.
- (f) Secure the adjusting lever fully on the maximum speed side so that its output will be  $0.6 \pm 0.025$  V
- (g) tighten the 2 screws holding the throttle position sensor to the bracket.

### 37. SEAL PARTS

- (a) Seal the full load set screw with new cap seal.
- (b) Seal the maximum speed adjusting screw with new lead seal.

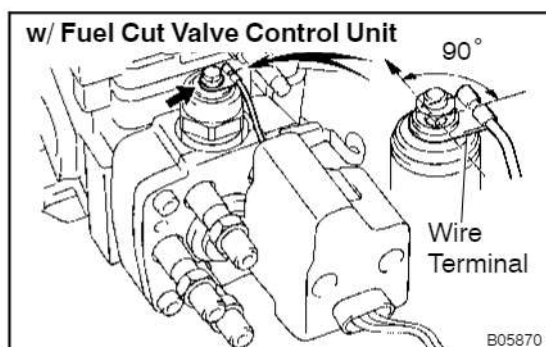

### 38. w/ Fuel Cut Valve Control Unit: INSTALL FUEL CUT VALVE CONTROL UNIT

- (a) Install the lead wire of the fuel cut valve control unit to the fuel cut solenoid terminal with the nut.

#### NOTICE:

**Be careful of the wire terminal installation direction.**

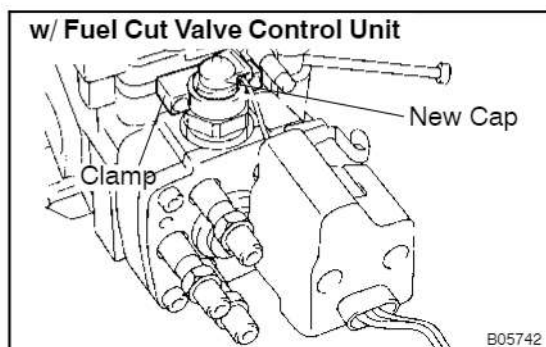

- (b) Install a new cap to the fuel cut solenoid terminal.
- (c) Place the clamp in position as shown in the illustration.

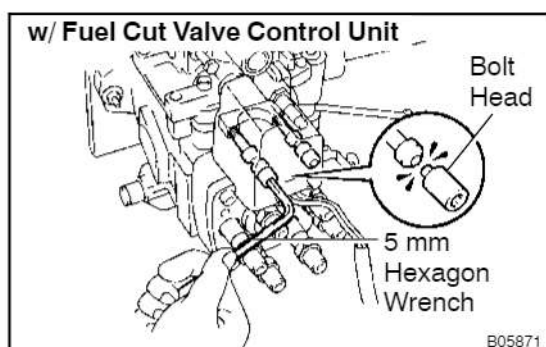

- (d) Attach the fuel cut valve control unit to the fuel cut solenoid.
- (e) Using 5 mm hexagon wrench, temporarily tighten the 2 new bolts.

#### NOTICE:

**Temporarily tighten the bolts while ensuring that the control unit is being placed securely.**

- (f) Alternately tighten the 2 bolts until the bolt heads break off.

## w/ Fuel Cut Valve Control Unit

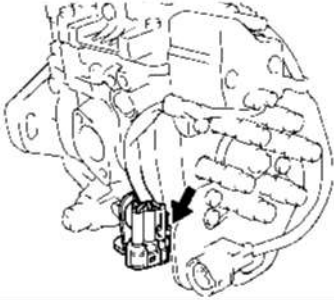

B05738

- (g) Using a 8 mm hexagon wrench, install the connector bracket with the bolt.
- (h) Connect the connector and wire.

## 1HZ (w/o HAC)

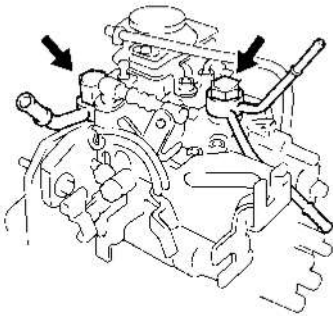

## Others

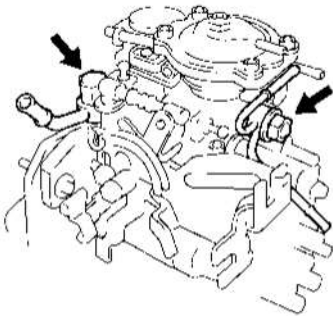

B05744

**39. INSTALL FUEL PIPES**

- (a) Install the nozzle leakage pipe No.2 and 2 new gaskets with the union bolt.

**Torque: 22.1 N·m (225 kgf·cm, 16 ft·lbf)**

- (b) Install the fuel inlet pipe and 2 new gaskets with the cap nut.

**Torque: 24.55 N·m (250 kgf·cm, 18 ft·lbf)**

**40. w/ A/C:****INSTALL IDLE-UP ACTUATOR**

**Torque: 9.35 N·m (95 kgf·cm, 83 in·lbf)**

**41. REMOVE INJECTION PUMP FROM SST (STAND)**

SST 09241-76022, 09245-54011

**42. INSTALL SET KEY OF INJECTION PUMP DRIVE PULLEY ON DRIVE SHAFT****43. REMOVE INJECTION PUMP FROM SST (STAND)**

SST 09241-76022, 09245-54010

## INSTALLATION

### 1. INSTALL INJECTION PUMP

#### NOTICE:

**Do not put the injection pump at an angle more than 45° from the horizontal.**

- (a) Install a new O-ring to the pump.
- (b) Apply a light coat of engine oil on the O-ring.
- (c) 1HD-T:  
Place the No.1 Cylinder block insulator.
- (d) Align the set key on the drive shaft and groove of the injection pump drive gear.

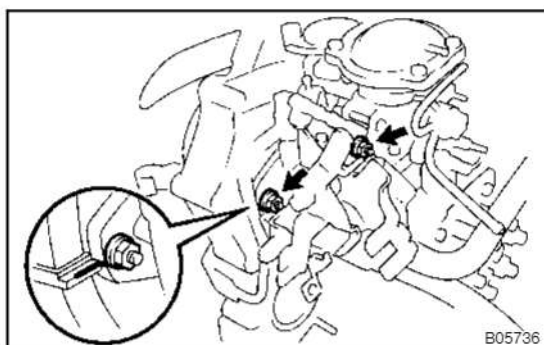
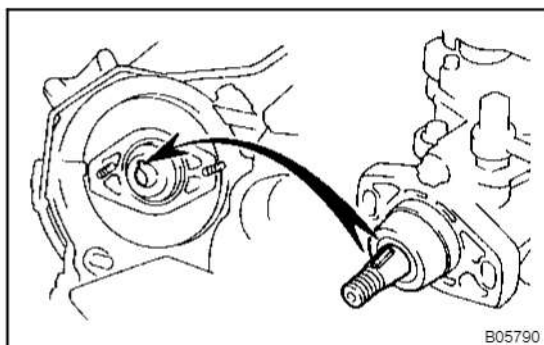

- (e) Align the period lines (or matchmarks) of the injection pump and timing belt case.
- (f) Install the 2 nuts holding the injection pump to the timing gear case.

**Torque: 18 N·m (185 kgf·cm, 13 ft·lbf)**

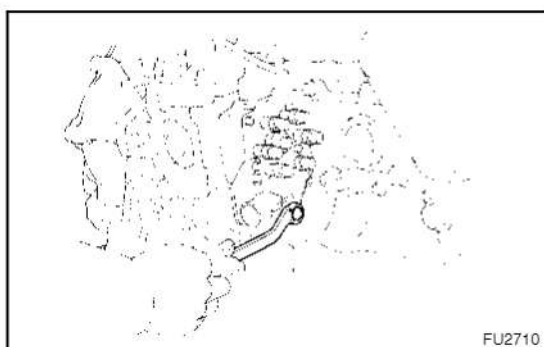

- (g) Install the injection pump stay with the bolt.  
**Torque: 69 N·m (700 kgf·cm, 51 ft·lbf)**

#### NOTICE:

**Before tightening to the standard torque, check whether the pump stay is up against the injection pump.**

If there is a gap, loosen the bolts joining the pump stay to the cylinder block and set the pump stay against the injection pump.

- (h) Install a new O-ring to the injection pump drive gear.

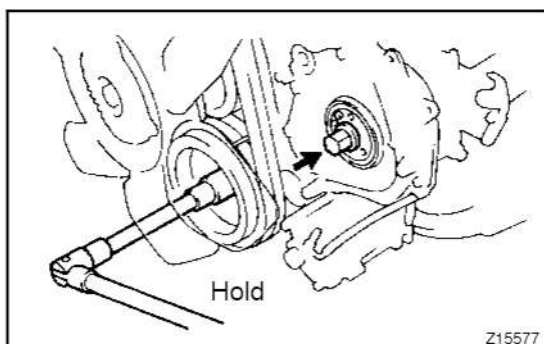

- (i) Install the injection pump drive gear set nut.
- (j) Hold the crankshaft pulley, and torque the nut.  
**Torque: 103 N·m (1,050 kgf·cm, 76 ft·lbf)**

#### NOTICE:

**Do not turn the crankshaft pulley. The valve heads will hit against the piston top.**

- (k) Check the thrust clearance of the injection pump drive shaft. (See page EM-11)

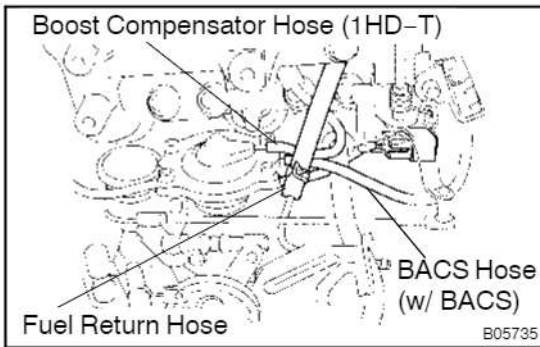

## 2. CONNECT HOSES

- (a) Connect the fuel return hose.
- (b) 1HD-T:  
Connect the boost compensator hose.
- (c) 1HD-T: (w/ BACS)  
Connect the BACS hose.

## 3. A/T:

### CONNECT THROTTLE POSITION SENSOR CONNECTOR TO ACCELERATOR LINK

## 4. w/ACSD:

### CONNECT WATER BYPASS HOSES TO THERMO WAX

## 5. INSTALL NO.2 CAMSHAFT TIMING PULLEY

(See page EM-31)

## 6. INSTALL TIMING BELT (See page EM-31)

## 7. CHECK INJECTION TIMING (See page EM-11)

## 8. INSTALL INJECTION PIPES (See page FU-13)

Torque:

1HZ: 14.7 N·m (150 kgf·cm, 11 ft·lbf)

1HD-T: 24.5 N·m (250 kgf·cm, 18 ft·lbf)

## 9. 1HD-T:

### INSTALL OIL FILTER (See page LU-2)

## 10. FILL WITH ENGINE COOLANT (See page CO-2)

## 11. START ENGINE AND CHECK FOR FUEL LEAKAGE

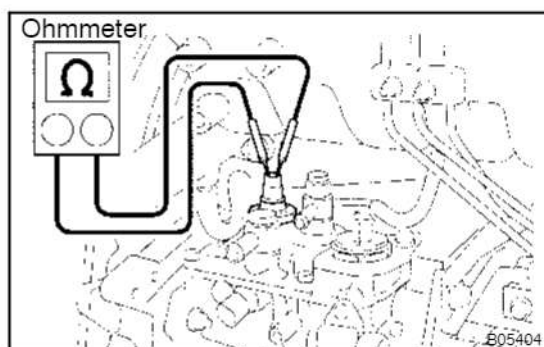

## INJECTION PUMP (1HD-FTE) ON-VEHICLE INSPECTION

FU08-01

### 1. INSPECT ENGINE SPEED SENSOR RESISTANCE

- (a) Disconnect the sensor connector.
- (b) Using an ohmmeter, measure the resistance between the terminals.

**Resistance: 205 – 255 Ω at 20 °C (68 °F)**

If the resistance is not as specified, replace the injection pump.

- (c) Reconnect the sensor connector.

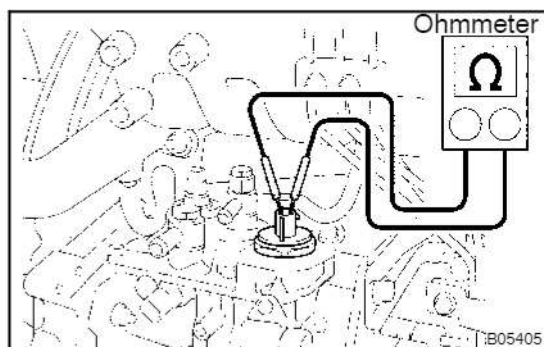

### 2. INSPECT SPILL CONTROL VALVE RESISTANCE

- (a) Disconnect the valve connector.
- (b) Using an ohmmeter, measure the resistance between the terminals.

**Resistance: 1 – 2 Ω at 20 °C (68 °F)**

If the resistance is not as specified, replace the injection pump.

- (c) Reconnect the valve connector.

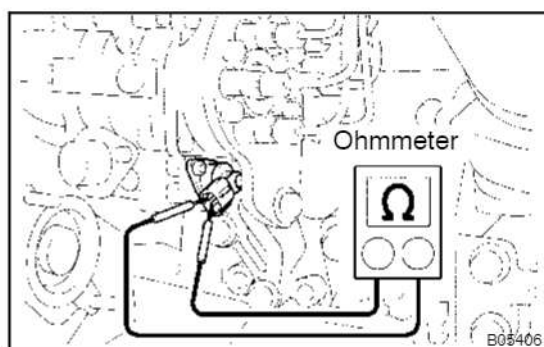

### 3. INSPECT TIMING CONTROL VALVE RESISTANCE

- (a) Disconnect the valve connector.
- (b) Using an ohmmeter, measure the resistance between terminals.

**Resistance: 10 – 14 Ω at 20 °C (68 °F)**

If the resistance is not as specified, replace the injection pump.

- (c) Reconnect the valve connector.

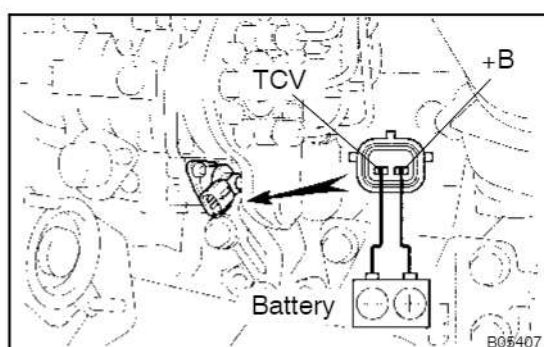

### 4. INSPECT TIMING CONTROL VALVE OPERATION

- (a) Disconnect the valve connector.
- (b) Connect the battery positive (+) terminal to the valve terminal +B.
- (c) Connect the battery negative (-) terminal to the valve terminal TCV.
- (d) Check that the solenoid makes a "clicks" sound.

If operation is not as specified, replace the injection pump.

#### NOTICE:

- Do not apply voltage for more than 30 seconds to avoid burning out the solenoid.
  - If repeating this step, wait until the solenoid cools down enough that it can be touched by hand.
- (e) Reconnect the valve connector.

### 5. INSPECT FUEL TEMPERATURE SENSOR

(See page ED-6)



# COMPONENTS

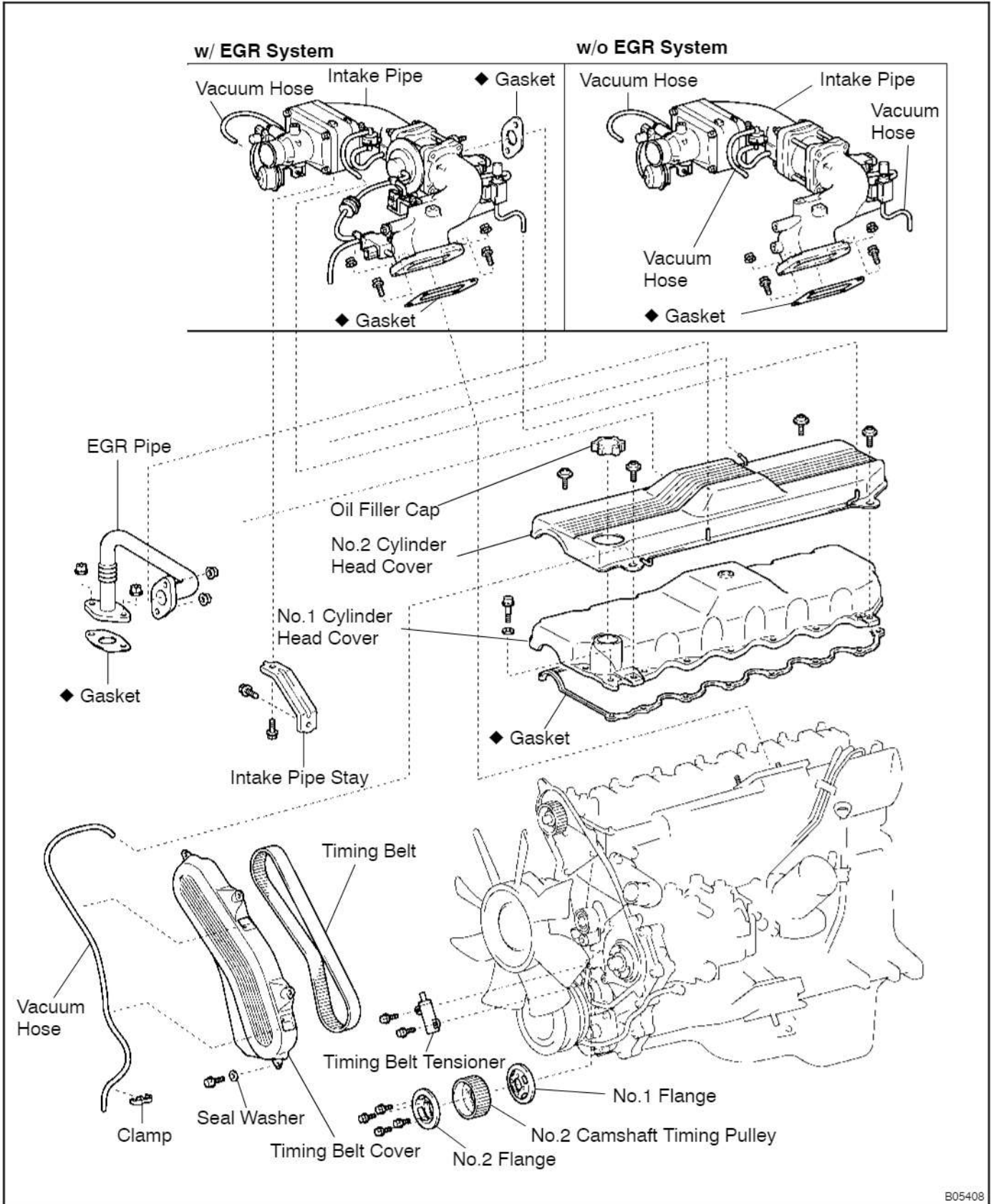

cardiagn.com

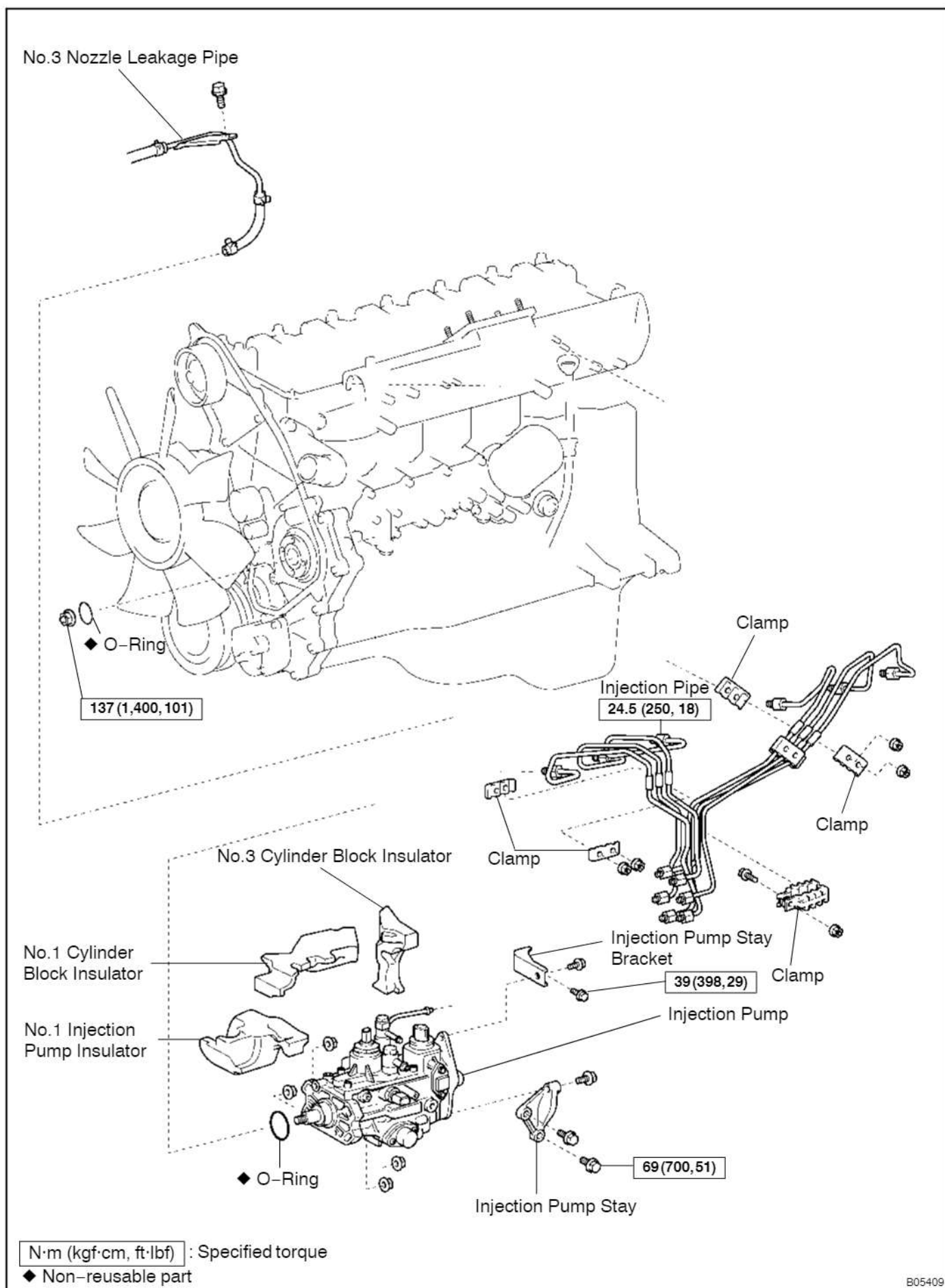

cardiagn.com

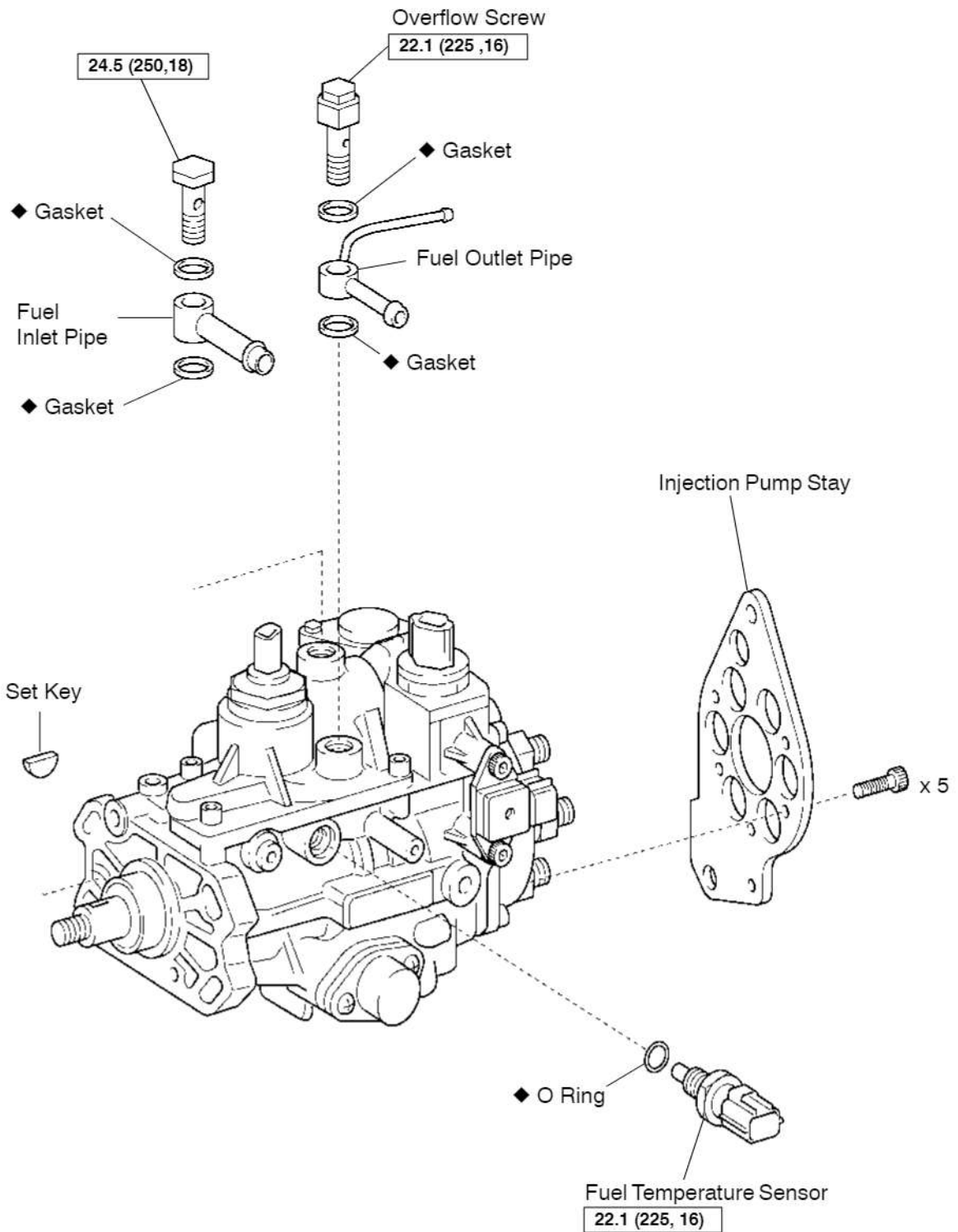

N·m (kgf·cm, ft·lbf) : Specified torque

◆ Non-reusable part

## REMOVAL

1. REMOVE INTAKE PIPE (See page EM-77)
2. REMOVE CYLINDER HEAD COVERS (See page EM-77)
3. REMOVE TIMING BELT (See page EM-77)
4. REMOVE NO.2 CAMSHAFT TIMING PULLEY (See page EM-27)
5. REMOVE INJECTION PIPES (See page FU-33)
6. DISCONNECT FUEL RETURN HOSE
7. DISCONNECT CONNECTORS

Disconnect these connectors:

- Engine speed sensor connector
- Spill control valve connector
- Correction resistor connector
- Timing control valve connector
- Fuel temperature sensor connector

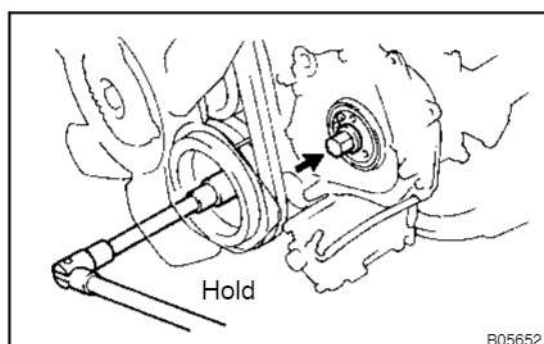

### 8. REMOVE INJECTION PUMP

- (a) Hold the crankshaft pulley, and remove the injection pump drive gear set nut.

#### NOTICE:

**Do not turn the crankshaft pulley. The valve heads will hit against the piston top.**

- (b) Remove the O-ring from the injection pump drive gear.

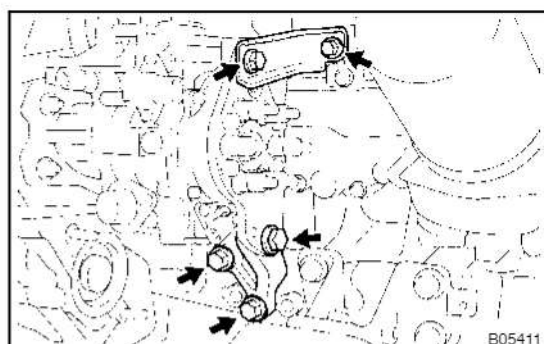

- (c) Remove the 2 bolts and pump stay bracket.
- (d) Remove the 3 bolts and injection pump stay.
- (e) Remove the No.3 cylinder block insulator.

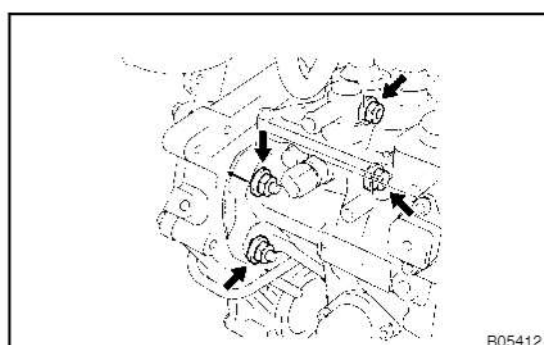

- (f) Before removing the injection pump, check if the period lines are aligned. If not, place new matchmarks for reinstallation.
- (g) Remove the 4 nuts holding the injection pump to the timing gear case.

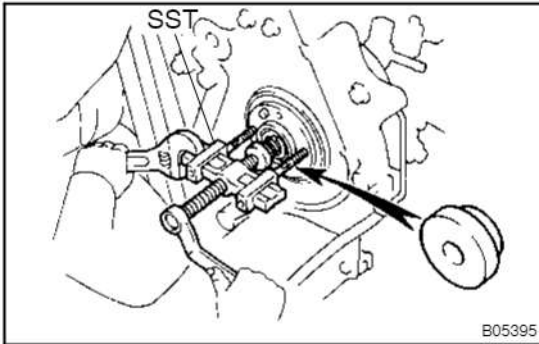

- (h) Using SST, remove the injection pump.  
SST 09950-40011 (09957-04010),  
09950-50010 (09951-05010, 09952-05010,  
09953-05020, 09954-05020)

**NOTICE:**

- **Tighten the 2 bolts more than 8 mm (0.31 in.).**
  - **Set SST so that it is balanced.**
- (i) Remove the No.1 cylinder block insulator and No.1 injection pump insulator.
- (j) Remove the O-ring from the injection pump.

## DISASSEMBLY

1. **MOUNTING PUMP ASSEMBLY TO SST (STAND)**  
(See page FU-53)  
SST 09241-76022, 09245-68010
2. **REMOVE SET KEY OF DRIVE PULLEY FROM DRIVE SHAFT**

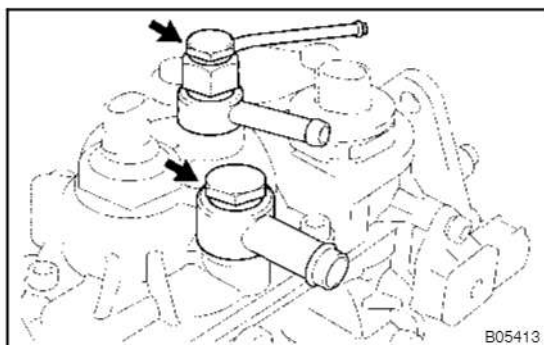

3. **REMOVE FUEL PIPES**
  - (a) Remove the over flow screw, fuel outlet pipe and 2 gaskets.
  - (b) Remove the union bolt, fuel inlet pipe and 2 gaskets.

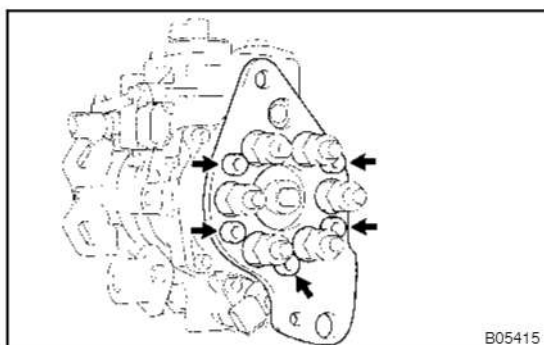

4. **REMOVE INJECTION PUMP STAY**  
Using a 6 mm hexagon wrench, remove the 5 bolts and injection pump stay.

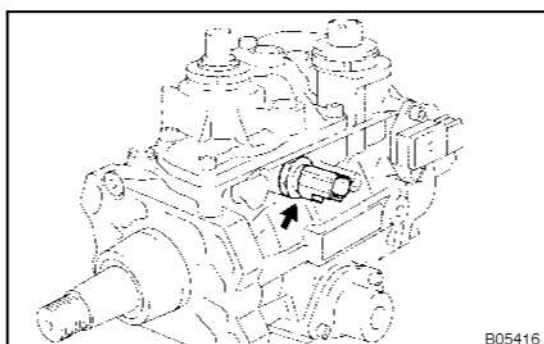

5. **REMOVE FUEL TEMPERATURE SENSOR**

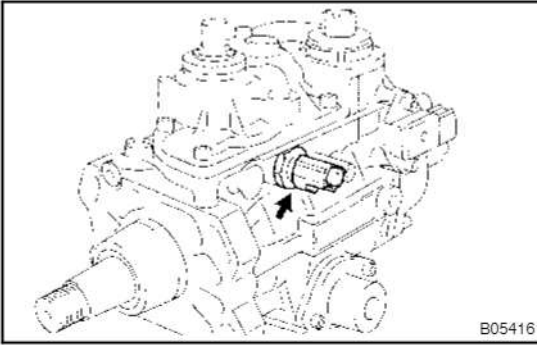

## REASSEMBLY

### 1. INSTALL FUEL TEMPERATURE SENSOR

Install a new O-ring and fuel temperature sensor.

**Torque: 22.1 N·m (225 kgf·cm, 16 ft·lbf)**

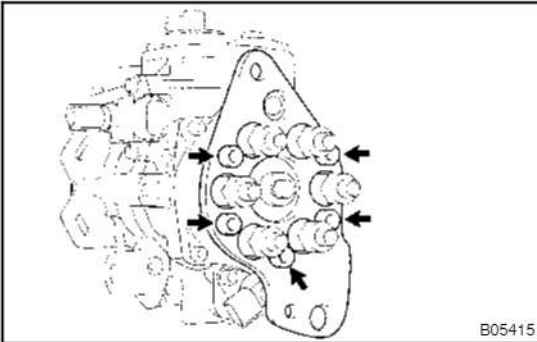

### 2. INSTALL INJECTION PUMP STAY

Using a 6 mm hexagon wrench, install the injection pump stay with the 5 bolts.

**Torque: 19.6 N·m (200 kgf·cm, 14 ft·lbf)**

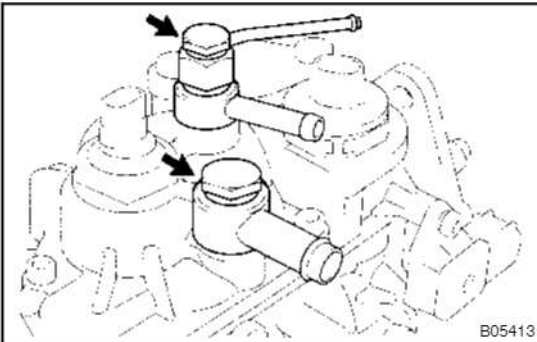

### 3. INSTALL FUEL PIPES

(a) Install the fuel inlet pipe and 2 new gaskets with the union bolt.

**Torque: 24.5 N·m (250 kgf·cm, 18 ft·lbf)**

(b) Install the fuel outlet pipe and 2 new gaskets with the over flow screw.

**Torque: 22.1 N·m (225 kgf·cm, 16 ft·lbf)**

### 4. INSTALL SET KEY OF INJECTION PUMP DRIVE PULLEY ON DRIVE SHAFT

### 5. REMOVE INJECTION PUMP FROM SST (STAND)

SST 09241-76022, 09245-68010

## INSTALLATION

### 1. INSTALL INJECTION PUMP

- (a) Install a new O-ring to the pump.
- (b) Apply a light coat of engine oil on the O-ring.

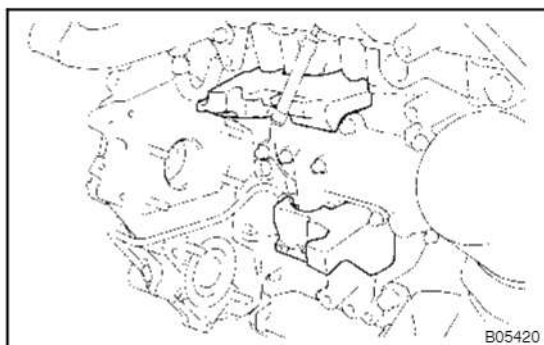

- (c) Place the No.1 injection pump insulator and No.1 cylinder block insulator to the cylinder block.

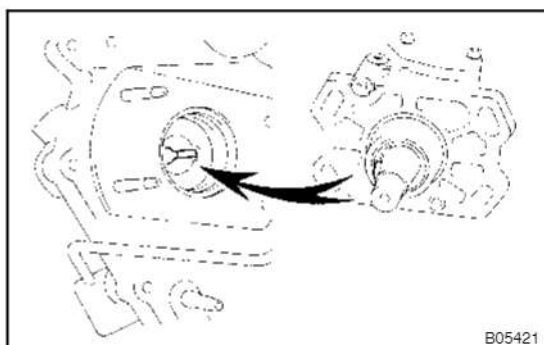

- (d) Align the set key on the drive shaft and groove of the injection pump drive gear.

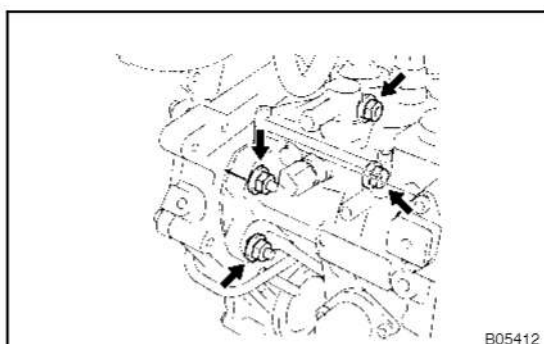

- (e) Align the period lines (or matchmarks) of the injection pump and timing belt case.
- (f) Install the 4 nuts holding the injection pump to the timing gear case.

**Torque: 18 N·m (185 kgf·cm, 13 ft·lbf)**

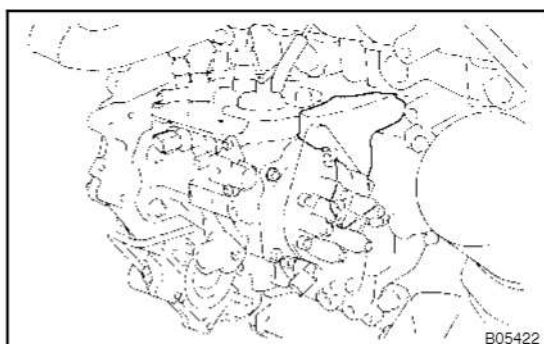

- (g) Install the No.3 cylinder block insulator.



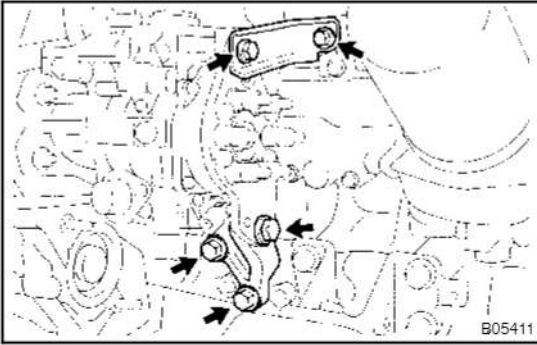

(h) Install the injection pump stay with the 3 bolts.

**Torque: 69 N·m (700 kgf·cm, 51 ft·lbf)**

**NOTICE:**

**Before tightening to the standard torque, check whether the pump stay is up against the injection pump.**

If there is a gap, loosen the bolts joining the pump stay to the cylinder block and set the pump stay against the injection pump.

(i) Install the pump stay bracket with the 2 bolts.

**Torque: 39 N·m (398 kgf·cm, 29 ft·lbf)**

(j) Install a new O-Ring to the injection pump drive gear.

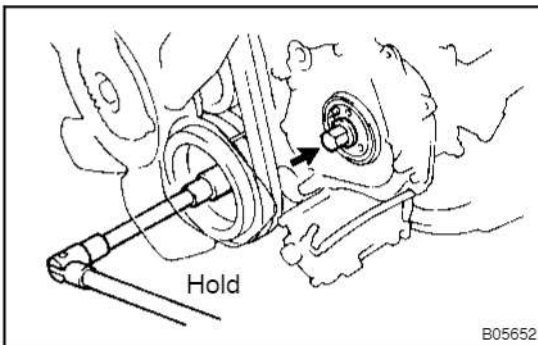

(k) Install the injection pump drive gear set nut.

(l) Hold the crankshaft pulley, and torque the nut.

**Torque: 137 N·m (1,400 kgf·cm, 101 ft·lbf)**

**NOTICE:**

**Do not turn the crankshaft pulley. The valve heads will hit against the piston top.**

**2. CONNECT CONNECTORS**

Connect these connectors:

- Engine speed sensor connector
- Spill control valve connector
- Correction resistor connector
- Timing control valve connector
- Fuel temperature sensor connector

**3. CONNECT FUEL RETURN HOSES**

**4. INSTALL INJECTION PIPE (See page FU-44)**

**5. INSTALL NO.2 CAMSHAFT TIMING PULLEY (See page EM-29)**

**6. INSTALL TIMING BELT (See page EM-29)**

**7. START ENGINE AND CHECK FOR FUEL LEAKAGE**

# COOLANT INSPECTION

COORE-01

## 1. CHECK ENGINE COOLANT LEVEL AT RADIATOR RESERVOIR

The engine coolant level should be between the "LOW" and "FULL" lines. If low, check for leaks and add engine coolant up to the "FULL" line.

## 2. CHECK ENGINE COOLANT QUALITY

(a) Remove the radiator cap.

### CAUTION:

**To avoid the danger of being burned, do not remove the radiator cap while the engine and radiator are still hot, as fluid and steam can be blown out under pressure.**

(b) there should not be any excessive deposits of rust or scale around the radiator cap or water filler hole, and the coolant should be free from oil.

If excessively dirty, replace the coolant.

(c) Reinstall the radiator cap.

## REPLACEMENT

### 1. DRAIN ENGINE COOLANT

- (a) Remove the radiator cap.

#### CAUTION:

**To avoid the danger of being burned, do not remove the radiator cap while the engine and radiator are still hot, as fluid and steam can be blown out under pressure.**

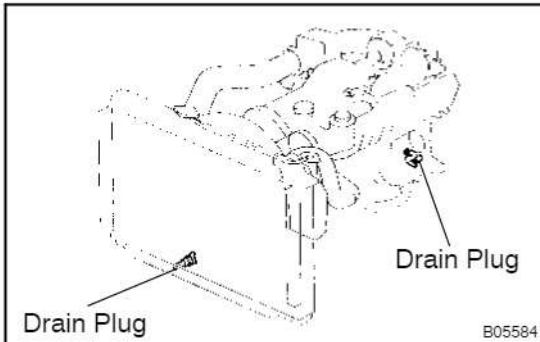

- (b) Loosen the radiator drain plug (on the left side of the radiator lower tank) and engine drain plug (on the left side of the cylinder block), and drain the coolant.

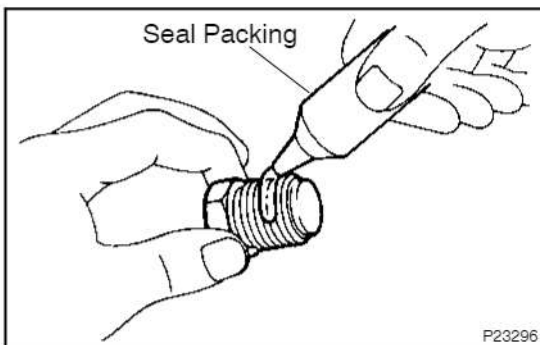

- (c) Apply seal packing to 2 or 3 threads of the engine drain plug.

**Seal packing: Part No. 08826-00100 or equivalent**

- (d) Close the drain plugs.

**Torque: 12.7 N·m (130 kgf·cm, 9 ft·lbf) for engine**

### 2. FILL ENGINE COOLANT

- (a) Slowly fill the system with the coolant.
- Use a good brand of ethylene-glycol base coolant and mix it according to the manufacturer's directions.
  - Using coolant which includes more than 50 % ethylene-glycol (but not more than 70 %) is recommended.

#### NOTICE:

- **Do not use an alcohol type coolant.**
- **The coolant should be mixed with demineralized water or distilled water.**

#### Capacity:

1HZ

G.C.C. countries

12.4 liters (13.1 US qts, 10.9 Imp. qts)

w/ rear heater

12.9 liters (13.6 US qts, 11.3 Imp. qts)

Australia M/T

12.4 liters (13.1 US qts, 10.9 Imp. qts)

w/ rear heater

12.9 liters (13.6 US qts, 11.3 Imp. qts)

Australia A/T

12.0 liters (12.7 US qts, 10.6 Imp. qts)

w/ rear heater

12.5 liters (13.2 US qts, 11.0 Imp. qts)

Others M/T

12.4 liters (13.1 US qts, 10.9 Imp. qts)

w/ rear heater

12.9 liters (13.6 US qts, 11.3 Imp. qts)

Others A/T

12.0 liters (12.7 US qts, 10.6 Imp. qts)

w/ rear heater

12.5 liters (13.2 US qts, 11.0 Imp. qts)

1HD-T

M/T

12.5 liters (13.2 US qts, 11.0 Imp. qts)

w/ rear heater

13.0 liters (13.7 US qts, 11.4 Imp. qts)

A/T

12.1 liters (12.8 US qts, 10.6 Imp. qts)

w/ rear heater

12.6 liters (13.3 US qts, 11.1 Imp. qts)

1HD-FTE

M/T

13.2 liters (13.9 US qts, 11.6 Imp. qts)

w/ viscous heater

13.7 liters (14.5 US qts, 11.2 Imp. qts)

A/T

12.8 liters (13.5 US qts, 11.2 Imp. qts)

w/ viscous heater

13.3 liters (14.1 US qts, 11.7 Imp. qts)

- (b) Install the radiator cap.
- (c) Start engine, and bleed the cooling system.
- (d) Refill the radiator reservoir with coolant until it reaches the "FULL" line.

### 3. CHECK ENGINE COOLANT FOR LEAKS

# WATER PUMP COMPONENTS

COORG-01

1HZ and 1HD-T

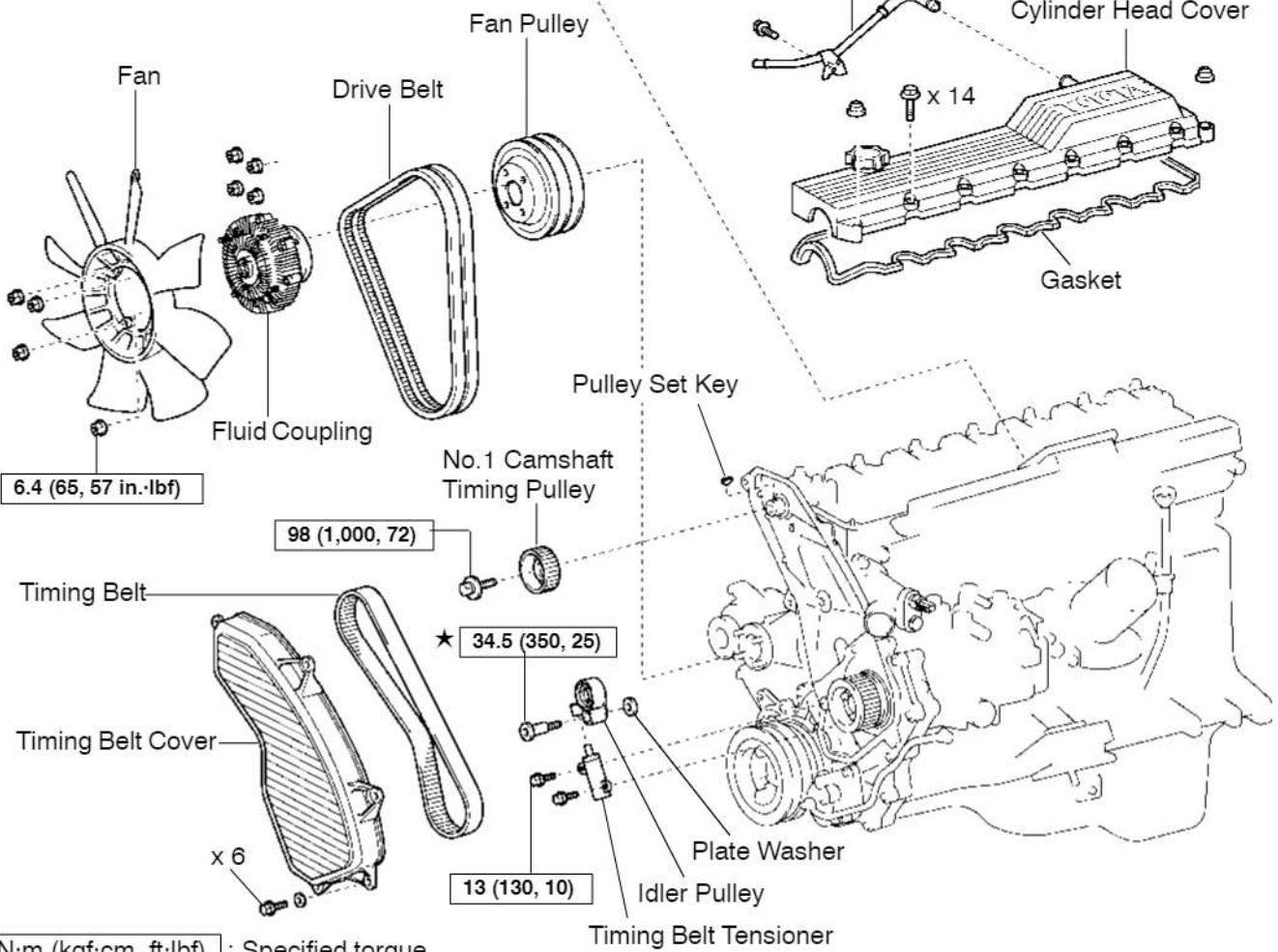
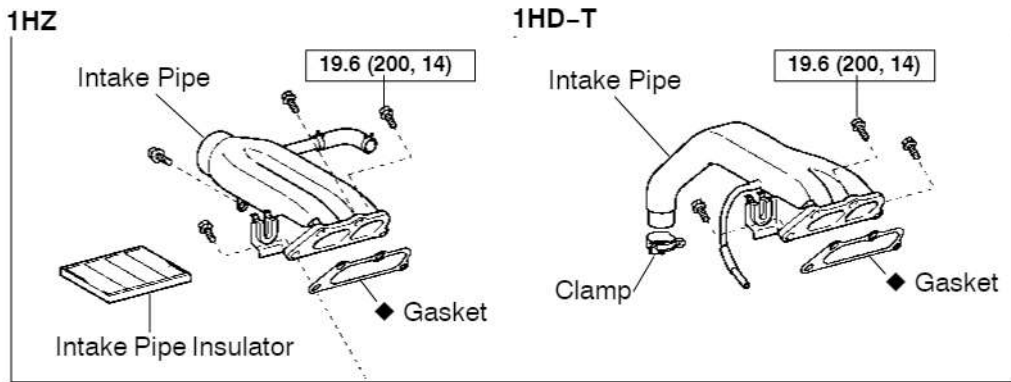

N·m (kgf·cm, ft·lbf) : Specified torque

◆ Non-reusable part

★ Precoated part

B05606

1HD-FTE

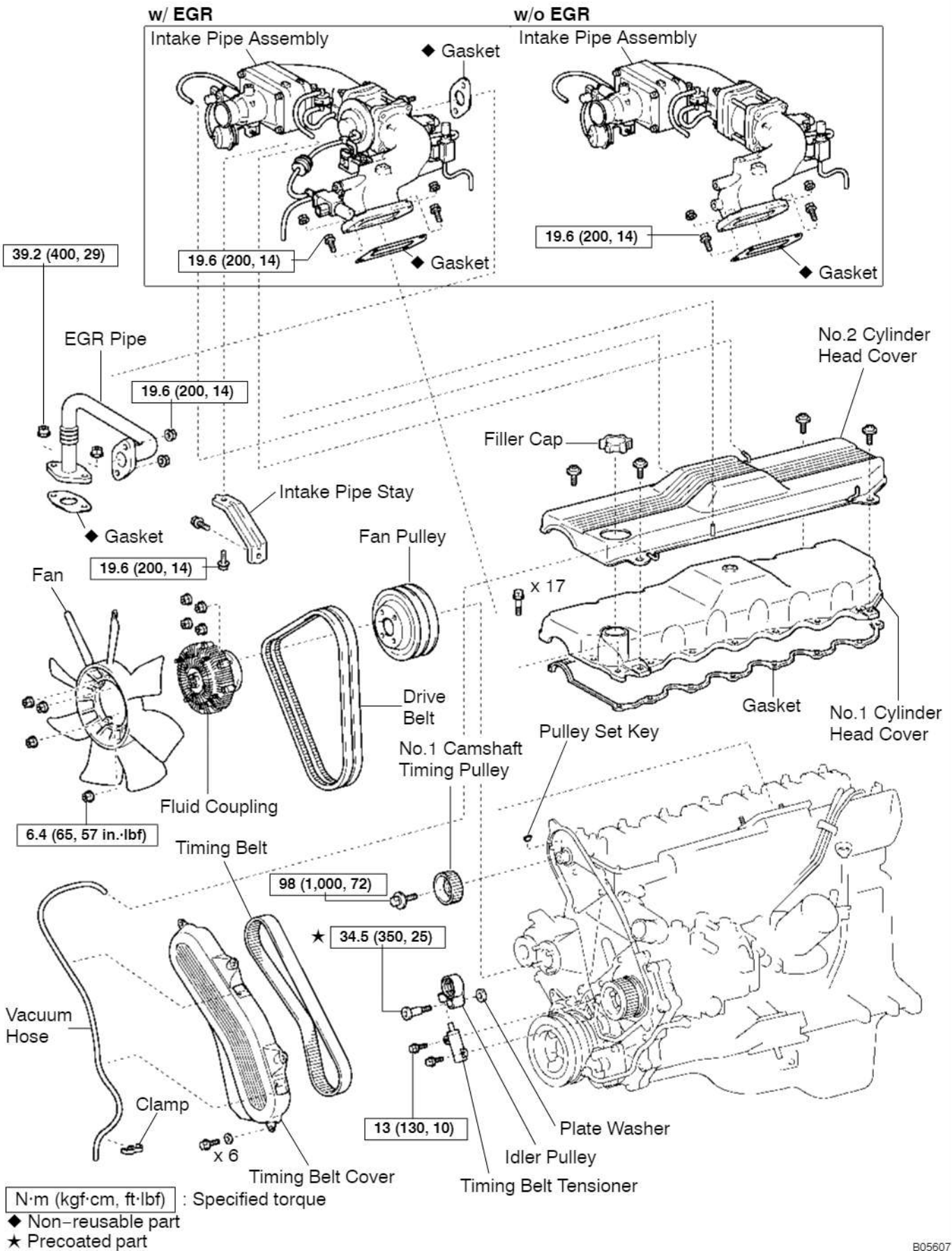

cardiagn.com

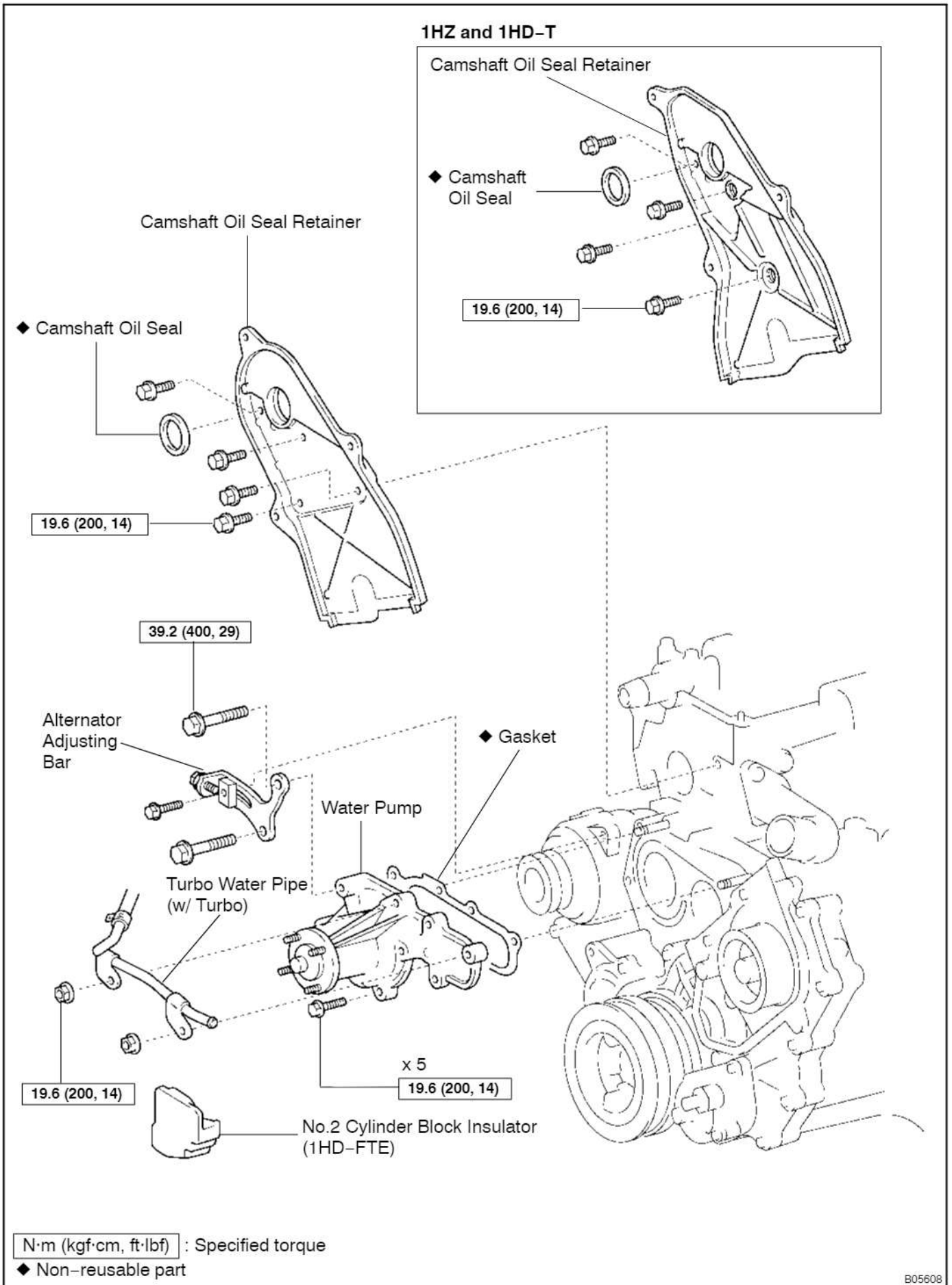

cardiagn.com

## REMOVAL

### 1. DRAIN ENGINE COOLANT

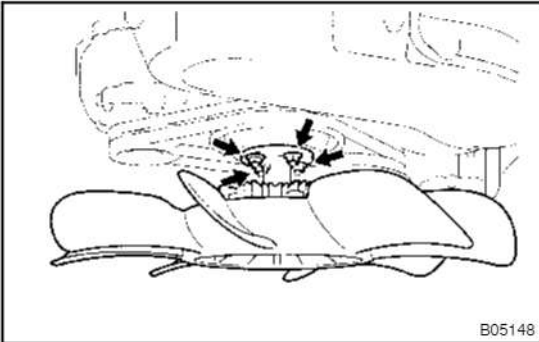

### 2. REMOVE DRIVE BELTS, FAN, FLUID COUPLING AND WATER PUMP PULLEY

- Loosen the 4 water pump pulley nuts.
- Loosen the alternator pivot bolt and adjusting lock bolt.
- Loosen the adjusting bolt, and remove the 2 drive belts.
- Remove the 4 nuts, the fan with fluid coupling and pulley.
- Remove the 4 nuts and fan from the fluid coupling.

### 3. REMOVE TIMING BELT (See page EM-27)

### 4. REMOVE IDLER PULLEY (See page EM-27)

### 5. REMOVE NO.1 CAMSHAFT TIMING PULLEY (See page EM-27)

### 6. REMOVE CAMSHAFT OIL SEAL RETAINER

(1HZ and 1HD-T: See page EM-48)

(1HD-FTE: See page EM-77)

### 7. 1HD-FTE:

REMOVE NO.2 CYLINDER BLOCK INSULATOR

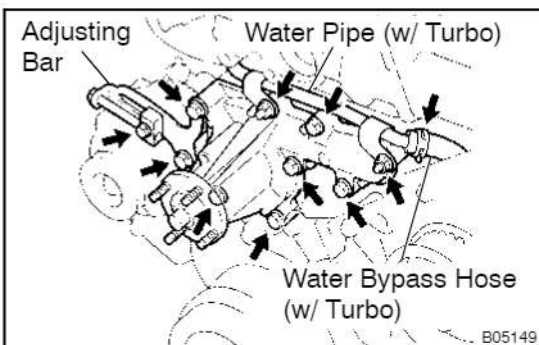

### 8. REMOVE WATER PUMP

- Remove the 3 bolts and alternator adjusting bar.
- Remove the 2 nuts.
- w/ Turbo:  
Disconnect the turbo water pipe from the water pump.
- w/ Turbo:  
Disconnect the turbo water pipe from the water bypass hose.
- Remove the 5 bolts, water pump and gasket.



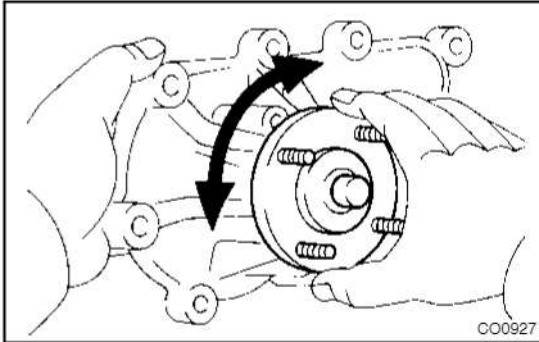

## INSPECTION

### 1. INSPECT WATER PUMP

Turn the pulley and check that the water pump bearing moves smoothly and quietly.

If necessary, replace the water pump.

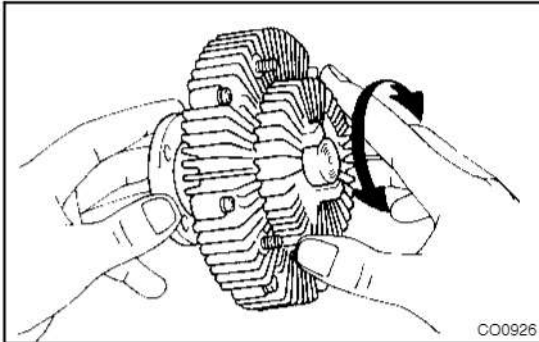

### 2. INSPECT FLUID COUPLING

Check the fluid coupling for damage and silicon oil leakage.

If necessary, replace the fluid coupling.

### 3. INSPECT TIMING BELT COMPONENTS

(See page EM-29)

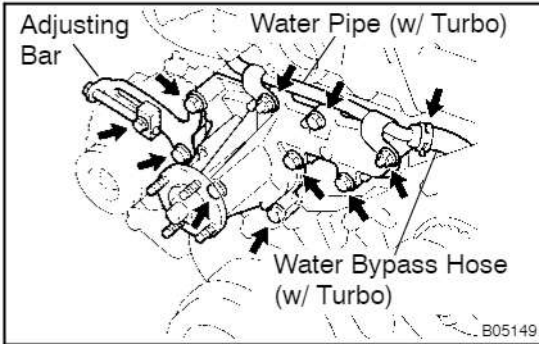

## INSTALLATION

### 1. INSTALL WATER PUMP

- (a) Temporarily install a new gasket and the water pump with the 5 bolts.
- (b) w/ Turbo:  
Connect the turbo water pipe to the water bypass hose.
- (c) w/ Turbo:  
Temporarily install the turbo water pipe with the 2 nuts.
- (d) w/o Turbo:  
Temporarily install the 2 nuts.
- (e) Temporarily install the alternator with the 3 bolts.
- (f) Uniformly tighten the 7 bolts and 2 nuts holding the water pump to the cylinder block.

#### Torque:

**19.6 N·m (200 kgf·cm, 14 ft·lbf) for 12 mm head**

**39.2 N·m (400 kgf·cm, 29 ft·lbf) for 14 mm head**

### 2. 1HD-FTE:

#### INSTALL NO.2 CYLINDER BLOCK INSULATOR

### 3. INSTALL CAMSHAFT OIL SEAL RETAINER

(1HZ and 1HD-T: [See page EM-31](#))

(1HD-FTE: [See page EM-31](#))

### 4. INSTALL NO.1 CAMSHAFT TIMING PULLEY

([See page EM-31](#))

### 5. INSTALL IDLER PULLEY ([See page EM-31](#))

### 6. INSTALL TIMING BELT ([See page EM-31](#))

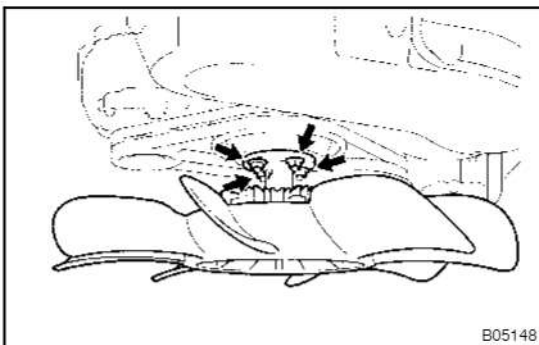

### 7. INSTALL WATER PUMP PULLEY, FLUID COUPLING FAN AND DRIVE BELTS

- (a) Install the fan to the fluid coupling with 4 new nuts.  
**Torque: 6.4 N·m (65 kgf·cm, 57 in·lbf)**
- (b) Temporarily install the pump pulley, the fan with fluid coupling with the 4 nuts.
- (c) Install and adjust the drive belt. ([See page CH-2](#))
- (d) tighten the 4 water pump pulley nuts.

**Torque: 19.6 N·m (200 kgf·cm, 14 ft·lbf)**

### 8. FILL WITH ENGINE COOLANT

### 9. START ENGINE, AND CHECK FOR COOLANT LEAKS

# THERMOSTAT COMPONENTS

COORIK-01

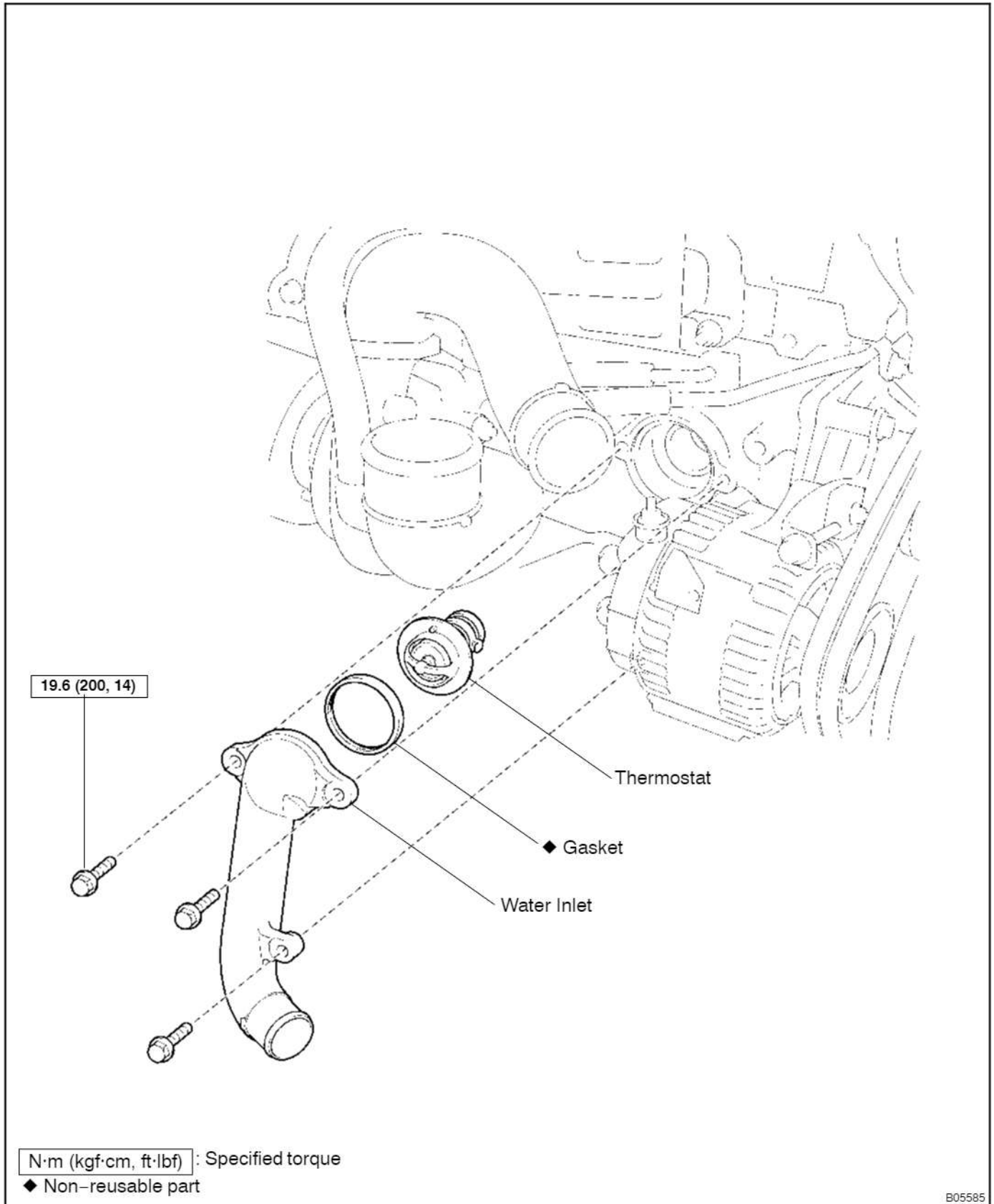

## REMOVAL

### HINT:

Removal of the thermostat would have an adverse effect, causing a lowering of cooling efficiency. Do not remove the thermostat, even if the engine tends to overheat.

### 1. DRAIN ENGINE COOLANT

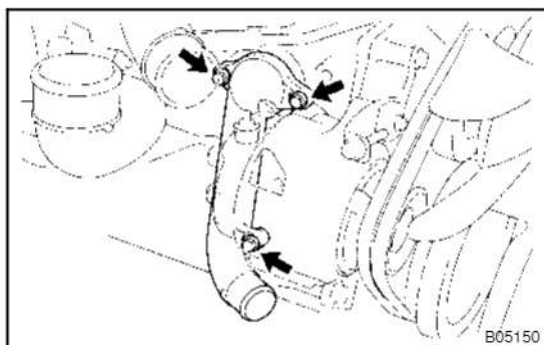

### 2. REMOVE THE WATER INLET AND THERMOSTAT

- (a) Remove the 3 bolts and water inlet.
- (b) Remove the thermostat.
- (c) Remove the gasket from the thermostat.

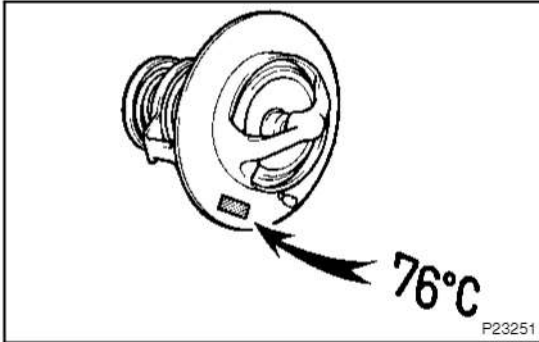

## INSPECTION

### INSPECT THERMOSTAT

#### HINT:

The thermostat is numbered with the valve opening temperature.

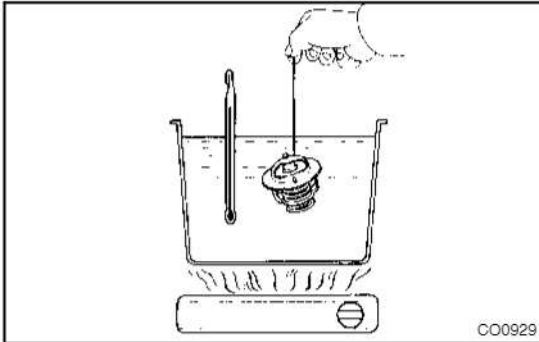

(a) Immerse the thermostat in water and gradually heat the water.

(b) Check the valve opening temperature.

**Valve opening temperature: 74 – 78 °C (165 – 172 °F)**

If the valve opening temperature is not as specified, replace the thermostat.

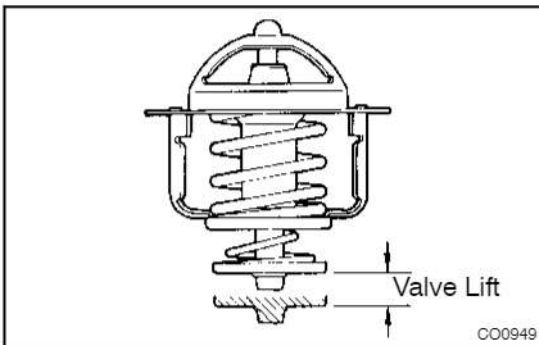

(c) Check the valve lift.

**Valve lift: 10 mm (0.39 in.) or more at 90 °C (194 °F)**

If the valve lift is not as specified, replace the thermostat.

(d) check that the valve spring is tight when the thermostat is fully closed.

If not closed, replace the thermostat.

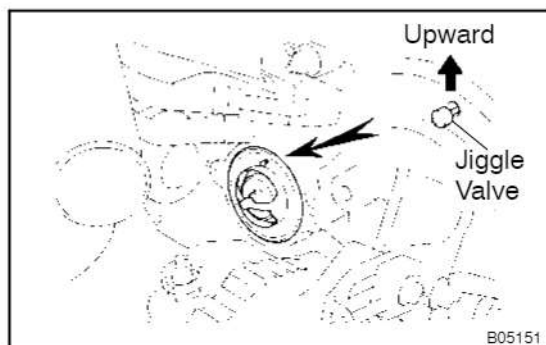

## INSTALLATION

### 1. PLACE THERMOSTAT IN CYLINDER BLOCK

- (a) Install a new gasket to the thermostat.
- (b) Install the thermostat with the jiggle valve upward.

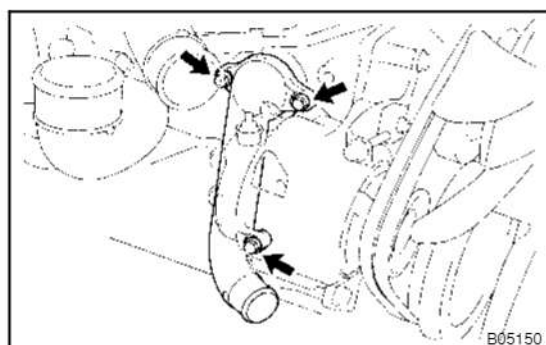

### 2. INSTALL WATER INLET

- (a) Temporarily install the water inlet with the 3 bolts.
- (b) Alternately tighten the 3 bolts in several passes.

**Torque: 19.6 N·m (200 kgf·cm, 14 ft·lbf)**

### 3. FILL WITH ENGINE COOLANT

### 4. START ENGINE AND CHECK FOR COOLANT LEAKS

# RADIATOR

## ON-VEHICLE CLEANING

COOPO-01

Using water or a steam cleaner, remove any mud and dirt from the radiator core.

**NOTICE:**

**If using a high pressure type cleaner, be careful no to deform the fins of the radiator core. If the cleaner nozzle pressure is 2,942 – 3,432 kPa (30 – 35 kgf/cm<sup>2</sup>, 427 – 498 psi), keep a distance of at least 40 – 50 cm (15.75 – 19.69 in.) between the radiator core and cleaner nozzle.**

## ON-VEHICLE INSPECTION

### 1. REMOVE RADIATOR CAP

#### CAUTION:

To avoid the danger of being burned, do not remove the radiator cap while the engine and radiator are still hot, as fluid and steam can be blown under pressure.

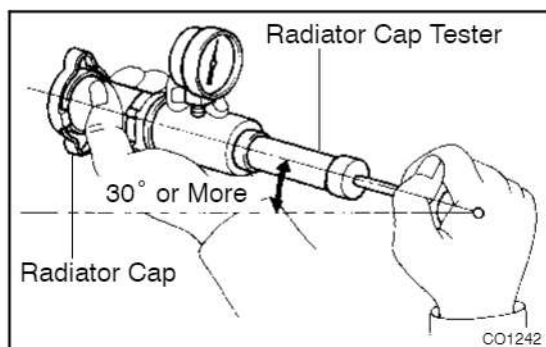

### 2. INSPECT RADIATOR CAP

#### NOTICE:

- If the radiator cap has contaminations, always rinse it with water.
  - Before using a radiator cap tester, wet the relief valve and pressure valve with engine coolant or water.
  - When performing steps (a) and (b) below, keep the tester at an angle of over 30° above the horizontal.
- (a) Using a radiator cap tester, slowly pump the tester and check that air is coming from the vacuum valve.  
**Pump speed: 1 push/(3 seconds or more)**

#### NOTICE:

**Push the pump at a constant speed.**

If air is not coming from the vacuum valve, replace the radiator cap.

- (b) Pump the radiator cap tester, and measure the relief valve opening pressure.

**Pump speed: 1 push within 1 second**

#### NOTICE:

**This pump speed is for the first pump only (in order to close the vacuum valve). After this, the pump speed can be reduced.**

**Standard opening pressure:**

**93 – 123 kPa (0.95 – 1.25 kgf/cm<sup>2</sup>, 13.5 – 17.8 psi)**

**Minimum opening pressure:**

**78 kPa (0.8 kgf/cm<sup>2</sup>, 11.4 psi)**

#### HINT:

Use the tester's maximum reading as the opening pressure.

If the opening pressure is less than minimum, replace the radiator cap.

### 3. INSPECT COOLING SYSTEM FOR LEAKS

- (a) Fill the radiator with coolant and attach a radiator cap tester.
- (b) Warm up the engine.
- (c) Pump it to 118 kPa (1.2 kgf/cm<sup>2</sup>, 17.1 psi), and check that the pressure does not drop.

If the pressure drops, check the hoses, radiator or water pump for leaks. If no external leaks are found, check the heater core, cylinder block and head.

### 4. REINSTALL RADIATOR CAP

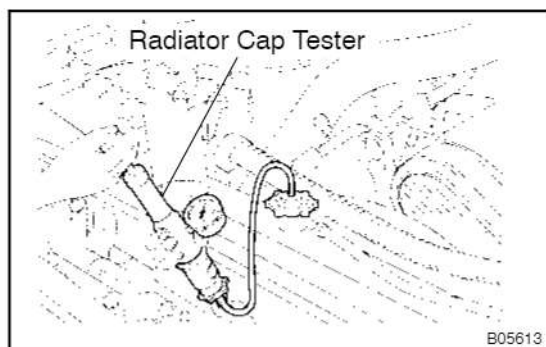

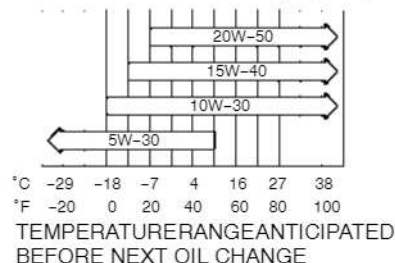
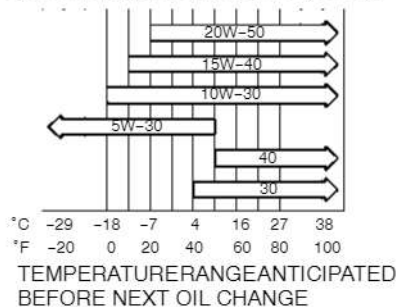

**Europe****Recommended Viscosity (SAE):****Except Europe****Recommended Viscosity (SAE):**B01537  
B01538

B01667

## OIL AND FILTER INSPECTION

LU060-01

**1. CHECK ENGINE OIL QUALITY**

Check the oil for deterioration, entry of water, discoloring or thinning.

If the quality is visibly poor, replace the oil.

**Oil grade:****API CF-4 (You may also use API CF, CE or CD)**

If you use SAE 10W-30 or higher viscosity oil in extremely low temperatures, the engine may become difficult to start, so SAE 5W-30 engine oil is recommended.

**2. CHECK ENGINE OIL LEVEL**

After warming up the engine and then 5 minutes after the engine stop, oil level should be between "L" and "F" of the dipstick. If low, check for leakage and add oil up to "F" mark.

**NOTICE:**

**Do not fill with engine oil above the "F" mark.**

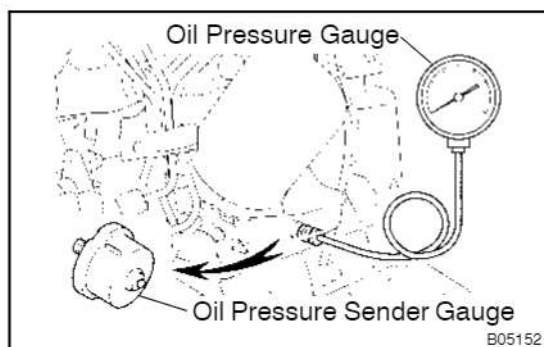

3. REMOVE OIL PRESSURE SENDER GAUGE
4. INSTALL OIL PRESSURE GAUGE
5. WARM UP ENGINE

Allow the engine to warm up to normal operating temperature.

**6. CHECK OIL PRESSURE****Oil pressure:**

**At idle: 29 kPa (0.3 kgf/cm<sup>2</sup>, 4.3 psi) or more**

**At 3,000 rpm:**

**250 - 600 kPa (2.5 - 6.1 kgf/cm<sup>2</sup>, 36 - 87 psi)**

7. REMOVE OIL PRESSURE GAUGE
8. REINSTALL OIL PRESSURE SENDER GAUGE

(a) Apply adhesive to 2 or 3 threads of the oil pressure sender gauge.

**Adhesive:**

**Part No. 08833-00080, THREE BOND 1344, LOCTITE 242 or equivalent**

(b) Install the oil pressure sender gauge.

9. START ENGINE AND CHECK FOR ENGINE OIL LEAKS

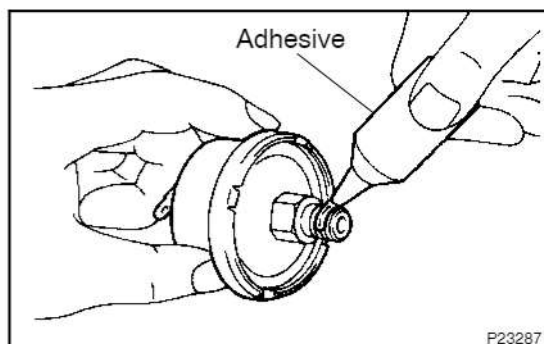

## REPLACEMENT

### CAUTION:

- Prolonged and repeated contact with mineral oil will result in the removal of natural fats from the skin, leading to dryness, irritation and dermatitis. In addition, used engine oil contains potentially harmful contaminants which may cause skin cancer.
- Care should be taken, therefore, when changing engine oil to minimize the frequency and length of time your skin is exposed to used engine oil. Protective clothing and gloves that cannot be penetrated by oil should be worn. The skin should be thoroughly washed with soap and water, or use water-less hand cleaner, to remove any used engine oil. Do not use gasoline, thinners, or solvents.
- In order to preserve the environment, used oil and used oil filters must be disposed of only at designated disposal sites.

### 1. DRAIN ENGINE OIL

- Remove the oil filler cap.
- Remove the oil drain plug and drain the oil into a container.

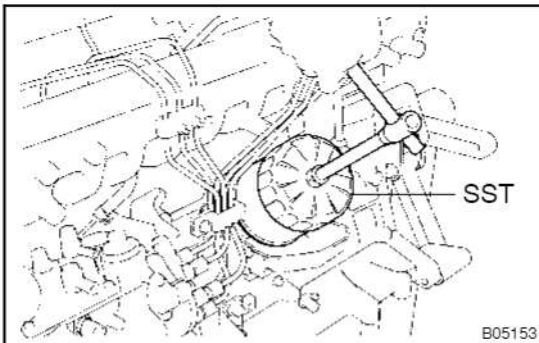

### 2. REPLACE OIL FILTER

- Using SST, remove the oil filter.  
SST 09228-10002
- Clean the oil filter contact surface on the oil filter mounting.
- Lubricate the filter rubber gasket with clean engine oil.
- Tighten the oil filter by hand until the rubber gasket contacts the seat of the filter mounting.

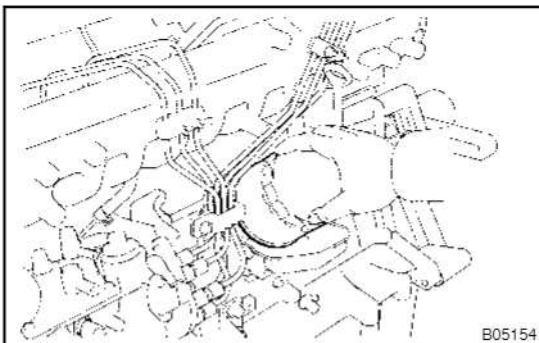

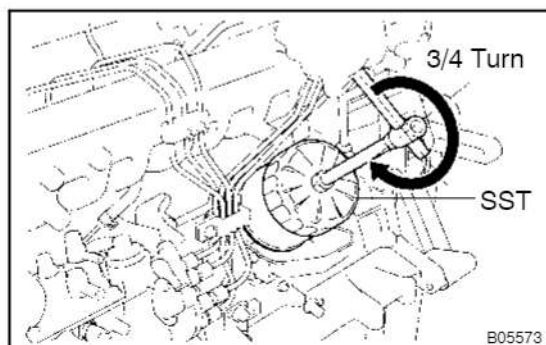

- (e) Using SST, give it an additional 3/4 turn to seat the filter.  
SST 09228-10002

### 3. REFILL WITH ENGINE OIL

- (a) Clean the drain plug and install a new gasket and it.

**Torque: 34.3 N·m (350 kgf·cm, 25 ft·lbf)**

- (b) Fill with new engine oil.

**Capacity:**

**1HZ**

**Drain and refill**

w/ oil filter change:

9.3 liters (9.9 US qts, 8.2 Imp. qts)

w/o oil filter change:

8.0 liters (8.5 US qts, 7.0 Imp. qts)

**Dry fill:**

10.4 liters (11.0 US qts, 9.2 Imp. qts)

**1HD-T**

**Drain and refill**

w/ oil filter change:

11.4 liters (12.0 US qts, 10.0 Imp. qts)

w/o oil filter change:

10.1 liters (10.7 US qts, 8.9 Imp. qts)

**Dry fill:**

11.7 liters (12.3 us qts, 10.3 Imp. qts)

**1HD-FTE**

**Drain and refill**

w/ oil filter change:

11.4 liters (12.0 US qts, 10.0 Imp. qts)

w/o oil filter change:

10.1 liters (10.7 US qts, 8.9 Imp. qts)

**Dry fill:**

12.1 liters (12.8 US qts, 10.6 Imp. qts)

- (c) Reinstall the oil filler cap.

### 4. START ENGINE AND CHECK FOR OIL LEAKS

### 5. RECHECK ENGINE OIL LEVEL

# OIL PUMP COMPONENTS

1HZ and 1HD-T

1HD-T

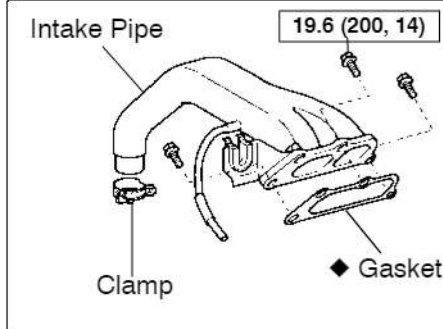

1HZ

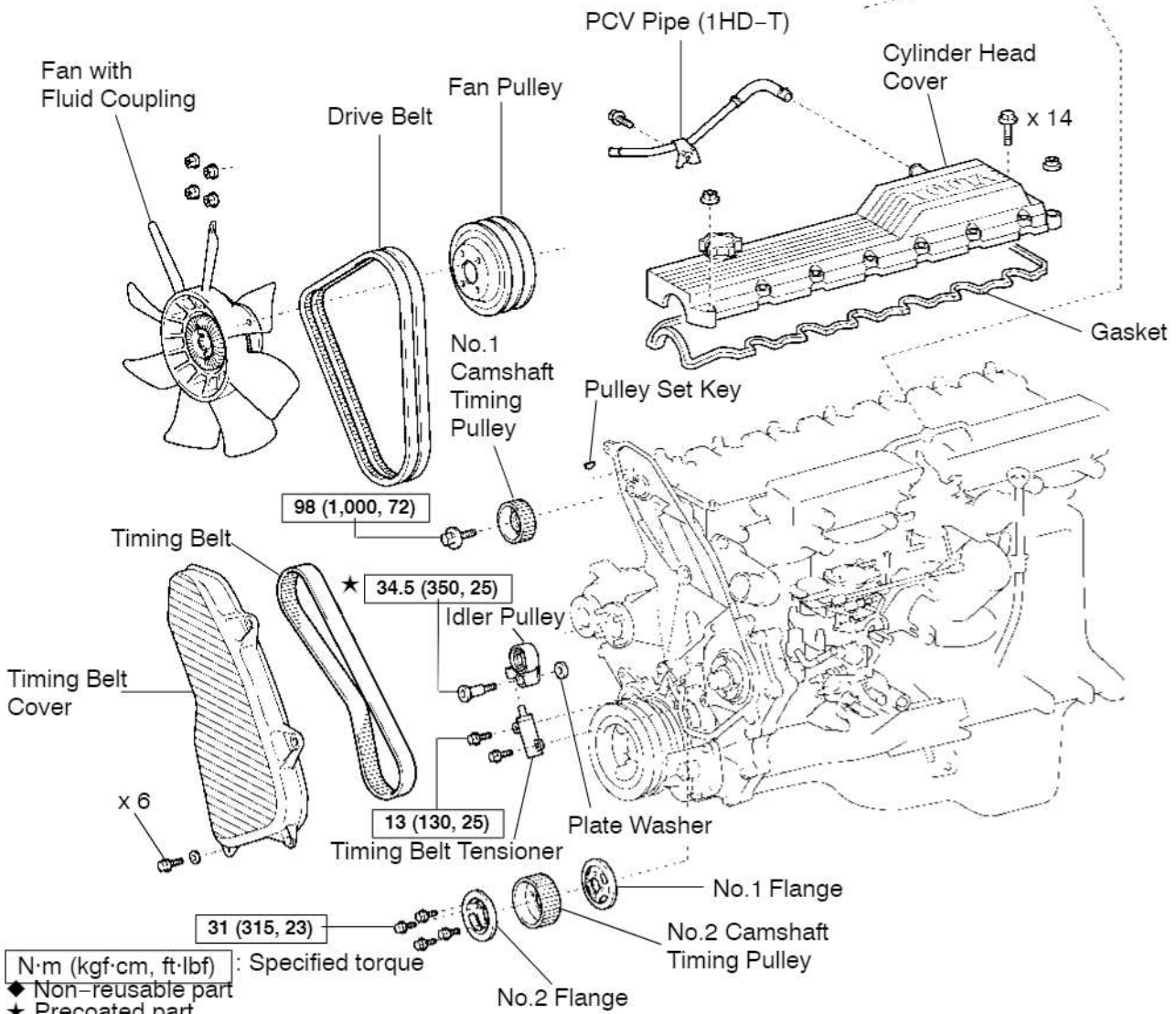
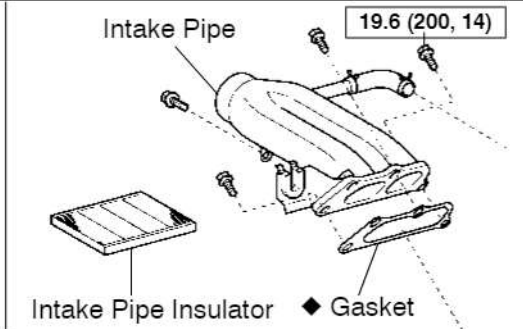

N·m (kgf·cm, ft·lbf) : Specified torque

◆ Non-reusable part

★ Precoated part

B05877

1HD-FTE

w/ EGR

w/o EGR

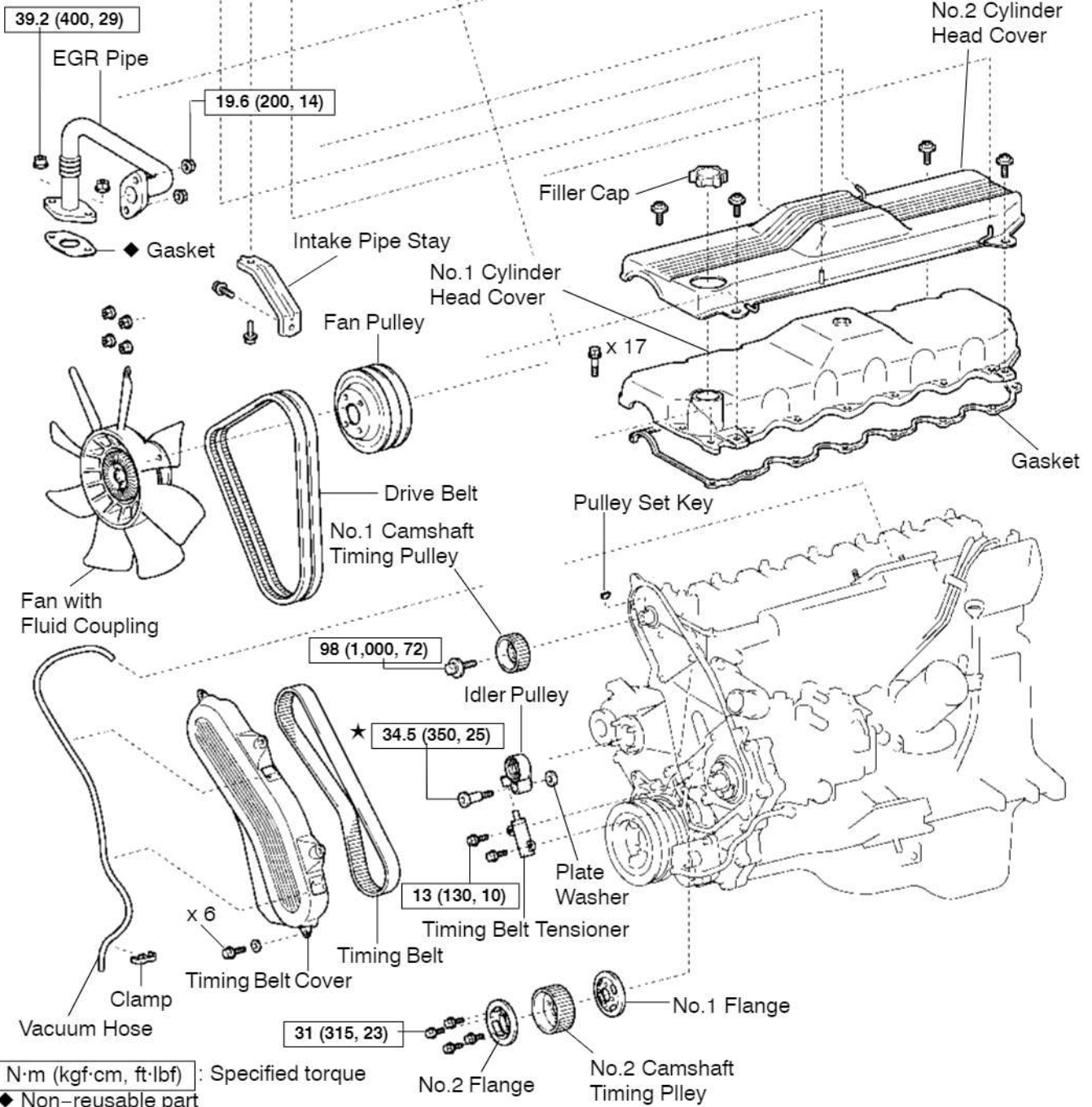
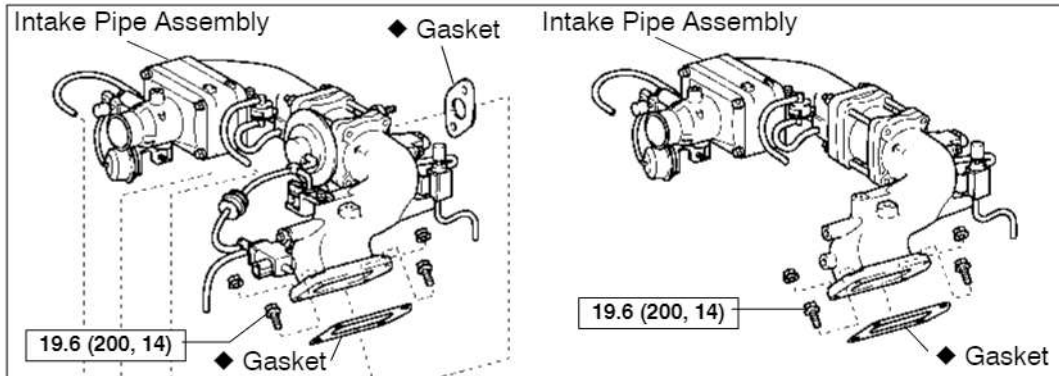

N·m (kgf·cm, ft·lbf) : Specified torque

◆ Non-reusable part

★ Precoated part

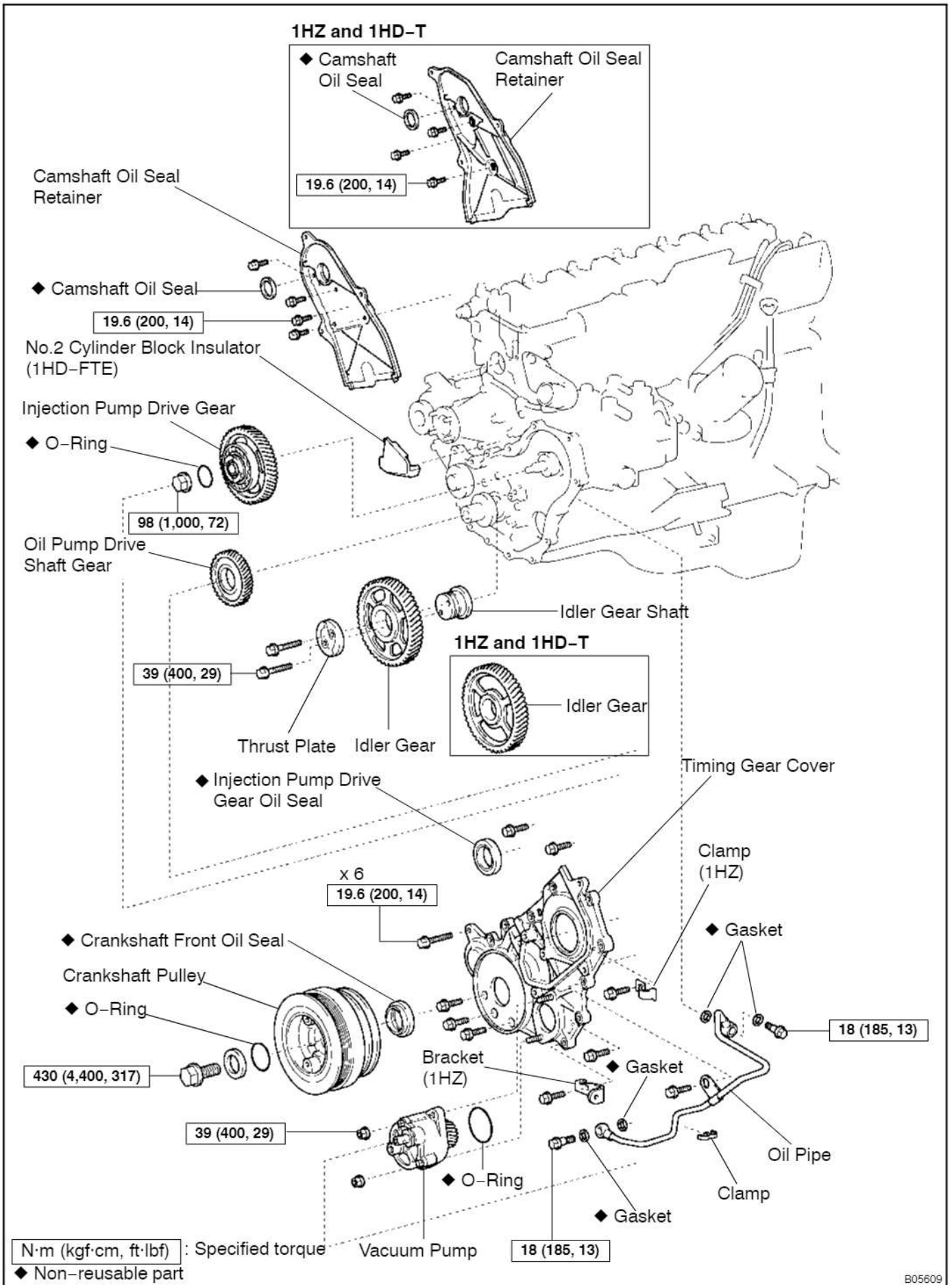

cardiagn.com

cardiagn.com

1HZ and 1HD-T

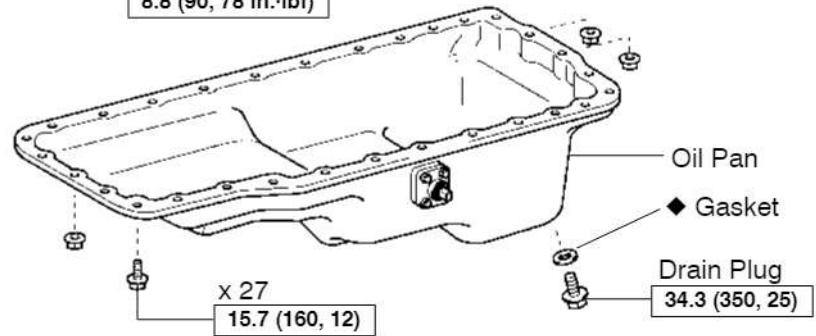
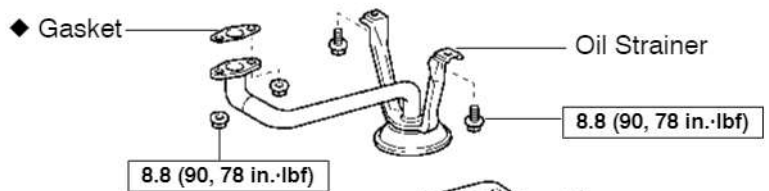
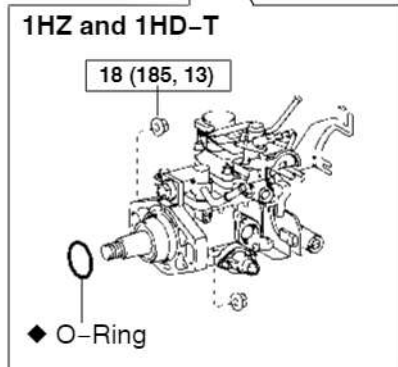
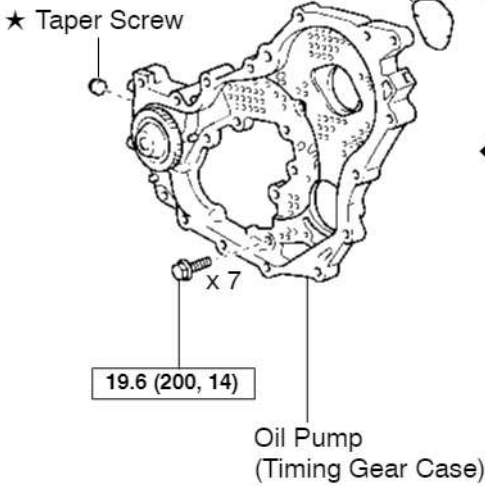
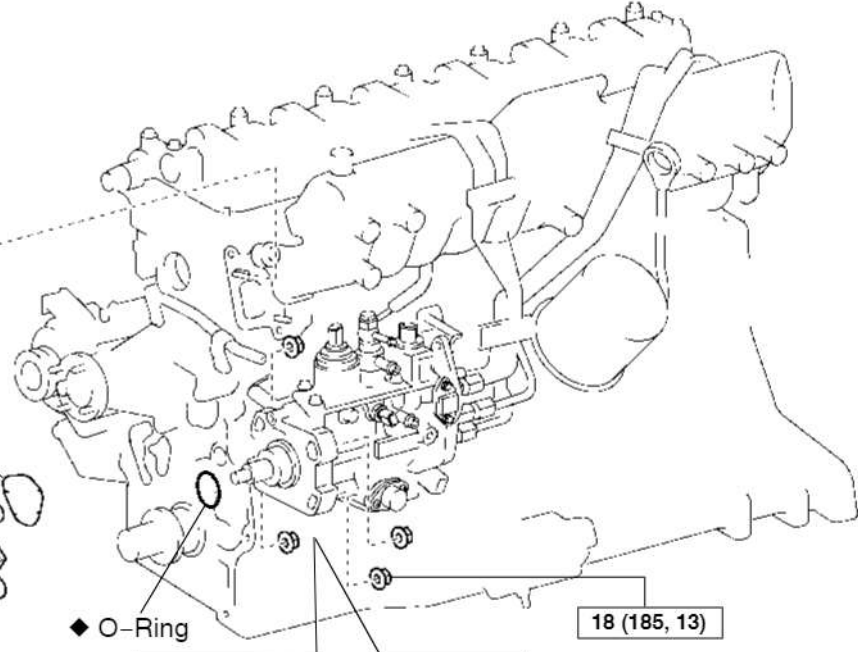
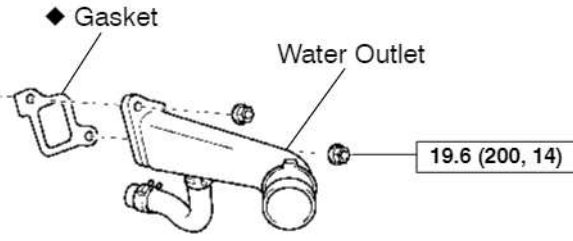
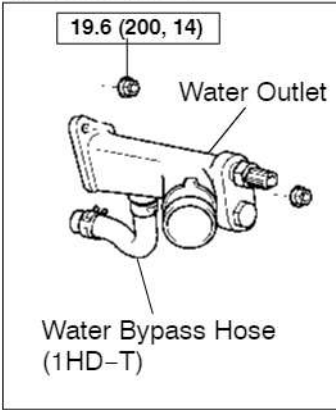

N·m (kgf·cm, ft·lbf) : Specified torque

◆ Non-reusable part  
★ Precoated part

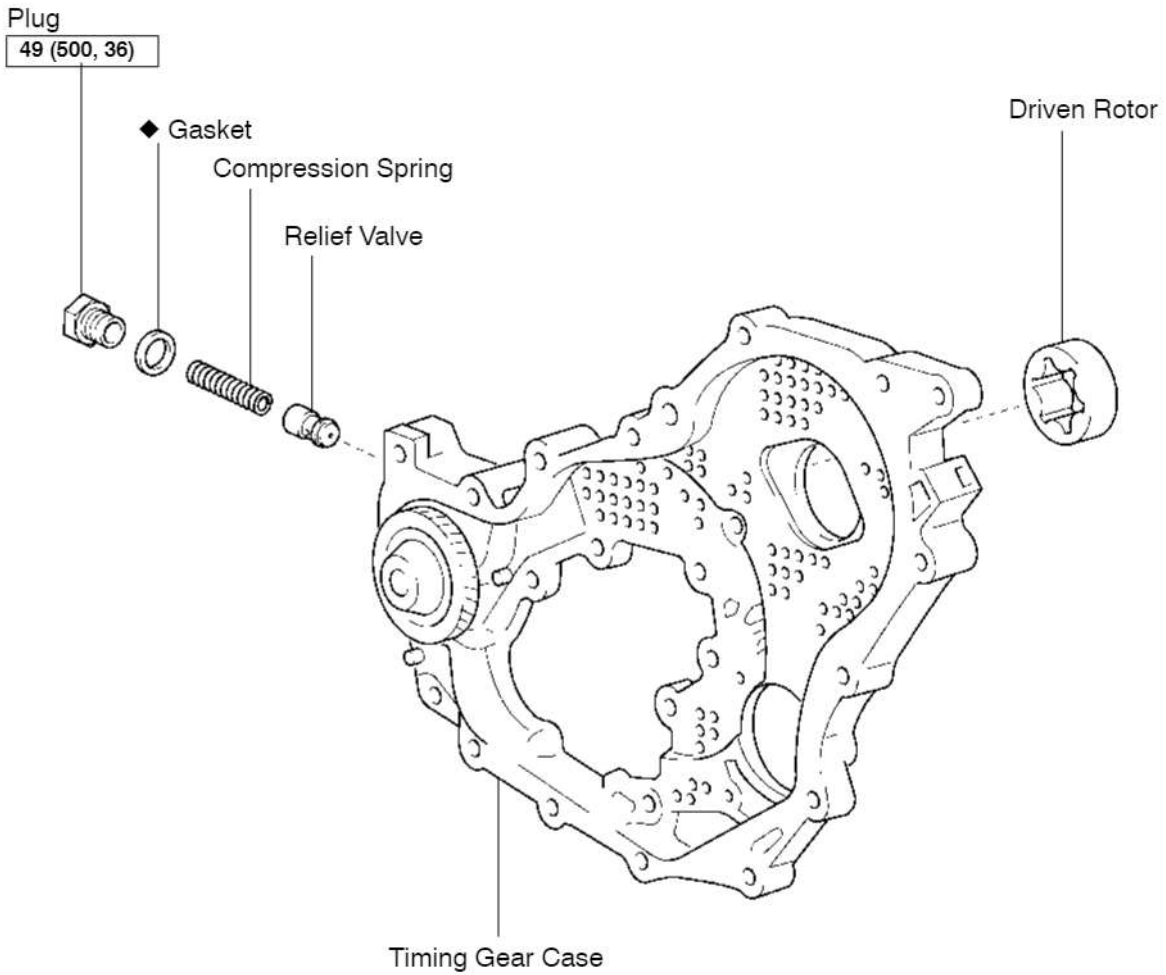

**N·m (kgf·cm, ft·lbf)** : Specified torque

◆ Non-reusable part

B05588



## REMOVAL

### HINT:

When repairing the oil pump, the oil pan and strainer should be removed and cleaned.

1. DRAIN ENGINE COOLANT
2. DRAIN ENGINE OIL
3. REMOVE TIMING GEARS (See page EM-37)
4. REMOVE OIL PAN
  - (a) Remove 27 bolts and 3 nuts.

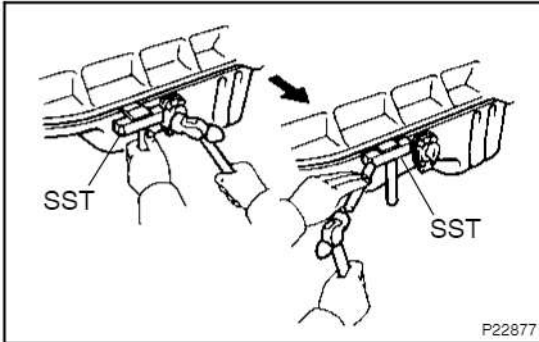

- (b) Insert the blade of SST between the cylinder block and oil pan, and cut off applied sealer and remove the oil pan  
SST 09032-00100

### NOTICE:

- Do not use SST for the oil pump body side and rear oil seal retainer.
  - Be careful not to damage the oil pan flange.
5. REMOVE WATER OUTLET
    - (1HZ and 1HD-T: See page EM-48)
    - (1HD-FTE: See page EM-77)

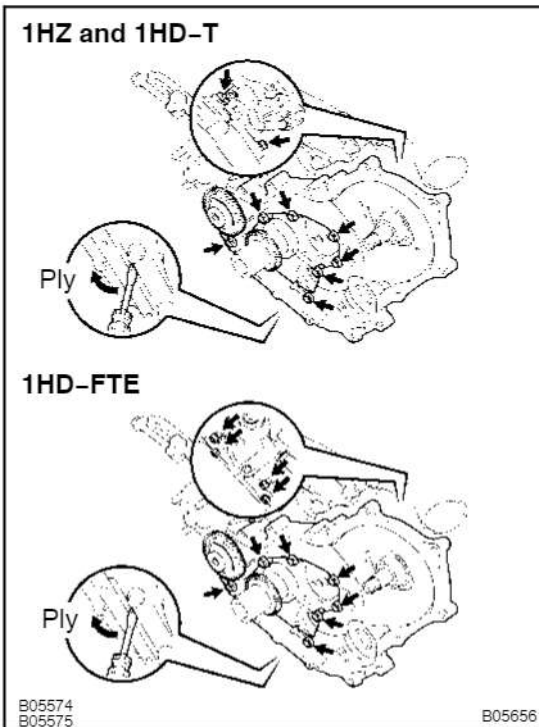

6. REMOVE OIL PUMP
  - (a) 1HZ and 1HD-T:  
Remove the 2 nuts holding the injection pump to the timing gear case.
  - (b) 1HD-FTE:  
Remove the 4 nuts holding the injection pump to the timing gear case.
  - (c) Remove the 7 bolts holding the timing gear case to the cylinder block.
  - (d) Using a screwdriver, remove the oil pump by prying the portions between the oil pump and cylinder block.
  - (e) Remove the gasket and O-ring.

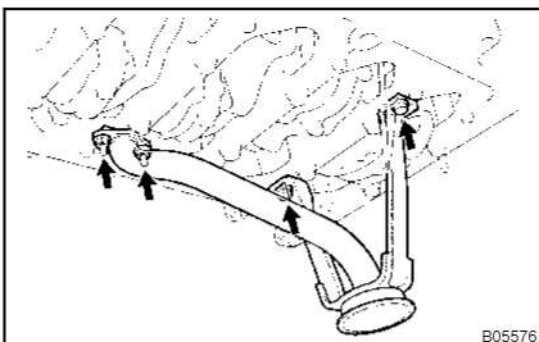

### 7. REMOVE OIL STRAINER

Remove the 2 bolts, 2nuts, oil strainer and gasket.

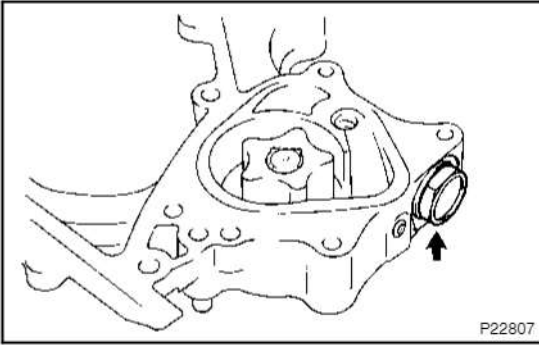

## DISASSEMBLY

1. REMOVE DRIVEN ROTOR
2. REMOVE RELIEF VALVE

Remove the plug, gasket, spring and relief valve.

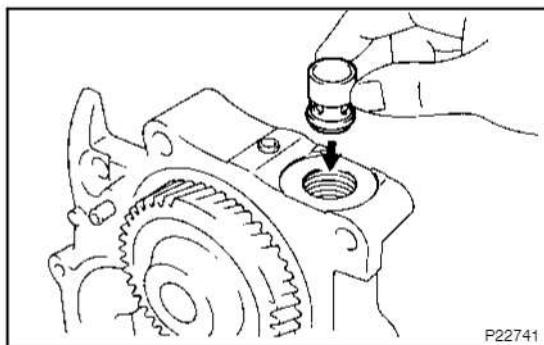

## INSPECTION

### 1. INSPECT RELIEF VALVE

Coat the valve with engine oil and check that it falls smoothly into the valve hole by its own weight.

If it doesn't, replace the relief valve. If necessary, replace the oil pump assembly.

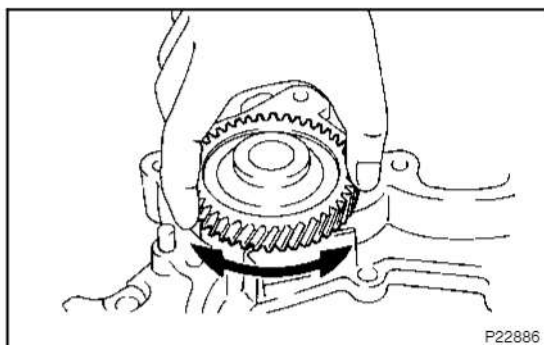

### 2. INSPECT DRIVE SHAFT

Turn the gear, and check that the drive shaft moves smoothly and quietly.

If necessary, replace the oil pump assembly.

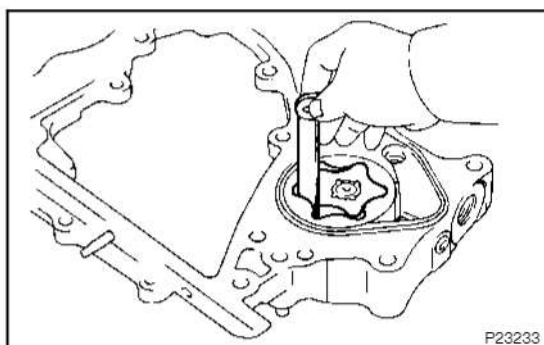

### 3. INSPECT DRIVE AND DRIVEN ROTORS FOR TIP CLEARANCE

Using a feeler gauge, measure the clearance between the drive and driven rotor tips.

**Standard tip clearance:**

**0.080 – 0.160 mm (0.0031 – 0.0063 in.)**

**Maximum tip clearance: 0.21 mm (0.0083 in.)**

If the tip clearance is greater than maximum, replace the oil pump assembly.

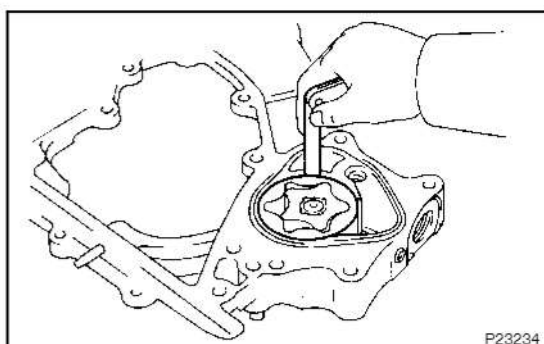

### 4. INSPECT DRIVE AND DRIVEN ROTORS FOR BODY CLEARANCE

Using a feeler gauge, measure the clearance between the driven rotor and body.

**Standard body clearance:**

**0.100 – 0.170 mm (0.0039 – 0.0067 in.)**

**Maximum body clearance: 0.20 mm (0.0079 in.)**

If the body clearance is greater than maximum, replace the oil pump assembly.

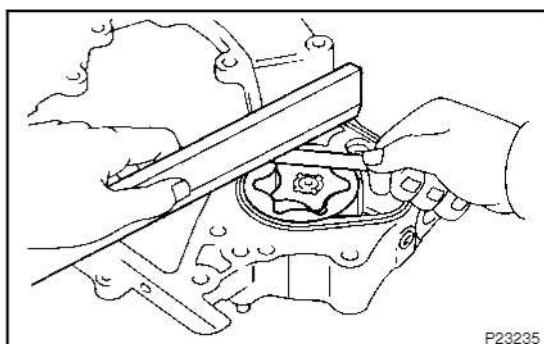

### 5. INSPECT DRIVE AND DRIVEN ROTORS FOR SIDE CLEARANCE

Using a feeler gauge and precision straight edge, measure the clearance between the rotors and precision straight edge.

**Standard side clearance:**

**0.030 – 0.090 mm (0.0012 – 0.0035 in.)**

**Maximum side clearance: 0.15 mm (0.0059 in.)**

If the side clearance is greater than maximum, replace the oil pump assembly.

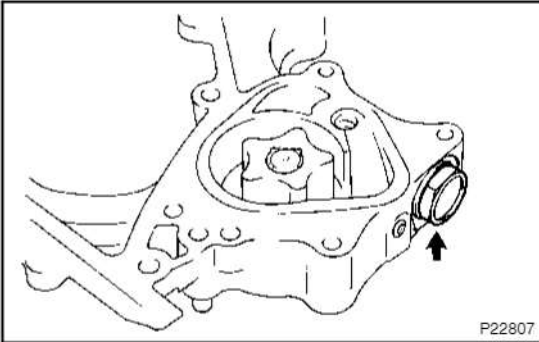

## REASSEMBLY

### 1. INSTALL RELIEF VALVE

- (a) Insert the relief valve and spring into the installation hole of the timing gear case.
- (b) Install a new gasket and the plug.

**Torque: 42 N·m (425 kgf·cm, 31 ft·lbf)**

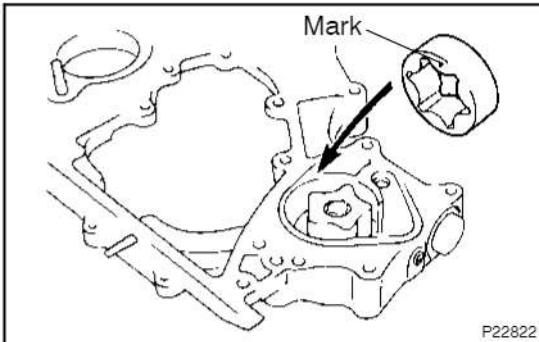

### 2. INSTALL DRIVEN ROTOR

Place the driven rotor into the timing gear case with the marks facing the timing gear case side.

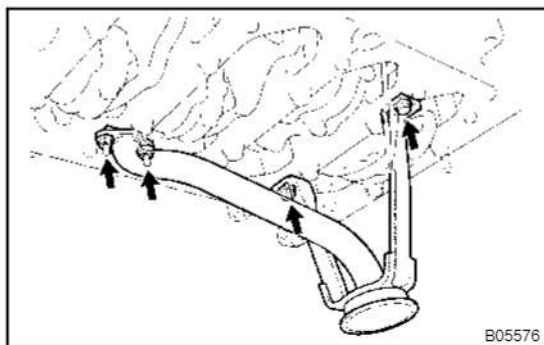

## INSTALLATION

### 1. INSTALL OIL STRAINER

Install a new gasket and the oil strainer with the 2 bolts and 2 nuts.

**Torque: 8.8 N·m (90 kgf·cm, 78 in.·lbf)**

### 2. INSTALL OIL PUMP (TIMING GEAR CASE)

(a) Remove the any old packing (FIPG) material and be careful no to drop any oil on the contact surfaces of the timing gear case and cylinder block.

- Using a razor blade and gasket scraper, remove all the old packing (FIPG) material from the gasket surfaces and sealing groove.
- Thoroughly clean all components to remove all the loose materials.
- Using a non-residue solvent, clean both sealing surfaces.

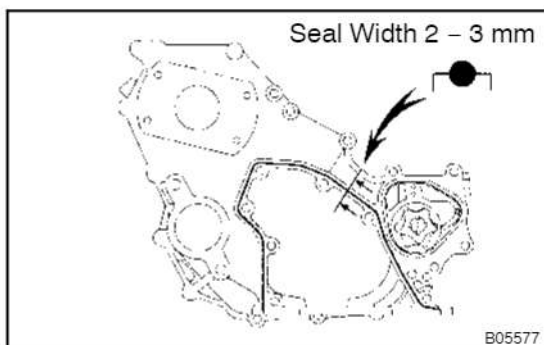

(b) Apply seal packing to the timing gear case as shown in the illustration.

**Seal packing: Part No. 08826-00080 or equivalent**

- Install a nozzle that has been cut to a 2 - 3 mm (0.08 - 0.12 in.) opening.
- Parts must be assembled within 5 minutes of application. Otherwise the material must be removed and reapplied.
- Immediately remove nozzle from the tube and reinstall it.

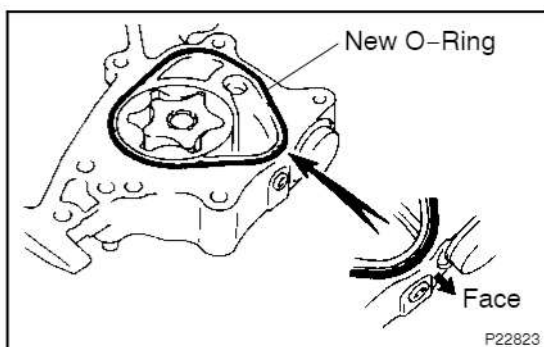

(c) Place a new gasket into the groove of the timing gear case as shown in the illustration.

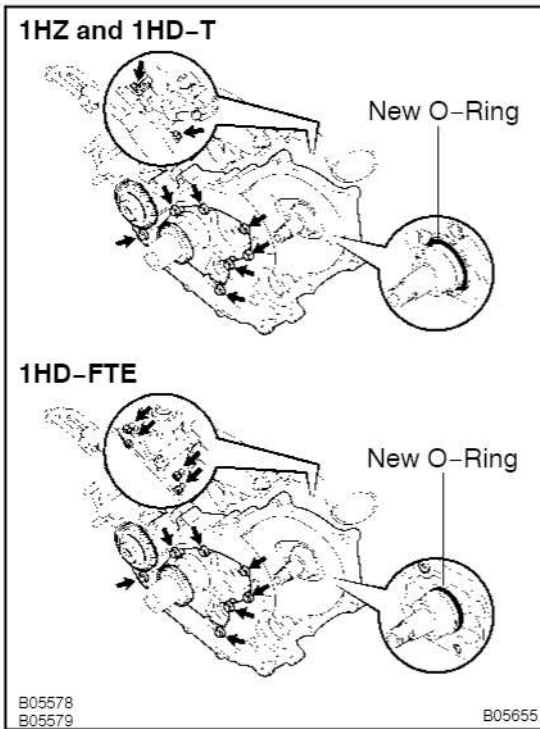

- (d) Install a new o-ring to the injection pump.
- (e) Install the timing gear case to the cylinder block with the 7 bolts. Uniformly tighten the bolts in several passes.  
**Torque: 19.6 N·m (200 kgf·cm, 14 ft·lbf)**
- (f) 1HZ and 1HD-T:  
Install the 2 nuts holding the injection pump to the timing gear case.  
**Torque: 18 N·m (185 kgf·cm, 13 ft·lbf)**
- (g) 1HD-FTE:  
Install the 4 nuts holding the injection pump to the timing gear case.  
**Torque: 18 N·m (185 kgf·cm, 13 ft·lbf)**

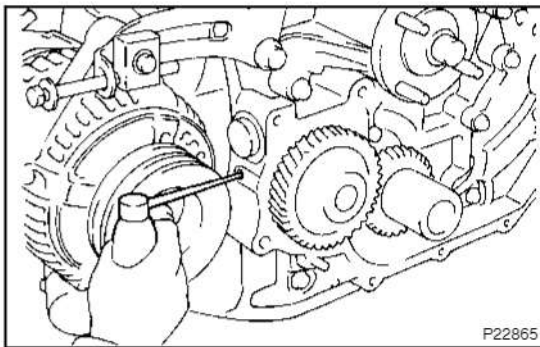

**3. POUR ENGINE OIL INTO OIL PUMP**

- (a) Using a 5 mm hexagon wrench, remove the taper screw plug.
- (b) Pour in approx. 10 cc (0.6 cu in.) of engine oil into the oil pump.

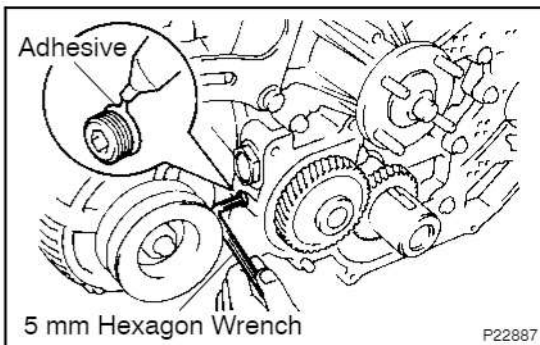

- (c) Apply adhesive to 2 or 3 threads of the taper screw plug.  
**Adhesive:**  
**part No. 08833-00080, THREE BOND 1344, LOCTITE 242 or equivalent**
- (d) Using a 5 mm hexagon wrench, install the taper screw plug.

**4. INSTALL WATER OUTLET**  
(1HZ and 1HD-T: [See page EM-66](#))  
(1HD-FTE: [See page EM-94](#))

**5. INSTALL OIL PAN**

- (a) Remove the any old packing (FIPG) material and be careful no to drop any oil on the contact surfaces of the timing gear case and cylinder block.
  - Using a razor blade and gasket scraper, remove all the old packing (FIPG) material from the gasket surfaces and sealing groove.
  - Thoroughly clean all components to remove all the loose materials.
  - Using a non-residue solvent, clean both sealing surfaces.

**NOTICE:**

**Do not use a solvent which will affect the painted surfaces.**

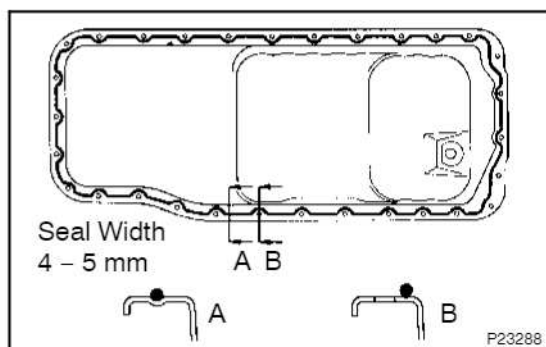

- (b) Apply seal packing to the oil pan as shown in the illustration.

**Seal packing: Part No. 08826-00080 or equivalent**

- Install a nozzle that has been cut to a 4 - 5 mm (0.15 - 0.20 in.) opening.
- Parts must be assembled within 5 minutes of application. Otherwise the material must be removed and reapplied.
- Immediately remove nozzle from the tube and re-install it.

- (c) Install the oil pan with the 27 bolts and 3 nuts. Uniformly tighten the bolts and nuts in several passes.

**Torque: 9.8 N·m (100 kgf·cm, 87 in·lbf)**

6. **INSTALL TIMING GEARS (See page EM-44)**
7. **FILL WITH ENGINE OIL**
8. **FILL WITH ENGINE COOLANT**
9. **START ENGINE AND CHECK FOR OIL LEAKS**
10. **RECHECK ENGINE OIL LEVEL**

# OIL COOLER COMPONENTS

LU0EW-01

1HZ and 1HD-T

1HZ

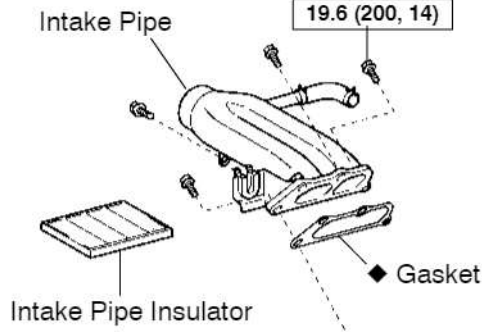

1HD-T

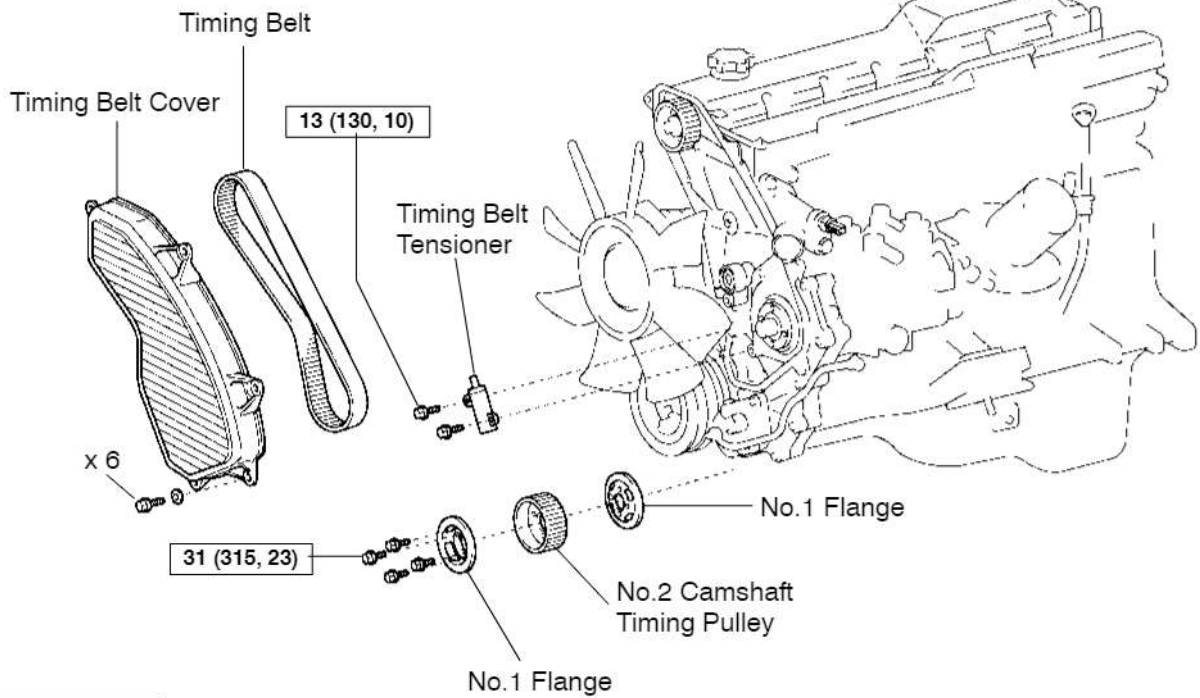
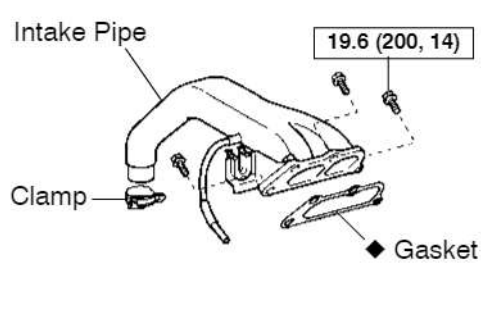

**N·m (kgf·cm, ft·lbf)** : Specified torque

◆ Non-reusable part

B05611

cardiagn.com



1HD-FTE

w/ EGR

Intake Pipe Assembly

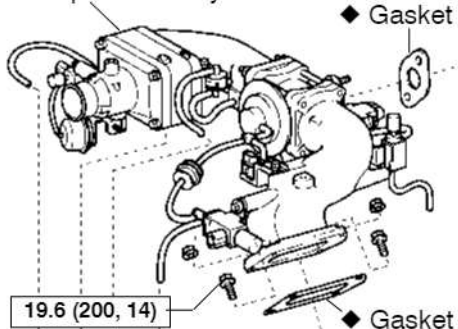

w/o EGR

Intake Pipe Assembly

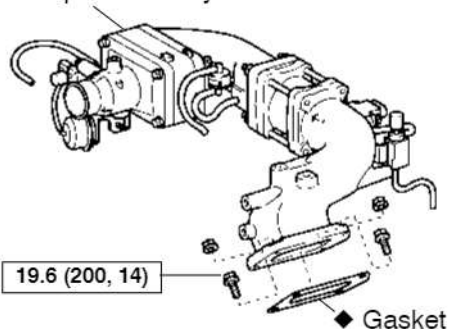

39.2 (400, 29)

EGR Pipe

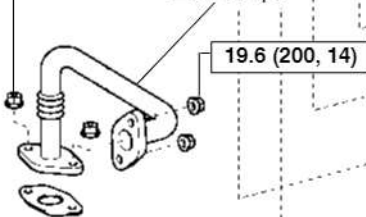

Intake Pipe Stay

19.6 (200, 14)



Timing Belt Cover

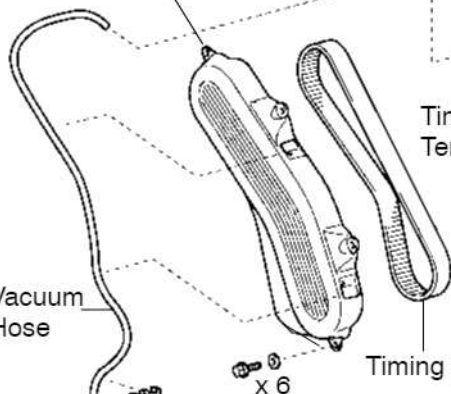

Timing Belt Tensioner

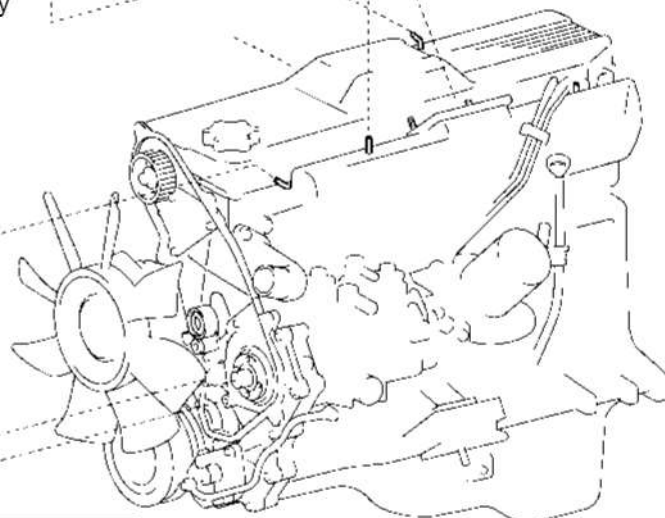

13 (130, 10)

Vacuum Hose

Clamp

x 6

Timing Belt

31 (315, 23)

No.1 Flange

No.2 Camshaft Timing Pulley

No.2 Flange

N·m (kgf·cm, ft·lbf) : Specified torque

◆ Non-reusable part

1HZ and 1HD-T

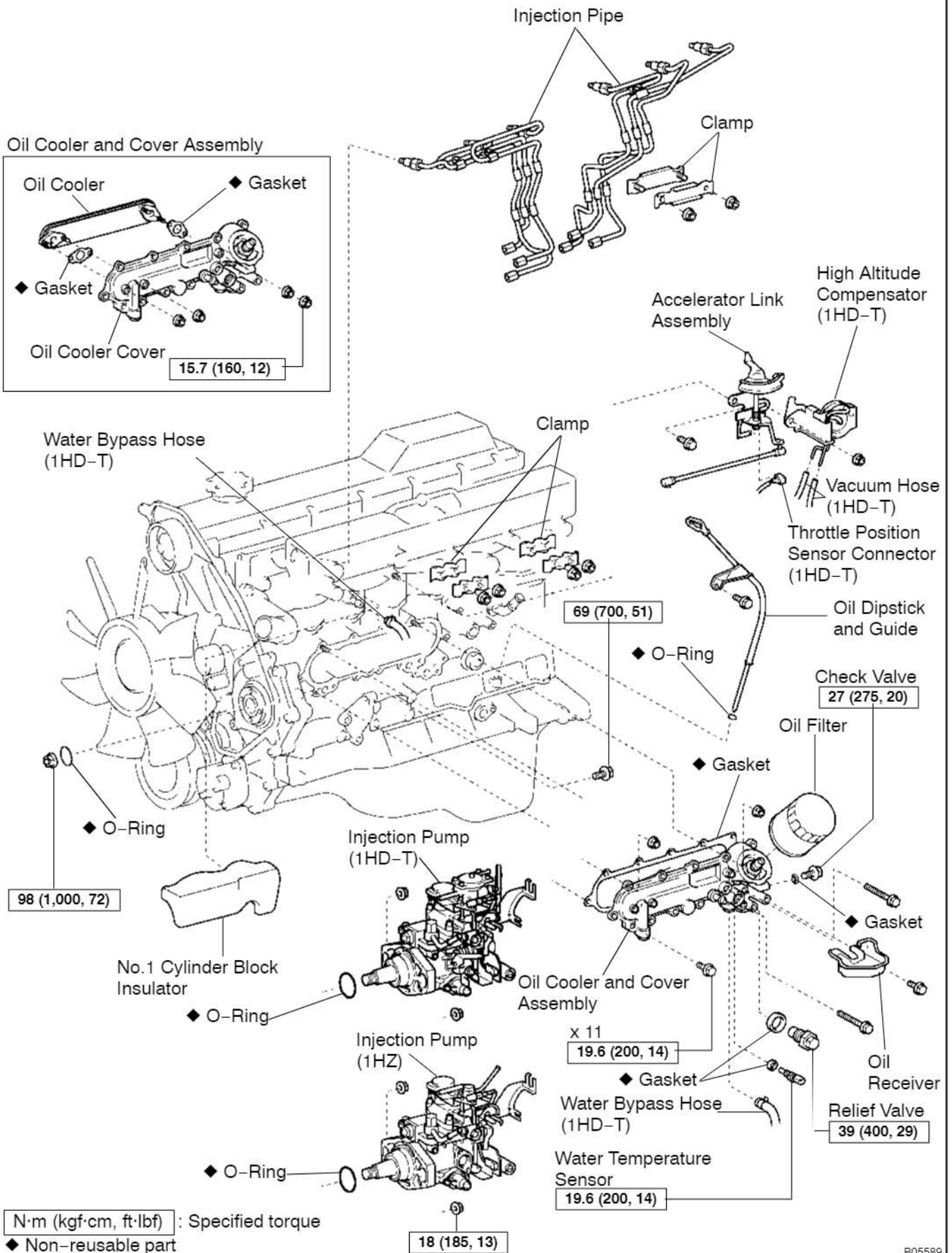

cardiagn.com

1HD-FTE

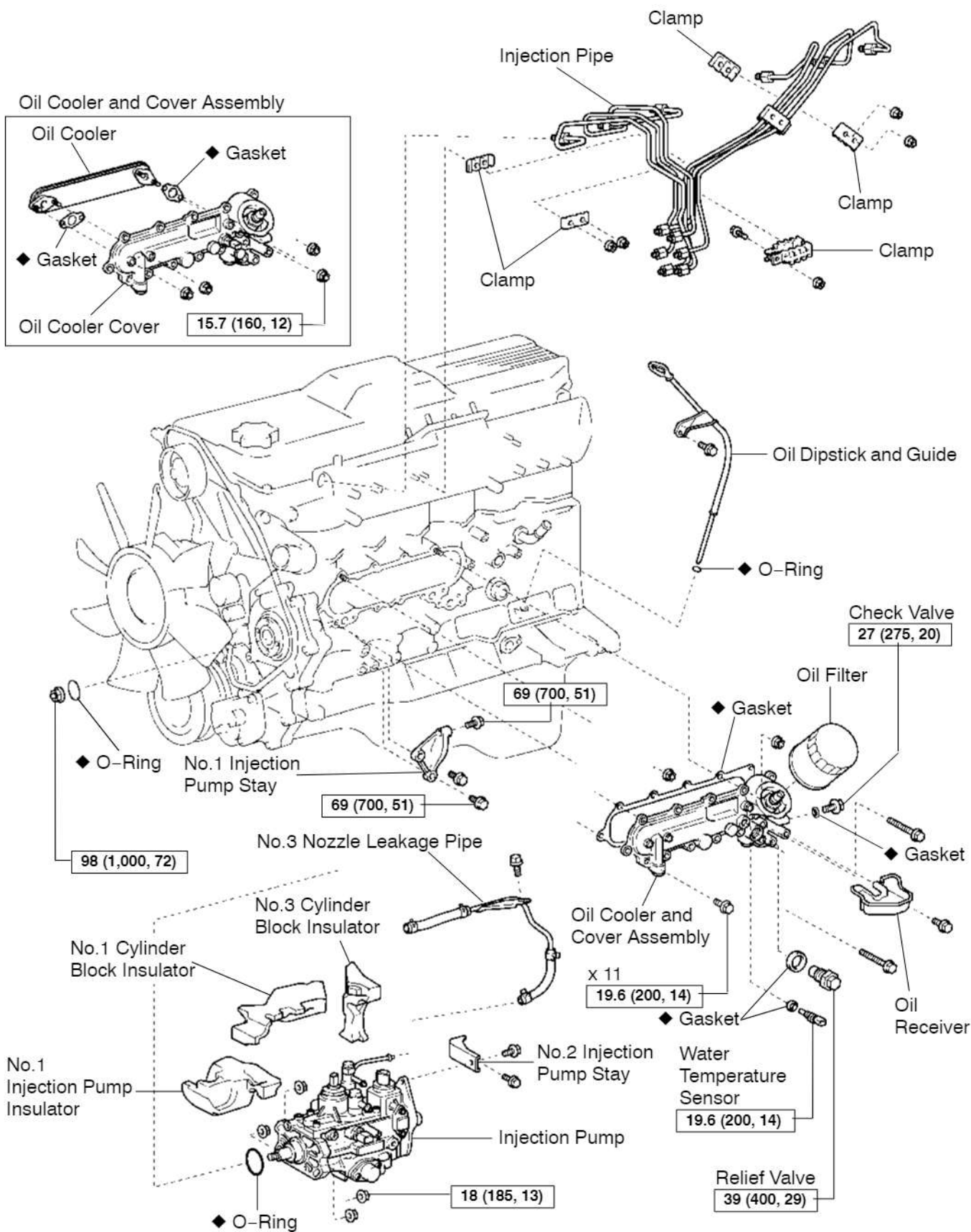

**N·m (kgf·cm, ft·lbf) :** Specified torque  
**◆** Non-reusable part

## REMOVAL

1. DRAIN ENGINE COOLANT
2. REMOVE TIMING BELT (See page EM-27)
3. REMOVE NO.2 CAMSHAFT TIMING PULLEY (See page EM-27)
4. REMOVE INJECTION PIPES  
(1HZ: See page FU-7)  
(1HD-T: See page FU-17)  
(1HD-FTE: See page FU-33)
5. REMOVE INJECTION PUMP  
(1HZ and 1HD-T: See page FU-51)  
(1HD-FTE: See page FU-117)
6. REMOVE OIL FILTER (See page LU-2)

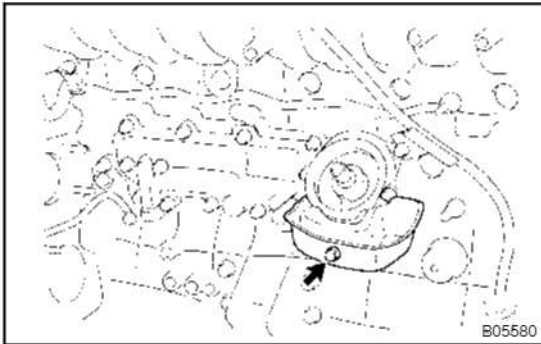

### 7. REMOVE OIL RECEIVER

Remove the bolt and oil receiver.

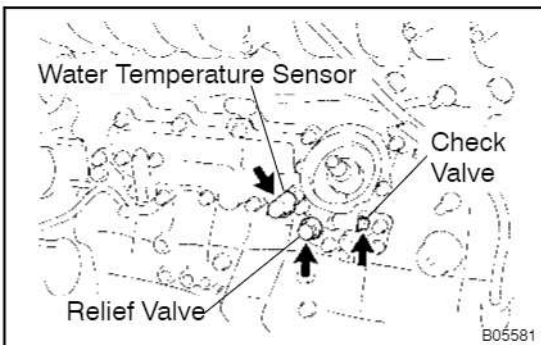

### 8. REMOVE RELIEF VALVE

Remove the relief valve and gasket.

### 9. REMOVE CHECK VALVE

Remove the check valve and gasket.

### 10. REMOVE WATER TEMPERATURE SENSOR

Remove the sensor and gasket.

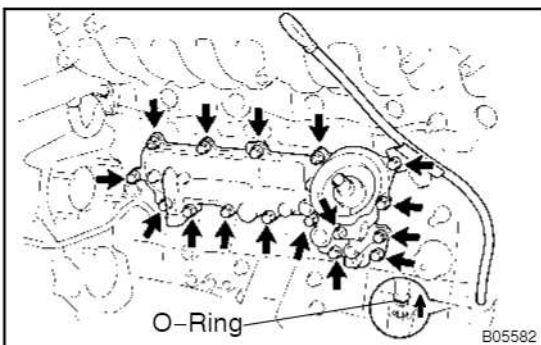

### 11. REMOVE OIL DIPSTICK AND GUIDE

- (a) Remove the bolt, and pull out the dipstick guide together with the dipstick from the oil pan.
- (b) Remove the O-ring from the dipstick guide.

### 12. REMOVE OIL COOLER AND COVER ASSEMBLY

Remove the 13 bolts, 2 nuts, the oil cooler, cover assembly and gasket.

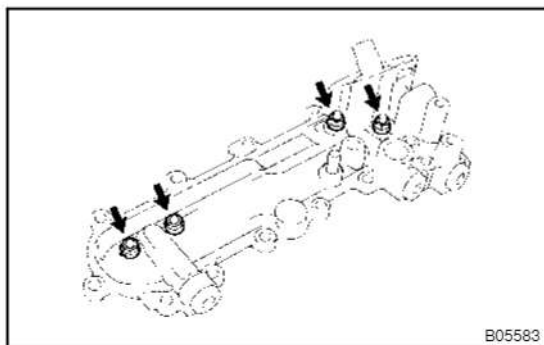

B05583

**13. REMOVE OIL COOLER FROM OIL COOLER COVER**

Remove the 4 nuts and oil cooler.

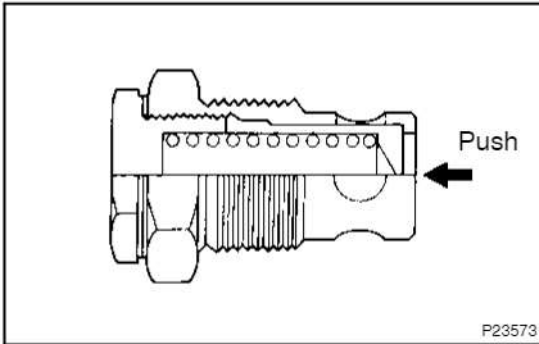

## INSPECTION

### 1. INSPECT RELIEF VALVE

Push the valve with a wooden stick to check if it is stuck. If stuck, replace the relief valve.

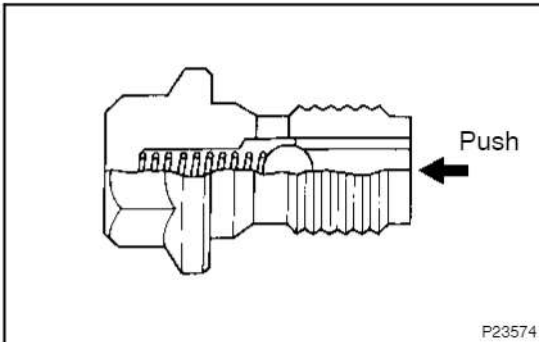

### 2. INSPECT CHECK VALVE

Push the valve with a wooden stick to check if it is stuck. If stuck, replace the check valve.

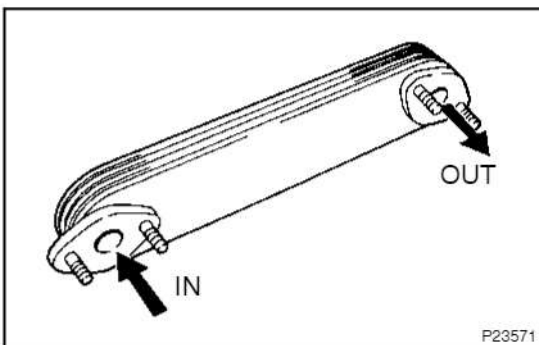

### 3. INSPECT OIL COOLER

Check the oil cooler for damage or clogging. If necessary, replace the oil cooler.

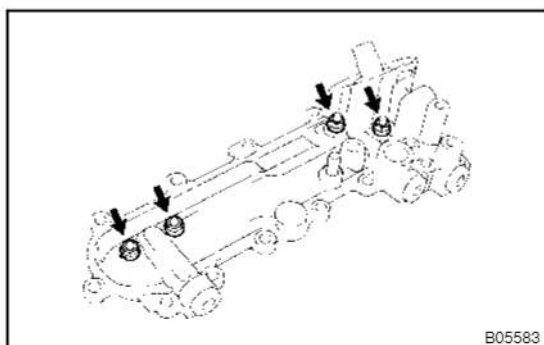

## INSTALLATION

### 1. INSTALL OIL COOLER TO OIL COOLER COVER

Install 2 new gaskets and the oil cooler to the oil cooler cover with the 4 nuts.

**Torque: 15.7 N·m (160 kgf·cm, 12 ft·lbf)**

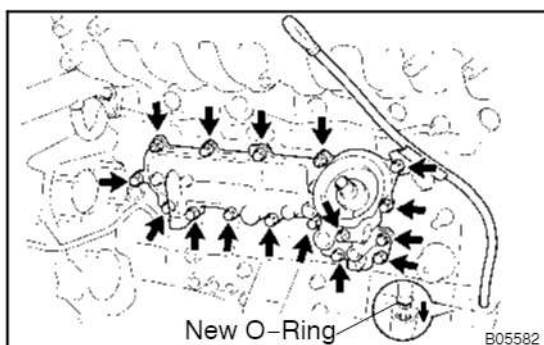

### 2. INSTALL OIL COOLER AND COVER ASSEMBLY

Install a new gasket, the oil cooler and cover assembly with the 13 bolts and 2 nuts. Uniformly tighten the bolts and nuts in several passes.

**Torque: 19.6 N·m (200 kgf·cm, 14 ft·lbf)**

### 3. INSTALL OIL DIPSTICK GUIDE AND DIPSTICK

- (a) Install a new O-ring to the dipstick guide.
- (b) Apply soapy water to the O-ring.
- (c) Push in the dipstick guide end into the guide hole of the cylinder block.
- (d) Install the oil dip stick guide with the bolt.  
**Torque: 19.6 N·m (200 kgf·cm, 14 ft·lbf)**
- (e) Install the dipstick.

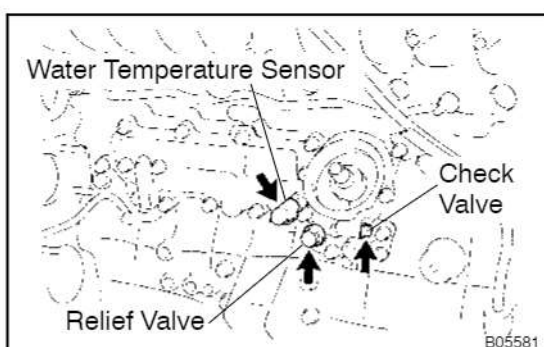

### 4. INSTALL RELIEF VALVE

Install a new gasket and the relief valve.

**Torque: 39 N·m (400 kgf·cm, 29 ft·lbf)**

### 5. INSTALL CHECK VALVE

Install a new gasket and the check valve.

**Torque: 27 N·m (275 kgf·cm, 20 ft·lbf)**

### 6. INSTALL WATER TEMPERATURE SENSOR

Install a new gasket and the sensor.

**Torque: 19.6 N·m (200 kgf·cm, 14 ft·lbf)**

### 7. INSTALL OIL RECEIVER

Install the oil receiver with the bolt.

**Torque: 19.6 N·m (200 kgf·cm, 14 ft·lbf)**

### 8. INSTALL OIL FILTER (See page LU-2)

### 9. INSTALL INJECTION PUMP

(1HZ and 1HD-T: See page FU-13)

(1HD-FTE: See page FU-121)

### 10. INSTALL INJECTION PIPES

(1HZ: See page FU-13)

(1HD-T: See page FU-30)

(1HD-FTE: See page FU-44)

11. INSTALL NO.2 CAMSHAFT TIMING PULLEY  
(See page EM-31)
12. INSTALL TIMING BELT (See page EM-31)
13. FILL WITH ENGINE COOLANT
14. START ENGINE AND CHECK FOR LEAKS
15. RECHECK ENGINE COOLANT LEVEL



# OIL NOZZLE COMPONENTS

LU0F0-01

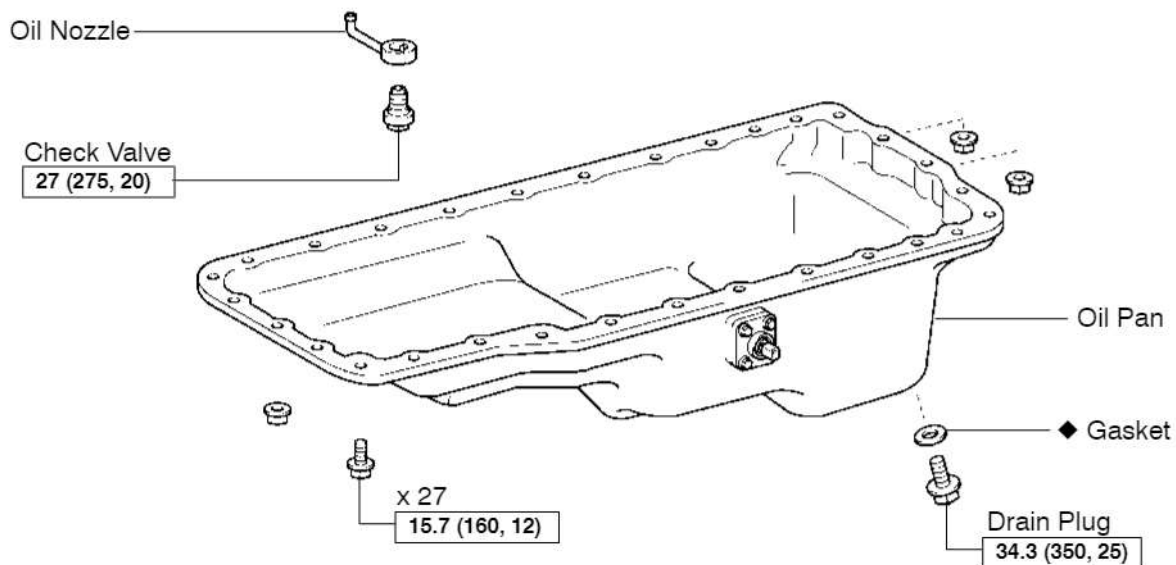
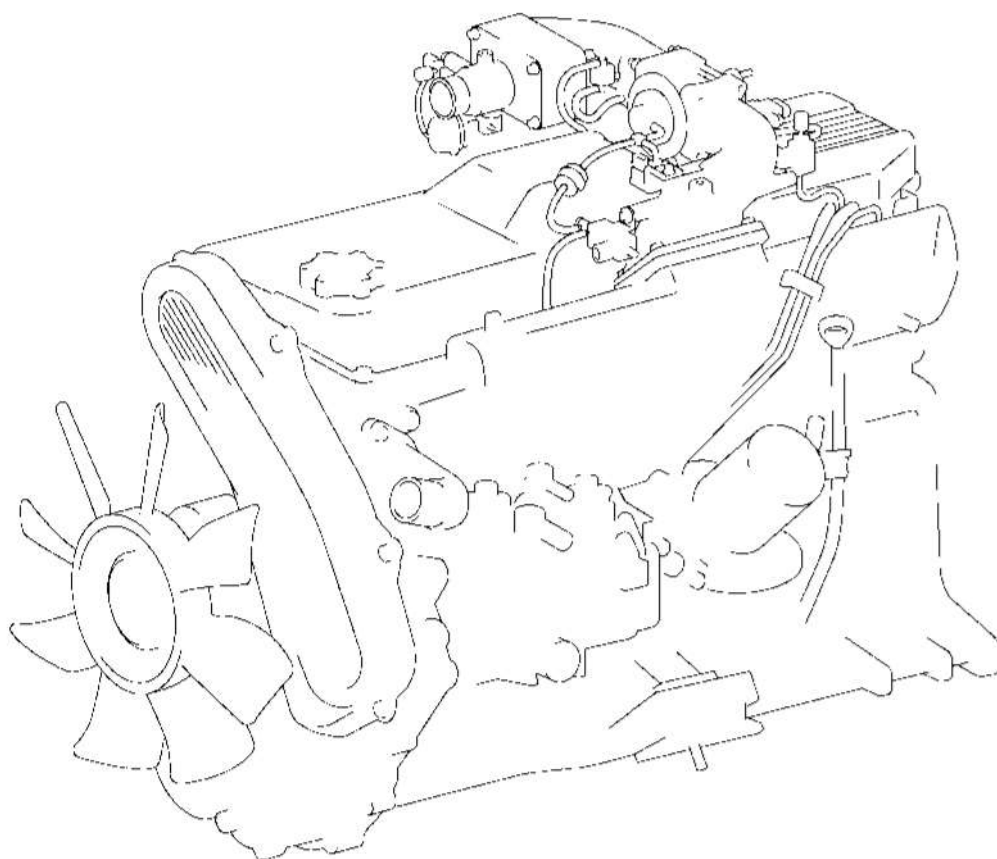

N·m (kgf·cm, ft·lbf) : Specified torque

◆ Non-reusable part

B05586

## REMOVAL

1. REMOVE OIL PAN (See page LU-9)

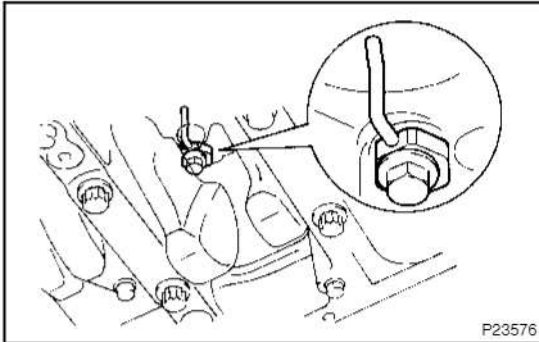

2. REMOVE CHECK VALVE AND OIL NOZZLE

Remove the 6 check valves and 6 oil nozzle.

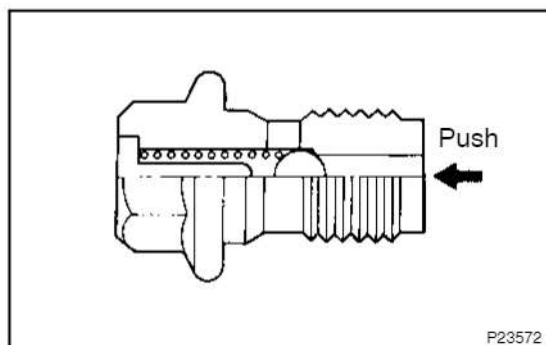

## INSPECTION

### 1. INSPECT CHECK VALVES

Push the valve with a wooden stick to check if it is stuck. If stuck, replace the check valve.

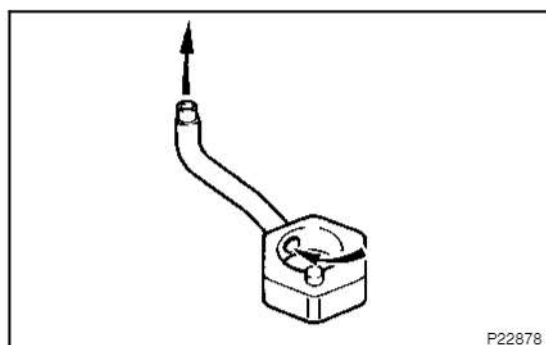

### 2. INSPECT OIL NOZZLES

Check the oil nozzle for damage or clogging. If necessary, replace the oil nozzle.

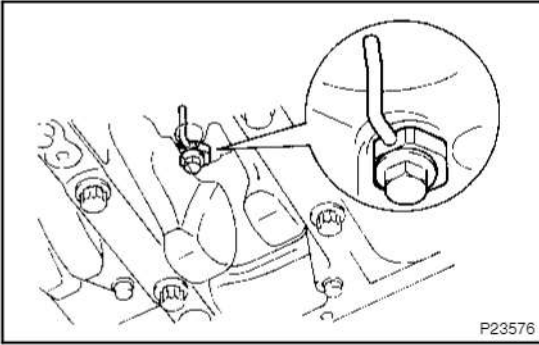

## INSTALLATION

### 1. INSTALL OIL NOZZLES AND CHECK VALVES

- (a) Align the pin of the nozzle with the pin hole of the cylinder block.
- (b) Install the oil nozzle with the check valve. Install the 6 oil nozzles and 6 check valves.

**Torque: 27 N·m (275 kgf·cm, 20 ft·lbf)**

### 2. INSTALL OIL PAN ([See page LU-13](#))



- (b) Inspect the pre-heating timer circuit.  
Check the connector on the wire harness side as shown in these chart:

Tester connection	Condition	Specified value
G-IND – Ground	Ignition switch OFF	No voltage
	Ignition switch ON	Battery voltage
IG – Ground	Ignition switch OFF	No voltage
	Ignition switch ON	Battery voltage
STA – Ground	Ignition switch OFF	No voltage
	Ignition switch START	Battery voltage
S-REL – Ground	-	Continuity
THW – Ground	-	Continuity
EG – Ground	-	Continuity

- (c) Reconnect the pre-heating timer connector.

#### 4. INSPECT GLOW PLUG RELAY

- (a) Remove the glow plug relay.  
LOCATION: See relay locations in Electrical Wiring Diagram.

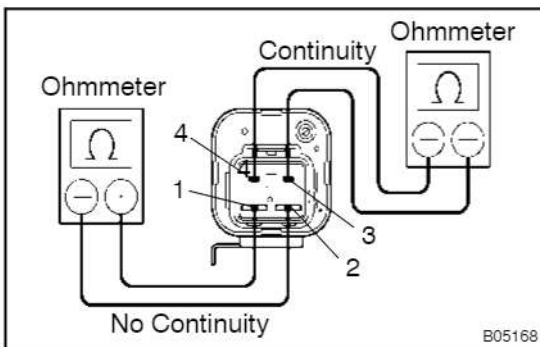

- (b) Inspect the glow plug relay continuity.  
(1) Using an ohmmeter, check that there is no continuity between terminals 1 and 2.  
If there is continuity, replace the relay.  
(2) Check that there is continuity between terminals 3 and 4.  
If there is no continuity, replace the relay.

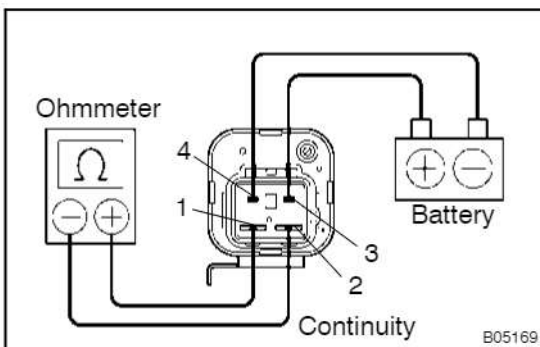

- (c) Inspect the glow plug relay operation.  
(1) Apply battery voltage across terminals 3 and 4.  
(2) Using an ohmmeter, check that there is continuity between terminals 1 and 2.  
If there is no continuity, replace the relay.  
(d) Reinstall the glow plug relay.

#### 5. INSPECT WATER TEMPERATURE SENSOR (See page ED-5)

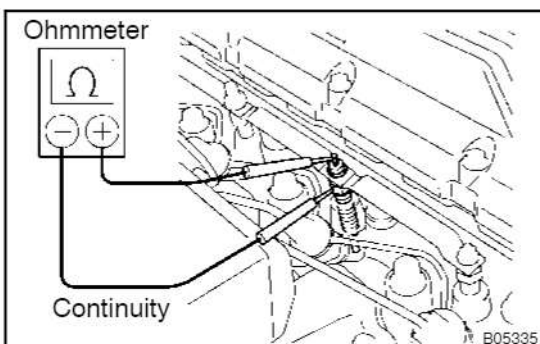

#### 6. INSPECT GLOW PLUGS

Using an ohmmeter, check that there is continuity between the glow plug terminal and ground.

**Standard resistance: Approx. 0.75  $\Omega$  at 20°C (68°F)**

If there is no continuity, replace the glow plug.

**Torque: 13 N·m (130 kgf·cm, 10 ft·lbf)**

#### NOTICE:

- Be careful not to damage the glow plug pipes as it could cause an open circuit or shorten life of the glow plugs.

- **Avoid getting oil and gasoline on the glow plug when cleaning.**
- **During inspection, be sure to wipe any oil of the terminal and bakelite washer with a dry cloth.**
- **Be careful no to apply more than 11 V to the glow plug as it could cause an open circuit.**

# INTAKE HEATER COMPONENTS

ST0F4-01

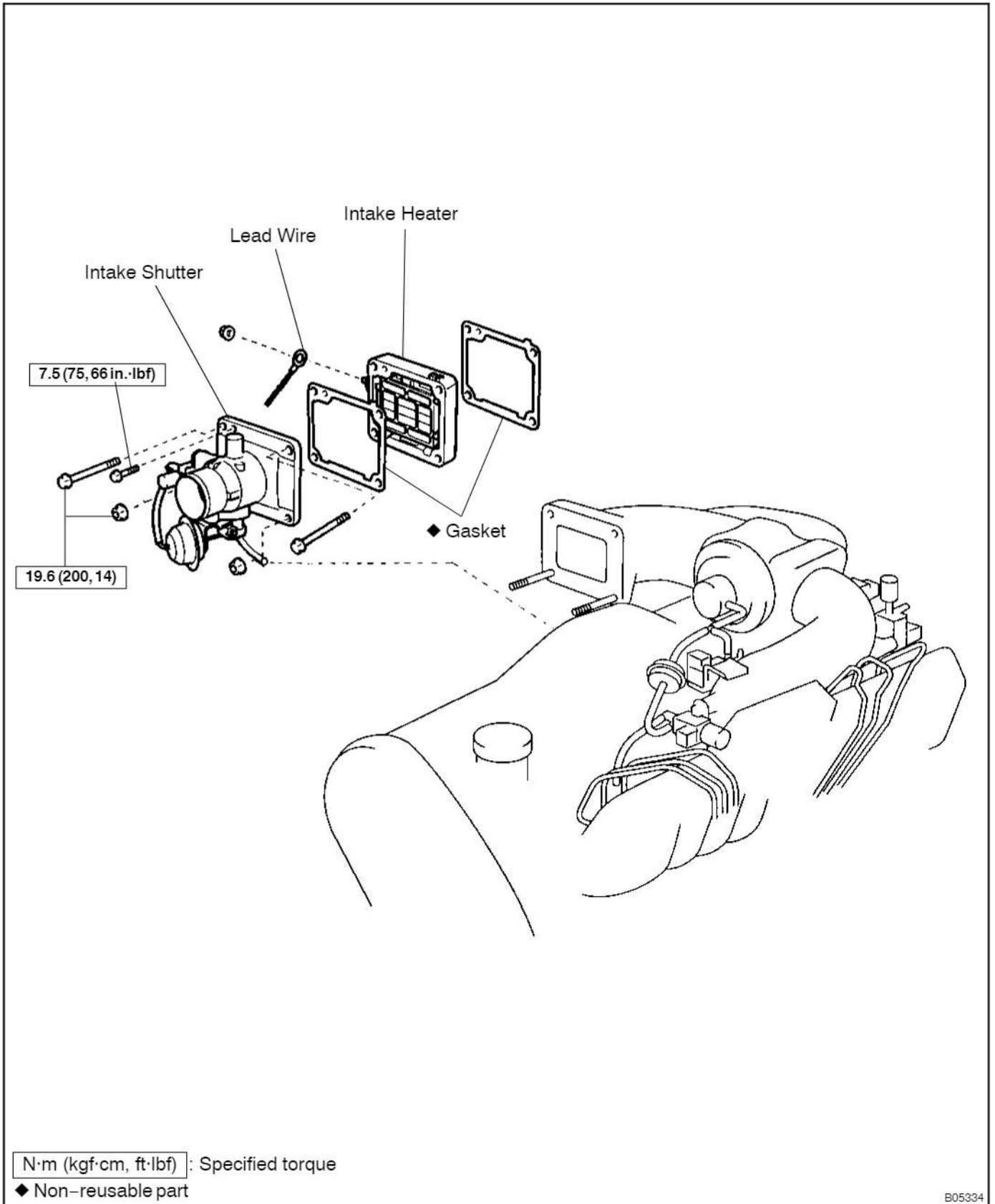



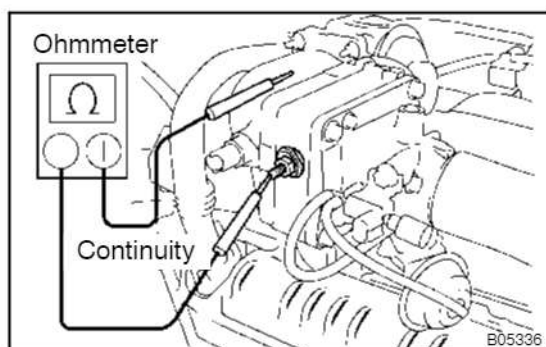

## INSPECTION

### INSPECT INTAKE HEATER

Using an ohmmeter, check that there is continuity between terminal of the intake heater and ground.

If there is no continuity, replace the intake heater.

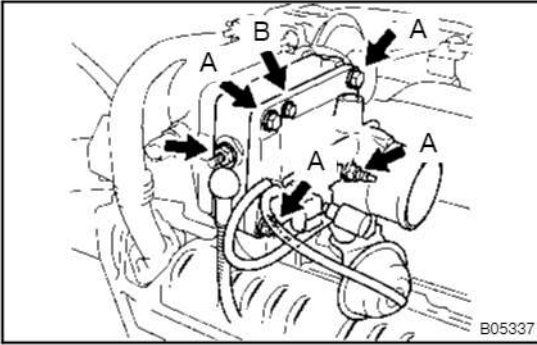

## REPLACEMENT

### INSTALL INTAKE HEATER AND DIESEL THROTTLE

- (a) Install the 2 gaskets and the intake heater.
- (b) Install the diesel throttle with the 3 bolts and 2 nuts.

**Torque:**

**A: 19.6 N·m (200 kgf·cm, 14 ft·lbf)**

**B: 7.5 N·m (75 kgf·cm, 66 in·lbf)**

- (c) Connect the VSV hose to the head cover.
- (d) Connect the lead wire to the intake heater.

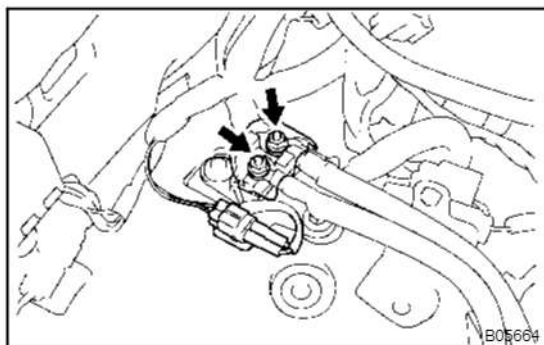

## INTAKE HEATER RELAY INSPECTION

ST077-01

### INSPECT INTAKE HEATER RELAY

- (a) Disconnect the intake heater relay connector.
- (b) Remove the intake heater relay cover, 2 nuts and 2 wires.

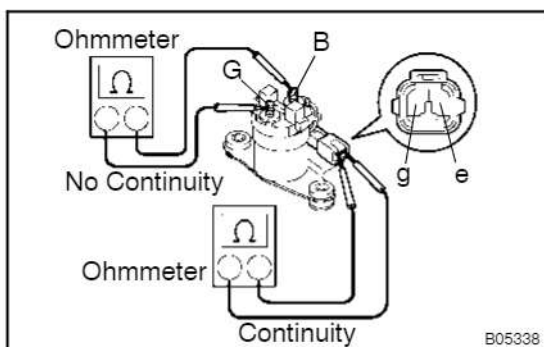

- (c) Inspect the relay continuity.
  - (1) Using an ohmmeter, check that there is continuity between terminals e and g.
  - (2) Check that there is no continuity between terminals B and G.

If continuity is not as specified, replace the relay.

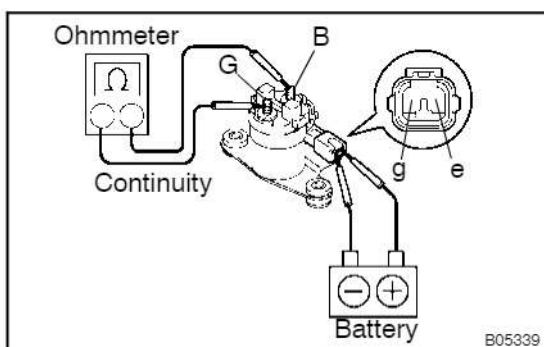

- (d) Inspect the relay operation.
  - (1) Apply battery voltage across terminals e and g.
  - (2) Using an ohmmeter, check that there is continuity between terminals B and G.

If operation is not as specified, replace the relay.

- (e) Reinstall the 2 wires with the 2 nuts and relay cover.  
**Torque: 3.5 N·m (35 kgf·cm, 31 in·lbf)**
- (f) Reconnect the intake heater relay connector.

# STARTER (2.5 kW) COMPONENTS

ST0FJ-01

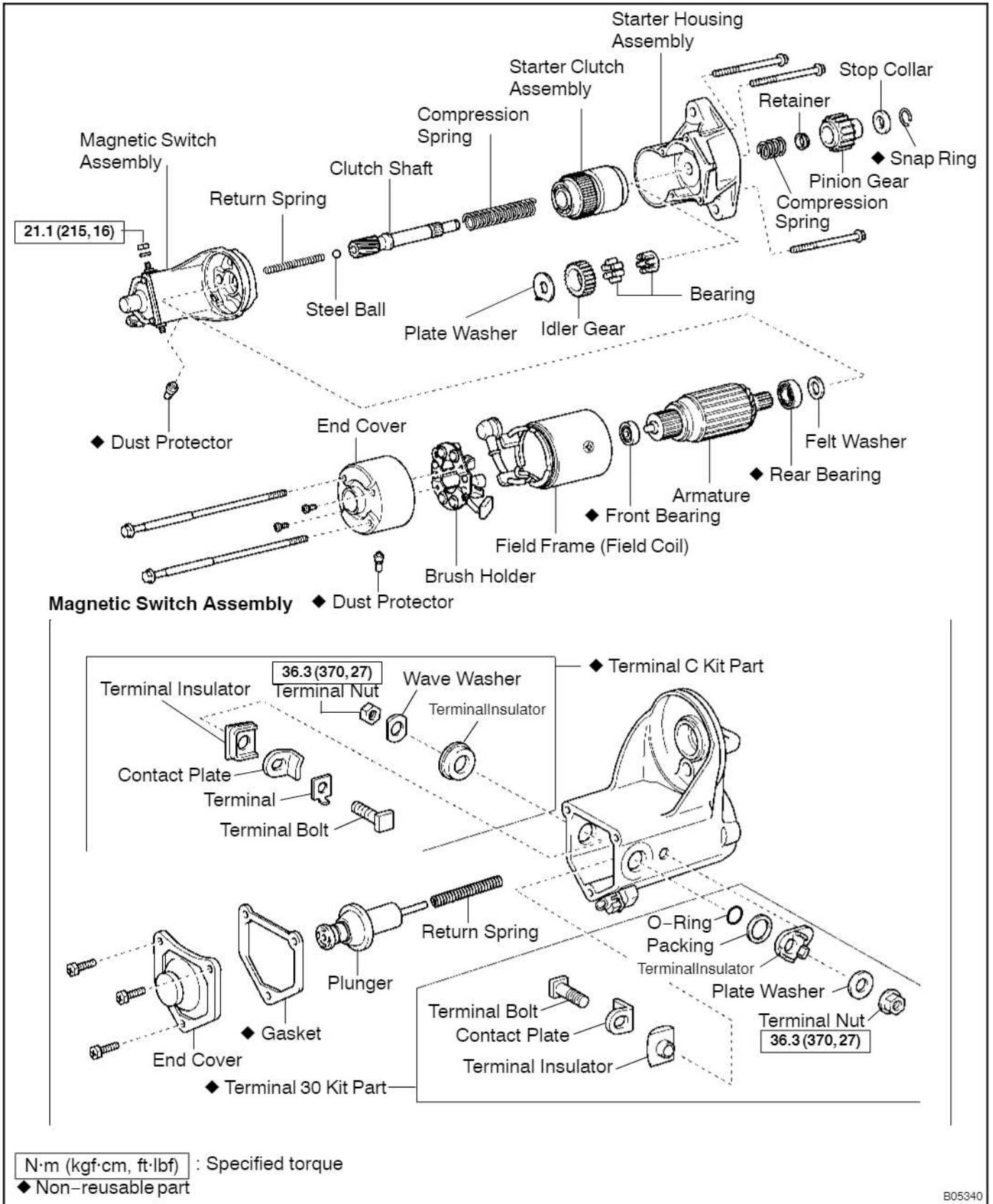

cardiagn.com

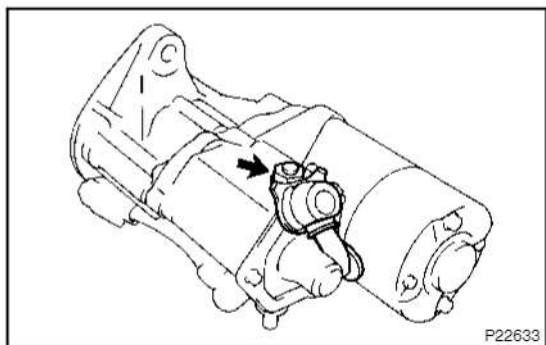

## DISASSEMBLY

### 1. REMOVE 2 DUST PROTECTORS

### 2. REMOVE FIELD FRAME AND ARMATURE

- (a) Remove the nut, and disconnect lead wire from the magnetic switch terminal.

**Torque: 24.0 N·m (245 kgf·cm, 18 ft·lbf)**

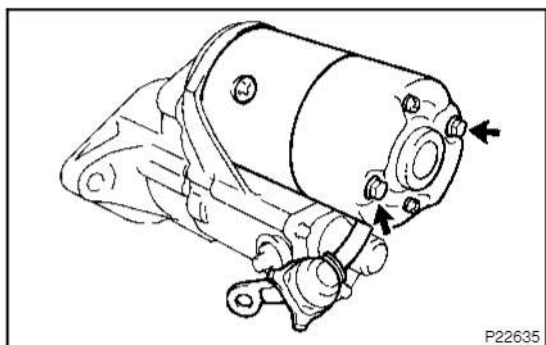

- (b) Remove the 2 through bolts.

**Torque: 9.3 N·m (95 kgf·cm, 82 in·lbf)**

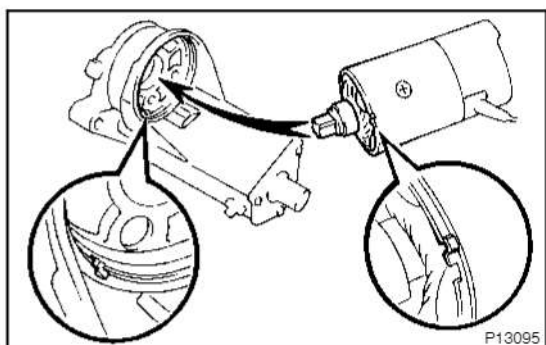

- (c) Pull out the field frame together with the armature from the magnetic switch assembly.

#### NOTICE:

**At the time of notice, please refer to the following items. Align the protrusion of the field frame with the groove of the magnetic switch.**

- (d) Remove the felt washer from the rear bearing.

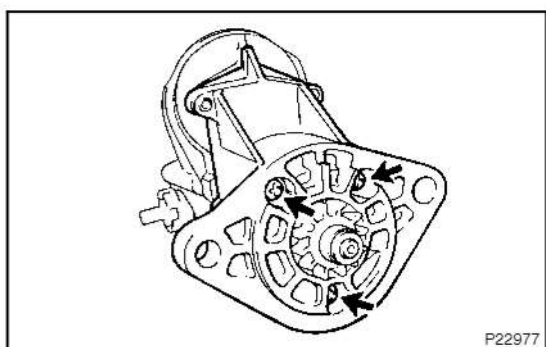

### 3. REMOVE STARTER HOUSING, CLUTCH ASSEMBLY AND GEAR

- (a) Remove the 3 screws.

**Torque: 9.3 N·m (95 kgf·cm, 82 in·lbf)**

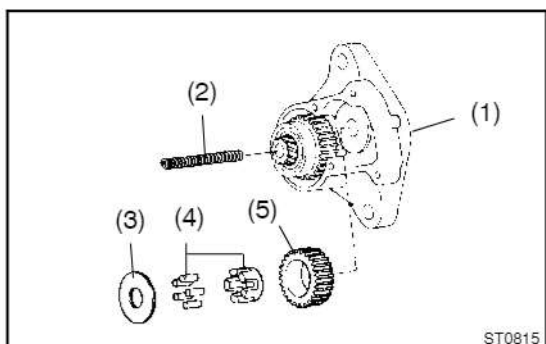

- (b) Remove these parts from the magnetic switch assembly:

- (1) Starter housing and clutch assembly
- (2) Return spring
- (3) Plate washer
- (4) Bearing
- (5) Idler gear

#### HINT:

At the time of assembly, please refer to the following items. Apply grease to the return spring and insert the return spring into the clutch shaft hole.

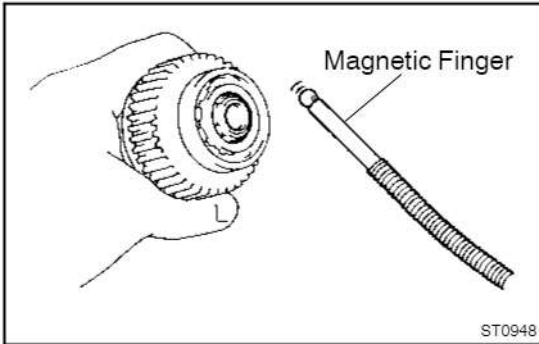

#### 4. REMOVE STEEL BALL

Using a magnetic finger, remove the steel ball from the clutch shaft hole.

HINT:

At the time of assembly, please refer to the following items.  
Apply grease to the steel ball and insert the steel ball into the clutch shaft hole.

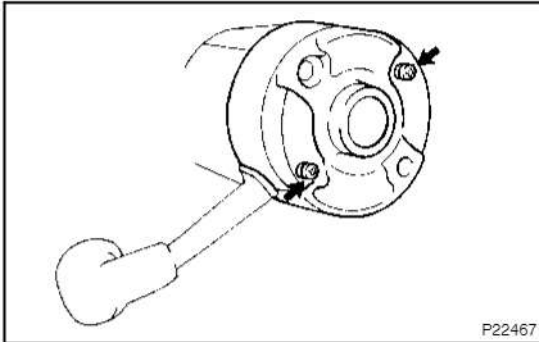

#### 5. REMOVE BRUSH HOLDER

(a) Remove the 2 screws and cover from the field frame.

**Torque: 3.6 N·m (37 kgf·cm, 32 in·lbf)**

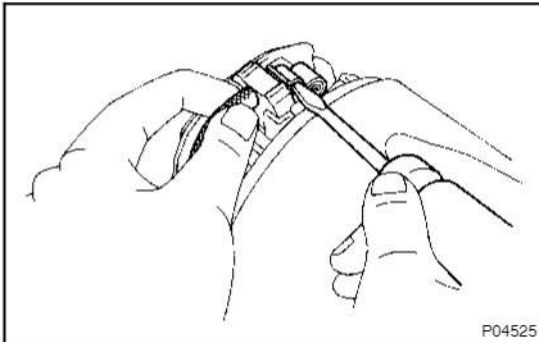

(b) Using a screwdriver, hold the spring tank back and disconnect the brush from the brush holder.

(c) Disconnect the 4 brushes, and remove the brush holder.

**NOTICE:**

**Check that the positive (+) lead wires are not grounded.**

#### 6. REMOVE ARMATURE FROM FIELD FRAME

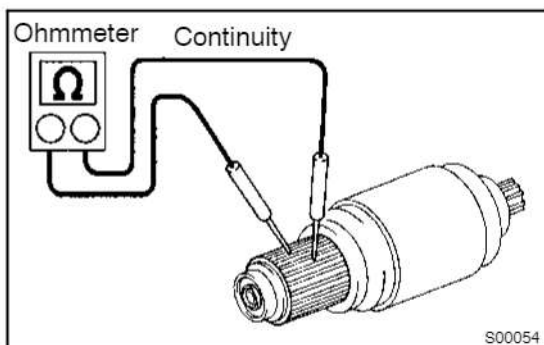

## INSPECTION

### 1. INSPECT COMMUTATOR FOR OPEN CIRCUIT

Using an ohmmeter, check that there is continuity between the segments of the commutator.

If there is no continuity between any segment, replace the armature.

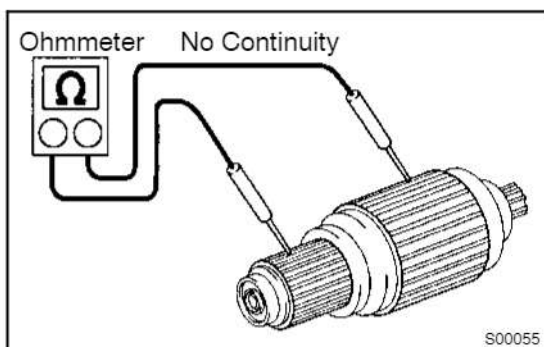

### 2. INSPECT COMMUTATOR FOR GROUND

Using an ohmmeter, check that there is no continuity between the commutator and armature coil core.

If there is continuity, replace the armature.

### 3. INSPECT COMMUTATOR FOR DIRTY AND BURNT SURFACE

If the surface is dirty or burnt, correct it with sandpaper (No.400) or on a lathe.

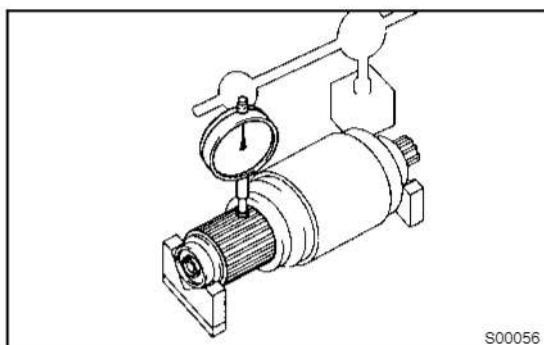

### 4. INSPECT COMMUTATOR CIRCLE RUNOUT

- Place the commutator on V-blocks.
- Using a dial indicator the circle runout.

**Maximum circle runout:**

**0.05 mm (0.0020 in.)**

If the circle runout is greater than maximum, correct it on a lathe.

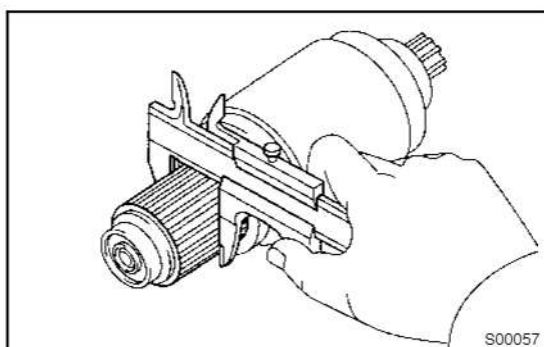

### 5. INSPECT COMMUTATOR DIAMETER

Using vernier calipers, measure the commutator diameter.

**Standard diameter:**

**36.0 mm (1.417 in.)**

**Minimum diameter:**

**35.0 mm (1.378 in.)**

If the diameter is less than minimum, replace the armature.

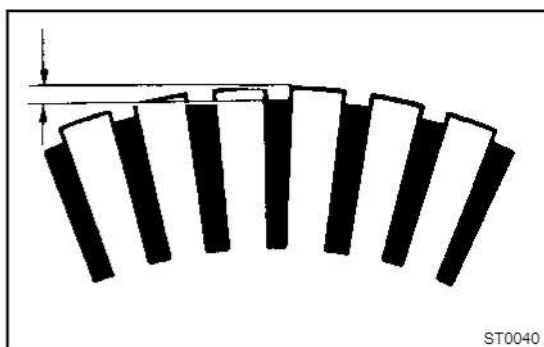

### 6. INSPECT UNDERCUT DEPTH

Check that the undercut depth is clean and free of foreign materials. Smooth out the edge.

**Standard undercut depth:**

**0.7 mm (0.028 in.)**

**Minimum undercut depth:**

**0.2 mm (0.008 in.)**

If the undercut depth is less than minimum, correct it with a hacksaw blade.

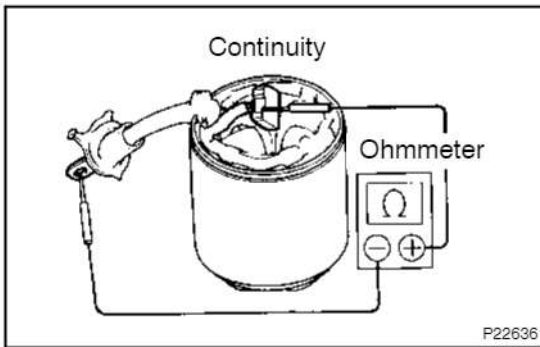
**7. INSPECT FIELD COIL FOR OPEN CIRCUIT**

Using an ohmmeter, check that there is continuity between the lead wire and field coil brush lead.

If there is no continuity, replace the field frame.

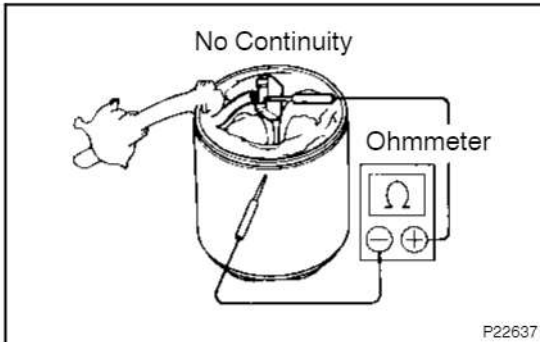
**8. INSPECT FIELD COIL FOR GROUND**

Using an ohmmeter, check that there is no continuity between the field coil end and field frame.

If there is continuity, repair or replace the field frame.

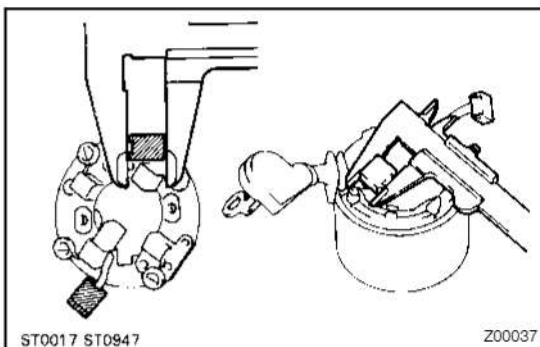
**9. INSPECT BRUSH LENGTH**

Using vernier calipers, measure the brush length.

**Standard length:**

**20.5 mm (0.807 in.)**

**Minimum length:**

**11.0 mm (0.433 in.)**

If the length is less than minimum, replace the brush holder and field frame.

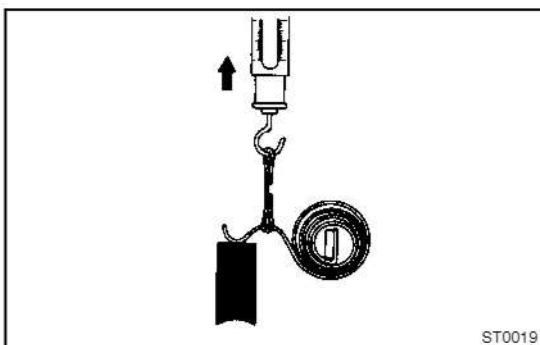
**10. INSPECT BRUSH SPRING LOAD**

Take the pull scale reading the instant the brush spring separates from the brush.

**Standard spring installed load:**

**34.3 - 42.1 N (3.4 - 4.1 kgf, 7.7 - 9.5 lbf)**

**Minimum spring installed load:**

**18.6 N (1.8 kgf, 2.7 lbf)**

If the installed load is less than minimum, replace the brush springs.

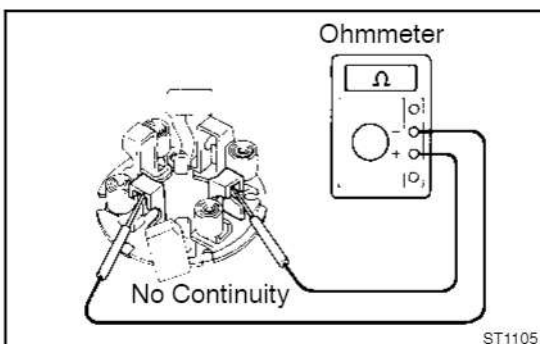
**11. INSPECT BRUSH HOLDER INSULATION**

Using an ohmmeter, check that there is no continuity between the positive (+) and negative (-) brush holders.

If there is continuity, repair or replace the brush holder.

**12. INSPECT GEAR TEETH**

Check the gear teeth on the pinion gear, idle gear and the clutch assembly for wear or damage.

If damaged, replace the gear or clutch assembly.

If damaged, also check the drive plate ring gear for wear or damage.

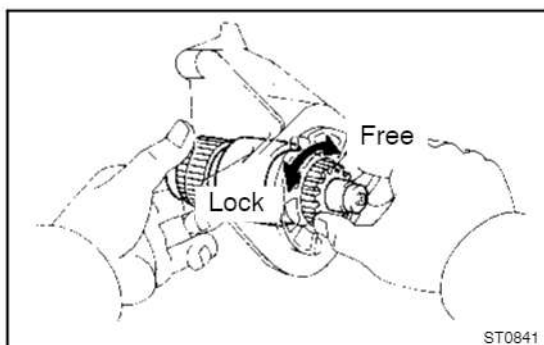

**13. INSPECT CLUTCH PINION GEAR**

Rotate the pinion gear clockwise, and check that it turns freely. Try to rotate the pinion gear counterclockwise and check that it locks.

If necessary, replace the clutch assembly.

**14. INSPECT FRONT AND REAR BEARING**

Turn the bearing by hand while applying inward force.

If resistance is felt or the bearing sticks, replace the bearing.

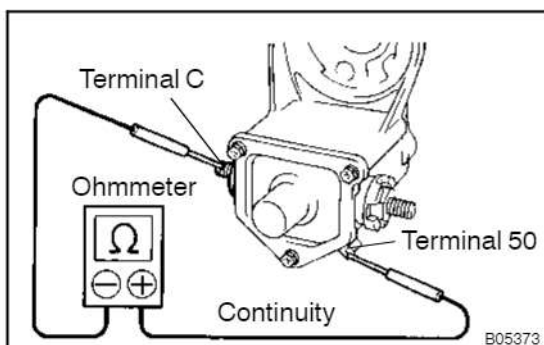
**15. DO PULL-IN COIL OPEN CIRCUIT TEST**

Using an ohmmeter, check that there is continuity between terminals 50 and C.

If there is no continuity, check and replace the magnetic switch.

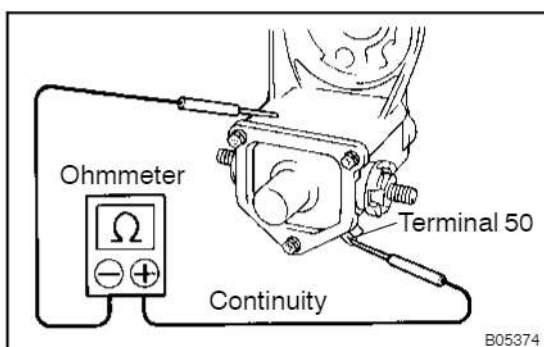
**16. DO HOLD-IN COIL OPEN CIRCUIT TEST**

Using an ohmmeter, check that there is continuity between terminal 50 and the switch body.

If there is no continuity, replace the magnetic switch.

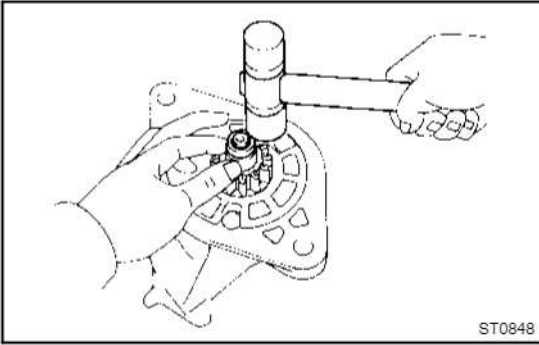

ST0848

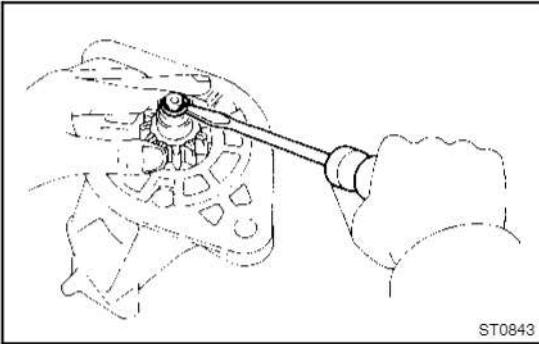

ST0843

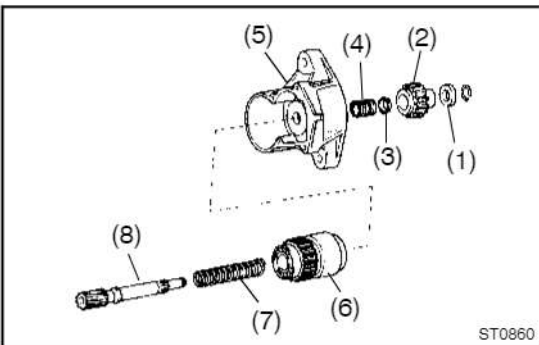

ST0860

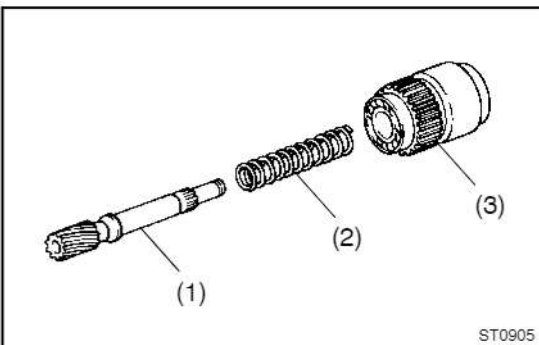

ST0905

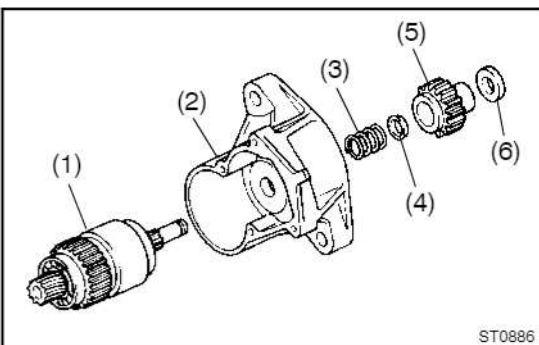

ST0886

## REPLACEMENT

### 1. REPLACE CLUTCH ASSEMBLY: DISASSEMBLY STARTER HOUSING AND CLUTCH ASSEMBLY

- (a) Push down the pinion gear and starter housing.
- (b) Using a plastic-faced hammer, tap down the stop collar.

- (c) Using a screwdriver, pry out the snap ring.

- (d) Disassemble these parts:

- (1) Stop collar
- (2) Pinion gear
- (3) Retainer
- (4) Compression spring
- (5) Starter housing
- (6) Starter clutch
- (7) Compression spring
- (8) Clutch shaft

### 2. REPLACE CLUTCH ASSEMBLY: ASSEMBLE STARTER HOUSING AND CLUTCH ASSEMBLY

- (a) 1st, assemble these parts:

- (1) Clutch shaft
- (2) Compression spring
- (3) Starter clutch

- (b) 2nd, assemble these parts:

- (1) Clutch shaft and starter shaft assembly
- (2) Starter housing
- (3) Compression spring
- (4) Retainer
- (5) Pinion gear
- (6) Stop collar

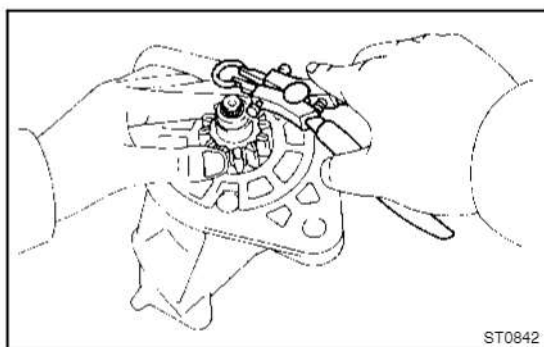

- (c) Push down the pinion gear and starter housing.
- (d) Using snap ring pliers, install a new snap ring.

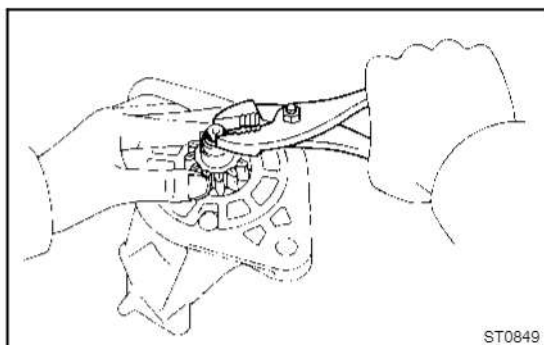

- (e) Using pliers, compress the snap ring.
- (f) Check that the snap ring fits correctly.

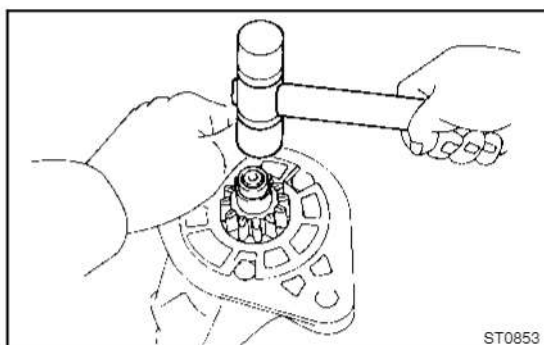

- (g) Using a plastic-faced hammer, tap the clutch shaft and install the stop collar onto the snap ring.

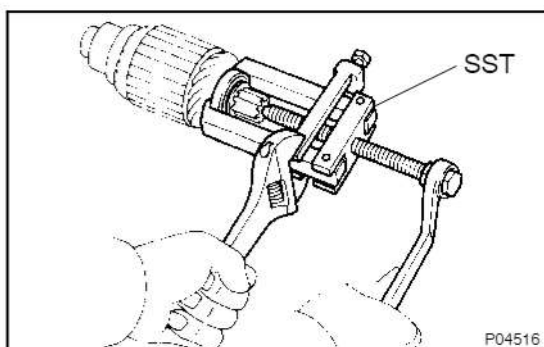

### 3. REPLACE FRONT AND REAR BEARINGS

- (a) Using SST, remove the front and rear bearings.  
SST 09286-46011

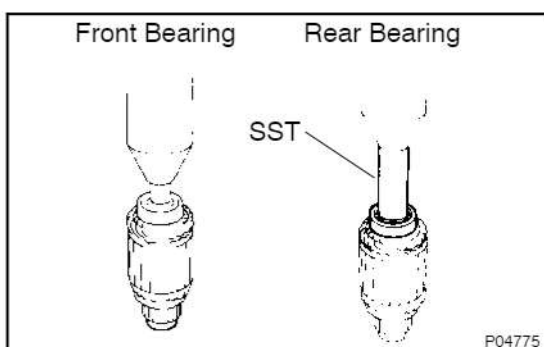

- (b) Using a press, press in a new front bearing.
- (c) Using SST and a press, press in a new rear bearing.  
SST 09820-00030

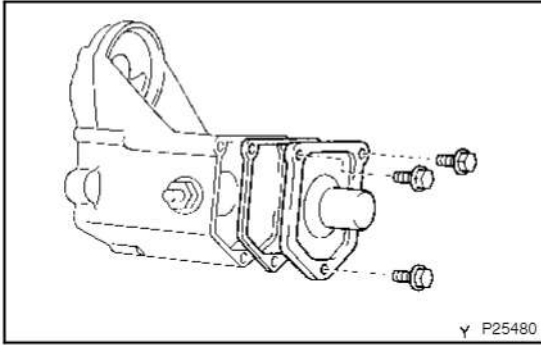

#### 4. REPLACE MAGNETIC SWITCH TERMINAL KIT PARTS

- (a) Remove magnetic switch end cover.  
Remove the 3 bolts, end cover, gasket and plunger.

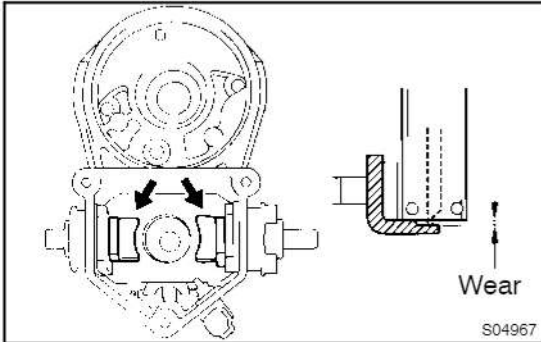

- (b) Inspect contact plate for wear.  
Using vernier calipers, measure the contact plate for depth of wear.

**Maximum wear:**  
**1.6 mm (0.063 in.)**

- If the depth of wear is greater than the maximum, replace the contact plate.

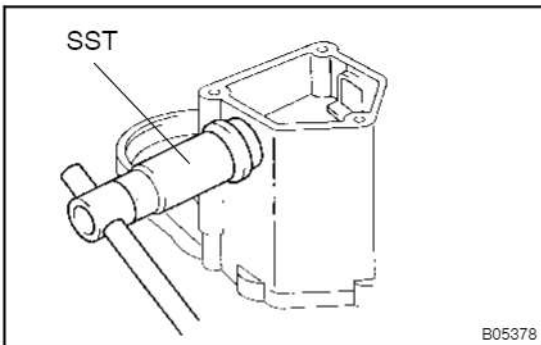

- (c) Remove terminal kit parts.
- (1) Using SST, loosen the terminal nuts.  
SST 09810-38140
  - (2) Terminal C:  
Remove the terminal nut, wave washer, terminal insulator (outside), terminal bolt, contact plate and terminal insulator (inside).
  - (3) Terminal 30:  
Remove the terminal nut, wave washer, terminal insulator (outside), O-ring, terminal bolt, contact plate, terminal insulator (inside).

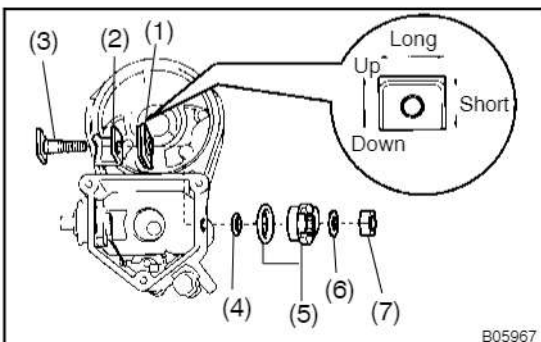

- (d) Temporarily install these new terminal 30 kit parts:
- (1) Terminal insulator (inside)
  - (2) Contact plate
  - (3) Terminal bolt
  - (4) O-ring
  - (5) Packing and terminal insulator (outside)
- Install the packing to the terminal insulator, and install them.

**HINT:**

Match the protrusion of the insulator with the indentation of the housing.

- (6) Plate washer
- (7) Terminal nut

**NOTICE:**

**Be careful to install the terminal insulator (inside) and wave washer in the correct direction.**

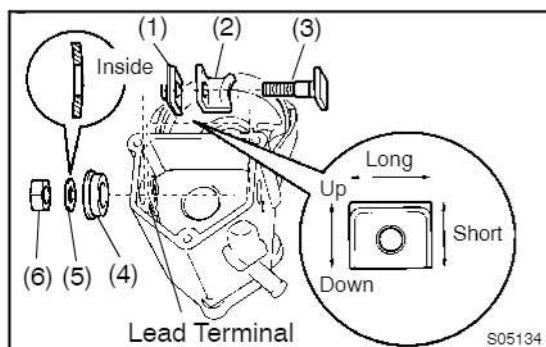

- (e) Temporarily install these new terminal C kit parts:

- (1) Terminal insulator (inside)
- (2) Contact plate
- (3) Terminal bolt
- (4) Terminal insulator (outside)
- (5) Wave washer
- (6) Terminal nut

**NOTICE:**

**Be careful to install the terminal insulator (inside) and wave washer in the correct direction.**

- (f) Temporarily tighten the terminal nuts.

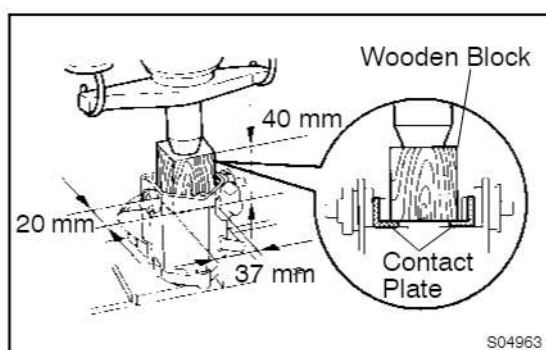

- (g) Tighten terminal nuts.

- (1) Put a wooden block on the contact plate and press it down with a hand press.

**Dimensions of wooden block:**

20 x 37 x 40 mm (0.79 x 1.46 x 1.57 in.)

**Press force:**

981 N (100 kgf, 221 lbf)

**NOTICE:**

- Check the diameter of the hand press ram. Then calculate the gauge pressure of the press when 981 N (100 kgf, 221 lbf) of force is applied.

**Gauge pressure:**

$$(\text{kgf/cm}^2) = \frac{100 \text{ kgf}}{\left(\frac{\text{Ram diameter (cm)}}{2}\right)^2 \times 3.14 (\pi)}$$

$$(\text{psi}) = \frac{221 \text{ lbf}}{\left(\frac{\text{Ram diameter (in.)}}{2}\right)^2 \times 3.14 (\pi)}$$

$$(\text{kPa}) = (\text{kgf/cm}^2) \times 98.1$$

$$(\text{kPa}) = (\text{psi}) \times 6.9$$

- If the contact plate is not pressed down with the specified pressure, the contact plate may tilt due to coil deformation or the tightening of the nut.

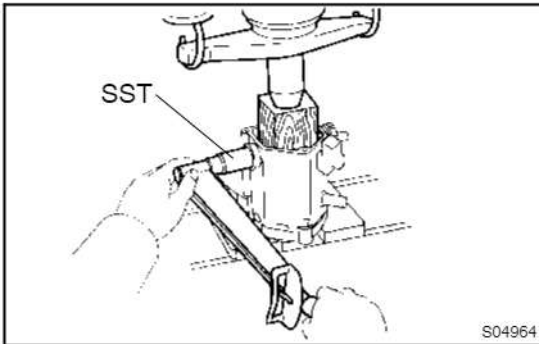

(2) Using SST, tighten the nuts to the specified torque.  
SST 09810-38140

**Torque: 36.3 N·m (370 kgf·cm, 27 ft·lbf)**

**NOTICE:**

If the nut is over tightened, it may cause cracks on the inside of the insulator.

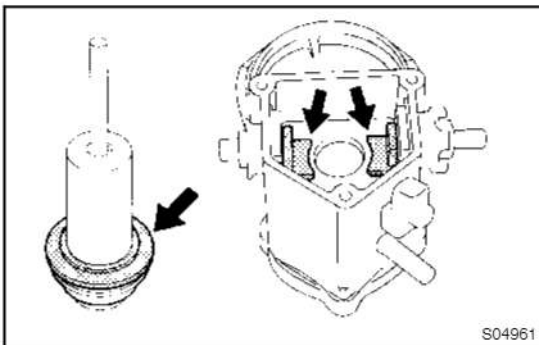

- (h) Clean contact surfaces of contact plate and plunger. Clean the contact surfaces of the remaining contact plate and plunger with a dry shop rag.
- (i) Reinstall magnetic switch end cover. Install the plunger, new gasket, end cover and lead clamp with the 3 bolts.

**Torque: 3.6 N·m (37 kgf·cm, 32 in·lbf)**

## REASSEMBLY

Reassembly is in the reverse order of disassembly.

(See page ST-9)

HINT:

At the time of assembly, please refer to the following items.

Use high-temperature grease to lubricate the bearing and gears when assembling the starter.

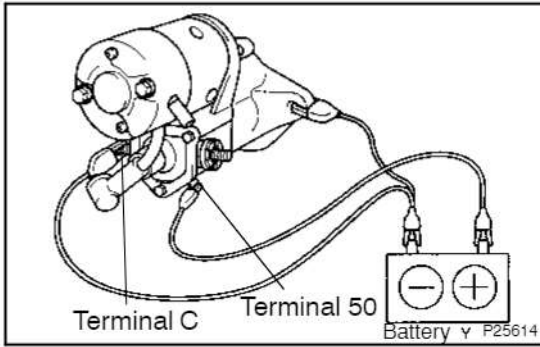

## TEST

### NOTICE:

These tests must be done within 3 to 5 seconds to avoid burning out the coil.

#### 1. DO PULL-IN TEST

- Disconnect the field coil lead wire from terminal C.
- Connect the battery to the magnetic switch as shown. Check that the pinion gear moves outward.

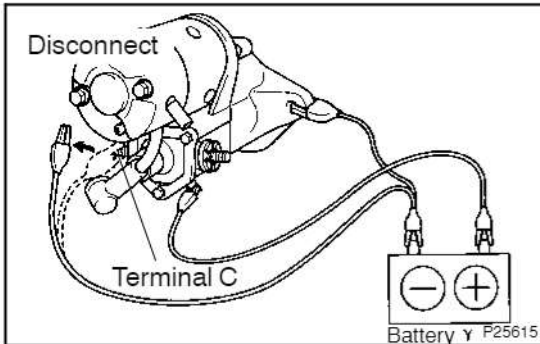

#### 2. DO HOLD-IN TEST

While connected as above with the pinion gear out, disconnect the negative (-) lead from terminal C. Check that the pinion gear remains out.

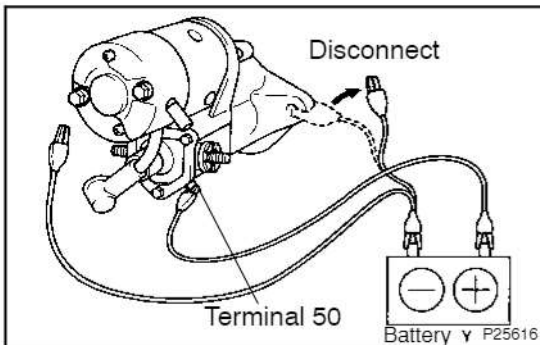

#### 3. INSPECT CLUTCH PINION GEAR RETURN

Disconnect the negative (-) lead from the starter body. Check that the pinion gear returns inward.

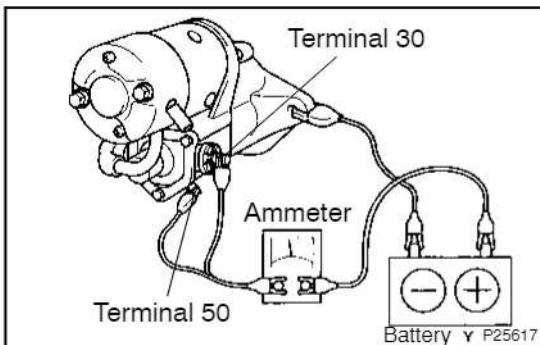

#### 4. DO NO-LOAD PERFORMANCE TEST

- Connect the battery and ammeter to the starter as shown.
- Check that the starter rotates smoothly and steadily with the pinion gear moving out. Check that the ammeter shows the specified current.

**Specified current:**

**180 A or less at 11.0 V**



# STARTER (3.0 kW) COMPONENTS

STOFD-01

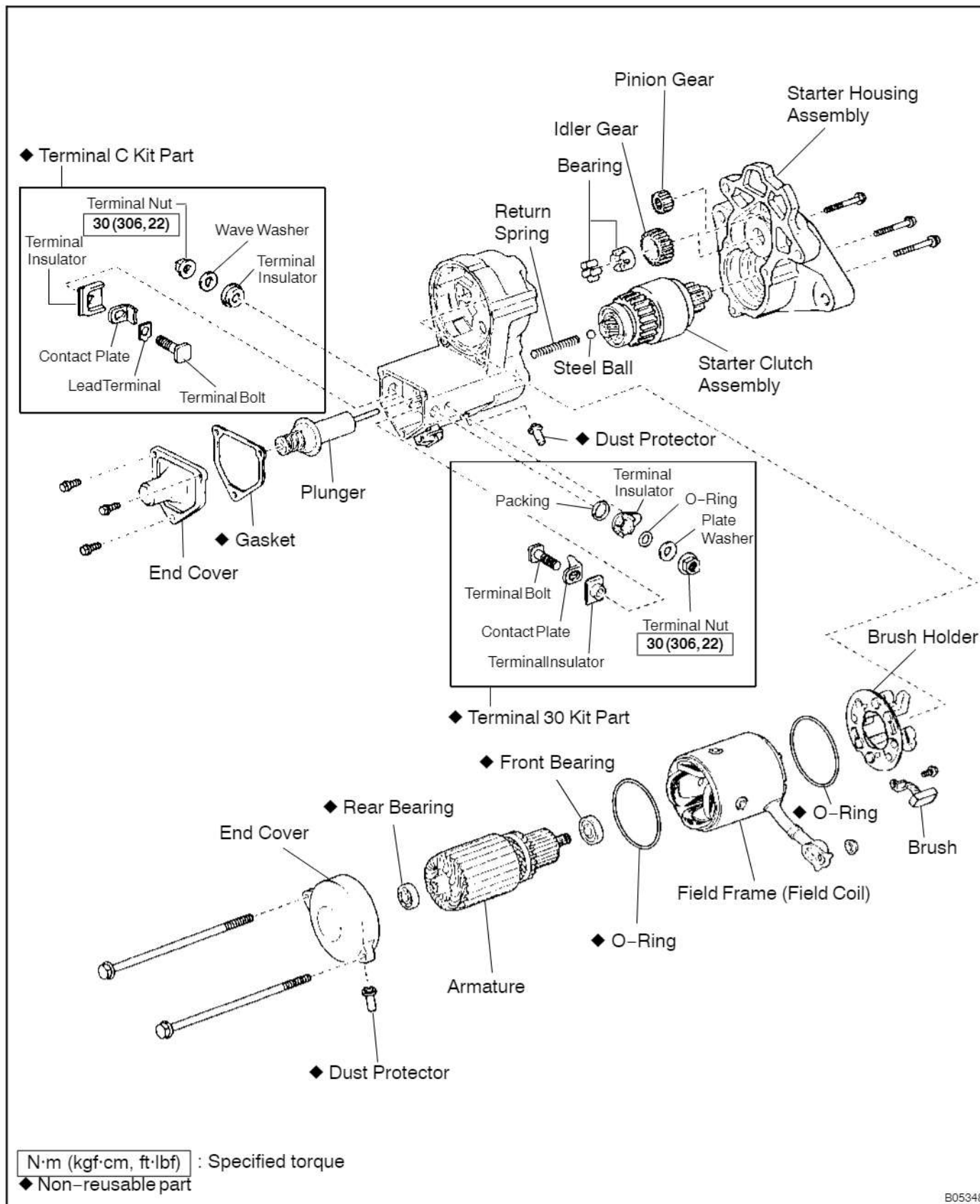

cardiagn.com

B05348

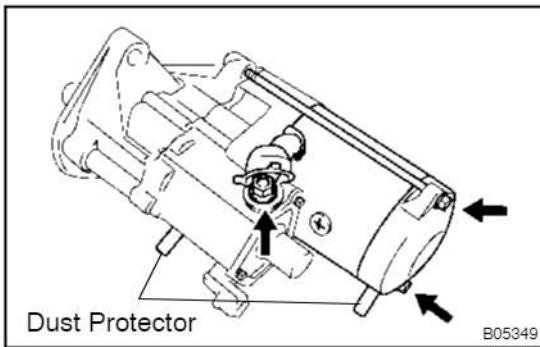

## DISASSEMBLY

### 1. REMOVE 2 DUST PROTECTORS

### 2. REMOVE FIELD FRAME AND ARMATURE

- Remove the nut, and disconnect lead wire from the magnetic switch terminal.
- Remove the 2 through bolts.
- Pull out the field frame together with the armature from the magnetic switch assembly.
- Remove the O-ring from the field frame.

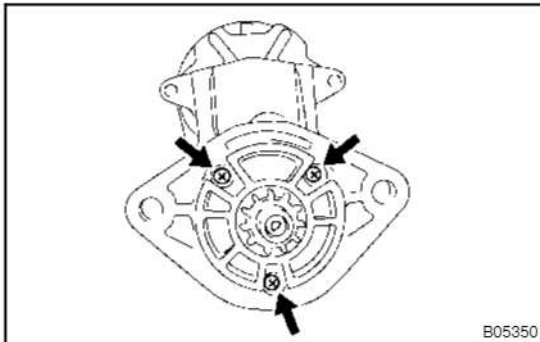

### 3. REMOVE STARTER HOUSING, CLUTCH ASSEMBLY AND GEAR

- Remove the 3 screws.

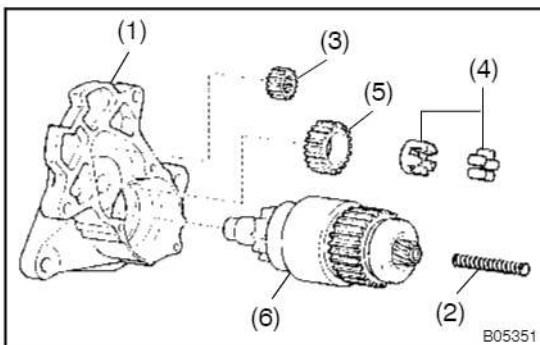

- Remove these parts from the magnetic switch assembly:

- Starter housing
- Return spring
- Pinion gear
- Bearing
- Idler gear
- Clutch assembly

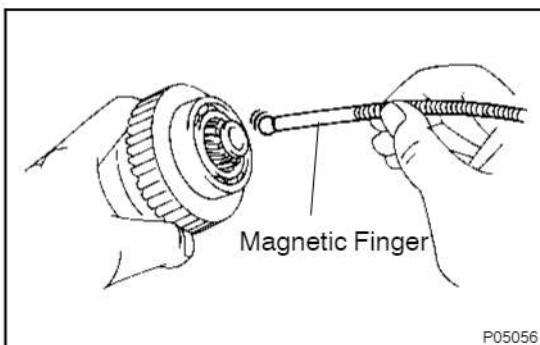

### 4. REMOVE STEEL BALL

Using a magnetic finger, remove the steel ball from the clutch shaft hole.

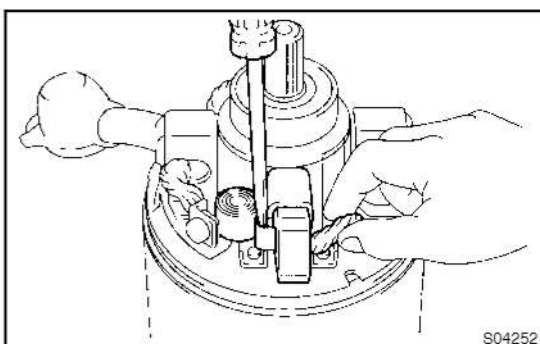

### 5. REMOVE BRUSH HOLDER

- Using a screwdriver, hold the spring back and disconnect the brush from the brush holder. Disconnect the 4 brushes.

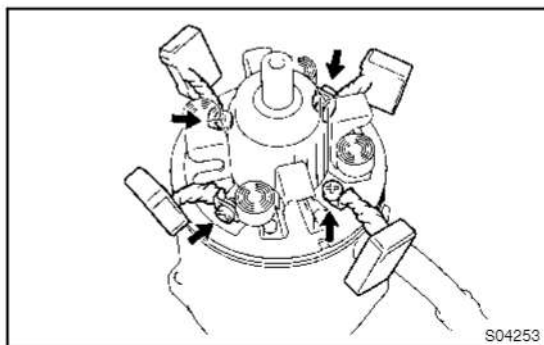

- (b) Remove the 4 screws and 4 brushes.
- (c) Remove the brush holder from the field frame.

**6. REMOVE ARMATURE WITH END COVER FROM FIELD FRAME**

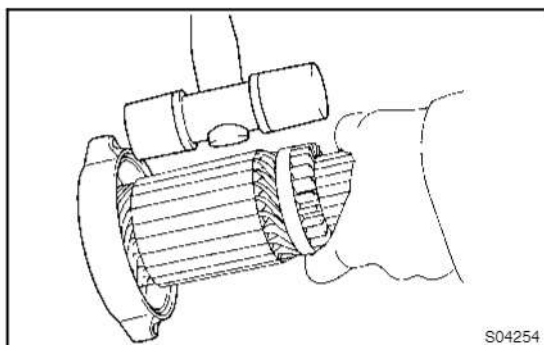

**7. REMOVE ARMATURE FROM END COVER**

Using a plastic hammer, tap the end cover to remove the armature from the end cover.

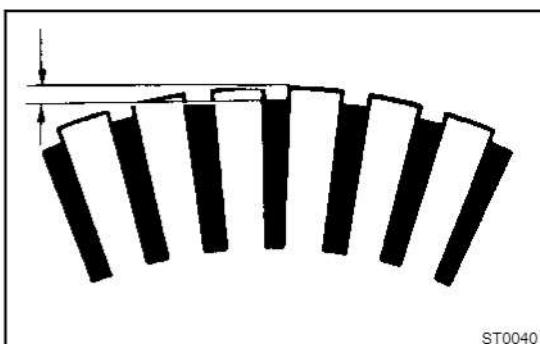
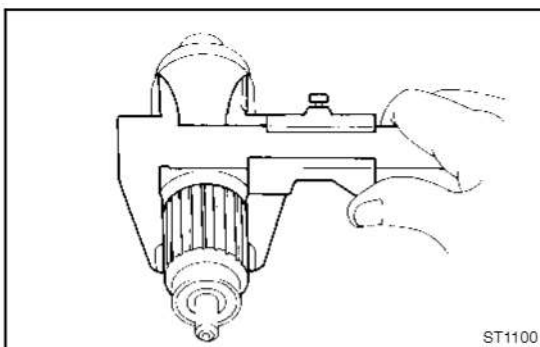
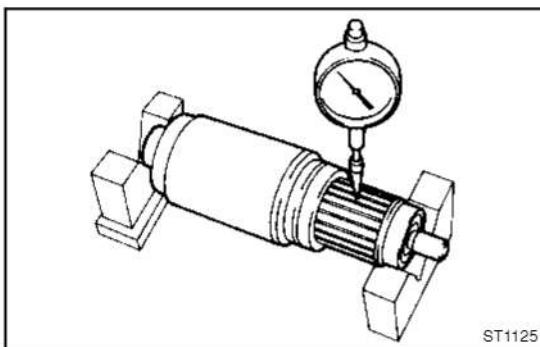
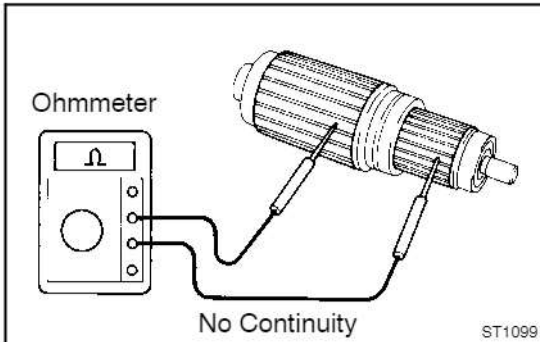
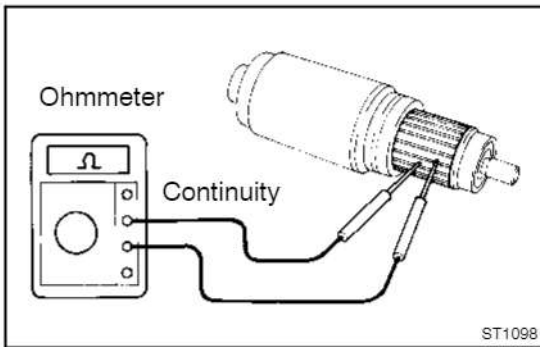

## INSPECTION

### 1. INSPECT COMMUTATOR FOR OPEN CIRCUIT

Using an ohmmeter, check that there is continuity between the segments of the commutator.

If there is no continuity between any segment, replace the armature.

### 2. INSPECT COMMUTATOR FOR GROUND

Using an ohmmeter, check that there is no continuity between the commutator and armature coil core.

If there is continuity, replace the armature.

### 3. INSPECT COMMUTATOR FOR DIRTY AND BURNT SURFACE

If the surface is dirty or burnt, correct it with sandpaper (No.400) or on a lathe.

### 4. INSPECT COMMUTATOR CIRCLE RUNOUT

(a) Place the commutator on V-blocks.

(b) Using a dial indicator the circle runout.

**Maximum circle runout:**

**0.05 mm (0.0020 in.)**

If the circle runout is greater than maximum, correct it on a lathe.

### 5. INSPECT COMMUTATOR DIAMETER

Using vernier calipers, measure the commutator diameter.

**Standard diameter:**

**43.0 mm (1.692 in.)**

**Minimum diameter:**

**42.0 mm (1.654 in.)**

If the diameter is less than minimum, replace the armature.

### 6. INSPECT UNDERCUT DEPTH

Check that the undercut depth is clean and free of foreign materials. Smooth out the edge.

**Standard undercut depth:**

**0.7 mm (0.028 in.)**

**Minimum undercut depth:**

**0.2 mm (0.008 in.)**

If the undercut depth is less than minimum, correct it with a hacksaw blade.

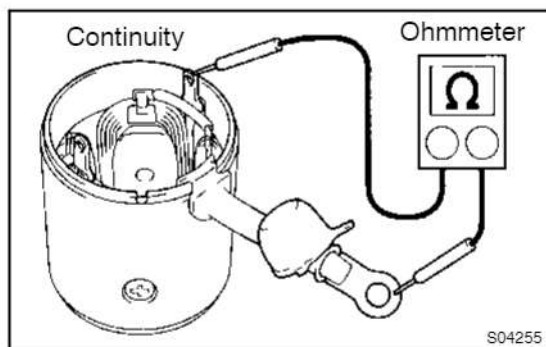
**7. INSPECT FIELD COIL FOR OPEN CIRCUIT**

Using an ohmmeter, check that there is continuity between the lead wire and field coil brush lead.

If there is no continuity, replace the field frame.

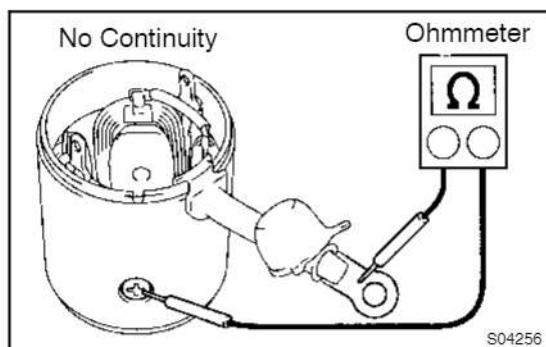
**8. INSPECT FIELD COIL FOR GROUND**

Using an ohmmeter, check that there is no continuity between the field coil end and field frame.

If there is continuity, repair or replace the field frame.

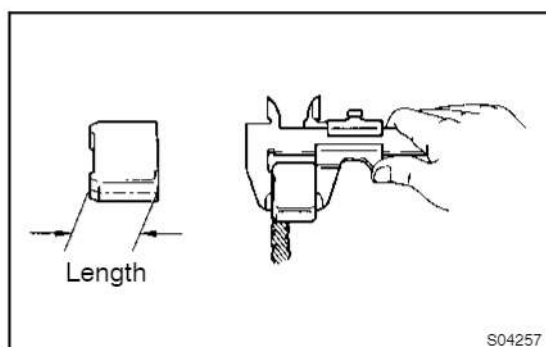
**9. INSPECT BRUSH LENGTH**

Using vernier calipers, measure the brush length.

**Standard length:**

**21.0 mm (0.828 in.)**

**Minimum length:**

**12.0 mm (0.472 in.)**

If the length is less than minimum, replace the brush holder and field frame.

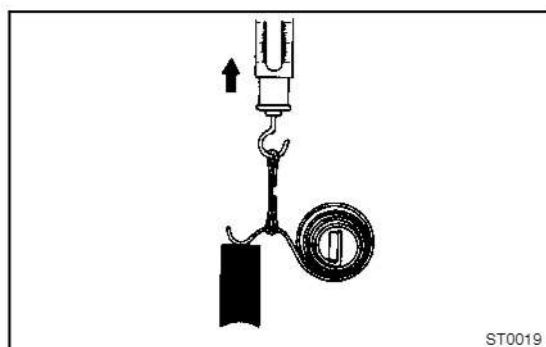
**10. INSPECT BRUSH SPRING LOAD**

Take the pull scale reading the instant the brush spring separates from the brush.

**Standard spring installed load:**

**27.5 – 37.3 N (2.8 – 3.8 kgf, 6.1 – 8.3 lbf)**

**Minimum spring installed load:**

**14.7 N (1.5 kgf, 3.3 lbf)**

If the installed load is less than minimum, replace the brush springs.

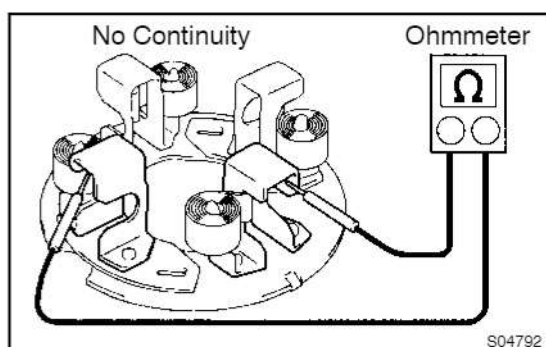
**11. INSPECT BRUSH HOLDER INSULATION**

Using an ohmmeter, check that there is no continuity between the positive (+) and negative (-) brush holders.

If there is continuity, repair or replace the brush holder.

**12. INSPECT GEAR TEETH**

Check the gear teeth on the pinion gear, idle gear and the clutch assembly for wear or damage.

If damaged, replace the gear or clutch assembly.

If damaged, also check the drive plate ring gear for wear or damage.

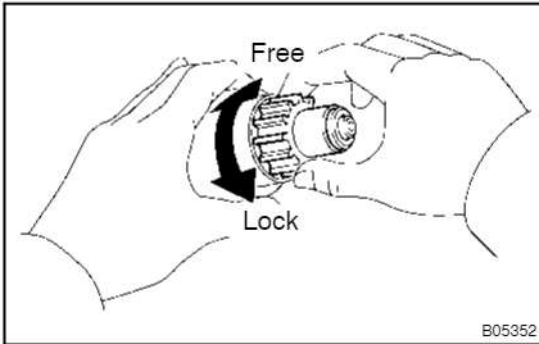
**13. INSPECT CLUTCH PINION GEAR**

Rotate the pinion gear clockwise, and check that it turns freely. Try to rotate the pinion gear counterclockwise and check that it locks.

If necessary, replace the clutch assembly.

**14. INSPECT FRONT AND REAR BEARING**

Turn the bearing by hand while applying inward force.

If resistance is felt or the bearing sticks, replace the bearing.

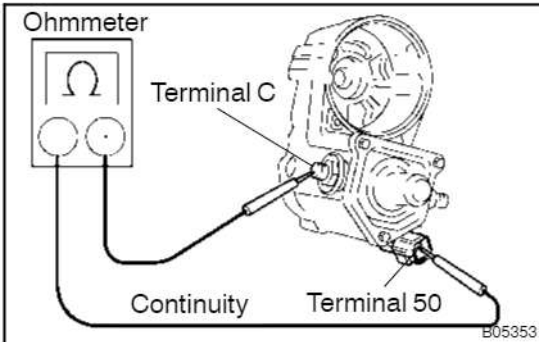
**15. DO PULL-IN COIL OPEN CIRCUIT TEST**

Using an ohmmeter, check that there is continuity between terminals 50 and C.

If there is no continuity, check and replace the magnetic switch.

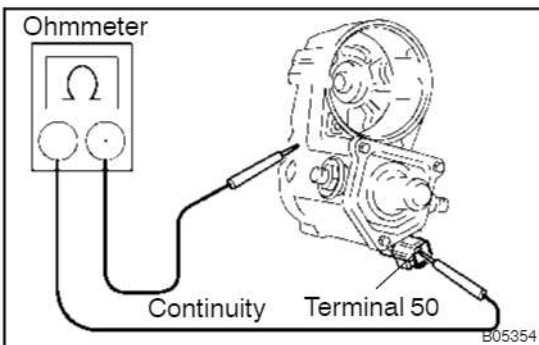
**16. DO HOLD-IN COIL OPEN CIRCUIT TEST**

Using an ohmmeter, check that there is continuity between terminal 50 and the switch body.

If there is no continuity, replace the magnetic switch.

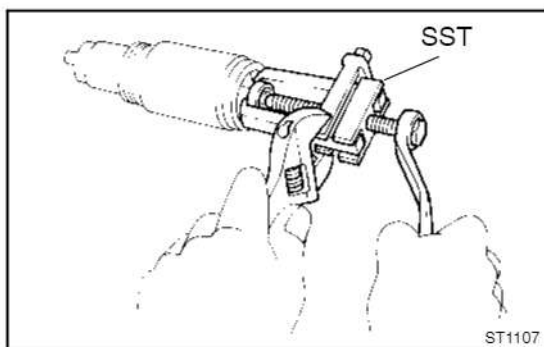

## REPLACEMENT

### 1. REPLACE REAR BEARING

- (a) Using SST, remove the bearing.  
SST 09286-46011

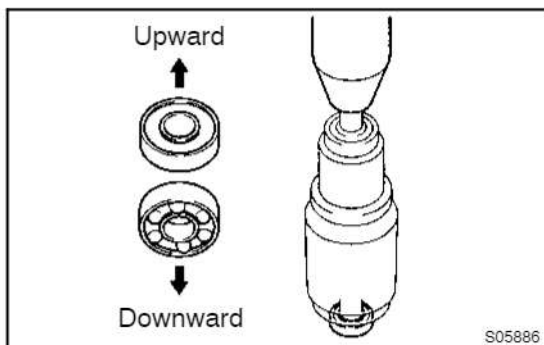

- (b) Using a press, press in a new bearing.

#### NOTICE:

Be careful of the bearing installation direction.

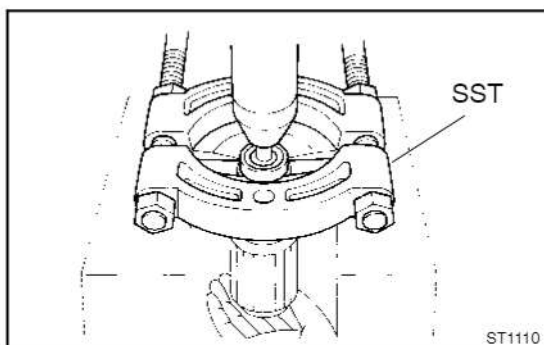

### 2. REPLACE FRONT BEARING

- (a) Using SST and a press, press out the bearing.  
SST 09950-00020

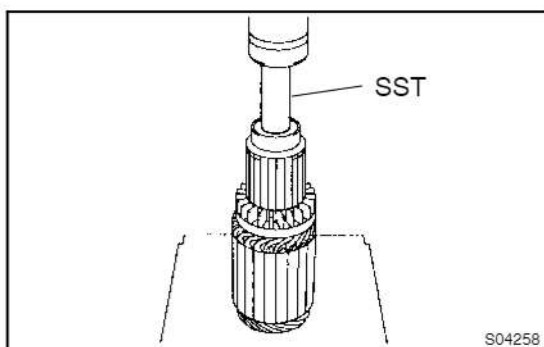

- (b) Using SST and a press, press in a new bearing.  
SST 09820-00030

### 3. REPLACE MAGNETIC SWITCH TERMINAL KIT PARTS

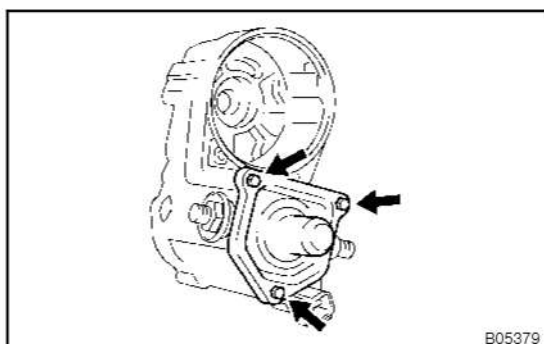

- (a) Remove the 3 bolts, end cover, gasket, and plunger.

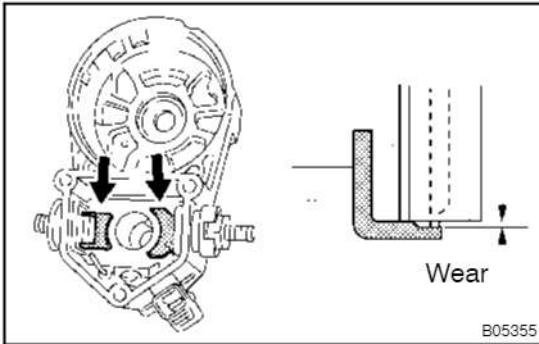

- (b) Inspect contact plate for wear.  
Using vernier calipers, measure the contact plate for depth of wear.

**Maximum wear:**

**1.6 mm (0.063 in.)**

If the depth of wear is greater than the maximum, replace the contact plate.

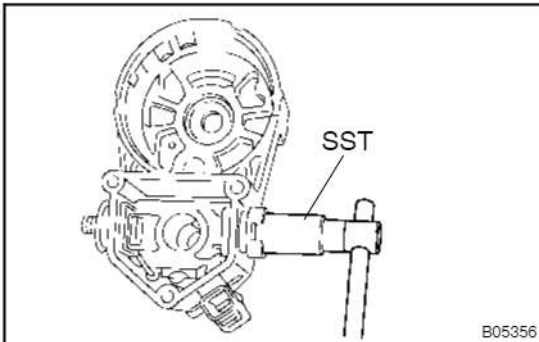

- (c) Remove terminal kit parts.  
(1) Using SST, loosen the terminal nuts.

SST 09810-38170

- (2) Terminal C:

Remove the terminal nut, wave washer, terminal insulator (outside), O-ring, terminal bolt, contact plate and terminal insulator (inside).

- (3) Terminal 30:

Remove the terminal nut, wave washer, terminal insulator (outside), O-ring, terminal bolt, contact plate, terminal insulator (inside) and insulation paper.

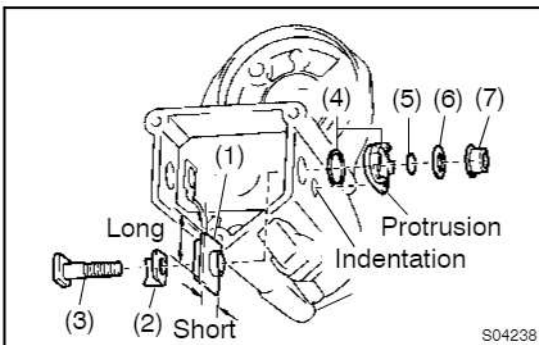

- (d) Temporarily install these new terminal 30 kit parts:

- (1) Terminal insulator (inside)
- (2) Contact plate
- (3) Terminal bolt
- (4) Packing and terminal insulator (outside)

Install the packing to the terminal insulator, and install them.

**HINT:**

Match the protrusion of the insulator with the indentation of the housing.

- (5) O-ring
- (6) Plate washer
- (7) Terminal nut

**NOTICE:**

**Be careful to install the terminal insulator (inside) and wave washer in the correct direction.**



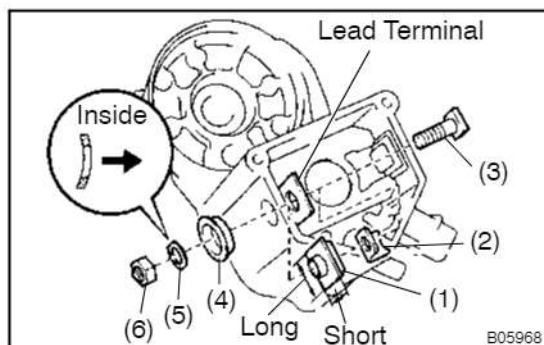

- (e) Temporarily install these new terminal C kit parts:
- (1) Terminal insulator (inside)
  - (2) Contact plate
  - (3) Terminal bolt
  - (4) Terminal insulator (outside)
  - (5) Wave washer
  - (6) Terminal nut

**NOTICE:**

**Be careful to install the terminal insulator (inside) and wave washer in the correct direction.**

- (f) Temporarily tighten the terminal nuts.

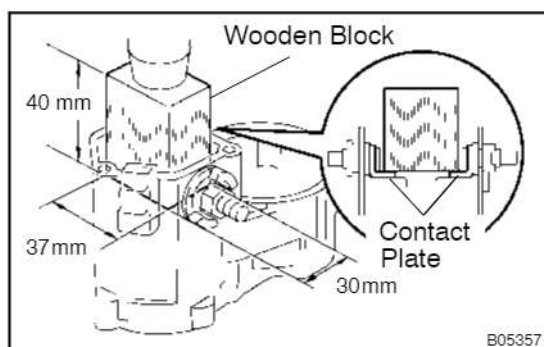

- (g) Tighten terminal nuts.
- (1) Put a wooden block on the contact plate and press it down with a hand press.

**Dimensions of wooden block:**

**30 x 37 x 40 mm (1.18 x 1.46 x 1.57 in.)**

**Press force:**

**981 N (100 kgf, 221 lbf)**

**NOTICE:**

- Check the diameter of the hand press ram. Then calculate the gauge pressure of the press when 981 N (100 kgf, 221 lbf) of force is applied.

**Gauge pressure:**

$$(\text{kgf/cm}^2) = \frac{100 \text{ kgf}}{\left( \frac{\text{Ram diameter (cm)}}{2} \right)^2 \times 3.14 (\pi)}$$

$$(\text{psi}) = \frac{221 \text{ lbf}}{\left( \frac{\text{Ram diameter (in.)}}{2} \right)^2 \times 3.14 (\pi)}$$

$$(\text{kPa}) = (\text{kgf/cm}^2) \times 98.1$$

$$(\text{kPa}) = (\text{psi}) \times 6.9$$

- If the contact plate is not pressed down with the specified pressure, the contact plate may tilt due to coil deformation or the tightening of the nut.

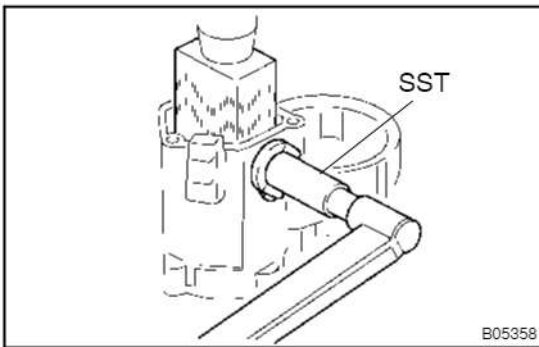

- (2) Using SST, tighten the nuts to the specified torque.  
SST 09810-38170

**Torque: 34.3 N·m (350 kgf·cm, 25 ft·lbf)**

**NOTICE:**

**If the nut is over tightened, it may cause cracks on the inside of the insulator.**

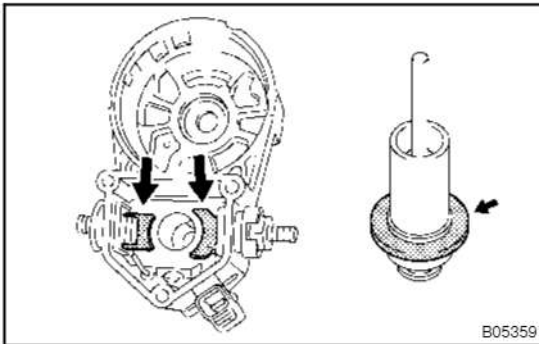

- (h) Clean contact surfaces of contact plate and plunger.  
Clean the contact surfaces of the remaining contact plate and plunger with a dry shop rag.

- (i) Reinstall magnetic switch end cover.  
Install the plunger, new gasket, end cover and lead clamp with the 3 bolts.

**Torque: 3.6 N·m (37 kgf·cm, 32 in·lbf)**

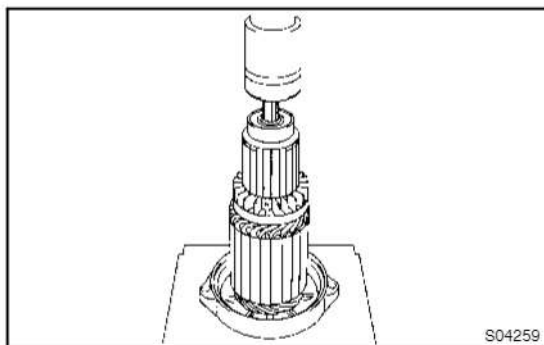

## REASSEMBLY

### HINT:

Use high-temperature grease to lubricate the bearings and gears when assembling the starter.

### 1. PLACE ARMATURE INTO END FRAME

- (a) Apply grease to the armature bearings.
- (b) Using a press, press the armature into the end frame.

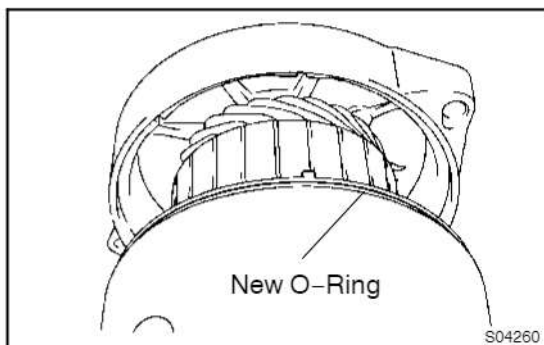

### 2. INSTALL ARMATURE WITH END FRAME TO FIELD FRAME

- (a) Place a new O-ring in position on the field frame.
- (b) Align the claw of the field frame with the groove of the end frame, install the armature end frame.

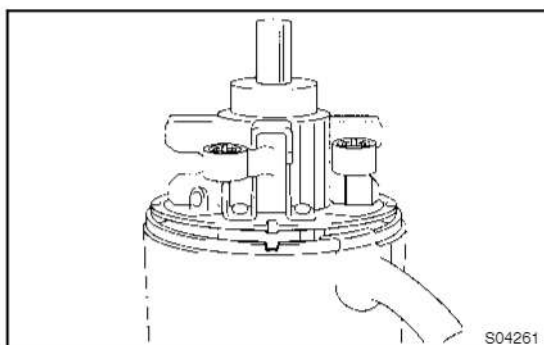

### 3. INSTALL BRUSH HOLDER

- (a) Align the claw of the brush holder with the claw groove of the field frame.
- (b) Place the brush holder on the field frame.

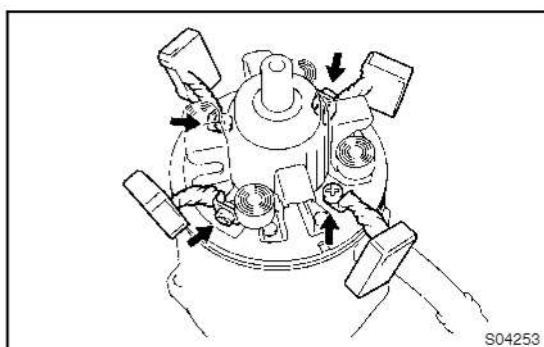

- (c) Install the 4 brushes with the 4 screws.  
**Torque: 3.6 N·m (37 kgf·cm, 32 in·lbf)**

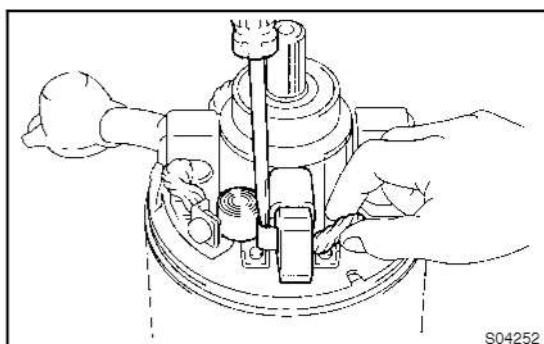

- (d) Using a screwdriver, hold the brush spring back, and connect the brush into the brush holder. Connect the 4 brushes.

### NOTICE:

**Check that the positive (+) lead wires are not grounded.**

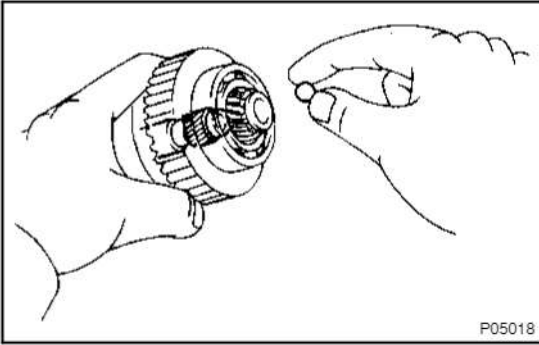

#### 4. INSERT STEEL BALL INTO CLUTCH SHAFT HOLE

- (a) Apply grease to the steel ball.
- (b) Insert the steel ball into the clutch shaft hole.

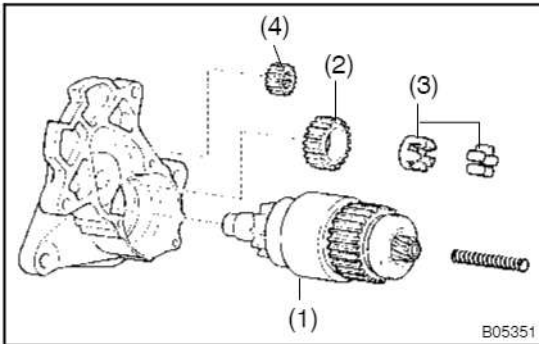

#### 5. INSTALL STARTER HOUSING, CLUTCH ASSEMBLY AND GEARS

- (a) Apply grease to the return spring.
- (b) Insert the return spring into the magnetic switch hole.
- (c) Place these parts in position on the starter housing:
  - (1) Clutch assembly
  - (2) Idler gear
  - (3) Bearing
  - (4) Pinion gear

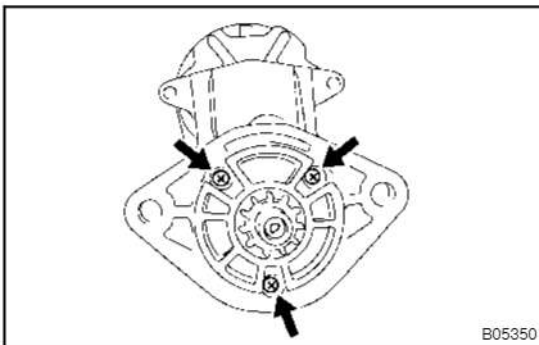

- (d) Assemble the starter housing and magnetic switch assembly and install the 3 screws.

**Torque: 11.3 N·m (115 kgf·cm, 8.3 ft·lbf)**

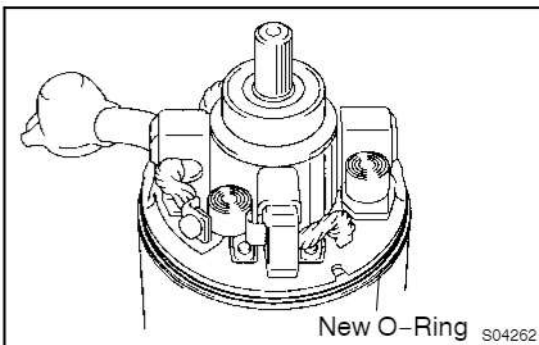

#### 6. INSTALL FIELD FRAME AND ARMATURE ASSEMBLY

- (a) Place a new O-ring in position on the field frame.

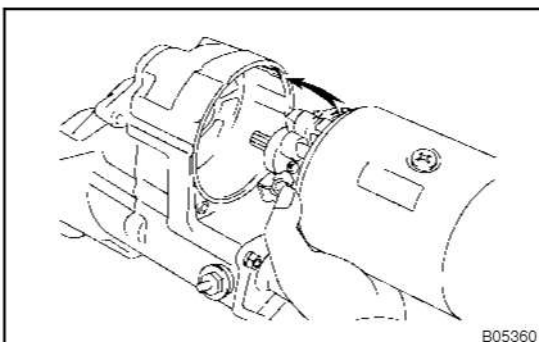

- (b) Align the claw of the brush holder with the groove of the magnetic switch, and install the field frame and armature shaft assembly.

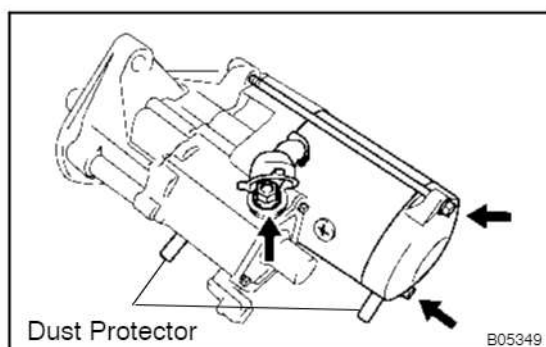

- (c) Install the field frame and armature assembly with the 2 through bolts.  
**Torque: 14.2 N·m (145 kgf·cm, 10 ft·lbf)**
- (d) Connect the lead wire to terminal C, and install the nut.  
**Torque: 24 N·m (245 kgf·cm, 18 ft·lbf)**
- (e) Install the 2 dust protectors.

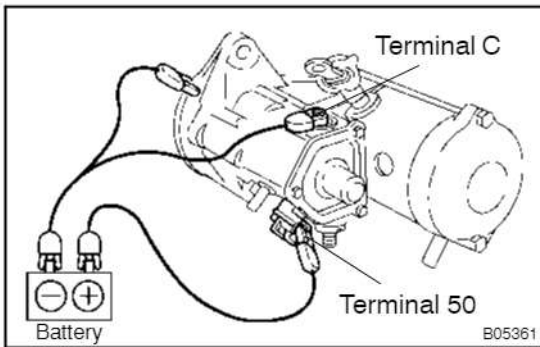

## TEST

### NOTICE:

These tests must be done within 3 to 5 seconds to avoid burning out the coil.

#### 1. DO PULL-IN TEST

- Disconnect the field coil lead wire from terminal C.
- Connect the battery to the magnetic switch as shown. Check that the pinion gear moves outward.

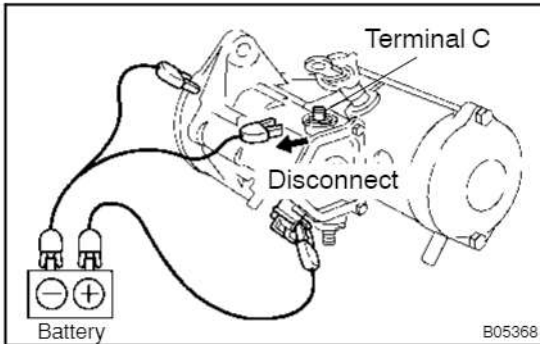

#### 2. DO HOLD-IN TEST

While connected as above with the pinion gear out, disconnect the negative (-) lead from terminal C. Check that the pinion gear remains out.

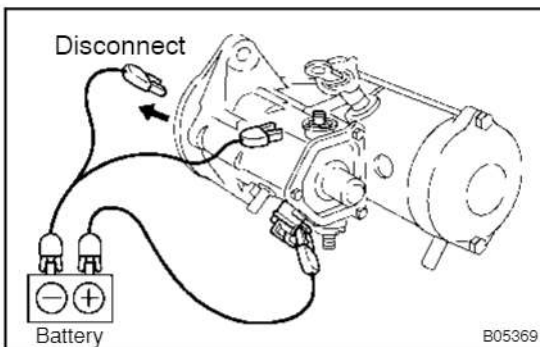

#### 3. INSPECT CLUTCH PINION GEAR RETURN

Disconnect the negative (-) lead from the starter body. Check that the pinion gear returns inward.

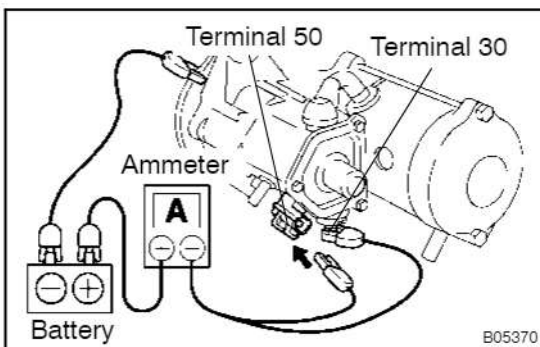

#### 4. DO NO-LOAD PERFORMANCE TEST

- Connect the battery and ammeter to the starter as shown.
- Check that the starter rotates smoothly and steadily with the pinion gear moving out. Check that the ammeter shows the specified current.

**Specified current:**

**220 A or less 11.0 V**

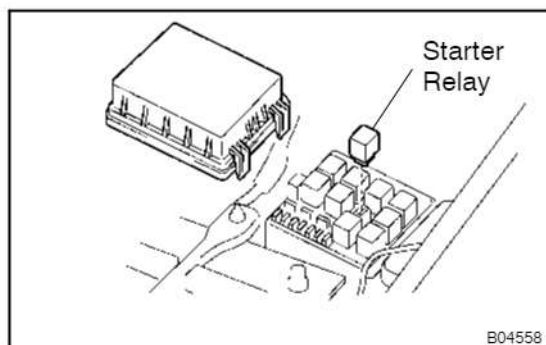

## STARTER RELAY INSPECTION

ST08J-02

### 1. REMOVE STARTER RELAY (Marking: "ST")

Remove the relay box cover and starter relay.

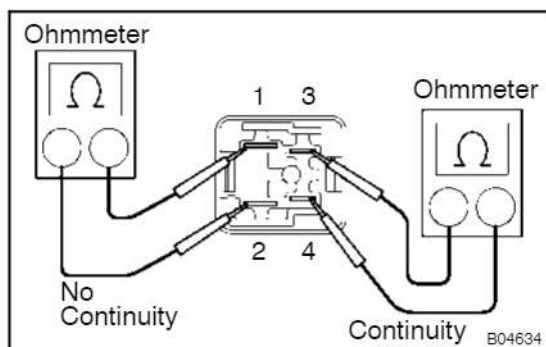

### 2. INSPECT RELAY CONTINUITY

(a) Using an ohmmeter, check that there is continuity between terminals 3 and 4.

If there is no continuity, replace the relay.

(b) Check that there is no continuity between terminals 1 and 2.

If there is continuity, replace the relay.

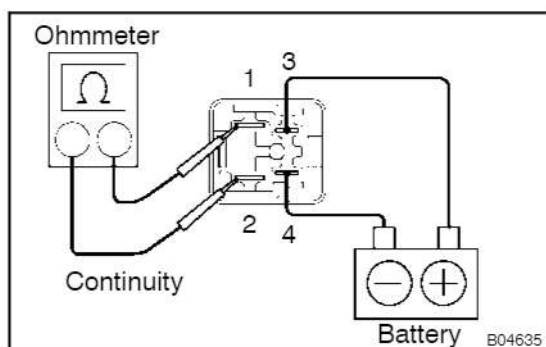

### 3. INSPECT RELAY OPERATION

(a) Apply battery voltage across terminals 3 and 4.

(b) Using an ohmmeter, check that there is continuity between terminals 1 and 2.

If there is no continuity, replace the relay.

### 4. REINSTALL STARTER RELAY

# CHARGING SYSTEM

## PRECAUTION

CH0AA-01

- Check that the battery cables are connected to the correct terminals.
- Disconnect the battery cables when the battery is given a quick charge.
- Do not perform tests with a high voltage insulation resistance tester.
- Never disconnect the battery while the engine is running.

cardiajn.com



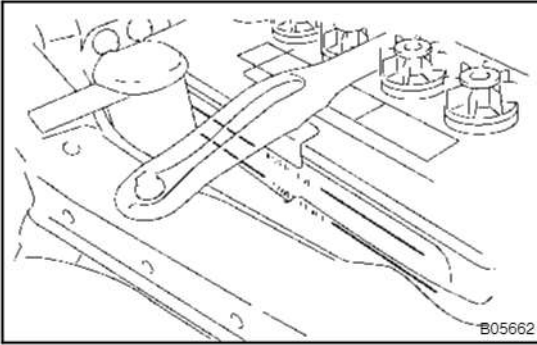

## ON-VEHICLE INSPECTION

### 1. CHECK BATTERY ELECTROLYTE LEVEL

Check the electrolyte quantity of each cell.

Maintenance-Free Battery:

If under the lower level, replace the battery (or add distilled water if possible) and check the charging system.

Except Maintenance-Free Battery:

If under the lower level, add distilled water.

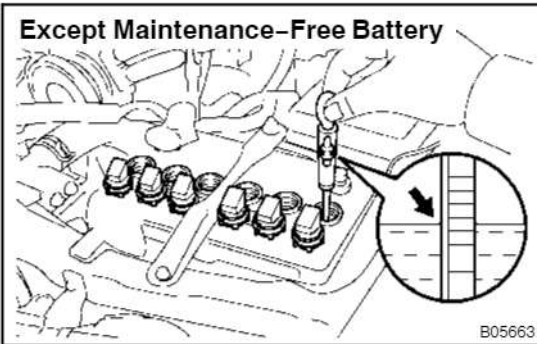

### 2. Except Maintenance-Free Battery:

#### CHECK BATTERY SPECIFIC GRAVITY

Check the specific gravity of each cell.

**Standard specific gravity:**

**1.25 - 1.29 at 20°C (68°F)**

If the specific gravity is less than specification, charge the battery.

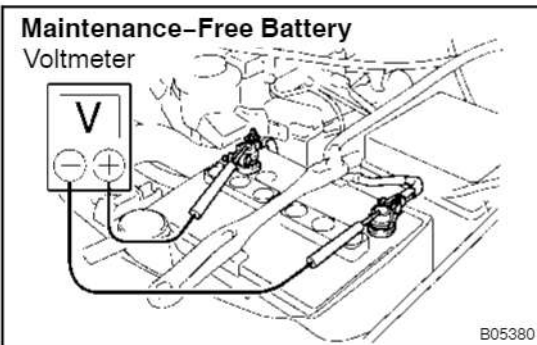

### 3. Maintenance-Free Battery:

#### CHECK BATTERY VOLTAGE

(a) After having driven the vehicle and in the case that 20 minutes have not passed after having stopped the engine, turn the ignition switch ON and turn on the electrical system (headlight, blower motor, rear defogger etc.) for 60 seconds to remove the surface charge.

(b) Turn the ignition switch OFF and turn off the electrical systems.

(c) Measure the battery voltage between the negative (-) and positive (+) terminals of the battery.

**Standard voltage:**

**12.5 - 12.9 V at 20°C (68°F)**

If the voltage is less than specification, charge the battery.

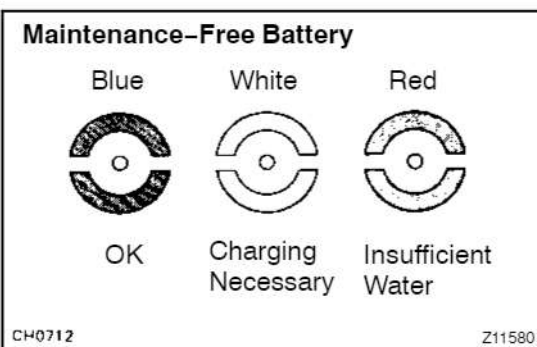

HINT:

Check the indicator as shown in the illustration.

### 4. CHECK BATTERY TERMINALS, FUSIBLE LINK AND FUSES

(a) Check that the battery terminals are not loose or corroded.

(b) Check the fusible link and fuses for continuity.

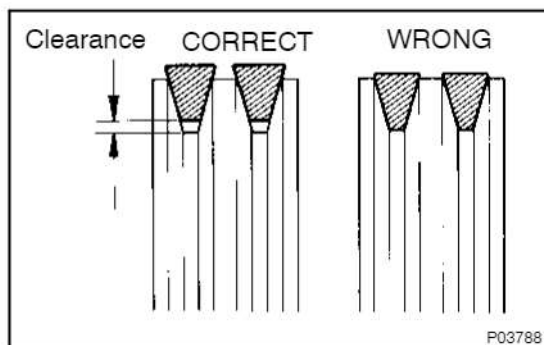

## 5. INSPECT DRIVE BELT

- (a) Visually check the drive belt for cracks, oiliness or wear. Check that the belt does not touch the bottom of the pulley groove.

If necessary, replace the drive belts as a set.

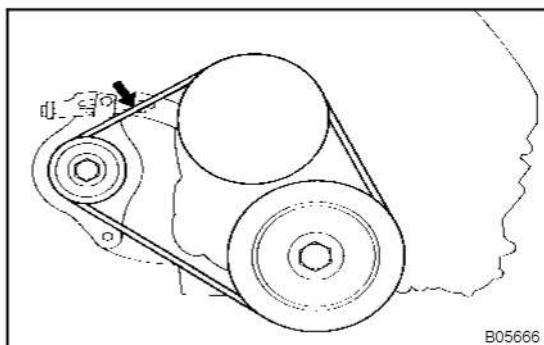

- (b) Check the drive belt deflection by pressing on the belt at the points indicated in the illustration with 98 N (10 kgf, 22 lbf) of pressure.

### Drive belt deflection:

**New belt 6 – 7 mm (0.24 – 0.28 in.)**

**Used belt 8 – 11 mm (0.31 – 0.43 in.)**

If necessary, adjust the drive belt deflection.

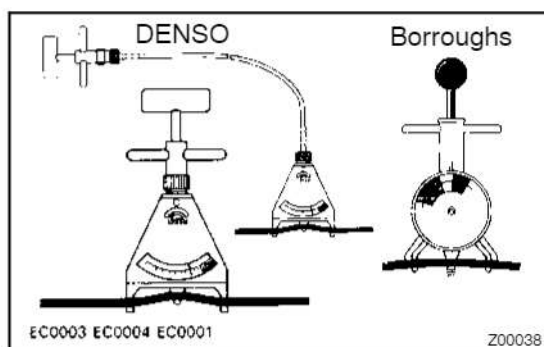

- (c) Using a belt tension gauge, measure the belt tension.

### Belt tension gauge:

**Denso BTG-20 (95506-00020)**

**Borroughs No. BT-33-73F**

### Drive belt tension:

**New belt 441 – 539 N (45 – 55 kgf)**

**Used belt 196 – 343 N (20 – 35 kgf)**

If the belt tension is not as specified, adjust it.

### HINT:

- "New belt" refers to a belt which has been used less than 5 minutes on a running engine.
- "Used belt" refers to a belt which has been used on a running engine for 5 minutes or more.
- After installing a belt, check that it fits properly in the ribbed grooves.
- Check with your hand to confirm that the belt has not slipped out of the groove on the bottom of the pulley.
- After installing a new belt, run the engine for about 5 minutes and recheck the belt tension.

## 6. VISUALLY CHECK ALTERNATOR WIRING AND LISTEN FOR ABNORMAL NOISES

- (a) Check that the wiring is in good condition.
- (b) Check that there is no abnormal noise from the alternator while the engine is running.

**7. INSPECT DISCHARGE WARNING LIGHT CIRCUIT**

- (a) Turn the ignition switch "ON". Check that the discharge warning light comes on.
  - (b) Start the engine. Check that the light goes off.
- If the light does not operate as specified, troubleshoot the discharge warning light circuit.

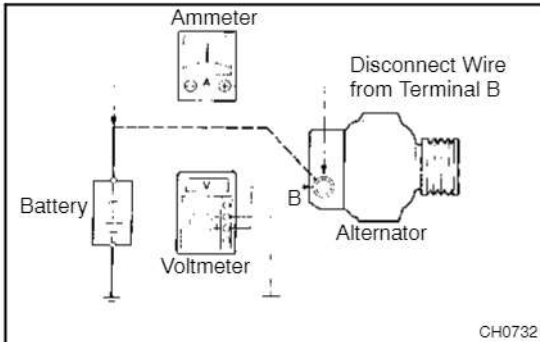
**8. INSPECT CHARGING CIRCUIT WITHOUT LOAD****HINT:**

If a battery/alternator tester is available, connect the tester to the charging circuit as per manufacturer's instructions.

- (a) If a tester is not available, connect a voltmeter and ammeter to the charging circuit as follows:
  - Disconnect the wire from terminal B of the alternator and connect it to the negative (-) lead of the ammeter.
  - Connect the positive (+) lead of the ammeter to terminal B of the alternator.
  - Connect the positive (+) lead of the voltmeter to terminal B of the alternator.
  - Ground the negative (-) lead of the voltmeter.
- (b) Check the charging circuit as follows:  
With the engine running from idle to 5,000 rpm, check the reading on the ammeter and voltmeter.

**Standard amperage:****10 A or less****Standard voltage:****13.2 – 14.8 V at 115°C (239°F)**

If the voltmeter reading is more than the standard voltage, replace the voltage regulator.

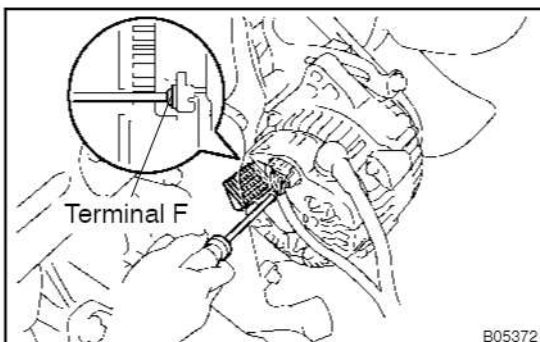

If the voltmeter reading is less than the standard voltage, check the voltage regulator and generator as follows:

- With terminal F grounded, start the engine and check the voltmeter reading of terminal B.
- If the voltmeter reading is more than the standard voltage, replace the IC regulator.
- If the voltmeter reading is less than the standard voltage, check the alternator.

**9. INSPECT CHARGING CIRCUIT WITH LOAD**

- (a) With the engine running at 2,000 rpm, turn on the high beam headlights and place the heater blower switch at "HI".
- (b) Check the reading on the ammeter.

**Standard amperage:**

**30 A or more**

If the ammeter reading is less than the standard amperage, repair the alternator.

HINT:

If the battery is fully charged, the indication will sometimes be less than the standard amperage.

# ALTERNATOR COMPONENTS

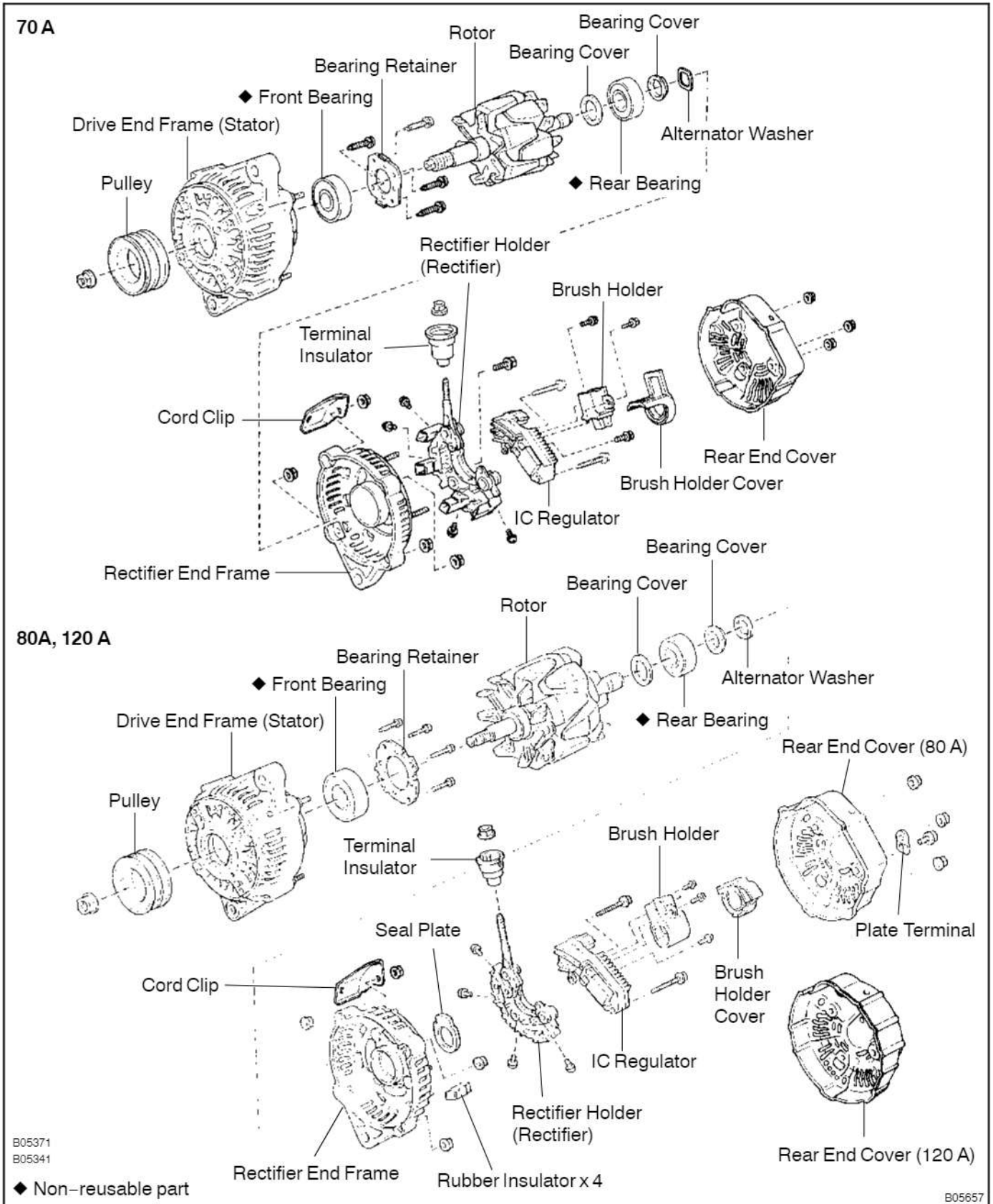

cardiagn.com

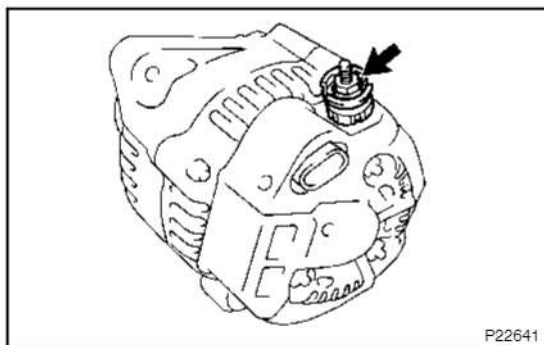

## DISASSEMBLY

### 1. REMOVE REAR END COVER

- (a) Remove the nut and terminal insulator.

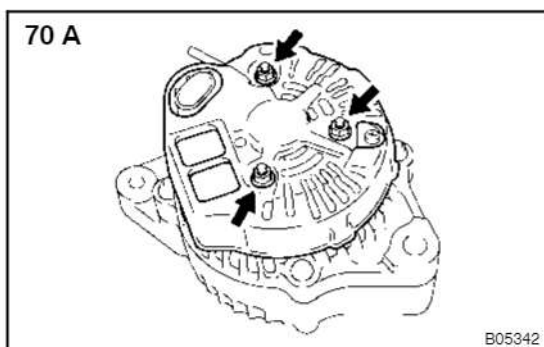

- (b) 70 A:  
Remove the 3 nuts and rear end cover.

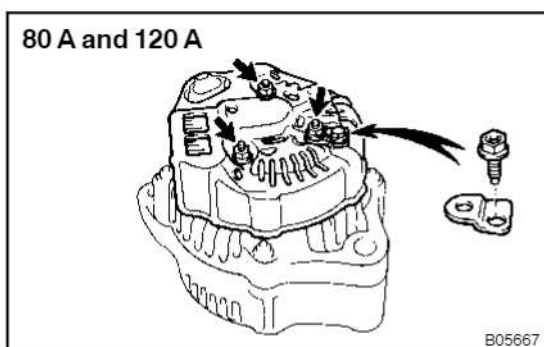

- (c) 80 A and 120 A:  
Remove the 3 nuts, bolt, plate terminal and rear end cover.

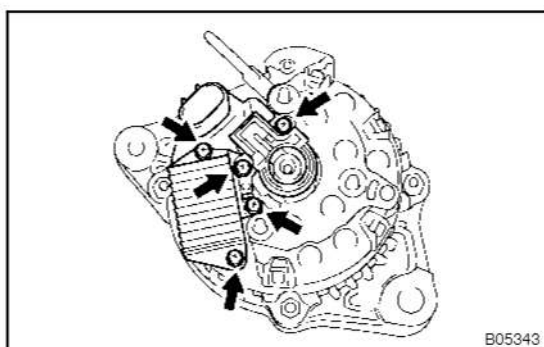

### 2. 70 A: REMOVE BRUSH HOLDER AND IC REGULATOR

- (a) Remove the 5 screws, brush holder w/ brush holder cover and IC regulator.

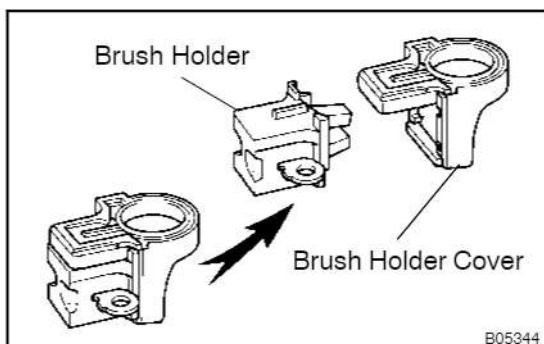

- (b) Remove the brush holder cover from the brush holder.

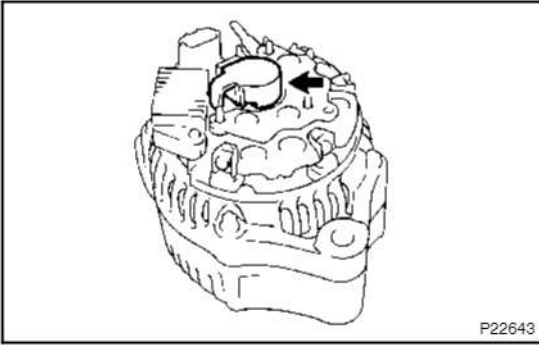
**3. 80 A and 120 A:****REMOVE BRUSH HOLDER AND IC REGULATOR**

- (a) Remove the brush holder cover from the brush holder.

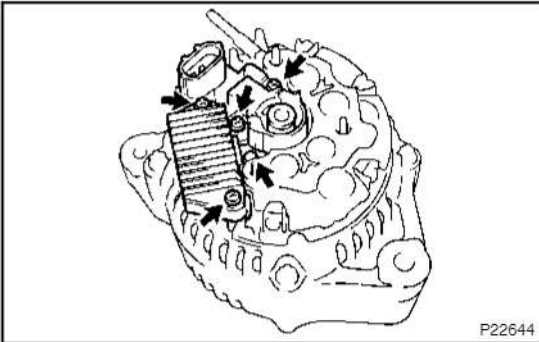

- (b) Remove the 5 screws, brush holder and IC regulator.

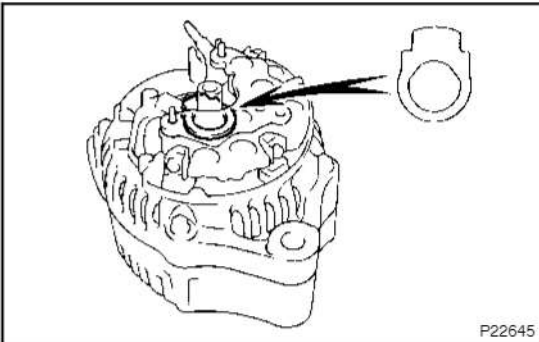

- (c) Remove the seal plate from the rectifier end frame.

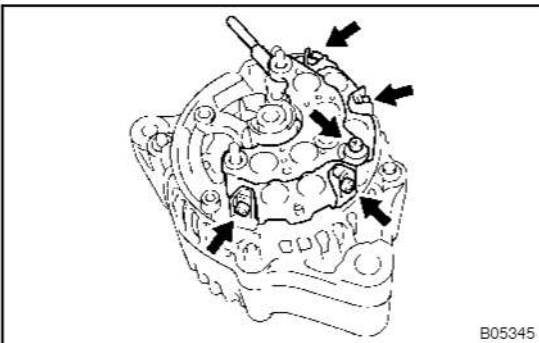
**4. 70 A:****REMOVE RECTIFIER HOLDER**

- (a) Remove the 4 screws, bolt and rectifier holder.

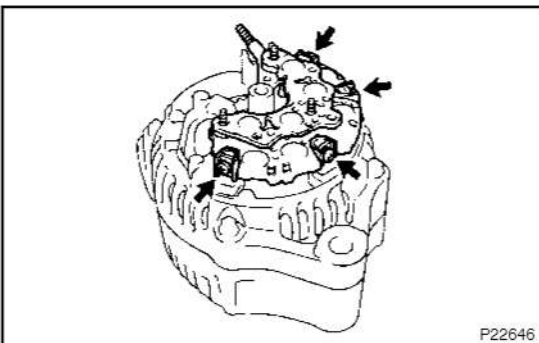
**5. 80 A and 120 A:****REMOVE RECTIFIER HOLDER**

- (a) Remove the 4 screws and rectifier holder.

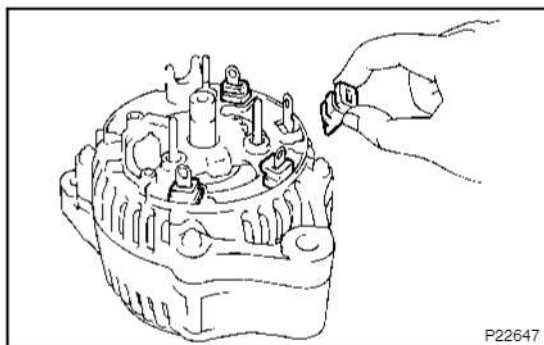

- (b) Remove the 4 rubber insulators.

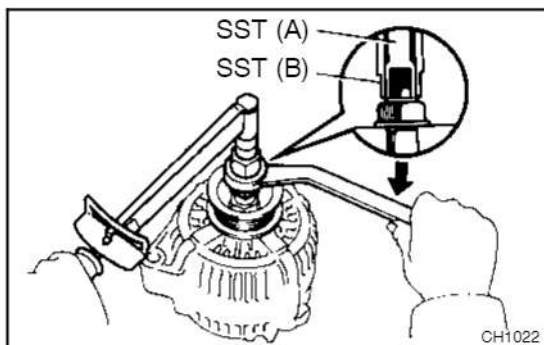

## 6. REMOVE PULLEY

- (a) Hold SST (A) with a torque wrench, and tighten SST (B) clockwise to the specified torque.  
SST 09820-63010  
**Torque: 39 N·m (400 kgf·cm, 29 ft·lbf)**  
(b) Check that SST (A) is secured to the rotor shaft.

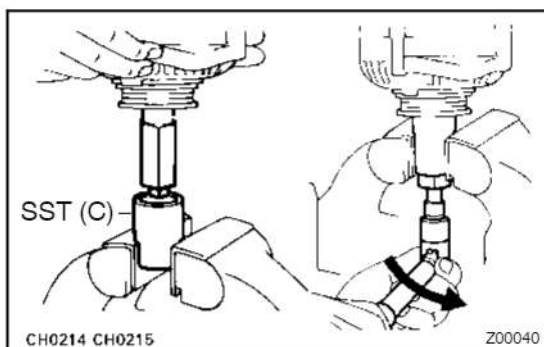

- (c) As shown in the illustration, mount SST (C) in a vise, and install the alternator to SST (C).  
(d) To loosen the pulley nut, turn SST (A) in the direction shown in the illustration.

### NOTICE:

**To prevent damage to the rotor shaft, do not loosen the pulley nut more than one-half of a turn.**

- (e) Remove the alternator from SST (C).  
(f) Turn SST (B), and remove SST (A and B).  
(g) Remove the pulley nut and pulley.

## 7. REMOVE RECTIFIER END FRAME

- (a) Remove the 4 nuts and cord clip.

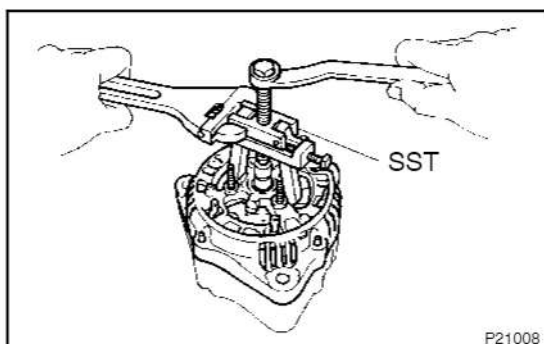
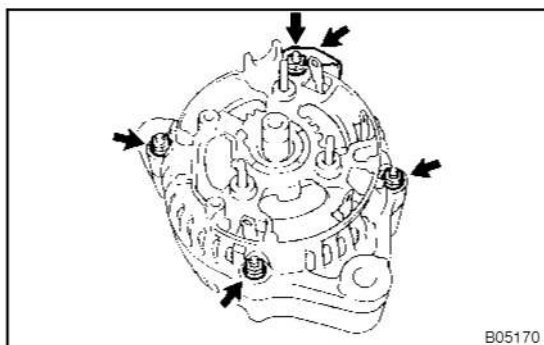

- (b) Using SST, remove the rectifier end frame.  
SST 09286-46011



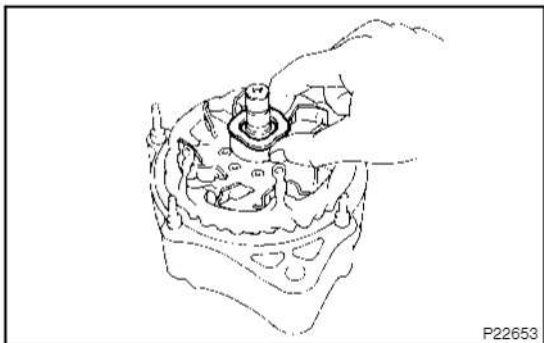

(c) Remove the alternator washer.

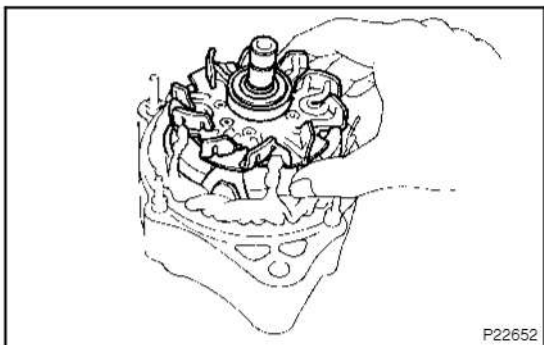

**8. REMOVE ROTOR FROM DRIVE END FRAME**

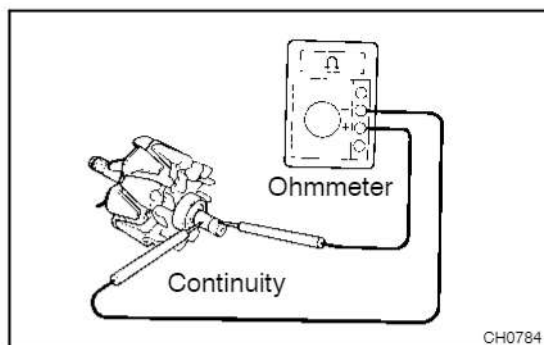

## INSPECTION

### 1. INSPECT ROTOR FOR OPEN CIRCUIT

Using an ohmmeter, check that there is continuity between the slip rings.

**Standard resistance:**

**2.1 – 2.5  $\Omega$  at 20°C (68°F)**

If there is no continuity, replace the rotor.

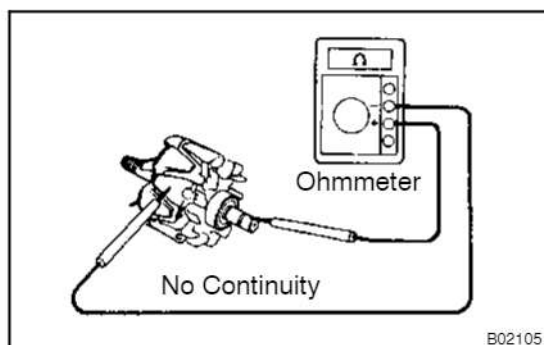

### 2. INSPECT ROTOR FOR GROUND

Using an ohmmeter, check that there is no continuity between the slip ring and rotor.

If there is continuity, replace the rotor.

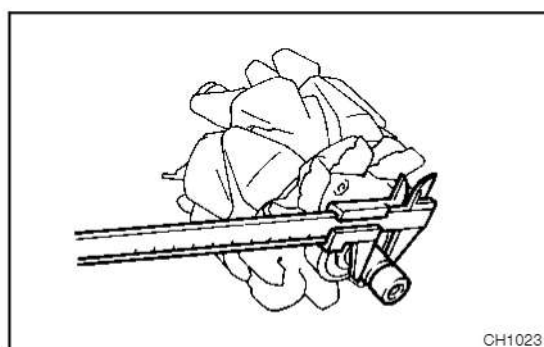

### 3. INSPECT SLIP RINGS

(a) Check that the slip rings are not rough or scored.

If rough or scored, replace the rotor.

(b) Using vernier calipers, measure the slip ring diameter.

**Standard diameter:**

**14.2 – 14.4 mm (0.559 – 0.567 in.)**

**Minimum diameter:**

**12.8 mm (0.504 in.)**

If the diameter is less than minimum, replace the rotor.

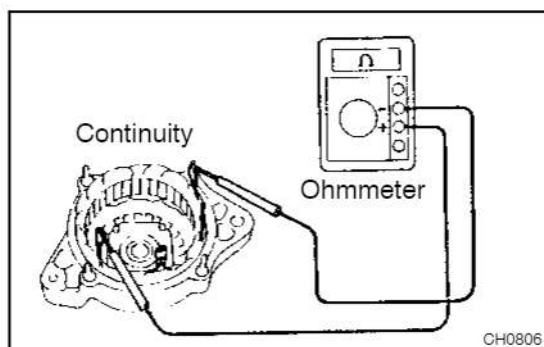

### 4. INSPECT STATOR FOR OPEN CIRCUIT

Using an ohmmeter, check that there is continuity between the coil leads.

If there is no continuity, replace the drive end frame assembly.

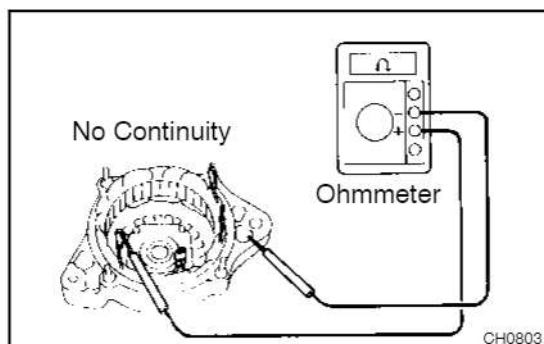

### 5. INSPECT STATOR FOR GROUND

Using an ohmmeter, check that there is no continuity between the coil lead and drive end frame.

If there is continuity, replace the drive end frame assembly.

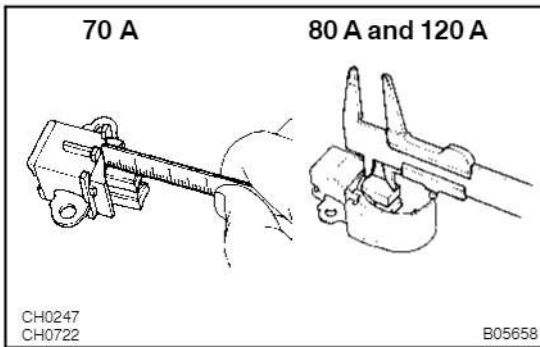

## 6. INSPECT EXPOSED BRUSH LENGTH

Using a scale and vernier caliper, measure the exposed brush length.

**Standard exposed length:**

**10.5 mm (0.413 in.)**

**Minimum exposed length:**

**1.5 mm (0.059 in.)**

If the exposed length is less than minimum, replace the brush holder.

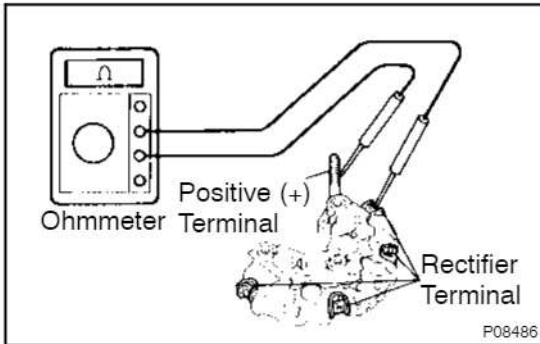

## 7. INSPECT POSITIVE RECTIFIER

- Using an ohmmeter, connect one tester probe to the positive (+) terminal and the other to each rectifier terminal.
- Reverse the polarity of the tester probes and repeat step (a).
- Check that one shows continuity and the other shows no continuity.

If continuity is not as specified, replace the rectifier holder.

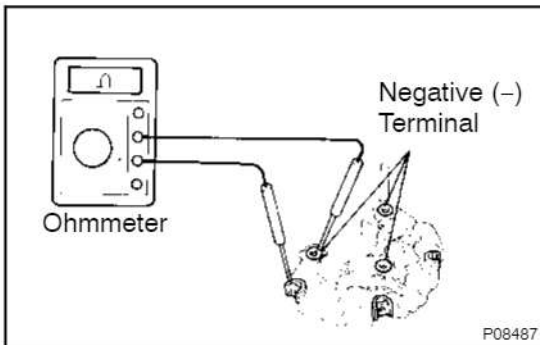

## 8. INSPECT NEGATIVE RECTIFIER

- Using an ohmmeter, connect one tester probe to each negative (-) terminal and the other to each rectifier terminal.
- Reverse the polarity of the tester probes and repeat step (a).
- Check that one shows continuity and the other shows no continuity.

If continuity is not as specified, replace the rectifier holder.

## 9. INSPECT FRONT AND REAR BEARING

Check that the bearing is not rough or worn.

If necessary, replace the bearing.

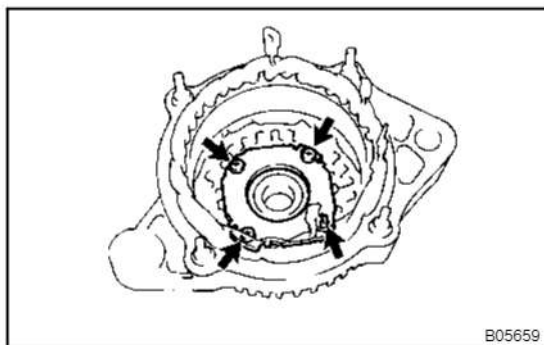

B05659

## REPLACEMENT

### 1. REPLACE FRONT BEARING

- (a) Remove the 4 screws and bearing retainer.

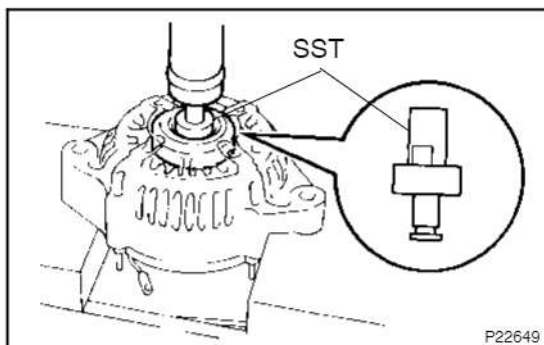

P22649

- (b) 70 A:  
Using SST and a press, press out the bearing.  
SST 09950-60010 (09951-00230, 09952-06010)

- (c) 80 A and 120 A:  
Using SST and a press, press out the bearing.  
SST 09950-60010 (09951-00260, 09952-06010)

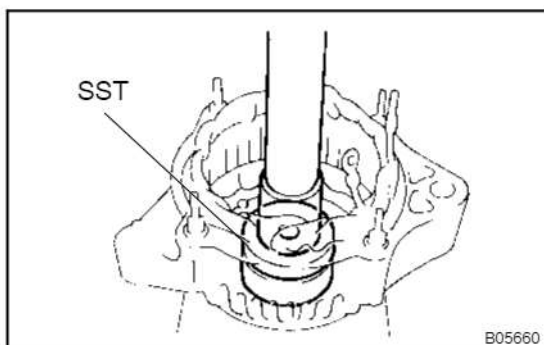

B05660

- (d) 70 A:  
Using SST and a press, press in a new bearing.  
SST 09950-60010 (09951-00450)

- (e) 80 A and 120 A:  
Using SST and a press, press in a new bearing.  
SST 09950-60010 (09951-00500)

- (f) Install the bearing retainer with the 4 screws.  
**Torque: 3.0 N·m (31 kgf·cm, 27 in·lbf)**

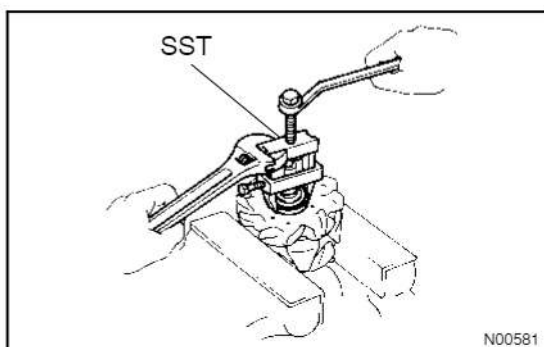

N00581

### 2. REPLACE REAR BEARING

- (a) Using SST, remove the bearing cover (outside) and bearing.  
SST 09820-00021

#### NOTICE:

**Be careful not to damage the fan.**

- (b) Remove the bearing cover (inside).

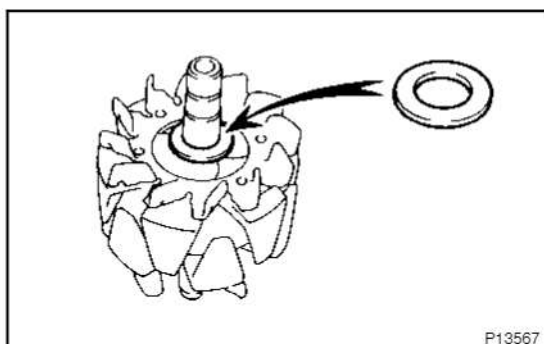

P13567

- (c) Place the bearing cover (inside) on the rotor.

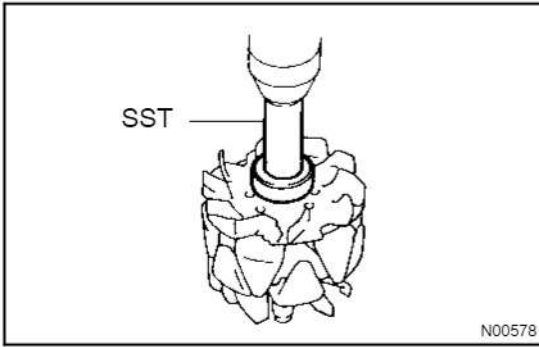

- (d) Using SST and a press, press in a new bearing.  
SST 09820-00030

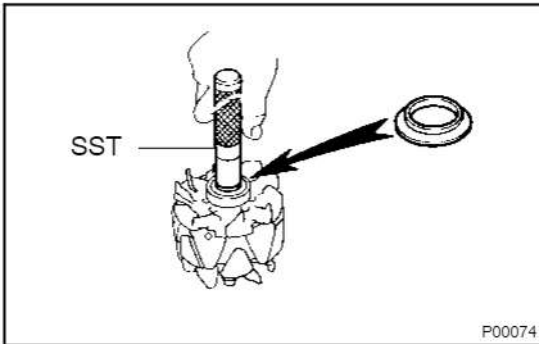

- (e) Using SST, push in the bearing cover (outside).  
SST 09285-76010

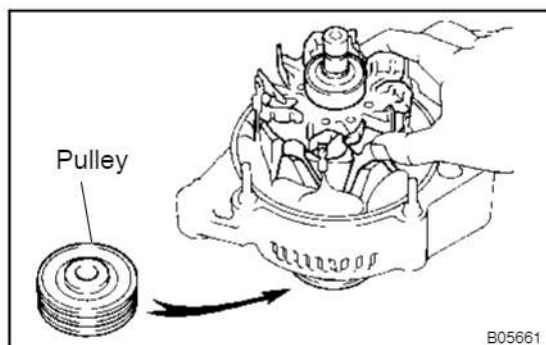

## REASSEMBLY

1. PLACE DRIVE END FRAME ON PULLEY
2. INSTALL ROTOR TO DRIVE END FRAME

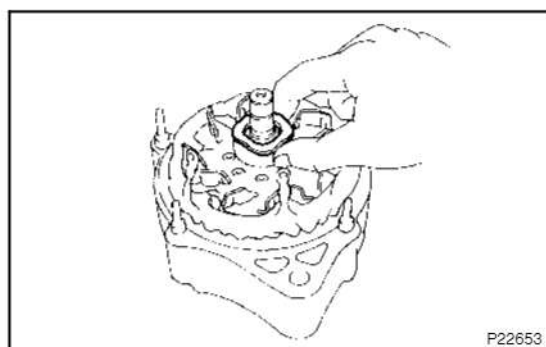

3. INSTALL RECTIFIER END FRAME
  - (a) Place the alternator washer on the rotor.

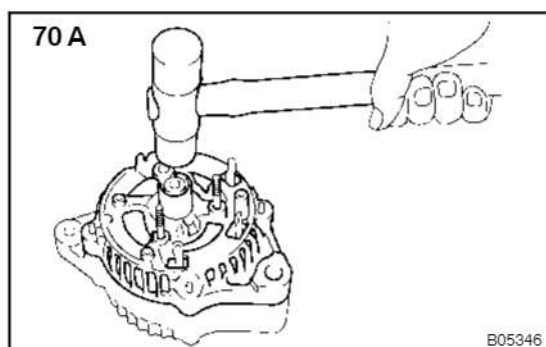

- (b) 70 A:
  - Using a plastic hammer, lightly tap in the end frame.



- (c) 80 A and 120 A:
  - Using a 29 mm socket wrench and press, slowly press in the rectifier end frame.

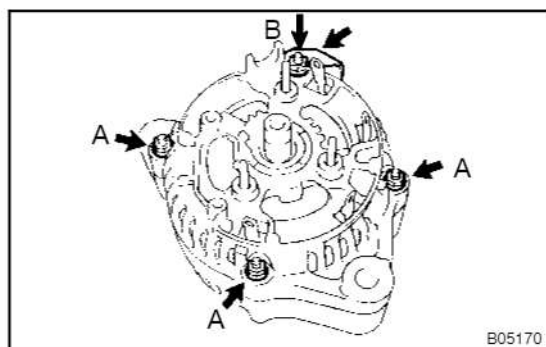

- (d) Install the cord clip and 4 nuts.

### Torque:

#### 70 A:

A, B: 4.5 N·m (46 kgf·cm, 40 in.·lbf)

#### 80 A and 120 A:

A: 4.5 N·m (46 kgf·cm, 40 in.·lbf)

B: 5.4 N·m (55 kgf·cm, 48 in.·lbf)

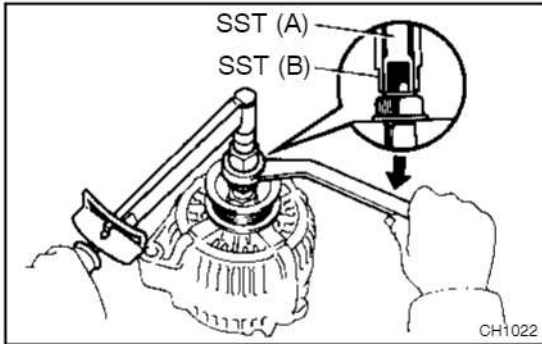

**4. INSTALL PULLEY**

- (a) Install the pulley to the rotor shaft by tightening the pulley nut by hand.
- (b) Hold SST (A) with a torque wrench, and tighten SST (B) clockwise to the specified torque.  
SST 09820-63010  
**Torque: 39 N·m (400 kgf·cm, 29 ft·lbf)**
- (c) Check that SST (A) is secured to the pulley shaft.

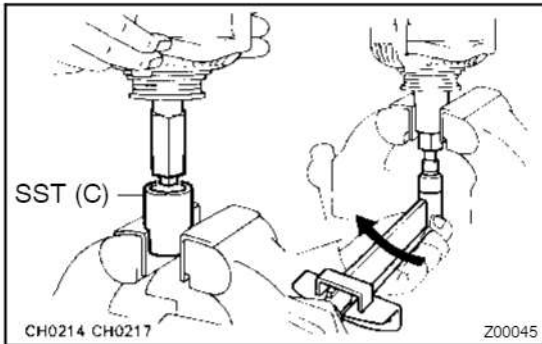

- (d) As shown in the illustration, mount SST (C) in a vise, and install the alternator to SST (C).
- (e) To torque the pulley nut, turn SST (A) in the direction shown in the illustration.  
**Torque: 110.5 N·m (1,125 kgf·cm, 81 ft·lbf)**
- (f) Remove the alternator from SST (C).
- (g) Turn SST (B), and remove SST (A and B).

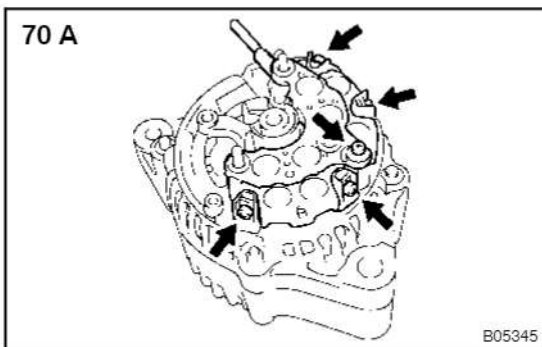

**5. INSTALL RECTIFIER HOLDER**

- (a) 70 A:  
Install the rectifier holder with the 4 screws and bolt.  
**Torque:**  
**Screws: 1.96 N·m (20 kgf·cm, 17 in·lbf)**  
**Bolt: 3.9 N·m (40 kgf·cm, 35 in·lbf)**

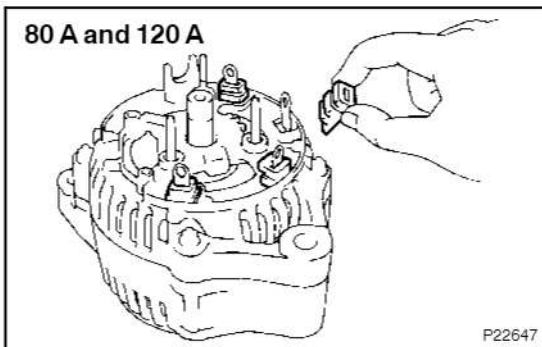

- (b) 80 A and 120 A:  
Install the 4 rubber insulators on the lead wires.

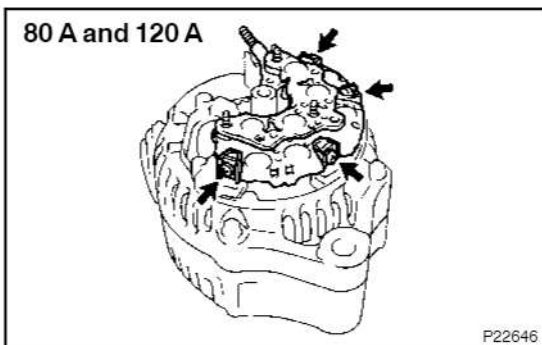

- (c) 80 A and 120 A  
Install the rectifier holder while pushing it with the 4 screws.  
**Torque: 2.94 N·m (30 kgf·cm, 26 in·lbf)**

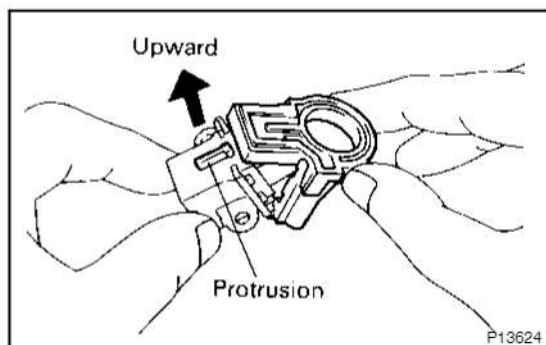

## 6. 70 A: INSTALL IC REGULATOR AND BRUSH HOLDER

- (a) Install the brush holder cover to the brush holder.

### NOTICE:

**Be careful of the holder installation direction.**

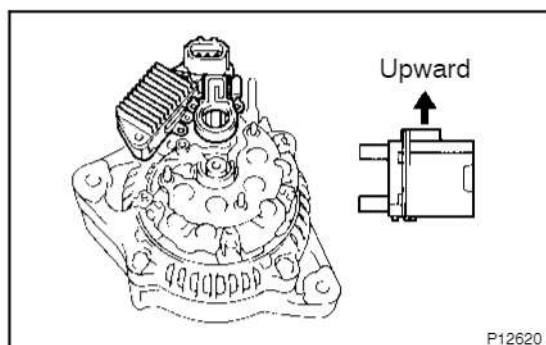

- (b) Place the IC regulator together with the brush holder horizontally on the rectifier end frame.

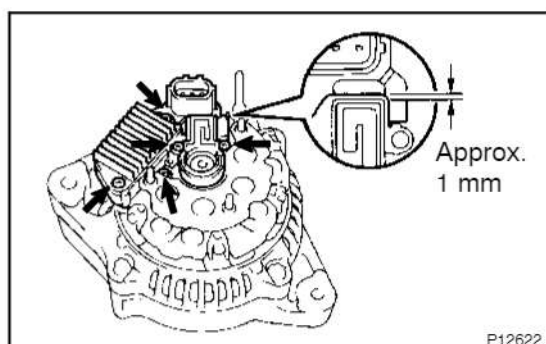

- (c) Install the 5 screws until there is a clearance of approx. 1 mm (0.04 in.) between the brush holder and connector.  
**Torque: 1.96 N·m (20 kgf·cm, 17 in.·lbf)**
- (d) Fit the brush holder cover.

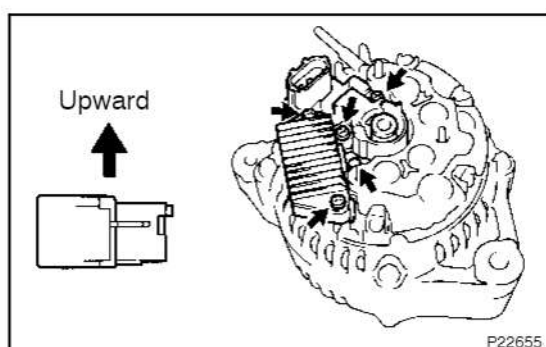

## 7. 80 A and 120 A: INSTALL IC REGULATOR AND BRUSH HOLDER

- (a) Place the seal plate on the rectifier end frame.  
(b) Place the IC regulator and brush holder on the rectifier end frame.

### NOTICE:

**Be careful of the holder installation direction.**

- (c) Install the 5 screws.  
**Torque: 2.0 N·m (20 kgf·cm, 18 in.·lbf)**
- (d) Place the brush holder cover on the brush holder.

## 8. INSTALL REAR END COVER

- (a) 70 A:  
Install the rear end cover with the 3 nuts.  
**Torque: 4.4 N·m (45 kgf·cm, 39 in.·lbf)**

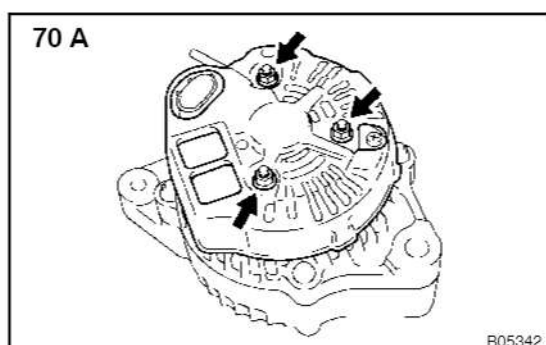



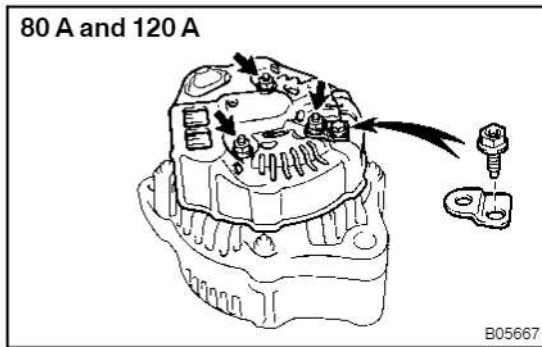

- (b) 80 A and 120 A:  
Install the rear end cover and plate terminal with the 3 nuts and screw.

**Torque:**

**Screw: 3.85 N·m (39 kgf·cm, 34 in·lbf)**

**Nuts: 4.4 N·m (45 kgf·cm, 39 in·lbf)**

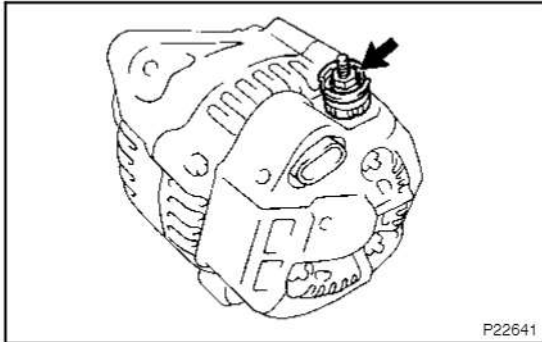

- (c) Install the terminal insulator with the nut.  
**Torque: 4.1 N·m (42 kgf·cm, 36 in·lbf)**
9. **CHECK THAT ROTOR ROTATES SMOOTHLY**