

# LAMPS

## CONTENTS

	page		page
BULB APPLICATION—XJ VEHICLES .....	18	INTERIOR LAMPS .....	16
GENERAL INFORMATION .....	1	SERVICE PROCEDURES .....	6

## GENERAL INFORMATION

Each vehicle is equipped with various lamp assemblies. A good ground is necessary for proper lighting operation. Grounding is provided by the lamp socket when it comes in contact with the metal body, or through a separate ground wire.

When changing lamp bulbs check the socket for corrosion. If corrosion is present, clean it with a wire brush and coat the inside of the socket lightly with Mopar Multi-Purpose Grease or equivalent.

### DIAGNOSTIC PROCEDURES—XJ

When a vehicle experiences problems with the headlamp system, verify the condition of the battery

connections, charging system, headlamp bulbs, wire connectors, relay, high beam dimmer switch and headlamp switch. Refer to Group 8W, Wiring Diagrams for component locations and circuit information.

Always begin any diagnosis by testing all of the fuses and circuit breakers in the system. Refer to Group 8W, Wiring Diagrams.

## HEADLAMP DIAGNOSIS

CONDITION	POSSIBLE CAUSES	CORRECTION
HEADLAMPS ARE DIM WITH ENGINE IDLING OR IGNITION TURNED OFF.	<ol style="list-style-type: none"> <li>1. Loose or corroded battery cables.</li> <li>2. Loose or worn generator drive belt.</li> <li>3. Charging system output too low.</li> <li>4. Battery has insufficient charge.</li> <li>5. Battery is sulfated or shorted.</li> <li>6. Poor lighting circuit Z1-ground.</li> <li>7. Both headlamp bulbs defective.</li> </ol>	<ol style="list-style-type: none"> <li>1. Clean and secure battery cable clamps and posts.</li> <li>2. Adjust or replace generator drive belt.</li> <li>3. Test and repair charging system, refer to Group 8A.</li> <li>4. Test battery state-of-charge, refer to Group 8A.</li> <li>5. Load test battery, refer to Group 8A.</li> <li>6. Test for voltage drop across Z1-ground locations, refer to Group 8W.</li> <li>7. Replace both headlamp bulbs.</li> </ol>
HEADLAMP BULBS BURN OUT FREQUENTLY.	<ol style="list-style-type: none"> <li>1. Charging system output too high.</li> <li>2. Loose or corroded terminals or splices in circuit.</li> </ol>	<ol style="list-style-type: none"> <li>1. Test and repair charging system, refer to Group 8A.</li> <li>2. Inspect and repair all connectors and splices, refer to Group 8W.</li> </ol>
HEADLAMPS ARE DIM WITH ENGINE RUNNING ABOVE IDLE.*	<ol style="list-style-type: none"> <li>1. Charging system output too low.</li> <li>2. Poor headlamp circuit ground.</li> <li>3. High resistance in headlamp circuit.</li> <li>4. Both headlamp bulbs defective.</li> </ol>	<ol style="list-style-type: none"> <li>1. Test and repair charging system, refer to Group 8A.</li> <li>2. Test voltage drop across Z1-ground, refer to Group 8W.</li> <li>3. Test amperage draw of headlamp circuit.</li> <li>4. Replace both headlamp bulbs.</li> </ol>
HEADLAMPS FLASH RANDOMLY.	<ol style="list-style-type: none"> <li>1. Poor headlamp circuit ground.</li> <li>2. High resistance in headlamp circuit.</li> <li>3. Faulty headlamp switch circuit breaker.</li> <li>4. Loose or corroded terminals or splices in circuit.</li> </ol>	<ol style="list-style-type: none"> <li>1. Repair circuit ground, refer to Group 8W.</li> <li>2. Test amperage draw of headlamp circuit.</li> <li>3. Replace headlamp switch.</li> <li>4. Repair connector terminals or splices, refer to Group 8W.</li> </ol>
HEADLAMPS DO NOT ILLUMINATE.	<ol style="list-style-type: none"> <li>1. No voltage to headlamps.</li> <li>2. No ground at headlamps.</li> <li>3. Faulty headlamp switch.</li> <li>4. Faulty headlamp dimmer switch.</li> <li>5. Broken connector terminal or wire splice in headlamp circuit.</li> </ol>	<ol style="list-style-type: none"> <li>1. Replace fuse, refer to group 8W.</li> <li>2. Repair circuit ground, refer to Group 8W.</li> <li>3. Replace headlamp switch.</li> <li>4. Replace headlamp dimmer switch.</li> <li>5. Repair connector terminal or wire splices.</li> </ol>

\* Canada vehicles must have lamps ON.

## FOG LAMP DIAGNOSIS

CONDITION	POSSIBLE CAUSES	CORRECTION
FOG LAMPS ARE DIM WITH ENGINE IDLING OR IGNITION TURNED OFF.	<ol style="list-style-type: none"> <li>1. Loose or corroded battery cables.</li> <li>2. Loose or worn generator drive belt.</li> <li>3. Charging system output too low.</li> <li>4. Battery has insufficient charge.</li> <li>5. Battery is sulfated or shorted.</li> <li>6. Poor lighting circuit Z1-ground.</li> <li>7. Both fog lamp bulbs defective.</li> </ol>	<ol style="list-style-type: none"> <li>1. Clean and secure battery cable clamps and posts.</li> <li>2. Adjust or replace generator drive belt.</li> <li>3. Test and repair charging system, refer to Group 8A.</li> <li>4. Test battery state-of-charge, refer to Group 8A.</li> <li>5. Load test battery, refer to Group 8A.</li> <li>6. Test for voltage drop across Z1-ground locations, refer to Group 8W.</li> <li>7. Replace both lamp bulbs.</li> </ol>
FOG LAMP BULBS BURN OUT FREQUENTLY.	<ol style="list-style-type: none"> <li>1. Charging system output too high.</li> <li>2. Loose or corroded terminals or splices in circuit.</li> </ol>	<ol style="list-style-type: none"> <li>1. Test and repair charging system, refer to Group 8A.</li> <li>2. Inspect and repair all connectors and splices, refer to Group 8W.</li> </ol>
FOG LAMPS ARE DIM WITH ENGINE RUNNING ABOVE IDLE.	<ol style="list-style-type: none"> <li>1. Charging system output too low.</li> <li>2. Poor fog lamp circuit ground.</li> <li>3. High resistance in fog lamp circuit.</li> <li>4. Both fog lamp bulbs defective.</li> </ol>	<ol style="list-style-type: none"> <li>1. Test and repair charging system, refer to Group 8A.</li> <li>2. Test voltage drop across Z1-ground, refer to Group 8W.</li> <li>3. Test amperage draw of fog lamp circuit.</li> <li>4. Replace both fog lamp bulbs.</li> </ol>
FOG LAMPS FLASH RANDOMLY.	<ol style="list-style-type: none"> <li>1. Poor fog lamp circuit ground.</li> <li>2. High resistance in fog lamp circuit.</li> <li>3. Faulty fog lamp switch circuit breaker.</li> <li>4. Loose or corroded terminals or splices in circuit.</li> </ol>	<ol style="list-style-type: none"> <li>1. Repair circuit ground, refer to Group 8W.</li> <li>2. Test amperage draw of fog lamp circuit.</li> <li>3. Replace fog lamp switch.</li> <li>4. Repair connector terminals or splices, refer to Group 8W.</li> </ol>
FOG LAMPS DO NOT ILLUMINATE.	<ol style="list-style-type: none"> <li>1. Blown fuse for fog lamps.</li> <li>2. No ground at fog lamps.</li> <li>3. Faulty fog lamp switch.</li> <li>4. Broken connector terminal or wire splice in fog lamp circuit.</li> </ol>	<ol style="list-style-type: none"> <li>1. Replace fuse, refer to group 8W.</li> <li>2. Repair circuit ground, refer to Group 8W.</li> <li>3. Replace fog lamp switch.</li> <li>4. Repair connector terminal or wire splices.</li> </ol>

## MULTI-FUNCTION SWITCH TESTING PROCEDURES—XJ

The multi-function switch contains electrical circuitry for:

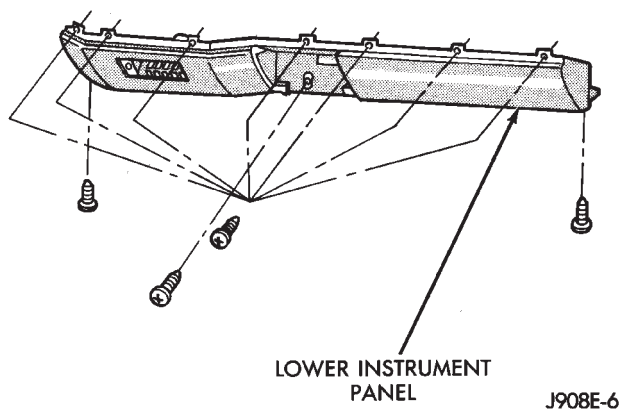
- Headlamp Dimmer Switch.
- Passing Lights.
- Turn Signals.
- Hazard Warning.
- Windshield Wiper.
- Pulse Wiper.
- Windshield Washer.

This integrated switch is mounted to the left hand side of the steering column. Should any function of the switch fail, the entire switch must be replaced.

The multi-function switch also serves as a fog lamp lock-out circuit. The circuit to the fog lamp switch is completed only when the dimmer switch is in the low beam position.

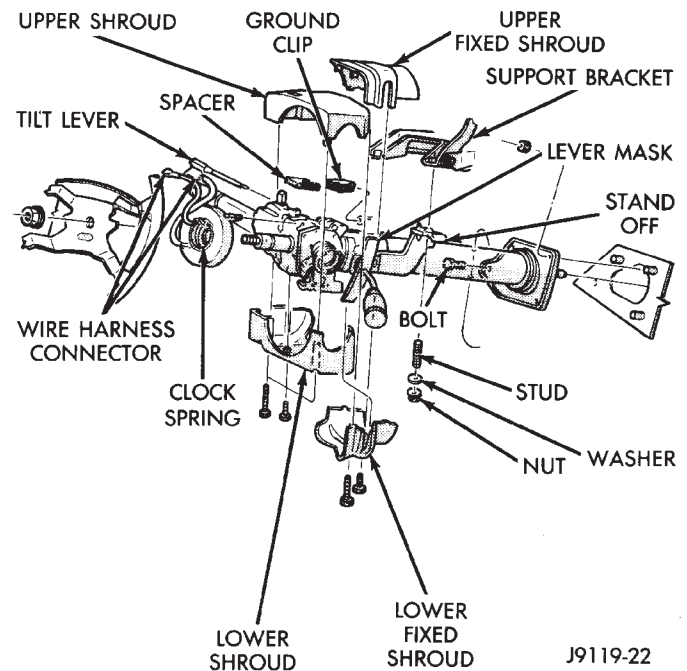
### SWITCH TEST

- (1) Disconnect battery negative cable.
- (2) Remove lower instrument panel screws along bottom edge of steering column (Fig. 1).

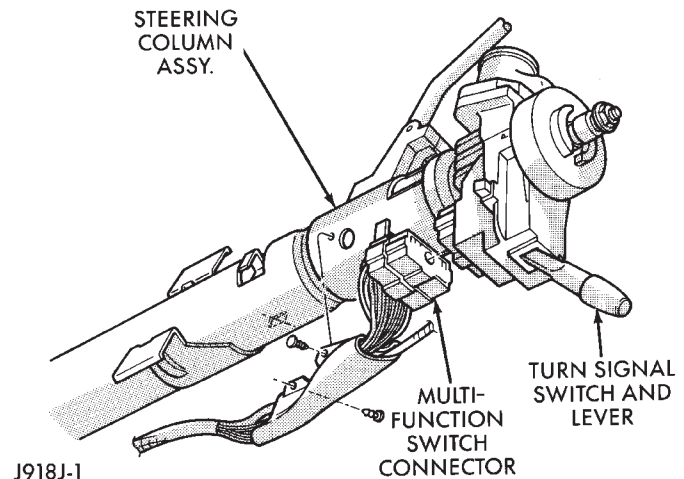


**Fig. 1 Lower Instrument Panel/Knee Blocker—XJ Vehicles**

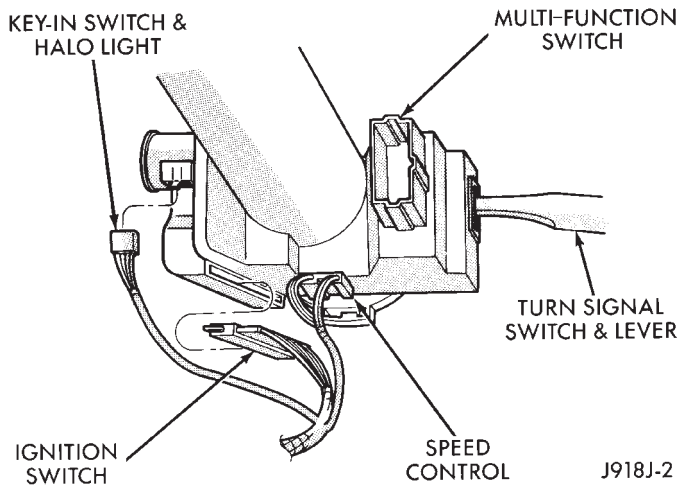
- (3) Remove lower instrument panel/knee blocker.
- (4) Remove tilt lever.
- (5) Remove upper and lower column shrouds to gain access to the switch connector (Fig. 2).
- (6) Remove lower fixed column shroud.
- (7) Loosen steering column upper bracket nuts. Do not remove nuts.
- (8) Move upper fixed column shroud to gain access to rear of multi-function switch.
- (9) Remove switch connector (Fig. 3 and 4).



**Fig. 2 Steering Column Shrouds**



**Fig. 3 Multi-function Switch Connector**

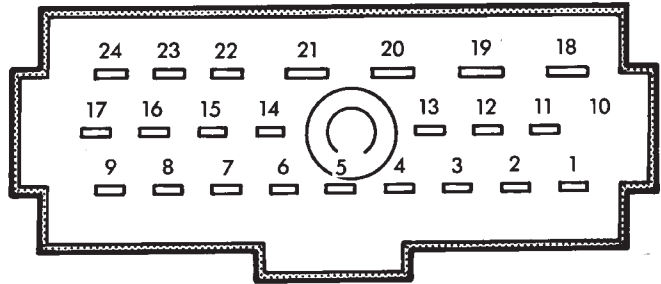


J918J-2

**Fig. 4 Steering Column Connectors**

(10) Use an ohmmeter to test for continuity between the terminals of the switch as shown in the continuity chart (Fig. 5).

(11) Refer to Service Procedures for assembly.



VIEW FROM TERMINAL SIDE

SWITCH POSITION	CONTINUITY BETWEEN
LOW BEAM	18 AND 19
HIGH BEAM	19 AND 20
OPTICAL HORN	20 AND 21

908J-5

**Fig. 5 Dimmer Switch Continuity Chart**

SERVICE PROCEDURES

INDEX

	page		page
Back-Up/Rear Turn Signal/Tail Lamp Bulb Replacement—XJ	12	Headlamp Delay Function Trouble Diagnosis—XJ	14
Center High Mounted Stop Lamp (CHMSL)—XJ	12	Headlamp Delay Module Replacement—XJ	14
Daytime Running Lights (Canada Only)—XJ	15	Headlamp Switch—XJ	10
Drl Module Replacement—XJ	15	Headlamp/Fog Lamp Adjustment Using Alignment Screen—XJ	7
Fog Lamp Replacement—XJ	9	License Plate Lamp—XJ	12
Fog Lamp Switch Replacement—XJ	10	Multi-Function Switch Service Procedures—XJ	11
Fog Lamps—XJ	7	Sentinel Headlamp Delay Module—XJ	14
Front Park/Turn Signal Lamp Bulb Replacement—XJ	9	Side Marker Lamp Bulb Replacement—XJ	10
Headlamp Alignment Preparation—XJ	6	Underhood Lamp Bulb Replacement—XJ	13
Headlamp Alignment—XJ	6	Underhood Lamp Replacement—XJ	13
Headlamp Bulb Replacement—XJ	7	Underhood Lamp Service Information—XJ	12

HEADLAMP ALIGNMENT—XJ

Headlamps can be aligned using the screen method provided in this section. Alignment Tool C4466-A or equivalent can also be used. Refer to instructions provided with the tool for proper procedures. **The preferred headlamp alignment setting is 0 for the left/right adjustment and 1" down for the up/down adjustment.**

HEADLAMP ALIGNMENT PREPARATION—XJ

- (1) Verify headlamp dimmer switch and high beam indicator operation.
- (2) Correct defective components that could hinder proper headlamp alignment.
- (3) Verify proper tire inflation.
- (4) Clean headlamp lenses.
- (5) Verify that luggage area is not heavily loaded.

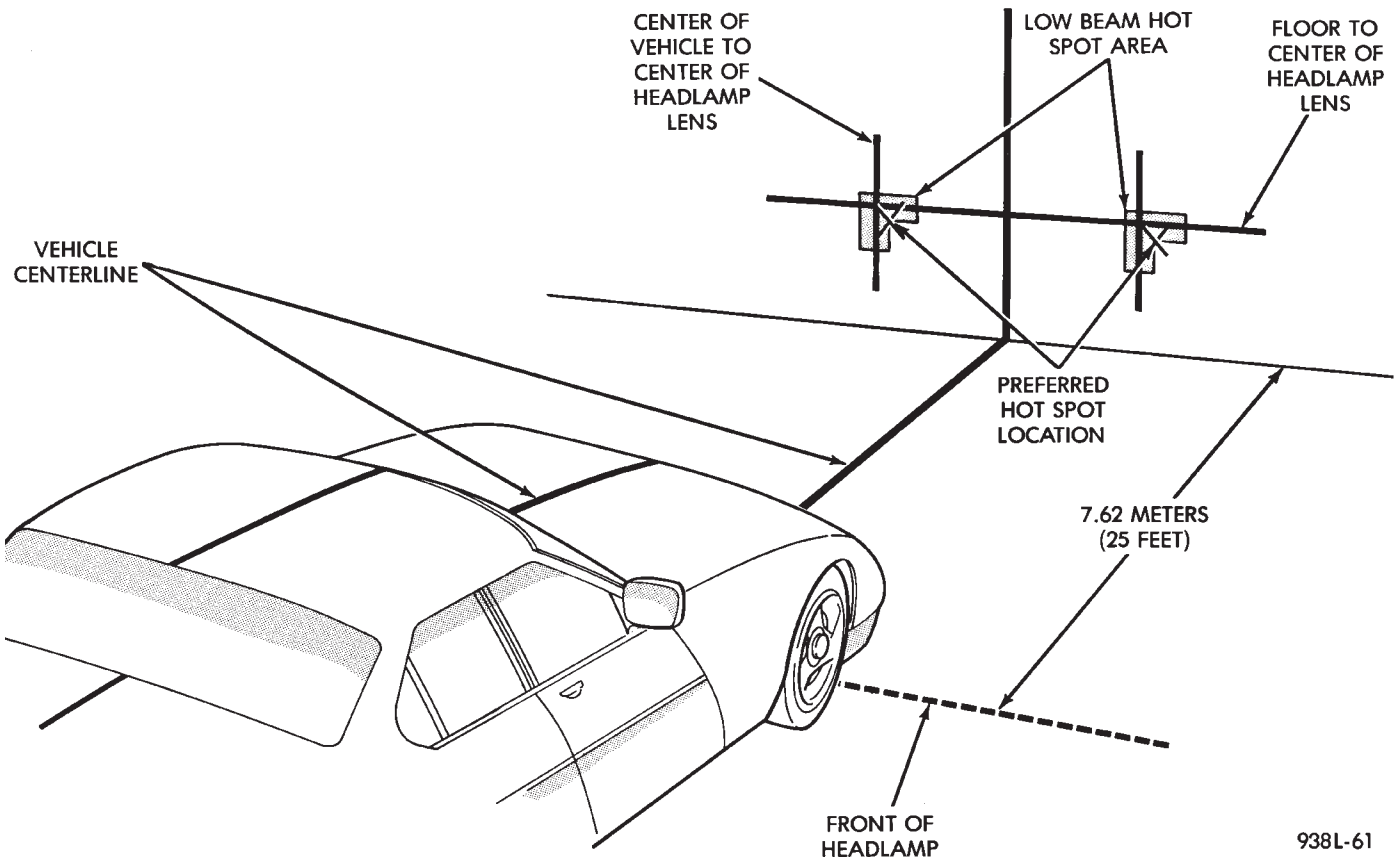


Fig. 1 Headlamp Alignment Screen—Typical

(6) Fuel tank should be FULL. Add 2.94 kg (6.5 lbs.) of weight over the fuel tank for each estimated gallon of missing fuel.

## HEADLAMP/FOG LAMP ADJUSTMENT USING ALIGNMENT SCREEN—XJ

### ALIGNMENT SCREEN PREPARATION

(1) Position vehicle on a level surface perpendicular to a flat wall 7.62 meters (25 ft) away from front of headlamp lens (Fig. 1).

(2) If necessary, tape a line on the floor 7.62 meters (25 ft) away from and parallel to the wall.

(3) Measure from the floor up 1.27 meters (5 ft) and tape a line on the wall at the centerline of the vehicle. Sight along the centerline of the vehicle (from rear of vehicle forward) to verify accuracy of the line placement.

(4) Rock vehicle side-to-side three times to allow suspension to stabilize.

(5) Jounce front suspension three times by pushing downward on front bumper and releasing.

(6) Measure the distance from the center of headlamp lens to the floor. Transfer measurement to the alignment screen (with tape). Use this line for up/down adjustment reference.

(7) Measure distance from the centerline of the vehicle to the center of each headlamp being aligned. Transfer measurements to screen (with tape) to each side of vehicle centerline. Use these lines for left/right adjustment reference.

### ADJUSTMENT

(1) Remove screws and both headlamp bezels.

(2) Clean front of the headlamps.

(3) Place headlamps on LOW beam.

(4) Cover front of the headlamp that is not being adjusted.

(5) Turn vertical adjustment screw (Fig. 2) until the headlamp beam pattern on screen/wall is similar to the pattern depicted in Figure 1.

#### When using a headlamp aiming screen:

- Adjust the headlamps so that the beam horizontal position is at 0.

- Adjust the beam vertical position is 25 mm (1 in) downward from the lamp horizontal centerline.

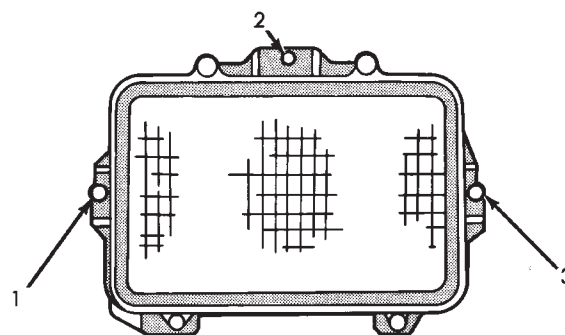
(6) Rotate the horizontal adjustment screw until the headlamp beam pattern on the aiming screen/wall similar to the pattern in Figure 1.

(7) Cover front of the headlamp that has been adjusted and adjust the other headlamp beam as instructed above.

(8) Install headlamp bezels. Tighten the screws securely.

### FOG LAMP ADJUSTMENT

Prepare an alignment screen. Refer to Alignment Screen Preparation paragraph in this section. A prop-



1. HORIZONTAL ADJ. SCREW - RH  
2. VERTICAL ADJ. SCREW  
3. HORIZONTAL ADJ. SCREW - LH

J908L-24

**Fig. 2 Headlamp Beam Adjustment Screws**

erly aligned fog lamp will project a pattern on the alignment screen 100 mm (4 in.) below the fog lamp centerline and straight ahead (Fig. 3)

## HEADLAMP BULB REPLACEMENT—XJ

### REMOVAL

(1) Remove the screws and the headlamp bezel (Fig. 4).

(2) Remove the screws and headlamp bulb retaining ring.

(3) Disconnect the headlamp bulb wire harness connector and remove the bulb from the bucket.

### INSTALLATION

(1) Position the bulb in the bucket and connect the wire harness connector.

(2) Position retaining ring on the headlamp bulb and install screws.

(3) Install the headlamp bezel. Tighten the screws securely.

## FOG LAMPS—XJ

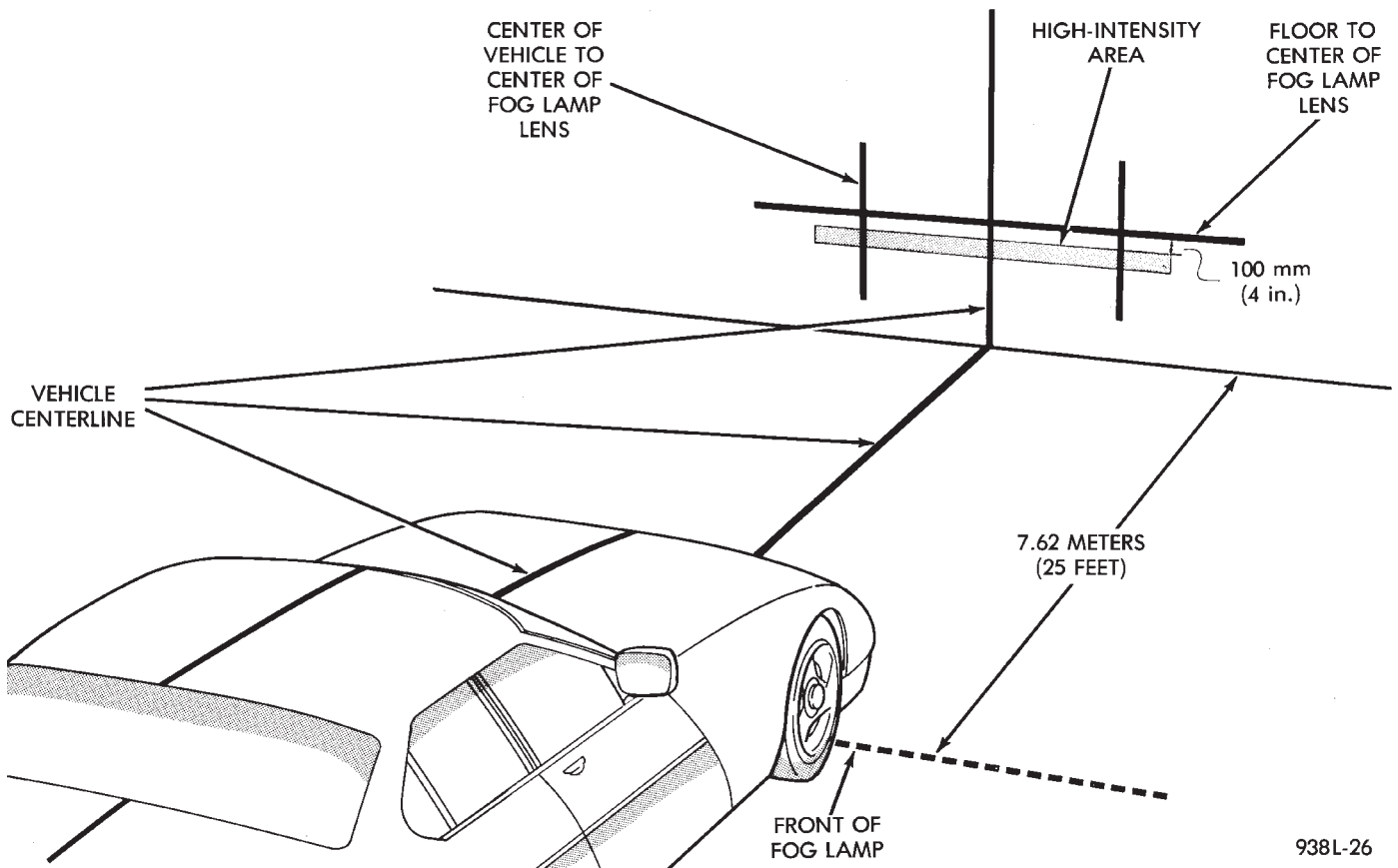
Fog lamps are turned OFF by the circuit relay when the high beam driving lamps are turned ON.

Fog lamps may be operated ONLY when low beam headlamps are ON. If the headlamps are switched to high beam, the low beam lamps and fog lamps will turn OFF. The fog lamps will go back on when the high beams are switched OFF.

The indicator lamp on the fog lamp switch will go:

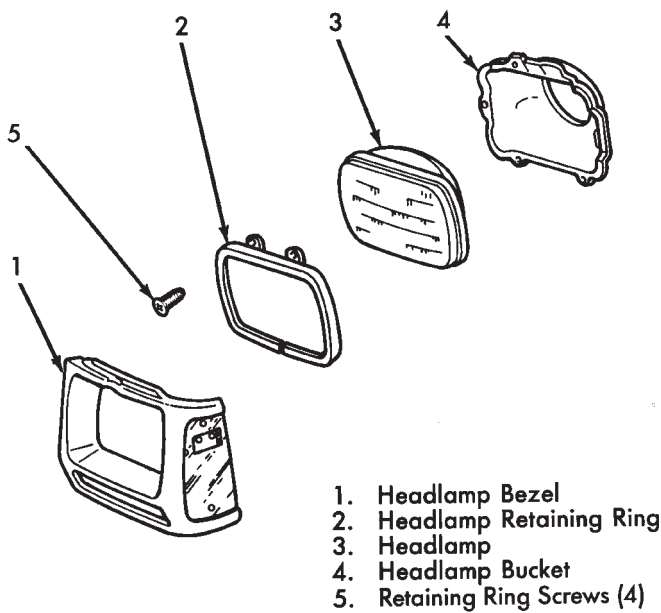
- OFF when the high beams lamps are switched ON.

- ON when the high beam lamps are switched OFF.



938L-26

**Fig. 3 Fog Lamp Alignment —Typical**

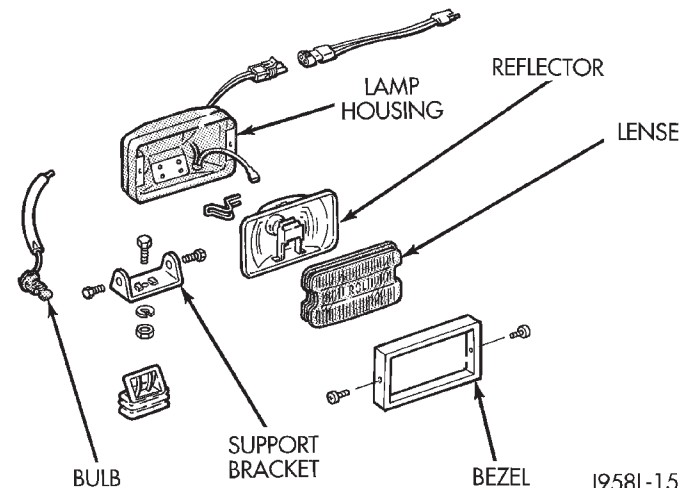


J918L-5

**Fig. 4 Headlamp Components**

**FOG LAMP BULB REPLACEMENT**

**CAUTION:** Do not touch the bulb glass with fingers or other oily surfaces. Reduced bulb life will result.



J958L-15

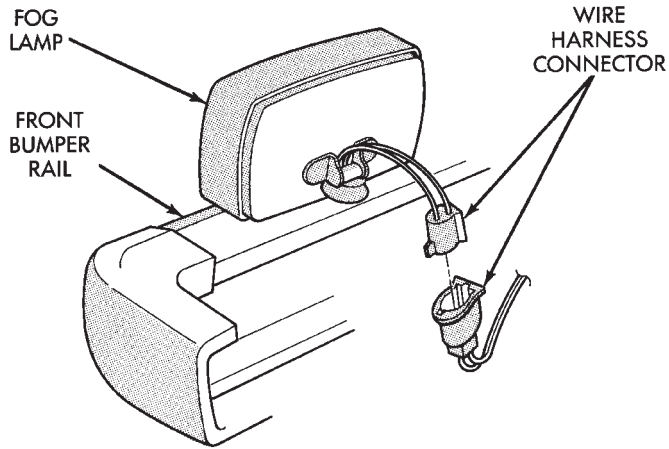
**Fig. 5 Fog Lamp Components**



**FOG LAMP REPLACEMENT—XJ**

**REMOVAL**

(1) Disconnect the fog lamp wire harness connector (Fig. 6).

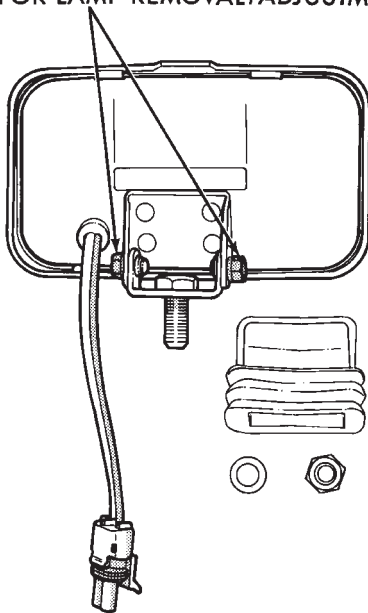


J9223-53

**Fig. 6 Fog Lamp Wire Harness Connector—XJ Vehicles**

(2) Remove the retaining nut and washer from each side of the support bracket and remove the fog lamp from the support bracket (Fig. 7).

**BOLTS AND WASHERS FOR LAMP REMOVAL/ADJUSTMENT**



J898L-37

**Fig. 7 Fog Lamp**

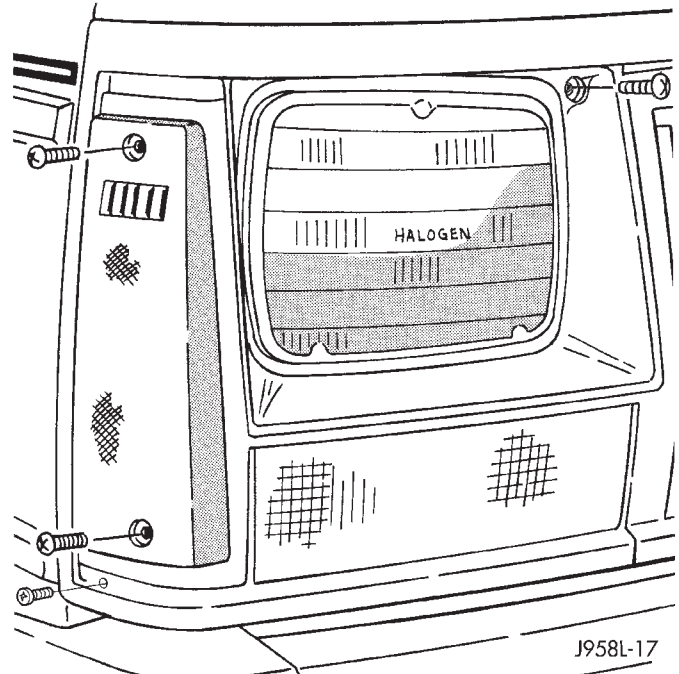
**INSTALLATION**

(1) Position the fog lamp in the support bracket and install the washer and nut at each side of the bracket. Tighten the nuts securely.  
 (2) Connect the fog lamp wire harness connector.

**FRONT PARK/TURN SIGNAL LAMP BULB REPLACEMENT—XJ**

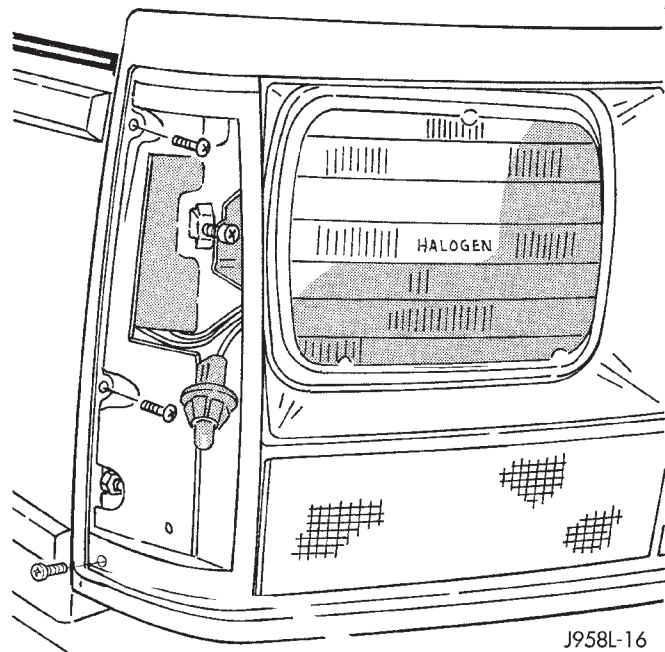
**REMOVAL**

(1) Remove the headlamp bezel screw and the side marker lamp lens/housing screw (Fig. 8).



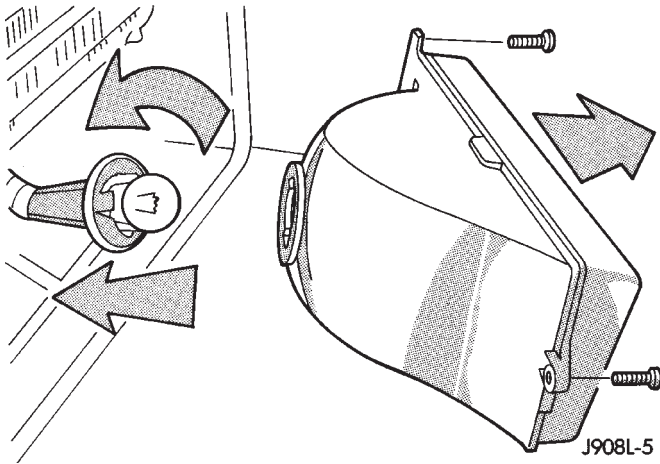
**Fig. 8 Headlamp Bezel & Side Marker Lamp**

(2) Separate the side marker lamp from the headlamp bezel and remove the screws from the headlamp bezel (Fig. 9).



**Fig. 9 Headlamp Bezel Removal/Installation**

(3) Remove screws from the park/turn signal lamp housing (Fig. 10).



**Fig. 10 Park/Turn Signal Lamp Housing Removal**

(4) Separate the lamp housing from the headlamp bezel.

(5) Rotate the bulb socket one-third turn and remove it from the lamp housing.

(6) Remove bulb from socket.

#### INSTALLATION

(1) Install a replacement bulb in the socket.

(2) Install bulb and socket in the lamp housing.

(3) Position the park/turn signal lamp housing on the headlamp bezel.

(4) Install lamp housing screws. Tighten the screws.

(5) Install the outer screws in the headlamp bezel. Tighten the screws.

(6) Position the side marker lamp lens/housing on the headlamp bezel.

(7) Install side marker lamp lens/housing screws and headlamp bezel (Fig. 8). Tighten the screws.

#### SIDE MARKER LAMP BULB REPLACEMENT—XJ

##### REMOVAL

(1) Remove the screws from the side marker lamp lens and housing. Separate lens and housing from the headlamp bezel (Fig. 11).

(2) Remove the bulb and socket from the back side of the lamp housing.

(3) Remove bulb from socket.

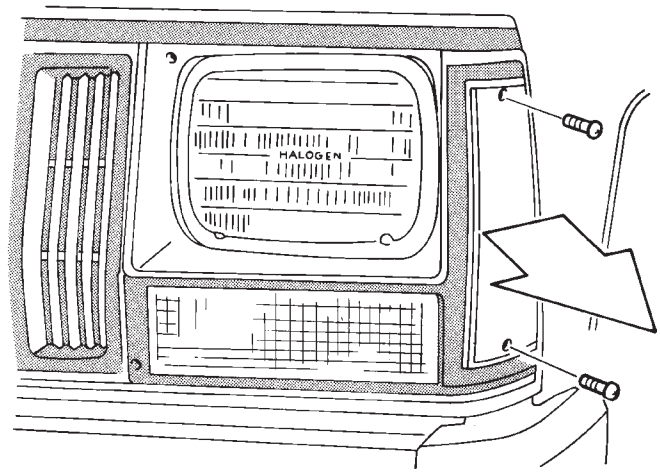
##### INSTALLATION

(1) Install a replacement bulb in the socket.

(2) Install bulb and socket in the back of side marker lamp housing.

(3) Position the side marker lens and housing on the headlamp bezel (Fig. 11).

(4) Install the side marker lamp screws. Tighten the screws.



J898L-19

**Fig. 11 Side Marker Lamp**

#### HEADLAMP SWITCH—XJ

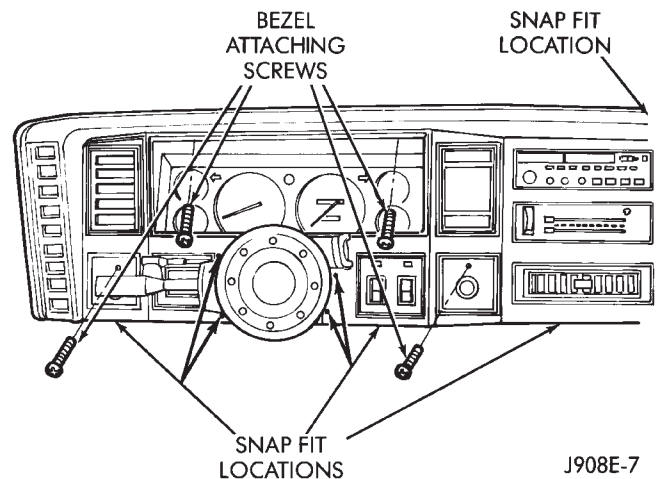
To remove or replace the headlamp switch. Refer to Group 8E, Instrument Panel and Gauges.

#### FOG LAMP SWITCH REPLACEMENT—XJ

##### REMOVAL

The fog lamp switch is located on the instrument panel at the left of the steering column.

(1) Remove instrument panel bezel attaching screws and remove the bezel (Fig. 12).



J908E-7

**Fig. 12 Instrument Panel Bezel**

(2) Remove the fog lamp switch cover.

(3) Disconnect the wire harness connector from the switch.

(4) Squeeze the tabs on the side of the switch and remove the switch from the instrument panel cavity.

**INSTALLATION**

(1) Squeeze the tabs on the side of the fog lamp switch and insert the switch in the instrument panel cavity.

(2) Connect the wire harness connector to the switch.

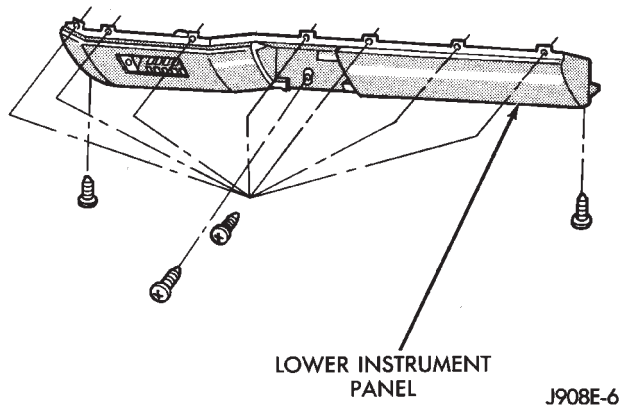
(3) Install the fog lamp switch cover.

(4) Position the bezel on the instrument panel and install the attaching screws. Tighten the screws securely.

**MULTI-FUNCTION SWITCH SERVICE PROCEDURES—XJ****REMOVAL**

(1) Disconnect battery negative cable.

(2) Remove lower instrument panel screws along bottom edge of steering column (Fig. 13).



**Fig. 13 Lower Instrument Panel/Knee Blocker**

(3) Remove lower instrument panel/knee blocker.  
 (4) Remove tilt lever.  
 (5) Remove both upper and lower lock shrouds from column (Fig. 14).

(6) Remove lower fixed column cover.

(7) Loosen steering column upper bracket nuts. Do not remove nuts.

(8) Move upper fixed column shroud to gain access to rear of multi-function switch.

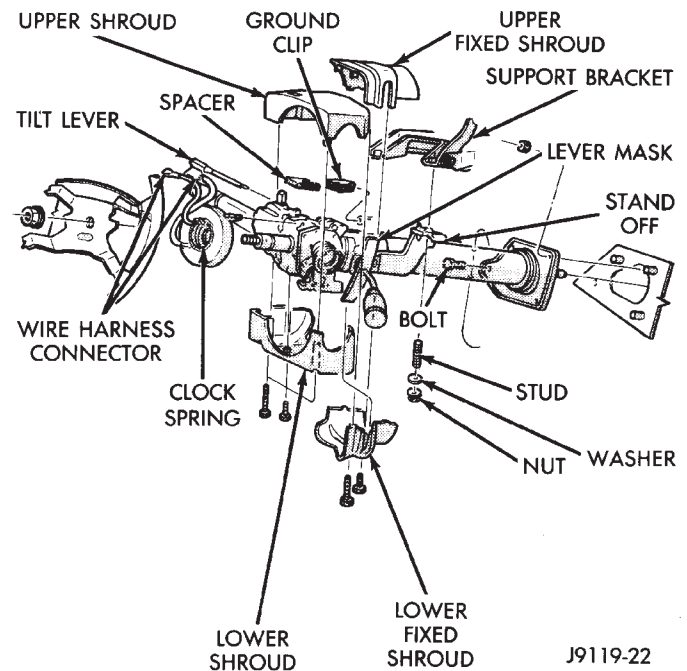
(9) Remove multi-function switch tamper proof mounting screws (tamperproof torx bit Snap On TTXR20B2 or equivalent required).

(10) Gently pull switch away from column. Loosen connector screw. The screw will remain in the connector.

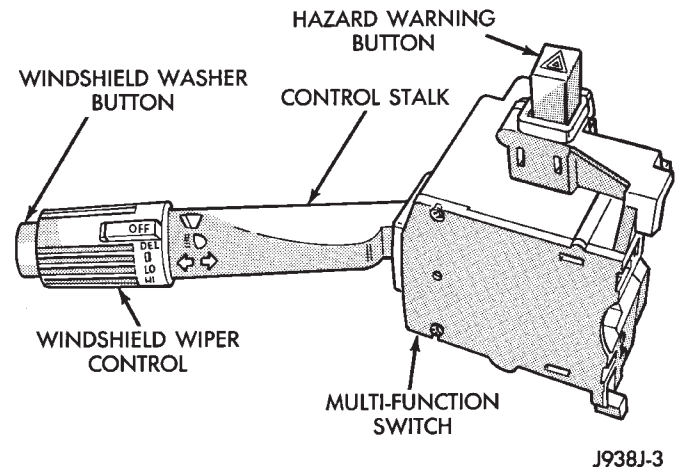
(11) Remove connector from multi-function switch (Fig. 15).

**INSTALLATION**

(1) Install wiring connector to switch and tighten connector screw to 2 N·m (17 in. lbs.).



**Fig. 14 Steering Column Shrouds**



**Fig. 15 Multi-function Switch**

(2) Mount multi-function switch to column and torque screws to 2 N·m (17 in. lbs.).

(3) Position upper fixed column shroud.

(4) Tighten steering column upper bracket nuts to 12 N·m (110 in. lbs.).

(5) Install lower fixed shroud and upper and lower lock shrouds.

(6) Install tilt lever (tilt column only).

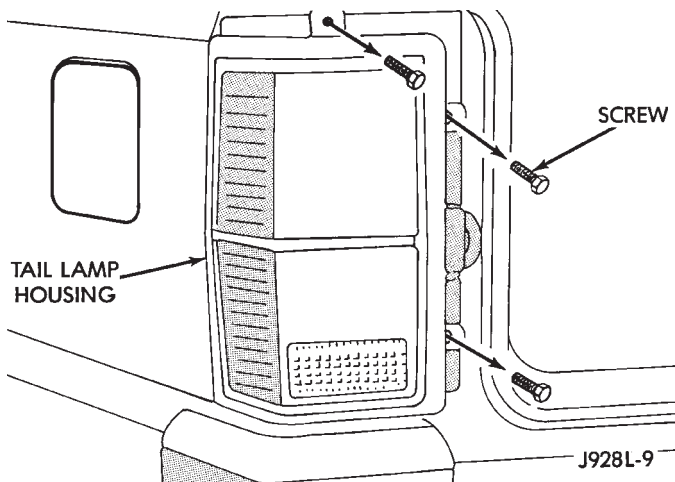
(7) Install battery negative cable.

(8) Check all functions of switch for proper operation.

## BACK-UP/REAR TURN SIGNAL/TAIL LAMP BULB REPLACEMENT—XJ

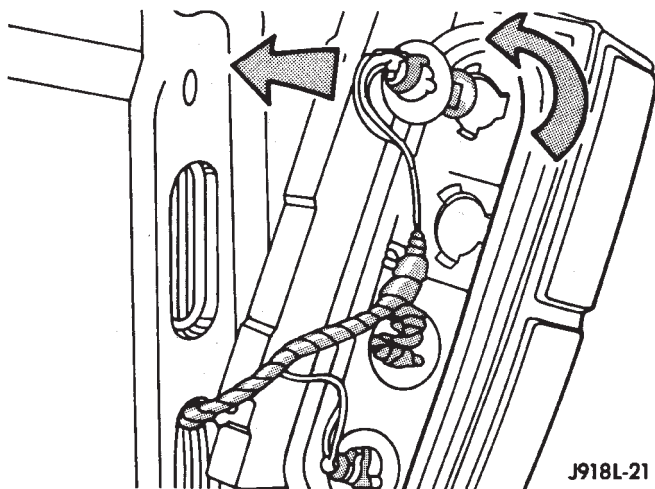
### REMOVAL

(1) Remove the tail lamp housing upper retaining screws (Fig. 16). Slide the lamp housing upward off the lower screw while tipping the top of the lamp away from the body and separate it from the rear of the vehicle.



**Fig. 16 Tail Lamp Housing**

(2) Rotate the bulb socket one-third turn and remove the bulb socket from the lamp housing (Fig. 17).



**Fig. 17 Bulb Socket Removal**

(3) Remove the bulb from the socket.

### INSTALLATION

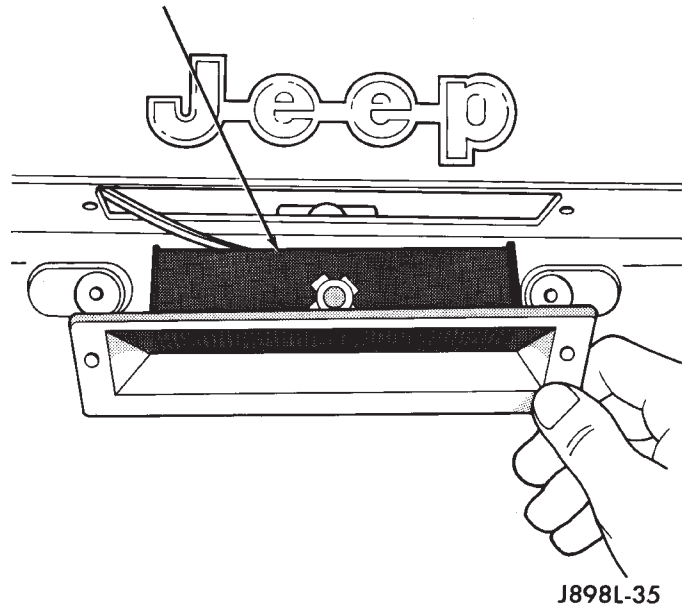
- (1) Install a replacement bulb in the socket.
- (2) Install the bulb and socket in the lamp housing.
- (3) Position the lamp housing in the opening at the rear of the vehicle.
- (4) Install the lamp housing screws. Tighten the screws securely.

## LICENSE PLATE LAMP—XJ

### REMOVAL

(1) Remove screws and the license plate lamp visor from the liftgate (Fig. 18).

### LICENSE PLATE BULB HOUSING



**Fig. 18 License Plate Lamp Visor**

(2) Remove the bulb from the lamp socket.

### INSTALLATION

- (1) Install a replacement bulb in the lamp socket.
- (2) Position the license plate lamp visor on the liftgate and install screws. Tighten the screws securely.

## CENTER HIGH MOUNTED STOP LAMP (CHMSL)—XJ

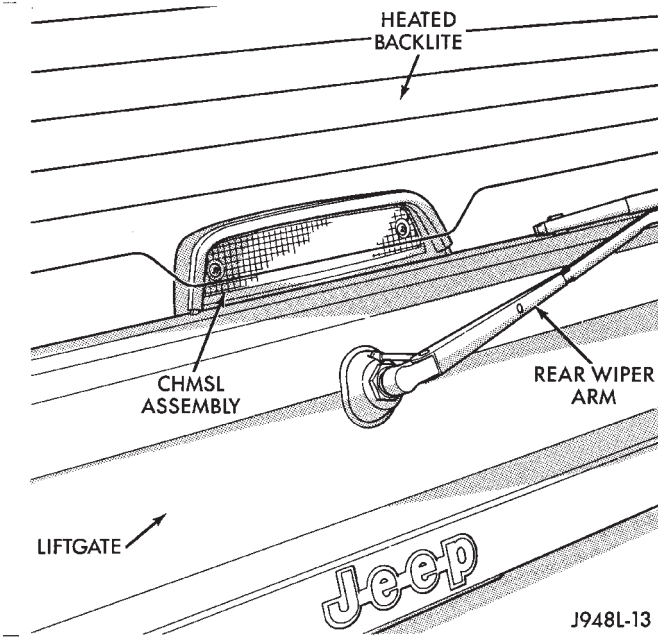
The CHMSL is mounted at the bottom of the rear window and has two bulbs (Fig. 19).

- (1) Raise liftgate.
- (2) Remove CHMSL access door (Fig. 20).
- (3) Remove CHMSL lamp mounting screws.
- (4) Remove CHMSL lamp assembly.
- (5) Replace bulbs if necessary (Fig. 21).

To install, reverse removal procedure.

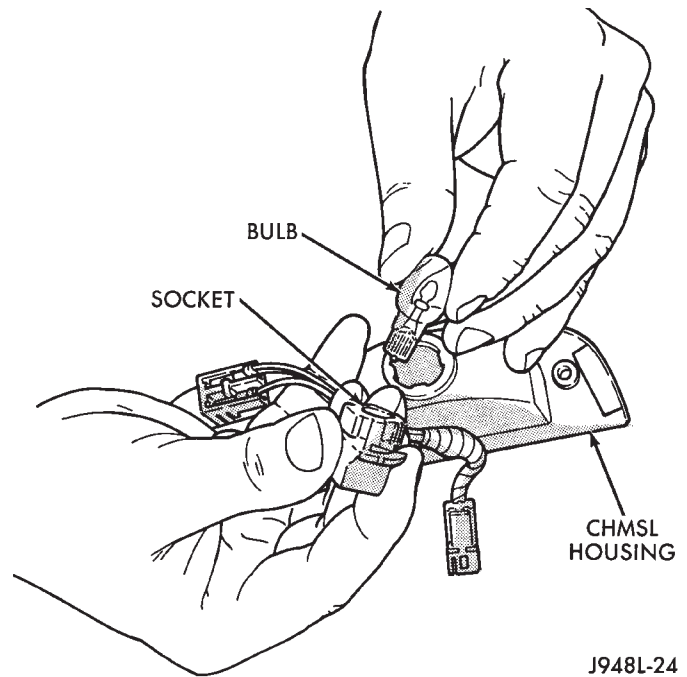
## UNDERHOOD LAMP SERVICE INFORMATION—XJ

When equipped, the underhood lamp is installed on the hood right, rear inner panel (Fig. 22). The lamp is illuminated when the hood is opened. The switch provides automatic ON/OFF functions each time the hood is opened and closed.



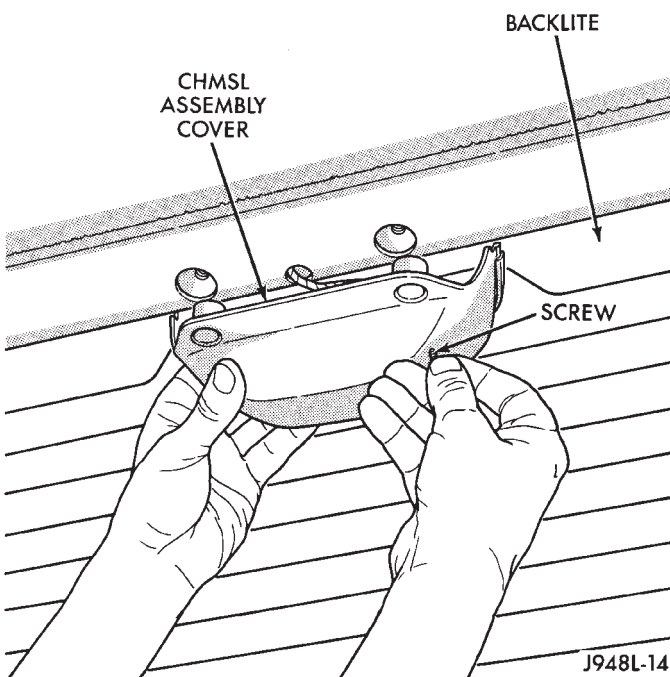
J948L-13

**Fig. 19 Center High Mounted Stop Lamp (CHMSL) Assembly**



J948L-24

**Fig. 21 Replacing CHMSL Bulb**

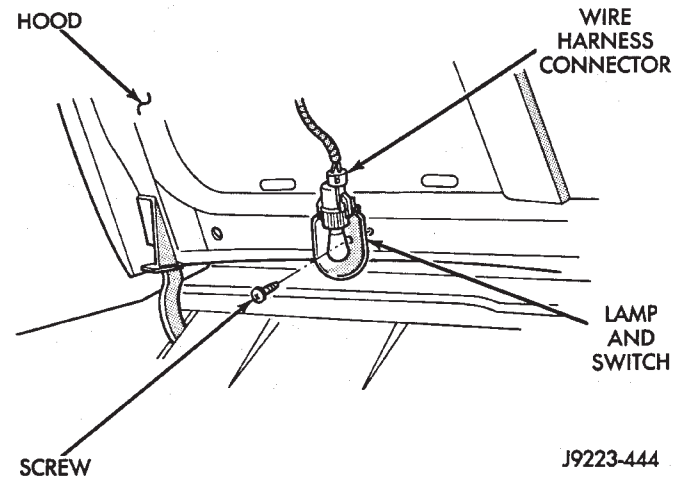


J948L-14

**Fig. 20 Removing CHMSL Access Door**  
**UNDERHOOD LAMP BULB REPLACEMENT—XJ**

**REMOVAL**

- (1) Disconnect the wire harness connector from the underhood lamp (Fig. 23).
- (2) Rotate the bulb counter-clockwise and remove it from the lamp base socket.



J9223-444

**Fig. 22 Underhood Lamp**

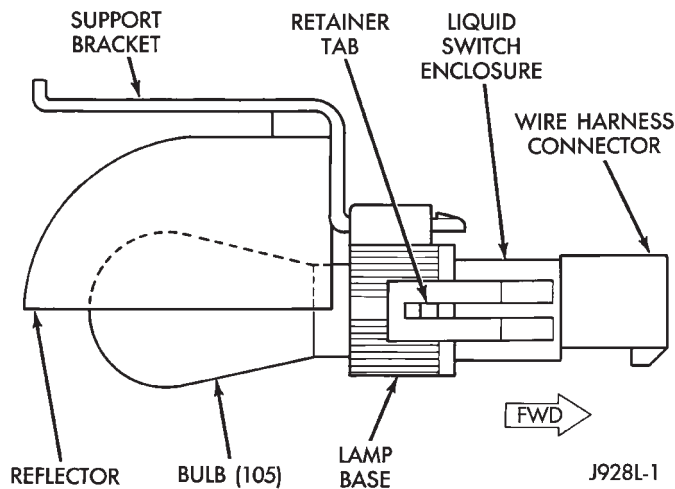
**INSTALLATION**

- (1) Insert a replacement bulb in the lamp base socket and rotate it clockwise.
- (2) Connect the wire harness connector to the lamp.

**UNDERHOOD LAMP REPLACEMENT—XJ**

**REMOVAL**

- (1) Disconnect the wire harness connector from the lamp.
- (2) Rotate the bulb counter-clockwise and remove it from the lamp base socket.
- (3) Remove the screw that attaches the lamp reflector and support bracket to the hood inner panel.
- (4) Remove the lamp from the hood inner panel.



**Fig. 23 Underhood Lamp Components**

#### INSTALLATION

- (1) Position the underhood lamp on the hood inner panel.
- (2) Install the attaching screw through the lamp and into the hood panel. Tighten the screw securely.
- (3) Insert a replacement bulb in the lamp base socket and rotate it clockwise.
- (4) Connect the wire harness connector to the lamp.

#### SENTINEL HEADLAMP DELAY MODULE—XJ

##### SERVICE INFORMATION

The Headlamp Module delays the de-activation of the headlamps for  $45 \pm 15$  seconds after the ignition switch is turned OFF. The driver engages the module by turning the ignition switch OFF, then turning the headlamps OFF.

The headlamp delay module is located behind the I/P next to the headlamp switch.

#### HEADLAMP DELAY MODULE REPLACEMENT—XJ

The headlamp delay module is attached to the inside of the instrument panel to the right of the headlamp switch.

#### REMOVAL

- (1) Remove the lower instrument panel.

(2) Remove the screw that attaches the module to the inside of the instrument panel.

(3) Disconnect the wire harness connector and remove the module from the instrument panel.

#### INSTALLATION

(1) Position the module inside the I/P and connect the wire harness connector to the module.

(2) Install the screw that attaches the module to the inside of the instrument panel.

(3) Remove the lower instrument panel.

#### HEADLAMP DELAY FUNCTION TROUBLE DIAGNOSIS—XJ

##### DELAY FUNCTION INOPERATIVE

(1) Remove, inspect and test the HD LP DLY fuse. Replace if defective.

(2) Remove the delay module from the I/P. Do not disconnect the wire harness connector. Turn the ignition switch to the RUN position. Place the headlamp switch in headlamps ON position. Turn the ignition to the OFF position for a resistance test.

(3) Measure the resistance from the delay module terminal 4 to vehicle body ground. The ohmmeter should indicate zero ohms. If not, repair the open circuit in the wire harness to vehicle body ground.

(4) Measure the voltage between the delay module terminal 8 and vehicle body ground. The voltmeter should indicate battery voltage. If not, repair the open circuit in the wire harness to the instrument cluster indicator connector terminal 14.

(5) Measure the voltage between the delay module terminal 6 and vehicle body ground. The voltmeter should indicate battery voltage. If not, repair the open circuit in the wire harness to the headlamp switch.

(6) Measure the voltage between the delay module terminal 2 and vehicle body ground. The voltmeter should indicate battery voltage. If not, repair the open circuit in the wire harness to the fuse.

## DAYTIME RUNNING LIGHTS (CANADA ONLY)—XJ

### SERVICE INFORMATION

The Daytime Running Lights (Headlamps) System is installed on vehicles manufactured for sale in Canada only. The headlamps are illuminated when the ignition switch is turned to the ON position. The DRL module receives a vehicle-moving signal from the vehicle speed sensor. This provides a constant **headlamps-on** condition as long as the vehicle is moving. The lamps are illuminated at less than 50 percent of normal intensity.

### DRL MODULE REPLACEMENT—XJ

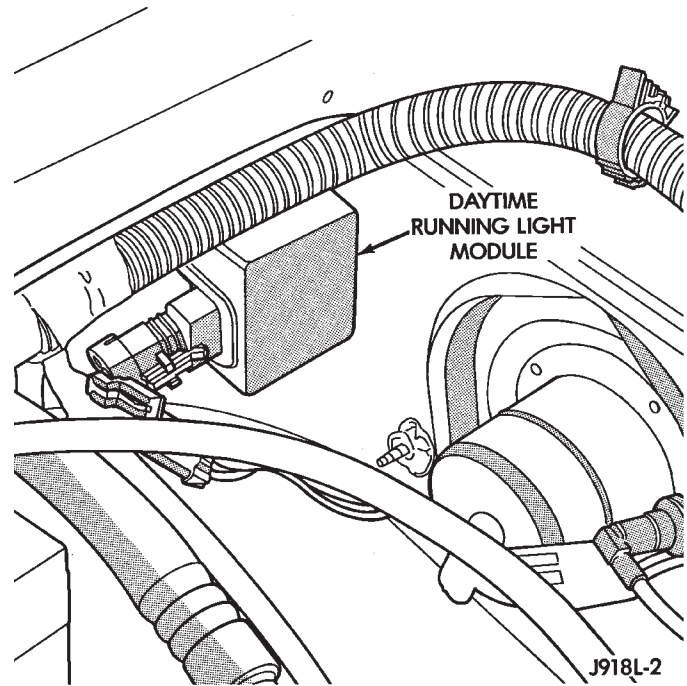
#### REMOVAL

The Daytime Running Lights (DRL) module is located on the right fender inner panel adjacent to the dash panel (Fig. 24).

- (1) Disconnect the wire harness connector from the module.
- (2) Remove the screws that attach the module to the fender inner panel.
- (3) Remove the module from the fender inner panel.

#### INSTALLATION

- (1) Position the module on the right fender inner panel.
- (2) Install the attaching screws. Tighten the screws securely.



**Fig. 24 Daytime Running Lights (DRL) Module**

- (3) Connect the wire harness connector to the module.

INTERIOR LAMPS

INDEX

	page		page
Dome Lamp Replacement—XJ	17	Lighted Vanity Mirror Trouble Diagnosis—XJ	16
Dome/Courtesy Lamp Service Information—XJ	16	Lighted Vanity Mirror—XJ	16
Dome/Courtesy Lamp Trouble Diagnosis—XJ	16	Overhead Console—XJ	17

**DOME/COURTESY LAMP SERVICE INFORMATION—XJ**

Voltage is applied at all times via the dome lamp fuse to each of the interior lamp bulbs. The interior lamp bulbs illuminate when they are connected to body ground via the switch:

- Headlamp switch.
- Glove box switch.
- Door pillar switch.
- Liftgate switch (if the cargo lamp is ON).

If equipped with Security Alarm Module, refer to Group 8Q, Vehicle Theft Security System.

**DOME/COURTESY LAMP TROUBLE DIAGNOSIS—XJ**

*ALL LAMPS INOPERATIVE*

(1) Rotate the headlamp switch rheostat clockwise. The lamps should light. If not OK, remove, inspect and test the dome lamp fuse. Replace if bad.

(2) If the fuse is OK, repair the open circuit in the wire harness to vehicle body ground.

*ONE LAMP INOPERATIVE*

(1) Measure the resistance across the bulb holder terminals. The ohmmeter should indicate zero ohms. If not, replace the bulb.

(2) Measure the voltage between the voltage side of the bulb holder and vehicle body ground. The voltmeter should indicate battery voltage. If not, repair the open circuit in the wire harness to the splice.

*LAMPS INOPERATIVE WITH ONE OR MORE DOORS OPENED*

(1) Remove the inoperative switch from the door pillar and connect the switch wire directly to ground. The lamp should light.

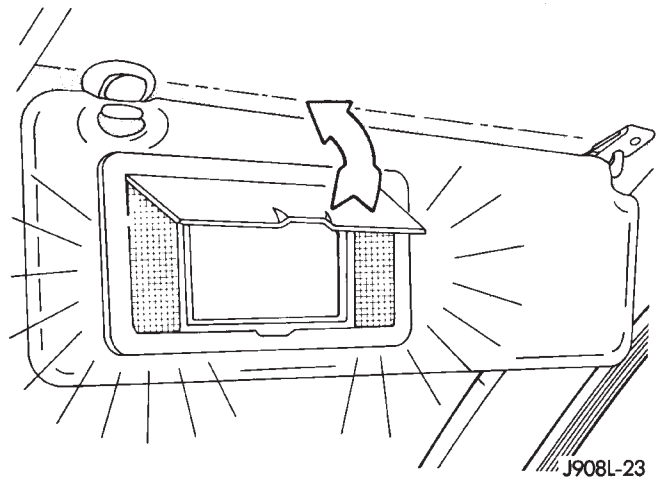
(2) If not, check for an open circuit in black (ground) wire. Repair as necessary. If lamps still do not light, replace the switch.

**LIGHTED VANITY MIRROR—XJ**

*SERVICE INFORMATION*

Both the driver and the front passenger sunvisor can be equipped with a lighted vanity mirror. A lamp

located at each side of the vanity mirror. The lamps are switched ON automatically when the mirror cover is lifted (Fig. 1).



**Fig. 1 Lighted Vanity Mirror**

Voltage is applied directly to the vanity lamp bulbs via the dome lamp fuse.

**LIGHTED VANITY MIRROR TROUBLE DIAGNOSIS—XJ**

*VANITY LAMPS INOPERATIVE*

(1) Remove, inspect and test the dome lamp fuse. Replace if defective.

(2) Test the dome lamp operation. If OK, go to the next step. If not OK, repair the open circuit in the wire harness from the splice.

(3) Measure the voltage between the pink wire on the switch connector and vehicle body ground. The voltmeter should indicate battery voltage. If not OK, repair the open circuit in the wire harness from the splice.

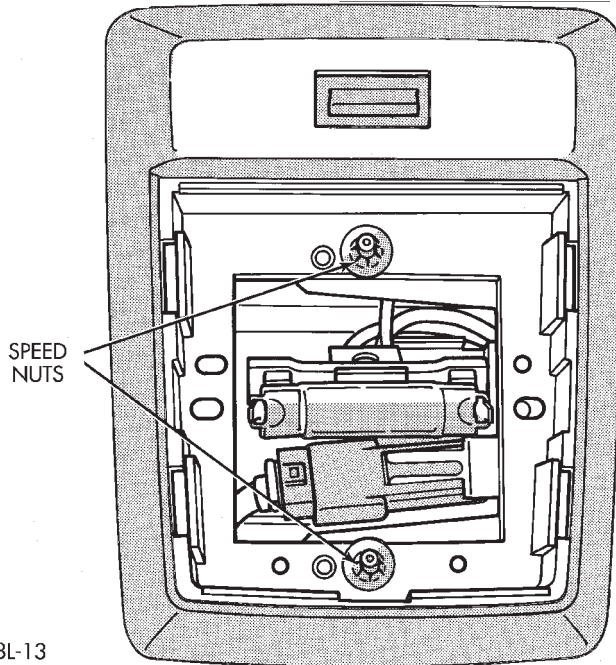
(4) Connect a jumper wire from the ground side of the switch to a good vehicle body ground. Measure the resistance to vehicle body ground. The ohmmeter should indicate zero ohms. If not, repair the open circuit in the wire harness to vehicle body ground.



## DOME LAMP REPLACEMENT—XJ

### REMOVAL

- (1) Remove the dome lamp lens by squeezing it at both sides. This will separate the lens retainer tabs from the lamp housing shoulders.
- (2) Pull the lens downward to remove it from the lamp housing.
- (3) Remove the lamp housing speed nuts (Fig. 2).



**Fig. 2 Dome Lamp Removal/Installation**

- (4) Disconnect the wire harness connector.
- (5) Remove the lamp housing from the headliner cavity.

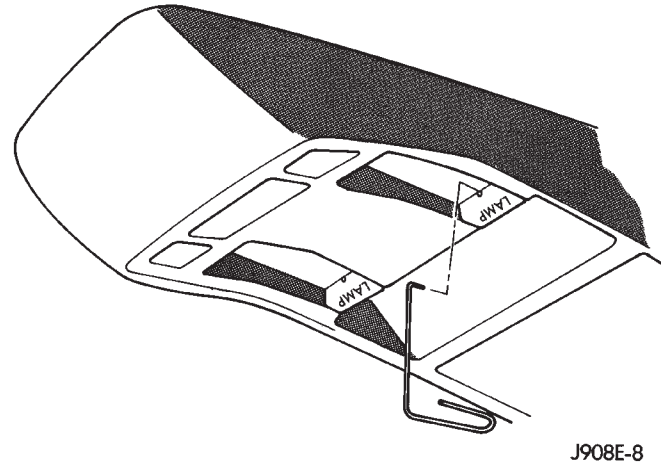
### INSTALLATION

- (1) Position the dome lamp housing at the headliner cavity.
- (2) Connect the wire harness connector.
- (3) Install the lamp housing speed nuts (Fig. 2).
- (4) Position the lens at the lamp housing and force it upward into the housing until the retainer tabs are seated on the lamp housing shoulders.

## OVERHEAD CONSOLE—XJ

### MAP READING LAMP LENS REMOVAL

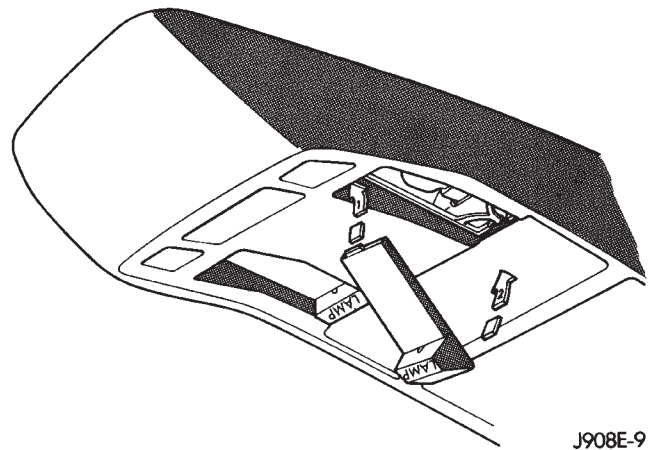
- (1) Make a straight hook at the end of a large paper clip or wire (approximately 1.5-mm/0.06-in diameter).
- (2) Insert the wire hook into the hole in the lamp lens and pull downward to detach the lens from the lamp housing (Fig. 3).



**Fig. 3 Map Reading Lamp Lens Removal**

### MAP READING LAMP LENS INSTALLATION

- (1) Insert the tab at the front of the lamp lens into the slot in the lamp housing—shown by arrow 1 in Figure 4.



**Fig. 4 Map Reading Lamp Lens Installation**

- (2) Force the rear of the lens upward until it is seated in the lamp housing—shown by arrow 2 in Figure 4.

## BULB APPLICATION—XJ VEHICLES

## GENERAL INFORMATION

The following Bulb Application Table lists the lamp title on the left side of the column and trade number or part number on the right.

**CAUTION:** Do not use bulbs that have a higher candle power than the bulb listed in the Bulb Application Table. Damage to lamp can result.

Do not touch halogen bulbs with fingers or other oily surfaces. Bulb life will be reduced.

## EXTERIOR LAMPS—XJ

Back-up .....	1156
Center High Mounted Stoplamp .....	922
Fog .....	H3
Front Side Marker .....	194
Headlamp/Sealed Beam .....	H6054
License Plate .....	168
License Plate W/Outside Spare .....	67
Park/Turn Signal .....	2057NA
Tail/Stop .....	2057
Turn Signal .....	1156

## INTERIOR LAMPS—XJ

Service procedures for most of the lamps in the instrument panel, Instrument cluster and switches are located in Group 8E, Instrument Panel and Gauges. Some components have lamps that can only be serviced by an Authorized Service Center (ASC) after the component is removed from the vehicle. Contact local dealer for location of nearest ASC.

Cargo .....	561
Dome .....	561
Dome/Reading .....	906

Glove Compartment .....	194
Overhead Console .....	912
Under Hood .....	105
Vanity Mirror .....	74
Underpanel Courtesy .....	168

## INDICATOR LAMPS

Service procedures for most of the lamps in the instrument panel, instrument cluster and switches are located in Group 8E, Instrument Panel and Gauges.

A/C Control .....	74
Airbag .....	74
Anti-lock Brake .....	74
Ash Receiver .....	1891
Brake Warning .....	74
Check Engine .....	74
Cigar Lighter .....	53
Diesel Wait .....	74
Fasten Seat Belts .....	74
Four Wheel Drive .....	74
Generator .....	194
Generator/Diesel .....	74
Heater Control .....	74
High Beam .....	194
Illumination .....	194
Low Fuel .....	194
Low Washer Fluid .....	74
Radio .....	ASC
Rocker Switch .....	37
Seat Belt .....	74
Transfer Case .....	658
Transmission Floor Shift .....	658
Turn Signal .....	194
Shift .....	74
Water In Fuel .....	74

# LAMPS

## CONTENTS

	page		page
BULB APPLICATION—YJ VEHICLES .....	32	INTERIOR LAMPS .....	31
GENERAL INFORMATION .....	19	SERVICE PROCEDURES .....	22

## GENERAL INFORMATION

Each vehicle is equipped with various lamp assemblies. A good ground is necessary for proper lighting operation. Grounding is provided by the lamp socket when it comes in contact with the metal body, or through a separate ground wire.

When changing lamp bulbs check the socket for corrosion. If corrosion is present, clean it with a wire brush and coat the inside of the socket lightly with Mopar Multi-Purpose Grease or equivalent.

### DIAGNOSTIC PROCEDURES—YJ

When a vehicle experiences problems with the headlamp system, verify the condition of the battery

connections, charging system, headlamp bulbs, wire connectors, relay, high beam dimmer switch and headlamp switch. Refer to Group 8W, Wiring Diagrams for component locations and circuit information.

Always begin any diagnosis by testing all of the fuses and circuit breakers in the system. Refer to Group 8W, Wiring Diagrams.

## HEADLAMP DIAGNOSIS

CONDITION	POSSIBLE CAUSES	CORRECTION
HEADLAMPS ARE DIM WITH ENGINE IDLING OR IGNITION TURNED OFF.	<ol style="list-style-type: none"> <li>1. Loose or corroded battery cables.</li> <li>2. Loose or worn generator drive belt.</li> <li>3. Charging system output too low.</li> <li>4. Battery has insufficient charge.</li> <li>5. Battery is sulfated or shorted.</li> <li>6. Poor lighting circuit Z1-ground.</li> <li>7. Both headlamp bulbs defective.</li> </ol>	<ol style="list-style-type: none"> <li>1. Clean and secure battery cable clamps and posts.</li> <li>2. Adjust or replace generator drive belt.</li> <li>3. Test and repair charging system, refer to Group 8A.</li> <li>4. Test battery state-of-charge, refer to Group 8A.</li> <li>5. Load test battery, refer to Group 8A.</li> <li>6. Test for voltage drop across Z1-ground locations, refer to Group 8W.</li> <li>7. Replace both headlamp bulbs.</li> </ol>
HEADLAMP BULBS BURN OUT FREQUENTLY.	<ol style="list-style-type: none"> <li>1. Charging system output too high.</li> <li>2. Loose or corroded terminals or splices in circuit.</li> </ol>	<ol style="list-style-type: none"> <li>1. Test and repair charging system, refer to Group 8A.</li> <li>2. Inspect and repair all connectors and splices, refer to Group 8W.</li> </ol>
HEADLAMPS ARE DIM WITH ENGINE RUNNING ABOVE IDLE.*	<ol style="list-style-type: none"> <li>1. Charging system output too low.</li> <li>2. Poor headlamp circuit ground.</li> <li>3. High resistance in headlamp circuit.</li> <li>4. Both headlamp bulbs defective.</li> </ol>	<ol style="list-style-type: none"> <li>1. Test and repair charging system, refer to Group 8A.</li> <li>2. Test voltage drop across Z1-ground, refer to Group 8W.</li> <li>3. Test amperage draw of headlamp circuit.</li> <li>4. Replace both headlamp bulbs.</li> </ol>
HEADLAMPS FLASH RANDOMLY.	<ol style="list-style-type: none"> <li>1. Poor headlamp circuit ground.</li> <li>2. High resistance in headlamp circuit.</li> <li>3. Faulty headlamp switch circuit breaker.</li> <li>4. Loose or corroded terminals or splices in circuit.</li> </ol>	<ol style="list-style-type: none"> <li>1. Repair circuit ground, refer to Group 8W.</li> <li>2. Test amperage draw of headlamp circuit.</li> <li>3. Replace headlamp switch.</li> <li>4. Repair connector terminals or splices, refer to Group 8W.</li> </ol>
HEADLAMPS DO NOT ILLUMINATE.	<ol style="list-style-type: none"> <li>1. No voltage to headlamps.</li> <li>2. No ground at headlamps.</li> <li>3. Faulty headlamp switch.</li> <li>4. Faulty headlamp dimmer switch.</li> <li>5. Broken connector terminal or wire splice in headlamp circuit.</li> </ol>	<ol style="list-style-type: none"> <li>1. Replace fuse, refer to group 8W.</li> <li>2. Repair circuit ground, refer to Group 8W.</li> <li>3. Replace headlamp switch.</li> <li>4. Replace headlamp dimmer switch.</li> <li>5. Repair connector terminal or wire splices.</li> </ol>
* Canada vehicles must have lamps ON.		

## FOG LAMP DIAGNOSIS

CONDITION	POSSIBLE CAUSES	CORRECTION
FOG LAMPS ARE DIM WITH ENGINE IDLING OR IGNITION TURNED OFF.	<ol style="list-style-type: none"> <li>1. Loose or corroded battery cables.</li> <li>2. Loose or worn generator drive belt.</li> <li>3. Charging system output too low.</li> <li>4. Battery has insufficient charge.</li> <li>5. Battery is sulfated or shorted.</li> <li>6. Poor lighting circuit Z1-ground.</li> <li>7. Both fog lamp bulbs defective.</li> </ol>	<ol style="list-style-type: none"> <li>1. Clean and secure battery cable clamps and posts.</li> <li>2. Adjust or replace generator drive belt.</li> <li>3. Test and repair charging system, refer to Group 8A.</li> <li>4. Test battery state-of-charge, refer to Group 8A.</li> <li>5. Load test battery, refer to Group 8A.</li> <li>6. Test for voltage drop across Z1-ground locations, refer to Group 8W.</li> <li>7. Replace both lamp bulbs.</li> </ol>
FOG LAMP BULBS BURN OUT FREQUENTLY.	<ol style="list-style-type: none"> <li>1. Charging system output too high.</li> <li>2. Loose or corroded terminals or splices in circuit.</li> </ol>	<ol style="list-style-type: none"> <li>1. Test and repair charging system, refer to Group 8A.</li> <li>2. Inspect and repair all connectors and splices, refer to Group 8W.</li> </ol>
FOG LAMPS ARE DIM WITH ENGINE RUNNING ABOVE IDLE.	<ol style="list-style-type: none"> <li>1. Charging system output too low.</li> <li>2. Poor fog lamp circuit ground.</li> <li>3. High resistance in fog lamp circuit.</li> <li>4. Both fog lamp bulbs defective.</li> </ol>	<ol style="list-style-type: none"> <li>1. Test and repair charging system, refer to Group 8A.</li> <li>2. Test voltage drop across Z1-ground, refer to Group 8W.</li> <li>3. Test amperage draw of fog lamp circuit.</li> <li>4. Replace both fog lamp bulbs.</li> </ol>
FOG LAMPS FLASH RANDOMLY.	<ol style="list-style-type: none"> <li>1. Poor fog lamp circuit ground.</li> <li>2. High resistance in fog lamp circuit.</li> <li>3. Faulty fog lamp switch circuit breaker.</li> <li>4. Loose or corroded terminals or splices in circuit.</li> </ol>	<ol style="list-style-type: none"> <li>1. Repair circuit ground, refer to Group 8W.</li> <li>2. Test amperage draw of fog lamp circuit.</li> <li>3. Replace fog lamp switch.</li> <li>4. Repair connector terminals or splices, refer to Group 8W.</li> </ol>
FOG LAMPS DO NOT ILLUMINATE.	<ol style="list-style-type: none"> <li>1. Blown fuse for fog lamps.</li> <li>2. No ground at fog lamps.</li> <li>3. Faulty fog lamp switch.</li> <li>4. Broken connector terminal or wire splice in fog lamp circuit.</li> </ol>	<ol style="list-style-type: none"> <li>1. Replace fuse, refer to group 8W.</li> <li>2. Repair circuit ground, refer to Group 8W.</li> <li>3. Replace fog lamp switch.</li> <li>4. Repair connector terminal or wire splices.</li> </ol>

SERVICE PROCEDURES

INDEX

	page		page
Back-Up/Rear Turn Signal/Tail Lamp Bulb Replacement—YJ	28	Headlamp Alignment—YJ	22
Center High Mounted Stop Lamp (CHMSL)—YJ	28	Headlamp Bulb Replacement—YJ	23
Daytime Running Lights (Canada Only)—YJ	30	Headlamp Dimmer Switch Replacement—YJ	26
Drl Module Replacement—YJ	30	Headlamp Switch—YJ	26
Fog Lamp Replacement—YJ	25	Headlamp/Fog Lamp Adjustment Using Alignment Screen—YJ	23
Fog Lamp Switch Replacement—YJ	26	Side Marker Lamp Bulb Replacement—YJ	25
Fog Lamps—YJ	23	Underhood Lamp Bulb Replacement—YJ	29
Front Park/Turn Signal Lamp Bulb Replacement—YJ	25	Underhood Lamp Replacement—YJ	29
Headlamp Alignment Preparation—YJ	22	Underhood Lamp Service Information—YJ	28

HEADLAMP ALIGNMENT—YJ

Headlamps can be aligned using the screen method provided in this section. Alignment Tool C4466-A or equivalent can also be used. Refer to instructions provided with the tool for proper procedures. **The preferred headlamp alignment setting is 0 for the left/right adjustment and 1" down for the up/down adjustment.**

HEADLAMP ALIGNMENT PREPARATION—YJ

- (1) Verify headlamp dimmer switch and high beam indicator operation.
- (2) Correct defective components that could hinder proper headlamp alignment.
- (3) Verify proper tire inflation.
- (4) Clean headlamp lenses.
- (5) Verify that luggage area is not heavily loaded.
- (6) Fuel tank should be FULL. Add 2.94 kg (6.5 lbs.) of weight over the fuel tank for each estimated gallon of missing fuel.

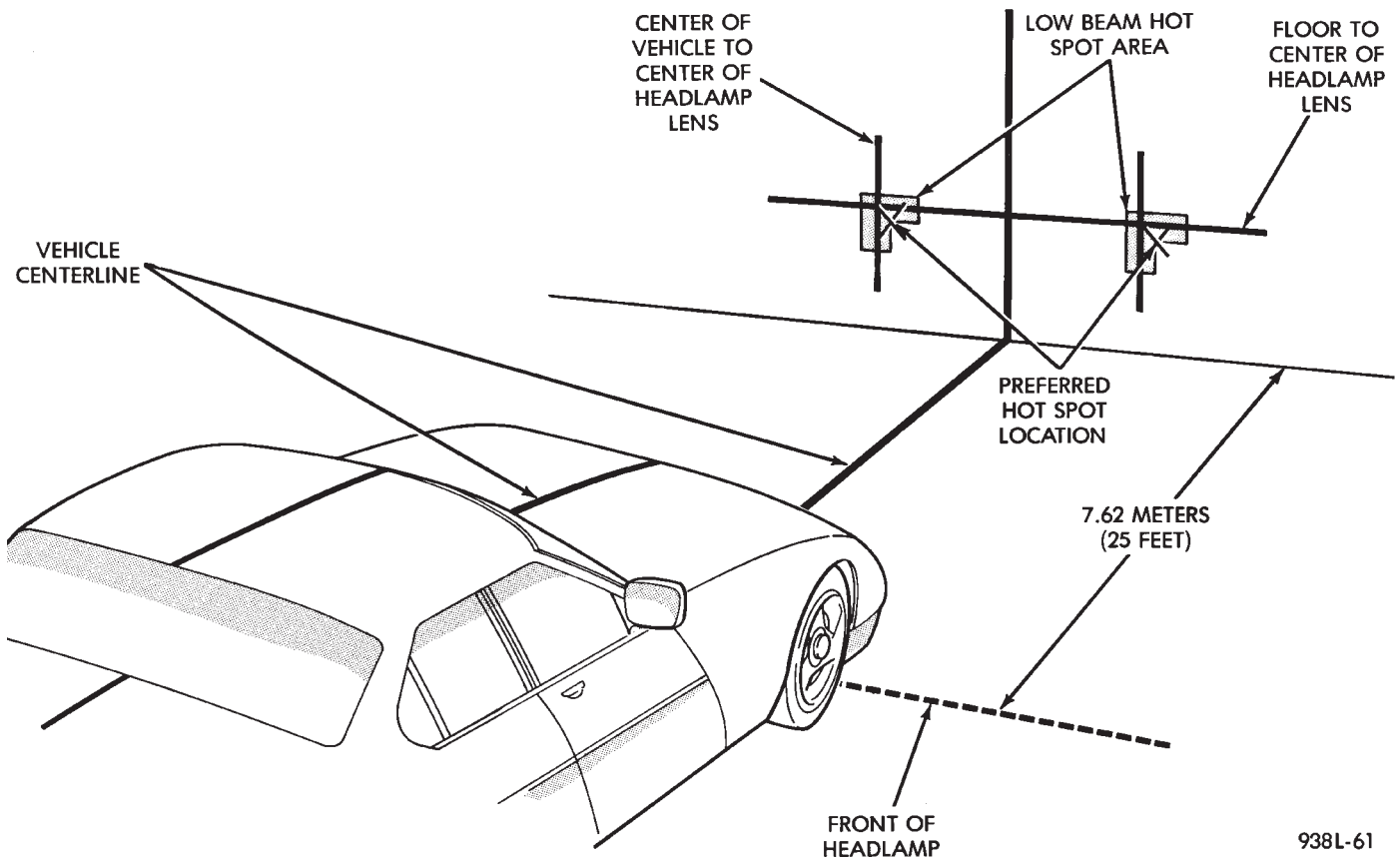


Fig. 1 Headlamp Alignment Screen—Typical

## HEADLAMP/FOG LAMP ADJUSTMENT USING ALIGNMENT SCREEN—YJ

### ALIGNMENT SCREEN PREPARATION

(1) Position vehicle on a level surface perpendicular to a flat wall 7.62 meters (25 ft) away from front of headlamp lens (Fig. 1).

(2) If necessary, tape a line on the floor 7.62 meters (25 ft) away from and parallel to the wall.

(3) Measure from the floor up 1.27 meters (5 ft) and tape a line on the wall at the centerline of the vehicle. Sight along the centerline of the vehicle (from rear of vehicle forward) to verify accuracy of the line placement.

(4) Rock vehicle side-to-side three times to allow suspension to stabilize.

(5) Jounce front suspension three times by pushing downward on front bumper and releasing.

(6) Measure the distance from the center of headlamp lens to the floor. Transfer measurement to the alignment screen (with tape). Use this line for up/down adjustment reference.

(7) Measure distance from the centerline of the vehicle to the center of each headlamp being aligned. Transfer measurements to screen (with tape) to each side of vehicle centerline. Use these lines for left/right adjustment reference.

### ADJUSTMENT

(1) Remove screws and both headlamp bezels.

(2) Clean front of the headlamps.

(3) Place headlamps on LOW beam.

(4) Cover front of the headlamp that is not being adjusted.

(5) Turn vertical adjustment screw (Fig. 2) until the headlamp beam pattern on screen/wall is similar to the pattern depicted in Figure 1.

**When using a headlamp aiming screen:**

- Adjust the headlamps so that the beam horizontal position is at 0.

- Adjust the beam vertical position is 25 mm (1 in) downward from the lamp horizontal centerline.

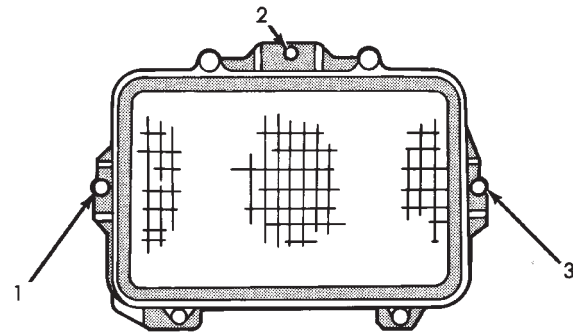
(6) Rotate the horizontal adjustment screw until the headlamp beam pattern on the aiming screen/wall similar to the pattern in Figure 1.

(7) Cover front of the headlamp that has been adjusted and adjust the other headlamp beam as instructed above.

(8) Install headlamp bezels. Tighten the screws securely.

### FOG LAMP ADJUSTMENT

Prepare an alignment screen. Refer to Alignment Screen Preparation paragraph in this section. A properly aligned fog lamp will project a pattern on the alignment screen 100 mm (4 in.) below the fog lamp centerline and straight ahead (Fig. 3)



1. HORIZONTAL ADJ. SCREW - RH
2. VERTICAL ADJ. SCREW
3. HORIZONTAL ADJ. SCREW - LH

J908L-24

**Fig. 2 Headlamp Beam Adjustment Screws**

### HEADLAMP BULB REPLACEMENT—YJ

(1) Remove the screws and the headlamp bezel (Fig. 4).

(2) Remove the screws and headlamp bulb retaining ring.

(3) Disconnect the headlamp bulb wire harness connector and remove the bulb from the bucket.

### INSTALLATION

(1) Position the bulb in the bucket and connect the wire harness connector.

(2) Position retaining ring on the headlamp bulb and install screws.

(3) Install the headlamp bezel. Tighten the screws securely.

### FOG LAMPS—YJ

Fog lamps are turned OFF by the circuit relay when the high beam driving lamps are turned ON.

Fog lamps may be operated ONLY when low beam headlamps are ON. If the headlamps are switched to high beam, the low beam lamps and fog lamps will turn OFF. The fog lamps will go back on when the high beams are switched OFF.

The indicator lamp on the fog lamp switch will go:

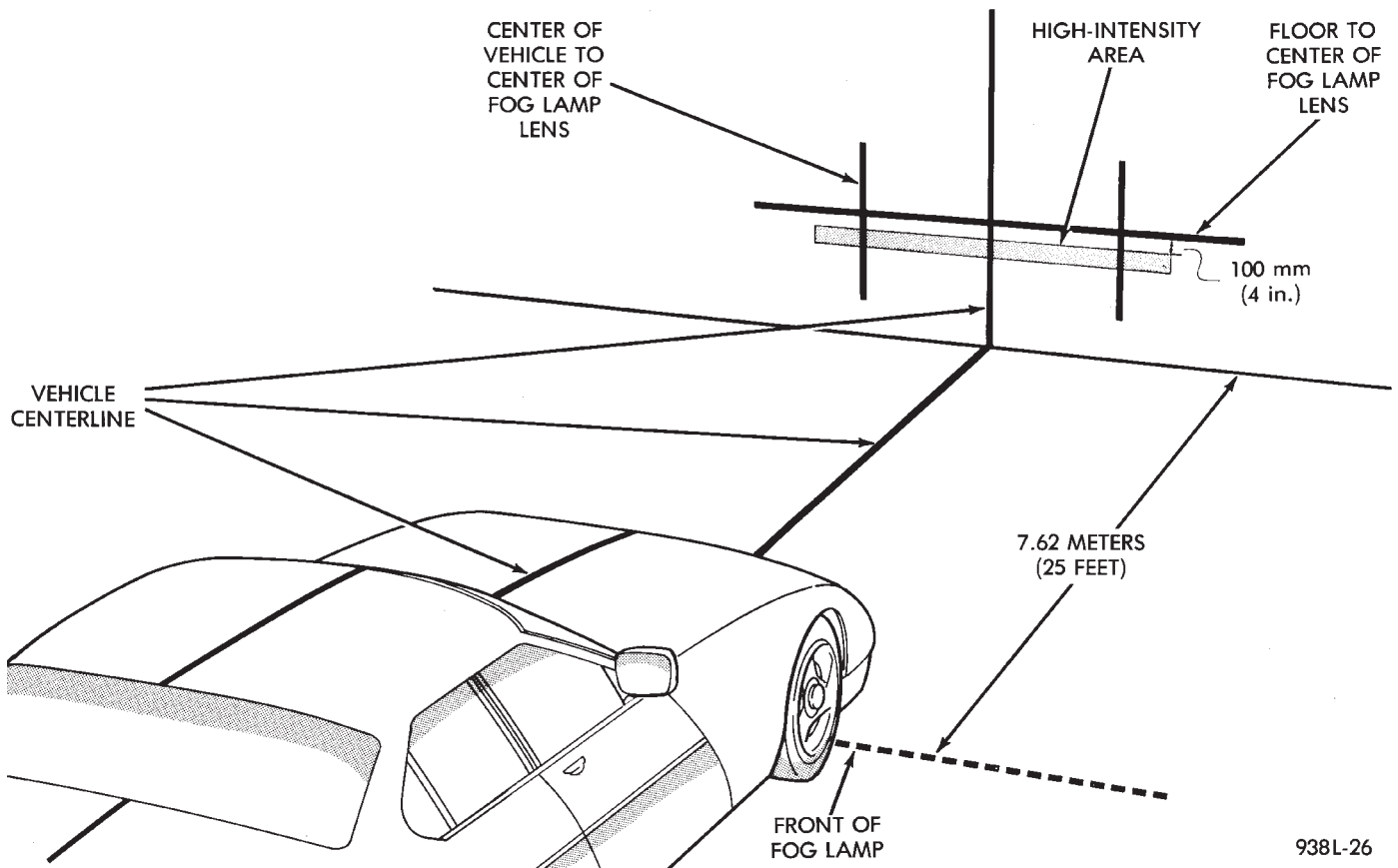
- OFF when the high beams lamps are switched ON.
- ON when the high beam lamps are switched OFF.

### FOG LAMP BULB REPLACEMENT

**CAUTION: Do not touch the bulb glass with fingers or other oily surfaces. Reduced bulb life will result.**

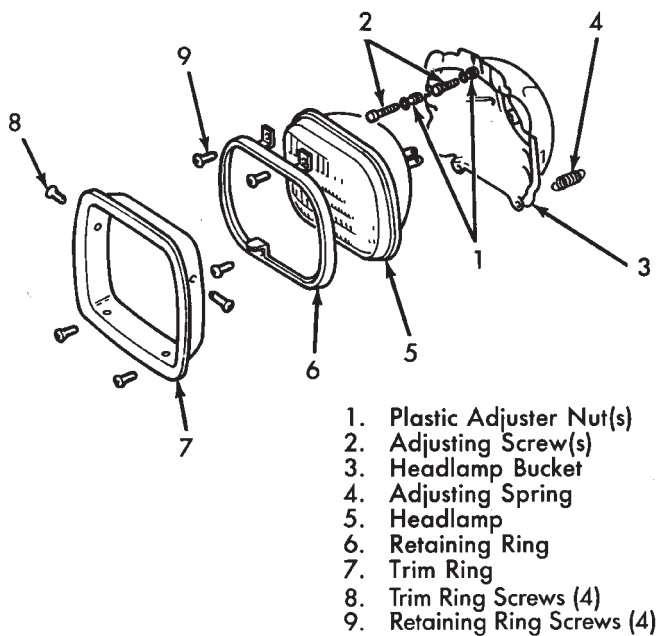
(1) Remove the screws that attach the stone shield and the reflector to the lamp housing. Remove the stone shield and reflector from the lamp housing (Fig. 5).

(2) Remove the bulb/element holder from the lens/reflector.



938L-26

**Fig. 3 Fog Lamp Alignment—Typical**



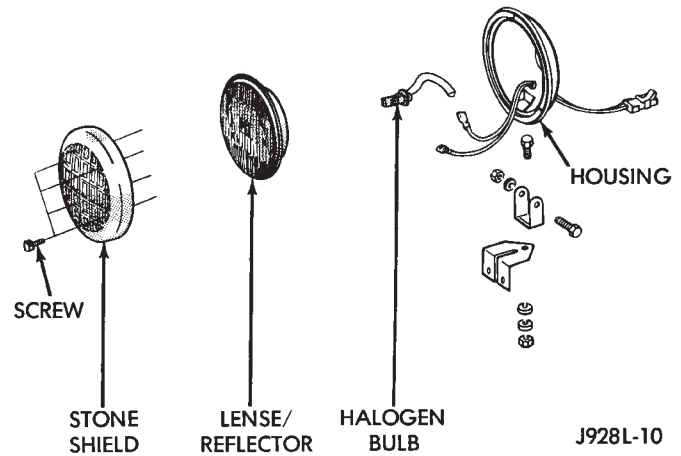
J918L-6

**Fig. 4 Headlamp Components**

(3) Remove the bulb/element from the holder.

**INSTALLATION**

(1) Use a clean cloth to install a replacement bulb holder.



J928L-10

**Fig. 5 Fog Lamp**

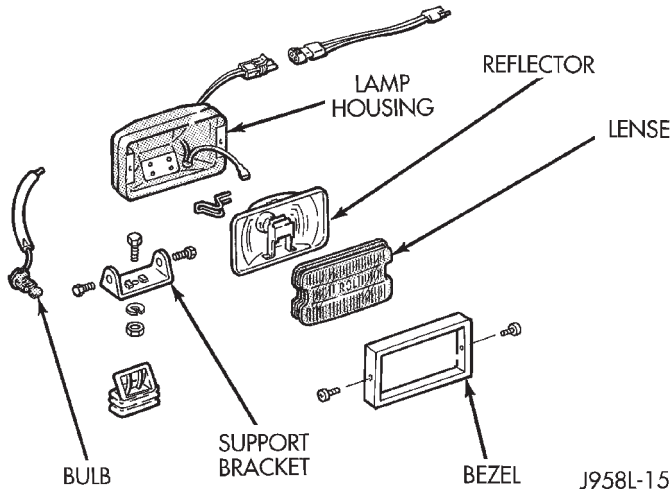
(2) Install the bulb holder in the lens/reflector.  
 (3) Position the stone shield and reflector on the lamp housing. Install the screws that attach the stone shield and the reflector to the lamp housing. Tighten the screws securely.



## FOG LAMP REPLACEMENT—YJ

### REMOVAL

- (1) Disconnect the fog lamp wire harness connector.
- (2) Remove the fog lamp nut(s), washers(s) and bolt(s) from the support bracket (Fig. 5 and 6).



**Fig. 6 Rectangular-Shaped Fog Lamp**

- (3) Remove the fog lamp from the support bracket.

### INSTALLATION

- (1) Position the fog lamp on the support bracket.
- (2) Install the fog lamp bolt(s), washer(s) and nut(s) in the support bracket.
- (3) Connect the fog lamp wire harness connector.

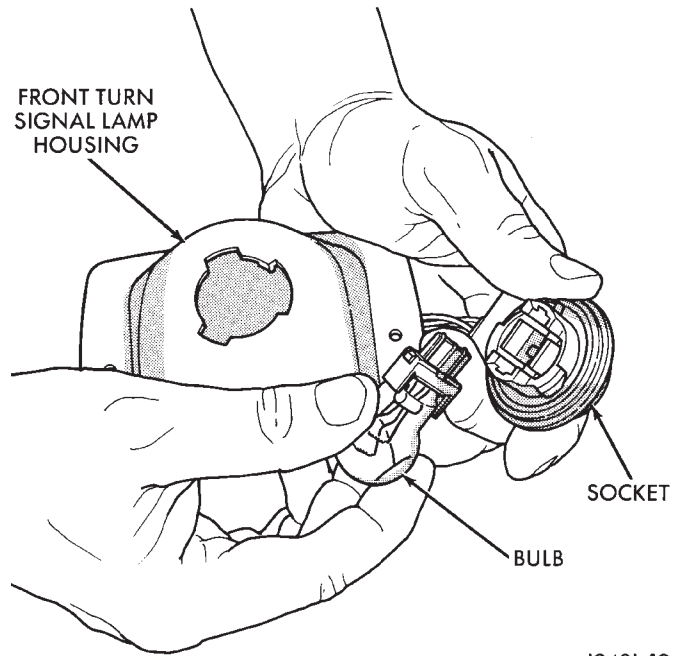
## FRONT PARK/TURN SIGNAL LAMP BULB REPLACEMENT—YJ

### REMOVAL

- (1) Remove the park/turn signal lamp housing screws (Fig. 7).
- (2) Separate the park/turn signal lamp housing from the grille panel.
- (4) Turn the bulb socket and remove it from the lamp housing.
- (3) Pull the bulb straight out of the socket.

### INSTALLATION

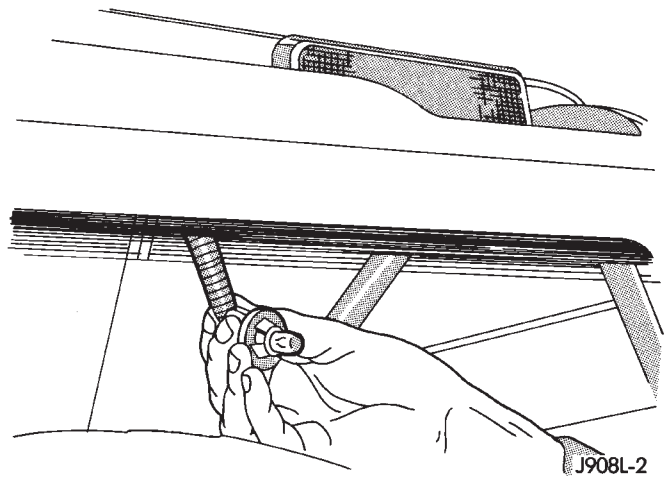
- (1) Install a replacement bulb in the socket.
- (2) Install the bulb and socket in the lamp housing.
- (3) Position the park/turn signal lamp housing at the opening in the grille panel.
- (4) Install the lamp housing retaining screws. Tighten the screws securely.



**Fig. 7 Park/Turn Signal Lamp Bulb Replacement**  
**SIDE MARKER LAMP BULB REPLACEMENT—YJ**

### REMOVAL

- (1) Remove side marker bulb socket via the underside of the fender. Rotate it one-third turn and separate it from the side marker lamp housing (Fig. 8).



**Fig. 8 Side Marker Lamp Bulb**

- (2) Remove the bulb from the socket by pulling it straight outward.

### INSTALLATION

- (1) Install a replacement bulb in the socket.
- (2) Install the bulb and socket in the side marker lamp housing (Fig. 8).

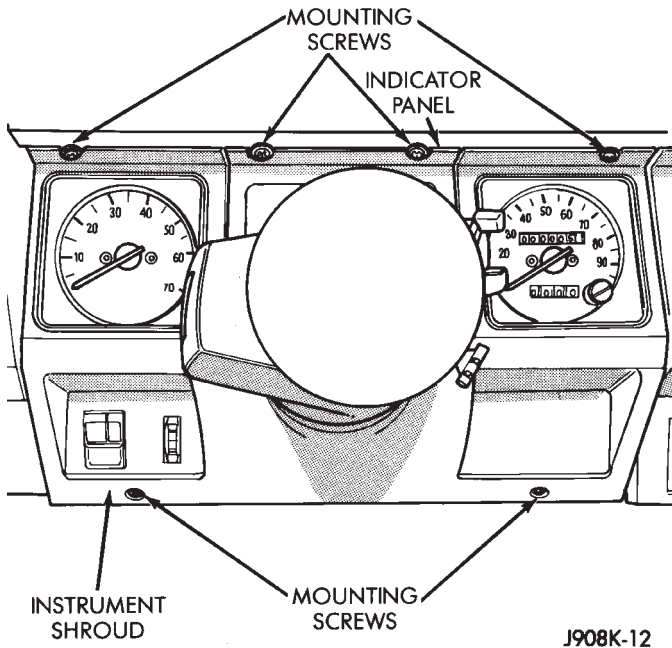
**HEADLAMP SWITCH—YJ**

To remove or replace the headlamp switch, refer to Group 8E, Instrument Panel and Gauges.

**FOG LAMP SWITCH REPLACEMENT—YJ****REMOVAL**

The fog lamp switch is located on the instrument panel at the right of the steering column. The fog lamp circuit relay is located below the left headlamp.

- (1) Disconnect the battery negative cable.
- (2) Remove the I/P shroud retaining screws (Fig. 9).

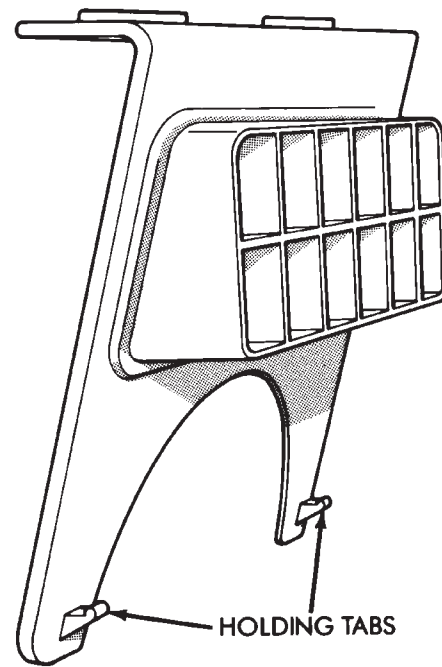


**Fig. 9 Instrument Panel Shroud**

- (3) Move the I/P shroud toward the steering wheel.
- (4) Apply upward force to the I/P shroud and downward force to the indicator panel. This will release the indicator panel holding tabs (Fig. 10).
- (5) Remove the shroud from the instrument panel.
- (6) Remove the fog lamp switch retaining screws.
- (7) Disconnect the wire harness connector from the fog lamp switch.
- (8) Remove the fog lamp switch from the instrument panel cavity.

**INSTALLATION**

- (1) Position the fog lamp switch in the instrument panel cavity and connect the wire harness connector to the switch.
- (2) Install the fog lamp switch retaining screws. Tighten the screws securely.
- (3) Position the I/P shroud under the steering column.
- (4) Slide the indicator panel holding tabs into the shroud notches.
- (5) Place the assembled I/P shroud over the indicator lamp foam gasket.



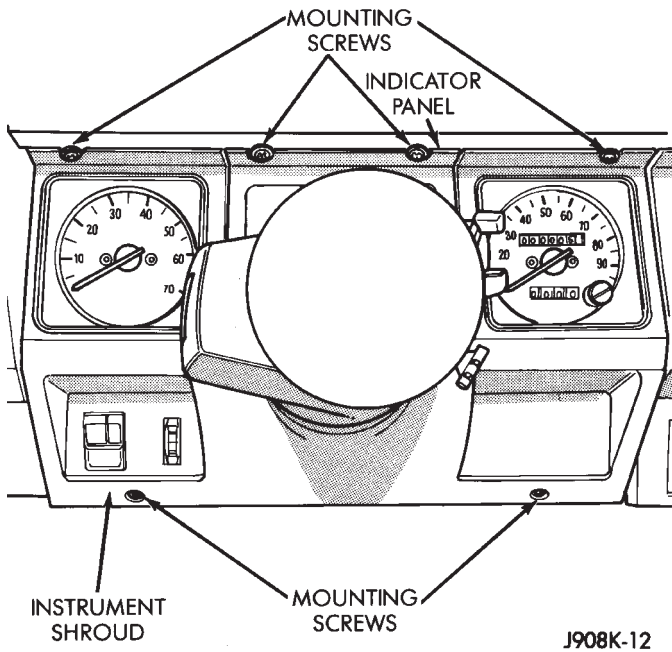
**Fig. 10 Indicator Panel Holding Tabs**

The foam gasket located on the back side of the indicator panel overlay is fragile. If it is either torn or distorted, replace it.

- (6) Install and tighten the indicator panel retaining screws.
- (7) Install the remaining shroud screws. Tighten the screws securely.
- (8) Connect the battery negative cable.

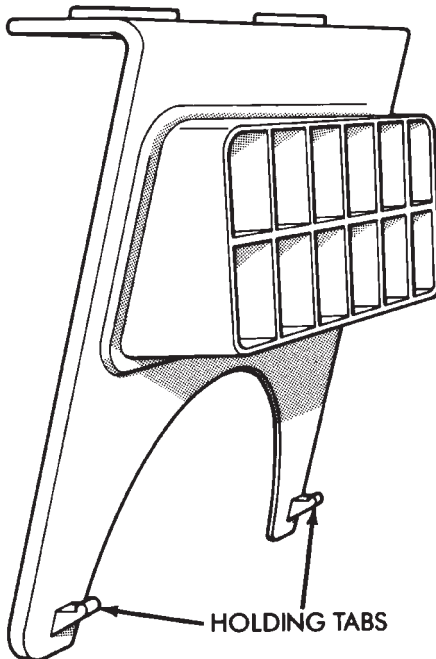
**HEADLAMP DIMMER SWITCH REPLACEMENT—YJ****REMOVAL**

- (1) Disconnect battery negative cable.
- (2) Remove the I/P shroud retaining screws (Fig. 11).
- (3) Move the I/P shroud toward the steering wheel and apply upward force to the I/P shroud and downward force to the indicator panel. This will release the indicator panel holding tabs (Fig. 12).
- (4) Remove the shroud from the instrument panel.
- (5) Support the A/C evaporator housing.
- (6) Remove the A/C evaporator housing-to-instrument panel screws (Fig. 13).
- (7) Remove the A/C evaporator housing support bracket screw.
- (8) Remove the support and lower the A/C evaporator housing.
- (9) Disconnect the dimmer switch wire harness connector.
- (10) Tape the dimmer switch actuator rod to the steering column.



J908K-12

**Fig. 11 Instrument Panel Shroud**



J898K-15

**Fig. 12 Indicator Panel Holding Tabs**

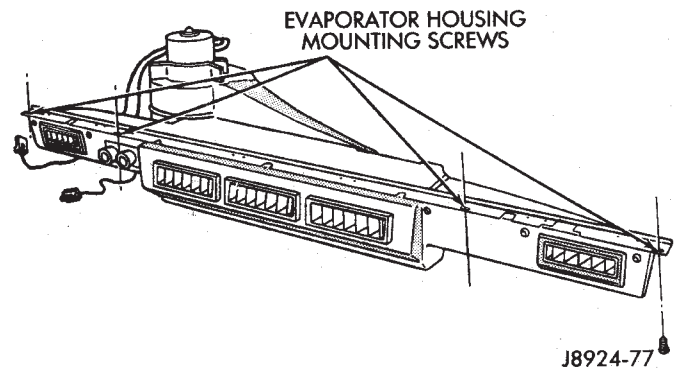
(11) Remove the dimmer switch screws and detach the switch from the rod.

#### INSTALLATION

(1) Force the dimmer switch onto the actuator rod and install screws. **DO NOT tighten the retaining screws at this time.**

(2) Remove the tape attaching the actuator rod to the steering column.

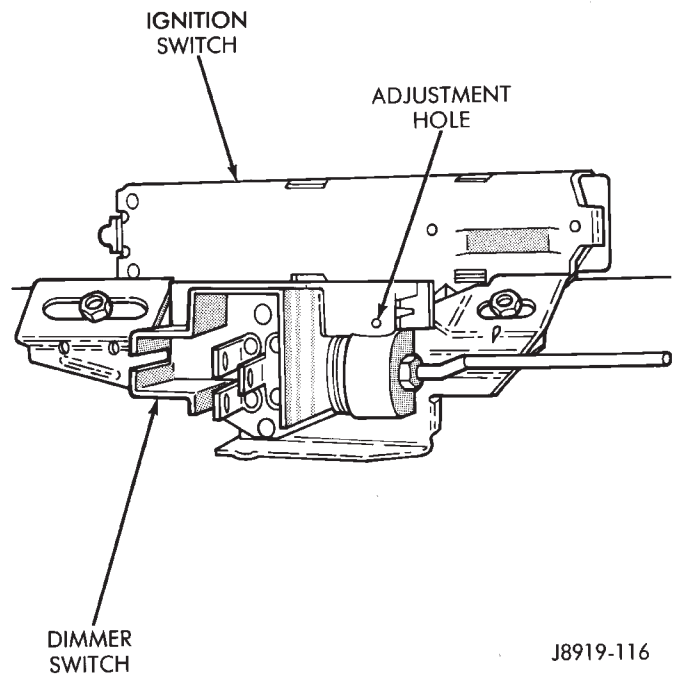
(3) Adjust the dimmer switch as follows:



J8924-77

**Fig. 13 A/C Evaporator Housing**

- Compress the switch and insert a 3/32-inch diameter drill bit into the adjustment hole (Fig. 14).
- The drill bit will prevent any horizontal movement of the switch.



J8919-116

**Fig. 14 Headlamp Dimmer Switch Adjustment**

- Move the switch toward the steering wheel to remove any existing actuator rod lash.
  - Tighten screws with 4 N·m (35 in. lbs.) torque.
  - Connect battery negative cable.
  - Remove drill bit and test the switch operation.
  - Re-adjust the switch, if necessary.
- (4) Position the I/P shroud under the steering column.
  - (5) Slide the indicator panel holding tabs (Fig. 12) into the shroud notches;
  - (6) Place the assembled I/P shroud over the indicator lamp gasket.
  - (7) Install and tighten screws.
  - (8) Install and tighten remaining shroud screws.

(9) Raise and support the A/C evaporator housing (Fig. 13).

(10) Install the evaporator housing-to-instrument panel screws and evaporator support bracket screw.

**BACK-UP/REAR TURN SIGNAL/TAIL LAMP BULB REPLACEMENT—YJ**

**REMOVAL**

- (1) Remove the lens retaining screws from the tail lamp housing (Fig. 15).
- (2) Separate the lens from the tail lamp housing.
- (3) Remove the bulb from the lamp socket.

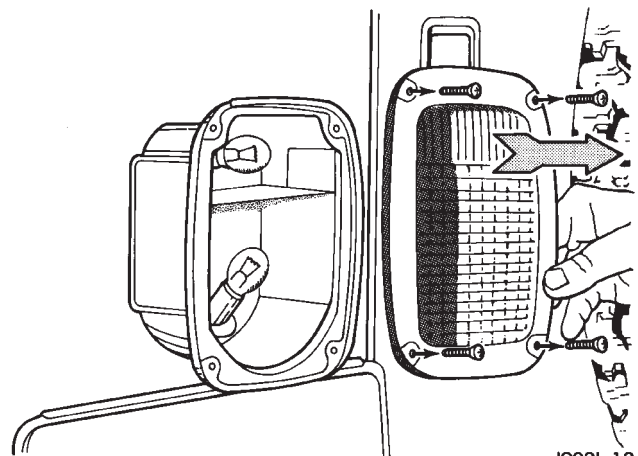
**INSTALLATION**

- (1) Install a replacement bulb in the lamp socket.
- (2) Position the lens on the lamp housing.
- (3) Install the lens retaining screws. Tighten the screws securely.

**CENTER HIGH MOUNTED STOP LAMP (CHMSL)—YJ**

The CHMSL is mounted on top of a bracket that attaches to the spare tire carrier (Fig. 16).

- (1) Remove the CHMSL lens (Fig. 17).
- (2) Remove CHMSL lamp housing (Fig. 18)



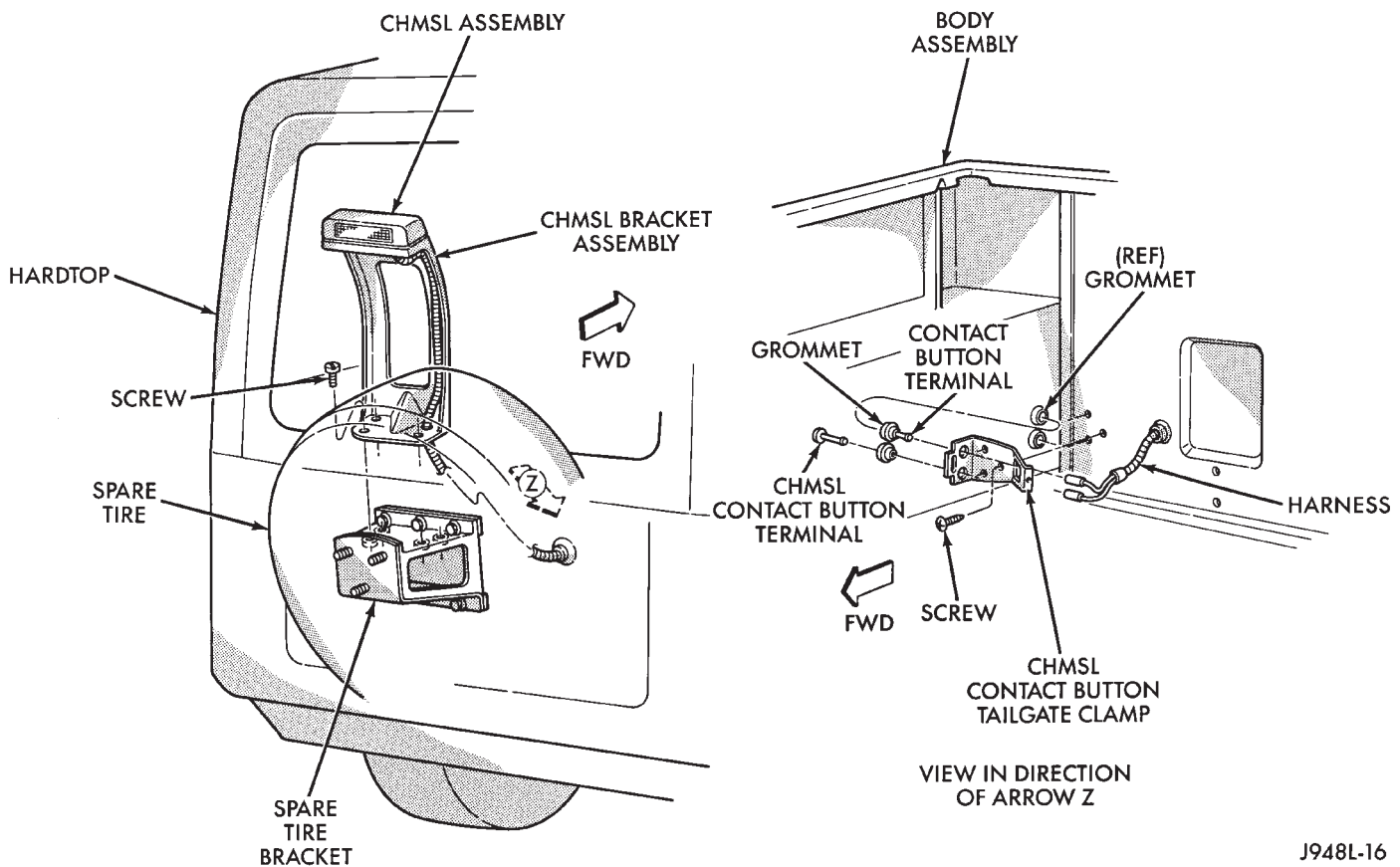
J908L-13

**Fig. 15 Back-up/Rear Turn Signal/Tail Lamp Bulb Replacement**

- (5) Replace bulbs if necessary. To install, reverse removal procedure.

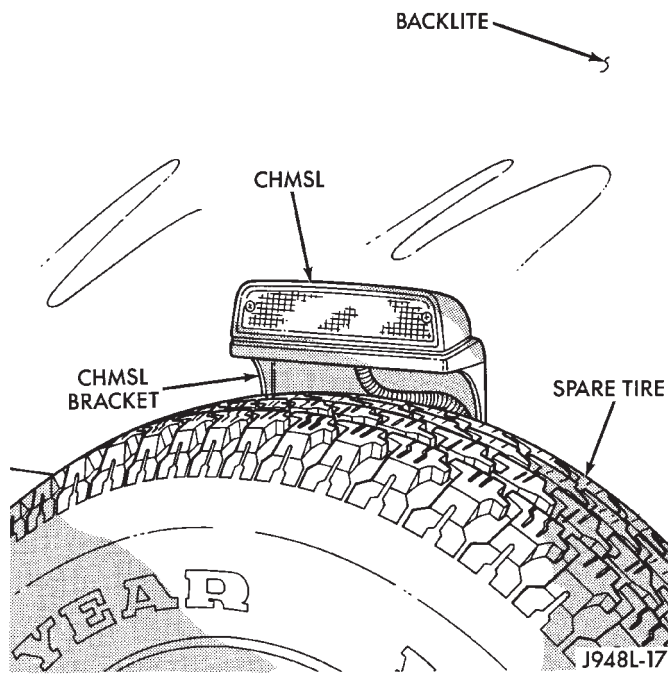
**UNDERHOOD LAMP SERVICE INFORMATION—YJ**

When equipped, the underhood lamp is installed on the hood right, rear inner panel (Fig. 19). The lamp is illuminated when the hood is opened. The switch

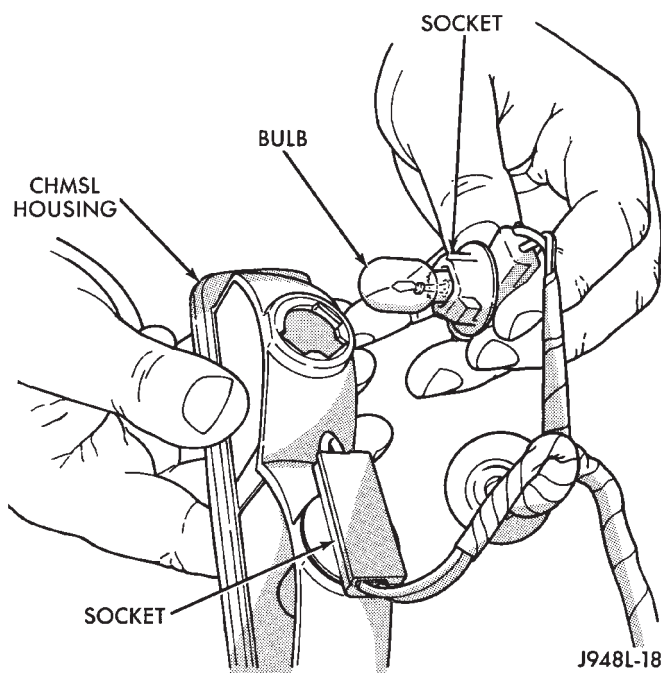


J948L-16

**Fig. 16 Center High Mounted Stop Lamp (CHMSL) Bracket Assembly**



**Fig. 17 Removing CHMSL Access Door**



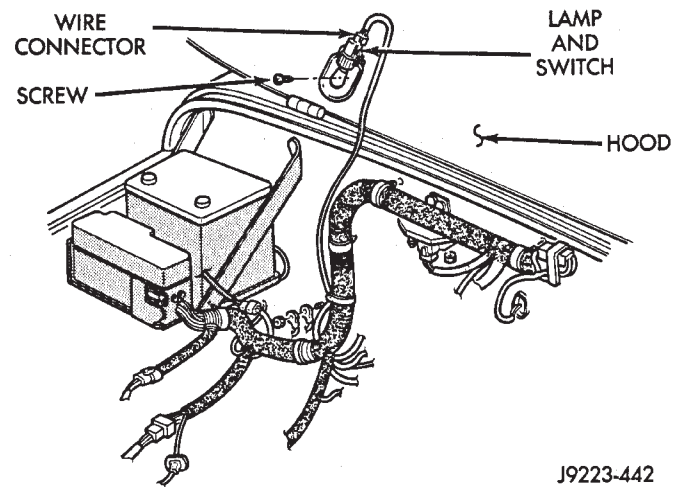
**Fig. 18 Replacing CHMSL Bulb**

provides automatic ON/OFF functions each time the hood is opened and closed.

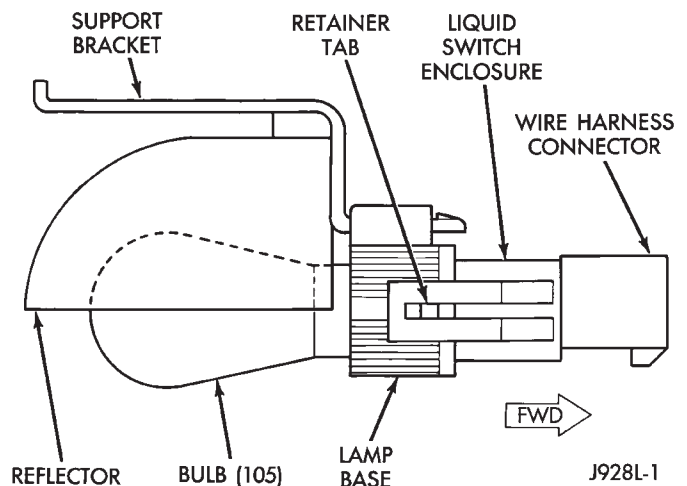
**UNDERHOOD LAMP BULB REPLACEMENT—YJ**

**REMOVAL**

- (1) Disconnect the wire harness connector (1) from the underhood lamp (Fig. 20).
- (2) Rotate the bulb counter-clockwise and remove it from the lamp base socket.



**Fig. 19 Underhood Lamp**



**Fig. 20 Underhood Lamp Components**

**INSTALLATION**

- (1) Insert a replacement bulb in the lamp base socket and rotate it clockwise.
- (2) Connect the wire harness connector to the lamp.

**UNDERHOOD LAMP REPLACEMENT—YJ**

**REMOVAL**

- (1) Disconnect the wire harness connector from the lamp.
- (2) Rotate the bulb counter-clockwise and remove it from the lamp base socket.
- (3) Remove the screw that attaches the lamp reflector and support bracket to the hood inner panel.
- (4) Remove the lamp from the hood inner panel.

**INSTALLATION**

- (1) Position the underhood lamp on the hood inner panel.
- (2) Install the attaching screw through the lamp and into the hood panel. Tighten the screw securely.

(3) Insert a replacement bulb in the lamp base socket and rotate it clockwise.

(4) Connect the wire harness connector to the lamp.

### DAYTIME RUNNING LIGHTS (CANADA ONLY)—YJ

The Daytime Running Lights (Headlamps) System is installed on vehicles manufactured for sale in Canada only. The headlamps are illuminated when the ignition switch is turned to the ON position. The DRL module receives a vehicle-moving signal from the vehicle speed sensor. This provides a constant **headlamps-on** condition as long as the vehicle is moving. The lamps are illuminated at less than 50 percent of normal intensity.

### DRL MODULE REPLACEMENT—YJ

#### REMOVAL

The daytime running light module is located on the left fender inner panel below the engine air cleaner housing.

(1) Remove the engine air cleaner housing for access to the DRL module.

(2) Disconnect the wire harness connector from the module.

(3) Remove the screws that attach the module to the fender inner panel (Fig. 21).

(4) Remove the module from the fender inner panel.

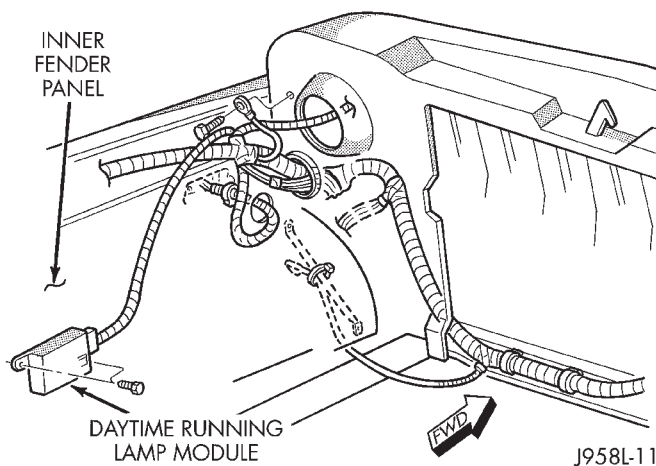
#### INSTALLATION

(1) Position the DRL module on the left, fender inner panel.

(2) Install the attaching screws. Tighten the screws securely.

(3) Connect the wire harness connector to the module.

(4) Install the air cleaner housing.



**Fig. 21 Daytime Running Lamp Module**

## INTERIOR LAMPS

### INDEX

	page	page
Dome/Courtesy Lamp Service Information—YJ . . .	31	
Dome/Courtesy Lamp Trouble Diagnosis—YJ . . . .	31	
Hardtop Dome/Cargo Lamp Bulb Replacement—YJ Vehicles . . . . .		31

### DOME/COURTESY LAMP SERVICE INFORMATION—YJ

The dome/cargo and underpanel courtesy lamps are controlled via ON/OFF switches. The ON/OFF switches are in the lamp ground circuits. Voltage via the dome/courtesy lamp fuse is applied directly to the lamp bulbs. When either door is opened, the door pillar switch contacts close and provide a direct path to vehicle body ground.

The dome/cargo and underpanel courtesy lamps can also be turned on via the interior lamp illumination rheostat.

### DOME/COURTESY LAMP TROUBLE DIAGNOSIS—YJ

#### ALL LAMPS INOPERATIVE FROM INTERIOR LAMP ILLUMINATION RHEOSTAT

- (1) Rotate the interior lamp illumination rheostat in an upward direction. The lamps should light. If not OK, remove, inspect and test the dome lamp fuse. Replace if bad.
- (2) If the fuse is OK, repair the open circuit in the wire harness to vehicle body ground.
- (3) If lamp still does not light, replace the switch.

#### ONE LAMP INOPERATIVE

- (1) Measure the resistance across the bulb holder terminals. The ohmmeter should indicate zero ohms. If not, replace the bulb.
- (2) Measure the voltage between the voltage side of the bulb holder and vehicle body ground. The voltmeter should indicate battery voltage. If not, repair the open circuit in the wire harness to the splice.

#### LAMPS INOPERATIVE WITH ONE OR MORE DOORS OPENED

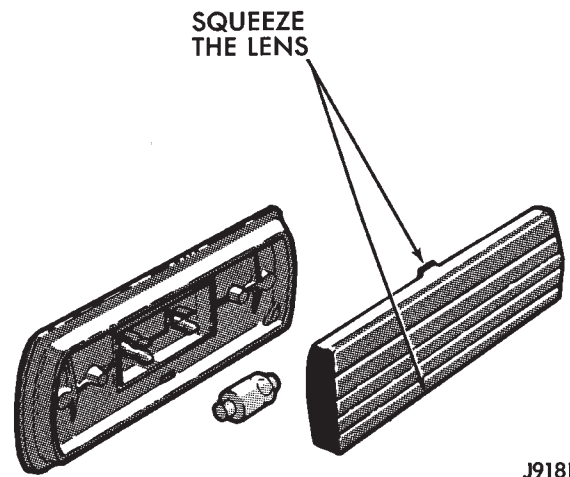
- (1) Remove the inoperative switch from the door pillar and connect the switch wire directly to ground. The lamp should light.

- (2) If not, check for an open circuit in black (ground) wire. Repair as necessary. If lamps still do not light, replace the switch.

### HARDTOP DOME/CARGO LAMP BULB REPLACEMENT—YJ VEHICLES

#### REMOVAL

- (1) Remove the dome/cargo lamp lens by squeezing it at both sides. This will separate the lens retainer tabs from the lamp housing shoulders (Fig. 1).



**Fig. 1 Hardtop Dome/Cargo Lamp**

- (2) Remove the lens from the lamp housing.
- (3) Pull the bulb straight out to remove from the bulb holder.

#### INSTALLATION

- (1) Insert the replacement bulb in the bulb holder.
- (2) Position lens at the lamp housing and force it into the housing until the retainer tabs are seated.

BULB APPLICATION—YJ VEHICLES

**GENERAL INFORMATION**

The following Bulb Application Table lists the lamp title on the left side of the column and trade number or part number on the right.

**CAUTION:** Do not use bulbs that have a higher candle power than the bulb listed in the Bulb Application Table. Damage to lamp can result.

Do not touch halogen bulbs with fingers or other oily surfaces. Bulb life will be reduced.

**EXTERIOR LAMPS—YJ**

Back-up .....	1156
Center High Mounted Stoplamp .....	912
Fog.....	H3
Front Side Marker.....	194
Headlamp/Sealed Beam.....	H6054
Park/Turn Signal.....	3157
Tail/Stop.....	1157

**INTERIOR LAMPS—YJ**

Service procedures for most of the lamps in the instrument panel, Instrument cluster and switches are located in Group 8E, Instrument Panel and Gauges. Some components have lamps that can only be serviced by an Authorized Service Center (ASC) after the component is removed from the vehicle. Contact local dealer for location of nearest ASC.

Dome/Cargo .....	212-2
Glove Compartment.....	194
Under Hood .....	105
Underpanel Courtesy.....	89

*INDICATOR LAMPS*

Service procedures for most of the lamps in the instrument panel, instrument cluster and switches are located in Group 8E, Instrument Panel and Gauges.

A/C Control.....	74
Anti-lock Brake .....	74
Ash Receiver.....	1891
Brake Warning.....	74
Cigar Lighter.....	53
Fasten Seat Belts .....	74
Four Wheel Drive .....	74
Generator .....	194
Hazard.....	74
Heater Control .....	194
High Beam.....	194
Illumination .....	194
Low Coolant.....	74
Radio.....	ASC
Rocker Switch.....	74
Seat Belt.....	74
Shift.....	74
Turn Signal.....	194