

# RESTRAINT SYSTEMS

## CONTENTS

	page		page
AIRBAG SYSTEM .....	1	GENERAL INFORMATION .....	1
DIAGNOSIS .....	2	SERVICE PROCEDURES .....	2

## AIRBAG SYSTEM

**WARNING: THIS AIRBAG SYSTEM IS A SENSITIVE, COMPLEX MECHANICAL UNIT. BEFORE ATTEMPTING TO REMOVE OR INSTALL THE AIRBAG SYSTEM OR RELATED STEERING WHEEL AND STEERING COLUMN COMPONENTS YOU MUST FIRST DISARM THE AIRBAG FIRING MECHANISM. FAILURE TO DO SO COULD RESULT IN ACCIDENTAL DEPLOYMENT AND POSSIBLE PERSONAL INJURY.**

**WARNING: THE AIRBAG MODULE INFLATOR/SENSOR ASSEMBLY CONTAINS SODIUM AZIDE AND POTASSIUM NITRATE. THESE MATERIALS ARE POISONOUS AND EXTREMELY FLAMMABLE. CONTACT WITH ACID, WATER OR HEAVY METALS MAY PRODUCE HARMFUL AND IRRITATING GASES (SODIUM HYDROXIDE IS FORMED IN THE PRESENCE OF MOISTURE) OR COMBUSTIBLE COMPOUNDS.**

**DO NOT ATTEMPT TO DISMANTLE THE MODULE OR TAMPER WITH ITS ARMING LEVER. DO NOT PUNCTURE, INCINERATE, OR BRING INTO CONTACT WITH ELECTRICITY. DO NOT STORE AT TEMPERATURES EXCEEDING 200°F.**

**WARNING: REPLACE AIRBAG SYSTEM COMPONENTS WITH PARTS SPECIFIED IN THE CHRYSLER MOPAR PARTS CATALOG ONLY. IT IS OF PARTICULAR IMPORTANCE THAT ANY COMPONENTS USED IN THIS MECHANICALLY-FIRED AIRBAG SYSTEM NOT BE MIXED WITH COMPONENTS FROM AN ELECTRICALLY-FIRED AIRBAG SYSTEM. SUBSTITUTE PARTS MAY APPEAR THE SAME, BUT INTERNAL DIFFERENCES MAY RESULT IN INFERIOR OCCUPANT PROTECTION.**

**WARNING: THE FASTENERS, SCREWS, AND BOLTS, ORIGINALLY USED FOR THE AIRBAG COMPONENTS, HAVE SPECIAL COATINGS AND ARE SPECIFICALLY DESIGNED FOR THE AIRBAG SYSTEM. THEY MUST NEVER BE REPLACED WITH ANY SUBSTITUTES. ANYTIME A NEW FASTENER IS NEEDED, REPLACE WITH THE CORRECT FASTENERS PROVIDED IN THE SERVICE PACKAGE OR SPECIFIED IN THE CHRYSLER MOPAR PARTS CATALOG.**

## GENERAL INFORMATION

The airbag system is a standard equipment safety device on XJ (Cherokee) models. It is designed to protect the driver from serious injury, caused by a frontal impact of the vehicle. If the airbag module assembly is defective and non-deployed, refer to Chrysler Corporation current return list for proper handling procedures.

Following are general descriptions of the major components in the airbag system.

### AIRBAG MODULE

The airbag module protective cover is the only visible part of the system. The module is mounted directly to the steering wheel. Under the airbag module cover, the airbag cushion and its supporting components are contained. The airbag module contains a housing to which the cushion and impact sensor/inflator assembly are attached and sealed. The airbag module is non-serviceable, and must be replaced if deployed or damaged in any way.

The impact sensor/inflator assembly is mounted to the back of the module. The inflator seals the hole in

the airbag cushion so it can discharge the gas it produces directly into the cushion. The protective cover is fitted to the front of the airbag module and forms a decorative cover in the center of the steering wheel. Upon airbag deployment, this cover will split horizontally.

#### STORAGE

The airbag module must be stored in its original, special container until used for service. Also, it must be stored in a clean, dry environment; away from sources of extreme heat, sparks, and high electrical energy. Always place or store the module on a surface with the trim cover facing up to minimize movement in case of accidental deployment.

#### IMPACT SENSOR/INFLATOR ASSEMBLY

The impact sensor/inflator assembly is mounted to the back of the airbag module. It seals the hole in the steering wheel side of the airbag cushion so that gas produced in the inflator can be discharged directly into the cushion.

The impact sensor provides verification of the direction and severity of the impact. A spherical sensing mass housed in a cylinder will move forward and rotate a D-shaft when the vehicle is subjected to a frontal impact of sufficient severity. Airbag inflation is designed to occur at a precisely calibrated vehicle deceleration force, and is not linked to vehicle road speed.

The D-shaft retains two spring-loaded firing pins. When a firing pin is released by the D-shaft, it strikes and ignites a primer. The primer then reacts with the pelletized, solid generant contained in the inflator to produce the nitrogen gas that inflates the airbag cushion.

#### ARMING/DISARMING MECHANISM

The steering wheel hub incorporates an airbag arming/disarming mechanism and a specially designed nut-blocker. The nut-blocker serves as a safety to prevent removal of the airbag module until the unit has been disarmed. A removable plastic cover plug on the top, outer hub of the steering wheel allows access to the arming screw.

When the airbag module is disarmed, the arming screw extends upward from the steering wheel hub. This will prevent installation of the plastic cover plug. Also, the nut-blocker is retracted to allow access to the two upper airbag module mounting nuts.

When the airbag module is armed, the plastic cover plug will install flush with the outer surface of the steering wheel hub. In addition, the nut-blocker will prevent access to the two upper airbag module mounting nuts.

## DIAGNOSIS

This mechanical airbag system can not be diagnosed or repaired. The only serviced component is the airbag module assembly. If the airbag module is

damaged in any way or deployed, it must be replaced.

## SERVICE PROCEDURES

#### AIRBAG SYSTEM SERVICE (DEPLOYED)

Any vehicle which is to be returned to use after an airbag deployment, must have the airbag module replaced. This is a one-time component and cannot be reused.

#### AIRBAG MODULE HANDLING

##### UNDEPLOYED

At no time should any source of electricity be permitted near the inflator on the back of the module. When carrying an undeployed module, the trim cover should be pointed away from the body to minimize

injury in the event of accidental deployment. If the module is placed on a bench or other surface, the plastic trim cover should be face up to minimize movement in case of accidental deployment.

In addition, the airbag module should be disarmed whenever the steering wheel or steering column requires service or removal. Failure to observe this warning could result in accidental airbag deployment and possible personal injury. Refer to Group 19 - Steering for more service procedures on steering wheel and steering column.

**DEPLOYED**

Following an airbag deployment, the vehicle interior will contain a powdery residue. This residue is primarily sodium bicarbonate (baking soda), used as an airbag cushion lubricant. However, there will also be traces of sodium hydroxide powder, a chemical byproduct of the generant used for airbag deployment. Since this powder can irritate the skin, eyes, nose or throat, be sure to wear safety glasses, rubber gloves and a long-sleeved shirt during cleanup (Fig. 1).

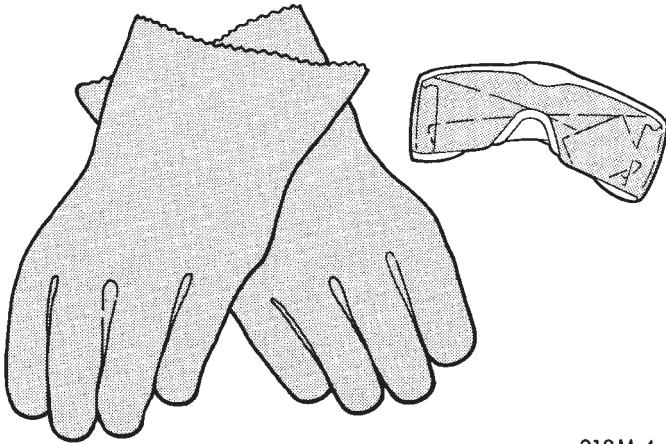

918M-4

**Fig. 1 Wear Safety Glasses and Rubber Gloves**

If you experience skin irritation during cleanup, run cool water over the affected area. Also, if you experience irritation of the nose or throat, exit the vehicle for fresh air until the irritation ceases. If irritation continues, see a physician.

**CLEANUP PROCEDURE**

Remove the airbag and airbag module from the vehicle. Use a vacuum cleaner to remove any residual powder from the vehicle interior. Clean from outside the vehicle and work your way inside, so that you avoid kneeling or sitting on an uncleaned area.

Be sure to vacuum the heater and A/C outlets as well (Fig. 2). Run the blower on low and vacuum any powder expelled from the plenum. You may need to vacuum the interior of the car a second time to recover all of the powder.

Place the deployed airbag and module in your vehicular scrap pile.

**AIRBAG MODULE REMOVE/INSTALL**

**WARNING: THIS AIRBAG SYSTEM IS A SENSITIVE, COMPLEX MECHANICAL UNIT. BEFORE ATTEMPT-**

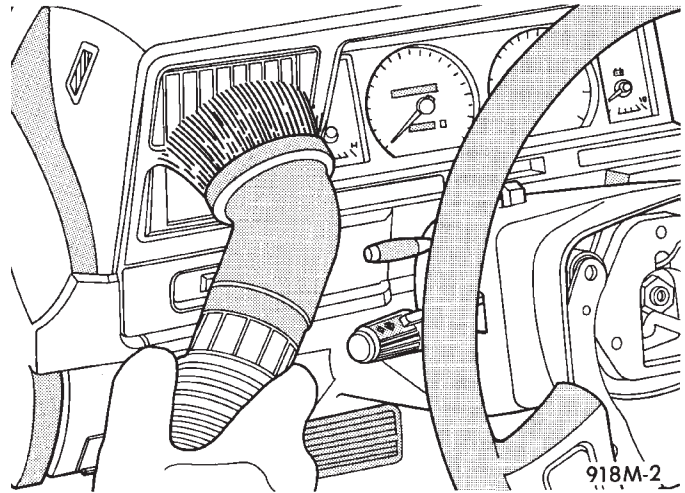
**Fig. 2 Vacuum Heater and A/C Outlets**

**ING TO REMOVE OR INSTALL THE AIRBAG SYSTEM OR RELATED STEERING WHEEL AND STEERING COLUMN COMPONENTS YOU MUST FIRST DISARM THE AIRBAG FIRING MECHANISM. FAILURE TO DO SO COULD RESULT IN ACCIDENTAL DEPLOYMENT AND POSSIBLE PERSONAL INJURY.**

**When removing a deployed airbag module, rubber gloves, eye protection and long-sleeved shirt should be worn. There may be deposits on the airbag module and other interior surfaces, which can cause irritation to the skin and eyes in large doses.**

- (1) Disconnect battery negative cable and isolate.
- (2) Using a small screwdriver, remove plastic cover plug from top outer surface of steering wheel hub. Exit vehicle and disarm airbag by reaching through driver's side window and turning arming screw counter-clockwise to its travel limit. When the screw has reached its travel limit it will extend 1 inch above the outer surface of the steering wheel hub cover. This is done using an 8mm socket and manual drive. **DO NOT USE POWER-DRIVEN TOOLS.**
- (3) From back side of steering wheel, remove 4 nuts attaching airbag module to steering wheel (Fig. 3). This is done using a 10mm socket and manual drive. **DO NOT USE POWER-DRIVEN TOOLS.**
- (4) Remove airbag module from steering wheel.
- (5) Reverse removal procedures to install. Tighten airbag module attaching nuts to 9 to 11 N·m (80 to 100 in. lbs.). Exit vehicle and arm airbag by reaching through driver's side window and turning arming screw clockwise to its travel limit. Arming screw torque should not exceed 1.1 to 1.7 N·m (10-15 in. lbs.). Reinstall plastic cover plug in steering wheel hub.

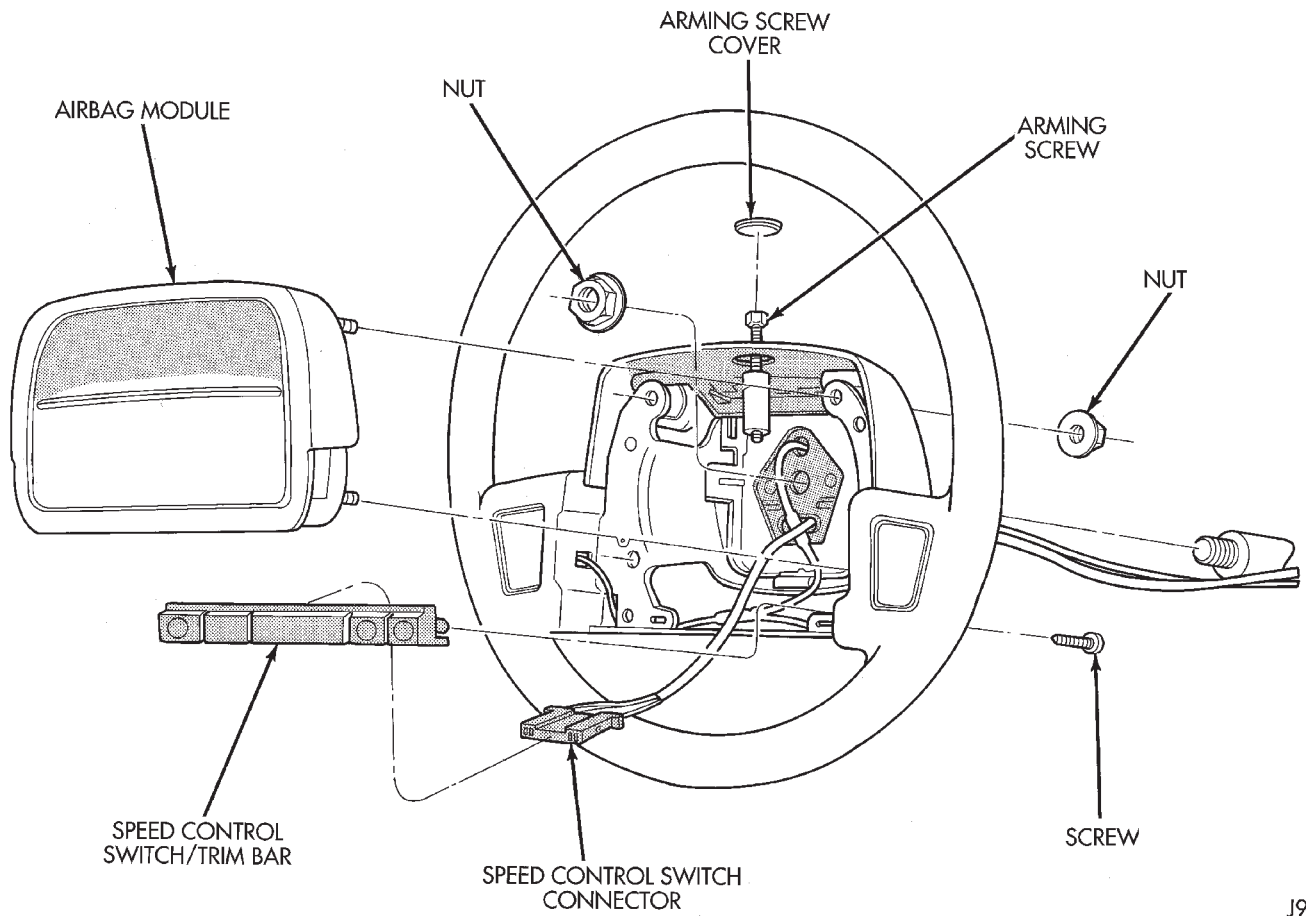

**Fig. 3 Airbag Module Remove/Install**

J958M-3