

POWER SEATS

CONTENTS

| | page | | page |
|---------------------------|------|--------------------------|------|
| DIAGNOSIS | 2 | SERVICE PROCEDURES | 3 |
| GENERAL INFORMATION | 1 | | |

GENERAL INFORMATION

A six-way driver's side power seat is an available option on XJ (Cherokee) models. The power seat system receives battery feed through fuse 6 in the power distribution center and circuit breaker 16 in the fuse-block module at all times.

Following are general descriptions of the major components in the power seat system. Refer to Group 8W - Wiring Diagrams for complete circuit descriptions and diagrams.

POWER SEAT SWITCH

The power seat can be adjusted in six different ways using the power seat switch (Fig. 1). The switch is located on the lower outboard side of the seat cushion. Refer to the owner's manual for more information on power seat switch functions and seat adjusting procedures. The individual switches cannot be repaired. If one switch fails, the entire switch module must be replaced.

POWER SEAT ADJUSTER/MOTORS

There are three reversible motors that operate the power seat adjuster. The motors are connected to worm-drive gearboxes in the adjuster by drive cables.

The front and rear of a seat are operated by different motors. They can be raised or lowered independently of each other. When the center seat switch is pushed to the UP or DOWN position, both front and rear motors operate in unison, moving the entire seat up or down. The forward-rearward motor is operated by pushing the center seat switch to the FORWARD or REARWARD position.

When a switch is actuated, battery feed and a ground path are applied through the switch contacts to the motor(s). The motor(s) operate to move the seat in the selected direction until the switch is released, or until the travel limit of the power seat ad-

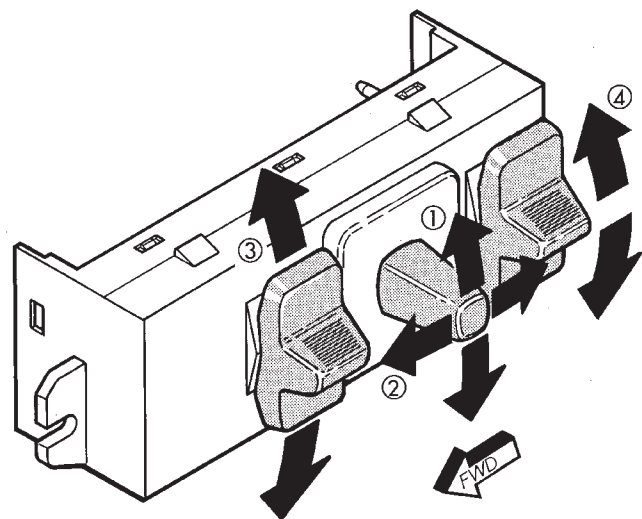

1. SEAT UP AND DOWN
2. SEAT FORWARD AND REARWARD
3. SEAT TILT (FRONT UP AND DOWN)
4. SEAT TILT (REAR UP AND DOWN)

J938R-4

Fig. 1 Power Seat Switch

juster is reached. When the switch is moved in the opposite direction, the battery feed and ground path to the motor(s) are reversed through the switch contacts. This causes the motor to run in the opposite direction.

Each motor contains a self-resetting circuit breaker to protect it from overload. Consecutive or frequent resetting must not be allowed to continue or the motors may be damaged. Make the necessary repairs.

The power seat adjuster and motors can not be repaired, and are serviced only as a complete unit. If any component in this unit should fail, the entire assembly must be replaced.

DIAGNOSIS

Before any testing is attempted the battery should be fully charged and all connections and pins cleaned and tightened to ensure proper continuity and grounds.

With the dome lamp on, apply switch in direction of the failure. If the dome lamp dims, the seat may be jamming. Check for binding or obstructions. If the dome lamp does not dim, then proceed with the following electrical tests.

POWER SEAT ADJUSTER/MOTORS

Operate the power seat switch to move all three seat motors. The seat should move in all directions. If not OK, proceed as follows. If one or more motors operate, see diagnosis for Power Seat Switch.

(1) Check circuit breaker 16 in the fuseblock module. If OK, go to next step. If not OK, replace circuit breaker.

(2) Remove switch mounting screws and check for battery voltage at red wire at switch connector. If OK, go to next step. If not OK, repair wiring to circuit breaker.

(3) Check for continuity between black wire at switch connector and a good ground. There should be continuity. If OK, go to next step. If not OK, repair wiring to ground.

(4) See diagnosis for Power Seat Switch. If switch continuity checks OK, replace faulty motor/adjuster assembly. If switch continuity is not OK, replace faulty switch.

POWER SEAT SWITCH

To check the power seat switch, remove the switch from its mounting position. Use an ohmmeter and see the Power Seat Switch Continuity chart. Determine if switch continuity is correct. If OK, see Power Seat Adjuster/Motors diagnosis. If not OK, replace faulty switch assembly.

POWER SEAT SWITCH CONTINUITY

| SWITCH POSITION | CONTINUITY BETWEEN |
|--------------------|---------------------------------|
| OFF | B-N, B-J, B-M, B-E, B-L, B-K |
| VERTICAL UP | A-E, A-M, B-N, B-J |
| VERTICAL DOWN | A-J, A-N, B-M, B-E |
| HORIZONTAL FORWARD | A-L, B-K |
| HORIZONTAL AFT | A-K, B-L |
| FRONT TILT UP | A-M, B-N |
| FRONT TILT DOWN | A-N, B-M |
| REAR TILT UP | A-E, B-J |
| REAR TILT DOWN | A-J, B-E |

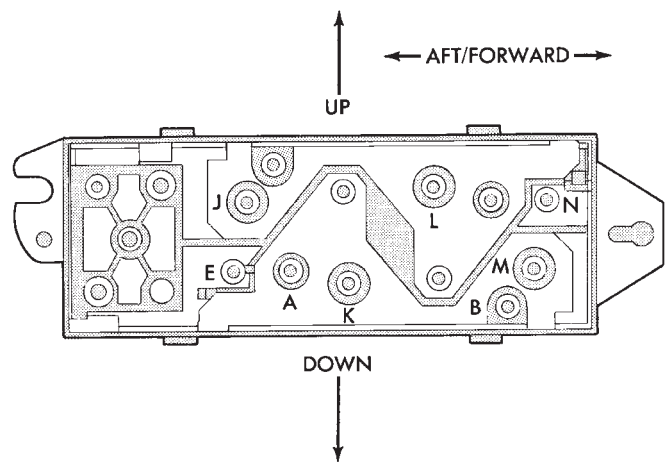

TERMINALS SHOWN AS VIEWED
FROM REAR OF SWITCH

SERVICE PROCEDURES

POWER SEAT SWITCH REMOVE/INSTALL

- (1) Disconnect battery negative cable.
- (2) Reach under seat and release switch and bezel retainer snap clips (Fig. 2), while pulling gently on switch and bezel assembly.

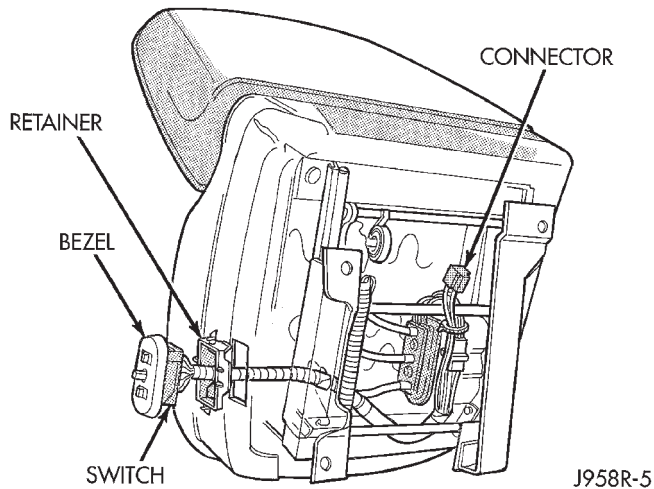
**Fig. 2 Power Seat Switch Remove/Install**

- (3) Pull switch, bezel, and retainer out from seat frame far enough to access multiple terminal block. Carefully release locking tabs and separate switch retainer and switch bezel from switch body.
- (4) Carefully release locking tabs securing multiple terminal block to switch and remove switch.
- (5) Reverse removal procedures to install.

POWER SEAT ADJUSTER/MOTORS REMOVE/INSTALL

- (1) Disconnect battery negative cable.
- (2) Remove 4 bolts securing seat adjuster to floor (Fig. 3).

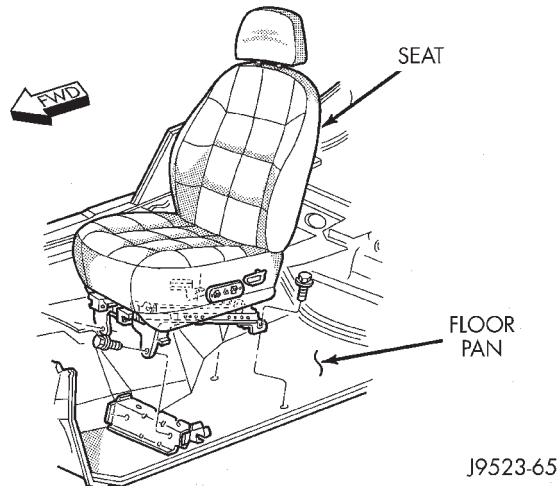
**Fig. 3 Power Seat Adjuster Remove/Install**

- (3) Disconnect power seat feed wiring connector.
- (4) Remove 4 bolts securing power seat adjuster/motor assembly to seat cushion frame.
- (5) Disconnect wiring from power seat switch to power seat motors and remove power seat adjuster/motor assembly.
- (6) Reverse removal procedures to install. Tighten seat mounting hardware to 34 N·m (25 ft. lbs.) torque.

