

LUBRICATION AND MAINTENANCE

TABLE OF CONTENTS

| | | | |
|-----------------------------|------|--|------|
| | page | | page |
| LUBRICANTS | 1 | JUMP STARTING, TOWING AND HOISTING | 9 |
| MAINTENANCE SCHEDULES | 4 | | |

LUBRICANTS

TABLE OF CONTENTS

| | | | |
|-----------------------------|------|-----------------------------------|------|
| | page | | page |
| SERVICE PROCEDURES | | CLASSIFICATION OF LUBRICANTS..... | 1 |
| PARTS AND LUBRICANT | | SPECIFICATIONS | |
| RECOMMENDATIONS | 1 | FLUID CAPACITIES | 3 |
| INTERNATIONAL SYMBOLS | 1 | | |

SERVICE PROCEDURES

PARTS AND LUBRICANT RECOMMENDATIONS

RECOMMENDATIONS

When service is required, DaimlerChrysler Corporation recommends that only Mopar® brand parts, lubricants and chemicals be used. Mopar provides the best engineered products for servicing DaimlerChrysler Corporation vehicles.

INTERNATIONAL SYMBOLS

DaimlerChrysler Corporation uses international symbols to identify engine compartment lubricant and fluid inspection and fill locations (Fig. 1).

CLASSIFICATION OF LUBRICANTS

Only lubricants bearing designations defined by the following organization should be used to service a DaimlerChrysler Corporation vehicle.

- Society of Automotive Engineers (SAE)
- American Petroleum Institute (API) (Fig. 2)
- National Lubricating Grease Institute (NLGI) (Fig. 3)

| | | | |
|-----------------------------|------------------------------|--|-------------------------|
| CHRYSLER CORPORATION | | | |
| | ENGINE OIL | | BRAKE FLUID |
| | AUTOMATIC TRANSMISSION FLUID | | POWER STEERING FLUID |
| | ENGINE COOLANT | | WINDSHIELD WASHER FLUID |

9500-1

Fig. 1 International Symbols

ENGINE OIL

SAE VISCOSITY RATING INDICATES ENGINE OIL VISCOSITY

An SAE viscosity grade is used to specify the viscosity of engine oil. SAE 30 specifies a single viscosity engine oil. Engine oils also have multiple viscosities. These are specified with a dual SAE viscosity grade which indicates the cold-to-hot temperature viscosity range.

- SAE 30 = single grade engine oil.
- SAE 10W-30 = multiple grade engine oil.

DaimlerChrysler Corporation only recommends multiple grade engine oils.

SERVICE PROCEDURES (Continued)

API QUALITY CLASSIFICATION

This symbol (Fig. 2) on the front of an oil container means that the oil has been certified by the American Petroleum Institute (API) to meet all the lubrication requirements specified by DaimlerChrysler Corporation.

Refer to Group 9, Engine for gasoline engine oil specification.

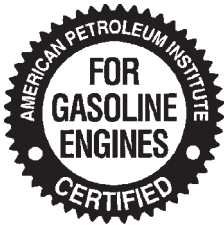

9400-9

Fig. 2 API Symbol

GEAR LUBRICANTS

SAE ratings also apply to multiple grade gear lubricants. In addition, API classification defines the lubricants usage.

LUBRICANTS AND GREASES

Lubricating grease is rated for quality and usage by the NLGI. All approved products have the NLGI symbol (Fig. 3) on the label. At the bottom NLGI symbol is the usage and quality identification letters. Wheel bearing lubricant is identified by the letter "G". Chassis lubricant is identified by the letter "L". The letter following the usage letter indicates the quality of the lubricant. The following symbols indicate the highest quality.



9200-7

Fig. 3 NLGI Symbol

- 1 - WHEEL BEARINGS
- 2 - CHASSIS LUBRICATION
- 3 - CHASSIS AND WHEEL BEARINGS

SPECIFICATIONS

FLUID CAPACITIES

FUEL TANK

All 76.4 L (20.2 gal.)

ENGINE OIL W/FILTER CHANGE

2.5L 3.8 L (4.0 qts.)

4.0L 5.7 L (6.0 qts.)

COOLING SYSTEM

2.5L 9.5 L (10 qts.)*

4.0L 11.4 L (12 qts.)**

*Includes 2.2 L (2.3 qts) for coolant recovery reservoir.

**Includes 0.9 L (1.0 qt) for coolant recovery reservoir.

AUTOMATIC TRANSMISSION

Dry fill capacity*

AW4 7.8 L (16.5 pts.)

30RH 4.67 L (9.86pts.)

*Depending on type and size of internal cooler, length and inside diameter of cooler lines, or use of an auxiliary cooler, these figures may vary. Refer to Group 21, Transmission for proper fluid fill procedure.

MANUAL TRANSMISSION

AX5 (4X2) 3.5 L (3.7 qts.)

AX5 (4X4) 3.3 L (3.5 qts.)

AX15 (4X2) 3.15 L (3.3 qts.)

AX15 (4X4) 3.15 L (3.3 qts.)

TRANSFER CASE

SELEC-TRAC 242 1.3 L (2.85 pts.)

COMMAND-TRAC 231 1.0 L (2.2 pts.)

FRONT AXLE

181-FBI 1.48 L (3.13 pts.)

186-FBI 1.18L (2.5pts.)

REAR AXLE

194-RBI 1.66 L (3.5 pts.)*

8-1/4 2.08 L (4.4 pts.**)

* When equipped with TRAC-LOK, include 3.5 ounces of Friction Modifier Additive.

** When equipped with TRAC-LOK, include 4 ounces of Friction Modifier Additive.

POWER STEERING

Power steering fluid capacities are dependent on engine/chassis options as well as steering gear/cooler options. Depending on type and size of internal cooler, length and inside diameter of cooler lines, or use of an auxiliary cooler, these capacities may vary. Refer to Section 19 of the service manual for proper fill and bleed procedures.

MAINTENANCE SCHEDULES

TABLE OF CONTENTS

| | | |
|---------------------------|------|-----------------------------------|
| | page | page |
| SERVICE PROCEDURES | | |
| DESCRIPTION | 4 | UNSCHEMULU INSPECTION 4 |

SERVICE PROCEDURES

DESCRIPTION

Service and maintenance procedures for components and systems listed in Schedule "A" or "B" can be found by using the Group Tab Locator index at the front of this manual. If it is not clear which group contains the information needed, refer to the index at the back of this manual.

There are two maintenance schedules that show proper service based on the conditions that the vehicle is subjected to.

Schedule "A", lists scheduled maintenance to be performed when the vehicle is used for general transportation.

Schedule "B", lists maintenance intervals for vehicles that are operated under the conditions listed at the beginning of that schedule section.

Use the schedule that best describes the driving conditions.

Where time and mileage are listed, follow the interval that occurs first.

UNSCHEMULU INSPECTION

At Each Stop For Fuel

- Check engine oil level, add as required.
- Check windshield washer solvent and add if required.

Once A Month

- Check tire pressure and look for unusual wear or damage.
- Inspect battery and clean and tighten terminals as required. Check electrolyte level and add water as needed.
- Check fluid levels of coolant reservoir, power steering, brake master cylinder, and transmission and add as needed.
- Check all lights and all other electrical items for correct operation.

At Each Oil Change

- Inspect exhaust system.
- Inspect brake hoses.

- Rotate the tires at each oil change interval shown on Schedule "A" (7,500 miles) or every other interval shown on Schedule "B" (6,000 miles).
- Check coolant level, hoses, and clamps.
- After completion of off-road operation, the underside of the vehicle should be thoroughly inspected. Examine threaded fasteners for looseness.

EMISSION CONTROL SYSTEM MAINTENANCE

The scheduled emission maintenance listed in **bold type** on the Maintenance Schedules, must be done at the mileage specified to assure the continued proper functioning of the emission control system. These, and all other maintenance services included in this manual, should be done to provide the best vehicle performance and reliability. More frequent maintenance may be needed for vehicles in severe operating conditions such as dusty areas and very short trip driving.

FLUID FILL LOCATIONS AND LUBRICATION POINTS

The fluid fill/check locations and lubrication points are located in each applicable group.

SCHEDULE "A"

7,500 Miles (12 000 km) or at 6 months

- Change engine oil.
- Replace engine oil filter.
- Lubricate steering linkage (4x4 only).

15,000 Miles (24 000 km) or at 12 months

- Change engine oil.
- Replace engine oil filter.
- Lubricate steering linkage.
- Lubricate steering and suspension ball joints.

22,500 Miles (36 000 km) or at 18 months

- Change engine oil.
- Replace engine oil filter.
- Inspect brake linings.
- Lubricate steering linkage (4x4 only).

SERVICE PROCEDURES (Continued)

30,000 Miles (48 000 km) or at 24 months

- Change engine oil.
- Replace engine oil filter.
- **Replace air cleaner element.**
- **Replace spark plugs.**
- Inspect drive belt, adjust tension as necessary.
- Lubricate steering linkage.
- Drain and refill automatic transmission fluid.
- Drain and refill transfer case fluid.
- Lubricate steering and suspension ball joints.

37,500 Miles (60 000 km) or at 30 months

- Change engine oil.
- Replace engine oil filter.
- Lubricate steering linkage (4x4 only).
- Drain and refill manual transmission fluid.

45,000 Miles (72 000 km) or at 36 months

- Change engine oil.
- Replace engine oil filter.
- Lubricate steering linkage.
- Inspect brake linings.
- Flush and replace engine coolant at 36 months, regardless of mileage.
- Lubricate steering and suspension ball joints.

52,500 Miles (84 000 km) or at 42 months

- Change engine oil.
- Replace engine oil filter.
- Flush and replace engine coolant if not done at 36 months.
- Lubricate steering linkage (4x4 only).

60,000 Miles (96 000 km) or at 48 months

- Change engine oil.
- Replace engine oil filter.
- **Replace engine air cleaner element.**
- **Replace ignition cables.**
- **Replace spark plugs.**
- Inspect drive belt, adjust tension as necessary.
- Lubricate steering linkage.
- Drain and refill automatic transmission fluid.
- Drain and refill transfer case fluid.
- Lubricate steering and suspension ball joints.

67,500 Miles (108 000 km) or at 54 months

- Change engine oil.
- Replace engine oil filter.
- Inspect brake linings.
- Lubricate steering linkage (4x4 only).

75,000 Miles (120 000 km) or at 60 months

- Change engine oil.
- Replace engine oil filter.
- Lubricate steering linkage.

- Flush and replace engine coolant if it has been 30,000 miles (48 000 km) or 24 months since last change.

- Lubricate steering and suspension ball joints.
- Drain and refill manual transmission fluid.

82,500 Miles (133 000 km) or at 66 months

- Change engine oil.
- Replace engine oil filter.
- Flush and replace engine coolant if it has been 30,000 miles (48 000 km) or 24 months since last change.

- Lubricate steering linkage (4x4 only).

90,000 Miles (144 000 km) or at 72 months

- Change engine oil.
- Replace engine oil filter.
- **Replace engine air cleaner element.**
- **Replace spark plugs.**
- Inspect drive belt, adjust tension as necessary.
- Lubricate steering linkage.
- Drain and refill automatic transmission fluid.
- Drain and refill transfer case fluid.
- Inspect brake linings.
- Lubricate steering and suspension ball joints.

97,500 Miles (156 000 km) or at 78 months

- Change engine oil.
- Replace engine oil filter.
- Lubricate steering linkage (4x4 only).

105,000 Miles (168 000 km) or at 84 months

- Change engine oil.
- Replace engine oil filter.
- Lubricate steering linkage.
- Flush and replace engine coolant if it has been 30,000 miles (48 000 km) or 24 months since last change.
- Lubricate steering and suspension ball joints.

112,500 Miles (180 000 km) or at 90 months

- Change engine oil.
- Replace engine oil filter.
- Inspect brake linings.
- Flush and replace engine coolant if it has been 30,000 miles (48 000 km) or 24 months since last change.
- Lubricate steering linkage (4x4 only).
- Drain and refill manual transmission fluid.

120,000 Miles (192 000 km) or at 96 months

- Change engine oil.
- Replace engine oil filter.
- **Replace engine air cleaner element.**
- **Replace ignition cables.**
- **Replace spark plugs.**
- Inspect drive belt, adjust tension as necessary.

SERVICE PROCEDURES (Continued)

- Lubricate steering linkage.
- Drain and refill automatic transmission fluid.
- Drain and refill transfer case fluid.
- Lubricate steering and suspension ball joints.

Important: Inspection and service should also be performed any time a malfunction is observed or suspected.

SCHEDULE "B"

Follow Schedule "B" if the vehicle is usually operated under one or more of the following conditions.

- Frequent short trips driving less than 5 miles (8 km).
- Frequent driving in dusty conditions.
- Frequent trailer towing.
- Extensive idling.
- More than 50% of driving is at sustained high speeds during hot weather, above 90°F (32°C).
- Off-road driving.
- Desert operation.

3,000 Miles (5 000 km)

- Change engine oil.
- Replace engine oil filter.
- Lubricate steering linkage.

6,000 Miles (10 000 km)

- Change engine oil.
- Replace engine oil filter.
- Lubricate steering linkage.
- Lubricate steering and suspension ball joints.

9,000 Miles (14 000 km)

- Change engine oil.
- Replace engine oil filter.
- Lubricate steering linkage.

12,000 Miles (19 000 km)

- Change engine oil.
- Replace engine oil filter.
- Lubricate steering linkage.
- Drain and refill automatic transmission fluid.
- Drain and refill front and rear axles.‡
- Inspect brake linings.
- Lubricate steering and suspension ball joints.

15,000 Miles (24 000 km)

- Change engine oil.
- Replace engine oil filter.
- **Inspect engine air cleaner element, replace as necessary.**
- Lubricate steering linkage.

18,000 Miles (29 000 km)

- Change engine oil.
- Replace engine oil filter.
- Lubricate steering linkage.

- Lubricate steering and suspension ball joints.
- Drain and refill manual transmission fluid.

21,000 Miles (34 000 km)

- Change engine oil.
- Replace engine oil filter.
- Lubricate steering linkage.

24,000 Miles (38 000 km)

- Change engine oil.
- Replace engine oil filter.
- Lubricate steering linkage.
- Drain and refill automatic transmission fluid.
- Drain and refill front and rear axles.‡
- Inspect brake linings.
- Lubricate steering and suspension ball joints.

27,000 Miles (43 000 km)

- Change engine oil.
- Replace engine oil filter.
- Lubricate steering linkage.

30,000 Miles (48 000 km)

- Change engine oil.
- Replace engine oil filter.
- **Replace engine air cleaner element.**
- **Replace spark plugs.**
- Inspect drive belt, adjust tension as necessary.
- Lubricate steering linkage.
- Drain and refill transfer case fluid.
- Lubricate steering and suspension ball joints.

33,000 Miles (53 000 km)

- Change engine oil.
- Replace engine oil filter.
- Lubricate steering linkage.

36,000 Miles (58 000 km)

- Change engine oil.
- Replace engine oil filter.
- Lubricate steering linkage.
- Drain and refill automatic transmission fluid.
- Drain and refill front and rear axles.‡
- Inspect brake linings.
- Lubricate steering and suspension ball joints.
- Drain and refill manual transmission fluid.

39,000 Miles (62 000 km)

- Change engine oil.
- Replace engine oil filter.
- Lubricate steering linkage.

42,000 Miles (67 000 km)

- Change engine oil.
- Replace engine oil filter.
- Lubricate steering linkage.
- Lubricate steering and suspension ball joints.

SERVICE PROCEDURES (Continued)

45,000 Miles (72 000 km)

- Change engine oil.
- Replace engine oil filter.
- **Inspect engine air cleaner element, replace as necessary.**
- Lubricate steering linkage.

48,000 Miles (77 000 km)

- Change engine oil.
- Replace engine oil filter.
- Lubricate steering linkage.
- Drain and refill automatic transmission fluid.
- Drain and refill front and rear axles.‡
- Inspect brake linings.
- Lubricate steering and suspension ball joints.

51,000 Miles (82 000 km)

- Change engine oil.
- Replace engine oil filter.
- Flush and replace engine coolant.
- Lubricate steering linkage.

54,000 Miles (86 000 km)

- Change engine oil.
- Replace engine oil filter.
- Lubricate steering linkage.
- Lubricate steering and suspension ball joints.
- Drain and refill manual transmission fluid.

57,000 Miles (91 000 km)

- Change engine oil.
- Replace engine oil filter.
- Lubricate steering linkage.

60,000 Miles (96 000 km)

- Change engine oil.
- Replace engine oil filter.
- **Replace engine air cleaner element.**
- **Replace ignition cables.**
- **Replace spark plugs.**
- Inspect drive belt, adjust tension as necessary.
- Lubricate steering linkage.
- Drain and refill automatic transmission fluid.
- Drain and refill transfer case fluid.
- Drain and refill front and rear axles.‡
- Inspect brake linings.
- Lubricate steering and suspension ball joints.

63,000 Miles (101 000 km)

- Change engine oil.
- Replace engine oil filter.
- Lubricate steering linkage.

66,000 Miles (106 000 km)

- Change engine oil.
- Replace engine oil filter.
- Lubricate steering linkage.
- Lubricate steering and suspension ball joints.

69,000 Miles (110 000 km)

- Change engine oil.
- Replace engine oil filter.
- Lubricate steering linkage.

72,000 Miles (115 000 km)

- Change engine oil.
- Replace engine oil filter.
- Lubricate steering linkage.
- Drain and refill automatic transmission fluid.
- Drain and refill front and rear axles.‡
- Inspect brake linings.
- Lubricate steering and suspension ball joints.
- Drain and refill manual transmission fluid.

75,000 Miles (120 000 km)

- Change engine oil.
- Replace engine oil filter.
- **Inspect engine air cleaner element, replace as necessary.**
- Lubricate steering linkage.

78,000 Miles (125 000 km)

- Change engine oil.
- Replace engine oil filter.
- Lubricate steering linkage.
- Lubricate steering and suspension ball joints.

81,000 Miles (130 000 km)

- Change engine oil.
- Replace engine oil filter.
- Flush and replace engine coolant if it has been 30,000 miles (48 000 km) since last change.
- Lubricate steering linkage.

84,000 Miles (134 000 km)

- Change engine oil.
- Replace engine oil filter.
- Lubricate steering linkage.
- Drain and refill automatic transmission fluid.
- Drain and refill front and rear axles.‡
- Inspect brake linings.
- Lubricate steering and suspension ball joints.

SERVICE PROCEDURES (Continued)

87,000 Miles (139 000 km)

- Change engine oil.
- Replace engine oil filter.
- Lubricate steering linkage.

90,000 Miles (144 000 km)

- Change engine oil.
- Replace engine oil filter.
- **Replace engine air cleaner element.**
- **Replace spark plugs.**
- Inspect drive belt, adjust tension as necessary.
- Lubricate steering linkage.
- Drain and refill transfer case fluid.
- Lubricate steering and suspension ball joints.
- Drain and refill manual transmission fluid.

93,000 Miles (149 000 km)

- Change engine oil.
- Replace engine oil filter.
- Lubricate steering linkage.

96,000 Miles (154 000 km)

- Change engine oil.
- Replace engine oil filter.
- Lubricate steering linkage.
- Drain and refill automatic transmission fluid.
- Drain and refill front and rear axles.‡
- Inspect brake linings.
- Lubricate steering and suspension ball joints.

99,000 Miles (158 000 km)

- Change engine oil.
- Replace engine oil filter.
- Lubricate steering linkage.

102,000 Miles (163 000 km)

- Change engine oil.
- Replace engine oil filter.
- Lubricate steering linkage.
- Lubricate steering and suspension ball joints.

105,000 Miles (168 000 km)

- Change engine oil.
- Replace engine oil filter.
- **Inspect engine air cleaner element, replace as necessary.**
- Lubricate steering linkage.

108,000 Miles (173 000 km)

- Change engine oil.
- Replace engine oil filter.

- Lubricate steering linkage.
- Drain and refill automatic transmission fluid.
- Drain and refill front and rear axles.‡
- Inspect brake linings.
- Lubricate steering and suspension ball joints.
- Drain and refill manual transmission fluid.

111,000 Miles (178 000 km)

- Change engine oil.
- Replace engine oil filter.
- Flush and replace engine coolant if it has been 30,000 miles (48 000 km) since last change.
- Lubricate steering linkage.

114,000 Miles (182 000 km)

- Change engine oil.
- Replace engine oil filter.
- Lubricate steering linkage.
- Lubricate steering and suspension ball joints.

117,000 Miles (187 000 km)

- Change engine oil.
- Replace engine oil filter.
- Lubricate steering linkage.

120,000 Miles (192 000 km)

- Change engine oil.
 - Replace engine oil filter.
 - **Replace engine air cleaner element.**
 - **Replace ignition cables.**
 - **Replace spark plugs.**
 - Inspect drive belt, adjust tension as necessary.
 - Lubricate steering linkage.
 - Drain and refill automatic transmission fluid.
 - Drain and refill transfer case fluid.
 - Drain and refill front and rear axles.‡
 - Inspect brake linings.
 - Lubricate steering and suspension ball joints.
- ‡Off-highway operation, trailer towing, taxi, limousine, bus, snow plowing, or other types of commercial service or prolonged operation with heavy loading, especially in hot weather, require front and rear axle service indicated with a ‡ in Schedule "B". Perform these services if the vehicle is usually operated under these conditions.

Important: Inspection and service should also be performed any time a malfunction is observed or suspected.

JUMP STARTING, TOWING AND HOISTING

TABLE OF CONTENTS

| | page | | page |
|--|------|---|------|
| SERVICE PROCEDURES | | FOUR-WHEEL-DRIVE VEHICLE TOWING | 10 |
| JUMP STARTING PROCEDURE | 9 | EMERGENCY TOW HOOKS | 11 |
| TWO-WHEEL-DRIVE VEHICLE TOWING | 10 | HOISTING RECOMMENDATIONS | 11 |

SERVICE PROCEDURES

JUMP STARTING PROCEDURE

WARNING: REVIEW ALL SAFETY PRECAUTIONS AND WARNINGS IN GROUP 8A, BATTERY/STARTING/CHARGING SYSTEMS DIAGNOSTICS. DO NOT JUMP START A FROZEN BATTERY, PERSONAL INJURY CAN RESULT. DO NOT JUMP START WHEN MAINTENANCE FREE BATTERY INDICATOR DOT IS YELLOW OR BRIGHT COLOR. DO NOT JUMP START A VEHICLE WHEN THE BATTERY FLUID IS BELOW THE TOP OF LEAD PLATES. DO NOT ALLOW JUMPER CABLE CLAMPS TO TOUCH EACH OTHER WHEN CONNECTED TO A BOOSTER SOURCE. DO NOT USE OPEN FLAME NEAR BATTERY. REMOVE METALLIC JEWELRY WORN ON HANDS OR WRISTS TO AVOID INJURY BY ACCIDENTAL ARCING OF BATTERY CURRENT. WHEN USING A HIGH OUTPUT BOOSTING DEVICE, DO NOT ALLOW BATTERY VOLTAGE TO EXCEED 16 VOLTS. REFER TO INSTRUCTIONS PROVIDED WITH DEVICE BEING USED.

CAUTION: When using another vehicle as a booster, do not allow vehicles to touch. Electrical systems can be damaged on either vehicle.

TO JUMP START A DISABLED VEHICLE:

- (1) Raise hood on disabled vehicle and visually inspect engine compartment for:
- Battery cable clamp condition, clean if necessary.
 - Frozen battery.
 - Yellow or bright color test indicator, if equipped.
 - Low battery fluid level.
 - Generator drive belt condition and tension.
 - Fuel fumes or leakage, correct if necessary.

CAUTION: If the cause of starting problem on disabled vehicle is severe, damage to booster vehicle charging system can result.

(2) When using another vehicle as a booster source, turn off all accessories, place gear selector in park or neutral, set park brake and operate engine at 1200 rpm.

(3) On disabled vehicle, place gear selector in park or neutral and set park brake. Turn off all accessories.

(4) Connect jumper cables to booster battery. RED clamp to positive terminal (+). BLACK clamp to negative terminal (-). DO NOT allow clamps at opposite end of cables to touch, electrical arc will result. Review all warnings in this procedure.

(5) On disabled vehicle, connect RED jumper cable clamp to positive (+) terminal. Connect BLACK jumper cable clamp to engine ground as close to the ground cable attaching point as possible (Fig. 1).

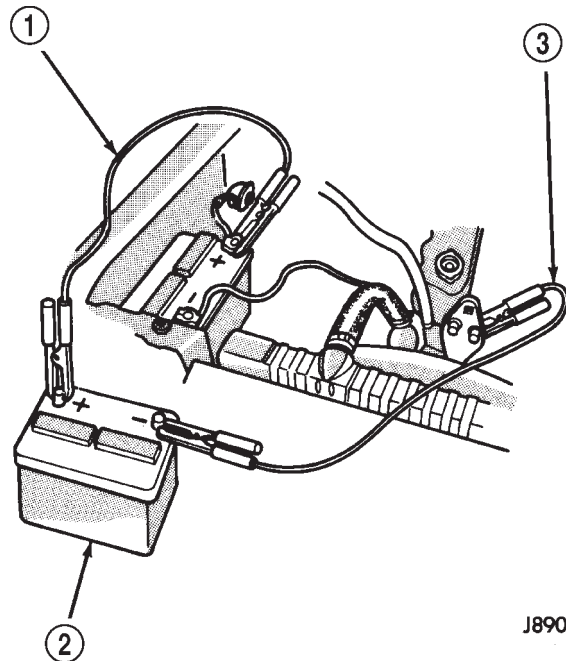

J8900-7

Fig. 1 Jumper Cable Connections—Typical

- 1 - POSITIVE CABLE CONNECTION
- 2 - BOOSTER BATTERY
- 3 - NEGATIVE OR GROUND CABLE CONNECTION

SERVICE PROCEDURES (Continued)

CAUTION: Do not crank starter motor on disabled vehicle for more than 15 seconds, starter will over-heat and could fail.

(6) Allow battery in disabled vehicle to charge to at least 12.4 volts (75% charge) before attempting to start engine. If engine does not start within 15 seconds, stop cranking engine and allow starter to cool (15 min.), before cranking again.

DISCONNECT CABLE CLAMPS AS FOLLOWS:

- Disconnect BLACK cable clamp from engine ground on disabled vehicle.
- When using a Booster vehicle, disconnect BLACK cable clamp from battery negative terminal. Disconnect RED cable clamp from battery positive terminal.
- Disconnect RED cable clamp from battery positive terminal on disabled vehicle.

TWO-WHEEL-DRIVE VEHICLE TOWING

TOWING-REAR END LIFTED (SLING-TYPE)

WARNING: WHEN TOWING A DISABLED VEHICLE AND THE DRIVE WHEELS ARE SECURED IN A WHEEL LIFT OR TOW DOLLIES, ENSURE THE TRANSMISSION IS IN THE PARK POSITION (AUTOMATIC TRANSMISSION) OR A FORWARD DRIVE GEAR (MANUAL TRANSMISSION).

CAUTION: Do not use steering column lock to secure steering wheel during towing operation.

2WD XJ vehicles can be towed with the front wheels on the surface for extended distances at speeds not exceeding 48 km/h (30 mph). If the vehicle is equipped with a factory installed trailer tow package, use a SAE approved wheel lift device.

- (1) Attach J-hooks around the axle shaft tube outboard of the shock absorber.
- (2) Place the sling crossbar under and forward of the bumper.
- (3) Attach safety chains around the frame rails.
- (4) Turn the ignition switch to the OFF position to unlock the steering wheel.
- (5) Secure steering wheel in the straight ahead position with a clamp device designed for towing.
- (6) Verify that steering components are in good condition.
- (7) Shift the transmission to NEUTRAL.

TOWING-REAR END LIFTED (WHEEL LIFT)

- (1) Raise front of vehicle off ground and install tow dollies under front wheels.
- (2) Attach wheel lift to rear wheels.
- (3) Place transmission in neutral.
- (4) Raise vehicle to towing height.
- (5) Place transmission in park (automatic transmission) or first gear (manual transmission).

TOWING-FRONT END LIFTED

To prevent damage to front fascia components, use only a Wheel-Lift type towing device or Flat-Bed hauling equipment.

If using the wheel-lift towing method:

- (1) Raise rear of vehicle off ground and install tow dollies under rear wheels.
- (2) Attach wheel lift to front wheels.
- (3) Place transmission in neutral.
- (4) Raise vehicle to towing height.
- (5) Place transmission in park (automatic transmission) or first gear (manual transmission).

FOUR-WHEEL-DRIVE VEHICLE TOWING

DaimlerChrysler Corporation recommends that a 4WD vehicle be transported on a flat bed device. A wheel lift or sling type device can be used provided all wheels are lifted off the ground using tow dollies.

If the vehicle is equipped with a factory installed trailer tow package, use a SAE approved wheel lift device.

WARNING: WHEN TOWING A DISABLED VEHICLE AND THE DRIVE WHEELS ARE SECURED IN A WHEEL LIFT OR TOW DOLLIES, ENSURE THE TRANSMISSION IS IN THE PARK POSITION (AUTOMATIC TRANSMISSION) OR A FORWARD DRIVE GEAR (MANUAL TRANSMISSION).

TOWING-REAR END LIFTED (SLING TYPE)

- (1) Raise front of vehicle off ground and install tow dollies under front wheels.
- (2) Attach J-hooks around rear axle shaft tube outboard of shock absorber.
- (3) Place sling crossbar under and forward of bumper.
- (4) Attach safety chains around frame rails.
- (5) Turn ignition switch to OFF position to unlock steering wheel.
- (6) Secure steering wheel in the straight ahead position with a clamp device designed for towing.
- (7) Shift transfer case to neutral.

SERVICE PROCEDURES (Continued)

TOWING-REAR END LIFTED (WHEEL LIFT)

- (1) Raise front of vehicle off ground and install tow dollies under front wheels.
- (2) Attach wheel lift to rear wheels.
- (3) Place transmission in neutral.
- (4) Raise vehicle to towing height.
- (5) Place transmission in park (automatic transmission) or first gear (manual transmission).

TOWING-FRONT END LIFTED

To prevent damage to front fascia components, use only a Wheel-Lift type towing device or Flat-Bed hauling equipment.

- (1) Raise the rear of the vehicle off the ground and install tow dollies under rear wheels.
- (2) Attach wheel lift to front wheels.
- (3) Place transmission in neutral.
- (4) Raise vehicle to towing height.
- (5) Place transmission in park (automatic transmission) or first gear (manual transmission).

EMERGENCY TOW HOOKS

WARNING: REMAIN AT A SAFE DISTANCE FROM A VEHICLE THAT IS BEING TOWED VIA ITS TOW HOOKS. THE TOW STRAPS/CHAINS COULD BREAK AND CAUSE SERIOUS INJURY.

Some Jeep vehicles are equipped with front and rear emergency tow hooks. The tow hooks should be used for **EMERGENCY** purposes only.

CAUTION: DO NOT use emergency tow hooks for tow truck hook-up or highway towing.

HOISTING RECOMMENDATIONS

Refer to the Owner's Manual for emergency vehicle lifting procedures.

FLOOR JACK

When properly positioned, a floor jack can be used to lift a Jeep vehicle (Fig. 2) and (Fig. 3). Support the vehicle in the raised position with jack stands at the front and rear ends of the frame rails.

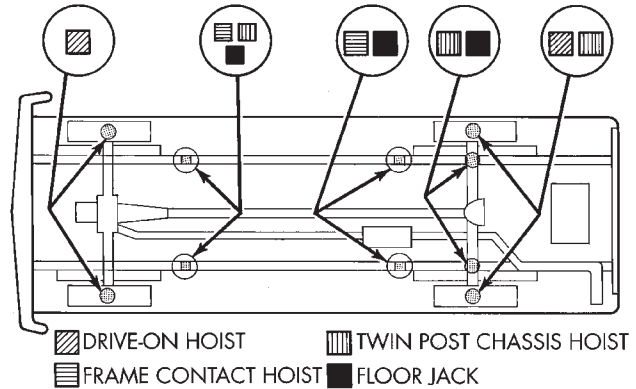
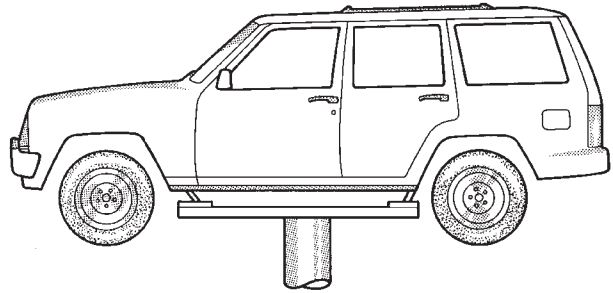

J9500-2

Fig. 2 Vehicle Lifting Locations

SERVICE PROCEDURES (Continued)

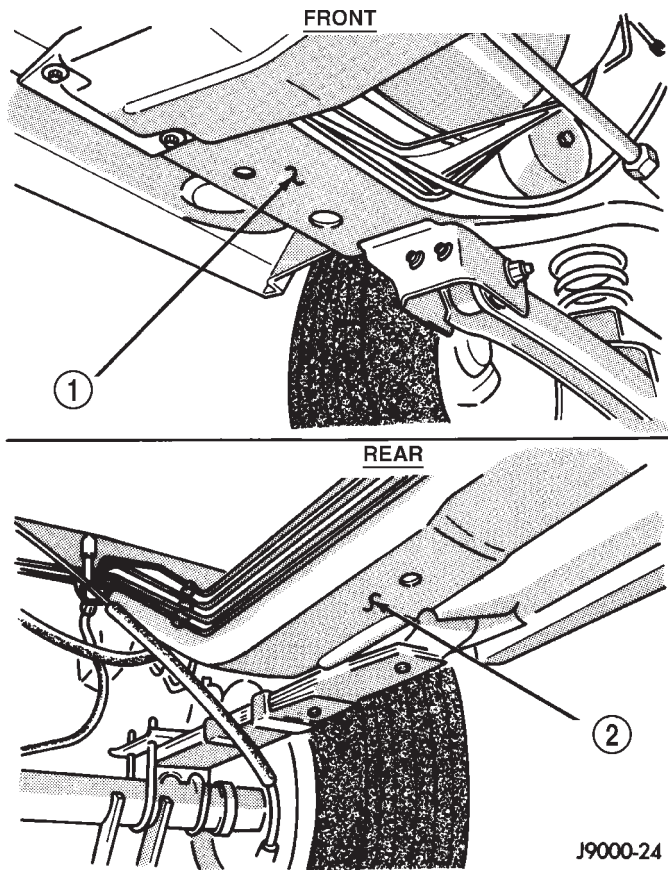

Fig. 3 Correct Vehicle Lifting Locations

- 1 - SUB-FRAME RAIL LOCATION
2 - SUB-FRAME RAIL LOCATION

CAUTION: Do not attempt to lift a Jeep vehicle with a floor jack positioned under:

- An axle tube.
- A body side sill.
- A steering linkage component.
- A drive shaft.
- The engine or transmission oil pan.
- The fuel tank.
- A front suspension arm.

NOTE: Use the correct sub-frame rail or frame rail lifting locations only.

HOIST

A vehicle can be lifted with:

- A single-post, frame-contact hoist.
- A twin-post, chassis hoist.
- A ramp-type, drive-on hoist.

NOTE: When a frame-contact type hoist is used, verify that the lifting pads are positioned properly.

WARNING: THE HOISTING AND JACK LIFTING POINTS PROVIDED ARE FOR A COMPLETE VEHICLE. WHEN A CHASSIS OR DRIVETRAIN COMPONENT IS REMOVED FROM A VEHICLE, THE CENTER OF GRAVITY IS ALTERED MAKING SOME HOISTING CONDITIONS UNSTABLE. PROPERLY SUPPORT OR SECURE VEHICLE TO HOISTING DEVICE WHEN THESE CONDITIONS EXIST.

J9000-24

LUBRICATION AND MAINTENANCE

TABLE OF CONTENTS

| | page | | page |
|------------------|------|---------------------------|------|
| LUBRICANTS | 1 | MAINTENANCE SCHEDULE..... | 2 |

LUBRICANTS

TABLE OF CONTENTS

| | page | | page |
|--|--------|--|---------|
| SPECIFICATIONS | | FLUID CAPACITIES | 1 |
| ENGINE OIL—DIESEL ENGINES | 1 | COOLING SYSTEM | |
| SPECIFICATIONS | | 2.5L Diesel | 8.0 L |
| ENGINE OIL—DIESEL ENGINES | | MANUAL TRANSMISSION | |
| Use only Diesel Engine Oil meeting standard MIL-2104C or API Classification CD or higher or CCML D4, D5 . | | Recommended lubricant for AX15 transmissions is Mopar® 75W-90, API Grade GL-3 gear lubricant, or equivalent. | |
| SAE VISCOSITY GRADE | | Correct lubricant level is from the bottom edge, to no more than 6 mm (1/4 in.) below the bottom edge of the fill plug hole. | |
| CAUTION: Low viscosity oils must have the proper API quality or the CCMC G5 designation. | | Approximate dry fill lubricant capacity is: | |
| To assure of properly formulated engine oils, it is recommended that SAE Grade 15W-40 engine oils that meet Chrysler material standard MS-6395, be used. European Grade 10W-40 oils are also acceptable. | | • 3.10 liters (3.27 qts.) for 4-wheel drive applications. | |
| Oils of the SAE 5W-40 or 8W-80 grade number are preferred when minimum temperatures consistently fall below -12°C. | | • 3.15 liters (3.32 qts.) for 2-wheel drive applications. | |
| FLUID CAPACITIES | | TRANSFER CASE | |
| FUEL TANK | | COMMAND-TRAC 231 | 1.3 L |
| Diesel Engine Equipped Vehicles | 76.4 L | FRONT AXLE | |
| ENGINE OIL | | Model 181 | 1.2 L |
| 2.5L Diesel Engine (includes filter) | 6.8 L | REAR AXLE | |
| Oil Filter Replacement Only | 0.4 L | Model 194 | 1.6 L* |
| | | 8-1/4 | 2.3 L** |
| | | * When equipped with TRAC-LOK, include 4 ounces of Friction Modifier Additive. | |
| | | ** When equipped with TRAC-LOK, include 5 ounces of Friction Modifier Additive. | |

MAINTENANCE SCHEDULE

TABLE OF CONTENTS

| | page | page |
|--|------|------------------------|
| DESCRIPTION AND OPERATION | | |
| MAINTENANCE SCHEDULE—DIESEL ENGINE . . . | 2 | |
| SERVICE PROCEDURES | | |
| SCHEDULE—A | 2 | |
| | | SCHEDULE—B 3 |

DESCRIPTION AND OPERATION

MAINTENANCE SCHEDULE—DIESEL ENGINE

DESCRIPTION

The following are engine related Maintenance items which are unique to Diesel engine-equipped vehicles. Refer to the 2000 XJ Service Manual for gasoline engine and non-engine related Maintenance Schedules

The service intervals are based on odometer readings in kilometers. There are two maintenance schedules that show proper service intervals. Use the schedule that best describes the conditions the vehicle is operated under. **Schedule-A** lists all the scheduled maintenance to be performed under normal operating conditions. **Schedule-B** is the schedule for vehicles that are operated under one or more of the following conditions:

- Day and night temperatures are below freezing.
- Stop and go driving.
- Long periods of engine idling.
- Driving in dusty conditions.
- Short trips of less than 8 kilometers (5 miles).
- Operation at sustained high speeds during hot weather above 32°C (90°F).
- Taxi, police or delivery service.
- Trailer towing.

AT EACH STOP FOR FUEL OR SCHEDULED

SERVICE STOP

- Check engine oil level.
- Check engine coolant level.
- Inspect drive belt.
- Visually inspect intercooler for obstruction. Clean as necessary.
- Visually inspect radiator for obstruction. Clean as necessary.
- Inspect for fuel, oil or coolant leaks.
- Inspect battery cable connection and excessive corrosion.
- Inspect for presence of water in fuel filter/water separator, drain if necessary.

SERVICE PROCEDURES

SCHEDULE—A

1 000 KM

- Change engine oil.
- Change engine oil filter.
- Check all fluid levels.
- Check correct torque, intake manifold mounting nuts.
- Check correct torque, exhaust manifold mounting nuts.
- Check correct torque, turbocharger mounting nuts.
- Check correct torque, water manifold bolts.

10 000 KM

- Change engine oil.
- Change engine oil filter.

20 000 KM

- Change engine oil.
- Change engine oil filter.
- Replace air filter element.
- Drive belt visual inspection.

30 000 KM

- Change engine oil.
- Change engine oil filter.

40 000 KM

- Change engine oil.
- Change engine oil filter.
- Replace air filter element.
- Drive belt visual inspection.
- Replace fuel filter/water separator element.**

50 000 KM

- Change engine oil.
- Change engine oil filter.

60 000 KM

- Change engine oil.
- Change engine oil filter.

SERVICE PROCEDURES (Continued)

- Replace air filter element.
- Replace drive belt.
- Check engine smoke.
- Replace engine coolant.

70 000 KM

- Change engine oil.
- Change engine oil filter.

80 000 KM

- Change engine oil.
- Change engine oil filter.
- Replace air filter element.
- Drive belt visual inspection.
- Replace fuel filter/water separator element.**

90 000 KM

- Change engine oil.
- Change engine oil filter.

100 000 KM

- Change engine oil.
- Change engine oil filter.
- Replace air filter element.
- Drive belt visual inspection.
- Check glow plug operation.

EVERY 40 000 KM AFTER 80 000 KM

- Replace fuel filter/water separator element.**

**The fuel filter/water separator element should be replaced once a year if the vehicle is driven less than 40 000 km annually or if power loss from fuel starvation is detected.

EVERY 10 000 KM AFTER 100 000 KM

- Change engine oil.
- Change engine oil filter.

EVERY 20 000 KM AFTER 100 000 KM

- Change engine oil.
- Change engine oil filter.
- Replace air filter element.
- Drive belt visual inspection.
- Check glow plug operation.

SCHEDULE—B**500 KM**

- Check correct torque, intake manifold mounting nuts.
- Check correct torque, exhaust manifold mounting nuts.
- Check correct torque, turbocharger mounting nuts.
- Check correct torque, water manifold bolts.

1 000 KM

- Change engine oil.
- Change engine oil filter.
- Check all fluid levels.

5 000 KM

- Change engine oil.
- Change engine oil filter.

10 000 KM

- Change engine oil.
- Change engine oil filter.
- Replace air filter element.
- Drive belt visual inspection.

15 000 KM

- Change engine oil.
- Change engine oil filter.

20 000 KM

- Change engine oil.
- Change engine oil filter.
- Replace air filter element.
- Drive belt visual inspection.

25 000 KM

- Change engine oil.
- Change engine oil filter.

30 000 KM

- Change engine oil.
- Change engine oil filter.
- Replace air filter element.
- Replace drive belt.
- Check engine smoke.
- Replace engine coolant.

35 000 KM

- Change engine oil.
- Change engine oil filter.

40 000 KM

- Change engine oil.
- Change engine oil filter.
- Replace air filter element.
- Drive belt visual inspection.
- Replace fuel filter/water separator element.

45 000 KM

- Change engine oil.
- Change engine oil filter.

50 000 KM

- Change engine oil.
- Change engine oil filter.
- Replace air filter element.
- Drive belt visual inspection.

SERVICE PROCEDURES (Continued)

55 000 KM

- Change engine oil.
- Change engine oil filter.

60 000 KM

- Change engine oil.
- Change engine oil filter.
- Replace air filter element.
- Drive belt visual inspection.
- Replace fuel filter/water separator element.

65 000 KM

- Change engine oil.
- Change engine oil filter.

70 000 KM

- Change engine oil.
- Change engine oil filter.
- Replace air filter element.
- Drive belt visual inspection.

75 000 KM

- Change engine oil.
- Change engine oil filter.

80 000 KM

- Change engine oil.
- Change engine oil filter.
- Replace air filter element.
- Replace drive belt.
- Check engine smoke.
- Replace engine coolant.

85 000 KM

- Change engine oil.
- Change engine oil filter.

90 000 KM

- Change engine oil.
- Change engine oil filter.
- Replace air filter element.
- Drive belt visual inspection.

95 000 KM

- Change engine oil.
- Change engine oil filter.

100 000 KM

- Change engine oil.
- Change engine oil filter.
- Replace air filter element.
- Drive belt visual inspection.
- Check glow plug operation.
- Replace fuel filter/water separator element.

EVERY 5 000 KM AFTER 100 000 KM

- Change engine oil.
- Change engine oil filter.

EVERY 10 000 KM AFTER 100 000 KM

- Change engine oil.
- Change engine oil filter.
- Replace air filter element.
- Drive belt visual inspection.
- Check glow plug operation.

EVERY 20 000 KM AFTER 100 000 KM

- Replace fuel filter/water separator element.

EXHAUST SYSTEM

TABLE OF CONTENTS

| | page | | page |
|----------------------------------|------|---------------------------------|------|
| DESCRIPTION AND OPERATION | | REMOVAL AND INSTALLATION | |
| EXHAUST SYSTEM..... | 1 | EXHAUST PIPE..... | 5 |
| CATALYTIC CONVERTERS | 2 | CATALYTIC CONVERTER..... | 6 |
| MUFFLER | 3 | MUFFLER AND TAILPIPE | 6 |
| TAILPIPE..... | 4 | HEAT SHIELDS..... | 8 |
| DIAGNOSIS AND TESTING | | SPECIFICATIONS | |
| EXHAUST SYSTEM..... | 4 | TORQUE SPECIFICATIONS..... | 8 |

DESCRIPTION AND OPERATION

EXHAUST SYSTEM

DESCRIPTION

The basic exhaust system consists of exhaust manifold(s), exhaust pipe with oxygen sensors, catalytic converter(s), heat shield(s), muffler and tailpipe (Fig. 1) (Fig. 2) (Fig. 3)

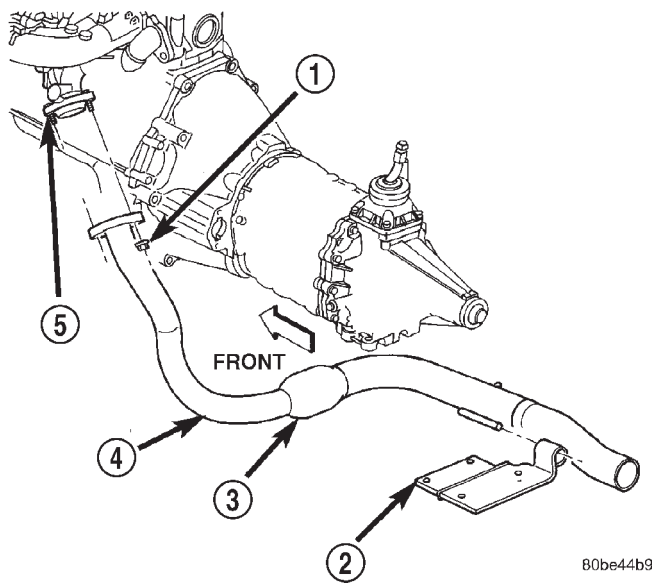

Fig. 1 Exhaust Pipe—2.5L

- 1 - NUT
- 2 - TRANSMISSION SUPPORT
- 3 - MINI CATALYTIC CONVERTER
- 4 - EXHAUST PIPE
- 5 - EXHAUST MANIFOLD

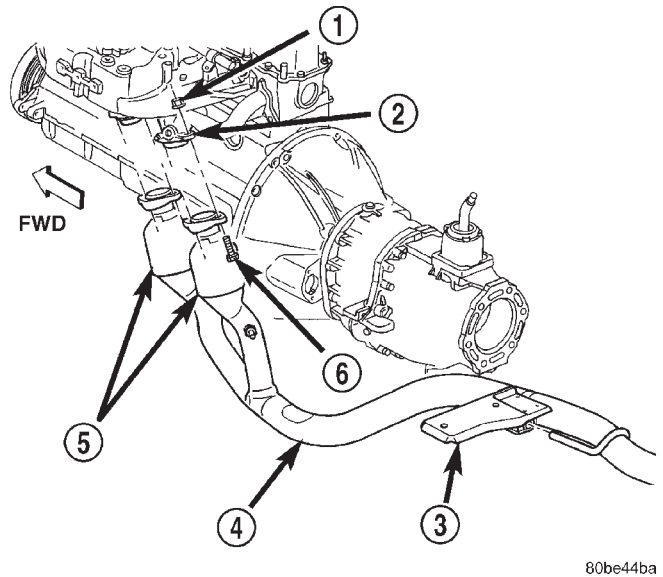
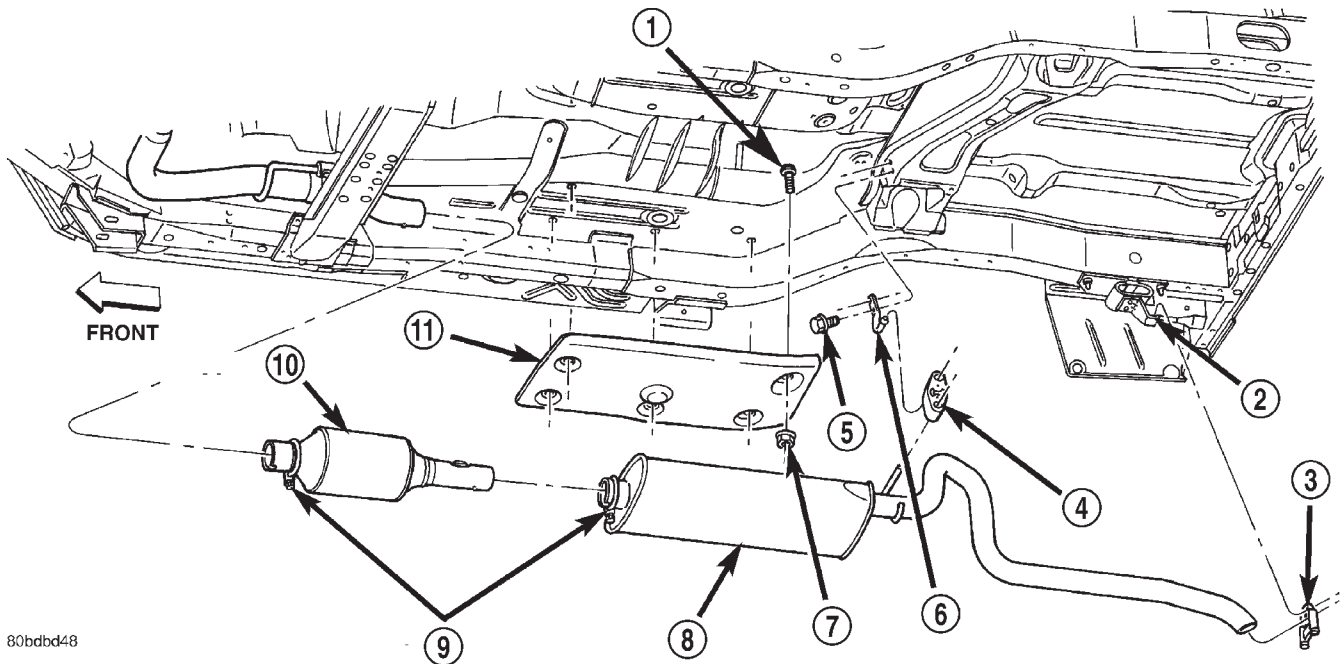

Fig. 2 Exhaust Pipe—4.0L

- 1 - NUT
- 2 - EXHAUST MANIFOLD
- 3 - TRANSMISSION SUPPORT
- 4 - EXHAUST PIPE
- 5 - MINI CATALYTIC CONVERTER
- 6 - BOLT

DESCRIPTION AND OPERATION (Continued)



80bdbd48

Fig. 3 Exhaust System—Typical

- | | |
|----------------------|--------------------------|
| 1 - STUD | 7 - NUT |
| 2 - TAIL PIPE HANGER | 8 - MUFFLER |
| 3 - CLAMP | 9 - CLAMP |
| 4 - ISOLATOR | 10 - CATALYTIC CONVERTER |
| 5 - BOLT | 11 - HEAT SHIELD |
| 6 - TAIL PIPE HANGER | |

CATALYTIC CONVERTERS**DESCRIPTION**

California emissions vehicles incorporate two mini catalytic converters into the exhaust system. These catalytic converters are made of stainless steel designed to operate at extremely high temperatures.

The stainless steel catalytic converter body is designed to last the life of the vehicle. Excessive heat can result in bulging or other distortion, but exces-

sive heat will not be the fault of the converter. If unburned fuel enters the converter, overheating may occur. If a converter is heat-damaged, correct the cause of the damage at the same time the converter is replaced. Also, inspect all other components of the exhaust system for heat damage.

Unleaded gasoline must be used to avoid contaminating the catalyst core.

DESCRIPTION AND OPERATION (Continued)

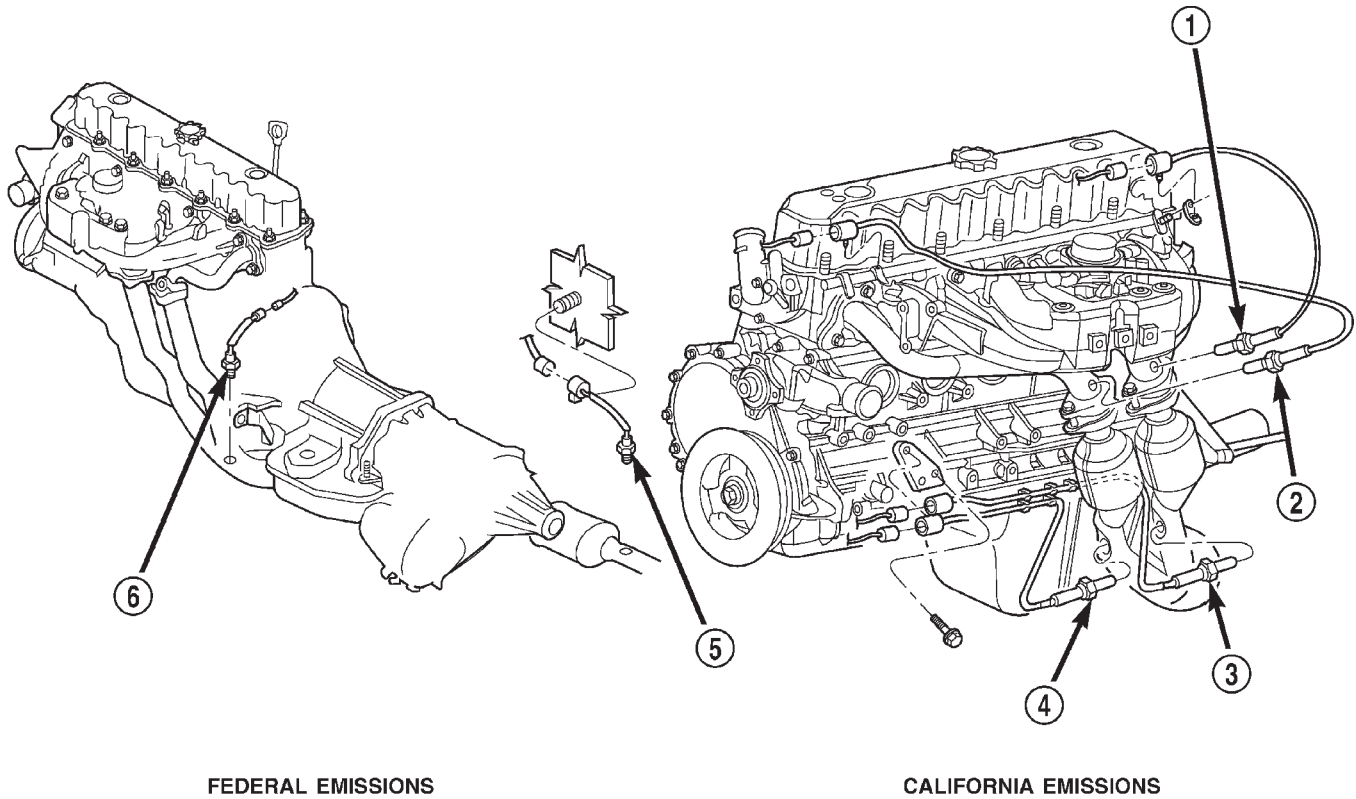

FEDERAL EMISSIONS

CALIFORNIA EMISSIONS

80bbc2fe

Fig. 4 4.0L Catalytic Converter and O2 Sensor Configuration—(California Emissions only)

- 1 - O2 SENSOR
- 2 - O2 SENSOR
- 3 - O2 SENSOR

- 4 - O2 SENSOR
- 5 - O2 SENSOR
- 6 - O2 SENSOR

Federal emission vehicles use only one catalytic converter; However, California emission vehicles incorporate two mini catalytic converters located after the exhaust manifolds and before the inline catalytic converter (Fig. 4).

MUFFLER

DESCRIPTION

Both the 2.5L and 4.0L engines use a galvanized steel muffler to control exhaust noise levels and exhaust back pressure.

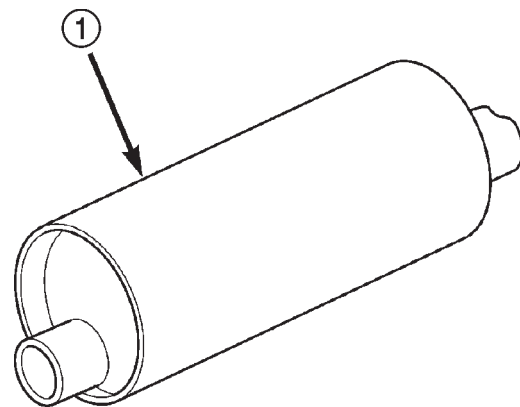

80bcea59

Fig. 5 Muffler—Typical

- 1 - MUFFLER

DESCRIPTION AND OPERATION (Continued)

TAILPIPE

DESCRIPTION

The tail pipe is also made of galvanized steel.

OPERATION

The tailpipe channels the exhaust out of the muffler and out from under the vehicle to control noise and prevent exhaust gas fumes from entering the passenger compartment.

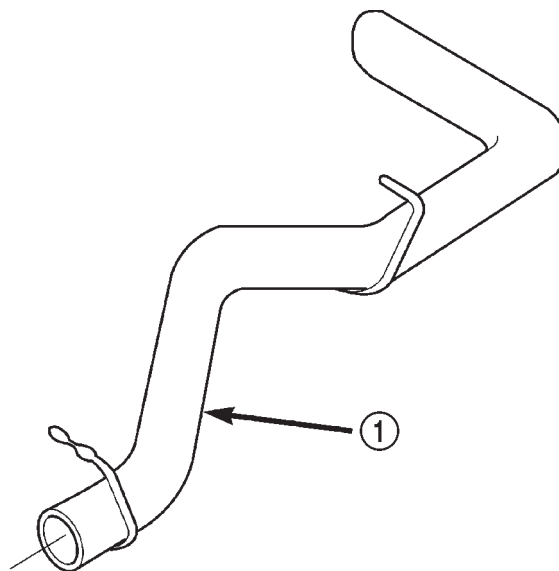

80bcea58

Fig. 6 Tailpipe—Typical

1 - TAILPIPE

DIAGNOSIS AND TESTING

EXHAUST SYSTEM

EXHAUST SYSTEM DIAGNOSIS CHART

| CONDITION | POSSIBLE CAUSE | CORRECTION |
|--|--|--|
| EXCESSIVE EXHAUST NOISE OR LEAKING EXHAUST GASES | 1. Leaks at pipe joints. 2. Rusted or blown out muffler. 3. Broken or rusted out exhaust pipe. 4. Exhaust pipe leaking at manifold flange. 5. Exhaust manifold cracked or broken. 6. Leak between exhaust manifold and cylinder head. 7. Catalytic converter rusted or blown out. 8. Restriction in exhaust system. | 1. Tighten clamps/bolts at leaking joints. 2. Replace muffler. Inspect exhaust system. 3. Replace exhaust pipe. 4. Tighten/replace flange attaching nuts/bolts. 5. Replace exhaust manifold. 6. Tighten exhaust manifold to cylinder head bolts. 7. Replace catalytic converter assy. 8. Remove restriction, if possible. Replace restricted part if necessary. |

When servicing and replacing exhaust system components, disconnect the oxygen sensor connector(s). Allowing the exhaust to hang by the oxygen sensor wires will damage the harness and/or sensor.

REMOVAL AND INSTALLATION

EXHAUST PIPE

WARNING: IF TORCHES ARE USED WHEN WORKING ON THE EXHAUST SYSTEM, DO NOT ALLOW THE FLAME NEAR THE FUEL LINES.

CAUTION: When servicing exhaust system components, disconnect the oxygen sensor connector. Allowing the exhaust system to hang by the oxygen sensor harness will damage the wiring and/or sensor.

REMOVAL

- (1) Raise and support the vehicle.
- (2) Saturate the bolts and nuts with Mopar® Rust Penetrant (Fig. 7) (Fig. 8). Allow 5 minutes for penetration.

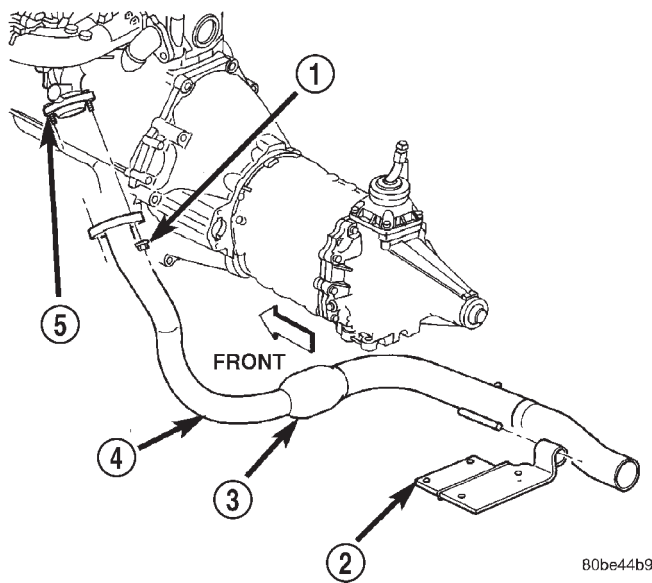

Fig. 7 Exhaust Pipe Removal—2.5L

- 1 - NUT
- 2 - TRANSMISSION SUPPORT
- 3 - MINI CATALYTIC CONVERTER
- 4 - EXHAUST PIPE
- 5 - EXHAUST MANIFOLD

- (3) Disconnect the oxygen sensor connector(s).
- (4) Disconnect the exhaust pipe from the engine exhaust manifold. Discard the seal (4.0L engine, only).
- (5) Support the transmission and remove the rear crossmember.
- (6) Remove the clamp nuts and clamp. To remove the exhaust pipe from the catalytic converter, apply heat until the metal becomes cherry red. Disconnect

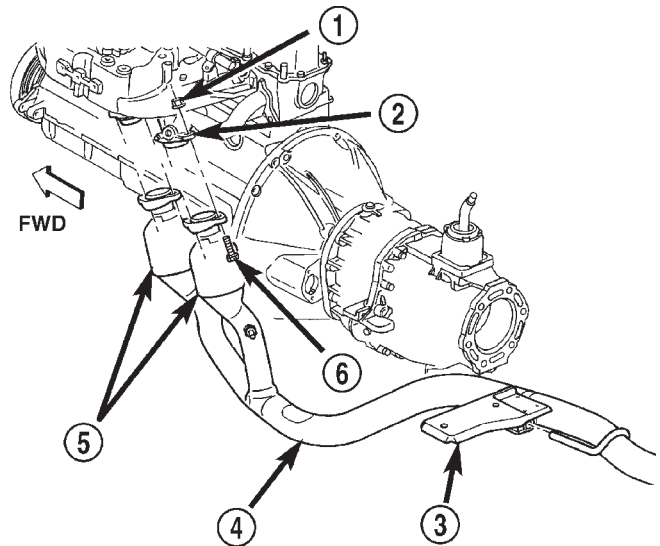

Fig. 8 Exhaust Pipe Removal—4.0L

- 1 - NUT
- 2 - EXHAUST MANIFOLD
- 3 - TRANSMISSION SUPPORT
- 4 - EXHAUST PIPE
- 5 - MINI CATALYTIC CONVERTER
- 6 - BOLT

the exhaust pipe from the catalytic converter. Remove the exhaust pipe.

INSTALLATION

- (1) Assemble exhaust pipe to manifold and catalytic converter loosely to permit proper alignment of all parts.
- (2) Use a new clamp and tighten the nuts to 61 N·m (45 ft. lbs.) torque.
- (3) Connect the exhaust pipe to the engine exhaust manifold (Fig. 7) (Fig. 8). Install a new seal between the exhaust manifold and the exhaust pipe (4.0L engine only). Tighten the nuts to 31 N·m (23 ft. lbs.) torque.
- (4) Install the rear crossmember. Install and tighten the four (4) crossmember to rear mount nuts to 22 N·m (16 ft. lbs.) Install and tighten the crossmember to sill bolts to 42 N·m (31 ft. lbs.) torque. Remove the support from the transmission.
- (5) Carefully coat the threads on the oxygen sensor(s) with anti-seize compound. Install the sensor and tighten the nut to 27 N·m (20 ft. lbs.) torque.
- (6) Lower the vehicle.
- (7) Start the engine and inspect for exhaust leaks and exhaust system contact with the body panels. Adjust the alignment, if needed.

REMOVAL AND INSTALLATION (Continued)

CATALYTIC CONVERTER

WARNING: IF TORCHES ARE USED WHEN WORKING ON THE EXHAUST SYSTEM, DO NOT ALLOW THE FLAME NEAR THE FUEL LINES.

CAUTION: When servicing exhaust system components, disconnect the oxygen sensor connector. Allowing the exhaust system to hang by the oxygen sensor harness will damage the wiring and/or sensor.

REMOVAL

- (1) Raise and support the vehicle.
- (2) Remove the clamps from the catalytic converter and muffler connection (Fig. 9).
- (3) Disconnect and remove the oxygen sensor from the catalytic converter.
- (4) Heat the catalytic converter and muffler connection with an oxyacetylene torch until the metal becomes cherry red.
- (5) While the metal is still cherry red, twist the muffler assembly back and forth to separate it from the catalytic converter.
- (6) Disconnect the exhaust pipe from the catalytic converter (Fig. 9). If needed, heat up the pipes to separate.

INSTALLATION

- (1) Connect the catalytic converter to the exhaust pipe and the muffler/tailpipe assy. (Fig. 9). Use a new clamp and tighten the nuts to 61 N·m (45 ft. lbs.) torque.
- (2) Install the muffler onto the catalytic converter until the alignment tab is inserted into the alignment slot.
- (3) Install a new clamp at the muffler and catalytic converter connection (Fig. 9). Tighten the clamp nut to 61 N·m (45 ft. lbs.) torque.
- (4) Coat the oxygen sensor with anti-seize compound. Install the sensor and tighten the nut to 27 N·m (20 ft. lbs.) torque.
- (5) Lower the vehicle.
- (6) Start the engine and inspect for exhaust leaks and exhaust system contact with the body panels. Adjust the alignment, if needed.

MUFFLER AND TAILPIPE

All original equipment exhaust systems are manufactured with the exhaust tailpipe welded to the muffler. Service replacement mufflers and exhaust tailpipes are either clamped together or welded together.

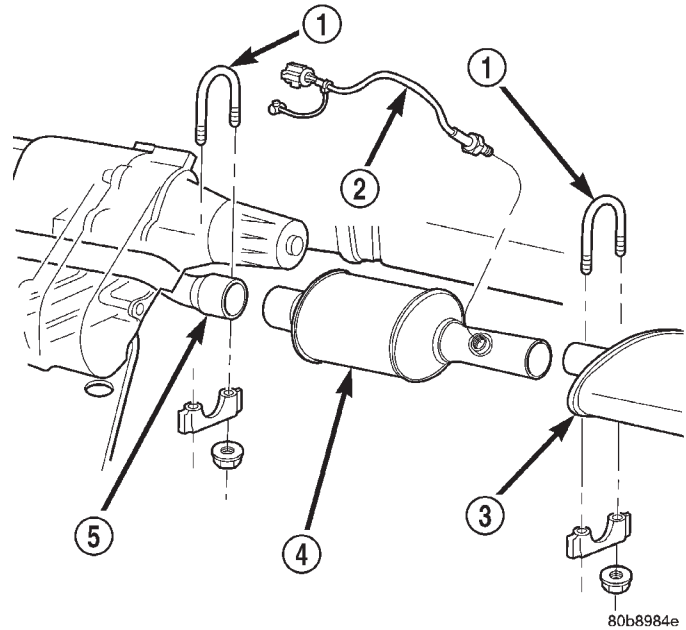

Fig. 9 Catalytic Converter to Muffler and Exhaust Pipe Connection

- 1 - EXHAUST CLAMP ASSEMBLY
- 2 - OXYGEN SENSOR
- 3 - MUFFLER
- 4 - CATALYTIC CONVERTER
- 5 - EXHAUST PIPE

WARNING: IF TORCHES ARE USED WHEN WORKING ON THE EXHAUST SYSTEM, DO NOT ALLOW THE FLAME NEAR THE FUEL LINE.

CAUTION: When servicing exhaust system components, disconnect the oxygen sensor connector. Allowing the exhaust system to hang by the oxygen sensor harness will damage the wiring and/or sensor.

REMOVAL

- (1) Raise and support the vehicle.
- (2) Disconnect front tailpipe hanger from the insulator (Fig. 10).
- (3) Remove the front exhaust clamp from the catalytic converter and muffler connection (Fig. 11).
- (4) Heat the catalytic converter-to-muffler connection with an oxyacetylene torch until the metal becomes cherry red.
- (5) While the metal is still cherry red, remove the exhaust muffler/tailpipe assembly from the catalytic converter.
- (6) Slide the muffler/tailpipe assy. rearward and out of the rear exhaust tailpipe mounting bracket (Fig. 11).

REMOVAL AND INSTALLATION (Continued)

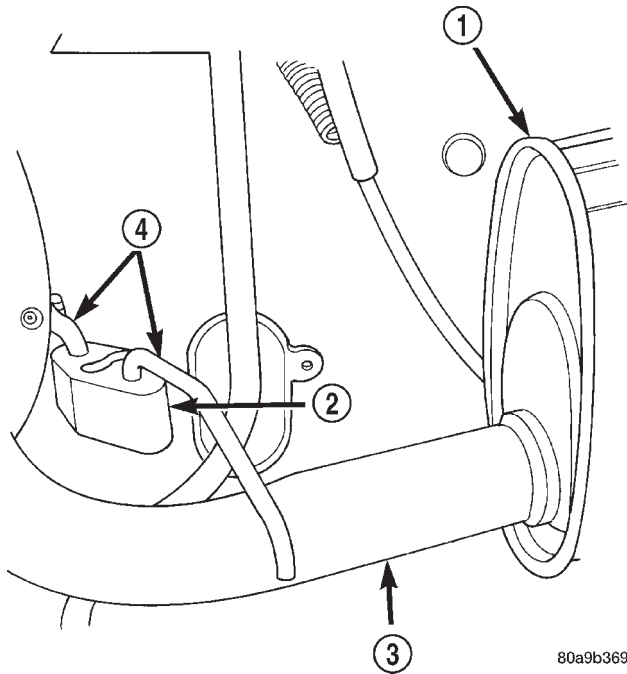

80a9b369

Fig. 10 Front Exhaust Tailpipe Hanger

- 1 - MUFFLER
- 2 - INSULATOR
- 3 - TAILPIPE
- 4 - FRONT TAILPIPE HANGER

- To remove an original equipment exhaust muffler/tailpipe combination, cut the exhaust tailpipe close to the muffler. Collapse the part remaining in the muffler and remove.
- To remove a service exhaust tailpipe/muffler combination, apply heat until the metal becomes cherry red. Remove the exhaust tailpipe/muffler clamp and twist the exhaust tailpipe out of the muffler.

INSTALLATION

- (1) Install the muffler onto the catalytic converter. Install the clamp and tighten the nut finger tight.
- (2) Install the exhaust tailpipe into the rear of the muffler.
- (3) Install the exhaust tailpipe/muffler assembly on the rear exhaust tailpipe mounting bracket. Make sure that the exhaust tailpipe has sufficient clearance from the floor pan.
- (4) Install front tailpipe hanger into the insulator (Fig. 10).
- (5) Align the muffler and tighten the nuts on the muffler-to-catalytic converter clamp to 61 N·m (45 ft. lbs.) torque (Fig. 11).
- (6) Align the tailpipe and install a new clamp at the tailpipe to tailpipe connection.
- (7) Tighten the muffler to tailpipe clamp to 61 N·m (45 ft. lbs.)
- (8) Lower the vehicle.

(7) Remove the muffler from the exhaust tailpipe:

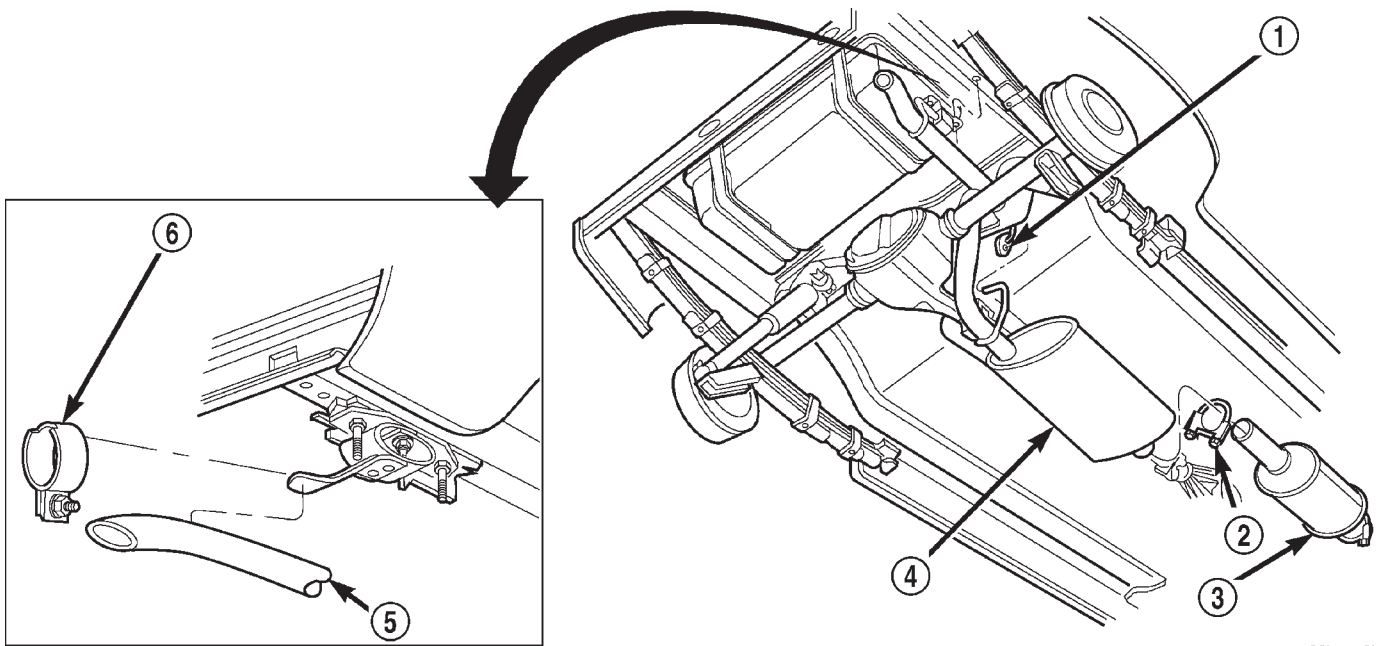

80bcea9b

Fig. 11 Muffler/Tailpipe Removal and Installation

- 1 - MUFFLER AND TAIL PIPE HANGER
- 2 - CLAMP
- 3 - CATALYTIC CONVERTER
- 4 - MUFFLER AND TAIL PIPE ASSEMBLY
- 5 - TAIL PIPE
- 6 - TAIL PIPE HANGER CLAMP

REMOVAL AND INSTALLATION (Continued)

(9) Start the engine and inspect for exhaust leaks and exhaust system contact with the body panels. Adjust the alignment, if needed.

HEAT SHIELDS

REMOVAL

- (1) Raise and support the vehicle.
- (2) Remove the screws and/or nuts holding the heat shields to the frame and/or floor pan (Fig. 12).

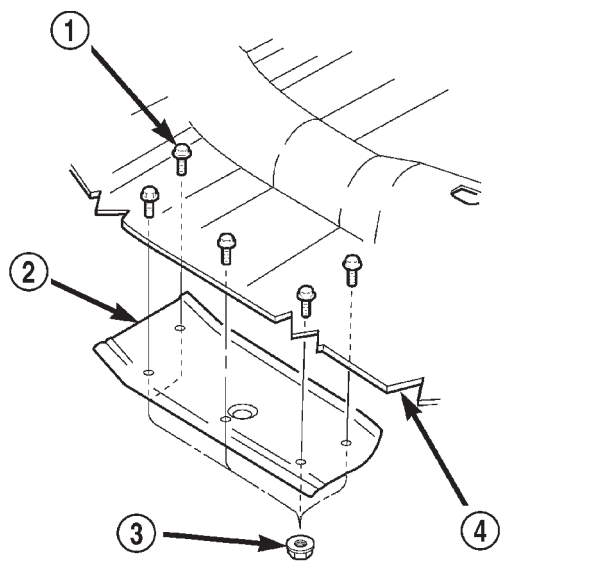

Fig. 12 Heat Shield Removal/Installation

- 1 - BOLTS
- 2 - MUFFLER HEAT SHIELD
- 3 - NUTS
- 4 - FLOOR PAN

- (3) When removing muffler heat shield, the muffler front support bracket must be removed first.
- (4) Slide the shields out around the exhaust system.

INSTALLATION

- (1) Position the heat shields to the floor pan or the frame and install the screws and/or nuts.
- (2) Tighten the nuts and/or screws to 45 N·m (33 ft. lbs.) (Fig. 12).
- (3) Lower the vehicle.

SPECIFICATIONS

TORQUE SPECIFICATIONS

| DESCRIPTION | N·m | Ft. Lbs. | In. Lbs. |
|--|-----|----------|----------|
| Catalytic Converter/Exhaust Pipe | | | |
| Exhaust Clamp—Nuts | 61 | 45 | — |
| Crossmember to Sill—Bolts | 42 | 31 | — |
| Crossmember to Transmission Mount—Nuts | 22 | 16 | — |
| Exhaust Pipe to Manifold—Nuts | 31 | 23 | — |
| Exhaust Manifold to Engine 2.5L | | | |
| Engine— | | | |
| Bolt #1 | 41 | 40 | — |
| Bolts #2–5 | 31 | 23 | — |
| Nuts #6&7 | 31 | 23 | — |
| Exhaust Manifold to Engine 4.0L | | | |
| Engine— | | | |
| Nuts #6&7 | 31 | 23 | — |
| Nuts/Bolts #1,2,3,4,5,8,9,10&11 | 33 | 24 | — |
| Muffler to Catalytic Converter— | | | |
| Exhaust Clamp Nut | 61 | 45 | — |
| Oxygen Sensors | 27 | 20 | — |
| Rear Tail Pipe Hanger—Nuts | 54 | 40 | — |

EXHAUST SYSTEM AND TURBOCHARGER

TABLE OF CONTENTS

| | page | | page |
|-----------------------------------|------|--|------|
| DESCRIPTION AND OPERATION | | EXHAUST MANIFOLD AND TURBOCHARGER | |
| EXHAUST SYSTEM..... | 1 | (LHD)..... | 2 |
| EXHAUST HEAT SHIELDS | 1 | EXHAUST MANIFOLD AND TURBOCHARGER | |
| REMOVAL AND INSTALLATION | | (RHD)..... | 5 |
| EXHAUST PIPE..... | 1 | INTAKE MANIFOLD..... | 10 |
| MUFFLER AND EXHAUST TAILPIPE..... | 2 | SPECIFICATIONS | |
| | | TORQUE SPECIFICATIONS..... | 10 |

DESCRIPTION AND OPERATION

EXHAUST SYSTEM

The basic exhaust system consists of an engine exhaust manifold, turbocharger, exhaust down pipe, exhaust pipe, exhaust heat shield(s), muffler and exhaust tailpipe

The exhaust system uses a single muffler.

The exhaust system must be properly aligned to prevent stress, leakage and body contact. If the system contacts any body panel, it will transfer objectionable noises originating from the engine to the body.

When inspecting an exhaust system, critically inspect for cracked or loose joints, stripped screw or bolt threads, corrosion damage and worn, cracked or broken hangers. Replace all components that are badly corroded or damaged. DO NOT attempt to repair.

When replacement is required, use original equipment parts (or equivalent). This will assure proper alignment and provide acceptable exhaust noise levels.

CAUTION: Avoid application of rust prevention compounds or undercoating materials to exhaust system floor pan exhaust heat shields. Light overspray near the edges is permitted. Application of coating will result in excessive floor pan temperatures and objectionable fumes.

EXHAUST HEAT SHIELDS

Exhaust heat shields are needed to protect both the vehicle and the environment from the high temperatures (Fig. 1).

DO NOT allow the engine to operate at fast idle for extended periods (over 5 minutes). This condition

may result in excessive temperatures in the exhaust system and on the floor pan.

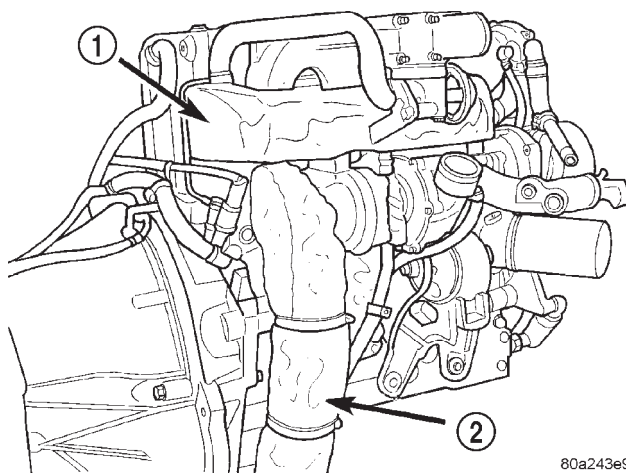

80a243e9

Fig. 1 Heat Shields

- 1 - EXHAUST MANIFOLD HEAT SHIELD
- 2 - DOWN PIPE HEAT SHIELD

REMOVAL AND INSTALLATION

EXHAUST PIPE

WARNING: IF TORCHES ARE USED WHEN WORKING ON THE EXHAUST SYSTEM, DO NOT ALLOW THE FLAME NEAR THE FUEL LINES.

REMOVAL

- (1) Raise and support the vehicle.
- (2) Saturate the bolts and nuts at turbo down pipe to exhaust pipe with heat valve lubricant. Allow 5 minutes for penetration..
- (3) Disconnect bolts from exhaust pipe to turbo down pipe (Fig. 2).

REMOVAL AND INSTALLATION (Continued)

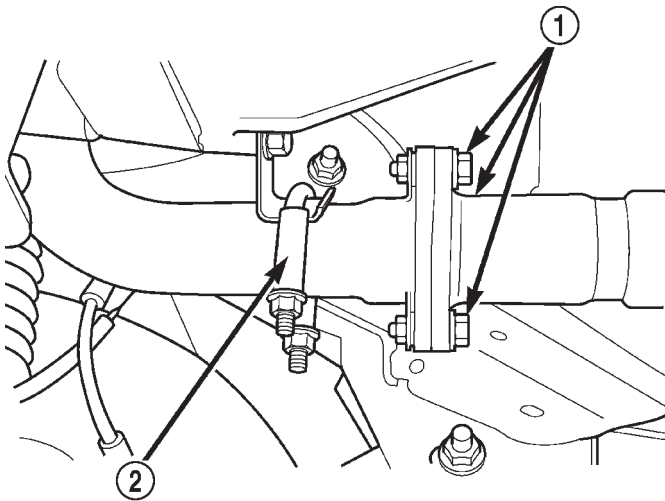

80b9a496

Fig. 2 Exhaust Down Pipe to Exhaust Pipe

- 1 - EXHAUST INLET PIPE RETAINING BOLTS
2 - EXHAUST SYSTEM SUPPORT CLAMP

(4) Remove the clamp nuts at muffler (Fig. 3). To remove the exhaust pipe from the muffler, apply heat until the metal becomes cherry red. Disconnect the exhaust pipe from the muffler. Remove the exhaust pipe.

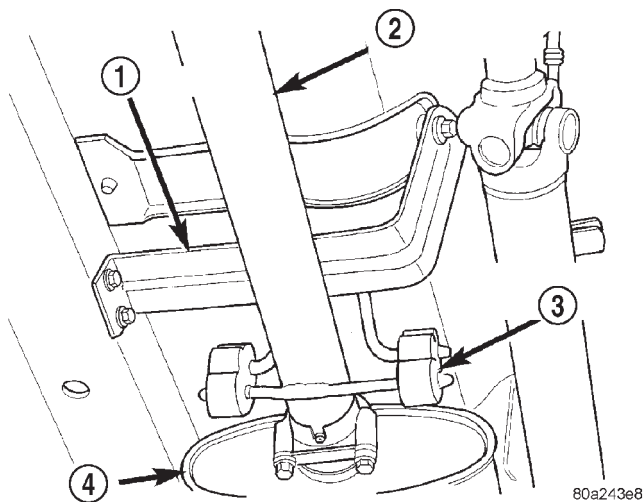

80a243e8

Fig. 3 Front Pipe to Muffler

- 1 - BRACKET
2 - FRONT PIPE
3 - RUBBER ISOLATOR
4 - MUFFLER

INSTALLATION

- (1) Assemble exhaust pipe to muffler, loosely to permit proper alignment of all parts.
- (2) Connect the exhaust pipe to the turbo down pipe manifold. Tighten the bolts to 22.5 N·m torque.

- (3) Use a new clamp and tighten the nuts to 43 N·m torque.
- (4) Lower the vehicle.
- (5) Start the engine and inspect for exhaust leaks and exhaust system contact with the body panels. Adjust the alignment, if needed.

MUFFLER AND EXHAUST TAILPIPE

All original equipment exhaust systems are manufactured with the exhaust tailpipe welded to the muffler. Service replacement mufflers and exhaust tailpipes are either clamped together or welded together.

WARNING: IF TORCHES ARE USED WHEN WORKING ON THE EXHAUST SYSTEM, DO NOT ALLOW THE FLAME NEAR THE FUEL LINES.

REMOVAL

- (1) Raise and support the vehicle.
- (2) Remove the front muffler clamp from the exhaust pipe and muffler connection.
- (3) Remove the rear exhaust tailpipe hanger clamp and remove the exhaust tailpipe from the front exhaust tailpipe hanger.
- (4) Remove the exhaust tailpipe assembly from the muffler.

INSTALLATION

- (1) Install the muffler onto the exhaust pipe. Install the clamp and tighten the nuts finger tight.
- (2) Install the exhaust tailpipe into the rear of the muffler.
- (3) Install the exhaust tailpipe/muffler assembly on the rear exhaust tailpipe hanger. Make sure that the exhaust tailpipe has sufficient clearance from the floor pan.
- (4) Install the remaining clamps and the front exhaust tailpipe hanger.
- (5) Tighten the nuts on the muffler-to-exhaust pipe clamp to 43 N·m torque.
- (6) Lower the vehicle.
- (7) Start the engine and inspect for exhaust leaks and exhaust system contact with the body panels. Adjust the alignment, if needed.

EXHAUST MANIFOLD AND TURBOCHARGER (LHD)**REMOVAL**

- (1) Disconnect the negative battery cable
- (2) Disconnect the breather hose from air cleaner outlet hose (Fig. 4).

REMOVAL AND INSTALLATION (Continued)

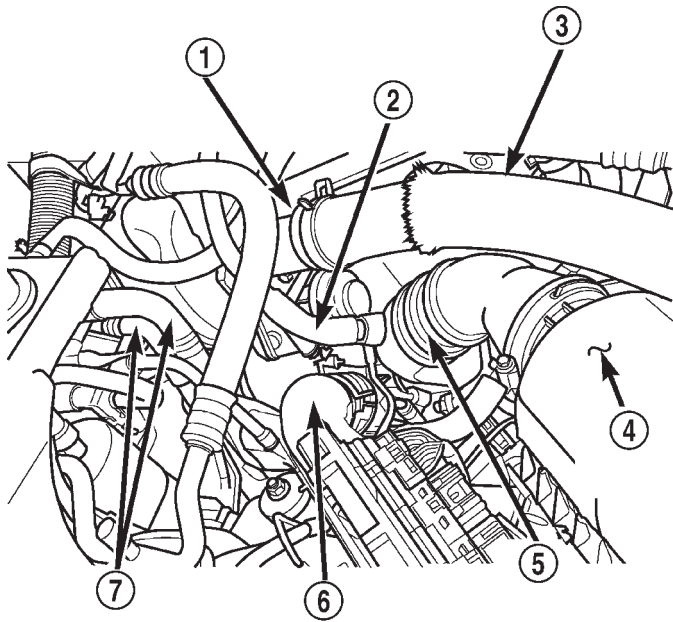

80b8992c

Fig. 4 Engine Compartment

- 1 - INTAKE MANIFOLD ELBOW
- 2 - BREATHER HOSE
- 3 - INNERCOOLER OUTLET HOSE
- 4 - AIR FILTER COVER
- 5 - AIR FILTER OUTLET (FRESH AIR) HOSE
- 6 - INNERCOOLER INLET HOSE
- 7 - HEATER CORE COOLANT SUPPLY HOSES

(3) Remove the air filter cover and hose from turbocharger, remove the assembly (Fig. 4).

(4) Remove the EGR vacuum supply hose from the EGR valve.

(5) Remove the innercooler inlet and outlet hoses from the engine (Fig. 4).

(6) Remove the (2) bolts holding the EGR tube to the EGR valve.

(7) Remove the intake manifold elbow and EGR valve as an assembly.

(8) Raise the vehicle on a hoist.

(9) Drain the cooling system. Refer to Group 7, Cooling System for procedure.

(10) Remove the exhaust system support clamp (Fig. 5).

(11) Disconnect the exhaust system at the (3) bolt flange (Fig. 5).

CAUTION: Heatshield is very sharp. Wear gloves to prevent injury.

(12) Unstrap the exhaust downpipe heatshield (Fig. 6).

(13) Disconnect the turbocharger oil return hose from the engine block (Fig. 7).

(14) Lower the vehicle from the hoist.

(15) Remove the EGR tube from exhaust manifold.

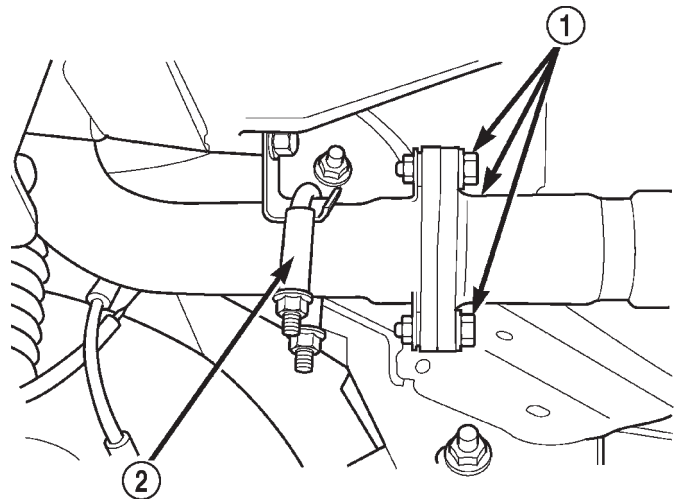

80b9a496

Fig. 5 Exhaust System Inlet Pipe Connection

- 1 - EXHAUST INLET PIPE RETAINING BOLTS
- 2 - EXHAUST SYSTEM SUPPORT CLAMP

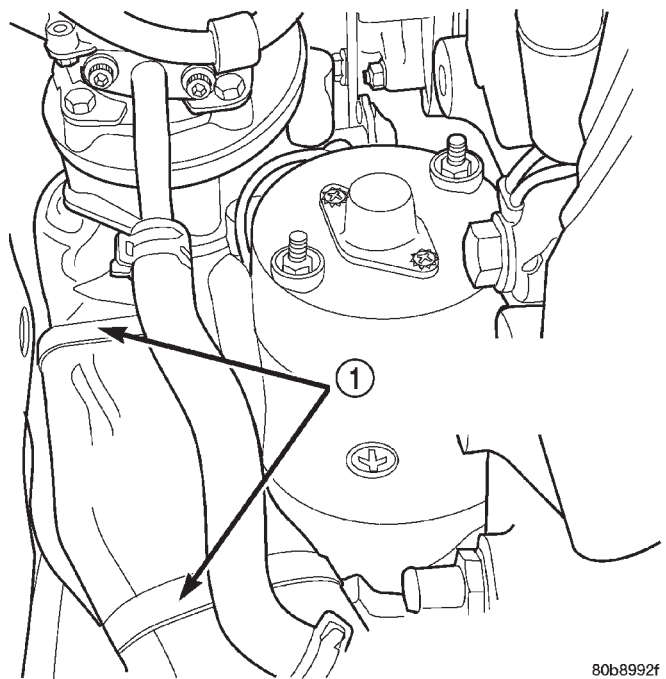

80b8992f

Fig. 6 Exhaust Downpipe Heatshield

- 1 - EXHAUST MANIFOLD DOWNPIPE HEATSHIELD RETAINING STRAPS

(16) Remove the (2) exhaust manifold heatshield retaining bolts and remove the heatshield.

(17) Remove the heater supply and return hoses from the vehicle.

(18) Remove the oil pressure supply line bango bolt from the turbocharger.

REMOVAL AND INSTALLATION (Continued)

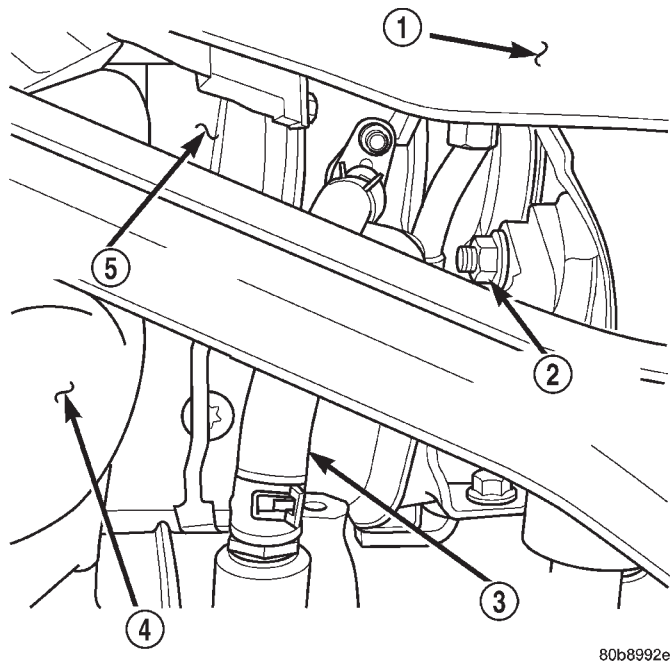

80b8992e

Fig. 7 Turbocharger Oil Return Hose

- 1 - VEHICLE UNDERBODY
- 2 - RIGHT ENGINE MOUNT THROUGHBOLT NUT
- 3 - TURBOCHARGER OIL RETURN HOSE
- 4 - EXHAUST MANIFOLD DOWNPIPE
- 5 - TURBOCHARGER

CAUTION: Heatshield is very sharp. Wear gloves to prevent injury.

(19) Remove the exhaust downpipe heatshield by pulling straight up.

(20) Remove the (5) bolts attaching the exhaust downpipe to the turbocharger and remove pipe.

(21) Remove the (8) exhaust manifold retaining bolts, it is necessary to access the bolt behind the manifold outlet from the underneath of the vehicle.

(22) Remove the exhaust manifold and turbocharger assembly from the vehicle

(23) Place assembly in a vice to remove the (3) exhaust manifold to turbocharger retaining nuts (Fig. 8).

Cleaning

Always use new gaskets during assembly. All gasket mating surfaces must be cleaned of old gasket material to produce a smooth and dirt free sealing surface for the new gasket.

INSTALLATION

(1) Transfer the oil return line to the new turbocharger (Fig. 8).

(2) Install the turbo on the exhaust manifold (Fig. 8). Torque the nuts to 32 N·m (23 ft. lbs.).

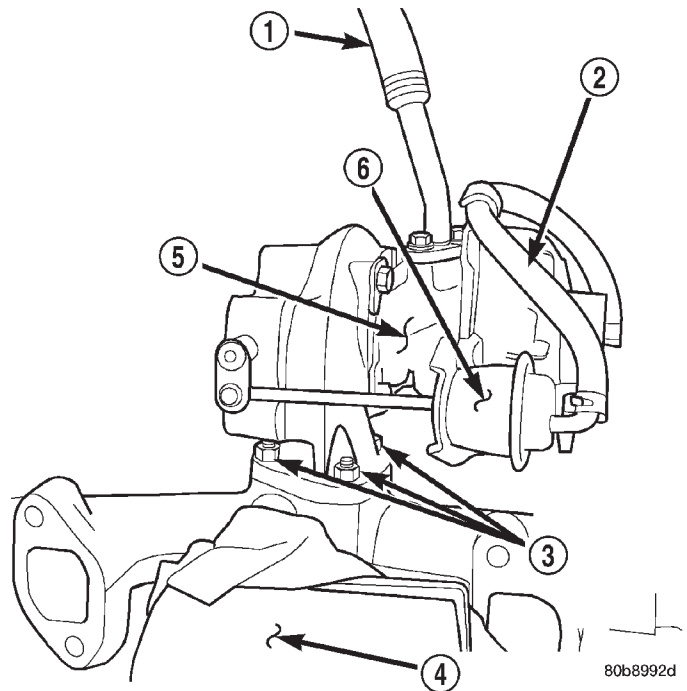

80b8992d

Fig. 8 Turbocharger / Exhaust Manifold Assembly

- 1 - OIL RETURN LINE
- 2 - WASTEGATE VACUUM SUPPLY HOSE
- 3 - TURBO TO EXHAUST MANIFOLD RETAINING NUTS
- 4 - BENCH VISE
- 5 - TURBOCHARGER ASSEMBLY (REMOVED FROM VEHICLE)
- 6 - WASTEGATE VACUUM ACTUATOR

(3) Install the exhaust manifold and turbocharger assembly in the vehicle

(4) Install the (8) exhaust manifold retaining nuts. Torque nuts to 32 N·m (23 ft. lbs.).

(5) Install the exhaust manifold downpipe. Torque bolts to 32 N·m (23 ft. lbs.).

CAUTION: Heatshield is very sharp. Wear gloves to prevent injury.

(6) Slide the exhaust downpipe heatshield down over pipe. Do not attempt to strap heatshield in position at this time, wait until vehicle is raised on hoist.

(7) Install the oil supply line on turbocharger. Torque bango bolt fitting to 27 N·m (20 ft. lbs.).

(8) Connect the heater hoses.

(9) Position and install the exhaust manifold heatshield. Torque bolts to 11 N·m (97 in. lbs.).

(10) Raise the vehicle on a hoist.

(11) Connect the turbocharger oil return line to the engine block (Fig. 9).

(12) Strap the exhaust downpipe heatshield in its original position.

(13) Install the exhaust system support clamp (Fig. 10). Torque nuts to 23 N·m (17 ft. lbs.).

REMOVAL AND INSTALLATION (Continued)

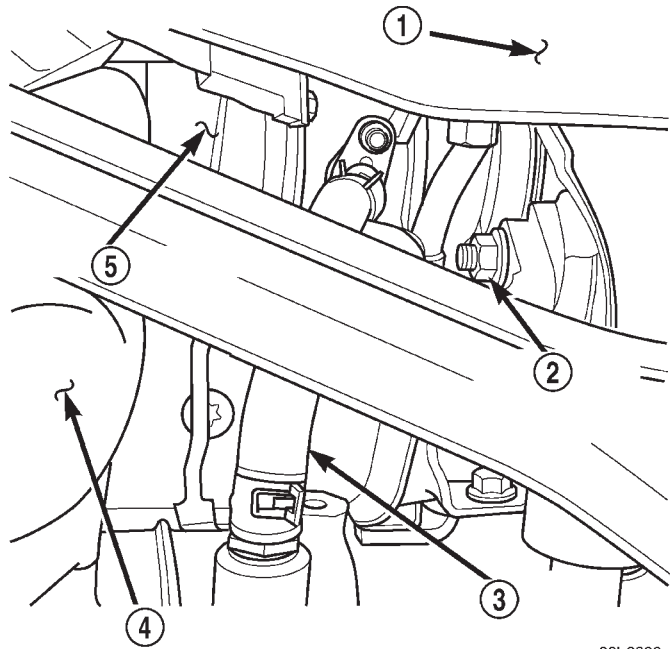

80b8992e

Fig. 9 Turbocharger Oil Return Hose

- 1 - VEHICLE UNDERBODY
- 2 - RIGHT ENGINE MOUNT THROUGHBOLT NUT
- 3 - TURBOCHARGER OIL RETURN HOSE
- 4 - EXHAUST MANIFOLD DOWNPIPE
- 5 - TURBOCHARGER

(14) Connect the exhaust system at the (3) bolt flange (Fig. 10). Torque the bolts to 23 N·m (17 ft. lbs.).

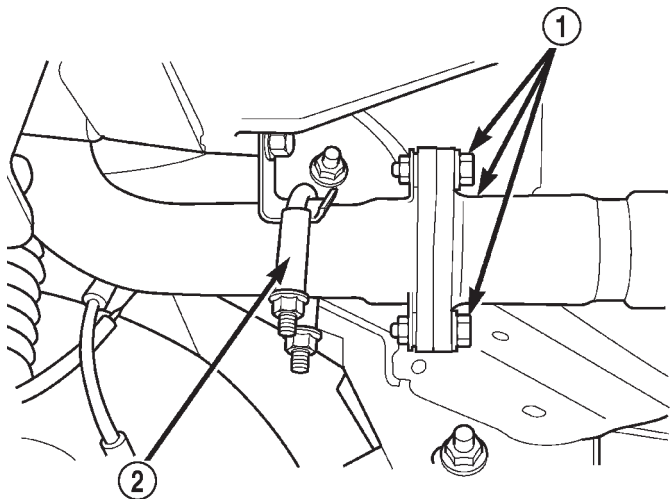

80b9a496

Fig. 10 Exhaust System Inlet Pipe Connection

- 1 - EXHAUST INLET PIPE RETAINING BOLTS
- 2 - EXHAUST SYSTEM SUPPORT CLAMP

(15) Lower the vehicle from the hoist.

(16) Install the intake manifold elbow and EGR valve as an assembly. Torque bolts to 27 N·m (20 ft. lbs.).

(17) Install the (2) bolts holding the EGR tube to the EGR valve. Torque bolts to 27 N·m (20 ft. lbs.).

(18) Install the innercooler inlet and outlet hoses on the engine (Fig. 11).

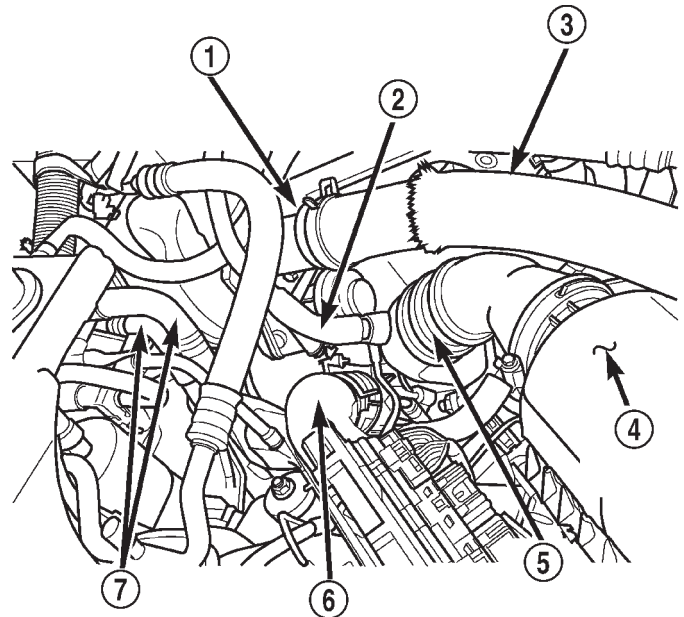

80b8992c

Fig. 11 Engine Compartment

- 1 - INTAKE MANIFOLD ELBOW
- 2 - BREATHER HOSE
- 3 - INNERCOOLER OUTLET HOSE
- 4 - AIR FILTER COVER
- 5 - AIR FILTER OUTLET (FRESH AIR) HOSE
- 6 - INNERCOOLER INLET HOSE
- 7 - HEATER CORE COOLANT SUPPLY HOSES

(19) Install the EGR vacuum supply hose on the EGR valve.

(20) Install the air filter cover and outlet hose on turbocharger (Fig. 11).

(21) Connect the breather hose on the air cleaner outlet hose (Fig. 11).

(22) Fill the cooling system. Refer to Group 7, Cooling System for procedure.

(23) Connect the negative battery cable

(24) Start the engine and check for leaks.

EXHAUST MANIFOLD AND TURBOCHARGER (RHD)

REMOVAL

(1) Disconnect the negative battery cable

(2) Disconnect the breather hose from the air cleaner outlet hose.

REMOVAL AND INSTALLATION (Continued)

(3) Remove the air filter cover and the hose from the turbocharger, remove the assembly.

(4) Raise the vehicle on a hoist.

(5) Drain the cooling system. Refer to Group 7, Cooling System for the procedure.

(6) Remove the exhaust system support clamp (Fig. 12).

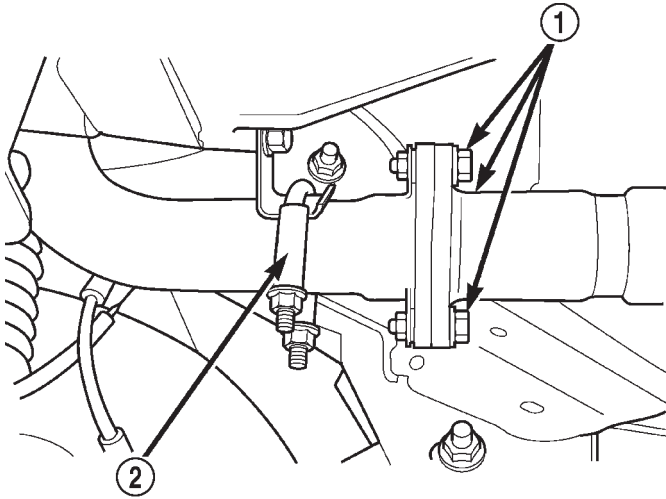

80b9a496

Fig. 12 Exhaust System Inlet Pipe Connection

- 1 - EXHAUST INLET PIPE RETAINING BOLTS
- 2 - EXHAUST SYSTEM SUPPORT CLAMP

(7) Disconnect the exhaust system at the (3) bolt flange (Fig. 12).

CAUTION: Heatshield is very sharp. Wear gloves to prevent injury.

(8) Unstrap the exhaust downpipe heatshield (Fig. 13).

CAUTION: Heatshield is very sharp. Wear gloves to prevent injury.

(9) Remove the exhaust downpipe heatshield by pulling straight down.

(10) Disconnect the turbocharger oil return hose from the engine block (Fig. 14).

(11) Lower the vehicle from the hoist.

(12) Disconnect the heater supply and return hoses from the right side of the engine. Remove the steel line support bracket from the top of the rocker cover and position the assembly out of the way

(13) Remove the EGR vacuum supply hose from the EGR valve.

(14) Remove the innercooler inlet and outlet hoses from the engine.

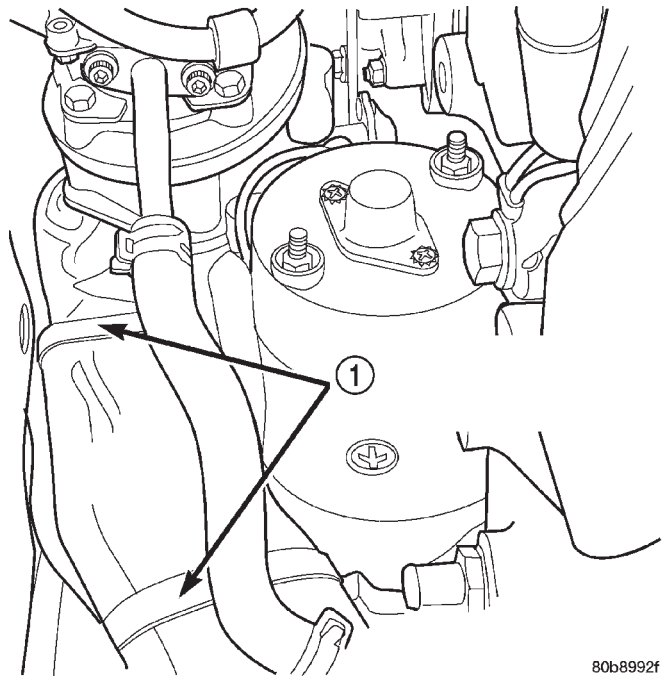

80b8992f

Fig. 13 Exhaust Downpipe Heatshield

- 1 - EXHAUST MANIFOLD DOWNPIPE HEATSHIELD RETAINING STRAPS

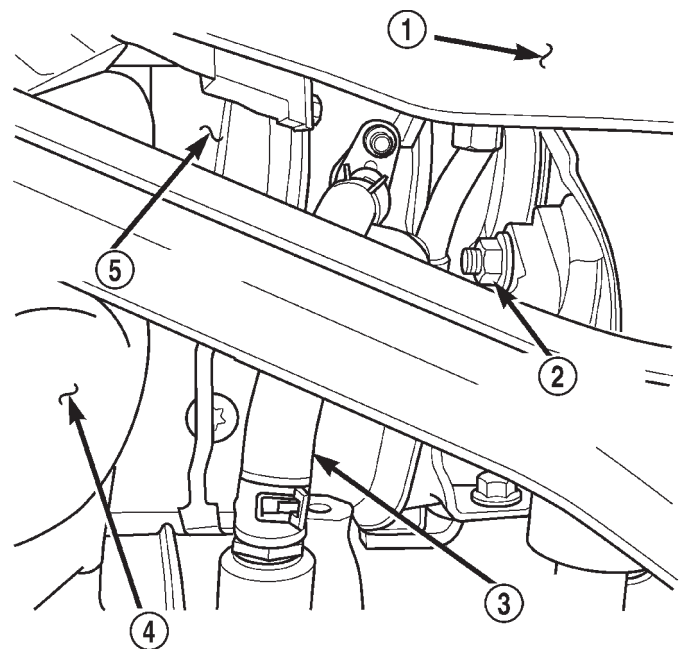

80b8992e

Fig. 14 Turbocharger Oil Return Hose

- 1 - VEHICLE UNDERBODY
- 2 - RIGHT ENGINE MOUNT THROUGHBOLT NUT
- 3 - TURBOCHARGER OIL RETURN HOSE
- 4 - EXHAUST MANIFOLD DOWNPIPE
- 5 - TURBOCHARGER

(15) Remove the (2) bolts holding the EGR tube to the EGR valve.

REMOVAL AND INSTALLATION (Continued)

(16) Remove the intake manifold elbow and the EGR valve as an assembly.

(17) Remove the EGR tube from the exhaust manifold.

(18) Remove the (2) exhaust manifold heatshield retaining bolts and remove the heatshield (Fig. 15).

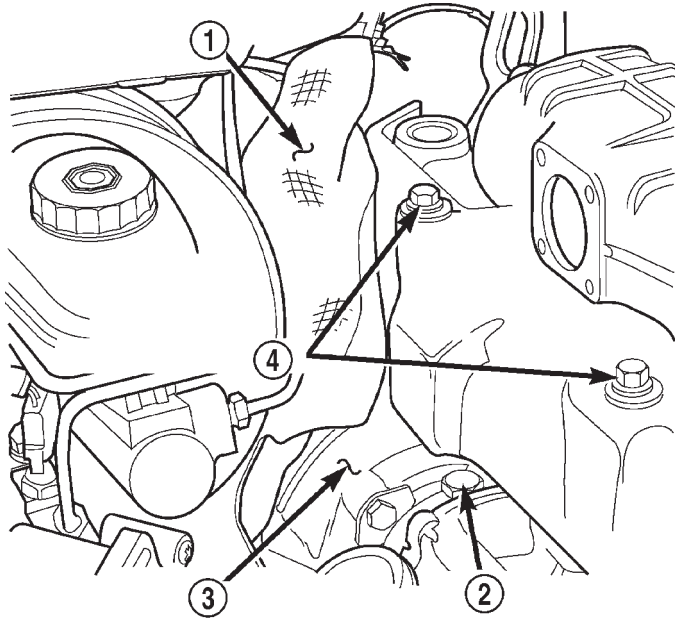

80b89933

Fig. 15 2.5L Turbo Diesel — Heatshields

- 1 - CLUTCH MASTER CYLINDER HEATSHIELD
- 2 - TURBO OIL PRESSURE SUPPLY LINE
- 3 - TURBOCHARGER
- 4 - EXHAUST MANIFOLD HEATSHIELD RETAINING BOLTS

(19) Remove the oil pressure supply line from the turbocharger (Fig. 15).

(20) Remove the clutch master cylinder heatshield (Fig. 15).

(21) Remove the turbocharger oil supply line from the engine block (Fig. 16).

(22) Working inside of the vehicle, remove the Knee Blocker. Refer to Group 8E, Instrument Panel Systems for the procedure.

(23) Disconnect the neutral safety switch electrical connector at the clutch pedal.

(24) Remove the (2) clutch master cylinder retaining nuts from the bulkhead.

(25) Working from the inside of the engine compartment, remove the clutch master cylinder from the bulkhead and position the cylinder and line assembly out of the way.

(26) Remove the (5) bolts attaching the exhaust downpipe to the turbocharger and remove the pipe.

(27) Remove the (8) exhaust manifold retaining bolts, it is necessary to access the bolt behind the manifold outlet from the underneath of the vehicle.

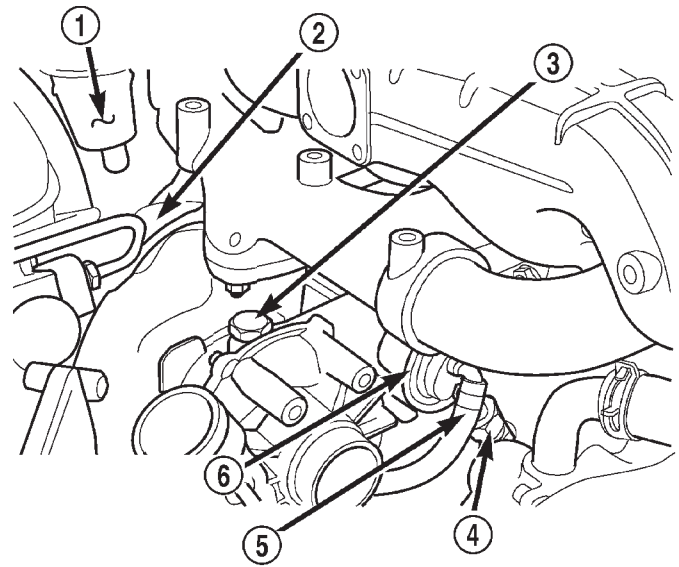

80b89932

Fig. 16 R. H. D. Turbo Position & Orientation

- 1 - CLUTCH MASTER CYLINDER
- 2 - EXHAUST DOWNPIPE HEATSHIELD
- 3 - TURBOCHARGER OIL PRESSURE SUPPLY LINE AT TURBO
- 4 - TURBOCHARGER OIL PRESSURE SUPPLY LINE AT ENGINE BLOCK
- 5 - ACTUATOR VACUUM SUPPLY
- 6 - TURBOCHARGER WASTEGATE ACTUATOR

(28) Remove the steering shaft pinchbolt and slide the shaft straight off of the gearbox input shaft. Position aside.

(29) Remove the exhaust manifold and the turbocharger assembly from the vehicle

(30) Place the turbo assembly in a vice to remove the (3) exhaust manifold to turbocharger retaining nuts (Fig. 17).

Cleaning

Always use new gaskets during assembly. All gasket mating surfaces must be cleaned of all old gasket material to produce a smooth and dirt free sealing surface for the new gasket.

INSTALLATION

(1) Install the turbocharger on the exhaust manifold (Fig. 17). Torque nuts to 32 N·m (23 ft. lbs.).

(2) Install the exhaust manifold and turbocharger assembly in the vehicle

(3) Install the (8) exhaust manifold retaining nuts, it is necessary to access the bolt behind the manifold outlet from underneath the vehicle. Torque nuts to 32 N·m (23 ft. lbs.).

(4) Install the exhaust manifold downpipe. Torque the bolts to 32 N·m (23 ft. lbs.).

REMOVAL AND INSTALLATION (Continued)

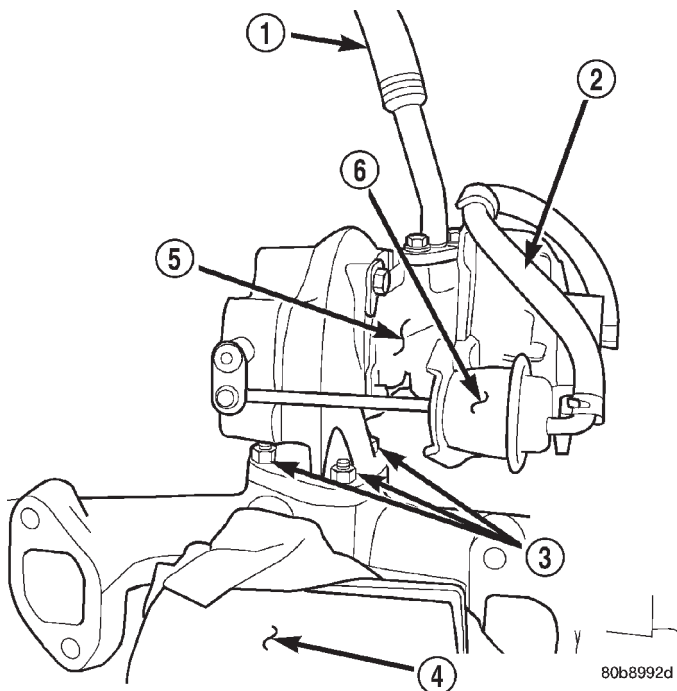

80b8992d

Fig. 17 Turbocharger / Exhaust Manifold Assembly

- 1 - OIL RETURN LINE
- 2 - WASTEGATE VACUUM SUPPLY HOSE
- 3 - TURBO TO EXHAUST MANIFOLD RETAINING NUTS
- 4 - BENCH VISE
- 5 - TURBOCHARGER ASSEMBLY (REMOVED FROM VEHICLE)
- 6 - WASTEGATE VACUUM ACTUATOR

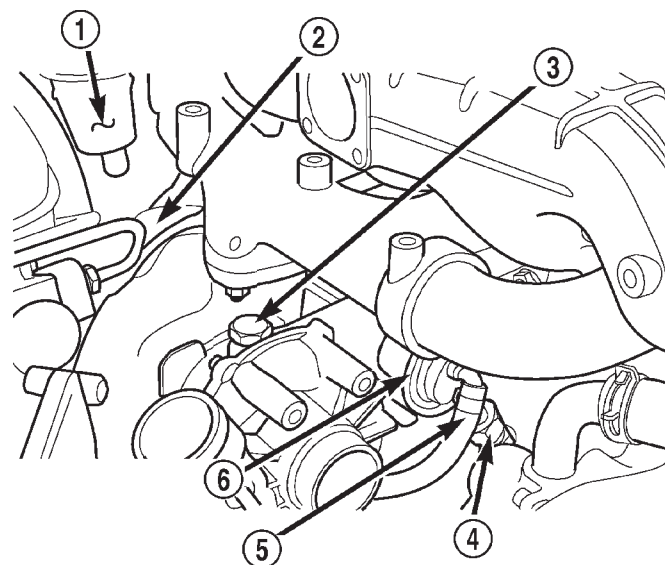

80b89932

Fig. 18 R. H. D. Turbo Position & Orientation

- 1 - CLUTCH MASTER CYLINDER
- 2 - EXHAUST DOWNPIPE HEATSHIELD
- 3 - TURBOCHARGER OIL PRESSURE SUPPLY LINE AT TURBO
- 4 - TURBOCHARGER OIL PRESSURE SUPPLY LINE AT ENGINE BLOCK
- 5 - ACTUATOR VACUUM SUPPLY
- 6 - TURBOCHARGER WASTEGATE ACTUATOR

(5) Position the turbocharger oil pressure supply line in its original position (Fig. 18). Torque the turbo fitting to 27 N·m (20 ft. lbs.).

(6) Install the exhaust manifold heatshield (Fig. 19). Torque bolts to 11 N·m (97 in. lbs.).

(7) Install the EGR tube on the exhaust manifold. Leave loose at this time.

(8) Raise the vehicle on a hoist.

CAUTION: Heatshield is very sharp. Wear gloves to prevent injury.

(9) Slide the exhaust downpipe heatshield up over the pipe and strap it in its original position (Fig. 20).

(10) Install the steering shaft. Torque the pinch bolt to 49 N·m (36 ft. lbs.).

(11) Install the turbocharger oil return hose on the engine block (Fig. 21).

(12) Install the exhaust system support clamp (Fig. 22). Torque nuts to 23 N·m (17 ft. lbs.).

(13) Connect the exhaust system at the (3) bolt flange (Fig. 22). Torque the bolts to 23 N·m (17 ft. lbs.).

(14) Lower the vehicle on hoist.

(15) Install the clutch master cylinder through the bulkhead.

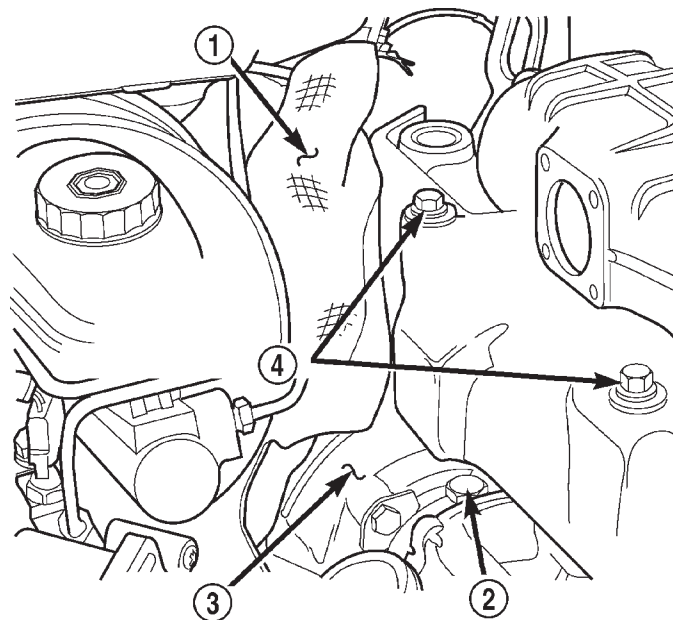

80b89933

Fig. 19 2.5L Turbo Diesel — Heatshields

- 1 - CLUTCH MASTER CYLINDER HEATSHIELD
- 2 - TURBO OIL PRESSURE SUPPLY LINE
- 3 - TURBOCHARGER
- 4 - EXHAUST MANIFOLD HEATSHIELD RETAINING BOLTS

REMOVAL AND INSTALLATION (Continued)

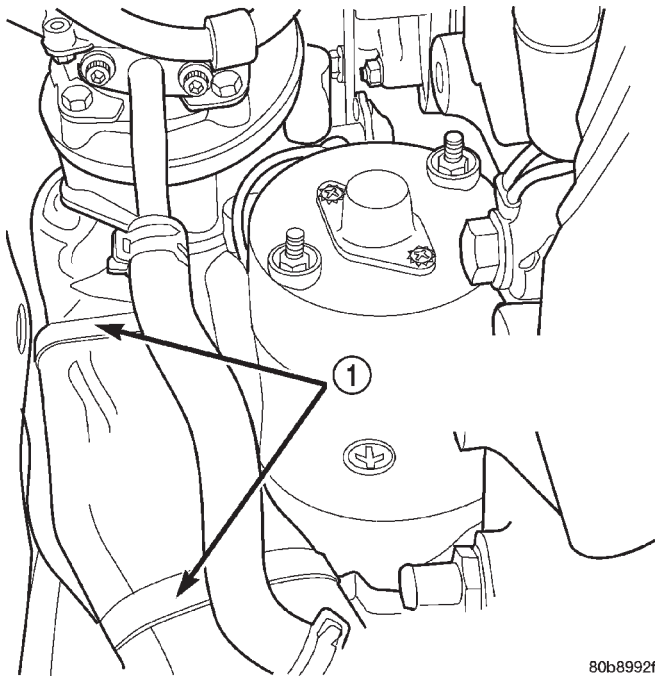

80b8992f

Fig. 20 Exhaust Downpipe Heatshield

- 1 - EXHAUST MANIFOLD DOWNPIPE HEATSHIELD RETAINING STRAPS

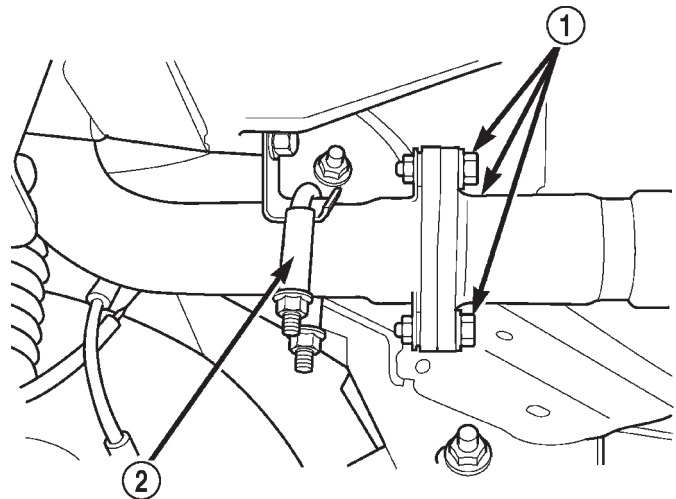

80b9a496

Fig. 22 Exhaust System Inlet Pipe Connection

- 1 - EXHAUST INLET PIPE RETAINING BOLTS
- 2 - EXHAUST SYSTEM SUPPORT CLAMP

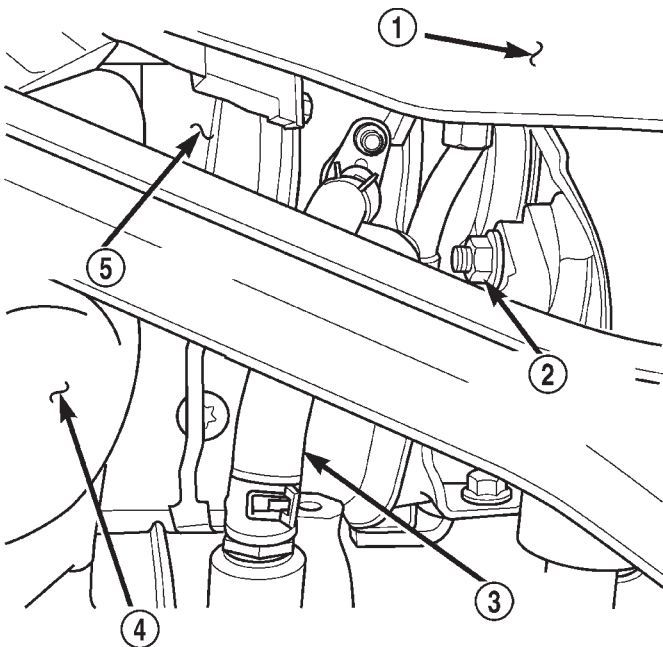

80b8992e

Fig. 21 Turbocharger Oil Return Hose

- 1 - VEHICLE UNDERBODY
- 2 - RIGHT ENGINE MOUNT THROUGHBOLT NUT
- 3 - TURBOCHARGER OIL RETURN HOSE
- 4 - EXHAUST MANIFOLD DOWNPIPE
- 5 - TURBOCHARGER

(16) Working from the inside of the vehicle, Install the (2) clutch master cylinder retaining nuts.

(17) Connect the neutral safety switch at the clutch pedal.

(18) Install the Knee Blocker. Refer to Group 8E, Instrument Panel Systems for procedure.

(19) Install the clutch master cylinder heatshield.

(20) Install the intake manifold elbow and the EGR valve as an assembly. Torque the intake elbow bolts to 11 N·m (97 in.lbs.).

(21) Install the (2) bolts holding the EGR tube to the EGR valve. Torque to bolts 27 N·m (20 ft. lbs.).

(22) Torque the EGR tube on the exhaust manifold to 28 N·m (21 ft. lbs.).

(23) Install the innercooler inlet and outlet hoses on the engine.

(24) Install the EGR vacuum supply hose on the EGR valve.

(25) Install the air filter cover and outlet hose on the turbocharger.

(26) Connect the breather hose on the air cleaner outlet hose.

(27) Install the heater core coolant supply and the brake vacuum supply lines in there original position.

(28) Connect the negative battery cable

(29) Fill the cooling system. Refer to Group 7, Cooling System for the procedure.

(30) Start the engine and check for leaks.

REMOVAL AND INSTALLATION (Continued)

INTAKE MANIFOLD

REMOVAL

- (1) Remove exhaust manifold and turbocharger assembly.
- (2) Remove water manifold.
- (3) Remove intake manifold.

CLEANING

Clean the intake manifold and cylinder head mating surfaces. **DO NOT allow foreign material to enter either the intake manifold or the ports in the cylinder head.**

INSTALLATION

- (1) Install the new intake manifold gasket.
- (2) Position the intake manifold in place and finger tighten the mounting nuts.
- (3) Tighten the fasteners in sequence and to the specified torque 30 N·m.
- (4) Position the water manifold in place and finger tighten the mounting nuts.
- (5) Tighten the fasteners to the specified torque 12 N·m.
- (6) Install exhaust manifold and turbocharger assembly.
- (7) Install charge air cooler hose to intake manifold.
- (8) Connect the battery negative cable.
- (9) Start engine and check for leaks.

SPECIFICATIONS

TORQUE SPECIFICATIONS

| Description | Torque |
|---|---------------|
| EGR | |
| Attaching Bolts | 27N·m |
| EGR | |
| Tube Nut | 34 N·m |
| EGR | |
| Tube Flange Bolts | 27 N·m |
| Exhaust Manifold | |
| Nuts | 32 N·m |
| Exhaust Manifold | |
| Heat Shield Bolts | 11 N·m |
| Exhaust Pipe | |
| Support Clamp Bolts | 22.5 N·m |
| Exhaust Pipe | |
| Support Clamp Screw | 22.5 N·m |
| Intake Elbow to Intake Manifold | |
| Bolts | 11 N·m |
| Intake Manifold | |
| Nuts | 32 N·m |
| Muffler-to-Exhaust Pipe | |
| Clamp Nuts | 43 N·m |
| Tail Pipe Clamp | |
| Hanger bolt | 22.5 N·m |
| Turbocharger-to-Exhaust manifold | |
| Nuts | 32 N·m |
| Turbocharger | |
| Oil Feed Line | 27.4 N·m |
| Turbocharger Down Pipe-to-Exhaust Pipe | |
| Bolts/Nuts | 22.5 N·m |
| Turbocharger Down Pipe-to-Turbocharger | |
| Bolts | 27 N·m |

FRAME AND BUMPERS

TABLE OF CONTENTS

| | page | | page |
|---------------------------------|------|-------------|------|
| DESCRIPTION AND OPERATION | 1 | FRAME | 6 |
| BUMPERS | 2 | | |

DESCRIPTION AND OPERATION

TABLE OF CONTENTS

| | page |
|--|------|
| DESCRIPTION AND OPERATION FRAME AND BUMPERS..... | 1 |

DESCRIPTION AND OPERATION

FRAME AND BUMPERS

FRAME

DESCRIPTION

Jeep Cherokee vehicles do not have a conventional frame. They are constructed as a unitized body and frame. Jeep unibodies are constructed from special high strength steel and coated metals. This process reduces weight and provides strength to withstand the forces applied against structural members. The structural members provide a unibody that has great structural strength.

BUMPERS

DESCRIPTION

The bumpers on the Jeep Cherokee are made up of the main bumper beam, the end caps, air deflector (front bumper) and mounting brackets. Some Cherokee models also have a tow hook support bracket.

OPERATION

The bumpers are fastened to the unitized body frame rails. The bumper end caps are fastened to the bumper and the body side sheet metal.



BUMPERS

TABLE OF CONTENTS

| | page | | page |
|---------------------------------|------|----------------------------------|------|
| REMOVAL AND INSTALLATION | | REAR BUMPER END CAP | 4 |
| FRONT BUMPER END CAP..... | 2 | REAR BUMPER | 4 |
| FRONT BUMPER..... | 3 | REAR TOW HOOK | 5 |
| FRONT TOW HOOK..... | 3 | | |

REMOVAL AND INSTALLATION

FRONT BUMPER END CAP

REMOVAL

- (1) Remove the rivet attaching the end cap to the air deflector.
- (2) Remove the bolts and nuts attaching the end cap to the bumper (Fig. 1).
- (3) Pull back the wheelhouse liner and remove the screws attaching the end cap to the front fender.

- (4) Lifting the end cap from the bottom, tilt slightly upward and slide it outward to disengage the retainer tab from the bumper (Fig. 2).
- (5) Separate the end cap from the bumper.

INSTALLATION

- (1) Position the end cap on the bumper and engage the retaining tab.
- (2) Install the screws attaching the end cap to the front fender.
- (3) Install the bolts attaching the end cap to the bumper. Tighten the nut to 9 N·m (7 ft. lbs.) torque.

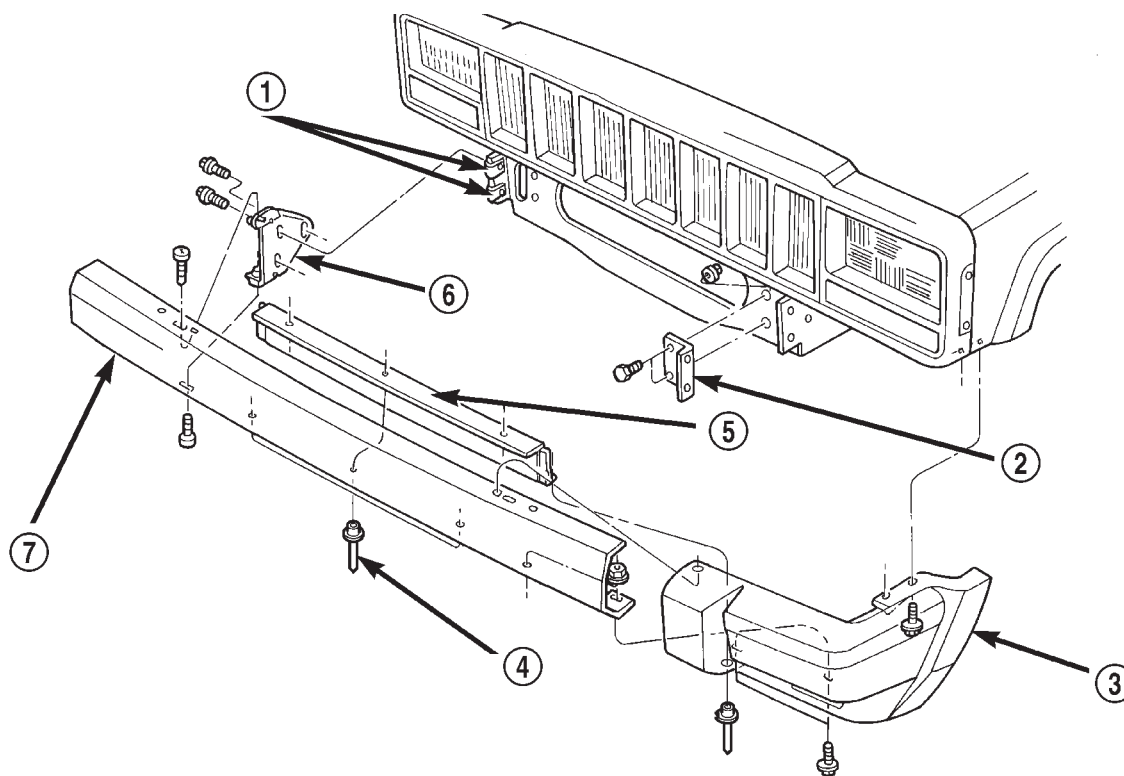
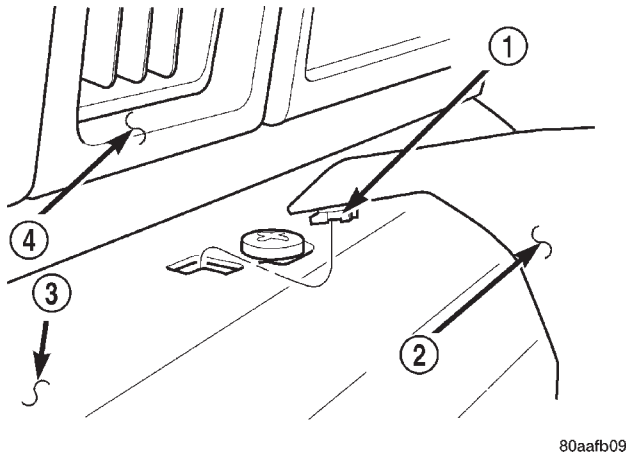

Fig. 1 Front Bumper

80b3b136

- | | |
|------------------------------|----------------------|
| 1 - U-NUT | 5 - AIR DEFLECTOR |
| 2 - TOW HOOK SUPPORT BRACKET | 6 - MOUNTING BRACKET |
| 3 - END CAP | 7 - BUMPER |
| 4 - RIVET | |

REMOVAL AND INSTALLATION (Continued)



80aafb09

Fig. 2 Bumper End Cap

- 1 - RETAINER TAB
- 2 - BUMPER END CAP
- 3 - BUMPER
- 4 - GRILLE

(4) Install the rivet attaching the end cap to air deflector.

FRONT BUMPER

REMOVAL

- (1) Remove bumper end caps.
- (2) If equipped, disengage fog lamp wire harness connectors.
- (3) Disconnect vacuum line from reservoir (Fig. 3).
- (4) Remove Torx-head bolts that attach bumper to mounting brackets (Fig. 1).
- (5) Remove bumper from vehicle.
- (6) If necessary, remove bolts attaching bumper mounting brackets to frame.

INSTALLATION

- (1) If removed, install bolts attaching bumper mounting brackets to frame. Tighten bolts to 55 N·m (41 ft. lbs.) torque.
- (2) Position bumper on front of vehicle.
- (3) Install Torx-head bolts that attach bumper to mounting brackets. Tighten bolts to 55 N·m (41 ft. lbs.) torque.
- (4) Connect vacuum line to reservoir.
- (5) If equipped, engage fog lamp wire harness connectors.
- (6) Install bumper end caps.

FRONT TOW HOOK

REMOVAL

- (1) Remove bolts attaching tow hook to tow hook reinforcement (Fig. 4).
- (2) Separate tow hook from reinforcement.

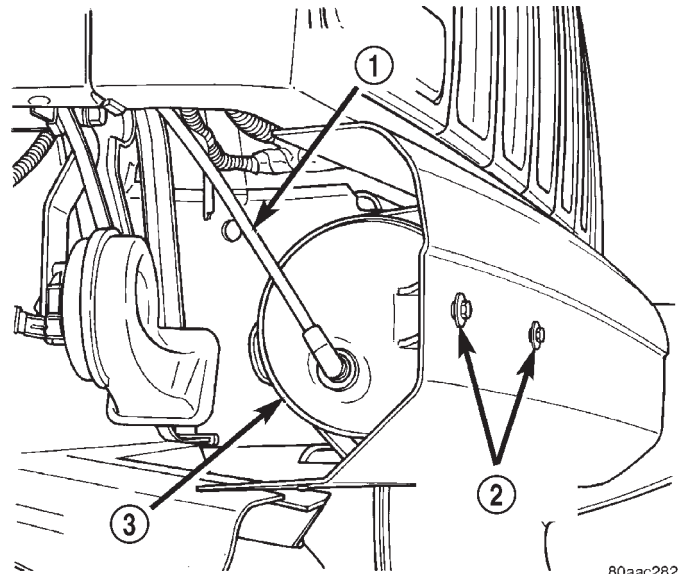

80aac282

Fig. 3 Vacuum Reservoir

- 1 - VACUUM LINE
- 2 - RESERVOIR SCREWS
- 3 - VACUUM RESERVOIR

(3) If necessary, remove bolt attaching tow hook reinforcement to frame.

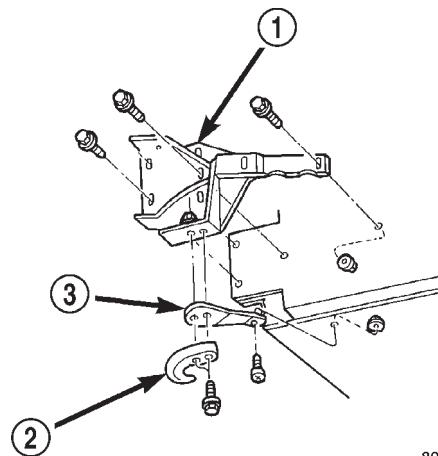

80b3b131

Fig. 4 Front Tow Hook

- 1 - MOUNTING BRACKET
- 2 - TOW HOOK
- 3 - TOW HOOK REINFORCEMENT

INSTALLATION

- (1) If removed, install bolt attaching tow hook reinforcement to frame. Tighten bolt to 30 N·m (22 ft. lbs.) torque.
- (2) Position tow hook on reinforcement.
- (3) Install bolts attaching tow hook to tow hook reinforcement. Tighten bolts to 100 N·m (74 ft. lbs.) torque.

REMOVAL AND INSTALLATION (Continued)

REAR BUMPER END CAP

REMOVAL

- (1) Remove the screws attaching the bumper end cap to the quarter panel and the bumper (Fig. 5).
- (2) Lift the end cap slightly upward and slide it rearward to release it from the retainer.
- (3) Separate the end cap from the vehicle.

INSTALLATION

- (1) Position the end cap on the rear of the retainer and the outer edge of the bumper.
- (2) Slide the end cap forward onto the retainer. Ensure the end cap overlaps the lip of the rear wheelhouse liner.
- (3) Install the screw attaching the front of the end cap to the underside of the quarter panel and bumper.

REAR BUMPER

REMOVAL

- (1) For vehicles equipped with a trailer hitch, remove hitch before removing bumper. If necessary,

refer to removal procedure within Group 13, Frame and Bumpers.

- (2) Remove bumper end caps.
- (3) Remove upper nuts that attach bumper to bumper support brackets (Fig. 5).
- (4) Remove lower bolts that attach bumper to bumper support brackets.
- (5) Remove bumper from vehicle.
- (6) If necessary, remove bumper support brackets from the rear sill.

INSTALLATION

- (1) If removed, install bumper support brackets on the rear sill. Tighten bolts to 55 N·m (41 ft. lbs.) torque.
- (2) Position bumper on support brackets.
- (3) Install bolts that attach bumper to bumper support brackets. Tighten nuts to 55 N·m (41 ft. lbs.) torque.
- (4) Install bumper end caps.
- (5) If removed, install trailer hitch.

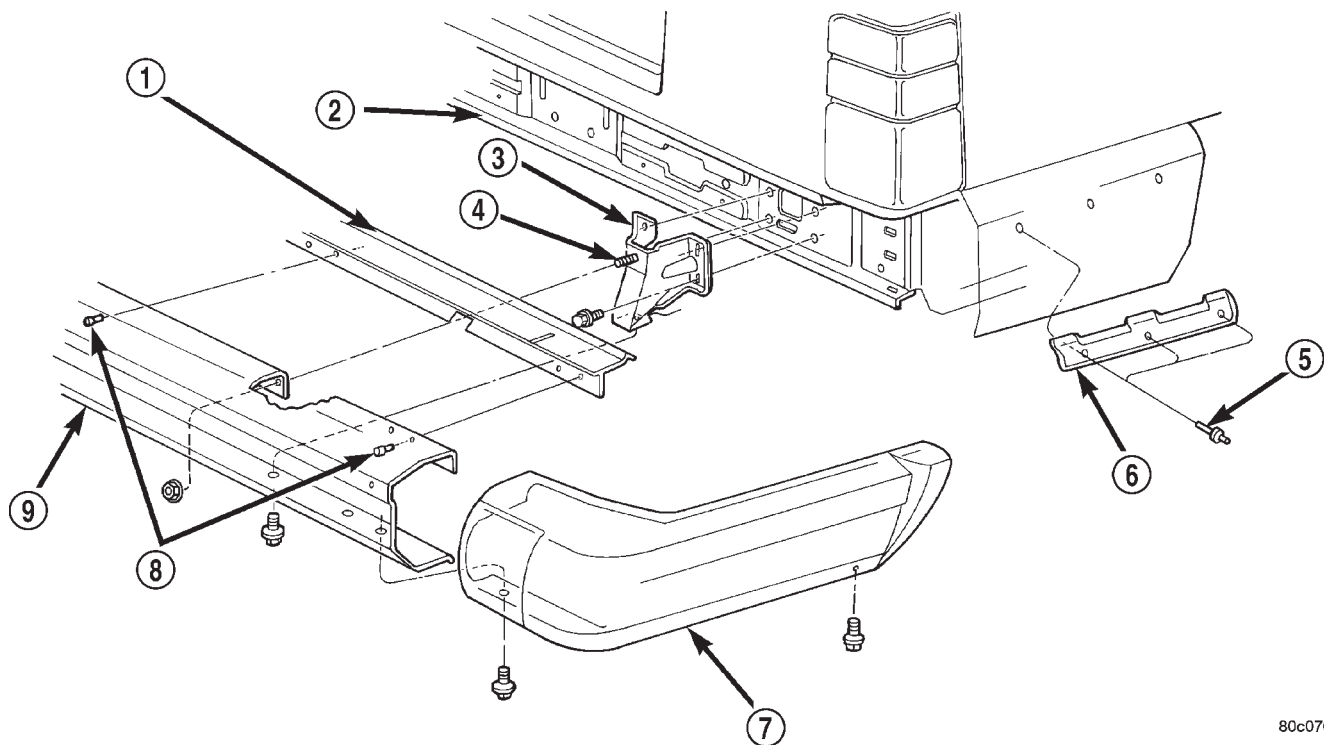

80c070e4

Fig. 5 REAR BUMPER END CAP

- | | |
|-------------------|-------------------------|
| 1 - SPLASH SHIELD | 6 - RETAINER |
| 2 - REAR SILL | 7 - END CAP |
| 3 - BRACKET | 8 - PLASTIC BLIND RIVET |
| 4 - STUD | 9 - BUMPER |
| 5 - RIVET | |

REMOVAL AND INSTALLATION (Continued)

REAR TOW HOOK

REMOVAL

- (1) Remove bolts that attach tow hook bracket and tow hook to frame rail (Fig. 6).
- (2) Remove bracket and tow hook from frame rail.

INSTALLATION

- (1) Position bracket and tow hook on frame rail.
- (2) Install bolts that attach tow hook bracket and tow hook to frame rail. Tighten bolts to 94 N·m (70 ft. lbs.) torque.

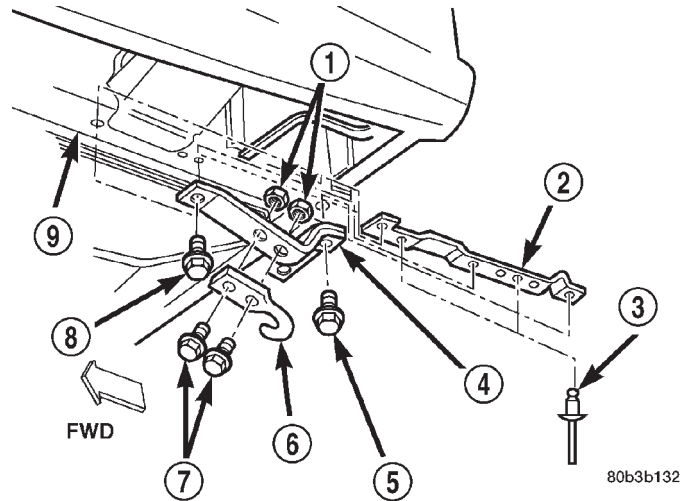

Fig. 6 Rear Tow Hook

- 1 - WELD NUT
- 2 - FRAME REINFORCEMENT BRACKET
- 3 - RIVET
- 4 - SUPPORT BRACKET
- 5 - BOLT
- 6 - TOW HOOK
- 7 - BOLT
- 8 - BOLT
- 9 - FRAME RAIL

FRAME

TABLE OF CONTENTS

| | page | | page |
|---------------------------------|------|-----------------------------------|------|
| REMOVAL AND INSTALLATION | | TRAILER HITCH | 7 |
| FRONT SKID PLATE | 6 | SPECIFICATIONS | |
| TRANSFER CASE SKID PLATE | 6 | FRAME DIMENSIONS | 7 |
| FUEL TANK SKID PLATE | 7 | FRAME TORQUE SPECIFICATIONS | 9 |

REMOVAL AND INSTALLATION

FRONT SKID PLATE

REMOVAL

- (1) Remove the screws that attach skid plate to side sills.
- (2) Remove the nuts that attach the skid plate to the crossmember (Fig. 1).
- (3) Remove the skid plate from the vehicle.

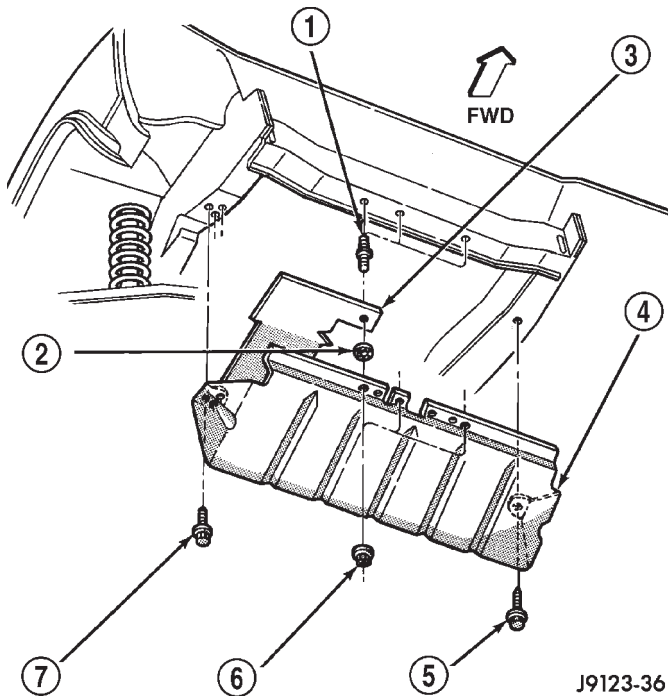

Fig. 1 Front Skid Plate

- 1 - STUD
- 2 - PUSH NUT
- 3 - SPLASH SHIELD
- 4 - SKID PLATE
- 5 - SCREW
- 6 - NUT
- 7 - SCREW

INSTALLATION

- (1) Position the skid plate at front crossmember and side sills.
- (2) Install the nuts to attach the skid plate to crossmember.
- (3) Install the screws to attach skid plate to side sills.

TRANSFER CASE SKID PLATE

REMOVAL

- (1) Support skid plate.
- (2) Remove bolts that attach skid plate to transmission support crossmember and frame sill (Fig. 2).
- (3) Remove support and skid plate from vehicle.

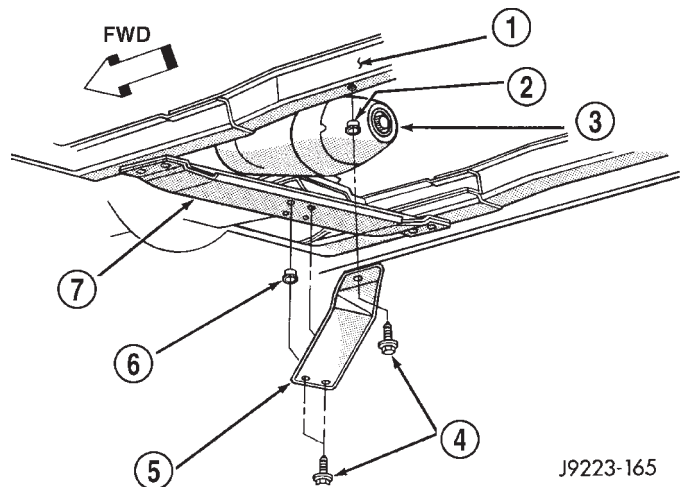

Fig. 2 Transfer Case Skid Plate

- 1 - FRAME SILL
- 2 - NUT-SERT
- 3 - TRANSFER CASE
- 4 - BOLT
- 5 - SKID PLATE
- 6 - NUT-SERT
- 7 - CROSSMEMBER

INSTALLATION

- (1) Position and support skid plate at frame sill and transmission support crossmember.
- (2) Attach skid plate to frame sill and crossmember with bolts. Tighten bolts to 22 N·m (16 ft. lbs.) torque.

REMOVAL AND INSTALLATION (Continued)

FUEL TANK SKID PLATE

REMOVAL

- (1) Position a support under skid plate.
- (2) Remove bolts that attach skid plate to underbody side rails (Fig. 3).
- (3) Remove support and skid plate from vehicle.

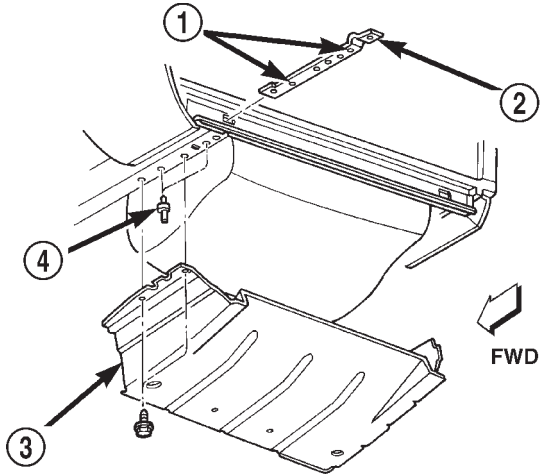

Fig. 3 Fuel Tank Skid Plate

80b5cc86

- 1 - RIVET HOLES
- 2 - REINFORCEMENT
- 3 - FUEL TANK SKID PLATE
- 4 - BLIND RIVET

INSTALLATION

- (1) Position and support skid plate under fuel tank.
- (2) Install bolts to attach skid plate to underbody rails. Tighten bolts to 74 N·m (55 ft. lbs.) torque.
- (3) Remove support from under skid plate.

TRAILER HITCH

REMOVAL

- (1) If necessary, remove the trailer tow wire harness connector from the hitch (Fig. 4).
- (2) Support the hitch.
- (3) Remove the bolts that attach the trailer hitch to the frame sills and reinforcement brackets (Fig. 5).
- (4) If equipped, remove the fuel tank skid plate.

NOTE: The reinforcement brackets are held on the frame sills with two blind rivets.

INSTALLATION

- (1) Install frame reinforcement brackets, if removed. Slide the brackets through the vehicle rear sill openings and attach to the frame sills with blind rivets.
- (2) Using an adequate lifting device, position hitch at the proper location for installation on vehicle and support it.
- (3) If equipped, position fuel tank skid plate on vehicle frame sills.

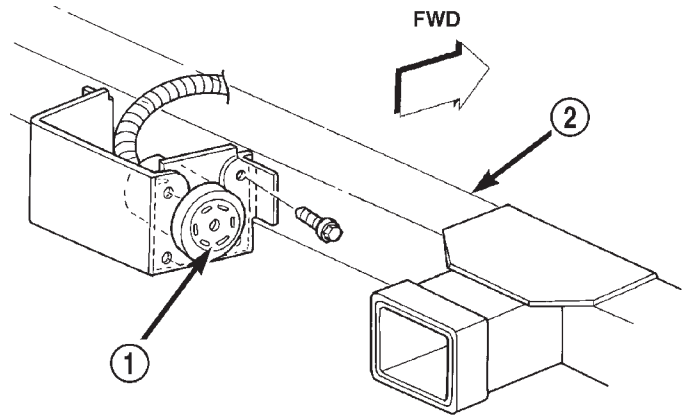

Fig. 4 Trailer Hitch Harness Connector

80aa0fe9

- 1 - CONNECTOR
- 2 - TRAILER HITCH

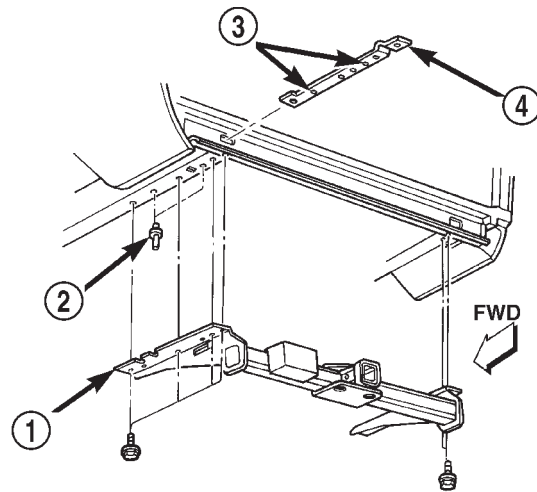

Fig. 5 Trailer Hitch

80aa0fe8

- 1 - TRAILER HITCH
- 2 - BLIND RIVET
- 3 - RIVET HOLES
- 4 - REINFORCEMENT

- (4) Loosely install the bolts to attach the trailer hitch (and the skid plate) to frame sills and reinforcement brackets.

- (5) Tighten all bolts/nuts to 74 N·m (55 ft. lbs.) torque.

- (6) Remove the lift/support.

- (7) If removed, attach the trailer wire harness connector to the hitch.

SPECIFICATIONS

FRAME DIMENSIONS

Frame dimensions are listed in millimeter scale. All dimensions are from center to center of Principal Locating Point (PLP), or from center to center of PLP and fastener location (Fig. 6).

SPECIFICATIONS (Continued)

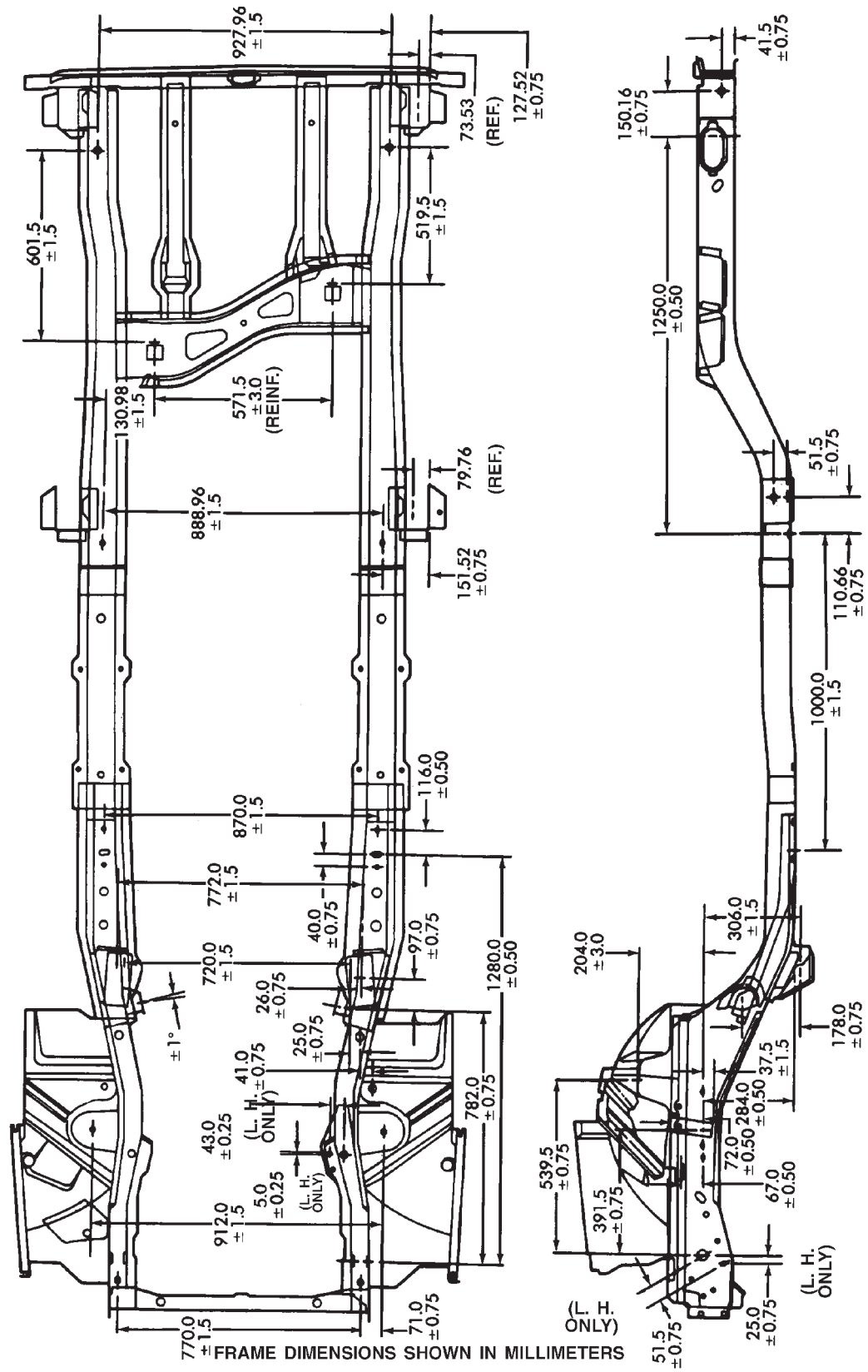

Fig. 6 Frame Dimensions

SPECIFICATIONS (Continued)

FRAME TORQUE SPECIFICATIONS

| DESCRIPTION | TORQUE |
|---|-------------------------|
| Front Skid Plate Screw | 42 N·m (31 ft. lbs.) |
| Front Skid Plate Nut | 17 N·m (125 in. lbs.) |
| Transfer Case Skid Plate Bolt . . | 22 N·m (16 ft. lbs.) |
| Fuel Tank Skid Plate Bolt | 74 N·m (55 ft. lbs.) |
| Front Bumper End Cap to Mounting | |
| Bracket Nut | 9 N·m (7 ft. lbs.) |
| Front Bumper Mounting Bracket to | |
| Frame Bolt | 55 N·m (41 ft. lbs.) |
| Front Bumper to Mounting Bracket Bolt . . | 55 N·m (41 ft. lbs.) |
| Front Tow Hook Bolt | 100 N·m (74 ft. lbs.) |
| Front Tow Hook Reinforcement Bolt | 30 N·m (22 ft. lbs.) |
| Rear Bumper to Mtg. Bracket Nut | 55 N·m (41 ft. lbs.) |
| Rear Bumper Mtg. Bracket to Rear | |
| Sill Bolt | 55 N·m (41 ft. lbs.) |
| Rear Tow Hook Bolt | 94 N·m (70 ft. lbs.) |
| Trailer Tow Reinforcement Brkt Bolt | 74 N·m (55 ft. lbs.) |

FRAME AND BUMPERS

TABLE OF CONTENTS

page

FRAME 1

FRAME

TABLE OF CONTENTS

page

DESCRIPTION AND OPERATION

EMERGENCY TOW EYES 1

DESCRIPTION AND OPERATION

EMERGENCY TOW EYES

DESCRIPTION

Some vehicles are equipped with emergency tow eyes, one can be found in the front and rear of the vehicle (Fig. 1). The tow eyes are attached to the frame rails and intended for short distance emergency towing only.

OPERATION

The front tow eye has two holes, the front hole is for short towing use only and the rear angled hole is for shipping use only.

The rear tow eye has one hole and is intended for short towing use only.

CAUTION: Do not use the angled hole for towing. You could damage your vehicle.

CAUTION: Tow eyes are for emergency use only, to rescue a vehicle stranded off road. Do not use tow eyes for tow truck hookup or highway towing. You could damage your vehicle.

WARNING: Stand clear of vehicles when pulling with tow eyes. Tow straps and chains may break, causing serious injury.

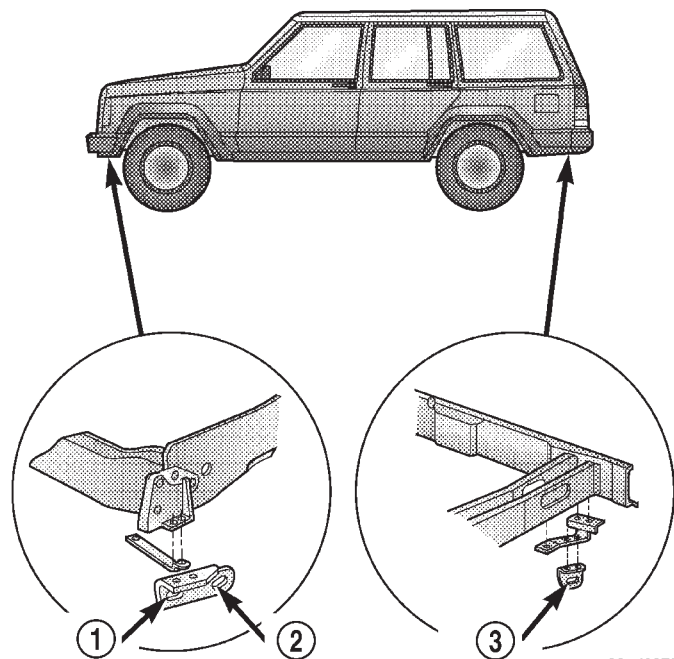

80ad087f

Fig. 1 Front and Rear Emergency Tow Eyes

- 1 - FRONT TOW EYE
- 2 - SHIPPING USE ONLY
- 3 - REAR TOW EYE

FUEL SYSTEM

TABLE OF CONTENTS

| | page | | page |
|---------------------------|------|-----------------------------|------|
| FUEL DELIVERY SYSTEM..... | 1 | FUEL INJECTION SYSTEM | 25 |

FUEL DELIVERY SYSTEM

TABLE OF CONTENTS

| | page | | page |
|---|------|--|------|
| DESCRIPTION AND OPERATION | | QUICK-CONNECT FITTINGS | |
| PCM VIN REPROGRAMMING | 1 | REMOVAL AND INSTALLATION | 10 |
| FUEL DELIVERY SYSTEM..... | 1 | FUEL FILTER/FUEL PRESSURE REGULATOR... | 13 |
| FUEL PUMP MODULE | 2 | FUEL PUMP MODULE | 14 |
| FUEL PUMP..... | 3 | FUEL PUMP INLET FILTER | 15 |
| FUEL GAUGE SENDING UNIT..... | 3 | FUEL GAUGE SENDING UNIT..... | 16 |
| FUEL FILTER/FUEL PRESSURE REGULATOR... | 3 | FUEL INJECTOR RAIL/FUEL DAMPER—2.5L | |
| FUEL TANK | 4 | ENGINE | 16 |
| FUEL INJECTORS | 4 | FUEL INJECTOR RAIL/FUEL DAMPER—4.0L | |
| FUEL INJECTOR RAIL/FUEL DAMPER—2.5L | | ENGINE | 17 |
| ENGINE | 5 | FUEL INJECTORS | 19 |
| FUEL RAIL/FUEL DAMPER—4.0L ENGINE..... | 5 | FUEL TANK | 19 |
| FUEL TANK FILLER TUBE CAP | 6 | FUEL TANK FILLER TUBE CAP | 21 |
| FUEL TUBES/LINES/HOSES AND CLAMPS | 6 | ACCELERATOR PEDAL..... | 21 |
| QUICK-CONNECT FITTINGS | 6 | THROTTLE CABLE | 22 |
| DIAGNOSIS AND TESTING | | SPECIFICATIONS | |
| FUEL PUMP PRESSURE TEST | 6 | FUEL TANK CAPACITY | 23 |
| FUEL PUMP CAPACITY TEST | 7 | FUEL SYSTEM PRESSURE..... | 23 |
| FUEL PRESSURE LEAK DOWN TEST..... | 7 | FUEL REQUIREMENTS | 23 |
| FUEL PUMP AMPERAGE TEST | 8 | TORQUE CHART | 24 |
| FUEL GAUGE SENDING UNIT..... | 10 | | |
| FUEL INJECTOR TEST | 10 | | |
| SERVICE PROCEDURES | | | |
| FUEL SYSTEM PRESSURE RELEASE | | | |
| PROCEDURE | 10 | | |

DESCRIPTION AND OPERATION

PCM VIN REPROGRAMMING

OPERATION

USE THE DRB SCAN TOOL TO REPROGRAM THE NEW POWERTRAIN CONTROL MODULE (PCM) WITH THE VEHICLES ORIGINAL IDENTIFICATION NUMBER (VIN) AND THE VEHICLES ORIGINAL MILEAGE. IF THIS STEP IS

NOT DONE, A DIAGNOSTIC TROUBLE CODE (DTC) MAY BE SET.

FUEL DELIVERY SYSTEM

DESCRIPTION

The fuel delivery system consists of:

- the fuel pump module containing the electric fuel pump, fuel filter/fuel pressure regulator, fuel gauge sending unit (fuel level sensor) and a separate fuel filter located at bottom of pump module

DESCRIPTION AND OPERATION (Continued)

- fuel tubes/lines/hoses
- quick-connect fittings
- fuel injector rail
- fuel injectors
- fuel tank
- fuel tank filler/vent tube assembly
- fuel tank filler tube cap
- accelerator pedal
- throttle cable

OPERATION

Fuel is returned through the fuel pump module and back into the fuel tank through the fuel filter/fuel pressure regulator. A separate fuel return line from the engine to the tank is not used.

The fuel tank assembly consists of: the fuel tank, fuel pump module assembly, fuel pump module locknut/gasket, and rollover valve (refer to Group 25, Emission Control System for rollover valve information).

A fuel filler/vent tube assembly using a pressure/vacuum, 1/4 turn fuel filler cap is used. The fuel filler tube contains a flap door located below the fuel fill cap.

Also to be considered part of the fuel system is the evaporation control system. This is designed to reduce the emission of fuel vapors into the atmosphere. The description and function of the Evaporative Control System is found in Group 25, Emission Control Systems.

Both fuel filters (at bottom of fuel pump module and within fuel pressure regulator) are designed for extended service. They do not require normal scheduled maintenance. Filters should only be replaced if a diagnostic procedure indicates to do so.

FUEL PUMP MODULE

DESCRIPTION

The fuel pump module is installed in the top of the fuel tank (Fig. 1) or (Fig. 2). The fuel pump module contains the following components:

- A combination fuel filter/fuel pressure regulator
- A separate fuel pick-up filter (strainer)
- An electric fuel pump
- A threaded locknut to retain module to tank
- A gasket between tank flange and module
- Fuel gauge sending unit (fuel level sensor)
- Fuel supply tube (line) connection

The fuel gauge sending unit, pick-up filter and fuel filter/fuel pressure regulator may be serviced separately. If the electrical fuel pump requires service, the entire fuel pump module must be replaced.

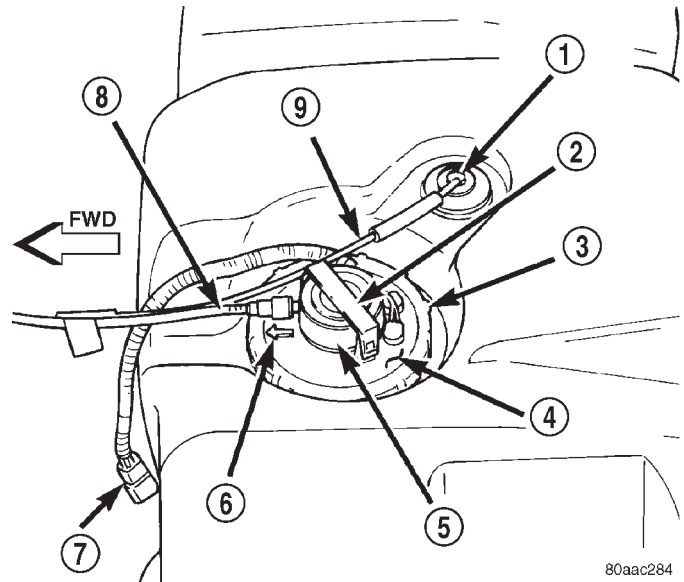

80aac284

Fig. 1 Fuel Tank/Fuel Pump Module (Top View)

- 1 - ROLLOVER VALVE
- 2 - RETAINER CLAMP
- 3 - LOCKNUT
- 4 - FUEL PUMP MODULE
- 5 - FUEL FILTER/FUEL PRESSURE REGULATOR
- 6 - ALIGNMENT ARROW
- 7 - PIGTAIL HARNESS
- 8 - FUEL SUPPLY TUBE
- 9 - EVAP CANISTER VENT LINE

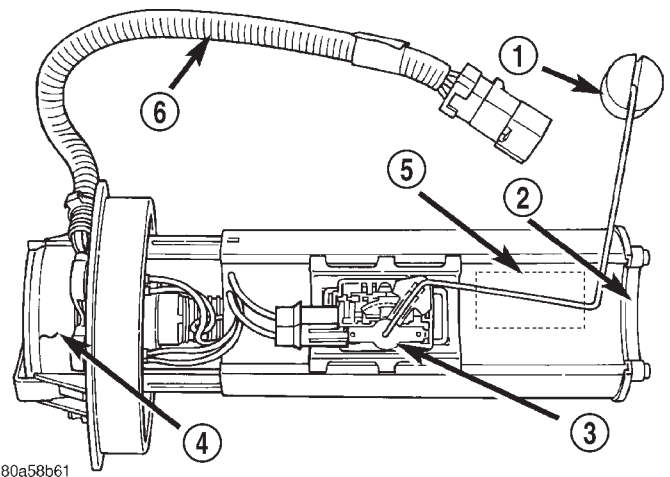

80a58b61

Fig. 2 Fuel Pump Module Components

- 1 - FUEL GAUGE FLOAT
- 2 - PICK-UP FILTER
- 3 - FUEL GAUGE SENDING UNIT
- 4 - FUEL FILTER/FUEL PRESSURE REGULATOR
- 5 - ELECTRIC FUEL PUMP
- 6 - PIGTAIL WIRING HARNESS

OPERATION

Refer to Fuel Pump, Fuel Filter/Fuel Pressure Regulator and Fuel Gauge Sending Unit.

DESCRIPTION AND OPERATION (Continued)

FUEL PUMP**DESCRIPTION**

The fuel pump is located inside of the fuel pump module. A 12 volt, permanent magnet, electric motor powers the fuel pump.

OPERATION

Voltage to operate the electric pump is supplied through the fuel pump relay.

Fuel is drawn in through a filter at the bottom of the module and pushed through the electric motor gearset to the pump outlet.

Check Valve Operation: The pump outlet contains a one-way check valve to prevent fuel flow back into the tank and to maintain fuel supply line pressure (engine warm) when pump is not operational. It is also used to keep the fuel supply line full of gasoline when pump is not operational. After the vehicle has cooled down, fuel pressure may drop to 0 psi (cold fluid contracts), but liquid gasoline will remain in fuel supply line between the check valve and fuel injectors. **Fuel pressure that has dropped to 0 psi on a cooled down vehicle (engine off) is a normal condition.** Refer to the Fuel Pressure Leak Down Test for more information.

FUEL GAUGE SENDING UNIT**DESCRIPTION**

The fuel gauge sending unit (fuel level sensor) is attached to the side of the fuel pump module. The sending unit consists of a float, an arm, and a variable resistor track (card).

OPERATION

The fuel pump module has 4 different circuits (wires). Two of these circuits are used for the fuel gauge sending unit for fuel gauge operation, and for certain OBD II emission requirements. The other 2 wires are used for electric fuel pump operation.

For Fuel Gauge Operation: A constant input voltage source of about 12 volts (battery voltage) is supplied to the resistor track on the fuel gauge sending unit. This is fed directly from the Powertrain Control Module (PCM). **NOTE: For diagnostic purposes, this 12V power source can only be verified with the circuit opened (fuel pump module electrical connector unplugged). With the connectors plugged, output voltages will vary from about .6 volts at FULL, to about 8.6 volts at EMPTY (about 8.6 volts at EMPTY for Jeep models, and about 7.0 volts at EMPTY for Dodge Truck models).** The resistor track is used to vary the voltage (resistance) depending on fuel tank float level. As fuel level increases, the float and arm

move up, which decreases voltage. As fuel level decreases, the float and arm move down, which increases voltage. The varied voltage signal is returned back to the PCM through the sensor return circuit.

Both of the electrical circuits between the fuel gauge sending unit and the PCM are hard-wired (not multi-plexed). After the voltage signal is sent from the resistor track, and back to the PCM, the PCM will interpret the resistance (voltage) data and send a message across the multi-plex bus circuits to the instrument panel cluster. Here it is translated into the appropriate fuel gauge level reading. Refer to Instrument Panel for additional information.

For OBD II Emission Monitor Requirements: The PCM will monitor the voltage output sent from the resistor track on the sending unit to indicate fuel level. The purpose of this feature is to prevent the OBD II system from recording/setting false misfire and fuel system monitor diagnostic trouble codes. The feature is activated if the fuel level in the tank is less than approximately 15 percent of its rated capacity. If equipped with a Leak Detection Pump (EVAP system monitor), this feature will also be activated if the fuel level in the tank is more than approximately 85 percent of its rated capacity.

FUEL FILTER/FUEL PRESSURE REGULATOR**DESCRIPTION**

The combination fuel filter and fuel pressure regulator is located on the top of fuel pump module (Fig. 1).

OPERATION

A combination fuel filter and fuel pressure regulator is used on all engines. A separate frame mounted fuel filter is not used with any engine.

Fuel Pressure Regulator Operation: The pressure regulator is a mechanical device that is not controlled by engine vacuum or the Powertrain Control Module (PCM).

The regulator is calibrated to maintain fuel system operating pressure of approximately 339 kPa \pm 34 kPa (49.2 psi \pm 5 psi) at the fuel injectors. It contains a diaphragm, calibrated springs and a fuel return valve. The internal fuel filter is also part of the assembly.

Fuel is supplied to the filter/regulator by the electric fuel pump through an opening tube at the bottom of filter/regulator (Fig. 3).

The regulator acts as a check valve to maintain some fuel pressure when the engine is not operating. This will help to start the engine. A second check valve is located at the outlet end of the electric fuel pump. **Refer to Fuel Pump—Description and**

DESCRIPTION AND OPERATION (Continued)

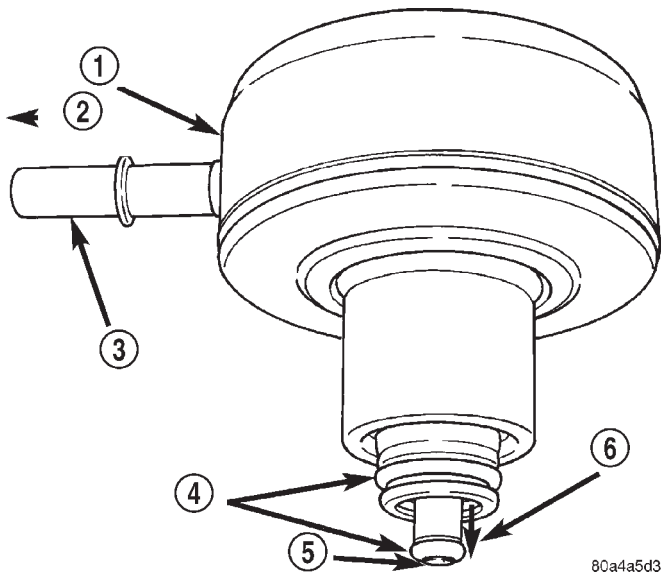

Fig. 3 Fuel Filter/Fuel Pressure Regulator

- 1 - FUEL FILTER/FUEL PRESSURE REGULATOR
- 2 - TO FUEL INJECTORS
- 3 - FUEL SUPPLY TUBE
- 4 - O-RINGS
- 5 - FUEL INLET FROM PUMP
- 6 - FUEL RETURN TO TANK

Operation for more information. Also refer to the Fuel Pressure Leak Down Test and the Fuel Pump Pressure Tests.

If fuel pressure at the pressure regulator exceeds approximately 49 psi, an internal diaphragm closes and excess fuel is routed back into the tank through the pressure regulator. A separate fuel return line is not used.

FUEL TANK

DESCRIPTION

The fuel tank is constructed of a plastic material. Its main functions are for fuel storage and for placement of the fuel pump module.

OPERATION

All models pass a full 360 degree rollover test without fuel leakage. To accomplish this, fuel and vapor flow controls are required for all fuel tank connections.

A rollover valve(s) is mounted into the top of the fuel tank (or pump module). Refer to Emission Control System for rollover valve information.

An evaporation control system is connected to the rollover valve(s) to reduce emissions of fuel vapors into the atmosphere. When fuel evaporates from the fuel tank, vapors pass through vent hoses or tubes to a charcoal canister where they are temporarily held. When the engine is running, the vapors are drawn

into the intake manifold. Certain models are also equipped with a self-diagnosing system using a Leak Detection Pump (LDP). Refer to Emission Control System for additional information.

FUEL INJECTORS

DESCRIPTION

An individual fuel injector (Fig. 4) is used for each individual cylinder.

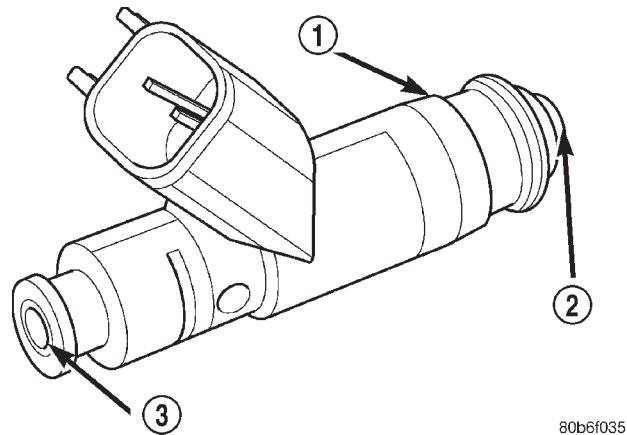

Fig. 4 Fuel Injector—Typical

- 1 - FUEL INJECTOR
- 2 - NOZZLE
- 3 - TOP (FUEL ENTRY)

OPERATION

The top (fuel entry) end of the injector (Fig. 4) is attached into an opening on the fuel rail.

The fuel injectors are electrical solenoids. The injector contains a pintle that closes off an orifice at the nozzle end. When electric current is supplied to the injector, the armature and needle move a short distance against a spring, allowing fuel to flow out the orifice. Because the fuel is under high pressure, a fine spray is developed in the shape of a pencil stream. The spraying action atomizes the fuel, adding it to the air entering the combustion chamber.

The nozzle (outlet) ends of the injectors are positioned into openings in the intake manifold just above the intake valve ports of the cylinder head. The engine wiring harness connector for each fuel injector is equipped with an attached numerical tag (INJ 1, INJ 2 etc.). This is used to identify each fuel injector.

The injectors are energized individually in a sequential order by the powertrain control module (PCM). The PCM will adjust injector pulse width by switching the ground path to each individual injector on and off. Injector pulse width is the period of time that the injector is energized. The PCM will adjust

DESCRIPTION AND OPERATION (Continued)

injector pulse width based on various inputs it receives.

Battery voltage is supplied to the injectors through the ASD relay.

The PCM determines injector pulse width based on various inputs.

FUEL INJECTOR RAIL/FUEL DAMPER—2.5L ENGINE

DESCRIPTION

The fuel injector rail is used to mount the fuel injectors to the engine (Fig. 5). On the 2.5L 4-cylinder engine, a **fuel damper** is located at the front of the fuel rail (Fig. 5).

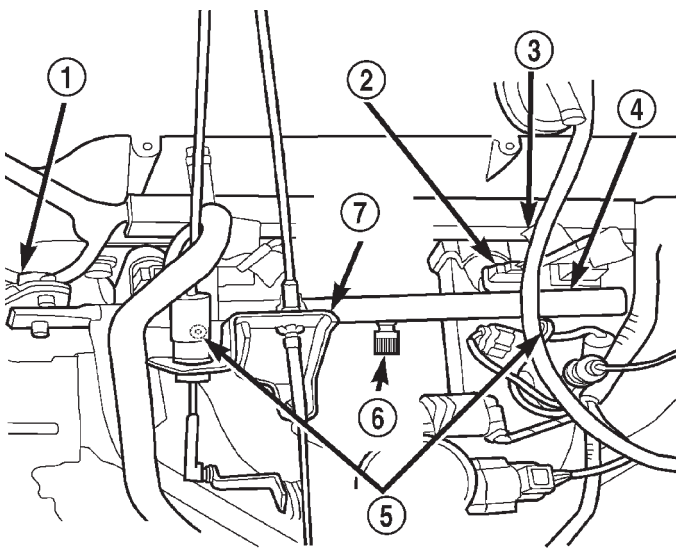

80b6f034

Fig. 5 Fuel Injector Rail/Fuel Damper—2.5L Engine

- 1 - FUEL DAMPER
- 2 - FUEL INJECTOR
- 3 - NUMBERED TAG
- 4 - FUEL RAIL
- 5 - FUEL RAIL MOUNTING BOLTS/NUTS
- 6 - TEST PORT
- 7 - CABLE BRACKET

OPERATION

The fuel injector rail supplies the necessary fuel to each individual fuel injector.

The fuel damper is used only to help control fuel pressure pulsations. These pulsations are the result of the firing of the fuel injectors. It is **not used** as a fuel pressure regulator. The fuel pressure regulator is **not mounted** to the fuel rail on any engine. It is located on the fuel tank mounted fuel pump module. Refer to Fuel Filter/Fuel Pressure Regulator in this group for information.

The fuel rail is not repairable.

FUEL RAIL/FUEL DAMPER—4.0L ENGINE

DESCRIPTION

The fuel rail is mounted to the intake manifold (Fig. 6). It is used to mount the fuel injectors to the engine. On the 4.0L 6-cylinder engine, a **fuel damper** is located near the center of the fuel rail (Fig. 6).

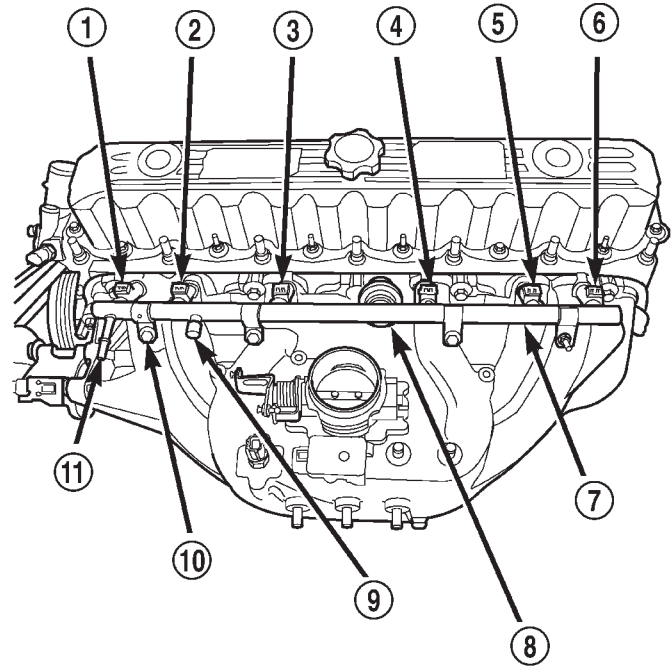

80bfe150

Fig. 6 Fuel Rail/Fuel Damper—4.0L Engine

- 1 - INJ. #1
- 2 - INJ. #2
- 3 - INJ. #3
- 4 - INJ. #4
- 5 - INJ. #5
- 6 - INJ. #6
- 7 - FUEL INJECTOR RAIL
- 8 - FUEL DAMPER
- 9 - PRESSURE TEST PORT CAP
- 10 - MOUNTING BOLTS (4)
- 11 - QUICK-CONNECT FITTING

OPERATION

The fuel injector rail supplies the necessary fuel to each individual fuel injector.

The fuel damper is used only to help control fuel pressure pulsations. These pulsations are the result of the firing of the fuel injectors. It is **not used** as a fuel pressure regulator. The fuel pressure regulator is **not mounted** to the fuel rail on any engine. It is located on the fuel tank mounted fuel pump module.

DESCRIPTION AND OPERATION (Continued)

Refer to Fuel Filter/Fuel Pressure Regulator in this group for information.

The fuel rail is not repairable.

FUEL TANK FILLER TUBE CAP

DESCRIPTION

The plastic fuel tank filler tube cap is threaded onto the end of the fuel fill tube. Certain models are equipped with a 1/4 turn cap.

OPERATION

The loss of any fuel or vapor out of fuel filler tube is prevented by the use of a pressure-vacuum fuel fill cap. Relief valves inside the cap will release fuel tank pressure at predetermined pressures. Fuel tank vacuum will also be released at predetermined values. This cap must be replaced by a similar unit if replacement is necessary. This is in order for the system to remain effective.

CAUTION: Remove fill cap before servicing any fuel system component to relieve tank pressure. If equipped with a California emissions package and a Leak Detection Pump (LDP), the cap must be tightened securely. If cap is left loose, a Diagnostic Trouble Code (DTC) may be set.

FUEL TUBES/LINES/HOSES AND CLAMPS

DESCRIPTION

Also refer to Quick-Connect Fittings.

WARNING: THE FUEL SYSTEM IS UNDER A CONSTANT PRESSURE (EVEN WITH THE ENGINE OFF). BEFORE SERVICING ANY FUEL SYSTEM HOSES, FITTINGS OR LINES, THE FUEL SYSTEM PRESSURE MUST BE RELEASED. REFER TO THE FUEL SYSTEM PRESSURE RELEASE PROCEDURE IN THIS GROUP.

The lines/tubes/hoses used on fuel injected vehicles are of a special construction. This is due to the higher fuel pressures and the possibility of contaminated fuel in this system. If it is necessary to replace these lines/tubes/hoses, only those marked EFM/EFI may be used.

If equipped: The hose clamps used to secure rubber hoses on fuel injected vehicles are of a special rolled edge construction. This construction is used to prevent the edge of the clamp from cutting into the hose. Only these rolled edge type clamps may be used in this system. All other types of clamps may cut into the hoses and cause high-pressure fuel leaks.

Use new original equipment type hose clamps.

QUICK-CONNECT FITTINGS

DESCRIPTION

Different types of quick-connect fittings are used to attach various fuel system components, lines and tubes. These are: a single-tab type, a two-tab type or a plastic retainer ring type. Some are equipped with safety latch clips. Some may require the use of a special tool for disconnection and removal. Refer to Quick-Connect Fittings Removal/Installation for more information.

CAUTION: The interior components (o-rings, clips) of quick-connect fittings are not serviced separately, but new plastic spacers are available for some types. If service parts are not available, do not attempt to repair the damaged fitting or fuel line (tube). If repair is necessary, replace the complete fuel line (tube) assembly.

DIAGNOSIS AND TESTING

FUEL PUMP PRESSURE TEST

Use this test in conjunction with the Fuel Pump Capacity Test, Fuel Pressure Leak Down Test and Fuel Pump Amperage Test found elsewhere in this group.

Check Valve Operation: The electric fuel pump outlet contains a one-way check valve to prevent fuel flow back into the tank and to maintain fuel supply line pressure (engine warm) when pump is not operational. It is also used to keep the fuel supply line full of gasoline when pump is not operational. After the vehicle has cooled down, fuel pressure may drop to 0 psi (cold fluid contracts), but liquid gasoline will remain in fuel supply line between the check valve and fuel injectors. **Fuel pressure that has dropped to 0 psi on a cooled down vehicle (engine off) is a normal condition.** When the electric fuel pump is activated, fuel pressure should **immediately** (1–2 seconds) rise to specification.

All fuel systems are equipped with a fuel tank module mounted, combination fuel filter/fuel pressure regulator. The fuel pressure regulator is not controlled by engine vacuum.

WARNING: THE FUEL SYSTEM IS UNDER CONSTANT FUEL PRESSURE EVEN WITH THE ENGINE OFF. BEFORE DISCONNECTING FUEL LINE AT FUEL RAIL, THIS PRESSURE MUST BE RELEASED. REFER TO THE FUEL SYSTEM PRESSURE RELEASE PROCEDURE.

(1) Remove protective cap at fuel rail test port. Connect the 0–414 kPa (0–60 psi) fuel pressure gauge

DIAGNOSIS AND TESTING (Continued)

(from gauge set 5069) to test port pressure fitting on fuel rail (Fig. 7). **The DRB III Scan Tool along with the PEP module, the 500 psi pressure transducer, and the transducer-to-test port adapter may also be used in place of the fuel pressure gauge.**

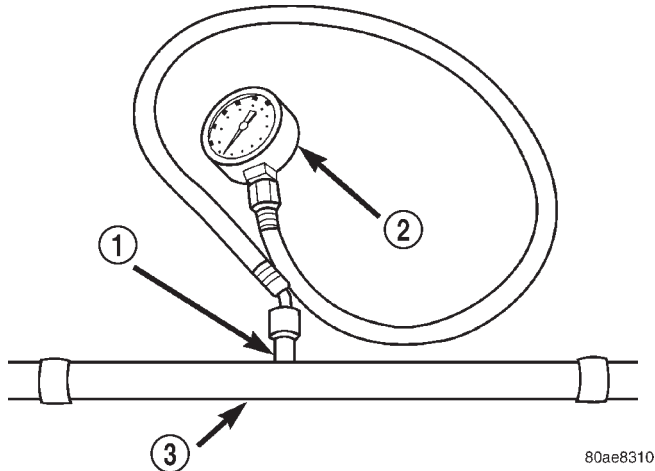

Fig. 7 Fuel Pressure Test Gauge (Typical Gauge Installation at Test Port)

- 1 - SERVICE (TEST) PORT
2 - FUEL PRESSURE TEST GAUGE
3 - FUEL RAIL

(2) Start and warm engine and note pressure gauge reading. Fuel pressure should be 339 kPa \pm 34 kPa (49.2 psi \pm 5 psi) at idle.

(3) If engine runs, but pressure is below 44.2 psi, check for a kinked fuel supply line somewhere between fuel rail and fuel pump module. If line is not kinked, but specifications for either the Fuel Pump Capacity, Fuel Pump Amperage or Fuel Pressure Leak Down Tests were not met, replace fuel pump module assembly. Refer to Fuel Pump Module Removal/Installation.

(4) If operating pressure is above 54.2 psi, electric fuel pump is OK, but fuel pressure regulator is defective. Replace fuel filter/fuel pressure regulator. Refer to Fuel Filter/Fuel Pressure Regulator Removal/Installation for more information.

(5) Install protective cap to fuel rail test port.

FUEL PUMP CAPACITY TEST

Before performing this test, verify fuel pump pressure. Refer to Fuel Pump Pressure Test. Use this test in conjunction with the Fuel Pressure Leak Down Test.

(1) Release fuel system pressure. Refer to Fuel Pressure Release Procedure.

(2) Disconnect fuel supply line at fuel rail. Refer to Quick-Connect Fittings. Some engines may require air cleaner housing removal before line disconnection.

(3) Obtain correct Fuel Line Pressure Test Adapter Tool Hose. Tool number 6539 is used for 5/16" fuel lines and tool number 6631 is used for 3/8" fuel lines.

(4) Connect correct Fuel Line Pressure Test Adapter Tool Hose into disconnected fuel supply line. Insert other end of Adaptor Tool Hose into a graduated container.

(5) Remove fuel fill cap.

(6) To activate fuel pump and pressurize system, obtain DRB scan tool and actuate ASD Fuel System Test.

(7) A good fuel pump will deliver at least 1/4 liter of fuel in 7 seconds. Do not operate fuel pump for longer than 7 seconds with fuel line disconnected as fuel pump module reservoir may run empty.

(a) If capacity is lower than specification, but fuel pump can be heard operating through fuel fill cap opening, check for a kinked/damaged fuel supply line somewhere between fuel rail and fuel pump module.

(b) If line is not kinked/damaged, and fuel pressure is OK, but capacity is low, replace fuel filter/fuel pressure regulator. The filter/regulator may be serviced separately on certain applications. Refer to Fuel Filter/Fuel Pressure Regulator Removal/Installation for additional information.

(c) If both fuel pressure and capacity are low, replace fuel pump module assembly. Refer to Fuel Pump Module Removal/Installation.

FUEL PRESSURE LEAK DOWN TEST

Use this test in conjunction with the Fuel Pump Pressure Test and Fuel Pump Capacity Test.

Check Valve Operation: The electric fuel pump outlet contains a one-way check valve to prevent fuel flow back into the tank and to maintain fuel supply line pressure (engine warm) when pump is not operational. It is also used to keep the fuel supply line full of gasoline when pump is not operational. After the vehicle has cooled down, fuel pressure may drop to 0 psi (cold fluid contracts), but liquid gasoline will remain in fuel supply line between the check valve and fuel injectors. **Fuel pressure that has dropped to 0 psi on a cooled down vehicle (engine off) is a normal condition.** When the electric fuel pump is activated, fuel pressure should **immediately** (1-2 seconds) rise to specification.

Abnormally long periods of cranking to restart a hot engine that has been shut down for a short period of time may be caused by:

- Fuel pressure bleeding past a fuel injector(s).
- Fuel pressure bleeding past the check valve in the fuel pump module.

(1) Disconnect the fuel inlet line at fuel rail. Refer to Fuel Tubes/Lines/Hoses and Clamps in this section of the group for procedures. On some engines, air

DIAGNOSIS AND TESTING (Continued)

cleaner housing removal may be necessary before fuel line disconnection.

(2) Obtain correct Fuel Line Pressure Test Adapter Tool Hose. Tool number 6539 is used for 5/16" fuel lines and tool number 6631 is used for 3/8" fuel lines.

(3) Connect correct Fuel Line Pressure Test Adapter Tool Hose between disconnected fuel line and fuel rail (Fig. 8).

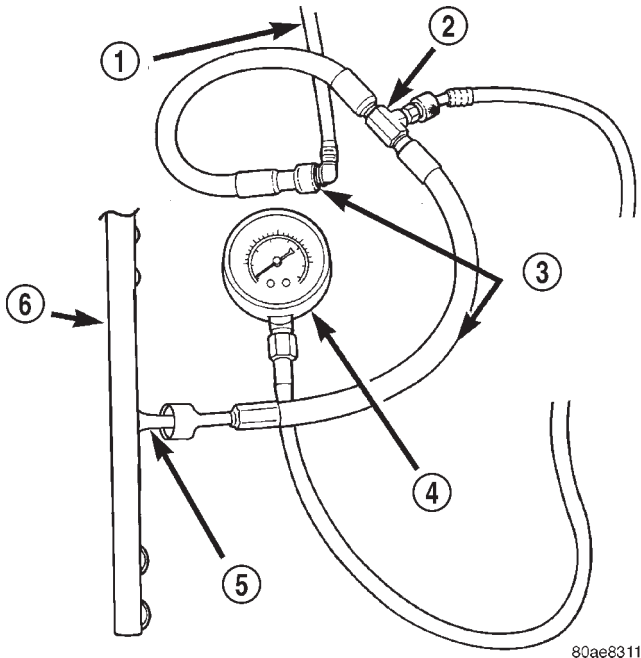

80ae8311

Fig. 8 Connecting Adapter Tool—Typical

- 1 - VEHICLE FUEL LINE
- 2 - TEST PORT "T"
- 3 - SPECIAL TOOL 6923, 6631, 6541 OR 6539
- 4 - FUEL PRESSURE TEST GAUGE
- 5 - FUEL LINE CONNECTION AT RAIL
- 6 - FUEL RAIL

(4) Connect the 0-414 kPa (0-60 psi) fuel pressure test gauge (from Gauge Set 5069) to the test port on the appropriate Adaptor Tool. **The DRB III Scan Tool along with the PEP module, the 500 psi pressure transducer, and the transducer-to-test port adapter may also be used in place of the fuel pressure gauge.**

The fittings on both tools must be in good condition and free from any small leaks before performing the proceeding test.

(5) Start engine and bring to normal operating temperature.

(6) Observe test gauge. Normal operating pressure should be 339 kPa \pm 34 kPa (49.2 psi \pm 5 psi).

(7) Shut engine off.

(8) Pressure should not fall below **30 psi for five minutes.**

(9) If pressure falls below 30 psi, it must be determined if a fuel injector, the check valve within the fuel pump module, or a fuel tube/line is leaking.

(10) Again, start engine and bring to normal operating temperature.

(11) Shut engine off.

(12) **Testing for fuel injector or fuel rail leakage:** Clamp off the rubber hose portion of Adaptor Tool between the fuel rail and the test port "T" on Adaptor Tool. If pressure now holds at or above 30 psi, a fuel injector or the fuel rail is leaking.

(13) **Testing for fuel pump check valve, filter/regulator check valve or fuel tube/line leakage:** Clamp off the rubber hose portion of Adaptor Tool between the vehicle fuel line and test port "T" on Adaptor Tool. If pressure now holds at or above 30 psi, a leak may be found at a fuel tube/line. If no leaks are found at fuel tubes or lines, one of the check valves in either the electric fuel pump or filter/regulator may be leaking.

Note: A quick loss of pressure usually indicates a defective check valve in the filter/regulator. A slow loss of pressure usually indicates a defective check valve in the electric fuel pump.

The electric fuel pump is not serviced separately. Replace the fuel pump module assembly. The filter/regulator may be replaced separately on certain applications. Refer to Fuel Filter/Fuel Pressure Regulator Removal/Installation for additional information.

FUEL PUMP AMPERAGE TEST

This amperage (current draw) test is to be done in conjunction with the Fuel Pump Pressure Test, Fuel Pump Capacity Test and Fuel Pressure Leak Down Test. Before performing the amperage test, be sure the temperature of the fuel tank is above 50° F (10° C).

The DRB Scan Tool along with the DRB Low Current Shunt (LCS) adapter (Fig. 9) and its test leads will be used to check fuel pump amperage specifications.

(1) Be sure fuel tank contains fuel before starting test. If tank is empty or near empty, amperage readings will be incorrect.

(2) Obtain LCS adapter.

(3) Plug cable from LCS adapter into DRB scan tool at SET 1 receptacle.

(4) Plug DRB into vehicle 16-way connector (data link connector).

(5) Connect (-) and (+) test cable leads into LCS adapter receptacles. Use **10 amp (10A +)** receptacle and common (-) receptacles.

(6) Gain access to MAIN MENU on DRB screen.

(7) Press DVOM button on DRB.

DIAGNOSIS AND TESTING (Continued)

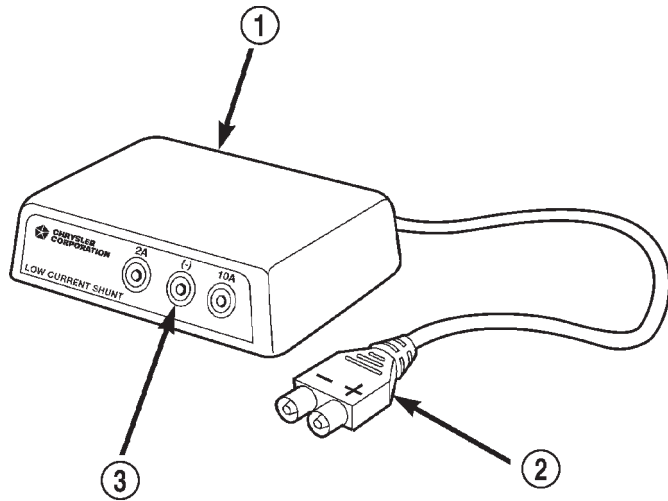

80add391

Fig. 9 Low Current Shunt Adapter

- 1 - LOW CURRENT SHUNT ADAPTER
- 2 - PLUG TO DRB
- 3 - TEST LEAD RECEPTACLES

(8) Using left/right arrow keys, highlight CHANNEL 1 function on DRB screen.

(9) Press ENTER three times.

(10) Using up/down arrow keys, highlight RANGE on DRB screen (screen will default to 2 amp scale).

(11) Press ENTER to change 2 amp scale to 10 amp scale. **This step must be done to prevent damage to DRB scan tool or LCS adapter (blown fuse).**

(12) Remove cover from Power Distribution Center (PDC).

(13) Remove fuel pump relay from PDC. Refer to label on PDC cover for relay location.

WARNING: BEFORE PROCEEDING TO NEXT STEP, NOTE THE FUEL PUMP WILL BE ACTIVATED AND SYSTEM PRESSURE WILL BE PRESENT. THIS WILL OCCUR AFTER CONNECTING TEST LEADS FROM LCS ADAPTER INTO FUEL PUMP RELAY CAVITIES. THE FUEL PUMP WILL OPERATE EVEN WITH IGNITION KEY IN OFF POSITION. BEFORE ATTACHING TEST LEADS, BE SURE ALL FUEL LINES AND FUEL SYSTEM COMPONENTS ARE CONNECTED.

CAUTION: TO PREVENT POSSIBLE DAMAGE TO THE VEHICLE ELECTRICAL SYSTEM AND LCS ADAPTER, THE TEST LEADS MUST BE CONNECTED INTO RELAY CAVITIES EXACTLY AS SHOWN IN FOLLOWING STEPS.

Depending upon vehicle model, year or engine configuration, three different types of relays may be used: Type-1, type-2 and type-3.

(14) If equipped with **type-1 relay** (Fig. 10), attach test leads from LCS adapter into PDC relay cavities number 30 and 87. For location of these cavities, refer to numbers stamped to bottom of relay (Fig. 10).

(15) If equipped with **type-2 relay** (Fig. 11), attach test leads from LCS adapter into PDC relay cavities number 30 and 87. For location of these cavities, refer to numbers stamped to bottom of relay (Fig. 11).

(16) If equipped with **type-3 relay** (Fig. 12), attach test leads from LCS adapter into PDC relay cavities number 3 and 5. For location of these cavities, refer to numbers stamped to bottom of relay (Fig. 12).

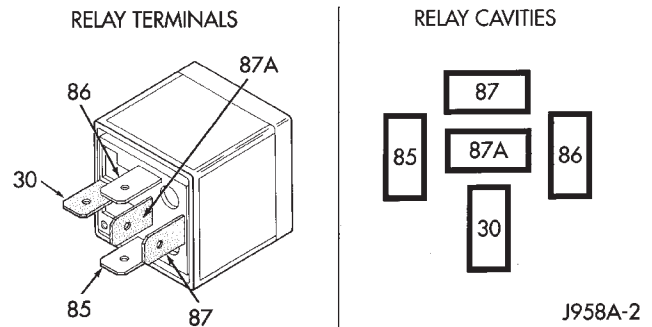

J958A-2

| TERMINAL LEGEND | |
|-----------------|-----------------|
| NUMBER | IDENTIFICATION |
| 30 | COMMON FEED |
| 85 | COIL GROUND |
| 86 | COIL BATTERY |
| 87 | NORMALLY OPEN |
| 87A | NORMALLY CLOSED |

Fig. 10 Type-1 Relay

(17) When LCS adapter test leads are attached into relay cavities, fuel pump **will be activated**. Determine fuel pump amperage on DRB screen. Amperage should be below 10.0 amps. If amperage is below 10.0 amps, and specifications for the Fuel Pump Pressure, Fuel Pump Capacity and Fuel Pressure Leak Down tests were met, the fuel pump module is OK.

(18) If amperage is more than 10.0 amps, replace fuel pump module assembly. The electric fuel pump is not serviced separately.

(19) Disconnect test leads from relay cavities immediately after testing.

DIAGNOSIS AND TESTING (Continued)

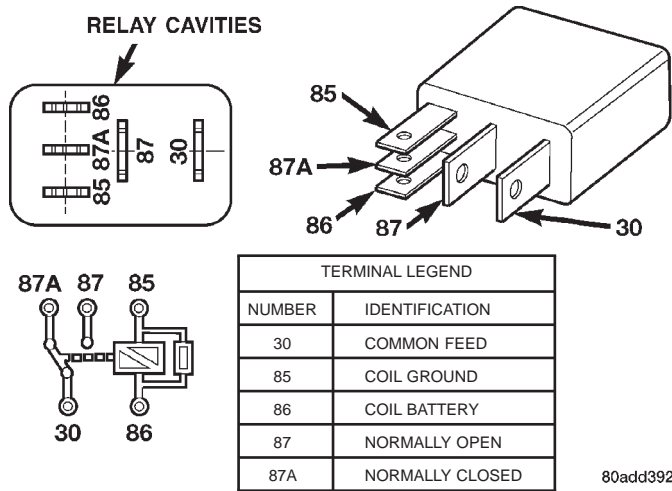

Fig. 11 Type-2 Relay

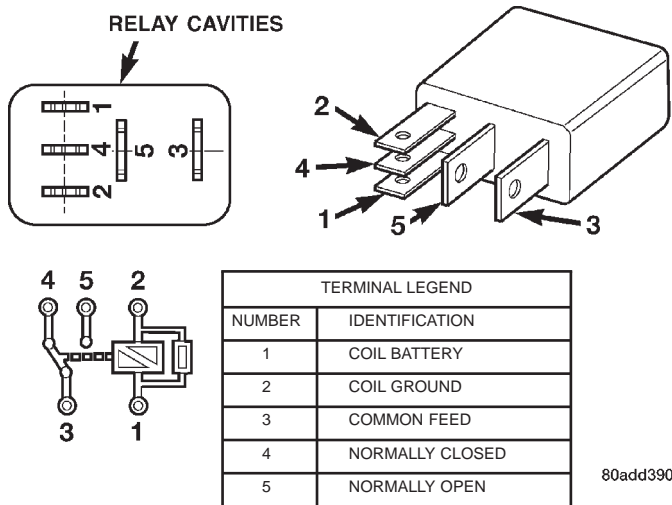

Fig. 12 Type-3 Relay

FUEL GAUGE SENDING UNIT

The fuel gauge sending unit contains a variable resistor (track). As the float moves up or down, electrical resistance will change. Refer to Instrument Panel and Gauges for Fuel Gauge testing. To test the gauge sending unit only, it must be removed from vehicle. The unit is part of the fuel pump module. Refer to Fuel Pump Module Removal/Installation for procedures. Measure the resistance across the sending unit terminals. With float in up position, resistance should be 20 ohms (+/- 5%). With float in down position, resistance should be 270 ohms (+/- 5%).

FUEL INJECTOR TEST

To perform a complete test of the fuel injectors and their circuitry, use the DRB scan tool and refer to the appropriate Powertrain Diagnostics Procedures manual. To test the injector only, refer to the following:

Disconnect the fuel injector wire harness connector from the injector. The injector is equipped with 2

electrical terminals (pins). Place an ohmmeter across the terminals. Resistance reading should be approximately 12 ohms \pm 1.2 ohms at 20°C (68°F).

SERVICE PROCEDURES

FUEL SYSTEM PRESSURE RELEASE PROCEDURE

Use following procedure if the fuel injector rail is, or is not equipped with a fuel pressure test port.

- (1) Remove fuel fill cap.
- (2) Remove fuel pump relay from Power Distribution Center (PDC). For location of relay, refer to label on underside of PDC cover.
- (3) Start and run engine until it stalls.
- (4) Attempt restarting engine until it will no longer run.
- (5) Turn ignition key to OFF position.

CAUTION: Steps 1, 2, 3 and 4 must be performed to relieve high pressure fuel from within fuel rail. Do not attempt to use following steps to relieve this pressure as excessive fuel will be forced into a cylinder chamber.

- (6) Unplug connector from any fuel injector.
- (7) Attach one end of a jumper wire with alligator clips (18 gauge or smaller) to either injector terminal.
- (8) Connect other end of jumper wire to positive side of battery.
- (9) Connect one end of a second jumper wire to remaining injector terminal.

CAUTION: Powering an injector for more than a few seconds will permanently damage the injector.

- (10) Momentarily touch other end of jumper wire to negative terminal of battery for no more than a few seconds.
- (11) Place a rag or towel below fuel line quick-connect fitting at fuel rail.
- (12) Disconnect quick-connect fitting at fuel rail. Refer to Quick-Connect Fittings.
- (13) Return fuel pump relay to PDC.
- (14) One or more Diagnostic Trouble Codes (DTC's) may have been stored in PCM memory due to fuel pump relay removal. The DRB scan tool must be used to erase a DTC.

QUICK-CONNECT FITTINGS

Also refer to Fuel Tubes/Lines/Hoses and Clamps. Different types of quick-connect fittings are used to attach various fuel system components, lines and tubes. These are: a single-tab type, a two-tab type or a plastic retainer ring type. Safety latch clips are

SERVICE PROCEDURES (Continued)

used on certain components/lines. Certain fittings may require use of a special tool for disconnection.

DISCONNECTING

WARNING: THE FUEL SYSTEM IS UNDER A CONSTANT PRESSURE (EVEN WITH ENGINE OFF). BEFORE SERVICING ANY FUEL SYSTEM HOSE, FITTING OR LINE, FUEL SYSTEM PRESSURE MUST BE RELEASED. REFER TO FUEL SYSTEM PRESSURE RELEASE PROCEDURE.

CAUTION: The interior components (o-rings, spacers) of some types of quick-connect fitting are not serviced separately. If service parts are not available, do not attempt to repair a damaged fitting or fuel line. If repair is necessary, replace complete fuel line assembly.

(1) Perform fuel pressure release procedure. Refer to Fuel Pressure Release Procedure in this group.

(2) Disconnect negative battery cable from battery.

(3) Clean fitting of any foreign material before disassembly.

(4) **Single-Tab Type Fitting:** This type of fitting is equipped with a single pull tab (Fig. 13). The tab is removable. After tab is removed, quick-connect fitting can be separated from fuel system component.

(a) Press release tab on side of fitting to release pull tab (Fig. 14). **If release tab is not pressed prior to releasing pull tab, pull tab will be damaged.**

(b) While pressing release tab on side of fitting, use screwdriver to pry up pull tab (Fig. 14).

(c) Raise pull tab until it separates from quick-connect fitting (Fig. 15).

(5) **Two-Tab Type Fitting:** This type of fitting is equipped with tabs located on both sides of fitting (Fig. 16). The tabs are supplied for disconnecting quick-connect fitting from component being serviced.

(a) To disconnect quick-connect fitting, squeeze plastic retainer tabs (Fig. 16) against sides of quick-connect fitting with your fingers. Tool use is not required for removal and may damage plastic retainer.

(b) Pull fitting from fuel system component being serviced.

(c) The plastic retainer will remain on component being serviced after fitting is disconnected. The o-rings and spacer will remain in quick-connect fitting connector body.

(6) **Plastic Retainer Ring Type Fitting:** This type of fitting can be identified by the use of a full-round plastic retainer ring (Fig. 17) usually black in color.

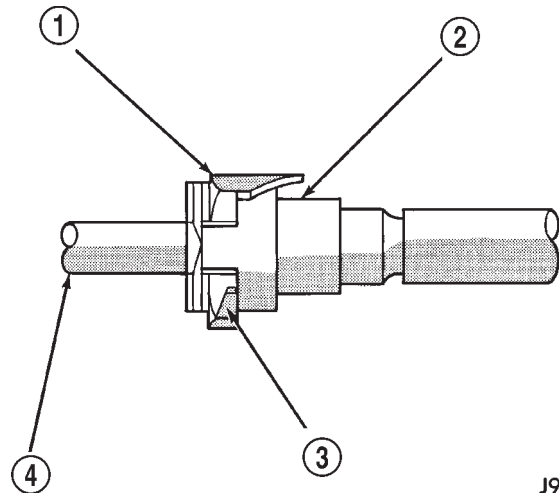

J9414-24

Fig. 13 Single-Tab Type Fitting

- 1 - PULL TAB
- 2 - QUICK-CONNECT FITTING
- 3 - PRESS HERE TO REMOVE PULL TAB
- 4 - INSERTED TUBE END

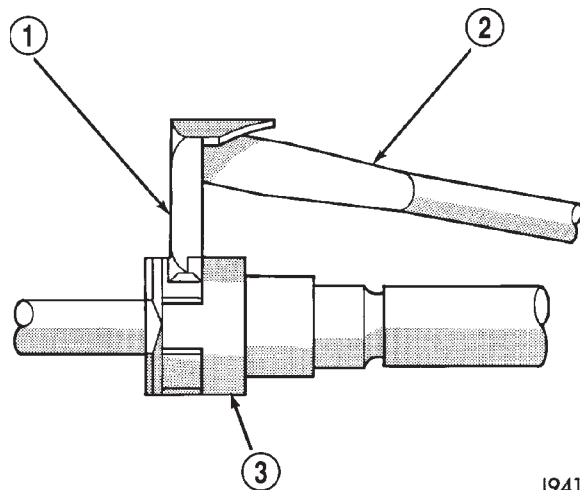

J9414-25

Fig. 14 Disconnecting Single-Tab Type Fitting

- 1 - PULL TAB
- 2 - SCREWDRIVER
- 3 - QUICK-CONNECT FITTING

(a) To release fuel system component from quick-connect fitting, firmly push fitting towards component being serviced while firmly pushing plastic retainer ring into fitting (Fig. 17). With plastic ring depressed, pull fitting from component. **The plastic retainer ring must be pressed squarely into fitting body. If this retainer is cocked during removal, it may be difficult to disconnect fitting. Use an open-end wrench on shoulder of plastic retainer ring to aid in disconnection.**

(b) After disconnection, plastic retainer ring will remain with quick-connect fitting connector body.

SERVICE PROCEDURES (Continued)

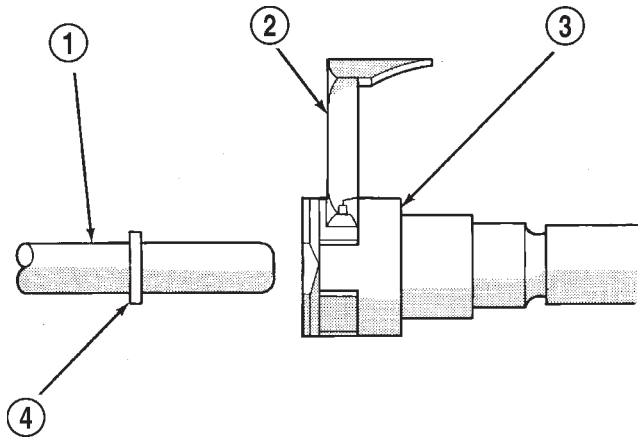

J9414-26

Fig. 15 Removing Pull Tab

- 1 - FUEL TUBE OR FUEL SYSTEM COMPONENT
- 2 - PULL TAB
- 3 - QUICK-CONNECT FITTING
- 4 - FUEL TUBE STOP

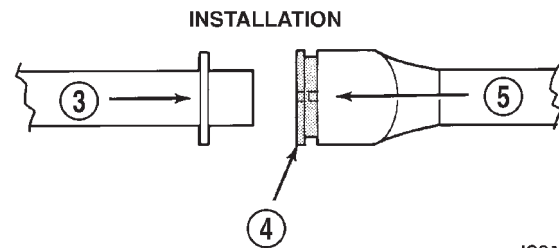
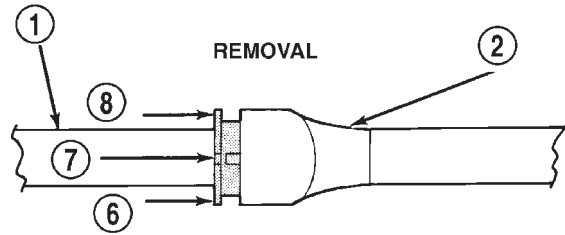

J9314-100

Fig. 17 Plastic Retainer Ring Type Fitting

- 1 - FUEL TUBE
- 2 - QUICK CONNECT FITTING
- 3 - PUSH
- 4 - PLASTIC RETAINER
- 5 - PUSH
- 6 - PUSH
- 7 - PUSH
- 8 - PUSH

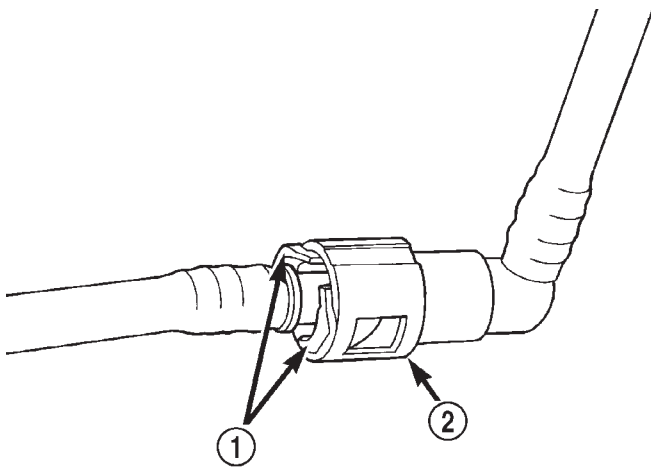

80a35405

Fig. 16 Typical Two-Tab Type Quick-Connect Fitting

- 1 - TAB(S)
- 2 - QUICK-CONNECT FITTING

(c) Inspect fitting connector body, plastic retainer ring and fuel system component for damage. Replace as necessary.

(7) **Latch Clips:** Depending on vehicle model and engine, 2 different types of safety latch clips are used (Fig. 18) or (Fig. 19). Type-1 is tethered to fuel line and type-2 is not. A special tool will be necessary to disconnect fuel line after latch clip is removed. The latch clip may be used on certain fuel line/fuel rail connection, or to join fuel lines together.

(a) Type 1: Pry up on latch clip with a screwdriver (Fig. 18).

(b) Type 2: Separate and unlatch 2 small arms on end of clip (Fig. 19) and swing away from fuel line.

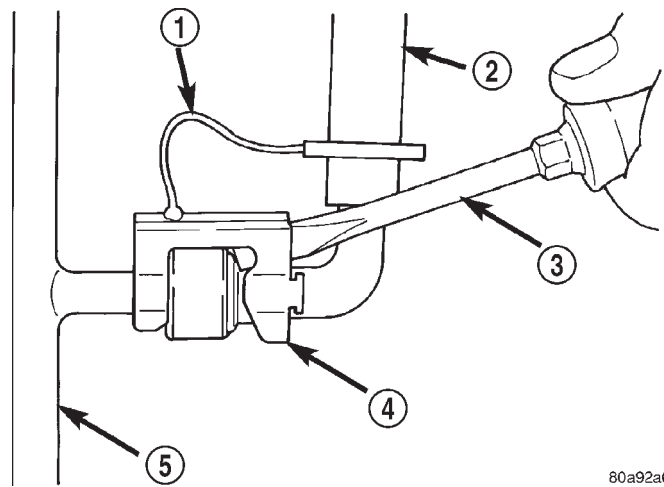

80a92a66

Fig. 18 Latch Clip—Type 1

- 1 - TETHER STRAP
- 2 - FUEL LINE
- 3 - SCREWDRIVER
- 4 - LATCH CLIP
- 5 - FUEL RAIL

(c) Slide latch clip toward fuel rail while lifting with screwdriver.

SERVICE PROCEDURES (Continued)

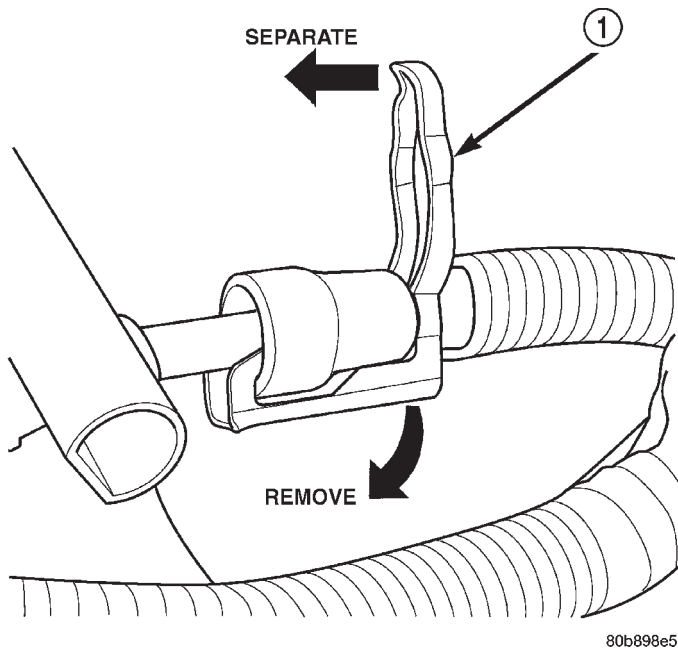

Fig. 19 Latch Clip—Type 2

1 - LATCH CLIP

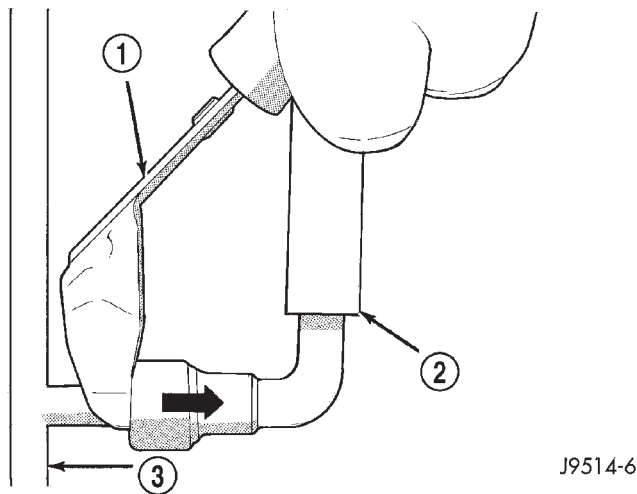

Fig. 20 Fuel Line Disconnection Using Special Tool

1 - SPECIAL FUEL LINE TOOL

2 - FUEL LINE

3 - FUEL RAIL

(d) Insert special fuel line removal tool (Snap-On number FIH 9055-1 or equivalent) into fuel line (Fig. 20). Use tool to release locking fingers in end of line.

(e) With special tool still inserted, pull fuel line from fuel rail.

(f) After disconnection, locking fingers will remain within quick-connect fitting at end of fuel line.

(8) Disconnect quick-connect fitting from fuel system component being serviced.

CONNECTING

(1) Inspect quick-connect fitting body and fuel system component for damage. Replace as necessary.

(2) Prior to connecting quick-connect fitting to component being serviced, check condition of fitting and component. Clean parts with a lint-free cloth. Lubricate with clean engine oil.

(3) Insert quick-connect fitting into fuel tube or fuel system component until built-on stop on fuel tube or component rests against back of fitting.

(4) Continue pushing until a click is felt.

(5) Single-tab type fitting: Push new tab down until it locks into place in quick-connect fitting.

(6) Verify a locked condition by firmly pulling on fuel tube and fitting (15-30 lbs.).

(7) Latch Clip Equipped: Install latch clip (snaps into position). **If latch clip will not fit, this indicates fuel line is not properly installed to fuel rail (or other fuel line). Recheck fuel line connection.**

(8) Connect negative cable to battery.

(9) Start engine and check for leaks.

REMOVAL AND INSTALLATION

FUEL FILTER/FUEL PRESSURE REGULATOR

The combination Fuel Filter/Fuel Pressure Regulator is located on the fuel pump module. The fuel pump module is located on top of fuel tank.

The filter/regulator may be removed without removing fuel pump module although fuel tank must be removed.

REMOVAL

(1) Remove fuel tank. Refer to Fuel Tank Removal/Installation.

(2) Clean area around filter/regulator.

(3) Disconnect fuel line at filter/regulator. Refer to Quick-Connect Fittings in this group for procedures.

(4) Remove retainer clamp from top of filter/regulator (Fig. 21). Clamp snaps to tabs on pump module. Discard old clamp.

(5) Pry filter/regulator from top of pump module with 2 screwdrivers. Unit is snapped into module.

(6) Discard gasket below filter/regulator (Fig. 22).

(7) Before discarding filter/regulator assembly, inspect assembly to verify that o-rings (Fig. 23) are intact. If the smallest of the two o-rings can not be found on bottom of filter/regulator, it may be necessary to remove it from the fuel inlet passage in fuel pump module.

REMOVAL AND INSTALLATION (Continued)

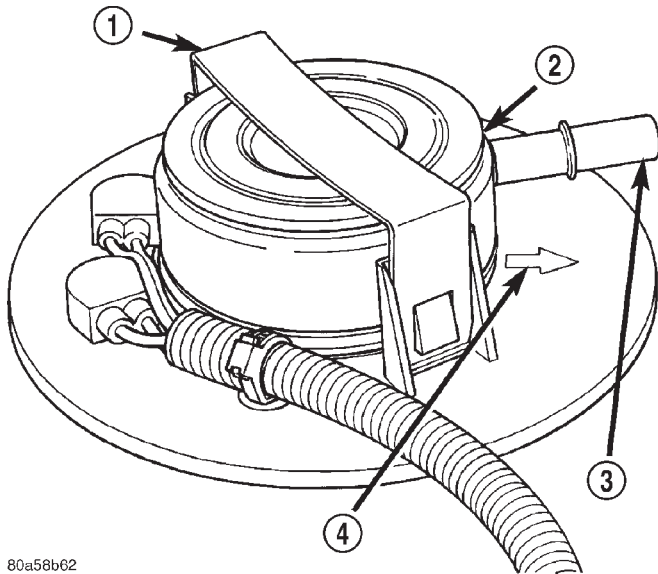

80a58b62

Fig. 21 Fuel Filter/Fuel Pressure Regulator

- 1 - RETAINER CLAMP
- 2 - FUEL FILTER/FUEL PRESSURE REGULATOR
- 3 - FUEL SUPPLY TUBE
- 4 - ALIGNMENT ARROW

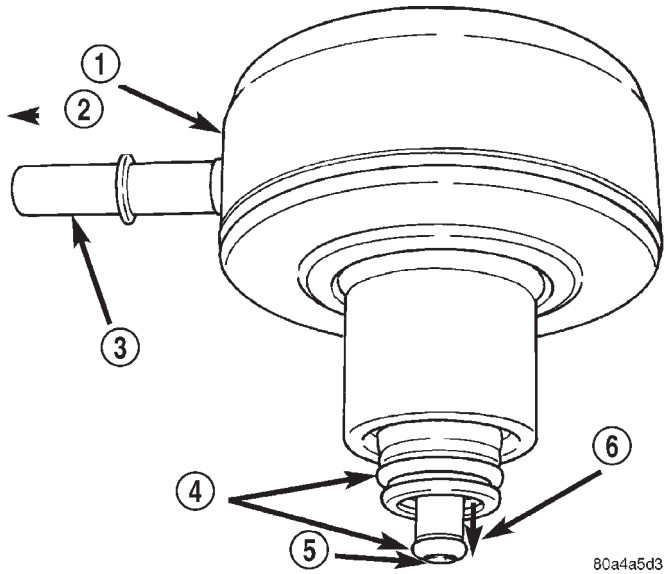

80a4a5d3

Fig. 23 Fuel Filter/Fuel Pressure Regulator O-Rings

- 1 - FUEL FILTER/FUEL PRESSURE REGULATOR
- 2 - TO FUEL INJECTORS
- 3 - FUEL SUPPLY TUBE
- 4 - O-RINGS
- 5 - FUEL INLET FROM PUMP
- 6 - FUEL RETURN TO TANK

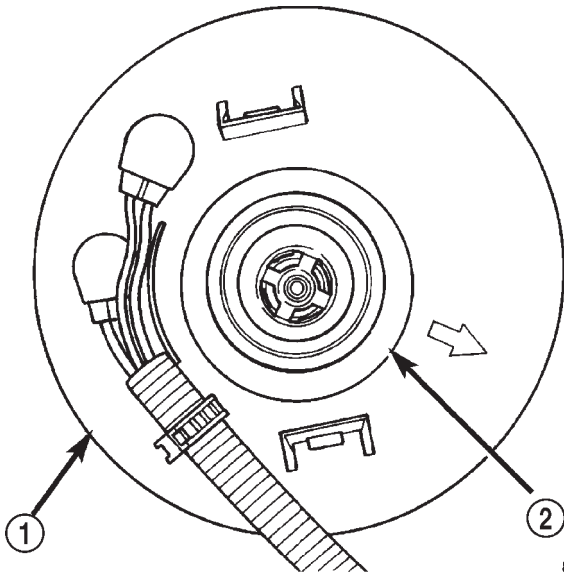

80a58b63

Fig. 22 Fuel Filter/Fuel Pressure Regulator Gasket

- 1 - TOP OF MODULE
- 2 - GASKET

INSTALLATION

- (1) Clean recessed area in pump module where filter/regulator is to be installed.
- (2) Obtain new filter/regulator (two new o-rings should already be installed).
- (3) Apply a small amount of clean engine oil to o-rings. **Do not install o-rings separately into**

fuel pump module. They will be damaged when installing filter/regulator.

- (4) Install new gasket to top of fuel pump module.
- (5) Press new filter/regulator into top of pump module until it snaps into position (a positive click must be heard or felt).
- (6) The arrow (Fig. 21) molded into top of fuel pump module should be pointed towards front of vehicle (12 o'clock position).
- (7) Rotate filter/regulator until fuel supply tube (fitting) is pointed towards front of vehicle (12 o'clock position).
- (8) Install new retainer clamp (clamp snaps over top of filter/regulator and locks to flanges on pump module).
- (9) Connect fuel line at filter/regulator. Refer to Quick-Connect Fittings in this group for procedures.
- (10) Install fuel tank. Refer to Fuel Tank Removal/Installation.

FUEL PUMP MODULE

Fuel tank removal will be necessary for fuel pump module removal.

REMOVAL

WARNING: THE FUEL SYSTEM IS UNDER A CONSTANT PRESSURE EVEN WITH ENGINE OFF. BEFORE SERVICING THE FUEL PUMP MODULE, FUEL SYSTEM PRESSURE MUST BE RELEASED.

REMOVAL AND INSTALLATION (Continued)

(1) Drain fuel tank and remove tank. Refer to the Fuel Tank Removal/Installation section of this group.

(2) Thoroughly wash and clean area around pump module to prevent contaminants from entering tank.

(3) Disconnect fuel line at filter/regulator. Refer to Quick-Connect Fittings in this group for procedures.

(4) The plastic fuel pump module locknut is threaded onto fuel tank (Fig. 24). Install Special Tool 6856 to fuel pump module locknut and remove locknut (Fig. 25). The fuel pump module will spring up when locknut is removed.

(5) Remove module from fuel tank.

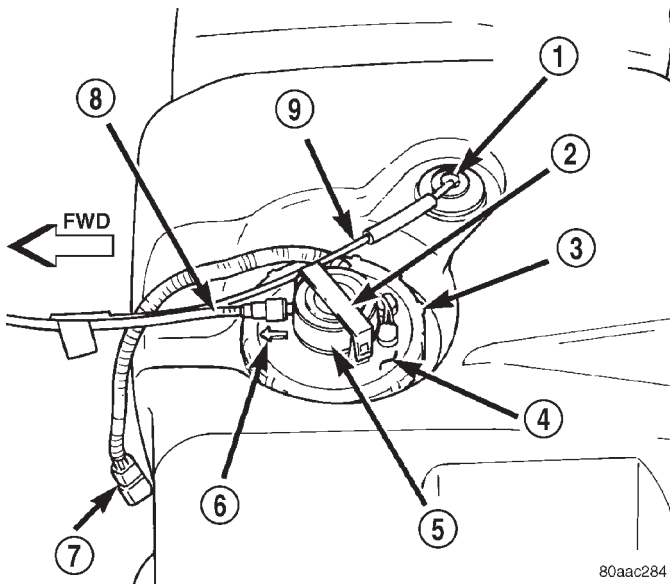

Fig. 24 Top View of Fuel Tank and Fuel Pump Module

- 1 - ROLLOVER VALVE
- 2 - RETAINER CLAMP
- 3 - LOCKNUT
- 4 - FUEL PUMP MODULE
- 5 - FUEL FILTER/FUEL PRESSURE REGULATOR
- 6 - ALIGNMENT ARROW
- 7 - PIGTAIL HARNESS
- 8 - FUEL SUPPLY TUBE
- 9 - EVAP CANISTER VENT LINE

INSTALLATION

CAUTION: Whenever fuel pump module is serviced, module gasket must be replaced.

(1) Thoroughly clean locknut threads and mating fuel tank threads. Use a soap/water solution. Do not use carburetor cleaner to clean threads.

(2) Using a new gasket, position gasket and fuel pump module into opening in fuel tank.

(3) Apply clean water to gasket and locknut threads.

(4) Position locknut over top of fuel pump module.

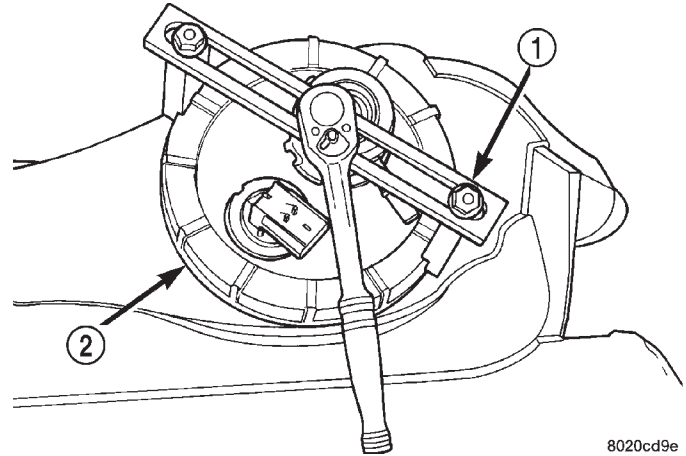

Fig. 25 Locknut Removal/Installation—Typical

- 1 - SPECIAL TOOL 6856
- 2 - LOCKNUT

(5) Rotate module until molded arrow (Fig. 24) is pointed toward front of vehicle (12 o'clock position). This step must be done to prevent float/float rod assembly from contacting sides of fuel tank.

(6) Install Special Tool 6856 to locknut.

(7) Tighten locknut to 74 N·m (55 ft. lbs.) torque.

(8) Rotate fuel filter/fuel pressure regulator until its fitting is pointed toward front of vehicle (12 o'clock position).

(9) Connect fuel line at filter/regulator. Refer to Quick-Connect Fittings in this group for procedures.

(10) Install fuel tank. Refer to Fuel Tank Installation in this section.

FUEL PUMP INLET FILTER

The fuel pump inlet filter (strainer) is located on the bottom of fuel pump module (Fig. 26). The fuel pump module is located on top of fuel tank.

REMOVAL

(1) Remove fuel tank. Refer to Fuel Tank Removal/Installation.

(2) Remove fuel pump module. Refer to Fuel Pump Module Removal/Installation.

(3) Remove filter by prying from bottom of module with 2 screwdrivers. Filter is snapped to module.

(4) Clean bottom of pump module.

INSTALLATION

(1) Snap new filter to bottom of module.

(2) Install fuel pump module. Refer to Fuel Pump Module Removal/Installation.

(3) Install fuel tank. Refer to Fuel Tank Removal/Installation.

REMOVAL AND INSTALLATION (Continued)

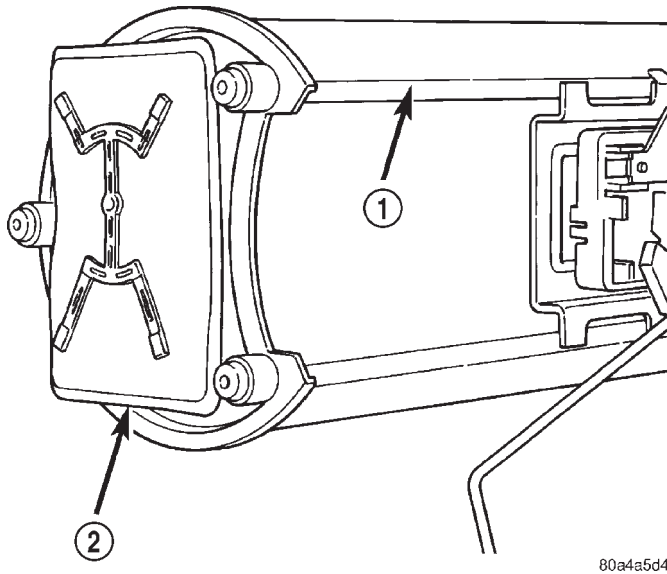
**Fig. 26 Fuel Pump Inlet Filter**

- 1 - FUEL PUMP MODULE
- 2 - FUEL PUMP INLET FILTER

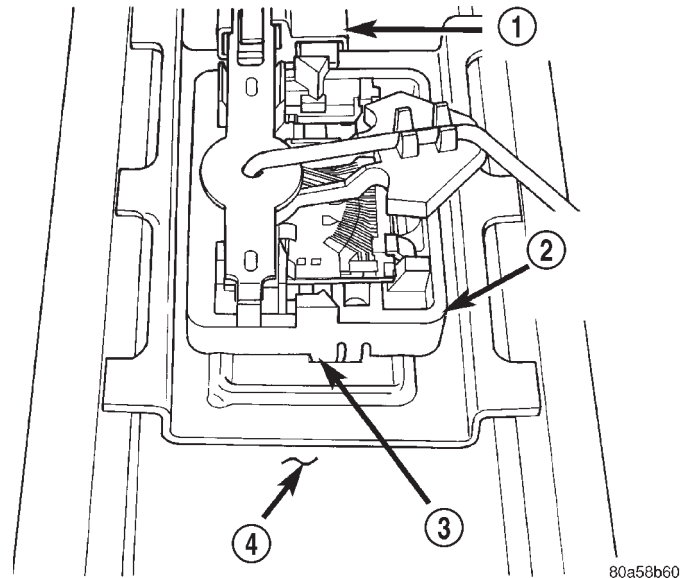
**Fig. 28 Fuel Gauge Sending Unit Release Tab**

- 1 - ELECTRICAL CONNECTOR
- 2 - FUEL GAUGE SENDING UNIT
- 3 - RELEASE TAB
- 4 - FUEL PUMP MODULE

FUEL GAUGE SENDING UNIT

The fuel gauge sending unit (fuel level sensor) and float assembly is located on the side of fuel pump module (Fig. 27). The fuel pump module is located within the fuel tank.

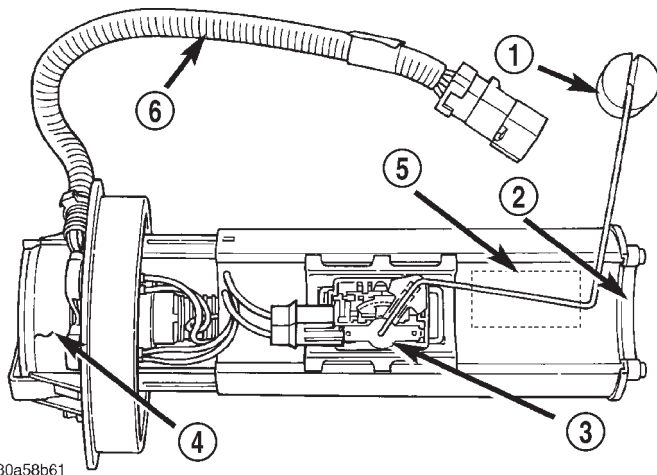
**Fig. 27 Fuel Gauge Sending Unit Location**

- 1 - FUEL GAUGE FLOAT
- 2 - PICK-UP FILTER
- 3 - FUEL GAUGE SENDING UNIT
- 4 - FUEL FILTER/FUEL PRESSURE REGULATOR
- 5 - ELECTRIC FUEL PUMP
- 6 - PIGTAIL WIRING HARNESS

REMOVAL

(1) Remove fuel tank. Refer to Fuel Tank Removal/Installation.

- (2) Remove fuel pump module. Refer to Fuel Pump Module Removal/Installation.
- (3) Remove electrical wire connector at sending unit terminals.
- (4) Press on release tab (Fig. 28) to remove sending unit from pump module.

INSTALLATION

- (1) Position sending unit to pump module and snap into place.
- (2) Connect electrical connector to terminals.
- (3) Install fuel pump module. Refer to Fuel Pump Module Removal/Installation.
- (4) Install fuel tank. Refer to Fuel Tank Removal/Installation.

FUEL INJECTOR RAIL/FUEL DAMPER—2.5L ENGINE**REMOVAL**

The fuel damper is not serviced separately.

WARNING: THE FUEL SYSTEM IS UNDER CONSTANT FUEL PRESSURE EVEN WITH ENGINE OFF. THIS PRESSURE MUST BE RELEASED BEFORE SERVICING FUEL RAIL.

- (1) Remove fuel tank filler tube cap.
- (2) Perform Fuel System Pressure Release Procedure as described in this Group.
- (3) Disconnect negative battery cable from battery.

REMOVAL AND INSTALLATION (Continued)

(4) Remove air tube at top of throttle body. Note: Some engine/vehicles may require removal of air cleaner ducts at throttle body.

(5) Remove injector harness electrical connectors at each injector. Each injector connector should have a numerical tag attached identifying its corresponding cylinder (Fig. 29). If not, identify each connector before removal.

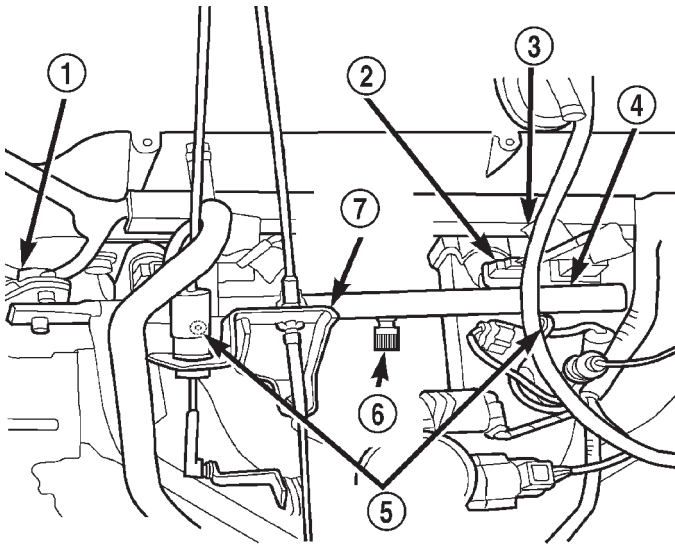

80b6f034

Fig. 29 Fuel Rail Mounting—2.5L Engine

- 1 - FUEL DAMPER
- 2 - FUEL INJECTOR
- 3 - NUMBERED TAG
- 4 - FUEL RAIL
- 5 - FUEL RAIL MOUNTING BOLTS/NUTS
- 6 - TEST PORT
- 7 - CABLE BRACKET

(6) Disconnect fuel supply line latch clip and fuel line at fuel rail. Refer to Quick-Connect Fittings in this group for procedures.

(7) Disconnect throttle cable at throttle body. Refer to Throttle Cable Removal/Installation in this group for procedures.

(8) Disconnect speed control cable at throttle body (if equipped). Refer to Speed Control Cable in Group 8H, Speed Control System for procedures.

(9) Disconnect automatic transmission cable at throttle body (if equipped).

(10) Remove cable routing bracket (Fig. 29) at intake manifold.

(11) Remove nut securing crankshaft position sensor pigtail harness to fuel rail mounting stud. Remove clamp and harness from fuel rail mounting stud.

(12) Clean dirt/debris from each fuel injector at intake manifold.

(13) Remove fuel rail mounting nuts/bolts (Fig. 29).

(14) Remove fuel rail by gently rocking until all the fuel injectors are out of intake manifold.

INSTALLATION

(1) Clean each injector bore at intake manifold.

(2) Apply a small amount of clean engine oil to each injector o-ring. This will aid in installation.

(3) Position tips of all fuel injectors into the corresponding injector bore in intake manifold. Seat injectors into manifold.

(4) Install and tighten fuel rail mounting bolts to 11 ± 3 N·m (100 ± 25 in. lbs.) torque.

(5) Position crankshaft position sensor pigtail wire harness clamp and wire harness to fuel rail mounting stud. Install nut securing harness to fuel rail mounting stud.

(6) Connect tagged injector harness connectors to appropriate injector.

(7) Connect fuel line and fuel line latch clip to fuel rail. Refer Quick-Connect Fittings in this group for procedures.

(8) Install protective cap to pressure test port fitting (if equipped).

(9) Install cable routing bracket to intake manifold.

(10) Connect throttle cable at throttle body.

(11) Connect speed control cable at throttle body (if equipped).

(12) Connect automatic transmission cable at throttle body (if equipped).

(13) Install air tube (or duct) at top of throttle body.

(14) Install fuel tank cap.

(15) Connect negative battery cable to battery.

(16) Start engine and check for fuel leaks.

FUEL INJECTOR RAIL/FUEL DAMPER—4.0L ENGINE**REMOVAL**

The fuel damper is not serviced separately.

WARNING: THE FUEL SYSTEM IS UNDER CONSTANT FUEL PRESSURE EVEN WITH ENGINE OFF. THIS PRESSURE MUST BE RELEASED BEFORE SERVICING FUEL RAIL.

(1) Remove fuel tank filler tube cap.

(2) Perform Fuel System Pressure Release Procedure.

(3) Disconnect negative battery cable from battery.

(4) Remove air tube at top of throttle body. Note: Some engine/vehicles may require removal of air cleaner ducts at throttle body.

REMOVAL AND INSTALLATION (Continued)

(5) Disconnect electrical connectors at all 6 fuel injectors. To remove connector refer to (Fig. 30). Push red colored slider away from injector (1). While pushing slider, depress tab (2) and remove connector (3) from injector. The factory fuel injection wiring harness is numerically tagged (INJ 1, INJ 2, etc.) for injector position identification. If harness is not tagged, note wiring location before removal.

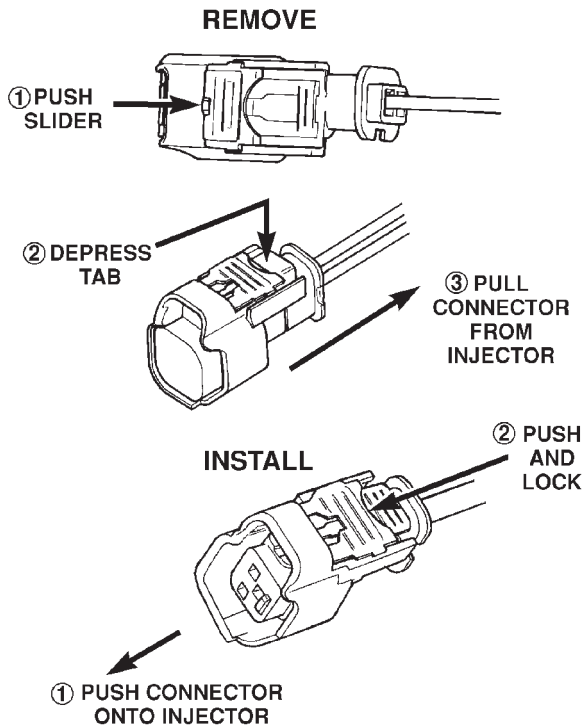

**Fig. 30 Remove/Install Fuel Injector Connector—
2.5L/4.0L Engine**

(6) Disconnect fuel supply line latch clip and fuel line at fuel rail. Refer to Quick-Connect Fittings.

(7) Disconnect throttle cable at throttle body. Refer to Throttle Cable Removal/Installation.

(8) Disconnect speed control cable at throttle body (if equipped). Refer to Speed Control Cable in Group 8H, Speed Control System.

(9) Disconnect automatic transmission cable at throttle body (if equipped).

(10) Remove cable routing bracket at intake manifold.

(11) If equipped, remove wiring harnesses at injection rail studs by removing nuts.

(12) Clean dirt/debris from each fuel injector at intake manifold.

(13) Remove fuel rail mounting nuts/bolts (Fig. 31).

(14) Remove fuel rail by gently rocking until all the fuel injectors are out of intake manifold.

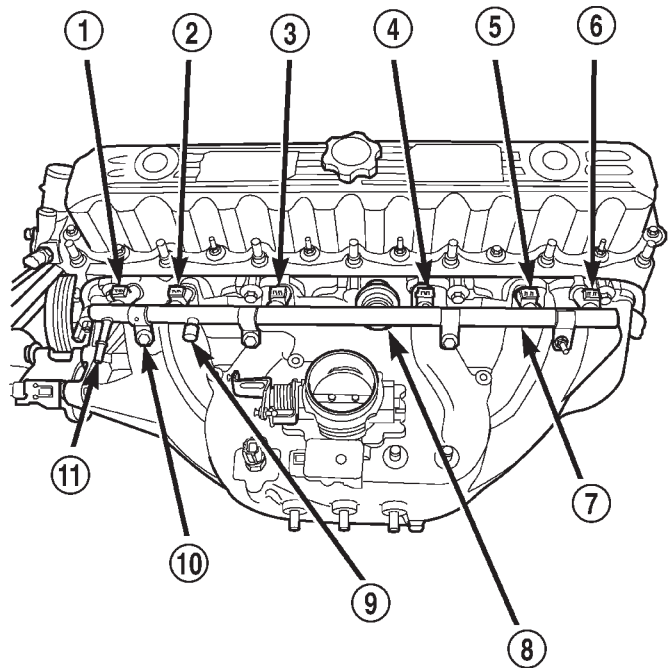

80bfe150

Fig. 31 Fuel Rail Mounting—4.0L Engine

- 1 - INJ. #1
- 2 - INJ. #2
- 3 - INJ. #3
- 4 - INJ. #4
- 5 - INJ. #5
- 6 - INJ. #6
- 7 - FUEL INJECTOR RAIL
- 8 - FUEL DAMPER
- 9 - PRESSURE TEST PORT CAP
- 10 - MOUNTING BOLTS (4)
- 11 - QUICK-CONNECT FITTING

INSTALLATION

(1) Clean each injector bore at intake manifold.

(2) Apply a small amount of clean engine oil to each injector o-ring. This will aid in installation.

(3) Position tips of all fuel injectors into the corresponding injector bore in intake manifold. Seat injectors into manifold.

(4) Install and tighten fuel rail mounting bolts to 11 ± 3 N·m (100 ± 25 in. lbs.) torque.

(5) If equipped, connect wiring harnesses to injection rail studs.

(6) Connect electrical connectors at all fuel injectors. To install connector, refer to (Fig. 30). Push connector onto injector (1) and then push and lock red colored slider (2). Verify connector is locked to injector by lightly tugging on connector.

(7) Connect fuel line and fuel line latch clip to fuel rail. Refer Quick-Connect Fittings..

REMOVAL AND INSTALLATION (Continued)

- (8) Install protective cap to pressure test port fitting (if equipped).
- (9) Install cable routing bracket to intake manifold.
- (10) Connect throttle cable at throttle body.
- (11) Connect speed control cable at throttle body (if equipped).
- (12) Connect automatic transmission cable at throttle body (if equipped).
- (13) Install air tube (or duct) at top of throttle body.
- (14) Install fuel tank cap.
- (15) Connect negative battery cable to battery.
- (16) Start engine and check for fuel leaks.

FUEL INJECTORS

REMOVAL

- (1) Remove fuel rail. Refer to Fuel Injector Rail Removal in this section.
- (2) Disconnect clip(s) that retain fuel injector(s) to fuel rail (Fig. 32).

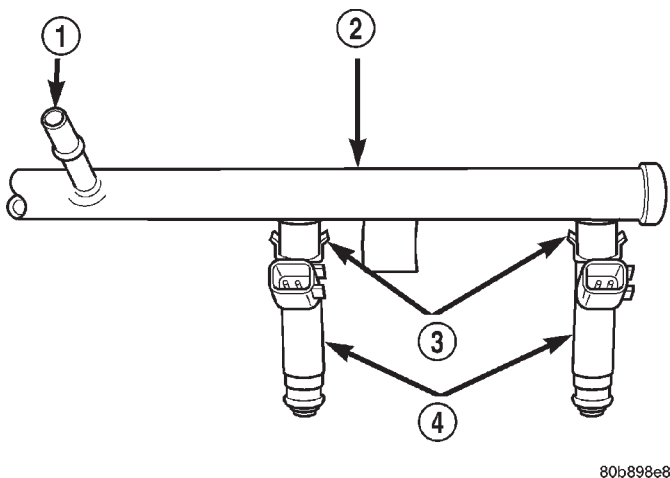
**Fig. 32 Fuel Injector Mounting**

- 1 - INLET FITTING
- 2 - FUEL INJECTOR RAIL
- 3 - CLIP
- 4 - FUEL INJECTOR

INSTALLATION

- (1) Install fuel injector(s) into fuel rail assembly and install retaining clip(s).
- (2) If same injector(s) is being reinstalled, install new o-ring(s).
- (3) Apply a small amount of clean engine oil to each injector o-ring. This will aid in installation.
- (4) Install fuel rail. Refer to Fuel Rail Installation.
- (5) Start engine and check for fuel leaks.

FUEL TANK

WARNING: THE FUEL SYSTEM IS UNDER CONSTANT FUEL PRESSURE EVEN WITH THE ENGINE OFF. THIS PRESSURE MUST BE RELEASED BEFORE SERVICING FUEL TANK.

Two different procedures may be used to drain fuel tank (lowering tank or using DRB scan tool).

The quickest draining procedure involves lowering the fuel tank.

As an alternative procedure, the electric fuel pump may be activated allowing tank to be drained at fuel rail connection. Refer to DRB scan tool for fuel pump activation procedures. Before disconnecting fuel line at fuel rail, release fuel pressure. Refer to the Fuel System Pressure Release Procedure in this group for procedures. Attach end of special test hose tool number 6541, 6539, 6631 or 6923 at fuel rail disconnection (tool number will depend on model and/or engine application). Position opposite end of this hose tool to an approved gasoline draining station. Activate fuel pump and drain tank until empty.

If electric fuel pump is not operating, tank must be lowered for fuel draining. Refer to following procedures.

REMOVAL

- (1) Disconnect negative battery cable at battery.
- (2) Release fuel system pressure. Refer to the Fuel System Pressure Release Procedure in this group.
- (3) Raise and support vehicle.
- (4) If Equipped: Remove fuel tank skid plate. Refer to Group 23, Body for procedures.
- (5) Remove 4 fuel hose shield mounting bolts and remove fuel hose shield (Fig. 33) from body.
- (6) Remove fuel tank fill hose and vent hose clamps at fuel tank filler tube (Fig. 34). Remove both hoses at fuel filler tube (Fig. 34).
- (7) Remove exhaust tailpipe heat shield mounting bolts and remove shield.

CAUTION: To protect fuel tank from exhaust heat, this shield must be reinstalled after tank installation.

- (8) Place a hydraulic jack to bottom of fuel tank.

WARNING: PLACE A SHOP TOWEL AROUND FUEL LINES TO CATCH ANY EXCESS FUEL.

(9) Disconnect fuel supply line from fuel extension line near front of fuel tank (Fig. 35). Refer to Fuel Tubes/Lines/Hoses and Clamps in this group. Also refer to Quick-Connect Fittings for procedures.

(10) Disconnect EVAP canister vent line near front of tank (Fig. 35).

REMOVAL AND INSTALLATION (Continued)

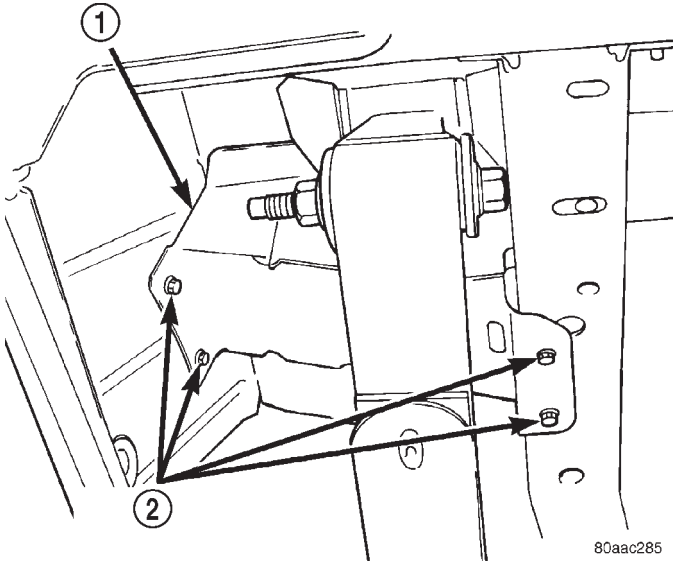

Fig. 33 Fuel Hose Shield

- 1 - FUEL HOSE SHIELD
- 2 - MOUNTING BOLTS (4)

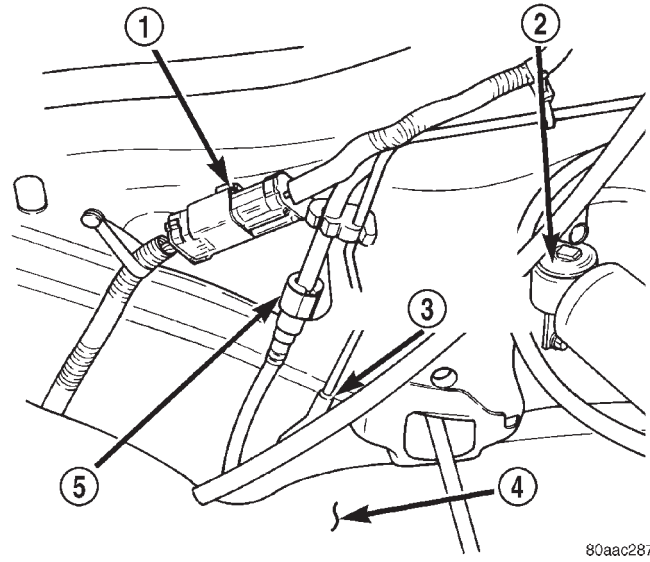

Fig. 35 Fuel Tank Connections at Front of Fuel Tank

- 1 - FUEL PUMP MODULE CONNECTOR
- 2 - LEFT-REAR SHOCK ABSORBER
- 3 - EVAP CANISTER VENT LINE CONNECTION
- 4 - FRONT OF FUEL TANK
- 5 - FUEL SUPPLY LINE CONNECTION

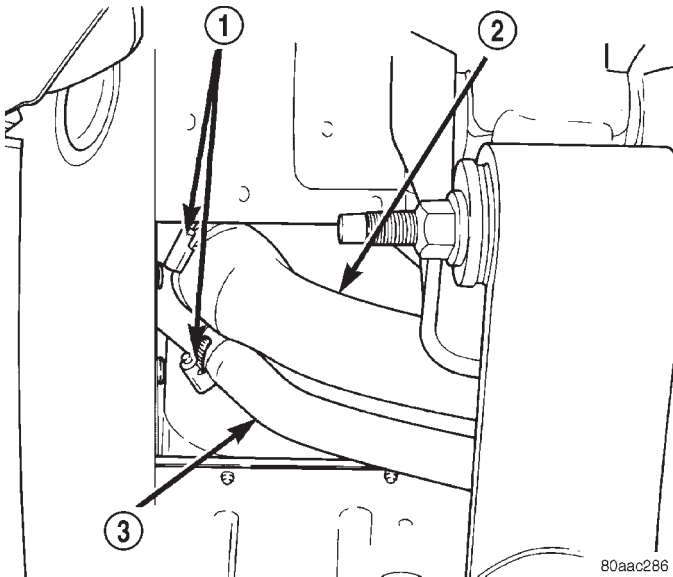

Fig. 34 Fuel Fill and Vent Hoses

- 1 - CLAMPS
- 2 - FUEL FILL HOSE
- 3 - FUEL VENT HOSE

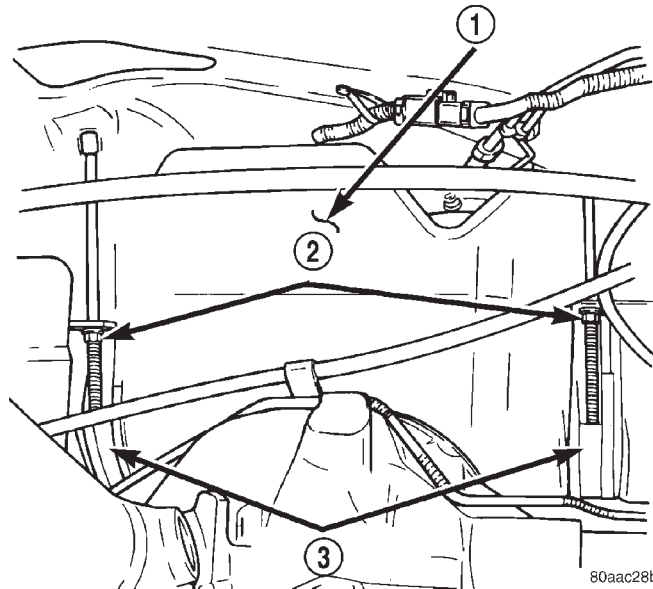

Fig. 36 Fuel Tank Mounting Straps/Nuts

- 1 - FRONT OF FUEL TANK
- 2 - NUTS (2)
- 3 - STRAPS (2)

(11) Disconnect fuel pump module electrical connector (pigtail harness) near front of tank (Fig. 35). Harness connector is clipped to body.

(12) Remove two fuel tank strap nuts (Fig. 36). Position both tank support straps away from tank.

(13) Carefully lower right side of tank while feeding both fuel hoses through access hole in body. **Fuel Tank Full And Not Drained Using DRB Scan Tool:** To prevent fuel loss through hoses, keep left side of tank higher than right side while lowering.

Do not allow hose openings to drop lower than top of tank.

(14) Continue lowering tank until clear of vehicle. Place tank on floor with left side (hose side) higher than right side.

(15) Drain tank by removing fuel fill hose at tank. Fuel fill hose is largest of 2 hoses (Fig. 37). Insert the

REMOVAL AND INSTALLATION (Continued)

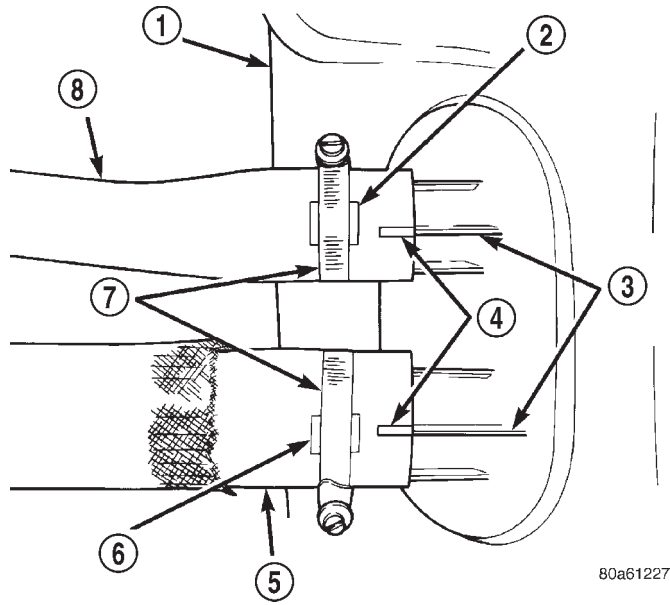

Fig. 37 Fuel Fill/Vent Hose Index Marks

- 1 - FUEL TANK
- 2 - CLAMP INDEX MARKS
- 3 - TANK INDEX TANGS
- 4 - HOSE INDEX MARKS
- 5 - FUEL FILL HOSE
- 6 - CLAMP INDEX MARKS
- 7 - CLAMPS
- 8 - FUEL VENT HOSE

drain hose (from an approved gasoline draining station) into hose opening. Drain tank until empty.

(16) If fuel pump module removal is necessary, refer to Fuel Pump Module Removal/Installation in this group for procedures.

INSTALLATION

(1) If fuel pump module is being installed, refer to Fuel Pump Module Removal/Installation in this group for procedures.

(2) Install fuel fill/vent hoses to tank fittings. To prevent hose from kinking, rotate each hose until index mark on hose is aligned to index tang on fuel tank (Fig. 37).

(3) Install hose clamps to hoses. Position clamps between index marks on each hose (Fig. 37).

(4) Position fuel tank to hydraulic jack.

(5) Raise tank into position while guiding fuel fill and vent hoses into and through access hole in body.

(6) Continue raising tank until positioned to body.

(7) Attach two fuel tank mounting straps and mounting nuts. Tighten nuts to 10 N·m (90 in. lbs.) torque. Do not over tighten nuts.

(8) Install both fuel hoses to fuel fill tube. Tighten both retaining clamps.

(9) Position fuel hose shield to body. Install and tighten 4 mounting bolts.

(10) Connect fuel pump module pigtail harness electrical connector near front of tank.

(11) Connect fuel pump module supply line near front of tank. Refer to Quick-Connect Fittings for procedures.

(12) Connect EVAP hose near front of tank.

(13) Install exhaust tailpipe heat shield.

(14) Install fuel tank skid plate (if equipped).

(15) Lower vehicle and connect battery cable to battery.

FUEL TANK FILLER TUBE CAP

REMOVAL/INSTALLATION

If replacement of the 1/4 turn fuel tank filler tube cap is necessary, it must be replaced with an identical cap to be sure of correct system operation.

CAUTION: Remove the fuel tank filler tube cap to relieve fuel tank pressure. The cap must be removed prior to disconnecting any fuel system component or before draining the fuel tank.

ACCELERATOR PEDAL

REMOVAL

The accelerator pedal is connected to the throttle body linkage by the throttle cable. The cable is protected by a plastic sheathing and is connected to the throttle body linkage by a ball socket. It is connected to the upper part of the accelerator pedal arm by a plastic retainer (clip) (Fig. 38). This retainer (clip) snaps into the top of the accelerator pedal arm. Retainer tabs (built into the cable sheathing) (Fig. 38) fasten the cable to the dash panel.

Dual throttle return springs (attached to the throttle shaft) are used to close the throttle.

CAUTION: Never attempt to remove or alter these springs.

CAUTION: Be careful not to damage or kink the cable core wire (within the cable sheathing) while servicing the accelerator pedal or throttle cable.

(1) From inside the vehicle, hold up accelerator pedal. Remove plastic cable retainer (clip) and throttle cable core wire from upper end of accelerator pedal arm (Fig. 38). Plastic cable retainer (clip) snaps into pedal arm.

(2) Remove accelerator pedal mounting bracket nuts. Remove accelerator pedal assembly.

REMOVAL AND INSTALLATION (Continued)

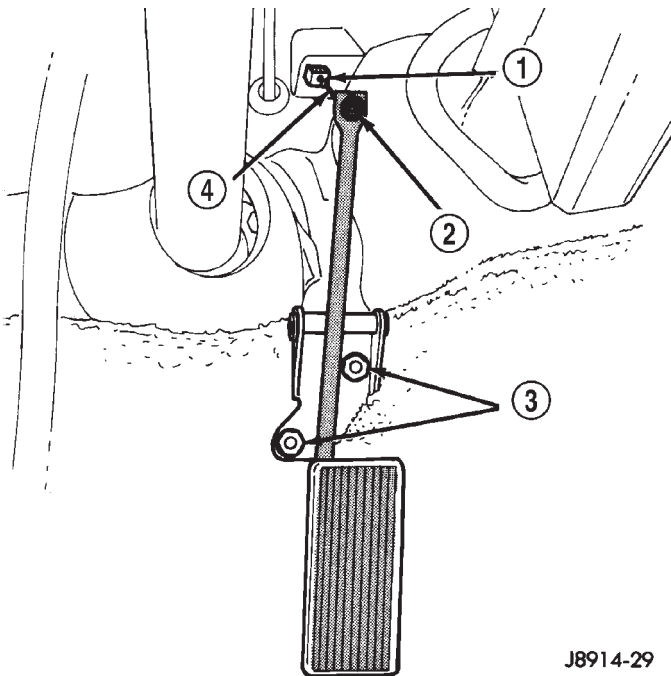

J8914-29

Fig. 38 Accelerator Pedal Mounting—Typical

- 1 - RETAINER TABS
- 2 - CLIP
- 3 - MOUNTING NUTS
- 4 - CABLE

INSTALLATION

(1) Place accelerator pedal assembly over studs protruding from floor pan. Tighten mounting nuts to 5 N·m (36 in. lbs.) torque.

(2) Slide throttle cable into opening in top of pedal arm. Push plastic cable retainer (clip) into accelerator pedal arm opening until it snaps into place.

(3) Before starting engine, operate accelerator pedal to check for any binding.

THROTTLE CABLE**REMOVAL**

(1) From inside vehicle, hold up accelerator pedal. Remove plastic cable retainer (clip) and throttle cable core wire from upper end of accelerator pedal arm (Fig. 38). Plastic cable retainer (clip) snaps into pedal arm.

(2) Remove cable core wire at pedal arm.

(3) From inside vehicle, pinch both sides of cable housing retainer tabs (Fig. 38) at dash panel. Remove cable housing from dash panel and pull into engine compartment.

(4) Remove cable from cable guide on engine cylinder head (valve) cover.

(5) Remove throttle cable ball end socket at throttle body by pushing ball socket towards rear of vehicle (ball snaps off throttle body pin) (Fig. 39).

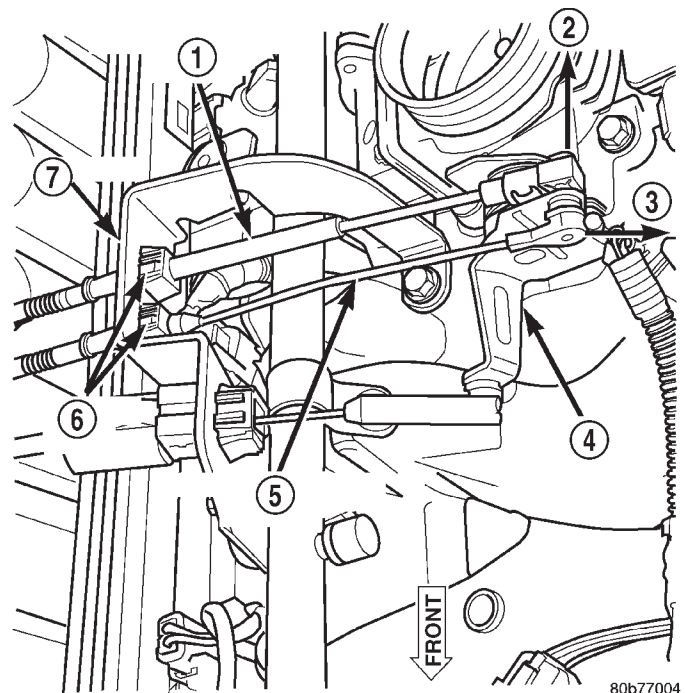

80b77004

Fig. 39 Throttle Cable at Throttle Body

- 1 - ACCELERATOR CABLE
- 2 - OFF
- 3 - OFF
- 4 - THROTTLE BODY BELLCRANK
- 5 - SPEED CONTROL CABLE
- 6 - RELEASE TABS
- 7 - BRACKET

(6) Remove throttle cable from throttle body mounting bracket by compressing release tabs (Fig. 39) and pushing cable through hole in bracket.

(7) Remove throttle cable from vehicle.

INSTALLATION

(1) Slide throttle cable through hole in throttle body bracket until retainer tabs lock into bracket.

(2) Connect cable ball end to throttle body linkage ball (snaps on).

(3) Snap cable into cable guide on engine cylinder head (valve) cover.

(4) Push other end of cable through opening in dash panel until retaining tabs lock into panel.

(5) From inside drivers compartment, slide throttle cable core wire into opening in top of accelerator pedal arm. Push cable retainer (clip) into pedal arm opening until it snaps in place.

(6) Before starting engine, operate accelerator pedal to check for any binding.

SPECIFICATIONS

FUEL TANK CAPACITY

| Models | Liters | U. S. Gallons |
|---|--------|---------------|
| All | 76 | 20 |
| Nominal refill capacities are shown. A variation may be observed from vehicle to vehicle due to manufacturing tolerance and refill procedure. | | |

FUEL SYSTEM PRESSURE

339 kPa ± 34 kPa (49.2 psi ± 2 psi).

FUEL REQUIREMENTS

Your engine is designed to meet all emissions regulations and provide excellent fuel economy and performance when using high quality unleaded gasoline having an octane rating of 87. The use of premium gasoline is not recommended. The use of premium gasoline will provide no benefit over high quality regular gasoline, and in some circumstances may result in poorer performance.

Light spark knock at low engine speeds is not harmful to your engine. However, continued heavy spark knock at high speeds can cause damage and immediate service is required. Engine damage resulting from operation with a heavy spark knock may not be covered by the new vehicle warranty.

Poor quality gasoline can cause problems such as hard starting, stalling and hesitations. If you experience these symptoms, try another brand of gasoline before considering service for the vehicle.

Over 40 auto manufacturers world-wide have issued and endorsed consistent gasoline specifications (the Worldwide Fuel Charter, WWFC) to define fuel properties necessary to deliver enhanced emissions, performance and durability for your vehicle. We recommend the use of gasolines that meet the WWFC specifications if they are available.

REFORMULATED GASOLINE

Many areas of the country require the use of cleaner burning gasoline referred to as “reformulated” gasoline. Reformulated gasoline contain oxygenates, and are specifically blended to reduce vehicle emissions and improve air quality.

We strongly supports the use of reformulated gasoline. Properly blended reformulated gasoline will provide excellent performance and durability for the engine and fuel system components.

GASOLINE/OXYGENATE BLENDS

Some fuel suppliers blend unleaded gasoline with oxygenates such as 10% ethanol, MTBE, and ETBE. Oxygenates are required in some areas of the country

during the winter months to reduce carbon monoxide emissions. Fuels blended with these oxygenates may be used in your vehicle.

CAUTION: DO NOT use gasoline containing METHANOL. Gasoline containing methanol may damage critical fuel system components.

MMT IN GASOLINE

MMT is a manganese-containing metallic additive that is blended into some gasoline to increase octane. Gasoline blended with MMT provide no performance advantage beyond gasoline of the same octane number without MMT. Gasoline blended with MMT reduce spark plug life and reduce emission system performance in some vehicles. We recommend that gasolines free of MMT be used in your vehicle. The MMT content of gasoline may not be indicated on the gasoline pump; therefore, you should ask your gasoline retailer whether or not his/her gasoline contains MMT.

It is even more important to look for gasoline without MMT in Canada because MMT can be used at levels higher than allowed in the United States. MMT is prohibited in Federal and California reformulated gasoline.

SULFUR IN GASOLINE

If you live in the northeast United States, your vehicle may have been designed to meet California low emission standards with Cleaner-Burning California reformulated gasoline with low sulfur. If such fuels are not available in states adopting California emission standards, your vehicles will operate satisfactorily on fuels meeting federal specifications, but emission control system performance may be adversely affected. Gasoline sold outside of California is permitted to have higher sulfur levels which may affect the performance of the vehicle’s catalytic converter. This may cause the Malfunction Indicator Lamp (MIL), Check Engine or Service Engine Soon light to illuminate. We recommend that you try a different brand of unleaded gasoline having lower sulfur to determine if the problem is fuel related prior to returning your vehicle to an authorized dealer for service.

CAUTION: If the Malfunction Indicator Lamp (MIL), Check Engine or Service Engine Soon light is flashing, immediate service is required; see on-board diagnostics system section.

MATERIALS ADDED TO FUEL

All gasoline sold in the United States and Canada are required to contain effective detergent additives.

SPECIFICATIONS (Continued)

Use of additional detergents or other additives is not needed under normal conditions.

FUEL SYSTEM CAUTIONS

CAUTION: Follow these guidelines to maintain your vehicle's performance:

- The use of leaded gas is prohibited by Federal law. Using leaded gasoline can impair engine performance, damage the emission control system, and could result in loss of warranty coverage.
- An out-of-tune engine, or certain fuel or ignition malfunctions, can cause the catalytic converter to overheat. If you notice a pungent burning odor or some light smoke, your engine may be out of tune or malfunctioning and may require immediate service. Contact your dealer for service assistance.
- When pulling a heavy load or driving a fully loaded vehicle when the humidity is low and the temperature is high, use a premium unleaded fuel to help prevent spark knock. If spark knock persists, lighten the load, or engine piston damage may result.
- The use of fuel additives which are now being sold as octane enhancers is not recommended. Most

of these products contain high concentrations of methanol. Fuel system damage or vehicle performance problems resulting from the use of such fuels or additives is not the responsibility of Daimler-Chrysler Corporation and may not be covered under the new vehicle warranty.

NOTE: Intentional tampering with emissions control systems can result in civil penalties being assessed against you.

TORQUE CHART

| DESCRIPTION | TORQUE |
|---|-------------------------|
| Accelerator Pedal Bracket Mounting Nuts . . . | 5 N·m (36 in. lbs.) |
| Fuel Hose Clamps | 3 N·m (25 in. lbs.) |
| Fuel Rail Mounting Bolts | 11 N·m (100 in. lbs.) |
| Fuel Tank Mounting Strap Nuts | 10 N·m (90 in. lbs.) |
| Fuel Pump Module Locknut | 74 N·m (55 ft. lbs.) |

FUEL INJECTION SYSTEM

TABLE OF CONTENTS

| | page | | page |
|--|------|---|------|
| DESCRIPTION AND OPERATION | | | |
| POWERTRAIN CONTROL MODULE (PCM) | 25 | FUEL INJECTORS—PCM OUTPUT | 35 |
| MODES OF OPERATION | 26 | FUEL PUMP RELAY-PCM OUTPUT | 35 |
| AUTOMATIC SHUTDOWN (ASD) RELAY | | IDLE AIR CONTROL (IAC) MOTOR—PCM | |
| SENSE—PCM INPUT | 29 | OUTPUT | 35 |
| BATTERY VOLTAGE—PCM INPUT | 29 | RADIATOR FAN RELAY—PCM OUTPUT | 36 |
| BRAKE SWITCH—PCM INPUT | 29 | THROTTLE BODY | 36 |
| FIVE VOLT SENSOR SUPPLIES—PRIMARY | | DIAGNOSIS AND TESTING | |
| AND SECONDARY | 29 | VISUAL INSPECTION | 37 |
| FUEL LEVEL SENSOR—PCM INPUT | 30 | ASD AND FUEL PUMP RELAYS | 41 |
| ENGINE COOLANT TEMPERATURE | | THROTTLE BODY MINIMUM AIR FLOW | |
| SENSOR—PCM INPUT | 30 | CHECK PROCEDURE | 42 |
| EXTENDED IDLE SWITCH—PCM INPUT | 30 | REMOVAL AND INSTALLATION | |
| OXYGEN SENSOR—PCM INPUT | 30 | AUTOMATIC SHUTDOWN (ASD) RELAY | 43 |
| IGNITION CIRCUIT SENSE—PCM INPUT | 31 | FUEL PUMP RELAY | 44 |
| INTAKE MANIFOLD AIR TEMPERATURE | | THROTTLE BODY | 44 |
| SENSOR—PCM INPUT | 32 | THROTTLE POSITION SENSOR (TPS) | 45 |
| MANIFOLD ABSOLUTE PRESSURE (MAP) | | IDLE AIR CONTROL (IAC) MOTOR | 45 |
| SENSOR—PCM INPUT | 32 | MANIFOLD ABSOLUTE PRESSURE (MAP) | |
| OIL PRESSURE SENSOR—PCM INPUT | 33 | SENSOR | 46 |
| POWER GROUNDS | 33 | POWERTRAIN CONTROL MODULE (PCM) | 46 |
| POWER STEERING PRESSURE SWITCH— | | POWER STEERING PRESSURE SWITCH— | |
| PCM INPUT | 33 | 2.5L ENGINE | 47 |
| SENSOR RETURN—PCM INPUT | 34 | OXYGEN SENSOR | 47 |
| THROTTLE POSITION SENSOR (TPS)—PCM | | AIR CLEANER ELEMENT (FILTER) | 49 |
| INPUT | 34 | ENGINE COOLANT TEMPERATURE SENSOR | 49 |
| VEHICLE SPEED AND DISTANCE SENSOR— | | INTAKE MANIFOLD AIR TEMPERATURE | |
| PCM INPUT | 34 | SENSOR | 50 |
| AUTO SHUTDOWN (ASD) RELAY—PCM | | VEHICLE SPEED SENSOR | 51 |
| OUTPUT | 34 | SPECIFICATIONS | |
| CCD BUS (+/-) CIRCUITS-PCM OUTPUTS | 35 | TORQUE CHART | 51 |
| DATA LINK CONNECTOR—PCM INPUT AND | | SPECIAL TOOLS | |
| OUTPUT | 35 | FUEL SYSTEM | 52 |

DESCRIPTION AND OPERATION

POWERTRAIN CONTROL MODULE (PCM)

DESCRIPTION

The Powertrain Control Module (PCM) is located in the engine compartment (Fig. 1). The PCM is referred to as JTEC.

OPERATION

The PCM operates the fuel system. The PCM is a pre-programmed, triple microprocessor digital computer. It regulates ignition timing, air-fuel ratio, emission control devices, charging system, certain

transmission features, speed control, air conditioning compressor clutch engagement and idle speed. The PCM can adapt its programming to meet changing operating conditions.

The PCM receives input signals from various switches and sensors. Based on these inputs, the PCM regulates various engine and vehicle operations through different system components. These components are referred to as Powertrain Control Module (PCM) Outputs. The sensors and switches that provide inputs to the PCM are considered Powertrain Control Module (PCM) Inputs.

The PCM adjusts ignition timing based upon inputs it receives from sensors that react to: engine rpm, manifold absolute pressure, engine coolant tem-

DESCRIPTION AND OPERATION (Continued)

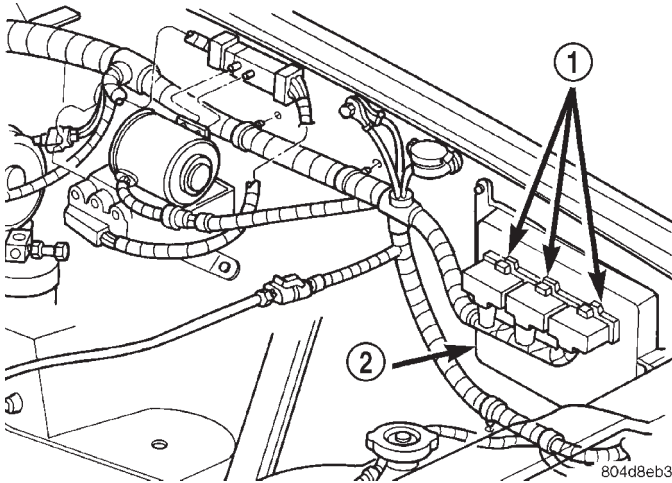

Fig. 1 PCM Location

- 1 - (3) 32-WAY CONNECTORS
2 - PCM

perature, throttle position, transmission gear selection (automatic transmission), vehicle speed, power steering pump pressure (2.5L engine only), and the brake switch.

The PCM adjusts idle speed based on inputs it receives from sensors that react to: throttle position, vehicle speed, transmission gear selection, engine coolant temperature and from inputs it receives from the air conditioning clutch switch and brake switch.

Based on inputs that it receives, the PCM adjusts ignition coil dwell. The PCM also adjusts the generator charge rate through control of the generator field and provides speed control operation.

NOTE: PCM Inputs:

- A/C request (if equipped with factory A/C)
- A/C select (if equipped with factory A/C)
- Auto shutdown (ASD) sense
- Battery temperature
- Battery voltage
- Brake switch
- CCD bus (+) circuits
- CCD bus (-) circuits
- Camshaft position sensor signal
- Crankshaft position sensor
- Data link connection for DRB scan tool
- Engine coolant temperature sensor
- Extended idle switch (4.0L engine with police package)
 - Fuel level
 - Generator (battery voltage) output
 - Ignition circuit sense (ignition switch in on/off/crank/run position)
 - Intake manifold air temperature sensor
 - Leak detection pump (switch) sense (if equipped)

- Manifold absolute pressure (MAP) sensor
- Oil pressure
- Oxygen sensors
- Park/neutral switch (auto. trans. only)
- Power ground
- Power steering pressure switch (2.5L engine only)
 - Sensor return
 - Signal ground
 - Speed control multiplexed single wire input
 - Throttle position sensor
 - Vehicle speed sensor

NOTE: PCM Outputs:

- A/C clutch relay
- Auto shutdown (ASD) relay
- CCD bus (+/-) circuits for: speedometer, voltmeter, fuel gauge, oil pressure gauge/lamp, engine temp. gauge and speed control warn. lamp
 - Data link connection for DRB scan tool
 - EGR valve control solenoid (if equipped)
 - EVAP canister purge solenoid
 - Five volt sensor supply (primary)
 - Five volt sensor supply (secondary)
 - Fuel injectors
 - Fuel pump relay
 - Generator field driver (-)
 - Generator field driver (+)
 - Idle air control (IAC) motor
 - Ignition coil
 - Leak detection pump (if equipped)
 - Malfunction indicator lamp (Check engine lamp). Driven through CCD circuits.
 - Radiator cooling fan relay
 - Speed control vacuum solenoid
 - Speed control vent solenoid
 - Tachometer (if equipped). Driven through CCD circuits.
 - Transmission convertor clutch circuit

MODES OF OPERATION

OPERATION

As input signals to the Powertrain Control Module (PCM) change, the PCM adjusts its response to the output devices. For example, the PCM must calculate different injector pulse width and ignition timing for idle than it does for wide open throttle (WOT).

The PCM will operate in two different modes: **Open Loop and Closed Loop.**

During Open Loop modes, the PCM receives input signals and responds only according to preset PCM programming. Input from the oxygen (O₂S) sensors is not monitored during Open Loop modes.

During Closed Loop modes, the PCM will monitor the oxygen (O₂S) sensors input. This input indicates

DESCRIPTION AND OPERATION (Continued)

to the PCM whether or not the calculated injector pulse width results in the ideal air-fuel ratio. This ratio is 14.7 parts air-to-1 part fuel. By monitoring the exhaust oxygen content through the O₂S sensor, the PCM can fine tune the injector pulse width. This is done to achieve optimum fuel economy combined with low emission engine performance.

The fuel injection system has the following modes of operation:

- Ignition switch ON
- Engine start-up (crank)
- Engine warm-up
- Idle
- Cruise
- Acceleration
- Deceleration
- Wide open throttle (WOT)
- Ignition switch OFF

The ignition switch On, engine start-up (crank), engine warm-up, acceleration, deceleration and wide open throttle modes are Open Loop modes. The idle and cruise modes, (with the engine at operating temperature) are Closed Loop modes.

IGNITION SWITCH (KEY-ON) MODE

This is an Open Loop mode. When the fuel system is activated by the ignition switch, the following actions occur:

- The PCM pre-positions the idle air control (IAC) motor.
- The PCM determines atmospheric air pressure from the MAP sensor input to determine basic fuel strategy.
- The PCM monitors the engine coolant temperature sensor input. The PCM modifies fuel strategy based on this input.
- Intake manifold air temperature sensor input is monitored.
- Throttle position sensor (TPS) is monitored.
- The auto shutdown (ASD) relay is energized by the PCM for approximately three seconds.
- The fuel pump is energized through the fuel pump relay by the PCM. The fuel pump will operate for approximately three seconds unless the engine is operating or the starter motor is engaged.
- The O₂S sensor heater element is energized via the ASD relay. The O₂S sensor input is not used by the PCM to calibrate air-fuel ratio during this mode of operation.

ENGINE START-UP MODE

This is an Open Loop mode. The following actions occur when the starter motor is engaged.

The PCM receives inputs from:

- Battery voltage
- Engine coolant temperature sensor

- Crankshaft position sensor
- Intake manifold air temperature sensor
- Manifold absolute pressure (MAP) sensor
- Throttle position sensor (TPS)
- Camshaft position sensor signal

The PCM monitors the crankshaft position sensor. If the PCM does not receive a crankshaft position sensor signal within 3 seconds of cranking the engine, it will shut down the fuel injection system.

The fuel pump is activated by the PCM through the fuel pump relay.

Voltage is applied to the fuel injectors with the ASD relay via the PCM. The PCM will then control the injection sequence and injector pulse width by turning the ground circuit to each individual injector on and off.

The PCM determines the proper ignition timing according to input received from the crankshaft position sensor.

ENGINE WARM-UP MODE

This is an Open Loop mode. During engine warm-up, the PCM receives inputs from:

- Battery voltage
- Crankshaft position sensor
- Engine coolant temperature sensor
- Intake manifold air temperature sensor
- Manifold absolute pressure (MAP) sensor
- Throttle position sensor (TPS)
- Camshaft position sensor signal (in the distributor)
- Park/neutral switch (gear indicator signal—auto. trans. only)
- Air conditioning select signal (if equipped)
- Air conditioning request signal (if equipped)

Based on these inputs the following occurs:

- Voltage is applied to the fuel injectors with the ASD relay via the PCM. The PCM will then control the injection sequence and injector pulse width by turning the ground circuit to each individual injector on and off.
- The PCM adjusts engine idle speed through the idle air control (IAC) motor and adjusts ignition timing.
- The PCM operates the A/C compressor clutch through the A/C compressor clutch relay. This is done if A/C has been selected by the vehicle operator and specified pressures are met at the high and low-pressure A/C switches. Refer to Group 24, Heating and Air Conditioning for additional information.
- When engine has reached operating temperature, the PCM will begin monitoring O₂S sensor input. The system will then leave the warm-up mode and go into closed loop operation.

DESCRIPTION AND OPERATION (Continued)

IDLE MODE

When the engine is at operating temperature, this is a Closed Loop mode. At idle speed, the PCM receives inputs from:

- Air conditioning select signal (if equipped)
- Air conditioning request signal (if equipped)
- Battery voltage
- Crankshaft position sensor
- Engine coolant temperature sensor
- Extended idle switch (4.0L engine with police package only)
 - Intake manifold air temperature sensor
 - Manifold absolute pressure (MAP) sensor
 - Throttle position sensor (TPS)
- Camshaft position sensor signal (in the distributor)
 - Battery voltage
 - Park/neutral switch (gear indicator signal—auto. trans. only)
 - Oxygen sensors
 - Power steering pressure switch (2.5L engine only)

Based on these inputs, the following occurs:

- Voltage is applied to the fuel injectors with the ASD relay via the PCM. The PCM will then control injection sequence and injector pulse width by turning the ground circuit to each individual injector on and off.
- The PCM monitors the O2S sensor input and adjusts air-fuel ratio by varying injector pulse width. It also adjusts engine idle speed through the idle air control (IAC) motor.
- The PCM adjusts ignition timing by increasing and decreasing spark advance.
- The PCM operates the A/C compressor clutch through the A/C compressor clutch relay. This is done if A/C has been selected by the vehicle operator and specified pressures are met at the high and low-pressure A/C switches. Refer to Group 24, Heating and Air Conditioning for additional information.

The optional Extended Idle Switch is used to raise and hold the engine idle speed to approximately 1000 rpm. This is when the shifter is in either the Park or Neutral position and throttle pedal is not used. A rocker-type switch (extended idle switch) is mounted to the instrument panel. This switch will supply a ground circuit (input) to the PCM. **The switch is available only with 4.0L engine when supplied with optional police package.**

On 2.5L 4-cylinder engines, a power steering pressure switch is used to supply an input to the PCM when steering pump pressure is high. This will raise engine speed. Refer to Power Steering Pressure Switch in this group for additional information. **The 4.0L 6-cylinder engine does not use this switch.**

CRUISE MODE

When the engine is at operating temperature, this is a Closed Loop mode. At cruising speed, the PCM receives inputs from:

- Air conditioning select signal (if equipped)
- Air conditioning request signal (if equipped)
- Battery voltage
- Engine coolant temperature sensor
- Crankshaft position sensor
- Intake manifold air temperature sensor
- Manifold absolute pressure (MAP) sensor
- Throttle position sensor (TPS)
- Camshaft position sensor signal (in the distributor)
 - Park/neutral switch (gear indicator signal—auto. trans. only)
 - Oxygen (O2S) sensors

Based on these inputs, the following occurs:

- Voltage is applied to the fuel injectors with the ASD relay via the PCM. The PCM will then adjust the injector pulse width by turning the ground circuit to each individual injector on and off.
- The PCM monitors the O2S sensor input and adjusts air-fuel ratio. It also adjusts engine idle speed through the idle air control (IAC) motor.
- The PCM adjusts ignition timing by turning the ground path to the coil on and off.
- The PCM operates the A/C compressor clutch through the clutch relay. This happens if A/C has been selected by the vehicle operator and requested by the A/C thermostat.

ACCELERATION MODE

This is an Open Loop mode. The PCM recognizes an abrupt increase in throttle position or MAP pressure as a demand for increased engine output and vehicle acceleration. The PCM increases injector pulse width in response to increased throttle opening.

DECELERATION MODE

When the engine is at operating temperature, this is an Open Loop mode. During hard deceleration, the PCM receives the following inputs.

- Air conditioning select signal (if equipped)
- Air conditioning request signal (if equipped)
- Battery voltage
- Engine coolant temperature sensor
- Crankshaft position sensor
- Intake manifold air temperature sensor
- Manifold absolute pressure (MAP) sensor
- Throttle position sensor (TPS)
- Camshaft position sensor signal (in the distributor)
 - Park/neutral switch (gear indicator signal—auto. trans. only)
 - Vehicle speed sensor

DESCRIPTION AND OPERATION (Continued)

If the vehicle is under hard deceleration with the proper rpm and closed throttle conditions, the PCM will ignore the oxygen sensor input signal. The PCM will enter a fuel cut-off strategy in which it will not supply a ground to the injectors. If a hard deceleration does not exist, the PCM will determine the proper injector pulse width and continue injection.

Based on the above inputs, the PCM will adjust engine idle speed through the idle air control (IAC) motor.

The PCM adjusts ignition timing by turning the ground path to the coil on and off.

WIDE OPEN THROTTLE MODE

This is an Open Loop mode. During wide open throttle operation, the PCM receives the following inputs.

- Battery voltage
- Crankshaft position sensor
- Engine coolant temperature sensor
- Intake manifold air temperature sensor
- Manifold absolute pressure (MAP) sensor
- Throttle position sensor (TPS)
- Camshaft position sensor signal (in the distributor)

During wide open throttle conditions, the following occurs:

- Voltage is applied to the fuel injectors with the ASD relay via the PCM. The PCM will then control the injection sequence and injector pulse width by turning the ground circuit to each individual injector on and off. The PCM ignores the oxygen sensor input signal and provides a predetermined amount of additional fuel. This is done by adjusting injector pulse width.

- The PCM adjusts ignition timing by turning the ground path to the coil on and off.

IGNITION SWITCH OFF MODE

When ignition switch is turned to OFF position, the PCM stops operating the injectors, ignition coil, ASD relay and fuel pump relay.

AUTOMATIC SHUTDOWN (ASD) RELAY SENSE—PCM INPUT**DESCRIPTION**

The ASD relay is located in the Power Distribution Center (PDC). The PDC is located in the engine compartment. Refer to label on PDC cover for relay location.

OPERATION

A 12 volt signal at this input indicates to the PCM that the ASD has been activated. The relay is used to

connect the oxygen sensor heater element, ignition coil and fuel injectors to 12 volt + power supply.

This input is used only to sense that the ASD relay is energized. If the powertrain control module (PCM) does not see 12 volts at this input when the ASD should be activated, it will set a diagnostic trouble code (DTC).

BATTERY VOLTAGE—PCM INPUT**OPERATION**

The battery voltage input provides power to the Powertrain Control Module (PCM). It also informs the PCM what voltage level is supplied to the ignition coil and fuel injectors.

If battery voltage is low, the PCM will increase injector pulse width (period of time that the injector is energized). This is done to compensate for the reduced flow through injector caused by the lowered voltage.

BRAKE SWITCH—PCM INPUT**OPERATION**

When the brake light switch is activated, the Powertrain Control Module (PCM) receives an input indicating that the brakes are being applied. After receiving this input, the PCM maintains idle speed to a scheduled rpm through control of the Idle Air Control (IAC) motor. The brake switch input is also used to disable vent and vacuum solenoid output signals to the speed control servo.

FIVE VOLT SENSOR SUPPLIES—PRIMARY AND SECONDARY**DESCRIPTION**

Two different Powertrain Control Module (PCM) five volt supply circuits are used; primary and secondary.

OPERATION

These 2 circuits will:

- supply the required 5 volt power source to the Crankshaft Position (CKP) sensor.
- supply the required 5 volt power source to the Camshaft Position (CMP) sensor.
- supply a reference voltage for the Manifold Absolute Pressure (MAP) sensor.
- supply a reference voltage for the Throttle Position Sensor (TPS) sensor.
- supply the required 5 volt power source to the oil pressure sensor.
- supply the required 5 volt power source for the Vehicle Speed Sensor (VSS) (if equipped).

DESCRIPTION AND OPERATION (Continued)

- supply the 5 volt power source to the transmission pressure sensor (if equipped with an RE automatic transmission).

FUEL LEVEL SENSOR—PCM INPUT**DESCRIPTION**

The fuel level sensor (fuel gauge sending unit) is located on the fuel pump module.

OPERATION

Refer to Fuel Gauge Sending Unit in the Fuel Delivery section for information.

ENGINE COOLANT TEMPERATURE SENSOR—PCM INPUT**DESCRIPTION**

The Engine Coolant Temperature (ECT) sensor is used to sense engine coolant temperature. The sensor protrudes into an engine water jacket.

The ECT sensor is a two-wire Negative Thermal Coefficient (NTC) sensor. Meaning, as engine coolant temperature increases, resistance (voltage) in the sensor decreases. As temperature decreases, resistance (voltage) in the sensor increases.

OPERATION

At key-on, the Powertrain Control Module (PCM) sends out a regulated 5 volt signal to the ECT sensor. The PCM then monitors the signal as it passes through the ECT sensor to the sensor ground (sensor return).

When the engine is cold, the PCM will operate in Open Loop cycle. It will demand slightly richer air-fuel mixtures and higher idle speeds. This is done until normal operating temperatures are reached.

The PCM uses inputs from the ECT sensor for the following calculations:

- for engine coolant temperature gauge operation through CCD or PCI (J1850) communications
- Injector pulse-width
- Spark-advance curves
- ASD relay shut-down times
- Idle Air Control (IAC) motor key-on steps
- Pulse-width prime-shot during cranking
- O2 sensor closed loop times
- Purge solenoid on/off times
- EGR solenoid on/off times (if equipped)
- Leak Detection Pump operation (if equipped)
- Radiator fan relay on/off times (if equipped)
- Target idle speed

EXTENDED IDLE SWITCH—PCM INPUT**DESCRIPTION**

USED ONLY WITH OPTIONAL POLICE PACKAGE WHEN EQUIPPED WITH A 4.0L ENGINE: The extended idle switch is a rocker-type switch mounted to the instrument panel.

OPERATION

The extended idle switch is used to raise the engine idle speed to approximately 1000 rpm by supplying a ground circuit to the Powertrain Control Module (PCM). This idle speed control can only be operated when the shifter is in either the Park or Neutral position.

OXYGEN SENSOR—PCM INPUT**DESCRIPTION**

The Oxygen Sensors (O2S) are attached to, and protrude into the vehicle exhaust system. Depending on the emission package, the vehicle may contain either 2 or 4 sensors. On non-California emissions packages, 2 sensors are used: upstream (referred to as 1/1) and downstream (referred to as 1/2). On California emissions packages, 4 sensors are used: 2 upstream (referred to as 1/1 and 2/1) and 2 downstream (referred to as 1/2 and 2/2).

OPERATION

An O2 sensor is a galvanic battery that provides the PCM with a voltage signal (0-1 volt) inversely proportional to the amount of oxygen in the exhaust. In other words, if the oxygen content is low, the voltage output is high; if the oxygen content is high the output voltage is low. The PCM uses this information to adjust injector pulse-width to achieve the 14.7-to-1 air/fuel ratio necessary for proper engine operation and to control emissions.

An O2 sensor must have a source of oxygen from outside of the exhaust stream for comparison. Current O2 sensors receive their fresh oxygen (outside air) supply through the wire harness. This is why it is important to never solder an O2 sensor connector, or pack the connector with grease.

Four wires (circuits) are used on each O2 sensor: a 12-volt feed circuit for the sensor heating element; a ground circuit for the heater element; a low-noise sensor return circuit to the PCM, and an input circuit from the sensor back to the PCM to detect sensor operation.

Oxygen Sensor Heaters/Heater Relays: On a certain non-California emission package, the heaters on both sensors are fed battery voltage from the ASD relay which is controlled by the PCM. Refer to ASD relay for more information. On another non-Califor-

DESCRIPTION AND OPERATION (Continued)

nia emission package, the heaters on both sensors are fed battery voltage from the two O₂S heater relays. The O₂S relays are also controlled by the PCM. On the California emission package, the heaters on all 4 sensors are fed battery voltage from the two O₂S Heater Relays.

The O₂ sensor uses a Positive Thermal Co-efficient (PTC) heater element. As temperature increases, resistance increases. At ambient temperatures around 70°F, the resistance of the heating element is approximately 6 ohms. As the sensor's temperature increases, resistance in the heater element increases. This allows the heater to maintain the optimum operating temperature of approximately 930°-1100°F (500°-600° C). Although the sensors operate the same, there are physical differences, due to the environment that they operate in, that keep them from being interchangeable.

Maintaining correct sensor temperature at all times allows the system to enter into closed loop operation sooner. Also, it allows the system to remain in closed loop operation during periods of extended idle.

In Closed Loop operation, the PCM monitors certain O₂ sensor input(s) along with other inputs, and adjusts the injector pulse width accordingly. During Open Loop operation, the PCM ignores the O₂ sensor input. The PCM adjusts injector pulse width based on preprogrammed (fixed) values and inputs from other sensors.

Upstream Sensor (Non-California Emissions): The upstream O₂S sensor (1/1 sensor) is located in the exhaust downpipe before the catalytic convertor. It provides an input voltage to the PCM. The input tells the PCM the oxygen content of the exhaust gas. The PCM uses this information to fine tune fuel delivery to maintain the correct oxygen content at the downstream oxygen sensor. The PCM will change the air/fuel ratio until the upstream sensor inputs a voltage that the PCM has determined will make the downstream sensor output (oxygen content) correct.

The upstream oxygen sensor also provides an input to determine catalyst efficiency.

Downstream Sensor (Non-California Emissions): The downstream heated oxygen sensor (1/2 sensor) is located near the outlet end of the catalytic convertor. The downstream sensor is also used to determine the correct air fuel ratio. As the oxygen content changes at the downstream the PCM calculates how much air fuel ratio change is required. The PCM then looks at the upstream oxygen sensor voltage and changes fuel delivery until the upstream sensor voltage changes enough to correct the downstream sensor voltage (oxygen content).

The downstream oxygen sensor also provides an input to determine catalyst efficiency.

Upstream Sensors (California Emissions): Two upstream sensors are used (1/1 and 2/1). The 1/1 sensor is the first sensor to receive exhaust gases from the #1 cylinder. Both of the upstream O₂S sensors are located in the exhaust manifold just before the mini-catalytic convertors. They provide an input voltage to the PCM. The input tells the PCM the oxygen content of the exhaust gas. The PCM uses this information to fine tune fuel delivery to maintain the correct oxygen content at the downstream oxygen sensors. The PCM will change the air/fuel ratio until the upstream sensors input a voltage that the PCM has determined will make the downstream sensors output (oxygen content) correct.

The upstream oxygen sensors also provide an input to determine mini-catalyst efficiency.

Downstream Sensors (California Emissions): Two downstream sensors are used (1/2 and 2/2). The downstream sensors are located in the exhaust downpipes just after the mini-catalytic convertors. The downstream is also used to determine the correct air fuel ratio. As the oxygen content changes at the downstream the PCM calculates how much air fuel ratio change is required. The PCM then looks at the upstream oxygen sensor voltage and changes fuel delivery until the upstream sensor voltage changes enough to correct the downstream sensor voltage (oxygen content).

The downstream oxygen sensors also provide an input to determine mini-catalyst efficiency.

IGNITION CIRCUIT SENSE—PCM INPUT

DESCRIPTION

This circuit ties the ignition switch to the Powertrain Control Module (PCM).

OPERATION

The ignition circuit sense input tells the PCM the ignition switch has energized the ignition circuit.

Battery voltage is also supplied to the PCM through the ignition switch when the ignition is in the RUN or START position. This is referred to as the "ignition sense" circuit and is used to "wake up" the PCM. Voltage on the ignition input can be as low as 6 volts and the PCM will still function. Voltage is supplied to this circuit to power the PCM's 8-volt regulator and to allow the PCM to perform fuel, ignition and emissions control functions. The battery voltage on this line is supplied to the 8-volt regulator which then passes on a power-up supply to the 5-volt regulator.

DESCRIPTION AND OPERATION (Continued)

INTAKE MANIFOLD AIR TEMPERATURE SENSOR—PCM INPUT**DESCRIPTION**

The 2-wire Intake Manifold Air Temperature (IAT) sensor is installed in the intake manifold with the sensor element extending into the air stream.

The IAT sensor is a two-wire Negative Thermal Coefficient (NTC) sensor. Meaning, as intake manifold temperature increases, resistance (voltage) in the sensor decreases. As temperature decreases, resistance (voltage) in the sensor increases.

OPERATION

The IAT sensor provides an input voltage to the Powertrain Control Module (PCM) indicating the density of the air entering the intake manifold based upon intake manifold temperature. At key-on, a 5-volt power circuit is supplied to the sensor from the PCM. The sensor is grounded at the PCM through a low-noise, sensor-return circuit.

The PCM uses this input to calculate the following:

- Injector pulse-width
- Adjustment of spark timing (to help prevent spark knock with high intake manifold air-charge temperatures)

The resistance values of the IAT sensor is the same as for the Engine Coolant Temperature (ECT) sensor.

MANIFOLD ABSOLUTE PRESSURE (MAP) SENSOR—PCM INPUT**DESCRIPTION**

The Manifold Absolute Pressure (MAP) sensor is attached to the side of the engine throttle body with 2 screws. The sensor is connected to the throttle body with a rubber L-shaped fitting.

OPERATION

The MAP sensor is used as an input to the Powertrain Control Module (PCM). It contains a silicon based sensing unit to provide data on the manifold vacuum that draws the air/fuel mixture into the combustion chamber. The PCM requires this information to determine injector pulse width and spark advance. When manifold absolute pressure (MAP) equals Barometric pressure, the pulse width will be at maximum.

A 5 volt reference is supplied from the PCM and returns a voltage signal to the PCM that reflects manifold pressure. The zero pressure reading is 0.5V and full scale is 4.5V. For a pressure swing of 0–15 psi, the voltage changes 4.0V. To operate the sensor, it is supplied a regulated 4.8 to 5.1 volts. Ground is provided through the low-noise, sensor return circuit at the PCM.

The MAP sensor input is the number one contributor to fuel injector pulse width. The most important function of the MAP sensor is to determine barometric pressure. The PCM needs to know if the vehicle is at sea level or at a higher altitude, because the air density changes with altitude. It will also help to correct for varying barometric pressure. Barometric pressure and altitude have a direct inverse correlation; as altitude goes up, barometric goes down. At key-on, the PCM powers up and looks at MAP voltage, and based upon the voltage it sees, it knows the current barometric pressure (relative to altitude). Once the engine starts, the PCM looks at the voltage again, continuously every 12 milliseconds, and compares the current voltage to what it was at key-on. The difference between current voltage and what it was at key-on, is manifold vacuum.

During key-on (engine not running) the sensor reads (updates) barometric pressure. A normal range can be obtained by monitoring a known good sensor.

As the altitude increases, the air becomes thinner (less oxygen). If a vehicle is started and driven to a very different altitude than where it was at key-on, the barometric pressure needs to be updated. Any time the PCM sees Wide Open Throttle (WOT), based upon Throttle Position Sensor (TPS) angle and RPM, it will update barometric pressure in the MAP memory cell. With periodic updates, the PCM can make its calculations more effectively.

The PCM uses the MAP sensor input to aid in calculating the following:

- Manifold pressure
- Barometric pressure
- Engine load
- Injector pulse-width
- Spark-advance programs
- Shift-point strategies (certain automatic transmissions only)
 - Idle speed
 - Decel fuel shutoff

The MAP sensor signal is provided from a single piezoresistive element located in the center of a diaphragm. The element and diaphragm are both made of silicone. As manifold pressure changes, the diaphragm moves causing the element to deflect, which stresses the silicone. When silicone is exposed to stress, its resistance changes. As manifold vacuum increases, the MAP sensor input voltage decreases proportionally. The sensor also contains electronics that condition the signal and provide temperature compensation.

The PCM recognizes a decrease in manifold pressure by monitoring a decrease in voltage from the reading stored in the barometric pressure memory cell. The MAP sensor is a linear sensor; meaning as pressure changes, voltage changes proportionately.

DESCRIPTION AND OPERATION (Continued)

The range of voltage output from the sensor is usually between 4.6 volts at sea level to as low as 0.3 volts at 26 in. of Hg. Barometric pressure is the pressure exerted by the atmosphere upon an object. At sea level on a standard day, no storm, barometric pressure is approximately 29.92 in Hg. For every 100 feet of altitude, barometric pressure drops .10 in. Hg. If a storm goes through it can change barometric pressure from what should be present for that altitude. You should know what the average pressure and corresponding barometric pressure is for your area.

OIL PRESSURE SENSOR—PCM INPUT**DESCRIPTION**

The 3-wire, solid-state engine oil pressure sensor (sending unit) is located in an engine oil pressure gallery.

OPERATION

The oil pressure sensor uses three circuits. They are:

- A 5-volt power supply from the Powertrain Control Module (PCM)
- A sensor ground through the PCM's sensor return
- A signal to the PCM relating to engine oil pressure

The oil pressure sensor has a 3-wire electrical function very much like the Manifold Absolute Pressure (MAP) sensor. Meaning different pressures relate to different output voltages.

A 5-volt supply is sent to the sensor from the PCM to power up the sensor. The sensor returns a voltage signal back to the PCM relating to engine oil pressure. This signal is then transferred (bussed) to the instrument panel on either a CCD or PCI bus circuit (depending on vehicle line) to operate the oil pressure gauge and the check gauges lamp. Ground for the sensor is provided by the PCM through a low-noise sensor return.

POWER GROUNDS**OPERATION**

The Powertrain Control Module (PCM) has 2 main grounds. Both of these grounds are referred to as power grounds. All of the high-current, noisy, electrical devices are connected to these grounds as well as all of the sensor returns. The sensor return comes into the sensor return circuit, passes through noise suppression, and is then connected to the power ground.

The power ground is used to control ground circuits for the following PCM loads:

- Generator field winding
- Fuel injectors
- Ignition coil(s)
- Certain relays/solenoids
- Certain sensors

POWER STEERING PRESSURE SWITCH—PCM INPUT**DESCRIPTION**

A pressure sensing switch (Fig. 2) is included in the power steering system (mounted on the high-pressure line). This switch will be used only on vehicles equipped with a 2.5L engine and power steering.

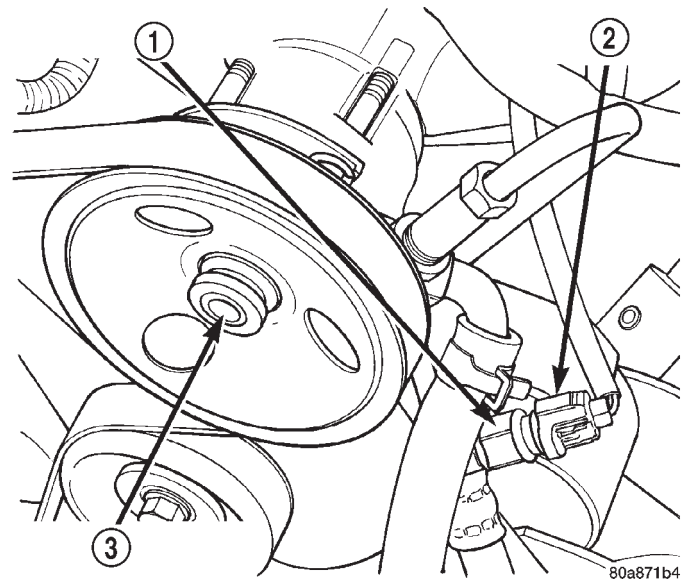

Fig. 2 Power Steering Pump Pressure Switch—2.5L Engine

- 1 - POWER STEERING PRESSURE SWITCH
- 2 - ELECTRICAL CONNECTOR
- 3 - POWER STEERING PUMP

OPERATION

The power steering pressure switch provides an input to the Powertrain Control Module (PCM). This input is provided during periods of high pump load and low engine rpm; such as during parking maneuvers. The PCM will then increase the idle speed through the Idle Air Control (IAC) motor. This is done to prevent the engine from stalling under the increased load.

When steering pump pressure exceeds 3275 kPa \pm 690 kPa (475 psi \pm 100 psi), the normally closed switch will open and the PCM will increase the engine idle speed. This will prevent the engine from stalling.

DESCRIPTION AND OPERATION (Continued)

When pump pressure drops to approximately 1379 kPa (200 psi), the switch circuit will re-close and engine idle speed will return to its previous setting.

SENSOR RETURN—PCM INPUT**OPERATION**

The Sensor Return circuits are internal to the Powertrain Control Module (PCM).

Sensor Return provides a low-noise ground reference for all engine control system sensors. Refer to Power Grounds for more information.

THROTTLE POSITION SENSOR (TPS)—PCM INPUT**DESCRIPTION**

The 3-wire Throttle Position Sensor (TPS) is mounted on the throttle body and is connected to the throttle blade.

OPERATION

The TPS is a 3-wire variable resistor that provides the Powertrain Control Module (PCM) with an input signal (voltage) that represents the throttle blade position of the throttle body. The sensor is connected to the throttle blade shaft. As the position of the throttle blade changes, the resistance (output voltage) of the TPS changes.

The PCM supplies approximately 5 volts to the TPS. The TPS output voltage (input signal to the PCM) represents the throttle blade position. The PCM receives an input signal voltage from the TPS. This will vary in an approximate range of from 2.6 volts at minimum throttle opening (idle), to 4.49 volts at wide open throttle. Along with inputs from other sensors, the PCM uses the TPS input to determine current engine operating conditions. In response to engine operating conditions, the PCM will adjust fuel injector pulse width and ignition timing.

The PCM needs to identify the actions and position of the throttle blade at all times. This information is needed to assist in performing the following calculations:

- Ignition timing advance
- Fuel injection pulse-width
- Idle (learned value or minimum TPS)
- Off-idle (0.06 volt)
- Wide Open Throttle (WOT) open loop (2.608 volts above learned idle voltage)
 - Deceleration fuel lean out
 - Fuel cutoff during cranking at WOT (2.608 volts above learned idle voltage)
 - A/C WOT cutoff (certain automatic transmissions only)

VEHICLE SPEED AND DISTANCE SENSOR—PCM INPUT**DESCRIPTION**

The 3-wire Vehicle Speed Sensor (VSS) is located on the speedometer pinion gear adapter. If equipped with 4WD, this adapter is located on the extension housing of the transfer case (drivers side). If equipped with 2WD, this adapter is located on the left side of the transmission extension housing.

OPERATION

The VSS is a 3-circuit (3-wire), magnetic, hall-effect sensor.

The 3 circuits are:

- A 5-volt power supply from the Powertrain Control Module (PCM).
- A ground is provided for the sensor though a low-noise sensor return circuit in the PCM.
- An input to the PCM is used to determine vehicle speed and distance traveled.

The speed sensor generates 8 pulses per sensor revolution. These signals, in conjunction with a closed throttle signal from the throttle position sensor, indicate a closed throttle deceleration to the PCM. When the vehicle is stopped at idle, a closed throttle signal is received by the PCM (but a speed sensor signal is not received).

Under deceleration conditions, the PCM adjusts the Idle Air Control (IAC) motor to maintain a desired MAP value. Under idle conditions, the PCM adjusts the IAC motor to maintain a desired engine speed.

AUTO SHUTDOWN (ASD) RELAY—PCM OUTPUT**DESCRIPTION**

The 5-pin, 12-volt, Automatic Shutdown (ASD) relay is located in the Power Distribution Center (PDC). Refer to label on PDC cover for relay location.

OPERATION

The ASD relay supplies battery voltage (12+ volts) to the fuel injectors and ignition coil(s). With certain emissions packages it also supplies 12-volts to the oxygen sensor heating elements.

The ground circuit for the coil within the ASD relay is controlled by the Powertrain Control Module (PCM). The PCM operates the ASD relay by switching its ground circuit on and off.

The ASD relay will be shut-down, meaning the 12-volt power supply to the ASD relay will be deactivated by the PCM if:

DESCRIPTION AND OPERATION (Continued)

- the ignition key is left in the ON position. This is if the engine has not been running for approximately 1.8 seconds.

- there is a crankshaft position sensor signal to the PCM that is lower than pre-determined values.

The PCM will sense if or when the ASD relay has been activated through a “sense circuit”. Refer to Automatic Shut-Down (ASD) Relay Sense-PCM Input for additional information.

CCD BUS (+/-) CIRCUITS-PCM OUTPUTS**OPERATION**

The Powertrain Control Module (PCM) sends certain output signals through the CCD bus circuits. These signals are used to control certain instrument panel located items and to determine certain identification numbers.

Refer to Group 8E, Instrument Panel and Gauges for additional information.

DATA LINK CONNECTOR—PCM INPUT AND OUTPUT**DESCRIPTION**

The data link connector is located at the lower edge of the instrument panel near the steering column.

OPERATION

The 16-way data link connector (diagnostic scan tool connector) links the Diagnostic Readout Box (DRB) scan tool or the Mopar Diagnostic System (MDS) with the Powertrain Control Module (PCM).

FUEL INJECTORS—PCM OUTPUT**DESCRIPTION**

The fuel injectors are connected to the engine with the fuel injector rail.

OPERATION

The nozzle ends of the injectors are positioned into openings in the intake manifold just above the intake valve ports of the cylinder head. The engine wiring harness connector for each fuel injector is equipped with an attached numerical tag (INJ 1, INJ 2 etc.). This is used to identify each fuel injector with its respective cylinder number.

The injectors are energized individually in a sequential order by the Powertrain Control Module (PCM). The PCM will adjust injector pulse width by switching the ground path to each individual injector on and off. Injector pulse width is the period of time that the injector is energized. The PCM will adjust

injector pulse width based on various inputs it receives.

Battery voltage (12 volts +) is supplied to the injectors through the ASD relay. The ASD relay will shut-down the 12 volt power source to the fuel injectors if the PCM senses the ignition is on, but the engine is not running. This occurs after the engine has not been running for approximately 1.8 seconds.

The PCM determines injector on-time (pulse width) based on various inputs.

FUEL PUMP RELAY-PCM OUTPUT**DESCRIPTION**

The 5-pin, 12-volt, fuel pump relay is located in the Power Distribution Center (PDC). Refer to the label on the PDC cover for relay location.

OPERATION

The Powertrain Control Module (PCM) energizes the electric fuel pump through the fuel pump relay. The fuel pump relay is energized by first applying battery voltage to it when the ignition key is turned ON, and then applying a ground signal to the relay from the PCM.

Whenever the ignition key is turned ON, the electric fuel pump will operate. But, the PCM will shut-down the ground circuit to the fuel pump relay in approximately 1–3 seconds unless the engine is operating or the starter motor is engaged.

IDLE AIR CONTROL (IAC) MOTOR—PCM OUTPUT**DESCRIPTION**

The IAC stepper motor is mounted to the throttle body, and regulates the amount of air bypassing the control of the throttle plate. As engine loads and ambient temperatures change, engine rpm changes. A pintle on the IAC stepper motor protrudes into a passage in the throttle body, controlling air flow through the passage. The IAC is controlled by the Powertrain Control Module (PCM) to maintain the target engine idle speed.

OPERATION

At idle, engine speed can be increased by retracting the IAC motor pintle and allowing more air to pass through the port, or it can be decreased by restricting the passage with the pintle and diminishing the amount of air bypassing the throttle plate.

The IAC is called a stepper motor because it is moved (rotated) in steps, or increments. Opening the IAC opens an air passage around the throttle blade which increases RPM.

DESCRIPTION AND OPERATION (Continued)

The PCM uses the IAC motor to control idle speed (along with timing) and to reach a desired MAP during decel (keep engine from stalling).

The IAC motor has 4 wires with 4 circuits. Two of the wires are for 12 volts and ground to supply electrical current to the motor windings to operate the stepper motor in one direction. The other 2 wires are also for 12 volts and ground to supply electrical current to operate the stepper motor in the opposite direction.

To make the IAC go in the opposite direction, the PCM just reverses polarity on both windings. If only 1 wire is open, the IAC can only be moved 1 step (increment) in either direction. To keep the IAC motor in position when no movement is needed, the PCM will energize both windings at the same time. This locks the IAC motor in place.

In the IAC motor system, the PCM will count every step that the motor is moved. This allows the PCM to determine the motor pintle position. If the memory is cleared, the PCM no longer knows the position of the pintle. So at the first key ON, the PCM drives the IAC motor closed, regardless of where it was before. This zeros the counter. From this point the PCM will back out the IAC motor and keep track of its position again.

When engine rpm is above idle speed, the IAC is used for the following:

- Off-idle dashpot (throttle blade will close quickly but idle speed will not stop quickly)
- Deceleration air flow control
- A/C compressor load control (also opens the passage slightly before the compressor is engaged so that the engine rpm does not dip down when the compressor engages)
- Power steering load control

The PCM can control polarity of the circuit to control direction of the stepper motor.

IAC Stepper Motor Program: The PCM is also equipped with a memory program that records the number of steps the IAC stepper motor most recently advanced to during a certain set of parameters. For example: The PCM was attempting to maintain a 1000 rpm target during a cold start-up cycle. The last recorded number of steps for that may have been 125. That value would be recorded in the memory cell so that the next time the PCM recognizes the identical conditions, the PCM recalls that 125 steps were required to maintain the target. This program allows for greater customer satisfaction due to greater control of engine idle.

Another function of the memory program, which occurs when the power steering switch (if equipped), or the A/C request circuit, requires that the IAC stepper motor control engine rpm, is the recording of the last targeted steps into the memory cell. The PCM

can anticipate A/C compressor loads. This is accomplished by delaying compressor operation for approximately 0.5 seconds until the PCM moves the IAC stepper motor to the recorded steps that were loaded into the memory cell. Using this program helps eliminate idle-quality changes as loads change. Finally, the PCM incorporates a "No-Load" engine speed limiter of approximately 1800 - 2000 rpm, when it recognizes that the TPS is indicating an idle signal and IAC motor cannot maintain engine idle.

A (factory adjusted) set screw is used to mechanically limit the position of the throttle body throttle plate. **Never attempt to adjust the engine idle speed using this screw.** All idle speed functions are controlled by the IAC motor through the PCM.

RADIATOR FAN RELAY—PCM OUTPUT

DESCRIPTION

The electric radiator cooling fan relay is located in the Power Distribution Center (PDC).

OPERATION

An electric radiator cooling fan is used with certain models/engines. It is controlled by the Powertrain Control Module (PCM) through the radiator fan relay. **Not Equipped With A/C:** The relay is energized when coolant temperature is above 103°C (217°F). It will then de-energize when coolant temperature drops to 98°C (208°F). Refer to Cooling Systems for additional information. **Equipped With A/C:** In addition to using coolant temperatures to control cooling fan operation, a two-gang A/C high-pressure switch is also used to control cooling fan operation. When equipped with this high-pressure switch, the cooling fan **will not operate** each time the A/C clutch is engaged. Refer to Heating and Air Conditioning for additional information.

THROTTLE BODY

DESCRIPTION

The throttle body is located on the intake manifold. Fuel does not enter the intake manifold through the throttle body. Fuel is sprayed into the manifold by the fuel injectors.

OPERATION

Filtered air from the air cleaner enters the intake manifold through the throttle body. The throttle body contains an air control passage controlled by an Idle Air Control (IAC) motor. The air control passage is used to supply air for idle conditions. A throttle valve (plate) is used to supply air for above idle conditions.

Certain sensors are attached to the throttle body. The accelerator pedal cable, speed control cable and

DESCRIPTION AND OPERATION (Continued)

transmission control cable (when equipped) are connected to the throttle body linkage arm.

A (factory adjusted) set screw is used to mechanically limit the position of the throttle body throttle plate. **Never attempt to adjust the engine idle speed using this screw.** All idle speed functions are controlled by the PCM.

DIAGNOSIS AND TESTING

VISUAL INSPECTION

A visual inspection for loose, disconnected or incorrectly routed wires and hoses should be made. This should be done before attempting to diagnose or service the fuel injection system. A visual check will help spot these faults and save unnecessary test and diagnostic time. A thorough visual inspection will include the following checks:

(1) Verify the three 32-way electrical connectors are fully inserted into the connector of the Powertrain Control Module (PCM) (Fig. 3).

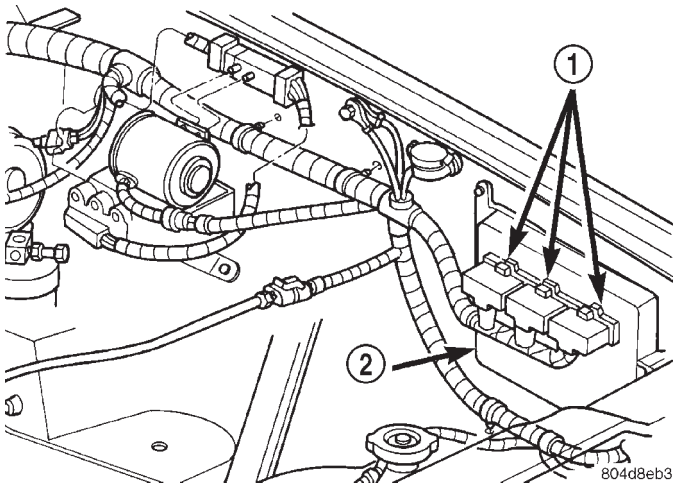

Fig. 3 Powertrain Control Module (PCM)

- 1 - (3) 32-WAY CONNECTORS
- 2 - PCM

(2) Inspect battery cable connections. Be sure they are clean and tight.

(3) Inspect fuel pump relay and air conditioning compressor clutch relay (if equipped). Inspect ASD relay connections. Inspect starter motor relay connections. Inspect relays for signs of physical damage and corrosion. The relays are located in Power Distribution Center (PDC) (Fig. 4). Refer to label on PDC cover for relay location.

(4) 2.5L Engine: Inspect ignition coil primary connection. Verify coil secondary cable is firmly connected to coil (Fig. 5).

(5) 4.0L Engine: Inspect ignition coil connection (Fig. 6).

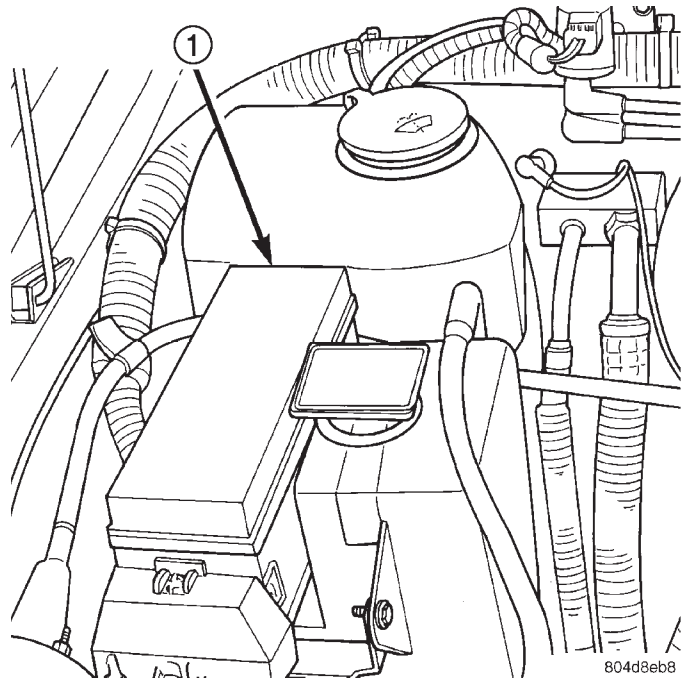

Fig. 4 Power Distribution Center (PDC)

- 1 - POWER DISTRIBUTION CENTER (PDC)

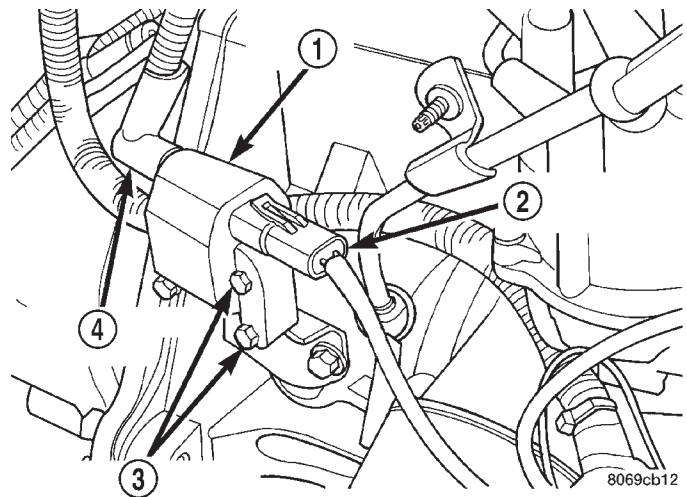

Fig. 5 Ignition Coil—2.5L Engine

- 1 - IGNITION COIL
- 2 - ELECTRICAL CONNECTOR
- 3 - MOUNTING BOLTS
- 4 - SECONDARY CABLE

(6) 2.5L Engine: Verify that distributor cap is correctly attached to distributor. Be sure that spark plug cables are firmly connected to the distributor cap and spark plugs are in their correct firing order. Be sure that coil cable is firmly connected to distributor cap and coil.

DIAGNOSIS AND TESTING (Continued)

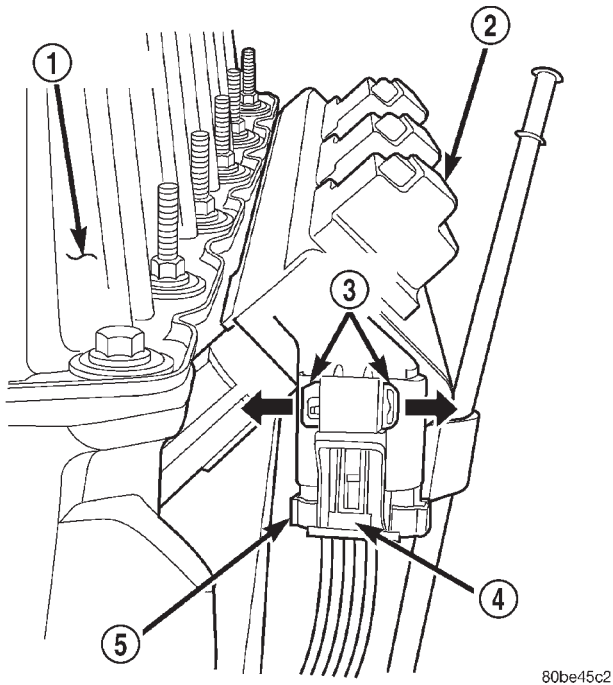

Fig. 6 Ignition Coil—4.0L Engine

- 1 - REAR OF VALVE COVER
- 2 - COIL RAIL
- 3 - SLIDE TAB
- 4 - RELEASE LOCK
- 5 - COIL CONNECTOR

(7) Connect vehicle to an oscilloscope and inspect spark events for fouled or damaged spark plugs or cables.

(8) Verify generator output wire, generator connector and ground wire are firmly connected to generator.

(9) Inspect system body grounds for loose or dirty connections. Refer to Group 8, Wiring for ground locations.

(10) Verify crankcase ventilation (CCV) operation. Refer to Group 25, Emission Control System for additional information.

(11) Inspect fuel tube quick-connect fitting-to-fuel rail connections.

(12) Verify hose connections to all ports of vacuum fittings on intake manifold are tight and not leaking.

(13) Inspect accelerator cable, transmission throttle cable (if equipped) and cruise control cable connections (if equipped). Check their connections to throttle arm of throttle body for any binding or restrictions.

(14) If equipped with vacuum brake booster, verify vacuum booster hose is firmly connected to fitting on

intake manifold. Also check connection to brake vacuum booster.

(15) Inspect air cleaner inlet and air cleaner element for dirt or restrictions.

(16) Inspect radiator grille area, radiator fins and air conditioning condenser for restrictions.

(17) Verify intake manifold air temperature sensor wire connector is firmly connected to harness connector (Fig. 7) or (Fig. 8).

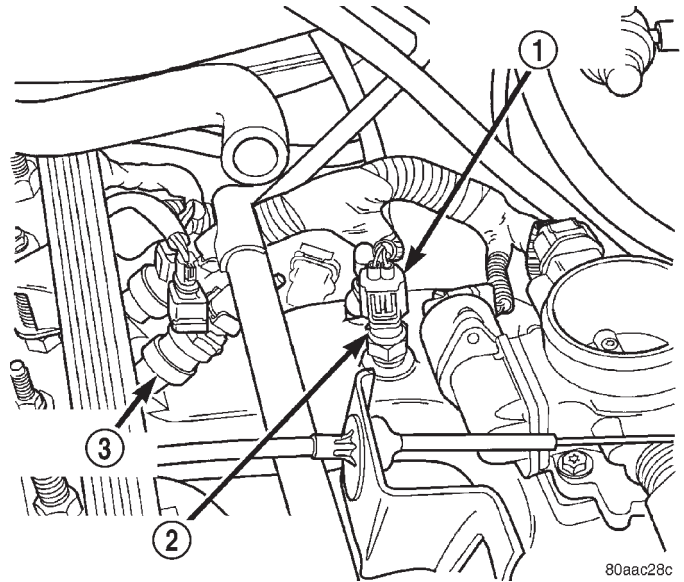

Fig. 7 Intake Manifold Air Temp. Sensor Location—2.5L Engine

- 1 - ELECTRICAL CONNECTOR
- 2 - INTAKE MANIFOLD TEMPERATURE SENSOR
- 3 - FUEL INJECTOR

(18) Verify MAP sensor electrical connector is firmly connected to MAP sensor (Fig. 8). Also verify rubber L-shaped fitting from MAP sensor to throttle body is firmly connected (Fig. 9).

(19) Verify fuel injector wire harness connectors are firmly connected to injectors in correct order. Each harness connector is numerically tagged with injector number (INJ 1, INJ 2 etc.) of its corresponding fuel injector and cylinder number.

(20) Verify harness connectors are firmly connected to idle air control (IAC) motor and throttle position sensor (TPS) (Fig. 8).

(21) Verify wire harness connector is firmly connected to engine coolant temperature sensor (Fig. 10).

(22) Raise and support vehicle.

DIAGNOSIS AND TESTING (Continued)

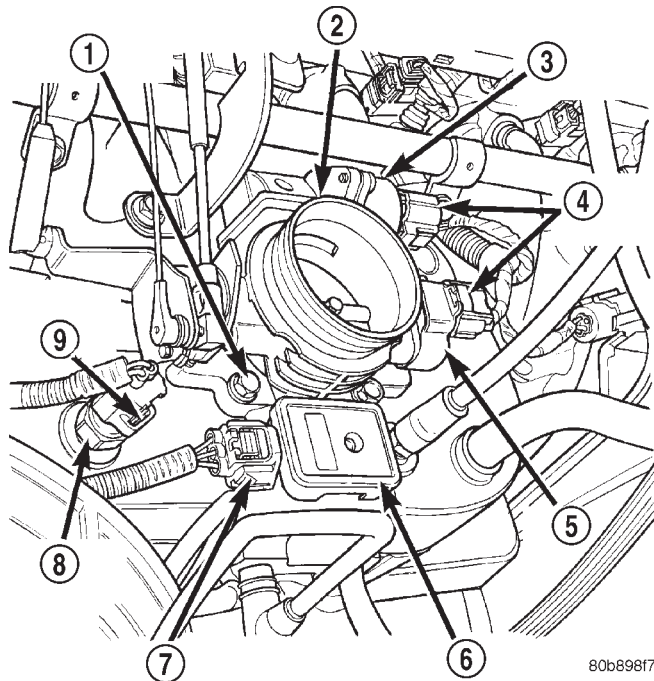

Fig. 8 Sensor Locations—4.0L Engine

- 1 - MOUNTING BOLTS (4)
- 2 - THROTTLE BODY
- 3 - IAC MOTOR
- 4 - ELEC. CONN.
- 5 - TPS
- 6 - MAP SENSOR
- 7 - ELEC. CONN.
- 8 - IAT SENSOR
- 9 - ELEC. CONN.

80b89817

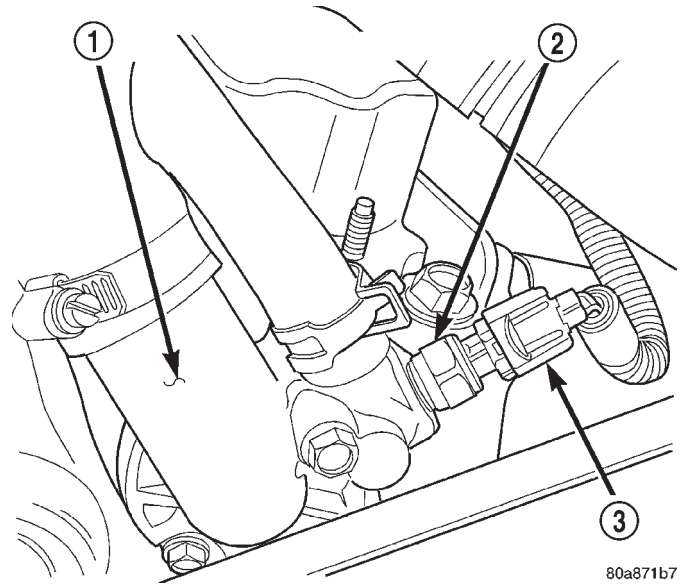

Fig. 10 Engine Coolant Temperature Sensor—Typical

- 1 - THERMOSTAT HOUSING
- 2 - ENGINE COOLANT TEMPERATURE SENSOR
- 3 - ELECTRICAL CONNECTOR

80a871b7

(23) Verify that all oxygen sensor wire connectors are firmly connected to sensors. Inspect sensors and connectors for damage (Fig. 11), (Fig. 12), (Fig. 13) or (Fig. 14).

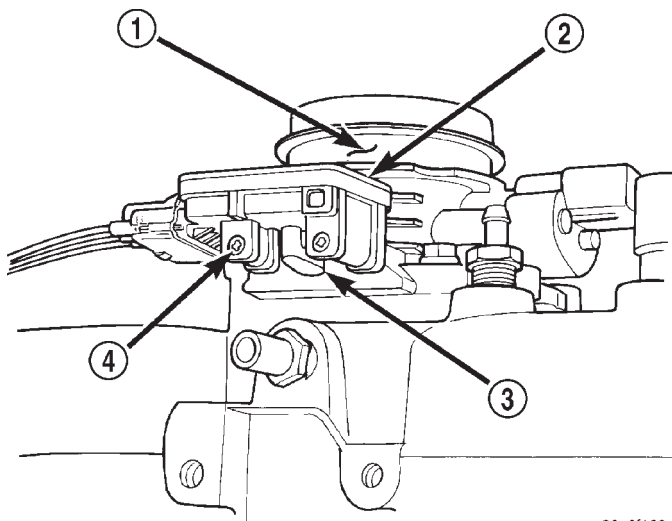

Fig. 9 Rubber L-Shaped Fitting—MAP Sensor-to-Throttle Body

- 1 - THROTTLE BODY
- 2 - MAP SENSOR
- 3 - RUBBER FITTING
- 4 - MOUNTING SCREWS (2)

80a8f168

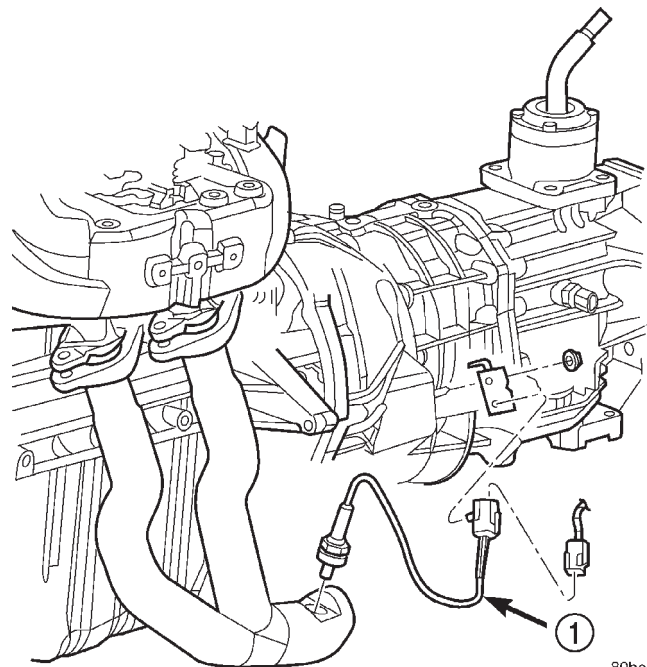

Fig. 11 Front Oxygen Sensor—4.0L—Federal Emissions

- 1 - 1/1 O2S

80be46f3

DIAGNOSIS AND TESTING (Continued)

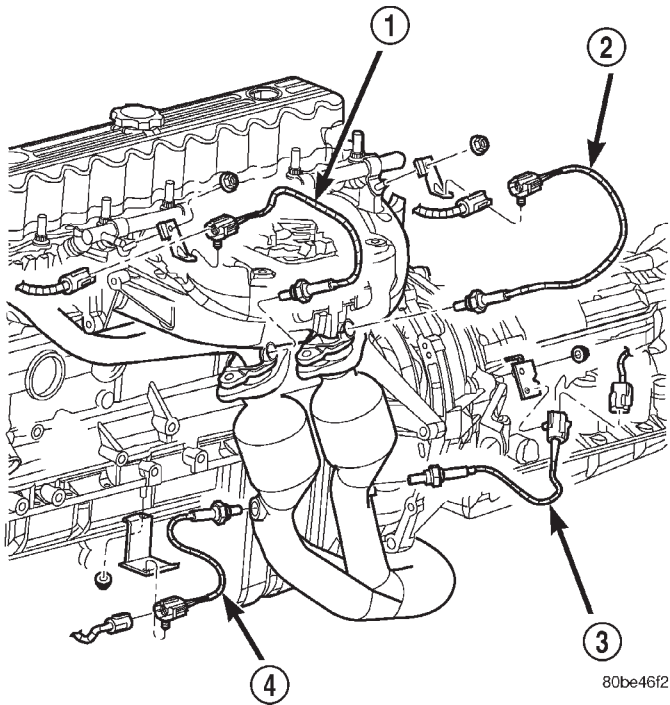

Fig. 12 Oxygen Sensors—4.0L—California Emissions

- 1 - 1/1 O2S
- 2 - 2/1 O2S
- 3 - 2/2 O2S
- 4 - 1/2 O2S

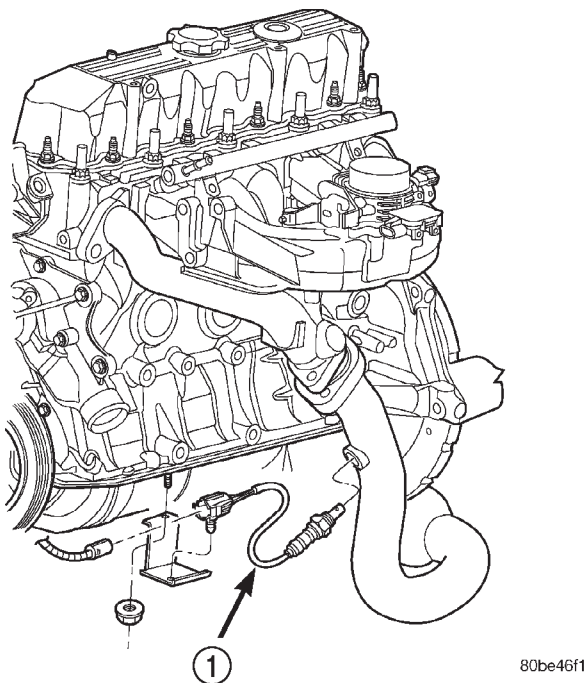

Fig. 13 Front Oxygen Sensor—2.5L—Federal Emissions

- 1 - 1/1 O2S

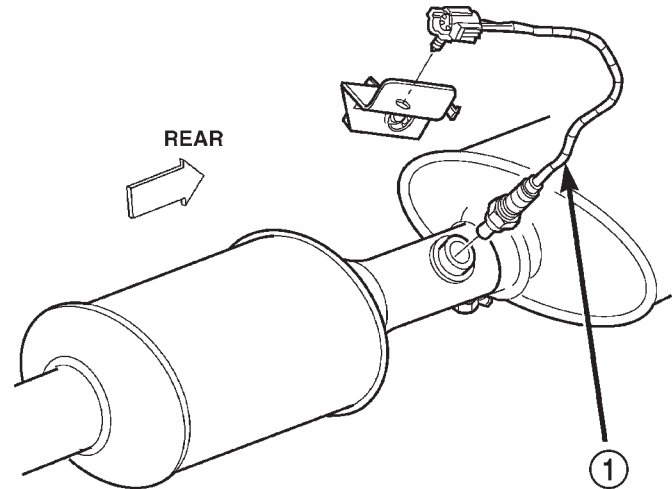

Fig. 14 Rear Oxygen Sensor—2.5L/4.0L—Federal Emissions

- 1 - 1/2 O2S

(24) Inspect for pinched or leaking fuel tubes. Inspect for pinched, cracked or leaking fuel hoses.

(25) Inspect for exhaust system restrictions such as pinched exhaust pipes, collapsed muffler or plugged catalytic converter.

(26) If equipped with automatic transmission, verify electrical harness is firmly connected to park/neutral switch. Refer to Automatic Transmission section of Group 21.

(27) Verify that electrical harness connector is firmly connected to the vehicle speed sensor (Fig. 15).

(28) 2.5L 4-Cylinder Engine Only: Verify good electrical connection at power steering pressure switch (Fig. 16). This switch is not used with 4.0L engines.

(29) Verify good electrical connections at fuel pump module connector at front of fuel tank (Fig. 17).

(30) Verify good EVAP canister vent line connection at front of fuel tank (Fig. 17).

(31) Verify good fuel supply line connection at front of fuel tank (Fig. 17).

(32) Inspect all fuel lines/hoses for cracks or leaks.

(33) Inspect transmission torque converter housing (automatic transmission) or clutch housing (manual transmission) for damage to timing ring on drive plate/flywheel.

(34) Verify battery cable and solenoid feed wire connections to starter solenoid are tight and clean. Inspect for chaffed wires or wires rubbing up against other components.

DIAGNOSIS AND TESTING (Continued)

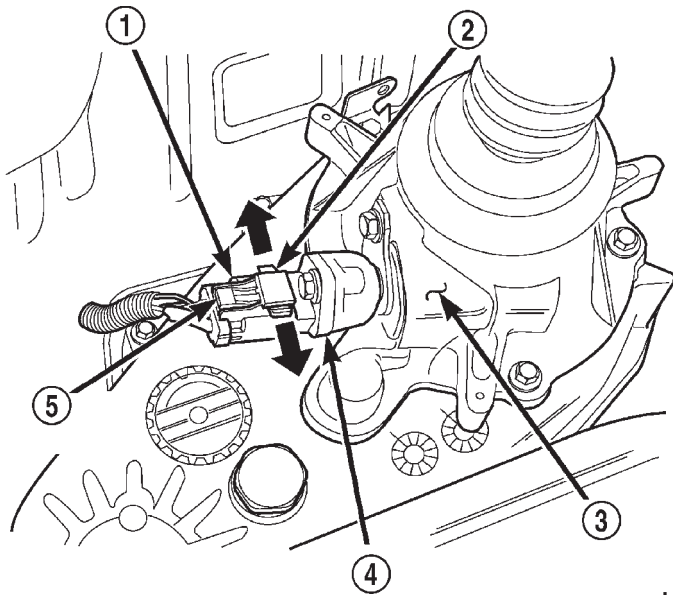

**Fig. 15 Vehicle Speed Sensor—Typical—
4WD Shown**

- 1 - SENSOR ELECTRICAL CONNECTOR
- 2 - SLIDE TAB
- 3 - 4WD TRANSFER CASE EXTENSION
- 4 - VEHICLE SPEED SENSOR
- 5 - RELEASE LOCK

I
80be46f0

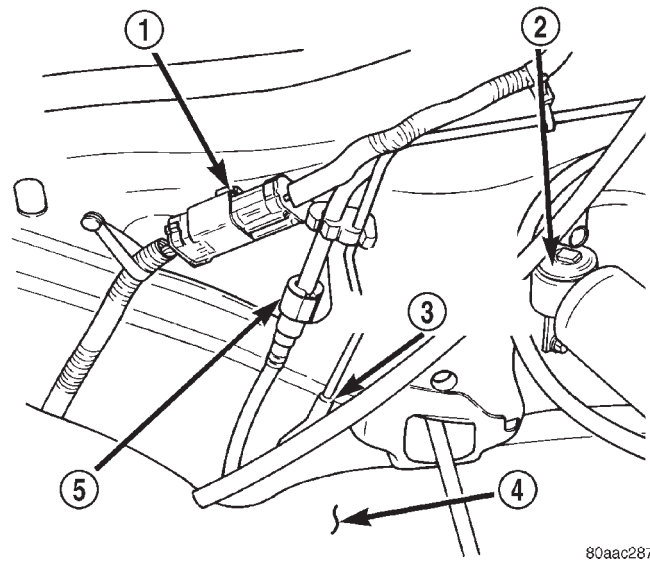

80aac287

Fig. 17 Fuel Tank Connections at Front of Fuel Tank

- 1 - FUEL PUMP MODULE CONNECTOR
- 2 - LEFT-REAR SHOCK ABSORBER
- 3 - EVAP CANISTER VENT LINE CONNECTION
- 4 - FRONT OF FUEL TANK
- 5 - FUEL SUPPLY LINE CONNECTION

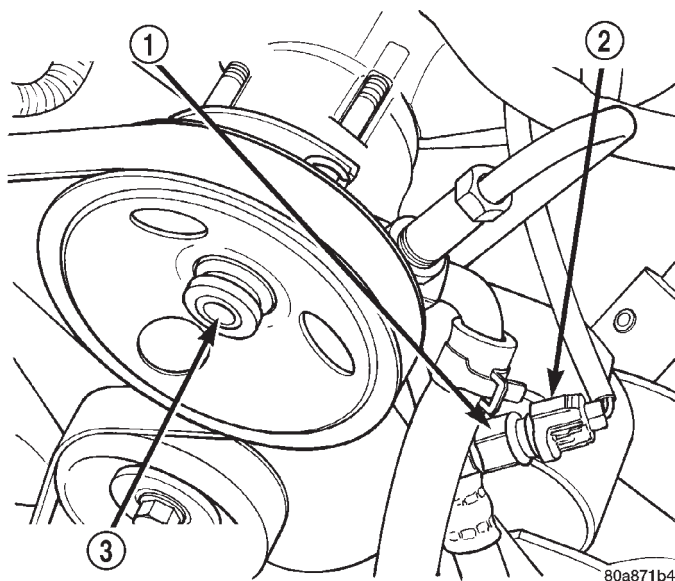

80a871b4

**Fig. 16 Power Steering Pressure Switch—
2.5L Engine**

- 1 - POWER STEERING PRESSURE SWITCH
- 2 - ELECTRICAL CONNECTOR
- 3 - POWER STEERING PUMP

ASD AND FUEL PUMP RELAYS

The following description of operation and tests apply only to the Automatic Shutdown (ASD) and fuel pump relays. The terminals on the bottom of each relay are numbered. Two different types of relays may be used, (Fig. 18) or (Fig. 19).

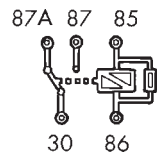
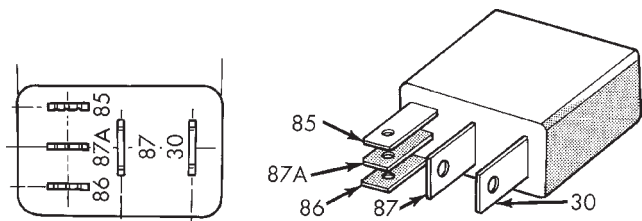

| TERMINAL LEGEND | |
|-----------------|-----------------|
| NUMBER | IDENTIFICATION |
| 30 | COMMON FEED |
| 85 | COIL GROUND |
| 86 | COIL BATTERY |
| 87 | NORMALLY OPEN |
| 87A | NORMALLY CLOSED |

**Fig. 18 ASD and Fuel Pump Relay Terminals—
Type 1**

DIAGNOSIS AND TESTING (Continued)

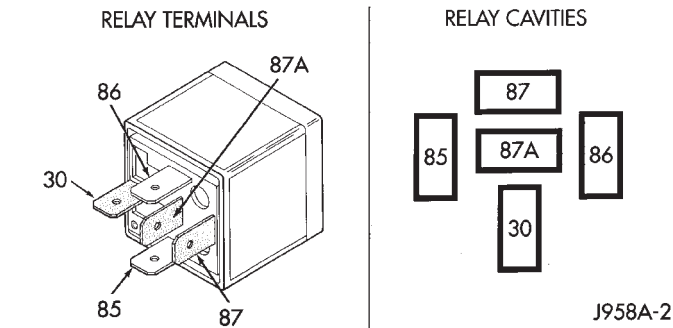

| TERMINAL LEGEND | |
|-----------------|-----------------|
| NUMBER | IDENTIFICATION |
| 30 | COMMON FEED |
| 85 | COIL GROUND |
| 86 | COIL BATTERY |
| 87 | NORMALLY OPEN |
| 87A | NORMALLY CLOSED |

**Fig. 19 ASD and Fuel Pump Relay Terminals—
Type 2**

OPERATION

- Terminal number 30 is connected to battery voltage. For both the ASD and fuel pump relays, terminal 30 is connected to battery voltage at all times.
- The PCM grounds the coil side of the relay through terminal number 85.
- Terminal number 86 supplies voltage to the coil side of the relay.
- When the PCM de-energizes the ASD and fuel pump relays, terminal number 87A connects to terminal 30. This is the Off position. In the off position, voltage is not supplied to the rest of the circuit. Terminal 87A is the center terminal on the relay.
- When the PCM energizes the ASD and fuel pump relays, terminal 87 connects to terminal 30. This is the On position. Terminal 87 supplies voltage to the rest of the circuit.

TESTING

The following procedure applies to the ASD and fuel pump relays.

- (1) Remove relay from connector before testing.
- (2) With the relay removed from the vehicle, use an ohmmeter to check the resistance between terminals 85 and 86. The resistance should be between 75 \pm 5 ohms.
- (3) Connect the ohmmeter between terminals 30 and 87A. The ohmmeter should show continuity between terminals 30 and 87A.
- (4) Connect the ohmmeter between terminals 87 and 30. The ohmmeter should not show continuity at this time.

(5) Connect one end of a jumper wire (16 gauge or smaller) to relay terminal 85. Connect the other end of the jumper wire to the ground side of a 12 volt power source.

(6) Connect one end of another jumper wire (16 gauge or smaller) to the power side of the 12 volt power source. **Do not attach the other end of the jumper wire to the relay at this time.**

WARNING: DO NOT ALLOW OHMMETER TO CONTACT TERMINALS 85 OR 86 DURING THIS TEST.

(7) Attach the other end of the jumper wire to relay terminal 86. This activates the relay. The ohmmeter should now show continuity between relay terminals 87 and 30. The ohmmeter should not show continuity between relay terminals 87A and 30.

(8) Disconnect jumper wires.

(9) Replace the relay if it did not pass the continuity and resistance tests. If the relay passed the tests, it operates properly. Check the remainder of the ASD and fuel pump relay circuits. Refer to the Wiring Diagrams.

THROTTLE BODY MINIMUM AIR FLOW CHECK PROCEDURE

The following test procedure has been developed to check throttle body calibrations for correct idle conditions. The procedure should be used to diagnose the throttle body for conditions that may cause idle problems. **This procedure should be used only after normal diagnostic procedures have failed to produce results that indicate a throttle body related problem. Be sure to check for proper operation of the idle air control motor before performing this test.**

A special fixed orifice tool (number 6714) (Fig. 20) must be used for the following test. This tool has a fixed internal diameter of 0.185".

SPECIAL TOOL 6714

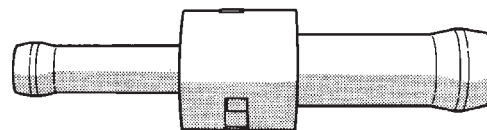

J9414-7

Fig. 20 6714 Fixed Orifice Tool

DIAGNOSIS AND TESTING (Continued)

(1) Start the engine and bring to operating temperature. Be sure all accessories are off before performing this test.

(2) Shut off engine and remove air duct at throttle body.

(3) **2.5L 4-Cylinder Engine:** Near front/top of valve cover, disconnect CCV tube at fixed orifice fitting (Fig. 21). Insert Special Tool 6714 into end of disconnected CCV tube (insert either end of tool into tube). Let tool and tube hang disconnected at side of engine.

(4) **4.0L 6-Cylinder Engine:** Disconnect CCV tube (Fig. 22) at intake manifold fitting. Attach a short piece of rubber hose to special tool 6714 (insert rubber hose to either end of tool). Install rubber hose/tool to intake manifold fitting. Let CCV tube hang disconnected at side of engine.

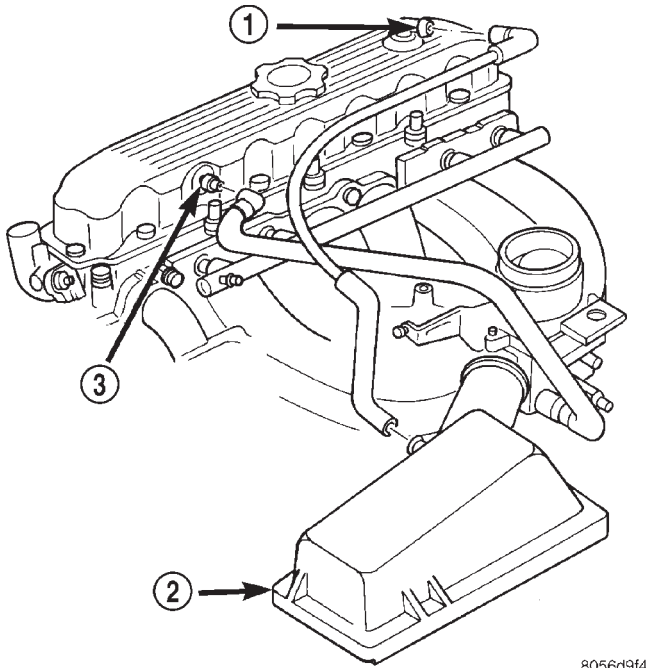

8056d9f4

Fig. 21 Install Orifice Tool 2.5L 4-Cylinder Engine

- 1 - AIR INLET FITTING
- 2 - AIR FILTER COVER
- 3 - FIXED ORIFICE FITTING

(5) Connect DRB scan tool to 16-way data link connector. This connector is located at lower edge of instrument panel near steering column. Refer to appropriate Powertrain Diagnostic Procedures service manual for DRB operation.

(6) Start engine and allow to warm up.

(7) Using the DRB scan tool, scroll through menus as follows: select—Stand Alone DRB III, select the year 2000 Diagnostics, select—Engine, select—System Test, select—Minimum Air Flow.

(8) The DRB scan tool will count down to stabilize idle rpm and display minimum air flow idle rpm. The

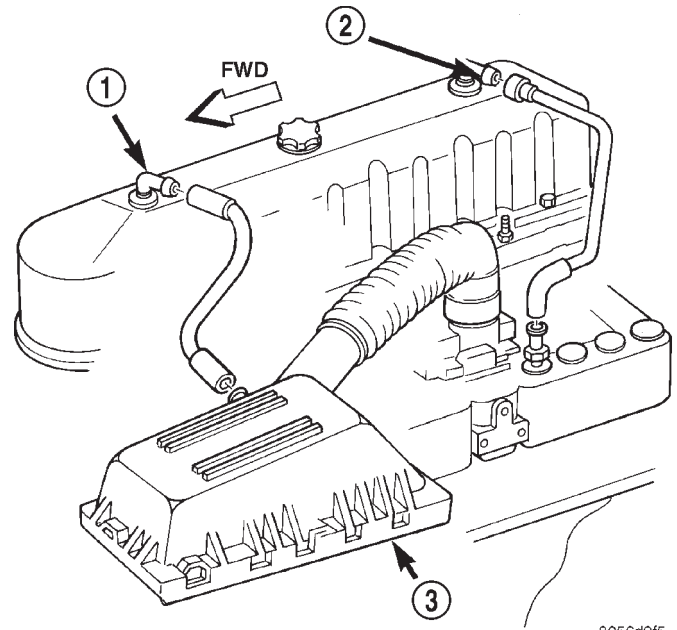

8056d9f5

Fig. 22 Install Orifice Tool 4.0L 6-Cylinder Engine

- 1 - AIR INLET FITTING
- 2 - FIXED ORIFICE FITTING
- 3 - AIR FILTER COVER

idle rpm should be between **500 and 900 rpm**. If idle speed is outside these specifications, replace throttle body. Refer to Throttle Body Removal/Installation.

(9) Disconnect DRB scan tool from vehicle.

(10) Remove orifice tool and connect CCV tube to engine.

(11) Install air duct to throttle body.

REMOVAL AND INSTALLATION

AUTOMATIC SHUTDOWN (ASD) RELAY

The ASD relay is located in the Power Distribution Center (PDC) (Fig. 23). Refer to label on PDC cover for relay location.

REMOVAL

- (1) Remove PDC cover.
- (2) Remove relay from PDC.
- (3) Check condition of relay terminals and PDC connector terminals for damage or corrosion. Repair if necessary before installing relay.
- (4) Check for pin height (pin height should be the same for all terminals within the PDC connector). Repair if necessary before installing relay.

INSTALLATION

- (1) Install relay to PDC.
- (2) Install cover to PDC.

REMOVAL AND INSTALLATION (Continued)

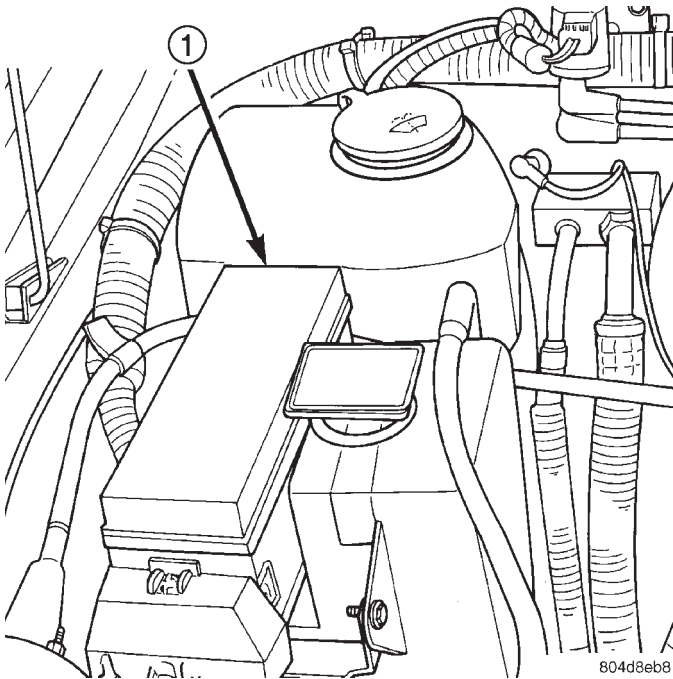

Fig. 23 Power Distribution Center (PDC)

1 - POWER DISTRIBUTION CENTER (PDC)

FUEL PUMP RELAY

The fuel pump relay is located in the Power Distribution Center (PDC) (Fig. 23). Refer to label on PDC cover for relay location.

REMOVAL

- (1) Remove PDC cover.
- (2) Remove relay from PDC.
- (3) Check condition of relay terminals and PDC connector terminals for damage or corrosion. Repair if necessary before installing relay.
- (4) Check for pin height (pin height should be the same for all terminals within the PDC connector). Repair if necessary before installing relay.

INSTALLATION

- (1) Install relay to PDC.
- (2) Install cover to PDC.

THROTTLE BODY

A (factory adjusted) set screw is used to mechanically limit the position of the throttle body throttle plate. **Never attempt to adjust the engine idle speed using this screw.** All idle speed functions are controlled by the Powertrain Control Module (PCM).

REMOVAL

- (1) Remove air cleaner tube at throttle body.
- (2) Disconnect throttle body electrical connectors at MAP sensor, IAC motor and TPS (Fig. 24) or (Fig. 25).

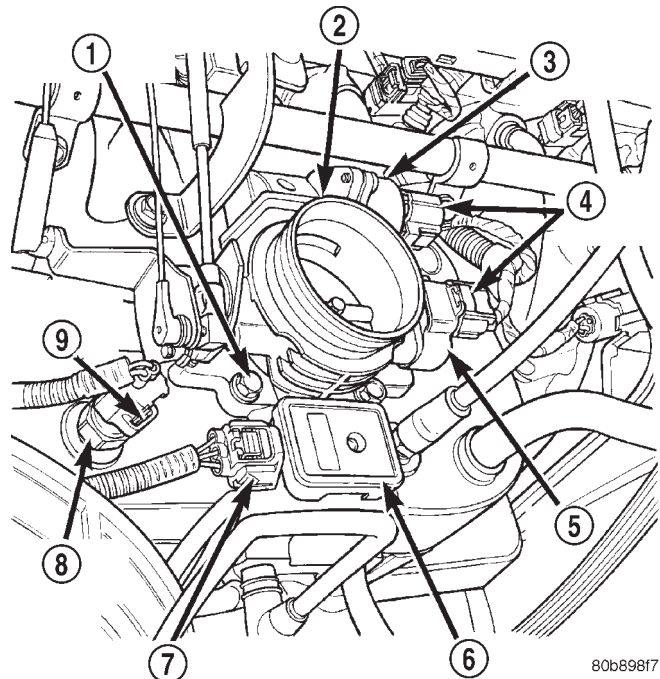

Fig. 24 Throttle Body and Sensor Locations—4.0L Engine

- 1 - MOUNTING BOLTS (4)
- 2 - THROTTLE BODY
- 3 - IAC MOTOR
- 4 - ELEC. CONN.
- 5 - TPS
- 6 - MAP SENSOR
- 7 - ELEC. CONN.
- 8 - IAT SENSOR
- 9 - ELEC. CONN.

(3) Remove all control cables from throttle body (lever) arm. Refer to the Accelerator Pedal and Throttle Cable section of this group for additional information.

- (4) Remove four throttle body mounting bolts.
- (5) Remove throttle body from intake manifold.
- (6) Discard old throttle body-to-intake manifold gasket.

INSTALLATION

(1) Clean mating surfaces of throttle body and intake manifold.

- (2) Install new throttle body-to-intake manifold gasket.
- (3) Install throttle body to intake manifold.
- (4) Install four mounting bolts. Tighten bolts to 11 N·m (100 in. lbs.) torque.
- (5) Install control cables.
- (6) Install electrical connectors.
- (7) Install air cleaner at throttle body.

REMOVAL AND INSTALLATION (Continued)

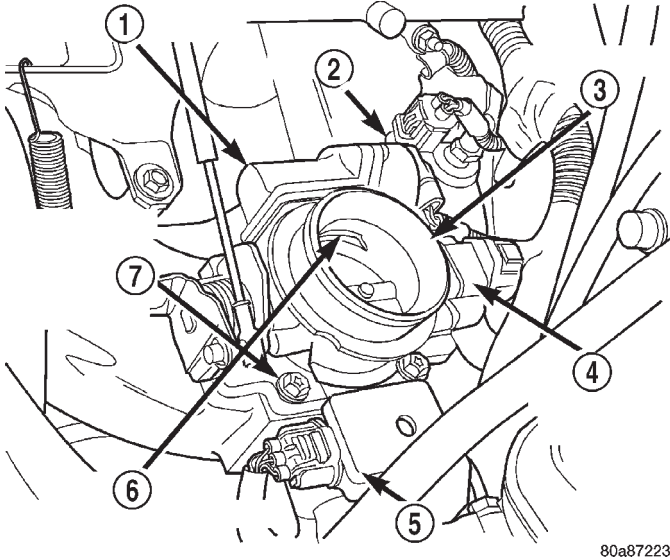

Fig. 25 Throttle Body and Sensor Locations—2.5L Engine

- 1 - IDLE AIR CONTROL MOTOR
- 2 - IAT SENSOR
- 3 - THROTTLE BODY
- 4 - THROTTLE POSITION SENSOR
- 5 - MAP SENSOR
- 6 - IDLE AIR CONTROL PASSAGE INLET
- 7 - THROTTLE BODY MOUNTING BOLTS (4)

THROTTLE POSITION SENSOR (TPS)

The TPS is mounted to the throttle body (Fig. 24) or (Fig. 25).

REMOVAL

- (1) Remove air cleaner tube at throttle body.
- (2) Disconnect TPS electrical connector.
- (3) Remove TPS mounting screws (Fig. 26).
- (4) Remove TPS.

INSTALLATION

The throttle shaft end of the throttle body slides into a socket in the TPS (Fig. 27). The TPS must be installed so that it can be rotated a few degrees. (If the sensor will not rotate, install the sensor with the throttle shaft on the other side of the socket tangs). The TPS will be under slight tension when rotated.

- (1) Install TPS and retaining screws.
- (2) Tighten screws to 7 N·m (60 in. lbs.) torque.
- (3) Connect TPS electrical connector to TPS.
- (4) Manually operate throttle (by hand) to check for any TPS binding before starting engine.
- (5) Install air cleaner tube to throttle body.

IDLE AIR CONTROL (IAC) MOTOR

The IAC motor is located on the side of the throttle body (Fig. 24) or (Fig. 25).

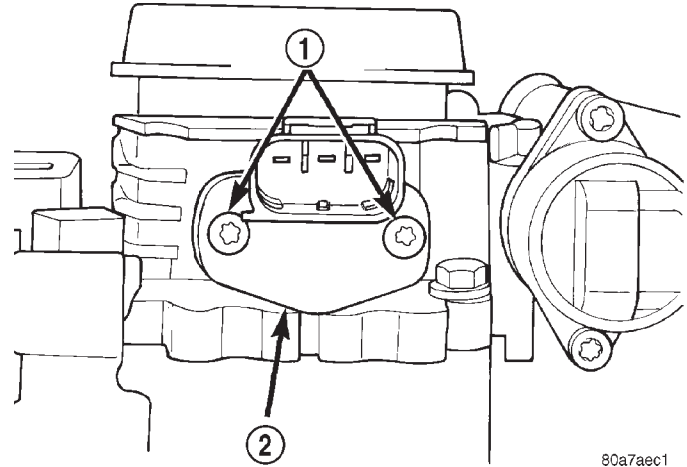

Fig. 26 TPS Mounting Screws

- 1 - MOUNTING SCREWS
- 2 - TPS

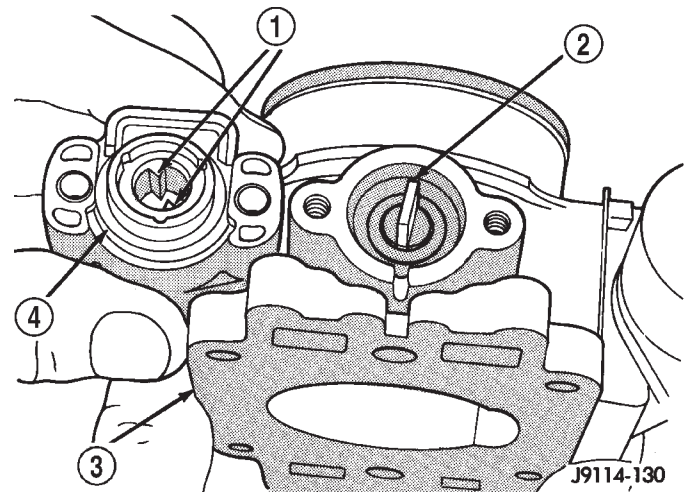

Fig. 27 Throttle Position Sensor—Installation

- 1 - TANGS
- 2 - THROTTLE SHAFT
- 3 - THROTTLE BODY
- 4 - TPS

REMOVAL

- (1) Remove air cleaner tube at throttle body.
- (2) Disconnect electrical connector from IAC motor.
- (3) Remove two mounting bolts (screws) (Fig. 28).
- (4) Remove IAC motor from throttle body.

INSTALLATION

- (1) Install IAC motor to throttle body.
- (2) Install and tighten two mounting bolts (screws) to 7 N·m (60 in. lbs.) torque.
- (3) Install electrical connector.
- (4) Install air cleaner tube to throttle body.

REMOVAL AND INSTALLATION (Continued)

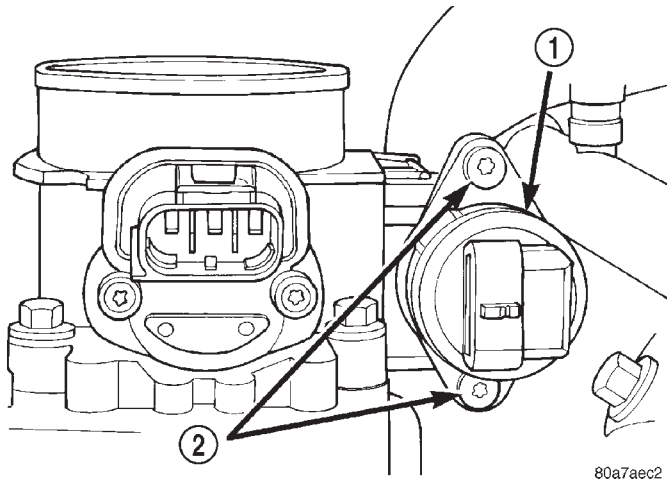

Fig. 28 Mounting Bolts (Screws)—IAC Motor

- 1 - IDLE AIR CONTROL MOTOR
2 - MOUNTING SCREWS

MANIFOLD ABSOLUTE PRESSURE (MAP) SENSOR

The MAP sensor is mounted to the side of the throttle body (Fig. 24) or (Fig. 25). An L-shaped rubber fitting is used to connect the MAP sensor to throttle body (Fig. 29).

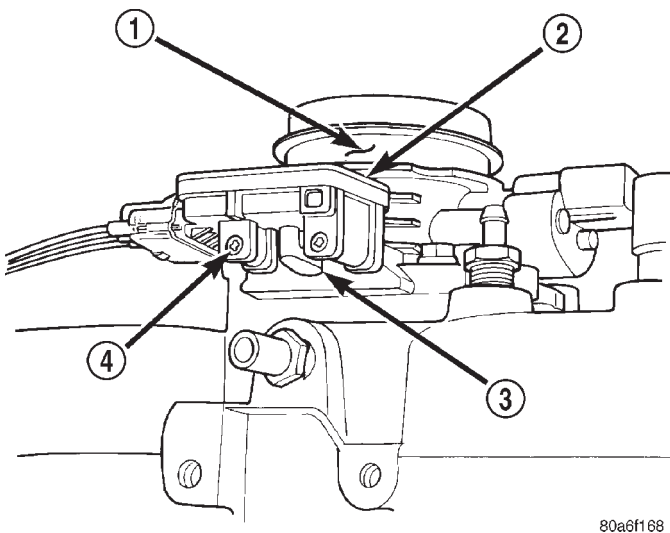

Fig. 29 MAP Sensor Mounting

- 1 - THROTTLE BODY
2 - MAP SENSOR
3 - RUBBER FITTING
4 - MOUNTING SCREWS (2)

REMOVAL

- (1) Remove air cleaner intake tube at throttle body.
- (2) Remove two MAP sensor mounting bolts (screws) (Fig. 29).

(3) While removing MAP sensor, slide the rubber L-shaped fitting (Fig. 29) from throttle body.

(4) Remove rubber L-shaped fitting from MAP sensor.

INSTALLATION

- (1) Install rubber L-shaped fitting to MAP sensor.
- (2) Position sensor to throttle body while guiding rubber fitting over throttle body vacuum nipple.
- (3) Install MAP sensor mounting bolts (screws). Tighten screws to 3 N·m (25 in. lbs.) torque.
- (4) Install air cleaner intake tube.

POWERTRAIN CONTROL MODULE (PCM)

The PCM is located in the engine compartment next to the air cleaner assembly (Fig. 30).

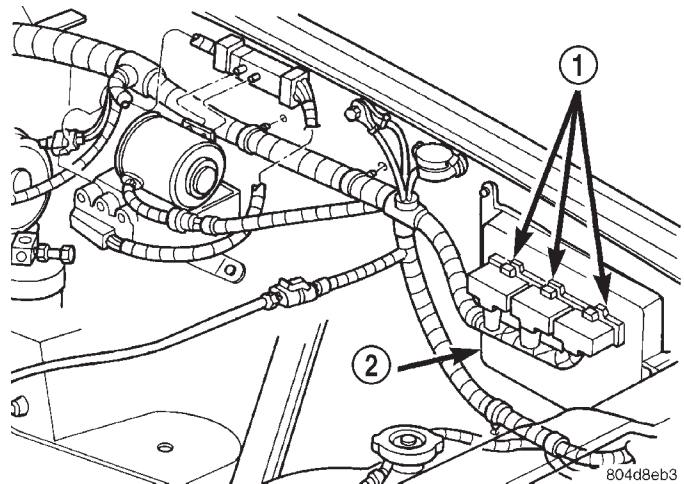

Fig. 30 PCM Location

- 1 - (3) 32-WAY CONNECTORS
2 - PCM

REMOVAL

To avoid possible voltage spike damage to the PCM, ignition key must be off, and negative battery cable must be disconnected before unplugging PCM connectors.

- (1) Disconnect negative battery cable at battery.
- (2) Remove cover over electrical connectors. Cover snaps onto PCM.
- (3) Carefully unplug the three 32-way connectors (Fig. 31) from PCM.
- (4) Remove three PCM mounting bolts and remove PCM from vehicle.

INSTALLATION

- (1) Install PCM and mounting bolts to vehicle.
- (2) Tighten bolts to 4 N·m (35 in. lbs.).
- (3) Check pin connectors in the PCM and the three 32-way connectors for corrosion or damage. Also, the pin heights in connectors should all be same. Repair as necessary before installing connectors.

REMOVAL AND INSTALLATION (Continued)

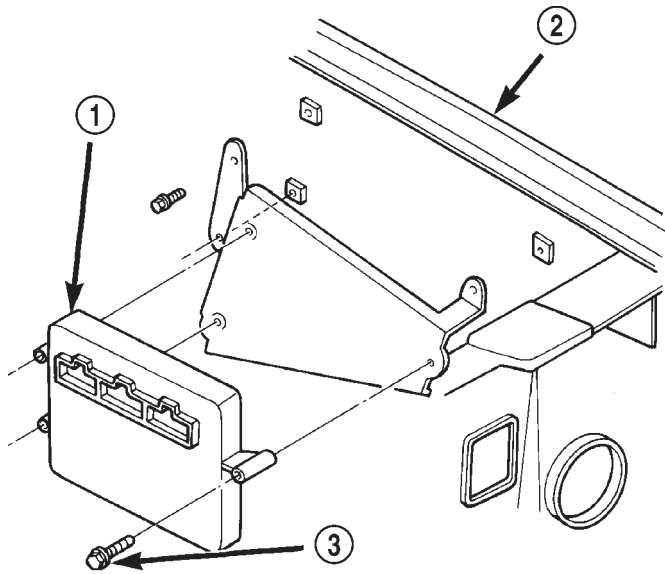

804d8eb2

Fig. 31 PCM Mounting

- 1 - PCM
- 2 - L. F. FENDER
- 3 - PCM MOUNTING BOLTS (3)

- (4) Install three 32-way connectors.
- (5) Install cover over electrical connectors. Cover snaps onto PCM.
- (6) Install battery cable.
- (7) Use the DRB scan tool to reprogram new PCM with vehicle's original Identification Number (VIN) and original vehicle mileage.

POWER STEERING PRESSURE SWITCH—2.5L ENGINE

This switch is not used with 4.0L six-cylinder engines.

The power steering pressure switch is installed in the power steering high-pressure hose (Fig. 32).

REMOVAL

- (1) Disconnect electrical connector from power steering pressure switch.
- (2) Place a small container or shop towel beneath switch to collect any excess fluid.
- (3) Remove switch. Use back-up wrench on power steering line to prevent line bending.

INSTALLATION

- (1) Install power steering switch into power steering line.
- (2) Tighten to 14–22 N·m (124–195 in. lbs.) torque.
- (3) Connect electrical connector to switch.
- (4) Check power steering fluid and add as necessary.

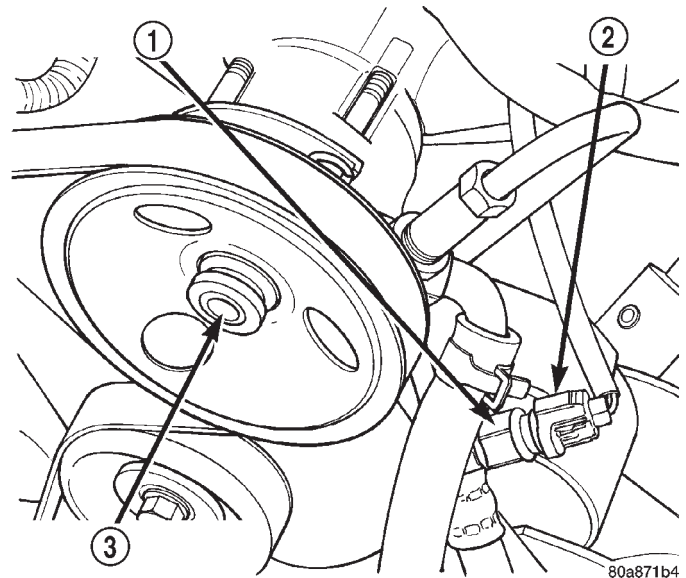

80a871b4

Fig. 32 Power Steering Pressure Switch

- 1 - POWER STEERING PRESSURE SWITCH
- 2 - ELECTRICAL CONNECTOR
- 3 - POWER STEERING PUMP

- (5) Start engine and again check power steering fluid. Add fluid if necessary.

OXYGEN SENSOR**REMOVAL**

Never apply any type of grease to the oxygen sensor electrical connector, or attempt any soldering of the sensor wiring harness. For sensor operation, it must have a comparison source of oxygen from outside the exhaust system. This fresh air is supplied to the sensor through its pigtail wiring harness.

Refer to (Fig. 33), (Fig. 34), (Fig. 35) or (Fig. 36) for O2S (oxygen sensor) location.

WARNING: THE EXHAUST MANIFOLD, EXHAUST PIPES AND CATALYTIC CONVERTER BECOME VERY HOT DURING ENGINE OPERATION. ALLOW ENGINE TO COOL BEFORE REMOVING OXYGEN SENSOR.

- (1) Raise and support vehicle.
- (2) Disconnect wire connector from O2S sensor.

CAUTION: When disconnecting sensor electrical connector, do not pull directly on wire going into sensor.

- (3) Remove O2S sensor with an oxygen sensor removal and installation tool.
- (4) Clean threads in exhaust pipe using appropriate tap.

REMOVAL AND INSTALLATION (Continued)

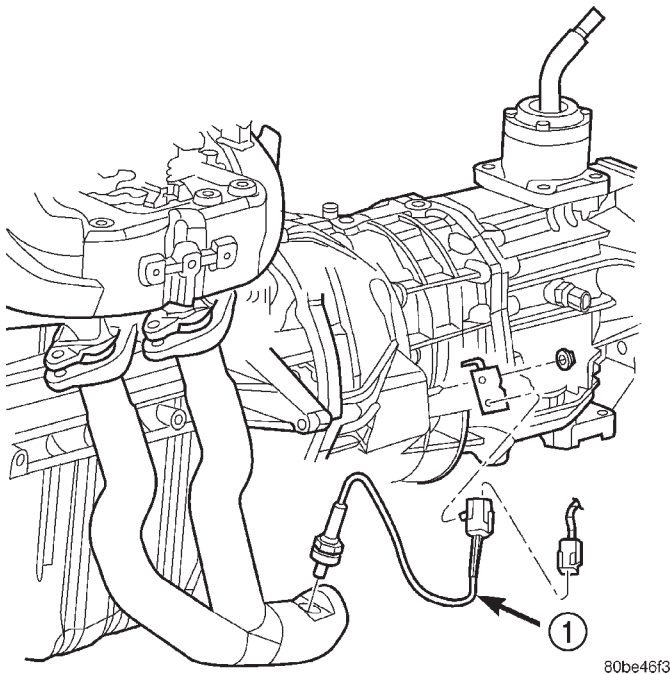

80be46f3

Fig. 33 Front Oxygen Sensor—4.0L—Federal Emissions

1 - 1/1 O2S

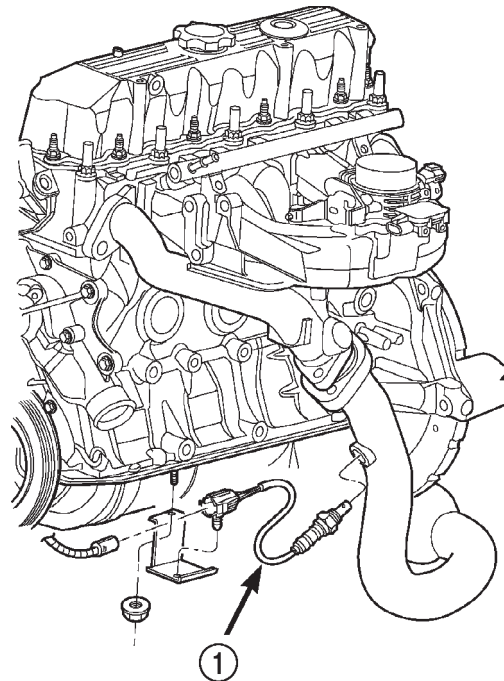

80be46f1

Fig. 35 Front Oxygen Sensor—2.5L—Federal Emissions

1 - 1/1 O2S

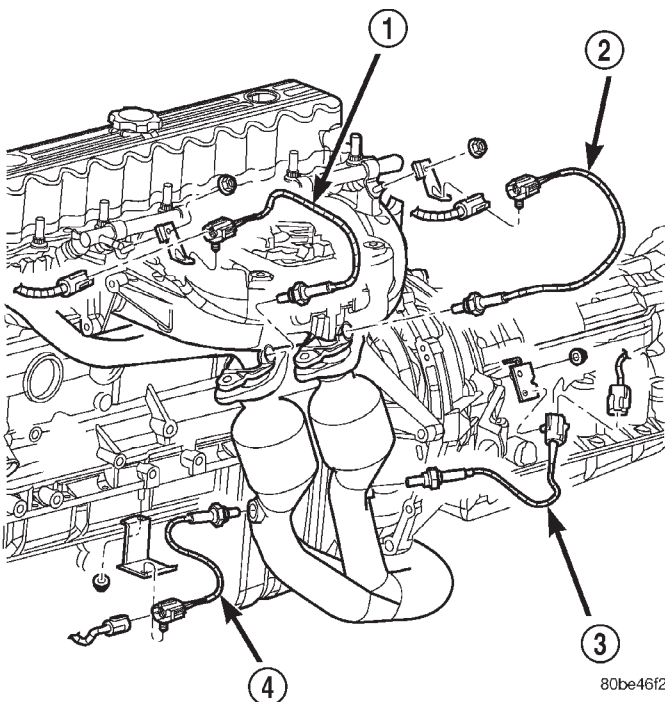

80be46f2

Fig. 34 Oxygen Sensors—4.0L—California Emissions

- 1 - 1/1 O2S
- 2 - 2/1 O2S
- 3 - 2/2 O2S
- 4 - 1/2 O2S

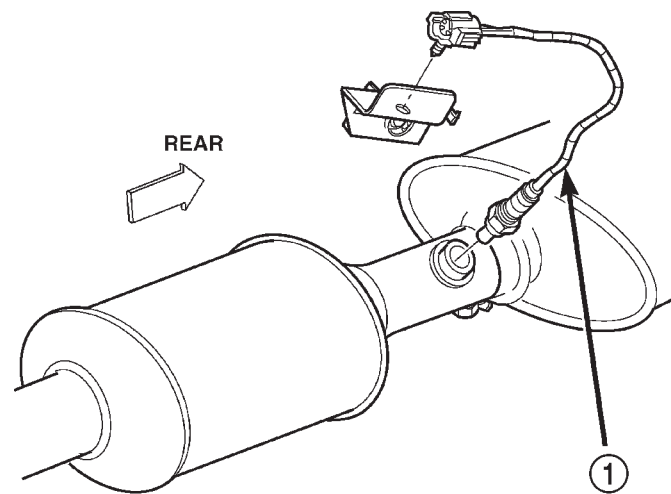

80be46f4

Fig. 36 Rear Oxygen Sensor—2.5L/4.0L—Federal Emissions

1 - 1/2 O2S

INSTALLATION

Threads of new oxygen sensors are factory coated with anti-seize compound to aid in removal. **DO NOT** add any additional anti-seize compound to threads of a new oxygen sensor.

REMOVAL AND INSTALLATION (Continued)

- (1) Install O2S sensor. Tighten to 30 N-m (22 ft. lbs.) torque.
- (2) Connect O2S sensor wire connector.
- (3) Lower vehicle.

AIR CLEANER ELEMENT (FILTER)

REMOVAL

- (1) Unlock air tube clamp (Fig. 37) at air cleaner cover. To unlock clamp, attach adjustable pliers to clamp and rotate pliers as shown in (Fig. 38).
- (2) Remove air tube at cover.
- (3) Pry back three clips retaining air cleaner cover to air cleaner housing.
- (4) Remove housing cover and remove air cleaner element.
- (5) Clean inside of housing before replacing element.

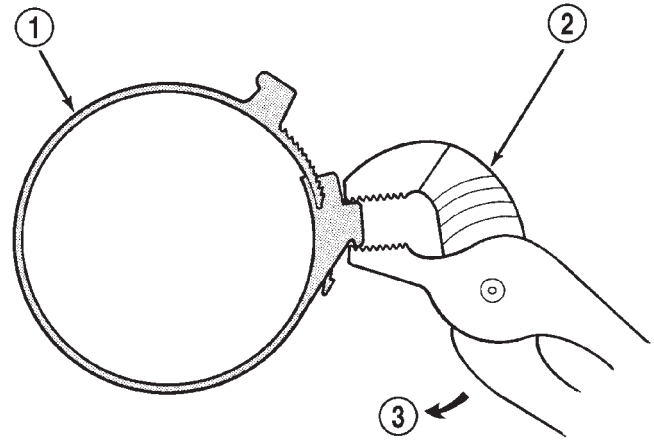

J9314-136

Fig. 38 Clamp Removal

- 1 - CLAMP
- 2 - ADJUSTABLE PLIERS
- 3 - REMOVAL

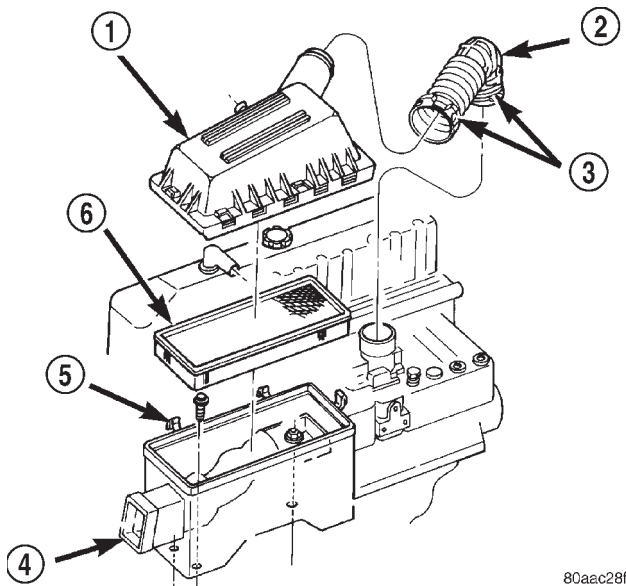

80aac28f

Fig. 37 Air Cleaner Housing and Element (Filter)

- 1 - COVER
- 2 - AIR TUBE
- 3 - CLAMPS (2)
- 4 - HOUSING
- 5 - CLIPS (3)
- 6 - ELEMENT (FILTER)

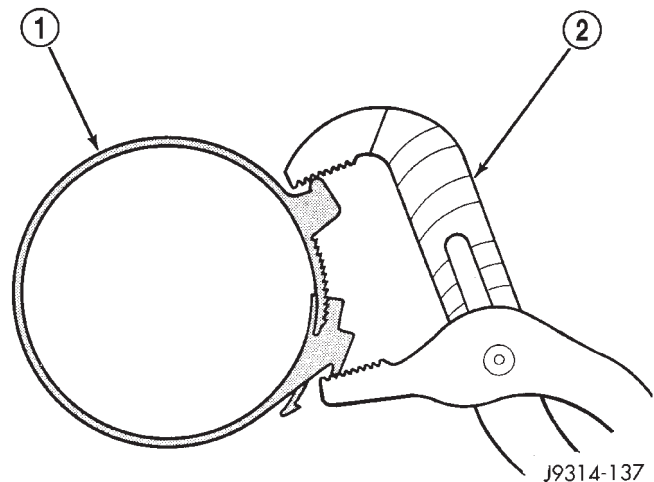

J9314-137

Fig. 39 Clamp Installation

- 1 - CLAMP
- 2 - ADJUSTABLE PLIERS

INSTALLATION

- (1) Install air cleaner element into housing.
- (2) Install air cleaner cover to housing (three clips). Be sure cover is properly seated to air cleaner housing.
- (3) Install air tube and clamp to cover. Compress clamp snugly with adjustable pliers as shown in (Fig. 39).

ENGINE COOLANT TEMPERATURE SENSOR

WARNING: HOT, PRESSURIZED COOLANT CAN CAUSE INJURY BY SCALDING. COOLING SYSTEM MUST BE PARTIALLY DRAINED BEFORE REMOVING THE COOLANT TEMPERATURE SENSOR. REFER TO GROUP 7, COOLING.

The coolant temperature sensor is installed in the thermostat housing (Fig. 40).

REMOVAL

- (1) Partially drain cooling system until coolant level is below cylinder head. Observe the **WARNINGS** in Group 7, Cooling.

REMOVAL AND INSTALLATION (Continued)

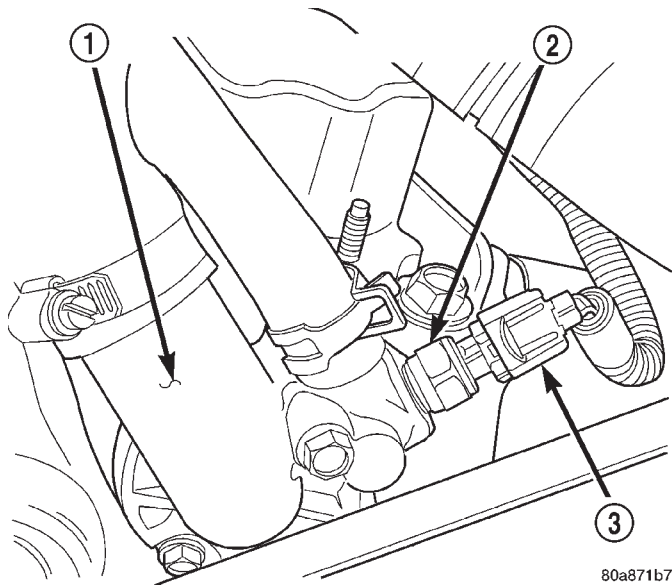

Fig. 40 Engine Coolant Temperature Sensor—Typical

- 1 - THERMOSTAT
- 2 - ENGINE COOLANT TEMPERATURE SENSOR
- 3 - ELECTRICAL CONNECTOR

(2) Disconnect coolant temperature sensor wire connector.

(3) Remove sensor from thermostat housing.

INSTALLATION

(1) Apply sealant to sensor threads (new replacement sensors will have sealant already applied).

(2) Install coolant temperature sensor into thermostat housing. Tighten to 11 N·m (8 ft. lbs.) torque.

(3) Connect wire connector.

(4) Fill cooling system. Refer to Group 7, Cooling System.

INTAKE MANIFOLD AIR TEMPERATURE SENSOR

The intake manifold air temperature (IAT) sensor is installed into intake manifold plenum near throttle body (Fig. 41) or (Fig. 42).

REMOVAL

(1) Disconnect electrical connector from IAT sensor.

(2) Remove sensor from intake manifold.

INSTALLATION

(1) Install IAT sensor into intake manifold. Tighten sensor to 28 N·m (20 ft. lbs.) torque.

(2) Connect electrical connector to sensor.

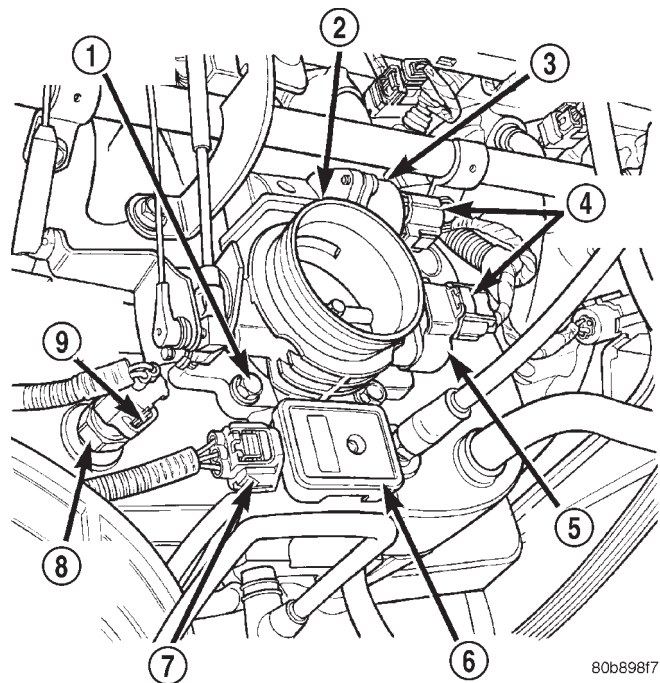

Fig. 41 IAT Sensor Location—4.0L Engine

- 1 - MOUNTING BOLTS (4)
- 2 - THROTTLE BODY
- 3 - IAC MOTOR
- 4 - ELEC. CONN.
- 5 - TPS
- 6 - MAP SENSOR
- 7 - ELEC. CONN.
- 8 - IAT SENSOR
- 9 - ELEC. CONN.

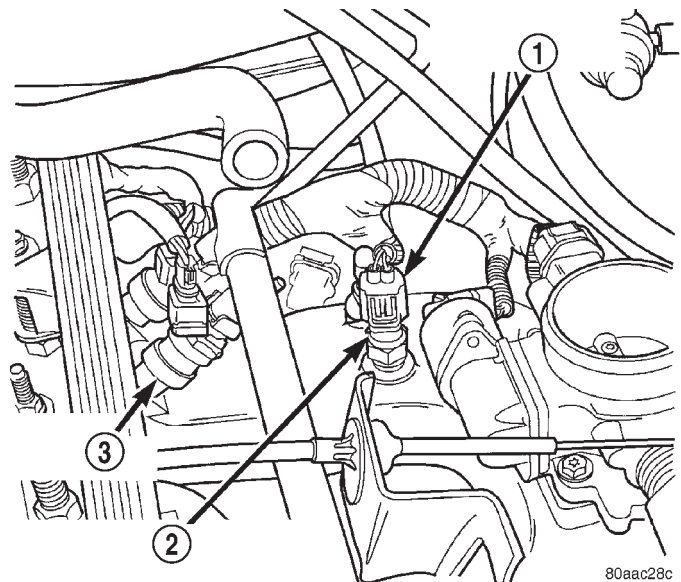

Fig. 42 IAT Sensor Location—2.5L Engine

- 1 - ELECTRICAL CONNECTOR
- 2 - INTAKE MANIFOLD TEMPERATURE SENSOR
- 3 - FUEL INJECTOR

REMOVAL AND INSTALLATION (Continued)

VEHICLE SPEED SENSOR

The Vehicle Speed Sensor (VSS) is located on the speedometer pinion gear adapter. If equipped with 4WD, this adapter is located on the transfer case extension (left side) (Fig. 43). If equipped with 2WD, this adapter is located on the extension housing of the transmission (left side).

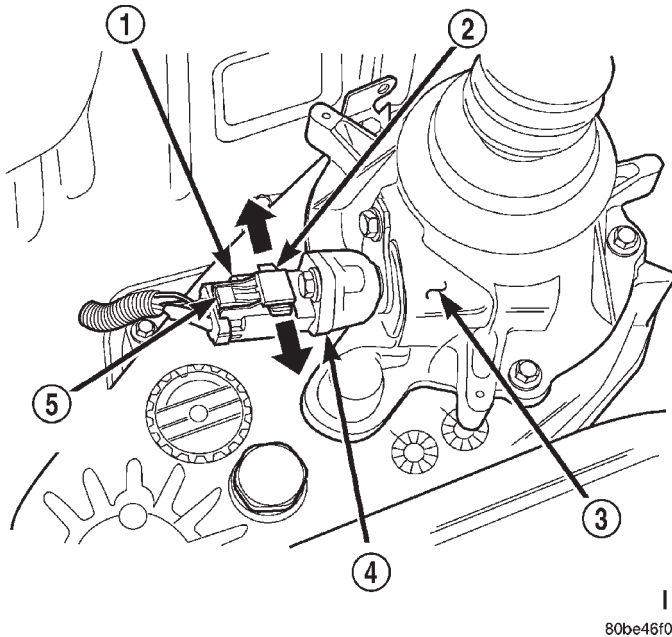

Fig. 43 VSS Location—4WD Shown

- 1 - SENSOR ELECTRICAL CONNECTOR
- 2 - SLIDE TAB
- 3 - 4WD TRANSFER CASE EXTENSION
- 4 - VEHICLE SPEED SENSOR
- 5 - RELEASE LOCK

REMOVAL

- (1) Raise and support vehicle.
- (2) Disconnect electrical connector from sensor by pushing slide tab (Fig. 43). After slide tab has been positioned, push in on secondary release lock (Fig. 43) on side of connector and pull connector from sensor.
- (3) Remove sensor mounting bolt (Fig. 44).
- (4) Remove sensor (pull straight out) from speedometer pinion gear adapter (Fig. 44). Do not remove gear adapter from transmission.

INSTALLATION

- (1) Clean inside of speedometer pinion gear adapter before installing speed sensor.
- (2) Install sensor into speedometer gear adapter and install mounting bolt. **Before tightening bolt, verify speed sensor is fully seated (mounted flush) to speedometer pinion gear adapter.**
- (3) Tighten sensor mounting bolt to 2.2 N·m (20 in. lbs.) torque.
- (4) Connect electrical connector to sensor.

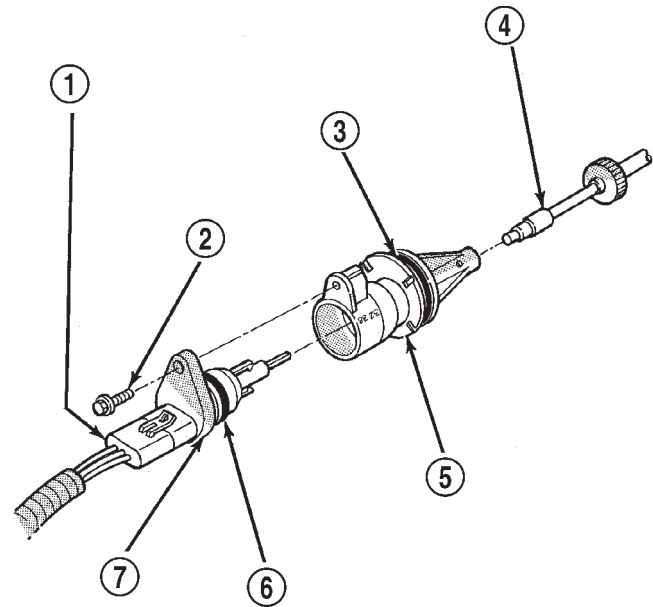

J9314-188

Fig. 44 VSS Removal/Installation

- 1 - ELECTRICAL CONNECTOR
- 2 - SENSOR MOUNTING BOLT
- 3 - O-RING
- 4 - SPEEDOMETER PINION GEAR
- 5 - SPEEDOMETER PINION GEAR ADAPTER
- 6 - O-RING
- 7 - VEHICLE SPEED SENSOR

SPECIFICATIONS

TORQUE CHART

| DESCRIPTION | TORQUE |
|--|---------------------------------|
| Air Cleaner Housing Mount. Bolts | 8 N·m (71 in. lbs.) |
| Engine Coolant Temperature Sensor | 11 N·m (96 in. lbs.) |
| IAC Motor-To-Throttle Body Bolts | 7 N·m (60 in. lbs.) |
| Intake Manifold Air Temp. Sensor | 28 N·m (20 ft. lbs.) |
| MAP Sensor Mounting Screws | 3 N·m (25 in. lbs.) |
| Oxygen Sensor | 30 N·m (22 ft. lbs.) |
| PCM Mounting Screws | 4 N·m (35 in. lbs.) |
| Power Steering Pressure Switch | 14–22 N·m (124–195 in. lbs.) |
| Throttle Body Mounting Bolts | 11 N·m (100 in. lbs.) |
| Throttle Position Sensor Mounting Screws | 7 N·m (60 in. lbs.) |
| Vehicle Speed Sensor Mounting Bolt | 2.2 N·m (20 in. lbs.) |

SPECIAL TOOLS

FUEL SYSTEM

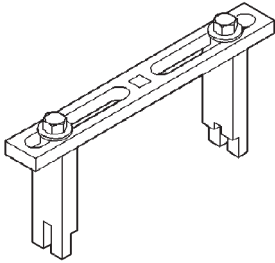

Spanner Wrench—6856



O2S (Oxygen Sensor) Remover/Installer—C-4907

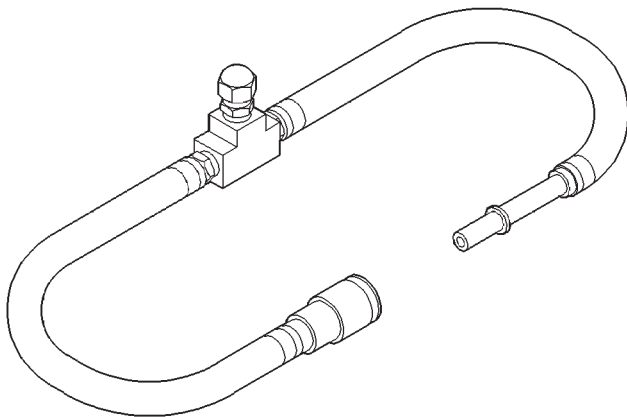

Adapters, Fuel Pressure Test—6539 and/or 6631

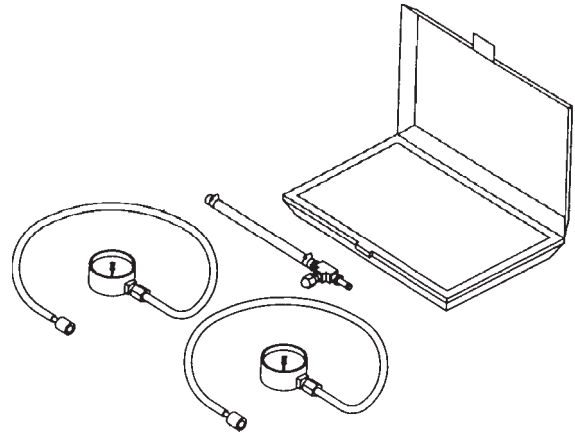

Test Kit, Fuel Pressure—5069

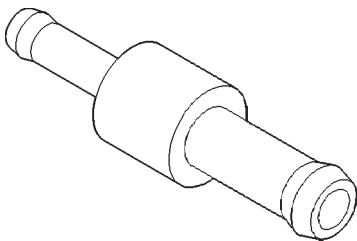

Fitting, Air Metering—6714

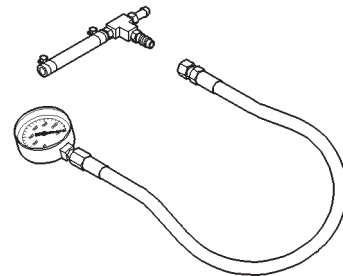

Test Kit, Fuel Pressure—C-4799-B



Fuel Line Removal Tool—6782

FUEL SYSTEM—2.5L DIESEL ENGINE

TABLE OF CONTENTS

| | page | | page |
|---|------|--|------|
| FUEL DELIVERY SYSTEM—2.5L DIESEL ENGINE | 1 | FUEL INJECTION SYSTEM—2.5L DIESEL ENGINE | 23 |

FUEL DELIVERY SYSTEM—2.5L DIESEL ENGINE

TABLE OF CONTENTS

| | page | | page |
|------------------------------------|------|---|------|
| DESCRIPTION AND OPERATION | | | |
| INTRODUCTION | 1 | FUEL INJECTION PUMP TEST | 10 |
| FUEL SYSTEM PRESSURE WARNING | 2 | FUEL SUPPLY RESTRICTIONS | 11 |
| FUEL TANK | 2 | FUEL SHUTDOWN SOLENOID TEST | 11 |
| FUEL TANK MODULE | 2 | HIGH-PRESSURE FUEL LINE LEAK TEST | 11 |
| FUEL GAUGE SENDING UNIT | 2 | SERVICE PROCEDURES | |
| FUEL FILTER/WATER SEPARATOR | 2 | AIR BLEED PROCEDURES | 12 |
| FUEL SHUTDOWN SOLENOID | 3 | FUEL INJECTION PUMP TIMING | 13 |
| FUEL INJECTION PUMP | 3 | REMOVAL AND INSTALLATION | |
| FUEL INJECTORS | 4 | ACCELERATOR PEDAL | 13 |
| FUEL TUBES/LINES/HOSES AND CLAMPS— | | FUEL DRAIN TUBES | 14 |
| LOW-PRESSURE TYPE | 4 | FUEL FILTER/WATER SEPARATOR | 14 |
| QUICK-CONNECT FITTINGS—LOW | | FUEL HEATER | 15 |
| PRESSURE TYPE | 5 | FUEL HEATER RELAY | 15 |
| HIGH-PRESSURE FUEL LINES | 5 | FUEL LEVEL SENSOR | 15 |
| FUEL DRAIN TUBES | 6 | FUEL INJECTION PUMP | 15 |
| FUEL HEATER | 6 | FUEL INJECTORS | 19 |
| FUEL HEATER RELAY | 6 | FUEL TANK | 20 |
| DIAGNOSIS AND TESTING | | | |
| GENERAL INFORMATION | 6 | FUEL RESERVOIR MODULE | 21 |
| VISUAL INSPECTION | 6 | HIGH-PRESSURE LINES | 22 |
| AIR IN FUEL SYSTEM | 9 | SPECIFICATIONS | |
| FUEL HEATER RELAY TEST | 9 | FUEL TANK CAPACITY | 22 |
| FUEL INJECTOR TEST | 10 | IDLE SPEED | 22 |
| FUEL INJECTOR / NEEDLE MOVEMENT | | FUEL INJECTOR FIRING SEQUENCE | 22 |
| SENSOR TEST | 10 | FUEL SYSTEM PRESSURE | 22 |

DESCRIPTION AND OPERATION

INTRODUCTION

DESCRIPTION

This Fuel Delivery section will cover components not controlled by the PCM. For components con-

trolled by the PCM, refer to the Fuel Injection System—2.5L Diesel Engine section of this group.

The fuel heater relay, fuel heater and fuel gauge are not operated by the PCM. These components are controlled by the ignition (key) switch. All other fuel system electrical components necessary to operate the engine are controlled or regulated by the PCM.

DESCRIPTION AND OPERATION (Continued)

FUEL SYSTEM PRESSURE WARNING

DESCRIPTION

WARNING: HIGH-PRESSURE FUEL LINES DELIVER DIESEL FUEL UNDER EXTREME PRESSURE FROM THE INJECTION PUMP TO THE FUEL INJECTORS. THIS MAY BE AS HIGH AS 45,000 KPA (6526 PSI). USE EXTREME CAUTION WHEN INSPECTING FOR HIGH-PRESSURE FUEL LEAKS. INSPECT FOR HIGH-PRESSURE FUEL LEAKS WITH A SHEET OF CARDBOARD (Fig. 1). HIGH FUEL INJECTION PRESSURE CAN CAUSE PERSONAL INJURY IF CONTACT IS MADE WITH THE SKIN.

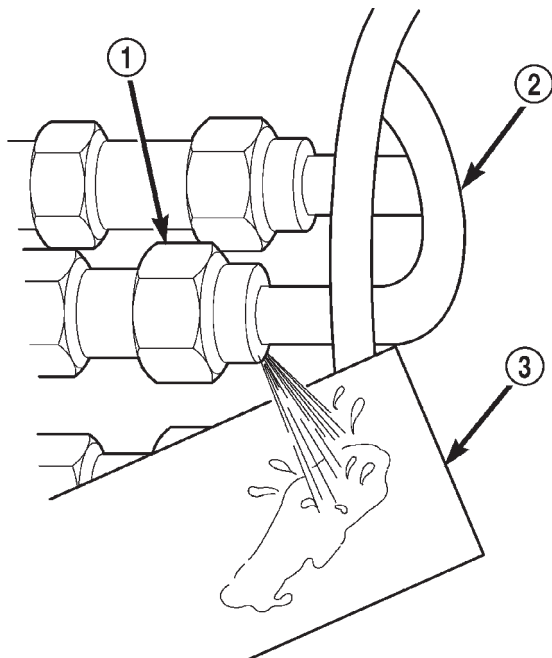

80ba77f9

Fig. 1 Typical Fuel Pressure Test at Injection Pump

- 1 - FITTING
2 - HIGH PRESSURE LINE
3 - CARDBOARD

FUEL TANK

DESCRIPTION

The fuel tank and tank mounting used with the diesel powered engine is the same as used with gasoline powered models, although the fuel tank module is different.

The fuel tank contains the fuel tank module and one rollover valve. Two fuel lines are routed to the fuel tank module. One line is used for fuel supply to the fuel filter/water separator. The other is used to return excess fuel back to the fuel tank.

The fuel tank module contains the fuel gauge electrical sending unit. **An electric fuel pump is not used with the diesel engine.**

FUEL TANK MODULE

DESCRIPTION

An electric fuel pump is not attached to the fuel tank module for diesel powered engines. Fuel is drawn by the fuel injection pump.

The fuel tank module is installed in the top of the fuel tank. The fuel tank module contains the following components:

- Fuel reservoir
- Electric fuel gauge sending unit
- Fuel supply line connection
- Fuel return line connection
- Wire harness
- Fuel inlet filter (Strainer)

FUEL GAUGE SENDING UNIT

DESCRIPTION

The fuel gauge sending unit is attached to the side of the fuel pump module. The sending unit consists of a float, an arm, and a variable resistor (track). The track is used to send an electrical signal used for fuel gauge operation.

As the fuel level increases, the float and arm move up. This decreases the sending unit resistance, causing the PCM to send a signal to the fuel gauge on the instrument panel to read full. As the fuel level decreases, the float and arm move down. This increases the sending unit resistance, causing the PCM to send a signal to the fuel gauge on the instrument panel to move toward empty.

FUEL FILTER/WATER SEPARATOR

DESCRIPTION

The fuel filter/water separator assembly is located in the engine compartment near the strut tower (Fig. 2).

The combination fuel filter/water separator protects the fuel injection pump by helping to remove water and contaminants from the fuel. Moisture collects at the bottom of the filter/separator in a plastic bowl.

The fuel filter/water separator assembly contains the fuel filter, fuel heater element, and water drain valve.

For information on the fuel heater, refer to Fuel Heater in this group.

Refer to the maintenance schedules in Group 0 in this manual for the recommended fuel filter replacement intervals.

For periodic draining of water from the bowl, refer to Fuel Filter/Water Separator Removal/Installation in this group.

DESCRIPTION AND OPERATION (Continued)

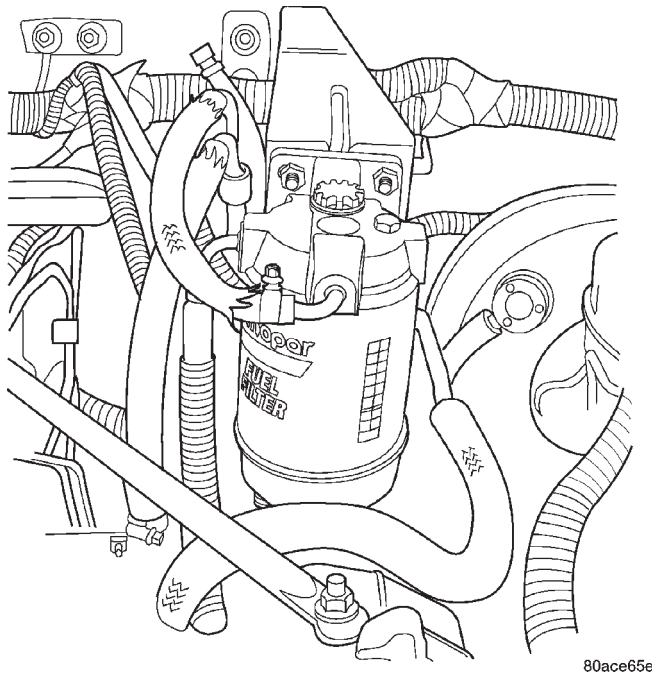

Fig. 2 Fuel Filter/Water Separator Location

FUEL SHUTDOWN SOLENOID

DESCRIPTION

The fuel shutdown solenoid is controlled and operated by the ECM.

The fuel shutdown (shut-off) solenoid is used to electrically shut off the diesel fuel supply to the high-pressure fuel injection pump. The solenoid is mounted to the rear of the injection pump.

The solenoid controls starting and stopping of the engine regardless of the position of the accelerator pedal. When the ignition (key) switch is OFF, the solenoid is shut off and fuel flow is not allowed to the fuel injection pump. When the key is placed in the ON or START positions, fuel supply is allowed at the injection pump.

FUEL INJECTION PUMP

DESCRIPTION

The fuel injection pump is a mechanical distributor-type, Bosch VP36 series (Fig. 3). A gear on the end of the injection pump shaft meshes with the drive gear at the front of engine. The pump is mechanically timed to the engine. The ECM regulates the timing of the injection pump.

The injection pump contains the fuel shutdown solenoid, fuel temperature sensor, control sleeve sensor, fuel quantity actuator and the fuel timing solenoid (Fig. 3).

In the electronically controlled injection pump, the pump plunger works the same as the pump plunger in a mechanically controlled injection pump, but the

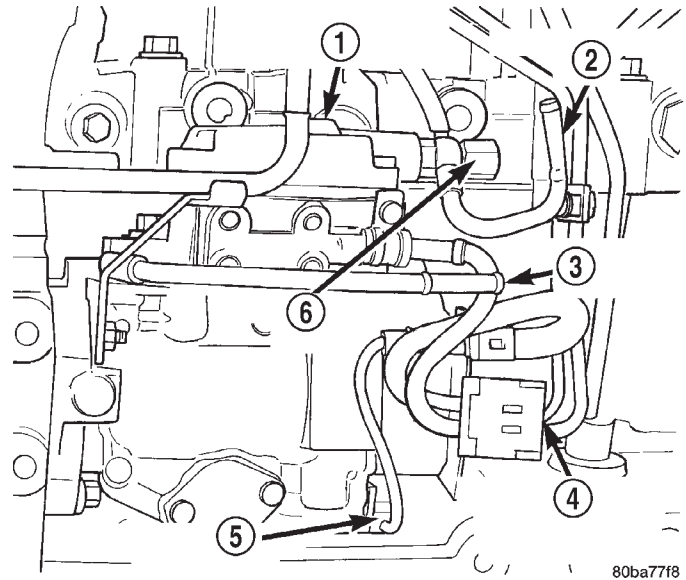

Fig. 3 Fuel Injection Pump

- 1 - FUEL INJECTION PUMP ASSEMBLY
- 2 - FUEL RETURN LINE
- 3 - FUEL SUPPLY LINE
- 4 - FUEL INJECTION PUMP 10-WAY CONNECTOR
- 5 - TIMING SOLENOID
- 6 - OVERFLOW VALVE

amount of fuel and the time the fuel is injected is controlled by the vehicle's ECM, instead of by a mechanical governor assembly. A solenoid controlled by the ECM is used in place of the mechanical governor assembly, and it moves a control sleeve inside the pump that regulates the amount of fuel being injected. There is no mechanical connection between the accelerator pedal and the electronically controlled injection pump. Instead, a sensor connected to the accelerator pedal sends a signal to the ECM that represents the actual position of the accelerator pedal. The ECM uses this input, along with input from other sensors to move the control sleeve to deliver the appropriate amount of fuel. This system is known as "Drive-By-Wire"

The actual time that the fuel is delivered is very important to the diesel combustion process. The ECM monitors outputs from the engine speed sensor (fly-wheel position in degrees), and the fuel injector sensor (mechanical movement within the #1 cylinder fuel injector). Outputs from the Accelerator Pedal Position sensor, engine speed sensor (engine rpm) and engine coolant temperature sensor are also used. The ECM will then compare its set values to these outputs to electrically adjust the fuel timing (amount of advance) within the injection pump. This is referred to as "Closed Loop" operation. The ECM monitors fuel timing by comparing its set value to when the injector #1 opens. If the value is greater than a preset value a fault will be set.

DESCRIPTION AND OPERATION (Continued)

Actual electric fuel timing (amount of advance) is accomplished by the fuel timing solenoid mounted to the bottom of the injection pump (Fig. 3). Fuel timing will be adjusted by the ECM, which controls the fuel timing solenoid.

An overflow valve is attached into the fuel return line at the rear of the fuel injection pump (Fig. 3). This valve serves two purposes. One is to ensure that a certain amount of residual pressure is maintained within the pump when the engine is switched off. This will prevent the fuel timing mechanism within the injection pump from returning to its zero position. The other purpose is to allow excess fuel to be returned to the fuel tank through the fuel return line. The pressure values within this valve are preset and can not be adjusted.

The fuel injection pump supplies high-pressure fuel of approximately 45,000 kPa (6526 psi) to each injector in precise metered amounts at the correct time.

For mechanical injection pump timing, refer to Fuel Injection Pump Timing in the Service Procedures section of this group.

FUEL INJECTORS

DESCRIPTION

The fuel injectors have controlled internal leakage which cools the injectors. Fuel drain tubes (Fig. 4) are used to route this fuel back to the overflow valve at the rear of the injection pump. This excess fuel is then returned to the fuel tank through the fuel return line.

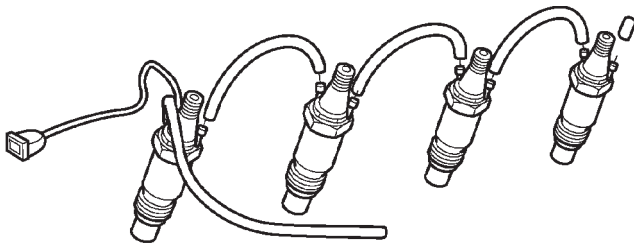

80ba77fa

Fig. 4 Fuel Injectors and Drain Tubes

The injectors are connected to the fuel injection pump by the high-pressure fuel lines. A separate injector is used for each of the four cylinders. An injector containing a sensor (Fig. 5) is used on the number one cylinder injector. This injector is called instrumented injector #1 or needle movement sensor. It is used to tell the ECM when the #1 injector's internal spring-loaded valve seat has been forced open by pressurized fuel being delivered to the cylinder, which is at the end of its compression stroke. When the instrumented injector's valve seat is force

open, it sends a small voltage spike pulse to the ECM. This tells the ECM that the #1 cylinder injector is firing. It is not used with the other three injectors.

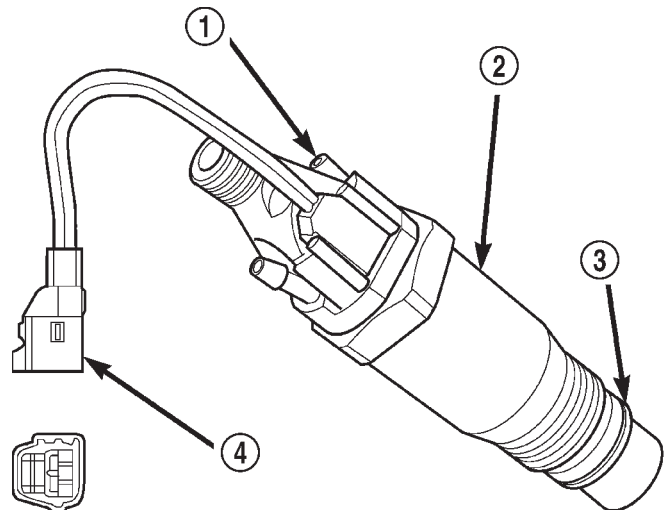

80ba7975

Fig. 5 Fuel Injector Sensor

- 1 - NEEDLE MOVEMENT SENSOR
- 2 - FUEL INJECTOR (NUMBER 1 CYLINDER ONLY)
- 3 - COPPER WASHER
- 4 - SENSOR CONNECTOR

Fuel enters the injector at the fuel inlet (top of injector) and is routed to the needle valve bore. When fuel pressure rises to approximately 15,000–15,800 kPa (2175–2291 psi), the needle valve spring tension is overcome. The needle valve rises and fuel flows through the spray holes in the nozzle tip into the combustion chamber. The pressure required to lift the needle valve is the injector opening pressure setting. This is referred to as the “pop-off” pressure setting.

Fuel pressure in the injector circuit decreases after injection. The injector needle valve is immediately closed by the needle valve spring and fuel flow into the combustion chamber is stopped. Exhaust gases are prevented from entering the injector nozzle by the needle valve.

A copper washer (gasket) is used at the base of each injector (Fig. 5) to prevent combustion gases from escaping.

Fuel injector firing sequence is 1–3–4–2.

FUEL TUBES/LINES/HOSES AND CLAMPS—LOW-PRESSURE TYPE

DESCRIPTION

Also refer to the proceeding section on Quick-Connect Fittings.

DESCRIPTION AND OPERATION (Continued)

Inspect all hose connections such as clamps, couplings and fittings to make sure they are secure and leaks are not present. The component should be replaced immediately if there is any evidence of degradation that could result in failure.

Never attempt to repair a plastic fuel line/tube or a quick-connect fitting. Replace complete line/tube as necessary.

Avoid contact of any fuel tubes/hoses with other vehicle components that could cause abrasions or scuffing. Be sure that the fuel lines/tubes are properly routed to prevent pinching and to avoid heat sources.

The lines/tubes/hoses are of a special construction. If it is necessary to replace these lines/tubes/hoses, use only original equipment type.

The hose clamps used to secure the rubber hoses are of a special rolled edge construction. This construction is used to prevent the edge of the clamp from cutting into the hose. Only these rolled edge type clamps may be used in this system. All other types of clamps may cut into the hoses and cause fuel leaks.

Where a rubber hose is joined to a metal tube (staked), do not attempt to repair. Replace entire line/tube assembly.

Use new original equipment type hose clamps. Tighten hose clamps to 2 N·m (20 in. lbs.) torque.

QUICK-CONNECT FITTINGS—LOW PRESSURE TYPE

DESCRIPTION

Different types of quick-connect fittings are used to attach various fuel system components. These are: a single-tab type, a two-tab type or a plastic retainer ring type (Fig. 6). Refer to Quick-Connect Fittings in the Removal/Installation section for more information.

CAUTION: The interior components (o-rings, spacers) of quick-connect fitting are not serviced separately, but new pull tabs are available for some types. Do not attempt to repair damaged fittings or fuel lines/tubes. If repair is necessary, replace the complete fuel tube assembly.

HIGH-PRESSURE FUEL LINES

DESCRIPTION

CAUTION: The high-pressure fuel lines must be held securely in place in their holders. The lines cannot contact each other or other components. Do not attempt to weld high-pressure fuel lines or to

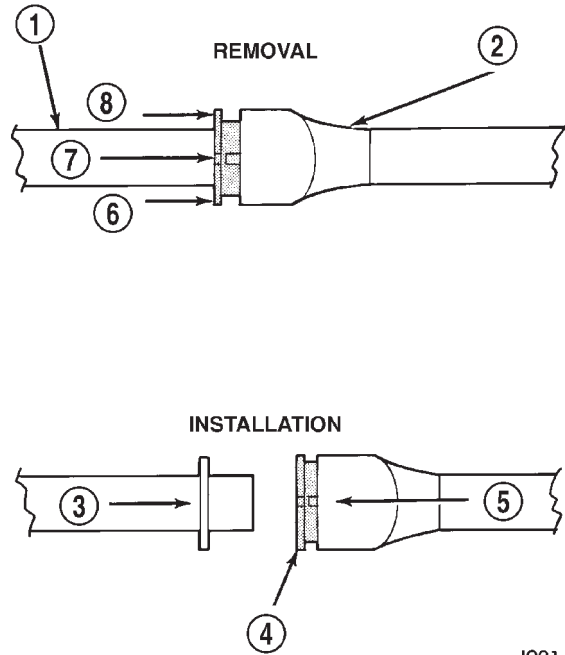

J9314-100

Fig. 6 Plastic Retainer Ring-Type Fitting

- 1 - FUEL TUBE
- 2 - QUICK CONNECT FITTING
- 3 - PUSH
- 4 - PLASTIC RETAINER
- 5 - PUSH
- 6 - PUSH
- 7 - PUSH
- 8 - PUSH

repair lines that are damaged. Only use the recommended lines when replacement of high-pressure fuel line is necessary.

High-pressure fuel lines deliver fuel under pressure of up to approximately 45,000 kPa (6526 PSI) from the injection pump to the fuel injectors. The lines expand and contract from the high-pressure fuel pulses generated during the injection process. All high-pressure fuel lines are of the same length and inside diameter. Correct high-pressure fuel line usage and installation is critical to smooth engine operation.

WARNING: USE EXTREME CAUTION WHEN INSPECTING FOR HIGH-PRESSURE FUEL LEAKS. INSPECT FOR HIGH-PRESSURE FUEL LEAKS WITH A SHEET OF CARDBOARD. HIGH FUEL INJECTION PRESSURE CAN CAUSE PERSONAL INJURY IF CONTACT IS MADE WITH THE SKIN.

DESCRIPTION AND OPERATION (Continued)

FUEL DRAIN TUBES

DESCRIPTION

These rubber tubes are low-pressure type. Some fuel is continually being returned to the fuel injection pump. During injection, a small amount of fuel flows past the injector needle and is not injected into the combustion chamber. This cools and lubricates the injectors. This fuel flows through the fuel drain tubes (Fig. 7) and back to the tee banjo fitting, which is connected to the same line as the overflow valve. The overflow valve is calibrated to open at a preset pressure. Excess fuel not required by the pump to maintain the minimum pump cavity pressure is then returned through the overflow valve and on to the fuel tank through the fuel return line.

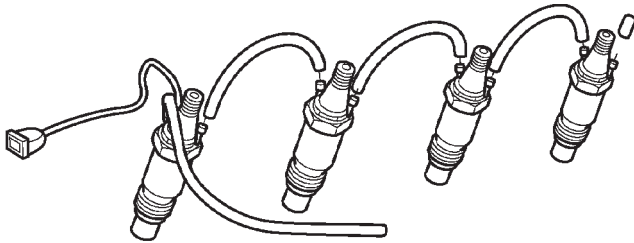

80ba77fa

Fig. 7 Fuel Drain Tubes

FUEL HEATER

DESCRIPTION

The fuel heater is used to prevent diesel fuel from waxing and plugging the fuel filter during cold weather operation. The fuel heater is located in the bottom plastic bowl of the fuel filter/water separator (Fig. 8).

The element inside the heater assembly is made of a Positive Temperature Coefficient (PTC) material, and has power applied to it by the fuel heater relay anytime the ignition key is in the "on" position. PTC material has a high resistance to current flow when its temperature is high, which means that it will not generate heat when the temperature is above a certain value. When the temperature is below 7°C (45° F), the resistance of the PTC element is lowered, and allows current to flow through the fuel heater element warming the fuel. When the temperature is above 29°C (85° F), the PTC element's resistance rises, and current flow through the heater element stops.

Voltage to operate the fuel heater is supplied from the ignition (key) switch and through the fuel heater relay. Refer to the following Fuel Heater Relay for additional information. **The fuel heater and fuel heater relay are not controlled by the Powertrain Control Module (PCM).**

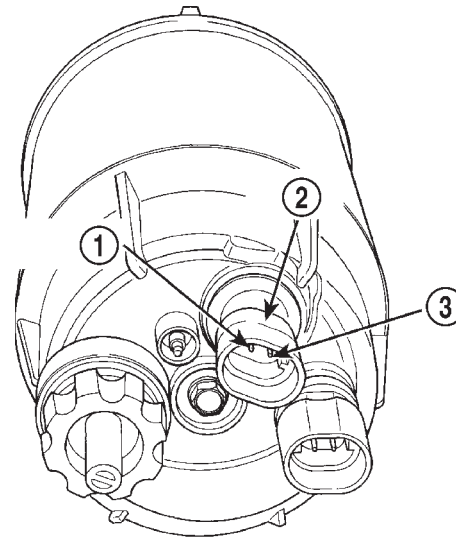

80b6b14f

Fig. 8 Fuel Heater Temperature Sensor and Element Location

- 1 - TERMINAL 2
- 2 - FUEL HEATER
- 3 - TERMINAL 1

FUEL HEATER RELAY

DESCRIPTION

Voltage to operate the fuel heater is supplied from the ignition (key) switch through the fuel heater relay. **The PCM or ECM is not used to control this relay.**

The fuel heater relay is located in the PDC. The PDC is located next to the battery in the engine compartment. For the location of the relay within the PDC, refer to label on PDC cover.

DIAGNOSIS AND TESTING

GENERAL INFORMATION

This section of the group will cover a general diagnosis of diesel engine fuel system components.

Diagnostic Trouble Codes: Refer to On-Board Diagnostics in Group 25, Emission Control System for a list of Diagnostic Trouble Codes (DTC's) for certain fuel system components.

VISUAL INSPECTION

A visual inspection for loose, disconnected, or incorrectly routed wires and hoses should be made before attempting to diagnose or service the diesel fuel injection system. A visual check will help find these conditions. It also saves unnecessary test and diagnostic time. A thorough visual inspection of the fuel injection system includes the following checks:

DIAGNOSIS AND TESTING (Continued)

- (1) Be sure that the battery connections are tight and not corroded.
- (2) Be sure that the 60 way connector is fully engaged with the PCM (Fig. 9).
- (3) Be sure that the 68 way connector is fully engaged with the MSA (Fig. 10)

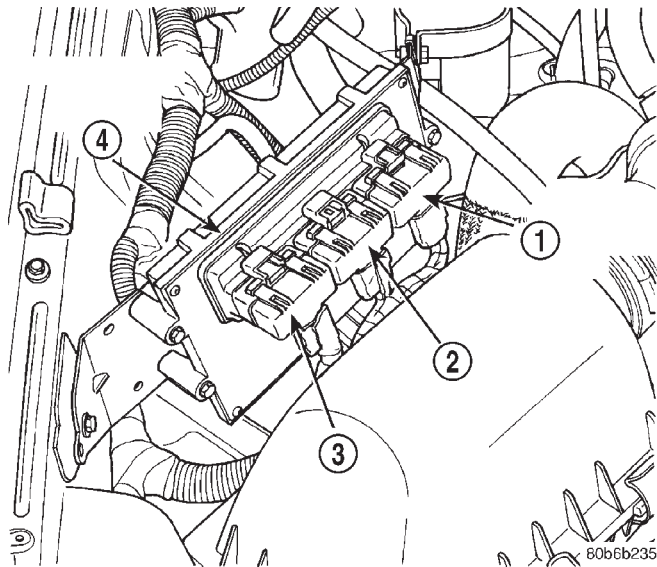

Fig. 9 PCM Location—Typical

- 1 - PCM HARNESS CONNECTOR C1
- 2 - PCM HARNESS CONNECTOR C2
- 3 - PCM HARNESS CONNECTOR C3
- 4 - POWERTRAIN CONTROL MODULE (PCM)

- (4) Verify that the electrical connections for the ASD relay are clean and free of corrosion. This relay is located in the PDC. For the location of the relay within the PDC, refer to label on PDC cover.
- (5) Verify that the electrical connections for the fuel heater relay are clean and free of corrosion. This relay is located in the PDC. For the location of the relay within the PDC, refer to label on PDC cover.
- (6) Be sure the electrical connectors at the ends of the glow plugs (Fig. 11) are tight and free of corrosion.

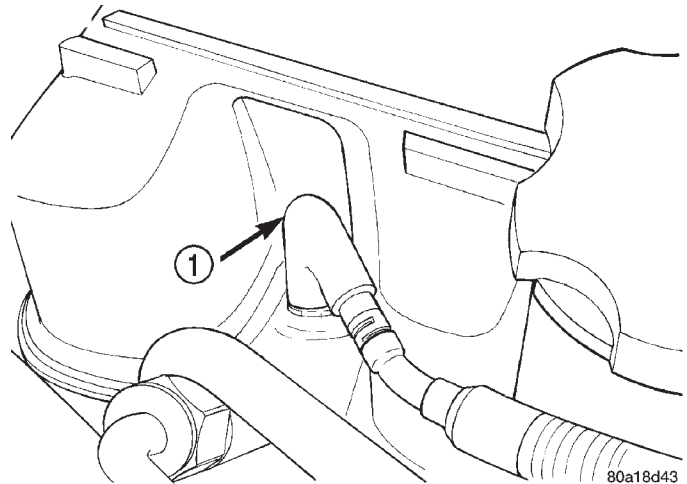

Fig. 11 Glow Plug Connector

- 1 - GLOW PLUG ELECTRICAL CONNECTOR

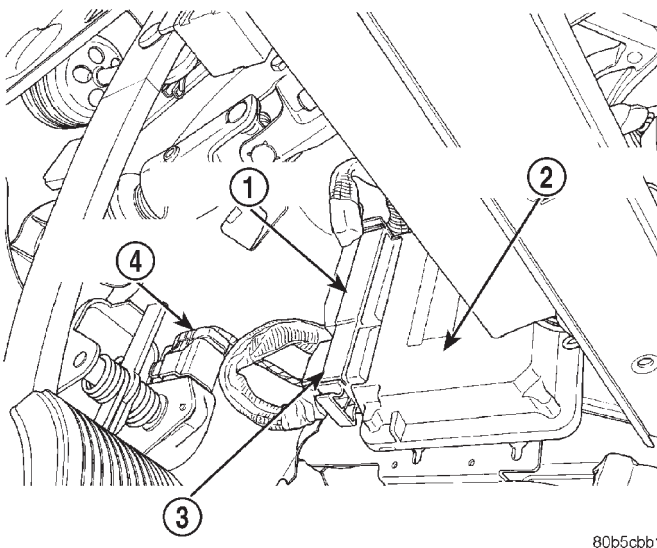
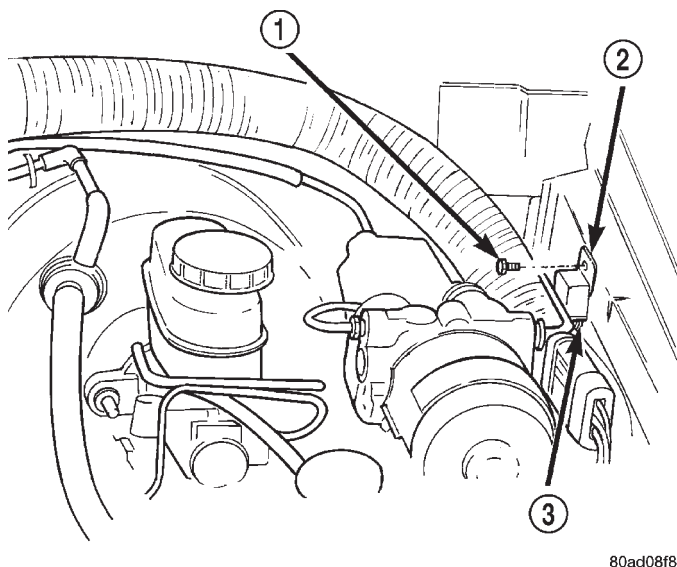

Fig. 10 ECM Location—LHD

- 1 - ECM HARNESS CONNECTOR C1
- 2 - ENGINE CONTROL MODULE (ECM)
- 3 - ECM HARNESS CONNECTOR C2
- 4 - ACCELERATOR PEDAL POSITION SENSOR

- (7) Be sure that the electrical connections at the glow plug relay are tight and not corroded. The glow plug relay is located in the engine compartment on the left-inner fender (Fig. 12).
- (8) Inspect the starter motor and starter solenoid connections for tightness and corrosion.
- (9) Verify that the Fuel Injection Pump electrical connector is firmly connected. Inspect the connector for corrosion or damaged wires. The solenoid is mounted to the rear of the injection pump (Fig. 13).
- (10) Verify that the fuel heater electrical connector is firmly attached to the filter bowl at the bottom of the fuel filter/water separator. Inspect the connector for corrosion or damaged wires.
- (11) Verify that the electrical pigtail connector (sensor connector) (Fig. 14) for the fuel injector sensor is firmly connected to the engine wiring harness. Inspect the connector for corrosion or damaged wires. This sensor is used on the #1 cylinder injector only.
- (12) Inspect for exhaust system restrictions such as pinched exhaust pipes or a collapsed or plugged muffler.
- (13) Verify that the harness connector is firmly connected to the vehicle speed sensor (Fig. 15).

DIAGNOSIS AND TESTING (Continued)



80ad08f8

Fig. 12 Glow Plug Relay Location

- 1 - MOUNTING BOLT
- 2 - GLOW PLUG RELAY
- 3 - ELECTRICAL CONNECTOR

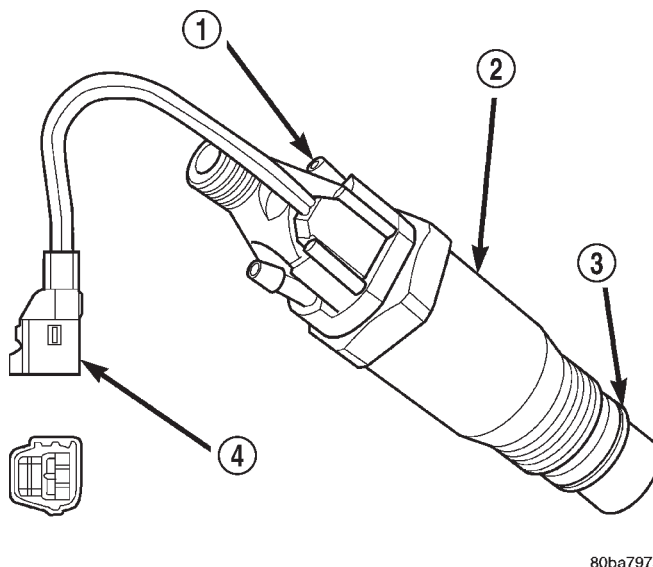

80ba7975

Fig. 14 Fuel Injector Sensor

- 1 - NEEDLE MOVEMENT SENSOR
- 2 - FUEL INJECTOR (NUMBER 1 CYLINDER ONLY)
- 3 - COPPER WASHER
- 4 - SENSOR CONNECTOR

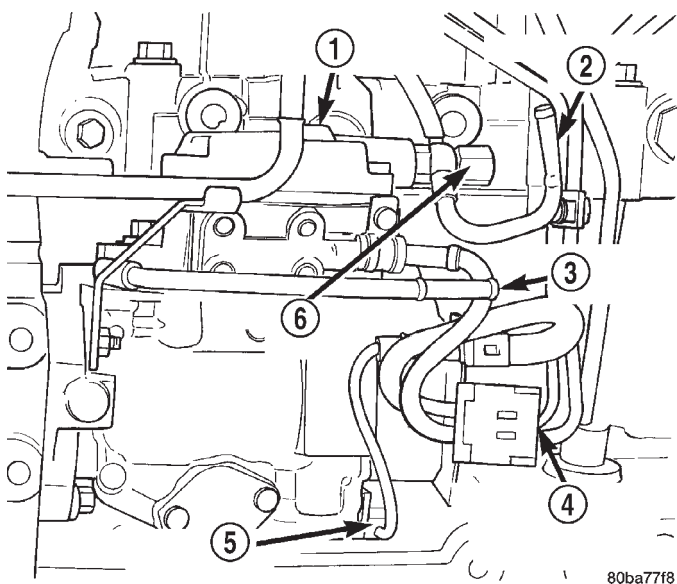

80ba77f8

Fig. 13 Fuel Shutdown Solenoid Location

- 1 - FUEL INJECTION PUMP ASSEMBLY
- 2 - FUEL RETURN LINE
- 3 - FUEL SUPPLY LINE
- 4 - FUEL INJECTION PUMP 10-WAY CONNECTOR
- 5 - TIMING SOLENOID
- 6 - OVERFLOW VALVE

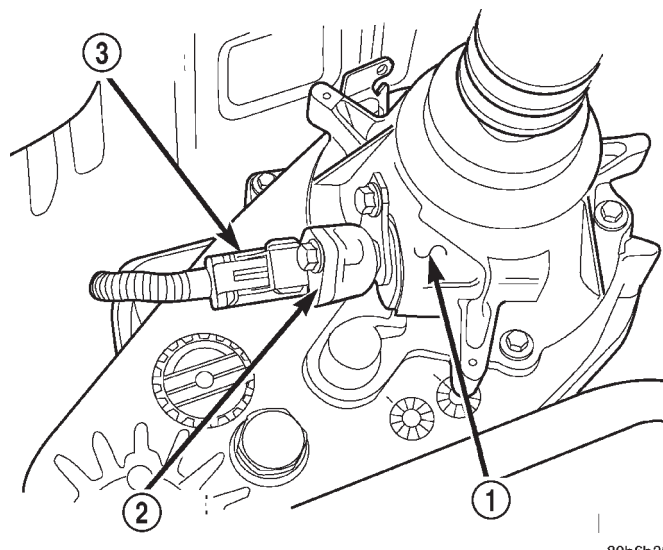

80b6b22c

Fig. 15 Vehicle Speed Sensor—4 Wheel Drive

- 1 - 4WD TRANSFER CASE EXTENSION
- 2 - VEHICLE SPEED SENSOR
- 3 - SENSOR ELECTRICAL CONNECTOR

(14) Verify turbocharger wastegate operation. Refer to Group 11, Exhaust System and Intake Manifold Group for information.

(15) Verify that the harness connector is firmly connected to the engine coolant temperature sensor.

The sensor is located on the side of cylinder head near the rear of fuel injection pump (Fig. 16).

(16) Check for air in the fuel system. Refer to the Air Bleed Procedure.

(17) Inspect all fuel supply and return lines for signs of leakage.

DIAGNOSIS AND TESTING (Continued)

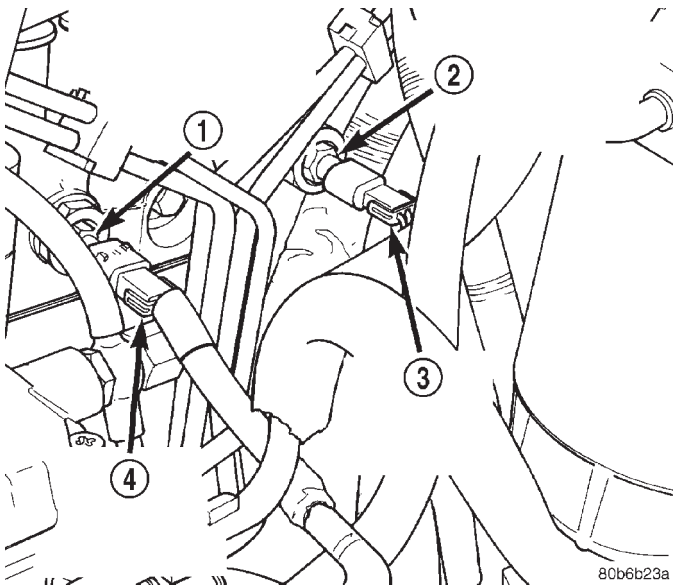

Fig. 16 Engine Coolant Temperature Sensor Location

- 1 - PCM ENGINE COOLANT TEMPERATURE (ECT) SENSOR
- 2 - ECM ENGINE COOLANT TEMPERATURE (ECT) SENSOR
- 3 - ECM ECT SENSOR HARNESS CONNECTOR
- 4 - PCM ECT SENSOR HARNESS CONNECTOR

(18) Be sure that the ground connections are tight and free of corrosion. Refer to Group 8, Wiring for locations of ground connections.

(19) Inspect the air cleaner element (filter) for restrictions.

(20) Be sure that the turbocharger output hose is properly connected to the charge air cooler (inter-cooler) inlet tube. Verify that the charge air cooler output hose is properly connected to the cooler and the intake manifold. Refer to Group 11, Exhaust System and Intake Manifold for information.

(21) Be sure that the vacuum hoses to the vacuum pump are connected and not leaking. The vacuum pump is located in the front of engine (internal) and is driven from the crankshaft gear (Fig. 17). Disconnect the hose and check for minimum vacuum from the pump. Refer to Group 5, Brake System for specifications and procedures.

(22) Be sure that the accessory drive belt is not damaged or slipping.

(23) Verify there is a good connection at the engine speed sensor. Refer to the Fuel Injection System in this section for location of the engine speed sensor location.

(24) Verify there is a good connection at the Boost Pressure Sensor, which is a part of the air intake assembly.

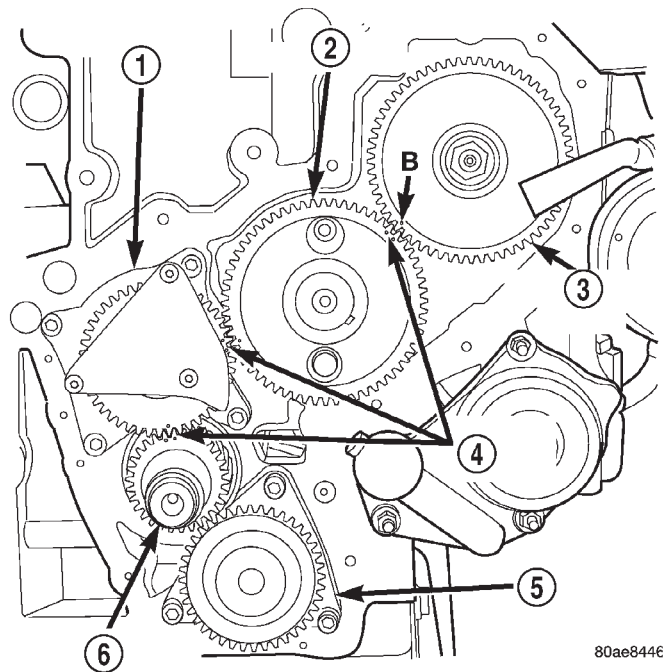

Fig. 17 Vacuum Pump at Front of Engine

- 1 - VACUUM PUMP
- 2 - CAMSHAFT
- 3 - INJECTION PUMP
- 4 - TIMING MARKS
- 5 - OIL PUMP
- 6 - CRANKSHAFT

AIR IN FUEL SYSTEM

Air will enter the fuel system whenever the fuel supply lines, fuel filter/water separator, fuel filter bowl, injection pump, high-pressure lines or injectors are removed or disconnected. Air will also enter the fuel system whenever the fuel tank has been run empty.

Air trapped in the fuel system can result in hard starting, a rough running engine, engine misfire, low power, excessive smoke and fuel knock. After service is performed, air must be bled from the system before starting the engine.

Inspect the fuel system from the fuel tank to the injectors for loose connections. Leaking fuel is an indicator of loose connections or defective seals. Air can also enter the fuel system between the fuel tank and the injection pump. Inspect the fuel tank and fuel lines for damage that might allow air into the system.

For air bleeding, refer to Air Bleed Procedure in the Service Procedures section of this group.

FUEL HEATER RELAY TEST

The fuel heater relay is located in the Power Distribution Center (PDC). Refer to Relays—Operation/

DIAGNOSIS AND TESTING (Continued)

Testing in Fuel Injection System section of this group for test procedures.

FUEL INJECTOR TEST

The fuel injection nozzels, located in the engine cylinder head, spray fuel under high pressure into the individual combustion chambers. Pressurized fuel, delivered by the fuel injection pump, unseats a spring-loaded needle valve inside the injector, and the fuel is atomized as it escapes through the injector opening into the engine's combustion chamber. If the fuel injector does not operate properly, the engine may misfire, or cause other driveability problems.

A leak in the injection pump-to-injector high-pressure fuel line can cause many of the same symptoms as a malfunctioning injector. Inspect for a leak in the high-pressure lines before checking for a malfunctioning fuel injector.

WARNING: THE INJECTION PUMP SUPPLIES HIGH-PRESSURE FUEL OF UP TO APPROXIMATELY 45,000 KPA (6526 PSI) TO EACH INDIVIDUAL INJECTOR THROUGH THE HIGH-PRESSURE LINES. FUEL UNDER THIS AMOUNT OF PRESSURE CAN PENETRATE THE SKIN AND CAUSE PERSONAL INJURY. WEAR SAFETY GOGGLES AND ADEQUATE PROTECTIVE CLOTHING. AVOID CONTACT WITH FUEL SPRAY WHEN BLEEDING HIGH-PRESSURE FUEL LINES.

WARNING: DO NOT BLEED AIR FROM THE FUEL SYSTEM OF A HOT ENGINE. DO NOT ALLOW FUEL TO SPRAY ONTO THE EXHAUST MANIFOLD WHEN BLEEDING AIR FROM THE FUEL SYSTEM.

To determine which fuel injector is malfunctioning, run the engine and loosen the high-pressure fuel line nut at the injector (Fig. 18). Listen for a change in engine speed. If engine speed drops, the injector was operating normally. If engine speed remains the same, the injector may be malfunctioning. After testing, tighten the line nut to 19 N·m (14 ft. lbs.) torque. Test all injectors in the same manner one at a time.

Once an injector has been found to be malfunctioning, remove it from the engine and test it. Refer to the Removal/Installation section of this group for procedures.

After the injector has been removed, install it to a bench-mount injector tester. Refer to operating instructions supplied with tester for procedures.

The opening pressure or "pop" pressure should be 15,000–15,800 kPa (2175–2291 psi). If the fuel injector needle valve is opening ("popping") too early or too late, replace the injector.

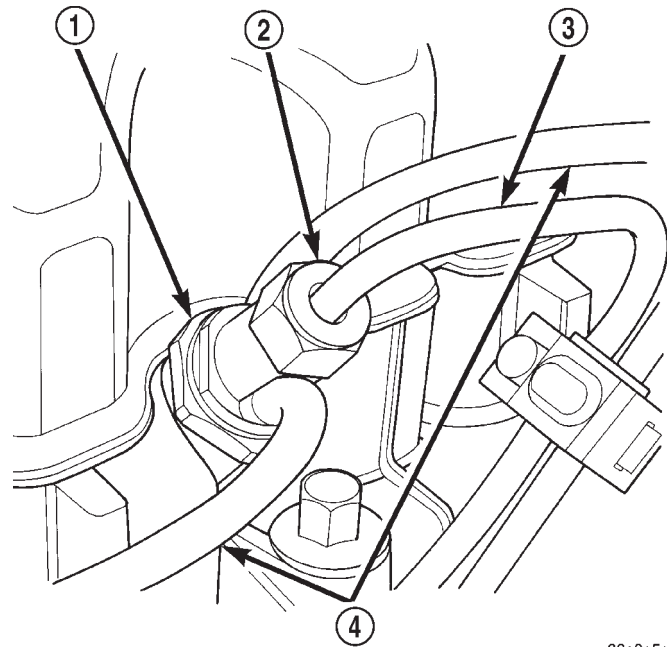

80a0c5d4

Fig. 18 Typical Inspection of Fuel Injector

- 1 – FUEL INJECTOR
- 2 – LINE FITTING
- 3 – HIGH-PRESSURE FUEL LINE
- 4 – FUEL DRAIN TUBES

FUEL INJECTOR / NEEDLE MOVEMENT SENSOR TEST

The needle movement sensor is used only on the number-1 cylinder fuel injector (Fig. 19). It is not used on the injectors for cylinders number 2, 3, or 4.

Testing the needle movement sensor requires the use of a DRB Scan tool. Refer to the Powertrain Diagnostic Procedures manual for additional information.

FUEL INJECTION PUMP TEST

The injection pump is not to be serviced or the warranty may be voided. If the injection pump requires service, the complete assembly must be replaced.

Incorrect injection pump timing (mechanical or electrical) can cause poor performance, excessive smoke and emissions and poor fuel economy.

A defective fuel injection pump, defective fuel timing solenoid or misadjusted mechanical pump timing can cause starting problems or prevent the engine from revving up. It can also cause:

- Engine surge at idle
- Rough idle (warm engine)
- Low power
- Excessive fuel consumption
- Poor performance
- Low power

DIAGNOSIS AND TESTING (Continued)

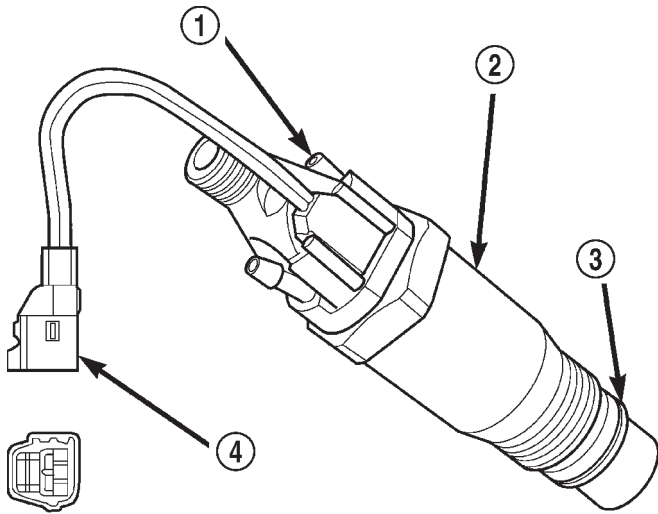

80ba7975

Fig. 19 Needle Movement Sensor Location

- 1 – NEEDLE MOVEMENT SENSOR
- 2 – FUEL INJECTOR (NUMBER 1 CYLINDER ONLY)
- 3 – COPPER WASHER
- 4 – SENSOR CONNECTOR

- Black smoke from the exhaust
- Blue or white fog like exhaust
- Incorrect idle or maximum speed

The electronically controlled fuel pump has no mechanical governor like older mechanically controlled fuel pumps. Do not remove the top cover of the fuel pump, or the screws fastening the wiring pigtail to the side of the pump. **The warranty of the injection pump and the engine may be void if those seals have been removed or tampered with.**

FUEL SUPPLY RESTRICTIONS

LOW-PRESSURE LINES

Restricted or Plugged supply lines or fuel filter can cause a timing fault that will cause the ECM to operate the engine in a "Limp Home" mode. See the introduction of the Fuel Injection System in this group for more information on the Limp Home mode. Fuel supply line restrictions can cause starting problems and prevent the engine from revving up. The starting problems include; low power and blue or white fog like exhaust. Test all fuel supply lines for restrictions or blockage. Flush or replace as necessary. Bleed the fuel system of air once a fuel supply line has been replaced. Refer to the Air Bleed Procedure section of this group for procedures.

HIGH-PRESSURE LINES

Restricted (kinked or bent) high-pressure lines can cause starting problems, poor engine performance and black smoke from exhaust.

Examine all high-pressure lines for any damage. Each radius on each high-pressure line must be smooth and free of any bends or kinks.

Replace damaged, restricted or leaking high-pressure fuel lines with the correct replacement line.

CAUTION: The high-pressure fuel lines must be clamped securely in place in the holders. The lines cannot contact each other or other components. Do not attempt to weld high-pressure fuel lines or to repair lines that are damaged. Only use the recommended lines when replacement of high-pressure fuel line is necessary.

FUEL SHUTDOWN SOLENOID TEST

Refer to 2000 XJ 2.5L Diesel Powertrain Diagnostic Manual for the Fuel Shutdown Solenoid test.

HIGH-PRESSURE FUEL LINE LEAK TEST

High-pressure fuel line leaks can cause starting problems and poor engine performance.

WARNING: DUE TO EXTREME FUEL PRESSURES OF UP TO 45,000 KPA (6526 PSI), USE EXTREME CAUTION WHEN INSPECTING FOR HIGH-PRESSURE FUEL LEAKS. DO NOT GET YOUR HAND, OR ANY PART OF YOUR BODY NEAR A SUSPECTED LEAK. INSPECT FOR HIGH-PRESSURE FUEL LEAKS WITH A SHEET OF CARDBOARD. HIGH FUEL INJECTION PRESSURE CAN CAUSE PERSONAL INJURY IF CONTACT IS MADE WITH THE SKIN.

Start the engine. Move the cardboard over the high-pressure fuel lines and check for fuel spray onto the cardboard (Fig. 20). If a high-pressure line connection is leaking, bleed the system and tighten the connection. Refer to the Air Bleed Procedure in this group for procedures. Replace damaged, restricted or leaking high-pressure fuel lines with the correct replacement line.

CAUTION: The high-pressure fuel lines must be clamped securely in the holders. The lines cannot contact each other or other components. Do not attempt to weld high-pressure fuel lines or to repair lines that are damaged. Only use the recommended lines when replacement of high-pressure fuel line is necessary.

DIAGNOSIS AND TESTING (Continued)

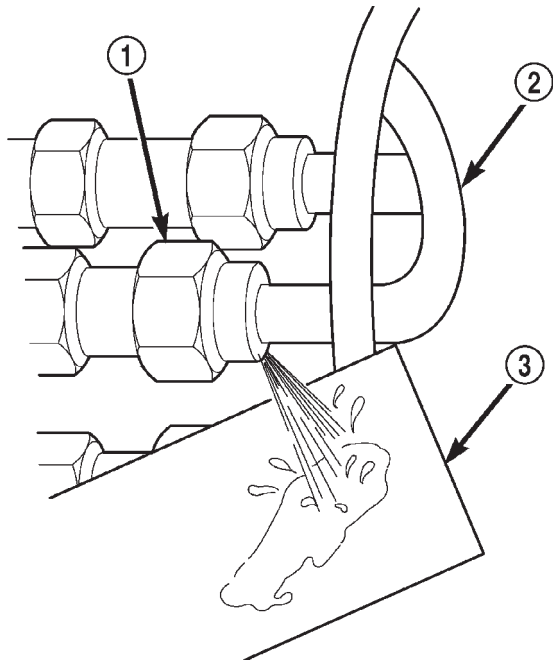

80ba77f9

Fig. 20 Typical Fuel Pressure Test at Injection Pump

- 1 - FITTING
- 2 - HIGH PRESSURE LINE
- 3 - CARDBOARD

SERVICE PROCEDURES

AIR BLEED PROCEDURES

AIR BLEEDING AT FUEL FILTER

A certain amount of air may become trapped in the fuel system when fuel system components are serviced or replaced. Bleed the system as needed after fuel system service according to the following procedures.

WARNING: DO NOT BLEED AIR FROM THE FUEL SYSTEM OF A HOT ENGINE. DO NOT ALLOW FUEL TO SPRAY ONTO THE EXHAUST MANIFOLD WHEN BLEEDING AIR FROM THE FUEL SYSTEM.

Some air enters the fuel system when the fuel filter or injection pump supply line is changed. This small amount of air is vented automatically from the injection pump through the fuel drain manifold tubes if the filter was changed according to instructions. Ensure the the fuel filter/water separator is full of fuel

It may be necessary to manually bleed the system if:

- The bowl of the fuel filter/water separator is not partially filled before installation of a new filter
- The injection pump is replaced
- High-pressure fuel line connections are loosened or lines replaced

- Initial engine start-up or start-up after an extended period of no engine operation
- Running fuel tank empty

FUEL INJECTION PUMP BLEEDING

(1) If the fuel injection pump has been replaced, air should be bled at the overflow valve before attempting to start engine.

(a) Loosen the overflow valve (Fig. 21) at the rear of the injection pump.

(b) Place a towel below the valve.

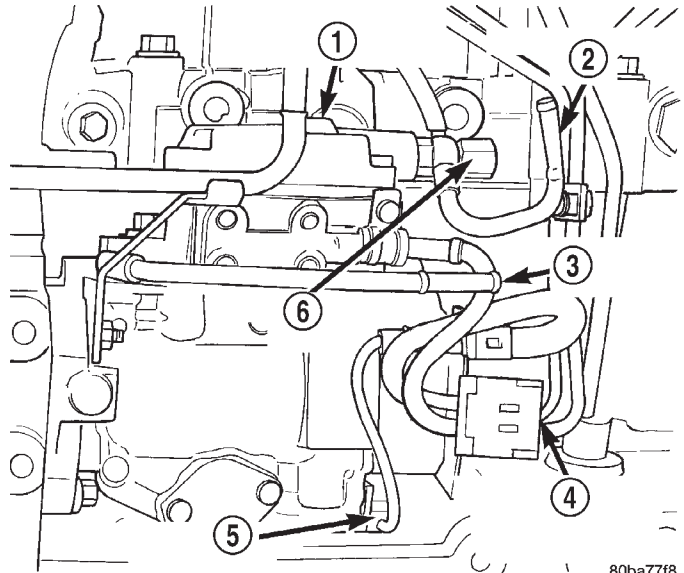

80ba77f8

Fig. 21 Overflow Valve

- 1 - FUEL INJECTION PUMP ASSEMBLY
- 2 - FUEL RETURN LINE
- 3 - FUEL SUPPLY LINE
- 4 - FUEL INJECTION PUMP 10-WAY CONNECTOR
- 5 - TIMING SOLENOID
- 6 - OVERFLOW VALVE

WARNING: WHEN CRANKING THE ENGINE TO BLEED AIR FROM THE INJECTION PUMP, THE ENGINE MAY START. PLACE THE TRANSMISSION IN NEUTRAL OR PARK AND SET PARKING BRAKE BEFORE ENGAGING THE STARTER MOTOR.

CAUTION: Do not engage the starter motor for more than 30 seconds at a time. Allow 2 minutes between cranking intervals.

(2) Crank the engine for 30 seconds at a time to allow air trapped in the injection pump to vent out the fuel injector drain tubes. Continue this procedure until the engine starts. Observe the previous WARNING and CAUTION.

(3) Tighten overflow valve.

SERVICE PROCEDURES (Continued)

HIGH-PRESSURE FUEL LINE BLEEDING

WARNING: THE INJECTION PUMP SUPPLIES HIGH-PRESSURE FUEL OF APPROXIMATELY 45,000 KPA (6,526 PSI) TO EACH INDIVIDUAL INJECTOR THROUGH THE HIGH-PRESSURE LINES. FUEL UNDER THIS AMOUNT OF PRESSURE CAN PENETRATE THE SKIN AND CAUSE PERSONAL INJURY. WEAR SAFETY GOGGLES AND ADEQUATE PROTECTIVE CLOTHING AND AVOID CONTACT WITH FUEL SPRAY WHEN BLEEDING HIGH-PRESSURE FUEL LINES.

WARNING: DO NOT BLEED AIR FROM THE FUEL SYSTEM OF A HOT ENGINE. DO NOT ALLOW FUEL TO SPRAY ONTO THE EXHAUST MANIFOLD WHEN BLEEDING AIR FROM THE FUEL SYSTEM.

Bleed air from one injector at time.

(1) Loosen the high-pressure fuel line fitting at the injector (Fig. 22).

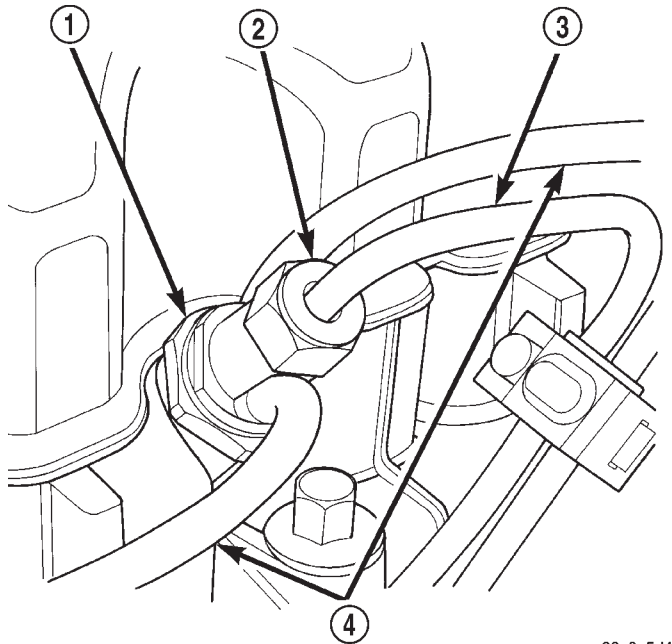

80a0c5d4

Fig. 22 Bleeding High-Pressure Fuel Line—Typical

- 1 - FUEL INJECTOR
- 2 - LINE FITTING
- 3 - HIGH-PRESSURE FUEL LINE
- 4 - FUEL DRAIN TUBES

(2) Crank the engine until all air has been bled from the line. **Do not operate the starter motor for longer than 30 seconds. Wait 2 minutes between cranking intervals.**

(3) Start the engine and bleed one injector at a time until the engine runs smoothly.

FUEL INJECTION PUMP TIMING

Refer to the Fuel Injection Pump Removal and Installation procedure in Service Procedures later in this Group.

REMOVAL AND INSTALLATION

ACCELERATOR PEDAL

REMOVAL

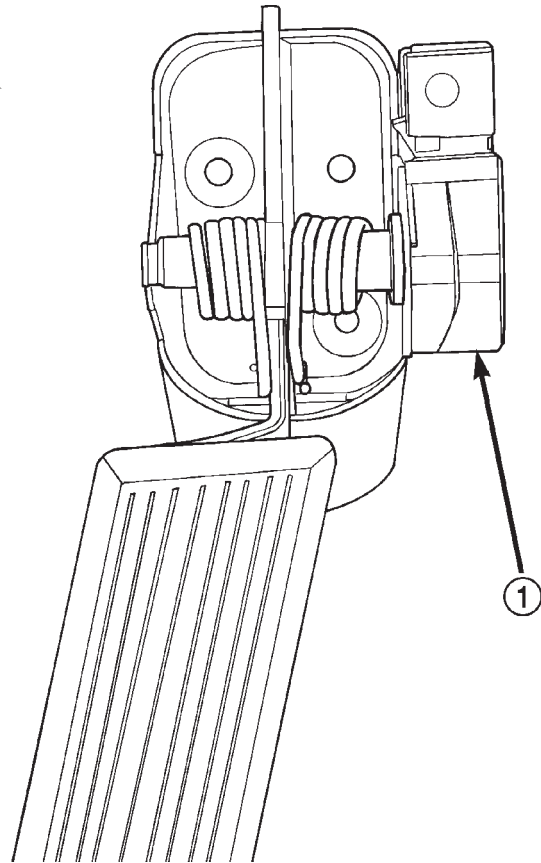

80a38325

Fig. 23 Accelerator Pedal Mounting—Typical

- 1 - PEDAL POSITION SENSOR

- (1) Disconnect electrical connector.
- (2) Remove accelerator pedal mounting bracket nuts. Remove accelerator pedal assembly.

INSTALLATION

(1) Place accelerator pedal assembly over studs protruding from floor pan. Tighten mounting nuts to 5 N·m (46 in. lbs.) torque.

(2) Connect electrical connector.

(3) Before starting the engine, operate the accelerator pedal to check for any binding.

REMOVAL AND INSTALLATION (Continued)

FUEL DRAIN TUBES

The fuel drain tubes (Fig. 24) are low-pressure type.

Pull each tube from the injector for removal. Push on for installation. Clamps are not required for these tubes.

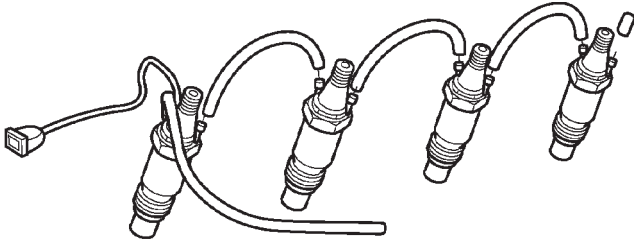

80ba77fa

Fig. 24 Fuel Injectors and Drain Tubes

FUEL FILTER/WATER SEPARATOR

The fuel filter/water separator is located in the engine compartment on the left side near the shock tower. (Fig. 25).

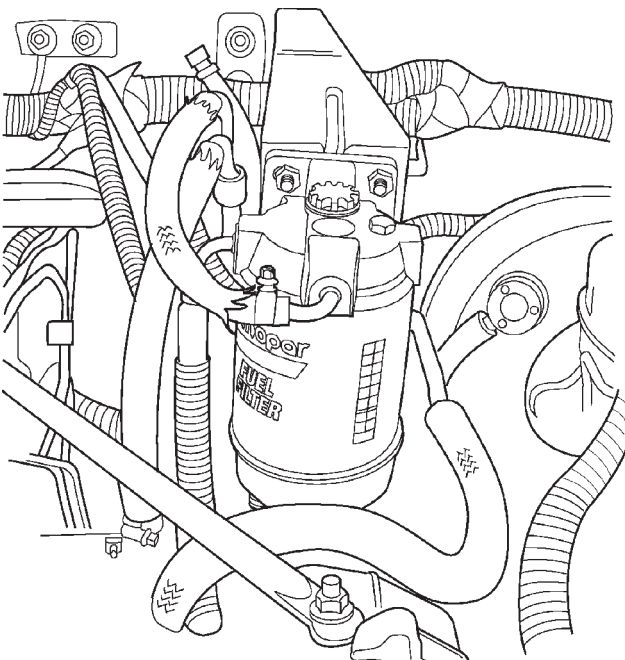

80ace65e

Fig. 25 Fuel Filter/Water Separator Location

The fuel filter/water separator assembly contains the fuel filter, fuel heater element, and fuel drain valve (Fig. 25).

DRAINING WATER FROM FILTER BOWL

Moisture (water) collects at the bottom of the filter/separator in a plastic bowl. Water entering the fuel injection pump can cause serious damage to the pump. **Note that the bulb will be illuminated for approximately 2 seconds each time the key is**

initially placed in the ON position. This is done for a bulb check.

WARNING: DO NOT ATTEMPT TO DRAIN WATER FROM THE FILTER/SEPARATOR WITH THE ENGINE HOT.

(1) The bottom of the filter/separator bowl is equipped with a drain valve (Fig. 25). The drain valve is equipped with a fitting. Attach a piece of rubber hose to this fitting. This hose is to be used as a drain hose.

(2) Place a drain pan under the drain hose.

(3) Open the vent valve at top of fuel filter/water separator.

(4) With the engine not running, open the drain valve by unscrewing the valve (**drain valve has right hand threads**) from the filter/separator bowl. To gain access to this fitting, the two filter-to-mounting bracket nuts (Fig. 25) may have to be loosened a few turns.

(5) Hold the drain open until clean fuel exits the drain.

(6) After draining, close drain valve.

(7) Remove rubber drain hose.

(8) Dispose of mixture in drain pan according to applicable local or federal regulations.

FUEL FILTER REMOVAL

(1) Drain all fuel and/or water from fuel filter/water separator assembly. Refer to the previous Draining Water From Filter Bowl.

(2) Unplug the electrical connectors at bottom of plastic bowl.

(3) Remove plastic bowl from bottom of fuel filter (unscrews).

(4) Remove fuel filter from bottom of filter base (unscrews).

FUEL FILTER INSTALLATION

(1) Clean bottom of fuel filter base.

(2) Apply clean diesel fuel to new fuel filter gasket.

(3) Install and tighten filter to filter base. The beveled part of the rubber gasket should be facing up towards the filter base.

(4) Clean the inside of bowl with a soap and water mixture before installation. Carefully clean any residue between the two metal probes at the top of the water-in-fuel sensor. Do not use chemical cleaners as damage to the plastic bowl may result.

(5) Install filter bowl to bottom of filter.

(6) Install the electrical connectors at bottom of bowl.

(7) Tighten the filter-to-mounting bracket nuts (Fig. 25) to 28 N·m (250 in. lbs.) torque.

REMOVAL AND INSTALLATION (Continued)

FUEL HEATER

If the fuel heater element needs replacement, the plastic filter bowl assembly must be replaced. Refer to Fuel Filter/Water Separator for information.

FUEL HEATER RELAY

The fuel heater relay is located in the PDC. For the location of the relay within the PDC (Fig. 26), refer to label on PDC cover.

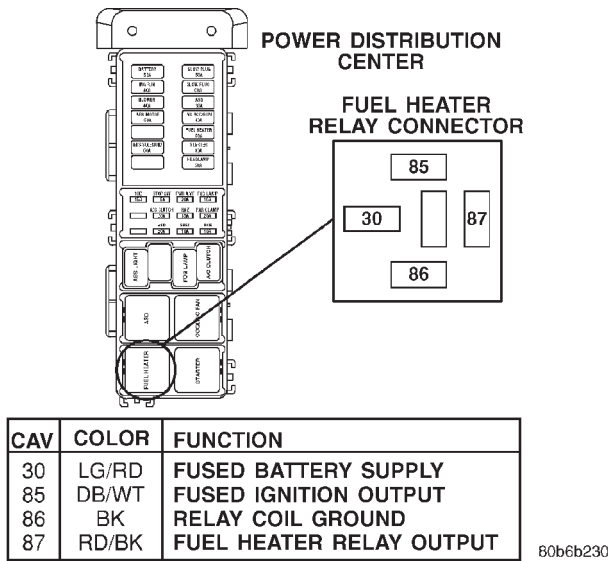

Fig. 26 Power Distribution Center (PDC) Location

FUEL LEVEL SENSOR

The fuel level sensor is located on the side of the fuel pump module. (Fig. 27)

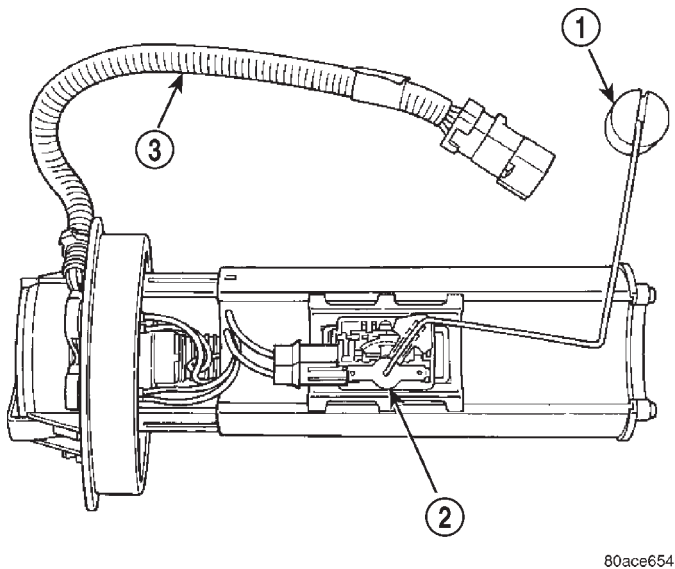

Fig. 27 Fuel Level Sensor

- 1 - FUEL GAUGE FLOAT
- 2 - FUEL GAUGE SENDING UNIT
- 3 - PIGTAIL WIRING HARNESS

REMOVAL

- (1) Remove fuel tank. Refer to Fuel Tank Removal/Installation.
- (2) Remove fuel pump module. Refer to Fuel Pump Module Removal/Installation
- (3) Remove electrical wire connector at sending unit terminals.
- (4) Press on release tab (Fig. 28) to remove sending unit from pump module.

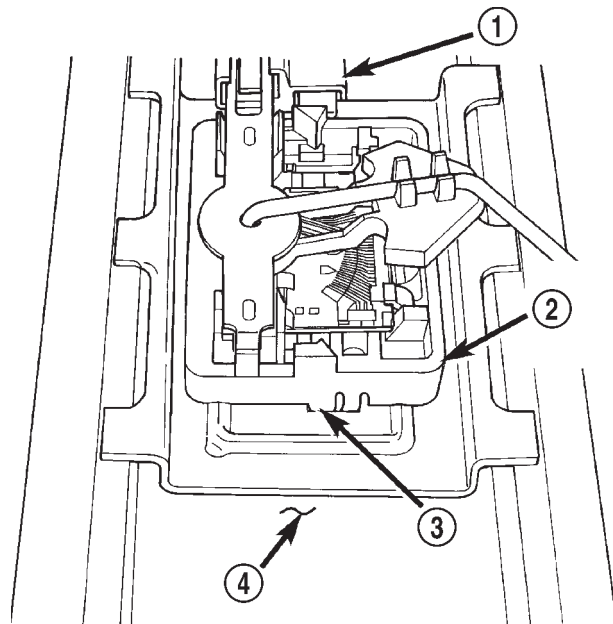

Fig. 28 Fuel Level Sensor Release Tab

- 1 - ELECTRICAL CONNECTOR
- 2 - FUEL LEVEL SENSOR
- 3 - RELEASE TAB
- 4 - FUEL RESERVOIR MODULE

FUEL INJECTION PUMP

REMOVAL

- (1) Disconnect the negative battery cable.
- (2) Thoroughly clean the area around the injection pump and fuel lines of all dirt, grease and other contaminants. **Due to the close internal tolerances of the injection pump, this step must be performed before removing pump.**
- (3) Remove the engine accessory drive belt. Refer to Group 7, Cooling System for procedures.
- (4) Remove the generator assembly.
- (5) Remove the rubber fuel return and supply hoses from the metal lines at the pump (Fig. 29).
- (6) Remove the electrical connector at engine coolant temperature sensor.
- (7) Disconnect the Fuel Injection Pump electrical connector at fuel pump. (Fig. 29).

REMOVAL AND INSTALLATION (Continued)

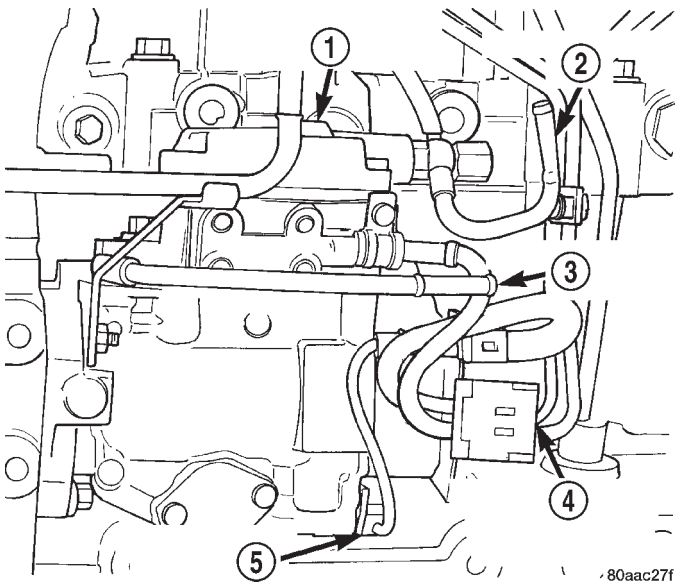
**Fig. 29 Fuel Injection Pump**

- 1 - FUEL INJECTION PUMP ASSEMBLY
- 2 - FUEL RETURN LINE
- 3 - FUEL SUPPLY LINE
- 4 - FUEL INJECTION PUMP 10-WAY CONNECTOR
- 5 - FUEL TIMING SOLENOID

(8) Disconnect the main engine wiring harness from the glow plugs.

(9) Disconnect the four high-pressure fuel lines from the fuel injection pump. Also disconnect fuel lines at the fuel injectors. For procedures, refer to High-Pressure Fuel Lines in this group. Place a rag beneath the fittings to catch excess fuel.

(10) Remove the plug from timing gear cover.

(11) The "Top Dead Center" (TDC) compression firing stroke for the #1 cylinder can be determined as follows:

(a) Using a socket attached to the front of the crankshaft, rotate the engine clockwise until special alignment tool VM# 1043 can be inserted through the hole in the bottom of the clutch housing, stopping the flywheel rotation. This position is TDC or 180° away from TDC. **Engine must be at TDC #1 compression firing stroke.**

(b) To verify that you are at #1 TDC Compression. Remove the oil fill cap from the cylinder head cover and the alignment tool from the clutch housing.

(c) Rotate the crankshaft one-quarter turn clockwise and counter-clockwise while observing the rocker arm through the oil fill cap hole. If the rocker arm moves you are not at #1 TDC Compression.

(d) If #1 TDC Compression was found continue, if not rotate the crankshaft one revolution until the alignment tool can be re-installed in the flywheel. You are now at TDC for the #1 cylinder compression firing stroke. Mark the damper and timing

cover for reference to TDC. Remove the alignment tool from the clutch housing.

(12) Remove access plug and plug washer at rear of pump (Fig. 30). Thread special dial indicator and adapter tool VM.1011 (Fig. 31) into this opening. Hand tighten only.

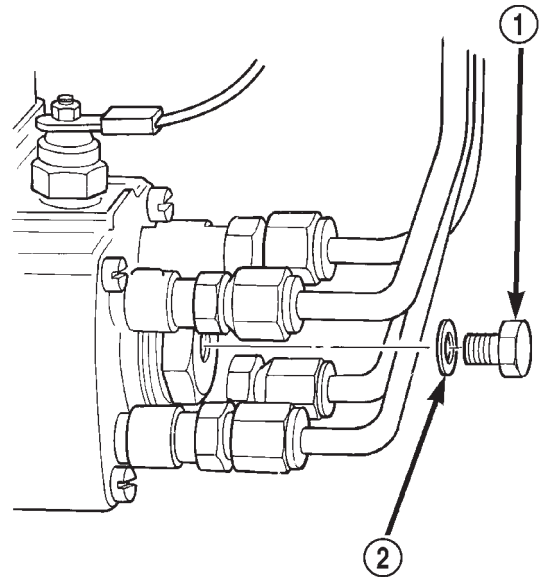
**Fig. 30 Access Plug at Rear of Pump**

- 1 - ACCESS PLUG
- 2 - WASHER

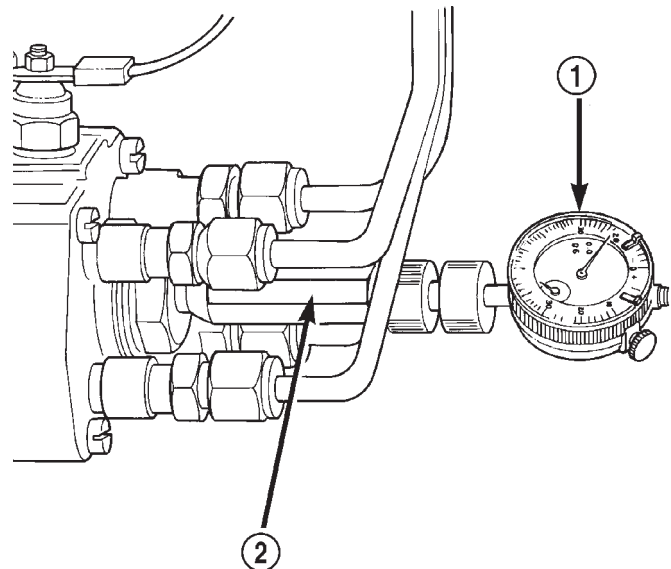
**Fig. 31 Installing Dial Indicator and Special Adapter Tools**

- 1 - DIAL INDICATOR TOOL
- 2 - ADAPTER TOOL VM1011

REMOVAL AND INSTALLATION (Continued)

(13) Slightly rotate the engine in a counter-clockwise direction until the dial gauge indicator stops moving (20°-25° before TDC).

(14) Remove injection pump drive gear nut (Fig. 32).

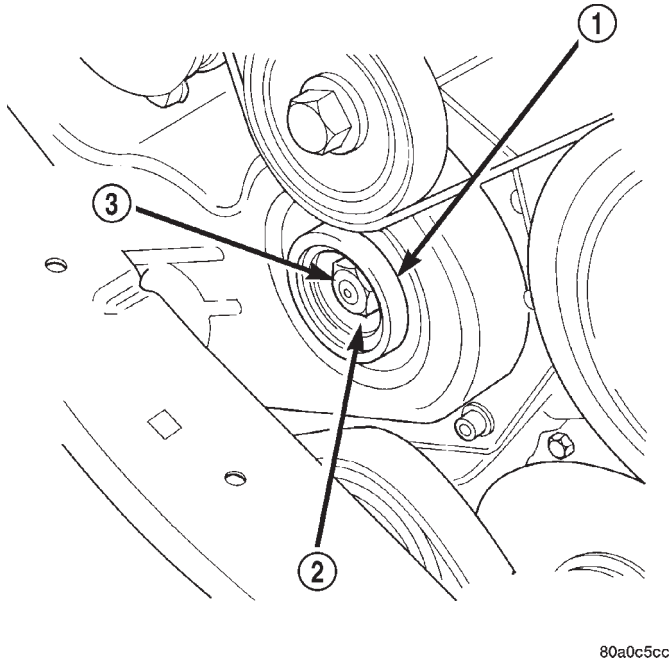

80a0c5cc

Fig. 32 Removing Pump Drive Gear Nut

- 1 - TIMING GEAR COVER
- 2 - INJECTION PUMP GEAR
- 3 - PUMP GEAR NUT

(15) A special 3-piece gear removal tool set VM.1003 (Fig. 33) must be used to remove the injection pump drive gear from the pump shaft.

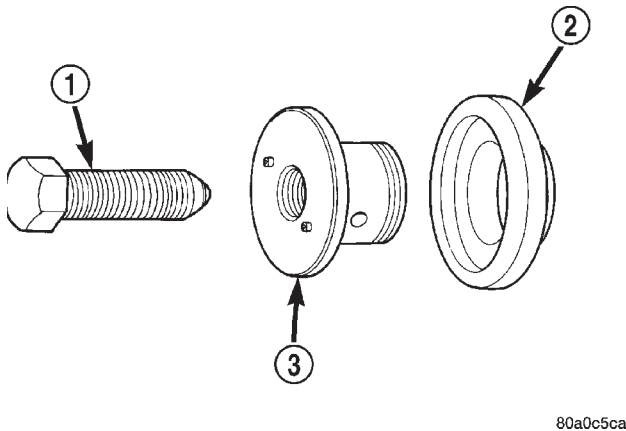

80a0c5ca

Fig. 33 Pump Gear Tools

- 1 - DRIVE BOLT
- 2 - TIMING COVER ADAPTER
- 3 - GEAR PULLER

(a) Thread the adapter (Fig. 34) into the timing cover.

(b) Thread the gear puller into the injection pump drive gear (Fig. 34). This tool is also used to hold the gear in synchronization during pump removal.

(c) Remove the three injection pump-to-gear cover mounting nuts (Fig. 35). **CAUTION: This step must be done to prevent injection pump damage.**

(d) Install the drive bolt into the gear puller (Fig. 34). Tighten the drive bolt to press (remove) the drive gear from injection pump shaft while driving injection pump rearward from timing gear cover mounting studs.

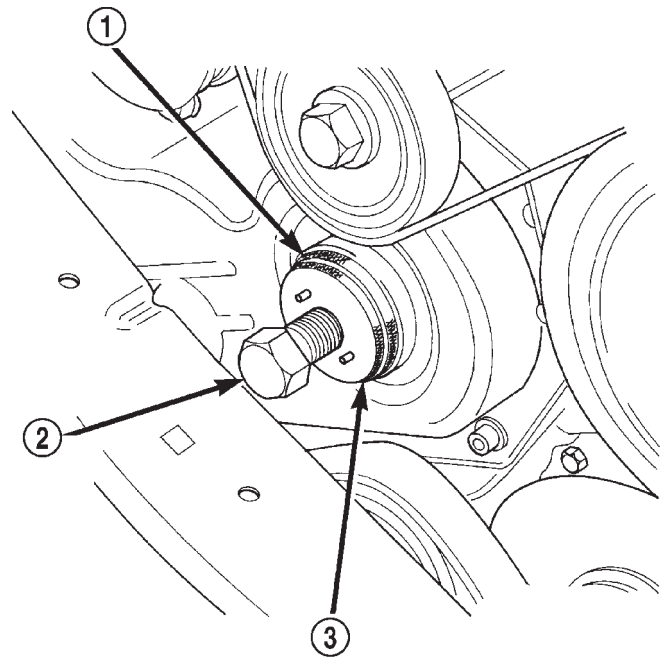

80a0c5cb

Fig. 34 Installing Pump Drive Gear Removal Tools

- 1 - ADAPTER
- 2 - DRIVE BOLT
- 3 - GEAR PULLER

(16) Remove pump from engine. **Do not rotate engine while gear puller is installed. Engine damage will occur.**

INSTALLATION/ADJUSTING PUMP TIMING

(1) Clean the mating surfaces of injection pump and timing gear cover.

(2) Install a new injection pump-to-timing gear cover gasket.

(3) Remove the gear removing bolt (drive bolt) from gear puller. **CAUTION: Do not remove the special gear puller or timing cover adapter tools from timing cover at this time. Gear misalignment will result.**

REMOVAL AND INSTALLATION (Continued)

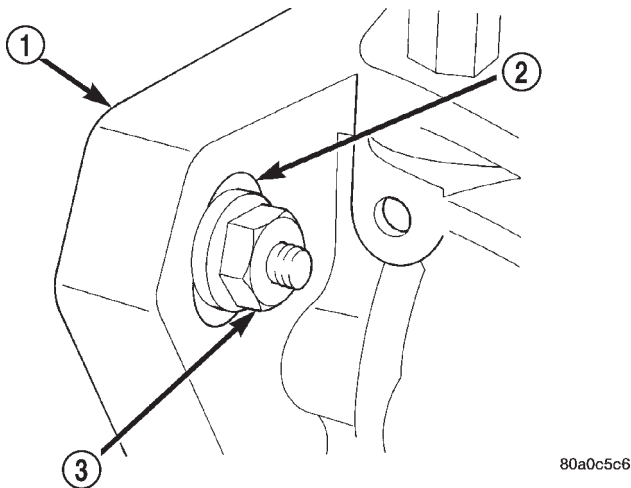

Fig. 35 Injection Pump Mounting Nuts

- 1 - MOUNTING FLANGE
- 2 - SLOTTED HOLES (3)
- 3 - PUMP MOUNTING NUTS (3)

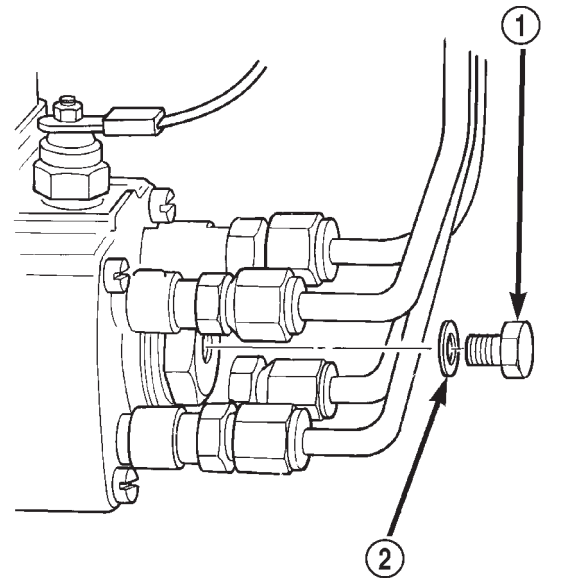

Fig. 36 Access Plug at Rear of Pump

- 1 - ACCESS PLUG
- 2 - WASHER

(4) Place the key way on the pump shaft to the 11 o'clock position as viewed from the front of pump. Install the pump into the rear of timing gear cover while aligning key way on pump shaft into pump gear.

(5) Install and snug the 3 injection pump mounting nuts. This is not the final tightening sequence.

(6) Remove the special gear puller and adapter tools from timing gear cover.

(7) Install the injection pump drive gear nut. Tighten nut to 88 N·m (65 ft. lbs.) torque.

(8) Remove the access plug and plug washer at rear of pump (Fig. 36). Thread special dial indicator adapter tool VM.1011 (Fig. 37) into this opening. Hand tighten only.

(9) Attach special dial indicator tool VM.1013 into the adapter tool (Fig. 37)

(10) Using a socket attached to the front of the crankshaft, rotate the engine in a counter-clockwise direction until the dial gage indicator stops moving (20–25° before TDC).

(11) Set the dial indicator to 0mm. Be sure the tip of the dial indicator is touching the tip inside the adapter tool.

(12) Rotate the engine clockwise until special alignment tool VM# 1043 can be inserted through the hole in the bottom of the clutch housing, stopping the flywheel rotation. This position is #1Cylinder TDC Compression. **Engine must be at TDC #1 compression firing stroke.**

(13) The gauge reading should be at 0.55 mm (**with new gears installed specification should be 0.59–0.60mm**). If not, the pump must be rotated for adjustment:

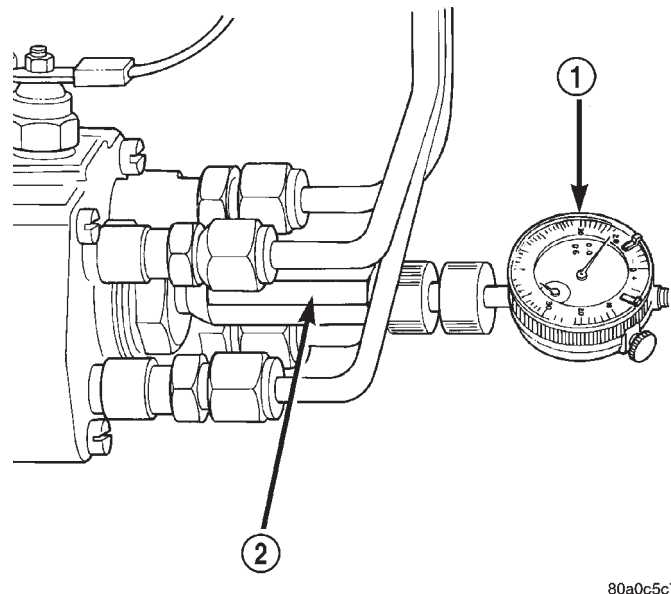

Fig. 37 Installing Dial Indicator and Special Adapter Tools

- 1 - DIAL INDICATOR TOOL
- 2 - ADAPTER TOOL VM1011

(a) Loosen the three injection pump mounting nuts at the mounting flanges. These flanges are equipped with slotted holes. The slotted holes are used to rotate and position the injection pump for fuel timing. Loosen the three nuts just enough to rotate the pump.

REMOVAL AND INSTALLATION (Continued)

(b) Rotate the pump until 0.55 mm is indicated on the dial indicator gauge. If while rotating the pump the 0.55 mm specification is passed do not attempt to rotate the pump in the opposite direction. You must rotate the pump back below the 0.25 mm specification and start the procedure over from the start of the TDC procedure. This will prevent a false reading due to gear backlash.

(c) Tighten the three pump mounting nuts to 30 N·m (22 ft. lbs.) torque.

(d) Recheck the dial indicator after tightening the pump mounting nuts. Gauge should still be reading 0.55 mm.

(14) Remove dial indicator and adapter tools.

(15) Install access plug and washer to rear of injection pump.

(16) Install plug at timing gear cover.

(17) Install and connect the four high-pressure fuel lines to the fuel injection pump. Also connect fuel lines at the fuel injectors. For procedures, refer to High-Pressure Fuel Lines in this group.

(18) Install electrical connector at engine coolant temperature sensor.

(19) Connect electrical connector at fuel shutdown solenoid.

(20) Connect the main engine wiring harness to the glow plugs.

(21) Connect the fuel timing solenoid pigtail harness to the engine wiring harness.

(22) Connect the overflow valve/banjo fitting (fuel return line assembly). Replace copper gaskets before installing.

(23) Connect the rubber fuel return and supply hoses to metal lines at pump. Tighten hose clamps to 2 N·m (20 in. lbs.) torque.

(24) Install generator assembly.

(25) Install engine accessory drive belt. Refer to Group 7, Cooling System for procedures.

(26) Install negative battery cable to battery.

(27) Start the engine and bring to normal operating temperature.

(28) Check for fuel leaks.

FUEL INJECTORS

Four fuel injectors are used on each engine. Of these four, two different types are used. The fuel injector used on cylinder number one is equipped with a fuel injector sensor (Fig. 38). The other three fuel injectors are identical. **Do not place the fuel injector equipped with the fuel injector sensor into any other location except the cylinder number one position.**

REMOVAL

(1) Disconnect negative battery cable at battery.

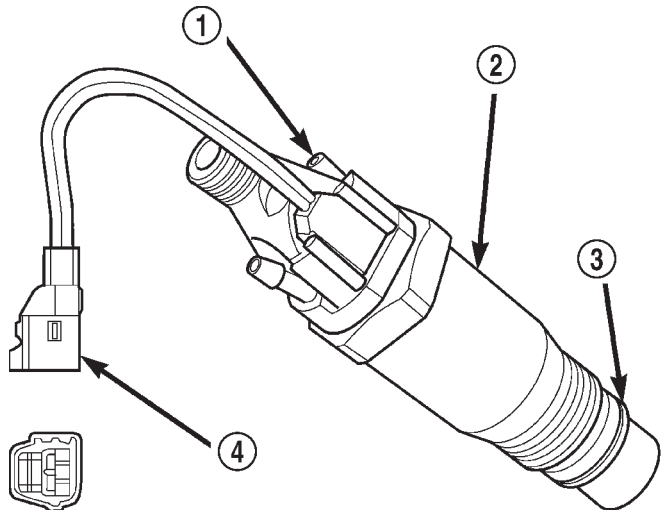

80ba7975

Fig. 38 Fuel Injector Sensor — #1 Cylinder

- 1 - NEEDLE MOVEMENT SENSOR
- 2 - FUEL INJECTOR (NUMBER 1 CYLINDER ONLY)
- 3 - COPPER WASHER
- 4 - SENSOR CONNECTOR

(2) Thoroughly clean the area around the injector with compressed air.

(3) Remove the fuel drain hoses (tubes) at each injector (Fig. 39) being serviced. Each of these hoses is slip-fit to the fitting on injector.

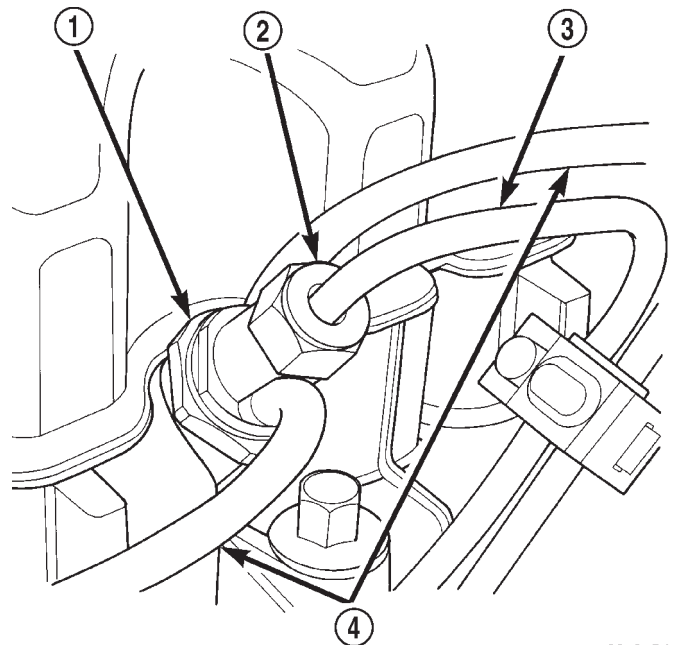

80a0c5d4

Fig. 39 Fuel Injector—Typical

- 1 - FUEL INJECTOR
- 2 - LINE FITTING
- 3 - HIGH-PRESSURE FUEL LINE
- 4 - FUEL DRAIN TUBES

REMOVAL AND INSTALLATION (Continued)

(4) Remove the high-pressure fuel line at injector being removed. Refer to High-Pressure Fuel Lines in this group for procedures.

(5) Remove the injector using special socket tool number VM.1012A. When removing cylinder number one injector, thread the wiring harness through the access hole on the special socket (Fig. 40).

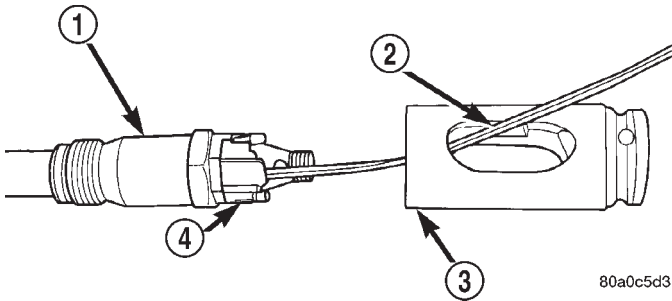

Fig. 40 Wiring Harness Through Socket

- 1 - FUEL INJECTOR
- 2 - WIRING HARNESS (NUMBER 1 CYLINDER ONLY)
- 3 - SPECIAL SOCKET
- 4 - FUEL INJECTOR SENSOR (NUMBER 1 CYLINDER ONLY)

(6) Remove and discard the copper washer (seal) at bottom of injector (Fig. 38).

INSTALLATION

- (1) Clean the injector threads in cylinder head.
- (2) Install new copper washer (seal) to injector.
- (3) Install injector to engine. Tighten to 70 N·m (52 ft. lbs.) torque.
- (4) Install high-pressure fuel lines. Refer to High-Pressure Fuel Lines in this group for procedures.
- (5) Install fuel drain hoses (tubes) to each injector. Do not use clamps at fuel drain hoses.
- (6) Connect negative battery cable to battery.
- (7) Bleed the air from the high-pressure lines. Refer to the Air Bleed Procedure section of this group.

FUEL TANK

REMOVAL

- (1) Disconnect negative cable from battery.
- (2) Insert fuel siphon hose into fuel filler neck and push it into the tank.
- (3) Drain fuel tank dry into holding tank or a properly labeled **diesel** safety container.
- (4) Raise vehicle on hoist.
- (5) Disconnect both the fuel fill and fuel vent rubber hoses at the fuel tank.
- (6) Disconnect fuel supply and return lines from the steel supply line (Fig. 41).

The fuel reservoir module electrical connector has a retainer that locks it in place.

- (7) Slide electrical connector lock to unlock.

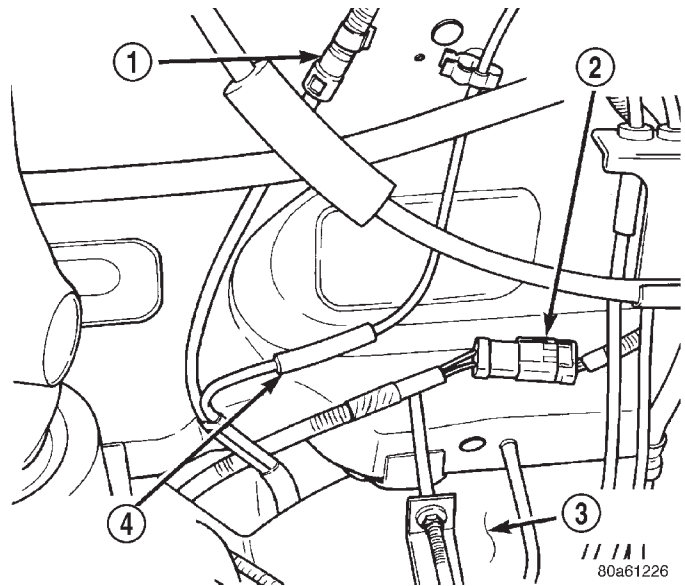

Fig. 41 Fuel Tank Connections at Front of Tank

- 1 - FUEL SUPPLY LINE CONNECTION
- 2 - FUEL PUMP MODULE CONNECTOR
- 3 - FRONT OF FUEL TANK
- 4 - EVAP CANISTER VENT LINE CONNECTION

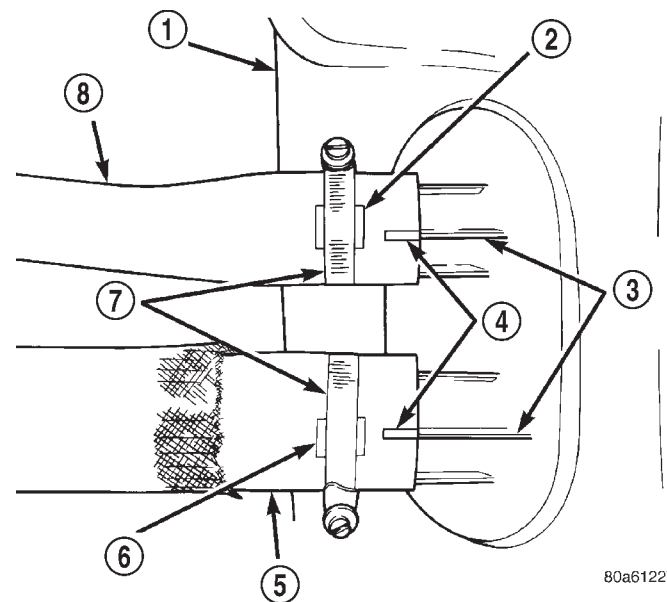
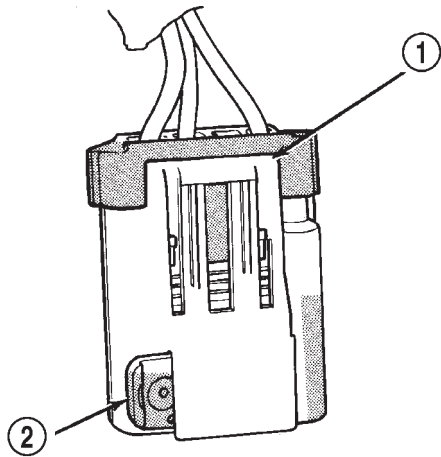

Fig. 42 Fuel Fill/Vent Hose Index Marks

- 1 - FUEL TANK
- 2 - CLAMP INDEX MARKS
- 3 - TANK INDEX TANGS
- 4 - HOSE INDEX MARKS
- 5 - FUEL FILL HOSE
- 6 - CLAMP INDEX MARKS
- 7 - CLAMPS
- 8 - FUEL VENT HOSE

- (8) Push down on connector retainer (Fig. 43) and pull connector off module.

REMOVAL AND INSTALLATION (Continued)



9514-41

Fig. 43 Module Connector Retainer and Lock

- 1 - PUSH DOWN ON RETAINER
2 - CONNECTOR LOCK

(9) Use a transmission jack to support fuel tank. Remove bolts from fuel tank straps.

(10) Lower tank slightly. Carefully remove filler hose from tank.

(11) Lower the fuel tank. Remove clamp and remove fuel filler tube vent hose. Remove fuel tank from vehicle.

INSTALLATION

(1) Position fuel tank on transmission jack. Connect fuel filler tube vent hose and replace clamp.

(2) Raise tank into position and carefully work filler tube into tank. A light coating of clean engine oil on the tube end may be used to aid assembly.

(3) Feed filler vent line thorough frame rail. Careful not to cross lines.

(4) Tighten strap bolts to 9 N·m (80 in. lbs.). Remove transmission jack.

CAUTION: Ensure straps are not twisted or bent before or after tightening strap nuts.

(5) Connect module electrical connector. Place retainer in locked position.

(6) Lubricate the fuel supply and return lines with clean 30 weight engine oil, install the quick connect fuel fitting. Refer to Tube/Fitting Assembly in the Fuel Delivery section of this Group.

(7) Attach filler line to filler tube. Pull on connector to make sure of connection.

(8) Fill fuel tank, replace cap, and connect battery negative cable.

FUEL RESERVOIR MODULE**REMOVAL**

WARNING: THE FUEL RESERVOIR OF THE FUEL MODULE DOES NOT EMPTY OUT WHEN THE TANK IS DRAINED. THE FUEL IN THE RESERVOIR WILL SPILL OUT WHEN THE MODULE IS REMOVED.

- (1) Disconnect negative cable from battery.
- (2) Drain fuel tank dry into holding tank or a properly labeled **diesel** safety container.
- (3) Raise vehicle on hoist.
- (4) Use a transmission jack to support the fuel tank. Remove bolts from fuel tank straps. Lower tank slightly.
- (5) Clean area around fuel reservoir module and tank to keep dirt and foreign material out of tank.
- (6) Disconnect fuel lines from fuel module by depressing quick connect retainers with thumb and fore finger.
- (7) Slide module electrical connector lock to unlock.
- (8) Push down on connector retainer and pull connector off module.
- (9) Using Special Tool 6856, remove plastic locknut counterclockwise to release pump module (Fig. 44).

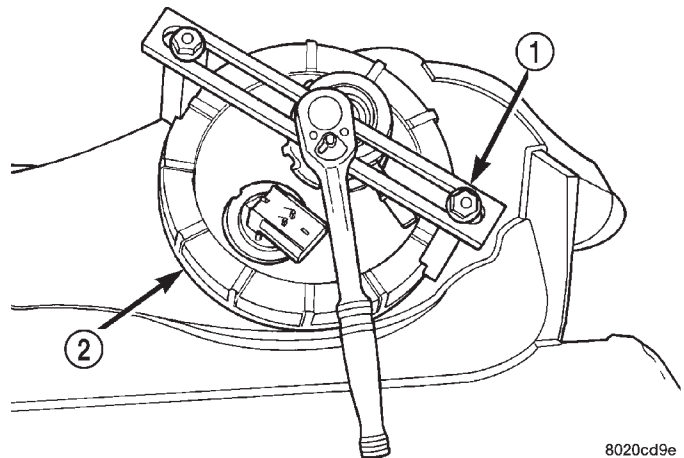

8020cd9e

Fig. 44 Fuel Reservoir Module Lock Nut Removal

- 1 - SPECIAL TOOL 6856
2 - LOCKNUT

- (10) Carefully remove module and o-ring from tank.
- (11) Discard old o-ring.

INSTALLATION

(1) Thoroughly clean locknut threads and mating fuel tank threads. Use a soap/water solution. **Do Not use carburetor cleaner to clean threads.**

(2) Apply clean water to the o-ring seal and place on the mating fuel tank threads.

REMOVAL AND INSTALLATION (Continued)

- (3) Wipe seal area of tank clean and place a new o-ring seal in position on pump.
- (4) Position fuel reservoir module in tank with locknut.
- (5) Tighten locknut to 75 N·m (55 ft. lbs.).
- (6) Connect fuel lines.
- (7) Plug in electrical connector. Slide connector lock into position.
- (8) Raise fuel tank, install bolts into fuel tank straps and tighten.
- (9) Lower vehicle on hoist.
- (10) Connect negative cable from battery.
- (11) Fill fuel tank. Check for leaks.
- (12) Install fuel filler cap.

HIGH-PRESSURE LINES

All high-pressure fuel lines are of the same length and inside diameter. Correct high-pressure fuel line usage and installation is critical to smooth engine operation.

CAUTION: The high-pressure fuel lines must be clamped securely in place in the holders. The lines cannot contact each other or other components. Do not attempt to weld high-pressure fuel lines or to repair lines that are damaged. Only use the recommended lines when replacement of high-pressure fuel line is necessary.

REMOVAL

- (1) Disconnect negative battery cable from battery.
- (2) Remove the necessary clamps holding the lines to the engine.
- (3) Clean the area around each fuel line connection. Disconnect each line at the top of each fuel injector (Fig. 45).
- (4) Disconnect each high-pressure line fitting at each fuel injection pump delivery valve.
- (5) Very carefully remove each line from the engine. Note the position (firing order) of each line while removing. **Do not bend the line while removing.**

CAUTION: Be sure that the high-pressure fuel lines are installed in the same order that they were removed. Prevent the injection pump delivery valve holders from turning when removing or installing high-pressure lines from injection pump.

INSTALLATION

- (1) Carefully position each high-pressure fuel line to the fuel injector and fuel injection pump delivery valve holder in the correct firing order. Also position each line in the correct line holder.
- (2) Loosely install the line clamp/holder bolts.
- (3) Tighten each line at the delivery valve to 19 N·m (168 in. lbs.) torque.

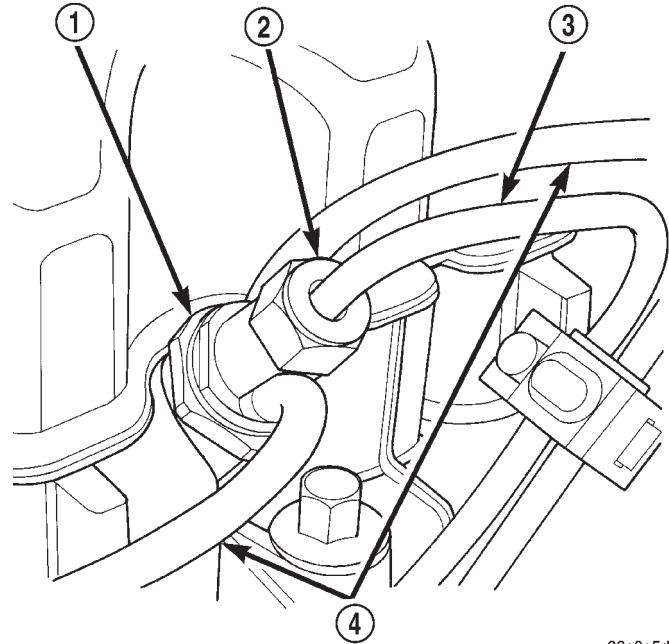

Fig. 45 Fuel Lines at Fuel Injectors

80a0c5d4

- 1 - FUEL INJECTOR
- 2 - LINE FITTING
- 3 - HIGH-PRESSURE FUEL LINE
- 4 - FUEL DRAIN TUBES

- (4) Tighten each line at the fuel injector to 19 N·m (168 in. lbs.) torque.

Be sure the lines are not contacting each other or any other component.

- (5) Bleed air from the fuel system. Refer to the Air Bleed Procedure section of this group.

SPECIFICATIONS

FUEL TANK CAPACITY

75 Liters (20.0 Gals.)

Nominal refill capacities are shown. A variation may be observed from vehicle to vehicle due to manufacturing tolerances, ambient temperatures and refill procedures.

IDLE SPEED

750 RPM \pm 25 RPM with engine at normal operating temperature.

FUEL INJECTOR FIRING SEQUENCE

1-3-4-2

FUEL SYSTEM PRESSURE

Peak Injection Pressure/Fuel Injection Pump Operating Pressure: 40,000–45,000 kPa (5801–6526 psi).

Opening Pressure of Fuel Injector: 16,500–17,300 kPa (2393–2509 psi).

FUEL INJECTION SYSTEM—2.5L DIESEL ENGINE

TABLE OF CONTENTS

| | page | | page |
|---|------|--|------|
| DESCRIPTION AND OPERATION | | | |
| FUEL INJECTION SYSTEM | 23 | AIR CONDITIONING RELAY—ECM OUTPUT | 29 |
| POWERTRAIN CONTROL MODULE (PCM) | 24 | TIMING SOLENOID—ECM OUTPUT | 29 |
| BOOST PRESSURE SENSOR | 25 | TACHOMETER—PCM OUTPUT | 30 |
| VEHICLE THEFT ALARM | 25 | GLOW PLUG RELAY—ECM OUTPUT | 30 |
| BATTERY VOLTAGE—PCM INPUT | 25 | GLOW PLUGS | 30 |
| SENSOR RETURN—ECM/PCM INPUT (ANALOG GROUND) | 26 | ELECTRIC VACUUM MODULATOR (EVM)— ECM OUTPUT | 31 |
| IGNITION CIRCUIT SENSE—ECM/PCM INPUT | 26 | DIAGNOSIS AND TESTING | |
| IGNITION CIRCUIT SENSE—PCM INPUT | 26 | DIESEL DIAGNOSTICS | 31 |
| POWER GROUND | 26 | ASD RELAY TEST | 31 |
| NEEDLE MOVEMENT OR INSTRUMENTED FIRST INJECTOR—ECM INPUT | 26 | ENGINE SPEED SENSOR TEST | 31 |
| FUEL INJECTOR SENSOR—GROUND | 26 | ENGINE COOLANT TEMPERATURE SENSOR TEST | 31 |
| ENGINE COOLANT TEMPERATURE SENSOR—ECM/PCM INPUT | 26 | GLOW PLUG TEST | 31 |
| ENGINE SPEED SENSOR—ECM INPUT | 26 | GLOW PLUG RELAY TEST | 33 |
| AIR CONDITIONING (A/C) CONTROLS—ECM INPUTS | 27 | RELAYS—OPERATION/TESTING | 34 |
| BRAKE SWITCH—ECM INPUT | 28 | BOOST / PRESSURE SENSOR | 34 |
| DATA LINK CONNECTOR—PCM AND ECM INPUT AND OUTPUT | 28 | VEHICLE SPEED SENSOR TEST | 35 |
| VEHICLE SPEED SENSOR—ECM INPUT | 28 | DIAGNOSTIC TROUBLE CODES | 35 |
| SPEED CONTROL—ECM INPUT | 28 | REMOVAL AND INSTALLATION | |
| ASD RELAY—ECM INPUT | 29 | ASD RELAY | 35 |
| FIVE VOLT POWER—ECM/PCM OUTPUT | 29 | A/C CLUTCH RELAY | 35 |
| ENGINE COOLANT GAUGE—PCM OUTPUT | 29 | ENGINE SPEED SENSOR | 35 |
| ENGINE OIL PRESSURE GAUGE—PCM OUTPUT | 29 | ENGINE COOLANT TEMPERATURE SENSOR | 35 |
| GLOW PLUG LAMP—PCM OUTPUT | 29 | GLOW PLUGS | 35 |
| SPEED CONTROL—PCM OUTPUTS | 29 | GLOW PLUG RELAY | 36 |
| | | POWERTRAIN CONTROL MODULE (PCM) | 36 |
| | | VEHICLE SPEED SENSOR | 37 |
| | | SPECIFICATIONS | |
| | | GLOW PLUG CURRENT DRAW | 38 |
| | | TORQUE CHART—2.5L DIESEL | 38 |

DESCRIPTION AND OPERATION

FUEL INJECTION SYSTEM

DESCRIPTION

This section will cover components either regulated or controlled by the ECM controller and the Powertrain Control Module (PCM). The fuel heater relay and fuel heater are not operated by the ECM controller or the PCM. These components are controlled by the ignition (key) switch. All other fuel system electrical components necessary to operate the engine are controlled or regulated by the ECM controller, which interfaces with the PCM. Refer to the following description for more information.

Certain fuel system component failures may cause a no start, or prevent the engine from running. It is important to know that the ECM has a feature where, if possible, it will ignore the failed sensor, set a code related to the sensor, and operate the engine in a "Limp Home" mode. When the ECM is operating in a "Limp Home" mode, the Check Engine Lamp on the instrument panel may be constantly illuminated, and the engine will most likely have a noticeable loss of performance. An example of this would be an Accelerator Pedal Position Sensor failure, and in that situation, the engine would run at a constant 1100 RPM, regardless of the actual position of the pedal. This is the most extreme of the three "Limp Home" modes.

When the Check Engine Lamp is illuminated constantly with the key on and the engine running, it

DESCRIPTION AND OPERATION (Continued)

usually indicates a problem has been detected somewhere within the fuel system. The DRBIII scan tool is the best method for communicating with the ECM and PCM to diagnose faults within the system.

POWERTRAIN CONTROL MODULE (PCM)

DESCRIPTION

On LHD vehicles, the ECM is mounted behind the lower Instrument Panel to the right of the accelerator pedal (Fig. 1). On RHD vehicles, the ECM is mounted behind the lower Instrument Panel to the left of the clutch pedal. The Powertrain Control Module (PCM) is mounted in the engine compartment (Fig. 2).

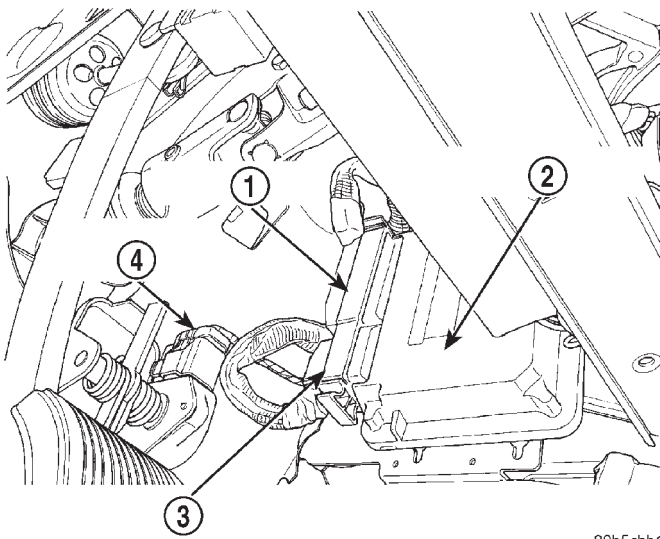

Fig. 1 ECM Location—LHD

- 1 - ECM HARNESS CONNECTOR C1
- 2 - ENGINE CONTROL MODULE (ECM)
- 3 - ECM HARNESS CONNECTOR C2
- 4 - ACCELERATOR PEDAL POSITION SENSOR

The ECM Controller is a pre-programmed, digital computer. It will either directly operate or partially regulate the:

- Speed Control
- Speed Control lamp
- Fuel Timing Solenoid
- Check Engine Light
- Glow Plug Relay
- Glow Plugs
- Glow Plug Lamp
- ASD Relay
- Air Conditioning
- Tachometer
- Electric Vacuum Modulator (EVM)

The ECM can adapt its programming to meet changing operating conditions.

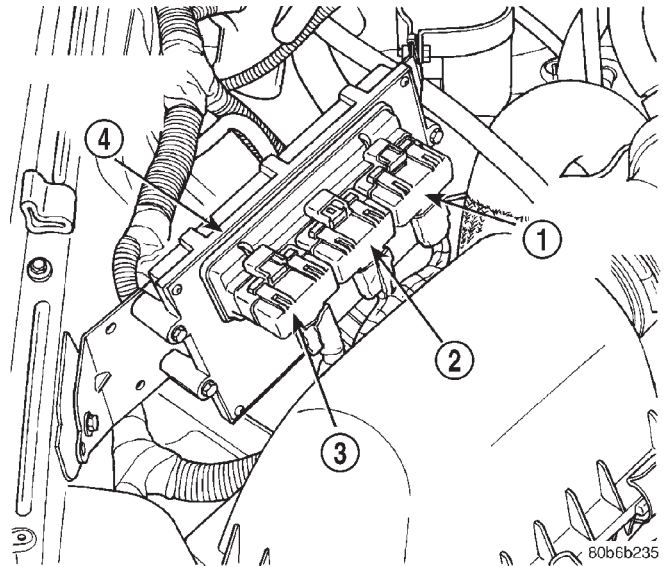

Fig. 2 PCM Location—LHD

- 1 - PCM HARNESS CONNECTOR C1
- 2 - PCM HARNESS CONNECTOR C2
- 3 - PCM HARNESS CONNECTOR C3
- 4 - POWERTRAIN CONTROL MODULE (PCM)

The ECM receives input signals from various switches and sensors. Based on these inputs, the ECM regulates various engine and vehicle operations through different system components. These components are referred to as **ECM Outputs**. The sensors and switches that provide inputs to the ECM are considered **ECM Inputs**.

ECM Inputs are:

- Air Conditioning Selection
- Theft Alarm
- ASD Relay
- Control Sleeve Position Sensor
- Fuel Temperature Sensor
- Mass Air Flow Sensor
- Accelerator Pedal Position Sensor
- Engine Coolant Temperature Sensor
- Low Idle Position Switch
- 5 Volt Supply
- Vehicle Speed Sensor
- Engine Speed/Crank Position Sensor (rpm)
- Needle Movement Sensor
- Starter Signal
- Brake Switch
- Speed Control Switch
- Power Ground
- Ignition (key) Switch Sense

ECM Outputs:

After inputs are received by the ECM and PCM, certain sensors, switches and components are controlled or regulated by the ECM and PCM. These are considered **ECM Outputs**. These outputs are for:

- A/C Clutch Relay (for A/C clutch operation)

DESCRIPTION AND OPERATION (Continued)

- Speed Control Lamp
- ASD Relay
- 5 Volts Supply
- Fuel Quantity Actuator
- Fuel Timing Solenoid
- Fuel Shutdown Solenoid
- Glow Plug Lamp
- Check Engine Lamp (“On/Off” signal)
- Electric Vacuum Modulator (EVM)
- Glow Plug Relay
- Tachometer

The PCM sends and receives signals to and from the ECM controller. **PCM inputs are:**

- Power Ground
- 5 Volts Supply
- Vehicle Speed Sensor
- Water-In-Fuel Sensor
- Coolant Temperature Sensor
- Low Coolant Sensor
- Sensor Return
- Fuel Level Sensor
- Oil Pressure Sensor
- Tachometer Signal
- Glow Plug Lamp
- Check Engine Lamp (“On/Off” signal)
- Brake On/Off Switch
- Battery Voltage
- ASD Relay

PCM Outputs:

- A/C On Signal
- Vehicle Theft Alarm “Ok to Run” signal
- Body Control Module CCD Bus (+)
- Body Control Module CCD Bus (-)
- Scan Tool Data Link Receive
- Scan Tool Data Link Transmit
- Low Coolant Lamp
- Generator Control

duced by the Intake Air Temperature Sensor changes inversely to the temperature, and is measured by the PCM. As a general rule, when the temperature of the air in the intake is high, the voltage signal produced by the Intake Air Temperature Sensor is low. The component of the Boost Pressure Sensor that measures manifold vacuum and turbo boost produces a voltage signal that is proportional to the pressure in the intake manifold. When the intake manifold pressure is low, the voltage is low, and when the pressure is high, the voltage is high. The PCM uses the voltage signals from the Boost Pressure Sensor, and the Intake Air Temperature Sensor to determine the amount of air flowing through the intake manifold.

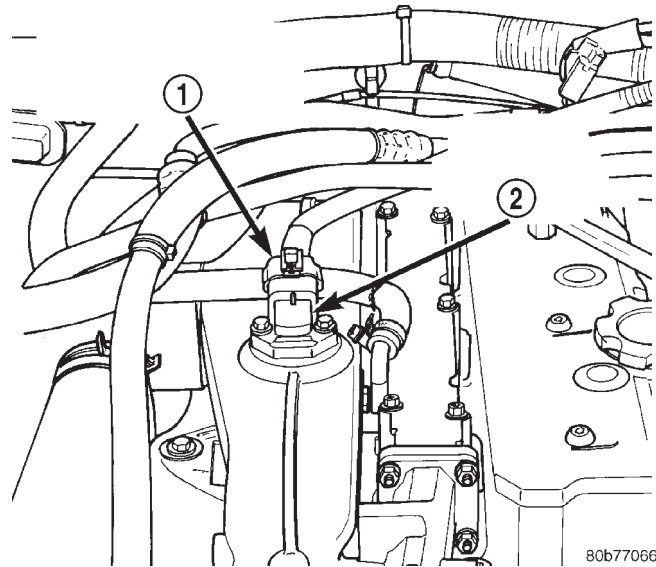

Fig. 3 Boost Pressure Sensor Location

- 1 – BOOST PRESSURE SENSOR HARNESS CONNECTOR
2 – BOOST PRESSURE SENSOR

BOOST PRESSURE SENSOR**DESCRIPTION**

The Boost Pressure Sensor is mounted to the top of the intake manifold (Fig. 3). It is a sensor that measures both manifold vacuum and turbo boost, and it also contains an integrated intake air temperature sensor. The Boost Pressure Sensor takes the place of the Mass Air Flow (MAF). In the Intake Air Temperature Sensor component, there is a ceramic element that changes its resistance based on temperature. The ceramic element is part of an electronic circuit connected to the PCM, and has a voltage applied to it. The ceramic element is exposed to the air inside the intake. This air has a cooling effect on the ceramic element, and its resistance changes. This causes the voltage flowing through the intake air temperature circuit to vary. The voltage signal pro-

VEHICLE THEFT ALARM**DESCRIPTION**

The PCM can learn if the vehicle has a Vehicle Theft Alarm (VTA) system. Once it detects the vehicle having VTA, **the controller can ONLY BE USED ON VEHICLES WITH VTA.**

If the PCM is put on a vehicle without VTA the Glow Plug Lamp will start to blink and the vehicle will not start.

The PCM cannot be flashed to remove the VTA.

BATTERY VOLTAGE—PCM INPUT**DESCRIPTION**

The battery voltage input provides power to the PCM. It also informs the PCM what voltage level is being supplied by the generator once the vehicle is running.

DESCRIPTION AND OPERATION (Continued)

The battery input also provides the voltage that is needed to keep the PCM memory alive. The memory stores Diagnostic Trouble Code (DTC) messages. Trouble codes will still be stored even if the battery voltage is lost.

SENSOR RETURN—ECM/PCM INPUT (ANALOG GROUND)

DESCRIPTION

Sensor Return provides a low noise Analog ground reference for all system sensors.

IGNITION CIRCUIT SENSE—ECM/PCM INPUT

DESCRIPTION

The ignition circuit sense input signals the ECM and PCM that the ignition (key) switch has been turned to the ON position. This signal initiates the glow plug control routine to begin the “pre-heat” cycle.

IGNITION CIRCUIT SENSE—PCM INPUT

The ignition circuit sense input signals the PCM that the ignition (key) switch has been turned to the ON position. This signal initiates the glow plug control routine to begin the “pre-heat” cycle.

POWER GROUND

DESCRIPTION

Provides a common ground for power devices (solenoid and relay devices).

NEEDLE MOVEMENT OR INSTRUMENTED FIRST INJECTOR—ECM INPUT

DESCRIPTION

This input from the ECM supplies a constant 30 mA electrical current source for the first injector sensor. It will vary the voltage to this sensor when it senses a mechanical movement within the injector needle (pintle) of the number-1 cylinder fuel injector. When this voltage has been determined by the ECM, it will then control an output to the fuel timing solenoid (the fuel timing solenoid is located on the fuel injection pump). Also refer to Fuel Injection Pump for additional information.

The first injector sensor is a magnetic (inductive) type.

The first injector sensor is used only on the fuel injector for the number-1 cylinder (Fig. 4). It is not used on the injectors for cylinders number 2, 3, or 4.

FUEL INJECTOR SENSOR—GROUND

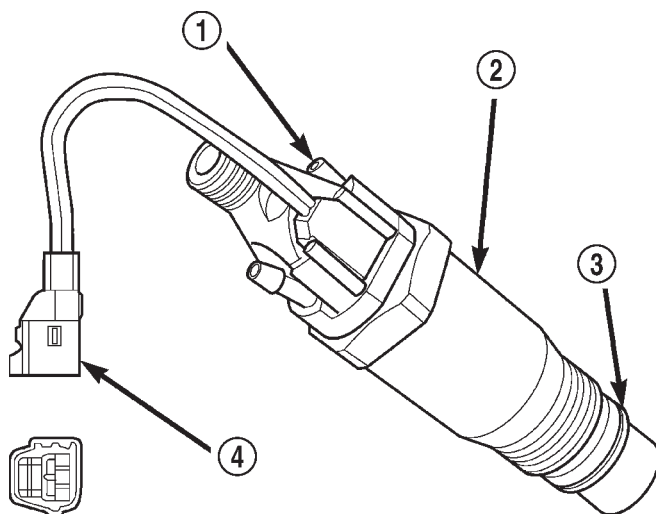

80ba7975

Fig. 4 Fuel Injector Sensor

- 1 - NEEDLE MOVEMENT SENSOR
- 2 - FUEL INJECTOR (NUMBER 1 CYLINDER ONLY)
- 3 - COPPER WASHER
- 4 - SENSOR CONNECTOR

DESCRIPTION

Provides a low noise ground for the fuel injector sensor only.

ENGINE COOLANT TEMPERATURE SENSOR—ECM/PCM INPUT

DESCRIPTION

The 0-5 volt input from this sensor tells the ECM and PCM the temperature of the engine coolant. Based on the voltage received at the ECM, it will then determine operation of the fuel timing solenoid, glow plug relay, electrical vacuum modulator (emission component) and generator (charging system).

The sensor is located on the side of the #3 cylinder head near the rear of fuel injection pump (Fig. 5).

ENGINE SPEED SENSOR—ECM INPUT

DESCRIPTION

The engine speed sensor is mounted to the transmission bellhousing at the left/rear side of the engine block (Fig. 6).

The engine speed sensor produces its own output signal. If this signal is not received, the ECM will not allow the engine to start.

The engine speed sensor input is used in conjunction with the first injector sensor to establish fuel injection pump timing.

DESCRIPTION AND OPERATION (Continued)

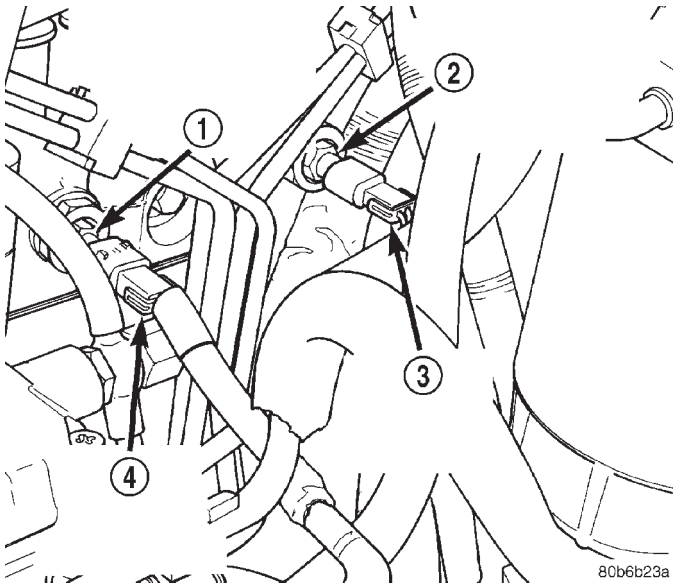

Fig. 5 Engine Coolant Temperature Sensor Location
 1 - PCM ENGINE COOLANT TEMPERATURE (ECT) SENSOR
 2 - ECM ENGINE COOLANT TEMPERATURE (ECT) SENSOR
 3 - ECM ECT SENSOR HARNESS CONNECTOR
 4 - PCM ECT SENSOR HARNESS CONNECTOR

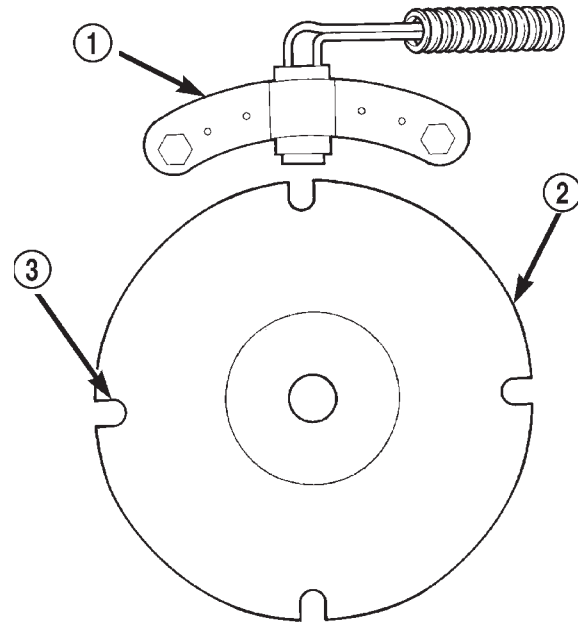

Fig. 7 Speed Sensor Operation
 1 - ENGINE SPEED SENSOR
 2 - FLYWHEEL
 3 - NOTCHES

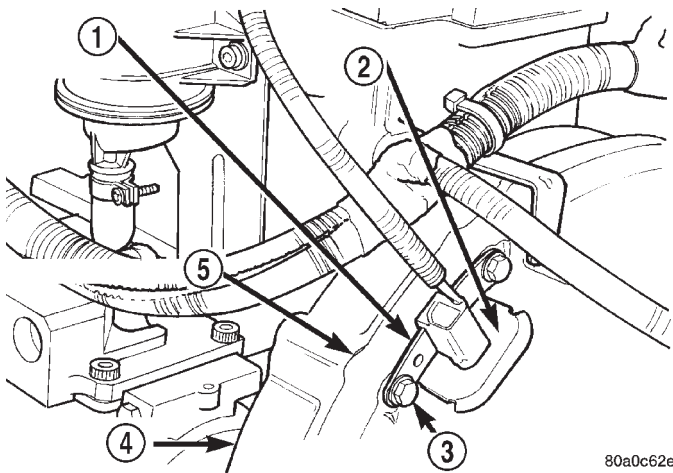

Fig. 6 Engine Speed Sensor Location
 1 - ENGINE SPEED SENSOR
 2 - GROMMET
 3 - MOUNTING BOLT(S)
 4 - LEFT REAR OF ENGINE
 5 - TRANSMISSION

The flywheel has four notches at its outer edge (Fig. 7). Each notch is spaced equally every 90°. The notches cause a pulse to be generated when they pass under the speed sensor (Fig. 7). These pulses are the input to the ECM. The input from this sensor determines crankshaft position (in degrees) by monitoring the notches.

The sensor also generates an rpm signal to the ECM. This signal is used as an input for the control

of the generator field, vehicle speed control, and instrument panel mounted tachometer.

If the engine speed sensor should fail, the system is unable to compensate for the problem and the car will stop.

AIR CONDITIONING (A/C) CONTROLS—ECM INPUTS

DESCRIPTION

The A/C control system information applies to factory installed air conditioning units.

A/C REQUEST SIGNAL: When either the A/C or Defrost mode has been selected and the A/C low and high-pressure switches are closed, an input signal is sent to the ECM. The ECM uses this input to cycle the A/C compressor through the A/C relay.

If the A/C low or high-pressure switch opens, the ECM will not receive an A/C request signal. The PCM will then remove the ground from the A/C relay. This will deactivate the A/C compressor clutch. Also, if the engine coolant reaches a temperature outside normal of its normal range, or it overheats, the ECM will deactivate the A/C clutch.

DESCRIPTION AND OPERATION (Continued)

BRAKE SWITCH—ECM INPUT

DESCRIPTION

When the brake light switch is activated, the ECM receives an input indicating that the brakes are being applied. After receiving this input, the ECM is used to control the speed control system. There is a Primary and a Secondary brake switch. The Secondary brake switch is closed until the brake pedal is pressed.

DATA LINK CONNECTOR—PCM AND ECM INPUT AND OUTPUT

The 16-way data link connector (diagnostic scan tool connector) links the Diagnostic Readout Box (DRB) scan tool with the PCM and ECM. The data link connector is located under the instrument panel near the left body side cowl panel on left hand drive vehicles (Fig. 8). And near the right body side cowl panel on right hand drive vehicles (Fig. 9).

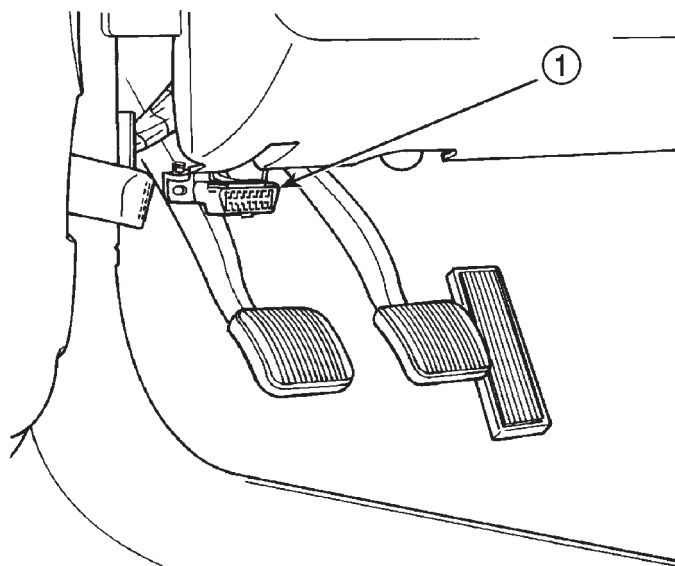

80a4835f

Fig. 8 Data Link Connector Location – LHD

1 – 16-WAY DATA LINK CONNECTOR

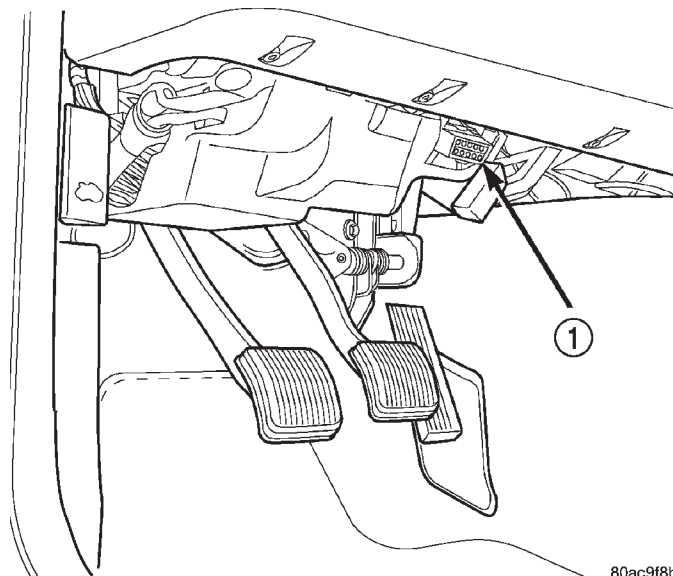

80ac9f8b

Fig. 9 Data Link Connector Location –RHD

1 – DATA LINK CONNECTOR

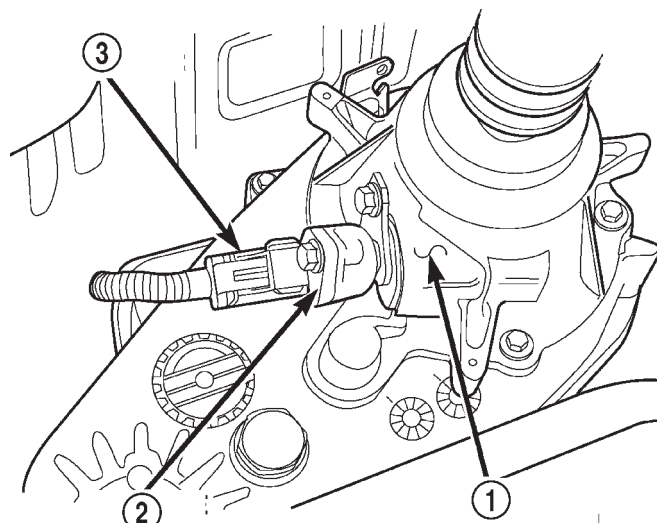

80b6b22c

Fig. 10 Vehicle Speed Sensor—4 Wheel Drive

1 – 4WD TRANSFER CASE EXTENSION
2 – VEHICLE SPEED SENSOR
3 – SENSOR ELECTRICAL CONNECTOR

VEHICLE SPEED SENSOR—ECM INPUT

The vehicle speed sensor is located in the transfer case extension housing (Fig. 10). The sensor input is used by the ECM to determine vehicle speed and distance traveled.

The speed sensor generates 8 pulses per sensor revolution. These signals, in conjunction with a closed throttle signal from the accelerator pedal position sensor, indicate an idle deceleration to the ECM. When the vehicle is stopped at idle, a released pedal signal is received by the ECM (but a speed sensor signal is not received).

In addition to determining distance and vehicle speed, the output from the sensor is used to control speed control operation.

SPEED CONTROL—ECM INPUT

DESCRIPTION

The speed control system provides five separate inputs to the ECM: On/Off, Set, Resume/Accel, Cancel, and Decel.. The On/Off input informs the ECM that the speed control system has been activated. The Set input

DESCRIPTION AND OPERATION (Continued)

informs the ECM that a fixed vehicle speed has been selected. The Resume input indicates to the ECM that the previous fixed speed is requested.

Speed control operation will start at 50 km/h–142 km/h (35–85 mph). The upper range of operation is not restricted by vehicle speed. Inputs that effect speed control operation are vehicle speed sensor and accelerator pedal position sensor.

Refer to Group 8H for further speed control information.

ASD RELAY—ECM INPUT

DESCRIPTION

A 12 volt signal at this input indicates to the ECM that the ASD relay has been activated. The ASD relay is located in the PDC. The PDC is located next to the battery in the engine compartment. For the location of the relay within the PDC, refer to label on PDC cover.

This input is used only to sense that the ASD relay is energized. If the ECM does not see 12 volts (+) at this input when the ASD relay should be activated, it will set a Diagnostic Trouble Code (DTC).

FIVE VOLT POWER—ECM/PCM OUTPUT

DESCRIPTION

This circuit supplies approximately 5 volts to power the Accelerator Pedal Position Sensor, and the Boost Pressure Sensor.

ENGINE COOLANT GAUGE—PCM OUTPUT

DESCRIPTION

Refer to the Instrument Panel and Gauges group for additional information.

ENGINE OIL PRESSURE GAUGE—PCM OUTPUT

DESCRIPTION

Refer to the Instrument Panel and Gauges group for additional information.

GLOW PLUG LAMP—PCM OUTPUT

DESCRIPTION

The Glow Plug lamp (malfunction indicator lamp) illuminates on the message center each time the ignition (key) switch is turned on. It will stay on for about two seconds as a bulb test.



Fig. 11 Glow Plug Lamp Symbol

SPEED CONTROL—PCM OUTPUTS

DESCRIPTION

These two circuits control the fuel quantity actuator to regulate vehicle speed. Refer to Group 8H for Speed Control information.

AIR CONDITIONING RELAY—ECM OUTPUT

DESCRIPTION

This circuit controls a ground signal for operation of the A/C clutch relay. Also refer to Air Conditioning (A/C) Controls—ECM Input for additional information.

The A/C relay is located in the Power Distribution Center (PDC). The PDC is located next to the battery in the engine compartment. For the location of the relay within the PDC, refer to label on PDC cover.

TIMING SOLENOID—ECM OUTPUT

DESCRIPTION

The timing solenoid is located on the bottom of the fuel injection pump (Fig. 12).

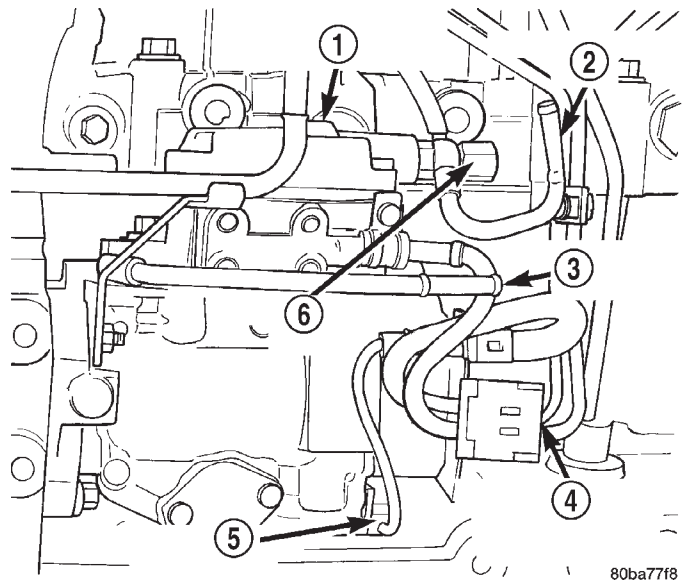

Fig. 12 Timing Solenoid

- 1 - FUEL INJECTION PUMP ASSEMBLY
- 2 - FUEL RETURN LINE
- 3 - FUEL SUPPLY LINE
- 4 - FUEL INJECTION PUMP 10-WAY CONNECTOR
- 5 - TIMING SOLENOID
- 6 - OVERFLOW VALVE

This 12(+) volt, pulse width modulated (duty-cycle) output controls the amount of fuel timing (advance) in the fuel injection pump. The higher the duty-cycle, the lower the advance. The lower the duty-cycle, the more advanced the fuel timing.

DESCRIPTION AND OPERATION (Continued)

The duty-cycle is determined by the ECM from inputs it receives from the fuel injector sensor and engine speed sensor.

TACHOMETER—PCM OUTPUT

DESCRIPTION

The PCM receives engine rpm values from the ECM controller, and then supplies engine rpm values to the Body Controller that then supplies the instrument cluster mounted tachometer (if equipped). Refer to Group 8E for tachometer information.

GLOW PLUG RELAY—ECM OUTPUT

DESCRIPTION

When the ignition (key) switch is placed in the ON position, a signal is sent to the ECM relating current engine coolant temperature. This signal is sent from the engine coolant temperature sensor.

After receiving this signal, the ECM will determine if, when and for how long a period the glow plug relay should be activated. This is done before, during and after the engine is started. Whenever the glow plug relay is activated, it will control the 12V+ 100 amp circuit for the operation of the four glow plugs.

In this chart, Pre-Heat and Post-Heat times are mentioned. Pre-heat is the amount of time the glow plug relay circuit is activated when the ignition (key) switch is ON, but the engine has yet to be started. Post-heat is the amount of time the glow plug relay circuit is activated after the engine is operating. The Glow Plug lamp will not be illuminated during the post-heat cycle.

GLOW PLUG CONTROL

| ENGINE COOLANT TEMPERATURE KEY ON | WAIT-TO-START LAMP ON (SECONDS) | PRE-HEAT CYCLE (GLOW PLUGS ON) (SECONDS) | POST-HEAT CYCLE (SECONDS) |
|-----------------------------------|---------------------------------|--|---------------------------|
| -30 C | 15 SEC. | 45 SEC. | 200 SEC. |
| -10 C | 8 SEC. | 35 SEC. | 180 SEC. |
| +10 C | 6 SEC. | 25 SEC. | 118 SEC. |
| +30 C | 5 SEC. | 20 SEC. | 70 SEC. |
| +40 C | 4 SEC. | 16 SEC. | 60 SEC. |
| +70 C | 3 SEC. | 16 SEC. | 20 SEC. |

GLOW PLUGS

DESCRIPTION

Glow plugs are used to help start a cold or cool engine. The plug will heat up and glow to heat the combustion chamber of each cylinder. An individual plug is used for each cylinder. Each plug is threaded into the cylinder head above the fuel injector (Fig. 14).

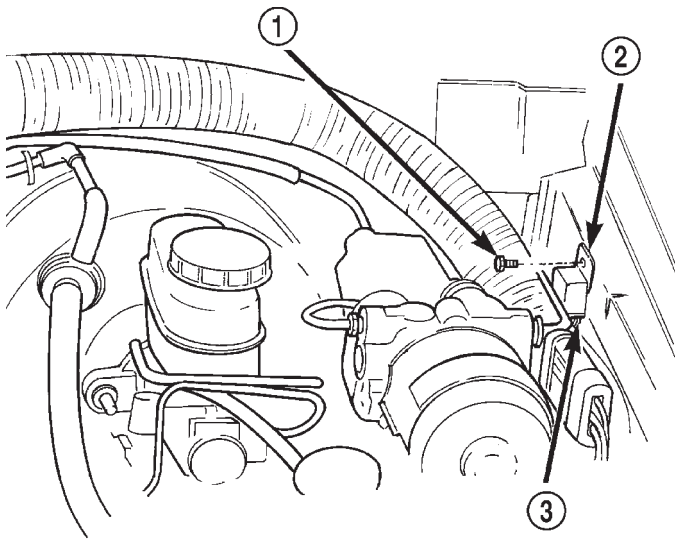

80ad08f8

Fig. 13 Glow Plug Relay Location

- 1 - MOUNTING BOLT
- 2 - GLOW PLUG RELAY
- 3 - ELECTRICAL CONNECTOR

With a cold engine, the glow plug relay and glow plugs may be activated for a maximum time of 200 seconds. Refer to the following Glow Plug Control chart for a temperature/time comparison of glow plug relay operation.

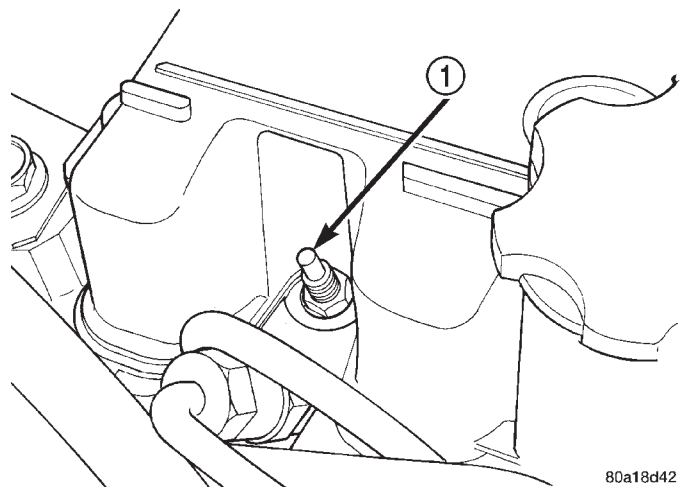

80a18d42

Fig. 14 Glow Plug

- 1 - GLOW PLUG

Each plug will momentarily draw approximately 25 amps of electrical current during the initial key-on

DESCRIPTION AND OPERATION (Continued)

cycle. This is on a cold or cool engine. After heating, the current draw will drop to approximately 9–12 amps per plug.

Total momentary current draw for all four plugs is approximately 100 amps on a cold engine dropping to a total of approximately 40 amps after the plugs are heated.

Electrical operation of the glow plugs are controlled by the glow plug relay. Refer to the previous Glow Plug Relay—ECM Output for additional information.

ELECTRIC VACUUM MODULATOR (EVM)—ECM OUTPUT

DESCRIPTION

This circuit controls operation of the Electric Vacuum Modulator (EVM). The EVM controls operation of the EGR valve.

Refer to Group 25, Emission Control System for information. See Electric Vacuum Modulator.

DIAGNOSIS AND TESTING

DIESEL DIAGNOSTICS

The ECM controllers perform engine off diagnostic tests, which may be heard for about 60 seconds after turning the key off.

ASD RELAY TEST

To perform a test of the relay and its related circuitry, refer to the DRB scan tool. To test the relay only, refer to Relays—Operation/Testing in this section of the group.

Diagnostic Trouble Codes: Refer to On-Board Diagnostics in Group 25, Emission Control System for a list of Diagnostic Trouble Codes (DTC's) for certain fuel system components.

ENGINE SPEED SENSOR TEST

To perform a test of the engine speed sensor and its related circuitry, refer to the 3.1L Powertrain Diagnostic Procedures Manual.

Diagnostic Trouble Codes: Refer to On-Board Diagnostics in Group 25, Emission Control System for a list of Diagnostic Trouble Codes (DTC's) for certain fuel system components.

ENGINE COOLANT TEMPERATURE SENSOR TEST

The sensor is located on the side of cylinder head near the rear of fuel injection pump (Fig. 15).

For a list of Diagnostic Trouble Codes (DTC's) for certain fuel system components, refer to On-Board

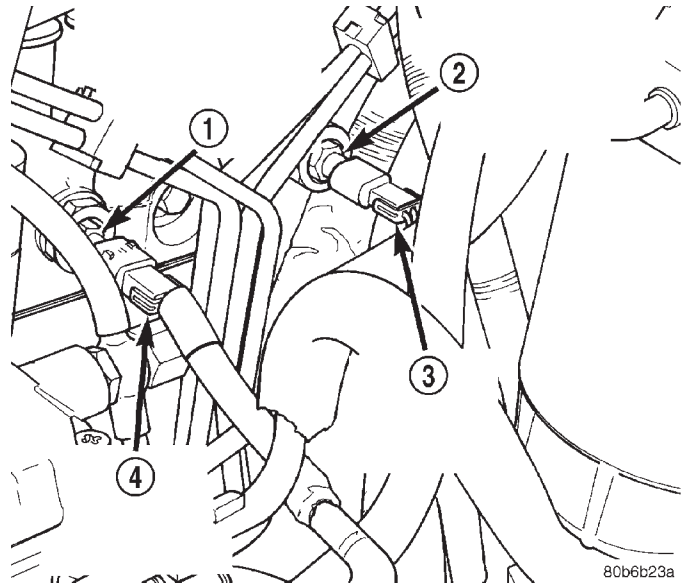

Fig. 15 Engine Coolant Temperature Sensor Location

- 1 - PCM ENGINE COOLANT TEMPERATURE (ECT) SENSOR
- 2 - ECM ENGINE COOLANT TEMPERATURE (ECT) SENSOR
- 3 - ECM ECT SENSOR HARNESS CONNECTOR
- 4 - PCM ECT SENSOR HARNESS CONNECTOR

Diagnostics in Group 25, Emission Control System. To test the sensor only, refer to the following:

(1) Disconnect wire harness connector from coolant temperature sensor.

(2) Test the resistance of the sensor with a high input impedance (digital) volt-ohmmeter. The resistance (as measured across the sensor terminals) should be less than 1340 ohms with the engine warm. Refer to the following Sensor Resistance (OHMS) chart. Replace the sensor if it is not within the range of resistance specified in the chart.

(3) Test continuity of the wire harness. Do this between the ECM wire harness connector and the sensor connector terminal. Also test continuity of wire harness to the sensor connector terminal. Refer to Group 8W for wiring connector and circuitry information. Repair the wire harness if an open circuit is indicated.

(4) After tests are completed, connect electrical connector to sensor.

GLOW PLUG TEST

Hard starting or a rough idle after starting may be caused by one or more defective glow plugs. Before testing the glow plugs, a test of the glow plug relays should be performed. This will ensure that 12V+ is available at the plugs when starting the engine. Refer to the Glow Plug Relay Test for information.

For accurate test results, the glow plugs should be removed from the engine. The plugs must be checked

DIAGNOSIS AND TESTING (Continued)

SENSOR RESISTANCE (OHMS)
 SENSOR RESISTANCE (OHMS)—COOLANT
 TEMPERATURE SENSOR/INTAKE AIR
 TEMPERATURE SENSOR

| TEMPERATURE | | RESISTANCE (OHMS) | |
|-------------|-----|-------------------|---------|
| C | F | MIN | MAX |
| -40 | -40 | 291,490 | 381,710 |
| -20 | -4 | 85,850 | 108,390 |
| -10 | 14 | 49,250 | 61,430 |
| 0 | 32 | 29,330 | 35,990 |
| 10 | 50 | 17,990 | 21,810 |
| 20 | 68 | 11,370 | 13,610 |
| 25 | 77 | 9,120 | 10,880 |
| 30 | 86 | 7,370 | 8,750 |
| 40 | 104 | 4,900 | 5,750 |
| 50 | 122 | 3,330 | 3,880 |
| 60 | 140 | 2,310 | 2,670 |
| 70 | 158 | 1,630 | 1,870 |
| 80 | 176 | 1,170 | 1,340 |
| 90 | 194 | 860 | 970 |
| 100 | 212 | 640 | 270 |
| 110 | 230 | 480 | 540 |
| 120 | 248 | 370 | 410 |

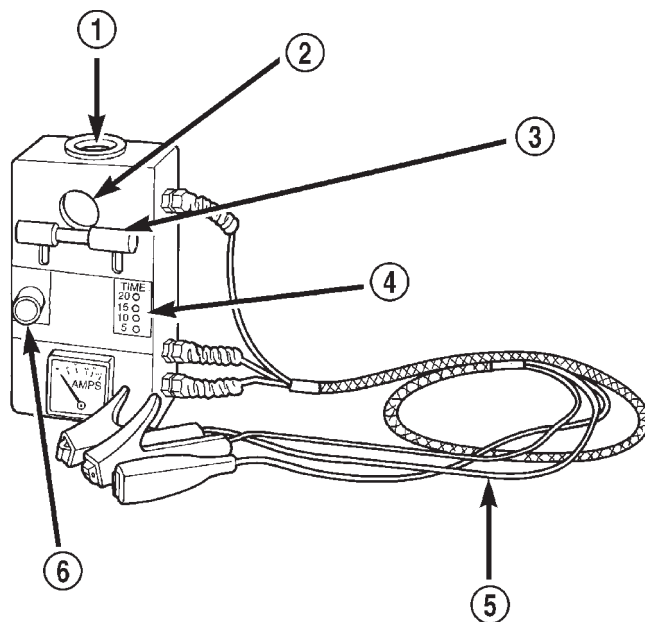

80a0c62c

Fig. 16 Typical Glow Plug Tester

- 1 - INSERT GLOW PLUG HERE
- 2 - OBSERVATION WINDOW
- 3 - SPRING LOADED BAR
- 4 - TIMER LAMPS (4)
- 5 - TEST LEADS
- 6 - TESTER BUTTON

when cold. **Do not check the plugs if the engine has recently been operated. If plugs are checked when warm, incorrect amp gauge readings will result.**

Use Churchill Glow Plug Tester DX.900 or an equivalent (Fig. 16) for the following tests. This tester is equipped with 4 timer lamps.

(1) Remove the glow plugs from the engine. Refer to Glow Plug Removal/Installation.

(2) Attach the red lead of the tester to the 12V+ (positive) side of the battery.

(3) Attach the black lead of the tester to the 12V- (negative) side of the battery.

(4) Fit the glow plug into the top of the tester and secure it with the spring loaded bar (Fig. 16).

(5) Attach the third lead wire of the tester to the electrical terminal at the end of the glow plug.

(6) When performing the test, the tester button (Fig. 16) should be held continuously without release for 20 seconds as indicated by the 4 timer lamps. Each illuminated lamp represents a 5 second time lapse.

(a) Press and hold the tester button (Fig. 16) and note the amp gauge reading. The gauge read-

ing should indicate a momentary, initial current draw (surge) of approximately 25 amps. After the initial surge, the amp gauge reading should begin to fall off. The glow plug tip should start to glow an orange color after 5 seconds. If the tip did not glow after 5 seconds, replace the glow plug. Before discarding the glow plug, check the position of the circuit breaker on the bottom of the plug tester. It may have to be reset. Reset if necessary.

(b) Continue to hold the tester button while observing the amp gauge and the 4 timer lamps. When all 4 lamps are illuminated, indicating a 20 second time lapse, the amp gauge reading should indicate a 9-12 amp current draw. If not, replace the glow plug. Refer to Glow Plug Removal/Installation.

(7) Check each glow plug in this manner using one 20 second cycle. If the glow plug is to be retested, it must first be allowed to cool to room temperature.

WARNING: THE GLOW PLUG WILL BECOME EXTREMELY HOT (GLOWING) DURING THESE TESTS. BURNS COULD RESULT IF IMPROPERLY HANDLED. ALLOW THE GLOW PLUG TO COOL BEFORE REMOVING FROM TESTER.

(8) Remove the glow plug from the tester.

DIAGNOSIS AND TESTING (Continued)

GLOW PLUG RELAY TEST

The glow plug relay is located in the engine compartment on the left-inner fender (Fig. 17).

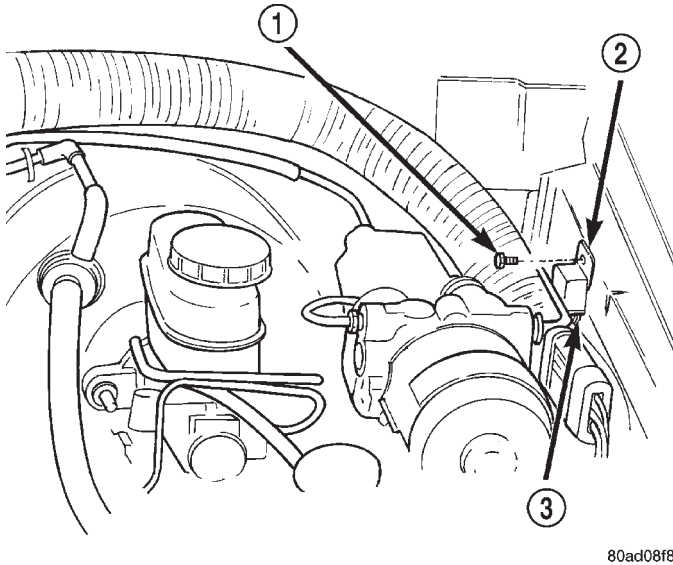

Fig. 17 Glow Plug Relay Location

- 1 - MOUNTING BOLT
- 2 - GLOW PLUG RELAY
- 3 - ELECTRICAL CONNECTOR

When the ignition (key) switch is placed in the ON position, a signal is sent to the ECM relating engine coolant temperature. This signal is sent from the engine coolant temperature sensor.

After receiving this signal, the ECM will determine if, when and for how long a period the glow plug relay should be activated. This is done before, during and after the engine is started. Whenever the glow plug relay is activated, it will control the 12V+ 100 amp circuit for the operation of the four glow plugs.

The Glow Plug lamp is tied to this circuit. Lamp operation is also controlled by the ECM.

With a cold engine, the glow plug relay and glow plugs may be activated for a maximum time of 200 seconds. Refer to the Glow Plug Control chart for a temperature/time comparison of glow plug relay operation.

In this chart, Pre-Heat and Post-Heat times are mentioned. Pre-heat is the amount of time the glow plug relay circuit is activated when the ignition (key) switch is ON, but the engine has yet to be started. Post-heat is the amount of time the glow plug relay circuit is activated after the engine is operating. The Glow Plug lamp will not be illuminated during the post-heat cycle.

TESTING:

Disconnect and isolate the electrical connectors (Fig. 18) at all four glow plugs. With the engine cool or cold, and the key in the ON position, check for

10-12 volts + at each electrical connector. 10-12 volts + should be at each connector whenever the ECM is operating in the pre-heat or post-heat cycles (refer to the following Glow Plug Control chart). **Be very careful not to allow any of the four disconnected glow plug electrical connectors to contact a metal surface. When the key is turned to the ON position, approximately 100 amps at 12 volts is supplied to these connectors.** If 10-12 volts + is not available at each connector, check continuity of wiring harness directly to the relay. If continuity is good directly to the relay, the fault is either with the relay or the relay input from the ECM. To test the relay only, refer to Relays—Operation/Testing in this section of the group. If the relay test is good, refer to the DRB scan tool.

Diagnostic Trouble Codes: Refer to On-Board Diagnostics in Group 25, Emission Control System for a list of Diagnostic Trouble Codes (DTC's) for certain fuel system components.

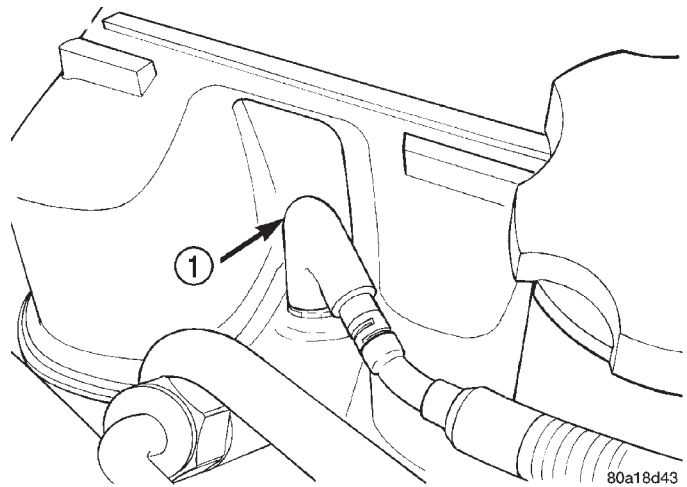

Fig. 18 Wiring Connection at Glow Plug

- 1 - GLOW PLUG ELECTRICAL CONNECTOR

GLOW PLUG CONTROL

| ENGINE COOLANT TEMPERATURE KEY ON | WAIT-TO-START LAMP ON (SECONDS) | PRE-HEAT CYCLE (GLOW PLUGS ON) (SECONDS) | POST-HEAT CYCLE (SECONDS) |
|-----------------------------------|---------------------------------|--|---------------------------|
| -30 C | 15 SEC. | 45 SEC. | 200 SEC. |
| -10 C | 8 SEC. | 35 SEC. | 180 SEC. |
| +10 C | 6 SEC. | 25 SEC. | 118 SEC. |
| +30 C | 5 SEC. | 20 SEC. | 70 SEC. |
| +40 C | 4 SEC. | 16 SEC. | 60 SEC. |
| +70 C | 3 SEC. | 16 SEC. | 20 SEC. |

DIAGNOSIS AND TESTING (Continued)

RELAYS—OPERATION/TESTING

The following description of operation and tests apply only to the ASD and other relays. The terminals on the bottom of each relay are numbered (Fig. 19).

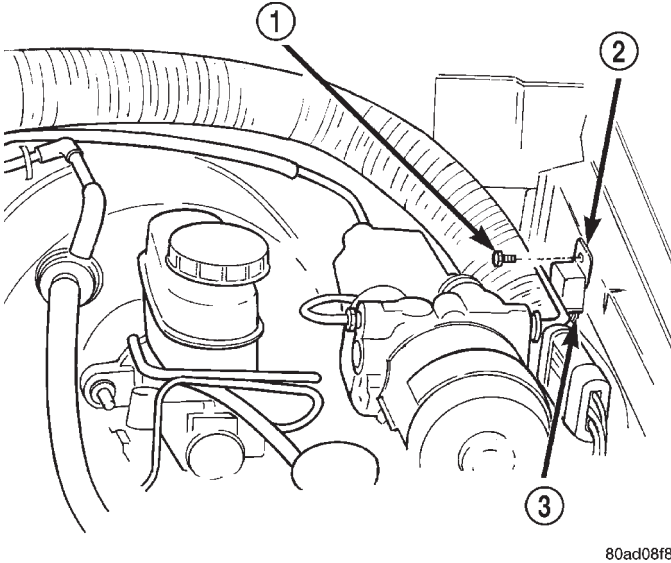

80ad08f8

Fig. 19 Glow Plug Relay Location

- 1 - MOUNTING BOLT
- 2 - GLOW PLUG RELAY
- 3 - ELECTRICAL CONNECTOR

OPERATION

- Terminal number 30 is connected to battery voltage. For both the ASD and other relays, terminal 30 is connected to battery voltage at all times.
- The ECM grounds the coil side of the relay through terminal number 85.
- Terminal number 86 supplies voltage to the coil side of the relay.
- When the PCM de-energizes the ASD and other relays, terminal number 87A connects to terminal 30. This is the Off position. In the off position, voltage is not supplied to the rest of the circuit. Terminal 87A is the center terminal on the relay.
- When the ECM energizes the ASD and other relays, terminal 87 connects to terminal 30. This is the On position. Terminal 87 supplies voltage to the rest of the circuit.

TESTING

The following procedure applies to the ASD and other relays.

- (1) Remove relay from connector before testing.
- (2) With the relay removed from the vehicle, use an ohmmeter to check the resistance between terminals 85 and 86. The resistance should be between 75 \pm 5 ohms.

(3) Connect the ohmmeter between terminals 30 and 87A. The ohmmeter should show continuity between terminals 30 and 87A.

(4) Connect the ohmmeter between terminals 87 and 30. The ohmmeter should not show continuity at this time.

(5) Connect one end of a jumper wire (16 gauge or smaller) to relay terminal 85. Connect the other end of the jumper wire to the ground side of a 12 volt power source.

(6) Connect one end of another jumper wire (16 gauge or smaller) to the power side of the 12 volt power source. **Do not attach the other end of the jumper wire to the relay at this time.**

WARNING: DO NOT ALLOW OHMMETER TO CONTACT TERMINALS 85 OR 86 DURING THIS TEST.

(7) Attach the other end of the jumper wire to relay terminal 86. This activates the relay. The ohmmeter should now show continuity between relay terminals 87 and 30. The ohmmeter should not show continuity between relay terminals 87A and 30.

(8) Disconnect jumper wires.

(9) Replace the relay if it did not pass the continuity and resistance tests. If the relay passed the tests, it operates properly. Check the remainder of the ASD and other relay circuits. Refer to group 8W, Wiring Diagrams.

BOOST / PRESSURE SENSOR

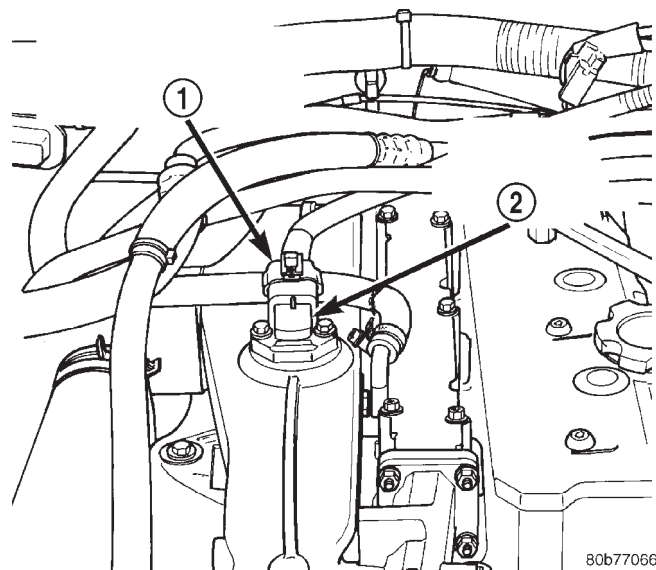

80b77066

Fig. 20 Boost Pressure Sensor Location

- 1 - BOOST PRESSURE SENSOR HARNESS CONNECTOR
- 2 - BOOST PRESSURE SENSOR

If the boost pressure sensor fails, the PCM records a DTC into memory and continues to operate the

DIAGNOSIS AND TESTING (Continued)

engine in one of the three “limp-in” modes. When the PCM is operating in this mode, a loss of power will be present, as if the turbocharger was not operating. The best method for diagnosing faults with the boost pressure sensor is with the DRB III scan tool. **Diagnostic Trouble Codes:** Refer to On-Board Diagnostics in Group 25, Emission Control System for a list of Diagnostic Trouble Codes (DTC's) for certain fuel system components.

VEHICLE SPEED SENSOR TEST

To perform a test of the sensor and its related circuitry, refer to DRB scan tool.

Diagnostic Trouble Codes: Refer to On-Board Diagnostics in Group 25, Emission Control System for a list of Diagnostic Trouble Codes (DTC's) for certain fuel system components.

DIAGNOSTIC TROUBLE CODES

For a list of Diagnostic Trouble Codes (DTC's), refer to Group 25, Emission Control System for information. See On-Board Diagnostics.

REMOVAL AND INSTALLATION

ASD RELAY

The ASD relay is located in the PDC. For the location of the relay within the PDC, refer to label on PDC cover.

A/C CLUTCH RELAY

The A/C clutch relay is located in the PDC. For the location of the relay within the PDC, refer to label on PDC cover.

ENGINE SPEED SENSOR

The engine speed sensor is mounted to the transmission bellhousing at the rear of the engine block (Fig. 21).

REMOVAL

- (1) Disconnect the harness (on the sensor) from the main electrical harness.
- (2) Remove the sensor mounting bolts.
- (3) Remove the sensor.

INSTALLATION

- (1) Install the sensor flush against the opening in the transmission housing.
- (2) Install and tighten the sensor mounting bolt to 19 N·m (14 ft. lbs.) torque.
- (3) Connect the electrical connector to the sensor.

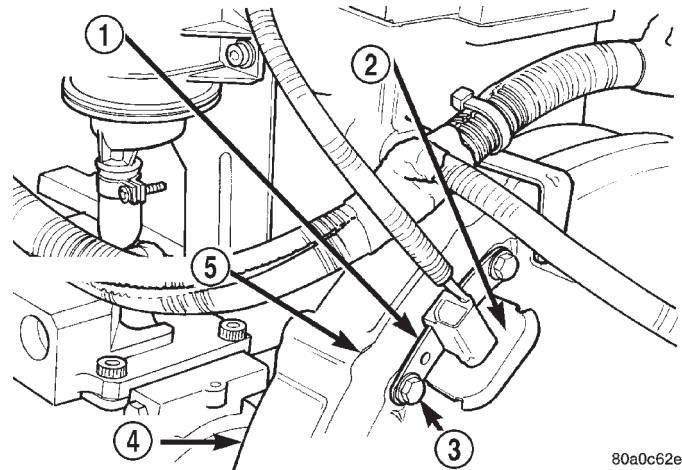

80a0c62e

Fig. 21 Engine Speed Sensor

- 1 - ENGINE SPEED SENSOR
- 2 - GROMMET
- 3 - MOUNTING BOLT(S)
- 4 - LEFT REAR OF ENGINE
- 5 - TRANSMISSION

ENGINE COOLANT TEMPERATURE SENSOR

The sensor is located on the side of cylinder head near the rear of fuel injection pump.

REMOVAL

WARNING: HOT, PRESSURIZED COOLANT CAN CAUSE INJURY BY SCALDING. COOLING SYSTEM MUST BE PARTIALLY DRAINED BEFORE REMOVING THE COOLANT TEMPERATURE SENSOR. REFER TO GROUP 7, COOLING.

- (1) Partially drain cooling system. Refer to Group 7, Cooling.
- (2) Disconnect electrical connector from sensor.
- (3) Remove sensor from cylinder head.

INSTALLATION

- (1) Install a new copper gasket to sensor.
- (2) Install sensor to cylinder head.
- (3) Tighten sensor to 18 N·m (13 ft. lbs.) torque.
- (4) Connect electrical connector to sensor.
- (5) Replace any lost engine coolant. Refer to Group 7, Cooling System.

GLOW PLUGS

The glow plugs are located above each fuel injector (Fig. 22). Four individual plugs are used.

REMOVAL

- (1) Disconnect the negative battery cable at the battery.
- (2) Clean the area around the glow plug with compressed air before removal.

REMOVAL AND INSTALLATION (Continued)

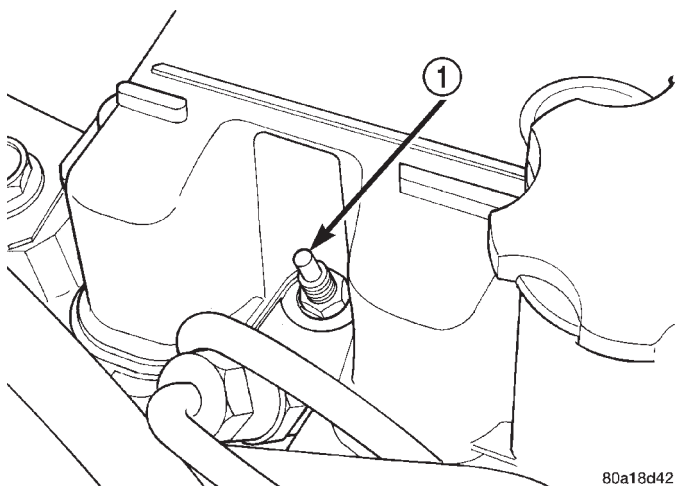
**Fig. 22 Glow Plug**

1 - GLOW PLUG

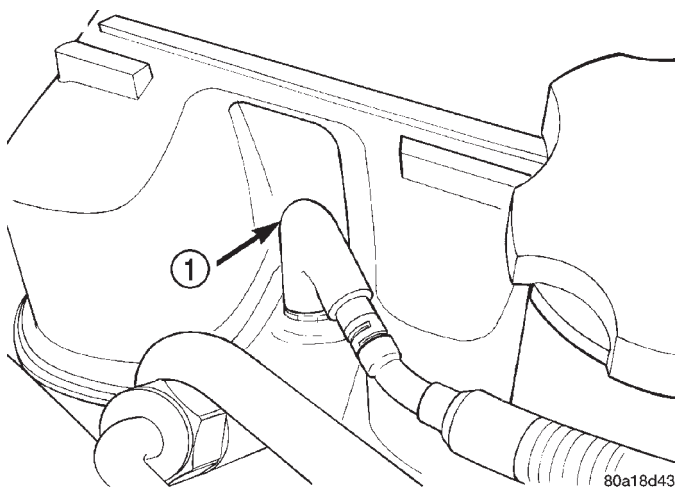
**Fig. 23 Glow Plug Electrical Connector**

1 - GLOW PLUG ELECTRICAL CONNECTOR

(3) Disconnect electrical connector (Fig. 23) at glow plug.

(4) Remove the glow plug (Fig. 22) from cylinder head.

INSTALLATION

(1) Apply high-temperature anti-seize compound to glow plug threads before installation

(2) Install the glow plug into the cylinder head. Tighten to 14 N·m (123 in. lbs.) torque.

(3) Connect battery cable to battery.

GLOW PLUG RELAY

The glow plug relay is located in the engine compartment on the left-inner fender (Fig. 24).

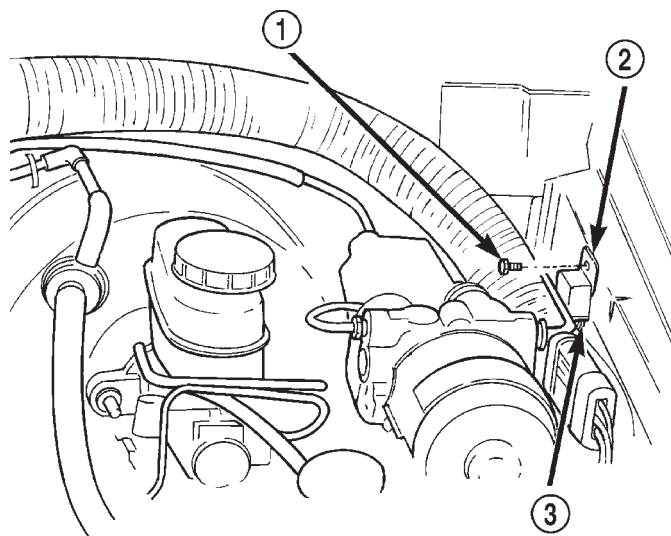
**Fig. 24 Glow Plug Relay Location**

1 - MOUNTING BOLT
2 - GLOW PLUG RELAY
3 - ELECTRICAL CONNECTOR

REMOVAL

(1) Disconnect the negative battery cable at the battery.

(2) Remove relay mounting bolt.

(3) Disconnect electrical connector at relay and remove relay.

INSTALLATION

(1) Check condition of electrical connector for damage or corrosion. Repair as necessary.

(2) Install electrical connector to relay.

(3) Install relay to inner fender.

(4) Connect battery cable to battery.

POWERTRAIN CONTROL MODULE (PCM)

The PCM is mounted to a bracket mounted to the inner side of the right fender well behind the air cleaner assembly. (Fig. 25).

REMOVAL

(1) Disconnect the negative battery cable at the battery.

(2) Loosen the 60-Way connector (Fig. 25). The electrical connector has a sliding bar which moves inward to lock or outward to unlock.

(3) Remove the electrical connector by pulling straight out.

(4) Remove PCM.

INSTALLATION

(1) After the PCM electrical connector has been separated from the PCM, inspect the pins for corro-

REMOVAL AND INSTALLATION (Continued)

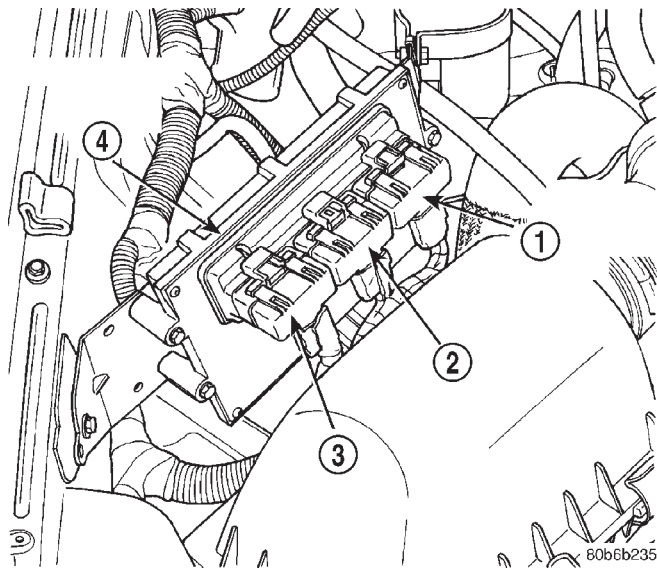

Fig. 25 PCM Location

- 1 - PCM HARNESS CONNECTOR C1
- 2 - PCM HARNESS CONNECTOR C2
- 3 - PCM HARNESS CONNECTOR C3
- 4 - POWERTRAIN CONTROL MODULE (PCM)

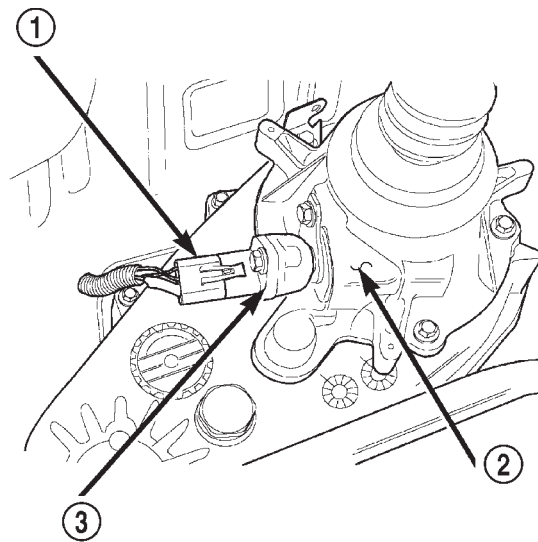

Fig. 26 Vehicle Speed Sensor Location—4WD

80a35409

- 1 - SENSOR ELECTRICAL CONNECTOR
- 2 - 4WD TRANSFER CASE EXTENSION
- 3 - VEHICLE SPEED SENSOR

sion, being spread apart, bent or misaligned. Also inspect the pin heights in the connector. If the pin heights are different, this would indicate a pin has separated from the connector. Repair as necessary.

(2) Engage 60-way connector into PCM. Move slide bar to lock connector.

(3) Connect negative cable to battery.

VEHICLE SPEED SENSOR

The vehicle speed sensor is located in the transfer case housing for 4 wheel drive vehicles (Fig. 26).

REMOVAL

(1) Raise and support vehicle.

(2) Clean the area around the sensor before removal.

(3) Disconnect the electrical connector from the sensor (Fig. 27).

(4) Remove the sensor mounting bolt (Fig. 27).

(5) Pull the sensor from the speedometer pinion gear adapter for removal.

INSTALLATION

(1) Install new sensor into speedometer gear adapter.

(2) Tighten sensor mounting bolt. To prevent damage to sensor or speedometer adapter, be sure the sensor is mounted flush to the adapter before tightening.

(3) Connect electrical connector to sensor.

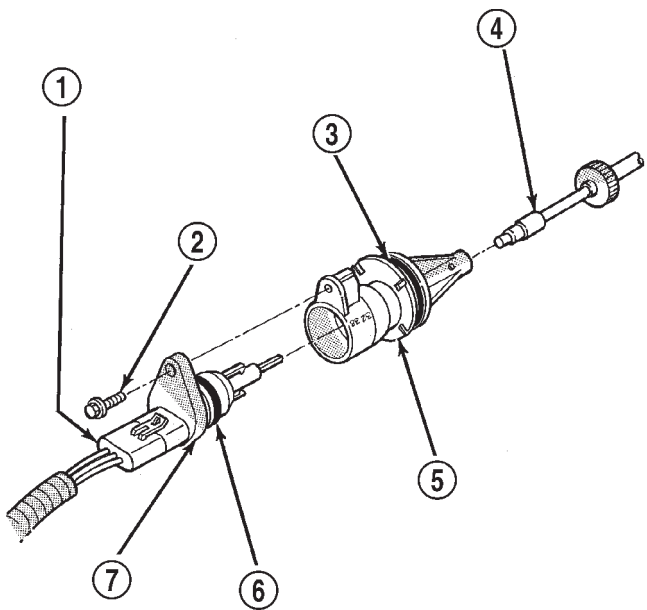

Fig. 27 Sensor Removal/Installation—Typical

J9314-188

- 1 - ELECTRICAL CONNECTOR
- 2 - SENSOR MOUNTING BOLT
- 3 - O-RING
- 4 - SPEEDOMETER PINION GEAR
- 5 - SPEEDOMETER PINION GEAR ADAPTER
- 6 - O-RING
- 7 - VEHICLE SPEED SENSOR

SPECIFICATIONS

GLOW PLUG CURRENT DRAW

Initial Current Draw: Approximately 22–25 amps per plug.

After 20 seconds of operation: Approximately 9–12 amps per plug.

TORQUE CHART—2.5L DIESEL

| DESCRIPTION | TORQUE |
|---|-------------------------|
| Accelerator Pedal Bracket Mounting Nuts . . | 5 N·m (46 in. lbs.) |
| Banjo-Type Fittings | 19 N·m (14 ft. lbs.) |
| Engine Coolant Temperature Sensor | 18 N·m (13 ft. lbs.) |
| Engine Speed Sensor Bolts | 19 N·m (14 ft. lbs.) |
| Fuel Hose (Tube) Clamps For Rubber Hose . . . | 2 N·m (20 in. lbs.) |
| Fuel Injector | 70 N·m (52 ft. lbs.) |
| Fuel Injector Line At Injector . . | 30 N·m (22 ft. lbs.) |
| Fuel Injector Line At Injector Pump | 30 N·m (22 ft. lbs.) |
| Fuel Injection Pump Mounting Nuts | 30 N·m (22 ft. lbs.) |
| Fuel Injection Pump Drive Gear | 88 N·m (65 ft. lbs.) |
| Fuel Line Clamp Bracket Bolts . | 24 N·m (18 ft. lbs.) |
| Fuel Tank Nuts | 11 N·m (100 in. lbs.) |
| Glow Plugs | 23 N·m (203 in. lbs.) |
| Powertrain Control Module Mounting Bolts . . | 1 N·m (9 in. lbs.) |
| Throttle Position Sensor Mounting Bolts . . . | 7 N·m (60 in. lbs.) |
| Vehicle Speed Sensor Mounting Bolts | 3 N·m (26 in. lbs.) |

STEERING

TABLE OF CONTENTS

| | page | | page |
|---------------------------|------|------------------------|------|
| POWER STEERING | 1 | STEERING LINKAGE | 22 |
| POWER STEERING PUMP | 5 | STEERING COLUMN | 26 |
| POWER STEERING GEAR | 11 | | |

POWER STEERING

TABLE OF CONTENTS

| | page | | page |
|----------------------------------|------|--|------|
| DESCRIPTION AND OPERATION | | DIAGNOSIS AND TESTING | |
| STEERING SYSTEM | 1 | POWER STEERING SYSTEM DIAGNOSIS CHARTS | 2 |

DESCRIPTION AND OPERATION

STEERING SYSTEM

DESCRIPTION

The power steering system has a hydraulic pump. The pump is a constant flow rate and displacement, vane-type pump. The pump on the 4.0L engine has a reservoir mounted to it (Fig. 1). The 2.5L engine has a remote mounted reservoir.

The steering gear (Fig. 1) used is a recirculating ball type gear with 14:1 gear ratio. A tilt and non-tilt column provide steering input.

NOTE: Right hand drive (RHD) and left hand drive (LHD) service procedures and torque specifications for steering linkage, gear and column are the same. The power steering pump procedures are different. Refer to appropriate service procedures regarding each component in the system.

OPERATION

The steering gear acts as a rolling thread between the worm shaft and the rack piston. Power assist is provided by the hydraulic pump. When the steering wheel is turned the worm shaft turns which moves

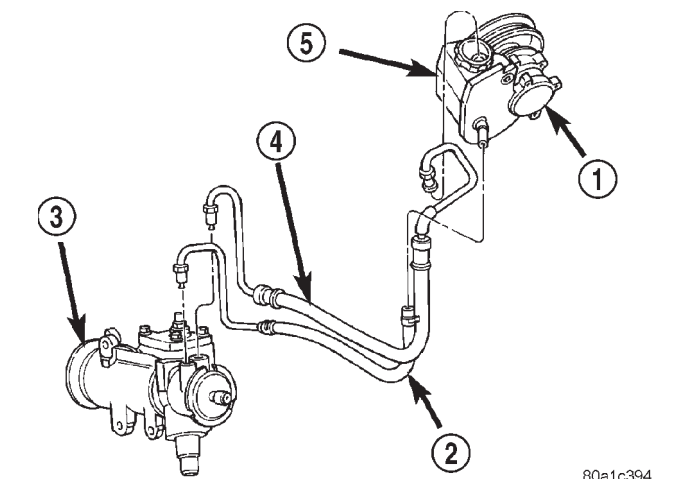

Fig. 1 Power Steering Gear & Pump - 4.0L

- 1 - 4.0 L PUMP
- 2 - RETURN HOSE
- 3 - STEERING GEAR
- 4 - PRESSURE HOSE
- 5 - RESERVOIR

the rack piston. The rack piston movement turns the pitman shaft which is connected to the steering linkage by the pitman arm.

DIAGNOSIS AND TESTING

POWER STEERING SYSTEM DIAGNOSIS CHARTS

STEERING NOISE

There is some noise in all power steering systems. One of the most common is a hissing sound evident at a standstill parking. Or when the steering wheel is at the end of it's travel. Hiss is a high frequency noise similar to that of a water tap being closed slowly. The noise is present in all valves that have a high velocity fluid passing through an orifice. There is no relationship between this noise and steering performance.

| CONDITION | POSSIBLE CAUSES | CORRECTION |
|-----------------------------|---|---|
| OBJECTIONAL HISS OR WHISTLE | <ol style="list-style-type: none"> 1. Steering intermediate shaft to dash panel seal. 2. Noisy valve in power steering gear. | <ol style="list-style-type: none"> 1. Check and repair seal at dash panel. 2. Replace steering gear. |
| RATTLE OR CLUNK | <ol style="list-style-type: none"> 1. Gear mounting bolts loose. 2. Loose or damaged suspension components/track bar. 3. Loose or damaged steering linkage. 4. Internal gear noise. 5. Pressure hose in contact with other components. | <ol style="list-style-type: none"> 1. Tighten bolts to specification. 2. Inspect and repair suspension. 3. Inspect and repair steering linkage. 4. Replace gear. 5. Reposition hose. |
| CHIRP OR SQUEAL | <ol style="list-style-type: none"> 1. Loose belt. | <ol style="list-style-type: none"> 1. Adjust or replace. |
| WHINE OR GROWL | <ol style="list-style-type: none"> 1. Low fluid level. 2. Pressure hose in contact with other components. 3. Internal pump noise. 4. Air in the system. | <ol style="list-style-type: none"> 1. Fill to proper level. 2. Reposition hose. 3. Replace pump. 4. Perform pump initial operation. |
| SUCKING AIR SOUND | <ol style="list-style-type: none"> 1. Loose return line clamp. 2. O-ring missing or damaged on hose fitting. 3. Low fluid level. 4. Air leak between pump and reservoir. | <ol style="list-style-type: none"> 1. Replace clamp. 2. Replace o-ring. 3. Fill to proper level. 4. Repair as necessary. |
| SCRUBBING OR KNOCKING | <ol style="list-style-type: none"> 1. Wrong tire size. 2. Wrong gear. | <ol style="list-style-type: none"> 1. Verify tire size. 2. Verify gear. |

DIAGNOSIS AND TESTING (Continued)

BINDING AND STICKING

| CONDITION | POSSIBLE CAUSE | CORRECTION |
|--|---|---|
| DIFFICULT TO TURN WHEEL STICKS OR BINDS | <ol style="list-style-type: none"> 1. Low fluid level. 2. Tire pressure. 3. Steering component. 4. Loose belt. 5. Low pump pressure. 6. Column shaft coupler binding. 7. Steering gear worn or out of adjustment. 8. Ball joints binding. | <ol style="list-style-type: none"> 1. Fill to proper level. 2. Adjust tire pressure. 3. Inspect and lube. 4. Adjust or replace. 5. Pressure test and replace if necessary. 6. Replace coupler. 7. Repair or replace gear. 8. Inspect and repair as necessary. |

INSUFFICIENT ASSIST OR POOR RETURN TO CENTER

| CONDITION | POSSIBLE CAUSE | CORRECTION |
|---|--|---|
| HARD TURNING OR MOMENTARY INCREASE IN TURNING EFFORT | <ol style="list-style-type: none"> 1. Tire pressure. 2. Low fluid level. 3. Loose belt. 4. Lack of lubrication. 5. Low pump pressure. 6. Internal gear leak. | <ol style="list-style-type: none"> 1. Adjust tire pressure. 2. Fill to proper level. 3. Adjust or replace. 4. Inspect and lubricate steering and suspension components. 5. Pressure test and repair as necessary. 6. Pressure and flow test, and repair as necessary. |
| STEERING WHEEL DOES NOT WANT TO RETURN TO CENTER POSITION | <ol style="list-style-type: none"> 1. Tire pressure. 2. Wheel alignment. 3. Lack of lubrication. 4. High friction in steering gear. 5. Ball joints binding. | <ol style="list-style-type: none"> 1. Adjust tire pressure. 2. Align front end. 3. Inspect and lubricate steering and suspension components. 4. Test and adjust as necessary. 5. Inspect and repair as necessary. |

Some roads will cause a vehicle to drift, due to the crown in the road.

DIAGNOSIS AND TESTING (Continued)

LOOSE STEERING AND VEHICLE LEADS/DRIFTS

| CONDITION | POSSIBLE CAUSE | CORRECTION |
|--|--|---|
| EXCESSIVE PLAY IN STEERING WHEEL | <ol style="list-style-type: none"> 1. Worn or loose suspension or steering components. 2. Worn or loose wheel bearings. 3. Steering gear mounting. 4. Gear out of adjustment. 5. Worn or loose steering coupler. | <ol style="list-style-type: none"> 1. Repair as necessary. 2. Repair as necessary. 3. Tighten gear mounting bolts to specification. 4. Adjust gear to specification. 5. Repair as necessary. |
| VEHICLE PULLS TO ONE SIDE DURING BRAKING | <ol style="list-style-type: none"> 1. Tire Pressure. 2. Air in brake hydraulics system. 3. Worn brake components. | <ol style="list-style-type: none"> 1. Adjust tire pressure. 2. Bleed brake system. 3. Repair as necessary. |
| VEHICLE LEADS OR DRIFTS FROM STRAIGHT AHEAD DIRECTION ON UNCROWNED ROAD. | <ol style="list-style-type: none"> 1. Tire pressure. 2. Radial tire lead. 3. Brakes dragging. 4. Wheel alignment. 5. Weak or broken spring. 6. Loose or worn steering/suspension components. 7. Cross caster out of spec. | <ol style="list-style-type: none"> 1. Adjust tire pressure. 2. Cross front tires. 3. Repair as necessary. 4. Align vehicle. 5. Replace spring. 6. Repair as necessary. 7. Adjust or replace axle as necessary. |

POWER STEERING PUMP

TABLE OF CONTENTS

| | page | page |
|---|------|------|
| DESCRIPTION AND OPERATION | | |
| POWER STEERING PUMP | 5 | |
| POWER STEERING PRESSURE LINE | 5 | |
| POWER STEERING RETURN LINE | 6 | |
| DIAGNOSIS AND TESTING | | |
| POWER FLOW AND PRESSURE | 6 | |
| PUMP LEAKAGE DIAGNOSIS | 7 | |
| SERVICE PROCEDURES | | |
| POWER STEERING PUMP - INITIAL OPERATION | 7 | |
| REMOVAL AND INSTALLATION | | |
| POWER STEERING PUMP | 7 | |
| PUMP RESERVOIR-2.5L | 7 | |
| DISASSEMBLY AND ASSEMBLY | | |
| PUMP PULLEY | 8 | |
| PUMP RESERVOIR | 8 | |
| SPECIFICATIONS | | |
| TORQUE CHART | 10 | |
| SPECIAL TOOLS | | |
| POWER STEERING PUMP | 10 | |

DESCRIPTION AND OPERATION

POWER STEERING PUMP

DESCRIPTION

Hydraulic pressure for the power steering system is provided by a belt driven power steering pump (Fig. 1). The pump shaft has a pressed-on high strength plastic drive pulley that is belt driven by the crankshaft pulley. The reservoir is attached to the pump body with spring clips on the 4.0L engine. A remote pump reservoir is used on the 2.5L engine mounted to the fan shroud. The power steering pump is connected to the steering gear by the pressure and return hoses.

OPERATION

The power steering pump is a constant flow rate and displacement, vane-type pump. The pump internal parts operate submerged in fluid. The flow control orifice is part of the high pressure line fitting. The pressure relief valve inside the flow control valve limits the pump pressure.

NOTE: Power steering pumps have different pressure rates and are not interchangeable with other pumps.

POWER STEERING PRESSURE LINE

DESCRIPTION

The hose consists of two metal ends and rubber center section that contains a tuning cable.

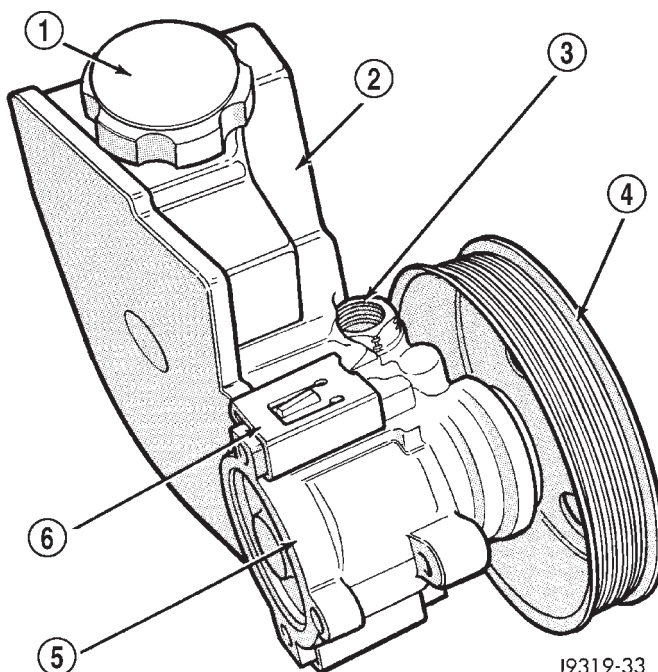

J9319-33

Fig. 1 Pump With Integral Reservoir

- 1 - CAP
- 2 - FLUID RESERVOIR (TYPICAL)
- 3 - HIGH-PRESSURE FITTING
- 4 - DRIVE PULLEY
- 5 - PUMP BODY
- 6 - RESERVOIR CLIP

OPERATION

Power steering pressure line, is used to transfer high pressure power steering fluid, from the power steering pump to the power steering gear.

DESCRIPTION AND OPERATION (Continued)

POWER STEERING RETURN LINE

DESCRIPTION

Power steering return line is a hose which is clamped at the pump and the gear.

OPERATION

Power steering return line, is used to transfer low pressure power steering fluid, from the power steering gear to the power steering pump.

DIAGNOSIS AND TESTING

POWER FLOW AND PRESSURE

The following procedure is used to test the operation of the power steering system on the vehicle. This test will provide the gallons per minute (GPM) or flow rate of the power steering pump along with the maximum relief pressure. Perform test any time a power steering system problem is present. This test will determine if the power steering pump or power steering gear is not functioning properly. The following pressure and flow test is performed using Power Steering Analyzer Tool Kit 6815 (Fig. 2) and Adapter Kit 6893.

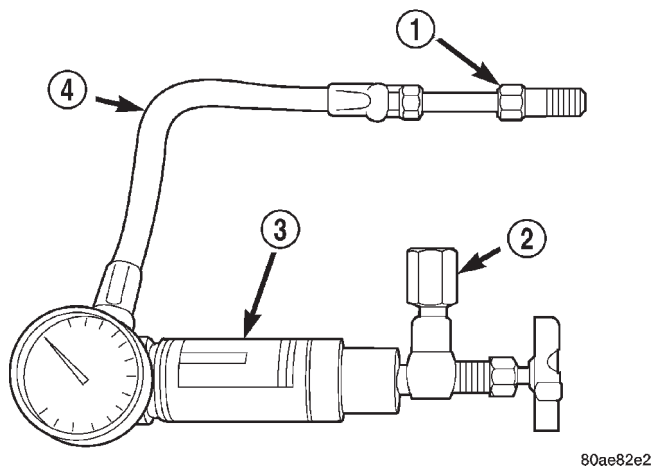

80ae82e2

Fig. 2 Power Steering Analyzer

- 1 - TUBE
- 2 - ADAPTER FITTINGS
- 3 - ANALYZER
- 4 - GAUGE HOSE

FLOW AND PRESSURE TEST

(1) Check the power steering belt to ensure it is in good condition and adjusted properly.

(2) Connect pressure gauge hose from the Power Steering Analyzer to Tube 6865.

(3) Connect Adapter 6826 to Power Steering Analyzer test valve end.

(4) Disconnect high pressure hose at the pump. Use a container for dripping fluid.

(5) Connect Tube 6865 to the pump hose fitting.

(6) Connect the power steering hose from the steering gear to Adapter 6826.

(7) Open the test valve completely.

(8) Start engine and let idle long enough to circulate power steering fluid through flow/pressure test gauge and to get air out of the fluid. Then shut off engine.

(9) Check fluid level, add fluid as necessary. Start engine again and let idle.

(10) Gauge should read below 862 kPa (125 psi), if above, inspect the hoses for restrictions and repair as necessary. The initial pressure reading should be in the range of 345-552 kPa (50-80 psi).

(11) Increase the engine speed to 1500 RPM and read the flow meter. The reading should be 2.4 - 2.8 GPM, if the reading is below this specification the pump should be replaced.

CAUTION: The next step involves testing maximum pump pressure output and flow control valve operation. Do not leave valve closed for more than three seconds as the pump could be damaged.

(12) Close valve fully three times and record highest pressure indicated each time. **All three readings must be above specifications and within 345 kPa (50 psi) of each other.**

- Pressures above specifications but not within 345 kPa (50 psi) of each other, replace pump.

- Pressures within 345 kPa (50 psi) of each other but below specifications, replace pump.

(13) Open the test valve, turn steering wheel extreme left and right positions against the stops. Record the highest indicated pressure at each position. Compare readings to specifications. If highest output pressures are not the same against either stop, the gear is leaking internally and must be repaired.

CAUTION: Do not force the pump to operate against the stops for more than 2 to 3 seconds at a time because, pump damage will result.

PUMP SPECIFICATIONS

| ENGINE | RELIEF PRESSURE ± 50 | FLOW RATE (GPM) |
|--------|--------------------------|---------------------------|
| 2.5L | 9653 kPa (1400 psi) | 1500 RPM 2.4 - 2.8 GPM |
| 4.0L | 9653 kPa (1400 psi) | |

DIAGNOSIS AND TESTING (Continued)

PUMP LEAKAGE DIAGNOSIS

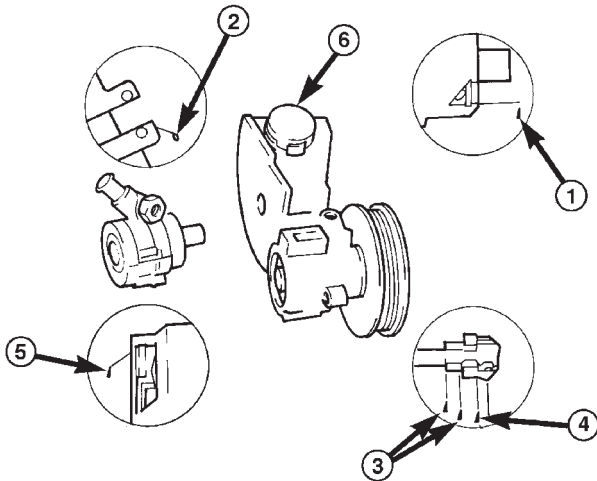

1. BUSHING (BEARING) WORN, SEAL WORN. REPLACE PUMP.
2. REPLACE RESERVOIR O-RING SEAL.
3. TORQUE HOSE FITTING NUT TO SPECIFICATIONS. IF LEAKAGE PERSISTS, REPLACE O-RING SEAL.
4. TORQUE FITTING TO SPECIFICATIONS. IF LEAKAGE PERSISTS, REPLACE O-RING SEAL.
5. REPLACE PUMP.
6. CHECK OIL LEVEL: IF LEAKAGE PERSISTS WITH THE LEVEL CORRECT AND CAP TIGHT, REPLACE THE CAP.

80a1c3c3

SERVICE PROCEDURES

POWER STEERING PUMP - INITIAL OPERATION

WARNING: THE FLUID LEVEL SHOULD BE CHECKED WITH ENGINE OFF TO PREVENT INJURY FROM MOVING COMPONENTS.

CAUTION: Use MOPAR Power Steering Fluid or equivalent. Do not use automatic transmission fluid and do not overfill.

Wipe filler cap clean, then check the fluid level. The dipstick should indicate **COLD** when the fluid is at normal ambient temperature.

- (1) Fill the pump fluid reservoir to the proper level and let the fluid settle for at least two minutes.
- (2) Start the engine and let run for a few seconds then turn engine off.
- (3) Add fluid if necessary. Repeat the above procedure until the fluid level remains constant after running the engine.
- (4) Raise the front wheels off the ground.
- (5) Slowly turn the steering wheel right and left, lightly contacting the wheel stops at least 20 times.
- (6) Check the fluid level add if necessary.
- (7) Lower the vehicle, start the engine and turn the steering wheel slowly from lock to lock.

(8) Stop the engine and check the fluid level and refill as required.

(9) If the fluid is extremely foamy or milky looking, allow the vehicle to stand a few minutes and repeat the procedure.

CAUTION: Do not run a vehicle with foamy fluid for an extended period. This may cause pump damage.

REMOVAL AND INSTALLATION

POWER STEERING PUMP

NOTE: The power steering pump is mounted in the same position on LHD and RHD vehicles. On 4.0L RHD vehicles the front bracket is different. The service procedures are the same.

REMOVAL

- (1) Remove serpentine drive belt, refer to Group 7 Cooling.
- (2) Remove pressure and return hoses from pump, and drain pump.
- (3) Remove 3 pump mounting bolts through pulley access holes.
- (4) Loosen the 3 pump bracket bolts (Fig. 3) and (Fig. 4).
- (5) Tilt pump downward and remove from engine.
- (6) Remove pulley from pump.

INSTALLATION

- (1) Install pulley on pump.
- (2) Install pump on engine.
- (3) Tighten pump bracket bolts to 47 N·m (35 ft. lbs.).
- (4) Install 3 pump mounting bolts and tighten to 27 N·m (20 ft. lbs.).
- (5) Install the pressure and return hoses to pump.
- (6) Install drive belt, refer to Group 7 Cooling.
- (7) Add power steering fluid and perform Power Steering Pump Initial Operation.

PUMP RESERVOIR-2.5L

REMOVAL

- (1) Remove the hoses from the bottom of the reservoir and drain the reservoir.
- (2) Remove the push-in fastener from the top of the fan shroud.
- (3) Slide reservoir up off the fan shroud.

INSTALLATION

- (1) Slide reservoir down onto fan shroud.
- (2) Install the push-in fastener in the top of fan shroud.

REMOVAL AND INSTALLATION (Continued)

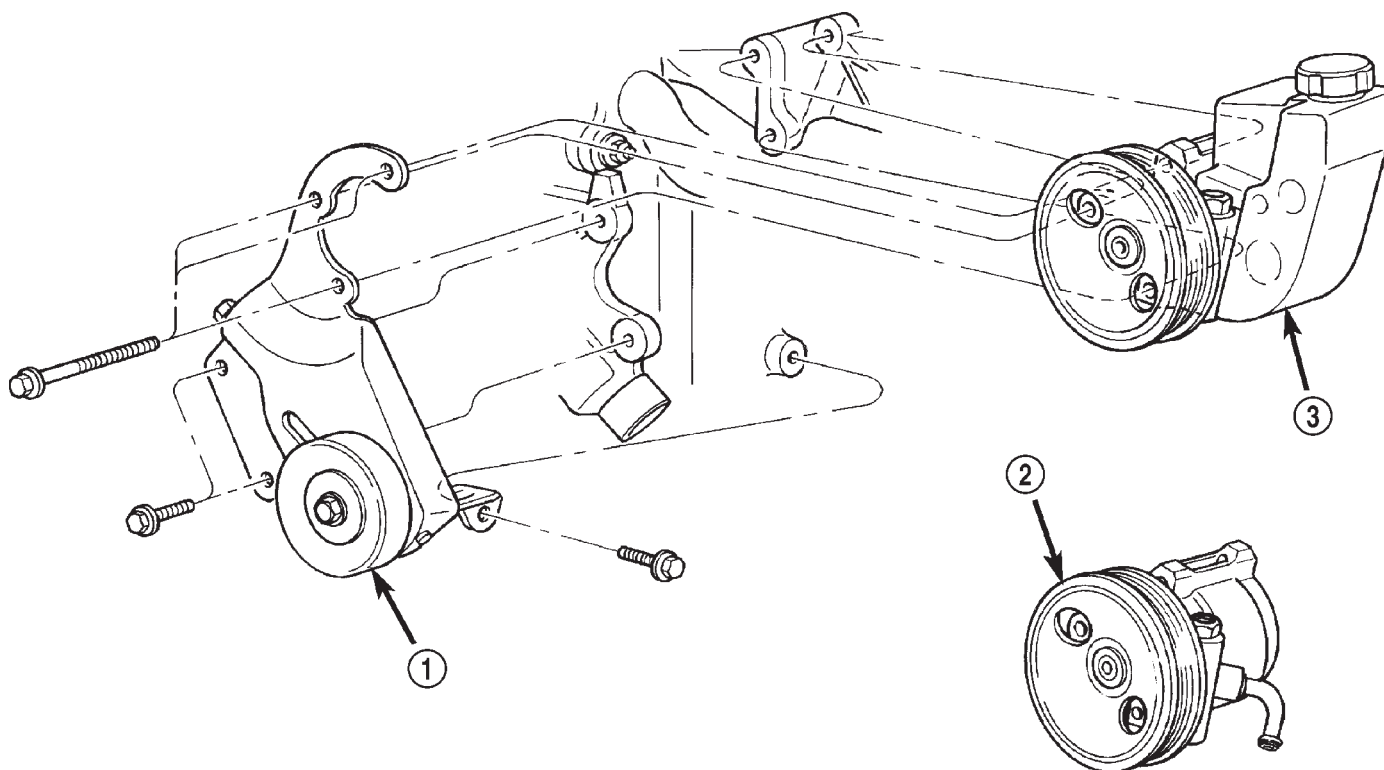

80ae8361

Fig. 3 Pump Mounting LHD

1 - PUMP BRACKET
2 - PUMP ASSEMBLY 2.5L

3 - PUMP ASSEMBLY 4.0L

- (3) Install the pump hoses.
(4) Fill reservoir to proper level. Refer to Power Steering Pump Initial Operation.

DISASSEMBLY AND ASSEMBLY**PUMP PULLEY****DISASSEMBLY**

- (1) Remove pump assembly.
(2) Remove pulley from pump with Puller C-4333 or equivalent puller (Fig. 5).

ASSEMBLY

NOTE: The pulley is marked front for installation.

- (1) Replace pulley if bent, cracked, or loose.
(2) Install pulley on pump with Installer C-4063-B or equivalent installer (Fig. 6). The pulley must be flush with the end of the shaft. Ensure the tool and pulley are aligned with the pump shaft.
(3) Install pump assembly.

- (4) With Serpentine Belt, run engine until warm (5 min.) and note any belt chirp. If chirp exists, move pulley outward approximately 0.5 mm (0.020 in.). If noise increases, press on 1.0 mm (0.040 in.). **Be careful that pulley does not contact mounting bolts.**

PUMP RESERVOIR**DISASSEMBLY**

- (1) Remove power steering pump.
(2) Clean exterior of pump.
(3) Clamp the pump body in a soft jaw vice.
(4) Pry up tab and slide the retaining clips off (Fig. 7).

NOTE: Use new retaining clips for installation.

- (5) Remove fluid reservoir from pump body. Remove and discard O-ring seal.

ASSEMBLY

- (1) Lubricate new O-ring Seal with Mopar Power Steering Fluid or equivalent.

DISASSEMBLY AND ASSEMBLY (Continued)

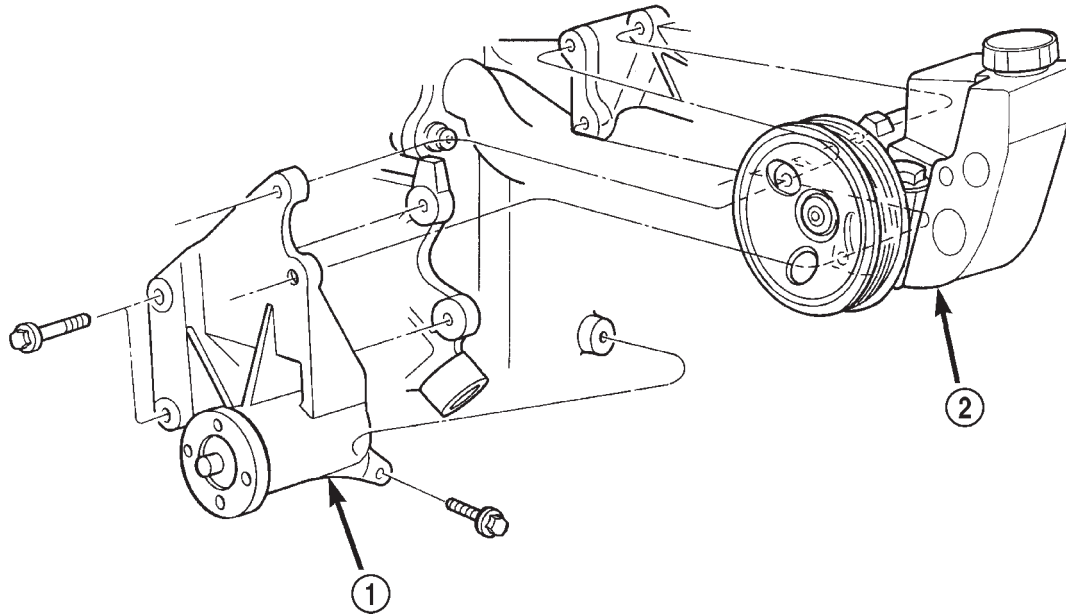

80500554

Fig. 4 Pump Mounting 4.0L RHD

- 1 - BRACKET
- 2 - PUMP ASSEMBLY

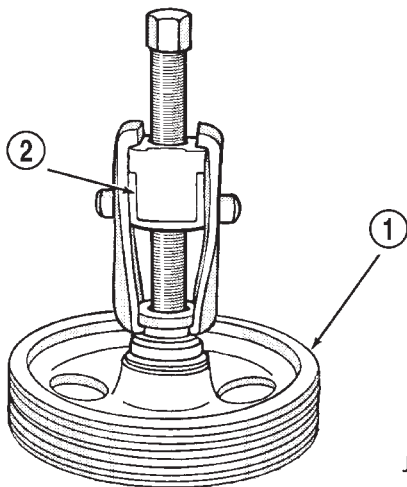

J9319-45

Fig. 5 Pulley Removal

- 1 - POWER STEERING PUMP DRIVE PULLEY
- 2 - SPECIAL TOOL C-4333

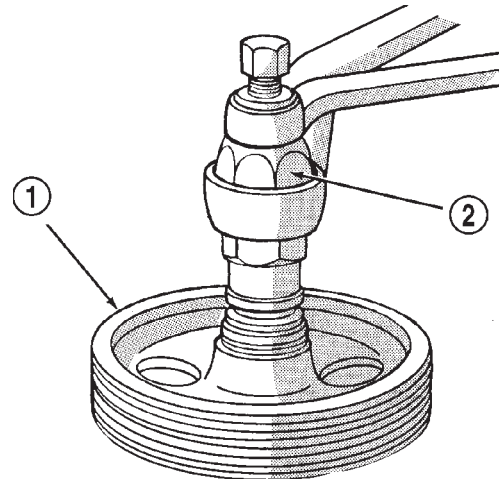

J9519-1

Fig. 6 Pulley Installation

- 1 - POWER STEERING PUMP DRIVE PULLEY
- 2 - SPECIAL TOOL C-4063-B

- (2) Install O-ring seal in housing.
- (3) Install reservoir onto housing.
- (4) Slide and tap in **new** reservoir retainer clips until tab locks to housing.

- (5) Install power steering pump.
- (6) Add power steering fluid, refer to Pump Initial Operation.

DISASSEMBLY AND ASSEMBLY (Continued)

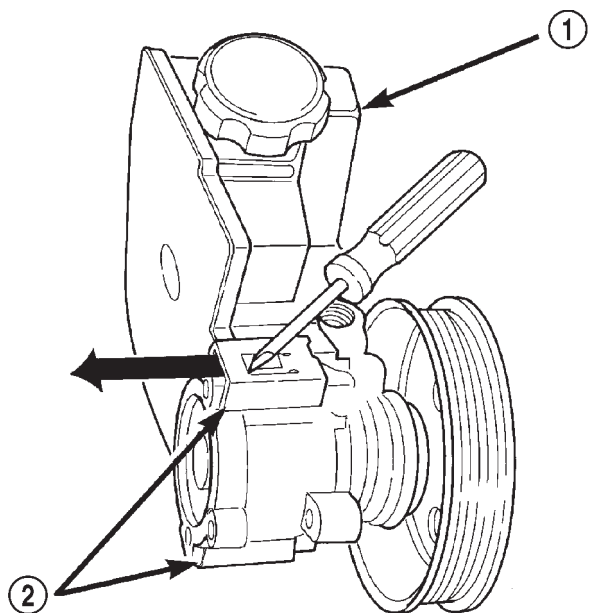

803f5897

Fig. 7 Pump Reservoir Clips

- 1 - RESERVOIR
- 2 - RETAINING CLIPS

SPECIAL TOOLS
POWER STEERING PUMP

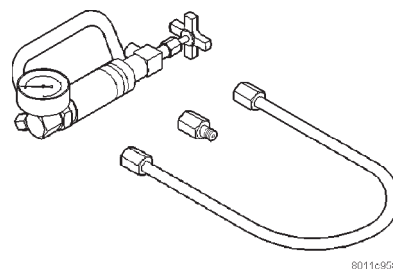

8011c908

Analyzer Set, Power Steering Flow/Pressure 6815

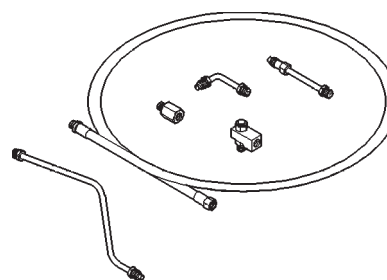

Adapters, Power Steering Flow/Pressure Tester 6893

SPECIFICATIONS

TORQUE CHART

| DESCRIPTION | TORQUE |
|------------------------------|----------------------|
| Power Steering Pump | |
| Bracket to Pump | 28 N·m (21 ft. lbs.) |
| Bracket to Engine | 47 N·m (35 ft. lbs.) |
| Flow Control Valve | 75 N·m (55 ft. lbs.) |
| Pressure Line | 28 N·m (21 ft. lbs.) |

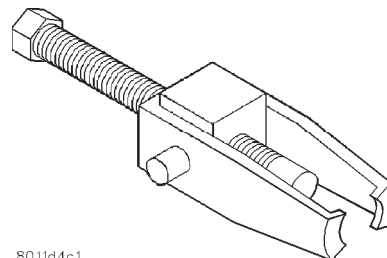

8011d4c1

Puller C-4333

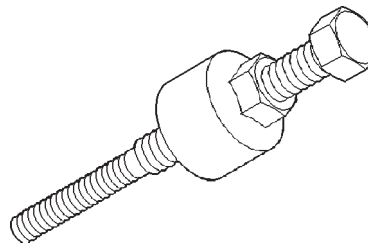

Installer, Power Steering Pulley C-4063B

POWER STEERING GEAR

TABLE OF CONTENTS

| | page | | page |
|-----------------------------------|------|---|------|
| DESCRIPTION AND OPERATION | | SPOOL VALVE | 14 |
| POWER STEERING GEAR | 11 | RACK PISTON AND WORM SHAFT | 16 |
| DIAGNOSIS AND TESTING | | ADJUSTMENTS | |
| POWER STEERING GEAR LEAKAGE | 11 | STEERING GEAR | 19 |
| REMOVAL AND INSTALLATION | | SPECIFICATIONS | |
| STEERING GEAR | 12 | POWER STEERING GEAR | 21 |
| DISASSEMBLY AND ASSEMBLY | | TORQUE CHART | 21 |
| HOUSING END PLUG | 12 | SPECIAL TOOLS | |
| PITMAN SHAFT/SEALS/BEARING | 12 | POWER STEERING GEAR | 21 |

DESCRIPTION AND OPERATION

POWER STEERING GEAR

DESCRIPTION

The power steering gear is a recirculating ball type gear with a 14:1 ratio.

OPERATION

The gear acts as a rolling thread between the worm shaft and rack piston. The worm shaft is supported by a thrust bearing at the lower end and a bearing assembly at the upper end. When the worm shaft is turned the rack piston moves. The rack piston teeth mesh with the pitman shaft. Turning the worm shaft turns the pitman shaft, which turns the steering linkage.

CAUTION: Components attached with a nut and cotter pin must be torqued to specification. Then if the slot in the nut does not line up with the cotter pin hole, tighten nut until it is aligned. Never loosen the nut to align the cotter pin hole.

DIAGNOSIS AND TESTING

POWER STEERING GEAR LEAKAGE

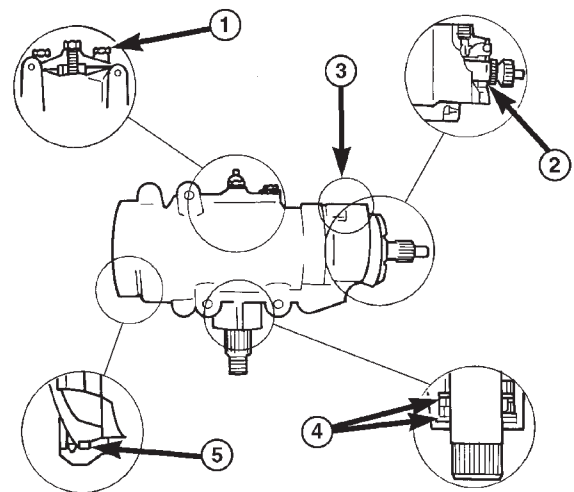

- | | |
|--|--|
| <p>1. SIDE COVER LEAK - TORQUE SIDE COVER BOLTS TO SPECIFICATION. REPLACE THE SIDE COVER SEAL IF THE LEAKAGE PERSISTS.</p> <p>2. ADJUSTER PLUG SEAL - REPLACE THE ADJUSTER PLUG SEALS.</p> | <p>3. PRESSURE LINE FITTING - TORQUE THE HOSE FITTING NUT TO SPECIFICATIONS. IF LEAKAGE PERSISTS, REPLACE THE SEAL.</p> <p>4. PITMAN SHAFT SEALS - REPLACE THE SEALS.</p> <p>5. TOP COVER SEAL - REPLACE THE SEAL.</p> |
|--|--|

REMOVAL AND INSTALLATION

STEERING GEAR

REMOVAL

- (1) Place the front wheels in the straight ahead position with the steering wheel centered.
- (2) Disconnect and cap the fluid hoses from steering gear.
- (3) Remove the column coupler shaft from the gear.
- (4) Remove pitman arm from gear.
- (5) Remove the steering gear retaining bolts and remove the gear (Fig. 1).

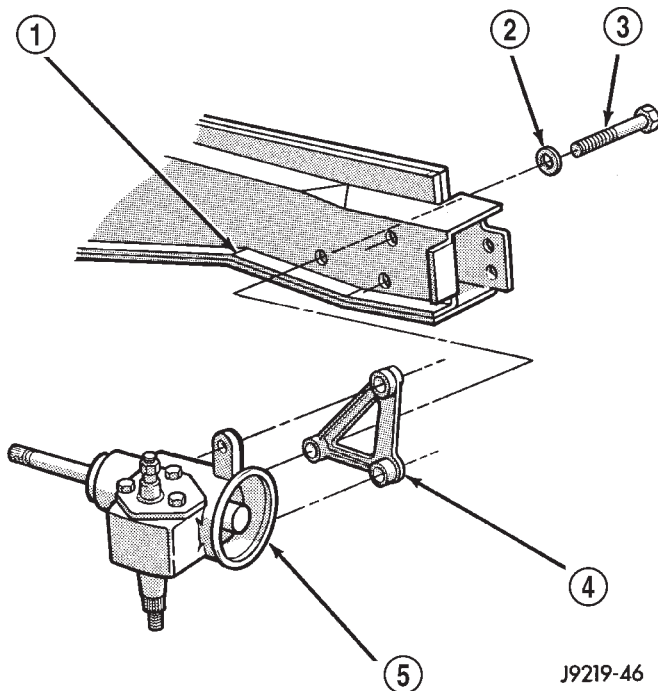

Fig. 1 Steering Gear Mounting (LHD)

- 1 - FRAME
- 2 - WASHER
- 3 - SCREW
- 4 - ADAPTER
- 5 - GEAR

INSTALLATION

- (1) Install steering gear (and bracket) on the frame rail and tighten bolts to 95 N·m (70 ft. lbs.).
- (2) Align the column coupler shaft to steering gear. Install a **new** pinch bolt and tighten to 49 N·m (36 ft. lbs.).
- (3) Align and install the pitman arm and tighten nut to 251 N·m (185 ft. lbs.).
- (4) Connect fluid hoses to steering gear and tighten to 28 N·m (21 ft. lbs.).
- (5) Fill power steering system to proper level.

DISASSEMBLY AND ASSEMBLY

HOUSING END PLUG

DISASSEMBLY

- (1) Unseat and remove retaining ring from groove with a punch through the hole in the end of the housing (Fig. 2).

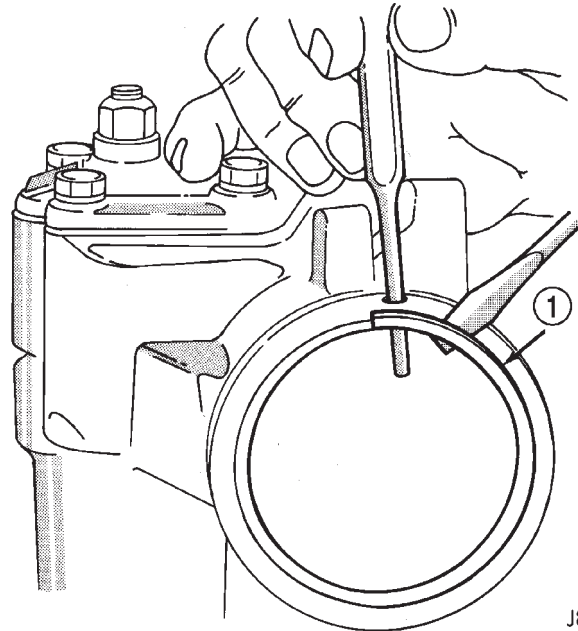

J8919-31

Fig. 2 End Plug Retaining Ring

1 - RETAINING RING

- (2) Slowly rotate stub shaft with 12 point socket COUNTER-CLOCKWISE to force the end plug out from housing.

CAUTION: Do not turn stub shaft any further than necessary. The rack piston balls will drop out of the rack piston circuit if the stub shaft is turned too far.

- (3) Remove O-ring from the housing (Fig. 3).

ASSEMBLY

- (1) Lubricate O-ring with power steering fluid and install into the housing.
- (2) Install end plug by tapping the plug lightly with a plastic mallet into the housing.
- (3) Install retaining ring so one end of the ring covers the housing access hole (Fig. 4).

PITMAN SHAFT/SEALS/BEARING

DISASSEMBLY

- (1) Clean exposed end of pitman shaft and housing with a wire brush.
- (2) Remove preload adjuster nut (Fig. 5).

DISASSEMBLY AND ASSEMBLY (Continued)

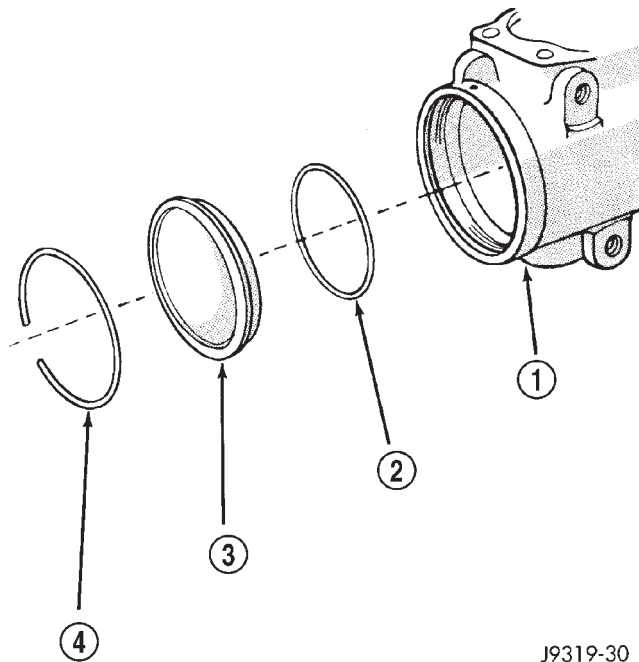

Fig. 3 End Plug Components

- 1 - HOUSING ASSEMBLY
- 2 - HOUSING END PLUG O-RING SEAL
- 3 - HOUSING END PLUG
- 4 - RETAINING RING

J9319-30

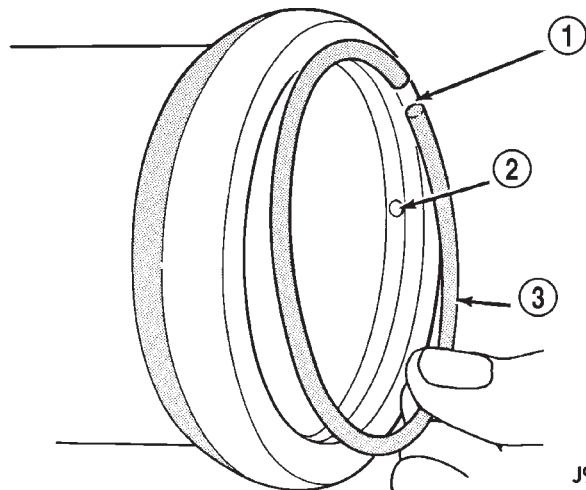

Fig. 4 Installing The Retaining Ring

- 1 - RING CAP
- 2 - PUNCH ACCESS HOLE
- 3 - RETAINER RING

J9219-32

- (3) Rotate the stub shaft with a 12 point socket from stop to stop and count the number of turns.
- (4) Center the stub shaft by rotating it from the stop 1/2 of the total amount of turns.
- (5) Remove side cover bolts and remove side cover, gasket and pitman shaft as an assembly (Fig. 5).

NOTE: The pitman shaft will not clear the housing if it is not centered.

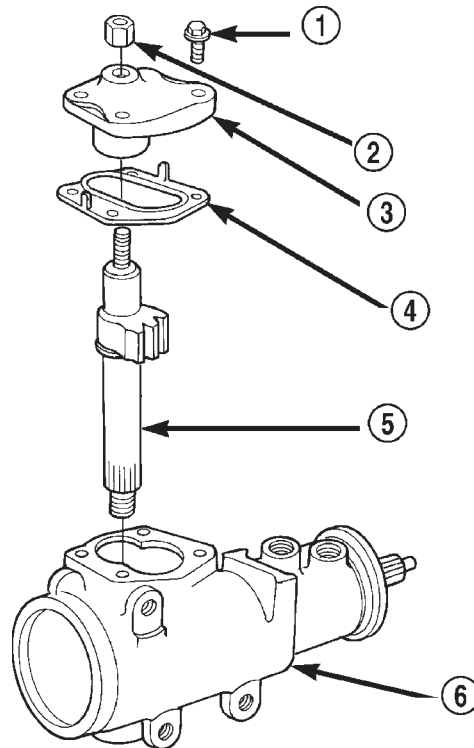

Fig. 5 Side Cover and Pitman Shaft

- 1 - SIDE COVER BOLTS
- 2 - PRELOAD ADJUSTER NUT
- 3 - SIDE COVER
- 4 - GASKET SEAL
- 5 - PITMAN SHAFT GEAR
- 6 - HOUSING ASSEMBLY

80a3543f

- (6) Remove pitman shaft from the side cover.
- (7) Remove dust seal from the housing with a seal pick (Fig. 6).

CAUTION: Use care not to score the housing bore when prying out seals and washer.

- (8) Remove retaining ring with snap ring pliers.
- (9) Remove washer from the housing.
- (10) Remove oil seal from the housing with a seal pick.
- (11) Remove pitman shaft bearing from housing with a bearing driver and handle (Fig. 7).

ASSEMBLY

- (1) Install pitman shaft bearing into housing with a bearing driver and handle.
- (2) Coat the oil seal and washer with **special grease** supplied with the new seal.
- (3) Install the oil seal with a driver and handle.
- (4) Install backup washer.

DISASSEMBLY AND ASSEMBLY (Continued)

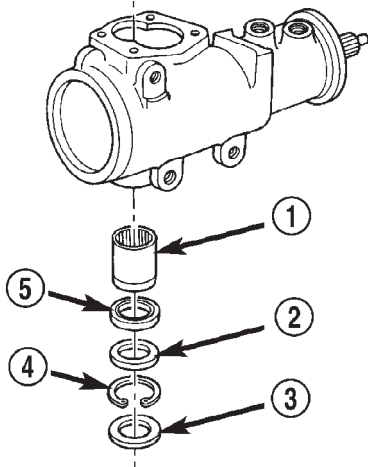

80aa4bf0

Fig. 6 Pitman Shaft Seals & Bearing

- 1 - BEARING
- 2 - WASHER
- 3 - DUST SEAL
- 4 - RETAINER
- 5 - OIL SEAL

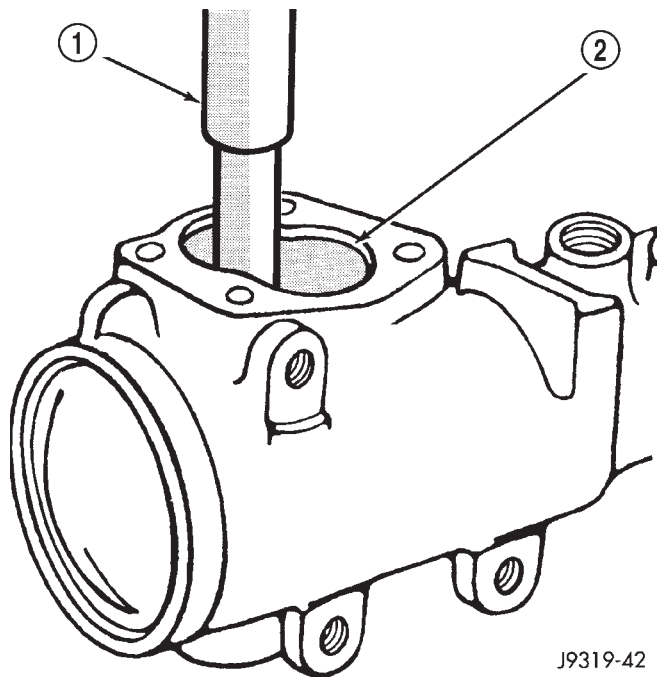

J9319-42

Fig. 7 Needle Bearing Removal

- 1 - REMOVER
- 2 - SIDE COVER AREA

- (5) Install the retainer ring with snap ring pliers.
- (6) Coat the dust seal with **special grease** supplied with the new seal.
- (7) Install dust seal with a driver and handle.
- (8) Install pitman shaft to side cover by screwing shaft in until it fully seats to side cover.

(9) Install preload adjuster nut. **Do not tighten nut until after Over-Center Rotation Torque adjustment has been made.**

(10) Install gasket to side cover and bend tabs around edges of side cover (Fig. 5).

(11) Install pitman shaft assembly and side cover to housing.

(12) Install side cover bolts and tighten to 60 N-m (44 ft. lbs.).

(13) Perform over-center rotation torque adjustment.

SPOOL VALVE**DISASSEMBLY**

(1) Remove lock nut (Fig. 8).

(2) Remove adjuster nut with Spanner Wrench C-4381.

(3) Remove thrust support assembly out of the housing (Fig. 9).

(4) Pull stub shaft and valve assembly from the housing (Fig. 10).

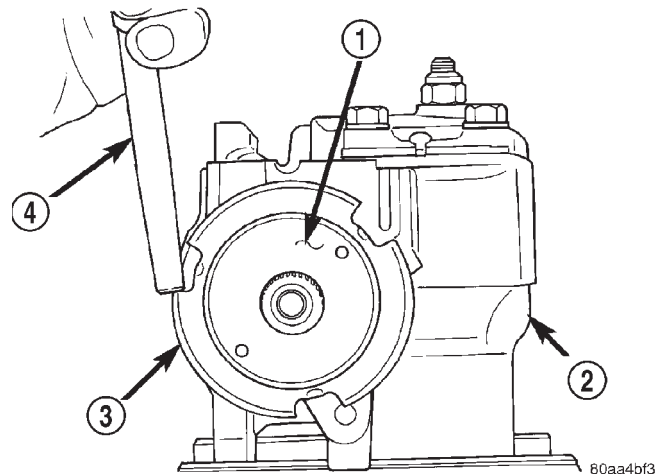

80aa4bf3

Fig. 8 Lock Nut and Adjuster Nut

- 1 - ADJUSTER NUT
- 2 - STEERING GEAR
- 3 - LOCK NUT
- 4 - PUNCH

(5) Remove stub shaft from valve assembly by lightly tapping shaft on a block of wood to loosen shaft. Then disengage stub shaft pin from hole in spool valve and separate the valve assembly from stub shaft (Fig. 11).

(6) Remove spool valve from valve body by pulling and rotating the spool valve from the valve body (Fig. 12).

(7) Remove spool valve O-ring and valve body teflon rings and O-rings underneath the teflon rings (Fig. 13).

DISASSEMBLY AND ASSEMBLY (Continued)

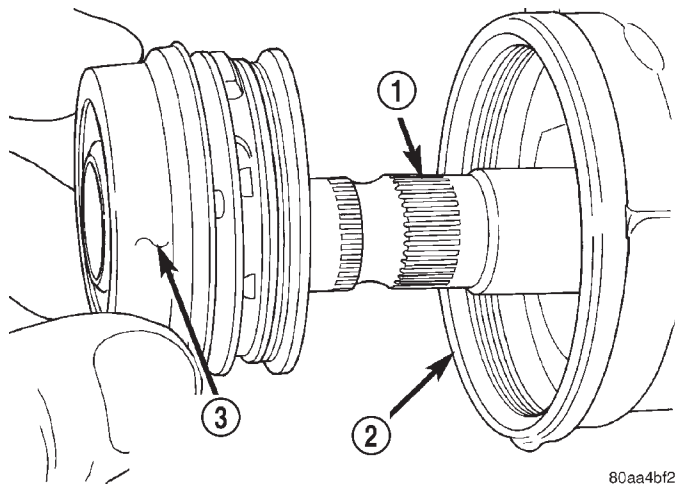

80aa4bf2

Fig. 9 Thrust Support Assembly

- 1 - STUB SHAFT
- 2 - HOUSING
- 3 - THRUST SUPPORT ASSEMBLY

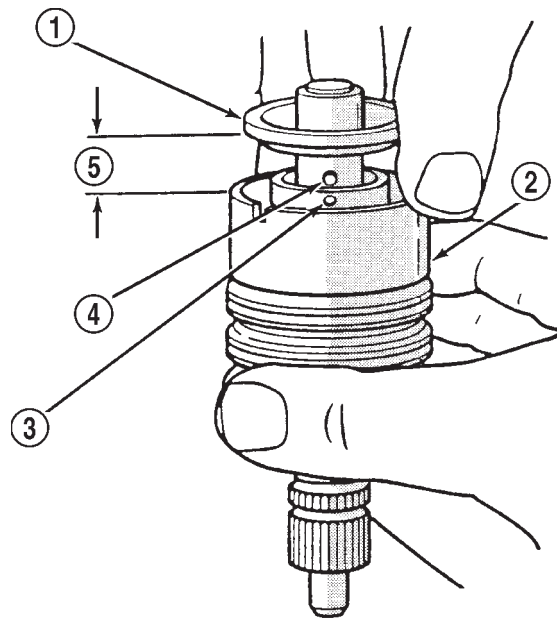

J9319-36

Fig. 11 Stub Shaft

- 1 - STUB SHAFT
- 2 - VALVE BODY
- 3 - HOLE IN SPOOL
- 4 - SHAFT PIN
- 5 - 6mm (1/4")

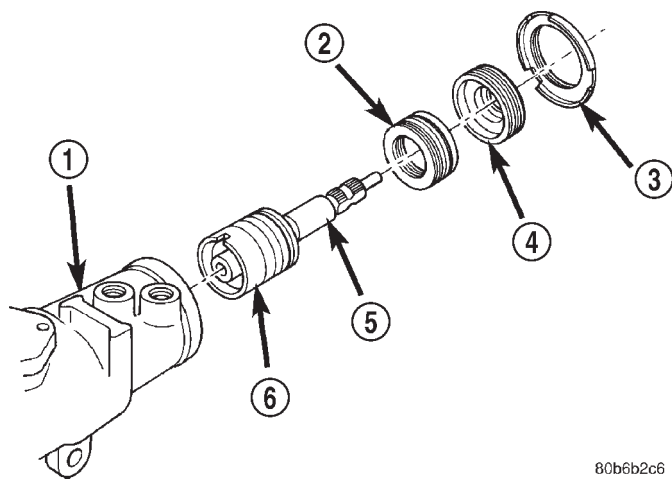

80b6b2c6

Fig. 10 Valve Assembly With Stub Shaft

- 1 - GEAR
- 2 - THRUST SUPPORT
- 3 - LOCK NUT
- 4 - ADJUSTER NUT
- 5 - STUB SHAFT
- 6 - VALVE ASSEMBLY

(8) Remove the O-ring between the worm shaft and the stub shaft.

ASSEMBLY

NOTE: Clean and dry all components, then lubricate with power steering fluid.

- (1) Install spool valve spool O-ring.
- (2) Install spool valve in valve body by pushing and rotating. Hole in spool valve for stub shaft pin must be accessible from opposite end of valve body.

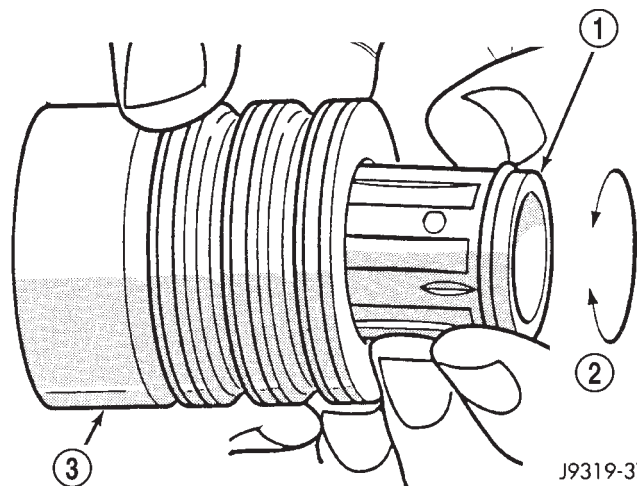

J9319-37

Fig. 12 Spool Valve

- 1 - SPOOL VALVE
- 2 - ROTATE VALVE TO REMOVE
- 3 - VALVE BODY

(3) Install stub shaft in valve spool and engage locating pin on stub shaft into spool valve hole (Fig. 14).

NOTE: Notch in stub shaft cap must fully engage valve body pin and seat against valve body shoulder.

DISASSEMBLY AND ASSEMBLY (Continued)

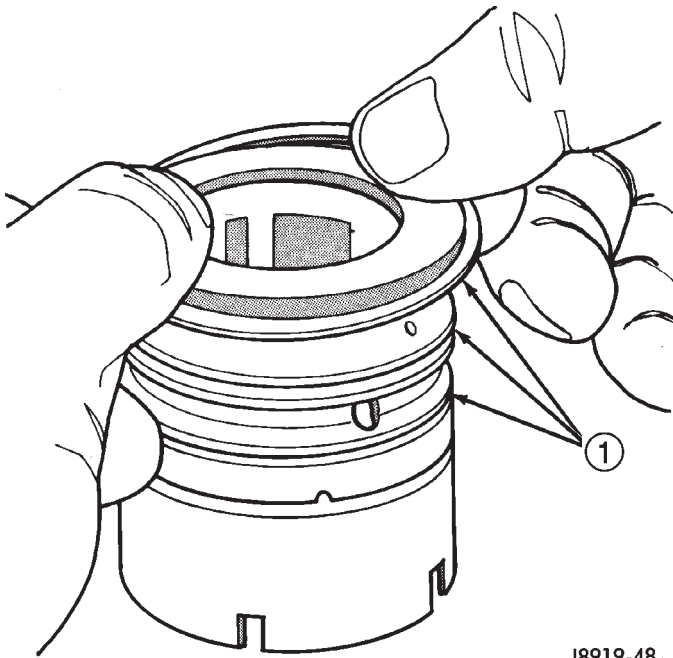

Fig. 13 Valve Seals

1 - O-RING SEALS

J8919-48

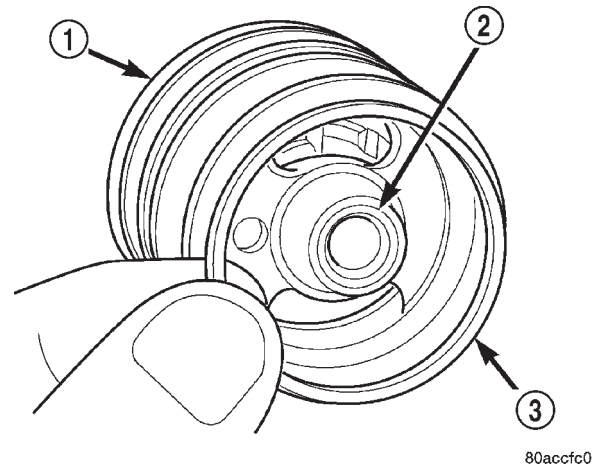

Fig. 15 Stub Shaft Cap O-Ring

1 - VALVE BODY
2 - STUB SHAFT CAP
3 - O-RING

80accfc0

(6) Install stub shaft and valve assembly in the housing. Line up worm shaft to slots in the valve assembly.

(7) Install thrust support assembly.

NOTE: The thrust support is serviced as an assembly. If any component of the thrust support is damaged the assembly must be replaced.

(8) Install adjuster nut and lock nut.

(9) Adjust Thrust Bearing Preload and Over-Center Rotating Torque.

RACK PISTON AND WORM SHAFT

DISASSEMBLY

(1) Remove housing end plug.

(2) Remove rack piston plug (Fig. 16).

(3) Remove side cover and pitman shaft.

(4) Turn stub shaft **COUNTERCLOCKWISE** until the rack piston begins to come out of the housing.

(5) Insert Arbor C-4175 into bore of rack piston (Fig. 17) and hold tool tightly against worm shaft.

(6) Turn the stub shaft with a 12 point socket **COUNTERCLOCKWISE**, this will force the rack piston onto the tool and hold the rack piston balls in place.

(7) Remove the rack piston and tool together from housing.

(8) Remove tool from rack piston.

(9) Remove rack piston balls.

(10) Remove clamp bolts, clamp and ball guide (Fig. 18).

(11) Remove teflon ring and O-ring from the rack piston (Fig. 19).

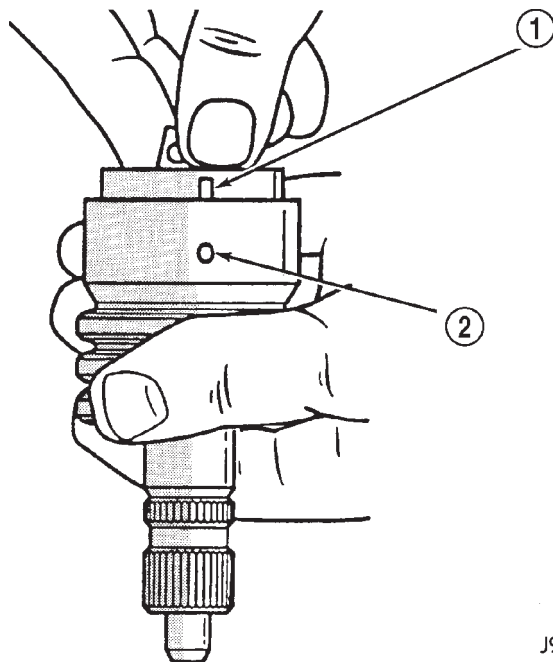

Fig. 14 Stub Shaft Installation

1 - NOTCH IN CAP
2 - VALVE BODY PIN

J9319-38

(4) Install O-rings and teflon rings over the O-rings on valve body.

(5) Install O-ring into the back of the stub shaft cap (Fig. 15).

DISASSEMBLY AND ASSEMBLY (Continued)

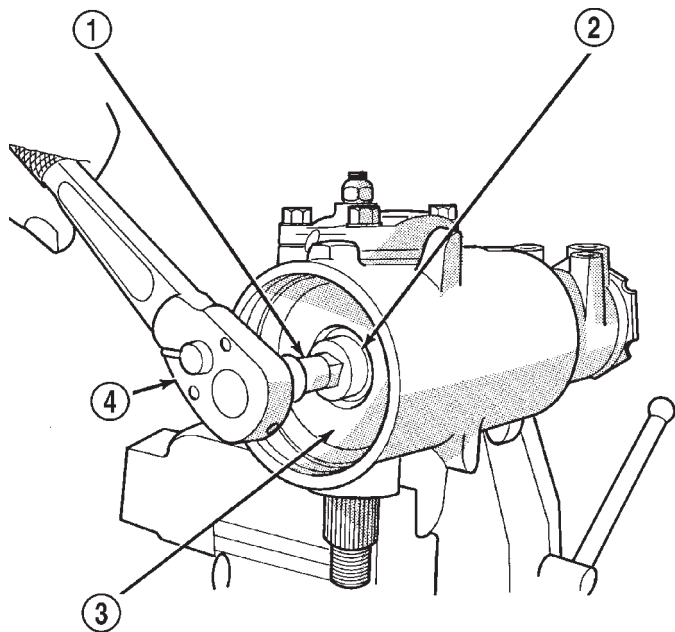

J9219-9

Fig. 16 Rack Piston End Plug

- 1 - EXTENSION
- 2 - END PLUG
- 3 - RACK PISTON
- 4 - RATCHET

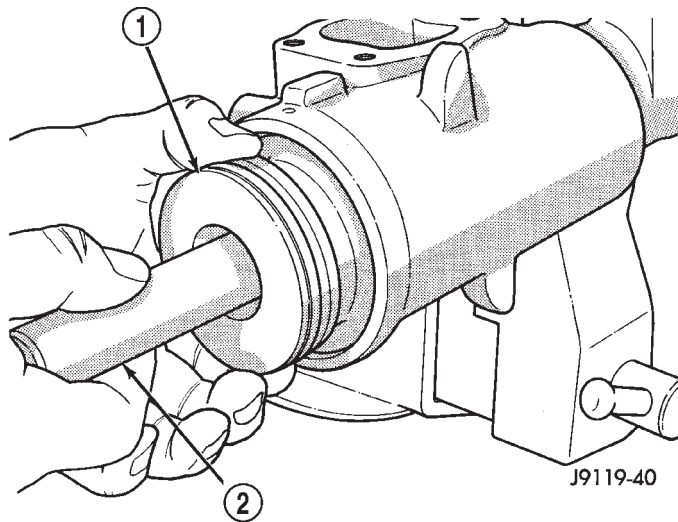

J9119-40

Fig. 17 Rack Piston with Arbor

- 1 - RACK PISTON
- 2 - SPECIAL TOOL C-4175

(12) Remove the adjuster lock nut and adjuster nut from the stub shaft.

(13) Pull the stub shaft with the spool valve and thrust support assembly out of the housing.

(14) Remove the worm shaft from the housing (Fig. 20).

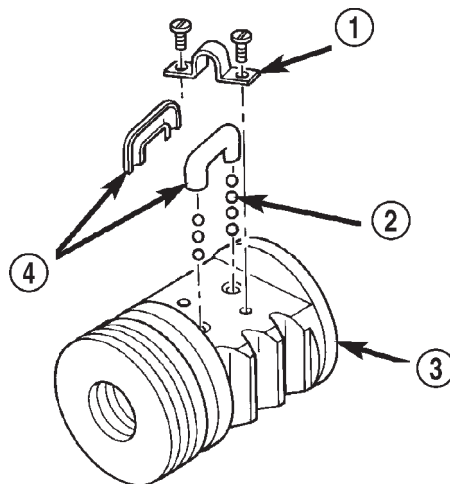

80aa4bf4

Fig. 18 Rack Piston

- 1 - CLAMP
- 2 - BALLS
- 3 - RACK PISTON
- 4 - BALL GUIDE

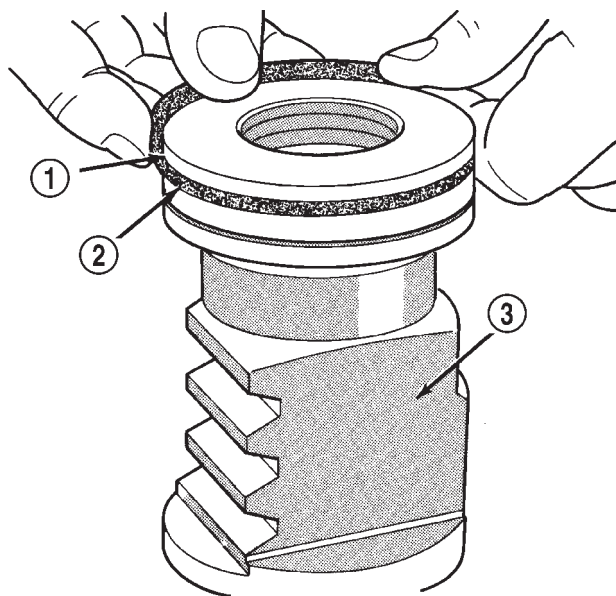

J9219-12

Fig. 19 Rack Piston Teflon Ring and O-Ring

- 1 - TEFLON SEAL
- 2 - BACK-UP O-RING MUST BE INSTALLED UNDER PISTON RING
- 3 - RACK PISTON NUT

ASSEMBLY

NOTE: Clean and dry all components and lubricate with power steering fluid.

(1) Check for scores, nicks or burrs on the rack piston finished surface. Slight wear is normal on the worm gear surfaces.

DISASSEMBLY AND ASSEMBLY (Continued)

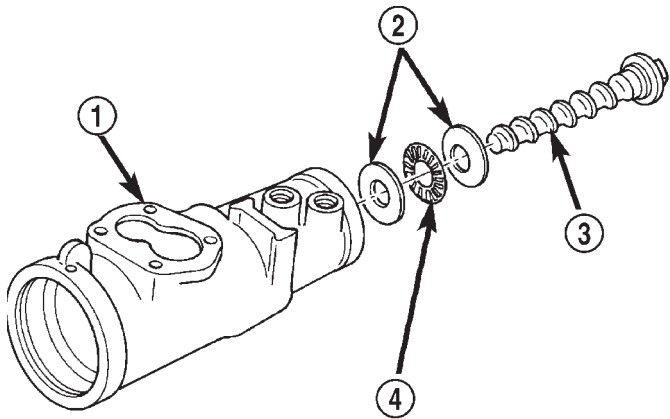

80aa4bf5

Fig. 20 Worm Shaft

- 1 - GEAR HOUSING
- 2 - BEARING RACE
- 3 - WORM SHAFT
- 4 - BEARING

(2) Install O-ring and teflon ring on the rack piston.

(3) Install worm shaft in the rack piston and align worm shaft spiral groove with rack piston ball guide hole (Fig. 21).

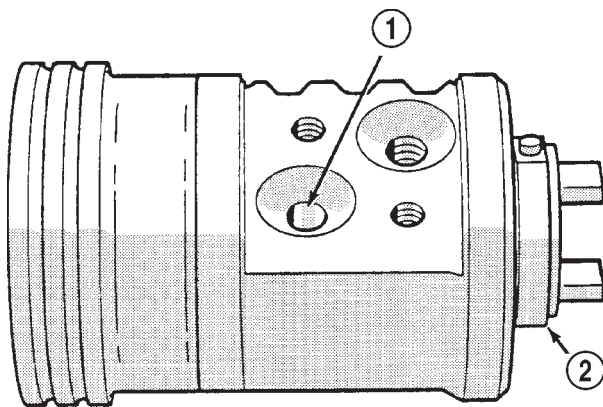

J9319-39

Fig. 21 Installing Balls in Rack Piston

- 1 - INSTALL BALLS IN THIS HOLE WHILE SLOWLY ROTATING WORM COUNTER CLOCKWISE
- 2 - WORM FLANGE

CAUTION: The rack piston balls must be installed alternately into the rack piston and ball guide. This maintains worm shaft preload. There are 12 black balls and 12 silver (Chrome) balls. The black balls are smaller than the silver balls.

(4) Lubricate and install rack piston balls through return guide hole while turning worm shaft COUNTERCLOCKWISE (Fig. 21).

(5) Install remaining balls in guide using grease to hold the balls in place (Fig. 22).

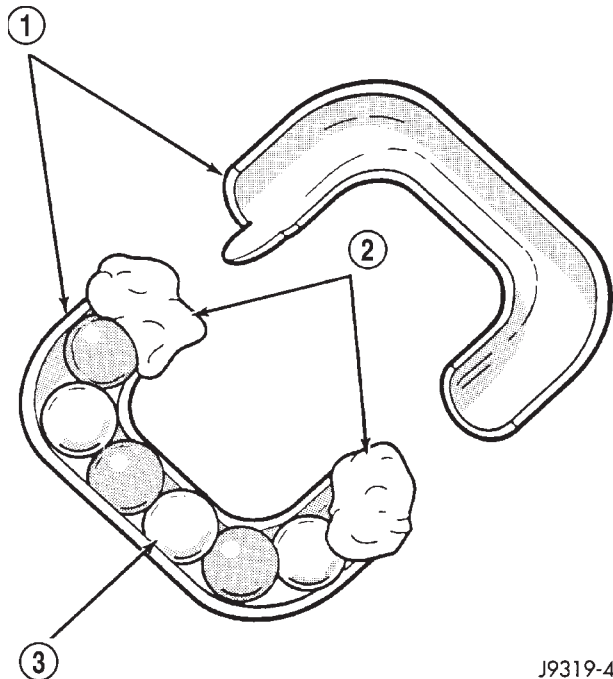

J9319-40

Fig. 22 Balls in the Return Guide

- 1 - GUIDE
- 2 - PETROLEUM JELLY
- 3 - BALLS

(6) Install the guide onto rack piston and install clamp and clamp bolts. Tighten bolts to 4.8 N·m (43 in. lbs.).

(7) Insert Arbor C-4175 into bore of rack piston and hold tool tightly against worm shaft.

(8) Turn the worm shaft COUNTERCLOCKWISE while pushing on the arbor. This will force the rack piston onto the arbor and hold the rack piston balls in place.

(9) Install the races and thrust bearing on the worm shaft and install shaft in the housing (Fig. 20).

(10) Install the stub shaft with spool valve, thrust support assembly and adjuster nut in the housing.

(11) Install the rack piston and arbor tool into the housing.

(12) Hold arbor tightly against worm shaft and turn stub shaft CLOCKWISE until rack piston is seated on worm shaft.

(13) Install pitman shaft and side cover in the housing.

(14) Install rack piston plug and tighten to 150 N·m (111 ft. lbs.).

(15) Install housing end plug.

(16) Adjust worm shaft thrust bearing preload and over-center rotating torque.

ADJUSTMENTS

STEERING GEAR

CAUTION: Steering gear must be adjusted in the proper order. If adjustments are not performed in order, gear damage and improper steering response may result.

NOTE: Adjusting the steering gear in the vehicle is not recommended. Remove gear from the vehicle and drain the fluid. Then mount gear in a vise to perform adjustments.

WORM THRUST BEARING PRELOAD

- (1) Mount the gear carefully into a vise.

CAUTION: Do not overtighten the vise on the gear case. This may affect the adjustment

- (2) Remove adjuster plug locknut (Fig. 23).
- (3) Rotate the stub shaft back and forth with a 12 point socket to drain the remaining fluid.

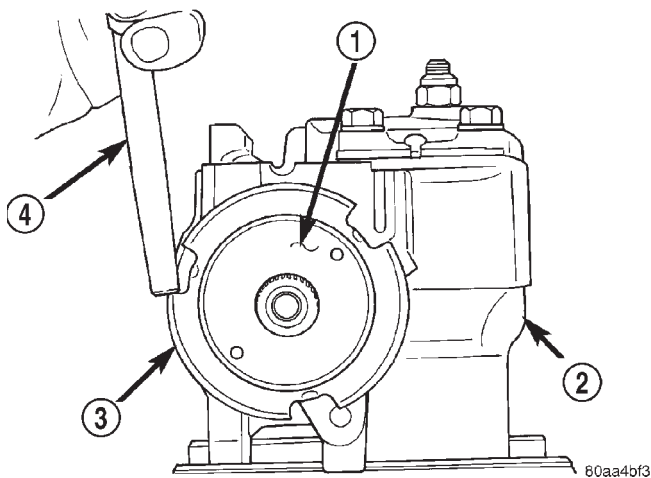

Fig. 23 Adjuster Lock Nut

- 1 - ADJUSTER NUT
- 2 - STEERING GEAR
- 3 - LOCK NUT
- 4 - PUNCH

(4) Turn the adjuster in with Spanner Wrench C-4381. Tighten the plug and thrust bearing in the housing until firmly bottomed in the housing about 34 N·m (25 ft. lbs.).

(5) Place an index mark on the housing even with one of the holes in adjuster plug (Fig. 24).

(6) Measure back (counterclockwise) 5.08 mm (0.20 in) and mark housing (Fig. 25).

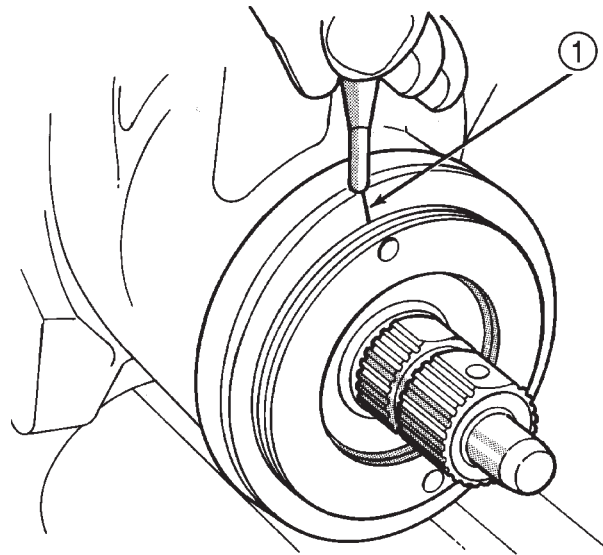

J8919-58

Fig. 24 Alignment Marking On Housing

1 - INDEX

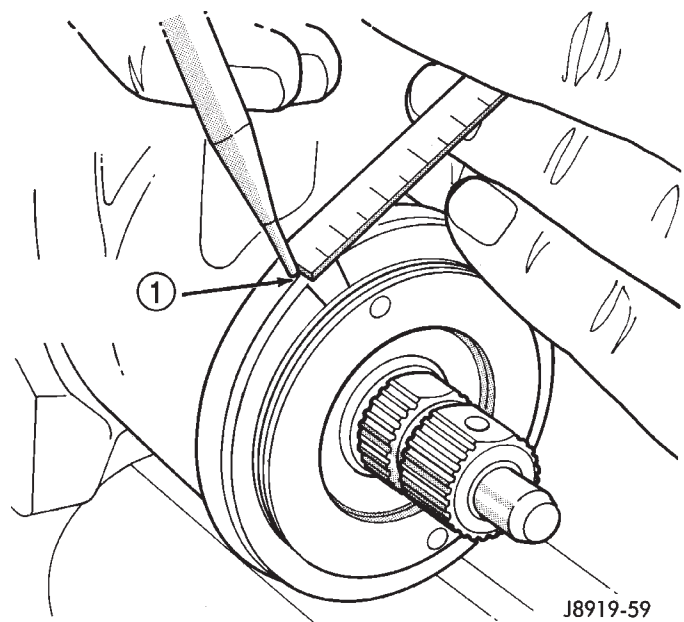

J8919-59

Fig. 25 Second Marking On Housing

1 - REFERENCE MARK

(7) Rotate adjustment cap back (counterclockwise) with spanner wrench until hole is aligned with the second mark (Fig. 26).

(8) Install and tighten locknut to 108 N·m (80 ft. lbs.). Be sure adjustment cap does not turn while tightening the locknut.

ADJUSTMENTS (Continued)

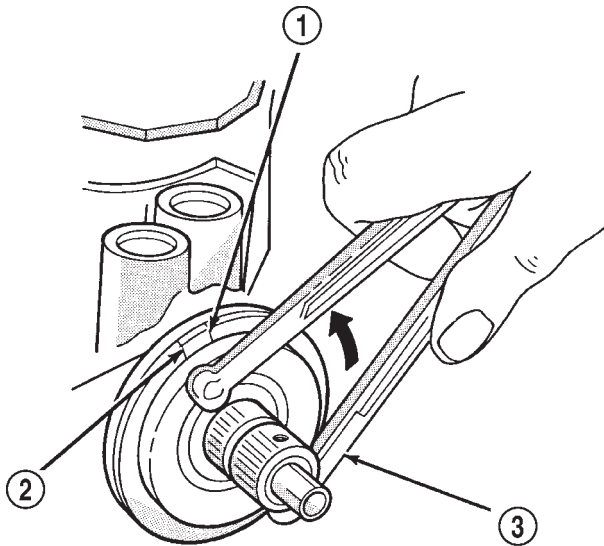

J9219-30

Fig. 26 Aligning To The Second Mark

- 1 - FIRST MARK
- 2 - SECOND MARK
- 3 - SPANNER WRENCH

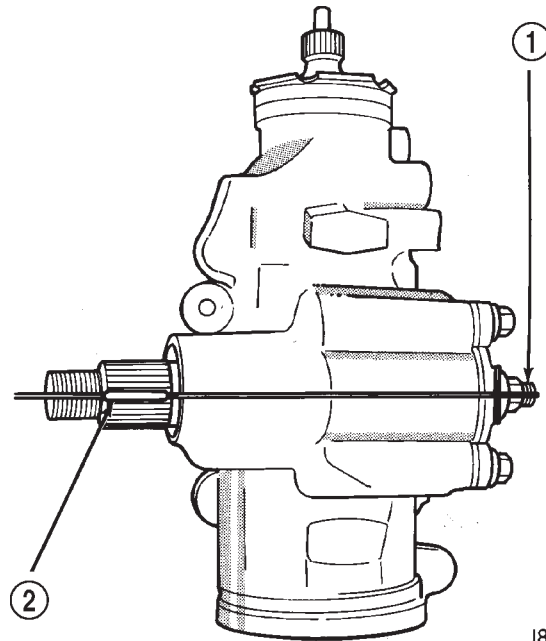

J8919-62

Fig. 27 Steering Gear Centered

- 1 - ADJUSTMENT SCREW
- 2 - MASTER SPLINE

OVER-CENTER

NOTE: Before performing this procedure, the worm bearing preload adjustment must be performed.

(1) Rotate the stub shaft with a 12 point socket from stop to stop and count the number of turns.

(2) Starting at either stop, turn the stub shaft back 1/2 the total number of turns. This is the center of the gear travel (Fig. 27).

(3) Place the torque wrench in the vertical position on the stub shaft. Rotate the wrench 45 degrees each side of the center and record the highest rotational torque in this range (Fig. 28). This is the Over-Center Rotating Torque.

NOTE: The stub shaft must rotate smoothly without sticking or binding.

(4) Rotate the stud shaft between 90° and 180° to the left of center and record the left off-center preload. Repeat this to the right of center and record the right off-center preload. The average of these two recorded readings is the Preload Rotating Torque.

(5) The Over-Center Rotating Torque should be 0.40-0.70 N-m (3-7 in. lbs.) **higher** than the Preload Rotating Torque.

(6) If an adjustment to the Over-Center Rotating Torque is necessary, first loosen the adjuster lock nut. Then turn the pitman shaft adjuster screw back

(COUNTERCLOCKWISE) until fully extended, then turn back in (CLOCKWISE) one full turn.

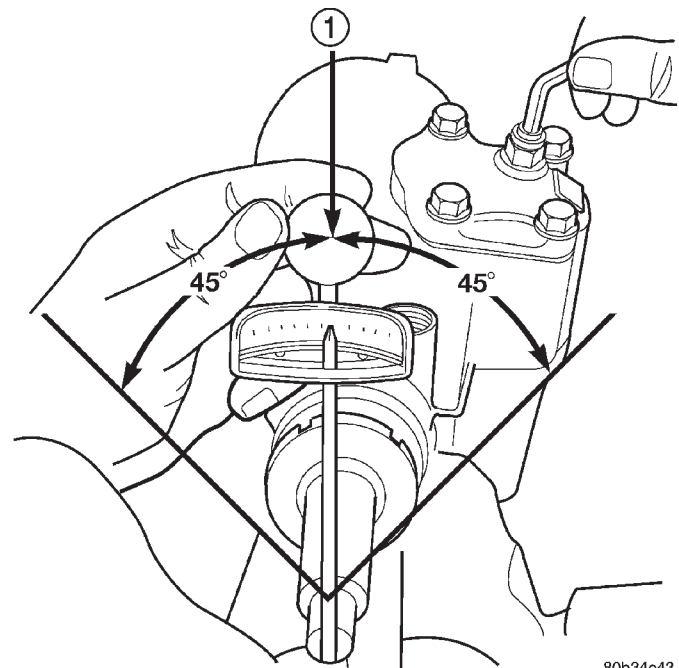

80b34e43

Fig. 28 Checking Over-center Rotation Torque

- 1 - CENTER

(7) Remeasure Over-Center Rotating Torque. If necessary turn the adjuster screw and repeat mea-

ADJUSTMENTS (Continued)

surement until correct Over-Center Rotating Torque is reached.

NOTE: To increase the Over-Center Rotating Torque turn the screw **CLOCKWISE**.

(8) Prevent the adjuster screw from turning while tightening adjuster lock nut. Tighten the adjuster lock nut to 49 N·m (36 ft. lbs.).

SPECIFICATIONS

POWER STEERING GEAR

Steering Gear

Type Recirculating Ball

Gear Ratio

RHD 14:1

LHD 14:1

Worm Shaft Bearing

Preload 0.45–1.13 N·m (4–10 in. lbs.)

Pitman Shaft Overcenter Drag

New Gear (under 400 miles) 0.45–0.90 N·m (4–8 in. lbs.) + Worm Shaft Preload

Used Gear (over 400 miles) 0.5–0.6 N·m (4–5 in. lbs.) + Worm Shaft Preload

TORQUE CHART

DESCRIPTION

TORQUE

Power Steering Gear

| | |
|-------------------------------|------------------------|
| Adjustment Cap Locknut . . . | 108 N·m (80 ft. lbs.) |
| Adjustment Screw Locknut . . | 49 N·m (36 ft. lbs.) |
| Gear to Frame Bolts | 95 N·m (70 ft. lbs.) |
| Pitman Shaft Nut | 251 N·m (185 ft. lbs.) |
| Rack Piston Plug | 102 N·m (75 ft. lbs.) |
| Side Cover Bolts | 60 N·m (44 ft. lbs.) |
| Pressure Line | 28 N·m (21 ft. lbs.) |
| Return Line | 28 N·m (21 ft. lbs.) |
| Return Guide Clamp Bolt . . . | 58 N·m (43 ft. lbs.) |

SPECIAL TOOLS

POWER STEERING GEAR



Remover/Installer, Steering Plug C-4381

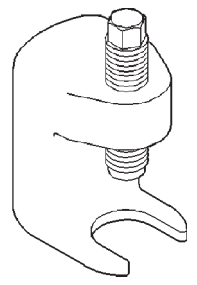

Remover, Pitman Arm C-4150A

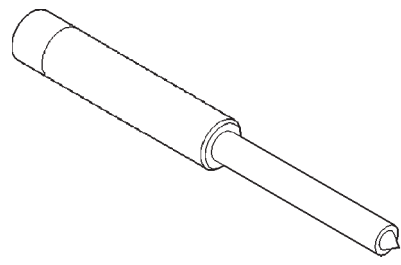

Remover/Installer Steering Rack Piston C-4175

STEERING LINKAGE

TABLE OF CONTENTS

| | page | | page |
|----------------------------------|------|----------------------------------|------|
| DESCRIPTION AND OPERATION | | DRAG LINK | 24 |
| STEERING LINKAGE | 22 | STEERING DAMPER | 25 |
| SERVICE PROCEDURES | | SPECIFICATIONS | |
| STEERING LINKAGE | 23 | TORQUE CHART | 25 |
| REMOVAL AND INSTALLATION | | SPECIAL TOOLS | |
| TIE ROD | 23 | STEERING LINKAGE | 25 |
| PITMAN ARM | 24 | | |

DESCRIPTION AND OPERATION

STEERING LINKAGE

DESCRIPTION

The steering linkage consist of a pitman arm, drag link, tie rod, tie rod ends and a steering damper (Fig. 1) and (Fig. 2). The service procedures and torque

specifications are the same for LHD and RHD vehicles.

CAUTION: Components attached with a nut and cotter pin must be torqued to specification. Then if the slot in the nut does not line up with the cotter pin hole, tighten nut until it is aligned. Never loosen the nut to align the cotter pin hole.

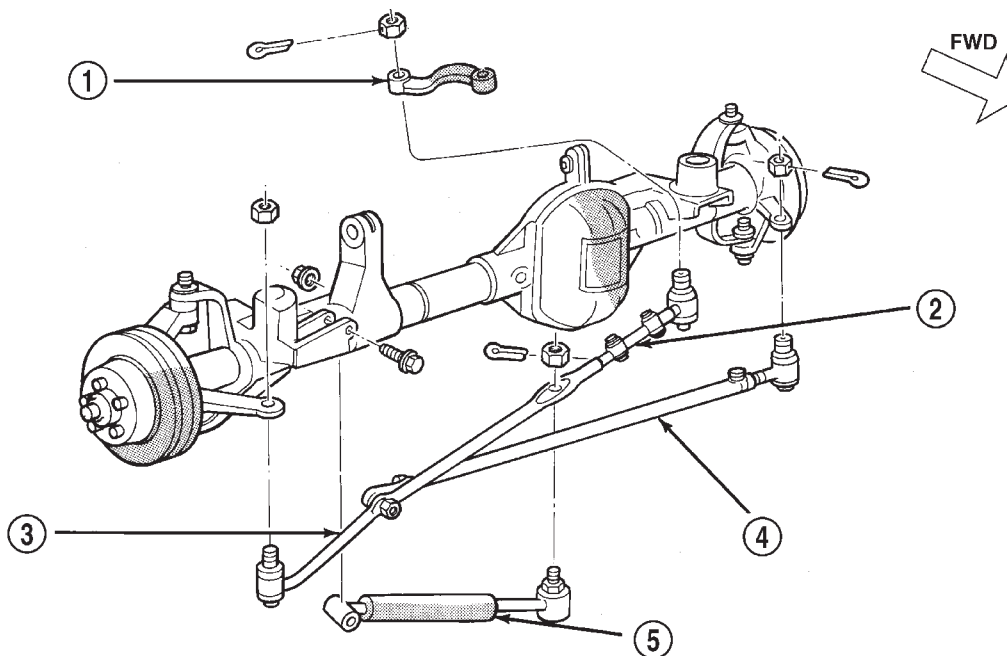

J9502-7

Fig. 1 Steering Linkage—LHD

- | | |
|-----------------------|-----------------------|
| 1 - PITMAN ARM | 4 - TIE ROD |
| 2 - ADJUSTMENT SLEEVE | 5 - STEERING DAMPENER |
| 3 - DRAG LINK | |

DESCRIPTION AND OPERATION (Continued)

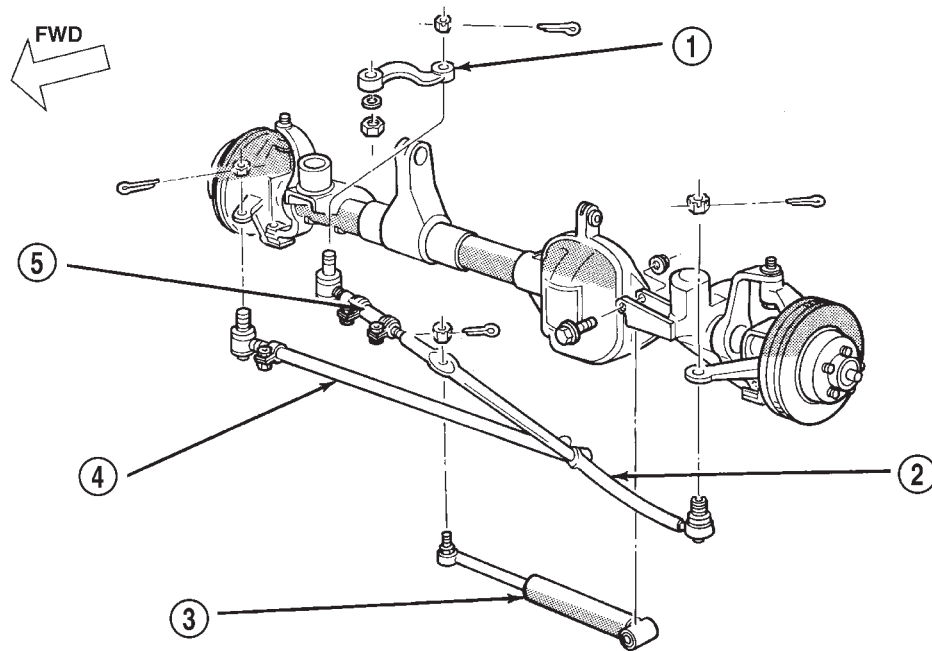

J9502-6

Fig. 2 Steering Linkage—RHD

1 - PITMAN ARM
2 - DRAG LINK
3 - STEERING DAMPNER

4 - TIE ROD
5 - ADJUSTMENT SLEEVE

SERVICE PROCEDURES

STEERING LINKAGE

The tie rod end and ball stud seals should be inspected during all oil changes. If a seal is damaged, it should be replaced. Before installing a new seal, inspect ball stud at the throat opening. Check for lubricant loss, contamination, ball stud wear or corrosion. If these conditions exist, replace the tie rod. A replacement seal can be installed if lubricant is in good condition. Otherwise, a complete replacement ball stud end should be installed.

CAUTION: If any steering components are replaced or serviced an alignment must be performed, to ensure the vehicle meets all alignment specifications.

CAUTION: Components attached with a nut and cotter pin must be torqued to specification. Then if the slot in the nut does not line up with the cotter pin hole, tighten nut until it is aligned. Never loosen the nut to align the cotter pin hole.

REMOVAL AND INSTALLATION

TIE ROD

CAUTION: Use a Puller tool C-3894-A for tie rod removal. Failure to use this tool could damage the ball stud and seal (Fig. 3).

REMOVAL

- (1) Remove the cotter pins and nuts at the tie rod ball studs and drag link.
- (2) Loosen the ball studs with a puller tool to remove the tie rod.
- (3) Loosen clamp bolts and unthread the tie rod end from the tube.

INSTALLATION

- (1) Thread the tie rod end into the tube and position the clamp to it's original position (Fig. 4). Tighten the clamp bolts to 27 N·m (20 ft. lbs.).
- (2) Install the tie rod on the drag link and steering knuckle. Install the retaining nuts.
- (3) Tighten the ball stud nut on the steering knuckle to 47 N·m (35 ft. lbs.). Tighten the ball stud nut to drag link to 74 N·m (55 ft. lbs.). Install new cotter pins.

REMOVAL AND INSTALLATION (Continued)

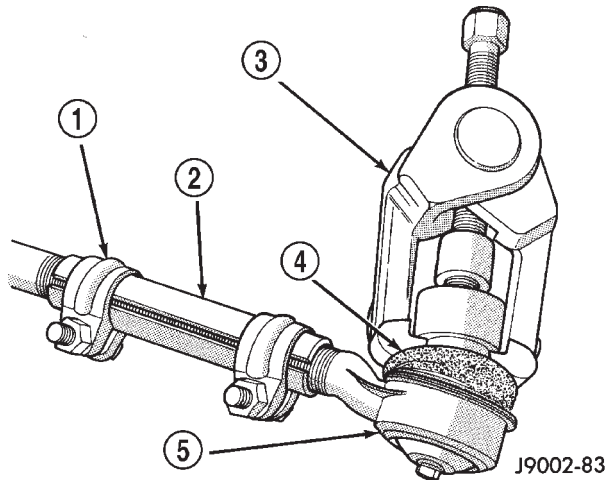
**Fig. 3 Ball Stud Puller**

- 1 - CLAMP
- 2 - ADJUSTMENT SLEEVE
- 3 - PULLER TOOL C-3894-A
- 4 - SEAL
- 5 - TIE-ROD END

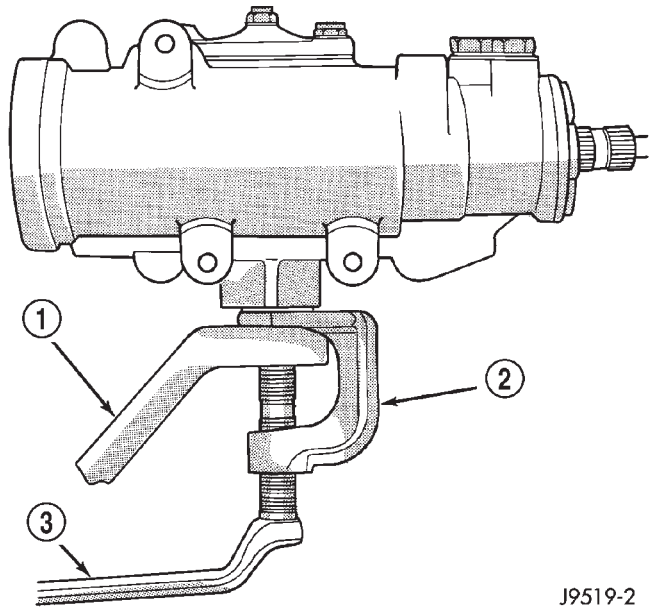
**Fig. 5 Pitman Arm Puller**

- 1 - PITMAN ARM
- 2 - SPECIAL TOOL C-4150-A
- 3 - WRENCH

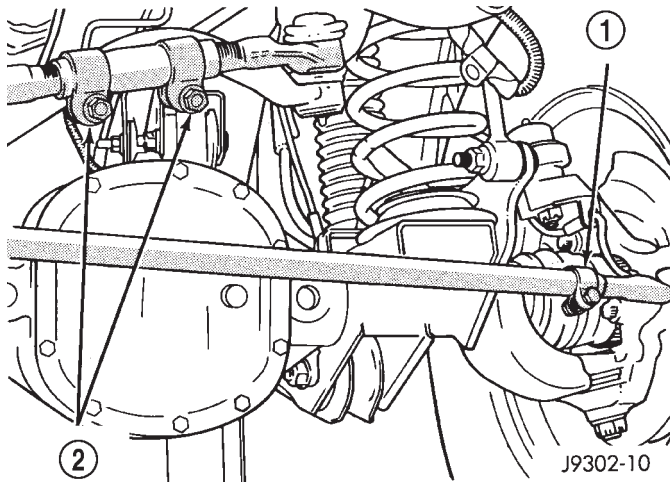
**Fig. 4 Tie Rod/Drag Link Clamps**

- 1 - TIE ROD CLAMP
- 2 - DRAG LINK CLAMPS

PITMAN ARM**REMOVAL**

- (1) Remove the cotter pin and nut from the drag link at the pitman arm.
- (2) Remove the drag link ball stud from the pitman arm with a puller.
- (3) Remove the nut and washer from the steering gear shaft. Mark the pitman shaft and pitman arm for installation reference. Remove the pitman arm from steering gear with Puller C-4150-A (Fig. 5).

INSTALLATION

- (1) Align and install the pitman arm on steering gear shaft.
- (2) Install the washer and nut on the shaft and tighten nut to 251 N·m (185 ft. lbs.).
- (3) Install drag link ball stud to pitman arm install nut and tighten to 74 N·m (55 ft. lbs.). Install a new cotter pin.

DRAG LINK**REMOVAL**

- (1) Remove cotter pins and nuts from drag link
- (2) Remove the steering damper ball stud from the drag link.
- (3) Remove tie rod from drag link
- (4) Remove drag link from the steering knuckle and pitman arm.

INSTALLATION

- (1) Install the drag link onto steering knuckle and pitman arm.
- (2) Install nut at steering knuckle and tighten to 47 N·m (35 ft. lbs.). Install new cotter pins.
- (3) Install nut at pitman arm and tighten to 74 N·m (55 ft. lbs.). Install new cotter pins.
- (4) Install tie rod onto drag link and install nut. Tighten nut to 74 N·m (55 ft. lbs.) and install new cotter pins.

REMOVAL AND INSTALLATION (Continued)

(5) Install steering damper onto drag link and install nut. Tighten nut to 74 N·m (55 ft. lbs.) and install a new cotter pin.

STEERING DAMPER

REMOVAL

- (1) Remove the steering damper retaining bolt from the axle bracket.
- (2) Remove the cotter pin and nut from the ball stud at the drag link.
- (3) Remove the steering damper ball stud from the drag link with Puller C-3894-A.

INSTALLATION

- (1) Install steering damper onto the axle bracket and drag link.
- (2) Install steering damper bolt in axle bracket and tighten nut to 75 N·m (55 ft. lbs.).
- (3) Install ball stud nut at the drag link and tighten nut to 75 N·m (55 ft. lbs.). Install a new cotter pin.

SPECIFICATIONS

TORQUE CHART

| DESCRIPTION | TORQUE |
|------------------------|------------------------|
| Pitman Arm | |
| Shaft | 251 N·m (185 ft. lbs.) |
| Drag Link | |
| Ball Studs | 74 N·m (55 ft. lbs.) |
| Clamp | 49 N·m (36 ft. lbs.) |
| Tie Rod Ends | |
| Ball Studs | 74 N·m (55 ft. lbs.) |
| Clamp | 27 N·m (20 ft. lbs.) |
| Tie Rod | |
| Ball Stud | 47 N·m (35 ft. lbs.) |
| Steering Damper | |
| Frame | 74 N·m (55 ft. lbs.) |
| Drag Link | 74 N·m (55 ft. lbs.) |

SPECIAL TOOLS

STEERING LINKAGE

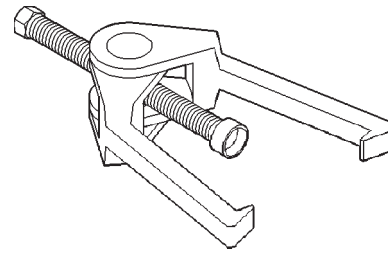

Puller C-3894-A

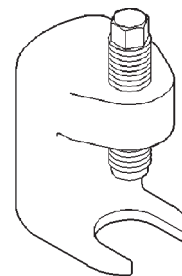

Remover Pitman C-4150A

STEERING COLUMN

TABLE OF CONTENTS

| | page | | page |
|----------------------------------|------|------------------------|------|
| DESCRIPTION AND OPERATION | | SPECIFICATIONS | |
| STEERING COLUMN | 26 | TORQUE CHART | 28 |
| REMOVAL AND INSTALLATION | | | |
| STEERING COLUMN | 26 | | |

DESCRIPTION AND OPERATION

STEERING COLUMN

DESCRIPTION

The standard non-tilt and tilt steering column has been designed to be serviced as an assembly. The key cylinder, switches, clock spring, trim shrouds and steering wheel are serviced separately. On the non-tilt column the upper mounting bracket is also serviced separately.

The column is mounted to the column support bracket studs and secured by four nuts. The column is connected to the steering gear by a one piece collapsible shaft with a coupler at each end. The couplers secure the shaft to the steering column and steering gear.

SERVICE PRECAUTIONS

Safety goggles should be worn at all times when working on steering columns.

To service the steering wheel, switches or airbag, refer to Group 8M and follow all WARNINGS and CAUTIONS.

WARNING: THE AIRBAG SYSTEM IS A SENSITIVE, COMPLEX ELECTRO-MECHANICAL UNIT. BEFORE ATTEMPTING TO DIAGNOSE, REMOVE OR INSTALL THE AIRBAG SYSTEM COMPONENTS YOU MUST FIRST DISCONNECT AND ISOLATE THE BATTERY NEGATIVE (GROUND) CABLE. THEN WAIT TWO MINUTES FOR THE SYSTEM CAPACITOR TO DISCHARGE. FAILURE TO DO SO COULD RESULT IN ACCIDENTAL DEPLOYMENT OF THE AIRBAG AND POSSIBLE PERSONAL INJURY. THE FASTENERS, SCREWS, AND BOLTS, ORIGINALLY USED FOR THE AIRBAG COMPONENTS, HAVE SPECIAL COATINGS AND ARE SPECIFICALLY DESIGNED FOR THE AIRBAG SYSTEM. THEY MUST NEVER BE REPLACED WITH ANY SUBSTITUTES. ANYTIME A NEW FASTENER IS NEEDED, REPLACE WITH THE CORRECT FASTENERS PROVIDED IN THE SERVICE PACKAGE OR FASTENERS LISTED IN THE PARTS BOOKS.

REMOVAL AND INSTALLATION

STEERING COLUMN

WARNING: BEFORE SERVICING THE STEERING COLUMN THE AIRBAG SYSTEM MUST BE DISARMED. REFER TO GROUP 8M RESTRAINT SYSTEMS FOR SERVICE PROCEDURES. FAILURE TO DO SO MAY RESULT IN ACCIDENTAL DEPLOYMENT OF THE AIRBAG AND POSSIBLE PERSONAL INJURY.

CAUTION: Keep clock spring from turning during removal and installation. Failure to do so may damage the clock spring.

REMOVAL

- (1) Position front wheels **straight ahead**.
- (2) Remove and isolate the negative battery ground cable.
- (3) Remove the airbag, refer to Group 8M Restraint Systems for service procedures.

NOTE: If equipped with cruise control, disconnect clock spring harness from cruise switch harness on the steering wheel.

- (4) Remove the steering wheel with an appropriate puller (Fig. 1).

CAUTION: Ensure the puller bolts are fully engaged into the steering wheel and not into the clock-spring, before attempting to remove the wheel. Failure to do so may damage the steering wheel.

- (5) Turn ignition cylinder to the on position and remove cylinder by pressing release through lower shroud access hole (Fig. 2).

REMOVAL AND INSTALLATION (Continued)

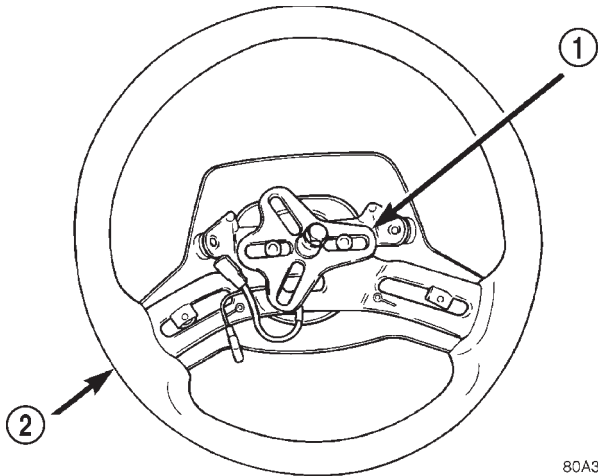

80A35440

Fig. 1 Steering Wheel

- 1 - PULLER
- 2 - STEERING WHEEL

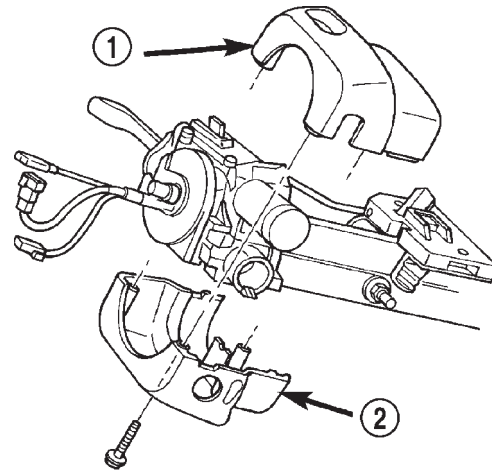

80aac1ba

Fig. 3 Column Shrouds

- 1 - UPPER SHROUD
- 2 - LOWER SHROUD

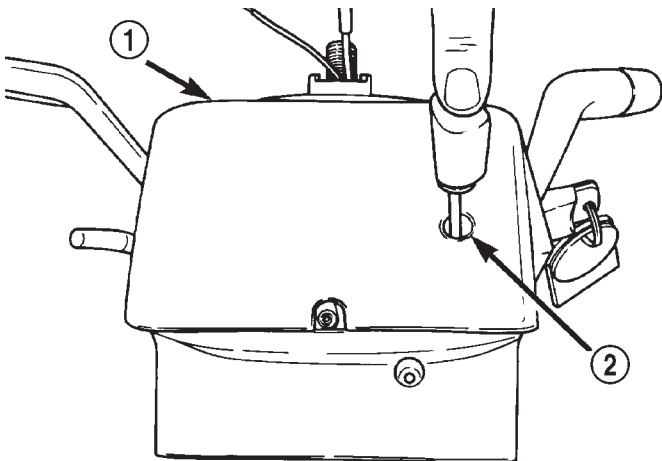

80a35441

Fig. 2 Key Cylinder Release Access Hole

- 1 - LOWER SHROUD
- 2 - RELEASE ACCESS HOLE

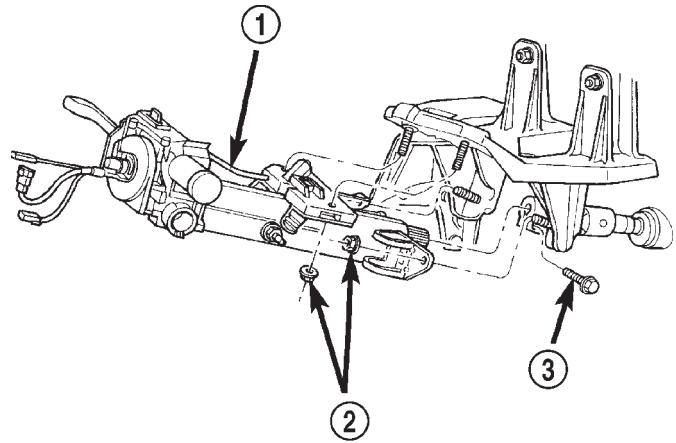

80aac1bb

Fig. 4 Tilt Steering Column Mounting

- 1 - STEERING COLUMN
- 2 - MOUNTING NUTS
- 3 - COUPLER BOLT

(6) Remove knee blocker cover and knee blocker, Refer to Group 8E Instrument Panel Systems.

(7) Remove screws from the lower column shroud (Fig. 3) and remove lower shroud.

(8) Remove the steering coupler bolt and column mounting nuts (Fig. 4) then lower column off the mounting stud.

(9) Remove upper column shroud (Fig. 3).

(10) Disconnect and remove the wiring harness from the column (Fig. 5).

NOTE: If vehicle is equipped with automatic transmission, remove shifter interlock cable. Refer to Group 21 Transmission and Transfer Case for procedure.

(11) Remove column.

(12) Remove nut and bolt from the upper column mounting bracket on non-tilt column (Fig. 6). Remove the bracket from the column and **note the mounting location and orientation of the bracket.**

(13) Remove clock spring, switches, (SKIM if equipped) and ignition key cylinder, refer to Group 8 Electrical for service procedures.

INSTALLATION

(1) Install upper column mounting bracket on non-tilt column. Install the mounting bolt and tighten the nut to 17 N·m (150 in. lbs.).

(2) Install switches, refer to Group 8 Electrical for service procedures.

REMOVAL AND INSTALLATION (Continued)

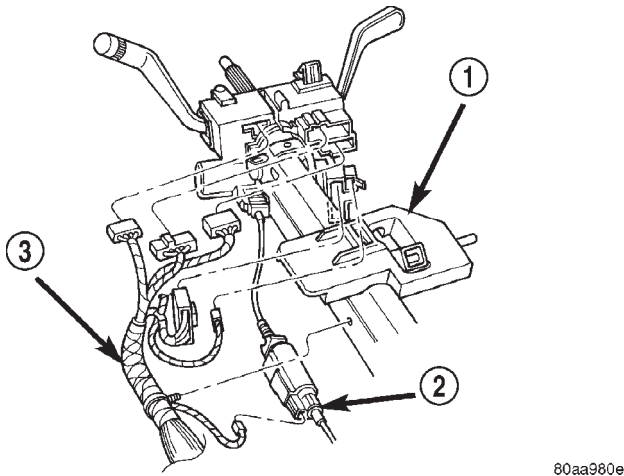

Fig. 5 Steering Column Harness

- 1 - STEERING COLUMN
- 2 - INTERLOCK CABLE
- 3 - COLUMN HARNESS

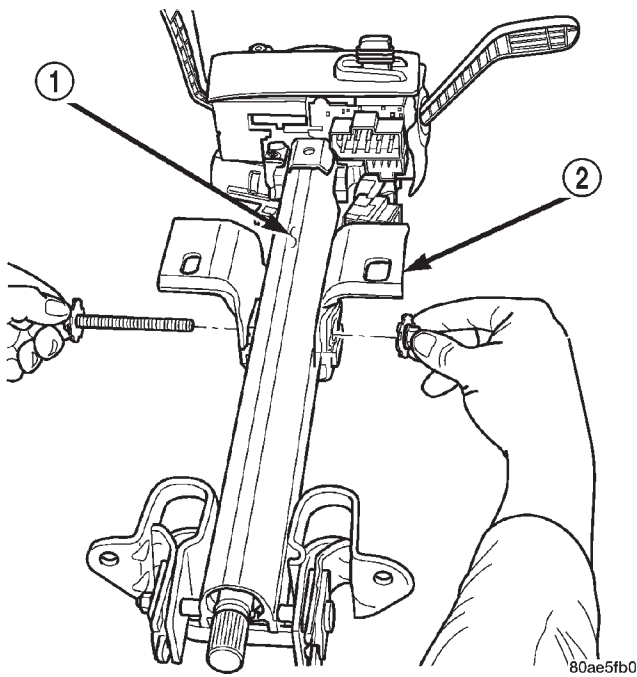

Fig. 6 Non-Tilt Column

- 1 - NON-TILT COLUMN
- 2 - UPPER BRACKET

(3) Align and install column into the steering coupler.

(4) Install column harness and connect harness to switches.

NOTE: If vehicle is equipped with automatic transmission install shifter interlock cable. Refer to Group 21 Transmission and Transfer Case for installation and adjustment.

(5) Install upper column shrouds.
 (6) Install column onto the mounting studs.
 (7) Install mounting nuts and tighten to 23 N·m (17 ft. lbs.).

(8) Install steering column coupler bolt and tighten to 49 N·m (36 ft. lbs.).

(9) Center the clock spring (if necessary) and install it on the column, refer to Group 8 Electrical for service procedures.

(10) Install lower column shroud and install mounting screws.

(11) Install ignition cylinder.

(12) Install knee blocker and knee blocker cover, Refer to Group 8E Instrument Panel Systems.

(13) Install steering wheel and tighten nut to 54 N·m (40 ft. lbs.).

NOTE: If equipped with cruise control, connect clock spring harness to cruise switch harness on the steering wheel.

(14) Install airbag, refer to Group 8M Restraint Systems for service procedures.

(15) Install negative battery terminal.

SPECIFICATIONS

TORQUE CHART

| DESCRIPTION | TORQUE |
|---------------------------------|-----------------------|
| Tilt Steering Column | |
| Steering Wheel Nut | 54 N·m (40 ft. lbs.) |
| Mounting Nuts | 23 N·m (17 ft. lbs.) |
| Coupler Bolt | 49 N·m (36 ft. lbs.) |
| Non-Tilt Steering Column | |
| Steering Wheel Nut | 54 N·m (40 ft. lbs.) |
| Mounting Nuts | 23 N·m (17 ft. lbs.) |
| Coupler Bolt | 49 N·m (36 ft. lbs.) |
| Upper Bracket Nut | 17 N·m (150 in. lbs.) |

STEERING

TABLE OF CONTENTS

| | page | page |
|--|------|--|
| POWER STEERING SYSTEM – 2.5L VM DIESEL | 1 | POWER STEERING PUMP – 2.5L VM DIESEL ... 2 |

POWER STEERING SYSTEM – 2.5L VM DIESEL

TABLE OF CONTENTS

| | page |
|---|------|
| DESCRIPTION AND OPERATION | |
| POWER STEERING PUMP | 1 |
| DESCRIPTION AND OPERATION | |
| POWER STEERING PUMP | |
| The power steering pump used with the 2.5L VM Diesel engine operates the same way as the power steering pump used with the 2.5/4.0L gasoline engines. Refer to the Description and Operation section for the 2.5/4.0L gasoline engine power steering pump for more information. | |

POWER STEERING PUMP – 2.5L VM DIESEL

TABLE OF CONTENTS

| | page | page |
|---|------|---------------------------------|
| SERVICE PROCEDURES | | |
| POWER STEERING PUMP - INITIAL OPERATION | 2 | POWER STEERING PUMP — RHD |
| REMOVAL AND INSTALLATION | | STEERING GEAR - RHD |
| POWER STEERING PUMP — LHD | 2 | |

SERVICE PROCEDURES

POWER STEERING PUMP - INITIAL OPERATION

WARNING: THE FLUID LEVEL SHOULD BE CHECKED WITH ENGINE OFF TO PREVENT INJURY FROM MOVING COMPONENTS.

CAUTION: Use MOPAR Power Steering Fluid or equivalent. Do not use automatic transmission fluid and do not overfill.

Wipe filler cap clean, then check the fluid level. The dipstick should indicate **COLD** when the fluid is at normal ambient temperature.

- (1) Fill the pump fluid reservoir to the proper level and let the fluid settle for at least two minutes.
- (2) Start the engine and let run for a few seconds then turn engine off.
- (3) Add fluid if necessary. Repeat the above procedure until the fluid level remains constant after running the engine.
- (4) Raise the front wheels off the ground.
- (5) Slowly turn the steering wheel right and left, lightly contacting the wheel stops at least 20 times.
- (6) Check the fluid level add if necessary.
- (7) Lower the vehicle, start the engine and turn the steering wheel slowly from lock to lock.
- (8) Stop the engine and check the fluid level and refill as required.
- (9) If the fluid is extremely foamy or milky looking, allow the vehicle to stand a few minutes and repeat the procedure.

CAUTION: Do not run a vehicle with foamy fluid for an extended period. This may cause pump damage.

REMOVAL AND INSTALLATION

POWER STEERING PUMP — LHD

Removal

- (1) Disconnect the negative battery cable.
- (2) Remove the A/C line support bracket from the rear of the rocker cover.
- (3) Disconnect the A/C compressor electrical connector.
- (4) Remove the (2) engine mount upper sill plate nuts (Fig. 1).

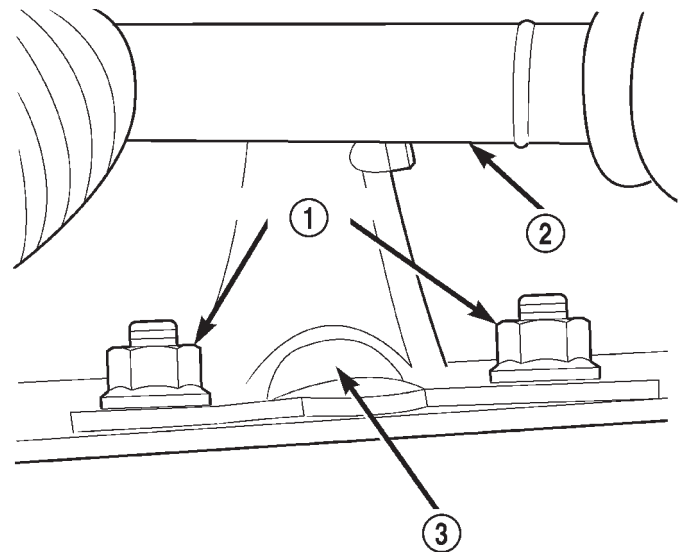

80b9a4c1

Fig. 1 Engine Mount Sill Plate Nuts

- 1 – SILL PLATE NUTS
- 2 – STEERING SHAFT
- 3 – ENGINE MOUNT

- (5) Make sure the steering wheel is in the unlocked position.
- (6) Raise the vehicle on a hoist.
- (7) Remove the steering shaft pinch bolt and slide the steering shaft straight off the gearbox input shaft, position the shaft aside.

REMOVAL AND INSTALLATION (Continued)

CAUTION: Avoid turning the steering shaft while disconnected from the steering gearbox. Damage to steering column clockspring could occur.

(8) Remove the power steering fluid supply hose from the pump and let the fluid drain.

(9) Loosen the (4) H-Block retaining bolts. Do not remove the bolts at this time.

(10) Remove the accessory drive belt from the power steering pump pulley. Refer to Group 7, Cooling System for procedure.

(11) Remove the power steering pump pulley. Use a hex socket to secure the pump shaft while removing the pulley nut with a box wrench (Fig. 2).

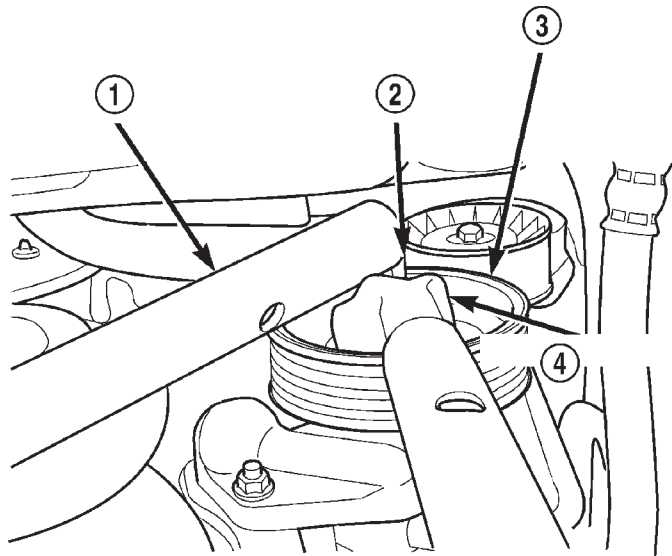

80b9a4c2

Fig. 2 Removing the Power Steering Pump Pulley

- 1 - LEVERAGE PIPE
- 2 - HEX WRENCH
- 3 - POWER STEERING PUMP PULLEY
- 4 - BOX WRENCH

NOTE: Mark the position of the H-Block in relation to the A/C Compressor so it may be reinstalled in the same position.

(12) Remove the (2) bolts retaining the H-Block to the power steering pump shaft coupler.

(13) Loosen the coupler pinch bolt and slide the coupler towards the pump.

(14) Remove the power steering pump pressure line from the steering gear. This is more accessible, but will require you to install the pressure line on the new pump prior to installation.

(15) Remove the remaining 2 bolts from the H-Block and remove the H-Block from the compressor.

(16) Support the A/C compressor with mechanics wire before proceeding to the next step.

(17) Remove the (4) A/C compressor retaining bolts.

(18) Remove the left engine mount throughbolt nut only. Do not remove the bolt at this time.

(19) Position a jack stand and raise weight off left engine mount.

(20) Remove the track bar support bracket retaining bolts and remove bracket (Fig. 3).

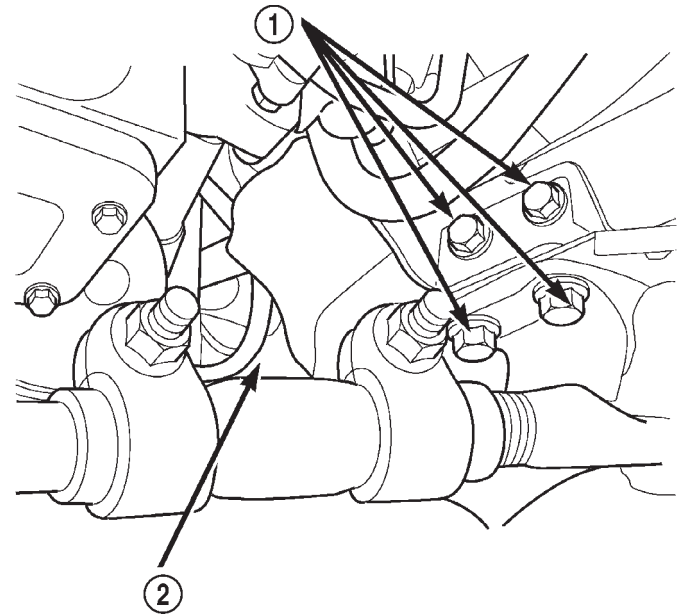

80b9a4be

Fig. 3 Engine Mount Retaining Bolts

- 1 - TRACK BAR SUPPORT BRACKET RETAINING BOLTS
- 2 - ENGINE MOUNT SILL PLATE BOLT

(21) Remove the lower engine mount bolt from the sill plate (Fig. 3).

(22) Remove the (4) engine mount bracket bolts from the engine block.

(23) Remove the engine mount throughbolt.

(24) Remove the engine mount and engine mount bracket from the vehicle.

(25) Remove the (2) power steering pump retaining nuts (Fig. 4).

(26) Remove the power steering pump from the vehicle.

Installation

WARNING: Power steering system fluid may be contaminated with metal shavings, overheated or improper fluid. All fluid should be drained from the system. After component replacement, system should be flushed and filled with Mopar Power Steering Fluid, or equivalent.

REMOVAL AND INSTALLATION (Continued)

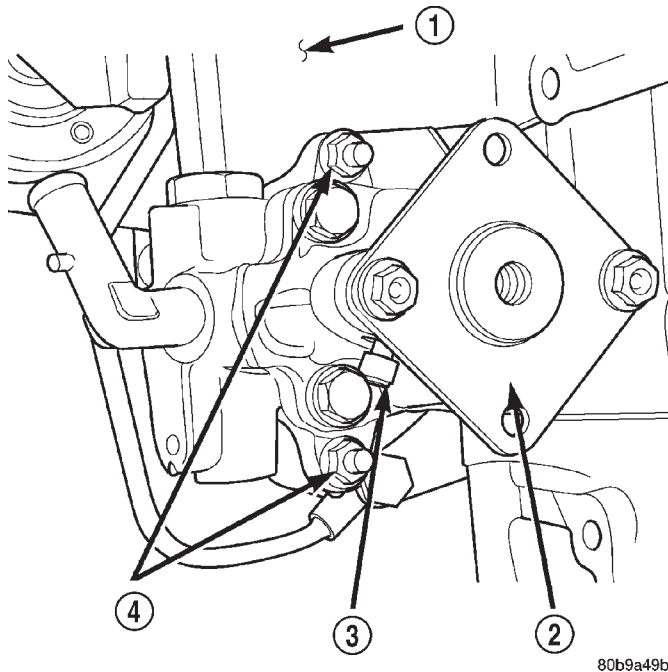
**Fig. 4 Power Steering Pump**

- 1 - ENGINE BLOCK
- 2 - COUPLER
- 3 - COUPLER PINCH BOLT
- 4 - POWER STEERING PUMP RETAINING NUTS

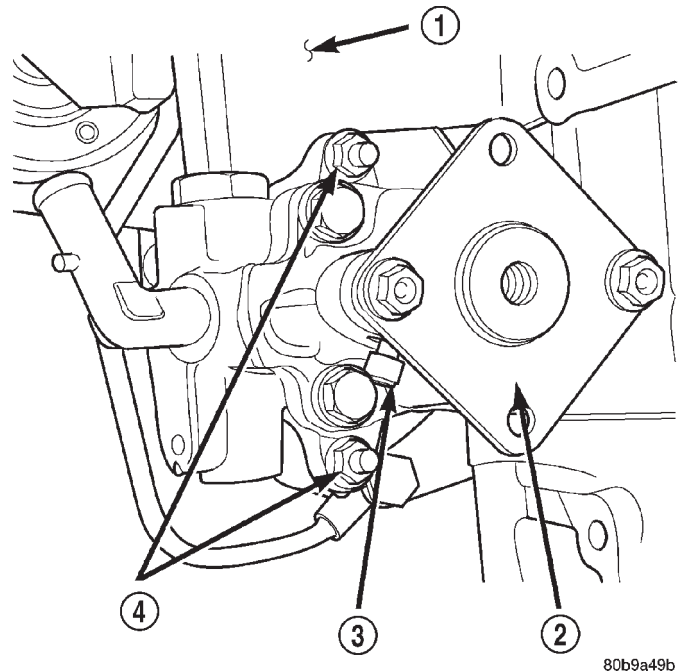
**Fig. 5 Power Steering Pump**

- 1 - ENGINE BLOCK
- 2 - COUPLER
- 3 - COUPLER PINCH BOLT
- 4 - POWER STEERING PUMP RETAINING NUTS

(1) Transfer the pressure line to the new pump, making sure line is in original position.

(2) Transfer the coupler to the new pump leaving pinch bolt loose at this time (Fig. 5).

(3) Install the power steering pump (Fig. 5).

(4) Install the engine mount and the engine mount bracket in the vehicle.

(5) Install the engine mount throughbolt and leave loose at this time.

(6) Install, but do not torque the engine mount and track bar support bracket bolts (Fig. 6).

(7) Install the (4) engine mount bracket to engine block retaining bolts. Torque bolts to 47 N·m (35 ft. lbs.).

(8) Torque the engine mount sill plate bolts to 41 N·m (30 ft. lbs.).

(9) Torque the larger trackbar support bracket bolts to 125 N·m (92ft. lbs.).

(10) Remove the jack stand.

(11) Install the H-Block on the A/C compressor in its original position and leave the bolts loose at this time.

(12) Position and install the A/C compressor.

(13) Slide the drive coupler in its original position and install the remaining (2) H-Block bolts.

(14) Install the power steering pump pulley (Fig. 7). Torque nut to 166 N·m (120 ft. lbs.).

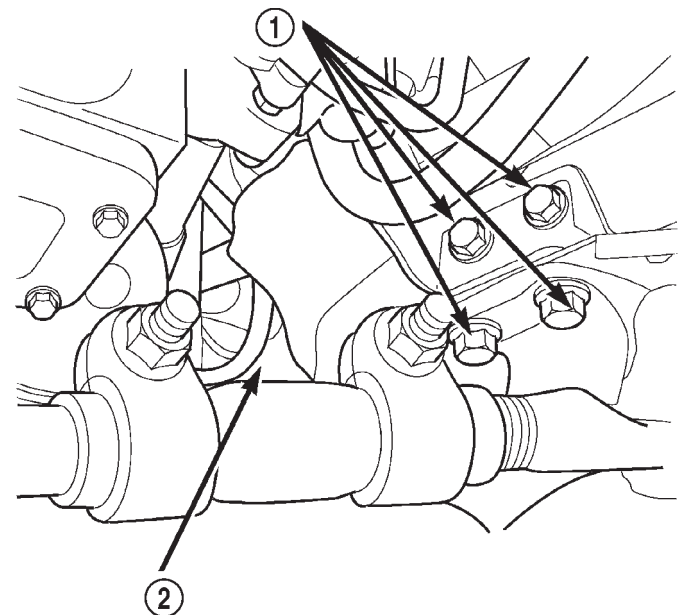
**Fig. 6 Engine Mount Retaining Bolts**

- 1 - TRACK BAR SUPPORT BRACKET RETAINING BOLTS
- 2 - ENGINE MOUNT SILL PLATE BOLT

(15) Install the accessory drive belt. See Group 7, Cooling System for procedure.

(16) Torque all the H-Block bolts.

REMOVAL AND INSTALLATION (Continued)

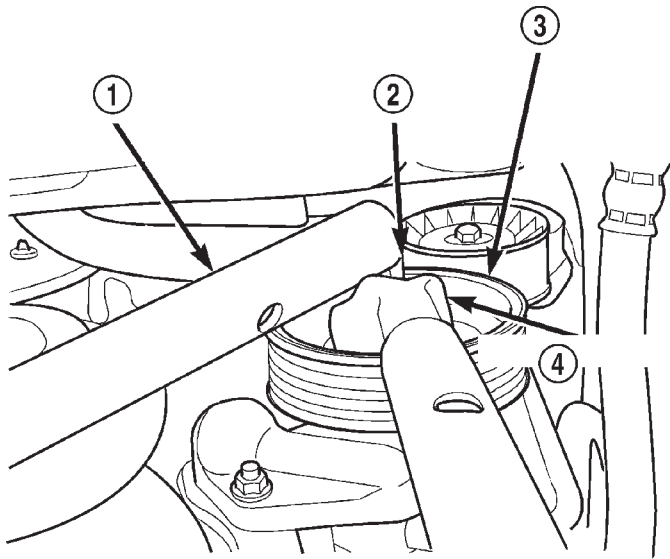

80b9a4c2

Fig. 7 Installing Pump Pulley

- 1 - LEVERAGE PIPE
- 2 - HEX WRENCH
- 3 - POWER STEERING PUMP PULLEY
- 4 - BOX WRENCH

(17) Install the steering shaft. Torque the steering shaft pinch bolt to 49 N·m (36 ft. lbs.).

(18) Install the pressure line on steering gear. Torque nut to 28 N·m (21 ft. lbs.).

(19) Install the power steering fluid supply hose on the pump.

(20) Lower the vehicle from the hoist.

(21) Install and torque the engine mount upper sill plate nuts to 41 N·m (30 ft. lbs.) (Fig. 8).

(22) Connect the A/C compressor electrical connector.

(23) Install the A/C line support bracket bolt at the rear of the valve cover.

(24) Fill the power steering fluid. See Group 19, Steering for Power Steering Pump-Initial operation procedure.

(25) Connect the negative battery cable.

POWER STEERING PUMP — RHD**Removal**

- (1) Disconnect the negative battery cable.
- (2) Remove the refrigerent line support bracket bolt from the top of the radiator.
- (3) Remove the A/C filter-drier assembly support bracket nuts from left fender well.
- (4) Disconnect the A/C compressor electrical connector.
- (5) Raise the vehicle on a hoist.

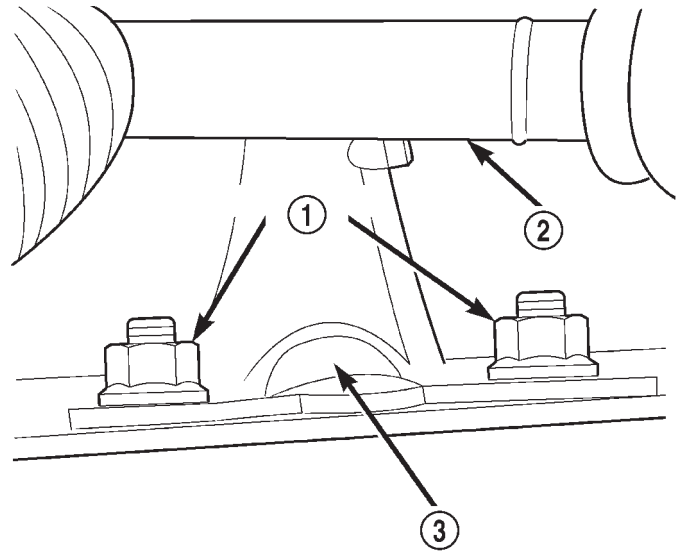

80b9a4c1

Fig. 8 Engine Mount Sill Plate Nuts

- 1 - SILL PLATE NUTS
- 2 - STEERING SHAFT
- 3 - ENGINE MOUNT

(6) Remove the power steering fluid supply hose from pump and drain fluid.

(7) Remove power steering line support bracket bolt from below radiator.

(8) Remove the engine mount upper sill plate nuts.

(9) Loosen the (4) H-Block retaining bolts. Do not remove at this time.

(10) Remove the accessory drive belt from the power steering pump pulley. See Group 7, Cooling System for procedure.

(11) Remove the power steering pump pulley. Use a hex socket to secure the pump shaft while removing the pulley nut with a box wrench (Fig. 9).

NOTE: Mark position of the H-Block in relation to the A/C Compressor so it can be installed in the same position.

(12) Remove the (2) bolts retaining the H-Block to the power steering pump shaft coupler.

(13) Loosen the coupler pinch bolt and slide coupler towards pump.

(14) Remove the left engine mount throughbolt nut only. Do not remove the bolt at this time.

(15) Remove the remaining 2 bolts from the H-Block and remove the H-Block from the compressor.

(16) Position a jack stand and raise weight off left engine mount.

(17) Remove the (2) engine mount sill plate bolts.

(18) Remove the (4) engine mount bracket bolts from the engine block.

REMOVAL AND INSTALLATION (Continued)

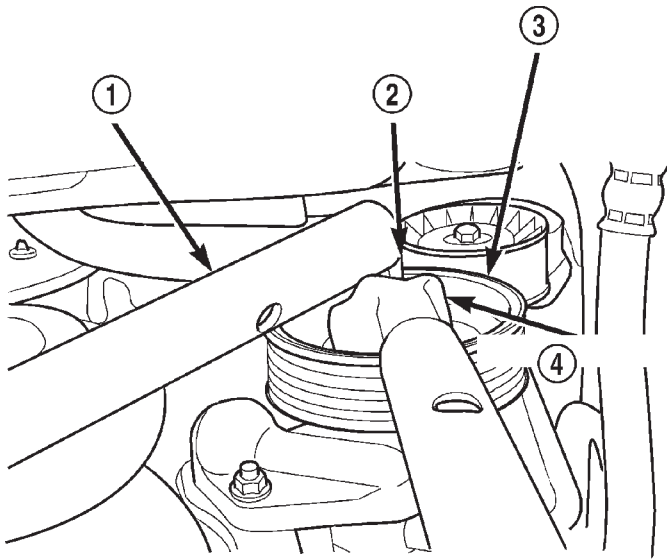

80b9a4c2

Fig. 9 Removing Pump Pulley

- 1 - LEVERAGE PIPE
- 2 - HEX WRENCH
- 3 - POWER STEERING PUMP PULLEY
- 4 - BOX WRENCH

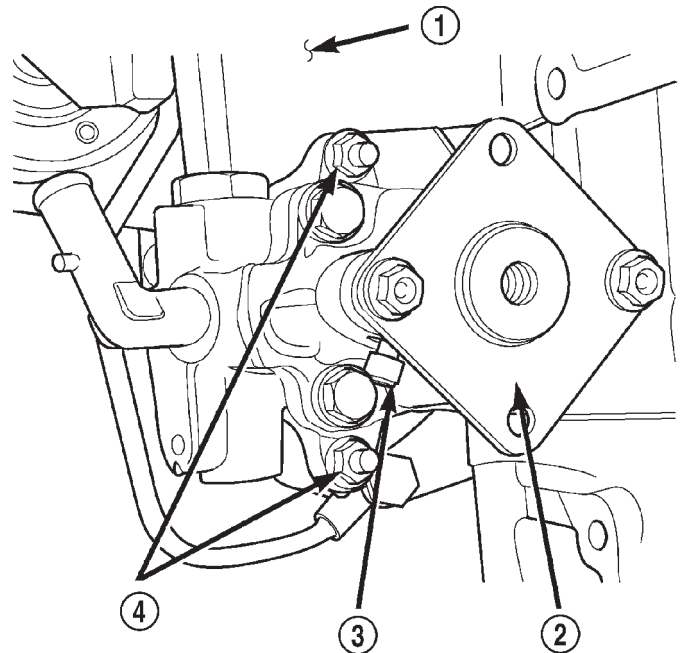

80b9a49b

Fig. 10 Power Steering Pump

- 1 - ENGINE BLOCK
- 2 - COUPLER
- 3 - COUPLER PINCH BOLT
- 4 - POWER STEERING PUMP RETAINING NUTS

- (19) Remove the engine mount throughbolt.
- (20) Remove the engine mount and engine mount bracket from vehicle.
- (21) Remove the (2) power steering pump retaining nuts (Fig. 10).
- (22) Slide pump off mounting studs and position so pressure line can be removed. This will require you to install pressure line on the new pump prior to installing it in the engine block.
- (23) Remove the power steering pump from the vehicle.

Installation

WARNING: Power steering system fluid may be contaminated with metal shavings, overheated or improper fluid. All fluid should be drained from the system. After component replacement, system should be flushed and filled with Mopar Power Steering Fluid, or equivalent.

- (1) Install the pressure line on pump in original position.
- (2) Transfer the drive coupler to new pump leaving pinch bolt loose at this time (Fig. 11).
- (3) Install the power steering pump in the engine block. Torque retaining nuts to 24 N·m (18 ft. lbs.) (Fig. 11).
- (4) Install the engine mount and engine mount bracket in vehicle.

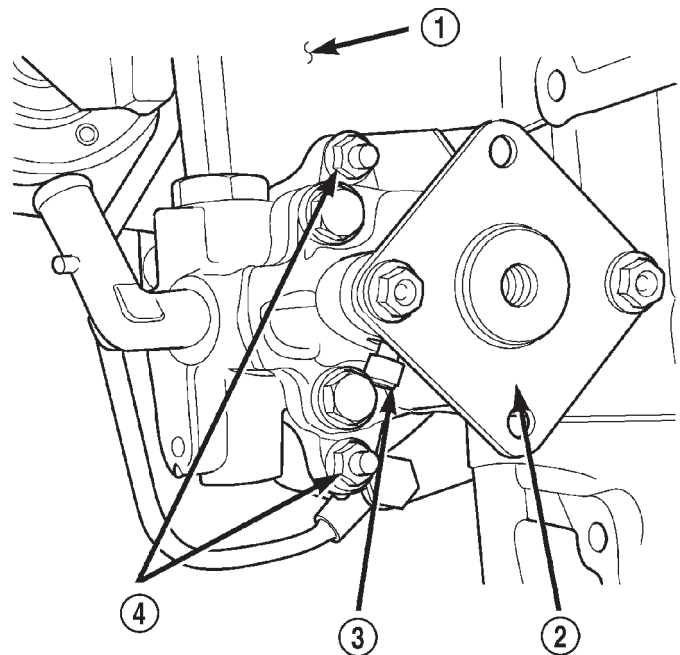

80b9a49b

Fig. 11 Power Steering Pump

- 1 - ENGINE BLOCK
- 2 - COUPLER
- 3 - COUPLER PINCH BOLT
- 4 - POWER STEERING PUMP RETAINING NUTS

REMOVAL AND INSTALLATION (Continued)

- (5) Install the engine mount throughbolt and leave loose at this time.
- (6) Install, do not torque engine mount sill plate nuts and bolts.
- (7) Install (4) engine mount bracket to engine block retaining bolts and Torque to 61 N·m (45 ft. lbs.).
- (8) Torque the engine mount sill plate nuts to 41 N·m (30 ft. lbs.).
- (9) Torque the engine mount sill plate bolts to 41 N·m (30 ft. lbs.).
- (10) Remove jack stand.
- (11) Install the H-Block on the A/C compressor in the original position and leave bolts loose at this time.
- (12) Position and install A/C compressor.
- (13) Slide the drive coupler into its original position and start remaining (2) H-Block bolts.
- (14) Install the power steering pump pulley (Fig. 12). Torque nut to 166 N·m (120 ft. lbs.).

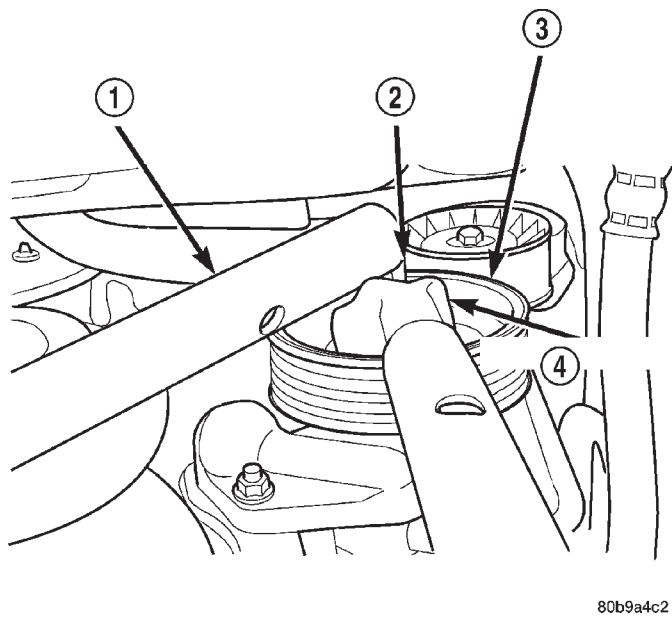

80b9a4c2

Fig. 12 Installing Pump Pulley

- 1 - LEVERAGE PIPE
- 2 - HEX WRENCH
- 3 - POWER STEERING PUMP PULLEY
- 4 - BOX WRENCH

- (15) Install the accessory drive belt. See Group 7, Cooling for procedure.
- (16) Torque all the H-Block bolts.
- (17) Torque the engine mount throughbolt nut to 65 N·m (48 ft. lbs.).
- (18) Install the power steering fluid supply hose on pump.
- (19) Install the power steering line support bracket bolt.
- (20) Lower the vehicle from hoist.

- (21) Install the refrigerent line support bracket and bolt on the top of the radiator.
- (22) Install the A/C filter-drier assembly support bracket nuts on the left fender well.
- (23) Reconnect the A/C compressor electrical connector.
- (24) Re-fill the power steering fluid. Refer to Group 19, Steering for Power Steering Pump-Initial Operation for procedure.
- (25) Connect the negative battery cable.

STEERING GEAR - RHD

REMOVAL

- (1) Open the hood and disconnect the negative battery cable.
- (2) Place the front wheels in the straight ahead position and lock the steering wheel.

CAUTION: Be certain to lock the steering wheel in position prior to disconnecting the steering column coupler. This will prevent clockspring damage.

- (3) Disconnect the power steering pressure and return lines from the steering gear (Fig. 13).

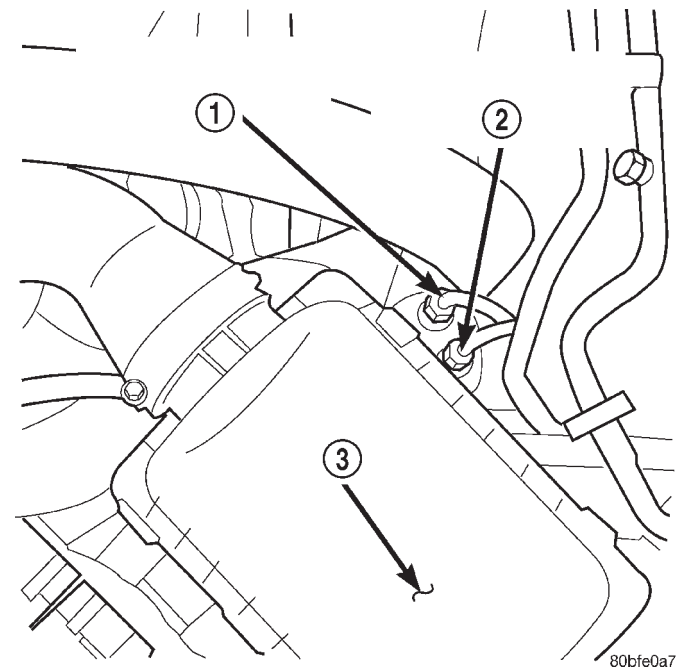

80bfe0a7

Fig. 13 Power Steering Fluid Pressure and Return Line Location - RHD

- 1 - POWER STEERING FLUID RETURN LINE
- 2 - POWER STEERING FLUID PRESSURE LINE
- 3 - AIR FILTER COVER

- (4) Remove the steering column coupler pinch bolt. Located just to the rear of the fluid lines (Fig. 13).

REMOVAL AND INSTALLATION (Continued)

(5) Separate steering shaft from gearbox by pulling straight apart.

(6) Raise the vehicle on a hoist.

(7) Remove the stabilizer bar clamp retaining bolts from the frame (Fig. 14). Allow stabilizer bar to hang free.

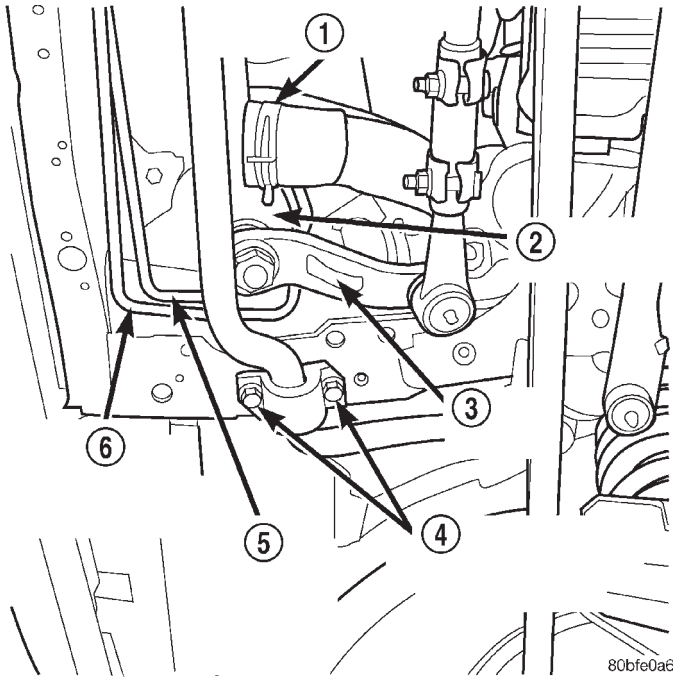

Fig. 14 Steering Gear

- 1 - LOWER RADIATOR HOSE/CLAMP
- 2 - STEERING GEAR
- 3 - PITMAN ARM
- 4 - STABILIZER BAR RETAINING BOLTS
- 5 - POWER STEERING FLUID PRESSURE LINE
- 6 - POWER STEERING FLUID RETURN LINE

(8) Remove the Pittman arm from the steering gear (Fig. 14). Refer to Group 19, Steering for the procedure.

(9) Remove the small right front splash from the vehicle.

(10) Remove the (3) steering gear retaining bolts (Fig. 15).

(11) Rotate the lower radiator hose clamp, so that the tangs are facing straight down. This will aid in gear removal.

(12) Remove the steering gear from the vehicle.

INSTALLATION

(1) Center the steering gear travel. Rotate gear output shaft until stop. Make a reference mark in the same position on the gear shaft and gear housing.

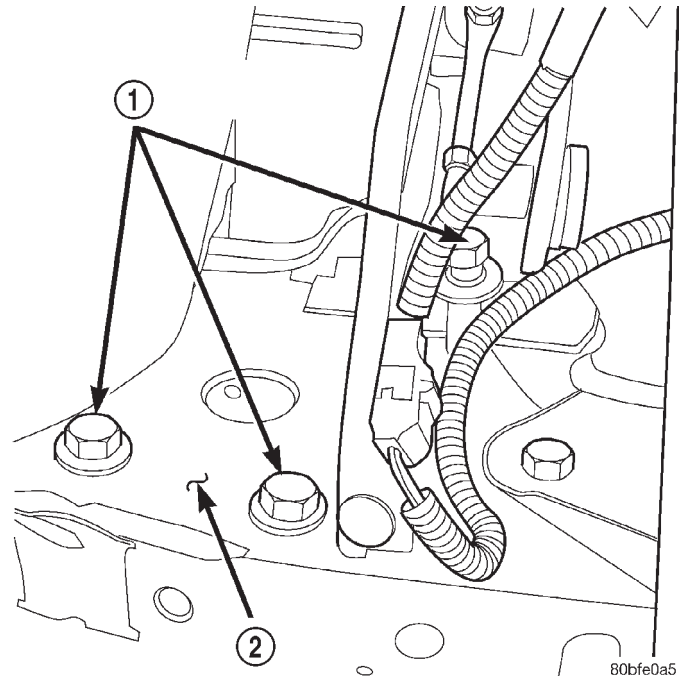

Fig. 15 Steering Gear Retaining Bolts

- 1 - STEERING GEAR RETAINING BOLTS
- 2 - VEHICLE FRAME RAIL

Rotate gear shaft in the opposite direction until stop while noting the number of turns. Divide that number in half and position the reference mark made previously at that position.

(2) Install the steering gear in the vehicle.

(3) Install the (3) steering gear retaining bolts. Torque to 95 N·m (70 ft. lbs.).

(4) Install the small right front splash on the vehicle.

(5) Install the Pittman arm on the steering gear. Refer to Group 19, Steering for the procedure. Torque nut to 251 N·m (185 ft. lbs.).

(6) Position the stabilizer bar and install the clamp retaining bolts. Refer to Group 2, Suspension for a detailed procedure. Torque the bolts to 75 N·m (40 ft. lbs.).

(7) Lower the vehicle on the hoist.

(8) Install the steering column shaft coupler on the steering gear and install pinch bolt. Torque the bolt to 35 N·m (26 ft. lbs.).

(9) Install the power steering pressure and return lines on the steering gear. Torque the lines to 28 N·m (21 ft. lbs.).

(10) Connect the negative battery cable.

(11) Check and correct vehicle front end alignment specifications if necessary. Refer to Group 2, Suspension for the procedure.

SUSPENSION

TABLE OF CONTENTS

| | page | | page |
|------------------------|------|-----------------------|------|
| ALIGNMENT | 1 | REAR SUSPENSION | 16 |
| FRONT SUSPENSION | 7 | | |

ALIGNMENT

TABLE OF CONTENTS

| | page | | page |
|-------------------------------------|------|---------------------------|------|
| DESCRIPTION AND OPERATION | | SERVICE PROCEDURES | |
| WHEEL ALIGNMENT | 1 | PRE-ALIGNMENT | 4 |
| DIAGNOSIS AND TESTING | | WHEEL ALIGNMENT | 4 |
| SUSPENSION AND STEERING SYSTEM..... | 3 | SPECIFICATIONS | |
| | | ALIGNMENT | 6 |

DESCRIPTION AND OPERATION

WHEEL ALIGNMENT

DESCRIPTION

Wheel alignment involves the correct positioning of the wheels in relation to the vehicle. The positioning is accomplished through suspension and steering linkage adjustments. An alignment is considered essential for efficient steering, good directional stability and to minimize tire wear. The most important measurements of an alignment are caster, camber and toe position (Fig. 1).

CAUTION: Never attempt to modify suspension or steering components by heating or bending.

CAUTION: Components attached with a nut and cotter pin must be torqued to specification. Then if the slot in the nut does not line up with the cotter pin hole, tighten nut until it is aligned. Never loosen the nut to align the cotter pin hole.

NOTE: Periodic lubrication of the front suspension/steering system components may be required. Rubber bushings must never be lubricated. Refer to Group 0, Lubrication And Maintenance for the recommended maintenance schedule.

OPERATION

- **CASTER** is the forward or rearward tilt of the steering knuckle from vertical. Tilting the top of the knuckle rearward provides positive caster. Tilting the top of the knuckle forward provides negative caster. Caster is a directional stability angle. This angle enables the front wheels to return to a straight ahead position after turns.

- **CAMBER** is the inward or outward tilt of the wheel relative to the center of the vehicle. Tilting the top of the wheel inward provides negative camber. Tilting the top of the wheel outward provides positive camber. Incorrect camber will cause wear on the inside or outside edge of the tire. The angle is not adjustable, damaged component(s) must be replaced to correct the camber angle.

- **WHEEL TOE POSITION** is the difference between the leading inside edges and trailing inside edges of the front tires. Incorrect wheel toe position is the most common cause of unstable steering and uneven tire wear. The wheel toe position is the **final** front wheel alignment adjustment.

- **STEERING AXIS INCLINATION ANGLE** is measured in degrees and is the angle that the steering knuckles are tilted. The inclination angle has a fixed relationship with the camber angle. It will not change except when a spindle or ball stud is damaged or bent. The angle is not adjustable, damaged component(s) must be replaced to correct the steering axis inclination angle.

DESCRIPTION AND OPERATION (Continued)

• **THRUST ANGLE** is the angle of the rear axle relative to the centerline of the vehicle. Incorrect thrust angle can cause off-center steering and excessive tire wear. This angle is not adjustable, damaged component(s) must be replaced to correct the thrust angle.

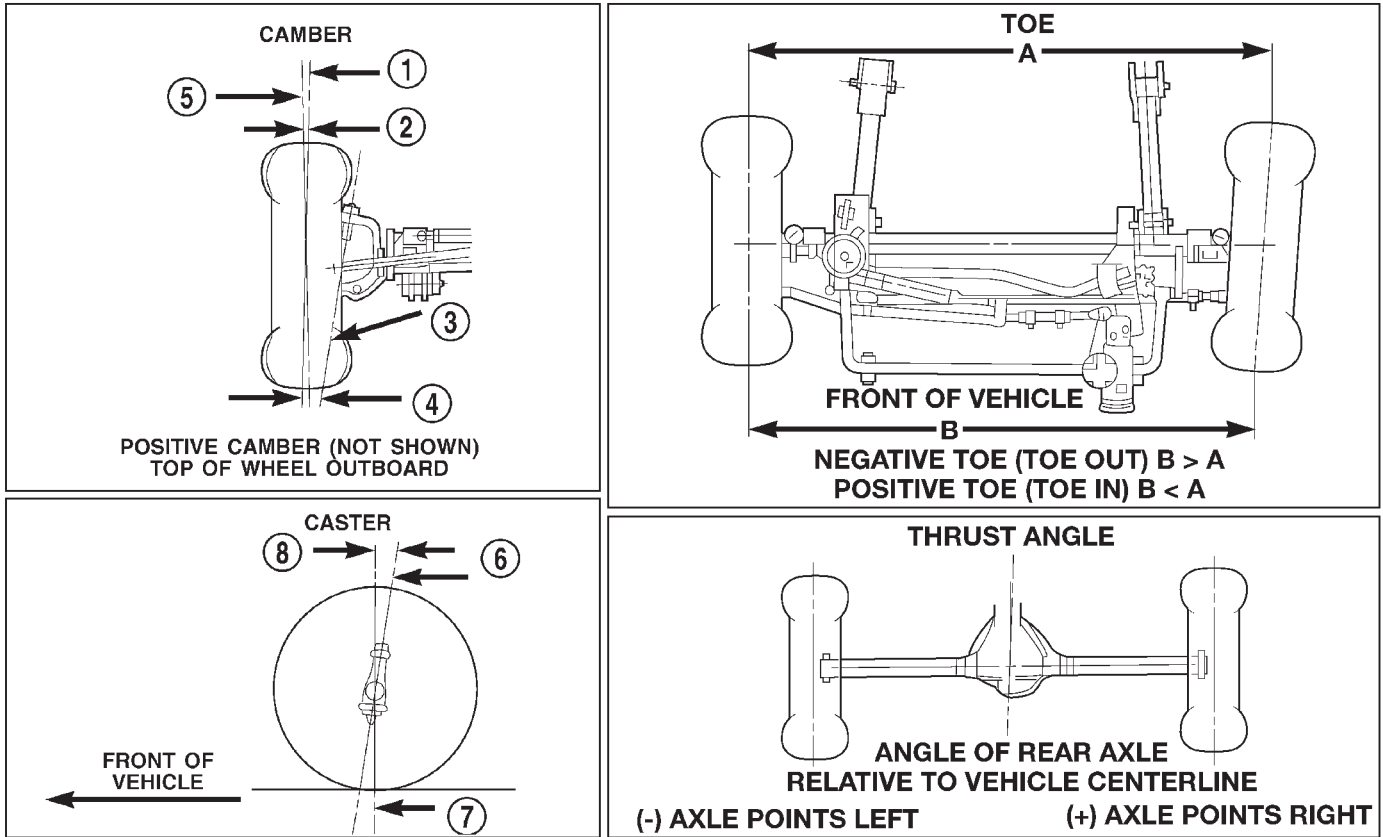

80b34eaf

Fig. 1 Wheel Alignment Measurements

- | | |
|---------------------------|---------------------|
| 1 - WHEEL CENTERLINE | 5 - TRUE VERTICAL |
| 2 - NEGATIVE CAMBER ANGLE | 6 - KING PIN |
| 3 - PIVOT CENTERLINE | 7 - VERTICAL |
| 4 - SCRUB RADIUS | 8 - POSITIVE CASTER |

DIAGNOSIS AND TESTING

SUSPENSION AND STEERING SYSTEM

| CONDITION | POSSIBLE CAUSES | CORRECTION |
|---|--|--|
| FRONT END NOISE | <ol style="list-style-type: none"> 1. Loose or worn wheel bearings. 2. Loose or worn steering or suspension components. | <ol style="list-style-type: none"> 1. Adjust or replace wheel bearings. 2. Tighten or replace components as necessary. |
| EXCESSIVE PLAY IN STEERING | <ol style="list-style-type: none"> 1. Loose or worn wheel bearings. 2. Loose or worn steering or suspension components. 3. Loose or worn steering gear. | <ol style="list-style-type: none"> 1. Adjust or replace wheel bearings. 2. Tighten or replace components as necessary. 3. Adjust or replace steering gear. |
| FRONT WHEELS SHIMMY | <ol style="list-style-type: none"> 1. Loose or worn wheel bearings. 2. Loose or worn steering or suspension components. 3. Tires worn or out of balance. 4. Alignment. 5. Leaking steering dampener. | <ol style="list-style-type: none"> 1. Adjust or replace wheel bearings. 2. Tighten or replace components as necessary. 3. Replace or balance tires. 4. Align vehicle to specifications. 5. Replace steering dampener. |
| VEHICLE INSTABILITY | <ol style="list-style-type: none"> 1. Loose or worn wheel bearings. 2. Loose or worn steering or suspension components. 3. Tire pressure. 4. Alignment. | <ol style="list-style-type: none"> 1. Adjust or replace wheel bearings. 2. Tighten or replace components as necessary. 3. Adjust tire pressure. 4. Align vehicle to specifications. |
| EXCESSIVE STEERING EFFORT | <ol style="list-style-type: none"> 1. Loose or worn steering gear. 2. Power steering fluid low. 3. Column coupler binding. 4. Tire pressure. 5. Alignment. | <ol style="list-style-type: none"> 1. Adjust or replace steering gear. 2. Add fluid and repair leak. 3. Replace coupler. 4. Adjust tire pressure. 5. Align vehicle to specifications. |
| VEHICLE PULLS TO ONE SIDE DURING BRAKING | <ol style="list-style-type: none"> 1. Uneven tire pressure. 2. Worn brake components. 3. Air in brake line. | <ol style="list-style-type: none"> 1. Adjust tire pressure. 2. Repair brakes as necessary. 3. Repair as necessary. |
| VEHICLE LEADS OR DRIFTS FROM STRAIGHT AHEAD DIRECTION ON UNCROWNED ROAD | <ol style="list-style-type: none"> 1. Radial tire lead. 2. Brakes dragging. 3. Weak or broken spring. 4. Uneven tire pressure. 5. Wheel Alignment. 6. Loose or worn steering or suspension components. 7. Cross caster out of spec. | <ol style="list-style-type: none"> 1. Cross front tires. 2. Repair brake as necessary. 3. Replace spring. 4. Adjust tire pressure. 5. Align vehicle. 6. Repair as necessary. 7. Align vehicle. |

DIAGNOSIS AND TESTING (Continued)

| CONDITION | POSSIBLE CAUSES | CORRECTION |
|---------------------------------|--|---|
| KNOCKING, RATTLING OR SQUEAKING | <ol style="list-style-type: none"> 1. Worn shock bushings. 2. Loose, worn or bent steering/suspension components. 3. Shock valve. | <ol style="list-style-type: none"> 1. Replace shock. 2. Inspect, tighten or replace components as necessary. 3. Replace shock. |
| IMPROPER TRACKING | <ol style="list-style-type: none"> 1. Loose, worn or bent track bar. 2. Loose, worn or bent steering/suspension components. | <ol style="list-style-type: none"> 1. Inspect, tighten or replace component as necessary. 2. Inspect, tighten or replace components as necessary. |

SERVICE PROCEDURES

PRE-ALIGNMENT

Before starting wheel alignment, the following inspection and necessary corrections must be completed. Refer to Suspension and Steering System Diagnosis Chart for additional information.

- (1) Inspect tires for size and tread wear.
- (2) Set tire air pressure.
- (3) Inspect front wheel bearings for wear.
- (4) Inspect front wheels for excessive radial or lateral runout and balance.
- (5) Inspect ball studs, linkage pivot points and steering gear for looseness, roughness or binding.
- (6) Inspect suspension components for wear and noise.

WHEEL ALIGNMENT

Before each alignment reading, the vehicle should be jounced (rear first, then front). Grasp each bumper at the center and jounce the vehicle up and down several times. Always release the bumper in the down position. Set the front end alignment to specifications with the vehicle at its NORMAL RIDE HEIGHT.

CAMBER

The wheel camber angle is preset. This angle is not adjustable and cannot be altered.

CASTER

Before checking the caster of the front axle for correct angle, be sure the axle is not bent or twisted.

Road test the vehicle, make left and right turns. If the steering wheel returns to the center position unassisted, the caster angle is correct. If steering wheel does not return toward the center position unassisted, an incorrect caster angle is probable.

Caster can be adjusted by installing the appropriate size shims (Fig. 2).

NOTE: Changing caster angle will also change the front propeller shaft angle. The propeller shaft angle has priority over caster. Refer to Group 3 Differential & Driveline for additional information.

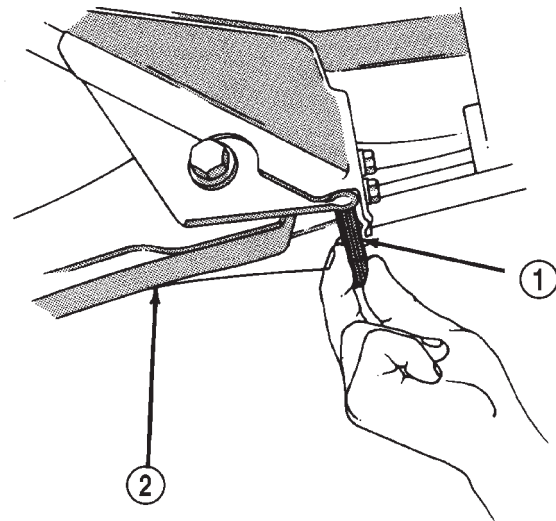

J8916-22

Fig. 2 Caster Adjustment

- 1 - SHIM
2 - SUSPENSION ARM

TOE POSITION (LHD)

NOTE: The wheel toe position adjustment is the final adjustment. The engine must remain running during the entire toe position adjustment.

- (1) Start the engine and turn wheels both ways before straightening the wheels. Secure the steering wheel with the front wheels in the straight-ahead position.
- (2) Loosen the adjustment sleeve clamp bolts (Fig. 3).
- (3) Adjust the right wheel toe position with the drag link. Turn the sleeve until the right wheel is at correct TOE-IN specifications. Position the clamp

SERVICE PROCEDURES (Continued)

bolts as shown (Fig. 4) and tighten to 49 N·m (36 ft. lbs.).

NOTE: Make sure the toe setting does not change during clamp tightening.

(4) Adjust the left wheel toe position with the tie rod. Turn the sleeve until the left wheel is at specifications. Position the clamp bolts as shown (Fig. 4) and tighten to 27 N·m (20 ft. lbs.).

NOTE: Make sure the toe setting does not change during clamp tightening.

(5) Verify the right toe setting and turn off engine.

(6) Road test the vehicle on a flat level road to verify the steering wheel is centered.

NOTE: Once the toe setting is correct, the steering wheel can be re-centered by adjusting only the drag link.

TOE POSITION (RHD)

NOTE: The wheel toe position adjustment is the final adjustment. The engine must remain running during the entire toe position adjustment.

(1) Start the engine and turn wheels both ways before straightening the wheels. Secure the steering

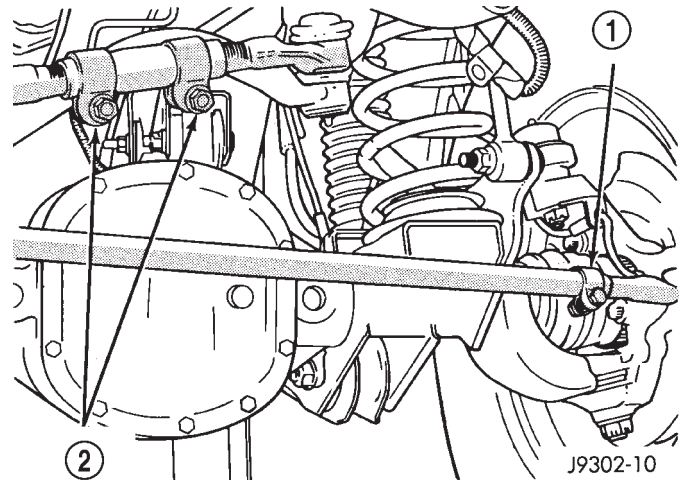

Fig. 4 Drag Link and Tie Rod Clamp (LHD)

- 1 - TIE ROD CLAMP
- 2 - DRAG LINK CLAMPS

wheel with the front wheels in the straight-ahead position.

(2) Loosen the adjustment sleeve clamp bolts (Fig. 5).

(3) Adjust the left wheel toe position with the drag link. Turn the sleeve until the left wheel is at the correct TOE-IN specifications. Position the clamp bolts to their original position and tighten to 49 N·m (36 ft. lbs.).

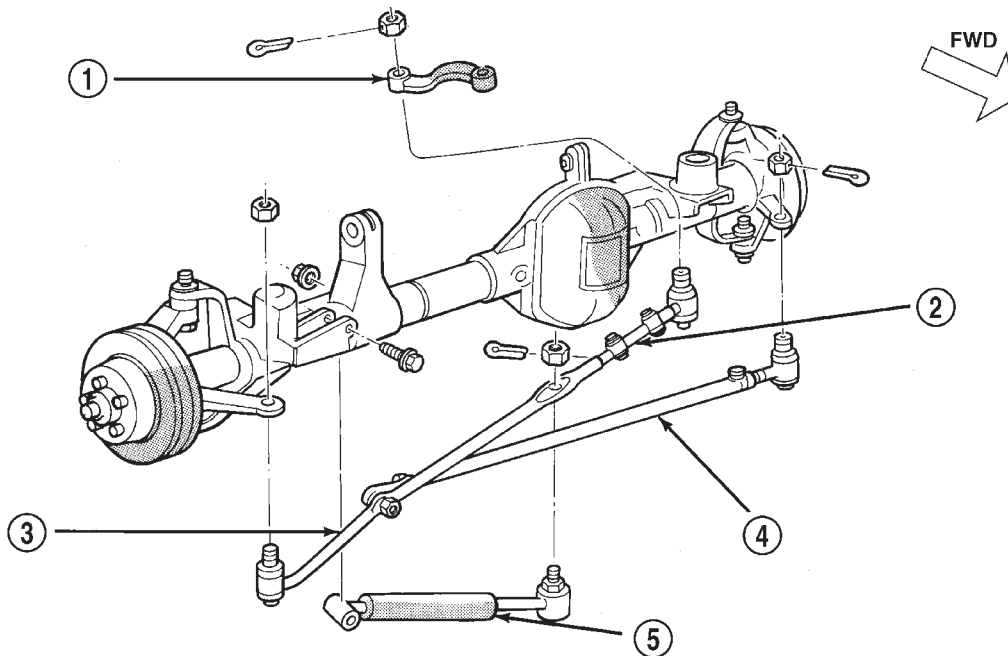
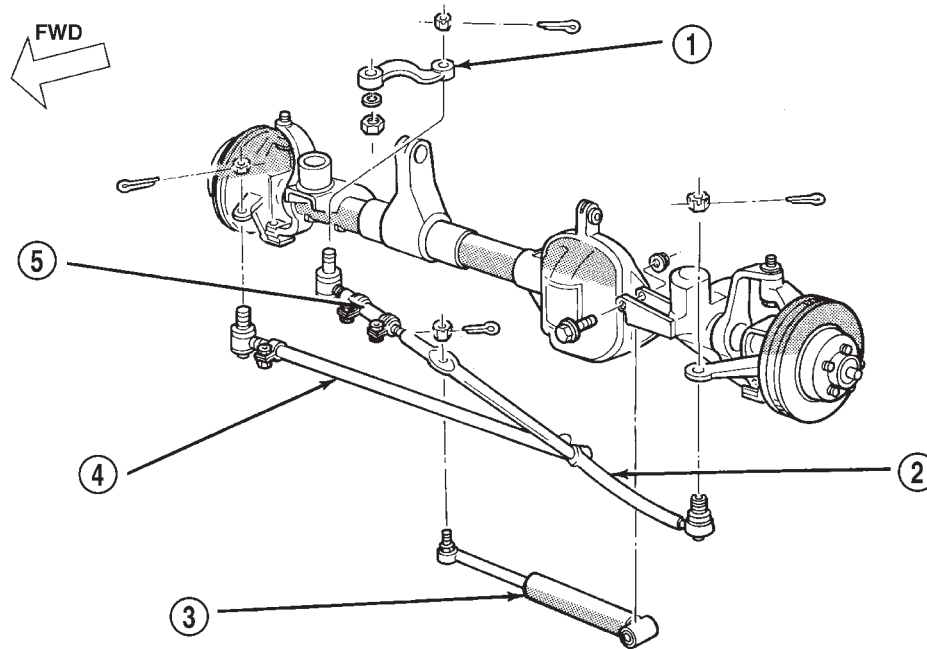

Fig. 3 Steering Linkage (LHD)

- 1 - PITMAN ARM
- 2 - ADJUSTMENT SLEEVE
- 3 - DRAG LINK
- 4 - TIE ROD
- 5 - STEERING DAMPENER

SERVICE PROCEDURES (Continued)



J9502-6

Fig. 5 Steering Linkage (RHD)

- 1 - PITMAN ARM
- 2 - DRAG LINK
- 3 - STEERING DAMPNER

- 4 - TIE ROD
- 5 - ADJUSTMENT SLEEVE

NOTE: Make sure the toe setting does not change during clamp tightening.

(4) Adjust the right wheel toe position with the tie rod. Turn the sleeve until the right wheel is at correct TOE-IN specifications. Position the clamp bolts to their original position and tighten to 27 N·m (20 ft. lbs.).

NOTE: Make sure the toe setting does not change during clamp tightening.

(5) Verify the right toe setting and turn off engine.
 (6) Road test the vehicle on a flat level road to verify the steering wheel is centered.

NOTE: Once the toe setting is correct, the steering wheel can be re-centered by adjusting only the drag link.

SPECIFICATIONS

ALIGNMENT

NOTE: All alignment specifications are in degrees.

| ANGLE | PREFERRED | RANGE | MAX RT/LT DIFFERENCE |
|-------------------------|-----------|-------------------|----------------------|
| CASTER | + 7.0° | + 5.25° to + 8.5° | 1.25° |
| CAMBER (fixed angle) | - 0.25° | - 0.75° to + 0.5° | 1.0° |
| TOTAL TOE-IN | + 0.25° | 0° to + 0.45° | .05° |
| THRUST ANGLE 0° ± 0.15° | | | |

FRONT SUSPENSION

TABLE OF CONTENTS

| | page | | page |
|--|------|---------------------------------|------|
| DESCRIPTION AND OPERATION | | COIL SPRING/JOUNCE BUMPER | 9 |
| SUSPENSION COMPONENTS | 7 | STEERING KNUCKLE | 10 |
| SHOCK ABSORBERS | 7 | LOWER SUSPENSION ARM | 10 |
| JOUNCE BUMPER | 7 | UPPER SUSPENSION ARM | 11 |
| COIL SPRINGS AND ISOLATORS | 8 | FRONT AXLE BUSHING | 11 |
| LOWER SUSPENSION ARMS AND BUSHINGS ... | 8 | STABILIZER BAR | 12 |
| UPPER SUSPENSION ARMS AND BUSHINGS ... | 8 | TRACK BAR | 12 |
| STABILIZER BAR | 9 | HUB BEARING | 12 |
| TRACK BAR | 9 | WHEEL MOUNTING STUDS | 13 |
| HUB/BEARING | 9 | SPECIFICATIONS | |
| DIAGNOSIS AND TESTING | | TORQUE CHART | 14 |
| SHOCK DIAGNOSIS | 9 | SPECIAL TOOLS | |
| REMOVAL AND INSTALLATION | | FRONT SUSPENSION | 15 |
| SHOCK ABSORBER | 9 | | |

DESCRIPTION AND OPERATION

SUSPENSION COMPONENTS

The front suspension is a link/coil design (Fig. 1). This suspension is use on Left Hand Drive (LHD) and Right Hand Drive (RHD) vehicles. The suspension is comprised of:

- Drive axle (4WD), tube axle (2WD)
- Dual-action shock absorbers
- Coil springs
- Upper and lower suspension arms
- Stabilizer bar
- Track bar
- Jounce bumpers

CAUTION: Components attached with a nut and cotter pin must be torqued to specification. Then if the slot in the nut does not line up with the cotter pin hole, tighten nut until it is aligned. Never loosen the nut to align the cotter pin hole.

CAUTION: Suspension components with rubber/urethane bushings (except stabilizer bar) should be tightened with the vehicle at normal ride height. It is important to have the springs supporting the weight of the vehicle when the fasteners are torqued. If springs are not at their normal ride position, vehicle ride comfort could be affected and premature bushing wear may occur.

NOTE: Periodic lubrication of the front suspension/steering system components may be required. Rubber bushings must never be lubricated. Refer to Group 0, Lubrication And Maintenance for the recommended maintenance schedule.

SHOCK ABSORBERS

DESCRIPTION

The top of the shock absorbers are bolted to a frame bracket. The bottom of the shocks are bolted to the axle brackets.

OPERATION

The shock absorbers dampen jounce and rebound motion of the vehicle over various road conditions and limit suspension rebound travel.

JOUNCE BUMPER

DESCRIPTION

The jounce bumpers are mounted under the frame rail inside of the coil spring.

OPERATION

The jounce bumpers are used to limit suspension travel in compression.

DESCRIPTION AND OPERATION (Continued)

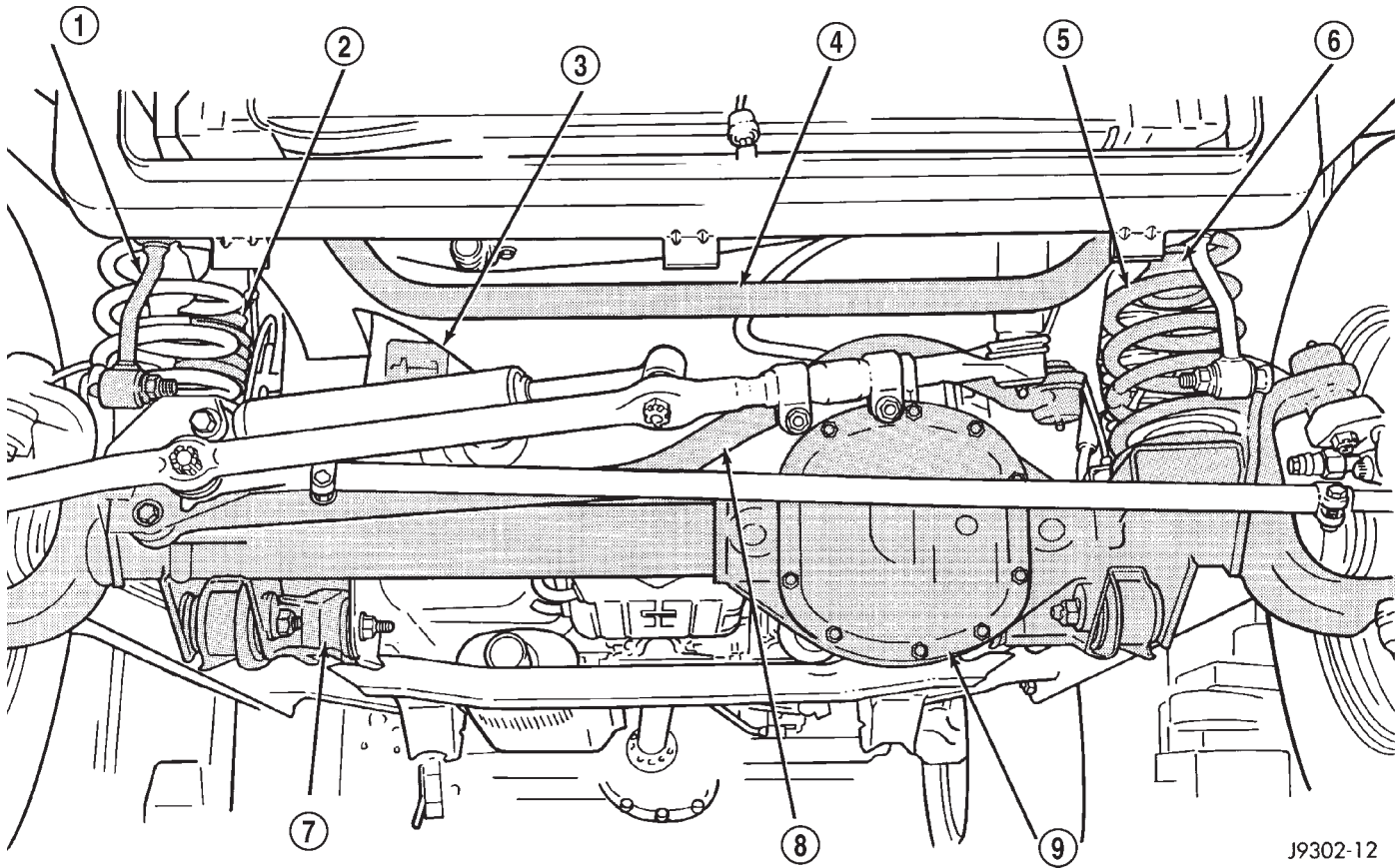

J9302-12

Fig. 1 Suspension Components (LHD)

- | | |
|--------------------------|--------------------------|
| 1 - LINKS | 6 - JOUNCE BUMPER |
| 2 - SHOCK ABSORBER | 7 - LOWER SUSPENSION ARM |
| 3 - UPPER SUSPENSION ARM | 8 - TRACK BAR |
| 4 - STABILIZER BAR | 9 - AXLE |
| 5 - COIL SPRING | |

COIL SPRINGS AND ISOLATORS**DESCRIPTION**

The coil springs mount up in the wheelhouse which is part of the unitized body bracket. A rubber doughnut isolator is located between the top of the spring and the bracket. The bottom of the spring seats on a axle pad and retained with a clip.

OPERATION

The coil springs control ride quality and maintain proper ride height. The isolators provide road noise isolation.

LOWER SUSPENSION ARMS AND BUSHINGS**DESCRIPTION**

The lower suspension arms are steel and use bushings at one end of the arm. The arms mount to the frame rail bracket and the axle brackets.

OPERATION

The arm and bushings provide location and react to loads from the axle. The bushings provide isolation from the axle. The lower suspension arms can be used to adjust caster and pinion angle, through the use of shims at the frame rail bracket.

UPPER SUSPENSION ARMS AND BUSHINGS**DESCRIPTION**

The upper suspension arms are steel and use rubber bushings at each end of the arm. The arms mount to the frame rail bracket and the axle brackets.

OPERATION

The arm and bushings provide location and react to loads from the axle. The bushings provide isolation from the axle.

DESCRIPTION AND OPERATION (Continued)

STABILIZER BAR**DESCRIPTION**

The spring steel bar extends across the underside of the chassis frame rails. Links are connected from the bar to the axle brackets. The stabilizer bar and links are isolated by rubber bushings.

OPERATION

The stabilizer bar is used to control vehicle body roll during turns. The bar helps to control the vehicle body in relationship to the suspension.

TRACK BAR**DESCRIPTION**

The bar is attached to a frame rail bracket with a ball stud and an axle bracket with a bushing. The bar is forged and has non replaceable isolator bushing and ball stud.

OPERATION

The track bar is used to control front axle lateral movement and provides cross car location of the axle assembly.

HUB/BEARING**DESCRIPTION**

The bearing used on the front hub of this vehicle is the combined hub and bearing unit type assembly. This unit assembly combines the front wheel mounting hub (flange) and the front wheel bearing into a one piece unit. The wheel mounting studs are the only replaceable component of the hub/bearing assembly.

OPERATION

The hub/bearing assembly is mounted to the steering knuckle and is retained by three mounting bolts accessible from the back of the steering knuckle. The hub/bearing unit is not serviceable and must be replaced as an assembly if the bearing or the hub is determined to be defective.

DIAGNOSIS AND TESTING**SHOCK DIAGNOSIS**

A knocking or rattling noise from a shock absorber may be caused by movement between mounting bushings and metal brackets or attaching components. These noises can usually be stopped by tightening the attaching nuts. If the noise persists, inspect for damaged and worn bushings, and attach-

ing components. Repair as necessary if any of these conditions exist.

A squeaking noise from the shock absorber may be caused by the hydraulic valving and may be intermittent. This condition is not repairable and the shock absorber must be replaced.

The shock absorbers are not refillable or adjustable. If a malfunction occurs, the shock absorber must be replaced. To test a shock absorber, hold it in an upright position and force the piston in and out of the cylinder four or five times. The action throughout each stroke should be smooth and even.

The shock absorber bushings do not require any type of lubrication. Do not attempt to stop bushing noise by lubricating them. Grease and mineral oil-base lubricants will deteriorate the bushing.

REMOVAL AND INSTALLATION**SHOCK ABSORBER****REMOVAL**

- (1) Remove the nut, retainer and grommet from the upper stud in the engine compartment (Fig. 2).
- (2) Remove the lower nuts and bolts from the axle bracket.
- (3) Remove the shock absorber.

INSTALLATION

- (1) Position the lower retainer and grommet on the shock stud. Insert the shock absorber through the shock tower hole.
- (2) Install the lower bolts and nuts. Tighten nuts to 23 N·m (17 ft. lbs.).
- (3) Install the upper grommet and retainer on the stud. Install the nut and tighten to 22 N·m (16 ft. lbs.).

COIL SPRING/JOUNCE BUMPER**REMOVAL**

- (1) Raise and support the vehicle. Position a hydraulic jack under the axle to support it.
- (2) Remove the wheel and tire assemblies.
- (3) Mark and disconnect the front propeller shaft from the axle.
- (4) Remove lower suspension arms mounting nuts and bolts from the axle (Fig. 2).
- (5) Remove the stabilizer bar link and shock absorber from the axle.
- (6) Remove the track bar from the body rail bracket.
- (7) Remove the drag link from the pitman arm.

REMOVAL AND INSTALLATION (Continued)

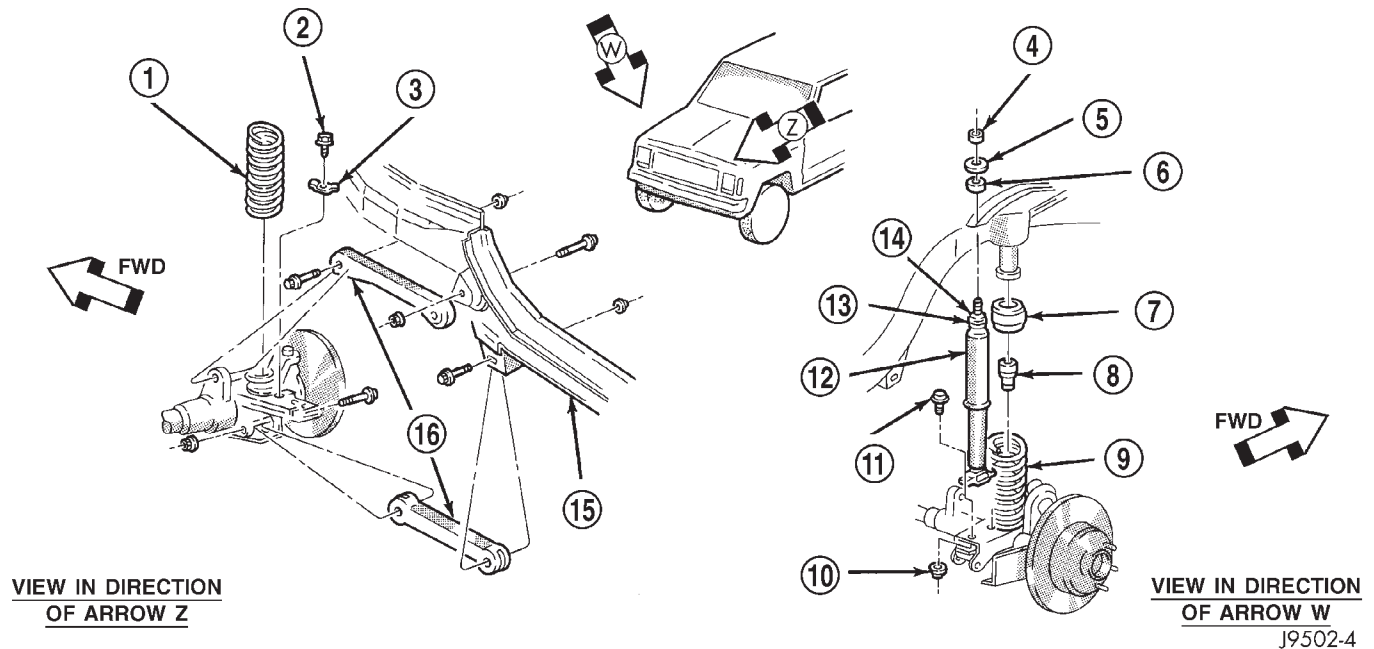

Fig. 2 Coil Spring & Shock Absorber

- 1 - SPRING
- 2 - SCREW
- 3 - SPRING RETAINER
- 4 - NUT
- 5 - RETAINER
- 6 - GROMMET
- 7 - ISOLATOR
- 8 - BUMPER

- 9 - SPRING
- 10 - NUT
- 11 - SCREW
- 12 - SHOCK ABSORBER
- 13 - RETAINER
- 14 - GROMMET
- 15 - FRAME
- 16 - CONTROL ARM

(8) Lower the axle until the spring is free from the upper mount. Remove the coil spring clip and remove the spring.

(9) Pull jounce bumper out of mount.

INSTALLATION

(1) Install jounce bumper into mount.

(2) Position the coil spring on the axle pad. Install the spring clip and bolt. Tighten bolt to 21 N·m (16 ft. lbs.).

(3) Raise the axle into position until the spring seats in the upper mount.

(4) Install the stabilizer bar links and shock absorbers to the axle bracket.

(5) Install the track bar to the body rail bracket.

(6) Install the lower suspension arms to the axle. Install mounting bolts and nuts finger tight.

(7) Install the front propeller shaft to the axle.

(8) Install the wheel and tire assemblies.

(9) Remove the supports and lower the vehicle.

(10) Tighten lower suspension arms nuts to 115 N·m (85 ft. lbs.).

STEERING KNUCKLE

For service procedures on the steering knuckle and ball joints refer to Group 3 Differentials And Driveline.

LOWER SUSPENSION ARM**REMOVAL**

(1) Raise and support the vehicle.

(2) Remove the lower suspension arm nut and bolt from the axle bracket.

(3) Remove the nut and bolt from the rear bracket and remove the lower suspension arm (Fig. 3).

INSTALLATION

(1) Position the lower suspension arm at the axle bracket and rear bracket.

(2) Install the bolts and finger tighten the nuts.

(3) Remove support and lower the vehicle.

(4) Tighten the front and rear nuts to 115 N·m (85 ft. lbs.).

REMOVAL AND INSTALLATION (Continued)

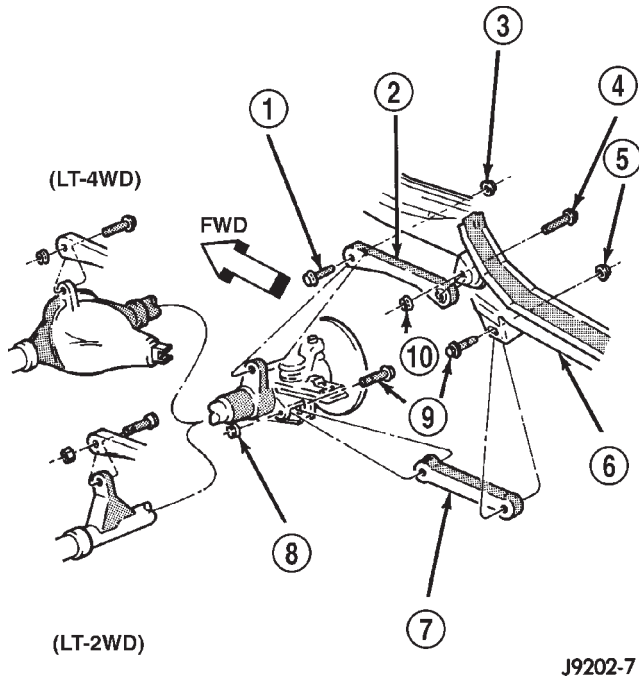

Fig. 3 Upper and Lower Suspension Arms

- 1 - BOLT
- 2 - UPPER ARM
- 3 - NUT
- 4 - BOLT
- 5 - NUT
- 6 - FRAME RAIL
- 7 - LOWER ARM
- 8 - NUT
- 9 - BOLT
- 10 - NUT

UPPER SUSPENSION ARM

REMOVAL

- (1) Raise and support the vehicle.
- (2) Remove the upper suspension arm nut and bolt at the axle bracket.
- (3) Remove the nut and bolt at the frame rail and remove the upper suspension arm (Fig. 3).

INSTALLATION

- (1) Position the upper suspension arm at the axle and frame rail.
- (2) Install the bolts and finger tighten the nuts.
- (3) Remove the supports and lower the vehicle.
- (4) Tighten the nut at the axle to 75 N·m (55 ft. lbs.). Tighten the nut at the frame bracket to 90 N·m (66 ft. lbs.).

FRONT AXLE BUSHING

REMOVAL

- (1) Remove the upper suspension arm from axle.

- (2) Position Spacer 7932-3 over the axle bushing on a 4x2 vehicle and right side on a 4x4 vehicle.
- (3) Place Receiver 7932-1 over flanged end of the bushing. (Fig. 4).
- (4) Place small end of Remover/Install 7932-2 against other side of the bushing.
- (5) Install bolt 7604 through remover, bushing and receiver.
- (6) Install Long Nut 7603 and tighten nut too pull bushing out of the axle bracket.

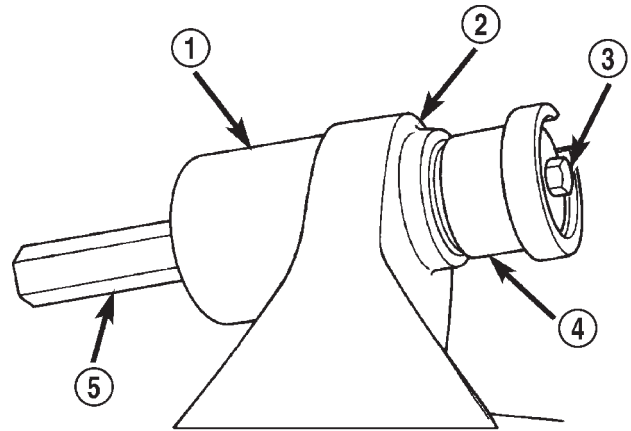

Fig. 4 Bushing Removal

- 1 - RECEIVER
- 2 - AXLE BRACKET
- 3 - BOLT
- 4 - REMOVER/INSTALLER
- 5 - LONG NUT

- (7) Remove nut, bolt, receiver, remover and bushing.

NOTE: On 4x2 vehicle and right side of 4x4 vehicle, leave Spacer 7932-3 in position for bushing installation.

INSTALLATION

- (1) Place Receiver 7932-1 on the other side of the axle bracket.
- (2) Position new bushing up to the axle bracket., and large end of Remover/Install 7932-2 against the bushing (Fig. 5).
- (3) Install bolt 7604 through receiver, bushing and installer.
- (4) Install Long Nut 7603 and tighten nut to draw the bushing into the axle bracket.
- (5) Remove tools and install the upper suspension arm.

REMOVAL AND INSTALLATION (Continued)

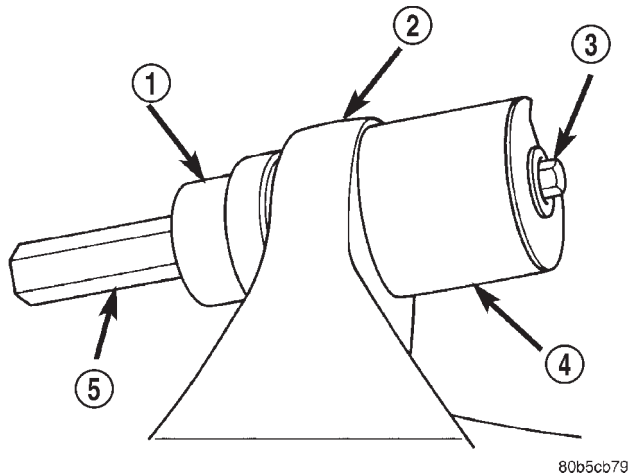
**Fig. 5 Bushing Installation**

- 1 - REMOVER/INSTALLER
- 2 - AXLE BRACKET
- 3 - BOLT
- 4 - RECEIVER
- 5 - LONG NUT

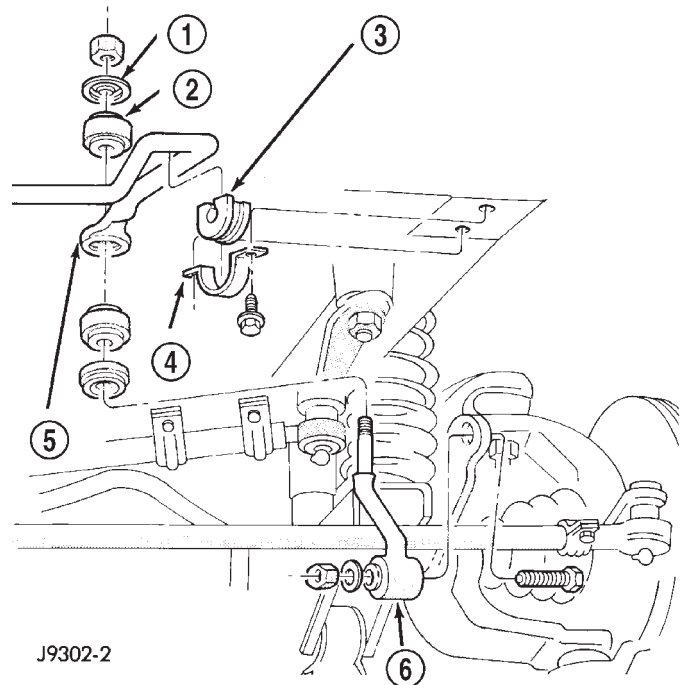
**Fig. 6 Stabilizer Bar (LHD)**

- 1 - RETAINER
- 2 - GROMMET
- 3 - BUSHING
- 4 - CLAMP
- 5 - STABILIZER BAR
- 6 - LINK

STABILIZER BAR**REMOVAL**

- (1) Raise and support the vehicle.
- (2) Remove nuts, retainers and grommets from the links at the stabilizer bar (Fig. 6).
- (3) Remove the links mounting nuts and bolts from the axle brackets.
- (4) Remove the stabilizer bar clamps from the body rails. Remove the stabilizer bar.

INSTALLATION

- (1) Inspect stabilizer bar bushings. Replace bushings if cracked, cut, distorted, or worn.
- (2) Position the stabilizer bar on the body rail and install the bushings and clamps. Ensure the bar is centered with equal spacing on both sides. Tighten the bolts to 75 N·m (40 ft. lbs.).
- (3) Install the links and grommets onto the stabilizer bar and axle brackets.
- (4) Tighten the link nuts at the axle bracket to 95 N·m (70 ft. lbs.).
- (5) Tighten the link nuts at the stabilizer bar to 36 N·m (27 ft. lbs.).
- (6) Remove the supports and lower the vehicle.

TRACK BAR**REMOVAL**

- (1) Raise and support the vehicle.
- (2) Remove the cotter pin and nut from the ball stud end at the body rail bracket.
- (3) Use a universal puller tool to separate the ball stud from the frame rail bracket.

- (4) Remove the bolt and flag nut from the axle shaft tube bracket (Fig. 7).
- (5) Remove the track bar.

INSTALLATION

- (1) Install the track bar at axle tube bracket. Loosely install the retaining bolt and flag nut.
- (2) It may be necessary to pry the axle assembly over to install the track bar at the body rail. Install track bar at the body rail bracket. Install the retaining nut on the stud.
- (3) Remove the supports and lower the vehicle.
- (4) Tighten the retaining bolt at the axle shaft tube bracket to 54 N·m (40 ft. lbs.).
- (5) Tighten the ball stud nut to 81 N·m (60 ft. lbs.). Install a new cotter pin.

HUB BEARING**REMOVAL**

- (1) Raise and support the vehicle.
- (2) Remove the wheel and tire assembly.
- (3) Remove the brake caliper, rotor and ABS wheel speed sensor, refer to Group 5 Brakes.
- (4) Remove the cotter pin, nut retainer and axle hub nut (Fig. 8).

REMOVAL AND INSTALLATION (Continued)

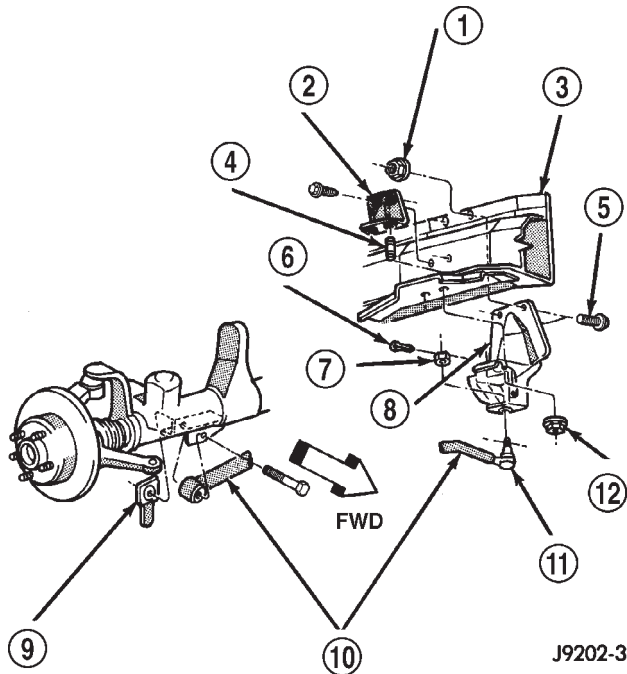

Fig. 7 Track Bar (LHD)

- 1 - NUT
- 2 - SUPPORT BRACKET
- 3 - LEFT FRAME RAIL
- 4 - STUD
- 5 - SCREW
- 6 - COTTER PIN
- 7 - NUT
- 8 - FRAME BRACKET
- 9 - NUT PLATE
- 10 - TRACK BAR
- 11 - BALL STUD END
- 12 - NUT

(5) Remove the hub bearing mounting bolts from the back of the steering knuckle. Remove hub bearing from the steering knuckle and off the axle shaft.

INSTALLATION

(1) Install the hub bearing and brake dust shield to the knuckle.

(2) Install the hub bearing to knuckle bolts and tighten to 102 N-m (75 ft. lbs.).

(3) Install the hub washer and nut. Tighten the hub nut to 237 N-m (175 ft. lbs.). Install the nut retainer and a new cotter pin.

(4) Install the brake rotor, caliper and ABS wheel speed sensor, refer to Group 5 Brakes.

(5) Install the wheel and tire assembly.

(6) Remove support and lower the vehicle.

WHEEL MOUNTING STUDS

CAUTION: Do not use a hammer to remove wheel studs.

REMOVAL

(1) Raise and support vehicle.

(2) Remove wheel and tire assembly.

(3) Remove brake caliper, caliper adapter and rotor, refer to Group 5 Brakes for procedure.

(4) Remove stud from hub with Remover C-4150A (Fig. 9).

INSTALLATION

(1) Install new stud into hub flange.

(2) Install three washers onto stud, then install lug nut with the flat side of the nut against the washers.

(3) Tighten lug nut until the stud is pulled into the hub flange. Verify that the stud is properly seated into the flange.

(4) Remove lug nut and washers.

(5) Install the brake rotor, caliper adapter, and caliper, refer to Group 5 Brakes for procedure.

(6) Install wheel and tire assembly, use new lug nut on stud or studs that were replaced.

(7) Remove support and lower vehicle.

REMOVAL AND INSTALLATION (Continued)

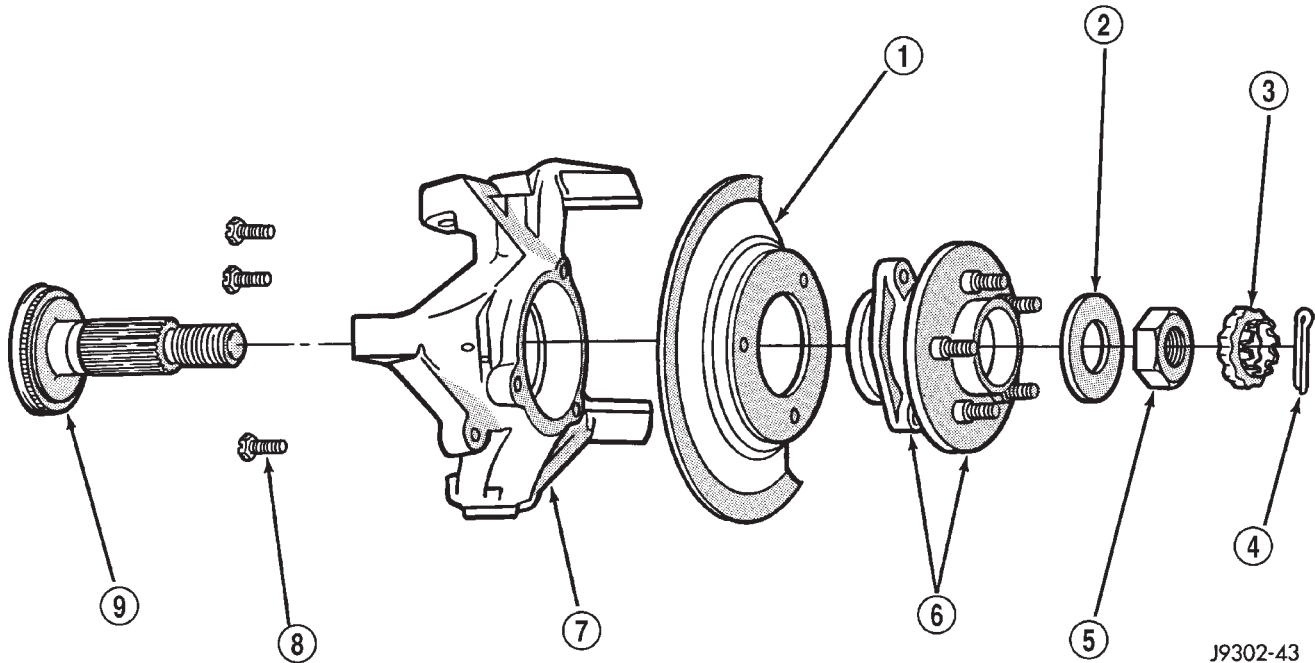

J9302-43

Fig. 8 Hub Bearing & Knuckle

- | | |
|------------------|------------------------------|
| 1 - BRAKE SHIELD | 6 - HUB AND BEARING ASSEMBLY |
| 2 - WASHER | 7 - STEERING KNUCKLE |
| 3 - RETAINER | 8 - BOLT |
| 4 - COTTER PIN | 9 - TONE WHEEL (ABS) |
| 5 - NUT | |

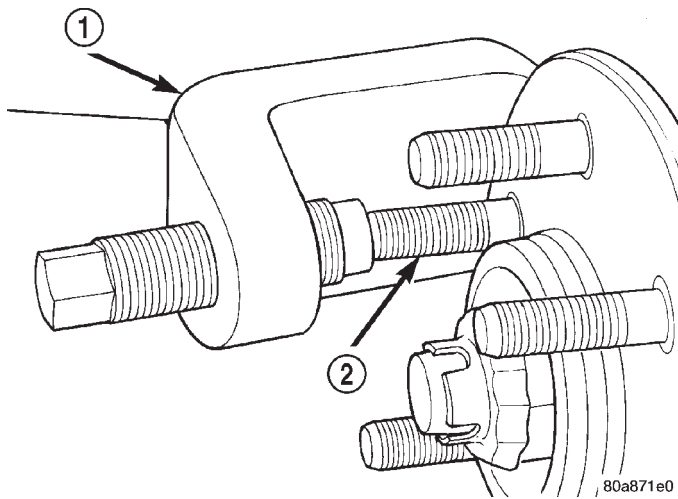

Fig. 9 Wheel Stud Removal

- | |
|----------------|
| 1 - REMOVER |
| 2 - WHEEL STUD |

SPECIFICATIONS

TORQUE CHART

| DESCRIPTION | TORQUE |
|-----------------------------|-----------------------|
| Shock Absorber | |
| Upper Nut | 22 N·m (16 ft. lbs.) |
| Lower Nut | 23 N·m (17 ft. lbs.) |
| Suspension Arm Upper | |
| Front Nut | 74 N·m (55 ft. lbs.) |
| Rear Nut | 89 N·m (66 ft. lbs.) |
| Suspension Arm Lower | |
| Front Nut | 115 N·m (85 ft. lbs.) |
| Rear Nut | 115 N·m (85 ft. lbs.) |
| Stabilizer Bar | |
| Clamp Bolt | 54 N·m (40 ft. lbs.) |
| Link Upper Nut | 36 N·m (27 ft. lbs.) |
| Link Lower Nut | 95 N·m (70 ft. lbs.) |
| Track Bar | |
| Ball Stud Nut | 81 N·m (60 ft. lbs.) |
| Axle Bracket Bolt | 54 N·m (40 ft. lbs.) |

SPECIFICATIONS (Continued)

| DESCRIPTION | TORQUE |
|--------------------------|------------------------|
| Track Bar Bracket | |
| Bolts | 125 N·m (92 ft. lbs.) |
| Nut | 100 N·m (74 ft. lbs.) |
| Support Bolts | 42 N·m (31 ft. lbs.) |
| Hub/Bearing | |
| Bolts | 102 N·m (75 ft. lbs.) |
| Axle Nut | 237 N·m (175 ft. lbs.) |

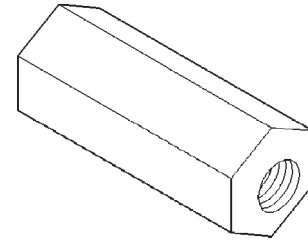

Nut, Long 7603

SPECIAL TOOLS

FRONT SUSPENSION

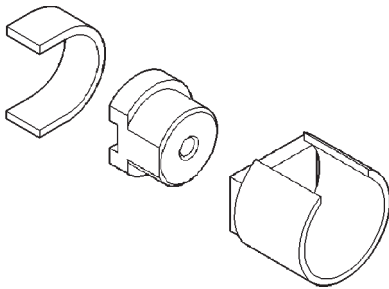

Remover/Installer Suspension Bushing 7932

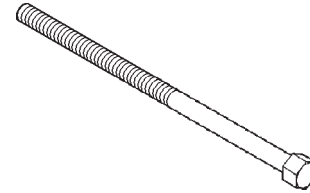

Bolt, Special 7604

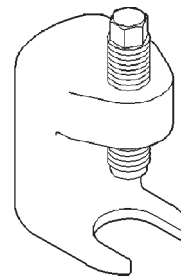

Remover C-4150A

REAR SUSPENSION

TABLE OF CONTENTS

| | page | | page |
|--------------------------------------|------|---|------|
| DESCRIPTION AND OPERATION | | REMOVAL AND INSTALLATION | |
| SUSPENSION COMPONENT | 16 | SHOCK ABSORBER | 17 |
| SHOCK ABSORBERS | 16 | STABILIZER BAR | 17 |
| JOUNCE BUMPERS | 16 | LEAF SPRING | 18 |
| STABILIZER BAR | 16 | LEAF SPRING AND SHACKLE BUSHING | 18 |
| COIL SPRINGS AND ISOLATORS | 16 | SPECIFICATIONS | |
| DIAGNOSIS AND TESTING | | TORQUE CHART | 19 |
| SPRING AND SHOCK | 17 | | |

DESCRIPTION AND OPERATION

SUSPENSION COMPONENT

The rear suspension is comprised of:

- Shock Absorbers
- Jounce Bumpers
- Stabilizer Bar (optional)
- Leaf Springs
- Drive Axle

CAUTION: A vehicle should always be loaded so the vehicle weight center-line is located immediately forward of the rear axle. Correct vehicle loading provides proper front tire-to-road contact. This results in maximum vehicle handling stability and safety. Incorrect vehicle weight distribution can cause excessive tire tread wear, spring fatigue or failure, and erratic steering.

CAUTION: Suspension components with rubber/urethane bushings (except stabilizer bar) should be tightened with the vehicle at normal ride height. It is important to have the springs supporting the weight of the vehicle when the fasteners are torqued. If springs are not at their normal ride position, vehicle ride comfort could be affected and premature bushing wear may occur.

SHOCK ABSORBERS

DESCRIPTION

The top of the shock absorbers are bolted to the body crossmember. The bottom of the shocks are bolted to the axle brackets.

OPERATION

The shock absorbers dampen jounce and rebound motion of the vehicle over various road conditions and limit suspension rebound travel.

JOUNCE BUMPERS

DESCRIPTION

The jounce bumpers are bolted to the bottom of the frame rail.

OPERATION

The jounce bumpers are used to limit suspension travel in compression.

STABILIZER BAR

DESCRIPTION

The spring steel bar extends across the axle and mounts to leaf spring brackets. Links are connected from the bar to the underside of the frame rail. The stabilizer bar and links are isolated by rubber bushings.

OPERATION

The stabilizer bar is used to control vehicle body roll during turns. The bar helps to control the vehicle body in relationship to the suspension.

COIL SPRINGS AND ISOLATORS

DESCRIPTION

The front of the multi-leaf springs mount to frame rail brackets. The rear of the spring mounts to shackles which mount the frame. The springs and shackles have bushing at the mounting points.

DESCRIPTION AND OPERATION (Continued)

OPERATION

The leaf springs control ride quality and maintain proper ride height. The shackles allow the springs to change their length as the vehicle moves over various road conditions. The bushings are used to isolate axle/road noise.

tent. This condition is not repairable and the shock absorber must be replaced.

The shock absorbers are not refillable or adjustable. If a malfunction occurs, the shock absorber must be replaced. To test a shock absorber, hold it in an upright position and force the piston in and out of the cylinder four or five times. The action throughout each stroke should be smooth and even.

DIAGNOSIS AND TESTING

SPRING AND SHOCK

A knocking or rattling noise from a shock absorber may be caused by movement between mounting bushings and metal brackets or attaching components. These noises can usually be stopped by tightening the attaching nuts. If the noise persists, inspect for damaged and worn bushings, and attaching components. Repair as necessary if any of these conditions exist.

The spring eye and shock absorber bushings do not require any type of lubrication. Do not attempt to stop spring bushing noise by lubricating them. Grease and mineral oil-base lubricants will deteriorate the bushing rubber.

If the vehicle is used for severe, off-road operation, the springs should be examined periodically. Check for broken and shifted leaves, loose and missing clips, and broken center bolts. Refer to Spring and Shock Absorber Diagnosis chart for additional information.

A squeaking noise from the shock absorber may be caused by the hydraulic valving and may be intermit-

SPRING AND SHOCK ABSORBER

| CONDITION | POSSIBLE CAUSES | CORRECTION |
|--------------|---|--|
| SPRING SAGS | 1. Broken leaf. 2. Spring fatigue. | 1. Replace spring. 2. Replace spring. |
| SPRING NOISE | 1. Loose spring clamp bolts. 2. Worn bushings. 3. Worn or missing spring tip inserts. | 1. Tighten to specification. 2. Replace bushings. 3. Replace spring tip inserts. |
| SHOCK NOISE | 1. Loose mounting fastener. 2. Worn bushings. 3. Leaking shock. | 1. Tighten to specification. 2. Replace shock. 3. Replace shock. |

REMOVAL AND INSTALLATION

SHOCK ABSORBER

REMOVAL

- (1) Remove the shock absorber upper bolts from the body bracket (Fig. 1).
- (2) Remove lower attaching nut and washer from the bracket stud. Remove the shock absorber.

INSTALLATION

- (1) Install the shock absorber lower eye on the spring bracket stud. Install the shock absorber and upper bolts on the body bracket.
- (2) Tighten the lower nut to 62 N·m (46 ft. lbs.).
- (3) Tighten the upper bolts to 23 N·m (17 ft. lbs.).

STABILIZER BAR

REMOVAL

- (1) Raise and support the vehicle.
- (2) Disconnect stabilizer bar links from spring brackets (Fig. 2).
- (3) Disconnect the stabilizer bar brackets from the body rails. Remove the stabilizer bar and links.

INSTALLATION

- (1) Position the stabilizer bar links at the spring brackets. Install the attaching bolts and nuts and tighten to 74 N·m (55 ft. lbs.).
- (2) Attach the stabilizer bar to the body rail brackets with the bolts. Tighten to 54 N·m (40 ft. lbs.).
- (3) Remove the supports and lower the vehicle.

REMOVAL AND INSTALLATION (Continued)

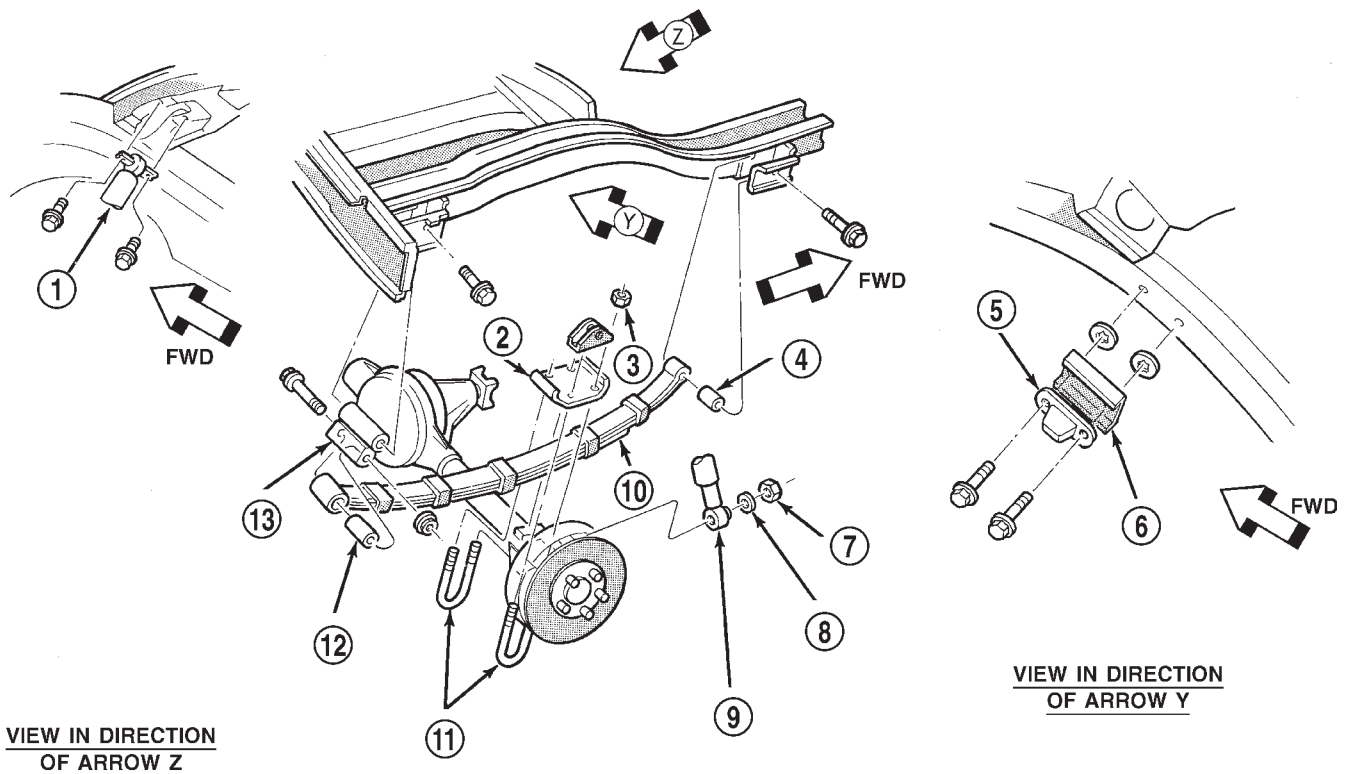

VIEW IN DIRECTION
OF ARROW Z

VIEW IN DIRECTION
OF ARROW Y

J9503-6

Fig. 1 Rear Suspension Components

- | | |
|--------------------|--------------------|
| 1 - SHOCK ABSORBER | 8 - RETAINER |
| 2 - SPRING BRACKET | 9 - SHOCK ABSORBER |
| 3 - NUT | 10 - SPRING |
| 4 - BUSHING | 11 - U-BOLTS |
| 5 - BUMPER | 12 - BUSHING |
| 6 - BRACKET | 13 - SHACKLE |
| 7 - NUT | |

LEAF SPRING

REMOVAL

- (1) Raise vehicle at body rails.
- (2) Remove the wheel and tire assemblies.
- (3) Support axle with hydraulic jack to relieve axle weight.
- (4) Disconnect the stabilizer bar link from the spring bracket stud.
- (5) Remove nuts, U-bolts and spring bracket from axle.
- (6) Remove nut and bolt attaching spring front eye to shackle.
- (7) Remove nut and bolt from spring rear eye.
- (8) Remove spring from vehicle.

INSTALLATION

- (1) Position the spring front eye in the bracket. Loosely install the attaching bolt and nut. Do not tighten at this time.

- (2) Position the rear eye in the shackle bracket. Loosely install the attaching bolt and nut. Do not tighten at this time.

- (3) Position the axle. Install the spring bracket, U-bolts and nuts. Tighten the nuts to 70 N·m (52 ft. lbs.).

- (4) Connect the stabilizer bar link to the spring bracket.

- (5) Remove the hydraulic jack.

- (6) Lower the vehicle.

- (7) Tighten the spring front eye attaching bolts to 156 N·m (115 ft. lbs.).

- (8) Tighten the spring rear eye attaching bolts to 108 N·m (80 ft. lbs.).

- (9) Tighten the stabilizer bar link to 74 N·m (55 ft. lbs.).

LEAF SPRING AND SHACKLE BUSHING

For front bushings bend tabs DOWN before removal. Use an appropriate driver tool and force the original bushing out of the spring eye.

REMOVAL AND INSTALLATION (Continued)

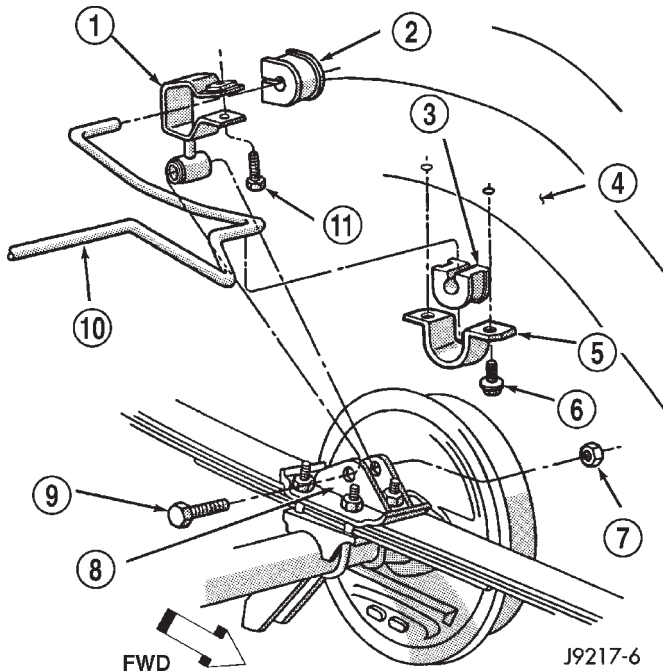

Fig. 2 Stabilizer Bar

- 1 - LINK
- 2 - BUSHING
- 3 - GROMMET
- 4 - FRAME RAIL
- 5 - CLAMP
- 6 - SCREW
- 7 - NUT
- 8 - SPRING BRACKET
- 9 - BOLT
- 10 - SWAY BAR
- 11 - SCREW

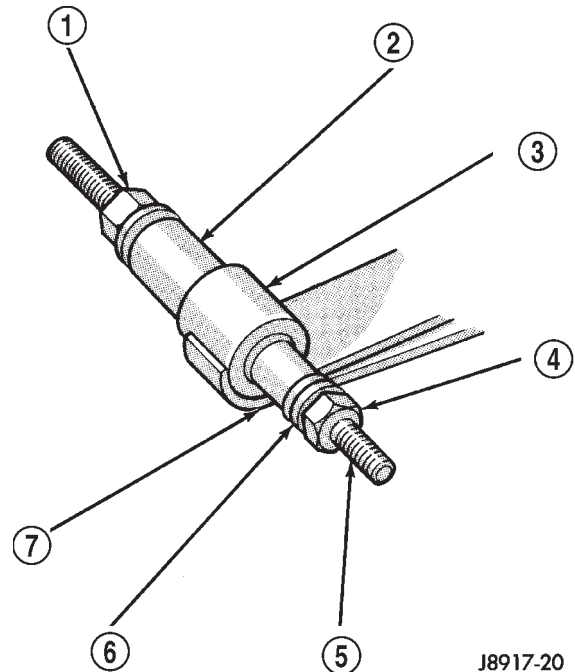

Fig. 3 Spring Eye Bushing Removal

- 1 - NUT
- 2 - PIPE (RECEIVER)
- 3 - SPRING EYE
- 4 - NUT
- 5 - THREADED ROD
- 6 - FLAT WASHER
- 7 - SOCKET WRENCH (DRIVER)

(1) Assemble tools shown (Fig. 3). Tighten nut at the socket wrench end of the threaded rod until the bushing is forced out.

(2) Assemble and align the bushing installation tools.

(3) Align the bushing with the spring eye or shackle eye and tighten the nut at the socket wrench end of the threaded rod. Tighten until the bushing is forced into the spring eye.

NOTE: The bushing must be centered in the spring eye. The ends of the bushing must be flush or slightly recessed within the end surfaces of the spring eye.

(4) For front bushings bend tabs up after installation.

SPECIFICATIONS

TORQUE CHART

| DESCRIPTION | TORQUE |
|------------------------------|------------------------|
| Shock Absorber | |
| Upper Bolt | 23 N·m (17 ft. lbs.) |
| Lower Nut | 62 N·m (46 ft. lbs.) |
| Stabilizer Bar | |
| Clamp Bolt | 54 N·m (40 ft. lbs.) |
| Link Upper Bolt | 12 N·m (9 ft. lbs.) |
| Link Lower Nut | 74 N·m (55 ft. lbs.) |
| Spring | |
| U-Bolt Nut | 70 N·m (52 ft. lbs.) |
| Front Pivot Bolt | 156 N·m (115 ft. lbs.) |
| Upper Shackle Bolt | 156 N·m (115 ft. lbs.) |
| Lower Shackle Bolt | 108 N·m (80 ft. lbs.) |

TRANSMISSION AND TRANSFER CASE

TABLE OF CONTENTS

| | page | | page |
|-----------------------------------|------|-----------------------------------|------|
| AX5 MANUAL TRANSMISSION | 1 | AW-4 AUTOMATIC TRANSMISSION | 217 |
| NV3550 MANUAL TRANSMISSION | 42 | NV231 TRANSFER CASE | 346 |
| AUTOMATIC TRANSMISSION—30RH | 88 | NV242 TRANSFER CASE | 375 |

AX5 MANUAL TRANSMISSION

TABLE OF CONTENTS

| | page | | page |
|----------------------------------|------|---------------------------------------|------|
| DESCRIPTION AND OPERATION | | SHIFT MECHANISM AND GEARTRAIN | 17 |
| AX5 MANUAL TRANSMISSION | 1 | COUNTERSHAFT..... | 30 |
| LUBRICANT..... | 2 | INPUT SHAFT | 30 |
| DIAGNOSIS AND TESTING | | OUTPUT SHAFT | 31 |
| LOW LUBRICANT LEVEL..... | 3 | SEMI-SYNCHRONIZED REVERSE IDLER | |
| HARD SHIFTING | 3 | GEAR | 36 |
| TRANSMISSION NOISE..... | 3 | CLEANING AND INSPECTION | |
| REMOVAL AND INSTALLATION | | AX5 MANUAL TRANSMISSION COMPONENTS .. | 37 |
| TRANSMISSION | 3 | SPECIFICATIONS | |
| FRONT BEARING RETAINER SEAL..... | 6 | TORQUE | 39 |
| EXTENSION HOUSING SEAL | 7 | SPECIAL TOOLS | |
| ADAPTER HOUSING SEAL | 7 | AX5 | 40 |
| DISASSEMBLY AND ASSEMBLY | | | |
| ADAPTER/EXTENSION HOUSING AND | | | |
| FRONT BEARING RETAINER | 8 | | |

DESCRIPTION AND OPERATION

AX5 MANUAL TRANSMISSION

DESCRIPTION

The AX5 is a five speed manual transmission with fifth gear being the overdrive range. An adapter housing is used to attach the transmission to the transfer case on 4-wheel drive applications. A standard style extension housing is used for the 2-wheel drive applications. The shift mechanism is integral to the transmission assembly and mounted in the shift tower portion of the adapter/extension housing (Fig. 1).

GEAR RATIOS

Gear ratios for the AX5 manual transmission are as follows:

- First gear: 3.93:1

- Second gear: 2.33:1
- Third gear: 1.45:1
- Fourth gear: 1.00:1
- Fifth gear: 0.85:1
- Reverse gear: 4.74:1

TRANSMISSION IDENTIFICATION

The AX5 identification code is on the bottom surface of the transmission case near the fill plug (Fig. 2). The first number is year of manufacture. The second and third numbers indicate month of manufacture. The next series of numbers is the transmission serial number.

OPERATION

The manual transmission receives power through the clutch assembly from the engine. The clutch disc is splined to the transmission input shaft and is turned at engine speed at all times that the clutch is

DESCRIPTION AND OPERATION (Continued)

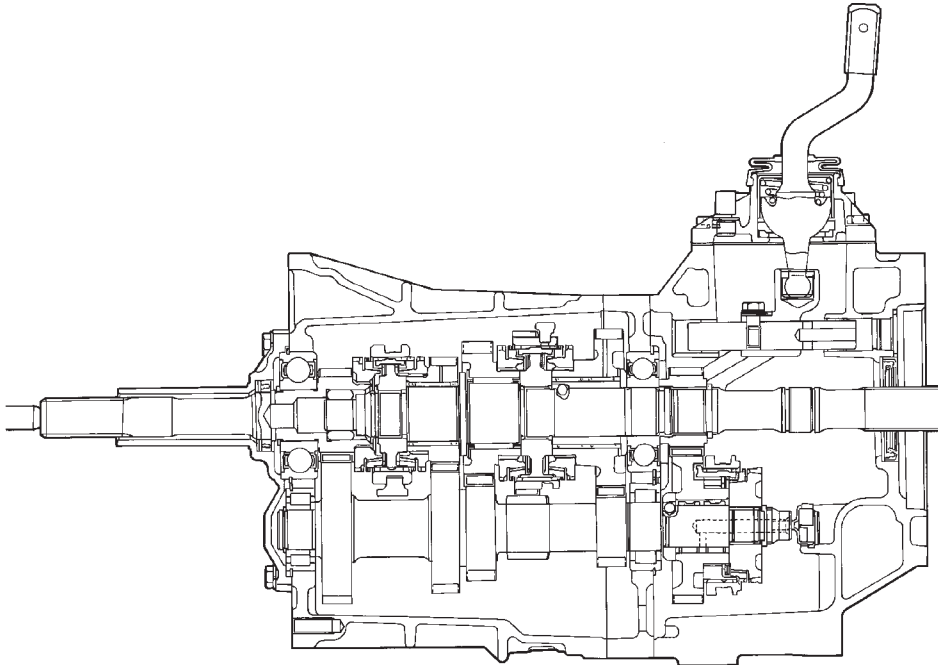

80abfee7

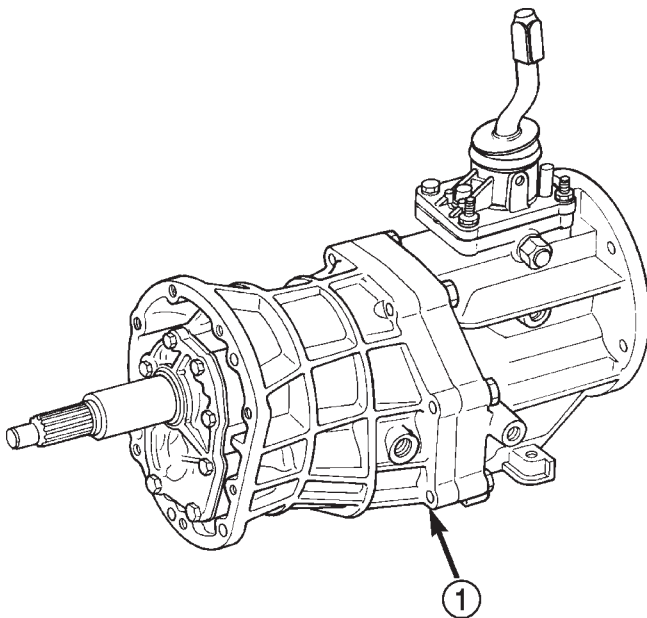
Fig. 1 AX5 Manual Transmission

80abfee5

Fig. 2 Transmission Identification

1 - I. D. CODE ON CASE NEAR DRAIN PLUG

engaged. The input shaft is connected to the transmission countershaft through the mesh of fourth speed gear on the input shaft and the fourth countershaft gear. At this point, all the transmission gears are spinning.

The driver selects a particular gear by moving the shift lever to the desired gear position. This movement moves the internal transmission shift compo-

nents to begin the shift sequence. As the shift lever moves the selected shift rail, the shift fork attached to that rail begins to move. The fork is positioned in a groove in the outer circumference of the synchronizer sleeve. As the shift fork moves the synchronizer sleeve, the synchronizer begins to speed-up or slow down the selected gear (depending on whether we are up-shifting or down-shifting). The synchronizer does this by having the synchronizer hub splined to the mainshaft, or the countershaft in some cases, and moving the blocker ring into contact with the gear's friction cone. As the blocker ring and friction cone come together, the gear speed is brought up or down to the speed of the synchronizer. As the two speeds match, the splines on the inside of the synchronizer sleeve become aligned with the teeth on the blocker ring and the friction cone and eventually will slide over the teeth, locking the gear to the mainshaft, or countershaft, through the synchronizer.

LUBRICANT

DESCRIPTION

Recommended lubricant for AX5 transmissions is Mopar® 75W-90, API Grade GL-3 gear lubricant, or equivalent.

Correct lubricant level is from the bottom edge, to no more than 6 mm (1/4 in.) below the bottom edge of the fill plug hole.

The fill plug is on the passenger side of the adapter housing (Fig. 3). The drain plug is on the bottom of the case.

DESCRIPTION AND OPERATION (Continued)

Approximate dry fill lubricant capacity is:

- 3.3 liters (3.49 quarts) for 4-wheel drive applications.
- 3.5 liters (3.70 quarts) for 2-wheel drive applications.

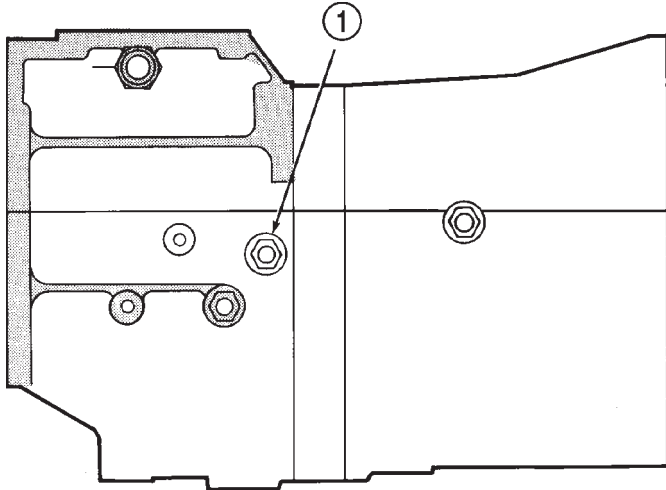

J8921-4

Fig. 3 Fill Plug Location

1 - FILL PLUG LOCATION

DIAGNOSIS AND TESTING

LOW LUBRICANT LEVEL

A low transmission lubricant level is generally the result of a leak, inadequate lubricant fill, or an incorrect lubricant level check.

Leaks can occur at the mating surfaces of the gear case, intermediate plate and adaptor or extension housing, or from the front/rear seals. A suspected leak could also be the result of an overfill condition.

Leaks at the rear of the extension or adapter housing will be from the housing oil seals. Leaks at component mating surfaces will probably be the result of inadequate sealer, gaps in the sealer, incorrect bolt tightening, or use of a non-recommended sealer.

A leak at the front of the transmission will be from either the front bearing retainer or retainer seal. Lubricant may be seen dripping from the clutch housing after extended operation. If the leak is severe, it may also contaminate the clutch disc causing the disc to slip, grab, and/or chatter.

A correct lubricant level check can only be made when the vehicle is level. Also allow the lubricant to settle for a minute or so before checking. These recommendations will ensure an accurate check and avoid an underfill or overfill condition. Always check the lubricant level after any addition of fluid to avoid an incorrect lubricant level condition.

HARD SHIFTING

Hard shifting is usually caused by a low lubricant level, improper, or contaminated lubricants. The consequence of using non-recommended lubricants is noise, excessive wear, internal bind, and hard shifting. Substantial lubricant leaks can result in gear, shift rail, synchro, and bearing damage. If a leak goes undetected for an extended period, the first indications of component damage are usually hard shifting and noise.

Component damage, incorrect clutch adjustment, or a damaged clutch pressure plate or disc are additional probable causes of increased shift effort. Incorrect adjustment or a worn/damaged pressure plate or disc can cause incorrect release. If the clutch problem is advanced, gear clash during shifts can result. Worn or damaged synchro rings can cause gear clash when shifting into any forward gear. In some new or rebuilt transmissions, new synchro rings may tend to stick slightly causing hard or noisy shifts. In most cases, this condition will decline as the rings wear-in.

TRANSMISSION NOISE

Most manual transmissions make some noise during normal operation. Rotating gears generate a mild whine that is audible, but generally only at extreme speeds.

Severe, highly audible transmission noise is generally the initial indicator of a lubricant problem. Insufficient, improper, or contaminated lubricant will promote rapid wear of gears, synchros, shift rails, forks and bearings. The overheating caused by a lubricant problem, can also lead to gear breakage.

REMOVAL AND INSTALLATION

TRANSMISSION

REMOVAL

- (1) Shift transmission into first or third gear.
- (2) Raise and support vehicle on suitable safety stands.
- (3) Support engine with adjustable jack stand. Position wood block between jack and oil pan to avoid damaging pan.
- (4) Remove crossmember/skid plate.
- (5) Disconnect necessary exhaust system components.
- (6) Remove skid plate, if equipped.
- (7) Remove slave cylinder (Fig. 4) from clutch housing.
- (8) Mark rear propeller shaft and rear axle yokes for installation alignment (Fig. 5).

REMOVAL AND INSTALLATION (Continued)

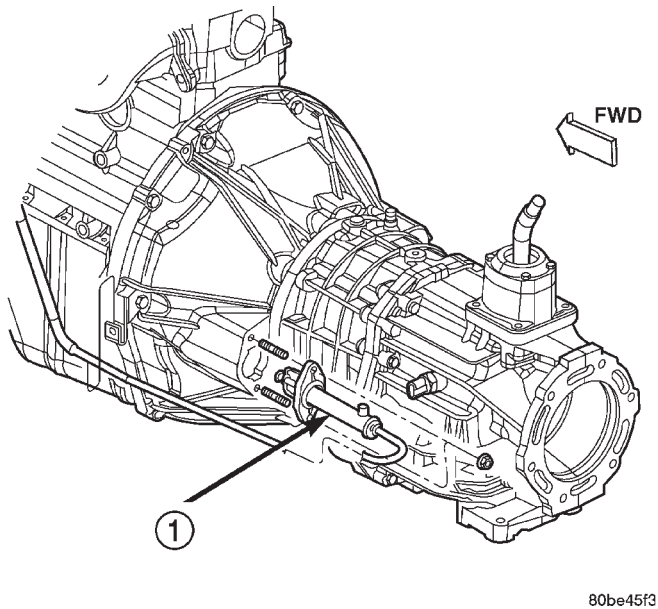
**Fig. 4 Slave Cylinder—Typical**

1 - CLUTCH SLAVE CYLINDER

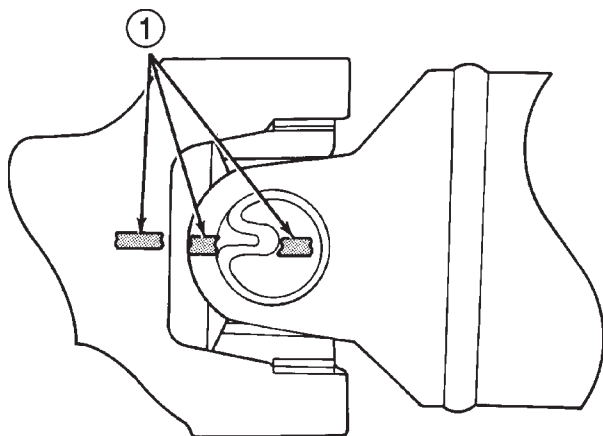
**Fig. 5 Marking Propeller Shaft And Axle Yokes**

1 - REFERENCE MARKS

(9) Mark front propeller shaft, axle, and transfer case yokes for installation alignment, if equipped.

(10) Remove propeller shaft(s).

(11) Unclip wire harnesses from transmission and transfer case, if equipped.

(12) Disconnect transfer case vent hose, if equipped.

(13) Disengage any wire connectors attached to transmission or transfer case, if equipped, components.

(14) Support transfer case, if equipped, with transmission jack.

(15) Secure transfer case, if equipped, to jack with safety chains.

(16) Disconnect transfer case shift linkage at transfer case, if equipped.

(17) Remove nuts attaching transfer case to transmission, if equipped.

(18) Remove transfer case, if equipped.

(19) Remove crankshaft position sensor (Fig. 6).

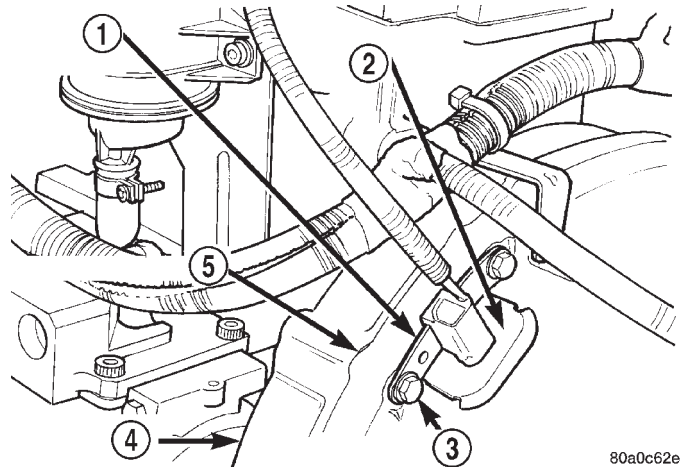
**Fig. 6 Crankshaft Position Sensor —2.5 and 4.0L Engine**

1 - ENGINE SPEED SENSOR

2 - GROMMET

3 - MOUNTING BOLT(S)

4 - LEFT REAR OF ENGINE

5 - TRANSMISSION

CAUTION: It is important that the crankshaft position sensor be removed prior to transmission removal. The sensor can easily be damaged if left in place during removal operations.

(20) Support engine with adjustable jack stand. Position wood block between jack and oil pan to avoid damaging pan.

(21) Support transmission with transmission jack.

(22) Secure transmission to jack with safety chains.

(23) Disconnect rear cushion and bracket from transmission.

(24) Remove rear crossmember.

(25) Disconnect transmission shift lever as follows:
(a) Lower transmission approximately 7–8 cm (3 in.) for access to shift lever.

(b) Reach up and around transmission case and unseat shift lever dust boot from transmission shift tower (Fig. 7). Move boot upward on shift lever for access to retainer that secures lever in shift tower.

(c) Reach up and around transmission case and press shift lever retainer downward with finger pressure. Turn retainer counterclockwise to release it.

(d) Lift lever and retainer out of shift tower (Fig. 7). Do not remove the shift lever from the floor con-

REMOVAL AND INSTALLATION (Continued)

sole shifter boots. Leave the lever in place for transmission installation.

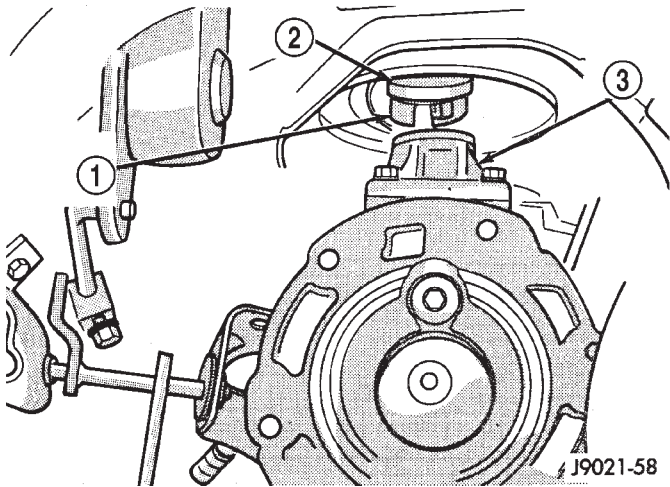

Fig. 7 Removing/Installing Shift Lever

- 1 - SHIFT LEVER RETAINER
- 2 - DUST BOOT
- 3 - SHIFT TOWER

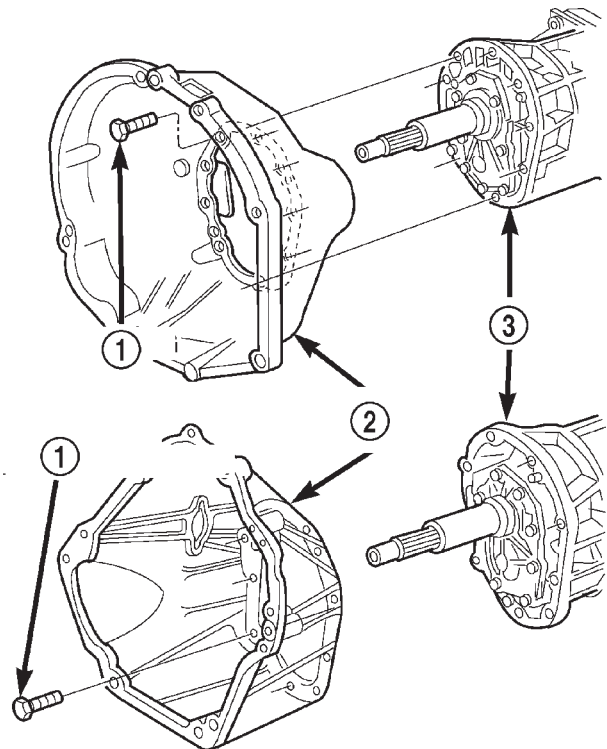

Fig. 8 Clutch Housing

- 1 - HOUSING-TO-TRANSMISSION BOLTS (46 N-m/34 ft. lbs.)
- 2 - CLUTCH HOUSING
- 3 - TRANSMISSION

- (26) Remove clutch housing brace rod.
- (27) Remove clutch housing-to-engine bolts.
- (28) Pull transmission jack rearward until input shaft clears clutch. Then slide transmission out from under vehicle.
- (29) Remove clutch release bearing, release fork, and retainer clip.
- (30) Remove clutch housing from transmission (Fig. 8).

INSTALLATION

- (1) Install clutch housing (Fig. 8) on transmission. Tighten housing bolts to 46 N-m (34 ft. lbs.) torque.
- (2) Lubricate contact surfaces of release fork pivot ball stud and release fork with high temp grease.
- (3) Install release bearing, fork, and retainer clip.
- (4) Position and secure transmission on transmission jack.
- (5) Lightly lubricate pilot bearing and transmission input shaft splines with Mopar® high temp grease.
- (6) Raise transmission and align transmission input shaft and clutch disc splines. Then slide transmission into place.
- (7) Install and tighten clutch housing-to-engine bolts to the appropriate torque: **Be sure the housing is properly seated on engine block before tightening bolts.**
 - Tighten 3/8" diameter bolts to 37 N-m (27 ft.lbs.).
 - Tighten 7/16" diameter bolts to 58 N-m (43 ft.lbs.).

- Tighten M12 bolts to 75 N-m (55 ft.lbs.).
- (8) Install clutch housing brace rod.
- (9) Lower transmission approximately 7-8 cm (3 in.) for access to shift tower. Be sure transmission is in first or third gear.
- (10) Reach up and around transmission and insert shift lever in shift tower. Press lever retainer downward and turn it clockwise to lock it in place. Then install lever dust boot on shift tower.
- (11) Install rear crossmember. Tighten crossmember-to-frame bolts to 41 N-m (31 ft. lbs.) torque.
- (12) Install fasteners to hold rear cushion and bracket to transmission. Then tighten transmission-to-rear support bolts/nuts to 54 N-m (40 ft. lbs.) torque.
- (13) Remove support stands from engine and transmission.
- (14) Install and connect crankshaft position sensor.
- (15) Position transfer case on transmission jack, if equipped.
- (16) Secure transfer case to jack with safety chains, if equipped.
- (17) Raise transfer case, if equipped, and align transfer case input shaft to the transmission output shaft.

REMOVAL AND INSTALLATION (Continued)

(18) Slide transfer case forward until case is seated on transmission, if necessary.

(19) Install nuts to attach transfer case to transmission, if equipped. Tighten transfer case-to-transmission nuts to 35 N·m (26 ft. lbs.) torque.

(20) Connect transfer case shift linkage at transfer case, if equipped.

(21) Connect transfer case vent hose, if equipped.

(22) Secure wire harnesses in clips/tie straps on transmission and transfer case, if equipped.

(23) Engage wire connectors attached to all necessary transmission or transfer case, if equipped, components.

(24) Install rear propeller shaft slip yoke to transmission or transfer case, if equipped, output shaft.

(25) Align marks on rear propeller shaft and rear axle yokes (Fig. 9).

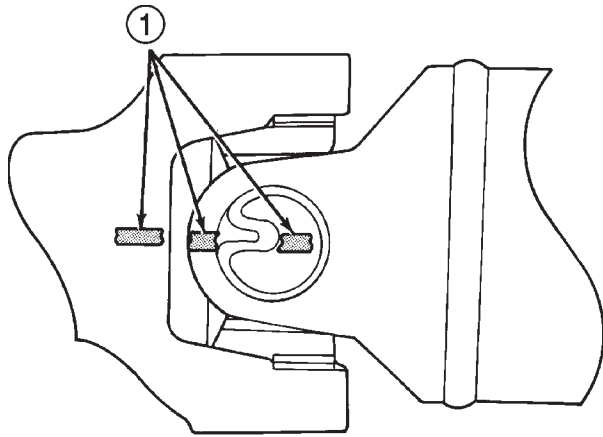

J9316-2

Fig. 9 Align Propeller Shaft And Rear Axle Yokes Alignment Marks

1 - REFERENCE MARKS

(26) Install and tighten propeller shaft U-joint clamp bolts to 19 N·m (170 in. lbs.) torque.

(27) Align marks on front propeller shaft, axle, and transfer case yokes, if equipped.

(28) Install and tighten propeller shaft U-joint clamp bolts to 19 N·m (170 in. lbs.) torque.

(29) Install slave cylinder in clutch housing.

(30) Install skid plate, if equipped. Tighten bolts to 42 N·m (31 ft. lbs.) torque. Tighten stud nuts to 17 N·m (150 in. lbs.) torque.

(31) Fill transmission and transfer case, if equipped, with recommended lubricants. Refer to the Lubricant Recommendation sections of the appropriate component for correct fluid.

(32) Lower vehicle.

FRONT BEARING RETAINER SEAL

REMOVAL

(1) Remove release bearing and lever from the transmission.

(2) Remove the bolts holding the front bearing retainer to the transmission case.

(3) Remove the front bearing retainer from the transmission case.

(4) Using a suitable pry tool, remove the front bearing retainer seal.

INSTALLATION

(1) Using Tool Handle C-4171 and Seal Installer 8211, install new seal in to the front bearing retainer (Fig. 10).

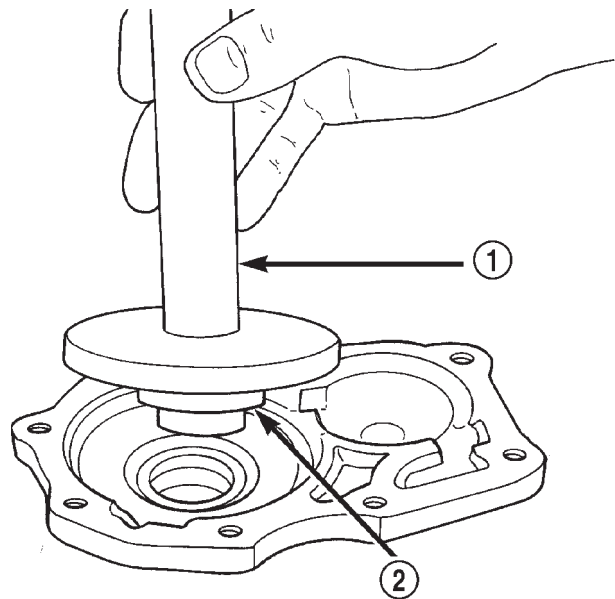

80b099ca

Fig. 10 Install Front Bearing Retainer Seal

1 - SPECIAL TOOL C-4171

2 - SPECIAL TOOL 8211 (AX5) OR 8209 (AX15)

(2) Remove any residual gasket material from the sealing surfaces of the bearing retainer and the transmission case.

(3) Install new front bearing retainer gasket to the front bearing retainer.

(4) Install the front bearing retainer onto the transmission case.

(5) Install the bolts to hold the bearing retainer onto the transmission case.

(6) Tighten the bolts to 17 N·m (12 ft. lbs.).

(7) Install release bearing and lever onto the transmission.

REMOVAL AND INSTALLATION (Continued)

EXTENSION HOUSING SEAL

REMOVAL

- (1) Raise and support vehicle.
- (2) Remove propeller shaft. Refer to Group 3, Differential and Driveline, for proper procedures.
- (3) Using a suitable seal puller or screw with a slide hammer, remove the extension housing seal (Fig. 11).

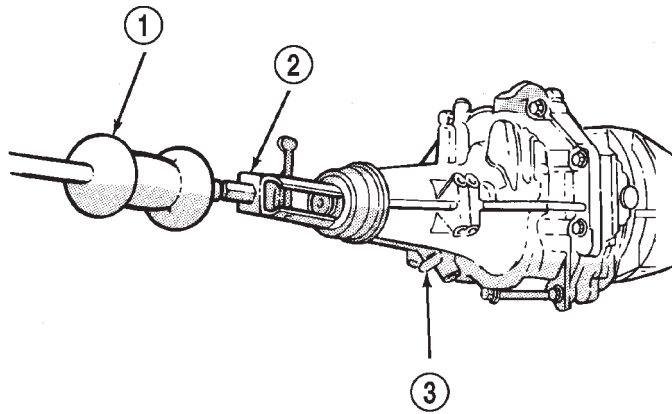

J9121-385

Fig. 11 Remove Extension Housing Seal

- 1 - SLIDE HAMMER
- 2 - SEAL PULLER
- 3 - 2WD EXTENSION HOUSING

INSTALLATION

- (1) Clean seal bore of extension housing of any residual sealer material from original seal.
- (2) Using Tool Handle C-4171 and Seal Installer 8212, install new extension housing seal so that the seal is located 0 ± 0.5 mm (0 ± 0.02 in.) to the face of the extension housing (Fig. 12).
- (3) Install propeller shaft. Refer to Group 3, Differential and Driveline, for proper procedures.
- (4) Check and add fluid to transmission as necessary. Refer to the Recommended Lubricant section for proper fluid requirements.
- (5) Lower vehicle.

ADAPTER HOUSING SEAL

REMOVAL

- (1) Hoist and support vehicle.
- (2) Remove transfer case.
- (3) Using a suitable pry tool, or a slide hammer mounted screw, remove the adapter housing seal (Fig. 13).

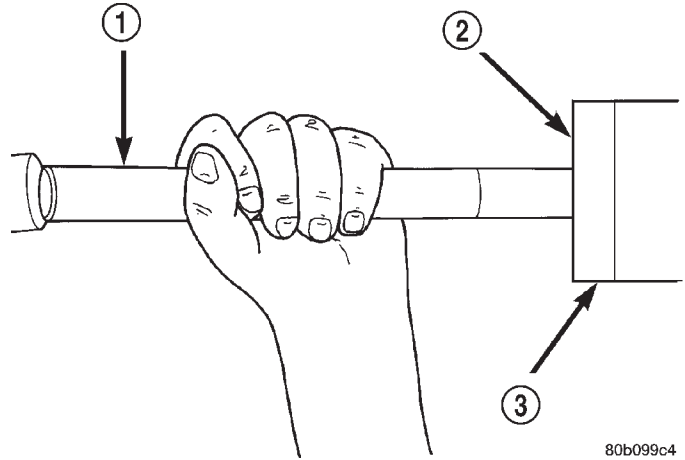

80b099c4

Fig. 12 Install Extension Housing Seal

- 1 - SPECIAL TOOL C-4171
- 2 - SPECIAL TOOL 8212
- 3 - EXTENSION HOUSING

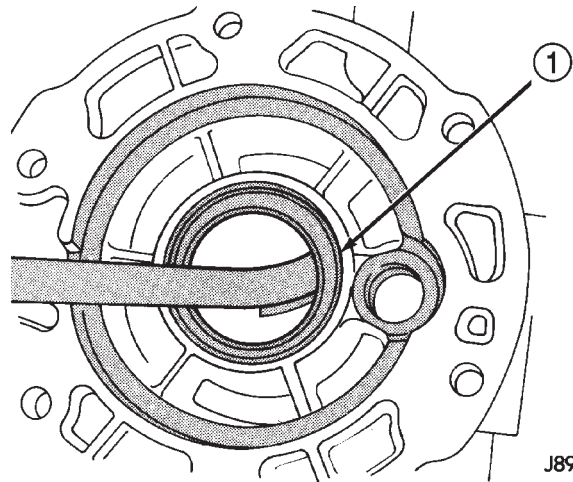

J8921-1045

Fig. 13 Remove Adapter Housing Seal

- 1 - ADAPTER HOUSING OIL SEAL

INSTALLATION

- (1) Clean seal bore of adapter housing of any residual sealer material from original seal.
- (2) Using Tool Handle C-4171 and Seal Installer 8208, install new seal so that the seal is located 0 ± 0.2 mm (0 ± 0.008 in.) to the seal bore face of adapter housing (Fig. 14).
- (3) Install transfer case.
- (4) Check and add fluid to transmission as necessary. Refer to the Recommended Lubricant section for proper fluid requirements.
- (5) Lower vehicle.

REMOVAL AND INSTALLATION (Continued)

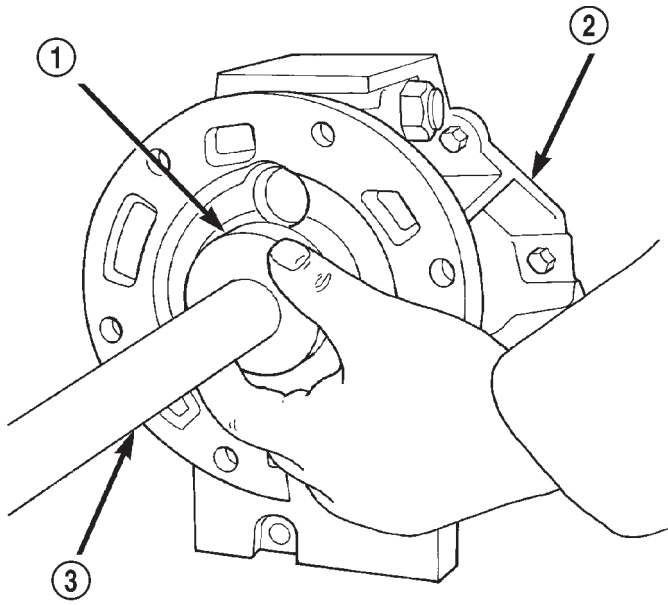

80b099c5

Fig. 14 Install Adapter Housing Seal

- 1 - SPECIAL TOOL 8208
- 2 - ADAPTER HOUSING
- 3 - SPECIAL TOOL C-4171

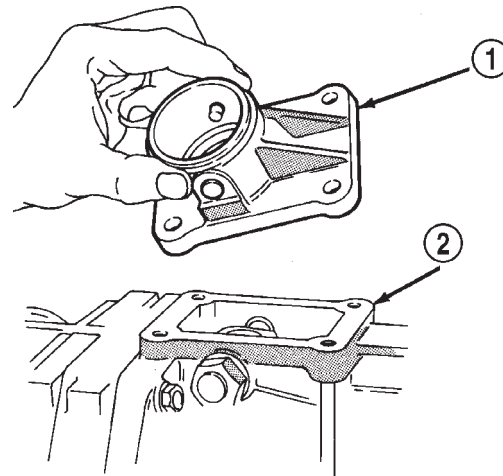

J8921-1032

Fig. 15 Remove Shift Tower

- 1 - SHIFT TOWER
- 2 - ADAPTER/EXTENSION HOUSING

DISASSEMBLY AND ASSEMBLY

ADAPTER/EXTENSION HOUSING AND FRONT BEARING RETAINER

DISASSEMBLY

- (1) Drain transmission lubricant, if necessary.
- (2) Remove release bearing and lever.
- (3) Remove clutch housing bolts and remove housing (Fig. 17).
- (4) Remove vehicle speed sensor and speedometer adapter, if necessary.
- (5) Remove bolts holding shift tower to transmission case.
- (6) Remove shift tower from transmission case (Fig. 15).
- (7) Remove shift tower gasket from shift tower or transmission case (Fig. 16).

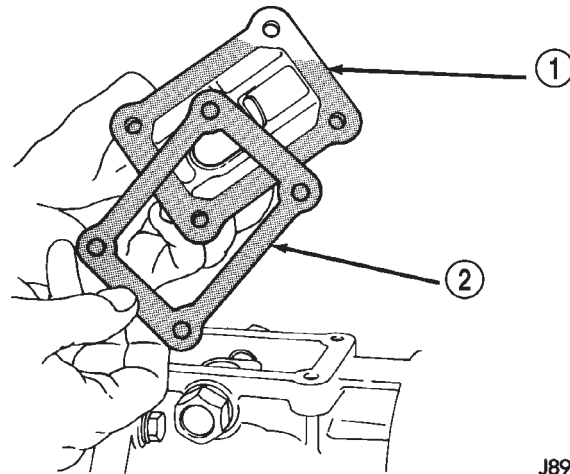

J8921-1033

Fig. 16 Remove Shift Tower Gasket

- 1 - SHIFT TOWER
- 2 - GASKET

- (8) Remove detent ball plug (Fig. 18).
- (9) Remove detent spring and ball with pencil magnet (Fig. 19), (Fig. 20).

DISASSEMBLY AND ASSEMBLY (Continued)

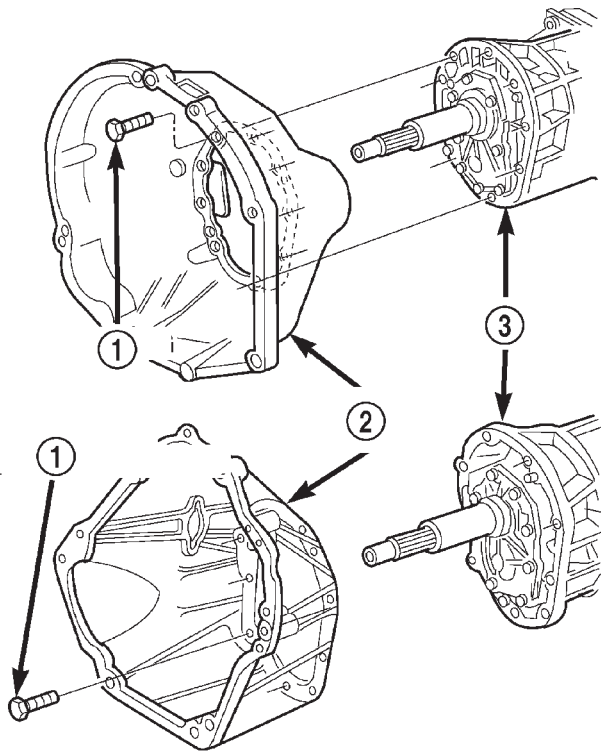

80be4510

Fig. 17 Clutch Housing

- 1 - HOUSING-TO-TRANSMISSION BOLTS (46 N-m/34 ft. lbs.)
- 2 - CLUTCH HOUSING
- 3 - TRANSMISSION

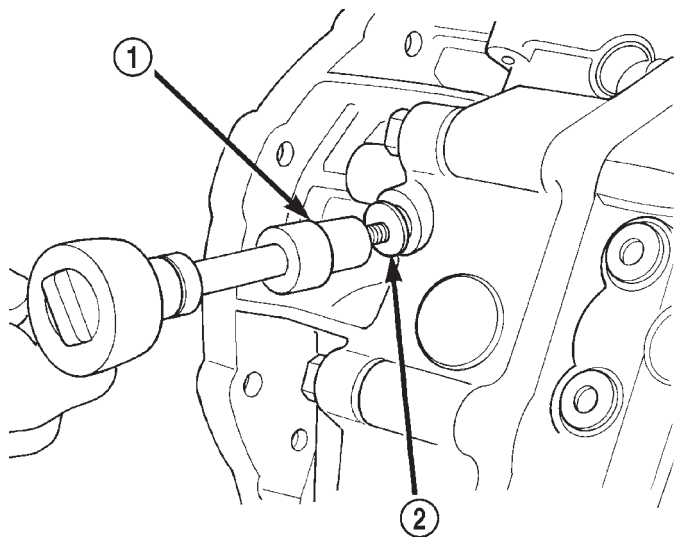

80abfeed

Fig. 18 Remove Detent Ball Plug

- 1 - TORX BIT
- 2 - DETENT BALL PLUG

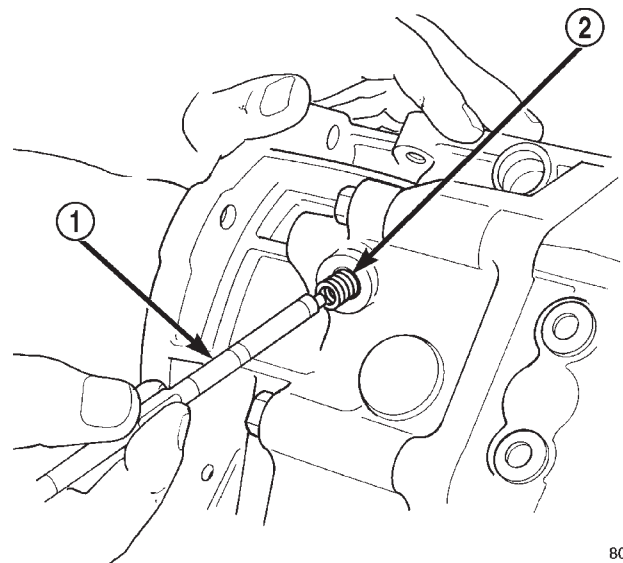

80abfeee

Fig. 19 Remove Detent Spring

- 1 - PENCIL MAGNET
- 2 - DETENT BALL SPRING

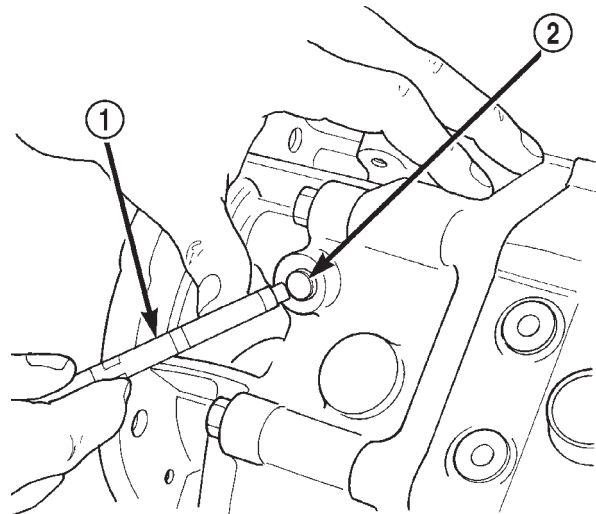

80abfeef

Fig. 20 Remove Detent Ball

- 1 - PENCIL MAGNET
- 2 - SHIFT DETENT BALL

DISASSEMBLY AND ASSEMBLY (Continued)

- (10) Remove shift arm retainer bolt (Fig. 21).
- (11) Remove shift arm restrictor pins (Fig. 22).

NOTE: The restrictor pins are not interchangeable and are color coded. Note which color restrictor pin is removed from each side of the transmission and be sure to install it into the same location.

- (12) Remove shift lever shaft plug (Fig. 23).
- (13) Remove shifter shaft with large magnet (Fig. 24).
- (14) Remove the shift arm from the adapter housing.

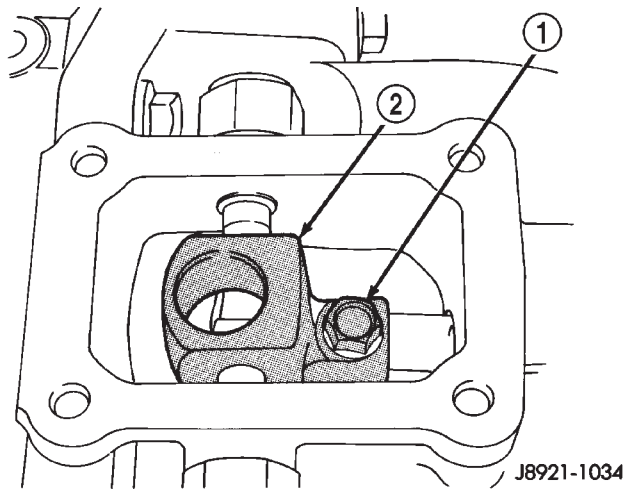

Fig. 21 Shift Arm Retainer Bolt Removal

- 1 - RETAINER BOLT
- 2 - SHIFT ARM

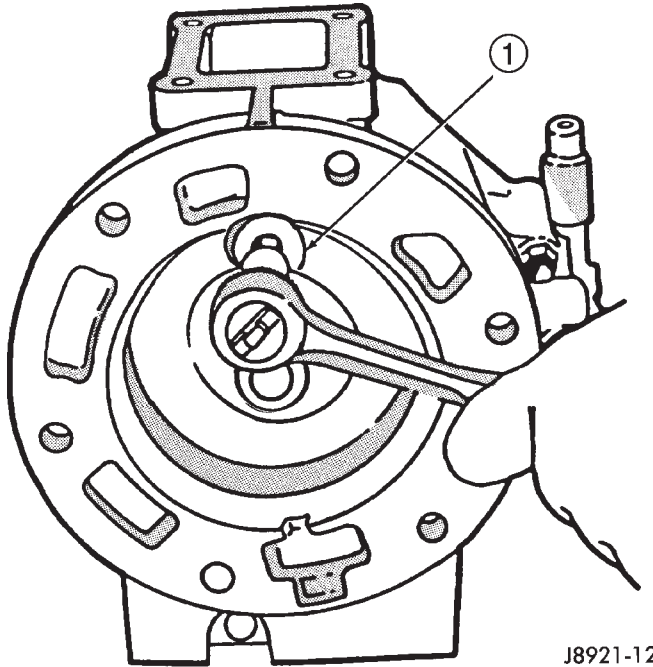

Fig. 23 Removing Shift Lever Shaft Plug

- 1 - SHIFT LEVER SHAFT PLUG

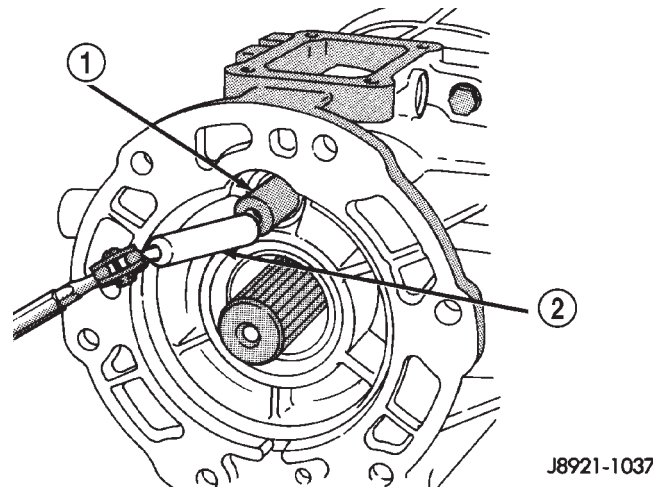

Fig. 24 Remove Shifter Shaft

- 1 - SHIFT ARM SHAFT
- 2 - LARGE MAGNET

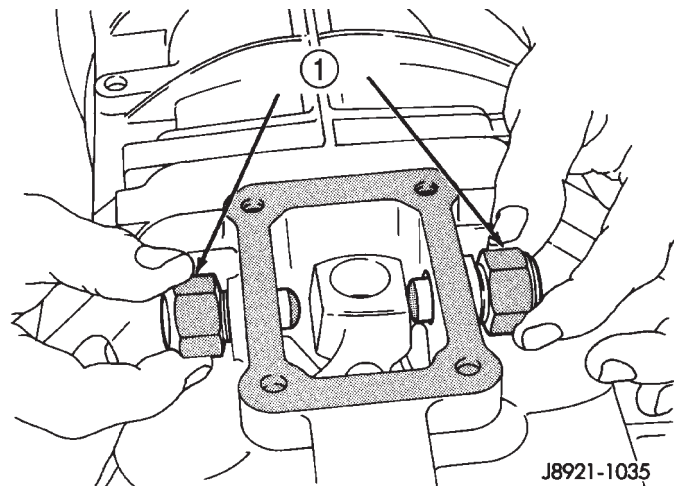

Fig. 22 Shift Arm Restrictor Pins

- 1 - RESTRICTOR PINS

- (15) Remove adapter/extension housing bolts.
- (16) Loosen adapter/extension housing by tapping it loose with plastic mallet (Fig. 25).

DISASSEMBLY AND ASSEMBLY (Continued)

(17) Remove adapter/extension housing (Fig. 26).

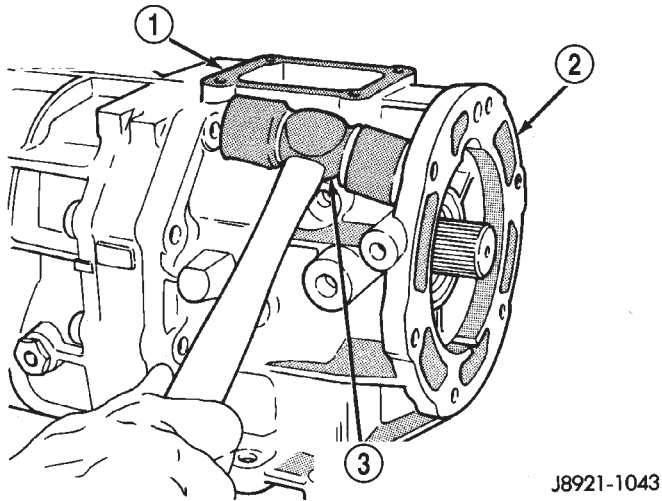

J8921-1043

Fig. 25 Loosen Adapter/Extension Housing

- 1 - INTERMEDIATE PLATE
- 2 - ADAPTER HOUSING
- 3 - RUBBER FACED Mallet

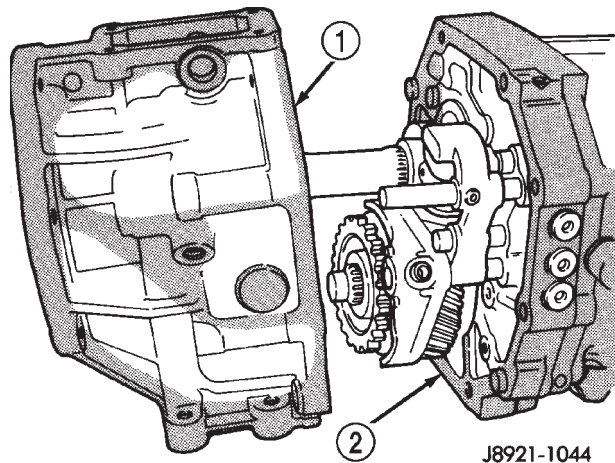

J8921-1044

Fig. 26 Remove Adapter/Extension Housing—Typical

- 1 - ADAPTER HOUSING
- 2 - INTERMEDIATE PLATE

(18) On 4x2 transmissions;

- (a) Remove speedometer gear retaining snap-ring from output shaft.
- (b) Remove speedometer gear from output shaft and remove speedometer gear lock ball from output shaft.
- (c) Remove speedometer drive gear locating snap-ring (Fig. 27).

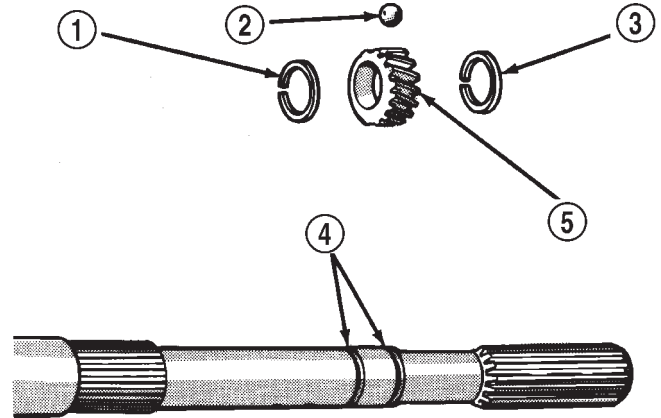

J8921-1119

Fig. 27 Speedometer Drive Gear Assembly

- 1 - SNAP RING
- 2 - LOCK BALL
- 3 - SNAP RING
- 4 - OUTPUT SHAFT GROOVES
- 5 - SPEEDOMETER GEAR

(19) Remove the bolts holding the front bearing retainer to the transmission case.

(20) Remove the bearing retainer from transmission case (Fig. 28).

(21) Remove input shaft bearing snap-ring (Fig. 29).

(22) Remove countershaft front bearing snap-ring.

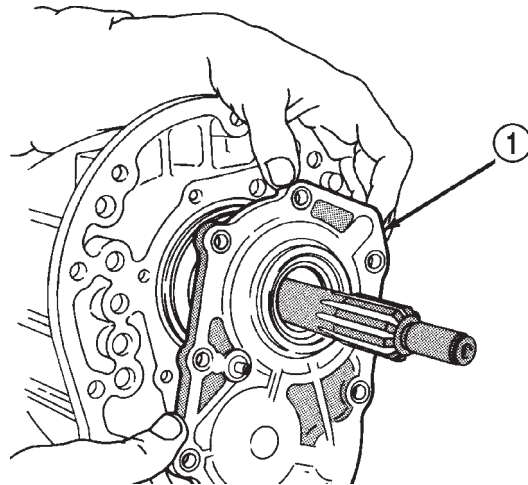

J8921-1046

Fig. 28 Remove Front Bearing Retainer

- 1 - FRONT BEARING RETAINER

DISASSEMBLY AND ASSEMBLY (Continued)

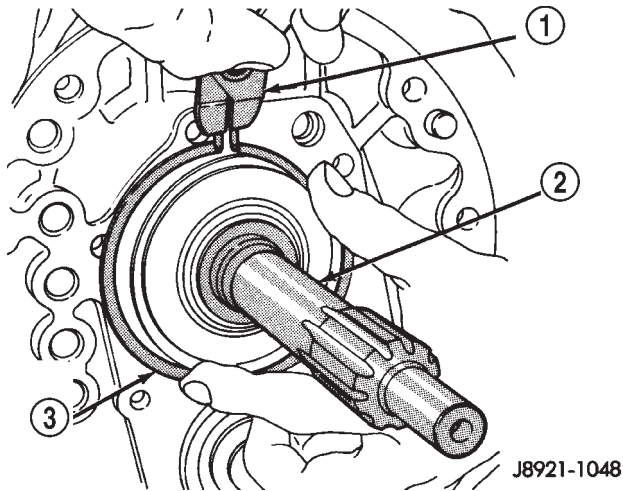

J8921-1048

Fig. 29 Remove Input Shaft Bearing Snap-ring

- 1 - SNAP RING PLIERS
- 2 - INPUT SHAFT
- 3 - INPUT SHAFT BEARING SNAP RING

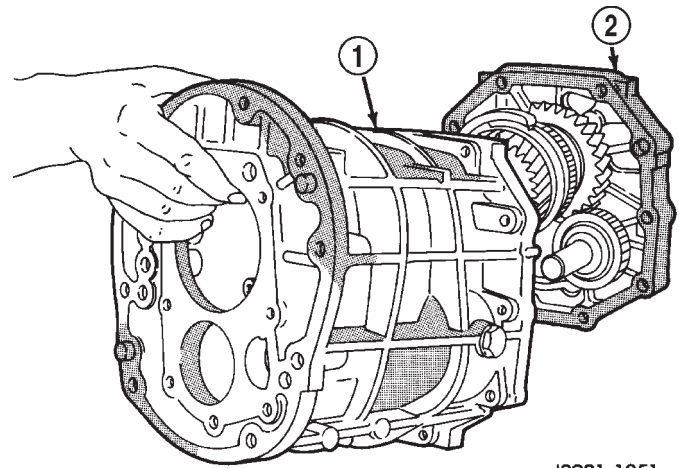

J8921-1051

Fig. 31 Remove Intermediate Plate from Transmission Case

- 1 - GEAR CASE
- 2 - INTERMEDIATE PLATE

(23) Separate intermediate plate and transmission case by tapping them loose with plastic mallet (Fig. 30).

(24) Separate the intermediate plate from the transmission case (Fig. 31).

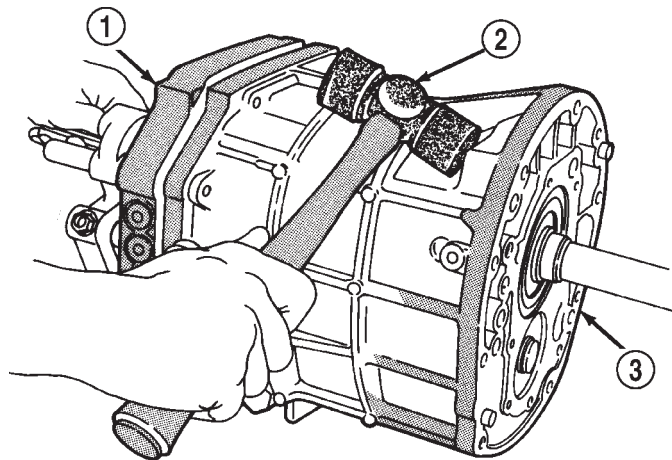

J8921-1050

Fig. 30 Separate Intermediate Plate and Transmission Case

- 1 - INTERMEDIATE PLATE
- 2 - RUBBER Mallet
- 3 - GEAR CASE

ASSEMBLY

(1) Remove any residual sealer from transmission case, intermediate plate, and adapter/extension housing.

(2) Apply a 1/8 to 3/16 inch wide bead of Threebond® Liquid Gasket TB1281, P/N 83504038, as shown, making sure to keep sealer bead to inside of bolt holes (Fig. 32).

(3) Align geartrain and shift rails with mating holes in transmission case and install transmission case to the intermediate plate (Fig. 33). Verify that the transmission case is seated on the intermediate plate locating pins.

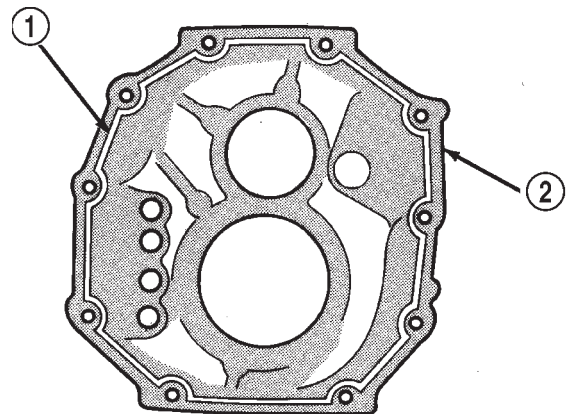

J8921-1118

Fig. 32 Apply Sealer to Transmission Gear Case

- 1 - SEALER BEAD (1/8" - 3/16" WIDE)
- 2 - GEAR CASE

DISASSEMBLY AND ASSEMBLY (Continued)

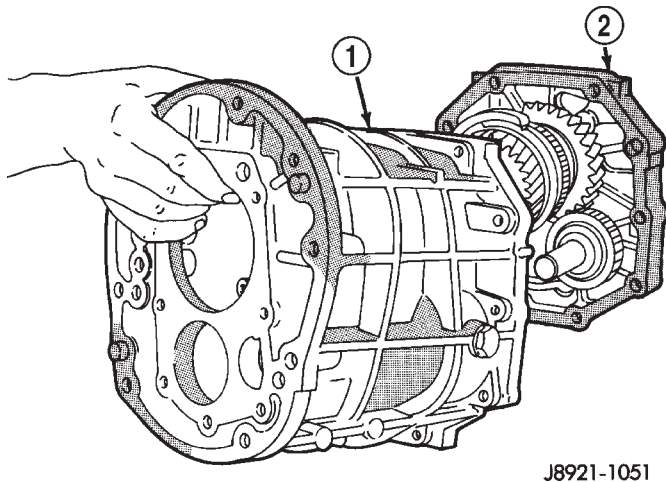

J8921-1051

Fig. 33 Install Transmission Gear Case to the Intermediate Plate

- 1 - GEAR CASE
- 2 - INTERMEDIATE PLATE

(4) Install new front bearing snap rings (Fig. 34).

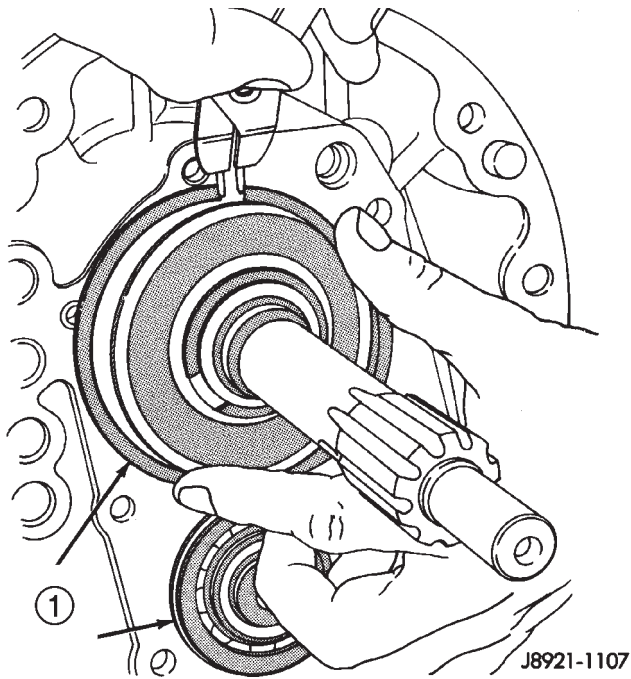

J8921-1107

Fig. 34 Install Front Bearing Snap-rings

- 1 - FRONT BEARING SNAP RINGS

(5) Install front bearing retainer gasket to front bearing retainer.

(6) Install the front bearing retainer (Fig. 35) and tighten bolts to 17 N·m (12 ft. lbs.).

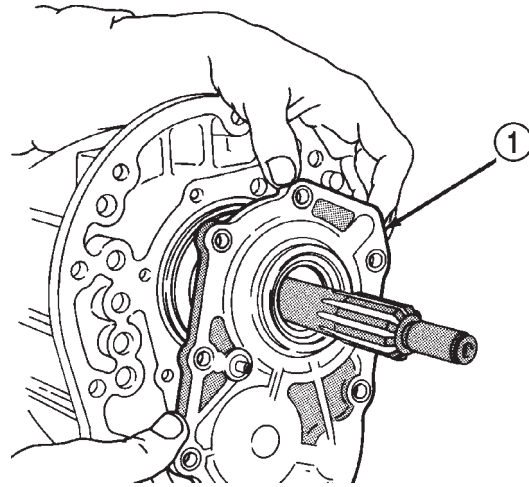

J8921-1046

Fig. 35 Install Front Bearing Retainer

- 1 - FRONT BEARING RETAINER

(7) On 4x2 transmissions;

(a) Install speedometer drive gear locating snap-ring (Fig. 36).

(b) Install speedometer gear lock ball in output shaft and install speedometer gear onto output shaft.

(c) Install speedometer gear retaining snap-ring onto output shaft.

(8) Apply a 1/8 to 3/16 inch wide bead of Threebond® Liquid Gasket TB1281, P/N 83504038, to sealing surface of adapter/extension housing, making sure to keep sealer bead to inside of bolt holes.

(9) Install adapter or extension housing on intermediate plate (Fig. 37). Tighten housing bolts to 34 N·m (25 ft. lbs.) torque.

(10) Position shift arm in shifter tower opening of adapter or extension housing (Fig. 38). Be sure that the shifter arm is engaged into the shift rails.

DISASSEMBLY AND ASSEMBLY (Continued)

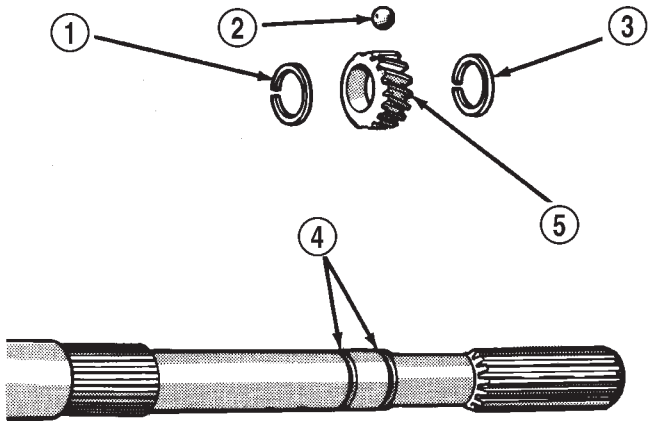

J8921-1119

Fig. 36 Speedometer Drive Gear Assembly

- 1 - SNAP RING
- 2 - LOCK BALL
- 3 - SNAP RING
- 4 - OUTPUT SHAFT GROOVES
- 5 - SPEEDOMETER GEAR

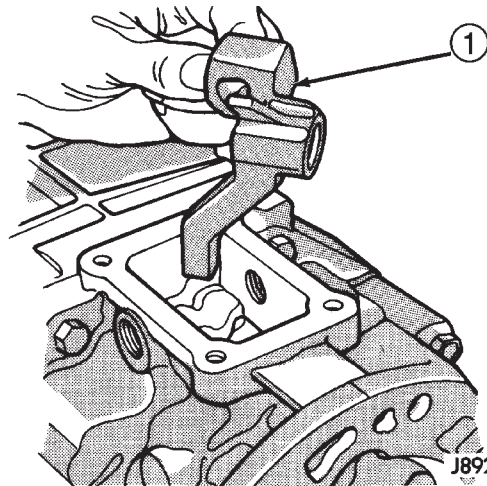

J8921-1127

Fig. 38 Position Shift Arm in Adapter or Extension Housing

- 1 - SHIFT ARM

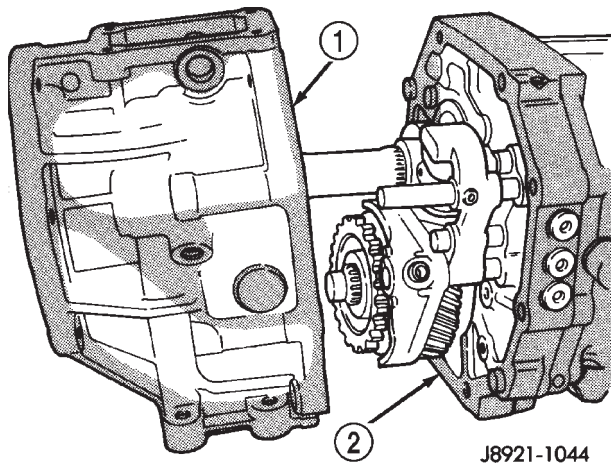

J8921-1044

Fig. 37 Install Adapter/Extension Housing—Typical

- 1 - ADAPTER HOUSING
- 2 - INTERMEDIATE PLATE

(11) Start shifter arm shaft in hole in back of adapter or extension housing. Align shift arm and shifter arm shaft and insert shifter arm shaft through the shifter arm and into the forward portion of the adapter or extension housing (Fig. 39).

(12) Rotate the shifter arm shaft until the hole in the shift arm is aligned with the hole in the shaft.

(13) Install the shift arm retainer bolt and tighten to 38 N·m (28 ft. lbs.) (Fig. 40).

(14) Install and tighten shifter arm shaft plug to 18 N·m (13 ft. lbs.) torque (Fig. 41).

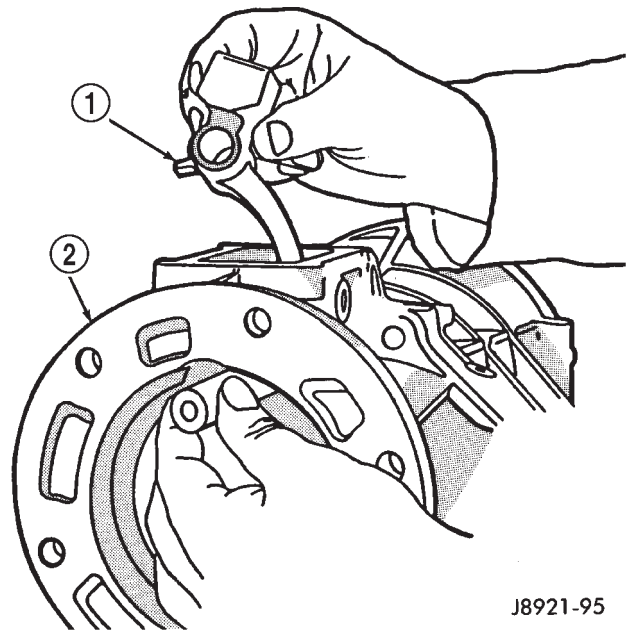

J8921-95

Fig. 39 Install Shifter Arm Shaft

- 1 - SHIFT ARM
- 2 - ADAPTER OR EXTENSION HOUSING

DISASSEMBLY AND ASSEMBLY (Continued)

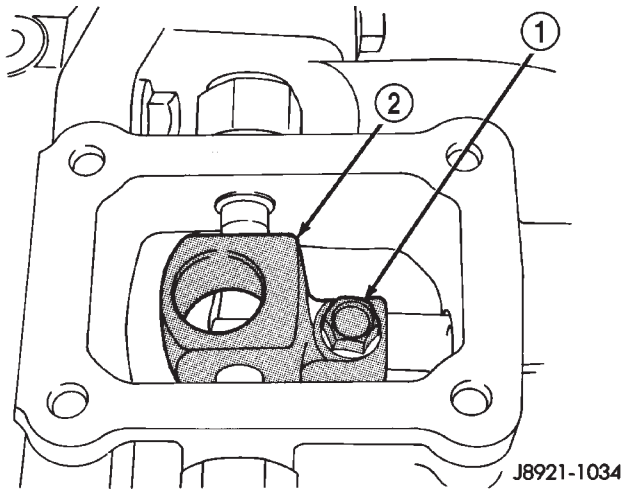

Fig. 40 Install Shift Arm Retainer Bolt

- 1 - RETAINER BOLT
- 2 - SHIFT ARM

NOTE: The restrictor pins are not interchangeable and are color coded. Be sure to install the pin into the same location from which it was removed.

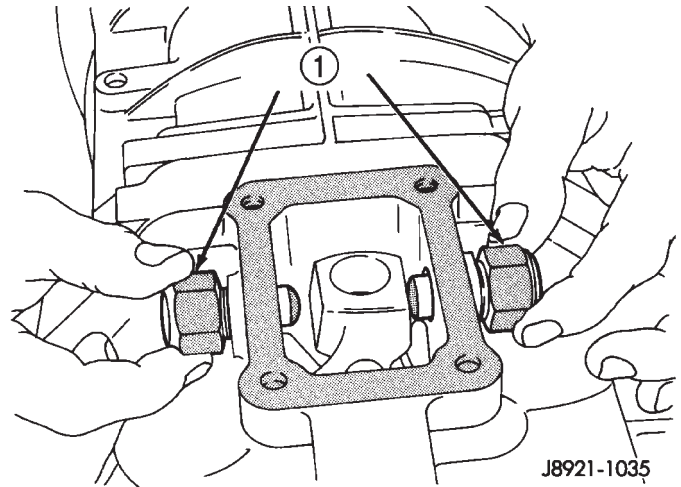

Fig. 42 Install Shifter Restrictor Pins

- 1 - RESTRICTOR PINS

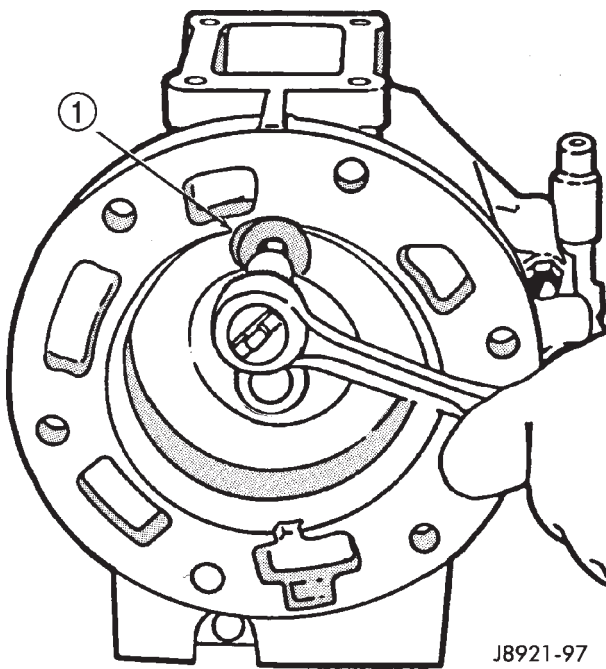

Fig. 41 Shifter Arm Shaft Plug Installation

- 1 - SHAFT PLUG

(16) Install shift detent ball in detent opening of case (Fig. 43).

(17) Install detent spring in case (Fig. 44).

(18) Install detent plug and tighten to 19 N·m (14 ft. lbs.) (Fig. 45).

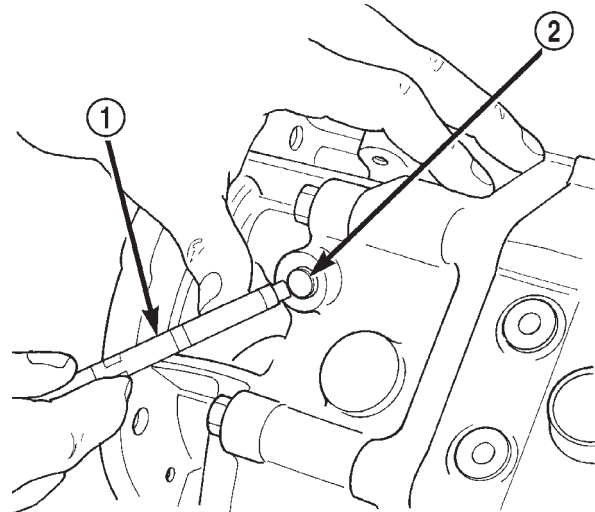

Fig. 43 Install Detent Ball

- 1 - PENCIL MAGNET
- 2 - SHIFT DETENT BALL

(15) Install shift restrictor pins in shift tower and tighten to 27 N·m (20 ft. lbs.) (Fig. 42).

80abfeef

DISASSEMBLY AND ASSEMBLY (Continued)

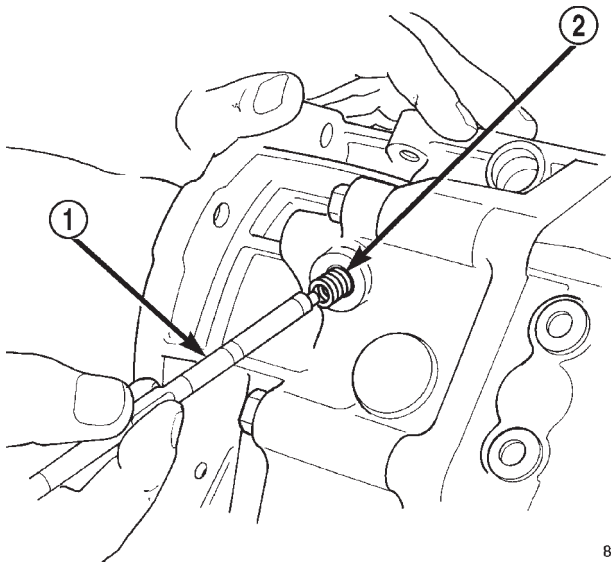

80abfeee

Fig. 44 Install Detent Spring

- 1 - PENCIL MAGNET
- 2 - DETENT BALL SPRING

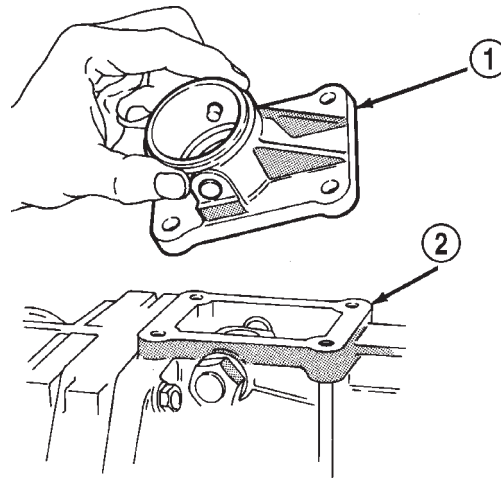

J8921-1032

Fig. 46 Install Shift Tower

- 1 - SHIFT TOWER
- 2 - ADAPTER/EXTENSION HOUSING

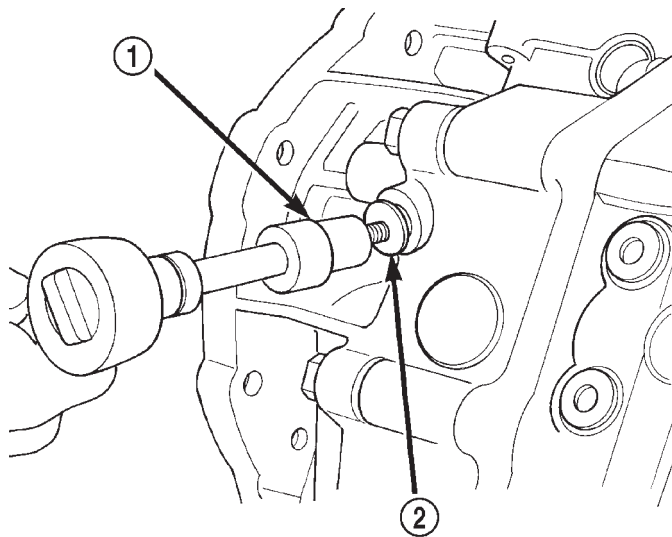

80abfeed

Fig. 45 Install Detent Ball Plug

- 1 - TORX BIT
- 2 - DETENT BALL PLUG

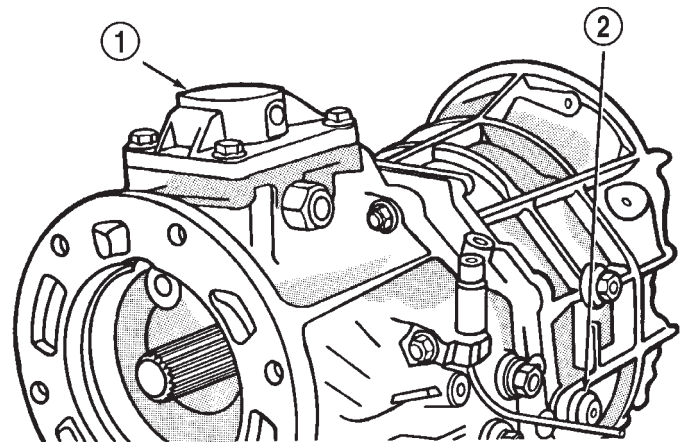

J8921-100

Fig. 47 Install Backup Lamp Switch

- 1 - SHIFT TOWER
- 2 - BACKUP LAMP SWITCH

- (19) Install shift tower gasket onto shift tower.
- (20) Install the shift tower oil deflector and gasket onto the adapter or extension housing.
- (21) Install shift tower onto transmission case (Fig. 46).
- (22) Install bolts to hold shift tower to transmission case. Tighten tower bolts to 18 N·m (13 ft. lbs.) torque.

- (23) Install new metal o-ring onto the backup lamp switch.
- (24) Install backup lamp switch (Fig. 47). Tighten switch to 44 N·m (32.5 ft. lbs.) torque.
- (25) Install new seal in adapter/extension housing.
- (26) Install vehicle speed sensor, if necessary.
- (27) Install clutch housing, release bearing, release fork and retainer clip.

DISASSEMBLY AND ASSEMBLY (Continued)

SHIFT MECHANISM AND GEARTRAIN

DISASSEMBLY

(1) Install suitable bolts and washers in intermediate plate (Fig. 48). Then clamp plate and gear assembly in vise. Use enough washers to prevent bolts from touching. Also be sure vise jaws are clamped on bolt heads.

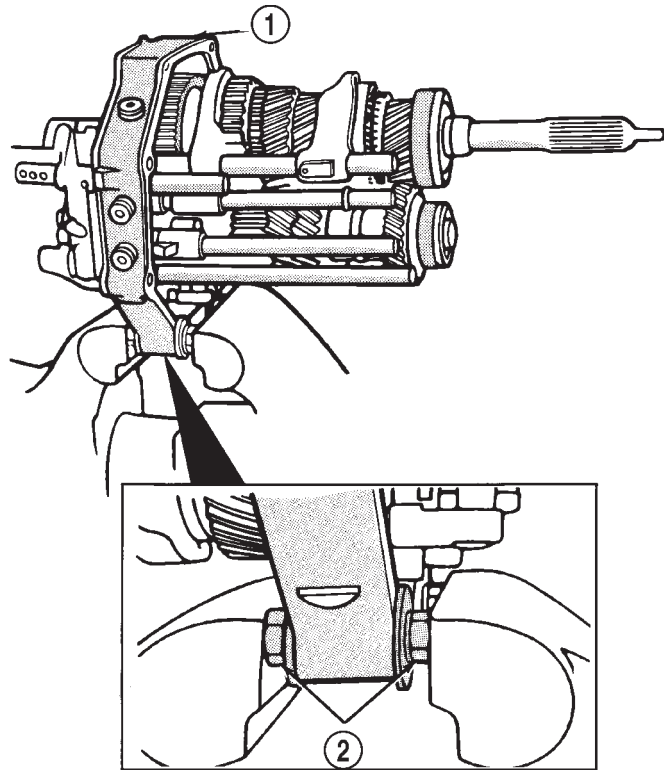

J8921-15

Fig. 48 Positioning Intermediate Plate In Vise

- 1 - INTERMEDIATE PLATE
- 2 - BOLTS

(2) Remove countershaft fifth gear retaining snap-ring (Fig. 49).

(3) Remove bolt holding fifth gear shift fork to shift rail (Fig. 50).

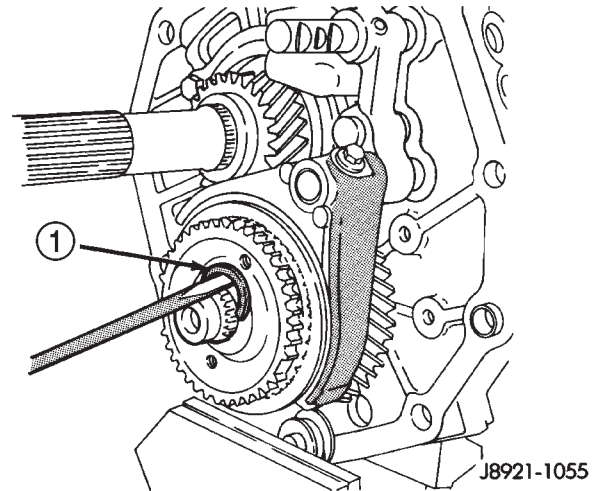

J8921-1055

Fig. 49 Remove Fifth Gear Snap-ring

- 1 - FIFTH GEAR SNAP RING (SELECT FIT)

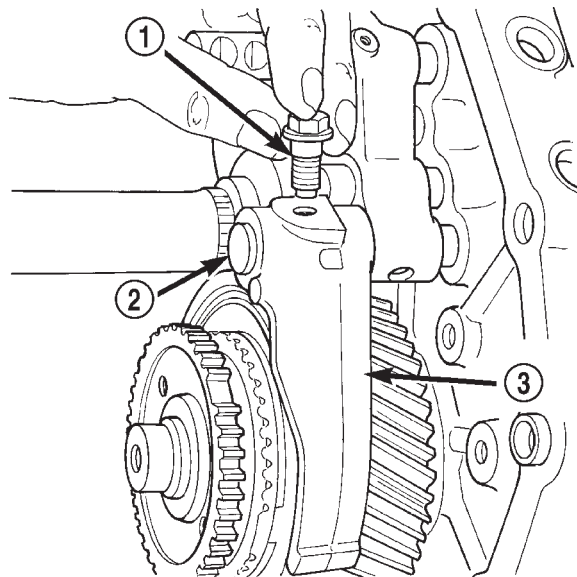

80ac2c56

Fig. 50 Remove Shift Fork Retainer Bolt

- 1 - SHIFT FORK RETAINER BOLT
- 2 - FIFTH GEAR SHIFT RAIL
- 3 - FIFTH GEAR SHIFT FORK

DISASSEMBLY AND ASSEMBLY (Continued)

(4) Remove fifth gear blocker ring from countershaft assembly with Puller L-4407 (Fig. 51).

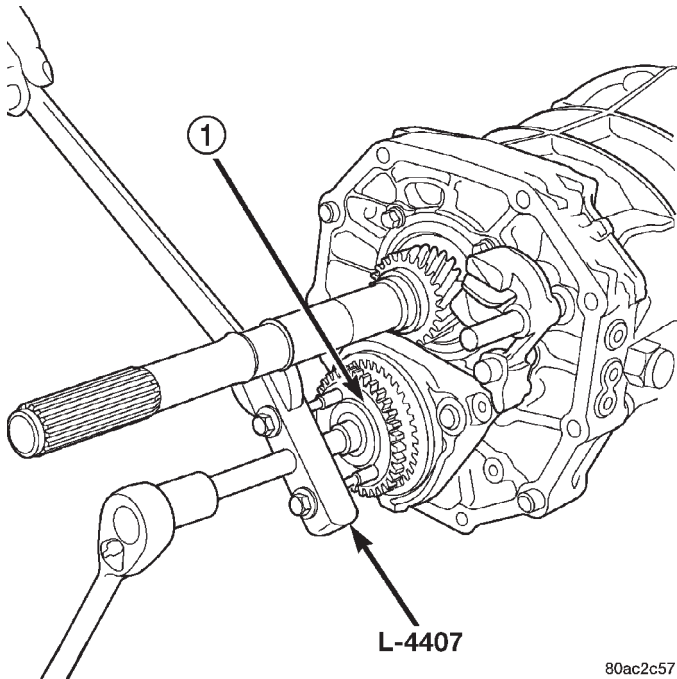

Fig. 51 Remove Fifth Gear Blocker Ring

- 1 - FIFTH GEAR BLOCKER RING

(5) Remove fifth gear synchro ring (Fig. 52).
 (6) Remove the countershaft fifth gear assembly from countershaft (Fig. 53).

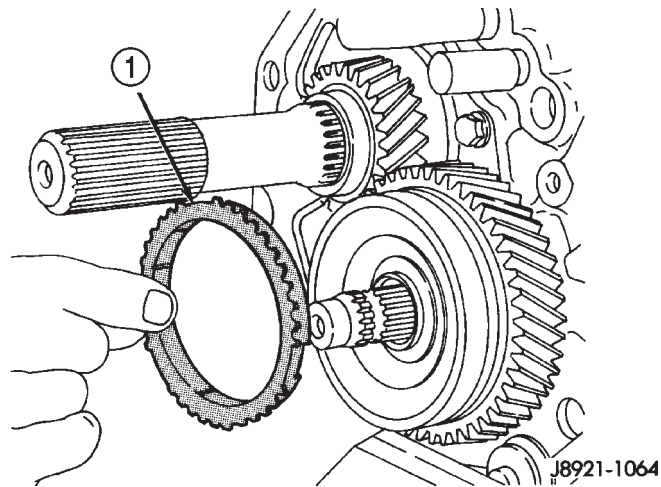

Fig. 52 Remove Fifth Gear Synchro Ring

- 1 - FIFTH GEAR SYNCHRO RING

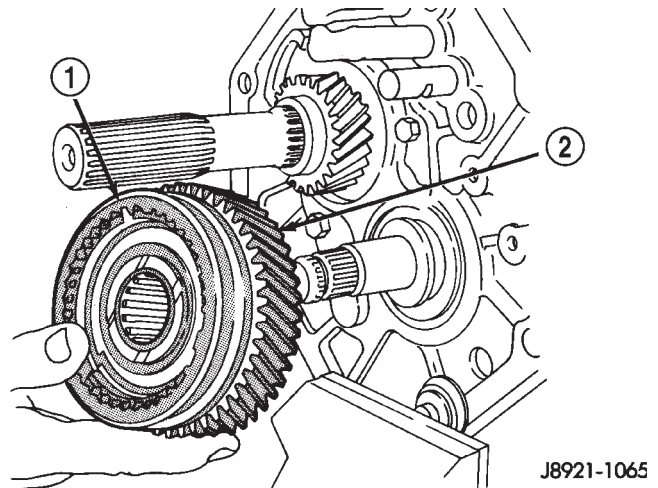

Fig. 53 Remove Fifth Gear and Synchro Assembly

- 1 - FIFTH GEAR SYNCHRO SLEEVE ASSEMBLY
- 2 - COUNTER FIFTH GEAR

(7) Remove fifth gear thrust ring from countershaft (Fig. 54).

(8) Remove fifth gear thrust ring lock ball from countershaft (Fig. 55).

NOTE: There are many lock balls, check balls, interlock balls, and interlock pins used in various places in the transmission. Whenever a pin or ball is removed, it should be identified in such a way that it can be reinstalled in the same location from which it was removed.

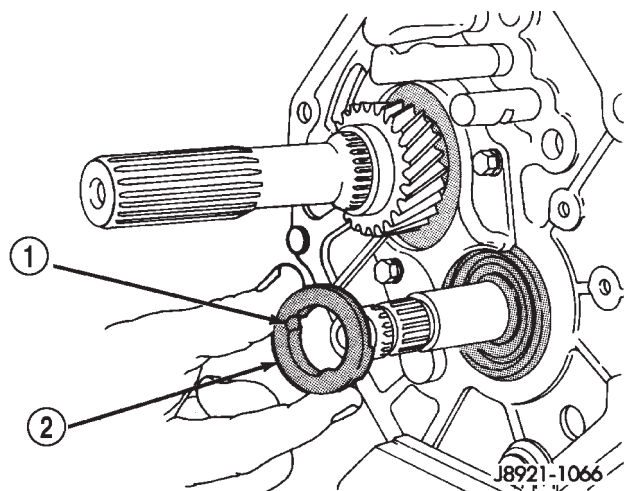
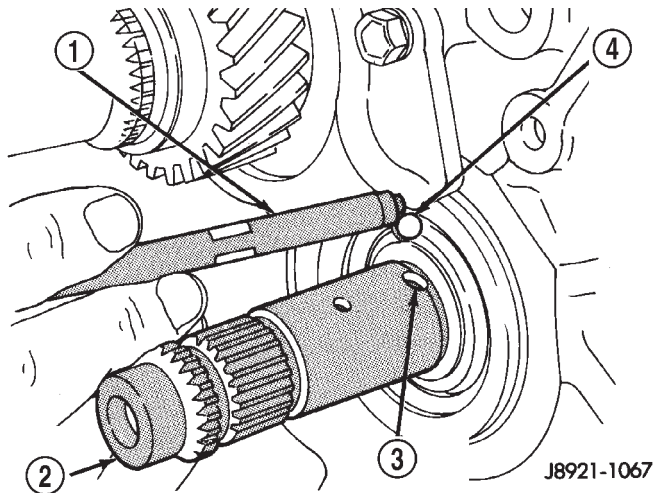

Fig. 54 Remove Fifth Gear Thrust Ring

- 1 - LOCK BALL NOTCH
- 2 - FIFTH GEAR THRUST RING

DISASSEMBLY AND ASSEMBLY (Continued)



J8921-1067

Fig. 55 Remove Fifth Gear Thrust Ring Lock Ball

- 1 - PENCIL MAGNET
- 2 - CLUSTER GEAR
- 3 - LOCK BALL RECESS
- 4 - THRUST RING LOCK BALL

(9) Remove bolt holding reverse idler gear shaft lock plate to the intermediate plate.

(10) Remove reverse idler gear shaft and reverse idler gear assembly (Fig. 56).

NOTE: Be sure to retrieve the pin and compression spring from the reverse idler shaft.

(11) Remove bolts holding output shaft rear bearing retainer to the intermediate plate and remove retainer (Fig. 57).

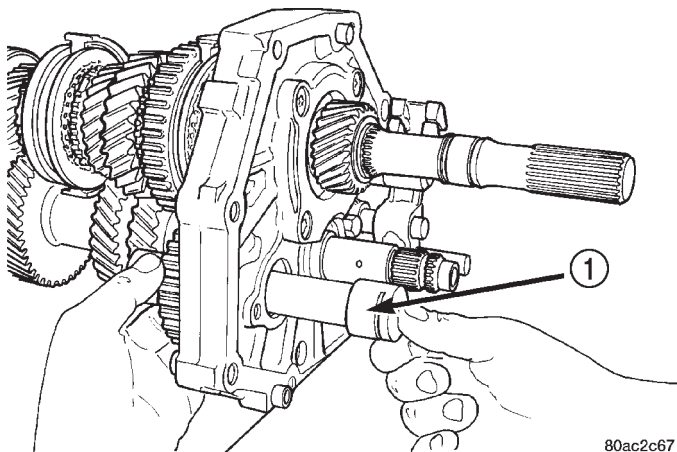

80ac2c67

Fig. 56 Remove Reverse Idler Shaft

- 1 - REVERSE IDLER SHAFT

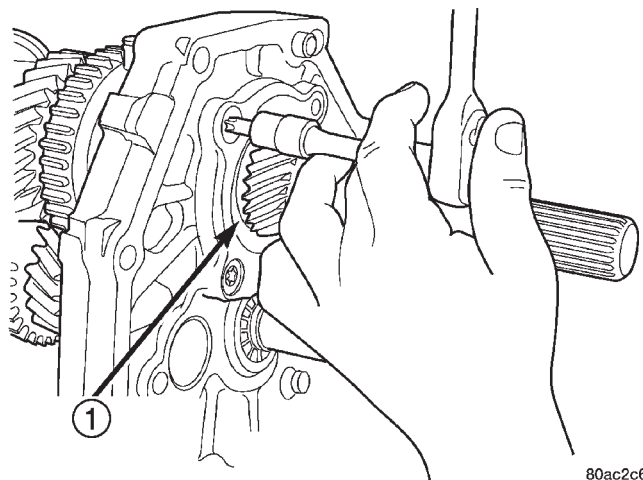

80ac2c68

Fig. 57 Remove Output Shaft Rear Bearing Retainer

- 1 - OUTPUT SHAFT REAR BEARING RETAINER

(12) Remove bolts holding 1-2 and 3-4 shift forks to the shift rails (Fig. 58) and discard bolts.

(13) Remove bolts holding reverse shift arm bracket to intermediate plate (Fig. 59).

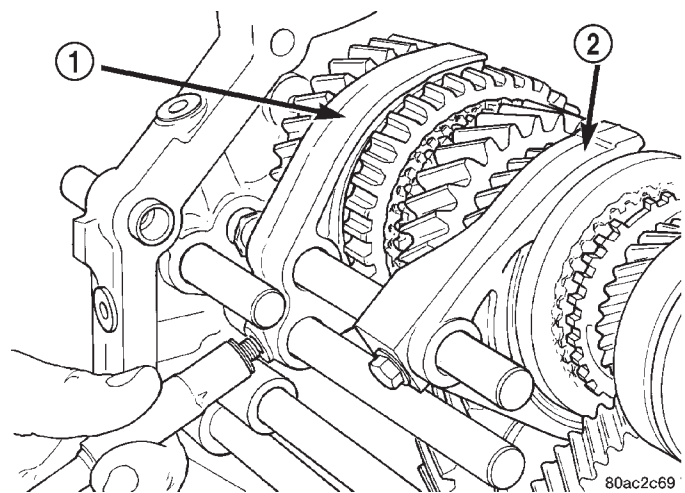

80ac2c69

Fig. 58 Remove Shift Fork To Shift Rail Bolts

- 1 - 1-2 SHIFT FORK
- 2 - 3-4 SHIFT FORK

DISASSEMBLY AND ASSEMBLY (Continued)

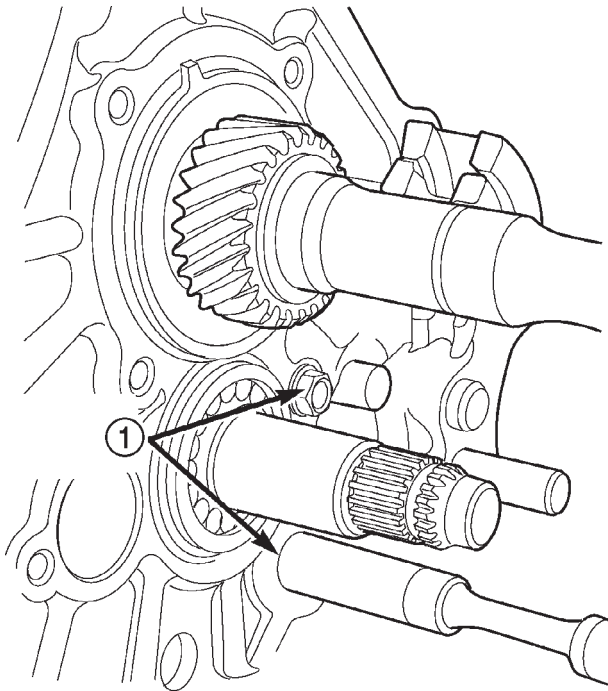

80ac2c6a

Fig. 59 Remove Reverse Shift Arm Bracket Bolts

1 - REVERSE SHIFT ARM BOLTS

(14) Remove snap-ring holding output shaft rear bearing into the intermediate plate (Fig. 60).

(15) Remove countershaft rear bearing snap-ring.

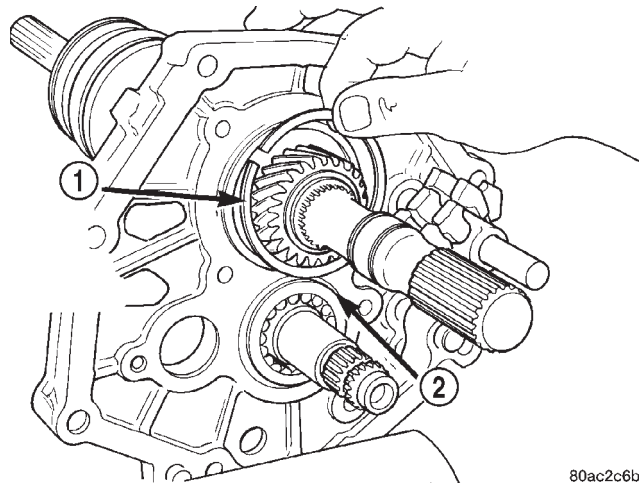

80ac2c6b

Fig. 60 Remove Output Shaft Rear Bearing Snap-ring

1 - OUTPUT SHAFT REAR BEARING SNAP-RING
2 - COUNTERSHAFT REAR BEARING SNAP-RING

(16) With aid of an assistant, support the mainshaft and countershaft. Tap on the rear of the mainshaft and countershaft with a suitable plastic mallet. This will release the countershaft from the countershaft rear bearing and the mainshaft rear bearing

from the intermediate plate. The countershaft will release from the countershaft bearing first and can be removed by moving the countershaft rearward and downward (Fig. 61).

(17) Remove the mainshaft by moving the mainshaft forward until the mainshaft rear bearing is clear of the intermediate plate and then rotating the mainshaft downward out of the shift forks (Fig. 62).

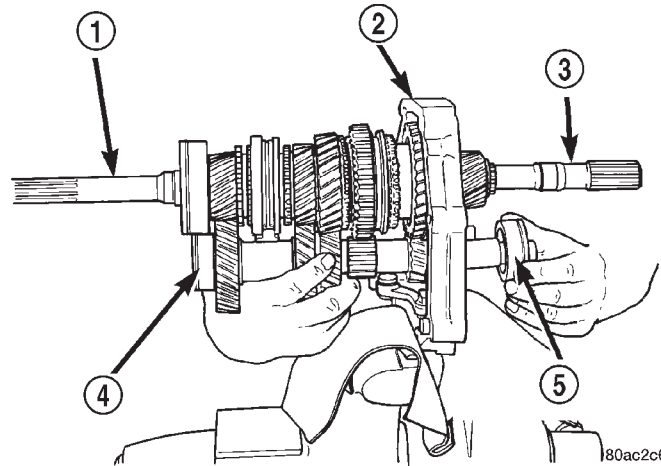

80ac2c6c

Fig. 61 Remove Countershaft and Countershaft Rear Bearing

1 - INPUT SHAFT
2 - INTERMEDIATE PLATE
3 - OUTPUT SHAFT
4 - COUNTERSHAFT
5 - COUNTERSHAFT REAR BEARING

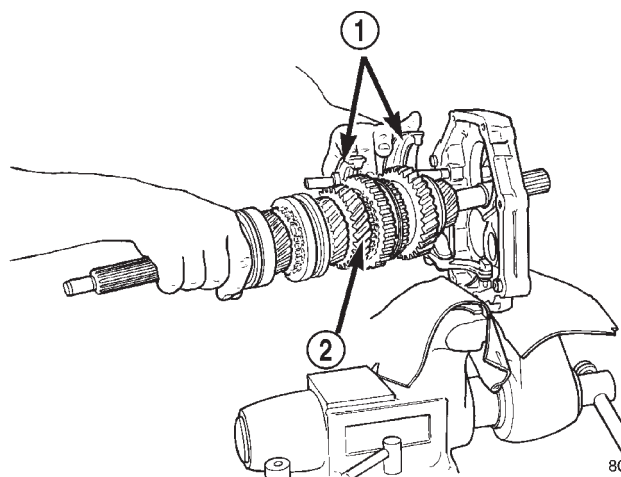

80ac2c6d

Fig. 62 Remove Mainshaft

1 - SHIFT FORKS
2 - MAINSHAFT

(18) Remove the 3-4 shift fork from the 3-4 shift rail (Fig. 63).

(19) Remove the snap-ring from near the end of the 1-2 shift rail to allow the removal of the 1-2 shift fork.

DISASSEMBLY AND ASSEMBLY (Continued)

(20) Remove the 1-2 shift fork from the 1-2 and the 3-4 shift rails (Fig. 64).

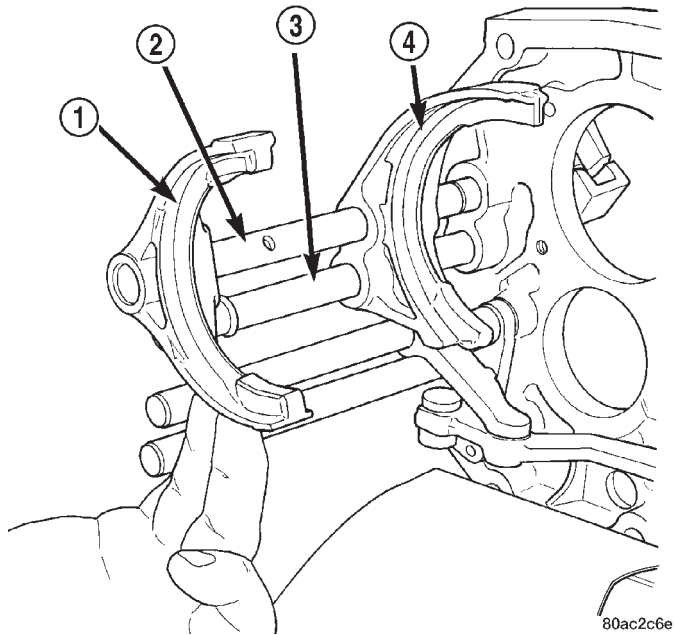

Fig. 63 Remove 3-4 Shift Fork

- 1 - 3-4 SHIFT FORK
- 2 - 3-4 SHIFT RAIL
- 3 - 1-2 SHIFT RAIL
- 4 - 1-2 SHIFT FORK

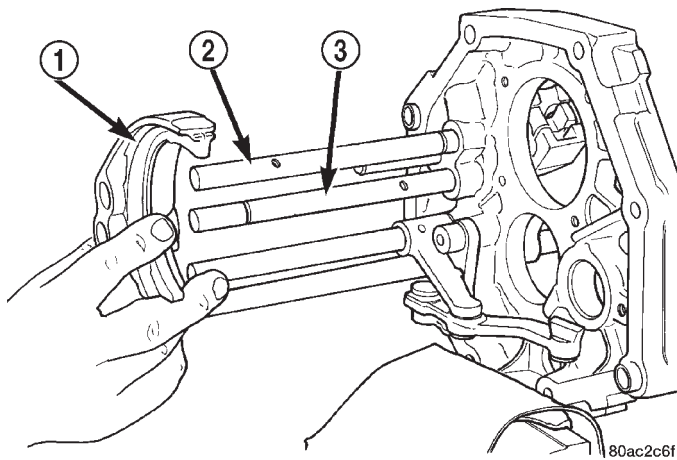

Fig. 64 Remove 1-2 Shift Fork

- 1 - 1-2 SHIFT FORK
- 2 - 3-4 SHIFT RAIL
- 3 - 1-2 SHIFT RAIL

(21) Remove threaded plugs from intermediate plate. Then remove lock ball and spring from plug holes with pencil magnet (Fig. 65). Note that the bottom spring is shorter in length than the other two springs.

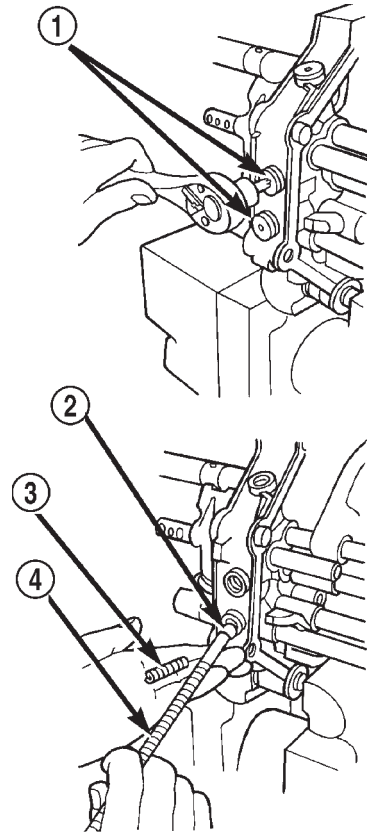

Fig. 65 Remove Lock Ball And Spring

- 1 - THREADED PLUGS
- 2 - LOCK BALL
- 3 - SPRING
- 4 - PENCIL MAGNET

(22) Remove the intermediate plate from the vise, rotate the plate 180°, and reinstall the plate in the vise using the same bolt and washer mounting set-up.

CAUTION: The interlock balls and pins are different sizes and shapes. Be sure to correctly identify which position an item is removed from to ensure that it is reinstalled in the same location.

DISASSEMBLY AND ASSEMBLY (Continued)

(23) Remove fifth gear shift rail (Fig. 66).

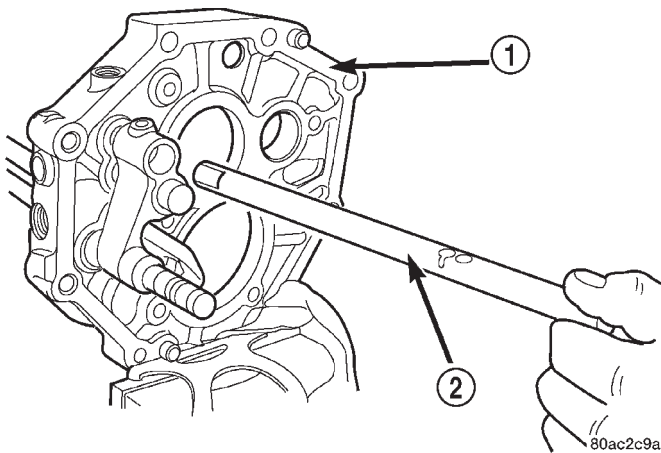

Fig. 66 Remove Fifth Gear Shift Rail

- 1 - INTERMEDIATE PLATE
- 2 - FIFTH GEAR SHIFT RAIL

(24) Remove fifth gear check ball (Fig. 67) and interlock pin.

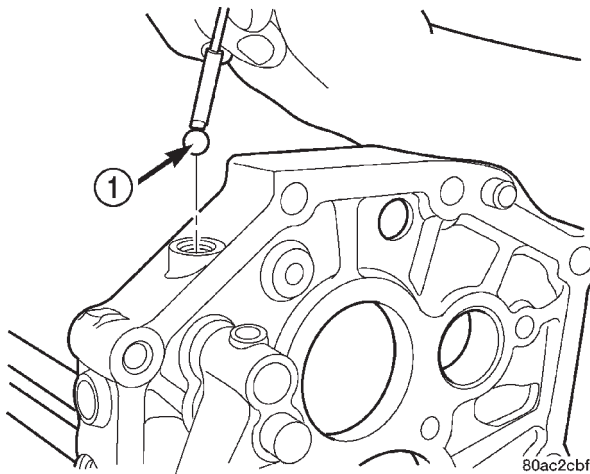

Fig. 67 Remove Fifth Gear Check Ball

- 1 - FIFTH GEAR CHECK BALL

(25) Remove reverse shift head and rail assembly (Fig. 68).

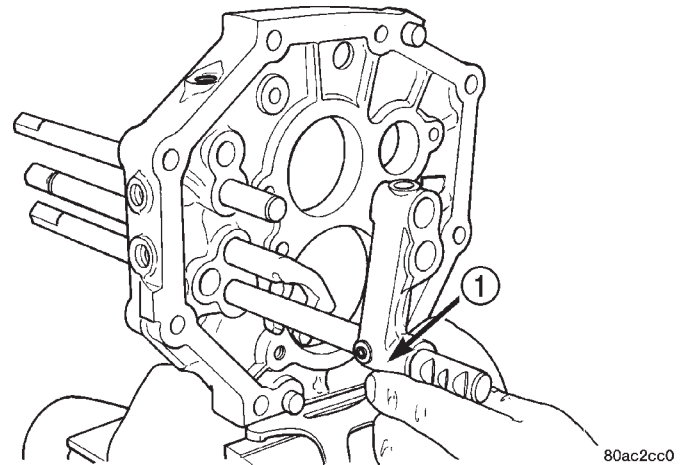

Fig. 68 Remove Reverse Shift Head And Rail Assembly

- 1 - REVERSE SHIFT HEAD AND RAIL ASSEMBLY

(26) Remove snap-ring holding reverse shift rail into intermediate plate.

(27) Remove reverse shift rail and reverse shift fork and arm assembly from intermediate plate (Fig. 69).

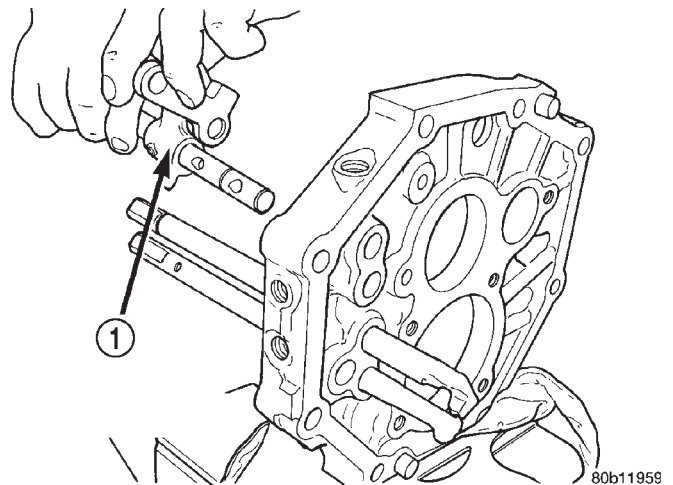
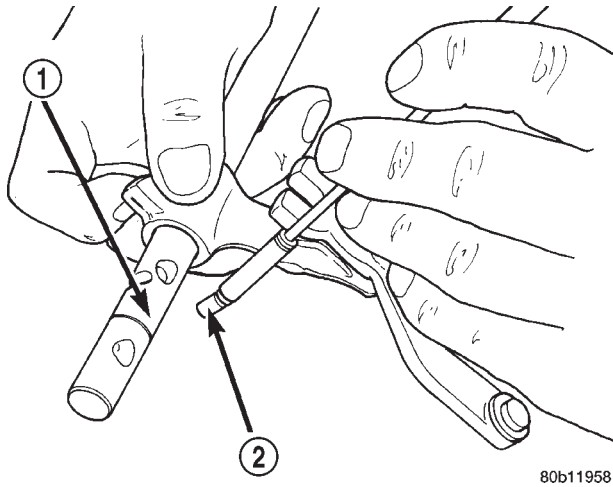

Fig. 69 Remove Reverse Shift Rail

- 1 - REVERSE SHIFT RAIL AND REVERSE FORK ASSEMBLY

DISASSEMBLY AND ASSEMBLY (Continued)

(28) Remove interlock pin from reverse shift rail (Fig. 70).



80b11958

Fig. 70 Remove Interlock Pin From Reverse Shift Rail

- 1 - REVERSE SHIFT RAIL
- 2 - INTERLOCK PIN

(30) Remove snap-ring on 3-4 shift rail.
 (31) Remove 1-2 shift rail from intermediate plate.
 (32) Remove interlock pin from 1-2 shift rail (Fig. 72).

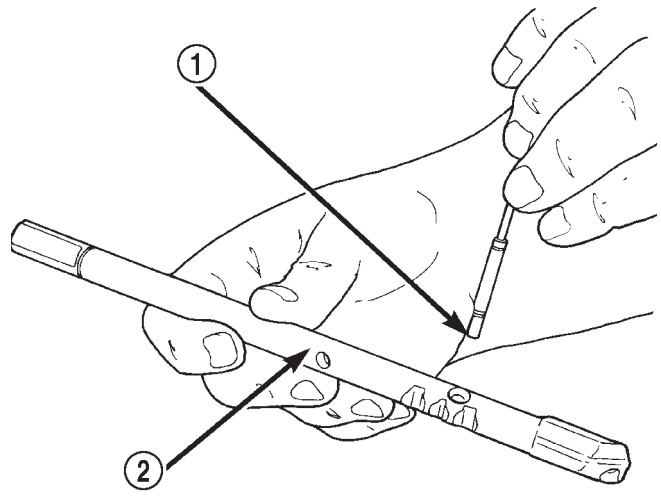

80ac6997

Fig. 72 Remove 1-2 Shift Rail Interlock Pin

- 1 - INTERLOCK PIN
- 2 - 1-2 SHIFT RAIL

(29) Remove reverse elongated check ball (Fig. 71).

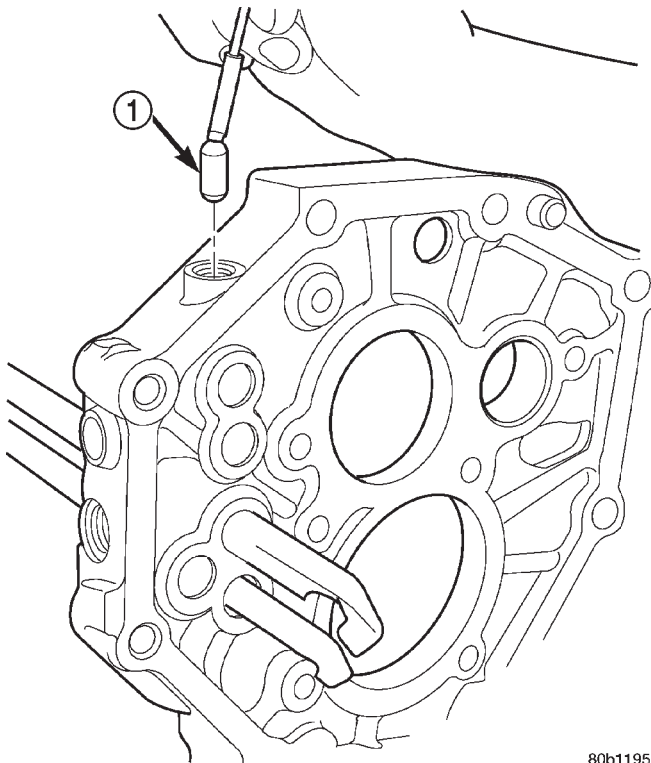

80b11957

Fig. 71 Remove Reverse Check Ball

- 1 - REVERSE CHECK BALL

(33) Remove 1-2 shift rail elongated check ball from intermediate plate (Fig. 73).
 (34) Remove 3-4 shift rail from intermediate plate.

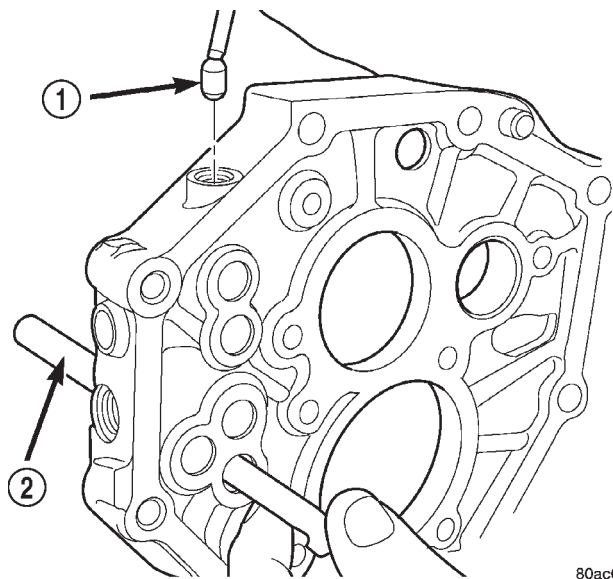

80ac6998

Fig. 73 Remove 1-2 Check Ball

- 1 - 1-2 CHECK BALL
- 2 - 3-4 SHIFT RAIL

DISASSEMBLY AND ASSEMBLY (Continued)

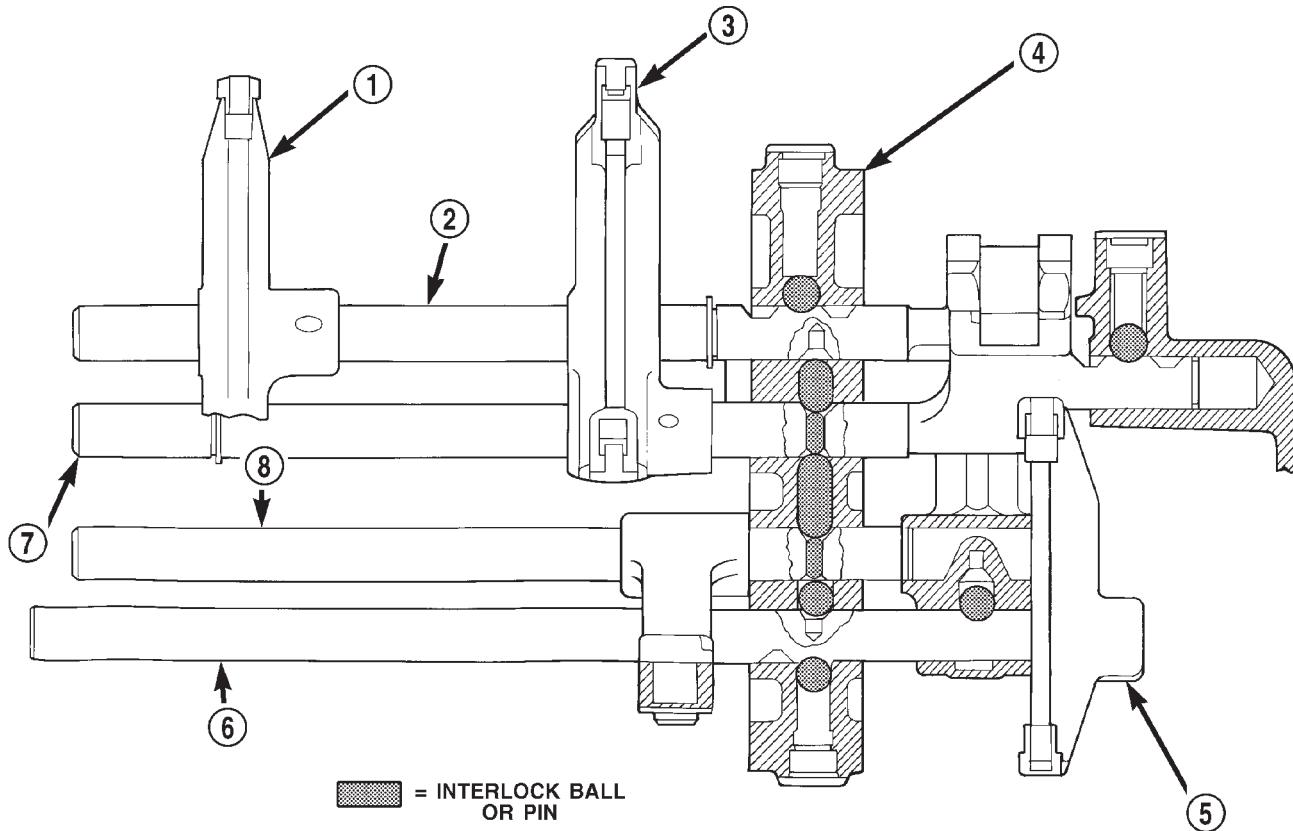

80b11956

Fig. 74 Shift Rail Components

- | | |
|---|---|
| <p>1 - 3-4 FORK 2 - 3-4 SHIFT RAIL 3 - 1-2 FORK 4 - INTERMEDIATE PLATE</p> | <p>5 - FIFTH GEAR FORK 6 - FIFTH GEAR SHIFT RAIL 7 - 1-2 SHIFT RAIL 8 - REVERSE SHIFT RAIL</p> |
|---|---|

ASSEMBLY

Refer to (Fig. 74) while assembling and installing the shift rail components. Also, verify that all shift rail components are in their neutral position when installing the check balls and interlock pins.

- (1) Install the 3-4 shift rail into the intermediate plate.
- (2) Install the 1-2 elongated check ball into the intermediate plate (Fig. 75).
- (3) Install the interlock pin into the 1-2 shift rail (Fig. 76).
- (4) Install the 1-2 shift rail into the intermediate plate.

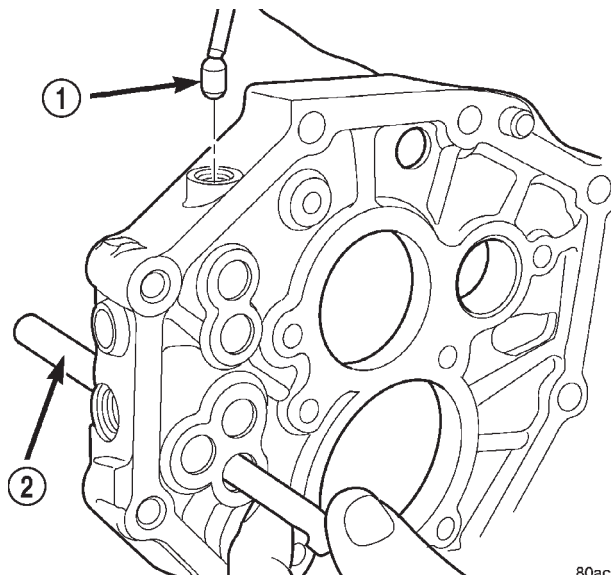

80ac6998

Fig. 75 Install 1-2 Check Ball

- | |
|---|
| <p>1 - 1-2 CHECK BALL 2 - 3-4 SHIFT RAIL</p> |
|---|

DISASSEMBLY AND ASSEMBLY (Continued)

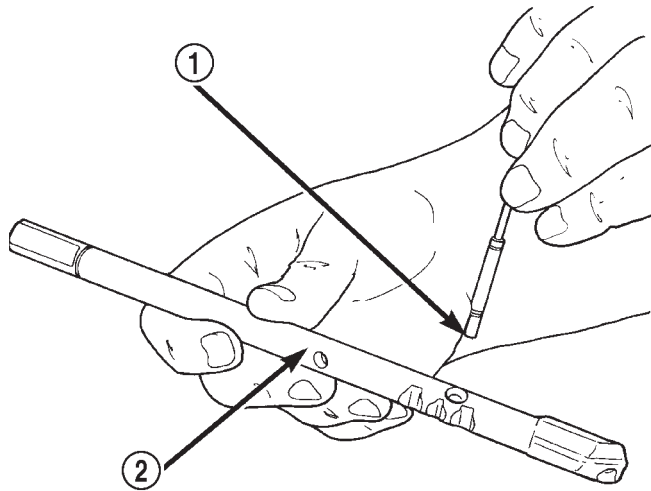

80ac6997

Fig. 76 Install 1-2 Shift Rail Interlock Pin

- 1 - INTERLOCK PIN
- 2 - 1-2 SHIFT RAIL

- (5) Install snap-ring onto 3-4 shift rail.
- (6) Install the reverse check ball into the intermediate plate (Fig. 77).

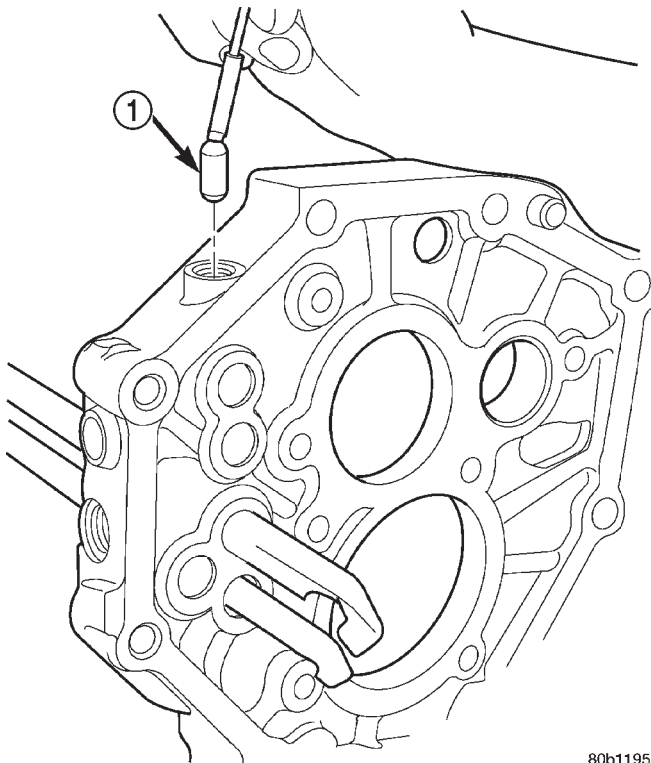

80b11957

Fig. 77 Install Reverse Check Ball

- 1 - REVERSE CHECK BALL

- (7) Install the interlock pin into the reverse shift rail (Fig. 78).

- (8) Assemble the reverse arm bracket to the reverse fork (Fig. 79).

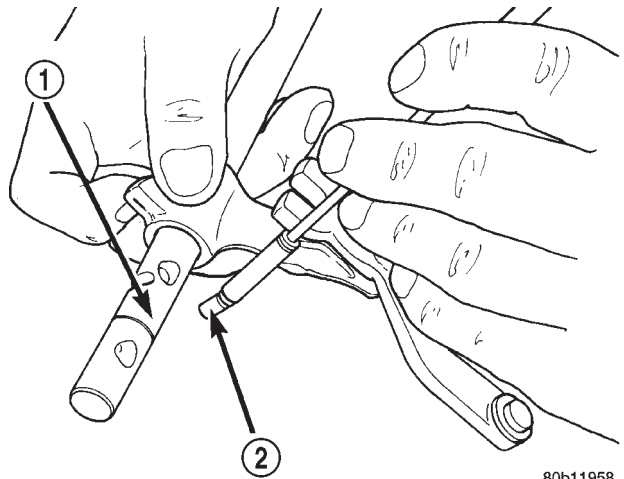

80b11958

Fig. 78 Install Reverse Interlock Pin

- 1 - REVERSE SHIFT RAIL
- 2 - INTERLOCK PIN

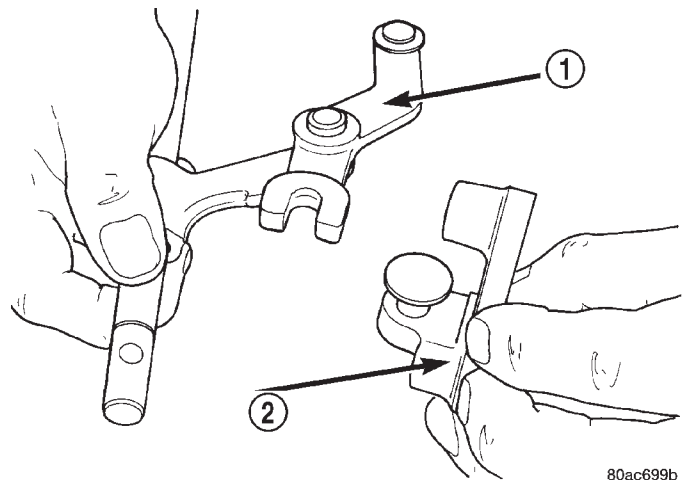

80ac699b

Fig. 79 Install Reverse Arm Bracket to Fork

- 1 - REVERSE SHIFT FORK
- 2 - REVERSE ARM BRACKET

- (9) Install reverse shift rail into intermediate plate and position reverse arm bracket to intermediate plate (Fig. 80).

DISASSEMBLY AND ASSEMBLY (Continued)

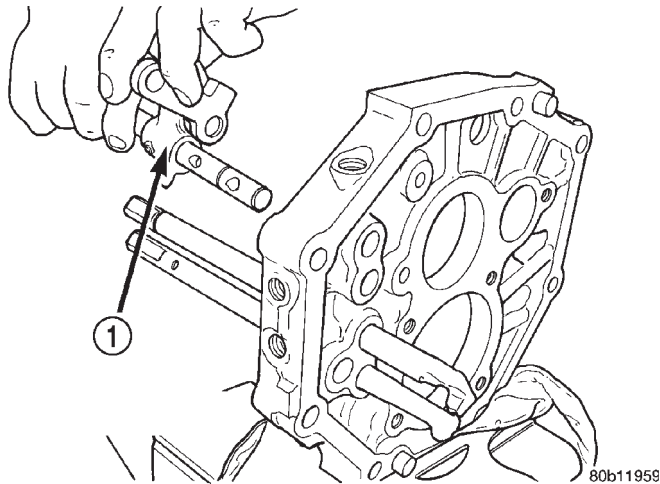

Fig. 80 Install Reverse Shift Rail

1 - REVERSE SHIFT RAIL AND REVERSE FORK ASSEMBLY

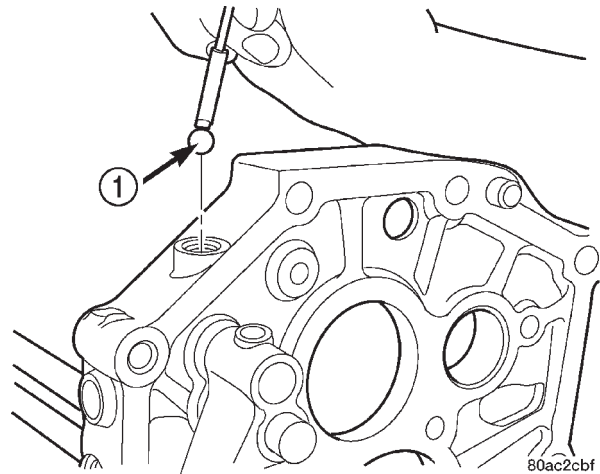

Fig. 82 Install Fifth Gear Check Ball

1 - FIFTH GEAR CHECK BALL

(10) Install snap-ring onto reverse shift rail (Fig. 81).

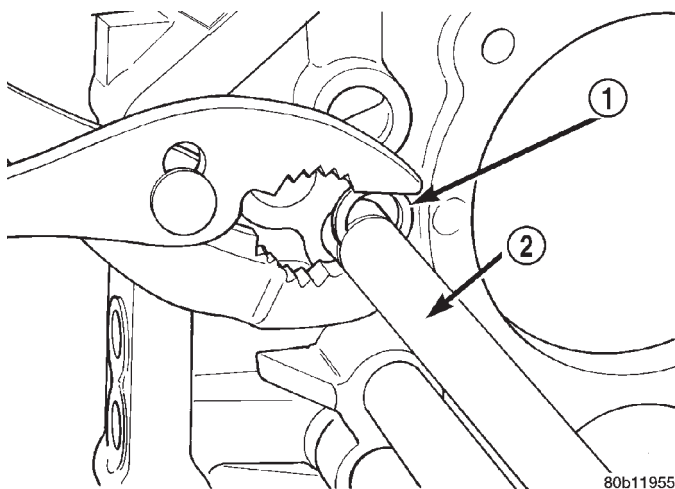

Fig. 81 Install Reverse Snap-ring

1 - SNAP RING
2 - REVERSE SHIFT RAIL

(11) Install reverse shift head and rail assembly into the intermediate plate.

(12) Install the fifth gear interlock ball and check ball (Fig. 82).

(13) Install fifth gear shift rail (Fig. 83).

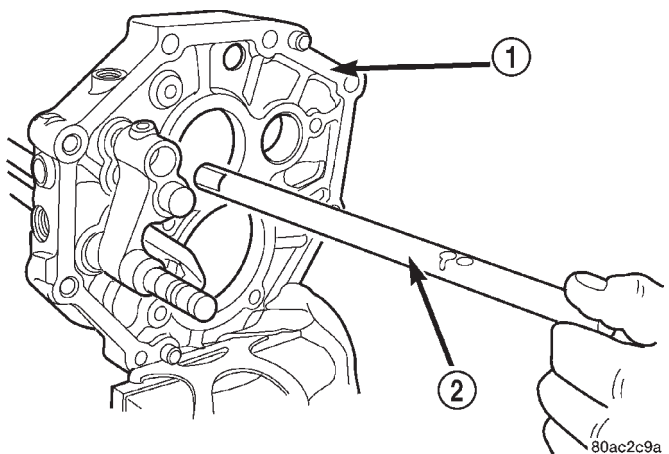

Fig. 83 Install Fifth Gear Shift Rail

1 - INTERMEDIATE PLATE
2 - FIFTH GEAR SHIFT RAIL

(14) Remove the intermediate plate from the vise, rotate the plate 180°, and reinstall the plate in the vise using the same bolt and washer mounting set-up.

(15) Install the shift rail detent balls in the intermediate plate.

DISASSEMBLY AND ASSEMBLY (Continued)

(16) Install the shift rail detent springs in the intermediate plate. Note that the bottom detent spring is shorter than the others.

(17) Install the shift rail detent plugs in the intermediate plate.

(18) Install the 1-2 shift fork onto the 1-2 and 3-4 shift rails (Fig. 84).

(19) Install the snap-ring onto the 1-2 shift rail.

(20) Install the 3-4 shift fork onto the 3-4 shift rail (Fig. 85).

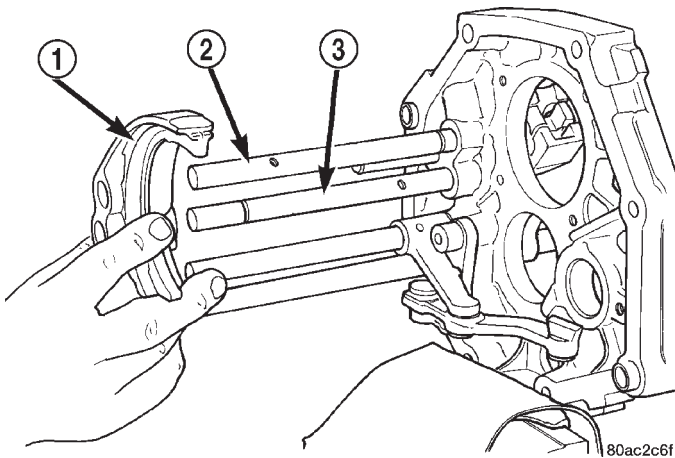

Fig. 84 Install 1-2 Shift Fork

- 1 - 1-2 SHIFT FORK
- 2 - 3-4 SHIFT RAIL
- 3 - 1-2 SHIFT RAIL

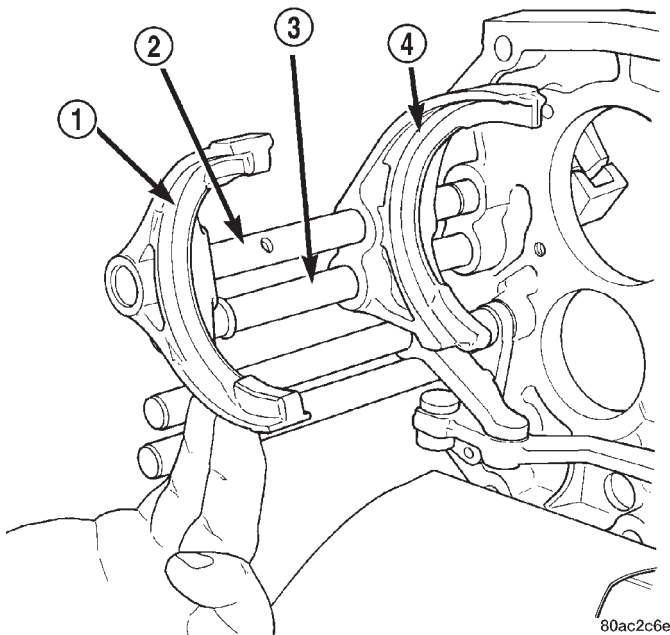

Fig. 85 Install 3-4 Shift Fork

- 1 - 3-4 SHIFT FORK
- 2 - 3-4 SHIFT RAIL
- 3 - 1-2 SHIFT RAIL
- 4 - 1-2 SHIFT FORK

(21) Install mainshaft into the intermediate plate by guiding the output shaft through opening in intermediate plate until the shift forks are aligned with the appropriate synchronizer sleeves. The mainshaft rear bearing will be started in the intermediate plate but not fully driven in at this point.

(22) While an assistant supports the mainshaft, align rear of countershaft with inner race of countershaft rear bearing.

(23) Raise countershaft upward until gears mesh with the mating gears on the mainshaft.

(24) Using a suitable rubber mallet, tap on the input shaft and the front of the countershaft equally to install the mainshaft rear bearing into the intermediate plate and the rear of the countershaft into the rear countershaft bearing. It may be necessary to occasionally hold the countershaft into the intermediate plate and tap the countershaft rear bearing onto the countershaft and into the intermediate plate.

(25) Install snap-rings onto the rear mainshaft and countershaft bearings.

(26) Install the bolts to hold the reverse shift arm bracket to the intermediate plate.

(27) Install new bolts to hold the shift forks to the shift rails (Fig. 86).

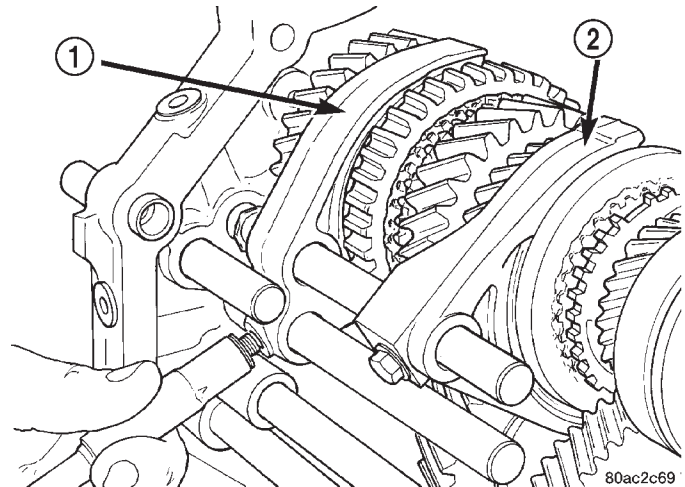

Fig. 86 Install Shift Fork Bolts

- 1 - 1-2 SHIFT FORK
- 2 - 3-4 SHIFT FORK

(28) Position the mainshaft rear bearing retainer over the output shaft and onto the intermediate plate.

(29) Install new bolts to hold the bearing retainer to the intermediate plate.

(30) Move the reverse shift arm into the reverse gear position. The reverse gear position is with the arm moved away from the intermediate plate (Fig. 87).

(31) Install the reverse idler gear assembly into position on the mainshaft and reverse shift arm.

DISASSEMBLY AND ASSEMBLY (Continued)

(32) Install the compression spring and pin into the reverse idler gear shaft (Fig. 88).

(33) Install the reverse idler shaft through the intermediate plate and reverse idler gear assembly (Fig. 89) until the idler shaft pin contacts the gear assembly. Make sure that the notched cut-out in the idler shaft is to the rear of the transmission.

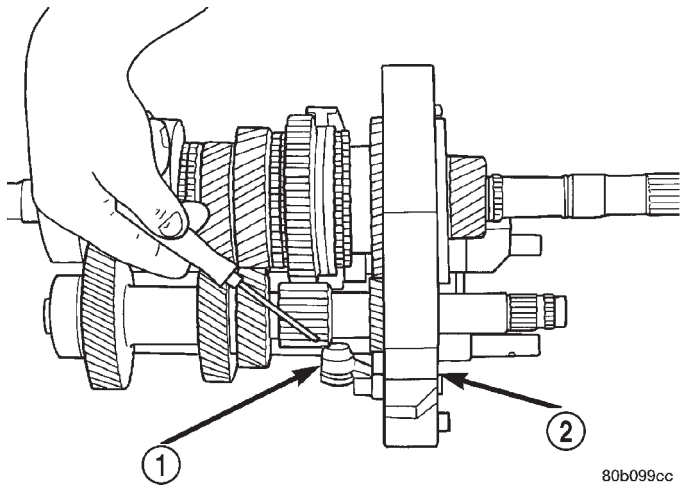

Fig. 87 Reverse Shift Arm Position

- 1 - REVERSE SHIFT ARM
- 2 - INTERMEDIATE PLATE

80b099cc

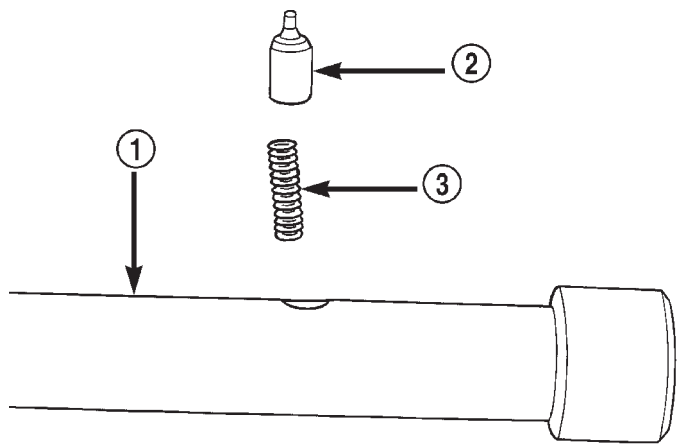
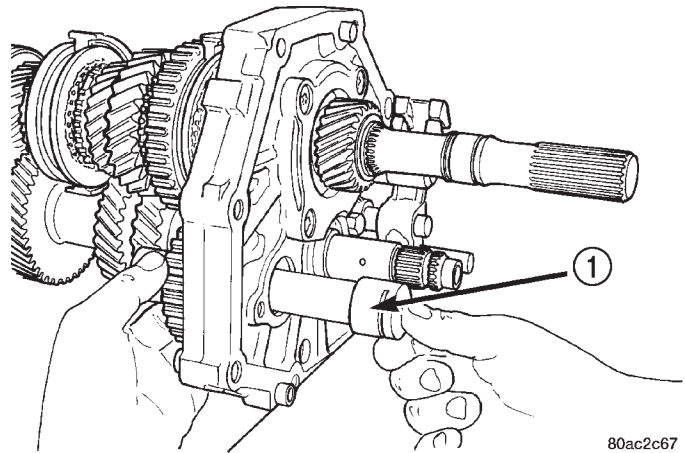

Fig. 88 Install Compression Spring And Pin

- 1 - REVERSE IDLER GEAR SHAFT
- 2 - PIN
- 3 - COMPRESSION SPRING

80b099ed



80ac2c67

Fig. 89 Install Reverse Idler Shaft

- 1 - REVERSE IDLER SHAFT

(34) Align the pin with the alignment notch in the reverse idler gear assembly (Fig. 90). The alignment notch in the reverse idler gear race/hub is a small relief cut above one of the main longitudinal slots. Be sure that the pin is aligned with the proper slot, the opposite slot has an oil drain hole which the pin will drop into. The assembly will then be locked onto the shaft and will need to be disassembled in order to be removed.

(35) Depress compression spring and pin in reverse idler gear shaft (Fig. 91).

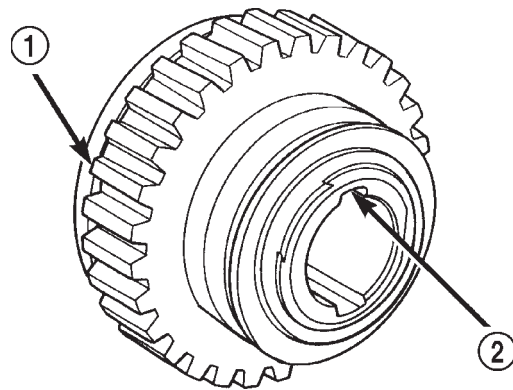

80b099ce

Fig. 90 Align Idler Shaft Pin

- 1 - REVERSE IDLER GEAR ASSEMBLY
- 2 - ALIGNMENT NOTCH

(36) Install the reverse idler gear shaft the remainder of the way through the reverse idler gear assembly.

DISASSEMBLY AND ASSEMBLY (Continued)

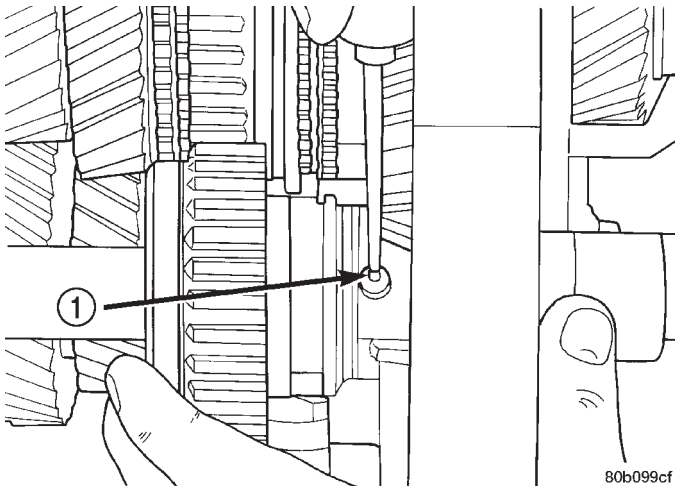

Fig. 91 Depress Pin In Reverse Idler Gear Shaft

- 1 - DEPRESS PIN

(37) Position the reverse idler gear shaft lock plate onto the intermediate plate.

(38) Install a new bolt to hold the idler gear shaft lock plate to the intermediate plate.

(39) Install the fifth gear thrust ring lock ball to the countershaft (Fig. 92).

(40) Install the fifth gear thrust ring onto the countershaft and over the lock ball (Fig. 93).

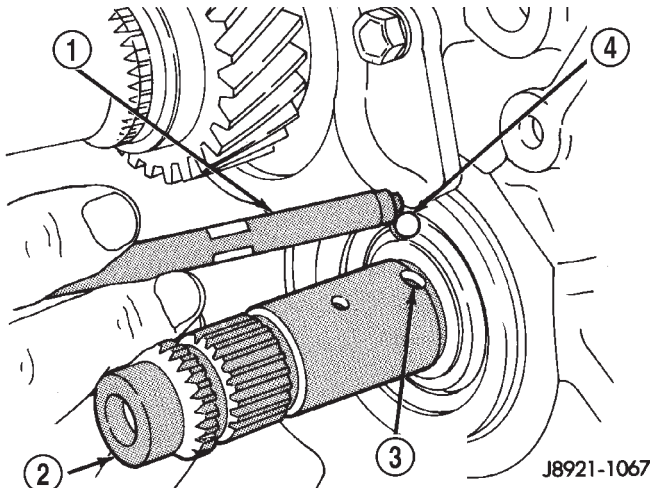

Fig. 92 Install Fifth Gear Thrust Ring Lock Ball

- 1 - PENCIL MAGNET
- 2 - CLUSTER GEAR
- 3 - LOCK BALL RECESS
- 4 - THRUST RING LOCK BALL

(41) Install fifth gear shift fork to the countershaft fifth gear assembly.

(42) Install the countershaft fifth gear bearings into the countershaft fifth gear assembly.

(43) Position the countershaft fifth gear assembly on the countershaft. Ensure that the fifth gear fork is installed onto the fifth gear shift rail.

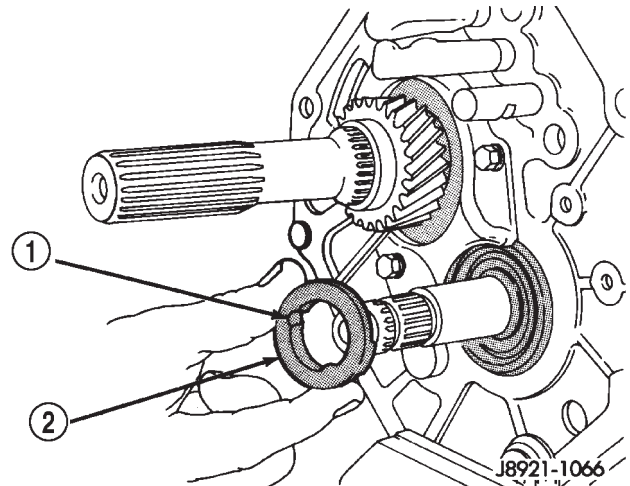

Fig. 93 Install Fifth Gear Thrust Ring

- 1 - LOCK BALL NOTCH
- 2 - FIFTH GEAR THRUST RING

(44) Install the fifth gear synchro ring.

(45) Position the fifth gear blocker ring onto the countershaft.

(46) Using a suitable mallet and spacer, tap the fifth gear blocker ring onto the countershaft.

(47) Install new bolt to hold fifth gear shift fork to the fifth gear shift rail (Fig. 94).

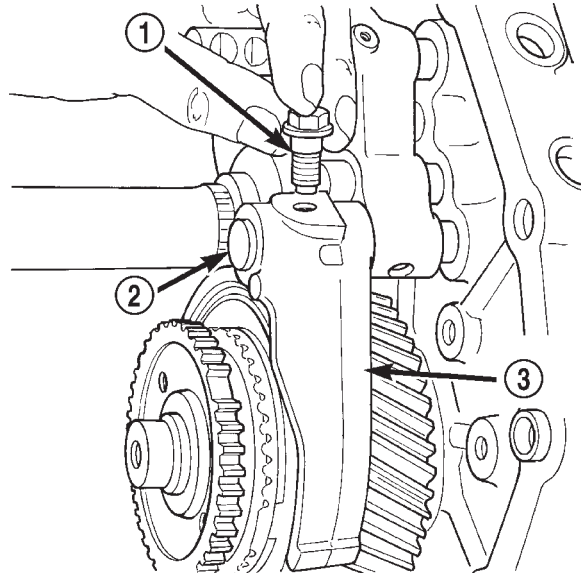

Fig. 94 Install Fifth Gear Retainer Bolt

- 1 - SHIFT FORK RETAINER BOLT
- 2 - FIFTH GEAR SHIFT RAIL
- 3 - FIFTH GEAR SHIFT FORK

(48) Measure countershaft fifth gear thrust clearance.

(49) Select a snap-ring so that the thrust clearance is 0.10–0.30 mm (0.004–0.010 in.).

(50) Install snap-ring to hold fifth gear blocker ring onto countershaft.

DISASSEMBLY AND ASSEMBLY (Continued)

(51) Remove intermediate plate from vise and remove bolts and washers from intermediate.

COUNTERSHAFT

DISASSEMBLY

(1) Remove select fit snap-ring holding the countershaft front bearing onto the countershaft (Fig. 95).

(2) Using Bearing Splitter P-334, a suitable spacer on center of countershaft, and a shop press, remove the countershaft front bearing from the countershaft.

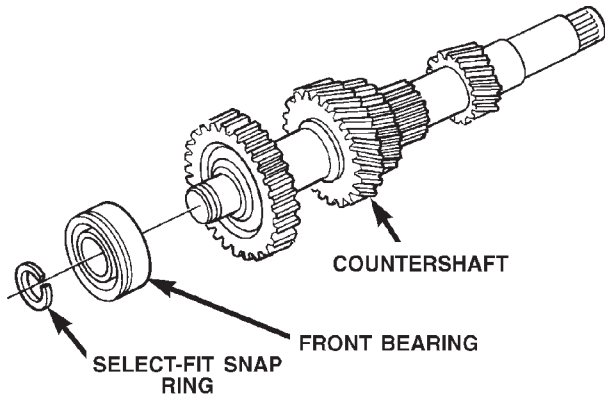

| I. D. MARK | SNAP RING THICKNESS MM (IN.) | |
|------------|------------------------------|-------------------|
| 1 | 2.05 - 2.10 | (0.0807 - 0.0827) |
| 2 | 2.10 - 2.15 | (0.0827 - 0.0846) |
| 3 | 2.15 - 2.20 | (0.0846 - 0.0866) |
| 4 | 2.20 - 2.25 | (0.0866 - 0.0886) |
| 5 | 2.25 - 2.30 | (0.0886 - 0.0906) |
| 6 | 2.30 - 2.35 | (0.0906 - 0.0925) |

80ac6a0a

Fig. 95 Countershaft Front Bearing Snap-ring

ASSEMBLY

(1) Remove any nicks or burrs on countershaft hub with fine emery or crocus cloth.

(2) Position countershaft front bearing on end of countershaft.

(3) Using Special Tool 8109 and a shop press, press bearing onto countershaft.

(4) Select the thickest snap-ring that will fit into the snap-ring groove of the countershaft (Fig. 95).

(5) Install snap-ring to hold countershaft front bearing onto countershaft.

INPUT SHAFT

DISASSEMBLY

(1) Verify that the 3-4 synchronizer is in the neutral position.

(2) Separate input shaft from output shaft (Fig. 96). Note that the output shaft pilot bearing is an uncaged roller type bearing.

(3) Remove the output shaft pilot bearing rollers from the input shaft and the output shaft.

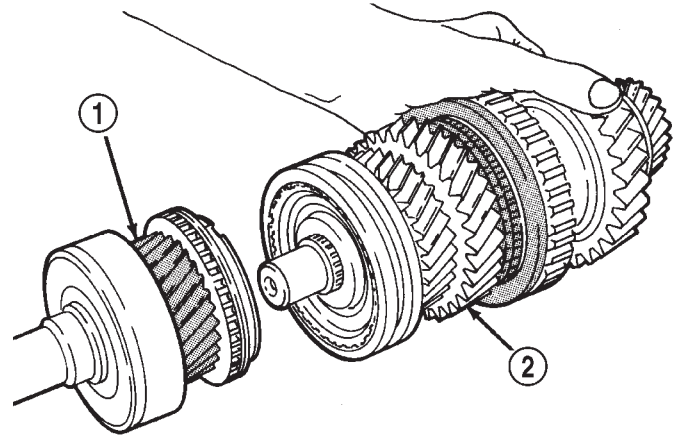

J8921-1089

Fig. 96 Separate Input and Output Shafts

- 1 - INPUT SHAFT ASSEMBLY
- 2 - OUTPUT SHAFT AND GEAR ASSEMBLY

(4) Remove the fourth gear synchronizer ring from the input shaft (Fig. 97).

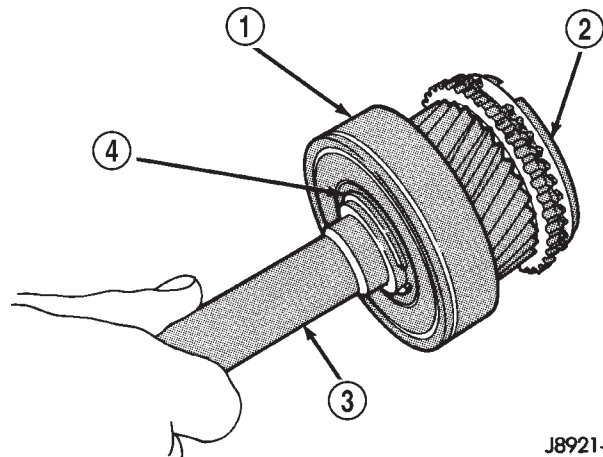

J8921-1091

Fig. 97 Input Shaft Components

- 1 - BEARING
- 2 - SYNCHRO RING
- 3 - INPUT SHAFT
- 4 - BEARING SNAP RING

(5) Remove the select fit snap-ring holding the input shaft bearing onto the input shaft.

(6) Using Bearing Splitter P-334 and a shop press, remove the bearing from the input shaft.

ASSEMBLY

(1) Position input shaft bearing onto input shaft.

(2) Using Driver L-4507, drive bearing onto input shaft.

(3) Select the thickest snap-ring that will fit into the snap-ring groove of the input shaft (Fig. 98).

(4) Lubricate output shaft pilot bearing bore of input shaft with petroleum jelly.

DISASSEMBLY AND ASSEMBLY (Continued)

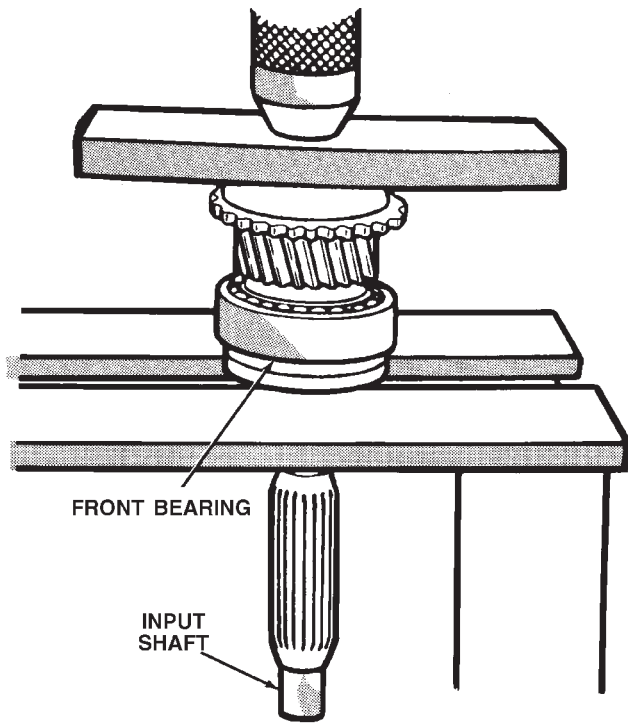

FRONT BEARING

INPUT SHAFT

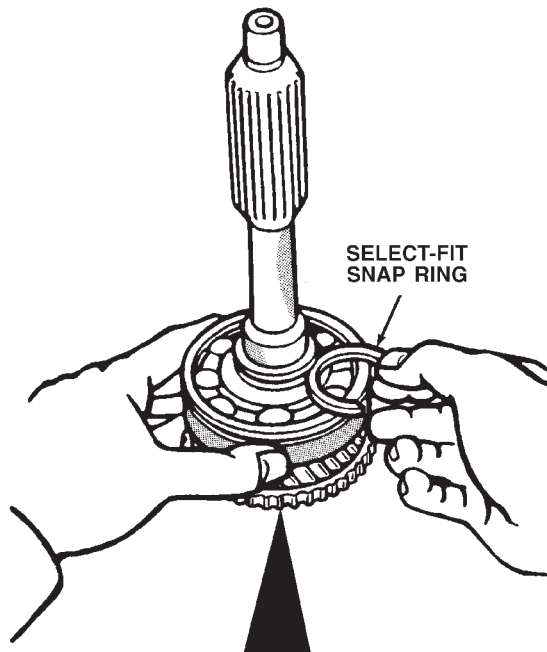

SELECT-FIT SNAP RING

| I. D. Mark | Snap Ring Thickness mm (in.) |
|------------|------------------------------|
| 0 | 2.05-2.10 (0.0807-0.0827) |
| 1 | 2.10-2.15 (0.0827-0.0846) |
| 2 | 2.15-2.20 (0.0846-0.0866) |
| 3 | 2.20-2.25 (0.0866-0.0886) |
| 4 | 2.25-2.30 (0.0886-0.0906) |
| 5 | 2.30-2.35 (0.0906-0.0925) |

J8921-50

Fig. 98 Select Input Shaft Bearing Snap-ring

(5) Install output shaft pilot bearing rollers in input shaft bore (Fig. 99). Ensure to use sufficient petroleum jelly to hold rollers in position.

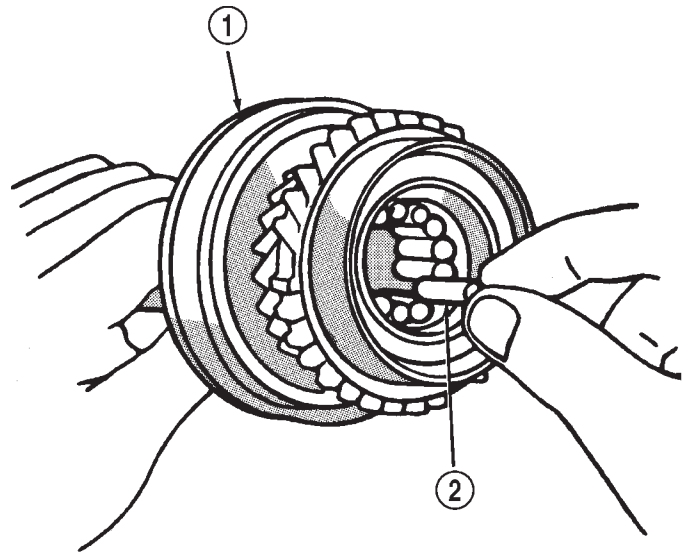

J8921-64

Fig. 99 Install Output Shaft Pilot Bearing Rollers

- 1 - INPUT SHAFT
- 2 - BEARING ROLLERS

(6) Install the fourth gear synchronizer ring onto the input shaft.

(7) Install input shaft to output shaft. Use care when mating the two shafts not to displace any output shaft pilot bearing rollers.

OUTPUT SHAFT

DISASSEMBLY

(1) Remove input shaft and output shaft pilot bearing rollers from output shaft.

(2) Measure and note thrust clearance of output shaft gears (Fig. 100). Clearance should be 0.10 - 0.25 mm (0.004 - 0.010 in.).

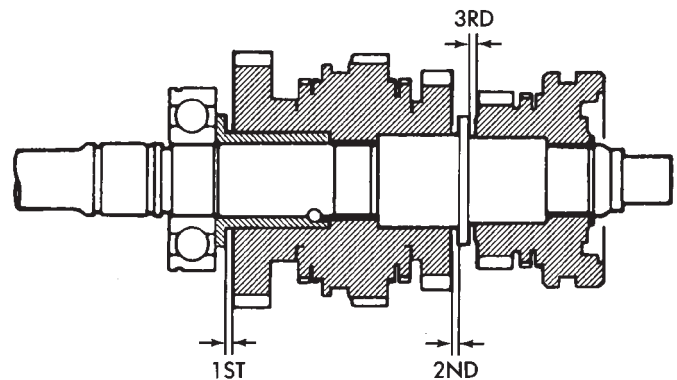

THRUST CLEARANCE IS 0.004 TO 0.012 INCH (0.10 TO 0.25 mm)

J8921-36

Fig. 100 Check Output Shaft Gear Thrust Clearance

DISASSEMBLY AND ASSEMBLY (Continued)

(3) Remove output shaft fifth gear snap ring with two screwdrivers (Fig. 101).

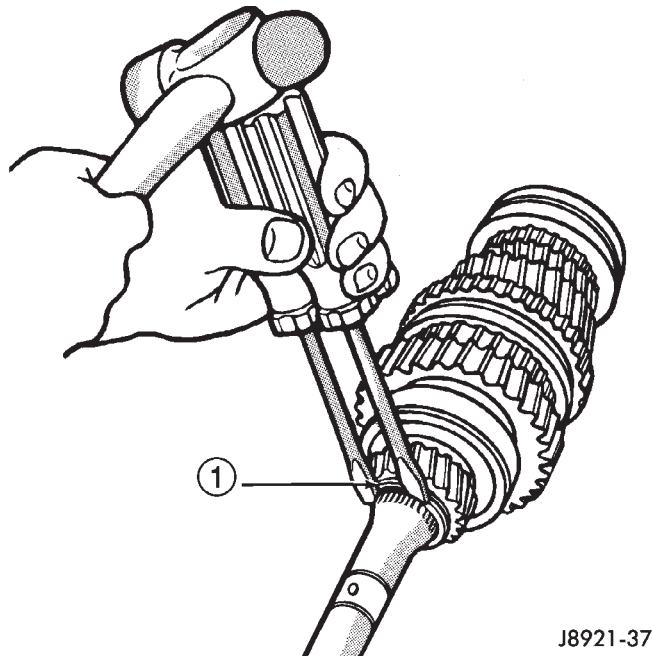

J8921-37

Fig. 101 Remove Fifth Gear Snap-ring

1 - SNAP RING

(4) Using Bearing Splitter P-334 or suitable press plates positioned under first gear, press fifth gear, rear bearing, first gear, and first gear bearing inner race off output shaft (Fig. 102).

(5) Remove first gear needle roller bearing from output shaft.

(6) Remove first gear bearing inner race lock ball with pencil magnet (Fig. 103).

(7) Remove first gear synchronizer ring.

(8) Using Bearing Splitter P-334 or suitable press plates positioned under second gear, press 1-2 synchronizer, reverse gear, and second gear from output shaft (Fig. 104).

(9) Remove second gear needle roller bearing from the output shaft or second gear.

(10) Remove select fit snap-ring holding the 3-4 synchronizer onto the output shaft (Fig. 105).

(11) Using Bearing Splitter P-334 or suitable press plates positioned under third gear, press the 3-4 synchronizer and third gear from output shaft (Fig. 106).

(12) Remove third gear needle roller bearing from output shaft or gear.

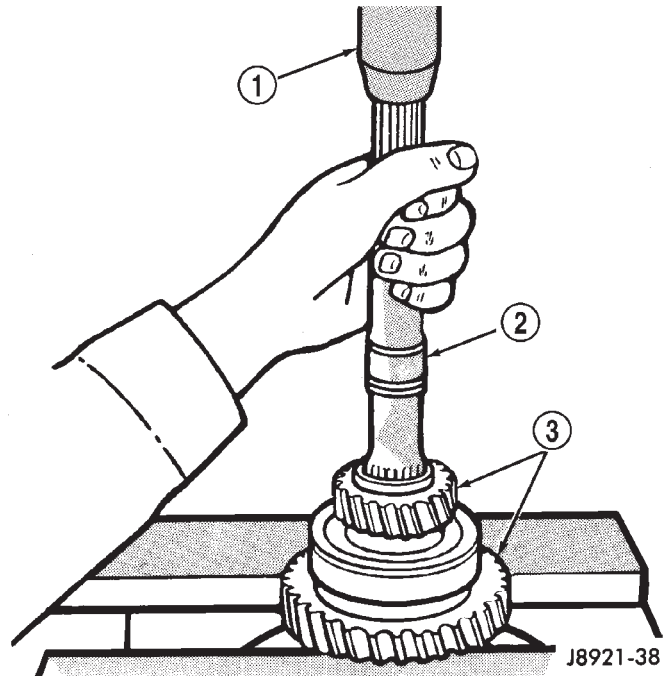

J8921-38

Fig. 102 Remove Fifth Gear, First Gear Bearing, And Race

1 - PRESS RAM

2 - OUTPUT SHAFT

3 - FIRST-FIFTH GEAR-BEARING ASSEMBLY

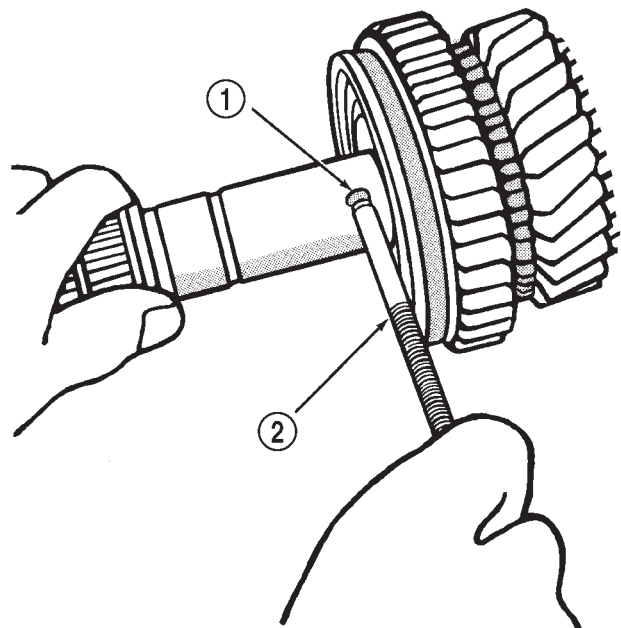

J8921-39

Fig. 103 Remove First Gear Bearing Inner Race Lock Ball

1 - LOCK BALL

2 - PENCIL MAGNET

DISASSEMBLY AND ASSEMBLY (Continued)

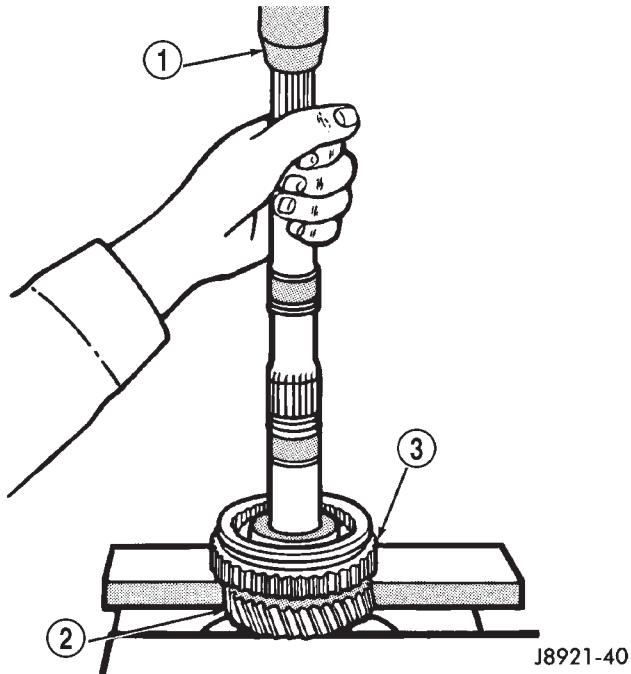

Fig. 104 Remove Second Gear, Reverse Gear, And 1-2 Synchronizer

- 1 - PRESS RAM
- 2 - SECOND GEAR
- 3 - 1-2 SYNCHRONIZER HUB

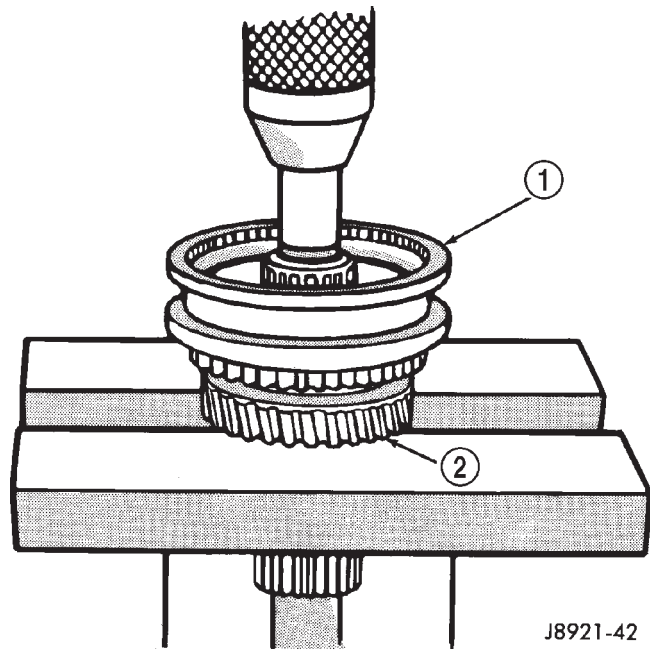

Fig. 106 Remove 3-4 Synchronizer And Third Gear

- 1 - 3-4 SYNCHRONIZER
- 2 - THIRD GEAR

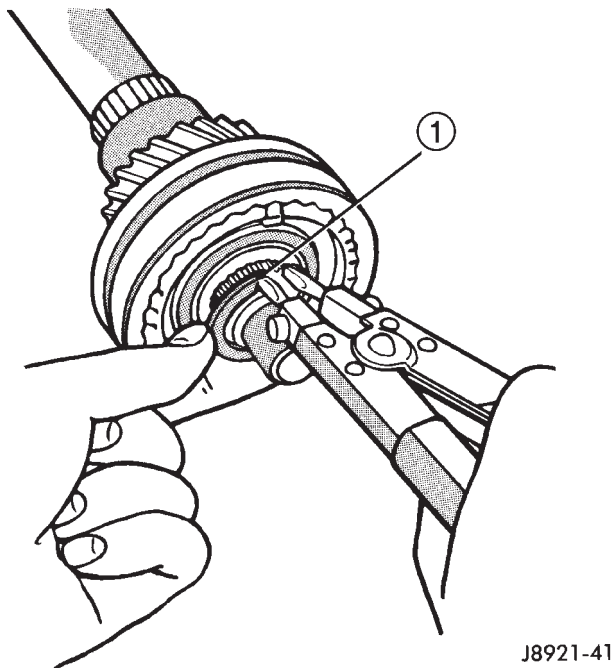

Fig. 105 Remove 3-4 Synchronizer Snap Ring

- 1 - 3-4 SYNCHRONIZER SNAP RING

ASSEMBLY

TRANSMISSION ASSEMBLY INFORMATION

Lubricate the transmission components with Mopar® 75W-90, GL 3 gear lubricant during assembly. Use petroleum jelly to lubricate seal lips and/or hold parts in place during installation.

Refer to (Fig. 107) during assembly for AX5 gear assembly identification.

- (1) Lubricate transmission components with specified gear lubricant.
- (2) If necessary, assemble 1-2 and 3-4 synchronizer hubs, sleeves, springs and key inserts (Fig. 108).
- (3) Install third gear needle bearing onto the output shaft.
- (4) Install third gear over bearing and onto output shaft flange.
- (5) Install third gear synchronizer ring to third gear.
- (6) Position the 3-4 synchronizer onto the output shaft.
- (7) Using Adapter 6747-1A and a shop press, press the 3-4 synchronizer onto the output shaft.

DISASSEMBLY AND ASSEMBLY (Continued)

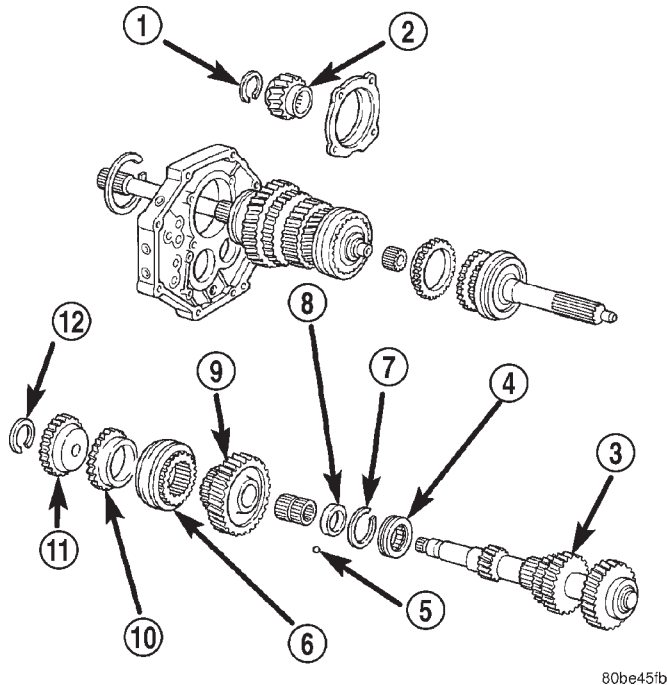

Fig. 107 Geartrain Components

- 1 - SNAP RING
- 2 - FIFTH GEAR
- 3 - COUNTER GEAR
- 4 - BEARING
- 5 - LOCK BALL
- 6 - SYNCHRO HUB/SLEEVE
- 7 - SNAP RING
- 8 - SPACER
- 9 - COUNTER 5TH GEAR
- 10 - SYNCHRO RING
- 11 - 5TH SPLINE GEAR
- 12 - SNAP RING

(8) Select the thickest snap-ring that will fit into the snap-ring groove of the output shaft (Fig. 109).

(9) Install snap-ring to hold 3-4 synchronizer onto output shaft.

(10) Verify third gear thrust clearance with feeler gauge (Fig. 110). Clearance should be 0.10 - 0.25 mm (0.004 - 0.010 in.). If clearance is out of specification, refer to Cleaning and Inspection section within this group.

(11) Install second gear needle bearing onto output shaft.

(12) Install second gear over bearing and onto output shaft flange.

(13) Install second gear synchronizer ring onto second gear.

(14) Position 1-2 synchronizer assembly onto splines of output shaft.

(15) Using Driver MD-998805, Adapter 6747-1A, and a shop press, press the 1-2 synchronizer onto the output shaft.

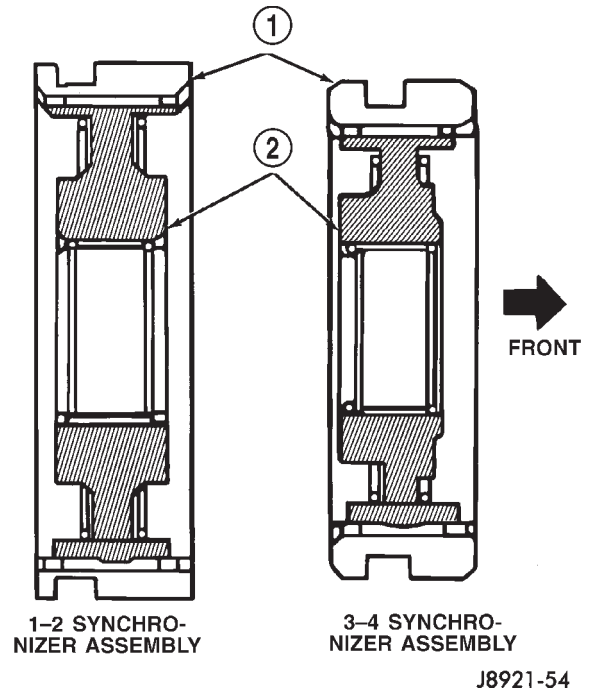
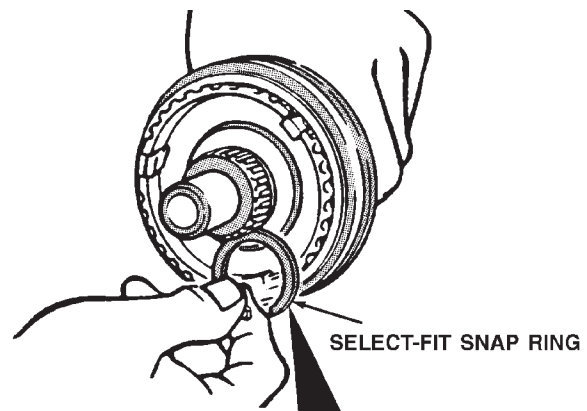

Fig. 108 Synchronizer Identification

- 1 - SLEEVES
- 2 - HUBS



| I. D. Mark | Snap Ring Thickness mm (in.) |
|------------|------------------------------|
| C-1 | 1.75-1.80 (0.0689-0.0709) |
| D | 1.80-1.85 (0.0709-0.0728) |
| D-1 | 1.85-1.90 (0.0728-0.0748) |
| E | 1.90-1.95 (0.0748-0.0768) |
| E-1 | 1.95-2.00 (0.0768-0.0787) |
| F | 2.00-2.05 (0.0788-0.0807) |
| F-1 | 2.05-2.10 (0.0807-0.0827) |

J8921-55

Fig. 109 Select 3-4 Synchronizer Snap-ring

(16) Install first gear synchronizer ring into 1-2 synchronizer.

(17) Install first gear bearing inner race lock ball in output shaft (Fig. 111).

(18) Install first gear needle bearing onto output shaft (Fig. 112).

DISASSEMBLY AND ASSEMBLY (Continued)

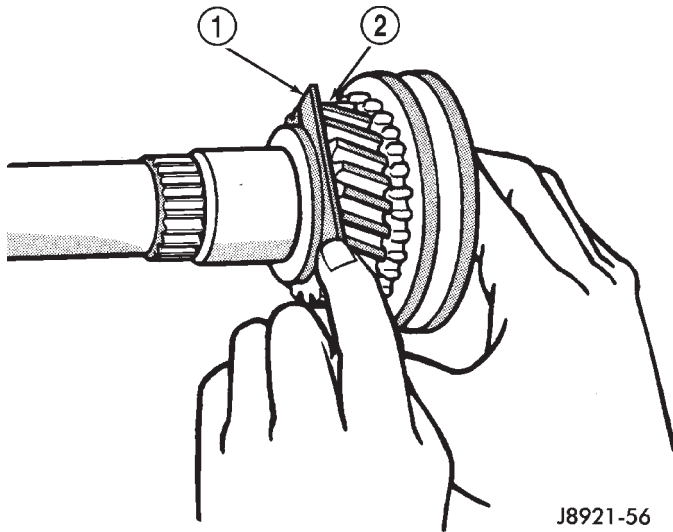

Fig. 110 Check Third Gear Clearance

- 1 - FEELER GAUGE
- 2 - THIRD GEAR

(23) Install snap-ring onto output shaft rear bearing outer race.

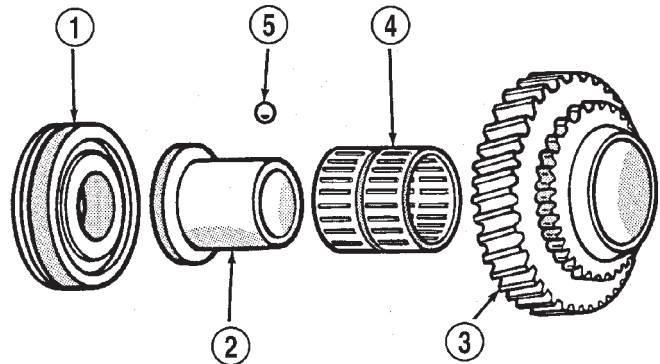

Fig. 112 First Gear Components

- 1 - REAR BEARING
- 2 - INNER RACE
- 3 - FIRST GEAR
- 4 - NEEDLE BEARING
- 5 - FIRST GEAR LOCK BALL

J8921-59

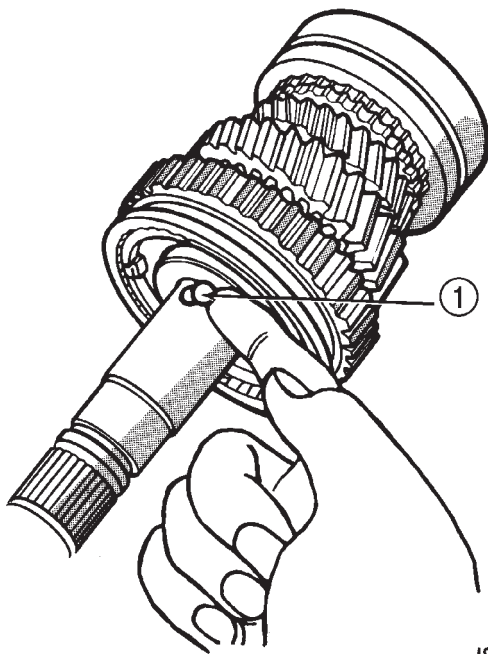
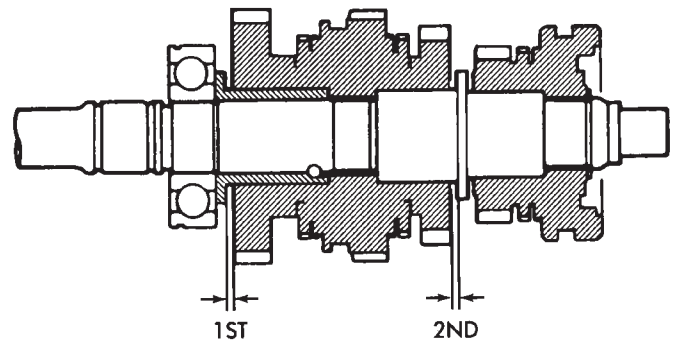

Fig. 111 Install First Gear Bearing Inner Race Lock Ball

- 1 - FIRST GEAR LOCK BALL

(24) Check first-second gear thrust clearance (Fig. 113). Standard clearance is 0.10 - 0.25 mm (0.004 - 0.010 in.). If clearance is out of specification, refer to Cleaning and Inspection section within this group.



STANDARD CLEARANCE
0.004-0.010 INCH
(0.10-0.25 mm)

J8921-61

(19) Install first gear onto output shaft and over bearing.

(20) Install first gear bearing inner race onto output shaft and inside first gear bearing. Rotate bearing race until race installs over lock ball.

(21) Position output shaft rear bearing onto output shaft. Ensure that the snap ring groove in bearing outer race is toward rear of output shaft.

(22) Using Driver L-4507 and suitable mallet, drive bearing onto output shaft.

Fig. 113 Check First-Second Gear Thrust Clearance

(25) Position fifth gear onto output shaft with the gear's short shoulder toward the rear of shaft. Ensure that the gear and output shaft splines are aligned.

(26) Using Adapter 6747-1A, Driver L-4507, and a shop press, press fifth gear onto output shaft.

(27) Select the thickest snap-ring that will fit into the snap-ring groove of the output shaft (Fig. 114).

DISASSEMBLY AND ASSEMBLY (Continued)

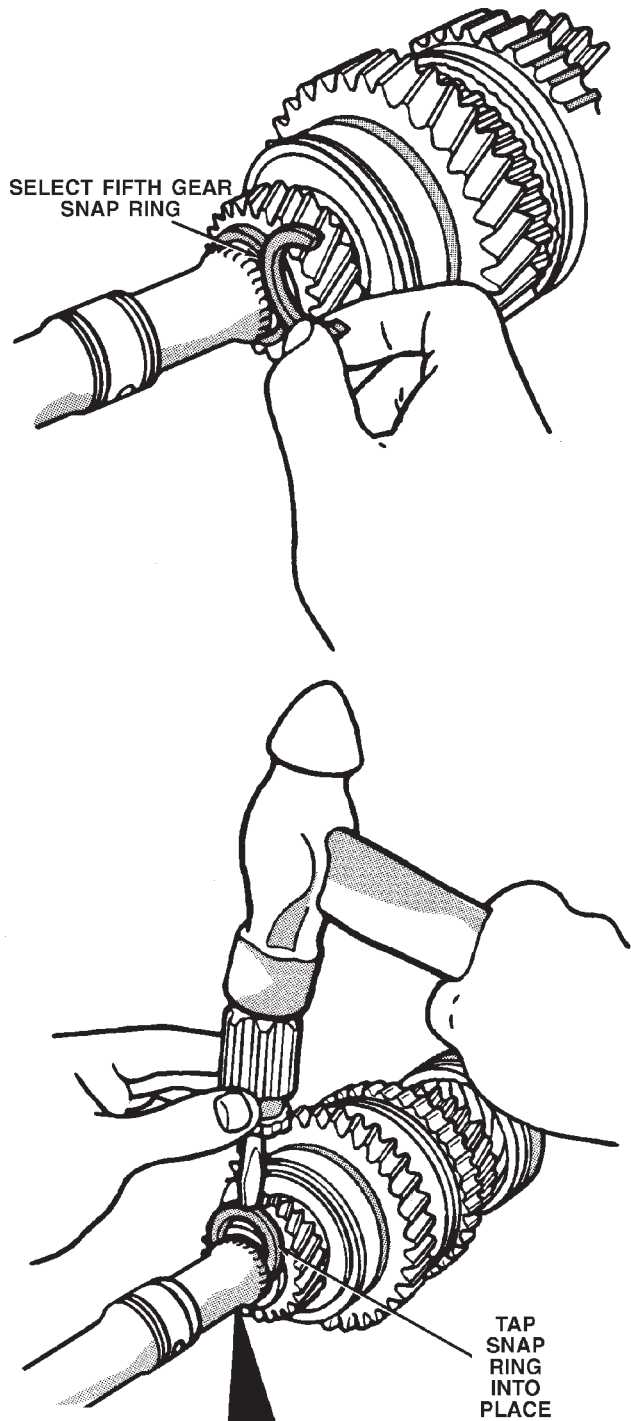

| I. D. Mark | Snap Ring Thickness mm (in.) |
|------------|------------------------------|
| A | 2.67-2.72 (0.1051-0.1071) |
| B | 2.73-2.78 (0.1075-0.1094) |
| C | 2.79-2.84 (0.1098-0.1118) |
| D | 2.85-2.90 (0.1122-0.1142) |
| E | 2.91-2.96 (0.1146-0.1165) |
| F | 2.97-3.02 (0.1169-0.1189) |
| G | 3.03-3.08 (0.1193-0.1213) |
| H | 3.09-3.14 (0.1217-0.1236) |
| J | 3.15-3.20 (0.1240-0.1260) |
| K | 3.21-3.26 (0.1264-0.1283) |
| L | 3.27-3.32 (0.1287-0.1307) |

J8921-63

Fig. 114 Select/Install Fifth Gear Snap Ring

(28) Install snap-ring to hold fifth gear onto output shaft.

SEMI-SYNCHRONIZED REVERSE IDLER GEAR

DISASSEMBLY

- (1) Remove snap-ring holding the reverse idler gear onto the reverse idler gear hub/race (Fig. 115).
- (2) Remove the plate washer from the reverse idler gear hub/race (Fig. 116).

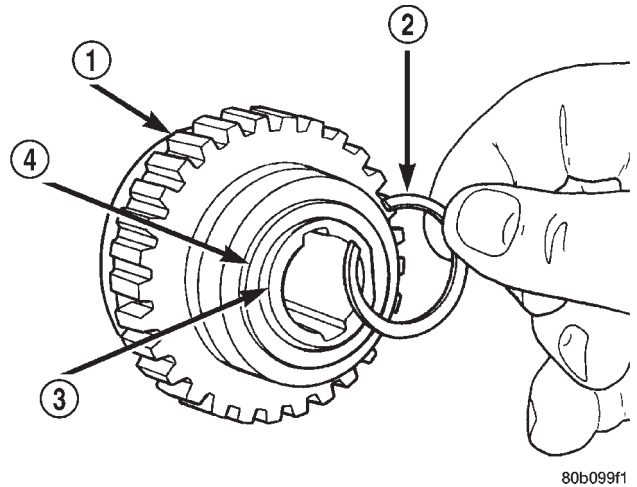

80b099f1

Fig. 115 Remove Reverse Idler Gear Snap-ring

- 1 - REVERSE IDLER GEAR
- 2 - SNAP-RING
- 3 - REVERSE IDLER GEAR HUB
- 4 - PLATE WASHER

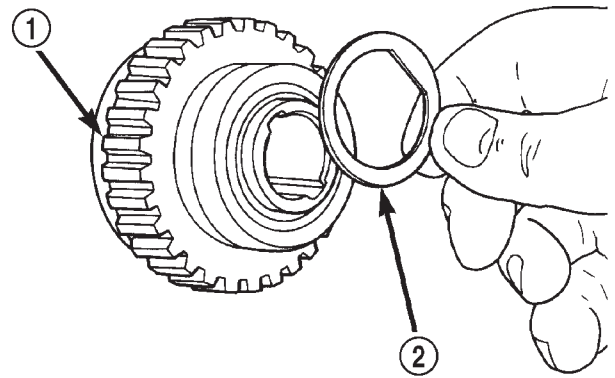

80b099f2

Fig. 116 Remove Reverse Idler Gear Plate Washer

- 1 - REVERSE IDLER GEAR
- 2 - PLATE WASHER

- (3) Remove the reverse idler gear from the reverse idler gear hub/race (Fig. 117).
- (4) Remove the reverse idler gear synchronizer ring from the reverse idler gear hub/race (Fig. 118).

DISASSEMBLY AND ASSEMBLY (Continued)

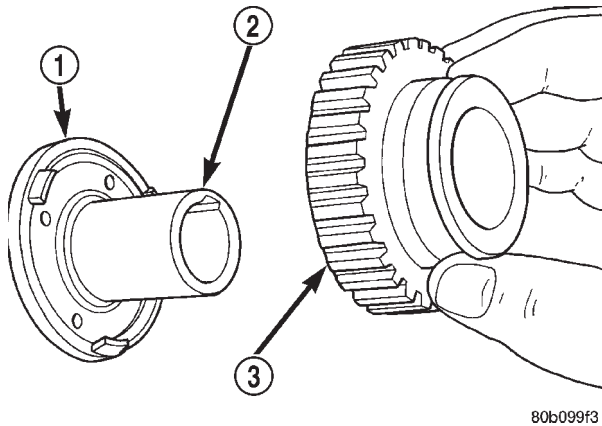
**Fig. 117 Remove Reverse Idler Gear**

- 1 - REVERSE SYNCHRONIZER RING
 2 - REVERSE IDLER GEAR HUB
 3 - REVERSE IDLER GEAR

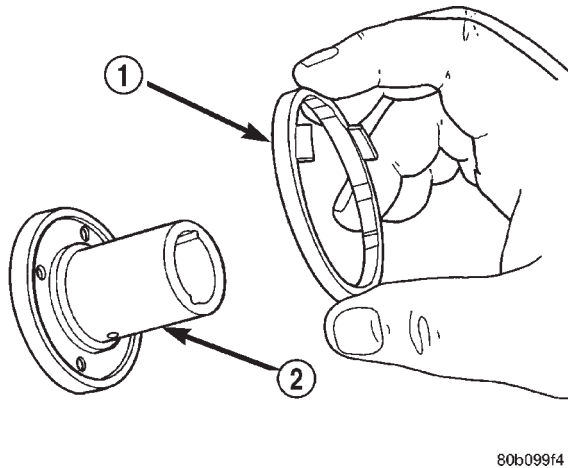
**Fig. 118 Remove Reverse Idler Gear Synchronizer Ring**

- 1 - REVERSE SYNCHRONIZER RING
 2 - REVERSE IDLER GEAR HUB

ASSEMBLY

(1) Install the reverse idler gear synchronizer ring onto the reverse idler gear hub/race. Apply a film of 75W-90 GL-3 transmission oil to the contact surface of the synchronizer ring prior to assembly.

(2) Install the reverse idler gear onto the reverse idler gear hub/race. Apply a film of 75W-90 GL-3 transmission oil to the reverse idler gear bushing prior to assembly. Verify that the teeth on the synchronizer ring are properly engaged into the recesses of the reverse idler gear.

(3) Install the plate washer over the reverse idler gear hub/race and onto the reverse idler gear.

(4) Install the snap-ring to hold the reverse idler gear onto the reverse idler hub/race.

CLEANING AND INSPECTION**AX5 MANUAL TRANSMISSION COMPONENTS****GENERAL INFORMATION**

Clean the transmission components in solvent. Dry the cases, gears, shift mechanism and shafts with compressed air. Dry the bearings with clean, dry shop towels only. Never use compressed air on the bearings. This could cause severe damage to the bearing roller and race surfaces.

If output shaft or inner race flange thickness is within specification but any gear thrust clearance is out of specification, replace the necessary gear and gear needle bearing as an assembly.

GEAR CASE, ADAPTER/EXTENSION HOUSING, INTERMEDIATE PLATE

Clean the case, housing, and intermediate plate with solvent and dry with compressed air. Replace the case if cracked, porous, or if any of the bearing and gear bores are damaged.

Inspect the threads in the case, housing, and plate. Minor thread damage can be repaired with steel thread inserts, if necessary. Do not attempt to repair any threads which show evidence of cracks around the threaded hole.

OUTPUT SHAFT

Check thickness of the output shaft and inner bearing race flanges with a micrometer or vernier calipers (Fig. 119).

- Minimum thickness for shaft flange is 4.80 mm (0.189 in.)

- Minimum thickness for first gear bearing inner race flange is 3.99 mm (0.157 in.)

Measure diameter of the output shaft journal surfaces with a micrometer. Replace the shaft if either of these surfaces are worn beyond specified limits.

- Second gear surface minimum diameter is 37.964 mm (1.495 in.)

- Third gear surface minimum diameter is 34.984 mm (1.377 in.)

Measure diameter of the first gear bearing inner race. Minimum diameter is 38.985 mm (1.535 in.).

Measure output shaft runout with a dial indicator (Fig. 120). Runout should not exceed 0.05 mm (0.002 in.).

Replace output shaft or first gear inner bearing race if measurement of any surface is out of specification. Do not attempt to repair out of specification components.

CLEANING AND INSPECTION (Continued)

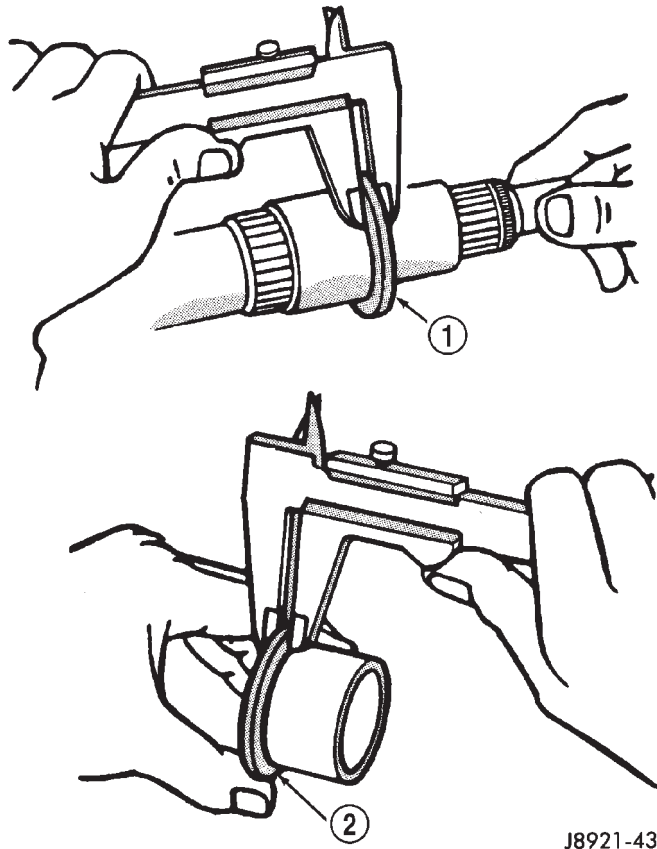

J8921-43

Fig. 119 Check Shaft And Bearing Race Flange Thickness

- 1 - OUTPUT SHAFT FLANGE
2 - INNER RACE FLANGE

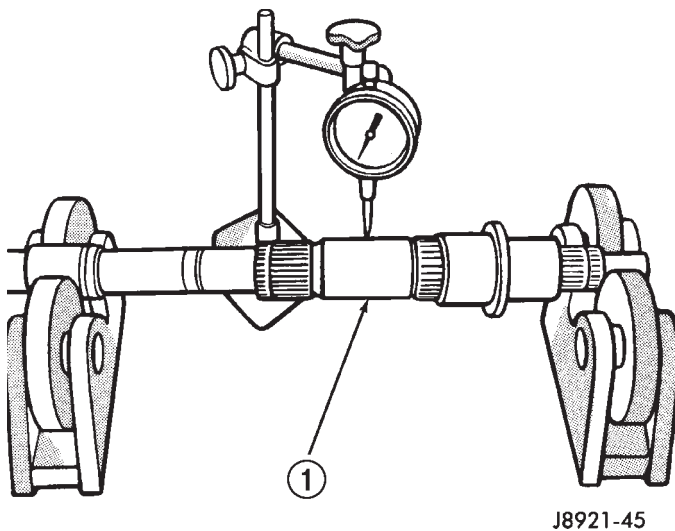

J8921-45

Fig. 120 Check Output Shaft Runout

- 1 - OUTPUT SHAFT JOURNAL

COUNTERSHAFT

Inspect the countershaft gear teeth. Replace the countershaft if any teeth are worn or damaged. Inspect the bearing surfaces and replace shaft if any surface shows damage or wear.

Check condition of the countershaft front bearing. Replace the bearing if worn, noisy, or damaged.

GEAR AND SYNCHRONIZER

Install the needle bearing and inner race in the first gear. Then check oil clearance between the gear and inner race (Fig. 121). Clearance should be 0.009 - 0.032 mm (0.0004 - 0.0013 in.).

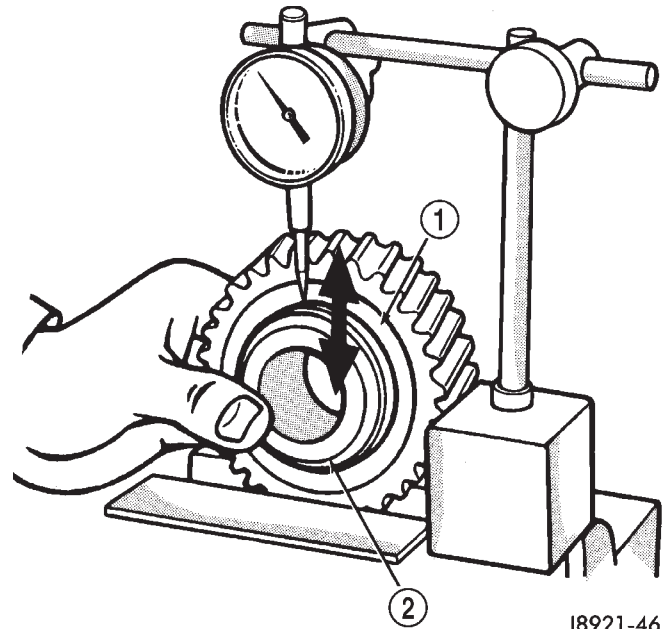

J8921-46

Fig. 121 Check Gear-To-Race Clearance

- 1 - GEAR
2 - INNER RACE

Install the needle bearings and the second, third and counter fifth gears on the output shaft. Then check oil clearance between the gears and shaft with a dial indicator (Fig. 122). Oil clearance for all three gears is 0.009 - 0.0013 mm (0.0004 - 0.0013 in.).

Check synchronizer ring wear (Fig. 123). Insert each ring in matching gear. Measure clearance between each ring and gear with feeler gauge. Replace ring if clearance exceeds 2.0 mm (0.078 in.).

Check shift fork-to-synchronizer hub clearance with a feeler gauge (Fig. 124). Replace the fork if clearance exceeds 1.0 mm (0.039 in.).

(1) Inspect all mainshaft gear teeth. Replace any gear which shows any worn or damaged teeth.

CLEANING AND INSPECTION (Continued)

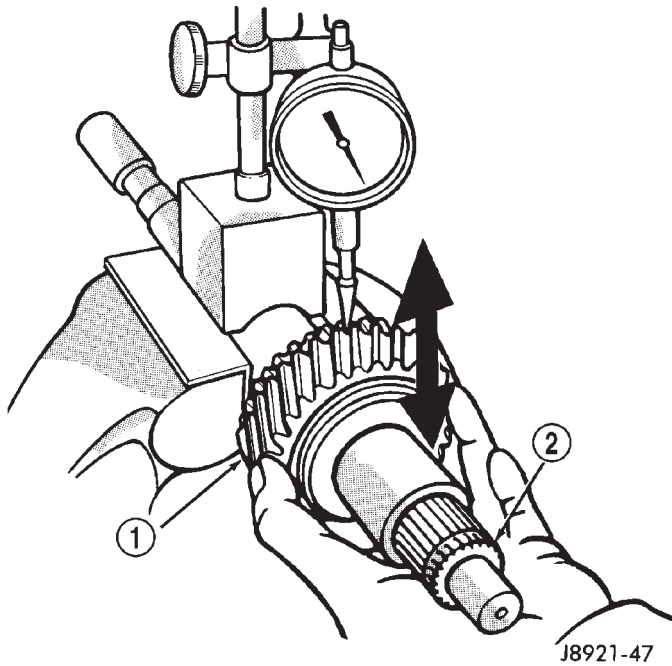

Fig. 122 Check Gear-To-Shaft Oil Clearance

- 1 - GEAR BEING CHECKED
- 2 - OUTPUT SHAFT

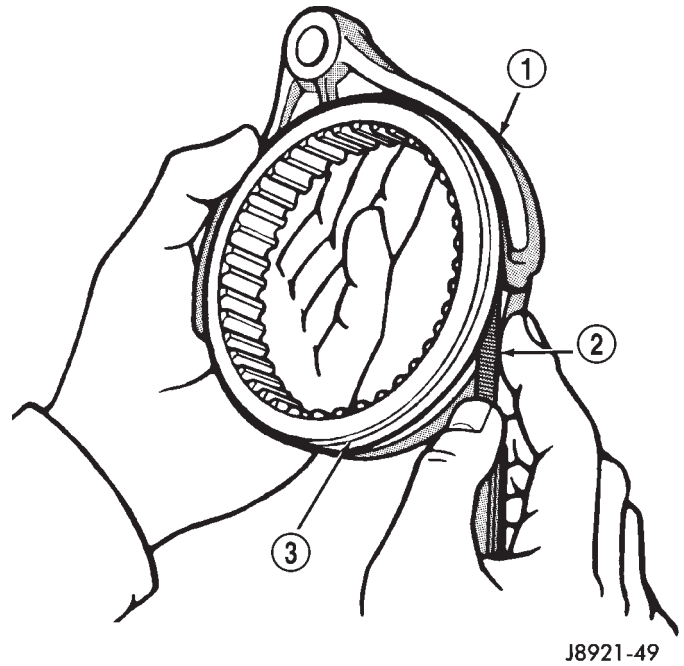

Fig. 124 Check Fork-To-Hub Clearance

- 1 - SHIFT FORK
- 2 - FEELER GAUGE
- 3 - SYNCHRONIZER SLEEVE

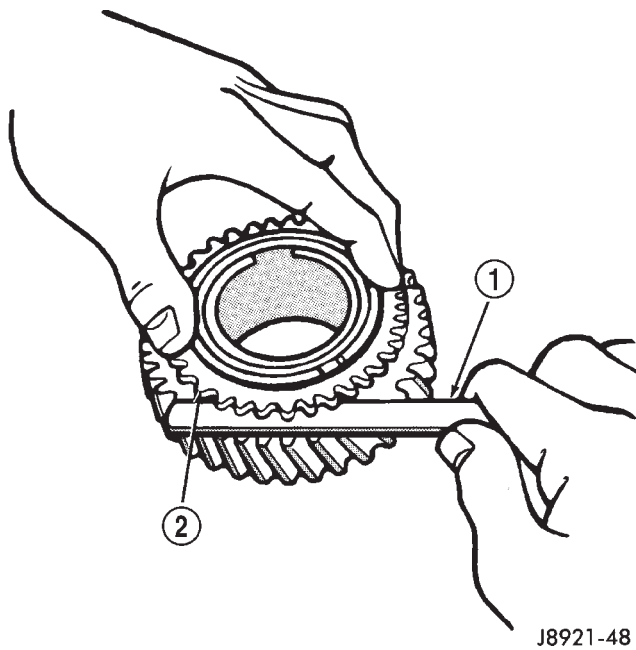

Fig. 123 Check Synchronizer Ring Wear

- 1 - FEELER GAUGE
- 2 - SYNCHRONIZER RING

SPECIFICATIONS

TORQUE

| DESCRIPTION | TORQUE |
|---|--------------------------------|
| Plugs, Access | 19 N·m (14 ft.lbs.) |
| Bolts, Adapter Housing | 34 N·m (25 ft.lbs.) |
| Switch, Back-up Light | 44 N·m (32.5 ft.lbs.) |
| Plugs, Drain and Fill | 44 N·m (32.5 ft.lbs.) |
| Bolts, Front Bearing Retainer | 17 N·m (12 ft.lbs.) |
| Plugs, Interlock and Detent | 19 N·m (14 ft.lbs.) |
| Screws, Propeller Shaft Clamp | 16-23 N·m (140-200 in.lbs.) |
| Bolts, Rear Mount to Transmission | 33-60 N·m (24-44 ft.lbs.) |
| Nut, Rear Mount Clevis | 54-75 N·m (40-55 ft.lbs.) |
| Nuts, Rear Mount to Crossmember | 41-68 N·m (30-50 ft.lbs.) |
| Pins, Restrictor | 27.4 N·m (20 ft.lbs.) |
| Bolts, Reverse Shift Arm Bracket | 18 N·m (13 ft.lbs.) |
| Screw, Shift Arm Set | 38 N·m (28 ft.lbs.) |
| Screws, Shift Fork Set | 20 N·m (15 ft.lbs.) |
| Nut, Shift Knob | 20-34 N·m (15-25 ft.lbs.) |
| Screws, Shifter Floor Cover | 2-3 N·m (17-30 in.lbs.) |
| Bolts, Shift Tower | 18 N·m (13 ft.lbs.) |
| Nuts, Transfer Case Mounting | 30-41 N·m (22-30 ft.lbs.) |

SPECIAL TOOLS

AX5

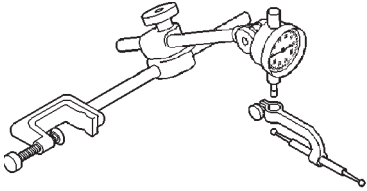

9011d42b

C-3339 Dial Indicator Set

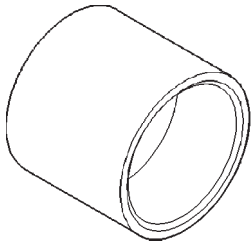

C-3995-A Installer, Extension Housing Seal

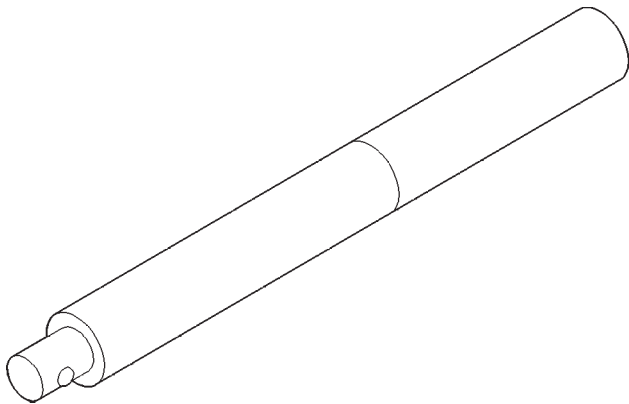

C-4171 Handle, Universal Tool

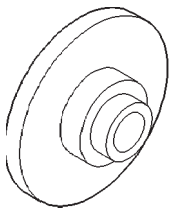

8211 Installer, Seal

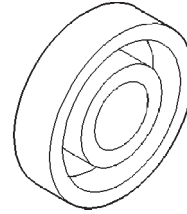

8212 Installer, Seal

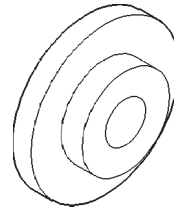

8208 Installer, Seal

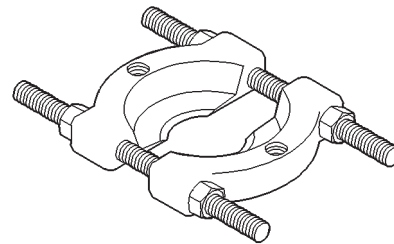

P-334 Splitter, Bearing

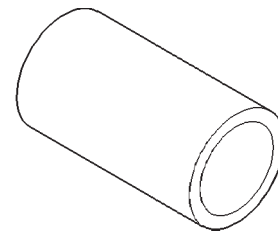

8109 Cup, Installer



L-4507 Tube, Driver

SPECIAL TOOLS (Continued)

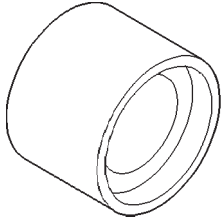

6747-1A Adapter, Fixture

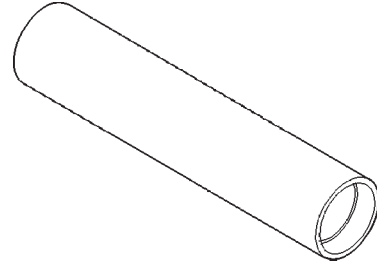

MD-998805 Installer, Seal

NV3550 MANUAL TRANSMISSION

TABLE OF CONTENTS

| | | | |
|-------------------------------------|------|-------------------------------------|------|
| | page | | page |
| GENERAL INFORMATION | | YOKE SEAL—2WD | 47 |
| NV3550 MANUAL TRANSMISSION. | 42 | REAR HOUSING YOKE BUSHING | 48 |
| LUBRICANT | 43 | DISASSEMBLY AND ASSEMBLY | |
| DIAGNOSIS AND TESTING | | TRANSMISSION. | 48 |
| LOW LUBRICANT LEVEL. | 44 | CLEANING AND INSPECTION | |
| HARD SHIFTING | 44 | TRANSMISSION COMPONENTS | 83 |
| TRANSMISSION NOISE. | 44 | SPECIFICATIONS | |
| REMOVAL AND INSTALLATION | | TORQUE | 85 |
| TRANSMISSION. | 44 | SPECIAL TOOLS | |
| SHIFT TOWER. | 47 | NV3550 MANUAL TRANSMISSION. | 85 |

GENERAL INFORMATION NV3550 MANUAL TRANSMISSION

DESCRIPTION

The NV3550 is a medium-duty, 5-speed, constant mesh, fully synchronized manual transmission. Fifth gear is an overdrive range with a ratio of 0.78:1. The NV3550 is available in two and four-wheel drive configurations.

The transmission gear case consists of two aluminum housings. The clutch housing is a removable component. It is not an integral part of the transmission front housing.

A combination of roller and ball bearings are used to support the transmission shafts in the two housings. The transmission gears all rotate on caged type needle bearings. A roller bearing is used between the input and output shaft.

The NV3550 has a single shaft shift mechanism with three shift forks all mounted on the shaft. The shaft is supported in the front and rear housings by bushings and one linear ball bearing. Internal shift components consist of the forks, shaft, shift lever socket, and detent components (Fig. 1).

GEAR RATIOS

Gear ratios for the NV3550 are as follows:

| RANGE | RATIO |
|-----------|--------|
| FIRST | 4.01:1 |
| SECOND | 2.32:1 |
| THIRD = | 1.40:1 |
| FOURTH = | 1:1 |
| FIFTH = | 0.78:1 |
| REVERSE = | 3.55:1 |

IDENTIFICATION

The NV3550 identification and part number bar code tags (Fig. 2) are located on the top of the transmission, forward of the shift tower.

OPERATION

The manual transmission receives power through the clutch assembly from the engine. The clutch disc is splined to the transmission input shaft and is turned at engine speed at all times that the clutch is engaged. The input shaft is connected to the transmission countershaft through the mesh of fourth speed gear on the input shaft and the fourth countershaft gear. At this point, all the transmission gears are spinning.

The driver selects a particular gear by moving the shift lever to the desired gear position. This movement moves the internal transmission shift components to begin the shift sequence. As the shift lever moves the selected shift rail, the shift fork attached to that rail begins to move. The fork is positioned in a groove in the outer circumference of the synchronizer sleeve. As the shift fork moves the synchronizer sleeve, the synchronizer begins to speed-up or slow down the selected gear (depending on whether we are up-shifting or down-shifting). The synchronizer does this by having the synchronizer hub splined to the mainshaft, or the countershaft in some cases, and moving the blocker ring into contact with the gear's friction cone. As the blocker ring and friction cone come together, the gear speed is brought up or down to the speed of the synchronizer. As the two speeds match, the splines on the inside of the synchronizer sleeve become aligned with the teeth on the blocker ring and the friction cone and eventually will slide over the teeth, locking the gear to the mainshaft, or countershaft, through the synchronizer.

GENERAL INFORMATION (Continued)

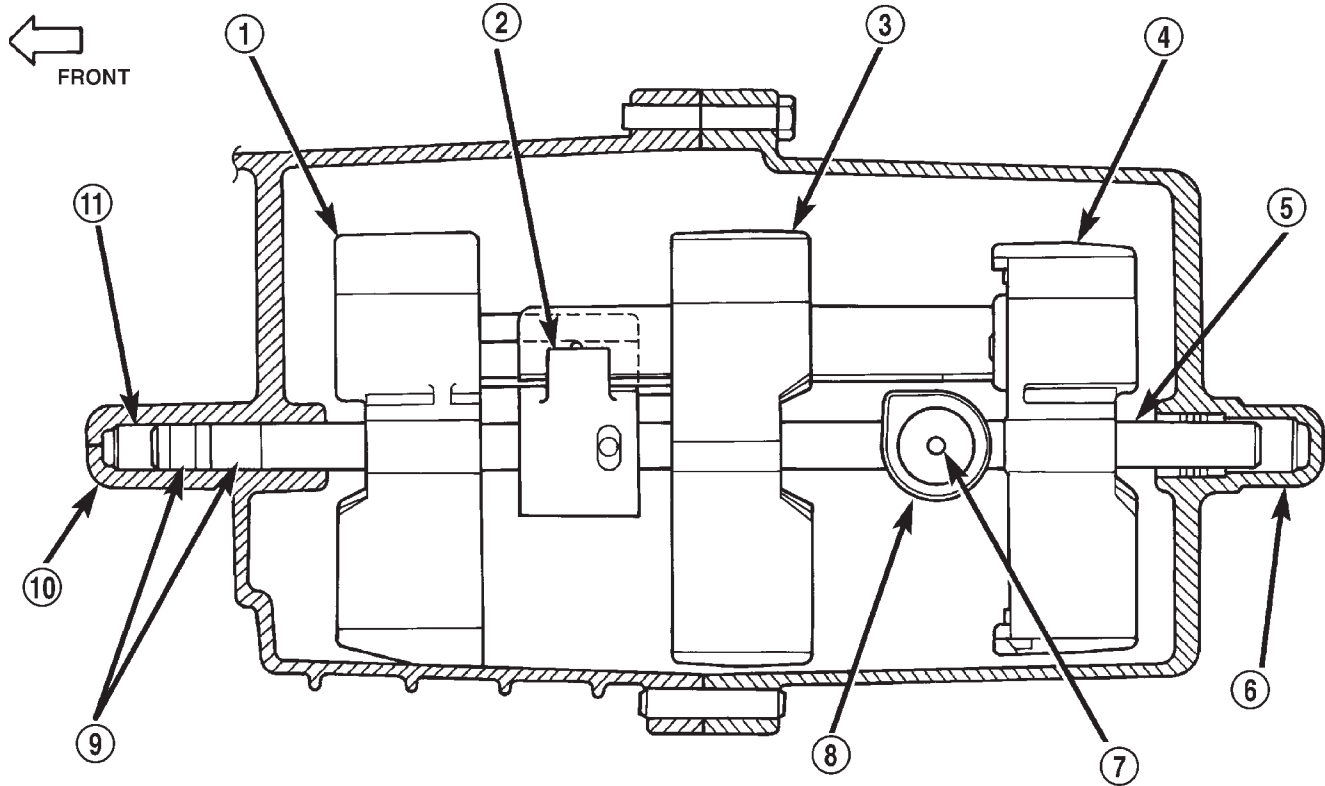

80c07015

Fig. 1 NV3550 Shift Mechanism

- | | |
|-----------------------------------|------------------------|
| 1 - 3-4 FORK | 7 - ROLL PIN |
| 2 - SHIFT SHAFT LEVER AND BUSHING | 8 - SHIFT LEVER SOCKET |
| 3 - 1-2 FORK | 9 - SHAFT RAIL DETENTS |
| 4 - FIFTH-REVERSE FORK | 10 - FRONT HOUSING |
| 5 - SHIFT SHAFT | 11 - SHIFT SHAFT |
| 6 - REAR HOUSING | |

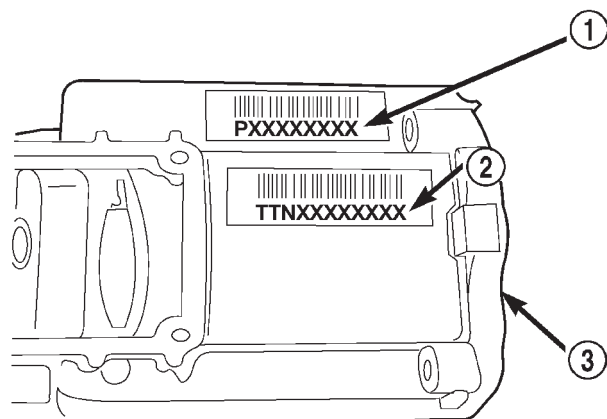

80c07133

Fig. 2 NV3550 Identification

- | |
|---------------------------|
| 1 - PART NUMBER TAG |
| 2 - IDENTIFICATION TAG |
| 3 - FRONT OF REAR HOUSING |

LUBRICANT

DESCRIPTION

Required lubricant for the NV3550 is Mopar® Manual Transmission Lubricant, P/N 4761526. This is the **only** lubricant to be used in NV3550 transmissions. No other lubricants are acceptable, or recommended.

The correct transmission lubricant level is to the bottom edge of the fill plug hole (Fig. 3).

The transmission must be level to obtain an accurate lubricant level check. A drive-on type of hoist is recommended for this purpose.

Lubricant capacity of the NV3500 is approximately 2.28 liters (4.8 pints). This represents the approximate quantity needed to refill the transmission after a lubricant change or overhaul.

DRAIN AND FILL PLUG LOCATIONS

The NV3550 fill plug is located in the front housing. The drain plug is at the bottom rear of the housing (Fig. 3).

GENERAL INFORMATION (Continued)

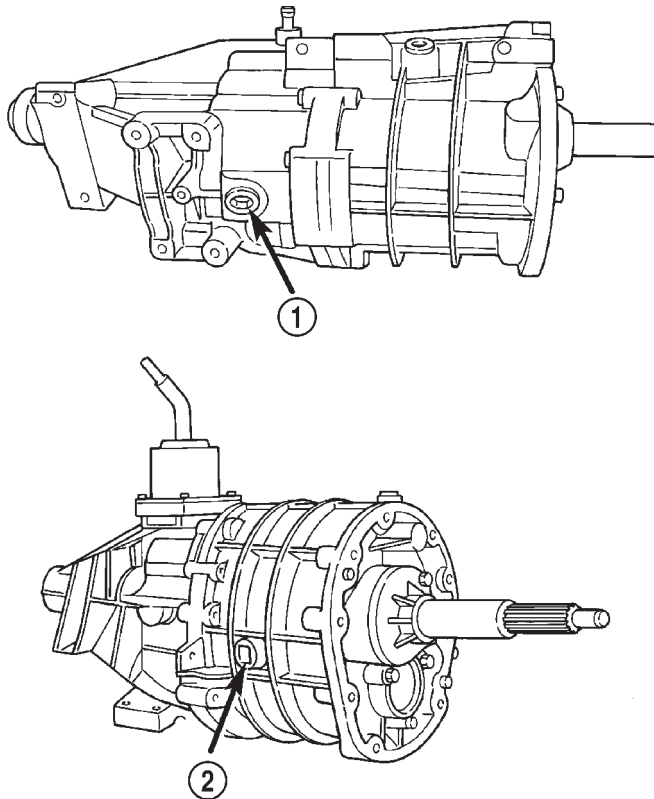

80c070f7

Fig. 3 Drain and Fill Plug Locations

- 1 - DRAIN PLUG
- 2 - FILL PLUG

DIAGNOSIS AND TESTING

LOW LUBRICANT LEVEL

A low transmission lubricant level is generally the result of a leak, inadequate lubricant fill, or an incorrect lubricant level check.

Leaks can occur at the mating surfaces of the housings, or from the front/rear seals. A suspected leak could also be the result of an overfill condition.

Leaks at component mating surfaces will probably be the result of inadequate sealer, gaps in the sealer, incorrect bolt tightening, or use of a non-recommended sealer.

A leak at the front of the transmission will be from either a loose or damaged, front bearing retainer or retainer seal. Lubricant may also drip from the transmission clutch housing after extended operation. If the leak is severe, it will contaminate the clutch disc causing slip, grab and chatter.

Transmissions filled from air or electrically powered lubricant containers can be under filled. Always check the lubricant level after filling to avoid an under fill condition.

A correct lubricant level check can only be made when the vehicle is level; use a drive-on hoist to ensure this. Also allow the lubricant to settle for a minute or so before checking. These recommendations will ensure an accurate check and avoid an under-or-overfill condition.

HARD SHIFTING

Hard shifting is usually caused by a low lubricant level, improper or contaminated lubricants, transmission component damage, clutch linkage malfunction, or by a damaged clutch pressure plate or disc.

Substantial lubricant leaks can result in gear, shift component, synchro and bearing damage. If a leak goes undetected for an extended period, the first indications of a problem are usually hard shifting and noise.

Incorrect or contaminated lubricants can also contribute to hard shifting. The consequence of using non-recommended lubricants is noise, excessive wear, internal bind and hard shifting.

Improper clutch release is a frequent cause of hard shifting. Incorrect adjustment or a worn, damaged pressure plate or disc can cause incorrect release. If the clutch problem is advanced, gear clash during shifts can result.

Worn or damaged synchro rings can cause gear clash when shifting into any forward gear. In some new or rebuilt transmissions, new synchro rings may tend to stick slightly causing stiff and/or noisy shifts. In most cases, this condition will decline as the rings wear in.

TRANSMISSION NOISE

Most manual transmissions make some noise during normal operation. Rotating gears can generate a mild whine that may only be audible at extreme speeds.

Severe, obviously audible transmission noise is generally the result of a lubricant problem. Insufficient, improper, or contaminated lubricant can promote rapid wear of gears, synchros, shift rails, forks and bearings. The overheating caused by a lubricant problem, can also lead to gear breakage.

REMOVAL AND INSTALLATION**TRANSMISSION****REMOVAL**

- (1) Shift transmission into first or third gear.
- (2) Remove the floor console and shift boot as necessary to access the bottom of the shift lever at the shift tower attachment.

REMOVAL AND INSTALLATION (Continued)

- (3) Install nuts on two M6X1.0 bolts and thread the bolts into the threaded holes at the base of the shift lever.
- (4) Tighten the nuts equally until the shift lever loosens on the shift tower stub shaft.
- (5) Remove the shift lever from the shift tower.
- (6) Raise and support vehicle on suitable safety stands.
- (7) Support engine with adjustable jack stand. Position wood block between jack and oil pan to avoid damaging pan.
- (8) Remove crossmember/skid plate.
- (9) Disconnect necessary exhaust system components.
- (10) Remove skid plate, if equipped.
- (11) Remove slave cylinder (Fig. 4) from clutch housing.

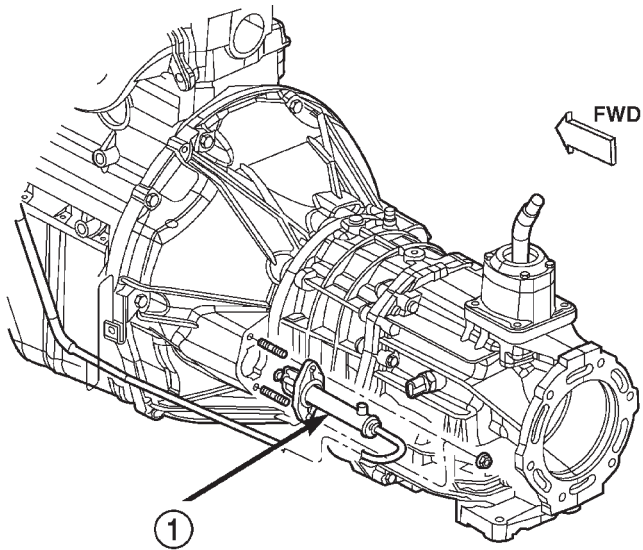

80be45f3

Fig. 4 Slave Cylinder

1 - CLUTCH SLAVE CYLINDER

- (12) Mark rear propeller shaft and rear axle yokes for installation alignment (Fig. 5).
- (13) Mark front propeller shaft, axle, and transfer case yokes for installation alignment, if equipped.
- (14) Remove propeller shaft(s).
- (15) Unclip wire harnesses from transmission and transfer case, if equipped.
- (16) Disconnect transfer case vent hose, if equipped.
- (17) Disengage any wire connectors attached to transmission or transfer case, if equipped, components.
- (18) Support transfer case, if equipped, with transmission jack.
- (19) Secure transfer case, if equipped, to jack with safety chains.

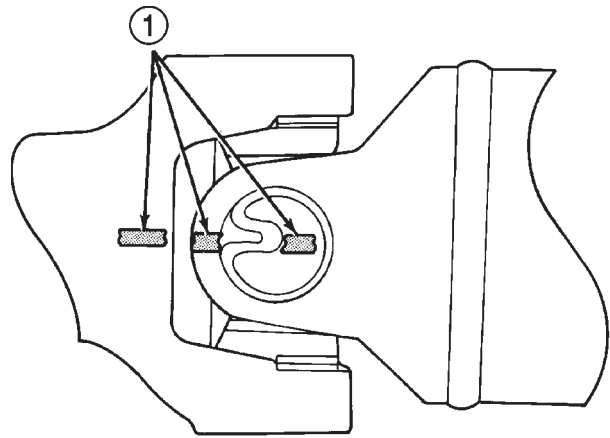

J9316-2

Fig. 5 Marking Propeller Shaft And Axle Yokes

1 - REFERENCE MARKS

- (20) Disconnect transfer case shift linkage at transfer case, if equipped.
- (21) Remove nuts attaching transfer case to transmission, if equipped.
- (22) Remove transfer case, if equipped.
- (23) Remove crankshaft position sensor (Fig. 6).

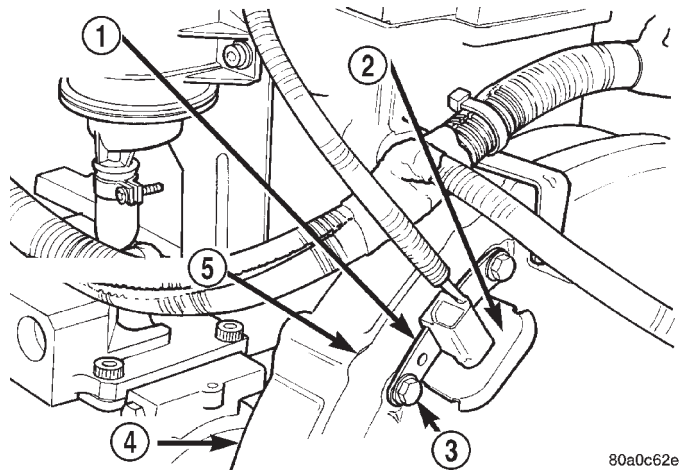

80a0c62e

Fig. 6 Crankshaft Position Sensor —2.5 and 4.0L Engine

1 - ENGINE SPEED SENSOR
 2 - GROMMET
 3 - MOUNTING BOLT(S)
 4 - LEFT REAR OF ENGINE
 5 - TRANSMISSION

CAUTION: It is important that the crankshaft position sensor be removed prior to transmission removal. The sensor can easily be damaged if left in place during removal operations.

REMOVAL AND INSTALLATION (Continued)

(24) Support engine with adjustable jack stand. Position wood block between jack and oil pan to avoid damaging pan.

(25) Support transmission with transmission jack.

(26) Secure transmission to jack with safety chains.

(27) Disconnect rear cushion and bracket from transmission.

(28) Remove rear crossmember.

(29) Remove clutch housing-to-engine bolts.

(30) Pull transmission jack rearward until input shaft clears clutch. Then slide transmission out from under vehicle.

(31) Remove clutch release bearing, release fork, and retainer clip.

(32) Remove clutch housing from transmission (Fig. 7).

(5) Lightly lubricate pilot bearing and transmission input shaft splines with Mopar® high temp grease.

(6) Raise transmission and align transmission input shaft and clutch disc splines. Then slide transmission into place.

(7) Install and tighten clutch housing-to-engine bolts to the appropriate torque: **Be sure the housing is properly seated on engine block before tightening bolts.**

- Tighten 3/8" diameter bolts to 37 N-m (27 ft.lbs.).

- Tighten 7/16" diameter bolts to 58 N-m (43 ft.lbs.).

- Tighten M12 bolts to 75 N-m (55 ft.lbs.).

(8) Be sure transmission is in first or third gear.

(9) Install rear crossmember. Tighten crossmember-to-frame bolts to 41 N-m (31 ft. lbs.) torque.

(10) Install fasteners to hold rear cushion and bracket to transmission. Then tighten transmission-to-rear support bolts/nuts to 54 N-m (40 ft. lbs.) torque.

(11) Remove support stands from engine and transmission.

(12) Install and connect crankshaft position sensor.

(13) Position transfer case on transmission jack, if equipped.

(14) Secure transfer case to jack with safety chains, if equipped.

(15) Raise transfer case, if equipped, and align transfer case input shaft to the transmission output shaft.

(16) Slide transfer case forward until case is seated on transmission, if necessary.

(17) Install nuts to attach transfer case to transmission, if equipped. Tighten transfer case-to-transmission nuts to 35 N-m (26 ft. lbs.) torque.

(18) Connect transfer case shift linkage at transfer case, if equipped.

(19) Connect transfer case vent hose, if equipped.

(20) Secure wire harnesses in clips/tie straps on transmission and transfer case, if equipped.

(21) Engage wire connectors attached to all necessary transmission or transfer case, if equipped, components.

(22) Install rear propeller shaft slip yoke to transmission or transfer case, if equipped, output shaft.

(23) Align marks on rear propeller shaft and rear axle yokes (Fig. 8).

(24) Install and tighten propeller shaft U-joint clamp bolts to 19 N-m (170 in. lbs.) torque.

(25) Align marks on front propeller shaft, axle, and transfer case yokes, if equipped.

(26) Install and tighten propeller shaft U-joint clamp bolts to 19 N-m (170 in. lbs.) torque.

(27) Install slave cylinder in clutch housing.

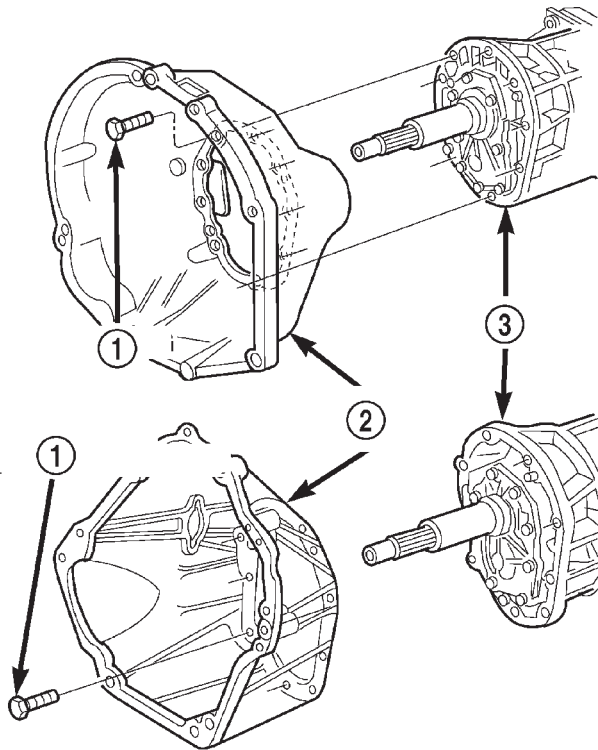

80be4510

Fig. 7 Clutch Housing

1 - HOUSING-TO-TRANSMISSION BOLTS (46 N-m/34 ft. lbs.)

2 - CLUTCH HOUSING

3 - TRANSMISSION

INSTALLATION

(1) Install clutch housing (Fig. 7) on transmission. Tighten housing bolts to 46 N-m (34 ft. lbs.) torque.

(2) Lubricate contact surfaces of release fork pivot ball stud and release fork with high temp grease.

(3) Install release bearing, fork, and retainer clip.

(4) Position and secure transmission on transmission jack.

REMOVAL AND INSTALLATION (Continued)

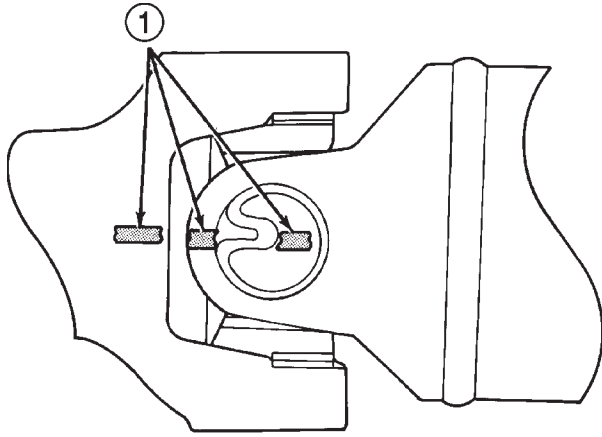

J9316-2

**Fig. 8 Align Propeller Shaft And Rear Axle Yokes
Alignment Marks**

1 - REFERENCE MARKS

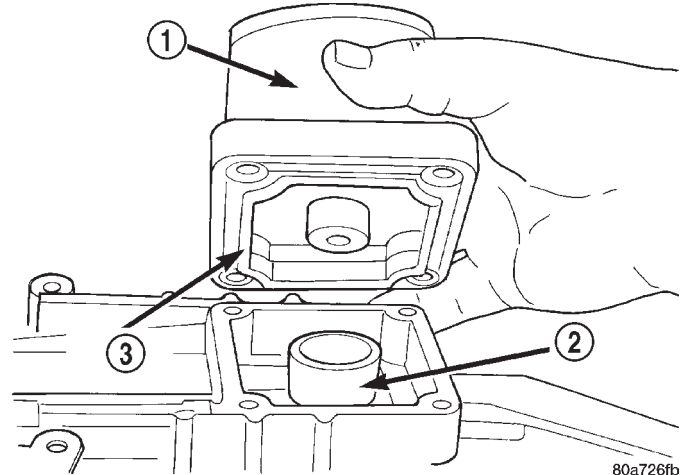

80a726fb

Fig. 9 Remove Shift Tower

1 - SHIFT TOWER AND LEVER ASSEMBLY
2 - SHIFT SOCKET
3 - SEAL

(28) Install skid plate, if equipped. Tighten bolts to 42 N-m (31 ft. lbs.) torque. Tighten stud nuts to 17 N-m (150 in. lbs.) torque.

(29) Fill transmission and transfer case, if equipped, with recommended lubricants. Refer to the Lubricant Recommendation sections of the appropriate component for correct fluid.

(30) Lower vehicle.

(31) Install nuts on two M6X1.0 bolts and thread the bolts into the threaded holes at the base of the shift lever.

(32) Tighten the nuts equally until the shift lever will slide over the shift tower stub shaft.

(33) Install the floor console and shift boot.

SHIFT TOWER

REMOVAL

- (1) Shift transmission into Neutral.
- (2) Unscrew and remove the shift lever extension from the shift
- (3) Remove any floor console components necessary to access the transmission shift tower.
- (4) Remove the bolts holding the shift tower to the isolator plate and transmission gear case.
- (5) Remove the shift tower (Fig. 9) from the transmission.

INSTALLATION

- (1) Shift transmission into third gear.
- (2) Clean the mating surfaces of shift tower and transmission gear case with suitable wax and grease remover.
- (3) Install the shift tower onto the transmission case. No sealant is necessary between the shift tower and transmission case.

(4) Install the bolts to hold the shift tower to the isolator plate and the transmission gear case. Tighten the shift tower bolts to 8.5 N-m (6.3 ft. lbs.).

(5) Install the shift lever extension and any floor console components previously removed.

YOKE SEAL—2WD

REMOVAL

- (1) Raise vehicle.
- (2) Mark propeller shaft and axle yoke for alignment reference.
- (3) Disconnect and remove propeller shaft.
- (4) Remove old seal with Seal Remover C-3985-B (Fig. 10) from transmission housing.

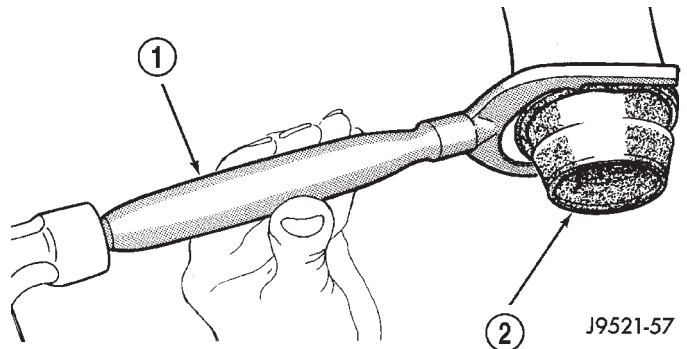

J9521-57

Fig. 10 Removing Transmission Housing Yoke Seal

1 - SPECIAL TOOL C-3985-B
2 - SEAL

INSTALLATION

- (1) Place seal in position on transmission housing.
- (2) Drive seal into transmission housing with Seal Installer C-3972-A (Fig. 11).

REMOVAL AND INSTALLATION (Continued)

(3) Carefully guide propeller shaft slip yoke into housing and onto output shaft splines.

(4) Align marks made at removal and connect propeller shaft to rear axle pinion yoke.

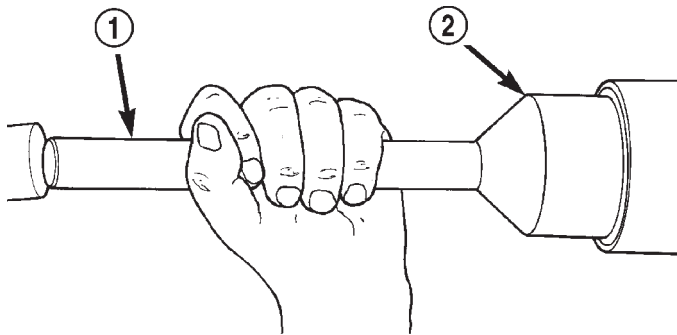

80a7e2be

Fig. 11 Installing Transmission Housing Yoke Seal

- 1 - SPECIAL TOOL C-4171
2 - SPECIAL TOOL C-3972-A

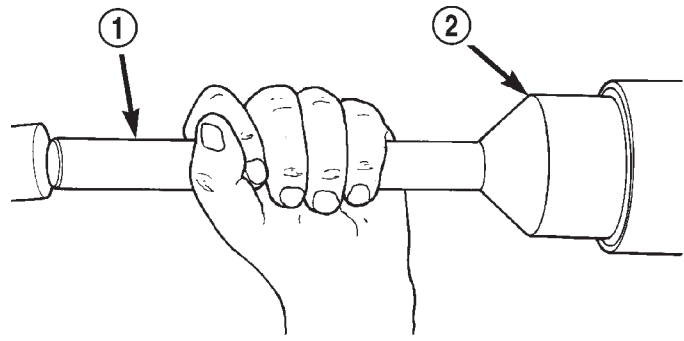

80a7e2be

Fig. 13 Rear Housing Seal Installation

- 1 - SPECIAL TOOL C-4171
2 - SPECIAL TOOL C-3972-A

DISASSEMBLY AND ASSEMBLY TRANSMISSION

DISASSEMBLY

FRONT HOUSING

(1) If necessary, temporarily reinstall shift lever assembly. Shift transmission into Neutral.

(2) If lubricant was not drained out of transmission during removal, remove drain plug and drain lubricant into container at this time.

(3) Inspect drain plug magnet for debris.

(4) Remove backup light switch. Switch is located on passenger side of rear housing (Fig. 14).

REAR HOUSING YOKE BUSHING

REMOVAL

(1) Remove housing yoke seal.

(2) Insert Remover 6957 into rear housing. Tighten tool to bushing and remove bushing (Fig. 12).

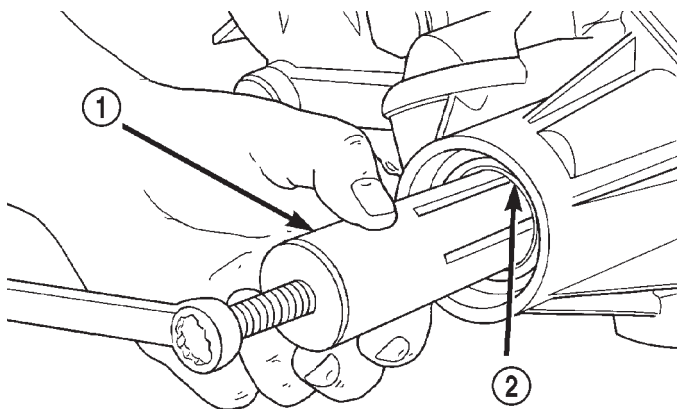

80a11095

Fig. 12 Bushing Removal—Typical

- 1 - REMOVER 6957
2 - EXTENSION HOUSING BUSHING

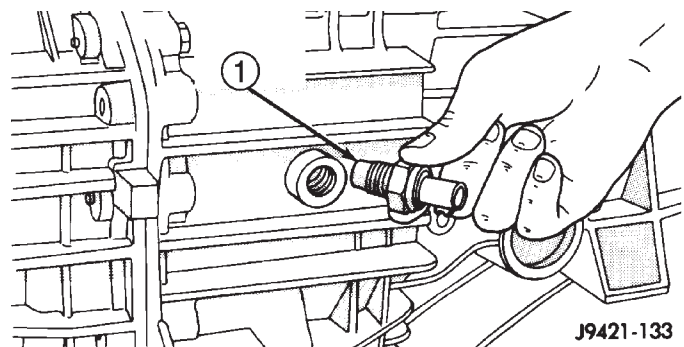

J9421-133

Fig. 14 Backup Light Switch Location

- 1 - BACKUP LIGHT SWITCH

INSTALLATION

(1) Align bushing oil hole with oil slot in rear housing.

(2) Tap bushing into place with Installer 6951 and Handle C-4171.

(3) Install new oil seal in housing using Seal Installer C-3972-A (Fig. 13).

(5) If necessary, remove shift tower bolts and remove tower and lever assembly (Fig. 15).

(6) Remove shift shaft lock bolt (Fig. 16). Bolt is located at top of front housing just forward of shift tower. Bolt is a shoulder bolt that secures the shift shaft bushing and lever.

(7) Use Remover 8117 and suitable slide hammer to remove shift shaft detent plug.

DISASSEMBLY AND ASSEMBLY (Continued)

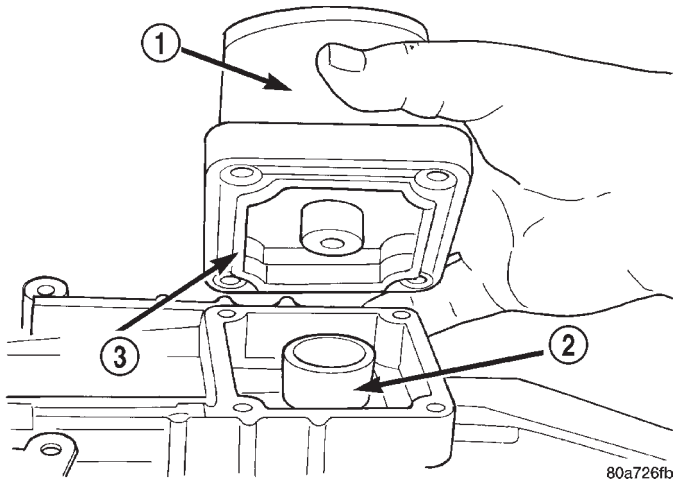

Fig. 15 Shift Tower Removal

- 1 - SHIFT TOWER AND LEVER ASSEMBLY
- 2 - SHIFT SOCKET
- 3 - SEAL

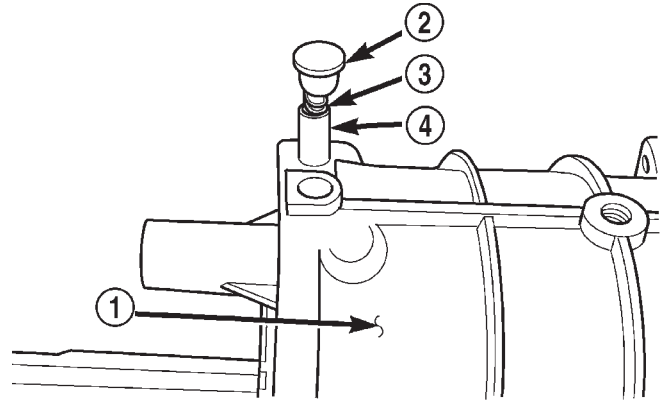

Fig. 17 Detent Plunger And Spring Removal

- 1 - FRONT HOUSING
- 2 - PLUG
- 3 - SPRING
- 4 - PLUNGER

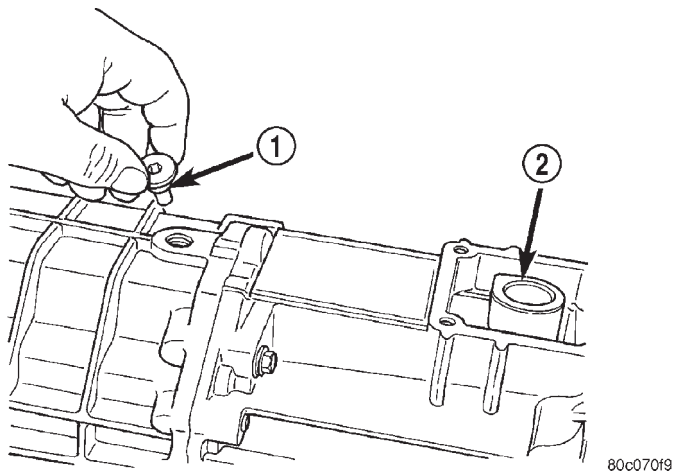
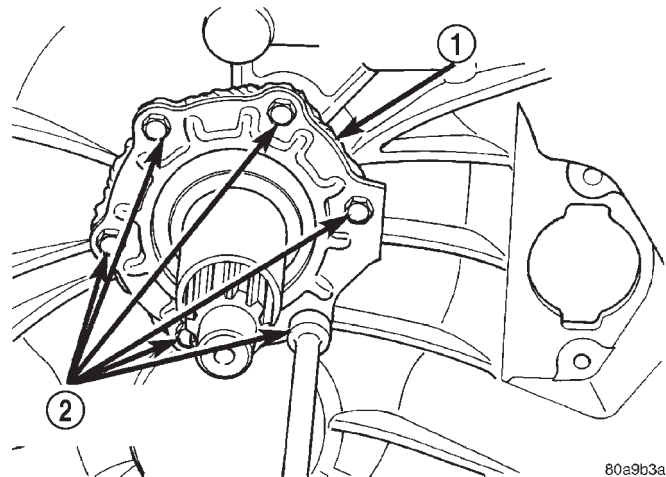

Fig. 16 Shift Shaft Lock Bolt Removal

- 1 - SHIFT SHAFT LOCK BOLT
- 2 - SHAFT SOCKET



**Fig. 18 Input Shaft Bearing Retainer Bolt Removal—
Typical**

- 1 - INPUT SHAFT BEARING RETAINER
- 2 - RETAINER BOLTS

(8) Remove shift shaft detent plunger and spring (Fig. 17). Use pencil magnet to remove spring then plunger, if necessary.

(9) Remove bolts attaching input shaft bearing retainer to front housing (Fig. 18).

DISASSEMBLY AND ASSEMBLY (Continued)

(10) Remove input shaft bearing retainer. Use pry tool to carefully lift retainer and break sealer bead (Fig. 19).

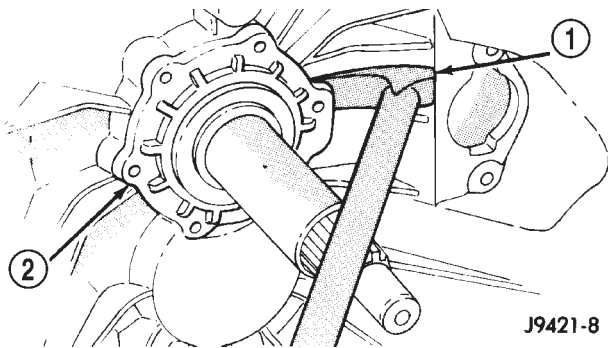

Fig. 19 Loosening Bearing Retainer Sealer Bead—Typical

- 1 - PRY TOOL
- 2 - INPUT SHAFT BEARING RETAINER

(11) Remove bearing retainer from input shaft (Fig. 20).

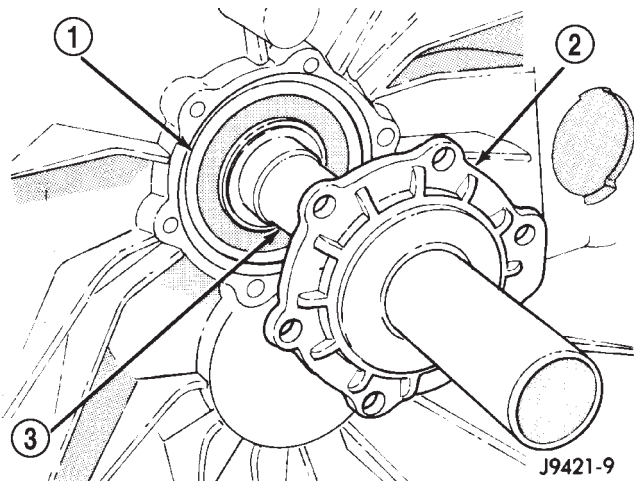

Fig. 20 Input Shaft Bearing Retainer Removal—Typical

- 1 - SHAFT BEARING
- 2 - BEARING RETAINER
- 3 - INPUT SHAFT

(12) Remove snap ring that secures input shaft in front bearing (Fig. 21).

(13) Remove bolts that attach front housing to rear housing (Fig. 22). Three bolts at extreme rear of housing are actually for the output shaft bearing retainer. It is not necessary to remove all three bolts at this time. Leave at least one bolt in place until geartrain is ready to be removed from case.

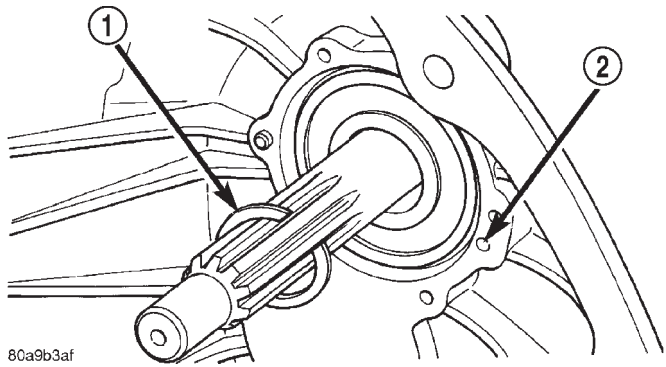

Fig. 21 Input Shaft Snap Ring Removal—Typical

- 1 - INPUT SHAFT SNAP RING
- 2 - OIL FEED

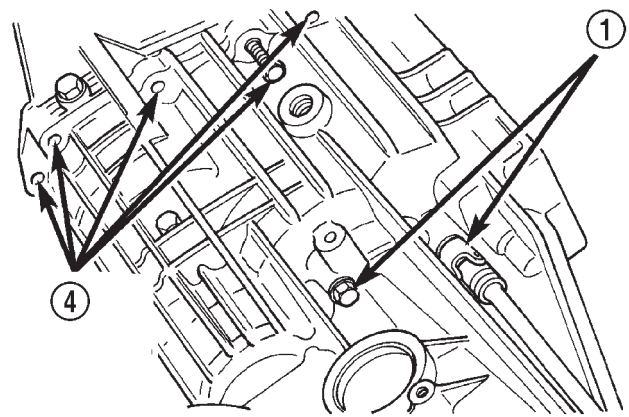

Fig. 22 Housing And Bearing Retainer Bolt Locations

- 1 - RETAINER BOLTS
- 2 - HOUSING BOLTS
- 3 - RETAINER BOLT
- 4 - HOUSING BOLT LOCATIONS

DISASSEMBLY AND ASSEMBLY (Continued)

(14) Separate front housing from rear housing (Fig. 23). Use plastic mallet to tap front housing off alignment dowels.

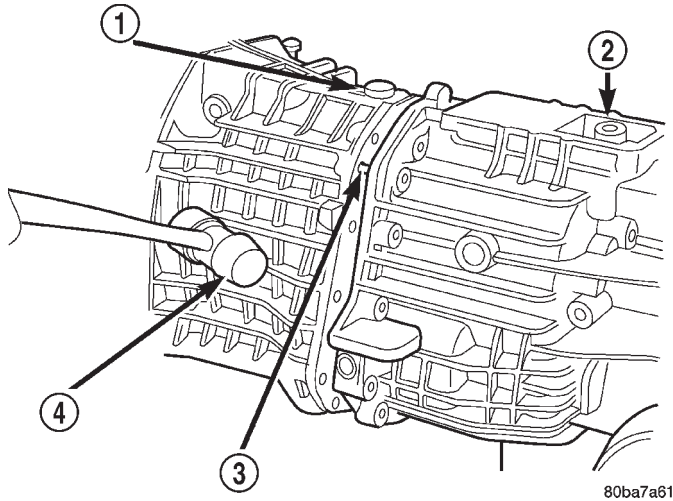

Fig. 23 Front Housing Removal

- 1 - FRONT HOUSING
- 2 - REAR HOUSING
- 3 - DOWELS (2)
- 4 - PLASTIC MALLET

(15) Remove and inspect input shaft bearing. Inspect countershaft front bearing race (Fig. 24).

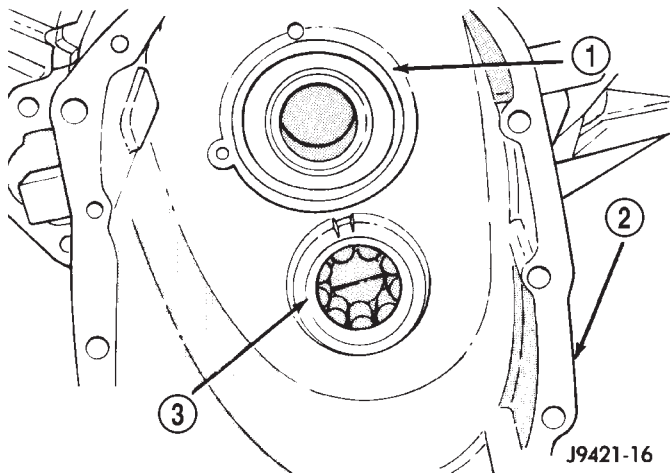

Fig. 24 Input Shaft Bearing and Countershaft Front Bearing Race Location

- 1 - INPUT SHAFT BEARING
- 2 - FRONT HOUSING
- 3 - COUNTERSHAFT FRONT BEARING

(16) Note position of input shaft, shift shaft and forks, and geartrain components in housing (Fig. 25).

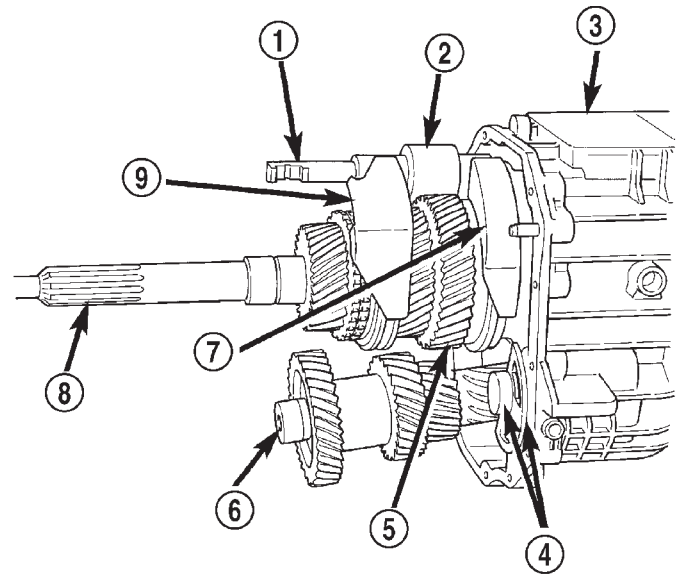

Fig. 25 Geartrain And Shift Component Identification

- 1 - SHIFT SHAFT
- 2 - BUSHING
- 3 - REAR HOUSING
- 4 - REVERSE IDLER AND SUPPORT
- 5 - OUTPUT SHAFT AND GEARS
- 6 - COUNTERSHAFT
- 7 - 1-2 FORK
- 8 - INPUT SHAFT
- 9 - 3-4 FORK

SHIFT SHAFT, SHIFT FORKS AND REVERSE IDLER SEGMENT

(1) Unseat the roll pin that secures the shift socket to the shift shaft with Special Tool 6858 as follows:

- (a) Position Tool 6858 on the shift shaft. Center the tool over the roll pin and verify that the tool legs are firmly seated on the shift socket (Fig. 26).
- (b) Tilt the socket toward the side of the case. This positions the roll pin at a slight angle to avoid trapping the pin between the gear teeth.
- (c) Tighten the tool punch to press the roll pin downward and out of the shift socket (Fig. 26). The roll pin does not have to be completely removed from the shift socket. The roll pin must only be clear of the shift shaft. Be careful not to push the pin into the geartrain.

(2) Using a hammer and suitable punch, drive out roll pin that secures shift bushing and lever to shift shaft (Fig. 27).

(16) Note position of input shaft, shift shaft and forks, and geartrain components in housing (Fig. 25).

NOTE: Be sure to use the proper size punch to avoid bending the shift shaft.

DISASSEMBLY AND ASSEMBLY (Continued)

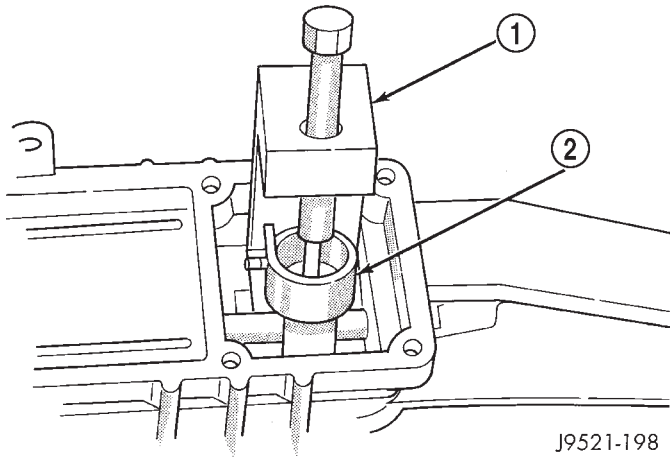

J9521-198

Fig. 26 Removing the Shift Socket Roll Pin

- 1 - SPECIAL TOOL 6858
- 2 - SHIFT SOCKET

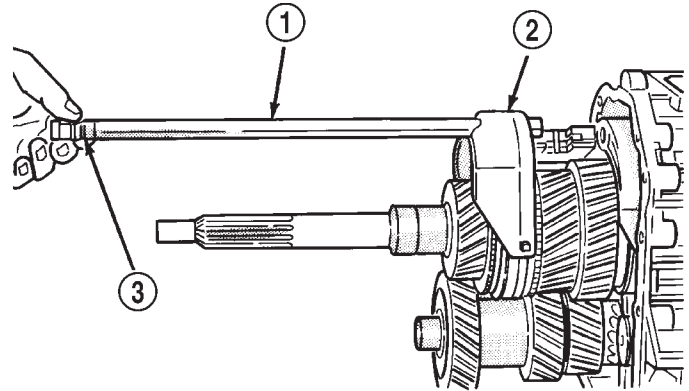

J9421-42

Fig. 28 Shift Shaft Removal

- 1 - SHIFT SHAFT
- 2 - 3-4 FORK
- 3 - SHAFT DETENT NOTCHES

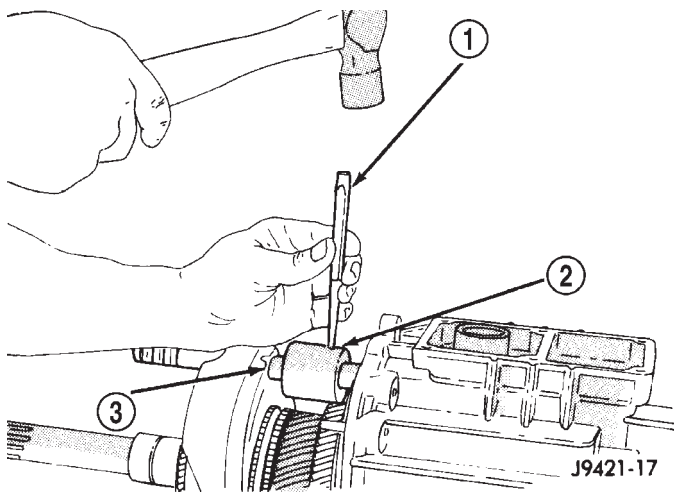

J9421-17

Fig. 27 Removing Shift Shaft Lever And Bushing Roll Pin

- 1 - PIN PUNCH
- 2 - BUSHING AND LEVER
- 3 - SHIFT SHAFT

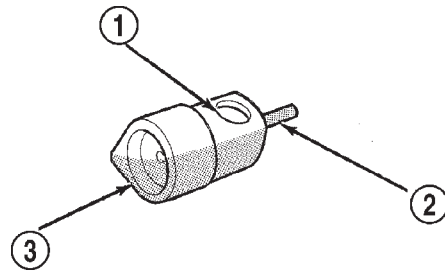

J9521-151

Fig. 29 Shift Socket And Roll Pin

- 1 - SHAFT BORE
- 2 - ROLL PIN
- 3 - SHIFT SOCKET

(3) Pull shift shaft straight out of rear housing, shift socket, fifth-reverse fork, and 1-2 fork (Fig. 28).

(4) Remove shift socket from rear housing (Fig. 29).

(5) Remove lever and bushing (Fig. 30).

(6) Remove 3-4 fork. Rotate 3-4 fork around synchro sleeve until fork clears shift arms on 1-2 and fifth-reverse forks. Then remove 3-4 fork (Fig. 31).

(7) Remove the reverse idler shaft support bolt (front bolt) (Fig. 32).

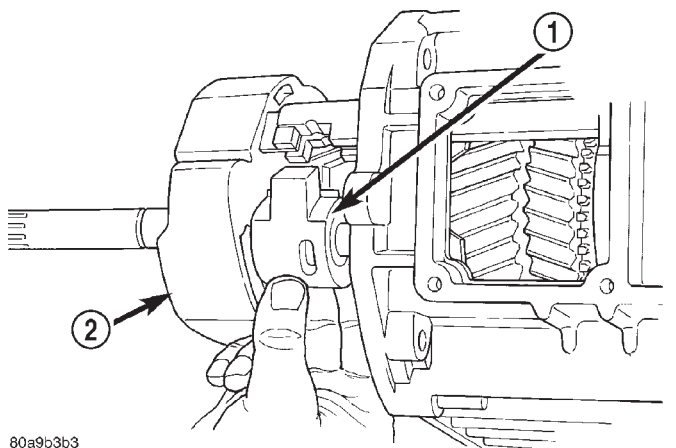

80a9b3b3

Fig. 30 Removing Shift Shaft Lever And Bushing

- 1 - SHAFT LEVER AND BUSHING
- 2 - 3-4 FORK

DISASSEMBLY AND ASSEMBLY (Continued)

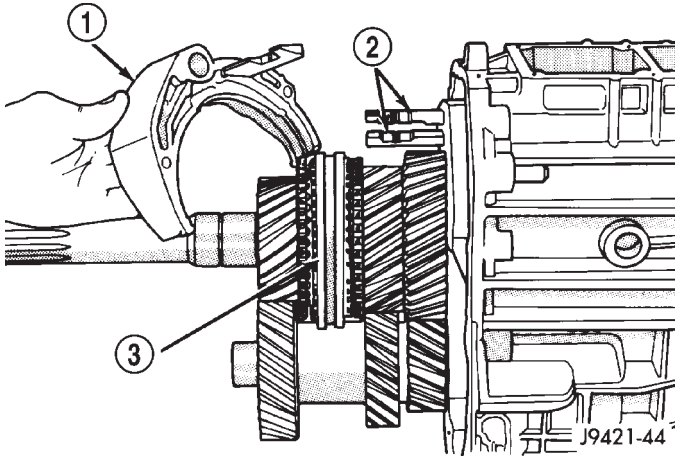

Fig. 31 Removing 3-4 Shift Fork

- 1 - 3-4 FORK
- 2 - 1-2 AND 5TH-REVERSE FORK ARMS
- 3 - 3-4 SYNCHRO SLEEVE

(8) Loosen rear reverse idler shaft bolt (rear bolt) (Fig. 32).

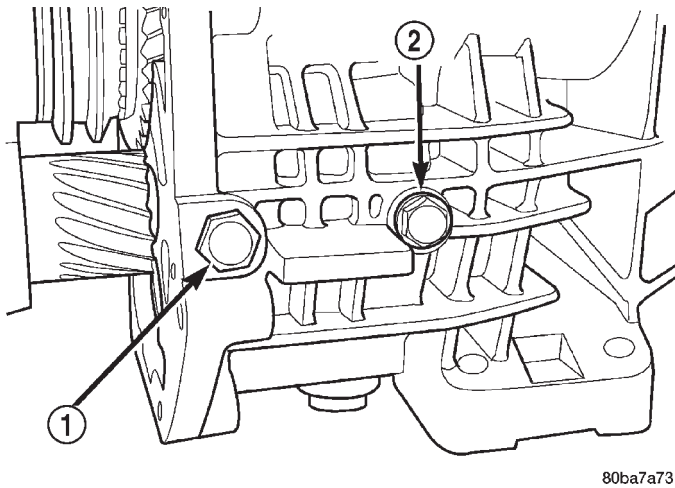

Fig. 32 Reverse Idler Shaft/Support Bolts

- 1 - SUPPORT BOLT
- 2 - SHAFT BOLT

(9) Remove reverse idler shaft support segment by sliding it straight out of housing.

(10) Support geartrain and rear housing on Assembly Fixture Tool 6747 as follows:

(a) Adjust height of reverse idler pedestal rod until the reverse idle shaft bottoms in Cup 8115.

(b) Position Adapters 6747-1A and 6747-2A on Assembly Fixture 6747.

(c) Slide fixture tool onto input shaft, countershaft and idler gear (Fig. 33).

(d) Stand geartrain and rear housing upright on fixture (Fig. 34). Have helper hold fixture tool in

place while housing and geartrain is being rotated into upright position.

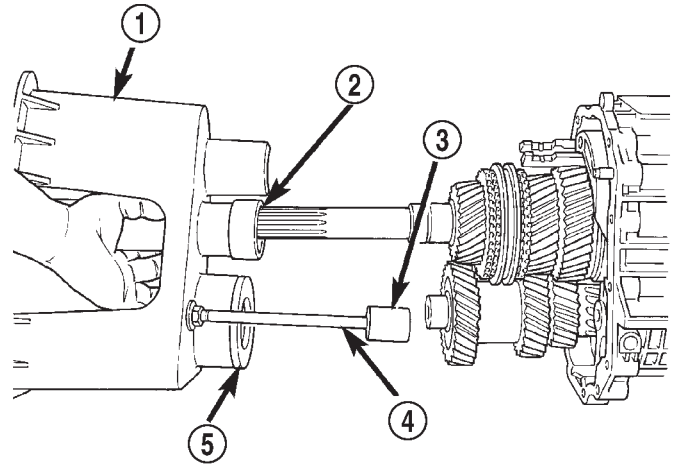

Fig. 33 Installing Assembly Fixture On Geartrain

- 1 - SPECIAL TOOL 6747
- 2 - SPECIAL TOOL 6747-1A
- 3 - SPECIAL TOOL 8115
- 4 - REVERSE IDLER PEDESTAL
- 5 - SPECIAL TOOL 6747-2A

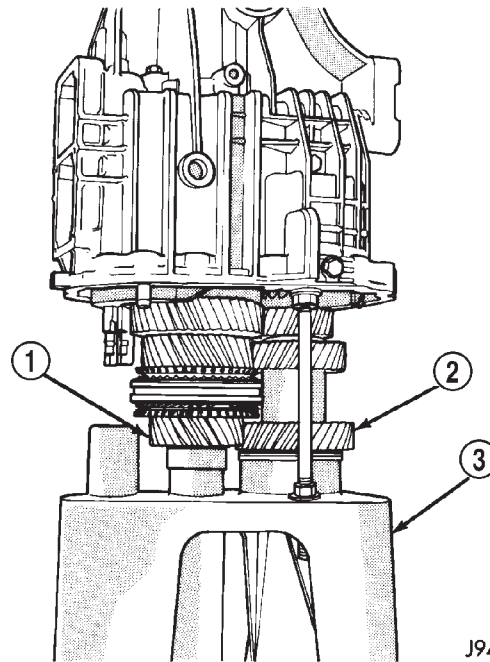

Fig. 34 Geartrain And Housing Mounted On Fixture Tool

- 1 - INPUT SHAFT
- 2 - COUNTERSHAFT
- 3 - SPECIAL TOOL 6747

(11) Remove rear bolt holding reverse idler shaft in housing.

DISASSEMBLY AND ASSEMBLY (Continued)

REAR HOUSING REMOVAL—2WD

(1) On 2-wheel drive transmission, remove three bolts that attach output shaft bearing retainer to rear case (Fig. 35). Bolts are rear of shift tower opening.

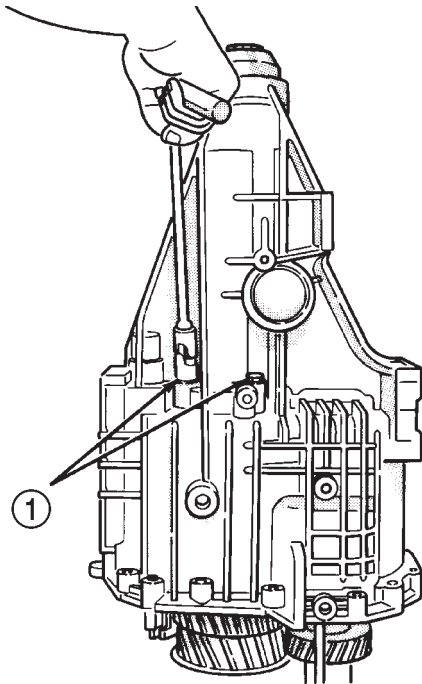

J9421-50

Fig. 35 Removing/Installing Output Shaft Bearing Retainer Bolts—2WD

1 - OUTPUT SHAFT BEARING RETAINER BOLTS (THIRD BOLT IS AT OPPOSITE SIDE OF CASE)

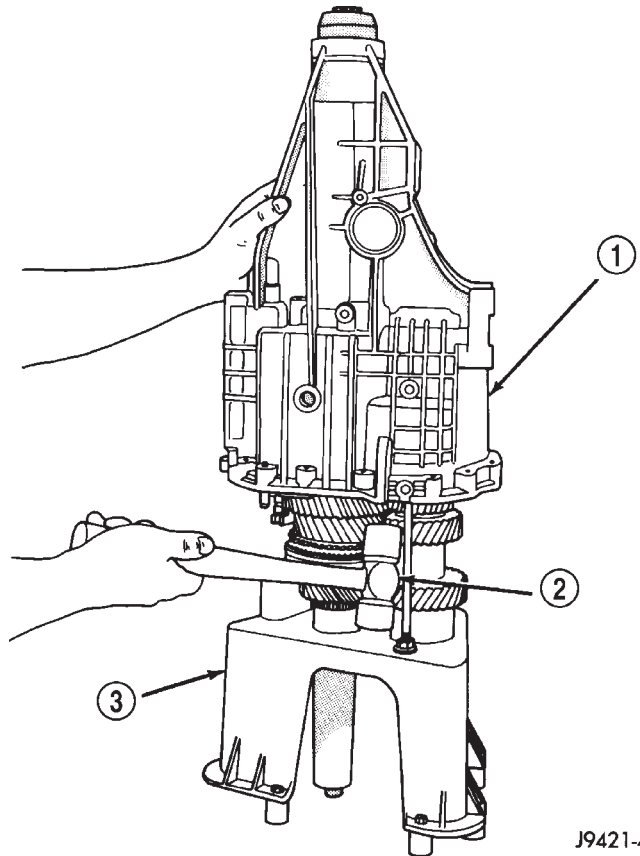

J9421-49

Fig. 36 Unseating Rear Housing From Output Shaft Bearing—2WD

1 - REAR HOUSING
2 - PLASTIC OR RAWHIDE MALLET
3 - FIXTURE TOOL

(2) Unseat output shaft bearing from bearing bore in rear housing. Use plastic or rawhide mallet to tap rear housing upward and off output shaft bearing as shown (Fig. 36).

(3) Lift rear housing up and off geartrain (Fig. 37).

(4) Remove countershaft rear bearing from countershaft (Fig. 38).

(5) Examine condition of bearing bore and idler shaft notch in rear housing. Replace housing if any of these components are damaged.

REAR ADAPTER HOUSING REMOVAL—4WD

(1) Locate dimples in face of rear seal (Fig. 39). Use a suitable slide hammer mounted screw to remove seal by inserting screw into seal at dimple locations (Fig. 40).

DISASSEMBLY AND ASSEMBLY (Continued)

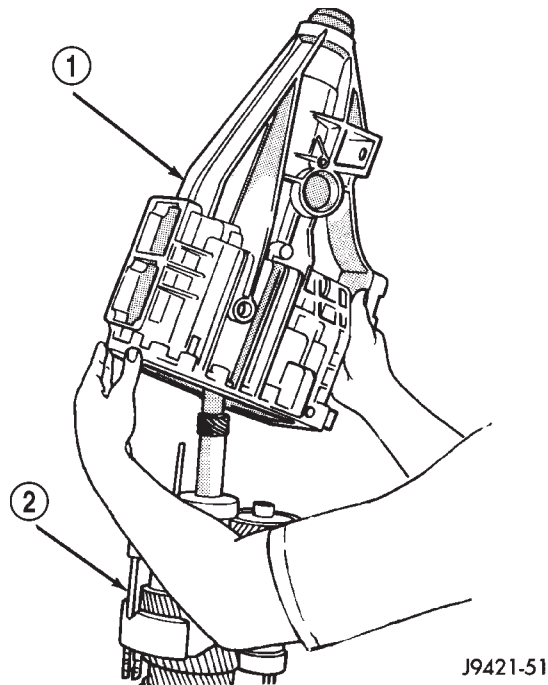

Fig. 37 Rear Housing Removal—2WD

- 1 - REAR HOUSING
- 2 - SHIFT FORKS AND GEARTRAIN

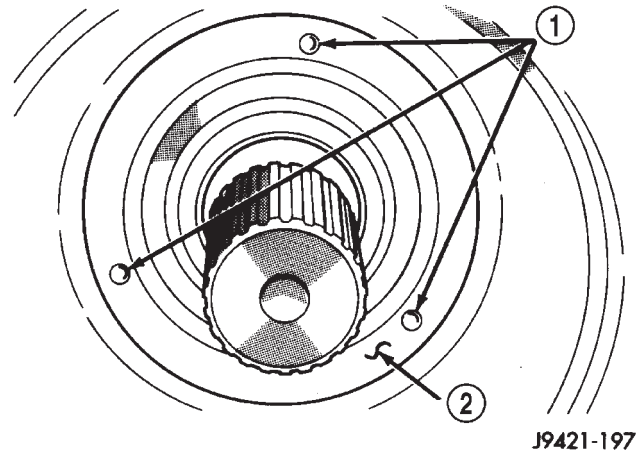

Fig. 39 Location Of Dimples In Seal Face—4WD

- 1 - LOCATION OF DIMPLES
- 2 - SEAL FACE

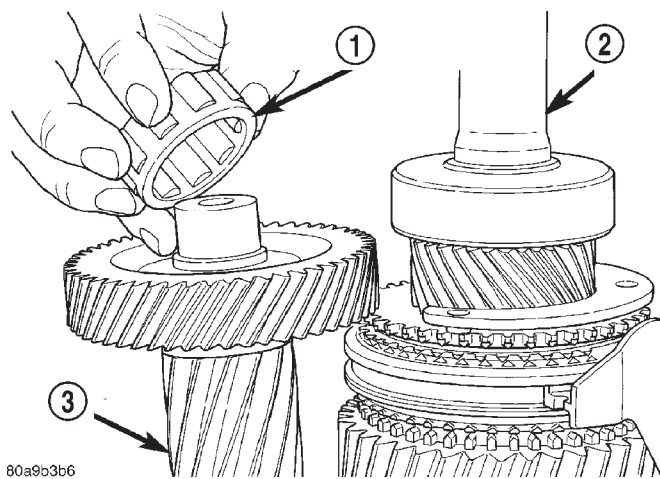

Fig. 38 Remove Countershaft Rear Bearing

- 1 - COUNTERSHAFT REAR BEARING
- 2 - OUTPUT SHAFT
- 3 - COUNTER SHAFT

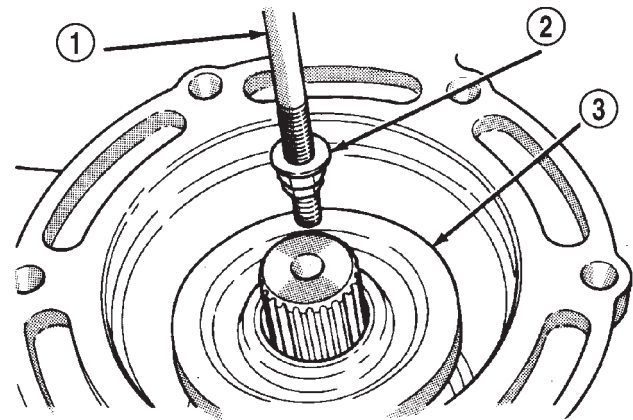

Fig. 40 Rear Seal Removal—4WD

- 1 - SLIDE HAMMER
- 2 - REMOVER TOOL
- 3 - REAR SEAL

(2) Remove rear bearing snap ring from output shaft with heavy duty snap ring pliers (Fig. 41).

(3) Lift rear adapter housing upward and off geartrain (Fig. 42).

DISASSEMBLY AND ASSEMBLY (Continued)

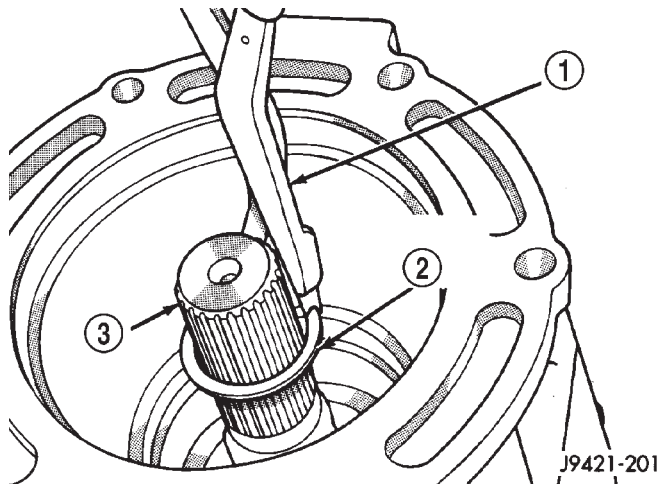
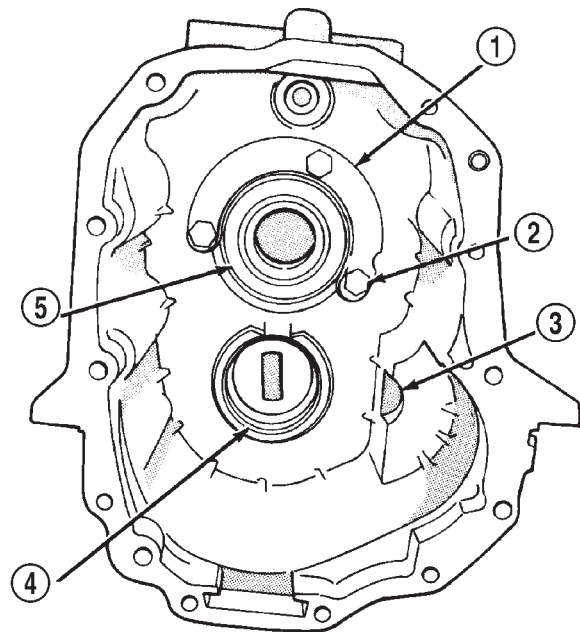

Fig. 41 Rear Bearing Snap Ring Removal—4WD

- 1 - HEAVY DUTY SNAP RING PLIERS
- 2 - REAR BEARING SNAP RING
- 3 - OUTPUT SHAFT



J9421-203

Fig. 43 Rear Adapter Housing Components

- 1 - BEARING RETAINER
- 2 - RETAINER BOLTS (3)
- 3 - IDLER SHAFT NOTCH
- 4 - COUNTERSHAFT REAR BEARING RACE
- 5 - REAR BEARING

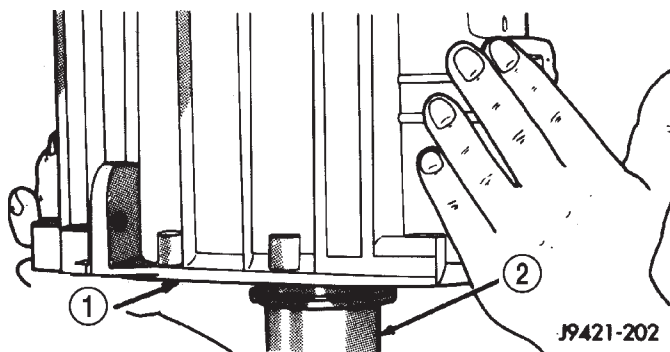

J9421-202

Fig. 42 Rear Adapter Housing Removal

- 1 - REAR ADAPTER HOUSING
- 2 - OUTPUT SHAFT

(4) Remove bearing retainer bolts and remove rear bearing retainer and rear bearing (Fig. 43). Use hammer handle to push or tap bearing out of housing if needed.

(5) Examine condition of bearing bore, countershaft rear bearing race and idler shaft notch in rear housing. Replace housing if race, bore or notch are worn or damaged.

GEARTRAIN DISASSEMBLY FROM FIXTURE

- (1) Remove reverse idler gear assembly from assembly fixture cup.
- (2) Remove 1-2 and fifth-reverse forks from synchro sleeves.
- (3) Slide countershaft out of fixture tool.
- (4) Remove output shaft bearing retainer from rear surface of fifth gear (retainer will drop onto gear after bolts are removed).
- (5) Lift and remove output shaft and gears off input shaft.
- (6) Lift and remove input shaft, pilot bearing and fourth gear synchro ring from assembly fixture tool.

DISASSEMBLY AND ASSEMBLY (Continued)

OUTPUT SHAFT

NOTE: The synchronizer hubs and sleeves are different and must not be intermixed. It is recommended that each synchronizer unit be removed as an assembly to avoid intermixing parts. It is also recommended that each synchro hub and sleeve be marked with a scribe or paint for correct assembly reference.

- (1) Remove snap ring that secures 3-4 synchro hub on output shaft.
- (2) Remove 3-4 synchro assembly, third gear synchro ring, and third gear with shop press and Remover Tool 1130. Position Tool 1130 between second and third gears.
- (3) Remove third gear needle bearing (Fig. 44).

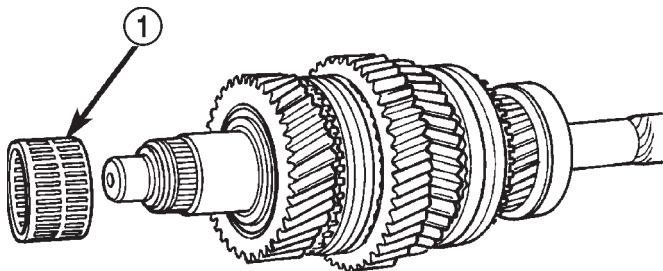

80a9b3b7

Fig. 44 Third Gear Needle Bearing Removal

- 1 - THIRD GEAR NEEDLE BEARING

- (4) Remove retaining ring that secures two-piece thrust washer on shaft (Fig. 45). Use small pry tool to remove retaining ring.

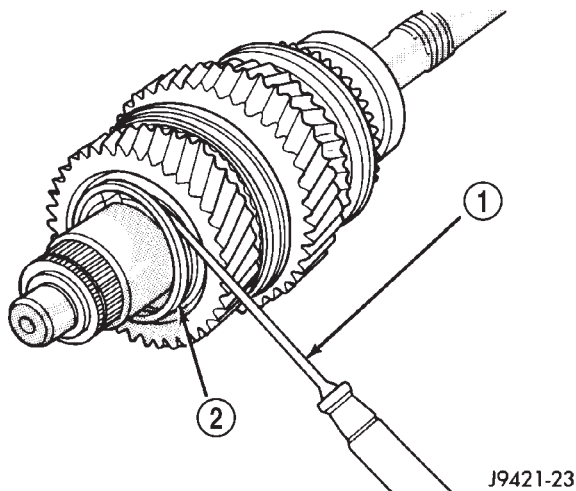

J9421-23

Fig. 45 Thrust Washer Retaining Ring Removal

- 1 - PRY TOOL
- 2 - THRUST WASHER RETAINING RING

- (5) Remove two-piece thrust washer (Fig. 46). Note position of washer locating lugs in shaft notches for installation reference.

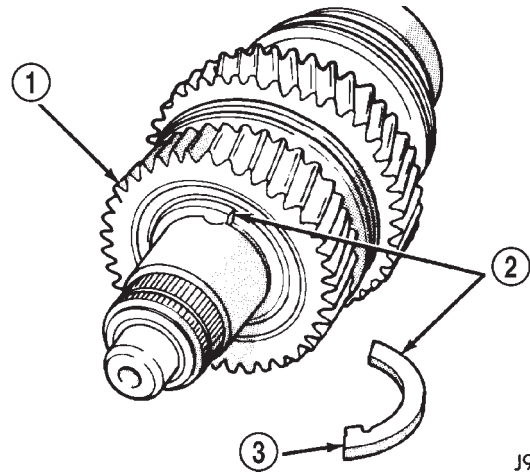

J9421-24

Fig. 46 Two-Piece Thrust Washer Removal

- 1 - SECOND GEAR
- 2 - THRUST WASHER (2-PIECE)
- 3 - WASHER LOCATING LUG

- (6) Remove second gear and needle bearing (Fig. 47).

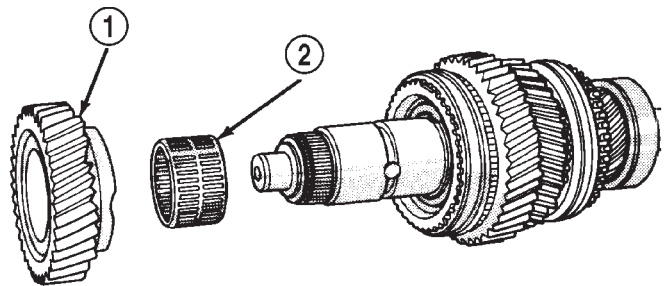

J9421-25

Fig. 47 Second Gear And Needle Bearing Removal

- 1 - SECOND GEAR
- 2 - SECOND GEAR NEEDLE BEARING

- (7) Remove second gear synchro ring, synchro friction cone, and synchro cone (Fig. 48).
- (8) Remove interm ring.
- (9) Remove 1-2 synchro hub snap ring.
- (10) Remove 1-2 synchro hub and sleeve and first gear from output shaft with shop press and Remover Tool 1130 (Fig. 49). Position Tool 1130 between first and reverse gears.

DISASSEMBLY AND ASSEMBLY (Continued)

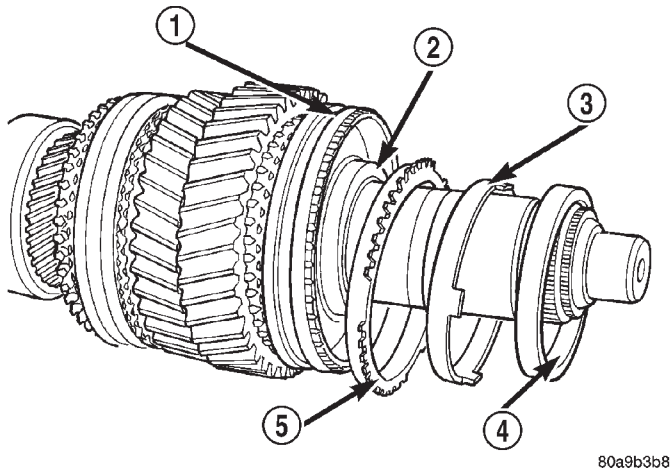

80a9b3b8

Fig. 48 Second Gear Synchro Ring And Cones Removal

- 1 - 1-2 SYNCHRO HUB AND SLEEVE
- 2 - INTERM RING
- 3 - SYNCHRO FRICTION CONE
- 4 - SYNCHRO CONE
- 5 - SYNCHRO RING

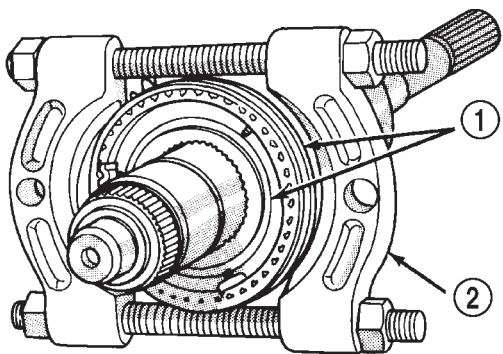

J9421-27

Fig. 49 Hub And Sleeve Removal—1-2 Synchro

- 1 - 1-2 SYNCHRO HUB AND SLEEVE
- 2 - SPECIAL TOOL 1130

- (11) Remove first gear needle bearing (Fig. 50).
- (12) Remove output shaft bearing snap ring (Fig. 51).
- (13) On 2-wheel drive models, remove output shaft bearing.
- (14) Remove fifth gear (Fig. 52).

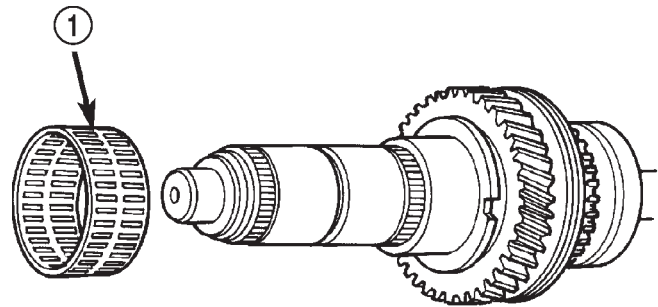

80a9b3b9

Fig. 50 First Gear Needle Bearing Removal

- 1 - FIRST GEAR NEEDLE BEARING

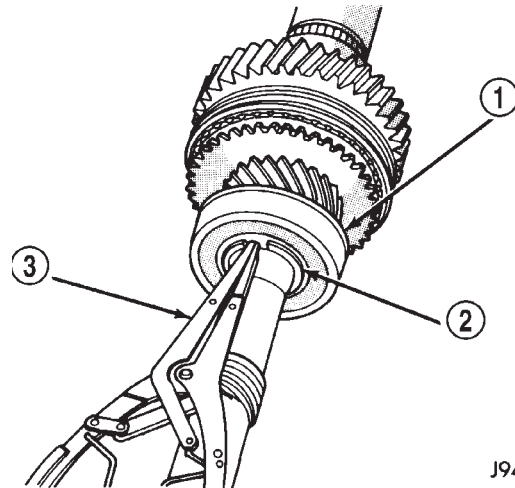

J9421-29

Fig. 51 Output Shaft Bearing Snap Ring Removal

- 1 - OUTPUT SHAFT BEARING
- 2 - BEARING SNAP RING
- 3 - SNAP RING PLIERS

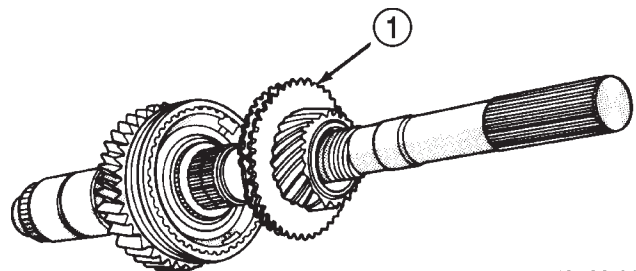

J9421-31

Fig. 52 Fifth Gear Removal

- 1 - FIFTH GEAR AND SYNCHRO RING

DISASSEMBLY AND ASSEMBLY (Continued)

(15) Remove fifth gear needle bearing. Spread bearing apart just enough to clear shoulder on output shaft (Fig. 53).

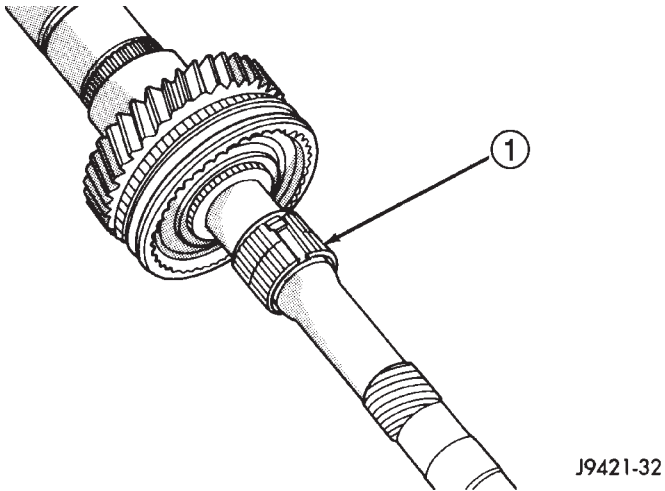

Fig. 53 Fifth Gear Needle Bearing Removal

- 1 - FIFTH GEAR NEEDLE BEARING (SPREAD BEARING TO CLEAR SHOULDER ON SHAFT)

(16) Remove fifth-reverse synchro hub snap ring (Fig. 54).

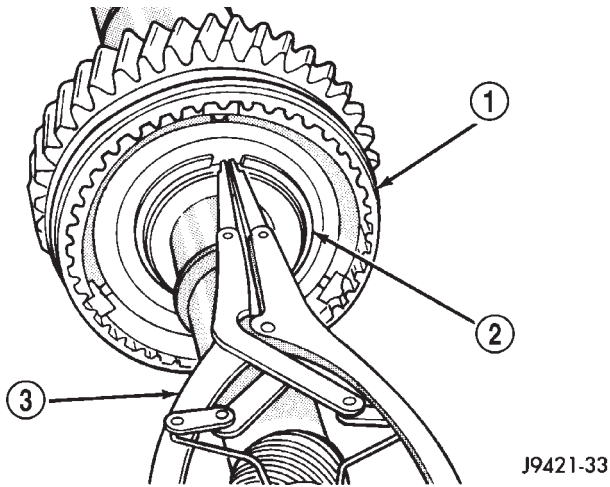

Fig. 54 Fifth-Reverse Synchro Hub Snap Ring Removal

- 1 - FIFTH-REVERSE SYNCHRO HUB AND SLEEVE
- 2 - SYNCHRO HUB SNAP RING
- 3 - SNAP RING PLIERS

(17) Remove fifth-reverse synchro hub and sleeve with shop press (Fig. 55).

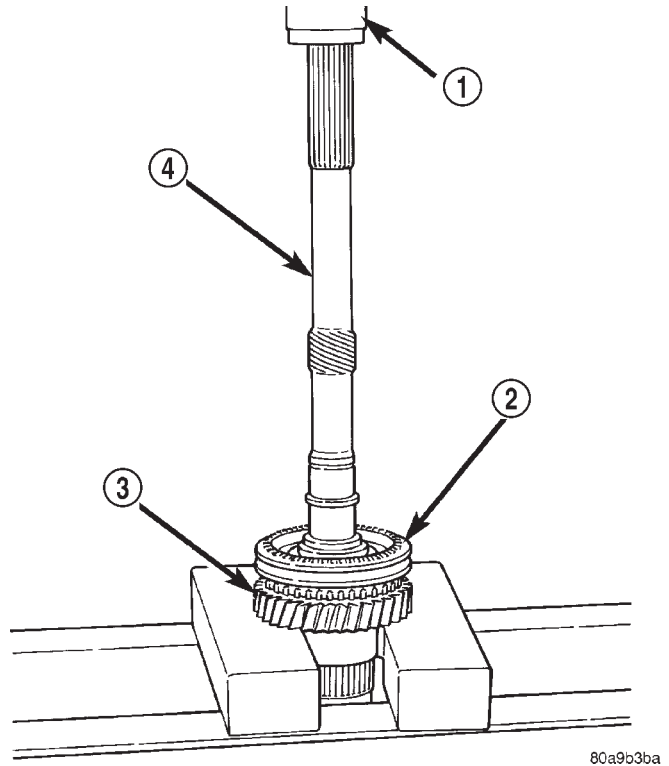

Fig. 55 Fifth-Reverse Synchro Hub And Sleeve Removal

- 1 - PRESS
- 2 - FIFTH-REVERSE SYNCHRO HUB AND SLEEVE
- 3 - REVERSE GEAR
- 4 - OUTPUT SHAFT

(18) Remove reverse gear and needle bearing (Fig. 56).

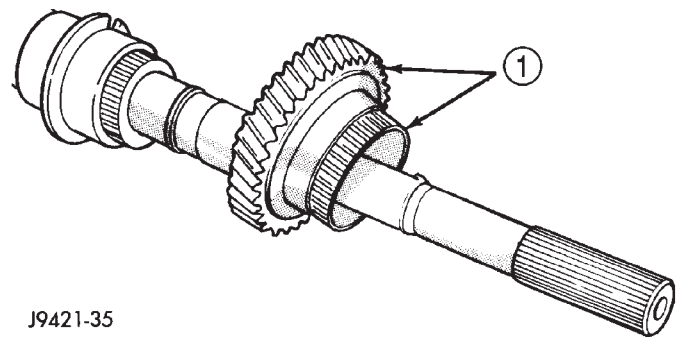
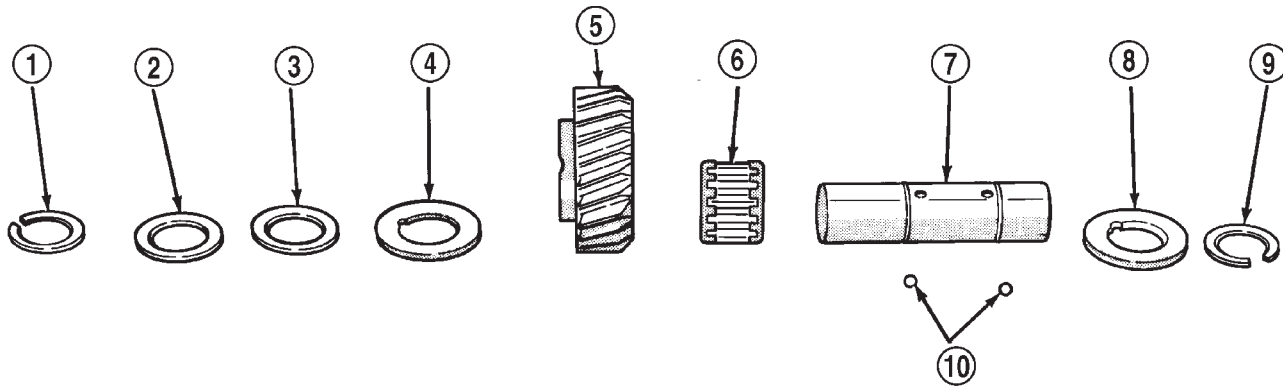

Fig. 56 Reverse Gear And Needle Bearing Removal

- 1 - REVERSE GEAR AND NEEDLE BEARING

DISASSEMBLY AND ASSEMBLY (Continued)



J9421-53

Fig. 57 Reverse Idler Components

- | | |
|------------------------|-------------------------------|
| 1 – SNAP RING | 6 – IDLER GEAR BEARING |
| 2 – FLAT WASHER | 7 – IDLER SHAFT |
| 3 – WAVE WASHER | 8 – THRUST WASHER |
| 4 – THRUST WASHER | 9 – SNAP RING |
| 5 – REVERSE IDLER GEAR | 10 – THRUST WASHER LOCK BALLS |

REVERSE IDLER DISASSEMBLY

- (1) Remove idler gear snap rings (Fig. 57).
- (2) Remove thrust washer, wave washer, thrust plate and idler gear from shaft.
- (3) Remove idler gear needle bearing from shaft.

ASSEMBLY

Gaskets are not used in the NV3550 transmission. Sealers are used at all case joints. Recommended sealers are Mopar® Gasket Maker for all case joints and Mopar® silicone sealer, or equivalent, for the input shaft bearing retainer. Apply these products as indicated in the assembly procedures.

NOTE: It is very important that the transmission shift components be in Neutral position during assembly. This is necessary to prevent damaging synchro and shift components when the housings are installed.

The 3-4, 1-2 and fifth-reverse synchro hub snap rings can be fitted selectively. New snap rings are available in 0.05 mm (0.0019 in.) thickness increments. Use the thickest snap ring that will fit in each snap ring groove.

SYNCHRONIZER

The easiest method of assembling each synchro is to install the springs, struts and detent balls one at a time as follows:

- (1) Slide the sleeve part way onto the hub. Leave enough room to install the spring in the hub and the strut in the hub groove.
- (2) Install the first spring in the hub. Then install a strut over the spring. Be sure the spring is seated in the spring bore in the strut.
- (3) Slide the sleeve onto the hub just far enough to hold the first strut and spring in place.
- (4) Place the detent ball in the top of the strut. Then carefully work the sleeve over the ball to hold it in place. A small flat blade screwdriver can be used to press the ball into place while moving the sleeve over it.
- (5) Repeat the procedure for the remaining springs, struts and balls. Tape, or a rubber band can be used to temporarily secure each strut and ball as they are installed.
- (6) Verify synchro assembly. Be sure the three springs, struts and detent balls are all in place (Fig. 58).

DISASSEMBLY AND ASSEMBLY (Continued)

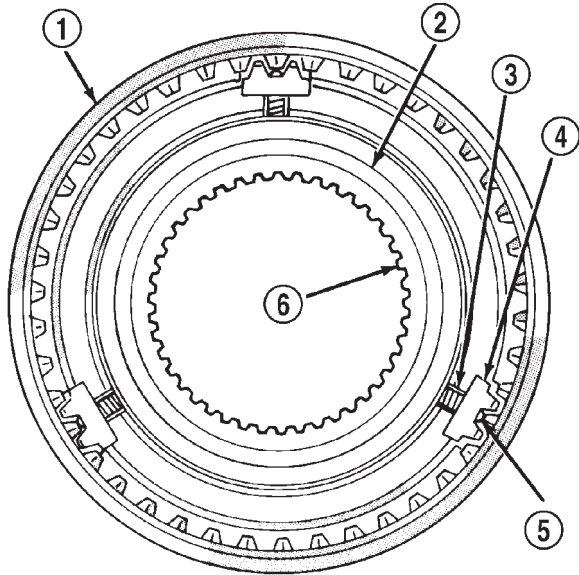

J9421-57

Fig. 58 Assembled View Of Synchro Components

- 1 - SLEEVE
- 2 - HUB SHOULDER
- 3 - SPRING (3)
- 4 - STRUT (3)
- 5 - DETENT BALL (3)
- 6 - HUB

OUTPUT SHAFT

(1) Lubricate shaft, gears and bearings with recommended lubricant during assembly. Petroleum jelly can be used to hold parts in place.

(2) Check bearing surfaces of output shaft for nicks or scratches. Smooth surfaces with 320/400 grit emery cloth if necessary. Apply oil to emery cloth and shaft surface before polishing.

(3) Inspect and replace any synchro ring that exhibits wear or damage. Completely immerse each synchro ring in lubricant before installation.

(4) Lubricate and install reverse gear needle bearing on shaft (Fig. 59). Slide bearing up against shoulder on output shaft.

(5) Install reverse gear over needle bearing (Fig. 60).

(6) Install solid brass synchro ring on reverse gear (Fig. 61).

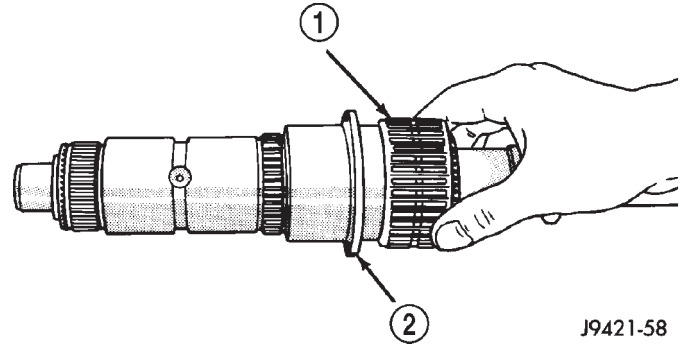

J9421-58

Fig. 59 Reverse Gear Bearing Installation

- 1 - REVERSE GEAR BEARING
- 2 - SHOULDER

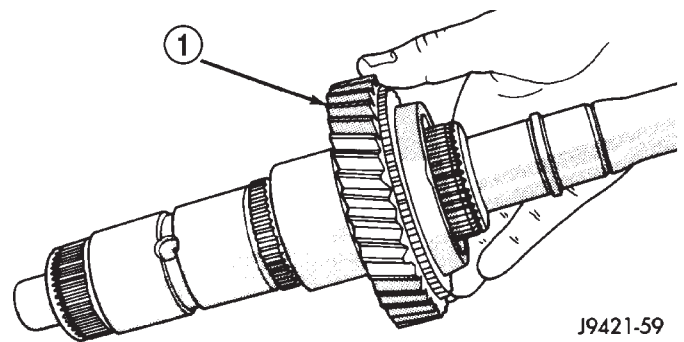

J9421-59

Fig. 60 Reverse Gear Installation

- 1 - REVERSE GEAR

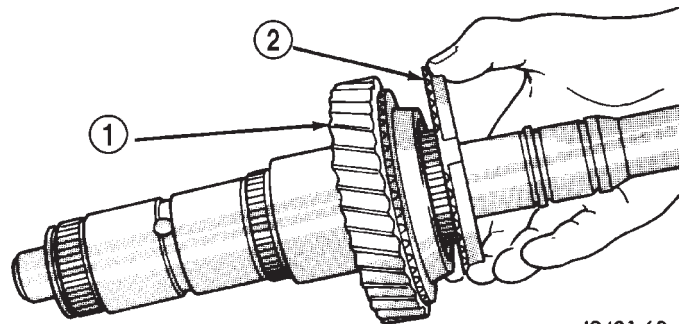

J9421-60

Fig. 61 Reverse Gear Synchro Ring Installation

- 1 - REVERSE GEAR
- 2 - SYNCHRO RING (SOLID BRASS)

DISASSEMBLY AND ASSEMBLY (Continued)

(7) Assemble fifth-reverse synchro hub, sleeve, struts, springs and detent balls, if not previously done.

CAUTION: The fifth-reverse synchro hub and sleeve can be installed backwards if care is not exercised. One side of the hub has shoulders around the hub bore. Make sure this side of the hub is facing the front of the shaft. In addition, one side of the sleeve is tapered. Be sure the sleeve is installed so the tapered side will be facing the front of the shaft.

(8) Start fifth-reverse synchro assembly on output shaft splines by hand. Then seat synchro onto shaft with shop press and Remover 6310-1 (Fig. 62).

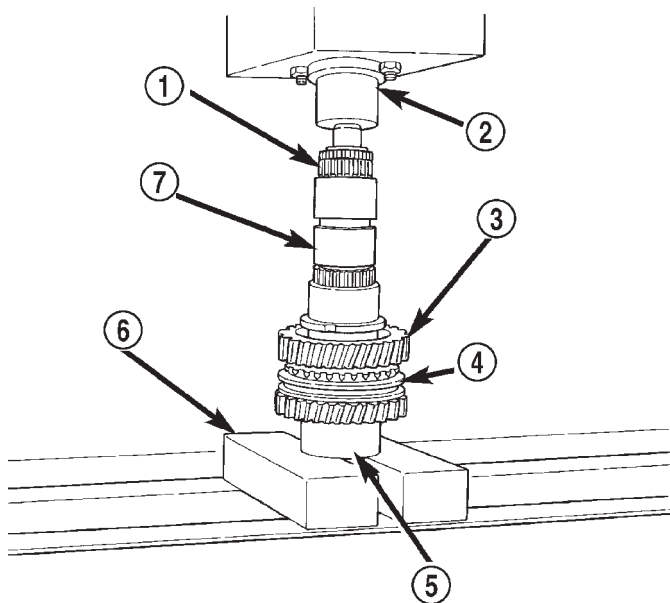

80a9b3bb

Fig. 62 Fifth-Reverse Synchro Assembly Installation

- 1 - SPACER
- 2 - PRESS RAM
- 3 - REVERSE GEAR
- 4 - FIFTH-REVERSE SYNCHRO ASSEMBLY
- 5 - SPECIAL TOOL 6310-1
- 6 - PRESS BLOCKS
- 7 - OUTPUT SHAFT

(9) Install new fifth-reverse hub snap ring (Fig. 63) as follows:

(a) Snap rings are available in thicknesses from 2.00 mm to 2.20 mm (0.078 to 0.086 in.).

(b) Install thickest snap ring that will fit in shaft groove.

(c) Verify that snap ring is completely seated in groove before proceeding.

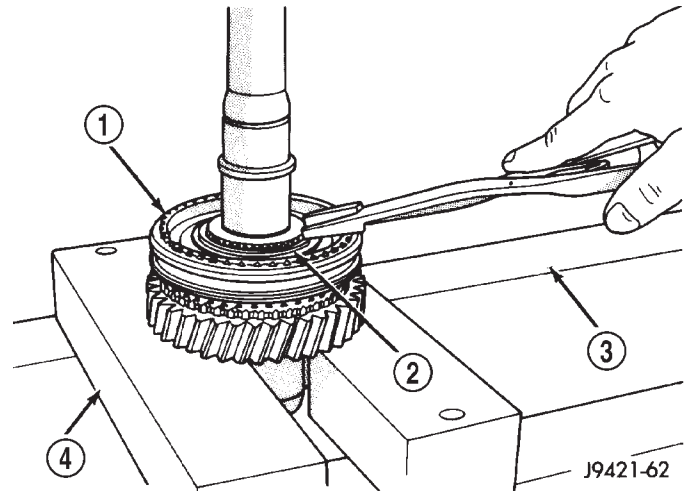

J9421-62

Fig. 63 Installing Fifth-Reverse Synchro Hub Snap Ring

- 1 - FIFTH-REVERSE SYNCHRO ASSEMBLY
- 2 - SNAP RING
- 3 - PRESS BED
- 4 - PRESS BLOCKS

(10) Install fifth gear synchro ring in synchro hub and sleeve (Fig. 64).

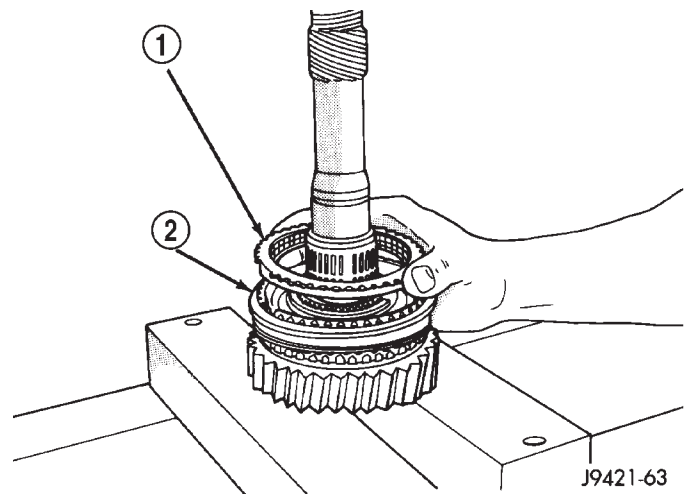

J9421-63

Fig. 64 Installing Fifth Gear Synchro Ring

- 1 - FIFTH-SPEED SYNCHRO RING
- 2 - FIFTH-REVERSE SYNCHRO ASSEMBLY

(11) Install fifth gear bearing. Spread bearing only enough to clear shoulder on output shaft (Fig. 65). Be sure bearing is properly seated after installation.

(12) Install fifth gear on shaft and onto bearing (Fig. 66).

DISASSEMBLY AND ASSEMBLY (Continued)

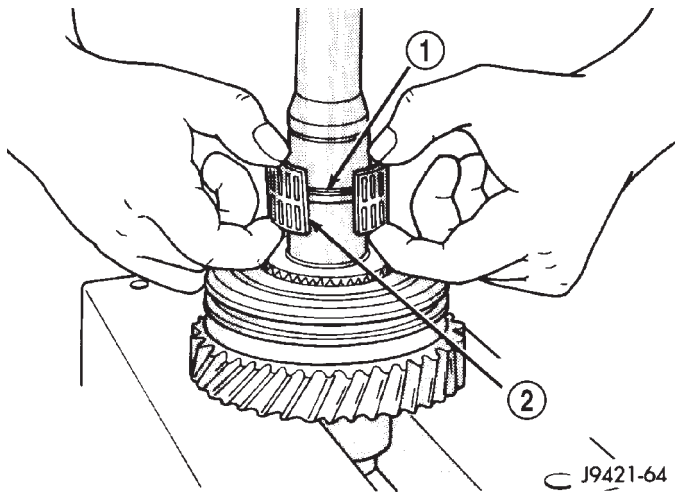

Fig. 65 Installing Fifth Gear Bearing

- 1 - SHAFT SHOULDER
- 2 - FIFTH GEAR BEARING

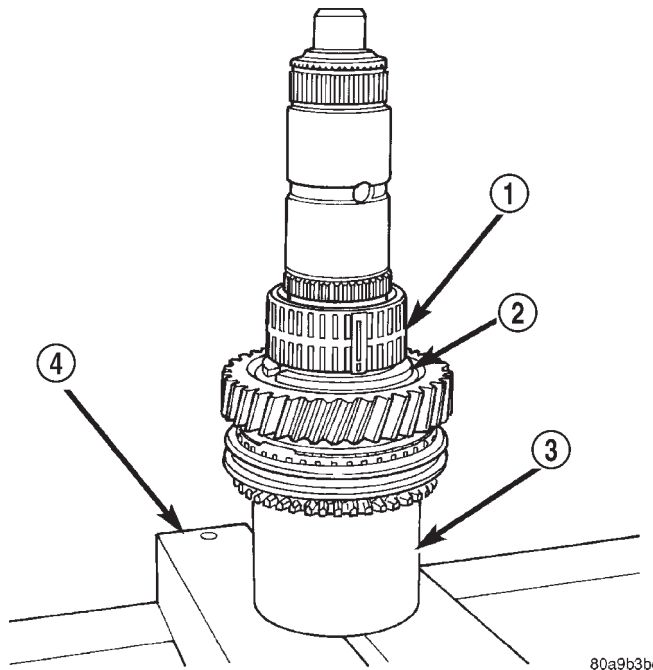

Fig. 67 First Gear Bearing Installation

- 1 - FIRST GEAR BEARING
- 2 - SHAFT SHOULDER
- 3 - SPECIAL TOOL 6310-1
- 4 - PRESS BLOCKS

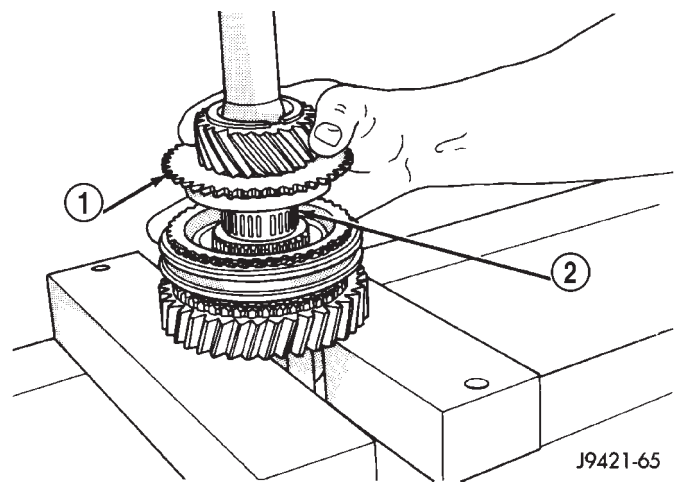

Fig. 66 Fifth Gear Installation

- 1 - FIFTH GEAR
- 2 - BEARING

(13) Invert output shaft and set the shaft in Remover 6310-1 so that fifth gear is seated on the tool (Fig. 67).

(14) Install first gear bearing on output shaft (Fig. 67). Be sure bearing is seated on shaft shoulder and is properly joined.

(15) Install first gear on shaft and over bearing (Fig. 68). Make sure bearing synchro cone is facing up as shown.

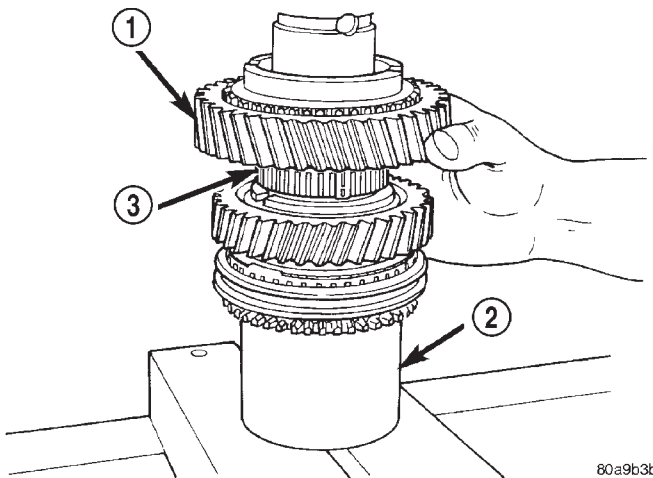
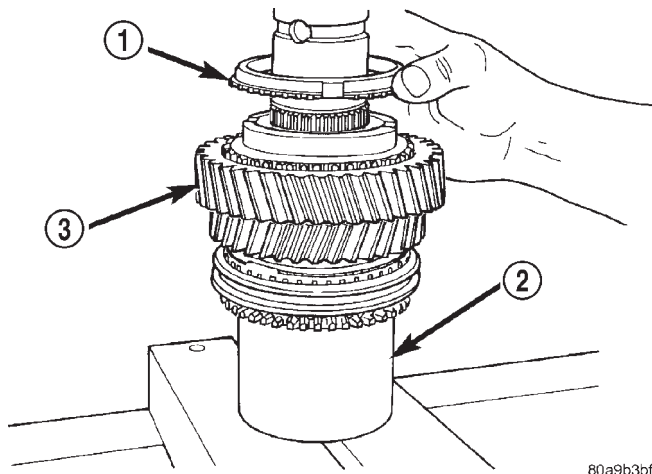

Fig. 68 First Gear Installation

- 1 - FIRST GEAR
- 2 - SPECIAL TOOL 6310-1
- 3 - BEARING

DISASSEMBLY AND ASSEMBLY (Continued)

(16) Install first gear synchro ring (Fig. 69).



80a9b3bf

Fig. 69 First Gear Synchro Ring Installation

- 1 - FIRST GEAR SYNCHRO RING
- 2 - SPECIAL TOOL 6310-1
- 3 - FIRST GEAR

(17) Assemble 1-2 synchro hub sleeve, springs, struts and detent balls.

CAUTION: The 1-2 synchro hub and sleeve can be installed backwards if care is not exercised. One side of the synchro sleeve is marked First Gear Side. Be sure this side of the sleeve will face first gear after installation.

(18) Start 1-2 synchro assembly on shaft by hand (Fig. 70). Be sure synchro sleeve is properly positioned. Side marked first side must be facing first gear.

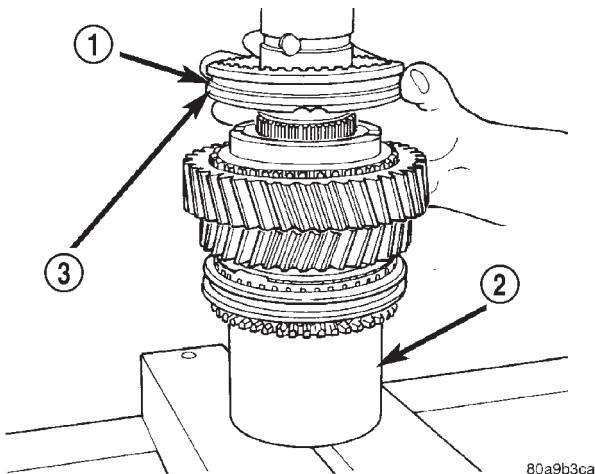

80a9b3ca

Fig. 70 Starting 1-2 Synchro On Shaft

- 1 - 1-2 SYNCHRO ASSEMBLY
- 2 - SPECIAL TOOL 6310-1
- 3 - BE SURE THIS IS "FIRST GEAR SIDE" OF SYNCHRO SLEEVE

(19) Press 1-2 synchro onto output shaft using suitable size pipe tool and shop press (Fig. 71).

CAUTION: Take time to align the synchro ring and sleeve as hub the is being pressed onto the shaft. The synchro ring can be cracked if it becomes misaligned.

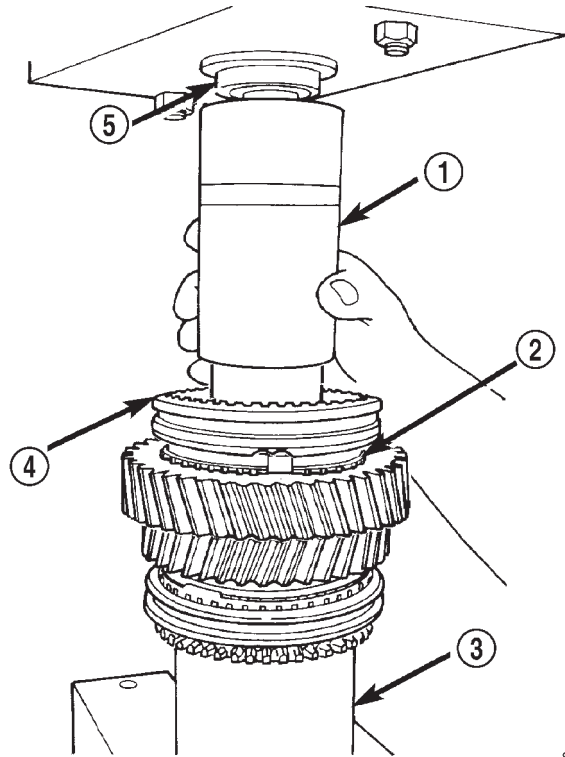

80a9b3cb

Fig. 71 Pressing 1-2 Synchro Assembly Onto Output Shaft

- 1 - SUITABLE SIZE PIPE TOOL
- 2 - SYNCHRO RING
- 3 - SPECIAL TOOL 6310-1
- 4 - 1-2 SYNCHRO ASSEMBLY
- 5 - PRESS RAM

(20) Install interm ring.

(21) Install new 1-2 synchro hub snap ring (Fig. 72) as follows:

- (a) Snap rings are available in thicknesses from 1.80 mm to 2.00 mm (0.070 to 0.078 in.).
- (b) Install thickest snap ring that will fit in shaft groove.
- (c) Verify that snap ring is completely seated in groove before proceeding.

(22) Install second gear synchro ring in 1-2 synchro hub and sleeve (Fig. 73). Be sure synchro ring is properly seated in sleeve.

DISASSEMBLY AND ASSEMBLY (Continued)

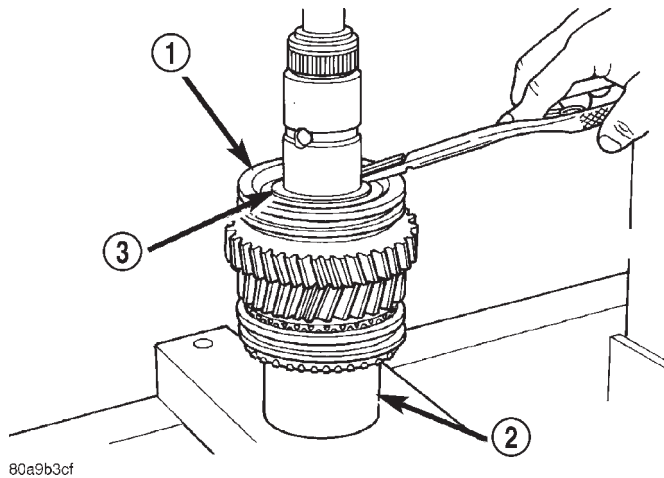

Fig. 72 Installing 1-2 Synchro Hub Snap Ring

- 1 - 1-2 SYNCHRO
- 2 - SPECIAL TOOL 6310-1
- 3 - SYNCHRO SNAP RING

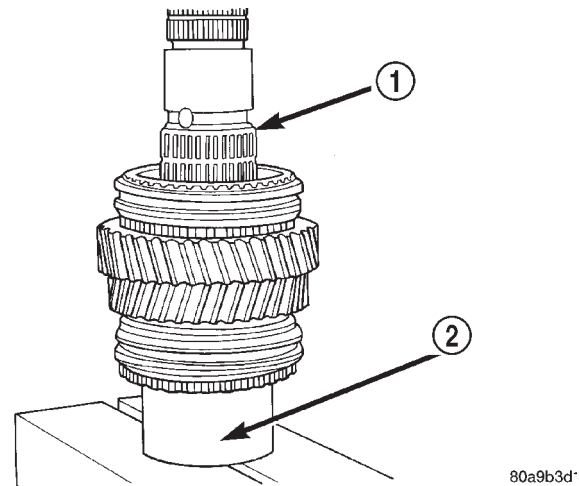

Fig. 74 Second Gear Bearing Installation

- 1 - SECOND GEAR BEARING
- 2 - SPECIAL TOOL 6310-1

(23) Install synchro friction cone and synchro cone in synchro ring.

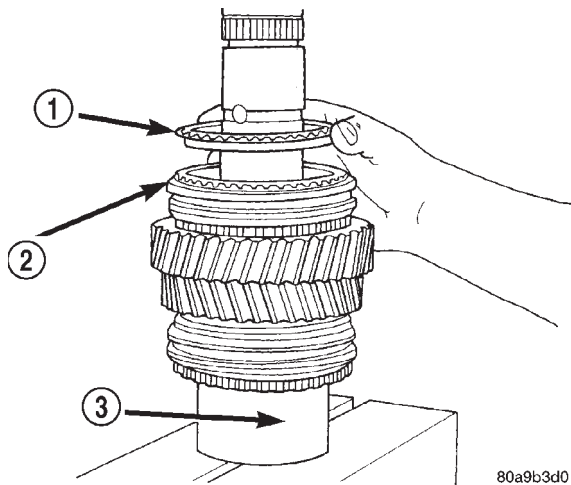

Fig. 73 Second Gear Synchro Ring Installation

- 1 - SECOND GEAR SYNCHRO RING
- 2 - 1-2 SYNCHRO
- 3 - SPECIAL TOOL 6310-1

(24) Install second gear needle bearing on shaft (Fig. 74).

(25) Install second gear onto shaft and bearing (Fig. 75). Make sure that second gear is fully seated on synchro components.

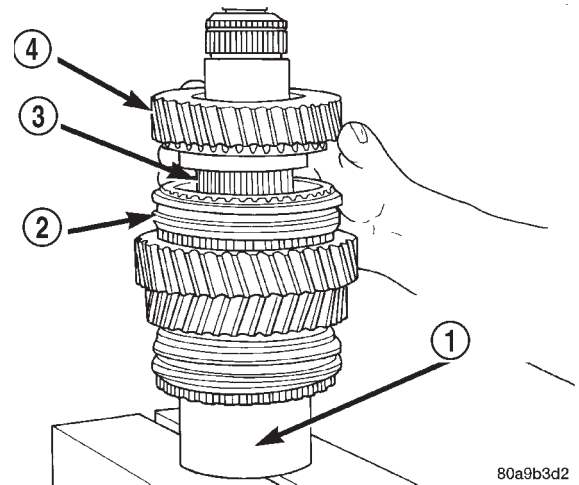
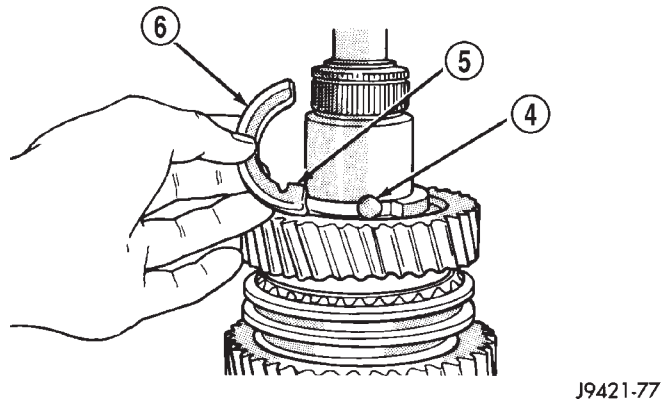
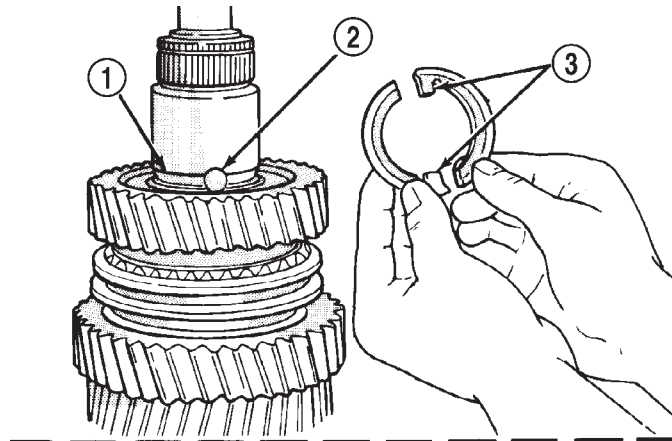

Fig. 75 Second Gear Installation

- 1 - SPECIAL TOOL 6310-1
- 2 - 1-2 SYNCHRO ASSEMBLY
- 3 - BEARING
- 4 - SECOND GEAR

DISASSEMBLY AND ASSEMBLY (Continued)

(26) Install two-piece thrust washer (Fig. 76). Be sure washer halves are seated in shaft groove and that washer lugs are seated in shaft lug bores. Also, ensure that the i.d. grooves and markings noted during removal are facing the correct direction.



J9421-77

Fig. 76 Installing Two-Piece Thrust Washer

- 1 - WASHER GROOVE IN SHAFT
- 2 - LUG BORE
- 3 - THRUST WASHER LUGS
- 4 - LUG BORE
- 5 - LUG
- 6 - WASHER HALF

(27) Start retaining ring around two-piece thrust washer (Fig. 77). Make sure that the locating dimple is between the thrust washer halves.

(28) Seat thrust washer retaining ring with plastic mallet (Fig. 78).

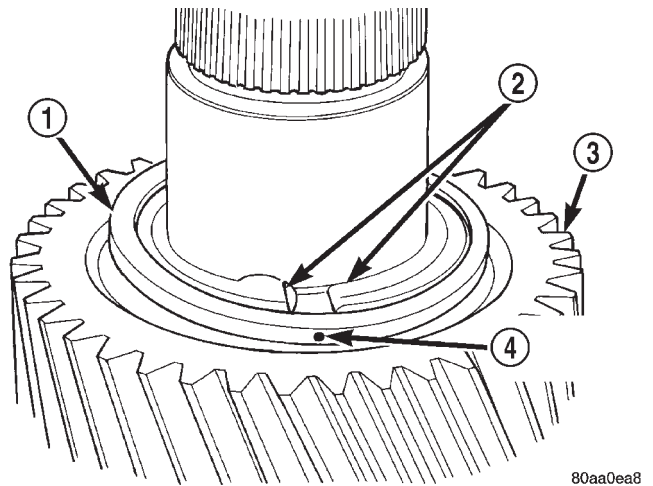

80aa0ea8

Fig. 77 Starting Retaining Ring Over Two-Piece Thrust Washer

- 1 - THRUST WASHER RETAINING RING
- 2 - THRUST WASHER HALVES
- 3 - SECOND GEAR
- 4 - LOCATING DIMPLE

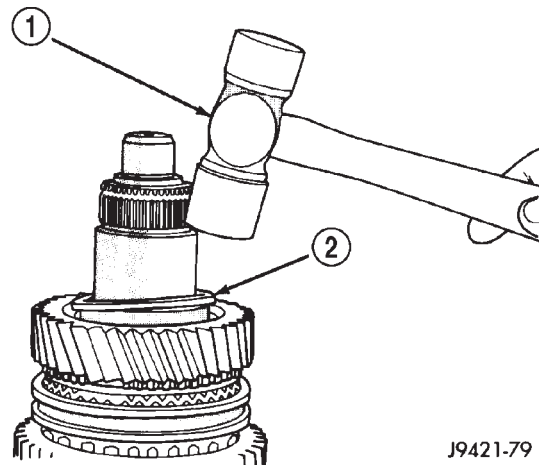

J9421-79

Fig. 78 Seating Thrust Washer Retaining Ring

- 1 - PLASTIC MALLET
- 2 - THRUST WASHER RETAINING RING

DISASSEMBLY AND ASSEMBLY (Continued)

(29) Install third gear needle bearing on shaft (Fig. 79).

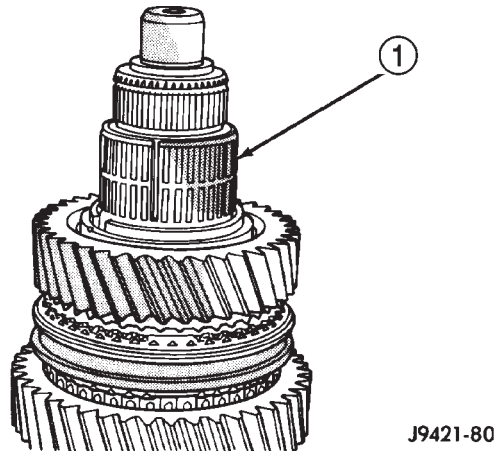

Fig. 79 Third Gear Bearing Installation

1 - THIRD GEAR BEARING

(30) Install third gear on shaft and bearing (Fig. 80).

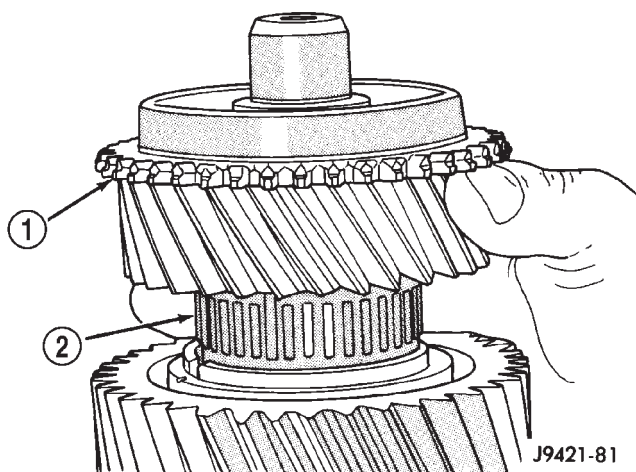

Fig. 80 Installing Third Gear

1 - THIRD GEAR
2 - BEARING

(31) Install third speed synchro ring on third gear (Fig. 81).

(32) Assemble 3-4 synchro hub, sleeve, springs, struts and detent balls.

CAUTION: The 3-4 synchro hub and sleeve can be installed backwards if care is not exercised. One side of the sleeve has grooves in it. Be sure this side of sleeve is also facing the front of the shaft.

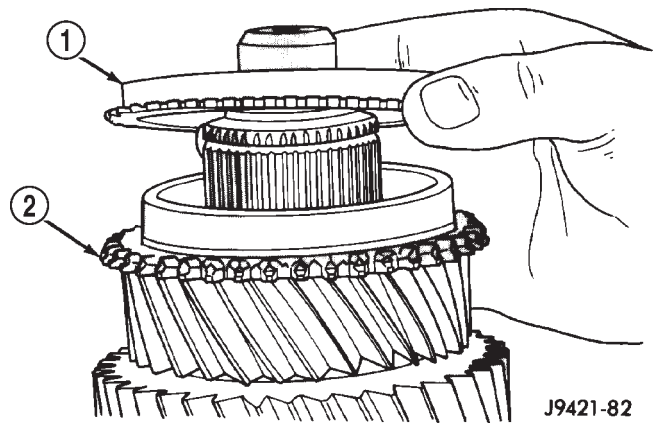

Fig. 81 Third Speed Synchro Ring Installation

1 - THIRD SPEED SYNCHRO RING
2 - THIRD GEAR

(33) Start 3-4 synchro hub on output shaft splines by hand (Fig. 82).

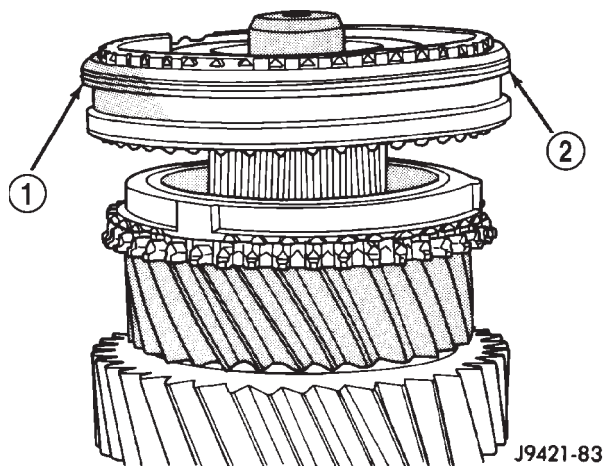

Fig. 82 Starting 3-4 Synchro Hub On Output Shaft

1 - GROOVED SIDE OF SLEEVE (TO FRONT)
2 - 3-4 SYNCHRO ASSEMBLY

(34) Press 3-4 synchro assembly onto output shaft with shop press and suitable size pipe tool (Fig. 83). Make sure that the tool presses on hub as close to output shaft as possible but does not contact the shaft splines.

DISASSEMBLY AND ASSEMBLY (Continued)

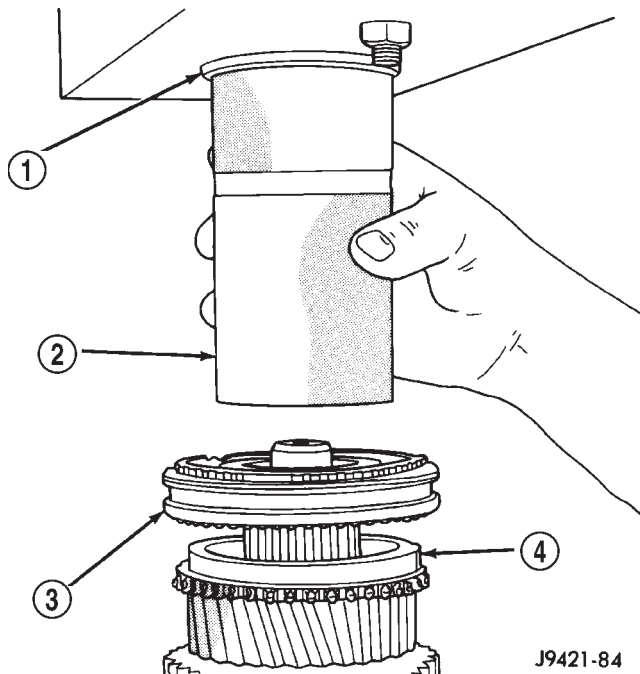

Fig. 83 Pressing 3-4 Synchro Assembly On Output Shaft

- 1 - PRESS RAM
- 2 - PIPE TOOL
- 3 - 3-4 SYNCHRO
- 4 - THIRD SPEED SYNCHRO RING

(35) Install 3-4 synchro hub snap ring (Fig. 84) as follows:

(a) Snap rings are available in thicknesses from 2.00 mm to 2.30 mm (0.078 to 0.090 in.).

(b) Install thickest snap ring that will fit in shaft groove. Use heavy duty snap ring pliers to install new ring.

(c) Verify that snap ring is completely seated in groove before proceeding.

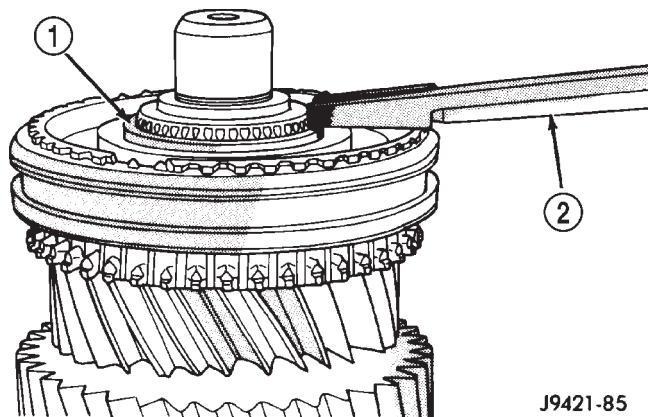

Fig. 84 Installing 3-4 Synchro Hub Snap Ring

- 1 - 3-4 SYNCHRO HUB SNAP RING
- 2 - HEAVY DUTY SNAP RING PLIERS

(36) Install output shaft bearing.

(37) Install output shaft bearing snap ring (Fig. 85). Use heavy duty snap ring pliers and spread snap ring only enough to install it. Be sure snap ring is completely seated in shaft groove before proceeding.

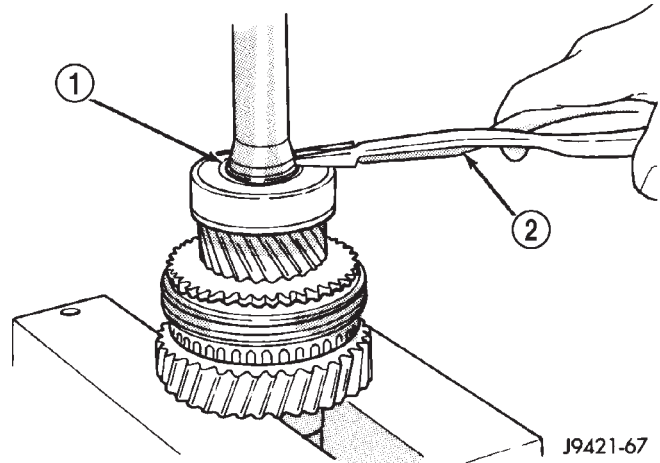

Fig. 85 Installing Output Shaft Bearing Snap Ring

- 1 - BEARING SNAP RING
- 2 - HEAVY DUTY SNAP RING PLIERS

(38) Verify correct position of synchro sleeves before proceeding with assembly operations (Fig. 86). Grooved side of 3-4 sleeve should be facing forward. First gear side of 1-2 sleeve should be facing first gear. Tapered side of fifth-reverse sleeve should be facing forward.

REVERSE IDLER ASSEMBLY

(1) Lubricate idler components with gear lube.

(2) Slide idler gear bearing on shaft (Fig. 87). Bearing fits either way on shaft.

(3) Slide gear onto shaft. Side of gear with recess goes to rear (Fig. 87).

(4) Place first lock ball in dimple at rear end of idler shaft (Fig. 87). Petroleum jelly can be used to hold ball in place if desired.

(5) Slide thrust rear thrust washer onto shaft and over lock ball (Fig. 88).

(6) Install snap ring in groove at rear of shaft (Fig. 88).

(7) Install lock ball in dimple at front of shaft. Hold ball in place with petroleum jelly if desired.

DISASSEMBLY AND ASSEMBLY (Continued)

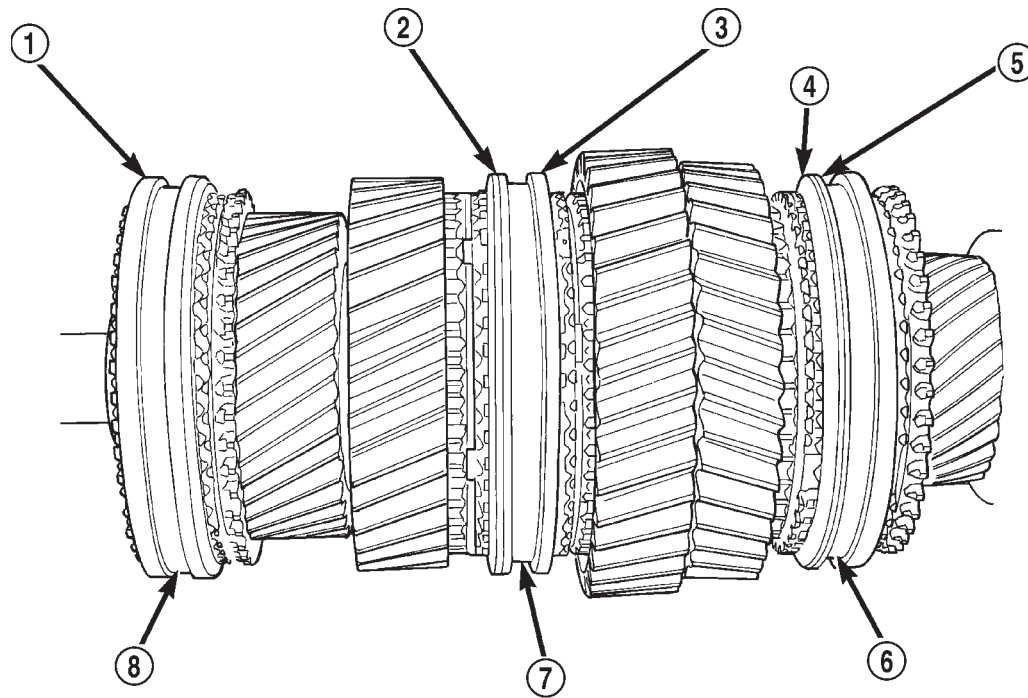

80aa0ea9

Fig. 86 Correct Synchro Sleeve Position

- | | |
|---|----------------------------|
| 1 - DOUBLE GROOVE FORWARD | 5 - GROOVE FORWARD |
| 2 - GROOVE FORWARD | 6 - 5TH-REV SYNCHRO SLEEVE |
| 3 - FIRST GEAR SIDE MARKING TOWARD FIRST GEAR | 7 - 1-2 SYNCHRO SLEEVE |
| 4 - TAPER FORWARD | 8 - 3-4 SYNCHRO SLEEVE |

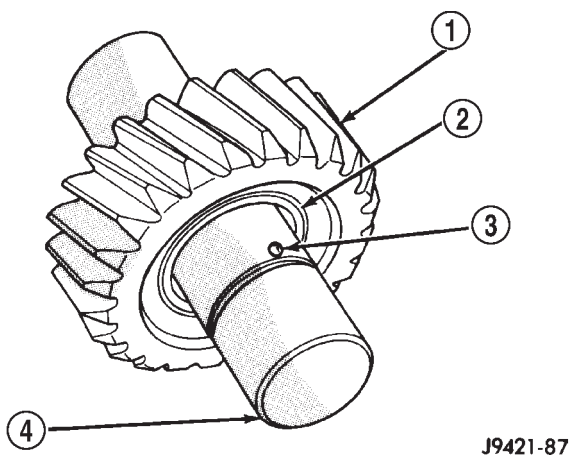

Fig. 87 Idler Gear And Bearing Installation

- 1 - IDLER GEAR
- 2 - BEARING
- 3 - LOCK BALL
- 4 - REAR OF SHAFT

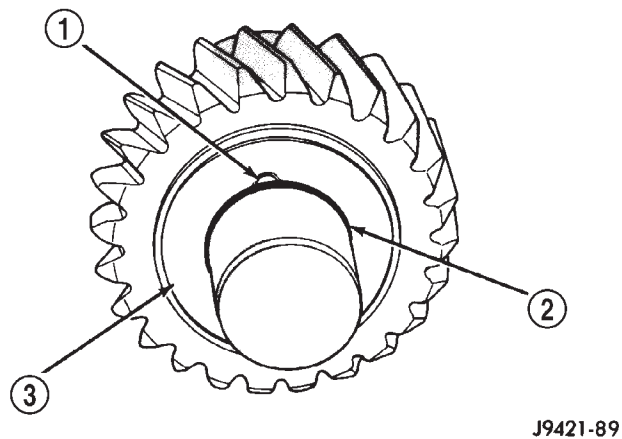

Fig. 88 Idler Gear Rear Thrust Washer Installation

- 1 - LOCK BALL
- 2 - SNAP RING GROOVE
- 3 - THRUST WASHER

(8) Install front thrust washer on shaft and slide washer up against gear and over lock ball (Fig. 89).

(9) Install wave washer, flat washer and remaining snap ring on idler shaft (Fig. 89). Be sure snap ring is fully seated.

DISASSEMBLY AND ASSEMBLY (Continued)

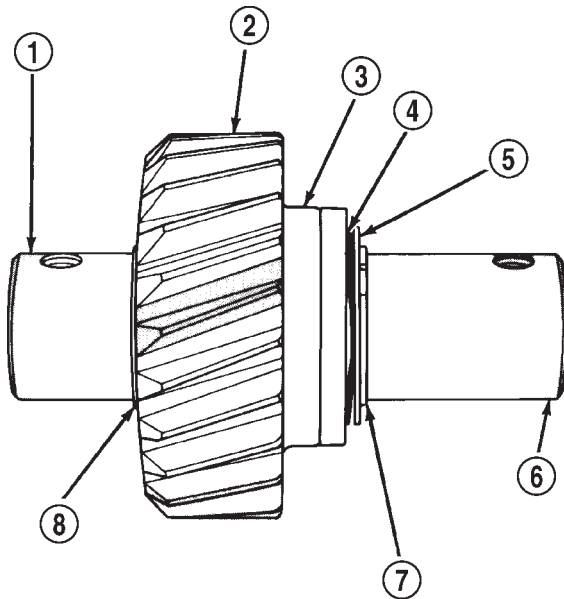

J9421-90

Fig. 89 Idler Gear And Shaft Assembly

- 1 - REAR OF SHAFT
- 2 - GEAR
- 3 - THRUST WASHER AND BALL
- 4 - WAVE WASHER
- 5 - FLAT WASHER
- 6 - FRONT OF SHAFT
- 7 - SNAP RING
- 8 - SNAP RING

SHIFT SHAFT AND DETENT PLUNGER BUSHINGS/BEARINGS

(1) Inspect shift shaft bushing and bearing for damage.

(2) If necessary, the shift shaft bushing can be replaced as follows:

(a) Locate a bolt that will thread into the bushing without great effort.

(b) Thread the bolt into the bushing, allowing the bolt to make its own threads in the bushing.

(c) Attach a slide hammer or suitable puller to the bolt and remove bushing.

(d) Use the short end of Installer 8119 to install the new bushing.

(e) The bushing is correctly installed if the bushing is flush with the transmission case.

(3) If necessary, the shift shaft bearing can be replaced as follows:

(a) Locate a bolt that will thread into the bearing without great effort.

(b) Thread the bolt into the bearing as much as possible.

(c) Attach a slide hammer or suitable puller to the bolt and remove the bearing.

(d) Use the short end of Installer 8119 to install the new bearing.

(e) The bearing is correctly installed if the bearing is flush with the transmission case.

(4) Inspect detent plunger bushings for damage.

NOTE: The detent plunger bushings are installed to a specific depth. The space between the two bushings when correctly installed contain an oil feed hole. Do not attempt to install the bushings with anything other than the specified tool or this oil hole may become restricted.

(5) If necessary, the detent plunger bushings can be replaced as follows:

(a) Using the long end of Installer 8119, drive the detent bushings through the outer case and into the shift shaft bore.

(b) Remove the bushings from the shift shaft bore.

(c) Install a new detent plunger bushing on the long end of Installer 8118.

(d) Start the bushing in the detent plunger bore in the case.

(e) Drive the bushing into the bore until the tool contacts the transmission case.

(f) Install a new detent plunger bushing on the short end of Installer 8118.

(g) Start the bushing in the detent plunger bore in the case.

(h) Drive the bushing into the bore until the tool contacts the transmission case.

GEARTRAIN ASSEMBLY

(1) Install Adapter 6747-1A on input shaft hub of fixture tool (Fig. 90). Then install Adapter 6747-2A on front bearing hub of countershaft. Adapter 6747-2A has a raised shoulder on one side. Be sure the shoulder is seated against the countershaft.

(2) Install input shaft in fixture tool. Make sure Adapter Tool 6747-1A is positioned under shaft as shown (Fig. 91).

(3) Install pilot bearing in input shaft (Fig. 91).

NOTE: There is a correct and an incorrect way to install the pilot bearing into the input shaft. The side of the pilot bearing with the small diameter goes toward the input shaft.

DISASSEMBLY AND ASSEMBLY (Continued)

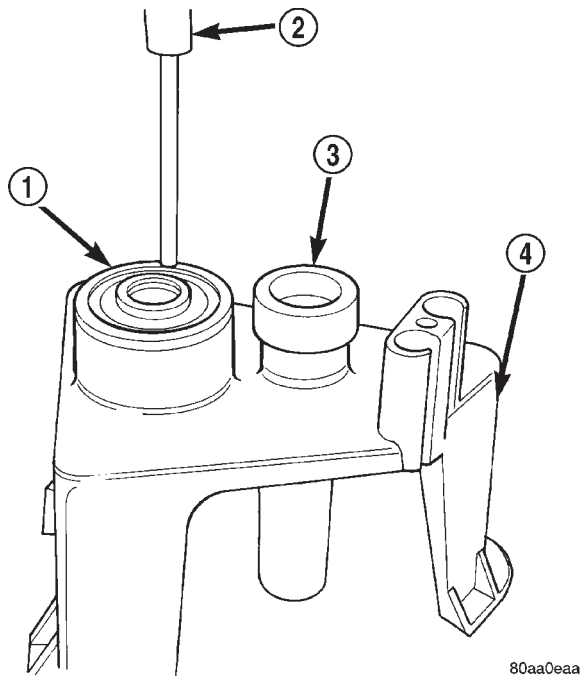

80aa0eaa

Fig. 90 Preparing Assembly Fixture For Geartrain Build-up

- 1 - SPECIAL TOOL 6747-2A (INSTALL ON COUNTERSHAFT FRONT HUB)
- 2 - SPECIAL TOOL 8115
- 3 - SPECIAL TOOL 6747-1A
- 4 - SPECIAL TOOL 6747

(4) Install fourth gear synchro ring on input shaft (Fig. 92).

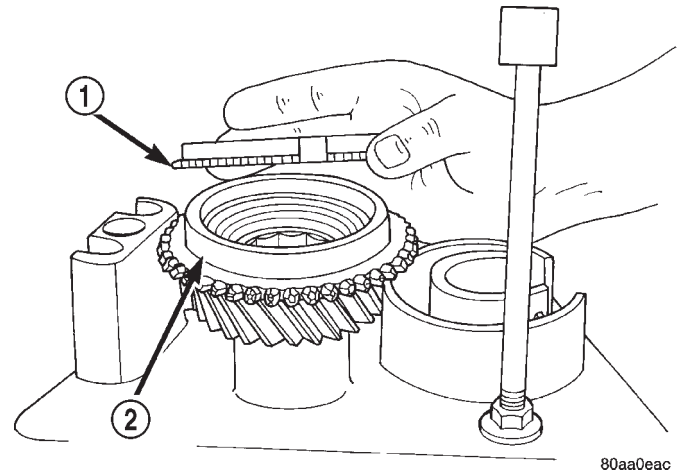

80aa0eac

Fig. 92 Installing Fourth Gear Synchro Ring On Input Shaft

- 1 - FOURTH GEAR SYNCHRO RING
- 2 - INPUT SHAFT

(5) Adjust height of idler gear pedestal on assembly fixture (Fig. 93). Start with a basic height of 18.4 cm (7-1/4 in.). Final adjustment can be made after gear is positioned on pedestal.

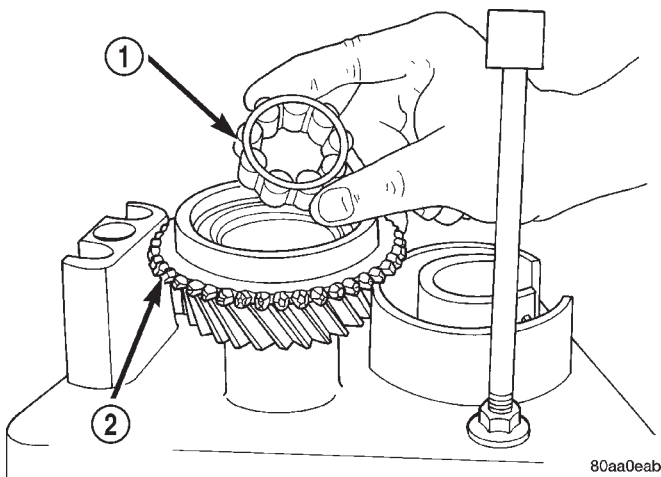

80aa0eab

Fig. 91 Installing Pilot Bearing In Input Shaft

- 1 - PILOT BEARING
- 2 - INPUT SHAFT

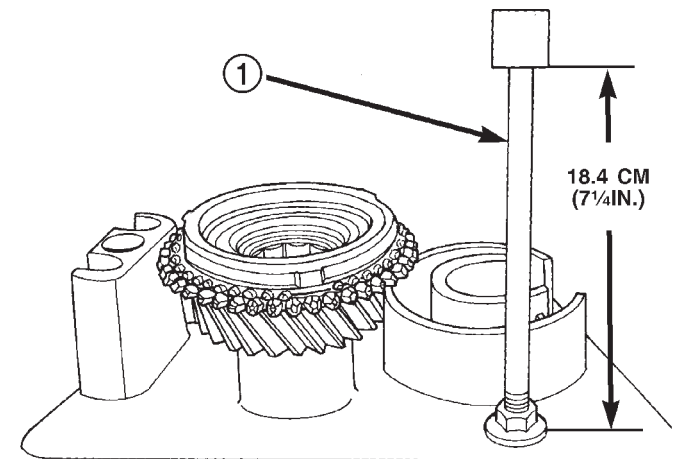

80aa0ead

Fig. 93 Idler Pedestal Basic Height Adjustment

- 1 - REVERSE IDLER PEDESTAL

(6) Install assembled output shaft and geartrain in input shaft (Fig. 94). Carefully rotate output shaft until the 3-4 synchro ring seats in synchro hub and sleeve.

DISASSEMBLY AND ASSEMBLY (Continued)

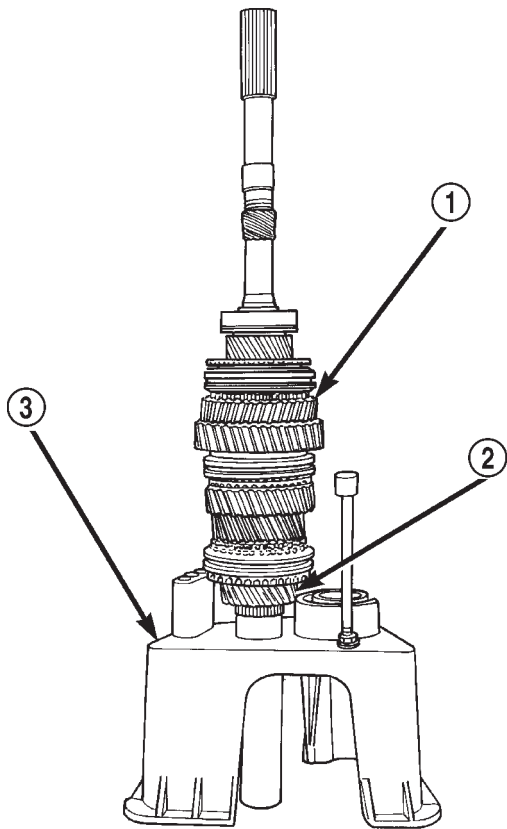

80aa0eae

Fig. 94 Output Shaft And Geartrain Installed In Input Shaft

- 1 - OUTPUT SHAFT AND GEARTRAIN
- 2 - INPUT SHAFT
- 3 - SPECIAL TOOL
6747

(7) Install Adapter 6747-2A on front bearing hub of countershaft, if not previously done. The adapter has a shoulder on one side. The shoulder goes toward the countershaft.

(8) Slide countershaft (and adapter) into fixture slot. Verify that countershaft and output shaft gears are fully meshed with the mainshaft gears before proceeding (Fig. 95).

(9) Check alignment of countershaft and output shaft gear teeth. Note that gears may not align perfectly. A difference in height of 1.57 to 3.18 mm (1/16 to 1/8 in.) will probably exist. This difference will not interfere with assembly. However, if the difference is greater than this, the countershaft adapter tool is probably upside down. Remove countershaft, reverse adapter tool, reinstall countershaft and check alignment again.

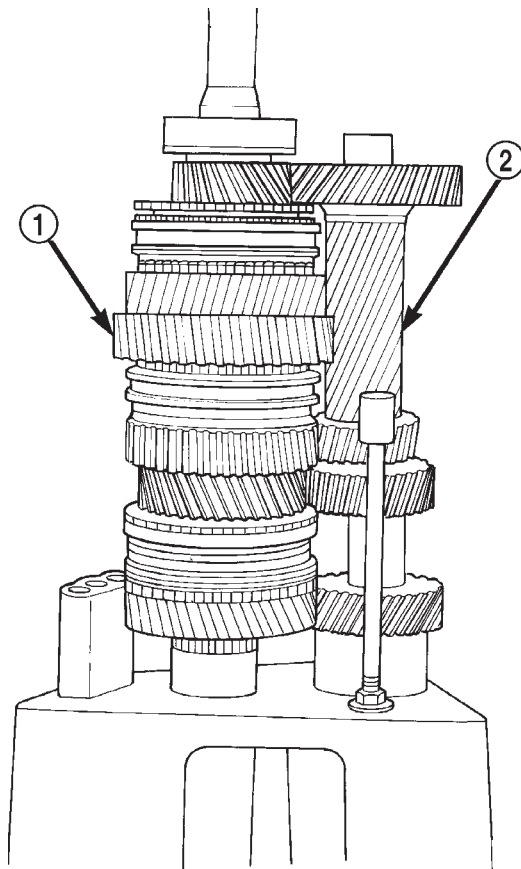

80aa0eaf

Fig. 95 Countershaft Installed On Fixture Tool

- 1 - OUTPUT SHAFT AND GEARTRAIN
- 2 - COUNTERSHAFT (SLIDE INTO PLACE ON FIXTURE TOOL)

DISASSEMBLY AND ASSEMBLY (Continued)

(10) Position reverse idler in support cup of assembly fixture (Fig. 96). Be sure idler gear is properly meshed and aligned with shaft gear teeth and that bolt holes are facing out and not toward geartrain. Adjust pedestal up or down if necessary. Also be sure that short end of idler shaft is facing up as shown.

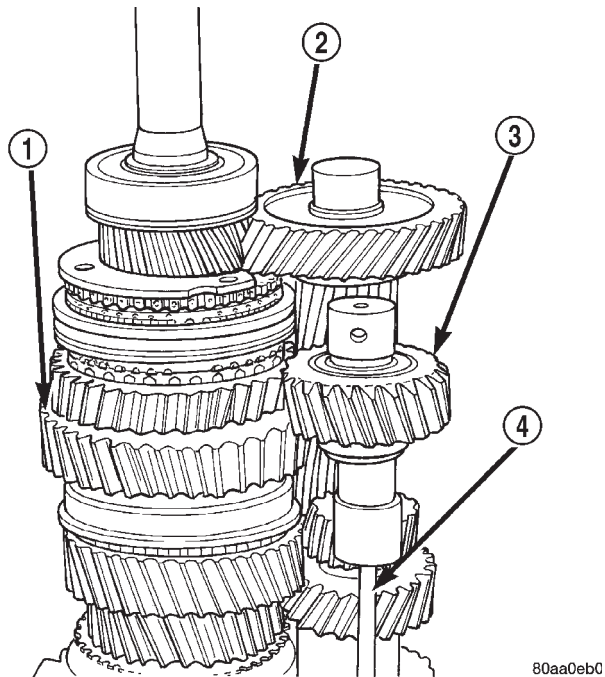
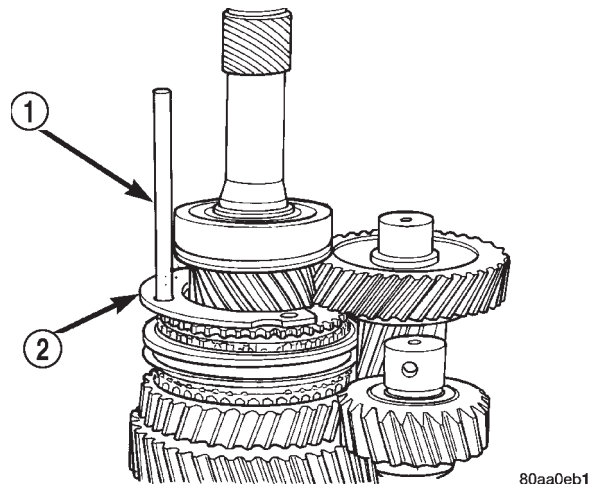

Fig. 96 Reverse Idler Assembly Positioned On Assembly Fixture Pedestal

- 1 - OUTPUT SHAFT AND GEARTRAIN
- 2 - COUNTERSHAFT
- 3 - REVERSE IDLER ASSEMBLY
- 4 - TOOL PEDESTAL

(11) On 2-wheel drive transmission, thread one Pilot Stud 8120 in center or passenger side hole of output shaft bearing retainer. Then position retainer on fifth gear as shown (Fig. 97).

(12) Assemble 1-2 and fifth reverse-shift forks (Fig. 98). Arm of fifth-reverse fork goes through slot in 1-2 fork.



80aa0eb1

Fig. 97 Positioning Output Shaft Bearing Retainer For Rear Housing Installation

- 1 - SPECIAL TOOL
8120
- 2 - OUTPUT SHAFT BEARING RETAINER

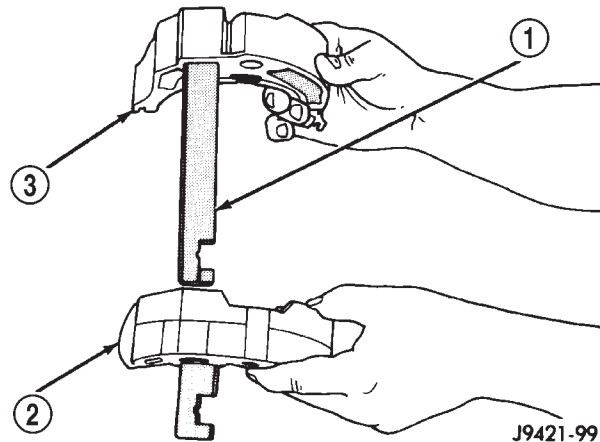

J9421-99

Fig. 98 Assembling 1-2 And Fifth-Reverse Shift Forks

- 1 - INSERT ARM THROUGH 1-2 FORK
- 2 - 1-2 FORK
- 3 - FIFTH-REVERSE FORK

DISASSEMBLY AND ASSEMBLY (Continued)

(13) Install assembled shift forks in synchro sleeves (Fig. 99). Be sure forks are properly seated in sleeves.

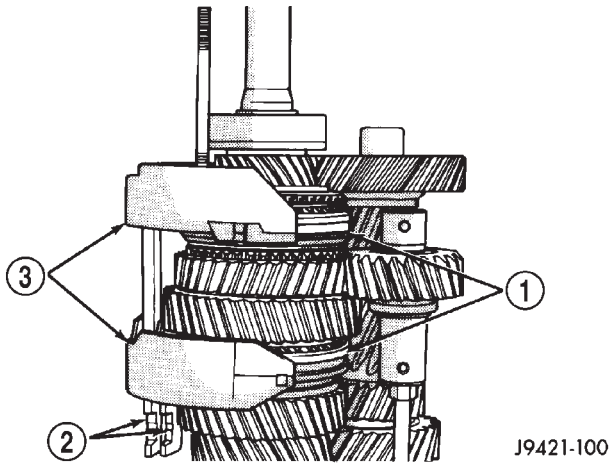

Fig. 99 Shift Forks Installed In Synchro Sleeves

- 1 - SYNCHRO SLEEVES
- 2 - FORK ARMS
- 3 - SHIFT FORKS

REAR HOUSING—2WD

(1) Drive adapter housing alignment dowels back into housing until dowels are flush with mounting surface (Fig. 100).

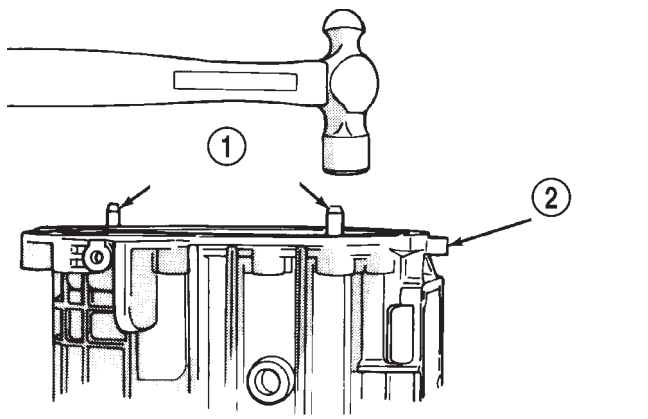

Fig. 100 Preparing Rear Housing Dowels For Installation

- 1 - HOUSING ALIGNMENT DOWELS
- 2 - REAR HOUSING
- 3 - DOWEL FLUSH WITH SURFACE

(2) Apply liberal quantity of petroleum jelly to countershaft rear bearing and bearing race.

(3) Install countershaft rear bearing in bearing race (Fig. 101).

CAUTION: The countershaft bearings can be installed backwards if care is not exercised. Be sure the large diameter side of the roller retainer faces the countershaft and the small diameter side faces the race and housing (Fig. 102).

(4) Apply extra petroleum jelly to hold countershaft rear bearing in place when housing is installed.

(5) Apply light coat of petroleum jelly to shift shaft bushing/bearing in rear housing (Fig. 102).

(6) Reach into countershaft rear bearing with finger, and push each bearing roller outward against race. Then apply extra petroleum jelly to hold rollers in place. This avoids having rollers becoming displaced during housing installation. This will result in misalignment between bearing and countershaft bearing hub.

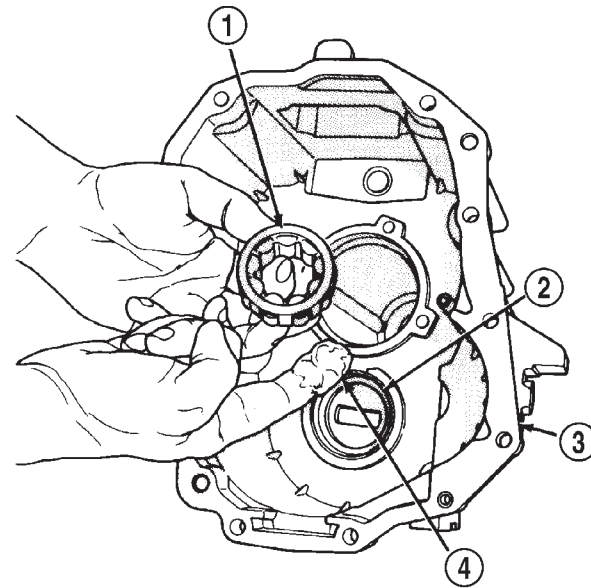

Fig. 101 Lubricating Countershaft Rear Bearing

- 1 - COUNTERSHAFT REAR BEARING
- 2 - REAR BEARING RACE
- 3 - REAR HOUSING
- 4 - PETROLEUM JELLY (APPLY TO BEARING AND RACE)

DISASSEMBLY AND ASSEMBLY (Continued)

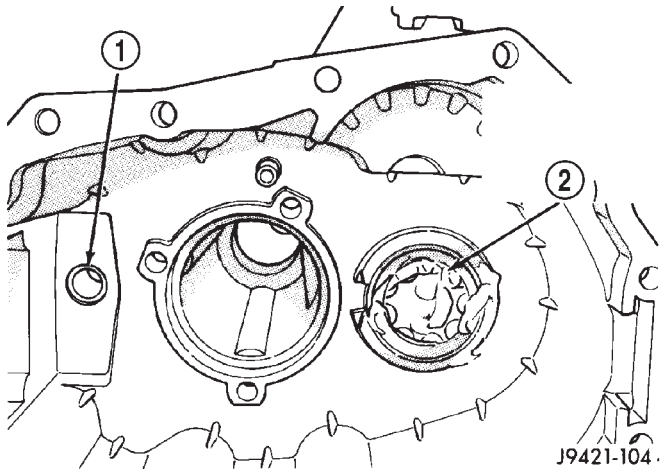

Fig. 102 Countershaft Rear Bearing Seated In Seated in Race

- 1 - SHIFT SHAFT BUSHING/BEARING
- 2 - COUNTERSHAFT REAR BEARING (SEATED IN RACE)

(7) Install rear housing onto geartrain (Fig. 103). Be sure bearing retainer pilot stud is in correct bolt hole in housing. Also be sure countershaft and output shaft bearings are aligned in housing and on countershaft. It may be necessary to lift upward on countershaft slightly to ensure that the countershaft rear bearing engages to the countershaft before the rear output shaft bearing engages the housing.

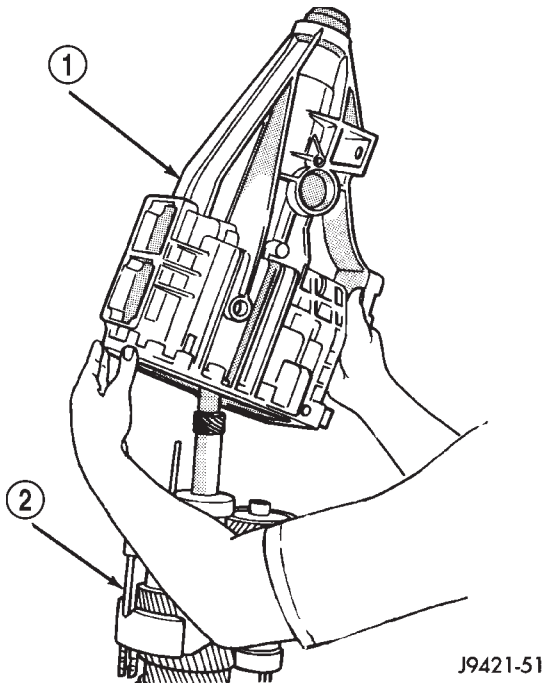

Fig. 103 Rear Housing Installation—2WD

- 1 - REAR HOUSING
- 2 - SHIFT FORKS AND GEARTRAIN

(8) Seat rear housing on output shaft rear bearing and countershaft. Use plastic or rawhide mallet to tap housing into place.

(9) Install the three bolts that secure rear bearing retainer to rear housing as follows:

(a) Apply Mopar® Gasket Maker, or equivalent, to bolt threads, bolt shanks and under bolt heads (Fig. 104).

(b) Start first two bolts in retainer (Fig. 105). It may be necessary to move retainer rearward (with pilot stud) in order to start bolts in retainer.

(c) Remove Pilot Stud 8120 and install last retainer bolt (Fig. 105).

(d) Tighten all three retainer bolts to 30-35 N-m (22-26 ft. lbs.) torque.

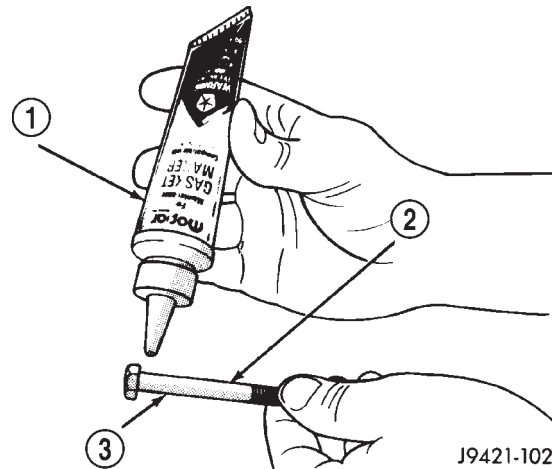

Fig. 104 Applying Sealer To Retainer And Housing Bolts

- 1 - MOPAR GASKET MAKER (OR LOCTITE 518)
- 2 - RETAINER AND HOUSING BOLTS
- 3 - APPLY SEALER TO UNDERSIDE OF BOLT HEAD, SHANK AND THREADS

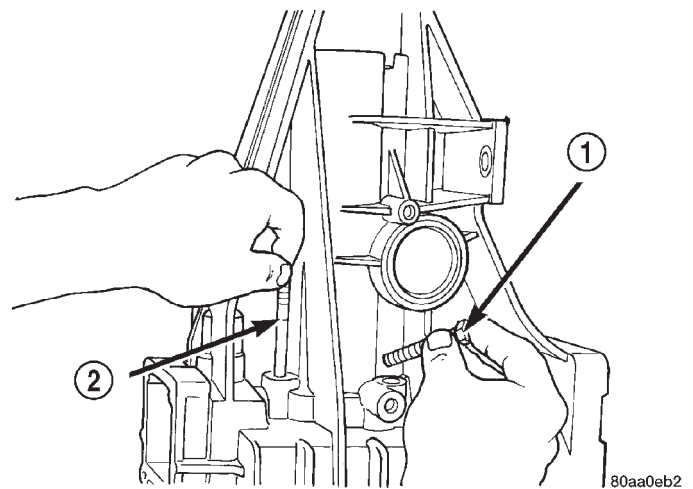

Fig. 105 Removing Pilot Stud Tool And Installing Retainer Bolts—2WD

- 1 - BEARING RETAINER BOLT
- 2 - SPECIAL TOOL 8120

DISASSEMBLY AND ASSEMBLY (Continued)

ADAPTER HOUSING—4WD

(1) Install rear bearing in adapter housing. Use wood hammer handle or wood dowel to tap bearing into place.

(2) Position rear bearing retainer in adapter housing (Fig. 106).

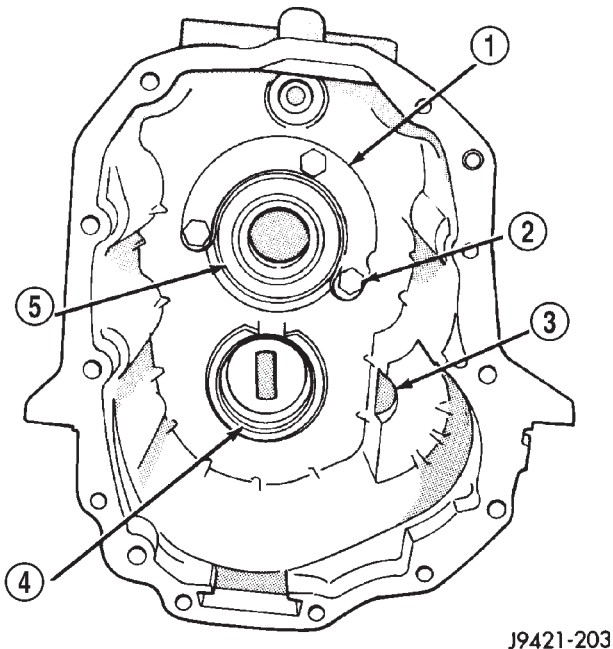

J9421-203

Fig. 106 Preparing Adapter Housing For Installation—4WD

- 1 - BEARING RETAINER
- 2 - RETAINER BOLTS (3)
- 3 - IDLER SHAFT NOTCH
- 4 - COUNTERSHAFT REAR BEARING RACE
- 5 - REAR BEARING

(3) Apply Mopar® Gasket Maker, or equivalent, to threads, bolt shanks and under hex heads of bearing retainer bolts (Fig. 107).

(4) Apply liberal quantity of petroleum jelly to countershaft rear bearing and bearing race.

(5) Install countershaft rear bearing in bearing race (Fig. 102).

CAUTION: The countershaft bearings can be installed backwards if care is not exercised. Be sure the large diameter side of the roller retainer faces the countershaft and the small diameter side faces the race and housing (Fig. 102).

(6) Apply extra petroleum jelly to hold countershaft rear bearing in place when housing is installed.

(7) Apply light coat of petroleum jelly to shift shaft bushing/bearing in adapter housing (Fig. 102).

(8) Install adapter housing on geartrain.

(9) Install rear bearing snap ring on output shaft (Fig. 107).

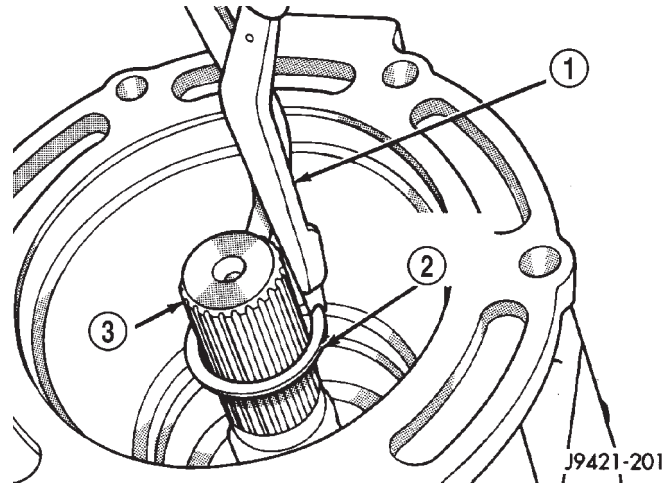

J9421-201

Fig. 107 Installing Rear Bearing Snap Ring—4WD

- 1 - HEAVY DUTY SNAP RING PLIERS
- 2 - REAR BEARING SNAP RING
- 3 - OUTPUT SHAFT

(10) Lubricate lip of new rear seal (Fig. 108) with Mopar® Door Ease, or transmission fluid.

(11) Install new rear seal in adapter housing bore with Installer C-3860-A. Be sure seal is fully seated in housing bore (Fig. 108).

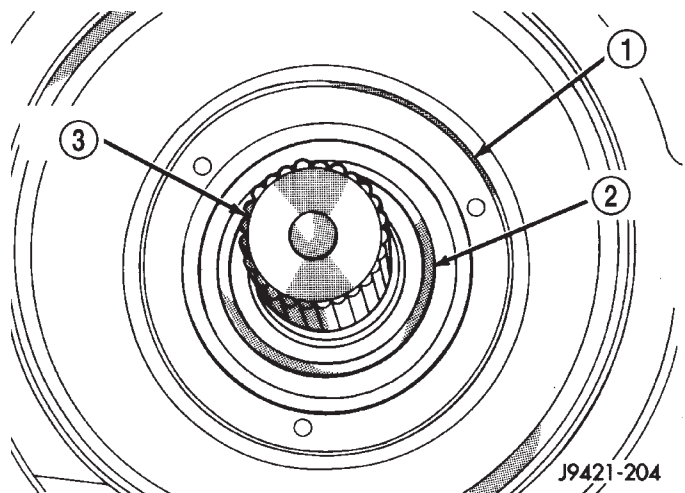

J9421-204

Fig. 108 Rear Seal Installation—4WD

- 1 - REAR SEAL
- 2 - SEAL LIP
- 3 - OUTPUT SHAFT

SHIFT SHAFT, SHAFT LEVER AND BUSHING AND SHIFT SOCKET

(1) Before proceeding, verify that all synchro sleeves are in Neutral position (centered on hub). Move sleeves into neutral if necessary.

DISASSEMBLY AND ASSEMBLY (Continued)

CAUTION: The transmission synchros must all be in Neutral position for proper reassembly. Otherwise, the housings, shift forks and gears can be damaged during installation of the two housings.

(2) Install 3-4 shift fork in synchro sleeve (Fig. 109). Verify that groove in fork arm is aligned with grooves in 1-2 and fifth-reverse fork arms as shown.

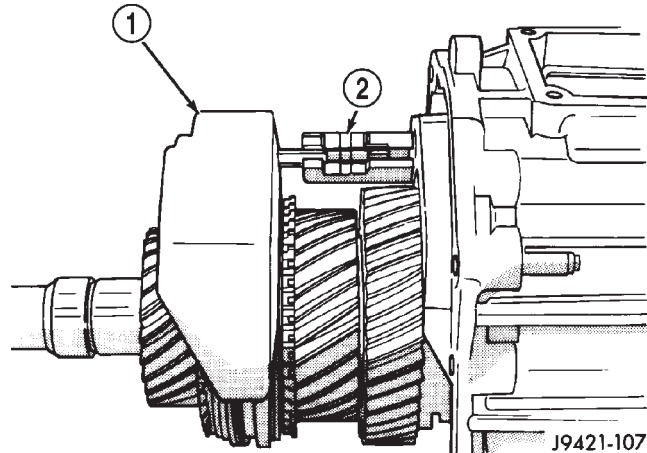

Fig. 109 Installing 3-4 Shift Fork

- 1 - 3-4 FORK
- 2 - ALIGN GROOVES IN FORK ARMS

(3) Slide shift shaft through 3-4 shift fork (Fig. 110). Be sure shaft detent notches are to front.

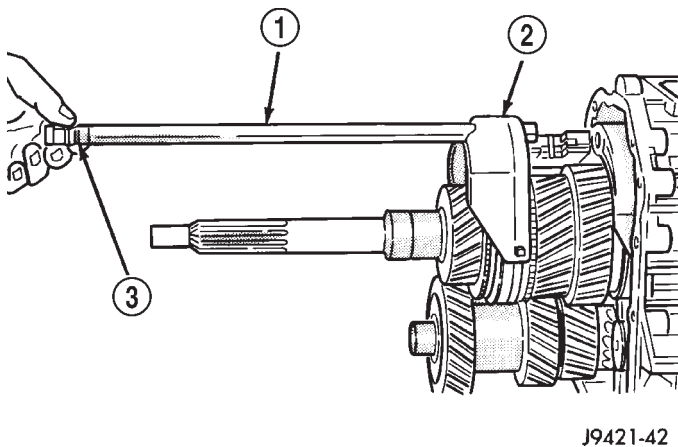

Fig. 110 Shift Shaft Installation

- 1 - SHIFT SHAFT
- 2 - 3-4 FORK
- 3 - SHAFT DETENT NOTCHES

(4) Assemble shift shaft shift lever and bushing (Fig. 111). Be sure slot in bushing is facing up and roll pin hole for lever is aligned with hole in shaft.

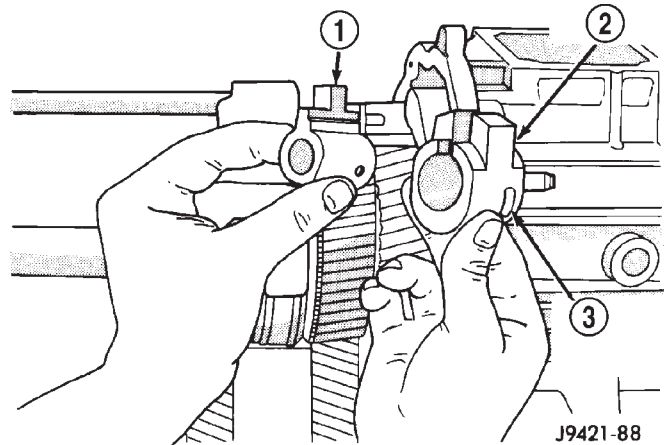

Fig. 111 Assembling Shift Shaft Lever And Bushing

- 1 - SHAFT LEVER
- 2 - LEVER BUSHING
- 3 - BUSHING LOCK PIN SLOT

(5) Install assembled lever and bushing on shift shaft (Fig. 112).

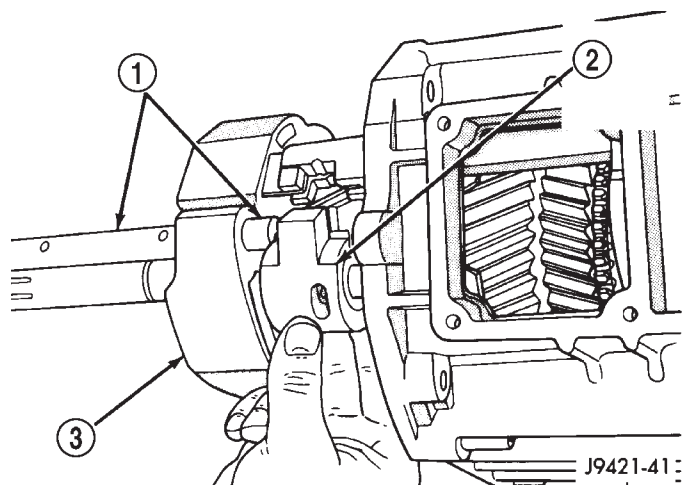

Fig. 112 Installing Shift Shaft Lever And Bushing

- 1 - SHIFT SHAFT
- 2 - SHAFT LEVER AND BUSHING
- 3 - 3-4 FORK

(6) Slide shift shaft through 1-2 and fifth-reverse fork and into shift lever opening in rear housing (Fig. 113).

(7) Align shift socket with shaft and slide shaft through socket and into shift shaft bearing in rear housing (Fig. 114).

(8) Rotate shift shaft so detent notches in shaft are facing the TOP of the transmission housing.

DISASSEMBLY AND ASSEMBLY (Continued)

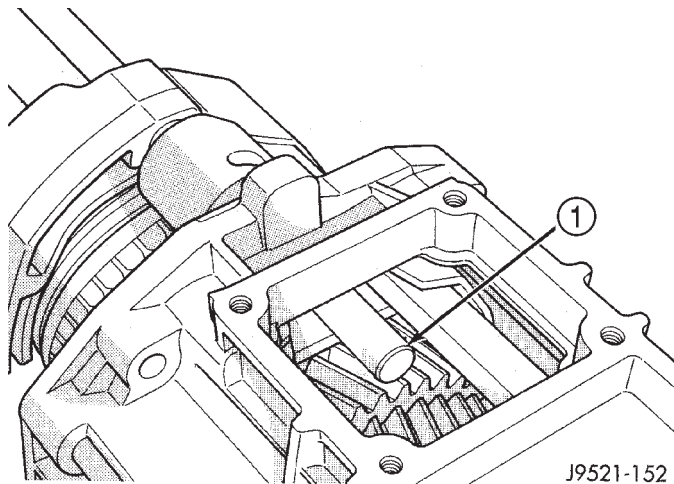

J9521-152

Fig. 113 Inserting Shaft Into Lever Opening In Housing

- 1 - SHIFT SHAFT

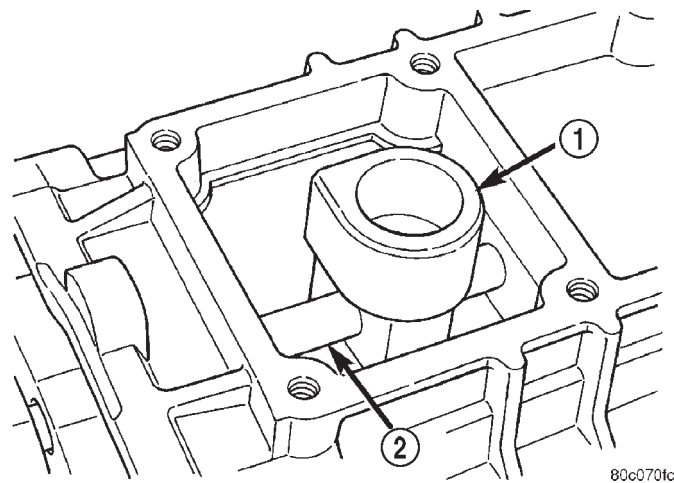

80c0701c

Fig. 114 Shift Socket Installation

- 1 - SHIFT SOCKET
- 2 - SHIFT SHAFT

CAUTION: Correct positioning of the shift shaft detent notch is important. Both of the shaft roll pins can be installed even when the shaft is 180° off. If this occurs, the transmission will have to be disassembled again to correct shaft alignment.

(9) Select correct new roll pin for shift shaft lever (Fig. 115). Shaft lever roll pin is approximately 22 mm (7/8 in.) long. Shift socket roll pin is approximately 33 mm (1-1/4 in.) long.

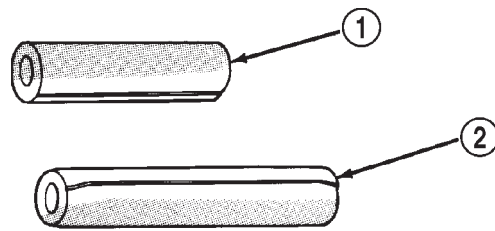

J9421-86

Fig. 115 Roll Pin Identification—Shaft Lever And Shift Socket

- 1 - SHAFT LEVER ROLL PIN
- 2 - SHIFT SOCKET ROLL PIN

(10) Align roll pin holes in shift shaft, lever and bushing. Then start roll pin into shaft lever by hand (Fig. 116).

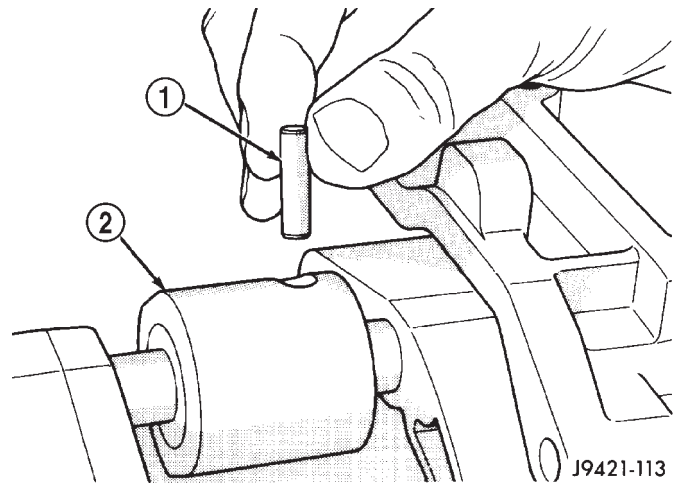

J9421-113

Fig. 116 Starting Roll Pin In Shift Shaft Lever

- 1 - SHAFT LEVER ROLL PIN (7/8" LONG)
- 2 - LEVER AND BUSHING

(11) Seat shaft lever roll pin with pin punch (Fig. 117).

CAUTION: The shaft lever roll pin must be flush with the surface of the lever. The lever bushing will bind on the roll pin if the pin is not seated flush.

(12) Before proceeding, verify that lock pin slot in lever bushing is positioned as shown (Fig. 117).

(13) Align roll pin holes in shift socket and shift shaft. Then start roll pin into shift shaft by hand (Fig. 118).

DISASSEMBLY AND ASSEMBLY (Continued)

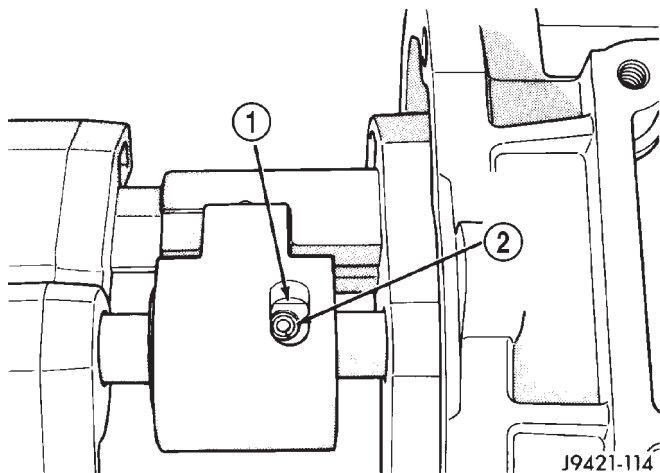

Fig. 117 Correct Seating Of Shift Shaft Lever Roll Pin

- 1 - BUSHING LOCK PIN SLOT
- 2 - SEAT ROLL PIN FLUSH WITH LEVER

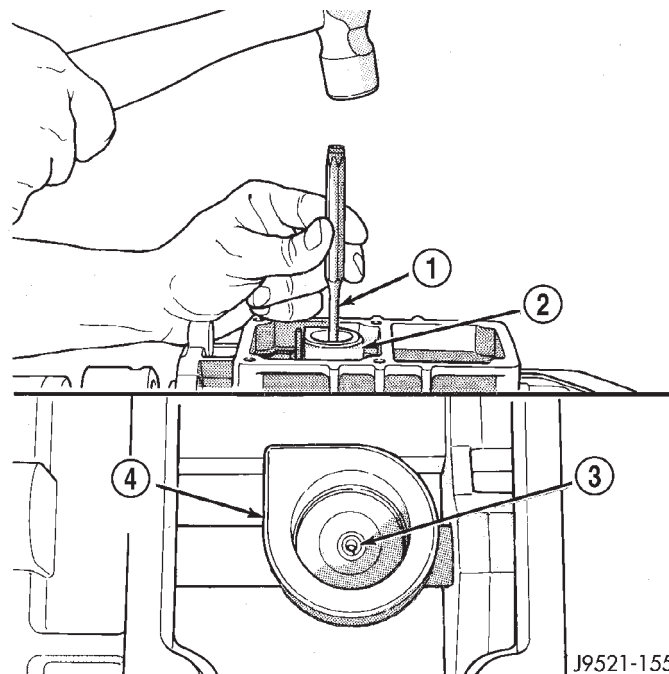

Fig. 119 Seating Shift Socket Roll Pin

- 1 - PIN PUNCH
- 2 - SHIFT SOCKET
- 3 - SEAT ROLL PIN FLUSH
- 4 - SHIFT SOCKET

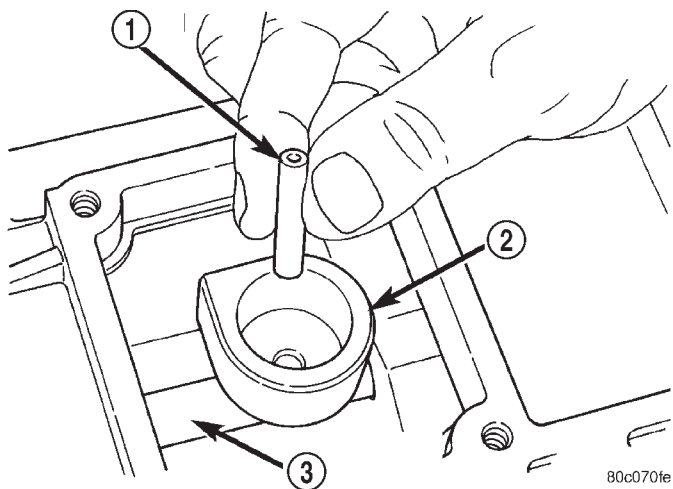

Fig. 118 Starting Roll Pin In Shift Socket

- 1 - ROLL PIN
- 2 - SHIFT SOCKET
- 3 - SHIFT SHAFT

(14) Seat roll pin in shift socket with pin punch. Roll pin must be flush with socket after installation (Fig. 119).

(15) Verify that notches in shift fork arms are aligned. Realign arms if necessary.

FRONT HOUSING AND INPUT SHAFT BEARING RETAINER

(1) If previously removed, install input shaft bearing in front housing bore (Fig. 120). Install snap ring and use plastic mallet to seat bearing. Bearing goes in from front side of housing only.

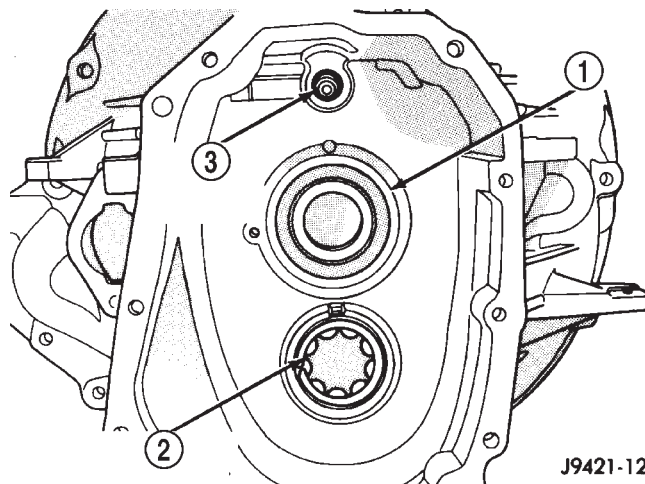

Fig. 120 Input Shaft Bearing And Countershaft Front Bearing

- 1 - INPUT SHAFT BEARING
- 2 - COUNTERSHAFT FRONT BEARING
- 3 - SHIFT SHAFT BUSHING

DISASSEMBLY AND ASSEMBLY (Continued)

(2) Apply liberal quantity of petroleum jelly to countershaft front bearing. Then insert bearing in front housing race (Fig. 120). Large diameter side of bearing cage goes toward countershaft (Fig. 121). Small diameter side goes toward bearing race in housing.

(3) Reach into countershaft front bearing with finger, and push each bearing roller outward against race. Then apply extra petroleum jelly to hold rollers in place. This avoids having rollers becoming displaced during housing installation. This will result in misalignment between bearing and countershaft bearing hub.

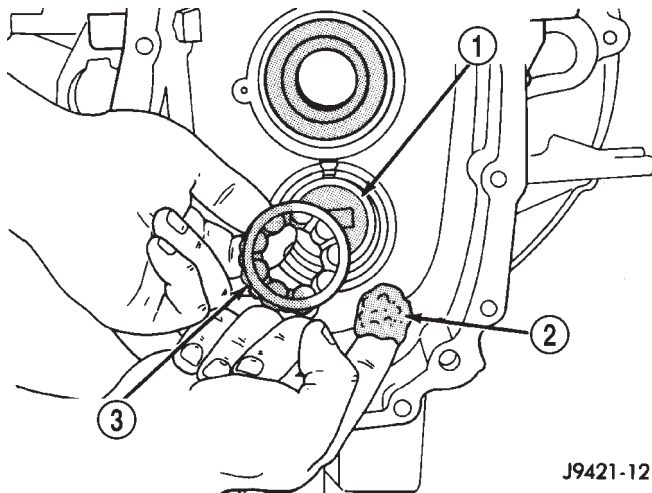

J9421-121

Fig. 121 Lubricating/Positioning Countershaft Front Bearing

- 1 - BEARING RACE
- 2 - PETROLEUM JELLY
- 3 - COUNTERSHAFT FRONT BEARING

(4) Apply small amount of petroleum jelly to shift shaft bushing in front housing.

(5) Apply 1/8 in. wide bead of Mopar® Gasket Maker, or equivalent, to mating surfaces of front and rear housings (Fig. 122).

(6) Have helper hold rear housing and geartrain in upright position. Then install front housing on rear housing and geartrain.

(7) Work front housing downward onto geartrain until seated on rear housing.

CAUTION: If the front housing will not seat on the rear housing, either the shift components are not in Neutral, or one or more components are misaligned. Do not force the front housing into place. This will only result in damaged components.

(8) Tap rear housing alignment dowels back into place with hammer and pin punch. Both dowels should be flush fit in each housing. Have helper hold

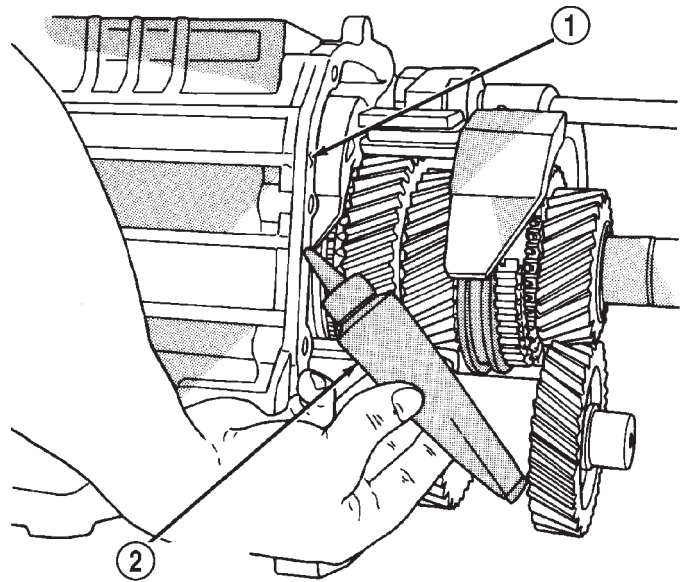

J9421-123

Fig. 122 Applying Sealer To Front/Rear Housings

- 1 - HOUSING FLANGE SURFACE
- 2 - MOPAR GASKET MAKER (OR LOCTITE 518)

transmission upright while dowels are tapped back into place.

(9) Place transmission in horizontal position.

(10) Apply Mopar® Gasket Maker, or equivalent, to housing attaching bolts. Apply sealer material sealer to underside of bolt heads and to bolt shanks and threads (Fig. 123).

(11) Install and start housing attaching bolts by hand (Fig. 123). Then tighten bolts to 34 N·m (25 ft. lbs.) torque.

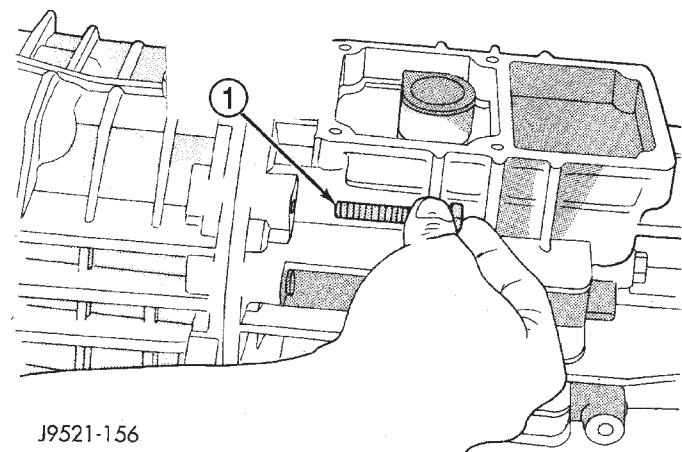

J9521-156

Fig. 123 Installing Housing Attaching Bolts

- 1 - HOUSING ATTACHING BOLTS (APPLY SEALER BEFOREHAND)

DISASSEMBLY AND ASSEMBLY (Continued)

(12) Install shift shaft bushing lock bolt (Fig. 124). Apply Mopar® Gasket Maker, or equivalent, to bolt threads, shank and underside of bolt head before installation.

CAUTION: If the lock bolt cannot be fully installed, do not try to force it into place. Either the shift shaft is not in Neutral, or the shaft bushing (or lever) is misaligned.

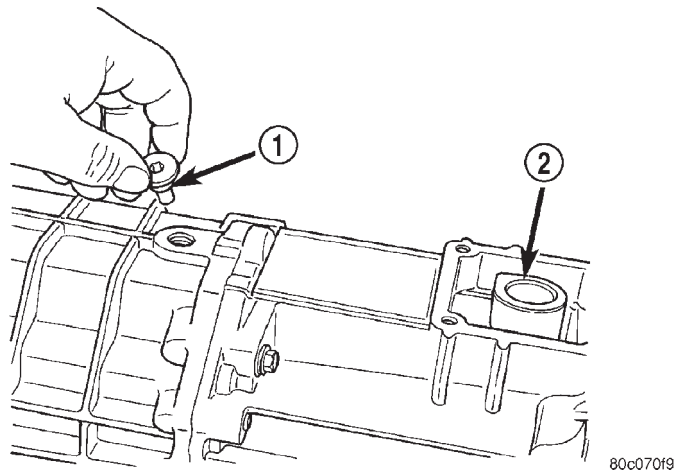

Fig. 124 Installing Shift Shaft Bushing Lock Bolt

- 1 - SHIFT SHAFT LOCK BOLT
- 2 - SHAFT SOCKET

(13) Lubricate then install shift shaft detent plunger in housing bore (Fig. 125). Lubricate plunger with petroleum jelly or gear lubricant. **Be sure plunger is fully seated in detent notch in shift shaft.**

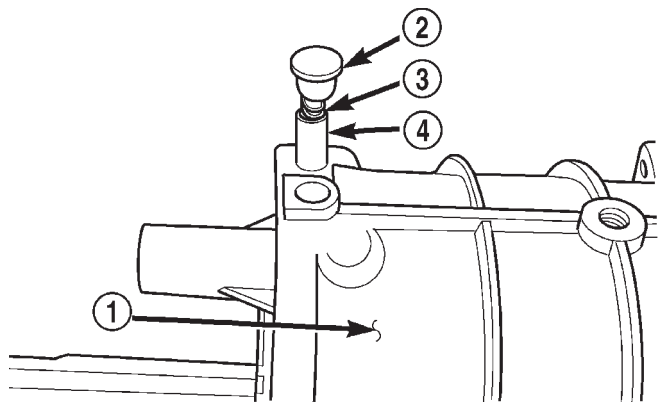

Fig. 125 Installing Shift Shaft Detent Plunger, Spring, and Plug

- 1 - FRONT HOUSING
- 2 - PLUG
- 3 - SPRING
- 4 - PLUNGER

(14) Install detent spring inside plunger (Fig. 125).

(15) Install detent plug as follows:

(a) Install detent plug in end of Installer 8123.

(b) Position plug on detent spring and compress spring until detent plug pilots in detent plunger bore.

(c) Drive detent plug into transmission case until plug seats.

(16) Install backup light switch (Fig. 126).

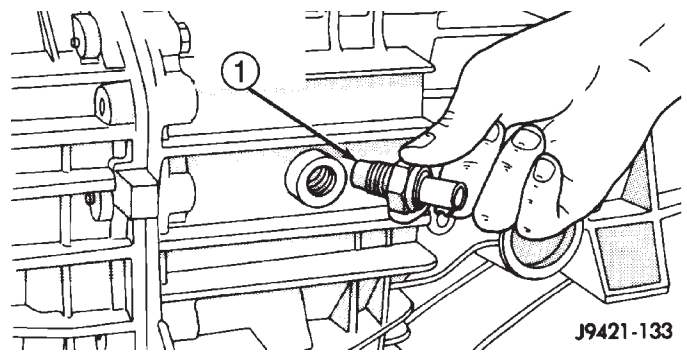

Fig. 126 Installing Backup Light Switch

- 1 - BACKUP LIGHT SWITCH

(17) Install input shaft snap ring (Fig. 127).

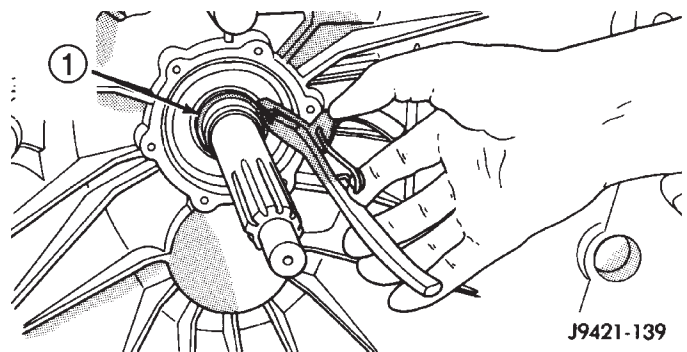

Fig. 127 Installing Input Shaft Snap Ring—Typical

- 1 - INPUT SHAFT SNAP RING

(18) Install new oil seal in front bearing retainer with Installer Tool 6448 (Fig. 128).

(19) Apply bead of Mopar® silicone sealer, or equivalent, to flange surface of front bearing retainer (Fig. 129).

DISASSEMBLY AND ASSEMBLY (Continued)

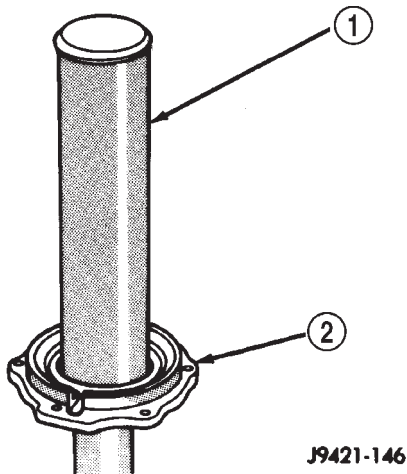

Fig. 128 Installing Oil Seal In Front Bearing Retainer

- 1 - SPECIAL TOOL
6448
- 2 - FRONT BEARING RETAINER

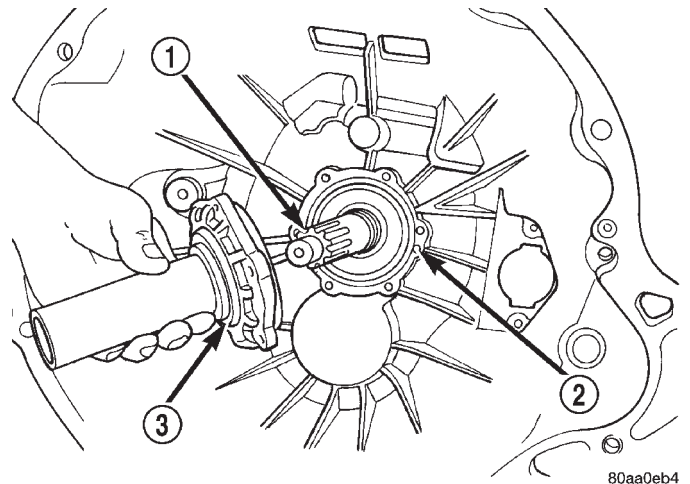

Fig. 130 Installing Input Shaft Bearing Retainer—Typical

- 1 - INPUT SHAFT
- 2 - OIL FEED
- 3 - BEARING RETAINER

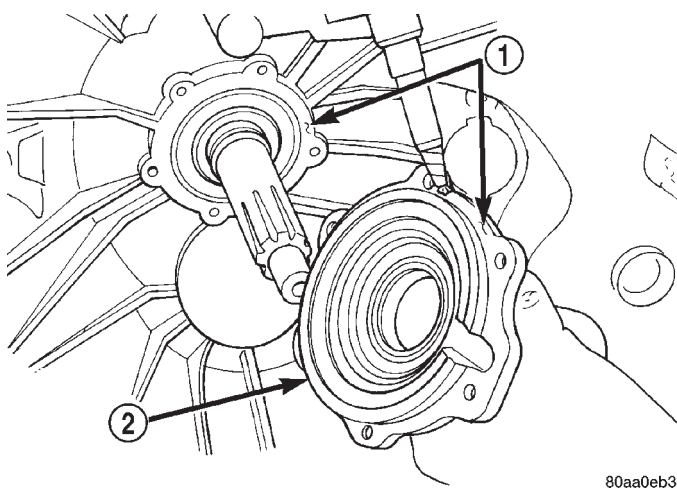

Fig. 129 Applying Sealer To Bearing Retainer And Housing—Typical

- 1 - APPLY SEALER BEAD
- 2 - INPUT SHAFT BEARING RETAINER

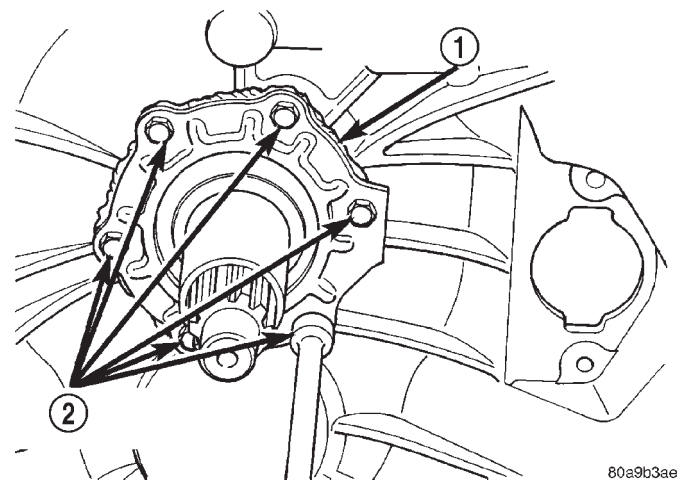

Fig. 131 Installing Input Shaft Bearing Retainer Bolts—Typical

- 1 - INPUT SHAFT BEARING RETAINER
- 2 - RETAINER BOLTS

(20) Align and install front bearing retainer over input shaft and onto housing mounting surface (Fig. 130). Although retainer is one-way fit on housing, be sure bolt holes are aligned before seating retainer.

NOTE: Be sure that no sealer gets into the oil feed hole in the transmission case or bearing retainer.

(21) Install and tighten bearing retainer bolts to 7-10 N·m (5-7 ft. lbs.) torque (Fig. 131).

SHIFT TOWER AND LEVER ASSEMBLY

- (1) Apply petroleum jelly to ball end of shift lever and interior of shift socket.
- (2) Shift the transmission into third gear.
- (3) Align and install shift tower and lever assembly (Fig. 132). Be sure shift ball is seated in socket and the offset in the tower is toward the passenger side of the vehicle before installing tower bolts.

DISASSEMBLY AND ASSEMBLY (Continued)

(4) Install shift tower bolts (Fig. 133). Tighten bolts to 8.5 N·m (75.2 in. lbs.) torque.

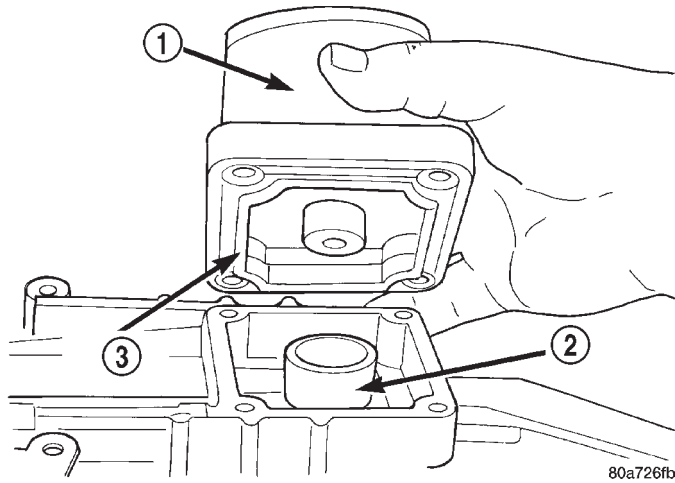

Fig. 132 Shift Tower Installation

- 1 - SHIFT TOWER AND LEVER ASSEMBLY
- 2 - SHIFT SOCKET
- 3 - SEAL

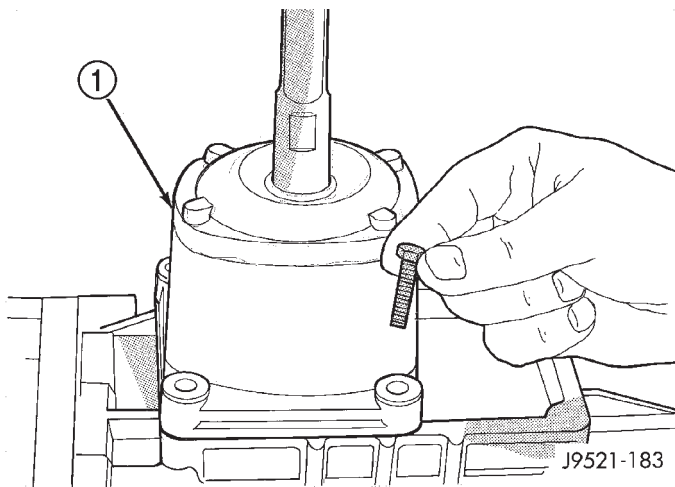

Fig. 133 Shift Tower Bolt Installation

- 1 - SHIFT TOWER AND LEVER ASSEMBLY

(5) Fill transmission to bottom edge of fill plug hole with Mopar® Transmission Lubricant, P/N 4761526.

(6) Install and tighten fill plug to 34 N·m (25 ft. lbs.) torque.

(7) Check transmission vent. Be sure vent is open and not restricted.

CLEANING AND INSPECTION

TRANSMISSION COMPONENTS

Clean the gears, shafts, shift components and transmission housings with a standard parts cleaning solvent. Do not use acid or corrosive base solvents. Dry all parts except bearings with compressed air.

Clean the shaft bearings with a mild solvent such as Mopar® degreasing solvent, Gunk, or similar solvents. Do not dry the bearings with compressed air. Allow the bearings to either air dry, or wipe them dry with clean shop towels.

SHIFT LEVER ASSEMBLY

The shift lever assembly is not serviceable. Replace the lever and shift tower as an assembly if the tower, lever, lever ball, or internal components are worn, or damaged.

SHIFT SHAFT AND FORKS

Inspect the shift fork interlock arms and synchro sleeve contact surfaces (Fig. 134). Replace any fork exhibiting wear or damage in these areas. Do not attempt to salvage shift forks.

Check condition of the shift shaft detent plunger and spring. The plunger should be smooth and free of nicks, or scores. The plunger spring should be straight and not collapsed, or distorted. Minor scratches, or nicks on the plunger can be smoothed with 320/400 grit emery soaked in oil. Replace the plunger and spring if in doubt about condition. Check condition of detent plunger bushings. Replace if damaged.

Inspect the shift shaft, shift shaft bushing and bearing, the shaft lever, and the lever bushing that fits over the lever. Replace the shaft if bent, cracked, or severely scored. Minor burrs, nicks, or scratches can be smoothed off with 320/400 grit emery cloth followed by polishing with crocus cloth. Replace the shift shaft bushing or bearing if damaged.

Replace the shaft lever and bushing if either part is deformed, or worn. Do not attempt to salvage these parts as shift fork binding will occur. Replace the roll pin that secures the lever to the shaft.

FRONT/REAR HOUSINGS AND BEARING RETAINERS

Inspect the housings carefully. Look for cracks, stripped threads, scored mating surfaces, damaged bearing bores, or worn dowel pin holes. Minor nicks on mating surfaces can be dressed off with a fine file, or emery cloth. Damaged threads can be renewed by either re-tapping or installing Helicoil inserts.

CLEANING AND INSPECTION (Continued)

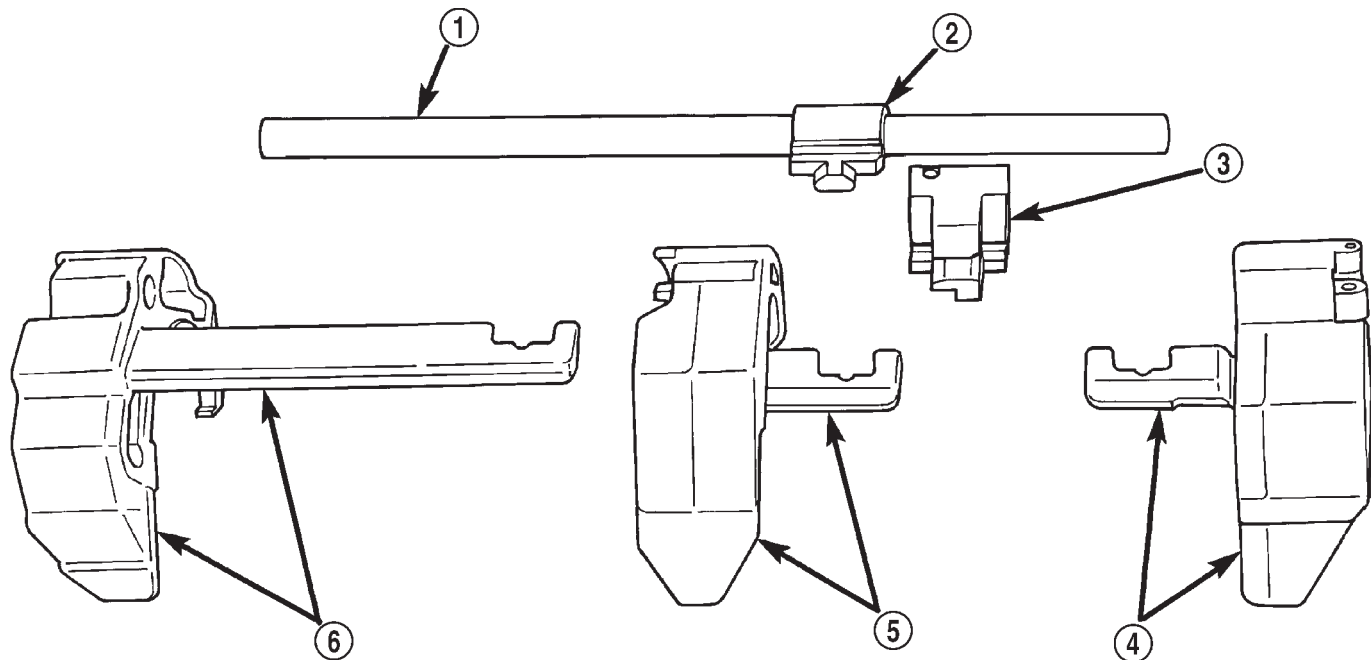

80c070ff

Fig. 134 Shift Forks And Shaft

- | | |
|-------------------------|------------------------------|
| 1 - SHIFT SHAFT | 4 - 3-4 SHIFT FORK |
| 2 - SHAFT LEVER | 5 - 1-2 SHIFT FORK |
| 3 - SHAFT LEVER BUSHING | 6 - FIFTH-REVERSE SHIFT FORK |

NOTE: The front housing contains the countershaft front bearing race. The rear housing contains the countershaft rear bearing race. Be advised that these components are NOT serviceable items. The front housing will have to be replaced if the countershaft bearing race is loose, worn, or damaged. The rear housing will have to be replaced if the countershaft rear bearing race is loose, worn, or damaged.

Inspect the input shaft bearing retainer. Be sure the release bearing slide surface of the retainer is in good condition. Minor nicks on the surface can be smoothed off with 320/420 grit emery cloth and final polished with oil coated crocus cloth. Replace the retainer seal if necessary.

Inspect the output shaft bearing retainer. Be sure the U-shaped retainer is flat and free of distortion. Replace the retainer if the threads are damaged, or if the retainer is bent, or cracked.

COUNTERSHAFT BEARINGS AND RACES

The countershaft bearings and races are machine lapped during manufacture to form matched sets. The bearings and races should not be interchanged.

NOTE: The bearing races are a permanent press fit in the housings and are NOT serviceable. If a bear-

ing race becomes damaged, it will be necessary to replace the front or rear housing as necessary. A new countershaft bearing will be supplied with each new housing for service use.

The countershaft bearings can be installed backwards if care is not exercised. The bearing roller cage is a different diameter on each side. Be sure the bearing is installed so the large diameter side of the cage is facing the countershaft gear (Fig. 135). The small diameter side goes in the bearing race.

REVERSE IDLER COMPONENTS

Inspect the idler gear, bearing, shaft, thrust washer, wave washer and thrust plate. Replace the bearing if any of the needle bearing rollers are worn, chipped, cracked, flat-spotted, or brinnelled. Also replace the bearing if the plastic bearing cage is damaged or distorted.

Replace the thrust washer, wave washer, or thrust plate if cracked, chipped, or worn. Replace the idler gear if the teeth are chipped, cracked or worn thin. Replace the shaft if worn, scored, or the bolt threads are damaged beyond repair. Replace the support segment if cracked, or chipped and replace the idler attaching bolts if the threads are damaged.

CLEANING AND INSPECTION (Continued)

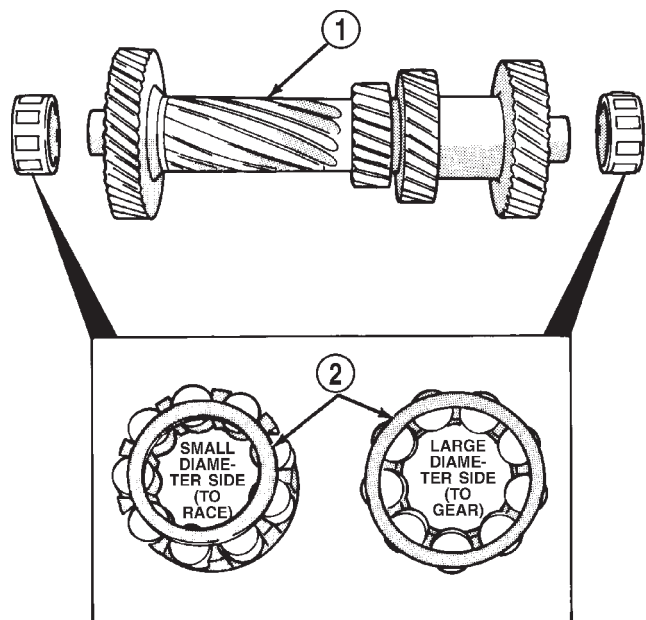

J9421-55

Fig. 135 Correct Countershaft Bearing Installation

- 1 - COUNTERSHAFT
- 2 - BEARING CAGE

Shift Socket

Inspect the shift socket for wear or damage. replace the socket if the roll pin, or shift shaft bores are damaged. Minor nicks in the shift lever ball seat in the socket can be smoothed down with 400 grit emery or wet/dry paper. Replace the socket if the ball seat is worn, or cracked. Do not reuse the original shift socket roll pin. Install a new pin during reassembly. The socket roll pin is approximately is approximately 33 mm (1-1/4 in.) long.

Output Shaft And Geartrain

Inspect all of the gears for worn, cracked, chipped, or broken teeth. Also check condition of the bearing bore in each gear. The bores should be smooth and free of surface damage. Discoloration of the gear bores is a normal occurrence and is not a reason for replacement. Replace gears only when tooth damage has occurred, or if the bores are brinnelled or severely scored.

Inspect the shaft splines and bearings surfaces. Minor nicks on the bearing surfaces can be smoothed with 320/420 grit emery and final polished with crocus cloth. Replace the shaft if the splines are damaged or bearing surfaces are deeply scored, worn, or brinnelled.

SPECIFICATIONS

TORQUE

| Description | Torque |
|---|-------------------------------|
| Clutch Housing Bolts . . . | 54-61 N·m (40-45 ft. lbs.) |
| Crossmember-To-Frame Bolts | 61-75 N·m (44-55 ft. lbs.) |
| Crossmember-To-Insulator Nuts | 54-61 N·m (40-45 ft. lbs.) |
| Drain/Fill Plug | 9-27 N·m (14-20 ft. lbs.) |
| Front-To-Rear Housing Bolts | 30-35 N·m (22-26 ft. lbs.) |
| Front Bearing Retainer Bolts | 7-10 N·m (5-7 ft. lbs.) |
| Idler Shaft Bolts | 19-25 N·m (14-18 ft. lbs.) |
| Rear Bearing Retainer Bolts | 30-35 N·m (22-26 ft. lbs.) |
| Shift Tower Bolts | 7-10 N·m (5-7 ft. lbs.) |
| Slave Cylinder Attaching Nuts | 23 N·m (200 in. lbs.) |
| Transfer Case Attaching Nuts . . . | 47 N·m (35 ft. lbs.) |
| U-Joint Clamp Bolts | 19 N·m (170 in. lbs.) |

SPECIAL TOOLS

NV3550 MANUAL TRANSMISSION

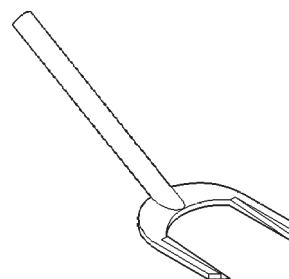

Remover, Seal—C-3985-B

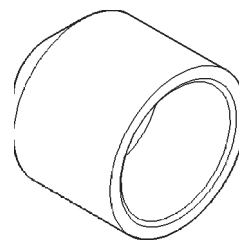

Installer, Seal—C-3972-A

SPECIAL TOOLS (Continued)

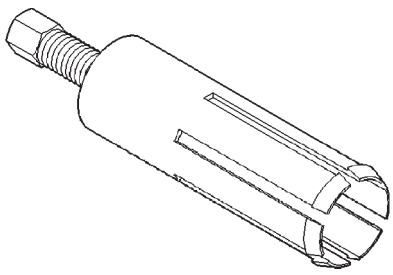

Remover, Bushing—6957

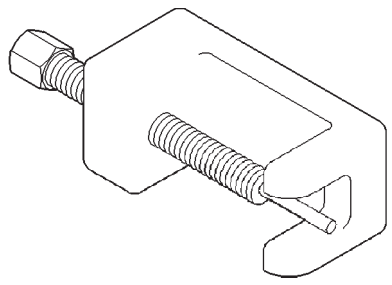

Remover/Installer, NV3550 Shift Rail Roll Pin—6858

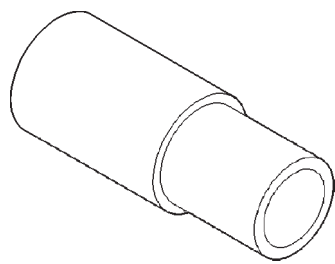

Installer, Bushing—6951

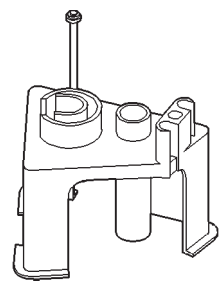

Fixture, NV3550—6747

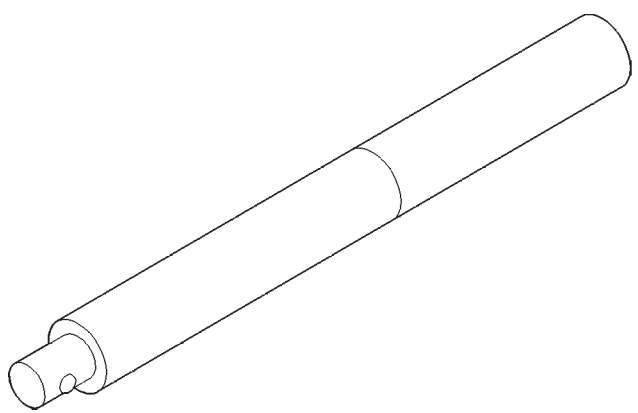

Handle—C-4171

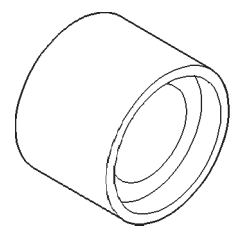

Adapter, Fixture—6747-1A

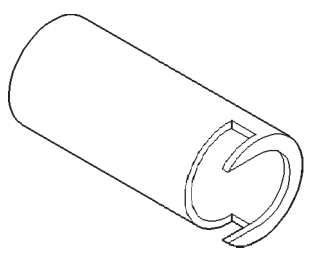

Remover—8117

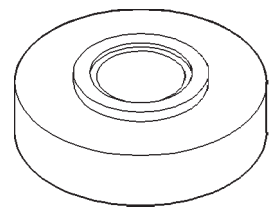

Adapter, Fixture—6747-2A

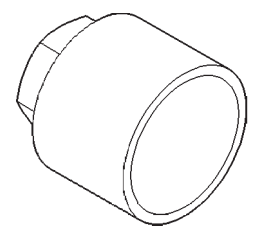

Cup, Fixture—8115

SPECIAL TOOLS (Continued)

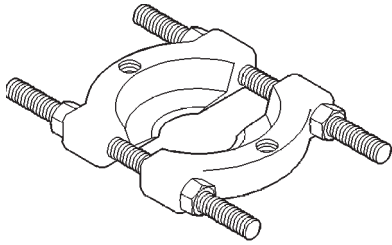

113C-80109ac3

Splitter, Bearing—1130

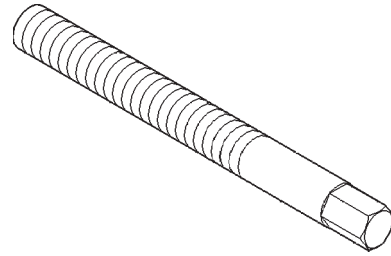

Stud, Alignment—8120

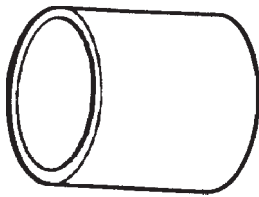

Tube—6310-1

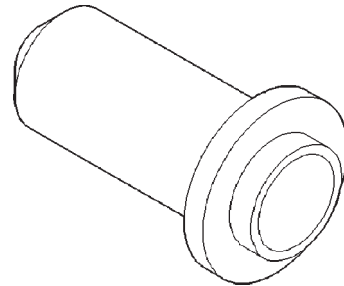

Installer, Seal—C-3860-A

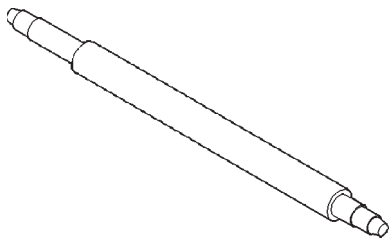

Installer—8118

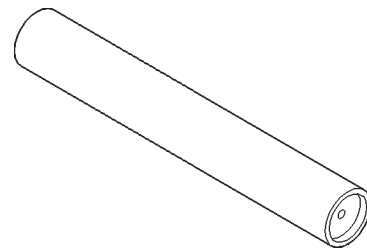

Installer—8123

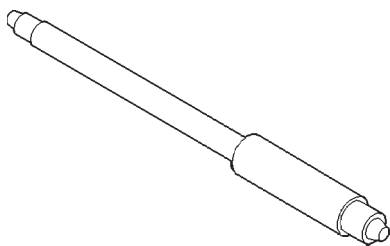

Remover/Installer—8119

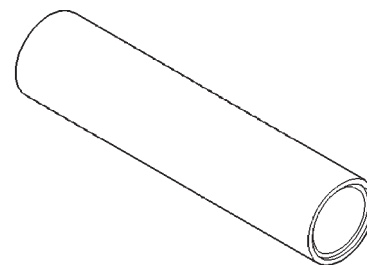

Installer, Bearing Cone—6448

AUTOMATIC TRANSMISSION—30RH

TABLE OF CONTENTS

| | page | | page |
|--|------|--|------|
| DESCRIPTION AND OPERATION | | | |
| 30RH AUTOMATIC TRANSMISSION..... | 89 | ADAPTER HOUSING | 147 |
| FLUID | 96 | SPEEDOMETER ADAPTER | 148 |
| TORQUE CONVERTER | 97 | PARK/NEUTRAL POSITION SWITCH | 149 |
| OIL PUMP | 101 | GEARSHIFT CABLE | 150 |
| VALVE BODY | 102 | BRAKE TRANSMISSION SHIFT INTERLOCK ... | 150 |
| ACCUMULATOR | 117 | VALVE BODY | 151 |
| PISTONS | 118 | OUTPUT SHAFT REAR BEARING | 153 |
| FRONT CLUTCH | 120 | GOVERNOR AND PARK GEAR | 153 |
| REAR CLUTCH | 121 | PARK LOCK | 154 |
| OVERRUNNING CLUTCH | 122 | DISASSEMBLY AND ASSEMBLY | |
| PLANETARY GEARSET | 122 | GOVERNOR AND PARK GEAR | 154 |
| BANDS | 123 | VALVE BODY | 156 |
| SERVOS | 123 | TRANSMISSION | 163 |
| GOVERNOR | 124 | OVERRUNNING CLUTCH/LOW-REVERSE | |
| GEARSHIFT MECHANISM | 124 | DRUM | 175 |
| CONVERTER DRAINBACK VALVE | 125 | FRONT SERVO PISTON | 176 |
| BRAKE TRANSMISSION SHIFT INTERLOCK | | REAR SERVO PISTON | 177 |
| MECHANISM | 125 | OIL PUMP AND REACTION SHAFT SUPPORT. . | 177 |
| DIAGNOSIS AND TESTING | | | |
| AUTOMATIC TRANSMISSION DIAGNOSIS..... | 126 | FRONT CLUTCH | 180 |
| EFFECTS OF INCORRECT FLUID LEVEL | 126 | REAR CLUTCH | 181 |
| CAUSES OF BURNT FLUID | 126 | PLANETARY GEARTRAIN/OUTPUT SHAFT | 185 |
| FLUID CONTAMINATION | 127 | CLEANING AND INSPECTION | |
| PRELIMINARY DIAGNOSIS | 128 | GOVERNOR AND PARK GEAR | 191 |
| PARK/NEUTRAL POSITION SWITCH | 128 | EXTENSION HOUSING AND PARK LOCK | 191 |
| GEARSHIFT CABLE | 128 | VALVE BODY | 191 |
| THROTTLE VALVE CABLE | 129 | TRANSMISSION | 194 |
| ROAD TESTING | 129 | OVERRUNNING CLUTCH/LOW-REVERSE | |
| ANALYZING ROAD TEST | 129 | DRUM/OVERDRIVE PISTON RETAINER | 195 |
| HYDRAULIC PRESSURE TEST | 129 | FRONT SERVO | 195 |
| AIR TESTING TRANSMISSION CLUTCH AND | | REAR SERVO | 195 |
| BAND OPERATION | 131 | OIL PUMP AND REACTION SHAFT SUPPORT. . | 195 |
| CONVERTER HOUSING FLUID LEAK | | FRONT CLUTCH | 196 |
| DIAGNOSIS | 132 | REAR CLUTCH | 196 |
| DIAGNOSIS CHARTS | 133 | PLANETARY GEARTRAIN/OUTPUT SHAFT | 197 |
| SERVICE PROCEDURES | | | |
| FLUID LEVEL CHECK | 141 | ADJUSTMENTS | |
| FLUID AND FILTER REPLACEMENT | 141 | GEARSHIFT CABLE | 197 |
| TRANSMISSION FILL PROCEDURE | 142 | BRAKE TRANSMISSION SHIFT INTERLOCK | |
| CONVERTER DRAINBACK CHECK VALVE | | CABLE ADJUSTMENT | 198 |
| SERVICE | 142 | TRANSMISSION THROTTLE VALVE CABLE | |
| OIL PUMP VOLUME CHECK | 142 | ADJUSTMENT | 198 |
| FLUSHING COOLERS AND TUBES | 143 | FRONT BAND ADJUSTMENT | 199 |
| ALUMINUM THREAD REPAIR | 144 | REAR BAND ADJUSTMENT | 200 |
| REMOVAL AND INSTALLATION | | | |
| TRANSMISSION | 144 | VALVE BODY | 200 |
| TORQUE CONVERTER | 146 | SCHEMATICS AND DIAGRAMS | |
| YOKE SEAL REPLACEMENT | 147 | HYDRAULIC SCHEMATICS | 201 |
| EXTENSION HOUSING BUSHING | 147 | SPECIFICATIONS | |
| | | 30RH AUTOMATIC TRANSMISSION | 212 |
| | | TORQUE | 213 |
| | | SPECIAL TOOLS | |
| | | 30RH TRANSMISSIONS | 213 |

DESCRIPTION AND OPERATION

30RH AUTOMATIC TRANSMISSION

DESCRIPTION

The 30RH automatic transmission is used with the 2.5L engine (Fig. 1). The 30RH is three speed transmissions with a lock-up clutch in the torque converter. The transmissions contain a front and rear clutch which function as the input driving components. They also contain the kickdown (front) and the low/reverse (rear) bands which, along with the over-running clutch, serve as the holding components. The driving and holding components combine to select the necessary planetary gear components, in the front and rear planetary gear set, transfer the engine power from the input shaft through to the output shaft. The transmissions contain a governor that is mounted on the output shaft and supplies pressure to the valve body based on the output shaft speed. The valve body is mounted to the lower side of the transmission and contains the valves to control pressure regulation, fluid flow control, and clutch/band application. The oil pump is mounted at the front of the transmission and is driven by the torque converter hub. The pump supplies the oil pressure necessary for clutch/band actuation and transmission lubrication. The 30RH transmission is cooled by an integral fluid cooler inside the radiator.

DESCRIPTION AND OPERATION (Continued)

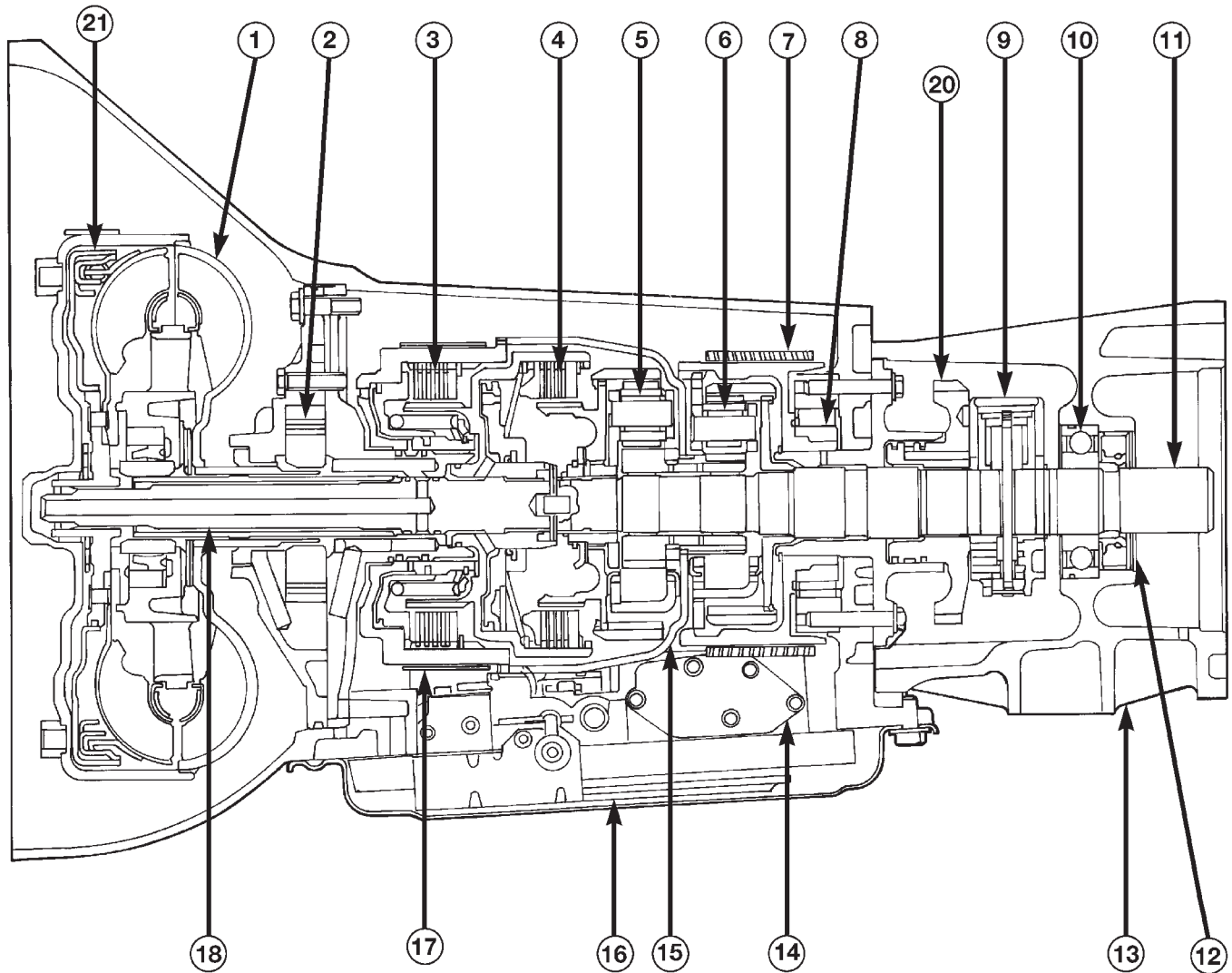

- | | |
|-------------------------------|--------------------------|
| ① CONVERTER | ⑪ OUTPUT SHAFT |
| ② OIL PUMP | ⑫ SEAL |
| ③ FRONT CLUTCH | ⑬ ADAPTER HOUSING |
| ④ REAR CLUTCH | ⑭ VALVE BODY |
| ⑤ FRONT PLANETARY GEAR SET | ⑮ SUN GEAR DRIVING SHELL |
| ⑥ REAR PLANETARY GEAR SET | ⑯ OIL FILTER |
| ⑦ LOW AND REVERSE (REAR) BAND | ⑰ KICK DOWN (FRONT) BAND |
| ⑧ OVERRUNNING CLUTCH | ⑱ PARK GEAR |
| ⑨ GOVERNOR | ⑳ CONVERTER CLUTCH |
| ⑩ BEARING | |

Fig. 1 30RH Automatic Transmission

DESCRIPTION AND OPERATION (Continued)

TRANSMISSION IDENTIFICATION

Transmission identification numbers are stamped on the left side of the case just above the oil pan gasket surface (Fig. 2). Refer to this information when ordering replacement parts.

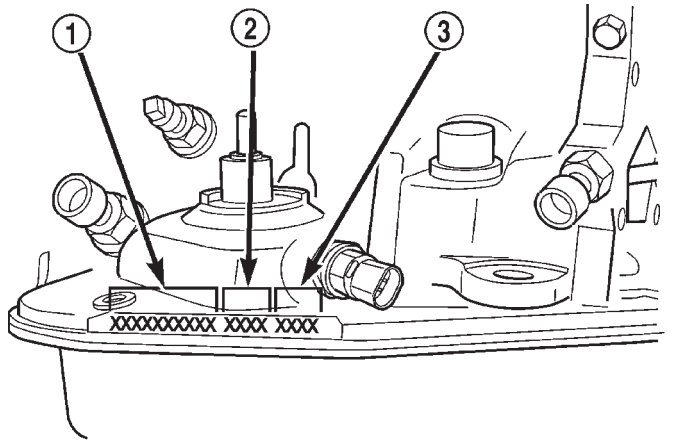

80b11960

Fig. 2 Transmission Part Number And Serial Number Location

- 1 - PART NUMBER
- 2 - BUILD DATE
- 3 - SERIAL NUMBER

OPERATION

The application of each driving or holding component is controlled by the valve body based upon the manual lever position and governor pressure. The governor pressure is a variable pressure input to the valve body and is one of the signals that a shift is necessary. First through third gear are obtained by selectively applying and releasing the different clutches and bands. Engine power is thereby routed to the various planetary gear assemblies which combine with the overrunning clutch assembly to generate the different gear ratios. The torque converter clutch is hydraulically applied and is released when fluid is vented from the hydraulic circuit by the torque converter control (TCC) solenoid on the valve body. The torque converter clutch is controlled by the Powertrain Control Module (PCM). The torque converter clutch engages in third gear when the vehicle is cruising on a level plane after the vehicle has warmed up. The torque converter clutch will disengage momentarily when an increase in engine load is sensed by the PCM, such as when the vehicle begins to go uphill or the throttle pressure is increased. The torque converter clutch feature increases fuel economy and reduces the transmission fluid temperature.

TRANSMISSION GEAR RATIOS

Forward gear ratios are:

- 2.74:1 (first gear)
- 1.54:1 (second gear)
- 1.00:1 (third gear)

DESCRIPTION AND OPERATION (Continued)

PARK POWERFLOW

As the engine is running and the crankshaft is rotating, the flexplate and torque converter, which are also bolted to it, are all rotating in a clockwise direction as viewed from the front of the engine. The notched hub of the torque converter is connected to the oil pump's internal gear, supplying the transmission with oil pressure. As the converter turns, it turns the input shaft in a clockwise direction. As the input shaft is rotating, the front clutch hub-rear clutch retainer and all their associated parts are also rotating, all being directly connected to the input shaft. The power flow from the engine through the front-clutch-hub and rear-clutch-retainer stops at the rear-clutch-retainer. Therefore, no power flow to the output shaft, occurs because no clutches are applied. The only mechanism in use at this time is the parking sprag (Fig. 3), which locks the parking gear on the output shaft to the transmission case.

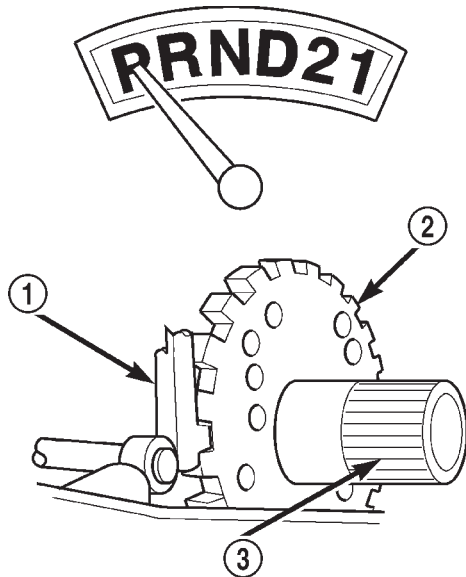

80c070a6

Fig. 3 Park Powerflow

- 1 - LEVER ENGAGED FOR PARK
- 2 - PARK SPRAG
- 3 - OUTPUT SHAFT

NEUTRAL POWERFLOW

With the gear selector in the neutral position (Fig. 4), the power flow of the transmission is essentially the same as in the park position. The only operational difference is that the parking sprag has been disengaged, unlocking the output shaft from the transmission case and allowing it to move freely.

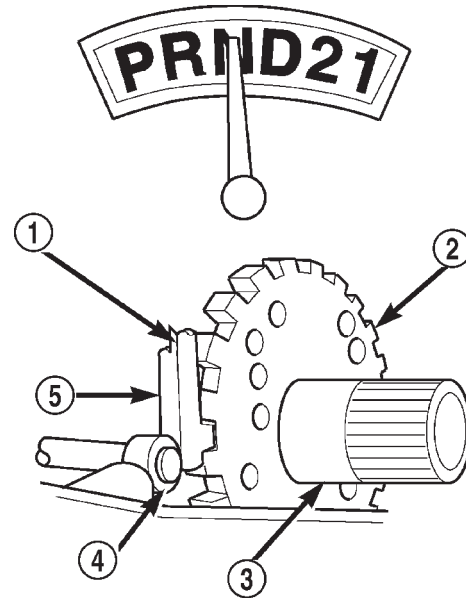

80c070a7

Fig. 4 Neutral Powerflow

- 1 - LEVER DISENGAGED FOR NEUTRAL
- 2 - PARK SPRAG
- 3 - OUTPUT SHAFT
- 4 - CAM
- 5 - LEVER

DESCRIPTION AND OPERATION (Continued)

REVERSE POWERFLOW

When the gear selector is moved into the reverse position (Fig. 5), the front clutch and the rear band are applied. With the application of the front clutch, engine torque is applied to the sun gear, turning it in a clockwise direction. The clockwise rotation of the sun gear causes the rear planet pinions to rotate against engine rotation in a counterclockwise direction. The rear band is holding the low reverse drum, which is splined to the rear carrier. Since the rear carrier is being held, the torque from the planet pinions is transferred to the rear annulus gear, which is splined to the output shaft. The output shaft in turn rotates with the annulus gear in a counterclockwise direction giving a reverse gear output. The entire transmission of torque is applied to the rear planetary gearset only. Although there is torque input to the front gearset through the sun gear, no other member of the gearset is being held. During the entire reverse stage of operation, the front planetary gears are in an idling condition.

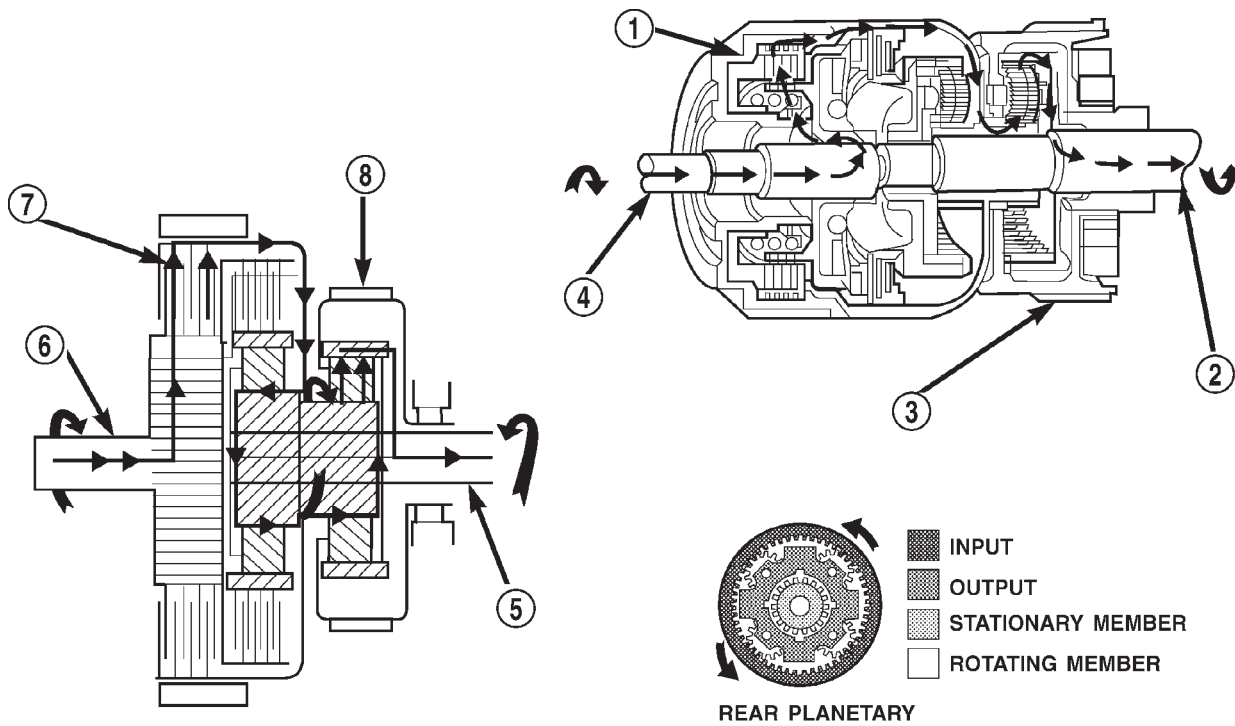

Fig. 5 Reverse Powerflow

- 1 - FRONT CLUTCH ENGAGED
- 2 - OUTPUT SHAFT
- 3 - LOW/REVERSE BAND APPLIED
- 4 - INPUT SHAFT

- 5 - OUTPUT SHAFT
- 6 - INPUT SHAFT
- 7 - FRONT CLUTCH ENGAGED
- 8 - LOW/REVERSE BAND APPLIED

80c070a8

DESCRIPTION AND OPERATION (Continued)

FIRST GEAR POWERFLOW

When the gearshift lever is moved into the drive position the transmission goes into first gear (Fig. 6). As soon as the transmission is shifted from park or neutral to drive, the rear clutch applies, applying the rear clutch pack to the front annulus gear. Engine torque is now applied to the front annulus gear turning it in a clockwise direction. With the front annulus gear turning in a clockwise direction, it causes the front planets to turn in a clockwise direction. The rotation of the front planets cause the sun to revolve in a counterclockwise direction. The sun gear now transfers its counterclockwise rotation to the rear planets which rotate back in a clockwise direction. With the rear annulus gear stationary, the rear planet rotation on the annulus gear causes the rear planet carrier to revolve in a counterclockwise direction. The rear planet carrier is splined into the low-reverse drum, and the low reverse drum is splined to the inner race of the over-running clutch. With the over-running clutch locked, the planet carrier is held, and the resulting torque provided by the planet pinions is transferred to the rear annulus gear. The rear annulus gear is splined to the output shaft and rotated along with it (clockwise) in an underdrive gear reduction mode.

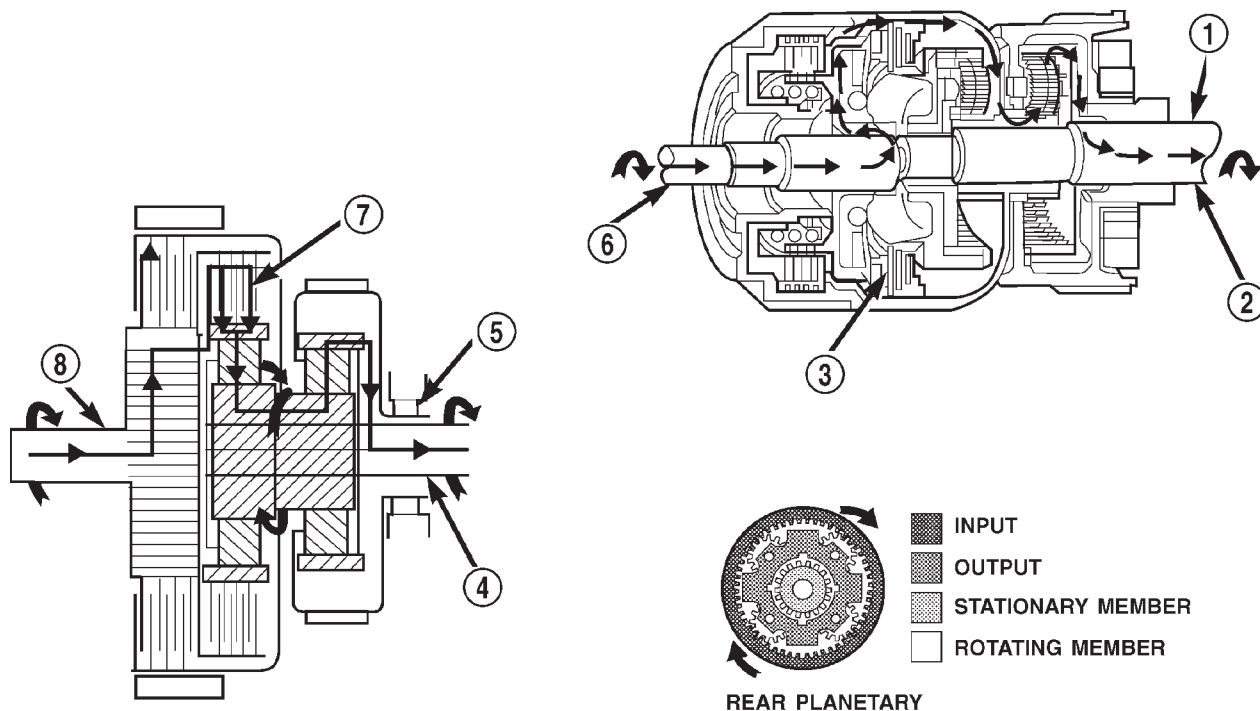

80c070a9

Fig. 6 First Gear Powerflow

- 1 - OUTPUT SHAFT
- 2 - OVER-RUNNING CLUTCH HOLDING
- 3 - REAR CLUTCH APPLIED
- 4 - OUTPUT SHAFT

- 5 - OVER-RUNNING CLUTCH HOLDING
- 6 - INPUT SHAFT
- 7 - REAR CLUTCH APPLIED
- 8 - INPUT SHAFT

DESCRIPTION AND OPERATION (Continued)

SECOND GEAR POWERFLOW

In drive-second (Fig. 7), the same elements are applied as in manual-second. Therefore, the power flow will be the same, and both gears will be discussed as one in the same. In drive-second, the transmission has proceeded from first gear to its shift point, and is shifting from first gear to second. The second gear shift is obtained by keeping the rear clutch applied and applying the front (kickdown) band. The front band holds the front clutch retainer that is locked to the sun gear driving shell. With the rear clutch still applied, the input is still on the front annulus gear turning it clockwise at engine speed. Now that the front band is holding the sun gear stationary, the annulus rotation causes the front planets to rotate in a clockwise direction. The front carrier is then also made to rotate in a clockwise direction but at a reduced speed. This will transmit the torque to the output shaft, which is directly connected to the front planet carrier. The rear planetary annulus gear will also be turning because it is directly splined to the output shaft. All power flow has occurred in the front planetary gear set during the drive-second stage of operation, and now the over-running clutch, in the rear of the transmission, is disengaged and freewheeling on its hub.

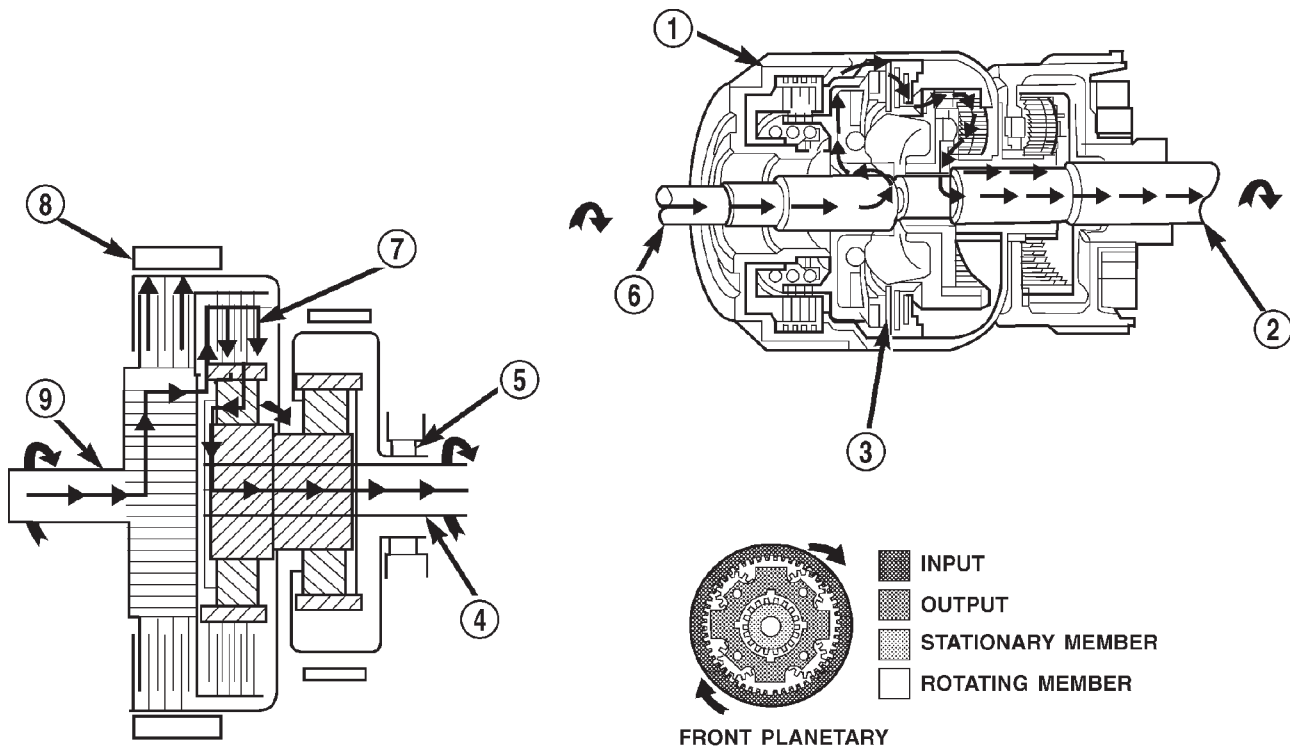

80c070aa

Fig. 7 Second Gear Powerflow

- 1 - KICKDOWN BAND APPLIED
- 2 - OUTPUT SHAFT
- 3 - REAR CLUTCH ENGAGED
- 4 - OUTPUT SHAFT
- 5 - OVER-RUNNING CLUTCH FREE-WHEELING
- 6 - INPUT SHAFT
- 7 - REAR CLUTCH APPLIED
- 8 - KICKDOWN BAND APPLIED
- 9 - INPUT SHAFT

DESCRIPTION AND OPERATION (Continued)

DIRECT DRIVE POWERFLOW

The vehicle has accelerated and reached the shift point for the 2-3 upshift into direct drive (Fig. 8). When the shift takes place, the front band is released, and the front clutch is applied. The rear clutch stays applied as it has been in all the forward gears. With the front clutch now applied, engine torque is now on the front clutch retainer, which is locked to the sun gear driving shell. This means that the sun gear is now turning in engine rotation (clockwise) and at engine speed. The rear clutch is still applied so engine torque is also still on the front annulus gear. If two members of the same planetary set are driven, direct drive results. Therefore, when two members are rotating at the same speed and in the same direction, it is the same as being locked up. The rear planetary set is also locked up, given the sun gear is still the input, and the rear annulus gear must turn with the output shaft. Both gears are turning in the same direction and at the same speed. The front and rear planet pinions do not turn at all in direct drive. The only rotation is the input from the engine to the connected parts, which are acting as one common unit, to the output shaft.

FLUID

NOTE: Refer to the maintenance schedules in Group 0, Lubrication and Maintenance for the recommended maintenance (fluid/filter change) intervals for this transmission.

NOTE: Refer to Service Procedures in this group for fluid level checking procedures.

DESCRIPTION

Mopar® ATF Plus 3, Type 7176, automatic transmission fluid is the recommended fluid for Daimler-Chrysler automatic transmissions.

Dexron II fluid IS NOT recommended. Clutch chatter can result from the use of improper fluid.

Mopar® ATF Plus 3, Type 7176, automatic transmission fluid when new is red in color. The ATF is dyed red so it can be identified from other fluids used in the vehicle such as engine oil or antifreeze. The red color is not permanent and is not an indicator of

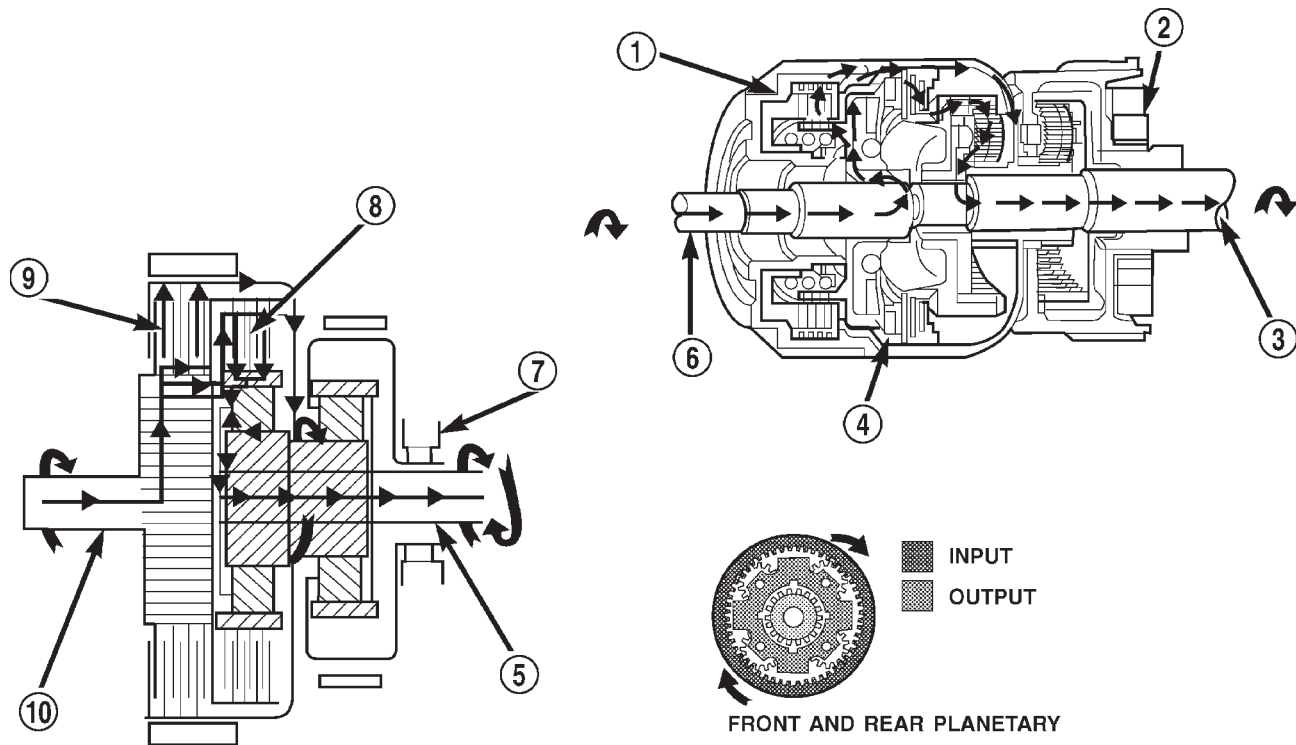

Fig. 8 Direct Drive Powerflow

80c070ab

- | | |
|---------------------------------------|---------------------------------------|
| 1 - FRONT CLUTCH APPLIED | 6 - INPUT SHAFT |
| 2 - OVER-RUNNING CLUTCH FREE-WHEELING | 7 - OVER-RUNNING CLUTCH FREE-WHEELING |
| 3 - OUTPUT SHAFT | 8 - REAR CLUTCH APPLIED |
| 4 - REAR CLUTCH APPLIED | 9 - FRONT CLUTCH APPLIED |
| 5 - OUTPUT SHAFT | 10 - INPUT SHAFT |

DESCRIPTION AND OPERATION (Continued)

fluid condition. As the vehicle is driven, the ATF will begin to look darker in color and may eventually become brown. **This is normal.** A dark brown/black fluid accompanied with a burnt odor and/or deterioration in shift quality may indicate fluid deterioration or transmission component failure.

FLUID ADDITIVES

DaimlerChrysler strongly recommends against the addition of any fluids to the transmission, other than those automatic transmission fluids listed above. Exceptions to this policy are the use of special dyes to aid in detecting fluid leaks.

Various "special" additives and supplements exist that claim to improve shift feel and/or quality. These additives and others also claim to improve converter clutch operation and inhibit overheating, oxidation, varnish, and sludge. These claims have not been supported to the satisfaction of DaimlerChrysler and these additives **must not be used.** The use of transmission "sealers" should also be avoided, since they may adversely affect the integrity of transmission seals.

OPERATION

The automatic transmission fluid is selected based upon several qualities. The fluid must provide a high level of protection for the internal components by providing a lubricating film between adjacent metal components. The fluid must also be thermally stable so that it can maintain a consistent viscosity through a large temperature range. If the viscosity stays constant through the temperature range of operation, transmission operation and shift feel will remain consistent. Transmission fluid must also be a good conductor of heat. The fluid must absorb heat from the internal transmission components and transfer that heat to the transmission case.

TORQUE CONVERTER

DESCRIPTION

The torque converter (Fig. 9) is a hydraulic device that couples the engine crankshaft to the transmission. The torque converter consists of an outer shell with an internal turbine, a stator, an overrunning clutch, an impeller and an electronically applied converter clutch. The converter clutch provides reduced engine speed and greater fuel economy when engaged. Clutch engagement also provides reduced transmission fluid temperatures. The converter clutch engages in third gear. The torque converter hub drives the transmission oil (fluid) pump.

The torque converter is a sealed, welded unit that is not repairable and is serviced as an assembly.

CAUTION: The torque converter must be replaced if a transmission failure resulted in large amounts of metal or fiber contamination in the fluid. If the fluid is contaminated, flush the fluid cooler and lines.

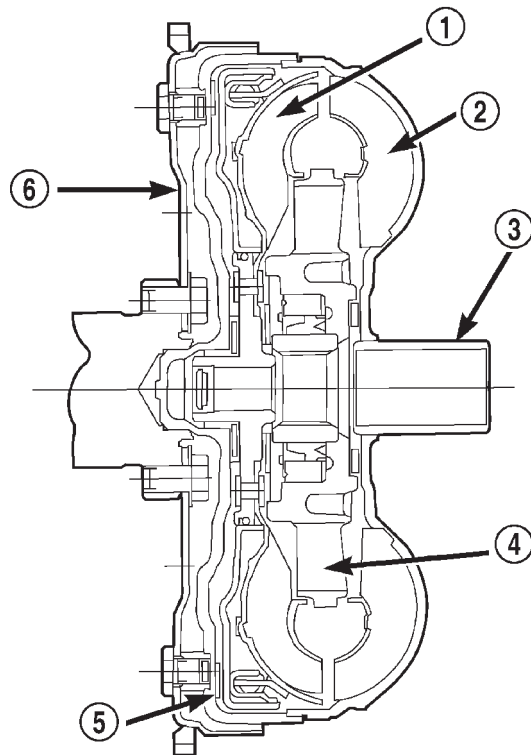

80be46a3

Fig. 9 Torque Converter Assembly

- 1 - TURBINE
- 2 - IMPELLER
- 3 - HUB
- 4 - STATOR
- 5 - CONVERTER CLUTCH DISC
- 6 - DRIVE PLATE

DESCRIPTION AND OPERATION (Continued)

IMPELLER

The impeller (Fig. 10) is an integral part of the converter housing. The impeller consists of curved blades placed radially along the inside of the housing on the transmission side of the converter. As the converter housing is rotated by the engine, so is the impeller, because they are one and the same and are the driving member of the system.

TURBINE

The turbine (Fig. 11) is the output, or driven, member of the converter. The turbine is mounted within the housing opposite the impeller, but is not attached to the housing. The input shaft is inserted through the center of the impeller and splined into the turbine. The design of the turbine is similar to the impeller, except the blades of the turbine are curved in the opposite direction.

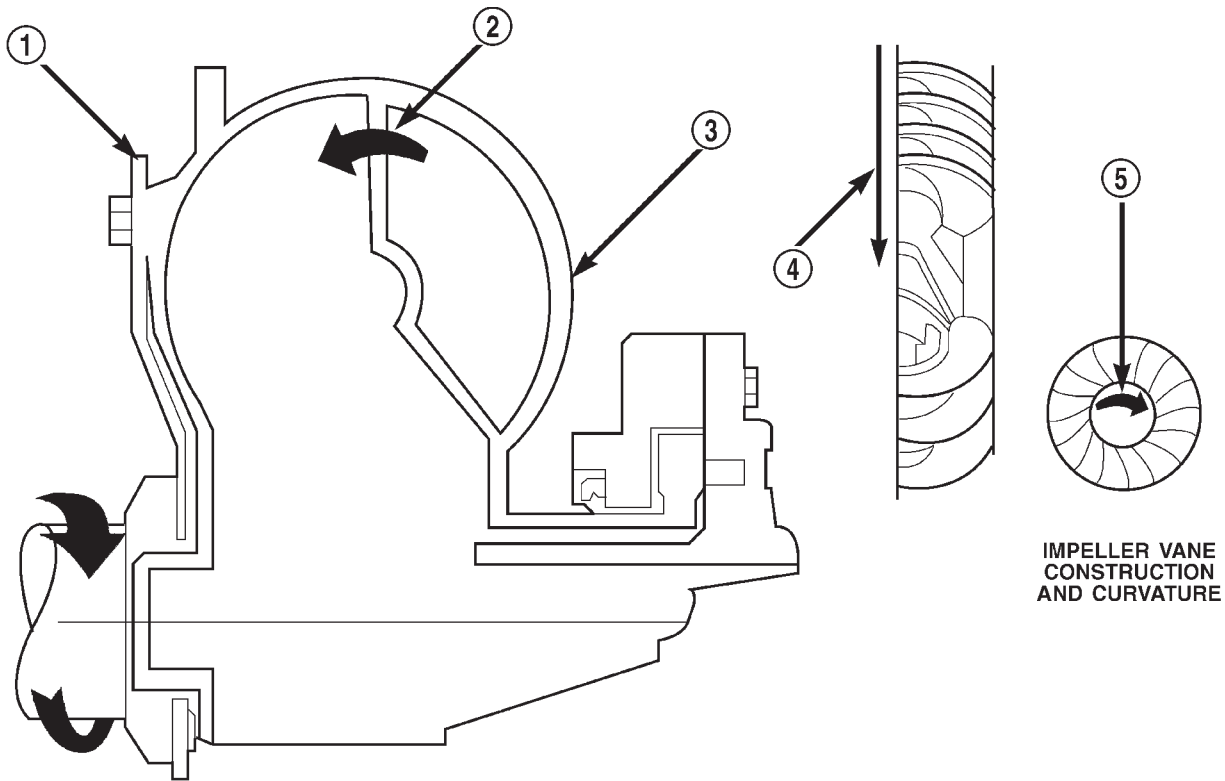

IMPELLER VANE
CONSTRUCTION
AND CURVATURE

80bfe26a

Fig. 10 Impeller

- | | |
|---|---------------------|
| 1 - ENGINE FLEXPLATE | 4 - ENGINE ROTATION |
| 2 - OIL FLOW FROM IMPELLER SECTION INTO TURBINE SECTION | 5 - ENGINE ROTATION |
| 3 - IMPELLER VANES AND COVER ARE INTEGRAL | |

DESCRIPTION AND OPERATION (Continued)

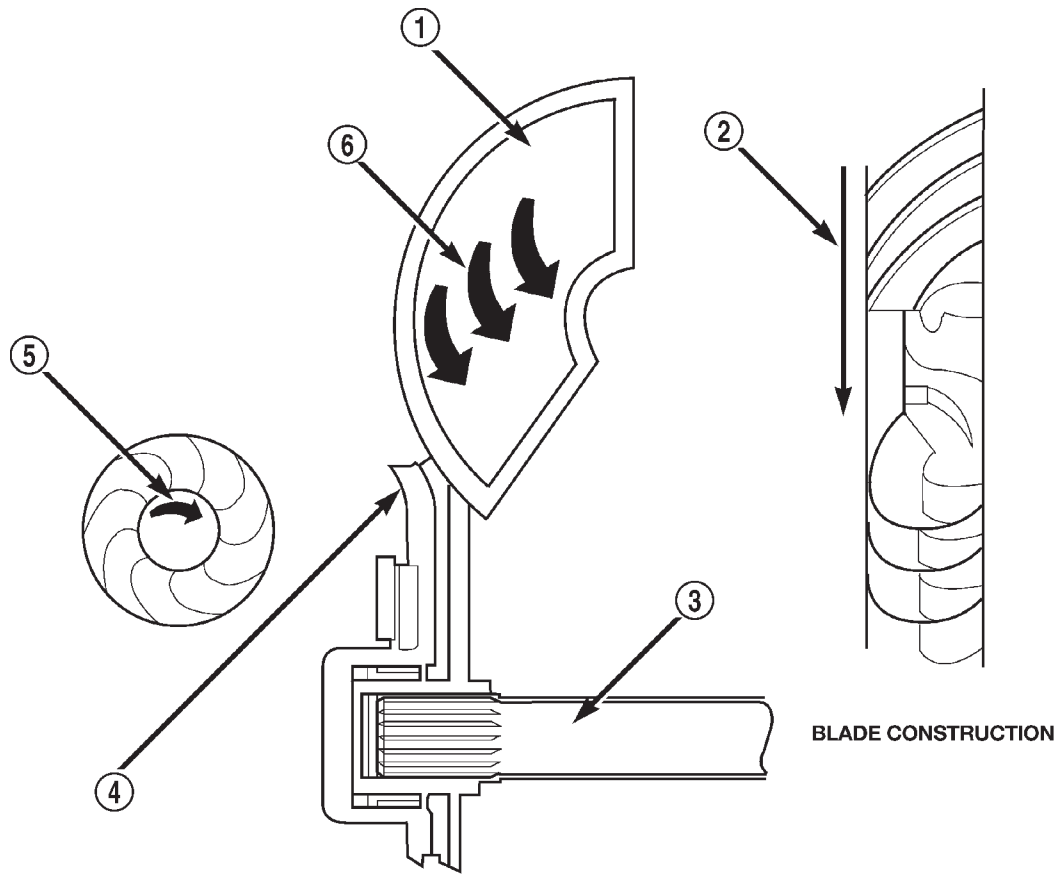

Fig. 11 Turbine

80bfe26b

- | | |
|---------------------|---------------------------------------|
| 1 - TURBINE VANE | 4 - PORTION OF TORQUE CONVERTER COVER |
| 2 - ENGINE ROTATION | 5 - ENGINE ROTATION |
| 3 - INPUT SHAFT | 6 - OIL FLOW WITHIN TURBINE SECTION |

STATOR

The stator assembly (Fig. 12) is mounted on a stationary shaft which is an integral part of the oil pump. The stator is located between the impeller and turbine within the torque converter case (Fig. 13). The stator contains an over-running clutch, which allows the stator to rotate only in a clockwise direction. When the stator is locked against the over-running clutch, the torque multiplication feature of the torque converter is operational.

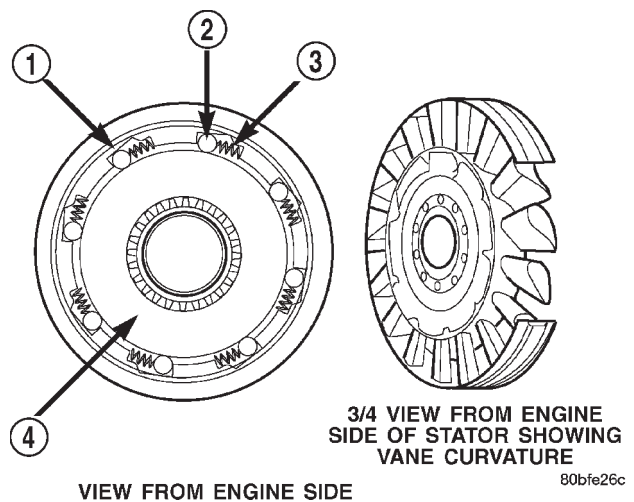

Fig. 12 Stator Components

- | |
|----------------------|
| 1 - CAM (OUTER RACE) |
| 2 - ROLLER |
| 3 - SPRING |
| 4 - INNER RACE |

DESCRIPTION AND OPERATION (Continued)

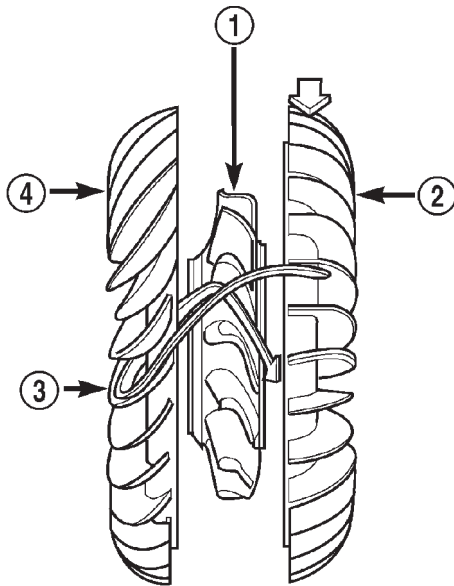

Fig. 13 Stator Location

- 1 - STATOR
- 2 - IMPELLER
- 3 - FLUID FLOW
- 4 - TURBINE

80bfe26d

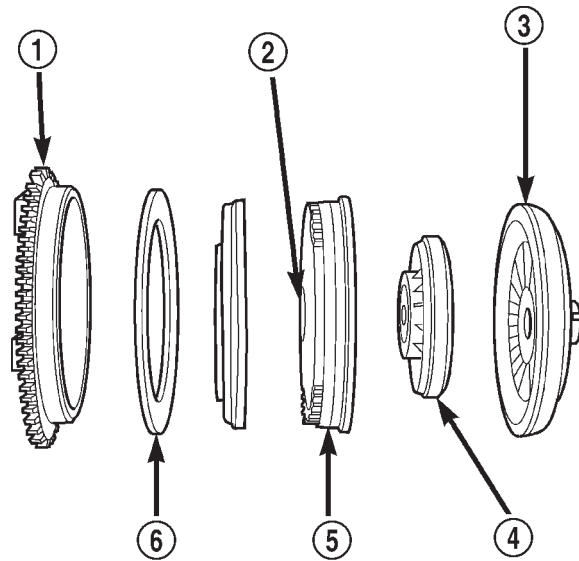

Fig. 14 Torque Converter Clutch (TCC)

- 1 - IMPELLER FRONT COVER
- 2 - THRUST WASHER ASSEMBLY
- 3 - IMPELLER
- 4 - STATOR
- 5 - TURBINE
- 6 - FRICTION DISC

80bfe26f

TORQUE CONVERTER CLUTCH (TCC)

The TCC (Fig. 14) was installed to improve the efficiency of the torque converter that is lost to the slippage of the fluid coupling. Although the fluid coupling provides smooth, shock-free power transfer, it is natural for all fluid couplings to slip. If the impeller and turbine were mechanically locked together, a zero slippage condition could be obtained. A hydraulic piston was added to the turbine, and a friction material was added to the inside of the front cover to provide this mechanical lock-up.

OPERATION

The converter impeller (Fig. 15) (driving member), which is integral to the converter housing and bolted to the engine drive plate, rotates at engine speed. The converter turbine (driven member), which reacts from fluid pressure generated by the impeller, rotates and turns the transmission input shaft.

TURBINE

As the fluid that was put into motion by the impeller blades strikes the blades of the turbine, some of the energy and rotational force is transferred into the turbine and the input shaft. This causes both of them (turbine and input shaft) to rotate in a clockwise direction following the impeller. As the fluid is leaving the trailing edges of the turbine's blades it continues in a "hindering" direction back toward the

impeller. If the fluid is not redirected before it strikes the impeller, it will strike the impeller in such a direction that it would tend to slow it down.

STATOR

Torque multiplication is achieved by locking the stator's over-running clutch to its shaft (Fig. 16). Under stall conditions (the turbine is stationary), the oil leaving the turbine blades strikes the face of the stator blades and tries to rotate them in a counter-clockwise direction. When this happens the over-running clutch of the stator locks and holds the stator from rotating. With the stator locked, the oil strikes the stator blades and is redirected into a "helping" direction before it enters the impeller. This circulation of oil from impeller to turbine, turbine to stator, and stator to impeller, can produce a maximum torque multiplication of about 2.4:1. As the turbine begins to match the speed of the impeller, the fluid that was hitting the stator in such a way as to cause it to lock-up is no longer doing so. In this condition of operation, the stator begins to free wheel and the converter acts as a fluid coupling.

TORQUE CONVERTER CLUTCH (TCC)

In a standard torque converter, the impeller and turbine are rotating at about the same speed and the

DESCRIPTION AND OPERATION (Continued)

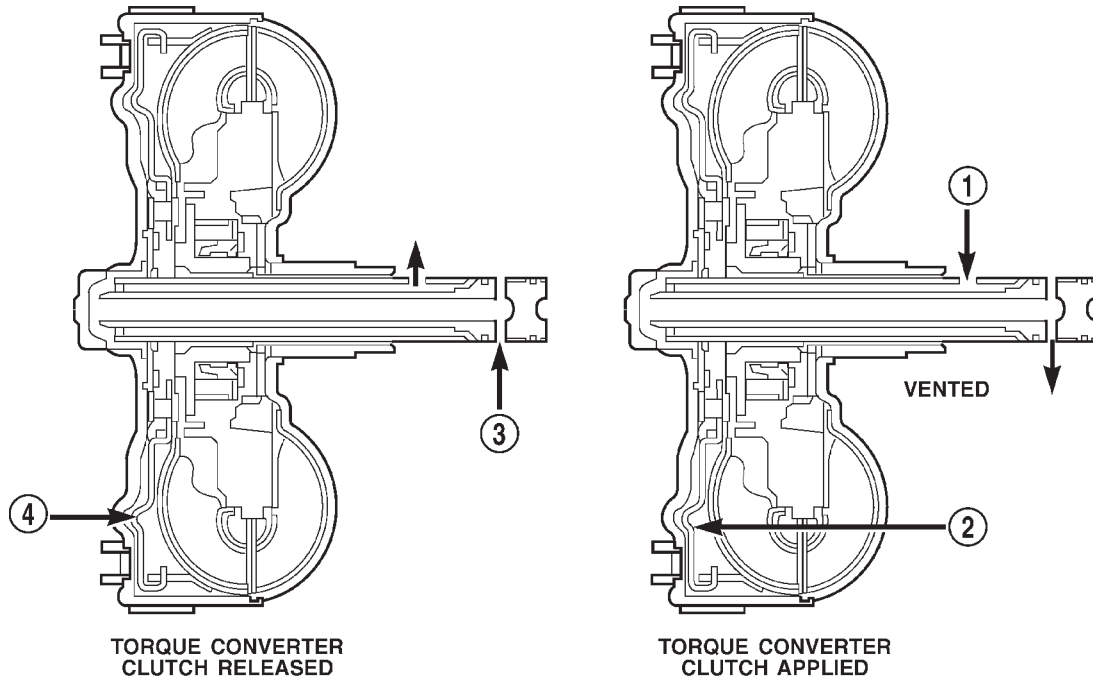

80bfe276

Fig. 15 Torque Converter Fluid Operation

- | | |
|---------------------------------------|--|
| 1 - APPLY PRESSURE | 3 - RELEASE PRESSURE |
| 2 - THE PISTON MOVES SLIGHTLY FORWARD | 4 - THE PISTON MOVES SLIGHTLY REARWARD |

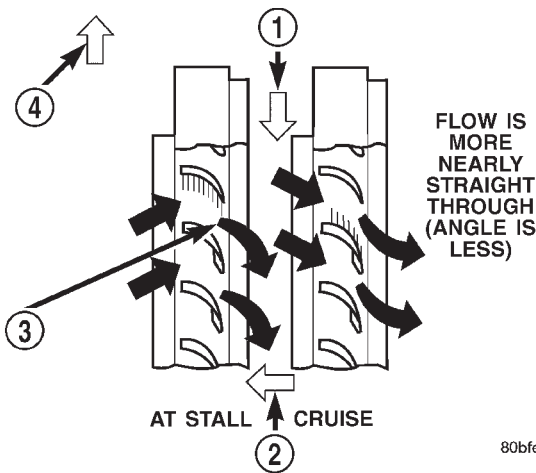

80bfe26e

Fig. 16 Stator Operation

- | |
|--|
| 1 - DIRECTION STATOR WILL FREE WHEEL DUE TO OIL PUSHING ON BACKSIDE OF VANES |
| 2 - FRONT OF ENGINE |
| 3 - INCREASED ANGLE AS OIL STRIKES VANES |
| 4 - DIRECTION STATOR IS LOCKED UP DUE TO OIL PUSHING AGAINST STATOR VANES |

stator is freewheeling, providing no torque multiplication. By applying the turbine's piston to the front cover's friction material, a total converter engagement can be obtained. The result of this engagement

is a direct 1:1 mechanical link between the engine and the transmission.

The engagement and disengagement of the TCC are automatic and controlled by the Powertrain Control Module (PCM). The engagement cannot be activated in the lower gears because it eliminates the torque multiplication effect of the torque converter necessary for acceleration. Inputs that determine clutch engagement are: coolant temperature, vehicle speed and throttle position. The torque converter clutch is engaged by the clutch solenoid on the valve body. The clutch will engage at approximately 56 km/h (35 mph) with light throttle, after the shift to third gear.

OIL PUMP

DESCRIPTION

The oil pump (Fig. 17) is located in the pump housing inside the bell housing of the transmission case. The oil pump consists of an inner and outer gear, a housing, and a cover that also serves as the reaction shaft support.

DESCRIPTION AND OPERATION (Continued)

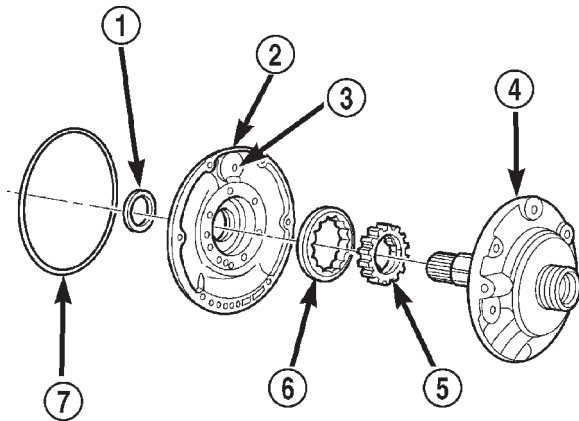

80be45f7

Fig. 17 Oil Pump Assembly

- 1 - OIL SEAL
- 2 - OIL PUMP BODY
- 3 - VENT
- 4 - REACTION SHAFT SUPPORT
- 5 - INNER ROTOR
- 6 - OUTER ROTOR
- 7 - "O" RING

OPERATION

As the torque converter rotates, the converter hub rotates the inner and outer gears. As the gears rotate, the clearance between the gear teeth increases in the crescent area, and creates a suction at the inlet side of the pump. This suction draws fluid through the pump inlet from the oil pan. As the clearance between the gear teeth in the crescent area decreases, it forces pressurized fluid into the pump outlet and to the valve body.

VALVE BODY**DESCRIPTION**

The valve body consists of a cast aluminum valve body, a separator plate, and transfer plate. The valve body contains valves and check balls that control fluid delivery to the torque converter clutch, bands, and frictional clutches. The valve body contains the following components (Fig. 18) and (Fig. 19):

- Regulator valve
- Regulator valve throttle pressure plug
- Line pressure plug and sleeve
- Kickdown valve
- Kickdown limit valve
- 1-2 shift valve
- 1-2 control valve
- 2-3 shift valve
- 2-3 governor plug
- Throttle valve
- Throttle pressure plug
- Switch valve
- Manual valve
- Converter clutch control valve
- Fail-safe valve
- Shuttle valve
- Shuttle valve throttle plug
- 9 check balls

By adjusting the spring pressure acting on the regulator valve, transmission line pressure can be adjusted.

OPERATION

NOTE: Refer to the Hydraulic Schematics for a visual aid in determining valve location, operation and design.

DESCRIPTION AND OPERATION (Continued)

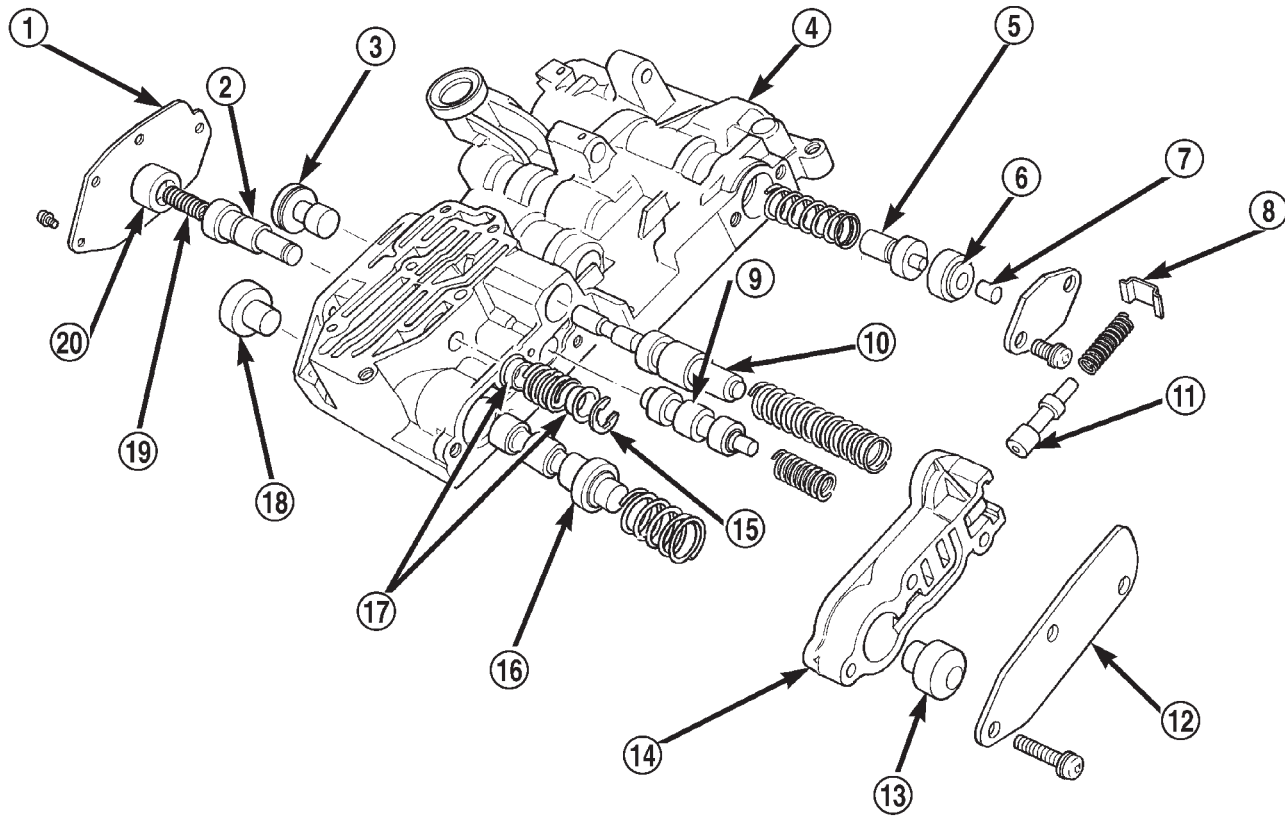

80a13872

Fig. 18 Valve Body Assembly

- | | |
|--|----------------------------------|
| 1 - GOVERNOR PLUG END PLATE | 11 - KICKDOWN LIMIT VALVE |
| 2 - SHUTTLE VALVE | 12 - END PLATE |
| 3 - 1-2 GOVERNOR PLUG | 13 - THROTTLE PRESSURE PLUG |
| 4 - VALVE BODY | 14 - KICKDOWN LIMIT VALVE BODY |
| 5 - REGULATOR VALVE THROTTLE PRESSURE PLUG | 15 - E-RING |
| 6 - SLEEVE | 16 - 2-3 SHIFT VALVE |
| 7 - LINE PRESSURE PLUG | 17 - GUIDES |
| 8 - RETAINER | 18 - 2-3 GOVERNOR PLUG |
| 9 - 1-2 SHIFT VALVE | 19 - PRIMARY SPRING |
| 10 - 1-2 SHIFT CONTROL VALVE | 20 - SHUTTLE VALVE THROTTLE PLUG |

REGULATOR VALVE

The pressure regulator valve is needed to control the hydraulic pressure within the system and reduce the amount of heat produced in the fluid. The pressure regulator valve is located in the valve body near the manual valve. The pressure regulator valve train controls the maximum pressure in the lines by metering the dumping of fluid back into the sump. Regulated pressure is referred to as "line pressure."

The regulator valve (Fig. 20) has a spring on one end that pushes the valve to the left. This closes a dump (vent) that is used to lower pressure. The closing of the dump will cause the oil pressure to increase. Oil pressure on the opposite end of the valve pushes the valve to the right, opening the dump and lowering oil pressure. The result is spring pressure working against oil pressure to maintain

the oil at specific pressures. With the engine running, fluid flows from the pump to the pressure regulator valve, manual valve, and the interconnected circuits. As fluid is sent through passages to the regulator valve, the pressure pushes the valve to the right against the large spring. It is also sent to the reaction areas on the left side of the throttle pressure plug and the line pressure plug. With the gear selector in the park position, fluid recirculates through the regulator and manual valves back to the sump.

DESCRIPTION AND OPERATION (Continued)

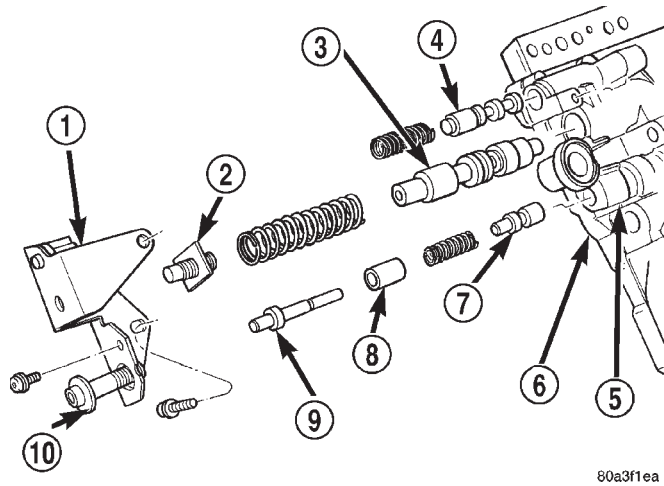

Fig. 19 Valve Body Assembly

- 1 - ADJUSTER BRACKET
- 2 - LINE PRESSURE ADJUSTER
- 3 - PRESSURE REGULATOR VALVE
- 4 - SWITCH VALVE
- 5 - VALVE BODY
- 6 - TRANSFER PLATE
- 7 - THROTTLE VALVE
- 8 - SLEEVE
- 9 - KICKDOWN VALVE
- 10 - THROTTLE PRESSURE ADJUSTER

Meanwhile, the torque converter is filled slowly. In all other gear positions (Fig. 21), fluid flows between two right side lands to the switch valve and torque converter. At low pump speeds, the flow is controlled by the pressure valve groove to reduce pressure to the torque converter. After the torque converter and switch valve fill with fluid, the switch valve becomes the controlling metering device for torque converter pressure. The regulator valve then begins to control the line pressure for the other transmission circuits. The balance of the fluid pressure pushing the valve to the right and the spring pressure pushing to the left determines the size of the metering passage at land #2 (land #1 being at the far right of the valve in the diagram). As fluid leaks past the land, it moves into a groove connected to the filter or sump. As the land meters the fluid to the sump, it causes the pressure to reduce and the spring decreases the size of the metering passage. When the size of the metering passage is reduced, the pressure rises again and the size of the land is increased again. Pressure is regulated by this constant balance of hydraulic and spring pressure.

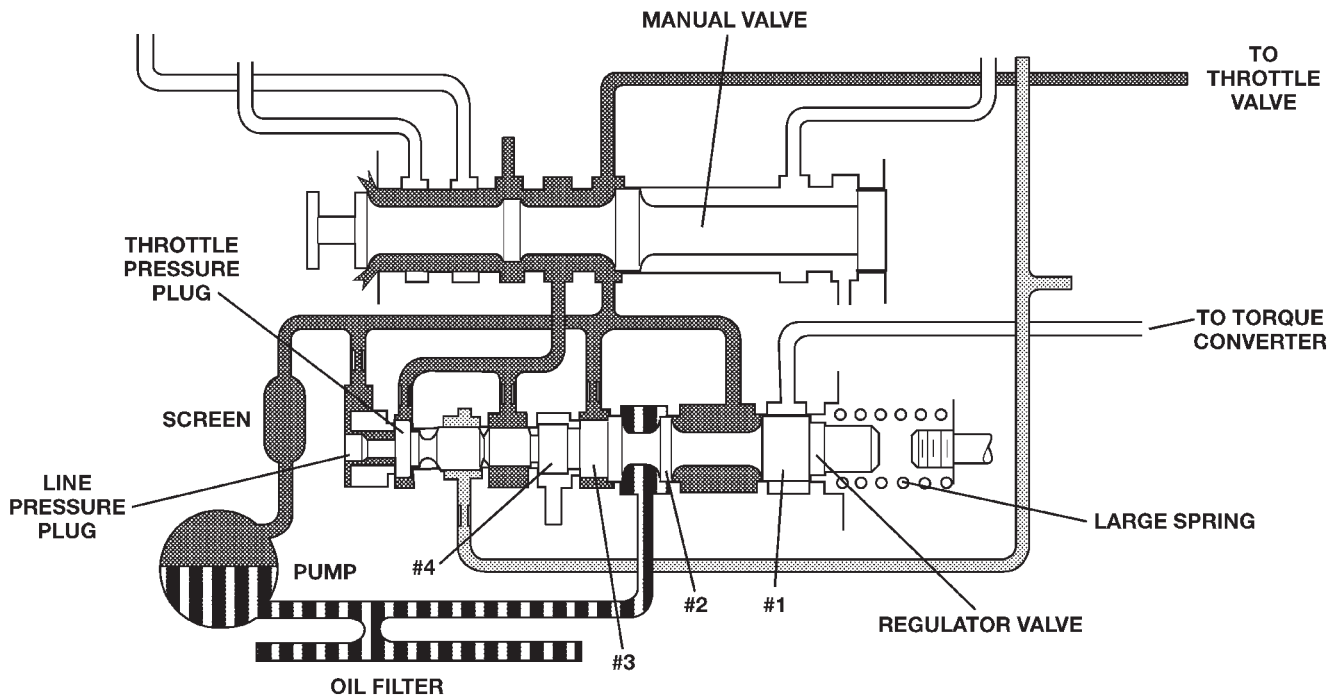
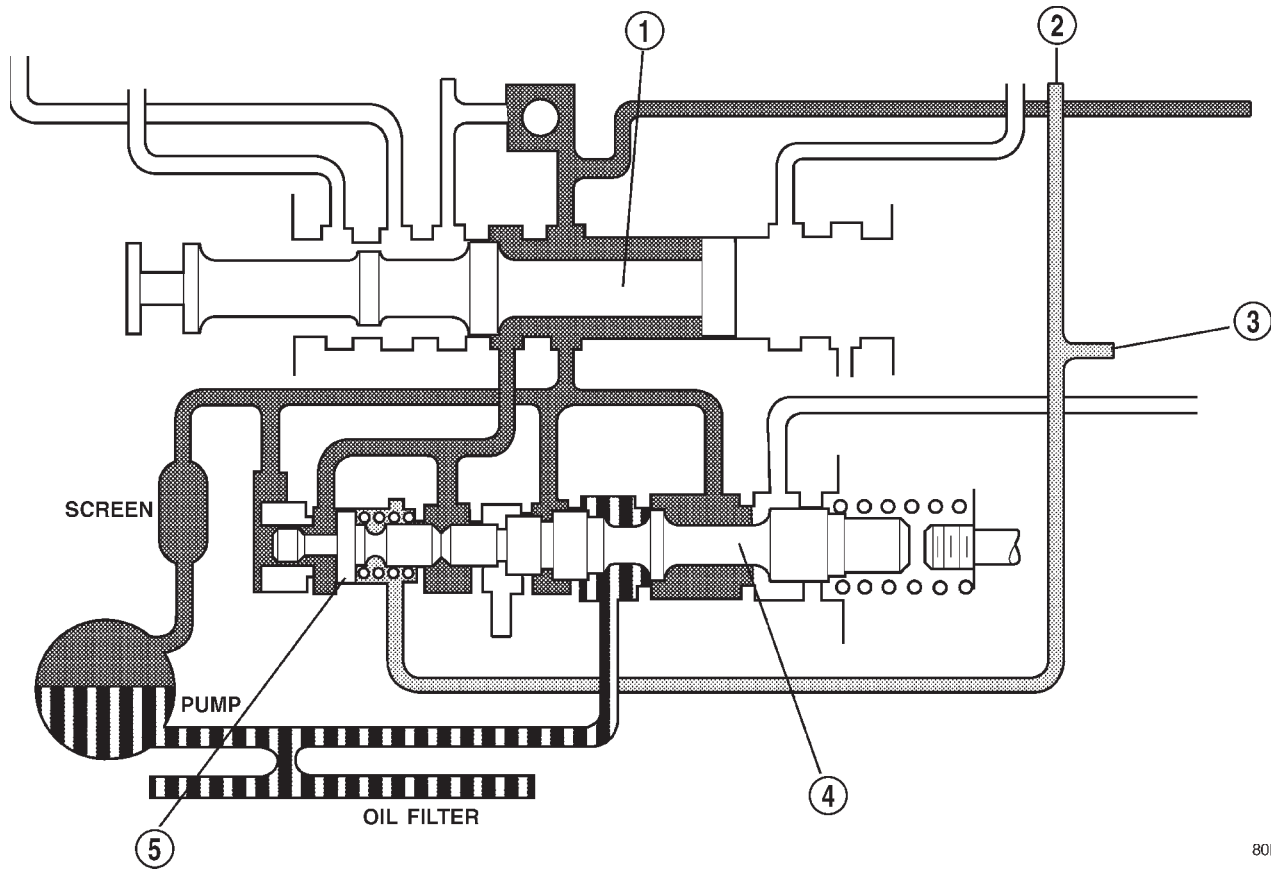

Fig. 20 Regulator Valve in Park Position

DESCRIPTION AND OPERATION (Continued)



80be4609

Fig. 21 Regulator Valve in Neutral Position

- | | |
|-------------------------|----------------------------|
| 1 - MANUAL VALVE | 4 - REGULATOR VALVE |
| 2 - TO SHIFT VALVE | 5 - THROTTLE PRESSURE PLUG |
| 3 - FROM THROTTLE VALVE | |

The metering at land #2 establishes the line pressure throughout the transmission. It is varied according to changes in throttle position, engine speed, and transmission condition within a range of 57-94 psi (except in reverse) (Fig. 22). The regulated line pressure in reverse (Fig. 23) is held at much higher pressures than in the other gear positions: 145-280 psi. The higher pressure for reverse is achieved by the manual valve blocking the supply of line pressure to the reaction area left of land #4. With this pressure blocked, there is less area for pressure to act on to balance the force of the spring on the right. This allows line pressure to push the valve train to the right, reducing the amount of fluid returned to the pump's inlet, increasing line pressure.

DESCRIPTION AND OPERATION (Continued)

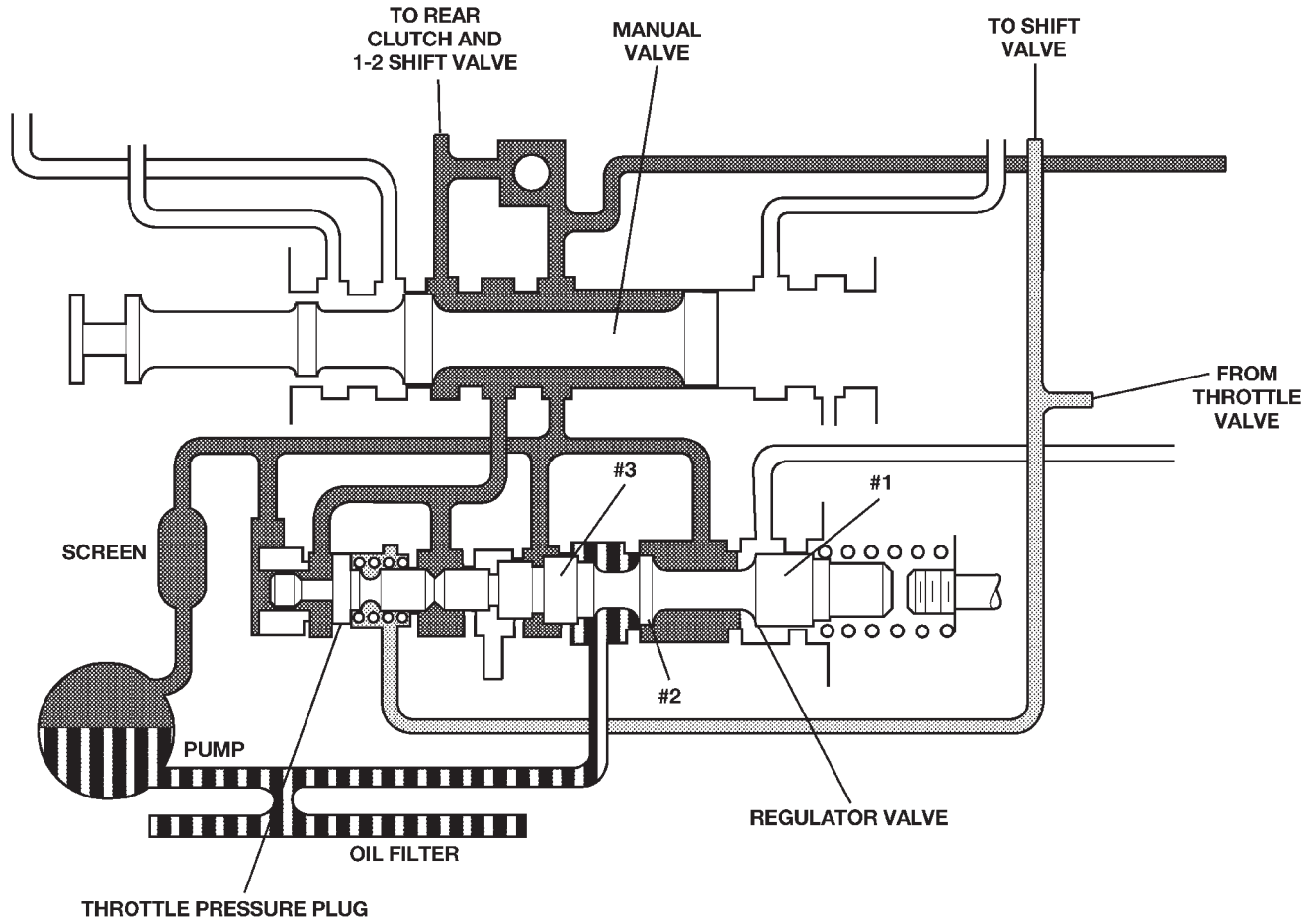

Fig. 22 Regulator Valve in Drive Position

80be460a

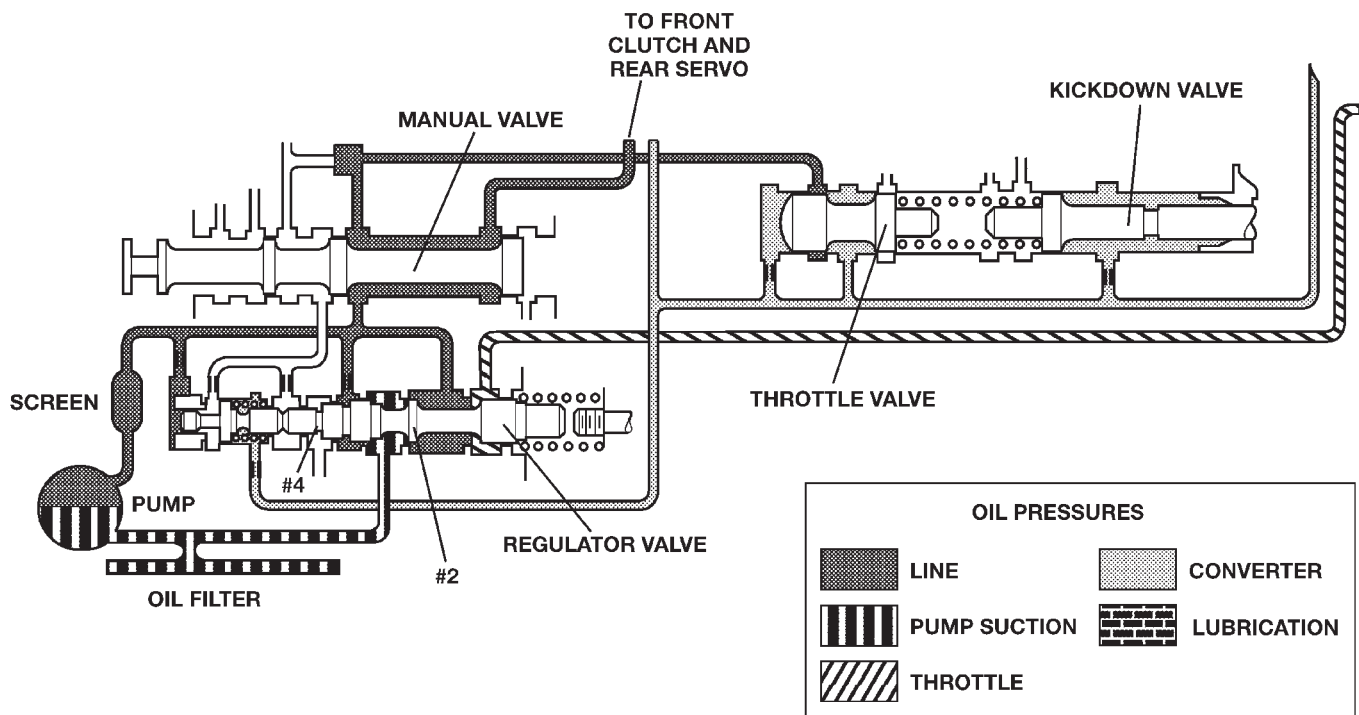
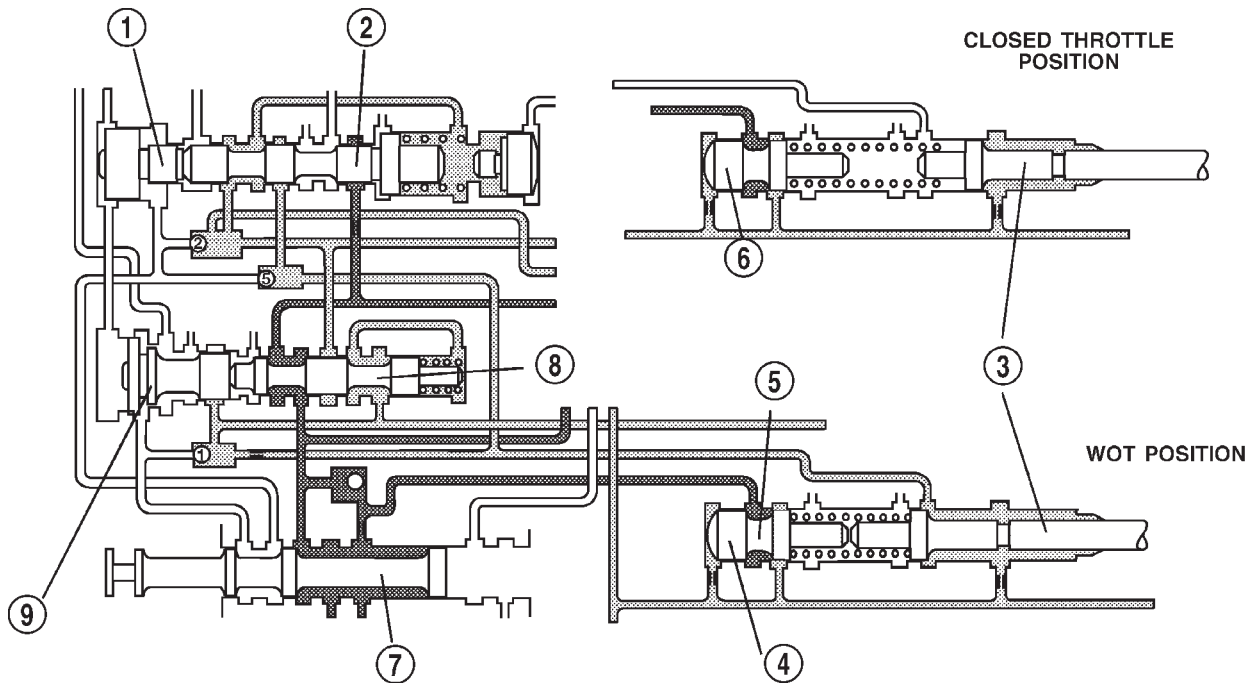

Fig. 23 Regulator Valve in Reverse Position

80be460b

DESCRIPTION AND OPERATION (Continued)



80be460c

Fig. 24 Kickdown Valve

- | | |
|-------------------------------|---------------------|
| 1 - GOVERNOR PLUG | 6 - THROTTLE VALVE |
| 2 - 2-3 SHIFT VALVE | 7 - MANUAL VALVE |
| 3 - KICKDOWN VALVE | 8 - 1-2 SHIFT VALVE |
| 4 - THROTTLE VALVE | 9 - GOVERNOR PLUG |
| 5 - MAXIMUM THROTTLE PRESSURE | |

KICKDOWN VALVE

When the throttle valve is as far over to the left as it can go, the maximum line pressure possible will enter the throttle pressure circuit. In this case, throttle pressure will equal line pressure. With the kickdown valve (Fig. 24) pushed into the bore as far as it will go, fluid initially flows through the annular groove of the 2-3 shift valve (which will be in the direct drive position to the right).

After passing the annular groove, the fluid is routed to the spring end of the 2-3 shift valve. Fluid pressure reacting on the area of land #1 overcomes governor pressure, downshifting the 2-3 shift valve into the kickdown, or second gear stage of operation. The valve is held in the kickdown position by throttle pressure routed from a seated check ball (#2). Again, if vehicle speed is low enough, throttle pressure will also push the 1-2 shift valve left to seat its governor plug, and downshift to drive breakaway.

KICKDOWN LIMIT VALVE

The purpose of the limit valve is to prevent a 3-2 downshift at higher speeds when a part-throttle downshift is not desirable. At these higher speeds only a full throttle 3-2 downshift will occur. At low road speeds (Fig. 25) the limit valve does not come into play and does not affect the downshifts. As the vehicle's speed increases (Fig. 26), the governor pressure also increases. The increased governor pressure acts on the reaction area of the bottom land of the limit valve overcoming the spring force trying to push the valve toward the bottom of its bore. This pushes the valve upward against the spring and bottoms the valve against the top of the housing. With the valve bottomed against the housing, the throttle pressure supplied to the valve will be closed off by the bottom land of the limit valve. When the supply of throttle pressure has been shut off, the 3-2 part throttle downshift plug becomes inoperative, because no pressure is acting on its reaction area.

DESCRIPTION AND OPERATION (Continued)

LOW ROAD SPEED

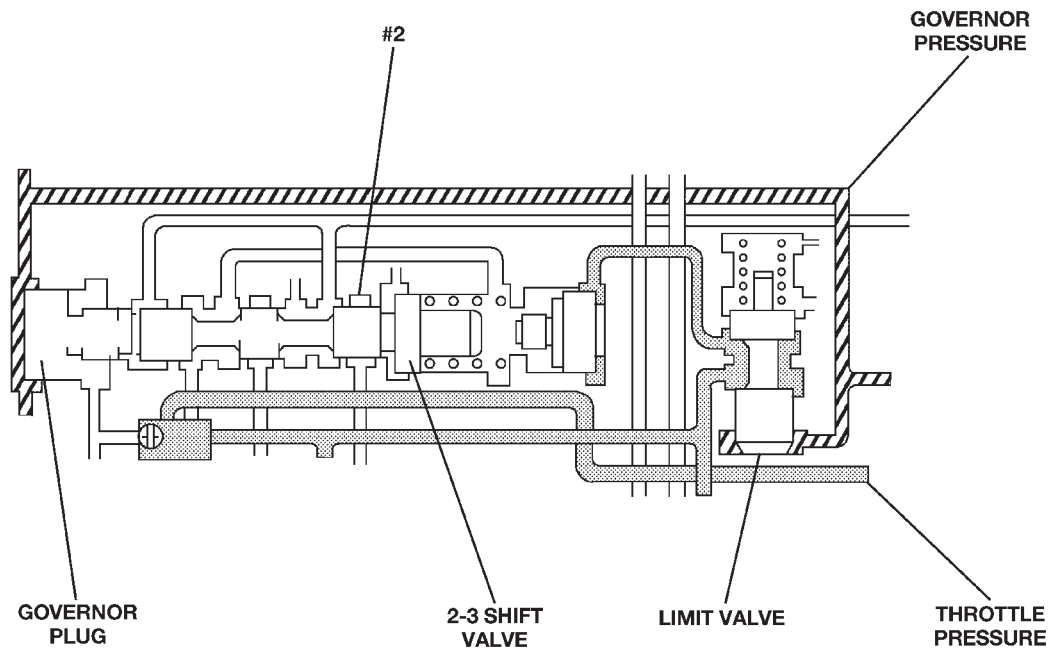

80be460d

Fig. 25 Kickdown Limit Valve-Low Speeds

HIGH ROAD SPEED

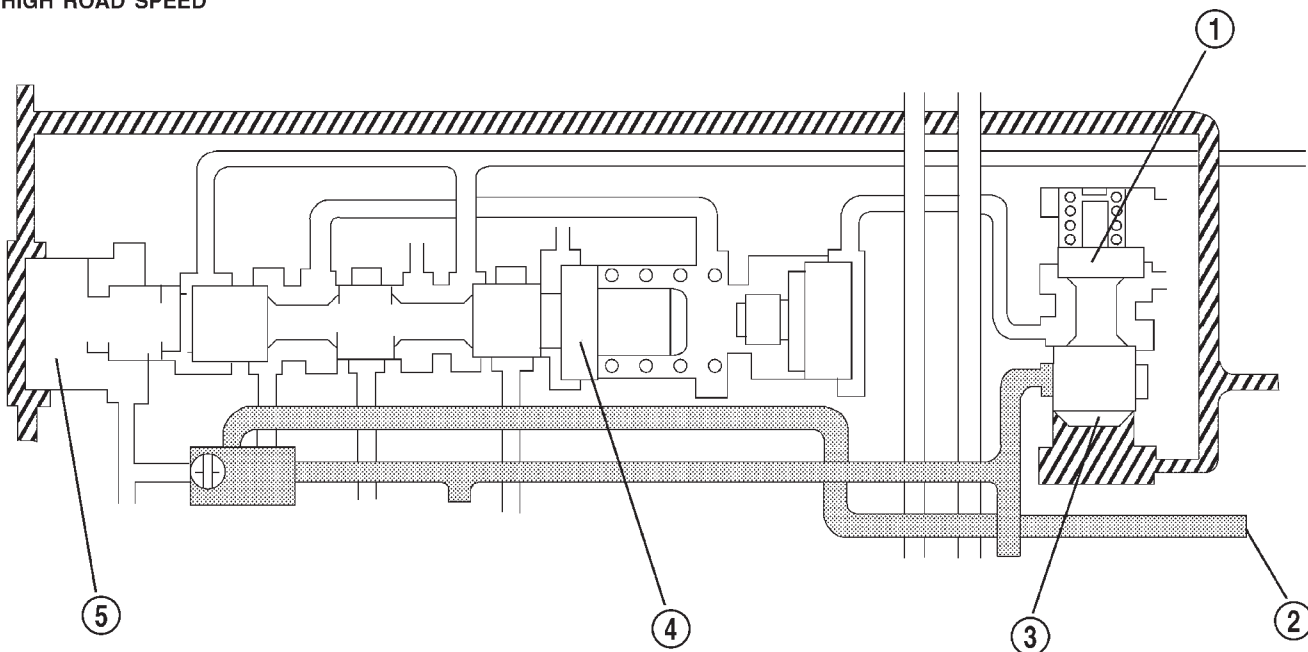

80be4601

Fig. 26 Kickdown Limit Valve-High Speeds

- | | |
|--|---------------------|
| 1 - GOVERNOR PRESSURE CLOSURES LIMIT VALVE | 4 - 2-3 SHIFT VALVE |
| 2 - THROTTLE PRESSURE | 5 - GOVERNOR PLUG |
| 3 - LIMIT VALVE | |

DESCRIPTION AND OPERATION (Continued)

BEFORE SHIFT

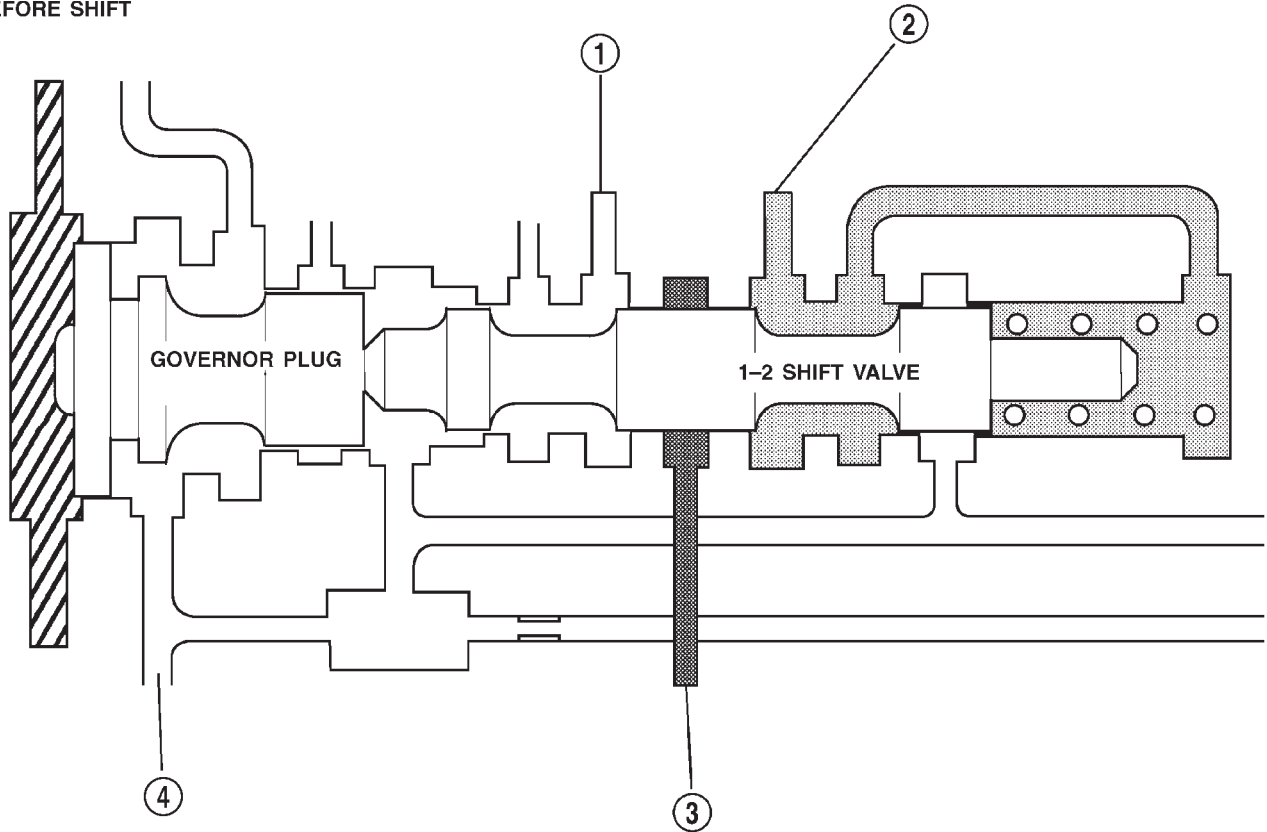

80be4611

Fig. 27 1-2 Shift Valve-Before Shift

- | | |
|--|---|
| 1 - TO FRONT SERVO AND 2-3 SHIFT VALVE | 3 - LINE PRESSURE |
| 2 - THROTTLE PRESSURE | 4 - LINE PRESSURE PASSAGE FOR MANUAL LOW POSITION |

1-2 SHIFT VALVE

The 1-2 shift valve assembly (Fig. 27), or mechanism, consists of: the 1-2 shift valve, governor plug, and a spring on the end of the valve. After the manual valve has been placed into a forward gear range, line pressure is directed to the 1-2 shift valve. As the throttle is depressed, throttle pressure is applied to the right side of the 1-2 shift valve assembly. With throttle pressure applied to the right side of the valve, there is now both spring pressure and throttle pressure acting on the valve, holding it against the governor plug. As the vehicle begins to move and build speed, governor pressure is created and is applied to the left of the valve at the governor plug.

DESCRIPTION AND OPERATION (Continued)

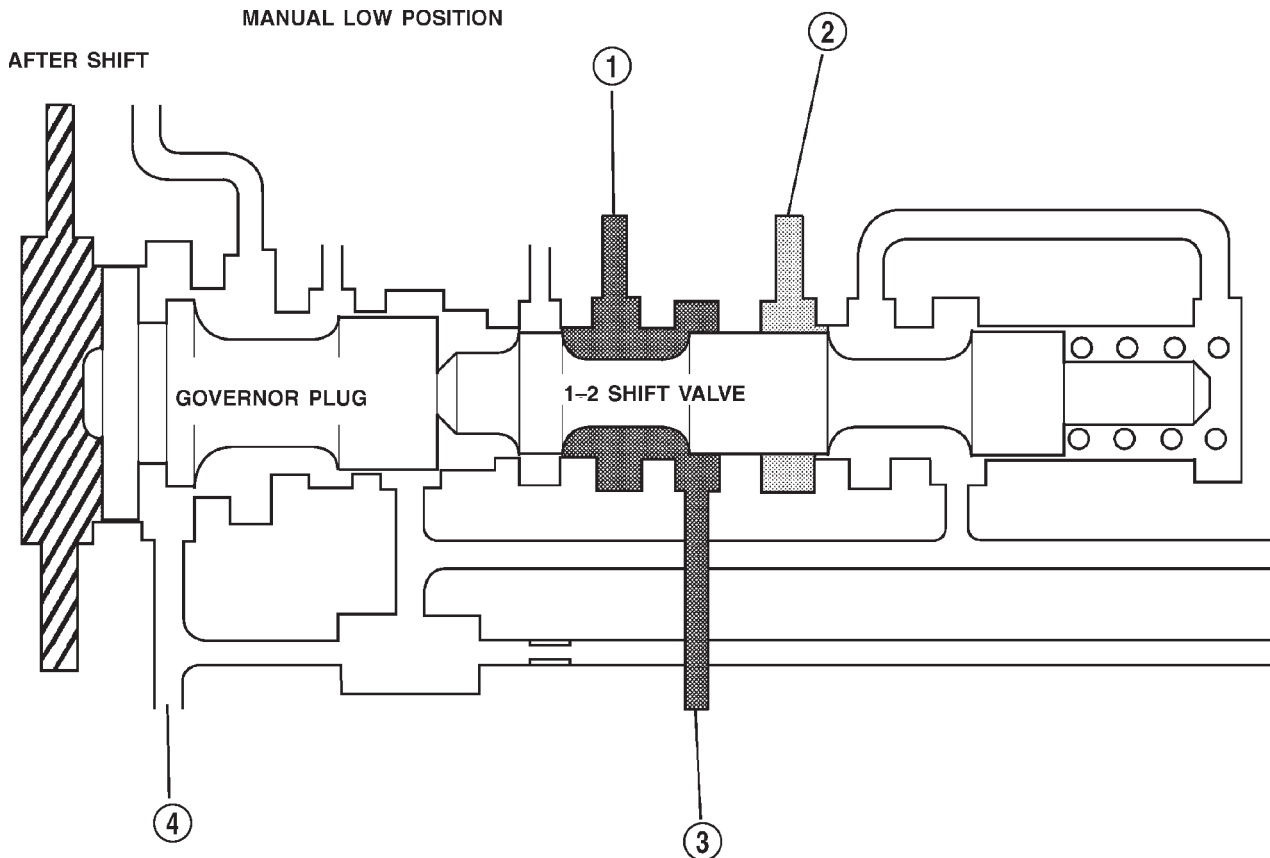

80be4612

Fig. 28 1-2 Shift Valve-After Shift

1 - TO FRONT SERVO AND 2-3 SHIFT VALVE
2 - THROTTLE PRESSURE

3 - LINE PRESSURE
4 - LINE PRESSURE PASSAGE FOR MANUAL LOW POSITION

When governor pressure builds to a point where it can overcome the combined force of the spring and throttle pressure on the other side of the valve, the valve will begin to move over to the right. As the valve moves to the right, the middle land of the valve will close off the circuit supplying the throttle pressure to the right side of the valve. When the throttle pressure is closed off, the valve will move even farther to the right, allowing line pressure to enter another circuit and energize the front servo, applying the front band (Fig. 28).

The governor plug serves a dual purpose: [0001]

- It allows the shift valves to move either left or right, allowing both upshifts and downshifts.
- When in a manual selection position, it will be hydraulically “blocked” into position so no upshift can occur.

The physical blocking of the upshift while in the manual “1” position is accomplished by the directing of line pressure between both lands of the governor plug. The line pressure reacts against the larger land of the plug, pushing the plug back against the end

plate overcoming governor pressure. With the combination of the line pressure and spring pressure, the valve cannot move, preventing any upshift.

1-2 SHIFT CONTROL VALVE

It contains a valve with four lands and a spring. It is used as both a “relay” and “balanced” valve.

The valve has two specific operations (Fig. 29):

- Aid in quality of the 1-2 upshift.
- Aid in the quality and timing of the 3-2 kick-down ranges.

When the manual valve is set to the Drive position and the transmission is in the first or second gear range, 1-2 shift control or “modulated throttle pressure” is supplied to the middle of the accumulator piston by the 1-2 shift control valve. During the 1-2 upshift, this pressure is used to control the kickdown servo apply pressure that is needed to apply the kickdown and accumulator pistons. Thus, the 1-2 shift point is “cushioned” and the quality is improved. During a WOT kickdown, kickdown pressure is applied between the kickdown valve and the 1-2

DESCRIPTION AND OPERATION (Continued)

shift control valve. This additional pressure is directed to the 1-2 shift control's spring cavity, adding to the spring load on the valve. The result of this increased "modulated" throttle pressure is a firmer WOT upshift.

SHUTTLE VALVE

The assembly is contained in a bore in the valve body above the shift valves. When the manual valve is positioned in the Drive range, throttle pressure acts on the throttle plug of the shuttle valve (Fig. 29) to move it against a spring, increasing the spring force on the shuttle valve. During a part or full throttle 1-2 upshift, the throttle plug is bottomed by throttle pressure, holding the shuttle valve to the right against governor pressure, and opening a by-pass circuit. The shuttle valve controls the quality of the kickdown shift by restricting the rate of

fluid discharge from the front clutch and servo release circuits. During a 3-2 kickdown, fluid discharges through the shuttle by-pass circuit. When the shuttle valve closes the by-pass circuit, fluid discharge is restricted and controlled for the application of the front band. During a 2-3 "lift foot" upshift, the shuttle valve by-passes the restriction to allow full fluid flow through the by-pass groove for a faster release of the band.

2-3 SHIFT VALVE

The 2-3 shift valve mechanism (Fig. 30) consists of the 2-3 shift valve, governor plug and spring, and a throttle plug. After the 1-2 shift valve has completed its operation and applied the front band, line pressure is directed to the 2-3 shift valve through the connecting passages from the 1-2 shift valve. The line pressure will then dead-end at land #2 until the

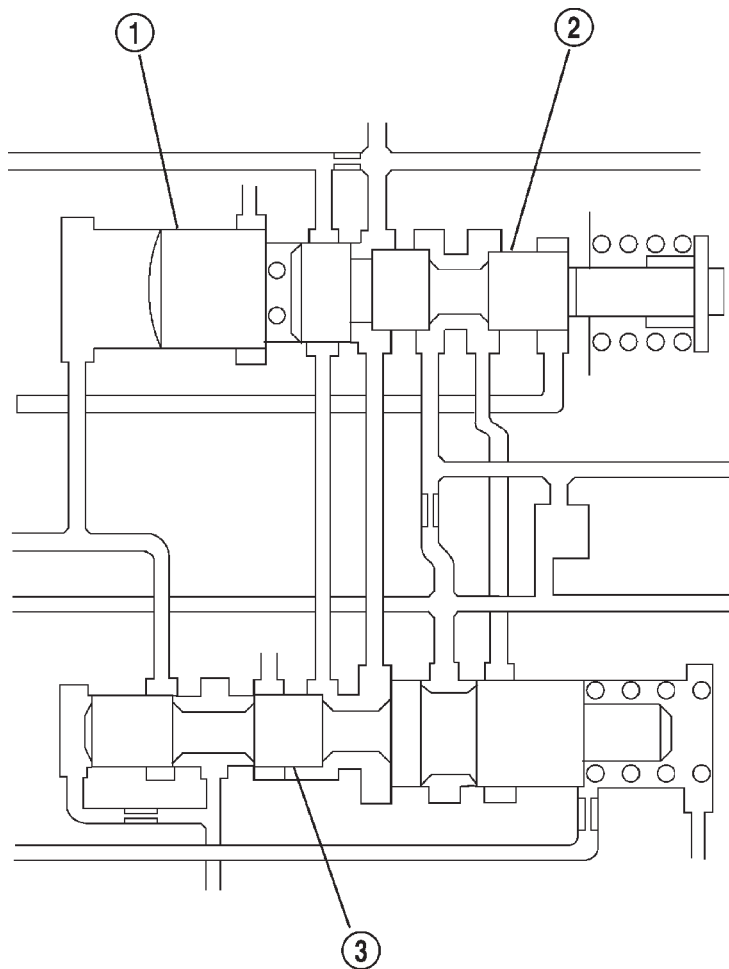

80be4613

Fig. 29 1-2 Shift Control Valve

1 - THROTTLE PLUG

2 - SHUTTLE VALVE

3 - 1-2 SHIFT CONTROL VALVE

DESCRIPTION AND OPERATION (Continued)

2-3 valve is ready to make its shift. Now that the vehicle is in motion and under acceleration, there is throttle pressure being applied to the spring side of the valve and between lands #3 and #4.

As vehicle speed increases, governor pressure increases proportionately, until it becomes great enough to overcome the combined throttle and spring pressure on the right side of the valve. When this happens, the governor plug is forced against the shift valve moving it to the right. The shift valve causes land #4 to close the passage supplying throttle pressure to the 2-3 shift valve. Without throttle pressure present in the circuit now, the governor plug will push the valve over far enough to bottom the valve in its bore. This allows land #2 to direct line pressure to the front clutch.

After the shift (Fig. 31), line pressure is directed to the land between the shift valve and the governor plug, and to the release side of the kickdown servo. This releases the front band and applies the front clutch, shifting into third gear or direct drive. The rear clutch remains applied, as it has been in the other gears. During a manual "1" or manual "2" gear selection, line pressure is sent between the two lands

of the 2-3 governor plug. This line pressure at the governor plug locks the shift valve into the second gear position, preventing an upshift into direct drive. The theory for the blocking of the valve is the same as that of the 1-2 shift valve.

THROTTLE VALVE

In all gear positions the throttle valve (Fig. 32) is being supplied with line pressure. The throttle valve meters and reduces the line pressure that now becomes throttle pressure. The throttle valve is moved by a spring and the kickdown valve, which is mechanically connected to the throttle. The larger the throttle opening, the higher the throttle pressure (to a maximum of line pressure). The smaller the throttle opening, the lower the throttle pressure (to a minimum of zero at idle). As engine speed increases, the increase in pump speed increases pump output. The increase in pressure and volume must be regulated to maintain the balance within the transmission. To do this, throttle pressure is routed to the reaction area on the right side of the throttle pressure plug (in the regulator valve).

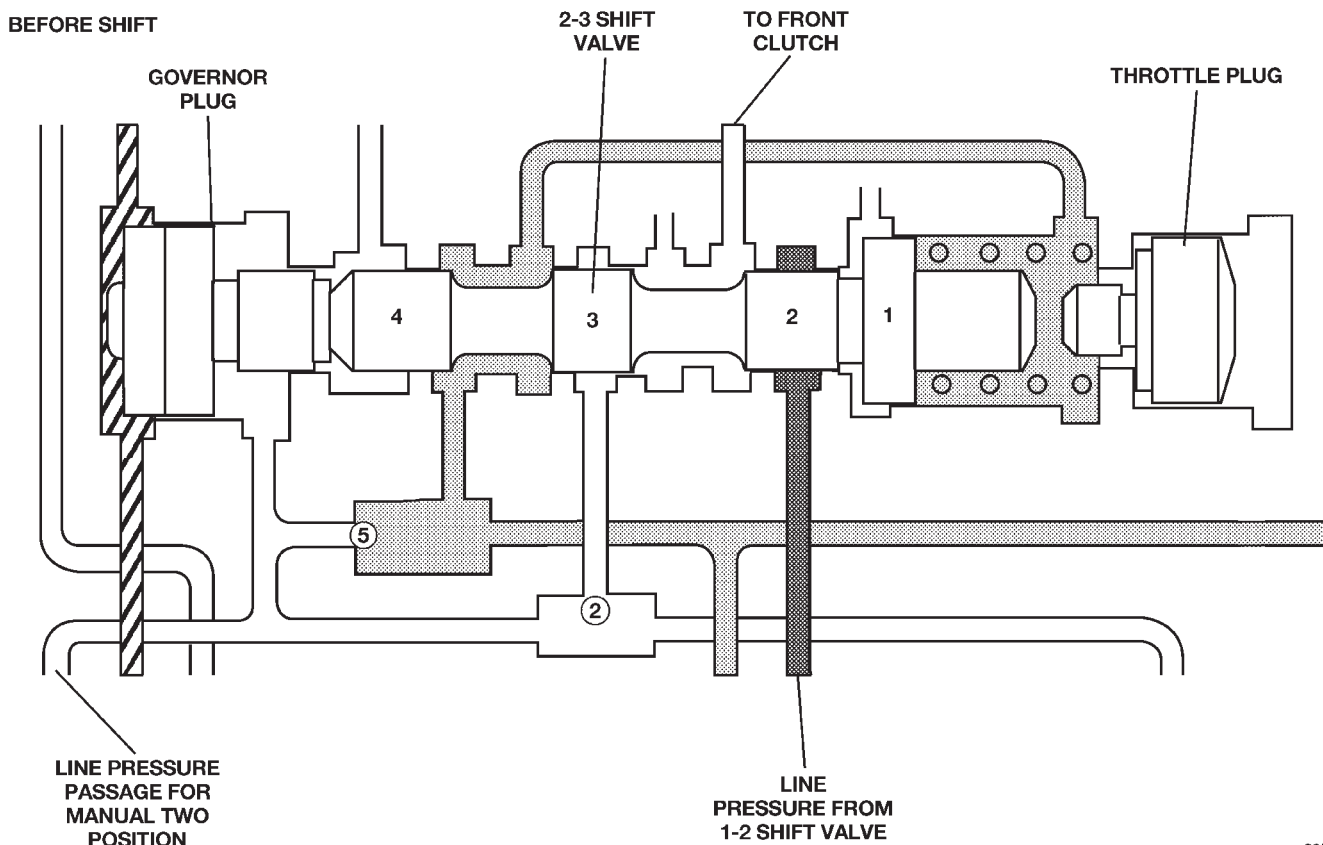

Fig. 30 2-3 Shift Valve-Before Shift

DESCRIPTION AND OPERATION (Continued)

AFTER SHIFT

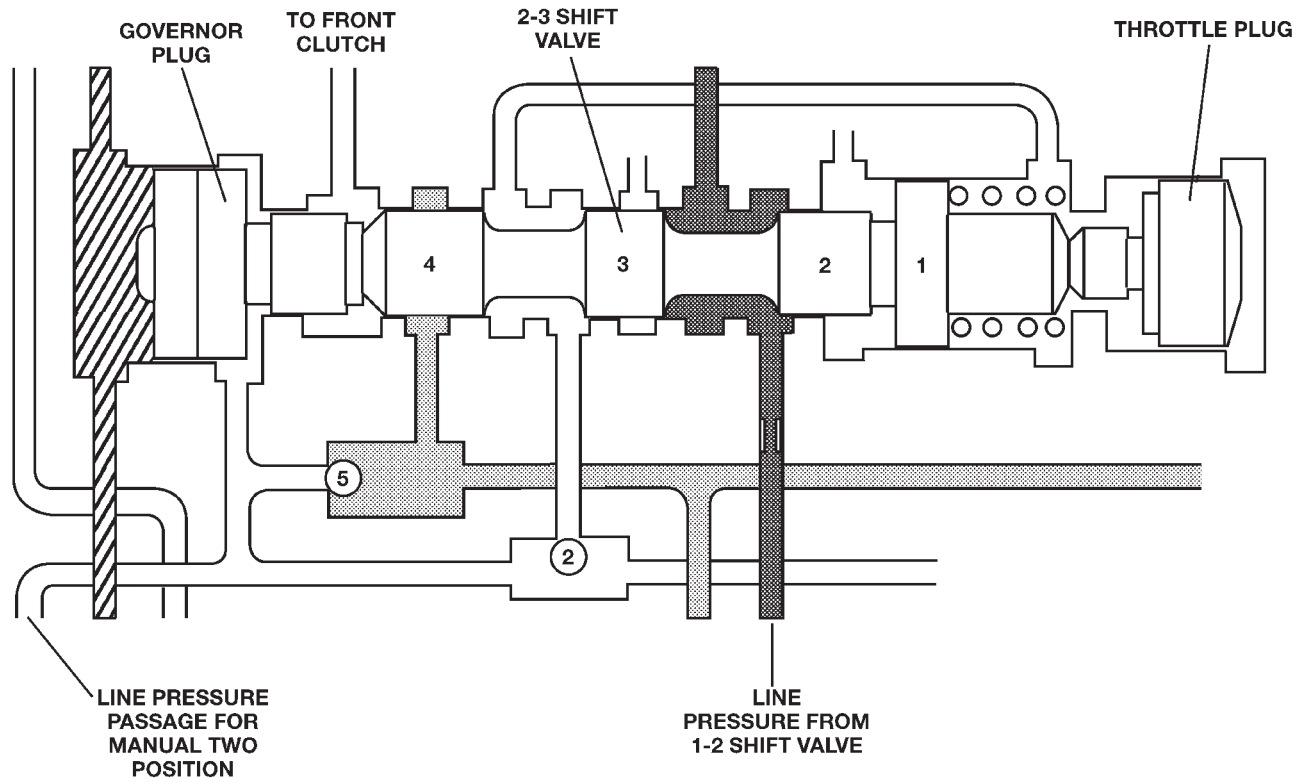

Fig. 31 2-3 Shift Valve-After Shift

80bfe262

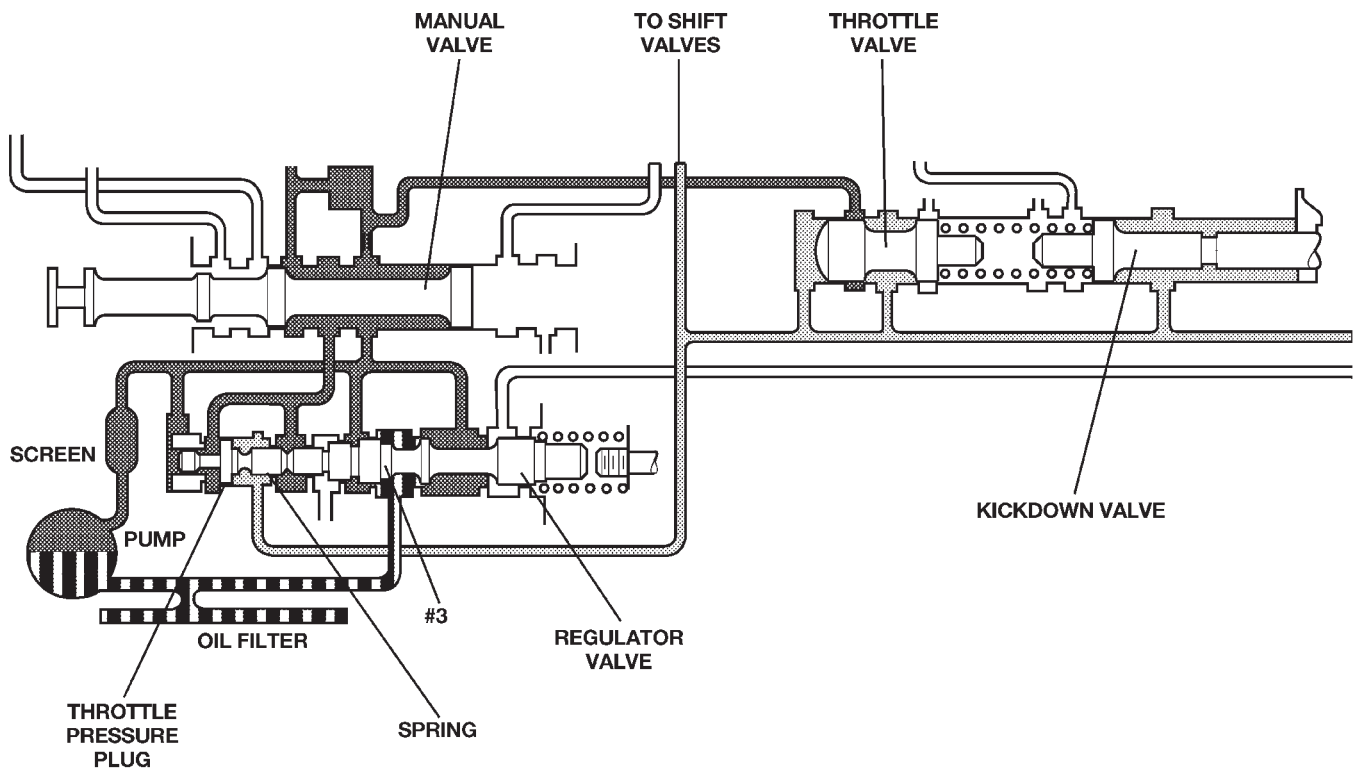

Fig. 32 Throttle Valve

80bfe263

DESCRIPTION AND OPERATION (Continued)

The higher engine speed and line pressure would open the vent too far and reduce line pressure too much. Throttle pressure, which increases with engine speed (throttle opening), is used to oppose the movement of the pressure valve to help control the metering passage at the vent. The throttle pressure is combined with spring pressure to reduce the force of the throttle pressure plug on the pressure valve. The larger spring at the right closes the regulator valve passage and maintains or increases line pressure. The increased line pressure works against the reaction area of the line pressure plug and the reaction area left of land #3 simultaneously moves the regulator valve train to the right and controls the metering passage.

The kickdown valve, along with the throttle valve, serve to delay upshifts until the correct vehicle and engine speed have been reached. It also controls downshifts upon driver demand, or increased engine load. If these valves were not in place, the shift points would be at the same speed for all throttle positions. The kickdown valve is actuated by a cam connected to the throttle. This is accomplished through either a linkage or a cable. The cam forces the kickdown valve toward the throttle valve compressing the spring between them and moving the throttle valve. As the throttle valve land starts to uncover its port, line pressure is "metered" out into the circuits and viewed as throttle pressure. This increased throttle pressure is metered out into the circuits it is applied to: the 1-2 and 2-3 shift valves. When the throttle pressure is high enough, a 3-2 downshift will occur. If the vehicle speed is low enough, a 2-1 downshift will occur.

SWITCH VALVE

When the transmission is in Drive Second just before the TCC application occurs (Fig. 33), the pressure regulator valve is supplying torque converter

pressure to the switch valve. The switch valve directs this pressure through the transmission input shaft, into the converter, through the converter, back out between the input shaft and the reaction shaft, and back up to the switch valve. From the switch valve, the fluid pressure is directed to the transmission cooler, and lubrication pressure returns from the cooler to lubricate different portions of the transmission.

Once the TCC control valve has moved to the left (Fig. 34), line pressure is directed to the fail-safe valve, and then to the tip of the switch valve, forcing the valve downward. The switch valve now vents oil from the front of the piston in the torque converter, and supplies line pressure to the (rear) apply side of the torque converter piston. This pressure differential causes the piston to apply against the friction material, cutting off any further flow of line pressure oil. After the switch valve is shuttled downward allowing line pressure to engage the TCC, torque converter pressure is directed past the switch valve into the transmission cooler and lubrication circuits.

CONVERTER CLUTCH CONTROL VALVE

The torque converter clutch (TCC) control valve controls the back (ON) side of the torque converter clutch. When the PCM energizes the TCC solenoid to engage the converter clutch piston, pressure is applied to the TCC control valve which moves to the left and applies pressure to the fail-safe valve.

FAIL-SAFE VALVE

The pressure coming from the TCC control valve dead-ends at the fail-safe valve until governor pressure on the right side of the valve increases. The pressure must be high enough to overcome the throttle and spring pressure on the left side of the valve and push the valve to the left. The pressure will then flow to the switch valve.

DESCRIPTION AND OPERATION (Continued)

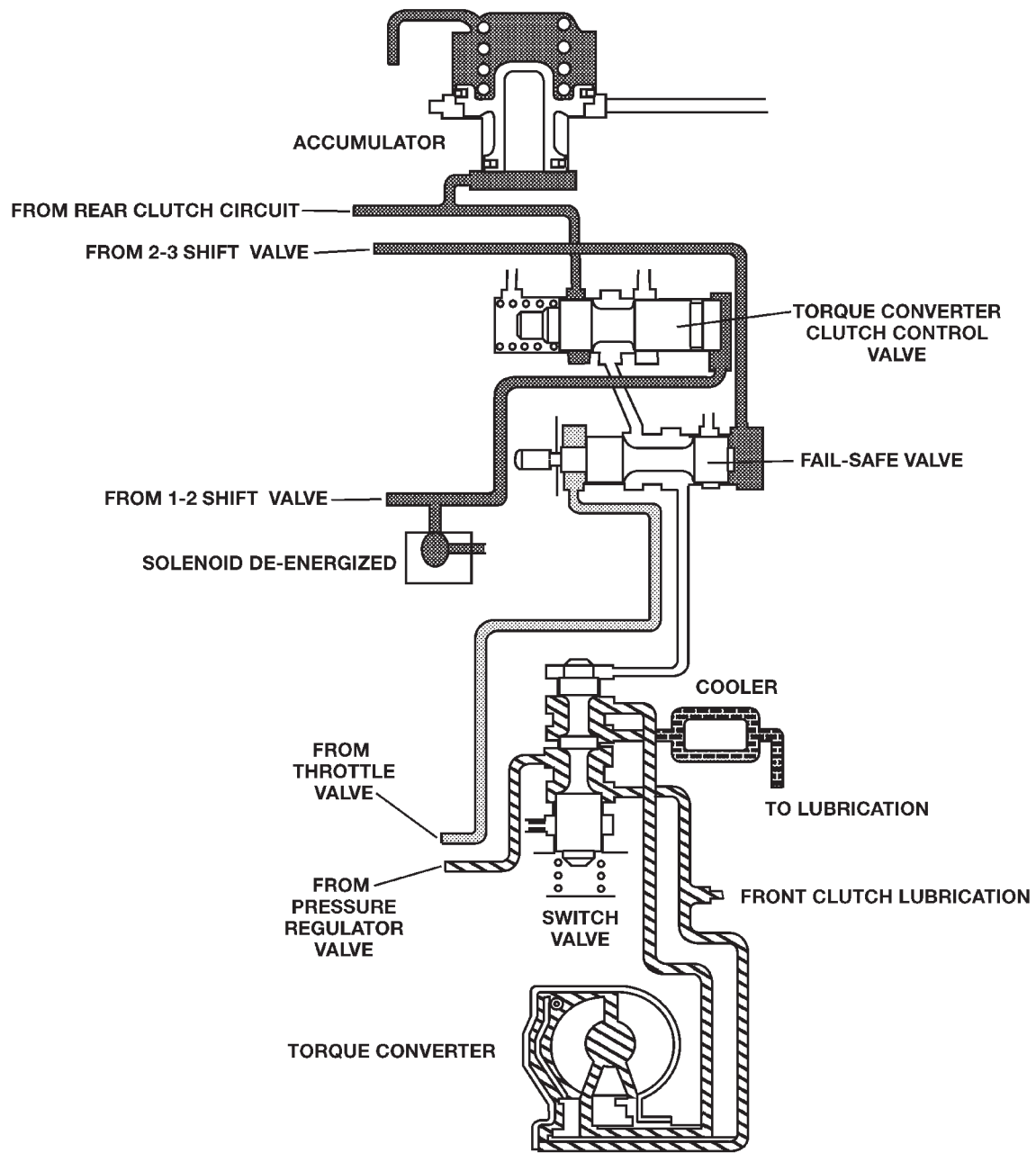

80bfe264

Fig. 33 Switch Valve-Torque Converter Unlocked

DESCRIPTION AND OPERATION (Continued)

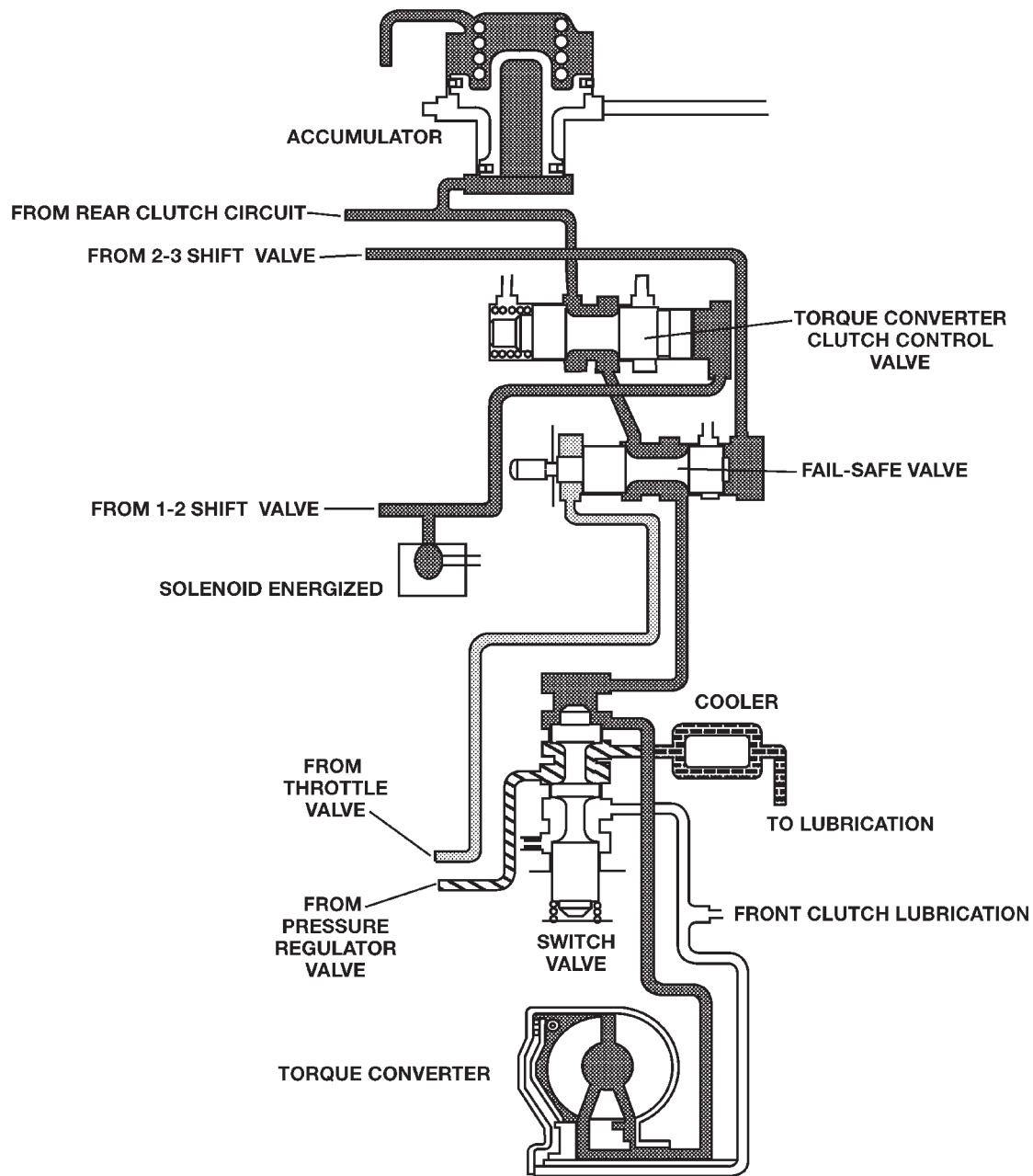

80bfe265

Fig. 34 Switch Valve-Torque Converter Locked

DESCRIPTION AND OPERATION (Continued)

MANUAL VALVE

The manual valve (Fig. 35) is a relay valve. The purpose of the manual valve is to direct fluid to the correct circuit needed for a specific gear or driving range. The manual valve, as the name implies, is manually operated by the driver with a lever located on the side of the valve body. The valve is connected mechanically by either a cable or linkage to the gear-shift mechanism. The valve is held in each of its positions by a spring-loaded roller or ball that engages the “roostercomb” of the manual valve.

ACCUMULATOR

DESCRIPTION

The accumulator (Fig. 36) is a hydraulic device that has the sole purpose of cushioning the application of a band or clutch. The accumulator consists of a dual-land piston and a spring located in a bore in the transmission case.

OPERATION

Line pressure is directed between the lands of the piston (Fig. 37), bottoming it against the accumulator plate. The accumulator stays in this position after the transmission is placed into a Drive position. When the 1-2 upshift occurs (Fig. 38), line pressure

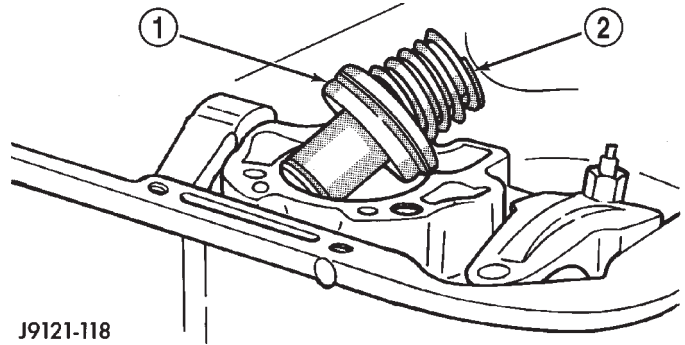

J9121-118

Fig. 36 Accumulator

- 1 - ACCUMULATOR PISTON
- 2 - PISTON SPRING

is directed to the large end of the piston and then to the kickdown servo. As the line pressure reaches the accumulator, the combination of spring pressure and line pressure forces the piston away from the accumulator plate. This causes a balanced pressure situation, which results in a cushioned band application. After the kickdown servo has become immovable, line pressure will finish pushing the accumulator up into its bore. When the large end of the accumulator piston is seated in its bore, the band or clutch is fully applied.

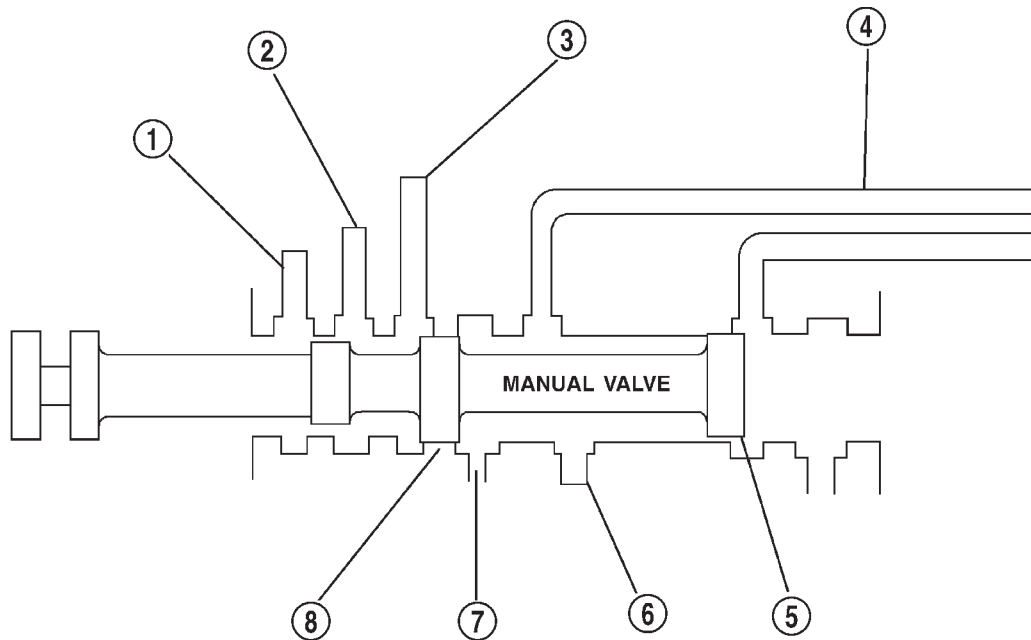
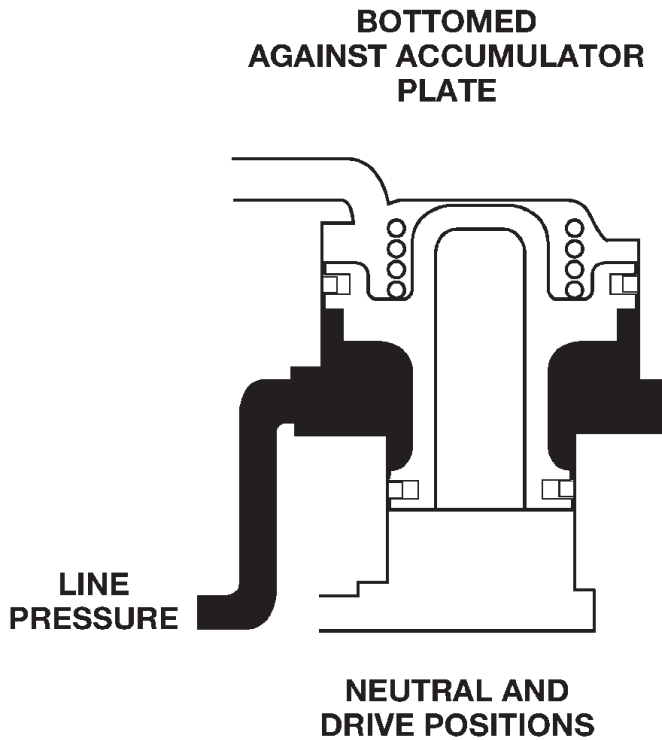

Fig. 35 Manual Valve

- 1 - 1-2 GOVERNOR PLUG
- 2 - 2-3 GOVERNOR PLUG
- 3 - GOVERNOR REAR CLUTCH ACCUMULATOR
- 4 - THROTTLE VALVE
- 5 - LAND #1
- 6 - PUMP
- 7 - PRESSURE REGULATOR
- 8 - LAND #2

DESCRIPTION AND OPERATION (Continued)

NOTE: The accumulator is shown in the inverted position for illustrative purposes.



80bfe270

Fig. 37 Accumulator in Neutral and Drive Positions

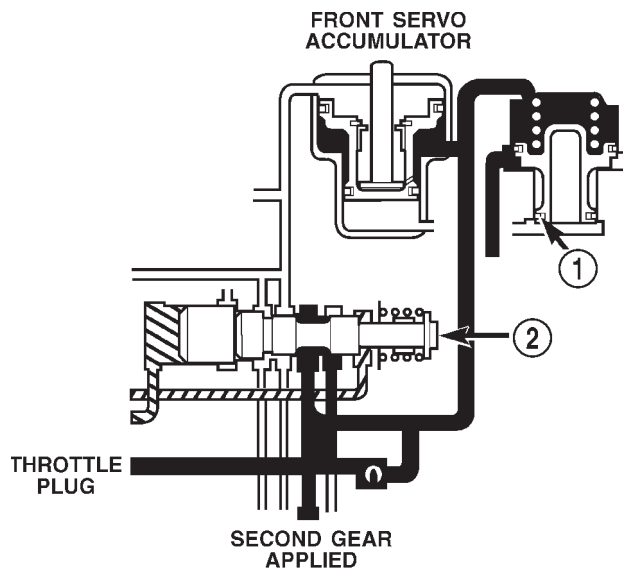

80bfe271

Fig. 38 Accumulator in Second Gear Position

- 1 - BOTTOM IN BORE
- 2 - SHUTTLE VALVE

PISTONS

DESCRIPTION

There are several sizes and types of pistons used in an automatic transmission. Some pistons are used to apply clutches, while others are used to apply bands. They all have in common the fact that they are round or circular in shape, located within a smooth walled cylinder, which is closed at one end and converts fluid pressure into mechanical movement. The fluid pressure exerted on the piston is contained within the system through the use of piston rings or seals.

OPERATION

The principal which makes this operation possible is known as Pascal's Law. Pascal's Law can be stated as: "Pressure on a confined fluid is transmitted equally in all directions and acts with equal force on equal areas."

PRESSURE

Pressure (Fig. 39) is nothing more than force (lbs.) divided by area (in or ft.), or force per unit area. Given a 100 lb. block and an area of 100 sq. in. on the floor, the pressure exerted by the block is: 100 lbs. 100 in or 1 pound per square inch, or PSI as it is commonly referred to.

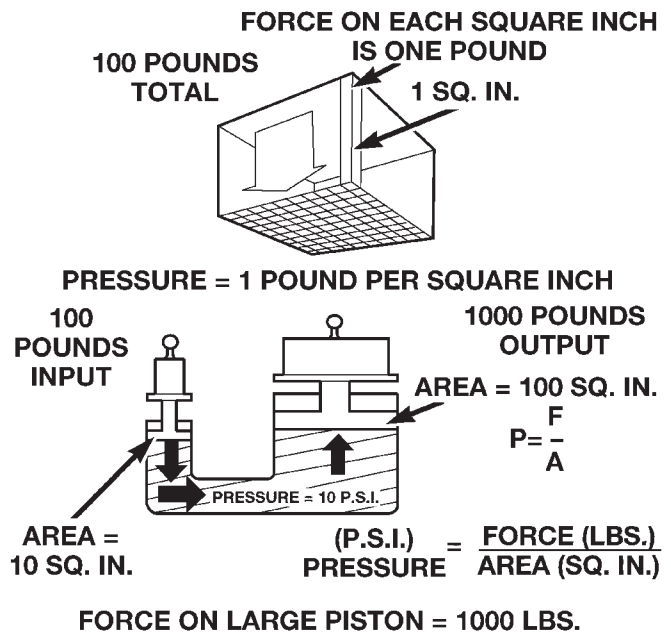

80bfe272

Fig. 39 Force and Pressure Relationship

PRESSURE ON A CONFINED FLUID

Pressure is exerted on a confined fluid (Fig. 40) by applying a force to some given area in contact with the fluid. A good example of this is a cylinder filled with fluid and equipped with a piston that is closely fitted to the cylinder wall. If a force is applied to the piston, pressure will be developed in the fluid. Of course, no

DESCRIPTION AND OPERATION (Continued)

pressure will be created if the fluid is not confined. It will simply “leak” past the piston. There must be a resistance to flow in order to create pressure. Piston sealing is extremely important in hydraulic operation. Several kinds of seals are used to accomplish this within a transmission. These include but are not limited to O-rings, D-rings, lip seals, sealing rings, or extremely close tolerances between the piston and the cylinder wall. The force exerted is downward (gravity), however, the principle remains the same no matter which direction is taken. The pressure created in the fluid is equal to the force applied, divided by the piston area. If the force is 100 lbs., and the piston area is 10 sq. in., then the pressure created equals 10 PSI. Another interpretation of Pascal’s Law is that regardless of container shape or size, the pressure will be maintained throughout, as long as the fluid is confined. In other words, the pressure in the fluid is the same everywhere within the container.

using a difference of area to create a difference in pressure to move an object.

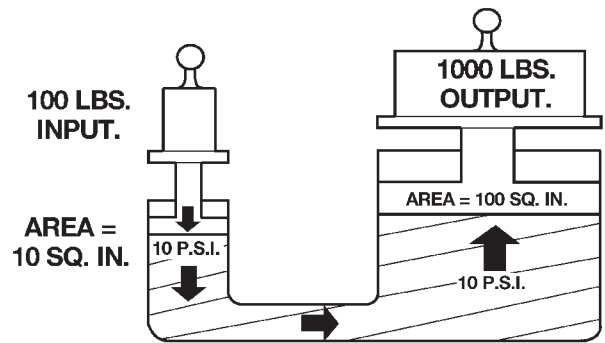

80bfe274

Fig. 41 Force Multiplication

PISTON TRAVEL

The relationship between hydraulic lever and a mechanical lever is the same. With a mechanical lever it’s a weight-to-distance output rather than a pressure-to-area output. Using the same forces and areas as in the previous example, the smaller piston (Fig. 42) has to move ten times the distance required to move the larger piston one inch. Therefore, for every inch the larger piston moves, the smaller piston moves ten inches. This principle is true in other instances also. A common garage floor jack is a good example. To raise a car weighing 2000 lbs., an effort of only 100 lbs. may be required. For every inch the car moves upward, the input piston at the jack handle must move 20 inches downward.

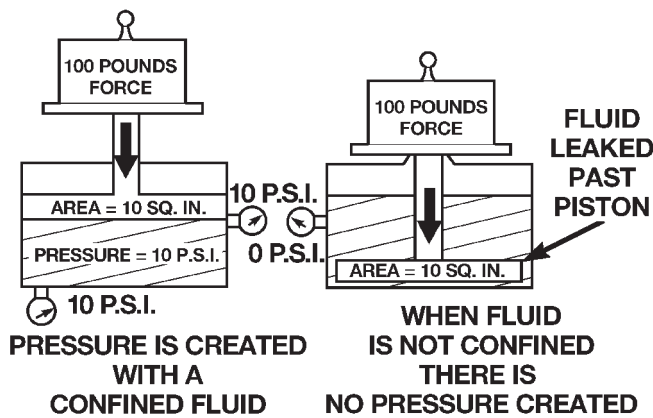

80bfe273

Fig. 40 Pressure on a Confined Fluid

FORCE MULTIPLICATION

Using the 10 PSI example used in the illustration (Fig. 41), a force of 1000 lbs. can be moved with a force of only 100 lbs. The secret of force multiplication in hydraulic systems is the total fluid contact area employed. The illustration, (Fig. 41), shows an area that is ten times larger than the original area. The pressure created with the smaller 100 lb. input is 10 PSI. The concept “pressure is the same everywhere” means that the pressure underneath the larger piston is also 10 PSI. Pressure is equal to the force applied divided by the contact area. Therefore, by means of simple algebra, the output force may be found. This concept is extremely important, as it is also used in the design and operation of all shift valves and limiting valves in the valve body, as well as the pistons, of the transmission, which activate the clutches and bands. It is nothing more than

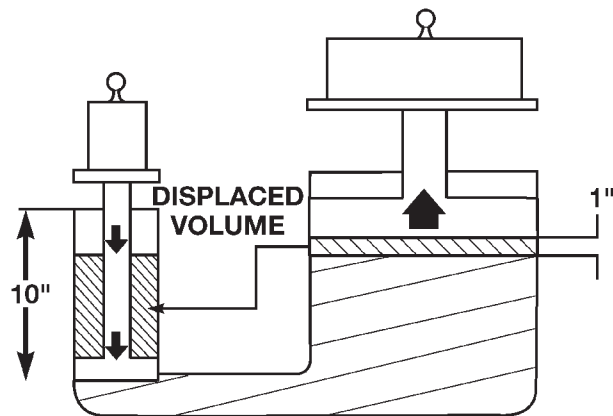

80bfe275

Fig. 42 Piston Travel

DESCRIPTION AND OPERATION (Continued)

FRONT CLUTCH

DESCRIPTION

The front clutch assembly (Fig. 43) is composed of the front clutch retainer, pressure plate, four clutch plates, four driving discs, piston, piston return spring, return spring retainer, and snap rings. The front clutch is the forwardmost component in the transmission geartrain and is directly behind the oil pump and is considered a driving component.

NOTE: The number of discs and plates may vary with each engine and vehicle combination.

OPERATION

To apply the clutch, pressure is applied between the clutch retainer and piston. The fluid pressure is provided by the oil pump, transferred through the control valves and passageways, and enters the clutch through the hub of the reaction shaft support.

With pressure applied between the clutch retainer and piston, the piston moves away from the clutch retainer and compresses the clutch pack. This action applies the clutch pack, allowing torque to flow through the input shaft into the driving discs, and into the clutch plates and pressure plate that are lugged to the clutch retainer. The waved snap ring is used to cushion the application of the clutch pack. In some transmissions, the snap ring is selective and used to adjust clutch pack clearance.

When pressure is released from the piston, the spring returns the piston to its fully released position and disengages the clutch. The release spring also helps to cushion the application of the clutch assembly. When the clutch is in the process of being released by the release spring, fluid flows through a vent and one-way ball-check-valve located in the clutch retainer. The check-valve is needed to eliminate the possibility of plate drag caused by centrifugal force acting on the residual fluid trapped in the clutch piston retainer.

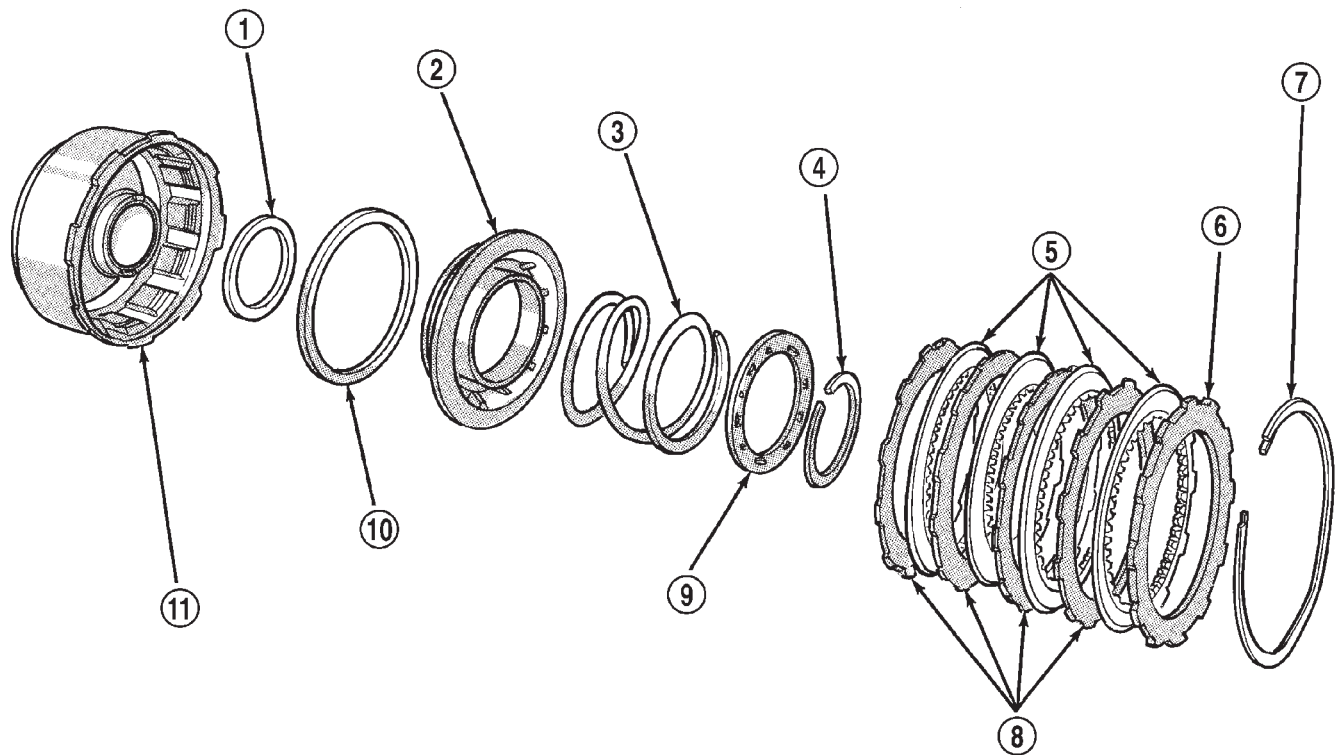

J9321-222

Fig. 43 Front Clutch

- | | |
|-------------------------------|----------------------------|
| 1 - RETAINER HUB SEAL | 7 - SNAP RING (WAVED) |
| 2 - CLUTCH PISTON | 8 - CLUTCH PLATES |
| 3 - PISTON SPRING | 9 - SPRING RETAINER |
| 4 - SPRING RETAINER SNAP RING | 10 - PISTON SEAL |
| 5 - CLUTCH DISCS | 11 - FRONT CLUTCH RETAINER |
| 6 - PRESSURE PLATE | |

DESCRIPTION AND OPERATION (Continued)

REAR CLUTCH

DESCRIPTION

The rear clutch assembly (Fig. 44) is composed of the rear clutch retainer, pressure plate, three clutch plates, four driving discs, piston, Belleville spring, and snap rings. The Belleville spring acts as a lever to multiply the force applied on to it by the apply piston. The increased apply force on the rear clutch pack, in comparison to the front clutch pack, is needed to hold against the greater torque load imposed onto the rear pack. The rear clutch is directly behind the front clutch and is considered a driving component.

NOTE: The number of discs and plates may vary with each engine and vehicle combination.

OPERATION

To apply the clutch, pressure is applied between the clutch retainer and piston. The fluid pressure is provided by the oil pump, transferred through the control valves and passageways, and enters the clutch through the hub of the reaction shaft support. With pressure applied between the clutch retainer and piston, the piston moves away from the clutch retainer and compresses the clutch pack. This action applies the clutch pack, allowing torque to flow through the input shaft into the driving discs, and into the clutch plates and pressure plate that are lugged to the clutch retainer. The waved snap ring is used to cushion the application of the clutch pack. In some transmissions, the snap ring is selective and used to adjust clutch pack clearance.

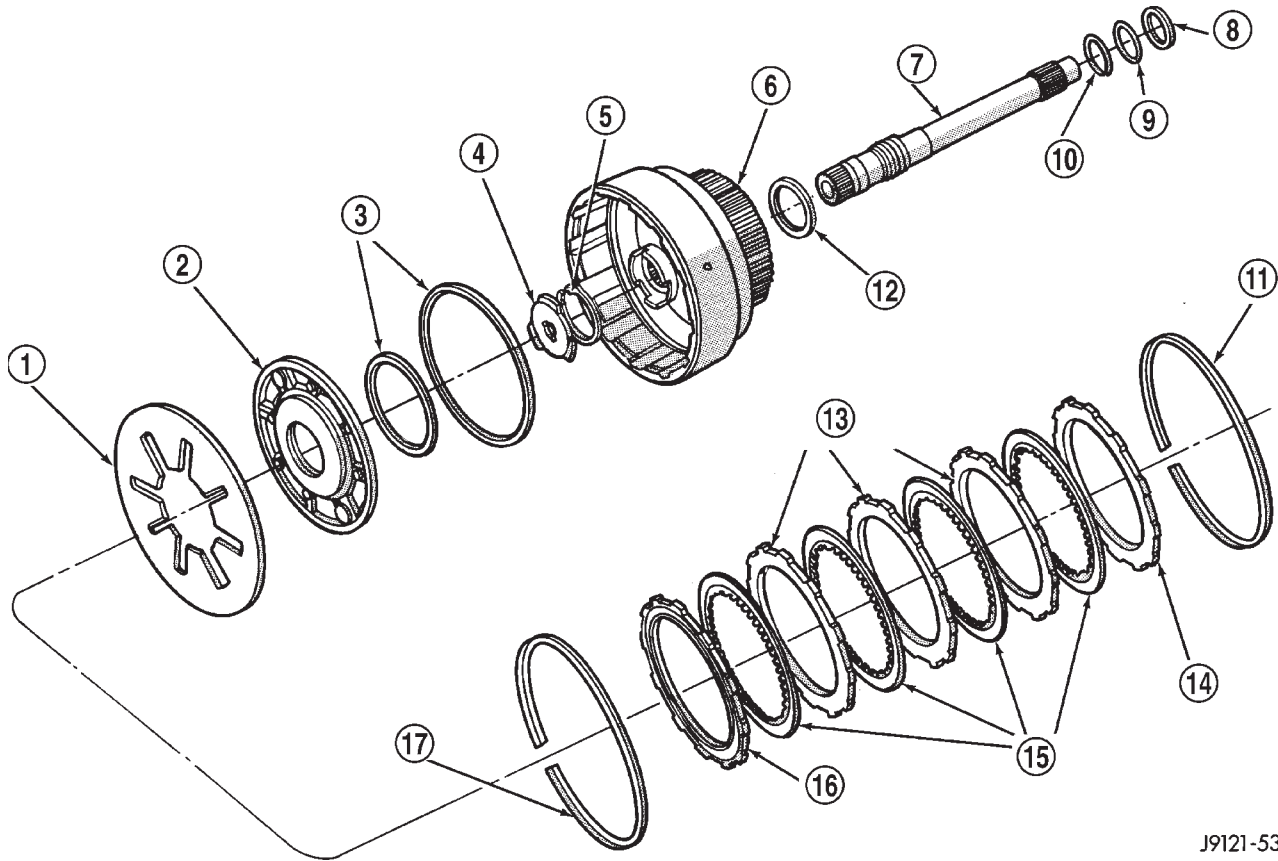

J9121-539

Fig. 44 Rear Clutch

- | | |
|--|--|
| 1 - PISTON SPRING | 10 - SHAFT REAR SEAL RING (METAL) |
| 2 - REAR CLUTCH PISTON | 11 - CLUTCH PACK SNAP RING (SELECTIVE) |
| 3 - CLUTCH PISTON SEALS | 12 - RETAINER SEAL RING |
| 4 - OUTPUT SHAFT THRUST WASHER (METAL) | 13 - CLUTCH PLATES (3) |
| 5 - INPUT SHAFT SNAP RING | 14 - TOP PRESSURE PLATE |
| 6 - REAR CLUTCH RETAINER | 15 - CLUTCH DISCS (4) |
| 7 - INPUT SHAFT | 16 - BOTTOM PRESSURE PLATE |
| 8 - REAR CLUTCH THRUST WASHER (FIBER) | 17 - WAVE SPRING |
| 9 - SHAFT FRONT SEAL RING (TEFLON) | |

DESCRIPTION AND OPERATION (Continued)

When pressure is released from the piston, the spring returns the piston to its fully released position and disengages the clutch. The release spring also helps to cushion the application of the clutch assembly. When the clutch is in the process of being released by the release spring, fluid flows through a vent and one-way ball-check-valve located in the clutch retainer. The check-valve is needed to eliminate the possibility of plate drag caused by centrifugal force acting on the residual fluid trapped in the clutch piston retainer.

OVERRUNNING CLUTCH

DESCRIPTION

The overrunning clutch (Fig. 45) consists of an inner race, an outer race (or cam), rollers and springs, and the spring retainer. The number of rollers and springs depends on what transmission and which overrunning clutch is being dealt with.

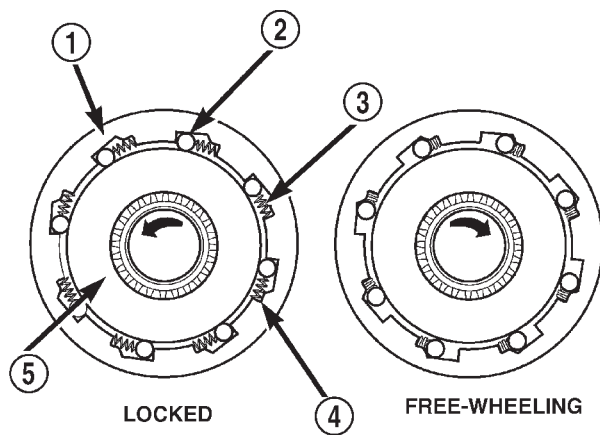

Fig. 45 Overrunning Clutch

- 1 - OUTER RACE (CAM)
- 2 - ROLLER
- 3 - SPRING
- 4 - SPRING RETAINER
- 5 - INNER RACE (HUB)

OPERATION

As the inner race is rotated in a clockwise direction (as viewed from the front of the transmission), the race causes the rollers to roll toward the springs, causing them to compress against their retainer. The compression of the springs increases the clearance between the rollers and cam. This increased clearance between the rollers and cam results in a free-wheeling condition. When the inner race attempts to rotate counterclockwise, the action causes the rollers to roll in the same direction as the race, aided by the pushing of the springs. As the rollers try to move in the same direction as the inner race, they are

wedged between the inner and outer races due to the design of the cam. In this condition, the clutch is locked and acts as one unit.

PLANETARY GEARSET

DESCRIPTION

The planetary gearsets (Fig. 46) are designated as the front and rear planetary gear assemblies and located in such order. A simple planetary gearset consists of three main members:

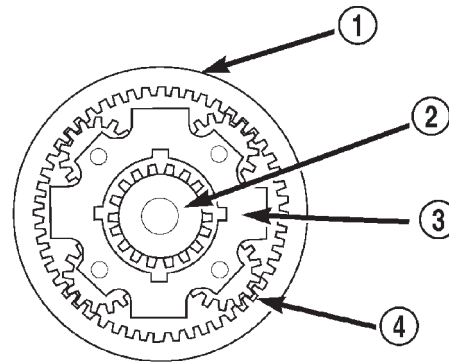

80be45f9

Fig. 46 Planetary Gearset

- 1 - ANNULUS GEAR
- 2 - SUN GEAR
- 3 - PLANET CARRIER
- 4 - PLANET PINIONS (4)

- The sun gear which is at the center of the system.
- The planet carrier with planet pinion gears which are free to rotate on their own shafts and are in mesh with the sun gear.
- The annulus gear, which rotates around and is in mesh with the planet pinion gears.

NOTE: The number of pinion gears does not affect the gear ratio, only the duty rating.

OPERATION

With any given planetary gearset, several conditions must be met for power to be able to flow:

- One member must be held.
- Another member must be driven or used as an input.
- The third member may be used as an output for power flow.
- For direct drive to occur, two gear members in the front planetary gearset must be driven.

NOTE: Gear ratios are dependent on the number of teeth on the annulus and sun gears.

DESCRIPTION AND OPERATION (Continued)

BANDS

DESCRIPTION

KICKDOWN (FRONT) BAND

The kickdown, or “front”, band (Fig. 47) holds the common sun gear of the planetary gear sets. The front (kickdown) band is made of steel, and faced on its inner circumference with a friction-type lining. One end of the band is anchored to the transmission case, and the other is acted on with a pushing force by a servo piston. The front band is a single-wrap design (the band does not completely encompass/wrap the drum that it holds).

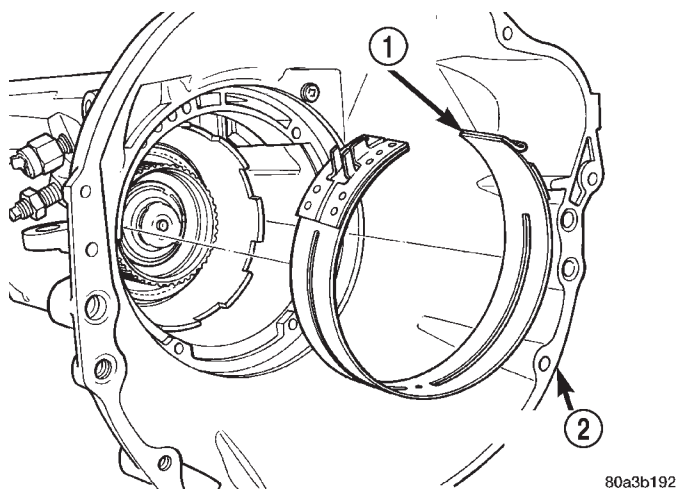

Fig. 47 Front Band

- 1 - FRONT BAND
- 2 - TRANSMISSION HOUSING

LOW/REVERSE (REAR) BAND

The low/reverse band, or “rear”, band (Fig. 48) is similar in appearance and operation to the front band. The rear band of the 32RH is slightly different in that it does not use a link bar, but is acted directly on by the apply lever. This is referred to as a double-wrap band design (the drum is completely encompassed/wrapped by the band). The double-wrap band provides a greater holding power in comparison to the single-wrap design.

OPERATION

KICKDOWN (FRONT) BAND

The kickdown band holds the common sun gear of the planetary gear sets by applying and holding the front clutch retainer, which is splined to the sun gear driving shell, and in turn splined directly to the sun gear. The application of the band by the servo is typically done by an apply lever and link bar.

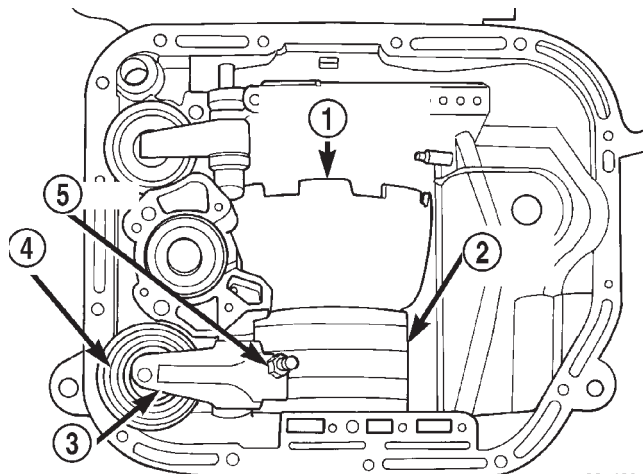

Fig. 48 Rear Band

- 1 - PLANETARY GEARTRAIN
- 2 - REAR BAND
- 3 - LEVER
- 4 - SERVO
- 5 - ADJUSTER

LOW/REVERSE (REAR) BAND

The rear band holds the rear planet carrier stationary by being mounted around and applied to the low/reverse drum.

SERVOS

DESCRIPTION

KICKDOWN (FRONT) SERVO

The kickdown servo (Fig. 49) consists of a two-land piston with an inner piston, a piston rod and guide, and a return spring. The dual-land piston uses seal rings on its outer diameters and an O-ring for the inner piston.

LOW/REVERSE (REAR) SERVO

The rear (low/reverse) servo consists of a single stage or diameter piston and a spring loaded plug. The spring is used to cushion the application of the rear (low/reverse) band.

OPERATION

KICKDOWN (FRONT) SERVO

The application of the piston is accomplished by applying pressure between the two lands of the piston. The pressure acts against the larger lower land to push the piston downward, allowing the piston rod to extend though its guide against the apply lever. Release of the servo at the 2-3 upshift is accomplished by a combination of spring and line pressure, acting on the bottom of the larger land of the piston.

DESCRIPTION AND OPERATION (Continued)

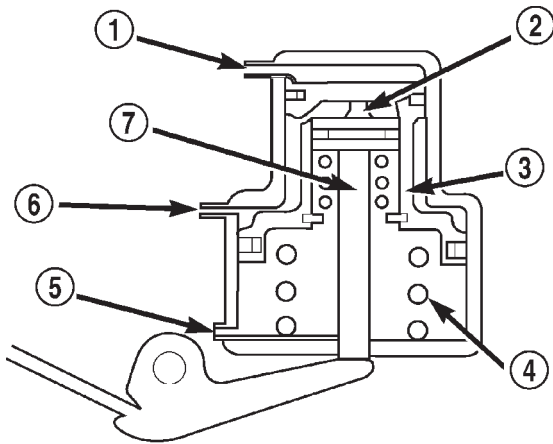
**Fig. 49 Front Servo**

80be45fa

- 1 - VENT
- 2 - INNER PISTON
- 3 - PISTON
- 4 - SPRING
- 5 - RELEASE PRESSURE
- 6 - APPLY PRESSURE
- 7 - PISTON ROD

The small piston is used to cushion the application of the band by bleeding oil through a small orifice in the larger piston. The release timing of the kickdown servo is very important to obtain a smooth but firm shift. The release has to be very quick, just as the front clutch application is taking place. Otherwise, engine runaway or a shift hesitation will occur. To accomplish this, the band retains its holding capacity until the front clutch is applied, giving a small amount of overlap between them.

LOW/REVERSE (REAR) SERVO

While in the de-energized state (no pressure applied), the piston is held up in its bore by the piston spring. The plug is held down in its bore, in the piston, by the plug spring. When pressure is applied to the top of the piston, the plug is forced down in its bore, taking up any clearance. As the piston moves, it causes the plug spring to compress, and the piston moves down over the plug. The piston continues to move down until it hits the shoulder of the plug and fully applies the band. The period of time from the initial application, until the piston is against the shoulder of the plug, represents a reduced shocking of the band that cushions the shift.

GOVERNOR**DESCRIPTION**

The governor (Fig. 50) valve body is attached to the output shaft of the transmission.

OPERATION

The governor meters hydraulic pressure (Fig. 51), and this metered pressure is used to signal the transmission when it is time for a shift to occur. It does this by balancing governor pressure on one side of a shift valve, and throttle pressure on the other. When governor pressure increases far enough to overcome the throttle pressure on the valve, a shift occurs.

With the gearshift selector in a forward driving range, line pressure flows from the manual valve and down to the governor valve. When the output shaft starts to rotate with vehicle motion (Fig. 52), the governor weight assembly will start to move outward due to centrifugal force. As the weight is moved outward, it will pull the valve with it until the land of the valve uncovers the line pressure port. As the port begins to become uncovered, governor pressure is metered. As the vehicle's speed continues to increase (Fig. 53), the weight assembly will be at a point at which governor pressure is acting on the left side of the reaction area of the valve. This produces sufficient force to compress the spring and allow the outer weight to move out against the outer governor body retaining ring. At a very high speed, the governor valve will be opened as far as possible. In this condition, it is possible for governor pressure to meet, but not to exceed, line pressure. Generally governor pressure ranges from 0–100 psi from idle to maximum speed, and rises proportionally with the increase in output shaft speed. Governor pressure and throttle pressure are acting upon the shift valves to determine when a shift will occur. Governor pressure is a direct indication of road speed, and throttle pressure is an indication of engine load. When both parameters have been met by the throttle and governor pressures, an upshift or downshift will occur.

GEARSHIFT MECHANISM**DESCRIPTION**

The shift mechanism is cable operated and provides six shift positions. The shift indicator is located on the console next to the gear shift. The shift positions are:

- Park (P)
- Reverse (R)
- Neutral (N)
- Drive (D)
- Manual Second (2)
- Manual Low (1)

OPERATION

Manual low (1) range provides first gear only. Over run braking is also provided in this range. Manual second (2) range provides first and second gear only.

DESCRIPTION AND OPERATION (Continued)

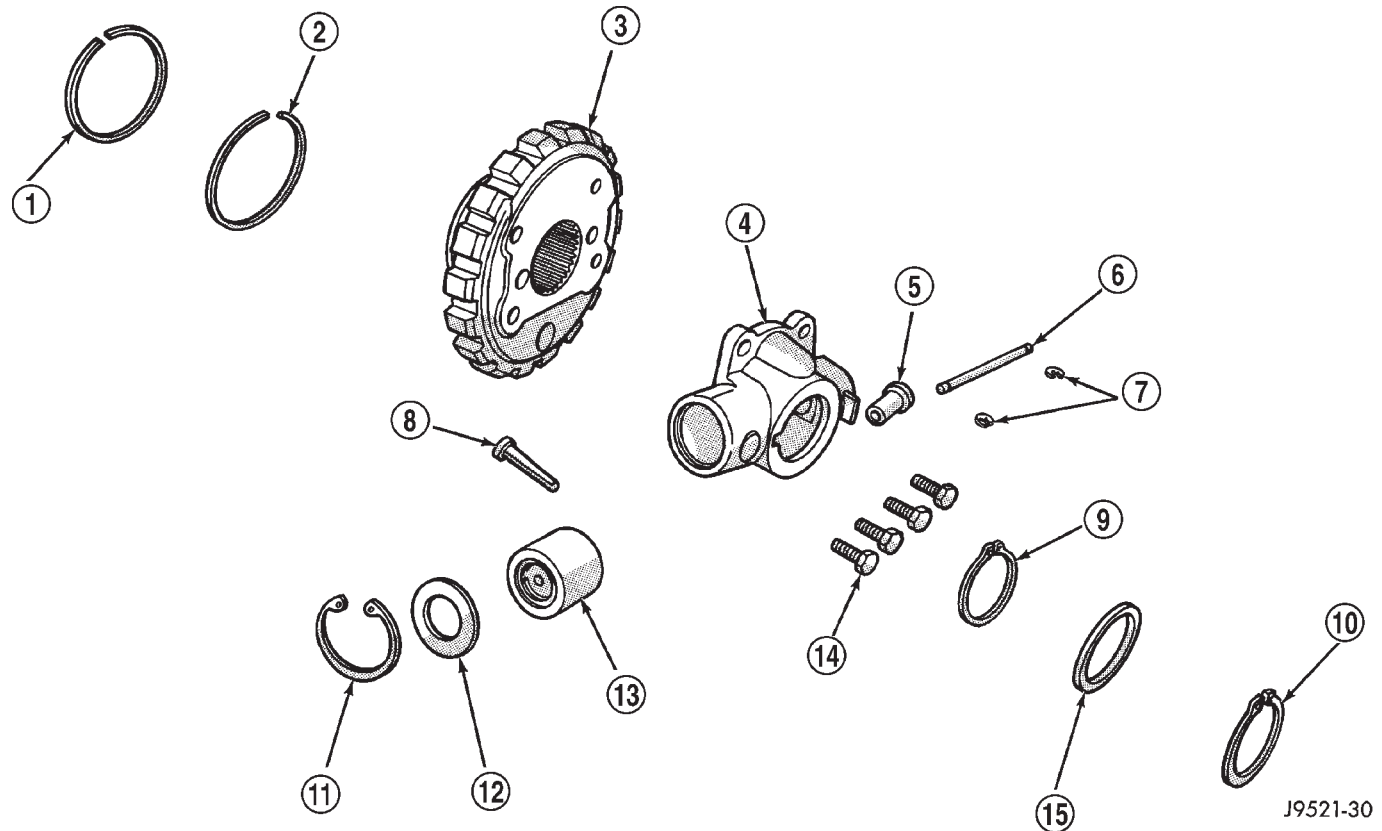

Fig. 50 Governor

- 1 - SEAL RING (PLAIN END)
- 2 - SEAL RING (HOOK END)
- 3 - PARK GEAR
- 4 - GOVERNOR BODY
- 5 - GOVERNOR VALVE
- 6 - VALVE SHAFT
- 7 - E-CLIPS (2)
- 8 - FILTER

- 9 - SNAP RING (THIN)
- 10 - SNAP RING (THICK)
- 11 - SNAP RING
- 12 - RETAINER WASHER
- 13 - GOVERNOR WEIGHT ASSEMBLY
- 14 - GOVERNOR BODY BOLTS (4)
- 15 - WASHER

Drive range provides first, second, and third gear ranges.

CONVERTER DRAINBACK VALVE

DESCRIPTION

The drainback valve is located in the transmission cooler outlet (pressure) line.

OPERATION

The valve prevents fluid from draining from the converter into the cooler and lines when the vehicle is shut down for lengthy periods. Production valves have a hose nipple at one end, while the opposite end is threaded for a flare fitting. All valves have an arrow (or similar mark) to indicate direction of flow through the valve.

BRAKE TRANSMISSION SHIFT INTERLOCK MECHANISM

DESCRIPTION

The Brake Transmission Shifter/Ignition Interlock (BTISI), is a cable and solenoid operated system. It interconnects the automatic transmission floor mounted shifter to the steering column ignition switch (Fig. 54).

OPERATION

The system locks the shifter into the PARK position. The Interlock system is engaged whenever the ignition switch is in the LOCK or ACCESSORY position. An additional electrically activated feature will prevent shifting out of the PARK position unless the brake pedal is depressed at least one-half an inch. A magnetic holding device in line with the park/brake interlock cable is energized when the ignition is in

DESCRIPTION AND OPERATION (Continued)

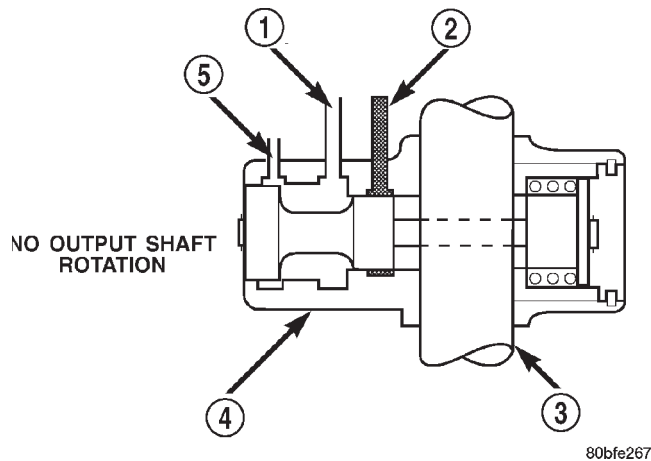

Fig. 51 Governor—No Output Shaft Rotation

- 1 - GOVERNOR PRESSURE
- 2 - LINE PRESSURE
- 3 - OUTPUT SHAFT
- 4 - GOVERNOR
- 5 - VENT

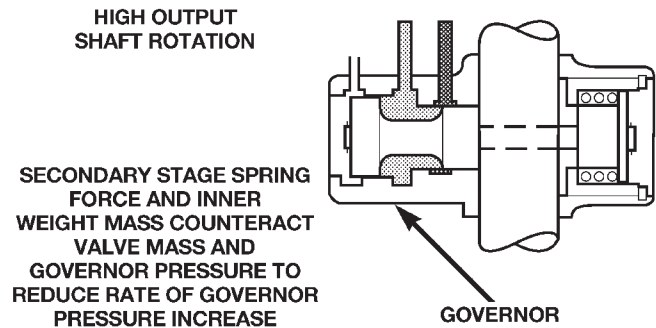

Fig. 53 Governor—High Output Shaft Rotation

functions. Begin diagnosis by checking the easily accessible items such as: fluid level and condition, linkage adjustments and electrical connections. A road test will determine if further diagnosis is necessary.

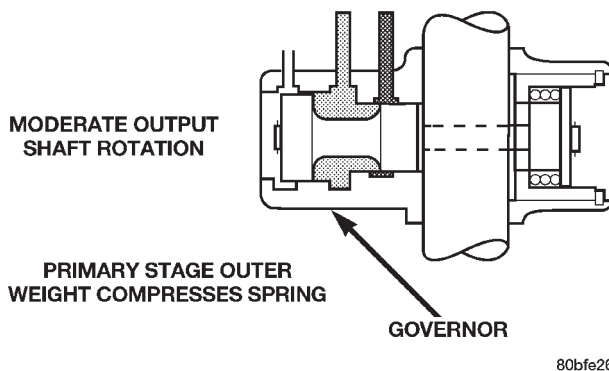

Fig. 52 Governor—Moderate Output Shaft Rotation

the RUN position. When the key is in the RUN position and the brake pedal is depressed, the shifter is unlocked and will move into any position. The interlock system also prevents the ignition switch from being turned to the LOCK or ACCESSORY position (Fig. 55) unless the shifter is fully locked into the PARK position.

DIAGNOSIS AND TESTING

AUTOMATIC TRANSMISSION DIAGNOSIS

Automatic transmission problems can be a result of poor engine performance, incorrect fluid level, incorrect linkage or cable adjustment, band or hydraulic control pressure adjustments, hydraulic system malfunctions or electrical/mechanical component mal-

EFFECTS OF INCORRECT FLUID LEVEL

A low fluid level allows the pump to take in air along with the fluid. Air in the fluid will cause fluid pressures to be low and develop slower than normal. If the transmission is overfilled, the gears churn the fluid into foam. This aerates the fluid and causing the same conditions occurring with a low level. In either case, air bubbles cause fluid overheating, oxidation and varnish buildup which interferes with valve, clutch and servo operation. Foaming also causes fluid expansion which can result in fluid overflow from the transmission vent or fill tube. Fluid overflow can easily be mistaken for a leak if inspection is not careful.

CAUSES OF BURNT FLUID

Burnt, discolored fluid is a result of overheating which has two primary causes.

(1) A result of restricted fluid flow through the main and/or auxiliary cooler. This condition is usually the result of a faulty or improperly installed drainback valve, a damaged main cooler, or severe restrictions in the coolers and lines caused by debris or kinked lines.

(2) Heavy duty operation with a vehicle not properly equipped for this type of operation. Trailer towing or similar high load operation will overheat the transmission fluid if the vehicle is improperly equipped. Such vehicles should have an auxiliary transmission fluid cooler, a heavy duty cooling system, and the engine/axle ratio combination needed to handle heavy loads.

DIAGNOSIS AND TESTING (Continued)

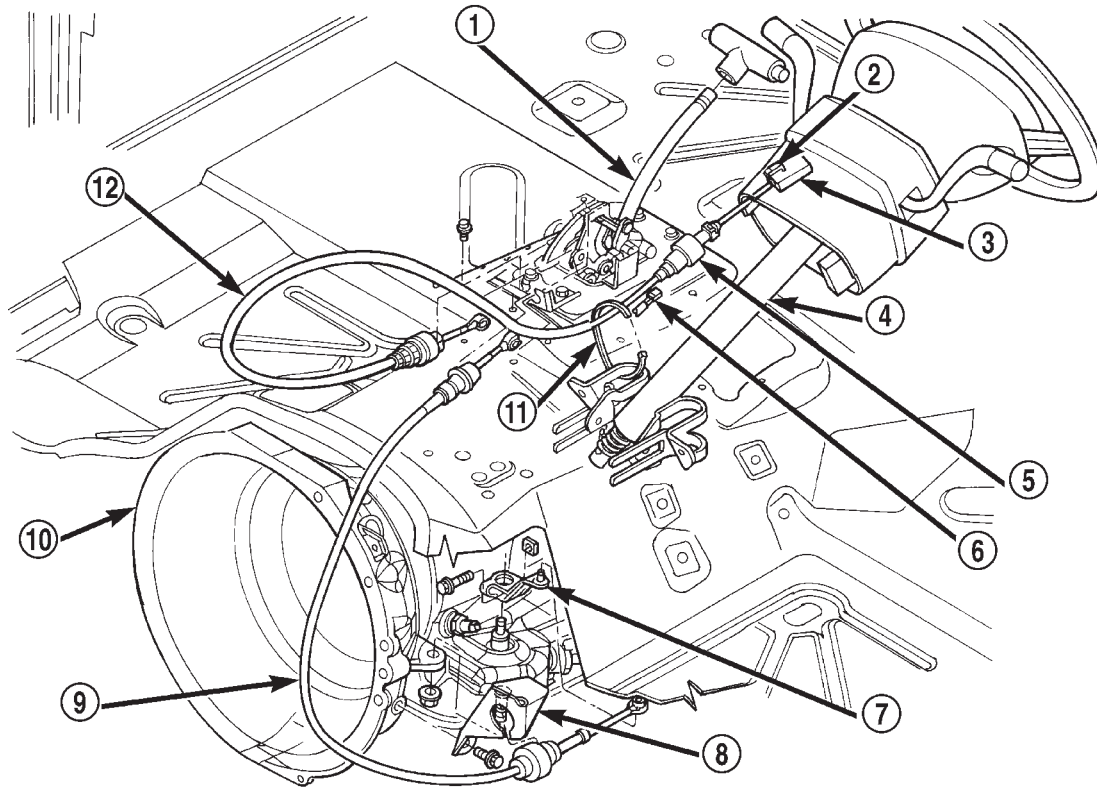

80a13876

Fig. 54 Ignition Interlock Cable Routing

- | | |
|-----------------------------|---------------------------------|
| 1 - SHIFT MECHANISM | 7 - LEVER |
| 2 - LOCK-TAB | 8 - MOUNT BRACKET |
| 3 - IGNITION LOCK INTERLOCK | 9 - SHIFT CABLE |
| 4 - STEERING COLUMN | 10 - AUTOMATIC TRANSMISSION |
| 5 - SOLENOID | 11 - TIE STRAP |
| 6 - WIRE CONNECTOR | 12 - PARK/BRAKE INTERLOCK CABLE |

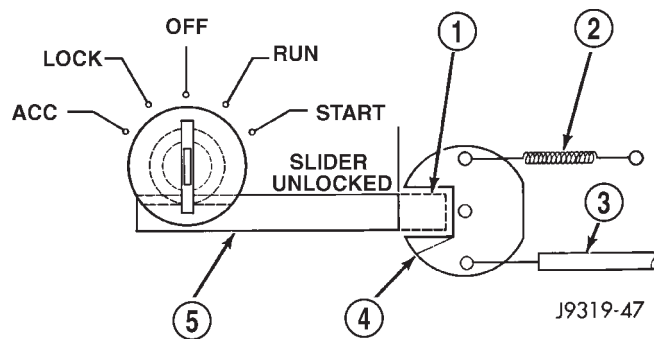

Fig. 55 Ignition Key Cylinder Actuation

- | |
|-----------------------|
| 1 - SLIDER LOCKED |
| 2 - CAM RETURN SPRING |
| 3 - INTERLOCK CABLE |
| 4 - CAM |
| 5 - SLIDER |

FLUID CONTAMINATION

Transmission fluid contamination is generally a result of:

- adding incorrect fluid
- failure to clean dipstick and fill tube when checking level
- engine coolant entering the fluid
- internal failure that generates debris
- overheat that generates sludge (fluid break-down)
- failure to reverse flush cooler and lines after repair

DIAGNOSIS AND TESTING (Continued)

- failure to replace contaminated converter after repair

The use of non recommended fluids can result in transmission failure. The usual results are erratic shifts, slippage, abnormal wear and eventual failure due to fluid breakdown and sludge formation. Avoid this condition by using recommended fluids only.

The dipstick cap and fill tube should be wiped clean before checking fluid level. Dirt, grease and other foreign material on the cap and tube could fall into the tube if not removed beforehand. Take the time to wipe the cap and tube clean before withdrawing the dipstick.

Engine coolant in the transmission fluid is generally caused by a cooler malfunction. The only remedy is to replace the radiator as the cooler in the radiator is not a serviceable part. If coolant has circulated through the transmission for some time, an overhaul may also be necessary; especially if shift problems had developed.

The transmission cooler and lines should be reverse flushed whenever a malfunction generates sludge and/or debris. The torque converter should also be replaced at the same time.

Failure to flush the cooler and lines will result in recontamination. Flushing applies to auxiliary coolers as well. The torque converter should also be replaced whenever a failure generates sludge and debris. This is necessary because normal converter flushing procedures will not remove all contaminants.

PRELIMINARY DIAGNOSIS

Two basic procedures are required. One procedure for vehicles that are drivable and an alternate procedure for disabled vehicles (will not back up or move forward).

VEHICLE IS DRIVEABLE

- (1) Check for transmission fault codes using DRB scan tool.
- (2) Check fluid level and condition.
- (3) Adjust throttle and gearshift linkage if complaint was based on delayed, erratic, or harsh shifts.
- (4) Road test and note how transmission upshifts, downshifts, and engages.
- (5) Perform stall test if complaint is based on sluggish acceleration. Or, if abnormal throttle opening is needed to maintain normal speeds with a properly tuned engine.
- (6) Perform hydraulic pressure test if shift problems were noted during road test.
- (7) Perform air-pressure test to check clutch-band operation.

VEHICLE IS DISABLED

- (1) Check fluid level and condition.
- (2) Check for broken or disconnected gearshift or throttle linkage.
- (3) Check for cracked, leaking cooler lines, or loose or missing pressure-port plugs.
- (4) Raise and support vehicle on safety stands, start engine, shift transmission into gear, and note following:
 - (a) If propeller shaft turns but wheels do not, problem is with differential or axle shafts.
 - (b) If propeller shaft does not turn and transmission is noisy, stop engine. Remove oil pan, and check for debris. If pan is clear, remove transmission and check for damaged drive plate, converter, oil pump, or input shaft.
 - (c) If propeller shaft does not turn and transmission is not noisy, perform hydraulic-pressure test to determine if problem is hydraulic or mechanical.

PARK/NEUTRAL POSITION SWITCH

The center terminal of the park/neutral position switch is the starter-circuit terminal. It provides the ground for the starter solenoid circuit through the selector lever in PARK and NEUTRAL positions only. The outer terminals on the switch are for the backup lamp circuit.

SWITCH TEST

To test the switch, remove the wiring connector. Test for continuity between the center terminal and the transmission case. Continuity should exist only when the transmission is in PARK or NEUTRAL.

Shift the transmission into REVERSE and test continuity at the switch outer terminals. Continuity should exist only when the transmission is in REVERSE. Continuity should not exist between the outer terminals and the case.

Check gearshift linkage adjustment before replacing a switch that tests faulty.

GEARSHIFT CABLE

- (1) The floor shifter lever and gate positions should be in alignment with all transmission PARK, NEUTRAL, and gear detent positions.
- (2) Engine starts must be possible with floor shift lever in PARK or NEUTRAL gate positions only. Engine starts must not be possible in any other gear position.
- (3) With floor shift lever handle push-button not depressed and lever in:
 - (a) PARK position—Apply forward force on center of handle and remove pressure. Engine starts must be possible.

DIAGNOSIS AND TESTING (Continued)

(b) PARK position—Apply rearward force on center of handle and remove pressure. Engine starts must be possible.

(c) NEUTRAL position—Normal position. Engine starts must be possible.

(d) NEUTRAL position—Engine running and brakes applied, apply forward force on center of shift handle. Transmission shall not be able to shift from neutral to reverse.

THROTTLE VALVE CABLE

Transmission throttle valve cable adjustment is extremely important to proper operation. This adjustment positions the throttle valve, which controls shift speed, quality, and part-throttle downshift sensitivity.

If cable setting is too loose, early shifts and slippage between shifts may occur. If the setting is too tight, shifts may be delayed and part throttle downshifts may be very sensitive. Refer to the Adjustments section for the proper adjustment procedure.

ROAD TESTING

Before road testing, be sure the fluid level and control cable adjustments have been checked and adjusted if necessary. Verify that diagnostic trouble codes have been resolved.

Observe engine performance during the road test. A poorly tuned engine will not allow accurate analysis of transmission operation.

Operate the transmission in all gear ranges. Check for shift variations and engine flare which indicates slippage. Note if shifts are harsh, spongy, delayed, early, or if part throttle downshifts are sensitive.

Slippage indicated by engine flare, usually means clutch, band or overrunning clutch problems. If the condition is advanced, an overhaul will be necessary to restore normal operation.

A slipping clutch or band can often be determined by comparing which internal units are applied in the various gear ranges. The Clutch and Band Application chart provides a basis for analyzing road test results.

ANALYZING ROAD TEST

Refer to the Clutch and Band Application chart and note which elements are in use in the various gear ranges.

Verify that the rear clutch is applied in all forward ranges (D, 2, 1). The transmission overrunning clutch is applied in first gear (D, 2 and 1 ranges) only. The rear band is applied in 1 and R range only.

Verify that the overdrive clutch is applied only in fourth gear and the overdrive direct clutch and overrunning clutch are applied in all ranges except fourth gear. For example: If slippage occurs in first gear in D and 2 range but not in 1 range, the transmission

| DRIVE ELEMENTS | Gearshift Lever Position | | | | | | | | |
|-----------------------|--------------------------|---|---|---|---|---|---|---|---|
| | P | R | N | D | | | 2 | | 1 |
| | | | | 1 | 2 | 3 | 1 | 2 | |
| FRONT CLUTCH | | • | | | | • | | | |
| FRONT BAND (KICKDOWN) | | | | | • | | | • | |
| REAR CLUTCH | | | | • | • | • | • | • | • |
| REAR BAND (LOW-REV.) | | • | | | | | | | • |
| OVER-RUNNING CLUTCH | | | | • | | | • | | • |

J9021-33

Fig. 56 Clutch And Band Application

overrunning clutch is faulty. Similarly, if slippage occurs in any two forward gears, the rear clutch is slipping.

Applying the same method of analysis, verify that the front and rear clutches are applied simultaneously only in D range third gear. If the transmission slips in third gear, either the front clutch or the rear clutch is slipping.

If slippage occurs during the third gear and the direct clutch were to fail, the transmission would lose both reverse gear and overrun braking in 2 position (manual second gear). If the transmission slips in any other forward gears, the transmission rear clutch is probably slipping.

This process of elimination can be used to identify a slipping unit and check operation. Proper use of the Clutch and Band Application Chart is the key.

Although road test analysis will help determine the slipping unit, the actual cause of a malfunction usually cannot be determined until hydraulic and air pressure tests are performed. Practically any condition can be caused by leaking hydraulic circuits or sticking valves.

Unless a malfunction is obvious, such as no drive in D range first gear, do not disassemble the transmission. Perform the hydraulic and air pressure tests to help determine the probable cause.

HYDRAULIC PRESSURE TEST

Hydraulic test pressures range from a low of one psi (6.895 kPa) governor pressure, to 300 psi (2068 kPa) at the rear servo pressure port in reverse.

An accurate tachometer and two test gauges are required for the pressure test. Test Gauge C-3292 has a 100 psi range and is used at the accumulator,

DIAGNOSIS AND TESTING (Continued)

governor, and front servo pressure ports. Test Gauge C-3293-SP has a 300 psi range and is used at the rear servo port and overdrive test ports where pressures are higher. In cases where two test gauges are required, the 300 psi gauge can be used at any of the other test ports.

Pressure Test Port Locations

Pressure test ports locations are provided at the accumulator, front servo, and rear servo, governor passage, and overdrive clutch pressure passage (Fig. 57), (Fig. 58) and (Fig. 59).

Line pressure is checked at the accumulator port on the right side of the case. The front servo pressure port is at the right side of the case just behind the filler tube opening.

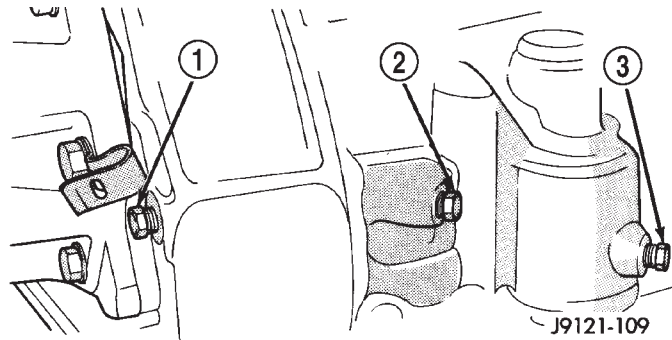

Fig. 57 Pressure Test Ports At Side Of Case

- 1 - REAR SERVO PORT
- 2 - LINE PRESSURE PORT
- 3 - FRONT SERVO PORT

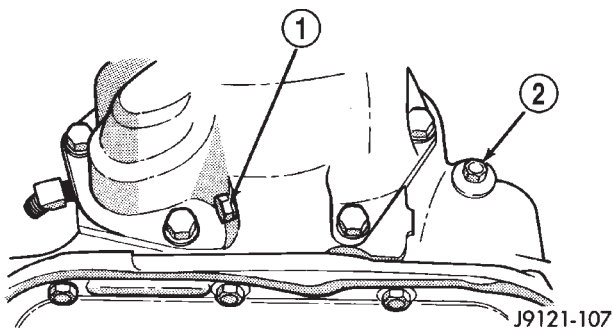

Fig. 58 Pressure Test Ports At Rear Of Case—2WD

- 1 - GOVERNOR PRESSURE PORT
- 2 - REAR SERVO PRESSURE PORT

Connect a tachometer to the engine. Position the tachometer so it can be observed from under the vehicle. Raise the vehicle on a hoist that will allow the wheels to rotate freely.

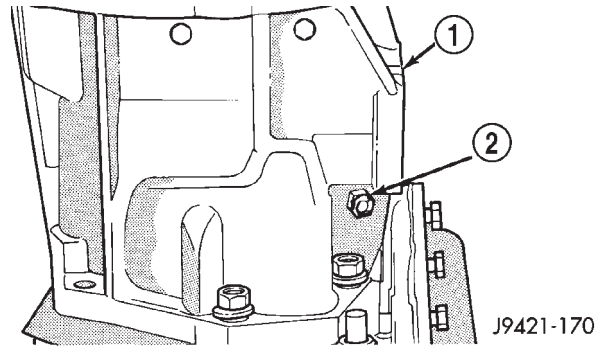

Fig. 59 Pressure Test Ports At Rear Of Case—4WD

- 1 - ADAPTER HOUSING
- 2 - GOVERNOR PRESSURE PORT PLUG

PRESSURE TEST PROCEDURE

Test One - Transmission In 1 Range

This test checks pump output, pressure regulation, and condition of the rear clutch and servo circuit. Test Gauges C-3292 and C-3293-SP are required for this test. Gauge C-3292 has a 100 psi range. Gauge C-3293-SP has a 300 psi range.

- (1) Connect 100 psi Gauge C-3292 to accumulator port.
- (2) Connect 300 psi Gauge C-3293-SP to rear servo port (Fig. 57) and (Fig. 58).
- (3) Disconnect throttle and gearshift rods from manual and throttle levers.
- (4) Start and run engine at 1000 rpm.
- (5) Move shift lever (on manual lever shaft) all the way forward into 1 range.
- (6) Move transmission throttle lever from full forward to full rearward position and note pressures on both gauges.
- (7) Line pressure at accumulator port should be 54-60 psi (372-414 kPa) with throttle lever forward and gradually increase to 90-96 psi (621-662 kPa) as lever is moved rearward.
- (8) Rear servo pressure should be same as line pressure within 3 psi (20.68 kPa).

Test Two - Transmission In 2 Range

This test checks pump output and pressure regulation. Use 100 psi Test Gauge C-3292 for this test.

- (1) Connect test gauge to accumulator pressure port (Fig. 57) and (Fig. 58).
- (2) Start and run engine at 1000 rpm.
- (3) Move shift lever on valve body manual lever shaft, one detent rearward from full forward position. This is 2 range.
- (4) Move transmission throttle lever from full forward to full rearward position and read pressure at both gauges.

DIAGNOSIS AND TESTING (Continued)

(5) Line pressure should be 54-60 psi (372-414 kPa) with throttle lever forward and gradually increase to 90-96 psi (621-662 kPa) as lever is moved rearward.

Test Three - Transmission In D Range

This test checks pressure regulation and condition of the clutch circuits. Use both pressure Test Gauges C-3292 and C-3293-SP for this test.

(1) Connect test gauges to accumulator and front servo ports (Fig. 57) and (Fig. 58). Use either test gauge at the two ports.

(2) Start and run engine at 1600 rpm for this test.

(3) Move selector lever to D range. This is two detents rearward from full forward position.

(4) Read pressures on both gauges as transmission throttle lever is moved from full forward to full rearward position.

(5) Line pressure should be 54-60 psi (372-414 kPa) with throttle lever forward and gradually increase as lever is moved rearward.

(6) Front servo is pressurized only in D range and should be same as line pressure within 3 psi (21 kPa) up to downshift point.

Test Four - Transmission In Reverse

This test checks pump output, pressure regulation and the front clutch and rear servo circuits. Use 300 psi Test Gauge C-3293-SP for this test.

(1) Connect 300 psi gauge to rear servo port (Fig. 57) and (Fig. 58).

(2) Start and run engine at 1600 rpm for test.

(3) Move valve body selector lever four detents rearward from the full forward position. This is Reverse range.

(4) Move throttle lever all way forward then all way rearward and note gauge readings.

(5) Pressure should be 145 - 175 psi (1000-1207 kPa) with lever forward and increase to 230 - 280 psi (1586-1931 kPa) as lever is moved rearward.

Test Five - Governor Pressure

This test checks governor operation by measuring governor pressure response to changes in engine speed. It is usually not necessary to check governor operation unless shift speeds are incorrect or if the transmission will not downshift.

(1) Connect 100 psi Test Gauge C-3292 to governor pressure port (Fig. 57) and (Fig. 58).

(2) Move shift lever to D range.

(3) Start and run engine at curb idle speed and note pressure. At idle and with vehicle stopped, pressure should be zero to 1.5 psi maximum. If pressure exceeds this figure, governor valve or weights are sticking open.

(4) Slowly increase engine speed and observe speedometer and pressure test gauge. Governor pressure should increase in proportion to vehicle speed.

(5) Pressure rise should be smooth and drop back to 0 to 1.5 psi when wheels stop rotating.

(6) Compare results of pressure tests with analysis charts (Fig. 60).

| TEST CONDITION | INDICATION |
|--|--|
| Line pressure OK during any one test | Pump and regulator valve OK |
| Line pressure OK in R but low in D, 2, 1 | Leakage in rear clutch area (servo, clutch seals, governor support seal rings on park gear) |
| Pressure OK in 1, 2 but low in D3 and R | Leakage in front clutch area (servo, clutch seals, retainer bore, pump seal rings) |
| Pressure OK in 2 but low in R and 1 | Leakage in rear servo |
| Front servo pressure in 2 | Leakage in servo (broken servo ring or cracked servo piston) |
| Pressure low in all positions | Clogged filter, stuck pressure regulator valve, worn or defective pump |
| Governor pressure too high at idle speed | Governor valve sticking open |
| Governor pressure low at all mph figures | Governor valve sticking closed |
| Lubrication pressure low at all throttle positions | Clogged drainback valve, oil cooler or lines, seal rings leaking, output shaft plugged with debris, worn bushings in pump or clutch retainer |

Fig. 60 Pressure Test Analysis

AIR TESTING TRANSMISSION CLUTCH AND BAND OPERATION

Air-pressure testing can be used to check transmission front/rear clutch and band operation. The test can be conducted with the transmission either in the vehicle or on the work bench, as a final check, after overhaul.

Air-pressure testing requires that the oil pan and valve body be removed from the transmission. The servo and clutch apply passages are shown (Fig. 61).

DIAGNOSIS AND TESTING (Continued)

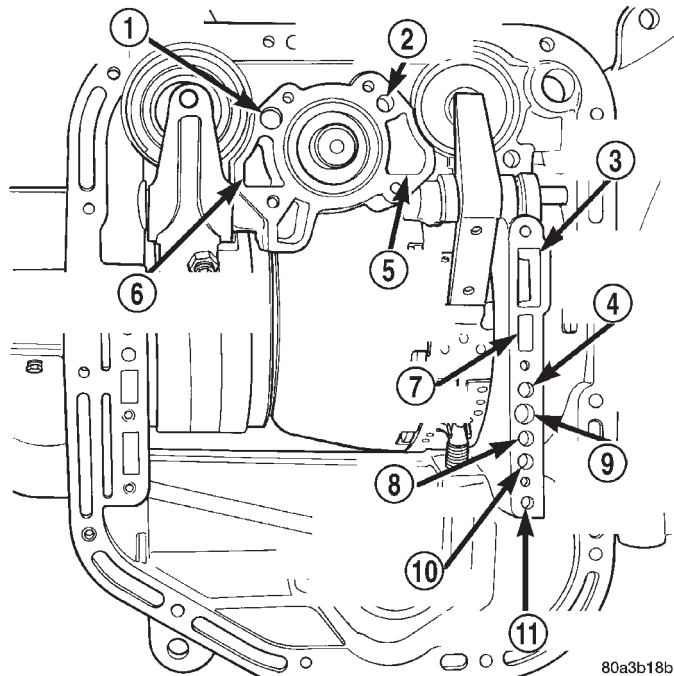

Fig. 61 Air Pressure Test Passages

- 1 - REAR SERVO APPLY
- 2 - FRONT SERVO APPLY
- 3 - PUMP SUCTION
- 4 - FRONT CLUTCH APPLY
- 5 - FRONT SERVO RELEASE
- 6 - LINE PRESSURE TO ACCUMULATOR
- 7 - PUMP PRESSURE
- 8 - TO CONVERTER
- 9 - REAR CLUTCH APPLY
- 10 - FROM CONVERTER
- 11 - TO COOLER

Front Clutch Air Test

Place one or two fingers on the clutch housing and apply air pressure through front clutch apply passage. Piston movement can be felt and a soft thump heard as the clutch applies.

Rear Clutch Air Test

Place one or two fingers on the clutch housing and apply air pressure through rear clutch apply passage. Piston movement can be felt and a soft thump heard as the clutch applies.

Front Servo Apply Air Test

Apply air pressure to the front servo apply passage. The servo rod should extend and cause the band to tighten around the drum. Spring pressure should release the servo when air pressure is removed.

Rear Servo Air Test

Apply air pressure to the rear servo apply passage. The servo rod should extend and cause the band to

tighten around the drum. Spring pressure should release the servo when air pressure is removed.

CONVERTER HOUSING FLUID LEAK DIAGNOSIS

When diagnosing converter housing fluid leaks, two items must be established before repair.

- (1) Verify that a leak condition actually exists.
- (2) Determined the true source of the leak.

Some suspected converter housing fluid leaks may not be leaks at all. They may only be the result of residual fluid in the converter housing, or excess fluid spilled during factory fill or fill after repair. Converter housing leaks have several potential sources. Through careful observation, a leak source can be identified before removing the transmission for repair. Pump seal leaks tend to move along the drive hub and onto the rear of the converter. Pump O-ring or pump body leaks follow the same path as a seal leak (Fig. 62). Pump vent or pump attaching bolt leaks are generally deposited on the inside of the converter housing and not on the converter itself (Fig. 62). Pump seal or gasket leaks usually travel down the inside of the converter housing. Front band lever pin plug leaks are generally deposited on the housing and not on the converter.

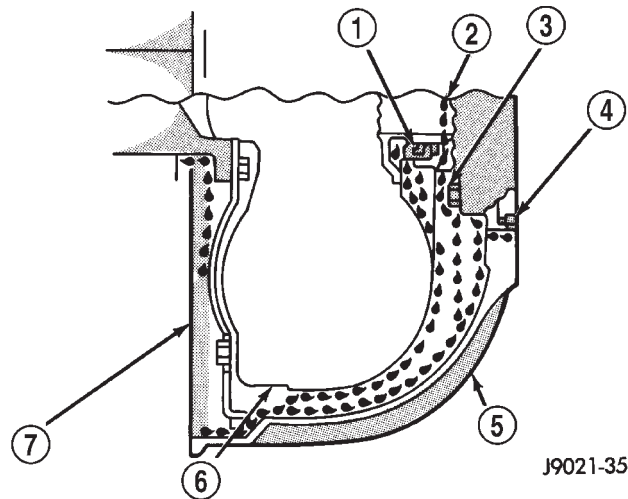

Fig. 62 Converter Housing Leak Paths

- 1 - PUMP SEAL
- 2 - PUMP VENT
- 3 - PUMP BOLT
- 4 - PUMP GASKET
- 5 - CONVERTER HOUSING
- 6 - CONVERTER
- 7 - REAR MAIN SEAL LEAK

TORQUE CONVERTER LEAK POINTS

Possible sources of converter leaks are:

- (1) Leaks at the weld joint around the outside diameter weld (Fig. 63).

DIAGNOSIS AND TESTING (Continued)

(2) Leaks at the converter hub weld (Fig. 63).

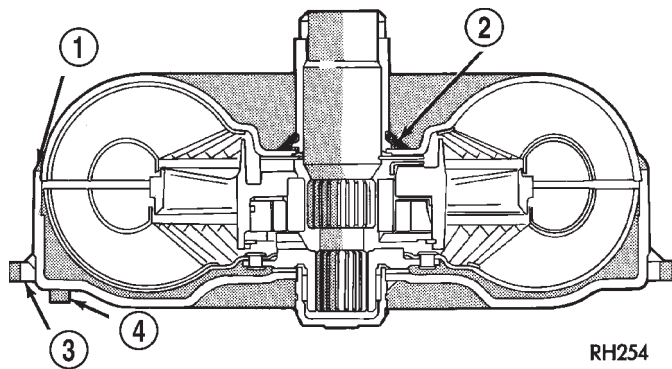

Fig. 63 Converter Leak Points—Typical

- 1 - OUTSIDE DIAMETER WELD
- 2 - TORQUE CONVERTER HUB WELD
- 3 - STARTER RING GEAR
- 4 - LUG

CONVERTER HOUSING AREA LEAK CORRECTION

- (1) Remove converter.
- (2) Tighten front band adjusting screw until band is tight around front clutch retainer. This prevents front/rear clutches from coming out when oil pump is removed.
- (3) Remove oil pump and remove pump seal. Inspect pump housing drainback and vent holes for obstructions. Clear holes with solvent and wire.
- (4) Inspect pump bushing and converter hub. If bushing is scored, replace it. If converter hub is

scored, either polish it with crocus cloth or replace converter.

(5) Install new pump seal, O-ring, and gasket. Replace oil pump if cracked, porous or damaged in any way. Be sure to loosen the front band before installing the oil pump, damage to the oil pump seal may occur if the band is still tightened to the front clutch retainer.

(6) Loosen kickdown lever pin access plug three turns. Apply Loctite 592, or Permatex No. 2 to plug threads and tighten plug to 17 N·m (150 in. lbs.) torque.

(7) Adjust front band.

(8) Lubricate pump seal and converter hub with transmission fluid or petroleum jelly and install converter.

(9) Install transmission and converter housing dust shield.

(10) Lower vehicle.

DIAGNOSIS CHARTS

The diagnosis charts provide additional reference when diagnosing a transmission fault. The charts provide general information on a variety of transmission, overdrive unit and converter clutch fault conditions.

The hydraulic flow charts, in the Schematics and Diagrams section of this group, outline fluid flow and hydraulic circuitry. Circuit operation is provided for neutral, third, fourth and reverse gear ranges. Normal working pressures are also supplied for each of the gear ranges.

DIAGNOSIS AND TESTING (Continued)

DIAGNOSIS CHART

| CONDITION | POSSIBLE CAUSES | CORRECTION |
|---|---|--|
| HARSH ENGAGEMENT FROM NEUTRAL TO DRIVE OR REVERSE | 1. Fluid Level Low | 1. Add Fluid |
| | 2. Throttle Linkage Misadjusted | 2. Adjust linkage - setting may be too long. |
| | 3. Mount and Driveline Bolts Loose | 3. Check engine mount, transmission mount, propeller shaft, rear spring to body bolts, rear control arms, crossmember and axle bolt torque. Tighten loose bolts and replace missing bolts. |
| | 4. U-Joint Worn/Broken | 4. Remove propeller shaft and replace U-Joint. |
| | 5. Axle Backlash Incorrect | 5. Check per Service Manual. Correct as needed. |
| | 6. Hydraulic Pressure Incorrect | 6. Check pressure. Remove, overhaul or adjust valve body as needed. |
| | 7. Band Misadjusted. | 7. Adjust rear band. |
| | 8. Valve Body Check Balls Missing. | 8. Inspect valve body for proper check ball installation. |
| | 9. Axle Pinion Flange Loose. | 9. Replace nut and check pinion threads before installing new nut. Replace pinion gear if threads are damaged. |
| | 10. Clutch, band or planetary component Damaged. | 10. Remove, disassemble and repair transmission as necessary. |
| | 11. Converter Clutch (if equipped) Faulty. | 11. Replace converter and flush cooler and line before installing new converter. |
| DELAYED ENGAGEMENT FROM NEUTRAL TO DRIVE OR REVERSE | 1. Fluid Level Low. | 1. Correct level and check for leaks. |
| | 2. Filter Clogged. | 2. Change filter. |
| | 3. Gearshift Linkage Misadjusted. | 3. Adjust linkage and repair linkage if worn or damaged. |
| | 4. Rear Band Misadjusted. | 4. Adjust band. |
| | 5. Valve Body Filter Plugged. | 5. Replace fluid and filter. If oil pan and old fluid were full of clutch disc material and/or metal particles, overhaul will be necessary. |
| | 6. Oil Pump Gears Worn/Damaged. | 6. Remove transmission and replace oil pump. |
| | 7. Hydraulic Pressure Incorrect. | 7. Perform pressure test, remove transmission and repair as needed. |
| | 8. Reaction Shaft Seal Rings Worn/Broken. | 8. Remove transmission, remove oil pump and replace seal rings. |
| | 9. Rear Clutch/Input Shaft, Rear Clutch Seal Rings Damaged. | 9. Remove and disassemble transmission and repair as necessary. |
| | 10. Governor Valve Stuck. | 10. Remove and inspect governor components. Replace worn or damaged parts. |
| | 11. Regulator Valve Stuck. | 11. Clean. |
| | 12. Cooler Plugged. | 12. Flush transmission cooler and inspect convertor drainback valve. |

DIAGNOSIS AND TESTING (Continued)

| CONDITION | POSSIBLE CAUSES | CORRECTION |
|--|---|--|
| NO DRIVE RANGE (REVERSE OK) | 1. Fluid Level Low. | 1. Add fluid and check for leaks if drive is restored. |
| | 2. Gearshift Linkage/Cable Loose/Misadjusted. | 2. Repair or replace linkage components. |
| | 3. Rear Clutch Burnt. | 3. Remove and disassemble transmission and rear clutch and seals. Repair/replace worn or damaged parts as needed. |
| | 4. Valve Body Malfunction. | 4. Remove and disassemble valve body. Replace assembly if any valves or bores are damaged. |
| | 5. Transmission Overrunning Clutch Broken. | 5. Remove and disassemble transmission. Replace overrunning clutch. |
| | 6. Input Shaft Seal Rings Worn/Damaged. | 6. Remove and disassemble transmission. Replace seal rings and any other worn or damaged parts. |
| | 7. Front Planetary Failed Broken. | 7. Remove and repair. |
| NO DRIVE OR REVERSE (VEHICLE WILL NOT MOVE) | 1. Fluid Level Low. | 1. Add fluid and check for leaks if drive is restored. |
| | 2. Gearshift Linkage/Cable Loose/Misadjusted. | 2. Inspect, adjust and reassemble linkage as needed. Replace worn/damaged parts. |
| | 3. U-Joint/Axle/Transfer Case Broken. | 3. Perform preliminary inspection procedure for vehicle that will not move. Refer to procedure in diagnosis section. |
| | 4. Filter Plugged. | 4. Remove and disassemble transmission. Repair or replace failed components as needed. Replace filter. If filter and fluid contained clutch material or metal particles, an overhaul may be necessary. Perform lube flow test. Flush oil. Replace cooler as necessary. |
| | 5. Oil Pump Damaged. | 5. Perform pressure test to confirm low pressure. Replace pump body assembly if necessary. |
| | 6. Valve Body Malfunctioned. | 6. Check press and inspect valve body. Replace valve body (as assembly) if any valve or bore is damaged. Clean and reassemble correctly if all parts are in good condition. |
| | 7. Transmission Internal Component Damaged. | 7. Remove and disassemble transmission. Repair or replace failed components as needed. Remove and disassemble transmission. Repair or replace failed components as needed. |
| | 8. Park Sprag not Releasing | 8. Remove, disassemble, repair. |
| | 9. Torque Converter Damage. | 9. Check Stall Speed, Worn/Damaged/Stuck. Inspect and replace as required. |

DIAGNOSIS AND TESTING (Continued)

| CONDITION | POSSIBLE CAUSES | CORRECTION |
|--|--|---|
| SHIFTS DELAYED OR ERRATIC (SHIFTS ALSO HARSH AT TIMES) | 1. Fluid Level Low/High. | 1. Correct fluid level and check for leaks if low. |
| | 2. Throttle Linkage Misadjusted. | 2. Adjust linkage as described in service section. |
| | 3. Throttle Linkage Binding. | 3. Check cable for binding. Check for return to closed throttle at transmission. |
| | 4. Gearshift Linkage/Cable Misadjusted. | 4. Adjust linkage/cable as described in service section. |
| | 5. Fluid Filter Clogged. | 5. Replace filter. If filter and fluid contained clutch material or metal particles, an overhaul may be necessary. Perform lube flow test. |
| | 6. Governor Valve Sticking. | 6. Inspect, clean or repair. |
| | 7. Governor Seal Rings Worn/Damaged. | 7. Inspect/replace. |
| | 8. Clutch or Servo Failure. | 8. Remove valve body and air test clutch, and band servo operation. Disassemble and repair transmission as needed. |
| | 9. Front Band Misadjusted. | 9. Adjust band. |
| | 10. Pump Suction Passage Leak. | 10. Check for excessive foam on dipstick after normal driving. Check for loose pump bolts, defective gasket. Replace pump assembly if needed. |
| NO REVERSE (D RANGES OK) | 1. Gearshift Linkage/Cable Misadjusted/Damaged. | 1. Repair or replace linkage parts as needed. |
| | 2. Park Sprag Sticking. | 2. Inspect and replace as necessary. |
| | 3. Rear Band Misadjusted/Worn. | 3. Adjust band; replace. |
| | 4. Valve Body Malfunction. | 4. Remove and service valve body. Replace valve body if any valves or valve bores are worn or damaged. |
| | 5. Rear Servo Malfunction. | 5. Remove and disassemble transmission. Replace worn/damaged servo parts as necessary. |
| | 6. Front Clutch Burnt. | 6. Remove and disassemble transmission. Replace worn, damaged clutch parts as required. |
| HAS FIRST/REVERSE ONLY (NO 1-2 OR 2-3 UPSHIFT) | 1. Governor Valve, Shaft, Weights or Body Damaged/Stuck. | 1. Remove governor assembly and clean or repair as necessary. |
| | 2. Valve Body Malfunction. | 2. Stuck 1-2 shift valve or governor plug. |
| | 3. Front Servo/Kickdown Band Damaged/Burned. | 3. Repair/replace. |
| MOVES IN 2ND OR 3RD GEAR, ABRUPTLY DOWNSHIFTS TO LOW | 1. Valve Body Malfunction. | 1. Remove, clean and inspect. Look for stuck 1-2 valve or governor plug. |
| | 2. Governor Valve Sticking. | 2. Remove, clean and inspect. Replace faulty parts. |

DIAGNOSIS AND TESTING (Continued)

| CONDITION | POSSIBLE CAUSES | CORRECTION |
|---|---|---|
| NO LOW GEAR (MOVES IN 2ND OR 3RD GEAR ONLY) | 1. Governor Valve Sticking. | 1. Remove governor, clean, inspect and repair as required. |
| | 2. Valve Body Malfunction. | 2. Remove, clean and inspect. Look for sticking 1-2 shift valve, 2-3 shift valve, governor plug or broken springs. |
| | 3. Front Servo Piston Cocked in Bore. | 3. Inspect servo and repair as required. |
| | 4. Front Band Linkage Malfunction | 4. Inspect linkage and look for bind in linkage. |
| NO KICKDOWN OR NORMAL DOWNSHIFT | 1. Throttle Linkage Misadjusted. | 1. Adjust linkage. |
| | 2. Accelerator Pedal Travel Restricted. | 2. Floor mat under pedal, accelerator cable worn or brackets bent. |
| | 3. Governor/Valve Body Hydraulic Pressures Too High or Too Low Due to Sticking Governor, Valve Body Malfunction or Incorrect Hydraulic Control Pressure Adjustments. | 3. Perform hydraulic pressure tests to determine cause and repair as required. Correct valve body pressure adjustments as required. |
| | 4. Valve Body Malfunction. | 4. Perform hydraulic pressure tests to determine cause and repair as required. Correct valve body pressure adjustments as required. |
| | 5. Valve Body Malfunction. | 5. Sticking 1-2, 2-3 shift valves, or governor plugs. |
| STUCK IN LOW GEAR (WILL NOT UPSHIFT) | 1. Throttle Linkage Misadjusted/Stuck. | 1. Adjust linkage and repair linkage if worn or damaged. Check for binding cable or missing return spring. |
| | 2. Gearshift Linkage Misadjusted. | 2. Adjust linkage and repair linkage if worn or damaged. |
| | 3. Governor/Valve Body, Governor Valve Stuck Closed; Loose Output Shaft Support or Governor Housing Bolts, Leaking Seal Rings or Valve Body Problem (i.e., Stuck 1- 2 Shift Valve/Gov. Plug). | 3. Check line and governor pressures to determine cause. Correct as required. |
| | 4. Front Band Out of Adjustment. | 4. Adjust Band. |
| | 5. Clutch or Servo Malfunction. | 5. Air pressure check operation of clutches and bands. Repair faulty component. |
| CREEPS IN NEUTRAL | 1. Gearshift Linkage Misadjusted. | 1. Adjust linkage. |
| | 2. Rear Clutch Dragging/Warped Welded. | 2. Disassemble and repair. |
| | 3. Valve Body Malfunction. | 3. Perform hydraulic pressure test to determine cause and repair as required. |

DIAGNOSIS AND TESTING (Continued)

| CONDITION | POSSIBLE CAUSES | CORRECTION |
|---|--|--|
| BUZZING NOISE | 1. Fluid Level Low | 1. Add fluid and check for leaks. |
| | 2. Shift Cable Misassembled. | 2. Route cable away from engine and bell housing. |
| | 3. Valve Body Misassembled. | 3. Remove, disassemble, inspect valve body. Reassemble correctly if necessary. Replace assembly if valves or springs are damaged. Check for loose bolts or screws. |
| | 4. Pump Passages Leaking | 4. Check pump for porous casting, scores on mating surfaces and excess rotor clearance. Repair as required. Loose pump bolts. |
| | 5. Cooling System Cooler Plugged. | 5. Flow check cooler circuit. Repair as needed. |
| | 6. Overrunning Clutch Damaged. | 6. Replace clutch. |
| SLIPS IN REVERSE ONLY | 1. Fluid Level Low. | 1. Add fluid and check for leaks. |
| | 2. Gearshift Linkage Misadjusted. | 2. Adjust linkage. |
| | 3. Rear Band Misadjusted. | 3. Adjust band. |
| | 4. Rear Band Worn. | 4. Replace as required. |
| | 5. Hydraulic Pressure Too Low. | 5. Perform hydraulic pressure tests to determine cause. |
| | 6. Rear Servo Leaking. | 6. Air pressure check clutch-servo operation and repair as required. |
| | 7. Band Linkage Binding. | 7. Inspect and repair as required. |
| SLIPS IN FORWARD DRIVE RANGES | 1. Fluid Level Low. | 1. Add fluid and check for leaks. |
| | 2. Fluid Foaming. | 2. Check for high oil level, bad pump gasket or seals, dirt between pump halves and loose pump bolts. Replace pump if necessary. |
| | 3. Throttle Linkage Misadjusted. | 3. Adjust linkage. |
| | 4. Gearshift Linkage Misadjusted. | 4. Adjust linkage. |
| | 5. Rear Clutch Worn. | 5. Inspect and replace as needed. |
| | 6. Low Hydraulic Pressure Due to Worn Pump, Incorrect Control Pressure Adjustments, Valve Body Warp or Malfunction, Sticking Governor, Leaking Seal Rings, Clutch Seals Leaking, Servo Leaks, Clogged Filter or Cooler Lines | 6. Perform hydraulic and air pressure tests to determine cause. |
| | 7. Rear Clutch Malfunction, Leaking Seals or Worn Plates. | 7. Air pressure check clutch-servo operation and repair as required. |
| | 8. Overrunning Clutch Worn, Not Holding (Slips in 1 Only). | 8. Replace Clutch. |
| SLIPS IN LOW GEAR "D" ONLY, BUT NOT IN 1 POSITION | Overrunning Clutch Faulty. | Replace overrunning clutch. |

DIAGNOSIS AND TESTING (Continued)

| CONDITION | POSSIBLE CAUSES | CORRECTION |
|---|--|---|
| GROWLING, GRATING OR SCRAPING NOISES | 1. Drive Plate Broken. | 1. Replace. |
| | 2. Torque Converter Bolts Hitting Dust Shield. | 2. Dust shield bent. Replace or repair. |
| | 3. Planetary Gear Set Broken/ Seized. | 3. Check for debris in oil pan and repair as required. |
| | 4. Overrunning Clutch Worn/Broken. | 4. Inspect and check for debris in oil pan. Repair as required. |
| | 5. Oil Pump Components Scored/ Binding. | 5. Remove, inspect and repair as required. |
| | 6. Output Shaft Bearing or Bushing Damaged. | 6. Remove, inspect and repair as required. |
| | 7. Clutch Operation Faulty. | 7. Perform air pressure check and repair as required. |
| | 8. Front and Rear Bands Misadjusted. | 8. Adjust bands. |
| DRAGS OR LOCKS UP | 1. Fluid Level Low. | 1. Check and adjust level. |
| | 2. Clutch Dragging/Failed | 2. Air pressure check clutch operation and repair as required. |
| | 3. Front or Rear Band Misadjusted. | 3. Adjust bands. |
| | 4. Case Leaks Internally. | 4. Check for leakage between passages in case. |
| | 5. Servo Band or Linkage Malfunction. | 5. Air pressure check servo operation and repair as required. |
| | 6. Overrunning Clutch Worn. | 6. Remove and inspect clutch. Repair as required. |
| | 7. Planetary Gears Broken. | 7. Remove, inspect and repair as required (look for debris in oil pan). |
| | 8. Converter Clutch Dragging. | 8. Check for plugged cooler. Perform flow check. Inspect pump for excessive side clearance. Replace pump as required. |
| WHINE/NOISE RELATED TO ENGINE SPEED | 1. Fluid Level Low. | 1. Add fluid and check for leaks. |
| | 2. Shift Cable Incorrect Routing. | 2. Check shift cable for correct routing. Should not touch engine or bell housing. |
| TORQUE CONVERTER LOCKS UP IN SECOND AND/OR THIRD GEAR | Lockup Solenoid, Relay or Wiring Shorted/Open. | Test solenoid, relay and wiring for continuity, shorts or grounds. Replace solenoid and relay if faulty. Repair wiring and connectors as necessary. |
| HARSH 1-2 OR 2-3 SHIFTS | Lockup Solenoid Malfunction. | Remove valve body and replace solenoid assembly. |

DIAGNOSIS AND TESTING (Continued)

| CONDITION | POSSIBLE CAUSES | CORRECTION |
|--|--|--|
| NO START IN PARK OR NEUTRAL | 1. Gearshift Linkage/Cable Misadjusted. | 1. Adjust linkage/cable. |
| | 2. Neutral Switch Wire Open/Cut. | 2. Check continuity with test lamp. Repair as required. |
| | 3. Neutral Switch Faulty. | 3. Refer to service section for test and replacement procedure. |
| | 4. Neutral Switch Connect Faulty. | 4. Connectors spread open. Repair. |
| | 5. Valve Body Manual Lever Assembly Bent/Worn/Broken. | 5. Inspect lever assembly and replace if damaged. |
| NO REVERSE (OR SLIPS IN REVERSE) | 1. Direct Clutch Pack (front clutch) Worn. | 1. Disassemble unit and rebuild clutch pack. |
| | 2. Rear Band Misadjusted. | 2. Adjust band. |
| | 3. Front Clutch Malfunctioned/Burnt. | 3. Air pressure test clutch operation. Remove and rebuild if necessary. |
| OIL LEAKS (ITEMS LISTED REPRESENT POSSIBLE LEAK POINTS AND SHOULD ALL BE CHECKED.) | 1. Speedometer Adapter Leaks. | 1. Replace both adapter seals. |
| | 2. Fluid Lines and Fittings Loose/Leaks/Damaged. | 2. Tighten fittings. If leaks persist, replace fittings and lines if necessary. |
| | 3. Filler Tube (where tube enters case) Leaks/Damaged. | 3. Replace O-ring seal. Inspect tube for cracks in tube. |
| | 4. Pressure Port Plug Loose Loose/Damaged. | 4. Tighten to correct torque. Replace plug or reseal if leak persists. |
| | 5. Pan Gasket Leaks. | 5. Tighten pan screws to 150 inch pounds. If leaks persist, replace gasket. Do no over tighten screws. |
| | 6. Valve Body Manual Lever Shaft Seal Leaks/Worn. | 6. Replace shaft seal. |
| | 7. Rear Bearing Access Plate Leaks. | 7. Replace gasket. Tighten screws. |
| | 8. Gasket Damaged or Bolts are Loose. | 8. Replace bolts or gasket or tighten both. |
| | 9. Adapter/Extension Gasket Damaged Leaks/Damaged. | 9. Replace gasket. |
| | 10. Neutral Switch Leaks/Damaged. | 10. Replace switch and gasket. |
| | 11. Converter Housing Area Leaks. | 11. Check for leaks at seal caused by worn seal or burr on converter hub (cutting seal), worn bushing, missing oil return, oil in front pump housing or hole plugged. Check for leaks past O-ring seal on pump or past pump-to-case bolts; pump housing porous, oil coming out vent due to overfill or leak past front band shaft access plug. |
| | 12. Pump Seal Leaks/Worn/Damaged. | 12. Replace seal. |
| | 13. Torque Converter Weld Leak/Cracked Hub. | 13. Replace converter. |
| | 14. Case Porosity Leaks. | 14. Replace case. |

SERVICE PROCEDURES

FLUID LEVEL CHECK

Transmission fluid level should be checked monthly under normal operation. If the vehicle is used for trailer towing or similar heavy load hauling, check fluid level and condition weekly. Fluid level is checked with the engine running at curb idle speed, the transmission in NEUTRAL and the transmission fluid at normal operating temperature.

FLUID LEVEL CHECK PROCEDURE

- (1) Transmission fluid must be at normal operating temperature for accurate fluid level check. Drive vehicle if necessary to bring fluid temperature up to normal hot operating temperature of 82°C (180°F).
- (2) Position vehicle on level surface.
- (3) Start and run engine at curb idle speed.
- (4) Apply parking brakes.
- (5) Shift transmission momentarily into all gear ranges. Then shift transmission back to Neutral.
- (6) Clean top of filler tube and dipstick to keep dirt from entering tube.
- (7) Remove dipstick (Fig. 64) and check fluid level as follows:
 - (a) Correct acceptable level is in crosshatch area.
 - (b) Correct maximum level is to MAX arrow mark.
 - (c) Incorrect level is at or below MIN line.
 - (d) If fluid is low, add only enough Mopar® ATF Plus 3 to restore correct level. Do not overfill.

CAUTION: Do not overfill the transmission. Overfilling may cause leakage out the pump vent which can be mistaken for a pump seal leak. Overfilling will also cause fluid aeration and foaming as the excess fluid is picked up and churned by the gear train. This will significantly reduce fluid life.

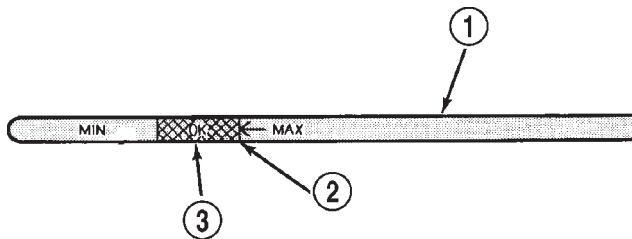

Fig. 64 Dipstick Fluid Level Marks—Typical

- 1 - DIPSTICK
- 2 - MAXIMUM CORRECT FLUID LEVEL
- 3 - ACCEPTABLE FLUID LEVEL

FLUID AND FILTER REPLACEMENT

Refer to the Maintenance Schedules in Group 0, Lubrication and Maintenance, for proper service

intervals. The service fluid fill after a filter change is approximately 3.8 liters (4.0 quarts).

REMOVAL

- (1) Hoist and support vehicle on safety stands.
- (2) Remove the transmission/skip plate as necessary to access the transmission oil pan.
- (3) Place a large diameter shallow drain pan beneath the transmission pan.
- (4) Remove bolts holding front and sides of pan to transmission (Fig. 65).
- (5) Loosen bolts holding rear of pan to transmission.
- (6) Slowly separate front of pan away from transmission allowing the fluid to drain into drain pan.
- (7) Hold up pan and remove remaining bolts holding pan to transmission.
- (8) While holding pan level, lower pan away from transmission.
- (9) Pour remaining fluid in pan into drain pan.
- (10) Remove screws holding filter to valve body (Fig. 66).
- (11) Separate filter from valve body and pour fluid in filter into drain pan.
- (12) Dispose used trans fluid and filter properly.

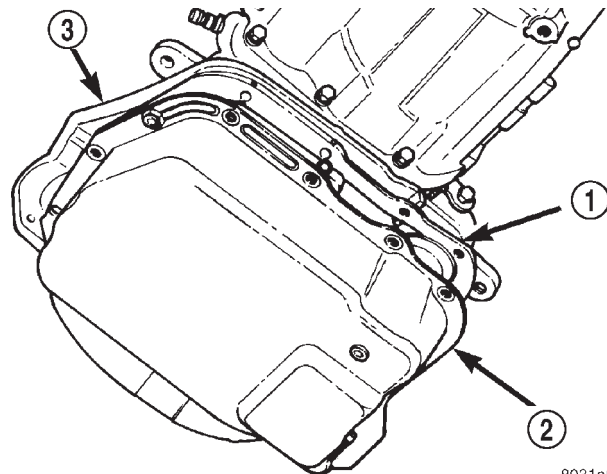

Fig. 65 Transmission Pan—Typical

8031e88b

- 1 - GASKET
- 2 - PAN
- 3 - TRANSMISSION

INSPECTION

Inspect bottom of pan and magnet for excessive amounts of metal or fiber contamination. A light coating of clutch or band material on the bottom of the pan does not indicate a problem unless accompanied by slipping condition or shift lag. If fluid and pan are contaminated with excessive amounts or debris, refer to the diagnosis section of this group.

Check the adjustment of the front and rear bands, adjust if necessary. Refer to Adjustment section of this group for proper procedure.

SERVICE PROCEDURES (Continued)

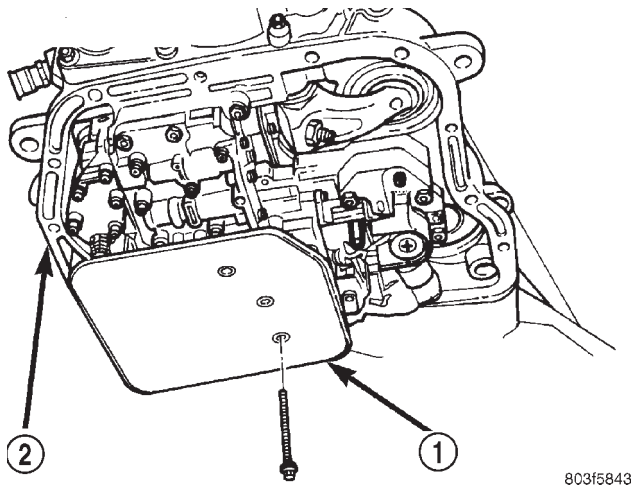

Fig. 66 Transmission Filter—Typical

- 1 - FILTER
2 - TRANSMISSION

CLEANING

- (1) Using a suitable solvent, clean pan and magnet.
- (2) Using a suitable gasket scraper, clean gasket material from gasket surface of transmission case and the gasket flange around the pan.

INSTALLATION

- (1) Place replacement filter in position on valve body.
- (2) Install screws to hold filter to valve body (Fig. 66). Tighten screws to 4 N·m (35 in. lbs.) torque.
- (3) Place new gasket in position on pan, and install pan on transmission.
- (4) Place pan in position on transmission.
- (5) Install screws to hold pan to transmission (Fig. 65). Tighten bolts to 17 N·m (150 in. lbs.) torque.
- (6) Install the transmission/skip plate.
- (7) Lower vehicle and fill transmission with Mopar® ATF Plus 3, type 7176 fluid.

TRANSMISSION FILL PROCEDURE

To avoid overfilling transmission after a fluid change or overhaul, perform the following procedure:

- (1) Remove dipstick and insert clean funnel in transmission fill tube.
- (2) Add following initial quantity of Mopar® ATF Plus 3 to transmission:
 - (a) If only fluid and filter were changed, add **3 pints (1-1/2 quarts)** of ATF Plus 3 to transmission.
 - (b) If transmission was completely overhauled, torque converter was replaced or drained, and cooler was flushed, add **12 pints (6 quarts)** of ATF Plus 3 to transmission.
- (3) Apply parking brakes.
- (4) Start and run engine at normal curb idle speed.

(5) Apply service brakes, shift transmission through all gear ranges then back to NEUTRAL, set parking brake, and leave engine running at curb idle speed.

(6) Remove funnel, insert dipstick and check fluid level. If level is low, **add fluid to bring level to MIN mark on dipstick**. Check to see if the oil level is equal on both sides of the dipstick. If one side is noticeably higher than the other, the dipstick has picked up some oil from the dipstick tube. Allow the oil to drain down the dipstick tube and re-check.

(7) Drive vehicle until transmission fluid is at normal operating temperature.

(8) With the engine running at curb idle speed, the gear selector in NEUTRAL, and the parking brake applied, check the transmission fluid level.

CAUTION: Do not overfill transmission, fluid foaming and shifting problems can result.

(9) Add fluid to bring level up to MAX arrow mark.

When fluid level is correct, shut engine off, release park brake, remove funnel, and install dipstick in fill tube.

CONVERTER DRAINBACK CHECK VALVE SERVICE

The converter drainback check valve is located in the cooler outlet (pressure) line near the radiator tank. The valve prevents fluid drainback when the vehicle is parked for lengthy periods. The valve check ball is spring loaded and has an opening pressure of approximately 2 psi.

The valve is serviced as an assembly; it is not repairable. Do not clean the valve if restricted, or contaminated by sludge, or debris. If the valve fails, or if a transmission malfunction occurs that generates significant amounts of sludge and/or clutch particles and metal shavings, the valve must be replaced.

The valve must be removed whenever the cooler and lines are reverse flushed. The valve can be flow tested when necessary. The procedure is exactly the same as for flow testing a cooler.

If the valve is restricted, installed backwards, or in the wrong line, it will cause an overheating condition and possible transmission failure.

CAUTION: The drainback valve is a one-way flow device. It must be properly oriented in terms of flow direction for the cooler to function properly. The valve must be installed in the pressure line. Otherwise flow will be blocked and would cause an overheating condition and eventual transmission failure.

OIL PUMP VOLUME CHECK

Measuring the oil pump output volume will determine if sufficient oil flow to the transmission oil

SERVICE PROCEDURES (Continued)

cooler exists, and whether or not an internal transmission failure is present.

Verify that the transmission fluid is at the proper level. Refer to the Fluid Level Check procedure in this section. If necessary, fill the transmission to the proper level with Mopar® ATF+3, type 7176, Automatic Transmission Fluid.

(1) Disconnect the **To cooler** line at the cooler inlet and place a collecting container under the disconnected line.

CAUTION: With the fluid set at the proper level, fluid collection should not exceed (1) quart or internal damage to the transmission may occur.

(2) Run the engine **at curb idle speed**, with the shift selector in neutral.

(3) If one quart of transmission fluid is collected in the container in 20 seconds or less, oil pump flow volume is within acceptable limits. If fluid flow is intermittent, or it takes more than 20 seconds to collect one quart of fluid, refer to the Hydraulic Pressure tests in this section for further diagnosis.

(4) Re-connect the **To cooler** line to the transmission cooler inlet.

(5) Refill the transmission to proper level.

FLUSHING COOLERS AND TUBES

When a transmission failure has contaminated the fluid, the oil cooler(s) must be flushed. The torque converter must also be replaced. This will insure that metal particles or sludged oil are not later transferred back into the reconditioned (or replaced) transmission.

The only recommended procedure for flushing coolers and lines is to use Tool 6906A Cooler Flusher.

CAUTION: The transmission oil cooler requires a two stage flushing procedure due to an internally mounted thermostat. Failure to follow the procedure can result in severe transmission damage.

WARNING: WEAR PROTECTIVE EYEWEAR THAT MEETS THE REQUIREMENTS OF OSHA AND ANSI Z87.1-1968. WEAR STANDARD INDUSTRIAL RUBBER GLOVES.

KEEP LIGHTED CIGARETTES, SPARKS, FLAMES, AND OTHER IGNITION SOURCES AWAY FROM THE AREA TO PREVENT THE IGNITION OF COMBUSTIBLE LIQUIDS AND GASES. KEEP A CLASS (B) FIRE EXTINGUISHER IN THE AREA WHERE THE FLUSHER WILL BE USED.

KEEP THE AREA WELL VENTILATED.

DO NOT LET FLUSHING SOLVENT COME IN CONTACT WITH YOUR EYES OR SKIN: IF EYE CONTAMINATION OCCURS, FLUSH EYES WITH WATER FOR

15 TO 20 SECONDS. REMOVE CONTAMINATED CLOTHING AND WASH AFFECTED SKIN WITH SOAP AND WATER. SEEK MEDICAL ATTENTION.

COOLER FLUSH USING TOOL 6906A

(1) Remove cover plate filler plug on Tool 6906A. Fill reservoir 1/2 to 3/4 full of fresh flushing solution. Flushing solvents are petroleum based solutions generally used to clean automatic transmission components. **DO NOT** use solvents containing acids, water, gasoline, or any other corrosive liquids.

(2) Reinstall filler plug on Tool 6906A.

(3) Verify pump power switch is turned OFF. Connect red alligator clip to positive (+) battery post. Connect black (-) alligator clip to a good ground.

(4) Disconnect the cooler lines at the transmission.

NOTE: When flushing transmission cooler and lines, **ALWAYS** reverse flush.

NOTE: The converter drainback valve must be removed and an appropriate replacement hose installed to bridge the space between the transmission cooler line and the cooler fitting. Failure to remove the drainback valve will prevent reverse flushing the system. A suitable replacement hose can be found in the adapter kit supplied with the flushing tool.

(5) Connect the BLUE pressure line to the OUTLET (From) cooler line.

(6) Connect the CLEAR return line to the INLET (To) cooler line

(7) Remove the transmission oil cooler from the vehicle. Refer to the Group 7, Cooling System, for the proper procedures.

(8) Remove the transmission oil cooler thermostat. Refer to the Group 7, Cooling System, for the proper procedures.

(9) Re-install the thermostat cover onto the oil cooler and install the snap ring.

(10) Re-connect the oil cooler to the transmission cooler lines.

(11) Turn pump ON for two to three minutes to flush cooler(s) and lines.

NOTE: This flushes the bypass circuit of the cooler only.

(12) Turn pump OFF.

(13) Remove the thermostat cover from the oil cooler.

(14) Install Special Tool Cooler Plug 8414 into the transmission oil cooler.

(15) Turn pump ON for two to three minutes to flush cooler(s) and lines.

SERVICE PROCEDURES (Continued)

NOTE: This flushes the main oil cooler core passages only.

- (16) Turn pump OFF.
- (17) Remove the thermostat cover from the oil cooler.
- (18) Remove Special Tool Cooler Plug 8414 from the transmission oil cooler.
- (19) Install a new thermostat spring, thermostat cover, and snap-ring into the transmission oil cooler.
- (20) Install the transmission oil cooler onto the vehicle.
- (21) Disconnect CLEAR suction line from reservoir at cover plate. Disconnect CLEAR return line at cover plate, and place it in a drain pan.
- (22) Turn pump ON for 30 seconds to purge flushing solution from cooler and lines. Turn pump OFF.
- (23) Place CLEAR suction line into a one quart container of Mopar® ATF Plus 3, type 7176 automatic transmission fluid.
- (24) Turn pump ON until all transmission fluid is removed from the one quart container and lines. This purges any residual cleaning solvent from the transmission cooler and lines. Turn pump OFF.
- (25) Disconnect alligator clips from battery. Reconnect flusher lines to cover plate, and remove flushing adapters from cooler lines.

ALUMINUM THREAD REPAIR

Damaged or worn threads in the aluminum transmission case and valve body can be repaired by the use of Heli-Coils, or equivalent. This repair consists of drilling out the worn-out damaged threads. Then tap the hole with a special Heli-Coil tap, or equivalent, and installing a Heli-Coil insert, or equivalent, into the hole. This brings the hole back to its original thread size.

Heli-Coil, or equivalent, tools and inserts are readily available from most automotive parts suppliers.

REMOVAL AND INSTALLATION

TRANSMISSION

CAUTION: The transmission and torque converter must be removed as an assembly to avoid component damage. The converter drive plate, pump bushing, or oil seal can be damaged if the converter is left attached to the driveplate during removal.

REMOVAL

- (1) Disconnect battery negative cable.
- (2) Disconnect and lower or remove necessary exhaust components.
- (3) Remove engine-to-transmission bending braces.

- (4) Disconnect fluid cooler lines at transmission.
- (5) Remove starter motor.
- (6) Disconnect and remove crankshaft position sensor (Fig. 67). Retain sensor attaching bolts.

CAUTION: The crankshaft position sensor can be damaged during transmission removal (or installation) if the sensor is left in place. To avoid damage, remove the sensor before removing the transmission.

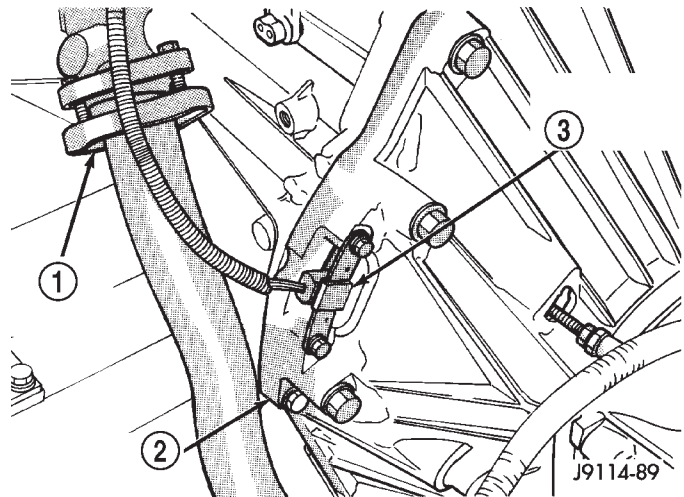

Fig. 67 Crankshaft Position Sensor—2.5L Engine

- 1 - EXHAUST DOWN PIPE
- 2 - TRANSMISSION HOUSING
- 3 - CRANKSHAFT POSITION SENSOR

- (7) Remove torque converter access cover.
- (8) If transmission is being removed for overhaul, remove transmission oil pan, drain fluid and reinstall pan.
- (9) Remove skid plate for access.
- (10) Remove the fill tube bracket bolts and pull tube out of transmission. Retain fill tube seal. On 4 x 4 models, it will also be necessary to remove bolt attaching transfer case vent tube to converter housing.
- (11) Rotate crankshaft in clockwise direction until converter bolts are accessible. Then remove bolts one at a time. Rotate crankshaft with socket wrench on dampener bolt.
- (12) Mark propeller shaft and axle yokes for assembly alignment. Then disconnect and remove propeller shafts.
- (13) Disconnect wires from park/neutral position switch and vehicle speed sensor.
- (14) Disconnect gearshift cable from transmission manual valve lever.
- (15) Disconnect throttle valve cable from transmission bracket and throttle valve lever.
- (16) Disconnect shift rod from transfer case shift lever or remove shift lever from transfer case.

REMOVAL AND INSTALLATION (Continued)

(17) Support rear of engine with safety stand or jack.

(18) Raise transmission slightly with service jack to relieve load on crossmember and supports.

(19) Remove bolts securing rear support and cushion to transmission and crossmember. Raise transmission slightly, slide exhaust hanger arm from bracket and remove rear support.

(20) Remove bolts attaching crossmember to frame and remove crossmember.

(21) Disconnect transfer case vent hose. Then disconnect vacuum switch harness.

(22) Remove transfer case.

(23) Remove all converter housing bolts.

(24) Carefully work transmission and torque converter assembly rearward off engine block dowels.

(25) Hold torque converter in place during transmission removal.

(26) Lower transmission and remove assembly from under the vehicle.

(27) To remove torque converter, carefully slide torque converter out of the transmission.

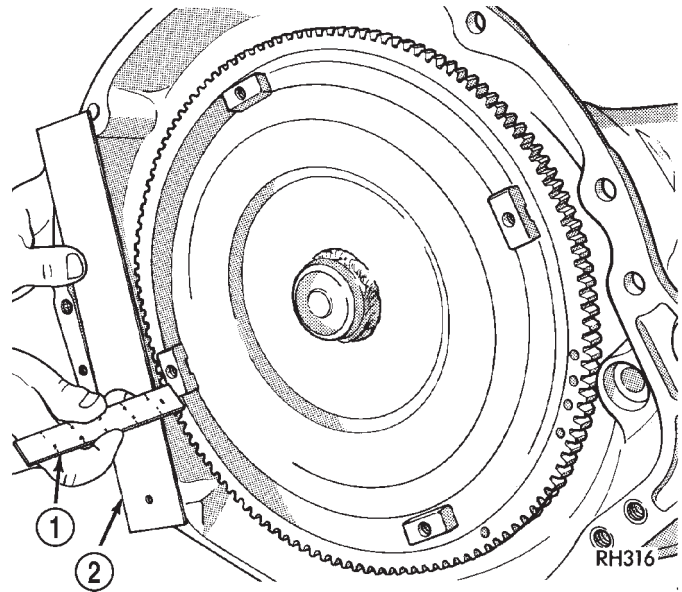

Fig. 68 Typical Method Of Checking Converter Seating

- 1 - SCALE
2 - STRAIGHTEDGE

INSTALLATION

(1) Check torque converter hub and hub drive notches for sharp edges burrs, scratches, or nicks. Polish the hub and notches with 320/400 grit paper and crocus cloth if necessary. The hub must be smooth to avoid damaging pump seal at installation.

(2) Lubricate converter drive hub and oil pump seal lip with transmission fluid.

(3) Align converter and oil pump.

(4) Carefully insert converter in oil pump. Then rotate converter back and forth until fully seated in pump gears.

(5) Check converter seating with steel scale and straightedge (Fig. 68). Surface of converter lugs should be 1/2 in. to rear of straightedge when converter is fully seated.

(6) Temporarily secure converter with C-clamp.

(7) Lubricate the pocket in the rear of the crankshaft, in which the converter pilot hub rides, with a light coating of Mopar® High-Temp Grease.

(8) Position transmission on jack and secure it with safety chains.

(9) Check condition of converter driveplate. Replace the plate if cracked, distorted or damaged. **Also be sure transmission dowel pins are seated in engine block and protrude far enough to hold transmission in alignment.**

(10) Raise transmission and align converter with drive plate and converter housing with engine block.

(11) Move transmission forward. Then raise, lower or tilt transmission to align converter housing with engine block dowels.

(12) Carefully work transmission forward and over engine block dowels until converter hub is seated in crankshaft.

(13) Install and tighten bolts that attach transmission converter housing to engine block (Fig. 69).

CAUTION: Be sure the converter housing is fully seated on the engine block dowels before tightening any bolts.

(14) Install torque converter attaching bolts. Tighten bolts to following torque.

- 54 N·m (40 ft. lbs.) with 9.5 in. 3-lug converter
- 74 N·m (55 ft. lbs.) with 9.5 in. 4-lug converter
- 74 N·m (55 ft. lbs.) with 10.0 in. 4-lug converter
- 31 N·m (270 in. lbs.) with 10.75 in. 4-lug converter

converter

(15) Install crankshaft position sensor.

(16) Install transmission fill tube and seal. Install new fill tube seal in transmission before installation.

(17) Connect transmission cooler lines to transmission.

(18) Install transfer case onto transmission.

(19) Install rear crossmember and attach transmission rear support to crossmember.

(20) Remove engine support fixture.

(21) Remove transmission jack.

(22) Connect vehicle speed sensor wires.

(23) Connect wires to park/neutral position switch.

(24) Install crankshaft position sensor.

(25) Install converter housing access cover.

(26) Install exhaust pipes and support brackets, if removed.

REMOVAL AND INSTALLATION (Continued)

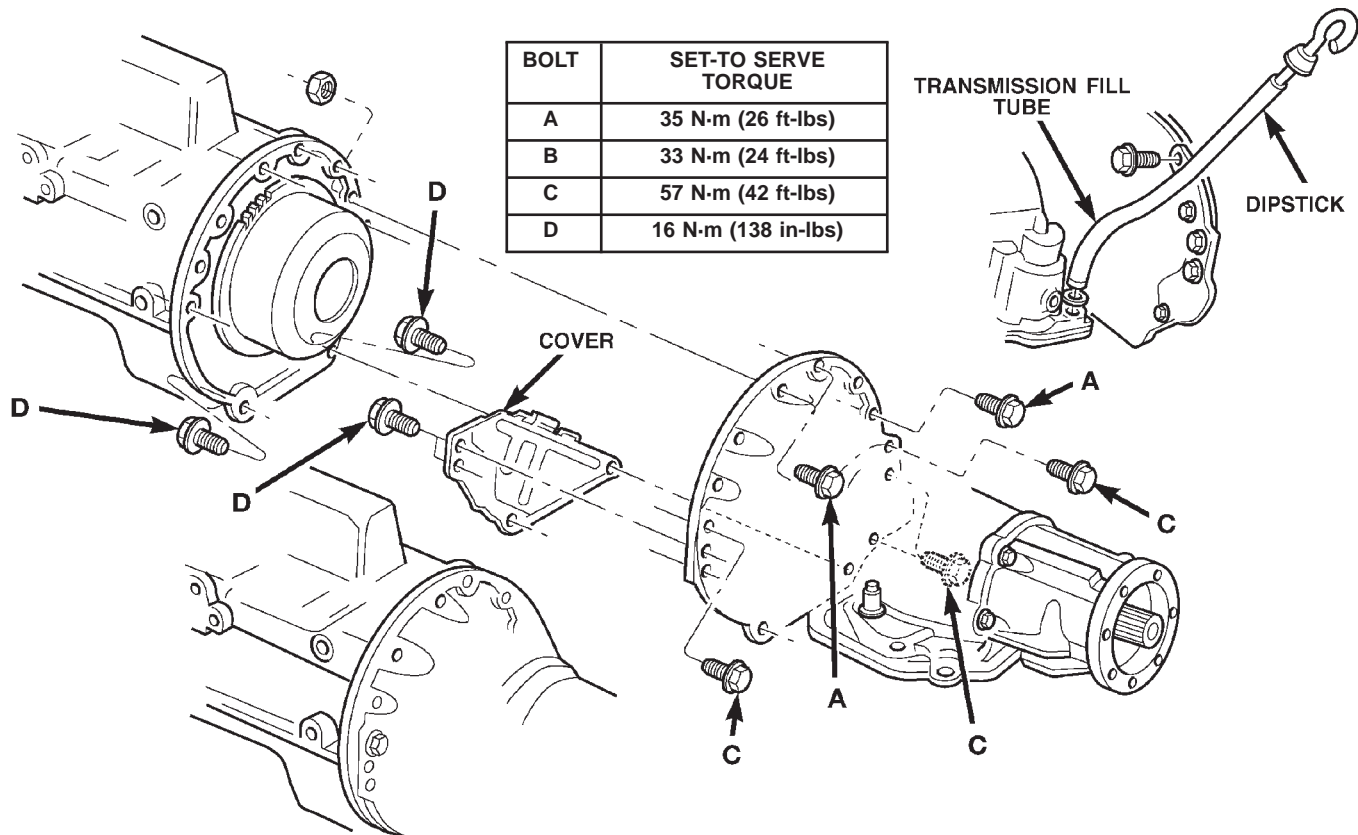

Fig. 69 Transmission Attachment

80c070a3

- (27) Install starter motor and cooler line bracket.
- (28) Install new plastic retainer grommet on any shift linkage rod or lever that was disconnected. Grommets should not be reused. Use pry tool to remove rod from grommet and cut away old grommet. Use pliers to snap new grommet into lever and to snap rod into grommet at assembly.
- (29) Connect gearshift and linkage and throttle cable.
- (30) Connect transfer case shift linkage.
- (31) Adjust gearshift linkage and throttle valve cable if necessary.
- (32) Align and connect propeller shaft(s).
- (33) Install skid plate, rear cushion and bracket, if removed.
- (34) Fill transfer case to bottom edge of fill plug hole.
- (35) Lower vehicle and fill transmission to correct level with Mopar® ATF Plus 3, type 7176 fluid.

TORQUE CONVERTER

REMOVAL

- (1) Remove transmission and torque converter from vehicle.
- (2) Place a suitable drain pan under the converter housing end of the transmission.

CAUTION: Verify that transmission is secure on the lifting device or work surface, the center of gravity of the transmission will shift when the torque converter is removed creating an unstable condition.

The torque converter is a heavy unit. Use caution when separating the torque converter from the transmission.

- (3) Pull the torque converter forward until the center hub clears the oil pump seal.

- (4) Separate the torque converter from the transmission.

INSTALLATION

Check converter hub and drive notches for sharp edges, burrs, scratches, or nicks. Polish the hub and notches with 320/400 grit paper or crocus cloth if necessary. The hub must be smooth to avoid damaging the pump seal at installation.

- (1) Lubricate converter hub and oil pump seal lip with transmission fluid.

- (2) Place torque converter in position on transmission.

CAUTION: Do not damage oil pump seal or bushing while inserting torque converter into the front of the transmission.

REMOVAL AND INSTALLATION (Continued)

- (3) Align torque converter to oil pump seal opening.
- (4) Insert torque converter hub into oil pump.
- (5) While pushing torque converter inward, rotate converter until converter is fully seated in the oil pump gears.
- (6) Check converter seating with a scale and straightedge (Fig. 70). Surface of converter lugs should be 1/2 in. to rear of straightedge when converter is fully seated.
- (7) If necessary, temporarily secure converter with C-clamp attached to the converter housing.
- (8) Install the transmission in the vehicle.
- (9) Fill the transmission with the recommended fluid.

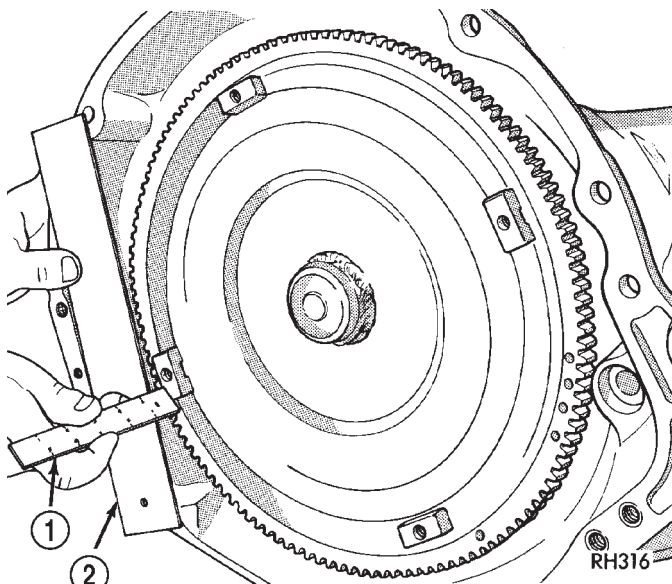

Fig. 70 Checking Torque Converter Seating

- 1 - SCALE
- 2 - STRAIGHTEDGE

YOKE SEAL REPLACEMENT

REMOVAL

- (1) Raise vehicle.
- (2) Mark propeller shaft and axle yoke for alignment reference.
- (3) Disconnect and remove propeller shaft.
- (4) Remove old seal with Seal Remover C-3985-B (Fig. 71) from extension housing.

INSTALLATION

- (1) Place seal in position on extension housing.
- (2) Drive seal into extension housing with Seal Installer C-3995-A or C-3972 (Fig. 72).
- (3) Carefully guide propeller shaft slip yoke into housing and onto output shaft splines. Align marks made at removal and connect propeller shaft to rear axle pinion yoke.

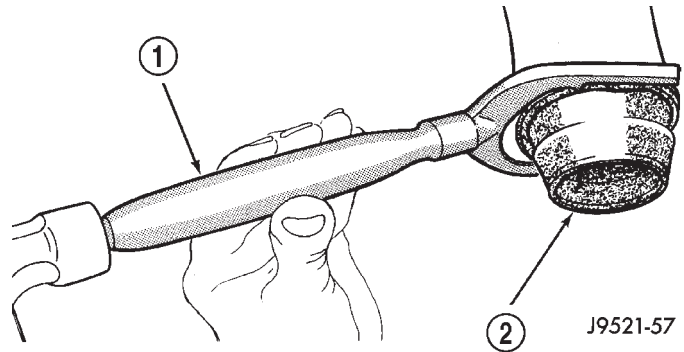

Fig. 71 Removing Extension Housing Yoke Seal

- 1 - SPECIAL TOOL C-3985-B
- 2 - SEAL

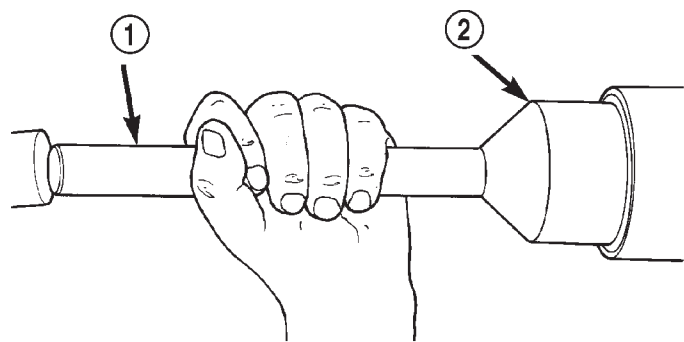

Fig. 72 Installing Extension Housing Yoke Seal

- 1 - SPECIAL TOOL C-4171
- 2 - SPECIAL TOOL C-3995-A

EXTENSION HOUSING BUSHING

REMOVAL

- (1) Remove housing yoke seal.
- (2) Insert Remover 6957 into extension housing. Tighten tool to bushing and remove bushing (Fig. 73).

INSTALLATION

- (1) Align bushing oil hole with oil slot in extension housing.
- (2) Tap bushing into place with Installer 6951 and Handle C-4171.
- (3) Install new oil seal in housing using Seal Installer C-3995-A (Fig. 74).

ADAPTER HOUSING

REMOVAL

- (1) Hoist and support vehicle on safety stands.
- (2) Support transmission with a suitable lifting device.
- (3) Remove transmission skid plate. Refer to Group 13, Frame and Bumpers, for proper procedure.

REMOVAL AND INSTALLATION (Continued)

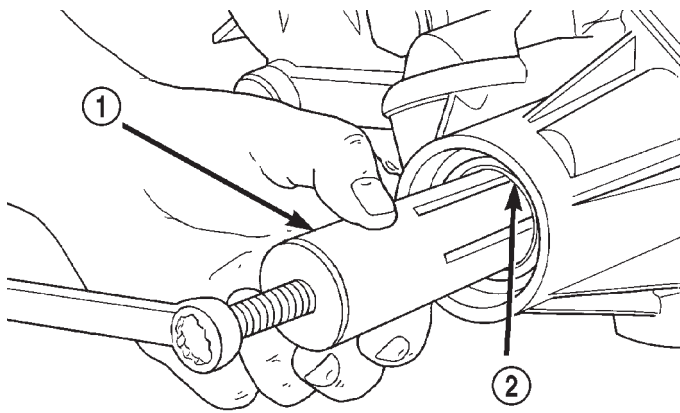
**Fig. 73 Bushing Removal—Typical**

80a11095

- 1 - REMOVER 6957
2 - EXTENSION HOUSING BUSHING

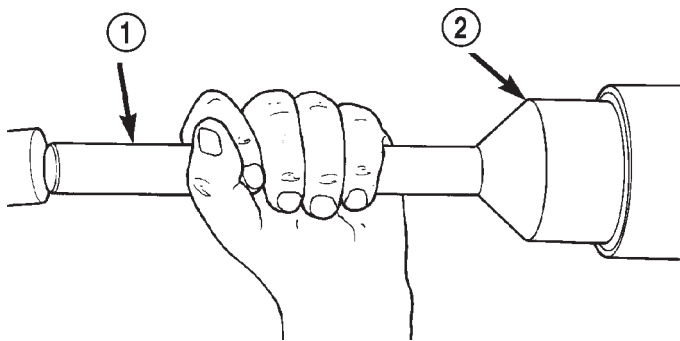

80a983a7

Fig. 74 Extension Housing Seal Installation

- 1 - SPECIAL TOOL C-4171
2 - SPECIAL TOOL C-3995-A

(4) Remove propeller shafts. Refer to Group 3, Differential and Driveline, for proper procedure.

(5) Remove transfer case.

(6) Remove bolts holding adapter housing to transmission case (Fig. 75).

(7) Separate adapter housing from transmission.

(8) Slide adapter housing rearward and off output shaft (Fig. 75).

INSTALLATION

Clear gasket material from sealing surfaces on adapter housing and rear of transmission. Replace output shaft bearing, if necessary.

(1) Install new rear seal in adapter housing. Use Tool Handle C-4171 and Seal Installer C-3860-A to install seal.

(2) Place adapter housing gasket in position on rear of transmission.

(3) Slide adapter housing forward and over output shaft (Fig. 75).

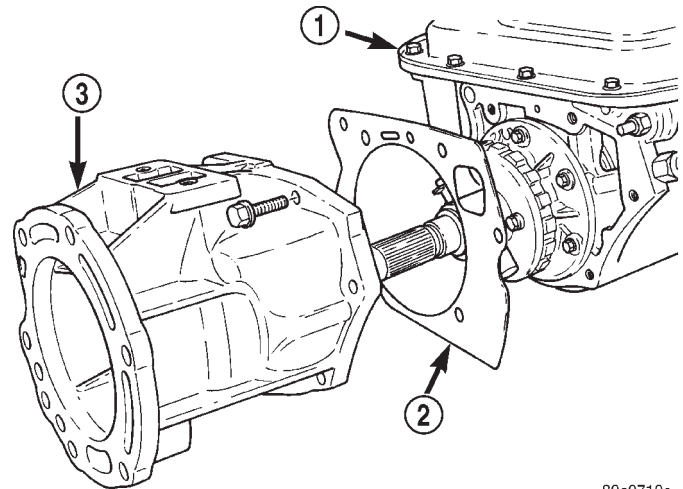

80c0710e

Fig. 75 Adapter Housing

- 1 - TRANSMISSION
2 - GASKET
3 - ADAPTER HOUSING

(4) Guide park shaft into park sprag and push adapter housing forward until rod passes through opening behind sprag. It may be necessary to use a wire to hold sprag to the side for rod to pass through.

(5) Install bolts to hold adapter housing to rear of transmission.

(6) Install transfer case.

(7) Install propeller shafts.

(8) Install rear transmission mount and skid plate.

(9) Lower vehicle and verify transmission fluid level. Add fluid as necessary.

SPEEDOMETER ADAPTER

Rear axle gear ratio and tire size determine speedometer pinion requirements.

REMOVAL

(1) Raise vehicle.

(2) Disconnect wires from vehicle speed sensor.

(3) Remove adapter clamp and screw (Fig. 76).

(4) Remove speed sensor and speedometer adapter as assembly.

(5) Remove speed sensor retaining screw and remove sensor from adapter.

(6) Remove speedometer pinion from adapter.

(7) Inspect sensor and adapter O-rings (Fig. 76). Remove and discard O-rings if worn or damaged.

(8) Inspect terminal pins in speed sensor. Clean pins with Mopar® electrical spray cleaner if dirty or oxidized. Replace sensor if faulty, or pins are loose, severely corroded, or damaged.

INSTALLATION

(1) Thoroughly clean adapter flange and adapter mounting surface in housing. Surfaces must be clean

REMOVAL AND INSTALLATION (Continued)

for proper adapter alignment and speedometer operation.

(2) Install new O-rings on speed sensor and speedometer adapter if necessary (Fig. 76).

(3) Lubricate sensor and adapter O-rings with transmission fluid.

(4) Install vehicle speed sensor in speedometer adapter. Tighten sensor attaching screw to 2-3 N-m (15-27 in. lbs.) torque.

(5) Install speedometer pinion in adapter.

(6) Count number of teeth on speedometer pinion. Do this before installing assembly in housing. Then lubricate pinion teeth with transmission fluid.

(7) Note index numbers on adapter body (Fig. 77). These numbers will correspond to number of teeth on pinion.

(8) Install speedometer assembly in housing.

(9) Rotate adapter until required range numbers are at 6 o'clock position. Be sure range index numbers correspond to number of teeth on pinion gear.

(10) Install speedometer adapter clamp and retaining screw. Tighten clamp screw to 10-12 N-m (90-110 in. lbs.) torque.

(11) Connect wires to vehicle speed sensor.

(12) Lower vehicle and top off transmission fluid level, if necessary.

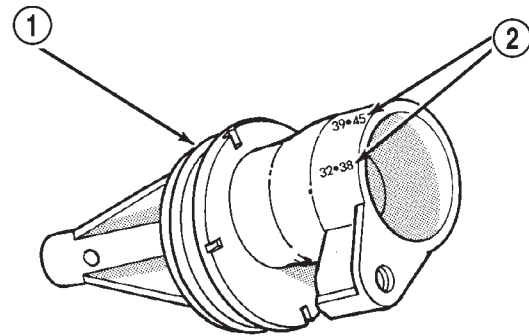

J9321-386

Fig. 77 Index Numbers On Speedometer Pinion Adapter

- 1 - SPEEDOMETER ADAPTER
- 2 - INDEX NUMBER LOCATION

PARK/NEUTRAL POSITION SWITCH

REMOVAL

- (1) Raise vehicle and position drain pan under switch.
- (2) Disconnect switch wires.
- (3) Remove switch from case.

| ITEM | TORQUE |
|------|-----------------------------|
| A | 2-3 N-m (15-27 in. lbs.) |
| B | 10-12 N-m (90-110 in. lbs.) |

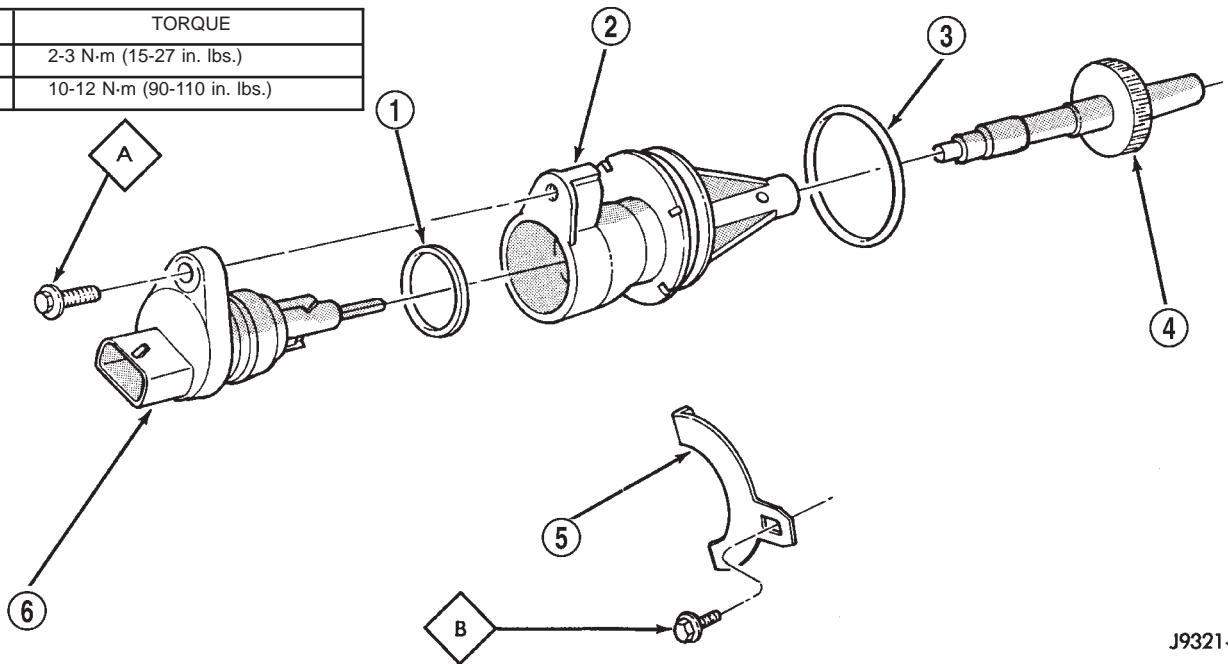

J9321-385

Fig. 76 Speedometer Pinion Adapter Components

- 1 - SENSOR O-RING
- 2 - SPEEDOMETER ADAPTER
- 3 - ADAPTER O-RING
- 4 - SPEEDOMETER PINION
- 5 - ADAPTER CLAMP
- 6 - VEHICLE SPEED SENSOR

REMOVAL AND INSTALLATION (Continued)

INSTALLATION

(1) Move shift lever to Park and Neutral positions. Verify that switch operating lever fingers are centered in switch opening in case (Fig. 78).

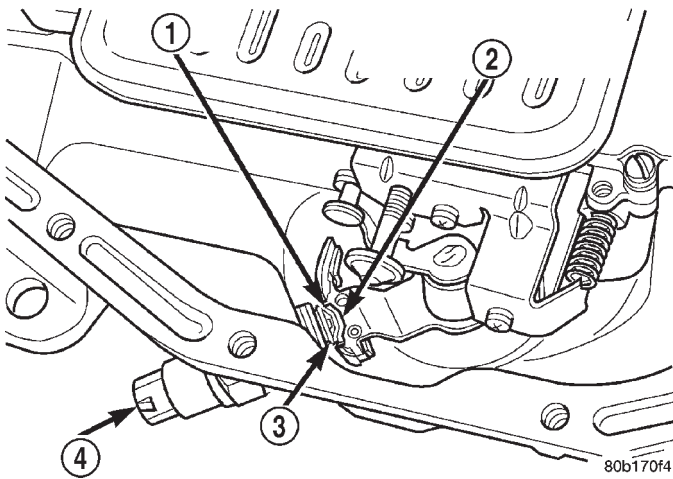

Fig. 78 Park/Neutral Position Switch

- 1 - NEUTRAL CONTACT
- 2 - MANUAL LEVER AND SWITCH PLUNGER IN REVERSE POSITION
- 3 - PARK CONTACT
- 4 - SWITCH

(2) Install new seal on switch and install switch in case. Tighten switch to 34 N·m (25 ft. lbs.) torque.

(3) Test continuity of new switch with 12V test lamp.

(4) Connect switch wires and lower vehicle.

(5) Top off transmission fluid level.

GEARSHIFT CABLE

REMOVAL

(1) Shift transmission into Park.

(2) Remove shift lever bezel and necessary console parts for access to shift lever assembly.

(3) Disconnect cable at shift lever and feed cable through dash panel opening to underside of vehicle.

(4) Raise vehicle.

(5) Disengage cable eyelet at transmission shift lever and pull cable adjuster out of mounting bracket. Then remove old cable from vehicle.

INSTALLATION

(1) Route cable through hole in dash panel. Fully seat cable grommet into dash panel.

(2) Place the auto transmission manual shift control lever in "Park" detent (rearmost) position and rotate prop shaft to ensure transmission is in park.

(3) Connect shift cable to shifter mechanism by snapping cable retaining ears into shifter bracket and press cable end fitting onto lever ball stud.

(4) Place the floor shifter lever in park position. Ensure that the pawl is seated within the confines of the adjustment gauge clip.

(5) Snap the cable into the transmission bracket so the retaining ears are engaged and connect cable end fitting onto the manual control lever ball stud.

(6) Lock shift cable into position by pushing upward on the adjusting lock button.

(7) Remove and discard the shift cable adjustment gauge clip from the park gate of the shifter.

BRAKE TRANSMISSION SHIFT INTERLOCK

REMOVAL

(1) Remove lower steering column cover. Refer to Group 8E, Instrument Panel and Gauges, for proper procedure.

(2) Remove lower steering column shroud. Refer to Group 19, Steering, for proper procedure.

(3) Remove tie strap near the solenoid retaining the brake transmission interlock cable to the steering column.

(4) Disengage wire connector from solenoid.

(5) With the ignition removed or in the unlocked position, disengage lock tab holding cable end to steering column (Fig. 79).

(6) Pull cable end from steering column.

(7) Remove the floor console and related trim. Refer to Group 23, Body, for proper procedure.

(8) Disconnect the cable eyelet from the bellcrank (Fig. 80).

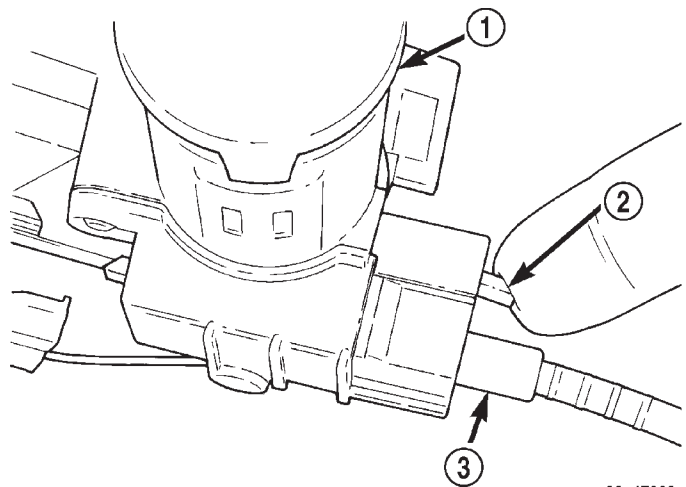
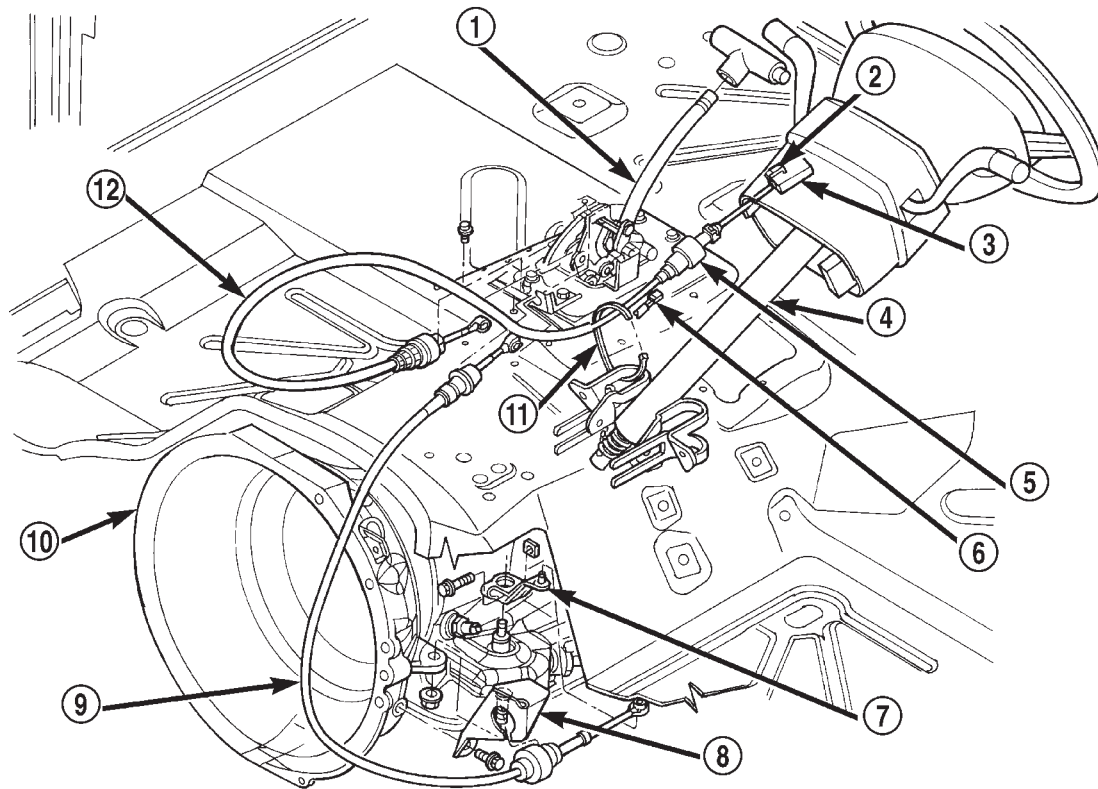

Fig. 79 Brake/Park Interlock Cable

- 1 - IGNITION LOCK
- 2 - LOCK TAB
- 3 - CABLE END

(9) Disconnect and remove the cable from the shift bracket.

REMOVAL AND INSTALLATION (Continued)



80a13876

Fig. 80 Cable and Shifter

- | | |
|-----------------------------|---------------------------------|
| 1 - SHIFT MECHANISM | 7 - LEVER |
| 2 - LOCK-TAB | 8 - MOUNT BRACKET |
| 3 - IGNITION LOCK INTERLOCK | 9 - SHIFT CABLE |
| 4 - STEERING COLUMN | 10 - AUTOMATIC TRANSMISSION |
| 5 - SOLENOID | 11 - TIE STRAP |
| 6 - WIRE CONNECTOR | 12 - PARK/BRAKE INTERLOCK CABLE |

INSTALLATION

(1) Route replacement cable behind instrument panel and under floor console area to shift mechanism (Fig. 80).

(2) Insert cable end into opening in steering column hub under ignition lock. Push cable inward until lock tab engages.

(3) Connect the cable end eyelet onto shifter bellcrank pin.

(4) Place gear selector in PARK.

(5) Push the spring-loaded cable adjuster forward and snap cable into bracket.

(6) Adjust the brake transmission shifter interlock cable. Refer to the Adjustment portion of this section for proper procedures.

(7) Verify that the cable adjuster lock clamp is pushed downward to the locked position.

(8) Test the park-lock cable operation.

(9) Install the floor console and related trim.

(10) Install tie strap to hold cable to base of steering column.

(11) Install lower steering column shroud and ignition lock.

(12) Install lower steering column cover.

VALVE BODY**REMOVAL**

(1) Raise vehicle.

(2) Remove oil pan and drain fluid.

(3) Loosen clamp bolts and remove throttle and manual valve levers from manual lever shaft.

(4) Remove park/neutral position switch.

(5) Remove filter from valve body.

(6) Depress retaining clip and pull solenoid wire from case connector (Fig. 81).

(7) Remove valve body attaching screws.

(8) Lower valve body enough to remove accumulator piston and piston spring (Fig. 82).

REMOVAL AND INSTALLATION (Continued)

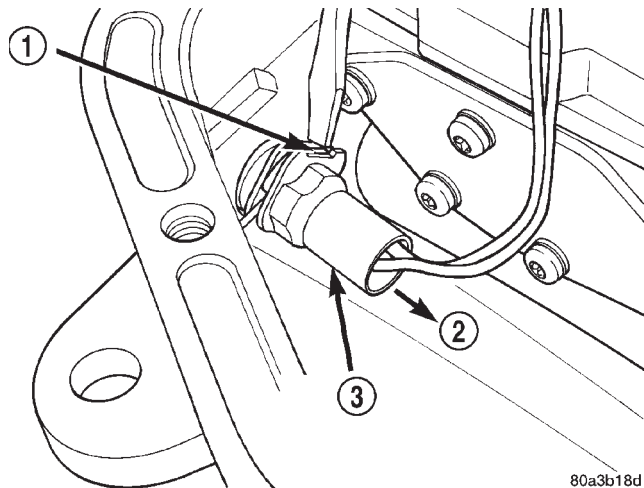
**Fig. 81 Solenoid Wire Connector**

- 1 - PUSH CLIP IN
- 2 - PULL
- 3 - CONVERTER CLUTCH SOLENOID CONNECTOR

(9) Pull valve body forward to disengage park rod.
 (10) Push manual lever shaft and solenoid case connector out of transmission case.

(11) Lower valve body, rotate it away from case, pull park lock rod out of sprag, and remove valve body (Fig. 83).

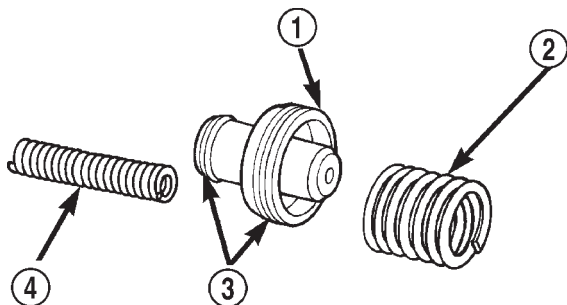
**Fig. 82 Accumulator Piston And Springs**

- 1 - ACCUMULATOR PISTON
- 2 - OUTER SPRING
- 3 - PISTON SEAL RINGS
- 4 - INNER SPRING (32RH)

INSTALLATION

(1) Verify that park/neutral position switch is **NOT** installed. Valve body cannot be installed with switch in place. Remove switch if necessary.

(2) Install new seals on accumulator piston if necessary, and install piston in case. Use small amount of petroleum jelly to hold piston in place.

(3) Place valve body manual lever in low (1 position) to ease inserting park rod into sprag.

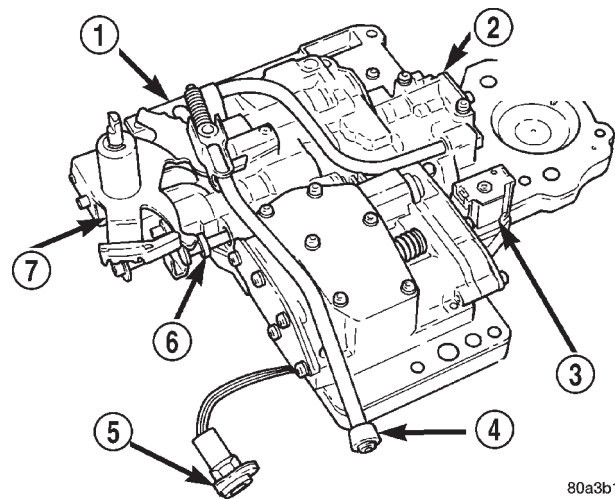
**Fig. 83 Valve Body**

- 1 - VALVE BODY
- 2 - CONVERTER CLUTCH MODULE
- 3 - SOLENOID
- 4 - PARK ROD
- 5 - CONVERTER CLUTCH SOLENOID CONNECTOR
- 6 - MANUAL VALVE
- 7 - MANUAL LEVER

(4) Use screwdriver to push park sprag into engagement with park gear. This makes clearance for knob on lock rod to move past sprag when valve body is installed. Rotate output shaft to verify sprag engagement.

(5) Position accumulator spring between accumulator piston and valve body.

(6) Position valve body on transmission and work knob on park lock rod past sprag. Be sure accumulator piston and spring remain in position.

(7) Hold valve body in position and install valve body screws finger tight.

(8) Install park/neutral position switch.

(9) Tighten valve body screws alternately and evenly to 11 N·m (100 in. lbs.) torque.

(10) Install new fluid filter on valve body. Install and tighten filter screws to 4 N·m (35 in. lbs.) torque.

(11) Connect solenoid wire to case connector.

(12) Install manual and throttle levers on throttle lever shaft. Tighten lever clamp screws and check for free operation. Shaft and levers must operate freely without any bind.

(13) Install oil pan and new gasket. Tighten pan bolts to 17 N·m (150 in. lbs.) torque. Install gasket dry; do not use sealer.

(14) Connect park/neutral position switch and converter clutch solenoid wires.

(15) Install speedometer pinion gear, adapter and speed sensor.

(16) Lower vehicle.

REMOVAL AND INSTALLATION (Continued)

- (17) Fill transmission with Mopar® ATF Plus 3, Type 7176 fluid.
- (18) Adjust gearshift and throttle cable if necessary.

OUTPUT SHAFT REAR BEARING

REMOVAL

- (1) Remove extension housing.
- (2) Remove snap ring that retains rear bearing on output shaft (Fig. 84).
- (3) Remove bearing from output shaft.

INSTALLATION

- (1) Install bearing on output shaft. Be sure retaining ring groove in outer circumference of bearing is toward the governor.
- (2) Install rear bearing retaining snap ring (Fig. 84).
- (3) Install extension housing.

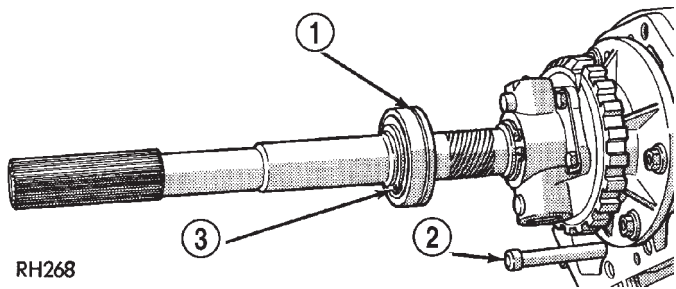

Fig. 84 Output Shaft Rear Bearing—Typical

- 1 - BEARING SNAP RING GROOVE
- 2 - PARK LOCK CONTROL ROD
- 3 - REAR SNAP RING

GOVERNOR AND PARK GEAR

REMOVAL

- (1) Hoist and support vehicle on safety stands.
- (2) Mark propeller shaft and axle yoke for assembly reference. Then disconnect and remove shaft.
- (3) Disconnect parking brake cable at equalizer and disconnect exhaust components as necessary.
- (4) Support transmission on a suitable lifting device.
- (5) Remove skid plate and rear transmission mount.
- (6) Remove extension housing.
- (7) Loosen but do not remove bolts that hold governor body to park gear.
- (8) Rotate transmission output shaft until governor weight assembly is accessible.
- (9) Remove E-clip at end of governor valve shaft (Fig. 85).

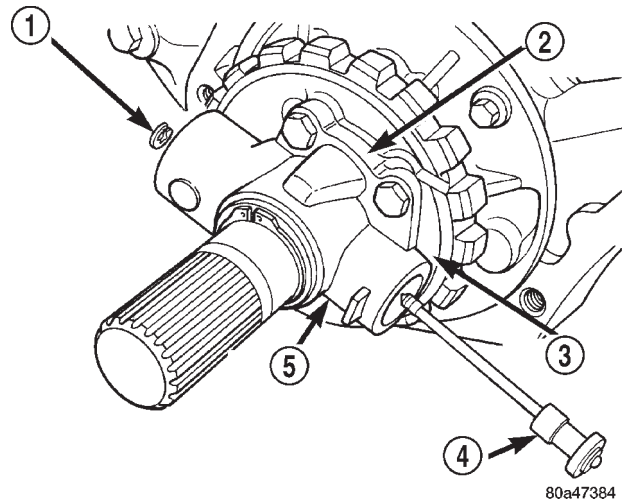

Fig. 85 Governor Valve

- 1 - E-CLIP
- 2 - PARK GEAR
- 3 - CURVER BOSS
- 4 - GOVERNOR VALVE
- 5 - GOVERNOR

- (10) Remove governor valve and shaft from governor body (Fig. 85).
- (11) Remove snap rings and spacer that retain governor body and park gear assembly on output shaft (Fig. 86).
- (12) Remove bolts holding governor body to park gear (Fig. 87).
- (13) Separate governor from park gear.
- (14) Pull park gear from rear support.

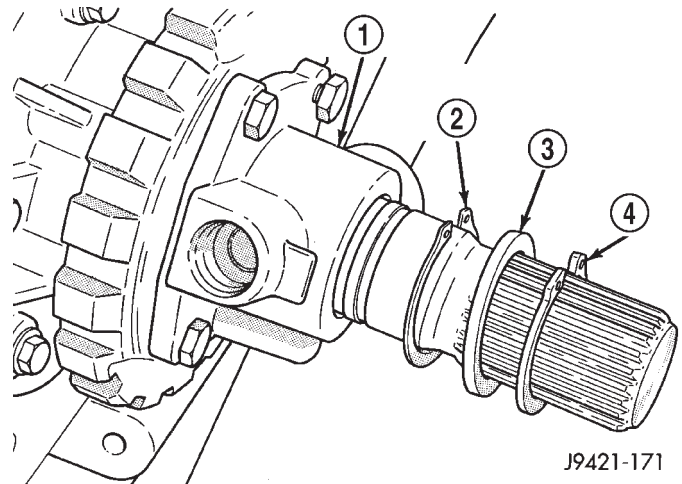

Fig. 86 Snap Rings And Spacer

- 1 - GOVERNOR BODY
- 2 - THIN SNAP RING
- 3 - THRUST WASHER
- 4 - THICK SNAP RING

REMOVAL AND INSTALLATION (Continued)

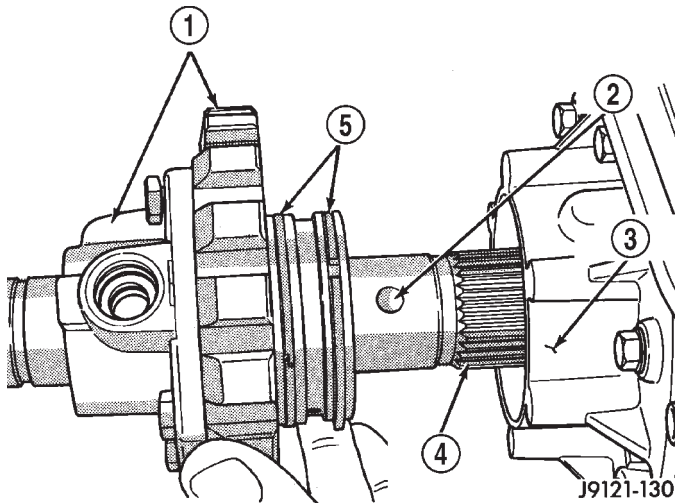

Fig. 87 Governor Body

- 1 - GOVERNOR/PARK ASSEMBLY
- 2 - GOVERNOR VALVE SHAFT BORE
- 3 - REAR SUPPORT
- 4 - OUTPUT SHAFT SPLINES
- 5 - SEAL RINGS

INSTALLATION

- (1) Install park gear into rear support so crown on curved boss is in line with hole through output shaft.
- (2) Install governor filter in park gear.
- (3) Slip governor body over output shaft and align port to filter.
- (4) Install bolts to hold governor body to park gear. Tighten bolts to 11 N·m (95 in. lbs.) torque (Fig. 87).
- (5) Install governor body-park gear snap rings and washer on output shaft as follows:
 - (a) Install thin snap ring first. Then install thrust washer second, and thick snap ring last (Fig. 86).
 - (b) Verify correct position of snap rings. **Be sure flat side of each snap ring is toward governor body.**
- (6) Insert governor valve and shaft through governor and install E-clip (Fig. 85).
- (7) Install extension housing and gasket on transmission. Tighten housing bolts to 32 N·m (24 ft. lbs.).
- (8) Install rear transmission mount and skid plate.
- (9) Install speed sensor and speedometer components and connect speed sensor wires.
- (10) Connect exhaust components and brake cable, if removed.
- (11) Install propeller shaft.
- (12) Remove supports and lower vehicle.
- (13) Check transmission fluid level. Add fluid if necessary.

PARK LOCK

REMOVAL

- (1) Raise vehicle and remove propeller shaft.
- (2) Remove extension housing.
- (3) Slide sprag shaft out of extension housing and remove sprag and spring (Fig. 88).
- (4) Remove snap ring and slide reaction plug and pin assembly out of housing.
- (5) If park rod requires service, it will be necessary to remove valve body.

INSTALLATION

- (1) Inspect sprag shaft for scores and free movement in housing and sprag. Inspect sprag and control rod springs for distortion and loss of tension. Replace worn, damaged parts as necessary.
- (2) Inspect square lug on sprag for broken edges. Check lugs on park gear for damage. Inspect knob on end of control rod for wear grooves, or being seized on rod. Replace rod if bent, if knob is worn/grooved, or it has seized on rod. Replace park gear if lugs are damaged. Replace the park lock rod if it is suspected that the rod is not the correct length.
- (3) Install reaction plug and pin assembly in housing and secure with new snap ring (Fig. 88).
- (4) Position sprag and spring in housing and insert sprag shaft. Be sure square lug on sprag is toward park gear. Also be sure spring is positioned so it moves sprag away from gear.
- (5) Install extension housing.
- (6) Install propeller shaft and lower vehicle.
- (7) Check transmission fluid level. Add fluid if necessary.

DISASSEMBLY AND ASSEMBLY

GOVERNOR AND PARK GEAR

DISASSEMBLY

- (1) Remove governor body from transmission.
- (2) Clean and inspect governor filter (Fig. 89).
- (3) Remove snap ring and washer that secure governor weight assembly in body (Fig. 90).
- (4) Remove governor weight assembly from governor body bore.
- (5) Slide intermediate and inner weight from outer weight.
- (6) Position intermediate weight on suitable size socket (Fig. 91).
- (7) Push inner weight downward with nut driver. Then remove inner weight snap ring with Miller Plier Tool 6823 (Fig. 91).
- (8) Remove inner weight and spring from intermediate weight.

DISASSEMBLY AND ASSEMBLY (Continued)

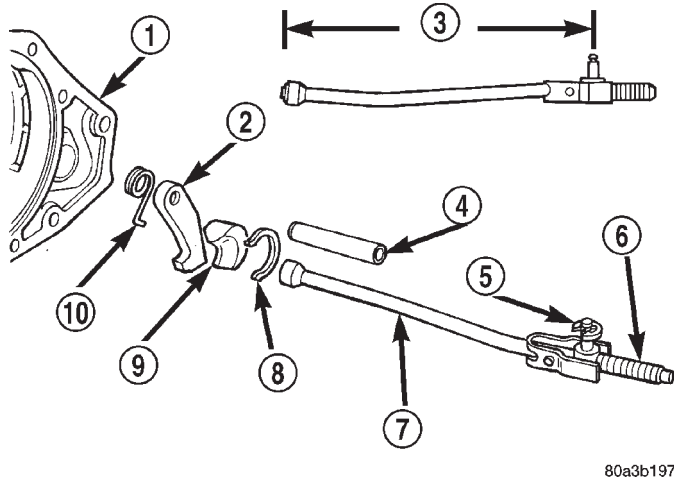

80a3b197

Fig. 88 Park Lock

- 1 - EXTENSION HOUSING
- 2 - SPRAG
- 3 - 8"
- 4 - SHAFT
- 5 - E-CLIP
- 6 - SPRING
- 7 - CONTROL ROD
- 8 - SNAP RING
- 9 - PLUG AND PIN
- 10 - SPRING

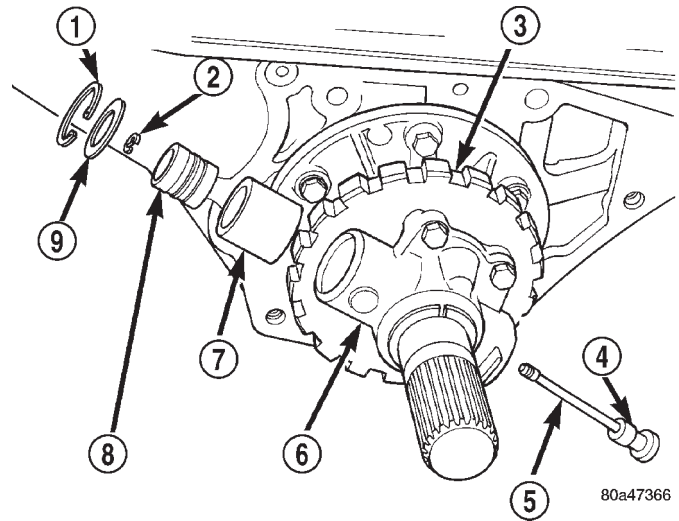

80a47366

Fig. 90 Snap Ring, Washer, and Outer Weight

- 1 - SNAP-RING
- 2 - E-CLIP
- 3 - PARK GEAR
- 4 - GOVERNOR VALVE
- 5 - SHAFT
- 6 - GOVERNOR
- 7 - OUTER WEIGHT
- 8 - INTERMEDIATE WEIGHT
- 9 - WASHER

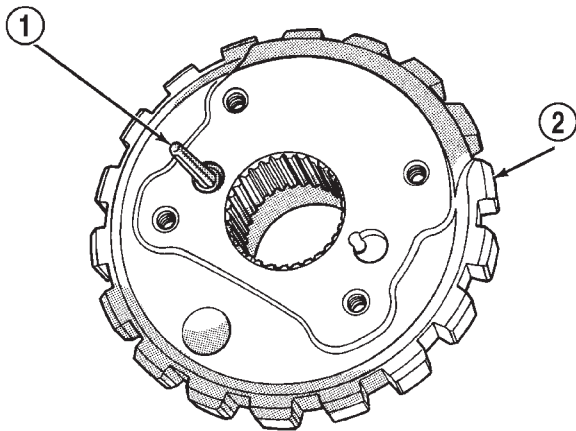

J9521-31

Fig. 89 Governor Filter

- 1 - GOVERNOR FILTER
- 2 - PARK GEAR

ASSEMBLY

CAUTION: Exercise care when installing the rings. They are easily broken if overspread or twisted during installation.

If it was necessary to remove the park gear, inspect the seal rings and bore in rear support.

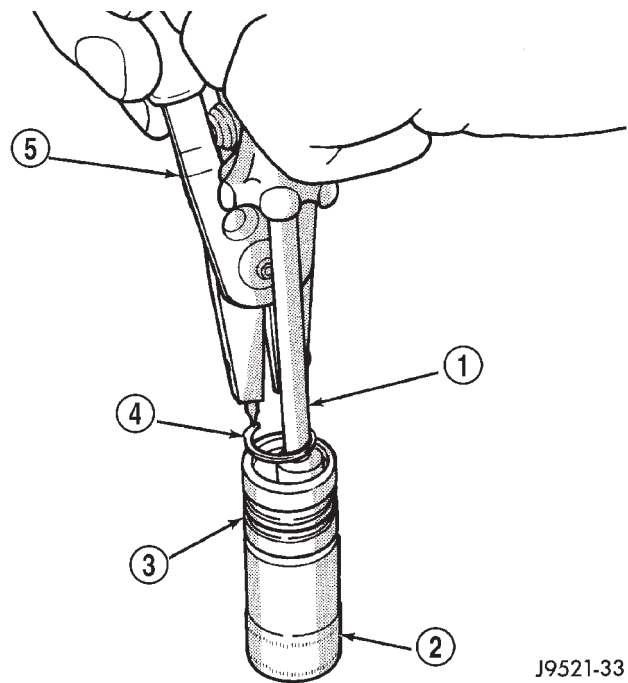

J9521-33

Fig. 91 Inner Weight Snap Ring

- 1 - NUT DRIVER
- 2 - SUITABLE SIZE SOCKET
- 3 - INTERMEDIATE WEIGHT
- 4 - INNER WEIGHT SNAP RING
- 5 - SPECIAL TOOL 6823

DISASSEMBLY AND ASSEMBLY (Continued)

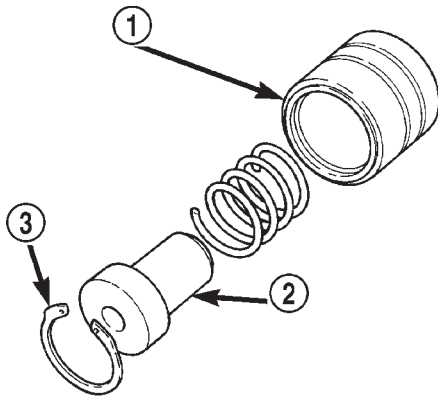

80a47367

Fig. 92 Intermediate and Inner Governor Weights

- 1 - INTERMEDIATE WEIGHT
- 2 - INNER WEIGHT
- 3 - SNAP-RING

Install new seal rings on park gear hub only if original rings are damaged, or worn. Install ring with interlock ends first and ring with plain ends last. Slip each ring on hub and seat them in grooves. Verify that rear ring ends are securely interlocked before proceeding. If the bore in rear support is damaged, replace the rear support.

(1) Lubricate governor components with Mopar® ATF Plus 3, Type 7176 transmission fluid before assembly.

(2) Clean and inspect governor weights and bores for scoring or wear. Replace the governor body and weights if damaged. Refer to Cleaning and Inspection section of this group for proper procedure.

(3) Insert spring into intermediate weight.

(4) Insert inner weight into intermediate weight and install snap-ring (Fig. 92). Verify snap-ring is fully seated in groove in intermediate weight (Fig. 91).

(5) Assemble governor weights into governor body (Fig. 90).

(6) Install washer and snap ring to hold weights in governor body.

(7) Install governor body in transmission

VALVE BODY**DISASSEMBLY**

Position the valve body on a clean work surface to avoid contamination.

CAUTION: Do not clamp any part of the valve body assembly (Fig. 93) in a vise. This practice will distort the valve body and transfer plate resulting in valve bind. Slide valves and plugs out carefully. Do not use force at any time. The valves and valve

body will be damaged if force is used. Also tag or mark the valve body springs for reference as they are removed. Do not allow them to become inter-mixed.

(1) Remove screws attaching adjusting screw bracket to valve body and transfer plate. Hold bracket firmly against spring force while removing last screw.

(2) Remove adjusting screw bracket, line pressure adjusting screw (Fig. 94).

(3) Remove switch valve and spring, pressure regulator valve and spring, kickdown valve and spring, and throttle valve from valve body (Fig. 94).

(4) Secure detent ball and spring in housing with Retainer Tool 6583 (Fig. 95).

(5) Remove manual shaft E-clip, washer, and seal (Fig. 96).

(6) Pull manual shaft and park rod assembly upward out of valve body and off throttle lever (Fig. 96).

(7) Remove manual valve from valve body (Fig. 97)

(8) Remove Retainer Tool 6583. Then remove and retain detent ball and spring (Fig. 96).

(9) Remove throttle lever (Fig. 96).

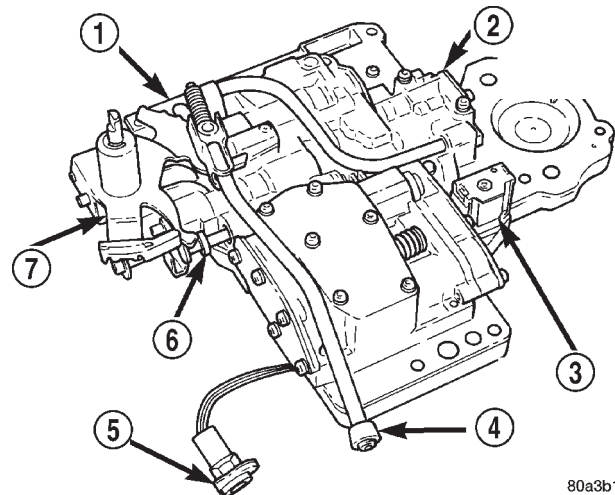

80a3b19f

Fig. 93 Valve Body Assembly

- 1 - VALVE BODY
- 2 - CONVERTER CLUTCH MODULE
- 3 - SOLENOID
- 4 - PARK ROD
- 5 - CONVERTER CLUTCH SOLENOID CONNECTOR
- 6 - MANUAL VALVE
- 7 - MANUAL LEVER

(10) Remove park rod E-clip and separate rod from manual lever (Fig. 98).

DISASSEMBLY AND ASSEMBLY (Continued)

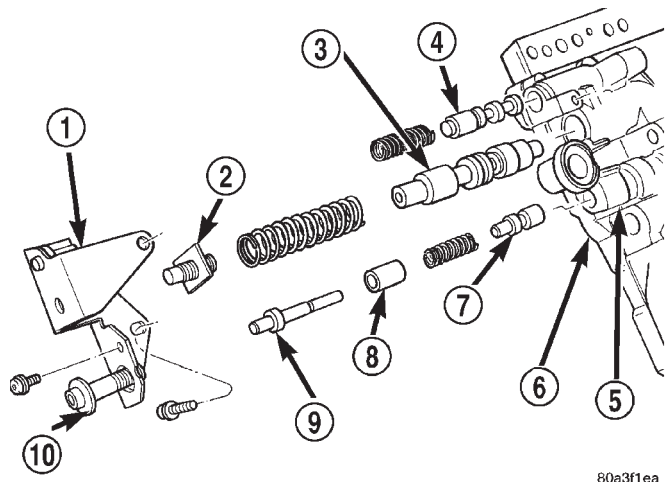

80a3f1ea

Fig. 94 Adjusting Screw Bracket, Springs, Valve Removal

- 1 - ADJUSTER BRACKET
- 2 - LINE PRESSURE ADJUSTER
- 3 - PRESSURE REGULATOR VALVE
- 4 - SWITCH VALVE
- 5 - VALVE BODY
- 6 - TRANSFER PLATE
- 7 - THROTTLE VALVE
- 8 - SLEEVE
- 9 - KICKDOWN VALVE
- 10 - THROTTLE PRESSURE ADJUSTER

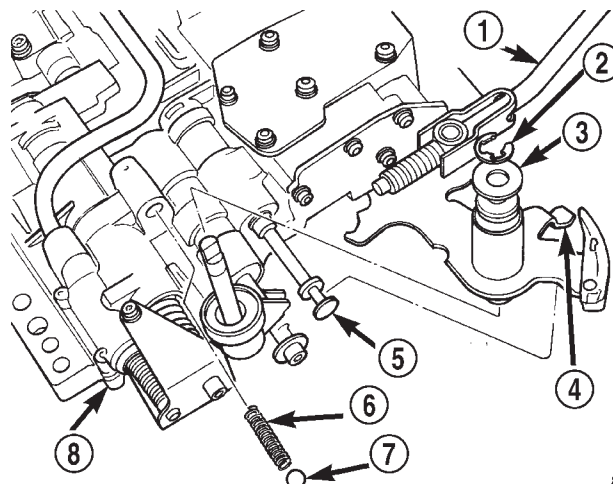

80a3f1eb

Fig. 96 Manual And Throttle Levers

- 1 - PARK ROD
- 2 - E-RING
- 3 - WASHER
- 4 - MANUAL LEVER
- 5 - MANUAL VALVE
- 6 - SPRING
- 7 - DETENT BALL
- 8 - VALVE BODY

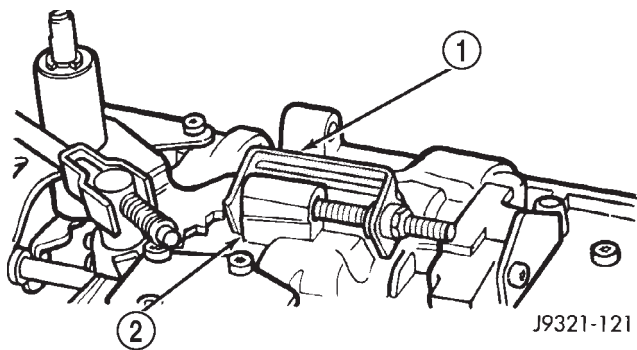

J9321-121

Fig. 95 Securing Detent Ball And Spring With Retainer Tool

- 1 - SPECIAL TOOL 6583
- 2 - DETENT BALL AND SPRING HOUSING

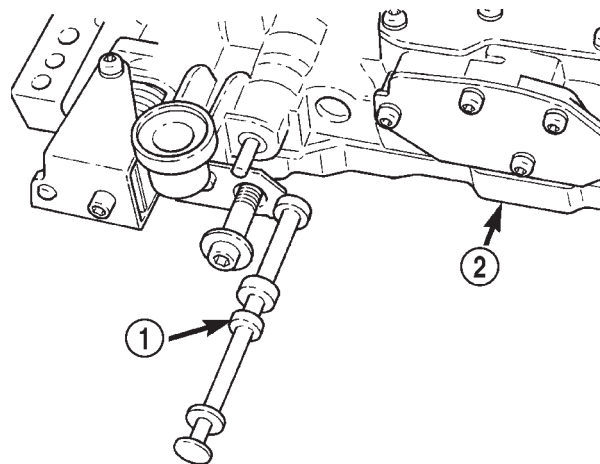

80a48368

Fig. 97 Manual Valve

- 1 - MANUAL VALVE
- 2 - VALVE BODY

(11) Remove converter clutch solenoid from separator plate (Fig. 99). A T25 torx bit is required to remove solenoid attaching screw.

(12) Remove screws attaching converter clutch module to valve body and remove module and connecting tube (Fig. 100).

(13) Remove screws attaching end cover plate to torque converter module (Fig. 101).

(14) Remove converter clutch valve, fail safe valve, and springs (Fig. 101)

(15) Turn valve body over so transfer plate is facing upward (Fig. 102). With valve body in this position, valve body check balls will remain in place and not fall out when transfer plate is removed.

(16) Remove screws attaching transfer plate to valve body (Fig. 102).

(17) Remove transfer plate and separator plate from valve body (Fig. 102). Note position of filter and clutch solenoid for reference. Remove valve body check balls.

DISASSEMBLY AND ASSEMBLY (Continued)

(18) Position transfer plate on bench so separator plate, and filter are facing up. This will avoid having rear clutch and rear servo check balls fall out when plates are separated.

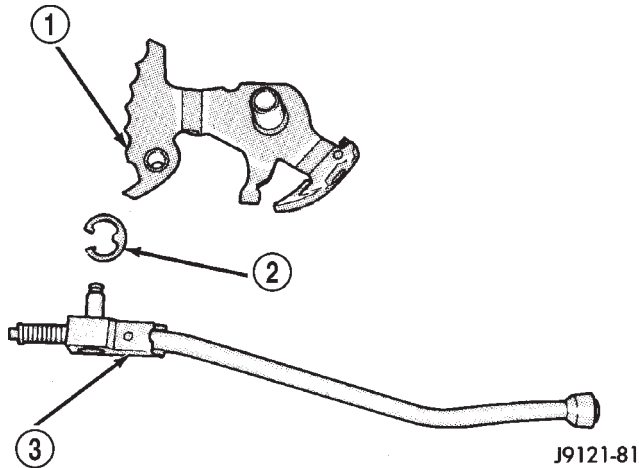

Fig. 98 Park Rod

J9121-81

- 1 - MANUAL LEVER
- 2 - E-CLIP
- 3 - PARK ROD

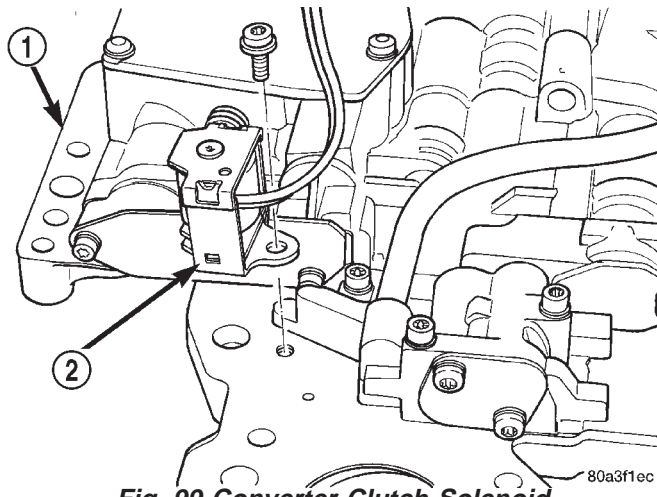

Fig. 99 Converter Clutch Solenoid

80a3f1ec

- 1 - VALVE BODY
- 2 - TORQUE CONVERTER CLUTCH SOLENOID

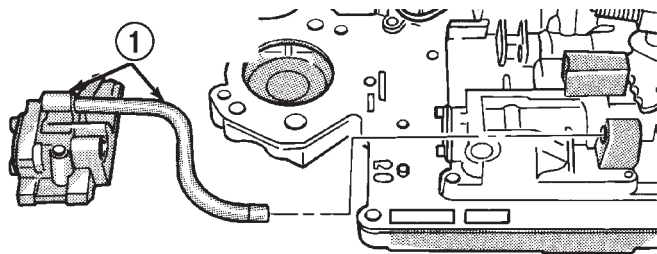
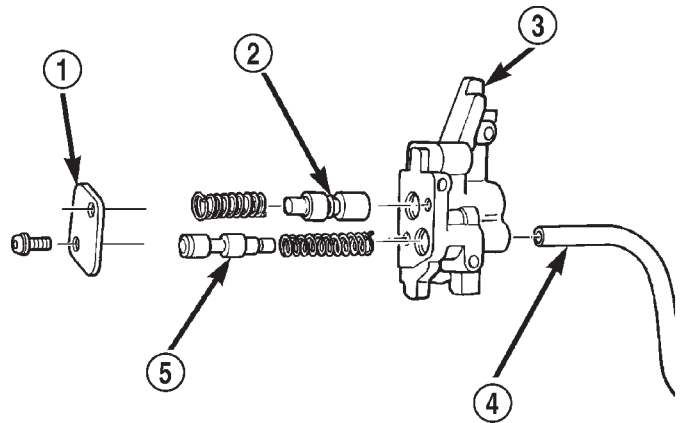

Fig. 100 Clutch Module And Connecting Tube

J9121-178

- 1 - MODULE AND CONNECTING TUBE



80a410c0

Fig. 101 Converter Clutch and Fail Safe Valves

- 1 - COVER PLATE
- 2 - CONVERTER CLUTCH VALVE
- 3 - TORQUE CONVERTER CLUTCH MODULE
- 4 - MODULE CONNECTING TUBE
- 5 - FAIL-SAFE VALVE

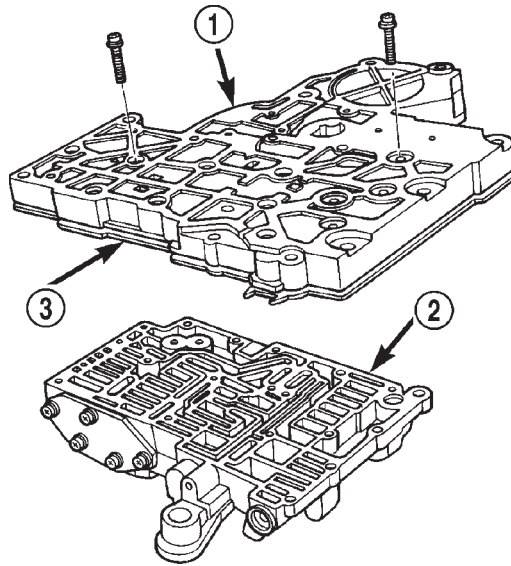

80a47394

Fig. 102 Valve Body Transfer Plate Screws

- 1 - TRANSFER PLATE
- 2 - VALVE BODY
- 3 - SEPARATOR PLATE

(19) Remove screws attaching separator plate to transfer plate (Fig. 103).

(20) Note position of filter, rear clutch servo and rear servo check balls for assembly reference (Fig. 103) and (Fig. 104).

(21) Remove shuttle valve end plate (Fig. 105).

(22) Remove shuttle valve E-clip and remove secondary spring and spring guides from end of valve (Fig. 106).

DISASSEMBLY AND ASSEMBLY (Continued)

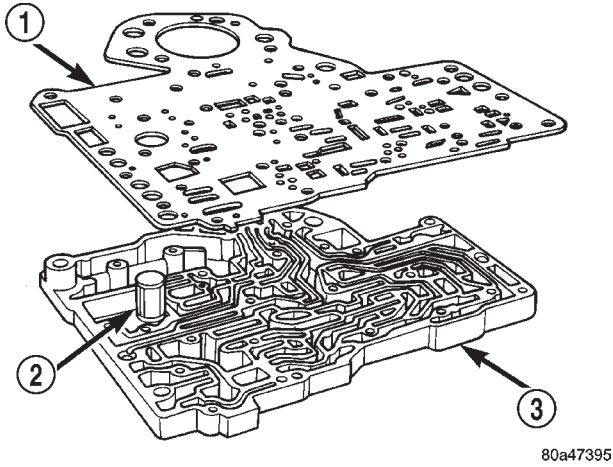

Fig. 103 Transfer And Separator Plates

- 1 - SEPARATOR PLATE
- 2 - FILTER
- 3 - TRANSFER PLATE

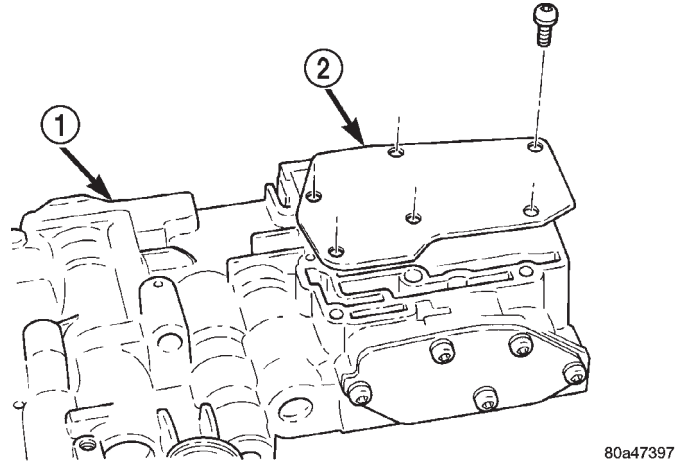

Fig. 105 Shuttle Valve End Plate

- 1 - VALVE BODY
- 2 - SHUTTLE VALVE END PLATE

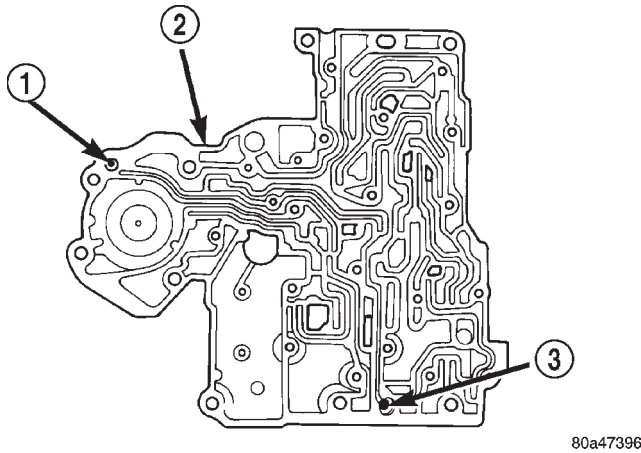

Fig. 104 Rear Servo and Rear Clutch Check Balls

- 1 - REAR SERVO CHECK BALL
- 2 - TRANSFER PLATE
- 3 - REAR CLUTCH CHECK BALL

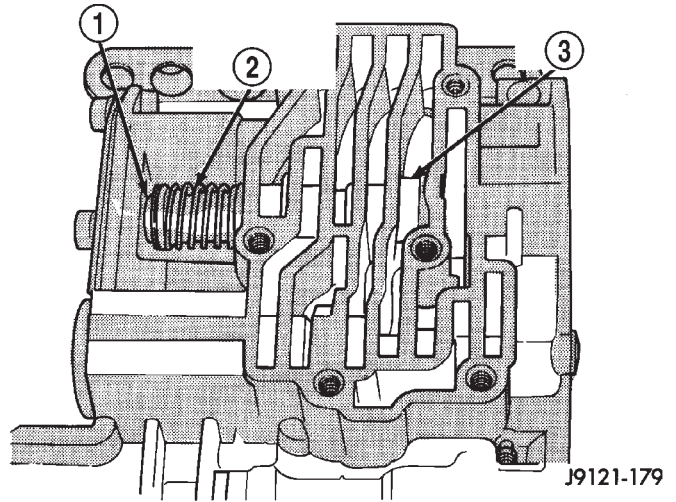

Fig. 106 Shuttle Valve E-Clip And Secondary Spring

- 1 - E-CLIP
- 2 - SECONDARY SPRING AND GUIDES
- 3 - SHUTTLE VALVE

- (23) Remove governor plug end plate (Fig. 107).
- (24) Remove 1-2 and 2-3 shift valve governor plugs from valve body (Fig. 107).
- (25) Remove shuttle valve throttle plug, primary spring and shuttle valve from valve body (Fig. 107).
- (26) Remove screws attaching kickdown limit valve body to valve body (Fig. 107).
- (27) Remove 1-2 shift control valve and spring from valve body (Fig. 107).
- (28) Remove 2-3 shift valve and spring from valve body (Fig. 107).
- (29) Remove 1-2 shift valve and spring from valve body (Fig. 107).
- (30) Remove throttle pressure plug from kickdown limit valve body (Fig. 107).

- (31) Remove retainer from end of kickdown limit valve body (Fig. 107).
- (32) Remove kickdown limit valve and spring from kickdown limit valve body (Fig. 107).
- (33) Remove regulator valve end plate from valve body (Fig. 107).
- (34) Remove regulator valve line pressure plug, pressure plug sleeve, regulator valve throttle pressure plug and spring (Fig. 107).

ASSEMBLY

Clean and inspect all valve body components for damage or wear. Refer to the Cleaning and Inspection section of this group for proper procedure.

DISASSEMBLY AND ASSEMBLY (Continued)

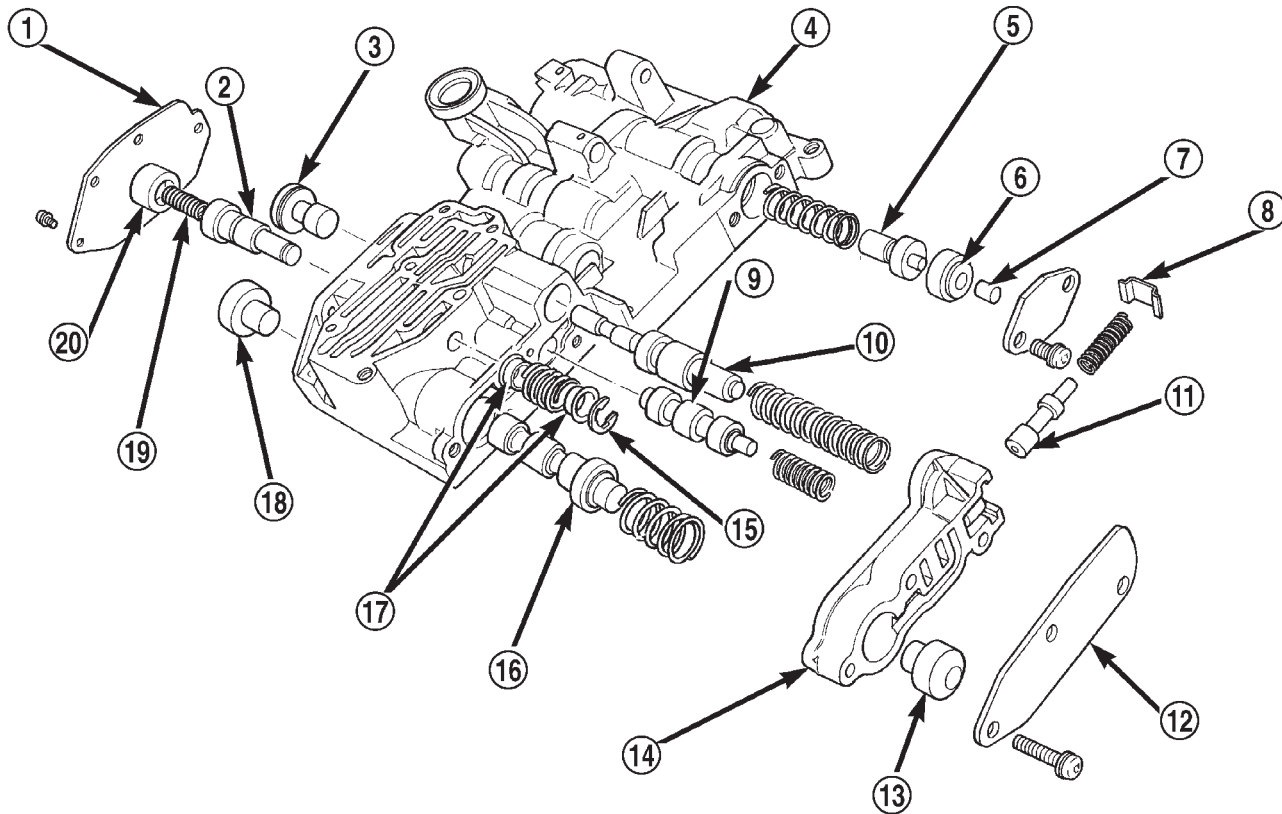

Fig. 107 Control Valves, Shift Valves, And Governor Plugs

80a13872

- | | |
|--|----------------------------------|
| 1 - GOVERNOR PLUG END PLATE | 11 - KICKDOWN LIMIT VALVE |
| 2 - SHUTTLE VALVE | 12 - END PLATE |
| 3 - 1-2 GOVERNOR PLUG | 13 - THROTTLE PRESSURE PLUG |
| 4 - VALVE BODY | 14 - KICKDOWN LIMIT VALVE BODY |
| 5 - REGULATOR VALVE THROTTLE PRESSURE PLUG | 15 - E-RING |
| 6 - SLEEVE | 16 - 2-3 SHIFT VALVE |
| 7 - LINE PRESSURE PLUG | 17 - GUIDES |
| 8 - RETAINER | 18 - 2-3 GOVERNOR PLUG |
| 9 - 1-2 SHIFT VALVE | 19 - PRIMARY SPRING |
| 10 - 1-2 SHIFT CONTROL VALVE | 20 - SHUTTLE VALVE THROTTLE PLUG |

CAUTION: Do not force valves or plugs into place during reassembly. If the valve body bores, valves, and plugs are free of distortion or burrs, the valve body components should all slide into place easily. In addition, do not overtighten the transfer plate and valve body screws during reassembly. Overtightening can distort the valve body resulting in valve sticking, cross leakage and unsatisfactory operation. Tighten valve body screws to recommended torque only.

(1) Lubricate valve body bores, valves and plugs with Mopar® ATF Plus 3, Type 7176, transmission fluid.

(2) Install regulator valve line pressure plug, pressure plug sleeve, regulator valve throttle pressure plug, and spring into valve body (Fig. 107). Verify valve components slide freely.

(3) Install regulator valve end plate on valve body (Fig. 107).

(4) Install kickdown limit valve and spring in kickdown limit valve body (Fig. 107). Verify valve components slide freely.

(5) Compress spring into kickdown limit valve body.

(6) Install retainer in grooves at end of kickdown limit valve body (Fig. 107).

(7) Install throttle pressure plug in kickdown limit valve body (Fig. 107).

(8) Install 1-2 shift valve and spring into valve body (Fig. 107).

(9) Install 2-3 shift valve and spring into valve body (Fig. 107).

(10) Install 1-2 shift control valve and spring into valve body (Fig. 107).

(11) Verify valve components slide freely.

DISASSEMBLY AND ASSEMBLY (Continued)

(12) Place kickdown limit valve body and end plate in position on valve body and compress springs (Fig. 107).

(13) Install screws to attach kickdown limit valve body to valve body (Fig. 107).

(14) Install shuttle valve throttle plug, primary spring and shuttle valve into valve body (Fig. 107). Verify valve components slide freely.

(15) Install 1-2 and 2-3 shift valve governor plugs into valve body (Fig. 107). Verify valve components slide freely.

(16) Place governor plug end plate in position on valve body and compress spring.

(17) Install screws to attach governor plug end plate to valve body (Fig. 107).

(18) Assemble shuttle valve spring and guides (Fig. 107). Place spring and guides in position on shuttle valve stem.

(19) Compress spring and install E-clip in groove on shuttle valve stem (Fig. 108).

(20) Place shuttle valve end plate in position on valve body (Fig. 109).

(21) Install screws to attach shuttle valve end plate to valve body (Fig. 109).

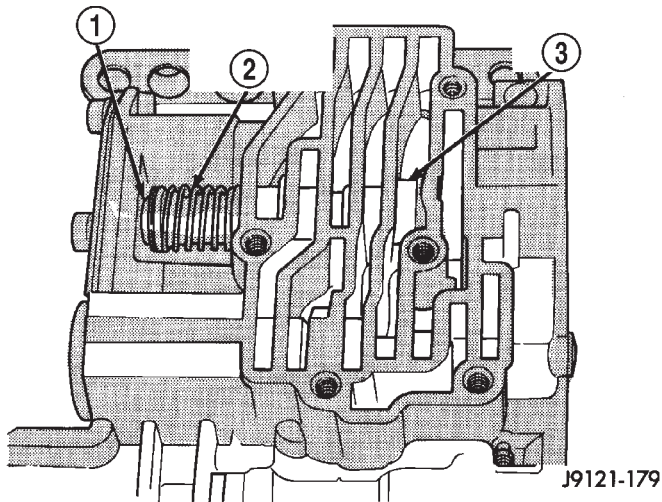

Fig. 108 Shuttle Valve E-Clip And Secondary Spring

- 1 - E-CLIP
- 2 - SECONDARY SPRING AND GUIDES
- 3 - SHUTTLE VALVE

(22) Install rear clutch servo and rear servo check balls in proper cavities in transfer plate (Fig. 110).

(23) Insert filter into opening in separator plate (Fig. 111).

(24) Place separator plate in position on transfer plate and install screws to attach separator plate to transfer plate (Fig. 111).

(25) Place one 11/32 in. check ball and six 1/4 in. check balls in the proper cavities in the valve body (Fig. 112).

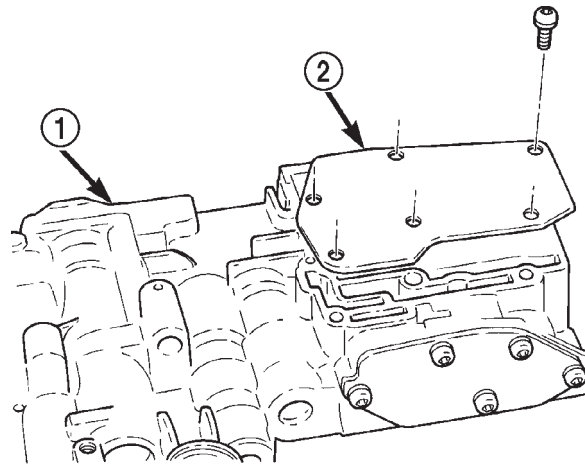

Fig. 109 Shuttle Valve End Plate

- 1 - VALVE BODY
- 2 - SHUTTLE VALVE END PLATE

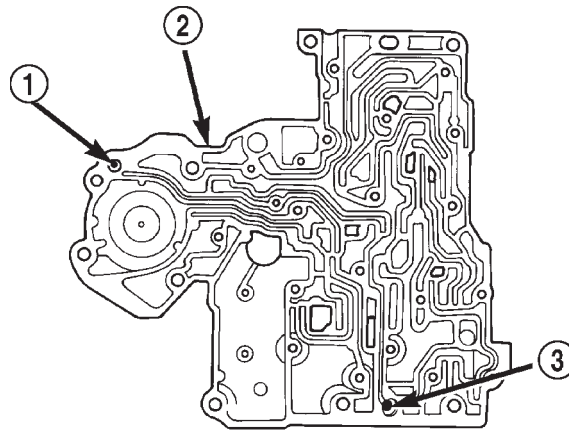

Fig. 110 Rear Servo and Rear Clutch Check Balls

- 1 - REAR SERVO CHECK BALL
- 2 - TRANSFER PLATE
- 3 - REAR CLUTCH CHECK BALL

(26) Place transfer plate in position on valve body (Fig. 113).

(27) Install screws to attach transfer plate to valve body (Fig. 113).

(28) Turn valve body over to expose the separator plate.

(29) Insert converter clutch valve and spring into converter clutch valve module (Fig. 114). Verify valve components slide freely.

(30) Insert spring and fail-safe valve into converter clutch valve module (Fig. 114). Verify valve components slide freely.

(31) Place cover plate in position on converter clutch valve module (Fig. 114).

(32) Install screws to attach cover to converter clutch valve module (Fig. 114).

DISASSEMBLY AND ASSEMBLY (Continued)

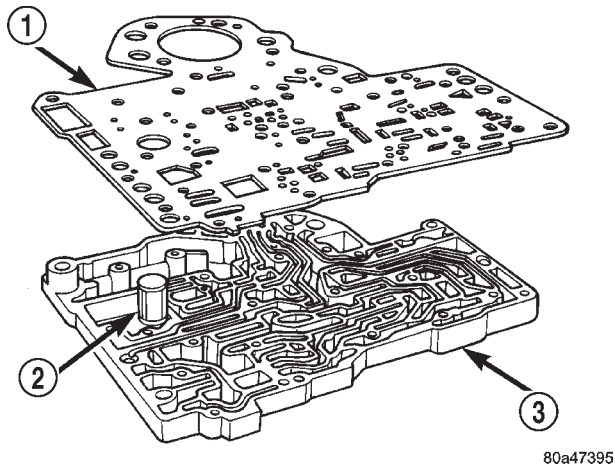

Fig. 111 Transfer And Separator Plates

- 1 - SEPARATOR PLATE
- 2 - FILTER
- 3 - TRANSFER PLATE

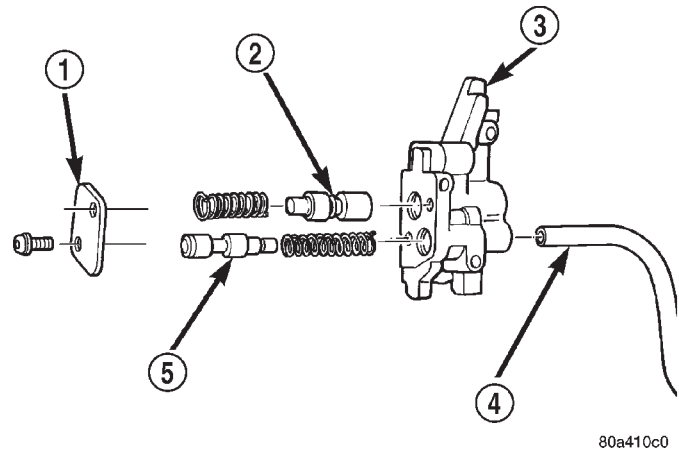

Fig. 114 Converter Clutch Valve Module

- 1 - COVER PLATE
- 2 - CONVERTER CLUTCH VALVE
- 3 - TORQUE CONVERTER CLUTCH MODULE
- 4 - MODULE CONNECTING TUBE
- 5 - FAIL-SAFE VALVE

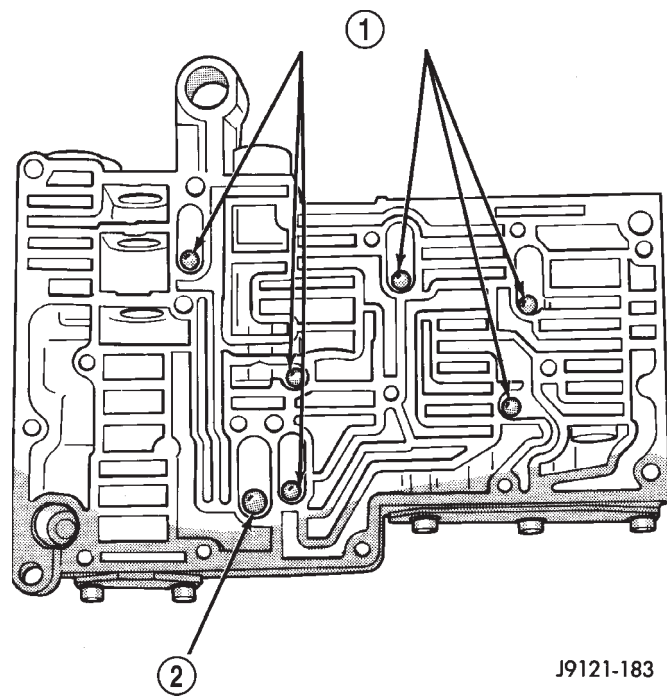

Fig. 112 Correct Position Of Valve Body Check Balls

- 1 - 1/4" CHECK BALLS (6)
- 2 - 11/32" CHECK BALL (1)

(33) Insert connecting tube into converter clutch valve module (Fig. 114).

(34) Insert connecting tube into valve body opening (Fig. 115).

(35) Place converter clutch valve module in position on separator plate. Install screws to attach converter clutch module to valve body (Fig. 115).

(36) If necessary, install a new O-ring on converter clutch solenoid (Fig. 116).

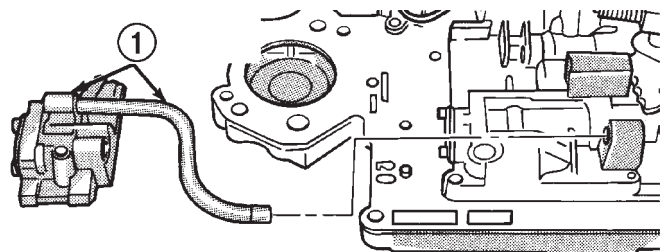

Fig. 115 Clutch Module And Connecting Tube

- 1 - MODULE AND CONNECTING TUBE

(37) Insert converter clutch solenoid into transfer plate (Fig. 116).

(38) Install screw to attach solenoid to transfer plate (Fig. 116).

(39) If necessary, insert park rod end into manual lever and install E-clip (Fig. 117).

(40) Insert detent spring and ball into opening in valve body and install Retainer Tool 6583 (Fig. 118).

(41) Install manual valve into valve body (Fig. 119).

(42) Insert throttle lever through transfer plate side of valve body and upward (Fig. 120).

(43) Insert throttle lever into groove in manual valve (Fig. 121).

(44) Install seal, washer, and E-clip to retain manual shaft to valve body (Fig. 120).

(45) Install switch valve and spring, pressure regulator valve and spring, kickdown valve and spring, and throttle valve into valve body (Fig. 122).

DISASSEMBLY AND ASSEMBLY (Continued)

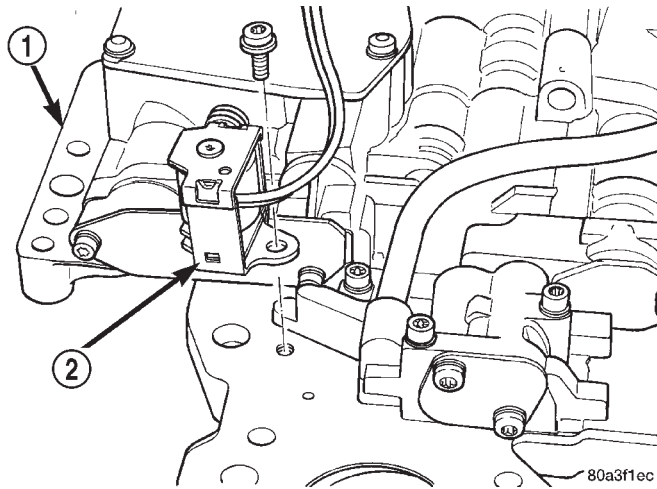

Fig. 116 Converter Clutch Solenoid

- 1 - VALVE BODY
- 2 - TORQUE CONVERTER CLUTCH SOLENOID

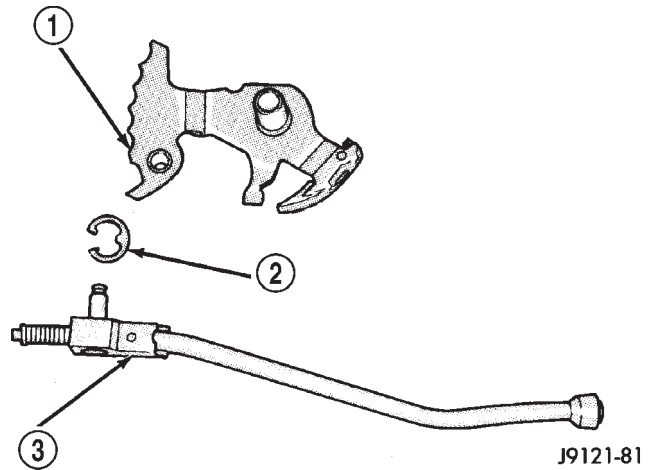

Fig. 117 Park Rod

- 1 - MANUAL LEVER
- 2 - E-CLIP
- 3 - PARK ROD

(46) Place adjusting screw bracket and line pressure adjusting screw in position on valve body and compress springs (Fig. 94).

(47) Install screws to attach adjuster bracket to valve body.

TRANSMISSION

DISASSEMBLY

(1) Remove transmission from vehicle.

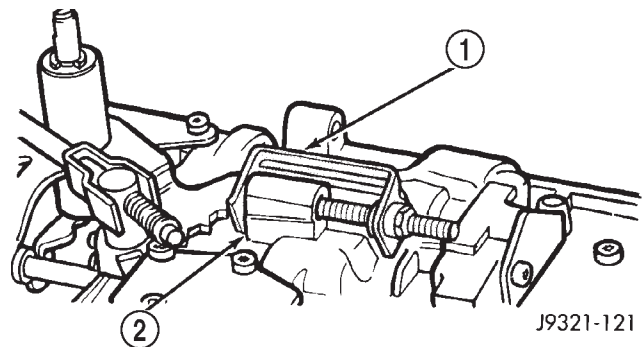

Fig. 118 Securing Detent Ball And Spring With Retainer Tool

- 1 - SPECIAL TOOL 6583
- 2 - DETENT BALL AND SPRING HOUSING

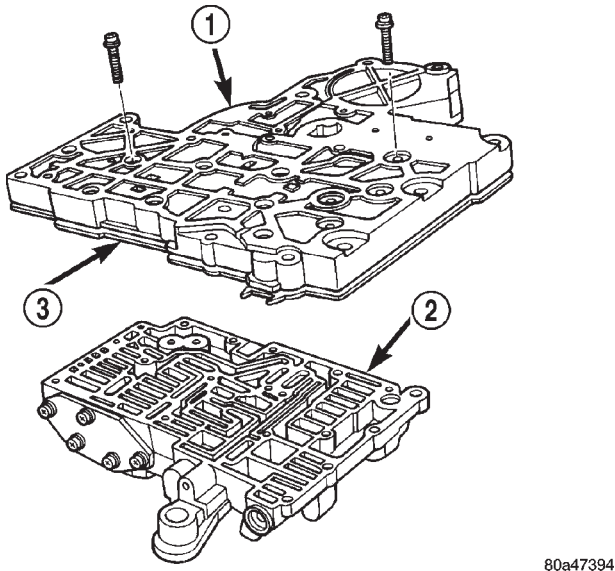

Fig. 113 Valve Body Transfer Plate Screws

- 1 - TRANSFER PLATE
- 2 - VALVE BODY
- 3 - SEPARATOR PLATE

(2) Install a suitable tail shaft housing plug to avoid contaminating internal components with cleaning solvents.

(3) Clean exterior of transmission with suitable solvent or pressure washer.

(4) Remove torque converter from transmission.

(5) Remove throttle and shift levers from valve body manual shaft and throttle lever shaft.

(6) Mount transmission in repair stand C-3750-B or similar type stand (Fig. 123).

(7) Remove extension housing.

(8) Remove fluid pan.

(9) Remove park/neutral position switch and seal (Fig. 124).

(10) Remove valve body.

(11) Remove accumulator spring and piston (Fig. 125).

(12) Loosen front band adjusting screw lock nut (Fig. 126) 4-5 turns. Then tighten band adjusting

DISASSEMBLY AND ASSEMBLY (Continued)

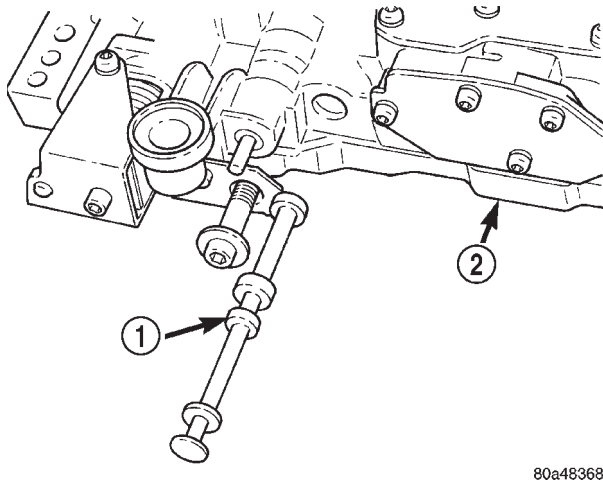

Fig. 119 Manual Valve

- 1 - MANUAL VALVE
- 2 - VALVE BODY

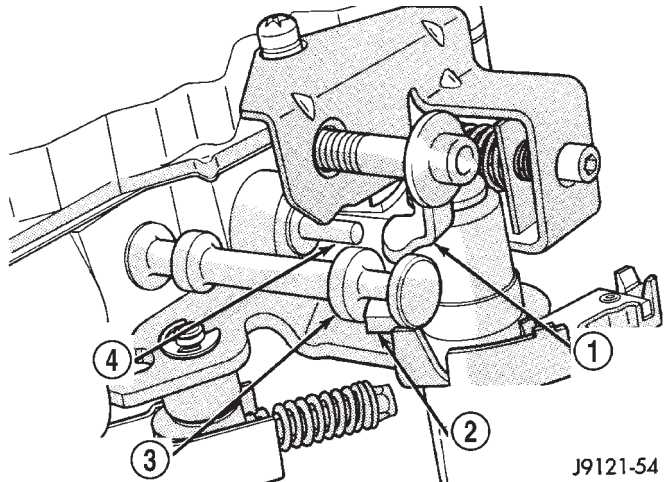

Fig. 121 Manual Valve And Throttle Lever Alignment

- 1 - THROTTLE LEVER
- 2 - MANUAL LEVER VALVE ARM
- 3 - MANUAL VALVE
- 4 - KICKDOWN VALVE

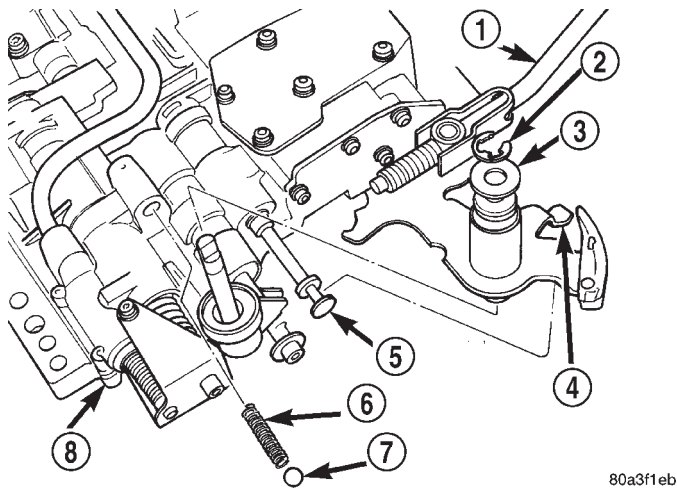

Fig. 120 Manual And Throttle Levers

- 1 - PARK ROD
- 2 - E-RING
- 3 - WASHER
- 4 - MANUAL LEVER
- 5 - MANUAL VALVE
- 6 - SPRING
- 7 - DETENT BALL
- 8 - VALVE BODY

screw until band is tight around front clutch. This prevents front/rear clutches from coming out with pump and possibly damaging clutch or pump components.

(13) Remove oil pump bolts.

(14) Thread bolts of Slide Hammer Tools C-3752 into threaded holes in pump body flange (Fig. 127).

(15) Bump slide hammer weights outward to remove pump and reaction shaft support assembly from case (Fig. 127).

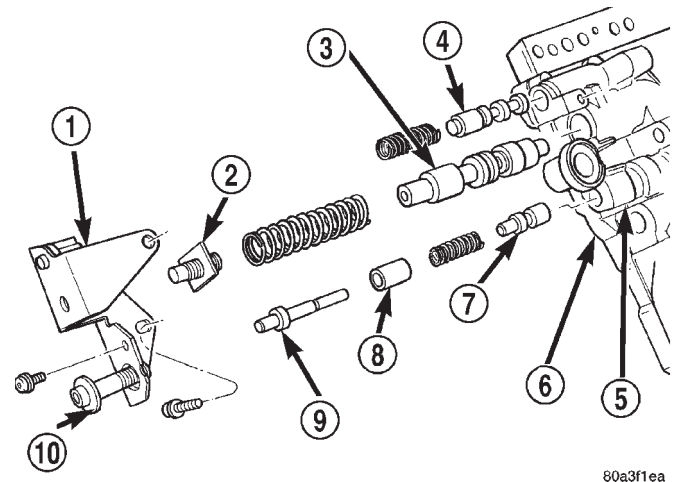

Fig. 122 Adjusting Screw Bracket, Springs, and Valves

- 1 - ADJUSTER BRACKET
- 2 - LINE PRESSURE ADJUSTER
- 3 - PRESSURE REGULATOR VALVE
- 4 - SWITCH VALVE
- 5 - VALVE BODY
- 6 - TRANSFER PLATE
- 7 - THROTTLE VALVE
- 8 - SLEEVE
- 9 - KICKDOWN VALVE
- 10 - THROTTLE PRESSURE ADJUSTER

(16) Loosen front band adjusting screw until band is completely loose (Fig. 126).

(17) Squeeze front band together and remove band strut (Fig. 128).

DISASSEMBLY AND ASSEMBLY (Continued)

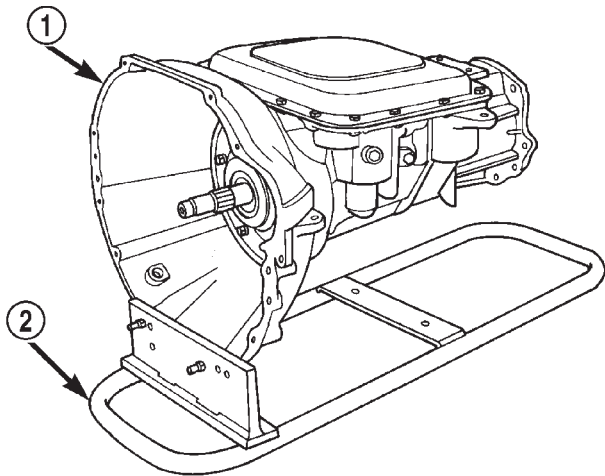

80a4836c

Fig. 123 Repair Stand

- 1 - TRANSMISSION
- 2 - STAND

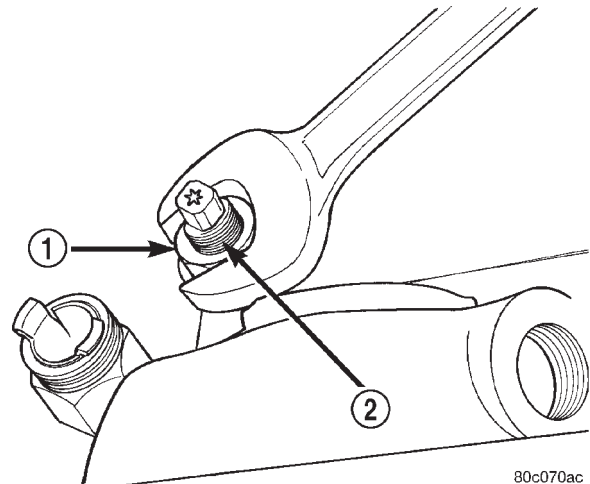

80c070ac

Fig. 126 Front Band Adjusting Screw Lock Nut

- 1 - LOCK-NUT
- 2 - FRONT BAND ADJUSTER

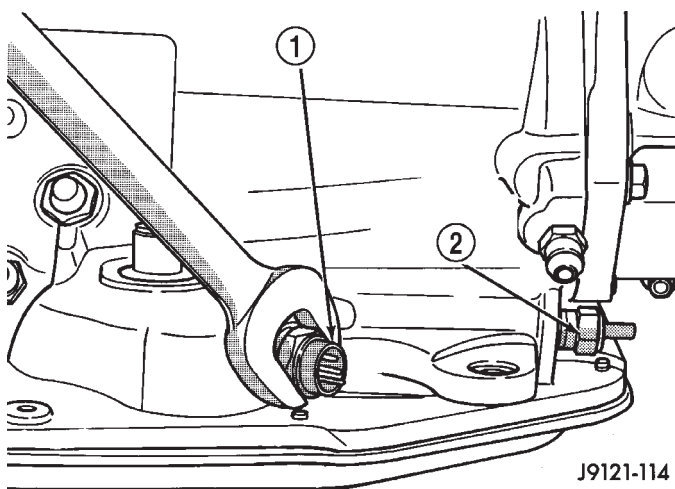

J9121-114

Fig. 124 Park/Neutral Position Switch

- 1 - NEUTRAL SWITCH
- 2 - SOLENOID CONNECTOR

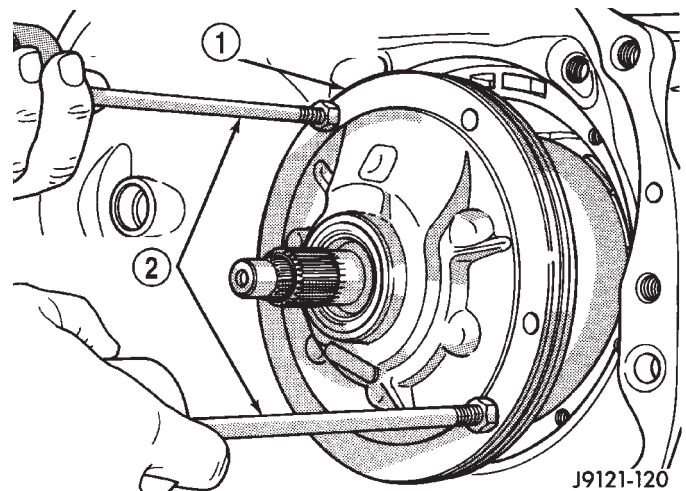

J9121-120

Fig. 127 Oil Pump/Reaction Shaft Support

- 1 - OIL PUMP AND REACTION SHAFT SUPPORT ASSEMBLY
- 2 - SLIDE HAMMER TOOLS C-3752

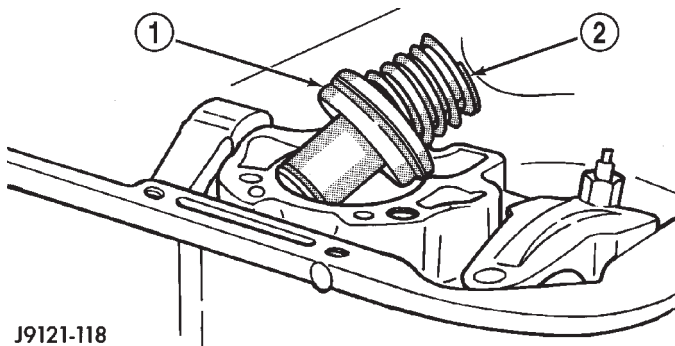

J9121-118

Fig. 125 Accumulator Piston And Spring

- 1 - ACCUMULATOR PISTON
- 2 - PISTON SPRING

DISASSEMBLY AND ASSEMBLY (Continued)

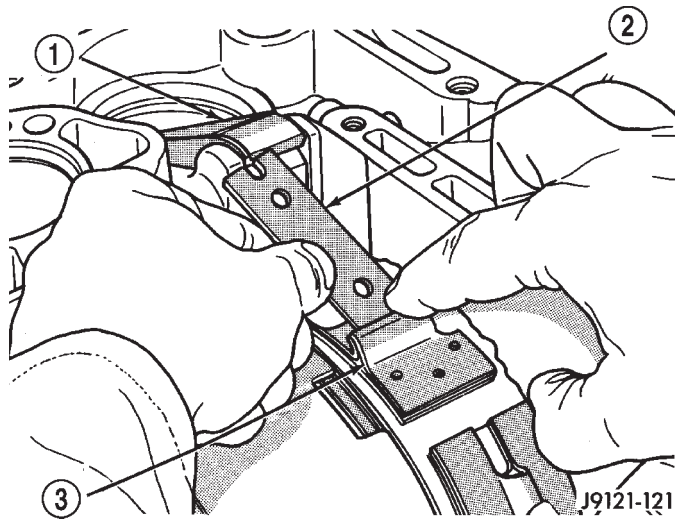

Fig. 128 Front Band Strut

- 1 - BAND LEVER
- 2 - BAND STRUT
- 3 - FRONT BAND

(18) Remove front and rear clutch units as an assembly. Grasp input shaft, hold clutch units together and remove them from case (Fig. 129).

(19) Lift front clutch off rear clutch (Fig. 130). Set clutch units aside for overhaul.

(20) Remove output shaft thrust washer from output shaft (or from rear clutch hub) (Fig. 131).

(21) Remove output shaft thrust plate and washer from output shaft hub (Fig. 131).

(22) Remove front band from case (Fig. 132).

(23) Remove extension housing from transmission case.

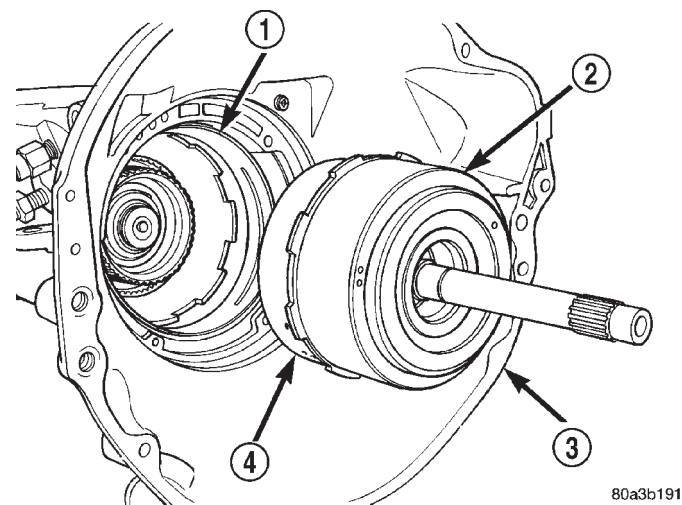

Fig. 129 Front/Rear Clutch Assemblies

- 1 - FRONT BAND
- 2 - FRONT CLUTCH AND DRUM
- 3 - TRANSMISSION HOUSING
- 4 - REAR CLUTCH

(24) Remove governor body and park gear from output shaft.

(25) Remove output shaft and planetary geartrain as assembly (Fig. 133). Support geartrain with both hands during removal. Do not allow machined surfaces on output shaft to become nicked or scratched.

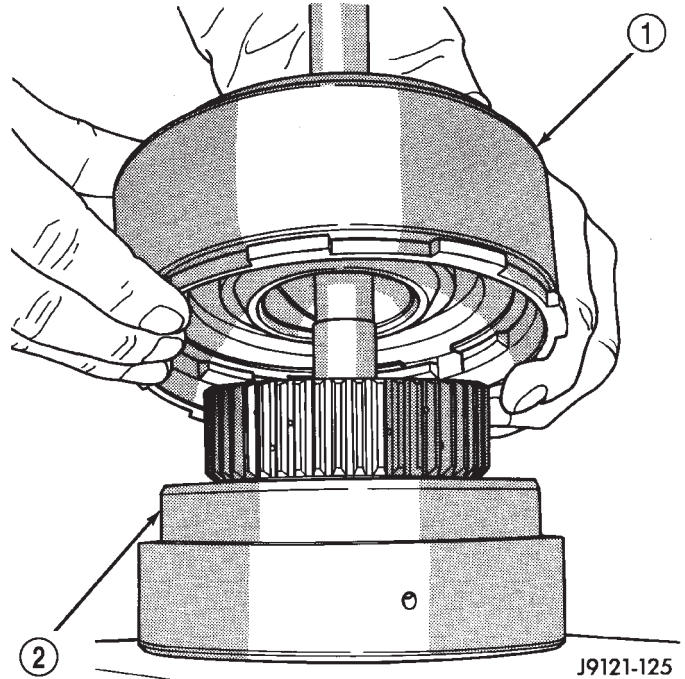

Fig. 130 Separating Front Clutch From Rear Clutch

- 1 - FRONT CLUTCH
- 2 - REAR CLUTCH

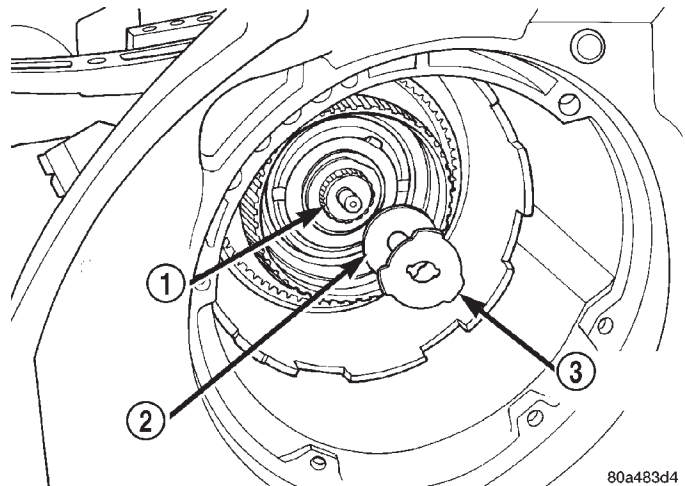

Fig. 131 Output Shaft Thrust Plate and Washer

- 1 - OUTPUT SHAFT
- 2 - THRUST PLATE
- 3 - THRUST WASHER

DISASSEMBLY AND ASSEMBLY (Continued)

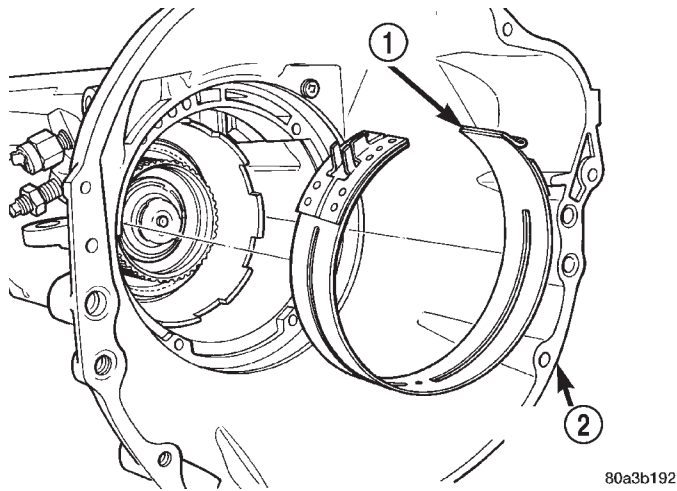

Fig. 132 Front Band

- 1 - FRONT BAND
- 2 - TRANSMISSION HOUSING

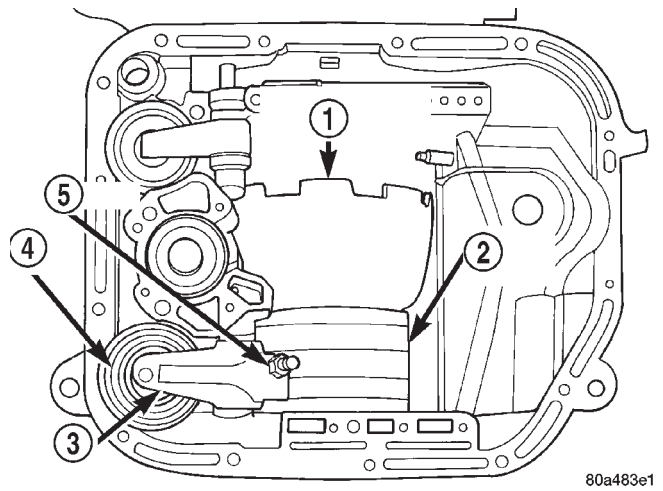

Fig. 134 Rear Band Adjuster Location

- 1 - PLANETARY GEARTRAIN
- 2 - REAR BAND
- 3 - LEVER
- 4 - SERVO
- 5 - ADJUSTER

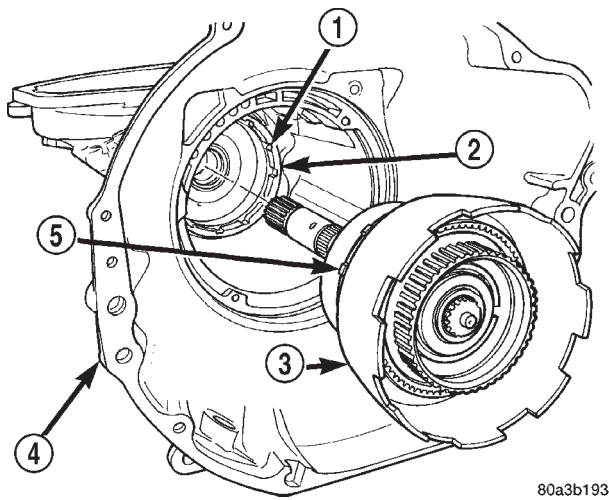

Fig. 133 Planetary Geartrain

- 1 - SLOTS
- 2 - LOW-REVERSE DRUM
- 3 - PLANETARY GEARTRAIN
- 4 - TRANSMISSION HOUSING
- 5 - LUGS

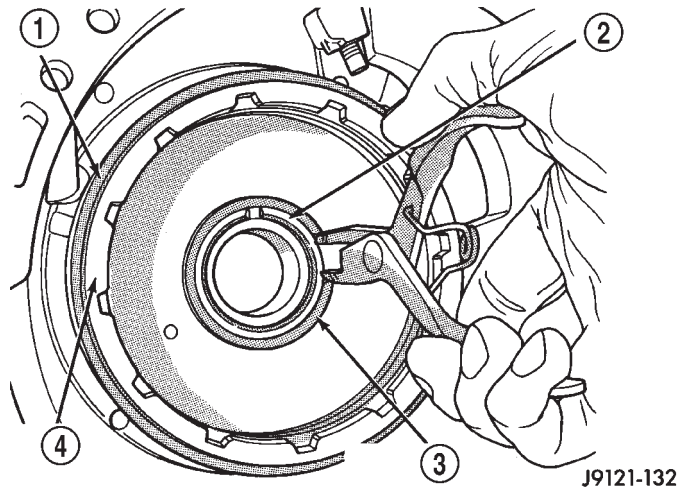

Fig. 135 Low-Reverse Drum Snap Ring

- 1 - REAR BAND
- 2 - REAR SUPPORT HUB
- 3 - LOW-REVERSE DRUM SNAP RING
- 4 - LOW-REVERSE DRUM

(26) Loosen rear band adjusting screw 4-5 turns (Fig. 134).

(27) Remove snap ring that secures low-reverse drum to rear support hub, however do not remove drum (Fig. 135).

(28) Remove bolts attaching rear support to transmission case and pull support from low-reverse drum (Fig. 136).

(29) Remove bolts attaching overrunning clutch cam and low-reverse drum to transmission case (Fig. 137).

DISASSEMBLY AND ASSEMBLY (Continued)

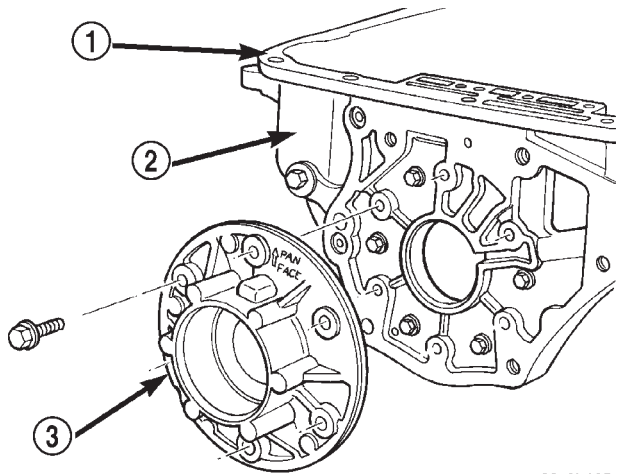

80a3b195

Fig. 136 Rear Support

- 1 - OIL PAN FACE
- 2 - TRANSMISSION HOUSING
- 3 - REAR SUPPORT

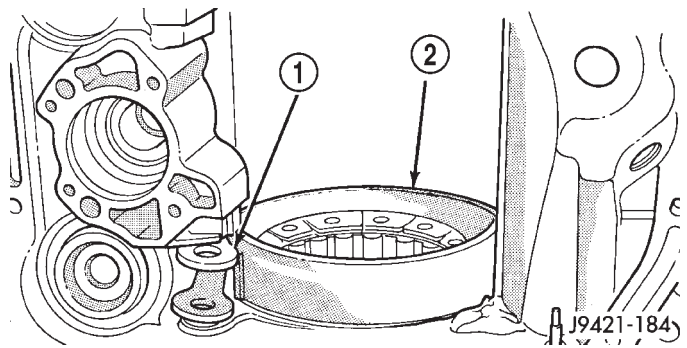

J9421-184

Fig. 138 Rear Band and Link

- 1 - LINK
- 2 - REAR BAND

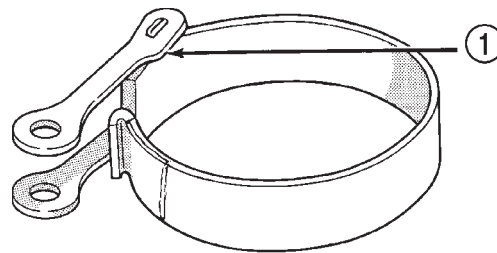

J9421-186

Fig. 139 Rear Band and Link

- 1 - NOTCHED SIDE OF LINK GOES TOWARD BAND

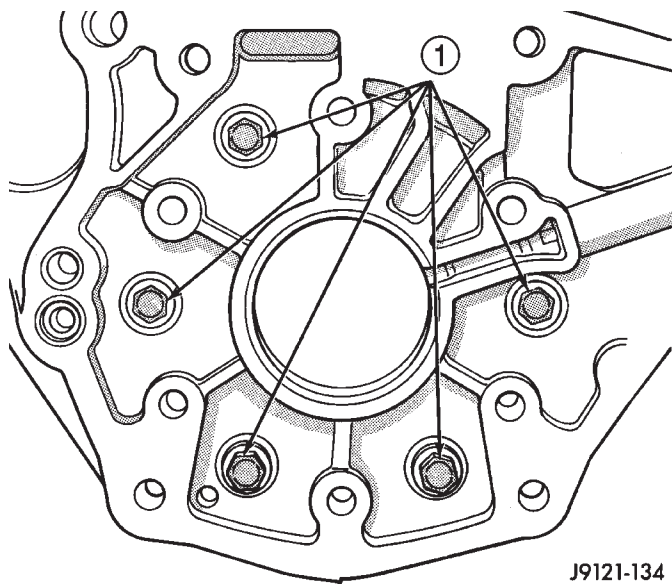

J9121-134

Fig. 137 Overrunning Clutch Cam Bolt Locations

- 1 - OVERRUNNING CLUTCH CAM BOLTS

(30) Using snap-ring plier, pull rear band anchor pin (located on the servo side of the rear support) from transmission case.

(31) Remove rear band and link from transmission (Fig. 138).

(32) Separate link from rear band (Fig. 139).

(33) If necessary remove front and rear band servo levers. All transmission components can be serviced without removing the levers.

(a) Using a 1/4 inch drive extension remove front band reaction pin access plug (Fig. 140).

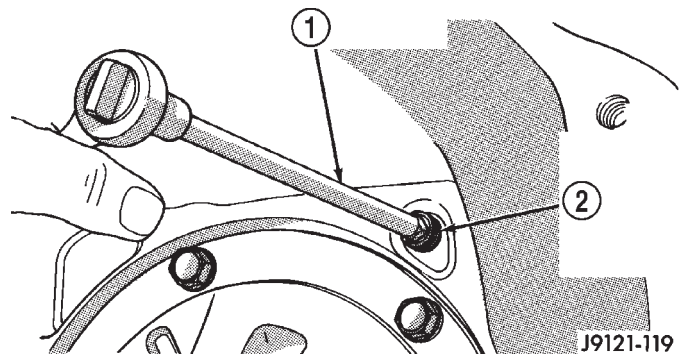

J9121-119

Fig. 140 Front Band Reaction Pin Access Plug

- 1 - 1/4" DRIVE EXTENSION
- 2 - FRONT BAND REACTION PIN ACCESS PLUG

(b) Remove front band reaction pin with pencil magnet. Pin is accessible from converter housing side of case (Fig. 141).

(c) Remove front band lever (Fig. 142).

(d) Using snap-ring plier, pull rear band lever pivot from transmission case (Fig. 143).

(e) Separate rear band servo lever from transmission.

DISASSEMBLY AND ASSEMBLY (Continued)

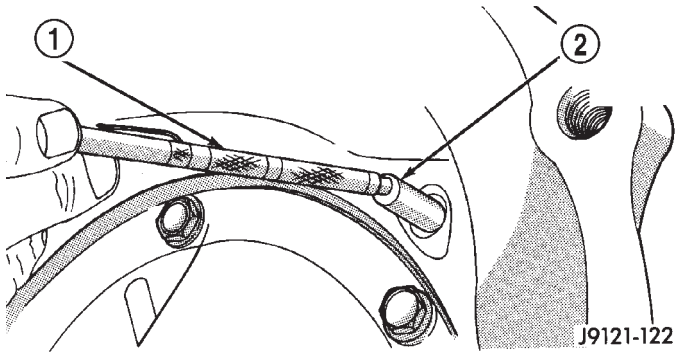

Fig. 141 Front Band Reaction Pin

- 1 - PENCIL MAGNET
- 2 - FRONT BAND REACTION PIN

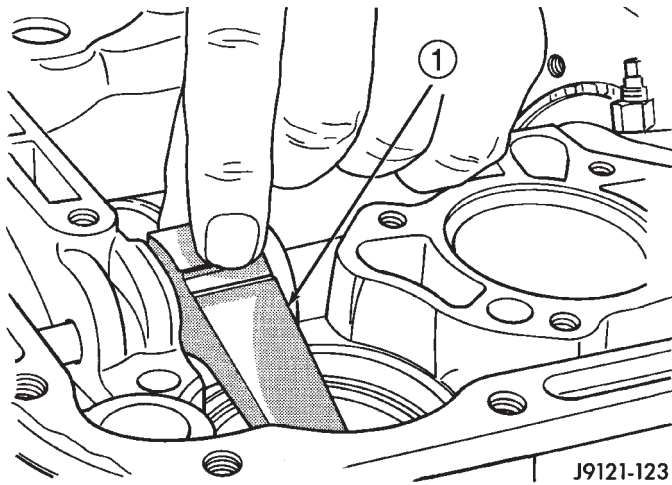

Fig. 142 Front Band Lever

- 1 - FRONT BAND LEVER

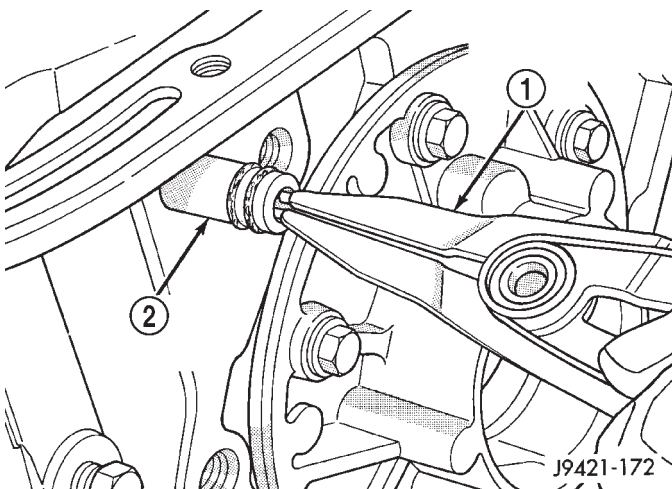

Fig. 143 Rear Band Servo Lever Pin

- 1 - PARALLEL JAW SNAP RING PLIERS
- 2 - REAR BAND LEVER PIVOT PIN

(34) Compress front servo rod guide about 1/8 in. with large C-clamp and Tool C-4470, or Spring Compressor Tool C-3422-B (Fig. 144).

(35) Remove front servo rod guide snap ring (Fig. 144). **Exercise caution when removing snap ring. Servo bore can be scratched or nicked if care is not exercised.**

(36) Remove compressor tools and remove front servo rod guide, spring and servo piston.

(37) Compress rear servo spring retainer about 1/16 in. with C-clamp and Tool C-4470 or SP-5560 (Fig. 145). Valve Spring Compressor C-3422-B can also be used to compress spring retainer.

(38) Remove rear servo spring retainer snap ring. Then remove compressor tools and remove rear servo spring and piston.

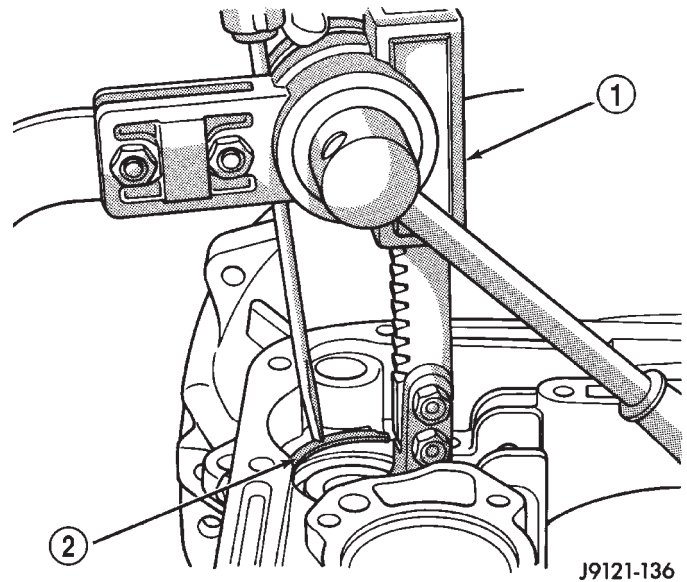

Fig. 144 Compressing Front Servo

- 1 - SPRING COMPRESSOR TOOL C-3422-B
- 2 - ROD GUIDE SNAP RING

ASSEMBLY

(1) Install rear servo piston, spring and spring retainer. Compress rear servo spring and retainer with Compressor Tool C-3422-B (Fig. 145) or a large C-clamp.

(2) Install front servo piston, spring, and rod guide. Compress front servo rod guide with Valve Spring Compressor C-3422-B and install servo snap ring (Fig. 144).

(3) Assemble link bar to band. Notched side of link toward band (Fig. 143).

(4) Insert rear band through pan opening in transmission case.

(5) Insert hook on band onto adjuster lever.

(6) Align holes in link bar with hole in transmission case outboard of rear support opening (Fig. 142).

(7) Insert anchor pin into case through link bar.

DISASSEMBLY AND ASSEMBLY (Continued)

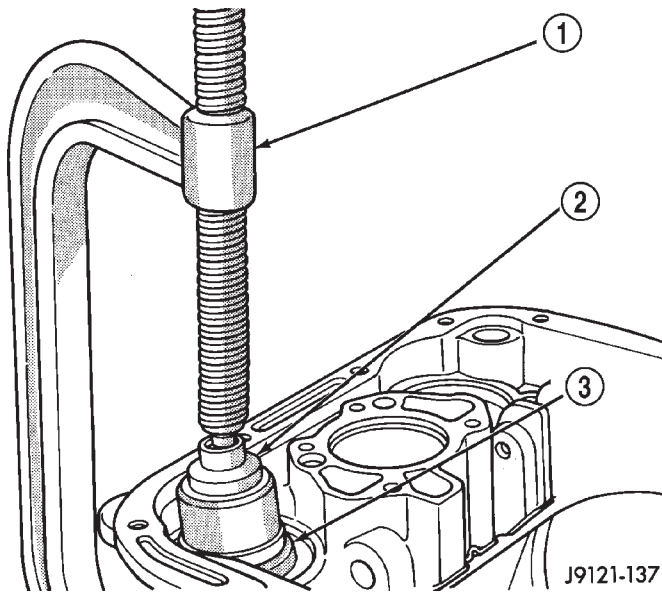

Fig. 145 Compressing Rear Servo Spring

- 1 - LARGE C-CLAMP
- 2 - TOOL C-4470 OR SP5560
- 3 - SERVO SPRING RETAINER

(8) Examine bolt holes in overrunning clutch cam. Note that one hole is **not threaded** (Fig. 146). This hole must align with blank area in clutch cam bolt circle.

NOTE: The bolt holes in cam are slightly countersunk on one side. This side of cam faces rearward (toward rear support).

(9) Lubricate overrunning clutch rollers, springs and cam with Mopar® ATF Plus 3, type 7176, transmission fluid.

(10) Position overrunning clutch on a clean, flat work surface with countersunk holes downward.

(11) Place rear of low-reverse drum over overrunning clutch and align clutch rollers to hub of drum.

(12) While slightly pivoting low-reverse drum, push hub of drum into overrunning clutch. Verify that countersunk holes are facing outward. **Cam should be able to rotate in the drum clockwise only.**

(13) Insert a suitable awl through the rear support mounting hole closest to the pan sealing face. The awl should be next to the wide space area at the back of transmission case.

(14) Insert low-reverse drum and overrunning clutch into front of transmission case and into rear band.

(15) Insert awl tip into the threaded hole next to the non-threaded hole in the overrunning clutch cam. Verify that non-threaded hole is aligned with wide space area on transmission case.

(16) Push low-reverse drum rearward to close gap between cam and case.

(17) Install overrunning clutch cam bolts. **Clutch cam bolts are shorter than rear support bolts.** Tighten cam bolts to 17 N·m (150 in. lbs. or 13 ft. lbs.) torque.

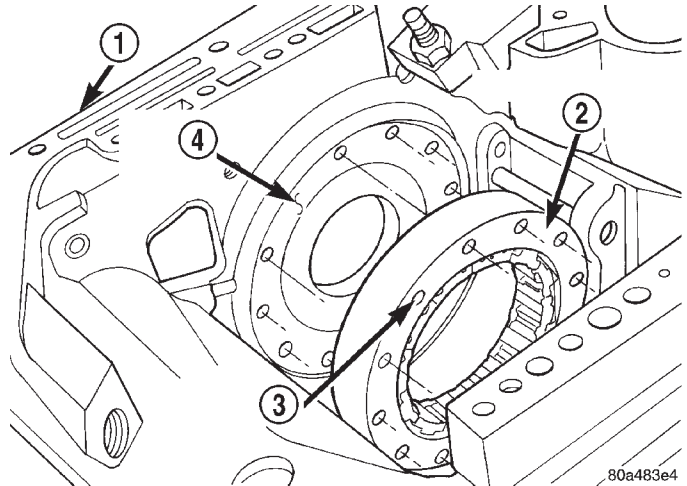

Fig. 146 Clutch Cam Alignment

- 1 - TRANSMISSION CASE
- 2 - OVERRUNNING CLUTCH
- 3 - NON-THREADER HOLE
- 4 - WIDE SPACE AREA

(18) Hold low-reverse drum in position so rear support will not push it out of overrunning clutch.

(19) Insert rear support into opening at rear of transmission case (Fig. 147).

(20) Align support with the embossed arrow in the direction of the pan face.

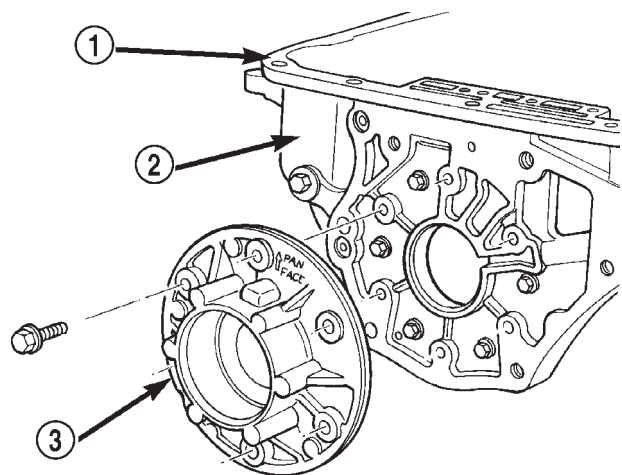

Fig. 147 Rear Support

- 1 - OIL PAN FACE
- 2 - TRANSMISSION HOUSING
- 3 - REAR SUPPORT

DISASSEMBLY AND ASSEMBLY (Continued)

(21) Install and tighten rear support bolts to 17 N·m (150 in. lbs.) torque.

(22) Install snap ring to retain low-reverse drum to hub of rear support (Fig. 148).

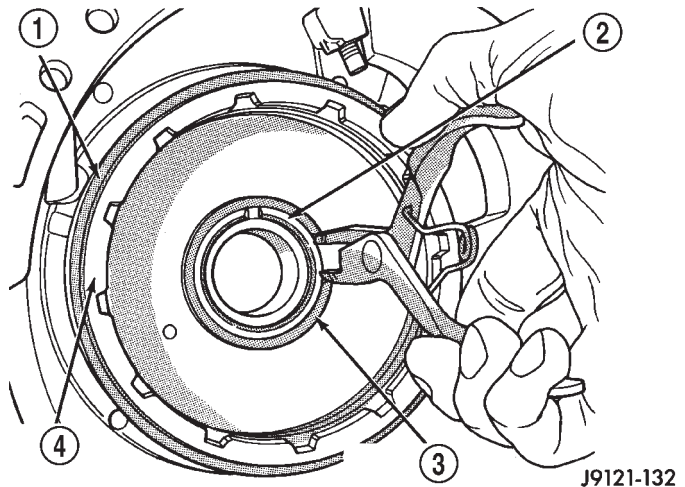

Fig. 148 Low-Reverse Drum Snap Ring

- 1 - REAR BAND
- 2 - REAR SUPPORT HUB
- 3 - LOW-REVERSE DRUM SNAP RING
- 4 - LOW-REVERSE DRUM

(23) Lubricate output shaft, rear support bore and low-reverse drum hub with transmission fluid.

(24) Install assembled output shaft and planetary geartrain in case (Fig. 149).

(25) Align drive lugs on rear planetary gear with slots in low-reverse drum (Fig. 149). Then seat planetary assembly in drum.

(26) Install governor on output shaft.

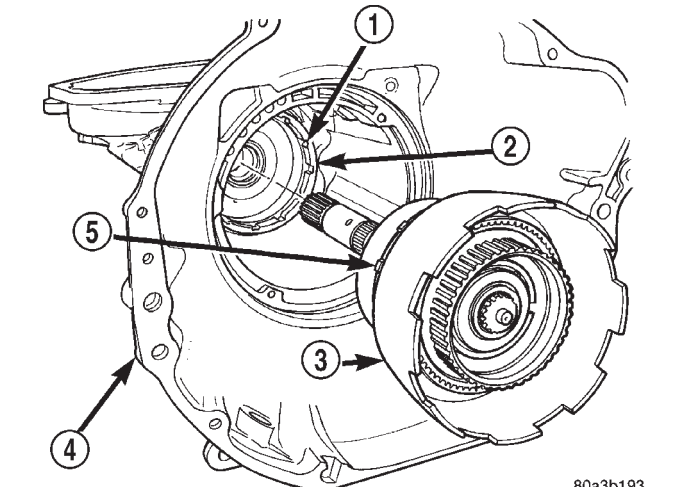

Fig. 149 Output Shaft And Planetary Geartrain

- 1 - SLOTS
- 2 - LOW-REVERSE DRUM
- 3 - PLANETARY GEARTRAIN
- 4 - TRANSMISSION HOUSING
- 5 - LUGS

(27) Turn and secure transmission so that front opening is upward.

(28) Assemble front and rear clutches together.

(a) Check input shaft seal rings (Fig. 150). Verify that diagonal-cut ends of Teflon™ seal ring are properly joined and ends of metal ring are correctly hooked together. Also be sure rings are installed in sequence shown.

(b) Align teeth on clutch discs in line.

(c) Insert input shaft on rear clutch into center of front clutch (Fig. 151).

(d) Engage teeth on rear clutch hub into teeth on clutch (Fig. 153). Rotate front clutch retainer back and forth until completely seated on rear clutch.

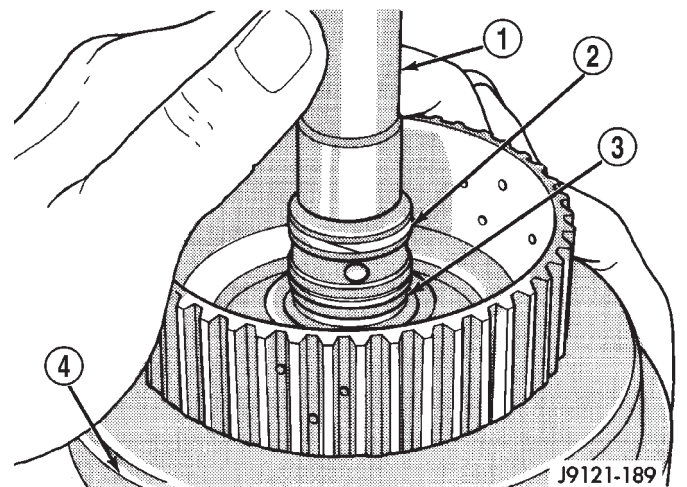

Fig. 150 Input Shaft Seal Ring Location

- 1 - INPUT SHAFT
- 2 - TEFLON SEAL RING
- 3 - METAL SEAL RING
- 4 - REAR CLUTCH RETAINER

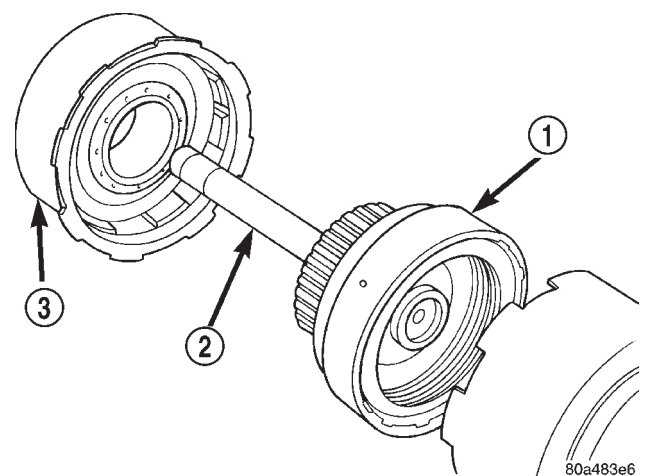

Fig. 151 Front and Rear Clutches

- 1 - REAR CLUTCH
- 2 - INPUT SHAFT
- 3 - FRONT CLUTCH

DISASSEMBLY AND ASSEMBLY (Continued)

(29) Install output shaft thrust plate on shaft hub in planetary geartrain driving shell (Fig. 152). Use petroleum jelly to hold thrust plate in place.

(30) Check rear clutch thrust washer. Use additional petroleum jelly to hold washer in place if necessary.

(31) Coat output shaft thrust washer with petroleum jelly. Install washer in rear clutch hub (Fig. 154). Use enough petroleum jelly to hold washer in place. **Be sure grooved side of washer faces rearward (toward output shaft) as shown. Also note that washer only fits one way in clutch hub.**

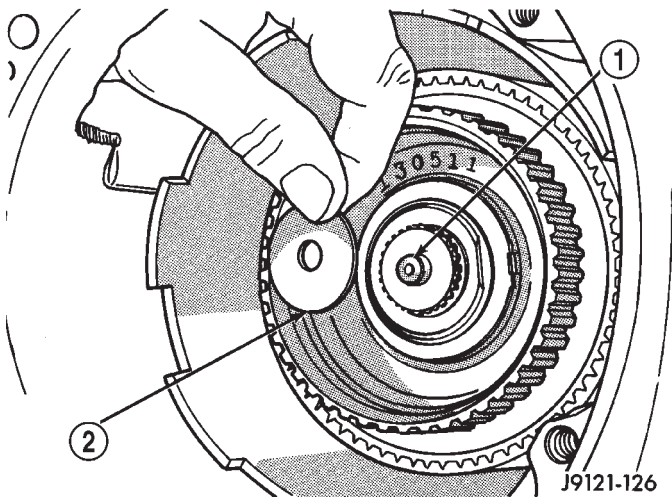

Fig. 152 Output Shaft Thrust Plate

- 1 - OUTPUT SHAFT HUB
- 2 - OUTPUT SHAFT THRUST PLATE

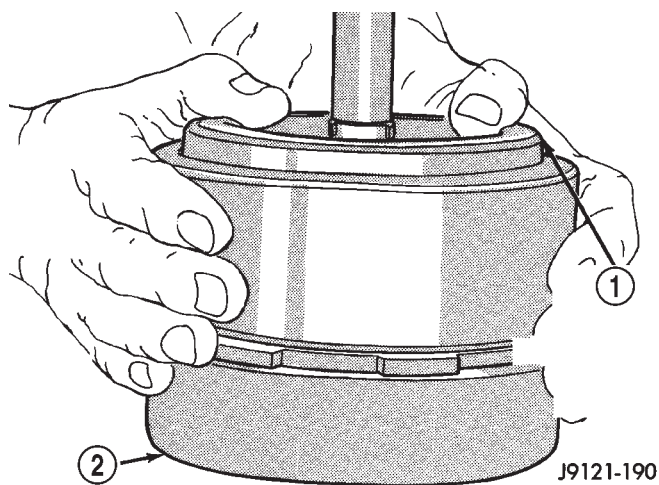

Fig. 153 Assembling Front And Rear Clutch Units

- 1 - TURN FRONT CLUTCH BACK & FORTH UNTIL SEATED
- 2 - REAR CLUTCH ASSEMBLY

(32) Align drive teeth on rear clutch discs with small screwdriver (Fig. 155). This will make installation into front of planetary geartrain easier.

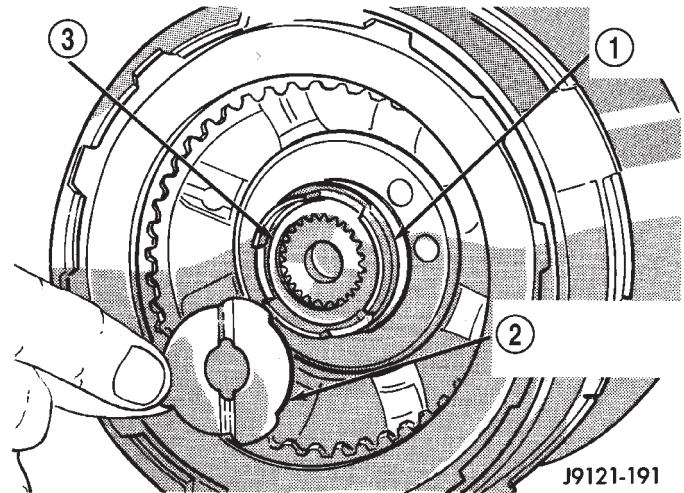

Fig. 154 Output Shaft Thrust Washer

- 1 - REAR CLUTCH HUB
- 2 - OUTPUT SHAFT THRUST WASHER
- 3 - OUTPUT SHAFT

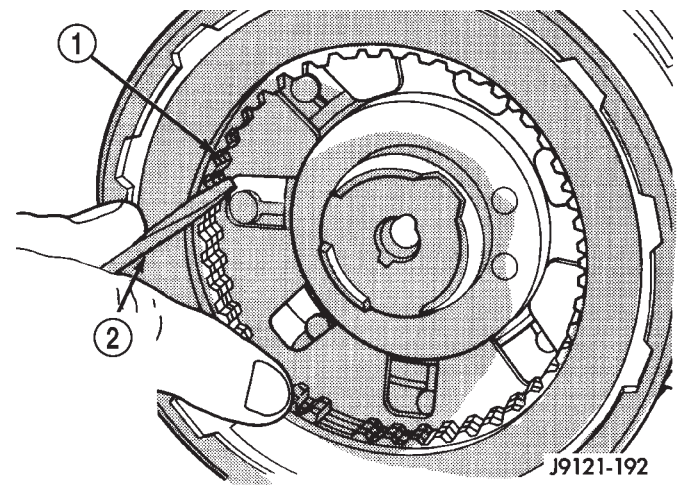

Fig. 155 Aligning Rear Clutch Disc Lugs

- 1 - REAR CLUTCH DISCS
- 2 - USE SMALL SCREWDRIVER TO ALIGN CLUTCH DISC TEETH

(33) Insert front band into opening at front of transmission case (Fig. 156).

(34) Install front and rear clutch units as assembly (Fig. 157). Align rear clutch with front annulus gear and install assembly in driving shell. **Be sure output shaft thrust washer and thrust plate are not displaced during installation.**

(35) Carefully work assembled clutches back and forth to engage and seat rear clutch discs on front annulus gear. Verify that front clutch drive lugs are

DISASSEMBLY AND ASSEMBLY (Continued)

fully engaged in slots of driving shell after installation.

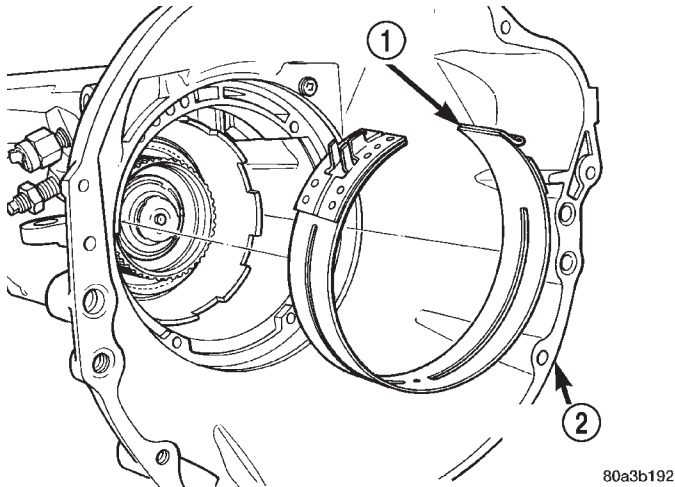

Fig. 156 Front Band

- 1 - FRONT BAND
- 2 - TRANSMISSION HOUSING

over reaction shaft hub and seat it on pump (Fig. 160).

CAUTION: The thrust washer bore (I. D.), is chamfered on one side. Make sure the chamfered side is installed so it faces the pump.

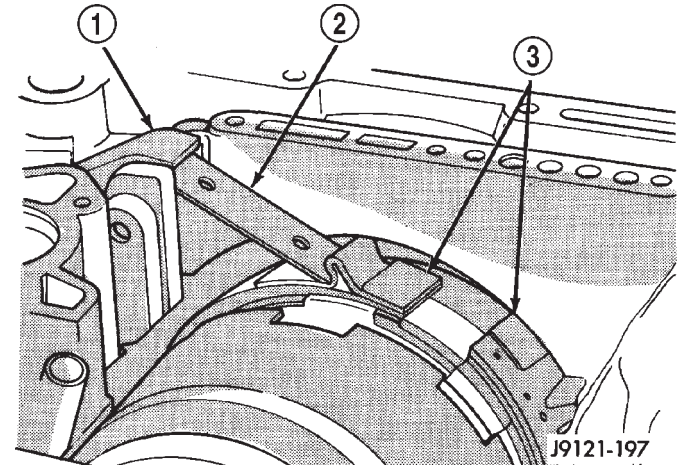

Fig. 158 Front Band Linkage Installation

- 1 - BAND LEVER
- 2 - BAND STRUT
- 3 - FRONT BAND

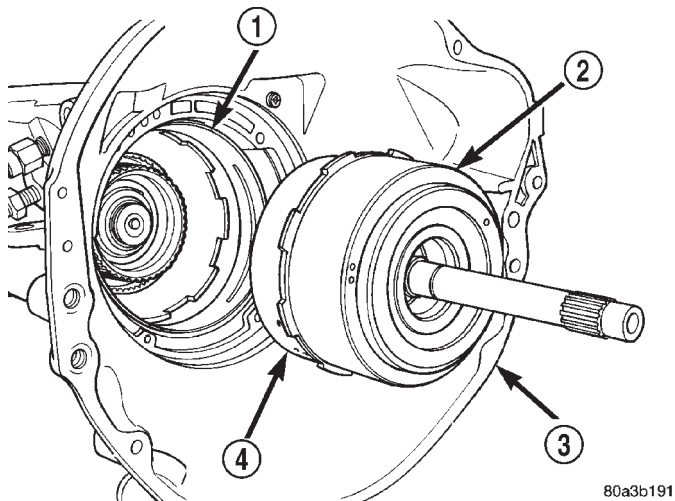

Fig. 157 Installing Front/Rear Clutch

- 1 - FRONT BAND
- 2 - FRONT CLUTCH AND DRUM
- 3 - TRANSMISSION HOUSING
- 4 - REAR CLUTCH

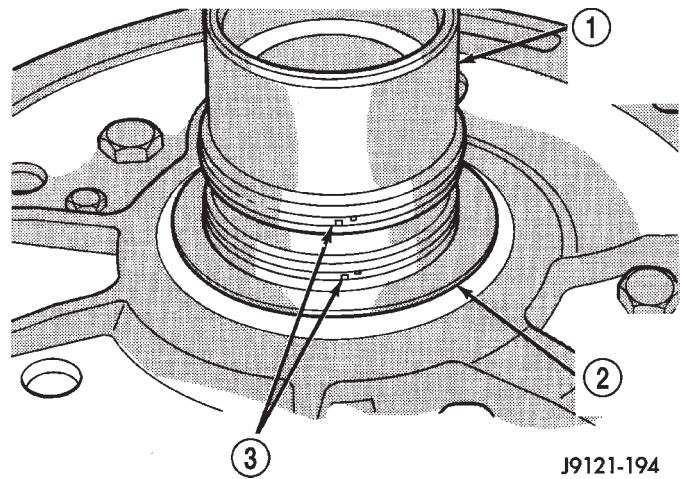

Fig. 159 Reaction Shaft Support Seal Rings

- 1 - REACTION SHAFT SUPPORT HUB
- 2 - FRONT CLUTCH THRUST WASHER
- 3 - SEAL RINGS

(36) Engage front band on adjusting screw and hold band in place.

(37) Install strut between band lever and front band (Fig. 158).

(38) Tighten front band adjusting screw until band just grips clutch retainer. Verify that front/rear clutches are still seated before continuing.

(39) Verify that reaction shaft support hub seal rings are hooked together (Fig. 159).

(40) Coat front clutch thrust washer with petroleum jelly to hold it in place. Then install washer

DISASSEMBLY AND ASSEMBLY (Continued)

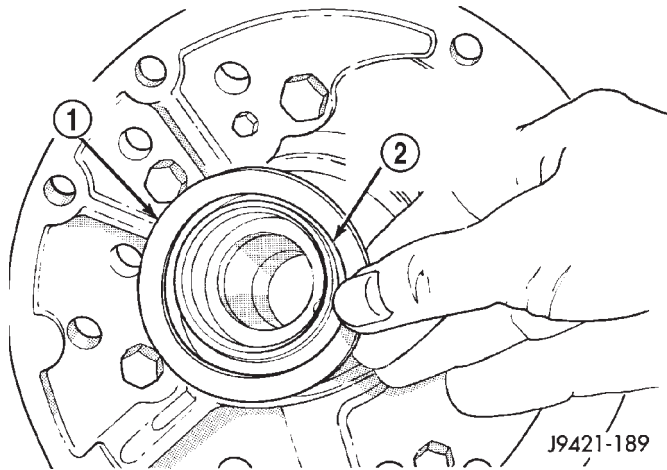

Fig. 160 Front Clutch Thrust Washer Installation

- 1 - THRUST WASHER
- 2 - CHAMFERED SIDE OF WASHER BORE GOES TOWARD PUMP

(41) Thread two Pilot Stud Tools C-3288-B into bolt holes in oil pump flange (Fig. 161).

(42) Align and install oil pump gasket (Fig. 161).

(43) Lubricate oil pump seals with Mopar® Door-Ease, or Ru-Glyde, Door Eze, or ATF Plus 3.

(44) Install oil pump (Fig. 162). Align and position pump on pilot studs. Slide pump down studs and work it into front clutch hub and case by hand. Then install two or three pump bolts to hold pump in place.

(45) Remove pilot stud tools and install remaining oil pump bolts. Tighten bolts alternately in diagonal pattern to 20 N·m (15 ft. lbs.).

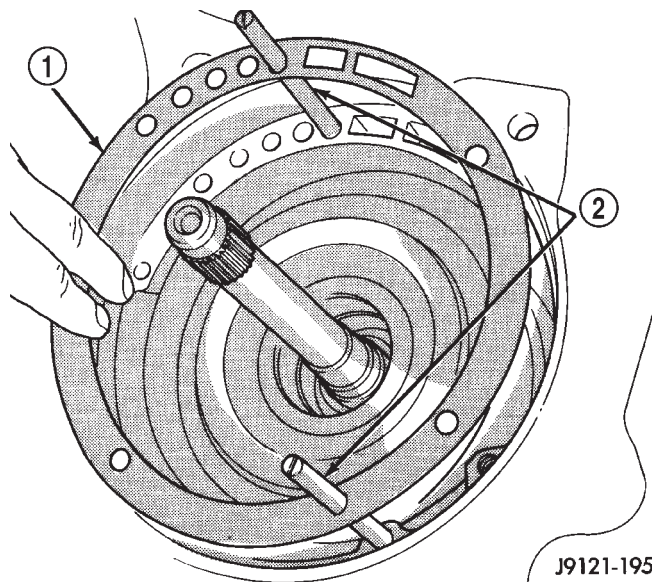

Fig. 161 Installing Pilot Studs And Oil Pump Gasket

- 1 - OIL PUMP GASKET
- 2 - PILOT STUD TOOLS C-3288-B

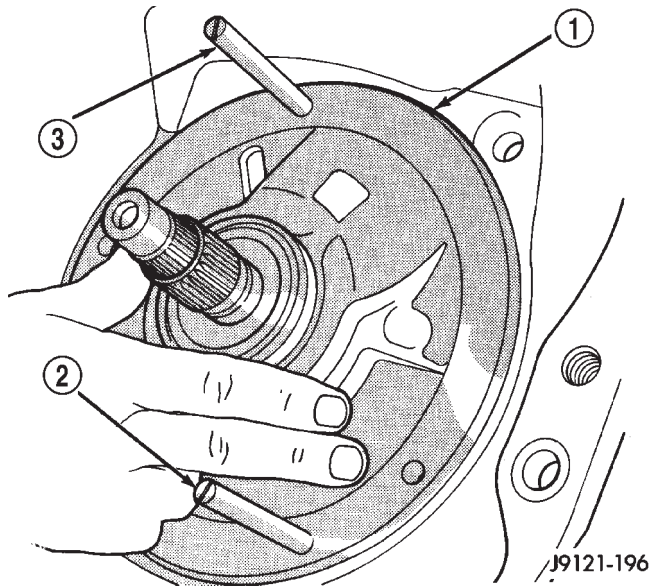

Fig. 162 Installing Oil Pump And Reaction Shaft Support

- 1 - OIL PUMP
- 2 - PILOT STUD TOOL
- 3 - PILOT STUD TOOL

(46) Measure input shaft end play (Fig. 163).

NOTE: If end play is incorrect, transmission is incorrectly assembled, or output shaft thrust washer and/or thrust plate are worn and need to be changed.

(a) Attach Adapter 8266-7 to Handle 8266-8.

(b) Attach dial indicator C-3339 to Handle 8266-8.

(c) Install the assembled tool onto the input shaft of the transmission and tighten the retaining screw on Adapter 8266-7 to secure it to the input shaft.

(d) Position the dial indicator plunger against a flat spot on the oil pump and zero the dial indicator.

(e) Move input shaft in and out and record reading. End play should be 0.56 - 2.31 mm (0.022 - 0.091 in.).

(47) Position transmission on work surface with pan face upward.

(48) Install valve body.

(49) Adjust front and rear bands.

(50) Install fluid filter and pan.

(51) Install rear extension housing.

(52) Install torque converter.

DISASSEMBLY AND ASSEMBLY (Continued)

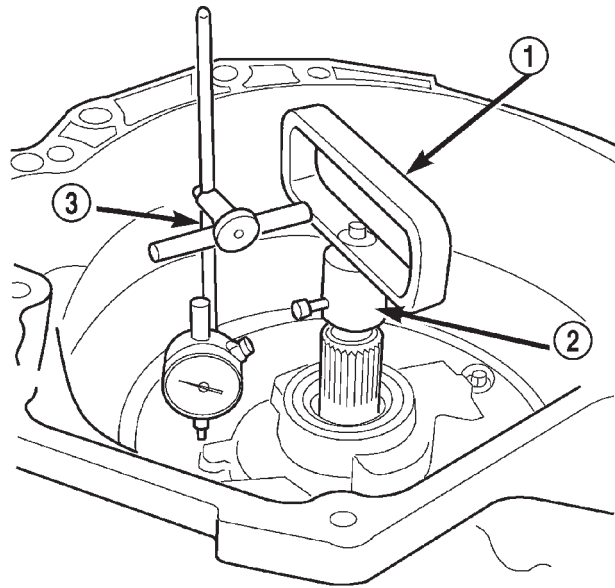

80c070b6

Fig. 163 Checking Input Shaft End Play

- 1 - TOOL 8266-8
- 2 - TOOL 8266-7
- 3 - TOOL C-3339

OVERRUNNING CLUTCH/LOW-REVERSE DRUM

DISASSEMBLY

(1) If the clutch assembly came out with the low-reverse drum, thread two clutch cam bolts into the cam. Then lift the cam out of the drum with the bolts (Fig. 164). Rotate the cam back and forth to ease removal if necessary.

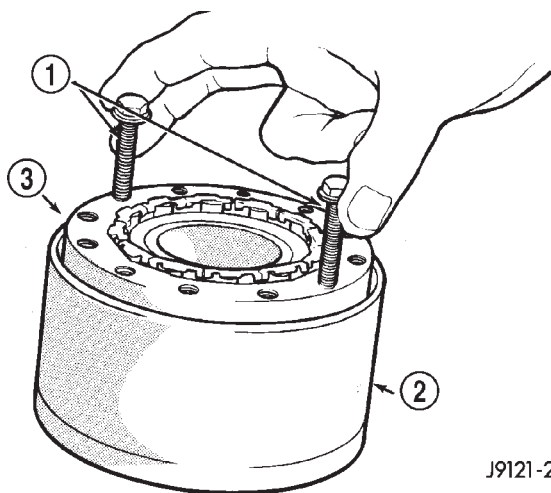

J9121-224

Fig. 164 Removing Overrunning Clutch From Low-Reverse Drum

- 1 - CAM BOLTS
- 2 - LOW-REVERSE DRUM
- 3 - OVERRUNNING CLUTCH AND CAM

(2) Remove the clutch roller and spring assembly from the overrunning clutch race.

ASSEMBLY

(1) Assemble clutch rollers and springs in retainer if necessary (Fig. 165).

(2) Install overrunning clutch roller, spring and retainer assembly in clutch cam (Fig. 166).

(3) Temporarily assemble and check overrunning clutch operation as follows:

(a) Assemble cam and clutch.

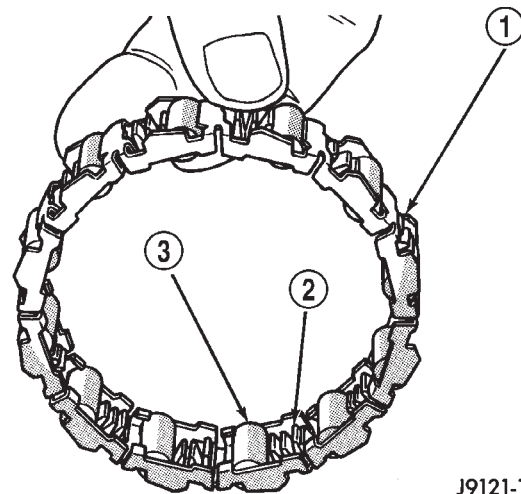

J9121-139

Fig. 165 Overrunning Clutch Rollers, Springs, Retainer

- 1 - RETAINER
- 2 - SPRING
- 3 - ROLLER

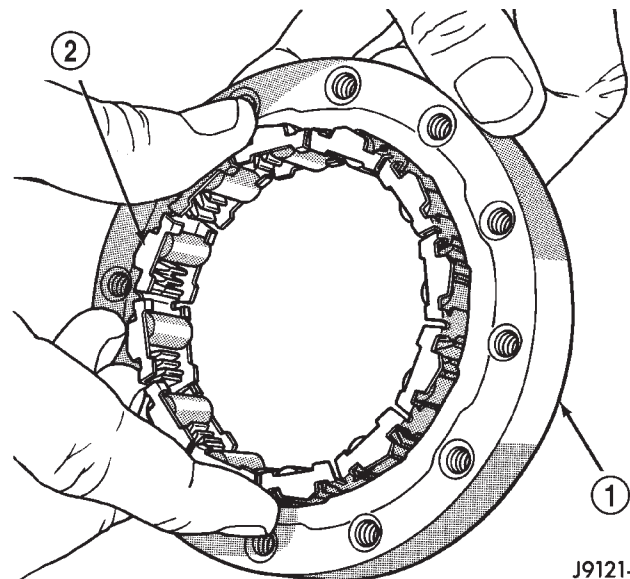

J9121-138

Fig. 166 Assembling Overrunning Clutch And Cam

- 1 - CLUTCH CAM
- 2 - CLUTCH ROLL ASSEMBLY

DISASSEMBLY AND ASSEMBLY (Continued)

(b) Install clutch assembly on low-reverse drum with twisting motion (Fig. 167).

(c) Install drum-clutch assembly in case and install clutch cam bolts.

(d) Install rear support and support attaching bolts.

(e) Check low-reverse drum rotation. **Drum should rotate freely in clockwise direction and lock when turned in counterclockwise direction (as viewed from front of case).**

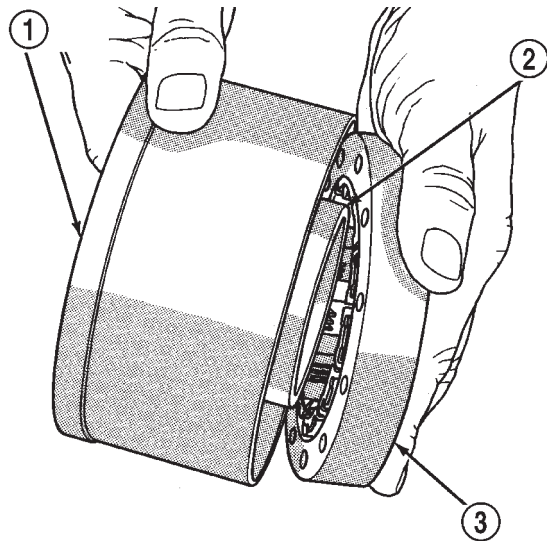

J9121-135

Fig. 167 Temporary Assembly Of Clutch And Drum To Check Operation

- 1 - LOW-REVERSE DRUM
- 2 - CLUTCH RACE (ON HUB OF DRUM)
- 3 - OVERRUNNING CLUTCH

FRONT SERVO PISTON

DISASSEMBLY

- (1) Remove seal ring from rod guide (Fig. 169).
- (2) Remove small snap ring from servo piston rod. Then remove piston rod, spring and washer from piston.
- (3) Remove and discard servo component O-ring and seal rings.

ASSEMBLY

- (1) Lubricate new O-ring and seal rings with petroleum jelly and install them on piston, guide and rod.
- (2) Install rod in piston. Install spring and washer on rod. Compress spring and install snap ring (Fig. 169).
- (3) Set servo components aside for installation during transmission reassembly.

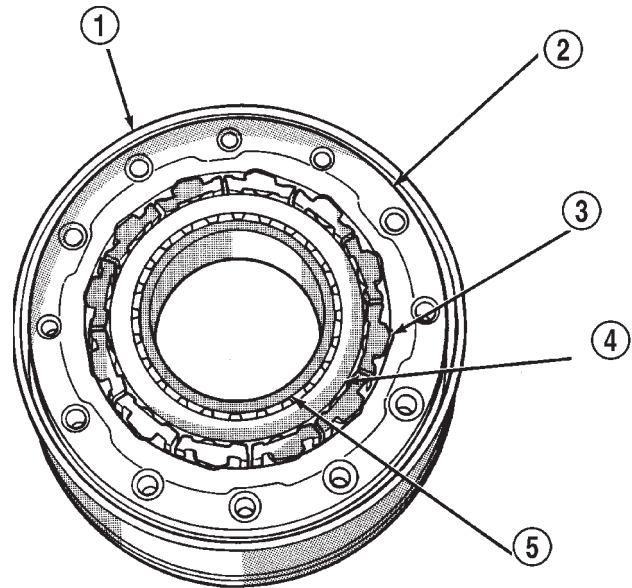

J9121-140

Fig. 168 Assembled Overrunning Clutch

- 1 - LOW-REVERSE DRUM
- 2 - OVERRUNNING CLUTCH CAM
- 3 - ROLLER AND SPRING ASSEMBLY
- 4 - CLUTCH RACE
- 5 - HUB OF LOW-REVERSE DRUM

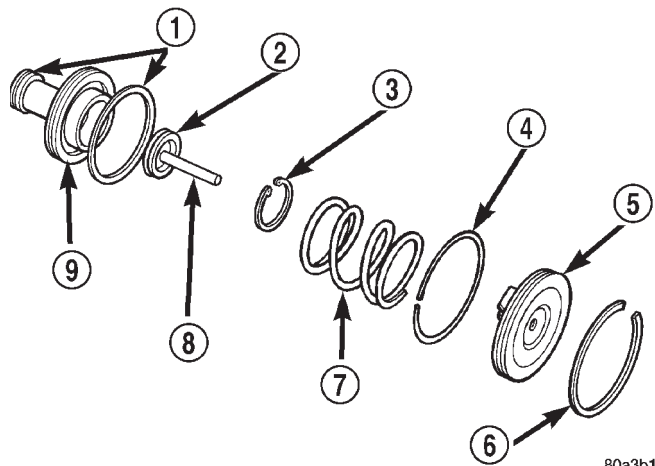

80a3b194

Fig. 169 Front Servo

- 1 - PISTON RINGS
- 2 - O-RING
- 3 - SNAP-RING
- 4 - SEAL RING
- 5 - PISTON ROD GUIDE
- 6 - SNAP-RING
- 7 - SERVO SPRING
- 8 - PISTON ROD
- 9 - SERVO PISTON

DISASSEMBLY AND ASSEMBLY (Continued)

REAR SERVO PISTON

DISASSEMBLY

- (1) Remove small snap ring and remove plug and spring from servo piston (Fig. 170).
- (2) Remove and discard servo piston seal ring.

ASSEMBLY

- (1) Lubricate piston and guide seals with petroleum jelly. Lubricate other servo parts with Mopar® ATF Plus 3, Type 7176, transmission fluid.
- (2) Install new seal ring on servo piston.
- (3) Assemble piston, plug, spring and new snap ring.
- (4) Lubricate piston seal lip with petroleum jelly.

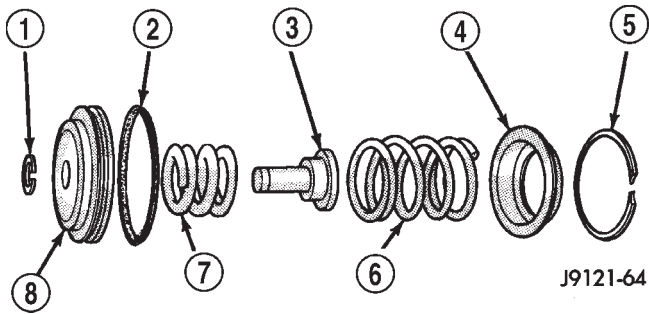
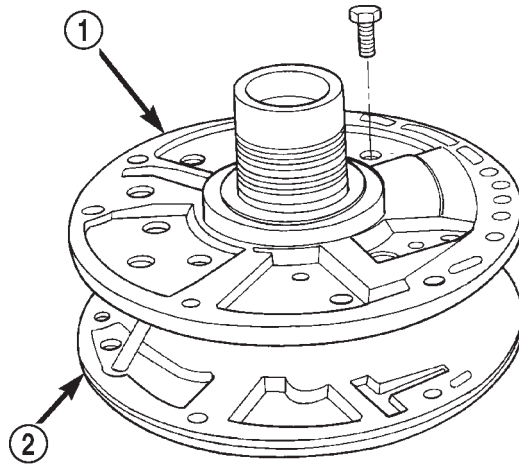

Fig. 170 Rear Servo Components

- 1 - SNAP RING
- 2 - PISTON SEAL
- 3 - PISTON PLUG
- 4 - SPRING RETAINER
- 5 - SNAP RING
- 6 - PISTON SPRING
- 7 - CUSHION SPRING
- 8 - PISTON

J9121-64

- (2) Mark pump housing and support assembly for alignment reference.
- (3) Remove bolts attaching pump body to support (Fig. 172).



80a483e7

Fig. 172 Pump Support Bolts

- 1 - REACTION SHAFT SUPPORT
- 2 - PUMP

- (4) Separate support from pump housing (Fig. 173).
- (5) Remove inner and outer gears from reaction shaft support (Fig. 174).
- (6) If pump seal was not removed during transmission disassembly, remove seal with punch and hammer.
- (7) Remove front clutch thrust washer from support hub (Fig. 175).

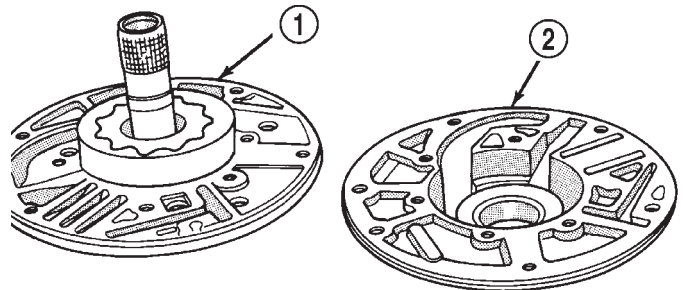

J9321-213

Fig. 173 Separating Pump Housing From Reaction Shaft Support

- 1 - REACTION SHAFT SUPPORT
- 2 - PUMP HOUSING

OIL PUMP AND REACTION SHAFT SUPPORT

DISASSEMBLY

- (1) Remove seal ring from housing and reaction shaft support (Fig. 171).

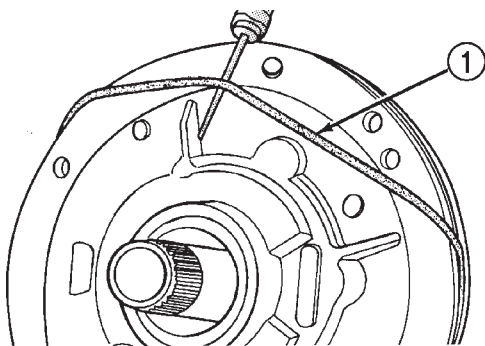

J9321-211

Fig. 171 Removing Pump Seal Ring

- 1 - PUMP HOUSING SEAL RING

DISASSEMBLY AND ASSEMBLY (Continued)

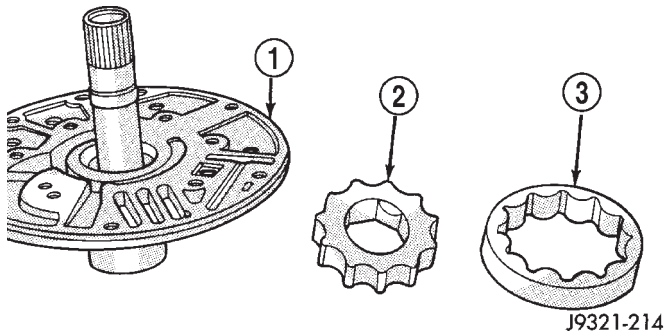

Fig. 174 Pump Gear Removal

- 1 - REACTION SHAFT SUPPORT
- 2 - INNER GEAR
- 3 - OUTER GEAR

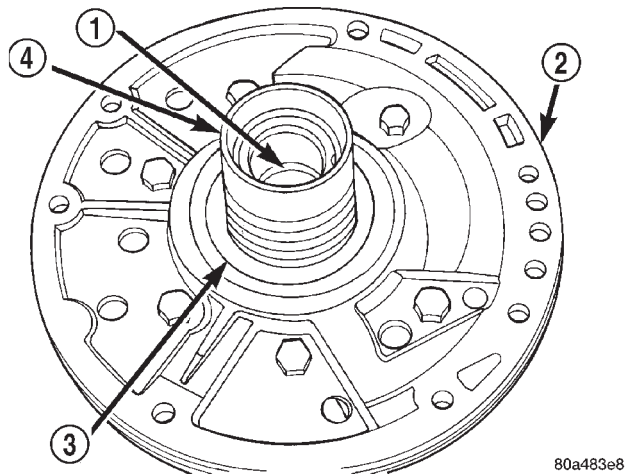

Fig. 175 Support Hub Thrust Washer

- 1 - BUSHING
- 2 - REACTION SHAFT SUPPORT
- 3 - THRUST WASHER
- 4 - HUB

OIL PUMP BUSHING REPLACEMENT

(1) Remove pump bushing with Tool Handle C-4171 and Bushing Remover SP-3551 from Tool Set C-3887-J (Fig. 176).

(2) Install new pump bushing with Tool Handle C-4171 and Bushing Installer SP-5117 (Fig. 176). Bushing should be flush with pump housing bore.

(3) Stake new pump bushing in two places with blunt punch (Fig. 177). Remove burrs from stake points with knife blade afterward.

REACTION SHAFT SUPPORT BUSHING REMOVAL

(1) Assemble Bushing Remover Tools SP-1191, 3633 and 5324 (Fig. 178). **Do not clamp any part of reaction shaft or support in vise.**

(2) Hold Cup Tool SP-3633 firmly against reaction shaft and thread remover SP-5324 into bushing as

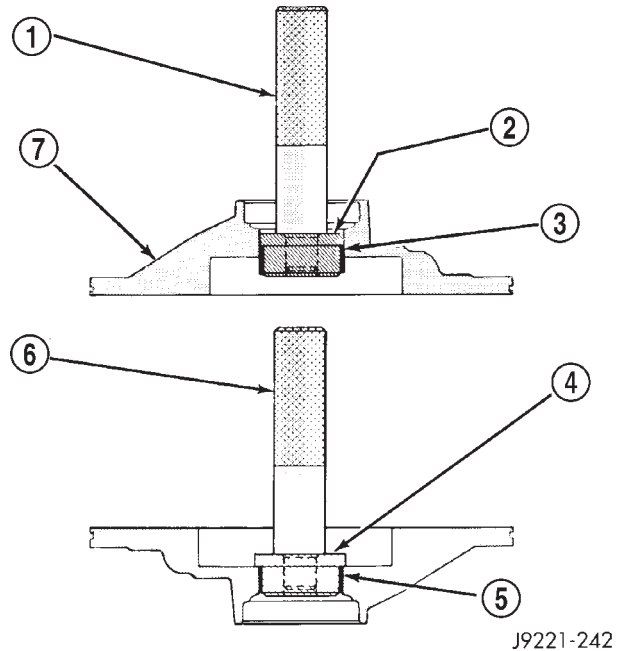

Fig. 176 Removing Oil Pump Bushing

- 1 - SPECIAL TOOL C-4171
- 2 - SPECIAL TOOL SP-3551
- 3 - BUSHING
- 4 - SPECIAL TOOL SP-5117
- 5 - BUSHING
- 6 - SPECIAL TOOL C-4171
- 7 - PUMP HOUSING

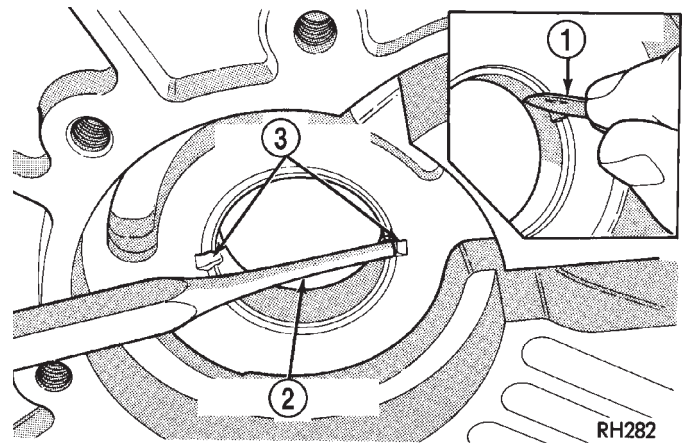

Fig. 177 Staking Oil Pump Bushing

- 1 - NARROW BLADE
- 2 - BLUNT PUNCH
- 3 - TWO STAKES

far as possible by hand. Then thread remover tool 3-4 additional turns into bushing with a wrench.

(3) Turn remover tool hex nut down against remover cup to pull bushing from shaft. Clean all chips from shaft after bushing removal.

DISASSEMBLY AND ASSEMBLY (Continued)

- (4) Lightly grip old bushing in vise or with pliers and back remover tool out of bushing.
- (5) Assemble Bushing Installer Tools C-4171 and SP-5325 (Fig. 178).
- (6) Slide new bushing onto Installer Tool SP-5325.
- (7) Position reaction shaft support upright on a clean smooth surface.
- (8) Align bushing in bore. Then tap bushing into place until Bushing Installer SP-5325 bottoms.
- (9) Clean reaction shaft support thoroughly after installing bushing.

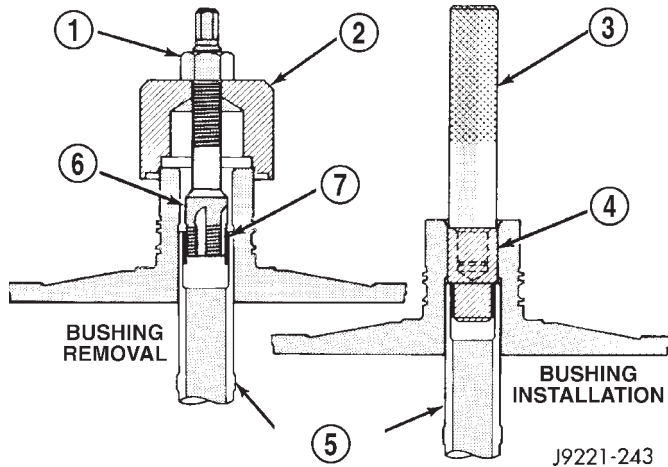

Fig. 178 Replacing Reaction Shaft Support Bushing

- 1 - SPECIAL TOOL SP-1191
- 2 - SPECIAL TOOL SP-3633
- 3 - SPECIAL TOOL C-4171
- 4 - SPECIAL TOOL SP-5325
- 5 - REACTION SHAFT
- 6 - SPECIAL TOOL SP-5324
- 7 - BUSHING

ASSEMBLY

- (1) Lubricate gear bore in pump housing with transmission fluid.
- (2) Lubricate pump gears with transmission fluid.
- (3) Support pump housing on wood blocks (Fig. 179).
- (4) Install outer gear in pump housing (Fig. 179). Gear can be installed either way (it is not a one-way fit).
- (5) Install pump inner gear (Fig. 180).

CAUTION: The pump inner gear is a one way fit. The bore on one side of the gear inside diameter (I. D.) is chamfered. Be sure the chamfered side faces forward (to front of pump).

- (6) Install new thrust washer on hub of reaction shaft support. Lubricate washer with transmission fluid or petroleum jelly.
- (7) If reaction shaft seal rings are being replaced, install new seal rings on support hub (Fig. 181).

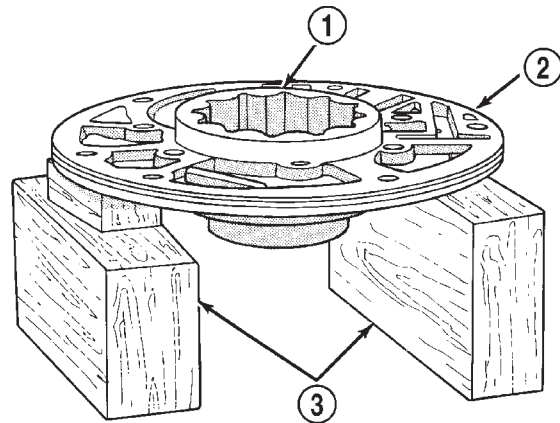

J9321-219

Fig. 179 Supporting Pump And Installing Outer Gear

- 1 - OUTER GEAR
- 2 - PUMP HOUSING
- 3 - WOOD BLOCKS

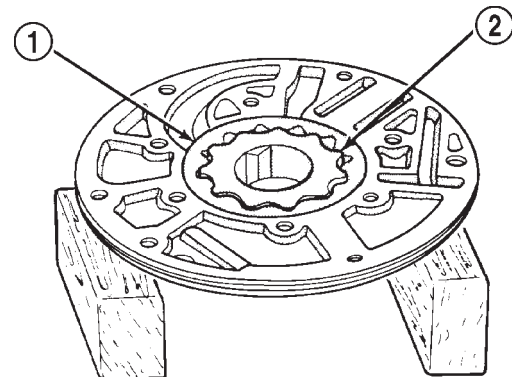

J9321-465

Fig. 180 Pump Inner Gear Installation

- 1 - OUTER GEAR
- 2 - INNER GEAR

Lubricate seal rings with transmission fluid or petroleum jelly after installation. Squeeze each ring until ring ends are securely hooked together.

CAUTION: The reaction shaft support seal rings will break if overspread, or twisted. If new rings are being installed, spread them only enough for installation. Also be very sure the ring ends are securely hooked together after installation. Otherwise, the rings will either prevent pump installation, or break during installation.

- (8) Install reaction shaft support on pump housing (Fig. 182).
- (9) Align reaction support on pump housing. Use alignment marks made at disassembly. Or, rotate support until bolt holes in support and pump housing are all aligned (holes are offset for one-way fit).

DISASSEMBLY AND ASSEMBLY (Continued)

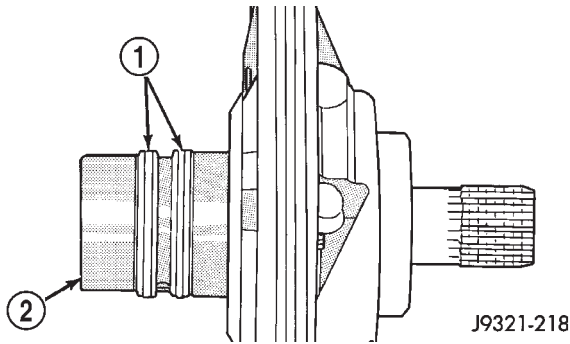

Fig. 181 Hub Seal Ring Position

- 1 - SEAL RINGS
2 - SUPPORT HUB

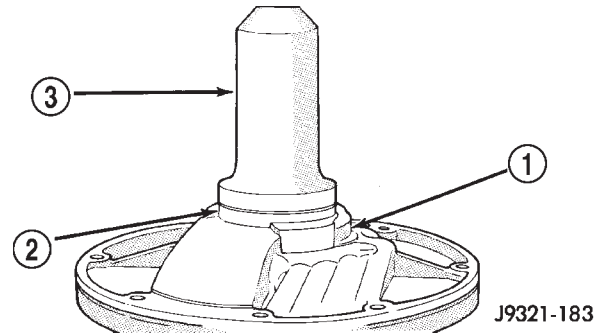

Fig. 183 Pump Oil Seal Installation

- 1 - PUMP BODY
2 - PUMP SEAL
3 - SPECIAL TOOL C-4193

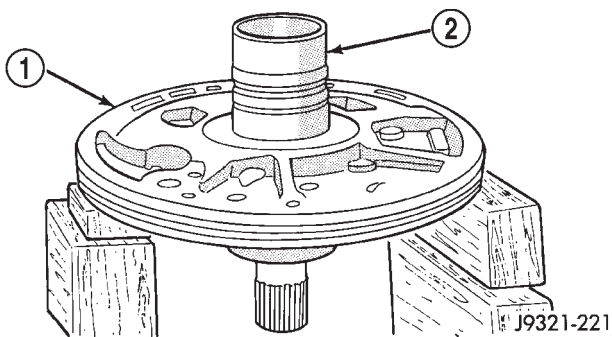

Fig. 182 Assembling Reaction Shaft Support And Pump Housing

- 1 - PUMP HOUSING
2 - REACTION SHAFT SUPPORT

(10) Install all bolts that attach support to pump housing. Then tighten bolts finger tight.

(11) Tighten support-to-pump bolts to required torque as follows:

(a) Reverse pump assembly and install it in transmission case. Position pump so bolts are facing out and are accessible.

(b) Secure pump assembly in case with 2 or 3 bolts, or with pilot studs.

(c) Tighten support-to-pump bolts to 20 N·m (15 ft. lbs.).

(d) Remove pump assembly from transmission case.

(12) Install new oil seal in pump with Special Tool C-4193 and Tool Handle C-4171 (Fig. 183). Be sure seal lip faces inward.

(13) Install new seal ring around pump housing. Be sure seal is properly seated in groove.

(14) Lubricate lip of pump oil seal and O-ring seal with transmission fluid.

FRONT CLUTCH

DISASSEMBLY

(1) Remove waved snap ring and remove pressure plate, clutch plates and clutch discs (Fig. 184).

(2) Compress clutch piston spring with Compressor Tool C-3575-A (Fig. 185). Be sure legs of tool are seated squarely on spring retainer before compressing spring.

(3) Remove retainer snap ring and remove compressor tool.

(4) Remove spring retainer and clutch spring. Note position of retainer on spring for assembly reference.

(5) Remove clutch piston from clutch retainer. Remove piston by rotating it up and out of retainer.

(6) Remove seals from clutch piston and clutch retainer hub. Discard both seals as they are not reusable.

ASSEMBLY

(1) Soak clutch discs in transmission fluid while assembling other clutch parts.

(2) Install new seals on piston and in hub of retainer. Be sure lip of each seal faces interior of clutch retainer.

(3) Lubricate lips of piston and retainer seals with liberal quantity of Mopar® Door Ease, or Ru-Glyde. Then lubricate retainer hub, bore and piston with light coat of transmission fluid.

(4) Install clutch piston in retainer (Fig. 186). Use twisting motion to seat piston in bottom of retainer. A thin strip of plastic (about 0.020" thick), can be used to guide seals into place if necessary.

CAUTION: Never push the clutch piston straight in. This will fold the seals over causing leakage and clutch slip. In addition, never use any type of metal tool to help ease the piston seals into place. Metal tools will cut, shave, or score the seals.

DISASSEMBLY AND ASSEMBLY (Continued)

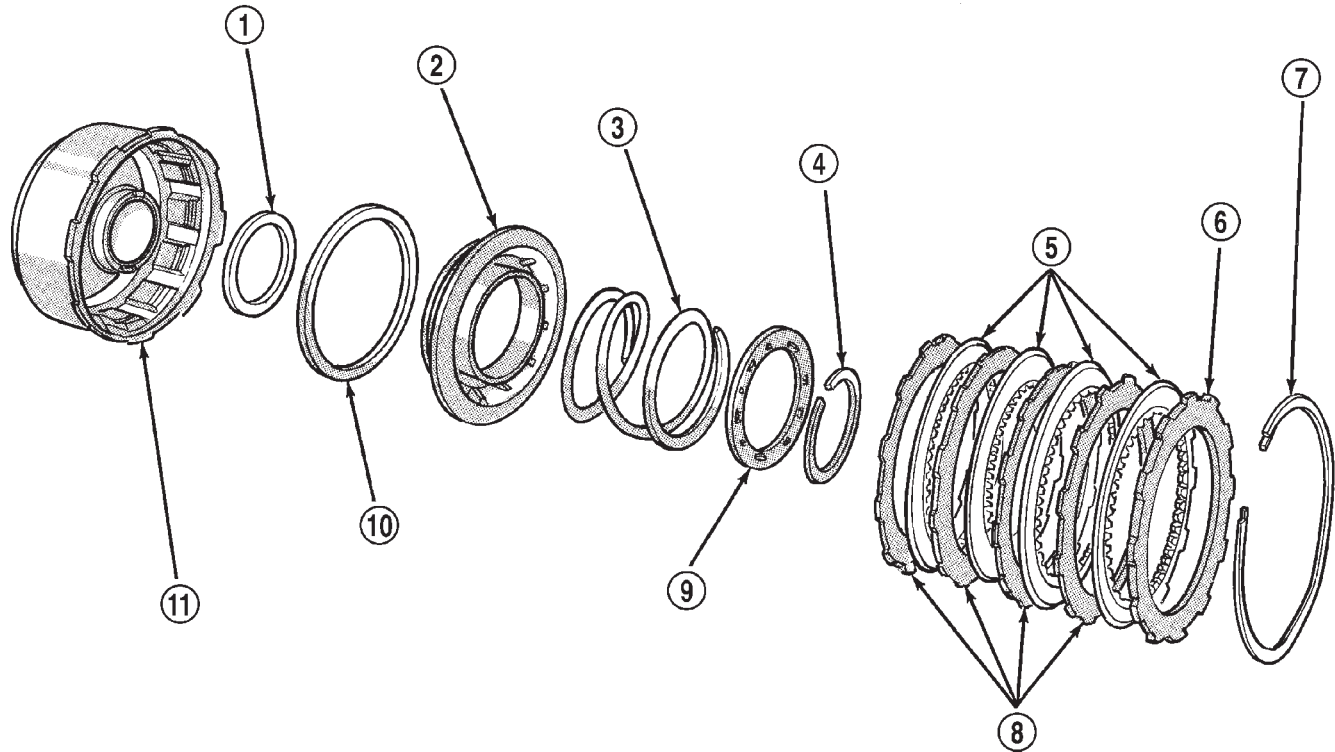

J9321-222

Fig. 184 Front Clutch Components

- | | |
|-------------------------------|----------------------------|
| 1 - RETAINER HUB SEAL | 7 - SNAP RING (WAVED) |
| 2 - CLUTCH PISTON | 8 - CLUTCH PLATES |
| 3 - PISTON SPRING | 9 - SPRING RETAINER |
| 4 - SPRING RETAINER SNAP RING | 10 - PISTON SEAL |
| 5 - CLUTCH DISCS | 11 - FRONT CLUTCH RETAINER |
| 6 - PRESSURE PLATE | |

(5) Position spring in clutch piston (Fig. 187).

(6) Position spring retainer on top of piston spring (Fig. 188). **Make sure retainer is properly installed. Small raised tabs should be facing upward. Semicircular lugs on underside of retainer are for positioning retainer in spring.**

(7) Compress piston spring and retainer with Compressor Tool C-3575-A (Fig. 185). Then install new snap ring to secure spring retainer and spring.

(8) Install clutch plates and discs (Fig. 184). Install steel plate then disc until all plates and discs are installed. The front clutch uses 4 clutch discs.

(9) Install pressure plate and waved snap ring (Fig. 184).

(10) Using a suitable gauge bar and dial indicator, measure clutch plate clearance (Fig. 189).

(a) Position gauge bar across the clutch drum with the dial indicator pointer on the pressure plate (Fig. 189).

(b) Using two small screw drivers, lift the pressure plate and compress the waved snap-ring. This

will assure that the snap-ring is at the top of the groove.

(c) Release the pressure plate and zero the dial indicator.

(d) Lift the pressure plate until it contacts the waved snap-ring and record the dial indicator reading.

Clearance should be 1.70 to 3.40 mm (0.067 to 0.134 in.). If clearance is incorrect, clutch discs, plates pressure plates and snap ring may have to be changed.

REAR CLUTCH**DISASSEMBLY**

(1) Remove thrust washer from forward side of clutch retainer.

(2) Remove input shaft front/rear seal rings.

(3) Remove selective clutch pack snap ring (Fig. 190).

DISASSEMBLY AND ASSEMBLY (Continued)

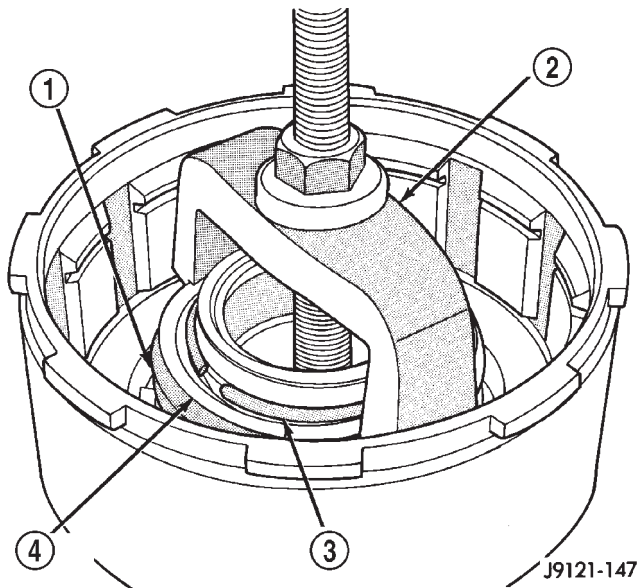
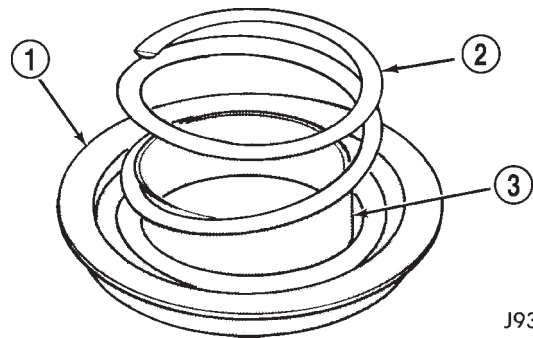

Fig. 185 Compressing Front Clutch Piston Spring

- 1 - FRONT CLUTCH SPRING
- 2 - COMPRESSOR TOOL C-3575-A
- 3 - RETAINER SNAP RING
- 4 - SPRING RETAINER



J9321-466

Fig. 187 Clutch Piston Spring Installation

- 1 - RETAINER
- 2 - CLUTCH SPRING
- 3 - PISTON

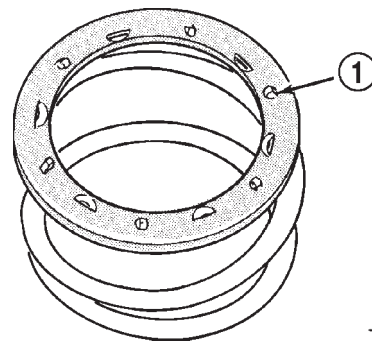

J9321-224

Fig. 188 Correct Spring Retainer Installed Position

- 1 - SMALL TABS ON RETAINER FACE UPWARD

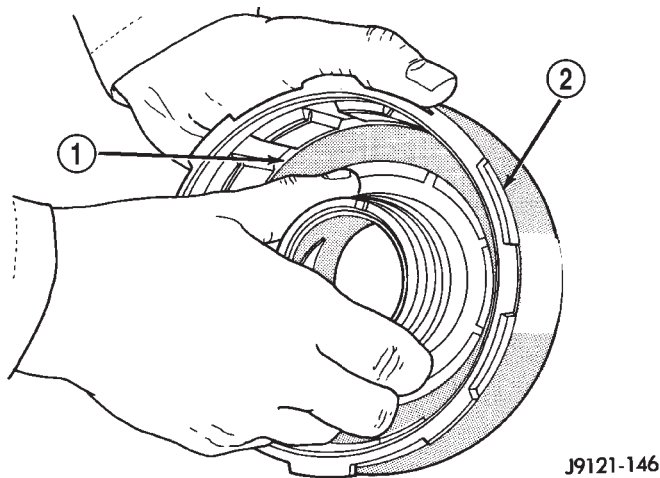

J9121-146

Fig. 186 Front Clutch Piston Installation

- 1 - CLUTCH PISTON
- 2 - FRONT CLUTCH RETAINER

(4) Remove top pressure plate, clutch discs, steel plates, bottom pressure plate and wave snap ring and wave spring (Fig. 190).

(5) Remove clutch piston with rotating motion.

(6) Remove and discard piston seals.

(7) Remove input shaft snap-ring (Fig. 191). It may be necessary to press the input shaft in slightly to relieve tension on the snap-ring

(8) Press input shaft out of retainer with shop press and suitable size press tool. Use a suitably

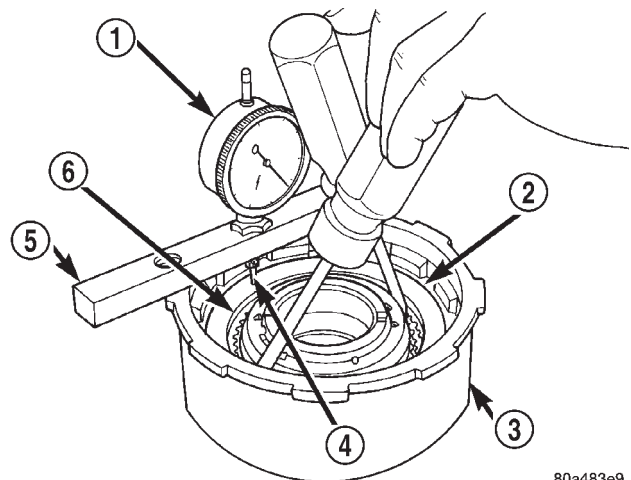

80a483e9

Fig. 189 Measuring Front Clutch Pack Clearance

- 1 - DIAL INDICATOR
- 2 - WAVED SNAP-RING
- 3 - FRONT CLUTCH
- 4 - POINTER
- 5 - GAUGE BAR
- 6 - PRESSURE PLATE

DISASSEMBLY AND ASSEMBLY (Continued)

sized press tool to support the retainer as close to the input shaft as possible.

ASSEMBLY

(1) Soak clutch discs in transmission fluid while assembling other clutch parts.

(2) Install new seal rings on clutch retainer hub and input shaft if necessary (Fig. 192).

(a) Be sure clutch hub seal ring is fully seated in groove and is not twisted.

(3) Lubricate splined end of input shaft and clutch retainer with transmission fluid. Then press input shaft into retainer. Use a suitably sized press tool to support retainer as close to input shaft as possible.

(4) Install input shaft snap-ring (Fig. 191).

(5) Invert retainer and press input shaft in opposite direction until snap-ring is seated.

(6) Install new seals on clutch piston. Be sure lip of each seal faces interior of clutch retainer.

(7) Lubricate lip of piston seals with generous quantity of Mopar® Door Ease. Then lubricate retainer hub and bore with light coat of transmission fluid.

(8) Install clutch piston in retainer. Use twisting motion to seat piston in bottom of retainer. A thin strip of plastic (about 0.020" thick), can be used to guide seals into place if necessary.

CAUTION: Never push the clutch piston straight in. This will fold the seals over causing leakage and clutch slip. In addition, never use any type of metal tool to help ease the piston seals into place. Metal tools will cut, shave, or score the seals.

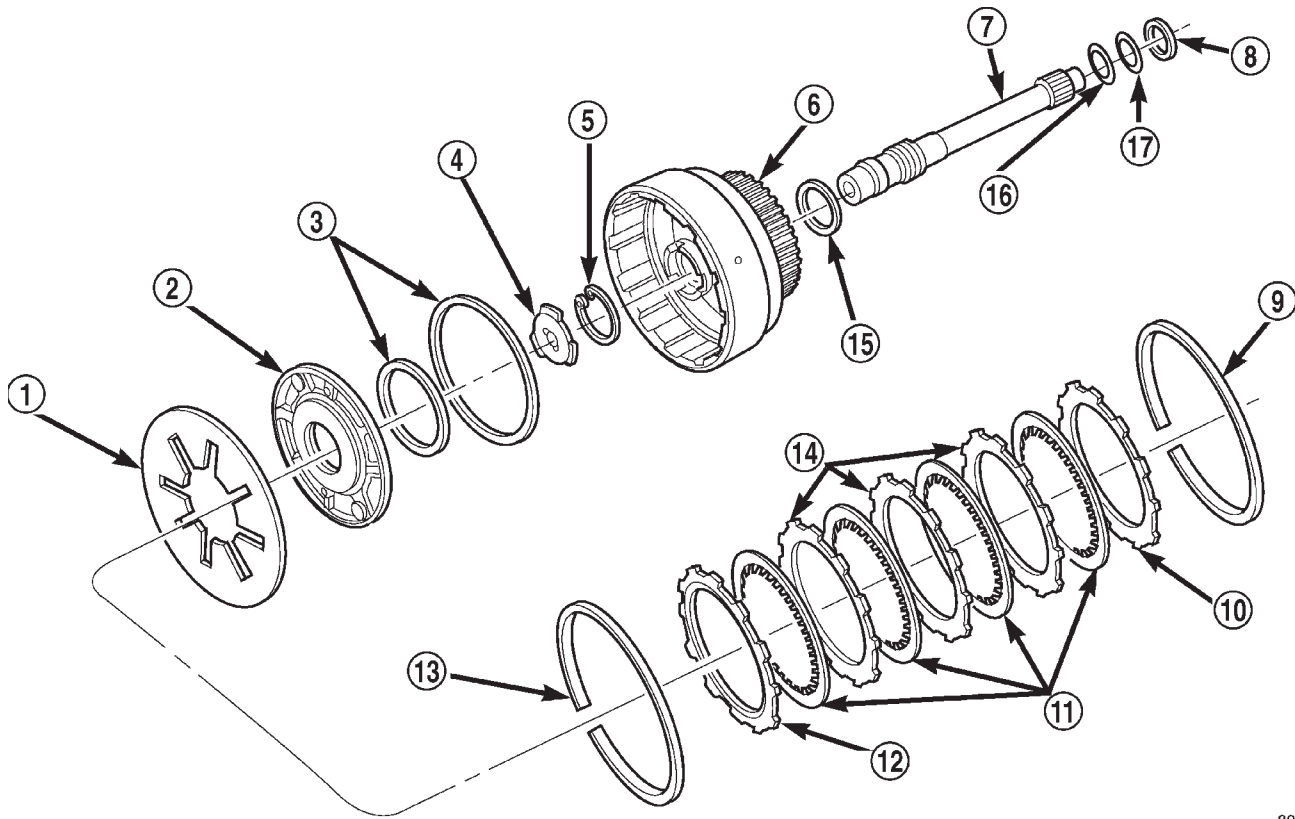

80c070a4

Fig. 190 Rear Clutch Components

- | | |
|--|-------------------------------------|
| 1 - PISTON SPRING | 10 - TOP PRESSURE PLATE |
| 2 - REAR CLUTCH PISTON | 11 - CLUTCH DISCS (4) |
| 3 - CLUTCH PISTON SEALS | 12 - BOTTOM PRESSURE PLATE |
| 4 - OUTPUT SHAFT THRUST WASHER (METAL) | 13 - WAVE SPRING |
| 5 - INPUT SHAFT SNAP RING | 14 - CLUTCH PLATES (3) |
| 6 - REAR CLUTCH RETAINER | 15 - RETAINER SEAL RING |
| 7 - INPUT SHAFT | 16 - SHAFT REAR SEAL RING (PLASTIC) |
| 8 - REAR CLUTCH THRUST WASHER (FIBER) | 17 - SHAFT FRONT SEAL RING (TEFLON) |
| 9 - CLUTCH PACK SNAP RING (SELECTIVE) | |

DISASSEMBLY AND ASSEMBLY (Continued)

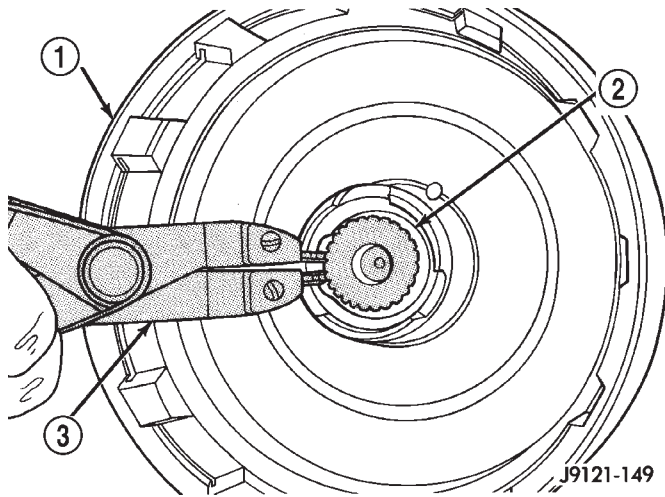
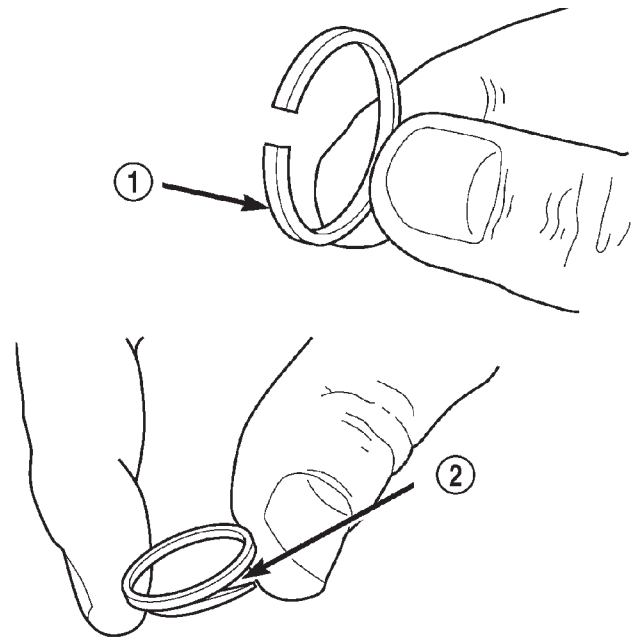

Fig. 191 Removing/Installing Input Shaft Snap-Ring

- 1 - REAR CLUTCH RETAINER
- 2 - INPUT SHAFT SNAP RING
- 3 - SNAP RING PLIERS



80c070a5

Fig. 193 Input Shaft Seal Ring Identification

- 1 - PLASTIC REAR SEAL RING
- 2 - TEFLON FRONT SEAL RING (SQUEEZE RING TOGETHER SLIGHTLY BEFORE INSTALLATION FOR BETTER FIT)

(9) Install piston spring in retainer and on top of piston (Fig. 195). Concave side of spring faces downward (toward piston).

(10) Install wave spring in retainer (Fig. 195). Be sure spring is completely seated in retainer groove.

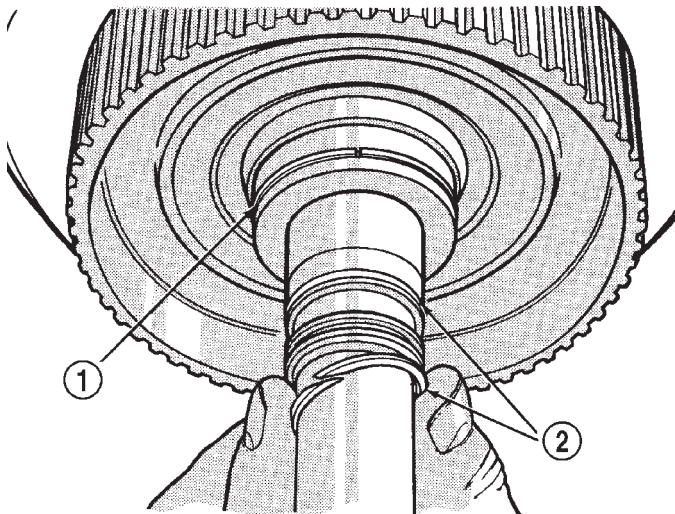

J9121-538

Fig. 192 Rear Clutch Retainer And Input Shaft Seal Ring Installation

- 1 - REAR CLUTCH RETAINER HUB SEAL RING
- 2 - INPUT SHAFT SEAL RINGS

(11) Install bottom pressure plate (Fig. 190). Ridged side of plate faces downward (toward piston) and flat side toward clutch pack.

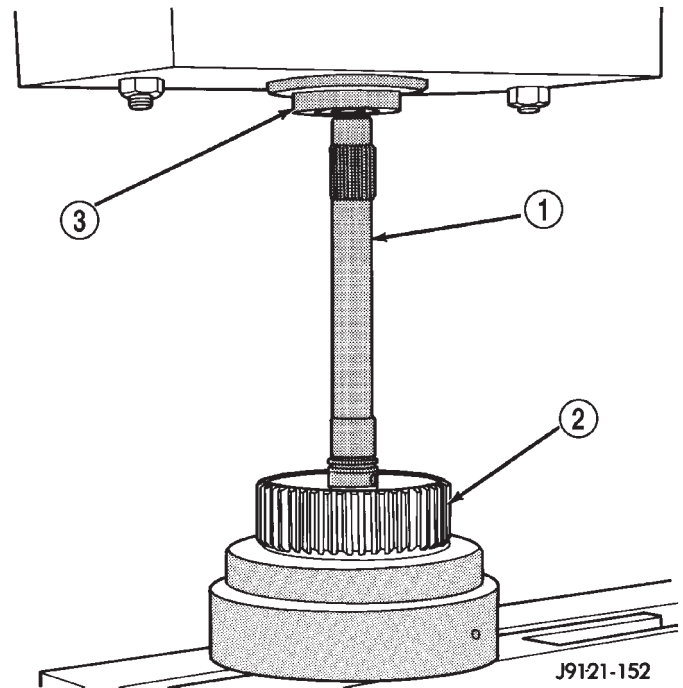

J9121-152

Fig. 194 Pressing Input Shaft Into Rear Clutch Retainer

- 1 - INPUT SHAFT
- 2 - REAR CLUTCH RETAINER
- 3 - PRESS RAM

DISASSEMBLY AND ASSEMBLY (Continued)

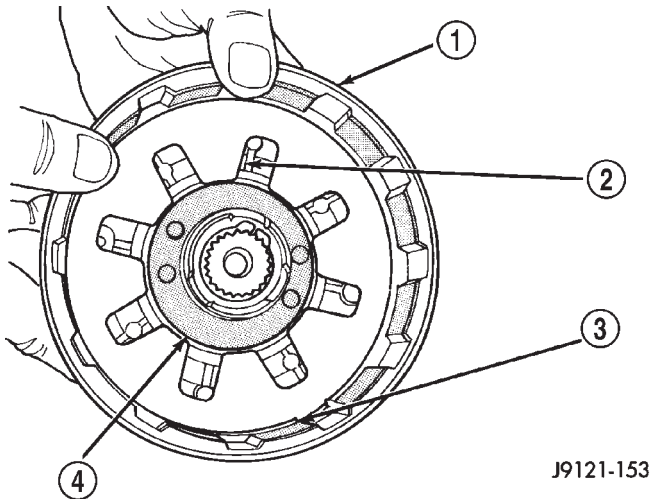

J9121-153

Fig. 195 Piston Spring/Wave Spring Position

- 1 - REAR CLUTCH RETAINER
- 2 - PISTON SPRING
- 3 - WAVE SPRING
- 4 - CLUTCH PISTON

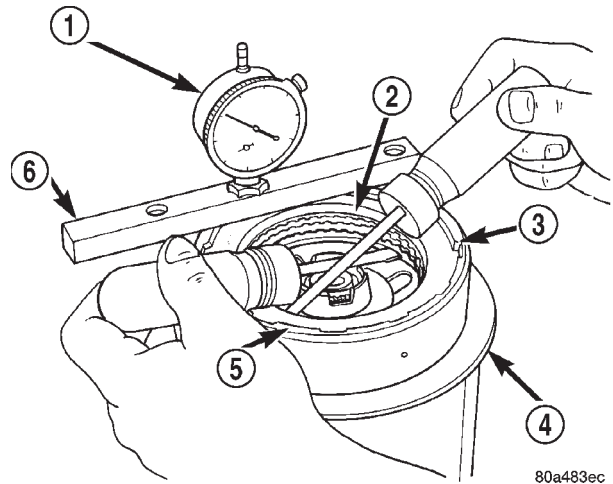

80a483ec

Fig. 196 Checking Rear Clutch Pack Clearance

- 1 - DIAL INDICATOR
- 2 - PRESSURE PLATE
- 3 - SNAP RING
- 4 - STAND
- 5 - REAR CLUTCH
- 6 - GAUGE BAR

(12) Install first clutch disc in retainer on top of bottom pressure plate. Then install a clutch plate followed by a clutch disc until entire clutch pack is installed (4 discs and 3 plates are required) (Fig. 190).

(13) Install top pressure plate.

(14) Install selective snap ring. Be sure snap ring is fully seated in retainer groove.

(15) Using a suitable gauge bar and dial indicator, measure clutch pack clearance (Fig. 196).

(a) Position gauge bar across the clutch drum with the dial indicator pointer on the pressure plate (Fig. 196).

(b) Using two small screw drivers, lift the pressure plate and release it.

(c) Zero the dial indicator.

(d) Lift the pressure plate until it contacts the snap-ring and record the dial indicator reading.

Clearance should be 0.64 - 1.14 mm (0.025 - 0.045 in.). If clearance is incorrect, steel plates, discs, selective snap ring and pressure plates may have to be changed.

The selective snap ring thicknesses are:

- .107-.109 in.
- .098-.100 in.
- .095-.097 in.
- .083-.085 in.
- .076-.078 in.
- .071-.073 in.
- .060-.062 in.

(16) Coat rear clutch thrust washer with petroleum jelly and install washer over input shaft and into clutch retainer (Fig. 197). Use enough petroleum jelly to hold washer in place.

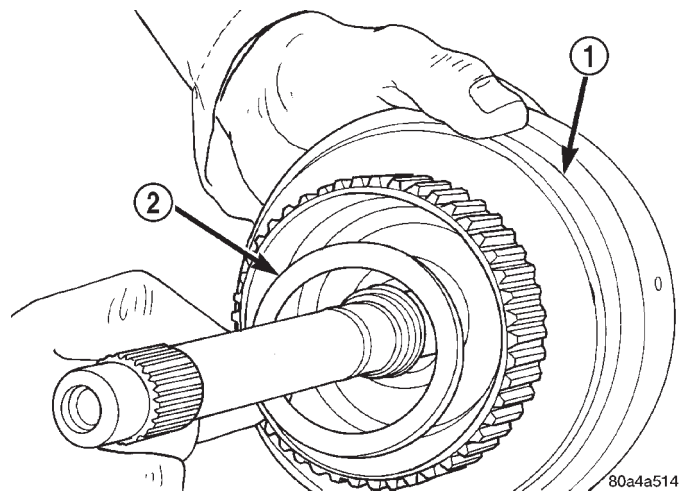

80a4a514

Fig. 197 Installing Rear Clutch Thrust Washer

- 1 - REAR CLUTCH RETAINER
- 2 - REAR CLUTCH THRUST WASHER

PLANETARY GEARTRAIN/OUTPUT SHAFT

DISASSEMBLY

- (1) Remove planetary snap ring (Fig. 198).
- (2) Remove front annulus and planetary assembly from driving shell (Fig. 198).
- (3) Remove snap ring that retains front planetary gear in annulus gear (Fig. 199).
- (4) Remove tabbed thrust washer and tabbed thrust plate from hub of front annulus (Fig. 200).
- (5) Separate front annulus and planetary gears (Fig. 200).

DISASSEMBLY AND ASSEMBLY (Continued)

(6) Remove front planetary gear front thrust washer from annulus gear hub.

(7) Separate and remove driving shell, rear planetary and rear annulus from output shaft (Fig. 201).

(8) Remove front planetary rear thrust washer from driving shell.

(9) Remove tabbed thrust washers from rear planetary gear.

(10) Remove lock ring that retains sun gear in driving shell. Then remove sun gear, spacer and thrust plates.

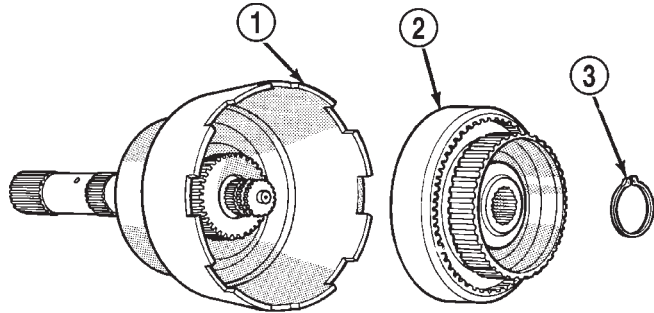

J9421-175

Fig. 198 Front Annulus And Planetary Assembly Removal

- 1 - DRIVING SHELL
- 2 - FRONT ANNULUS AND PLANETARY ASSEMBLY
- 3 - PLANETARY SNAP RING

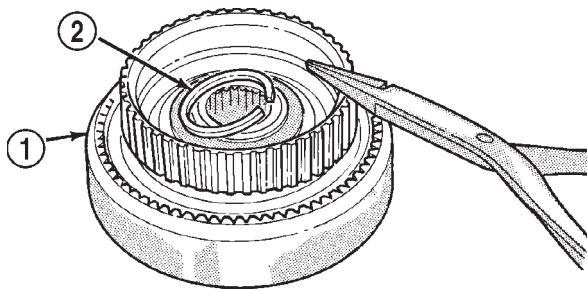

J9421-176

Fig. 199 Front Planetary Snap Ring Removal

- 1 - FRONT ANNULUS GEAR
- 2 - PLANETARY SNAP RING

ASSEMBLY

(1) Lubricate output shaft and planetary components with transmission fluid. Use petroleum jelly to lubricate and hold thrust washers and plates in position.

(2) Assemble rear annulus gear and support if disassembled. Be sure support snap ring is seated and that shoulder-side of support faces rearward (Fig. 202).

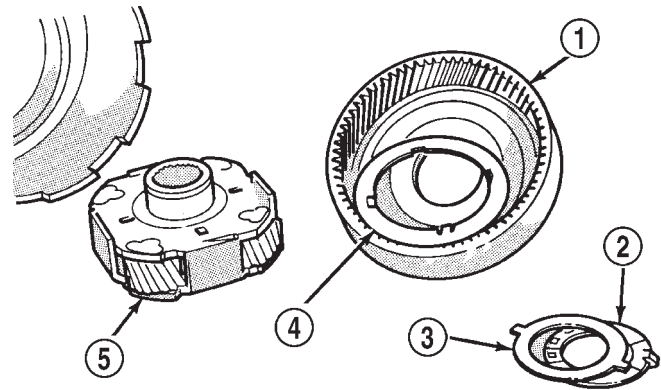

J9421-177

Fig. 200 Front Planetary And Annulus Gear Disassembly

- 1 - FRONT ANNULUS
- 2 - THRUST WASHER
- 3 - THRUST PLATE
- 4 - FRONT THRUST WASHER
- 5 - FRONT PLANETARY

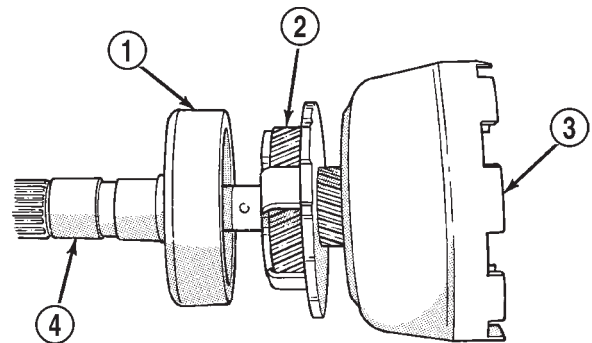

J9421-178

Fig. 201 Removing Driving Shell, Rear Planetary And Rear Annulus

- 1 - REAR ANNULUS
- 2 - REAR PLANETARY
- 3 - DRIVING SHELL
- 4 - OUTPUT SHAFT

(3) Install rear thrust washer on rear planetary gear. Use enough petroleum jelly to hold washer in place. Also be sure all four washer tabs are properly engaged in gear slots.

(4) Install rear annulus over and onto rear planetary gear (Fig. 202).

(5) Install assembled rear planetary and annulus gear on output shaft (Fig. 203). Verify that assembly is fully seated on shaft.

(6) Install front thrust washer on rear planetary gear (Fig. 204). Use enough petroleum jelly to hold

DISASSEMBLY AND ASSEMBLY (Continued)

washer on gear. Be sure all four washer tabs are seated in slots.

(7) Install spacer on sun gear (Fig. 205).

(8) Install thrust plate on sun gear (Fig. 206). Note that driving shell thrust plates are interchangeable. Use either plate on sun gear and at front/rear of shell.

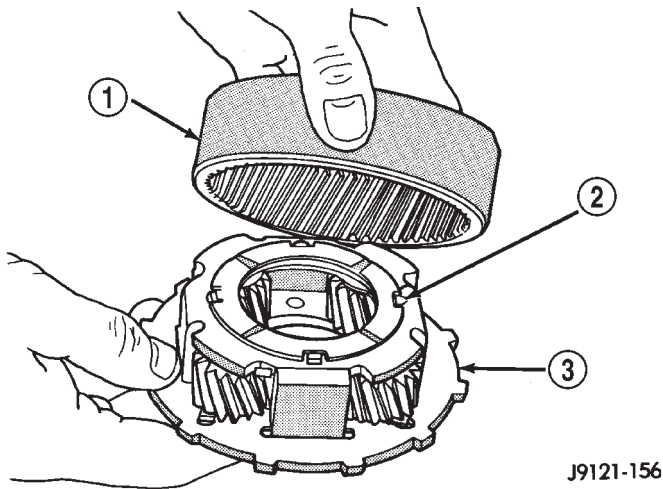

J9121-156

Fig. 202 Assembling Rear Annulus And Planetary Gear

- 1 - REAR ANNULUS GEAR
- 2 - TABBED THRUST WASHER
- 3 - REAR PLANETARY

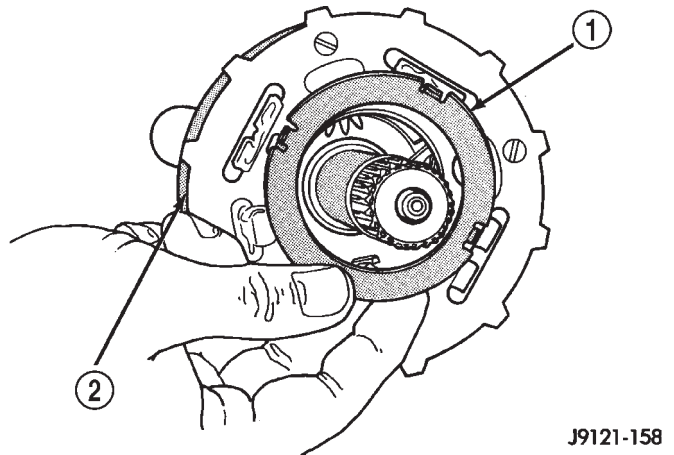

J9121-158

Fig. 204 Installing Rear Planetary Front Thrust Washer

- 1 - FRONT TABBED THRUST WASHER
- 2 - REAR PLANETARY GEAR

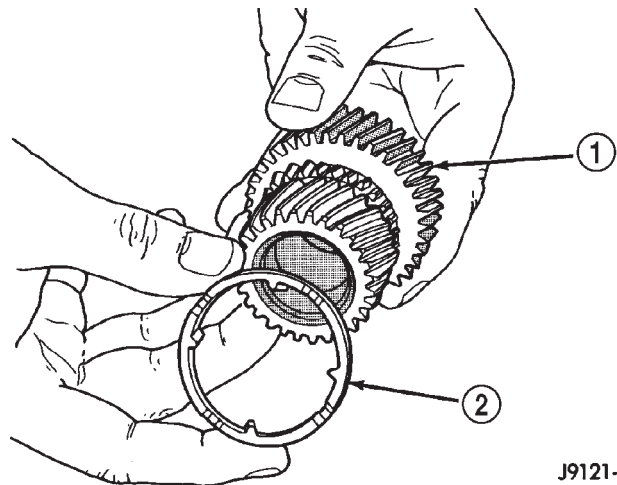

J9121-159

Fig. 205 Installing Spacer On Sun Gear

- 1 - SUN GEAR
- 2 - SUN GEAR SPACER

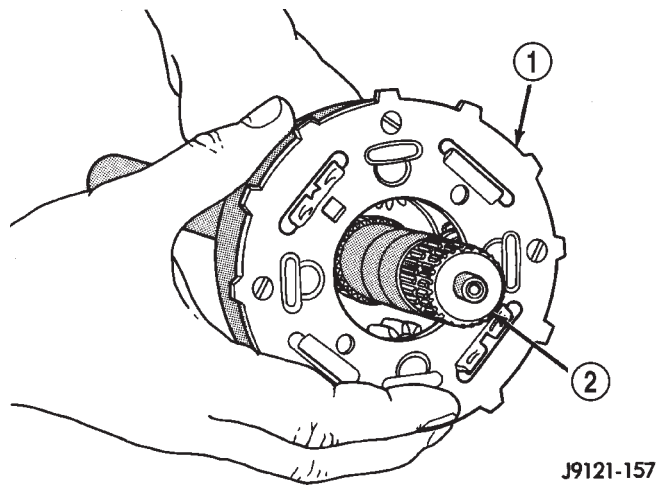

J9121-157

Fig. 203 Installing Rear Annulus And Planetary On Output Shaft

- 1 - REAR ANNULUS AND PLANETARY GEAR ASSEMBLY
- 2 - OUTPUT SHAFT

DISASSEMBLY AND ASSEMBLY (Continued)

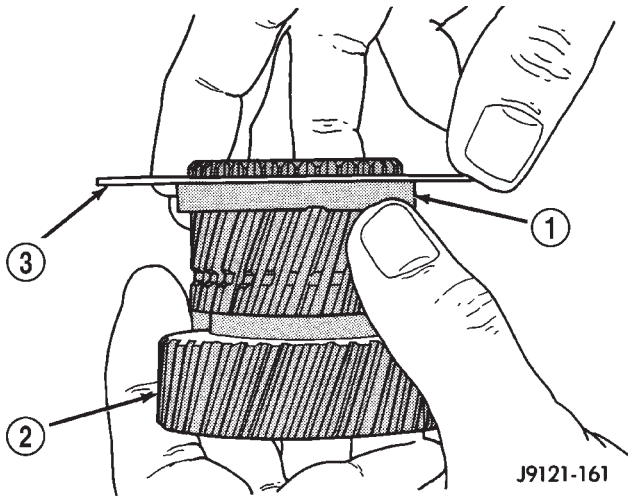

Fig. 206 Installing Driving Shell Front Thrust Plate On Sun Gear

- 1 - SPACER
- 2 - SUN GEAR
- 3 - THRUST PLATE

(9) Hold sun gear in place and install thrust plate over sun gear at rear of driving shell (Fig. 207).

(10) Position wood block on bench and support sun gear on block (Fig. 208). This makes it easier to align and install sun gear lock ring. Keep wood block handy as it will also be used for geartrain end play check.

(11) Align rear thrust plate on driving shell and install sun gear lock ring. Be sure ring is fully seated in sun gear ring groove (Fig. 209).

(12) Install assembled driving shell and sun gear on output shaft (Fig. 210).

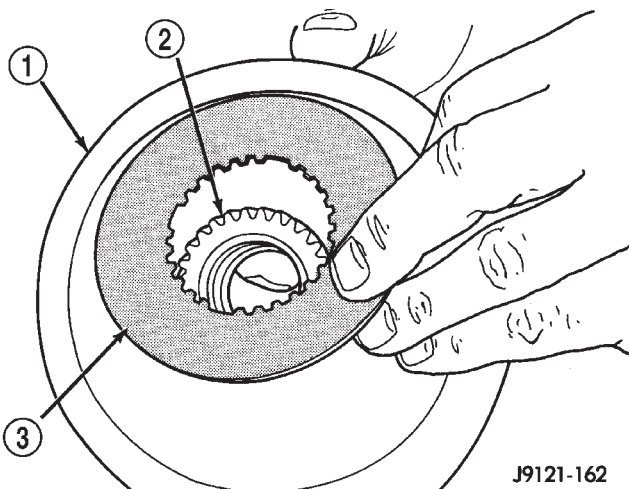

Fig. 207 Installing Driving Shell Rear Thrust Plate

- 1 - DRIVING SHELL
- 2 - SUN GEAR
- 3 - REAR THRUST PLATE

(13) Install rear thrust washer on front planetary gear (Fig. 211). Use enough petroleum jelly to hold washer in place and be sure all four washer tabs are seated.

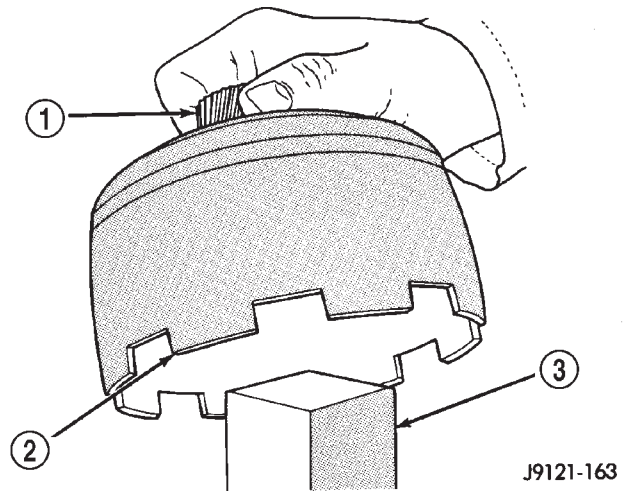

Fig. 208 Supporting Sun Gear On Wood Block

- 1 - SUN GEAR
- 2 - DRIVING SHELL
- 3 - WOOD BLOCK

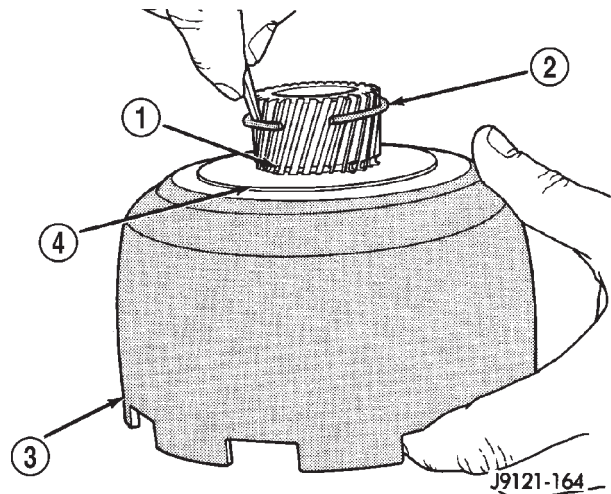

Fig. 209 Installing Sun Gear Lock Ring

- 1 - LOCK RING GROOVE
- 2 - SUN GEAR LOCK RING
- 3 - DRIVING SHELL
- 4 - REAR THRUST PLATE

DISASSEMBLY AND ASSEMBLY (Continued)

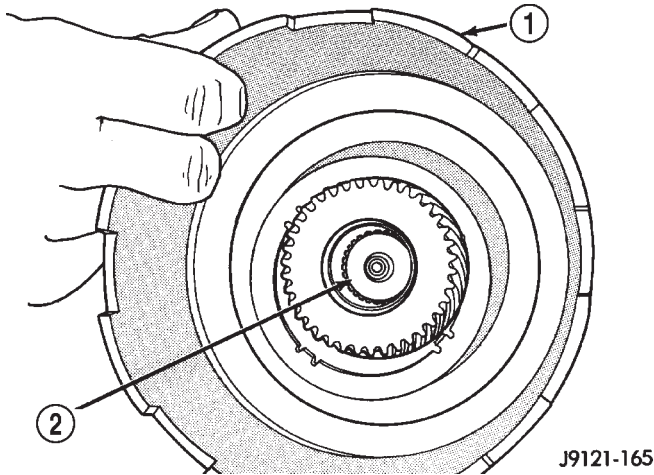

Fig. 210 Installing Assembled Sun Gear And Driving Shell On Output Shaft

- 1 - SUN GEAR/DRIVING SHELL ASSEMBLY
- 2 - OUTPUT SHAFT

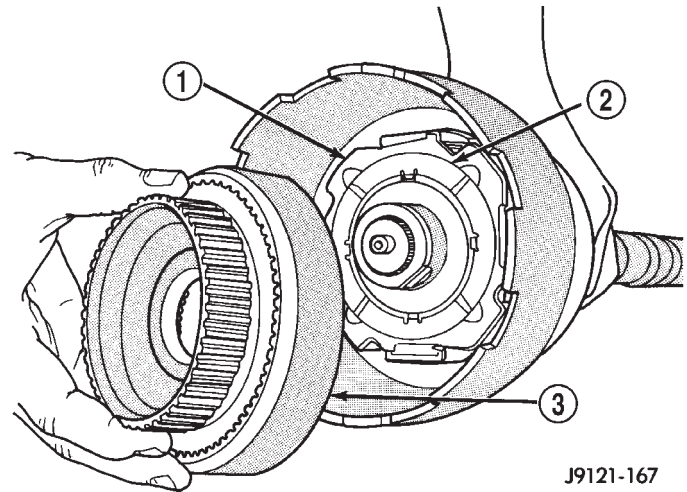

Fig. 212 Installing Front Planetary And Annulus Gears

- 1 - FRONT PLANETARY GEAR
- 2 - FRONT THRUST WASHER
- 3 - FRONT ANNULUS GEAR

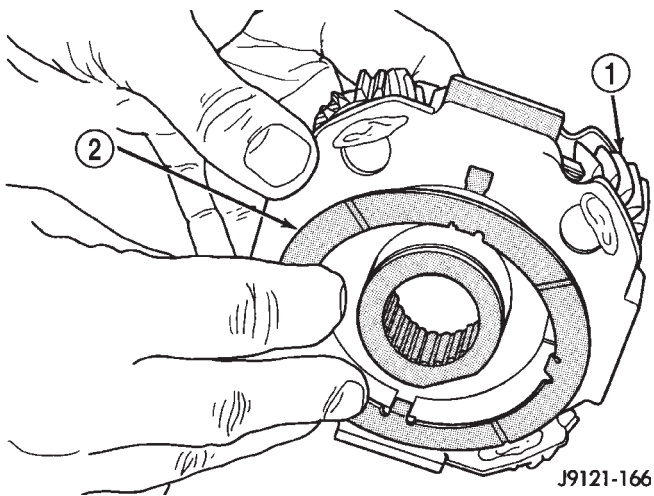

Fig. 211 Installing Rear Thrust Washer On Front Planetary Gear

- 1 - FRONT PLANETARY GEAR
- 2 - REAR TABBED THRUST WASHER

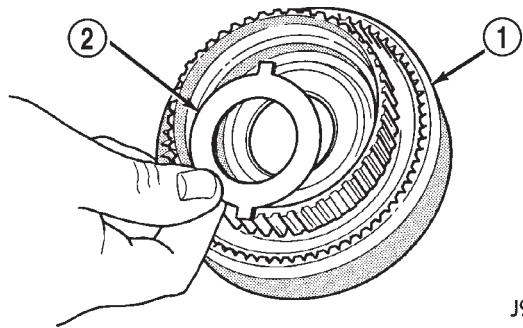

Fig. 213 Positioning Thrust Plate On Front Annulus Support

- 1 - FRONT ANNULUS
- 2 - THRUST PLATE

(14) Install front planetary gear on output shaft and in driving shell (Fig. 212).

(15) Install front thrust washer on front planetary gear. Use enough petroleum jelly to hold washer in place and be sure all four washer tabs are seated.

(16) Assemble front annulus gear and support, if necessary. Be sure support snap ring is seated.

(17) Install front annulus on front planetary (Fig. 212).

(18) Position thrust plate on front annulus gear support (Fig. 213). **Note that plate has two tabs on it. These tabs fit in notches of annulus hub.**

(19) Install thrust washer in front annulus (Fig. 214). **Align flat on washer with flat on planetary hub. Also be sure washer tab is facing up.**

(20) Install front annulus snap ring (Fig. 215). Use snap ring pliers to avoid distorting ring during installation. Also be sure ring is fully seated.

(21) Install planetary selective snap ring with snap ring pliers (Fig. 216). Be sure ring is fully seated.

(22) Turn planetary geartrain assembly over so driving shell is facing workbench. Then support geartrain on wood block positioned under forward end of output shaft. This allows geartrain components to move forward for accurate end play check.

(23) Check planetary geartrain end play with feeler gauge (Fig. 217). Gauge goes between shoulder on output shaft and end of rear annulus support.

DISASSEMBLY AND ASSEMBLY (Continued)

(24) Geartrain end play should be 0.12 to 1.22 mm (0.005 to 0.048 in.). If end play is incorrect, snap ring (or thrust washers) may have to be replaced. Snap ring is available in three different thicknesses for adjustment purposes.

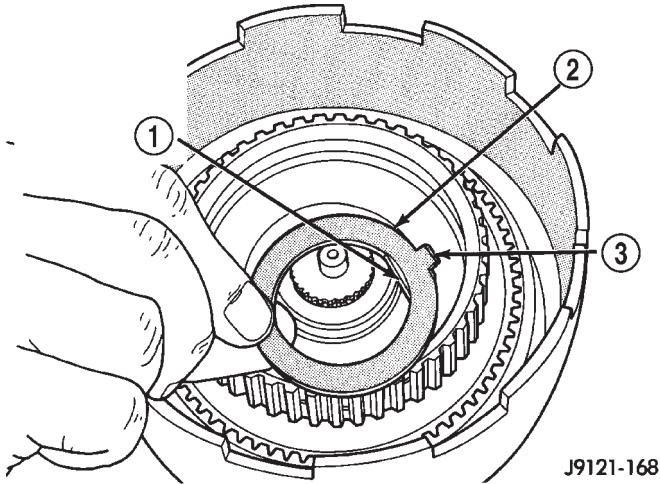

J9121-168

Fig. 214 Installing Front Annulus Thrust Washer

- 1 - WASHER FLAT ALIGNS WITH FLAT ON PLANETARY HUB
- 2 - FRONT ANNULUS THRUST WASHER
- 3 - TAB FACES FRONT

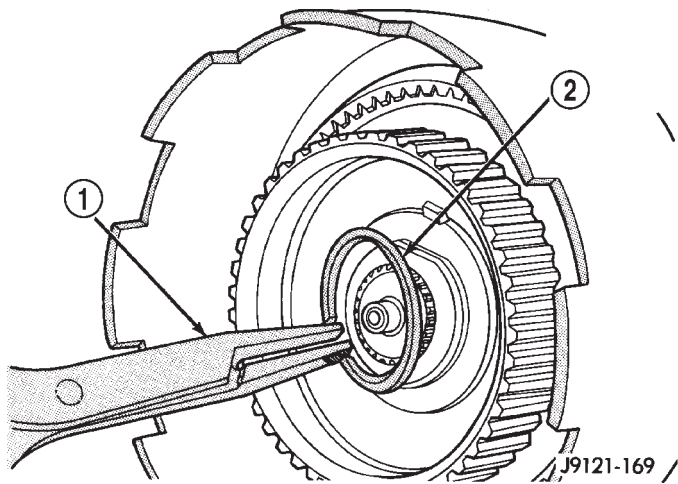

J9121-169 /

Fig. 215 Installing Front Annulus Snap Ring

- 1 - SNAP RING PLIERS
- 2 - FRONT ANNULUS SNAP RING

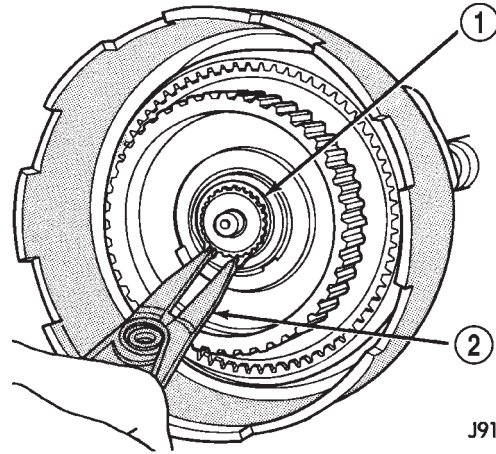

J9121-170

Fig. 216 Installing Planetary Selective Snap Ring

- 1 - SELECTIVE SNAP RING
- 2 - SNAP RING PLIERS

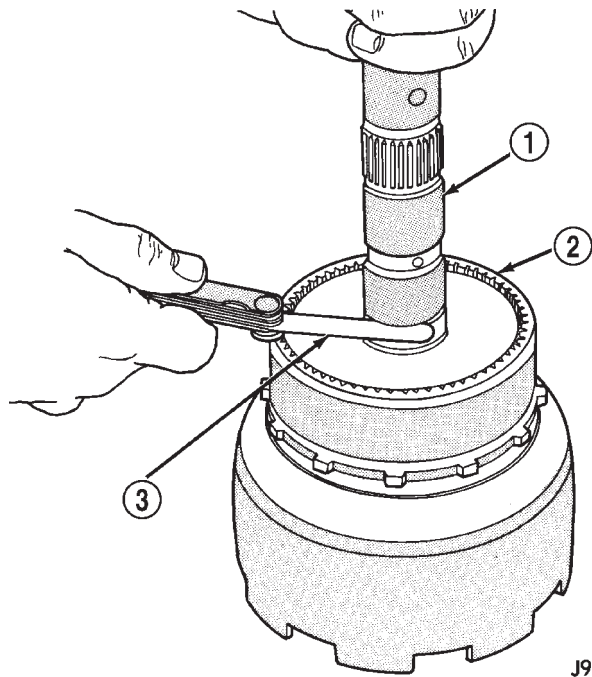

J9121-171

Fig. 217 Checking Planetary Geartrain End Play

- 1 - OUTPUT SHAFT
- 2 - REAR ANNULUS GEAR
- 3 - FEELER GAUGE

CLEANING AND INSPECTION

GOVERNOR AND PARK GEAR

Thoroughly clean all the governor parts in a suitable cleaning solution but do not use any type of caustic cleaning agents.

The governor weight components (Fig. 218) and the governor valve (Fig. 219), must slide freely in their bores when clean and dry. Minor surface scratches and burrs can be smoothed with crocus cloth.

The aluminum governor valve and outer weight have a hard coating on them. Check condition of this coating carefully. Do not reuse either part if the coating is damaged.

Inspect the governor weight spring for distortion. Replace the spring, if distorted, collapsed, or broken. Clean the filter in solvent and dry it with compressed air. Replace the filter, if damaged. Inspect the park gear for chipped or worn gear teeth or damaged ring grooves. Replace the gear, if damaged.

Check the teeth on the park gear for wear or damage. Replace the gear if necessary. Inspect the metal seal rings on the park gear hub. Replace the rings only if severely worn, or broken.

EXTENSION HOUSING AND PARK LOCK

Clean the housing and park lock components in solvent and dry them with compressed air.

Examine the park lock components in the housing. If replacement is necessary, remove the shaft with parallel jaw snap ring pliers (Fig. 220) and remove the sprag and spring. Then remove the spring clip and reaction plug (Fig. 221). **Compress the reaction plug spring clip only enough to remove and install it. Do not distort the clip during removal or installation.**

Be sure a replacement sprag is installed so the sprag locking lug will face the park gear (Fig. 222). Also be sure the spring is correctly positioned as shown (Fig. 222). The sprag may not retract if the spring is improperly installed.

VALVE BODY

Serviceable valve body components are:

- park lock rod and E-clip
- switch valve and spring
- pressure adjusting screw bracket
- throttle valve lever
- manual lever
- manual lever shaft seal, washer, E-clip and detent ball
- fluid filter
- converter clutch solenoid

The remaining valve body components are serviced only as part of a complete valve body assembly.

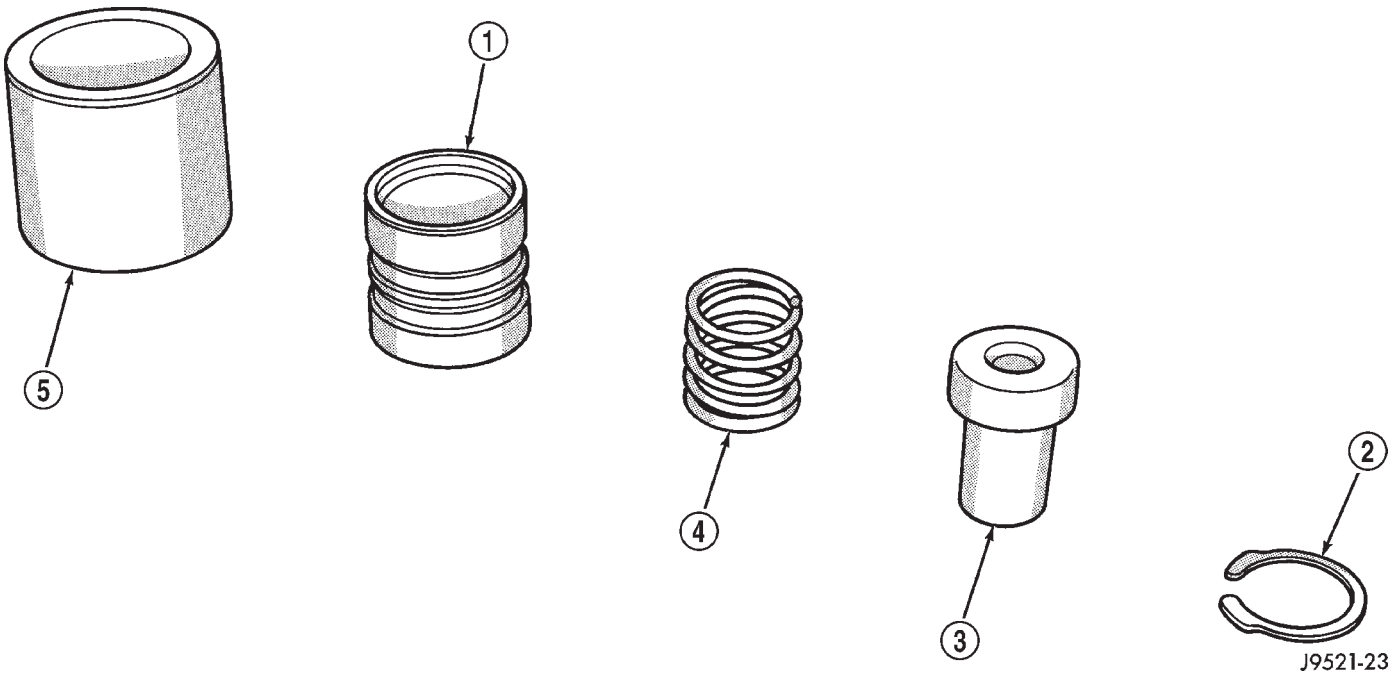

Fig. 218 Governor Weights

- 1 - INTERMEDIATE WEIGHT
2 - SNAP RING
3 - INNER WEIGHT

- 4 - INNER WEIGHT SPRING
5 - OUTER WEIGHT

CLEANING AND INSPECTION (Continued)

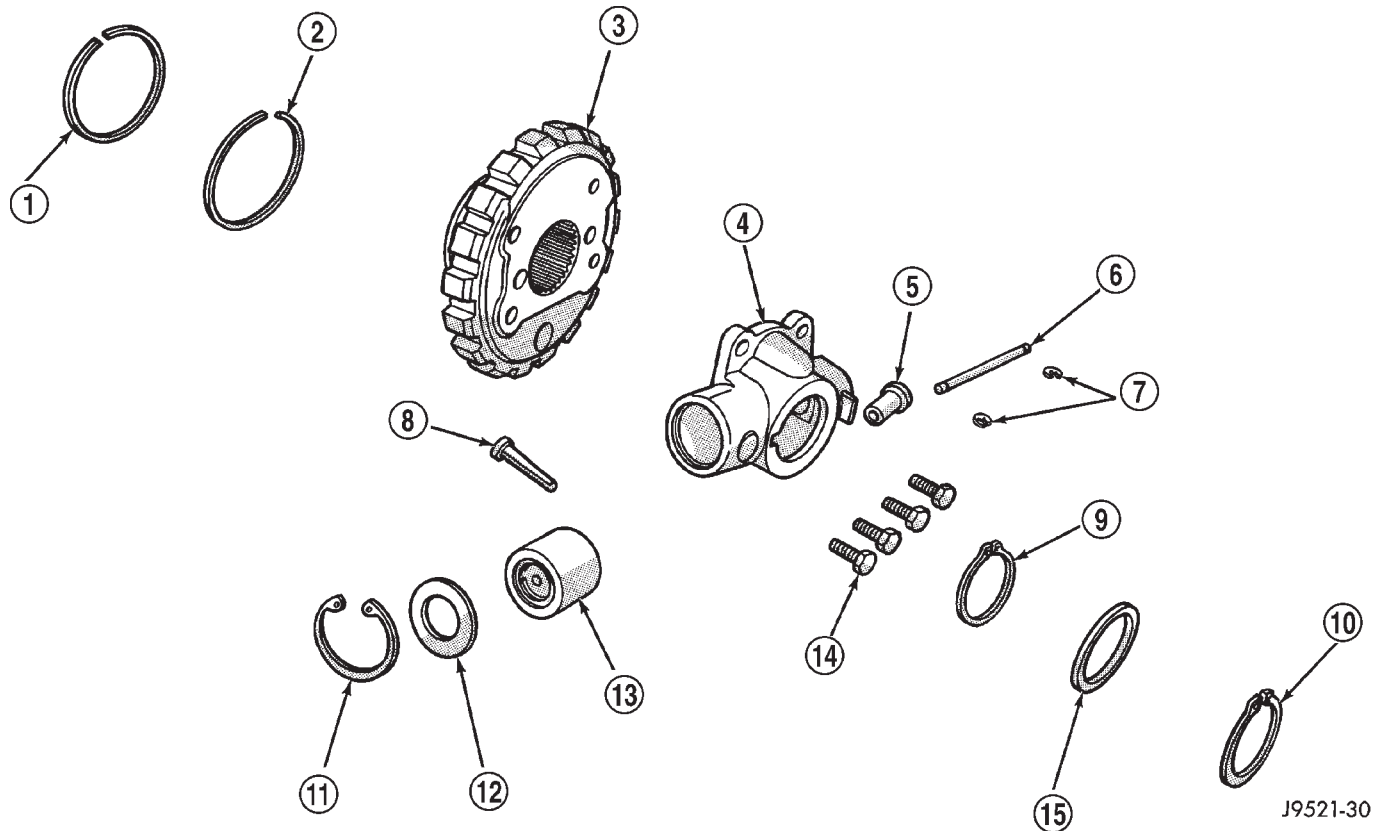

Fig. 219 Governor Components

- 1 - SEAL RING (PLAIN END)
- 2 - SEAL RING (HOOK END)
- 3 - PARK GEAR
- 4 - GOVERNOR BODY
- 5 - GOVERNOR VALVE
- 6 - VALVE SHAFT
- 7 - E-CLIPS (2)
- 8 - FILTER

- 9 - SNAP RING (THIN)
- 10 - SNAP RING (THICK)
- 11 - SNAP RING
- 12 - RETAINER WASHER
- 13 - GOVERNOR WEIGHT ASSEMBLY
- 14 - GOVERNOR BODY BOLTS (4)
- 15 - WASHER

J9521-30

Clean the valve body components in a parts cleaning solution only. Do not use gasoline, kerosene, or any type of caustic solution. Dry the parts with compressed air. Make sure all passages are clean and free from obstructions.

NOTE: Do not use rags or shop towels to wipe off valve body components. Lint from these materials will adhere to the valve body components. Lint will interfere with valve operation and may clog filters and fluid passages.

Inspect the throttle and manual valve levers and shafts. Do not attempt to straighten a bent shaft or correct a loose lever. Replace these components if worn, bent, loose or damaged in any way.

Inspect all of the valve body mating surfaces for scratches, nicks, burrs, or distortion. Use a straight-edge to check surface flatness. Minor scratches may

be removed with crocus cloth using only very light pressure.

Minor distortion of a valve body mating surface may be corrected by smoothing the surface with crocus cloth. The cloth should be in sheet form and be positioned on a surface plate, sheet of plate glass, or equally flat surface. However, if distortion is severe or any surfaces are heavily scored, the valve body will have to be replaced.

CAUTION: Many of the valve body valves and plugs are made of coated aluminum. Aluminum components can be identified by the dark color of the special coating applied to the surface (or by testing with a magnet). **DO NOT** polish or sand aluminum valves or plugs with any type of material, or under any circumstances. This practice might damage the special coating and cause the valves and plugs to stick and bind.

CLEANING AND INSPECTION (Continued)

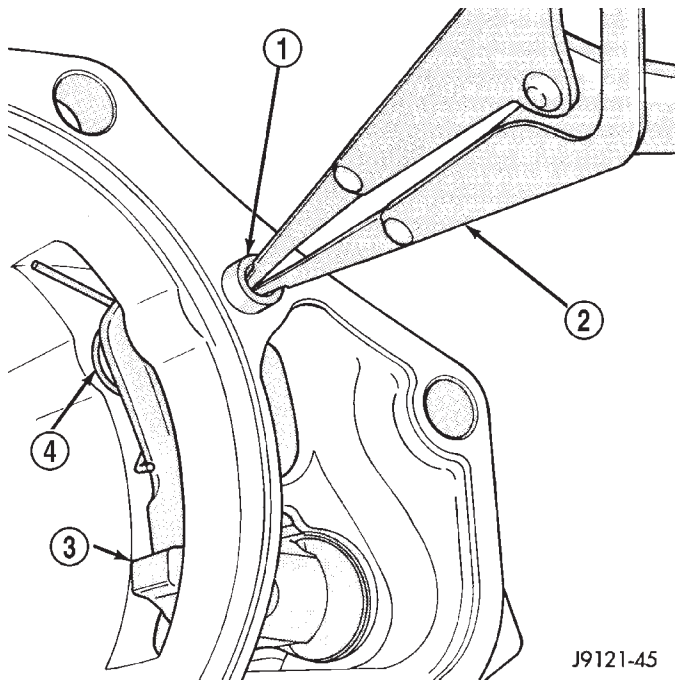

Fig. 220 Park Sprag, Shaft And Spring

- 1 - SPRAG SHAFT
- 2 - PARALLEL JAW SNAP RING PLIERS
- 3 - SPRAG
- 4 - SPRING

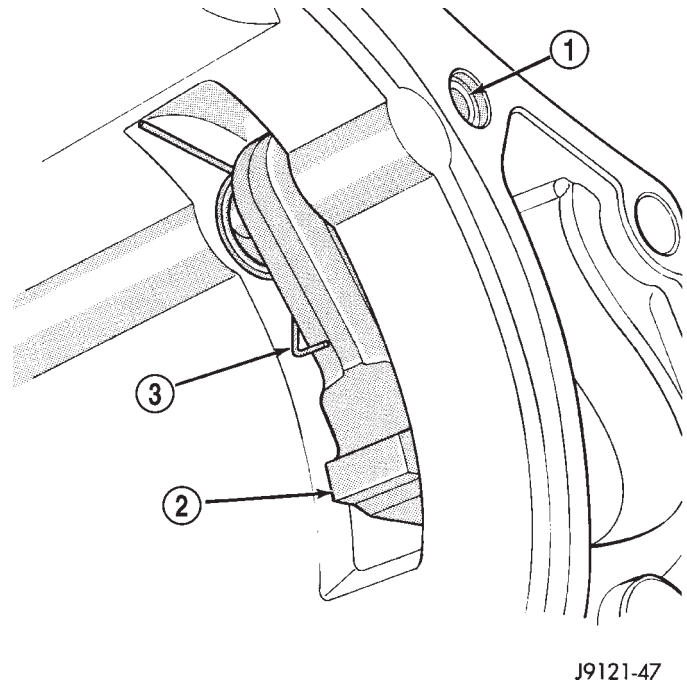

Fig. 222 Correct Position Of Sprag And Spring

- 1 - SPRAG SHAFT
- 2 - SPRAG LOCKING LUG
- 3 - SPRING

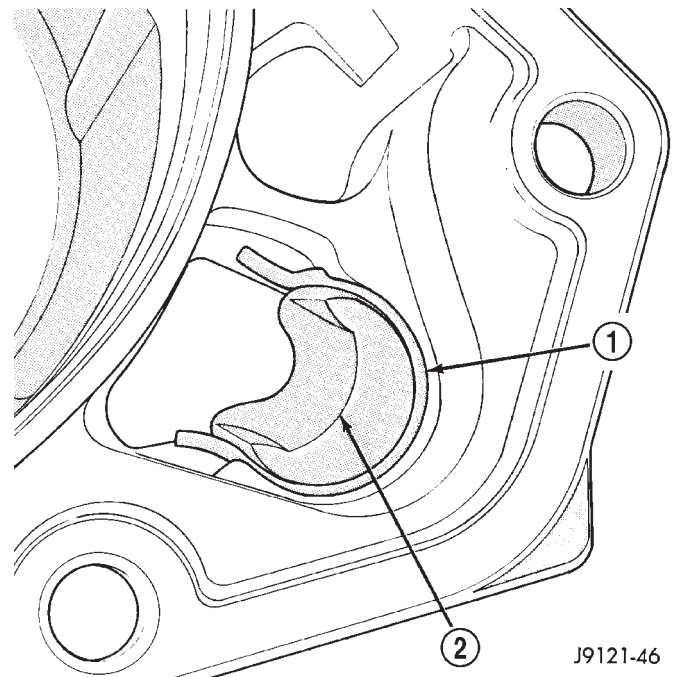

Fig. 221 Park Sprag Reaction Plug And Spring Location

- 1 - SPRING CLIP
- 2 - REACTION PLUG

Inspect the valves and plugs for scratches, burrs, nicks, or scores. Also inspect the coating on the aluminum valves and plugs (Fig. 223). If the coating is damaged or worn through, the valve (or valve body) should be replaced.

Aluminum valves and plugs should not be sanded or polished under any circumstances. However, minor burrs or scratches on steel valves and plugs can be removed with crocus cloth but do not round off the valve or plug edges. Squareness of these edges is vitally important. These edges prevent foreign matter from lodging between the valves, plugs and bore.

Inspect all the valve and plug bores in the valve body. Use a penlight to view the bore interiors. Replace the valve body if any bores are distorted or scored. Inspect all of the valve body springs. The springs must be free of distortion, warpage or broken coils.

Trial fit each valve and plug in its bore to check freedom of operation. When clean and dry, the valves and plugs should drop freely into the bores. Valve body bores do not change dimensionally with use. If the valve body functioned correctly when new, it will continue to operate properly after cleaning and inspection. It should not be necessary to replace a valve body assembly unless it is damaged in handling.

CLEANING AND INSPECTION (Continued)

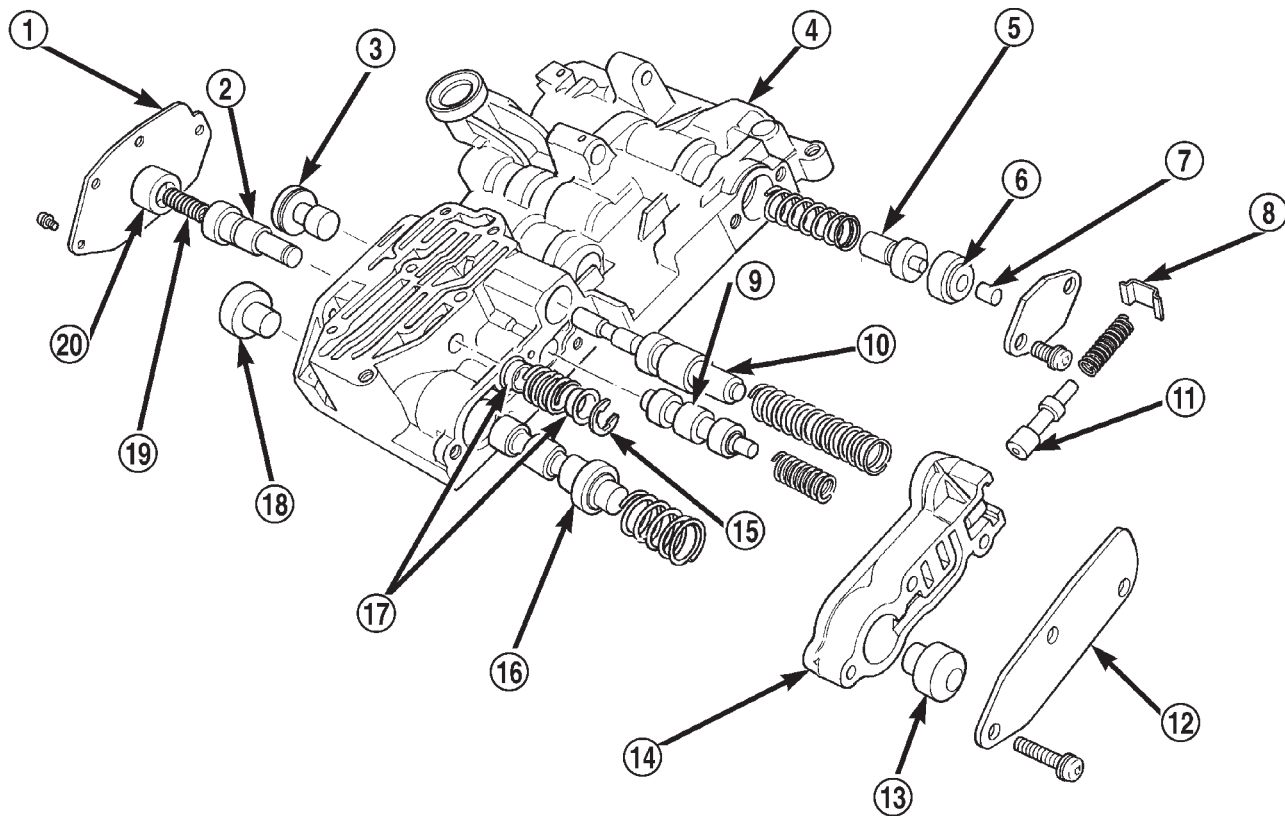

80a13872

Fig. 223 Valve Body Components

- | | |
|--|----------------------------------|
| 1 - GOVERNOR PLUG END PLATE | 11 - KICKDOWN LIMIT VALVE |
| 2 - SHUTTLE VALVE | 12 - END PLATE |
| 3 - 1-2 GOVERNOR PLUG | 13 - THROTTLE PRESSURE PLUG |
| 4 - VALVE BODY | 14 - KICKDOWN LIMIT VALVE BODY |
| 5 - REGULATOR VALVE THROTTLE PRESSURE PLUG | 15 - E-RING |
| 6 - SLEEVE | 16 - 2-3 SHIFT VALVE |
| 7 - LINE PRESSURE PLUG | 17 - GUIDES |
| 8 - RETAINER | 18 - 2-3 GOVERNOR PLUG |
| 9 - 1-2 SHIFT VALVE | 19 - PRIMARY SPRING |
| 10 - 1-2 SHIFT CONTROL VALVE | 20 - SHUTTLE VALVE THROTTLE PLUG |

TRANSMISSION

Clean the case in a solvent tank. Flush the case bores and fluid passages thoroughly with solvent. Dry the case and all fluid passages with compressed air. Be sure all solvent is removed from the case and that all fluid passages are clear.

NOTE: Do not use shop towels or rags to dry the case (or any other transmission component) unless they are made from lint-free materials. Lint will readily adhere to case surfaces and transmission components and will circulate throughout the transmission after assembly. A sufficient quantity of lint can block fluid passages and interfere with valve body operation.

Inspect the case for cracks, porous spots, worn servo bores, or damaged threads. However, the case will have to be replaced if it exhibits damage or wear.

Lubricate the front band adjusting screw and locknut with petroleum jelly and thread it part way into the case. Be sure the screw turns freely and does not bind. Install the locknut on the screw after checking screw thread operation.

Inspect all the transmission bushings during overhaul. Bushing condition is important as worn, scored bushings contribute to low pressures, clutch slip and accelerated wear of other components. Replace worn, or scored bushings, or if doubt exists about bushing condition.

Use recommended tools to replace bushings. The tools are sized and designed to remove, install and seat bushings correctly. The bushing replacement

CLEANING AND INSPECTION (Continued)

tools are included in Bushing Tool Sets C-3887-B, or C-3887-J.

Pre-sized service bushings are available for replacement purposes. Only the sun gear bushings are not serviced. Replace the gear as an assembly if the bushings are severely scored, or worn.

Heli-Coil inserts are recommended for repairing damaged, stripped or worn threads in aluminum parts. Stainless steel inserts are preferred.

The use of crocus cloth is permissible where necessary, providing it is used carefully. When used on valves, use extreme care to avoid rounding off sharp edges. Sharp edges are vital as they prevent foreign matter from getting between the valve and valve bore.

Do not reuse oil seals, gaskets, seal rings, or O-rings during overhaul. Replace these parts as a matter of course. Also do not reuse snap rings or E-clips that are bent or distorted. Replace these parts as well.

Lubricate transmission parts with Mopar® ATF Plus 3, Type 7176 transmission fluid during assembly. Use Mopar® Door Ease, or Ru-Glyde to lubricate piston seals and O-rings. Use petroleum jelly on thrust washers and to hold parts in place during reassembly.

OVERRUNNING CLUTCH/LOW-REVERSE DRUM/OVERDRIVE PISTON RETAINER

Clean the overrunning clutch assembly, clutch cam, low-reverse drum, and overdrive piston retainer in solvent. Dry them with compressed air after cleaning.

Inspect condition of each clutch part after cleaning. Replace the overrunning clutch roller and spring assembly if any rollers or springs are worn or damaged, or if the roller cage is distorted, or damaged. Replace the cam if worn, cracked or damaged.

Replace the low-reverse drum if the clutch race, roller surface or inside diameter is scored, worn or damaged. **Do not remove the clutch race from the low-reverse drum under any circumstances. Replace the drum and race as an assembly if either component is damaged.**

Examine the overdrive piston retainer carefully for wear, cracks, scoring or other damage. Be sure the retainer hub is a snug fit in the case and drum. Replace the retainer if worn or damaged.

FRONT SERVO

Clean the servo piston components with solvent and dry them with compressed air. Wipe the band clean with lint free shop towels.

Replace the front band if distorted, lining is burned, flaking off, or worn to the point where the grooves in the lining material are no longer visible.

Inspect the servo components (Fig. 224). Replace the springs if collapsed, distorted or broken. Replace the guide, rod and piston if cracked, bent, or worn. Discard the servo snap ring if distorted or warped.

Check the servo piston bore for wear. If the bore is severely scored, or damaged, it will be necessary to replace the case.

Replace any servo component if doubt exists about condition. Do not reuse suspect parts.

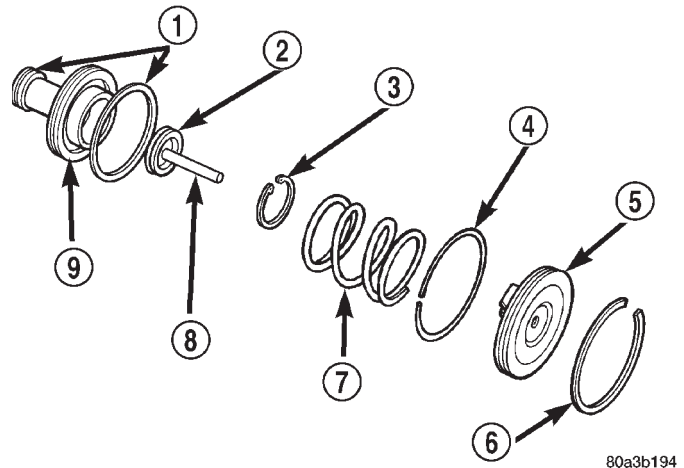

80a3b194

Fig. 224

- 1 - PISTON RINGS
- 2 - O-RING
- 3 - SNAP-RING
- 4 - SEAL RING
- 5 - PISTON ROD GUIDE
- 6 - SNAP-RING
- 7 - SERVO SPRING
- 8 - PISTON ROD
- 9 - SERVO PISTON

REAR SERVO

Remove and discard the servo piston seal ring (Fig. 225). Then clean the servo components with solvent and dry with compressed air. Replace either spring if collapsed, distorted or broken. Replace the plug and piston if cracked, bent, or worn. Discard the servo snap rings and use a new ones at assembly.

OIL PUMP AND REACTION SHAFT SUPPORT

(1) Clean pump and support components with solvent and dry them with compressed air.

(2) Check condition of the seal rings and thrust washer on the reaction shaft support. The seal rings do not need to be replaced unless cracked, broken, or severely worn.

(3) Inspect the pump and support components. Replace the pump or support if the seal ring grooves or machined surfaces are worn, scored, pitted, or damaged. Replace the pump gears if pitted, worn chipped, or damaged.

CLEANING AND INSPECTION (Continued)

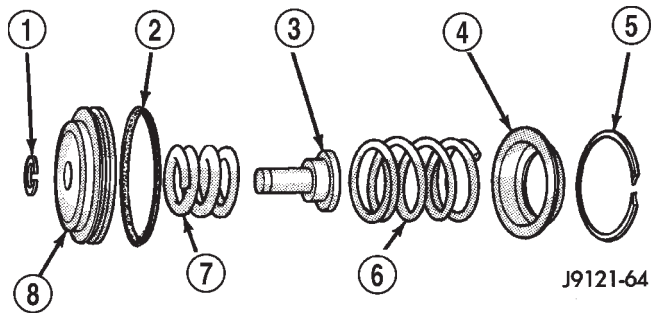

Fig. 225 Rear Servo Components

- 1 - SNAP RING
- 2 - PISTON SEAL
- 3 - PISTON PLUG
- 4 - SPRING RETAINER
- 5 - SNAP RING
- 6 - PISTON SPRING
- 7 - CUSHION SPRING
- 8 - PISTON

(4) Inspect the pump bushing. Then check the reaction shaft support bushing. Replace either bushing only if heavily worn, scored or damaged. It is not necessary to replace the bushings unless they are actually damaged.

(5) Install the gears in the pump body and measure pump component clearances as follows:

(a) Clearance between outer gear and reaction shaft housing should be 0.010 to 0.063 mm (0.0004 to 0.0025 in.). Clearance between inner gear and reaction shaft housing should be 0.010 to 0.063 mm (0.0004 to 0.0025 in.). Both clearances can be measured at the same time by:

(I) Installing the pump gears in the pump housing.

(II) Position an appropriate piece of Plastigage[™] across both gears.

(III) Align the plastigage to a flat area on the reaction shaft housing.

(IV) Install the reaction shaft to the pump housing.

(V) Separate the reaction shaft housing from the pump housing and measure the Plastigage[™] following the instructions supplied with it.

(b) Clearance between inner gear tooth and outer gear should be 0.08 to 0.19 mm (0.0035 to 0.0075 in.). Measure clearance with an appropriate feeler gauge.

(c) Clearance between outer gear and pump housing should also be 0.010 to 0.19 mm (0.0035 to 0.0075 in.). Measure clearance with an appropriate feeler gauge.

FRONT CLUTCH

Clean and inspect the front clutch components. Replace the clutch discs if warped, worn, scored,

burned or charred, or if the facing is flaking off. Replace the steel plates if heavily scored, warped, or broken. Be sure the driving lugs on the plates are in good condition. The lugs must not be bent, cracked or damaged in any way.

Replace the clutch spring and spring retainer if either is distorted, warped or broken.

Check the lug grooves in the clutch retainer. The steel plates should slide freely in the slots. Replace the retainer if the grooves are worn or damaged.

Check action of the check ball in the retainer (Fig. 226). The ball must move freely and not stick.

NOTE: Inspect the clutch retainer bushings carefully (Fig. 227). The retainer bushings are **NOT** serviceable. It will be necessary to replace the retainer if either bushing is scored, or worn.

Inspect the piston and retainer seal surfaces for nicks or scratches. Minor scratches can be removed with crocus cloth. However, replace the piston and/or retainer if the seal surfaces are seriously scored.

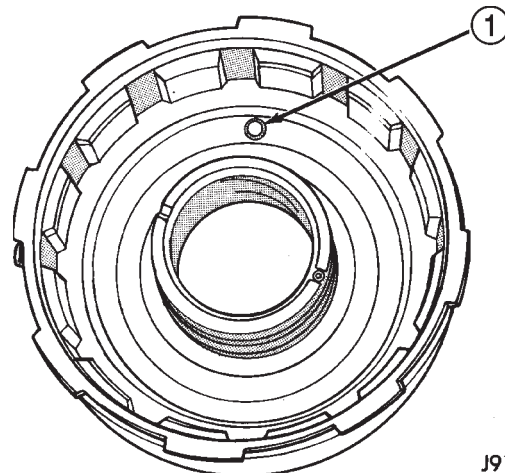

Fig. 226 Front Clutch Piston Retainer Check Ball Location

- 1 - RETAINER CHECK BALL

REAR CLUTCH

Clean the clutch components with solvent and dry them with compressed air.

Check condition of the input shaft seal rings. It is not necessary to remove or replace rings unless they are broken, cracked, or no longer securely hooked together.

Inspect the input shaft splines and machined surfaces. Very minor nicks or scratches can be smoothed off with crocus cloth. replace the shaft if the splines are damaged, or any of the machined surfaces are severely scored.

CLEANING AND INSPECTION (Continued)

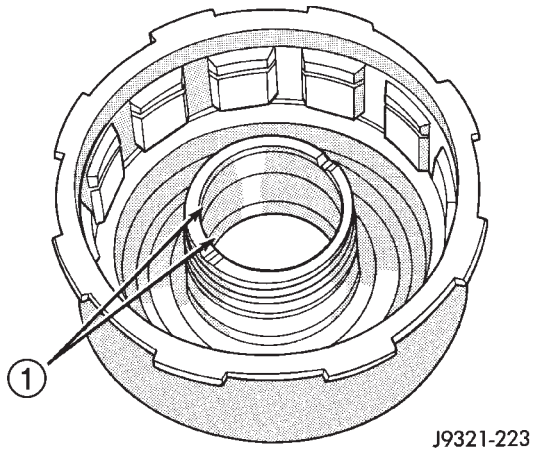

Fig. 227 Retainer Bushing Location/Inspection

1 – FRONT CLUTCH RETAINER BUSHINGS (NON-SERVICEABLE)

Replace the clutch discs if warped, worn, scored, burned/charred, the lugs are damaged, or if the facing is flaking off.

Replace the steel plates and the pressure plate if heavily scored, warped, or broken. Be sure the driving lugs on the discs and plates are also in good condition. The lugs must not be bent, cracked or damaged in any way.

Replace the piston spring and wave spring if either part is distorted, warped or broken.

Check the lug grooves in the clutch retainer. The steel plates should slide freely in the slots. Replace the retainer if the grooves are worn or damaged. Also check action of the retainer check ball. The ball must move freely and not stick.

Inspect the piston and retainer seal surfaces for nicks or scratches. Minor scratches can be removed with crocus cloth. However, replace the piston and/or retainer if the seal surfaces are seriously damaged.

Check thrust washer condition. Washer thickness should be 1.55 to 1.60 mm (0.061 to 0.063 in.). Replace the washer if worn or damaged.

Check condition of the two seal rings on the input shaft and the single seal ring on the piston retainer hub. Replace the seal rings only if severely worn, cracked, or cannot be hooked together.

PLANETARY GEARTRAIN/OUTPUT SHAFT

Clean the intermediate shaft and planetary components in solvent and dry them with compressed air. Do not spin the planetary pinion gears with compressed air.

Inspect the planetary gear sets and annulus gears. The planetary pinions, shafts, washers, and retaining pins are serviceable. However, if a pinion carrier is damaged, the entire planetary gear set must be replaced as an assembly.

Replace the annulus gears if the teeth are chipped, broken, or worn, or the gear is cracked. Replace the planetary thrust plates and the tabbed thrust washers if cracked, scored or worn.

Inspect the machined surfaces of the output shaft. Be sure the oil passages are open and clear. Replace the shaft if scored, pitted, or damaged.

Inspect the sun gear and driving shell. If either component is worn or damaged, remove the sun gear rear retaining ring and separate the sun gear and thrust plate from the driving shell. Then replace the necessary component.

Replace the sun gear as an assembly if the gear teeth are chipped or worn. Also replace the gear as an assembly if the bushings are scored or worn. The sun gear bushings are not serviceable. Replace the thrust plate if worn, or severely scored. Replace the driving shell if distorted, cracked, or damaged in any way.

Replace all snap rings during geartrain assembly. Reusing snap rings is not recommended.

ADJUSTMENTS

GEARSHIFT CABLE

Check adjustment by starting the engine in Park and Neutral. Adjustment is OK if the engine starts only in these positions. Adjustment is incorrect if the engine starts in one but not both positions. If the engine starts in any position other than Park or Neutral, or if the engine will not start at all, the park/neutral position switch may be faulty.

Gearshift Adjustment Procedure

- (1) Shift transmission into Park.
- (2) Raise vehicle.
- (3) Release cable adjuster clamp (at transmission end of cable) to unlock cable.
- (4) Unsnap cable from cable mounting bracket on transmission (Fig. 228).
- (5) Slide cable eyelet off transmission shift lever.
- (6) Verify transmission shift lever is in Park detent by moving lever fully rearward. Last rearward detent is Park position.
- (7) Verify positive engagement of transmission park lock by attempting to rotate propeller shaft. Shaft will not rotate when park lock is engaged.
- (8) Slide cable eyelet onto transmission shift lever.
- (9) Snap shift cable adjuster into mounting bracket on transmission.
- (10) Lock shift cable by pressing cable adjuster clamp down until it snaps into place.
- (11) Lower vehicle and check engine starting. Engine should start only in Park and Neutral.

ADJUSTMENTS (Continued)

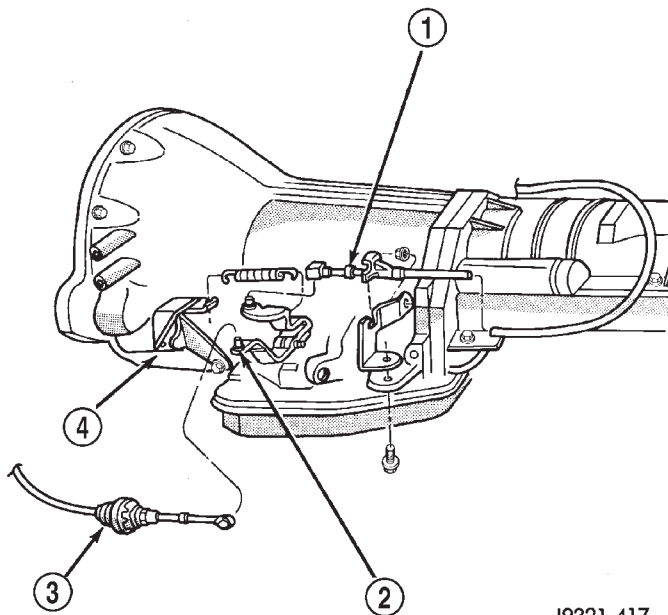

J9321-417

Fig. 228 Shift Cable Attachment At Transmission—Typical

- 1 - THROTTLE VALVE CABLE
- 2 - TRANSMISSION SHIFT LEVER
- 3 - SHIFT CABLE
- 4 - SHIFT CABLE BRACKET

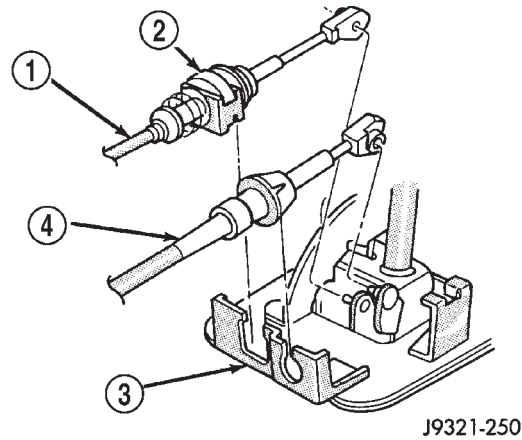

J9321-250

Fig. 229 Park Lock Cable Attachment

- 1 - PARK LOCK CABLE
- 2 - CABLE LOCK BUTTON
- 3 - SHIFT LEVER ASSEMBLY
- 4 - SHIFT CABLE

BRAKE TRANSMISSION SHIFT INTERLOCK CABLE ADJUSTMENT

- (1) Shift transmission into PARK.
- (2) Remove shift lever bezel and console screws. Raise bezel and console for access to cable.
- (3) Pull cable lock button up to release cable (Fig. 229).
- (4) Turn ignition switch to LOCK position.
- (5) Use a spacer to create a one millimeter gap between the shifter pawl and top of the shift gate.
- (6) Pull cable forward. Then release cable and press cable lock button down until it snaps in place.
- (7) Check adjustment as follows:
 - (a) Check movement of release shift handle button (floor shift) or release lever (column shift). You should not be able to press button inward or move column lever.
 - (b) Turn ignition switch to RUN position.
 - (c) Shifting out of park should not be possible.
 - (d) Apply the brake and attempt to shift out of PARK. Shifting should be possible.
 - (e) While the transmission is shifted out of PARK, release the brake and attempt to shift through all gears. Release the shift button at least once during this procedure. The ignition key should not go to the LOCK position.

(f) Return transmission to the PARK position without applying the brake.

(8) Move shift lever back to PARK and check ignition switch operation. You should be able to turn switch to LOCK position and shift lever release button/lever should not move.

TRANSMISSION THROTTLE VALVE CABLE ADJUSTMENT

The transmission throttle valve is operated by a cam on the throttle lever. The throttle lever is operated by an adjustable cable (Fig. 230). The cable is attached to an arm mounted on the throttle lever shaft. A retaining clip at the engine-end of the cable is removed to provide for cable adjustment. The retaining clip is then installed back onto the throttle valve cable to lock in the adjustment.

A correctly adjusted throttle valve cable will cause the throttle lever on the transmission to move simultaneously with the throttle body lever from the idle position. Proper adjustment will allow simultaneous movement without causing the transmission throttle lever to either move ahead of, or lag behind the lever on the throttle body.

Checking Throttle Valve Cable Adjustment

- (1) Turn ignition key to OFF position.
- (2) Remove air cleaner.
- (3) Verify that lever on throttle body is at curb idle position. Then verify that transmission throttle lever (Fig. 231) is also at idle (fully forward) position.
- (4) Slide cable off attachment stud on throttle body lever.
- (5) Compare position of cable end to attachment stud on throttle body lever:

ADJUSTMENTS (Continued)

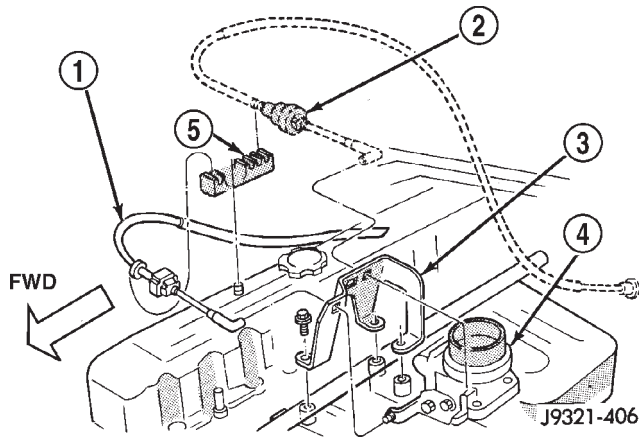
**Fig. 230 Throttle Cable Attachment At Engine**

- 1 - TRANSMISSION THROTTLE VALVE CABLE
- 2 - ACCELERATOR CABLE
- 3 - CABLE ENGINE BRACKET
- 4 - THROTTLE BODY
- 5 - CABLE GUIDE

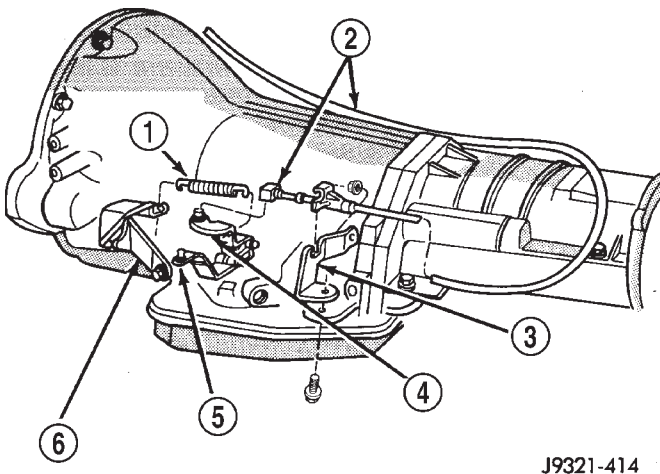
**Fig. 231 Throttle Cable Attachment At Transmission**

- 1 - RETURN SPRING
- 2 - THROTTLE VALVE CABLE
- 3 - THROTTLE VALVE CABLE BRACKET
- 4 - THROTTLE VALVE LEVER
- 5 - GEAR SELECTOR LEVER
- 6 - SHIFT CABLE BRACKET

- Cable end and attachment stud should be aligned (or centered on one another) to within 1 mm (0.039 in.) in either direction.

- If cable end and attachment stud are misaligned (off center), cable will have to be adjusted as described in Throttle Valve Cable Adjustment procedure.

(6) Reconnect cable end to attachment stud. Then with aid of a helper, observe movement of transmission throttle lever and lever on throttle body.

- If both levers move simultaneously from idle to half-throttle and back to idle position, adjustment is correct.

- If transmission throttle lever moves ahead of, or lags behind throttle body lever, cable adjustment will be necessary. Or, if throttle body lever prevents transmission lever from returning to closed position, cable adjustment will be necessary.

Throttle Valve Cable Adjustment Procedure

- (1) Turn ignition switch to OFF position.
- (2) Remove air cleaner if necessary.
- (3) Disconnect cable end from attachment stud.

Carefully slide cable off stud. Do not pry or pull cable off.

(4) Verify that transmission throttle lever is in fully closed position. Then be sure lever on throttle body is at curb idle position.

(5) Insert a small screwdriver under edge of retaining clip and remove retaining clip.

(6) Center cable end on attachment stud to within 1 mm (0.039 in.).

NOTE: Be sure that as the cable is pulled forward and centered on the throttle lever stud, the cable housing moves smoothly with the cable. Due to the angle at which the cable housing enters the spring housing, the cable housing may bind slightly and create an incorrect adjustment.

(7) Install retaining clip onto cable housing.

(8) Check cable adjustment. Verify transmission throttle lever and lever on throttle body move simultaneously.

FRONT BAND ADJUSTMENT

The front (kickdown) band adjusting screw is located on the left side of the transmission case above the manual valve and throttle valve levers.

(1) Raise vehicle.

(2) Loosen band adjusting screw locknut (Fig. 232). Then back locknut off 3-5 turns. Be sure adjusting screw turns freely in case. Apply lubricant to screw threads if necessary.

(3) Tighten band adjusting screw to 8 N·m (72 in. lbs.) torque with Inch Pound Torque Wrench C-3380-A, a 3-in. extension and appropriate Torx socket.

CAUTION: If Adapter C-3705 is needed to reach the adjusting screw, tighten the screw to only 5 N·m (47-50 in. lbs.) torque.

(4) Back off front band adjusting screw 2-1/2 turns.

(5) Hold adjuster screw in position and tighten locknut to 41 N·m (30 ft. lbs.) torque.

(6) Lower vehicle.

ADJUSTMENTS (Continued)

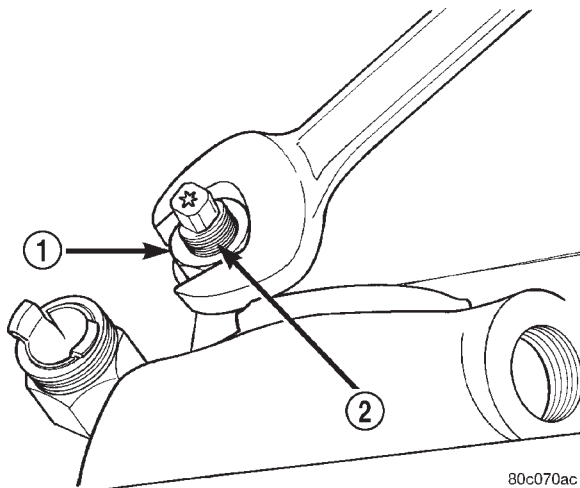

Fig. 232 Front Band Adjustment Screw Location

- 1 - LOCK-NUT
2 - FRONT BAND ADJUSTER

REAR BAND ADJUSTMENT

The transmission oil pan must be removed for access to the rear band adjusting screw.

- (1) Raise vehicle.
- (2) Remove transmission oil pan and drain fluid.
- (3) Loosen band adjusting screw locknut 5-6 turns. Be sure adjusting screw turns freely in lever.
- (4) Tighten adjusting screw to 5 N·m (41 in. lbs.) (Fig. 233).
- (5) Back off adjusting screw 7 turns.
- (6) Hold adjusting screw in place and tighten locknut to 34 N·m (25 ft. lbs.) torque.
- (7) Position new gasket on oil pan and install pan on transmission. Tighten pan bolts to 17 N·m (13 ft. lbs.) torque.
- (8) Lower vehicle and refill transmission with Mopar® ATF Plus 3, Type 7176, fluid.

VALVE BODY

CONTROL PRESSURE ADJUSTMENTS

There are two control pressure adjustments on the valve body;

- Line Pressure
- Throttle Pressure

Line and throttle pressures are interdependent because each affects shift quality and timing. As a result, both adjustments must be performed properly and in the correct sequence. Adjust line pressure first and throttle pressure last.

LINE PRESSURE ADJUSTMENT

Measure distance from the valve body to the inner edge of the adjusting screw with an accurate steel scale (Fig. 234).

Distance should be 33.4 mm (1-5/16 in.).

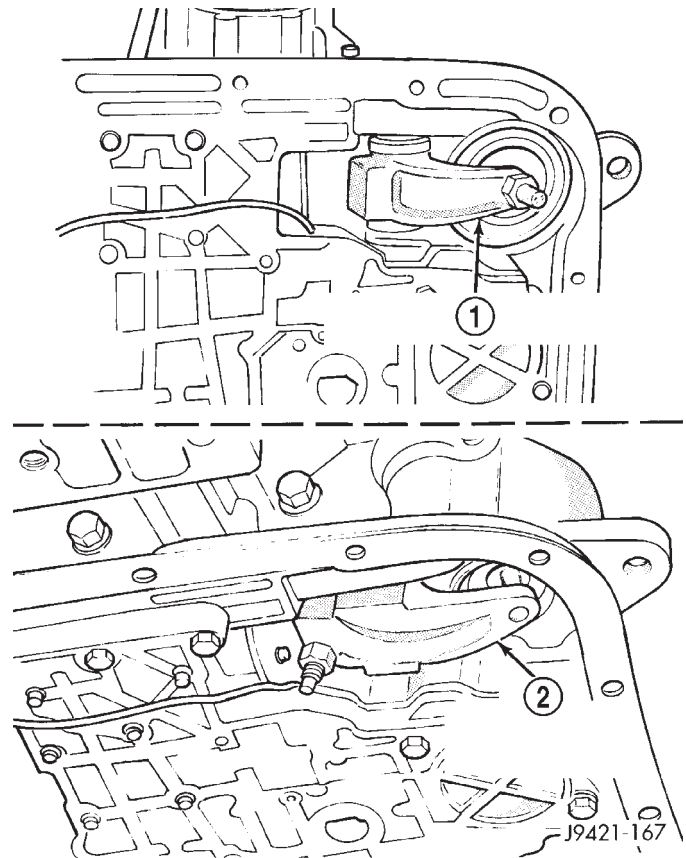

Fig. 233 Rear Band Adjustment Screw Location

- 1 - 30RH REAR BAND LEVER AND ADJUSTING SCREW
2 - 32RH REAR BAND LEVER AND ADJUSTING SCREW

If adjustment is required, turn the adjusting screw in, or out, to obtain required distance setting.

NOTE: The 33.4 mm (1-5/16 in.) setting is an approximate setting. Manufacturing tolerances may make it necessary to vary from this dimension to obtain desired pressure.

One complete turn of the adjusting screw changes line pressure approximately 1-2/3 psi (9 kPa).

Turning the adjusting screw counterclockwise increases pressure while turning the screw clockwise decreases pressure.

THROTTLE PRESSURE ADJUSTMENT

Insert Gauge Tool C-3763 between the throttle lever cam and the kickdown valve stem (Fig. 235).

Push the gauge tool inward to compress the kickdown valve against the spring and bottom the throttle valve.

Maintain pressure against kickdown valve spring. Turn throttle lever stop screw until the screw head touches throttle lever tang and the throttle lever cam touches gauge tool.

ADJUSTMENTS (Continued)

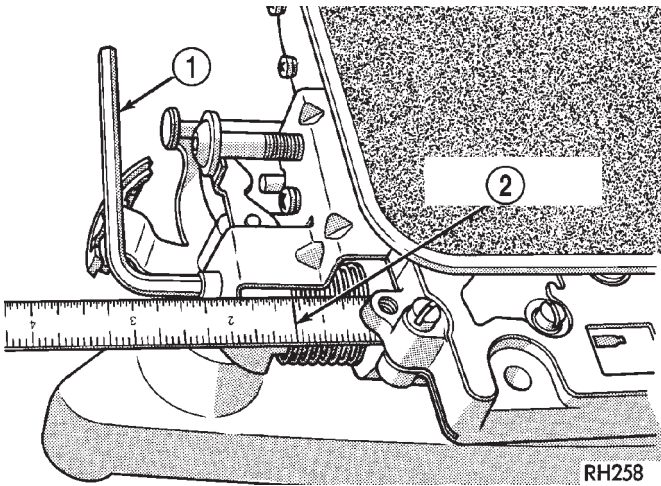

Fig. 234 Line Pressure Adjustment

- 1 - WRENCH
- 2 - 1-5/16 INCH

NOTE: The kickdown valve spring must be fully compressed and the kickdown valve completely bottomed to obtain correct adjustment.

SCHEMATICS AND DIAGRAMS

HYDRAULIC SCHEMATICS

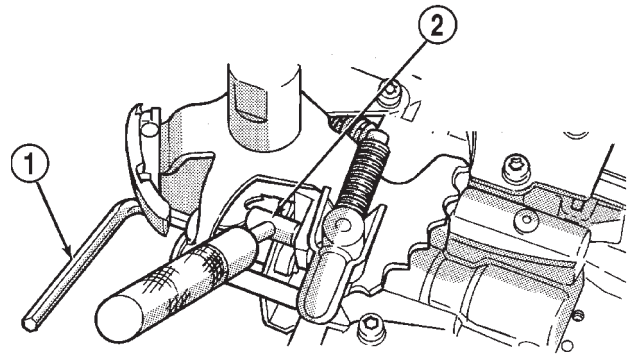
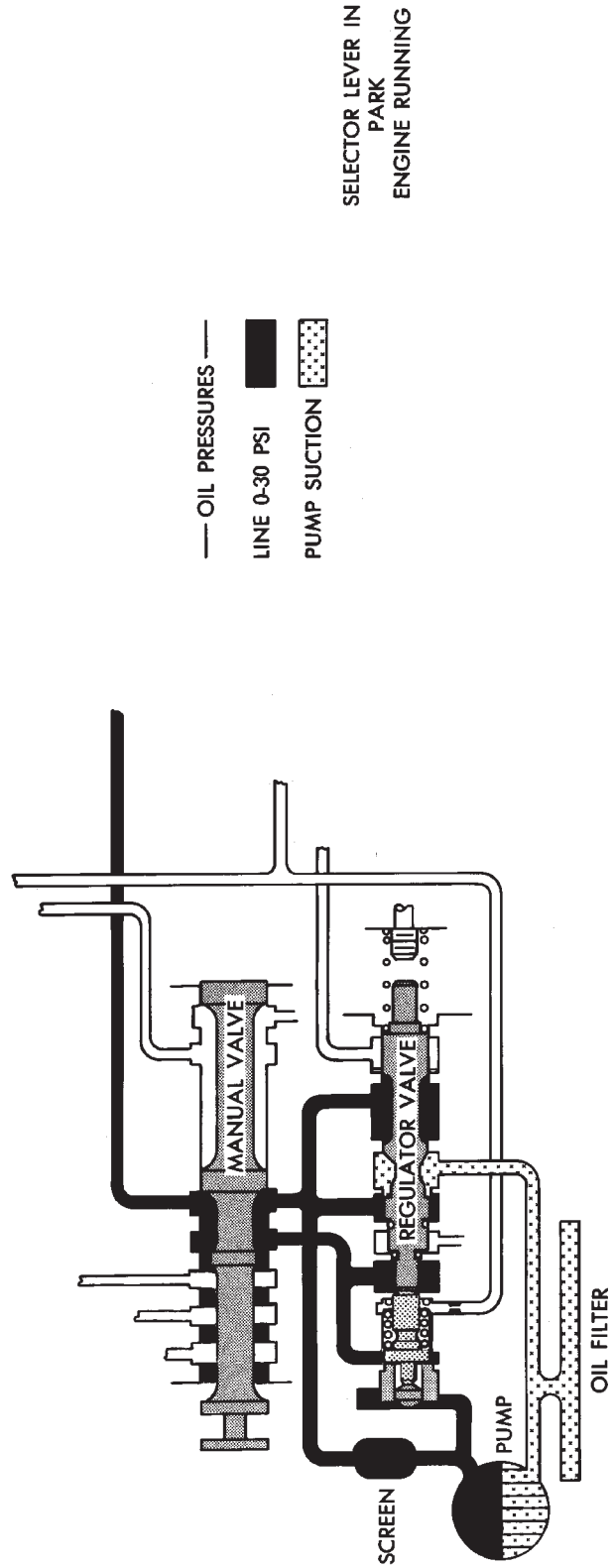
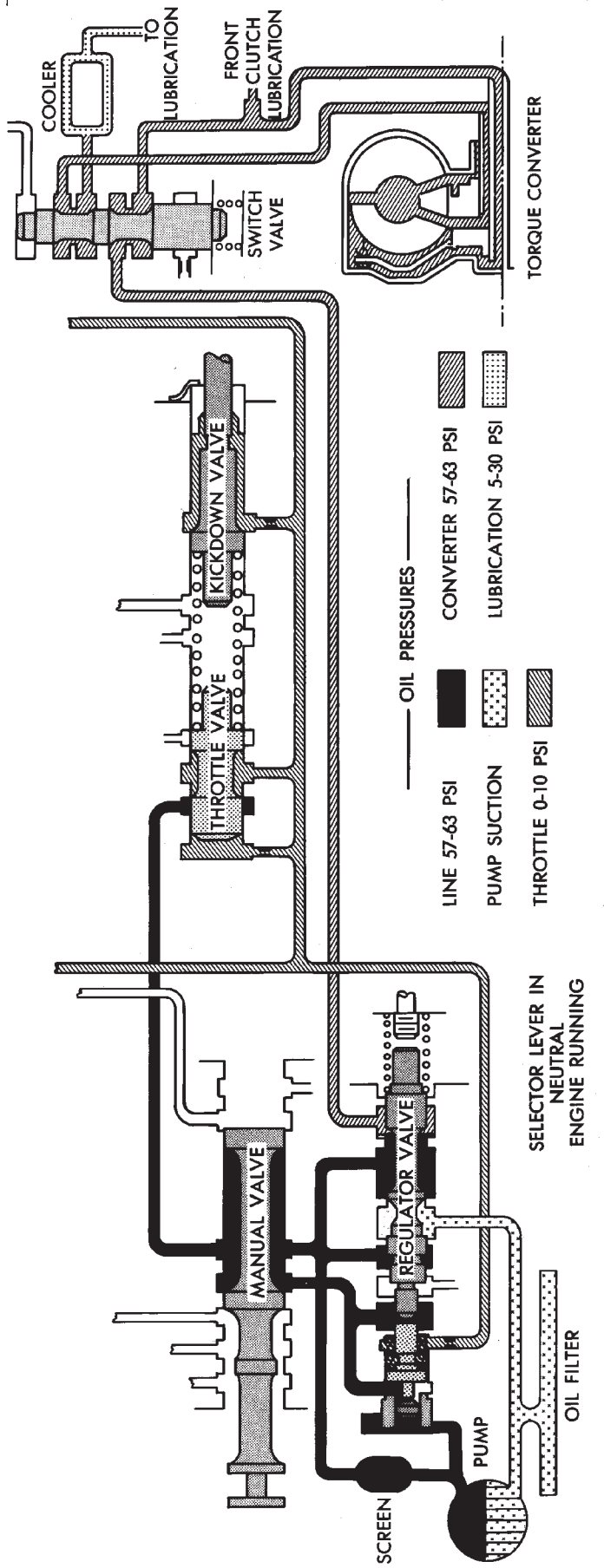

Fig. 235 Throttle Pressure Adjustment

- 1 - HEX WRENCH (IN THROTTLE LEVER ADJUSTING SCREW)
- 2 - SPECIAL TOOL C-3763 (POSITIONED BETWEEN THROTTLE LEVER AND KICKDOWN VALVE)

SCHEMATICS AND DIAGRAMS (Continued)



J9021-160

HYDRAULIC FLOW IN PARK/NEUTRAL

SCHEMATICS AND DIAGRAMS (Continued)

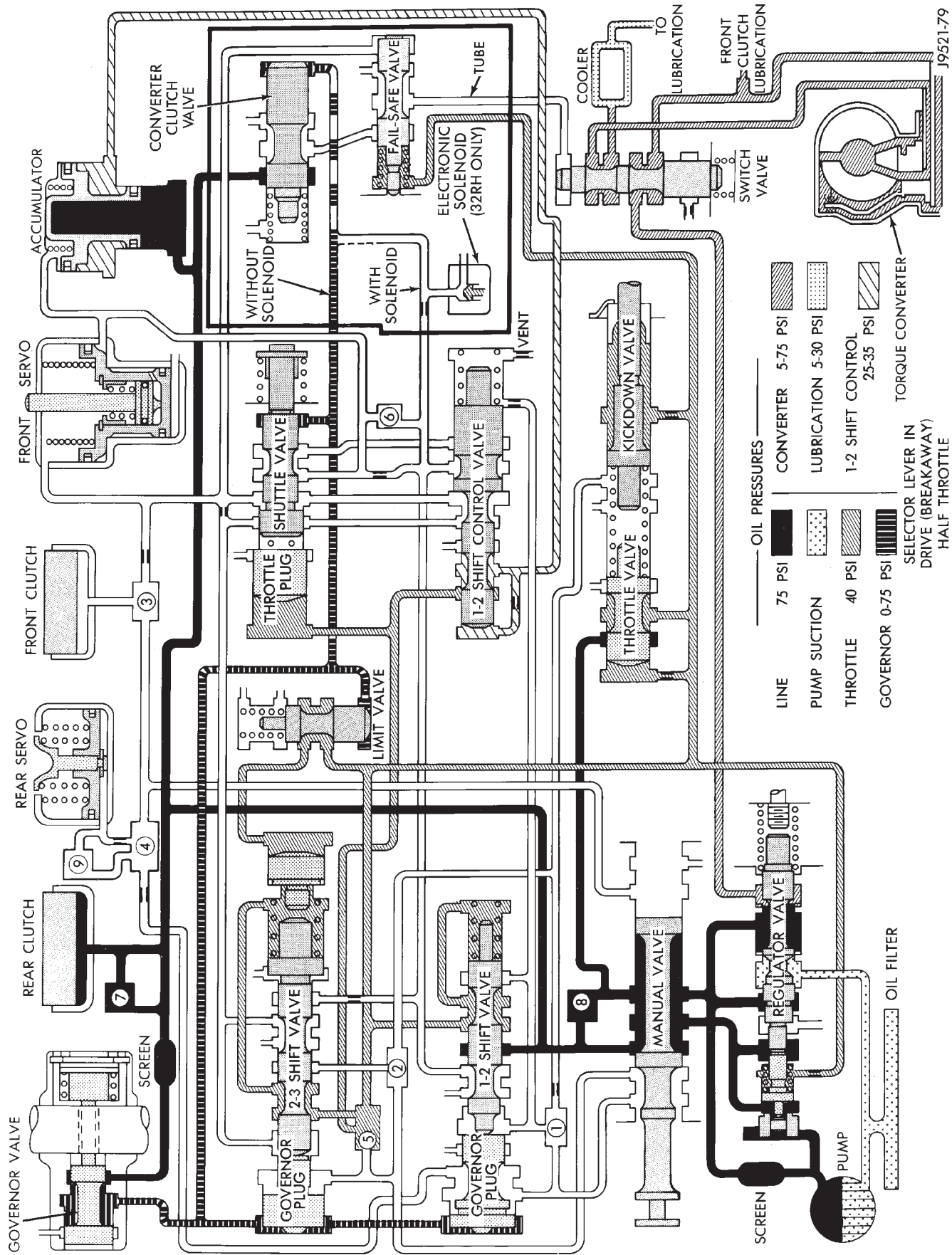

HYDRAULIC FLOW IN D-FIRST GEAR

SCHEMATICS AND DIAGRAMS (Continued)

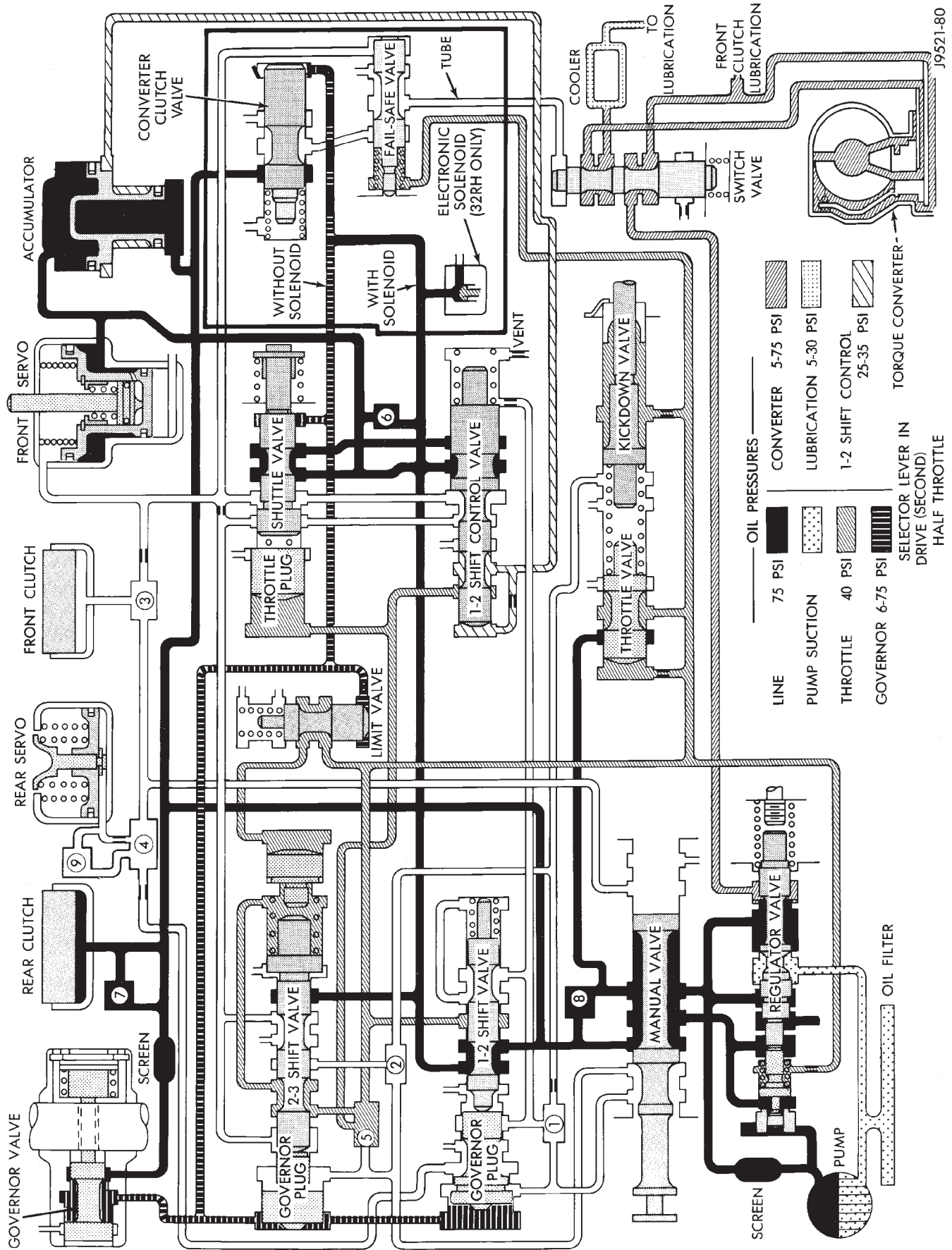

HYDRAULIC FLOW IN D-SECOND GEAR

SCHEMATICS AND DIAGRAMS (Continued)

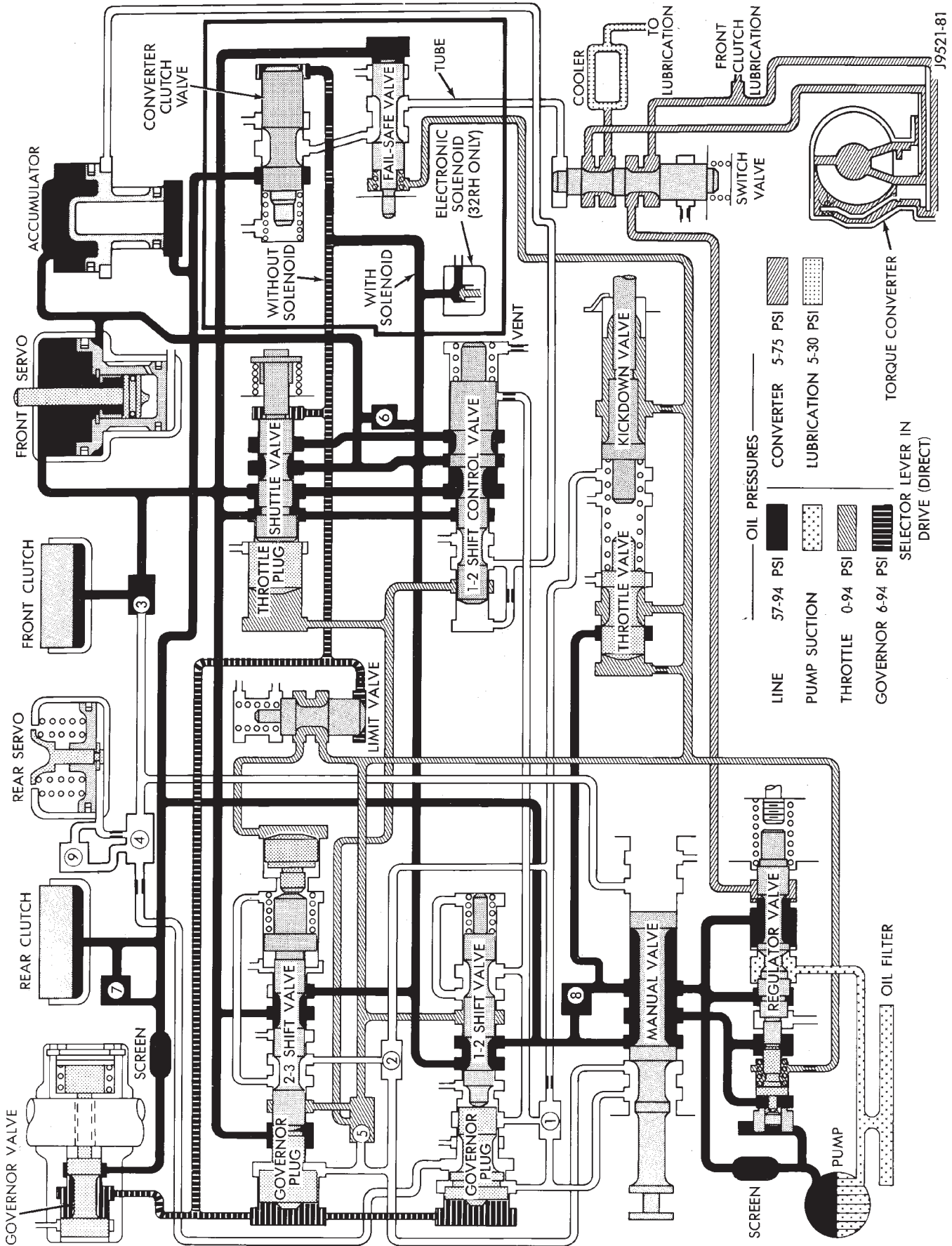

HYDRAULIC FLOW IN D-THIRD GEAR

J9521-81

SCHEMATICS AND DIAGRAMS (Continued)

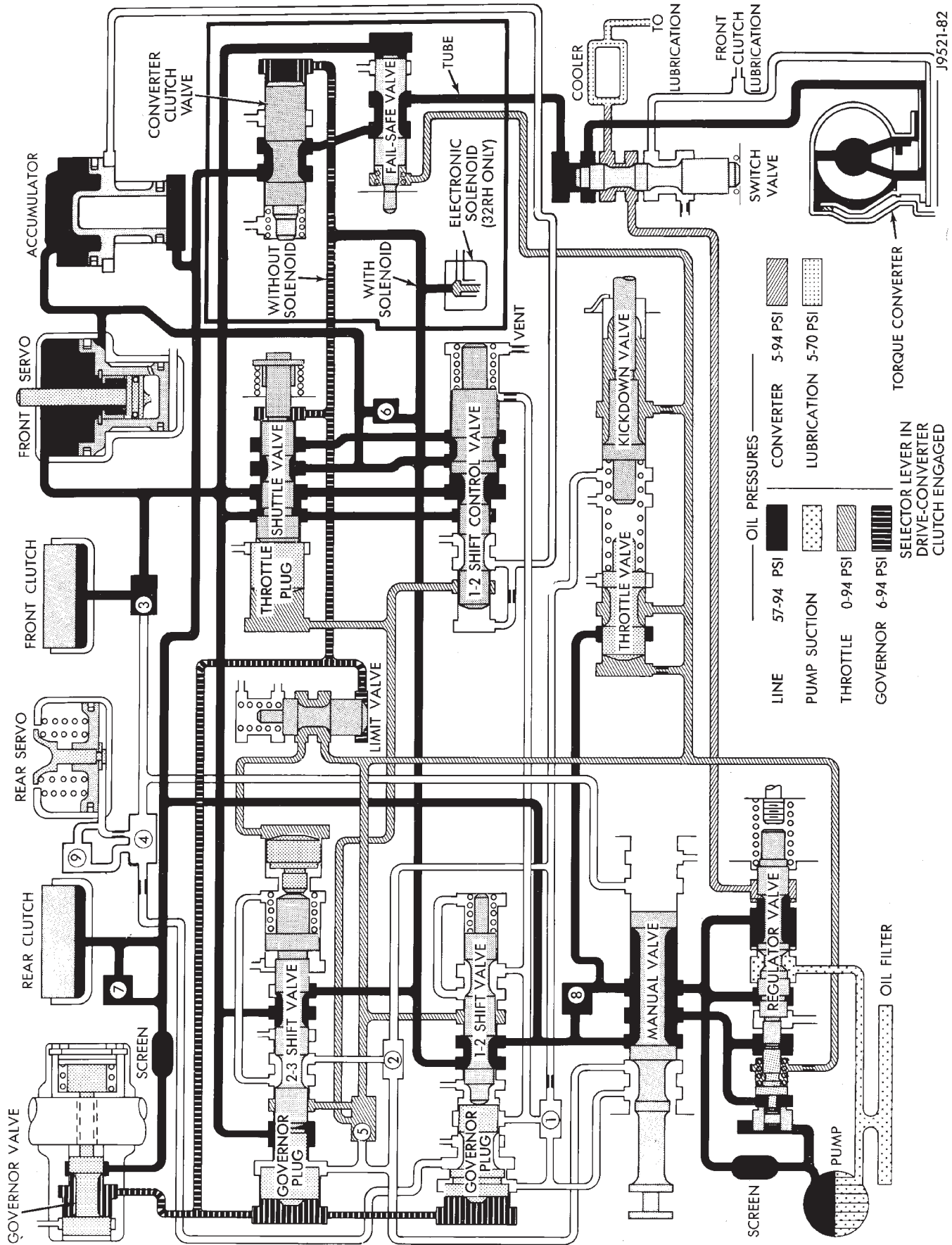

HYDRAULIC FLOW IN D-THIRD GEAR (CONVERTER CLUTCH APPLIED)

J9521-82

SCHEMATICS AND DIAGRAMS (Continued)

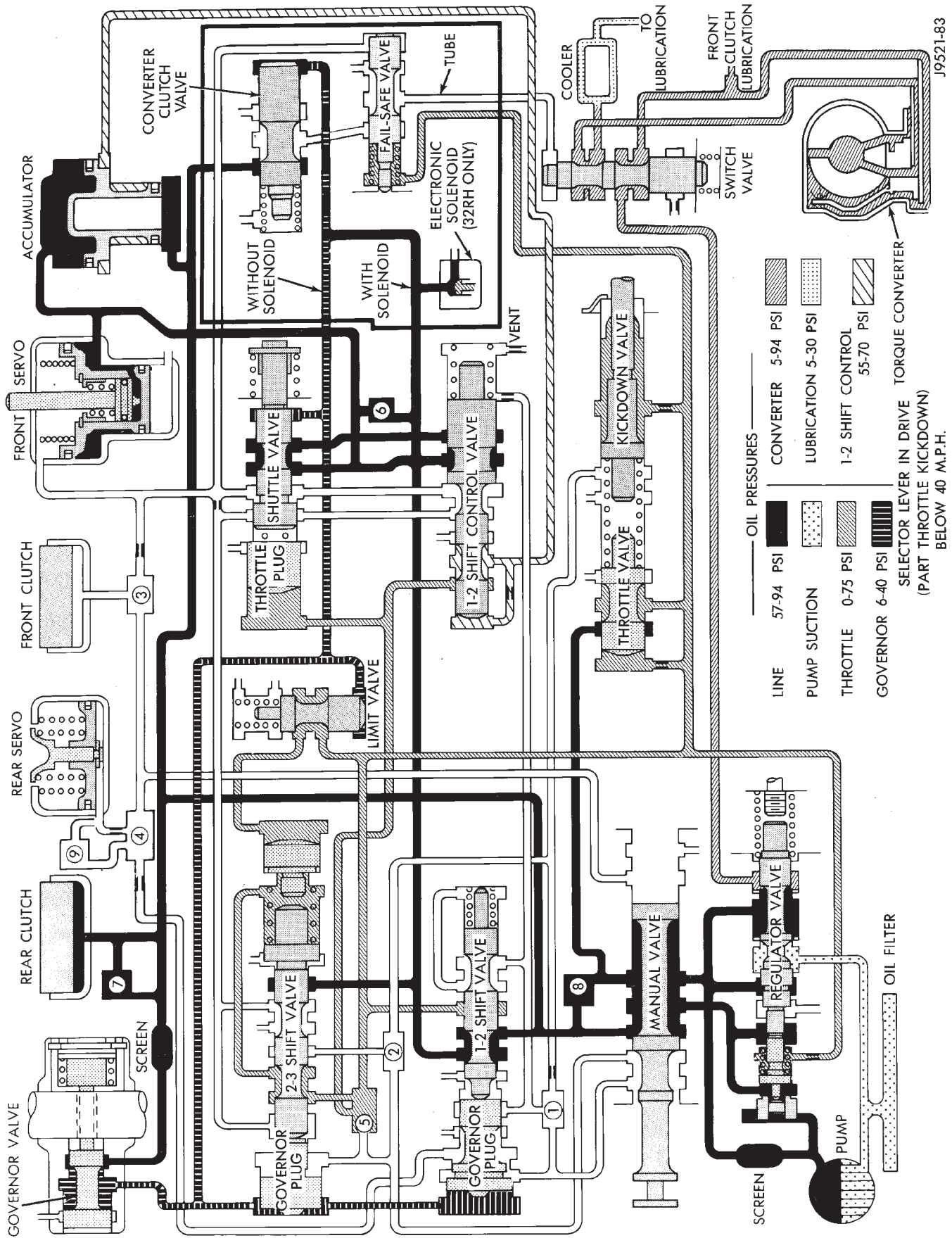

HYDRAULIC FLOW AT PART THROTTLE 3-2 KICKDOWN

SCHEMATICS AND DIAGRAMS (Continued)

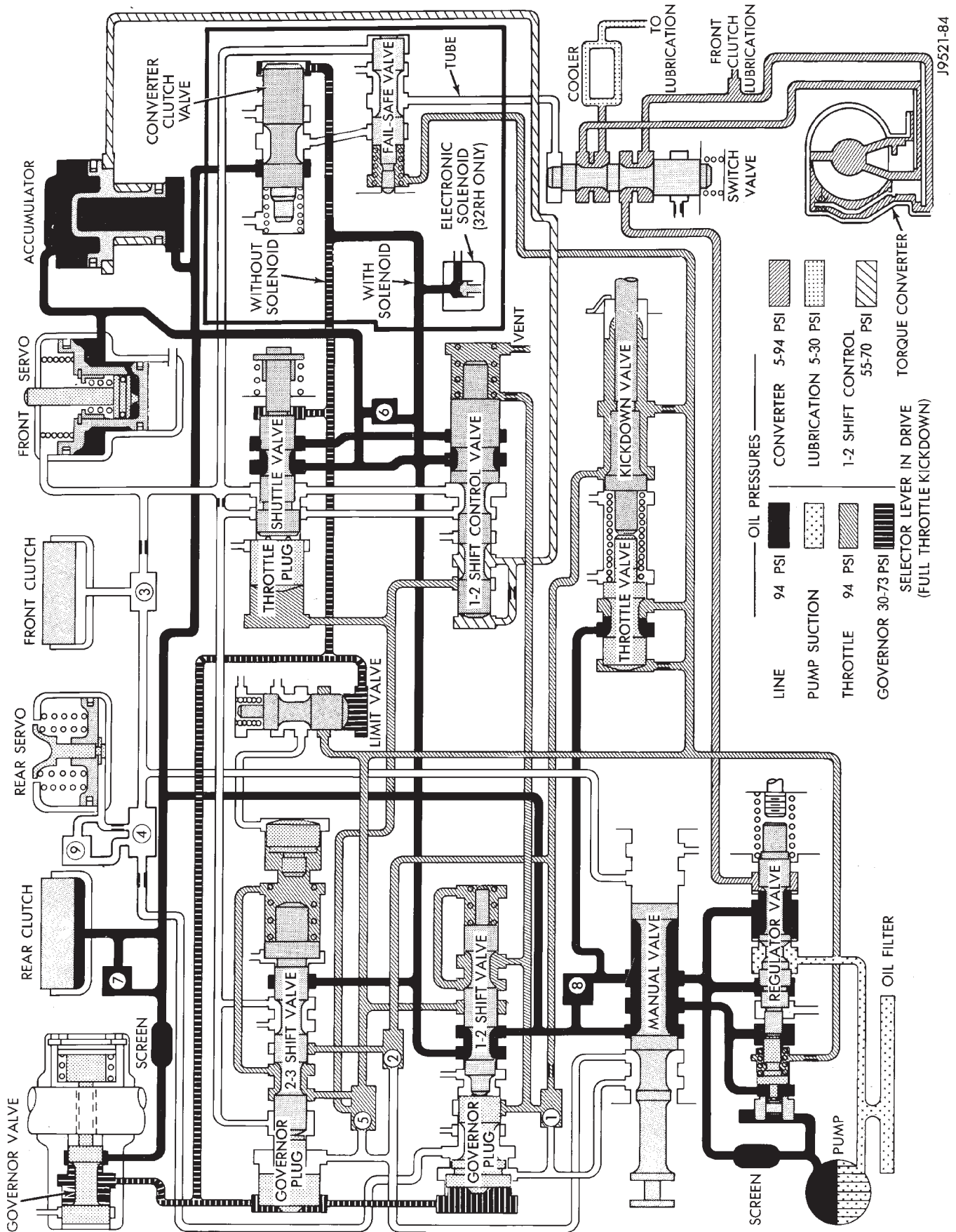

HYDRAULIC FLOW AT FULL THROTTLE 3-2 KICKDOWN

J9521-84

SCHEMATICS AND DIAGRAMS (Continued)

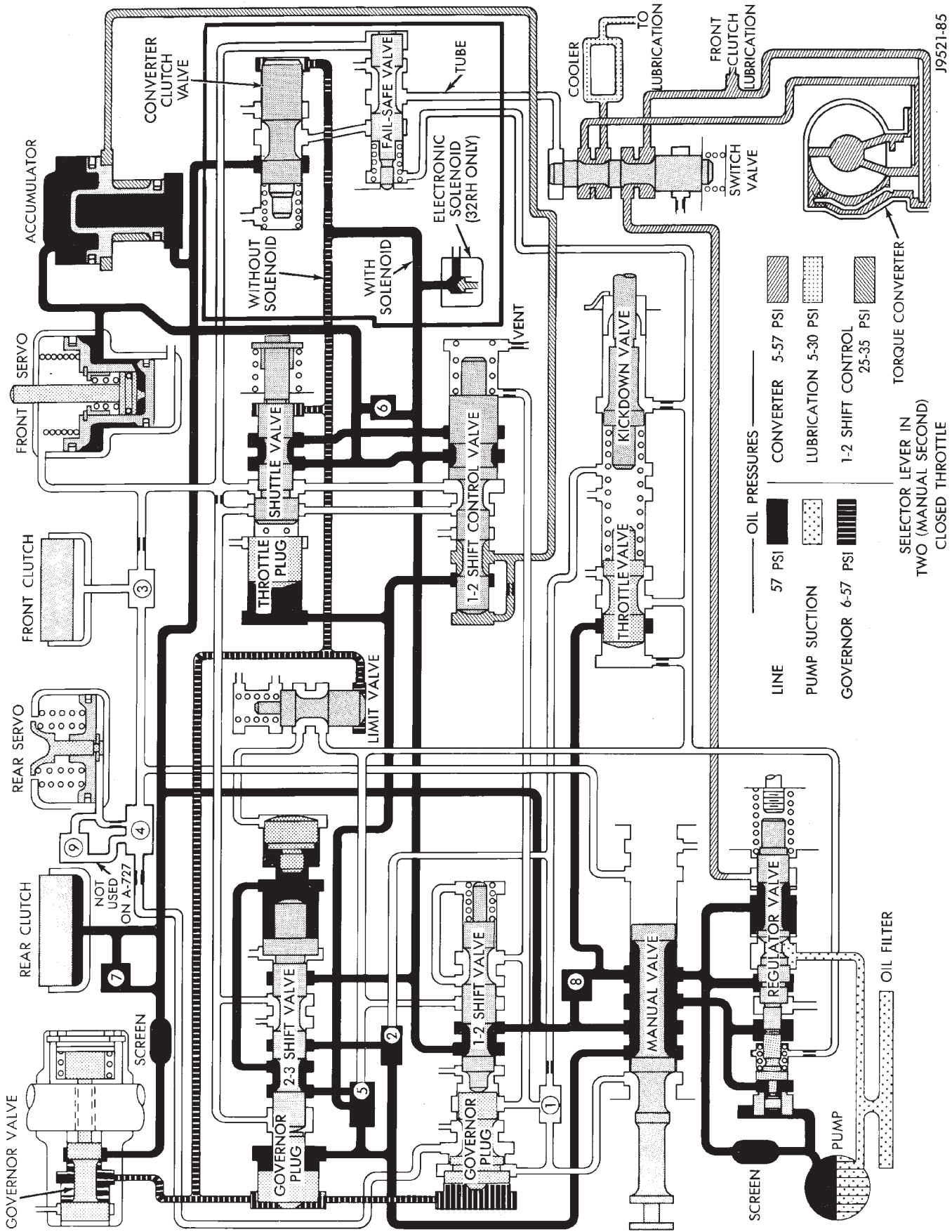

HYDRAULIC FLOW IN MANUAL SECOND

SCHEMATICS AND DIAGRAMS (Continued)

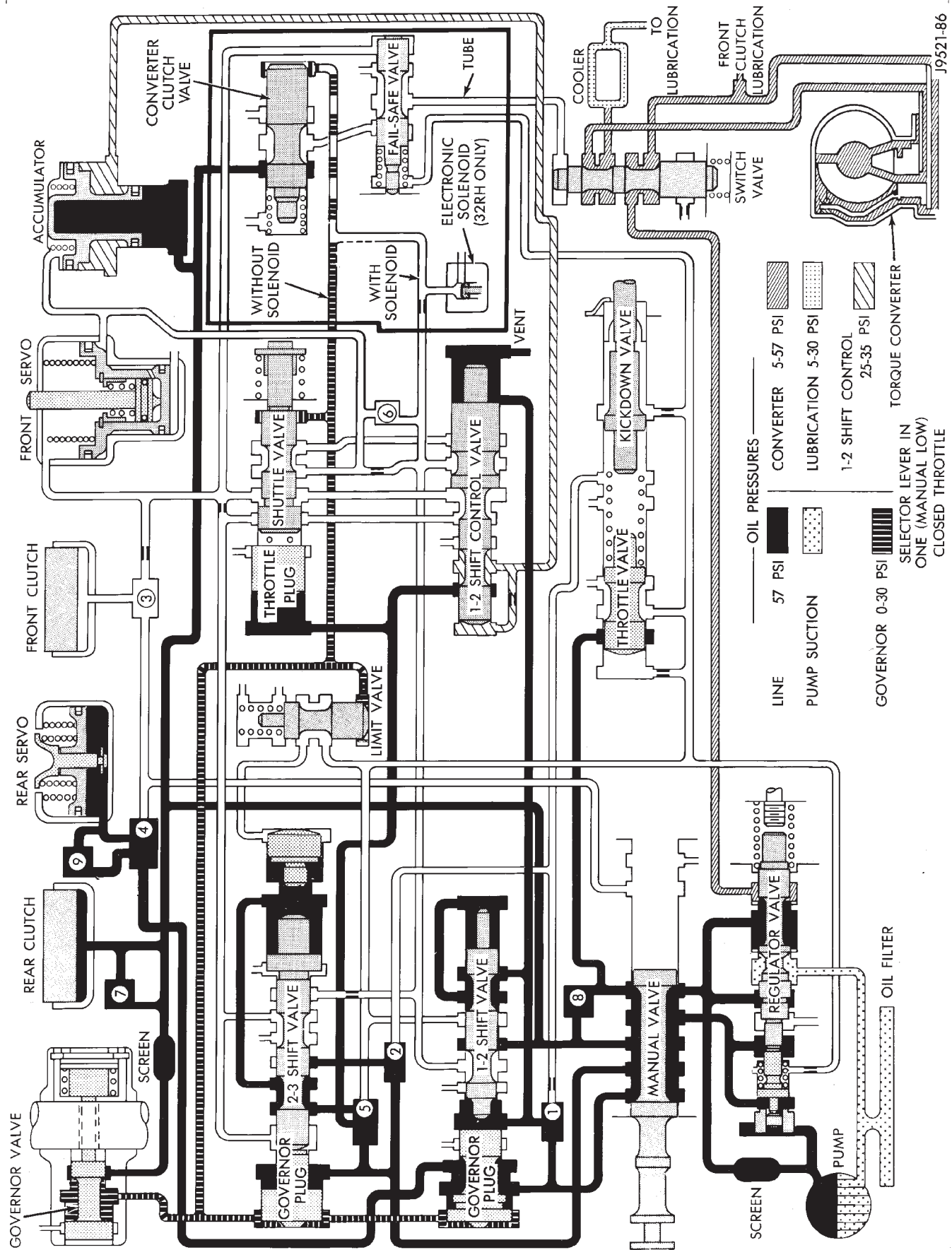

HYDRAULIC FLOW IN MANUAL LOW

J9521-86

SCHEMATICS AND DIAGRAMS (Continued)

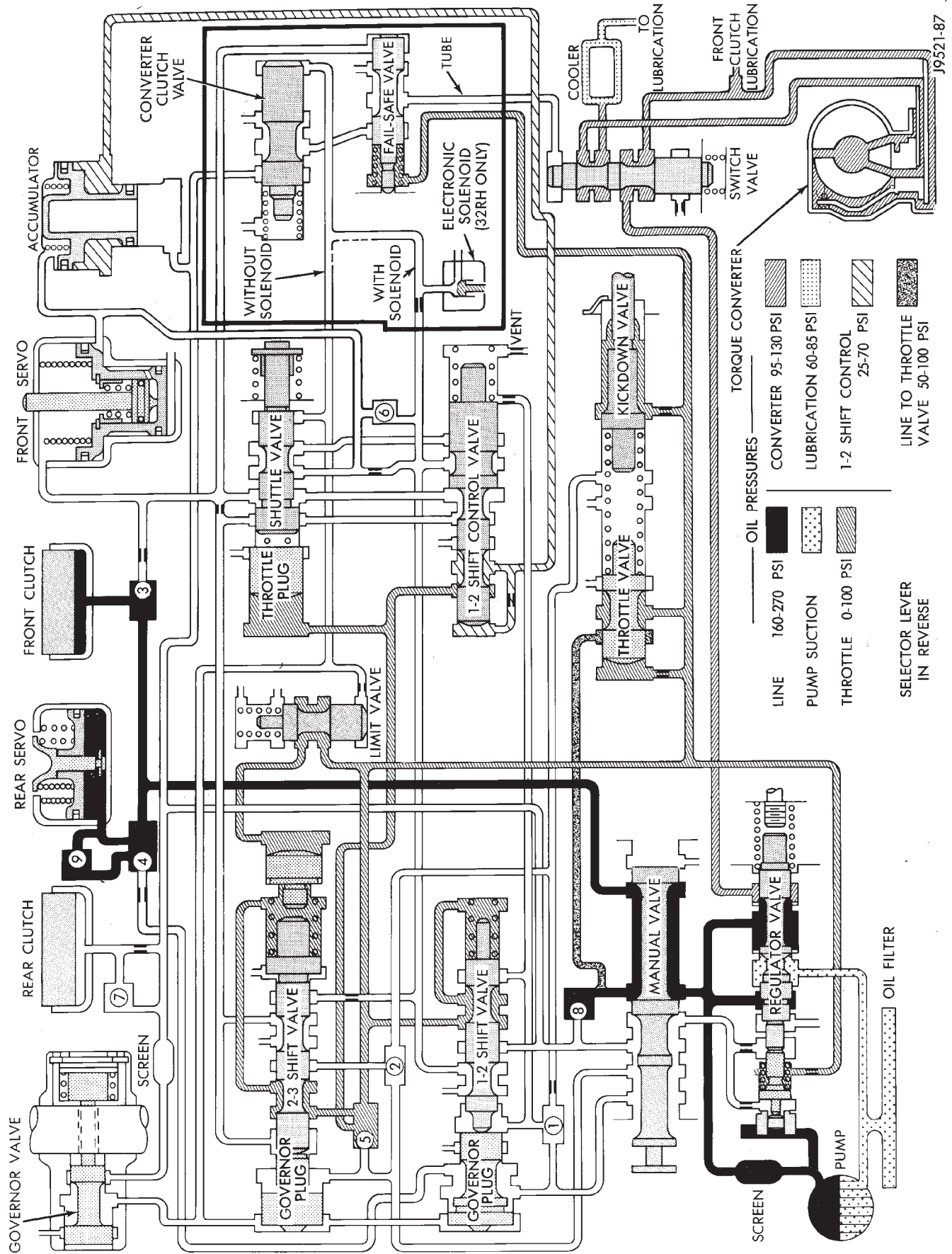

HYDRAULIC FLOW IN REVERSE

SPECIFICATIONS

30RH AUTOMATIC TRANSMISSION

GENERAL

| COMPONENT | METRIC | INCH |
|---|-------------------------------|-------------------|
| Oil pump gear tip clearance | 0.089-0.190 mm | 0.0035-0.0075 in. |
| Planetary end play | 0.125-1.19 mm | 0.001-0.047 in. |
| Input shaft end play | 0.56-2.31 mm | 0.022-0.091 in. |
| Clutch pack clearance/Front 4-disc. | 1.70-3.40 mm | 0.067-0.134 in. |
| Clutch pack clearance/Rear 4-disc. | 0.559-0.940 mm | 0.022-0.037 in. |
| Front clutch spring usage | 1 spring | |
| 30RH-Front Band adjustment from 72 in. lbs. | Back off 2.5 turns | |
| 30RH-Rear Band adjustment from 41 in. lbs. | Back off 7 turns | |
| Recommended fluid | Mopar®, ATF Plus 3, Type 7176 | |

THRUST WASHER/SPACER/SNAP RING DIMENSIONS

| COMPONENT | METRIC | INCH |
|---|------------|-----------------|
| Front clutch thrust washer (reaction shaft support hub) | 1.55 mm | 0.061 in. |
| Rear clutch thrust washer (clutch retainer) | 1.55 mm | 0.061 in. |
| Output shaft thrust plate (output shaft pilot hub) | 1.5-1.6mm | 0.060-0.063 in. |
| Output shaft thrust washer (rear clutch hub) | 1.3-1.4 mm | 0.052-0.054 in. |
| | 1.7-1.8 mm | 0.068-0.070 in. |
| | 2.1-2.2 mm | 0.083-0.086 in. |
| Rear clutch pack snap ring | 1.5-1.6 mm | 0.06-0.062 in. |
| | 1.7-1.8 mm | 0.068-0.070 in. |
| | 1.9-2.0 mm | 0.076-0.078 in. |
| Planetary geartrain snap ring (at front of output shaft) | 1.0-1.1 mm | 0.040-0.044 in. |
| | 1.6-1.7 mm | 0.062-0.066 in. |
| | 2.1-2.2 mm | 0.082-0.086 in. |

PRESSURE TEST—ALL

| ITEM | RANGE | PRESSURE |
|--------------------------------|--------------------|--|
| Line pressure (at accumulator) | Closed throttle | 372-414 kPa (54-60 psi). |
| Front servo | Third gear only | No more than 21 kPa (3 psi) lower than line pressure. |
| Rear servo | 1 range R range | No more than 21 kPa (3 psi) lower than line pressure. 1103 kPa (160 psi) at idle, builds to 1862 kPa (270 psi) at 1600 rpm. |

SPECIFICATIONS (Continued)

| ITEM | RANGE | PRESSURE |
|----------|-------------------------|--|
| Governor | D range closed throttle | Pressure should respond smoothly to changes in mph and return to 0-7 kPa (0-1.5 psi) when stopped with transmission in D, 1, 2. Pressure above 7 kPa (1.5 psi) at stand still will prevent transmission from downshifting. |

TORQUE

| DESCRIPTION | TORQUE |
|--------------------------------------|-----------------------|
| Bolt/nut, crossmember | 68 N·m (50 ft. lbs.) |
| Bolt, driveplate to crankshaft . . | 75 N·m (55 ft. lbs.) |
| Plug, front band reaction | 17 N·m (13 ft. lbs.) |
| Locknut, front band adj. | 34 N·m (25 ft. lbs.) |
| Switch, park/neutral | 34 N·m (25 ft. lbs.) |
| Bolt, fluid pan | 17 N·m (13 ft. lbs.) |
| Bolt, oil pump | 20 N·m (15 ft. lbs.) |
| Bolt, overrunning clutch cam . . | 17 N·m (13 ft. lbs.) |
| Plug, pressure test port | 14 N·m (10 ft. lbs.) |
| Bolt, reaction shaft support | 20 N·m (15 ft. lbs.) |
| Locknut, rear band | 41 N·m (30 ft. lbs.) |
| Bolt, speedometer adapter | 11 N·m (8 ft. lbs.) |
| Screw, fluid filter | 4 N·m (35 in. lbs.) |
| Bolt, valve body to case | 12 N·m (100 in. lbs.) |

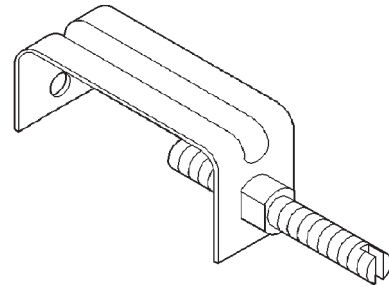

Retainer, Detent Ball and Spring—6583

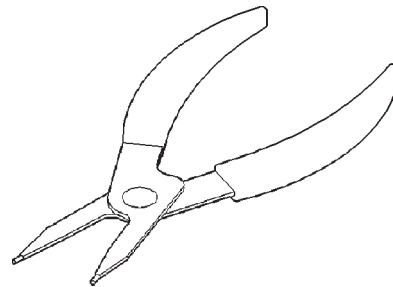

Snap-ring Plier—6823

SPECIAL TOOLS

30RH TRANSMISSIONS

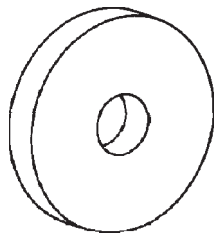

Remover—6957

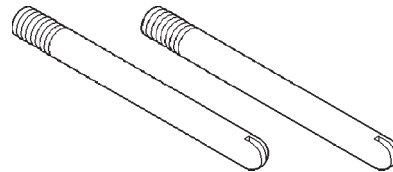

Pilot Stud—C-3288-B

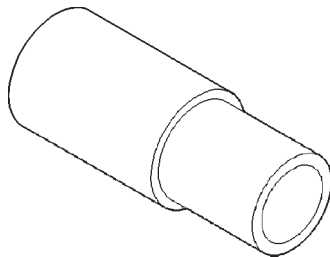

Installer—6951

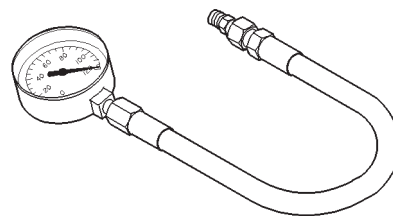

Pressure Gauge—C-3292

SPECIAL TOOLS (Continued)

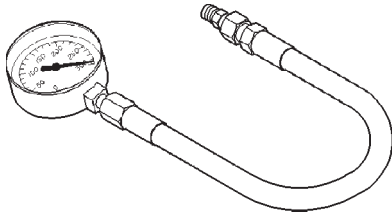

Pressure Gauge—C-3293SP

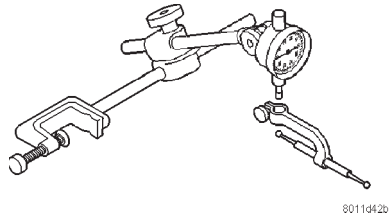

Dial Indicator—C-3339

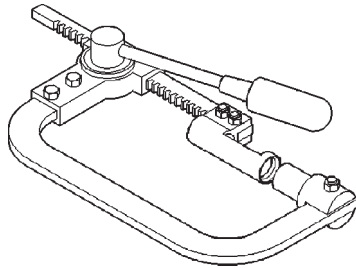

Spring Compressor—C-3422-B

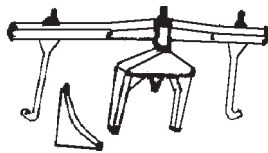

Fixture, Engine Support—C-3487-A

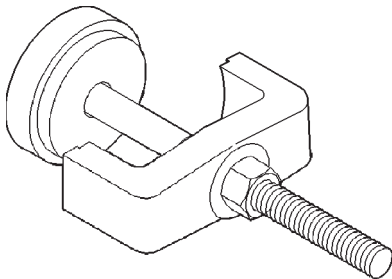

Spring Compressor—C-3575-A

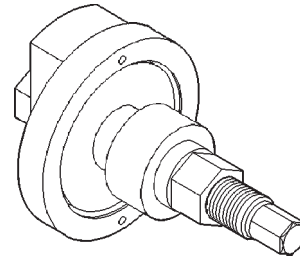

Spring Compressor—C-3863-A

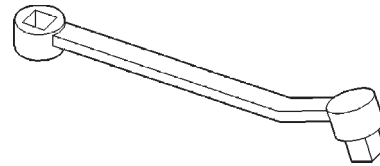

Adapter, Band Adjuster—C-3705

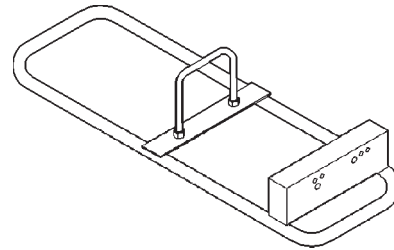

Transmission Repair Stand—C-3750-B

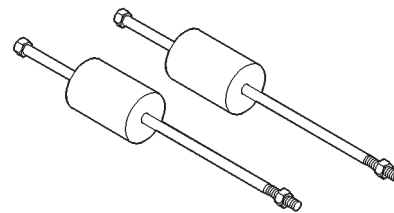

Puller, Slide Hammer—C-3752

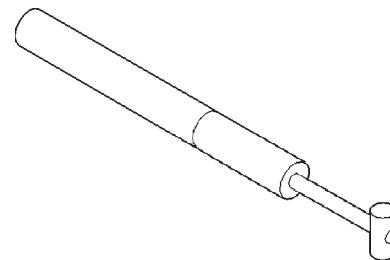

Gauge, Throttle Setting—C-3763

SPECIAL TOOLS (Continued)

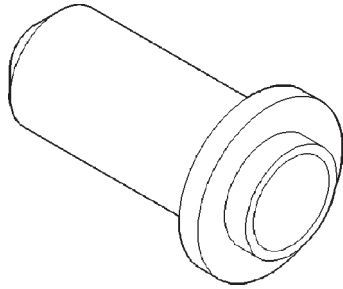

Seal Installer—C-3860-A

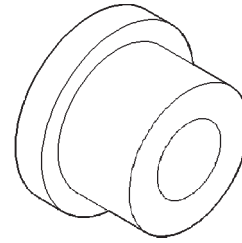

Installer, Bushing—SP-5302

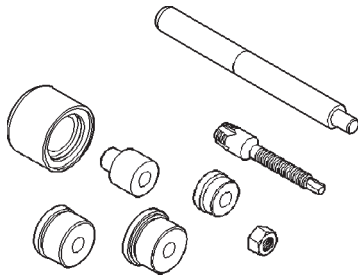

Bushing Remover/Installer—C-3887-J

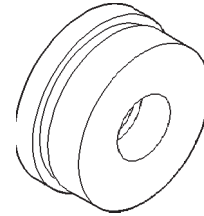

Remover, Bushing—SP-3550

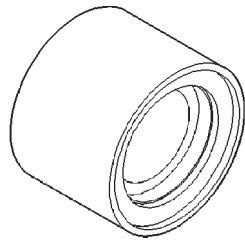

Cup, Remover—SP-3633

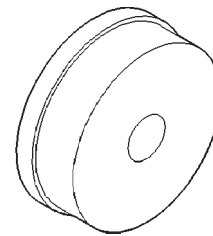

Remover, Bushing—SP-3629

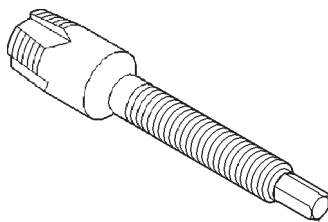

Remover, Bushing—SP-5301

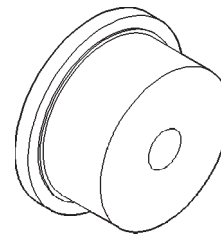

Installer, Bushing—SP-5511

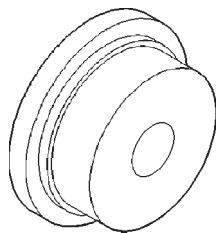

Installer, Bushing—SP-5118

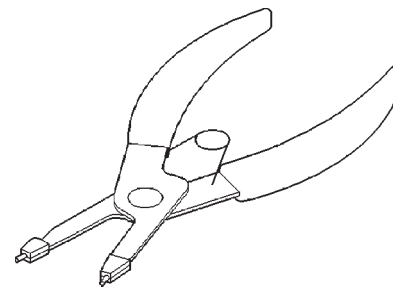

Snap-ring Plier—C-3915

SPECIAL TOOLS (Continued)

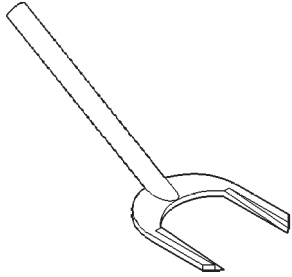

Seal Remover—C-3985-B

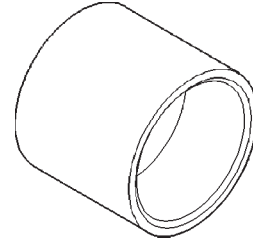

Installer—C-3995-A

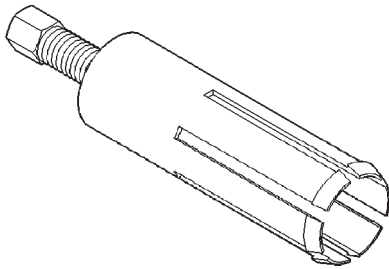

Bushing, Remover—6957

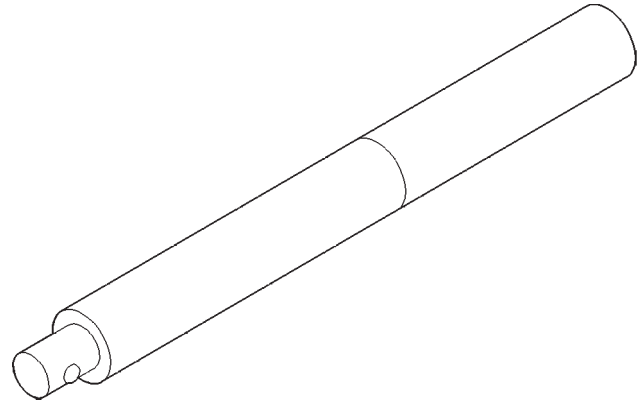

Universal Handle—C-4171

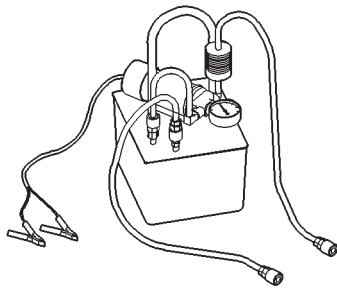

Flusher, Oil Cooler—6906

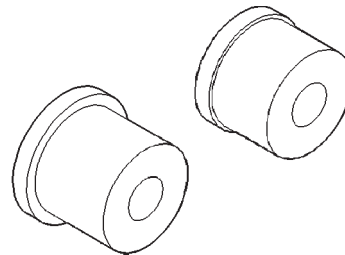

Remover/Installer—C-4470

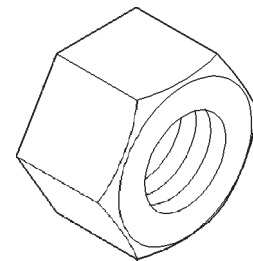

Nut, Bushing Remover—SP-1191

AW-4 AUTOMATIC TRANSMISSION

TABLE OF CONTENTS

| | page | | page |
|---|------|--|------|
| DESCRIPTION AND OPERATION | | REMOVAL AND INSTALLATION | |
| AW-4 AUTOMATIC TRANSMISSION | 218 | TRANSMISSION AND TORQUE CONVERTER | 250 |
| FLUID | 220 | TORQUE CONVERTER | 252 |
| TORQUE CONVERTER | 222 | ADAPTER HOUSING SEAL | 252 |
| OIL PUMP | 227 | SPEED SENSOR | 252 |
| TRANSMISSION VALVE BODY COMPONENTS | 228 | SPEEDOMETER ADAPTER | 253 |
| PISTONS | 234 | SPEED SENSOR ROTOR-SPEEDOMETER DRIVE GEAR | 254 |
| TRANSMISSION RANGES AND SHIFT LEVER POSITIONS | 236 | PARK/NEUTRAL POSITION SWITCH | 255 |
| TRANSMISSION CONTROL MODULE (TCM) | 237 | GEARSHIFT CABLE | 256 |
| HYDRAULIC SYSTEM | 237 | BRAKE TRANSMISSION SHIFT INTERLOCK | 256 |
| TRANSMISSION COOLER | 237 | TRANSMISSION VALVE BODY SOLENOIDS | 258 |
| BRAKE TRANSMISSION SHIFT INTERLOCK MECHANISM | 238 | TRANSMISSION VALVE BODY | 259 |
| DIAGNOSIS AND TESTING | | TRANSMISSION CONTROL MODULE | 260 |
| GENERAL DIAGNOSIS INFORMATION | 239 | SOLENOID HARNESS ADAPTER SEAL | 261 |
| EFFECTS OF INCORRECT FLUID LEVEL | 239 | MANUAL VALVE SHAFT SEAL | 262 |
| CAUSES OF BURNT FLUID | 240 | ACCUMULATOR PISTONS AND SPRINGS | 264 |
| FLUID CONTAMINATION | 240 | SECOND COAST BRAKE SERVO | 265 |
| PRELIMINARY INSPECTION AND ADJUSTMENT | 241 | PARK ROD AND PAWL | 266 |
| MANUAL SHIFTING TEST | 241 | TRANSMISSION THROTTLE CABLE | 267 |
| HYDRAULIC PRESSURE TEST | 241 | OIL PUMP SEAL | 268 |
| PRESSURE TEST ANALYSIS | 242 | DISASSEMBLY AND ASSEMBLY | |
| TIME LAG TEST | 242 | TRANSMISSION | 269 |
| TEST PROCEDURE | 242 | OIL PUMP | 298 |
| TIME LAG TEST ANALYSIS | 243 | OVERDRIVE PLANETARY GEAR AND CLUTCH | 301 |
| SERVICE DIAGNOSIS | 243 | OVERDRIVE SUPPORT | 309 |
| TRANSMISSION SOLENOID TESTING | 245 | DIRECT CLUTCH | 312 |
| PARK/NEUTRAL POSITION SWITCH | 245 | FORWARD CLUTCH | 317 |
| GEARSHIFT CABLE | 246 | FRONT PLANETARY GEAR | 322 |
| THROTTLE VALVE CABLE | 246 | SUN GEAR AND NO. 1 ONE-WAY CLUTCH | 324 |
| SPEED SENSOR TESTING | 246 | SECOND BRAKE | 327 |
| FLOW TESTING TRANSMISSION MAIN COOLER | 246 | PLANETARY/BRAKE PACK/OUTPUT SHAFT | 329 |
| TORQUE CONVERTER STATOR CLUTCH INSPECTION | 247 | TRANSMISSION VALVE BODY | 333 |
| SERVICE PROCEDURES | | CLEANING AND INSPECTION | |
| CHECKING FLUID LEVEL | 247 | TRANSMISSION PARTS CLEANING AND INSPECTION | 336 |
| CHECKING FLUID CONDITION | 248 | ADJUSTMENTS | |
| REFILLING AFTER OVERHAUL OR FLUID/ FILTER CHANGE | 248 | GEARSHIFT CABLE | 336 |
| TRANSMISSION CONTROL MODULE (TCM) SERVICE | 248 | BRAKE TRANSMISSION SHIFT INTERLOCK CABLE ADJUSTMENT | 336 |
| OIL PUMP VOLUME CHECK | 248 | TRANSMISSION THROTTLE VALVE CABLE ADJUSTMENT | 337 |
| FLUSHING COOLERS AND TUBES | 248 | SPECIFICATIONS | |
| ALUMINUM THREAD REPAIR | 249 | AW-4 AUTOMATIC TRANSMISSION | 338 |
| | | SPECIAL TOOLS | |
| | | AW-4 | 344 |

DESCRIPTION AND OPERATION

AW-4 AUTOMATIC TRANSMISSION

DESCRIPTION

The AW-4 is a 4-speed, electronically controlled automatic transmission (Fig. 1).

The running gear consists of an oil pump, planetary gear sets, clutch and brake units, hydraulic accumulators, a valve body with electrical solenoids, and a transmission control module (TCM). Cables are used to provide shift and throttle pressure control information. A park/neutral position switch permits engine starting in the Park and Neutral ranges only.

TRANSMISSION IDENTIFICATION

The transmission I. D. plate is attached to the case (Fig. 2). The plate contains the transmission serial and model numbers. Refer to the information on this plate when ordering service parts.

ELECTRONIC CONTROLS

The AW-4 is electronically controlled in 1, 2, 3 and D ranges. Controls consist of the transmission control module (TCM), valve body solenoids and various sensors. The sensors monitor vehicle speed, throttle opening, shift lever position and brake pedal application.

TRANSMISSION GEAR RATIOS

Fourth gear is an 0.75:1 ratio overdrive range. First, second, third and reverse gear are conventional ranges. Third gear ratio is 1:1. A separate planetary gear set provides overdrive operation in fourth gear.

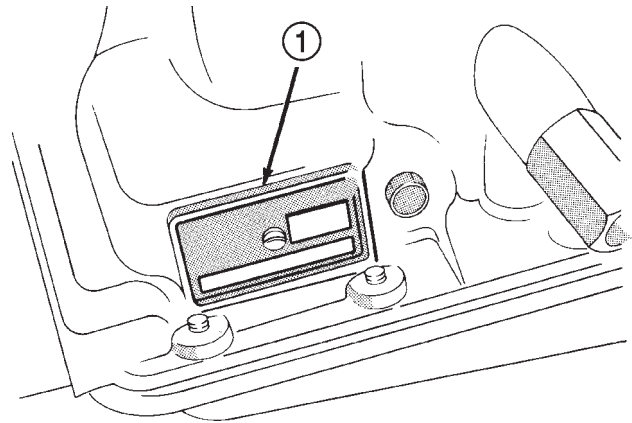

J8921-400

Fig. 2 Transmission Identification

1 - TRANSMISSION I. D. PLATE

OPERATION

GEARTRAIN OPERATION AND APPLICATION CHARTS

Operation and application of the first through fourth and reverse gear elements are outlined in the function and application charts.

The Component Function Chart describes basic function of various geartrain elements. The Component Application Chart indicates which elements (including valve body solenoids), are applied in the various gear ranges.

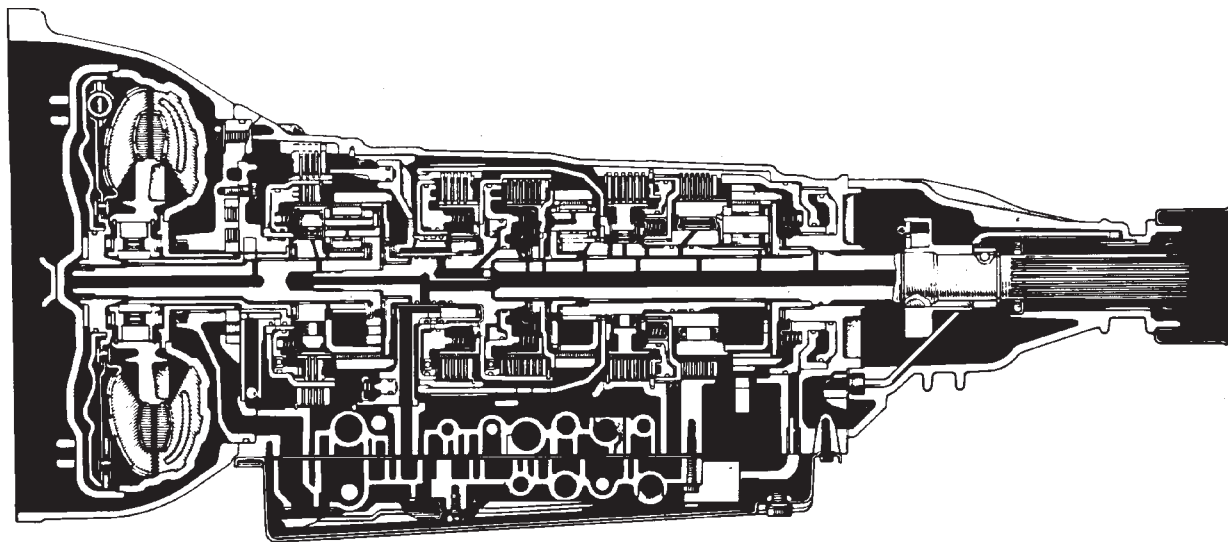

J8921-398

Fig. 1 AW-4 Automatic Transmission

DESCRIPTION AND OPERATION (Continued)

COMPONENT FUNCTION CHART

| COMPONENT NAME | COMPONENT FUNCTION |
|--------------------------|---|
| Overdrive Direct Clutch | Connects overdrive sun gear and overdrive carrier. |
| Overdrive Brake | Prevents overdrive sun gear from turning either clockwise or counter-clockwise. |
| Overdrive One-Way Clutch | When transmission is driven by engine, connects overdrive sun gear and overdrive carrier. |
| Forward Clutch | Connects input shaft and front ring gear. |
| Direct Clutch | Connects input shaft to the front and rear ring gears. |
| Second Coast Brake | Prevents front and rear sun gear from turning either clockwise or counter-clockwise. |
| Second Brake | Prevents outer race of number 1 one-way clutch from turning either clockwise or counter-clockwise, thus preventing the front and rear sun gears from turning counter-clockwise. |
| First/Reverse Brake | Prevents the rear planetary carrier from turning either clockwise or counter-clockwise. |
| Number 1 One-way Clutch | When second brake is operating, prevents the front and rear sun gears from turning counter-clockwise. |
| Number 2 One-Way Clutch | Prevents the rear planetary carrier from turning counter-clockwise. |

COMPONENT APPLICATION CHART

| Shift Lever Position | Gear | Valve Body Solenoid No. 1 | Valve Body Solenoid No. 2 | OVERDRIVE CLUTCH | FORWARD CLUTCH | DIRECT CLUTCH | OVERDRIVE BRAKE | SECOND COAST BRAKE | SECOND BRAKE | FIRST/REVERSE BRAKE | OVERDRIVE ONE-WAY CLUTCH | NO.1 ONE-WAY CLUTCH | NO.2 ONE-WAY CLUTCH |
|----------------------|---------|---------------------------|---------------------------|------------------|----------------|---------------|-----------------|--------------------|--------------|---------------------|--------------------------|---------------------|---------------------|
| P | Park | ON | OFF | • | | | | | | | | | |
| R | Reverse | ON | OFF | • | | • | | | | • | • | | |
| N | Neutral | ON | OFF | • | | | | | | | | | |
| D | First | ON | OFF | • | • | | | | | | • | | • |
| | Second | ON | ON | • | • | | | | • | | • | • | |
| | Third | OFF | ON | • | • | • | | | • | | • | | |
| | OD | OFF | OFF | | • | • | • | | • | | | | |
| 3 | First | ON | OFF | • | • | | | | | | • | | • |
| | Second | ON | ON | • | • | | | • | • | | • | • | |
| | Third | OFF | ON | • | • | • | | | • | | • | | |
| 1-2 | First | ON | OFF | • | • | | | | | • | • | | • |
| | Second | ON | ON | • | • | | | • | • | | • | • | |

• = Applied

DESCRIPTION AND OPERATION (Continued)

FIRST/SECOND/THIRD/REVERSE GEAR COMPONENTS

First through third and reverse gear components are outlined in (Fig. 3).

The input shaft is meshed with the direct clutch hub and the forward clutch drum. These elements rotate as a unit. The forward clutch hub rotates as a unit with the front planetary ring gear. The direct clutch drum is meshed with the forward end of the planetary sun gear.

The second brake hub serves as the outer race of one-way clutch No. 1. The clutch inner race is locked with the front/rear sun gear. The inner race of one-way clutch No. 2 is splined to the transmission case and is locked. The outer race rotates as a unit with the rear planetary carrier.

The rear planetary ring gear is splined to the output shaft. The front planetary carrier and rear carrier ring gear are meshed and rotate as a unit with the output shaft.

FOURTH GEAR OVERDRIVE COMPONENTS

The overdrive system consists of the input shaft, one-way clutch, planetary sun gear, ring gear, planetary carrier, overdrive clutch and overdrive brake (Fig. 4). The overdrive elements are controlled and

applied through transmission valve body solenoid number two.

In fourth gear, the overdrive brake prevents the overdrive sun gear from turning. The overdrive input shaft and planetary carrier rotate as a unit. The sun gear and overdrive direct clutch drum are in mesh and operate as a single unit. The direct clutch splines function as the hub for the overdrive brake. The one-way clutch outer race is in mesh with the planetary carrier. The inner race is fixed to the sun gear shaft.

FLUID

NOTE: Refer to the maintenance schedules in Group 0, Lubrication and Maintenance for the recommended maintenance (fluid/filter change) intervals for this transmission.

NOTE: Refer to Service Procedures in this group for fluid level checking procedures.

DESCRIPTION

Mopar® Dexron IIE/Mercon is the recommended fluid for the AW-4 automatic transmissions.

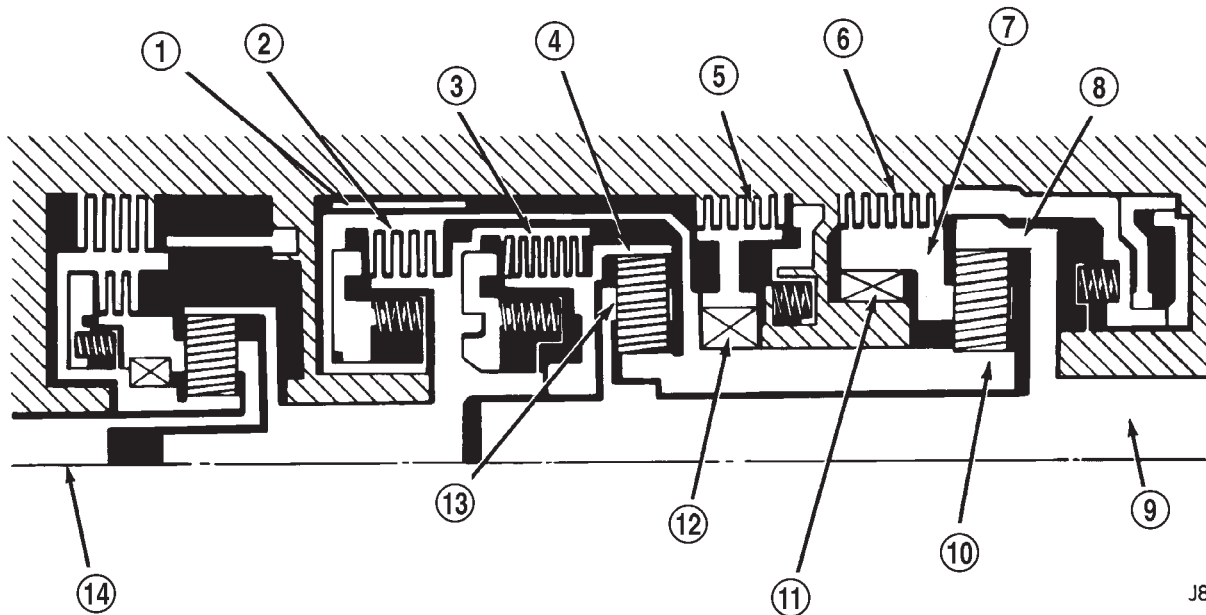

J8921-403

Fig. 3 First/Second/Third/Reverse Gear Components

- | | |
|-------------------------------|--------------------------------------|
| 1 - 2ND COAST BRAKE | 8 - REAR PLANETARY RING GEAR |
| 2 - DIRECT CLUTCH | 9 - OUTPUT SHAFT |
| 3 - FORWARD CLUTCH | 10 - FRONT & REAR PLANETARY SUN GEAR |
| 4 - FRONT PLANETARY RING GEAR | 11 - ONE-WAY CLUTCH NO. 2 |
| 5 - SECOND BRAKE | 12 - ONE-WAY CLUTCH NO. 1 |
| 6 - FIRST/REVERSE BRAKE | 13 - FRONT PLANETARY CARRIER |
| 7 - REAR PLANETARY CARRIER | 14 - INPUT SHAFT |

DESCRIPTION AND OPERATION (Continued)

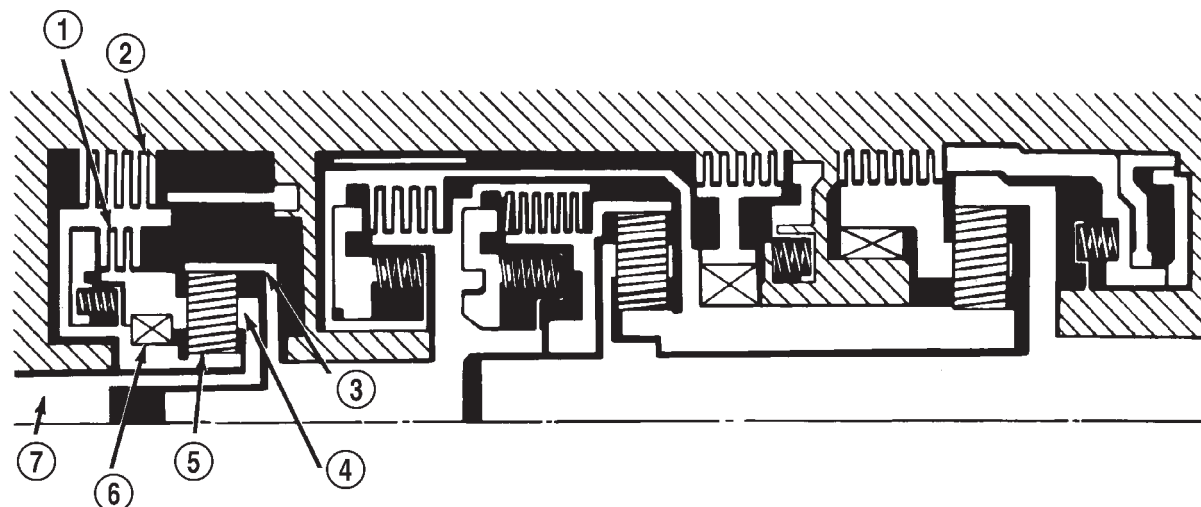

J8921-402

Fig. 4 Fourth Gear Overdrive Components

- | | |
|-----------------------|--------------------|
| 1 - CLUTCH | 5 - SUN GEAR |
| 2 - BRAKE | 6 - ONE-WAY CLUTCH |
| 3 - RING GEAR | 7 - INPUT SHAFT |
| 4 - PLANETARY CARRIER | |

Dexron II fluid IS NOT recommended. Clutch chatter can result from the use of improper fluid.

Mopar® Dexron IIE/Mercon automatic transmission fluid when new is red in color. The ATF is dyed red so it can be identified from other fluids used in the vehicle such as engine oil or antifreeze. The red color is not permanent and is not an indicator of fluid condition. As the vehicle is driven, the ATF will begin to look darker in color and may eventually become brown. **This is normal.** A dark brown/black fluid accompanied with a burnt odor and/or deterioration in shift quality may indicate fluid deterioration or transmission component failure.

FLUID ADDITIVES

DaimlerChrysler strongly recommends against the addition of any fluids to the transmission, other than those automatic transmission fluids listed above. Exceptions to this policy are the use of special dyes to aid in detecting fluid leaks.

Various "special" additives and supplements exist that claim to improve shift feel and/or quality. These additives and others also claim to improve converter

clutch operation and inhibit overheating, oxidation, varnish, and sludge. These claims have not been supported to the satisfaction of DaimlerChrysler and these additives **must not be used.** The use of transmission "sealers" should also be avoided, since they may adversely affect the integrity of transmission seals.

OPERATION

The automatic transmission fluid is selected based upon several qualities. The fluid must provide a high level of protection for the internal components by providing a lubricating film between adjacent metal components. The fluid must also be thermally stable so that it can maintain a consistent viscosity through a large temperature range. If the viscosity stays constant through the temperature range of operation, transmission operation and shift feel will remain consistent. Transmission fluid must also be a good conductor of heat. The fluid must absorb heat from the internal transmission components and transfer that heat to the transmission case.

DESCRIPTION AND OPERATION (Continued)

TORQUE CONVERTER

DESCRIPTION

The torque converter (Fig. 5) is a hydraulic device that couples the engine crankshaft to the transmission. The torque converter consists of an outer shell with an internal turbine, a stator, an overrunning clutch, an impeller and an electronically applied converter clutch. The converter clutch provides reduced engine speed and greater fuel economy when engaged. Clutch engagement also provides reduced transmission fluid temperatures. Torque converter clutch engagement occurs in second gear in 1-2 position; third gear in 3 position and third and fourth gear in D position. The torque converter hub drives the transmission oil (fluid) pump.

The torque converter is a sealed, welded unit that is not repairable and is serviced as an assembly.

CAUTION: The torque converter must be replaced if a transmission failure resulted in large amounts of metal or fiber contamination in the fluid. If the fluid is contaminated, flush the fluid cooler and lines.

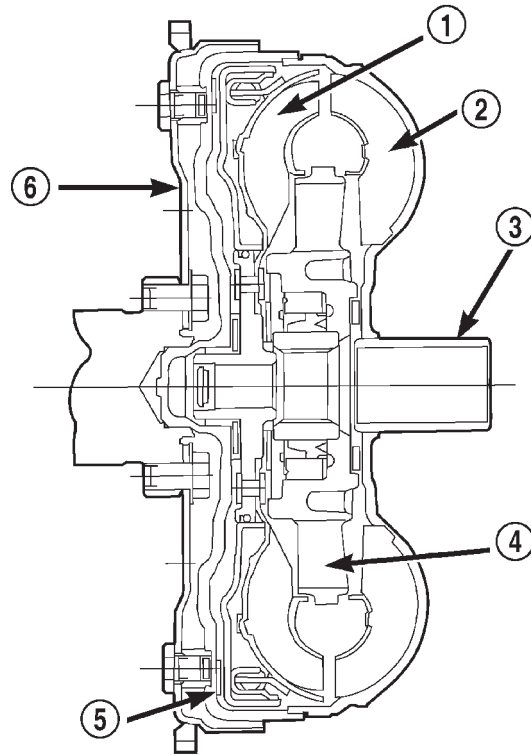

80be46a3

Fig. 5 Torque Converter Assembly

- 1 - TURBINE
- 2 - IMPELLER
- 3 - HUB
- 4 - STATOR
- 5 - CONVERTER CLUTCH DISC
- 6 - DRIVE PLATE

DESCRIPTION AND OPERATION (Continued)

IMPELLER

The impeller (Fig. 6) is an integral part of the converter housing. The impeller consists of curved vanes placed radially along the inside of the housing on the transmission side of the converter. As the converter housing is rotated by the engine, so is the impeller, because they are one in the same and are the driving member of the system.

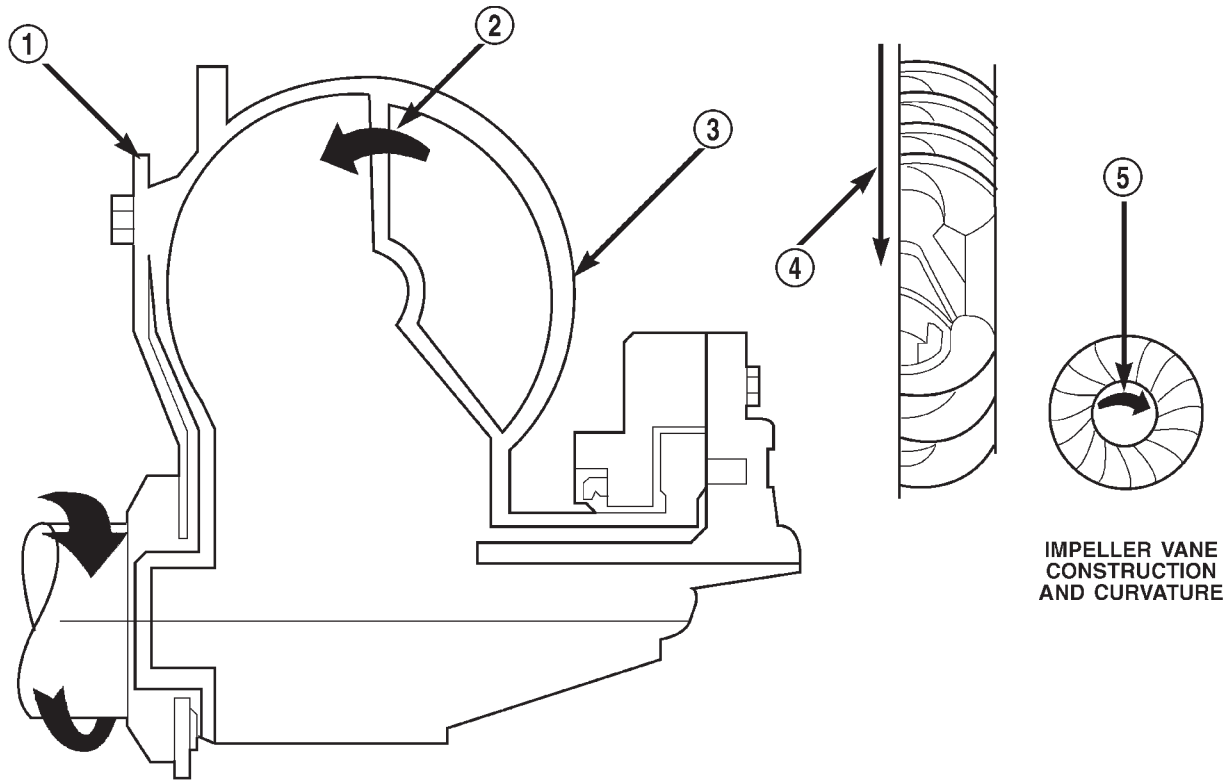

**IMPELLER VANE
CONSTRUCTION
AND CURVATURE**

80bfe26a

Fig. 6 Impeller

- | | |
|---|---------------------|
| 1 - ENGINE FLEXPLATE | 4 - ENGINE ROTATION |
| 2 - OIL FLOW FROM IMPELLER SECTION INTO TURBINE SECTION | 5 - ENGINE ROTATION |
| 3 - IMPELLER VANES AND COVER ARE INTEGRAL | |

DESCRIPTION AND OPERATION (Continued)

TURBINE

The turbine (Fig. 7) is the output, or driven, member of the converter. The turbine is mounted within the housing opposite the impeller, but is not mounted to the housing. The input shaft is inserted through the center of the impeller and splined into the turbine. The design of the turbine is similar to the impeller, except the blades of the turbine are curved in the opposite direction.

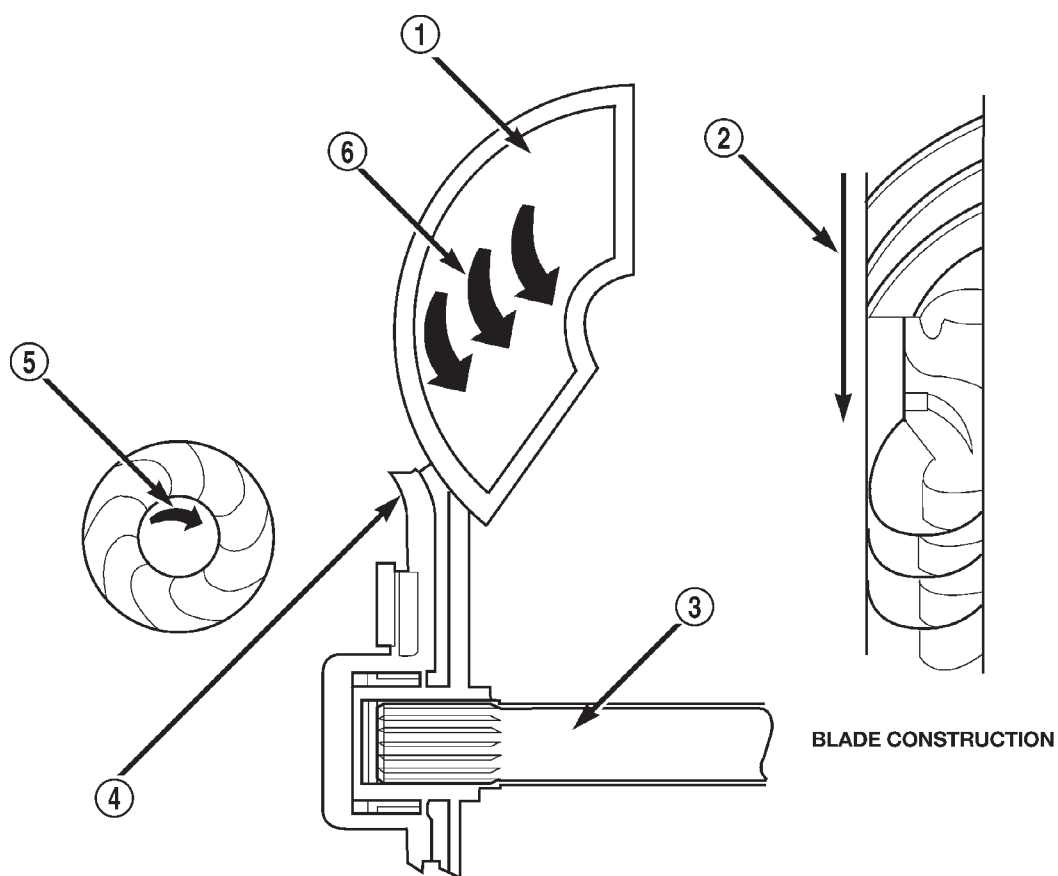

80bfe26b

Fig. 7 Turbine

- | | |
|---------------------|---------------------------------------|
| 1 - TURBINE VANE | 4 - PORTION OF TORQUE CONVERTER COVER |
| 2 - ENGINE ROTATION | 5 - ENGINE ROTATION |
| 3 - INPUT SHAFT | 6 - OIL FLOW WITHIN TURBINE SECTION |

DESCRIPTION AND OPERATION (Continued)

STATOR

The stator assembly (Fig. 8) is mounted on a stationary shaft which is an integral part of the oil pump. The stator also contains an over-running clutch. The stator is located between the impeller and turbine within the torque converter case (Fig. 9). The over-running clutch of the stator allows the stator to rotate only in a clockwise direction.

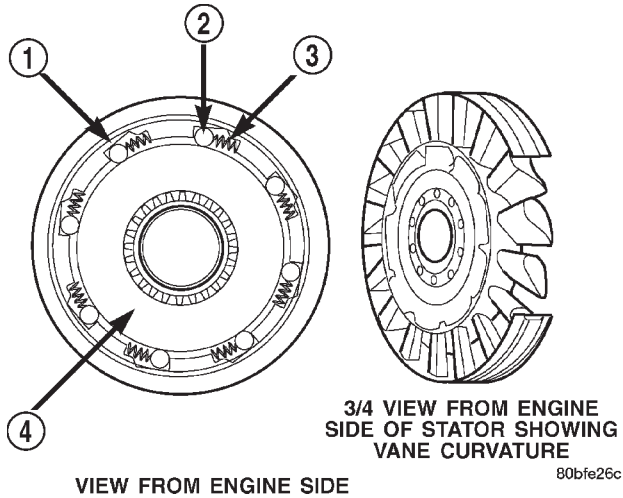

Fig. 8 Stator Components

- 1 - CAM (OUTER RACE)
- 2 - ROLLER
- 3 - SPRING
- 4 - INNER RACE

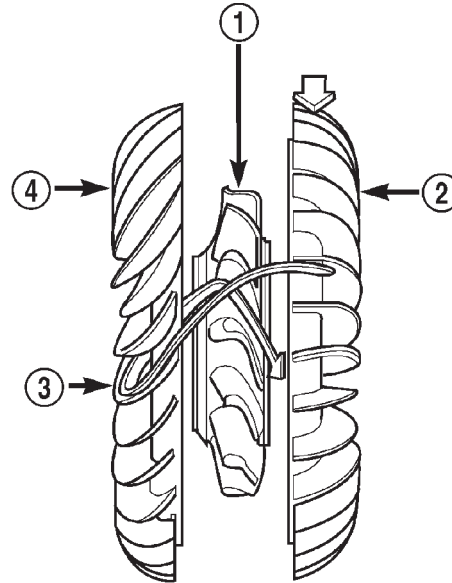

Fig. 9 Stator Location

- 1 - STATOR
- 2 - IMPELLER
- 3 - FLUID FLOW
- 4 - TURBINE

80bfe26d

TORQUE CONVERTER CLUTCH (TCC)

The TCC (Fig. 10) was installed to improve the efficiency of the torque converter that is lost to the slippage of the fluid coupling. Although the fluid coupling provides smooth, shock-free power transfer, it is natural for all fluid couplings to slip. If the impeller and turbine were mechanically locked together, a zero slippage condition could be obtained. A hydraulic piston was added to the turbine, and a friction material was added to the inside of the impeller housing to provide this mechanical lock-up.

OPERATION

The converter impeller (Fig. 11) (driving member), which is integral to the converter housing and bolted to the engine drive plate, rotates at engine speed. The converter turbine (driven member), which reacts from fluid pressure generated by the impeller, rotates and turns the transmission input shaft.

TURBINE

As the fluid that was put into motion by the impeller blades strikes the blades of the turbine, some of the energy and rotational force is transferred into the turbine and the input shaft. This causes both of them

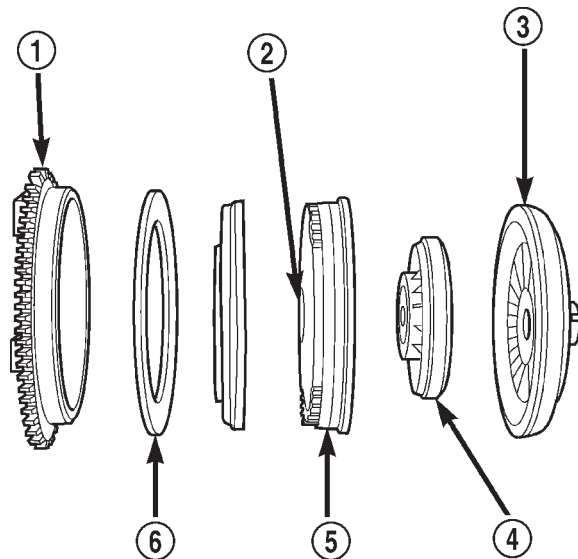
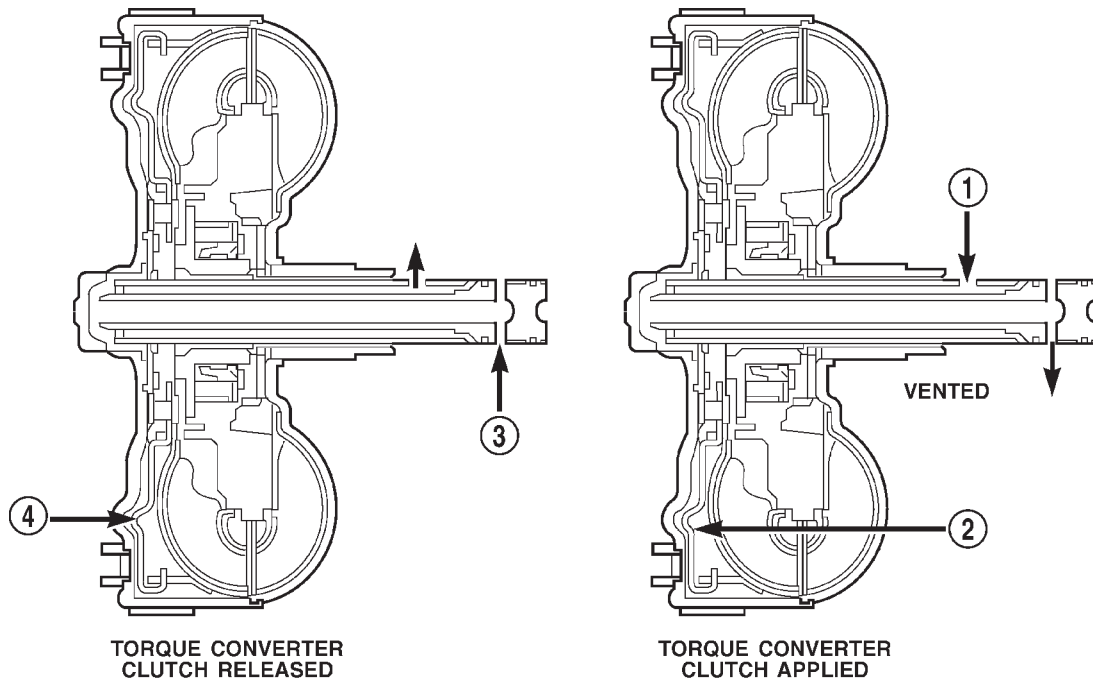

Fig. 10 Torque Converter Clutch (TCC)

- 1 - IMPELLER FRONT COVER
- 2 - THRUST WASHER ASSEMBLY
- 3 - IMPELLER
- 4 - STATOR
- 5 - TURBINE
- 6 - FRICTION DISC

80bfe26f

DESCRIPTION AND OPERATION (Continued)



80bfe276

Fig. 11 Torque Converter Fluid Operation

- | | |
|---------------------------------------|--|
| 1 - APPLY PRESSURE | 3 - RELEASE PRESSURE |
| 2 - THE PISTON MOVES SLIGHTLY FORWARD | 4 - THE PISTON MOVES SLIGHTLY REARWARD |

(turbine and input shaft) to rotate in a clockwise direction following the impeller. As the fluid is leaving the trailing edges of the turbine's vanes it continues in a "hindering" direction back toward the impeller. If the fluid is not redirected before it strikes the impeller, it will strike the impeller in such a direction that it would tend to slow it down.

STATOR

Torque multiplication is achieved by locking the clutch to its shaft (Fig. 12). Under stall conditions (the turbine is stationary), the oil leaving the turbine vanes strikes the face of the stator vanes and tries to rotate them in a counterclockwise direction. When this happens the over-running clutch of the stator locks and holds the stator from rotating. With the stator locked, the oil strikes the stator vanes and is redirected into a "helping" direction before it enters the impeller. This circulation of oil from impeller to turbine, turbine to stator, and stator to impeller, can produce a maximum torque multiplication of about 2.2:1. As the turbine begins to match the speed of the impeller, the fluid that was hitting the stator in such a way as to cause it to lock-up is no longer doing so. In this condition of operation, the stator begins to free wheel and the converter acts as a fluid coupling.

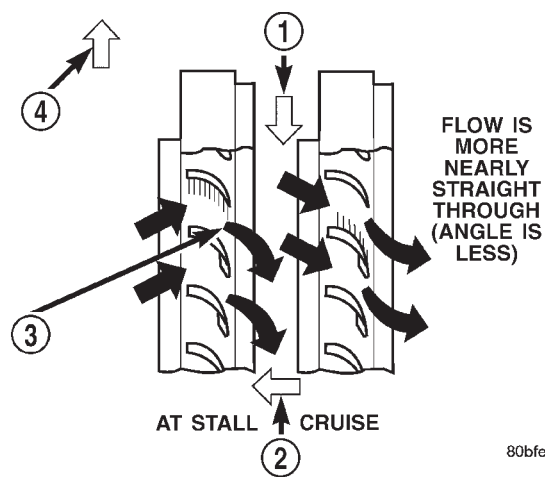

80bfe26e

Fig. 12 Stator Operation

- | |
|--|
| 1 - DIRECTION STATOR WILL FREE WHEEL DUE TO OIL PUSHING ON BACKSIDE OF VANES |
| 2 - FRONT OF ENGINE |
| 3 - INCREASED ANGLE AS OIL STRIKES VANES |
| 4 - DIRECTION STATOR IS LOCKED UP DUE TO OIL PUSHING AGAINST STATOR VANES |

DESCRIPTION AND OPERATION (Continued)

TORQUE CONVERTER CLUTCH (TCC)

In a standard torque converter, the impeller and turbine are rotating at about the same speed and the stator is freewheeling, providing no torque multiplication. By applying the turbine's piston to the impeller's friction material, a total converter engagement can be obtained. The result of this engagement is a direct 1:1 mechanical link between the engine and the transmission.

The engagement and disengagement of the TCC are automatic and controlled by the Transmission Control Module (TCM). Inputs that determine clutch engagement are: coolant temperature, vehicle speed and throttle position. Clutch engagement is controlled by transmission valve body solenoid number three and by the converter clutch relay valve. The solenoid channels line pressure to the clutch through the relay valve at clutch engagement speeds.

OIL PUMP

DESCRIPTION

The oil pump (Fig. 13) is located in the pump housing inside the bell housing of the transmission case. The oil pump consists of an inner and outer gear, a housing, and a cover that also serves as the reaction shaft support.

OPERATION

As the torque converter rotates, the converter hub rotates the inner and outer gears. As the gears rotate, the clearance between the gear teeth increases in the crescent area, and creates a suction at the inlet side of the pump. This suction draws fluid through the pump inlet from the oil pan. As the clearance between the gear teeth in the crescent area decreases, it forces pressurized fluid into the pump outlet and to the valve body.

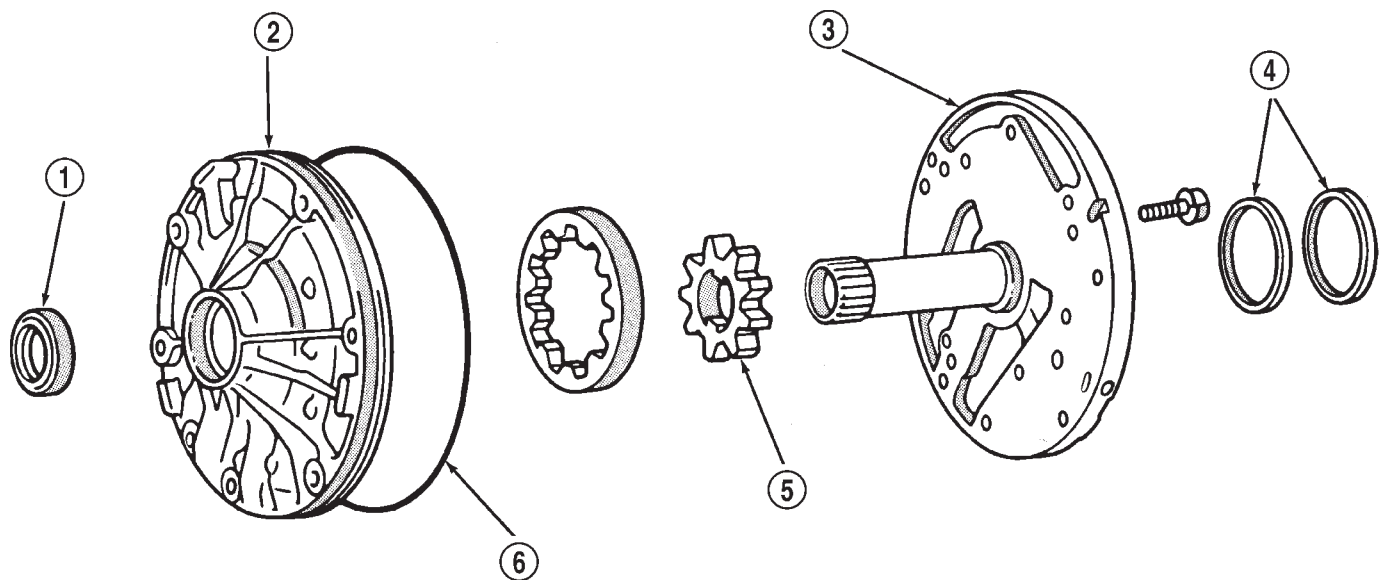

J8921-516

Fig. 13 Oil Pump Assembly

- | | |
|------------------|----------------|
| 1 - PUMP SEAL | 4 - SEAL RINGS |
| 2 - PUMP BODY | 5 - GEAR |
| 3 - STATOR SHAFT | 6 - O-RING |

DESCRIPTION AND OPERATION (Continued)

TRANSMISSION VALVE BODY COMPONENTS

DESCRIPTION

Transmission operating pressure is supplied to the clutch and brake apply circuits through the transmission valve body. The valve body consists of an upper body, lower body, separator plate and upper and lower gaskets (Fig. 14). The various spool valves, sleeves, plugs and springs are located within the two body sections.

The manual valve, 1-2 shift valve, primary regulator valve, accumulator control valve, check balls, and oil strainers are located in the lower body section (Fig. 15). The remaining control and shift valves plus check balls and one additional oil strainer are located in the upper body section (Fig. 16).

TRANSMISSION VALVE BODY SOLENOIDS

The solenoids are mounted on the valve body and operated by the TCM. The solenoids control operation of the converter clutch and shift valves in response to input signals from the module.

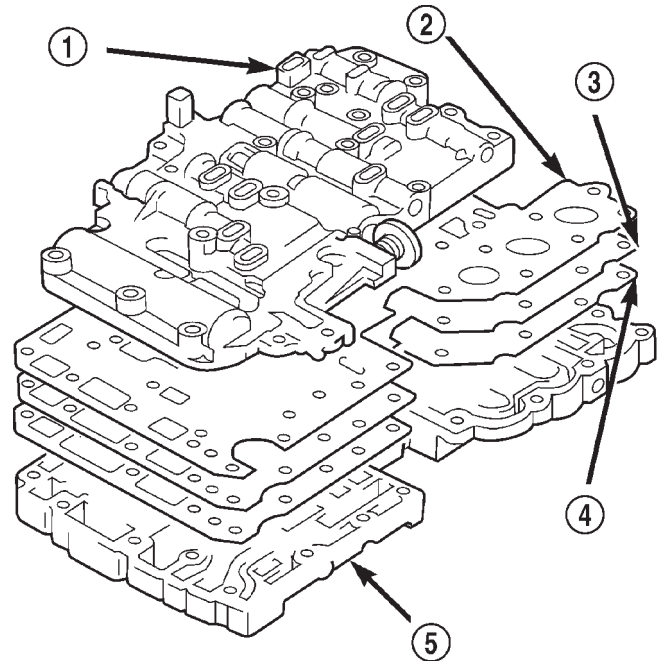

80aef261

Fig. 14 Two-Section Transmission Valve Body

- 1 - UPPER BODY
- 2 - UPPER GASKET
- 3 - SEPARATOR PLATE
- 4 - LOWER GASKET
- 5 - LOWER BODY

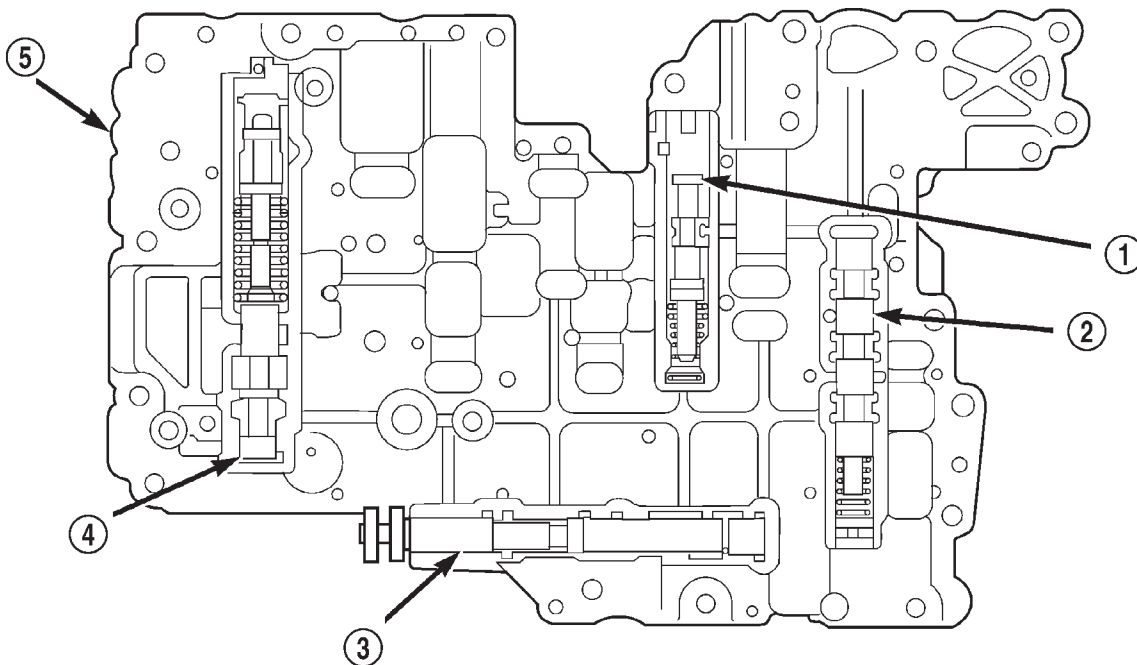

80aef262

Fig. 15 Upper Body Components

- 1 - ACCUMULATOR CONTROL VALVE
- 2 - 1-2 SHIFT VALVE
- 3 - MANUAL VALVE
- 4 - PRIMARY REGULATOR VALVE
- 5 - LOWER BODY

DESCRIPTION AND OPERATION (Continued)

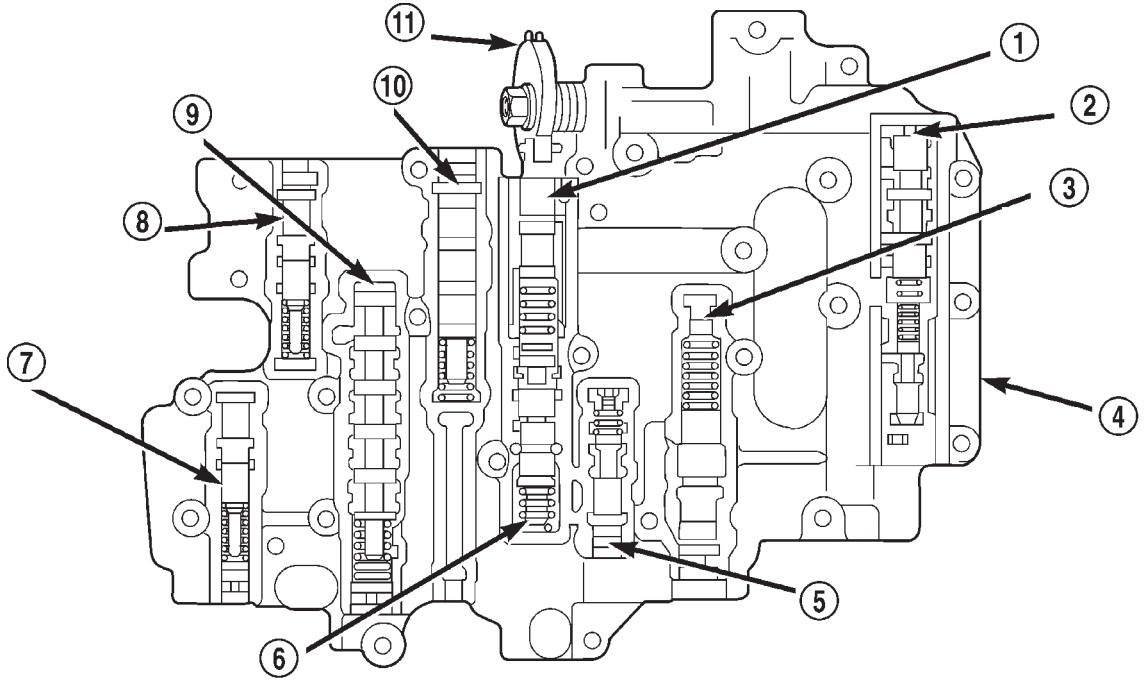

80aef263

Fig. 16 Lower Body Components

- | | |
|-------------------------------|-------------------------------------|
| 1 - DOWNSHIFT PLUG | 7 - LOW COAST MODULATOR VALVE |
| 2 - LOCK-UP RELAY VALVE | 8 - SECONDARY COAST MODULATOR VALVE |
| 3 - SECONDARY REGULATOR VALVE | 9 - 2-3 SHIFT VALVE |
| 4 - UPPER BODY | 10 - 3-4 SHIFT VALVE |
| 5 - CUT-BACK VALVE | 11 - THROTTLE CAM |
| 6 - THROTTLE VALVE | |

OPERATION

MANUAL VALVE

The manual valve is operated by the gearshift linkage. The valve diverts fluid to the apply circuits according to shift lever position (Fig. 17).

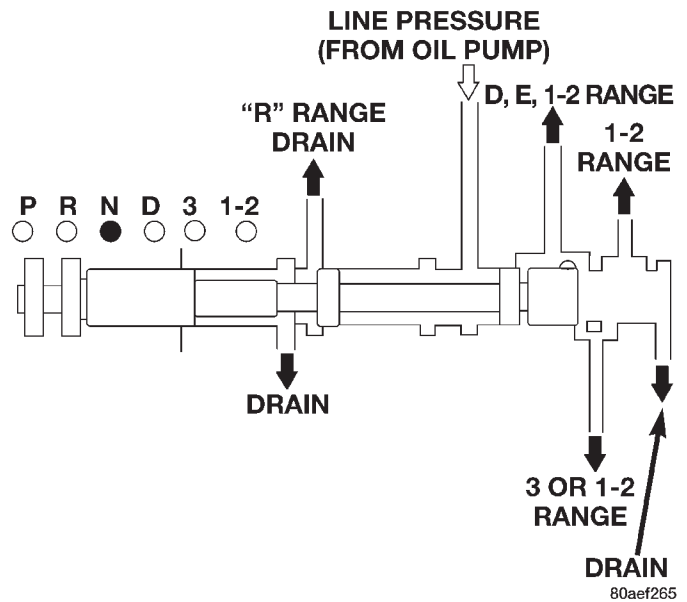

80aef265

Fig. 17 Manual Valve

DESCRIPTION AND OPERATION (Continued)

PRIMARY REGULATOR VALVE

The primary regulator valve (Fig. 18) modulates line pressure to the clutches and brakes according to engine load. The valve is actuated by throttle valve pressure.

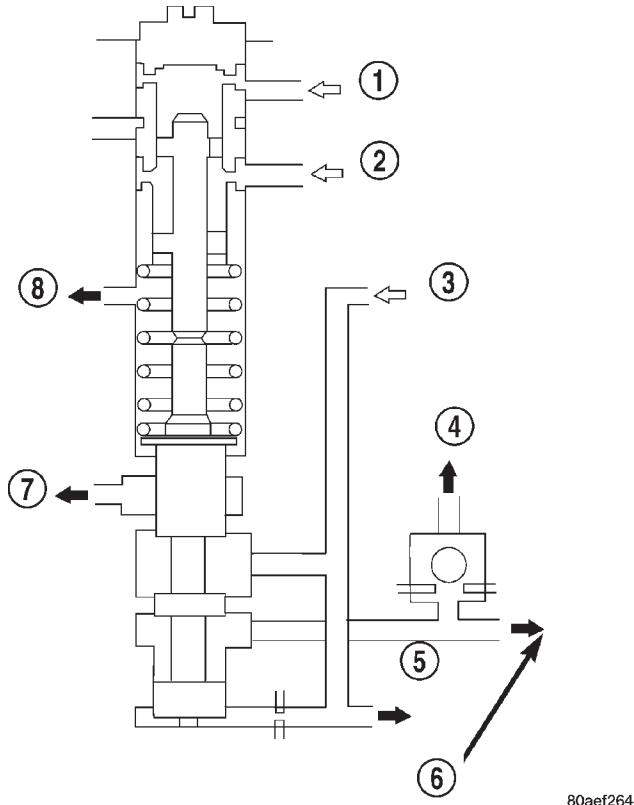

Fig. 18 Primary Regulator Valve

- 1 - THROTTLE PRESSURE
- 2 - LINE PRESSURE (FROM MANUAL VALVE "R" RANGE)
- 3 - LINE PRESSURE (FROM PUMP)
- 4 - CONVERTER PRESSURE TO CONVERTER CLUTCH RELAY VALVE
- 5 - LINE PRESSURE
- 6 - CONVERTER PRESSURE (TO SECONDARY REGULATOR VALVE)
- 7 - DRAIN
- 8 - DRAIN

80aef264

During high load operation, the valve increases line pressure to maintain positive clutch and brake engagement. At light load, the valve decreases line pressure just enough to maintain smooth engagement.

THROTTLE VALVE AND DOWNSHIFT PLUG

The throttle valve and downshift plug (Fig. 19) control throttle pressure to the primary regulator valve.

The downshift plug and throttle valve are operated by the throttle valve cam and throttle cable in response to engine throttle position. Throttle valve

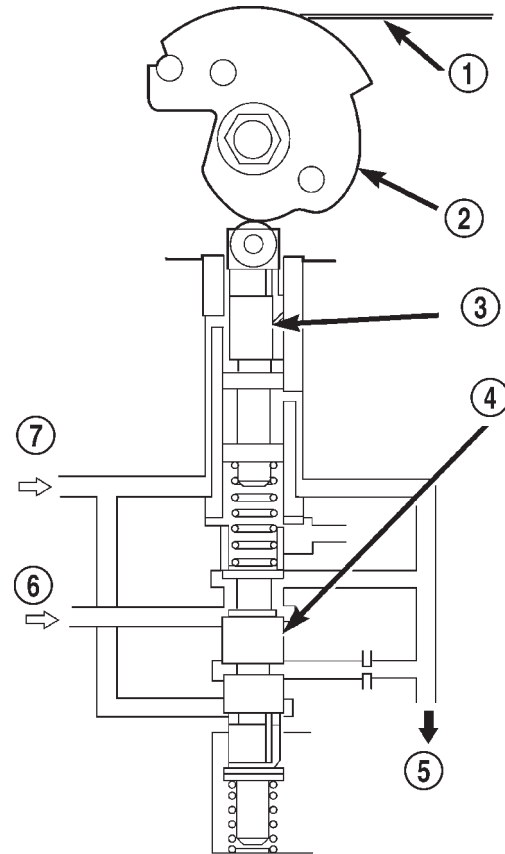

80aef266

Fig. 19 Throttle Valve And Downshift Plug

- 1 - LINE PRESSURE CABLE
- 2 - THROTTLE VALVE CAM
- 3 - DOWNSHIFT PLUG
- 4 - THROTTLE VALVE
- 5 - THROTTLE PRESSURE (TO PRIMARY REGULATOR VALVE)
- 6 - LINE PRESSURE
- 7 - CUT-BACK PRESSURE (FROM CUT-BACK VALVE)

pressure is also modulated by the cut-back valve in second, third and fourth gear ranges.

CUT-BACK VALVE

The cut-back valve (Fig. 20) helps prevent excessive pump pressure buildup in second, third and fourth gear. The valve is actuated by throttle pressure and by line pressure from the second brake. The valve also helps regulate line pressure by controlling the amount of cut-back pressure to the throttle valve.

SECONDARY REGULATOR VALVE

The secondary regulator valve (Fig. 21) regulates converter clutch and transmission lubrication pressure. When primary regulator valve pressure exceeds requirements for clutch engagement or transmission lubrication, the secondary regulator valve is moved upward exposing the drain port. Excess pressure then bleeds off as needed. As pressure drops, spring

DESCRIPTION AND OPERATION (Continued)

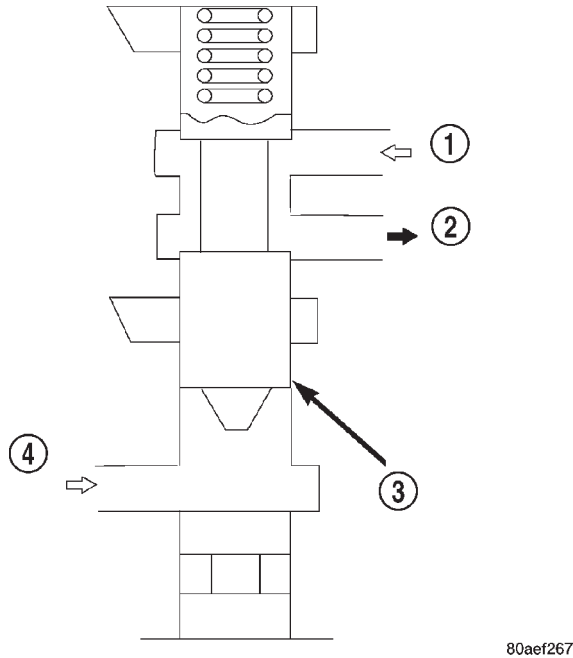

Fig. 20 Cut-Back Valve

- 1 - THROTTLE PRESSURE
- 2 - CUT-BACK PRESSURE TO THROTTLE VALVE
- 3 - CUT-BACK VALVE
- 4 - SECOND BRAKE LINE PRESSURE

tension moves the valve downward closing the drain port.

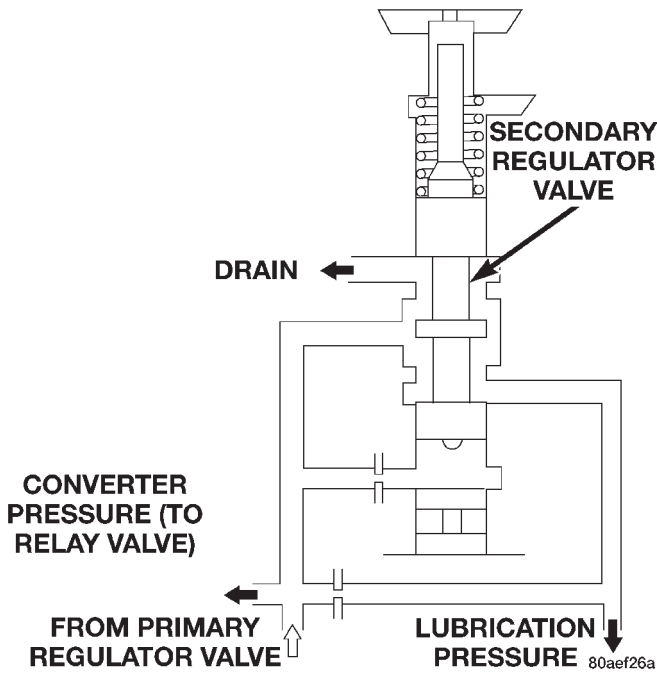

Fig. 21 Secondary Regulator Valve

CONVERTER CLUTCH RELAY VALVE

The converter clutch relay valve (Fig. 22) controls fluid flow to the converter clutch. The valve is oper-

ated by line pressure from the 1-2 shift valve and is controlled by solenoid valve number three.

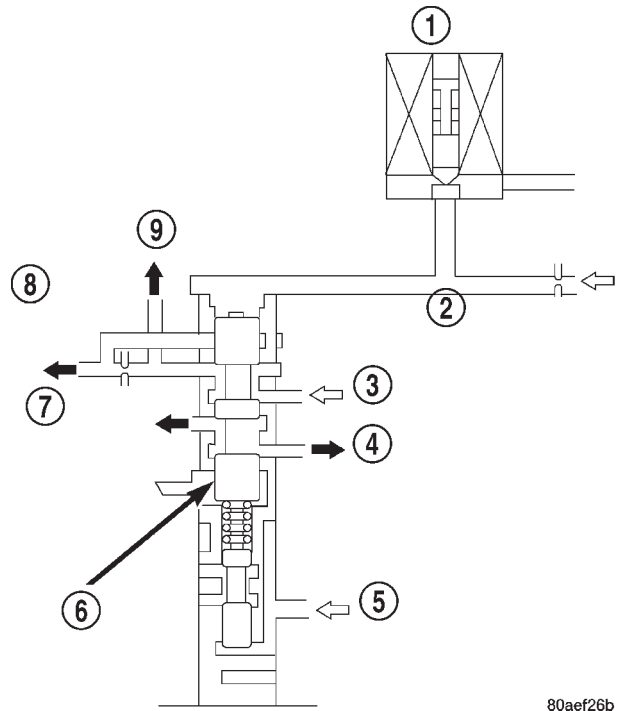

Fig. 22 Converter Clutch Relay Valve

- 1 - SOLENOID VALVE NO. 3
- 2 - LINE PRESSURE (FROM 1-2 SHIFT VALVE)
- 3 - CONVERTER PRESSURE
- 4 - DRAIN
- 5 - LINE PRESSURE (FROM PUMP)
- 6 - CONVERTER CLUTCH RELAY VALVE
- 7 - TO CONVERTER CLUTCH (DISENGAGED)
- 8 - TO OIL COOLER
- 9 - TO CONVERTER CLUTCH (ENGAGED)

1-2 SHIFT VALVE

The 1-2 shift valve (Fig. 23) controls the 1-2 upshifts and downshifts. The valve is operated by the No. 2 valve body solenoid and line pressure from the manual valve, second coast modulator valve and the 2-3 shift valve.

When the transmission control module deactivates the solenoid, line pressure at the top of the valve moves the valve down closing the second brake accumulator feed port. As the solenoid is activated and the drain port opens, spring force moves the valve up exposing the second brake feed port for the shift to second gear.

2-3 SHIFT VALVE

The 2-3 shift valve (Fig. 24) controls the 2-3 upshifts and downshifts. The valve is actuated by the No. 1 valve body solenoid and by line pressure from the manual valve and primary regulator valve.

DESCRIPTION AND OPERATION (Continued)

LINE PRESSURE
(FROM SOLENOID
VALVE NO. 2)

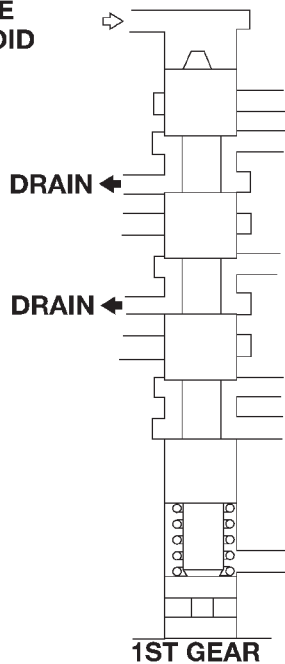

LINE PRESSURE
(FROM MANUAL
VALVE IN "D" "2"
OR "L" RANGE)

LINE PRESSURE
(FROM MANUAL
VALVE IN "R"
RANGE)

TO FIRST/REVERSE
BRAKE
FROM LOW COAST
MODULATOR
VALVE

LINE PRESSURE
(FROM 2-3 SHIFT
VALVE)

TO 2ND COAST
MODULATOR VALVE

TO ACCUMULATORS
AND SOLENOID
VALVE NO. 3

TO FIRST/REVERSE
BRAKE

LINE PRESSURE
(FROM 2-3 SHIFT
VALVE, IN 3RD
OR OD GEAR)

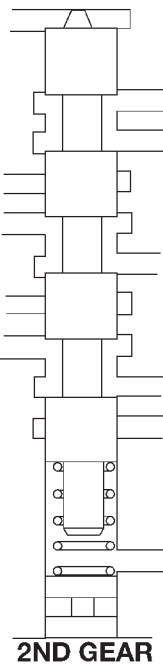

80aef26c

Fig. 23 1-2 Shift Valve

LINE PRESSURE
(FROM MANUAL
VALVE IN
1-2 POSITION)

TO 3-4 SHIFT VALVE
LINE PRESSURE
(FROM PRIMARY
REGULATOR
VALVE)

LINE PRESSURE
(FROM MANUAL
VALVE)

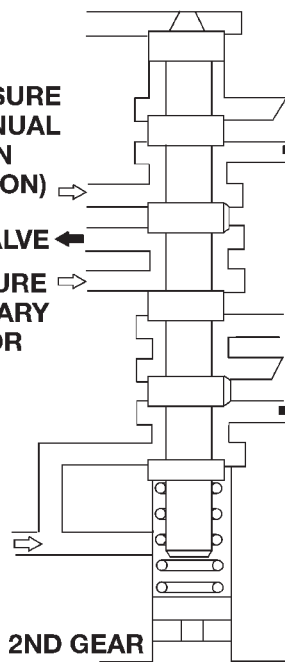

LINE PRESSURE
(FROM SOLENOID
VALVE NO. 1)

LINE PRESSURE
(FROM MANUAL
VALVE IN
1-2 POSITION)

LINE PRESSURE
(FROM PRIMARY
REGULATOR
VALVE)

TO LOW COAST
MODULATOR VALVE

TO DIRECT CLUTCH
ACCUMULATOR
AND 1-2
SHIFT VALVE

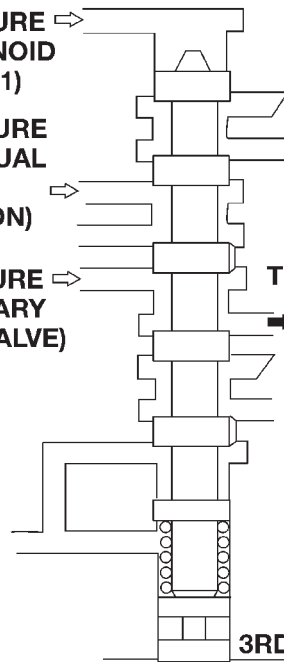

80aef26d

Fig. 24 2-3 Shift Valve

When the TCM activates solenoid No. 1, line pressure at the top of the 2-3 valve is released through the solenoid drain port. Spring tension moves the valve up to hold the valve in second gear position. As the solenoid is deactivated, line pressure then moves the valve down exposing the direct clutch feed port for the shift to third gear.

DESCRIPTION AND OPERATION (Continued)

3-4 SHIFT VALVE

The 3-4 shift valve (Fig. 25) is operated by the No. 2 solenoid and by line pressure from the manual valve, 2-3 valve and primary regulator valve.

Energizing the No. 2 solenoid causes line pressure at the top of the 3-4 valve to be released through the solenoid valve drain port. Spring tension moves the valve up exposing the overdrive clutch accumulator feed port to apply the clutch.

De-energizing the solenoid causes the drain port to close. Line pressure then moves the valve down exposing the overdrive brake accumulator feed port to apply the clutch.

In the 1-2 or 3 gearshift lever positions, line pressure from the 2-3 shift valve is applied to the lower end of the 3-4 valve. This holds the valve upward, closing off the overdrive brake feed port preventing a shift into fourth gear.

SECOND COAST MODULATOR VALVE

The second coast modulator valve (Fig. 26) momentarily reduces line pressure from the 1-2 shift valve. This cushions application of the second coast brake. The valve is operative when the shift lever and manual valve are in the 3 position.

LOW COAST MODULATOR VALVE

The low coast modulator valve (Fig. 27) momentarily reduces line pressure from the 2-3 shift valve;

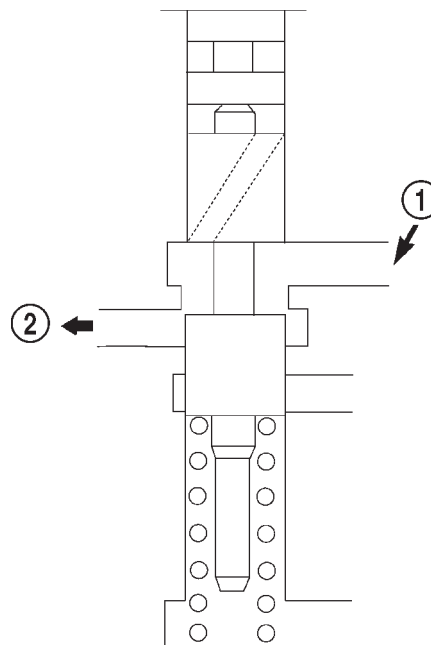

80aef26f

Fig. 26 Second Coast Modulator Valve

- 1 - LINE PRESSURE (FROM 1-2 SHIFT VALVE)
- 2 - LOW COAST MODULATOR PRESSURE SECOND COAST BRAKE

this action cushions application of the first/reverse

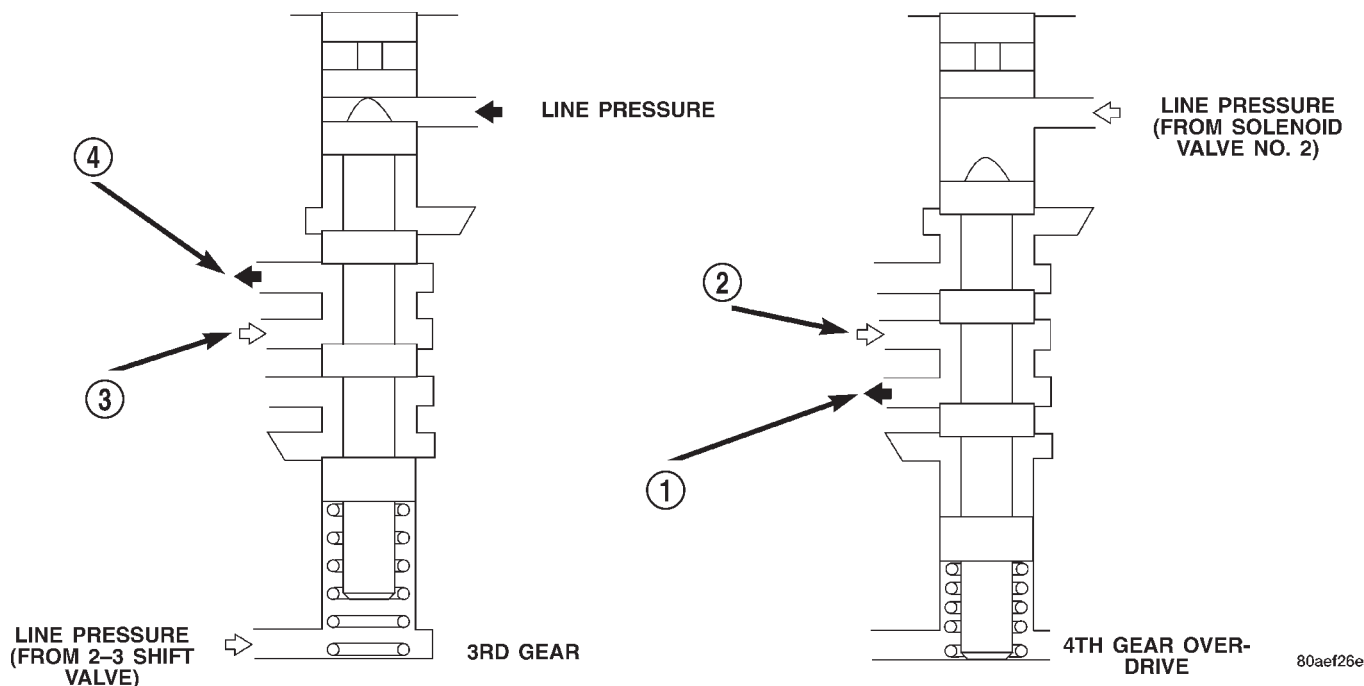

80aef26e

Fig. 25 3-4 Shift Valve

- 1 - TO OVER DRIVE BRAKE ACCUMULATOR
- 2 - LINE PRESSURE (FROM PRIMARY REGULATOR VALVE)
- 3 - LINE PRESSURE (FROM PRIMARY REGULATOR VALVE)
- 4 - TO OVERDRIVE CLUTCH ACCUMULATOR

DESCRIPTION AND OPERATION (Continued)

brake. The modulator valve operates when the shift lever and manual valve are in the 1-2 position.

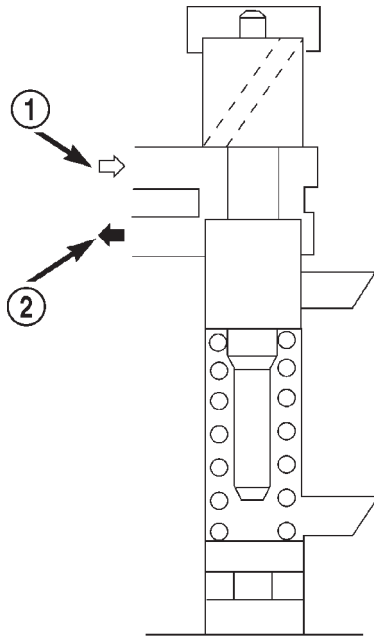

Fig. 27 Low Coast Modulator Valve

- 1 - LINE PRESSURE (FROM 2-3 SHIFT VALVE)
2 - LOW COAST MODULATOR PRESSURE TO FIRST/REVERSE BRAKE

80aef270

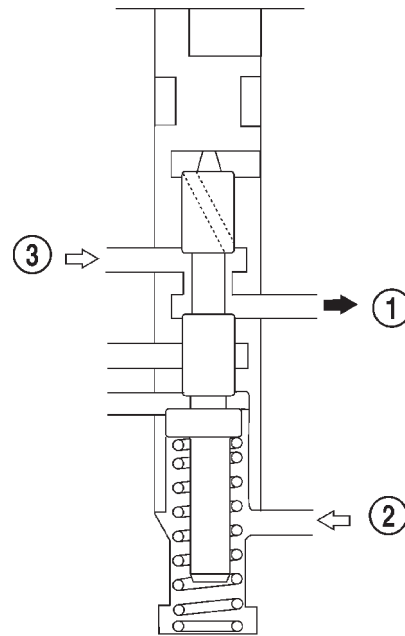

Fig. 28 Accumulator Control Valve

- 1 - ACCUMULATOR CONTROL PRESSURE (TO ACCUMULATORS)
2 - THROTTLE PRESSURE
3 - LINE PRESSURE (FROM PUMP)

80aef271

ACCUMULATOR CONTROL VALVE

The accumulator control valve (Fig. 28) cushions the transmission clutch and brake applications. This is achieved by reducing back pressure to the accumulators when throttle opening is small. The valve is operated by line and throttle pressure.

ACCUMULATORS

Four accumulators are used to cushion clutch and brake application. The accumulators (Fig. 29), consist of spring loaded pistons. The pistons dampen the initial surge of apply pressure to provide smooth engagement during shifts.

Control pressure from the accumulator control valve is continuously applied to the back pressure side of the accumulator pistons. This pressure plus spring tension holds the pistons down. As line pressure from the shift valves enters the opposite end of the piston bore, control pressure and spring tension momentarily delay application of full line pressure to cushion engagement. The accumulators are all located in the transmission case (Fig. 29).

TRANSMISSION VALVE BODY SOLENOIDS

Three solenoids are used (Fig. 30). The No. 1 and 2 solenoids control shift valve operation by applying or releasing line pressure. The signal to apply or release

pressure is provided by the transmission control module.

The No. 3 solenoid controls operation of the torque converter clutch. The solenoid operates in response to signals from the transmission control module.

When the No. 1 and 2 solenoids are activated, the solenoid plunger is moved off its seat opening the drain port to release line pressure. When either solenoid is deactivated, the plunger closes the drain port.

The No. 3 solenoid operates in reverse. When the solenoid is deactivated, the solenoid plunger is moved off its seat opening the drain port to release line pressure. When the solenoid is activated, the plunger closes the drain port.

PISTONS

DESCRIPTION

There are several sizes and types of pistons used in an automatic transmission. Some pistons are used to apply clutches, while others are used to apply bands. They all have in common the fact that they are round or circular in shape, located within a smooth walled cylinder, which is closed at one end and converts fluid pressure into mechanical movement. The fluid pressure exerted on the piston is contained within the system through the use of piston rings or seals.

DESCRIPTION AND OPERATION (Continued)

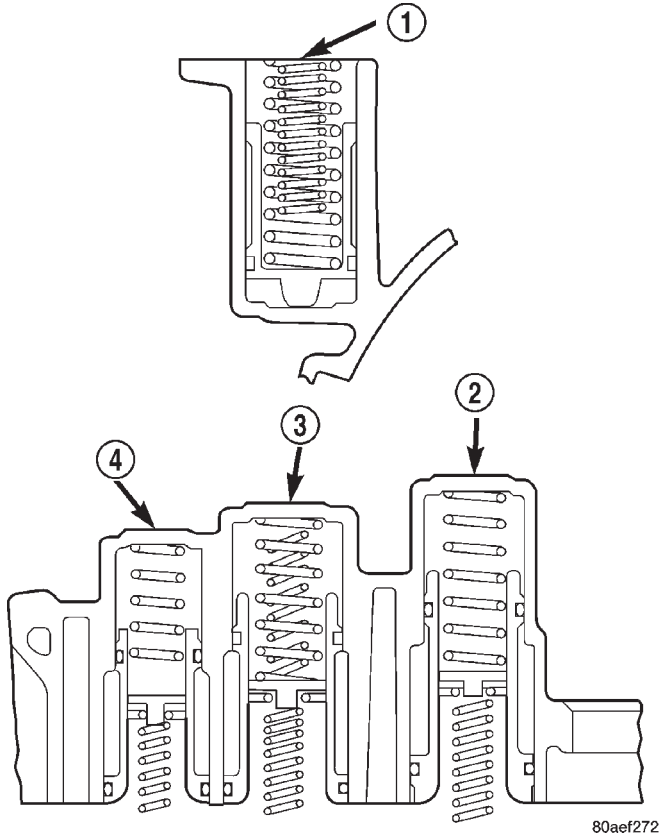

Fig. 29 Accumulators

- 1 - OVERDRIVE CLUTCH
- 2 - SECOND BRAKE
- 3 - DIRECT CLUTCH
- 4 - OVERDRIVE BRAKE

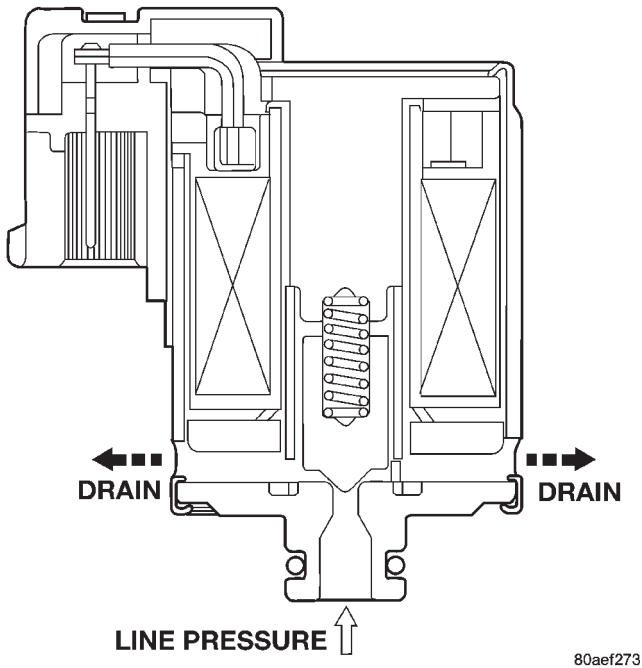

Fig. 30 Transmission Valve Body Solenoids

OPERATION

The principal which makes this operation possible is known as Pascal's Law. Pascal's Law can be stated as: "Pressure on a confined fluid is transmitted equally in all directions and acts with equal force on equal areas."

PRESSURE

Pressure (Fig. 31) is nothing more than force (lbs.) divided by area (in or ft.), or force per unit area. Given a 100 lb. block and an area of 100 sq. in. on the floor, the pressure exerted by the block is: 100 lbs. 100 in or 1 pound per square inch, or PSI as it is commonly referred to.

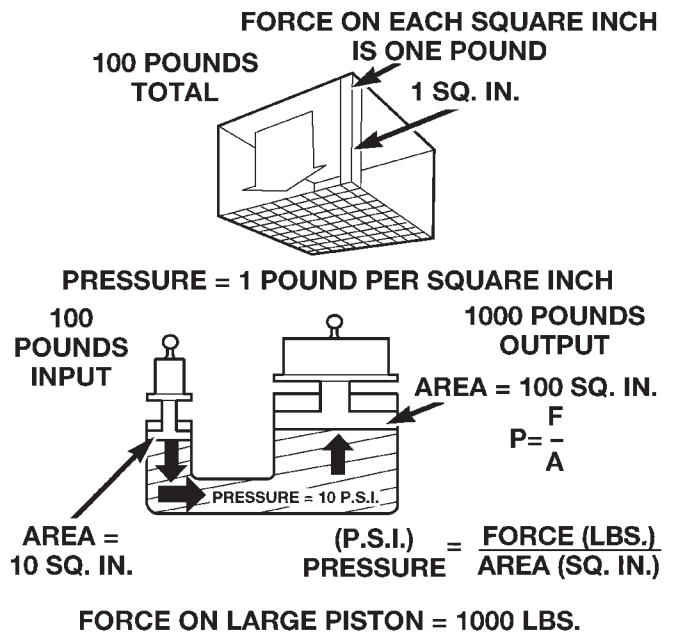

80bfe272

Fig. 31 Force and Pressure Relationship

PRESSURE ON A CONFINED FLUID

Pressure is exerted on a confined fluid (Fig. 32) by applying a force to some given area in contact with the fluid. A good example of this is a cylinder filled with fluid and equipped with a piston that is closely fitted to the cylinder wall. If a force is applied to the piston, pressure will be developed in the fluid. Of course, no pressure will be created if the fluid is not confined. It will simply "leak" past the piston. There must be a resistance to flow in order to create pressure. Piston sealing is extremely important in hydraulic operation. Several kinds of seals are used to accomplish this within a transmission. These include but are not limited to O-rings, D-rings, lip seals, sealing rings, or extremely close tolerances between the piston and the cylinder wall. The force exerted is downward (gravity), however, the principle remains the same no matter which direction is taken.

DESCRIPTION AND OPERATION (Continued)

The pressure created in the fluid is equal to the force applied, divided by the piston area. If the force is 100 lbs., and the piston area is 10 sq. in., then the pressure created equals 10 PSI. Another interpretation of Pascal's Law is that regardless of container shape or size, the pressure will be maintained throughout, as long as the fluid is confined. In other words, the pressure in the fluid is the same everywhere within the container.

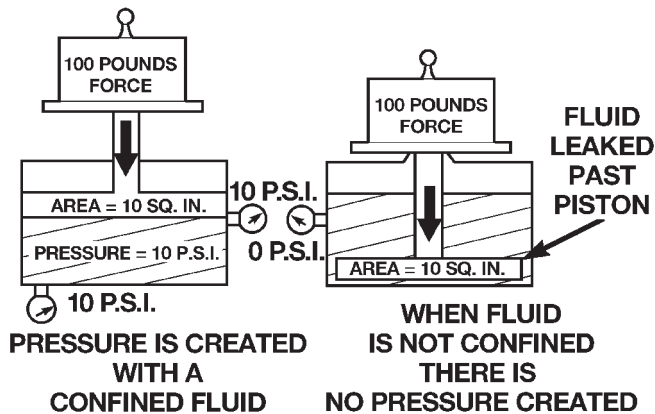

80bfe273

Fig. 32 Pressure on a Confined Fluid

FORCE MULTIPLICATION

Using the 10 PSI example used in the illustration (Fig. 33), a force of 1000 lbs. can be moved with a force of only 100 lbs. The secret of force multiplication in hydraulic systems is the total fluid contact area employed. The illustration, (Fig. 33), shows an area that is ten times larger than the original area. The pressure created with the smaller 100 lb. input is 10 PSI. The concept "pressure is the same everywhere" means that the pressure underneath the larger piston is also 10 PSI. Pressure is equal to the force applied divided by the contact area. Therefore, by means of simple algebra, the output force may be found. This concept is extremely important, as it is also used in the design and operation of all shift valves and limiting valves in the valve body, as well as the pistons, of the transmission, which activate the clutches and bands. It is nothing more than using a difference of area to create a difference in pressure to move an object.

PISTON TRAVEL

The relationship between hydraulic lever and a mechanical lever is the same. With a mechanical lever it's a weight-to-distance output rather than a pressure-to-area output. Using the same forces and areas as in the previous example, the smaller piston (Fig. 34) has to move ten times the distance required to move the larger piston one inch. Therefore, for every inch the larger piston moves, the smaller pis-

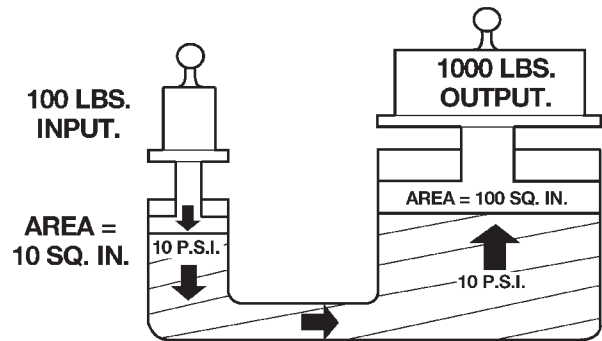

80bfe274

Fig. 33 Force Multiplication

ton moves ten inches. This principle is true in other instances also. A common garage floor jack is a good example. To raise a car weighing 2000 lbs., an effort of only 100 lbs. may be required. For every inch the car moves upward, the input piston at the jack handle must move 20 inches downward.

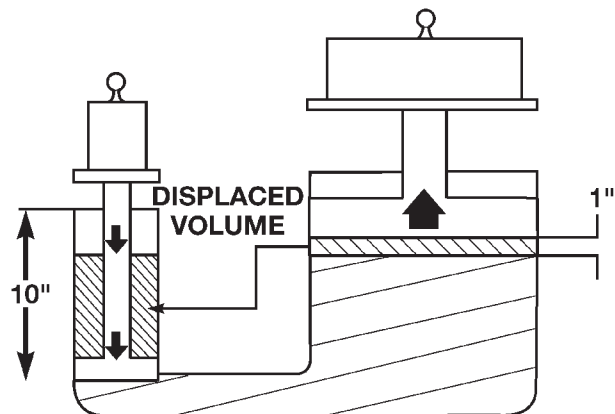

80bfe275

Fig. 34 Piston Travel

TRANSMISSION RANGES AND SHIFT LEVER POSITIONS

The AW-4 transmission has six ranges and shift lever positions. Park, Reverse and Neutral are conventional and mechanically operated. The 1-2, 3 and D ranges provide electronically controlled shifting.

The 1-2 position provides first and second gear only. The 3 position provides first, second and third gear.

DESCRIPTION AND OPERATION (Continued)

The D range provides first through fourth gear. Overdrive fourth gear range is available only when the shift lever is in D position (Fig. 35).

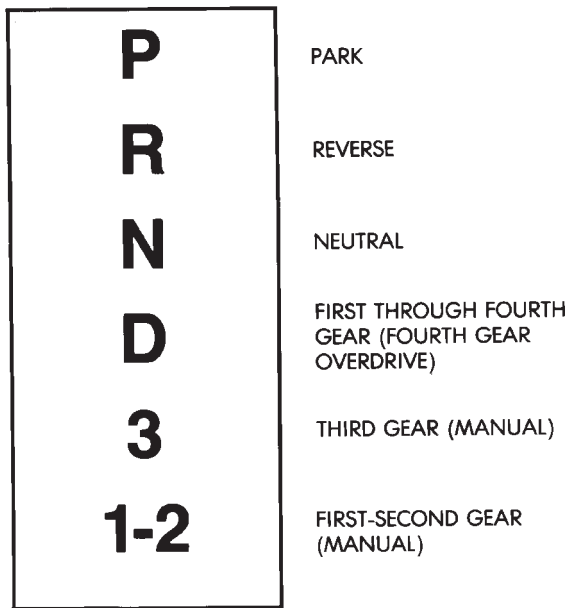

J8921-399

Fig. 35 AW-4 Shift Lever Positions And Transmission Ranges

TRANSMISSION CONTROL MODULE (TCM)

DESCRIPTION

The module determines shift and converter clutch engagement timing based on signals from sensors. The valve body solenoids are activated, or deactivated accordingly.

The TCM has a self diagnostic program. Component and circuitry malfunctions can be diagnosed with the DRB scan tool. Once a malfunction is noted and stored in control module memory, it is retained even after the problem has been corrected. To cancel a stored malfunction, disconnect and reconnect the "Trans." fuse in the module harness.

SENSORS

Sensors include:

- throttle position sensor (TPS)
- transmission speed sensor
- vehicle speed sensor
- park/neutral position switch
- brake switch

OPERATION

The throttle position sensor is mounted on the throttle body. It electronically determines throttle position and relays this information to the transmission control module to determine shift points and converter clutch engagement.

The transmission speed sensor consists of a rotor and magnet on the transmission output shaft and a switch in the extension housing or adapter. The sensor switch is activated each time the rotor and magnet complete one revolution. Sensor signals are sent to the transmission control module.

The park/neutral position switch is mounted on the valve body manual shaft. The switch signals shift linkage and manual valve position to the transmission control module through an interconnecting harness. The switch prevents engine starting in all gears other than Park or Neutral.

The brake switch is in circuit with the torque converter clutch solenoid. The switch disengages the converter clutch whenever the brakes are applied. The switch is mounted on the brake pedal bracket and signals the transmission control module when the pedal is pressed or released.

HYDRAULIC SYSTEM

DESCRIPTION

The hydraulic system consists of the pump, valve body and solenoids, and four hydraulic accumulators. The oil pump provides lubrication and operating pressure.

The valve body controls application of the clutches, brakes, second coast band, and the converter clutch. The valve body solenoids control sequencing of the 1-2, 2-3 and 3-4 shift valves. The solenoids are activated by signals from the transmission control module.

The accumulators are used in the clutch and brake feed circuits to control initial apply pressure. Spring loaded accumulator pistons modulate the initial surge of apply pressure for smooth engagement.

TRANSMISSION COOLER

DESCRIPTION

MAIN COOLER

The transmission main cooler is located in the radiator. The main cooler can be flushed when necessary, however, the cooler is not a repairable component. If the cooler is damaged, plugged, or leaking, the radiator will have to be replaced.

AUXILIARY COOLER

The auxiliary cooler is mounted in front of the radiator at the driver side of the vehicle (Fig. 36). The cooler can be flushed when necessary, while mounted in the vehicle. The cooler can also be removed for access, repair, or replacement as needed.

The main and auxiliary coolers should both be flushed whenever a transmission or converter clutch

DESCRIPTION AND OPERATION (Continued)

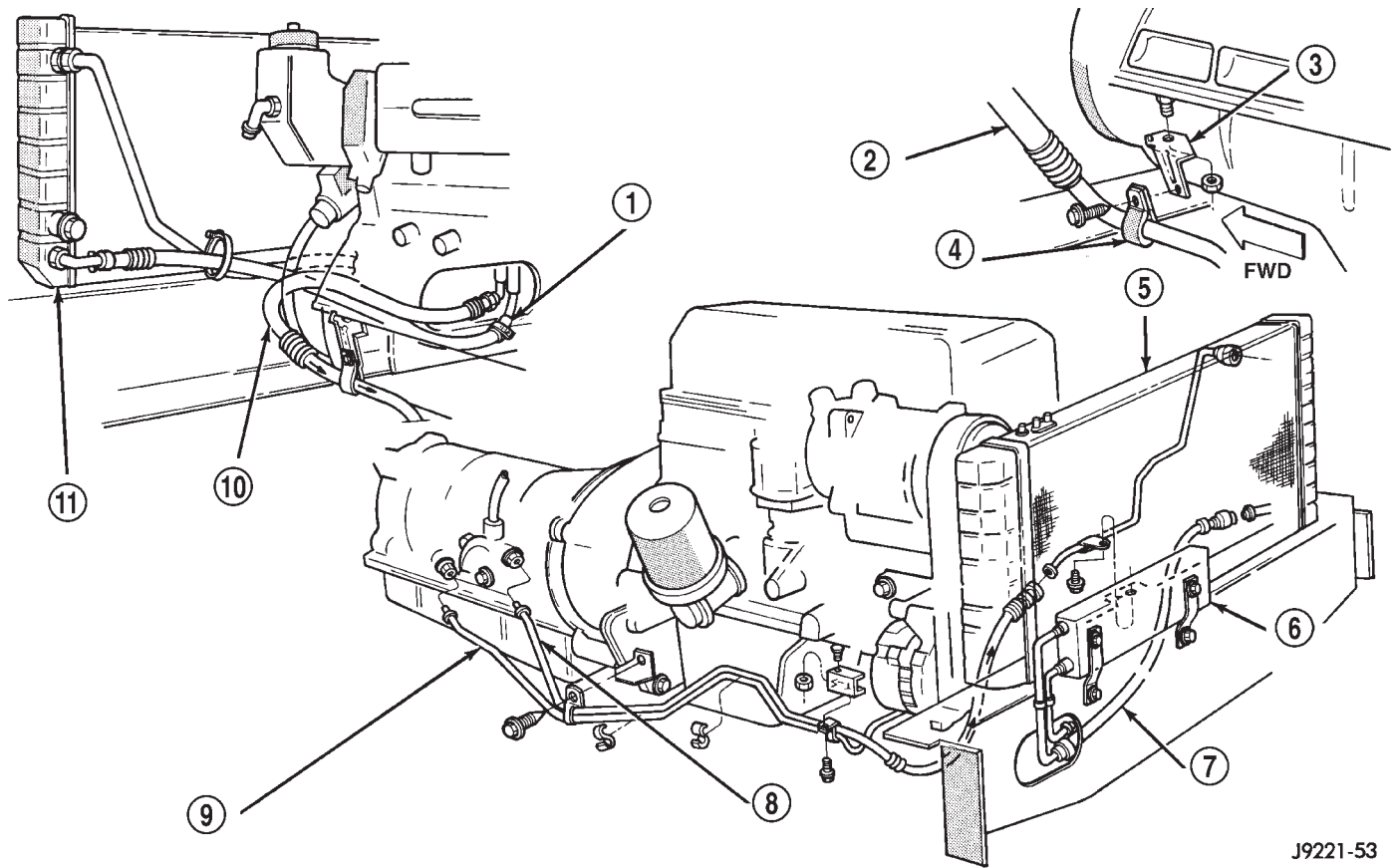

J9221-53

Fig. 36 Auxiliary Cooler Mounting (Left Hand Drive)

- | | |
|-------------------------|-------------------------------------|
| 1 - COOLER INLET LINE | 7 - COOLER RETURN LINE |
| 2 - COOLER RETURN LINE | 8 - OUTLET LINE (FROM TRANSMISSION) |
| 3 - COOLER LINE BRACKET | 9 - RETURN LINE (TO TRANSMISSION) |
| 4 - CLIP | 10 - COOLER RETURN LINE |
| 5 - RADIATOR | 11 - RADIATOR |
| 6 - AUXILIARY COOLER | |

malfunction generates sludge, debris, or particles of clutch friction material.

COOLER SERVICE

The main cooler (and radiator) and the auxiliary cooler can be removed for service or access to other components. Auxiliary cooler removal requires that the front bumper and radiator support be removed for access to the cooler lines and attaching bracket.

BRAKE TRANSMISSION SHIFT INTERLOCK MECHANISM**DESCRIPTION**

The Brake Transmission Shifter/Ignition Interlock (BTISI), is a cable and solenoid operated system. It interconnects the automatic transmission floor mounted shifter to the steering column ignition switch (Fig. 37).

OPERATION

The system locks the shifter into the PARK position. The Interlock system is engaged whenever the ignition switch is in the LOCK or ACCESSORY position. An additional electrically activated feature will prevent shifting out of the PARK position unless the brake pedal is depressed at least one-half an inch. A magnetic holding device in line with the park/brake interlock cable is energized when the ignition is in the RUN position. When the key is in the RUN position and the brake pedal is depressed, the shifter is unlocked and will move into any position. The interlock system also prevents the ignition switch from being turned to the LOCK or ACCESSORY position (Fig. 38) unless the shifter is fully locked into the PARK position.

DIAGNOSIS AND TESTING (Continued)

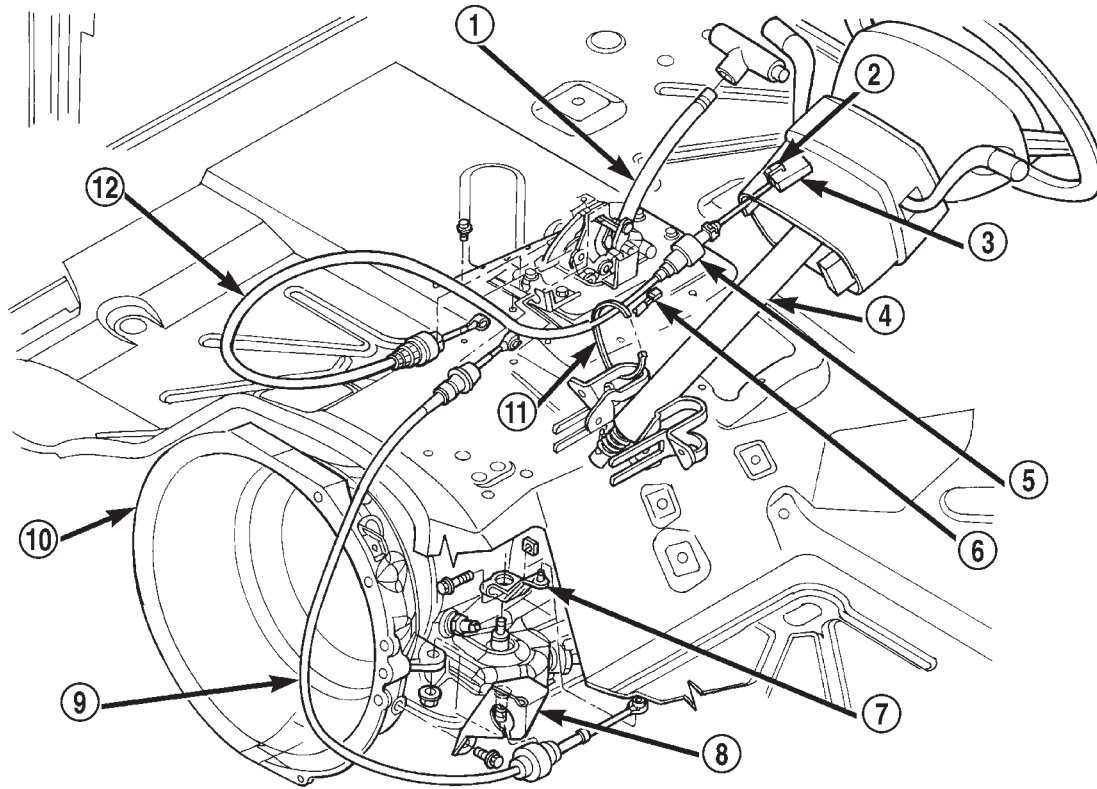

80a13876

Fig. 37 Ignition Interlock Cable Routing

- | | |
|-----------------------------|---------------------------------|
| 1 - SHIFT MECHANISM | 7 - LEVER |
| 2 - LOCK-TAB | 8 - MOUNT BRACKET |
| 3 - IGNITION LOCK INTERLOCK | 9 - SHIFT CABLE |
| 4 - STEERING COLUMN | 10 - AUTOMATIC TRANSMISSION |
| 5 - SOLENOID | 11 - TIE STRAP |
| 6 - WIRE CONNECTOR | 12 - PARK/BRAKE INTERLOCK CABLE |

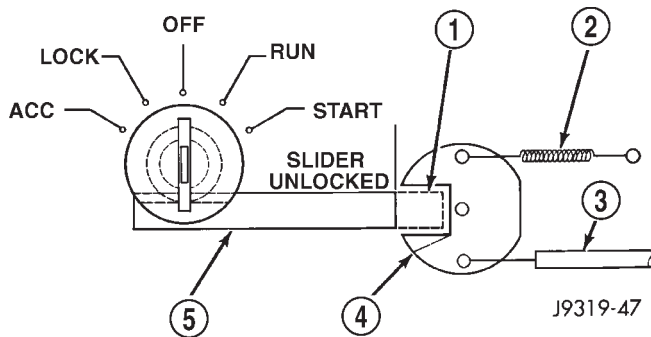

Fig. 38 Ignition Key Cylinder Actuation

- | |
|-----------------------|
| 1 - SLIDER LOCKED |
| 2 - CAM RETURN SPRING |
| 3 - INTERLOCK CABLE |
| 4 - CAM |
| 5 - SLIDER |

DIAGNOSIS AND TESTING

GENERAL DIAGNOSIS INFORMATION

Shift points are controlled by the transmission control module (TCM). Before attempting repair, determine if a malfunction is electrical or mechanical.

The TCM used with the AW-4 transmission has a self-diagnostic program compatible with the DRBIII scan tool. The tester will identify faults in the electrical control system.

Diagnosis should begin with the Preliminary Inspection And Adjustment procedure. It will help determine if a problem is mechanical or electrical. The first procedure step is Initial Inspection and Adjustment.

EFFECTS OF INCORRECT FLUID LEVEL

A low fluid level allows the pump to take in air along with the fluid. Air in the fluid will cause fluid pressures to be low and develop slower than normal.

DIAGNOSIS AND TESTING (Continued)

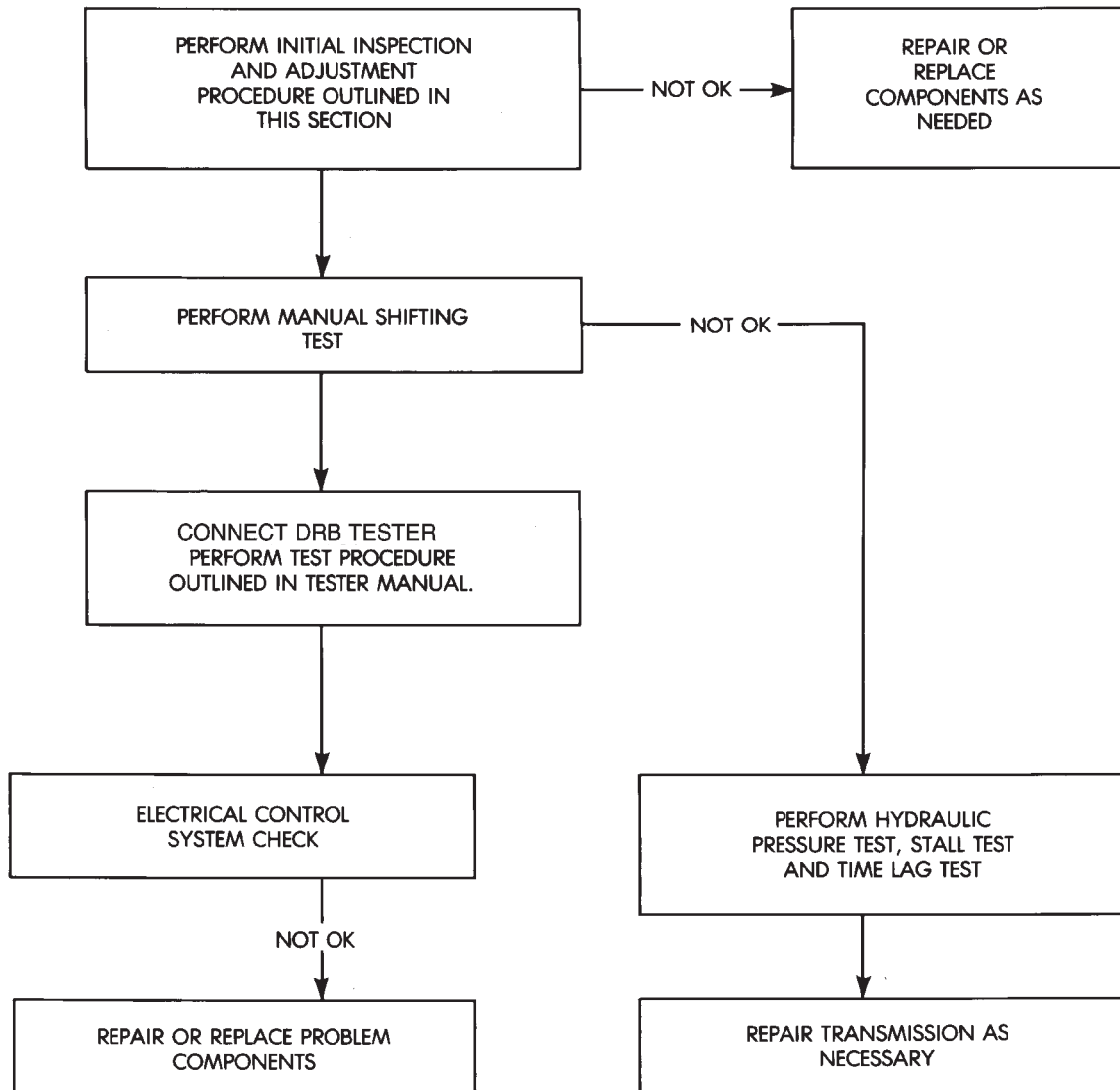

J8921-423

Preliminary Diagnosis Check Procedure

If the transmission is overfilled, the gears churn the fluid into foam. This aerates the fluid and causing the same conditions occurring with a low level. In either case, air bubbles cause fluid overheating, oxidation and varnish buildup which interferes with valve, clutch and servo operation. Foaming also causes fluid expansion which can result in fluid overflow from the transmission vent or fill tube. Fluid overflow can easily be mistaken for a leak if inspection is not careful.

CAUSES OF BURNT FLUID

Burnt, discolored fluid is a result of overheating which has two primary causes.

(1) A result of restricted fluid flow through the main and/or auxiliary cooler. This condition is usually the result of a faulty or improperly installed

drainback valve, a damaged main cooler, or severe restrictions in the coolers and lines caused by debris or kinked lines.

(2) Heavy duty operation with a vehicle not properly equipped for this type of operation. Trailer towing or similar high load operation will overheat the transmission fluid if the vehicle is improperly equipped. Such vehicles should have an auxiliary transmission fluid cooler, a heavy duty cooling system, and the engine/axle ratio combination needed to handle heavy loads.

FLUID CONTAMINATION

Transmission fluid contamination is generally a result of:

- adding incorrect fluid

DIAGNOSIS AND TESTING (Continued)

- failure to clean dipstick and fill tube when checking level
- engine coolant entering the fluid
- internal failure that generates debris
- overheat that generates sludge (fluid breakdown)
- failure to reverse flush cooler and lines after repair
- failure to replace contaminated converter after repair

The use of non recommended fluids can result in transmission failure. The usual results are erratic shifts, slippage, abnormal wear and eventual failure due to fluid breakdown and sludge formation. Avoid this condition by using recommended fluids only.

The dipstick cap and fill tube should be wiped clean before checking fluid level. Dirt, grease and other foreign material on the cap and tube could fall into the tube if not removed beforehand. Take the time to wipe the cap and tube clean before withdrawing the dipstick.

Engine coolant in the transmission fluid is generally caused by a cooler malfunction. The only remedy is to replace the radiator as the cooler in the radiator is not a serviceable part. If coolant has circulated through the transmission for some time, an overhaul may also be necessary; especially if shift problems had developed.

The transmission cooler and lines should be reverse flushed whenever a malfunction generates sludge and/or debris. The torque converter should also be replaced at the same time.

Failure to flush the cooler and lines will result in recontamination. Flushing applies to auxiliary coolers as well. The torque converter should also be replaced whenever a failure generates sludge and debris. This is necessary because normal converter flushing procedures will not remove all contaminants.

PRELIMINARY INSPECTION AND ADJUSTMENT

- (1) Check and adjust transmission shift cable if necessary.
- (2) Verify transmission throttle cable operation. Repair or replace cable if necessary.
- (3) Check engine throttle operation. Operate accelerator pedal and observe injector throttle plate movement. Adjust linkage if throttle plate does not reach wide open position.
- (4) Check transmission fluid level when fluid is at normal operating temperature. Start engine. Shift transmission through all gear ranges then back to Neutral. Correct level is to Full or Add mark on dipstick with engine at curb idle speed.
- (5) Check and adjust park/neutral position switch if necessary.

- (6) Check throttle position sensor adjustment and operation. Adjust the sensor if necessary.

MANUAL SHIFTING TEST

- (1) This test determines if problem is related to mechanical or electrical component.
- (2) Stop engine and disconnect transmission control module or module fuse.
- (3) Road test vehicle. Shift transmission into each gear range. Transmission should operate as follows:
 - lock in Park
 - back up in Reverse
 - not move in Neutral
 - provide first gear only with shift lever in 1-2 position
 - operate in third gear only with shift lever in 3 position
 - operate in overdrive fourth gear in D position
- (4) If transmission operates as described, proceed to next step. However, if forward gear ranges were difficult to distinguish (all feel the same), or vehicle would not back up, refer to diagnosis charts. Do not perform stall or time lag tests.

CAUTION: Do not over speed the engine during the next test step. Ease off the throttle and allow the vehicle to slow before downshifting.

- (5) Continue road test. Manually downshift transmission from D to 3, and from 3 to 1-2 position. Then manually upshift transmission through forward ranges again.

(6) If transmission operation is OK, perform stall, time lag and pressure tests. If transmission shifting problem is encountered, refer to diagnosis charts.

- (7) If a problem still exists, continue testing with DRB scan tool.

HYDRAULIC PRESSURE TEST**Pressure Test Procedure**

- (1) Connect pressure test gauge to test port on passenger side of transmission (Fig. 39). Use Adapter 7554 to connect gauge. Be sure test gauge has minimum capacity of 300 psi (2100 kPa).
- (2) Be sure transmission fluid is at normal operating temperature.
- (3) Apply parking brakes and block wheels.

WARNING: DO NOT ALLOW ANYONE TO STAND AT THE FRONT OR REAR OF THE VEHICLE WHILE PERFORMING THE FOLLOWING STEPS IN THE PRESSURE TEST.

- (4) Check and adjust engine curb idle speed.
- (5) Apply (and hold) service brakes.

DIAGNOSIS AND TESTING (Continued)

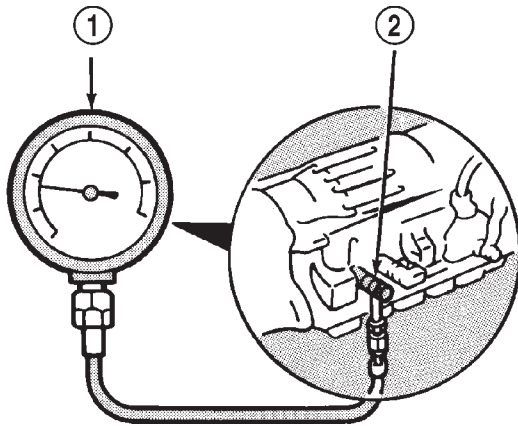

J8921-424

Fig. 39 Pressure Test Gauge Connection

- 1 - PRESSURE GAUGE
2 - TEST PORT

(6) Shift transmission into D range and note line pressure with engine at curb idle speed. Pressure should be 61-to-70 psi (421-to-481 kPa).

(7) Press accelerator pedal to wide open throttle position and note line pressure. Pressure should be 173-to-209 psi (1196-to-1442 kPa).

CAUTION: Do not hold wide open throttle for more than 3-4 seconds at a time.

(8) Shift transmission into Reverse and note line pressure with engine at curb idle speed. Pressure should be 75-to-90 psi (519-to-618 kPa).

(9) Press accelerator to wide open throttle position and note line pressure in Reverse. Pressure should be 213-to-263 psi (1471-to-1814 kPa).

CAUTION: Do not hold wide open throttle for more than 4 seconds.

(10) If line pressure is not within specifications, adjust transmission throttle cable and repeat pressure test.

PRESSURE TEST ANALYSIS

If pressures in D and Reverse are higher than specified in test, check for the following:

- throttle cable loose, worn, binding or out of adjustment
- throttle valve, downshift plug, throttle cam, or primary regulator valve are sticking, worn or damaged

If pressures in D and Reverse are lower than specified in test, check for following:

- throttle cable loose, worn, binding or out of adjustment
- throttle valve, downshift plug, or throttle cam sticking, worn or damaged
- primary regulator valve sticking, worn, or damaged
- oil pump gears or housing worn, or damaged
- overdrive clutch worn, or damaged

If pressures are low in D range only, check for following:

- forward clutch worn or damaged
- fluid leakage in D range circuit (component seal and O-rings)

If pressures are low in Reverse only, check for following:

- shift cable and manual valve out of adjustment
- fluid leakage in reverse circuit (component seal and O-rings)
- direct clutch worn or damaged
- first/reverse brake worn or damaged

TIME LAG TEST

This test checks general condition of the overdrive clutch, forward clutch, rear clutch and first/reverse brake. Condition is indicated by the amount of time required for clutch/brake engagement with the engine at curb idle speed. Engagement time is measured for D and Reverse positions. A stop watch is recommended for test accuracy.

TEST PROCEDURE

(1) Check and adjust transmission fluid level if necessary.

(2) Bring transmission to normal operating temperature.

(3) Apply parking brakes and turn off air conditioning unit.

(4) Shift transfer case into 2H range.

(5) Start engine and check curb idle speed. Adjust speed if necessary. Curb idle must be correct to ensure accurate test results.

(6) Shift transmission into Neutral and set stop watch.

(7) During following test steps, start stop watch as soon as shift lever reaches D and Reverse ranges.

(8) Shift transmission into D range and record time it takes for engagement. Repeat test two more times.

(9) Reset stop watch and shift transmission back to Neutral.

(10) Shift transmission into Reverse and record time it takes for engagement. Repeat test two more times.

DIAGNOSIS AND TESTING (Continued)

(11) Engagement time in D range should be a maximum of 1.2 seconds. Engagement time for Reverse should be a maximum of 1.5 seconds.

TIME LAG TEST ANALYSIS

If engagement time is longer than specified for D range, check for the following:

- shift cable misadjusted
- line pressure low

- forward clutch worn
 - overdrive clutch worn or damaged
- If engagement time is longer than specified for Reverse, check for the following:
- shift cable misadjusted
 - line pressure low
 - direct clutch worn
 - first/reverse brake worn
 - overdrive clutch worn or damaged

SERVICE DIAGNOSIS

DIAGNOSIS TABLE

| CONDITION | POSSIBLE CAUSE | CORRECTION |
|--|--|-------------------------------------|
| VEHICLE WILL NOT BACK UP OR MOVE FORWARD | Shift cable out of adjustment or damaged | Adjust cable or replace cable |
| | Valve body or primary regulator faulty | Inspect/repair valve body |
| | Park lock pawl faulty | Repair park pawl |
| | Torque converter faulty | Replace torque converter |
| | Converter drive plate broken | Replace drive plate |
| | Oil pump intake screen blocked | Clean screen |
| | Transmission faulty | Disassemble and repair transmission |
| SHIFT LEVER POSITION INCORRECT | Shift cable out of adjustment | Adjust cable |
| | Manual valve and lever faulty | Repair valve body |
| HARSH ENGAGEMENT | Throttle cable out of adjustment | Adjust throttle cable |
| | Valve body or primary regulator faulty | Repair valve body |
| | Accumulator pistons faulty | Repair pistons |
| | Transmission faulty | Disassemble and repair transmission |
| DELAYED 1-2, 2-3 OR 3-4 UP-SHIFT, OR DOWN-SHIFTS FROM 4-3 OR 3-2 AND SHIFTS BACK TO 4 OR 3 | Electronic control problem | Locate problem with DRB Tester |
| | Valve body faulty | Repair valve body |
| | Solenoid faulty | Repair solenoid |
| SLIPS ON 1-2, 2-3 OR 3-4 UP-SHIFT, OR SLIPS OR SHUDDERS DURING ACCELERATION | Shift cable out of adjustment | Adjust cable |
| | Throttle cable out of adjustment | Adjust cable |
| | Valve body faulty | Repair valve body |
| | Solenoid faulty | Replace solenoid |
| | Transmission faulty | Disassemble and repair transmission |

DIAGNOSIS AND TESTING (Continued)

| CONDITION | POSSIBLE CAUSE | CORRECTION |
|--|---|---|
| DRAG OR BIND ON 1-2, 2-3 OR 3-4 UP-SHIFT | Shift cable out of adjustment Valve body faulty Transmission faulty | Adjust cable Repair valve body Disassemble and repair transmission |
| CONVERTER CLUTCH DOES NOT ENGAGE IN 2ND, 3RD OR 4TH | Electronic control problem Valve body faulty Solenoid faulty Transmission faulty | Check with DRB Tester Repair valve body Replace solenoid Disassemble and repair transmission |
| HARSH DOWN-SHIFT | Throttle cable out of adjustment Throttle cable and cam faulty Accumulator pistons faulty Valve body faulty Transmission faulty | Adjust cable Replace cable and cam Repair pistons Repair valve body Disassemble and repair transmission |
| NO DOWN-SHIFT WHEN COASTING | Valve body faulty Solenoid faulty Electronic control problem | Repair valve body Replace solenoid Locate problem with DRB Tester |
| DOWN-SHIFT LATE OR EARLY DURING COAST | Throttle cable faulty Valve body faulty Transmission faulty | Replace cable Repair valve body Disassembly and repair transmission |
| NO 4-3, 3-2 OR 2-1 KICKDOWN | Solenoid faulty Electronic control problem Solenoid faulty Electronic control problem Valve body faulty | Replace solenoid Locate problem with DRB Tester Replace solenoid Locate problem with DRB Tester Repair valve body |
| NO ENGINE BRAKING IN 1-2 POSITION | Solenoid faulty Electronic control problem Valve body faulty Transmission faulty | Replace solenoid Locate problem with DRB Tester Repair valve body Disassemble and repair transmission |
| VEHICLE DOES NOT HOLD IN PARK | Shift cable out of adjustment Parking lock pawl cam and spring faulty | Adjust cable Replace cam and spring |
| OVERHEAT DURING NORMAL OPERATION (FLUID DISCOLORED, SMELLS BURNED) | Low fluid level Fluid cooler, lines blocked, or cooler cracked (oil in engine coolant) | Add fluid and check for leaks Flush cooler and lines and replace radiator if transmission fluid has entered coolant |

DIAGNOSIS AND TESTING (Continued)

| CONDITION | POSSIBLE CAUSE | CORRECTION |
|---|--|--|
| OVERHEAT DURING COMMERCIAL OPERATION OR WHILE TRAILER TOWING (FLUID DARK AND BURNED WITH SOME SLUDGE FORMATION) | Vehicle not properly equipped for trailer towing or commercial use | Be sure vehicle is equipped with recommended optional components (i.e. HD springs, transmission, axle, larger CID engine, auxiliary cooler, correct axle ratio, etc.). If vehicle is not so equipped, it should not be used for severe service operation |
| | Vehicle not equipped with auxiliary fluid cooler | Drain fluid, change filter, and install auxiliary cooler |
| | Extensive idling time or operation in heavy traffic in hot weather | Cut down on idling time; shift into neutral every so often and run engine at 1000 rpm to help circulate fluid through cooler |
| | Tow vehicle overloaded (exceeding vehicle tow capacity) | Be sure vehicle is properly equipped to handle load; do not tow Class III-type loads with a vehicle that is only rated for Class I or II operation |
| | Air flow to auxiliary cooler blocked by snow plow, front mounted spare tire, bug screen, or similar item | Remove or reposition item causing air flow blockage |
| OIL COMES OUT FILLER TUBE | Transmission overfilled | Drain fluid to correct level; remove neutral switch and drain through switch hole with suction gun |
| | Breather vent in oil pump blocked Fluid cooler or cooler lines plugged | Inspect and clear blockage Flush cooler and lines |

TRANSMISSION SOLENOID TESTING

Test solenoid resistance with an ohmmeter. Connect the ohmmeter leads to the solenoid mounting bracket and to the solenoid wire terminal (Fig. 40).

Solenoid resistance should be 11–15 ohms. Replace the solenoid if resistance is above or below the specified range.

PARK/NEUTRAL POSITION SWITCH

SWITCH TESTING

Test switch continuity with an ohmmeter. Disconnect the switch and check continuity at the connector terminal positions and in the gear ranges indicated in Figure 3. Switch continuity should be as follows:

- Continuity should exist between terminals B and C with the transmission in Park and Neutral only (Fig. 41).
- Continuity should exist between terminals A and E with the transmission in Reverse (Fig. 41).
- Continuity should exist between terminals A and G with the transmission in third gear (Fig. 41).
- Continuity should exist between terminals A and H with the transmission in first and/or second gear (Fig. 41).

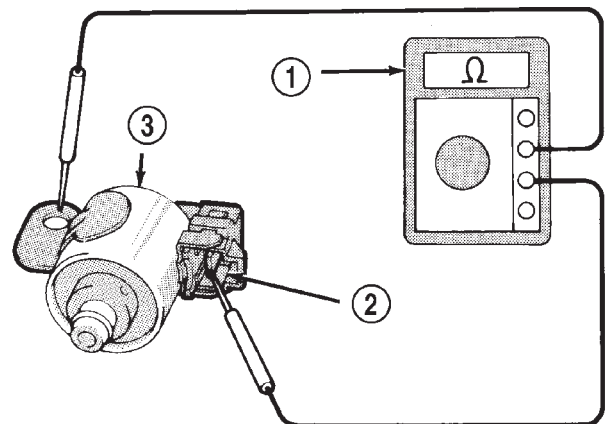

J8921-435

Fig. 40 Testing Transmission Valve Body Solenoid

- 1 - OHMMETER
- 2 - WIRE TERMINAL
- 3 - SOLENOID

- Continuity should not exist in D position.

DIAGNOSIS AND TESTING (Continued)

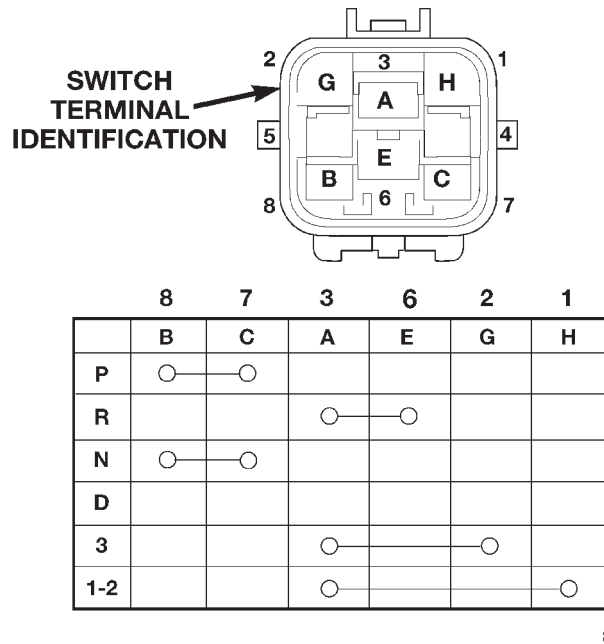

80c070ae

Fig. 41 Park/Neutral Position Switch Terminals And Testing

GEARSHIFT CABLE

(1) The floor shifter lever and gate positions should be in alignment with all transmission PARK, NEUTRAL, and gear detent positions.

(2) Engine starts must be possible with floor shift lever in PARK or NEUTRAL gate positions only. Engine starts must not be possible in any other gear position.

(3) With floor shift lever handle push-button not depressed and lever in:

(a) PARK position—Apply forward force on center of handle and remove pressure. Engine starts must be possible.

(b) PARK position—Apply rearward force on center of handle and remove pressure. Engine starts must be possible.

(c) NEUTRAL position—Normal position. Engine starts must be possible.

(d) NEUTRAL position—Engine running and brakes applied, apply forward force on center of shift handle. Transmission shall not be able to shift from neutral to reverse.

THROTTLE VALVE CABLE

Transmission throttle valve cable adjustment is extremely important to proper operation. This adjustment positions the throttle valve, which controls shift speed, quality, and part-throttle downshift sensitivity.

If cable setting is too loose, early shifts and slippage between shifts may occur. If the setting is too tight, shifts may be delayed and part throttle down-

shifts may be very sensitive. Refer to the Adjustments section for the proper adjustment procedure.

SPEED SENSOR TESTING

Test the speed sensor with an ohmmeter. Place the ohmmeter leads on the terminals in the sensor connector (Fig. 42).

Rotate the transmission output shaft and observe the ohmmeter needle. The needle should deflect indicating the switch is opening/closing as the rotor moves past the sensor (Fig. 42). Replace the sensor if the ohmmeter does not display any kind of reading.

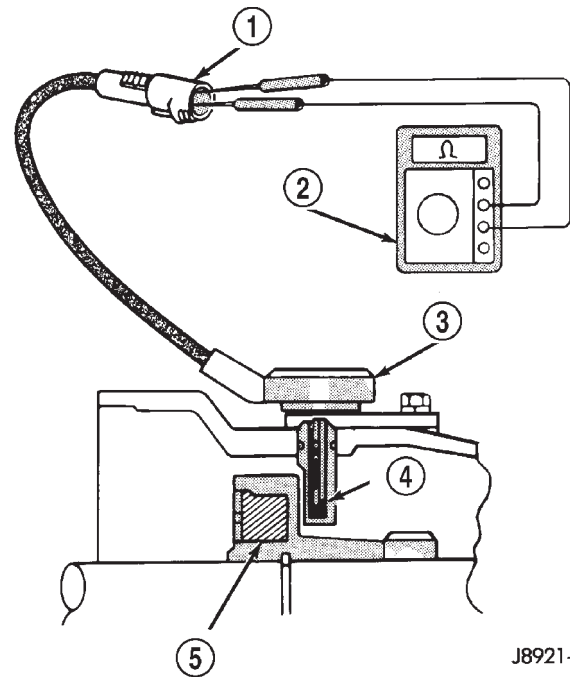

J8921-462

Fig. 42 Speed Sensor Testing

- 1 - CONNECTOR
- 2 - OHMMETER
- 3 - SENSOR
- 4 - SENSOR SWITCH
- 5 - ROTOR

If a digital ohmmeter is being used, the sensor should generate an ohmmeter readout each time the switch opens and closes.

FLOW TESTING TRANSMISSION MAIN COOLER

Cooler flow is checked by measuring the amount of fluid flow through the cooler in a 20 second time period. The test is performed with the engine running and transmission in neutral. Fluid is then pumped through the cooler by the transmission oil pump.

(1) Disconnect cooler inlet line at transmission fitting.

DIAGNOSIS AND TESTING (Continued)

- (2) Securely attach hose to end of inlet line and position line in a one quart test container.
- (3) Add extra quart of fluid to transmission.
- (4) Use stopwatch to check flow test time.
- (5) Shift transmission into neutral and set parking brake.
- (6) Start and run engine at curb idle speed and immediately note cooler flow. Approximately one quart of fluid should flow into test container in 20 second period.
- (7) If cooler flow is intermittent, flows less than one quart in 20 seconds, or does not flow at all, cooler is faulty and must be replaced.

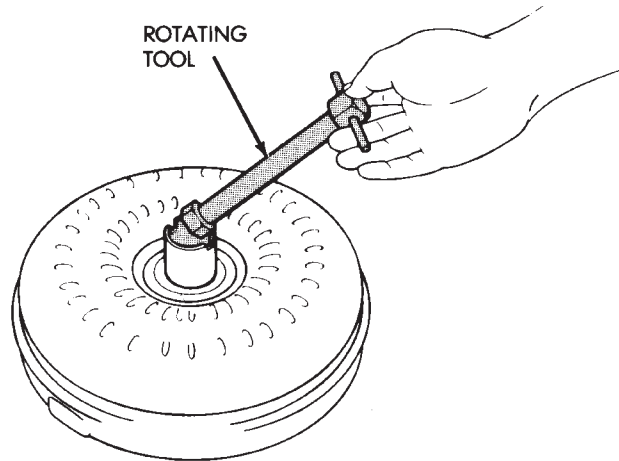

TORQUE CONVERTER STATOR CLUTCH INSPECTION

- (1) Insert Rotating Tool 7547 into converter hub and seat tool in one-way clutch (Fig. 43).
- (2) Insert Stopper Tool 7548 in one converter hub notch and into outer race of rotating tool.
- (3) Turn rotating tool clockwise. Converter clutch should rotate freely and smoothly. Less than 2.5 N-m (22 in. lbs.) of torque should be required to rotate clutch in clockwise direction.
- (4) Turn rotating tool in counterclockwise direction. Converter clutch should lock.
- (5) Replace converter if clutch binds or will not lock.

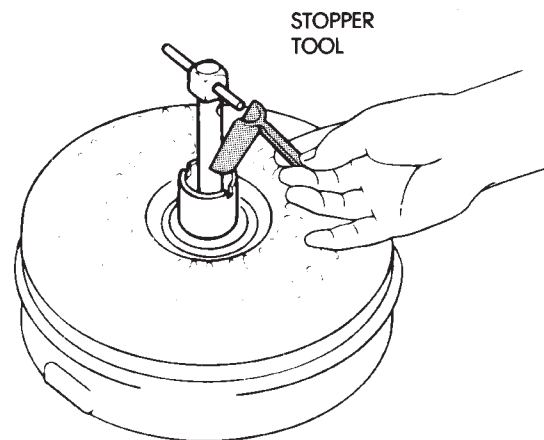

SERVICE PROCEDURES

CHECKING FLUID LEVEL

- (1) Be sure transmission fluid is at normal operating temperature. Normal operating temperature is reached after approximately 15 miles (25 km) of operation.
- (2) Position vehicle on level surface. This is important for an accurate fluid level check.
- (3) Shift transmission through all gear ranges and back to Park.
- (4) Apply parking brakes.
- (5) Verify that transmission is in Park.
- (6) Wipe off dipstick handle to prevent dirt from entering fill tube. Then remove dipstick and check fluid level and condition.
- (7) Correct fluid level is **to FULL mark on dipstick when fluid is at normal operating temperature** (Fig. 44).
- (8) If fluid level is low, top off level with Mopar Dexron IIE/Mercon. Mopar Dexron II can be used but only if Mercon is not available. **Do not overfill transmission. Add only enough fluid to bring level to Full mark.**
- (9) If too much fluid was added, excess amount can be removed with suction gun and appropriate diame-

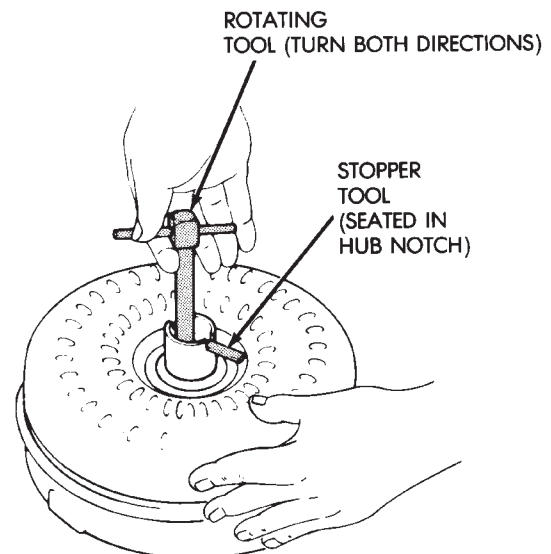

J8921-470

Fig. 43 Checking Operation Of Torque Converter Stator One-Way Clutch

SERVICE PROCEDURES (Continued)

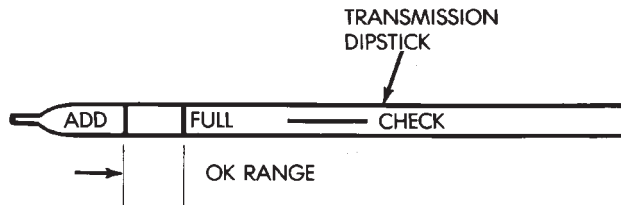

J8921-427

Fig. 44 Transmission Fluid Level

ter plastic tubing. Tubing only has to be long enough to extend into oil pan.

CHECKING FLUID CONDITION

Inspect the appearance of the fluid during the fluid level check. Fluid color should range from dark red to pink and be free of foreign material, or particles. If the fluid is dark brown or black in color and smells burnt, the fluid has been overheated and must be changed.

Transmission operation should also be checked if the fluid is severely discolored and contains quantities of foreign material, metal particles, or clutch disc friction material.

A small quantity of friction material or metal particles in the oil pan is normal. The particles are usually generated during the break-in period and indicate normal seating of the various transmission components.

REFILLING AFTER OVERHAUL OR FLUID/FILTER CHANGE

The best way to refill the transmission after a fluid change or overhaul is as follows:

- (1) If transmission has been overhauled, install transmission in vehicle.
- (2) Remove dipstick and insert clean funnel in transmission fill tube.
- (3) Add following initial quantity of Mopar Dexron IIE/Mercon to transmission:
 - (4) If fluid/filter change was performed, add **4 pints (2 quarts)** of fluid to transmission.
 - (a) If transmission was completely overhauled and torque converter was replaced or drained, add **10 pints (5 quarts)** of fluid to transmission.
 - (b) Remove funnel and install dipstick.
- (5) Operate vehicle until fluid reaches normal operating temperature.
- (6) Apply parking brakes.
- (7) Let engine run at normal curb idle speed, apply service brakes. Then shift transmission through all gear ranges and back to PARK (leave engine running).
- (8) Remove dipstick and check fluid level. Add only enough fluid to bring level to Full mark on dipstick.

Do not overfill. **If too much fluid is added, excess amount can be removed with suction gun and plastic tubing. Tubing only has to be long enough to extend into oil pan.**

(9) When fluid level is correct, shut engine off, release park brake, remove funnel, and reseal dipstick in fill tube.

TRANSMISSION CONTROL MODULE (TCM) SERVICE

Use the DRB scan tool to diagnose transmission control module function whenever a fault is suspected. Replace the module only when the scan tool indicates the module is actually faulty.

OIL PUMP VOLUME CHECK

Measuring the oil pump output volume will determine if sufficient oil flow to the transmission oil cooler exists, and whether or not an internal transmission failure is present.

Verify that the transmission fluid is at the proper level. Refer to the Fluid Level Check procedure in this section. If necessary, fill the transmission to the proper level with Mopar® ATF+3, type 7176, Automatic Transmission Fluid.

(1) Disconnect the **To cooler** line at the cooler inlet and place a collecting container under the disconnected line.

CAUTION: With the fluid set at the proper level, fluid collection should not exceed (1) quart or internal damage to the transmission may occur.

(2) Run the engine **at curb idle speed**, with the shift selector in neutral.

(3) If one quart of transmission fluid is collected in the container in 20 seconds or less, oil pump flow volume is within acceptable limits. If fluid flow is intermittent, or it takes more than 20 seconds to collect one quart of fluid, refer to the Hydraulic Pressure tests in this section for further diagnosis.

(4) Re-connect the **To cooler** line to the transmission cooler inlet.

(5) Refill the transmission to proper level.

FLUSHING COOLERS AND TUBES

When a transmission failure has contaminated the fluid, the oil cooler(s) must be flushed. The torque converter must also be replaced. This will insure that metal particles or sludged oil are not later transferred back into the reconditioned (or replaced) transmission.

The only recommended procedure for flushing coolers and lines is to use Tool 6906A Cooler Flusher.

SERVICE PROCEDURES (Continued)

CAUTION: The transmission oil cooler requires a two stage flushing procedure due to an internally mounted thermostat. Failure to follow the procedure can result in severe transmission damage.

WARNING: WEAR PROTECTIVE EYEWEAR THAT MEETS THE REQUIREMENTS OF OSHA AND ANSI Z87.1-1968. WEAR STANDARD INDUSTRIAL RUBBER GLOVES.

KEEP LIGHTED CIGARETTES, SPARKS, FLAMES, AND OTHER IGNITION SOURCES AWAY FROM THE AREA TO PREVENT THE IGNITION OF COMBUSTIBLE LIQUIDS AND GASES. KEEP A CLASS (B) FIRE EXTINGUISHER IN THE AREA WHERE THE FLUSHER WILL BE USED.

KEEP THE AREA WELL VENTILATED.

DO NOT LET FLUSHING SOLVENT COME IN CONTACT WITH YOUR EYES OR SKIN: IF EYE CONTAMINATION OCCURS, FLUSH EYES WITH WATER FOR 15 TO 20 SECONDS. REMOVE CONTAMINATED CLOTHING AND WASH AFFECTED SKIN WITH SOAP AND WATER. SEEK MEDICAL ATTENTION.

COOLER FLUSH USING TOOL 6906A

(1) Remove cover plate filler plug on Tool 6906A. Fill reservoir 1/2 to 3/4 full of fresh flushing solution. Flushing solvents are petroleum based solutions generally used to clean automatic transmission components. **DO NOT** use solvents containing acids, water, gasoline, or any other corrosive liquids.

(2) Reinstall filler plug on Tool 6906A.

(3) Verify pump power switch is turned OFF. Connect red alligator clip to positive (+) battery post. Connect black (-) alligator clip to a good ground.

(4) Disconnect the cooler lines at the transmission.

NOTE: When flushing transmission cooler and lines, **ALWAYS** reverse flush.

NOTE: The converter drainback valve must be removed and an appropriate replacement hose installed to bridge the space between the transmission cooler line and the cooler fitting. Failure to remove the drainback valve will prevent reverse flushing the system. A suitable replacement hose can be found in the adapter kit supplied with the flushing tool.

(5) Connect the BLUE pressure line to the OUTLET (From) cooler line.

(6) Connect the CLEAR return line to the INLET (To) cooler line

(7) Remove the transmission oil cooler from the vehicle. Refer to the Group 7, Cooling System, for the proper procedures.

(8) Remove the transmission oil cooler thermostat. Refer to the Group 7, Cooling System, for the proper procedures.

(9) Re-install the thermostat cover onto the oil cooler and install the snap ring.

(10) Re-connect the oil cooler to the transmission cooler lines.

(11) Turn pump ON for two to three minutes to flush cooler(s) and lines.

NOTE: This flushes the bypass circuit of the cooler only.

(12) Turn pump OFF.

(13) Remove the thermostat cover from the oil cooler.

(14) Install Special Tool Cooler Plug 8414 into the transmission oil cooler.

(15) Turn pump ON for two to three minutes to flush cooler(s) and lines.

NOTE: This flushes the main oil cooler core passages only.

(16) Turn pump OFF.

(17) Remove the thermostat cover from the oil cooler.

(18) Remove Special Tool Cooler Plug 8414 from the transmission oil cooler.

(19) Install a new thermostat spring, thermostat, cover, and snap-ring into the transmission oil cooler.

(20) Install the transmission oil cooler onto the vehicle.

(21) Disconnect CLEAR suction line from reservoir at cover plate. Disconnect CLEAR return line at cover plate, and place it in a drain pan.

(22) Turn pump ON for 30 seconds to purge flushing solution from cooler and lines. Turn pump OFF.

(23) Place CLEAR suction line into a one quart container of Mopar® ATF Plus 3, type 7176 automatic transmission fluid.

(24) Turn pump ON until all transmission fluid is removed from the one quart container and lines. This purges any residual cleaning solvent from the transmission cooler and lines. Turn pump OFF.

(25) Disconnect alligator clips from battery. Reconnect flusher lines to cover plate, and remove flushing adapters from cooler lines.

ALUMINUM THREAD REPAIR

Damaged or worn threads in the aluminum transmission case and valve body can be repaired by the use of Heli-Coils, or equivalent. This repair consists of drilling out the worn-out damaged threads. Then tap the hole with a special Heli-Coil tap, or equivalent, and installing a Heli-Coil insert, or equivalent,

SERVICE PROCEDURES (Continued)

into the hole. This brings the hole back to its original thread size.

Heli-Coil, or equivalent, tools and inserts are readily available from most automotive parts suppliers.

REMOVAL AND INSTALLATION

TRANSMISSION AND TORQUE CONVERTER

REMOVAL

- (1) Raise vehicle.
- (2) Drain transmission fluid and reinstall oil pan drain plug.
- (3) On models with 2-piece fill tube, remove upper half of tube (Fig. 45).

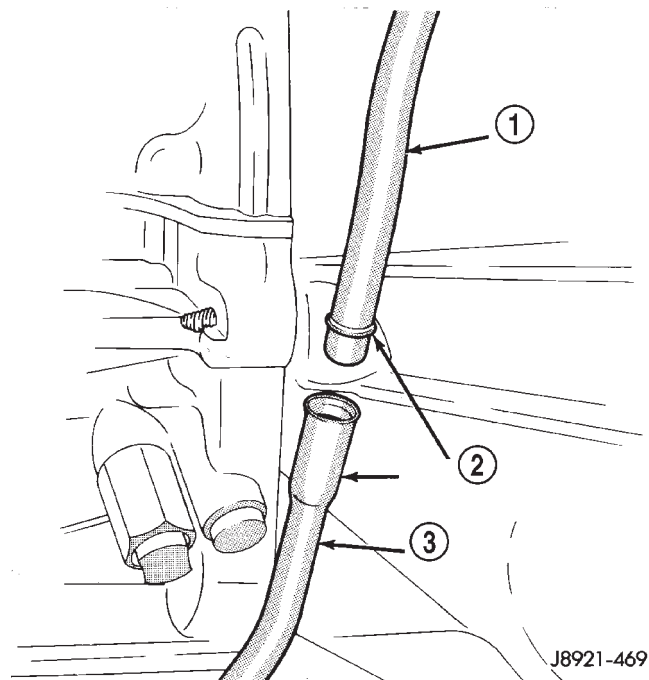

Fig. 45 Transmission Fill Tube (Two-Piece)

- 1 - UPPER HALF
- 2 - TRANSMISSION FILL TUBE
- 3 - LOWER HALF

- (4) Disconnect cooler lines at transmission.
- (5) Support engine with safety stand and support transmission with jack.

(6) Disconnect transmission and transfer case shift linkage.

(7) Remove necessary exhaust components.

(8) Disconnect vehicle speed sensor wires

(9) Mark position of front and rear propeller shafts for alignment reference. Then remove shafts from vehicle.

(10) Remove rear crossmember.

(11) Disconnect transmission shift cable at transmission. Then disconnect transmission throttle valve cable at engine.

(12) Disconnect necessary vacuum and fluid hoses.

(13) Remove transfer case from transmission.

(14) Disconnect and remove crankshaft position sensor (Fig. 46).

CAUTION: The crankshaft position sensor can be damaged during transmission removal (or installation) if the sensor is still bolted to the engine block. To avoid damage, remove the sensor before removing the transmission.

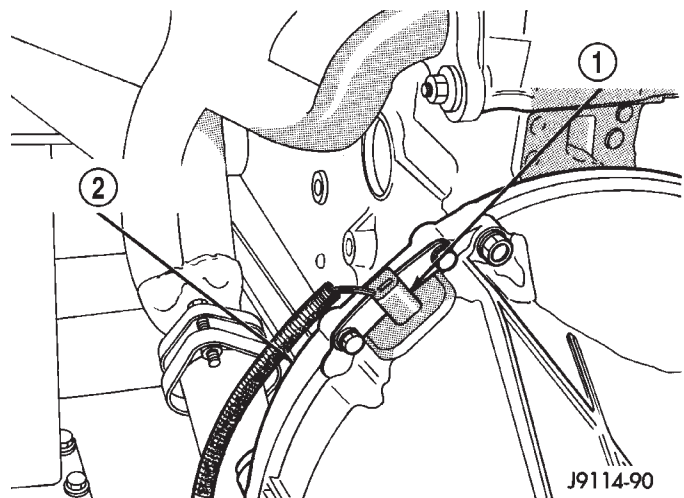

Fig. 46 Crankshaft Position Sensor

- 1 - CRANKSHAFT POSITION SENSOR
- 2 - TRANSMISSION HOUSING

- (15) Remove starter motor.
- (16) Remove bolts attaching converter to drive plate.
- (17) Remove bolts attaching converter housing to engine.

REMOVAL AND INSTALLATION (Continued)

- (18) Secure transmission to jack with safety chains.
- (19) Pull transmission rearward for access to converter. Then secure converter in pump with C-clamp or strap bolted to converter housing.
- (20) Remove transmission from under vehicle.
- (21) Remove torque converter if converter or oil pump seal are to be serviced.

INSTALLATION

- (1) Mount transmission on transmission jack. Then secure transmission to jack with safety chains.
- (2) Lubricate converter drive hub and oil pump seal lip with transmission fluid. Then install converter. Be sure converter is fully seated in oil pump gears before proceeding. Hold converter in place with C-clamp or strap attached to converter housing.
- (3) Lubricate the pocket in the rear of the crankshaft, in which the converter pilot hub rides, with a light coating of Mopar® High-Temp Grease.
- (4) Align and position transmission and converter on engine.

- (5) Remove clamp or strap used to hold torque converter in place.
- (6) Move transmission forward seat and it on engine. Be sure torque converter hub is fully seated.
- (7) Install converter housing-to-engine bolts (Fig. 47).
- (8) Install converter-to-drive plate bolts.
- (9) Install and connect starter motor.
- (10) Install and connect crankshaft position sensor.
- (11) Install transfer case on transmission.
- (12) Connect transfer case shift linkage and vacuum hoses.
- (13) Connect exhaust components.
- (14) Install rear crossmember and remove jack used to support transmission assembly.
- (15) Connect speed sensor wire harness to sensor.
- (16) Connect wire harness to park/neutral position switch.
- (17) Align and connect front and rear propeller shafts.
- (18) Connect transmission wire harnesses and transfer case vacuum and wire harnesses.

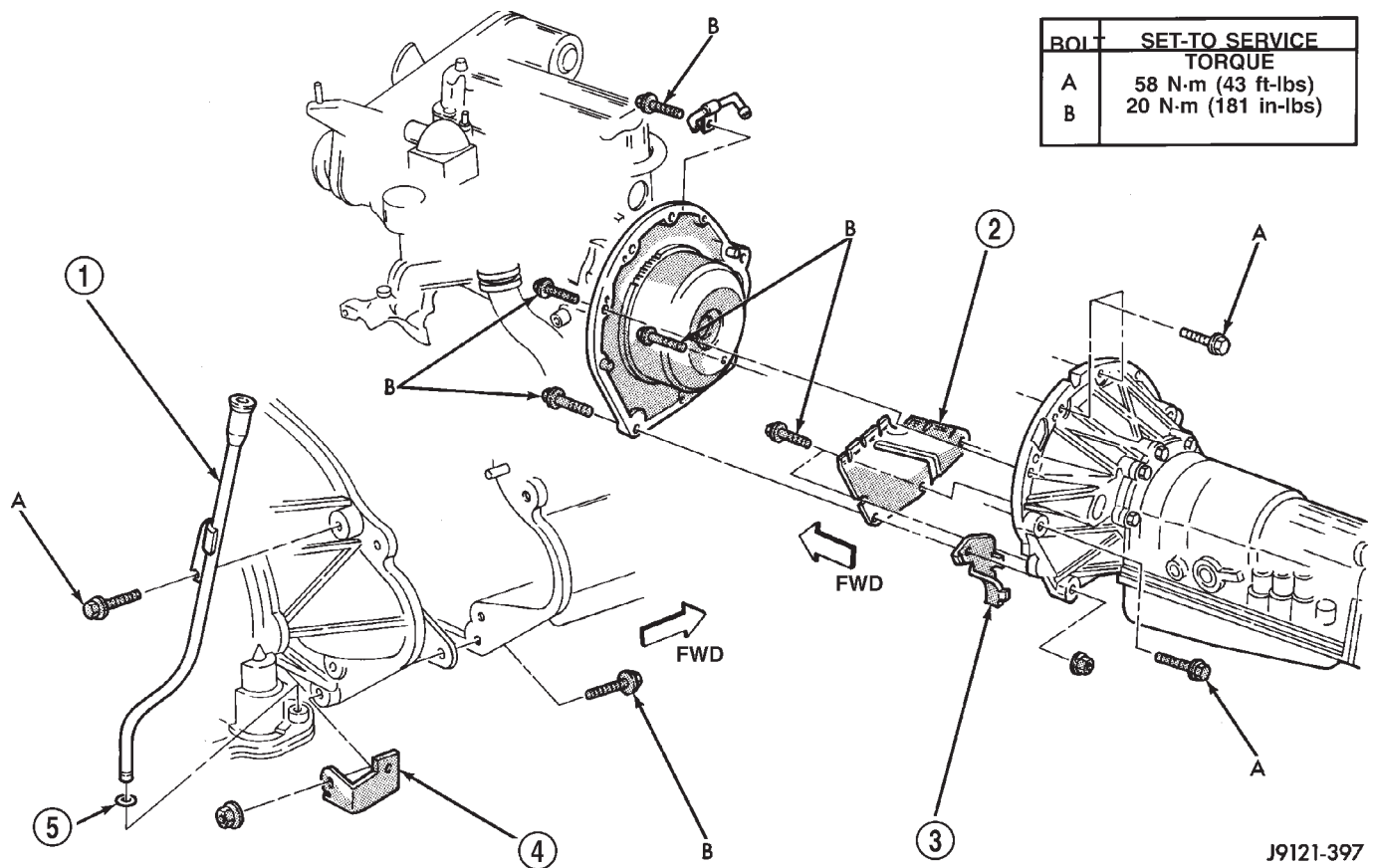

Fig. 47 Transmission Mounting

- 1 - TRANSMISSION FILL TUBE
- 2 - COVER
- 3 - BRACKET
- 4 - BRACKET
- 5 - FILL TUBE O-RING

J9121-397

REMOVAL AND INSTALLATION (Continued)

- (19) Connect transmission cooler lines.
- (20) Connect transmission throttle cable at engine.
- (21) Install new O-ring seal on upper half of transmission fill tube. Then connect upper and lower tube halves.
- (22) Lower vehicle.
- (23) Fill transmission with Mopar® Dexron IIE/Mercon automatic transmission fluid.

TORQUE CONVERTER

REMOVAL

- (1) Remove transmission and torque converter from vehicle.
- (2) Place a suitable drain pan under the converter housing end of the transmission.

CAUTION: Verify that transmission is secure on the lifting device or work surface, the center of gravity of the transmission will shift when the torque converter is removed creating an unstable condition.

The torque converter is a heavy unit. Use caution when separating the torque converter from the transmission.

- (3) Pull the torque converter forward until the center hub clears the oil pump seal.
- (4) Separate the torque converter from the transmission.

INSTALLATION

Check converter hub and drive notches for sharp edges, burrs, scratches, or nicks. Polish the hub and notches with 320/400 grit paper or crocus cloth if necessary. The hub must be smooth to avoid damaging the pump seal at installation.

- (1) Lubricate converter hub and oil pump seal lip with transmission fluid.
- (2) Place torque converter in position on transmission.

CAUTION: Do not damage oil pump seal or bushing while inserting torque converter into the front of the transmission.

- (3) Align torque converter to oil pump seal opening.
- (4) Insert torque converter hub into oil pump.
- (5) While pushing torque converter inward, rotate converter until converter is fully seated in the oil pump gears.
- (6) Check converter seating with a scale and straightedge (Fig. 48). Surface of converter lugs should be 1/2 in. to rear of straightedge when converter is fully seated.
- (7) If necessary, temporarily secure converter with C-clamp attached to the converter housing.

- (8) Install the transmission in the vehicle.
- (9) Fill the transmission with the recommended fluid.

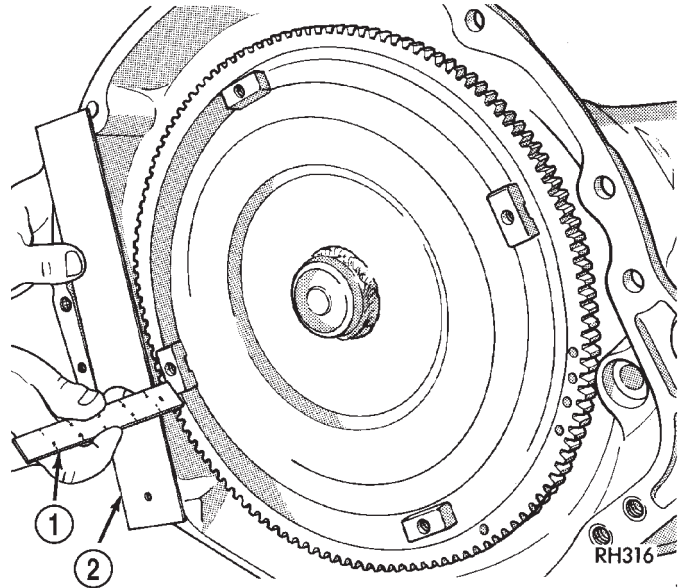

Fig. 48 Checking Torque Converter Seating

- 1 - SCALE
- 2 - STRAIGHTEDGE

ADAPTER HOUSING SEAL

REMOVAL

- (1) Raise vehicle.
- (2) Disconnect or remove components necessary to gain access to seal (e.g. propeller shaft, crossmember, shift linkage, transfer case, exhaust components, hoses, wires).
- (3) On 4X2 vehicles, remove dust shield from the adapter housing by tapping gently with a brass drift and hammer (Fig. 49).
- (4) On 4X2 vehicles, remove the adapter housing seal with Seal Puller 7550.
- (5) On 4X4 vehicles, remove the adapter housing seal using a slide hammer mounted screw.

INSTALLATION

- (1) Install new adapter housing seal with Seal Installer 7888.
- (2) On 4X2 vehicles, install dust shield using Special Tool D-187-B.
- (3) Reinstall components removed to gain access to seal.
- (4) Top off transmission fluid if necessary.

SPEED SENSOR

REMOVAL

- (1) Disconnect sensor wire harness connector.

REMOVAL AND INSTALLATION (Continued)

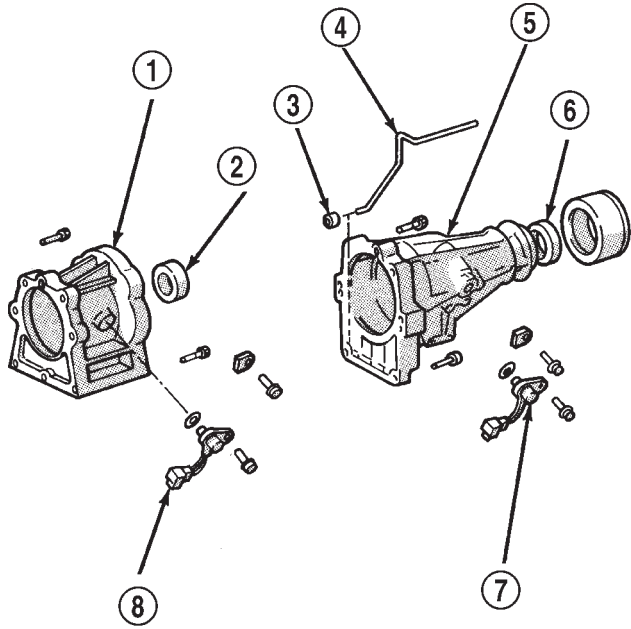

J9121-379

Fig. 49 Adapter Housing Seals

- 1 - 4WD ADAPTER HOUSING
- 2 - SEAL
- 3 - BUSHING
- 4 - OIL TUBE
- 5 - 2WD EXTENSION HOUSING
- 6 - SEAL
- 7 - SPEED SENSOR
- 8 - SPEED SENSOR

(2) Remove sensor retainer bolt and remove sensor (Fig. 50).

(3) Remove and discard speed sensor O-ring.

INSTALLATION

(1) Install new O-ring on speed sensor and install sensor in transmission case.

(2) Install sensor bracket and retainer bolt. Tighten bolt to 7.4 N·m (65 in. lbs.) torque.

(3) Connect sensor wire harness connector.

SPEEDOMETER ADAPTER

Rear axle gear ratio and tire size determine speedometer pinion requirements.

REMOVAL

- (1) Raise vehicle.
- (2) Disconnect wires from vehicle speed sensor.
- (3) Remove adapter clamp and screw (Fig. 51).
- (4) Remove speed sensor and speedometer adapter as assembly.
- (5) Remove speed sensor retaining screw and remove sensor from adapter.
- (6) Remove speedometer pinion from adapter.

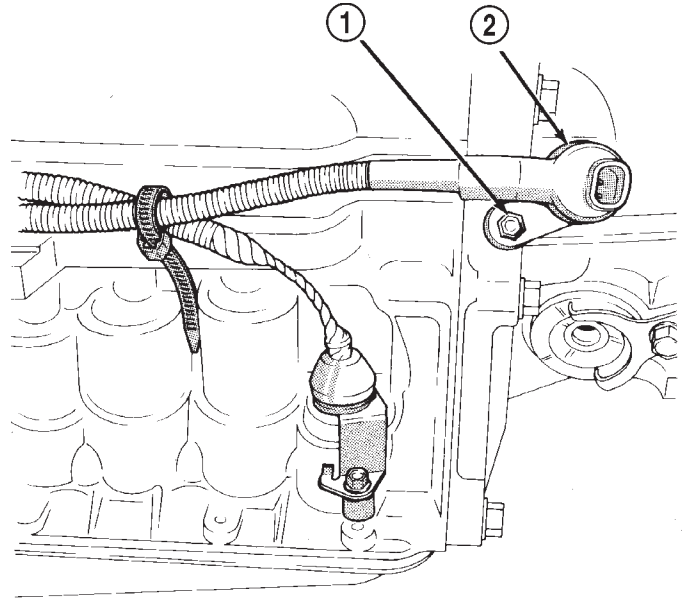

J8921-463

Fig. 50 Transmission Speed Sensor Removal/Installation

- 1 - RETAINER BOLT
- 2 - SPEED SENSOR

(7) Inspect sensor and adapter O-rings (Fig. 51). Remove and discard O-rings if worn or damaged.

(8) Inspect terminal pins in speed sensor. Clean pins with Mopar® electrical spray cleaner if dirty or oxidized. Replace sensor if faulty, or pins are loose, severely corroded, or damaged.

INSTALLATION

(1) Thoroughly clean adapter flange and adapter mounting surface in housing. Surfaces must be clean for proper adapter alignment and speedometer operation.

(2) Install new O-rings on speed sensor and speedometer adapter if necessary (Fig. 51).

(3) Lubricate sensor and adapter O-rings with transmission fluid.

(4) Install vehicle speed sensor in speedometer adapter. Tighten sensor attaching screw to 2-3 N·m (15-27 in. lbs.) torque.

(5) Install speedometer pinion in adapter.

(6) Count number of teeth on speedometer pinion. Do this before installing assembly in housing. Then lubricate pinion teeth with transmission fluid.

(7) Note index numbers on adapter body (Fig. 52). These numbers will correspond to number of teeth on pinion.

(8) Install speedometer assembly in housing.

(9) Rotate adapter until required range numbers are at 6 o'clock position. Be sure range index numbers correspond to number of teeth on pinion gear.

REMOVAL AND INSTALLATION (Continued)

(10) Install speedometer adapter clamp and retaining screw. Tighten clamp screw to 10-12 N·m (90-110 in. lbs.) torque.

(11) Connect wires to vehicle speed sensor.

(12) Lower vehicle and top off transmission fluid level, if necessary.

SPEED SENSOR ROTOR-SPEEDOMETER DRIVE GEAR

REMOVAL

- (1) Raise vehicle.
- (2) Remove components necessary to gain access to rotor and drive gear such as propeller shaft, transfer case, crossmember, and shift linkage.
- (3) Disengage wire connector from the output speed sensor.
- (4) Remove the bolt holding the output speed sensor to the adapter housing.
- (5) Remove the output speed sensor from the adapter housing.
- (6) Remove the bolts holding the adapter housing to the transmission case.
- (7) Tap the adapter housing at the joint line gently with a rubber mallet to separate the adapter housing from the transmission case.
- (8) Remove the adapter housing from the transmission case.

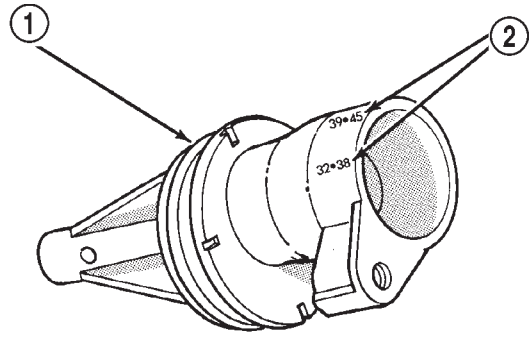

J9321-386

Fig. 52 Index Numbers On Speedometer Pinion Adapter

- 1 - SPEEDOMETER ADAPTER
- 2 - INDEX NUMBER LOCATION

- (9) Remove speedometer drive gear snap ring (Fig. 53).
- (10) Remove the speedometer drive gear and spacer, if equipped.
- (11) Remove rotor from the output shaft. It may be necessary to use a wood dowel or hammer handle (Fig. 54) to gently pry the rotor from the output

| ITEM | TORQUE |
|------|-----------------------------|
| A | 2-3 N·m (15-27 in. lbs.) |
| B | 10-12 N·m (90-110 in. lbs.) |

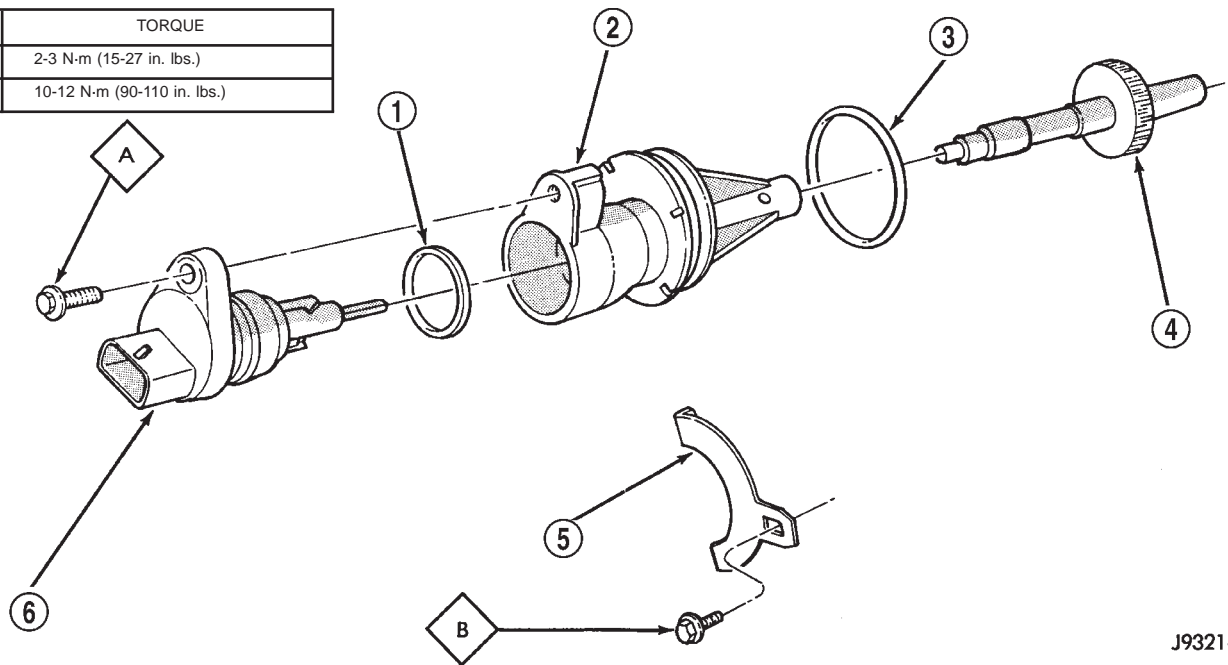

J9321-385

Fig. 51 Speedometer Pinion Adapter Components

- 1 - SENSOR O-RING
- 2 - SPEEDOMETER ADAPTER
- 3 - ADAPTER O-RING
- 4 - SPEEDOMETER PINION
- 5 - ADAPTER CLAMP
- 6 - VEHICLE SPEED SENSOR

REMOVAL AND INSTALLATION (Continued)

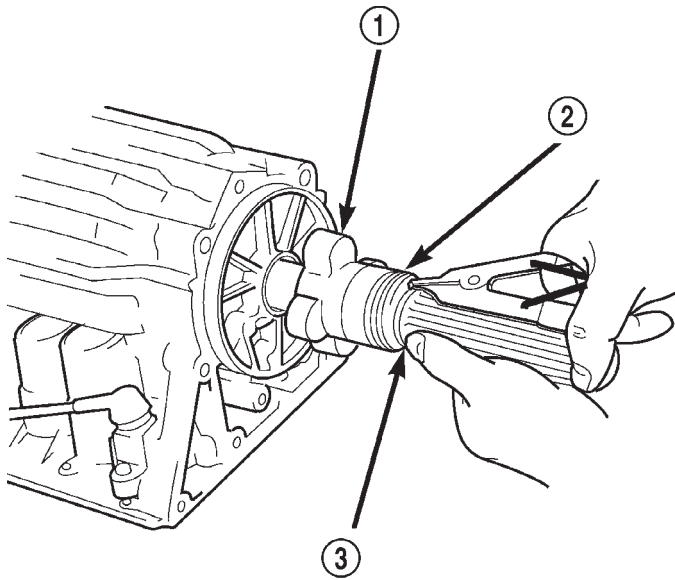

80c070af

Fig. 53 Removing/Installation Speedometer Drive Gear

- 1 - ROTOR
- 2 - SPEEDOMETER DRIVE GEAR
- 3 - SNAP RING

shaft. Be sure to retrieve the rotor locating key from the output shaft or rotor.

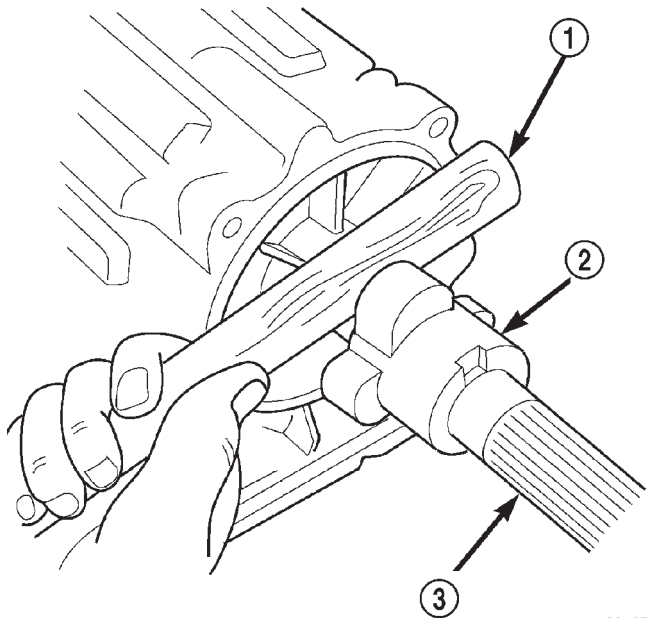

80c070b0

Fig. 54 Removing Speed Sensor Rotor

- 1 - WOOD DOWEL OR HAMMER HANDLE
- 2 - ROTOR
- 3 - OUTPUT SHAFT

INSTALLATION

- (1) Clean sealing surfaces of transmission case and extension/adaptor housing.
- (2) Install rotor, spacer (if equipped) and drive gear on output shaft. Then install drive gear snap ring (Fig. 53).
- (3) Apply 1/8 3/16 inch wide bead of Threebond® Liquid Gasket TB1281, P/N 83504038, to transmission case sealing surface and install extension/adaptor housing on case.
- (4) Tighten adaptor housing bolts to 34 N·m (25 ft. lbs.) torque.
- (5) Install components removed to gain access to rotor and drive gear.

PARK/NEUTRAL POSITION SWITCH

REMOVAL

- (1) Raise vehicle.
- (2) Disconnect switch wire harness connector.
- (3) Pry washer lock tabs upward and remove switch attaching nut and tabbed washer (Fig. 55).
- (4) Remove switch adjusting bolt (Fig. 55).
- (5) Slide switch off manual valve shaft.

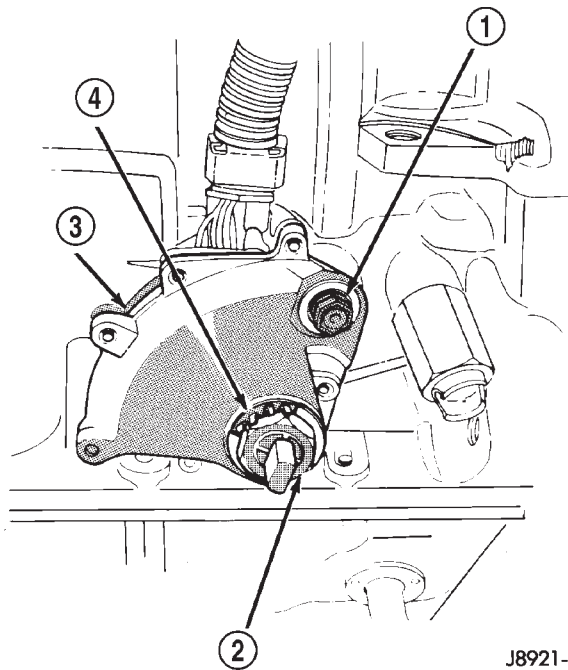

J8921-430

Fig. 55 Park/Neutral Position Switch Removal/Installation

- 1 - ADJUSTING BOLT
- 2 - ATTACHING NUT
- 3 - NEUTRAL SWITCH
- 4 - TABBED WASHER

REMOVAL AND INSTALLATION (Continued)

INSTALLATION

- (1) Disconnect shift linkage rod from shift lever on left side of transmission.
- (2) Rotate manual shift lever all the way rearward. Then rotate lever forward two detent positions to Neutral.
- (3) Install switch on manual valve shaft and install switch adjusting bolt finger tight. Do not tighten bolt at this time.
- (4) Install tabbed washer on manual valve shaft and install switch attaching nut. Tighten nut to 6.9 N·m (61 in. lbs.) torque but do not bend washer lock tabs over nut at this time.
- (5) Verify that transmission is in Neutral.
- (6) Rotate switch to align neutral standard line with vertical groove on manual valve shaft (Fig. 56).
- (7) Align switch standard line with groove or flat

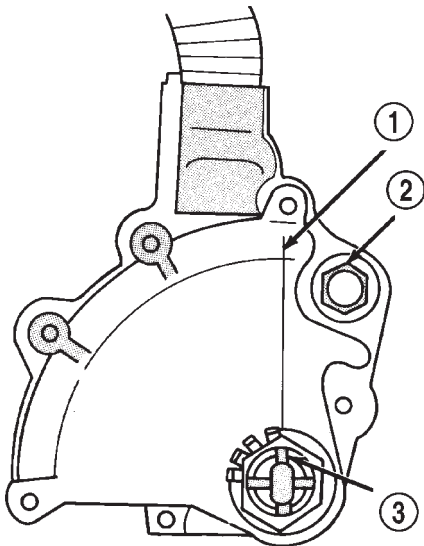

J8921-431

Fig. 56 Park/Neutral Position Switch Adjustment

- 1 - NEUTRAL STANDARD LINE
- 2 - ADJUSTING BOLT
- 3 - VERTICAL GROOVE ON MANUAL VALVE SHAFT

on manual valve shaft.

- (8) Tighten switch adjusting bolt to 13 N·m (9 ft. lbs.) torque.
- (9) Bend at least two washer lock tabs over switch attaching nut to secure it.
- (10) Connect shift linkage rod to shift lever on left side of case.
- (11) Connect switch wires to harness and lower vehicle.
- (12) Check switch operation. Engine should start in Park and Neutral only.

GEARSHIFT CABLE

REMOVAL

- (1) Shift transmission into Park.
- (2) Remove shift lever bezel and necessary console parts for access to shift lever assembly.
- (3) Disconnect cable at shift lever and feed cable through dash panel opening to underside of vehicle.
- (4) Raise vehicle.
- (5) Disengage cable eyelet at transmission shift lever and pull cable adjuster out of mounting bracket. Then remove old cable from vehicle.

INSTALLATION

- (1) Route cable through hole in dash panel. Fully seat cable grommet into dash panel.
- (2) Place the auto transmission manual shift control lever in "Park" detent (rearmost) position and rotate prop shaft to ensure transmission is in park.
- (3) Connect shift cable to shifter mechanism by snapping cable retaining ears into shifter bracket and press cable end fitting onto lever ball stud.
- (4) Place the floor shifter lever in park position. Ensure that the pawl is seated within the confines of the adjustment gauge clip.
- (5) Snap the cable into the transmission bracket so the retaining ears are engaged and connect cable end fitting onto the manual control lever ball stud.
- (6) Lock shift cable into position by pushing upward on the adjusting lock button.
- (7) Remove and discard the shift cable adjustment gauge clip from the park gate of the shifter.

BRAKE TRANSMISSION SHIFT INTERLOCK

REMOVAL

- (1) Remove lower steering column cover. Refer to Group 8E, Instrument Panel and Gauges, for proper procedure.
- (2) Remove lower steering column shroud. Refer to Group 19, Steering, for proper procedure.
- (3) Remove tie strap near the solenoid retaining the brake transmission interlock cable to the steering column.
- (4) Disengage wire connector from solenoid.
- (5) With the ignition removed or in the unlocked position, disengage lock tab holding cable end to steering column (Fig. 57).
- (6) Pull cable end from steering column.
- (7) Remove the floor console and related trim. Refer to Group 23, Body, for proper procedure.
- (8) Disconnect the cable eyelet from the bellcrank (Fig. 58).
- (9) Disconnect and remove the cable from the shift bracket.

REMOVAL AND INSTALLATION (Continued)

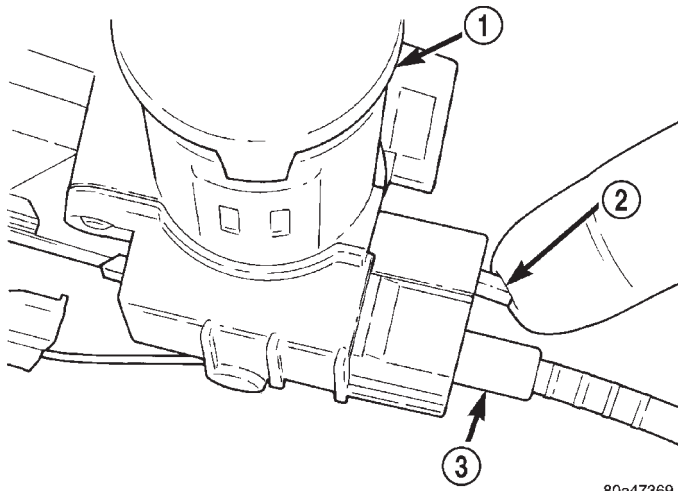

80a47369

Fig. 57 Brake/Park Interlock Cable

- 1 - IGNITION LOCK
- 2 - LOCK TAB
- 3 - CABLE END

INSTALLATION

- (1) Route replacement cable behind instrument panel and under floor console area to shift mechanism (Fig. 58).
- (2) Insert cable end into opening in steering column hub under ignition lock. Push cable inward until lock tab engages.
- (3) Connect the cable end eyelet onto shifter bellcrank pin.
- (4) Place gear selector in PARK.
- (5) Push the spring-loaded cable adjuster forward and snap cable into bracket.
- (6) Adjust the brake transmission shifter interlock cable. Refer to the Adjustment portion of this section for proper procedures.
- (7) Verify that the cable adjuster lock clamp is pushed downward to the locked position.
- (8) Test the park-lock cable operation.
- (9) Install the floor console and related trim.

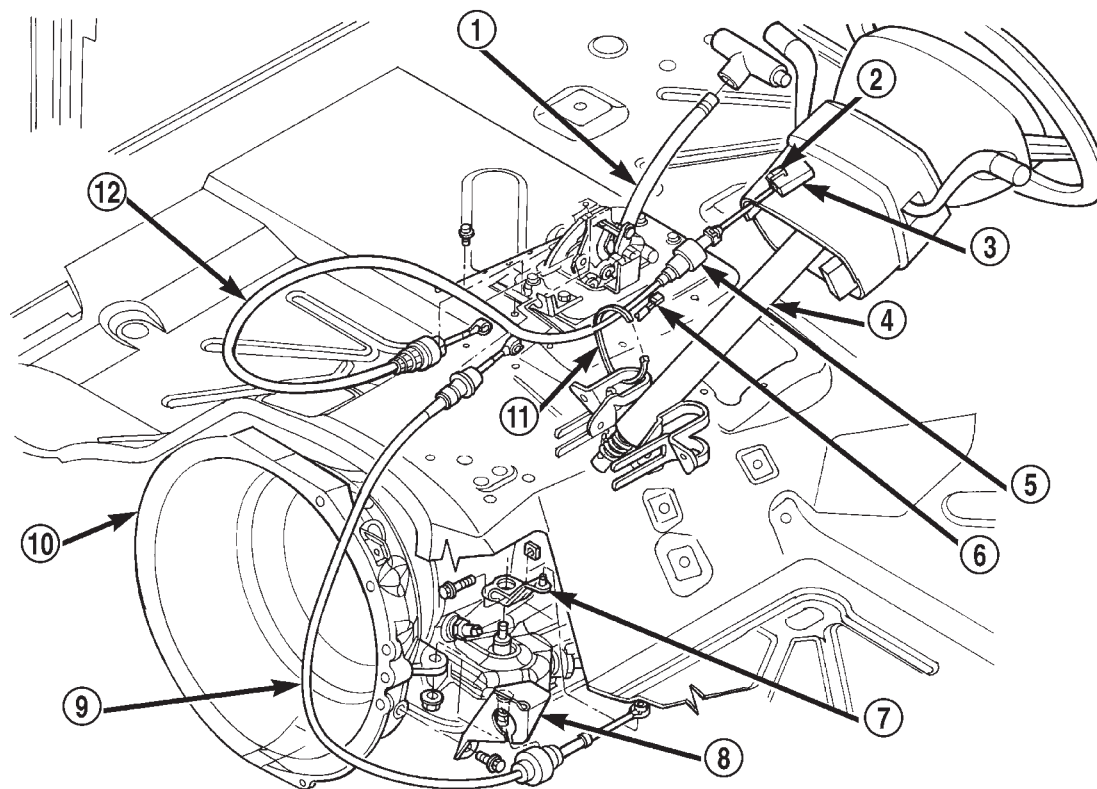

80a13876

Fig. 58 Cable and Shifter

- | | |
|---|---|
| <ul style="list-style-type: none"> 1 - SHIFT MECHANISM 2 - LOCK-TAB 3 - IGNITION LOCK INTERLOCK 4 - STEERING COLUMN 5 - SOLENOID 6 - WIRE CONNECTOR | <ul style="list-style-type: none"> 7 - LEVER 8 - MOUNT BRACKET 9 - SHIFT CABLE 10 - AUTOMATIC TRANSMISSION 11 - TIE STRAP 12 - PARK/BRAKE INTERLOCK CABLE |
|---|---|

REMOVAL AND INSTALLATION (Continued)

- (10) Install tie strap to hold cable to base of steering column.
- (11) Install lower steering column shroud and ignition lock.
- (12) Install lower steering column cover.

TRANSMISSION VALVE BODY SOLENOIDS

REMOVAL

- (1) Remove transmission oil pan drain plug and drain fluid.
- (2) Remove pan bolts and remove oil pan.
- (3) Remove oil screen bolts and remove screen (Fig. 59) and gasket. Discard the gasket.

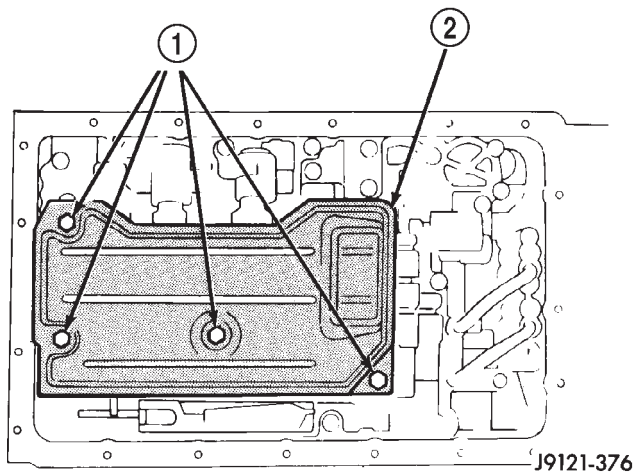

Fig. 59 Oil Screen Removal/Installation

- 1 - OIL SCREEN BOLTS
- 2 - OIL SCREEN

- (4) Disconnect solenoid wire connector (Fig. 60).
- (5) If all solenoids are being removed, mark or tag wires for assembly reference before disconnecting them.
- (6) Remove bolt attaching solenoids to valve body and remove solenoids (Fig. 61). Do not allow any valve body components to fall out when solenoids are removed.
- (7) Clean oil filter and pan with solvent and dry with compressed air.
- (8) Remove old sealer material from oil pan and transmission case.

INSTALLATION

- (1) Position solenoids on valve body and install solenoid bolts. Tighten bolts to 10 N·m (7 ft. lbs.) torque.
- (2) Connect feed wires to solenoids.
- (3) Install new gaskets on oil screen and install screen. Tighten screen bolts to 10 N·m (7 ft. lbs.) torque.

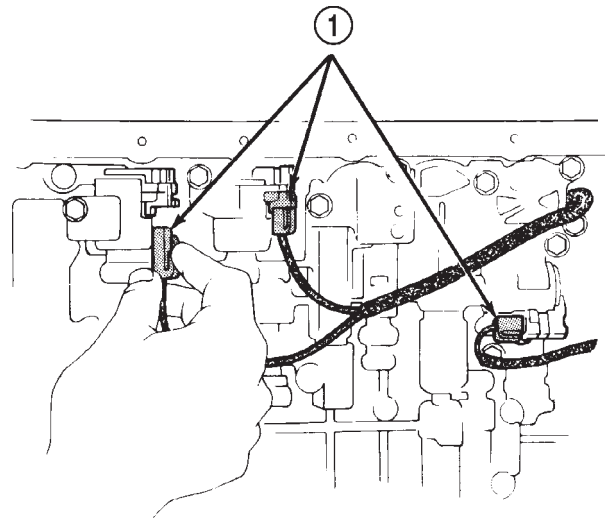

J8921-433

Fig. 60 Solenoid Wire Connectors

- 1 - SOLENOID WIRE CONNECTORS

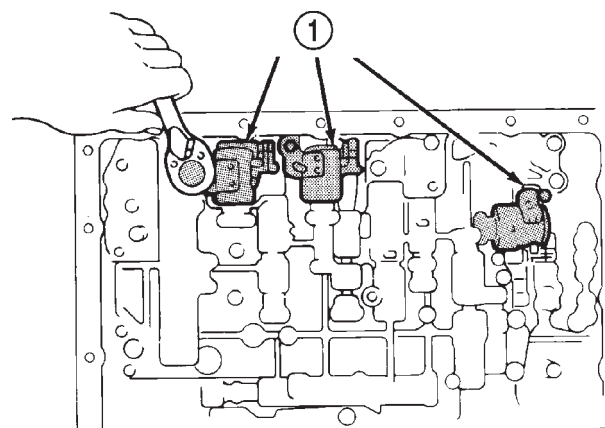

Fig. 61 Transmission Valve Body Solenoids

- 1 - VALVE BODY SOLENOIDS

- (4) Apply bead of Threebond® Liquid Gasket TB1281, P/N 83504038, sealer to oil pan sealing surface. Sealer bead should be at least 3.0 mm (1/8 in.) wide.
- (5) Install oil pan on transmission. Tighten pan bolts to 7 N·m (65 in. lbs.) torque.
- (6) Install and tighten oil pan drain plug to 20 N·m (15 ft. lbs.) torque.
- (7) Fill transmission with Mopar® Dexron IIE/Mercon.

REMOVAL AND INSTALLATION (Continued)

TRANSMISSION VALVE BODY

REMOVAL

- (1) Remove oil pan plug and drain transmission fluid.
- (2) Remove oil pan and oil screen. Clean pan and screen in solvent and dry them with compressed air.
- (3) Disconnect solenoid wire connectors (Fig. 62). Mark wires for assembly reference.

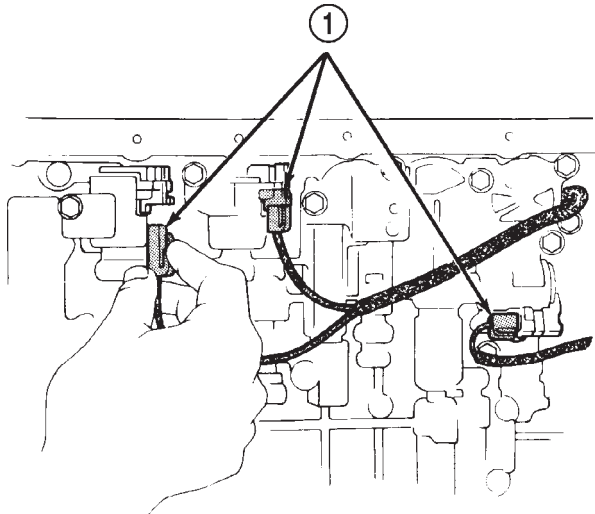

J8921-433

Fig. 62 Solenoid Wire Connectors

1 - SOLENOID WIRE CONNECTORS

- (4) Remove valve body oil tubes (Fig. 63). Carefully pry tubes out of valve body with screwdriver.
- (5) Disconnect throttle cable from throttle cam (Fig. 64).
- (6) Remove valve body bolts. Bolt locations are outlined in (Fig. 65).
- (7) Lower valve body and remove overdrive clutch accumulator springs, direct clutch accumulator springs and second brake accumulator spring (Fig. 66).
- (8) Remove valve body and check ball and spring (Fig. 67).

INSTALLATION

- (1) Connect cable to throttle cam (Fig. 64).
- (2) Install check ball and spring (Fig. 67).
- (3) Position accumulator springs and spacers on valve body.
- (4) Align valve body manual valve with shift sector (Fig. 68) and carefully position valve body on case.
- (5) Install valve body bolts (Fig. 65). Tighten bolts evenly to 10 N·m (7 ft. lbs.) torque.

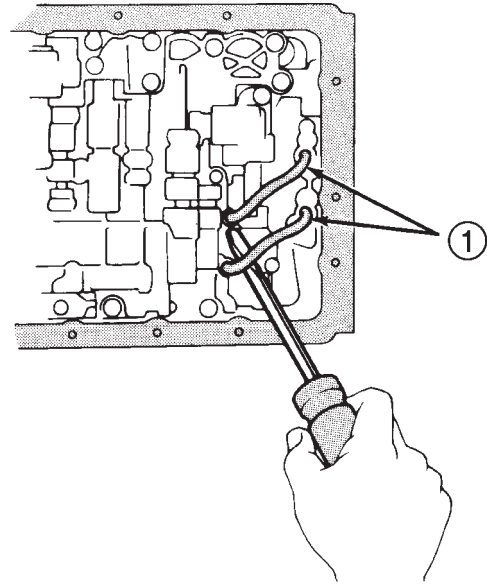

J8921-437

Fig. 63 Removing Transmission Valve Body Oil Tubes

1 - OIL TUBES

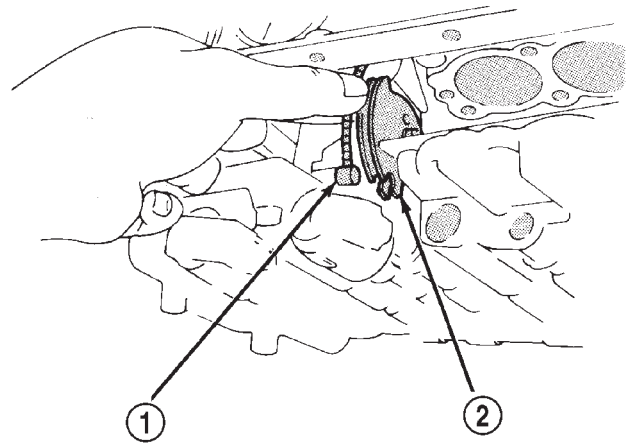

J8921-438

Fig. 64 Removing/Installing Throttle Cable

1 - THROTTLE CABLE
2 - CABLE BRACKET

- (6) Install valve body oil tubes. Be sure tube ends (L) and (M) are installed as shown in (Fig. 69).
- (7) Remove old sealer material from oil pan and transmission case.
- (8) Clean oil screen and oil pan with solvent (if not done previously). Dry both components with compressed air only. Do not use shop towels.
- (9) Install new gaskets on oil screen and install screen on case. Tighten screen attaching bolts to 10 N·m (7 ft. lbs.) torque.

REMOVAL AND INSTALLATION (Continued)

● = BOLT LOCATIONS

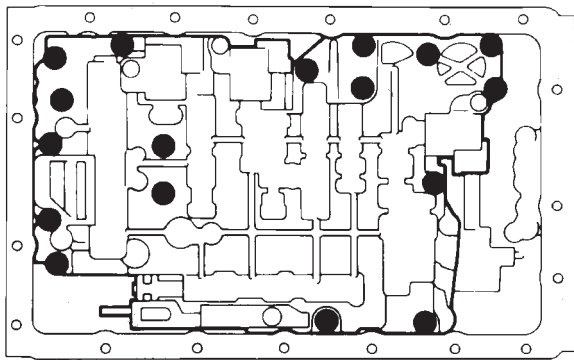

J8921-439

Fig. 65 Transmission Valve Body Bolt Locations

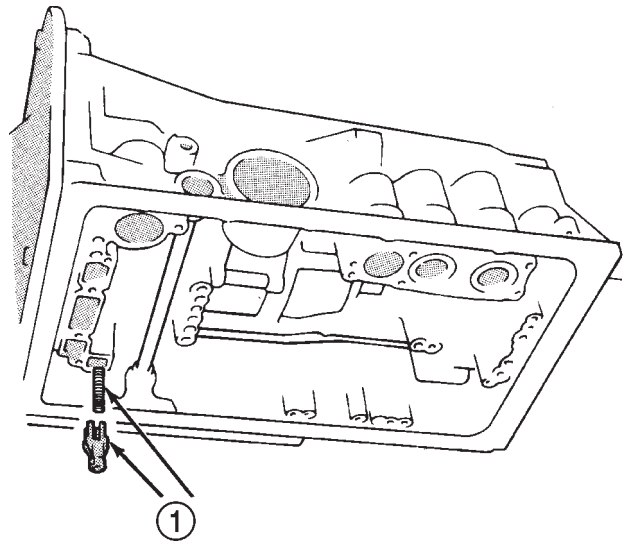

J8921-441

Fig. 67 Removing/Installing Check Ball And Spring

1 - CHECK BALL AND SPRING

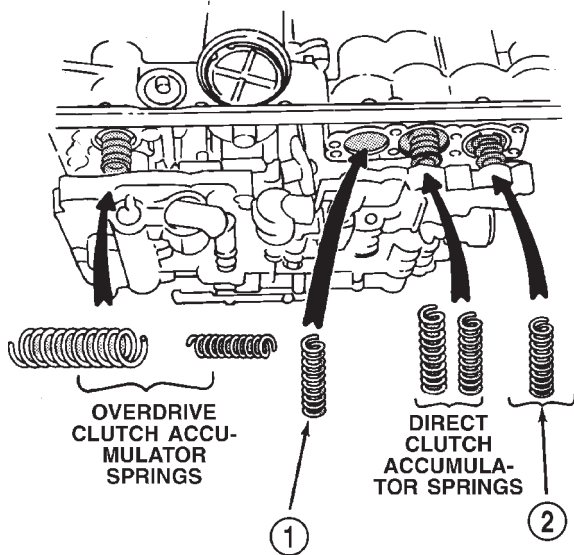

J9121-377

Fig. 66 Accumulator Springs

1 - OVERDRIVE BRAKE ACCUMULATOR SPRING
2 - SECOND BRAKE ACCUMULATOR SPRING

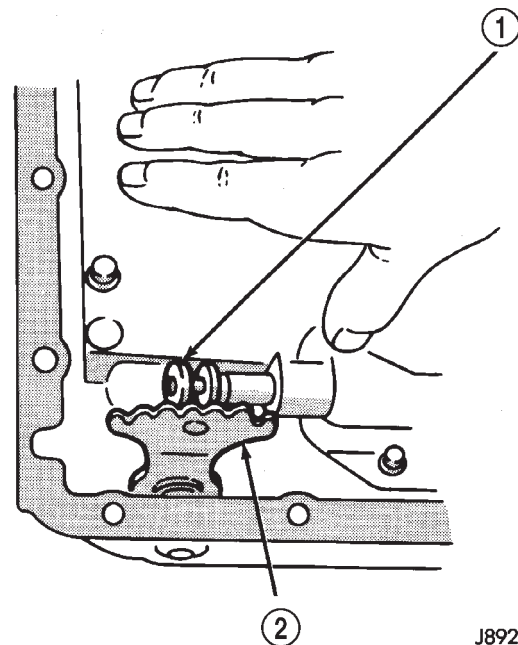

J8921-442

Fig. 68 Shift Sector And Manual Valve Alignment

1 - MANUAL VALVE
2 - SHIFT SECTOR

(10) Apply bead of Threebond® Liquid Gasket TB1281, P/N 83504038 to sealing surface of oil pan. Sealer bead should be at least 3 mm (1/8 in.) wide. Then install oil pan and tighten pan bolts to 7.4 N-m (65 in. lbs.) torque.

(11) Install new gasket on oil pan drain plug and install plug in pan. Tighten plug to 20 N-m (15 ft. lbs.) torque.

(12) Fill transmission with Mopar® Dexron IIE/Mercon.

TRANSMISSION CONTROL MODULE

The transmission control module is mounted under the instrument panel. On left hand drive models, it is at the driver side of the lower finish panel (Fig. 70). On right hand drive models, it is at the passenger side of the lower finish panel (Fig. 71).

To remove the module, disconnect the wire harness, remove the mounting screws and remove the

REMOVAL AND INSTALLATION (Continued)

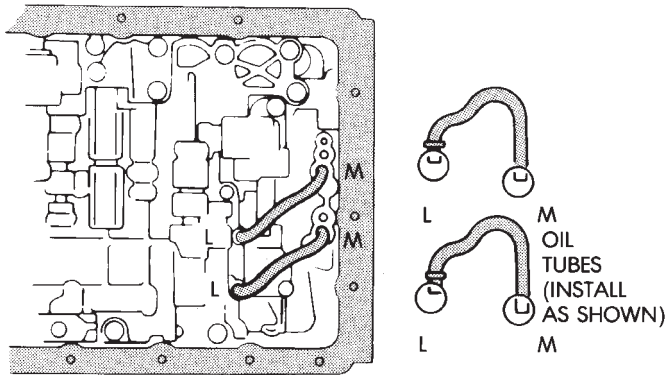

J8921-443

Fig. 69 Installing Transmission Valve Body Oil Tubes

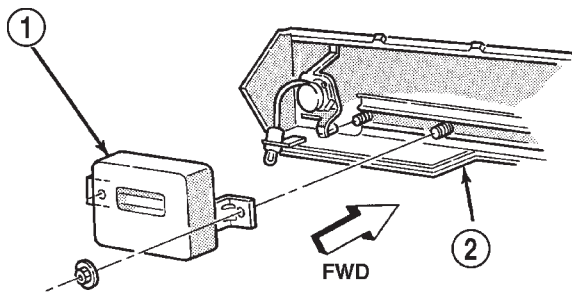

J9421-150

Fig. 70 TCM Location (Left Hand Drive)

- 1 - TCM
- 2 - LOWER FINISH PANEL

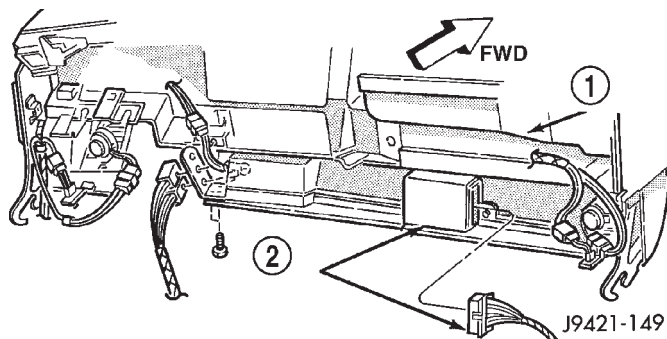

J9421-149

Fig. 71 TCM Location (Right Hand Drive)

- 1 - REAR SIDE OF INSTRUMENT PANEL
- 2 - TCM AND HARNESS

module from the finish panel. Tighten the module mounting screws securely after installation. Also be sure the wire harness is not twisted, kinked or touching any body panels.

SOLENOID HARNESS ADAPTER SEAL

REMOVAL

- (1) Remove oil pan and oil screen.
- (2) Disconnect solenoid wire connectors (Fig. 72).

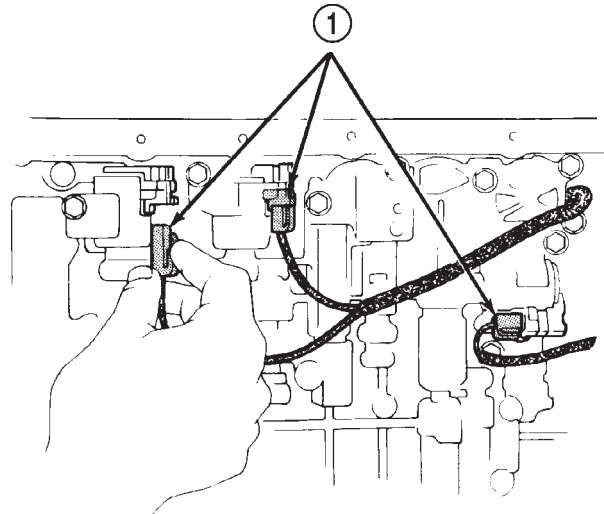

J8921-433

Fig. 72 Solenoid Wire Connectors

- 1 - SOLENOID WIRE CONNECTORS

- (3) Remove bracket securing solenoid harness adaptor (Fig. 73) to case.

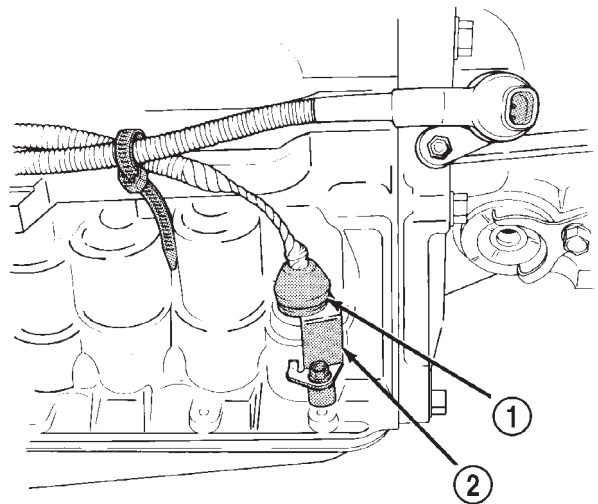

J8921-436

Fig. 73 Harness Adapter Removal/Installation

- 1 - HARNESS ADAPTER
- 2 - BRACKET

- (4) Pull harness adaptor and wires out of case.

REMOVAL AND INSTALLATION (Continued)

- (5) Remove and discard adapter O-ring.

INSTALLATION

- (1) Lubricate new O-ring and install it on adapter.
- (2) Install solenoid wire harness and adapter in case.
- (3) Install adapter bracket and bracket bolt.
- (4) Connect wires to solenoids.
- (5) Install oil screen.
- (6) Apply bead of Threebond® Liquid Gasket TB1281, P/N 83504038, to oil pan seal surface. Sealer bead should be at least 3 mm (1/8 in.) wide.
- (7) Install oil pan on transmission. Tighten pan bolts to 7 N·m (65 in. lbs.) torque.
- (8) Install and tighten oil pan drain plug to 20 N·m (15 ft. lbs.) torque.
- (9) Fill transmission with Mopar Dexron IIE/Mercon.

MANUAL VALVE SHAFT SEAL

REMOVAL

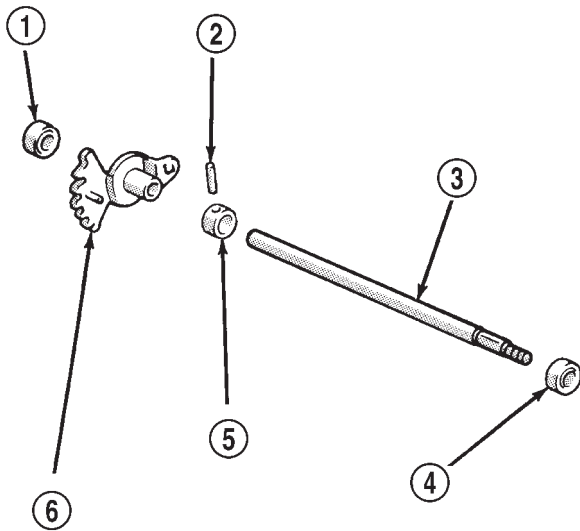

J8921-444

Fig. 74 Manual Valve Shaft And Seals

- 1 - SHAFT SEAL
- 2 - PIN
- 3 - MANUAL VALVE SHAFT
- 4 - SHAFT SEAL
- 5 - SPACER SLEEVE
- 6 - SHIFT SECTOR

- (1) Remove park/neutral position switch and disconnect transmission shift lever (Fig. 74).
- (2) Remove oil pan and valve body.
- (3) Remove bolts attaching park rod bracket to case (Fig. 75).

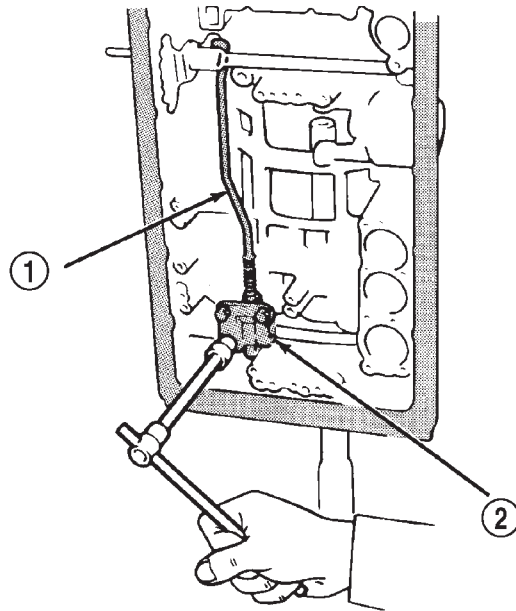

J8921-445

Fig. 75 Removing/Installing Park Rod Bracket

- 1 - PARK ROD
- 2 - PARK ROD BRACKET

- (4) Remove park rod from shift sector (Fig. 76).

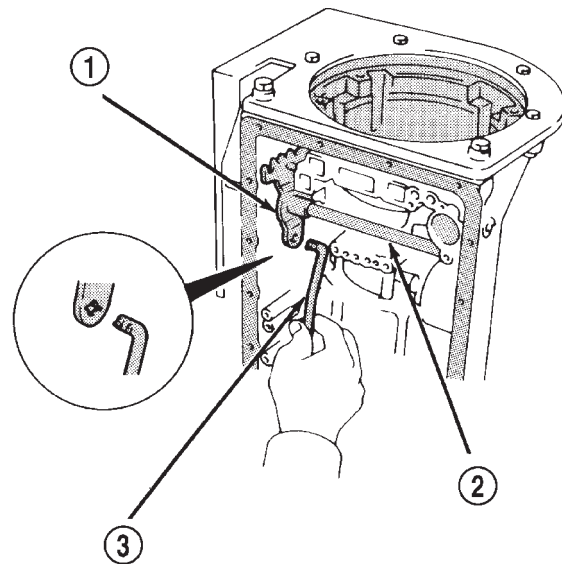

J8921-446

Fig. 76 Removing/Installing Park Rod

- 1 - SHIFT SECTOR
- 2 - MANUAL VALVE SHAFT
- 3 - PARK ROD

- (5) Cut spacer sleeve with chisel and remove it from manual valve shaft (Fig. 77).
- (6) Remove pin from shaft and sector with pin punch.
- (7) Remove shaft and sector from case.

REMOVAL AND INSTALLATION (Continued)

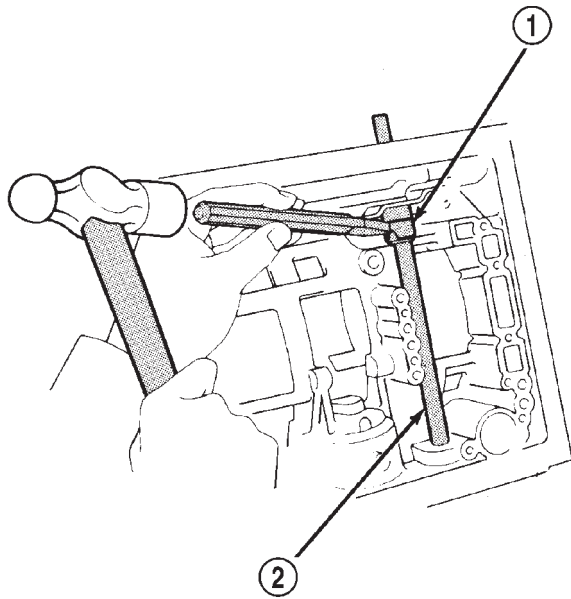

J8921-447

Fig. 77 Cutting Spacer Sleeve

- 1 - SPACER
- 2 - MANUAL VALVE SHAFT

(2) Coat replacement shaft seals with petroleum jelly and seat them in the case using an appropriately sized driver/socket (Fig. 79).

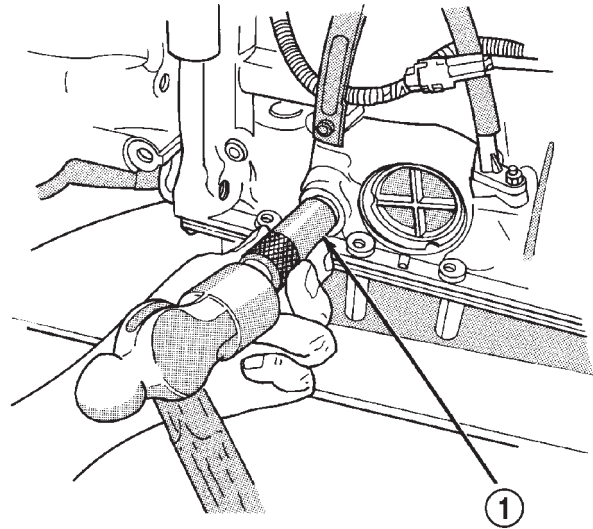

J8921-449

Fig. 79 Installing Manual Valve Shaft Seals

- 1 - SHAFT SEAL INSTALLER

(8) Pry shaft seals out of case (Fig. 78).

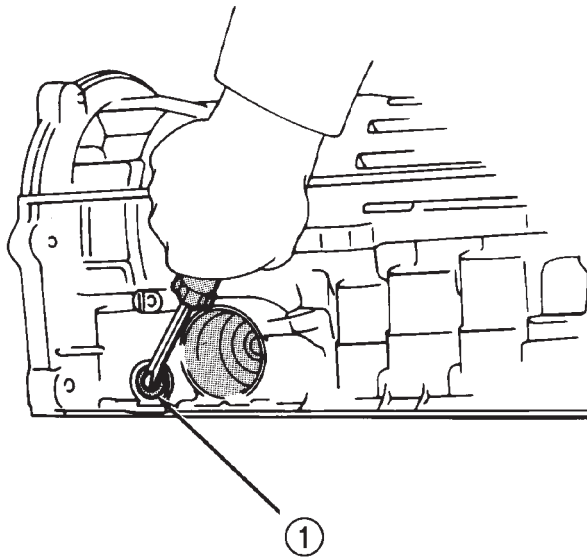

J8921-448

Fig. 78 Removing Manual Valve Shaft Seals

- 1 - MANUAL VALVE SHAFT SEAL

(3) Install new spacer sleeve on sector (Fig. 80).

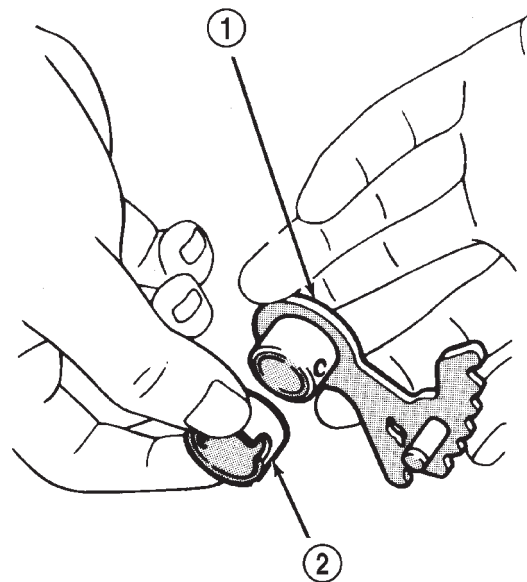

J8921-450

Fig. 80 Installing Spacer Sleeve On Sector

- 1 - SHIFT SECTOR
- 2 - SPACER SLEEVE

INSTALLATION

(1) Inspect the manual valve shaft and sector. Replace either component if worn or damaged.

(4) Lubricate manual valve shaft with petroleum jelly and install it through the left side of the transmission case.

REMOVAL AND INSTALLATION (Continued)

(5) Lubricate sector and sleeve with petroleum jelly and install them on shaft.

(6) Install the manual valve shaft through the remainder of the transmission case.

(7) Align hole in spacer sleeve with notch in sector. Then install shift sector roll pin. Tap pin into sector and shaft and securely stake sleeve to sector and shaft.

(8) Connect park rod to sector (Fig. 76).

(9) Install park rod bracket (Fig. 81). Tighten bracket bolts to 10 N·m (7 ft. lbs.) torque.

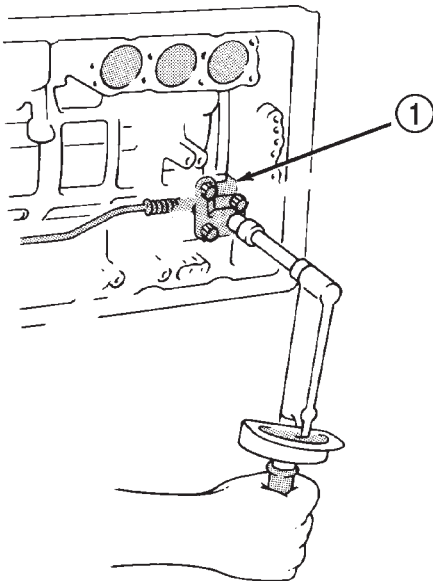

Fig. 81 Installing Park Rod Bracket

J8921-451

1 - PARK ROD BRACKET

(10) Install valve body, oil screen and oil pan.

(11) Install park/neutral position switch.

ACCUMULATOR PISTONS AND SPRINGS

REMOVAL

(1) Remove valve body.

(2) Remove accumulator pistons with compressed air (Fig. 82). Apply air through small feed hole next to each piston bore. Catch each piston in a shop towel as it exits bore.

CAUTION: Use only enough air pressure to ease each piston out of the bore. In addition, remove the pistons one at a time and tag the pistons and springs for assembly reference. Do not intermix them.

(3) Remove and discard piston O-ring seals. Then clean pistons and springs with solvent.

INSTALLATION

(1) Inspect pistons, springs and piston bores. Replace worn damaged pistons. Replace broken, col-

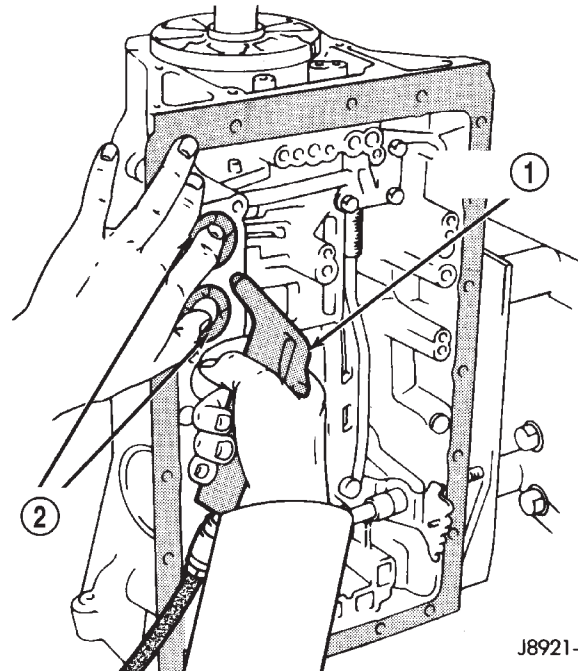

J8921-455

Fig. 82 Accumulator Piston Removal

1 - AIR GUN NOZZEL IN FEED HOLE

2 - PISTONS

lapsed or distorted springs. Replace case if piston bores are damaged.

(2) If small cushion spring in any piston must be replaced, remove spring retainer clip and remove spring from piston (Fig. 83). A small hooked tool or small thin blade screwdriver can be used to remove clip. A thin wall, deep socket, or pin punch can be used to seat clip after spring replacement.

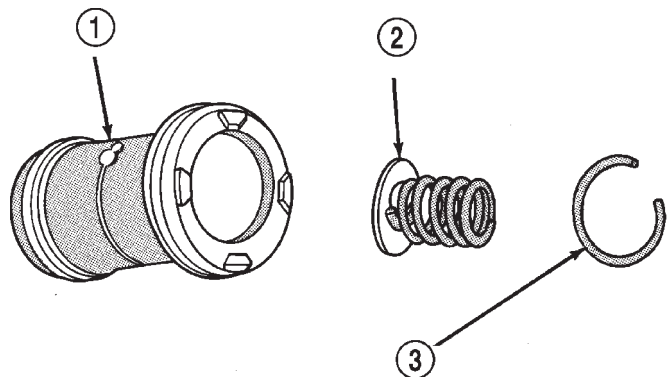

J9121-414

Fig. 83 Small Cushion Spring Retention

1 - ACCUMULATOR PISTON (TYPICAL)

2 - SMALL CUSHION SPRING

3 - RETAINER CLIP

REMOVAL AND INSTALLATION (Continued)

(3) Install new O-ring seals on pistons. Lubricate seals and pistons and piston bores with transmission fluid.

(4) Install pistons and springs (Fig. 84).

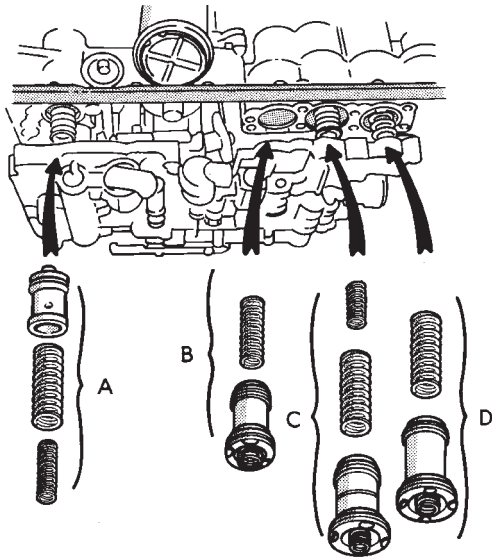

- A. OVERDRIVE CLUTCH ACCUMULATOR PISTON AND SPRINGS
- B. OVERDRIVE BRAKE ACCUMULATOR PISTON AND SPRINGS
- C. DIRECT CLUTCH ACCUMULATOR PISTON AND SPRINGS
- D. SECOND BRAKE ACCUMULATOR PISTON AND SPRINGS

J9121-378

Fig. 84 Accumulator Pistons, Springs And Spacers

(5) Install valve body, oil screen and oil pan.

SECOND COAST BRAKE SERVO

REMOVAL

- (1) Remove valve body.
- (2) Remove servo piston cover snap ring with snap ring pliers (Fig. 85).
- (3) Remove servo piston and cover with compressed air. Apply compressed air through oil hole in servo boss to ease piston out of bore (Fig. 86).

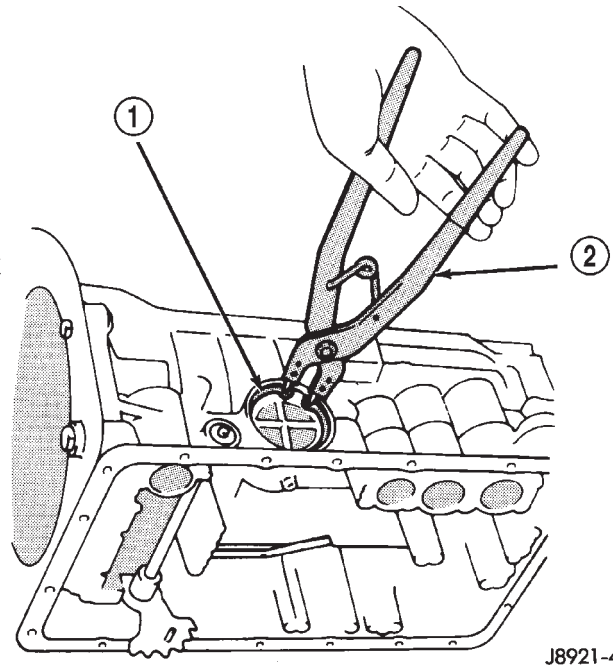

J8921-457

Fig. 85 Removing/Installing Servo Piston Cover Snap Ring

- 1 - SERVO PISTON COVER SNAP RING
- 2 - SNAP RING PLIERS

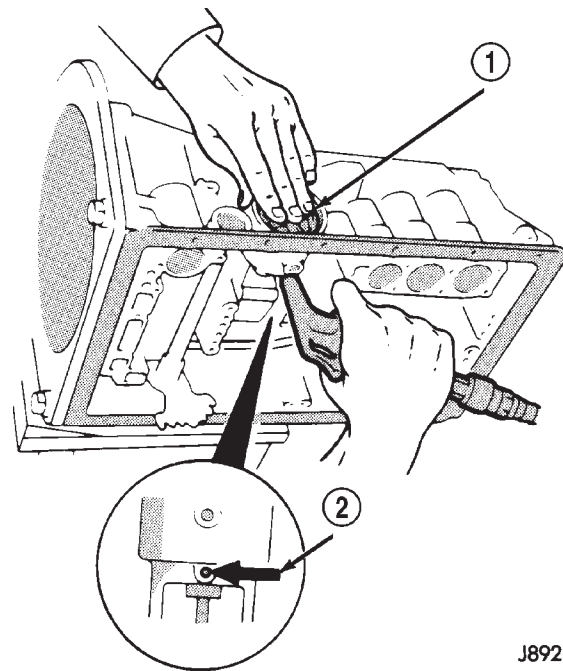

J8921-458

Fig. 86 Removing Servo Cover And Piston

- 1 - PISTON AND COVER
- 2 - OIL HOLE

REMOVAL AND INSTALLATION (Continued)

(4) Remove and discard seal and O-rings from cover and piston (Fig. 87). Inspect E-ring, piston, spring and retainer, piston rod and piston spring. Replace worn or damaged parts.

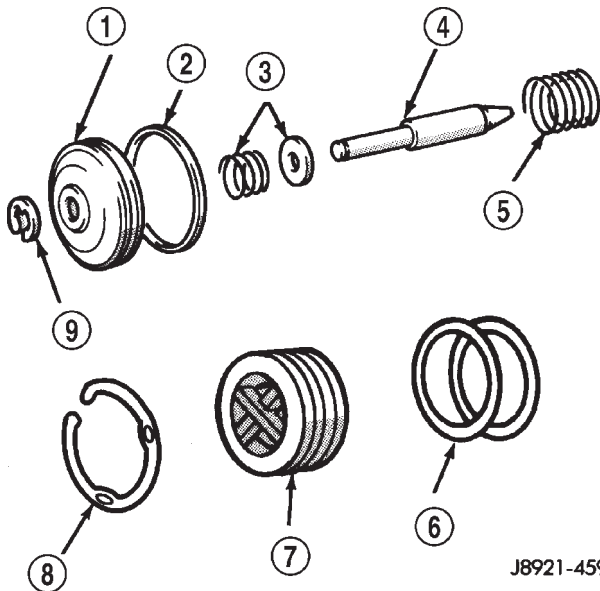

J8921-459

Fig. 87 Second Coast Brake Servo Components

- 1 - SERVO PISTON
- 2 - SEAL RING
- 3 - SPRING AND RETAINER
- 4 - PISTON ROD
- 5 - PISTON SPRING
- 6 - SERVO COVER O-RINGS
- 7 - SERVO COVER
- 8 - SNAP RING
- 9 - E-RING

INSTALLATION

- (1) Install new seals on cover and piston.
- (2) Lubricate servo components with transmission fluid.
- (3) Assemble and install servo components in case. Be sure servo piston rod is properly engaged in the second coast brake band.
- (4) Compress cover and piston and install cover snap ring.
- (5) Install valve body, oil screen and oil pan.

PARK ROD AND PAWL

REMOVAL

- (1) Remove valve body as outlined in this section.
- (2) Remove bolts attaching park rod bracket to case (Fig. 88).
- (3) Remove park rod from manual valve shaft sector (Fig. 89).
- (4) Remove park rod.

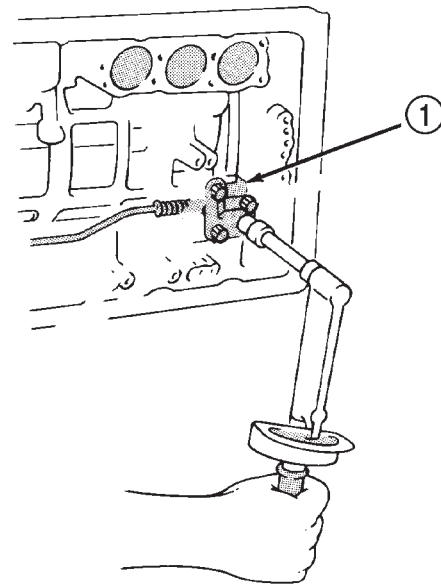

J8921-451

Fig. 88 Removing/Installing Park Rod Bracket

- 1 - PARK ROD BRACKET

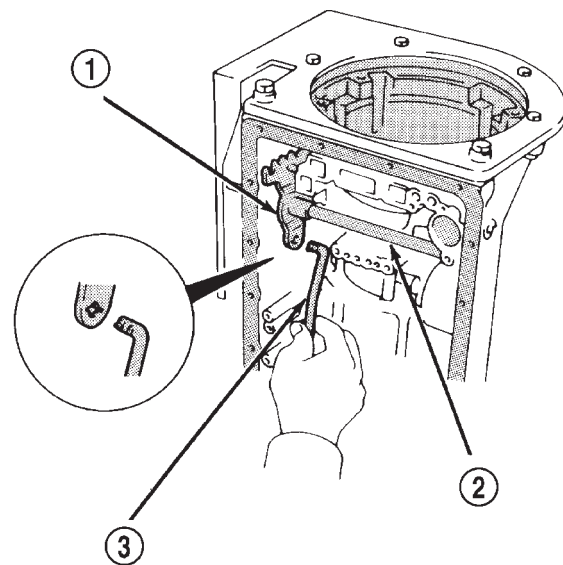

J8921-446

Fig. 89 Removing/Installing Park Rod

- 1 - SHIFT SECTOR
- 2 - MANUAL VALVE SHAFT
- 3 - PARK ROD

REMOVAL AND INSTALLATION (Continued)

(5) Remove park pawl, pin and spring (Fig. 90).

INSTALLATION

(1) Examine park rod, pawl, pin and spring. Replace any component that is worn or damaged.

(2) Install pawl in case. Insert pin and install spring. Be sure spring is positioned as shown in Figure 35.

(3) Install park rod and bracket (Fig. 88). Tighten bracket bolts to 10 N·m (7 ft. lbs.) torque.

(4) Install valve body, oil screen and oil pan.

TRANSMISSION THROTTLE CABLE

REMOVAL

(1) In engine compartment, disconnect cable from throttle linkage. Then compress cable mounting ears and remove cable from engine bracket (Fig. 91).

(2) Raise vehicle.

(3) Remove transmission oil pan.

(4) Disengage cable from throttle valve cam (Fig. 92).

(5) Remove cable bracket bolt and remove cable and bracket from case (Fig. 93).

(6) Remove and discard cable seal.

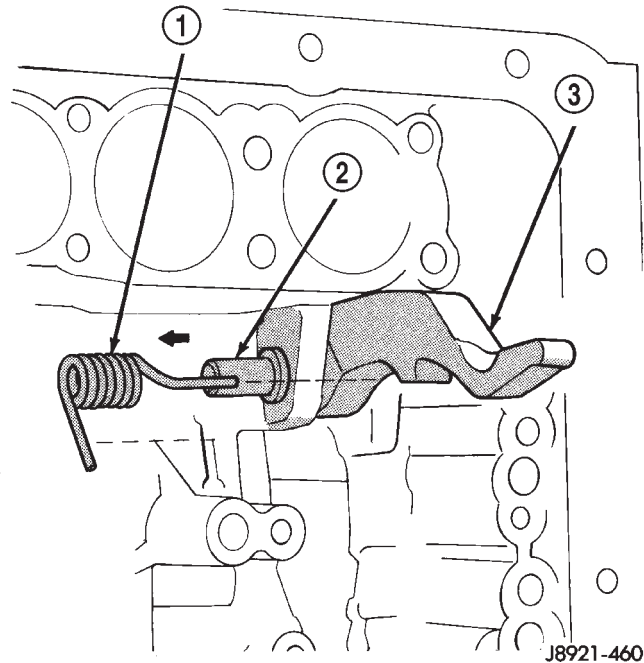

J8921-460

Fig. 90 Removing/Installing Park Pawl, Pin And Spring

- 1 - SPRING
- 2 - PIN
- 3 - PARK PAWL

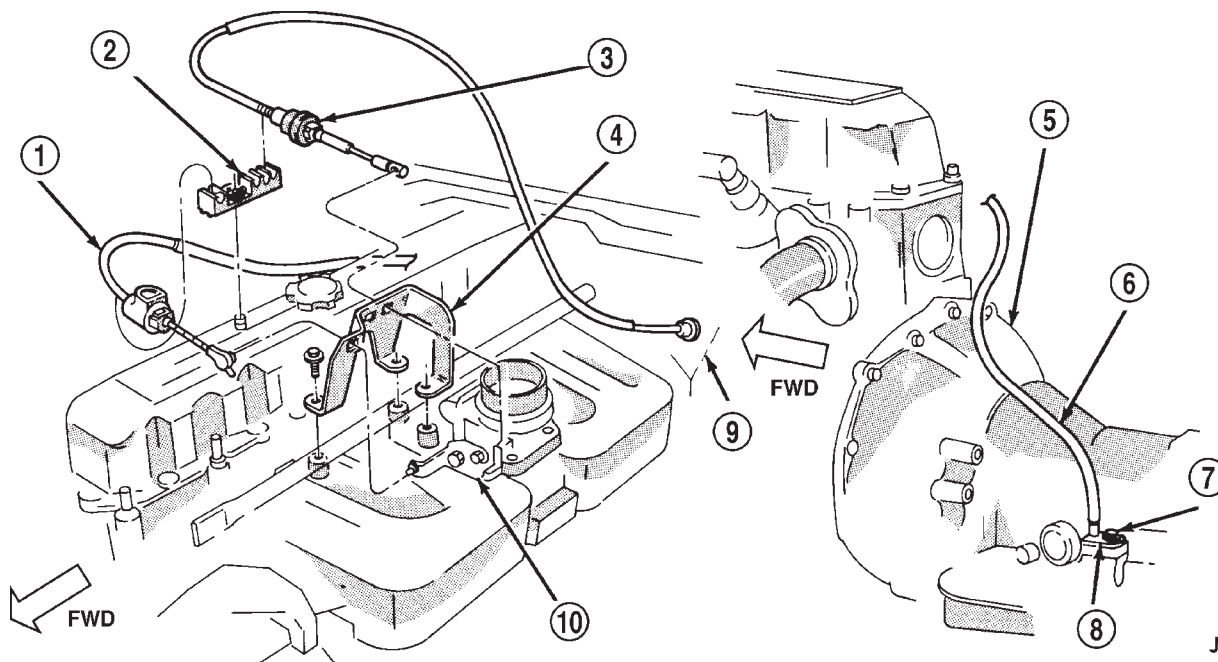

J9321-84

Fig. 91 Transmission Throttle Cable Attachment

- 1 - THROTTLE CABLE
- 2 - CABLE GUIDE
- 3 - ACCELERATOR CABLE
- 4 - CABLE ENGINE BRACKET
- 5 - CONVERTER HOUSING
- 6 - THROTTLE CABLE
- 7 - CABLE RETAINER SCREW
- 8 - CABLE BRACKET
- 9 - DASH PANEL
- 10 - THROTTLE BODY

REMOVAL AND INSTALLATION (Continued)

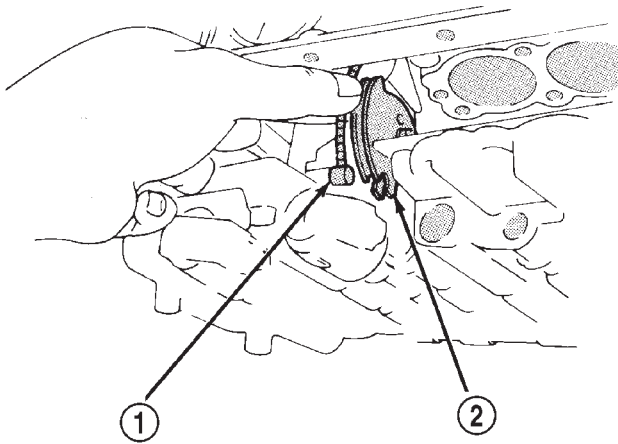

J8921-438

Fig. 92 Removing/Installing Transmission Throttle Cable

- 1 - THROTTLE CABLE
2 - CABLE BRACKET

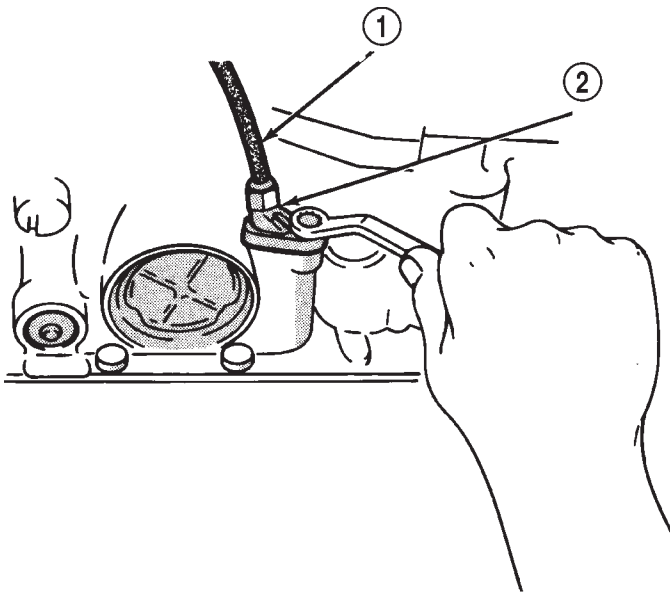

J8921-452

Fig. 93 Removing/Installing Transmission Throttle Cable And Bracket

- 1 - THROTTLE CABLE
2 - CABLE BRACKET

INSTALLATION

- (1) Lubricate and install new seal on cable.
- (2) Insert cable in transmission case.
- (3) Attach cable to throttle cam (Fig. 92).
- (4) Install cable bracket on case and tighten attaching bolt to 10 N·m (7 ft. lbs.) torque (Fig. 93).
- (5) Install pan and tighten pan bolts to 7 N·m (65 in. lbs.) torque.

(6) Install new gasket on oil pan drain plug. Install and tighten plug to 20 N·m (15 ft. lbs.) torque.

(7) Connect cable to engine bracket and throttle linkage.

(8) Fill transmission with Mopar® Dexron/Mercon IIE.

(9) Adjust the cable as described in cable adjustment procedure.

OIL PUMP SEAL

REMOVAL

- (1) Remove converter.
- (2) Remove old seal. Use blunt punch to collapse seal and pry seal out of pump housing. Do not scratch or damage seal bore.

INSTALLATION

- (1) Lubricate lip of new seal with transmission fluid and install seal in pump with tool 7549 (Fig. 94).

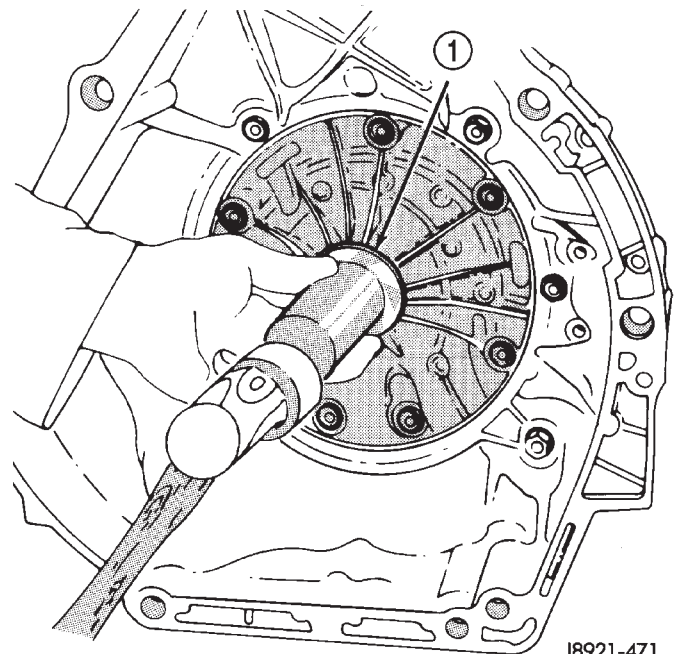

J8921-471

Fig. 94 Installing Oil Pump Seal

- 1 - PUMP SEALER INSTALLER

(2) Lubricate converter drive hub with transmission fluid.

(3) Align and install converter in oil pump.

DISASSEMBLY AND ASSEMBLY TRANSMISSION

DISASSEMBLY

- (1) Remove torque converter.
- (2) Remove clamps attaching wire harness and throttle cable (Fig. 95) to transmission.

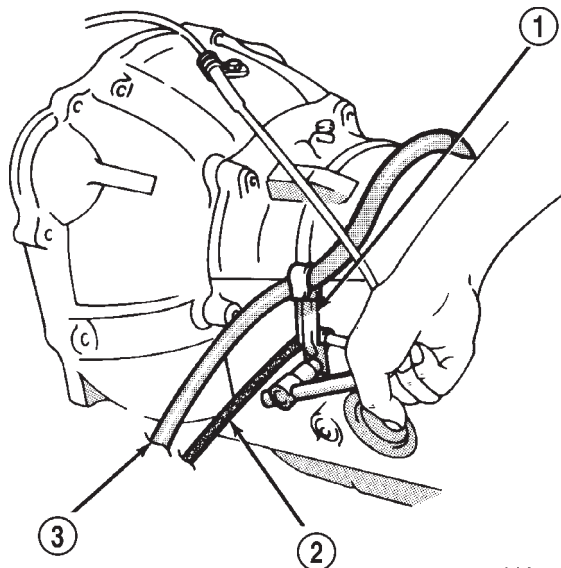

J8921-474

Fig. 95 Typical Harness And Cable Clamp Attachment

- 1 - CLAMP
- 2 - THROTTLE CABLE
- 3 - TRANSMISSION HARNESS

- (3) Remove shift lever from manual valve shaft at left side of transmission.
- (4) Remove park/neutral position switch.
- (5) Remove speed sensor.
- (6) Remove converter housing bolts and remove housing (Fig. 96) from case.
- (7) Remove adapter housing, speedometer drive gear, and speed sensor rotor.
- (8) Remove transmission oil pan, oil screen and screen gaskets (Fig. 97).

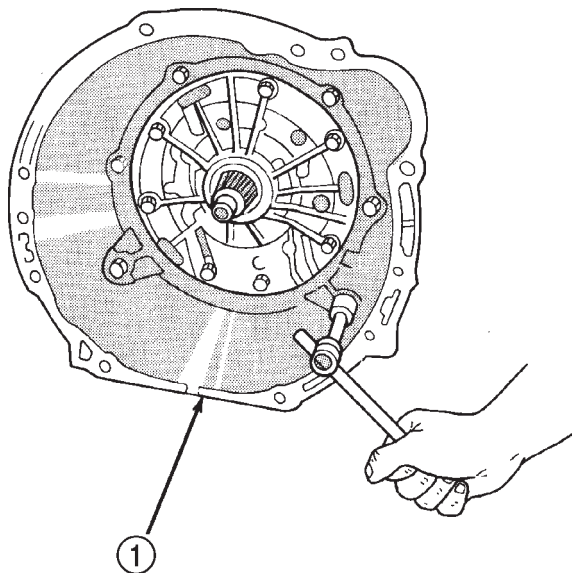

J8921-476

Fig. 96 Converter Housing Removal

- 1 - CONVERTER HOUSING

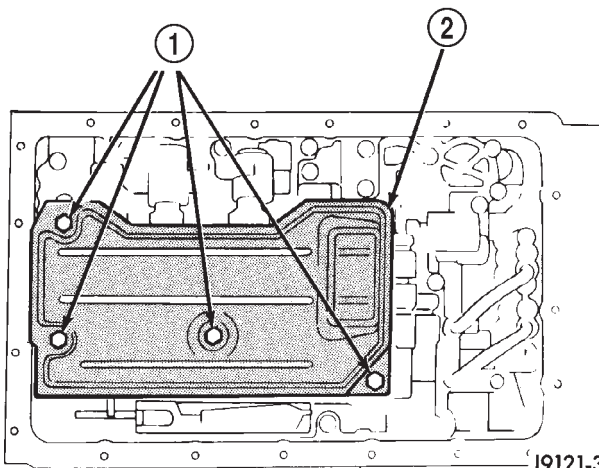

J9121-376

Fig. 97 Removing Oil Screen

- 1 - OIL SCREEN BOLTS
- 2 - OIL SCREEN

DISASSEMBLY AND ASSEMBLY (Continued)

(9) Remove valve body oil feed tubes (Fig. 98).

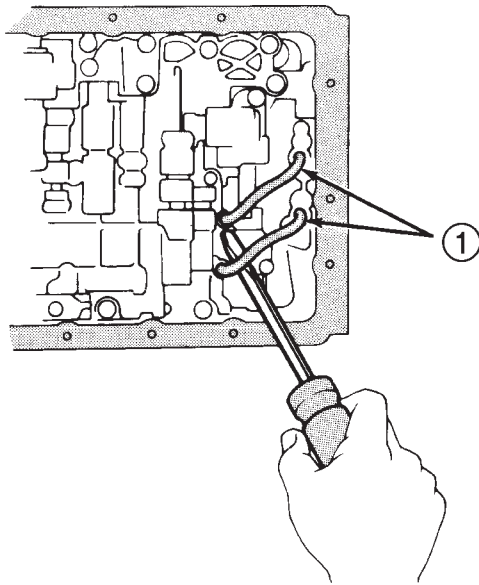

J8921-437

Fig. 98 Valve Body Oil Tube Removal

1 - OIL TUBES

(11) Remove harness bracket bolt and remove harness and bracket (Fig. 100).

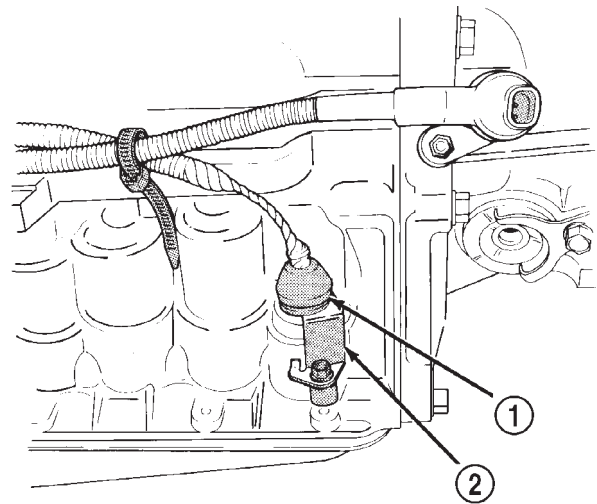

J8921-436

Fig. 100 Removing Bracket And Harness

1 - HARNESS ADAPTER
2 - BRACKET

(10) Disconnect valve body solenoid wires (Fig. 99).

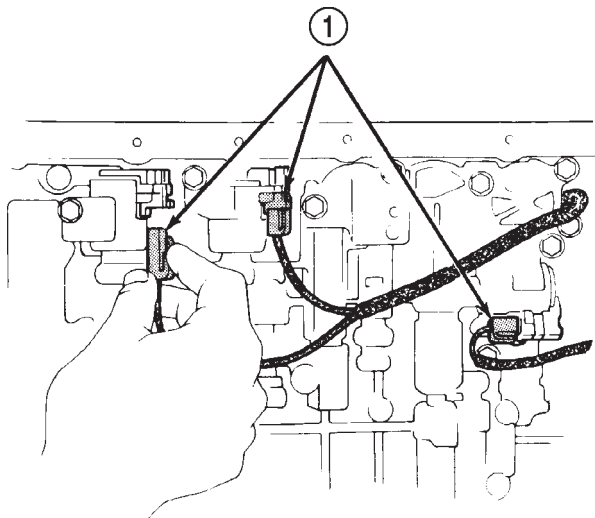

J8921-433

Fig. 99 Solenoid Wire Location

1 - SOLENOID WIRE CONNECTORS

(12) Remove valve body bolts (Fig. 101).

● = BOLT LOCATIONS

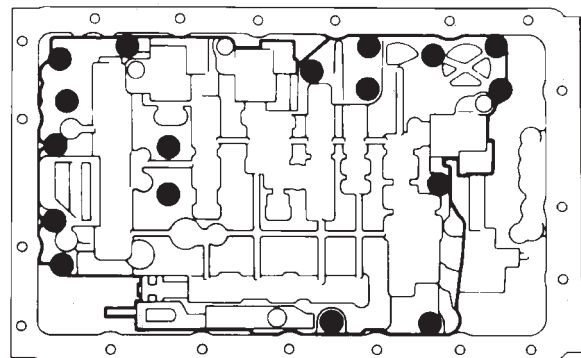

J8921-439

Fig. 101 Valve Body Bolt Locations

(13) Disconnect throttle cable from throttle cam (Fig. 102).

(14) Remove valve body from case. Then remove accumulator springs, check ball, and spring (Fig. 103).

DISASSEMBLY AND ASSEMBLY (Continued)

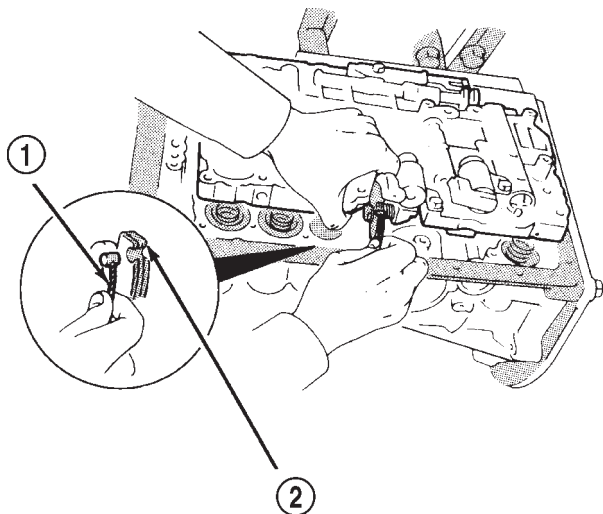

J8921-478

Fig. 102 Disconnecting Throttle Cable

- 1 - THROTTLE CABLE
- 2 - THROTTLE CAM

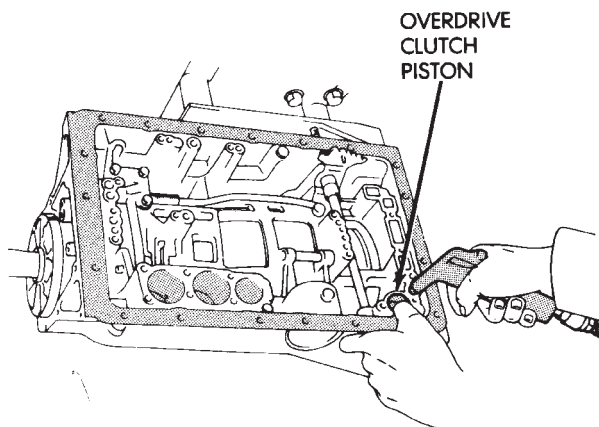
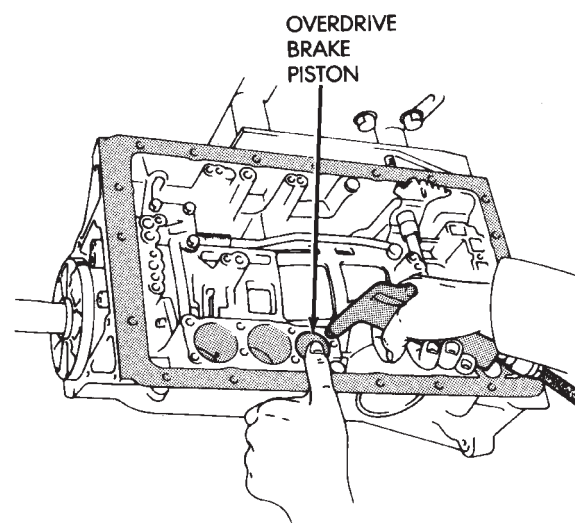
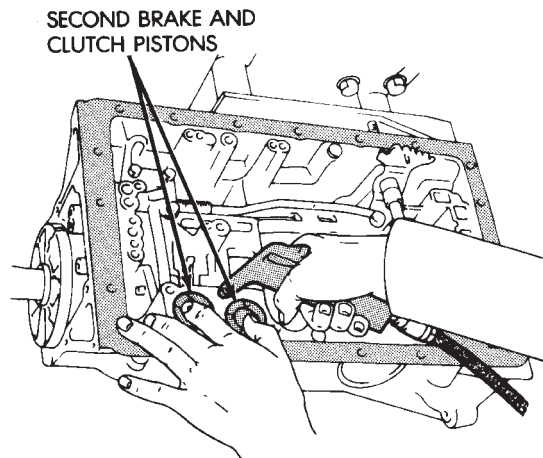

J8921-480

Fig. 104 Accumulator Piston Removal

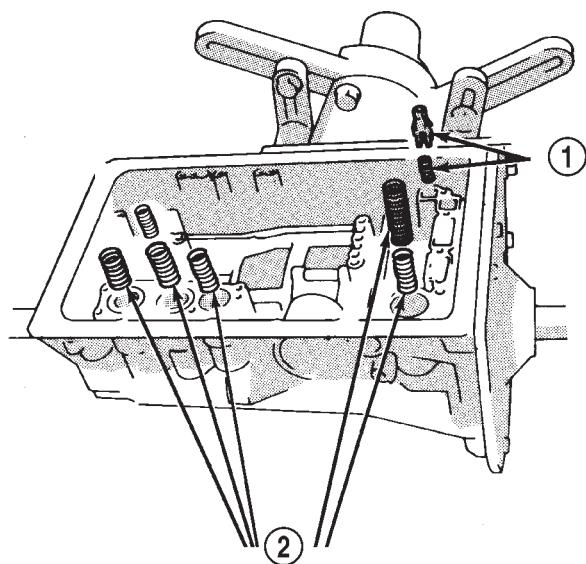

J9121-381

Fig. 103 Removing Accumulator Springs, Spacers And Check Ball

- 1 - CHECK BALL AND SPRING
- 2 - ACCUMULATOR SPRINGS

(15) Remove second brake and clutch accumulator pistons with compressed air (Fig. 104). Apply air pressure through feed port and ease the pistons and springs out of the bore. Note and identify the original location of all springs.

(16) Remove overdrive brake accumulator piston with compressed air (Fig. 104). Note and identify the original location of all springs.

(17) Remove overdrive clutch accumulator piston with compressed air (Fig. 104).

(18) Remove throttle cable.

DISASSEMBLY AND ASSEMBLY (Continued)

(19) Remove oil pump bolts and remove pump with bridge-type Puller 7536 (Fig. 105).

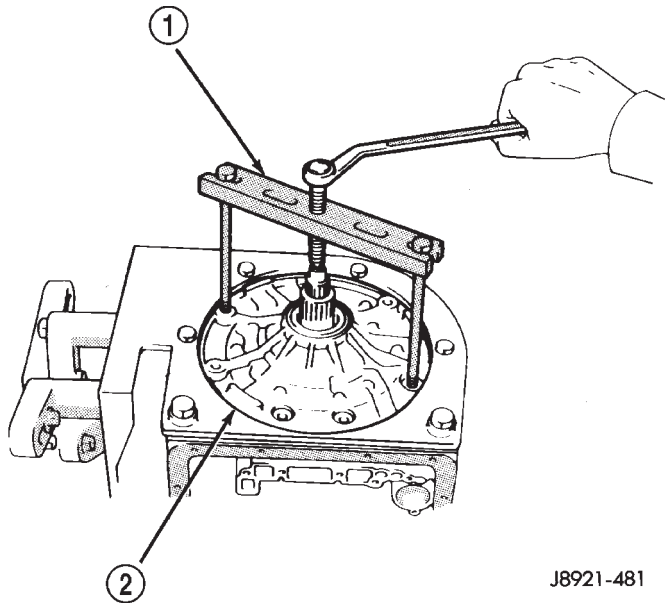

J8921-481

Fig. 105 Oil Pump Removal

- 1 - PULLER TOOL
- 2 - OIL PUMP

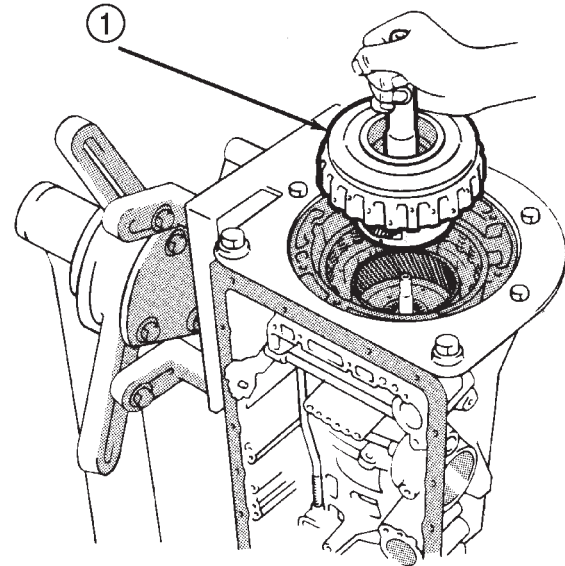

J8921-483

Fig. 107 Removing Overdrive Planetary And Clutch Assembly

- 1 - PLANETARY AND CLUTCH ASSEMBLY

(20) Remove race from oil pump (Fig. 106).

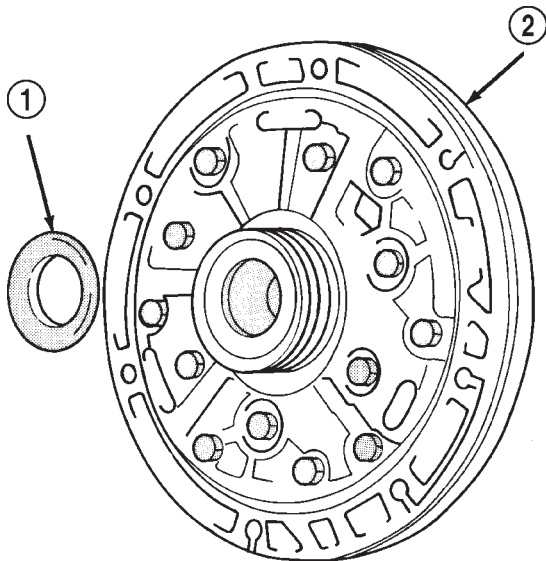

J8921-482

Fig. 106 Oil Pump Race Removal

- 1 - OIL PUMP RACE
- 2 - OIL PUMP

(21) Remove overdrive planetary gear and clutch assembly (Fig. 107).

(22) Remove race from overdrive planetary (Fig. 108).

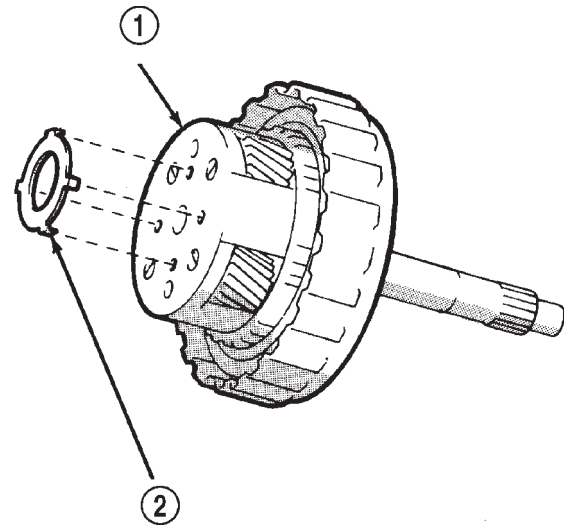

J8921-484

Fig. 108 Fourth Gear Planetary Race Removal

- 1 - PLANETARY (OVERDRIVE)
- 2 - RACE

(23) Remove thrust bearing, race and overdrive planetary ring gear (Fig. 109).

(24) Measure stroke length of overdrive brake piston as follows:

DISASSEMBLY AND ASSEMBLY (Continued)

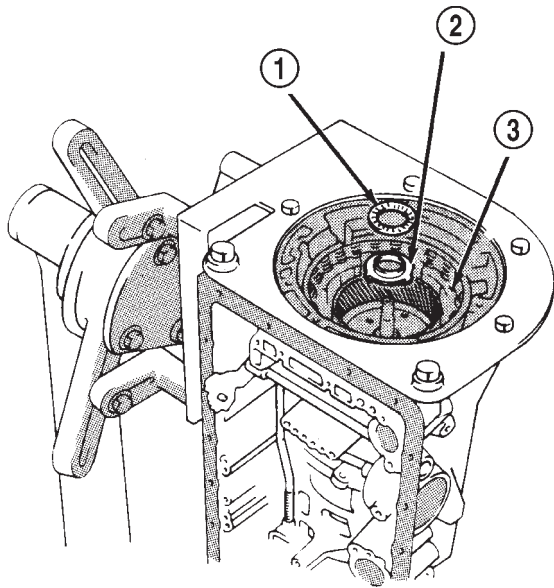

J8921-485

Fig. 109 Removing Bearing, Race And Planetary Ring Gear

- 1 - THRUST BEARING
- 2 - RACE
- 3 - OVERDRIVE PLANETARY RING GEAR

(28) Remove overdrive brake pack snap ring (Fig. 110).

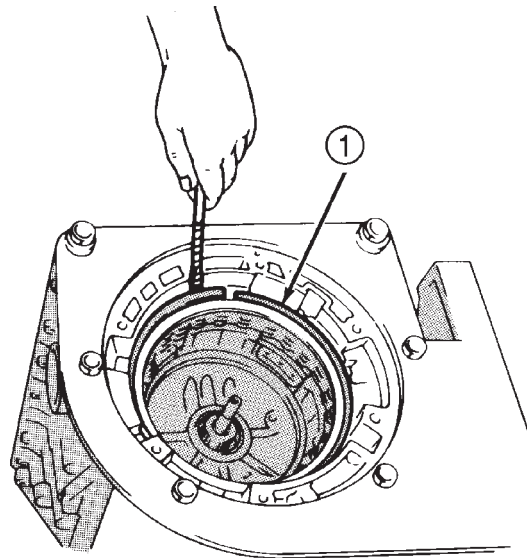

J8921-487

Fig. 110 Removing Overdrive Brake Pack Snap Ring

- 1 - OVERDRIVE BRAKE SNAP RING

(a) Mount dial indicator on case using Miller Tool C-3339 and a suitable bolt threaded into the transmission case.

(b) Verify that the dial indicator is mounted solidly and square to the direction of the piston travel.

(c) Apply 57-114 psi air pressure through piston apply port and note piston stroke on dial indicator. Stroke length should be: 1.40 - 1.70 mm (0.055 - 0.0699 in.).

(d) Record the reading for use during re-assembly.

(e) Remove the dial indicator set-up from the transmission.

(25) Measure stroke length of second coast brake piston rod as follows:

(a) Install a small wire tie strap around the second coast brake piston rod tight against the transmission case.

(b) Apply 57-114 psi air pressure through piston feed hole and check stroke length with Gauge Tool 7552.

(c) Stroke length should be 1.5 - 3.0 mm (0.059 - 0.118 in.).

(d) Record the reading for use during re-assembly.

(26) Remove the bolt holding the input speed sensor to the transmission case.

(27) Remove the input speed sensor from the transmission case.

(29) Remove overdrive brake pack discs and plates. Inspect and replace as necessary.

(30) Remove overdrive support lower race and upper bearing and race assembly (Fig. 111).

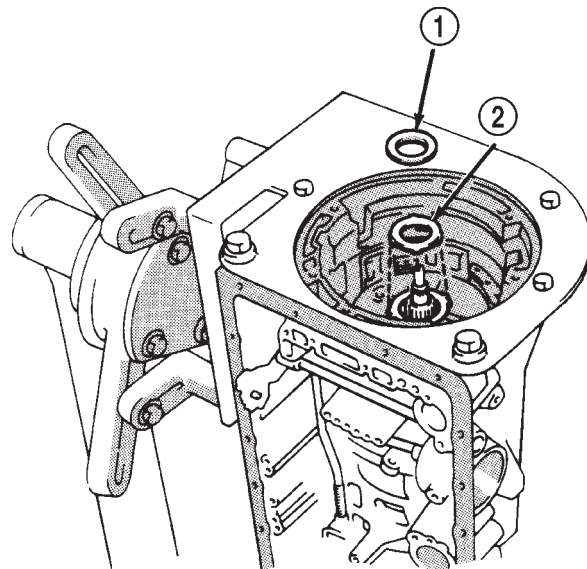

J8921-489

Fig. 111 Overdrive Support Bearing/Race Removal

- 1 - UPPER BEARING AND RACE
- 2 - LOWER RACE

DISASSEMBLY AND ASSEMBLY (Continued)

(31) Remove overdrive support snap ring with Snap Ring Plier Tool 7540 (Fig. 112).

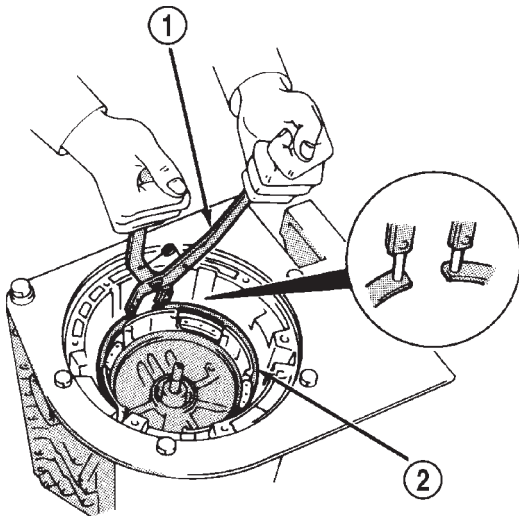

J8921-491

Fig. 112 Overdrive Support Snap Ring Removal/ Installation

- 1 - SNAP RING PLIERS
- 2 - SUPPORT SNAP RING

(32) Remove overdrive support bolts (Fig. 113).

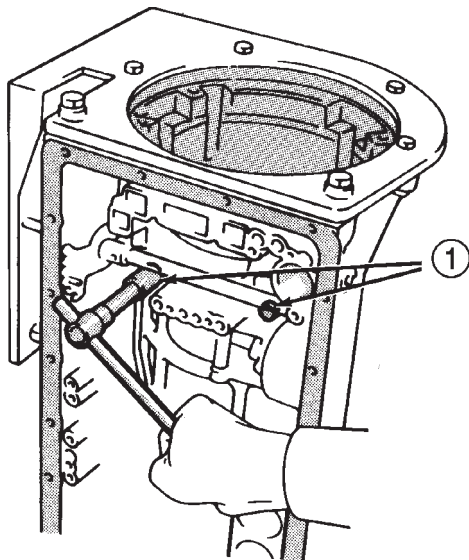

J8921-490

Fig. 113 Overdrive Support Bolt Removal

- 1 - SUPPORT BOLTS

(33) Remove overdrive support (Fig. 114) with bridge-type Puller 7536.

(34) Remove race from hub of overdrive support (Fig. 115).

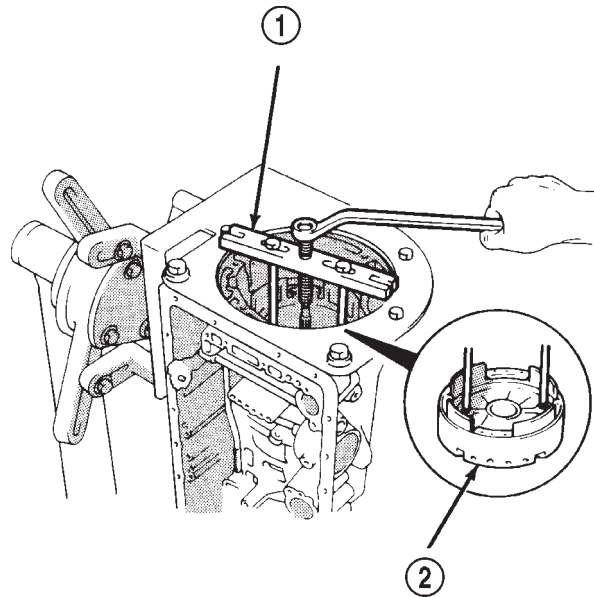

J8921-492

Fig. 114 Removing Overdrive Support

- 1 - BRIDGE-TYPE PULLER TOOL
- 2 - OVERDRIVE SUPPORT

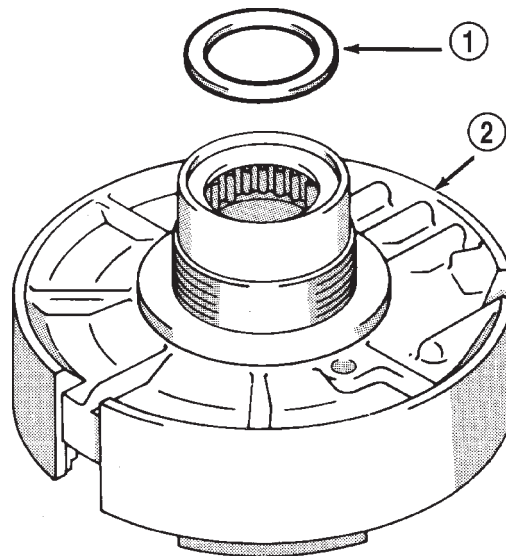

J8921-493

Fig. 115 Remove Overdrive Support Race

- 1 - RACE
- 2 - OVERDRIVE SUPPORT

(35) Remove second coast brake piston snap ring with Snap Ring Plier Tool 7540. Then remove piston cover and piston assembly.

(36) Disassemble second coast brake piston (Fig. 116), if necessary.

(37) Remove direct and forward clutch assembly (Fig. 117).

DISASSEMBLY AND ASSEMBLY (Continued)

(38) Remove thrust bearing and race from clutch hub (Fig. 118).

(39) Remove second coast brake band E-ring from band pin and remove pin and brake band (Fig. 119).

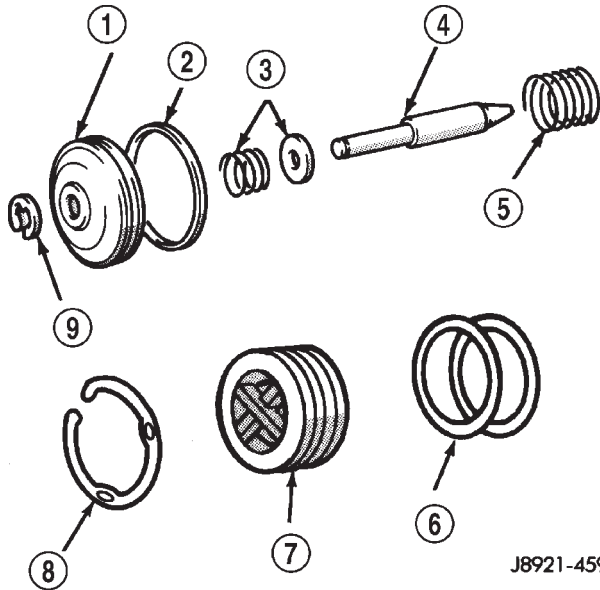

J8921-459

Fig. 116 Second Coast Brake Piston Components

- 1 - SERVO PISTON
- 2 - SEAL RING
- 3 - SPRING AND RETAINER
- 4 - PISTON ROD
- 5 - PISTON SPRING
- 6 - SERVO COVER O-RINGS
- 7 - SERVO COVER
- 8 - SNAP RING
- 9 - E-RING

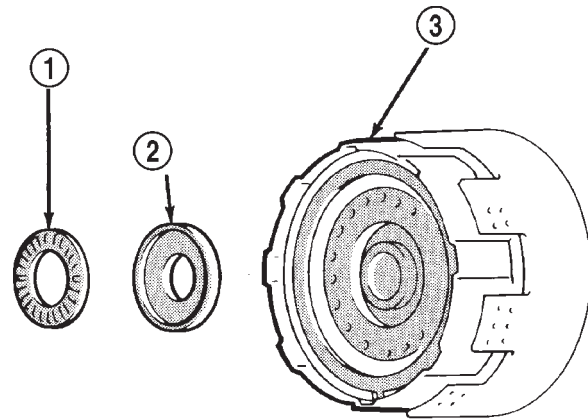

J8921-497

Fig. 118 Bearing And Race Removal From Clutch Hub

- 1 - BEARING
- 2 - RACE
- 3 - DIRECT CLUTCH

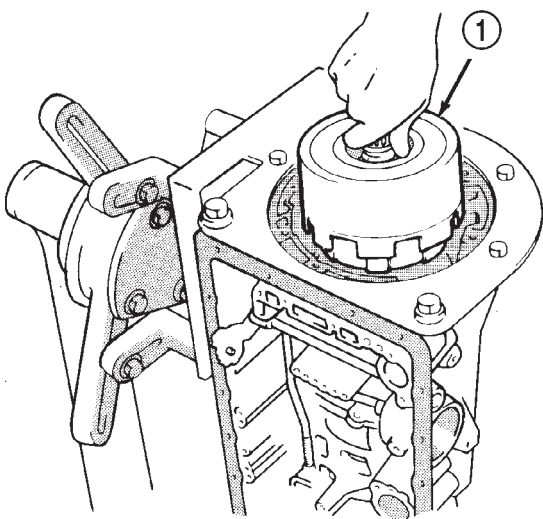

J8921-496

Fig. 117 Removing Direct And Forward Clutch Assembly

- 1 - DIRECT AND FORWARD CLUTCH ASSEMBLY

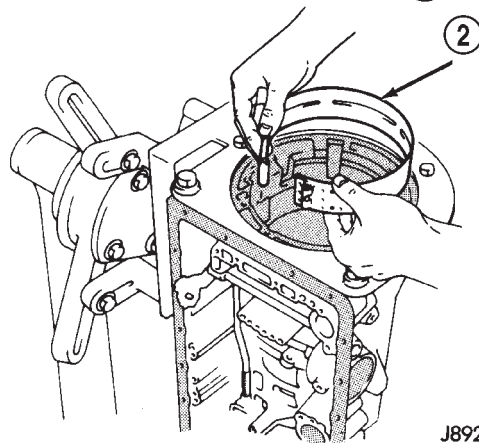
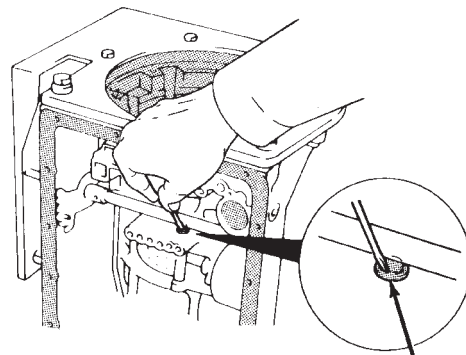

J8921-498

Fig. 119 Second Coast Brake Band Removal

- 1 - BRAKE BAND E-RING
- 2 - SECOND COAST BRAKE BAND

DISASSEMBLY AND ASSEMBLY (Continued)

(40) Remove front planetary bearing race and remove front planetary ring gear (Fig. 120).

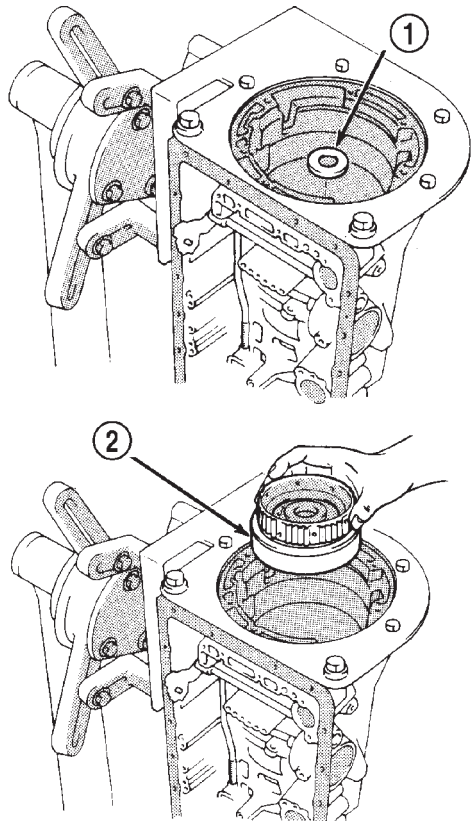

J8921-499

Fig. 120 Front Planetary Ring Gear Removal

- 1 - RING GEAR BEARING RACE (FRONT)
- 2 - FRONT PLANETARY RING GEAR

(41) Remove thrust bearing and rear race from ring gear (Fig. 121).

(42) Remove planetary thrust race.

(43) Push forward on output shaft to relieve the load on the planetary snap ring.

(44) Remove planetary snap ring and remove planetary gear (Fig. 122).

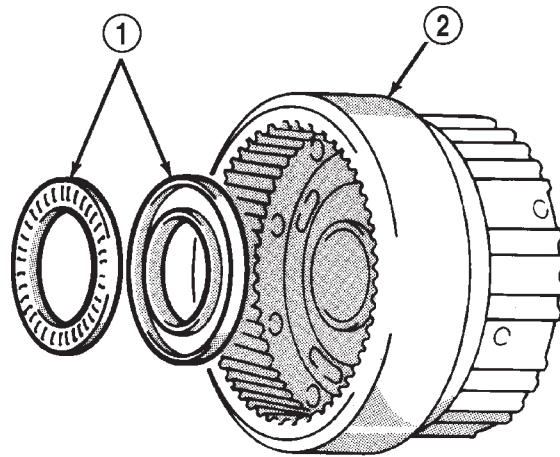

J8921-500

Fig. 121 Removing Ring Gear Bearing And Rear Race

- 1 - BEARING AND REAR RACE
- 2 - FRONT PLANETARY RING GEAR

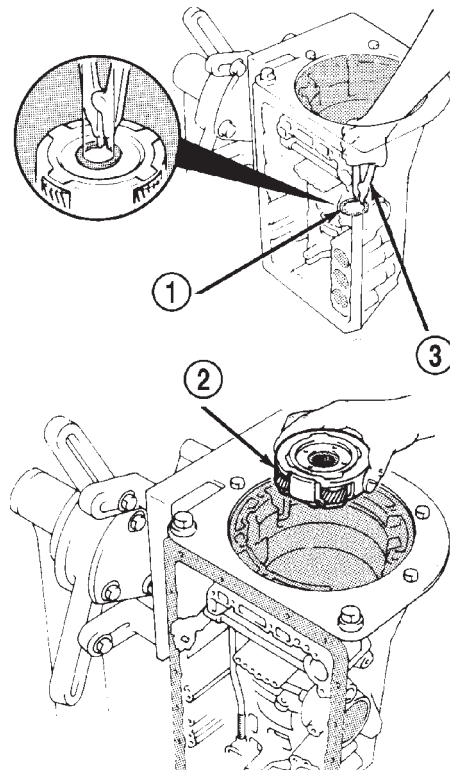

J8921-502

Fig. 122 Removing Planetary Snap Ring And Gear

- 1 - PLANETARY SNAP RING
- 2 - PLANETARY GEAR
- 3 - SNAP RING PLIERS

DISASSEMBLY AND ASSEMBLY (Continued)

(45) Remove sun gear, input drum, one-way clutch, and thrust washer as assembly (Fig. 123).

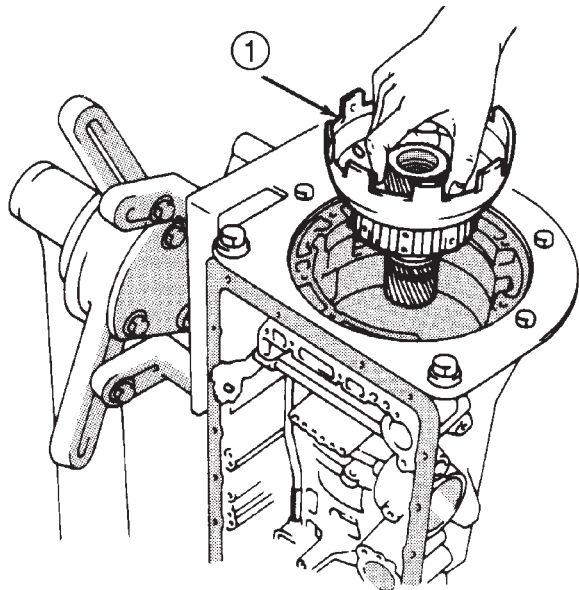

J8921-503

Fig. 123 Removing Sun Gear, Input Drum And One-Way Clutch

1 - SUN GEAR INPUT DRUM, ONE-WAY CLUTCH ASSEMBLY

(46) Measure second brake clutch pack clearance (Fig. 124). Clearance should be 0.62 - 1.98 mm (0.0244 - 0.0780 in.). Record measurement for use during re-assembly.

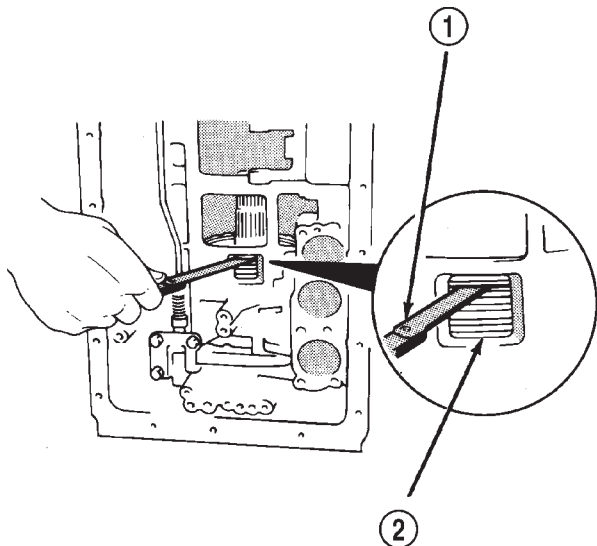

J8921-504

Fig. 124 Checking Second Brake Clutch Pack Clearance

1 - FEELER GAUGE
2 - SECOND BRAKE CLUTCH PACK

(47) Remove second brake clutch pack snap ring (Fig. 125).

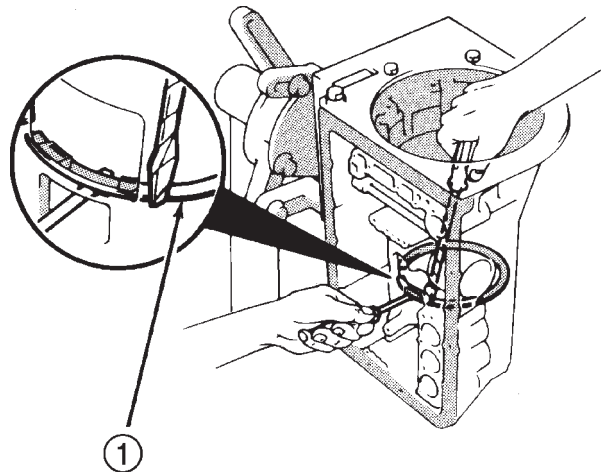

J8921-505

Fig. 125 Removing Second Brake Clutch Pack Snap Ring

1 - CLUTCH PACK SNAP RING

(48) Remove second brake clutch pack (Fig. 126). Inspect and replace as necessary.

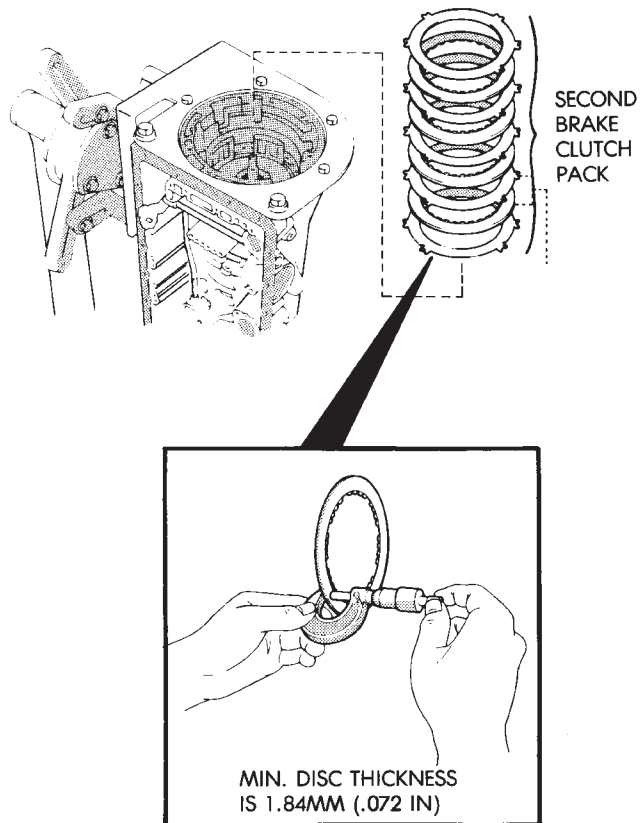

J8921-506

Fig. 126 Removing/Measuring Second Brake Clutch Disc Thickness

DISASSEMBLY AND ASSEMBLY (Continued)

(49) Remove bolts attaching park rod bracket to case. Then disconnect park rod from manual shaft lever and remove rod and bracket (Fig. 127).

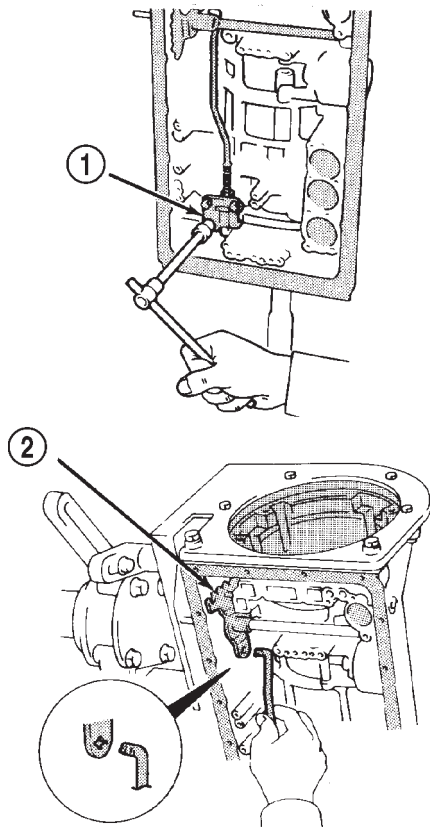

J8921-507

Fig. 127 Removing Park Rod And Bracket

- 1 - PARK ROD BRACKET
2 - SHIFT SETOR

(50) Remove park pawl spring, pin and pawl (Fig. 128).

(51) Measure clearance of first-reverse brake clutch pack (Fig. 129). Clearance should be: 0.70 - 1.2 mm (0.028 - 0.047 in.). record measurement for use during re-assembly.

(52) Remove second brake piston sleeve (Fig. 130).

(53) Remove second brake snap-ring.

(54) Remove rear planetary gear, second brake drum and output shaft as an assembly (Fig. 131).

(55) Remove planetary and brake drum thrust bearing and race assembly (Fig. 132).

(56) Remove second brake drum gasket from case with screwdriver.

(57) Measure inside diameter of transmission case rear bushing with bore gauge or inside micrometer (Fig. 133). Maximum allowable diameter is 38.18 mm (1.5031 in.). **Replace transmission case if bushing I. D. is greater than specified. Bushing is not serviceable.**

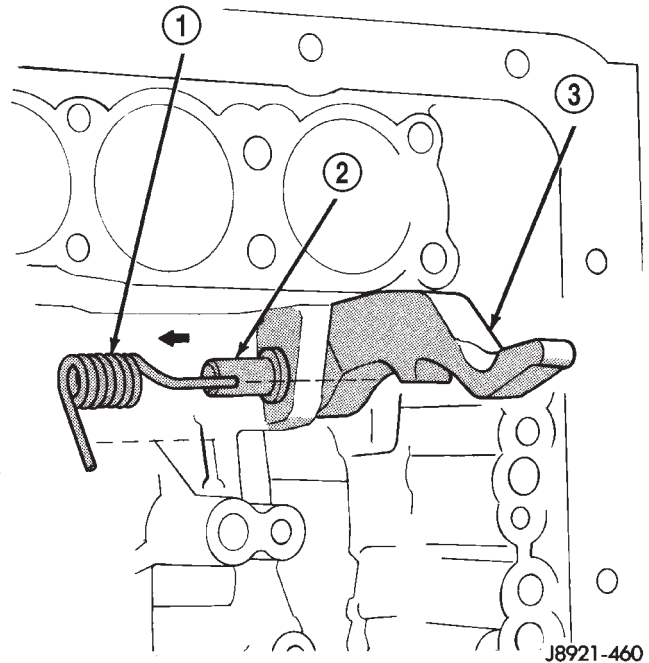

J8921-460

Fig. 128 Removing Park Pawl, Pin And Spring

- 1 - SPRING
2 - PIN
3 - PARK PAWL

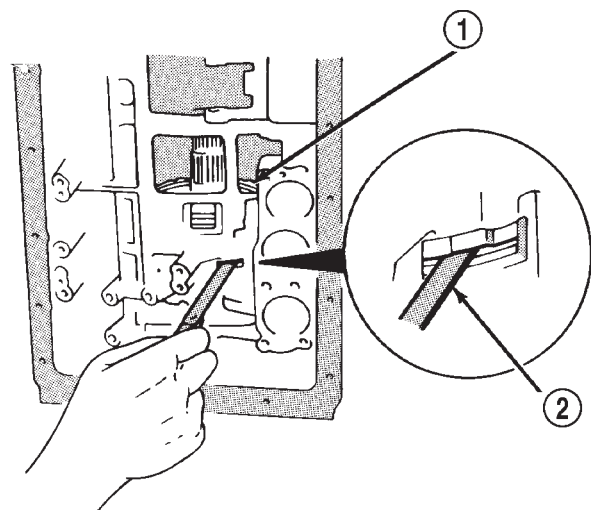

J8921-508

Fig. 129 Checking First-Reverse Brake Clutch Pack Clearance

- 1 - FIRST-REVERSE CLUTCH PACK
2 - FEELER GAUGE

DISASSEMBLY AND ASSEMBLY (Continued)

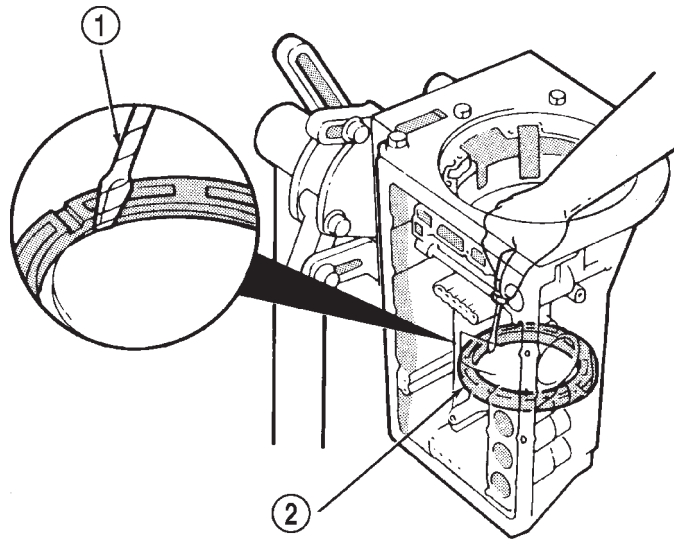

J8921-509

Fig. 130 Removing Second Brake Piston Sleeve

- 1 - REMOVER TOOL
- 2 - PISTON SLEEVE

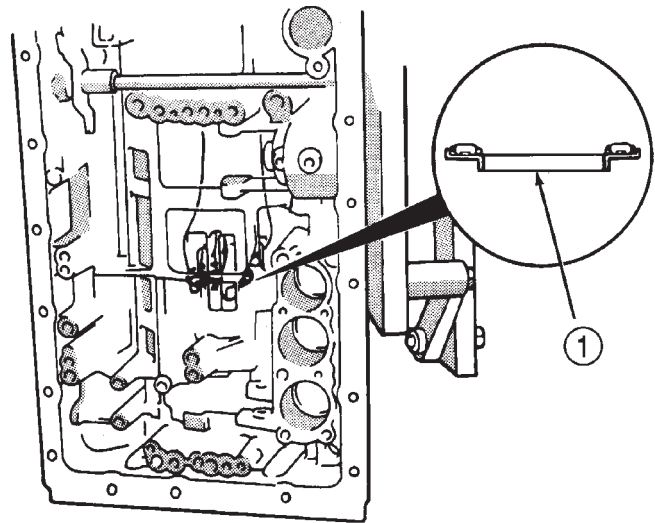

J8921-616

Fig. 132 Removing/Installing Bearing And Race Assembly

- 1 - BEARING AND RACE ASSEMBLY

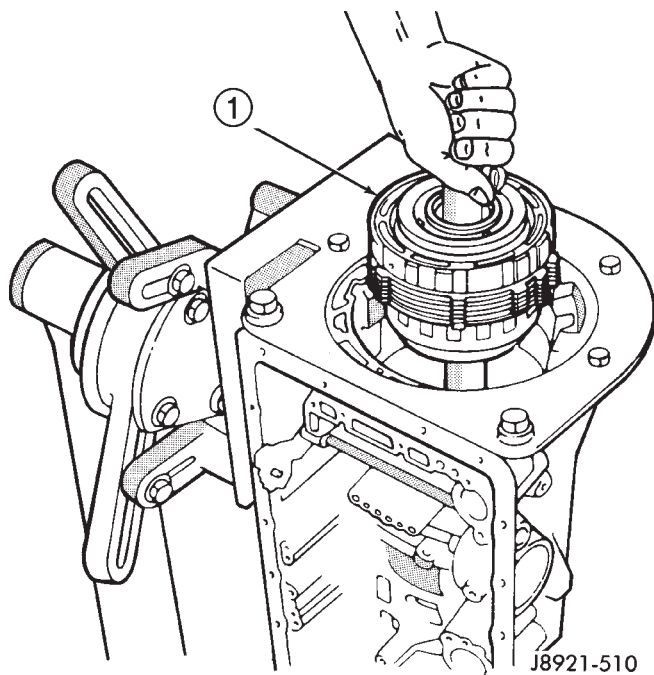

J8921-510

Fig. 131 Removing Rear Planetary, Second Brake Drum And Output Shaft

- 1 - PLANETARY, BRAKE DRUM AND OUTPUT SHAFT ASSEMBLY

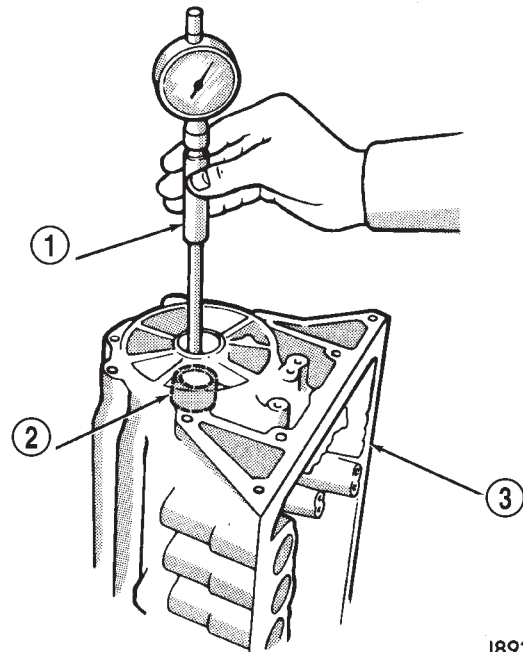

J8921-512

Fig. 133 Checking Rear Bushing Inside Diameter

- 1 - BORE GAUGE
- 2 - REAR BUSHING
- 3 - TRANSMISSION CASE

(58) Check first/reverse brake piston operation with compressed air (Fig. 134). Piston should move smoothly and not bind or stick. If piston operation is incorrect, case or piston may require replacement.

(59) Compress piston return springs with Tool 7539 and remove piston snap ring (Fig. 135).

(60) Remove Tool 7539 and remove piston return springs.

DISASSEMBLY AND ASSEMBLY (Continued)

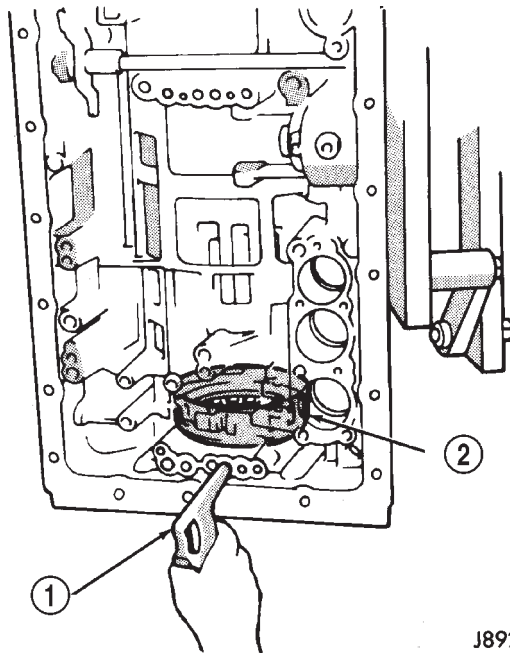

J8921-617

Fig. 134 Checking First-Reverse Brake Piston Operation

- 1 - LOW-PRESSURE AIR
- 2 - FIRST-REVERSE BRAKE (IN CASE)

(61) Remove No. 2 first-reverse brake piston with compressed air. Apply air through same transmission feed hole used for checking piston operation.

(62) Remove reaction sleeve with Sleeve Remover Tool 7542 (Fig. 136). Insert tool flanges under sleeve and lift tool and sleeve out of case.

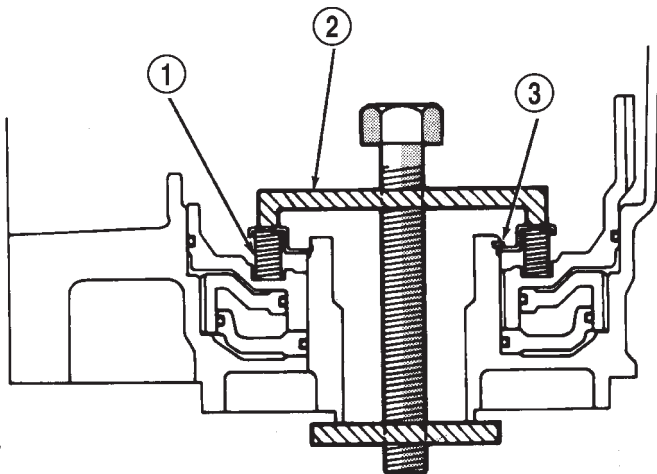

J8921-618

Fig. 135 Removing/Installing Piston Snap Ring

- 1 - RETURN SPRINGS
- 2 - COMPRESSOR TOOL
- 3 - PISTON SNAP RING

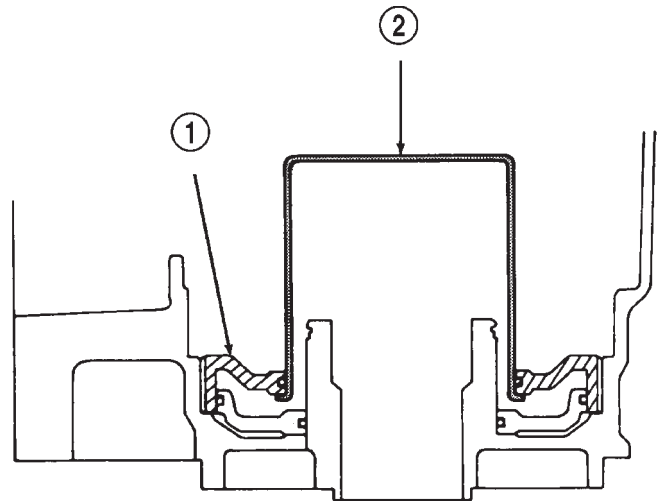

J8921-619

Fig. 136 Removing/Installing Reaction Sleeve

- 1 - REACTION SLEEVE
- 2 - TOOL

(63) Remove No. 1 first/reverse brake piston with Piston Puller 7543 (Fig. 137). Slip tool under piston and lift tool and piston out of case.

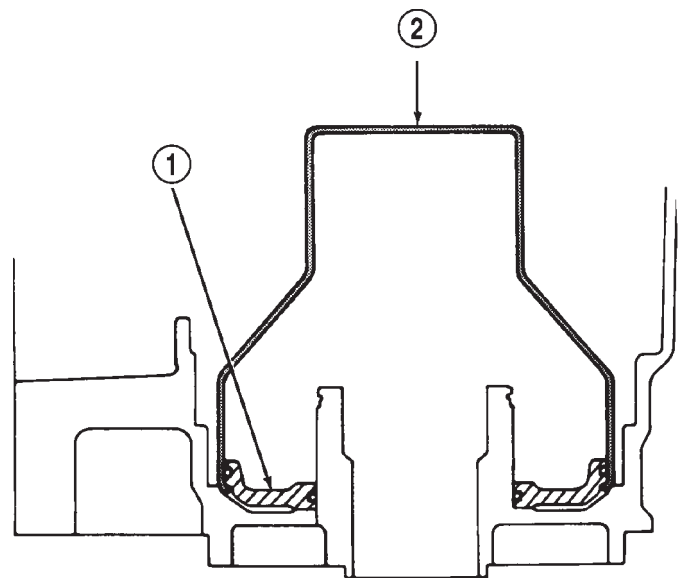

J8921-620

Fig. 137 Removing/Installing First-Reverse Brake No.1 Piston

- 1 - NO. 1 PISTON
- 2 - TOOL

ASSEMBLY

(1) During assembly, lubricate components with transmission fluid or petroleum jelly as indicated.

(2) Verify thrust bearing and race installation during assembly. Refer to the Thrust Bearing Chart (Fig.

DISASSEMBLY AND ASSEMBLY (Continued)

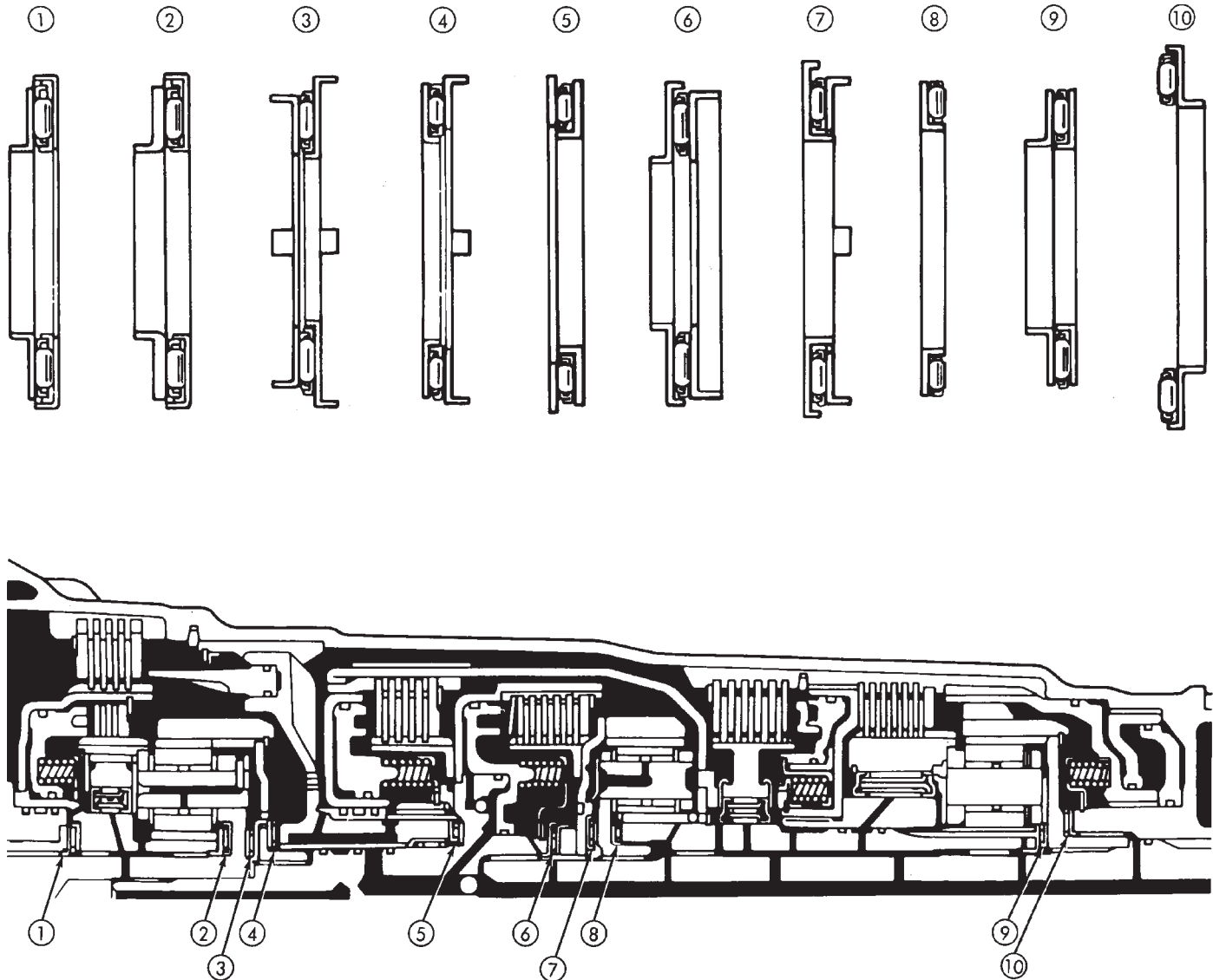

J8921-669

Fig. 138 Thrust Bearing Chart

138) for bearing and race location and correct positioning.

(3) Install new seals onto the No.1 first-reverse brake piston. Lubricate seals with transmission fluid.

(4) Install the No.1 first-reverse brake piston into the transmission case.

(5) Install new seal onto the first-reverse brake piston reaction sleeve. Lubricate seals with transmission fluid.

(6) Install the first-reverse brake piston reaction sleeve into the transmission case.

(7) Install new seal onto the No.2 first-reverse brake piston. Lubricate seals with transmission fluid.

(8) Install the No.2 first-reverse brake piston into the transmission case.

(9) Install the spring plate into the No.2 first-reverse brake piston.

(10) Install Spring Compressor 7539 onto the first-reverse brake piston.

(11) Compress the first-reverse brake piston spring and install the first-reverse brake piston snap-ring.

(12) Remove Spring Compressor 7539.

(13) Install rear planetary gear, second brake drum and output shaft as outlined in following steps:

(14) Verify No. 10 thrust bearing and race (Fig. 138). Bearing and race outer diameter is 57.7 mm (2.272 in.) and inside diameter is 39.2 mm (1.543 in.).

(15) Coat thrust bearing and race assembly with petroleum jelly and install in case (Fig. 139). Race faces down. Bearing rollers face up.

(16) Align teeth of second brake drum and clutch pack (Fig. 140).

DISASSEMBLY AND ASSEMBLY (Continued)

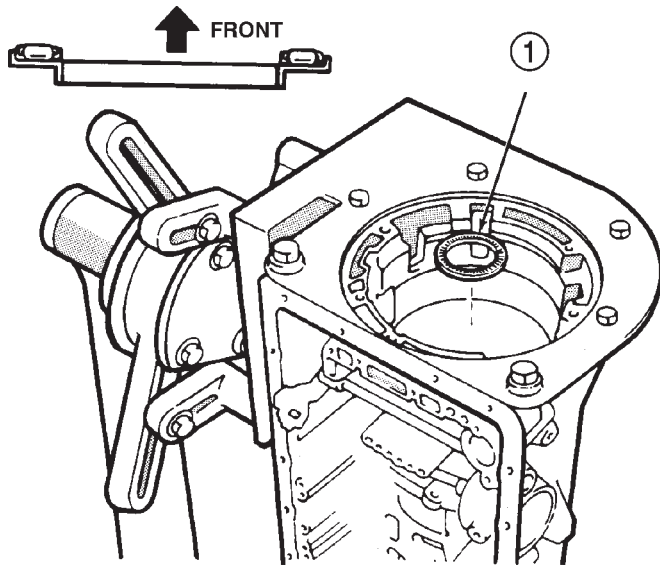

J8921-670

Fig. 139 Installing Thrust Bearing And No. 10 Race

1 - THRUST BEARING AND RACE

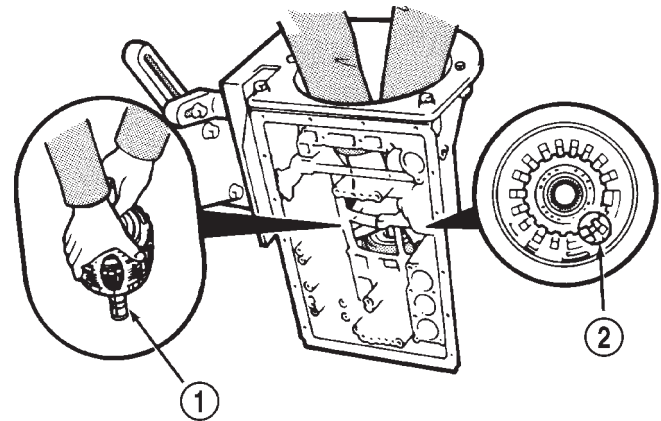

J8921-672

Fig. 141 Output Shaft/Rear Planetary Assembly Installation

1 - ALIGN CLUTCH/DRUM TEETH WITH CASE SLOTS
2 - CASE SLOTS

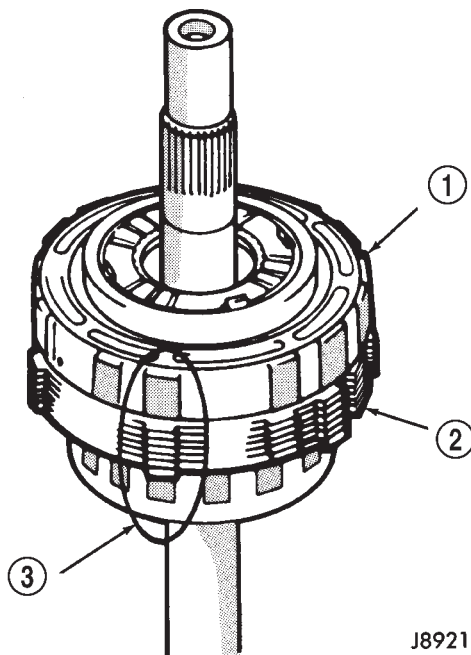

J8921-671

Fig. 140 Aligning Second Brake Drum And Clutch Pack Teeth

1 - SECOND BRAKE DRUM
2 - CLUTCH PACK
3 - ALIGN DRUM AND CLUTCH PACK TEETH

(17) Align rear planetary-output shaft assembly teeth with case slots and install assembly in case (Fig. 141).

(18) Install rear planetary snap ring with snap ring pliers. Chamfered side of snap ring faces up and toward case front (Fig. 142).

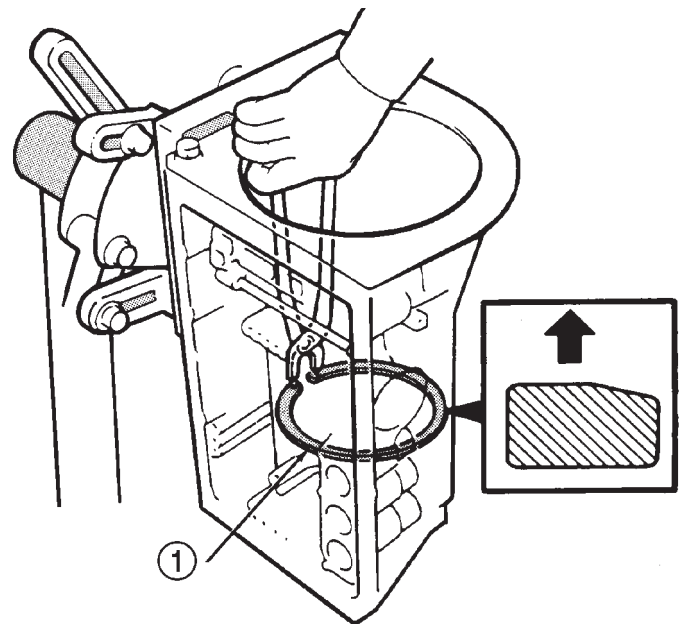

J8921-673

Fig. 142 Planetary Snap Ring Installation

1 - REAR PLANETARY SNAP RING

(19) Check first-reverse brake pack clearance with feeler gauge (Fig. 143). Clearance should be 0.70 - 1.20 mm (0.028 - 0.047 in.). If clearance is incorrect, planetary assembly, thrust bearing or snap ring is not properly seated in case. Remove and reinstall components if necessary.

(20) Install second brake piston sleeve (Fig. 144). Sleeve lip faces up and toward case front as shown.

(21) Install second brake drum gasket.

DISASSEMBLY AND ASSEMBLY (Continued)

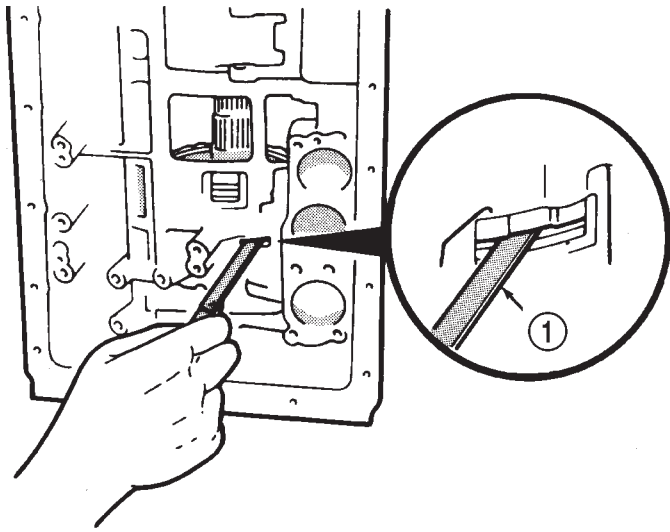

J8921-674

Fig. 143 Checking First-Reverse Brake Pack Clearance

1 - FEELER GAUGE

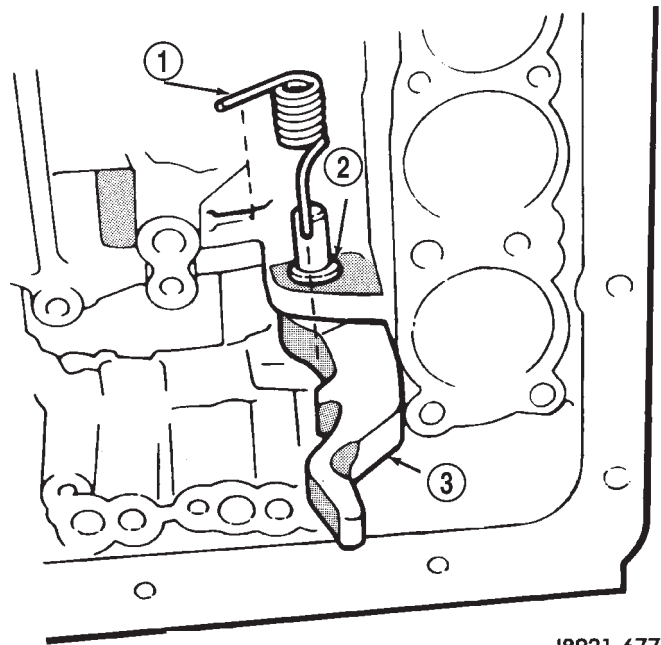

J8921-677

Fig. 145 Park Lock Pin, Spring And Pawl Installation

1 - SPRING
2 - PIN
3 - PAWL

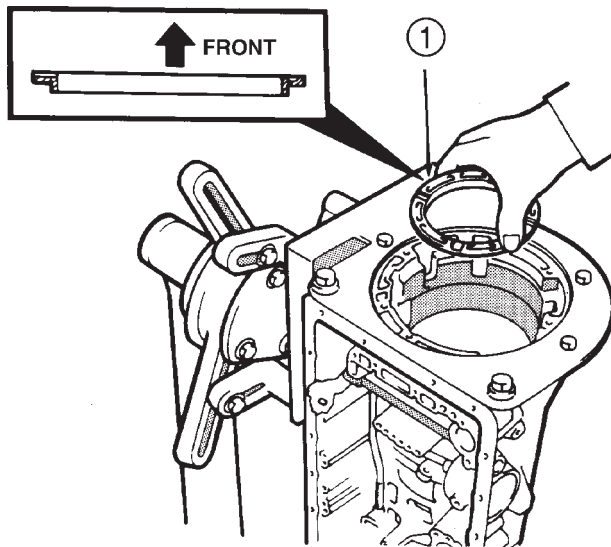

J8921-675

Fig. 144 Second Brake Piston Sleeve Installation

1 - PISTON SLEEVE

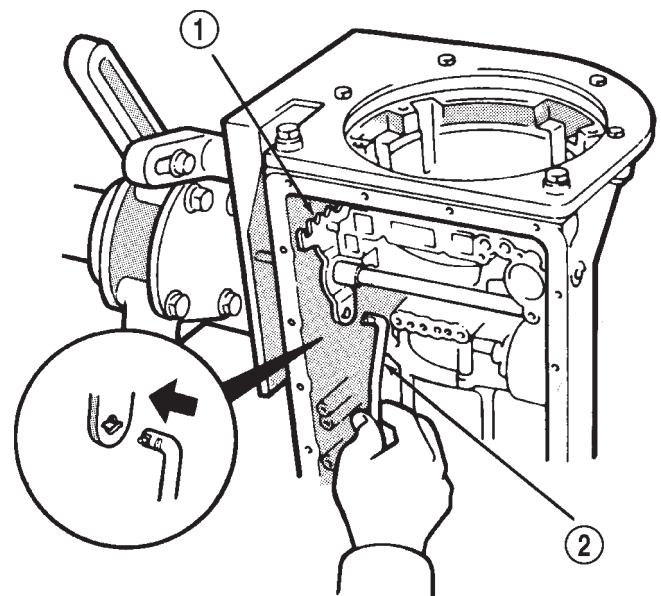

J8921-678

Fig. 146 Park Lock Rod Installation

1 - SHIFT SECTOR
2 - PARK LOCK ROD

(22) Install park lock pawl, spring and pin (Fig. 145).

(23) Install the manual valve shift assembly.

(24) Connect park lock rod to manual valve shift sector (Fig. 146).

DISASSEMBLY AND ASSEMBLY (Continued)

(25) Position park lock rod bracket on case and tighten bracket attaching bolts to 10 N·m (7 ft. lbs.) torque (Fig. 147).

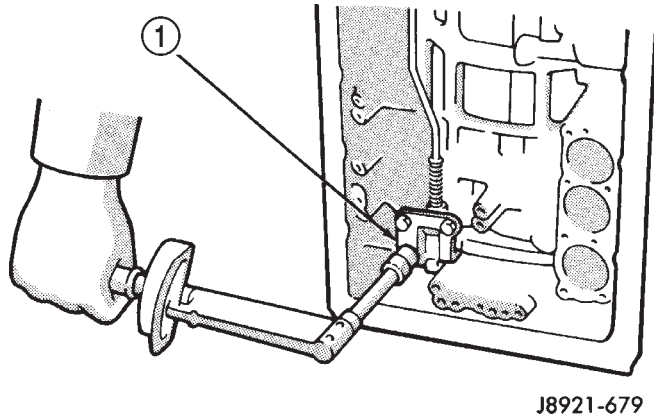

J8921-679

Fig. 147 Park Rod Bracket Installation

1 - PARK ROD BRACKET

(26) Verify park lock operation. Move shift sector to Park position. Park pawl should be firmly engaged (locked) in planetary ring gear (Fig. 148).

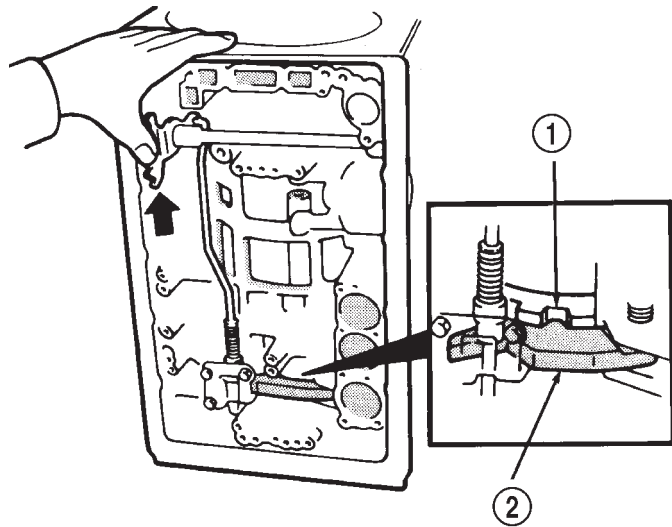

J8921-680

Fig. 148 Checking Park Pawl Engagement

1 - REAR PLANETARY RING GEAR
2 - PARK PAWL

(27) Install No. 1 one-way clutch (Fig. 149). Short flanged side of clutch faces up and toward case front.

(28) Install second brake pack (Fig. 150). Install disc then plate. Continue installation sequence until five discs and five plates are installed.

(29) Install second brake pack retainer with rounded edge of retainer facing disc.

(30) Install second brake pack snap ring.

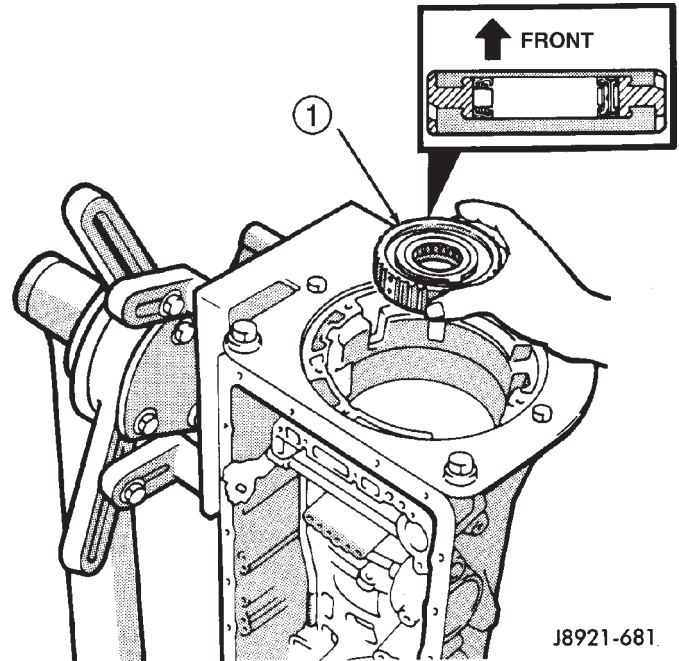

J8921-681

Fig. 149 Installing No. 1 One-Way Clutch

1 - NO. 1 ONE-WAY CLUTCH

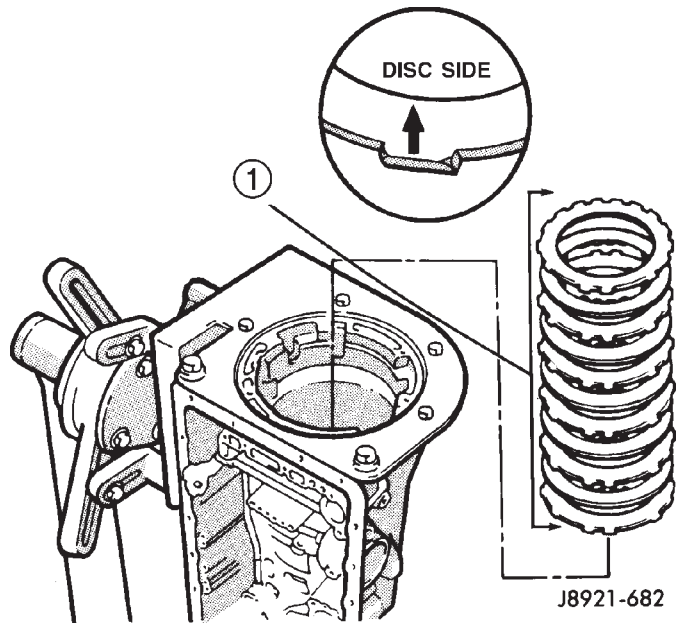

J8921-682

Fig. 150 Second Brake Pack Installation

1 - SECOND BRAKE PACK

DISASSEMBLY AND ASSEMBLY (Continued)

(31) Check brake pack clearance with feeler gauge (Fig. 151). Clearance should be 0.062 - 1.98 mm (0.024 - 0.078 in.). If brake pack clearance is not correct, brake pack components are not seated. Reassemble brake pack if necessary.

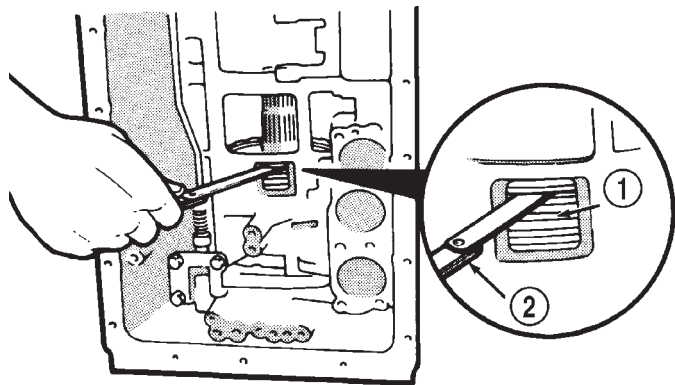

J8921-683

Fig. 151 Checking Second Brake Pack Clearance

- 1 - BRAKE PACK
- 2 - FEELER GAUGE

(32) Install planetary sun gear and input drum (Fig. 152). Be sure drum thrust washer tabs are seated in drum. Use petroleum jelly to hold thrust washer in position if necessary.

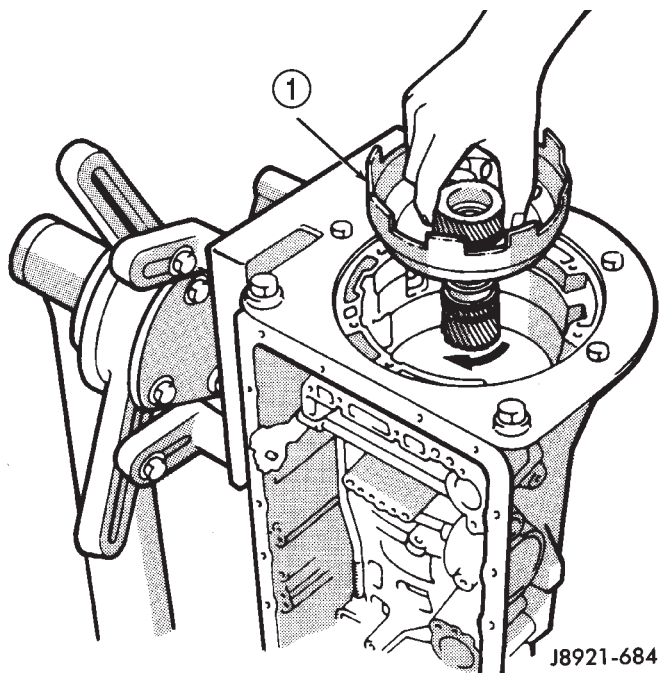

J8921-684

Fig. 152 Installing Sun Gear And Input Drum

- 1 - SUN GEAR AND INPUT DRUM

(33) Install front planetary gear on sun gear (Fig. 153).

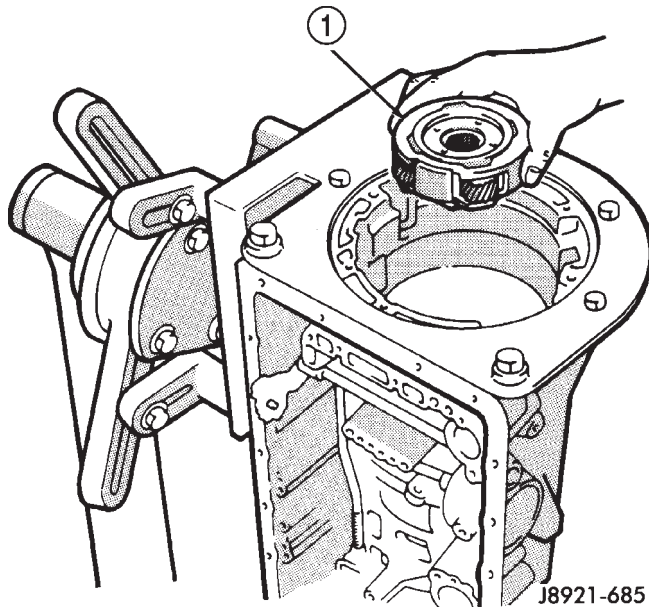

J8921-685

Fig. 153 Installing Front Planetary Gear

- 1 - FRONT PLANETARY GEAR

(34) Support output shaft with wood blocks (Fig. 154).

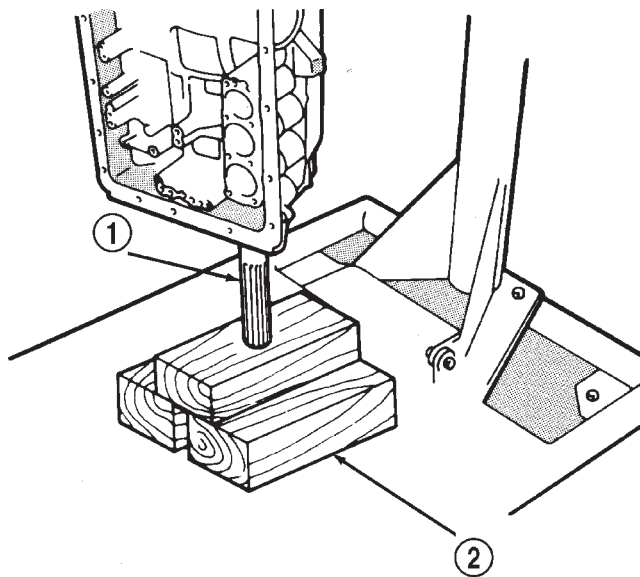

J8921-686

Fig. 154 Supporting Output Shaft

- 1 - OUTPUT SHAFT
- 2 - WOOD BLOCKS

DISASSEMBLY AND ASSEMBLY (Continued)

(35) Install planetary snap ring on sun gear with snap ring plier tool 7541 (Fig. 155).

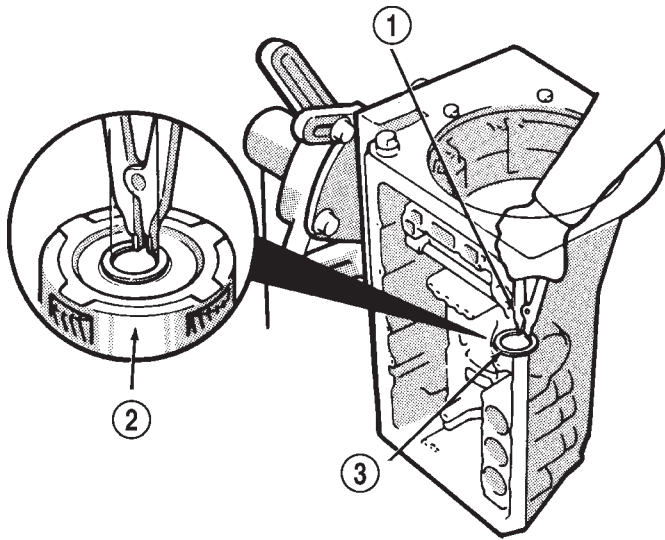

J8921-687

Fig. 155 Installing Front Planetary Snap Ring

- 1 - SNAP RING PLIER TOOL
- 2 - FRONT PLANETARY
- 3 - SNAP RING

(36) Install tabbed thrust race on front planetary gear. Washer tabs face down and toward gear. Race outer diameter is 47.8 mm (1.882 in.). Inside diameter is 34.3 mm (1.350 in.).

(37) Install second coast brake band (Fig. 156).

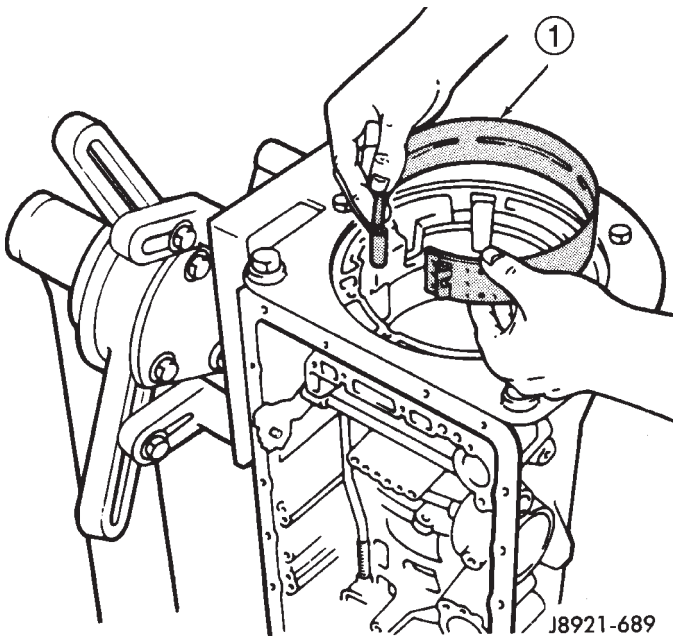

J8921-689

Fig. 156 Installing Second Coast Brake Band

- 1 - SECOND COAST BRAKE BAND

(38) Install pin in second coast brake band. Then install retaining ring on pin (Fig. 157).

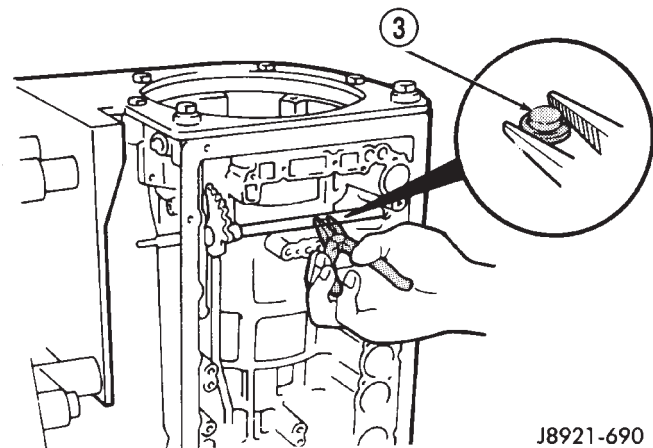
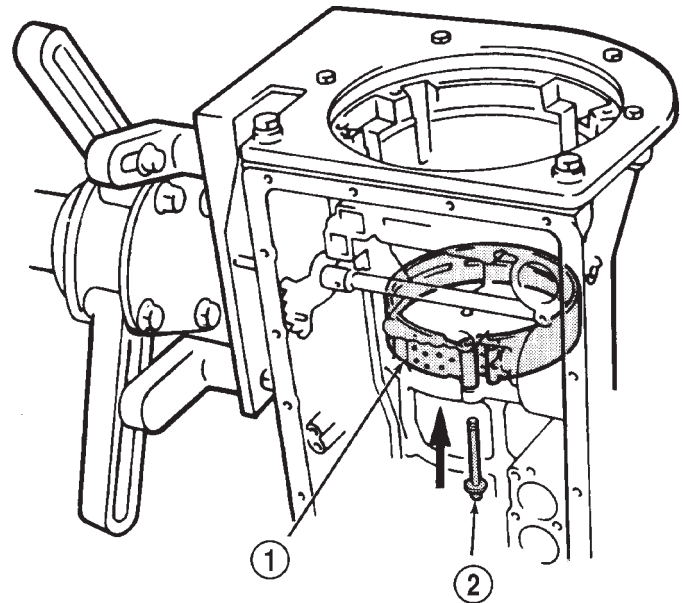

J8921-690

Fig. 157 Installing Second Coast Brake Band Retaining Pin

- 1 - SECOND COAST BRAKE BAND
- 2 - BAND RETAINING PIN
- 3 - RETAINING RING (INSTALL ON PIN)

(39) Install thrust bearing and race in forward-direct clutch (Fig. 158). Coat bearing/race with petroleum jelly to hold them in place.

(40) Verify forward-direct clutch thrust bearing size.

- Race outer diameter is 48.9 mm (1.925 in.) and inside diameter is 26.0 mm (1.024 in.).

- Bearing outer diameter is 46.7 mm (1.839 in.) and inside diameter is 26.0 mm (1.024 in.).

(41) Coat front planetary ring gear race with petroleum jelly and install it in ring gear (Fig. 159).

DISASSEMBLY AND ASSEMBLY (Continued)

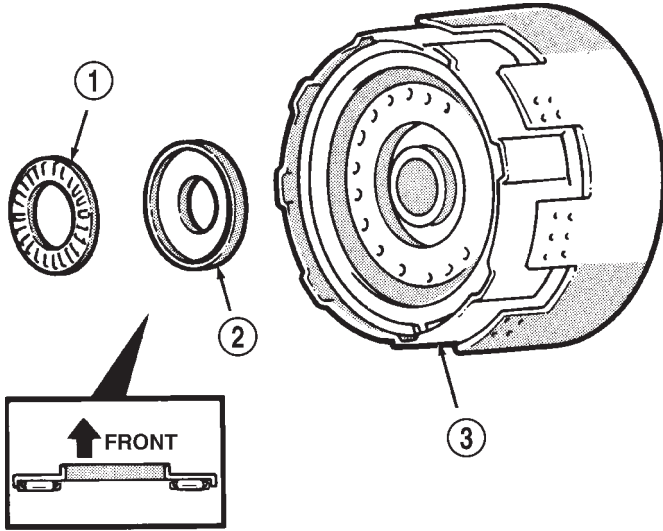

J8921-691

Fig. 158 Installing Forward-Direct Clutch Thrust Bearing And Race

- 1 - THRUST BEARING
- 2 - RACE
- 3 - FORWARD-DIRECT CLUTCH ASSEMBLY

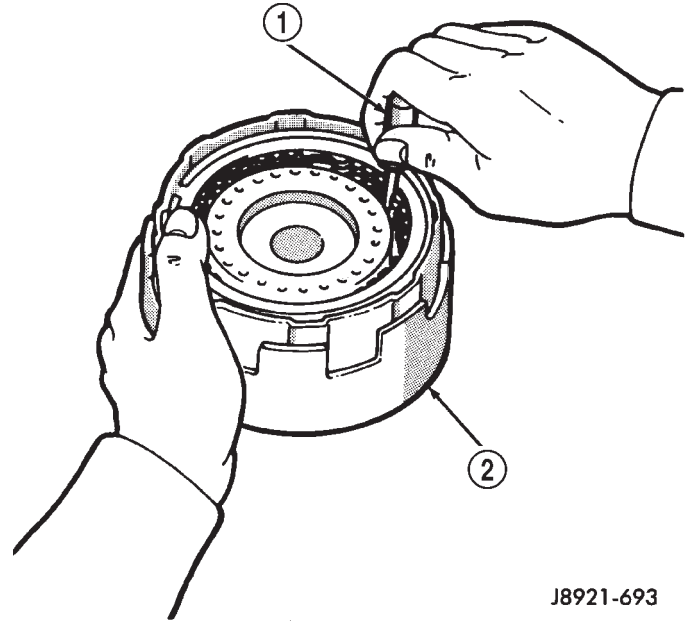

J8921-693

Fig. 160 Aligning Forward-Direct Clutch Splines

- 1 - CLUTCH SPLINE ALIGNING TOOL
- 2 - FORWARD-DIRECT CLUTCH

(42) Verify ring gear race size. Outer diameter is 47.0 mm (1.850 in.) and inside diameter is 26.5 mm (1.045 in.).

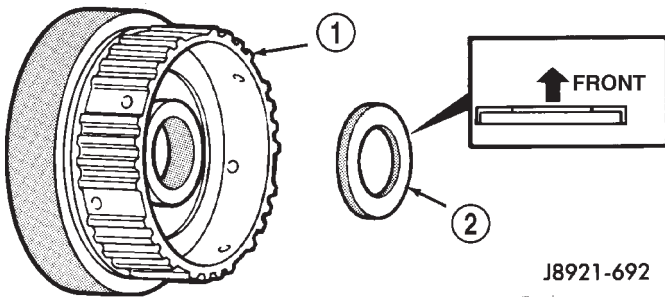

J8921-692

Fig. 159 Installing Planetary Ring Gear Race

- 1 - PLANETARY RING GEAR
- 2 - THRUST RACE

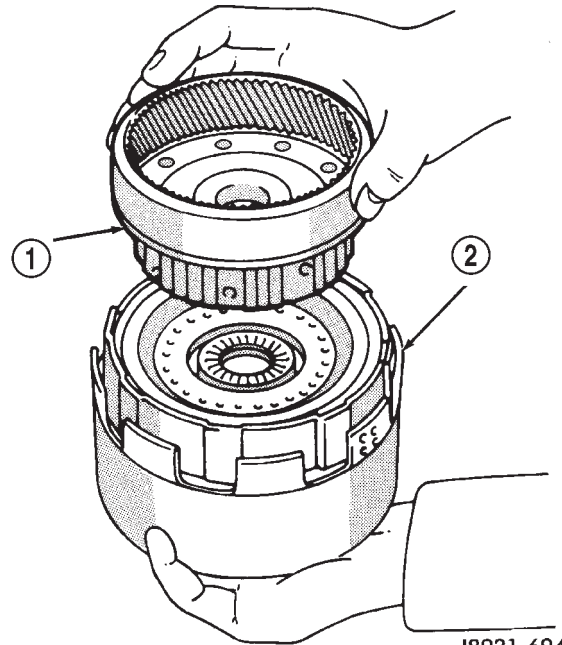

J8921-694

Fig. 161 Installing Front Planetary Ring Gear

- 1 - RING GEAR
- 2 - FORWARD-DIRECT CLUTCH

(43) Align forward-direct clutch disc splines with screwdriver (Fig. 160).

(44) Align and install front planetary ring gear in forward-direct clutch (Fig. 161).

(45) Coat bearing and race with petroleum jelly and install them in ring gear (Fig. 162). Verify bearing/race size.

- Bearing outer diameter is 47.7 mm (1.878 in.) and inside diameter is 32.6 mm (1.283 in.).

- Race outer diameter is 53.6 mm (2.110 in.) and inside diameter is 30.6 mm (1.205 in.).

(46) Install assembled planetary gear/forward-direct clutch (Fig. 163).

(47) Check clearance between sun gear input drum and direct clutch drum (Fig. 164). Clearance should be 9.8 - 11.8 mm (0.386 - 0.465 in.). If clearance is incorrect, planetary gear/forward-direct clutch assembly is not seated or is improperly assembled. Remove, and correct if necessary.

DISASSEMBLY AND ASSEMBLY (Continued)

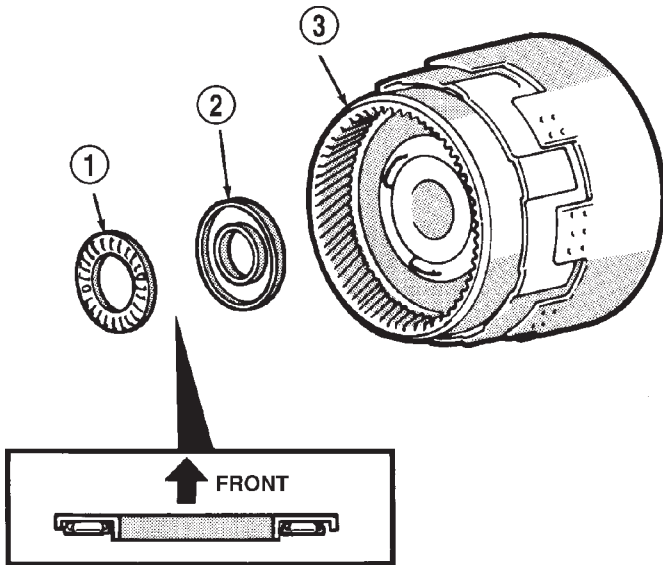

J8921-695

Fig. 162 Installing Ring Gear Bearing And Race

- 1 - THRUST BEARING
- 2 - RACE
- 3 - PLANETARY RING GEAR

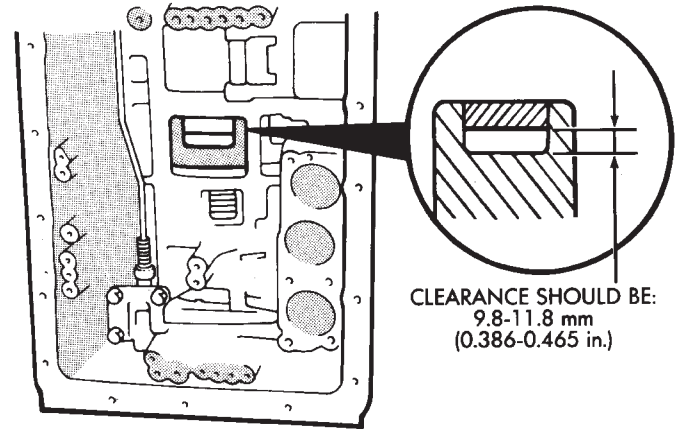

CLEARANCE SHOULD BE:
9.8-11.8 mm
(0.386-0.465 in.)

J8921-697

Fig. 164 Checking Input Drum-To-Direct Clutch Drum Clearance

mm (1.882 in.) and inside diameter is 33.6 mm (1.301 in.).

(49) Assemble second coast brake piston components (Fig. 165).

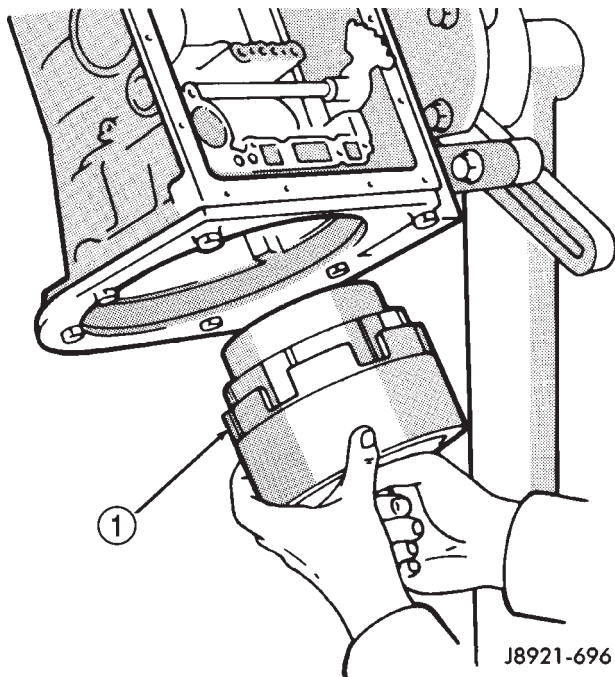

J8921-696

Fig. 163 Installing Front Planetary And Forward-Direct Clutch Assembly

- 1 - FRONT PLANETARY AND FOWARD-DIRECT CLUTCH ASSEMBLY

(48) Coat thrust bearing and race assembly with petroleum jelly and install it on clutch shaft. Bearing faces up and toward case front as shown. Verify bearing/race size. Bearing and race outer diameter is 47.8

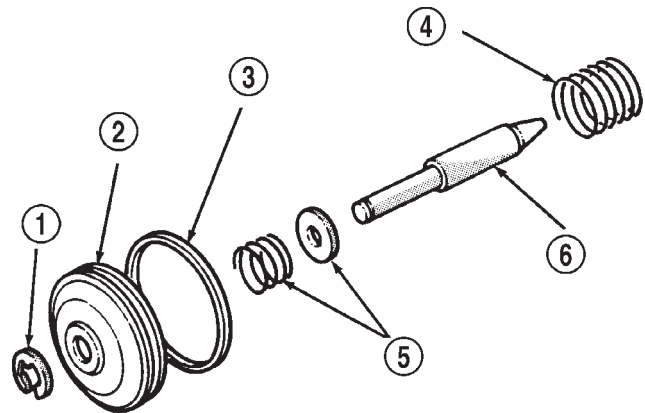

J8921-699

Fig. 165 Assembling Second Coast Brake Piston

- 1 - E-CLIP
- 2 - PISTON
- 3 - O-RING
- 4 - PISTON SPRING
- 5 - SPRING AND RETAINER
- 6 - PISTON ROD

(50) Install assembled second coast brake piston in case. Verify that the piston rod contacts the second coast brake band.

(51) Install replacement seals on second coast brake piston cover and install cover in case.

(52) Install second coast brake piston snap ring with snap ring plier tool (Fig. 166).

(53) Check second coast brake piston stroke as follows:

DISASSEMBLY AND ASSEMBLY (Continued)

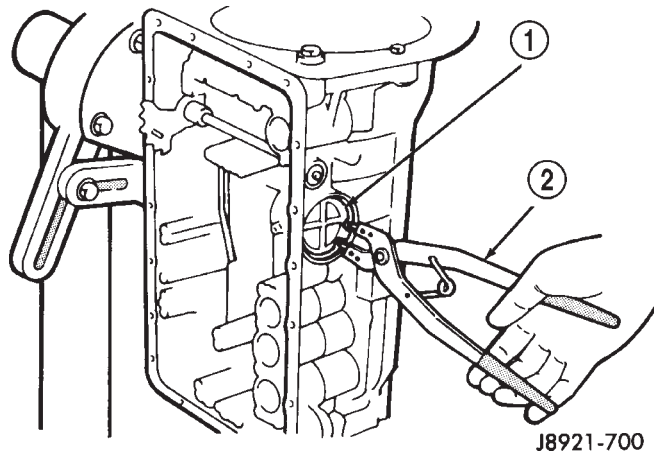

Fig. 166 Installing Second Coast Brake Piston Snap Ring

- 1 - PISTON SNAP RING
- 2 - SNAP RING TOOL

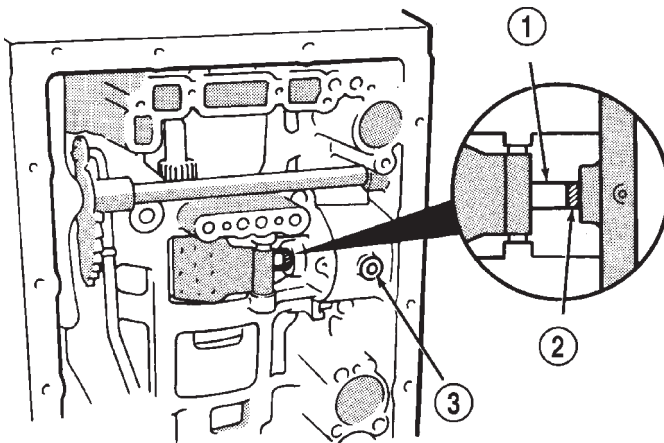

Fig. 167 Marking Brake Piston Rod

- 1 - BRAKE PISTON ROD
- 2 - REFERENCE MARK
- 3 - PISTON FEED HOLE

(a) Install a small wire tie strap around the second coast brake piston rod tight against the transmission case.

(b) Apply 57-114 psi air pressure through piston feed hole and check stroke length with Gauge Tool 7552.

(c) Stroke length should be 1.5 - 3.0 mm (0.059 - 0.118 in.).

(d) If stroke length is incorrect, piston, cover or snap ring is not seated. Reassemble and check stroke again if necessary.

(54) Coat thrust race and tabbed washer with petroleum jelly and install them on overdrive support (Fig. 169). Verify race size. Race outer diameter is 50.9 mm (2.004 in.) and inside diameter is 36.2 mm (1.426 in.).

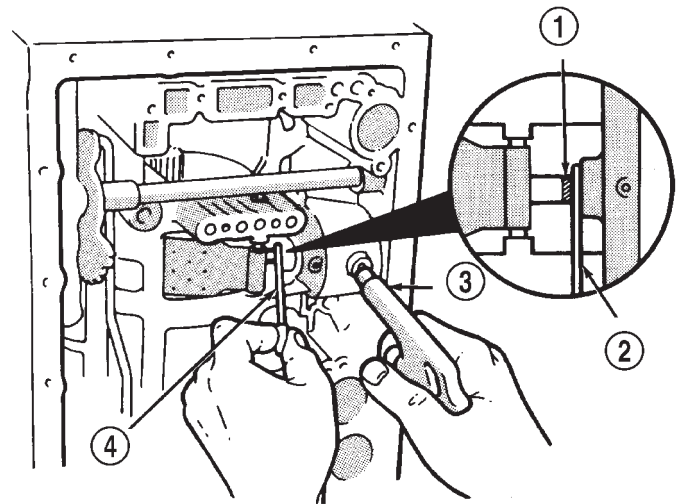

Fig. 168 Checking Second Coast Brake Piston Stroke

- 1 - PISTON ROD REFERENCE MARK
- 2 - GAUGE TOOL
- 3 - AIR GUN
- 4 - GAUGE TOOL

(55) Install overdrive support in case. Use two long bolts to help align and guide support into position (Fig. 170).

(56) Install overdrive support snap ring with Snap Ring Plier Tool 7540 (Fig. 171). Chamfered side of snap ring faces up and toward case front. **Snap ring ends must be aligned with case opening with ring ends approximately 24 mm (0.94 in.) from center line of case opening.**

(57) Install and tighten overdrive support bolts to 25 N·m (19 ft. lbs.) torque (Fig. 172).

DISASSEMBLY AND ASSEMBLY (Continued)

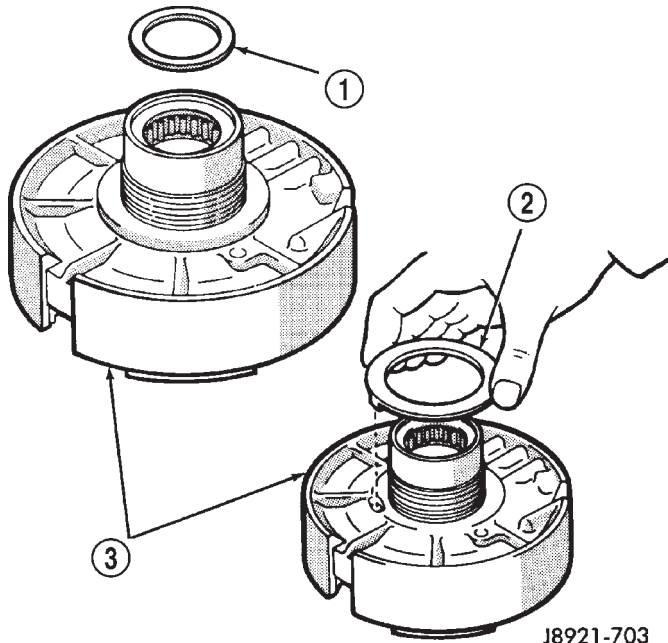

J8921-703

Fig. 169 Installing Overdrive Support Thrust Race And Washer

- 1 - THRUST RACE
- 2 - TABBED THRUST WASHER
- 3 - OVERDRIVE SUPPORT

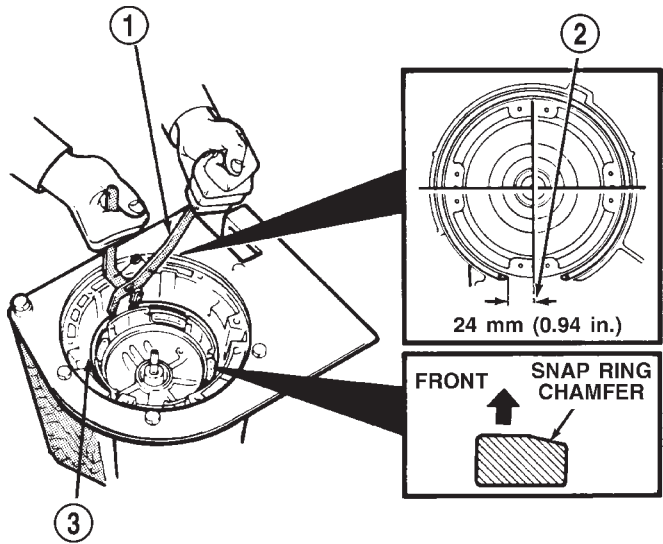

J8921-705

Fig. 171 Installing Overdrive Support Snap Ring

- 1 - SNAP RING TOOL
- 2 - SNAP RING ENDS CENTERED IN CASE OPENING
- 3 - SNAP RING

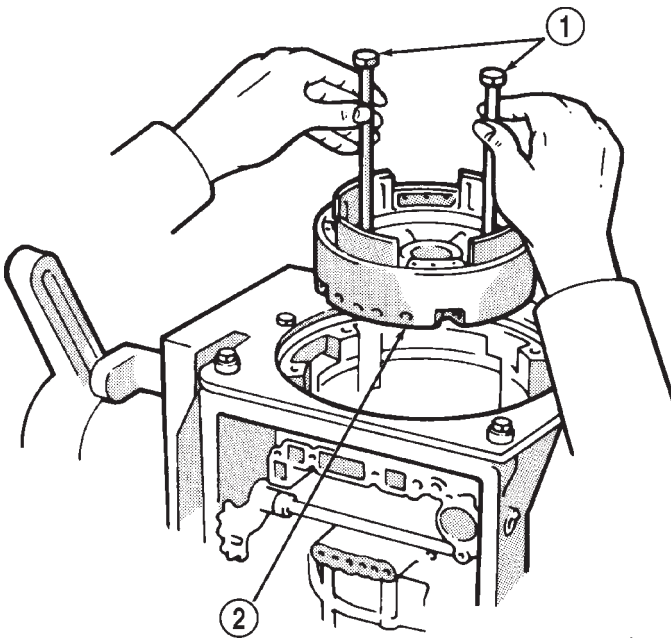

J8921-704

Fig. 170 Installing Overdrive Support

- 1 - USE LONG BOLTS TO INSTALL SUPPORT
- 2 - OVERDRIVE SUPPORT

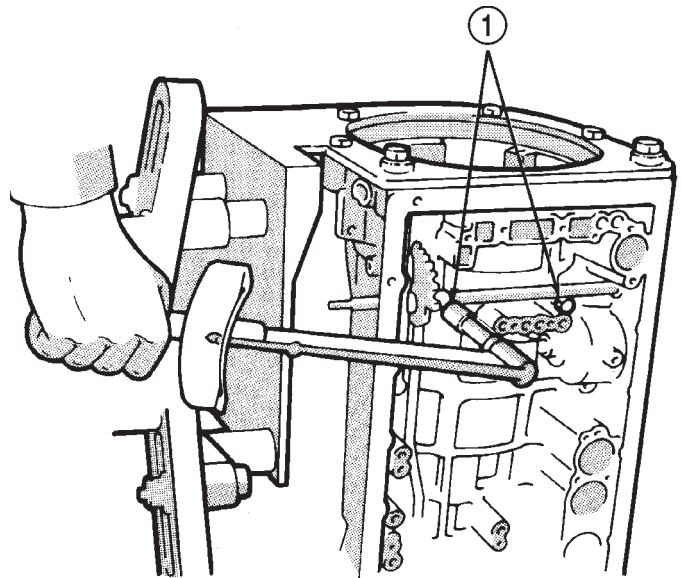

J8921-706

Fig. 172 Installing Overdrive Support Bolts

- 1 - OVERDRIVE SUPPORT BOLTS

DISASSEMBLY AND ASSEMBLY (Continued)

(58) Check output shaft end play with dial indicator (Fig. 173). End play should be 0.27 - 0.86 mm (0.0106 - 0.0339 in.).

(59) If output shaft end play is incorrect, one or more of installed components is not seated. Reassemble as necessary and check end play again.

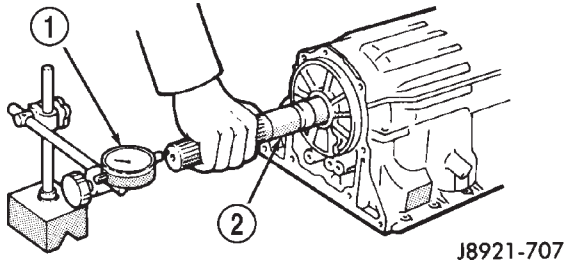
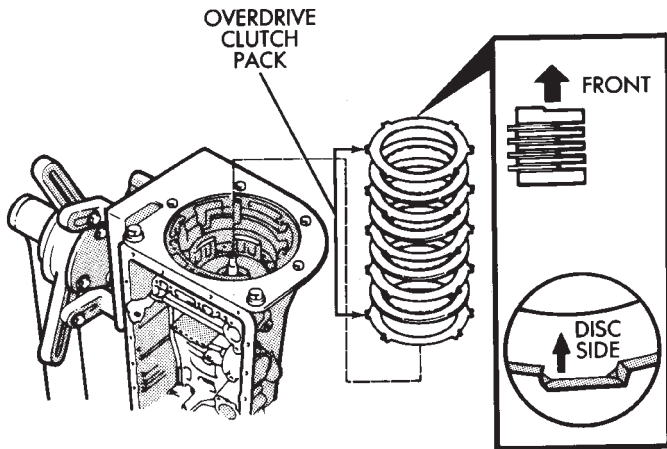

Fig. 173 Checking Output Shaft End Play

- 1 - DIAL INDICATOR
2 - OUTPUT SHAFT

(60) Install overdrive brake clutch pack (Fig. 174). Install thickest clutch plate first. Rounded edge of plate faces up. Install first disc followed by another plate until four discs and three plates are installed.



J8921-708

Fig. 174 Installing Overdrive Brake Clutch Pack

(61) Install stepped ring retainer plate with flat side facing disc. Then install brake pack snap ring (Fig. 175).

(62) Check overdrive brake piston stroke as follows:

(a) Mount dial indicator on case using Miller Tool C-3339 and a suitable bolt threaded into the transmission case.

(b) Verify that the dial indicator is mounted solidly and square to the direction of the piston travel.

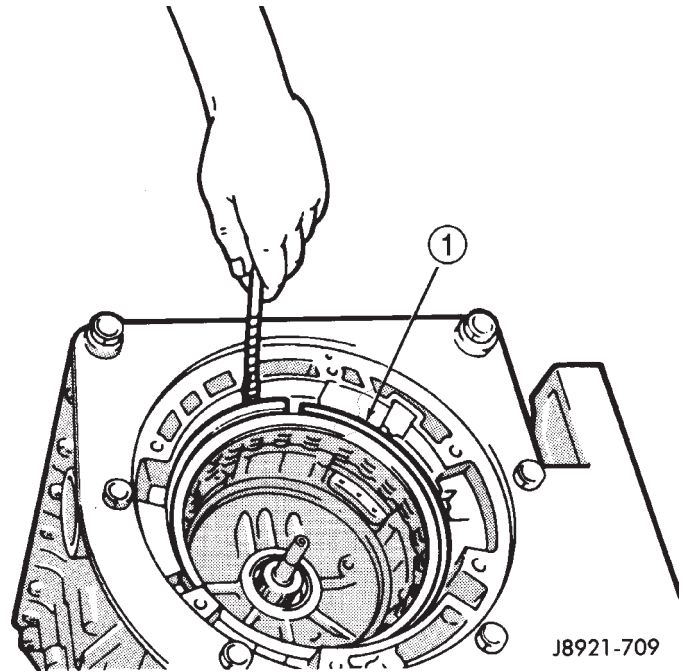

Fig. 175 Installing Overdrive Brake Snap Ring

- 1 - CLUTCH PACK SNAP RING

(c) Apply 57-114 psi air pressure through piston apply port and note piston stroke on dial indicator. Stroke length should be: 1.40 - 1.70 mm (0.055 - 0.0699 in.).

(d) If stroke is incorrect, brake pack or piston is installed incorrectly. Check and correct as necessary and measure piston stroke again.

(e) Remove the dial indicator set-up from the transmission.

(63) Coat overdrive lower race, thrust bearing and upper race with petroleum jelly and install them in overdrive support (Fig. 176). Be sure races and bearing are assembled and installed as shown.

(64) Verify bearing/race sizes before proceeding. Bearing race sizes are:

- Outer diameter of lower race is 47.8 mm (1.882 in.) and inside diameter is 34.3 mm (1.350 in.).
- Outer diameter of bearing is 47.7 mm (1.878 in.) and inside diameter is 32.7 mm (1.287 in.).
- Outer diameter of upper race is 47.8 mm (1.882 in.) and inside diameter is 30.7 mm (1.209 in.).

(65) Install overdrive planetary ring gear in support (Fig. 177).

(66) Coat ring gear thrust race and thrust bearing assembly with petroleum jelly and install them in gear (Fig. 178).

(67) Verify bearing/race size before proceeding.

- Outer diameter of ring gear race-bearing is 47.8 mm (1.882 in.) and inside diameter is 24.2 mm (0.953 in.).

DISASSEMBLY AND ASSEMBLY (Continued)

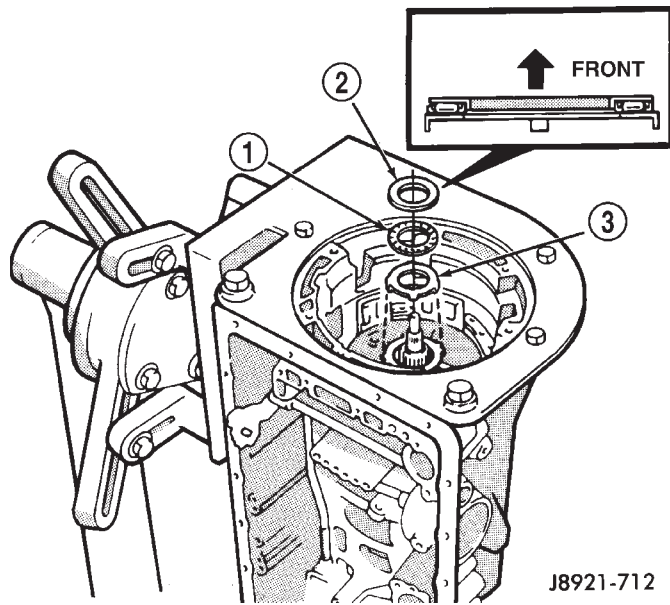

J8921-712

Fig. 176 Installing Overdrive Support Thrust Bearing And Races

- 1 - THRUST BEARING
- 2 - UPPER RACE
- 3 - LOWER RACE

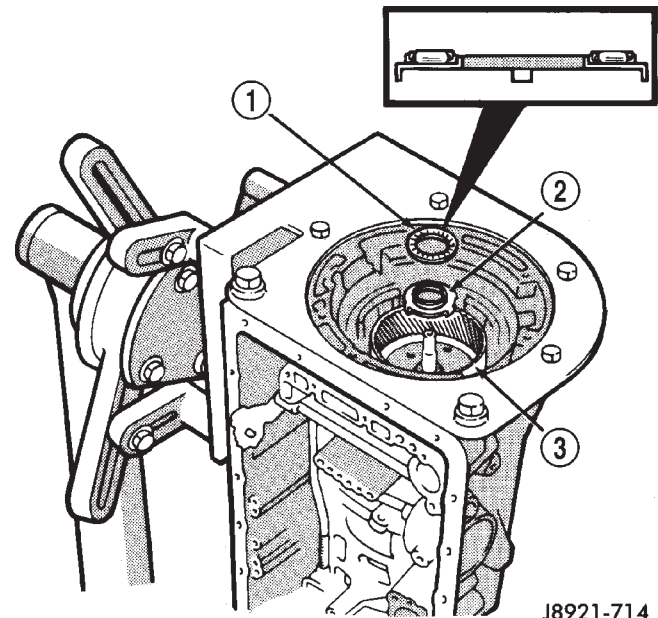

J8921-714

Fig. 178 Installing Ring Gear Thrust Bearing And Race

- 1 - THRUST BEARING-RACE ASSEMBLY
- 2 - THRUST RACE (TABBED)
- 3 - OVERDRIVE PLANETARY RING GEAR

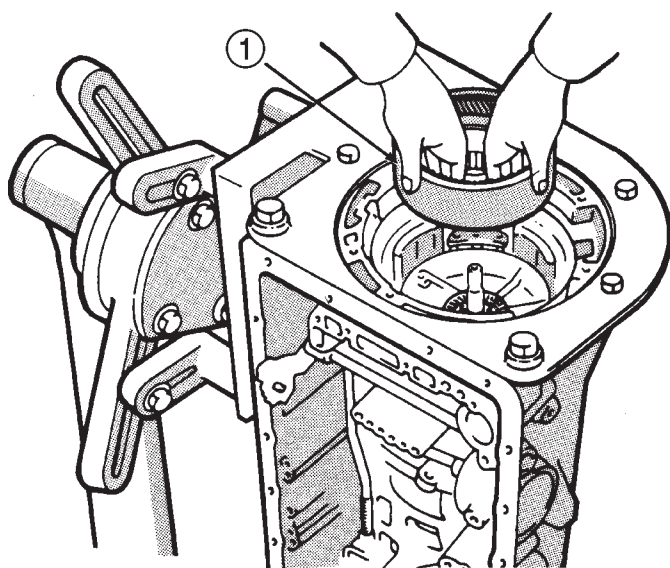

J8921-713

Fig. 177 Installing Overdrive Planetary Ring Gear

- 1 - OVERDRIVE PLANETARY RING GEAR

- Outer diameter of bearing is 46.8 mm (1.844 in.) and inside diameter is 26.0 mm (1.024 in.).

(68) Coat tabbed thrust race with petroleum jelly and install it on planetary gear (Fig. 179). Race outer diameter is 41.8 mm (1.646 in.) and inside diameter is 27.1 mm (1.067 in.).

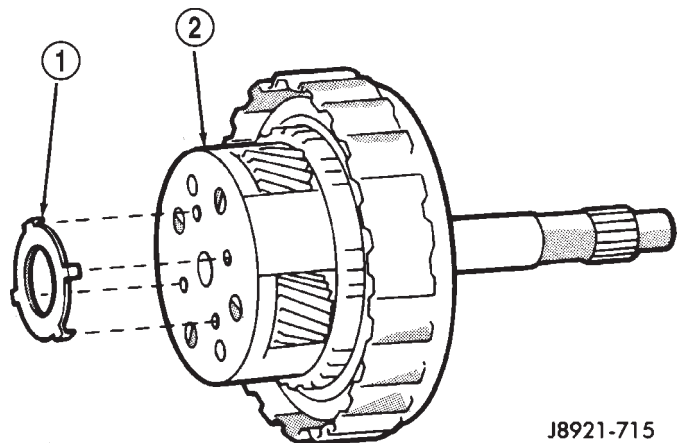

J8921-715

Fig. 179 Installing Planetary Thrust Race

- 1 - THRUST RACE (TABBED)
- 2 - OVERDRIVE PLANETARY

(69) Install assembled overdrive planetary gear and clutch (Fig. 180).

(70) Coat thrust bearing and race assembly with petroleum jelly and install it on clutch input shaft (Fig. 181). Bearing and race outer diameter is 50.2 mm (1.976 in.) and inside diameter is 28.9 mm (1.138 in.).

(71) Coat thrust bearing race with petroleum jelly and install it in oil pump (Fig. 182). Bearing race outer diameter is 47.2 mm (1.858 in.) and inside diameter is 28.1 mm (1.106 in.).

DISASSEMBLY AND ASSEMBLY (Continued)

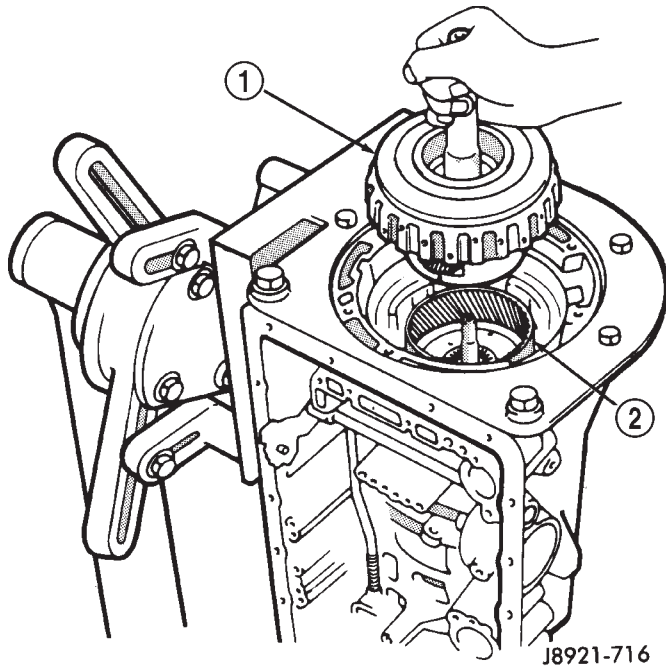

Fig. 180 Installing Overdrive Planetary And Clutch Assembly

- 1 - OVERDRIVE PLANETARY AND CLUTCH ASSEMBLY
- 2 - RING GEAR

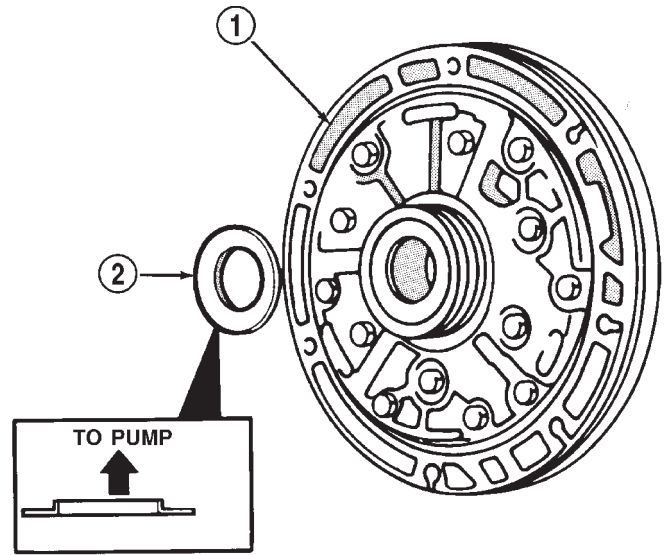

Fig. 182 Installing Oil Pump Thrust Race

- 1 - OIL PUMP
- 2 - PUMP THRUST RACE

CAUTION: Do not use force to seat the pump. The seal rings on the stator shaft could be damaged if they bind or stick to the direct clutch drum.

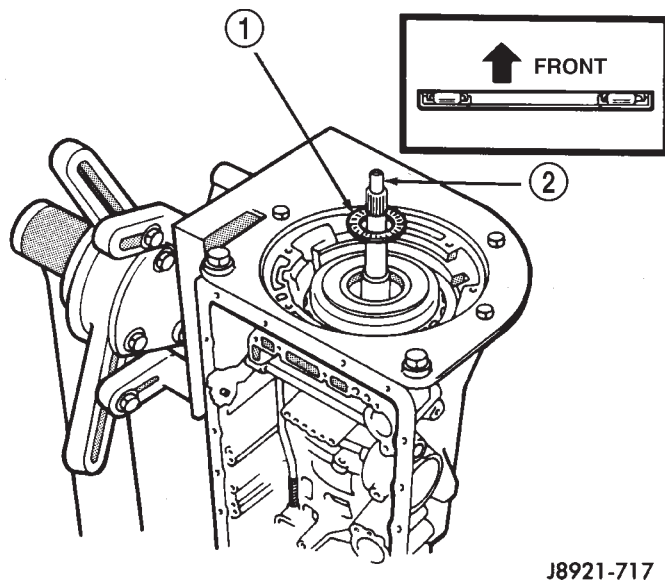

Fig. 181 Installing Input Shaft Thrust Bearing And Race Assembly

- 1 - THRUST BEARING AND RACE ASSEMBLY
- 2 - CLUTCH INPUT SHAFT

(72) Lubricate and install replacement O-ring on oil pump body.

(73) Install oil pump in case. Align pump and case bolt holes and carefully ease pump into place.

(74) Tighten oil pump bolts to 22 N·m (16 ft. lbs.) torque.

(75) Verify input shaft rotation. Shaft should rotate smoothly and not bind.

(76) Lubricate and install new O-ring on transmission throttle cable adapter and install cable in case (Fig. 183).

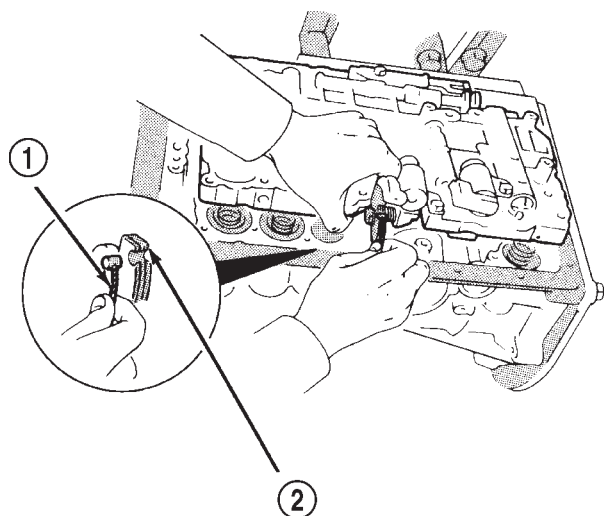

Fig. 183 Installing Transmission Throttle Cable

- 1 - THROTTLE CABLE
- 2 - THROTTLE CAM

J8921-478

DISASSEMBLY AND ASSEMBLY (Continued)

(77) Check clutch and brake operation. Operate clutches and brakes with compressed air applied through feed holes in case (Fig. 184). Listen for clutch and brake application. If you do not hear a clutch or brake apply, disassemble transmission and repair fault before proceeding. **It is necessary to block the overdrive clutch accumulator feed hole No. 8 (Fig. 184) in order to check direct clutch operation.**

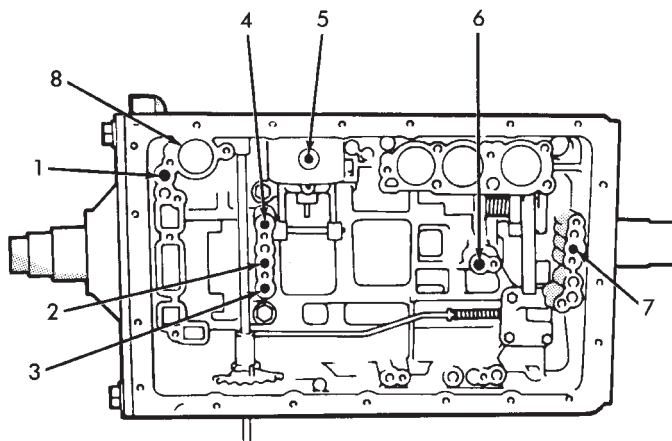

1. OVERDRIVE DIRECT CLUTCH FEED
2. DIRECT CLUTCH FEED
3. FORWARD CLUTCH FEED
4. OVERDRIVE BRAKE FEED
5. SECOND COAST BRAKE FEED
6. SECOND BRAKE FEED
7. FIRST-REVERSE BRAKE FEED
8. OVERDRIVE CLUTCH ACCUMULATOR PISTON HOLE (BLOCK THIS HOLE WHEN CHECKING DIRECT CLUTCH OPERATION)

J8921-721

Fig. 184 Clutch And Brake Feed Hole Locations

(78) Lubricate and install new O-rings on accumulator pistons (Fig. 185).

(79) Assemble and install accumulator pistons and springs (Fig. 185).

(80) Install new check ball body and spring (Fig. 186).

(81) Position valve body on case (Fig. 187).

(82) Install detent spring (Fig. 187).

(83) Align manual valve, detent spring and shift sector (Fig. 187).

(84) Connect transmission throttle cable to throttle valve cam (Fig. 188).

(85) Install and tighten valve body-to-case bolts to 10 N·m (7 ft. lbs.) torque.

(86) Connect valve body solenoid wires to solenoids (Fig. 189).

(87) Install new O-ring on solenoid harness adapter and secure adapter to case.

- (A) SECOND BRAKE ACCUMULATOR PISTON
- (B) DIRECT CLUTCH ACCUMULATOR PISTON
- (C) OVERDRIVE BRAKE ACCUMULATOR PISTON
- (D) OVERDRIVE CLUTCH ACCUMULATOR PISTON

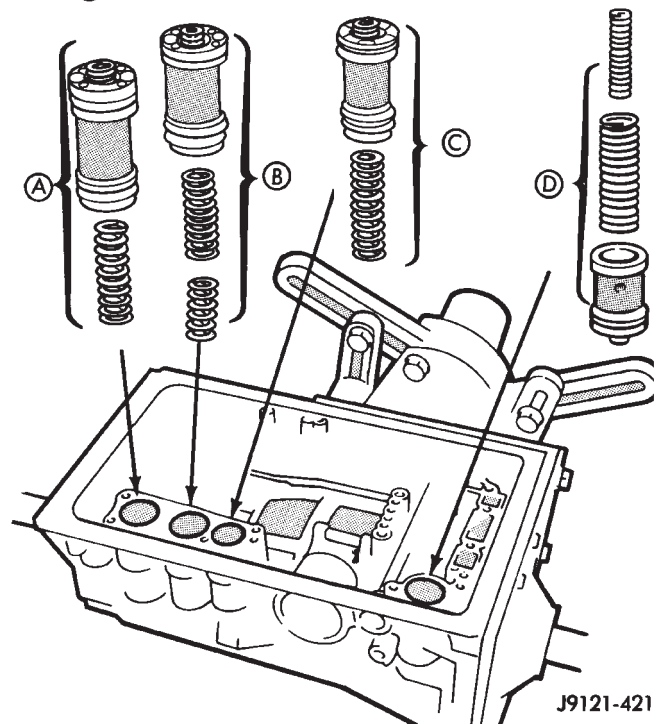

J9121-421

Fig. 185 Accumulator Piston And Spring Installation

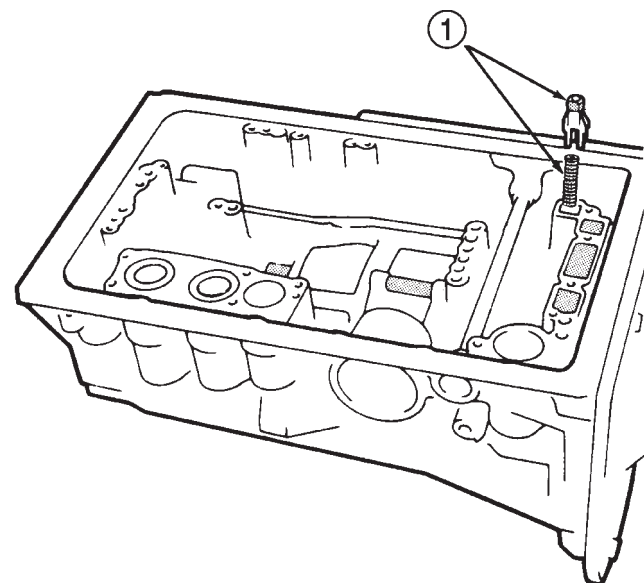

J8921-723

Fig. 186 Installing Check Ball Body And Spring

1 - CHECK BALL BODY AND SPRING

(88) Install valve body oil tubes (Fig. 190). Tap tubes into place with a plastic mallet. Be sure the

DISASSEMBLY AND ASSEMBLY (Continued)

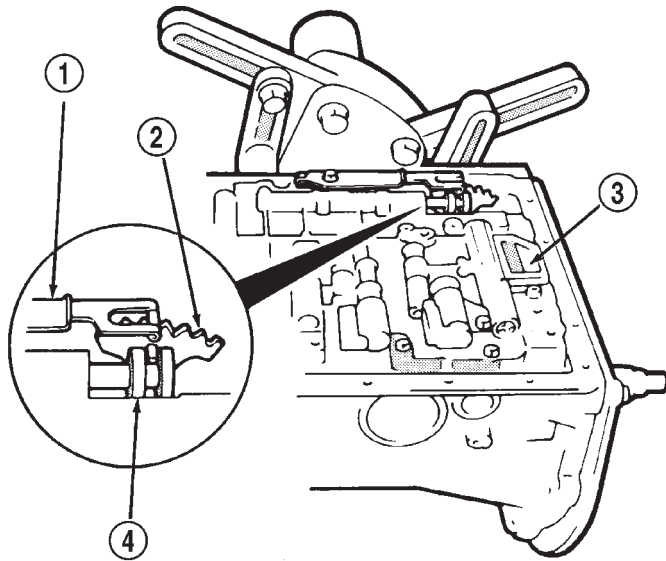

J8921-724

Fig. 187 Aligning Manual Valve, Shift Sector And Detent Spring

- 1 - DETENT SPRING
- 2 - SHIFT SECTOR
- 3 - VALVE BODY
- 4 - MANUAL VALVE

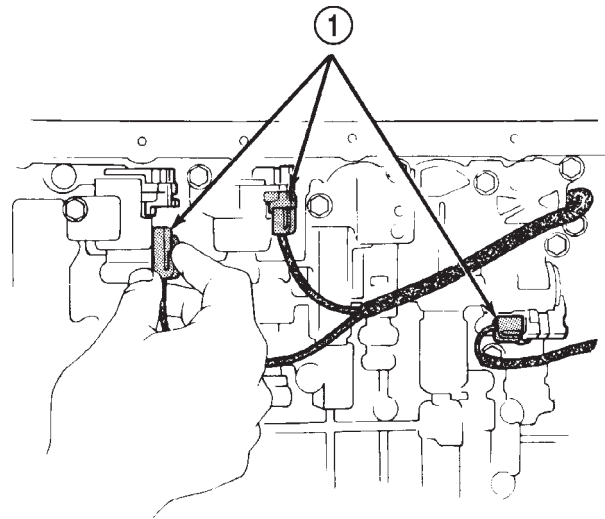

J8921-433

Fig. 189 Connecting Valve Body Solenoid Wires

- 1 - SOLENOID WIRE CONNECTORS

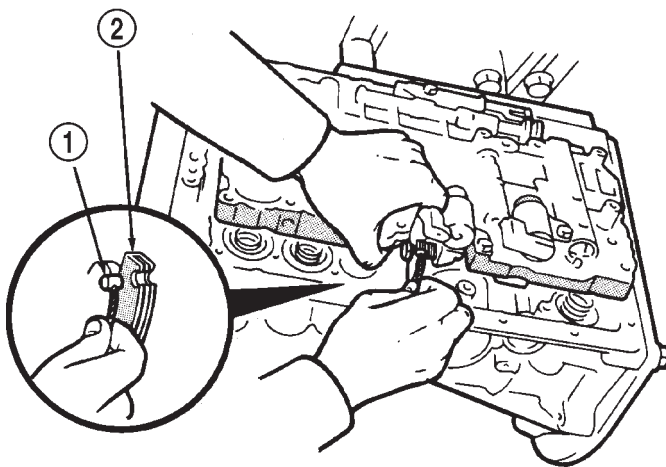

J8921-725

Fig. 188 Connecting Transmission Throttle Cable

- 1 - THROTTLE CABLE
- 2 - THROTTLE CAM

flanged tube ends and straight tube ends are installed as shown.

(89) Install new gaskets on oil screen and install screen on valve body. Tighten screen bolts to 10 N·m (7 ft. lbs.) torque.

(90) Install magnet in oil pan. Be sure magnet does not interfere with valve body oil tubes.

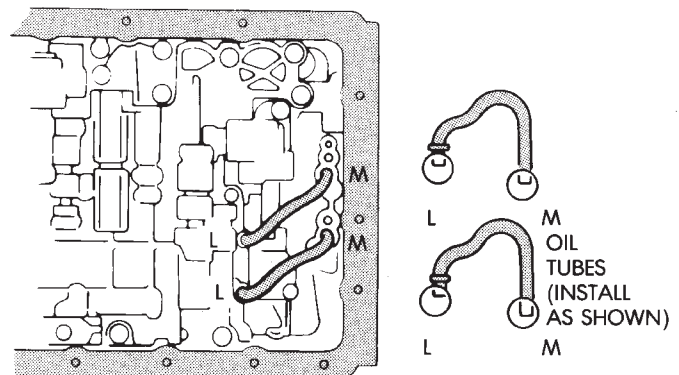

J8921-443

Fig. 190 Installing Valve Body Oil Tubes

(91) Apply Threebond® Liquid Gasket TB1281, P/N 83504038, to sealing surface of oil pan. Sealer bead should be at least 3 mm (1/8 in.) wide. Install pan on case and tighten pan bolts to 7 N·m (65 in. lbs.) torque.

(92) Install transmission speed sensor rotor and key on output shaft (Fig. 191).

(93) Install spacer and speedometer drive gear on output shaft. Then install retaining snap ring (Fig. 192).

(94) Apply bead of Threebond® Liquid Gasket TB1281, P/N 83504038, to sealing surface at rear of case (Fig. 193).

DISASSEMBLY AND ASSEMBLY (Continued)

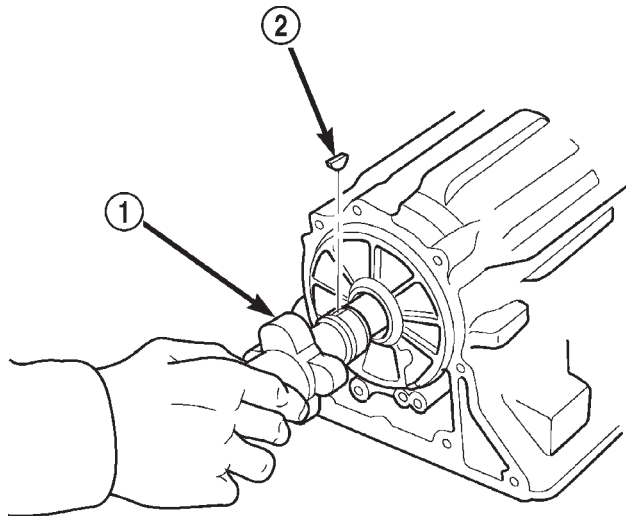

80c070b1

Fig. 191 Installing Transmission Speed Sensor Rotor And Key

- 1 - SPEED SENSOR ROTOR
2 - ROTOR KEY

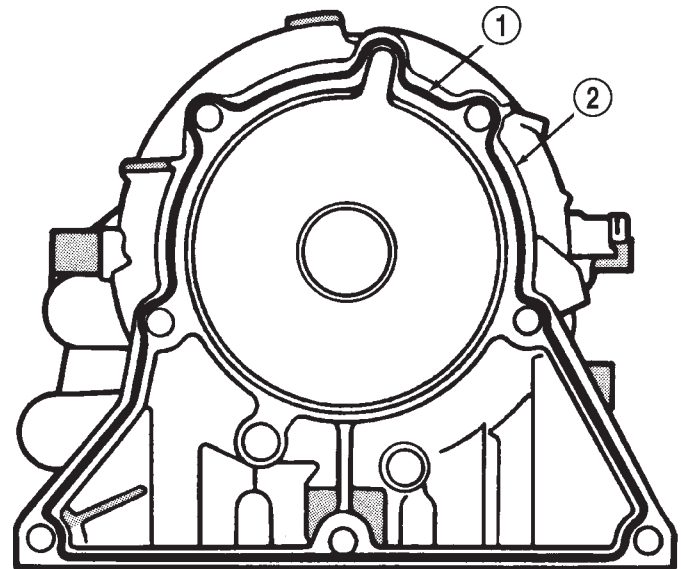

J8921-728

Fig. 193 Applying Sealer To Case Rear Flange

- 1 - SEALER BEAD
2 - CASE REAR FLANGE

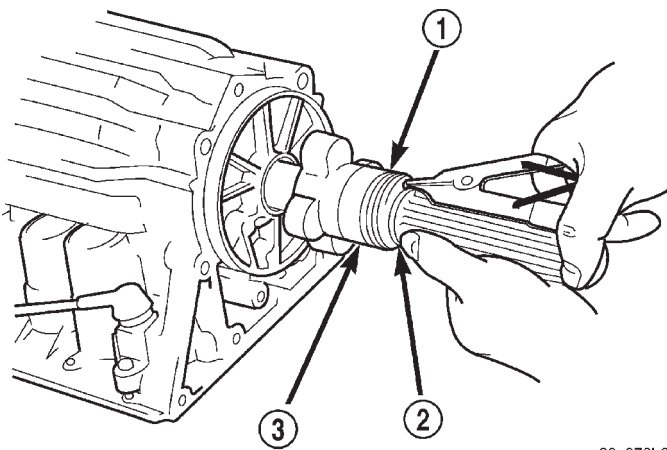

80c070b2

Fig. 192 Installing Spacer And Speedometer Drive Gear

- 1 - SPEEDOMETER DRIVE GEAR
2 - SNAP RING
3 - SPACER

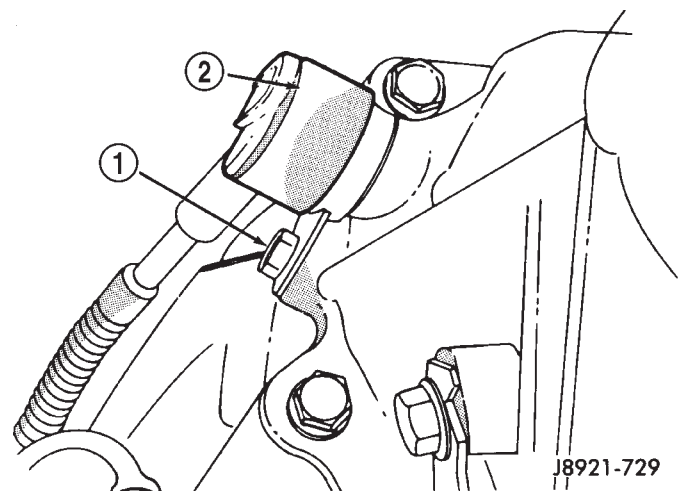

J8921-729

Fig. 194 Installing Transmission Speed Sensor

- 1 - SENSOR BOLT
2 - SPEED SENSOR

(95) Install adapter housing on transmission. Tighten adapter bolts to 34 N·m (25 ft. lbs.) torque.

(96) Install transmission speed sensor (Fig. 194). Tighten sensor bolt to 7.4 N·m (65 in. lbs.) torque and connect sensor wire harness connector.

(97) Install converter housing (Fig. 195). Tighten 12 mm diameter housing bolts to 57 N·m (42 ft. lbs.) torque. Tighten 10 mm diameter housing bolts to 34 N·m (25 ft. lbs.) torque.

(98) Install transmission shift lever on manual valve shaft. Do not install lever attaching nut at this time.

(99) Move transmission shift lever fully rearward. Then move lever two detent positions forward.

(100) Mount park/neutral position switch on manual valve shaft and tighten switch adjusting bolt just enough to keep switch from moving (Fig. 196).

(101) Install park/neutral position switch tabbed washer and retaining nut (Fig. 196). Tighten nut to

DISASSEMBLY AND ASSEMBLY (Continued)

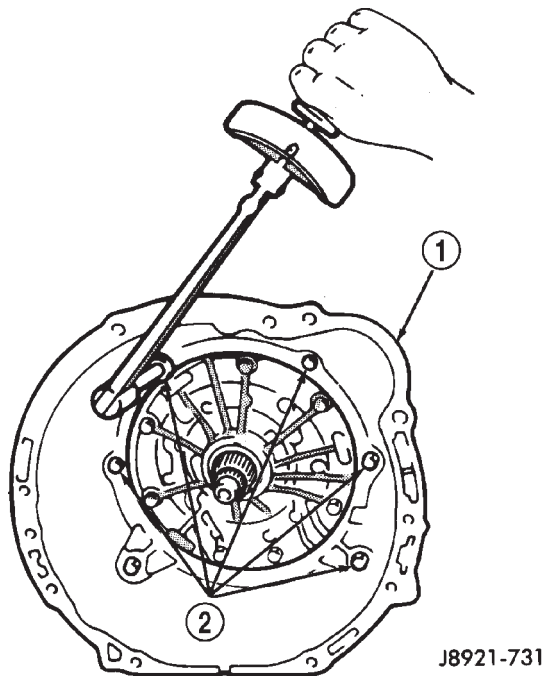

J8921-731

Fig. 195 Installing Converter Housing

- 1 - CONVERTER HOUSING
- 2 - HOUSING BOLTS

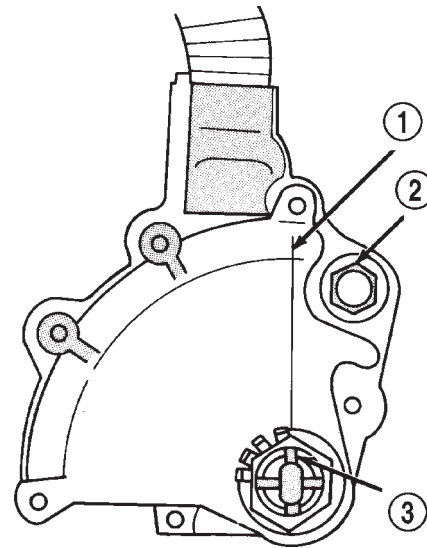

J8921-431

Fig. 196 Park/Neutral Position Switch Installation/Adjustment

- 1 - NEUTRAL STANDARD LINE
- 2 - ADJUSTING BOLT
- 3 - VERTICAL GROOVE ON MANUAL VALVE SHAFT

6.9 N·m (61 in. lbs.) torque, but do not bend any of the washer tabs against the nut at this time.

(102) Align park/neutral position switch standard line with groove or flat on manual shaft (Fig. 196).

(103) Tighten park/neutral position switch adjusting bolt to 13 N·m (9 ft. lbs.) torque.

(104) Install transmission shift lever on manual valve shaft. Tighten lever attaching nut to 16 N·m (12 ft. lbs.) torque.

(105) Install retaining clamp for wire harness and throttle cable (Fig. 197).

(106) Install torque converter.

(107) Verify that converter is seated by measuring distance between converter housing flange and one of the converter mounting pads (Fig. 198). Use straight-edge and vernier calipers to measure distance. On 6-cyl. transmissions, distance should be 16.5 mm (0.650 in.).

(108) Secure converter in transmission with C-clamp or metal strapping. Do this before mounting transmission on jack or moving transmission under vehicle.

(109) Install lower half of transmission fill tube (install upper half after transmission is in vehicle).

CAUTION: The transmission cooler and lines must be reverse flushed if overhaul corrected a malfunction that generated sludge, metal particles, or clutch friction material. The torque converter should also be replaced if contaminated by the same mal-

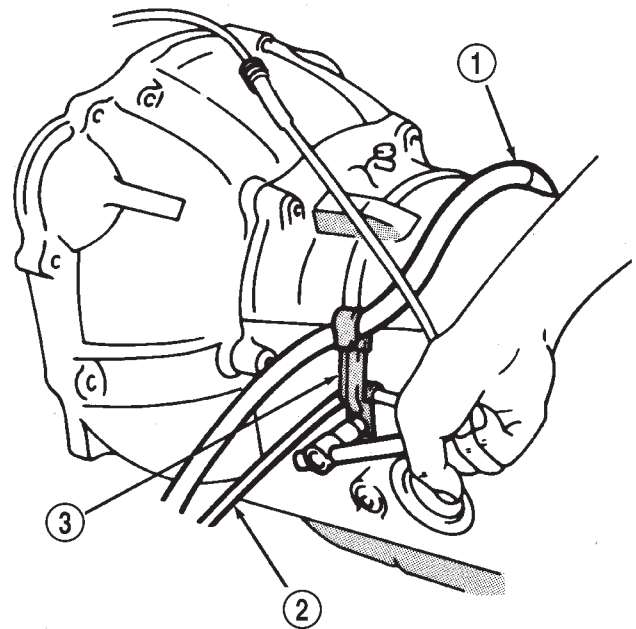

J8921-732

Fig. 197 Installing Cable/Harness Clamps

- 1 - TRANSMISSION HARNESS
- 2 - THROTTLE CABLE
- 3 - RETAINING CLAMPS

function. Debris and residue not flushed from the cooler and lines will flow back into the transmission and converter. The result will be a repeat failure and shop comeback.

DISASSEMBLY AND ASSEMBLY (Continued)

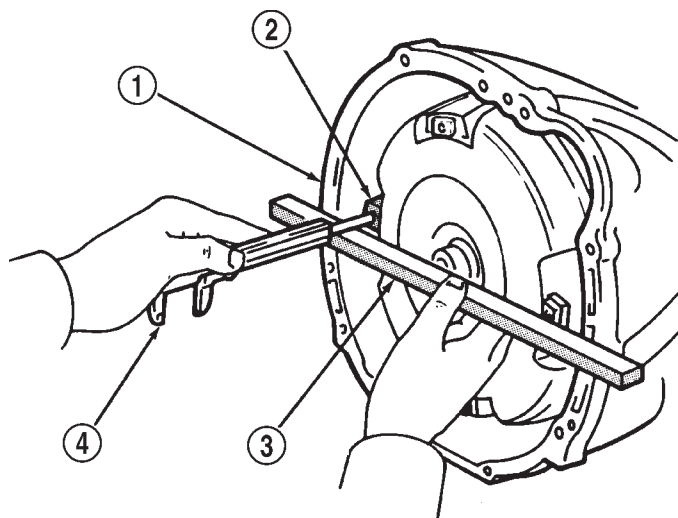

J8921-733

Fig. 198 Checking Converter Installation

- 1 - HOUSING FLANGE
- 2 - CONVERTER MOUNTING PAD
- 3 - STRAIGHTEDGE
- 4 - VERNIER CALIPERS

OIL PUMP**DISASSEMBLY**

- (1) Remove pump body O-ring (Fig. 199).
- (2) Remove pump seal.
- (3) Remove pump seal rings (Fig. 199).
- (4) Remove bolts attaching stator shaft to pump body and separate components.
- (5) Remove drive gear and driven gear from pump body (Fig. 199).

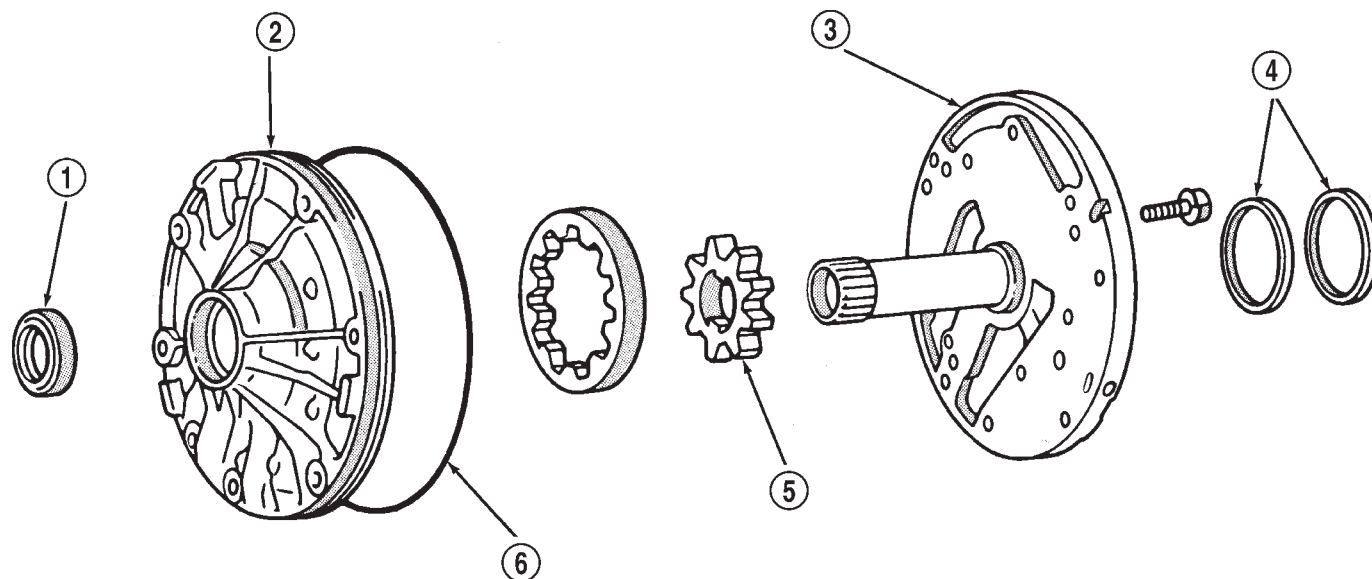

J8921-516

Fig. 199 Oil Pump Components

- 1 - PUMP SEAL
- 2 - PUMP BODY
- 3 - STATOR SHAFT
- 4 - SEAL RINGS
- 5 - GEAR
- 6 - O-RING

DISASSEMBLY AND ASSEMBLY (Continued)

ASSEMBLY

(1) Measure inside diameter of pump body bushing with bore gauge or inside micrometer (Fig. 200). Diameter should be maximum of 38.19 mm (1.5035 in.). Replace pump body if bushing I. D. is greater than specified.

(2) Measure inside diameter of stator shaft bushing (Fig. 200). Take measurements at front and rear of bushing. Diameter should be maximum of 21.58 mm (0.8496 in.) at front and 27.08 mm (1.0661 in.) at rear. Replace stator shaft if bushing diameter is greater than specified.

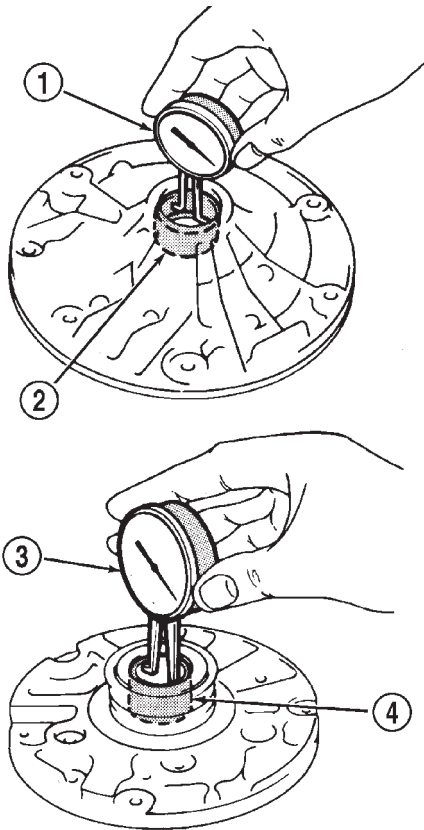

J8921-517

Fig. 200 Checking Pump/Stator Shaft Bushings

- 1 - BORE GAUGE
- 2 - PUMP BODY BUSHING
- 3 - BORE GAUGE
- 4 - STATOR SHAFT BUSHING

(3) Measure oil pump clearances (Fig. 201).

- Clearance between pump driven gear and pump body should be maximum of 0.3 mm (0.012 in).
- Clearance between tips of pump gear teeth should be maximum of 0.3 mm (0.012 in).
- Clearance between rear surface of pump housing and pump gears should be maximum of 0.1 mm (0.004 in.).

(4) Replace pump body and gears if any clearance is greater than specified.

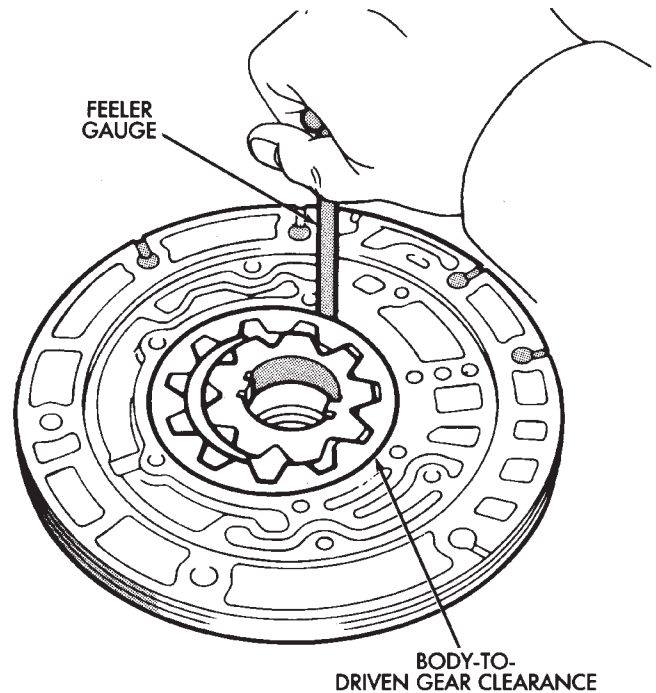

FEELER GAUGE

BODY-TO-DRIVEN GEAR CLEARANCE

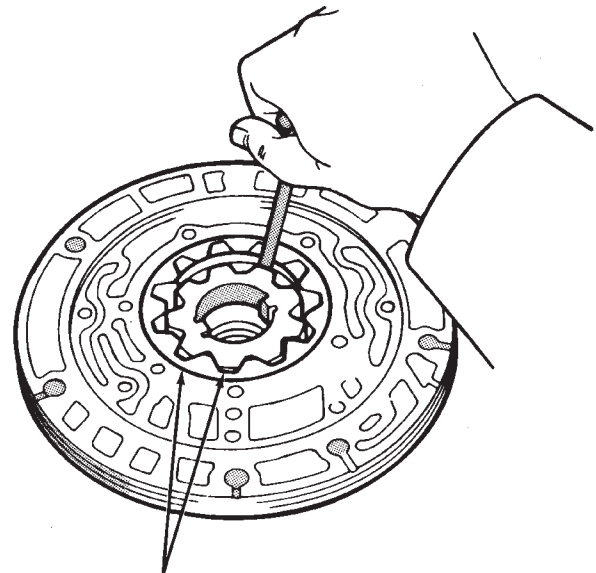

GEAR-TO-GEAR TOOTH CLEARANCE

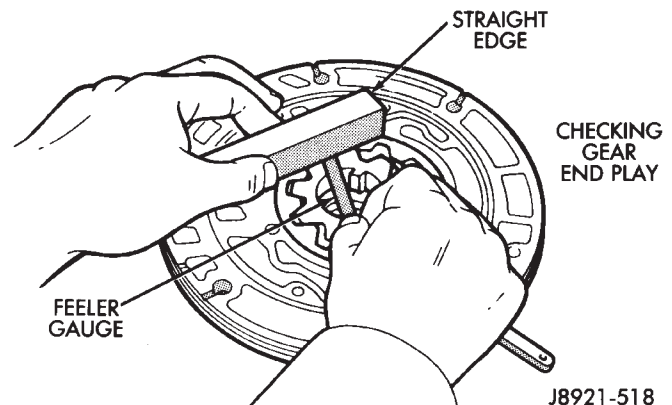

STRAIGHT EDGE

CHECKING GEAR END PLAY

FEELER GAUGE

J8921-518

Fig. 201 Checking Pump Gear Clearances

DISASSEMBLY AND ASSEMBLY (Continued)

(5) Install new seal with Seal Installer 7549 (Fig. 202).

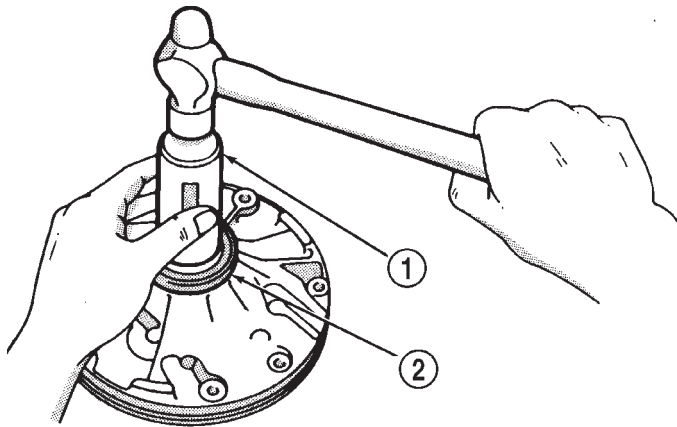

J8921-519

Fig. 202 Installing Pump Seal

- 1 - SEAL INSTALLER TOOL
2 - PUMP SEAL

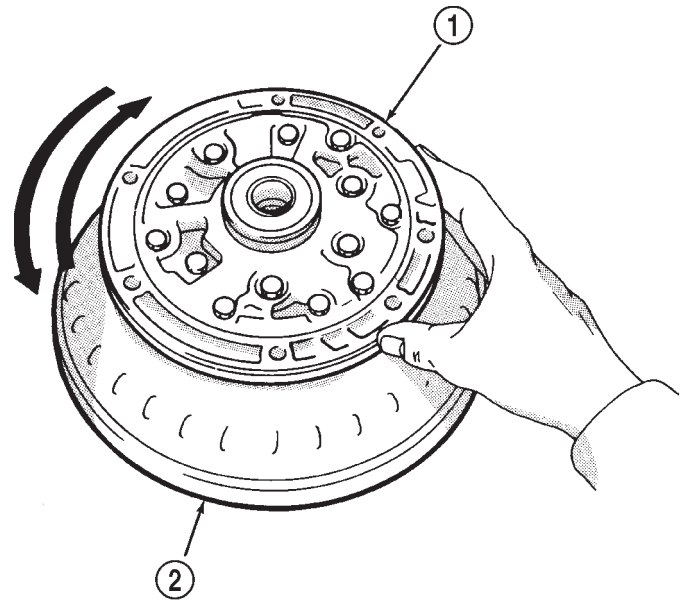

J8921-520

Fig. 203 Checking Pump Gear Rotation

- 1 - OIL PUMP
2 - TORQUE CONVERTER

(6) Lubricate and install gears in pump body.

(7) Assemble stator shaft and pump body. Tighten shaft-to-body bolts to 10 N·m (7 ft. lbs.) torque.

(8) Install new O-ring on pump body and new seal rings on stator shaft.

(9) Install pump in torque converter and check pump gear rotation (Fig. 203). Gears must rotate smoothly when turned clockwise and counterclockwise.

(10) Lubricate pump O-ring and seal rings with petroleum jelly.

DISASSEMBLY AND ASSEMBLY (Continued)

OVERDRIVE PLANETARY GEAR AND CLUTCH

(1) Check operation of one-way clutch in clutch drum (Fig. 204). Hold drum and turn planetary shaft clockwise and counterclockwise. Shaft should turn

DISASSEMBLY

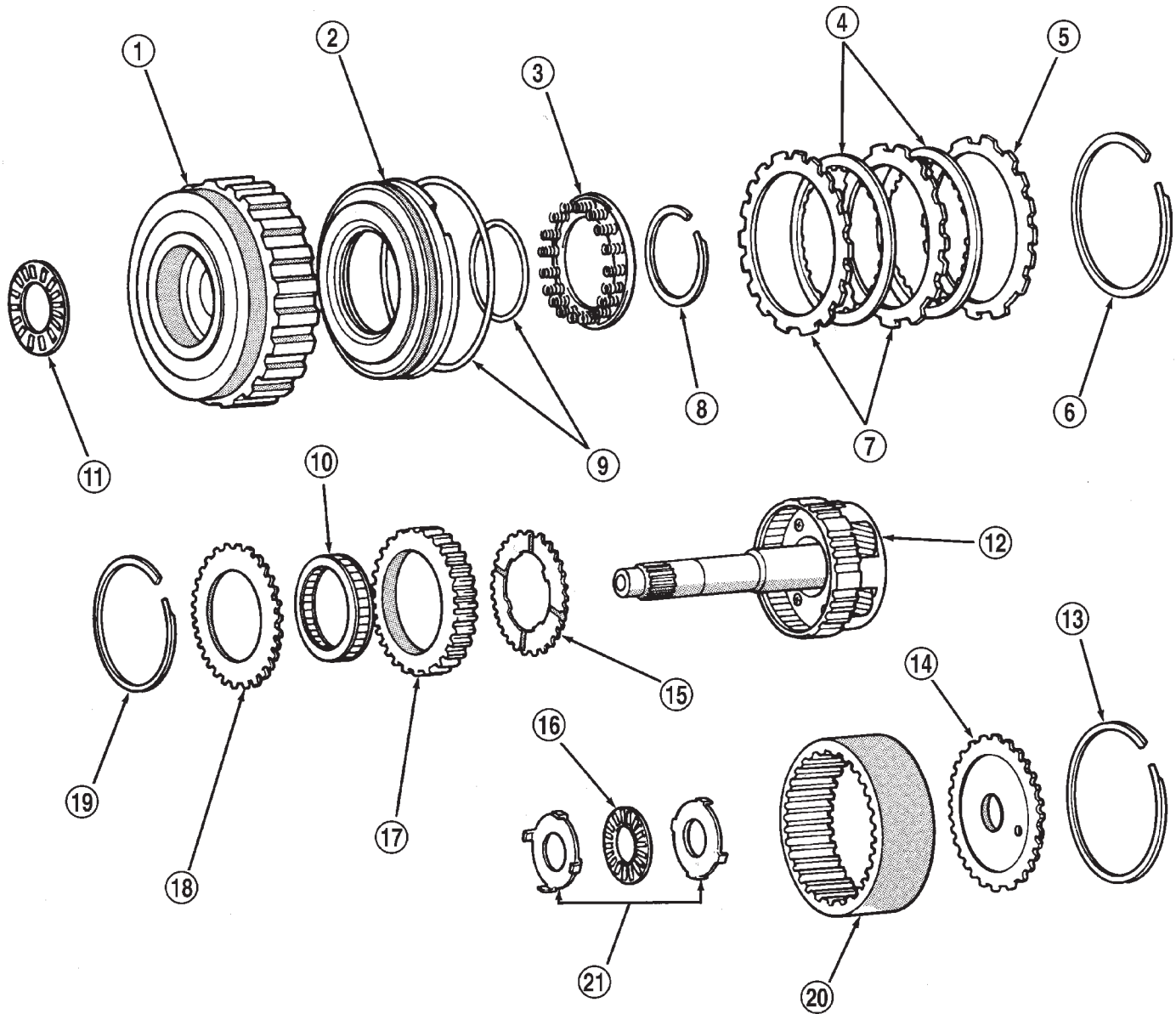

J8921-521

Overdrive Planetary Gear And Clutch Components

- | | |
|--|--------------------------------|
| 1 - CLUTCH DRUM | 12 - PLANETARY GEAR |
| 2 - CLUTCH PISTON | 13 - SNAP RING |
| 3 - PISTON RETURN SPRING | 14 - RING GEAR HUB |
| 4 - CLUTCH DISCS | 15 - THRUST WASHER |
| 5 - RETAINER PLATE | 16 - BEARING |
| 6 - CLUTCH PACK SNAP RING | 17 - ONE-WAY CLUTCH OUTER RACE |
| 7 - CLUTCH PLATES | 18 - RETAINING PLATE |
| 8 - PISTON SNAP RING | 19 - SNAP RING |
| 9 - O-RINGS | 20 - PLANETARY RING GEAR |
| 10 - ONE-WAY CLUTCH | 21 - RACE |
| 11 - CLUTCH DRUM BEARING AND RACE ASSEMBLY | |

DISASSEMBLY AND ASSEMBLY (Continued)

clockwise freely but lock when turned counterclockwise. Replace one-way clutch if necessary.

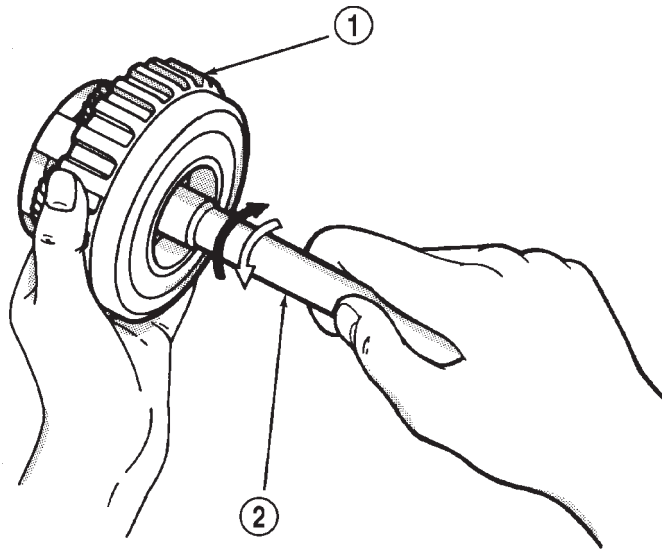

J8921-522

Fig. 204 Checking One-Way Clutch

- 1 - CLUTCH DRUM
2 - PLANETARY SHAFT

(2) Remove overdrive clutch from planetary gear (Fig. 205).

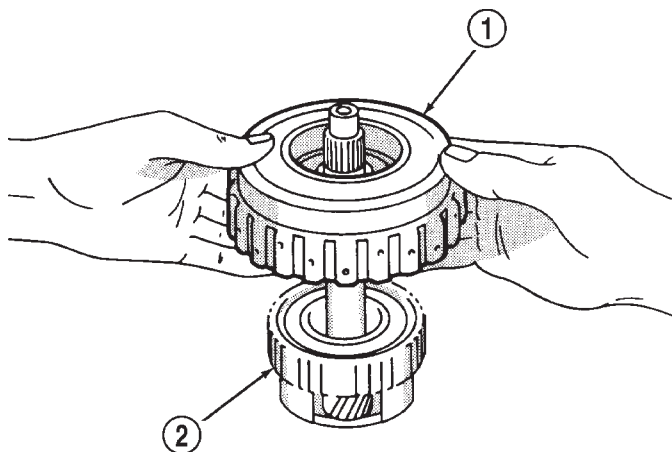

J8921-523

Fig. 205 Removing Overdrive Clutch From Gear

- 1 - OVERDRIVE CLUTCH
2 - PLANETARY GEAR

(3) Measure stroke length of overdrive clutch piston as follows:

(a) Mount oil pump on torque converter. Then mount clutch on oil pump (Fig. 206).

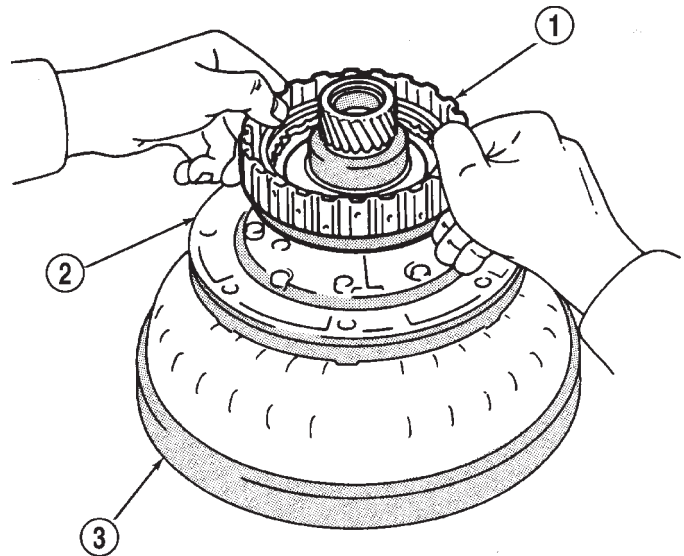

J8921-525

Fig. 206 Assembling Converter, Pump And Clutch For Test

- 1 - OVERDRIVE CLUTCH
2 - OIL PUMP
3 - TORQUE CONVERTER

(b) Install a suitable threaded bolt/rod into oil pump for use in mounting Miller Tool C-3339 dial indicator components securely.

(c) Mount dial indicator on the bolt/rod and position the dial indicator squarely on the clutch piston.

(d) Apply compressed air through clutch feed hole in oil pump and note piston stroke length. Stroke length should be 1.85 - 2.15 mm (0.0728 - 0.0846 in.).

(4) Remove thrust bearing and race assembly from clutch drum (Fig. 207).

(5) Remove clutch pack snap ring and remove the clutch pack (Fig. 208).

(6) Measure overdrive clutch disc thickness. Minimum allowable thickness is 1.84 mm (0.0724 in.).

(7) If the clutch pack stroke length is out of specification or any clutch disc fails to meet the minimum thickness, new discs will need to be installed during assembly.

(8) Compress piston return spring with Tool 7538 (Fig. 209). Remove snap ring and remove compressor tool.

(9) Remove the piston return springs.

(10) Mount oil pump on converter. Then mount clutch on oil pump (Fig. 210).

(11) Hold clutch piston by hand and apply compressed air through oil pump feed hole to ease piston

DISASSEMBLY AND ASSEMBLY (Continued)

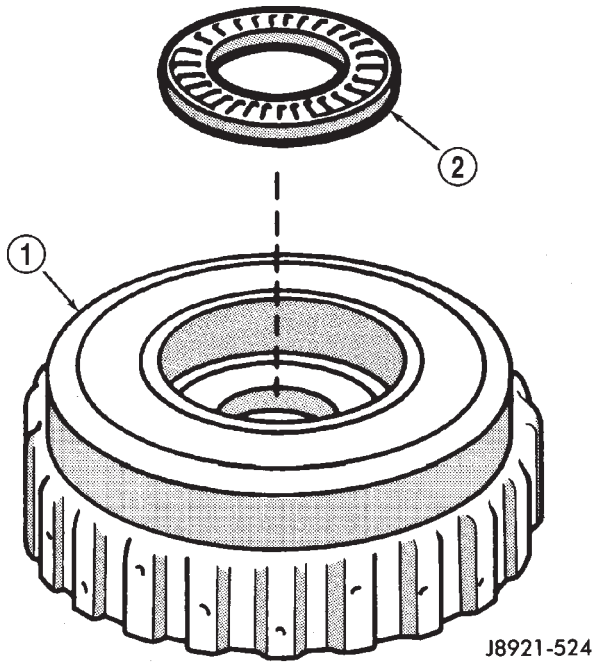

J8921-524

Fig. 207 Removing Clutch Drum Bearing And Race

- 1 - CLUTCH DRUM
- 2 - THRUST BEARING AND RACE

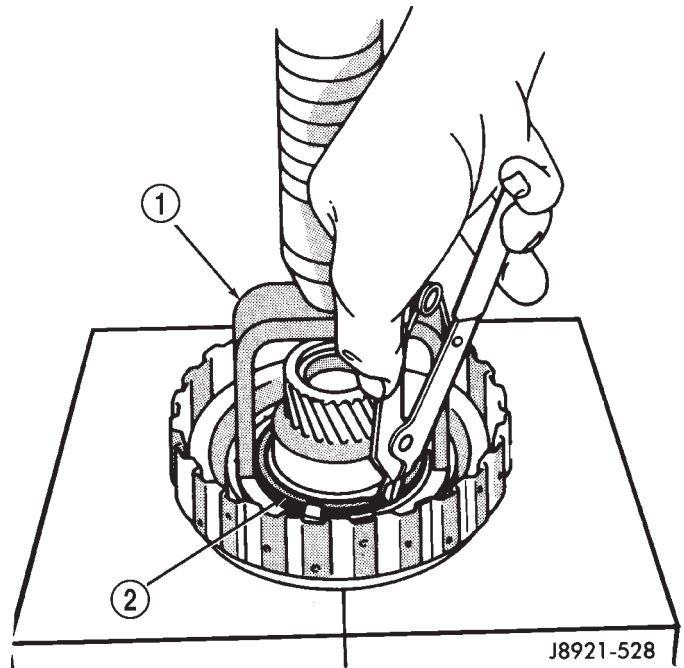

J8921-528

Fig. 209 Removing Clutch Piston Snap Ring

- 1 - COMPRESSOR TOOL
- 2 - CLUTCH PISTON SNAP RING

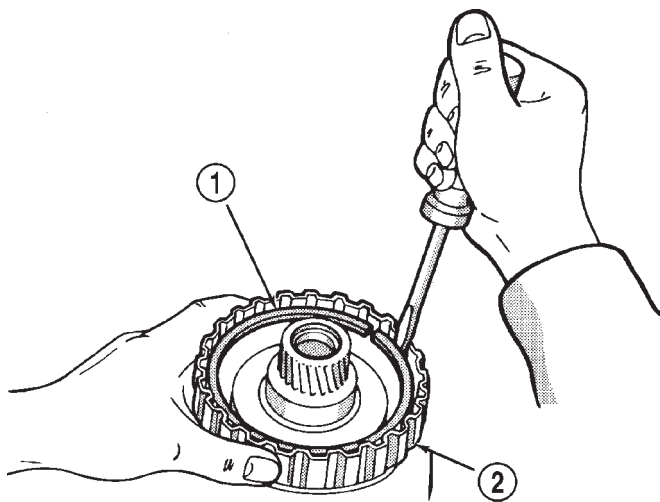

J8921-527

Fig. 208 Removing Clutch Pack Snap Ring

- 1 - SNAP RING
- 2 - CLUTCH RETAINER

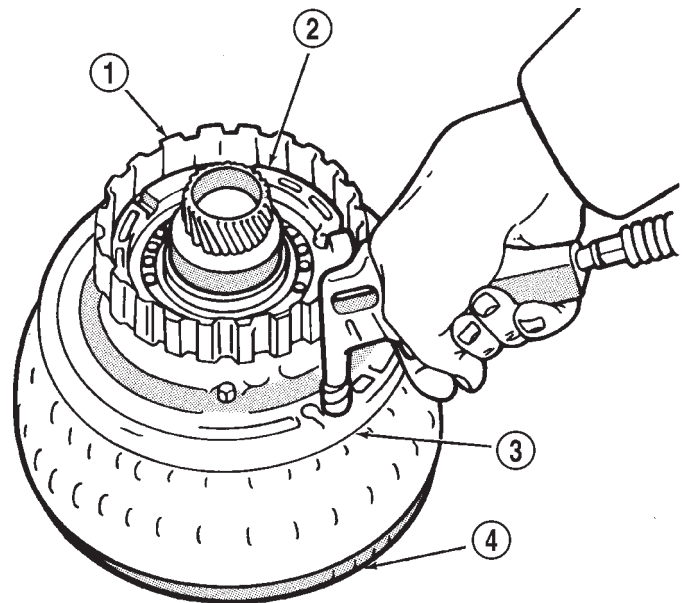

J8921-529

Fig. 210 Removing Overdrive Clutch Piston

- 1 - CLUTCH RETAINER
- 2 - CLUTCH PISTON
- 3 - OIL PUMP
- 4 - CONVERTER

out (Fig. 210). Apply only enough air pressure to remove piston.

(12) Measure free length of piston return springs with springs in retainer (Fig. 211). Length should be 16.8 mm (0.661 in.). Replace spring and retainer assembly if necessary.

(13) Check clutch piston check ball (Fig. 212). Shake piston to see if ball moves freely. Then check

ball sealing by applying low pressure compressed air to ball inlet as shown. Air should not leak past check ball.

DISASSEMBLY AND ASSEMBLY (Continued)

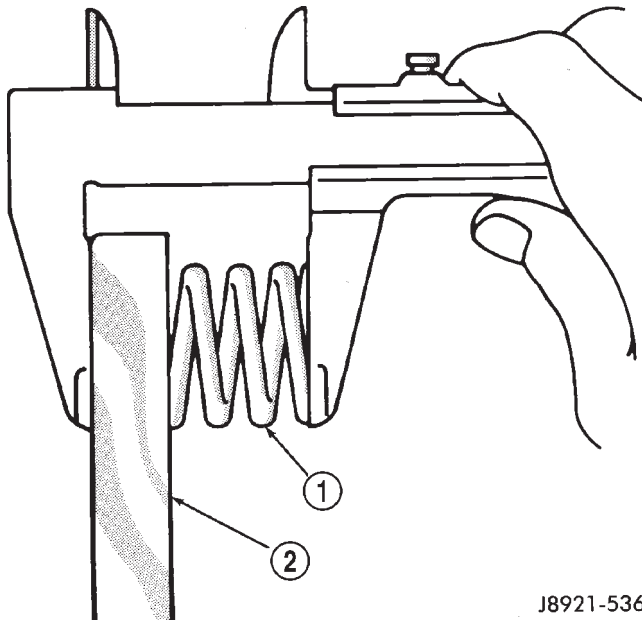

J8921-536

Fig. 211 Checking Piston Return Spring Length

- 1 - PISTON RETURN SPRINGS
- 2 - SPRING RETAINER

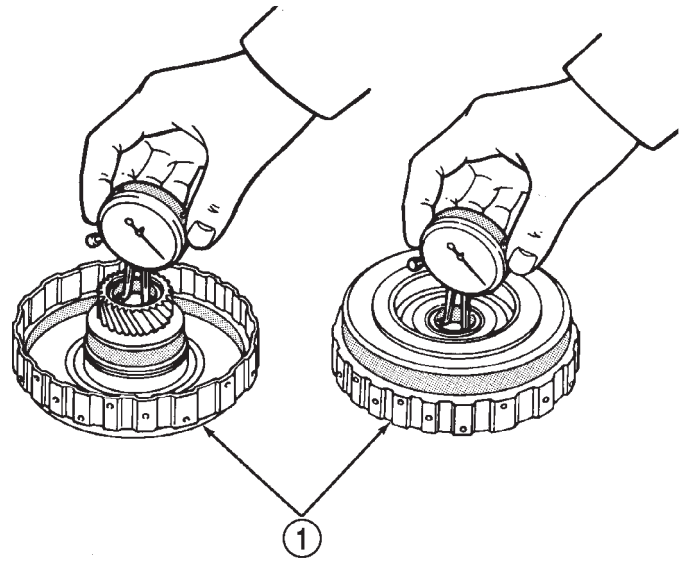

J8921-538

Fig. 213 Checking Clutch Drum Bushings

- 1 - CLUTCH DRUM

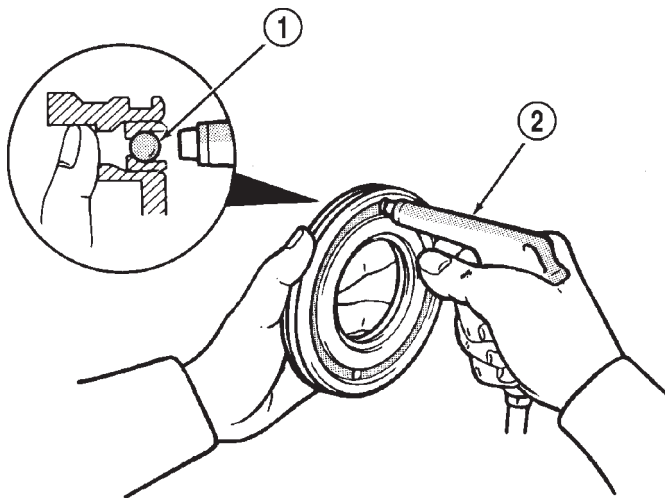

J8921-537

Fig. 212 Testing Clutch Piston Check Ball

- 1 - CLUTCH PISTON CHECK BALL
- 2 - USE LOW-PRESSURE COMPRESSED AIR TO TEST BALL SEATING

(14) Check inside diameter of clutch drum bushings with bore gauge or inside micrometer (Fig. 213). Maximum inside diameter is 27.11 mm (1.0673 in.). Replace drum if bushing inside diameter is greater than specified.

(15) Remove bearing and race from ring gear (Fig. 214).

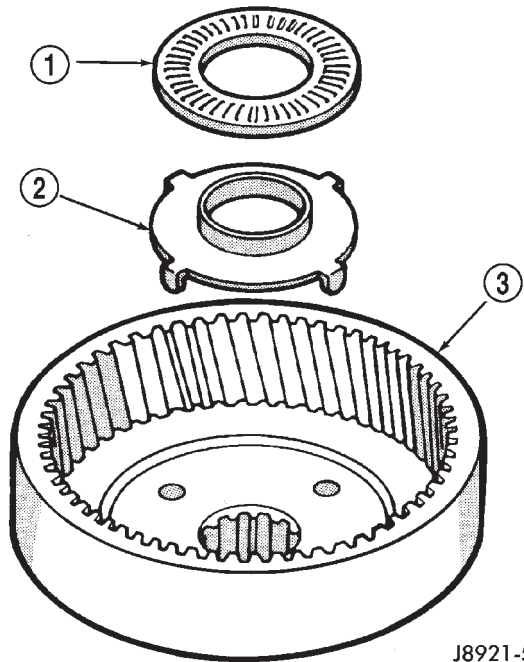

J8921-530

Fig. 214 Removing Ring Gear Bearing And Race

- 1 - BEARING
- 2 - RACE
- 3 - RING GEAR

DISASSEMBLY AND ASSEMBLY (Continued)

(16) Remove snap ring from ring gear and remove ring gear hub (Fig. 215).

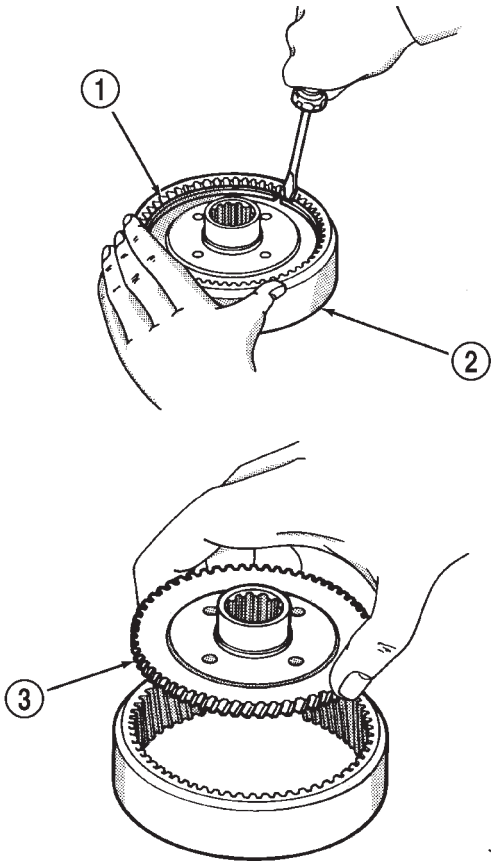

J8921-531

Fig. 215 Removing Ring Gear Hub

- 1 - SNAP RING
- 2 - RING GEAR
- 3 - RING GEAR HUB

(18) Remove snap ring and remove retaining plate (Fig. 217).

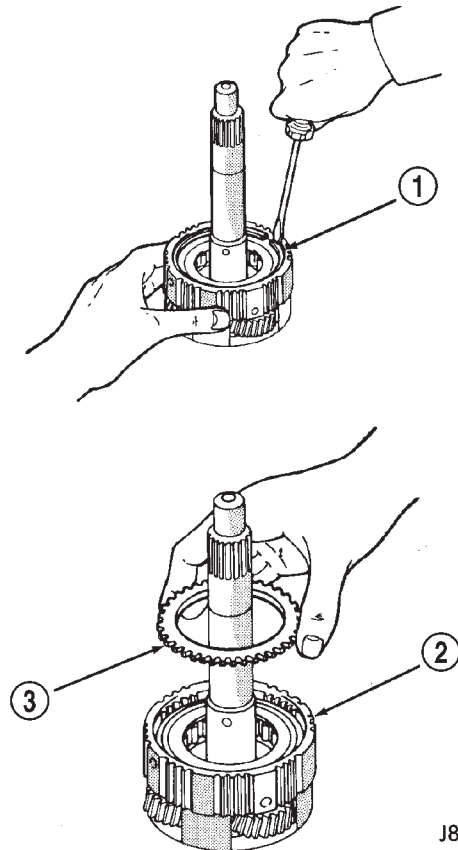

J8921-533

Fig. 217 Removing Snap Ring And Retaining Plate

- 1 - SNAP RING
- 2 - PLANETARY GEAR
- 3 - RETAINING PLATE

(17) Remove race from planetary gear (Fig. 216).

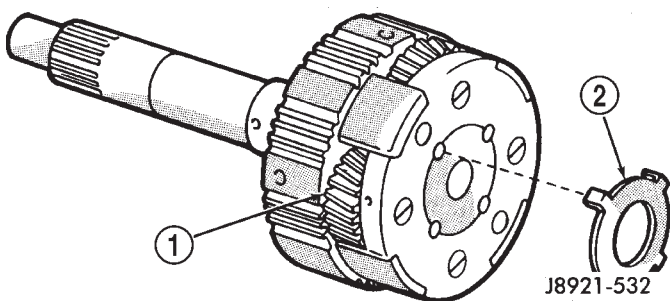

J8921-532

Fig. 216 Remove Planetary Gear Race

- 1 - PLANETARY GEAR
- 2 - RACE

DISASSEMBLY AND ASSEMBLY (Continued)

(19) Remove one-way clutch and outer race as assembly. Then separate race from clutch (Fig. 218).

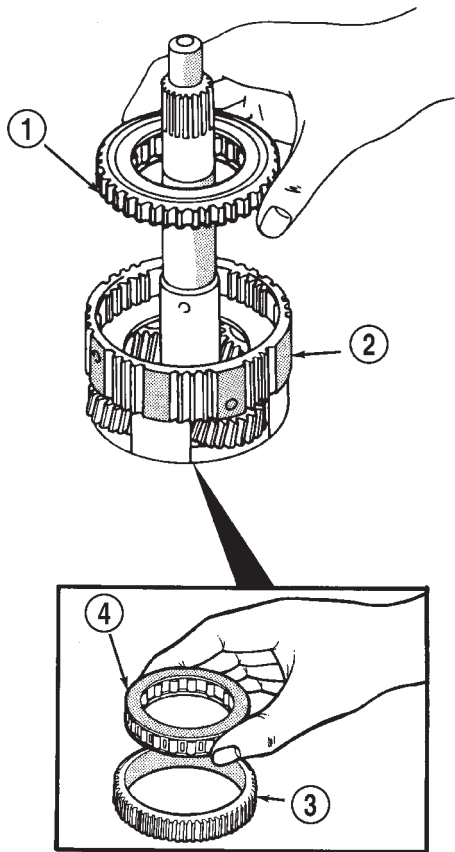

J8921-534

Fig. 218 Removing One-Way Clutch

- 1 - ONE-WAY CLUTCH AND OUTER RACE ASSEMBLY
- 2 - PLANETARY GEAR
- 3 - RACE
- 4 - CLUTCH

(20) Remove thrust washer (Fig. 219).

(21) Check inside diameter of planetary gear bushing (Fig. 220). Maximum inside diameter is 11.27 mm (0.4437 in.). Replace planetary gear if bushing inside diameter is greater than specified.

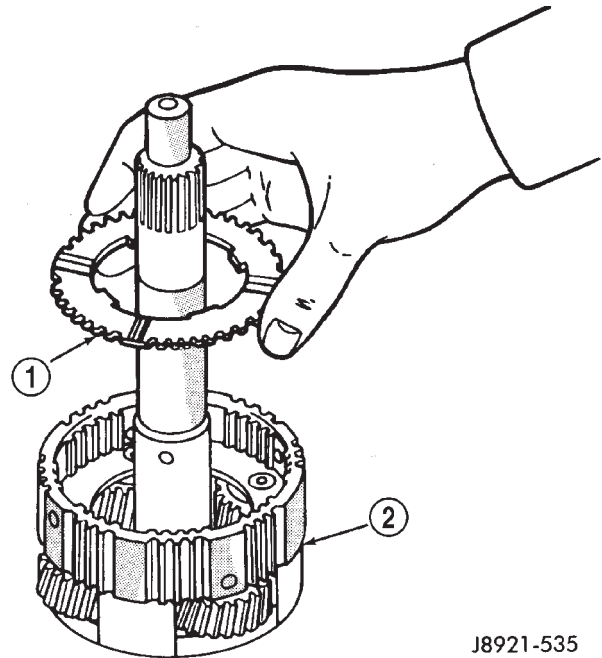

J8921-535

Fig. 219 Removing Planetary Thrust Washer

- 1 - THRUST WASHER
- 2 - PLANETARY GEAR

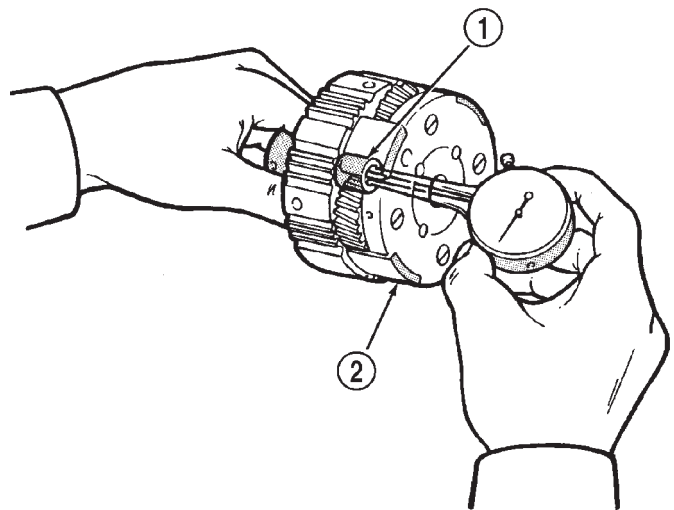

J8921-539

Fig. 220 Checking Planetary Bushing

- 1 - PLANETARY BUSHING
- 2 - PLANETARY GEAR

DISASSEMBLY AND ASSEMBLY (Continued)

ASSEMBLY

(1) Install thrust washer in planetary gear (Fig. 221). **Grooved side of washer faces up and toward front.**

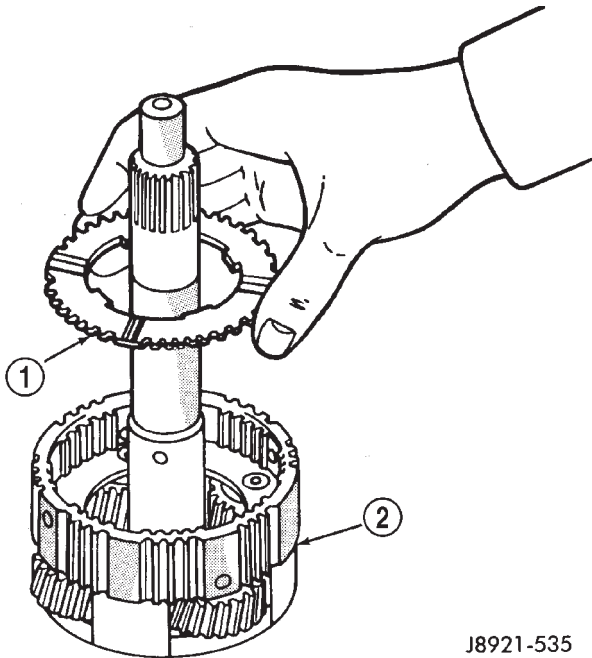

J8921-535

Fig. 221 Install Planetary Thrust Washer

- 1 - THRUST WASHER
- 2 - PLANETARY GEAR

- (2) Install clutch race into planetary gear.
- (3) Install one-way clutch into the outer race (Fig. 222). Be sure flanged side of clutch is facing upward.
- (4) Install clutch retaining plate and snap ring in planetary gear.
- (5) Coat planetary race with petroleum jelly and install it on planetary gear. Outside diameter of race should be 41.8 mm (1.646 in.); inside diameter is 27.1 mm (1.067 in.).
- (6) Install hub in planetary ring gear and install snap ring.
- (7) Coat race and bearing with petroleum jelly and install in planetary ring gear (Fig. 223).
- (8) Verify bearing/race size. Outside diameter of race is 47.8 mm (1.882 in.) and inside diameter is 24.2 mm (0.953 in.). Outside diameter of bearing is 46.8 mm (1.843 in.) and inside diameter is 26 mm (1.024 in.).
- (9) Lubricate new clutch piston O-rings with Mopar® Door Ease, or Ru-Glyde. Then install rings on clutch piston and install piston in clutch drum.
- (10) Install piston return springs in clutch piston (Fig. 224).

(11) Install piston snap ring. Compress piston return springs with Tool 7538 and shop press (Fig. 225).

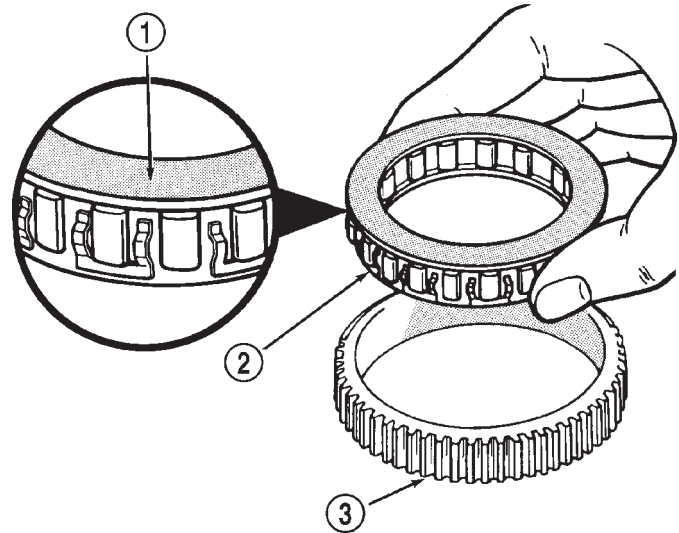

J8921-540

Fig. 222 Assembling One-Way Clutch And Race

- 1 - FLANGED SIDE OF CLUTCH FACES UP
- 2 - ONE-WAY CLUTCH
- 3 - CLUTCH RACE

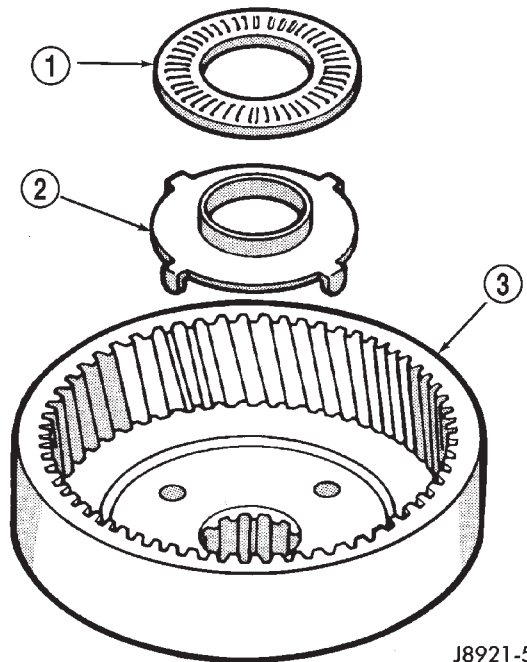

J8921-530

Fig. 223 Install Ring Gear Bearing And Race

- 1 - BEARING
- 2 - RACE
- 3 - RING GEAR

(12) Install overdrive clutch pack in drum. Install steel plate first, then a disc (Fig. 226). Continue

DISASSEMBLY AND ASSEMBLY (Continued)

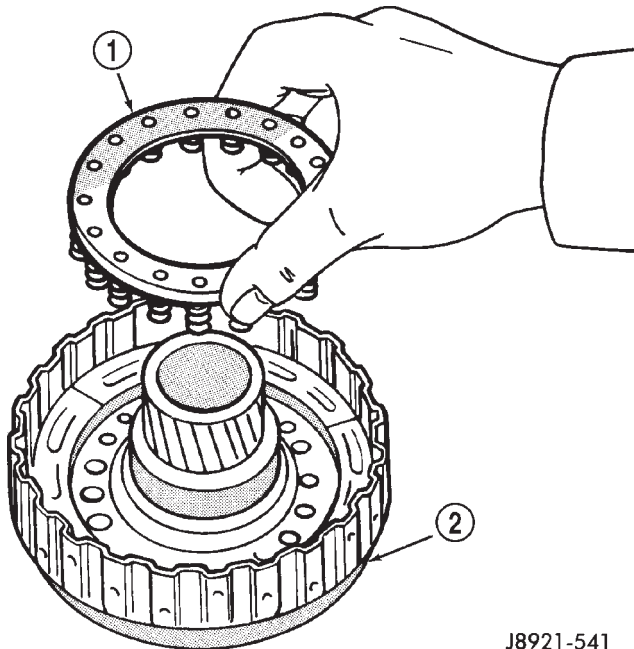

J8921-541

Fig. 224 Installing Piston Return Springs

- 1 - RETURN SPRINGS
- 2 - CLUTCH PISTON

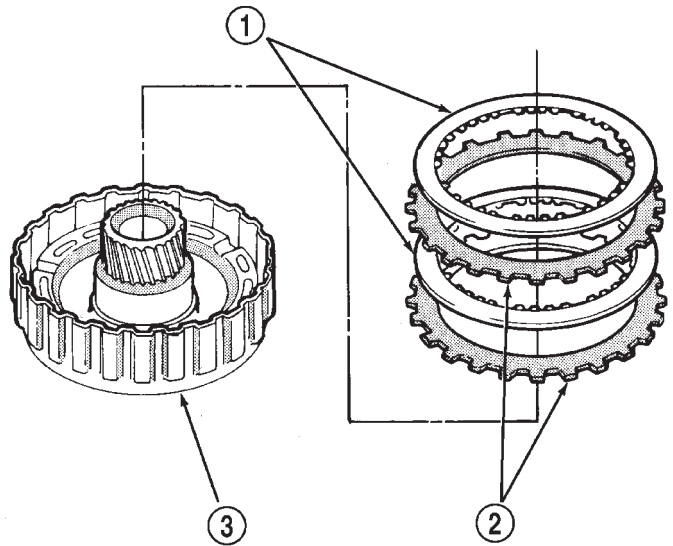

J8921-543

Fig. 226 Installing Overdrive Clutch Discs And Plates

- 1 - CLUTCH DISC
- 2 - STEEL PLATE
- 3 - CLUTCH DRUM

installation sequence until required number of discs and plates have been installed.

(13) Install clutch pack retainer with flat side facing downward. Then install retainer snap ring (Fig. 227). Compress springs with suitable tool.

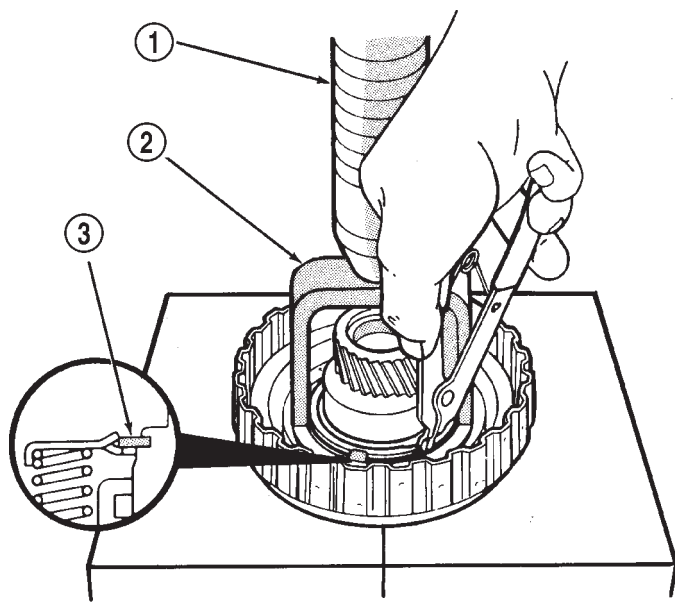

J8921-542

Fig. 225 Installing Clutch Piston Snap Ring

- 1 - PRESS RAM
- 2 - COMPRESSOR TOOL
- 3 - SNAP RING

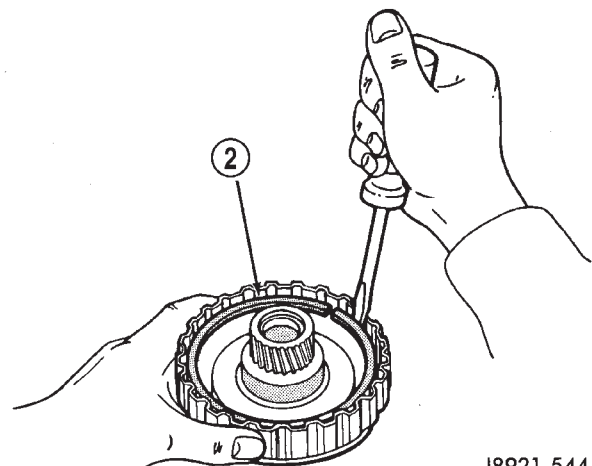
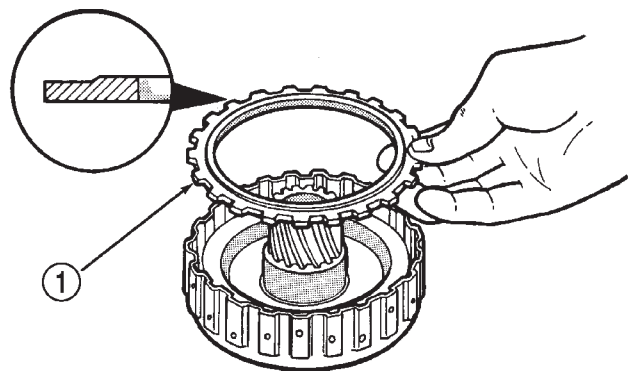

J8921-544

Fig. 227 Installing Retainer And Snap Ring

- 1 - CLUTCH PACK RETAINER
- 2 - RETAINER SNAP RING

DISASSEMBLY AND ASSEMBLY (Continued)

(14) Install clutch drum bearing and race assembly (Fig. 228). Be sure bearing rollers face upward as shown. Outside diameter of assembled bearing and race is 50.2 mm (1.976 in.). Inside diameter is 28.9 mm (1.138 in.).

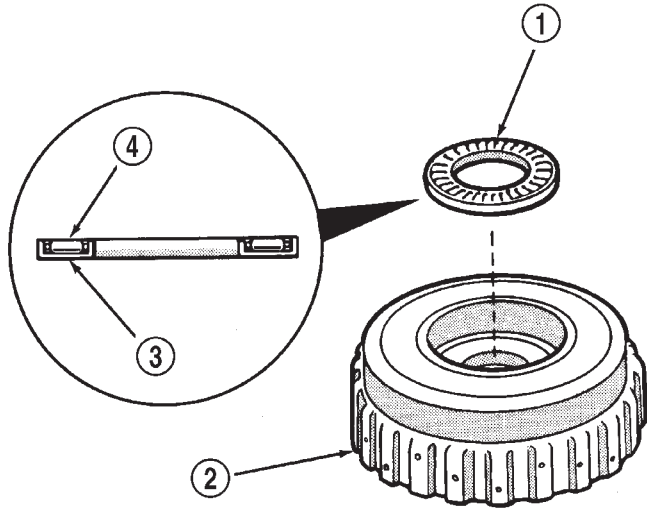

J8921-545

Fig. 228 Installing Clutch Drum Bearing And Race Assembly

- 1 - BEARING AND RACE ASSEMBLY
- 2 - CLUTCH DRUM
- 3 - RACE
- 4 - ROLLERS

(15) Install clutch on planetary gear.
 (16) Verify one-way clutch operation. Hold drum and turn planetary shaft clockwise and counterclockwise. Shaft should turn clockwise freely but lock when turned counterclockwise.

OVERDRIVE SUPPORT

DISASSEMBLY

- (1) Check brake piston operation. Mount support on clutch (Fig. 229).
- (2) Apply compressed air through support feed hole and observe brake piston movement (Fig. 229). Piston should move smoothly and not bind or stick. If operation is incorrect, replace piston and support.
- (3) Remove thrust bearing front race, thrust bearing and rear race (Fig. 230).
- (4) Turn overdrive support over and remove bearing race and clutch drum thrust washer (Fig. 231).
- (5) Compress piston return spring with Spring Compressor 7537 and remove piston snap ring (Fig. 232).

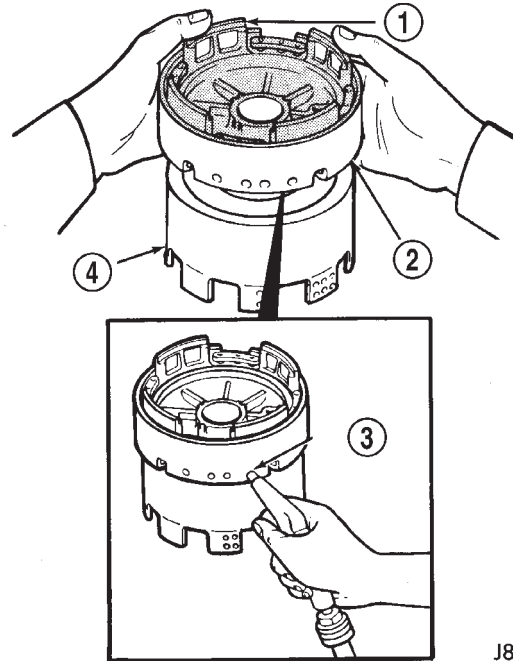

J8921-547

Fig. 229 Checking Brake Piston Movement

- 1 - BRAKE PISTON
- 2 - OVERDRIVE SUPPORT
- 3 - SUPPORT FEED HOLE
- 4 - CLUTCH

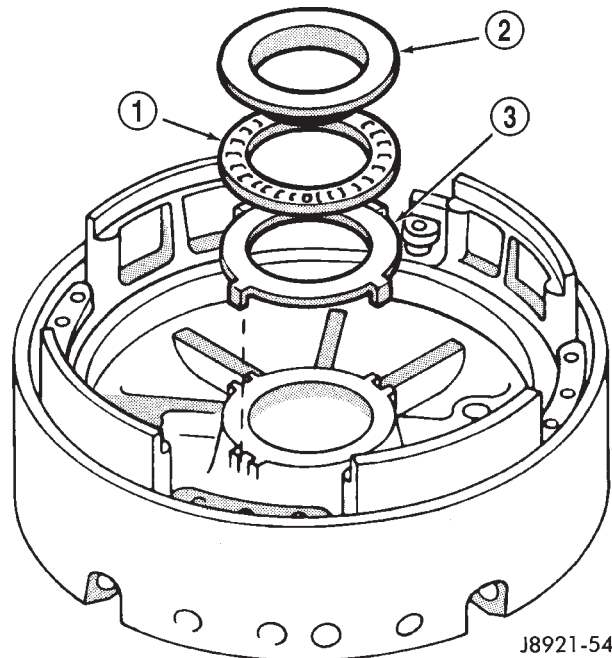

J8921-548

Fig. 230 Removing Support Thrust Bearing And Races

- 1 - THRUST BEARING
- 2 - FRONT RACE
- 3 - REAR RACE

DISASSEMBLY AND ASSEMBLY (Continued)

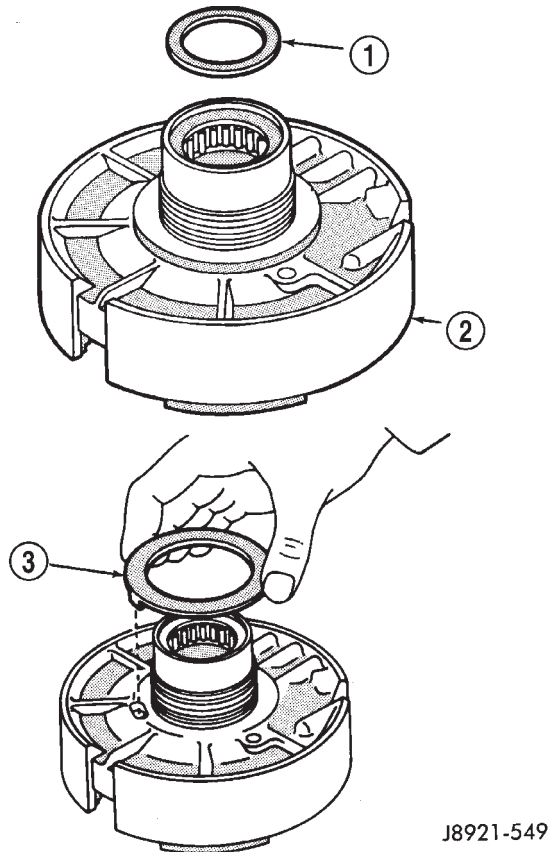

Fig. 231 Removing Clutch Drum Thrust Washer And Race

- 1 - BEARING RACE
- 2 - OVERDRIVE SUPPORT
- 3 - THRUST WASHER

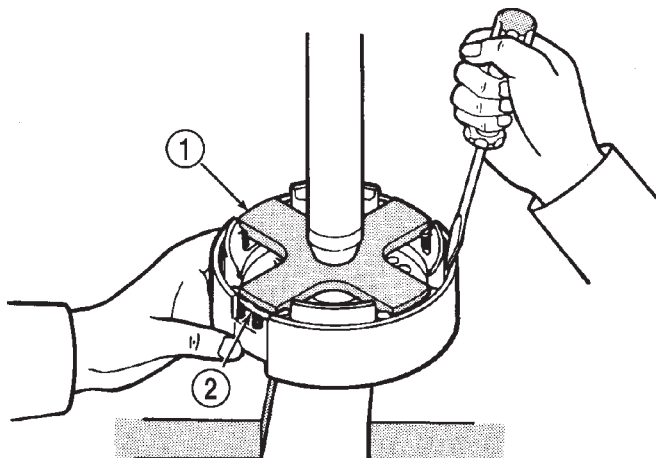

Fig. 232 Removing/Installing Piston Snap Ring

- 1 - COMPRESSOR TOOL
- 2 - SNAP RING

(6) Mount support in direct clutch and remove brake piston with compressed air. Apply air to same feed hole used when checking piston operation.

(7) Remove and discard support O-rings (Fig. 233).

(8) Remove support seal rings (Fig. 234).

(9) Measure free length of piston return springs with springs mounted in retainer (Fig. 235). Length should be 17.23 mm (0.678 in.).

(10) Clean support components and dry them with compressed air.

(11) Inspect overdrive support and brake piston. Replace support and piston if either part is worn or damaged.

ASSEMBLY

(1) Lubricate new support seal rings. Then compress rings and install them on support (Fig. 236).

(2) Lubricate and install new O-rings on brake piston. Then carefully seat piston in support.

(3) Install return springs on brake piston.

(4) Compress return springs with Spring Compressor 7537 (Fig. 232) and install piston snap ring.

(5) Install support bearing race and clutch drum thrust washer (Fig. 231).

(6) Install thrust bearing and front and rear bearing races. Thrust bearing rollers should face upward as shown (Fig. 236).

(7) Verify thrust bearing/race sizes (Fig. 237).

- Front race outer diameter is 47.8 mm (1.882 in.) and inside diameter is 30.7 mm (1.209 in.).

- Rear race outer diameter is 47.8 mm (1.882 in.) and inside diameter is 34.3 mm (1.350 in.).

- Bearing outer diameter is 47.7 mm (1.878 in.) and inside diameter is 32.7 mm (1.287 in.).

(8) Verify brake piston operation. Use same procedure described at beginning of disassembly. Piston should operate smoothly and not bind or stick.

DISASSEMBLY AND ASSEMBLY (Continued)

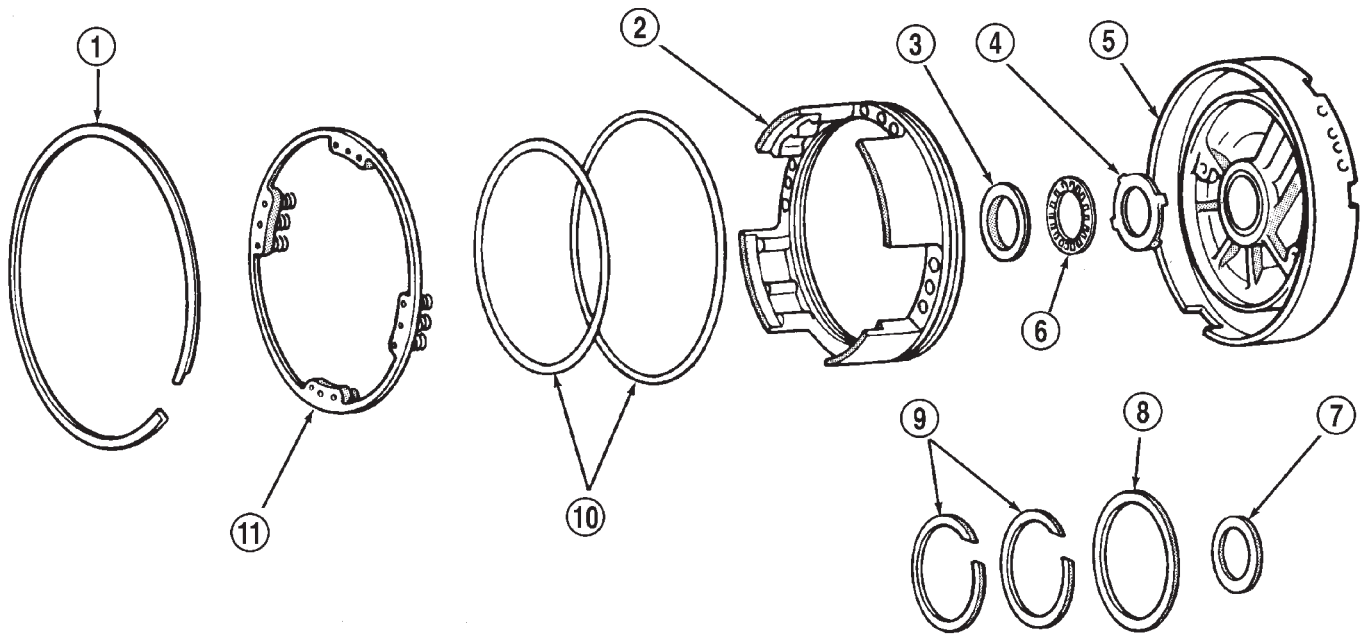

J8921-546

Fig. 233 Overdrive Support Components

- | | |
|-----------------------|-------------------------------|
| 1 - PISTON SNAP RING | 7 - BEARING RACE |
| 2 - BRAKE PISTON | 8 - CLUTCH DRUM THRUST WASHER |
| 3 - FRONT RACE | 9 - SUPPORT SEAL RINGS |
| 4 - REAR RACE | 10 - BRAKE PISTON O-RINGS |
| 5 - OVERDRIVE SUPPORT | 11 - PISTON RETURN SPRING |
| 6 - THRUST BEARING | |

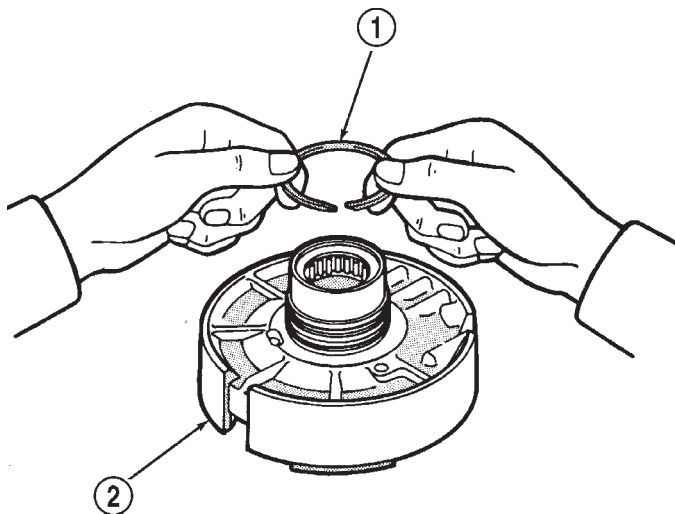

J8921-551

Fig. 234 Removing Support Seal Rings

- 1 - SEAL RINGS (2)
- 2 - SUPPORT

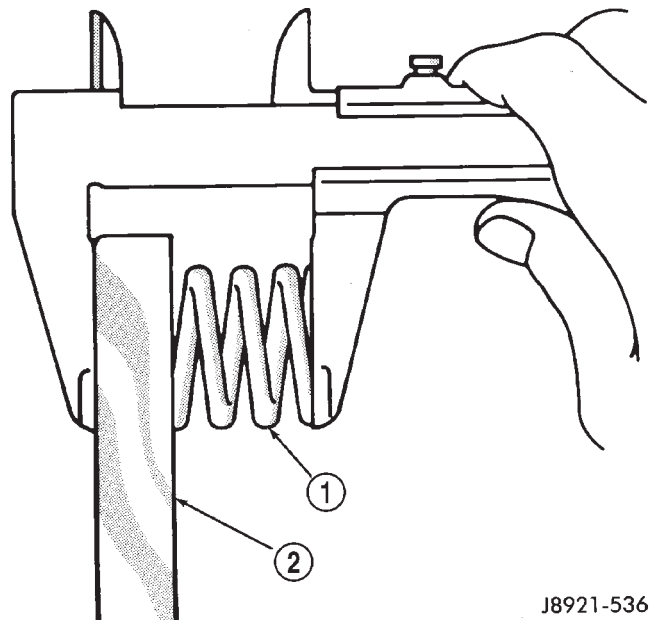

J8921-536

Fig. 235 Checking Piston Return Spring Length

- 1 - PISTON RETURN SPRINGS
- 2 - SPRING RETAINER

DISASSEMBLY AND ASSEMBLY (Continued)

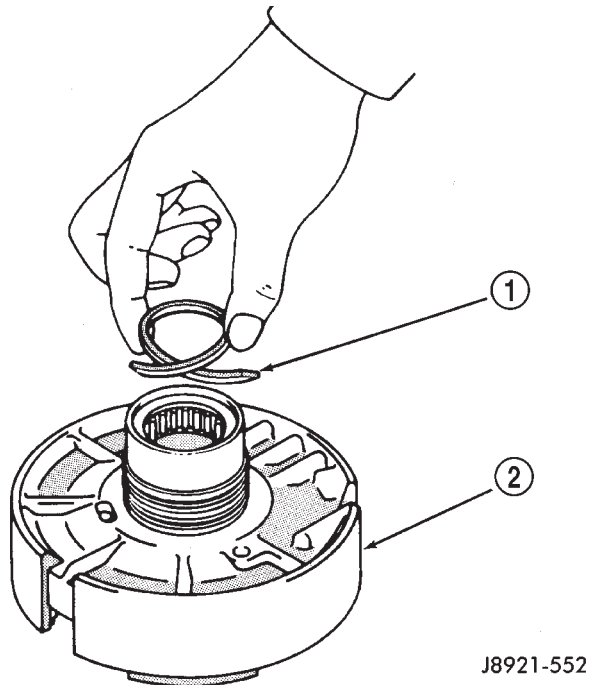

J8921-552

Fig. 236 Installing Support Seal Rings

- 1 - COMPRESS SEAL RINGS BEFORE INSTALLATION
- 2 - OVERDRIVE SUPPORT

DIRECT CLUTCH

DISASSEMBLY

- (1) Remove direct clutch from forward clutch (Fig. 238).

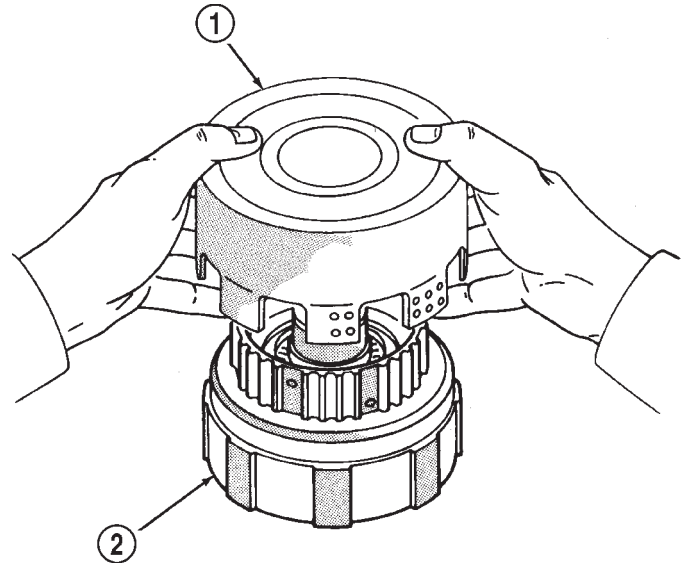

J8921-555

Fig. 238 Separate Direct Clutch From Forward Clutch

- 1 - DIRECT CLUTCH
- 2 - FORWARD CLUTCH

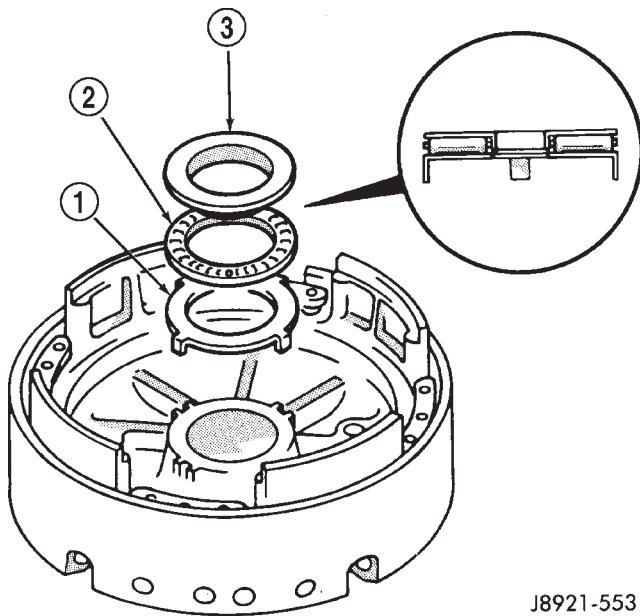

J8921-553

Fig. 237 Installing Support Thrust Bearing And Races

- 1 - REAR RACE
- 2 - THRUST BEARING
- 3 - FRONT RACE

- (2) Remove clutch drum thrust washer (Fig. 239).

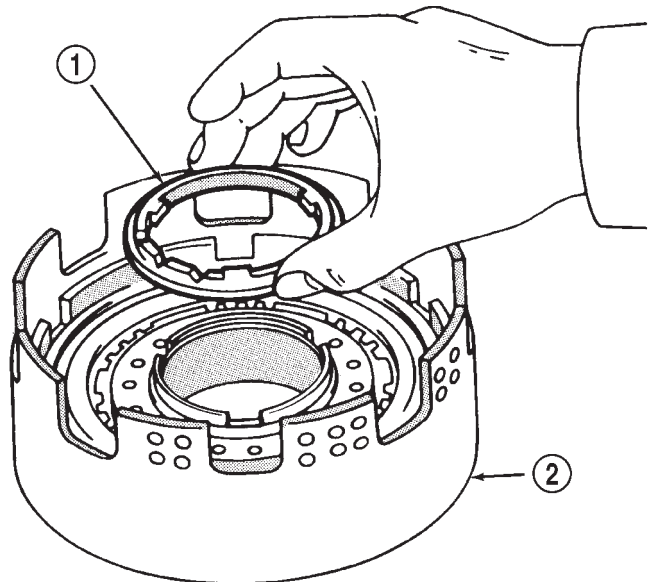

J8921-556

Fig. 239 Removing Clutch Drum Thrust Washer

- 1 - THRUST WASHER
- 2 - CLUTCH DRUM

DISASSEMBLY AND ASSEMBLY (Continued)

(3) Check clutch piston stroke length as outlined in following steps.

(4) Mount direct clutch on overdrive support assembly (Fig. 240).

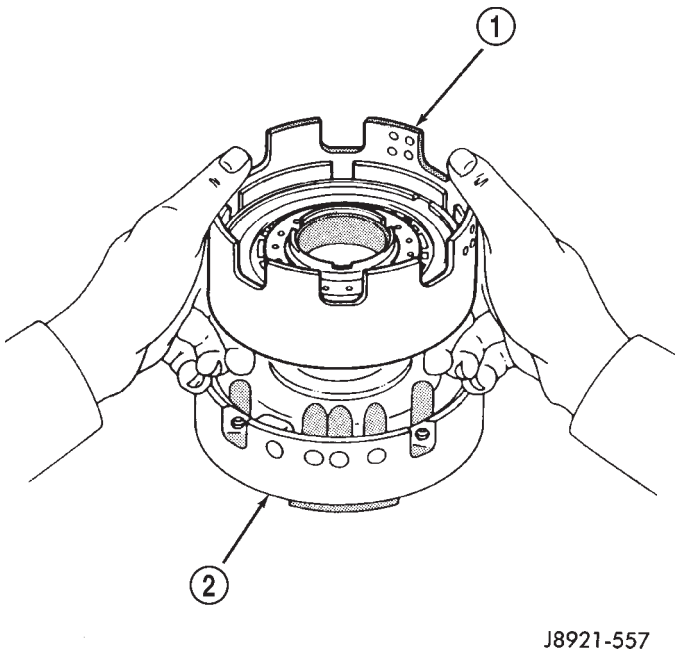

J8921-557

Fig. 240 Mount Direct Clutch On Overdrive Support

- 1 - DIRECT CLUTCH
- 2 - OVERDRIVE SUPPORT

(5) Mount dial indicator on clutch and position indicator plunger on clutch piston (Fig. 241).

(6) Apply 57-114 psi air pressure through feed hole in overdrive support and note piston stroke length (Fig. 241). Check stroke at least twice.

(7) Piston stroke length should be 1.37 mm - 1.67 mm (0.054 - 0.065 in.). If stroke length is incorrect, either the clutch pack retainer or clutch discs will have to be replaced.

(8) Remove clutch pack snap ring and remove retainer and clutch pack from drum (Fig. 242).

(9) Compress clutch piston return springs with tool 7538 and remove clutch piston snap ring (Fig. 243).

(10) Remove compressor tool and return spring.

(11) Remove clutch piston. Remount clutch on overdrive support (Fig. 244). Apply compressed air through piston feed hole in support to remove piston. Use only enough air to ease piston out.

(12) Remove and discard clutch piston O-rings.

(13) Measure clutch disc thickness. Minimum allowable thickness is 1.84 mm (0.0724 in). Replace clutch pack if any disc is below minimum thickness.

(14) Measure free length of piston return springs with springs in retainer (Fig. 245). Length should be 21.32 mm (0.839 in.). Replace return springs if not within specification.

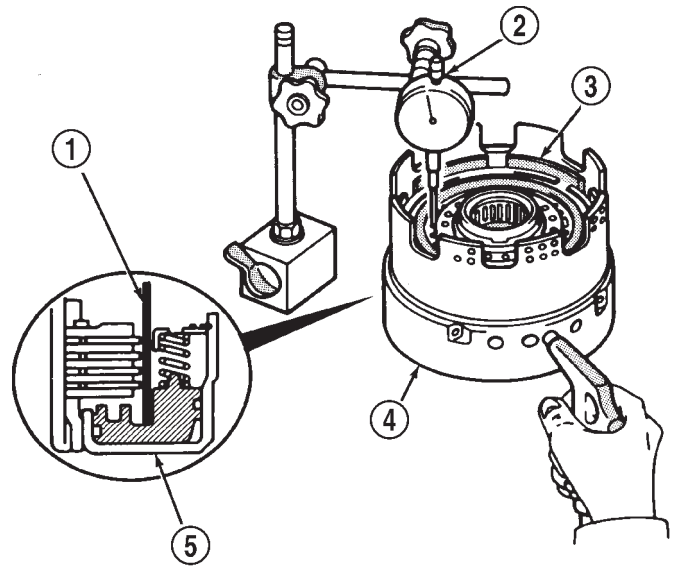

J8921-558

Fig. 241 Checking Direct Clutch Piston Stroke Length

- 1 - INDICATOR PLUNGER
- 2 - DIAL INDICATOR
- 3 - CLUTCH PISTON
- 4 - OVERDRIVE SUPPORT
- 5 - CLUTCH PISTON

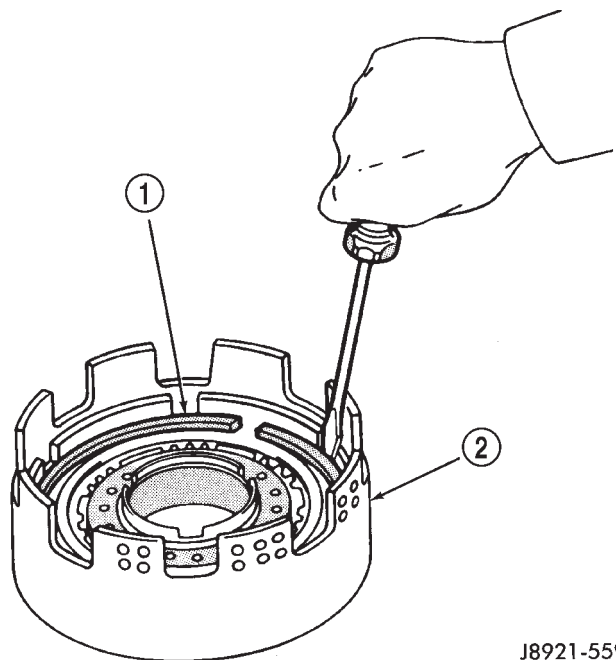

J8921-559

Fig. 242 Removing Clutch Pack Snap Ring

- 1 - CLUTCH PACK SNAP RING
- 2 - DIRECT CLUTCH DRUM

(15) Check clutch piston check ball (Fig. 246). Shake piston to see if ball moves freely. Then check ball seating by applying low pressure compressed air

DISASSEMBLY AND ASSEMBLY (Continued)

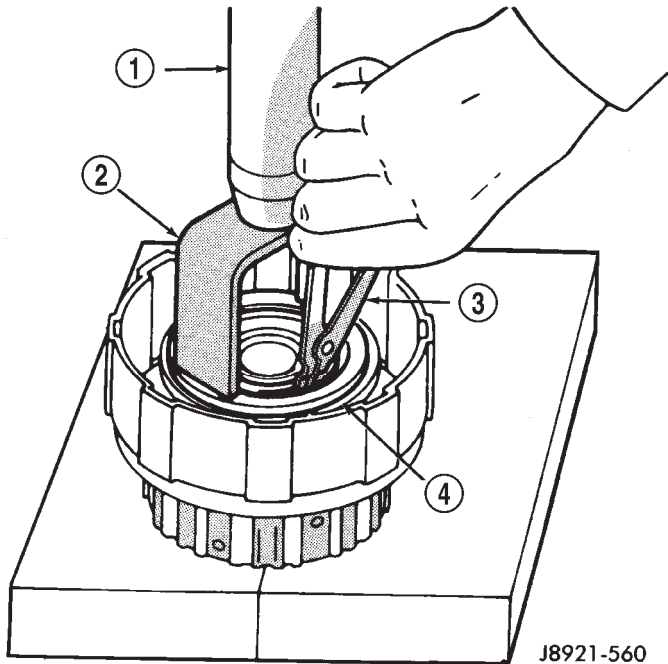

J8921-560

Fig. 243 Removing Piston Return Spring

- 1 - PRESS RAM
- 2 - COMPRESSOR TOOL
- 3 - SNAP RING PLIERS
- 4 - RETURN SPRING

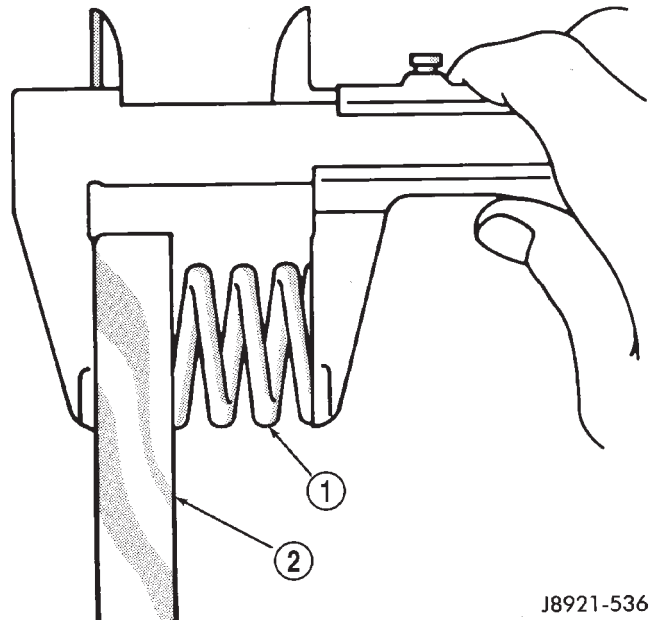

J8921-536

Fig. 245 Checking Piston Return Spring Length

- 1 - PISTON RETURN SPRINGS
- 2 - SPRING RETAINER

to ball inlet as shown. Air should not leak past check ball.

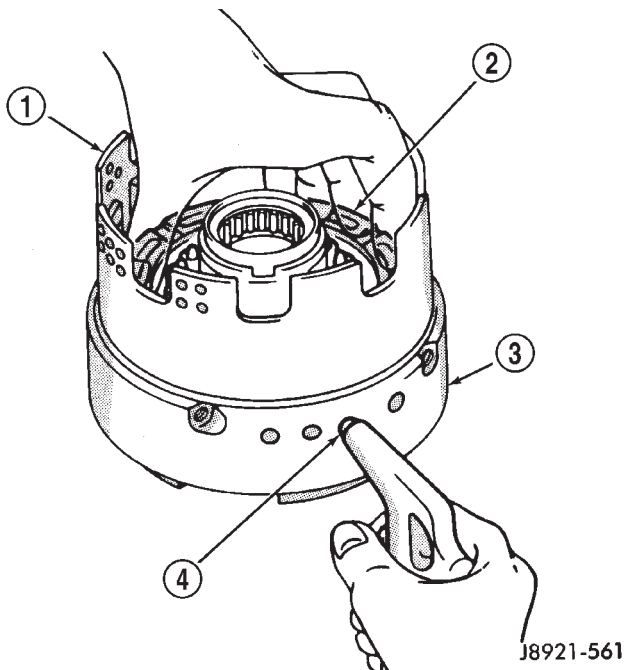

J8921-561

Fig. 244 Removing Direct Clutch Piston

- 1 - DIRECT CLUTCH DRUM
- 2 - CLUTCH PISTON
- 3 - OVERDRIVE SUPPORT
- 4 - SUPPORT FEED HOLE

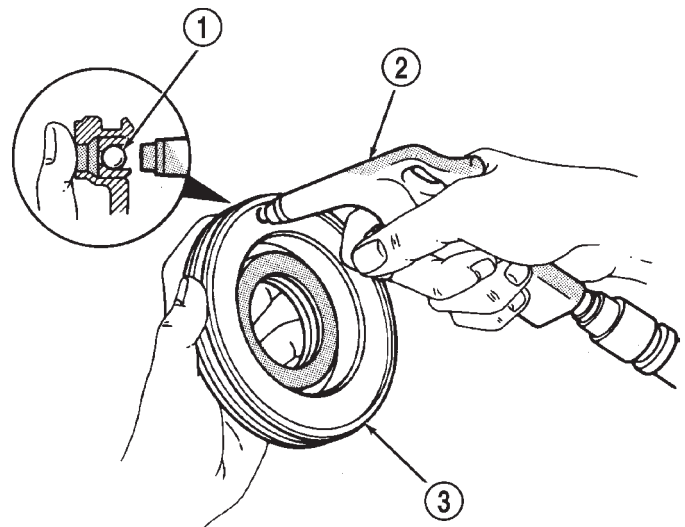

J8921-562

Fig. 246 Testing Piston Check Ball Seating

- 1 - PISTON CHECK BALL
- 2 - USE LOW-PRESSURE AIR TO CHECK SEATING
- 3 - DIRECT CLUTCH PISTON

(16) Measure inside diameter of clutch drum bushing. Inside diameter should be no more than 53.97 mm (2.1248 in.). Replace drum if bushing inside diameter is greater than specified.

DISASSEMBLY AND ASSEMBLY (Continued)

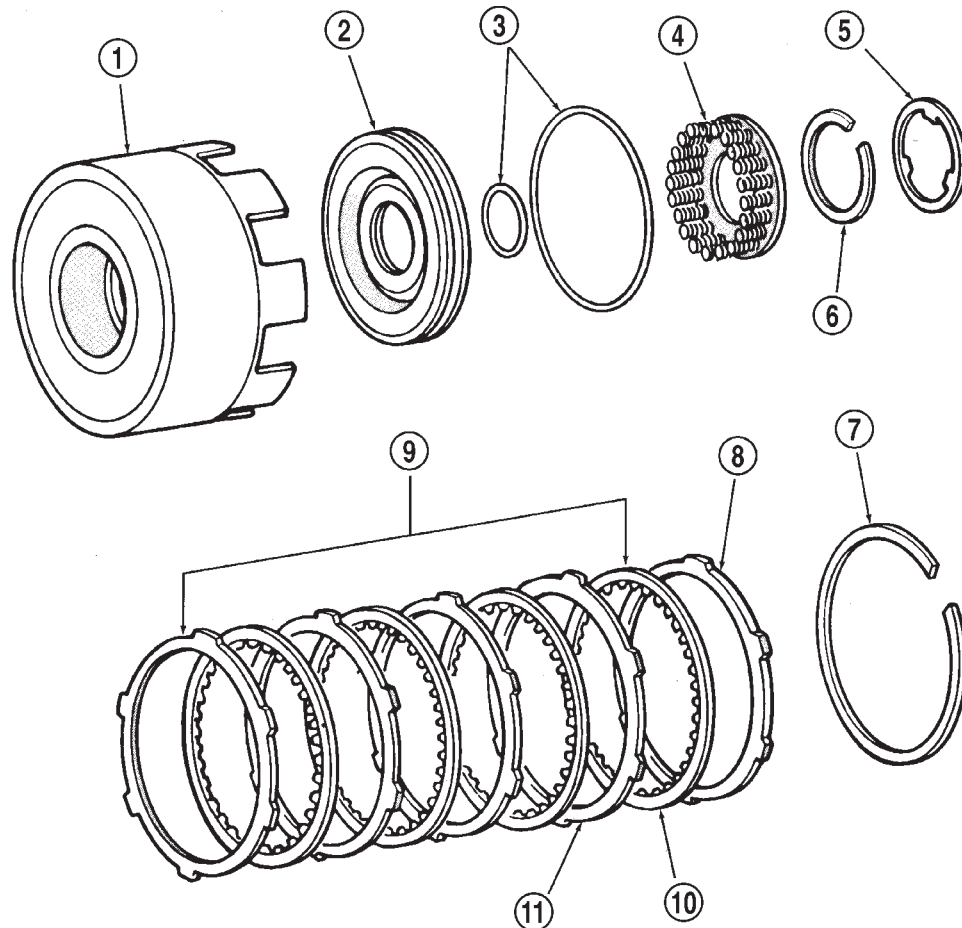

* 6-CYLINDER USES FOUR PLATES - FOUR DISCS

J8921-554

Fig. 247 Direct Clutch Components

- | | |
|-------------------------------|---------------------------|
| 1 - DIRECT CLUTCH DRUM | 7 - CLUTCH PACK SNAP RING |
| 2 - DIRECT CLUTCH PISTON | 8 - RETAINER |
| 3 - O-RINGS | 9 - CLUTCH PACK |
| 4 - PISTON RETURN SPRINGS | 10 - CLUTCH DISC* |
| 5 - CLUTCH DRUM THRUST WASHER | 11 - CLUTCH PLATE* |
| 6 - CLUTCH PISTON SNAP RING | |

ASSEMBLY

- (1) Lubricate and install replacement O-rings on clutch piston (Fig. 247).
- (2) Install clutch piston in drum and install return springs on piston.
- (3) Compress piston return springs with Tool 7538 and install snap ring (Fig. 243). Be sure snap ring end gap is not aligned with spring retainer tab.
- (4) Install clutch discs and plates (Fig. 248). Install plate then disc until all plates and discs are installed. Four plates and discs are required.
- (5) Install clutch pack retainer in drum (Fig. 249).
- (6) Install clutch pack snap ring (Fig. 249).
- (7) Check snap ring position. If necessary, shift snap ring until end gap is **not** aligned with any notches in clutch drum (Fig. 250).

- (8) Lubricate clutch drum thrust washer with petroleum jelly and install it in drum (Fig. 240).
- (9) Mount direct clutch assembly on forward clutch assembly and check assembled height (Fig. 251). Height should be 70.3 to 71.5 mm (2.767 to 2.815 in.).
- (10) If assembled height is incorrect, clutches are not seated.

DISASSEMBLY AND ASSEMBLY (Continued)

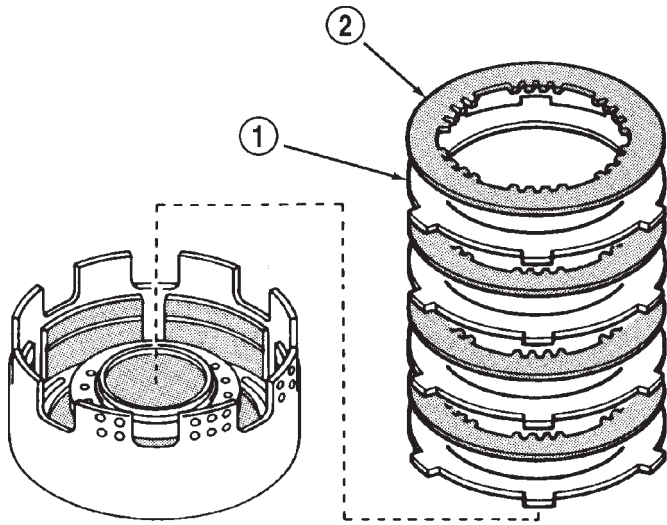

J8921-563

Fig. 248 Installing Direct Clutch Discs And Plates

- 1 - CLUTCH PLATES
- 2 - CLUTCH DISCS

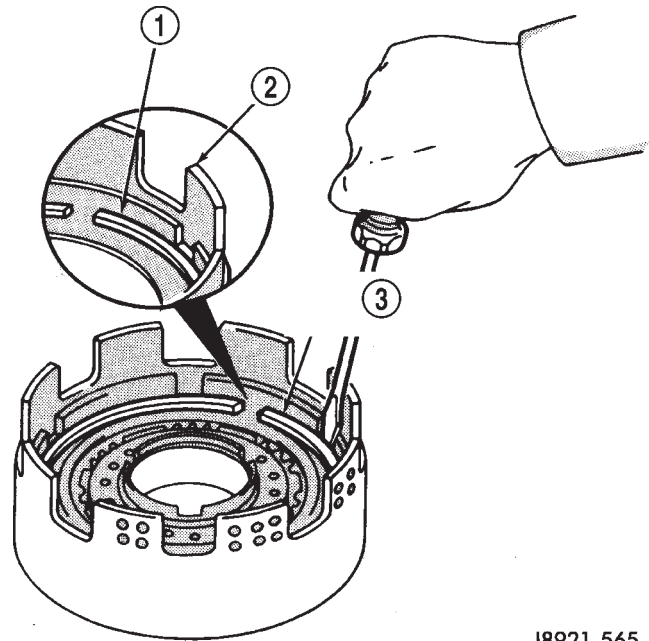

J8921-565

Fig. 250 Adjusting Clutch Pack Snap Ring Position

- 1 - CLUTCH PACK SNAP RING
- 2 - DRUM NOTCH
- 3 - SHIFT SNAP RING END GAP AWAY FROM DRUM NOTCHES

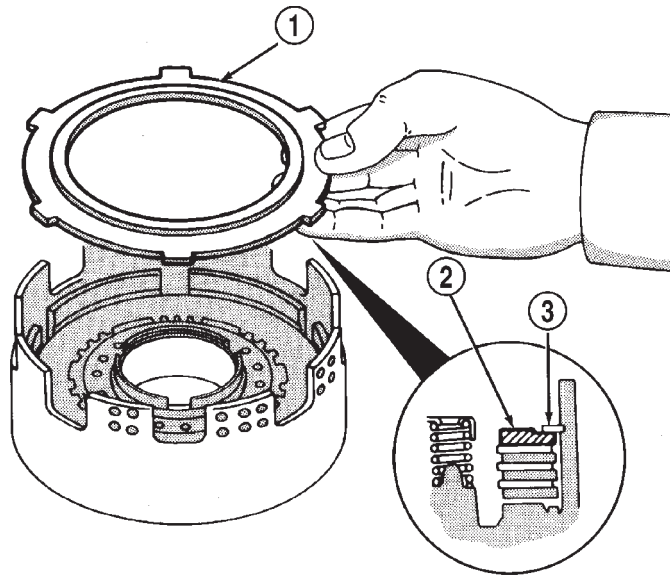

J8921-564

Fig. 249 Install Clutch Pack Retainer

- 1 - CLUTCH PACK RETAINER
- 2 - RETAINER
- 3 - SNAP RING

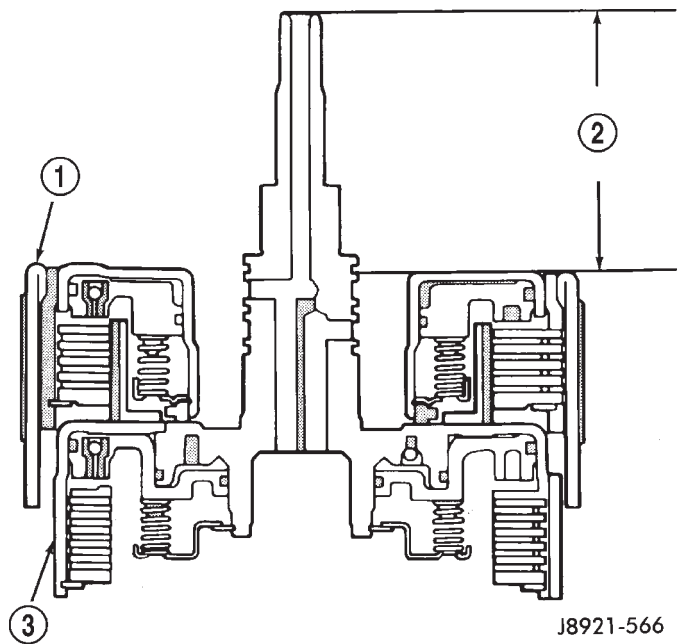

J8921-566

Fig. 251 Checking Direct Clutch Assembled Height

- 1 - DIRECT CLUTCH
- 2 - HEIGHT SHOULD BE 70.3-71.5 mm (2.767-2.815 in.)
- 3 - FORWARD CLUTCH

DISASSEMBLY AND ASSEMBLY (Continued)

FORWARD CLUTCH

DISASSEMBLY

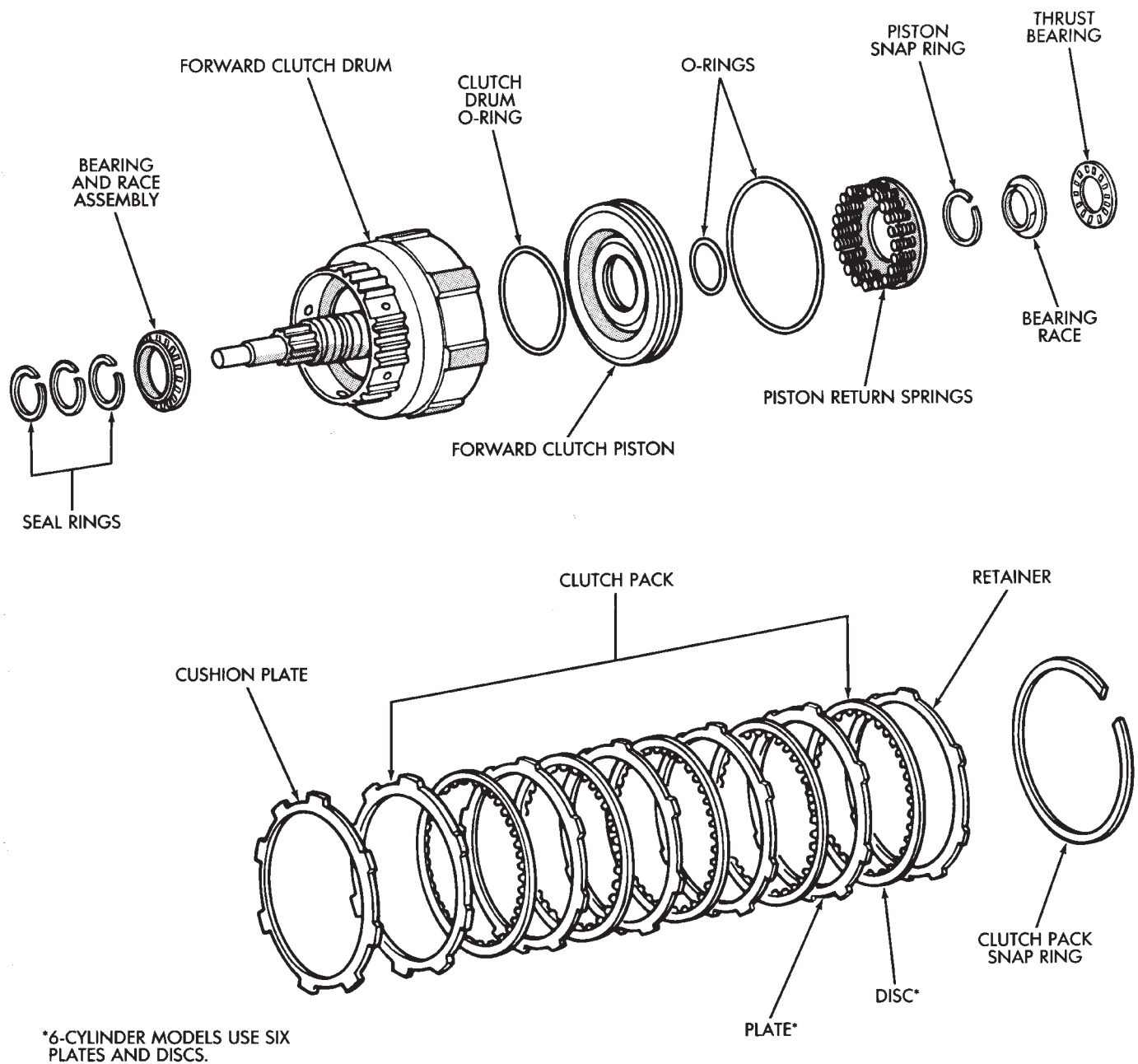

J8921-567

Fig. 252 Forward Clutch Components

- (1) Check clutch piston stroke as outlined in following steps.
- (2) Position overdrive support on wood blocks and mount forward clutch drum on support (Fig. 253).
- (3) Remove bearing and race from forward clutch drum (Fig. 253).
- (4) Install a suitable threaded bolt/rod into the side of the overdrive support.
- (5) Mount Miller Tool C-3339 dial indicator components onto the threaded rod as necessary.
- (6) Position dial indicator plunger squarely against clutch piston.

DISASSEMBLY AND ASSEMBLY (Continued)

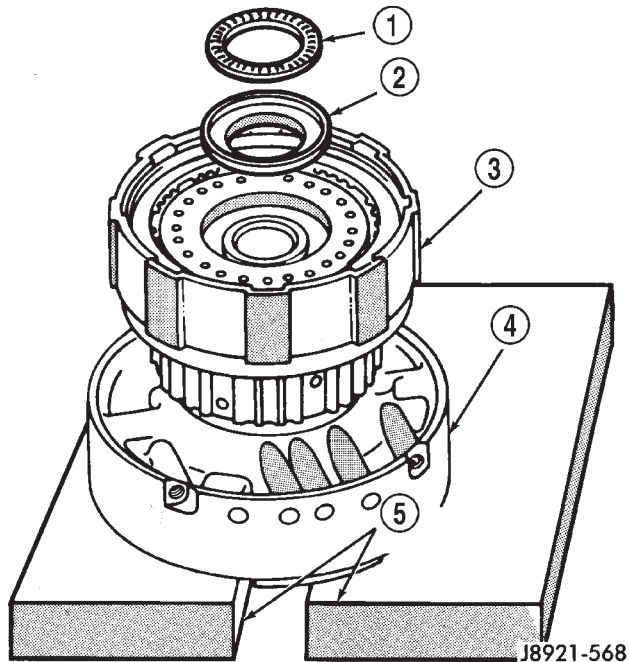

J8921-568

Fig. 253 Positioning Drum And Support On Wood Blocks

- 1 - THRUST BEARING
- 2 - BEARING RACE
- 3 - FORWARD CLUTCH DRUM
- 4 - OVERDRIVE SUPPORT
- 5 - WOOD BLOCKS

(7) Apply compressed air through right side feed hole in support and note piston stroke length on dial indicator.

(8) Stroke length should be 3.55 - 3.73 mm (0.1348 - 0.1469 in.).

(9) Replace clutch discs if stroke length is incorrect.

(10) Remove clutch pack snap ring and remove retainer and clutch pack (Fig. 254).

(11) Remove clutch pack cushion plate (Fig. 255).

(12) Compress clutch springs with Tool 7538 and remove piston snap ring.

(13) Remove spring compressor tool and piston return springs.

(14) Remount forward clutch drum on overdrive support (Fig. 256).

(15) Apply compressed air through feed hole in support to remove piston (Fig. 256). Use only enough air pressure to ease piston out of drum.

(16) Remove and discard clutch piston O-rings (Fig. 257).

(17) Remove clutch drum O-ring from rear hub of drum.

(18) Remove three seal rings from clutch drum shaft (Fig. 258).

(19) Remove thrust bearing and race assembly from clutch drum (Fig. 259).

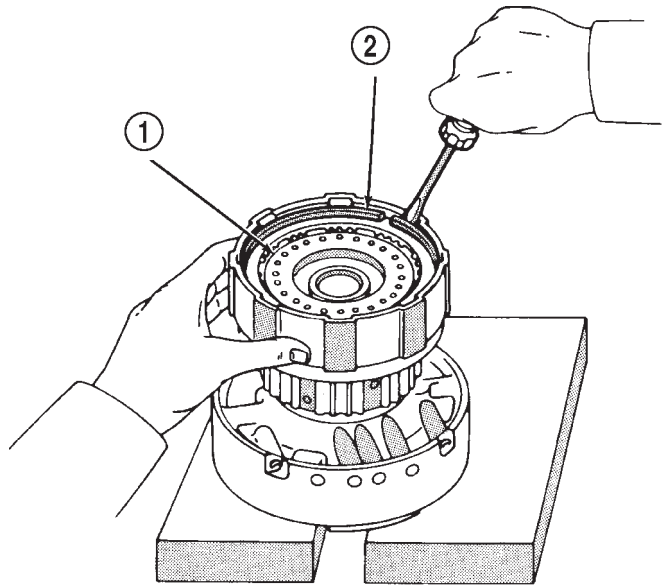

J8921-570

Fig. 254 Removing Retainer And Clutch Pack

- 1 - RETAINER AND CLUTCH PACK
- 2 - SNAP RING

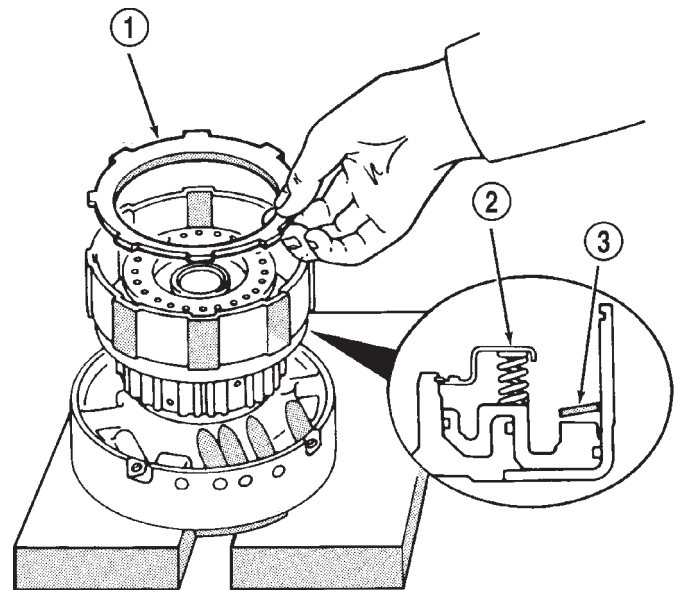

J8921-571

Fig. 255 Removing Cushion Plate

- 1 - CUSHION PLATE
- 2 - RETURN SPRINGS
- 3 - CUSHION PLATE

DISASSEMBLY AND ASSEMBLY (Continued)

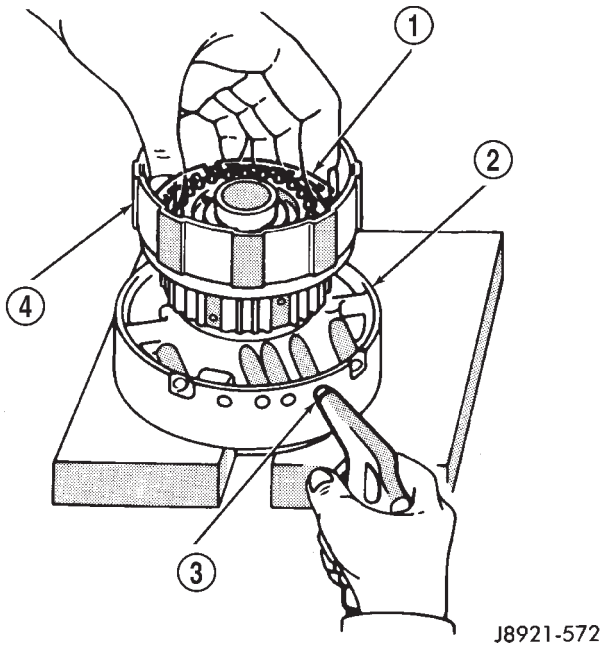

J8921-572

Fig. 256 Removing Forward Clutch Piston

- 1 - CLUTCH PISTON
- 2 - OVERDRIVE SUPPORT
- 3 - FEED HOLE
- 4 - CLUTCH DRUM

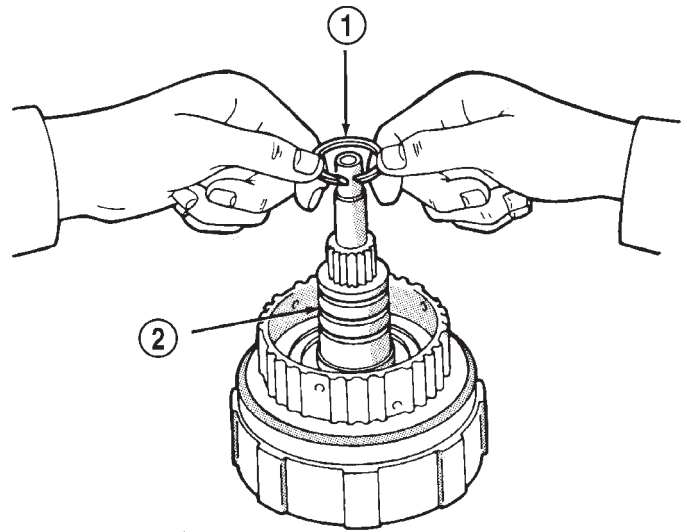

J8921-574

Fig. 258 Removing Clutch Drum Seal Rings

- 1 - SEAL RINGS
- 2 - CLUTCH DRUM SHAFT

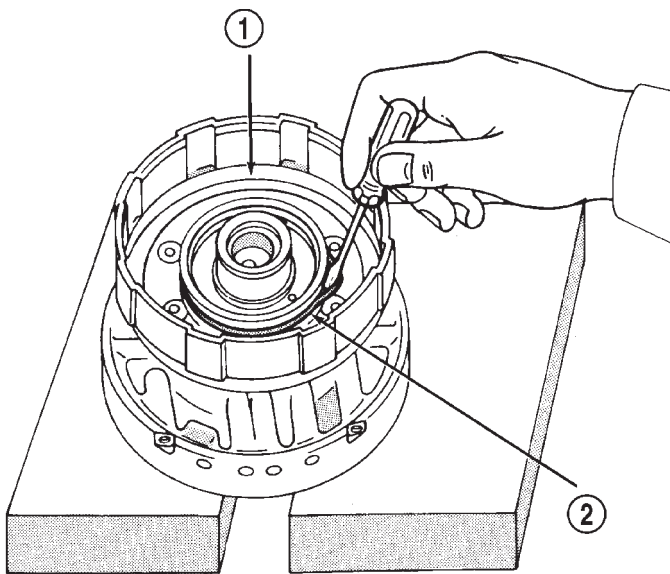

J8921-573

Fig. 257 Removing/Installing Clutch Drum O-Ring

- 1 - CLUTCH DRUM HUB
- 2 - O-RING

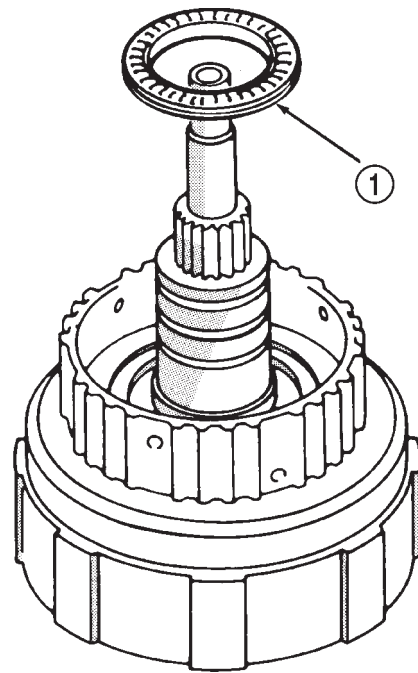

J8921-575

Fig. 259 Removing Clutch Drum Thrust Bearing Assembly

- 1 - THRUST BEARING AND RACE ASSEMBLY

DISASSEMBLY AND ASSEMBLY (Continued)

(20) Measure clutch disc thickness (Fig. 260). Minimum allowable thickness is 1.51 mm (0.0595 in.). Replace clutch pack if any disc falls below specified minimum thickness.

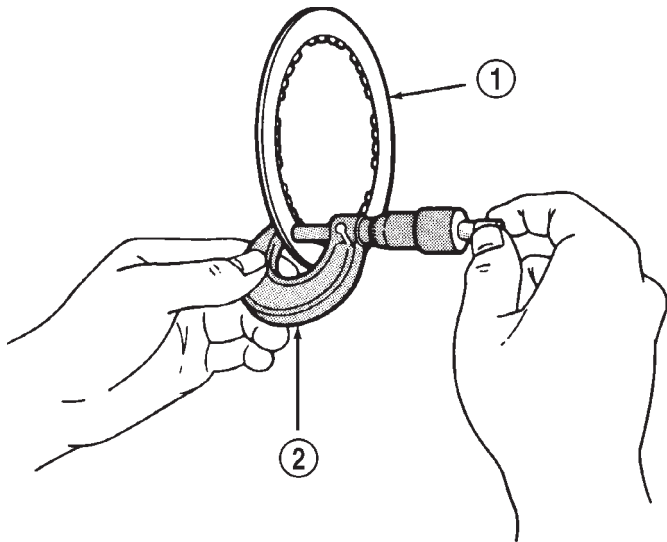

J8921-576

Fig. 260 Measuring Clutch Disc Thickness

- 1 - CLUTCH DISC
2 - MICROMETER

(21) Measure free length of piston return springs with springs mounted in retainer (Fig. 261). Length should be 19.47 mm (0.767 in.). Replace springs and retainer if length is incorrect.

(22) Inspect clutch piston check ball (Fig. 262). Ball should move freely within piston. Check ball seating by applying low pressure compressed air to ball feed hole. Ball should seat firmly and not leak air.

(23) Measure inside diameter of bushing in clutch drum hub. Maximum allowable diameter is 24.08 mm (0.9480 in.). Replace clutch drum if bushing inside diameter is greater than specified.

ASSEMBLY

(1) Lubricate bearing and race assembly with petroleum jelly and install it in clutch drum (Fig. 263). Race side of assembly faces downward and toward drum. Bearing rollers face up (Fig. 263)

(2) Coat new clutch drum shaft seal rings with petroleum jelly. Before installing drum shaft seal rings, squeeze each ring so ring ends overlap (Fig. 264). This tightens ring making clutch installation easier.

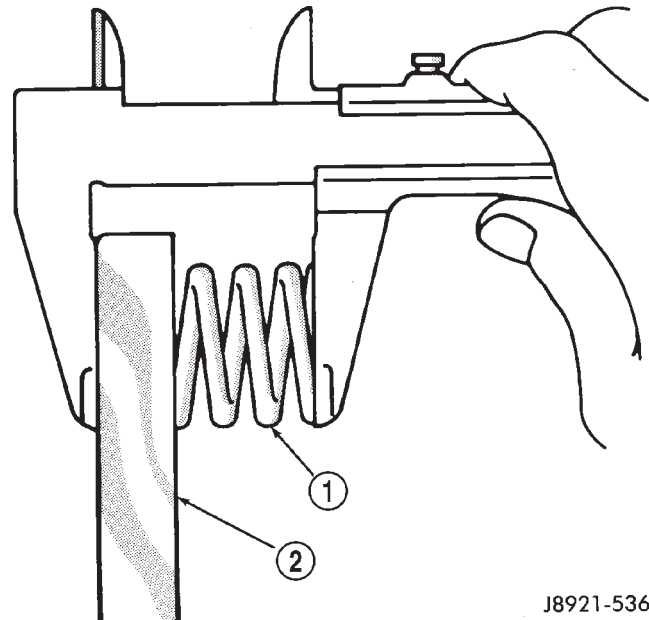

J8921-536

Fig. 261 Checking Return Spring Length

- 1 - PISTON RETURN SPRINGS
2 - SPRING RETAINER

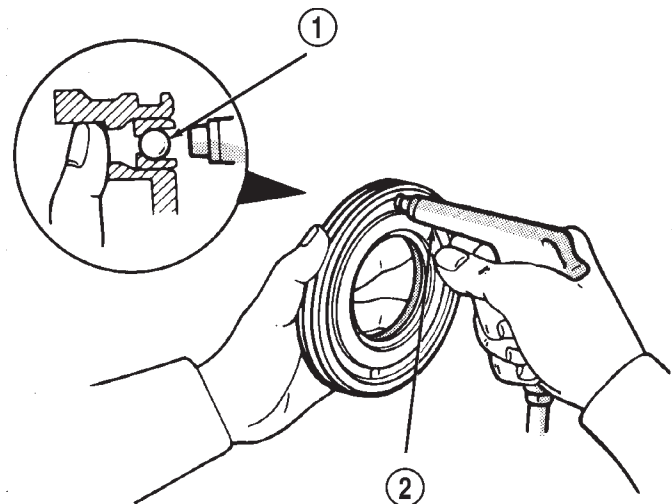

J8921-577

Fig. 262 Testing Piston Check Ball

- 1 - PISTON CHECK BALL
2 - USE LOW AIR PRESSURE FOR TEST

(3) Install seal rings on shaft. Keep rings closed as tightly as possible during installation. Avoid over-spreading them.

(4) Mount clutch drum on overdrive support.

(5) Lubricate and install new O-ring on clutch drum hub (Fig. 257).

DISASSEMBLY AND ASSEMBLY (Continued)

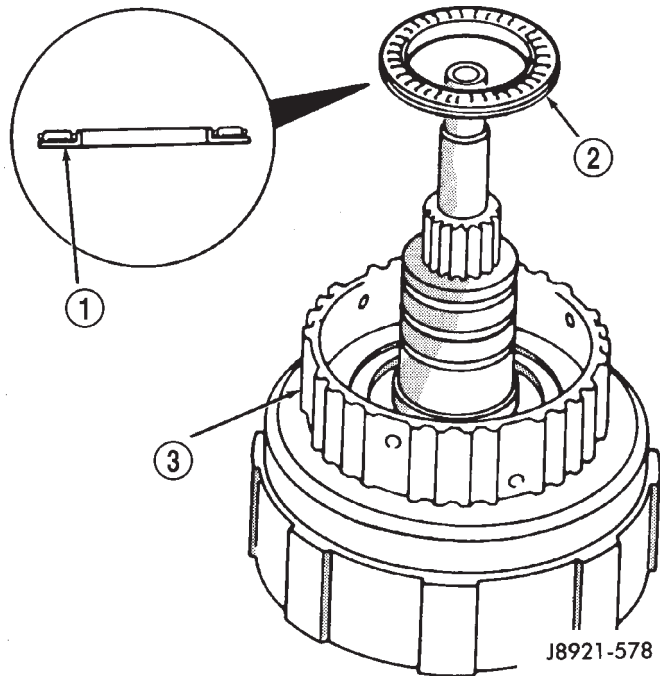

Fig. 263 Installing Thrust Bearing And Race

- 1 - BEARING ROLLERS FACE UP
- 2 - THRUST BEARING AND RACE
- 3 - FORWARD CLUTCH

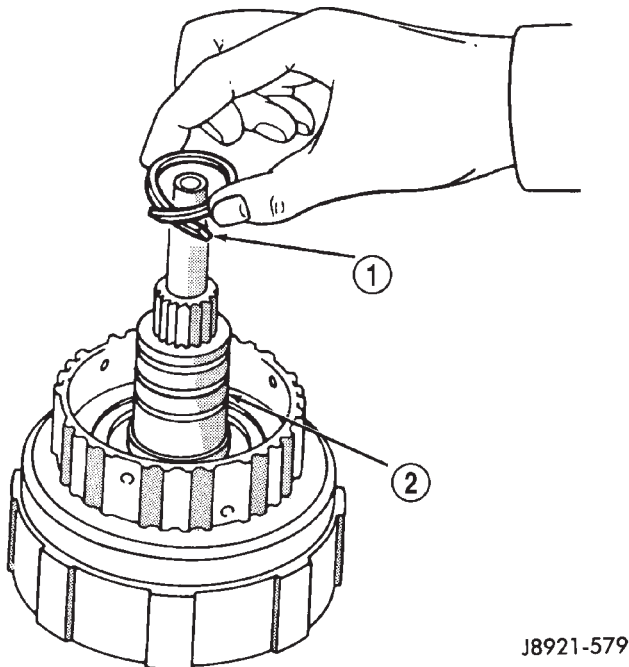

Fig. 264 Installing Clutch Drum Shaft Seal Rings

- 1 - SEAL RINGS (COMPRESS BEFORE INSTALLATION)
- 2 - CLUTCH DRUM SHAFT

(6) Lubricate new clutch piston O-rings with Mopar Door Ease, or Ru-Glyde. Install rings on clutch piston and install piston in drum.

- (7) Install piston return springs.
- (8) Compress piston return springs with Tool 7538 and shop press and install piston snap ring. Be sure snap ring end gap is not aligned with any notches in drum.
- (9) Install cushion plate in drum. Concave side of plate faces downward (Fig. 255).
- (10) Install clutch discs, plates and retainer (Fig. 265). Install tabbed plate followed by disc until required number of plates and discs are installed. Use six plates and discs.

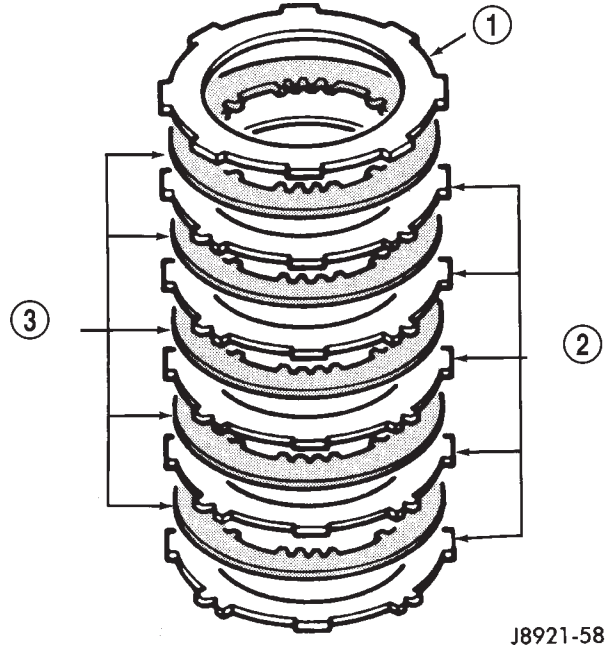
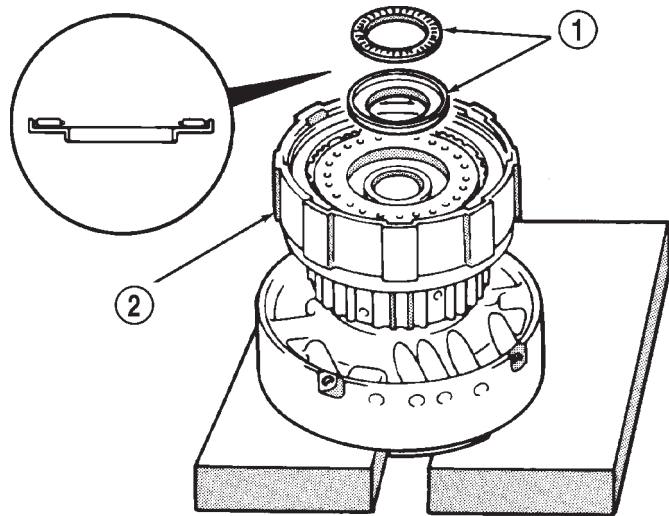

Fig. 265 Installing Forward Clutch Discs And Plates

- 1 - RETAINER
- 2 - CLUTCH PLATES
- 3 - CLUTCH DISCS

- (11) Install clutch pack snap ring.
- (12) Recheck clutch piston stroke length using same method outlined at beginning of disassembly procedure. If stroke length is not within specified limits, replace clutch discs.
- (13) Lubricate race and bearing with petroleum jelly and install them in clutch drum (Fig. 266). Be sure bearing rollers face up and race lip seats in drum as shown.
- (14) Verify bearing and race size.
 - Outer diameter of bearing is 46.7 mm (1.839 in).
 - Outer diameter of race is 48.9 mm (1.925 in).
 - Inner diameter of bearing and race is 26.0 mm (1.024 in).
- (15) Mount forward clutch on direct clutch and check assembled height (Fig. 267). Height should be 70.3 - 71.5 mm (2.767 - 2.815 in.).

DISASSEMBLY AND ASSEMBLY (Continued)



J8921-581

Fig. 266 Installing Thrust Bearing And Race

- 1 - THRUST BEARING AND RACE
- 2 - CLUTCH DRUM

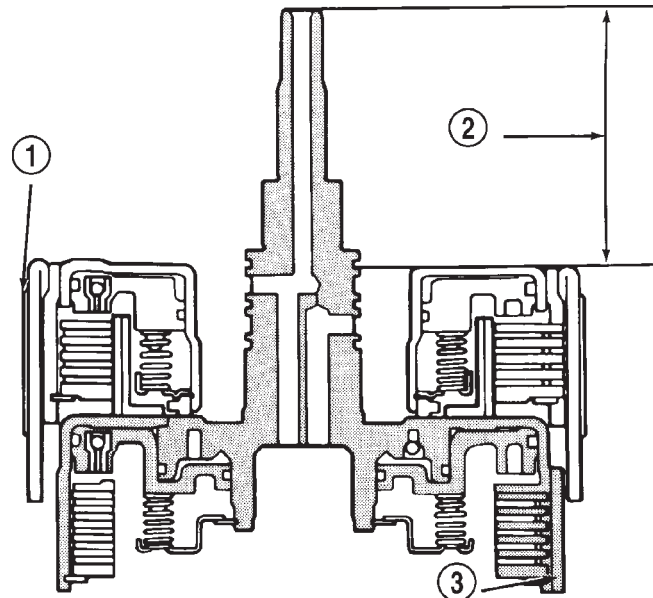

J8921-582

Fig. 267 Checking Forward Clutch Assembled Height

- 1 - DIRECT CLUTCH
- 2 - APPROXIMATELY 71.2 mm (2.80 in.)
- 3 - FORWARD CLUTCH

FRONT PLANETARY GEAR

DISASSEMBLY

- (1) Remove ring gear from planetary gear (Fig. 268).
- (2) Remove front bearing and the two races from ring gear (Fig. 268).

- (3) Remove tabbed thrust race from planetary gear (Fig. 268).
- (4) Remove snap ring attaching planetary gear to shaft and remove gear.

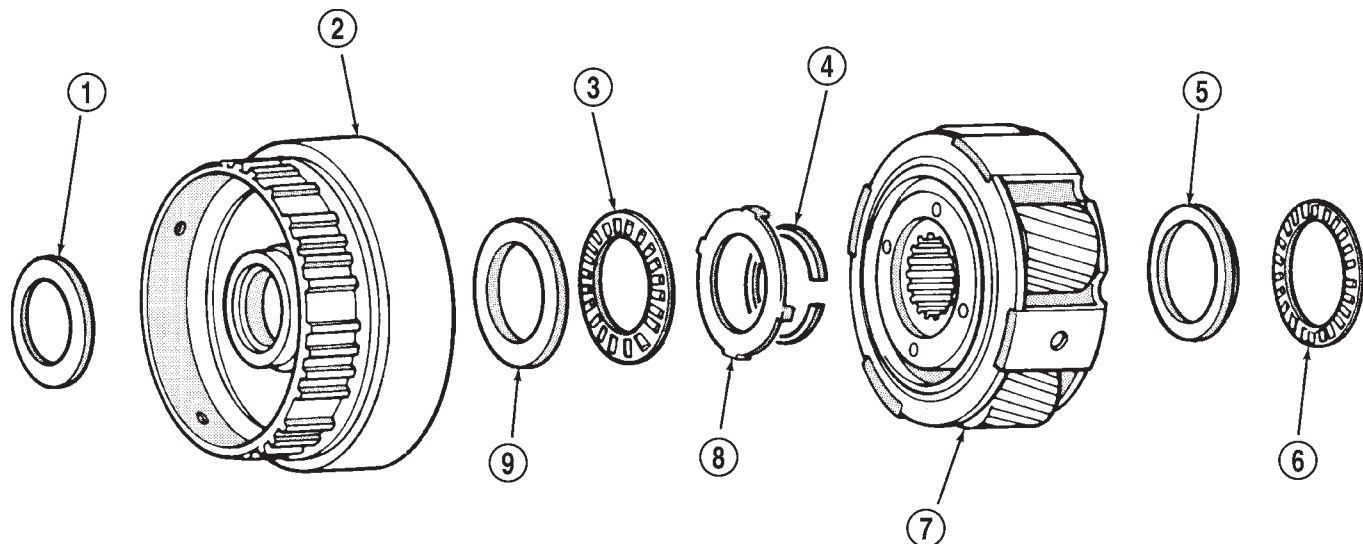

Fig. 268 Front Planetary Gear Components

J8921-583

- 1 - FORWARD RACE
- 2 - FRONT PLANETARY RING GEAR
- 3 - FRONT BEARING
- 4 - SNAP RING
- 5 - REAR RACE
- 6 - REAR BEARING
- 7 - FRONT PLANETARY GEAR
- 8 - THRUST RACE
- 9 - FRONT RACE

DISASSEMBLY AND ASSEMBLY (Continued)

- (5) Remove rear bearing and race from planetary gear.
- (6) Measure inside diameter of ring gear bushing. Maximum allowable diameter is 24.08 mm (0.9480 in.). Replace ring gear if bushing inside diameter is greater than specified.
- (7) Check condition of planetary gear. Replace gear if teeth are worn, pins are loose, or carrier is cracked, distorted, or worn.

ASSEMBLY

- (1) Lubricate planetary and ring gear bearings and races with petroleum jelly.
- (2) Identify planetary bearings and races before installation. (Fig. 268). Bearings and races can be identified by following dimensions:
 - Outer diameter of rear bearing is 47.7 mm (1.878 in.). Inner diameter is 35.5 mm (1.398 in.).
 - Outer diameter of rear race 47.6 mm (1.874 in.). Inner diameter is 33.7 mm (1.327 in.).
 - Outer diameter of front race is 53.6 mm (2.110 in.). Inner diameter is 30.5 mm (1.201 in.).
 - Outer diameter of front bearing is 47.7 mm (1.878 in.). Inner diameter is 32.6 (1.283 in.).
 - Outer diameter of forward race is 47.0 mm (1.850 in.). Inner diameter is 26.5 mm 1.043 in.).
- (3) Install rear race and bearing in gear (Fig. 269).
- (4) Turn planetary over and install thrust race (Fig. 270).
- (5) Install front race and bearing and forward race in ring gear (Fig. 271).

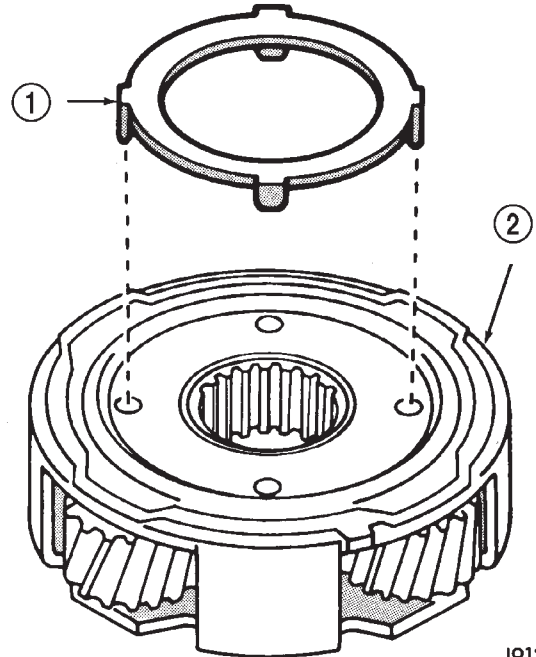

J9121-399
Fig. 270 Front Planetary Thrust Race Installation
 1 - TABBED THRUST RACE
 2 - PLANETARY GEAR

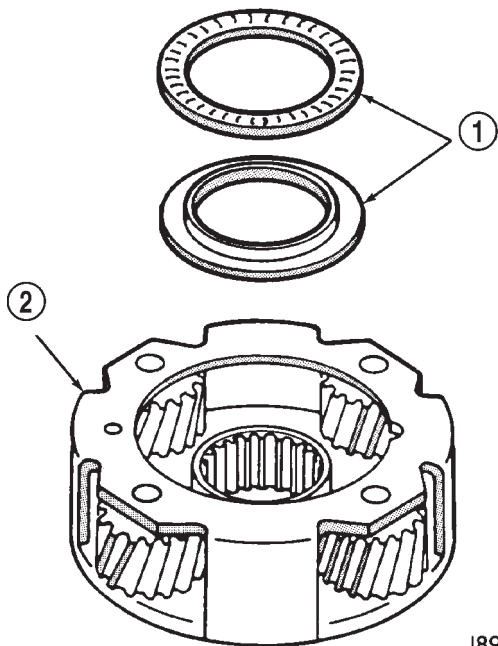

J8921-584
Fig. 269 Front Planetary Rear Bearing and Race Installation

- 1 - REAR BEARING AND RACE
- 2 - PLANETARY GEAR

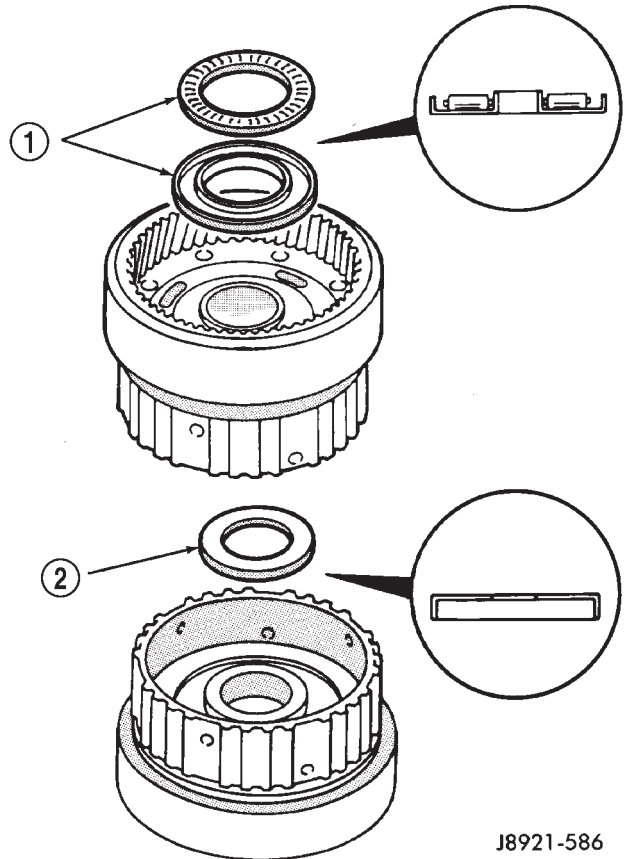

J8921-586
Fig. 271 Front Planetary Front Bearing And Races Installation

- 1 - FRONT BEARING AND RACE
- 2 - FORWARD RACE

DISASSEMBLY AND ASSEMBLY (Continued)

SUN GEAR AND NO. 1 ONE-WAY CLUTCH

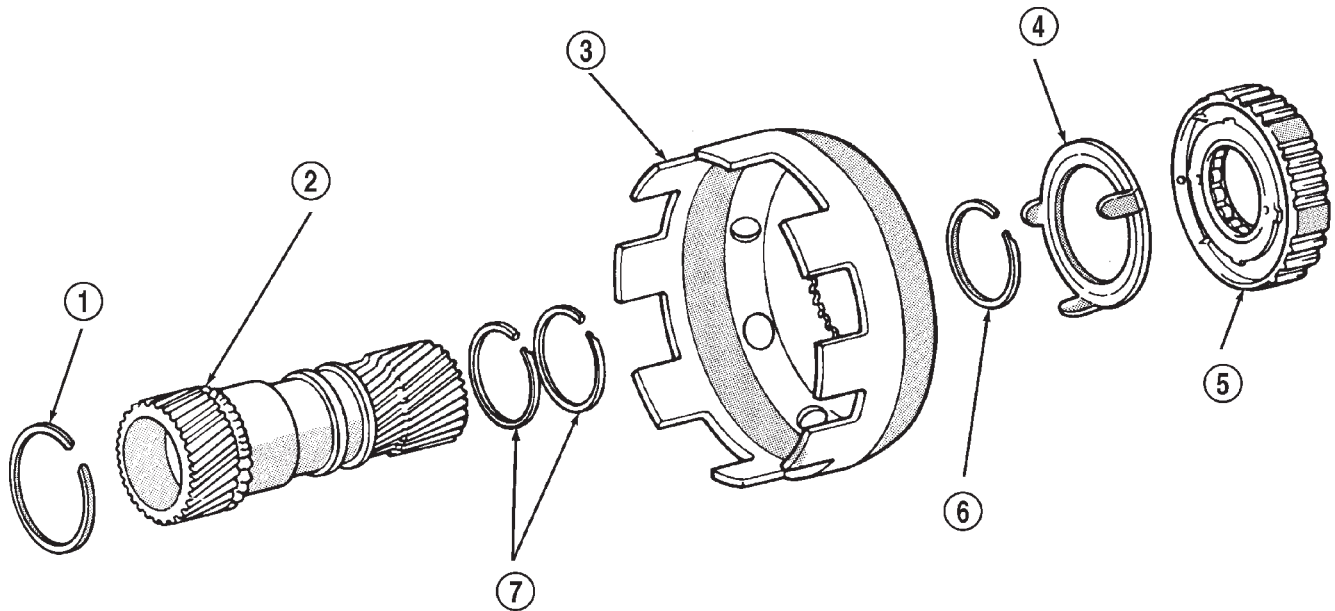

Sun Gear And One-Way Clutch Components

J9121-400

- 1 - SNAP RING
- 2 - SUN GEAR
- 3 - SUN GEAR INPUT DRUM
- 4 - THRUST WASHER

- 5 - ONE-WAY CLUTCH AND SECOND BRAKE HUB ASSEMBLY
- 6 - SNAP RING
- 7 - SEAL RINGS

DISASSEMBLY

(1) Hold sun gear and turn second brake hub clockwise and counterclockwise (Fig. 272). Hub should rotate freely clockwise but lock when turned

counterclockwise. Replace one-way clutch and hub if they do not operate properly.

(2) Remove one-way clutch/second brake hub assembly from drum (Fig. 273).

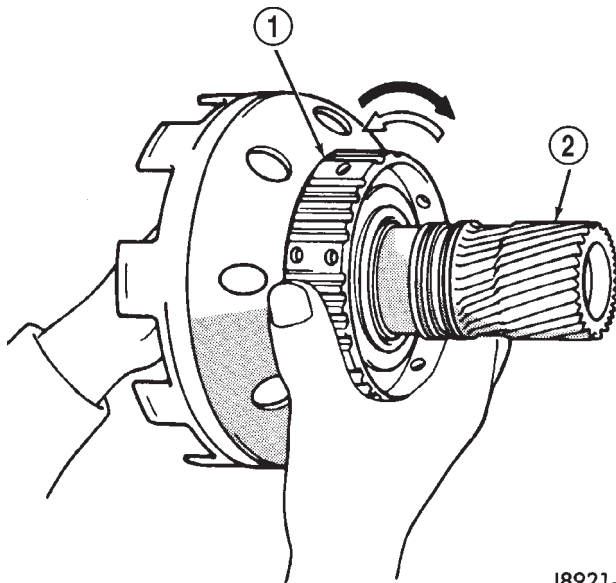

J8921-588

Fig. 272 Checking One-Way Clutch Operation

- 1 - SECOND BRAKE HUB
- 2 - SUN GEAR

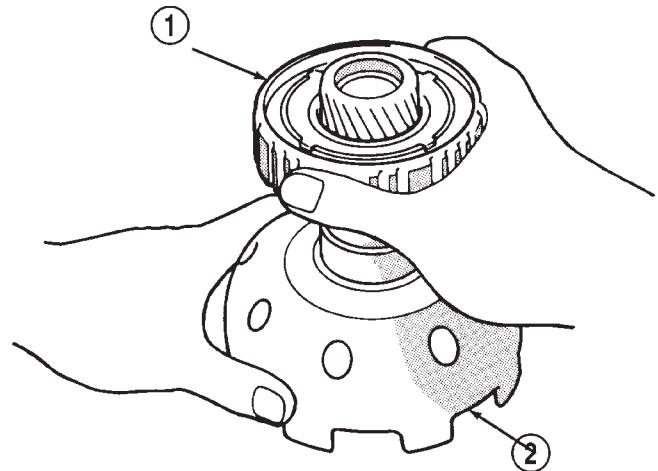

J8921-589

Fig. 273 Removing/Installing Brake Hub And Clutch Assembly

- 1 - HUB AND CLUTCH ASSEMBLY
- 2 - DRUM

DISASSEMBLY AND ASSEMBLY (Continued)

(3) Remove thrust washer from drum (Fig. 274).

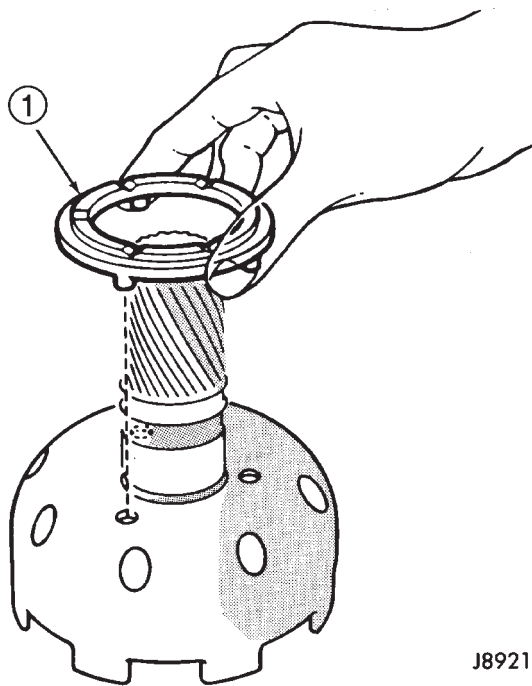

J8921-590

Fig. 274 Removing/Installing Thrust Washer

1 - THRUST WASHER

(4) Remove two seal rings from sun gear (Fig. 275).

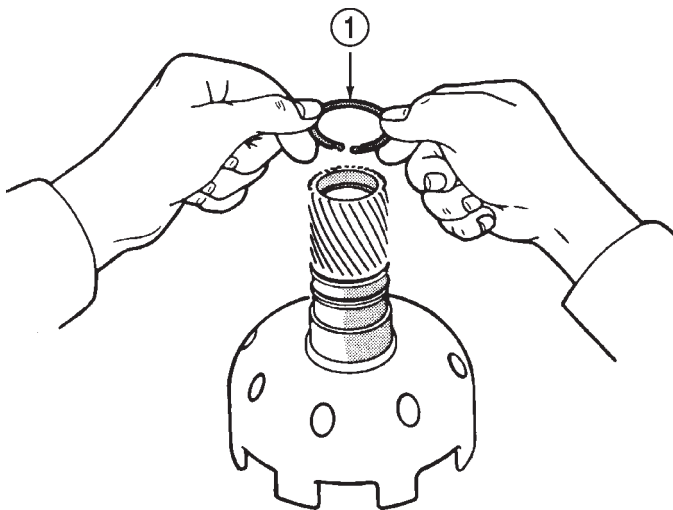

J8921-591

Fig. 275 Removing/Installing Sun Gear Seal Rings

1 - SEALS RINGS (2)

(5) Support sun gear on wood block (Fig. 276). Then remove first sun gear snap ring and separate drum from gear.

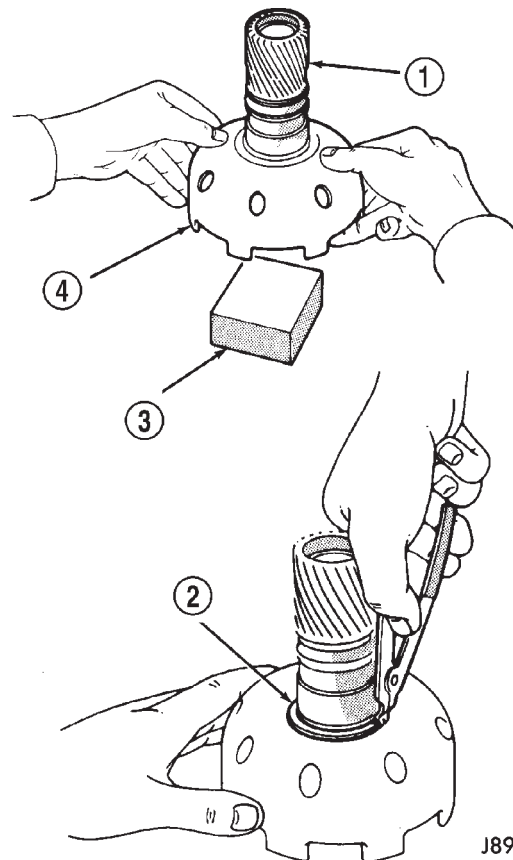

J8921-592

Fig. 276 Removing/Installing Sun Gear

1 - SUN GEAR
2 - SNAP RING
3 - WOOD BLOCK
4 - INPUT DRUM

(6) Remove remaining snap ring from sun gear (Fig. 277).

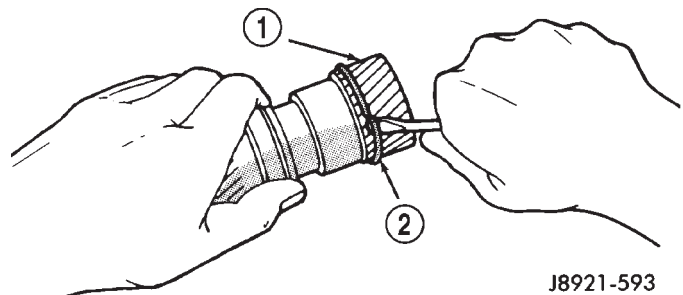

J8921-593

Fig. 277 Removing/Installing Second Snap Ring

1 - SUN GEAR
2 - SECOND SNAP RING

(7) Measure inside diameter of sun gear bushings with bore gauge or inside micrometer (Fig. 278). Maximum allowable diameter is 27.08 mm (1.0661 in.). Replace sun gear if bushing inside diameter is greater than specified.

DISASSEMBLY AND ASSEMBLY (Continued)

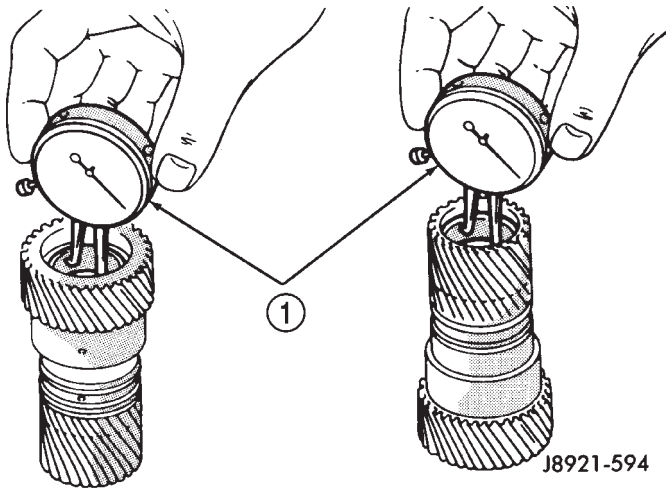

Fig. 278 Checking Sun Gear Bushings

1 - BORE GAUGE

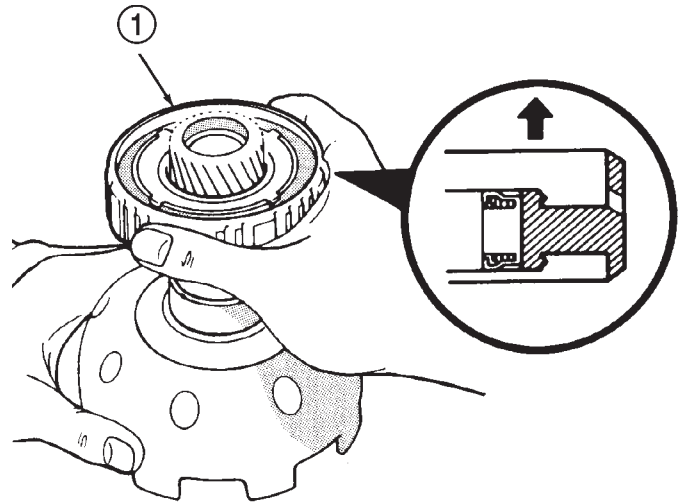

Fig. 279 Installing Clutch And Hub Assembly On Sun Gear

J8921-595

1 - CLUTCH AND HUB ASSEMBLY

ASSEMBLY

- (1) Install first snap ring on sun gear.
- (2) Install sun gear in drum and install remaining snap ring.
- (3) Coat replacement seal rings with petroleum jelly and install them on sun gear. **Be sure seal ring ends are interlocked.**
- (4) Install thrust washer. Be sure washer tabs are seated in drum slots.

- (5) Install one-way clutch/second brake hub assembly on sun gear. Deep side of hub flange faces upward (Fig. 279).

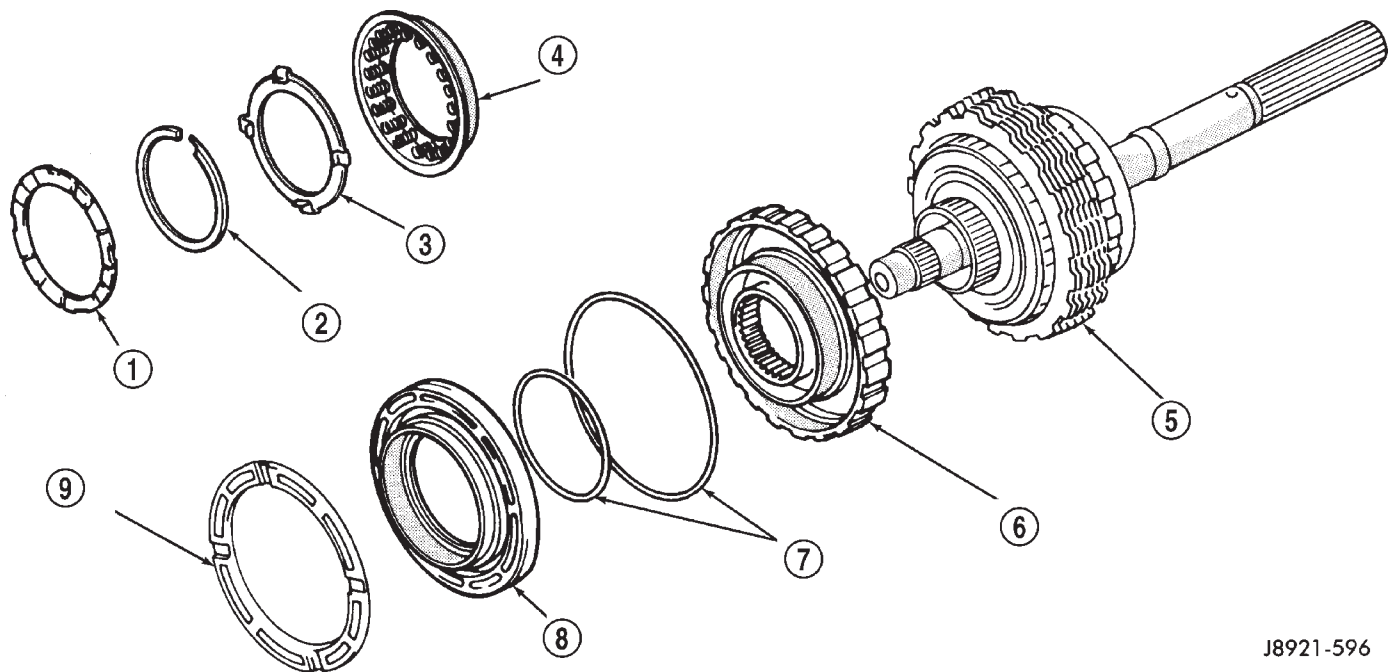

Second Brake Components

J8921-596

- | | |
|---|-------------------------|
| 1 - THRUST WASHER | 6 - SECOND BRAKE DRUM |
| 2 - SNAP RING | 7 - O-RINGS |
| 3 - SPRING RETAINER | 8 - SECOND BRAKE PISTON |
| 4 - PISTON RETURN SPRINGS | 9 - PISTON SLEEVE |
| 5 - REAR PLANETARY/OUTPUT SHAFT/FIRST-REVERSE BRAKE | |

DISASSEMBLY AND ASSEMBLY (Continued)

(6) Check one-way clutch operation again (Fig. 272). Hold sun gear and turn second brake hub clockwise and counterclockwise. Hub should turn clockwise freely, but lock when turned counterclockwise.

SECOND BRAKE

DISASSEMBLY

(1) Remove second brake drum from output shaft (Fig. 280).

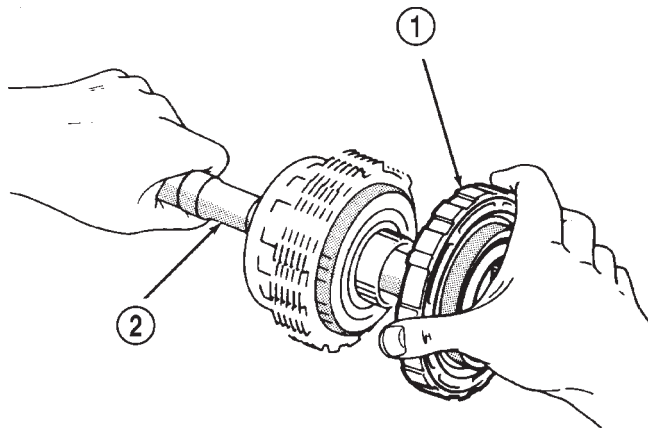

J8921-597

Fig. 280 Removing/Installing Second Brake Assembly

- 1 - SECOND BRAKE ASSEMBLY
- 2 - OUTPUT SHAFT

(2) Remove thrust washer from second brake drum (Fig. 281).

(3) Compress piston return springs with shop press and tool 7538. Then remove piston snap ring (Fig. 282).

(4) Remove compressor tool and remove spring retainer and return springs.

(5) Remove second brake piston and sleeve from drum with compressed air (Fig. 283). Use only enough air pressure to ease piston out of drum.

(6) Remove and discard brake piston O-rings.

(7) Measure free length of piston return springs with springs mounted in retainer (Fig. 284). Length should be approximately 16.05 mm (0.632 in.). Replace return springs if length is less than specified.

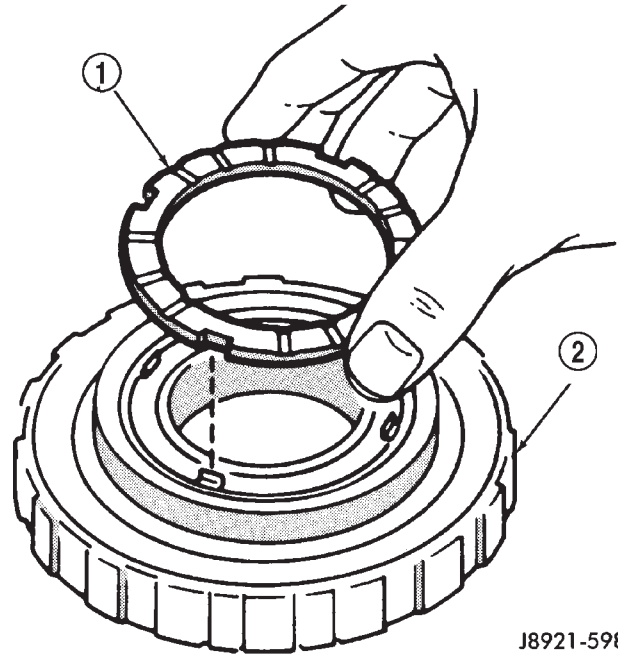

J8921-598

Fig. 281 Removing/Installing Second Brake Drum Thrust Washer

- 1 - THRUST WASHER
- 2 - SECOND BRAKE DRUM

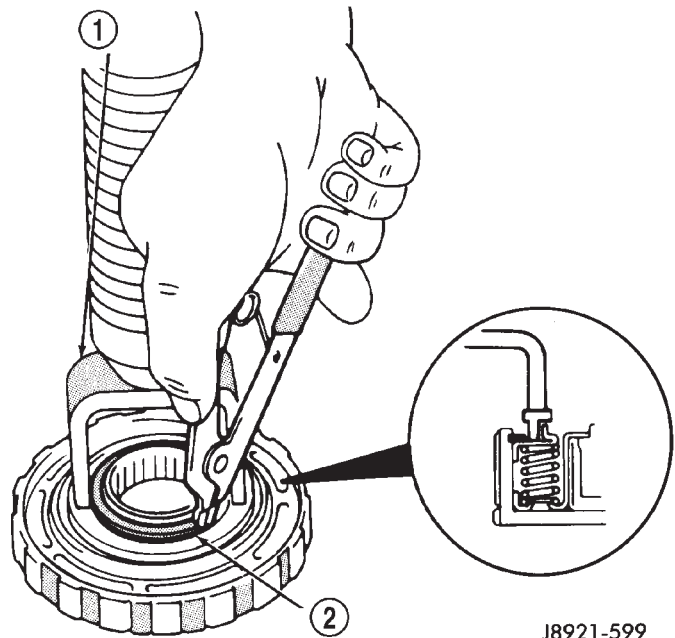

J8921-599

Fig. 282 Removing/Installing Second Brake Piston Snap Ring

- 1 - COMPRESSOR TOOL
- 2 - PISTON SNAP RING

DISASSEMBLY AND ASSEMBLY (Continued)

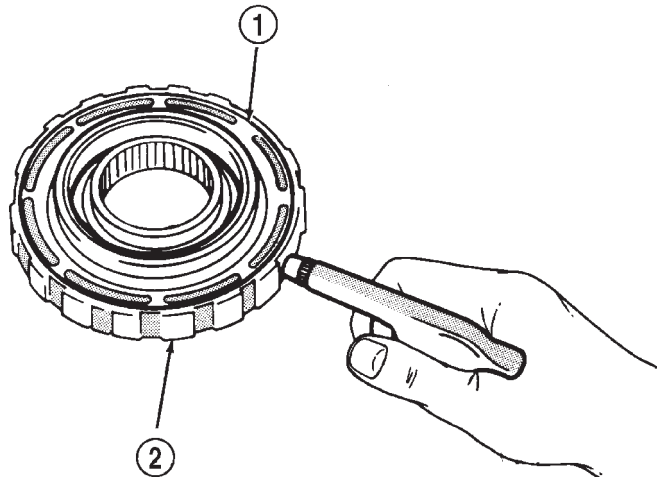

J8921-600

Fig. 283 Removing/Installing Piston And Sleeve

- 1 - PISTON AND SLEEVE
2 - DRUM

(4) Check brake piston operation with low pressure compressed air (Fig. 285). Apply air pressure through feed hole in drum. Piston should move smoothly when applying-releasing air pressure.

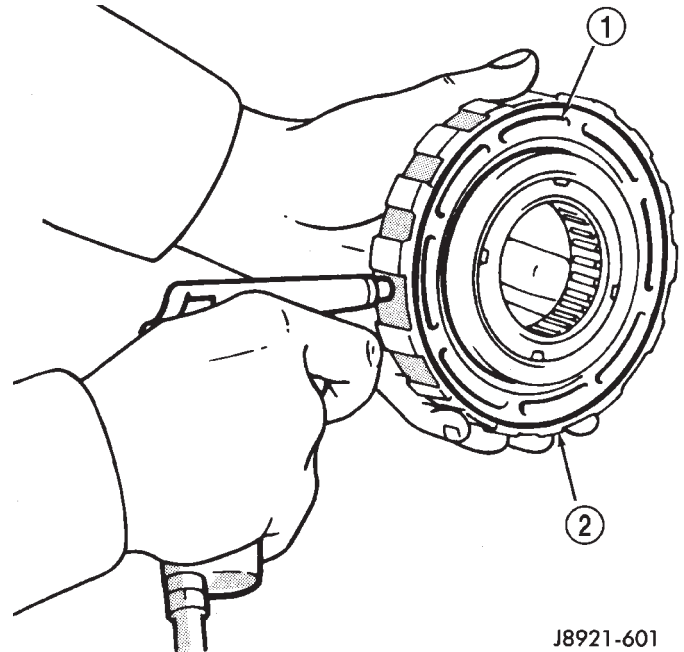

J8921-601

Fig. 285 Checking Second Brake Piston Operation

- 1 - PISTON
2 - DRUM

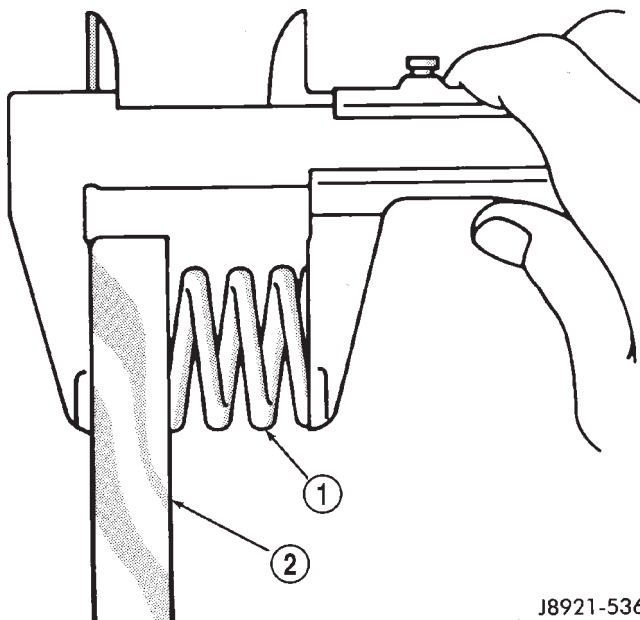

J8921-536

Fig. 284 Measuring Second Brake Piston Return Springs

- 1 - PISTON RETURN SPRINGS
2 - SPRING RETAINER

ASSEMBLY

(1) Lubricate and install new O-rings on brake piston. Then install brake piston in drum.

(2) Install return springs and retainer on brake piston.

(3) Compress return springs with shop press and Compressor Tool 7538. Install piston snap ring and remove brake assembly from press.

(5) Coat thrust washer with petroleum jelly and install it in drum. Be sure washer notches are aligned with tabs on spring retainer (Fig. 286).

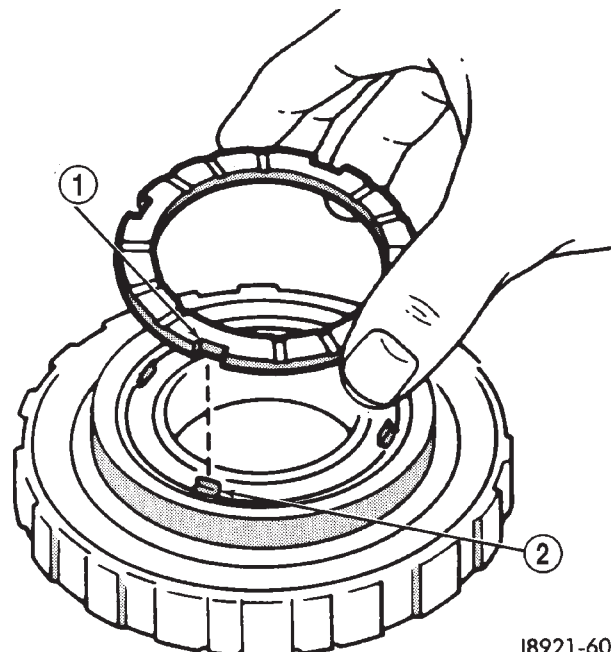

J8921-602

Fig. 286 Installing Second Brake Thrust Washer

- 1 - THRUST WASHER NOTCHES
2 - SPRING RETAINER TABS

DISASSEMBLY AND ASSEMBLY (Continued)

PLANETARY/BRAKE PACK/OUTPUT SHAFT

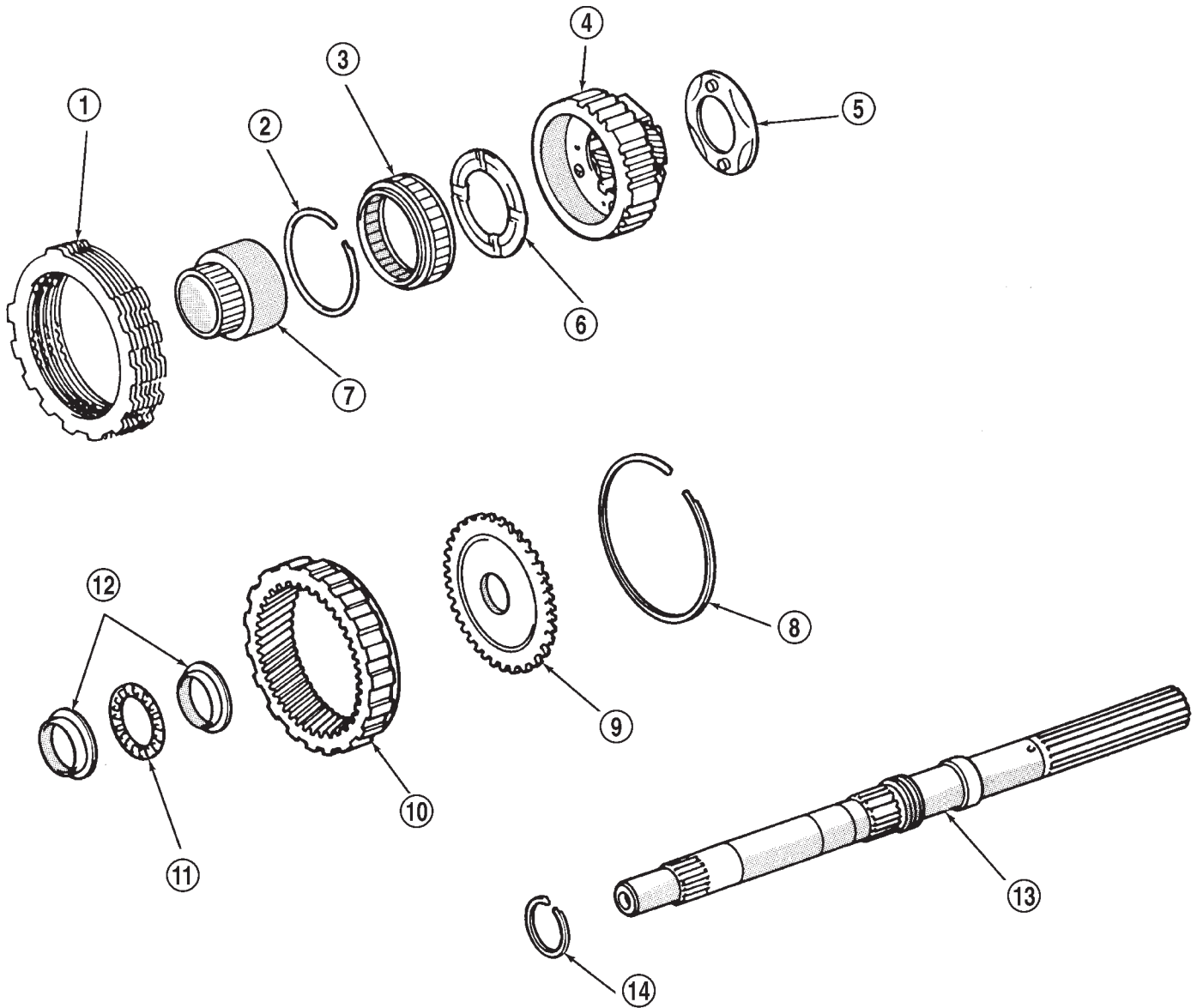

J8921-603

Rear Planetary, Brake Pack, Output Shaft Components

- | | |
|-------------------------------|-------------------------------|
| 1 - FIRST-REVERSE BRAKE PACK | 8 - SNAP RING |
| 2 - SNAP RING | 9 - RING GEAR HUB |
| 3 - NO. 2 ONE-WAY CLUTCH | 10 - REAR PLANETARY RING GEAR |
| 4 - REAR PLANETARY GEAR | 11 - THRUST BEARING |
| 5 - REAR THRUST WASHER | 12 - RACES |
| 6 - FRONT THRUST WASHER | 13 - OUTPUT SHAFT |
| 7 - ONE-WAY CLUTCH INNER RACE | 14 - SEAL RING |

DISASSEMBLY AND ASSEMBLY (Continued)

DISASSEMBLY

(1) Remove output shaft from gear assembly (Fig. 287).

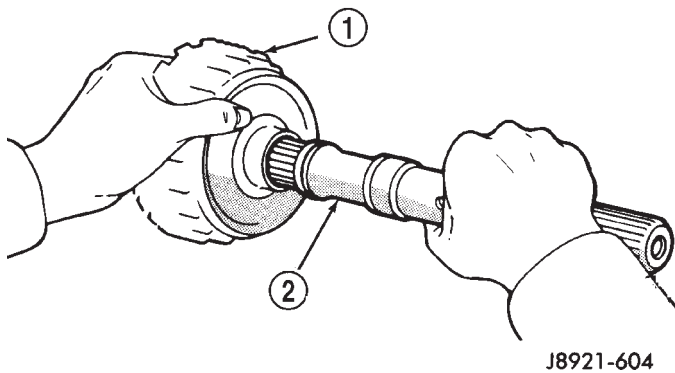

J8921-604

Fig. 287 Removing/Installing Output Shaft

- 1 - GEAR ASSEMBLY
- 2 - OUTPUT SHAFT

(2) Remove and discard shaft seal ring (Fig. 288).

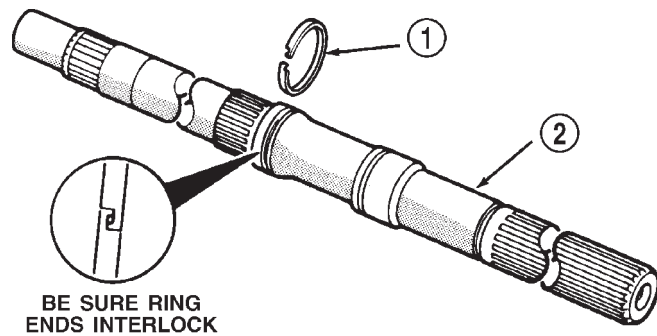

J8921-605

Fig. 288 Removing/Installing Shaft Seal Ring

- 1 - SEAL RING
- 2 - OUTPUT SHAFT

(3) Remove brake pack from planetary gear (Fig. 289).

(4) Remove planetary gear from ring gear (Fig. 290).

(5) Check No. 2 one-way clutch (Fig. 291). Hold planetary gear and turn clutch inner race in both directions. Race should turn freely counterclockwise, but lock when turned clockwise. Replace one-way clutch if necessary.

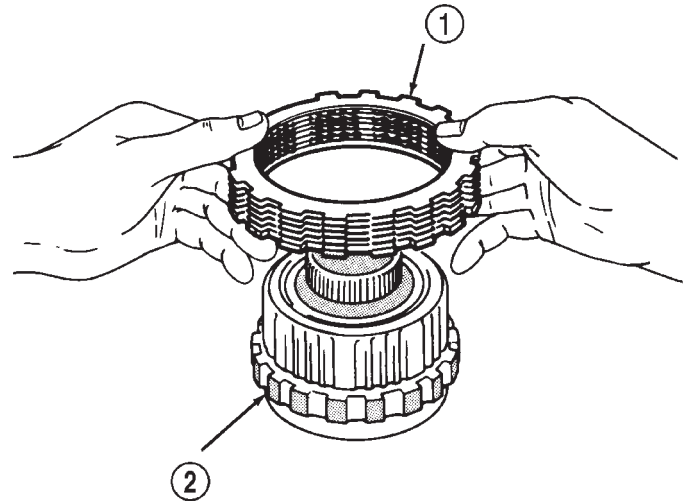

J8921-606

Fig. 289 Removing/Installing First-Reverse Brake Pack

- 1 - FIRST-REVERSE BRAKE PACK
- 2 - REAR PLANETARY GEAR

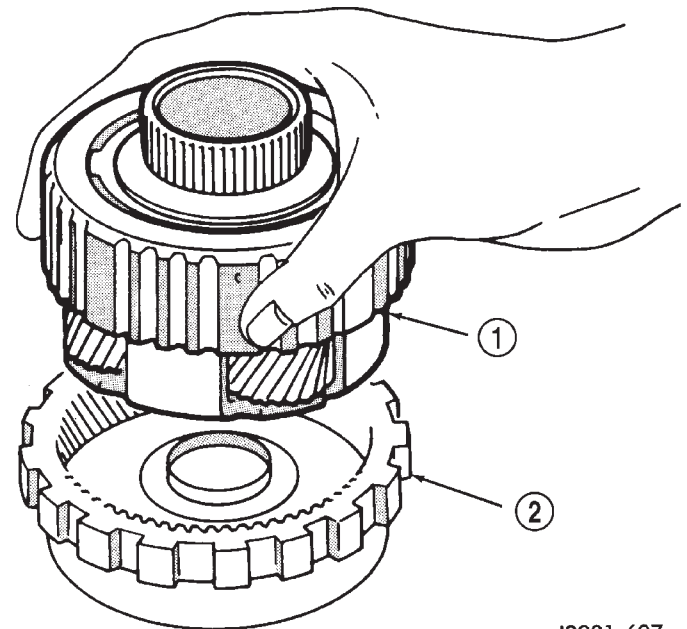

J8921-607

Fig. 290 Removing/Installing Rear Planetary

- 1 - REAR PLANETARY GEAR
- 2 - RING GEAR

DISASSEMBLY AND ASSEMBLY (Continued)

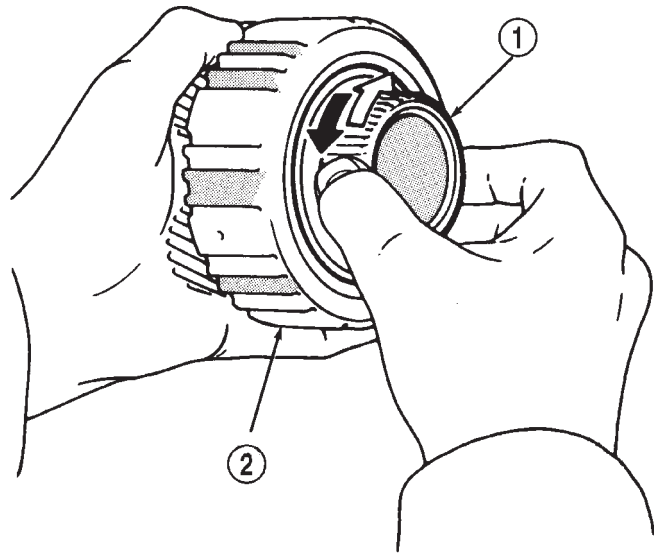

J8921-608

Fig. 291 Checking No. 2 One-Way Clutch Operation

- 1 - CLUTCH INNER RACE
- 2 - PLANETARY GEAR

(6) Remove clutch inner race from planetary gear (Fig. 292).

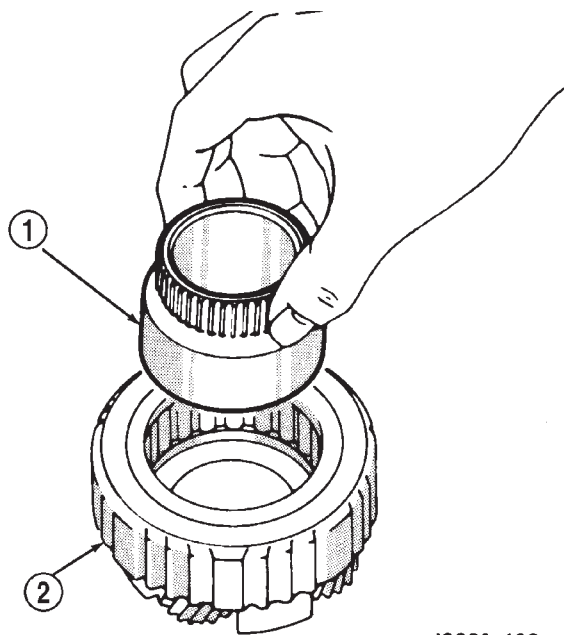

J8921-609

Fig. 292 Removing/Installing Clutch Inner Race

- 1 - CLUTCH INNER RACE
- 2 - REAR PLANETARY

(7) Remove clutch snap ring and remove No. 2 one-way clutch top end cap from planetary.

(8) Remove No. 2 one-way clutch from planetary (Fig. 293).

(9) Remove No. 2 one-way clutch bottom end cap from planetary.

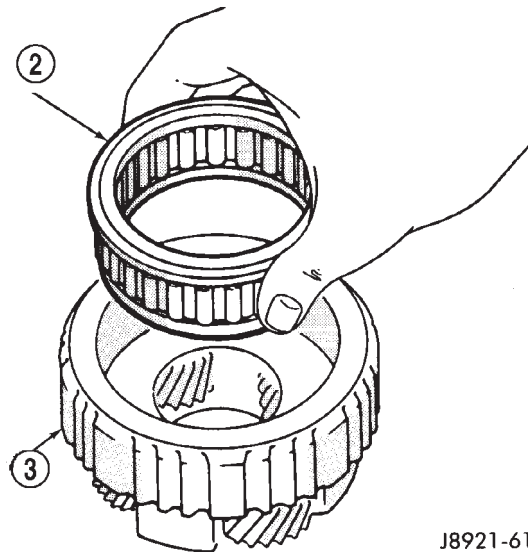
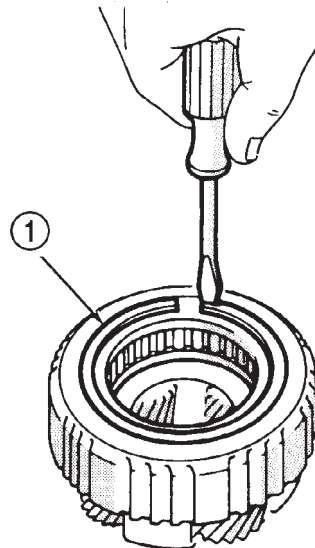

J8921-610

Fig. 293 Removing/Installing One-Way Clutch

- 1 - CLUTCH SNAP RING
- 2 - NO. 2 ONE-WAY CLUTCH
- 3 - PLANETARY GEAR

DISASSEMBLY AND ASSEMBLY (Continued)

(10) Remove front and rear thrust washers from planetary gear (Fig. 294).

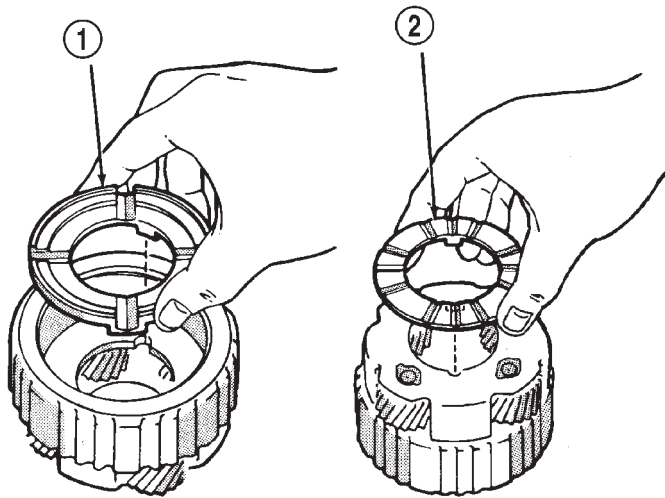

J8921-611

Fig. 294 Removing/Installing Rear Planetary Thrust Washers

- 1 - FRONT THRUST WASHER
- 2 - REAR THRUST WASHER

(11) Remove thrust bearing and washers from ring gear (Fig. 295).

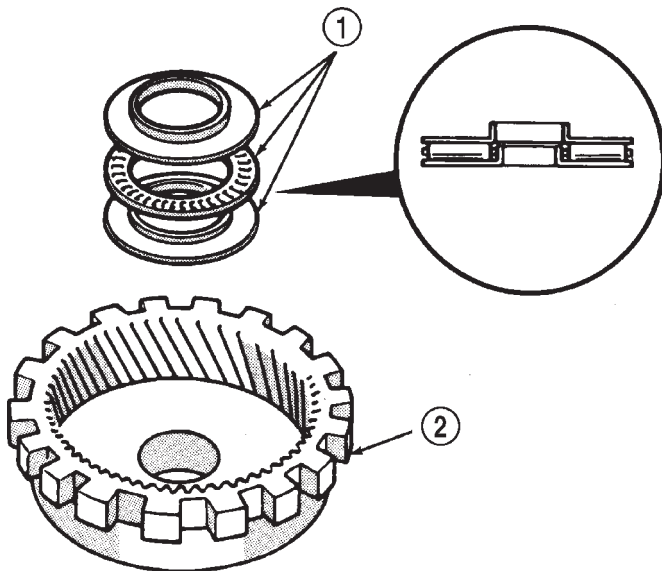

J8921-612

Fig. 295 Removing/Installing Ring Gear Thrust Bearing And Races

- 1 - THRUST BEARING AND RACES
- 2 - RING GEAR

(12) Remove ring gear snap ring and remove ring gear hub (Fig. 296).

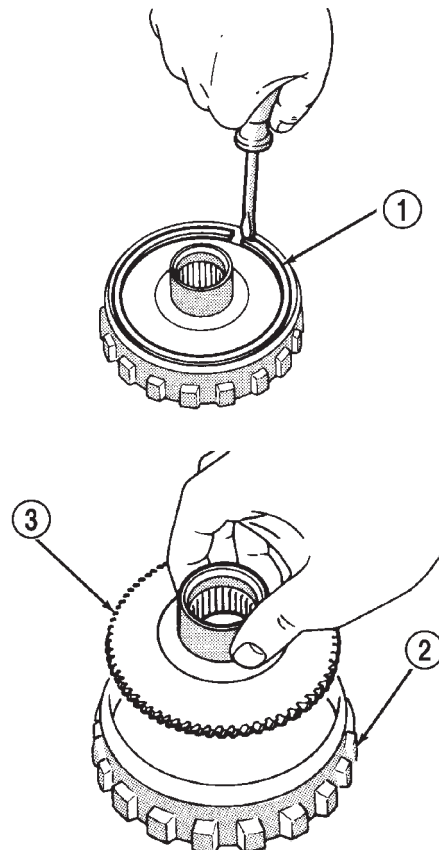

J8921-613

Fig. 296 Removing/Installing Ring Gear Hub

- 1 - SNAP RING
- 2 - RING GEAR
- 3 - HUB

(13) Inspect and replace any worn or damaged planetary gear components.

ASSEMBLY

(1) Measure thickness of each brake pack disc. Minimum thickness is 1.51 mm (0.0594 in.). Replace all discs if any disc is thinner than specified.

(2) Install hub and snap ring in ring gear (Fig. 296)

(3) Identify ring gear thrust bearing and races by following dimensions (Fig. 295) :

- Outer diameter of bottom race is 44.8 mm (1.764 in.) and inner diameter is 27.6 mm (1.087 in.).
- Outer diameter of bearing is 44.7 mm (1.760 in.) and inner diameter is 30.1 mm (1.185 in.).
- Outer diameter of upper race is 44.8 mm (1.764 in.) and inner diameter is 28.8 mm (1.134 in.).

(4) Lubricate ring gear thrust bearing and races with petroleum jelly and install them in ring gear (Fig. 295).

DISASSEMBLY AND ASSEMBLY (Continued)

(5) Coat planetary thrust washers with petroleum jelly and install them in gear (Fig. 294).

(6) Install No. 2 one-way clutch bottom end cap into the planetary gear.

(7) Install No. 2 one-way clutch in planetary gear. Be sure flanged side of clutch faces upward (Fig. 297).

(8) Install No. 2 one-way clutch top end cap into the planetary gear.

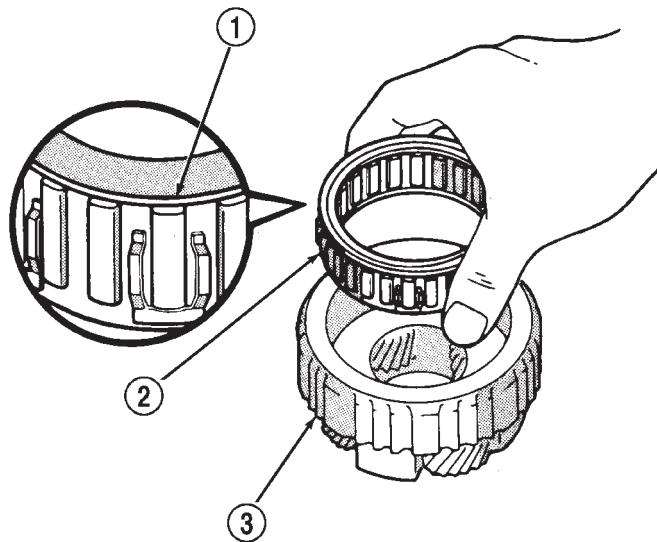

J8921-614

Fig. 297 Installing No. 2 One-Way Clutch

- 1 - FLANGED SIDE OF CLUTCH
 2 - NO. 2 ONE-WAY CLUTCH
 3 - REAR PLANETARY

(9) Install clutch retaining snap ring and install clutch inner race (Fig. 292). Turn race counterclockwise to ease installation.

(10) Verify one-way clutch operation. Hold gear and turn inner race in both directions. Race should turn freely counterclockwise, but lock when turned clockwise.

(11) Install planetary gear in ring gear.

(12) Install thrust bearing and washers onto the ring gear (Fig. 295).

(13) Assemble clutch discs and clutch plates (Fig. 289). Sequence is disc first, then a plate. Use seven discs and plates.

(14) Install brake pack on planetary gear (Fig. 289).

(15) Install new seal ring on output shaft (Fig. 288). Be sure ring ends are interlocked as shown.

TRANSMISSION VALVE BODY

The valve body assembly consists of two sections which are the upper body and lower body (Fig. 298) and (Fig. 299). Disassembly, inspection and overhaul procedures for each section are outlined separately. Refer to the appropriate procedure as needed.

DISASSEMBLY AND ASSEMBLY (Continued)

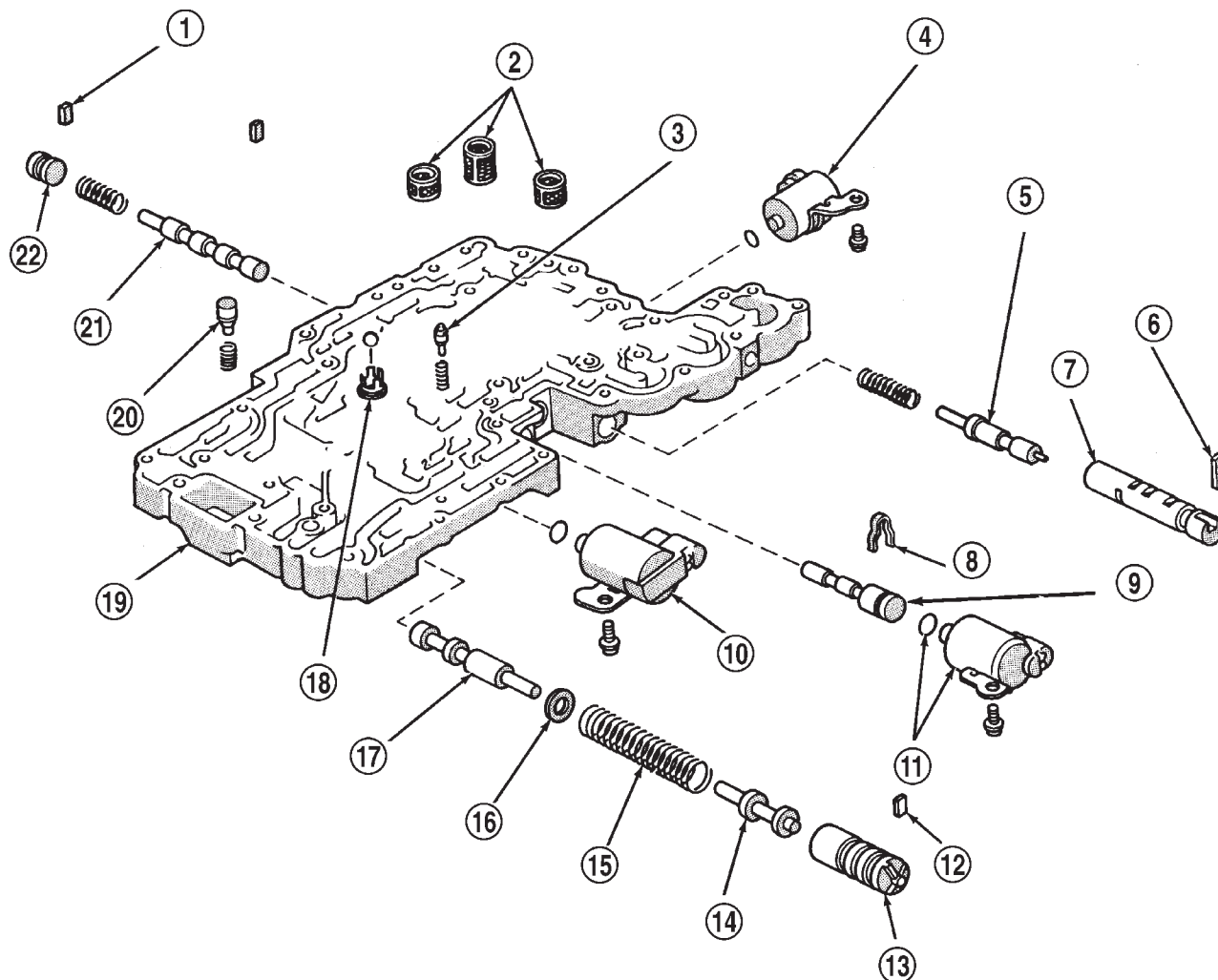

J9121-384

Fig. 298 Lower Body Components

- | | |
|--------------------------------|------------------------------|
| 1 - RETAINER | 12 - RETAINER |
| 2 - STRAINERS | 13 - SLEEVE |
| 3 - PRESSURE RELIEF VALVE | 14 - PLUNGER |
| 4 - NO. 2 SOLENOID AND O-RING | 15 - VALVE SPRING |
| 5 - ACCUMULATOR CONTROL VALVE | 16 - WASHER |
| 6 - RETAINER | 17 - PRIMARY REGULATOR VALVE |
| 7 - SLEEVE | 18 - CHECK VALVE AND BALL |
| 8 - CLIP | 19 - LOWER BODY |
| 9 - PRESSURE REDUCING PLUG | 20 - CHECK VALVE |
| 10 - NO. 3 SOLENOID AND O-RING | 21 - 1-2 SHIFT VALVE |
| 11 - NO. 1 SOLENOID AND O-RING | 22 - PLUG |

DISASSEMBLY AND ASSEMBLY (Continued)

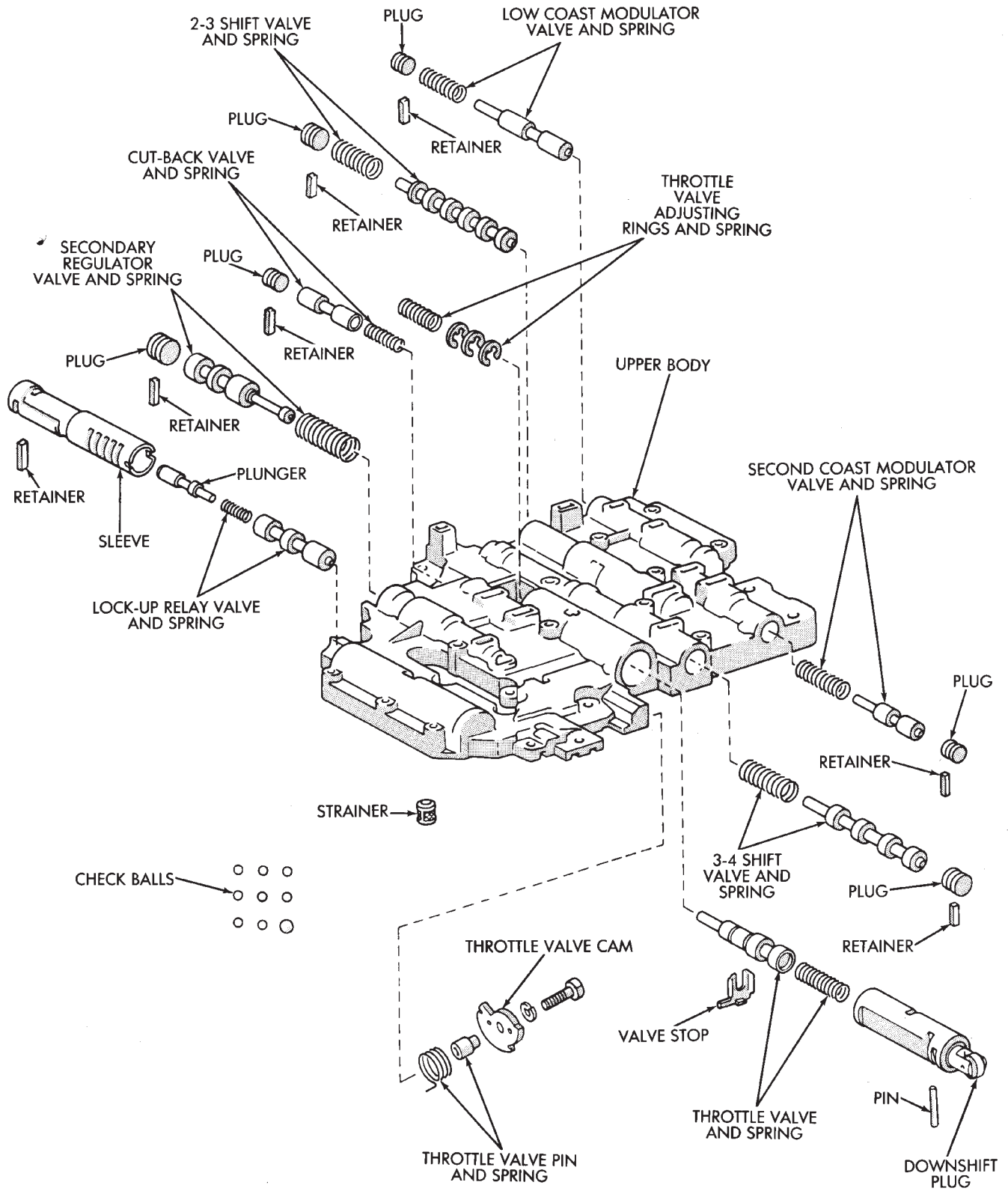

J8921-625

Fig. 299 Upper Body Components

CLEANING AND INSPECTION

TRANSMISSION PARTS CLEANING AND INSPECTION

Clean the transmission components with solvent and dry them with compressed air only. Do not use shop towels or rags.

Blow compressed air through all oil feed passages and channels to be sure they are clear. Inspect the transmission components for wear and damage. Replace components that are damaged or worn beyond the limits specified in the individual overhaul procedures.

Replace all O-rings, gaskets and seals. These components are not reusable. Also replace any snap ring that is distorted or damaged.

During overhaul assembly operations, lubricate the transmission components with Mopar Mercon™ automatic transmission fluid or petroleum jelly as indicated. Petroleum jelly should be used to prelubricate thrust bearings, washers and races. It can also be used to hold parts in position during assembly.

Soak replacement clutch and brake pack components in transmission fluid for at least 30 minutes before installation.

ADJUSTMENTS

GEARSHIFT CABLE

Check adjustment by starting the engine in Park and Neutral. Adjustment is OK if the engine starts only in these positions. Adjustment is incorrect if the engine starts in one but not both positions. If the engine starts in any position other than Park or Neutral, or if the engine will not start at all, the park/neutral position switch may be faulty.

Gearshift Adjustment Procedure

- (1) Shift transmission into Park.
- (2) Raise vehicle.
- (3) Release cable adjuster clamp (at transmission end of cable) to unlock cable.
- (4) Unsnap cable from cable mounting bracket on transmission (Fig. 300).
- (5) Slide cable eyelet off transmission shift lever.
- (6) Verify transmission shift lever is in Park detent by moving lever fully rearward. Last rearward detent is Park position.
- (7) Verify positive engagement of transmission park lock by attempting to rotate propeller shaft. Shaft will not rotate when park lock is engaged.
- (8) Slide cable eyelet onto transmission shift lever.
- (9) Snap shift cable adjuster into mounting bracket on transmission.

(10) Lock shift cable by pressing cable adjuster clamp down until it snaps into place.

(11) Lower vehicle and check engine starting. Engine should start only in Park and Neutral.

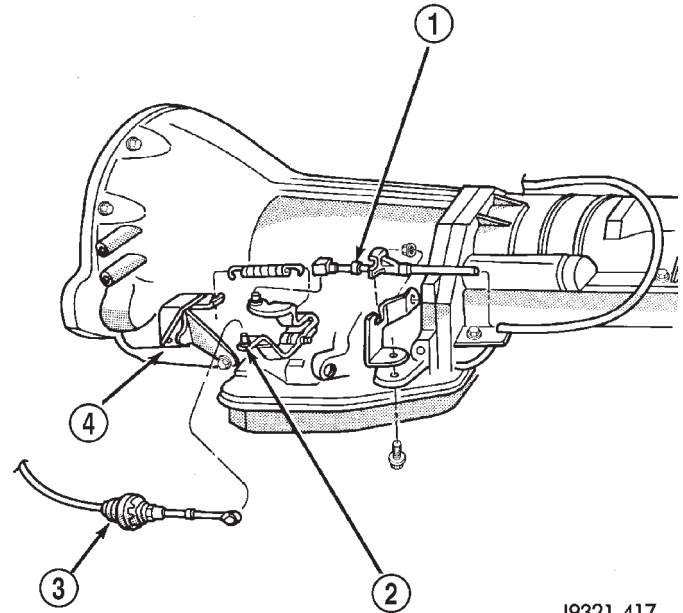

J9321-417

Fig. 300 Shift Cable Attachment At Transmission—Typical

- 1 - THROTTLE VALVE CABLE
- 2 - TRANSMISSION SHIFT LEVER
- 3 - SHIFT CABLE
- 4 - SHIFT CABLE BRACKET

BRAKE TRANSMISSION SHIFT INTERLOCK CABLE ADJUSTMENT

- (1) Shift transmission into PARK.
- (2) Remove shift lever bezel and console screws. Raise bezel and console for access to cable.
- (3) Pull cable lock button up to release cable (Fig. 301).
- (4) Turn ignition switch to LOCK position.
- (5) Use a spacer to create a one millimeter gap between the shifter pawl and top of the shift gate.
- (6) Pull cable forward. Then release cable and press cable lock button down until it snaps in place.
- (7) Check adjustment as follows:
 - (a) Check movement of release shift handle button (floor shift) or release lever (column shift). You should not be able to press button inward or move column lever.
 - (b) Turn ignition switch to RUN position.
 - (c) Shifting out of park should not be possible.
 - (d) Apply the brake and attempt to shift out of PARK. Shifting should be possible.
 - (e) While the transmission is shifted out of PARK, release the brake and attempt to shift

ADJUSTMENTS (Continued)

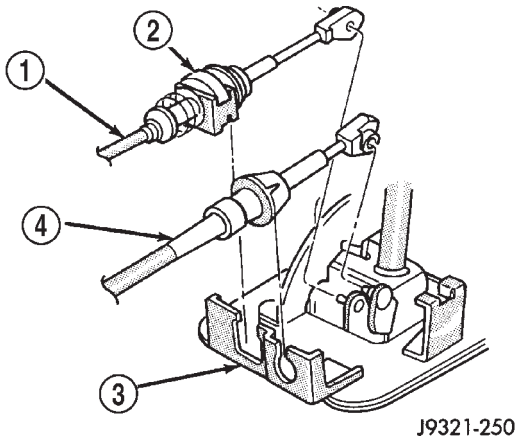

Fig. 301 Park Lock Cable Attachment

- 1 - PARK LOCK CABLE
- 2 - CABLE LOCK BUTTON
- 3 - SHIFT LEVER ASSEMBLY
- 4 - SHIFT CABLE

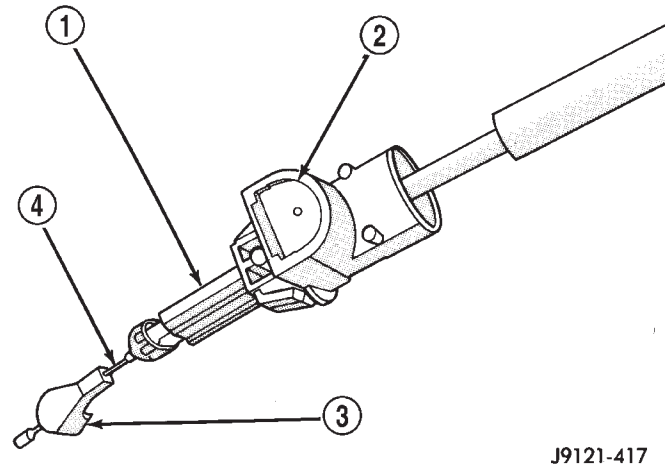

Fig. 302 Throttle Cable Components

- 1 - CONDUIT
- 2 - RELEASE BUTTON
- 3 - CABLE CONNECTOR
- 4 - CABLE

through all gears. Release the shift button at least once during this procedure. The ignition key should not go to the LOCK position.

(f) Return transmission to the PARK position without applying the brake.

(8) Move shift lever back to PARK and check ignition switch operation. You should be able to turn switch to LOCK position and shift lever release button/lever should not move.

TRANSMISSION THROTTLE VALVE CABLE ADJUSTMENT

(1) Shift transmission into Park, shut engine off and raise hood.

(2) Press cable release button (Fig. 302).

(3) Push cable conduit back into cable sheath as far as possible (Fig. 303).

(4) Rotate lever on throttle body to wide open throttle position. Cable will ratchet to correct adjustment point as lever is rotated (Fig. 303).

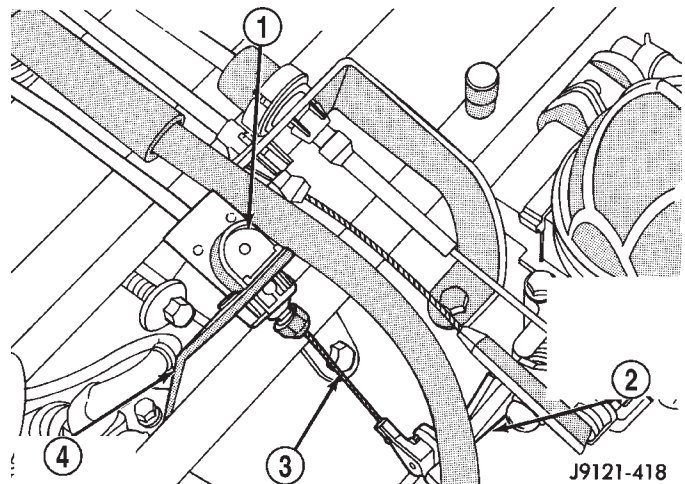

Fig. 303 Throttle Cable Adjustment

- 1 - RELEASE BUTTON
- 2 - ROTATE THROTTLE BODY LEVER TO W. O. T. POSITION
- 3 - CABLE
- 4 - CABLE BRACKET

SPECIFICATIONS

AW-4 AUTOMATIC TRANSMISSION

AW-4 GENERAL SPECIFICATIONS

Gear Ratios:

- First 2.804:1
- Second 1.531:1
- Third 1.000:1
- Fourth (Overdrive) 0.753:1
- Reverse 2.393:1

Transmission Fluid . . Jeep automatic transmission fluid or DEXRON® II

Fluid Level . To "Full" mark with fluid hot (normal operating temperature)

Fluid Capacity (all models) . . . 8.0 Liters (8.45 qts.)

Test Specifications

Stall Speed:

In D Range and Reverse 2100-2400 rpm

Line Pressure

- In D at Curb Idle 61-70 psi (421-481 kPa)
- In D at WOT 173-209 psi (1196-1442 kPa)
- In Reverse at Curb Idle . . 75-90 psi (519-618 kPa)
- In Reverse at WOT . . 213-263 psi (1471-1814 kPa)

Time Lag Test:

- Engagement in D Range 1.2 seconds
- Engagement in Reverse 1.5 seconds

Valve Body Solenoid Resistance 11-15 ohms

Transmission Fluid Normal Operating

Temperature 50-80°C (122-176°F)

TPS Input Voltage (AU) 5.0 Volts (approx.)

TPS Output Voltage

- 4-Cylinder 0.2 Volts (approx.)
- 6-Cylinder 4.2 Volts (approx.)

AW-4 OIL PUMP WEAR LIMITS

Drive Gear

- Tip Clearance:
- Standard . . . 0.11-0.14 mm (0.0043 -0.0055 in.)
- Maximum Allowance 0.3 mm (0.012 in.)

Gear-to-Pump Body

- End Clearance:
- Standard 0.02-0.05 mm (0.0008-0.0020 in.)
- Maximum Allowance 0.1 mm (0.004 in.)

Driven Gear-to-Pump

- Body Clearance:
- Standard 0.07-0.15 mm (0.0028-0.0059 in.)
- Maximum Allowance 0.3 mm (0.012 in.)

AW-4 CLUTCH DISC AND PLATE THICKNESS

| Component | Minimum Allowable Thickness |
|---|-----------------------------|
| Clutch Disc (all except first-reverse and forward clutch discs) | 1.84 mm (0.0724 in.) |
| 6-Cylinder Forward Clutch Disc | 1.51 mm (0.0594 in.) |
| 6-Cylinder Direct Clutch Plates: | |
| Thin Plate (1) | 2.3 mm (0.905 in.) |
| Thick Plates (3) | 3.0 mm (0.118 in.) |
| 6-Cylinder Forward Clutch Plate | 1.8 mm (0.070 in.) |
| First-Reverse Brake Disc (All) | 1.51 mm (0.0594 in.) |

SPECIFICATIONS (Continued)

AW-4 BUSHING AND PISTON CLEARANCE

BUSHING INSIDE DIAMETER (MAXIMUM)

| Bushing Location | Maximum Allowance Inside Diameter |
|------------------------------|--|
| Extension Housing | 38.09 mm (1.4996 in.) |
| Direct Clutch Drum | 53.97 mm (2.1248 in.) |
| Overdrive Planetary Gear | 11.27 mm (.4437 in.) |
| Overdrive Direct Clutch Drum | 27.11 mm (1.0673 in.) |
| Stator Shaft (Front) | 21.58 mm (.8496 in.) |
| Stator Shaft (Rear) | 27.08 mm (1.0661 in.) |
| Oil Pump Body | 38.19 mm (1.5035 in.) |
| Transmission Case | 38.18 mm (1.5031 in.) |

PISTON STROKE LENGTH

| Piston Location | Specification |
|-------------------------------|--------------------------------|
| Direct Clutch (all) | 1.37–1.67 mm (.0539–.0657 in.) |
| 6-Cylinder Overdrive Brake | 1.40–1.70 mm (.0551–.0669 in.) |
| Second Coast Brake (all) | 1.5–3.0 mm (.059–.118 in.) |
| 6-Cylinder Forward Clutch | 3.55–3.73 (.1397–.1468 in.) |
| Overdrive Direct Clutch (all) | 1.85–2.15 mm (.0728–.0846 in.) |

END PLAY AND CLEARANCE

| Component | Specification |
|---|------------------------------|
| Output Shaft End Play | .27–.86 mm (.0106–.0339 in.) |
| 6-Cylinder First-Reverse Brake Pack Clearance | .70–1.20 mm (.028–.047 in.) |
| 6-Cylinder Second Brake Pack Clearance | .62–1.98 mm (.024–.078 in.) |

SPECIFICATIONS (Continued)

AW-4 RETAINER AND PISTON SPECIFICATIONS

OVERDRIVE BRAKE RETAINER SELECTION

| Retainer No. | Thickness | Retainer No. | Thickness |
|--------------|-------------------|--------------|-------------------|
| 26 | 3.3 mm (.130 in.) | 11 | 3.8 mm (.150 in.) |
| 25 | 3.5 mm (.138 in.) | 23 | 3.9 mm (.154 in.) |
| 12 | 3.6 mm (.142 in.) | Not Marked | 4.0 mm (.157 in.) |
| 24 | 3.7 mm (.146 in.) | — | — |

DIRECT CLUTCH RETAINER SELECTION

| Retainer No. | Thickness | Retainer No. | Thickness |
|--------------|-------------------|--------------|-------------------|
| 33 | 3.0 mm (.118 in.) | 29 | 3.4 mm (.134 in.) |
| 32 | 3.1 mm (.122 in.) | 28 | 3.5 mm (.138 in.) |
| 31 | 3.2 mm (.126 in.) | 27 | 3.6 mm (.142 in.) |
| 30 | 3.3 mm (.130 in.) | 34 | 3.7 mm (.146 in.) |

OVERDRIVE CLUTCH RETAINER SELECTION

| Retainer No. | Thickness | Retainer No. | Thickness |
|--------------|-------------------|--------------|-------------------|
| 16 | 3.6 mm (.142 in.) | 19 | 3.3 mm (.130 in.) |
| 17 | 3.5 mm (.138 in.) | 20 | 3.2 mm (.126 in.) |
| 18 | 3.4 mm (.134 in.) | 21 | 3.1 mm (.122 in.) |

SECOND COAST BRAKE PISTON ROD SELECTION

| Rod | Rod Length |
|-------|---------------------|
| No. 1 | 71.4 mm (2.811 in.) |
| No. 2 | 72.9 mm (2.870 in.) |

FORWARD CLUTCH RETAINER SELECTION

| Retainer No. | Thickness | Retainer No. | Thickness |
|--------------|-------------------|--------------|-------------------|
| 42 | 4.0 mm (.157 in.) | 61 | 3.0 mm (.118 in.) |
| 44 | 3.8 mm (.149 in.) | 62 | 3.6 mm (.142 in.) |
| 45 | 3.4 mm (.134 in.) | 63 | 4.2 mm (.165 in.) |
| 60 | 3.2 mm (.126 in.) | 64 | 4.4 mm (.173 in.) |

FIRST-REVERSE BRAKE CLEARANCE SELECTION

| Retainer No. | Thickness | Retainer No. | Thickness |
|--------------|-------------------|--------------|-------------------|
| 50 | 5.0 mm (.197 in.) | 53 | 4.4 mm (.173 in.) |
| 51 | 4.8 mm (.189 in.) | 54 | 4.2 mm (.165 in.) |
| 52 | 4.6 mm (.181 in.) | 55 | 4.0 mm (.157 in.) |

SPECIFICATIONS (Continued)

AW-4 VALVE BODY BALL DIMENSIONS

| Check Ball | Diameter |
|-----------------|---------------------|
| (A) Rubber Ball | 6.35 mm (0.250 in.) |
| (B) Rubber Ball | 5.535 mm (.218 in.) |

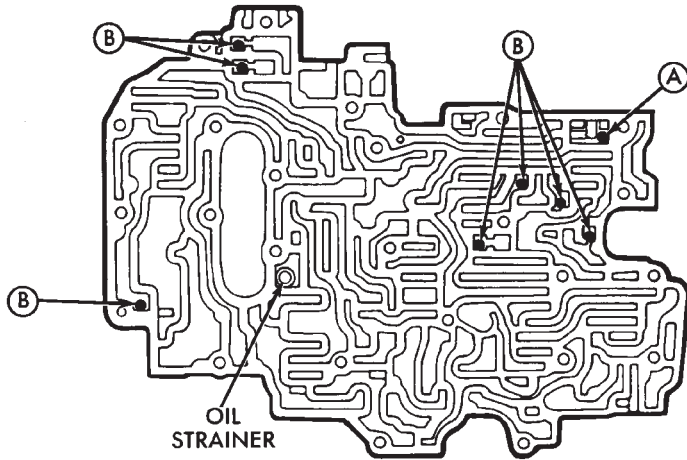

J9121-405

AW-4 CLUTCH AND BRAKE PACK REQUIREMENTS

| Component | Discs Required | Plates Required | Retainers Required |
|------------------------------------|----------------|-----------------|--------------------|
| 6-Cylinder Overdrive Brake | 4 | 3 | 2 |
| 6-Cylinder Second Brake | 5 | 5 | 1 |
| 6-Cylinder Overdrive Direct Clutch | 2 | 2 | 1 |
| 6-Cylinder Direct Clutch | 4 | 4 | 1 |
| 6-Cylinder Forward Clutch | 6 | 6 | 1 |
| 6-Cylinder First-Reverse Brake | 7 | 7 | 1 |

J9121-406

SPECIFICATIONS (Continued)

AW-4 VALVE AND SPRING IDENTIFICATION

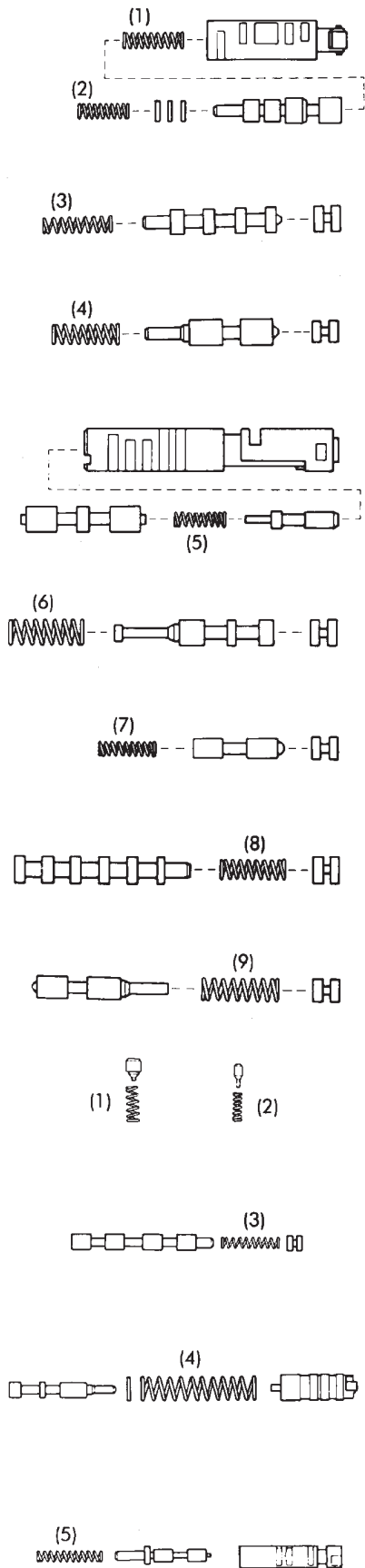

| Spring | Free Length |
|----------------------------------|---------------------|
| (1) Downshift Plug | 27.3 mm (1.074 in.) |
| (2) Throttle Valve | 20.6 mm (.811 in.) |
| (3) 3-4 Shift Valve | 30.8 mm (1.212 in.) |
| (4) Second Coast Modulator Valve | 25.3 mm (.996 in.) |
| (5) Lockup Relay Valve | 21.4 mm (.843 in.) |
| (6) Secondary Regulator Valve | 30.9 mm (1.217 in.) |
| (7) Cut-Back Valve | 21.8 mm (.858 in.) |
| (8) 2-3 Shift Valve | 30.8 mm (1.212 in.) |
| (9) Low Coast Modulator Valve | 27.8 mm (1.094 in.) |

| Spring | Spring Length |
|-------------------------------|---------------------|
| (1) Check Valve | 20.2 mm (.797 in.) |
| (2) Pressure Relief Valve | 11.2 mm (.441 in.) |
| (3) 1-2 Shift Valve | 30.8 mm (1.213 in.) |
| (4) Primary Regulator Valve | 62.3 mm (2.453 in.) |
| (5) Accumulator Control Valve | 29.8 mm (1.173 in.) |

SPECIFICATIONS (Continued)

AW-4 ACCUMULATOR COMPONENT IDENTIFICATION

| | Component | Approximate Outside Diameter |
|------------------------------|-----------|------------------------------|
| SECOND BRAKE ACCUMULATOR | SPRING A | 14.17 mm (.558 in.) |
| | PISTON B | 36.9 mm (1.453 in.) |
| | SPRING C | 19.91 mm (.784 in.) |
| DIRECT CLUTCH ACCUMULATOR | SPRING D | 12.07 mm (.475 in.) |
| | PISTON E | 36.9 mm (1.453 in.) |
| | SPRING F | 20.19 mm (.795 in.) |
| | SPRING G | 14.81 mm (.583 in.) |
| OVERDRIVE BRAKE ACCUMULATOR | SPRING H | 14.10 mm (.555 in.) |
| | PISTON J | 31.9 mm (1.256 in.) |
| | SPRING K | 19.99 mm (.785 in.) |
| OVERDRIVE CLUTCH ACCUMULATOR | SPRING L | 14.0 mm (0.551 in.) |
| | SPRING M | 20.3 mm (0.799 in.) |
| | PISTON N | 29.9 mm (1.177 in.) |

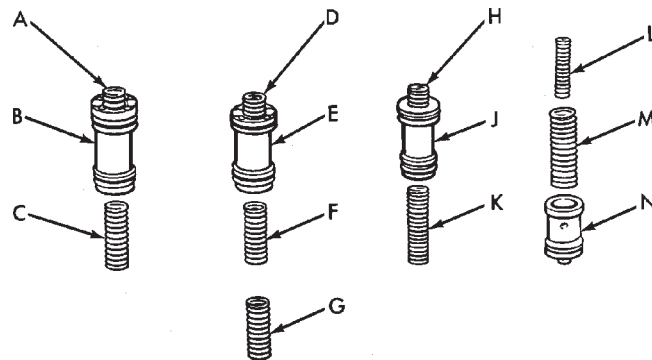

J9121-407

AW-4 TORQUE SPECIFICATIONS

| Description | Torque |
|---|------------------------------|
| Converter Housing Bolts | |
| 10 mm | 32-36 N·m (23-27 ft. lbs.) |
| 12 mm | 55-59 N·m (40-43 ft. lbs.) |
| Cooler Line Retaining Clip Nuts | 2-4 N·m (18-35 in. lbs.) |
| Cooler Line Bracket Nuts | 5-11 N·m (48-96 in. lbs.) |
| Cooler Line Fitting Nuts (at auto. trans. fittings) | 18-23 N·m (160-200 in. lbs.) |
| Detent Spring Bolt | 9-11 N·m (80-96 in. lbs.) |
| Dust Cover Nuts/Bolts | 18-23 N·m (159-203 in. lbs.) |
| Extension Housing Bolts | 32-36 N·m (23-27 ft. lbs.) |
| Fill Tube Bracket Bolt | 50-64 N·m (37-47 ft. lbs.) |
| Neutral Switch Bolt | 12-14 N·m (8-10 ft. lbs.) |
| Nut | 6-8 N·m (53-70 ft. lbs.) |
| OD Support Bolt (to case) | 23-27 N·m (18-20 ft. lbs.) |

| Description | Torque |
|---|------------------------------|
| Oil Pan Bolts | 6-8 N·m (53-70 in. lbs.) |
| Oil Pan Drain Plug | 19-21 N·m (14-16 ft. lbs.) |
| Oil Pump Bolt (to case) | 21-23 N·m (16-18 ft. lbs.) |
| Oil Pump Bolt (to stator shaft) | 9-11 N·m (80-96 in. lbs.) |
| Oil Screen Bolt | 9-11 N·m (80-96 in. lbs.) |
| Park Pawl Bracket | 9-11 N·m (80-96 in. lbs.) |
| Propeller Shaft Clamp Screws | 16-23 N·m (140-200 in. lbs.) |
| Rear Mount-To-Transmission Bolts | 60-81 N·m (44 ft. lbs.) |
| Rear Mount-To-Clevis Bracket Bolt/Nut | 54-75 N·m (40-55 ft. lbs.) |
| Rear Mount Clevis Bracket-To-Crossmember Nuts | 33-49 N·m (24-36 ft. lbs.) |
| Shift Cable Bracket Screws At Transmission | 25-39 N·m (221-345 in. lbs.) |
| Shift Lever Mounting Cover Screws | 1-2 N·m (9-20 in. lbs.) |
| Shift Lever Housing Nuts | 16-26 N·m (141-230 in. lbs.) |

SPECIFICATIONS (Continued)

| Description | Torque |
|---|---------------------------------|
| Solenoid Harness Bolt | 6-8 N·m (57-75 in. lbs.) |
| Speedometer Adapter Clamp Screw | 10-12 N·m (90-110 in. lbs.) |
| Speed Sensor Coupling Nut | 14-20 N·m (125-175 in. lbs.) |
| Throttle Cable Engine Bracket Screws | 7-11 N·m (63-94 in. lbs.) |
| Throttle Cable Retaining Screw (at transmission) | 8-10 N·m (70-98 in. lbs.) |
| Transfer Case Mounting Nuts | 30-41 N·m (22-30 ft. lbs.) |
| Transmission Shift Lever Nut | 15-17 N·m (134-154 in. lbs.) |
| Transmission-To-Engine Block Bolts | 50-64 N·m (37-47 ft. lbs.) |
| Valve Body Bolts (to case) | 9-11 N·m (80-96 in. lbs.) |
| Valve Body Bolts (to valve body) | 6-7 N·m (54-58 in. lbs.) |

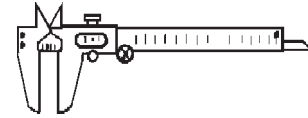

C-4959 Caliper, Metric Vernier



C-4960 Micrometer

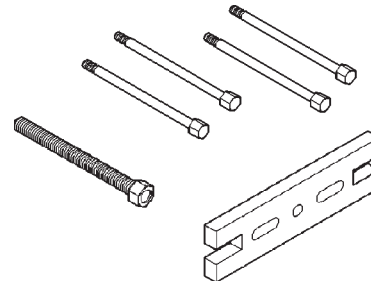

7536 Puller, Oil Pump

SPECIAL TOOLS

AW-4

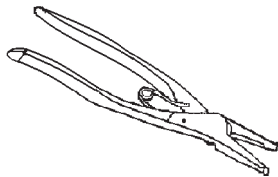

C-484 Snap Ring Plier

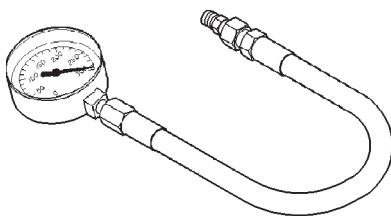

C-3293-SP Gauge

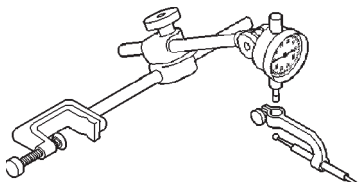

8011d42b

C-3339 Dial Indicator Set

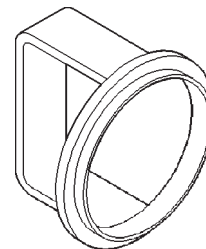

7538 Compressor, Piston #2 Spring

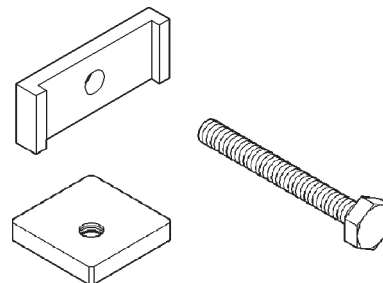

7539 Compressor, Piston #3 Spring

SPECIAL TOOLS (Continued)

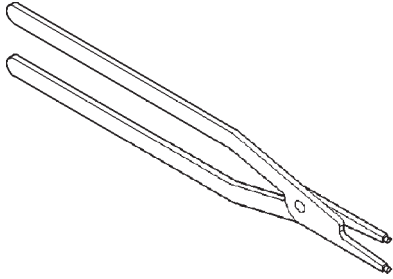

7540 Pliers, Large Snap Ring

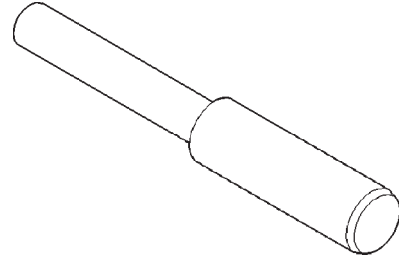

7544 Installer, Brake Drum Seal

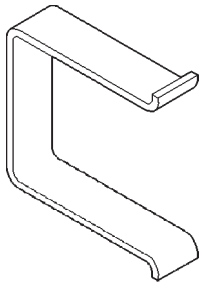

7542 Puller, Reaction Sleeve

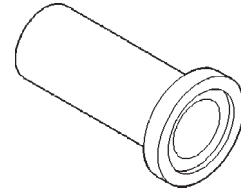

7549 Installer, Seal

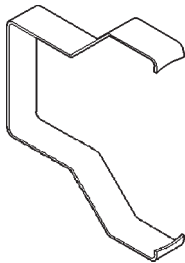

7543 Puller, Piston #1

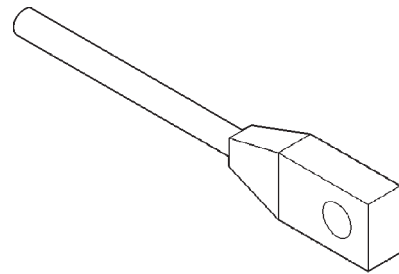

7552 Gauge, 3.0 mm Wire

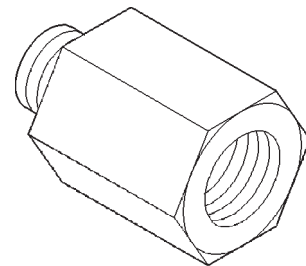

7554 Adapter, Pressure Port

NV231 TRANSFER CASE

TABLE OF CONTENTS

| | page | | page |
|----------------------------------|------|---------------------------------|------|
| DESCRIPTION AND OPERATION | | DISASSEMBLY AND ASSEMBLY | |
| NV231 TRANSFER CASE..... | 346 | NV231 TRANSFER CASE..... | 351 |
| LUBRICANT AND FILL LEVEL..... | 347 | CLEANING AND INSPECTION | |
| DIAGNOSIS AND TESTING | | NV231 TRANSFER CASE..... | 369 |
| NV231 DIAGNOSIS..... | 347 | ADJUSTMENTS | |
| REMOVAL AND INSTALLATION | | SHIFT LINKAGE ADJUSTMENT..... | 372 |
| TRANSFER CASE..... | 348 | SPECIFICATIONS | |
| SHIFT LEVER..... | 349 | TORQUE..... | 373 |
| SPEEDOMETER..... | 350 | SPECIAL TOOLS | |
| FRONT OUTPUT SHAFT SEAL..... | 350 | NV231..... | 373 |

DESCRIPTION AND OPERATION

NV231 TRANSFER CASE

DESCRIPTION

The NV231 is a part-time transfer case with a low range reduction gear system. The NV231 has three operating ranges plus a Neutral position. A low range system provides a reduction ratio for increased low speed torque capability.

The geartrain is mounted in two aluminum case halves attached with bolts. The mainshaft front and rear bearings are mounted in aluminum retainer housings bolted to the case halves.

OPERATING RANGES

Transfer case operating ranges are:

- 2WD (2-wheel drive)
- 4x4 (4-wheel drive)
- 4 Lo (4-wheel drive low range)

The 2WD range is for use on any road surface at any time.

The 4x4 and 4 Lo ranges are for off road use only. They are not for use on hard surface roads. The only exception being when the road surface is wet or slippery or covered by ice and snow.

The low range reduction gear system is operative in 4 Lo range only. This range is for extra pulling power in off road situations. Low range reduction ratio is 2.72:1.

SHIFT MECHANISM

Operating ranges are selected with a floor mounted shift lever. The shift lever is connected to the transfer case range lever by an adjustable linkage rod. A straight line shift pattern is used. Range positions are marked on the shifter bezel cover plate.

IDENTIFICATION

A circular ID tag is attached to the rear case of each transfer case (Fig. 1). The ID tag provides the transfer case model number, assembly number, serial number, and low range ratio.

The transfer case serial number also represents the date of build.

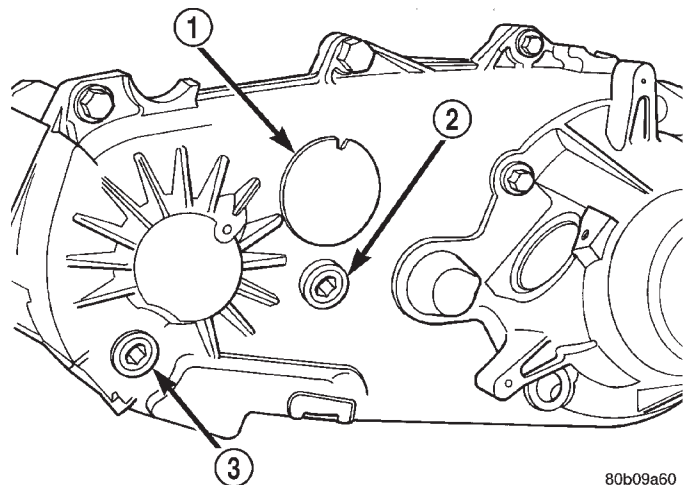

80b09a60

Fig. 1 Fill/Drain Plug And I. D. Tag Locations

- 1 - I. D. TAG
- 2 - FILL PLUG
- 3 - DRAIN PLUG

OPERATION

The input gear is splined to the transmission output shaft. The input gear drives the mainshaft through the planetary assembly and range hub. The front output shaft is operated by a drive chain that connects the shaft to a drive sprocket on the mainshaft. The drive sprocket is engaged/disengaged by the mode fork, which operates the mode sleeve and

DESCRIPTION AND OPERATION (Continued)

hub. The sleeve and hub are not equipped with a synchronizer mechanism for shifting.

LUBRICANT AND FILL LEVEL

DESCRIPTION

Recommended lubricant for the NV231 transfer case is Mopar® Dexron II, or ATF Plus 3, type 7176. Approximate lubricant fill capacity is 1.2 liters (2.5 pints).

The fill and drain plugs are both in the rear case (Fig. 2). Correct fill level is to the bottom edge of the fill plug hole. Be sure the vehicle is level to ensure an accurate fluid level check.

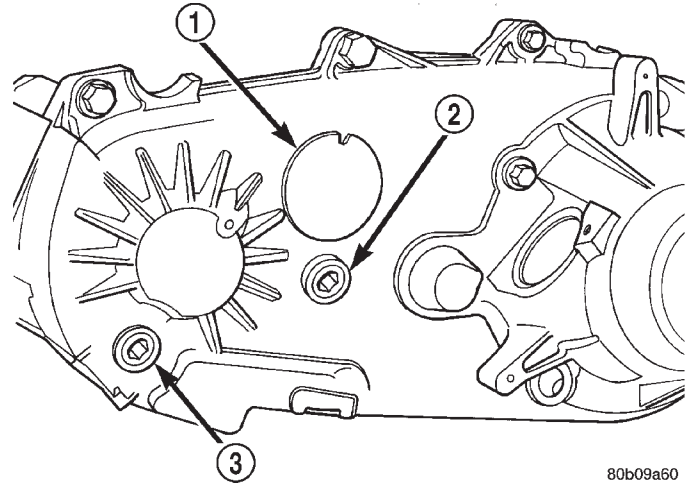

80b09a60

Fig. 2 Fill/Drain Plug Locations

- 1 - I. D. TAG
- 2 - FILL PLUG
- 3 - DRAIN PLUG

DIAGNOSIS AND TESTING

NV231 DIAGNOSIS

DIAGNOSIS CHART

| Condition | Possible Cause | Correction |
|--|--|---|
| Transfer case difficult to shift or will not shift into desired range. | 1) Vehicle speed too great to permit shifting. | 1) Slow vehicle and shift into desired range. |
| | 2) If vehicle was operated for an extended period in 4H mode on dry surface, driveline torque load may cause difficulty. | 2) Stop vehicle and shift transfer case to Neutral position. Transfer case can then be shifted to the desired mode. |
| | 3) Transfer case shift linkage binding. | 3) Repair or replace linkage as necessary. |
| | 4) Insufficient or incorrect lubricant. | 4) Drain and refill transfer case with the correct type and quantity of lubricant. |
| | 5) Internal transfer case components binding, worn, or damaged. | 5) Repair or replace components as necessary. |
| Transfer case noisy in all drive modes. | 1) Insufficient or incorrect lubricant. | 1) Drain and refill transfer case with the correct type and quantity of lubricant. |

DIAGNOSIS AND TESTING (Continued)

| Condition | Possible Cause | Correction |
|---|--|--|
| Transfer case noisy while in, or jumps out of, 4L mode. | 1) Transfer case not completely engaged in 4L position. | 1) Slow vehicle, shift transfer case to the Neutral position, and then shift into the 4L mode. |
| | 2) Transfer case shift linkage out of adjustment. | 2) Adjust linkage as necessary. |
| | 3) Transfer case shift linkage loose or binding. | 3) Repair, replace, or tighten linkage components as necessary. |
| | 4) Range fork damaged, inserts worn, or fork is binding on the shift rail. | 4) Repair or replace components as necessary. |
| | 5) Low range gear worn or damaged. | 5) Repair or replace components as necessary. |
| Lubricant leaking from transfer case seals or vent. | 1) Transfer case overfilled. | 1) Drain lubricant to the correct level. |
| | 2) Transfer case vent closed or restricted. | 2) Clean or replace vent as necessary. |
| | 3) Transfer case seals damaged or installed incorrectly. | 3) Replace suspect seal. |
| Abnormal tire wear. | 1) Extended operation in 4H mode on dry surfaces, | 1) Operate vehicle in 2H mode on dry surfaces. |

REMOVAL AND INSTALLATION

TRANSFER CASE

REMOVAL

- (1) Shift transfer case into Neutral.
- (2) Raise vehicle.
- (3) Drain transfer case lubricant.
- (4) Mark front and rear propeller shaft yokes for alignment reference.
- (5) Support transmission with jack stand.
- (6) Remove rear crossmember, or skid plate.
- (7) Disconnect front/rear propeller shafts at transfer case.
- (8) Disconnect vehicle speed sensor wires.
- (9) Disconnect transfer case linkage rod from range lever.
- (10) Disconnect transfer case vent hose (Fig. 3) and indicator switch harness, if necessary.
- (11) Support transfer case with transmission jack.
- (12) Secure transfer case to jack with chains.
- (13) Remove nuts attaching transfer case to transmission.
- (14) Pull transfer case and jack rearward to disengage transfer case.
- (15) Remove transfer case from under vehicle.

INSTALLATION

- (1) Mount transfer case on a transmission jack.
- (2) Secure transfer case to jack with chains.

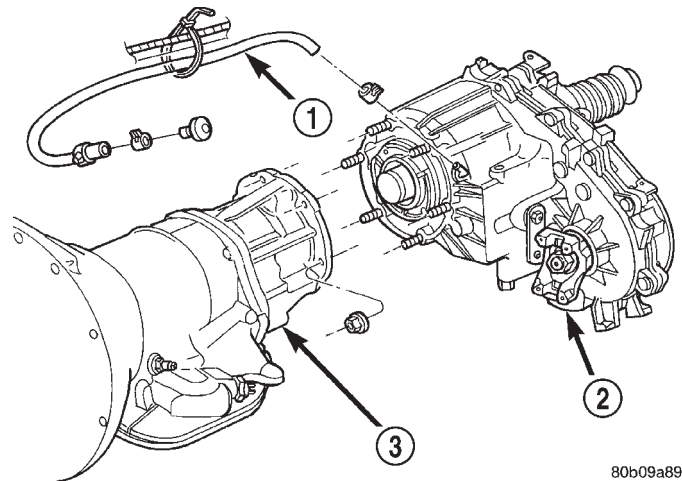

Fig. 3 Transfer Case Mounting

80b09a89

- 1 - VENT TUBE
- 2 - TRANSFER CASE
- 3 - TRANSMISSION

- (3) Position transfer case under vehicle.
- (4) Align transfer case and transmission shafts and install transfer case on transmission.
- (5) Install and tighten transfer case attaching nuts to 35 N·m (26 ft. lbs.) torque (Fig. 3).
- (6) Connect vehicle speed sensor wires, and vent hose.
- (7) Connect indicator switch harness to transfer case switch, if necessary. Secure wire harness to clips on transfer case.

REMOVAL AND INSTALLATION (Continued)

- (8) Align and connect propeller shafts. Refer to Group 3, Differential and Driveline, for proper procedures and specifications.
- (9) Fill transfer case with correct fluid. Check transmission fluid level. Correct as necessary.
- (10) Install rear crossmember, or skid plate. Tighten crossmember bolts to 41 N·m (30 ft. lbs.) torque.
- (11) Remove transmission jack and support stand.
- (12) Connect shift rod to transfer case range lever.
- (13) Adjust transfer case shift linkage.
- (14) Lower vehicle and verify transfer case shift operation.

SHIFT LEVER

REMOVAL

- (1) Shift transfer case into 4L.
- (2) Raise vehicle.
- (3) Loosen adjusting trunnion locknut and slide shift rod out of trunnion (Fig. 4). If rod lacks enough

- travel to come out of trunnion, push trunnion out of torque shaft.
- (4) Lower vehicle.
- (5) Remove console. Refer to Group 23, Body, for proper procedures.
- (6) Remove screws attaching lever assembly to floorpan and remove assembly and shift rod (if left attached).

INSTALLATION

- (1) If shift rod was not removed from lever assembly, work rod down through floorpan opening. Then position lever assembly on floorpan and install assembly attaching screws.
- (2) Install console. Refer to Group 23, Body, for proper procedures.
- (3) Raise vehicle.
- (4) Connect trunnion to torque shaft arm. Or, slide shift rod into trunnion on range lever. Be sure shift rod slides freely in trunnion.
- (5) Verify that range lever is in 4L position. Then tighten trunnion lock bolt.

| TORQUE | |
|--------|-----------------------------|
| A | 3-4 N•m (27-35 in. lbs.) |
| B | 11-14 N•m (97-123 in. lbs.) |
| C | 8-14 N•m (72-120 in. lbs.) |

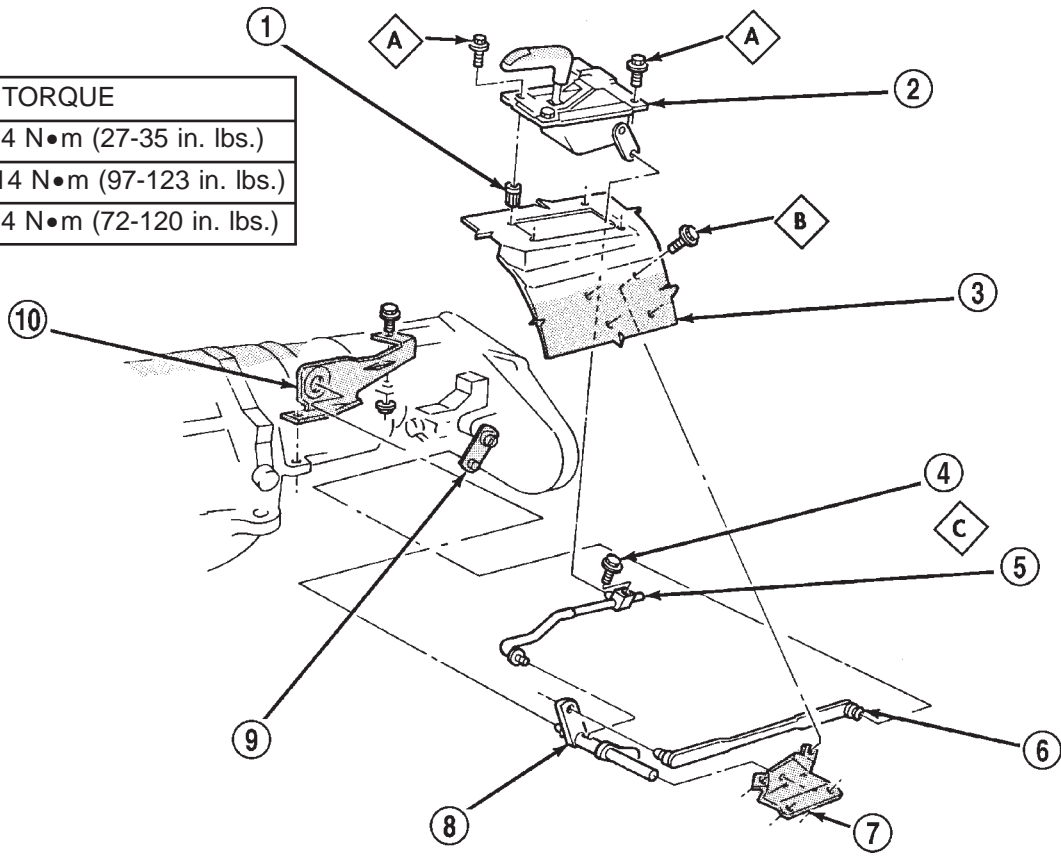

Fig. 4 Shift Linkage

J9321-185

- 1 - RIVNUT (4)
- 2 - SHIFT LEVER ASSEMBLY
- 3 - FLOORPAN
- 4 - TRUNNION LOCK BOLT
- 5 - SELECTOR ROD AND TRUNNION
- 6 - SHIFT LEVER ROD
- 7 - TORQUE SHAFT FRAME BRACKET
- 8 - TORQUE SHAFT
- 9 - TRANSFER CASE SHIFT LEVER
- 10 - TORQUE SHAFT TRANSFER CASE BRACKET

REMOVAL AND INSTALLATION (Continued)

(6) Lower vehicle and check transfer case shift operation.

SPEEDOMETER

REMOVAL

- (1) Raise vehicle.
- (2) Disconnect wires from vehicle speed sensor.
- (3) Remove adapter clamp and screw (Fig. 5).
- (4) Remove speed sensor and speedometer adapter as an assembly.
- (5) Remove speed sensor retaining screw and remove sensor from adapter.
- (6) Remove speedometer pinion from adapter. Replace pinion if chipped, cracked, or worn.
- (7) Inspect sensor and adapter O-rings (Fig. 5). Remove and discard O-rings if worn or damaged.
- (8) Inspect terminal pins in speed sensor. Clean pins with Mopar® electrical spray cleaner if dirty or oxidized. Replace sensor if faulty, or if pins are loose, severely corroded, or damaged.

INSTALLATION AND INDEXING

- (1) Thoroughly clean adapter flange and adapter mounting surface in housing. Surfaces must be clean for proper adapter alignment and speedometer operation.
- (2) Install new O-rings on speed sensor and speedometer adapter (Fig. 5), if necessary.

(3) Lubricate sensor and adapter O-rings with transmission fluid.

(4) Install vehicle speed sensor in speedometer adapter. Tighten sensor attaching screw to 2-3 N·m (15-27 in. lbs.) torque.

(5) Install speedometer pinion in adapter.

(6) Count number of teeth on speedometer pinion. Do this before installing assembly in housing. Then lubricate pinion teeth with transmission fluid.

(7) Note index numbers on adapter body (Fig. 6). These numbers will correspond to number of teeth on pinion.

(8) Install speedometer assembly in housing.

(9) Rotate adapter until required range numbers are at 6 o'clock position. Be sure range index numbers correspond to number of teeth on pinion gear.

(10) Install speedometer adapter clamp and retaining screw. Tighten clamp screw to 10-12 N·m (90-110 in. lbs.) torque.

(11) Connect wires to vehicle speed sensor.

(12) Lower vehicle and top off transmission fluid level if necessary.

FRONT OUTPUT SHAFT SEAL

REMOVAL

- (1) Raise vehicle.
- (2) Remove front propeller shaft. Refer to Group 3, Differential and Driveline, for proper procedure.

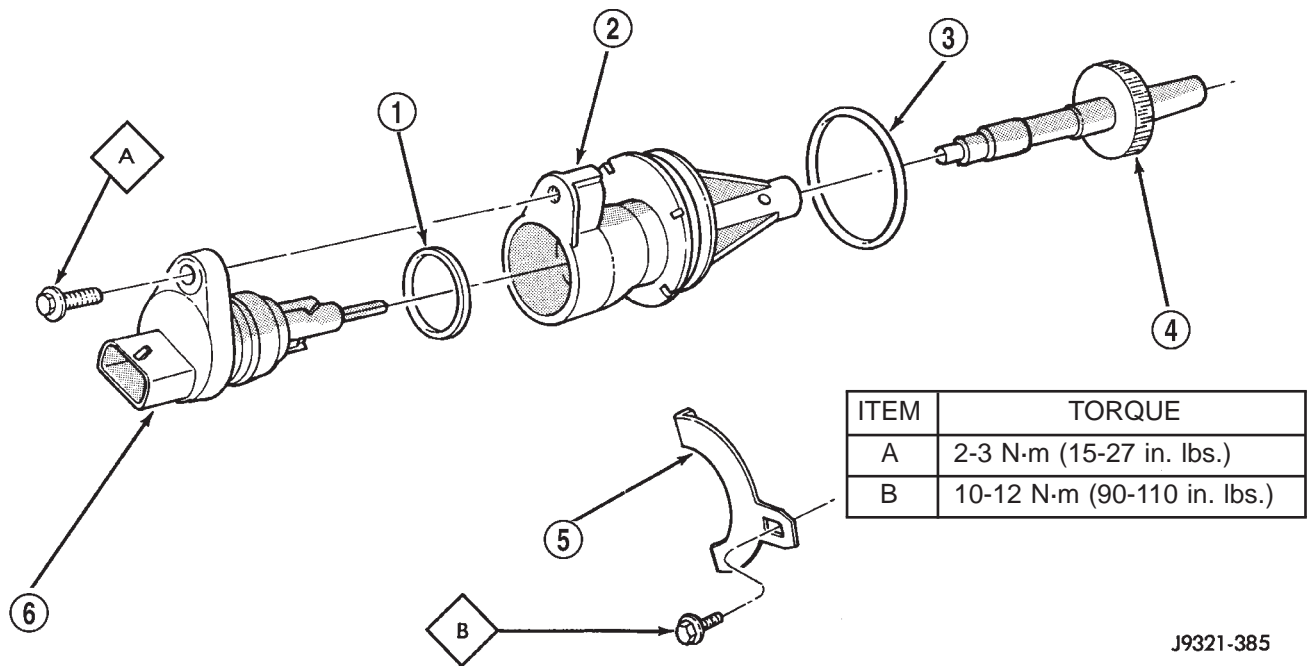

J9321-385

Fig. 5 Speedometer Components

- 1 - SENSOR O-RING
- 2 - SPEEDOMETER ADAPTER
- 3 - ADAPTER O-RING

- 4 - SPEEDOMETER PINION
- 5 - ADAPTER CLAMP
- 6 - VEHICLE SPEED SENSOR

REMOVAL AND INSTALLATION (Continued)

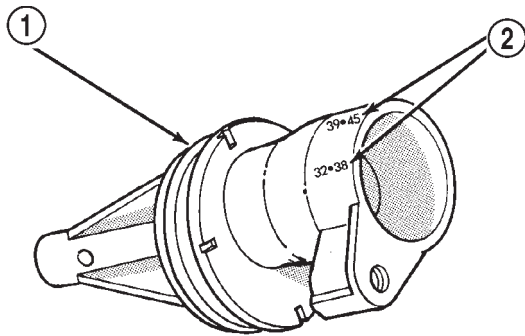

J9321-386
Fig. 6 Location Of Index Numbers On Speedometer Adapter

- 1 - SPEEDOMETER ADAPTER
- 2 - INDEX NUMBER LOCATION

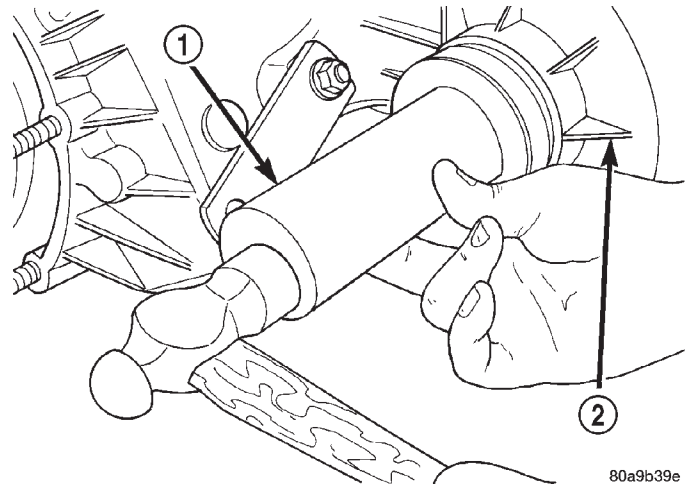

Fig. 8 Front Output Seal Installation

- 1 - INSTALLER 8143
- 2 - TRANSFER CASE

- (3) Remove front output shaft yoke.
- (4) Remove seal from front case with pry tool (Fig. 7).

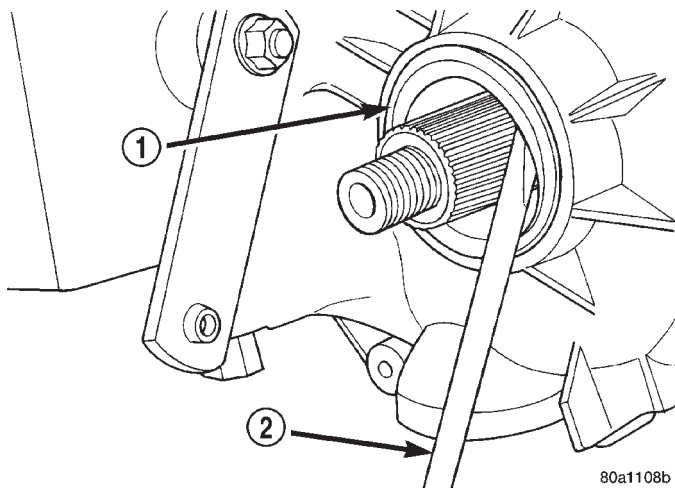

Fig. 7 Remove Front Output Shaft Seal

- 1 - OUTPUT SHAFT SEAL
- 2 - PRYBAR

INSTALLATION

- (1) Install new front output seal in front case with Installer Tool 8143 as follows:
 - (a) Place new seal on tool. Garter spring on seal goes toward interior of case.
 - (b) Start seal in bore with light taps from hammer (Fig. 8). Once seal is started, continue tapping seal into bore until installer tool seats against case.

DISASSEMBLY AND ASSEMBLY

NV231 TRANSFER CASE

DISASSEMBLY

Position transfer case on shallow drain pan. Remove drain plug and drain lubricant remaining in case.

REAR RETAINER AND OIL PUMP REMOVAL

- (1) Remove the speedometer adapter.
- (2) Spread band clamp which holds output shaft boot to slinger with a suitable awl, or equivalent.
- (3) Remove output shaft boot from slinger and output shaft.
- (4) Using Puller MD-998056-A, remove rear slinger (Fig. 9).
- (5) Use a suitable pry tool, or a slide hammer mounted screw, to remove the seal from the rear retainer (Fig. 10).
- (6) Remove the rear output bearing I. D. retaining ring (Fig. 11).
- (7) Remove the bolts holding the rear retainer to the rear case half.
- (8) Tap rear retainer with rawhide or rubber mallet to loosen sealer bead.

DISASSEMBLY AND ASSEMBLY (Continued)

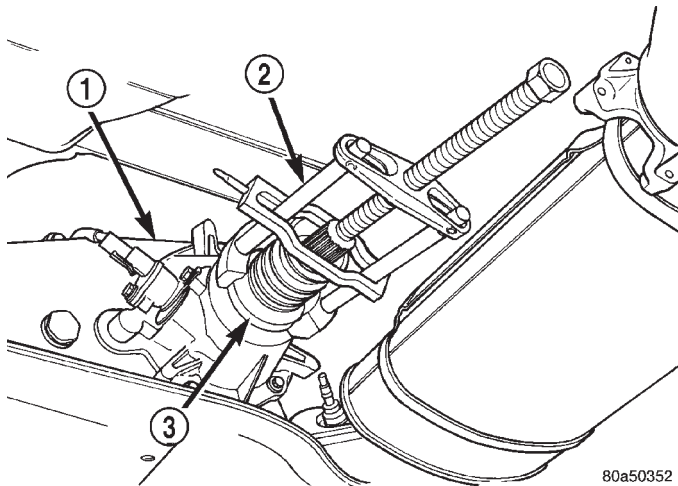

Fig. 9 Rear Slinger Removal

- 1 - TRANSFER CASE
- 2 - SPECIAL TOOL MD998056-A
- 3 - SLINGER

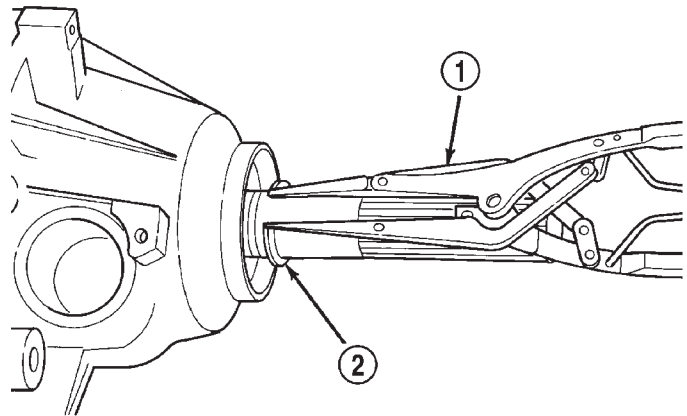

Fig. 11 Output Shaft Rear Bearing Retaining Ring

- 1 - REAR RETAINER
- 2 - OUTPUT SHAFT SEAL

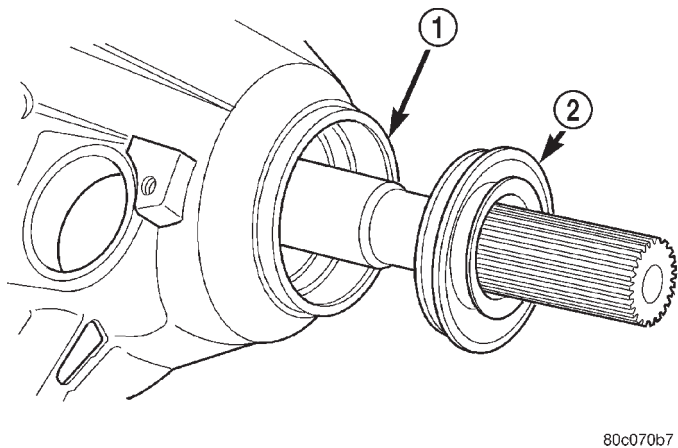

Fig. 10 Rear Retainer Seal

- 1 - REAR RETAINER
- 2 - OUTPUT SHAFT SEAL

(9) Remove rear retainer from rear case half (Fig. 12).

(10) Remove snap-ring holding oil pump in position on output shaft.

(11) Disengage oil pickup tube from oil pump and remove oil pump assembly. Remove oil pump by tilting the edge of the oil pump from under the edge of the rear case half and sliding the pump (Fig. 13).

(12) Remove pick-up tube o-ring from oil pump (Fig. 14), if necessary. Do not disassemble the oil pump, it is not serviceable.

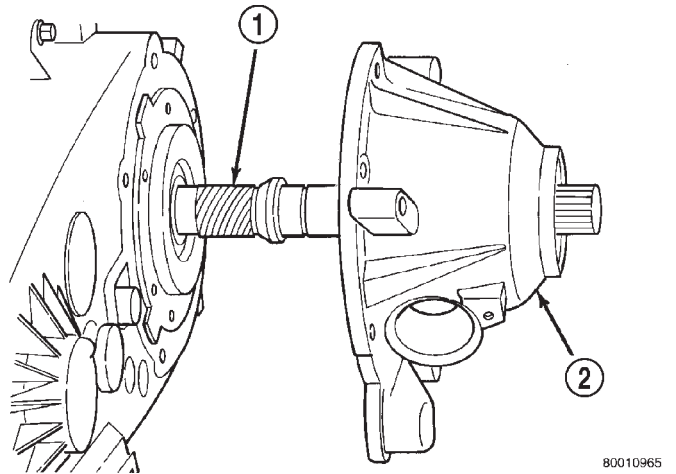

Fig. 12 Rear Retainer Removal

- 1 - MAINSHAFT
- 2 - REAR RETAINER

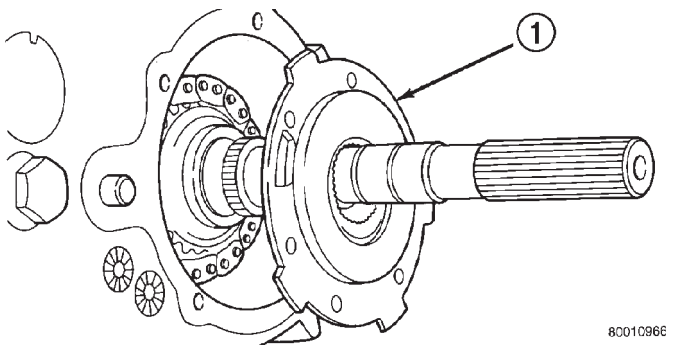
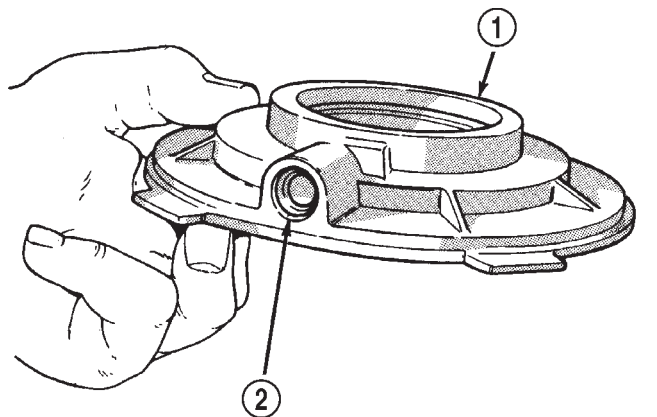

Fig. 13 Oil Pump Removal

- 1 - OIL PUMP

DISASSEMBLY AND ASSEMBLY (Continued)



RR21F27

Fig. 14 Pick-up Tube O-ring Location

- 1 - OIL PUMP
2 - O-RING

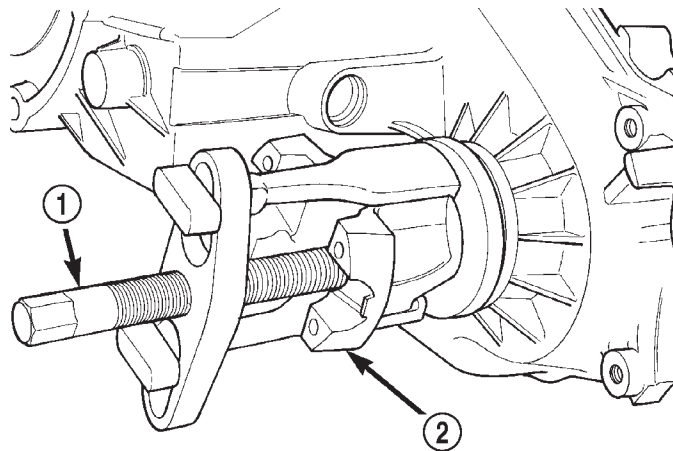

80010977

Fig. 16 Yoke Removal

- 1 - PULLER TOOL
2 - YOKE

YOKE AND RANGE LEVER REMOVAL

- (1) Remove transfer case indicator switch.
- (2) Remove front yoke nut as follows:
 - (a) Move range lever to 4L position.
 - (b) Then remove nut with socket and impact wrench (Fig. 15).
- (3) Remove yoke. If yoke is difficult to remove by hand, remove it with bearing splitter, or with standard two jaw puller (Fig. 16). Be sure puller tool is positioned on yoke and not on slinger as slinger will be damaged.

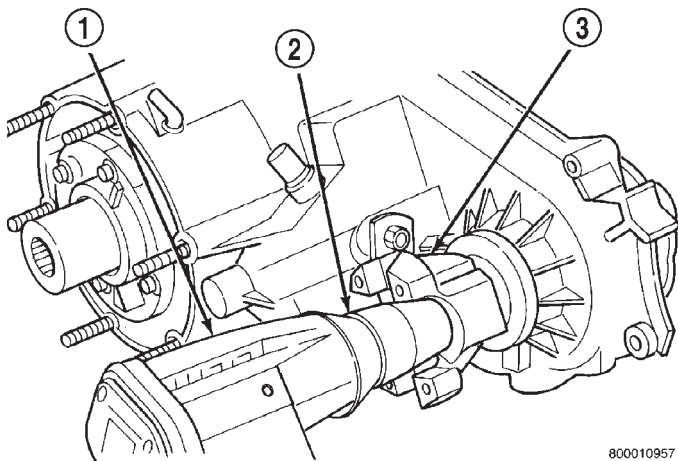

800010957

Fig. 15 Yoke Nut Removal

- 1 - IMPACT WRENCH
2 - SOCKET
3 - YOKE

- (4) Remove seal washer from front output shaft. Discard washer as it should not be reused.
- (5) Remove nut and washer that attach range lever to sector shaft. Then move sector to neutral position and remove range lever from shaft (Fig. 17).

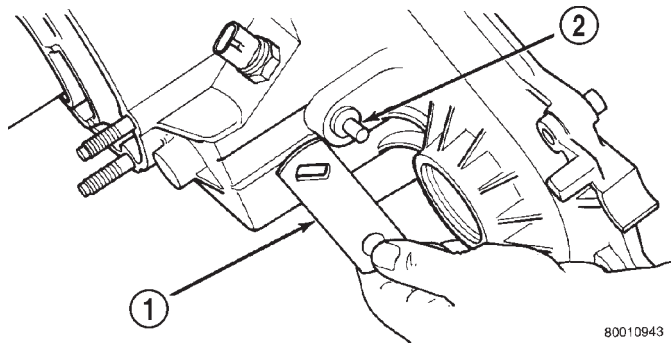

80010943

Fig. 17 Range Lever Removal

- 1 - RANGE LEVER
2 - SECTOR SHAFT

DISASSEMBLY AND ASSEMBLY (Continued)

FRONT OUTPUT SHAFT AND DRIVE CHAIN REMOVAL

- (1) Support transfer case so rear case is facing upward.
- (2) Remove bolts holding front case to rear case. The case alignment bolts require flat washers (Fig. 18).
- (3) Loosen rear case with flat blade screwdriver to break sealer bead. Insert pry tool blade only into notches provided at each end of case (Fig. 19).
- (4) Remove rear case from front case.

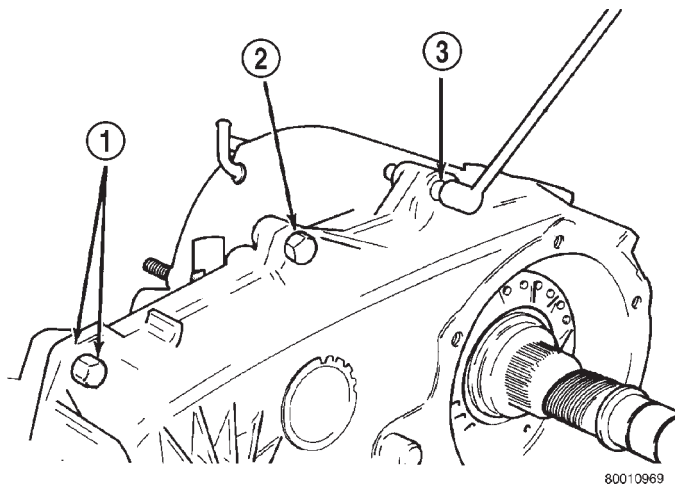

Fig. 18 Rear Case Alignment Bolt Locations

- 1 - DOWEL BOLT AND WASHER (2)
- 2 - CASE BOLT (5)
- 3 - SPLINE HEAD BOLT (1)

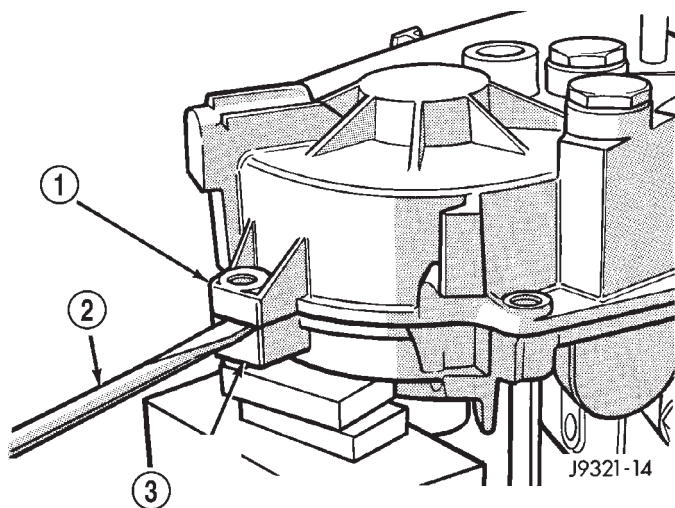

Fig. 19 Loosening Rear Case

- 1 - REAR CASE
- 2 - PRY TOOL (IN CASE SLOT)
- 3 - FRONT CASE

- (5) Remove oil pickup tube from rear case (Fig. 20).
- (6) Remove mode fork spring (Fig. 21).
- (7) Pull front output shaft upward and out of front output shaft bearing (Fig. 22).
- (8) Remove front output shaft and chain.

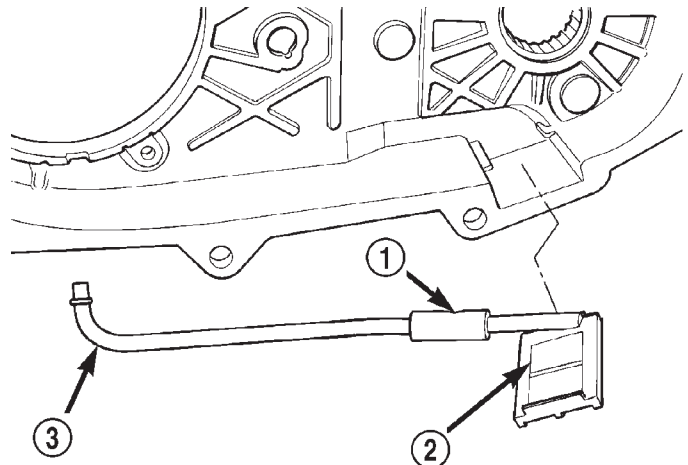

Fig. 20 Oil Pickup Tube Removal

- 1 - CONNECTING HOSE
- 2 - PICKUP SCREEN
- 3 - PICKUP TUBE

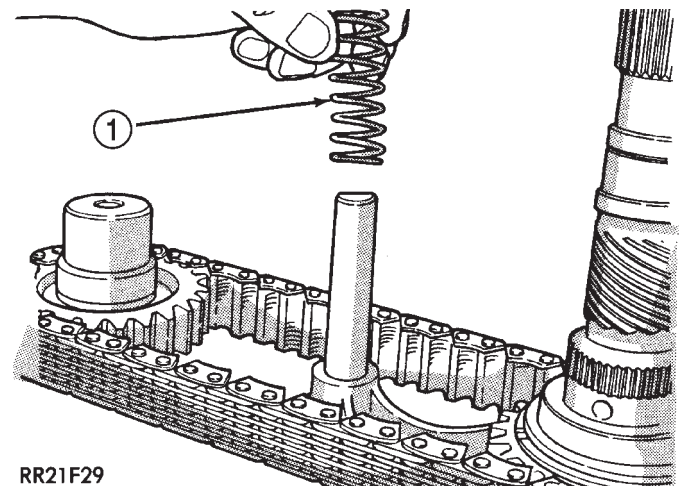
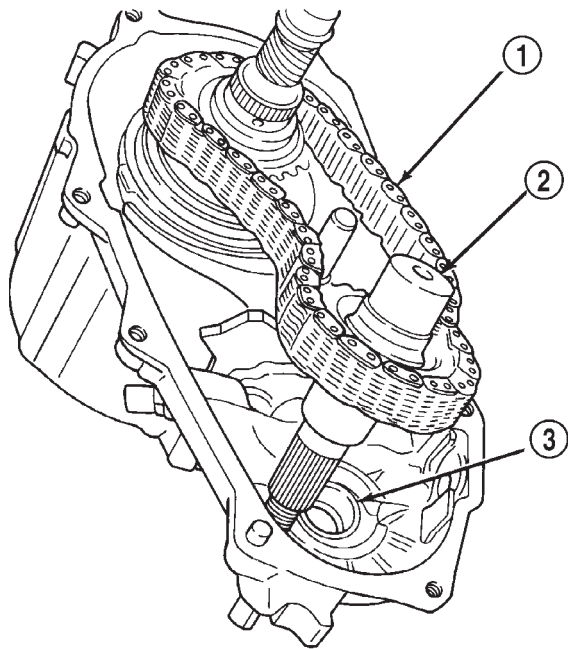

Fig. 21 Mode Fork Spring Removal

- 1 - MODE SPRING

DISASSEMBLY AND ASSEMBLY (Continued)



80C1096b

Fig. 22 Remove Front Output Shaft And Chain

- 1 - DRIVE CHAIN
- 2 - FRONT OUTPUT SHAFT
- 3 - SHAFT FRONT BEARING

SHIFT FORKS AND MAINSHAFT REMOVAL

(1) Remove detent plug, O-ring, detent spring and detent plunger (Fig. 23).

(2) Remove mainshaft from mode sleeve and input gear pilot bearing.

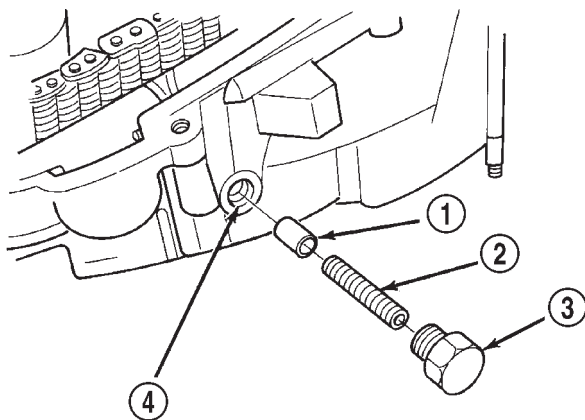

8001096a

Fig. 23 Detent Plug, Spring And Plunger Removal

- 1 - POPPET
- 2 - SPRING
- 3 - SCREW
- 4 - POPPET BORE (IN CASE)

(3) Remove mode fork and sleeve as an assembly (Fig. 24). Note position of sleeve for assembly reference. The short side of the sleeve faces upward.

(4) Remove range fork and hub as an assembly (Fig. 25). Note fork position for installation reference.

(5) Remove shift sector from front case (Fig. 26).

(6) Remove shift sector bushing and O-ring (Fig. 27).

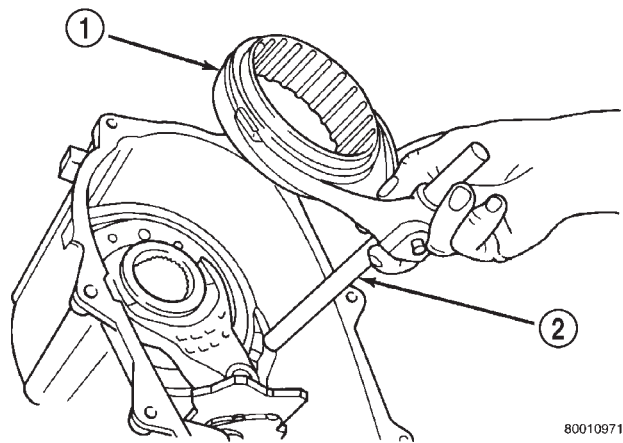

80010971

Fig. 24 Mode Fork And Sleeve Removal

- 1 - MODE SLEEVE
- 2 - MODE FORK AND RAIL

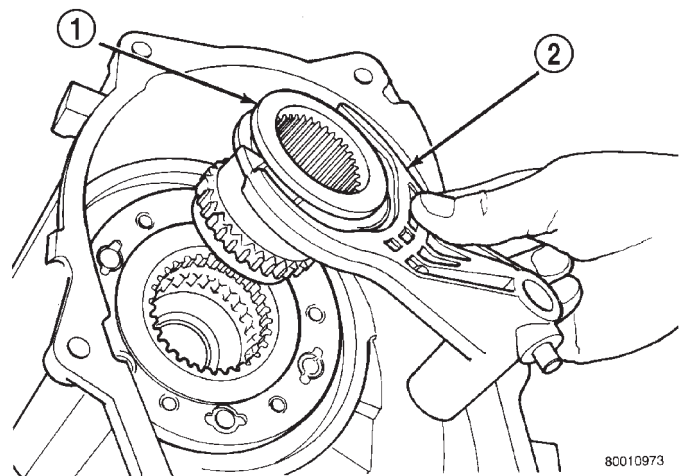

80010973

Fig. 25 Range Fork And Hub Removal

- 1 - RANGE HUB
- 2 - RANGE FORK

DISASSEMBLY AND ASSEMBLY (Continued)

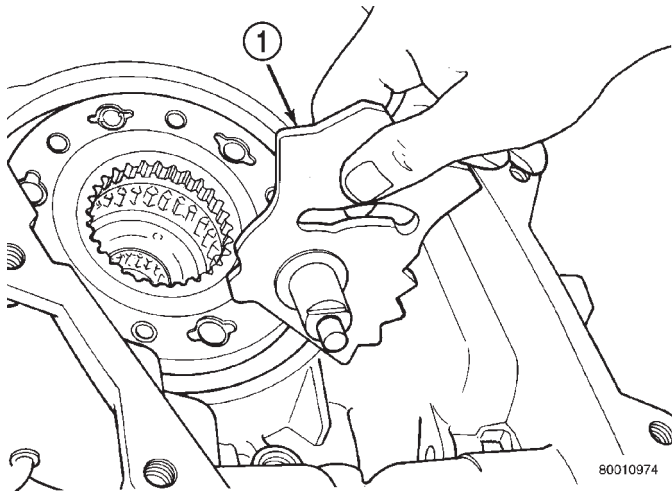
**Fig. 26 Shift Sector Removal**

1 - SHIFT SECTOR

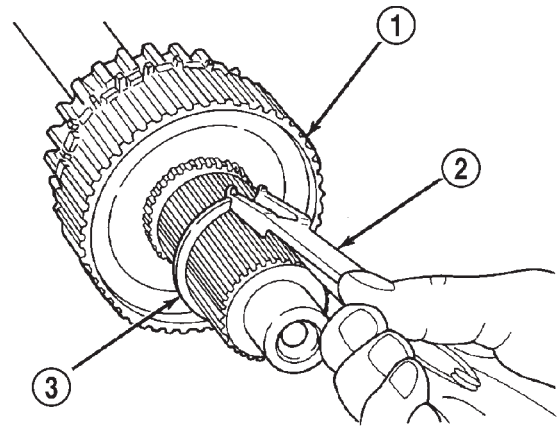
**Fig. 28 Mode Hub Retaining Ring Removal**

1 - MODE HUB
 2 - SNAP RING PLIERS (HEAVY DUTY)
 3 - MODE HUB RETAINING RING

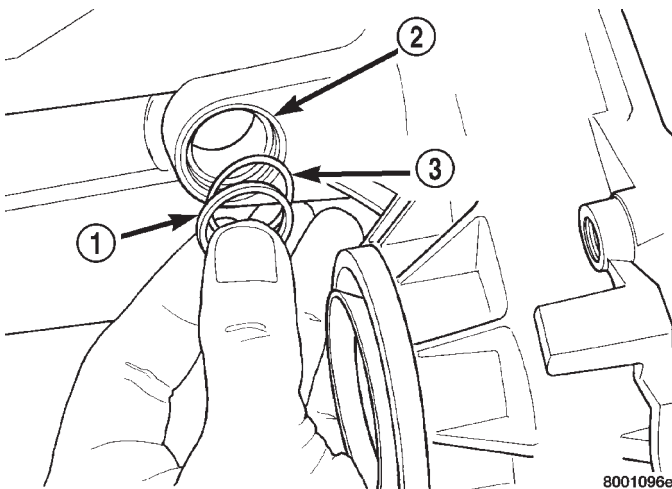
**Fig. 27 Sector Bushing And O-Ring Removal**

1 - SEAL RETAINER
 2 - SECTOR SHAFT BORE
 3 - O-RING SEAL

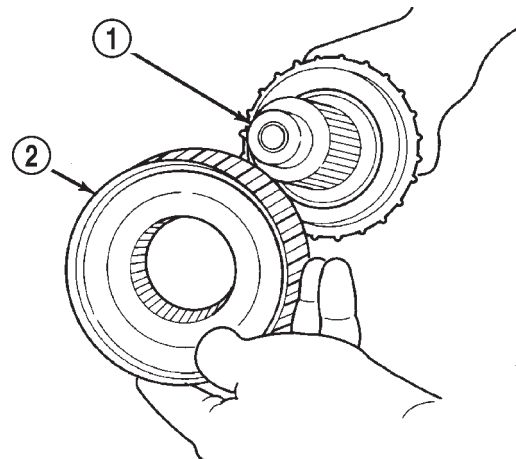
**Fig. 29 Mode Hub Removal**

1 - MAINSHAFT
 2 - MODE HUB

MAINSHAFT DISASSEMBLY

(1) Remove mode hub retaining ring with heavy duty snap-ring pliers (Fig. 28).

(2) Slide mode hub off mainshaft (Fig. 29).

(3) Slide drive sprocket off mainshaft (Fig. 30).

DISASSEMBLY AND ASSEMBLY (Continued)

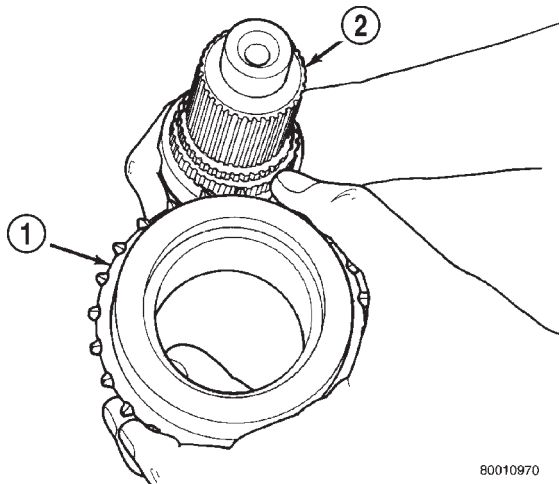

Fig. 30 Drive Sprocket Removal

- 1 - DRIVE SPROCKET
- 2 - MAINSHAFT

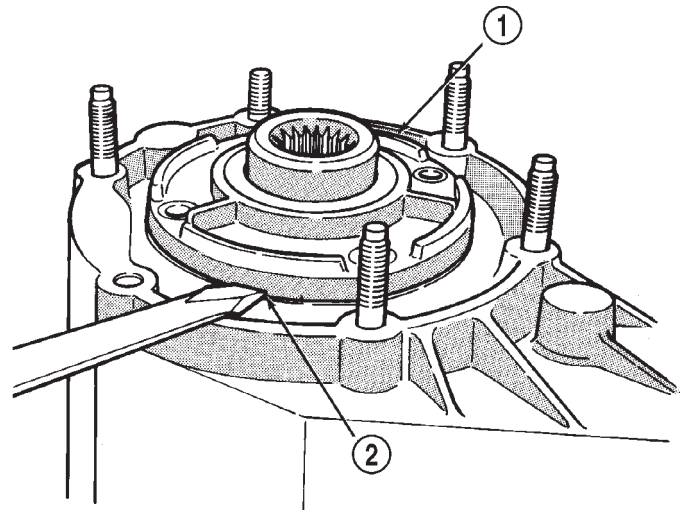

Fig. 32 Front Bearing Retainer Removal

- 1 - FRONT BEARING RETAINER
- 2 - RETAINER SLOT

INPUT GEAR AND LOW RANGE GEAR REMOVAL

(1) Remove front bearing retainer attaching bolts (Fig. 31).

(2) Remove front bearing retainer. Pry retainer loose with pry tool positioned in slots at each end of retainer (Fig. 32).

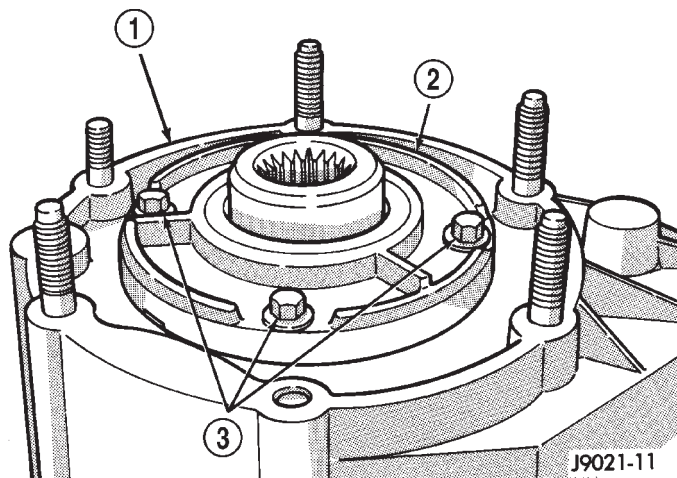

Fig. 31 Front Bearing Retainer Bolts

- 1 - FRONT CASE
- 2 - FRONT BEARING RETAINER
- 3 - RETAINER BOLTS

(3) Remove front bearing retainer seal. Tap seal out with drift and hammer.

(4) Remove input gear retaining ring with heavy duty snap-ring pliers (Fig. 33)

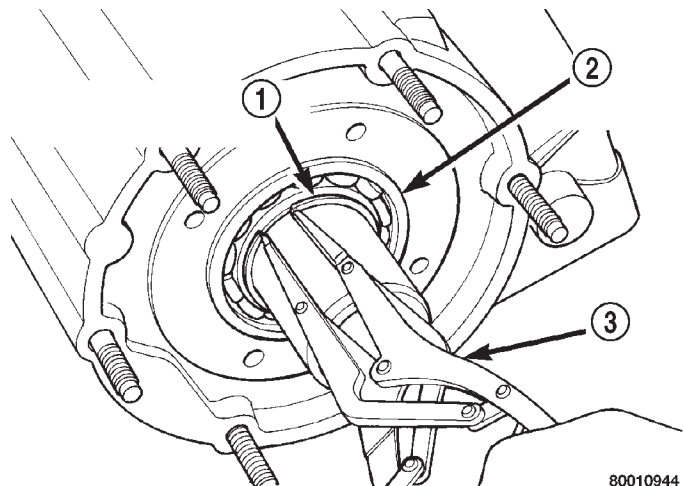

Fig. 33 Removing Input Gear Retaining Ring

- 1 - INPUT GEAR BEARING RETAINING RING
- 2 - INPUT GEAR BEARING
- 3 - SNAP RING PLIERS

DISASSEMBLY AND ASSEMBLY (Continued)

(5) Place front case in horizontal position. Then remove input gear and low range gear as an assembly (Fig. 34). Tap gear out of bearing with plastic mallet if necessary.

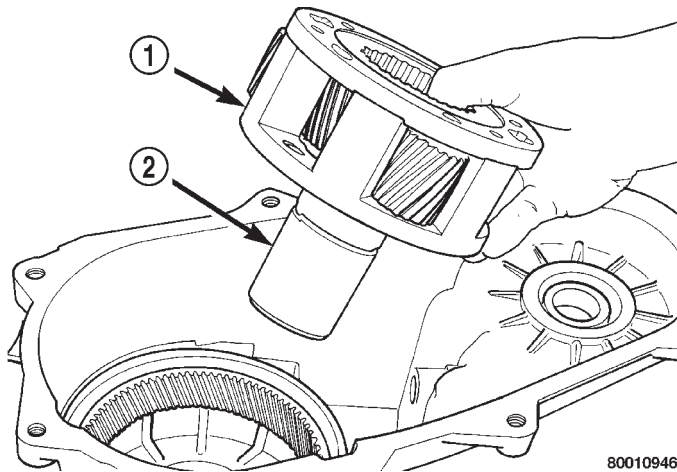

Fig. 34 Input Gear And Planetary Carrier Removal

- 1 - PLANETARY ASSEMBLY
- 2 - INPUT GEAR

INPUT AND LOW RANGE GEAR DISASSEMBLY

(1) Remove snap-ring that retains input gear in low range gear (Fig. 35).

(2) Remove retainer (Fig. 36).

(3) Remove front tabbed thrust washer (Fig. 37).

(4) Remove input gear (Fig. 38).

(5) Remove rear tabbed thrust washer from low range gear (Fig. 39).

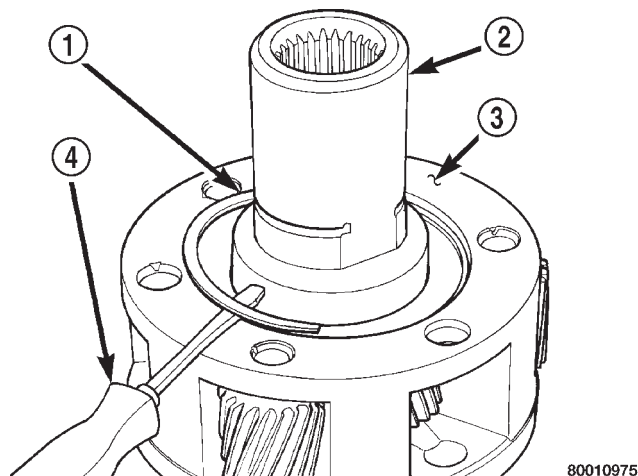

Fig. 35 Input Gear Snap-Ring Removal

- 1 - CARRIER LOCK RETAINING RING
- 2 - INPUT GEAR
- 3 - PLANETARY CARRIER
- 4 - SCREWDRIVER

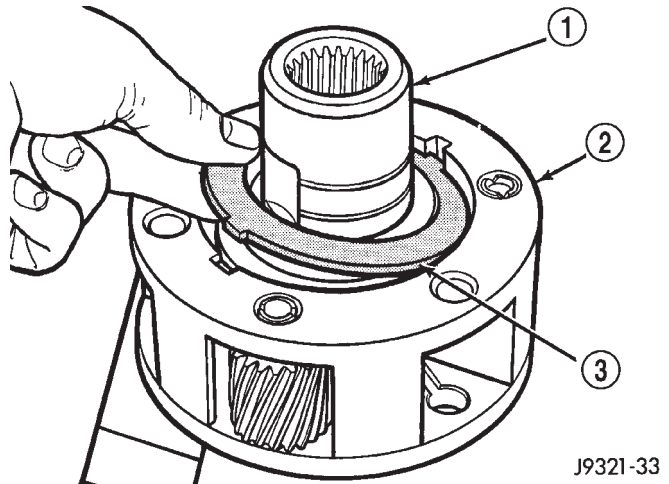

Fig. 36 Input Gear Retainer Removal

- 1 - INPUT GEAR
- 2 - LOW RANGE GEAR
- 3 - RETAINER

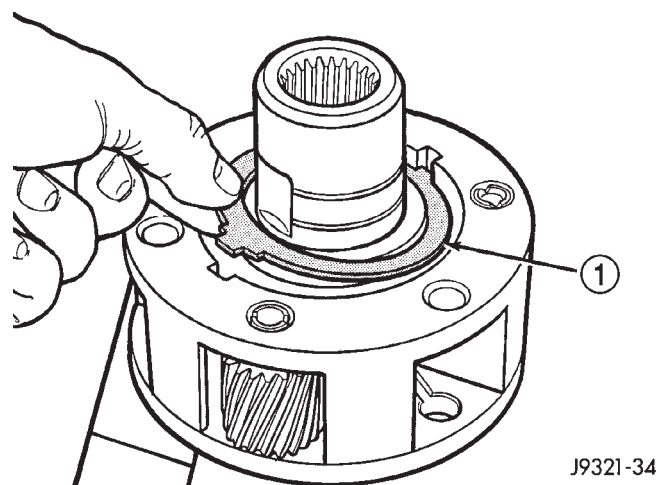

Fig. 37 Front Tabbed Thrust Washer Removal

- 1 - FRONT TABBED THRUST WASHER

DISASSEMBLY AND ASSEMBLY (Continued)

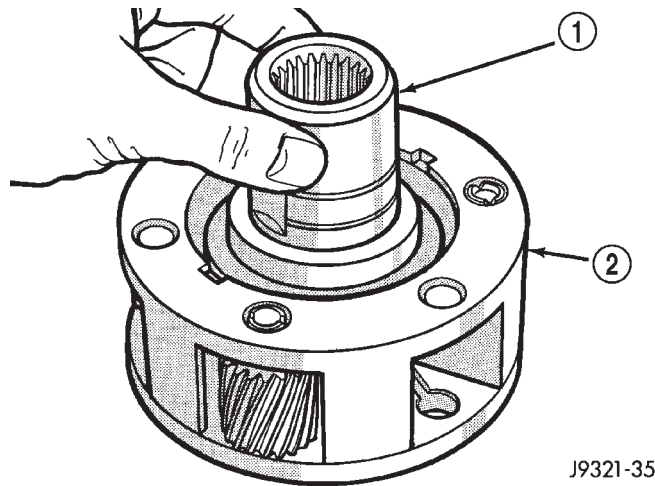

Fig. 38 Input Gear Removal

- 1 - INPUT GEAR
- 2 - LOW RANGE GEAR

J9321-35

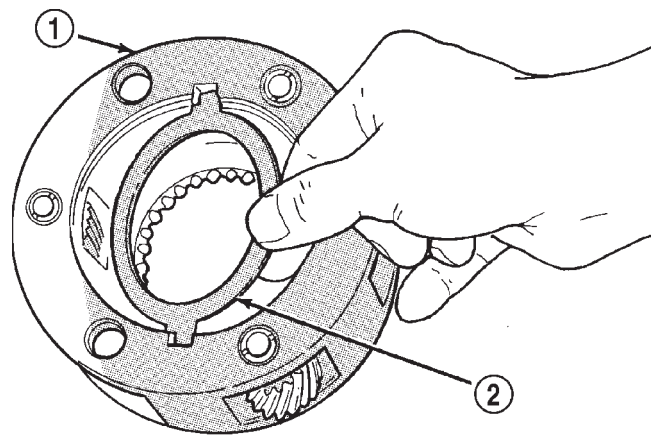

Fig. 39 Rear Tabbed Thrust Washer Removal

- 1 - LOW RANGE GEAR
- 2 - REAR TABBED THRUST WASHER

J9321-36

ASSEMBLY

Lubricate transfer case components with Mopar® Dexron II automatic transmission fluid or petroleum jelly (where indicated) during assembly.

BEARING AND SEAL INSTALLATION

CAUTION: The bearing bores in various transfer case components contain oil feed holes. Make sure replacement bearings do not block the holes.

- (1) Remove the front output shaft seal from case with pry tool (Fig. 40).
- (2) Remove the front output shaft bearing retaining ring with screwdriver (Fig. 41).
- (3) Remove bearing with Tool Handle C-4171 and Tool 5065 (Fig. 42).

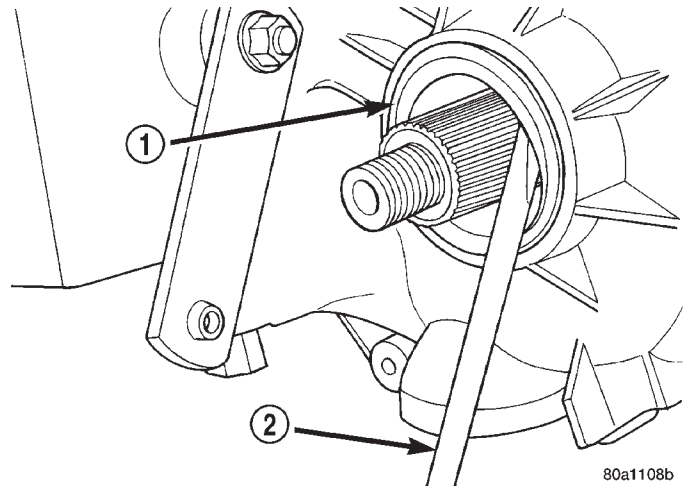

Fig. 40 Front Output Seal Removal

- 1 - OUTPUT SHAFT SEAL
- 2 - PRYBAR

80a1108b

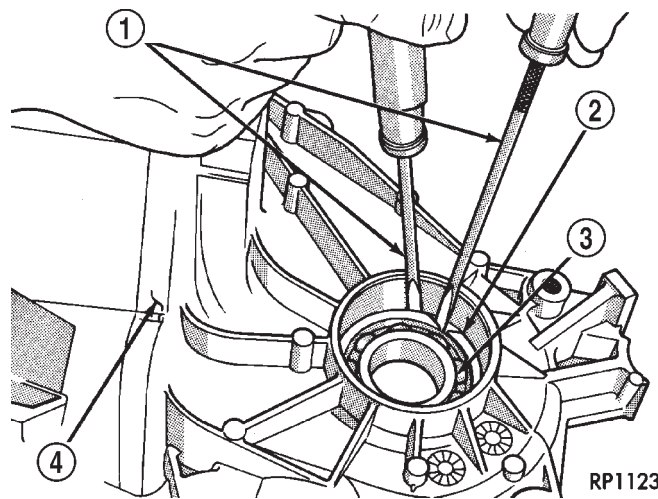

Fig. 41 Front Output Shaft Bearing Retaining Ring Removal

- 1 - SCREWDRIVERS
- 2 - SNAP RING
- 3 - FRONT OUTPUT SHAFT BEARING
- 4 - FRONT CASE

RP1123

DISASSEMBLY AND ASSEMBLY (Continued)

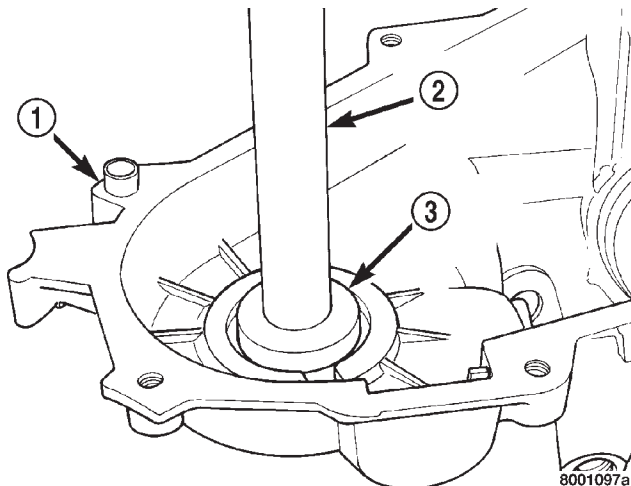

Fig. 42 Front Output Shaft Bearing Removal

- 1 - FRONT CASE
- 2 - SPECIAL TOOL C-4171
- 3 - SPECIAL TOOL 5065

(4) Install front output shaft front bearing in case with Tool Handle C-4171 and Installer 5064 (Fig. 43).

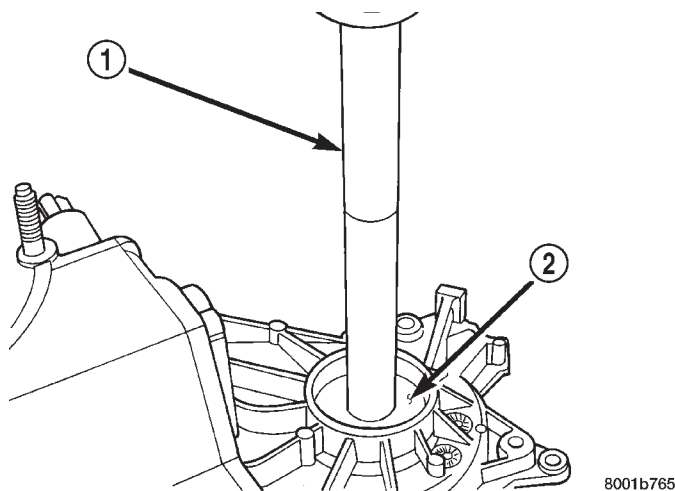

Fig. 43 Front Output Shaft Bearing Installation

- 1 - SPECIAL TOOL C-4171
- 2 - SPECIAL TOOL 5064

(5) Install output shaft front bearing retaining ring (Fig. 44). Start ring into place by hand. Then use small screwdriver to work ring into case groove. Be sure ring is fully seated before proceeding.

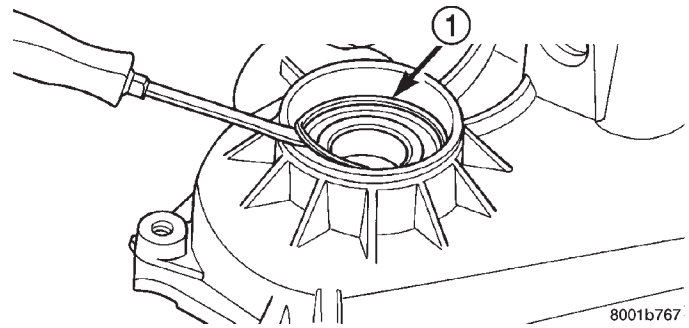

Fig. 44 Installing Output Shaft Front Bearing Retaining Ring

- 1 - WORK RETAINING RING INTO BORE GROOVE WITH SMALL SCREWDRIVER

(6) Install new front output seal in front case with Installer Tool 8143 as follows:

(a) Place new seal on tool. **Garter spring on seal goes toward interior of case.**

(b) Start seal in bore with light taps from hammer (Fig. 45). Once seal is started, continue tapping seal into bore until installer tool bottoms against case.

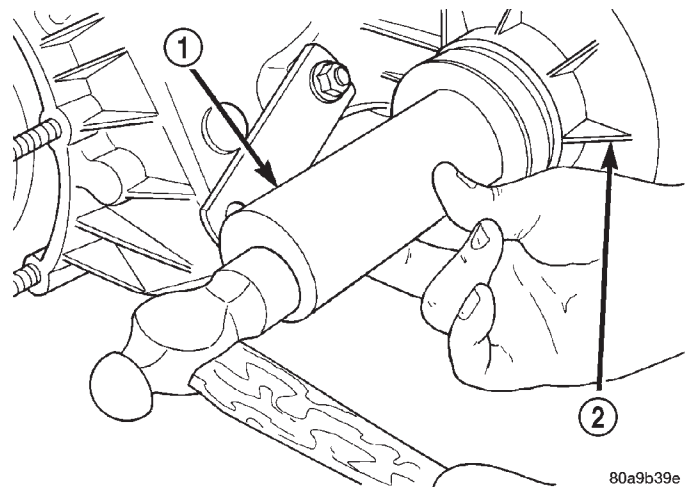

Fig. 45 Front Output Seal Installation

- 1 - INSTALLER 8143
- 2 - TRANSFER CASE

(7) Remove the output shaft rear bearing with the screw and jaws from Remover L-4454 and Cup 8148 (Fig. 46).

(8) Install new bearing with Tool Handle C-4171 and Installer 5066 (Fig. 47). The bearing bore is chamfered at the top. Install the bearing so it is flush with the lower edge of this chamfer (Fig. 48).

DISASSEMBLY AND ASSEMBLY (Continued)

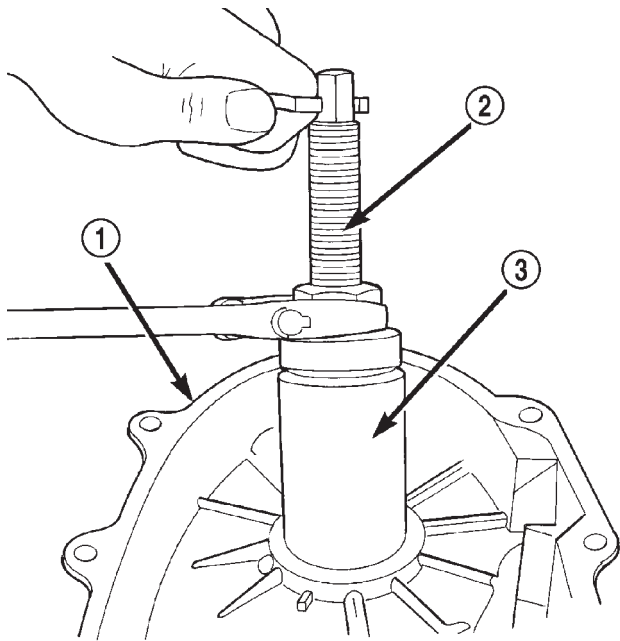

80a98366

Fig. 46 Output Shaft Rear Bearing Removal

- 1 - REAR CASE
- 2 - SPECIAL TOOL L-4454-1 AND L-4454-3
- 3 - SPECIAL TOOL 8148

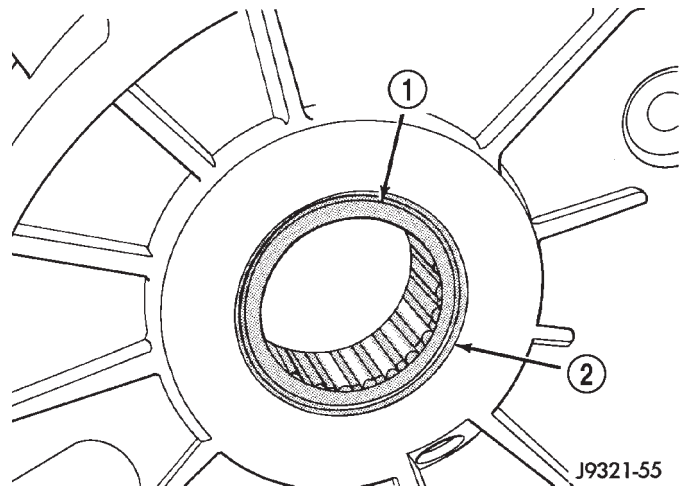
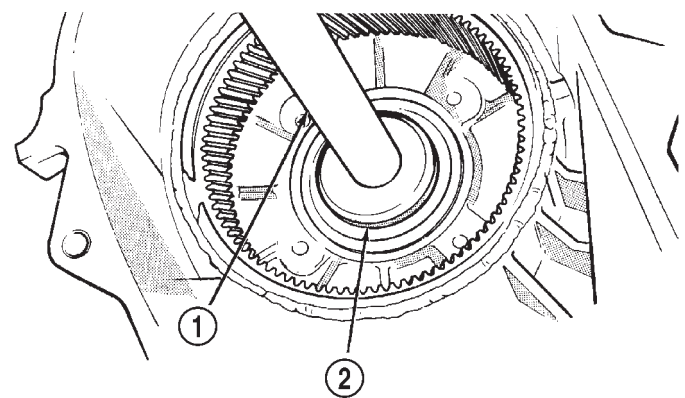

Fig. 48 Output Shaft Rear Bearing Installation Depth

- 1 - BEARING (SEATED) AT LOWER EDGE OF CHAMFER
- 2 - CHAMFER

(9) Using Remover C-4210 and Handle C-4171, drive input shaft bearing from inside the annulus gear opening in the case. (Fig. 49).



J9521-43

Fig. 49 Input Shaft Bearing Removal

- 1 - SPECIAL TOOL C-4171
- 2 - SPECIAL TOOL C-4210

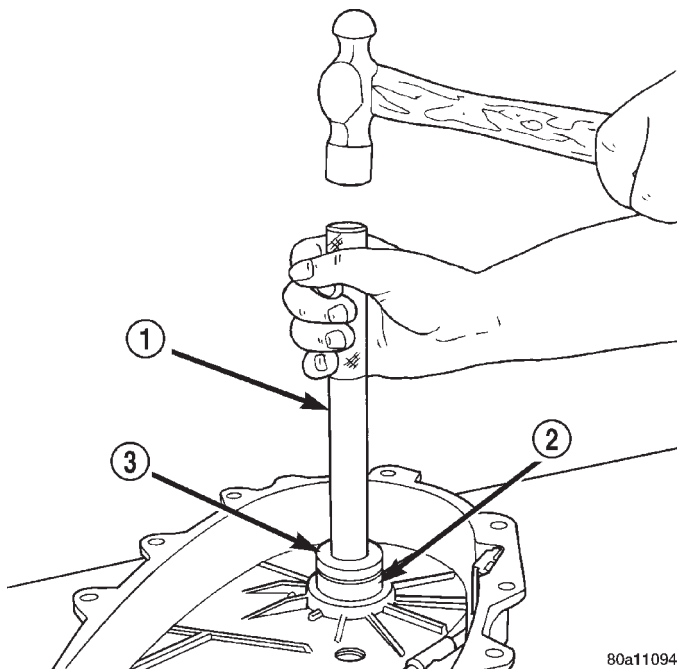

80a11094

Fig. 47 Output Shaft Rear Bearing Installation

- 1 - HANDLE C-4171
- 2 - OUTPUT SHAFT INNER BEARING
- 3 - INSTALLER 5066

(10) Install locating ring on new bearing.
 (11) Position case so forward end is facing upward.
 (12) Using Remover C-4210 and Handle C-4171, drive input shaft bearing into case. The bearing locating ring must be fully seated against case surface (Fig. 50).

(13) Remove input gear pilot bearing by inserting a suitably sized drift into the splined end of the input gear and driving the bearing out with the drift and a hammer (Fig. 51).

(14) Install new pilot bearing with Installer 5065 and Handle C-4171 (Fig. 52).

DISASSEMBLY AND ASSEMBLY (Continued)

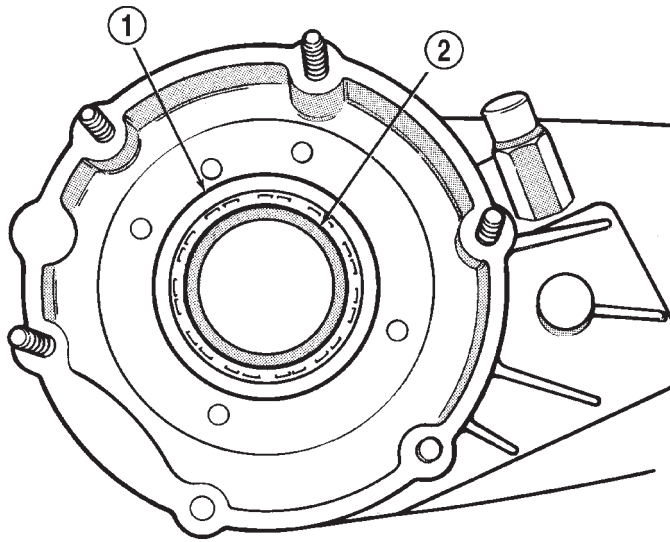

J8921-219

Fig. 50 Seating Input Shaft Bearing

- 1 - SNAP RING
- 2 - INPUT SHAFT BEARING

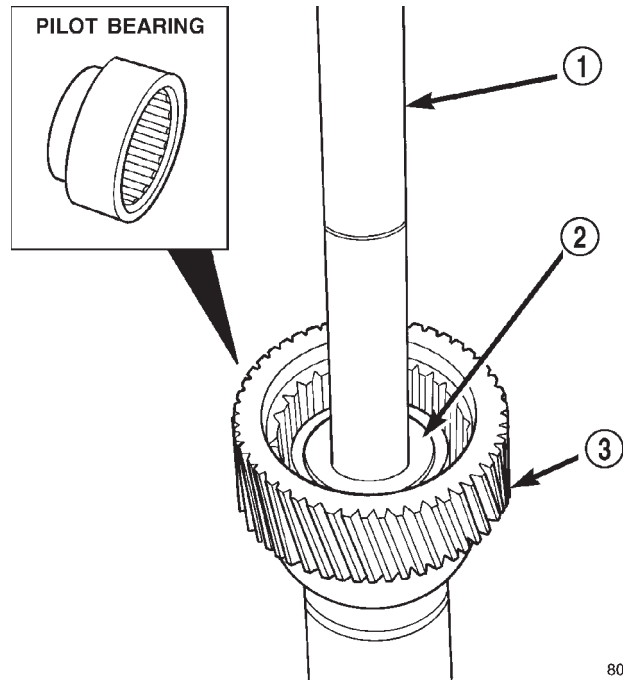

8001b777

Fig. 52 Install Input Gear Pilot Bearing

- 1 - SPECIAL TOOL C-4171
- 2 - SPECIAL TOOL 5065
- 3 - INPUT GEAR

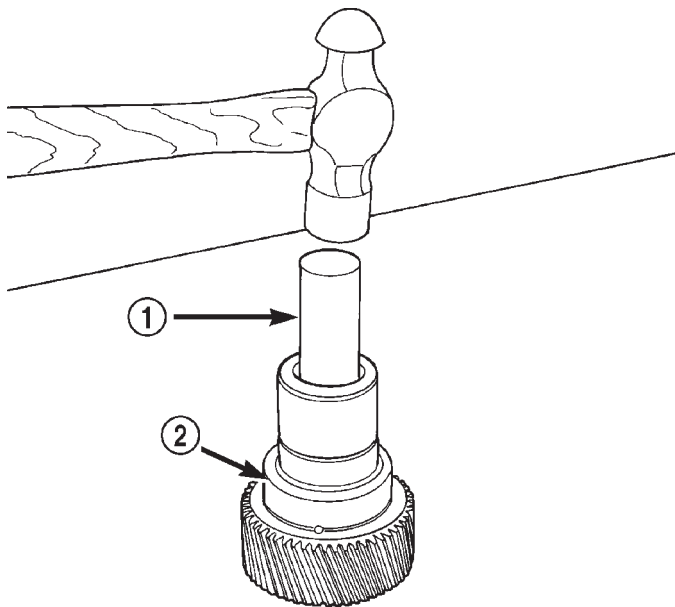

80a11090

Fig. 51 Remove Input Gear Pilot Bearing

- 1 - DRIFT
- 2 - INPUT GEAR

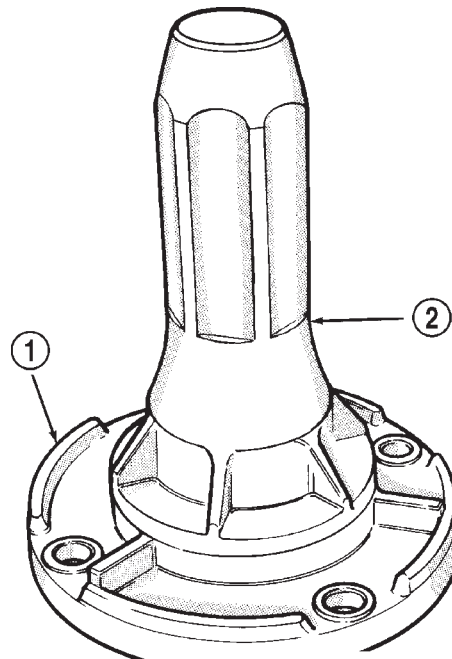

J9521-41

Fig. 53 Install Front Bearing Retainer Seal

- 1 - FRONT BEARING RETAINER
- 2 - SPECIAL TOOL 7884

(15) Remove front bearing retainer seal with suitable pry tool.

(16) Install new front bearing retainer seal with Installer 7884 (Fig. 53).

(17) Remove seal from oil pump housing with a suitable pry tool

DISASSEMBLY AND ASSEMBLY (Continued)

(18) Install new seal in oil pump housing with Installer 7888 (Fig. 54).

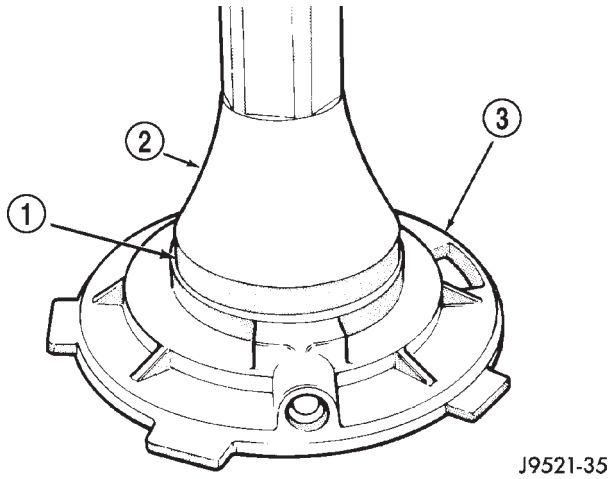

Fig. 54 Oil Pump Seal Installation

- 1 - HOUSING SEAL
- 2 - SPECIAL TOOL 7888
- 3 - OIL PUMP FEED HOUSING

(19) Remove rear retainer bearing with Installer 8128 and Handle C-4171.

(20) Install rear bearing in retainer with Handle C-4171 and Installer 5064 (Fig. 55).

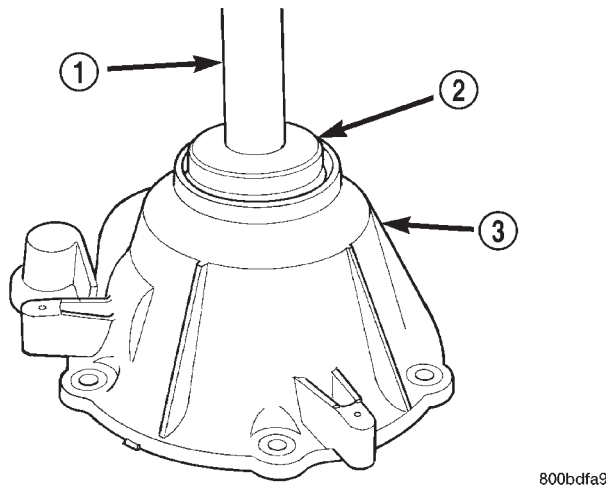

Fig. 55 Installing Rear Bearing In Retainer

- 1 - SPECIAL TOOL C-4171
- 2 - SPECIAL TOOL 5064
- 3 - REAR RETAINER

INPUT AND LOW RANGE GEAR ASSEMBLY

(1) Lubricate gears and thrust washers (Fig. 56) with recommended transmission fluid.

(2) Install first thrust washer in low range gear (Fig. 56). Be sure washer tabs are properly aligned in gear notches.

(3) Install input gear in low range gear. Be sure input gear is fully seated.

(4) Install remaining thrust washer in low range gear and on top of input gear. Be sure washer tabs are properly aligned in gear notches.

(5) Install retainer on input gear and install snap-ring.

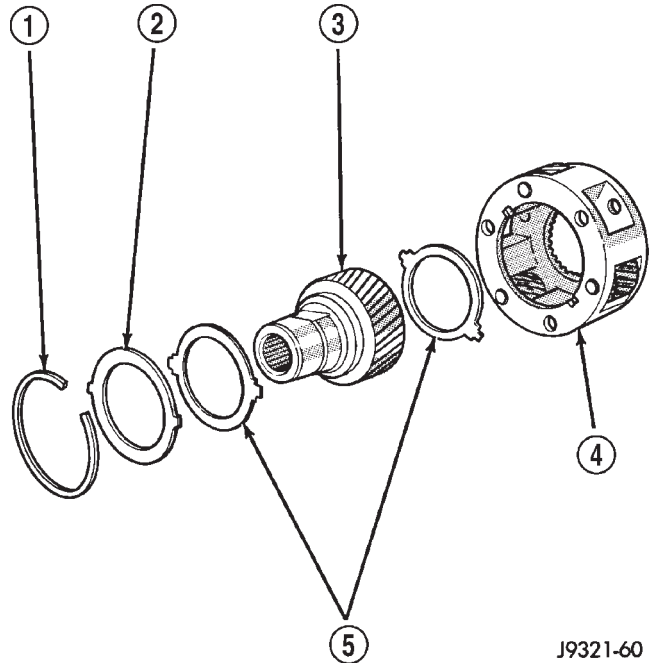

Fig. 56 Input/Low Range Gear Components

- 1 - SNAP RING
- 2 - RETAINER PLATE
- 3 - INPUT GEAR
- 4 - LOW RANGE GEAR
- 5 - THRUST WASHERS

INPUT GEAR AND LOW RANGE GEAR INSTALLATION

(1) Align and install low range/input gear assembly in front case (Fig. 57). Be sure low range gear pinions are engaged in annulus gear and that input gear shaft is fully seated in front bearing.

(2) Install snap-ring to hold input/low range gear into front bearing (Fig. 58).

(3) Clean gasket sealer residue from retainer and inspect retainer for cracks or other damage.

(4) Apply a 3 mm (1/8 in.) bead of Mopar® gasket maker or silicone adhesive to sealing surface of retainer.

(5) Align cavity in seal retainer with fluid return hole in front of case.

CAUTION: Do not block fluid return cavity on sealing surface of retainer when applying Mopar® gasket maker or silicone adhesive sealer. Seal failure and fluid leak can result.

(6) Install bolts to hold retainer to transfer case (Fig. 59). Tighten to 21 N·m (16 ft. lbs.) of torque.

DISASSEMBLY AND ASSEMBLY (Continued)

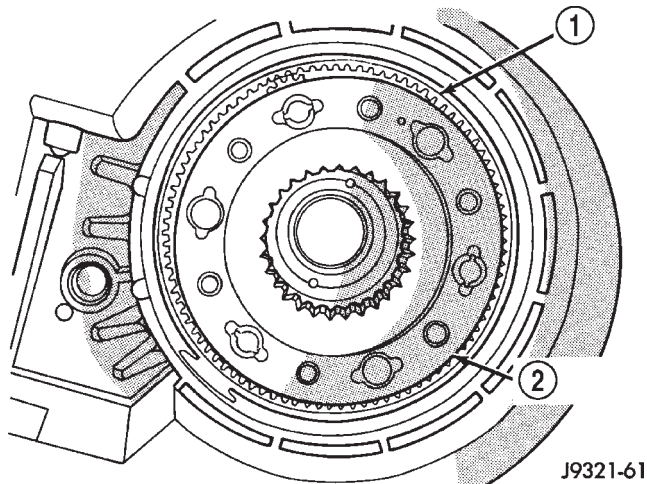
**Fig. 57 Input/Low Range Gear Installation**

- 1 - ANNULUS GEAR
2 - INPUT/LOW RANGE GEAR

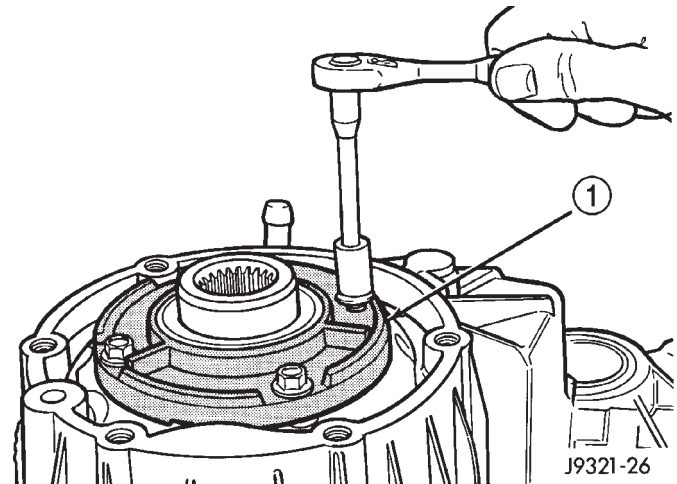
**Fig. 59 Install Front Bearing Retainer**

- 1 - FRONT BEARING RETAINER

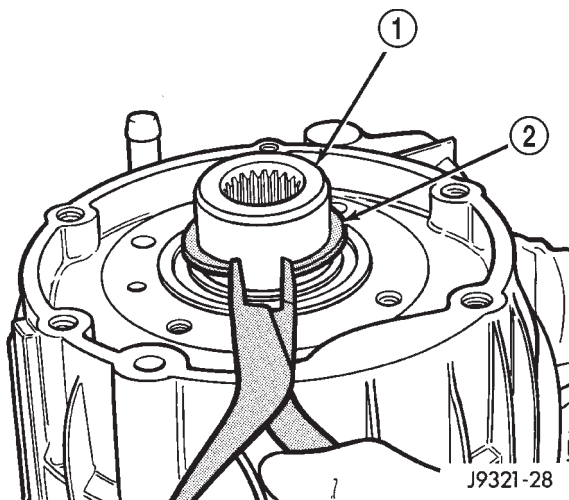
**Fig. 58 Install Snap-Ring**

- 1 - INPUT GEAR
2 - SNAP RING

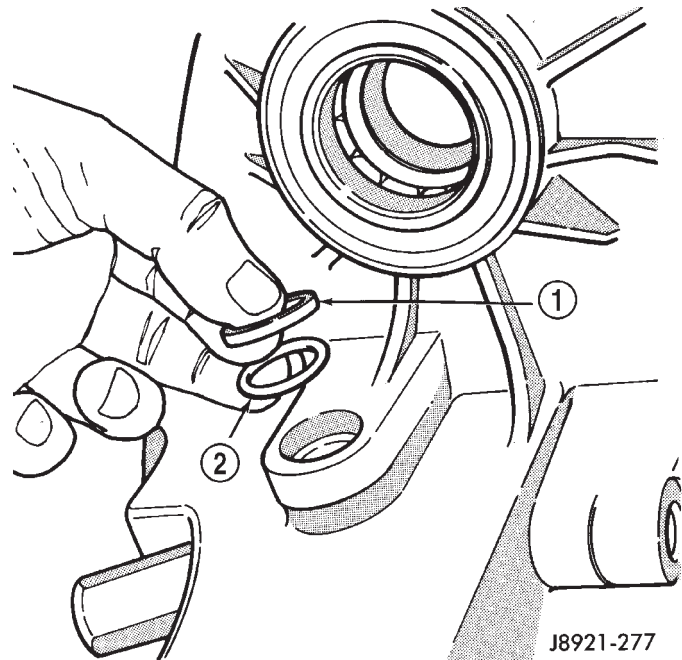
**Fig. 60 Sector O-Ring And Bushing Installation**

- 1 - SECTOR BUSHING
2 - O-RING

MAINSHAFT ASSEMBLY

- (1) Lubricate mainshaft splines with recommended transmission fluid.
- (2) Slide drive sprocket onto mainshaft.
- (3) Slide mode hub onto mainshaft.
- (4) Install mode hub retaining ring. Verify that the retaining ring is fully seated in mainshaft groove.

SHIFT FORKS AND MAINSHAFT INSTALLATION

- (1) Install new sector shaft O-ring and bushing (Fig. 60).
- (2) Install shift sector in case (Fig. 61). Lubricate sector shaft with transmission fluid before installation.

- (3) Install range lever, washer, and nut on sector shaft (Fig. 62). Tighten range lever nut to 27–34 N.m (20–25 ft. lbs.) torque.

- (4) Assemble and install range fork and hub (Fig. 63). Be sure hub is properly seated in low range gear and engaged to the input gear.

- (5) Align and insert range fork pin in shift sector slot.

- (6) Install assembled mainshaft (Fig. 64). Be sure shaft is seated in pilot bearing and input gear.

- (7) Install new pads on mode fork if necessary.

DISASSEMBLY AND ASSEMBLY (Continued)

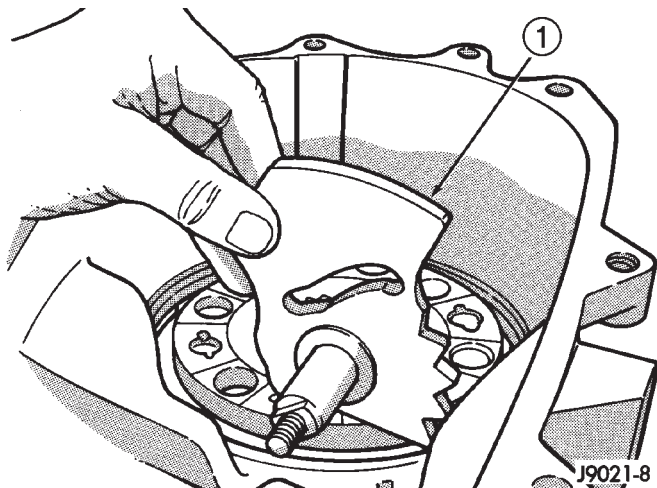
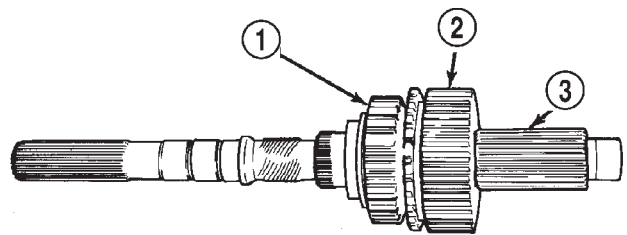

Fig. 61 Shift Sector Installation

- 1 - SHIFT SECTOR



8001096c

Fig. 64 Mainshaft Assembly Installation

- 1 - DRIVE SPROCKET
- 2 - MODE HUB
- 3 - MAINSHAFT

(8) Insert mode sleeve in mode fork mode fork. Be sure long side of sleeve is toward long end of shift rail (Fig. 65).

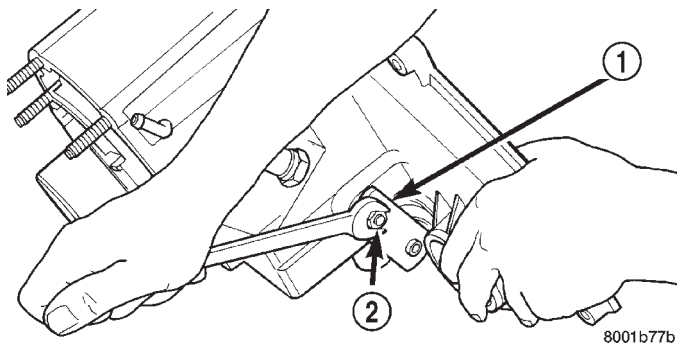

Fig. 62 Range Lever Installation

- 1 - RANGE LEVER
- 2 - LEVER NUT

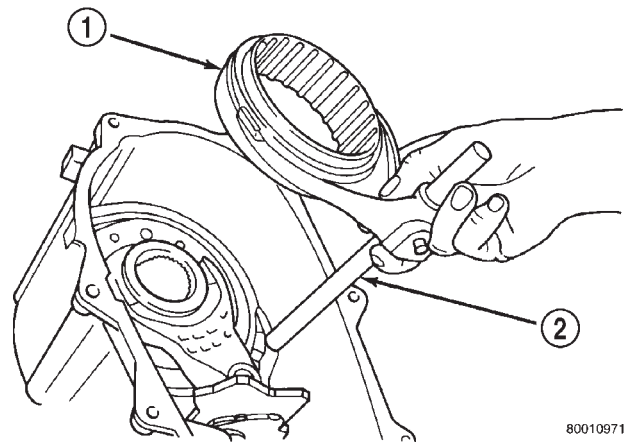

Fig. 65 Assembling Mode Fork And Sleeve

- 1 - MODE SLEEVE
- 2 - MODE FORK AND RAIL

(9) Install assembled mode fork and sleeve (Fig. 66). Be sure fork rail goes through range fork and into case bore. Also be sure sleeve is aligned and seated on mainshaft hub.

(10) Rotate sector to Neutral position.

(11) Install new O-ring on detent plug (Fig. 67).

(12) Lubricate detent plunger with transmission fluid or light coat of petroleum jelly.

(13) Install detent plunger, spring and plug (Fig. 67).

(14) Verify that plunger is properly engaged in sector.

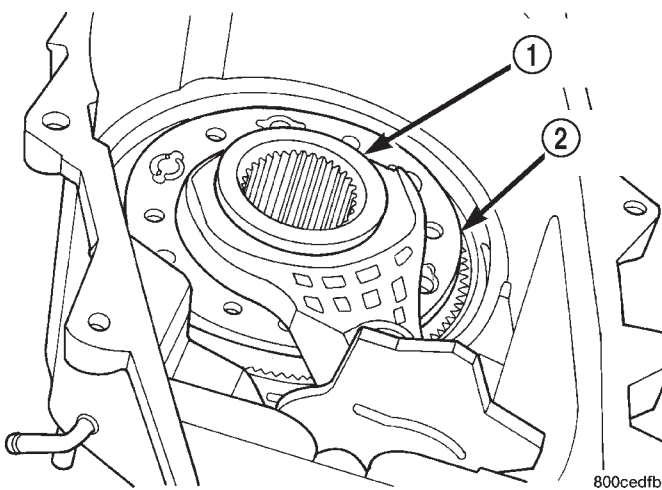

Fig. 63 Install Range Fork And Hub Assembly

- 1 - RANGE HUB
- 2 - RANGE FORK

FRONT OUTPUT SHAFT AND DRIVE CHAIN INSTALLATION

(1) Lubricate front output shaft-sprocket assembly, drive chain, and drive sprocket with transmission fluid.

DISASSEMBLY AND ASSEMBLY (Continued)

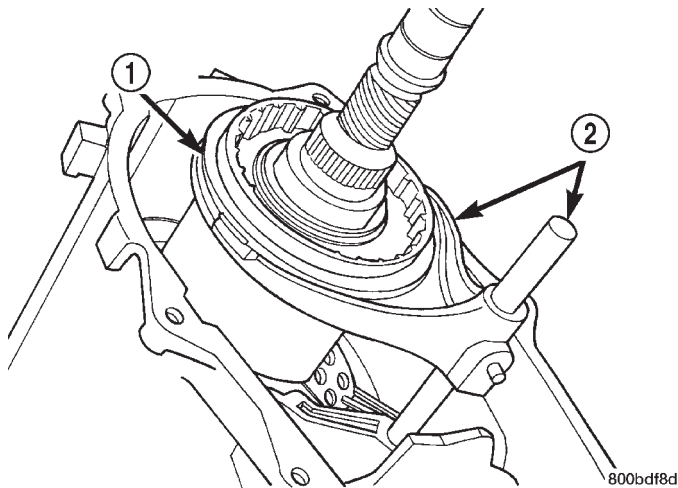

Fig. 66 Mode Fork And Sleeve Installation

- 1 - MODE SLEEVE
- 2 - MODE FORK AND RAIL

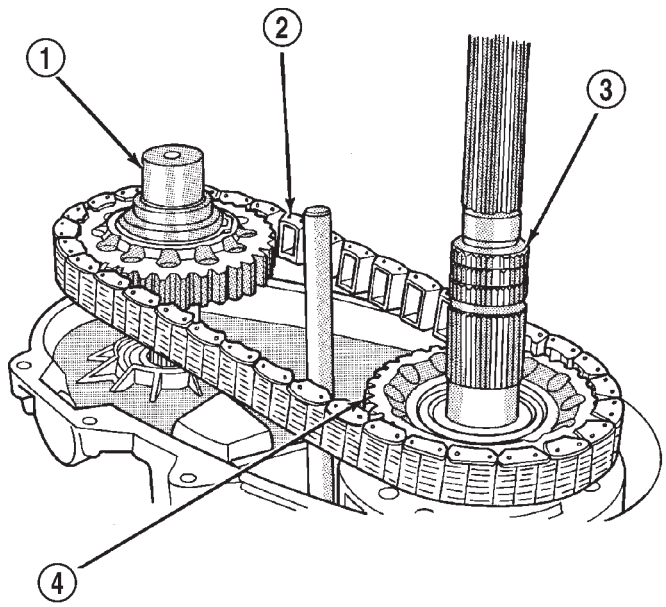

Fig. 68 Installing Drive Chain And Front Output Shaft

- 1 - FRONT OUTPUT SHAFT
- 2 - DRIVE CHAIN
- 3 - MAINSHAFT
- 4 - DRIVE SPROCKET

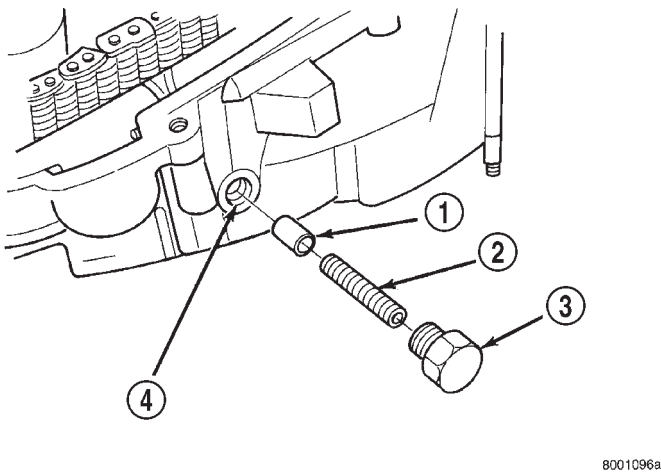

Fig. 67 Shift Detent Components

- 1 - POPPET
- 2 - SPRING
- 3 - SCREW
- 4 - POPPET BORE (IN CASE)

(2) Assemble drive chain and front output shaft (Fig. 68).

(3) Start chain on mainshaft drive sprocket.

(4) Guide front shaft into bearing and drive sprocket onto mainshaft drive gear (Fig. 68).

(5) Install mode spring on upper end of mode fork shift rail (Fig. 69).

OIL PUMP AND REAR CASE ASSEMBLY/INSTALLATION

(1) Install magnet in front case pocket (Fig. 70).

(2) Assemble oil pickup screen, connecting hose, and tube.

(3) Install new pickup tube O-ring in oil pump (Fig. 71).

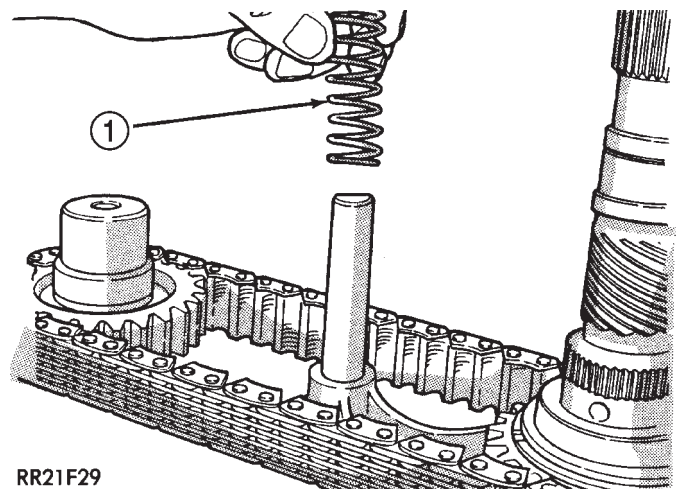

Fig. 69 Install Mode Fork Spring

- 1 - MODE SPRING

(4) Insert oil pickup tube in oil pump inlet.

(5) Position assembled oil pump and pickup tube in rear case. Be sure pickup screen is securely seated in case slot. Also be sure oil pump locating tabs are outside rear case (Fig. 72).

(6) Apply 3 mm (1/8 in.) wide bead of Mopar® gasket maker or silicone adhesive sealer to mounting

DISASSEMBLY AND ASSEMBLY (Continued)

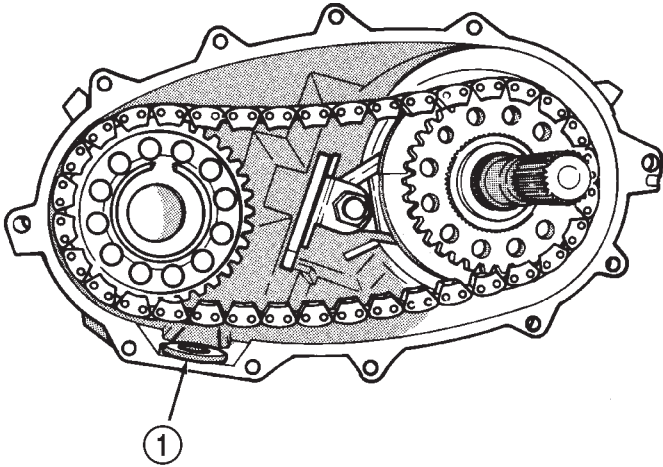

J8921-288

Fig. 70 Installing Case Magnet

- 1 - MAGNET

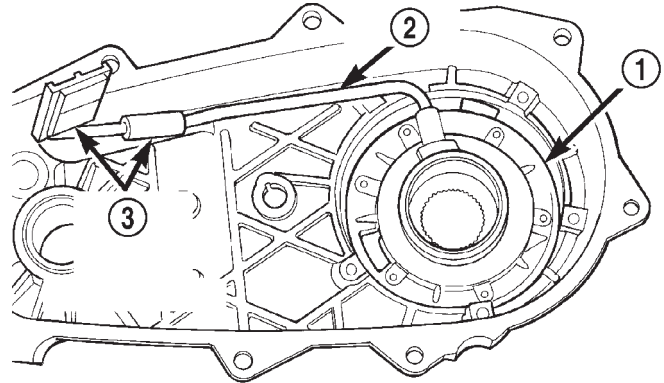

800bdf98

Fig. 72 Oil Pump And Pickup Tube Installation

- 1 - OIL PUMP
2 - PICKUP TUBE
3 - PICKUP SCREEN AND CONNECTOR

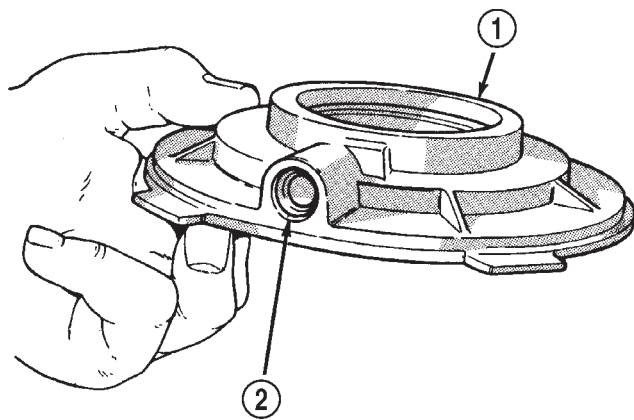

RR21F27

Fig. 71 Pickup Tube O-Ring Position

- 1 - OIL PUMP
2 - O-RING

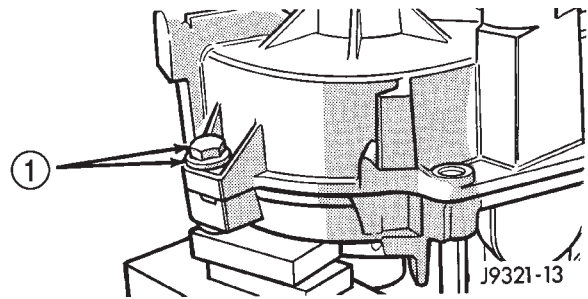

J9321-13

Fig. 73 Alignment Bolt Location

- 1 - ALIGNMENT BOLT AND WASHER (AT EACH END OF CASE)

flange of front case. Work sealer bead around bolt holes.

(7) Lift rear case and oil pump and carefully position assembly on front case. Be sure case dowels are aligned and that mode fork rail extends through rear case before seating rear case on front case.

(8) Install case attaching bolts. Alignment bolts at each end of case are only ones requiring washers (Fig. 73).

(9) Tighten case bolts to 27-34 N·m (20-25 ft. lbs.) torque.

YOKE AND RANGE LEVER INSTALLATION

(1) Install indicator switch in front case. Tighten switch to 20-34 N·m (15-25 ft. lbs.) torque.

(2) Install range lever, washer and locknut on sector shaft (Fig. 74). Tighten locknut to 27-34 N·m (20-25 ft. lbs.) torque.

(3) Install new seal washer on front output shaft (Fig. 76).

(4) Lubricate yoke hub with transmission fluid and install yoke on front shaft.

(5) Install new seal washer on front shaft.

(6) Install yoke and new yoke nut on front output shaft (Fig. 75).

(7) Tighten yoke nut to 122-176 N·m (90-130 ft. lbs.) torque. Use Tool C-3281, or similar tool to hold yoke while tightening yoke nut.

REAR RETAINER INSTALLATION

(1) Apply bead of Mopar® Sealer P/N 82300234, or Loctite® Ultra Gray, to mating surface of rear retainer. Sealer bead should be a maximum of 3/16 inch.

(2) Install rear retainer on rear case. Tighten retainer bolts to 20-27 N·m (15-20 ft. lbs.) torque.

(3) Install rear bearing I. D. retaining ring and spacer on output shaft.

DISASSEMBLY AND ASSEMBLY (Continued)

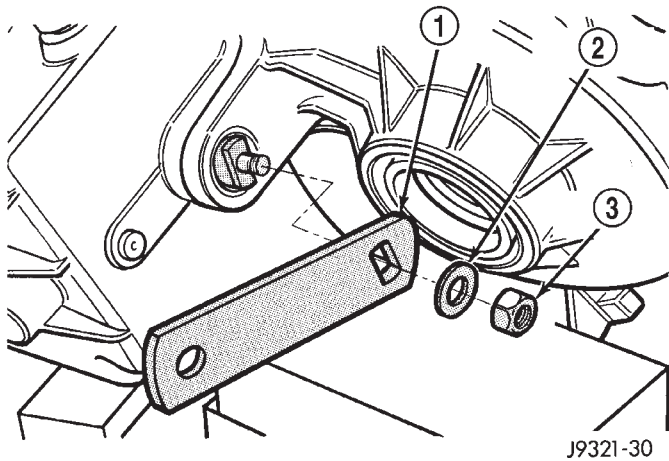

Fig. 74 Range Lever Installation

- 1 - RANGE LEVER
- 2 - WASHER
- 3 - LOCKNUT

J9321-30

(4) Apply liberal quantity of petroleum jelly to new rear seal and to output shaft. Petroleum jelly is needed to protect seal lips during installation.

(5) Slide seal onto Seal Protector 6992 (Fig. 77). Slide seal protector and seal onto output shaft.

(6) Slide Installer C-4076-B onto seal protector with the recessed side of the tool toward the seal. Drive seal into rear bearing retainer with Installer C-4076-B and Handle MD-998323 (Fig. 78).

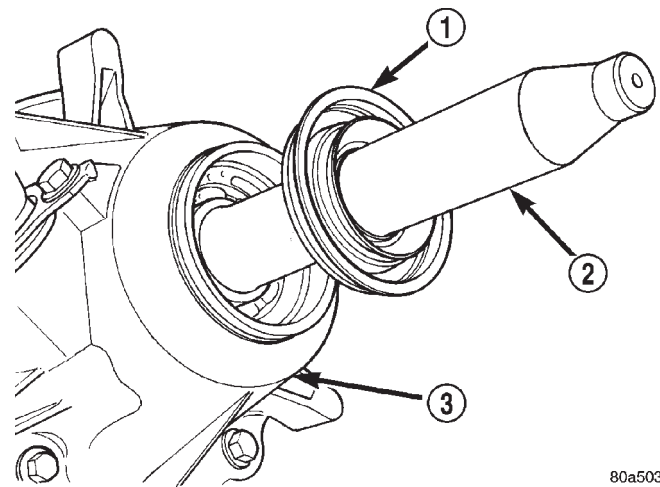

Fig. 77 Output Shaft Seal and Protector

- 1 - OUTPUT SHAFT SEAL
- 2 - SPECIAL TOOL 6992
- 3 - TRANSFER CASE

80a50355

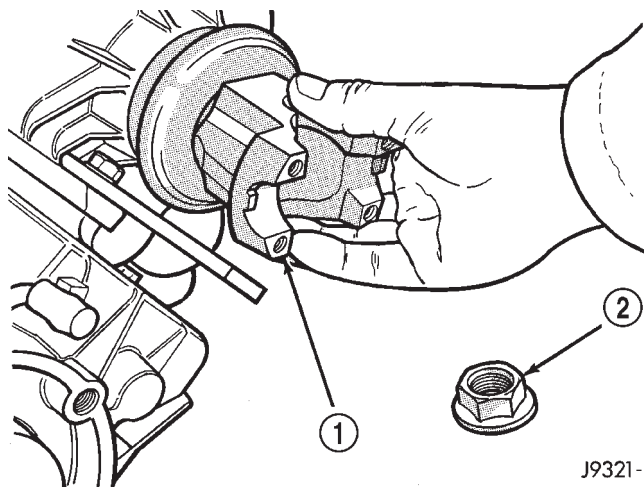

Fig. 75 Output Shaft Yoke Installation

- 1 - OUTPUT SHAFT YOKE
- 2 - YOKE NUT

J9321-1

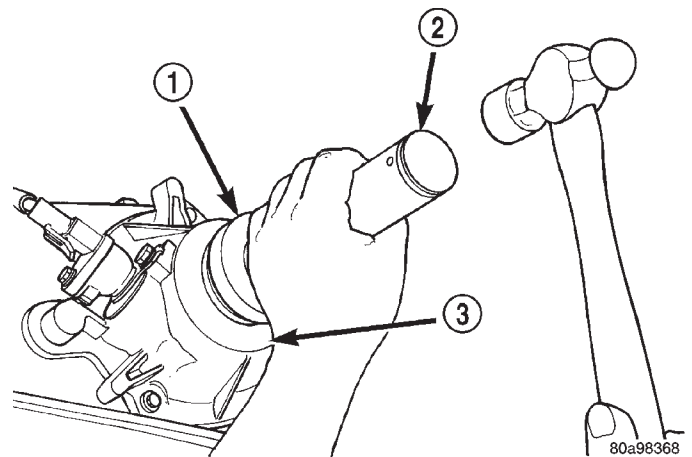

Fig. 78 Rear Seal Installation

- 1 - SPECIAL TOOL C-4076-B
- 2 - SPECIAL TOOL MD998323
- 3 - TRANSFER CASE

80a98368

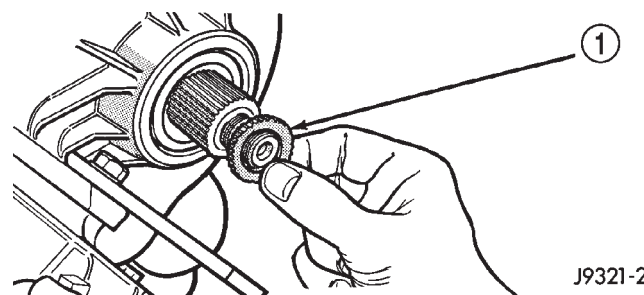

Fig. 76 Yoke Seal Washer Installation

- 1 - YOKE SEAL WASHER

J9321-2

(7) Install rear slinger with Installer 8408.

(8) Install boot on output shaft slinger and crimp retaining clamp with tool C-4975-A (Fig. 79).

CLEANING AND INSPECTION (Continued)

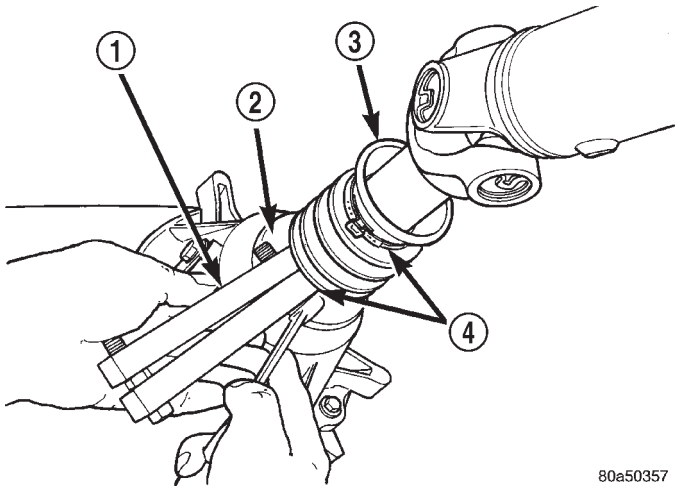

80a50357

Fig. 79 Slinger Boot Installation

- 1 - SPECIAL TOOL C-4975-A
- 2 - SLINGER
- 3 - BOOT
- 4 - CLAMP

CLEANING AND INSPECTION

NV231 TRANSFER CASE

Clean the transfer case parts with a standard parts cleaning solvent. Remove all traces of sealer from the cases and retainers with a scraper and 3M all purpose cleaner. Use compressed air to remove solvent residue from oil feed passages in the case halves, retainers, gears, and shafts.

The oil pickup screen can be cleaned with solvent. Shake excess solvent from the screen after cleaning and allow it to air dry. Do not use compressed air.

MAINSHAFT/SPROCKET/HUB INSPECTION

Inspect the splines on the hub and shaft and the teeth on the sprocket (Fig. 80). Minor nicks and scratches can be smoothed with an oilstone. However, replace any part that is damaged.

Check the contact surfaces in the sprocket bore and on the mainshaft. Minor nicks and scratches can be smoothed with 320-400 grit emery cloth but do not try to salvage the shaft if nicks or wear is severe.

INPUT GEAR AND PLANETARY CARRIER

Check the teeth on the gear (Fig. 81). Minor nicks can be dressed off with an oilstone but replace the gear if any teeth are broken, cracked, or chipped. The bearing surface on the gear can be smoothed with 300-400 grit emery cloth if necessary.

Examine the carrier body and pinion gears for wear or damage. The carrier will have to be replaced as an assembly if the body, pinion pins, or pinion gears are damaged.

Check the lock ring and both thrust washers for wear or cracks. Replace them if necessary. Also replace the lock retaining ring if bent, distorted, or broken.

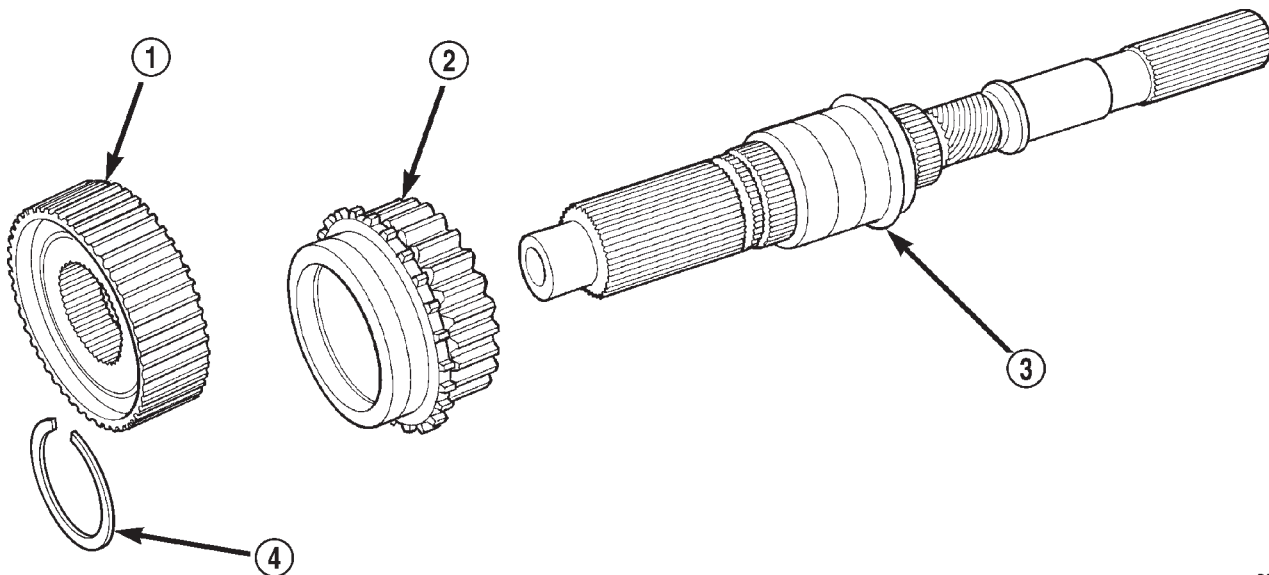

80c070b9

Fig. 80 Mainshaft, Mode Hub, And Drive Sprocket

- 1 - MODE HUB
- 2 - DRIVE SPROCKET
- 3 - MAINSHAFT
- 4 - MODE HUB RETAINING RING

CLEANING AND INSPECTION (Continued)

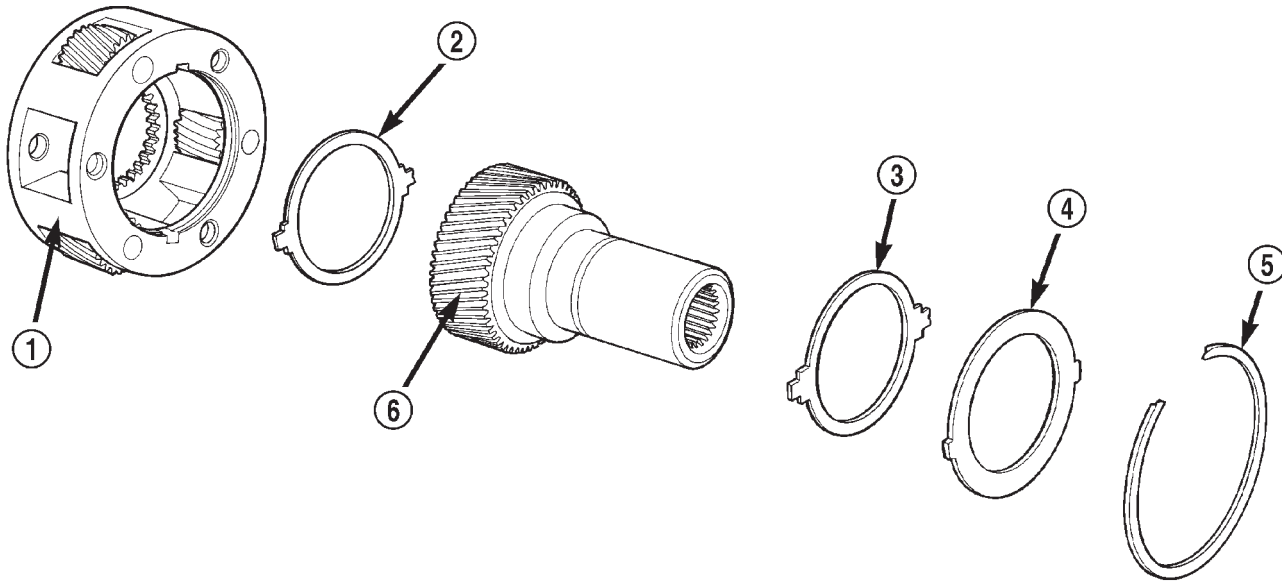

8001b75f

Fig. 81 Input Gear And Carrier Components

- | | |
|-------------------------|---------------------------------|
| 1 - PLANETARY CARRIER | 4 - CARRIER LOCK RING |
| 2 - REAR THRUST WASHER | 5 - CARRIER LOCK RETAINING RING |
| 3 - FRONT THRUST WASHER | 6 - INPUT GEAR |

SHIFT FORKS/HUBS/SLEEVES

Check condition of the shift forks and mode fork shift rail (Fig. 82). Minor nicks on the shift rail can be smoothed with 320-400 grit emery cloth.

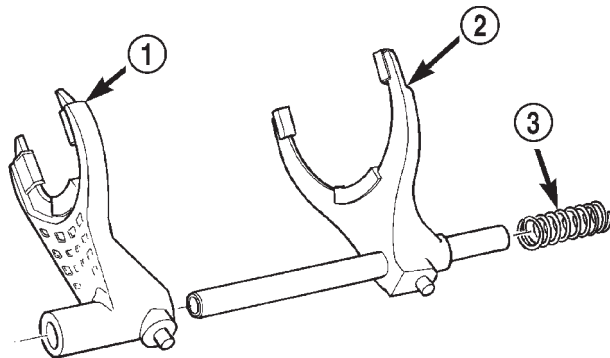

80010948

Fig. 82 Shift forks

- | |
|------------------------|
| 1 - RANGE FORK |
| 2 - MODE FORK AND RAIL |
| 3 - MODE SPRING |

The fork must be replaced as an assembly if the pads are worn or damaged.

Check both of the sleeves for wear or damage, especially on the interior teeth. Replace the sleeves if wear or damage is evident.

REAR RETAINER/BEARING/ SEAL/SLINGER/BOOT

Inspect the retainer components (Fig. 84). Replace the bearing if rough or noisy. Check the retainer for

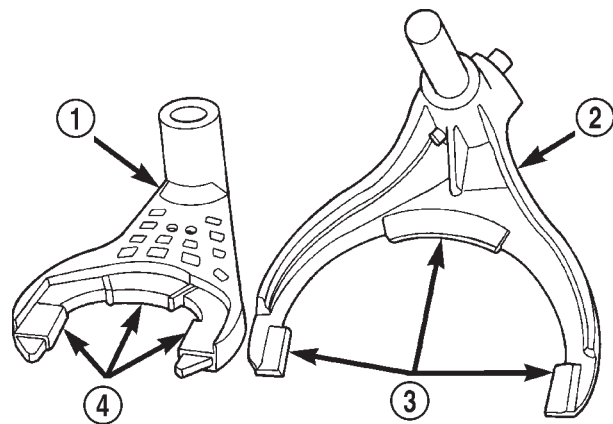

8001097c

Fig. 83 Shift Fork And Wear Pad Locations

- | |
|---------------------------------|
| 1 - RANGE FORK |
| 2 - MODE FORK |
| 3 - WEAR PADS (SERVICEABLE) |
| 4 - WEAR PADS (NON-SERVICEABLE) |

Inspect the shift fork wear pads (Fig. 83). The mode fork pads are serviceable and can be replaced if necessary. The range fork pads are not serviceable.

CLEANING AND INSPECTION (Continued)

cracks or wear in the bearing bore. Clean the retainer sealing surfaces with a scraper and 3M all purpose cleaner. This will ensure proper adhesion of the sealer during reassembly.

Replace the slinger and seal outright; do not reuse either part.

Replace any part if distorted, bent, or broken. Also replace the boot if cut or torn. Replace the boot band clamps, do not reuse them.

REAR OUTPUT SHAFT/YOKE/DRIVE CHAIN

Check condition of the seal contact surfaces of the yoke slinger (Fig. 85). This surface must be clean and smooth to ensure proper seal life. Replace the yoke nut and seal washer as neither part should be reused.

Inspect the shaft threads, sprocket teeth, and bearing surfaces. Minor nicks on the teeth can be smoothed with an oilstone. Use 320–400 grit emery to smooth minor scratches on the shaft bearing surfaces. Rough threads on the shaft can be chased if necessary. Replace the shaft if the threads are damaged, bearing surfaces are scored, or if any sprocket teeth are cracked or broken.

Examine the drive chain and shaft bearings. Replace the chain and both sprockets if the chain is stretched, distorted, or if any of the links bind. Replace the bearings if rough, or noisy.

LOW RANGE ANNULUS GEAR

Inspect annulus gear condition carefully. The gear is only serviced as part of the front case. If the gear is damaged, it will be necessary to replace the gear and front case as an assembly. Do not attempt to remove the gear (Fig. 86)

FRONT-REAR CASES AND FRONT RETAINER

Inspect the cases and retainer for wear and damage. Clean the sealing surfaces with a scraper and 3M all purpose cleaner. This will ensure proper sealer adhesion at assembly. Replace the input retainer seal; do not reuse it.

Check case condition. If leaks were a problem, look for gouges and severe scoring of case sealing surfaces. Also make sure the front case mounting studs are in good condition.

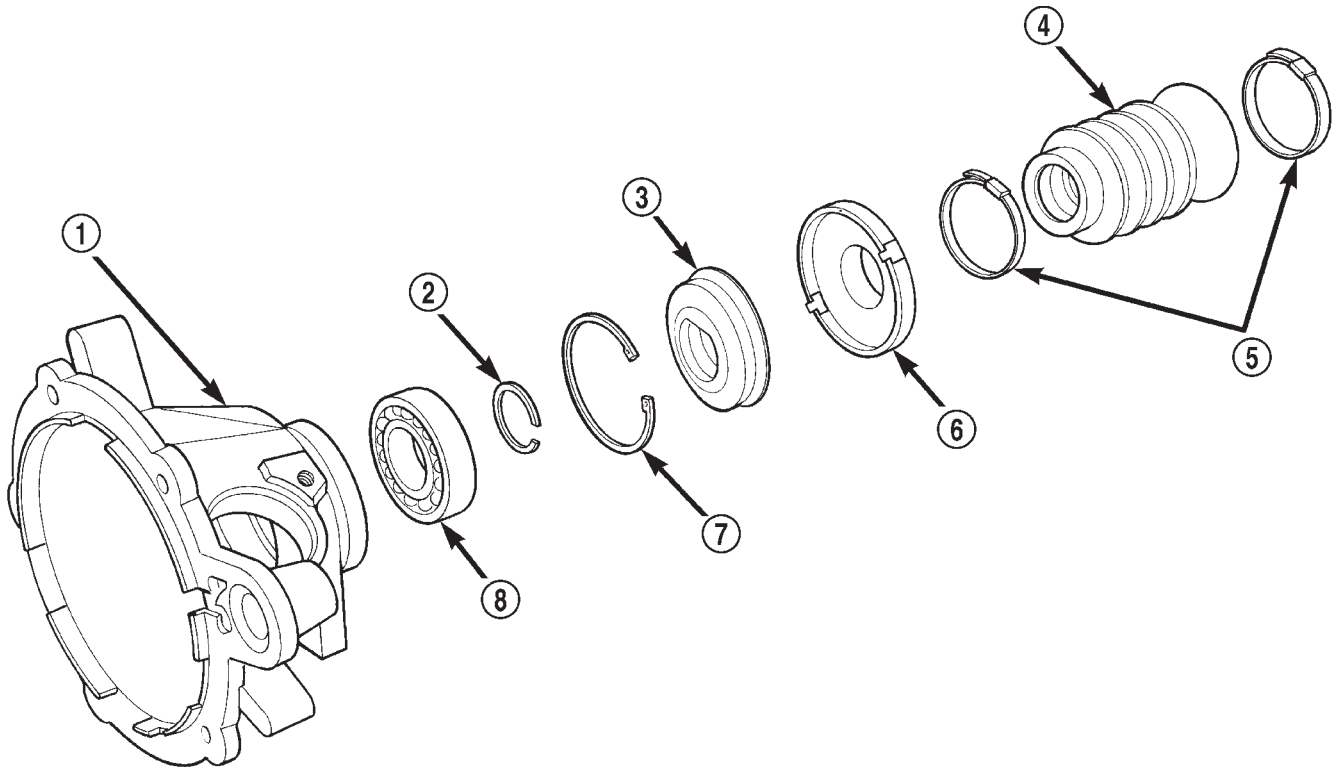
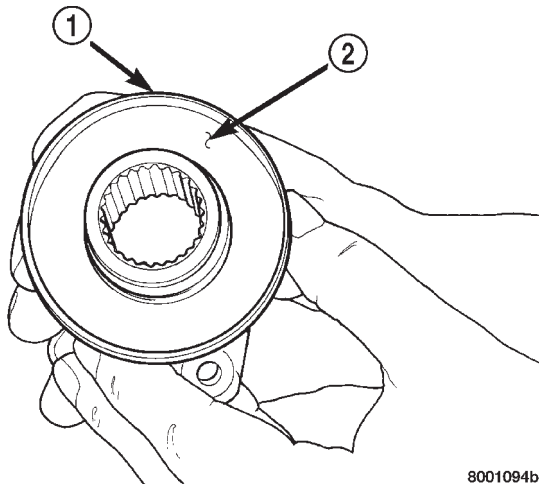

Fig. 84 Rear Retainer Components

- | | |
|---------------------------------------|---------------------------------------|
| 1 - REAR RETAINER | 5 - BAND CLAMPS |
| 2 - REAR BEARING I. D. RETAINING RING | 6 - REAR SLINGER |
| 3 - REAR SEAL | 7 - REAR BEARING O. D. RETAINING RING |
| 4 - BOOT | 8 - REAR BEARING |

CLEANING AND INSPECTION (Continued)



8001094b

Fig. 85 Seal Contact Surface Of Yoke Slinger

- 1 - FRONT SLINGER (PART OF YOKE)
2 - SEAL CONTACT SURFACE MUST BE CLEAN AND SMOOTH

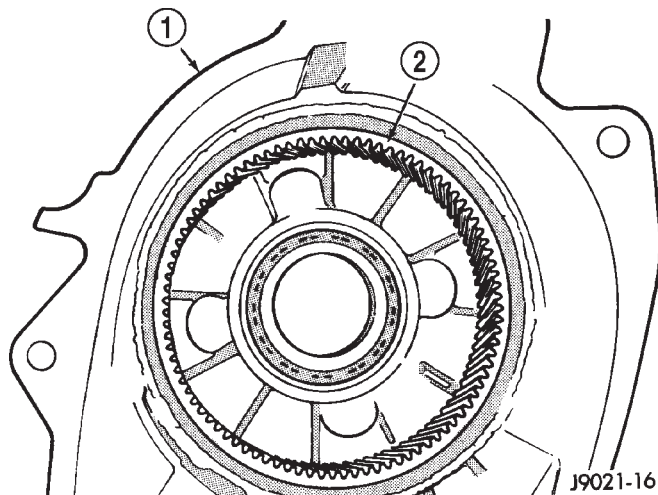

J9021-16

Fig. 86 Low Range Annulus Gear

- 1 - FRONT CASE
2 - LOW RANGE ANNULUS GEAR

Check the front case mounting studs and vent tube. The tube can be secured with Loctite 271 or 680 if loose. The stud threads can be cleaned up with a die if necessary. Also check condition of the fill/drain plug threads in the rear case. The threads can be repaired with a thread chaser or tap if necessary. Or the threads can be repaired with Helicoil stainless steel inserts if required.

OIL PUMP/OIL PICKUP

Examine the oil pump pickup parts. Replace the pump if any part appears to be worn or damaged. Do not disassemble the pump as individual parts are not available. The pump is only available as a complete

assembly. The pickup screen, hose, and tube are the only serviceable parts and are available separately.

ADJUSTMENTS**SHIFT LINKAGE ADJUSTMENT**

- (1) Shift transfer case into 4L position.
- (2) Raise vehicle.
- (3) Loosen lock bolt on adjusting trunnion (Fig. 87).
- (4) Be sure linkage rod slides freely in trunnion. Clean rod and apply spray lube if necessary.
- (5) Verify that transfer case range lever is fully engaged in 4L position.
- (6) Tighten adjusting trunnion lock bolt.
- (7) Lower vehicle.

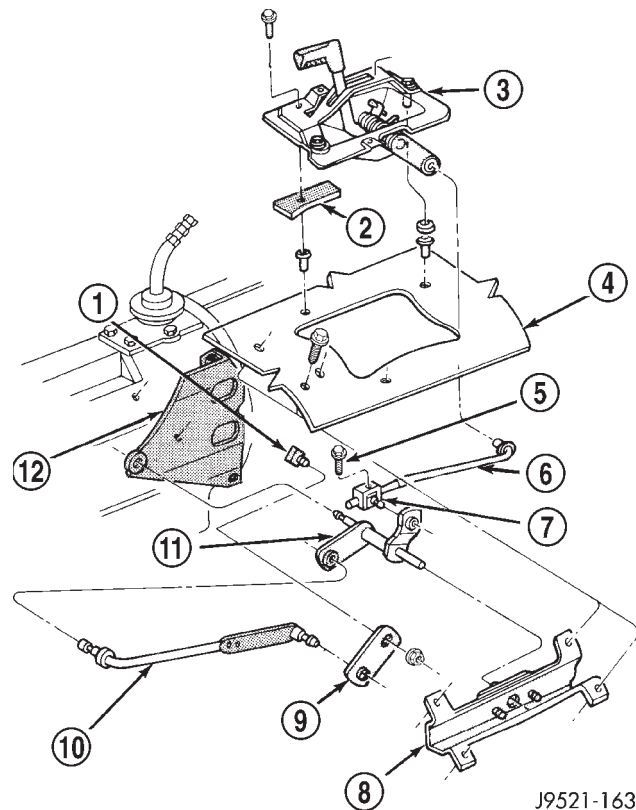

J9521-163

Fig. 87 Shift Linkage

- 1 - TRANSFER CASE SHIFT LEVER SHAFT
2 - SEAL
3 - TRANSFER CASE SHIFT LEVER ASSEMBLY
4 - FLOORPAN
5 - TRUNNION LOCK BOLT
6 - SHIFT ROD
7 - ADJUSTING TRUNNION
8 - TORQUE SHAFT BRACKET
9 - RANGE LEVER
10 - TORQUE SHAFT ROD
11 - TORQUE SHAFT
12 - LINKAGE BRACKET

SPECIFICATIONS

TORQUE

| DESCRIPTION | TORQUE |
|-------------------------------------|-------------------------------|
| Plug, Detent | 16–24 N·m (12–18 ft. lbs.) |
| Plug, Drain/Fill | 20–34 N·m (15–25 ft. lbs.) |
| Bolt, Front Brg. Retainer | 21 N·m (16 ft. lbs.) |
| Bolt, Front Brg. Retainer | 21 N·m (16 ft. lbs.) |
| Bolt, Case Half | 27–34 N·m (20–25 ft. lbs.) |
| Nut, Front Yoke | 122–176 N·m (90–130 ft. lbs.) |
| Nut, Range Lever | 27–34 N·m (20–25 ft. lbs.) |
| Bolt, Rear Retainer | 35–46 N·m (26–34 ft. lbs.) |
| Nuts, Mounting | 35–47 N·m (26–35 ft. lbs.) |
| Switch, Indicator | 20–34 N·m (15–25 ft. lbs.) |

SPECIAL TOOLS

NV231

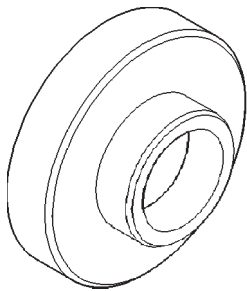

Installer—C-4076-B

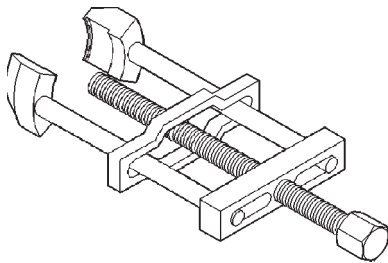

Puller, Slinger—MD-998056-A

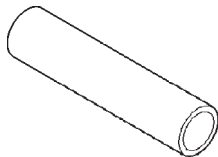

Installer—MD-998323

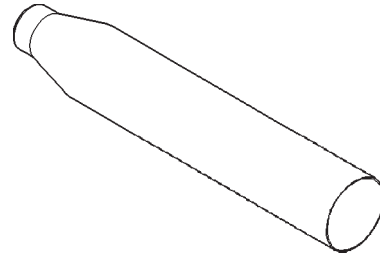

Seal Protector—6992

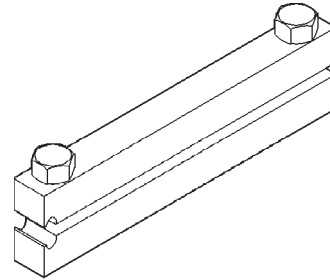

Installer, Boot Clamp—C-4975-A

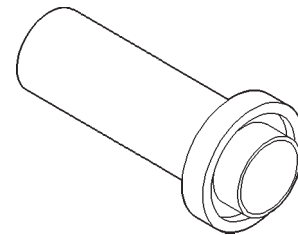

Installer, Seal—8143

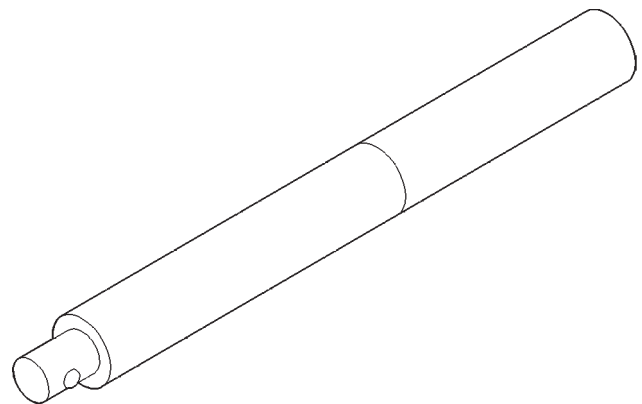

Handle, Universal—C-4171

SPECIAL TOOLS (Continued)

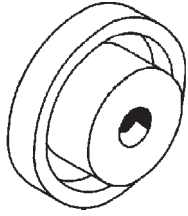

Installer, Seal—C-4210

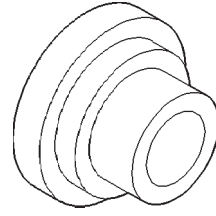

Installer, Bearing—8128

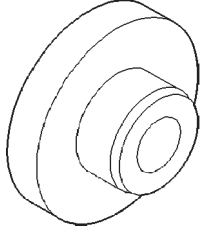

Installer, Bearing—5064

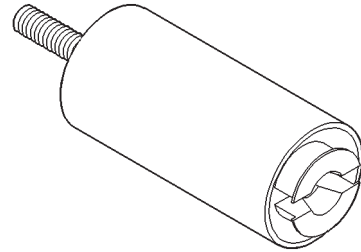

Remover—L-4454

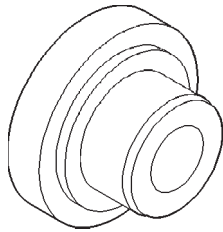

Installer, Bearing—5065

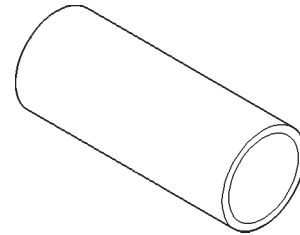

Cup—8148

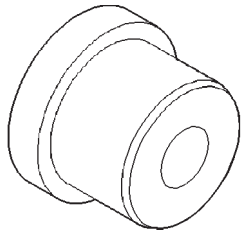

Installer, Bushing—5066

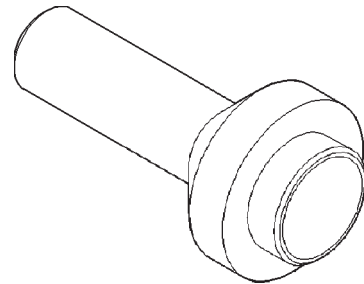

Installer, Seal—7884

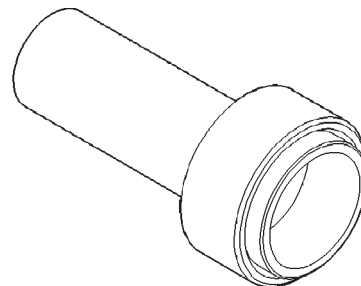

Installer, Pump Housing Seal—7888

NV242 TRANSFER CASE

TABLE OF CONTENTS

| | page | page |
|----------------------------------|------|------|
| DESCRIPTION AND OPERATION | | |
| NV242 TRANSFER CASE..... | 375 | |
| LUBRICANT AND FILL LEVEL..... | 376 | |
| DIAGNOSIS AND TESTING | | |
| NV242 DIAGNOSIS..... | 376 | |
| REMOVAL AND INSTALLATION | | |
| TRANSFER CASE..... | 377 | |
| SHIFT LEVER..... | 377 | |
| SPEEDOMETER..... | 378 | |
| FRONT OUTPUT SHAFT SEAL..... | 379 | |
| DISASSEMBLY AND ASSEMBLY | | |
| NV242 TRANSFER CASE..... | | 380 |
| CLEANING AND INSPECTION | | |
| NV242 TRANSFER CASE..... | | 402 |
| ADJUSTMENTS | | |
| SHIFT LINKAGE ADJUSTMENT..... | | 405 |
| SPECIFICATIONS | | |
| TORQUE..... | | 405 |
| SPECIAL TOOLS | | |
| NV242..... | | 406 |

DESCRIPTION AND OPERATION

NV242 TRANSFER CASE

DESCRIPTION

The NV242 is a full-time transfer case (Fig. 1). It provides full time 2-wheel, or 4-wheel drive operation.

A differential in the transfer case is used to control torque transfer to the front and rear axles. A low range gear provides increased low speed torque capability for off road operation. The low range provides a 2.72:1 reduction ratio.

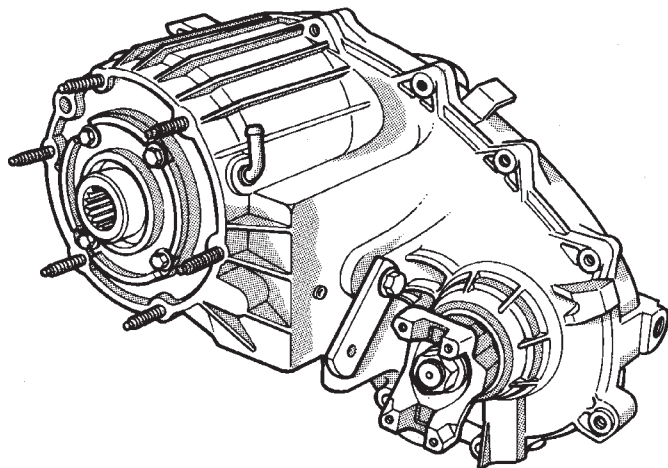

J8921-243

Fig. 1 NV242 Transfer Case

The input gear is splined to the transmission output shaft. It drives the mainshaft through the planetary gear and range hub. The front output shaft is operated by a drive chain that connects the shaft to a

drive sprocket on the mainshaft. The drive sprocket is engaged/disengaged by the mode fork, which operates the mode sleeve and hub. The sleeve and hub are not equipped with a synchro mechanism for shifting.

The geartrain is mounted in two aluminum case halves attached with bolts. The mainshaft front and rear bearings are mounted in aluminum retainer housings bolted to the case halves.

TRANSFER CASE IDENTIFICATION

A circular ID tag is attached to the rear case of each transfer case (Fig. 2). The ID tag provides the transfer case model number, assembly number, serial number, and low range ratio.

The transfer case serial number also represents the date of build.

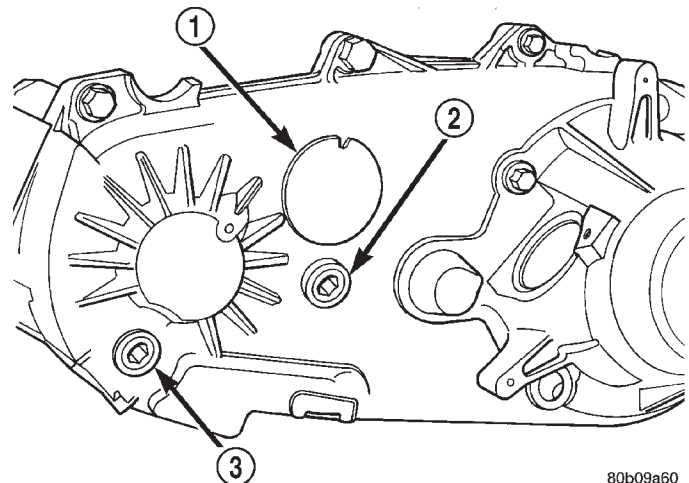

80b09a60

Fig. 2 Fill/Drain Plug And I. D. Tag Locations

- 1 - I. D. TAG
- 2 - FILL PLUG
- 3 - DRAIN PLUG

DESCRIPTION AND OPERATION (Continued)

OPERATING RANGES

NV242 operating ranges are 2WD (2-wheel drive), 4x4 part-time, 4x4 full time, and 4 Lo.

The 2WD and 4x4 full time ranges can be used at any time and on any road surface.

The 4x4 part-time and 4 Lo ranges are for off road use only. The only time these ranges can be used on hard surface roads, is when the surface is covered with snow and ice.

SHIFT MECHANISM

Operating ranges are selected with a floor mounted shift lever. The shift lever is connected to the transfer case range lever by an adjustable linkage rod. A straight line shift pattern is used. Range positions are marked on the shifter bezel cover plate, or on the shift knob.

LUBRICANT AND FILL LEVEL

DESCRIPTION

Recommended lubricant for the NV242 transfer case is Mopar® Dexron II, or ATF Plus, type 7176. Approximate lubricant fill capacity is 1.35 liters (2.85 pints).

The fill and drain plugs are both in the rear case (Fig. 3). Correct fill level is to the bottom edge of the

fill plug hole. Be sure the vehicle is level to ensure an accurate fluid level check.

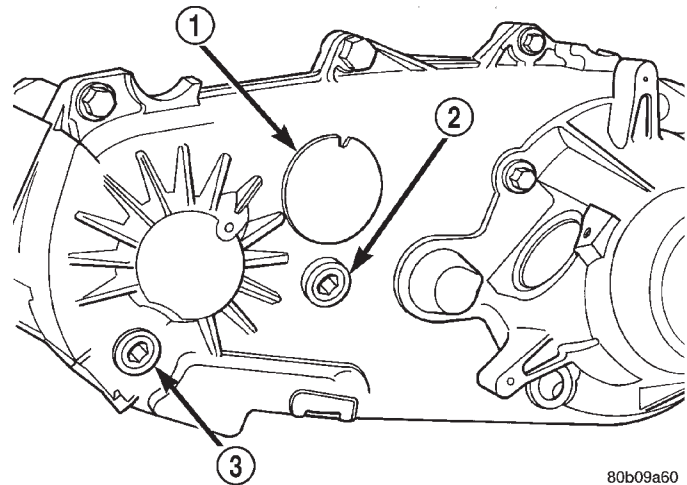

80b09a60

Fig. 3 Fill/Drain Plug Locations

- 1 - I. D. TAG
- 2 - FILL PLUG
- 3 - DRAIN PLUG

DIAGNOSIS AND TESTING

NV242 DIAGNOSIS

DIAGNOSIS CHART

| CONDITION | POSSIBLE CAUSE | CORRECTION |
|--|---|--|
| Transfer case difficult to shift or will not shift into desired range. | 1) Transfer case shift linkage binding. | 1) Repair or replace linkage as necessary. |
| | 2) Insufficient or incorrect lubricant. | 2) Drain and refill transfer case with the correct type and quantity of lubricant. |
| | 3) Internal transfer case components binding, worn, or damaged. | 3) Repair or replace components as necessary. |
| Transfer case noisy in all drive modes. | 1) Insufficient or incorrect lubricant. | 1) Drain and refill transfer case with the correct type and quantity of lubricant. |
| Lubricant leaking from transfer case seals or vent. | 1) Transfer case overfilled. | 1) Drain lubricant to the correct level. |
| | 2) Transfer case vent closed or restricted. | 2) Clean or replace vent as necessary. |
| | 3) Transfer case seals damaged or installed incorrectly. | 3) Replace suspect seal. |

DIAGNOSIS AND TESTING (Continued)

| CONDITION | POSSIBLE CAUSE | CORRECTION |
|---|--|---|
| Transfer case will not shift through 4X4 part time range (light remains on) | 1) Incomplete shift due to drivetrain torque load. | 1) Momentarily release the accelerator pedal to complete the shift. |
| | 2) Incorrect tire pressure. | 2) Correct tire pressure as necessary. |
| | 3) Excessive Tire wear. | 3) Correct tire condition as necessary. |
| | 4) Excessive vehicle loading. | 4) Correct as necessary. |

REMOVAL AND INSTALLATION

TRANSFER CASE

REMOVAL

- (1) Shift transfer case into Neutral.
- (2) Raise vehicle.
- (3) Drain transfer case lubricant.
- (4) Mark front and rear propeller shaft yokes for alignment reference.
- (5) Support transmission with jack stand.
- (6) Remove rear crossmember, or skid plate.
- (7) Disconnect front/rear propeller shafts at transfer case.
- (8) Disconnect vehicle speed sensor wires.
- (9) Disconnect transfer case linkage rod from range lever.
- (10) Disconnect transfer case vent hose (Fig. 4) and indicator switch harness, if necessary.
- (11) Support transfer case with transmission jack.
- (12) Secure transfer case to jack with chains.
- (13) Remove nuts attaching transfer case to transmission.
- (14) Pull transfer case and jack rearward to disengage transfer case.
- (15) Remove transfer case from under vehicle.

INSTALLATION

- (1) Mount transfer case on a transmission jack.
- (2) Secure transfer case to jack with chains.
- (3) Position transfer case under vehicle.
- (4) Align transfer case and transmission shafts and install transfer case on transmission.
- (5) Install and tighten transfer case attaching nuts to 35 N·m (26 ft. lbs.) torque (Fig. 4).
- (6) Connect vehicle speed sensor wires, and vent hose.
- (7) Connect indicator switch harness to transfer case switch, if necessary. Secure wire harness to clips on transfer case.
- (8) Align and connect propeller shafts. Refer to Group 3, Differential and Driveline, for proper procedures and specifications.

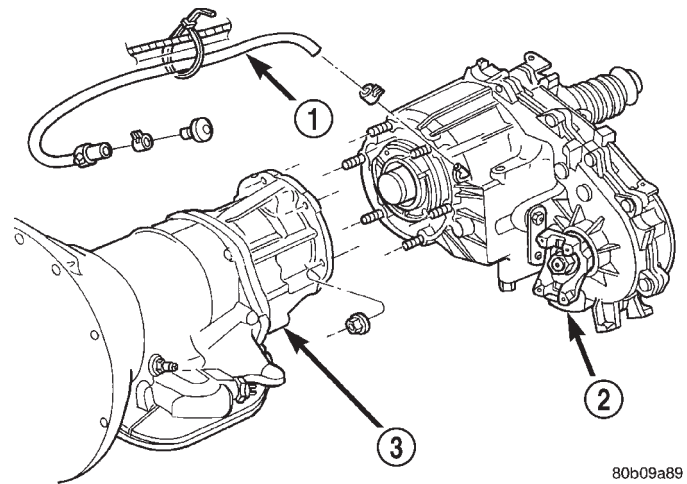

80b09a89

Fig. 4 Transfer Case Mounting

- 1 - VENT TUBE
- 2 - TRANSFER CASE
- 3 - TRANSMISSION

- (9) Fill transfer case with correct fluid. Check transmission fluid level. Correct as necessary.
- (10) Install rear crossmember, or skid plate. Tighten crossmember bolts to 41 N·m (30 ft. lbs.) torque.
- (11) Remove transmission jack and support stand.
- (12) Connect shift rod to transfer case range lever.
- (13) Adjust transfer case shift linkage.
- (14) Lower vehicle and verify transfer case shift operation.

SHIFT LEVER

REMOVAL

- (1) Shift transfer case into 4L.
- (2) Raise vehicle.
- (3) Loosen adjusting trunnion locknut and slide shift rod out of trunnion (Fig. 5). If rod lacks enough travel to come out of trunnion, push trunnion out of torque shaft.
- (4) Lower vehicle.
- (5) Remove console. Refer to Group 23, Body, for proper procedures.

REMOVAL AND INSTALLATION (Continued)

(6) Remove screws attaching lever assembly to floorpan and remove assembly and shift rod (if left attached).

INSTALLATION

(1) If shift rod was not removed from lever assembly, work rod down through floorpan opening. Then position lever assembly on floorpan and install assembly attaching screws.

(2) Install console. Refer to Group 23, Body, for proper procedures.

(3) Raise vehicle.

(4) Connect trunnion to torque shaft arm. Or, slide shift rod into trunnion on range lever. Be sure shift rod slides freely in trunnion.

(5) Verify that range lever is in 4L position. Then tighten trunnion lock bolt.

(6) Lower vehicle and check transfer case shift operation.

SPEEDOMETER

REMOVAL

(1) Raise vehicle.

(2) Disconnect wires from vehicle speed sensor.

(3) Remove adapter clamp and screw (Fig. 6).

(4) Remove speed sensor and speedometer adapter as an assembly.

(5) Remove speed sensor retaining screw and remove sensor from adapter.

(6) Remove speedometer pinion from adapter. Replace pinion if chipped, cracked, or worn.

(7) Inspect sensor and adapter O-rings (Fig. 6). Remove and discard O-rings if worn or damaged.

(8) Inspect terminal pins in speed sensor. Clean pins with Mopar® electrical spray cleaner if dirty or oxidized. Replace sensor if faulty, or if pins are loose, severely corroded, or damaged.

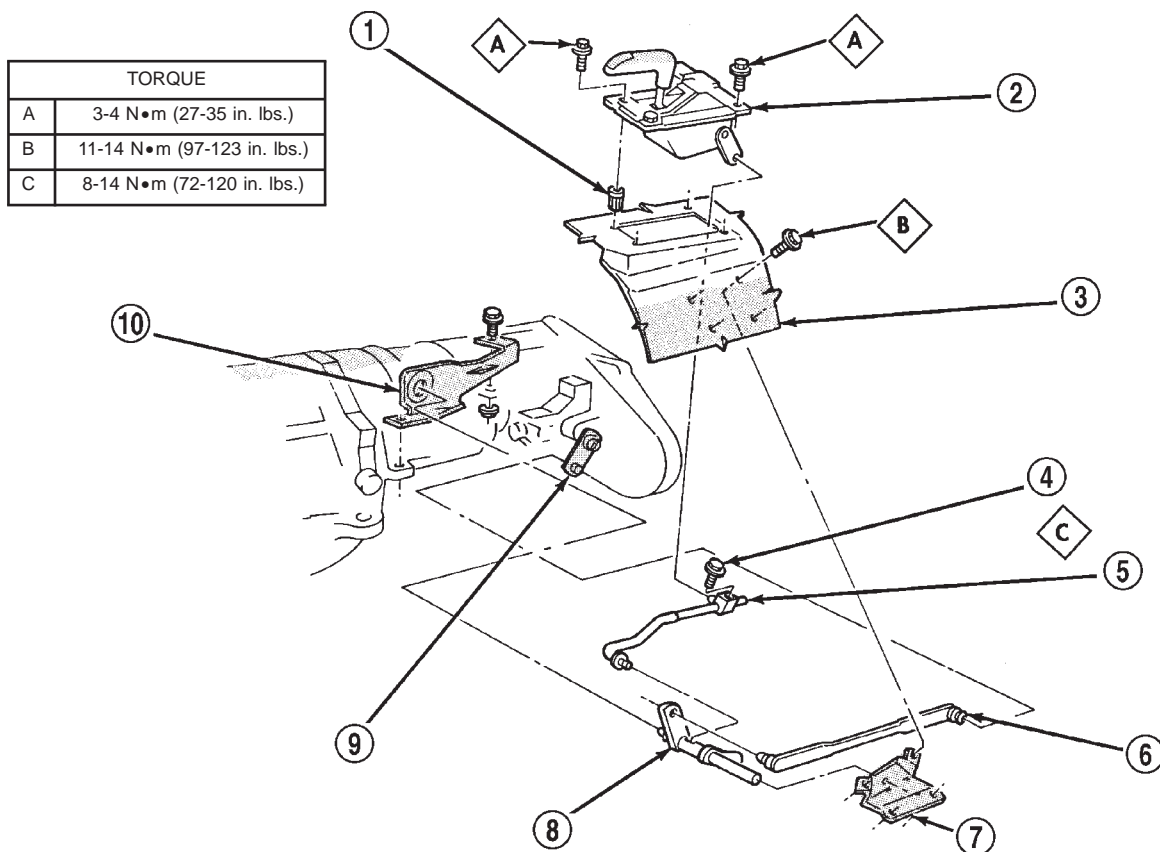

J9321-185

Fig. 5 Shift Linkage

1 - RIVNUT (4)

2 - SHIFT LEVER ASSEMBLY

3 - FLOORPAN

4 - TRUNNION LOCK BOLT

5 - SELECTOR ROD AND TRUNNION

6 - SHIFT LEVER ROD

7 - TORQUE SHAFT FRAME BRACKET

8 - TORQUE SHAFT

9 - TRANSFER CASE SHIFT LEVER

10 - TORQUE SHAFT TRANSFER CASE BRACKET

REMOVAL AND INSTALLATION (Continued)

| ITEM | TORQUE |
|------|-----------------------------|
| A | 2-3 N·m (15-27 in. lbs.) |
| B | 10-12 N·m (90-110 in. lbs.) |

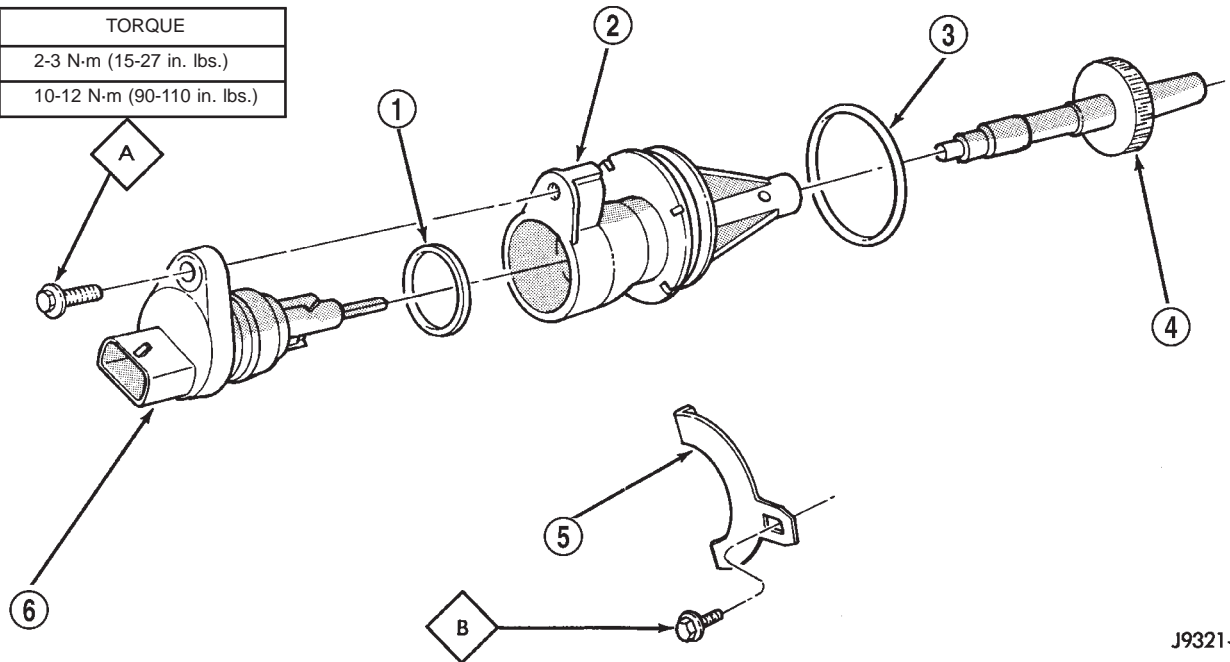

Fig. 6 Speedometer Components

- 1 - SENSOR O-RING
- 2 - SPEEDOMETER ADAPTER
- 3 - ADAPTER O-RING
- 4 - SPEEDOMETER PINION
- 5 - ADAPTER CLAMP
- 6 - VEHICLE SPEED SENSOR

INSTALLATION AND INDEXING

(1) Thoroughly clean adapter flange and adapter mounting surface in housing. Surfaces must be clean for proper adapter alignment and speedometer operation.

(2) Install new O-rings on speed sensor and speedometer adapter (Fig. 6), if necessary.

(3) Lubricate sensor and adapter O-rings with transmission fluid.

(4) Install vehicle speed sensor in speedometer adapter. Tighten sensor attaching screw to 2-3 N·m (15-27 in. lbs.) torque.

(5) Install speedometer pinion in adapter.

(6) Count number of teeth on speedometer pinion. Do this before installing assembly in housing. Then lubricate pinion teeth with transmission fluid.

(7) Note index numbers on adapter body (Fig. 7). These numbers will correspond to number of teeth on pinion.

(8) Install speedometer assembly in housing.

(9) Rotate adapter until required range numbers are at 6 o'clock position. Be sure range index numbers correspond to number of teeth on pinion gear.

(10) Install speedometer adapter clamp and retaining screw. Tighten clamp screw to 10-12 N·m (90-110 in. lbs.) torque.

(11) Connect wires to vehicle speed sensor.

(12) Lower vehicle and top off transmission fluid level if necessary.

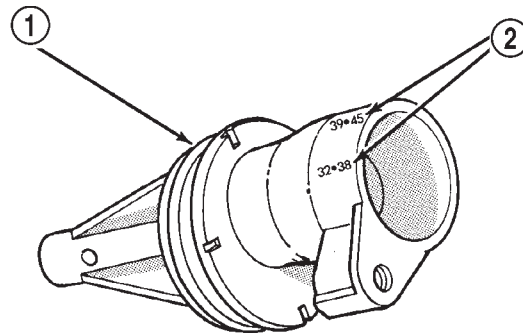

Fig. 7 Location Of Index Numbers On Speedometer Adapter

- 1 - SPEEDOMETER ADAPTER
- 2 - INDEX NUMBER LOCATION

FRONT OUTPUT SHAFT SEAL

REMOVAL

- (1) Raise vehicle.
- (2) Remove front propeller shaft. Refer to Group 3, Differential and Driveline, for proper procedure.

REMOVAL AND INSTALLATION (Continued)

- (3) Remove front output shaft yoke.
- (4) Remove seal from front case with pry tool (Fig. 8).

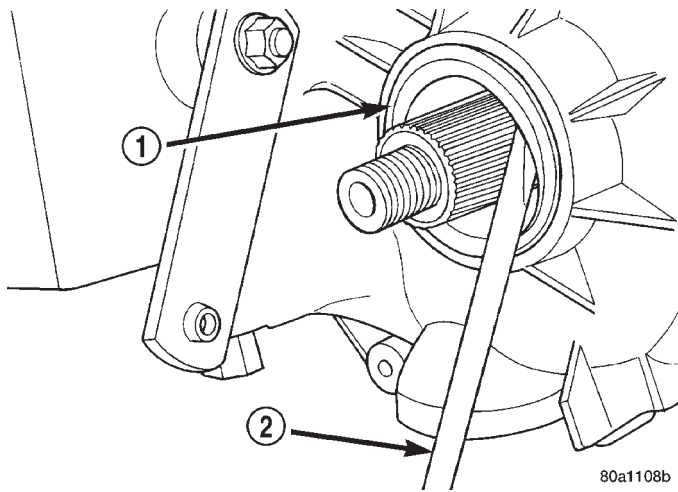

Fig. 8 Remove Front Output Shaft Seal

- 1 - OUTPUT SHAFT SEAL
- 2 - PRYBAR

INSTALLATION

(1) Install new front output seal in front case with Installer Tool 6952-A as follows:

- (a) Place new seal on tool. Garter spring on seal goes toward interior of case.
- (b) Start seal in bore with light taps from hammer (Fig. 9). Once seal is started, continue tapping seal into bore until installer tool seats against case.

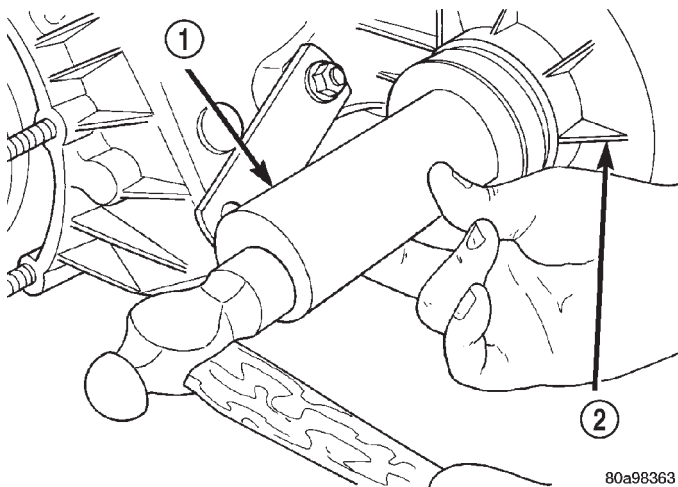

Fig. 9 Front Output Seal Installation

- 1 - INSTALLER 6952-A
- 2 - TRANSFER CASE

DISASSEMBLY AND ASSEMBLY
NV242 TRANSFER CASE

DISASSEMBLY

REAR RETAINER REMOVAL

(1) Remove output shaft boot. Spread band clamp that secures boot on slinger with a suitable awl. Then slide boot off shaft (Fig. 10).

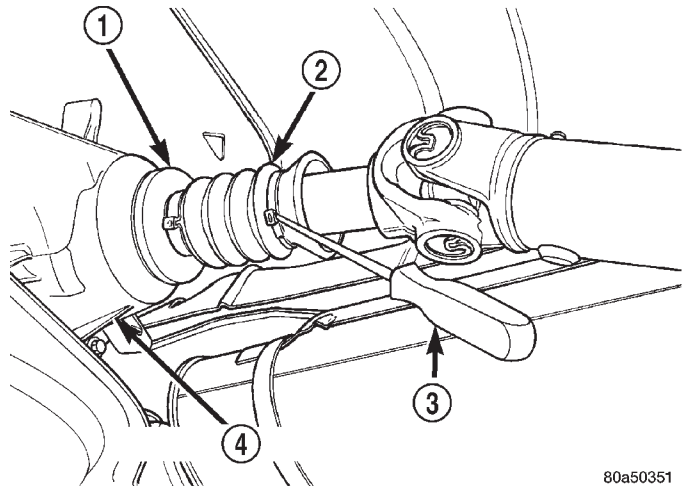

Fig. 10 Output Boot—Typical

- 1 - SLINGER
- 2 - BOOT
- 3 - AWL
- 4 - TRANSFER CASE

(2) Using puller MD-998056-A, remove rear slinger (Fig. 11).

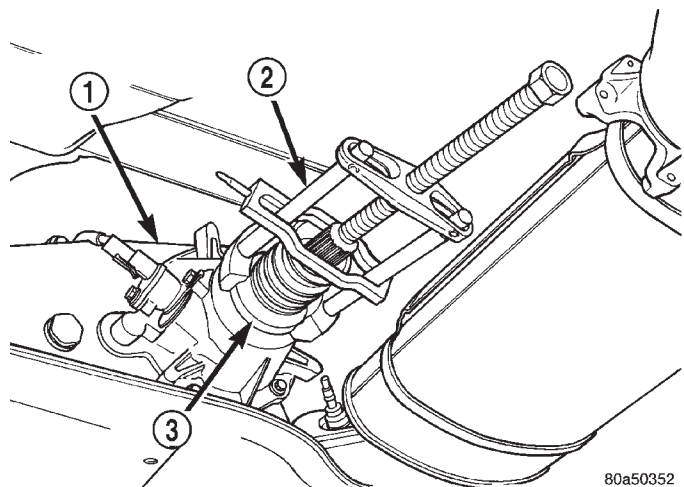
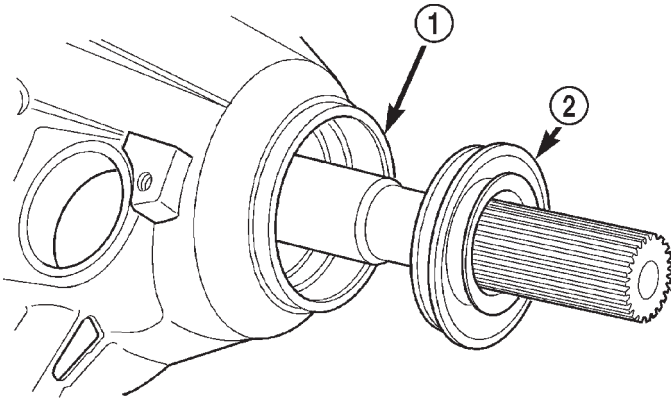

Fig. 11 Rear Slinger Removal

- 1 - TRANSFER CASE
- 2 - SPECIAL TOOL MD998056-A
- 3 - SLINGER

DISASSEMBLY AND ASSEMBLY (Continued)

(3) Remove rear seal from retainer (Fig. 12). Use pry tool, or collapse seal with punch to remove it.



80c070b7

Fig. 12 Rear Seal Removal

- 1 - REAR RETAINER
2 - OUTPUT SHAFT SEAL

(4) Remove rear output bearing I. D. retaining ring (Fig. 13).

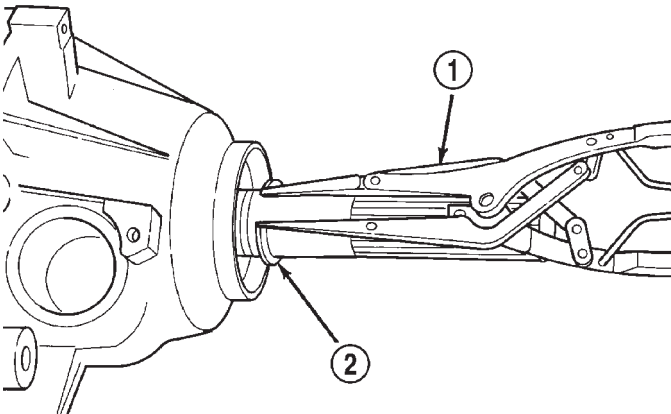

80c070b8

Fig. 13 Rear Bearing I. D. Retaining Ring Removal

- 1 - SNAP RING PLIERS
2 - REAR BEARING I. D. RETAINING RING

(5) Remove speedometer adapter.
(6) Remove rear retainer bolts.
(7) Remove rear retainer. Tap retainer with mallet and pry upward to break sealer bead. Then slide retainer off case and output shaft (Fig. 14).

(8) Remove rear bearing O. D. retaining ring with snap ring pliers. Then tilt pump and slide it off output shaft (Fig. 15)

(9) Remove pickup tube O-ring from pump (Fig. 16) but do not disassemble pump; it is not a repairable part.

(10) Remove seal from oil pump with pry tool.

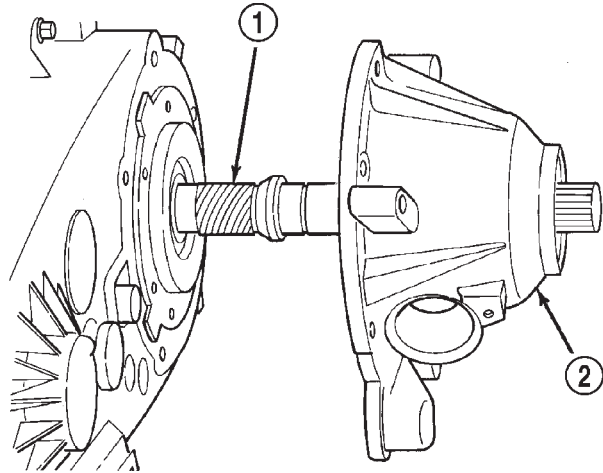

80010965

Fig. 14 Rear Retainer Removal

- 1 - MAINSHAFT
2 - REAR RETAINER

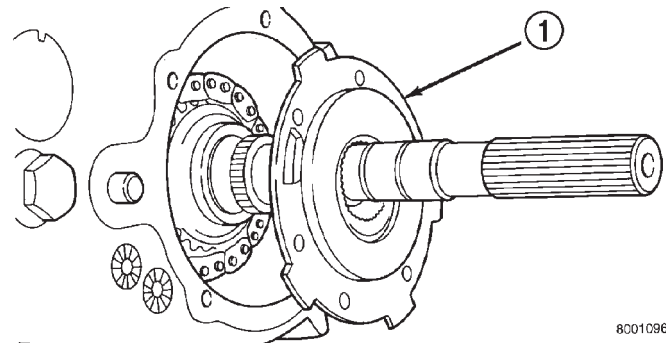

80010966

Fig. 15 Oil Pump Removal

- 1 - OIL PUMP

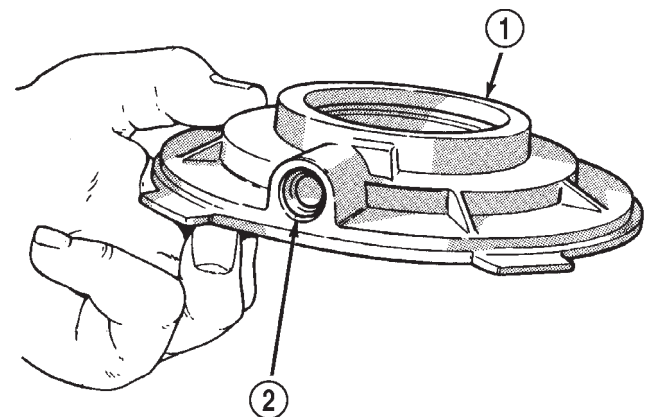

RR21F27

Fig. 16 Pickup Tube O-Ring Location

- 1 - OIL PUMP
2 - O-RING

(11) Remove bolts attaching rear case to front case (Fig. 17). Note position of the two black finish bolts

DISASSEMBLY AND ASSEMBLY (Continued)

at each end of the case. These bolts go through the case dowels and require a washer under the bolt head.

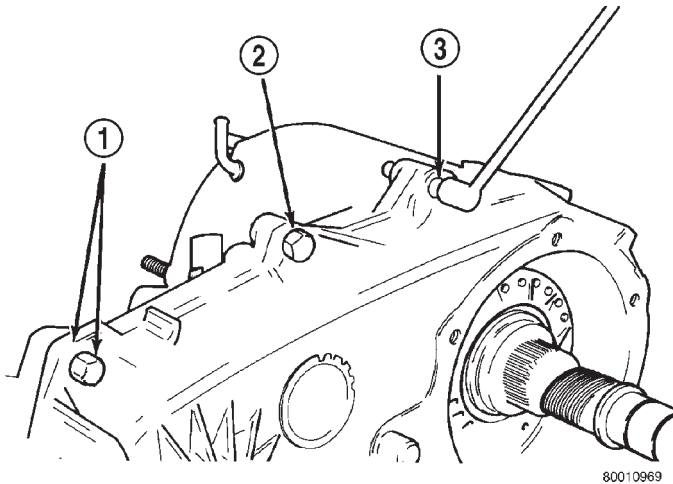

Fig. 17 Spline And Dowel Bolt Locations

- 1 - DOWEL BOLT AND WASHER (2)
- 2 - CASE BOLT (5)
- 3 - SPLINE HEAD BOLT (1)

(12) Remove rear case from front case (Fig. 18). Insert screwdrivers into slots cast into each end of case. Then pry upward to break sealer bead and remove rear case.

CAUTION: Do not pry on the sealing surface of either case half as the surfaces will become damaged.

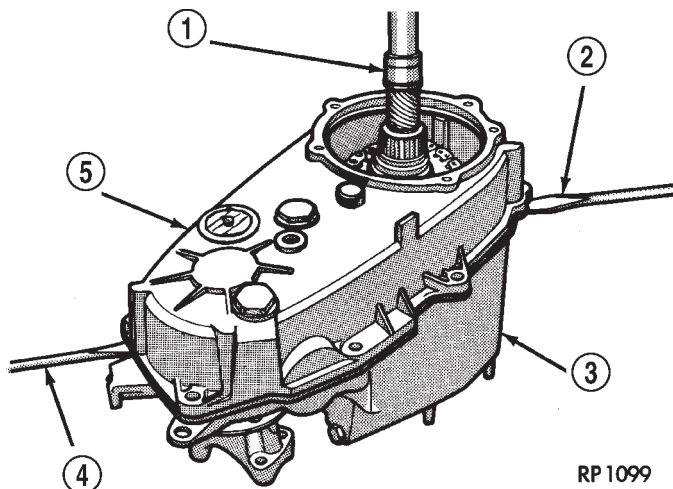
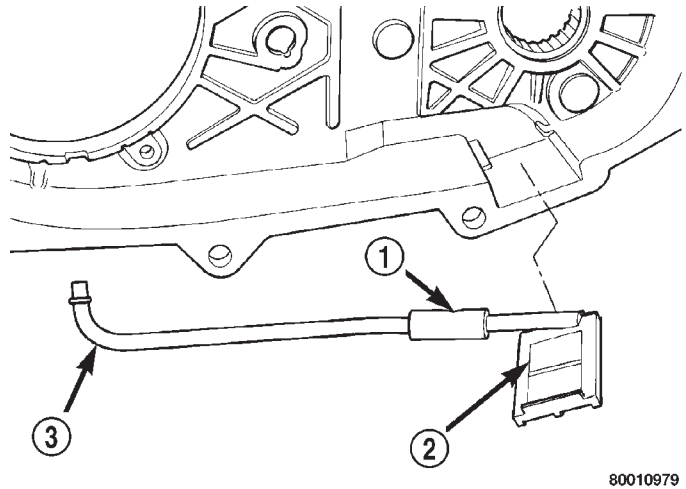

Fig. 18 Loosening/Removing Rear case

- 1 - MAINSHAFT
- 2 - SCREWDRIVER
- 3 - FRONT CASE
- 4 - SCREWDRIVER
- 5 - REAR CASE

(13) Remove oil pickup tube and screen from rear case (Fig. 19).



80010979

Fig. 19 Oil Pickup Screen, Hose And Tube Removal

- 1 - CONNECTING HOSE
- 2 - PICKUP SCREEN
- 3 - PICKUP TUBE

YOKE AND RANGE LEVER REMOVAL

(1) Remove front yoke nut:

(a) Move range lever to 4L position.

(b) Remove nut with socket and impact wrench (Fig. 20).

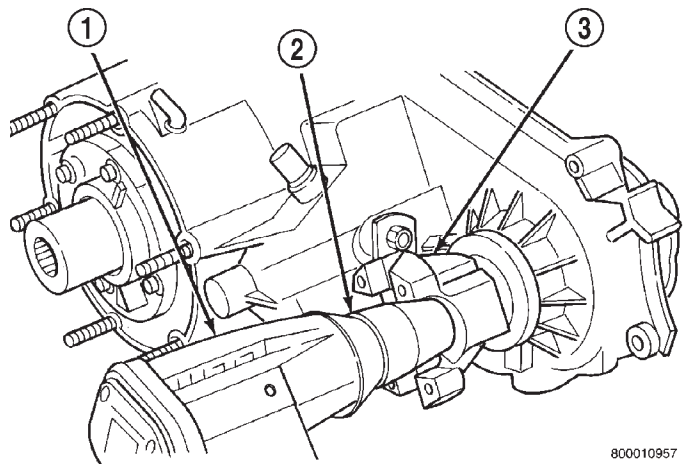

80010957

Fig. 20 Yoke Nut Removal

- 1 - IMPACT WRENCH
- 2 - SOCKET
- 3 - YOKE

(2) Remove yoke. If yoke is difficult to remove by hand, remove it with bearing splitter, or with standard two jaw puller (Fig. 21). Be sure puller tool is positioned on yoke and not on slinger as slinger will be damaged.

DISASSEMBLY AND ASSEMBLY (Continued)

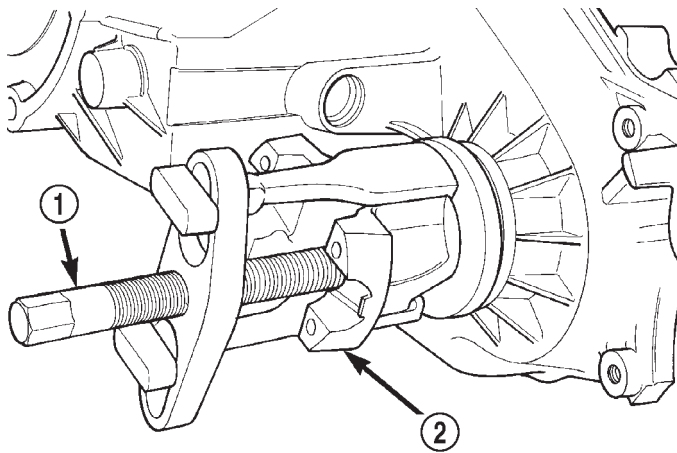

80010977

Fig. 21 Yoke Removal

- 1 - PULLER TOOL
2 - YOKE

(3) Remove seal washer from front output shaft. Discard washer as it should not be reused.

(4) Remove nut and washer that attach range lever to sector shaft. Then move sector to neutral position and remove range lever from shaft (Fig. 22).

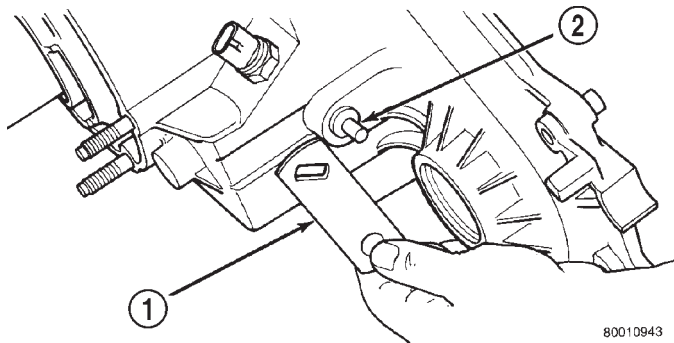

80010943

Fig. 22 Range Lever Removal

- 1 - RANGE LEVER
2 - SECTOR SHAFT

FRONT OUTPUT SHAFT AND DRIVE CHAIN REMOVAL

- (1) Remove drive sprocket snap-ring (Fig. 23).
- (2) Remove drive sprocket and chain (Fig. 24).
- (3) Remove front output shaft (Fig. 25).

SHIFT FORKS AND MAINSHAFT REMOVAL AND DISASSEMBLY

- (1) Remove shift detent plug, spring and pin (Fig. 26).
- (2) Remove seal plug from low range fork lockpin access hole. Then move shift sector to align low range fork lockpin with access hole.
- (3) Remove range fork lockpin with size number one easy-out tool as follows:

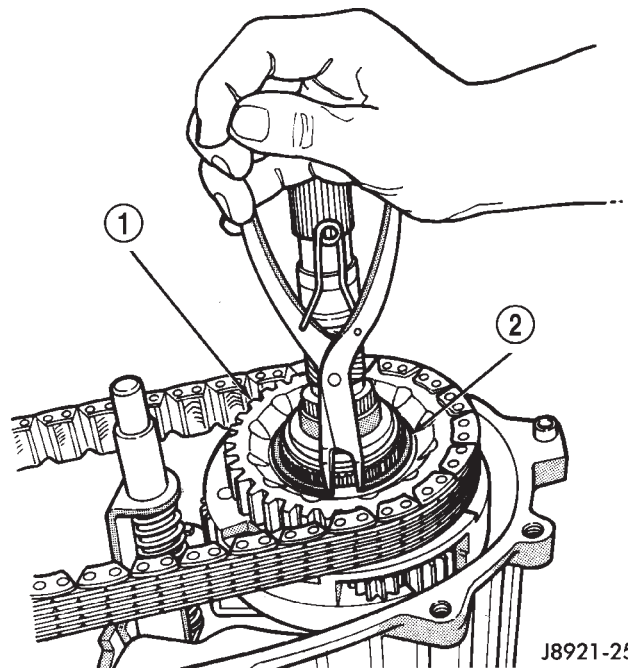

J8921-251

Fig. 23 Drive Sprocket Snap-Ring Removal

- 1 - DRIVE SPROCKET
2 - DRIVE SPROCKET SNAP RING

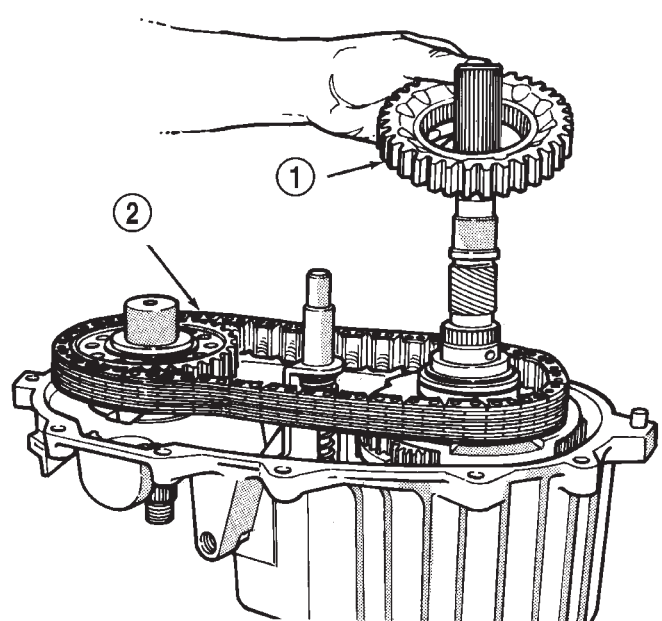

J8921-252

Fig. 24 Drive Sprocket And Chain Removal

- 1 - DRIVE SPROCKET
2 - DRIVE CHAIN

(a) Insert easy-out tool through access hole in side of transfer case and into lock-pin.

(b) Tap easy-out tool into lock-pin with hammer until tool is securely engaged into the lock-pin.

DISASSEMBLY AND ASSEMBLY (Continued)

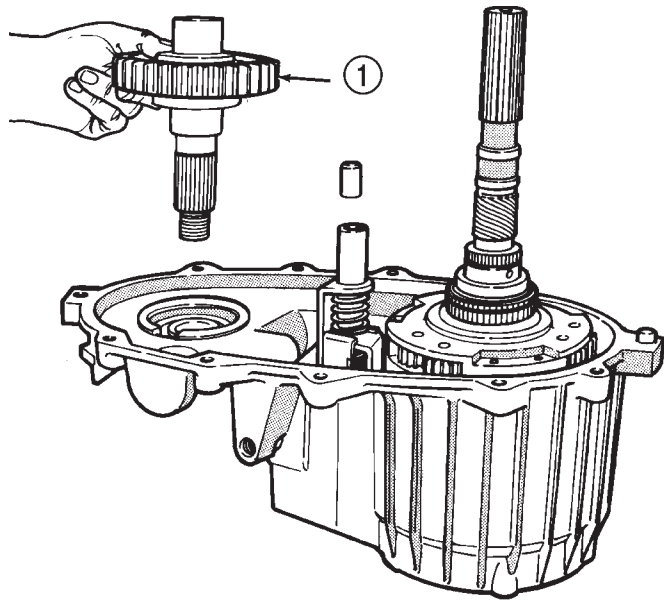

J8921-253

Fig. 25 Removing Front Output Shaft

1 - FRONT OUTPUT SHAFT

(6) Remove mode shift sleeve and mode fork assembly from mainshaft (Fig. 29). Note position of mode sleeve in fork and remove sleeve.

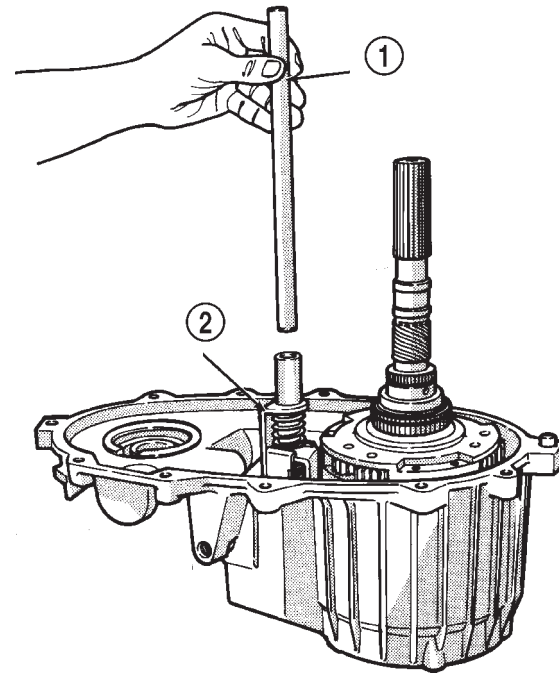

J8921-255

Fig. 27 Shift Rail Removal

1 - SHIFT RAIL
2 - MODE FORK

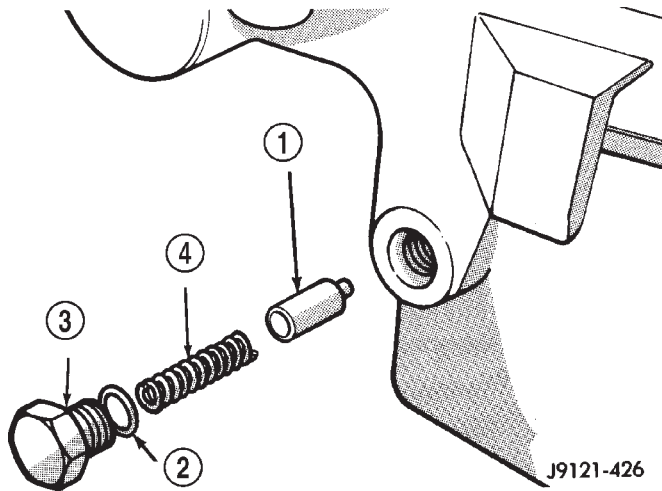

J9121-426

Fig. 26 Detent Component Removal

1 - PLUNGER
2 - O-RING
3 - PLUG
4 - SPRING

(c) Install a t-handle, such as from a tap and die set, onto the easy-out tool.

(d) Securely tighten the t-handle onto the tool.

(e) In one motion, pull upward and turn the t-handle counter-clockwise to remove the lock-pin.

(4) Remove shift rail by pulling it straight up and out of fork (Fig. 27).

(5) Remove mode fork and mainshaft as assembly (Fig. 28).

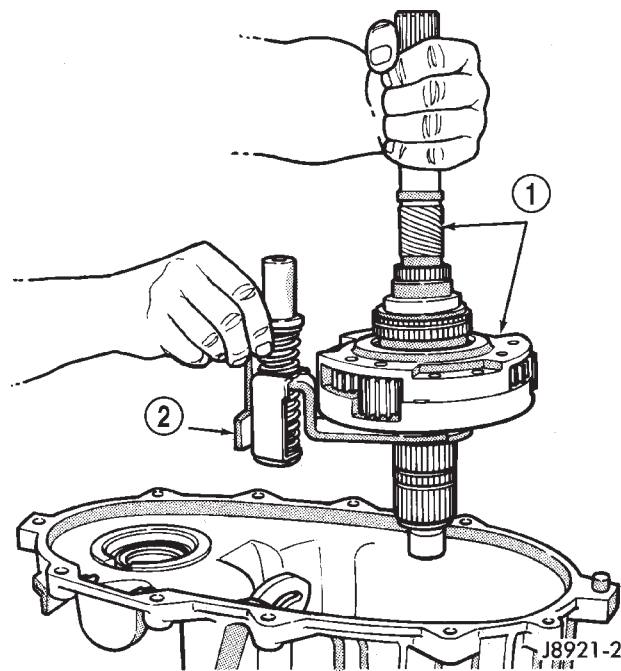

J8921-256

Fig. 28 Mode Fork And Mainshaft Removal

1 - MAINSHAFT ASSEMBLY
2 - MODE FORK

DISASSEMBLY AND ASSEMBLY (Continued)

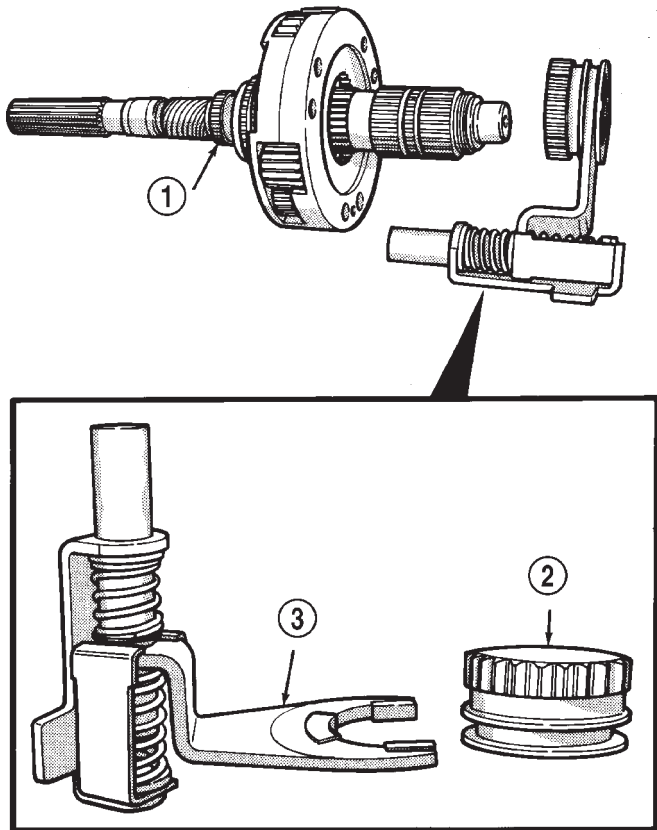

J8921-257

Fig. 29 Mode Fork And Sleeve Removal

- 1 - MAINSHAFT
- 2 - SLEEVE
- 3 - MODE FORK ASSEMBLY

(7) Remove intermediate clutch shaft snap-ring (Fig. 30).

(8) Remove clutch shaft thrust ring (Fig. 31).

(9) Remove intermediate clutch shaft (Fig. 32).

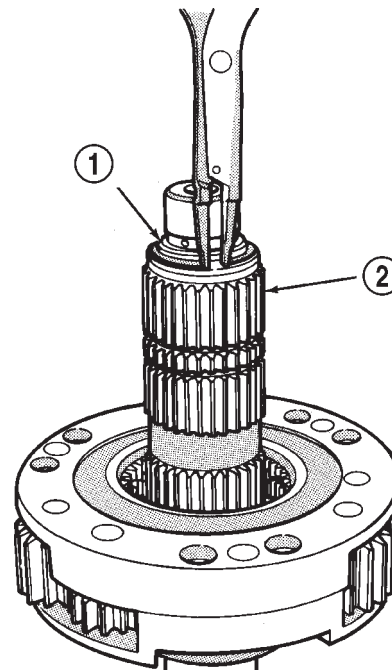

J8921-258

Fig. 30 Intermediate Clutch Shaft Snap-Ring Removal

- 1 - SNAP RING
- 2 - INTERMEDIATE CLUTCH SHAFT

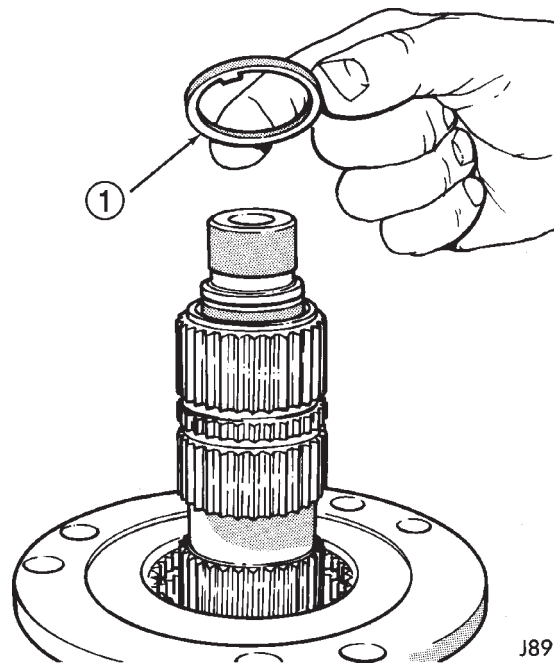

J8921-259

Fig. 31 Clutch Shaft Thrust Ring Removal

- 1 - CLUTCH SHAFT THRUST RING

DISASSEMBLY AND ASSEMBLY (Continued)

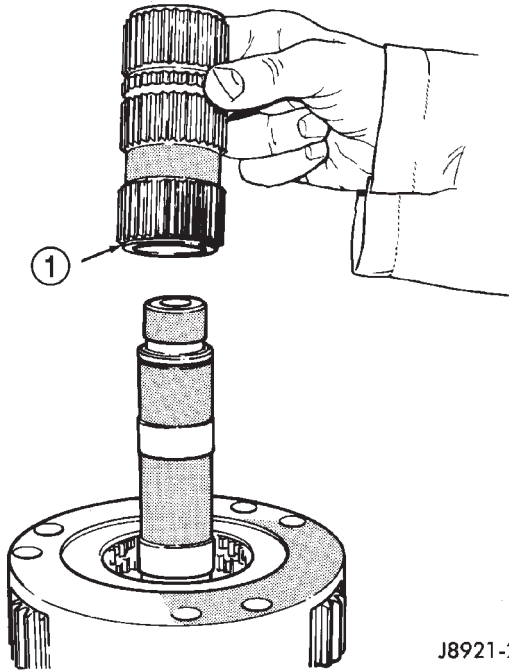

J8921-260

Fig. 32 Intermediate Clutch Shaft Removal

1 - INTERMEDIATE CLUTCH SHAFT

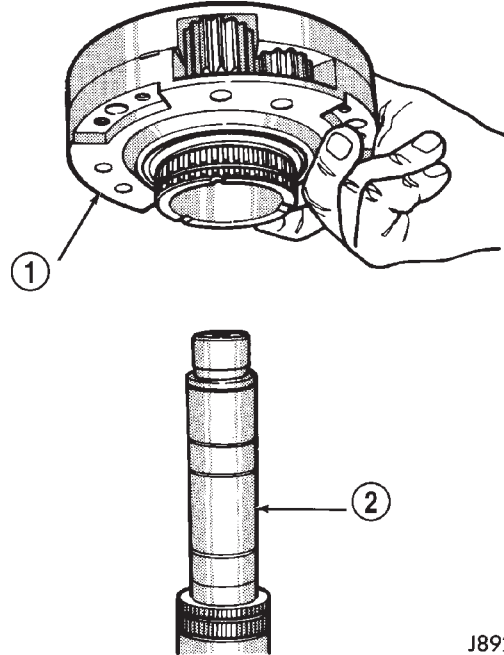

J8921-262

Fig. 34 Differential Removal

1 - DIFFERENTIAL
2 - MAINSHAFT

- (10) Remove differential snap-ring (Fig. 33).
- (11) Remove differential (Fig. 34).
- (12) Remove differential needle bearings and both needle bearing thrust washers from mainshaft.

- (15) Remove shift sector (Fig. 37).

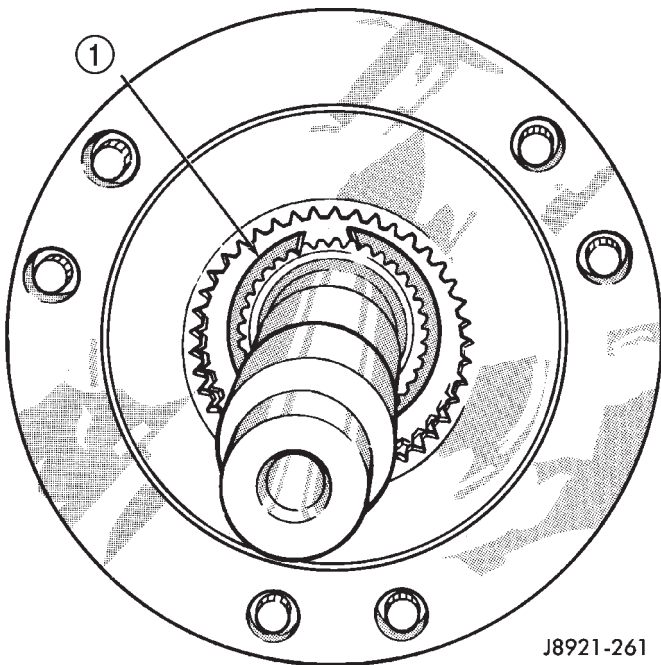

J8921-261

Fig. 33 Differential Snap-Ring Removal

1 - DIFFERENTIAL SNAP RING

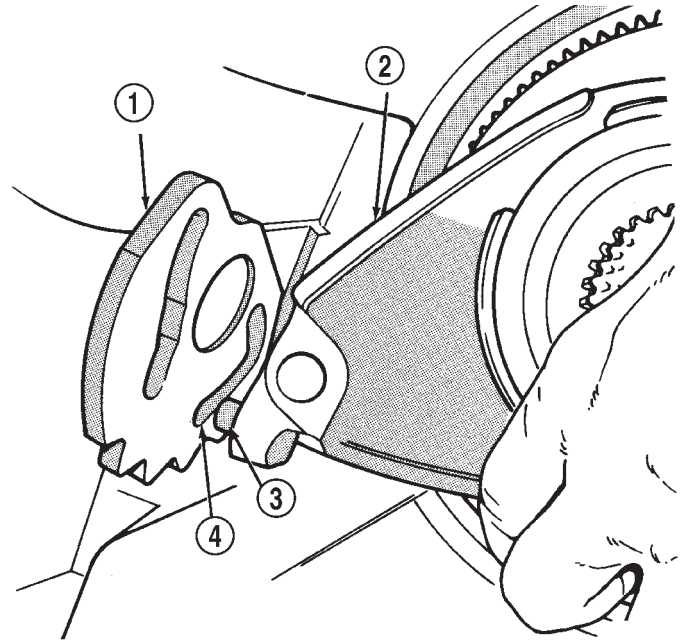

J8921-263

Fig. 35 Disengaging Low Range Fork

1 - SHIFT SECTOR
2 - LOW RANGE FORK
3 - PIN
4 - SLOT

- (13) Slide low range fork pin out of shift sector slot (Fig. 35).
- (14) Remove low range fork and hub (Fig. 36).

DISASSEMBLY AND ASSEMBLY (Continued)

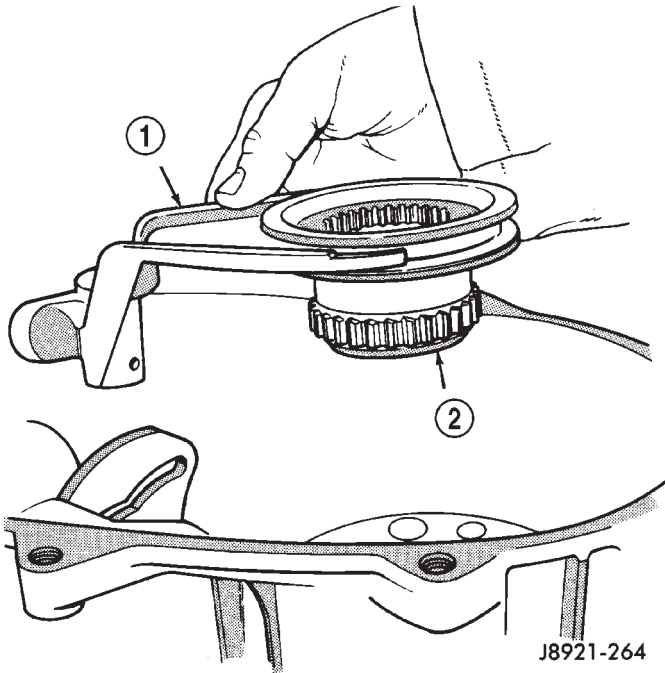

Fig. 36 Low Range Fork And Hub Removal

- 1 - LOW RANGE FORK
- 2 - FORK HUB

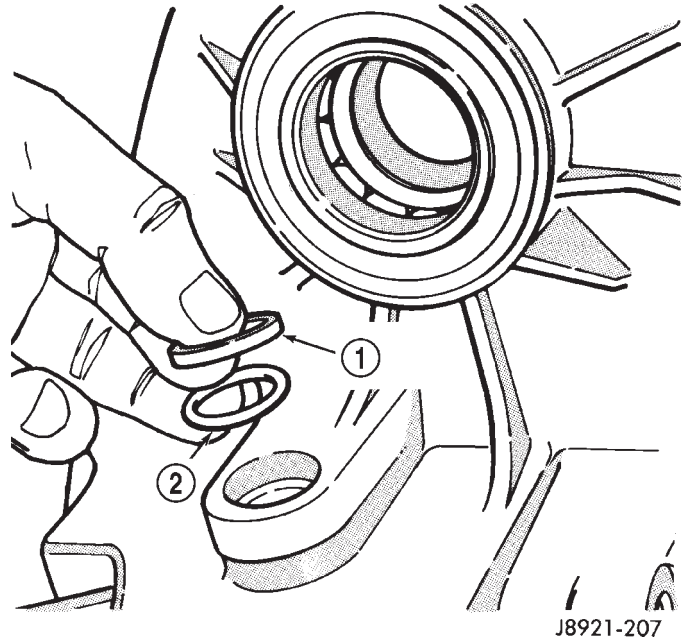

Fig. 38 Sector Bushing And O-Ring Removal

- 1 - SHIFT SECTOR BUSHING
- 2 - O-RING

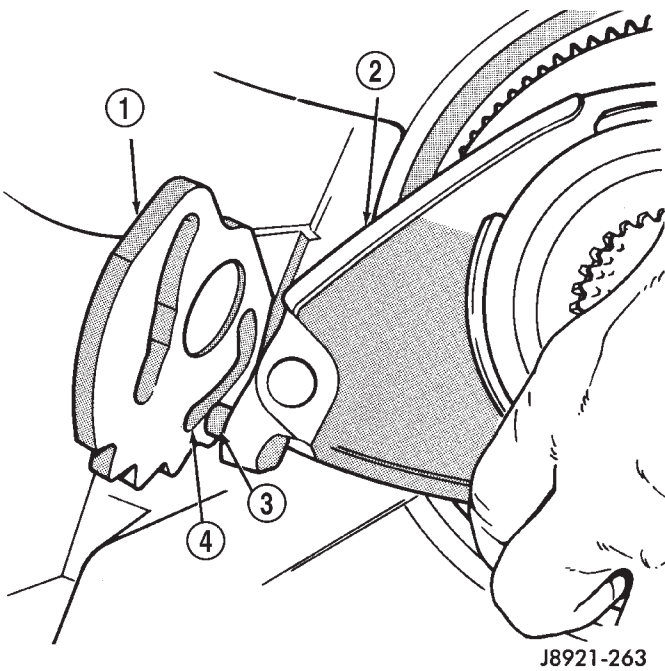

Fig. 37 Shift Sector Position

- 1 - SHIFT SECTOR
- 2 - LOW RANGE FORK
- 3 - PIN
- 4 - SLOT

INPUT GEAR/LOW RANGE ASSEMBLY REMOVAL AND DISASSEMBLY

- (1) Remove front bearing retainer bolts.
- (2) Remove front bearing retainer. Carefully pry retainer loose with screwdriver (Fig. 39). Position screwdriver in slots cast into retainer.
- (3) Remove input gear snap-ring (Fig. 40).

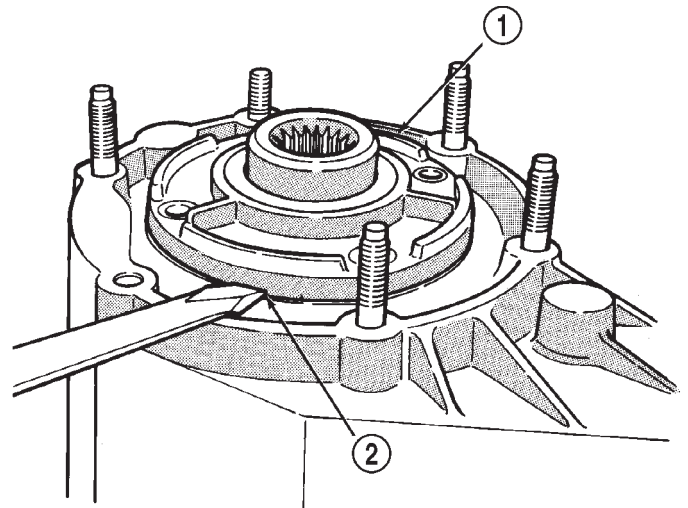
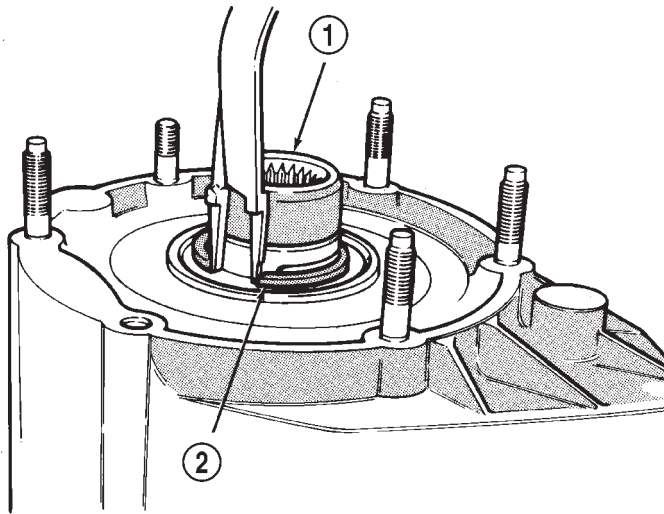

Fig. 39 Front Bearing Retainer Removal

- 1 - FRONT BEARING RETAINER
- 2 - RETAINER SLOT

(16) Remove shift sector bushing and O-ring (Fig. 38).

DISASSEMBLY AND ASSEMBLY (Continued)



J8921-267

Fig. 40 Input Gear Snap-Ring Removal

- 1 - INPUT GEAR
- 2 - SNAP RING

(4) Remove input/low range gear assembly from bearing with Tool Handle C-4171 and Tool 7829A (Fig. 41).

(5) Remove low range gear snap-ring (Fig. 42).

(6) Remove input gear retainer, thrust washers and input gear from low range gear (Fig. 43).

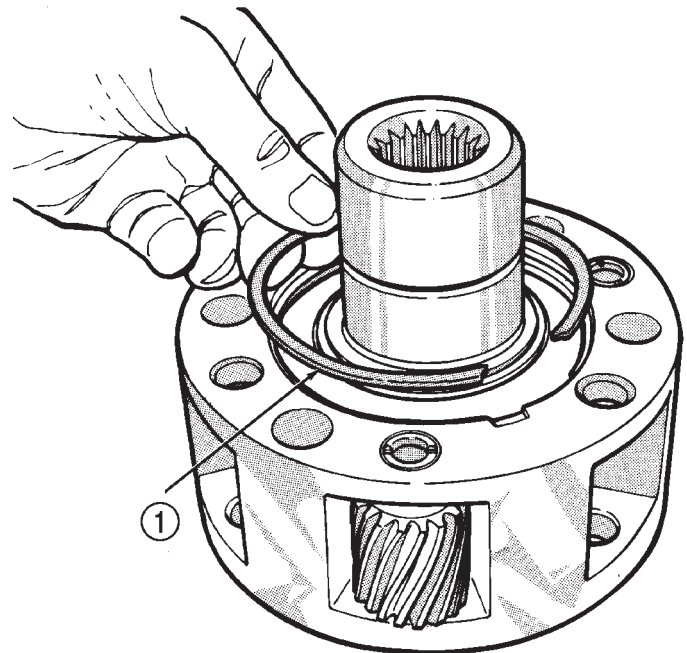

J8921-269

Fig. 42 Low Range Gear Snap-Ring Removal/Installation

- 1 - LOW RANGE GEAR SNAP RING

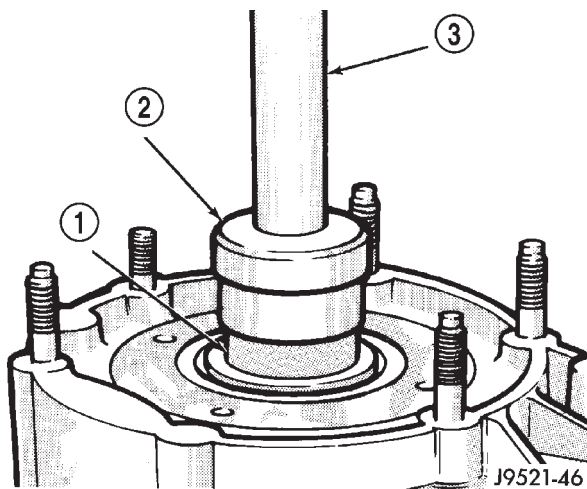

J9521-46

Fig. 41 Input And Low Range Gear Assembly Removal

- 1 - INPUT-LOW RANGE GEARS
- 2 - SPECIAL TOOL 7829A
- 3 - SPECIAL TOOL C-4171

(7) Inspect low range annulus gear (Fig. 44). **Gear is not a serviceable component. If damaged, replace gear and front case as assembly.**

(8) Remove oil seals from following components:

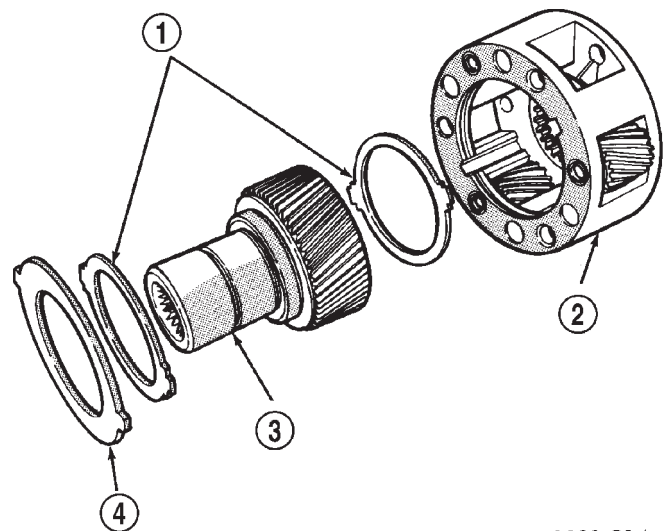

J8921-214

Fig. 43 Low Range Gear Disassembly

- 1 - THRUST WASHERS
- 2 - LOW RANGE GEAR
- 3 - INPUT GEAR
- 4 - RETAINER

- front bearing retainer.
- rear retainer.
- oil pump.
- case halves.

DISASSEMBLY AND ASSEMBLY (Continued)

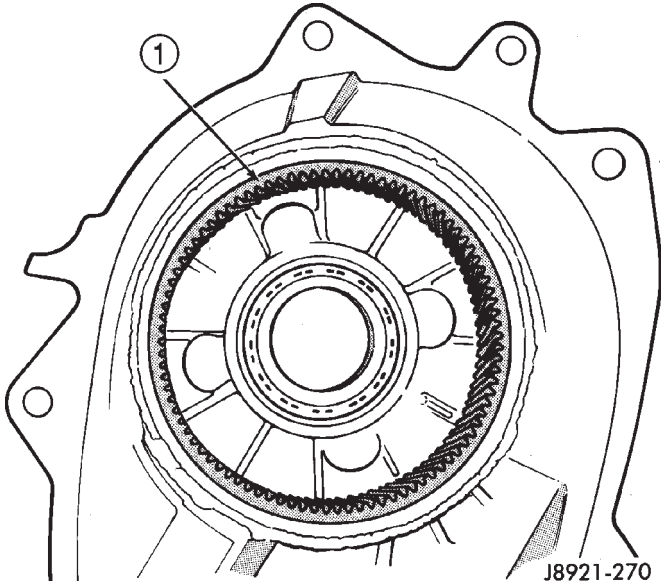

Fig. 44 Inspecting Low Range Annulus Gear

1 - LOW RANGE ANNULUS GEAR

DIFFERENTIAL DISASSEMBLY

- (1) Mark differential case halves for reference.
- (2) Remove differential case bolts.
- (3) Invert differential on workbench.
- (4) Separate top case from bottom case. Use slots in case halves to pry them apart (Fig. 45).

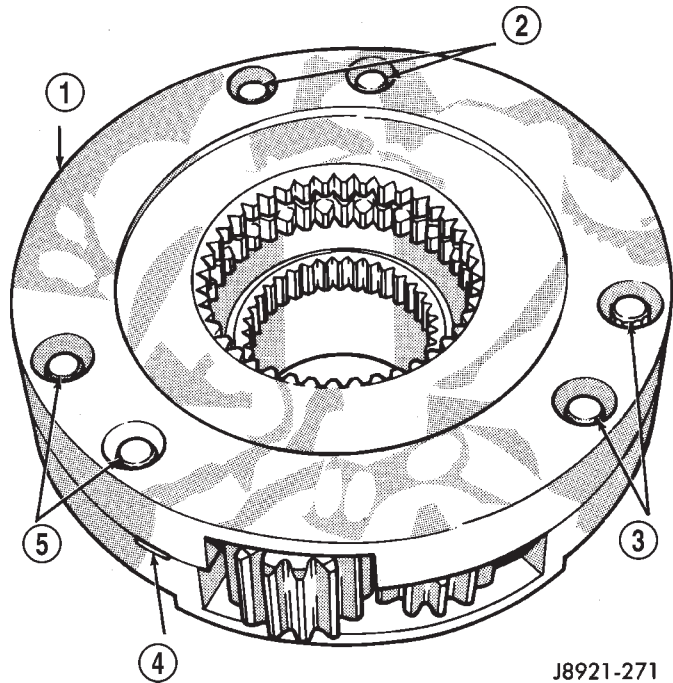

Fig. 45 Separating Differential Case Halves

1 - TOP CASE
 2 - CASE BOLTS
 3 - CASE BOLTS
 4 - CASE SLOTS
 5 - CASE BOLTS

- (5) Remove thrust washers and planet gears from case pins (Fig. 46).
- (6) Remove mainshaft and sprocket gears from bottom case (Fig. 47). Note gear position for reference before separating them.

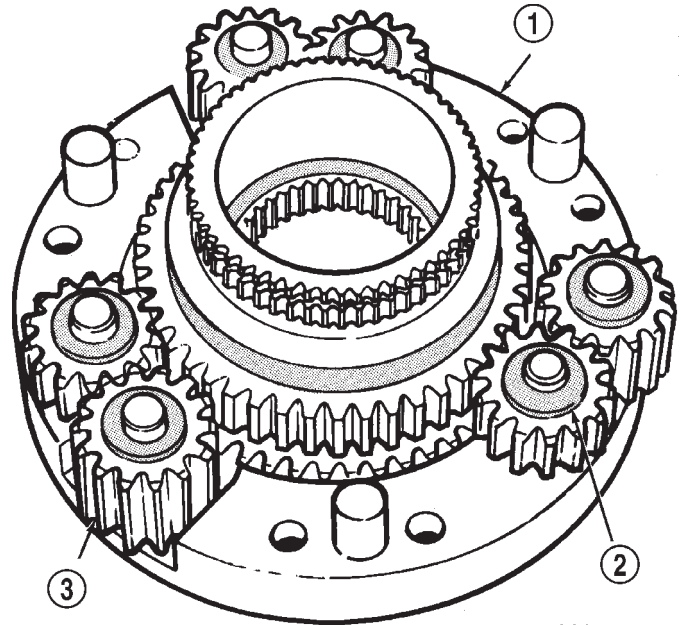

Fig. 46 Planet Gears And Thrust Washer Removal

1 - BOTTOM CASE
 2 - THRUST WASHERS (12)
 3 - PLANET GEARS (6)

ASSEMBLY

Lubricate transfer case components with automatic transmission fluid or petroleum jelly (where indicated) during assembly.

CAUTION: The bearing bores in various transfer case components contain oil feed holes. Make sure replacement bearings do not block the holes.

DISASSEMBLY AND ASSEMBLY (Continued)

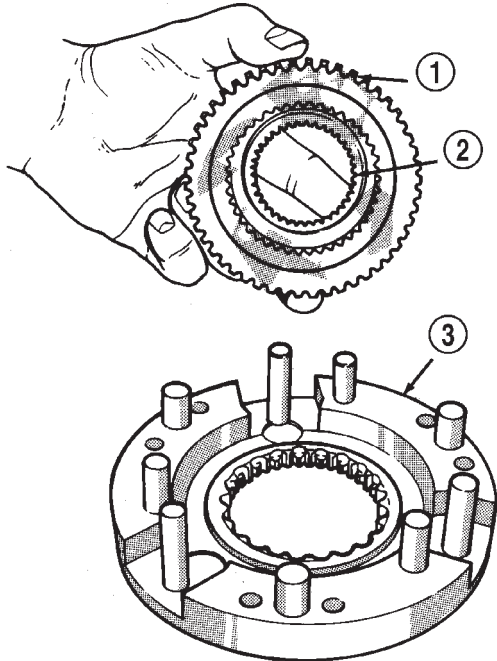

J8921-273

Fig. 47 Mainshaft And Sprocket Gear Removal

- 1 - MAINSHAFT GEAR
- 2 - SPROCKET GEAR
- 3 - BOTTOM CASE

BEARING AND SEAL INSTALLATION

(1) Remove snap-ring that retains front output shaft front bearing in case (Fig. 48). Then remove bearing. Use hammer handle, or hammer and brass punch to tap bearing out of case.

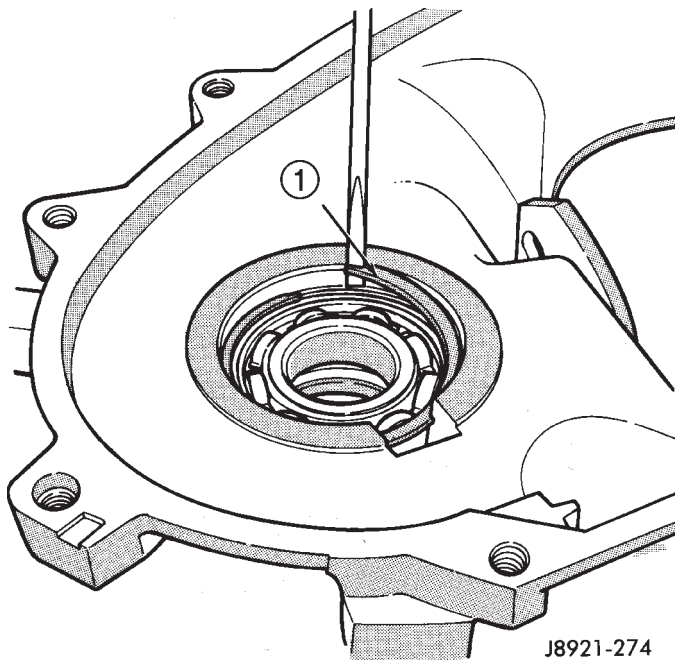

J8921-274

Fig. 48 Front Output Shaft Front Bearing Snap-Ring Removal

- 1 - FRONT BEARING SNAP RING

(2) Install new front output shaft front bearing with Tool Handle C-4171 and Installer 8033A with the tapered cone upward (Fig. 49).

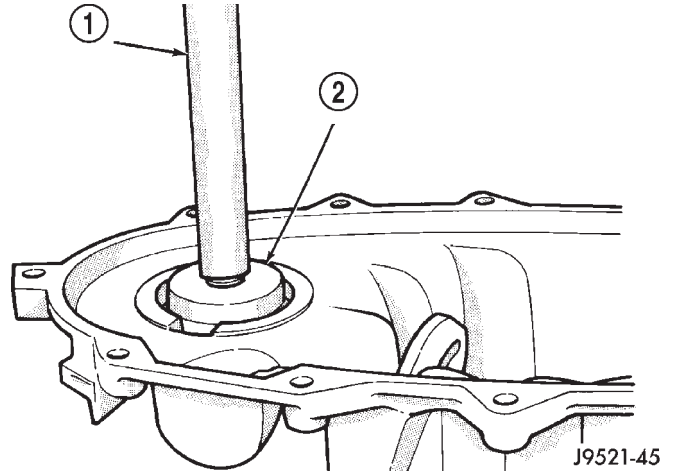

J9521-45

Fig. 49 Front Output Shaft Front Bearing Installation

- 1 - SPECIAL TOOL C-4171
- 2 - SPECIAL TOOL 8033A

(3) Install front bearing snap-ring (Fig. 48).
 (4) Remove front output shaft seal using an appropriate pry tool (Fig. 50) or slide-hammer mounted screw.
 (5) Install new front output shaft oil seal with Installer 6952-A (Fig. 51).

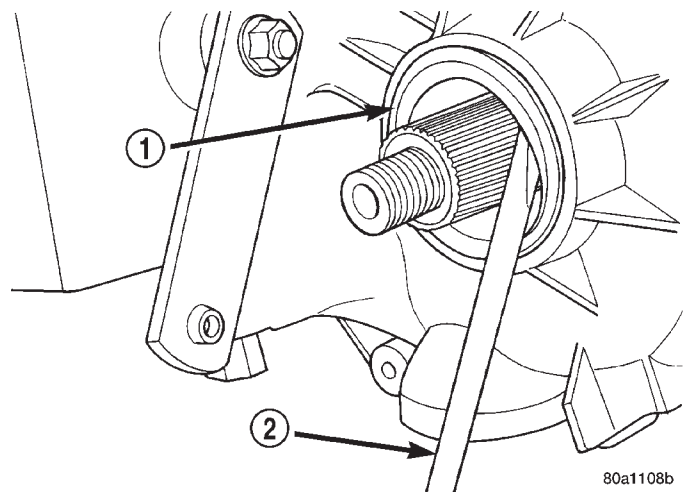

80a1108b

Fig. 50 Remove Front Output Shaft Seal

- 1 - OUTPUT SHAFT SEAL
- 2 - PRYBAR

DISASSEMBLY AND ASSEMBLY (Continued)

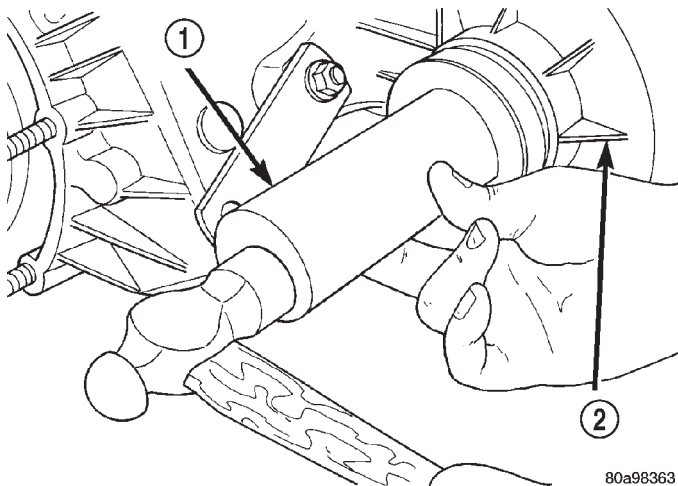

Fig. 51 Install Front Output Shaft Seal

- 1 - INSTALLER 6952-A
- 2 - TRANSFER CASE

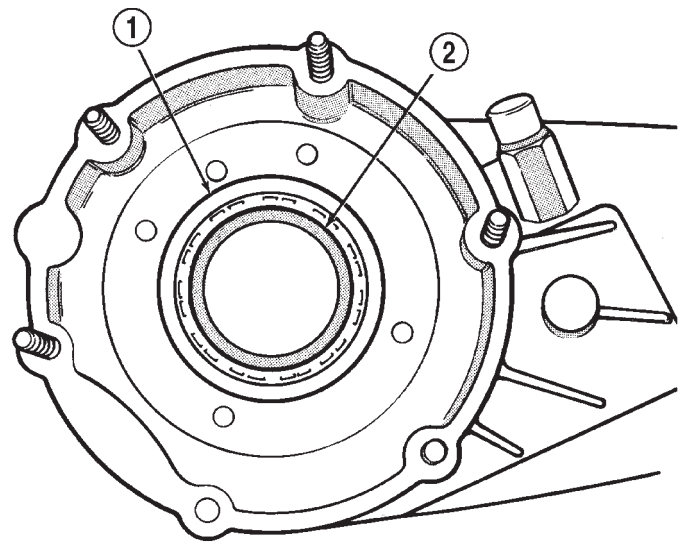

Fig. 53 Seating Input Gear Bearing

- 1 - SNAP RING
- 2 - INPUT SHAFT BEARING

- (6) Remove input gear bearing with Tool Handle C-4171 and Remover C-4210 (Fig. 52).
- (7) Install snap-ring on new input gear bearing.
- (8) Install new input gear bearing with Tool Handle C-4171 and Remover C-4210. Install bearing far enough to seat snap-ring against case (Fig. 53).

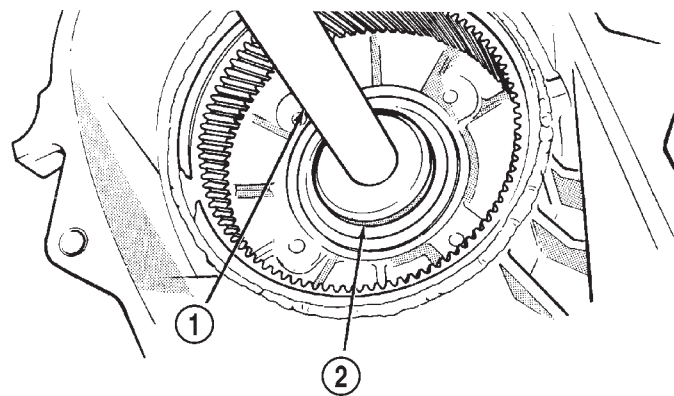

Fig. 52 Input Gear Bearing Removal

- 1 - SPECIAL TOOL C-4171
- 2 - SPECIAL TOOL C-4210

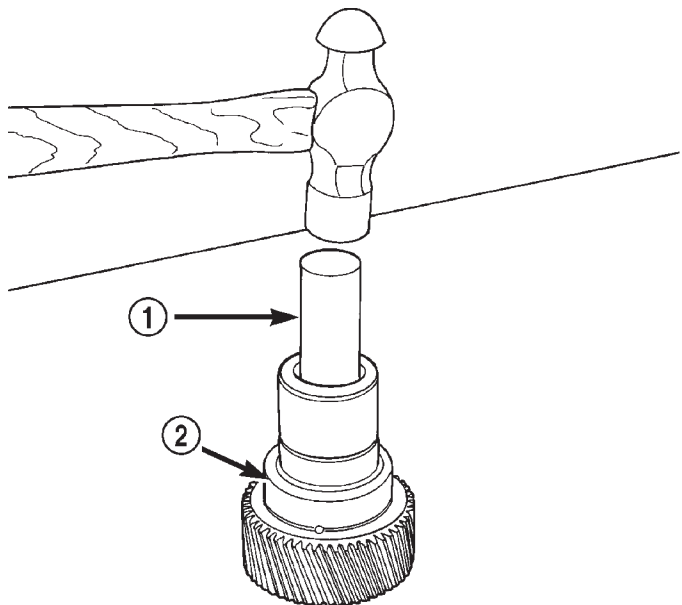

Fig. 54 Remove Input Gear Pilot Bearing

- 1 - DRIFT
- 2 - INPUT GEAR

- (9) Remove the input gear pilot bearing by inserting a suitably sized drift into the splined end of the input gear and driving the bearing out with the drift and a hammer (Fig. 54).

- (10) Install new pilot bearing with Installer 8128 and Handle C-4171 (Fig. 55).

- (11) Install new seal in front bearing retainer with Installer 7884 (Fig. 56).

- (12) Remove output shaft rear bearing with the screw and jaws from Remover L-4454 and Cup 8148 (Fig. 57).

J9521-43

J8921-219

80a11090

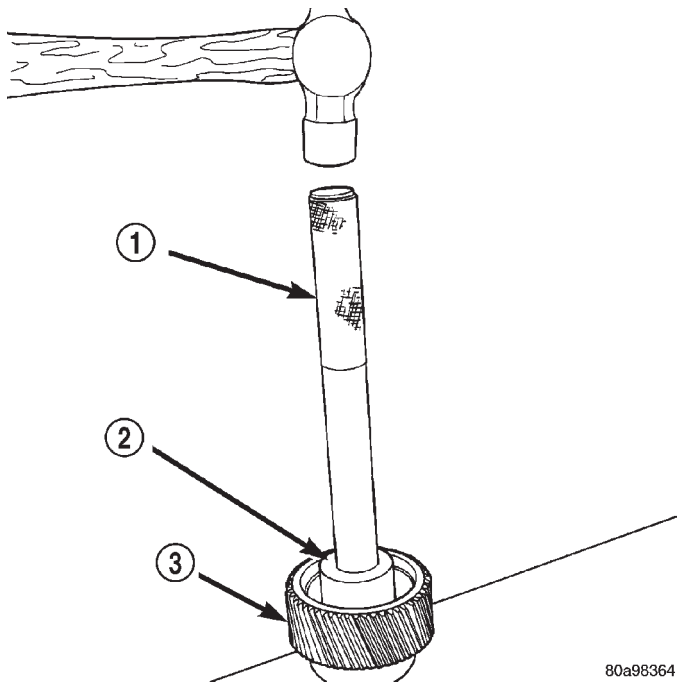

80a98364

Fig. 55 Install Input Gear Pilot Bearing

- 1 - HANDLE C-4171
- 2 - INSTALLER 8128
- 3 - INPUT GEAR

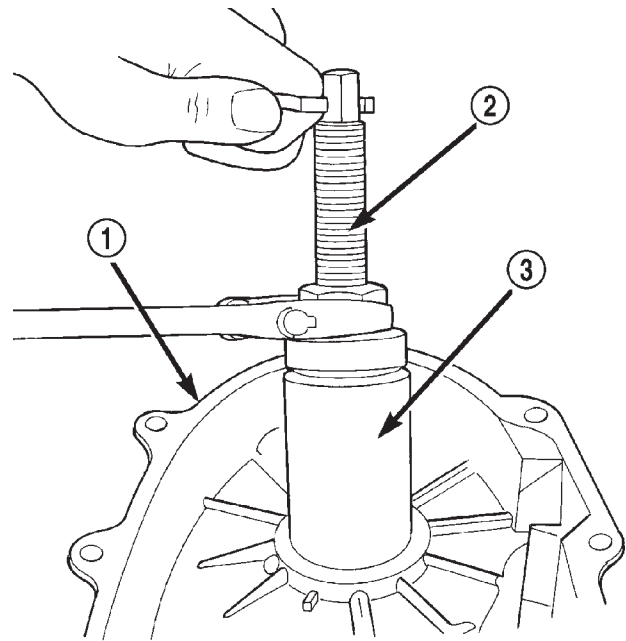

80a98366

Fig. 57 Remove Front Output Shaft Rear Bearing

- 1 - REAR CASE
- 2 - SPECIAL TOOL L-4454-1 AND L-4454-3
- 3 - SPECIAL TOOL 8148

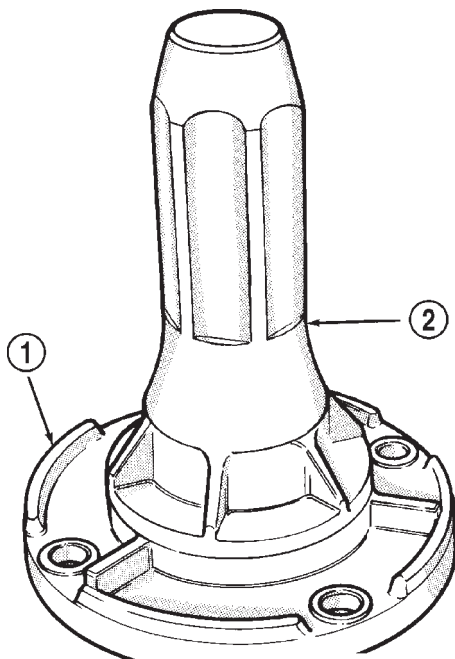

J9521-41

Fig. 56 Front Bearing Retainer Seal Installation

- 1 - FRONT BEARING RETAINER
- 2 - SPECIAL TOOL 7884

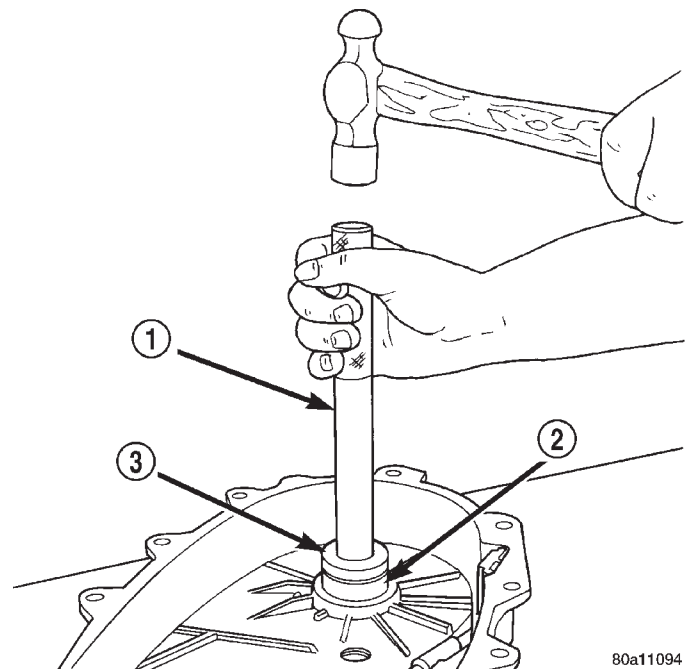

80a11094

Fig. 58 Install Front Output Shaft Rear Bearing

- 1 - HANDLE C-4171
- 2 - OUTPUT SHAFT INNER BEARING
- 3 - INSTALLER 5066

(13) Install new bearing with Tool Handle C-4171 and Installer 5066 (Fig. 58). Lubricate bearing after installation.

(14) Install new seal in oil pump feed housing with Special Tool 7888 (Fig. 59).

DISASSEMBLY AND ASSEMBLY (Continued)

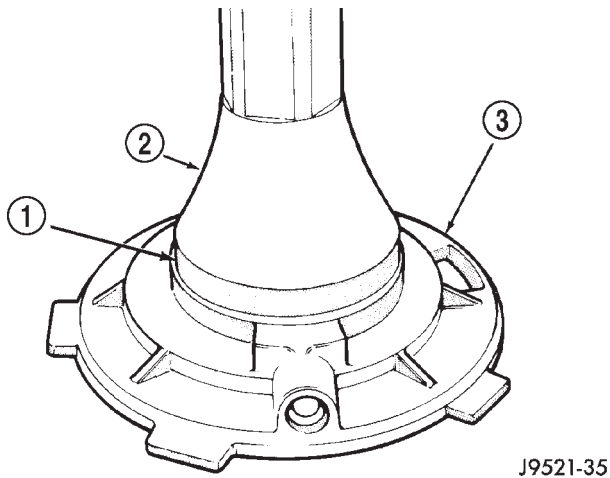
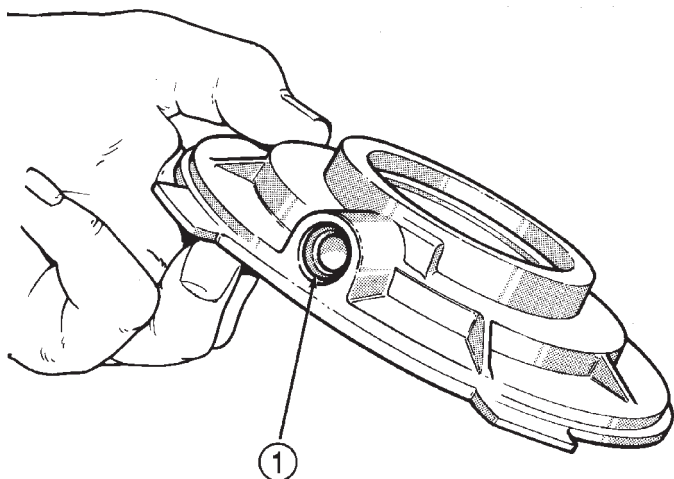

Fig. 59 Oil Pump Seal Installation

- 1 - HOUSING SEAL
- 2 - SPECIAL TOOL 7888
- 3 - OIL PUMP FEED HOUSING

(15) Install new pickup tube O-ring in oil pump (Fig. 60).



J8921-286

Fig. 60 Pickup Tube O-Ring Installation

- 1 - PICKUP TUBE O-RING

DIFFERENTIAL ASSEMBLY

- (1) Lubricate differential components with automatic transmission fluid.
- (2) Install sprocket gear in differential bottom case (Fig. 61).
- (3) Install differential planet gears and new thrust washers (Fig. 62). **Be sure thrust washers are installed at top and bottom of each planet gear.**

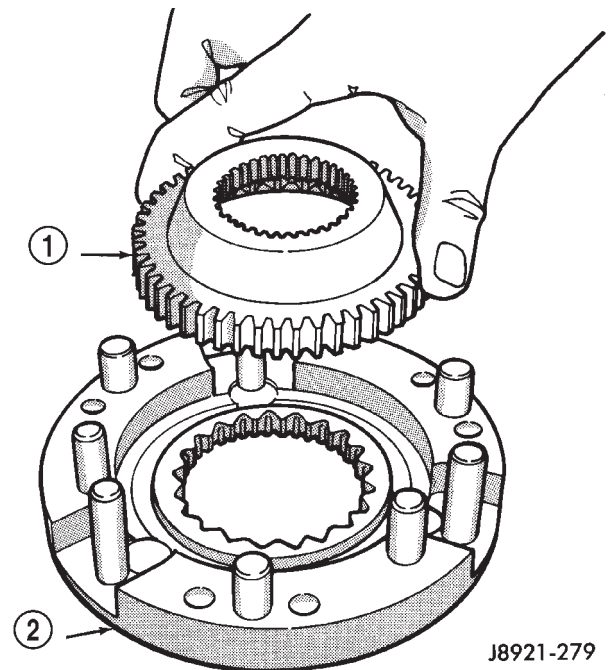

Fig. 61 Installing Differential Sprocket Gear

- 1 - SPROCKET GEAR
- 2 - BOTTOM CASE

- (4) Install differential mainshaft gear (Fig. 62).
- (5) Align and position differential top case on bottom case (Fig. 63). Align using scribe marks made at disassembly.
- (6) While holding differential case halves together, invert the differential and start the differential case bolts.
- (7) Tighten differential case bolts to specified torque.

INPUT GEAR/LOW RANGE ASSEMBLY

- (1) Assemble low range gear, input gear thrust washers, input gear and input gear retainer (Fig. 64).
- (2) Install low range gear snap ring (Fig. 65).

DISASSEMBLY AND ASSEMBLY (Continued)

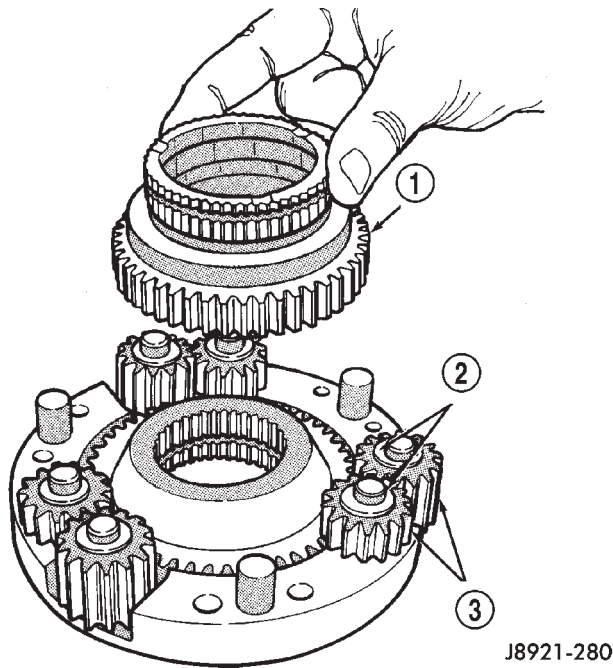

J8921-280

Fig. 62 Installing Mainshaft And Planet Gears

- 1 - MAINSHAFT GEAR
- 2 - THRUST WASHERS (12)
- 3 - PLANET GEARS (6)

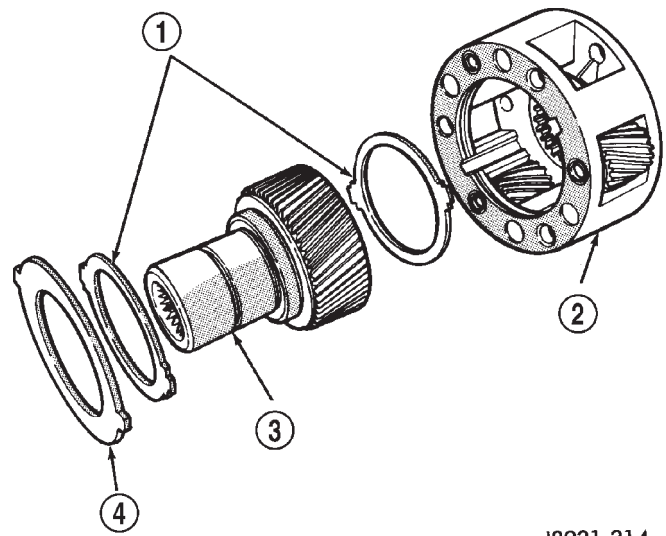

J8921-214

Fig. 64 Low Range And Input Gear Assembly

- 1 - THRUST WASHERS
- 2 - LOW RANGE GEAR
- 3 - INPUT GEAR
- 4 - RETAINER

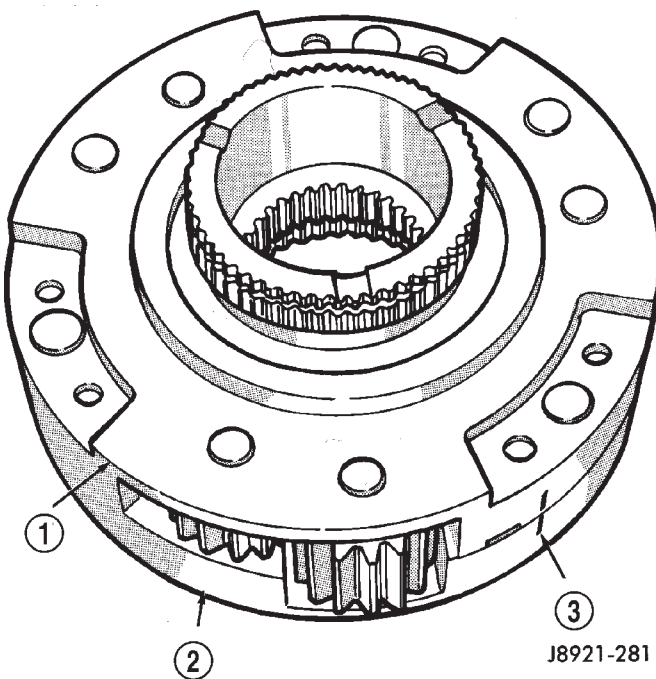

J8921-281

Fig. 63 Differential Case Assembly

- 1 - TOP CASE
- 2 - BOTTOM CASE
- 3 - CASE ALIGNMENT MARKS

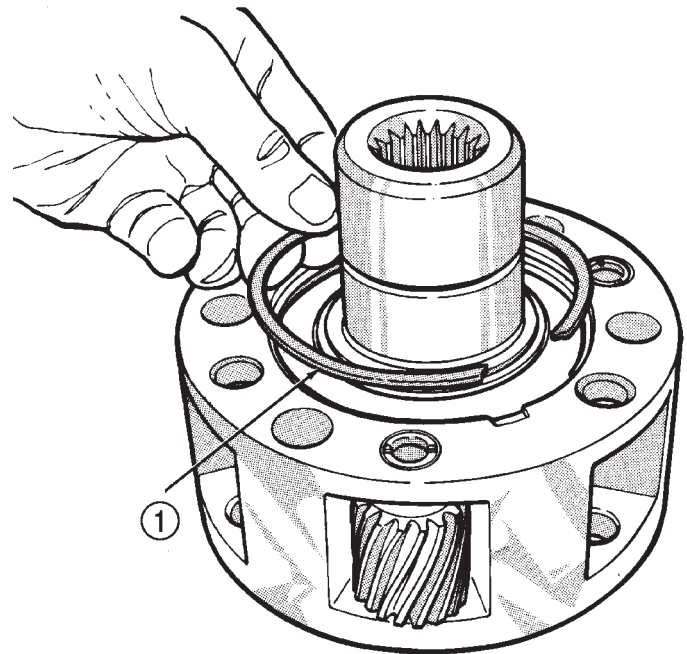

J8921-269

Fig. 65 Install Low Range Gear Snap Ring

- 1 - LOW RANGE GEAR SNAP RING

DISASSEMBLY AND ASSEMBLY (Continued)

- (3) Lubricate input gear and low range gears with automatic transmission fluid.
- (4) Start input gear shaft into front case bearing.
- (5) Press input gear shaft into front bearing.
- (6) Install new input gear snap ring (Fig. 66).

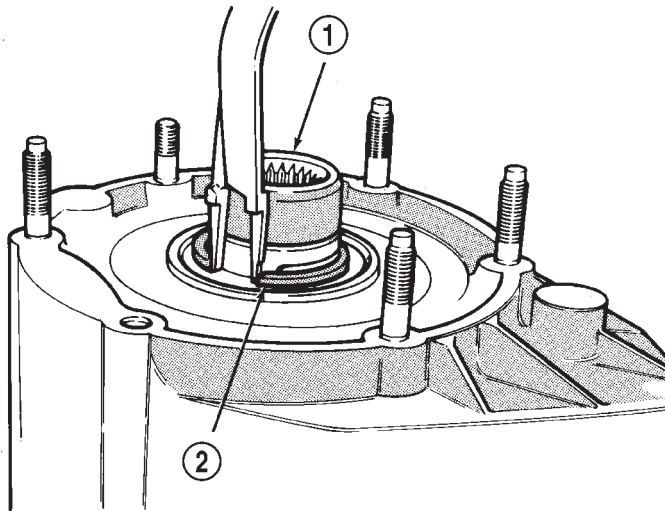

J8921-267

Fig. 66 Input Gear Snap Ring Installation

- 1 - INPUT GEAR
- 2 - SNAP RING

- (7) Apply 3 mm (1/8 in.) wide bead of Mopar® gasket maker or silicone adhesive sealer to seal surface of front bearing retainer.

- (8) Install front bearing retainer (Fig. 67). Tighten retainer bolts to 16 ft. lbs. (21 N·m) torque.

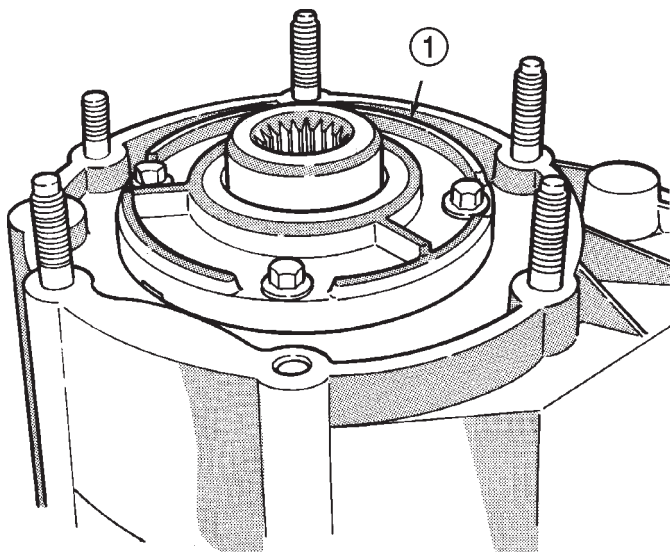

J8921-276

Fig. 67 Installing Front Bearing Retainer

- 1 - FRONT BEARING RETAINER

SHIFT FORKS AND MAINSHAFT INSTALLATION

- (1) Install new sector shaft O-ring and bushing (Fig. 68).

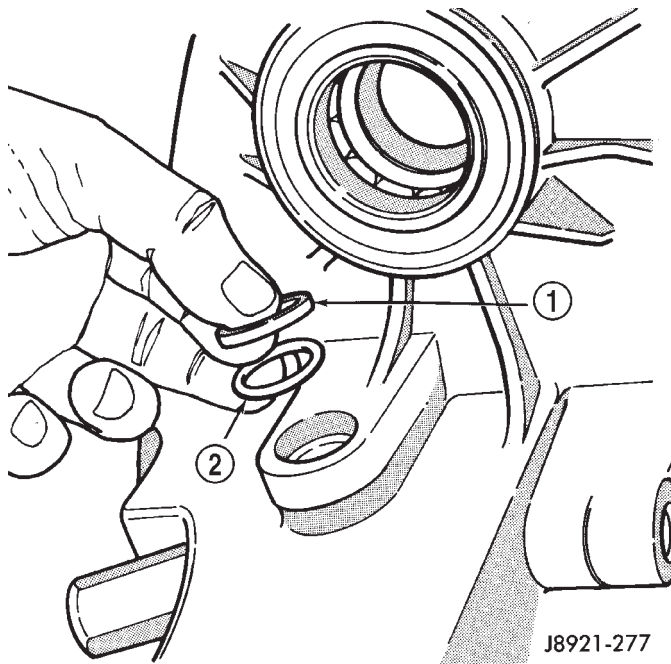

J8921-277

Fig. 68 Sector O-Ring And Bushing Installation

- 1 - SECTOR BUSHING
- 2 - O-RING

- (2) Install shift sector.
- (3) Install new pads on low range fork, if necessary, (Fig. 69).
- (4) Assemble low range fork and hub (Fig. 69).

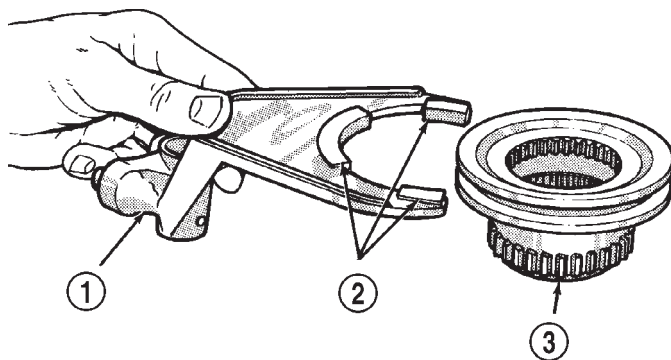

J8921-278

Fig. 69 Assembling Low Range Fork And Hub

- 1 - LOW RANGE FORK
- 2 - PADS
- 3 - HUB

DISASSEMBLY AND ASSEMBLY (Continued)

(5) Position low range fork and hub in case. Be sure low range fork pin is engaged in shift sector slot (Fig. 70).

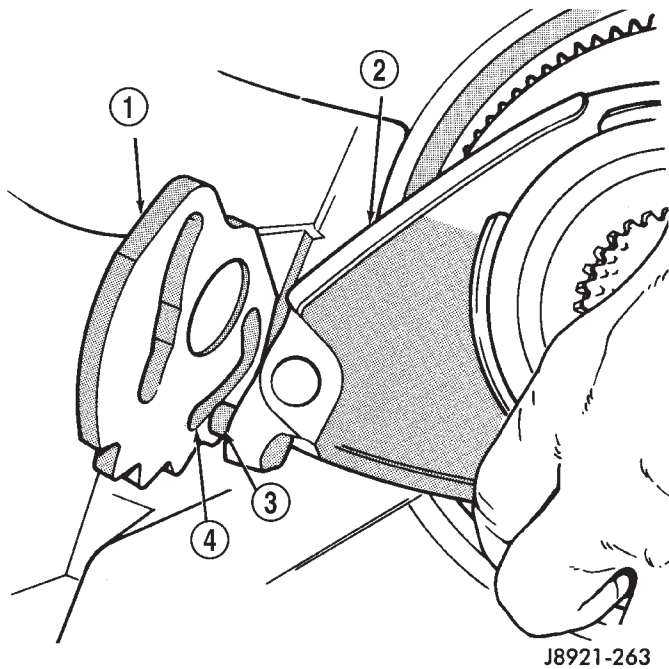

J8921-263

Fig. 70 Positioning Low Range Fork

- 1 - SHIFT SECTOR
- 2 - LOW RANGE FORK
- 3 - PIN
- 4 - SLOT

(6) Install first mainshaft bearing spacer on mainshaft (Fig. 71).

(7) Install bearing rollers on mainshaft (Fig. 71). **Coat bearing rollers with generous quantity of petroleum jelly to hold them in place.**

(8) Install remaining bearing spacer on mainshaft (Fig. 71). Do not displace any bearings while installing spacer.

(9) Install differential (Fig. 72). **Do not displace mainshaft bearings when installing differential.**

(10) Install differential snap-ring (Fig. 73).

(11) Install intermediate clutch shaft (Fig. 74).

(12) Install clutch shaft thrust washer (Fig. 75).

(13) Install clutch shaft snap-ring (Fig. 76).

(14) Inspect mode fork assembly (Fig. 77). Replace pads and bushing if necessary. Replace fork tube if bushings inside tube are worn or damaged. Also check springs and slider bracket (Fig. 77). Replace worn, damaged components.

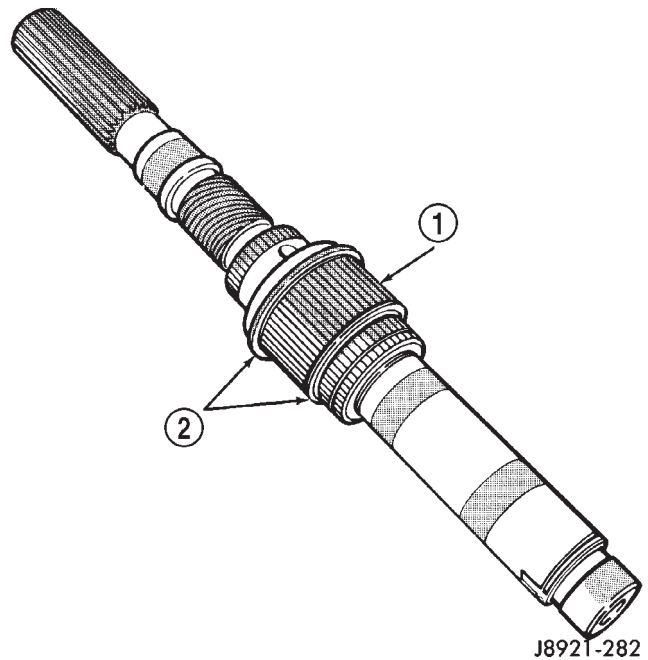

J8921-282

Fig. 71 Installing Mainshaft Bearing Rollers and Spacers

- 1 - MAINSHAFT BEARING ROLLERS
- 2 - BEARING SPACERS

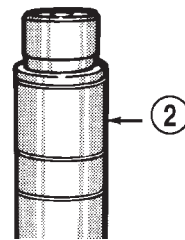
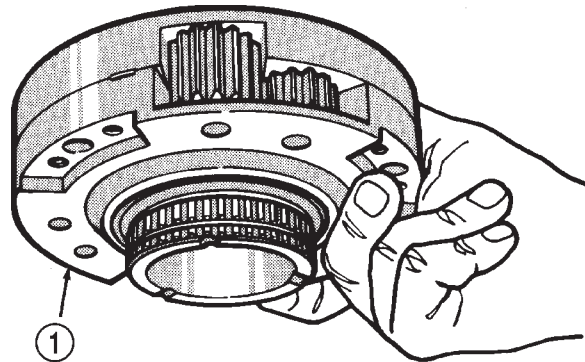

J8921-283

Fig. 72 Differential Installation

- 1 - DIFFERENTIAL
- 2 - MAINSHAFT

DISASSEMBLY AND ASSEMBLY (Continued)

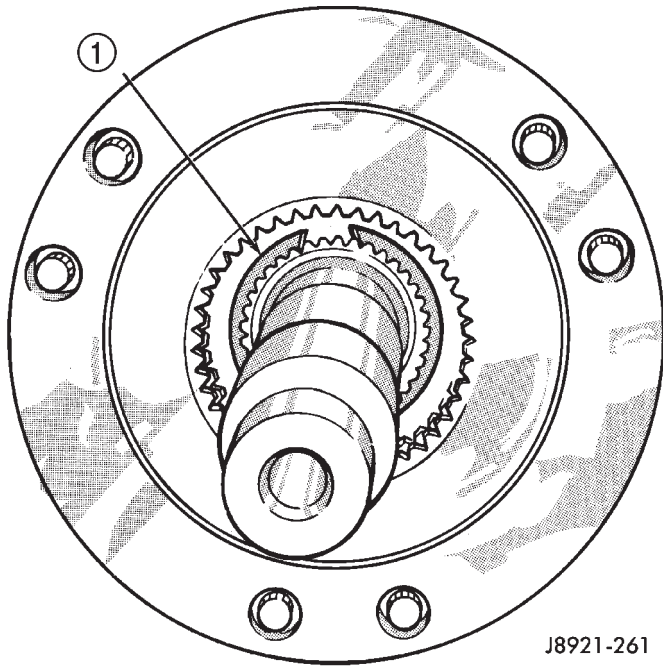

J8921-261

Fig. 73 Installing Differential Snap-Ring

1 - DIFFERENTIAL SNAP RING

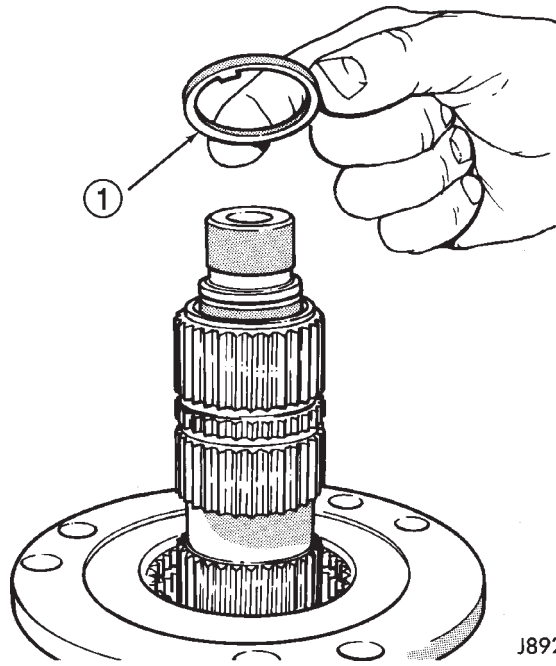

J8921-259

Fig. 75 Installing Clutch Shaft Thrust Washer

1 - CLUTCH SHAFT THRUST RING

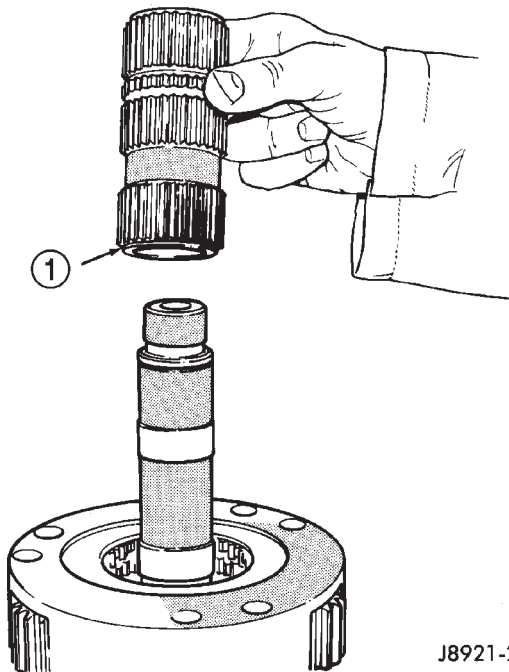

J8921-260

Fig. 74 Installing Intermediate Clutch Shaft

1 - INTERMEDIATE CLUTCH SHAFT

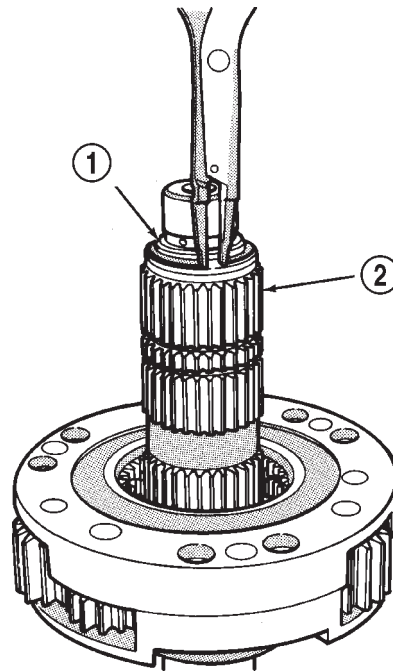

J8921-258

Fig. 76 Installing Clutch Shaft Snap-Ring

1 - SNAP RING
2 - INTERMEDIATE CLUTCH SHAFT

DISASSEMBLY AND ASSEMBLY (Continued)

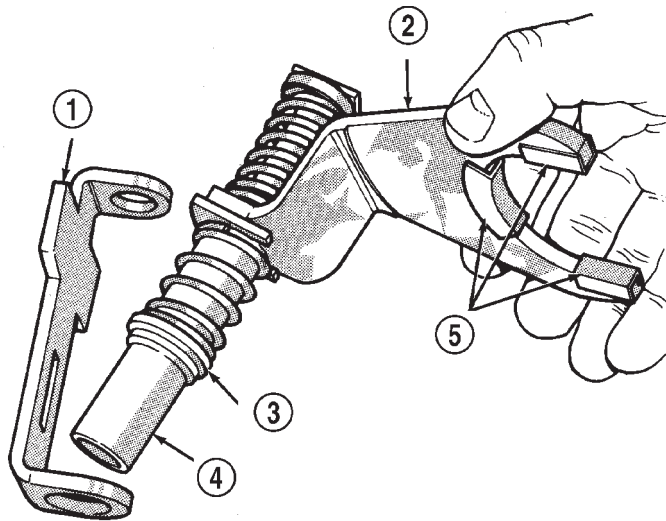

J8921-284

Fig. 77 Mode Fork Assembly Inspection

- 1 - SLIDER
- 2 - MODE FORK
- 3 - BUSHING/SPRING
- 4 - TUBE
- 5 - PADS

(15) Install mode sleeve in mode fork (Fig. 78). Then install assembled sleeve and fork on mainshaft. Be sure mode sleeve splines are engaged in differential splines.

(16) Install mode fork and mainshaft assembly in case (Fig. 79). Rotate mainshaft slightly to engage shaft with low range gears.

(17) Rotate mode fork pin into shift sector slot.

(18) Install shift rail (Fig. 80). **Be sure rail is seated in both shift forks.**

(19) Rotate shift sector to align lockpin hole in low range fork with access hole in case.

(20) Insert an easy-out in range fork lockpin to hold it securely for installation (Fig. 81). **Lockpin is slightly tapered on one end. Insert tapered end into fork and rail.**

(21) Insert lockpin through access hole and into shift fork (Fig. 81). Then remove easy-out and seat the pin with pin punch.

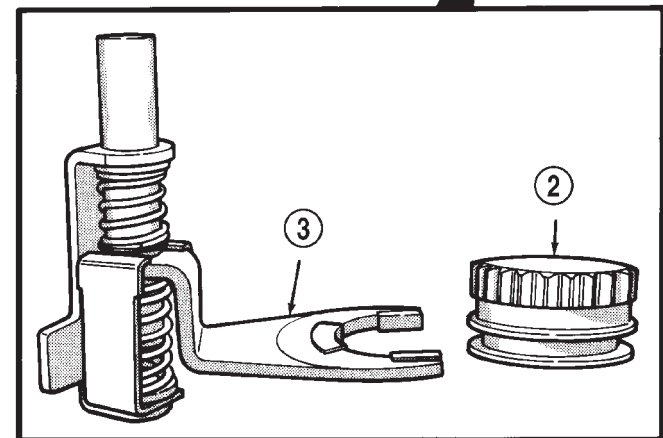
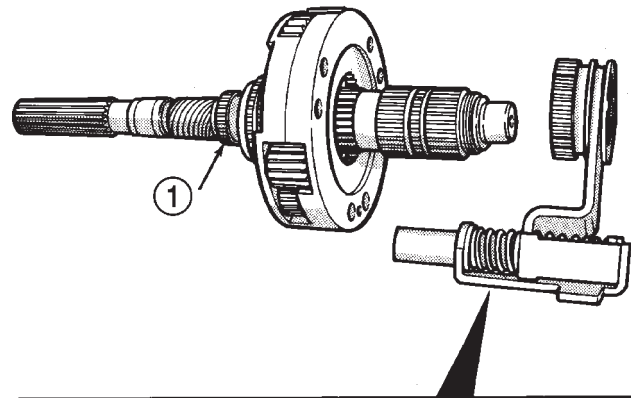

J8921-257

Fig. 78 Installing Mode Fork And Sleeve

- 1 - MAINSHAFT
- 2 - SLEEVE
- 3 - MODE FORK ASSEMBLY

(22) Install plug in lockpin access hole.

(23) Install detent plunger, detent spring and detent plug in case (Fig. 82).

FRONT OUTPUT SHAFT AND DRIVE CHAIN INSTALLATION

- (1) Install front output shaft (Fig. 83).
- (2) Install drive chain (Fig. 83). Engage chain with front output shaft sprocket teeth.
- (3) Install drive sprocket (Fig. 83). Engage drive sprocket teeth with chain. Then engage sprocket splines with mainshaft splines.

DISASSEMBLY AND ASSEMBLY (Continued)

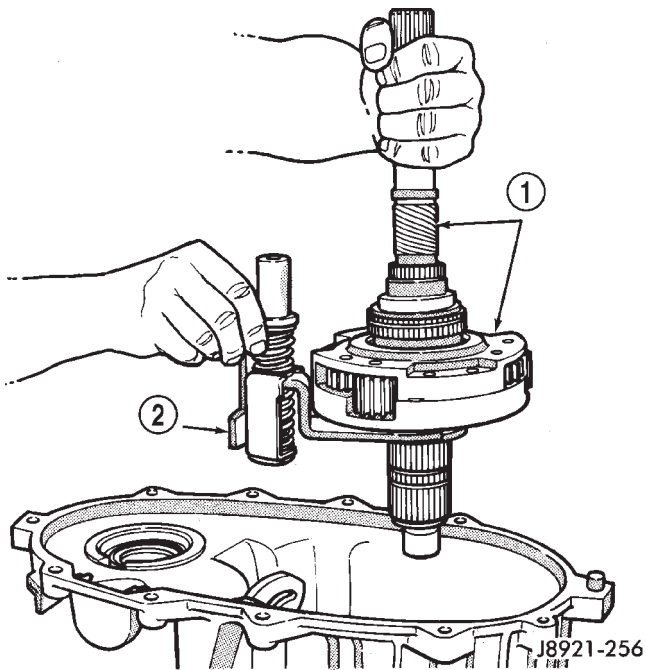

Fig. 79 Assembled Mainshaft And Mode Fork Installation

- 1 - MAINSHAFT ASSEMBLY
- 2 - MODE FORK

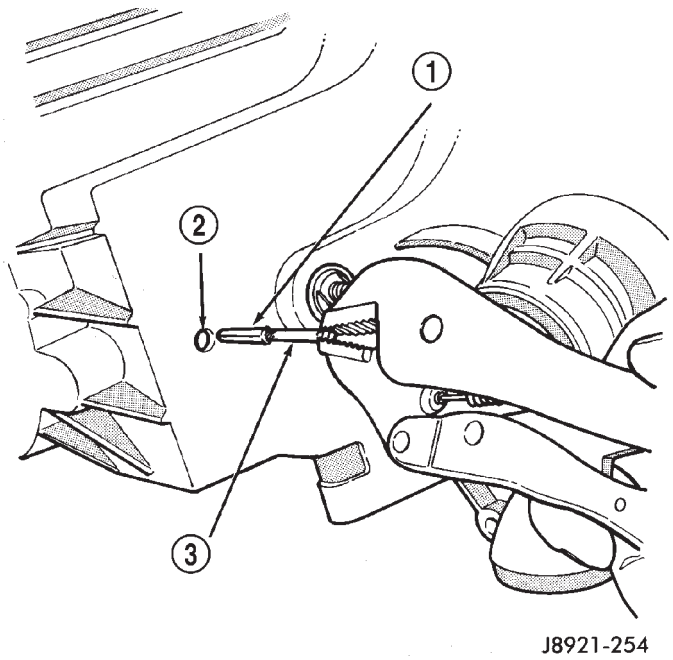

Fig. 81 Installing Low Range Fork Lockpin

- 1 - LOW RANGE FORK LOCK PIN
- 2 - ACCESS HOLE
- 3 - EASY-OUT

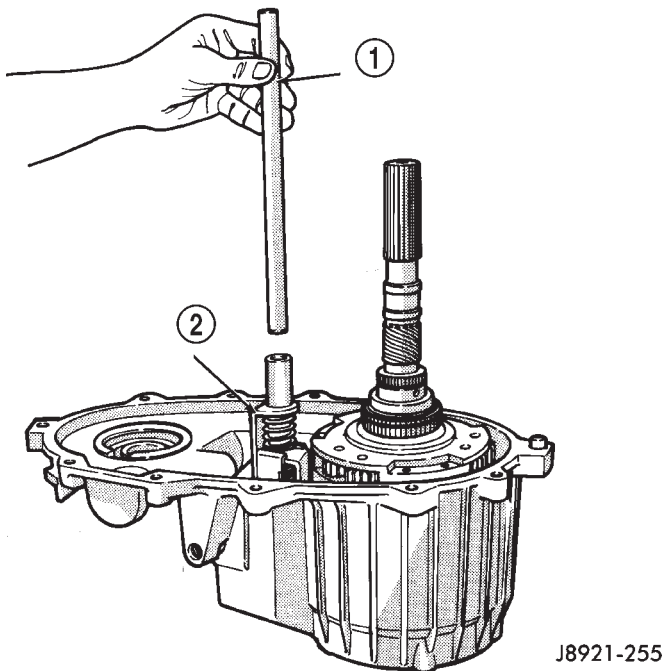

Fig. 80 Shift Rail Installation

- 1 - SHIFT RAIL
- 2 - MODE FORK

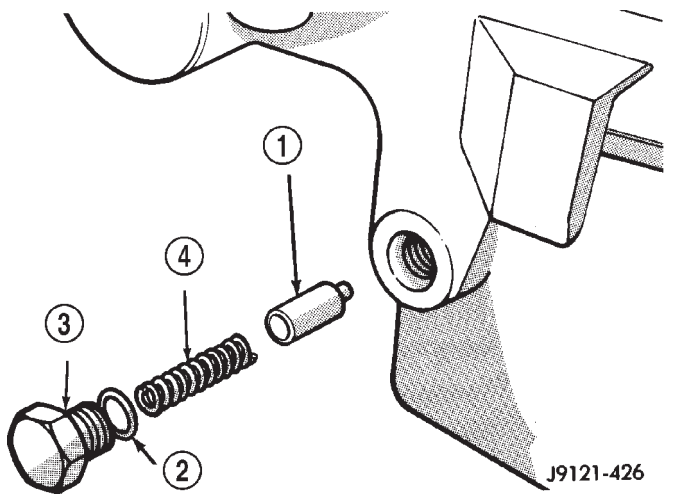
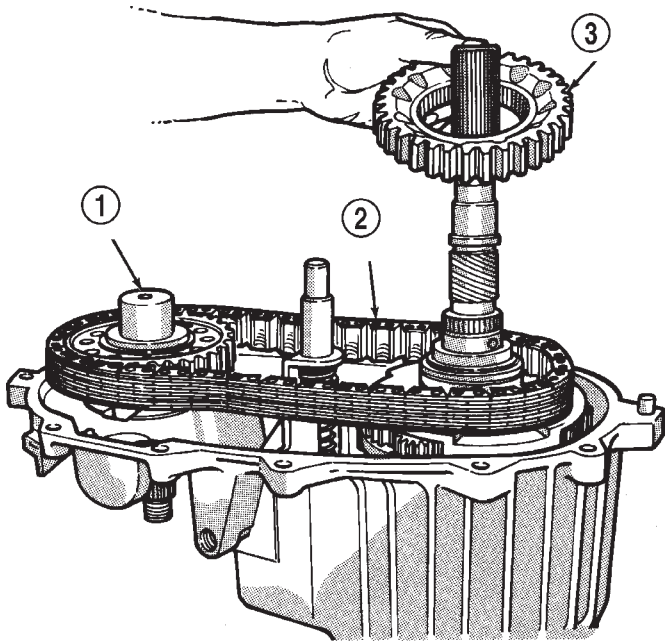

Fig. 82 Detent Pin, Spring And Plug Installation

- 1 - PLUNGER
- 2 - O-RING
- 3 - PLUG
- 4 - SPRING

DISASSEMBLY AND ASSEMBLY (Continued)



J8921-285

Fig. 83 Drive Chain And Sprocket Installation

- 1 - FRONT OUTPUT SHAFT
- 2 - DRIVE CHAIN
- 3 - DRIVE SPROCKET

(4) Install drive sprocket snap-ring (Fig. 84).

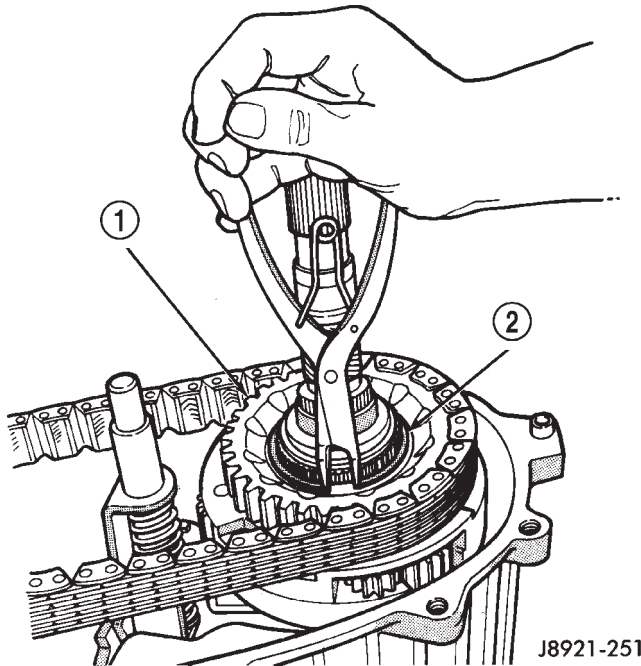

J8921-251

Fig. 84 Drive Sprocket Snap-Ring Installation

- 1 - DRIVE SPROCKET
- 2 - DRIVE SPROCKET SNAP RING

OIL PUMP AND REAR CASE INSTALLATION

(1) Insert oil pickup tube in oil pump and attach oil screen and connector hose to pickup tube. Then install assembled pump, tube and screen in rear case (Fig. 85). Be sure screen is seated in case slot as shown.

(2) Install magnet in front case pocket (Fig. 86).

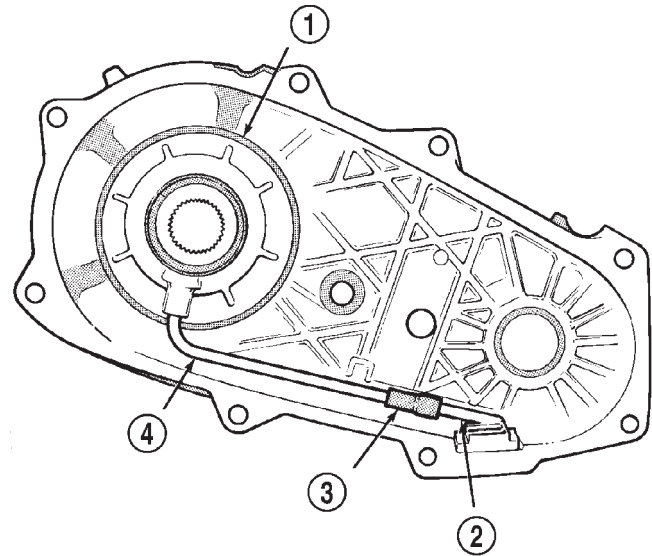

J8921-287

Fig. 85 Oil Screen And Pickup Tube Installation

- 1 - OIL PUMP
- 2 - OIL SCREEN
- 3 - CONNECTOR
- 4 - PICKUP TUBE

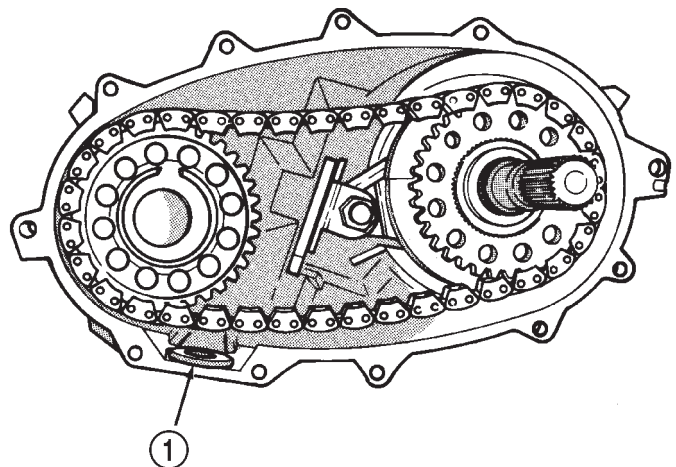

J8921-288

Fig. 86 Installing Case Magnet

- 1 - MAGNET

DISASSEMBLY AND ASSEMBLY (Continued)

(3) Apply 3 mm (1/8 in.) wide bead of Mopar gasket maker or silicone adhesive sealer to seal surface of front case.

(4) Align and install rear case on front case. Be sure case locating dowels are in place and that main-shaft splines are engaged in oil pump inner gear.

(5) Install and tighten front case-to-rear case bolts to 41 N·m (30 ft. lbs.) torque. **Be sure to install a washer under each bolt used at case dowel locations.**

REAR RETAINER INSTALLATION

(1) Remove rear bearing in retainer using Installer 8128 and Handle C-4171.

(2) Install rear bearing in retainer with Tools C-4171 and 5064 (Fig. 87).

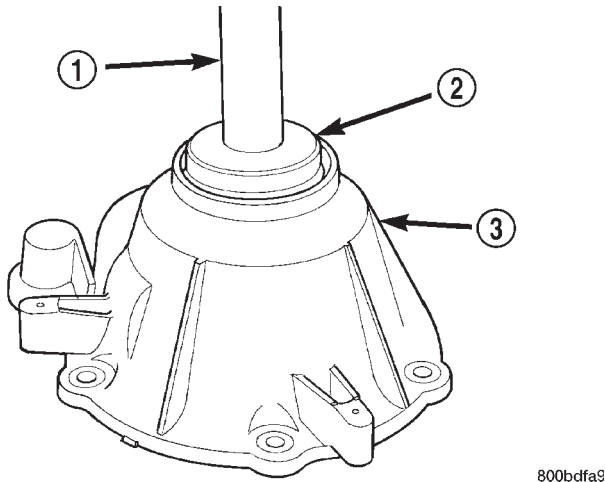

800bdfa9

Fig. 87 Installing Rear Bearing In Retainer

- 1 - SPECIAL TOOL C-4171
- 2 - SPECIAL TOOL 5064
- 3 - REAR RETAINER

(3) Install rear bearing O. D. retaining ring with snap-ring pliers (Fig. 88). Be sure retaining ring is fully seated in retainer groove.

(4) Apply bead of Mopar® Sealer P/N 82300234, or Loctite™ Ultra Gray, to mating surface of rear retainer. Sealer bead should be a maximum of 3/16 in.

(5) Install rear retainer on rear case. Tighten retainer bolts to 20–27 N·m (15–20 ft. lbs.) torque.

(6) Install rear bearing I. D. retaining ring and spacer on output shaft.

(7) Apply liberal quantity of petroleum jelly to new rear seal and to output shaft. Petroleum jelly is needed to protect seal lips during installation.

(8) Slide seal onto Seal Protector 6992 (Fig. 89). Slide seal protector and seal onto output shaft.

(9) Slide Installer C-4076-B onto seal protector with the recessed side of the tool toward the seal.

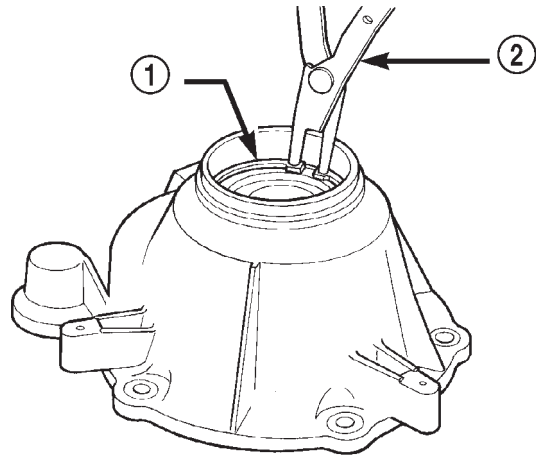

800bdfae

Fig. 88 Rear Bearing Retaining Ring Installation

- 1 - REAR BEARING O. D. RETAINING RING
- 2 - SNAP RING PLIERS

Drive seal into rear bearing retainer with Installer C-4076-B and Handle MD-998323 (Fig. 90).

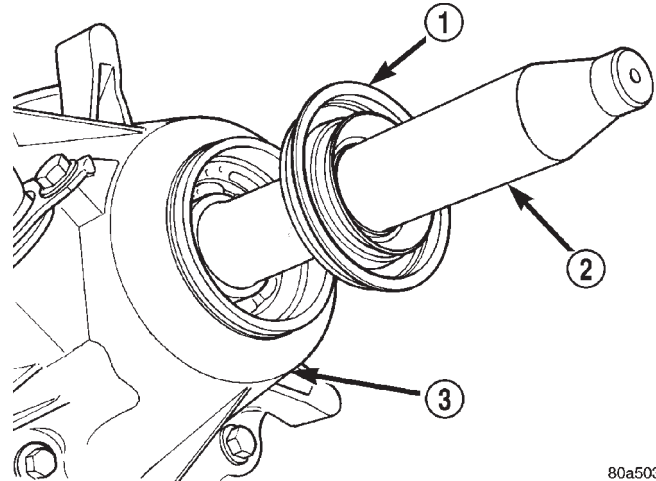

80a50355

Fig. 89 Output Shaft Seal and Protector

- 1 - OUTPUT SHAFT SEAL
- 2 - SPECIAL TOOL 6992
- 3 - TRANSFER CASE

(10) Install rear slinger with Installer 8408.

(11) Install boot on output shaft slinger and crimp retaining clamp with tool C-4975-A (Fig. 91).

FRONT YOKE AND SWITCH INSTALLATION

(1) Install indicator switch in front case. Tighten switch to 20–34 N·m (15–25 ft. lbs.) torque.

(2) Lubricate yoke hub with transmission fluid and install yoke on front shaft.

(3) Install new seal washer on front shaft.

(4) Install yoke on front shaft. Secure yoke with new nut.

DISASSEMBLY AND ASSEMBLY (Continued)

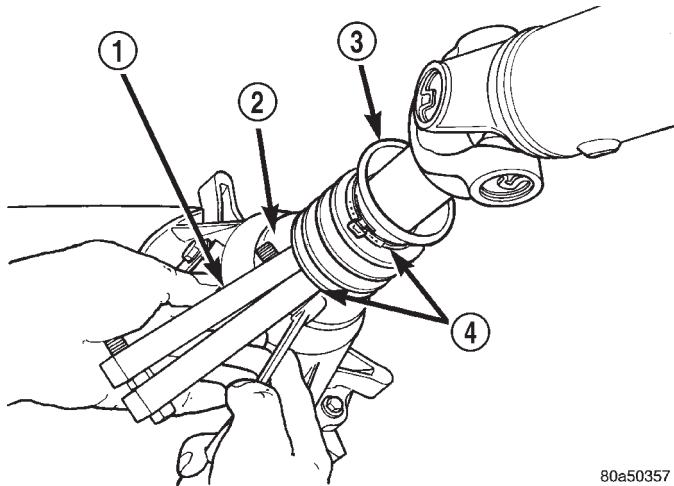

80a50357

Fig. 91 Slinger Boot Installation

- 1 - SPECIAL TOOL C-4975-A
- 2 - SLINGER
- 3 - BOOT
- 4 - CLAMP

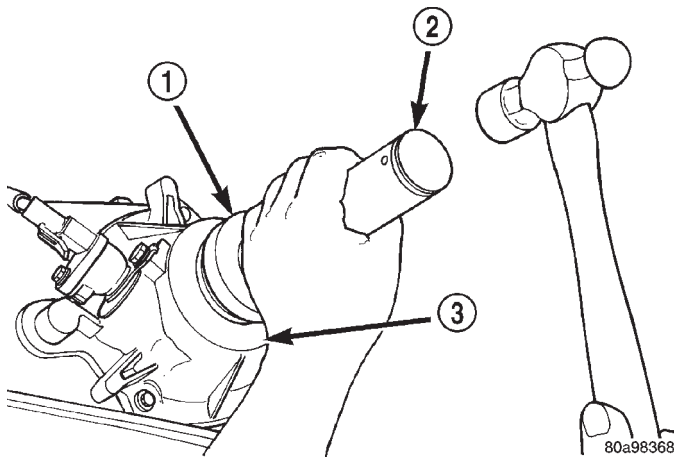

80a98368

Fig. 90 Rear Seal Installation

- 1 - SPECIAL TOOL C-4076-B
- 2 - SPECIAL TOOL MD998323
- 3 - TRANSFER CASE

CLEANING AND INSPECTION

NV242 TRANSFER CASE

Clean the transfer case parts with a standard parts cleaning solvent. Remove all traces of sealer from the cases and retainers with a scraper and all purpose cleaner. Use compressed air to remove solvent residue from oil feed passages in the case halves, retainers, gears, and shafts.

The oil pickup screen can be cleaned with solvent. Shake excess solvent from the screen after cleaning and allow it to air dry. Do not use compressed air.

MAINSHAFT/SPROCKET/HUB INSPECTION

Inspect the splines on the hub and shaft and the teeth on the sprocket. Minor nicks and scratches can be smoothed with an oilstone. However, replace any part is damaged.

Check the contact surfaces in the sprocket bore and on the mainshaft. Minor nicks and scratches can be smoothed with 320–400 grit emery cloth but do not try to salvage the shaft if nicks or wear is severe.

INPUT GEAR AND PLANETARY CARRIER

Check the teeth on the gear (Fig. 92). Minor nicks can be dressed off with an oilstone but replace the gear if any teeth are broken, cracked, or chipped. The bearing surface on the gear can be smoothed with 300–400 grit emery cloth if necessary.

Examine the carrier body and pinion gears for wear or damage. The carrier will have to be replaced as an assembly if the body, pinion pins, or pinion gears are damaged.

Check the lock ring and both thrust washers for wear or cracks. Replace them if necessary. Also replace the lock retaining ring if bent, distorted, or broken.

SHIFT FORKS/HUBS/SLEEVES

Check condition of the shift forks and mode fork shift rail (Fig. 93). Minor nicks on the shift rail can be smoothed with 320–400 grit emery cloth.

Inspect the shift fork wear pads. The mode fork pads are serviceable and can be replaced if necessary. The range fork pads are also serviceable.

Check both of the sleeves for wear or damage, especially on the interior teeth. Replace the sleeves if wear or damage is evident.

REAR RETAINER/BEARING/ SEAL/SLINGER/BOOT

Inspect the retainer components (Fig. 94). Replace the bearing if rough or noisy. Check the retainer for cracks or wear in the bearing bore. Clean the retainer sealing surfaces with a scraper and all purpose cleaner. This will ensure proper adhesion of the sealer during reassembly.

Replace the slinger and seal outright; do not reuse either part.

Inspect the retaining rings and washers. Replace any part if distorted, bent, or broken. Reuse is not recommended. Also replace the boot if cut or torn. Replace the boot band clamps, do not reuse them.

REAR OUTPUT SHAFT/YOKE/DRIVE CHAIN

Check condition of the seal contact surfaces of the yoke slinger (Fig. 95). This surface must be clean and smooth to ensure proper seal life. Replace the yoke nut and seal washer as neither part should be reused.

CLEANING AND INSPECTION (Continued)

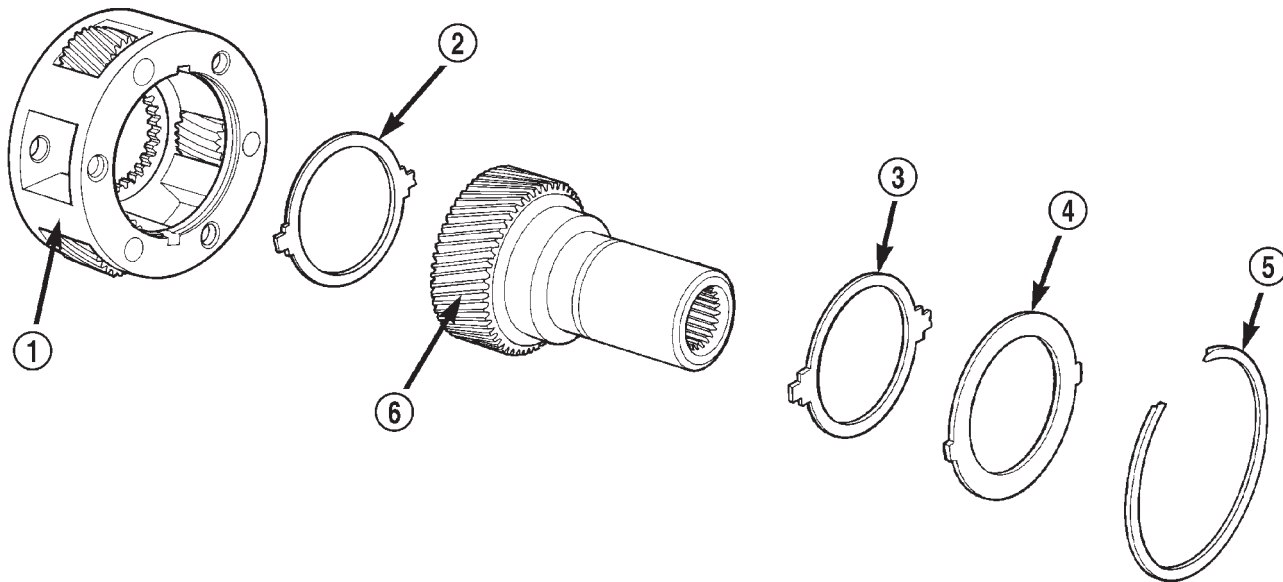

8001b75f

Fig. 92 Input Gear And Carrier Components

- | | |
|-------------------------|---------------------------------|
| 1 - PLANETARY CARRIER | 4 - CARRIER LOCK RING |
| 2 - REAR THRUST WASHER | 5 - CARRIER LOCK RETAINING RING |
| 3 - FRONT THRUST WASHER | 6 - INPUT GEAR |

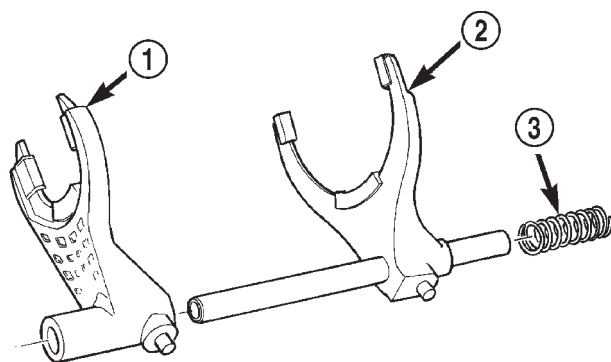

80010948

Fig. 93 Shift forks

- | |
|------------------------|
| 1 - RANGE FORK |
| 2 - MODE FORK AND RAIL |
| 3 - MODE SPRING |

Inspect the shaft threads, sprocket teeth, and bearing surfaces. Minor nicks on the teeth can be smoothed with an oilstone. Use 320–400 grit emery to smooth minor scratches on the shaft bearing surfaces. Rough threads on the shaft can be chased if necessary. Replace the shaft if the threads are damaged, bearing surfaces are scored, or if any sprocket teeth are cracked or broken.

Examine the drive chain and shaft bearings. Replace the chain and both sprockets if the chain is stretched, distorted, or if any of the links bind. Replace the bearings if rough, or noisy.

LOW RANGE ANNULUS GEAR

Inspect annulus gear condition carefully. The gear is only serviced as part of the front case. If the gear is damaged, it will be necessary to replace the gear and front case as an assembly. Do not attempt to remove the gear (Fig. 96).

FRONT-REAR CASES AND FRONT RETAINER

Inspect the cases and retainer for wear and damage. Clean the sealing surfaces with a scraper and all purpose cleaner. This will ensure proper sealer adhesion at assembly. Replace the input retainer seal; do not reuse it.

Check case condition. If leaks were a problem, look for gouges and severe scoring of case sealing surfaces. Also make sure the front case mounting studs are in good condition.

Check the front case mounting studs and vent tube. The tube can be secured with Loctite™ 271 or 680 if loose. The stud threads can be cleaned up with a die if necessary. Also check condition of the fill/drain plug threads in the rear case. The threads can be repaired with a thread chaser or tap if necessary. Or the threads can be repaired with Helicoil stainless steel inserts if required.

CLEANING AND INSPECTION (Continued)

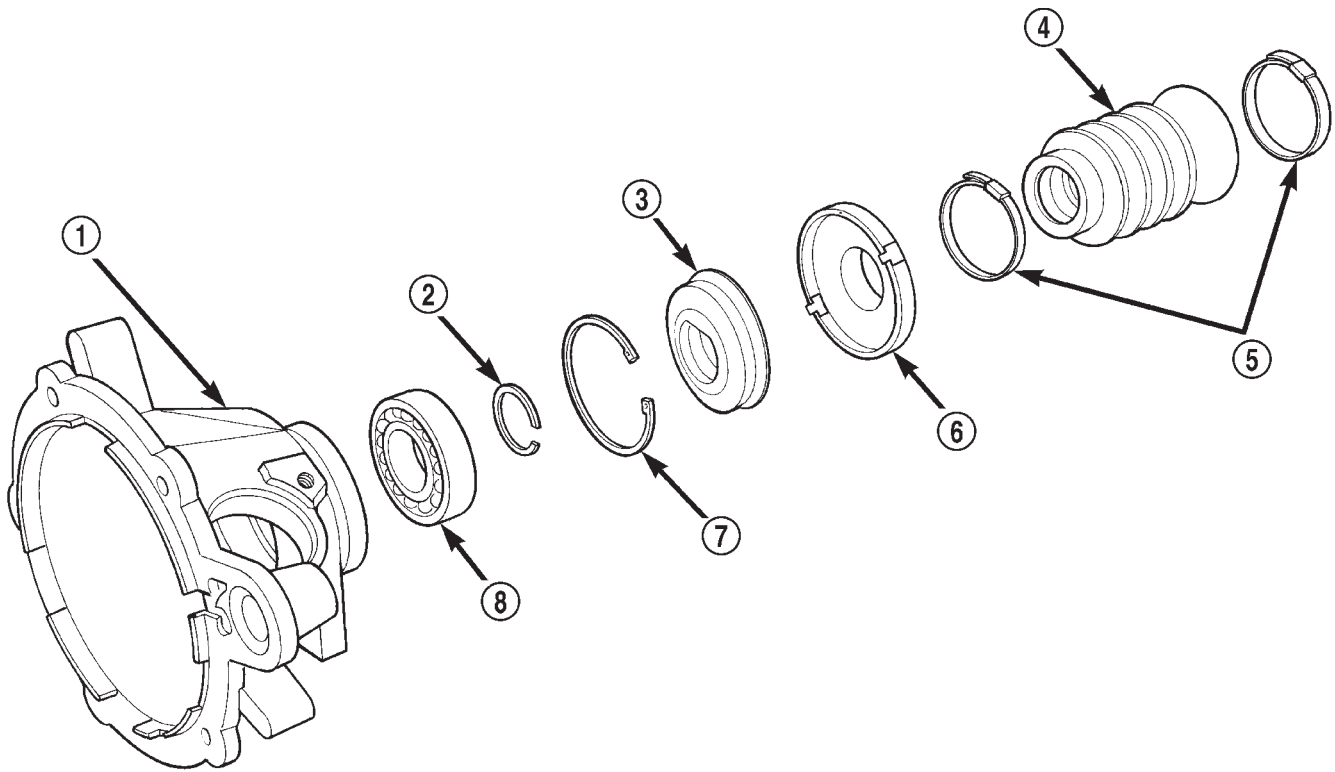

80c07014

Fig. 94 Rear Retainer Components

- | | |
|---------------------------------------|---------------------------------------|
| 1 - REAR RETAINER | 5 - BAND CLAMPS |
| 2 - REAR BEARING I. D. RETAINING RING | 6 - REAR SLINGER |
| 3 - REAR SEAL | 7 - REAR BEARING O. D. RETAINING RING |
| 4 - BOOT | 8 - REAR BEARING |

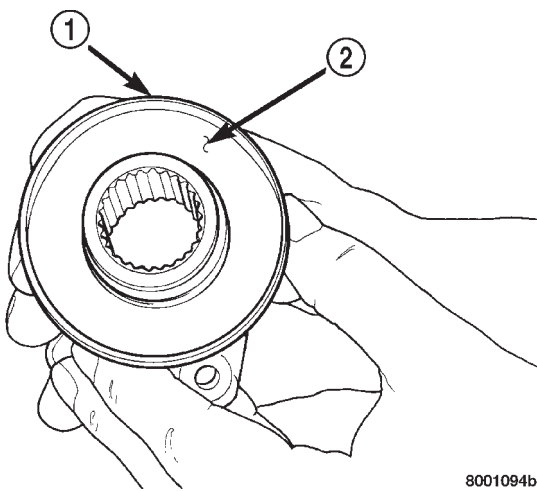

8001094b

Fig. 95 Seal Contact Surface Of Yoke Slinger

- 1 - FRONT SLINGER (PART OF YOKE)
 2 - SEAL CONTACT SURFACE MUST BE CLEAN AND SMOOTH

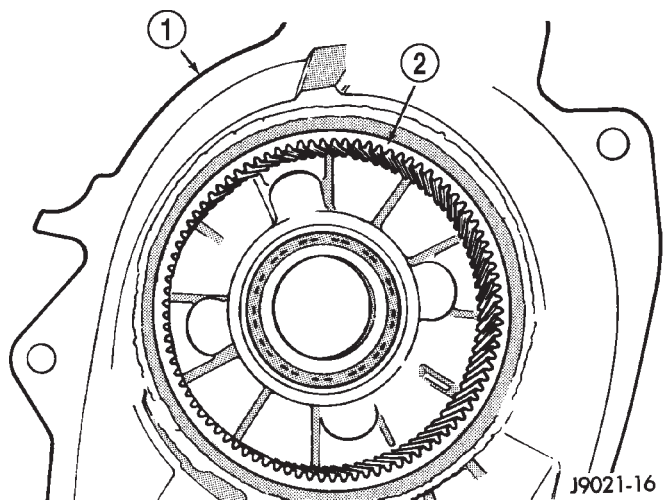

J9021-16

Fig. 96 Low Range Annulus Gear

- 1 - FRONT CASE
 2 - LOW RANGE ANNULUS GEAR

CLEANING AND INSPECTION (Continued)

OIL PUMP/OIL PICKUP

Examine the oil pump pickup parts. Replace the pump if any part appears to be worn or damaged. Do not disassemble the pump as individual parts are not available. The pump is only available as a complete assembly. The pickup screen, hose, and tube are the only serviceable parts and are available separately.

ADJUSTMENTS

SHIFT LINKAGE ADJUSTMENT

- (1) Shift transfer case into 4L position.
- (2) Raise vehicle.
- (3) Loosen lock bolt on adjusting trunnion (Fig. 97).
- (4) Be sure linkage rod slides freely in trunnion. Clean rod and apply spray lube if necessary.
- (5) Verify that transfer case range lever is fully engaged in 4L position.
- (6) Tighten adjusting trunnion lock bolt.
- (7) Lower vehicle.

SPECIFICATIONS

TORQUE

| DESCRIPTION | TORQUE |
|-------------------------------------|-------------------------------|
| Plug, Detent | 16-24 N·m (12-18 ft. lbs.) |
| Bolt, Diff. Case | 17-27 N·m (15-24 ft. lbs.) |
| Plug, Drain/Fill | 20-25 N·m (15-25 ft. lbs.) |
| Bolt, Front Brg. Retainer | 16-27 N·m (12-20 ft. lbs.) |
| Bolt, Case Half | 35-46 N·m (26-34 ft. lbs.) |
| Nut, Front Yoke | 122-176 N·m (90-130 ft. lbs.) |
| Screw, Oil Pump | 1.2-1.8 N·m (12-15 in. lbs.) |
| Nut, Range Lever | 27-34 N·m (20-25 ft. lbs.) |
| Bolt, Rear Retainer | 35-46 N·m (26-34 ft. lbs.) |
| Nuts, Mounting | 35 N·m (26 ft. lbs.) |
| Bolts, U-Joint | 19 N·m (17 ft. lbs.) |

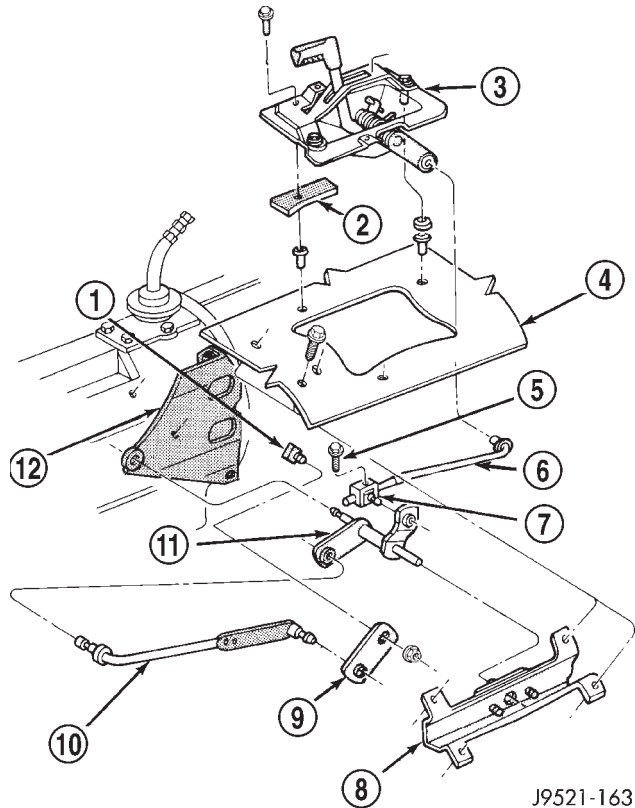

J9521-163

Fig. 97 Shift Linkage

- 1 - TRANSFER CASE SHIFT LEVER SHAFT
- 2 - SEAL
- 3 - TRANSFER CASE SHIFT LEVER ASSEMBLY
- 4 - FLOORPAN
- 5 - TRUNNION LOCK BOLT
- 6 - SHIFT ROD
- 7 - ADJUSTING TRUNNION
- 8 - TORQUE SHAFT BRACKET
- 9 - RANGE LEVER
- 10 - TORQUE SHAFT ROD
- 11 - TORQUE SHAFT
- 12 - LINKAGE BRACKET

SPECIAL TOOLS

NV242

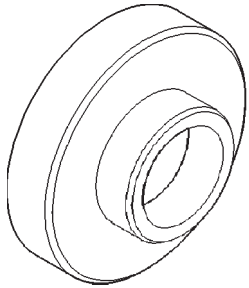

Installer—C-4076-B

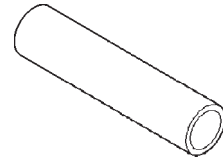

Installer—MD-998323

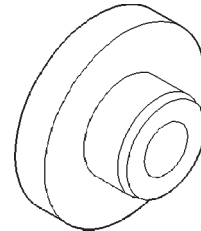

Installer, Bearing—5064

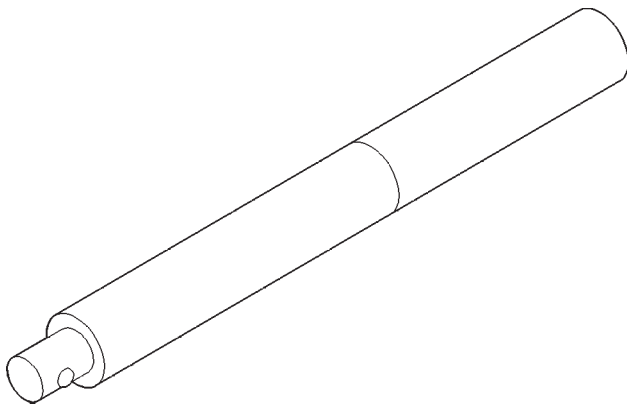

Handle, Universal—C-4171

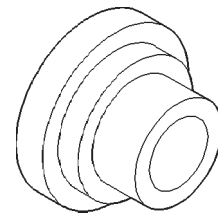

Installer—8128

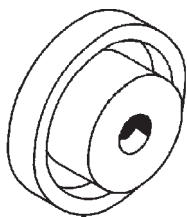

Remover—C-4210

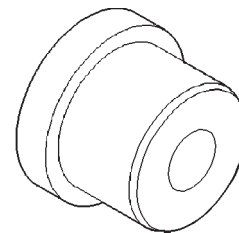

Installer—5066

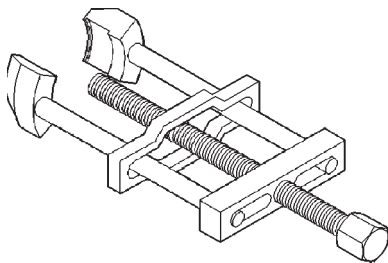

Puller, Slinger—MD-998056-A

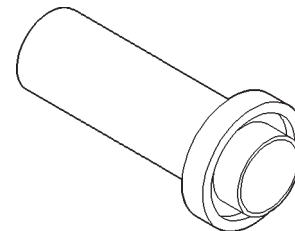

Installer—6952-A

SPECIAL TOOLS (Continued)

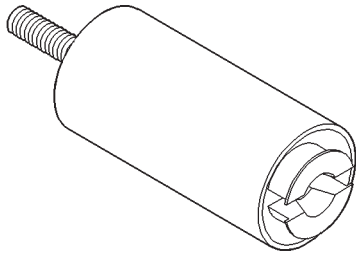

Remover—L-4454

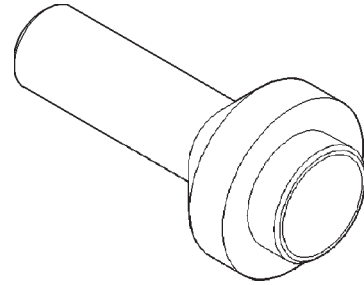

Installer, Seal—7884

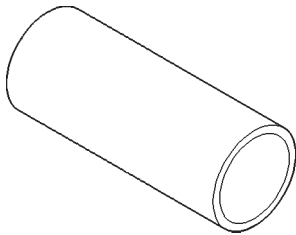

Cup—8148

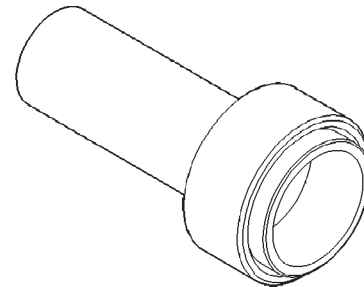

Installer, Pump Housing Seal—7888

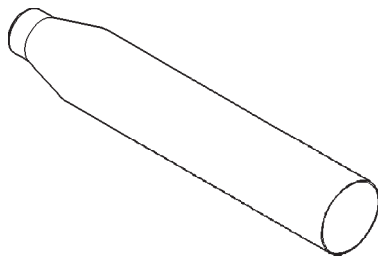

Seal Protector—6992

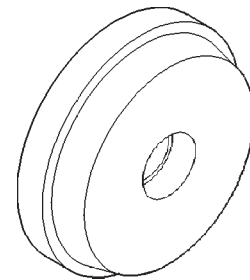

Installer, Bearing—8033-A

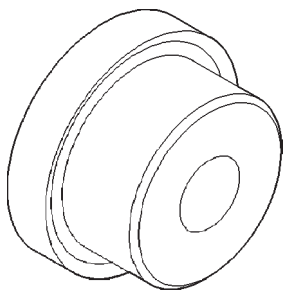

Installer, Input Gear Bearing—7829-A

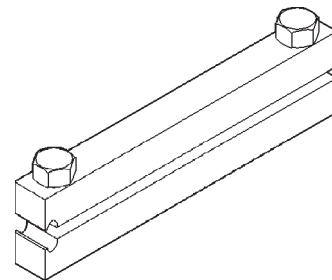

Installer, Boot Clamp—C-4975-A

TRANSMISSION AND TRANSFER CASE

TABLE OF CONTENTS

| | page | | page |
|----------------------------------|------|---------------------------|------|
| NV3550 MANUAL TRANSMISSION | 1 | NV231 TRANSFER CASE | 5 |

NV3550 MANUAL TRANSMISSION

TABLE OF CONTENTS

| | page | | page |
|----------------------------------|------|-----------------------|------|
| REMOVAL AND INSTALLATION | | SPECIFICATIONS | |
| TRANSMISSION - 2.5L TURBO DIESEL | | TORQUE | 4 |
| ENGINE | 1 | | |

REMOVAL AND INSTALLATION

TRANSMISSION - 2.5L TURBO DIESEL ENGINE

REMOVAL

1. Disconnect and isolate the negative battery cable.
2. Remove the floor console, shifter boot and shifter. Refer to group 23, Body for the procedure.
3. Raise the vehicle on a hoist.
4. Drain the transmission fluid (Fig. 1).

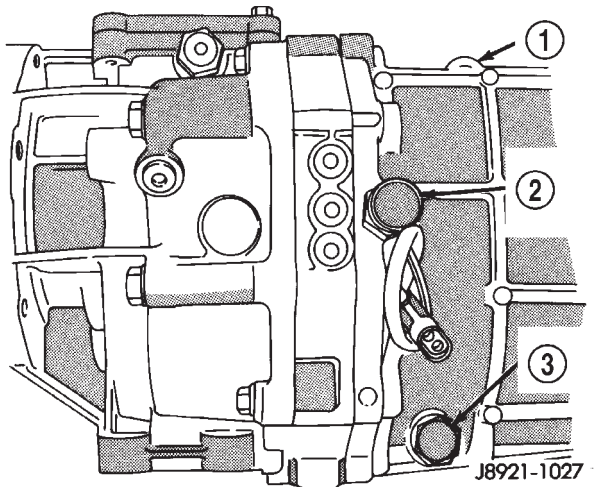

Fig. 1 Drain Plug and Backup Light Switch Location

- 1 - GEAR CASE
- 2 - BACKUP LIGHT SWITCH
- 3 - DRAIN PLUG

5. Remove exhaust pipe and heat shield.
6. Mark the front and rear propeller shafts for installation alignment (Fig. 2).

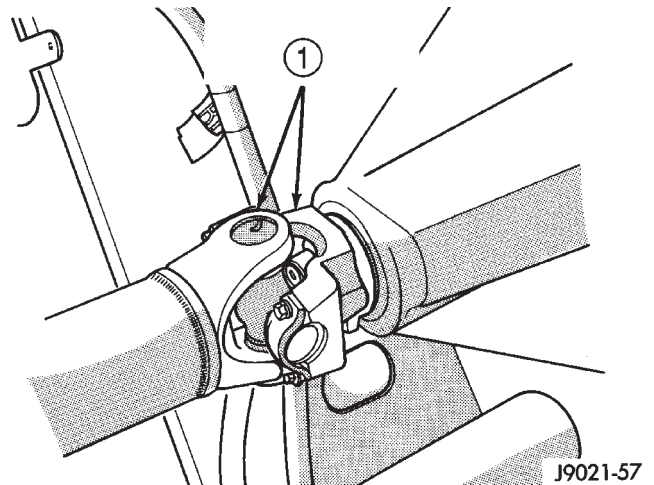
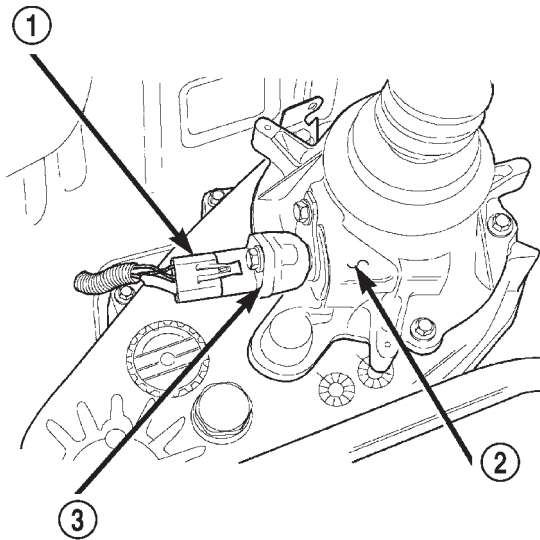

Fig. 2 Marking Propeller Shaft and Axle Yoke

- 1 - MARK BOTH YOKES FOR ALIGNMENT AT INSTALLATION

7. Remove the front propeller shaft.
8. Remove the rear propeller shaft.
9. Remove the transmission skid plate.
10. Disconnect the transfer case linkage and vehicle speed sensor electrical connector and vent tube hose (Fig. 3).
11. Support the engine with an adjustable jack stand.
12. Place a transmission jack under the transmission and secure the transmission with safety chains.

REMOVAL AND INSTALLATION (Continued)

**Fig. 3 Vehicle Speed Sensor**

- 1 - SENSOR ELECTRICAL CONNECTOR
- 2 - 4WD TRANSFER CASE EXTENSION
- 3 - VEHICLE SPEED SENSOR

80a35409

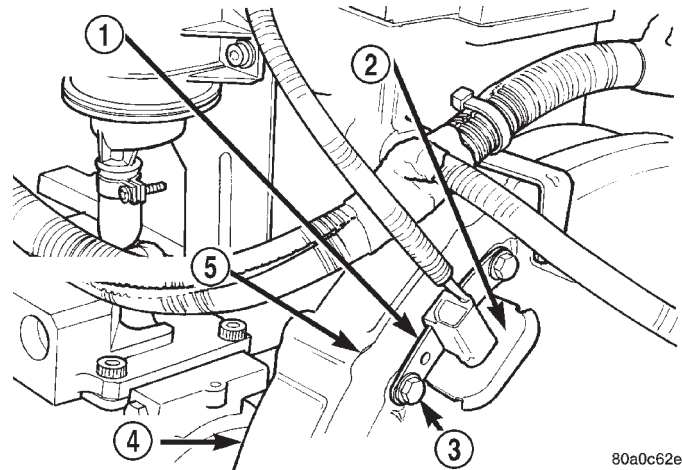

80a0c62e

Fig. 4 Engine Speed Sensor

- 1 - ENGINE SPEED SENSOR
- 2 - GROMMET
- 3 - MOUNTING BOLT(S)
- 4 - LEFT REAR OF ENGINE
- 5 - TRANSMISSION

- 13. Remove the rear transmission mount.
- 14. Remove the rear crossmember.
- 15. Remove the transfer case assembly. Refer to Transfer Case removal later in this Group.
- 16. Lower the engine and transmission no more than 7.6 cm.
- 17. Remove the two (2) upper and two (2) mid clutch housing to engine bolts.
- 18. Remove the engine speed sensor (crankshaft position sensor) (Fig. 4).
- 19. Remove the clutch slave cylinder from the clutch housing.
- 20. Remove the lower transmission bolts.
- 21. Remove the transmission assembly from the vehicle.

INSTALLATION

- 1. Mount the transmission on a transmission jack and secure the transmission with safety chains.
- 2. Position the transmission in the vehicle (Fig. 5).
- 3. Install the two (2) lower transmission bolts. Tighten the bolts to 74.6 N-m.
- 4. Install the clutch slave cylinder on the clutch housing.
- 5. Install the engine speed sensor (crankshaft position sensor) on the vehicle (Fig. 4).

- 6. Install the two (2) upper clutch housing to engine bolts. Tighten the bolts to 36.6 N-m.
- 7. Install the two (2) mid clutch housing to engine bolts. Tighten the bolts to 58.3 N-m.
- 8. Raise the engine and transmission with the adjustable jackstand.
- 9. Install the transfer case assembly. Refer to Transfer Case installation later in this Group.
- 10. Install the rear crossmember.
- 11. Install the rear transmission mount.
- 12. Connect the transfer case linkage and vehicle speed sensor electrical connector and vent tube (Fig. 3).
- 13. Install the transmission skid plate.
- 14. Install the front and rear propeller shafts in their original position, using the reference marks scribed earlier.
- 15. Install the exhaust pipe and heat shield.
- 16. Remove the transmission jack.
- 17. Fill the transmission with the proper fluid (Fig. 7).
- 18. Remove the adjustable jackstand from under the engine.
- 19. Lower the vehicle from the hoist.
- 20. Install the shifter, shifter boot and floor console.
- 21. Reconnect the negative battery cable.
- 22. Using the DRB III Scan Tool clear any DTC's and reset customer preferences.

SPECIFICATIONS (Continued)

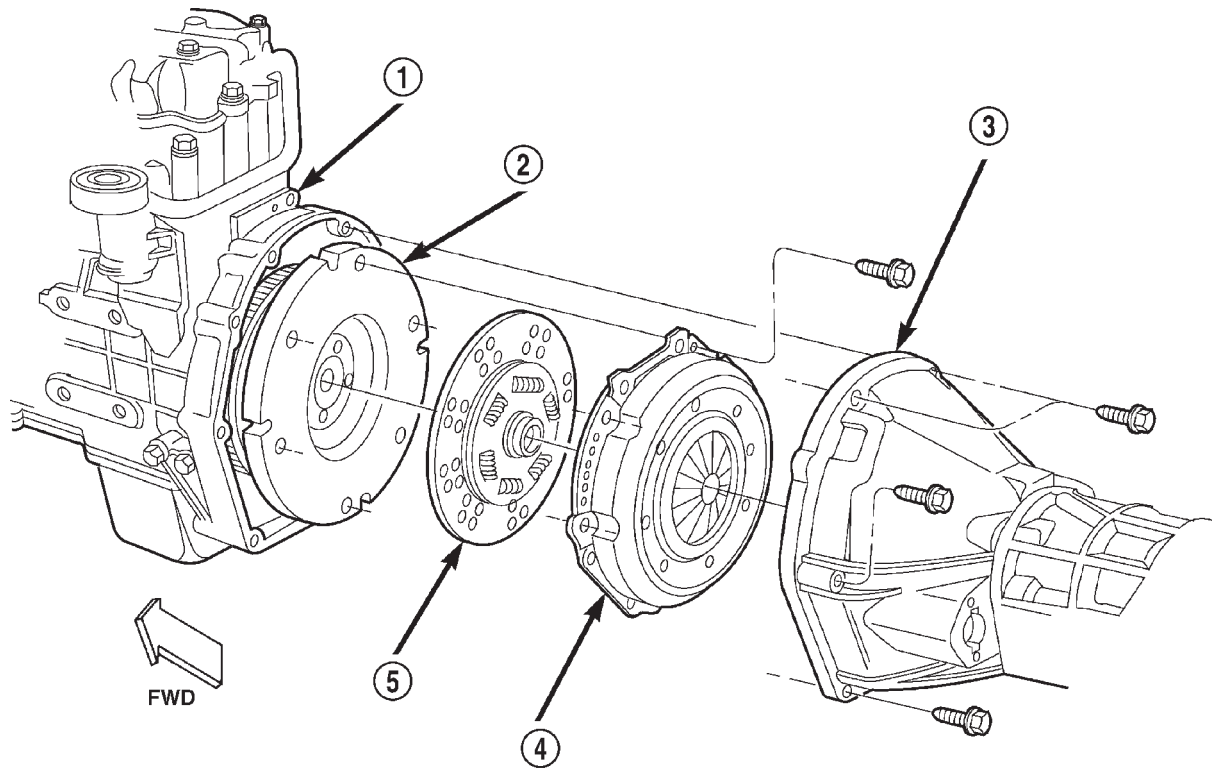

80abfe70

Fig. 5 Transmission to Engine Mounting

- | | |
|-------------------------------------|------------------|
| 1 - ENGINE BLOCK | 4 - CLUTCH COVER |
| 2 - FLYWHEEL | 5 - CLUTCH DISC |
| 3 - CLUTCH HOUSING AND TRANSMISSION | |

SPECIFICATIONS (Continued)

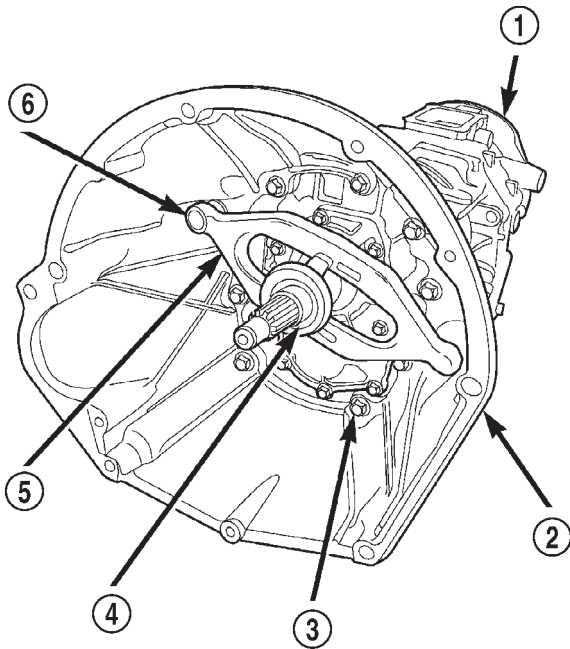

80ad087e

Fig. 6 Clutch Housing to Transmission

- 1 - TRANSMISSION
- 2 - CLUTCH HOUSING
- 3 - CLUTCH HOUSING BOLT
- 4 - RELEASE BEARING
- 5 - RELEASE FORK
- 6 - PIVOT

SPECIFICATIONS

TORQUE

| DESCRIPTION | TORQUE |
|---|---------------------------|
| Clutch Housing to Engine Top (2) Bolts . . . | 36.6 N·m (27 ft. lbs.) |
| Clutch Housing to Engine Mid-Point (2) Bolts | 58.3 N·m (43 ft. lbs.) |
| Clutch Housing to Engine Bottom (2) Bolts | 74.6 N·m (55 ft. lbs.) |
| Clutch Housing to Transmission bolts . . . | 38.0 N·m (28 ft. lbs.) |
| Transfer Case to Transmission | |
| Attaching Nuts | 35 N·m (26 ft. lbs.) |
| Propeller Shaft Bolts | 26.5 N·m (19.5 ft. lbs.) |

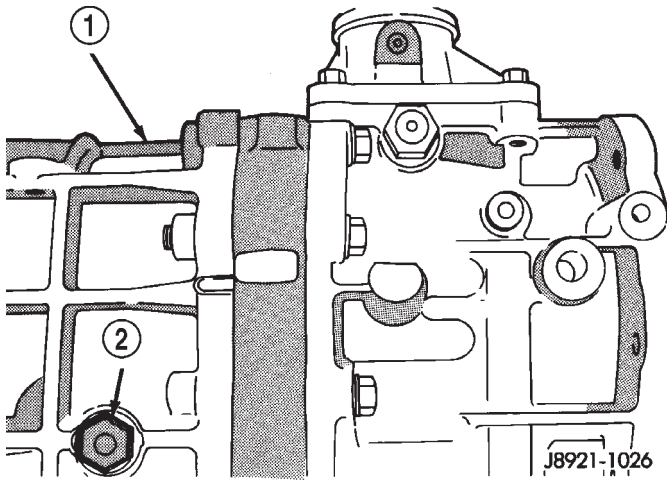

Fig. 7 Fill Plug Location

- 1 - GEAR CASE
- 2 - FILL PLUG

NV231 TRANSFER CASE

TABLE OF CONTENTS

| | | | |
|---------------------------------|------|-----------------------|------|
| | page | | page |
| REMOVAL AND INSTALLATION | | SPECIFICATIONS | |
| TRANSFER CASE | 5 | TORQUE | 5 |

REMOVAL AND INSTALLATION

TRANSFER CASE

REMOVAL

- (1) Shift transfer case into Neutral.
- (2) Raise vehicle.
- (3) Drain transfer case lubricant.
- (4) Mark front and rear propeller shaft yokes for alignment reference.
- (5) Support transmission with jack stand.
- (6) Remove rear crossmember and skid plate, if equipped.
- (7) Disconnect and support front/rear propeller shafts at transfer case.
- (8) Disconnect vehicle speed sensor wires.
- (9) Disconnect transfer case linkage rod from range lever.
- (10) Disconnect transfer case vent hose (Fig. 1) and indicator switch harness, if necessary.
- (11) Support transfer case with transmission jack.
- (12) Secure transfer case to jack with chains.
- (13) Remove nuts attaching transfer case to transmission.
- (14) Pull transfer case and jack rearward to disengage transfer case.
- (15) Remove transfer case from under vehicle.

INSTALLATION

- (1) Mount transfer case on a transmission jack.
- (2) Secure transfer case to jack with chains.
- (3) Position transfer case under vehicle.
- (4) Align transfer case and transmission shafts and install transfer case on transmission.
- (5) Install and tighten transfer case attaching nuts to 35 N·m (Fig. 1).
- (6) Connect vehicle speed sensor wires, and vent hose.
- (7) Connect indicator switch harness to transfer case switch, if necessary. Secure wire harness to clips on transfer case.

NOTE: Do not reuse bearing straps or bolts. Discard and replace with new.

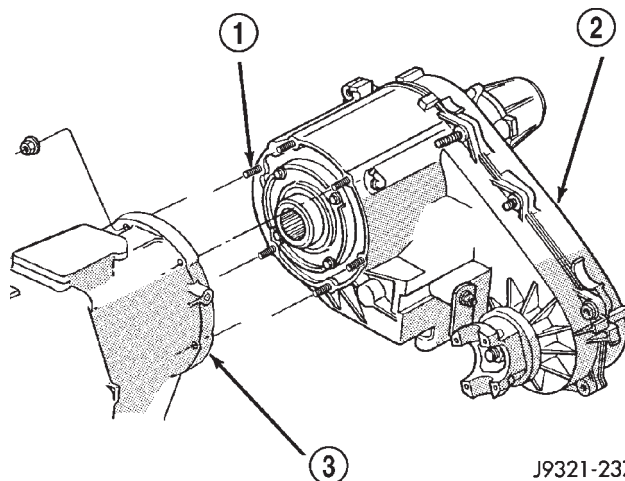

Fig. 1 Transfer Case Mounting

- 1 - MOUNTING STUDS
- 2 - TRANSFER CASE
- 3 - TRANSMISSION

- (8) Align and connect propeller shafts. Tighten shaft attaching bolts to 26.5 N·m torque.
- (9) Fill transfer case with correct fluid. Refer to Recommended Lubricant And Fill Level section for proper fluid and capacity.
- (10) Install rear crossmember and skid plate, if equipped. Tighten crossmember bolts.
- (11) Remove transmission jack and support stand.
- (12) Connect shift rod to transfer case range lever.
- (13) Adjust transfer case shift linkage.
- (14) Lower vehicle and verify transfer case shift operation.

SPECIFICATIONS

TORQUE

| DESCRIPTION | TORQUE |
|-----------------------------|--------|
| Plug, Drain/Fill | 40 N·m |
| Nuts, Mounting | 35 N·m |
| Switch, Indicator | 26 N·m |

TIRES AND WHEELS

TABLE OF CONTENTS

| | | | |
|-------------|------|--------------|------|
| | page | | page |
| TIRES | 1 | WHEELS | 7 |

TIRES

TABLE OF CONTENTS

| | | | |
|-----------------------------------|------|--------------------------------|------|
| | page | | page |
| DESCRIPTION AND OPERATION | | TIRE WEAR PATTERNS..... | 3 |
| TIRES | 1 | TIRE NOISE OR VIBRATION | 3 |
| RADIAL-PLY TIRES | 2 | SERVICE PROCEDURES | |
| SPARE TIRE-TEMPORARY | 2 | ROTATION..... | 4 |
| TIRE INFLATION PRESSURES | 2 | MATCH MOUNTING..... | 4 |
| TIRE PRESSURE FOR HIGH SPEED..... | 3 | REPAIRING LEAKS | 5 |
| REPLACEMENT TIRES | 3 | CLEANING AND INSPECTION | |
| DIAGNOSIS AND TESTING | | CLEANING TIRES | 6 |
| PRESSURE GAUGES | 3 | SPECIFICATIONS | |
| TREAD WEAR INDICATORS | 3 | TIRE SIZE | 6 |

DESCRIPTION AND OPERATION

TIRES

DESCRIPTION

Tires are designed and engineered for each specific vehicle. They provide the best overall performance for normal operation. The ride and handling characteristics match the vehicle's requirements. With proper care they will give excellent reliability, traction, skid resistance, and tread life.

Driving habits have more effect on tire life than any other factor. Careful drivers will obtain in most cases, much greater mileage than severe use or careless drivers. A few of the driving habits which will shorten the life of any tire are:

- Rapid acceleration
- Severe brake applications
- High speed driving
- Excessive speeds on turns
- Striking curbs and other obstacles

Radial-ply tires are more prone to irregular tread wear. It is important to follow the tire rotation interval shown in the section on Tire Rotation. This will help to achieve a greater tread life.

TIRE IDENTIFICATION

Tire type, size, aspect ratio and speed rating are encoded in the letters and numbers imprinted on the side wall of the tire. Refer to the chart to decipher the tire identification code (Fig. 1).

Performance tires have a speed rating letter after the aspect ratio number.

| LETTER | SPEED RATING |
|--------|--------------------|
| S | 180 km/h (112 mph) |
| T | 190 km/h (118 mph) |
| U | 200 km/h (124 mph) |
| H | 210 km/h (130 mph) |
| V | 240 km/h (149 mph) |
| W | 270 km/h (168 mph) |
| Y | 300 km/h (186 mph) |

The speed rating is not always printed on the tire sidewall.

DESCRIPTION AND OPERATION (Continued)

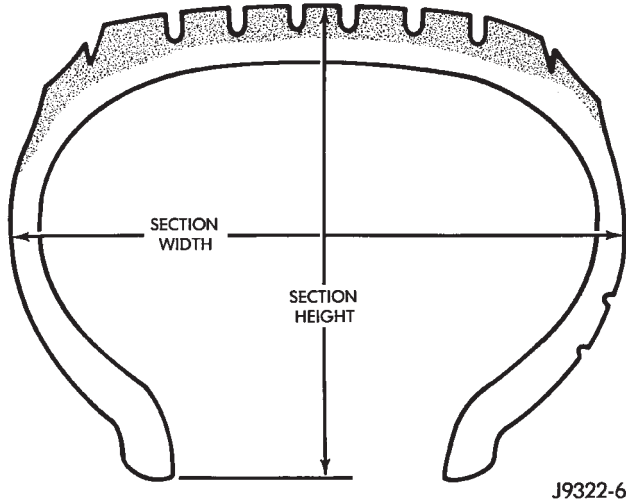
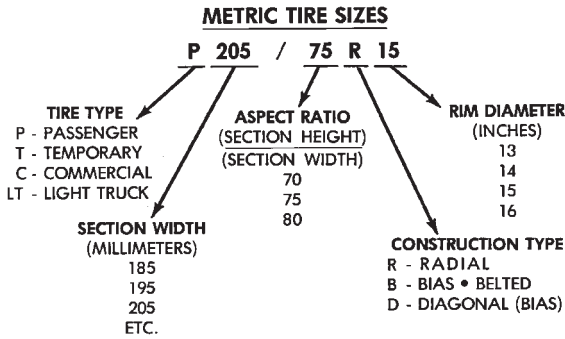

J9322-6

Fig. 1 Tire Identification

TIRE CHAINS

Tire snow chains may be used on **certain** models. Refer to the Owner's Manual for more information.

RADIAL-PLY TIRES

DESCRIPTION

Radial-ply tires improve handling, tread life and ride quality, and decrease rolling resistance.

Radial-ply tires must always be used in sets of four. Under no circumstances should they be used on the front only. They may be mixed with temporary spare tires when necessary. A maximum speed of 50 MPH is recommended while a temporary spare is in use.

Radial-ply tires have the same load-carrying capacity as other types of tires of the same size. They also use the same recommended inflation pressures.

The use of oversized tires, either in the front or rear of the vehicle, can cause vehicle drive train failure. This could also cause inaccurate wheel speed signals when the vehicle is equipped with Anti-Lock Brakes.

The use of tires from different manufactures on the same vehicle is NOT recommended. The proper tire pressure should be maintained on all four tires.

SPARE TIRE-TEMPORARY

DESCRIPTION

The temporary spare tire is designed for emergency use only. The original tire should be repaired or replaced at the first opportunity, then reinstalled. Do not exceed speeds of 50 M. P. H. when using the temporary spare tire. Refer to Owner's Manual for complete details.

TIRE INFLATION PRESSURES

Under inflation will cause rapid shoulder wear, tire flexing, and possible tire failure (Fig. 2).

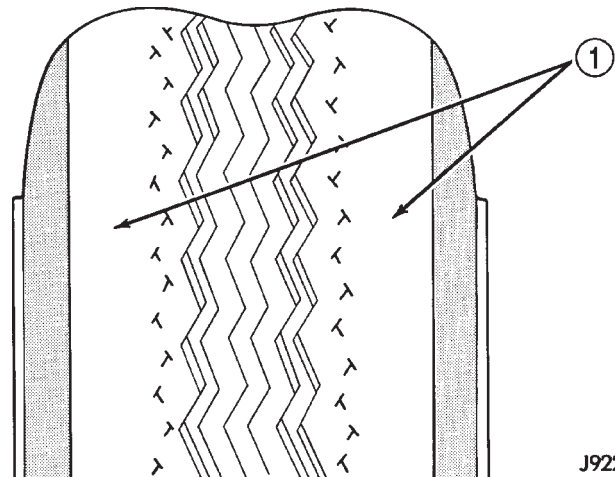

J9222-1

Fig. 2 Under Inflation Wear

1 - THIN TIRE THREAD AREAS

Over inflation will cause rapid center wear and loss of the tire's ability to cushion shocks (Fig. 3).

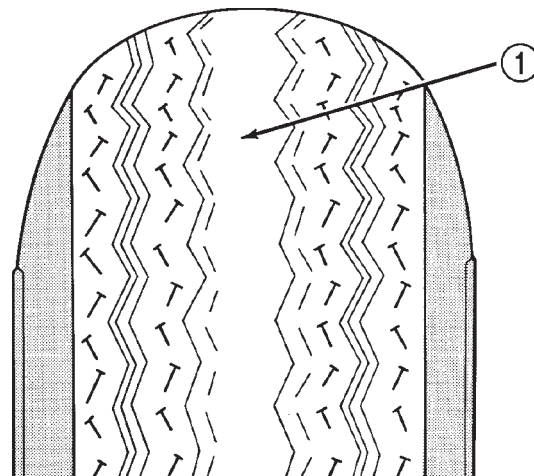

J9222-2

Fig. 3 Over Inflation Wear

1 - THIN TIRE THREAD AREA

Improper inflation can cause:

- Uneven wear patterns

DESCRIPTION AND OPERATION (Continued)

- Reduced tread life
- Reduced fuel economy
- Unsatisfactory ride
- Vehicle drift

For proper tire pressure specification refer to the Tire Inflation Pressure Chart provided with the vehicle.

Tire pressures have been chosen to provide safe operation, vehicle stability, and a smooth ride. Tire pressure should be checked cold once a month. The spare tire pressure should be checked at least twice annually. Tire pressure decreases as the ambient temperature drops. Check tire pressure frequently when ambient temperature varies widely.

Inflation pressures specified on the placards are cold inflation pressure. The vehicle must sit for at least 3 hours to obtain the correct cold inflation pressure reading. Or driven less than one mile after sitting for 3 hours. Tire inflation pressures may increase from 2 to 6 pounds per square inch (psi) during operation, due to increased tire temperature.

WARNING: OVER OR UNDER INFLATED TIRES CAN AFFECT VEHICLE HANDLING AND TREAD WEAR. THIS MAY CAUSE THE TIRE TO FAIL SUDDENLY, RESULTING IN LOSS OF VEHICLE CONTROL.

TIRE PRESSURE FOR HIGH SPEED

DESCRIPTION

Where speed limits allow the vehicle to be driven at high speeds, correct tire inflation pressure is very important. For speeds up to and including 120 km/h (75 mph), tires must be inflated to the pressures shown on the tire placard. For continuous speeds in excess of 120 km/h (75 mph), tires must be inflated to the maximum pressure specified on the tire sidewall.

Vehicles loaded to the maximum capacity should not be driven at continuous speeds above 75 mph (120 km/h).

For emergency vehicles that are driven at speeds over 90 mph (144 km/h), special high speed tires must be used. Consult tire manufacturer for correct inflation pressure recommendations.

REPLACEMENT TIRES

DESCRIPTION

The original equipment tires provide a proper balance of many characteristics such as:

- Ride
- Noise

- Handling
- Durability
- Tread life
- Traction
- Rolling resistance
- Speed capability

It is recommended that tires equivalent to the original equipment tires be used when replacement is needed.

Failure to use equivalent replacement tires may adversely affect the safety and handling of the vehicle.

The use of oversize tires may cause interference with vehicle components. Under extremes of suspension and steering travel, interference with vehicle components may cause tire damage.

WARNING: FAILURE TO EQUIP THE VEHICLE WITH TIRES HAVING ADEQUATE SPEED CAPABILITY CAN RESULT IN SUDDEN TIRE FAILURE.

DIAGNOSIS AND TESTING

PRESSURE GAUGES

A quality air pressure gauge is recommended to check tire pressure. After checking the air pressure, replace valve cap finger tight.

TREAD WEAR INDICATORS

Tread wear indicators are molded into the bottom of the tread grooves. When tread depth is 1.6 mm (1/16 in.), the tread wear indicators will appear as a 13 mm (1/2 in.) band (Fig. 4).

Tire replacement is necessary when indicators appear in two or more grooves or if localized balding occurs.

TIRE WEAR PATTERNS

Under inflation will cause wear on the shoulders of tire. Over inflation will cause wear at the center of tire.

Excessive camber causes the tire to run at an angle to the road. One side of tread is then worn more than the other (Fig. 5).

Excessive toe-in or toe-out causes wear on the tread edges and a feathered effect across the tread (Fig. 5).

TIRE NOISE OR VIBRATION

Radial-ply tires are sensitive to force impulses caused by improper mounting, vibration, wheel defects, or possibly tire imbalance.

To find out if tires are causing the noise or vibration, drive the vehicle over a smooth road at varying

DIAGNOSIS AND TESTING (Continued)

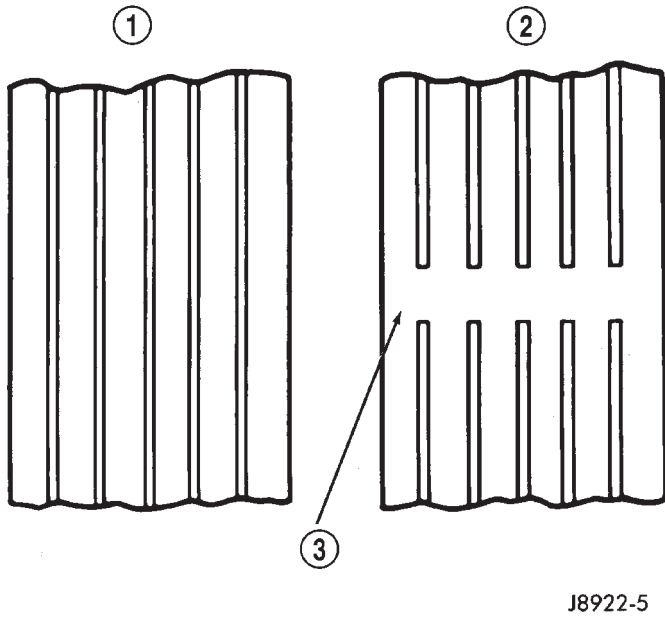

Fig. 4 Tread Wear Indicators

- 1 - THREAD ACCEPTABLE
- 2 - THREAD UNACCEPTABLE
- 3 - WEAR INDICATOR

patterns. These effects can be reduced by rotating the tires at regular intervals. The benefits of tire rotation are:

- Increase tread life
- Maintain traction levels
- A smooth, quiet ride

The suggested method of tire rotation is (Fig. 6). Other rotation methods can be used, but they will not provide all the tire longevity benefits.

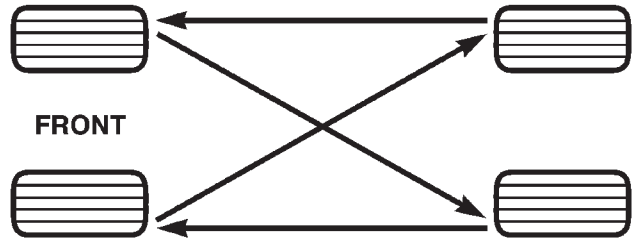

Fig. 6 Tire Rotation Pattern

8031e864

speeds. Note the noise level during acceleration, deceleration and slight left and right steering inputs.

SERVICE PROCEDURES

ROTATION

Tires on the front and rear operate at different loads and perform different steering, driving, and braking functions. For these reasons they wear at unequal rates and tend to develop irregular wear

MATCH MOUNTING

Tires and wheels are currently match mounted at the factory. Match mounting is a technique used to reduce runout in the wheel/tire assembly. This means that the high spot of the tire is aligned with the low spot on the wheel rim. The high spot on the tire is marked with a paint mark or a bright colored adhesive label on the outboard sidewall. The low spot on the rim is identified with a label on the outside of the rim and a dot on the inside of the rim. If the outside label has been removed the tire will have to be removed to locate the dot on the inside of the rim.

| CONDITION | RAPID WEAR AT SHOULDERS | RAPID WEAR AT CENTER | CRACKED TREADS | WEAR ON ONE SIDE | FEATHERED EDGE | BALD SPOTS | SCALLOPED WEAR |
|------------|--|--|-------------------------------------|---------------------------------|---------------------------------|----------------------------------|---|
| EFFECT | | | | | | | |
| CAUSE | UNDER-INFLATION OR LACK OF ROTATION | OVER-INFLATION OR LACK OF ROTATION | UNDER-INFLATION OR EXCESSIVE SPEED* | EXCESSIVE CAMBER | INCORRECT TOE | UNBALANCED WHEEL | LACK OF ROTATION OF TIRES OR WORN OR OUT-OF-ALIGNMENT SUSPENSION. |
| CORRECTION | ADJUST PRESSURE TO SPECIFICATIONS WHEN TIRES ARE COOL ROTATE TIRES | | | ADJUST CAMBER TO SPECIFICATIONS | ADJUST TOE-IN TO SPECIFICATIONS | DYNAMIC OR STATIC BALANCE WHEELS | ROTATE TIRES AND INSPECT SUSPENSION SEE GROUP 2 |

*HAVE TIRE INSPECTED FOR FURTHER USE.

RN797

Fig. 5 Tire Wear Patterns

SERVICE PROCEDURES (Continued)

Before dismounting a tire from its wheel, a reference mark should be placed on the tire at the valve stem location. This reference will ensure that it is remounted in the original position on the wheel.

(1) Use a dial indicator to locate the high spot of the tire on the center tread rib (Fig. 7). Record the indicator reading and mark the high spot on the tire. Place a mark on the tire at the valve stem location (Fig. 8).

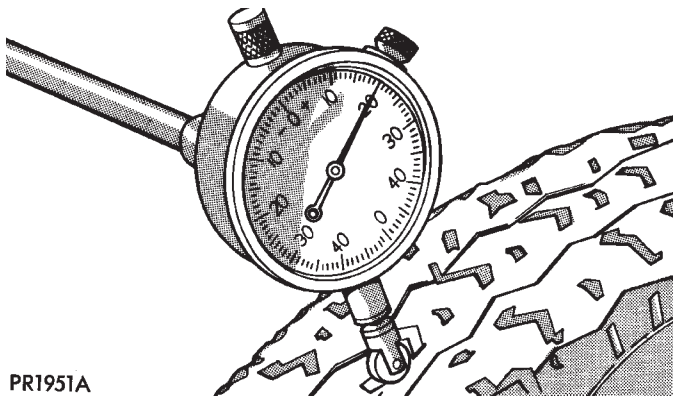

PR1951A

Fig. 7 Dial Indicator

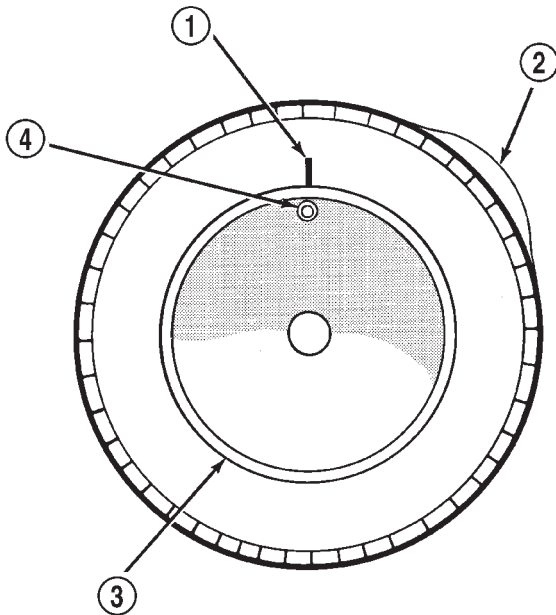

J9322-3

Fig. 8 First Measurement On Tire

- 1 - REFERENCE MARK
- 2 - 1ST MEASUREMENT HIGH SPOT MARK TIRE AND RIM
- 3 - WHEEL
- 4 - VALVE STEM

(2) Break down the tire and remount it 180 degrees on the rim (Fig. 9).

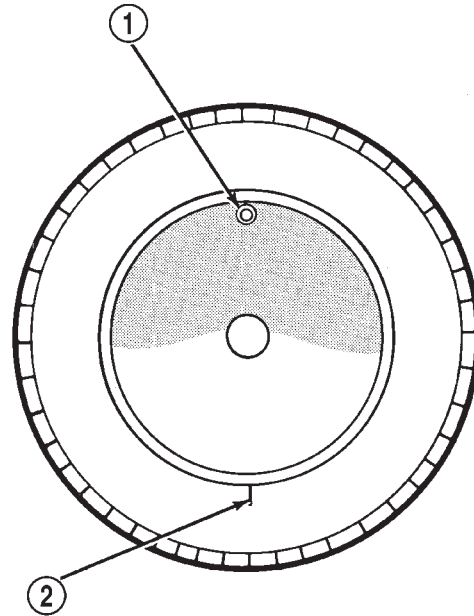

J9322-4

Fig. 9 Remount Tire 180 Degrees

- 1 - VALVE STEM
- 2 - REFERENCE MARK

(3) Measure the total runout again and mark the tire to indicate the high spot.

(4) If runout is still excessive use the following procedures.

(a) If the high spot is within 101.6 mm (4.0 in.) of the first spot and is still excessive, replace the tire.

(b) If the high spot is within 101.6 mm (4.0 in.) of the first spot on the wheel, the wheel may be out of specifications. Refer to Wheel and Tire Runout.

(c) If the high spot is NOT within 101.6 mm (4.0 in.) of either high spot, draw an arrow on the tread from second high spot to first. Break down the tire and remount it 90 degrees on rim in that direction (Fig. 10). This procedure will normally reduce the runout to an acceptable amount.

REPAIRING LEAKS

For proper repairing, a radial tire must be removed from the wheel. Repairs should only be made if the defect, or puncture, is in the tread area (Fig. 11). The tire should be replaced if the puncture is located in the sidewall.

SERVICE PROCEDURES (Continued)

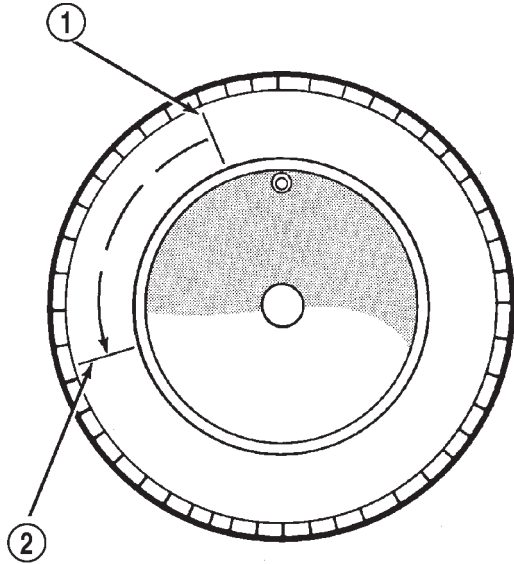

J9322-5

Fig. 10 Remount Tire 90 Degrees In Direction of Arrow

- 1 - 2ND HIGH SPOT ON TIRE
- 2 - 1ST HIGH SPOT ON TIRE

Deflate tire completely before removing the tire from the wheel. Use lubrication such as a mild soap solution when dismounting or mounting tire. Use tools free of burrs or sharp edges which could damage the tire or wheel rim.

Before mounting tire on wheel, make sure all rust is removed from the rim bead and repaint if necessary.

Install wheel on vehicle, and tighten to proper torque specification.

CLEANING AND INSPECTION

CLEANING TIRES

Remove the protective coating on the tires before delivery of a vehicle. This coating may cause deterioration of the tires.

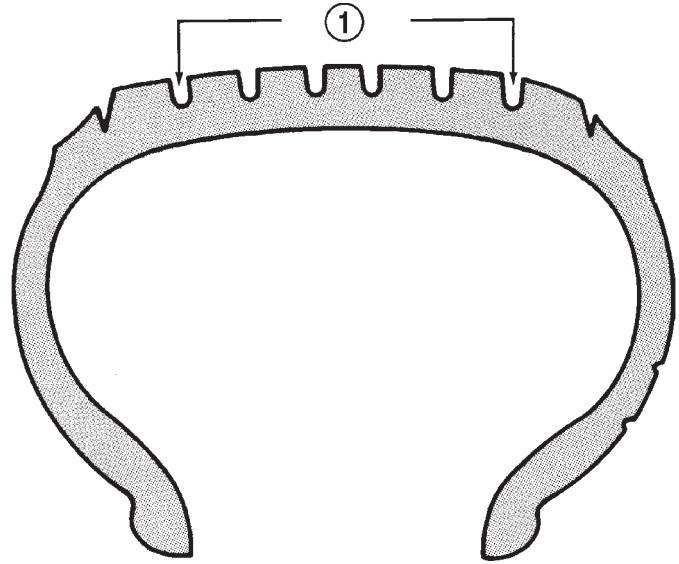

J8922-6

Fig. 11 Tire Repair Area

- 1 - REPAIRABLE AREA

To remove the protective coating, apply warm water and let it soak for a few minutes. Afterwards, scrub the coating away with a soft bristle brush. Steam cleaning may also be used to remove the coating.

NOTE: DO NOT use gasoline, mineral oil, oil-based solvent or a wire brush for cleaning.

SPECIFICATIONS

TIRE SIZE

| TIRE SIZE | SUPPLIER |
|------------|----------|
| P215/75R15 | Goodyear |
| P225/75R15 | Goodyear |
| P225/70R15 | Goodyear |
| P225/70R16 | Goodyear |

WHEELS

TABLE OF CONTENTS

| | page | | page |
|----------------------------------|------|------------------------------|------|
| DESCRIPTION AND OPERATION | | SERVICE PROCEDURES | |
| WHEEL | 7 | WHEEL INSTALLATION | 8 |
| DIAGNOSIS AND TESTING | | TIRE AND WHEEL BALANCE | 9 |
| WHEEL INSPECTION | 7 | SPECIFICATIONS | |
| TIRE AND WHEEL RUNOUT | 7 | TORQUE CHART | 11 |

DESCRIPTION AND OPERATION

WHEEL

DESCRIPTION

The rim size is on the vehicle safety certification label located on the drivers door shut face. The size of the rim is determined by the drivetrain package. Original equipment wheels/rims are designed for operation up to the specified maximum vehicle capacity.

All models use stamped steel, cast aluminum or forged aluminum wheels. Every wheel has raised sections between the rim flanges and rim drop well called safety humps (Fig. 1).

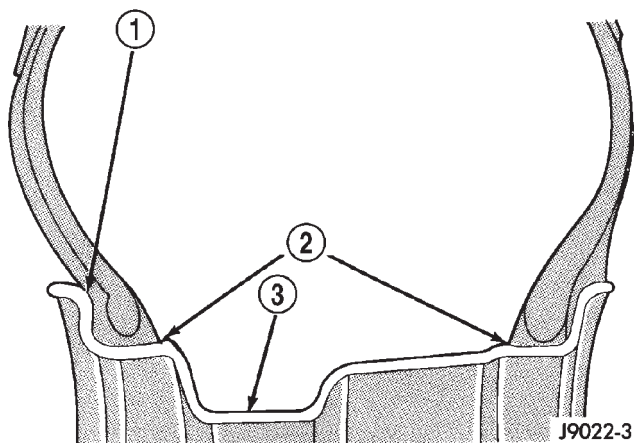

Fig. 1 Safety Rim

- 1 - FLANGE
- 2 - RIDGE
- 3 - WELL

Initial inflation of the tire forces the bead over these raised sections. In case of rapid loss of air pres-

sure, the raised sections help hold the tire on the wheel.

The wheel studs and nuts are designed for specific applications. All aluminum and some steel wheels have wheel stud nuts with an enlarged nose. This enlarged nose is necessary to ensure proper retention of the wheels. Do not use replacement studs or nuts with a different design or lesser quality.

DIAGNOSIS AND TESTING

WHEEL INSPECTION

Inspect wheels for:

- Excessive run out
- Dents or cracks
- Damaged wheel lug nut holes
- Air Leaks from any area or surface of the rim

NOTE: Do not attempt to repair a wheel by hammering, heating or welding.

If a wheel is damaged an original equipment replacement wheel should be used. When obtaining replacement wheels, they should be equivalent in load carrying capacity. The diameter, width, offset, pilot hole and bolt circle of the wheel should be the same as the original wheel.

WARNING: FAILURE TO USE EQUIVALENT REPLACEMENT WHEELS MAY ADVERSELY AFFECT THE SAFETY AND HANDLING OF THE VEHICLE. USED WHEELS ARE NOT RECOMMENDED. THE SERVICE HISTORY OF THE WHEEL MAY HAVE INCLUDED SEVERE TREATMENT OR VERY HIGH MILEAGE. THE RIM COULD FAIL WITHOUT WARNING.

TIRE AND WHEEL RUNOUT

Radial runout is the difference between the high and low points on the tire or wheel (Fig. 2).

Lateral runout is the **wobble** of the tire or wheel.

DIAGNOSIS AND TESTING (Continued)

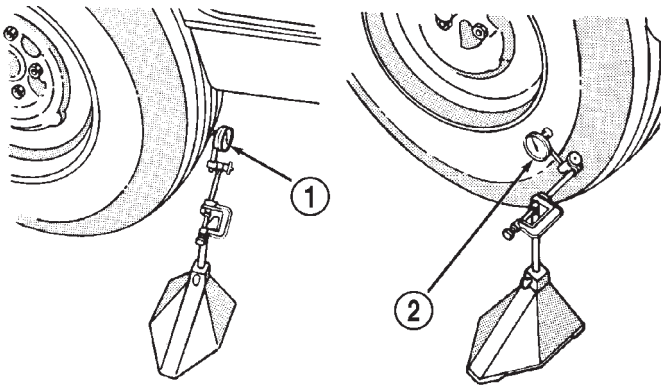

J9022-4

Fig. 2 Checking Tire/Wheel/Hub Runout

- 1 - RADIAL RUNOUT
2 - LATERAL RUNOUT

Radial runout of more than 1.5 mm (.060 inch) measured at the center line of the tread may cause the vehicle to shake.

Lateral runout of more than 2.0 mm (.080 inch) measured near the shoulder of the tire may cause the vehicle to shake.

Sometimes radial runout can be reduced. Relocate the wheel and tire assembly on the mounting studs (See Method 1). If this does not reduce runout to an acceptable level, the tire can be rotated on the wheel. (See Method 2).

METHOD 1 (RELOCATE WHEEL ON HUB)

(1) Drive vehicle a short distance to eliminate tire flat spotting from a parked position.

(2) Check wheel bearings and adjust if adjustable or replace if necessary.

(3) Check the wheel mounting surface.

(4) Relocate wheel on the mounting, two studs over from the original position.

(5) Tighten wheel nuts until all are properly torqued, to eliminate brake distortion.

(6) Check radial runout. If still excessive, mark tire sidewall, wheel, and stud at point of maximum runout and proceed to Method 2.

METHOD 2 (RELOCATE TIRE ON WHEEL)

NOTE: Rotating the tire on wheel is particularly effective when there is runout in both tire and wheel.

(1) Remove tire from wheel and mount wheel on service dynamic balance machine.

(2) Check wheel radial runout (Fig. 3) and lateral runout (Fig. 4).

- STEEL WHEELS: Radial runout 0.040 in., Lateral runout 0.045 in. (maximum)
 - ALUMINUM WHEELS: Radial runout 0.030 in., Lateral runout 0.035 in. (maximum)
- (3) If point of greatest wheel lateral runout is near original chalk mark, remount tire 180 degrees. Recheck runout, Refer to match mounting procedure.

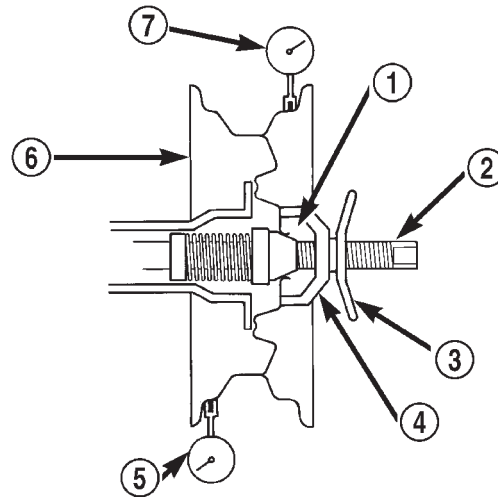

80a611da

Fig. 3 Radial Runout

- 1 - MOUNTING CONE
2 - SPINDLE SHAFT
3 - WING NUT
4 - PLASTIC CUP
5 - DIAL INDICATOR
6 - WHEEL
7 - DIAL INDICATOR

SERVICE PROCEDURES**WHEEL INSTALLATION**

The wheel studs and nuts are designed for specific applications. They must be replaced with equivalent parts. Do not use replacement parts of lesser quality or a substitute design. All aluminum and some steel wheels have wheel stud nuts which feature an enlarged nose. This enlarged nose is necessary to ensure proper retention of the aluminum wheels.

NOTE: Do not use chrome plated lug nuts with chrome plated wheels.

Before installing the wheel, be sure to remove any build up of corrosion on the wheel mounting surfaces. Ensure wheels are installed with good metal-to-metal contact. Improper installation could cause loosening of wheel nuts. This could affect the safety and handling of your vehicle.

To install the wheel, first position it properly on the mounting surface. All wheel nuts should then be tightened just snug. Gradually tighten them in

SERVICE PROCEDURES (Continued)

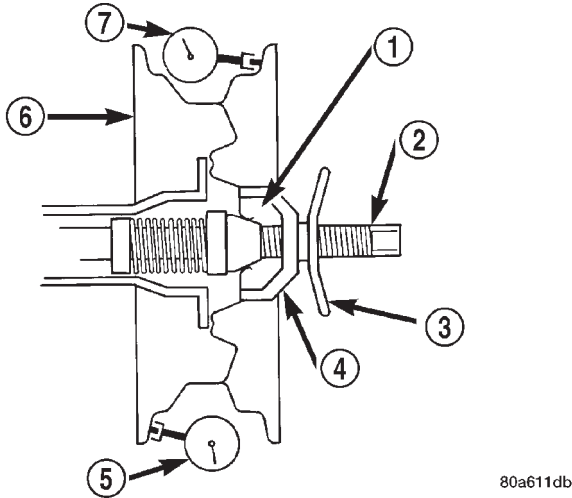

Fig. 4 Lateral Runout

- 1 - MOUNTING CONE
- 2 - SPINDLE SHAFT
- 3 - WING NUT
- 4 - PLASTIC CUP
- 5 - DIAL INDICATOR
- 6 - WHEEL
- 7 - DIAL INDICATOR

sequence to the proper torque specification (Fig. 5). **Never use oil or grease on studs or nuts.**

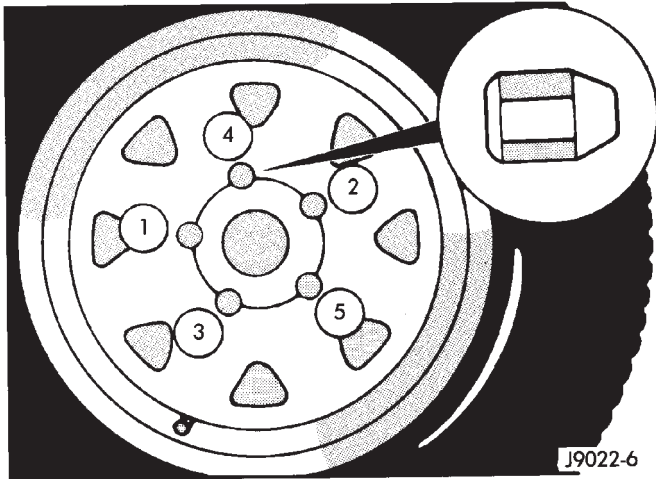

Fig. 5 Lug Nut Tightening Pattern

WHEEL REPLACEMENT

- Wheels must be replaced if they have:
- Excessive runout
 - Bent or dented

- Leak air through welds
 - Have damaged bolt holes
- Wheel repairs employing hammering, heating, or welding are not allowed.

Original equipment wheels are available through your dealer. Replacement wheels from any other source should be equivalent in:

- Load carrying capacity
- Diameter
- Width
- Offset
- Mounting configuration

Failure to use equivalent replacement wheels may affect the safety and handling of your vehicle. Replacement with **used** wheels is not recommended. Their service history may have included severe treatment.

TIRE AND WHEEL BALANCE

It is recommended that a two plane service dynamic balancer be used when a tire and wheel assembly require balancing. Refer to balancer operation instructions for proper cone mounting procedures. Typically use front cone mounting method for steel wheels. For aluminum wheel use back cone mounting method without cone spring.

NOTE: Static should be used only when a two plane balancer is not available.

NOTE: Cast aluminum and forged aluminum wheels require coated balance weights and special alignment equipment.

Wheel balancing can be accomplished with either on or off vehicle equipment. When using on-vehicle balancing equipment, remove the opposite wheel/tire. Off-vehicle balancing is recommended.

For static balancing, find location of heavy spot causing the imbalance. Counter balance wheel directly opposite the heavy spot. Determine weight required to counter balance the area of imbalance. Place half of this weight on the **inner** rim flange and the other half on the **outer** rim flange (Fig. 6).

For dynamic balancing, the balancing equipment is designed to locate the amount of weight to be applied to both the inner and outer rim flange (Fig. 7).

SERVICE PROCEDURES (Continued)

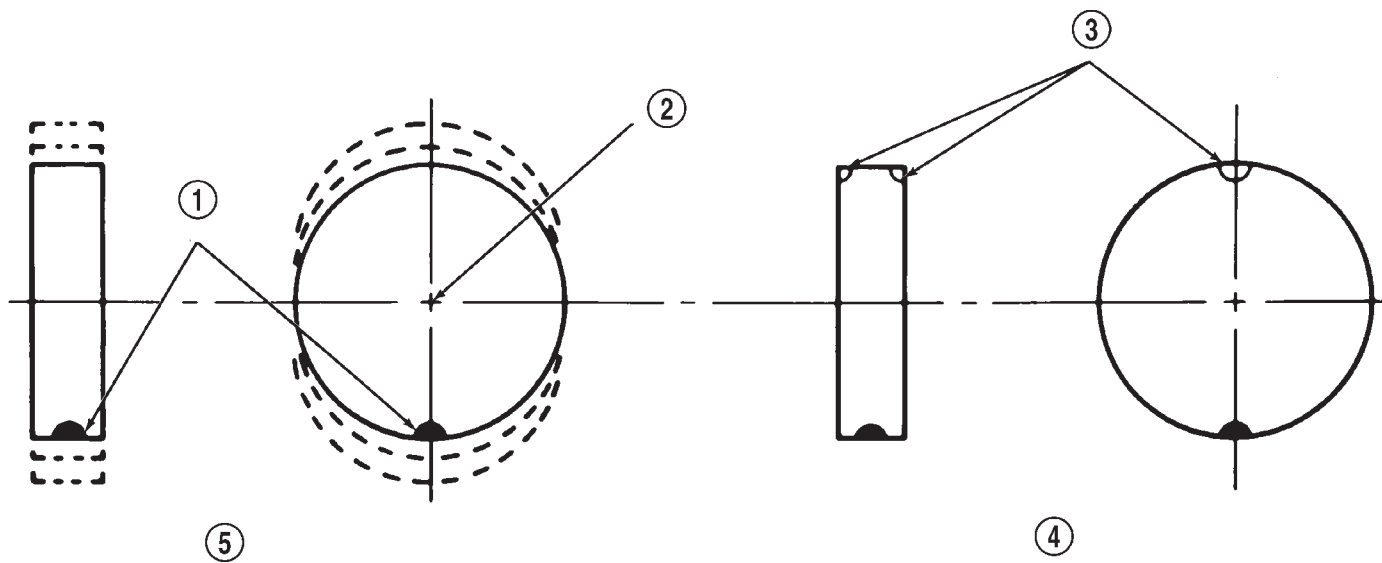

J8922-8

Fig. 6 Static Unbalance & Balance

- 1 - HEAVY SPOT
- 2 - CENTER LINE OF SPINDLE
- 3 - ADD BALANCE WEIGHTS HERE
- 4 - CORRECTIVE WEIGHT LOCATION
- 5 - TIRE OR WHEEL TRAMP, OR WHEEL HOP

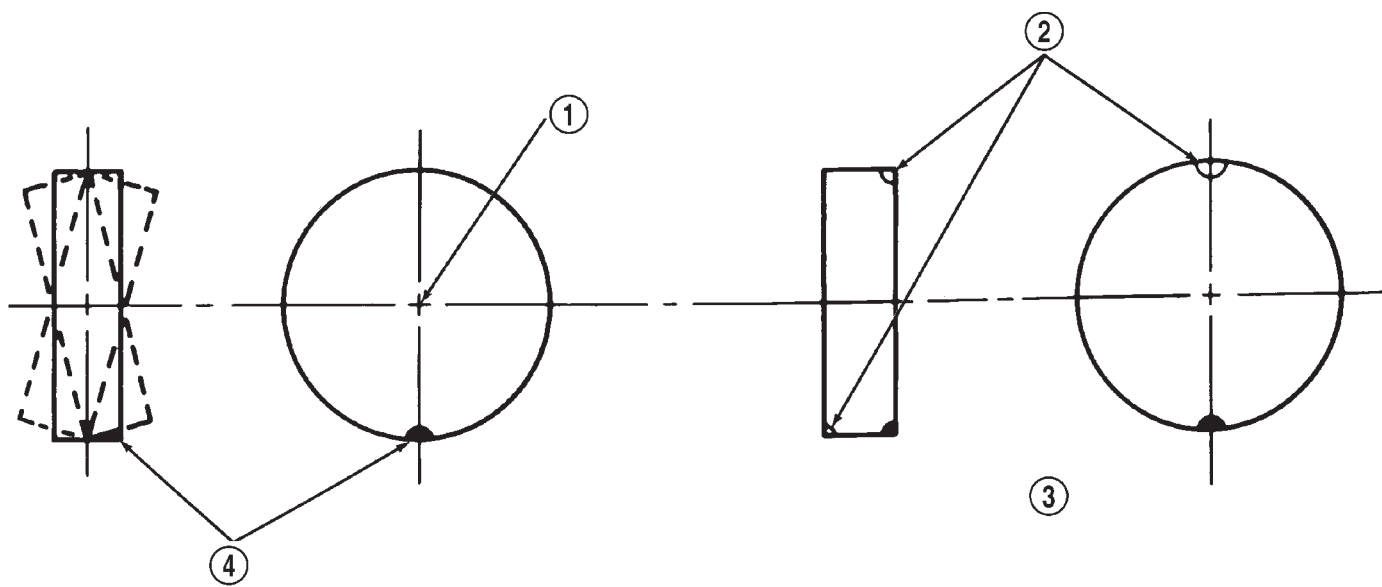

J8922-9

Fig. 7 Dynamic Unbalance & Balance

- 1 - CENTER LINE OF SPINDLE
- 2 - ADD BALANCE WEIGHTS HERE
- 3 - CORRECTIVE WEIGHT LOCATION
- 4 - HEAVY SPOT WHEEL SHIMMY AND VIBRATION

SPECIFICATIONS

TORQUE CHART

| DESCRIPTION | TORQUE |
|----------------------------------|----------------------------------|
| Lug Nut | |
| 1/2 X 20 with 60° Cone | 115-150 N·m (85-115 ft. lbs.) |

BODY

TABLE OF CONTENTS

| | page | | page |
|---------------------------------|------|------------------------------|------|
| DESCRIPTION AND OPERATION | 1 | STATIONARY GLASS..... | 6 |
| SAFETY PRECAUTIONS | 3 | SEATS | 13 |
| PAINT | 4 | BODY COMPONENT SERVICE | 21 |

DESCRIPTION AND OPERATION

TABLE OF CONTENTS

| | page |
|----------------------------------|------|
| DESCRIPTION AND OPERATION | |
| BODY COMPONENTS | 1 |

DESCRIPTION AND OPERATION

BODY COMPONENTS

PAINT

DESCRIPTION

The original equipment finish is a multi-step process that involves cleaning, electrodeposition (e-coat), base coat, and clear coat steps. Additionally, selected areas of the vehicle may be coated with an anti-chip finish.

OPERATION

On most vehicles a two-stage paint application (base coat/clear coat) is used. Color that is applied to primer is called base coat. The clear coat protects the base coat from ultraviolet light and provides a durable high-gloss finish.

STATIONARY GLASS

DESCRIPTION

Windshields and selected stationary glass are structural members of the vehicle. The windshield glass is bonded to the windshield frame with urethane adhesive.

OPERATION

Windshields are made of two pieces of glass with a plastic inner layer. Windshields and other stationary glass protect the occupants from the effects of the

elements. Windshields are also used to retain some airbags in position during deployment. Urethane bonded glass is difficult to salvage during removal. The urethane bonding is difficult to cut or clean from any surface. Before removing the glass, check the availability of replacement components.

SEATS

DESCRIPTION

Seat modules are made up of a seat frame, seat cushion, seat back cushion, a covering material, and the electrical components used for power operation, if equipped. Some seat systems also contain seat belt components and supplemental restraint systems.

OPERATION

Seat assemblies transport the occupants in comfort and safety. Seat assemblies also help position occupants correctly in the event of airbag deployment. Seat cushions, coverings, and electrical components are serviceable. Refer to the appropriate group in this manual.

EXTERIOR COMPONENTS

DESCRIPTION

Exterior sheet metal components make up the exterior of the vehicle. Some exterior metal systems are welded assemblies, such as doors and hoods. Some exterior trim items are made of composite.

DESCRIPTION AND OPERATION (Continued)

OPERATION

The exterior is finished in various metal stampings and composite moldings. These assemblies give the vehicle a finished appearance and protect the occupants from the elements. Some components are part of the energy absorbing system used to protect the occupants in collisions. The exterior sheet metal is repairable and adjustable for fit and finish. Welded

component systems are adjustable as a system. Trim components made of composite are stamped with the type of material used. DaimlerChrysler uses various fasteners to retain trim items. At times, it is not possible to remove trim items without damaging the fastener. If it is not possible to remove an item without damaging a component, cut or break the fasteners and use new ones when installing the component.

SAFETY PRECAUTIONS

TABLE OF CONTENTS

page

SERVICE PROCEDURES

SAFETY PRECAUTIONS AND WARNINGS 3

SERVICE PROCEDURES

SAFETY PRECAUTIONS AND WARNINGS

DESCRIPTION

WARNING: USE A OSHA APPROVED BREATHING FILTER WHEN SPRAYING PAINT OR SOLVENTS IN A CONFINED AREA. PERSONAL INJURY CAN RESULT.

AVOID PROLONGED SKIN CONTACT WITH PETROLEUM OR ALCOHOL – BASED CLEANING SOLVENTS. PERSONAL INJURY CAN RESULT.

DO NOT STAND UNDER A HOISTED VEHICLE THAT IS NOT PROPERLY SUPPORTED ON SAFETY STANDS. PERSONAL INJURY CAN RESULT.

CAUTION: When holes must be drilled or punched in an inner body panel, verify depth of space to the outer body panel, electrical wiring, or other components. Damage to vehicle can result.

Do not weld exterior panels unless combustible material on the interior of vehicle is removed from the repair area. Fire or hazardous conditions, can result.

Always have a fire extinguisher ready for use when welding.

Disconnect the negative (-) cable clamp from the battery when servicing electrical components that are live when the ignition is OFF. Damage to electrical system can result.

Do not use abrasive chemicals or compounds on painted surfaces. Damage to finish can result.

Do not use harsh alkaline based cleaning solvents on painted or upholstered surfaces. Damage to finish or color can result.

Do not hammer or pound on plastic trim panel when servicing interior trim. Plastic panels can break.

DaimlerChrysler Corporation uses many different types of push-in fasteners to secure the interior and exterior trim to the body. Most of these fasteners can be reused to assemble the trim during various repair procedures. At times, a push-in fastener cannot be removed without damaging the fastener or the component it is holding. If it is not possible to remove a fastener without damaging a component or body, cut or break the fastener and use a new one when installing the component. Never pry or pound on a plastic or pressed-board trim component. Using a suitable fork-type prying device, pry the fastener from the retaining hole behind the component being removed. When installing, verify fastener alignment with the retaining hole by hand. Push directly on or over the fastener until it seats. Apply a low-force pull to the panel to verify that it is secure.

When it is necessary to remove components to service another, it should not be necessary to apply excessive force or bend a component to remove it. Before damaging a trim component, verify hidden fasteners or captured edges holding the component in place.

PAINT

TABLE OF CONTENTS

| | page | | page |
|---|------|---|------|
| DESCRIPTION AND OPERATION | | PAINTED SURFACE TOUCH-UP | 4 |
| PAINT CODE | 4 | SPECIFICATIONS | |
| BASE COAT/CLEAR COAT FINISH. | 4 | AFTERMARKET PAINT REPAIR PRODUCTS | 5 |
| FINESSE SANDING, BUFFING, AND POLISHING. | 4 | | |

DESCRIPTION AND OPERATION

PAINT CODE

The paint code is identified on the Vehicle Safety Certification Label which is located on the drivers door shut face. The color names provided in the Paint and Trim Code Description chart are the color names used on most repair product containers.

BASE COAT/CLEAR COAT FINISH

DESCRIPTION

On most vehicles a two-part paint application (base coat/clear coat) is used. Color paint that is applied to primer is called base coat. The clear coat protects the base coat from ultraviolet light and provides a durable high-gloss finish.

CAUTION: Do not use abrasive chemicals or compounds on painted surfaces. Damage to finish can result.

Do not use harsh alkaline based cleaning solvents on painted surfaces. Damage to finish or color can result.

FINESSE SANDING, BUFFING, AND POLISHING

DESCRIPTION

Minor acid etching, orange peel, or smudging in clear coat or single-stage finishes can be reduced with light finesse sanding, hand buffing, and polishing. **If the finish has been finesse sanded in the past, it cannot be repeated. Finesse sanding operation should be performed by a trained automotive paint technician.**

CAUTION: Do not remove clear coat finish, if equipped. Base coat paint must retain clear coat for durability.

PAINTED SURFACE TOUCH-UP

DESCRIPTION

When a painted metal surface has been scratched or chipped, it should be touched-up as soon as possible to avoid corrosion. For best results, use Mopar® Scratch Filler/Primer, Touch-Up Paints and Clear Top Coat. Refer to Introduction group of this manual for Body Code Plate information.

WARNING: USE A OSHA APPROVED BREATHING FILTER WHEN SPRAYING PAINT OR SOLVENTS IN A CONFINED AREA. PERSONAL INJURY CAN RESULT.

OPERATION

- (1) Scrape loose paint and corrosion from inside scratch or chip.
- (2) Clean affected area with Mopar® Tar/Road Oil Remover, and allow to dry.
- (3) Fill the inside of the scratch or chip with a coat of filler/primer. Do not overlap primer onto good surface finish. The applicator brush should be wet enough to puddle-fill the defect without running. Do not stroke brush applicator on body surface. Allow the filler/primer to dry hard.
- (4) Cover the filler/primer with color touch-up paint. Do not overlap touch-up color onto the original color coat around the scratch or chip. Butt the new color to the original color, if possible. Do not stroke applicator brush on body surface. Allow touch-up paint to dry hard.
- (5) On vehicles without clear coat, the touch-up color can be lightly finesse sanded (1500 grit) and polished with rubbing compound.
- (6) On vehicles with clear coat, apply clear top coat to touch-up paint with the same technique as described in Step 4. Allow clear top coat to dry hard. If desired, Step 5 can be performed on clear top coat.

DESCRIPTION AND OPERATION (Continued)

WARNING: AVOID PROLONGED SKIN CONTACT WITH PETROLEUM OR ALCOHOL – BASED CLEANING SOLVENTS. PERSONAL INJURY CAN RESULT.

AVOID PROLONGED SKIN CONTACT WITH PETROLEUM OR ALCOHOL – BASED CLEANING SOLVENTS. PERSONAL INJURY CAN RESULT.

SPECIFICATIONS

AFTERMARKET PAINT REPAIR PRODUCTS

EXTERIOR COLOR

| EXTERIOR COLOR | DAIMLER CHRYSLER CODE | PPG | DuPONT | S-W** M-S** | AKZO NOBEL SIKKENS | SPIES HECKER | ICI** |
|--------------------------|-----------------------|-------|--------|----------------|-----------------------|--------------|-------|
| Flame Red Clear Coat | PR4 | 4679 | B9326 | 46916 | CHA93:PR4 | 30116 | 2NN6B |
| Chili Pepper Red | VEA | 5361 | B9823 | 54470 | CHA98:VEA | 33688 | HMT3B |
| Medium Fern Pearl Coat | RJP | 4969 | B9524 | 50270 | CHA99:RJP | 61088 | 7CD6B |
| Forest Green Pearl Coat | SG8 | 5065 | B9609 | 51062 | CHA95:SG8 | 61633 | 7MR8B |
| Intense Blue Pearl Coat | VB3 | 5357 | B9822 | 54468 | CHA98:VB3 | 55321 | HMR9B |
| Desert Sand | WTD | 5474 | B9884 | 56153 | CHA99:WTD | 81764 | KGC7B |
| Deep Amethyst Pearl Coat | TCN | 5246 | B9736 | 52026 | CHA97:TCN | 54755 | FNE4B |
| Black Clear Coat | DX8 | 9700 | 99 | 34858 | CHA85:DX8 | 73328 | TC60B |
| Gunmetal Pearl Coat | TQ7 | 5248 | B9735 | 52952 | CHA97:TQ7 | 73320 | ERA9B |
| Stone White Clear Coat | SW1 | 83542 | B9622 | 51539 | CHA96:SW1 | 15069 | 8KY5B |

INTERIOR COLOR

| INTERIOR COLOR | DIAMLER CHRYSLER CODE* | PPG | DuPONT | S-W** M-S** | AKZO NOBEL SIKKENS | SPIES HECKER | ICI** |
|--------------------|------------------------|------------------|--------|----------------|-----------------------|--------------|-------|
| Agate | AZ | 9856 / 2-1461 | C9208 | 45994 | CHALAZI | 75016 | 7WC8 |
| Camel / Dark Green | KG | N/A | N/A | N/A | N/A | NA | K5/G8 |

NOTE: *Herberts Standox and BASF use the Chrysler paint code as listed on the Body Code Plate and the Vehicle Safety Certification label. **

S-W = Sherwin-Williams, M-S = Martin Senour, ICI = ICI Autocolor.

STATIONARY GLASS

TABLE OF CONTENTS

| | page | | page |
|---|------|---|------|
| DESCRIPTION AND OPERATION | | REAR DOOR STATIONARY WINDOW GLASS | 9 |
| WINDSHIELD SAFETY PRECAUTIONS | 6 | REAR QUARTER WINDOW GLASS | 10 |
| REMOVAL AND INSTALLATION | | LIFTGATE GLASS | 11 |
| WINDSHIELD | 6 | | |

DESCRIPTION AND OPERATION

WINDSHIELD SAFETY PRECAUTIONS

DESCRIPTION

WARNING: DO NOT OPERATE THE VEHICLE WITHIN 24 HOURS OF WINDSHIELD INSTALLATION. IT TAKES AT LEAST 24 HOURS FOR URETHANE ADHESIVE TO CURE. IF IT IS NOT CURED, THE WINDSHIELD MAY NOT PERFORM PROPERLY IN AN ACCIDENT.

URETHANE ADHESIVES ARE APPLIED AS A SYSTEM. USE GLASS CLEANER, GLASS PREP SOLVENT, GLASS PRIMER, PVC (VINYL) PRIMER AND PINCH WELD (FENCE) PRIMER PROVIDED BY THE ADHESIVE MANUFACTURER. IF NOT, STRUCTURAL INTEGRITY COULD BE COMPROMISED.

DAIMLERCHRYSLER DOES NOT RECOMMEND GLASS ADHESIVE BY BRAND. TECHNICIANS SHOULD REVIEW PRODUCT LABELS AND TECHNICAL DATA SHEETS, AND USE ONLY ADHESIVES THAT THEIR MANUFACTURES WARRANT WILL RESTORE A VEHICLE TO THE REQUIREMENTS OF FMVSS 212. TECHNICIANS SHOULD ALSO INSURE THAT PRIMERS AND CLEANERS ARE COMPATIBLE WITH THE PARTICULAR ADHESIVE USED.

BE SURE TO REFER TO THE URETHANE MANUFACTURER'S DIRECTIONS FOR CURING TIME SPECIFICATIONS, AND DO NOT USE ADHESIVE AFTER ITS EXPIRATION DATE.

VAPORS THAT ARE EMITTED FROM THE URETHANE ADHESIVE OR PRIMER COULD CAUSE PERSONAL INJURY. USE THEM IN A WELL-VENTILATED AREA.

SKIN CONTACT WITH URETHANE ADHESIVE SHOULD BE AVOIDED. PERSONAL INJURY MAY RESULT.

ALWAYS WEAR EYE AND HAND PROTECTION WHEN WORKING WITH GLASS.

CAUTION: Protect all painted and trimmed surfaces from coming in contact with urethane or primers.

Be careful not to damage painted surfaces when removing moldings or cutting urethane around windshield.

OPERATION

The windshield is attached to the window frame with urethane adhesive. The urethane adhesive is applied cold and seals the surface area between the window opening and the glass. The primer adheres the urethane adhesive to the windshield.

It is difficult to salvage a windshield during the removal operation. The windshield is part of the structural support for the roof. The urethane bonding used to secure the windshield to the fence is difficult to cut or clean from any surface. If the moldings are set in urethane, it would also be unlikely they could be salvaged. Before removing the windshield, check the availability of the windshield and moldings from the parts supplier.

REMOVAL AND INSTALLATION

WINDSHIELD

The windshield is positioned in the reveal molding and is bonded to the windshield frame with urethane adhesive.

Depending on the circumstances, either one of two windshield glass installation methods can be used:

- The short method.
- The extended method.

The short method is used when the windshield glass is removed intact, and the body opening and the pinchweld flanges do not require repair.

The extended method must be used when the body opening or a flange is damaged. The extended method must also be used when urethane no longer adheres to either the windshield glass or the pinchweld flanges.

REMOVAL

- (1) Cover the interior and exterior body surface areas with a protective covering.

REMOVAL AND INSTALLATION (Continued)

(2) Remove the windshield wiper arms and the rearview mirror.

(3) Using a razor knife, slide the blade between the windshield glass and the inboard edge of the reveal molding.

(4) Cut around the interior perimeter of the reveal molding and sever the cap of the reveal molding.

(5) Using a cold knife, cut the urethane around the perimeter of the windshield (Fig. 1).

(6) Remove the windshield glass from the frame.

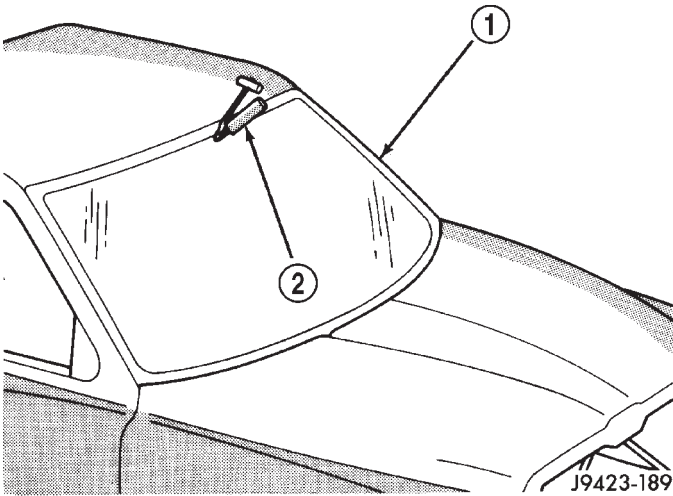

Fig. 1 Cutting Urethane Around Windshield—Typical

1 - WINDSHIELD
2 - COLD KNIFE

INSTALLATION—SHORT METHOD

WARNING: REVIEW ALL WARNINGS AND CAUTIONS IN THIS GROUP BEFORE PRECEDING WITH INSTALLATION.

(1) Trim the urethane from the pinchweld flanges. Leave a 3 mm (0.1 in.) level base of urethane on the pinchweld flanges.

WARNING: DO NOT USE SOLVENT BASED GLASS CLEANER TO CLEAN WINDSHIELD BEFORE APPLYING GLASS PREP AND PRIMER. POOR ADHESION CAN RESULT.

(2) Clean inside of windshield with ammonia based glass cleaner and lint-free cloth.

(3) Prime outer perimeter of interior side of glass 16 mm (5/8 inch) from edge. Use a wipe-off type urethane primer and wipe glass dry after primer application.

NOTE: The reveal molding has an adhesive applied to the windshield contact surface to help secure the molding to the windshield during the installation procedure.

(4) Apply the molding to the windshield:

- With the molding at room temperature, press the molding onto the windshield corners.

- From corner to corner, work the molding to the center of each side. (Some stretching of the molding may be required during this procedure.)

(5) Place the glass on the pinchweld flanges and inspect for gaps in the urethane. Gaps in excess of 3 mm (1/8 inch) must be filled with urethane.

(6) Adjust windshield glass position until it is aligned with the flanges and adhesive.

(7) Using a grease pencil or equivalent, make alignment marks on the glass and body.

(8) Remove replacement windshield from windshield opening.

(9) Position the windshield inside up on a suitable work surface with two padded, wood 10 cm by 10 cm by 50 cm (4 in. by 4 in. by 20 in.) blocks, placed parallel 75 cm (2.5 ft.) apart (Fig. 2).

CAUTION: Avoid spilling or dripping primer on painted surfaces. Clean spills or drips immediately. The primer will damage the paint if it remains on the surface for any length of time.

(10) If the replacement windshield glass does not have blackout primer:

- Attach a 25 mm (1 in) wide masking tape band around the interior side of the glass 16 mm (5/8 in) from the edge of the glass (Fig. 3).

- Do not attach tape along the bottom of the glass and **attach it only to the inside of the glass.**

- Clean the 16-mm (5/8-in) wide surface area around the glass with isopropyl alcohol.

- Thoroughly mix and apply glass blackout primer to the 16 mm (5/8 in) surface area around the interior side of the glass (Fig. 4).

- Allow the primer to dry for at least 10-12 minutes.

(11) Apply a small amount of adhesive to the bottom support spacers and attach the support spacers to the bottom of the windshield, 170 mm inboard from the outer windshield edge (Fig. 5).

(12) Cut the urethane adhesive applicator nozzle (Fig. 6).

CAUTION: Be prepared to install the glass immediately after applying the adhesive, as the adhesive will begin to cure in less than 10 minutes.

(13) Apply a continuous, 6-mm (1/4-in) diameter bead of urethane adhesive to the surface area.

(14) Align the glass with the reference marks and position the glass on the pinchweld flanges. Ensure that the windshield glass is correctly seated on the support spacers.

REMOVAL AND INSTALLATION (Continued)

(15) Force the windshield glass inward just enough to wet-out and set the urethane. Use care to avoid excessive squeeze-out of adhesive.

(16) Water test the windshield with a water spray after installation. Do not direct high pressure streams of water directly at urethane. If any leaks are detected, apply urethane as necessary.

(17) If used, remove the masking tape from the inner surface of the glass.

(18) Install all components and clean the vehicle.

(19) Open the vehicle windows to prevent interior pressure while the urethane is curing. **If not vented, pressure in the interior of the vehicle may interfere with proper glass bonding.**

(20) Install the rearview mirror.

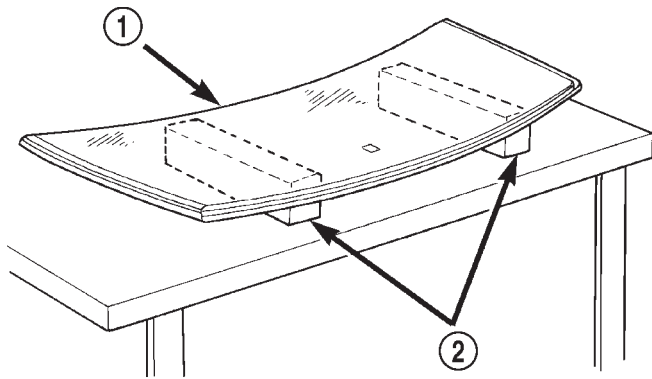

80a28c10

Fig. 2 Work Surface Set up

- 1 - WINDSHIELD AND MOLDINGS
- 2 - BLOCKS

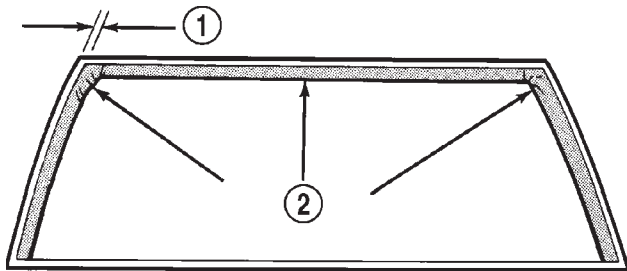

J8923-76

Fig. 3 Masking Tape Location For Blackout Primer

- 1 - POSITION TAPE 5/8 INCH FROM EDGE OF GLASS
- 2 - 1-INCH WIDE MASKING TAPE

INSTALLATION—EXTENDED METHOD

WARNING: REVIEW ALL WARNINGS AND CAUTIONS IN THIS GROUP BEFORE PRECEDING WITH INSTALLATION.

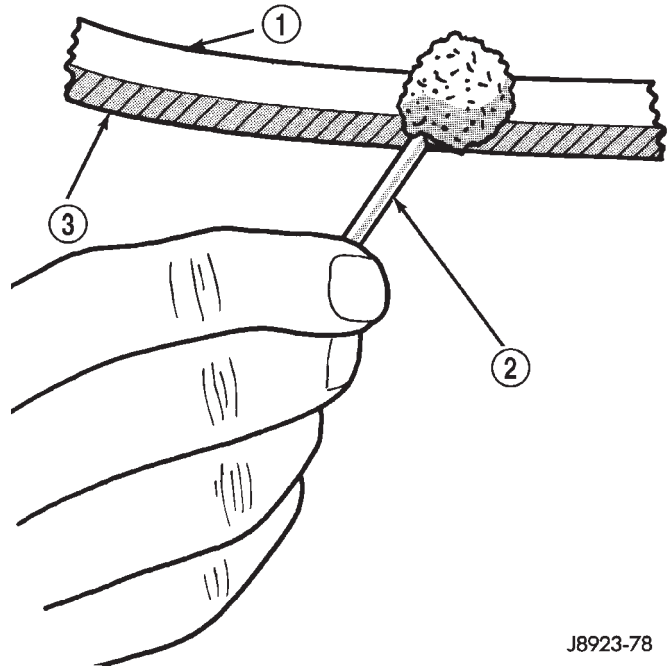

J8923-78

Fig. 4 Blackout Primer Application

- 1 - APPLY PRIMER TO THIS AREA OF GLASS
- 2 - BLACKOUT PRIMER APPLICATOR
- 3 - TAPE

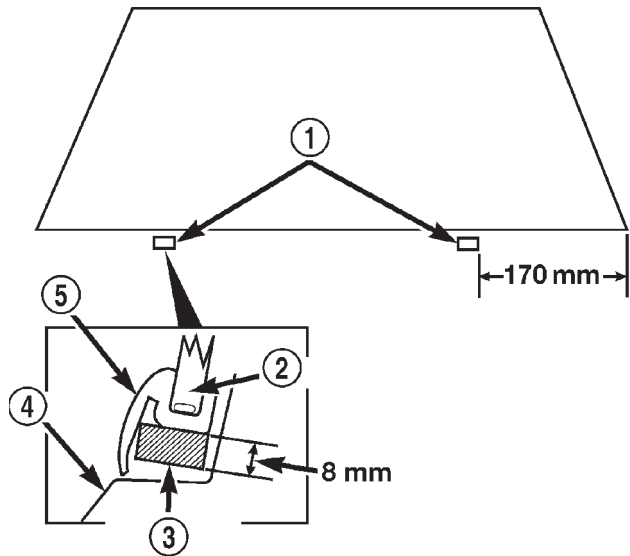

80ac2bd6

Fig. 5 Windshield Bottom Support Spacers

- 1 - SUPPORT SPACERS
- 2 - WINDSHIELD
- 3 - SUPPORT SPACER
- 4 - COWL
- 5 - MOLDING

(1) Remove the all of urethane from all pinchweld flanges.

REMOVAL AND INSTALLATION (Continued)

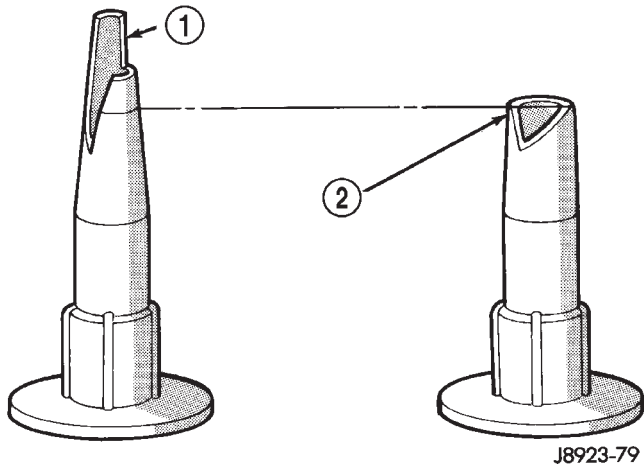

Fig. 6 Applicator Nozzle Preparation

- 1 - CUT NOZZLE THIS SHAPE FOR EXTENDED PROCEDURE
 2 - CUT NOZZLE THIS SHAPE FOR SHORT PROCEDURE

(2) Inspect and repair the windshield opening and pinchweld flanges.

(3) Prime the pinchweld flanges with a urethane base primer. However, if the flange is color-coated with paint, prime the flanges with a paint finish primer. **This is important because urethane adhesive will not adhere to all color-coat paints.** Allow primer sufficient time to dry.

NOTE: The reveal molding has an adhesive applied to the windshield contact surface to help secure the molding to the windshield during the installation procedure.

(4) Apply the reveal molding to the windshield:

- With the molding at room temperature, press the molding onto the windshield corners.
- From corner to corner, work the molding to the center of each side. (Some stretching of the molding may be required during this procedure).

(5) Install and inspect the fit of the windshield on the pinchweld flanges as follows:

- Position windshield until it is aligned within windshield opening.
- Measure the gap between the pinchweld flanges and glass around perimeter of the glass and flange.
- The reveal molding should equally cover the A-Pillars on both sides.
- The flanges should also extend above the glass edge equally around the perimeter of the opening.

(6) If the pinchweld flanges require repair, remove the windshield glass and straighten, align, or repair the flange(s) as necessary.

(7) Position the windshield in the opening and inspect the windshield fit again. Mark the windshield final position on the glass and body with a wax pencil (or use masking tape). The marks (or masking

tape) will be used for installation alignment reference.

(8) If the replacement windshield does not have blackout primer:

- Attach a 25-mm (1-in) wide masking tape band around the interior side of glass 16 mm (5/8 in) from edge of glass (Fig. 3).

- Do not attach tape along the bottom of the glass and **attach only to the inside of glass.**

- Thoroughly mix and apply blackout primer to the 16 mm (5/8 in) surface area around the interior side of the glass (Fig. 4).

- Allow the primer to dry for at least 10-12 minutes.

(9) Apply a small amount of adhesive to the bottom support spacers and attach the support spacers to the bottom of the windshield, 170 mm inboard from the outer windshield edge (Fig. 5).

(10) Cut the urethane applicator nozzle (Fig. 6).

(11) Apply a continuous bead of urethane to the surface area with blackout primer on the interior side of glass. The bead should be 9-mm (3/8-in) wide by 12.7-mm (1/2-in) deep for best results.

CAUTION: Be prepared to install the glass immediately after applying the adhesive, as the adhesive will begin to cure in less than 10 minutes.

(12) Align the windshield with the wax pencil installation alignment reference marks (or the tape strips). Position the windshield on pinchweld flanges and spacers.

(13) Force the windshield inward just enough to wet-out and set the urethane. Use care to avoid excessive squeeze-out of adhesive.

(14) Water test the windshield with a water spray after installation. Do not direct high pressure streams of water directly at the urethane. If any leaks are detected, apply urethane as necessary.

(15) If used, remove the masking tape from the inner surface of glass.

(16) Install all components and clean the vehicle. If necessary, refer to the installation procedures.

(17) Open the vehicle windows to prevent interior pressure while the urethane adhesive is curing. **If not vented, pressure in the interior of vehicle will interfere with glass bonding.**

(18) Install the rearview mirror on the bracket.

REAR DOOR STATIONARY WINDOW GLASS

REMOVAL

The rear door stationary window glass is bonded to the division bar and is serviced as an assembly.

(1) Lower the window glass.

(2) Remove the inner and outer beltline weather-strip.

REMOVAL AND INSTALLATION (Continued)

(3) Remove the trim panel and waterdam from door inner panel.

(4) Remove the screws attaching the division bar/glass to the door (Fig. 7).

(5) Tilt the division bar/glass forward and remove it from the door.

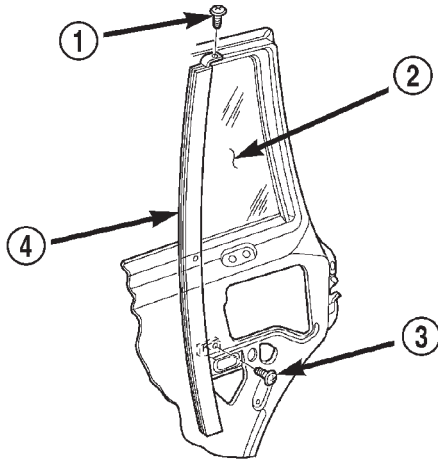

80ac2bd7

Fig. 7 Division Bar/Stationary Glass

- 1 - UPPER SCREW
- 2 - GLASS
- 3 - LOWER SCREW
- 4 - DIVISION BAR

INSTALLATION

- (1) Position the division bar/glass in the door.
- (2) Install the screws attaching the division bar/glass to the door. Finger tighten the screws.
- (3) Tighten the upper screw to 6 N·m (5 ft-lbs) torque.
- (4) Tighten the lower screw to 6 N·m (5 ft-lbs) torque.
- (5) Install the beltline weatherstrip.
- (6) Install the door waterdam and trim panel.

REAR QUARTER WINDOW GLASS

REMOVAL

- (1) If equipped, remove the quarter window reveal molding (Fig. 8).
- (2) Remove the quarter window interior trim covers.
- (3) Separate the weatherstrip seal lip from the window opening flanges. Use a pry tool and carefully push the window glass and seal outward.
- (4) Remove the weatherstrip seal and window glass from window opening.
- (5) Remove the weatherstrip seal from the window glass.

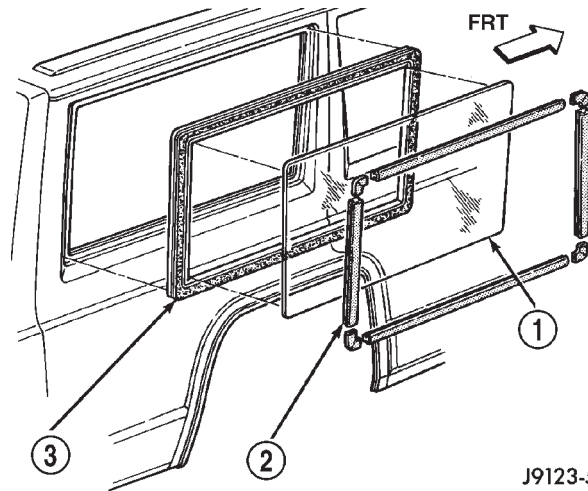

J9123-54

Fig. 8 Quarter Window Reveal Molding, Glass and Seal

- 1 - GLASS
- 2 - REVEAL MOULDING
- 3 - WEATHERSTRIP SEAL

INSTALLATION

- (1) Clean the original sealant from the weatherstrip channels and window opening flanges.
- (2) Apply a 4-mm (1/6-in) diameter bead of sealant to the window channel in the weatherstrip seal.
- (3) Install the weatherstrip on the window glass. Install the seal installation cord in the window opening flange channel (Fig. 9) as follows:
 - Moisten a length of 6-mm (1/4-in) diameter cord with a soap and water solution.
 - Ensure that the cord is long enough to go all the way around the perimeter of the weatherstrip.
 - Insert the cord into the window opening flange channel in the weatherstrip seal.
- (4) Apply a 6-mm (1/4-in) diameter bead of sealant to the window opening flanges.
- (5) For two-door vehicles, apply a 3-mm (1/8-in) diameter bead of sealant at the quarter panel applique and liftgate pillar seam.
- (6) Position the quarter window glass and the weatherstrip seal in the window opening (Fig. 10) with the free ends of the cord inside the vehicle (Fig. 11).
- (7) Pull on each end of the cord to pull the weatherstrip seal channel lip over the window opening flanges.
- (8) Test the vent window for water leaks.
- (9) Install the interior trim cover.
- (10) If equipped, install the quarter window reveal molding.

REMOVAL AND INSTALLATION (Continued)

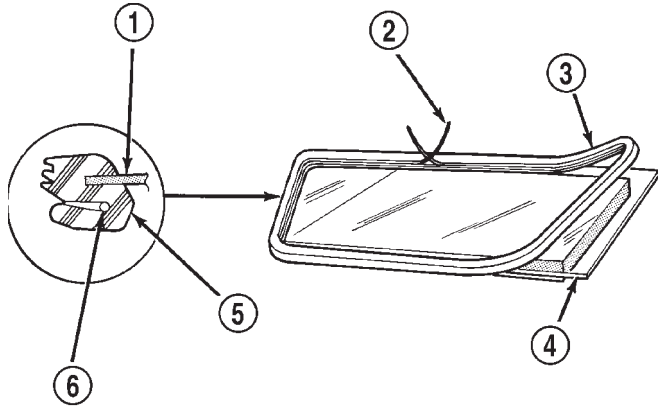

J9223-118

Fig. 9 Weatherstrip Seal and Cord Installation

- 1 - WINDOW GLASS
- 2 - INSTALLATION CORD END
- 3 - WEATHERSTRIP SEAL
- 4 - WINDOW GLASS
- 5 - WEATHERSTRIP SEAL
- 6 - INSTALLATION CORD

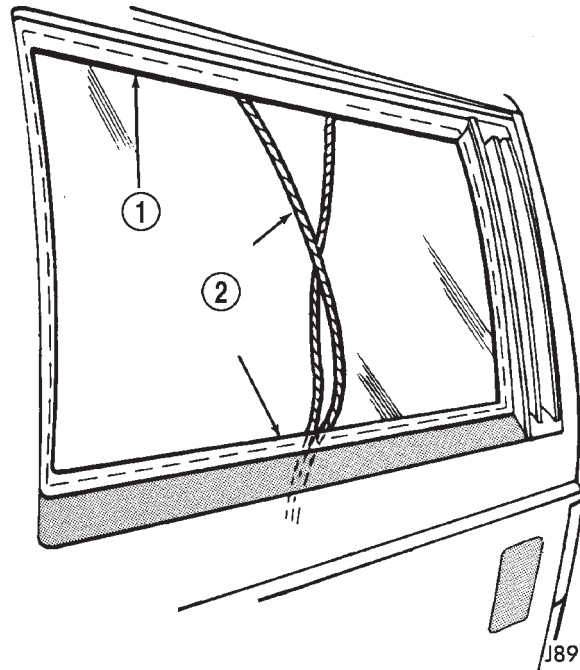

J8923-83

Fig. 11 Quarter Window Glass and Seal Installation

- 1 - WEATHERSTRIP
- 2 - 1/4-INCH DIAMETER CORD (POSITION IN WEATHERSTRIP GLASS CHANNEL)

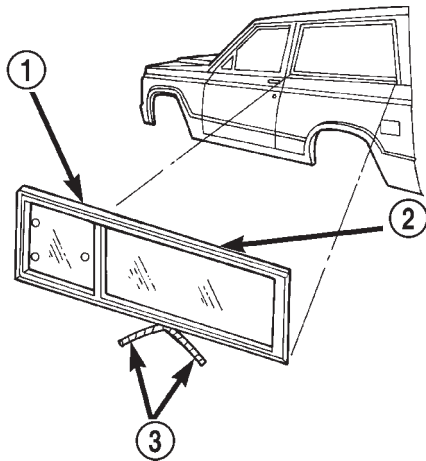

80abac2d

Fig. 10 Quarter Window With Vent

- 1 - QUARTER WINDOW W/VENT
- 2 - WEATHERSTRIP SEAL
- 3 - INSTALLATION CORD

LIFTGATE GLASS

REMOVAL

- (1) Open liftgate.
- (2) Remove liftgate trim panel.
- (3) Disconnect heated backlite (HBL) connector.
- (4) Remove wiper arm.
- (5) Remove CHMSL lens.
- (6) Using a razor knife, slide the blade between the liftgate glass and the inboard edge of the reveal molding.
- (7) Cut around the interior perimeter of the reveal molding and sever the cap of the reveal molding.

(8) Using a cold knife, cut urethane bonding from around liftgate glass. A pneumatic cutting device can be used if available.

(9) Separate glass from Liftgate.

INSTALLATION

CAUTION: Open a window before installing glass. This will avoid pressurizing the passenger compartment. If a door or liftgate is slammed before urethane is cured, water leaks can result.

(1) Trim the urethane from the liftgate glass opening flanges. Leave a 3 mm (0.1 in.) level base of urethane on the flanges.

(2) Starting in the corners, press reveal molding onto glass.

(3) Place replacement glass into liftgate opening and position glass in the center of the opening against flange.

(4) Verify the glass lays evenly against the fence at the sides, top and bottom. If not, the flange must be formed to the shape of the new glass.

(5) Using a grease pencil or equivalent, make references marks on the glass and body.

(6) Remove replacement glass from liftgate opening.

(7) Position the glass inside up on a suitable work surface.

REMOVAL AND INSTALLATION (Continued)

WARNING: DO NOT USE SOLVENT BASED GLASS CLEANER TO CLEAN WINDSHIELD BEFORE APPLYING GLASS PREP AND PRIMER. POOR ADHESION CAN RESULT.

(8) Clean inside of glass with Mopar Glass Cleaner and lint-free cloth.

(9) Apply PVC (vinyl) primer 25 mm (1 in.) wide around edge of glass. Wipe with clean/dry lint-free cloth.

(10) If necessary, apply fence primer around edge of fence. Allow at least eighteen minutes drying time.

(11) Apply a 10 mm (0.4 in.) bead of urethane around glass border.

(12) Position glass into liftgate opening and reference marks.

(13) Push the glass inward until the reveal molding is seated onto the liftgate frame. Use care to avoid excessive squeeze-out of adhesive.

(14) Open windows to prevent pressure build-up while the urethane is curing.

(15) Apply 150 mm (6 in.) lengths of 50 mm (2 in.) masking tape spaced 250 mm (10 in.) apart to hold glass in place until urethane cures.

(16) Install the wiper arm.

(17) Install CHMSL lens.

(18) Connect heated backlite (HBL) connector.

(19) After urethane has cured, remove tape strips and water test to verify repair.

(20) Install liftgate trim panel.

SEATS

TABLE OF CONTENTS

| | page | | page |
|---------------------------------|------|--|------|
| REMOVAL AND INSTALLATION | | | |
| HEAD RESTRAINT SLEEVE..... | 13 | BUCKET SEAT RECLINER..... | 17 |
| HEAD RESTRAINT COVER..... | 14 | REAR SEAT CUSHION..... | 17 |
| BUCKET SEAT..... | 15 | REAR SEATBACK..... | 18 |
| BUCKET SEAT TRACK..... | 15 | REAR SEAT CUSHION COVER..... | 19 |
| BUCKET SEAT PLATFORM..... | 15 | REAR SEATBACK LATCH STRIKER AND BUMPER..... | 19 |
| BUCKET SEATBACK COVER..... | 16 | REAR SEATBACK COVER..... | 20 |
| BUCKET SEATBACK..... | 16 | SPECIAL TOOLS | |
| BUCKET SEAT CUSHION COVER..... | 17 | SPECIAL TOOLS—SEATS..... | 20 |

REMOVAL AND INSTALLATION

HEAD RESTRAINT SLEEVE

REMOVAL

NOTE: When replacing a head restraint sleeve, the retaining tabs on the sleeve will be damaged during the removal process. Check the availability of replacement parts before servicing.

- (1) Raise head restraint to the full up position.
- (2) Turn head restraint lock thumbwheel to release head restraint and pull head restraint upward to remove from seat back.
- (3) Insert head restraint sleeve extractor (special tool 6773) (Fig. 1) and (Fig. 2) into the seat back.
- (4) The retaining tabs are positioned on each side of the sleeve, when inserting the extractor, ensure that the flat of the collar is facing the side of the seatback (Fig. 3).
- (5) Using a small hammer, tap extractor downward to release sleeve retaining tab.
- (6) Remove extractor tool from sleeve, rotate tool 180 degrees (Fig. 4) and repeat steps 3 and 4.

- (7) Remove extractor tool from sleeve and remove sleeve from seat back.

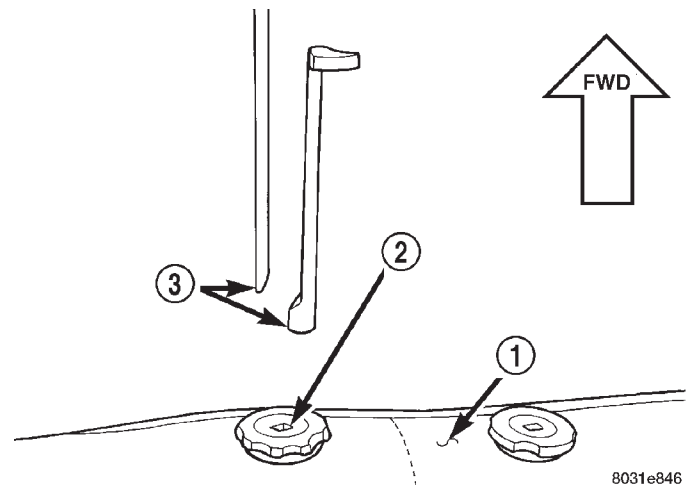
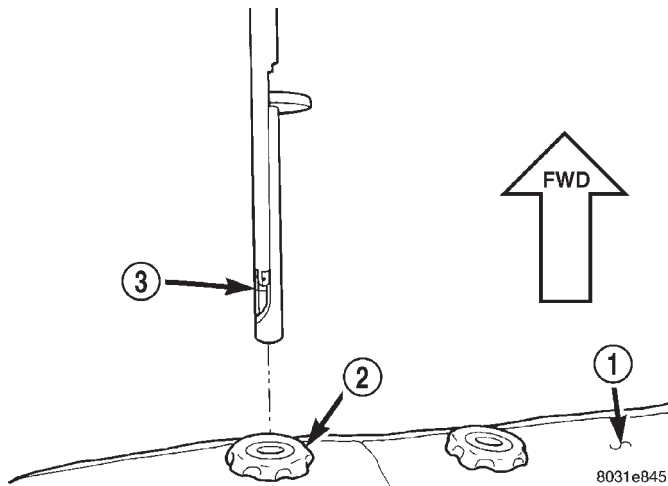

Fig. 1 Head Restraint Sleeve Extractor

- 1 - SEAT BACK
- 2 - HEAD RESTRAINT SLEEVE
- 3 - EXTRACTOR TOOL 6773

REMOVAL AND INSTALLATION (Continued)

**Fig. 2 Head Restraint Sleeve Extractor Installation**

- 1 - SEAT BACK
- 2 - HEAD RESTRAINT SLEEVE
- 3 - EXTRACTOR TOOL 6773

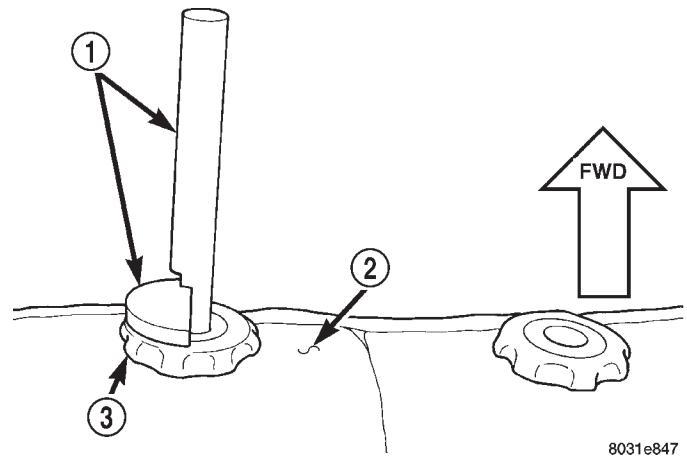
**Fig. 4 Head Restraint Sleeve Extractor Positioning**

- 1 - EXTRACTOR TOOL 6773
- 2 - SEAT BACK
- 3 - LOCK RELEASE THUMBWHEEL

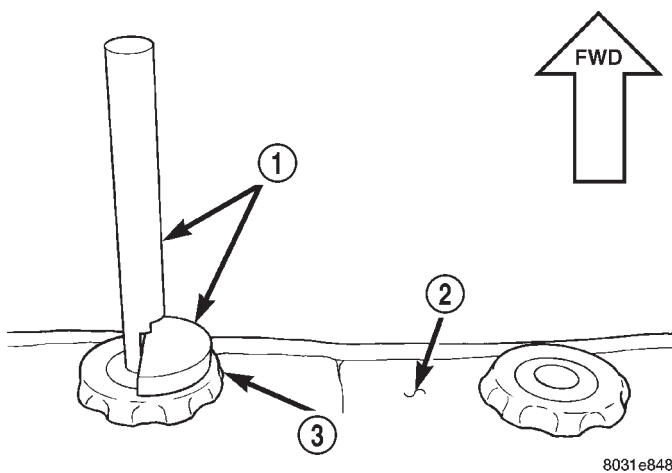
**Fig. 3 Head Restraint Sleeve Extractor Positioning**

- 1 - EXTRACTOR TOOL 6773
- 2 - SEAT BACK
- 3 - LOCK RELEASE THUMBWHEEL

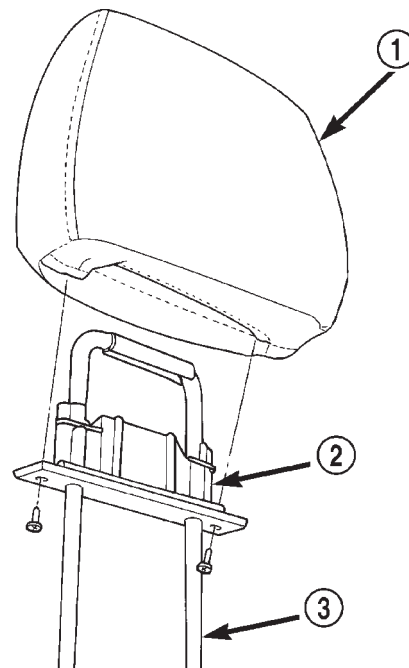
**Fig. 5 Head Restraint**

- 1 - HEAD RESTRAINT
- 2 - BEZEL
- 3 - ADJUSTER BAR

INSTALLATION

- (1) Position the sleeve in the seat back.
- (2) Firmly, push sleeve down to snap into place.
- (3) Install head restraint.

HEAD RESTRAINT COVER**REMOVAL**

- (1) Remove head restraint from the bucket seat.
- (2) Remove the screws attaching the bezel and adjuster bar to the head restraint (Fig. 5).
- (3) Pull the adjuster bar from the head restraint.
- (4) Roll the cover upward and separate from the head restraint cushion (Fig. 6).

INSTALLATION

- (1) Position the cover on the head restraint cushion and roll the cover downward.
- (2) Position the adjuster bar in the head restraint.
- (3) Install the screws attaching the bezel and adjuster bar to the head restraint.
- (4) Install head restraint in the bucket seat.

REMOVAL AND INSTALLATION (Continued)

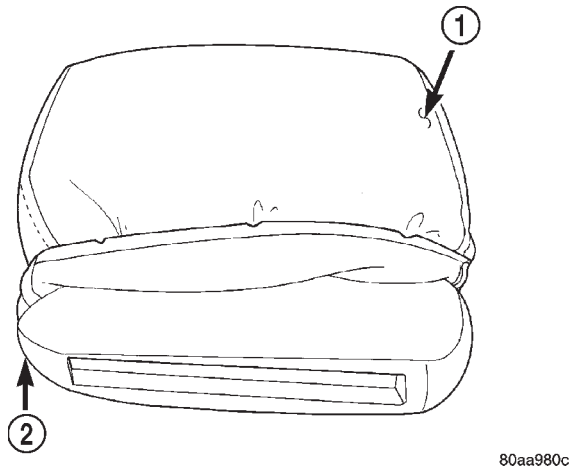
**Fig. 6 Head Restraint Cover**

- 1 - HEAD RESTRAINT COVER
2 - HEAD RESTRAINT CUSHION

BUCKET SEAT**REMOVAL**

- (1) Remove bolts attaching seat to floor pan (Fig. 7).
- (2) Remove nut attaching seat to floor pan.
- (3) For power seat, disconnect wire harness connector. If equipped, disconnect wire harness for heated seat.
- (4) Disconnect seat belt buckle warning wire harness connector.
- (5) Separate seat from floor panel.

INSTALLATION

- (1) Position seat on floor pan.
- (2) Connect seat belt buckle warning wire harness connector.
- (3) For power seats, connect wire harness connector. If equipped, connect harness for heated seat.
- (4) Install front fasteners attaching seat to floor pan. Tighten to 27 N·m (20 ft. lbs.) torque.
- (5) Install rear fasteners attaching seat to floor pan. Tighten to 27 N·m (20 ft. lbs.) torque.
- (6) Install nut attaching seat to floor pan. Tighten to 40 N·m (30 ft. lbs.) torque.

BUCKET SEAT TRACK**REMOVAL**

NOTE: If the vehicle is equipped with manually adjusted bucket seats, the inboard or outboard seat track may be serviced separately.

- (1) Remove bucket seat from vehicle.
- (2) Remove screws attaching the side shield trim cover from the seat.

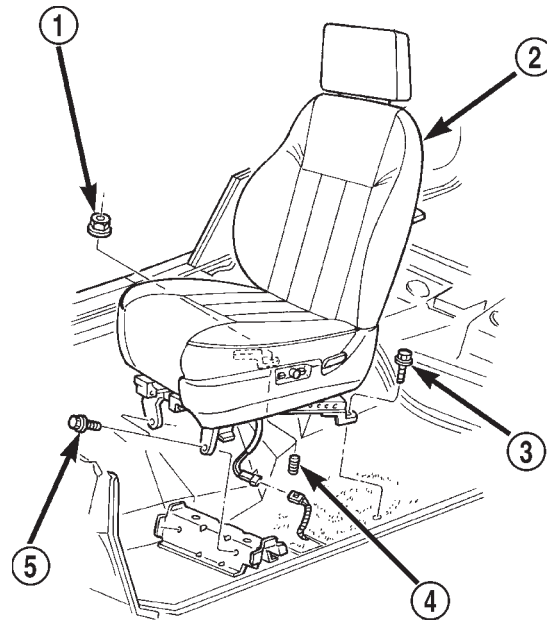
**Fig. 7 Bucket Seat—Power Seat**

- 1 - NUT
2 - DRIVER SIDE FRONT SEAT
3 - SCREW
4 - STUD
5 - SCREW

- (3) If equipped, disengage the power seat connector from the power seat switch.
- (4) Remove the nuts attaching the seat track to the bucket seat platform.
- (5) When separating the seat track from the platform, route the power seat switch connector through the access hole in the seat cushion frame, if equipped.

INSTALLATION

- (1) While positioning the seat track on the bucket seat platform, route the power seat switch connector through the access hole in the seat cushion frame, if equipped.
- (2) Install the nuts attaching the seat track to the bucket seat platform.
- (3) If equipped, engage the power seat connector to the power seat switch.
- (4) Install screws attaching the side shield trim cover to the seat.
- (5) Install bucket seat.

BUCKET SEAT PLATFORM

Bucket seat platforms are not repairable. If the seat platform is damaged, replace platform as a unit.

REMOVAL AND INSTALLATION (Continued)

BUCKET SEATBACK COVER

REMOVAL

- (1) Remove seat.
- (2) Remove head restraint, if equipped.
- (3) Remove screws attaching side shield trim cover to bucket seat.
- (4) If equipped, disengage power seat wire connector from power seat switch.
- (5) Remove the inboard seatback pivot bolt and large plastic washer.
- (6) Position the seatback in the full forward or full recline position.
- (7) Remove the seatback cover J straps from the base of the seatback.
- (8) Roll the seatback cover upward, disengage electrical connectors for heated seat grid, if equipped. (Fig. 8).
- (9) Disengage the hogrings attaching the seatback cover to the seatback cushion support wires (Fig. 9).
- (10) Roll the seatback cover upward and disengage the hook and loop fastener (Fig. 10).
- (11) Roll seatback cover up and over the head restraint sleeves, if equipped and separate from the seatback.

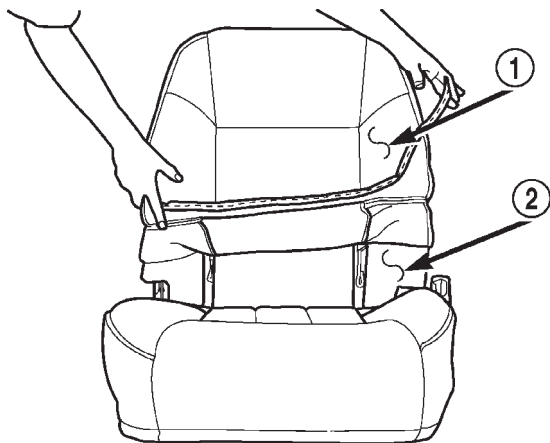

80aafb05

Fig. 8 Seatback Cover

- 1 - SEAT BACK COVER
- 2 - SEAT BACK CUSHION

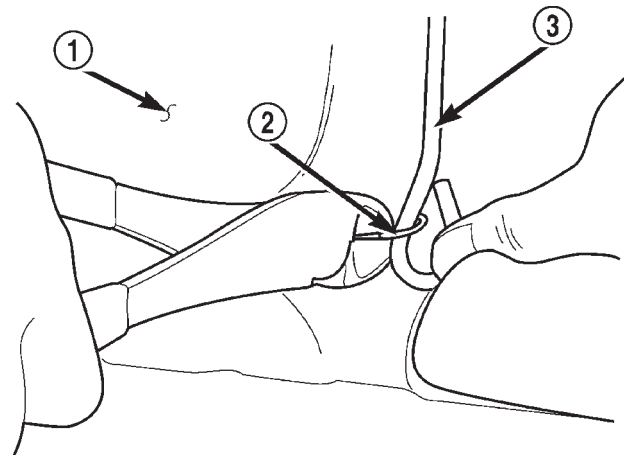

80aafb04

Fig. 9 Hog Ring

- 1 - SEAT BACK CUSHION
- 2 - HOG RING
- 3 - SUPPORT

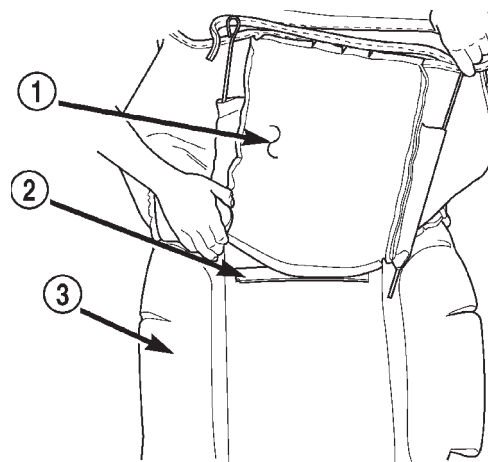

80aafb03

Fig. 10 Hook And Loop Fastener

- 1 - SEAT BACK COVER
- 2 - HOOK AND LOOP FASTENER
- 3 - SEAT BACK CUSHION

INSTALLATION

- (1) Position the seatback cover on the seatback cushion and roll seatback cover down over the head restraint sleeves. Route the sleeves through the access holes in the cover, if equipped.
- (2) Roll the seatback cover downward and engage the hook and loop fastener. Engage electrical connectors for heated seat grid, if equipped.
- (3) Continue rolling the cover downward and engage the hogrings attaching the seatback cover to the seatback cushion support wires.

- (4) Engage the seatback cover J straps to the base of the seatback.
- (5) Install the inboard seatback pivot bolt and large plastic washer.
- (6) Install the side shield trim cover.
- (7) Install head restraint, if equipped.
- (8) Install seat.

BUCKET SEATBACK

REMOVAL

- (1) Remove seat.
- (2) Remove side shield trim cover.
- (3) Remove inboard seatback pivot bolt and washer.

REMOVAL AND INSTALLATION (Continued)

- (4) Remove bolts attaching recliner to seat cushion frame (Fig. 11).
- (5) Separate seatback from vehicle.

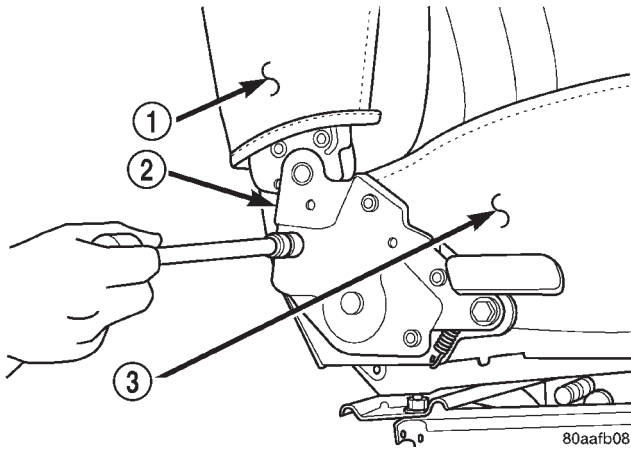

Fig. 11 Bucket Seatback

- 1 - SEAT BACK
- 2 - RECLINER
- 3 - SEAT CUSHION

INSTALLATION

- (1) Position seatback on seat cushion frame.
- (2) Install inboard seatback pivot bolt and washer.
- (3) Install bolts attaching recliner to seat cushion frame.
- (4) Install side shield trim cover.
- (5) Install seat.

BUCKET SEAT CUSHION COVER

REMOVAL

- (1) Remove seat from vehicle.
- (2) Remove side shield trim cover.
- (3) Remove seatback.
- (4) With the cushion side down, disengage the forward, rearward and inboard J-straps.
- (5) Disengage the clips attaching the outboard side of the cover to the cushion frame.
- (6) Turn the cushion over and roll the cover off the cushion.
- (7) Disengage the electrical connectors for the heated seat, if equipped.
- (8) Remove the hog rings attaching the cover to the cushion support wires (Fig. 12).
- (9) Separate the cover from the cushion.

INSTALLATION

- (1) Position the cover on the cushion.
- (2) Engage the electrical connectors for the heated seat, if equipped.
- (3) Install the hog rings attaching the cover to the cushion support wires.

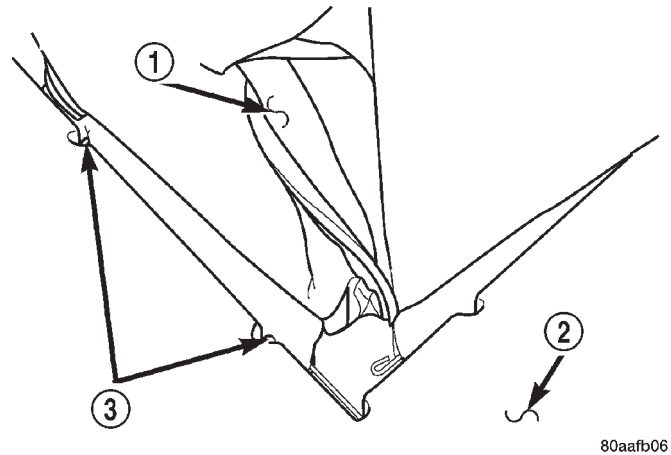

80aafb06

Fig. 12 Seat Cushion Cover Hog Rings

- 1 - SEAT CUSHION COVER
- 2 - SEAT CUSHION
- 3 - HOG RING

- (4) With the cushion side down, engage the forward, rearward and inboard J-straps.

- (5) Engage the clips attaching the outboard side of the cover to the cushion frame.

- (6) Install seatback.
- (7) Install side shield trim cover.
- (8) Install seat.

BUCKET SEAT RECLINER

REMOVAL

- (1) Remove side shield trim cover.
- (2) Disengage seatback cover zipper.
- (3) Roll outer seatback cover upward.
- (4) Remove bolts attaching recliner to seatback and seat cushion frames (Fig. 13).
- (5) Separate recliner from seat.

INSTALLATION

- (1) Position recliner on seat.
- (2) Install bolts attaching recliner to seatback and seat cushion frames (Fig. 13).
- (3) Roll seatback cover downward.
- (4) Engage seatback cover zipper.
- (5) Install side shield trim cover.

REAR SEAT CUSHION

REMOVAL

- (1) Disengage seat cushion at rear by pulling upward on release strap (Fig. 14).
- (2) Tilt seat cushion forward.
- (3) Disengage seat cushion latch with right side release lever. Separate right side latch and left side seat bracket from floor anchor bolts, and remove cushion from vehicle (Fig. 15).

REMOVAL AND INSTALLATION (Continued)

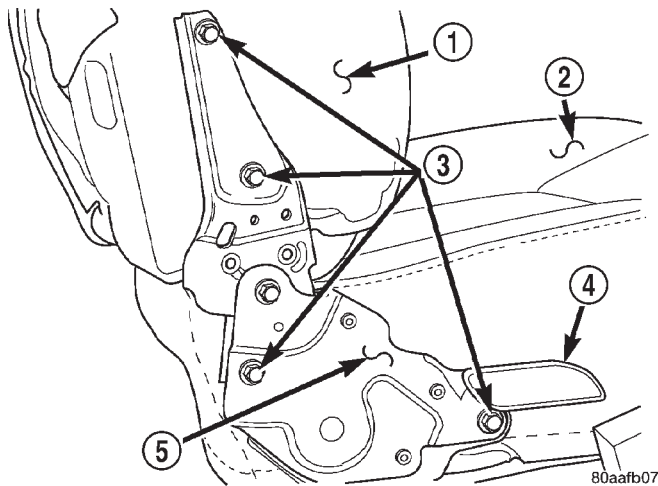
**Fig. 13 Bucket Seat Recliner**

- 1 - SEAT BACK CUSHION
- 2 - SEAT CUSHION
- 3 - REMOVE
- 4 - RECLINER HANDLE
- 5 - RECLINER

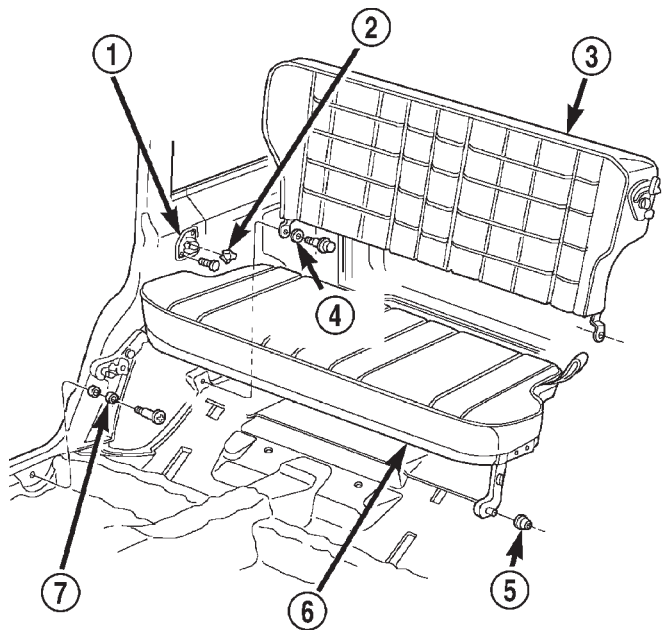
**Fig. 15 Rear Seat Cushion/Seat Back**

- 1 - SEAT BACK LATCH STRIKER BRACKET
- 2 - SEAT BACK LATCH STRIKER
- 3 - SEAT BACK
- 4 - PIVOT SPACER
- 5 - GROMMET
- 6 - SEAT CUSHION
- 7 - BUSHING

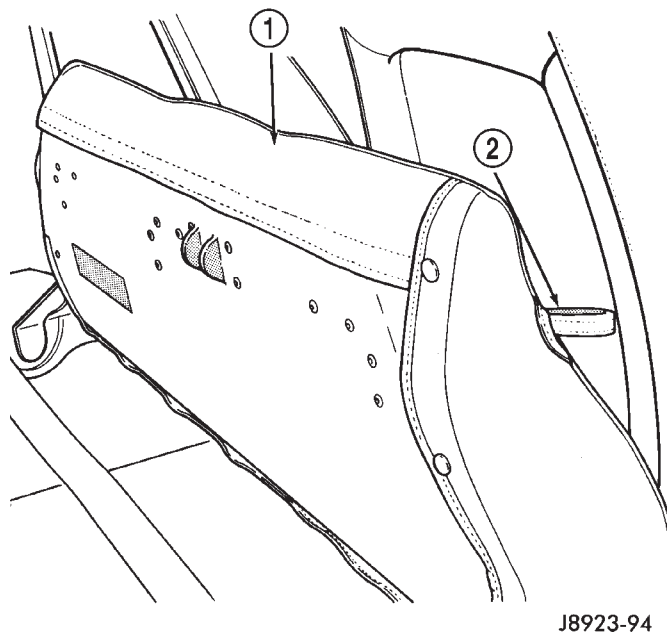
**Fig. 14 Seat Cushion Release Strap**

- 1 - REAR SEAT CUSHION
- 2 - RELEASE STRAP

INSTALLATION

- (1) Position seat cushion in vehicle.
- (2) Insert left pivot in anchor grommet.
- (3) Force right side latch onto anchor bolt and pivot seat cushion to horizontal position.
- (4) Lock seat cushion in-place by pressing firmly on center of cushion until latch engages.

REAR SEATBACK**REMOVAL**

- (1) Disengage the seat cushion at the rear by pulling upward on the release strap.
- (2) Tilt the seat cushion forward.
- (3) Remove the shoulder/lap belt buckles from the elastic straps.
- (4) Release the seatback latch from the striker.
- (5) Remove the pivot bolts and the washers from the wheelhouse panel anchors (Fig. 15).
- (6) Tilt the seatback forward, lift it upward and remove it from the vehicle.

INSTALLATION

- (1) Position the seatback in the vehicle.
- (2) Install the pivot bolts and the washer. Tighten the bolts with 33 N·m (25 ft. lbs.) torque.
- (3) Engage the seatback latch with the striker.
- (4) Insert the shoulder/lap belt buckles in the elastic straps.
- (5) Pivot the seat cushion to the horizontal position and lock it in-place by pressing firmly on the center of the cushion until the latch engages.

REMOVAL AND INSTALLATION (Continued)

REAR SEAT CUSHION COVER

REMOVAL

- (1) Remove the seat cushion from the vehicle.
- (2) Remove the cover side, front and rear retaining clips from the wire retainers with an appropriate removal tool (Fig. 16).
- (3) Remove the serrated retainers from the front ends of the cover with a trim panel removal tool (Fig. 17).
- (4) Remove the seat cover from the cushion.

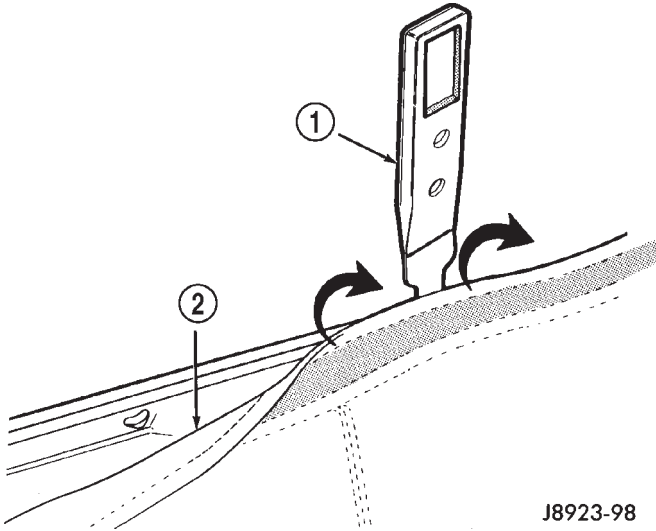

J8923-98

Fig. 16 Seat Cushion Cover Retaining Clip Removal

- 1 - REMOVER TOOL
- 2 - SEAT COVER

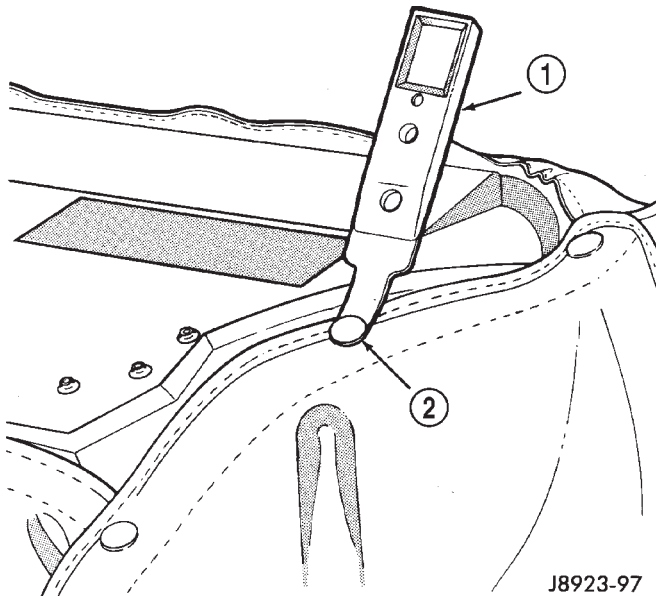

J8923-97

Fig. 17 Seat Cushion Cover Retaining Clip Removal

- 1 - CLIP REMOVER TOOL
- 2 - SEAT COVER CLIPS

INSTALLATION

- (1) Position the replacement cover on the cushion.
- (2) Compress the cover and attach the retaining clips to the front and rear wire retainers.
- (3) Install the serrated retainers at the ends of the cover.
- (4) Install the seat cushion in the vehicle. If necessary, refer to the installation procedure.

REAR SEATBACK LATCH STRIKER AND BUMPER

REMOVAL

- (1) Disengage seat cushion at the rear by pulling upward on the release strap.
- (2) Tilt seat cushion forward.
- (3) Release seatback latch from striker.
- (4) Tilt seatback forward for access to striker bracket.
- (5) Remove screws (Fig. 18) attaching latch striker bracket and shims to trim panel.

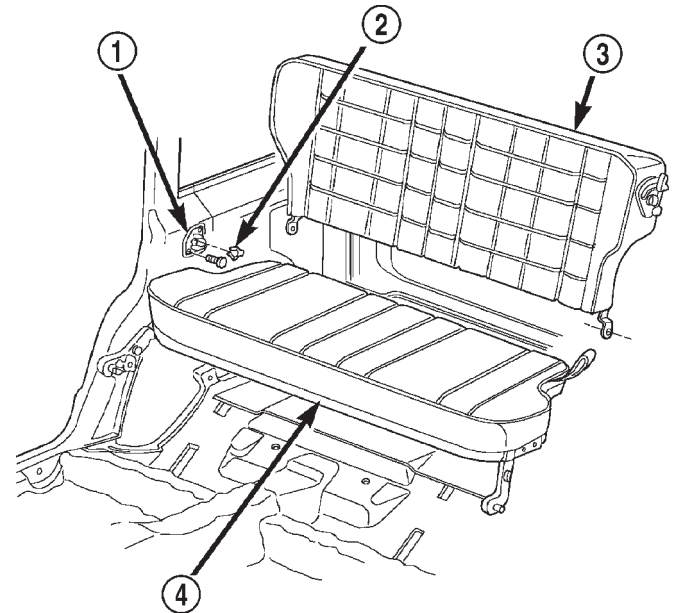

80b89834

Fig. 18 Seatback Latch Striker Bracket

- 1 - SEAT BACK LATCH STRIKER BRACKET
- 2 - SEAT BACK LATCH STRIKER
- 3 - SEAT BACK
- 4 - SEAT CUSHION

INSTALLATION

- (1) Position shims and latch striker bracket on trim panel.
- (2) Install screws attaching latch striker bracket and shims to trim panel. Tighten screws to 6 N-m (50 in. lbs.) torque.
- (3) Engage seatback latch with striker.

REMOVAL AND INSTALLATION (Continued)

(4) Pivot seat cushion to horizontal position and lock it in-place by pressing firmly on center of the cushion until latch engages.

REAR SEATBACK COVER

REMOVAL

- (1) Remove the seatback from the vehicle.
- (2) Remove the seatback latch release handle and bezel from the seatback.
- (3) Disengage the cover zippers.
- (4) Disengage the J-strap attaching the cover to the seat back frame (Fig. 19).
- (5) Remove the cover from the seatback pad.

INSTALLATION

- (1) Install the cover on the seatback.
- (2) Attach the cover J-strap to the seatback frame.
- (3) Engage the cover zippers.
- (4) Install the seat latch release bezel and handle.
- (5) Install the seatback in the vehicle.

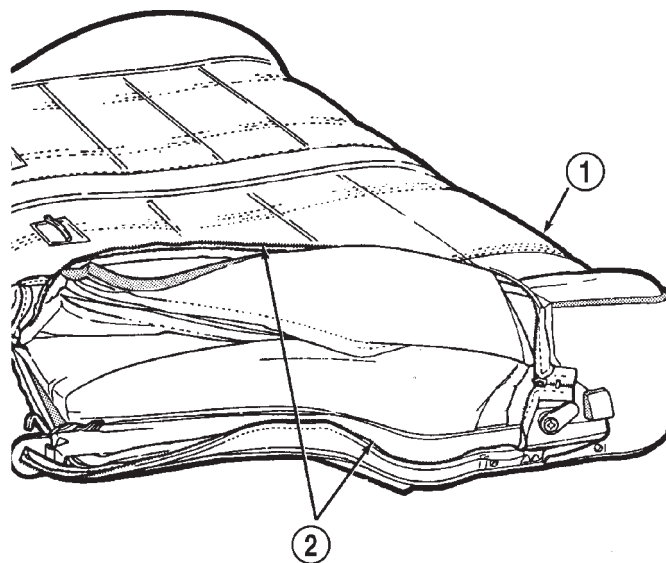

J8923-99

Fig. 19 Seatback Cover Removal

- 1 - SEAT BACK
2 - COVER ZIPPER

SPECIAL TOOLS

SPECIAL TOOLS—SEATS

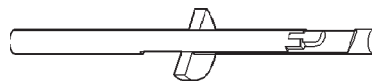

Extractor Head Restraint Sleeve 6773

BODY COMPONENT SERVICE

TABLE OF CONTENTS

| | page | | page |
|--|------|---|------|
| DIAGNOSIS AND TESTING | | | |
| WATER LEAKS | 22 | REAR DOOR WATERDAM | 42 |
| WIND NOISE | 23 | REAR DOOR | 43 |
| SERVICE PROCEDURES | | REAR DOOR RESTRAINT | 43 |
| BODY LUBRICATION | 23 | REAR DOOR HINGE | 43 |
| REMOVAL AND INSTALLATION | | REAR DOOR OUTSIDE HANDLE | 44 |
| GRILLE | 24 | REAR DOOR LATCH | 44 |
| GRILLE OPENING PANEL (GOP) | 24 | REAR DOOR LATCH STRIKER | 45 |
| HOOD | 24 | REAR DOOR INSIDE HANDLE ACTUATOR | 45 |
| HOOD HINGE | 26 | REAR DOOR INNER BELT WEATHERSTRIP | 45 |
| HOOD LATCH | 26 | REAR DOOR OUTER BELT WEATHERSTRIP | 45 |
| HOOD LATCH STRIKER | 26 | REAR DOOR GLASS RUN CHANNEL WEATHERSTRIP | 46 |
| HOOD RELEASE CABLE | 27 | REAR DOOR GLASS EXTERIOR MOLDING | 46 |
| HOOD SAFETY LATCH | 27 | REAR DOOR WEATHERSTRIP | 46 |
| SAFETY LATCH STRIKER | 27 | REAR DOOR WINDOW REGULATOR | 47 |
| HOOD SILENCER PAD | 27 | REAR DOOR WINDOW GLASS | 47 |
| COWL WEATHERSTRIP | 28 | BODY SIDE MOLDING | 48 |
| COWL GRILLE | 28 | REAR FENDER FLARE | 49 |
| BODY DECALS | 29 | QUARTER WINDOW APPLIQUE | 49 |
| EXTERIOR NAMEPLATES | 30 | DRIP RAIL MOLDING | 49 |
| SIDE VIEW MIRROR | 31 | LUGGAGE RACK | 50 |
| FRONT FENDER FLARE | 31 | AIR EXHAUST GRILLE | 50 |
| FRONT WHEELHOUSE LINER | 32 | A-PILLAR TRIM | 51 |
| RIGHT FRONT FENDER | 32 | LOWER A-PILLAR COWL TRIM | 51 |
| LEFT FRONT FENDER | 32 | FRONT INNER SCUFF PLATE | 52 |
| FRONT DOOR TRIM PANEL | 33 | DOOR SILL SCUFF PLATE | 52 |
| FRONT DOOR WATERDAM | 34 | ASSIST HANDLE | 52 |
| FRONT DOOR | 35 | B-PILLAR TRIM | 52 |
| FRONT DOOR HINGE | 35 | C-PILLAR TRIM | 53 |
| FRONT DOOR RESTRAINT | 35 | QUARTER PANEL TRIM EXTENSION | 54 |
| FRONT DOOR OUTSIDE HANDLE | 35 | QUARTER PANEL TRIM AND WHEELHOUSE COVER | 54 |
| FRONT DOOR LOCK CYLINDER | 36 | LIFTGATE PILLAR TRIM | 55 |
| LOCK CYLINDERS | 37 | LIFTGATE OPENING UPPER TRIM | 55 |
| FRONT DOOR LATCH | 37 | LIFTGATE SCUFF PLATE | 55 |
| FRONT DOOR LATCH STRIKER | 37 | FRONT SHOULDER BELT/BUCKLE | 55 |
| FRONT DOOR INSIDE HANDLE ACTUATOR | 37 | REAR SHOULDER/LAP BELT/BUCKLE | 57 |
| FRONT DOOR INNER BELT WEATHERSTRIP | 37 | FULL FLOOR CONSOLE | 57 |
| FRONT DOOR OUTER BELT WEATHERSTRIP | 38 | FRONT CARPET/MAT | 58 |
| FRONT DOOR GLASS RUN CHANNEL WEATHERSTRIP | 38 | REAR CARPET/MAT | 58 |
| FRONT DOOR OPENING WEATHERSTRIP | 38 | REARVIEW MIRROR | 59 |
| FRONT DOOR OPENING SECONDARY WEATHERSTRIP | 39 | REARVIEW MIRROR SUPPORT BRACKET | 59 |
| FRONT DOOR GLASS EXTERIOR MOLDING | 39 | SUNVISORS | 60 |
| FRONT DOOR WINDOW REGULATOR | 39 | HEADLINER | 60 |
| FRONT DOOR SPACER BLOCKS—TWO- DOOR VEHICLES | 41 | LIFTGATE TRIM PANEL | 61 |
| FRONT DOOR GLASS | 41 | LIFTGATE | 62 |
| REAR DOOR TRIM PANEL | 42 | LIFTGATE HINGE | 62 |
| | | LIFTGATE SUPPORT ROD CYLINDER | 63 |
| | | LIFTGATE SUPPORT ROD BALL STUD | 63 |

| | |
|-------------------------------|----|
| LIFTGATE OUTSIDE HANDLE | 63 |
| LIFTGATE LOCK CYLINDER | 64 |
| LIFTGATE LATCH | 64 |
| LIFTGATE LATCH STRIKER..... | 64 |
| LIFTGATE WEATHERSTRIP..... | 65 |
| ADJUSTMENTS | |
| HOOD | 65 |
| DOOR | 65 |
| DOOR LATCH ADJUSTMENT..... | 66 |
| LIFTGATE | 67 |
| REAR SEATBACK | 67 |

SPECIFICATIONS

| | |
|-------------------------------------|-----|
| BODY LUBRICANTS | 67 |
| WELD LOCATIONS | 68 |
| BODY SEALING LOCATIONS..... | 112 |
| STRUCTURAL ADHESIVE LOCATIONS | 124 |
| BODY GAP AND FLUSH MEASUREMENTS.... | 127 |
| BODY OPENING DIMENSIONS | 128 |
| TORQUE SPECIFICATIONS..... | 135 |

SPECIAL TOOLS

| | |
|-----------|-----|
| BODY..... | 135 |
|-----------|-----|

DIAGNOSIS AND TESTING

WATER LEAKS

Water leaks can be caused by poor sealing, improper body component alignment, body seam porosity, missing plugs, or blocked drain holes. Centrifugal and gravitational force can cause water to drip from a location away from the actual leak point, making leak detection difficult. All body sealing points should be water tight in normal wet-driving conditions. Water flowing downward from the front of the vehicle should not enter the passenger or luggage compartment. Moving sealing surfaces will not always seal water tight under all conditions. At times, side glass or door seals will allow water to enter the passenger compartment during high pressure washing or hard driving rain (severe) conditions. Overcompensating on door or glass adjustments to stop a water leak that occurs under severe conditions can cause premature seal wear and excessive closing or latching effort. After completing a repair, water test vehicle to verify leak has stopped before returning vehicle to use.

VISUAL INSPECTION BEFORE WATER LEAK TESTS

Verify that floor and body plugs are in place, body drains are clear, and body components are properly aligned and sealed. If component alignment or sealing is necessary, refer to the appropriate section of this group for proper procedures.

WATER LEAK TESTS

WARNING: DO NOT USE ELECTRIC SHOP LIGHTS OR TOOLS IN WATER TEST AREA. PERSONAL INJURY CAN RESULT.

When the conditions causing a water leak have been determined, simulate the conditions as closely as possible.

- If a leak occurs with the vehicle parked in a steady light rain, flood the leak area with an open-ended garden hose.

- If a leak occurs while driving at highway speeds in a steady rain, test the leak area with a reasonable velocity stream or fan spray of water. Direct the spray in a direction comparable to actual conditions.

- If a leak occurs when the vehicle is parked on an incline, hoist the end or side of the vehicle to simulate this condition. This method can be used when the leak occurs when the vehicle accelerates, stops or turns. If the leak occurs on acceleration, hoist the front of the vehicle. If the leak occurs when braking, hoist the back of the vehicle. If the leak occurs on left turns, hoist the left side of the vehicle. If the leak occurs on right turns, hoist the right side of the vehicle. For hoisting recommendations refer to Group 0, Lubrication and Maintenance, General Information section.

WATER LEAK DETECTION

To detect a water leak point-of-entry, do a water test and watch for water tracks or droplets forming on the inside of the vehicle. If necessary, remove interior trim covers or panels to gain visual access to the leak area. If the hose cannot be positioned without being held, have someone help do the water test.

Some water leaks must be tested for a considerable length of time to become apparent. When a leak appears, find the highest point of the water track or drop. The highest point usually will show the point of entry. After leak point has been found, repair the leak and water test to verify that the leak has stopped.

Locating the entry point of water that is leaking into a cavity between panels can be difficult. The trapped water may splash or run from the cavity, often at a distance from the entry point. Most water leaks of this type become apparent after accelerating, stopping, turning, or when on an incline.

MIRROR INSPECTION METHOD

When a leak point area is visually obstructed, use a suitable mirror to gain visual access. A mirror can also be used to deflect light to a limited-access area to assist in locating a leak point.

DIAGNOSIS AND TESTING (Continued)

BRIGHT LIGHT LEAK TEST METHOD

Some water leaks in the luggage compartment can be detected without water testing. Position the vehicle in a brightly lit area. From inside the darkened luggage compartment inspect around seals and body seams. If necessary, have a helper direct a drop light over the suspected leak areas around the luggage compartment. If light is visible through a normally sealed location, water could enter through the opening.

PRESSURIZED LEAK TEST METHOD

When a water leak into the passenger compartment cannot be detected by water testing, pressurize the passenger compartment and soap test exterior of the vehicle. To pressurize the passenger compartment, close all doors and windows, start engine, and set heater control to high blower in HEAT position. If engine can not be started, connect a charger to the battery to ensure adequate voltage to the blower. With interior pressurized, apply dish detergent solution to suspected leak area on the exterior of the vehicle. Apply detergent solution with spray device or soft bristle brush. If soap bubbles occur at a body seam, joint, seal or gasket, the leak entry point could be at that location.

WIND NOISE

Wind noise is the result of most air leaks. Air leaks can be caused by poor sealing, improper body component alignment, body seam porosity, or missing plugs in the engine compartment or door hinge pillar areas. All body sealing points should be airtight in normal driving conditions. Moving sealing surfaces will not always seal airtight under all conditions. At times, side glass or door seals will allow wind noise to be noticed in the passenger compartment during high cross winds. Over compensating on door or glass adjustments to stop wind noise that occurs under severe conditions can cause premature seal wear and excessive closing or latching effort. After a repair procedure has been performed, test vehicle to verify noise has stopped before returning vehicle to use.

Wind noise can also be caused by improperly fitted exterior moldings or body ornamentation. Loose moldings can flutter, creating a buzzing or chattering noise. An open cavity or protruding edge can create a whistling or howling noise. Inspect the exterior of the vehicle to verify that these conditions do not exist.

VISUAL INSPECTION BEFORE TESTS

Verify that floor and body plugs are in place and body components are aligned and sealed. If component alignment or sealing is necessary, refer to the appropriate section of this group for proper procedures.

ROAD TESTING WIND NOISE

(1) Drive the vehicle to verify the general location of the wind noise.

(2) Apply 50 mm (2 in.) masking tape in 150 mm (6 in.) lengths along weatherstrips, weld seams or moldings. After each length is applied, drive the vehicle. If noise goes away after a piece of tape is applied, remove tape, locate, and repair defect.

POSSIBLE CAUSE OF WIND NOISE

- Moldings standing away from body surface can catch wind and whistle.
- Gaps in sealed areas behind overhanging body flanges can cause wind-rushing sounds.
- Misaligned movable components.
- Missing or improperly installed plugs in pillars.
- Weld burn through holes.

SERVICE PROCEDURES

BODY LUBRICATION

All mechanisms and linkages should be lubricated when necessary. This will maintain ease of operation and provide protection against rust and excessive wear. The weatherstrip seals should be lubricated to prolong their life as well as to improve door sealing.

All applicable exterior and interior vehicle operating mechanisms should be inspected and cleaned. Pivot/sliding contact areas on the mechanisms should then be lubricated.

(1) When necessary, lubricate the operating mechanisms with the specified lubricants.

(2) Apply silicone lubricant to a cloth and wipe it on door seals to avoid over-spray that can soil passenger's clothing.

(3) Before applying lubricant, the component should be wiped clean. After lubrication, any excess lubricant should be removed.

(4) The hood latch, latch release mechanism, latch striker, and safety latch should be lubricated periodically.

(5) The door lock cylinders should be lubricated twice each year (preferably autumn and spring).

- Spray a small amount of lock cylinder lubricant directly into the lock cylinder.
- Apply a small amount to the key and insert it into the lock cylinder.
- Rotate it to the locked position and then back to the unlocked position several times.
- Remove the key. Wipe the lubricant from it with a clean cloth to avoid soiling of clothing.

REMOVAL AND INSTALLATION

GRILLE

REMOVAL

- (1) Remove the headlamp/park lamp bezels.
- (2) Remove the screws attaching the grille to the grille opening panel (GOP) (Fig. 1).
- (3) Separate the grille from the GOP.

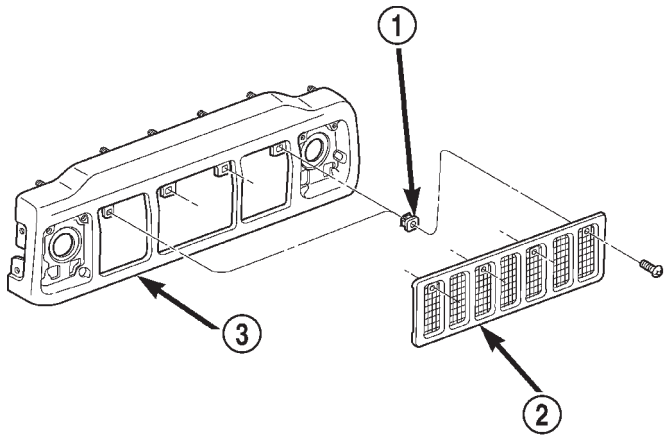

Fig. 1 Grille

- 1 - NUT
- 2 - GRILLE
- 3 - GRILLE OPENING PANEL

80aafb27

INSTALLATION

- (1) Position the grille in the GOP.
- (2) Install the screws.
- (3) Install the headlamp/park lamp bezels.

GRILLE OPENING PANEL (GOP)

REMOVAL

- (1) Remove headlamp bezels.
- (2) Remove grille.
- (3) Remove side marker lamps.
- (4) Remove headlamps and park/turn signal lamps.
- (5) Open hood.
- (6) Remove nuts that attach GOP to front fenders.
- (7) Remove nuts attaching GOP to support bracket.
- (8) Pull GOP forward and disconnect harness clips and front lamp harness connectors.
- (9) Remove GOP from vehicle.

INSTALLATION

- (1) Place GOP on bumper and secure all harness clips.
- (2) Connect all lamp wire harness connectors.

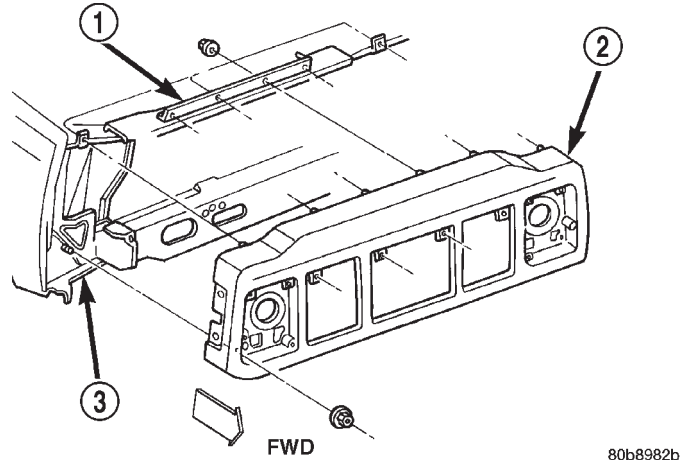

80b8982b

Fig. 2 Grille Opening Panel

- 1 - SUPPORT BRACKET
- 2 - GRILLE OPENING PANEL
- 3 - BODY

- (3) Position GOP on vehicle.
- (4) Install nuts attaching GOP to front fenders. Tighten nuts to 4 N·m (38 in-lbs) torque.
- (5) Install nuts attaching GOP to support bracket. Tighten nuts to 4 N·m (38 in-lbs) torque.
- (6) Install headlamps and park/turn signal lamps.
- (7) Install grille.
- (8) Install side marker lamps.
- (9) Install headlamp bezels.
- (10) Adjust headlamp aim, if necessary.

HOOD

REMOVAL

- (1) Raise hood.
- (2) Disconnect underhood lamp wire harness connector, if equipped.
- (3) Disconnect release cable from latch release bellcrank.
- (4) Remove latch release cable clips and remove cable from hood (Fig. 3).
- (5) Mark location of hood, hinges and hinge shims for installation.
- (6) Remove bolts that attach hinges to hood.
- (7) Remove hood from vehicle with aid of a helper.

INSTALLATION

- (1) Position hood on shims and hinges; finger-tighten hinge bolts.
- (2) Align hinges and shims with reference marks and tighten hinge bolts.
- (3) Connect latch release cable and latch connecting rod to bellcrank.
- (4) Attach latch release cable to clips.
- (5) Connect underhood lamp wire harness connector.

REMOVAL AND INSTALLATION (Continued)

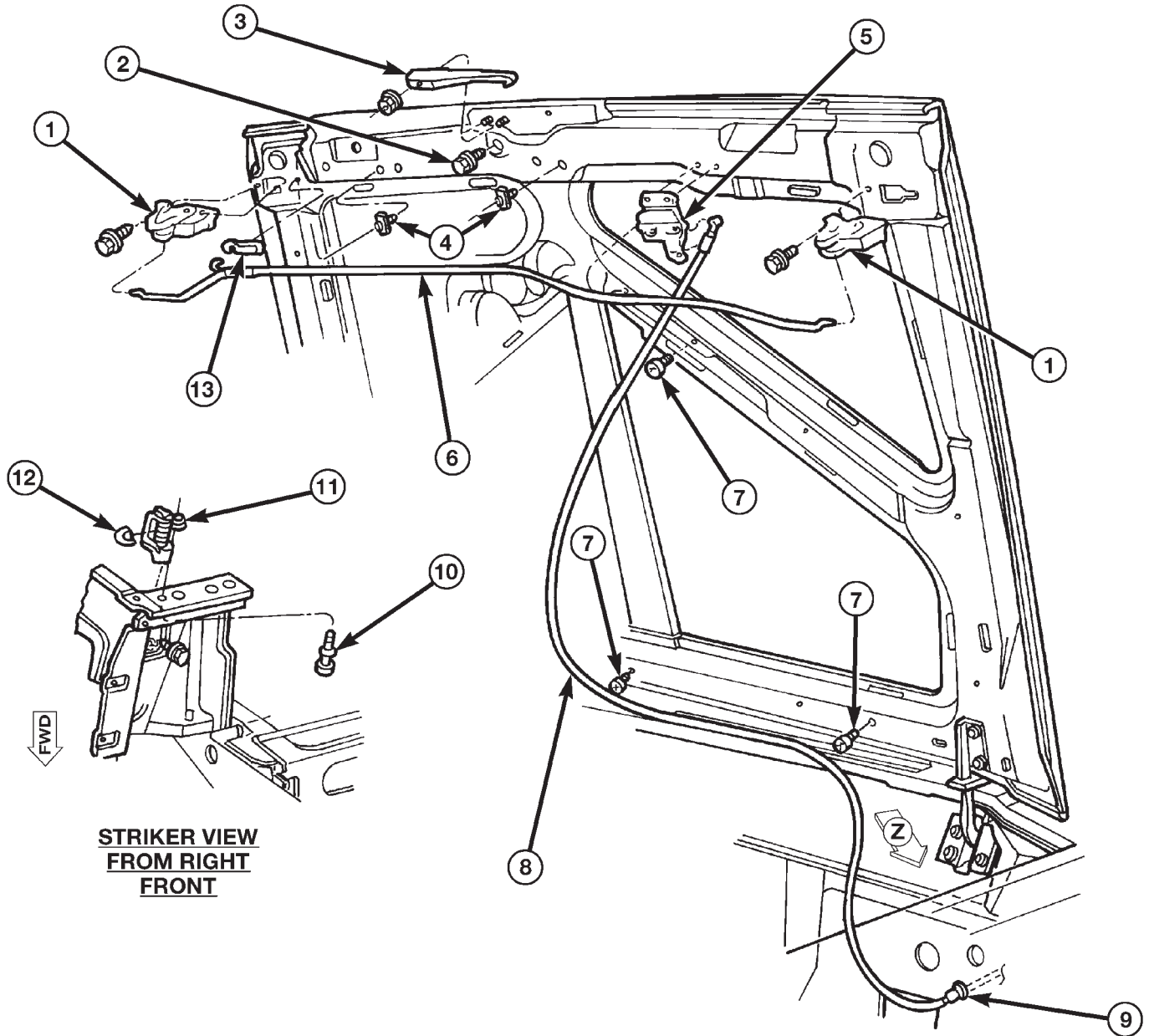

**STRIKER VIEW
FROM RIGHT
FRONT**

- 1. LATCH
- 2. BUMPER
- 3. CATCH
- 4. CLIP
- 5. BELLCRANK
- 6. ROD
- 7. CLIP
- 8. CABLE
- 9. GROMMET
- 10. SHOULDER BOLT
- 11. STRIKER
- 12. SHIM
- 13. SPRING

**VIEW IN DIRECTION
OF ARROW Z**

Fig. 3 Hood Components

REMOVAL AND INSTALLATION (Continued)

HOOD HINGE

REMOVAL

- (1) Raise and support hood.
- (2) Using a grease pencil or equivalent, mark position of hood.
- (3) Remove seal from hinge base (Fig. 4).
- (4) Remove hinge retaining nuts from studs.

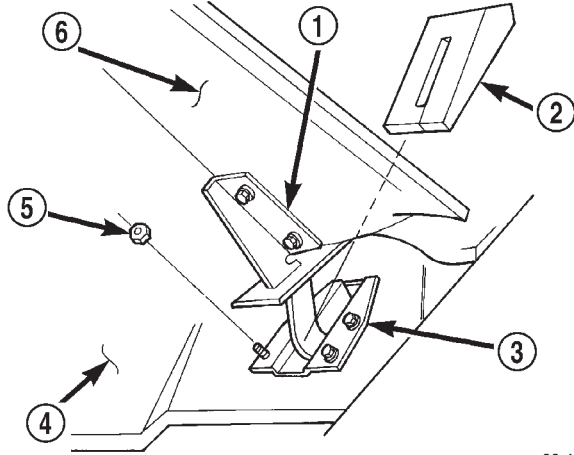

Fig. 4 Hood Hinge and Seal

- 1 - HINGE
- 2 - SEAL
- 3 - HINGE BASE
- 4 - DASH PANEL
- 5 - NUT
- 6 - HOOD

INSTALLATION

- (1) Position hinge over studs and align with reference marks.
- (2) Install nuts.

NOTE: If a replacement hinge seal is being installed, position it around hinge arm, force it against hinge base.

- (3) Position hinge seal around hinge arm and on hinge base.
- (4) Adjust hood as necessary.

HOOD LATCH

REMOVAL

- (1) Remove the screw that attaches the latch to the hood inner panel (Fig. 5).
- (2) Disconnect the latch connecting rod.
- (3) Remove the latch from the hood.

INSTALLATION

- (1) Connect the latch to the latch connecting rod and

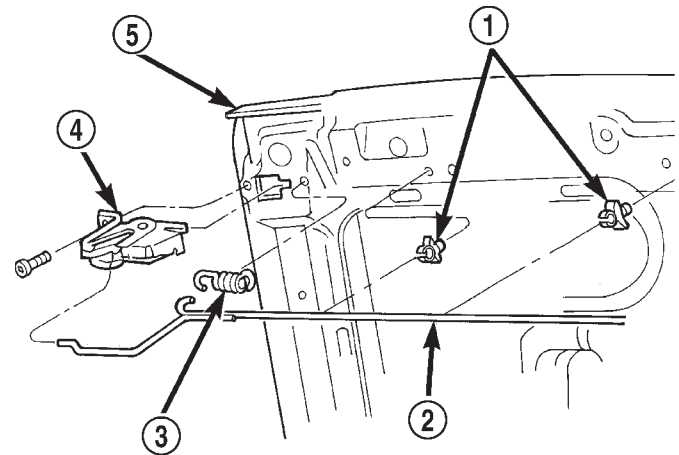

80ab5cd8

Fig. 5 Hood Latch

- 1 - RETAINER CLIP
- 2 - LATCH CONNECTING ROD
- 3 - ROD SPRING
- 4 - HOOD LATCH
- 5 - HOOD

- (2) Position the latch on the hood inner panel.
- (3) Install the screw that attaches the latch to the hood inner panel.

HOOD LATCH STRIKER

REMOVAL

- (1) Remove headlamp bezel.
- (2) Remove parklamp.
- (3) Release the spring attaching the headlamp mounting bucket to the grille opening panel (GOP).
- (4) Remove the headlamp with mounting bucket attached from the adjusting screws.
- (5) Remove the upper bolt attaching the striker to the top of the (GOP).
- (6) Remove the lower bolt attaching the striker to the (GOP).
- (7) Remove the striker and shims.

INSTALLATION

- (1) Position the shims and striker on the (GOP) and install the bolts.
- (2) Install the headlamp and mounting bucket.
- (3) Install parklamp.
- (4) Install the headlamp bezel.
- (5) Test the striker/hood alignment by opening and closing the hood several times. Adjust the striker, if necessary.

REMOVAL AND INSTALLATION (Continued)

HOOD RELEASE CABLE

REMOVAL

- (1) Drill out bellcrank to hood rivet heads and remove rivets (Fig. 6).
- (2) Disconnect bellcrank from latch rod and hood release cable. Remove bellcrank from hood.
- (3) Disconnect hood release cable from clips on hood.
- (4) Remove left cowl side trim panel.
- (5) Remove cable bracket screws from cowl side panel.
- (6) Route cable through dash panel and remove it from under instrument panel.

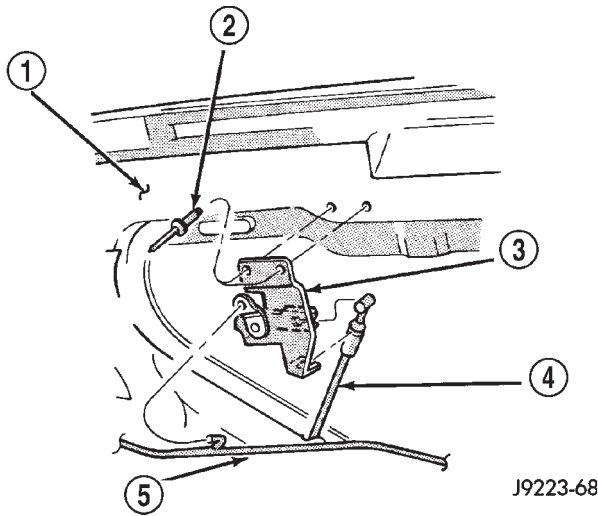

Fig. 6 Hood Release Cable Bellcrank

- 1 - HOOD INNER PANEL
- 2 - RIVET
- 3 - BELLCRANK
- 4 - LATCH RELEASE CABLE
- 5 - LATCH CONNECTING ROD

INSTALLATION

- (1) Insert replacement cable end through hole in dash panel into engine compartment.
- (2) Route cable forward and seat grommet in dash panel.
- (3) Position cable bracket on cowl side panel and install screws.
- (4) Install left cowl side trim panel.
- (5) Connect cable and latch rod to bellcrank.
- (6) Position bellcrank on hood and install rivets.
- (7) Attach cable to clips.
- (8) Test release cable for proper operation.

HOOD SAFETY LATCH

REMOVAL

- (1) Open and support hood.

- (2) Remove the nuts attaching the safety latch to the inner hood panel (Fig. 7).
- (3) Separate the safety latch from the hood.

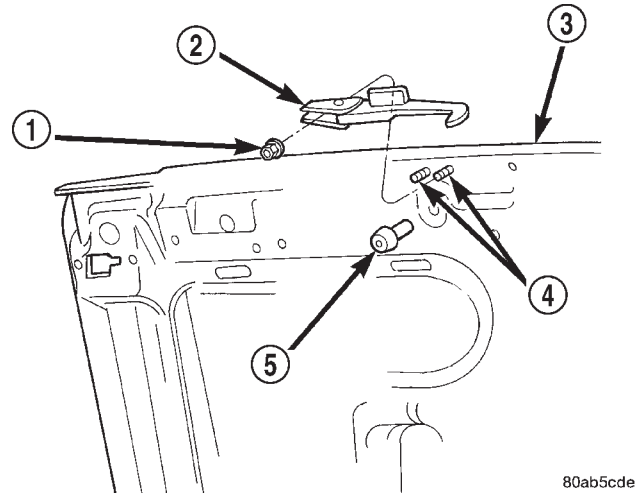

Fig. 7 Hood Safety Latch

- 1 - NUT
- 2 - HOOD SAFETY LATCH
- 3 - HOOD
- 4 - STUD
- 5 - HOOD BUMPER

INSTALLATION

- (1) Position the safety latch on the hood.
- (2) Install the nuts attaching the safety latch to the inner hood panel.
- (3) Close hood.

SAFETY LATCH STRIKER

REMOVAL

- (1) Remove striker screws from radiator support crossmember (Fig. 8).
- (2) Remove striker from crossmember.

INSTALLATION

- (1) Position striker on radiator support crossmember and install screws.
- (2) Test safety latch operation.

HOOD SILENCER PAD

REMOVAL

- (1) Open and support hood.
- (2) Remove the hood latch release bellcrank.
- (3) Remove the clips attaching the latch connecting rod to the hood inner panel.
- (4) Remove the retainers attaching the hood silencer pad to the inner hood panel (Fig. 9).
- (5) Separate the hood silencer pad from the hood.

REMOVAL AND INSTALLATION (Continued)

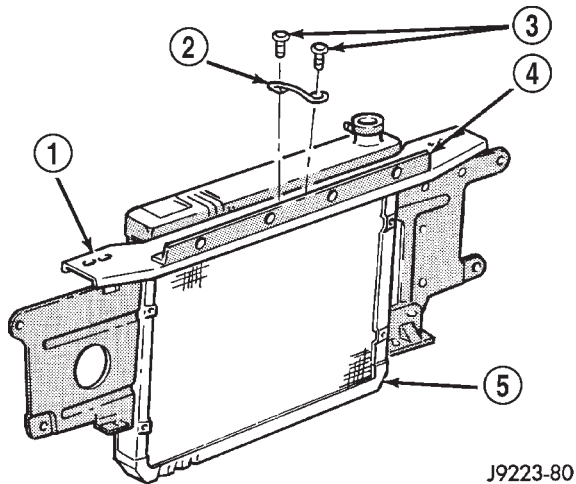

J9223-80

Fig. 8 Hood Safety Latch Striker

- 1 - RADIATOR SUPPORT CROSSMEMBER
- 2 - HOOD SAFETY LATCH STRIKER
- 3 - SCREW
- 4 - GOP BRACKET
- 5 - RADIATOR

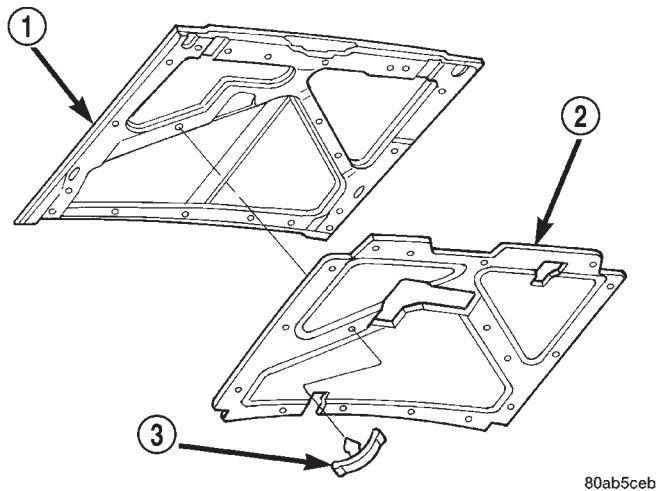

80ab5ceb

Fig. 9 Hood Silencer Pad

- 1 - HOOD
- 2 - SILENCER PAD
- 3 - RETAINER

INSTALLATION

- (1) Position the hood silencer pad on the hood inner panel.
- (2) Install the retainers attaching the hood silencer pad to the inner hood panel.
- (3) Install the clips attaching the latch connecting rod to the hood inner panel.
- (4) Install the hood latch release bellcrank.
- (5) Close hood.

COWL WEATHERSTRIP**REMOVAL**

The cowl weatherstrip is attached to the cowl with adhesive tape.

- (1) Peel weatherstrip from cowl (Fig. 10).

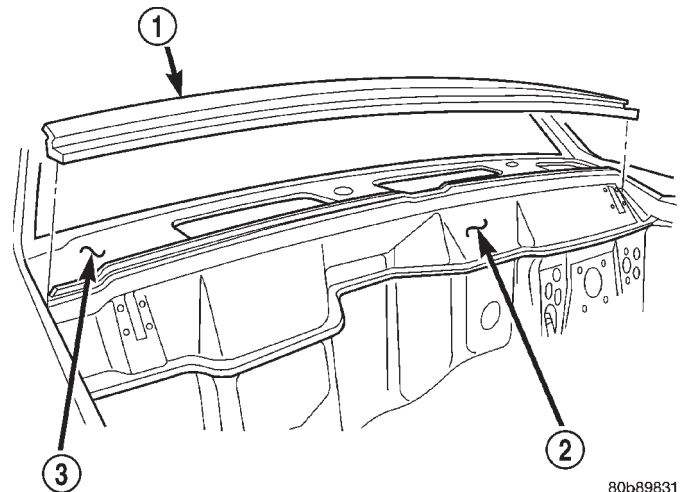

80b89831

Fig. 10 Cowl Weatherstrip

- 1 - WEATHERSTRIP
- 2 - DASH PANEL
- 3 - COWL

INSTALLATION

- (1) Clean contact surface with Mopar Super Kleen or equivalent.
- (2) Position weatherstrip on cowl.
- (3) Press weatherstrip into place.

COWL GRILLE**REMOVAL**

- (1) Remove the windshield wiper arms from the pivots.
- (2) Remove the screws that attach the grille to the cowl.
- (3) Remove the windshield washer tubes from the nozzles.
- (4) Remove the cowl grille and screen from the cowl (Fig. 11).

INSTALLATION

CAUTION: The washer fluid tubes must be routed and installed so that they are not pinched.

- (1) Position the cowl grille and screen on the cowl.
- (2) Install the windshield washer tubes on the nozzles.
- (3) Install the cowl screen and grille screws with new sealer. Tighten in sequence (Fig. 12).

REMOVAL AND INSTALLATION (Continued)

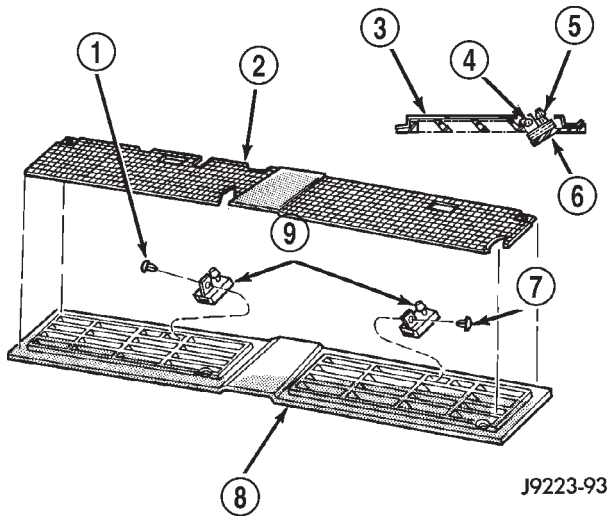

Fig. 11 Cowl Grille, Screen & Washer Nozzles

- 1 - PLASTIC PUSH-RIVET
- 2 - SCREEN
- 3 - SCREEN
- 4 - RIVET
- 5 - NOZZLE
- 6 - GRILLE
- 7 - PLASTIC PUSH-RIVET
- 8 - GRILLE
- 9 - NOZZLE

NOTE: Force the cowl grille rearward while tightening the screws.

(4) Install the windshield wiper arms on the pivots.

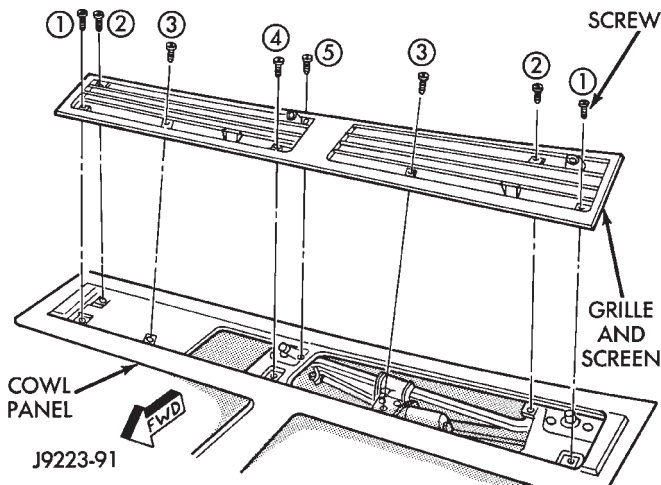

Fig. 12 Cowl Grille Screw Tightening Sequence

BODY DECALS

Small nicks, scratches and other surface marks in a decal can be touched-up with paint.

To eliminate blisters and air bubbles in a decal, pierce them with a needle or pin.

A heat gun can also be used to remove small wrinkles in a decal.

Decal replacement requires that the metal repair and paint refinish be completed first.

The work area temperature should be between 21°C (70°F) and 32°C (90°F). **A decal should not be replaced if the work area temperature is less than 21°C (70°F).**

The following equipment and material are necessary for removal and installation:

- Liquid dish detergent (for the wetting solution).
- Mixture of wetting solution.
- Commercial wax and silicone removal solution.
- Isopropyl (rubbing) alcohol.
- Small squeegee (plastic or hard rubber).
- Water bucket and sponge.
- Clean wiping rags or paper towels.
- Heat gun (or infra-red heat bulb).
- Wax pencil.
- Sharp knife, single edge razor blade or X-acto knife.
- Pair of scissors.
- Needle or pin.

WARNING: USE DECAL REMOVAL SOLUTION IN A WELL-VENTILATED AREA ONLY.

A decal removal solution can be used for removal at areas where a heat gun is ineffective. Follow the manufacturers instructions whenever this type of product is used.

REMOVAL

- (1) Clean the repaired surface as necessary.
- (2) Start at one end of the decal and apply heat with a heat gun. Slowly peel the decal from the panel by pulling it back. **Do not pull the decal outward from panel.**

INSTALLATION

- (1) The area that will be covered by the decal must be cleaned with cleaning solution.
- (2) Freshly painted surfaces must be thoroughly dry.
- (3) Clean the painted surface with a commercial wax and silicone removal solution. Wipe the surface with a clean cloth and allow it to dry.
- (4) Prepare a wetting solution by mixing two or three teaspoons of dish detergent with 1 gallon of water. Do not use soap.

NOTE: Too much detergent will reduce the effectiveness of the mixture.

- (5) Use a clean sponge and apply the wetting solution to the adhesive side of the decal and to the painted panel surface. The wetting solution will permit ease of decal movement when positioning it.

REMOVAL AND INSTALLATION (Continued)

(6) Align a straight edge with the existing decal ends (Fig. 13).

NOTE: If applicable, the body panel character line can be used as the decal alignment reference.

(7) Position the decal and carrier on the body panel (Fig. 14) and the mark length with a wax pencil.

(8) Position the decal and carrier on the body panel and hold it in-place with masking tape.

(9) Lift the bottom edge of decal and carrier. Use the tape sections as hinges, and reverse the position of decal and carrier.

CAUTION: Always remove the carrier from the decal, never remove the decal from carrier

(10) Bend a corner of carrier outward and then, with a flick of the finger, separate the corner of carrier from the decal.

(11) Return the decal back to its original position. If a solution is being used, position adhesive side of the decal on panel. Apply the solution to the outside of the decal.

(12) Hold the decal against the panel surface while separating the carrier from the decal.

(13) If applicable, remove the cover from face of decal.

(14) Using a squeegee smooth out the decal to remove wrinkles and/or air bubbles.

(15) Inspect the decal with reflected light to find any damage. Remove all the air and/or moisture bubbles.

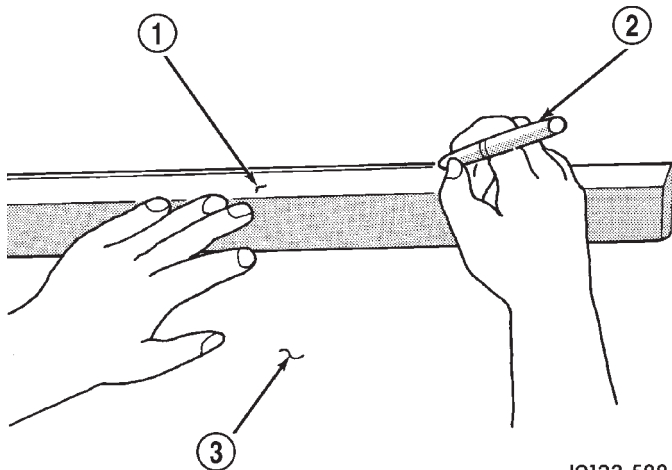

J9123-588

Fig. 13 Decal Alignment Reference Mark

- 1 - STRAIGHT EDGE
- 2 - GREASE PENCIL
- 3 - BODY PANEL

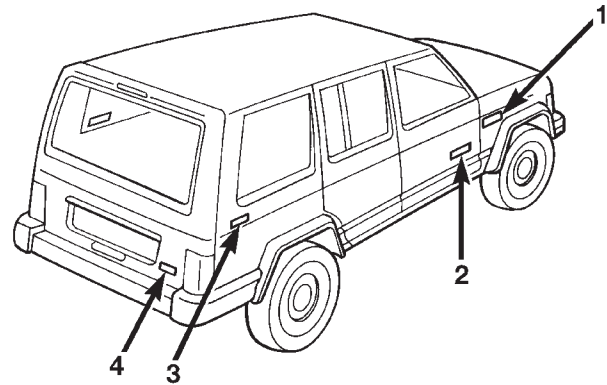

- 1 = SPORT
- 2 = CHEROKEE CLASSIC
- 3 = 4 X 4
- 4 = 4.0L

80be46ae

Fig. 14 Body Decals

EXTERIOR NAMEPLATES

REMOVAL

NOTE: Exterior nameplates are attached to body panels with adhesive tape.

(1) Apply a length of masking tape on the body, parallel to the top edge of the nameplate to use as a guide, if necessary.

(2) If temperature is below 21°C (70°F) warm emblem with a heat lamp or gun. Do not exceed 52°C (120°F) when heating emblem.

(3) Insert a plastic trim stick or a hard wood wedge behind the emblem to separate the adhesive backing from the body.

(4) Clean adhesive residue from body with MOPAR Super Clean solvent or equivalent.

INSTALLATION

(1) Remove protective cover from adhesive tape on back of emblem.

(2) Position emblem properly on body (Fig. 15).

(3) Press emblem firmly to body with palm of hand.

(4) If temperature is below 21°C (70°F) warm emblem with a heat lamp or gun to assure adhesion. Do not exceed 52°C (120°F) when heating emblem.

REMOVAL AND INSTALLATION (Continued)

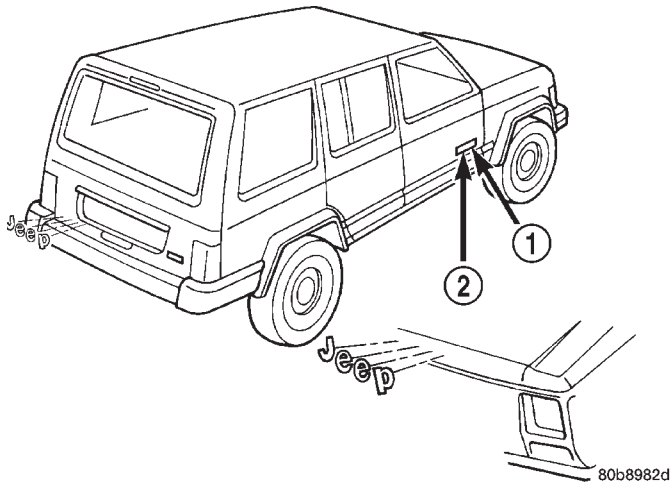

Fig. 15 Exterior Nameplates

- 1 - CHEROKEE
- 2 - LIMITED-SPORT-CLASSIC

SIDE VIEW MIRROR

REMOVAL

- (1) Remove the door trim panel.
- (2) Remove the screw attaching the mirror trim cover/speaker grille to the door inner panel.
- (3) remove push-in fastener attaching trim cover to door inner panel (use special tool C-4829).
- (4) Disconnect the power mirror wire connector, if equipped.
- (5) Remove the screws attaching the mirror to the door (Fig. 16).
- (6) Separate the mirror from the door.

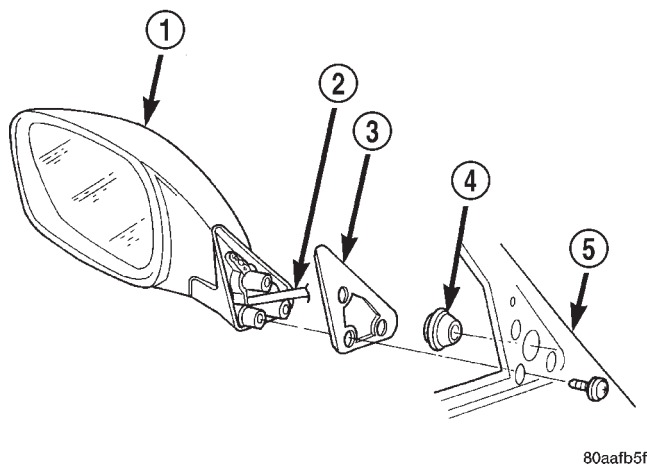

Fig. 16 Side View Mirror

- 1 - SIDE VIEW MIRROR
- 2 - WIRE HARNESS
- 3 - SEAL
- 4 - GROMMET
- 5 - DOOR

INSTALLATION

- (1) Position the mirror on the door.
- (2) Install the screws attaching the mirror to the door.
- (3) Connect the power mirror wire connector, if equipped.
- (4) Install new push-in fastener.
- (5) Install the mirror trim cover/speaker grille.
- (6) Install the door trim panel.

FRONT FENDER FLARE

REMOVAL

- (1) Remove the screw attaching the lower part of flare to the bottom of the fender.
- (2) Remove the nuts attaching the fender flare retainer to the wheelhouse splash shield (Fig. 17).
- (3) Remove the liner from the fender.
- (4) Remove the fasteners attaching the fender flare and retainer to the fender.
- (5) Separate the fender flare and retainer from the fender.

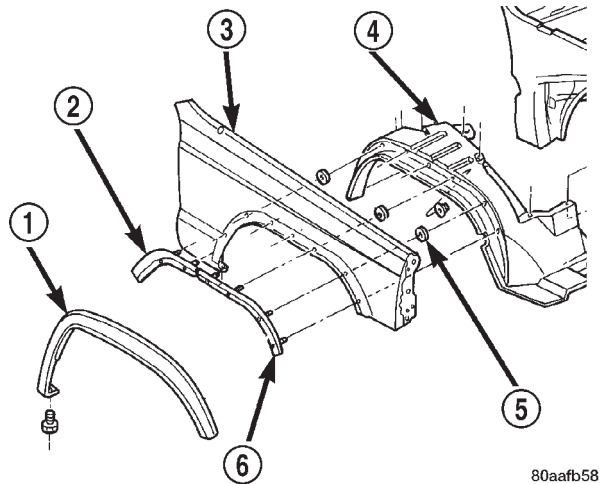

Fig. 17 Fender Flare

- 1 - FENDER FLARE
- 2 - RETAINER
- 3 - FENDER
- 4 - LINER
- 5 - PUSH NUT
- 6 - RETAINER

INSTALLATION

- (1) Position the fender flare and retainer on the fender.
- (2) Install the nuts attaching the fender flare and retainer to the wheelhouse fender.
- (3) Install the screw attaching the lower part of flare to the bottom of the fender.

REMOVAL AND INSTALLATION (Continued)

FRONT WHEELHOUSE LINER

REMOVAL

- (1) Hoist vehicle.
- (2) Remove tire.
- (3) Remove the push-in fasteners attaching the wheelhouse liner to the inner fender.
- (4) Separate the wheelhouse liner from the fender (Fig. 18).

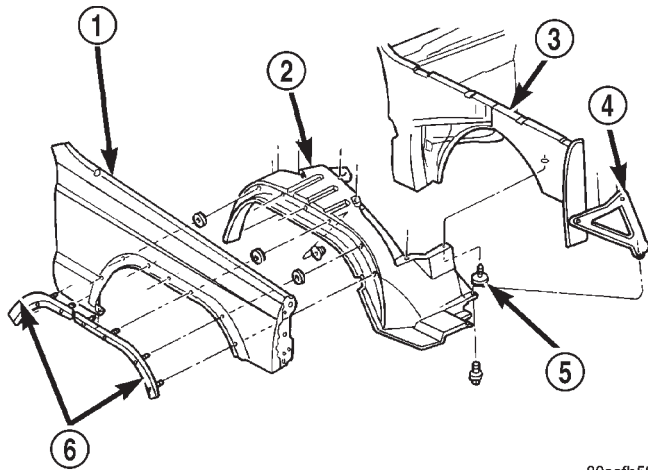

80aafb59

Fig. 18 Front Wheelhouse Liner

- 1 - FENDER
- 2 - WHEELHOUSE LINER
- 3 - INNER FENDER PANEL
- 4 - BRACE
- 5 - PUSH-IN FASTENER
- 6 - RETAINER

INSTALLATION

- (1) Position the wheelhouse liner in the fender.
- (2) Install new push-in fasteners attaching the wheelhouse liner to the inner fender.
- (3) Install tire.
- (4) Lower vehicle.

RIGHT FRONT FENDER

REMOVAL

- (1) Raise and support the hood.
- (2) Remove the grille opening panel (GOP).
- (3) If equipped, remove the radio antenna mast, and components from the fender.
- (4) Remove the coolant recovery bottle.
- (5) Raise and support the vehicle.
- (6) Remove the right front wheel.
- (7) Remove the front bumper end cap.
- (8) Remove the wheelhouse liner.
- (9) Remove the fender flare and retainers.
- (10) Disconnect all wire harness connectors.
- (11) Remove the air deflector.
- (12) Remove the fender lower screws (Fig. 19).

(13) Remove the fender top, front and the rear screws.

(14) Remove the screws attaching the fender to the inner support bracket (Fig. 20).

(15) Separate the fender from the inner fender panel.

INSTALLATION

- (1) Position the fender on the inner fender panel.
- (2) Install all fender screws finger-tight.
- (3) Align the fender with the body panels and tighten the screws attaching the fender to the body panels.
- (4) Install the air deflector.
- (5) Install the fender flare and retainers.
- (6) Install the wheelhouse liner.
- (7) Install the front bumper end cap.
- (8) Install the wheel, remove the support and lower the vehicle.
- (9) Install the grille opening panel (GOP).
- (10) Install the radio antenna.

LEFT FRONT FENDER

REMOVAL

- (1) Raise and support the hood.
- (2) Remove the grille opening panel (GOP).
- (3) Raise and support the vehicle.
- (4) Remove the left front wheel.
- (5) Remove the front bumper end cap.
- (6) Remove the fender flare and retainers.
- (7) Remove the wheelhouse liner.
- (8) Remove the air deflector.
- (9) Remove the fender lower screws.
- (10) Remove the fender top, front and the rear screws.
- (11) Remove the screws attaching the fender to the inner support bracket.
- (12) Separate the fender from the inner fender panel.

INSTALLATION

- (1) Position the fender on the inner fender panel.
- (2) Install all fender screws finger-tight.
- (3) Align the fender with the body panels and tighten the screws attaching the fender to the body panels.
- (4) Install the air deflector.
- (5) Install the wheelhouse liner.
- (6) Install the fender flare and retainers.
- (7) Install the front bumper.
- (8) Install the wheel, remove the support and lower the vehicle.
- (9) Install the grille opening panel (GOP).

REMOVAL AND INSTALLATION (Continued)

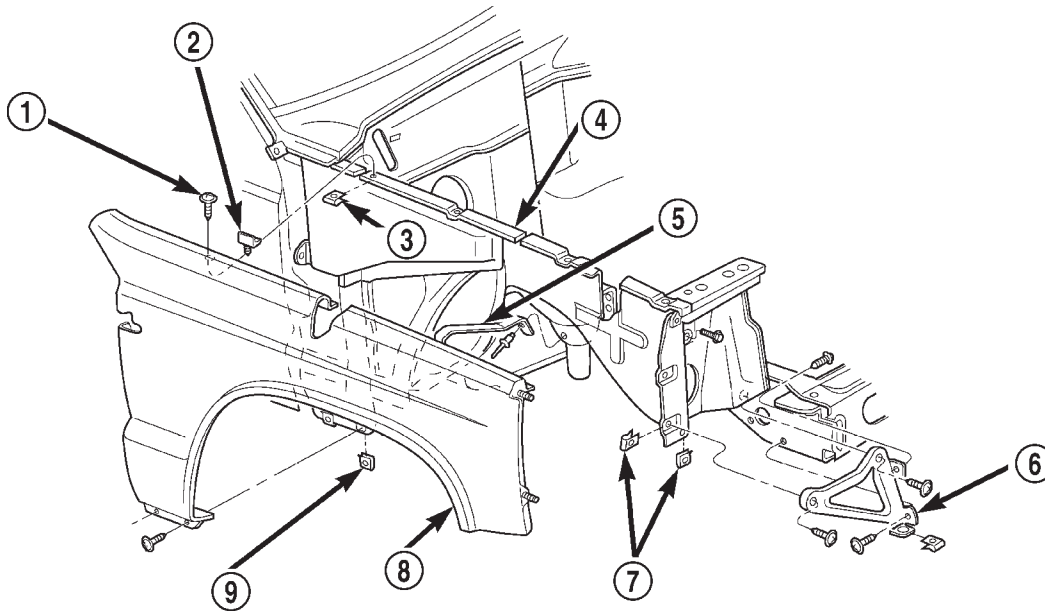

80ae8355

Fig. 19 Right Front Fender

- | | |
|------------------------|--------------------------------|
| 1 - SCREW | 6 - FRAME SILL-TO-BAFFLE BRACE |
| 2 - HOOD BUMPER | 7 - U-NUT |
| 3 - U-NUT | 8 - OUTER FENDER PANEL |
| 4 - INNER FENDER PANEL | 9 - U-NUT |
| 5 - FENDER BRACE | |

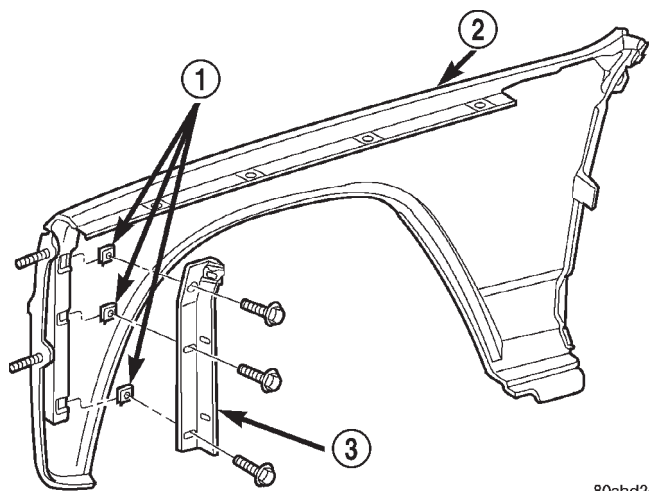

80abd2ef

Fig. 20 Inner Support Bracket

- | |
|---------------------|
| 1 - U-NUT |
| 2 - FRONT FENDER |
| 3 - SUPPORT BRACKET |

FRONT DOOR TRIM PANEL

REMOVAL

- (1) Roll window down.
- (2) Remove window crank, if equipped (Fig. 21).

(3) Remove the screws attaching the trim panel to the door inner panel (Fig. 22) and (Fig. 23).

(4) Separate the trim panel fasteners from door inner panel with a pry tool (use special tool C-4829) (Fig. 24).

(5) Lift the trim panel up and outward to separate from the inner belt seal.

(6) Move the door trim panel outward and disconnect the handle-to-latch rods.

(7) Disconnect the power door locks/windows/mirrors wire harness connectors, if equipped.

(8) Remove the trim panel from door.

INSTALLATION

(1) Replace any broken or damaged push-in fasteners.

(2) Connect the power door locks/windows/mirrors wire harness connectors, if equipped.

(3) Move the door trim panel outward and connect the handle-to-latch rods.

(4) Position the trim panel on the inner belt seal and push down to seat.

(5) Align the locating pins and push-in fasteners. Press inward to secure.

(6) Install the screws attaching the trim panel to the door inner panel.

(7) Install the window crank, if equipped.

REMOVAL AND INSTALLATION (Continued)

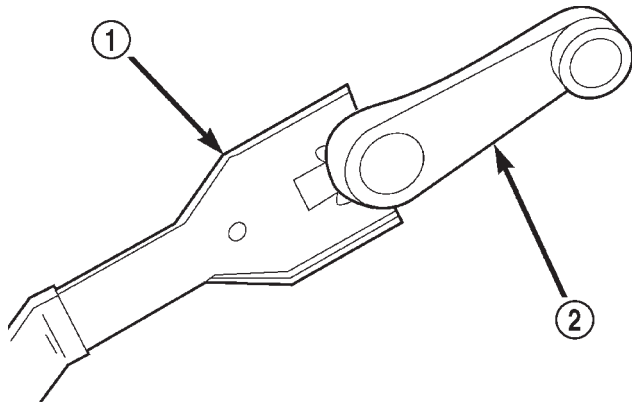

80ad2f28

Fig. 21 Window Crank—Typical

- 1 - WINDOW CRANK REMOVAL TOOL
- 2 - WINDOW CRANK

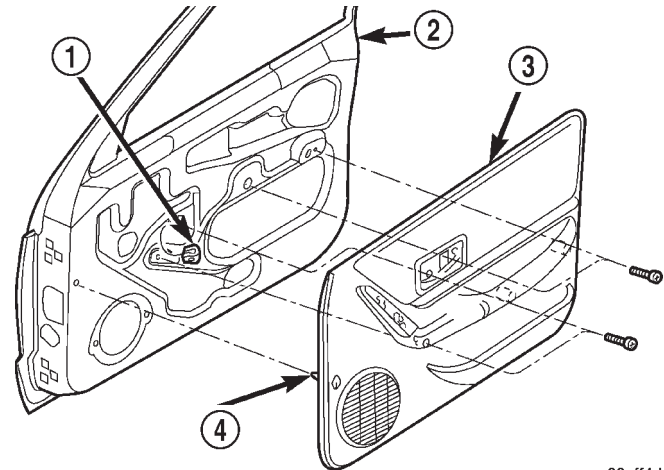

80aff4de

Fig. 23 Front Door Trim Panel-Power Window

- 1 - U-NUT
- 2 - DOOR
- 3 - TRIM PANEL
- 4 - PUSH-IN FASTENER

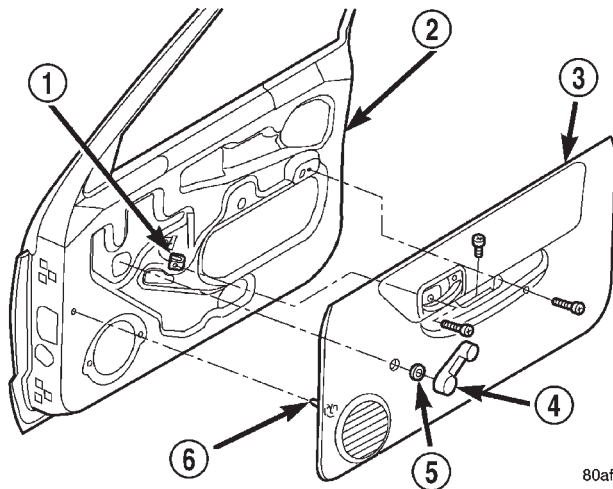

80aff43c

Fig. 22 Front Door Trim Panel-Manual Window

- 1 - U-NUT
- 2 - DOOR
- 3 - TRIM PANEL
- 4 - WINDOW CRANK
- 5 - SPACER
- 6 - PUSH-IN FASTENER

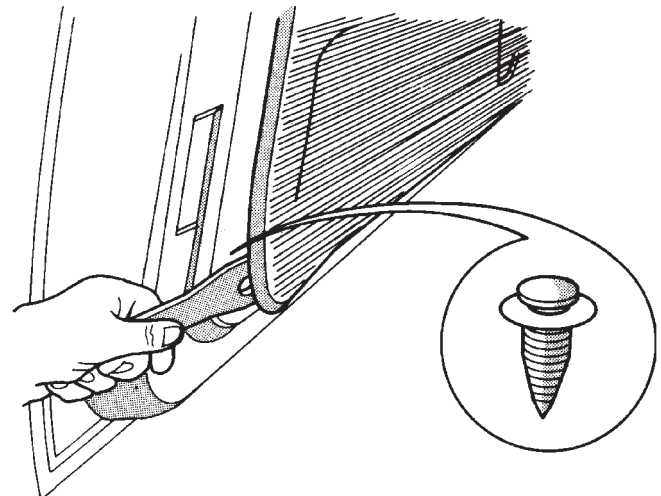

J898S-8

Fig. 24 Detaching Trim Panel Push-In Fasteners

(4) Grasp the upper and lower rearward corners of the waterdam and rapidly peel back the waterdam from the door inner panel.

(5) Separate the waterdam from the door inner panel.

INSTALLATION

(1) Route the latch rods through the waterdam.

(2) Position the waterdam on the door, apply adhesive as necessary and press into place.

(3) Route the harnesses/connectors through the waterdam.

FRONT DOOR WATERDAM**REMOVAL**

The waterdam is attached to the door inner panel with a butly adhesive. If cohesive separation of the butly between the waterdam and door inner panel occurs during the removal process, cut the strands of butly with a razor knife or equivalent.

(1) Remove door trim panel.

(2) Disengage clips attaching wire harnesses to the door inner panel.

(3) Push the harnesses/connectors through the waterdam and into the door.

REMOVAL AND INSTALLATION (Continued)

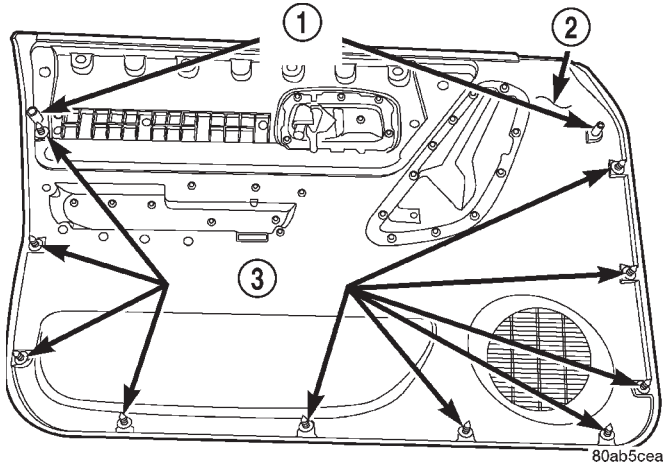
**Fig. 25 Push-In Fasteners**

- 1 - LOCATING PINS
- 2 - TRIM PANEL
- 3 - PUSH-IN FASTENERS

(4) Engage clips attaching wire harnesses to the door inner panel.

(5) Install door trim panel.

FRONT DOOR**REMOVAL**

- (1) Remove door restraint (check) retaining pin.
- (2) For vehicles equipped with power windows, power mirrors and power door locks, remove trim panel and waterdam. Disconnect all components and route wire harness out of door.
- (3) Remove bolts that attach hinge to door (Fig. 26).
- (4) Remove door from vehicle.

INSTALLATION

- (1) Position door in body opening.
- (2) Align door hinges, plates and shims and install bolts. Tighten bolts to 3 N·m (2 ft. lbs.) torque.
- (3) Install door restraint (check) pin.
- (4) If applicable, route and connect wire harness connectors.
- (5) Install door waterdam and trim panel.

FRONT DOOR HINGE**REMOVAL**

- (1) Remove door restraint (check) retaining pin.
- (2) Remove door hinge bolts and shims (Fig. 26).
- (3) Retain door hinge shims for correct installation.

INSTALLATION

- (1) Position hinge plates and shims on door face.

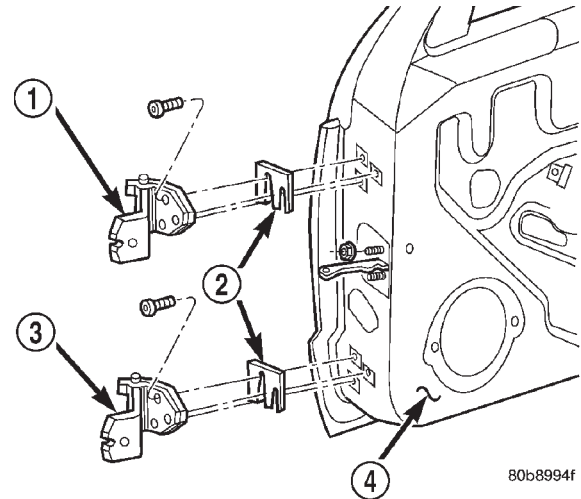
**Fig. 26 Front Door Hinge**

- 1 - UPPER HINGE
- 2 - SHIM
- 3 - LOWER HINGE
- 4 - FRONT DOOR

(2) Align door hinges and shims with bolt holes and install hinge bolts. Tighten bolts to 3 N·m (2 ft. lbs.) torque.

(3) Adjust/align latch striker and latch as necessary.

(4) Install door restraint (check) retaining pin.

FRONT DOOR RESTRAINT**REMOVAL**

- (1) Remove door trim panel.
- (2) Remove door radio speaker from door inner panel.
- (3) Remove door restraint (check) retaining pin from bracket with a punch.
- (4) Remove nuts and remove restraint via speaker opening. (Fig. 27).

INSTALLATION

- (1) Position door restraint in door by way of opening and install nuts.

NOTE: Ensure the spring on the door restraint is facing outward.

(2) Position door restraint in bracket with holes aligned and insert retaining pin.

(3) Install radio speaker and door trim panel.

FRONT DOOR OUTSIDE HANDLE**REMOVAL**

- (1) Remove the door trim panel and waterdam.

REMOVAL AND INSTALLATION (Continued)

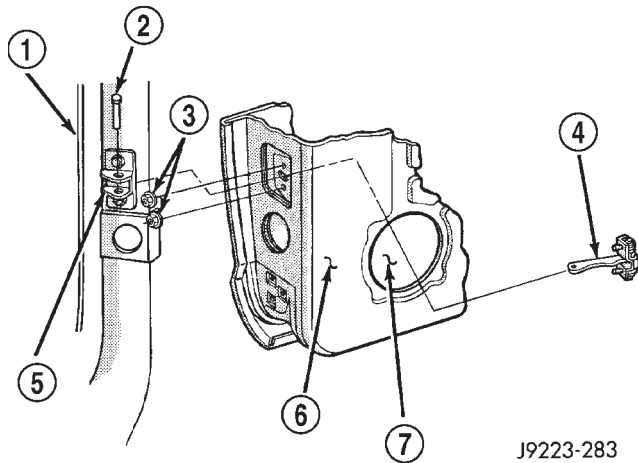

J9223-283

Fig. 27 Door Restraint (Check)

- 1 - A-PILLAR
- 2 - RETAINING PIN
- 3 - NUT
- 4 - DOOR RESTRAINT
- 5 - RESTRAINT BRACKET
- 6 - DOOR INNER PANEL
- 7 - SPEAKER OPENING

(2) Remove the access hole cover and remove the rearward nut attaching the door handle to the door. (Fig. 28).

(3) Disconnect the handle-to-latch rod from the handle latch release lever arm.

(4) Remove the forward nut attaching the handle to the door.

(5) Separate the handle from the door.

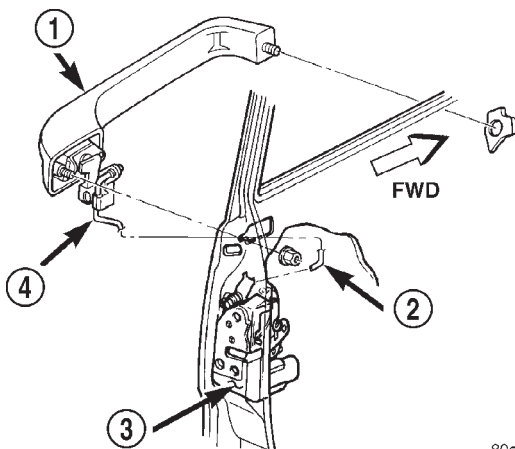

80aa4ad4

Fig. 28 Front Door Outside Handle

- 1 - OUTSIDE DOOR HANDLE
- 2 - OUTSIDE HANDLE TO LATCH ROD
- 3 - DOOR LATCH
- 4 - OUTSIDE HANDLE TO LATCH ROD

INSTALLATION

(1) Position the handle in the door.

(2) Install the forward nut attaching the handle to the door.

(3) Connect the latch to handle rod, to the handle latch release lever arm.

(4) Install the rearward nut attaching the door handle to the door.

(5) Install the access hole cover.

(6) Install the door waterdam and trim panel.

FRONT DOOR LOCK CYLINDER**REMOVAL**

(1) Remove the door trim panel.

(2) Peel back waterdam to access lock cylinder.

(3) Disconnect the door latch-to-lock cylinder rod at the door latch (Fig. 29).

(4) Remove the lock cylinder retainer clip.

(5) Remove the lock cylinder.

(6) If applicable, remove the door latch-to-lock cylinder rod from the original lock cylinder. Connect it to the replacement lock cylinder.

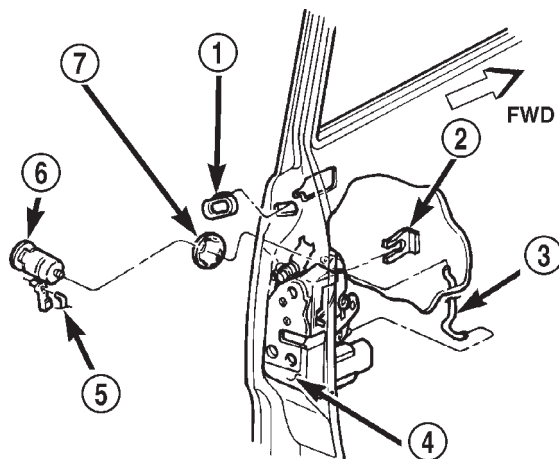

80aa4ad6

Fig. 29 Door Lock Cylinder

- 1 - ACCESS PLUG
- 2 - RETAINER
- 3 - LOCK CYLINDER TO LATCH ROD
- 4 - LATCH
- 5 - LOCK CYLINDER TO LATCH ROD
- 6 - LOCK CYLINDER
- 7 - GASKET

INSTALLATION

(1) Position the lock cylinder and in the door opening.

(2) Install the retainer clip.

(3) Connect the door latch-to-lock cylinder rod to the door latch.

(4) Press the waterdam into position.

(5) Install the door trim panel.

REMOVAL AND INSTALLATION (Continued)

LOCK CYLINDERS

Ignition, door, deck lid, and rear hatch lock cylinders are all codable to the key. Lock barrels, tumblers, and tumbler springs are available to allow the technician to change replacement locks cylinders to match the customer's original key set. See the appropriate section in this manual for lock cylinder removal. See the Mopar® catalogue for part numbers and lock coding procedures.

FRONT DOOR LATCH

REMOVAL

- (1) Remove door trim panel and waterdam.
- (2) Remove screws attaching latch to door.
- (3) Disconnect all rods from latch (Fig. 30).
- (4) Disconnect power lock motor wire connector, if equipped.
- (5) Remove latch from door face.

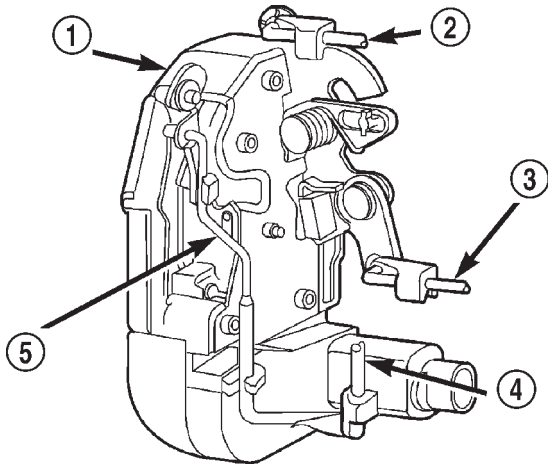

Fig. 30 Door Latch

- 1 - FRONT DOOR LATCH
- 2 - LOCK BUTTON TO LATCH ROD
- 3 - INSIDE HANDLE TO LATCH ROD
- 4 - OUTSIDE HANDLE TO LATCH ROD
- 5 - LOCK CYLINDER TO LATCH ROD

INSTALLATION

- (1) Position latch on door face.
- (2) Connect power lock motor wire connector, if equipped.
- (3) Connect all rods to latch.
- (4) Install screws attaching latch to door. Tighten screws to 11 N·m (8 ft. lbs.) torque.
- (5) Install waterdam and door trim panel.

FRONT DOOR LATCH STRIKER

REMOVAL

- (1) Using a grease pencil or equivalent, mark position of striker.

- (2) Remove screws attaching striker to B-pillar (Fig. 31).
- (3) Separate striker from B-pillar.

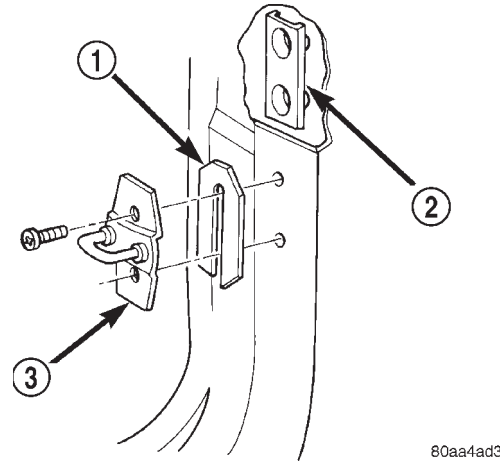

Fig. 31 Front Door Latch Striker

- 1 - SPACER
- 2 - TAPPING PLATE
- 3 - STRIKER

INSTALLATION

- (1) Position and align striker on B-pillar.
- (2) Install screws attaching striker to B-pillar. Tighten screws to 28 N·m (20 ft. lbs.) torque.

FRONT DOOR INSIDE HANDLE ACTUATOR

REMOVAL

The front door inside handle actuator is heat staked to the front door trim panel during the manufacturing process.

- (1) Remove the door trim panel.
- (2) Using an X-ACTO knife or equivalent, cut the melted tabs securing the inside handle to the door trim panel.
- (3) Separate the inside handle from the trim panel.

INSTALLATION

- (1) Position the inside handle in the trim panel.
- (2) Heat stake the inside handle to the trim panel.
- (3) Install the door trim panel.

FRONT DOOR INNER BELT WEATHERSTRIP

REMOVAL

- (1) Roll window down.
- (2) Remove door trim panel.
- (3) Pull up on the rear corner of the weatherstrip and lift from the door (Fig. 32).

REMOVAL AND INSTALLATION (Continued)

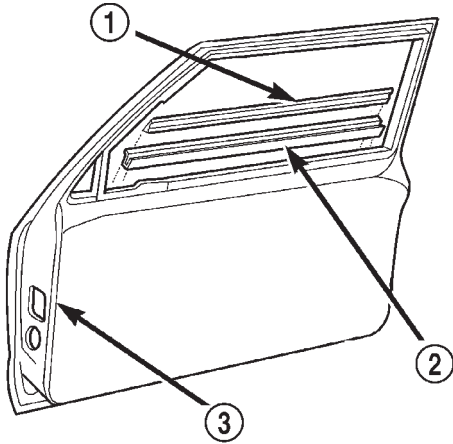

80aa0fe2

Fig. 32 Front Door Inner/Outer Belt Weatherstrip

- 1 - OUTER BELT WEATHERSTRIP
2 - INNER BELT WEATHERSTRIP
3 - DOOR INNER PANEL

INSTALLATION

- (1) Position the weatherstrip on the door.
- (2) Push weatherstrip down to seat onto door.
- (3) Install door trim panel.

FRONT DOOR OUTER BELT WEATHERSTRIP**REMOVAL**

- (1) Roll window down.
- (2) Using a trim stick, pry up the rear outer corner of the weatherstrip.
- (3) Lift the weatherstrip up to separate from the door (Fig. 32).

INSTALLATION

- (1) Position the weatherstrip on the door.
- (2) Push weatherstrip down to seat onto door.

FRONT DOOR GLASS RUN CHANNEL WEATHERSTRIP**REMOVAL**

- (1) Remove door trim panel.
- (2) Remove waterdam.
- (3) Starting at rear corner, peel weatherstrip from around door frame.

INSTALLATION

- (1) Install the weatherstrip in the following sequence:

- Press weatherstrip into upper rear corner.
- Press weatherstrip into lower front corner.
- Work/press the weatherstrip upward and to the upper front corner, seat the weatherstrip into the channel.

- Continue working/pressing the weatherstrip into the channel along the upper window frame.
 - Press weatherstrip into lower rear corner.
 - Work/press the weatherstrip upward and to the upper rear corner, seat the weatherstrip into the channel.
 - Press the weatherstrip to seat into the front lower glass run channel.
- (2) As applicable, move upward and forward evenly until the weatherstrip seal is fully seated in the channel.
 - (3) Install waterdam.
 - (4) Install door trim panel.

FRONT DOOR OPENING WEATHERSTRIP**REMOVAL**

- (1) Remove A-pillar trim panel.
- (2) Remove B-pillar upper trim panel.
- (3) Remove cowl side trim panel.
- (4) Remove inner scuff plate.
- (5) Remove B-pillar lower trim panel.
- (6) Grasp seal and separate from door opening.

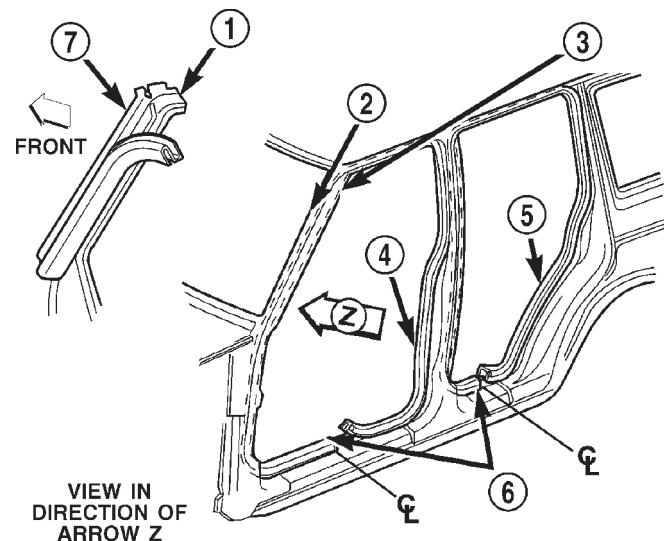

80aa0fd7

Fig. 33 Door Opening Weatherstrip

- 1 - FRONT DOOR SEAL
2 - A PILLAR
3 - SECONDARY DOOR SEAL
4 - FRONT DOOR SEAL
5 - REAR DOOR SEAL
6 - ENDS MEET AT CENTERLINE
7 - A PILLAR

REMOVAL AND INSTALLATION (Continued)

INSTALLATION

- (1) Position weatherstrip at corners.
- (2) Move upward and around edge of door opening. Seat seal on flange.
- (3) When installing a door opening weatherstrip seal, start at the door sill center line.
- (4) Move upward and around the perimeter of the door opening and seat the weatherstrip on the flange (Fig. 34).
- (5) Install cowl side trim panel.
- (6) Install inner scuff plate.
- (7) Install B-pillar lower trim panel.
- (8) Install B-pillar upper trim panel.
- (9) Install A-pillar trim panel.

(X) - PRESS INWARD FIRMLY AT INDICATED AREA

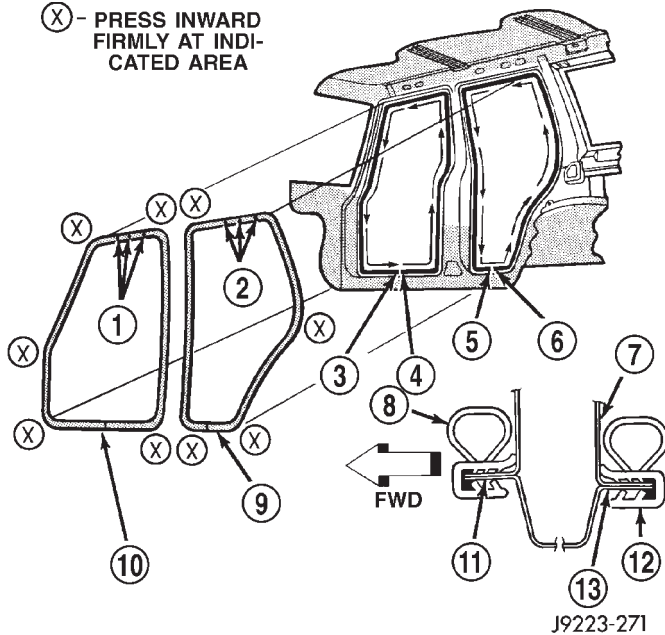

Fig. 34 Door Opening Weatherstrip

- 1 - VENT HOLES
- 2 - VENT HOLES
- 3 - FINISH
- 4 - START
- 5 - FINISH
- 6 - START
- 7 - B-PILLAR
- 8 - SEAL
- 9 - REAR DOOR WEATHERSTRIP SEAL
- 10 - FRONT DOOR WEATHERSTRIP SEAL
- 11 - FLANGE
- 12 - SEAL
- 13 - FLANGE

FRONT DOOR OPENING SECONDARY WEATHERSTRIP

REMOVAL

The front door opening secondary weatherstrip is attached to the A-pillar with adhesive tape (Fig. 33).

- (1) Using a heat gun, heat the weatherstrip and slowly peel the weatherstrip from the A-pillar

INSTALLATION

- (1) Clean the contact surface on the A-pillar.
- (2) Remove the carrier backing and position the weatherstrip on the A-pillar. Press into place.

FRONT DOOR GLASS EXTERIOR MOLDING

REMOVAL

- (1) Open the window completely.
- (2) Remove the outer belt weatherstrip.
- (3) Pry and pull the molding sections from the door panel flange (Fig. 35).

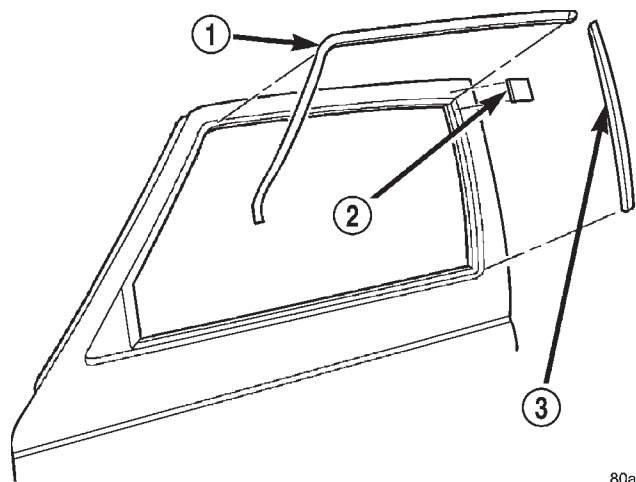

80aa0fe3

Fig. 35 Front Door Glass Exterior Molding

- 1 - UPPER MOLDING
- 2 - SHIM
- 3 - REAR MOLDING

INSTALLATION

- (1) Start at the forward end of the upper molding, force the molding onto the door panel and continue rearward until it is completely seated on the flange.
- (2) Mate the rear molding with the upper molding and force the molding edge inward.
- (3) Continue pressing and moving downward to complete the installation.
- (4) Install the outer belt weatherstrip.

FRONT DOOR WINDOW REGULATOR

REMOVAL

- (1) Remove the door trim panel.
- (2) Remove the waterdam.
- (3) Remove the window glass

REMOVAL AND INSTALLATION (Continued)

(4) Loosen the bolts attaching the regulator to the inner door panel (Fig. 36) and (Fig. 37) as applicable.

(5) Lift the regulator upward to release it from the key hole slots and remove it through the access hole in the door inner panel.

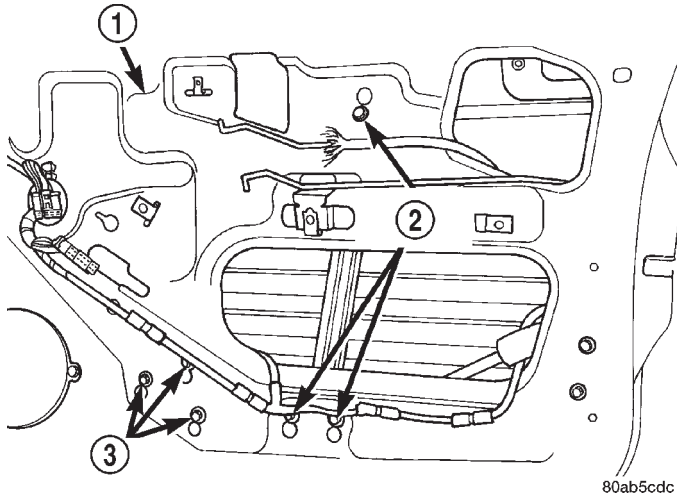

Fig. 36 Power Window Regulator

- 1 - FRONT DOOR
- 2 - LOOSEN BOLTS
- 3 - LOOSEN NUTS

INSTALLATION

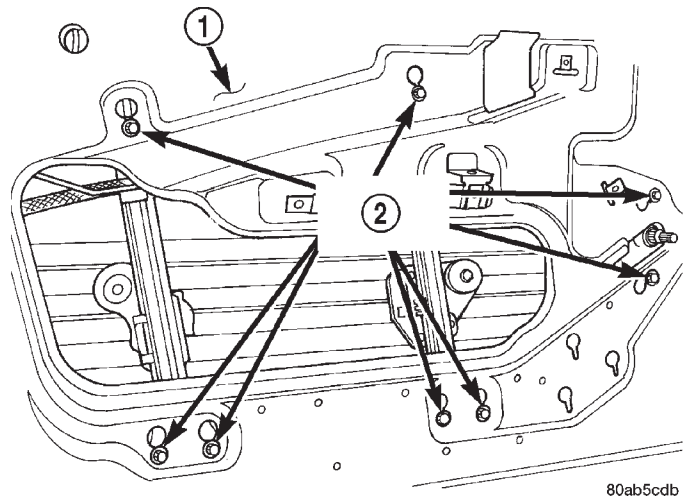

Fig. 37 Manual Window Regulator

- 1 - FRONT DOOR
- 2 - LOOSEN BOLTS

(1) Position the regulator in the door and align with key hole slots.

(2) Attach the regulator to door inner panel with bolts (Fig. 38).

(3) Install the window glass

(4) Install the waterdam.

(5) Install the trim panel.

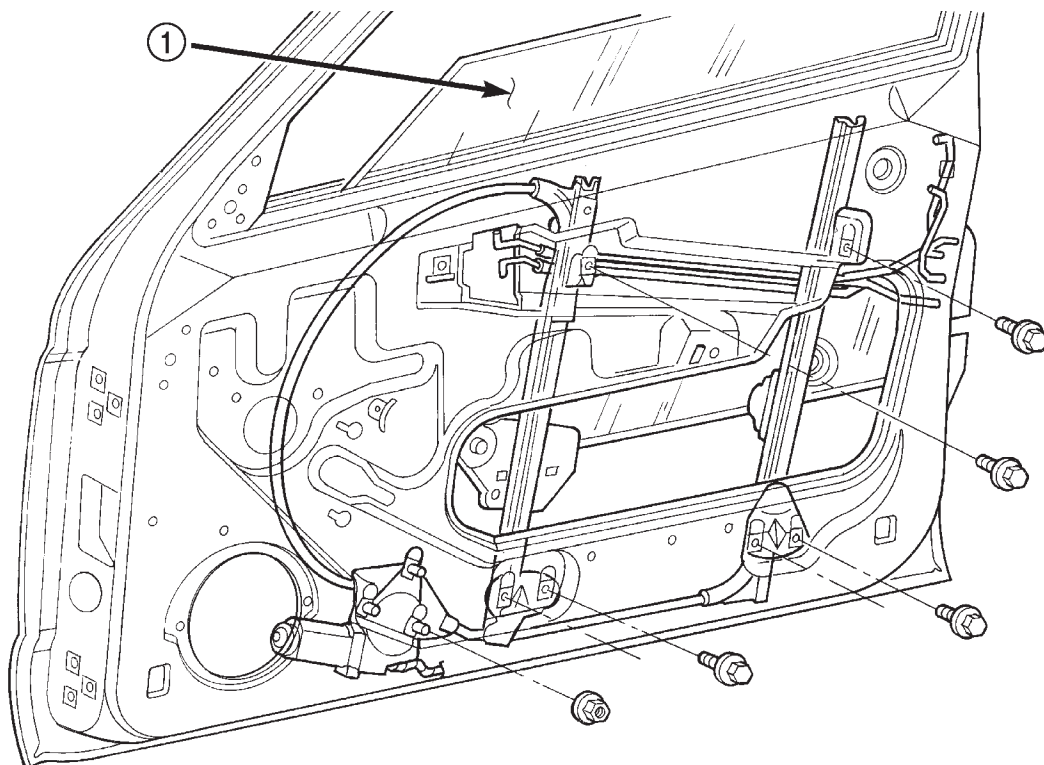

Fig. 38 Front Door Regulator

- 1 - GLASS

REMOVAL AND INSTALLATION (Continued)

FRONT DOOR SPACER BLOCKS—TWO-DOOR VEHICLES

REMOVAL

- (1) Upper spacer block: drill-out the rivet heads and remove them from the reinforcement plate (Fig. 39).
- (2) Lower spacer block: remove the screws from the door face (Fig. 40).
- (3) As applicable, remove the spacer block from the door window frame or door face.

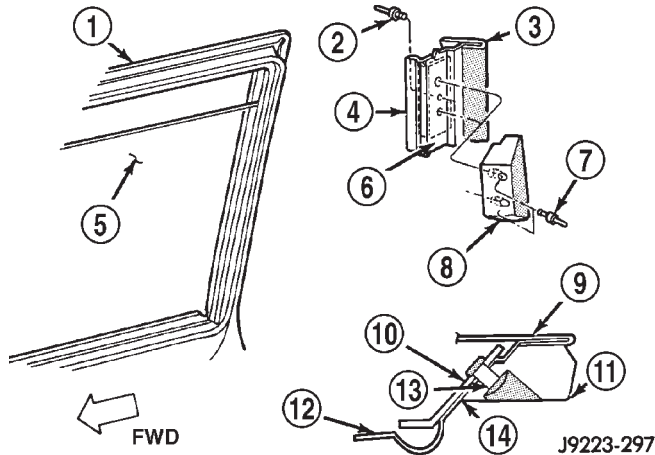

Fig. 39 Front Door Upper Spacer Block—Two-Door

- 1 - FRONT DOOR WINDOW FRAME
- 2 - RIVET
- 3 - WINDOW OUTER FRAME
- 4 - WINDOW INNER FRAME
- 5 - WINDOW GLASS
- 6 - REINFORCEMENT PLATE
- 7 - RIVET
- 8 - DOOR UPPER SPACER BLOCK
- 9 - WINDOW OUTER FRAME
- 10 - REINFORCEMENT PLATE
- 11 - DOOR UPPER SPACER BLOCK
- 12 - WINDOW INNER FRAME
- 13 - RIVET
- 14 - ADHESIVE

INSTALLATION

- (1) As applicable, position the spacer block on the door window frame or door face.
- (2) Upper spacer block: Install the replacement rivets in the spacer block and reinforcement plate.
- (3) Lower spacer block: install the screws in the door face. Tighten the screws to 1 N·m (11 in-lbs) torque.

FRONT DOOR GLASS

REMOVAL

- (1) Remove the door trim panel.
- (2) Remove the waterdam.

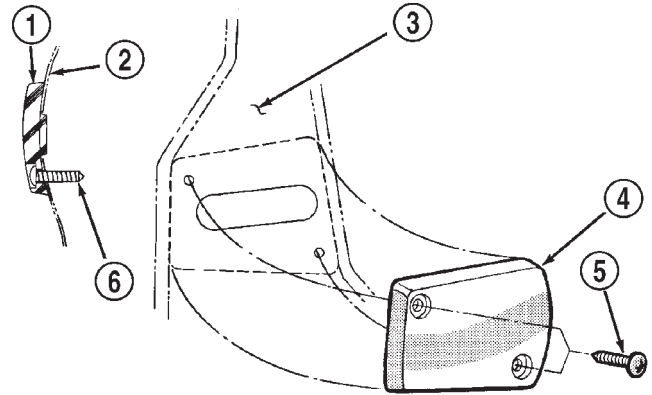

J9223-263

Fig. 40 Front Door Lower Spacer Block—Two-Door

- 1 - DOOR SPACER
- 2 - DOOR FACE
- 3 - DOOR FACE
- 4 - DOOR SPACER
- 5 - SCREW
- 6 - SCREW

- (3) Remove inner and outer belt weatherstrip.
- (4) Roll glass up to expose the bolts attaching the glass to the regulator.
- (5) Remove the bolts attaching the glass to the regulator (Fig. 41).
- (6) Lift the glass upward and out of the door.

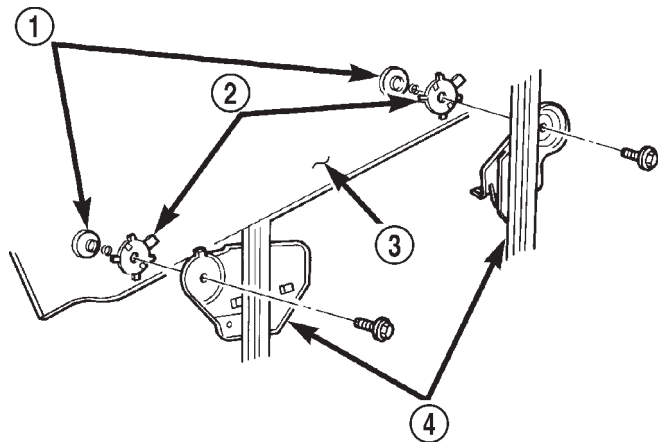

80aa4b5f

Fig. 41 Front Door Glass

- 1 - NUT
- 2 - RETAINER
- 3 - WINDOW GLASS
- 4 - REGULATOR

INSTALLATION

- (1) Position the glass in the door.
- (2) Install the bolts attaching the glass to the regulator. Tighten the bolts to 4 N·m (36 in-lbs) torque.
- (3) Install inner and outer belt weatherstrip.

REMOVAL AND INSTALLATION (Continued)

- (4) Attach the door waterdam to the door inner panel with adhesive/sealant.
- (5) Install the waterdam.
- (6) Install the door trim panel.

REAR DOOR TRIM PANEL

REMOVAL

- (1) Roll window down.
- (2) Remove window crank, if equipped (Fig. 42).
- (3) Remove the screws attaching the trim panel to the door inner panel (Fig. 43) and (Fig. 44).
- (4) Separate the trim panel fasteners from door inner panel with a pry tool (use special tool C-4829) (Fig. 45).
- (5) Lift the trim panel up and outward to separate from the inner belt seal.
- (6) Move the door trim panel outward and disconnect the handle-to-latch rods (Fig. 46).
- (7) Disconnect the power windows wire harness connectors, if equipped.
- (8) Remove the trim panel from door.

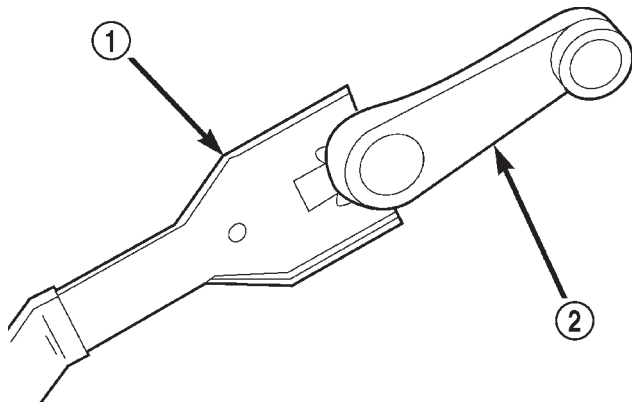

80ad2f28

Fig. 42 Window Crank—Typical

- 1 - WINDOW CRANK REMOVAL TOOL
- 2 - WINDOW CRANK

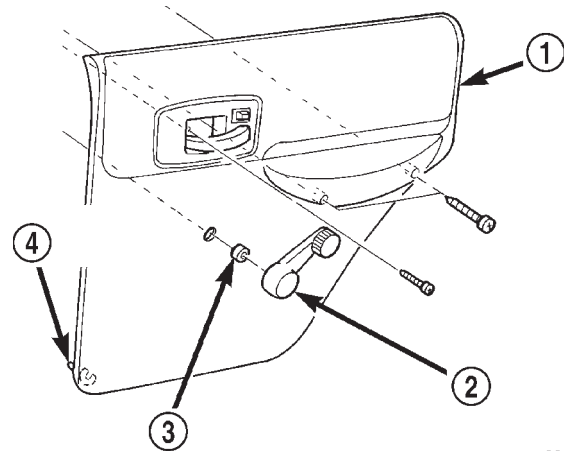

80aafb5b

Fig. 43 Rear Door Trim Panel—Manual Window

- 1 - TRIM PANEL
- 2 - WINDOW CRANK
- 3 - SPACER
- 4 - PUSH-IN FASTENER

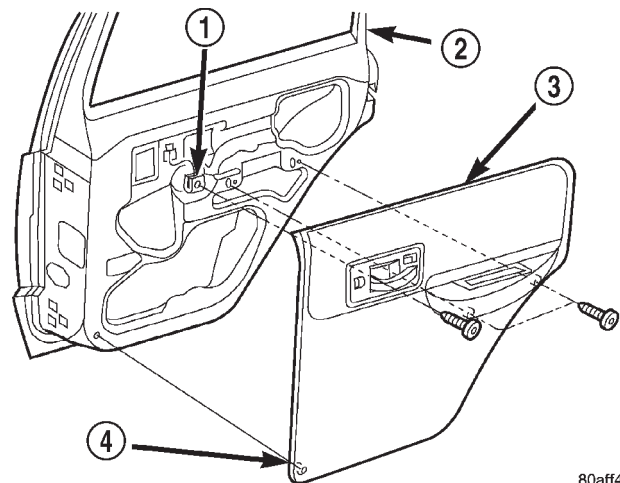

80aff4e4

Fig. 44 Rear Door Trim Panel—Power Window

- 1 - U-NUT
- 2 - REAR DOOR
- 3 - TRIM PANEL
- 4 - PUSH-IN FASTENER

INSTALLATION

- (1) Replace any broken or damaged push-in fasteners.
- (2) Connect the power window wire harness connectors, if equipped.
- (3) Move the door trim panel outward and connect the handle-to-latch rods.
- (4) Position the trim panel on the inner belt seal and push down to seat.
- (5) Align the locating pins and push-in fasteners (Fig. 47). Press inward to secure.
- (6) Install the screws attaching the trim panel to the door inner panel.
- (7) Install the window crank, if equipped.

REAR DOOR WATERDAM

REMOVAL

- (1) Remove door trim panel.
- (2) Peel the waterdam from the door.
- (3) Route the latch rods and wire harnesses through the waterdam.
- (4) Separate the waterdam from the door inner panel.

INSTALLATION

- (1) Route the latch rods and wire harnesses through the waterdam.

REMOVAL AND INSTALLATION (Continued)

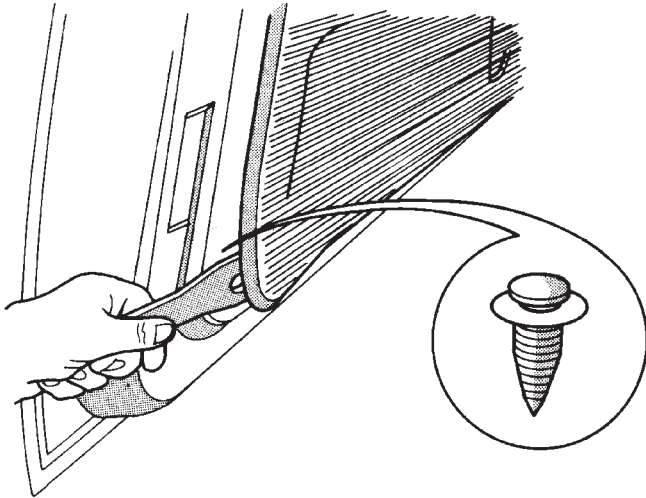

Fig. 45 Detaching Trim Panel Push-In Fasteners

J898S-8

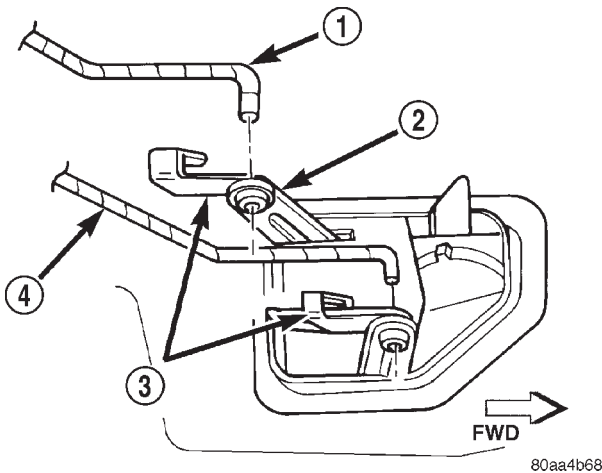

Fig. 46 Latch Rods

- 1 - INSIDE HANDLE TO LATCH ROD
- 2 - INSIDE HANDLE ACTUATOR
- 3 - CLIP
- 4 - LOCK TO LATCH ROD

(2) Position the waterdam on the door, apply adhesive as necessary and press into place.

(3) Install door trim panel.

REAR DOOR

REMOVAL

- (1) Remove door restraint (check) retaining pin.
- (2) For vehicles equipped with power windows and power door locks, remove trim panel and waterdam. Disconnect all components and route wire harness out of door.

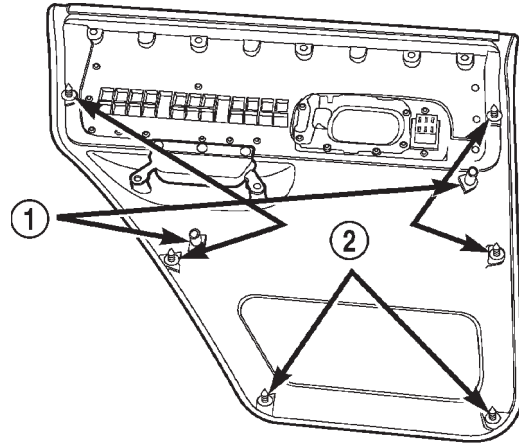

80ab5cdf

Fig. 47 Push-In Fasteners

- 1 - LOCATING PINS
- 2 - PUSH-IN FASTENERS

- (3) Remove bolts attaching hinge to door face.
- (4) Separate door from vehicle.

INSTALLATION

- (1) Position door in body opening.
- (2) Align door hinges, plates and shims and install bolts. Tighten bolts to 3 N-m (2 ft. lbs.) torque.
- (3) Install door restraint (check).
- (4) If applicable, route and connect wire harness connectors.
- (5) If necessary, install door waterdam and trim panel.

REAR DOOR RESTRAINT

REMOVAL

- (1) Remove the door trim panel.
- (2) Remove the door restraint (check) retaining pin from the bracket with a punch.
- (3) Remove the nuts and remove the restraint via the access opening in the door inner panel (Fig. 48).

INSTALLATION

- (1) Position the door restraint in the door by way of the opening and install the nuts. Tighten the nuts to 10 N-m (7 ft-lbs) torque.
- (2) Position the door restraint in bracket with the holes aligned and insert the retaining pin.

REAR DOOR HINGE

REMOVAL

- (1) Remove door restrain (check) pin.
- (2) Remove door hinge bolts and shims.
- (3) Retain bolts and shims for correct installation.

REMOVAL AND INSTALLATION (Continued)

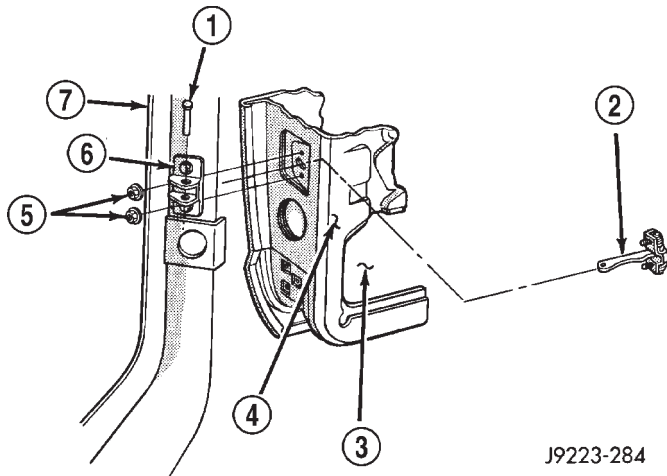

J9223-284

Fig. 48 Door Restraint (Check)

- 1 - RETAINING PIN
- 2 - DOOR RESTRAINT
- 3 - ACCESS OPENING
- 4 - DOOR INNER PANEL
- 5 - NUT
- 6 - RESTRAINT BRACKET
- 7 - B-PILLAR

INSTALLATION

- (1) Position hinge plates and shims on door face.
- (2) Align door hinges and shims with bolt holes and install hinges. Tighten bolts to 3 N·m (2 ft. lbs.).
- (3) Adjust/align latch striker and latch as necessary.
- (4) Install door restrain (check) retaining pin.

REAR DOOR OUTSIDE HANDLE**REMOVAL**

- (1) Remove the door trim panel.
- (2) Roll the window to the full up position.
- (3) Peel back the waterdam to access the fasteners for the outside handle.
- (4) Remove the latch.
- (5) Remove the access hole cover.
- (6) Remove the nuts attaching the door handle to the door (Fig. 49).
- (7) Disconnect the handle-to-latch rod from the handle latch release lever arm (Fig. 50).

INSTALLATION

- (1) Position the handle at the door panel.
- (2) Connect the latch-to-handle rod to the handle latch release lever arm.
- (3) Install nuts attaching the door handle to the door.
- (4) Install the latch.
- (5) Install the waterdam.
- (6) Install the trim panel.

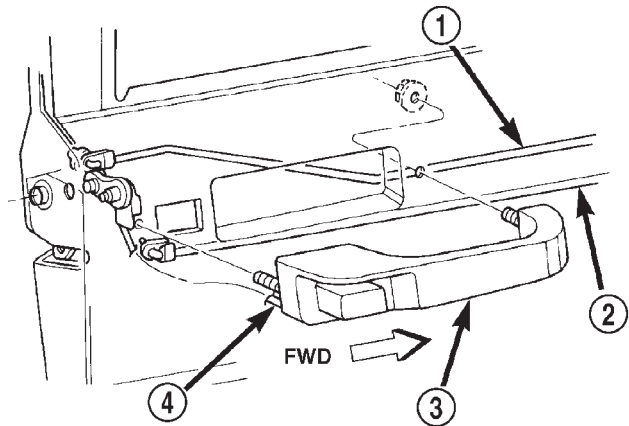

80aa4b60

Fig. 49 Rear Door Outside Handle

- 1 - INSIDE HANDLE TO LATCH ROD
- 2 - LOCK TO LATCH ROD
- 3 - OUTSIDE HANDLE
- 4 - OUTSIDE HANDLE TO LATCH ROD

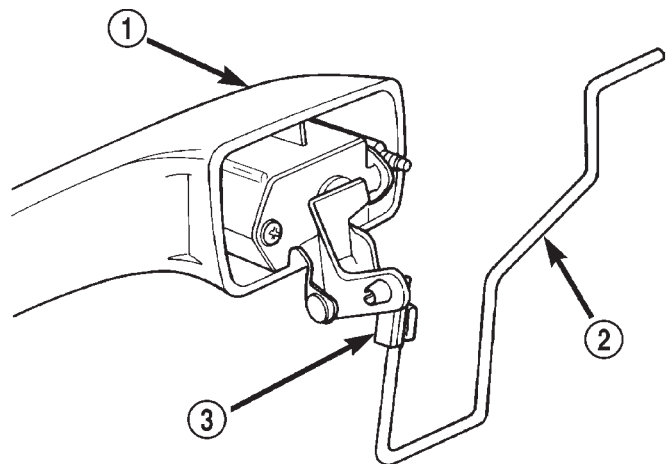

80aa4b69

Fig. 50 Latch Rod

- 1 - OUTSIDE HANDLE
- 2 - OUTSIDE HANDLE TO LATCH ROD
- 3 - CLIP

REAR DOOR LATCH**REMOVAL**

- (1) Remove access plug.
- (2) Remove door trim panel.
- (3) Remove waterdam.
- (4) Remove screws attaching door latch to door (Fig. 51).
- (5) Disconnect all rods from door latch.
- (6) Remove door latch from door.

INSTALLATION

- (1) Position door latch in door.
- (2) Connect all rods to door latch.

REMOVAL AND INSTALLATION (Continued)

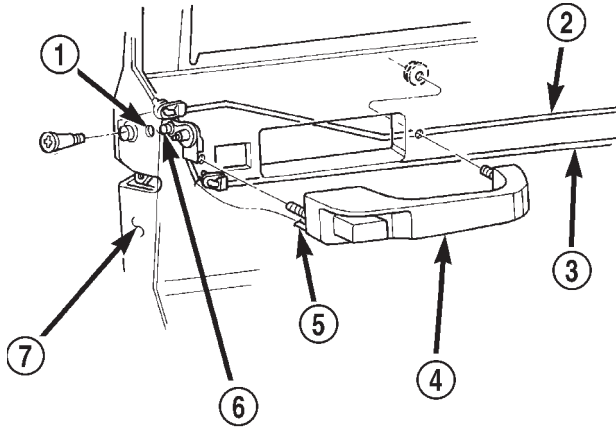

80524e45

Fig. 51 Rear Door Latch

- 1 - ACCESS HOLE
- 2 - INSIDE RELEASE TO LATCH ROD
- 3 - INSIDE LOCK TO LATCH ROD
- 4 - HANDLE
- 5 - LATCH ROD
- 6 - LATCH ADJUSTMENT SCREW
- 7 - REAR DOOR

- (3) Install screws attaching door latch to door. Tighten screws to 11 N·m (8 ft. lbs.) torque.
- (4) Install waterdam.
- (5) Install door trim panel.
- (6) Install access plug.

REAR DOOR LATCH STRIKER**REMOVAL**

- (1) Using a grease pencil or equivalent, mark position of striker.
- (2) Remove screws attaching striker to C-pillar (Fig. 52).
- (3) Separate striker from C-pillar.

INSTALLATION

- (1) Position and align striker on C-pillar.
- (2) Install screws attaching striker to C-pillar. Tighten screws to 28 N·m (20 ft. lbs.) torque.

REAR DOOR INSIDE HANDLE ACTUATOR**REMOVAL**

The rear door inside handle actuator is heat staked to the rear door trim panel during the manufacturing process.

- (1) Remove the door trim panel.
- (2) Using an X-ACTO knife or equivalent, cut the melted tabs securing the inside handle to the door trim panel.

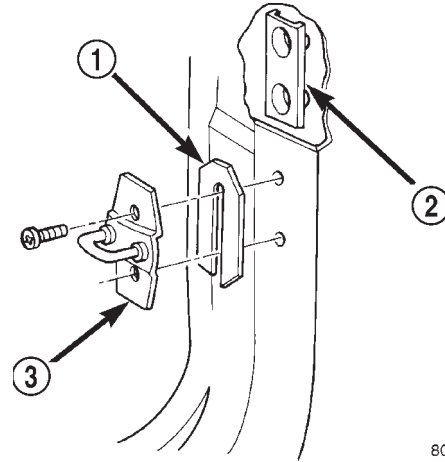

80aa4ad3

Fig. 52 Rear Door Latch Striker

- 1 - SPACER
- 2 - TAPPING PLATE
- 3 - STRIKER

- (3) Separate the inside handle from the trim panel.

INSTALLATION

- (1) Position the inside handle in the trim panel.
- (2) Heat stake the inside handle to the trim panel.
- (3) Install the door trim panel.

REAR DOOR INNER BELT WEATHERSTRIP**REMOVAL**

- (1) Roll window down.
- (2) Remove door trim panel.
- (3) Pull up on the rear corner of the weatherstrip and lift from the door (Fig. 53).

INSTALLATION

- (1) Position the weatherstrip on the door.
- (2) Push weatherstrip down to seat onto door.
- (3) Install door trim panel.

REAR DOOR OUTER BELT WEATHERSTRIP**REMOVAL**

- (1) Roll window down.
- (2) Using a trim stick, pry up the rear outer corner of the weatherstrip.
- (3) Slowly and carefully, lift the weatherstrip up to separate from the door (Fig. 53).

REMOVAL AND INSTALLATION (Continued)

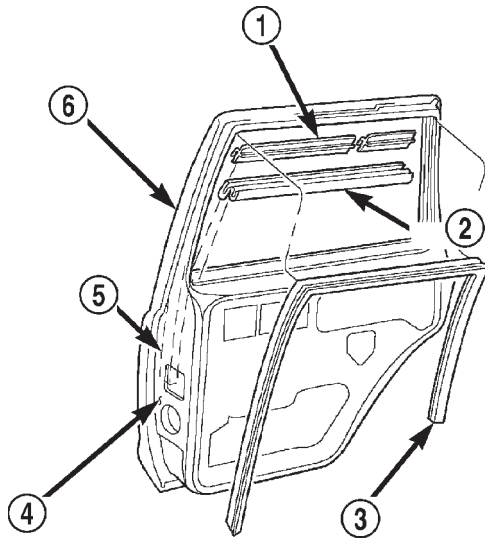

80aa0fe6

Fig. 53 Rear Door Inner/Outer Belt Weatherstrip

- 1 - OUTER BELT WEATHERSTRIP
- 2 - INNER BELT WEATHERSTRIP
- 3 - GLASS CHANNEL WEATHERSTRIP
- 4 - DOOR INNER PANEL
- 5 - GLASS CHANNEL
- 6 - DOOR OUTER PANEL

INSTALLATION

- (1) Position the weatherstrip on the door.
- (2) Push weatherstrip down to seat onto door.

REAR DOOR GLASS RUN CHANNEL WEATHERSTRIP**REMOVAL**

- (1) Remove door trim panel.
- (2) Remove waterdam.
- (3) Remove window glass.
- (4) Starting at rear corner, peel weatherstrip from around door frame (Fig. 53).

INSTALLATION

- (1) Starting at the top corner, press seal into place. A small amount of adhesive can be used to hold the weatherstrip in-place, if necessary.
- (2) As applicable, move downward evenly until the weatherstrip seal is fully seated in the channel.
- (3) Install window glass.
- (4) Install waterdam.
- (5) Install door trim panel.

REAR DOOR GLASS EXTERIOR MOLDING**REMOVAL**

- (1) Open the window.
- (2) Remove the outer belt molding.
- (3) Pry and pull the molding sections from the door panel flange (Fig. 54).

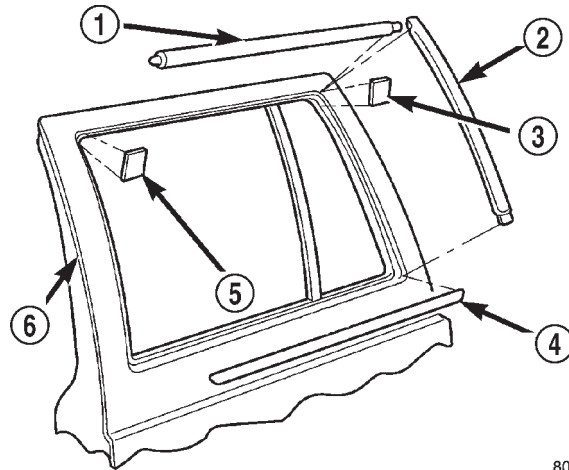

80aa0fe5

Fig. 54 Rear Glass Exterior Molding

- 1 - UPPER MOLDING
- 2 - MOLDING
- 3 - SHIM
- 4 - OUTER BELT MOLDING
- 5 - SHIM
- 6 - OUTER DOOR PANEL

INSTALLATION

- (1) Starting at the forward end of the upper molding, force the molding onto the door panel flange and continue rearward until it is completely seated on the flange.
- (2) Mate the rear molding with the upper molding and force the molding edge inward.
- (3) Continue pressing and moving downward to complete the installation.
- (4) Install the outer belt molding.

REAR DOOR WEATHERSTRIP**REMOVAL**

- (1) Remove B-pillar upper trim.
- (2) Remove inner scuff plate.
- (3) Remove B-pillar lower trim.
- (4) Remove upper door opening trim.
- (5) Grasp seal and separate from door opening (Fig. 55).

REMOVAL AND INSTALLATION (Continued)

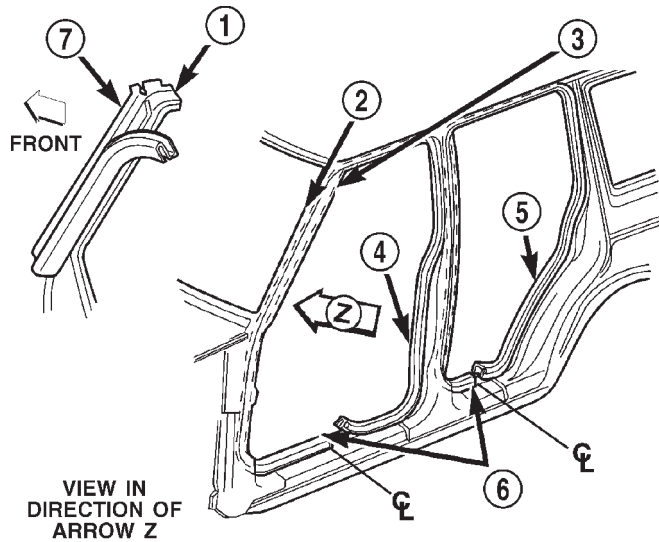

80aa0fd7

Fig. 55 Door Opening Weatherstrip

- 1 - FRONT DOOR SEAL
- 2 - A PILLAR
- 3 - SECONDARY DOOR SEAL
- 4 - FRONT DOOR SEAL
- 5 - REAR DOOR SEAL
- 6 - ENDS MEET AT CENTERLINE
- 7 - A PILLAR

INSTALLATION

- (1) When installing a door opening weatherstrip seal, start at the door sill center line.
- (2) Move upward and around edge of door opening. Seat seal on flange.
- (3) Move upward and around the perimeter of the door opening and seat the weatherstrip on the flange (Fig. 56).
- (4) Install upper door opening trim.
- (5) Install inner scuff plate.
- (6) Install B-pillar lower trim panel.
- (7) Install B-pillar upper trim panel.

REAR DOOR WINDOW REGULATOR**REMOVAL**

- (1) Remove the door trim panel.
- (2) Remove the waterdam.
- (3) Remove the bolt attaching the window glass to the regulator and support the glass (Fig. 57).
- (4) Remove the lower bolts attaching the regulator to the inner door panel (Fig. 58).
- (5) Remove the nuts attaching the regulator motor to the inner door panel, if equipped.
- (6) Loosen the upper bolt that attaches the regulator to the inner door panel.

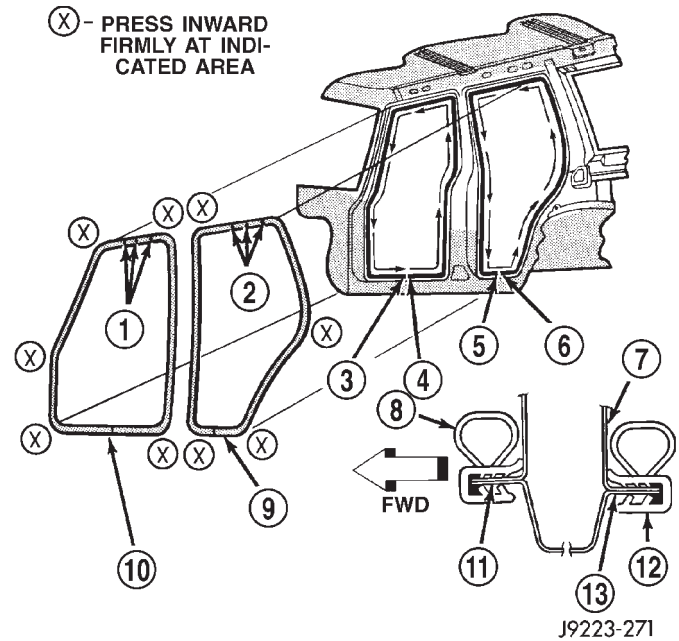

J9223-271

Fig. 56 Door Opening Weatherstrip

- 1 - VENT HOLES
- 2 - VENT HOLES
- 3 - FINISH
- 4 - START
- 5 - FINISH
- 6 - START
- 7 - B-PILLAR
- 8 - SEAL
- 9 - REAR DOOR WEATHERSTRIP SEAL
- 10 - FRONT DOOR WEATHERSTRIP SEAL
- 11 - FLANGE
- 12 - SEAL
- 13 - FLANGE

- (7) Disconnect the wire harness connector from the regulator drive motor, if equipped.
- (8) Remove the regulator and drive motor, if equipped.

INSTALLATION

- (1) Position window regulator and, if equipped, drive motor within the door panels.
- (2) Install the fasteners attaching the regulator to the door inner panel.
- (3) Connect the regulator wire harness connector.
- (4) Position the window glass at the regulator and install the retainer, bushing and bolt.
- (5) Install the waterdam.
- (6) Install the trim panel.

REAR DOOR WINDOW GLASS**REMOVAL**

- (1) Lower the window glass.
- (2) Remove the trim panel.

REMOVAL AND INSTALLATION (Continued)

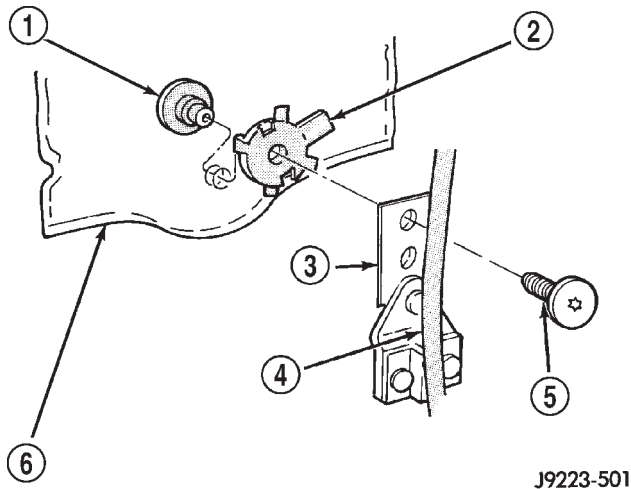

J9223-501

Fig. 57 Regulator To Glass Screw Removal/Installation

- 1 - ANCHOR
- 2 - RETAINER (WITH TABS)
- 3 - BRACKET
- 4 - REGULATOR
- 5 - SCREW AND BUSHING
- 6 - WINDOW GLASS

(8) Remove the window glass from door.

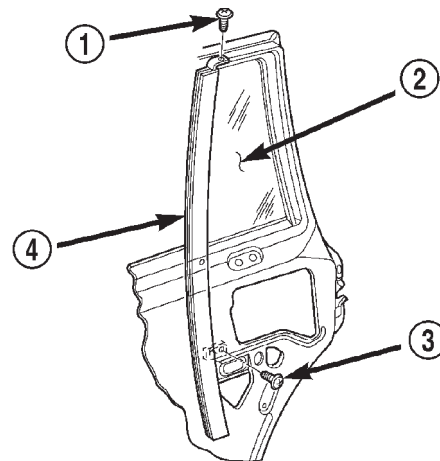

80ac2bd7

Fig. 59 Division Bar/Stationary Glass

- 1 - UPPER SCREW
- 2 - GLASS
- 3 - LOWER SCREW
- 4 - DIVISION BAR

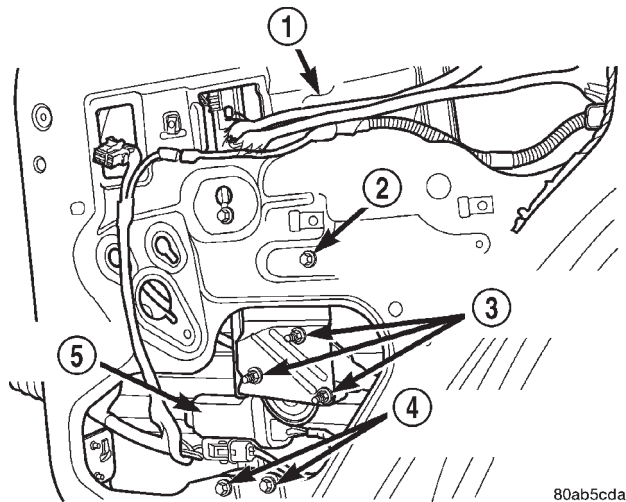

80ab5cda

Fig. 58 Rear Door Window

- 1 - REAR DOOR
- 2 - LOOSEN BOLT
- 3 - REMOVE NUTS
- 4 - REMOVE BOLTS
- 5 - REGULATOR MOTOR

- (3) Remove the waterdam.
- (4) Remove inner and outer beltline weatherstrip.
- (5) Remove the window weatherstrip from the door.
- (6) Remove the division bar/stationary glass (Fig. 59).
- (7) Remove the window glass screw, bushing and retainer from the regulator.

INSTALLATION

- (1) Install the glass in the door, and install the retainer, bushing and screw.
- (2) Tighten the glass attaching screw 6 N·m (53 in·lbs) torque.
- (3) Install the division bar/stationary glass in the door.
- (4) Install the glass run channel weatherstrip.
- (5) Install the inner and outer beltline weatherstrip.
- (6) Install the waterdam.
- (7) Install the trim panel.

BODY SIDE MOLDING

REMOVAL

- (1) Loosen the body side molding (Fig. 60) with a heat gun.
- (2) Lift edge of molding with a putty knife and peel molding from body panel. Apply heat to any location where the molding remains adhered to a panel.
- (3) Remove the adhesive from the body panel with Mopar Super Clean solvent or equivalent.
- (4) If the original molding will be installed, also remove all adhesive from it.

INSTALLATION

- (1) If the original molding will be installed, apply 3M 5344 double-sided tape on the molding.
- (2) For vertical alignment, use masking tape or a string as reference.

REMOVAL AND INSTALLATION (Continued)

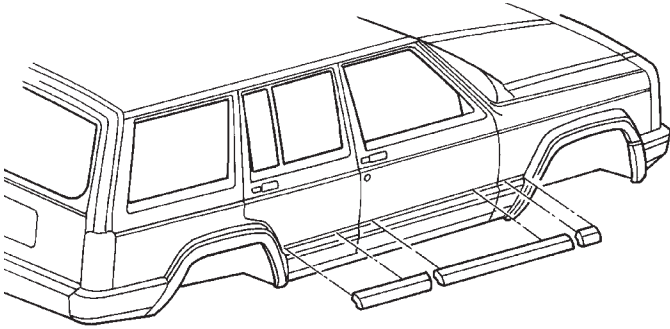

80aef1cb

Fig. 60 Body Side Molding—4-Door

- (3) Remove the backing from the tape, align the molding and position it on the body panel.
- (4) Press the molding onto the body panel with a roller or hand pressure.

REAR FENDER FLARE

REMOVAL

- (1) Remove the screw attaching the lower part of flare to the bottom of the fender.
- (2) Remove the nuts attaching the fender flare retainer to the wheelhouse liner (Fig. 61).
- (3) Separate the fender flare and retainer from the fender.

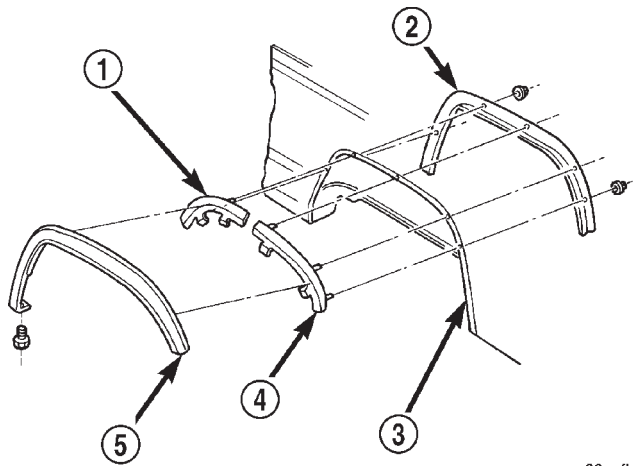

80aafb64

Fig. 61 Fender Flare

- 1 - CENTER RETAINER
- 2 - WHEELHOUSE LINER
- 3 - BODY
- 4 - REAR RETAINER
- 5 - FENDER FLARE

INSTALLATION

- (1) Position the fender flare and retainer on the fender.

- (2) Install the nuts attaching the fender flare and retainer to the wheelhouse liner.
- (3) Install the screw attaching the lower part of flare to the bottom of the fender.

QUARTER WINDOW APPLIQUE

REMOVAL

- (1) Remove the liftgate pillar trim.
- (2) Remove nuts from inside vehicle (Fig. 62).
- (3) Using a trim sick or equivalent, carefully pry the applique the from panel.

INSTALLATION

- (1) Position the replacement applique the on panel and install the nuts.
- (2) Install the liftgate pillar trim.

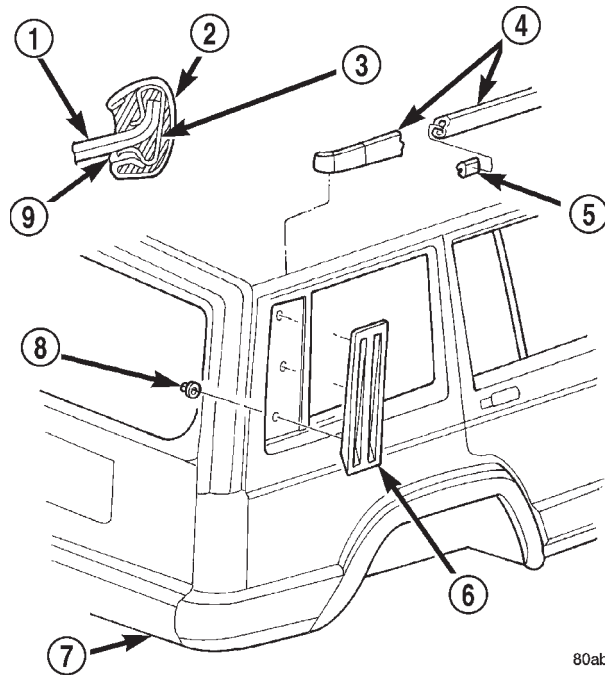

80abac3e

Fig. 62 Quarter Window Applique and Drip Molding

- 1 - VEHICLE ROOF
- 2 - DRIP MOLDING
- 3 - DRIP MOLDING CLIP
- 4 - DRIP MOLDING
- 5 - CLIP
- 6 - QUARTER WINDOW APPLIQUE
- 7 - VEHICLE BODY
- 8 - NUT
- 9 - SEALANT

DRIP RAIL MOLDING

REMOVAL

- (1) Pry the clips from the roof flange.
- (2) Remove the clips and molding from the roof flange (Fig. 62).

REMOVAL AND INSTALLATION (Continued)

(3) Remove the remaining sealant and clean the roof flange.

INSTALLATION

(1) Position the drip rail molding with clips at the roof flange and force the clips onto the roof flange.

(2) Apply sealant to the inner side of the molding to seal the roof flange.

LUGGAGE RACK

REMOVAL

(1) Remove slide rail screws (Fig. 63).

(2) Remove luggage rack from roof.

NOTE: Skid strips are attached to roof panel with adhesive.

(3) Loosen each skid strip with a heat gun.

(4) Lift one edge of each skid strip with a putty knife and peel it from roof panel.

(5) Remove original adhesive from roof with an adhesive removal solution.

(6) If original skid strips are installed, remove all original adhesive from m.

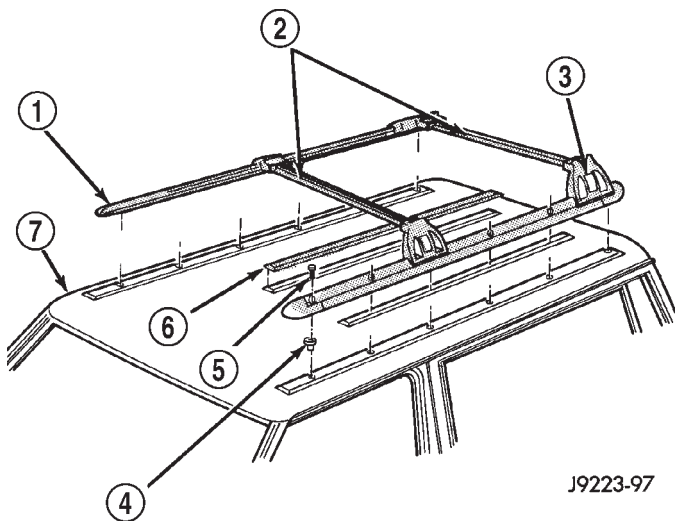

Fig. 63 Luggage Rack

- 1 - SIDE RAIL
- 2 - CROSS RAIL
- 3 - CROSS RAIL ADJUSTMENT RELEASE BUTTON
- 4 - RIVET-NUT
- 5 - SCREW
- 6 - SKID STRIP
- 7 - ROOF

INSTALLATION

(1) Install 3M 06379 double-sided tape, or an equivalent on skid strips.

(2) Remove backing from double-sided tape, align each skid strip on roof, and position it on roof panel.

(3) Verify that each skid strip is properly aligned.

(4) Press each skid strip onto roof panel with a roller (or use hand pressure).

NOTE: To prevent water leaks, apply 3M Drip-Chek Sealant, or equivalent.

(5) Position luggage rack on roof with screw holes aligned.

(6) Install and tighten slide rail screws.

AIR EXHAUST GRILLE

REMOVAL

(1) Remove the screw that attaches the grille to door the opening panel (Fig. 64).

(2) Pry the bottom edge of the grille from the door opening panel.

(3) Pull downward and remove the grille from exhaust port in the door opening panel.

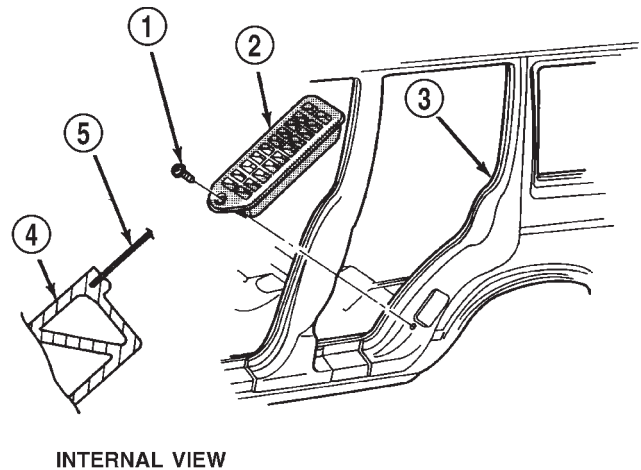

Fig. 64 Door Opening Air Exhaust Grille

- 1 - SCREW
- 2 - AIR EXHAUST GRILLE
- 3 - C-PILLER
- 4 - AIR EXHAUST GRILLE
- 5 - DOOR OPENING PANEL

INSTALLATION

(1) Position the slot located in the upper end of replacement grille at the exhaust port and insert edge in the slot.

(2) Push inward and seat the grille in the exhaust port.

(3) Install the screw to attach the grille to the door opening panel.

REMOVAL AND INSTALLATION (Continued)

A-PILLAR TRIM

REMOVAL

- (1) Remove front and rear assist handles, if equipped.
- (2) Remove the inner scuff plate.
- (3) Remove the lower A-pillar cowl trim.
- (4) Using a small flat blade, pry the trim plugs from the A-pillar trim.
- (5) Remove the screws attaching the A-pillar trim to the A-pillar (Fig. 65).
- (6) Separate the A-pillar trim from the A-pillar.

INSTALLATION

- (1) Position the A-pillar trim on the A-pillar.
- (2) Install the screws attaching the A-pillar trim to the A-pillar.

- (3) Install the trim plugs.
- (4) Install the lower A-pillar cowl trim.
- (5) Install the inner scuff plate.
- (6) Install the assist handles.

LOWER A-PILLAR COWL TRIM

REMOVAL

- (1) Remove the inner scuff plate.
- (2) Remove the nut behind the fuse panel access door (Right side only) (Fig. 66).
- (3) Remove the fasteners attaching the lower A-pillar cowl trim to the A-pillar lower cowl.
- (4) Separate the lower A-pillar cowl trim from the A-pillar lower cowl.

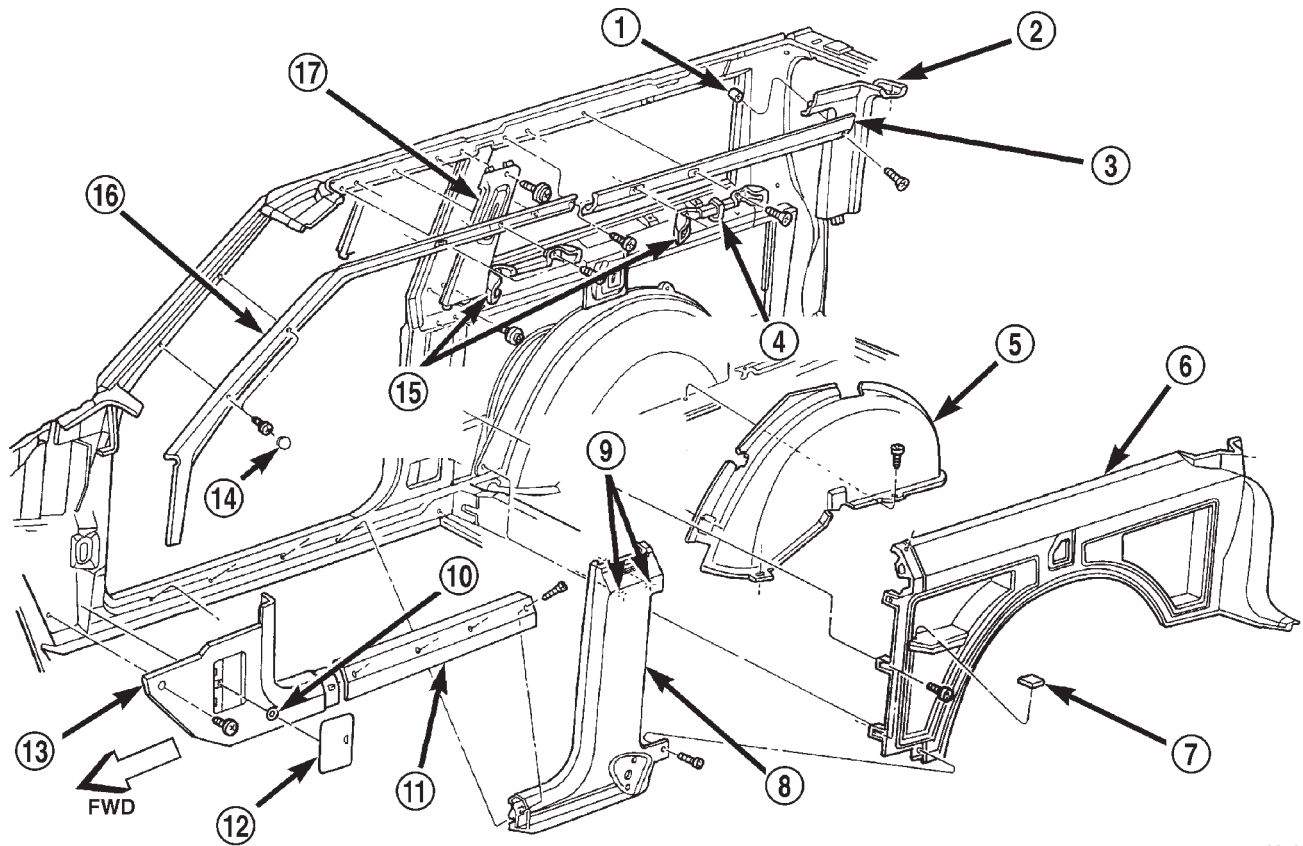

80a89433

Fig. 65 Trim Panels—2-Door Vehicles

- | | |
|------------------------------|-----------------------------|
| 1 - SPACER | 10 - NUT |
| 2 - LIFTGATE PILLAR TRIM | 11 - INNER SCUFF PLATE |
| 3 - UPPER QUARTER PANEL TRIM | 12 - ACCESS DOOR |
| 4 - COAT HOOK | 13 - COWL PANEL TRIM |
| 5 - WHEELHOUSE COVER | 14 - TRIM PLUG |
| 6 - LOWER QUARTER PANEL TRIM | 15 - OVERHEAD ASSIST HANDLE |
| 7 - COVER | 16 - A-PILLAR TRIM |
| 8 - LOWER B-PILLAR TRIM | 17 - UPPER B-PILLAR TRIM |
| 9 - PUSH-IN FASTENER | |

REMOVAL AND INSTALLATION (Continued)

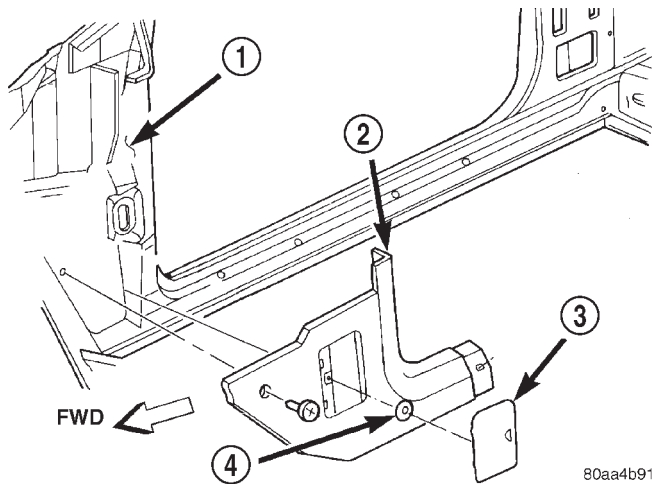
**Fig. 66 Lower A-Pillar Cowl Trim**

- 1 - COWL PANEL
- 2 - COWL PANEL TRIM
- 3 - ACCESS DOOR
- 4 - NUT

INSTALLATION

- (1) Position the lower A-pillar cowl trim on the A-pillar lower cowl.
- (2) Install the screws attaching the lower A-pillar cowl trim to the A-pillar lower cowl.
- (3) Install the nut behind the fuse panel access door (Right side only).
- (4) Install the inner scuff plate.

FRONT INNER SCUFF PLATE**REMOVAL**

- (1) If necessary, remove the bucket seat side shield trim cover.
- (2) Remove the screws attaching the inner scuff plate to the front door sill (Fig. 65).
- (3) Separate the inner scuff plate from the door sill.

INSTALLATION

- (1) Position the inner scuff plate on the front door sill.
- (2) Install the screws attaching the inner scuff plate to the front door sill.
- (3) If removed, install the bucket seat side shield trim cover.

DOOR SILL SCUFF PLATE**REMOVAL**

- (1) Remove the screws attaching the door sill scuff plate to the door sill (Fig. 67).
- (2) Separate the scuff plate from the door sill.

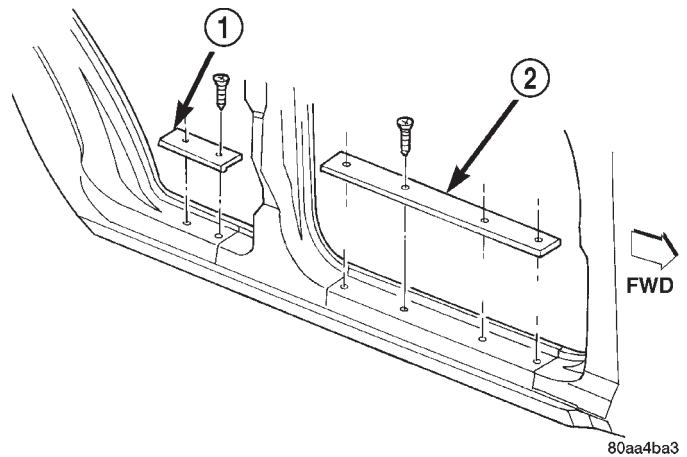
**Fig. 67 Door Sill Scuff Plate**

- 1 - REAR DOOR SILL SCUFF PLATE
- 2 - FRONT DOOR SILL SCUFF PLATE

INSTALLATION

- (1) Position the scuff plate on the door sill.
- (2) Install the screws attaching the door sill scuff plate to the door sill.

ASSIST HANDLE**REMOVAL**

- (1) Using a trim stick or equivalent, open the end covers to access the screws.
- (2) Remove the screws (Fig. 65).
- (3) Separate the assist handle from the trim.

INSTALLATION

- (1) Position the handle on the trim.
- (2) Install the screws.
- (3) Install the covers.

B-PILLAR TRIM**REMOVAL**

- (1) Remove the inner scuff plate.
- (2) Remove the upper door opening trim (4-door vehicles) (Fig. 68).
- (3) Remove the upper quarter panel trim (2-door vehicles) (Fig. 65).
- (4) Remove the rear A-pillar trim screw.
- (5) Remove the shoulder belt turning loop.
- (6) Remove the seat/shoulder belt anchor bolt.
- (7) Remove the screws attaching the B-pillar trim to the B-pillar (2-door vehicles).
- (8) Route the shoulder belt through the lower B-pillar trim (2-door vehicles).
- (9) Separate the B-pillar trim from the B-pillar.

REMOVAL AND INSTALLATION (Continued)

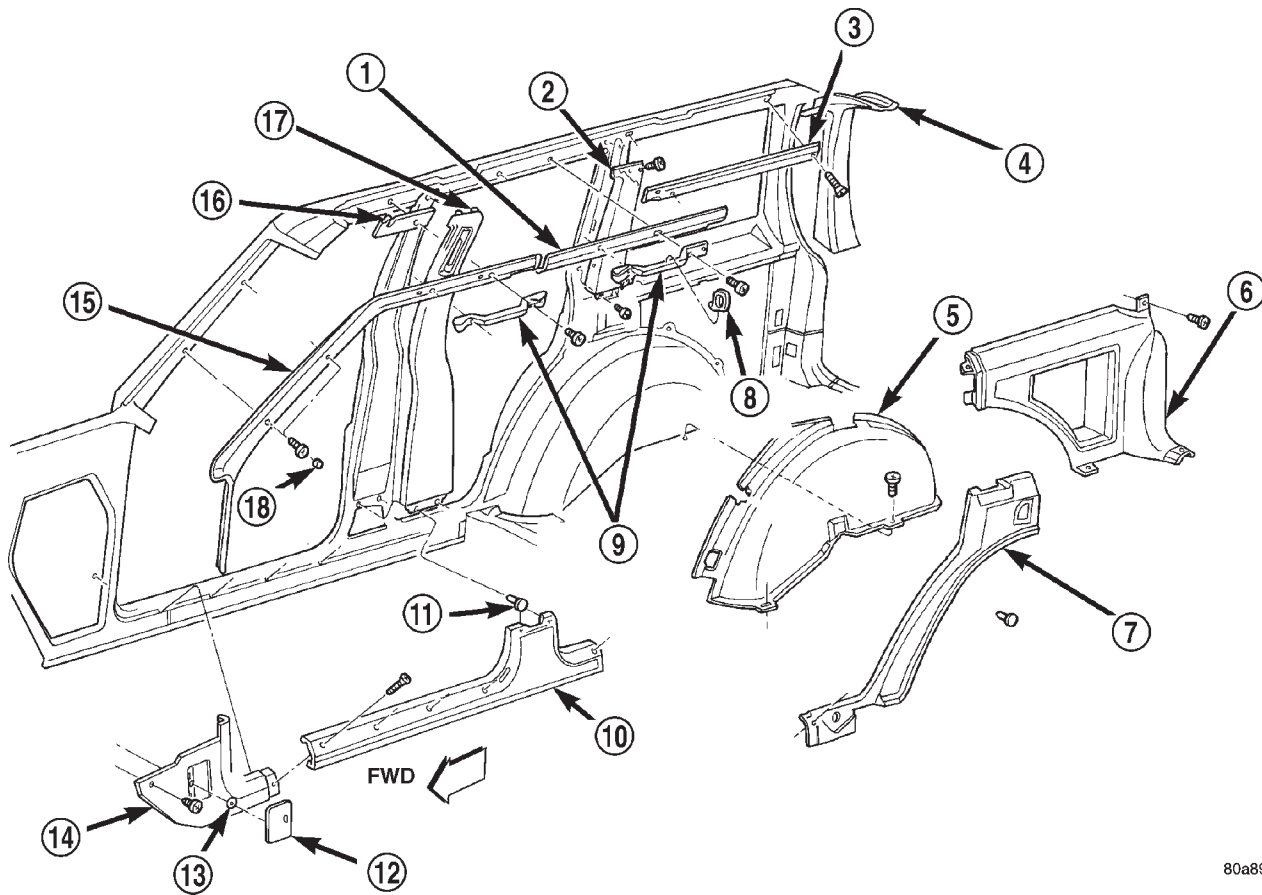

80a89434

Fig. 68 B-Pillar Trim—4-Door Vehicles

- | | |
|----------------------------------|------------------------|
| 1 - UPPER DOOR OPENING TRIM | 10 - INNER SCUFF PLATE |
| 2 - C-PILLAR TRIM | 11 - PUSH-IN FASTENER |
| 3 - UPPER QUARTER PANEL TRIM | 12 - ACCESS DOOR |
| 4 - LIFTGATE PILLAR TRIM | 13 - NUT |
| 5 - WHEEL HOUSE COVER | 14 - COWL PANEL TRIM |
| 6 - LOWER QUARTER PANEL TRIM | 15 - A-PILLAR TRIM |
| 7 - QUARTER PANEL TRIM EXTENSION | 16 - HEADLINER |
| 8 - COAT HOOK | 17 - B-PILLAR TRIM |
| 9 - OVERHEAD ASSIST HANDLE | 18 - TRIM PLUG |

INSTALLATION

- (1) Route the shoulder belt through the lower B-pillar trim (2-door vehicles).
- (2) Position the B-pillar trim on the B-pillar and align push-in fasteners.
- (3) Press the B-pillar trim on the B-pillar to secure.
- (4) Install the screws attaching the B-pillar trim to the B-pillar (2-door vehicles).
- (5) Install the seat/shoulder belt anchor bolt.
- (6) Install the shoulder belt turning loop.
- (7) Install the A-pillar trim.
- (8) Install the upper quarter panel trim (2-door vehicles) (Fig. 65).
- (9) Install the upper door opening trim (4-door vehicles) (Fig. 68).

- (10) Install the inner scuff plate.

C-PILLAR TRIM

REMOVAL

- (1) Remove the inner scuff plate.
- (2) Remove the upper door opening trim.
- (3) Remove the upper quarter panel trim.
- (4) Remove the quarter panel trim extension.
- (5) Remove the screws attaching the C-pillar trim to the C-pillar (Fig. 68).
- (6) Separate the C-pillar trim from the C-pillar.

INSTALLATION

- (1) Position the C-pillar trim on the C-pillar.

REMOVAL AND INSTALLATION (Continued)

- (2) Install the screws attaching the C-pillar trim to the C-pillar.
- (3) Install the quarter panel trim extension.
- (4) Install the upper quarter panel trim.
- (5) Install the upper door opening trim.
- (6) Install the inner scuff plate.

QUARTER PANEL TRIM EXTENSION

REMOVAL

- (1) Remove the inner scuff plate.
- (2) Separate quarter panel trim extension from the wheelhouse and quarter trim panels (Fig. 68).

INSTALLATION

- (1) Position the quarter panel trim extension on the wheelhouse and quarter trim panels.
- (2) Install the inner scuff plate.

QUARTER PANEL TRIM AND WHEELHOUSE COVER

REMOVAL

- (1) Remove the inner scuff plate.
- (2) Remove quarter panel trim extension.
- (3) Remove liftgate scuff plate.
- (4) Remove the screws attaching the quarter panel trim from the quarter panel and wheelhouse trim cover (Fig. 68) and (Fig. 65).
- (5) If necessary, remove the tire and mounting brackets from the left quarter panel trim (Fig. 69).
- (6) Remove the screws attaching the wheelhouse cover to the wheelhouse.
- (7) Separate the wheelhouse cover from the wheelhouse

INSTALLATION

- (1) Position the wheelhouse cover on the wheelhouse.
- (2) Install the screws attaching the wheelhouse cover to the wheelhouse.
- (3) If removed, install the tire and mounting bracket on the left quarter panel trim.

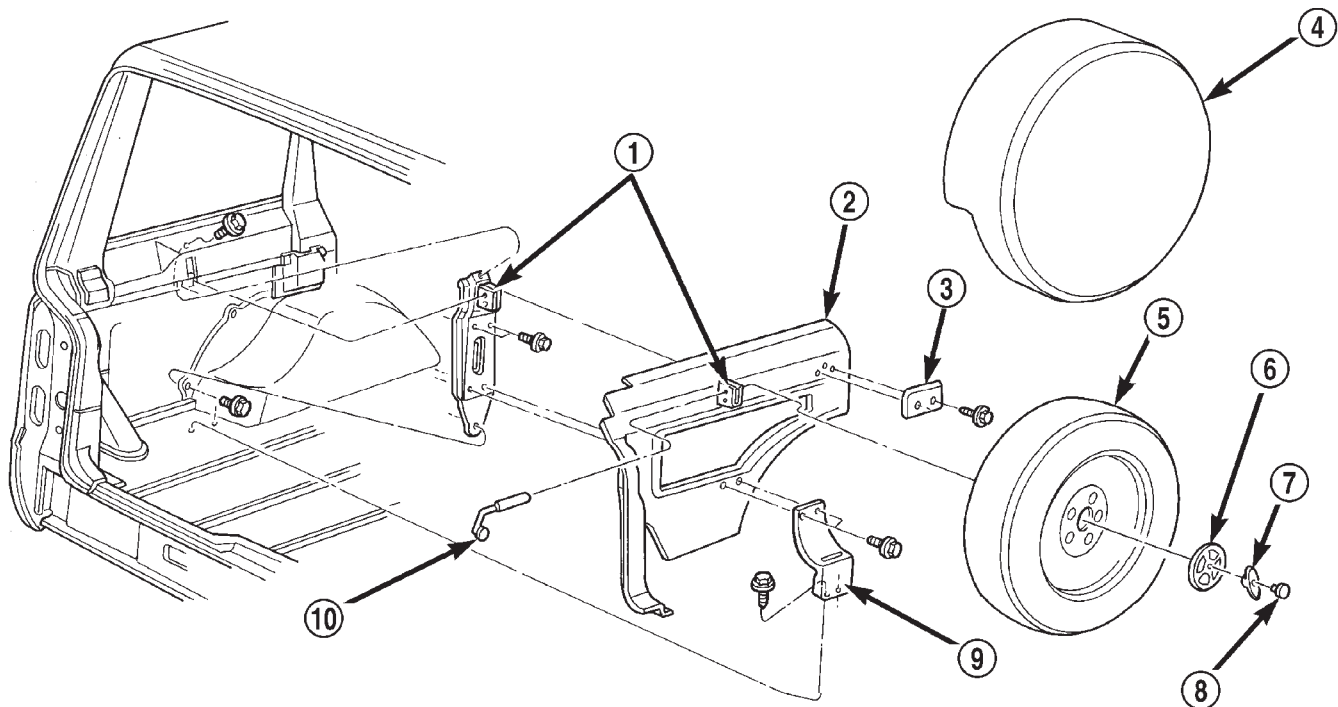

80a9f0f2

Fig. 69 Spare Tire

- | | |
|----------------------|----------------------|
| 1 - MOUNTING BRACKET | 6 - CUP |
| 2 - QUARTER TRIM | 7 - WING NUT |
| 3 - TIRE REST | 8 - CAP |
| 4 - COVER | 9 - MOUNTING BRACKET |
| 5 - TIRE/WHEEL | 10 - HOLD DOWN BOLT |

REMOVAL AND INSTALLATION (Continued)

- (4) Position the quarter panel trim on the quarter panel and wheelhouse cover.
- (5) Install the screws attaching quarter panel trim on the quarter panel and wheelhouse cover
- (6) Install liftgate scuff plate.
- (7) Install quarter panel trim extension.
- (8) Install the inner scuff plate.

LIFTGATE PILLAR TRIM

REMOVAL

- (1) Remove the liftgate opening upper trim.
- (2) Remove the liftgate pillar trim screws (Fig. 70).
- (3) Remove the screws attaching the lower quarter panel trim to the liftgate pillar.
- (4) Pull the trim panel outward to detach the spring steel clips attaching the trim panel to the pillar (2-dr vehicles).
- (5) Remove liftgate pillar trim.

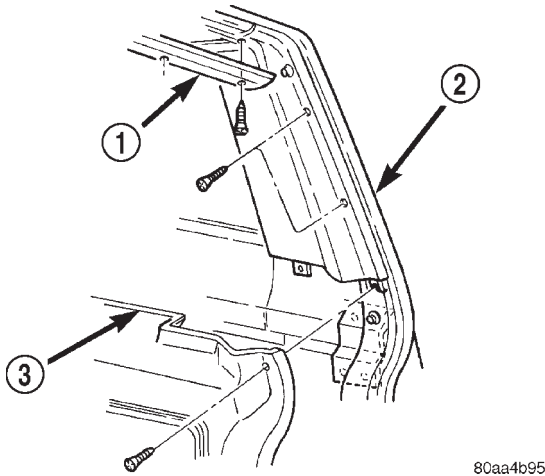

Fig. 70 Liftgate Pillar Trim

- 1 - UPPER LIFTGATE OPENING TRIM
- 2 - UPPER LIFTGATE PILLAR TRIM
- 3 - LOWER QUARTER TRIM

INSTALLATION

- (1) Position the liftgate pillar trim on the liftgate pillar.
- (2) Press the trim panel into place to engage the spring steel clips attaching the trim panel to the pillar (2-dr vehicles).
- (3) Install the screws attaching the lower quarter panel trim to the liftgate pillar.
- (4) Install the liftgate pillar trim screws.
- (5) Install the liftgate opening upper trim.

LIFTGATE OPENING UPPER TRIM

REMOVAL

- (1) Remove the screws attaching the liftgate opening upper trim to the roof panel (Fig. 71).

- (2) Pull downward to disengage steel clips attaching the liftgate opening upper trim to the roof panel.
- (3) Separate trim from vehicle.

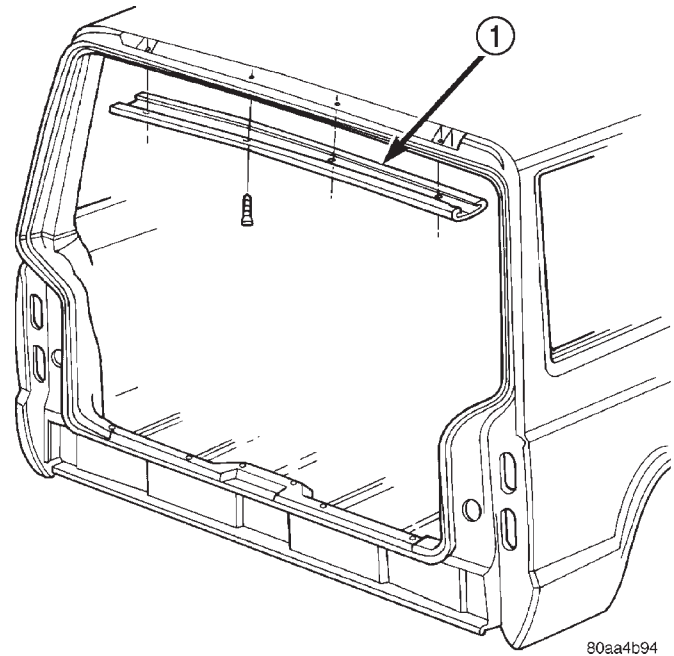

Fig. 71 Liftgate Opening Upper Trim

- 1 - UPPER LIFTGATE OPENING TRIM

INSTALLATION

Steel clips are used for manufacturing purposes and are not required for service.

- (1) Position trim on roof panel.
- (2) Install the screws attaching the liftgate opening upper trim to the roof panel.

LIFTGATE SCUFF PLATE

REMOVAL

- (1) Remove the screws attaching the liftgate scuff plate to the floor pan (Fig. 72).
- (2) Separate the scuff plate from the vehicle.

INSTALLATION

- (1) Position the scuff plate on the vehicle.
- (2) Center striker in opening.
- (3) Install the screws attaching the liftgate scuff plate to the floor pan.

FRONT SHOULDER BELT/BUCKLE

CAUTION: Inspect the front shoulder belts and buckles. Replace any belt that is either cut, frayed, torn or damaged in any way. Replace the shoulder belt if the retractor is damaged or inoperative.

REMOVAL AND INSTALLATION (Continued)

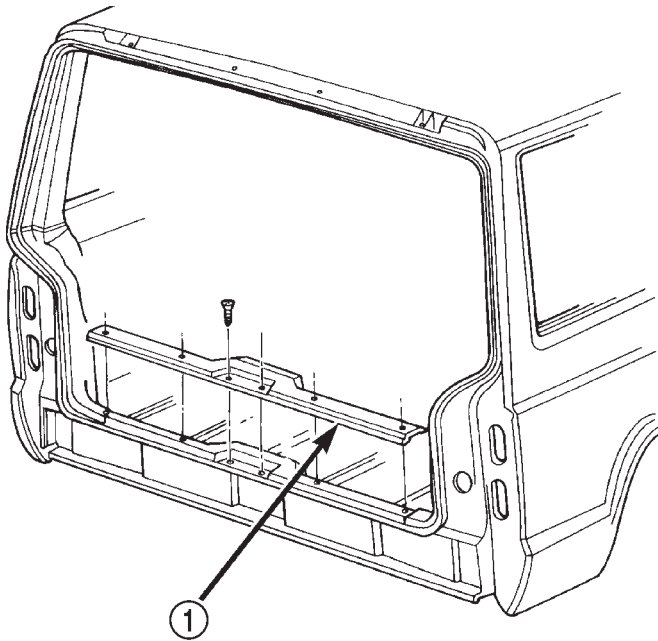

80aa4b93

Fig. 72 Liftgate Scuff Plate

1 - LIFTGATE SCUFF PLATE

REMOVAL

- (1) Slide the front seats all the way forward for access to the belt anchor bolt.
- (2) Disconnect the belt wire harness connector.
- (3) Remove the anchor bolt cover.
- (4) Remove the anchor bolt attaching the buckle to the seat.
- (5) Remove the turning loop cover concealing the shoulder belt upper anchor bolt.
- (6) Use a Torx bit to remove the upper anchor bolt (Fig. 73). Remove the support/guide washer.
- (7) Remove the inner scuff plate/trim panel from the door sill and remove the shoulder belt lower anchor bolt(s) with a Torx bit (Fig. 74) and (Fig. 75).
- (8) Remove the shoulder belt and the retractor.

INSTALLATION

- (1) Position the shoulder belt retractor in the shield and install the lower anchor bolt with a Torx bit. Tighten bolt to 43 N·m (32 ft. lbs.) torque.
- (2) Position the support/guide washer and shoulder belt upper anchor plate on the trim panel. Install the upper anchor bolt with a Torx bit.
- (3) Route belt through trim panel.
- (4) Tighten the upper and lower anchor bolts to 43 N·m (32 ft. lbs.) torque.
- (5) Install the door sill inner scuff plate/trim panel and install the cap over the upper anchor bolt.
- (6) Install the shoulder belt buckle and anchor bolt. Connect the wire harness connectors. Tighten the buckle anchor bolt to 43 N·m (32 ft. lbs.) torque.

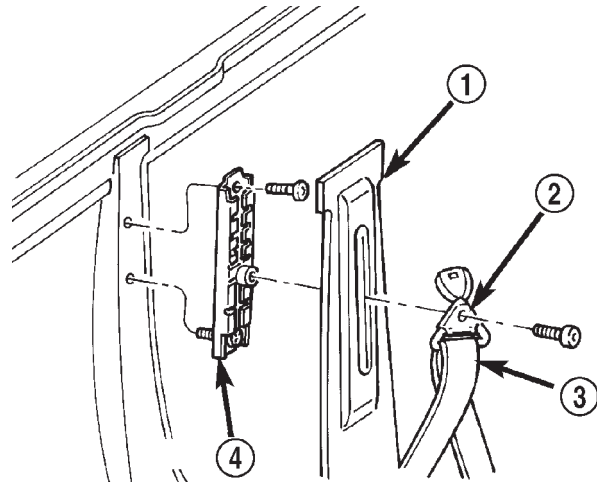

80abd242

Fig. 73 Anchor Bolt

- 1 - TRIM PANEL
- 2 - TURNING LOOP
- 3 - BELT
- 4 - ADJUSTER

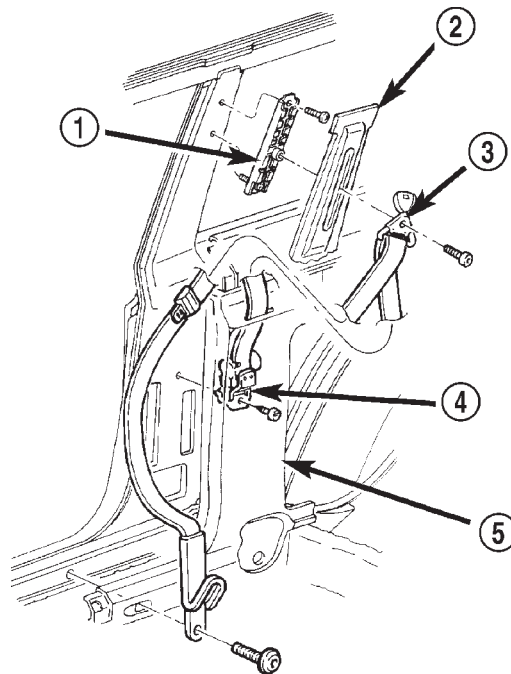

80b01c2d

Fig. 74 Front Shoulder Belt—2-Door Vehicles

- 1 - ADJUSTER
- 2 - TRIM PANEL
- 3 - TURNING LOOP
- 4 - RETRACTOR
- 5 - TRIM PANEL

REMOVAL AND INSTALLATION (Continued)

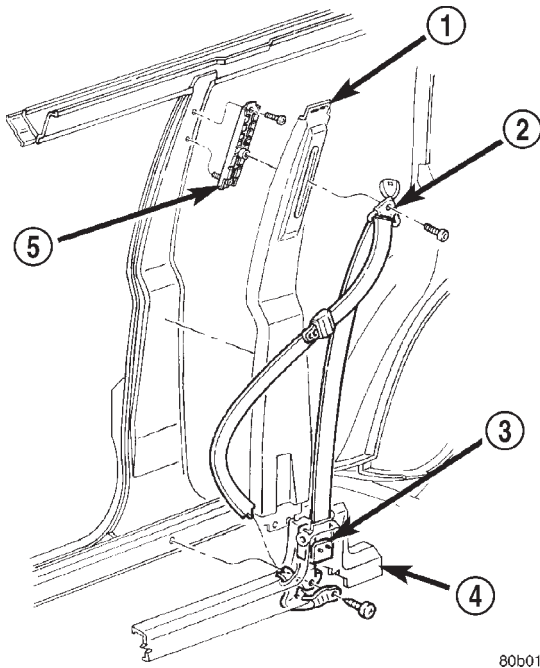

80b01c3c

Fig. 75 Front Shoulder Belt—4-Door Vehicles

- 1 - TRIM PANEL
- 2 - TURNING LOOP
- 3 - RETRACTOR
- 4 - TRIM PANEL
- 5 - ADJUSTER

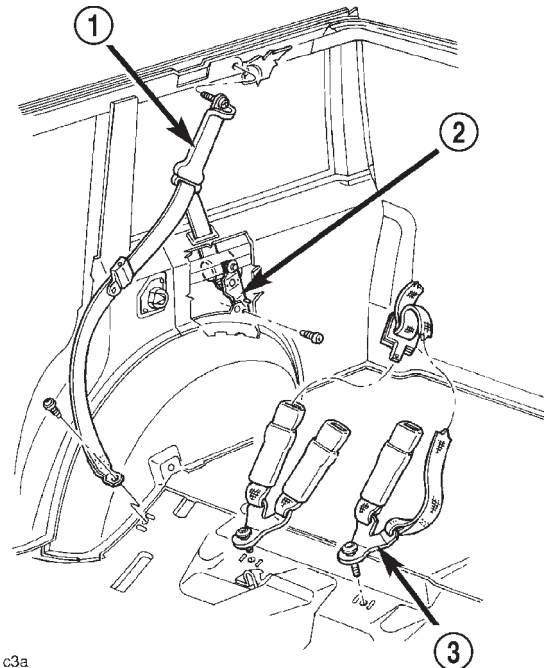

80b01c3a

Fig. 76 Rear Seat Shoulder/Lap Belts and Buckles

- 1 - TURNING LOOP
- 2 - RETRACTOR
- 3 - LAP BELT AND BUCKLE

REAR SHOULDER/LAP BELT/BUCKLE

WARNING: Inspect rear shoulder/lap belts and buckles. Replace any belt that is either cut, frayed, torn or damaged in any way. Replace shoulder belt if retractor is damaged or inoperative.

REMOVAL

- (1) Pull rear seat release strap and tilt seat cushion forward.
- (2) Remove shoulder belt buckle and lap belt/buckle anchor plate bolts from floor pan (Fig. 76).
- (3) Remove shoulder belt lower outer anchor bolt.
- (4) Remove quarter trim panel. If necessary, refer to removal procedure.
- (5) Remove shoulder belt upper anchor bolt.
- (6) Remove bolt attaching retractor to rear quarter rail.
- (7) Separate retractor and shoulder belt from trim panel.

INSTALLATION

- (1) Position shoulder belt buckle and lap belt/buckle anchor plates on floor panel.
- (2) Install anchor bolts. Tighten bolts to 43 N·m (32 ft. lbs.) torque.

- (3) Install retractor support on rear quarter rail. Tighten screw.
- (4) Route shoulder belt through quarter trim panel slot.
- (5) Position shoulder belt at roof rail and install upper anchor bolt. Tighten bolt to 43 N·m (32 ft. lbs.) torque.
- (6) Install quarter trim panel.
- (7) Install shoulder belt lower anchor bolt. Tighten bolt to 43 N·m (32 ft. lbs.) torque.
- (8) Return rear seat cushion to normal position and engage latch.

FULL FLOOR CONSOLE**REMOVAL**

- (1) Remove the transmission shift lever handle/knob:
 - Automatic transmissions, pull the handle straight upward to remove it.
 - Insert a thin-blade tool under the edge of the transmission shift indicator bezel and pry up to remove.
 - Manual transmissions, loosen the locknut and un-thread the shift knob from the shaft.
 - Pull the shift boot up to remove.
- (2) Insert a thin-blade tool under the edge of the transfer case shift indicator bezel or cover plate and pry up to remove.

REMOVAL AND INSTALLATION (Continued)

- (3) Open the console lid.
- (4) Remove the screws attaching the console to the floor and mounting bracket (Fig. 77).
- (5) Disconnect the wire harness connector.
- (6) Separate the console from the floor.

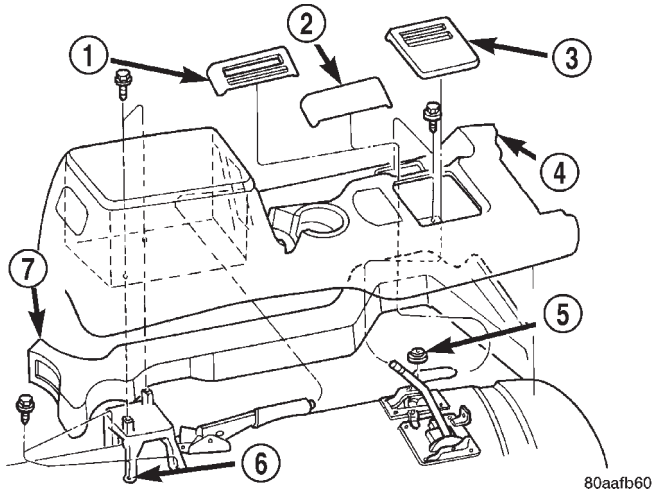
**Fig. 77 Floor Console**

- 1 - TRANSFER CASE SHIFT BEZEL
- 2 - COVER
- 3 - TRANS SHIFT BEZEL
- 4 - FLOOR CONSOLE
- 5 - WASHER (2WD)
- 6 - BRACKET
- 7 - DUCT

INSTALLATION

- (1) Position the console on the floor.
- (2) Attach the air duct to the air outlet duct.
- (3) Connect the wire harness connectors.
- (4) Install the screws attaching the console to the mounting bracket.
- (5) Install the shift indicator bezels (or cover plate).
- (6) Install the shift lever handle/knob.

FRONT CARPET/MAT**REMOVAL**

- (1) Remove the door sill inner scuff plates.
- (2) Remove the front and rear seats (as applicable).
- (3) Remove floor console.
- (4) As necessary, remove the trim panels and moldings.
- (5) Remove all other interfering components.
- (6) Remove the carpet and mat from the floor panel (Fig. 78).

INSTALLATION

- (1) Position the carpet and mat on the floor panel.

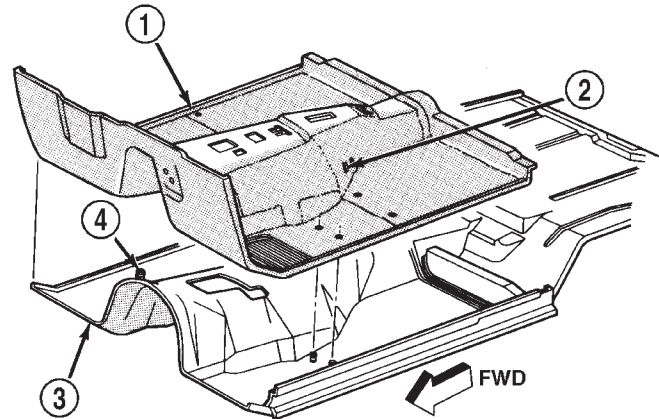

J9123-128

Fig. 78 Front Carpet and Mat

- 1 - CARPET AND MAT
- 2 - POWER SEAT WIRE HARNESS SLOT
- 3 - FLOOR PANEL
- 4 - SEAT FRAME STUD

- (2) Install all the components that were removed to facilitate carpet/mat removal.
- (3) Install the trim panels and moldings.
- (4) Install the door sill inner scuff plates.
- (5) Install floor console.
- (6) Install the front and rear seats (as applicable).

REAR CARPET/MAT**REMOVAL**

- (1) Remove the liftgate latch striker and scuff plate.
- (2) Drill-out the retaining rivet heads and remove the cargo tie-down footman loops from the carpet.
- (3) As necessary, remove the trim panels and moldings.
- (4) Remove the all other interfering components.
- (5) Remove the carpet and mat from the floor panel.
- (6) If necessary, remove the insulation from the wheelhouse (Fig. 79).

INSTALLATION

- (1) If removed, install the insulation on the wheelhouses.
- (2) Position the mat on the floor panel.
- (3) Position the carpet on the mat.
- (4) Install all the components that were removed to facilitate carpet and mat removal.
- (5) Install the trim panels and moldings.
- (6) Install the cargo tie-down footman loops on the carpet with replacement rivets.
- (7) Install the liftgate scuff plate and latch striker.

REMOVAL AND INSTALLATION (Continued)

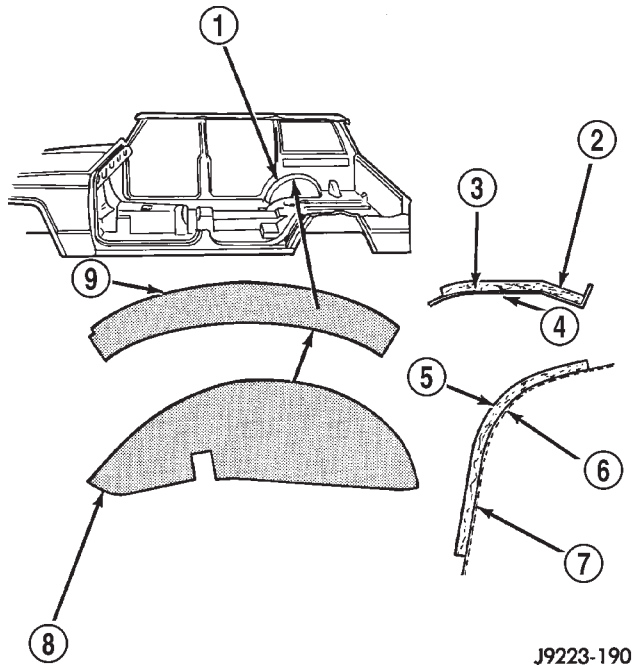

J9223-190

Fig. 79 Wheelhouse Insulation

- 1 - REAR WHEELHOUSE
- 2 - FACE SIDE
- 3 - ADHESIVE
- 4 - WHEELHOUSE PANEL
- 5 - FACE SIDE
- 6 - ADHESIVE
- 7 - WHEELHOUSE PANEL
- 8 - LOWER INSULATION
- 9 - UPPER INSULATION

REARVIEW MIRROR

REMOVAL

- (1) Loosen the mirror base setscrew (Fig. 80).
- (2) Slide the mirror base upward and off the bracket.

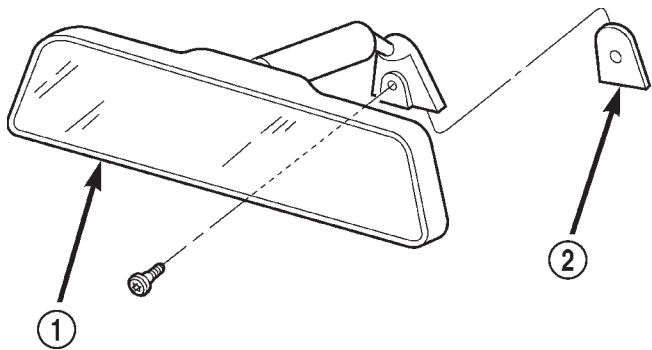

80ad2f1f

Fig. 80 Rearview Mirror

- 1 - MIRROR
- 2 - SUPPORT BUTTON

INSTALLATION

- (1) Position the mirror base at the bracket and slide it downward onto the support bracket.
- (2) Tighten setscrew to 1 N-m (9 in. lbs.) torque.

REARVIEW MIRROR SUPPORT BRACKET

INSTALLATION

- (1) Mark the position for the mirror bracket on the outside of the windshield glass with a wax pencil.
- (2) Clean the bracket contact area on the glass. Use a mild powdered cleanser on a cloth saturated with isopropyl (rubbing) alcohol. Finally, clean the glass with a paper towel dampened with alcohol.
- (3) Sand the surface on the support bracket with fine grit-sandpaper. Wipe the bracket surface clean with a paper towel.
- (4) Apply accelerator to the surface on the bracket according to the following instructions:
 - Crush the vial to saturate the felt applicator.
 - Remove the paper sleeve.
 - Apply accelerator to the contact surface on the bracket.
 - Allow the accelerator to dry for five minutes.
 - Do not touch the bracket contact surface after the accelerator has been applied.
- (5) Apply adhesive accelerator to the bracket contact surface on the windshield glass. Allow the accelerator to dry for one minute. Do not touch the glass contact surface after the accelerator has been applied.

- (6) Install the bracket according to the following instructions:
 - Apply one drop of adhesive at the center of the bracket contact-surface on the windshield glass.
 - Apply an even coat of adhesive to the contact surface on the bracket.
 - Align the bracket with the marked position on the windshield glass.
 - Press and hold the bracket in place for at least one minute.

NOTE: Verify that the mirror support bracket is correctly aligned, because the adhesive will cure rapidly.

- (7) Allow the adhesive to cure for 8-10 minutes. Remove any excess adhesive with an alcohol-dampened cloth.
- (8) Allow the adhesive to cure for an additional 8-10 minutes before installing the mirror.

REMOVAL AND INSTALLATION (Continued)

SUNVISORS

REMOVAL

(1) Remove the screws that attach the sunvisor arm support bracket to the headliner and the roof panel (Fig. 81) and (Fig. 82).

- (2) Disconnect vanity lamp connector, if equipped.
- (3) Detach the sunvisor from the support clip.
- (4) Remove the sunvisor from the vehicle.

(5) Remove the retaining screw and support clip. On vehicles equipped with an overhead console, the support clip is integral with the overhead console.

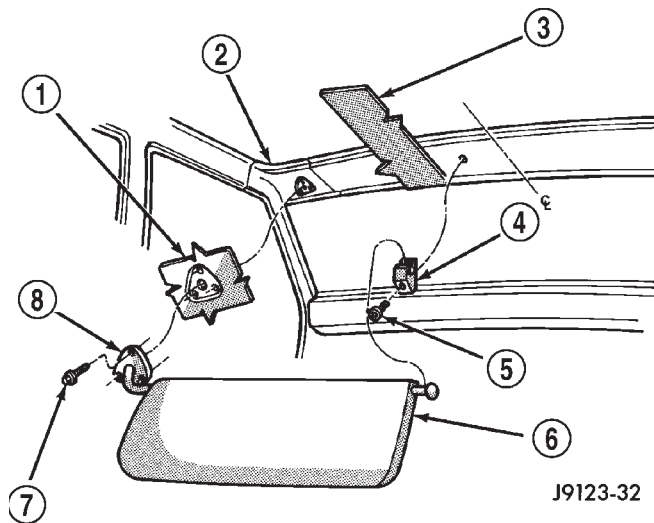

Fig. 81 Sunvisor

- 1 - HEADLINER
- 2 - VEHICLE ROOF
- 3 - HEADLINER
- 4 - SUPPORT CLIP
- 5 - SCREW
- 6 - SUN VISOR
- 7 - SCREW
- 8 - SUN VISOR ARM SUPPORT BRACKET

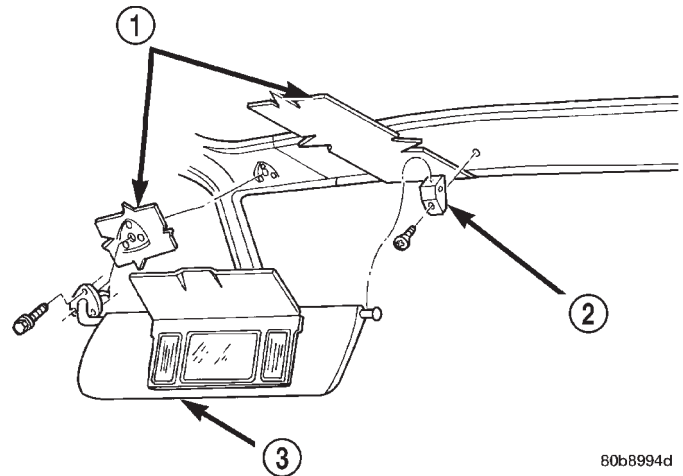

Fig. 82 Sunvisor w/Vanity Lamp

- 1 - HEADLINER
- 2 - SUPPORT CLIP
- 3 - SUNVISOR

80b8994d

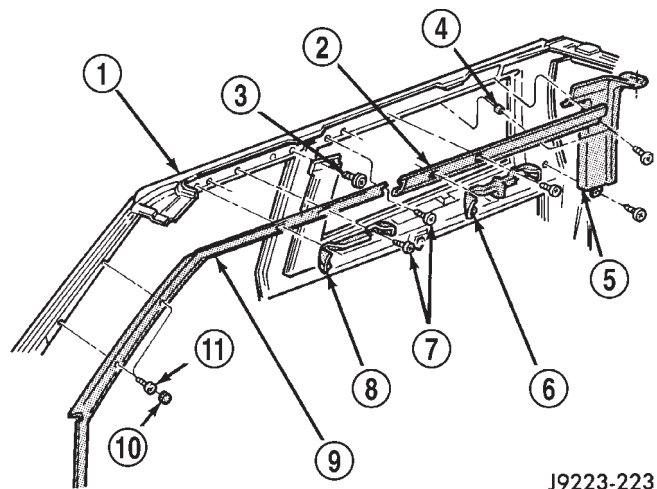

Fig. 83 Headliner Trim Moldings

- 1 - ROOF RAIL
- 2 - HEADLINER MOULDING
- 3 - SCREW
- 4 - SPACER
- 5 - LIFTGATE PILLAR TRIM COVER
- 6 - ASSIST HANDLE
- 7 - SCREW
- 8 - ASSIST HANDLE
- 9 - WINDSHIELD SIDE MOULDING
- 10 - COVER PLUG
- 11 - SCREW

J9223-223

INSTALLATION

(1) Install the support bracket and the retaining screw.

(2) Connect vanity lamp connector, if equipped.

(3) Position the sunvisor in the support clip and align the arm support bracket holes with the headliner holes.

(4) Install the screws that attach the sunvisor arm support bracket to the headliner and the roof panel.

HEADLINER

The upper trim moldings and the headliner are attached to the roof rail with a combination of screws, clip retainers and rail retainers (Fig. 83).

To remove a headliner, all of the upper trim moldings must be removed from the perimeter of the headliner along with (as applicable):

- Assist handles.
- Sunvisors.
- Dome/cargo lamps.
- Overhead console.
- All other attached/overlapping components.

REMOVAL AND INSTALLATION (Continued)

Refer to the appropriate removal and installation procedure locate in this section or in Group 8, Electrical.

REMOVAL

CAUTION: The headliner is a one-piece, molded component (Fig. 84). It has limited flexibility and must not be bent during removal/installation.

- (1) Remove the upper trim moldings from the perimeter of the headliner (Fig. 85).
- (2) Ensure that all the retainer clips and screws are disengaged before removing the headliner.
- (3) Disengage tabs attaching headliner/speaker structure to roof rail, if equipped (Fig. 84).
- (4) Disengage rear speaker harness connector, if equipped.

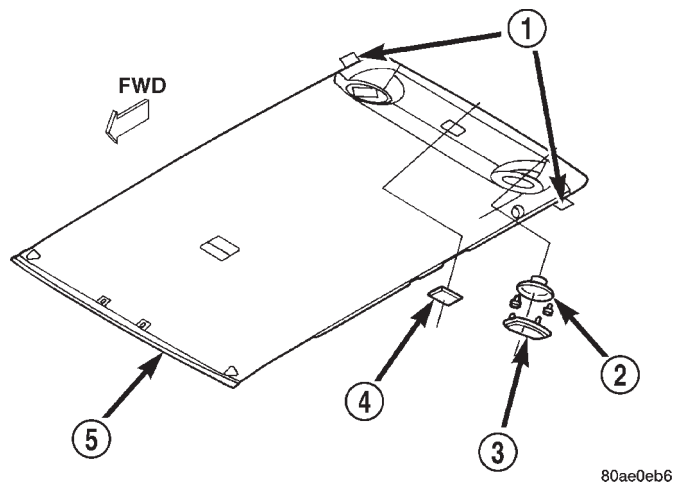
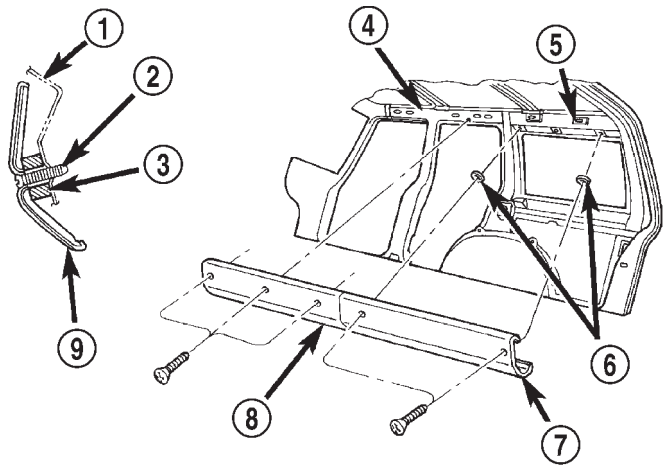

Fig. 84 Headliner

- 1 - TAB
- 2 - SPEAKER
- 3 - GRILLE
- 4 - CARGO LAMP
- 5 - HEADLINER

INSTALLATION

- (1) Engage tabs attaching headliner/speaker structure to roof rail, if equipped. (Fig. 84)
- (2) On vehicles without headliner speakers, ensure that the retainer clips on upper liftgate opening trim and rails are installed. (Fig. 86)
- (3) Engage rear speaker harness connector.
- (4) Install the upper trim moldings around the perimeter of the headliner. Tighten the retaining screws to 1 N-m (11 in. lbs.) torque.
- (5) As applicable, install:
 - Assist handles.
 - Sunvisors.
 - Dome/cargo lamps.
 - Overhead console.



80b01c2e

Fig. 85 Upper Trim Molding—4-Door

- 1 - ROOF RAIL
- 2 - SCREW
- 3 - SPACER
- 4 - ROOF RAIL
- 5 - HEADLINER SLOT
- 6 - SPACER
- 7 - REAR HEADLINER TRIM MOLDING
- 8 - FRONT HEADLINER TRIM MOLDING
- 9 - TRIM MOLDING

- All other attached/overlapping components.

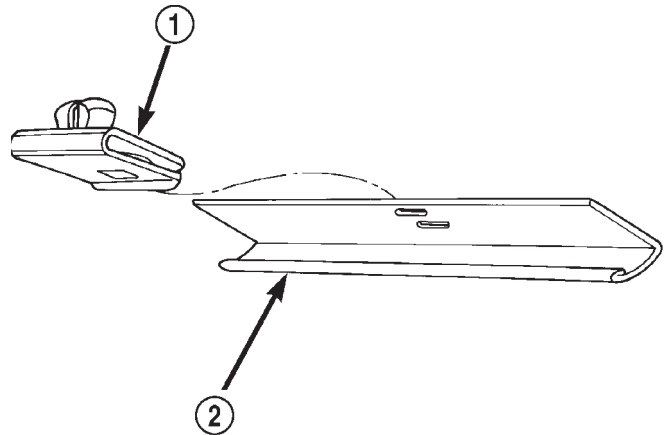

80ae0eb4

Fig. 86 Headliner Retainer Clip and Retainer Rail

- 1 - CLIP
- 2 - RETAINER REAR

LIFTGATE TRIM PANEL

REMOVAL

- (1) Using a small flat blade, pry out the trim plugs from the liftgate assist handle.
- (2) Remove the screws attaching the assist handle to the liftgate (Fig. 87).

REMOVAL AND INSTALLATION (Continued)

(3) Remove the screws that attach the liftgate trim panel to the liftgate.

(4) Using a trim panel removal tool, detach the push-in fasteners from the liftgate.

(5) Remove the trim panel from the liftgate.

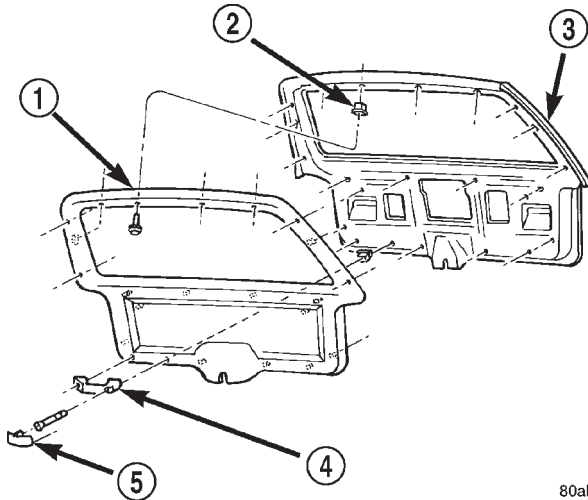

80abd2e1

Fig. 87 Liftgate Trim Panel

- 1 - TRIM PANEL
- 2 - PUSH NUT
- 3 - LIFTGATE
- 4 - ASSIST HANDLE
- 5 - PLUG

INSTALLATION

(1) Position the trim panel on liftgate.

(2) Using new push-in fasteners, align the push-in fasteners with the holes in the liftgate inner panel and press the trim panel into place.

(3) Install the screws to attach the liftgate trim panel to the liftgate.

(4) Install the screws attaching the assist handle to the liftgate.

(5) Press the trim plugs into the liftgate assist handle.

LIFTGATE

REMOVAL

WARNING: DO NOT DISCONNECT SUPPORT ROD CYLINDERS WITH LIFTGATE CLOSED. SUPPORT ROD PISTONS ARE OPERATED BY HIGH PRESSURE GAS. THIS COULD CAUSE DAMAGE AND/OR PERSONAL INJURY IF THEY ARE REMOVED WHILE PISTONS ARE COMPRESSED.

(1) Remove center high mounted stop lamp (CHMSL).

(2) Open and support liftgate.

(3) Remove liftgate trim panel.

(4) Disconnect and plug backlite washer fluid supply line.

(5) Remove screws that attach rear wiper and liftgate power lock wire harness connectors to liftgate and disconnect connectors.

(6) Using access hole created by removal of CHMSL, route backlite washer fluid supply line and rear wiper and liftgate power lock wire harness/grommets through access hole and separate from liftgate.

(7) Remove retainer clips that secure support rods to ball studs.

(8) Remove support rods from ball studs.

(9) Remove bolts attaching hinges to liftgate.

(10) Remove liftgate from vehicle.

INSTALLATION

(1) Position and support liftgate at opening in body and install bolts attaching hinges to liftgate. Tighten bolts to 26 N·m (19 ft. lbs.) torque.

(2) Connect liftgate support rods to ball studs and install retainer clips.

(3) Route backlite washer fluid supply line and rear wiper and liftgate power lock wire harnesses/grommets through access hole.

(4) Connect connectors and install screws that attach rear wiper and liftgate power lock wire harness connectors to liftgate

(5) Unplug and connect backlite washer fluid supply line.

(6) Install liftgate trim panel.

(7) Remove supports and close liftgate.

(8) Install (CHMSL).

LIFTGATE HINGE

REMOVAL

It is not necessary to remove the liftgate to replace one or both hinges.

(1) Open and support the liftgate.

(2) Remove the liftgate opening upper trim.

(3) Remove the bolts attaching the hinge to the header panel (Fig. 88).

(4) Remove the bolts attaching the hinge to the liftgate.

REMOVAL AND INSTALLATION (Continued)

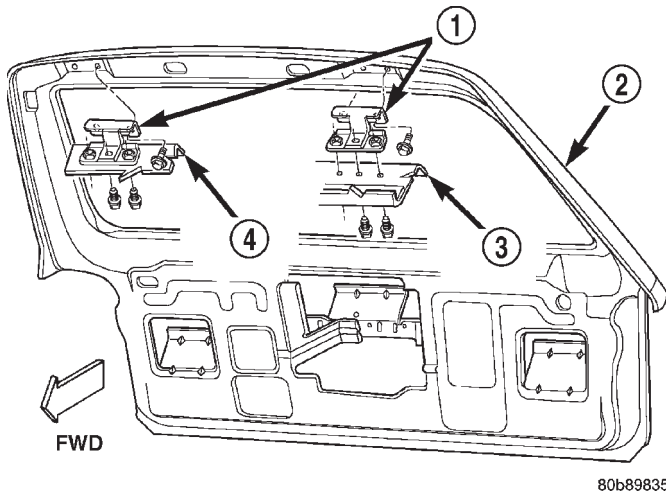

Fig. 88 Liftgate Hinge

- 1 - LIFTGATE HINGE
- 2 - LIFTGATE
- 3 - HEADER PANEL
- 4 - HEADER PANEL

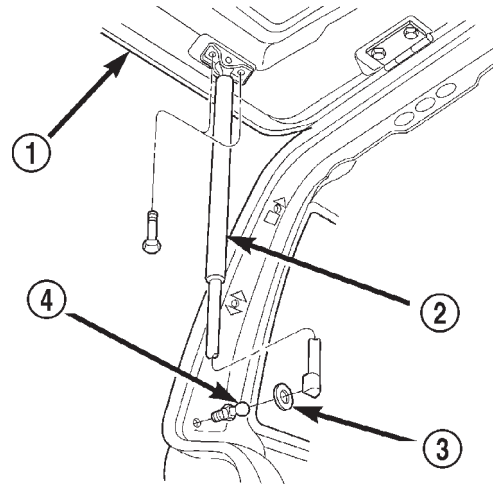

Fig. 89 Liftgate Support Rod

- 1 - LIFTGATE
- 2 - SUPPORT ROD CYLINDER
- 3 - WASHER
- 4 - BALL STUD

INSTALLATION

- (1) Position the hinge on the liftgate.
- (2) Install the bolts attaching the hinge to the liftgate. Tighten to 26 N·m (19 ft. lbs.) torque.
- (3) Install the bolts attaching the hinge to the header panel. Tighten to 26 N·m (19 ft. lbs.) torque.
- (4) Install the liftgate opening upper trim.
- (5) Remove the support and close the liftgate.

LIFTGATE SUPPORT ROD CYLINDER

REMOVAL

WARNING: DO NOT REMOVE A SUPPORT ROD CYLINDER WITH THE LIFTGATE CLOSED. EACH SUPPORT ROD PISTON IS OPERATED BY HIGH PRESSURE GAS. IT CAN CAUSE DAMAGE AND/OR PERSONAL INJURY IF IT IS REMOVED WITH THE PISTON COMPRESSED. DO NOT ATTEMPT TO DISASSEMBLE OR REPAIR A SUPPORT ROD CYLINDER.

- (1) Open the liftgate.
- (2) Support the liftgate in the open position.
- (3) Remove the clip attaching the support rod to the ball stud.
- (4) Disconnect the support rod from the ball stud.
- (5) Remove the bolts attaching the support rod to the liftgate (Fig. 89).
- (6) Separate the support rod from the liftgate.

INSTALLATION

- (1) Position the support rod on the liftgate.

- (2) Install the bolts attaching the support rod to the liftgate.
- (3) Connect the support rod to the ball stud.
- (4) Secure the support rod to the ball stud with the retainer clip.
- (5) Remove the support from the liftgate.

LIFTGATE SUPPORT ROD BALL STUD

REMOVAL

- (1) Open the liftgate.
- (2) Support the liftgate in the open position.
- (3) Remove the retainer clip attaching the support rod to the ball stud.
- (4) Disconnect the support rod from the ball stud.
- (5) Remove the ball stud.

INSTALLATION

- (1) Install the replacement ball stud.
- (2) Connect the support rod to the ball stud.
- (3) Secure the support rod to the ball stud with the clip.
- (4) Remove the support from the liftgate.

LIFTGATE OUTSIDE HANDLE

REMOVAL

- (1) Remove liftgate trim panel.
- (2) Disconnect liftgate actuator linkages.
- (3) Disconnect liftgate outside handle to latch rod.
- (4) Remove nut attaching outside handle to liftgate (Fig. 90).
- (5) Separate outside handle from liftgate.
- (6) If necessary, remove lock cylinder (Fig. 91).

REMOVAL AND INSTALLATION (Continued)

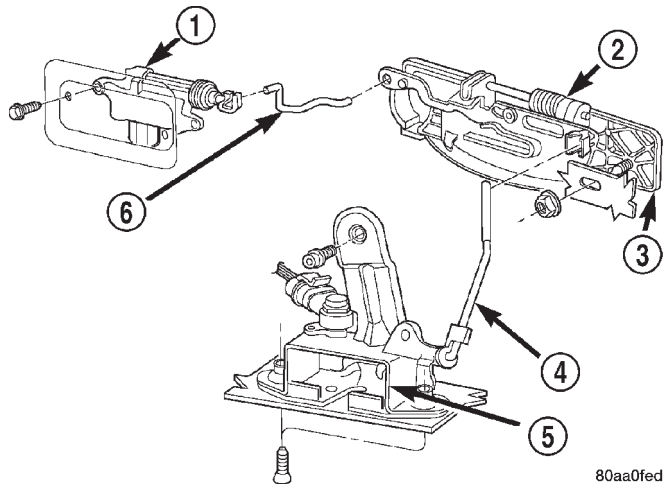

80aa0fed

Fig. 90 Liftgate Outside Handle

- 1 - POWER ACTUATOR
- 2 - LIFTGATE LOCK
- 3 - OUTSIDE HANDLE
- 4 - OUTSIDE HANDLE TO LATCH ROD
- 5 - LIFTGATE LATCH
- 6 - ACTUATOR TO LIFTGATE LOCK ROD

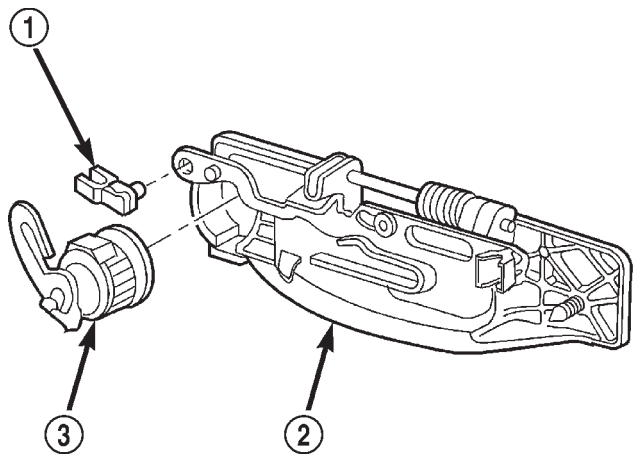

80aa0fef

Fig. 91 Liftgate Lock Cylinder

- 1 - CLIP
- 2 - OUTSIDE HANDLE
- 3 - LOCK CYLINDER

INSTALLATION

- (1) If necessary, install lock cylinder.
- (2) Position outside handle on liftgate.
- (3) Install nut attaching outside handle to liftgate.
- (4) Connect liftgate outside handle to latch rod.
- (5) Connect liftgate actuator linkages.
- (6) Install liftgate trim panel.

LIFTGATE LOCK CYLINDER

For service procedures, refer to the Liftgate Outside Handle Removal/Installation procedures.

LIFTGATE LATCH**REMOVAL**

- (1) Raise liftgate.
- (2) Remove liftgate trim panel.
- (3) Remove screws attaching latch to liftgate (Fig. 92).
- (4) Disconnect rod from latch.
- (5) Disconnect power lock connector from handle, if equipped.
- (6) Remove latch from liftgate.

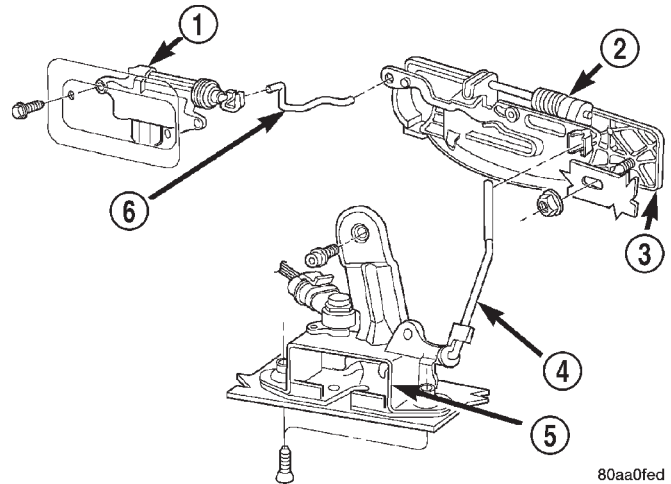

80aa0fed

Fig. 92 Liftgate Latch

- 1 - POWER ACTUATOR
- 2 - LIFTGATE LOCK
- 3 - OUTSIDE HANDLE
- 4 - OUTSIDE HANDLE TO LATCH ROD
- 5 - LIFTGATE LATCH
- 6 - ACTUATOR TO LIFTGATE LOCK ROD

INSTALLATION

- (1) Position latch in liftgate.
- (2) Connect power lock connector to handle, if equipped.
- (3) Connect latch rod.
- (4) Install screws attaching latch to liftgate. Tighten screws to 13 N·m (9 ft. lbs.) torque.
- (5) Install liftgate trim panel.

LIFTGATE LATCH STRIKER**REMOVAL**

- (1) From underside of vehicle, remove nuts attaching striker to floor pan (Fig. 93).
- (2) Separate striker from vehicle.

INSTALLATION

- (1) Position striker on vehicle.
- (2) Install nuts. Tighten nuts to 54 N·m (40 ft. lbs.) torque.

REMOVAL AND INSTALLATION (Continued)

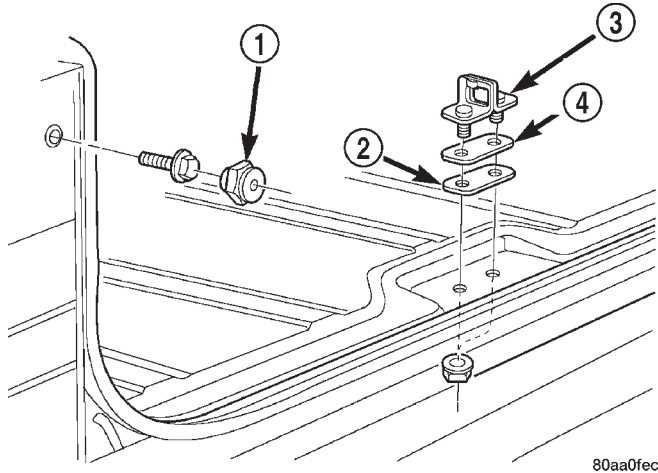
**Fig. 93 Liftgate Striker**

- 1 - OVERSLAM BUMPER
- 2 - STRIKER PLATE
- 3 - STRIKER
- 4 - SHIM

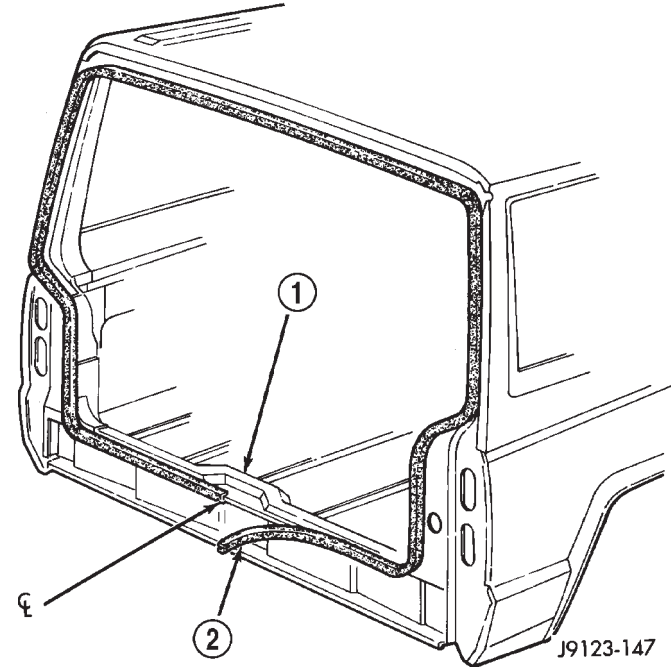
**Fig. 94 Liftgate Weatherstrip Installation**

- 1 - LIFTGATE OPENING
- 2 - WEATHERSTRIP SEAL

LIFTGATE WEATHERSTRIP**REMOVAL**

- (1) Pull the seal away from the flange around the perimeter of liftgate opening and remove it.
- (2) Clean the flange as necessary.

INSTALLATION

- (1) Position weatherstrip seal in the opening with the left end of the seal at the opening centerline. Install the seal in a clockwise direction.
- (2) Move to the left and mate the seal with the bottom-left flange (Fig. 94).
- (3) Move upward and mate the seal with the left-side flange.
- (4) Move to the right and mate the seal with the top-left roof flange.
- (5) Seat the installed part of the seal with a roller. Move the roller from the left-bottom end of seal to the top-left half of the seal.
- (6) Move to the right and mate the seal with the top-right roof flange.
- (7) Move downward and mate the seal with the right-side flange.
- (8) Move to the left and mate the seal with the bottom-right flange.
- (9) Center and butt seal the ends together at the centerline.
- (10) Seat the remaining part of the seal with a roller. Move the roller the from top-left half of the seal to the right-bottom end of the seal.

ADJUSTMENTS**HOOD**

The hood bolt holes are elongated for fore and aft and side-to-side adjustment.

- (1) If hood is low to the cowl panel, insert shims between the hinge and hood at the rear hinge bolts.
- (2) Adjust the hood bumper (Fig. 95) in or out to provide proper hood-to-fender height alignment.
- (3) Adjust the hood strikers (Fig. 96) with shims as necessary. Tighten the screws to 22 N·m (16 ft-lbs) torque after adjustment.
- (4) Align each latch and striker so that the striker enters latch squarely.

DOOR**IN AND OUT—MINOR ADJUSTMENT**

- (1) Loosen the latch striker.
- (2) Tap the latch striker inward if the door character line is outboard of the body character line or tap the latch striker outward if the door character line is inboard of the body character line.
- (3) Inspect alignment. If correct, tighten striker with 28 N·m (20 ft. lbs.) torque.

ADJUSTMENTS (Continued)

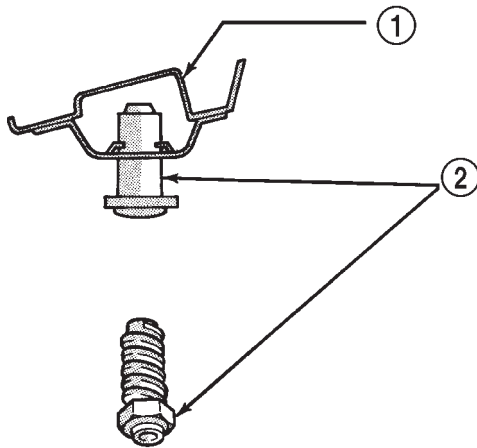

J9223-75

Fig. 95 Hood Bumper

- 1 - HOOD LATCH STRIKER REINFORCEMENT PANEL
2 - HOOD BUMPER

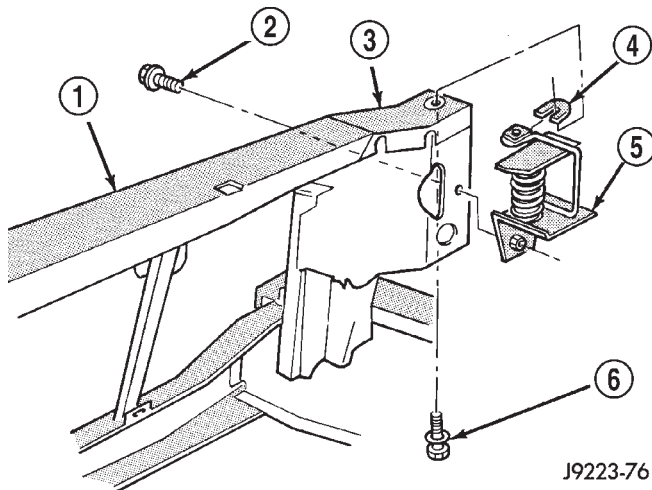

J9223-76

Fig. 96 Hood Latch Striker

- 1 - RADIATOR SUPPORT CROSSMEMBER
2 - SCREW
3 - RADIATOR BAFFLE
4 - SHIM
5 - HOOD LATCH STRIKER
6 - SCREW

UP AND DOWN—MINOR ADJUSTMENT

- (1) Loosen the latch striker.
- (2) Tap the latch striker downward if the door character line is higher than the body character line or tap the latch striker upward if the door character line is lower than the body character line.
- (3) Inspect alignment. If correct, tighten striker with 28 N-m (20 ft. lbs.) torque.

ALIGNMENT MAJOR—ADJUSTMENT

Adjustment for alignment of the door is made by installing shims between hinge and door face (Fig. 97).

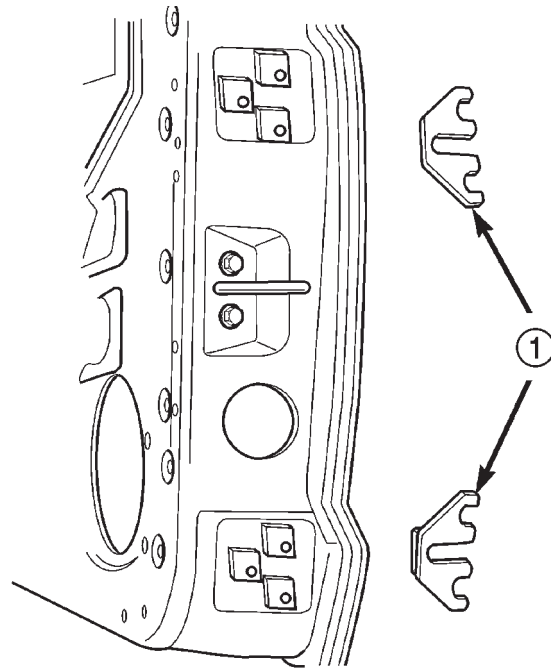

80b8994e

Fig. 97 Door Adjustment Shims

- 1 - ADJUSTMENT SHIMS

- (1) If not loosened, loosen the door hinge bolts.
- (2) Add or remove shims as necessary to obtain the best door fit.
- (3) Tighten door hinge bolts to 3 N-m (2 ft-lbs) torque after adjustment is completed.
- (4) Apply general purpose sealant around the door hinges/door face mating area.

DOOR LATCH ADJUSTMENT

- (1) Locate access hole (Fig. 98).
- (2) Insert a 5/32-inch hex-wrench through hole and into adjustment screw. Loosen screw.
- (3) Operate outside handle button several times to release any restriction because of mis-alignment.
- (4) Tighten adjustment screw to 3 N-m (30 in-lbs) torque.
- (5) Test handle button and lock cylinder for proper operation.

ADJUSTMENTS (Continued)

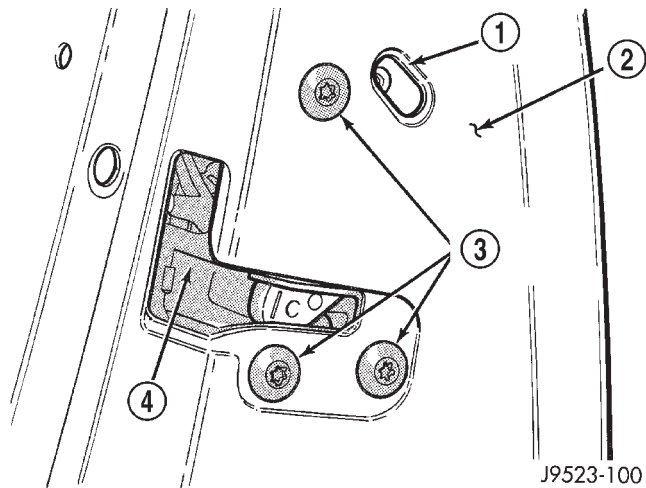

Fig. 98 Door Latch Adjustment

- 1 - ACCESS HOLE
- 2 - DOOR
- 3 - LATCH MOUNTING BOLTS
- 4 - LATCH

LIFTGATE

The position of liftgate can be adjusted upward or downward by use of slots in the hinge. An inward or outward adjustment is achieved by use of slots in the body. If an inward or outward adjustment is needed, use 3M™ Fast and Firm or equivalent on the hinge to body mating surface as a sealant.

REAR SEATBACK

- (1) Unlatch and position seatback in cargo position.
- (2) Loosen the screws attaching the strikers to the rear wheelhouse.
- (3) Position the seat back in the full upright position and secure the latch into the strikers.
- (4) From the cargo area of the vehicle, push the rear of the seatback forward.
- (5) Unlatch and position seatback in cargo position.
- (6) Tighten the screws attaching the strikers to the rear wheelhouse.
- (7) Position the seat back in the full upright position and secure the latch into the strikers.
- (8) Verify latch operation.

SPECIFICATIONS

BODY LUBRICANTS

| COMPONENT | SERVICE INTERVAL | LUBRICANT |
|--|--|---|
| Door Latches | As Required | Multi-Purpose Grease NLGI GC-LB (Water Resistant) (1) |
| Hood Latch, Release Mechanism & Safety Latch | As Required (When Performing Other Underhood Service) | Multi-Purpose Grease NLGI GC-LB 2 EP (2) |
| Hood Hinges | As Required | Engine Oil |
| Seat Track & Release Mechanism | As Required | Multi-Purpose Grease NLGI GC-LB 2 EP (2) |
| Liftgate Hinge | As Required | Multi-Purpose Grease NLGI GC-LB 2 EP (2) |
| Liftgate Support Arms | As Required | Engine Oil |
| Liftgate Latches | As Required | White Spray Lubricant (3) |
| Liftgate Release Handle (Pivot & Slide Contact Surfaces) | As Required | Multi-Purpose Grease NLGI GC-LB 2 EP (2) |
| Window System Components | As Required | White Spray Lubricant (3) |
| Lock Cylinders | Twice A Year | Lock Cylinder Lubricant (4) |
| Parking Brake Mechanism | As Required | Multi-Purpose Grease NLGI GC-LB 2 EP (1) |
| 1 = Mopar Wheel Bearing Grease (High Temp) 2 = Mopar Multi-Mileage Lubricant 3 = Mopar Spray White Lube 4 = Mopar Lock Cylinder Lubricant | | |

SPECIFICATIONS (Continued)

WELD LOCATIONS

UPPER COWL

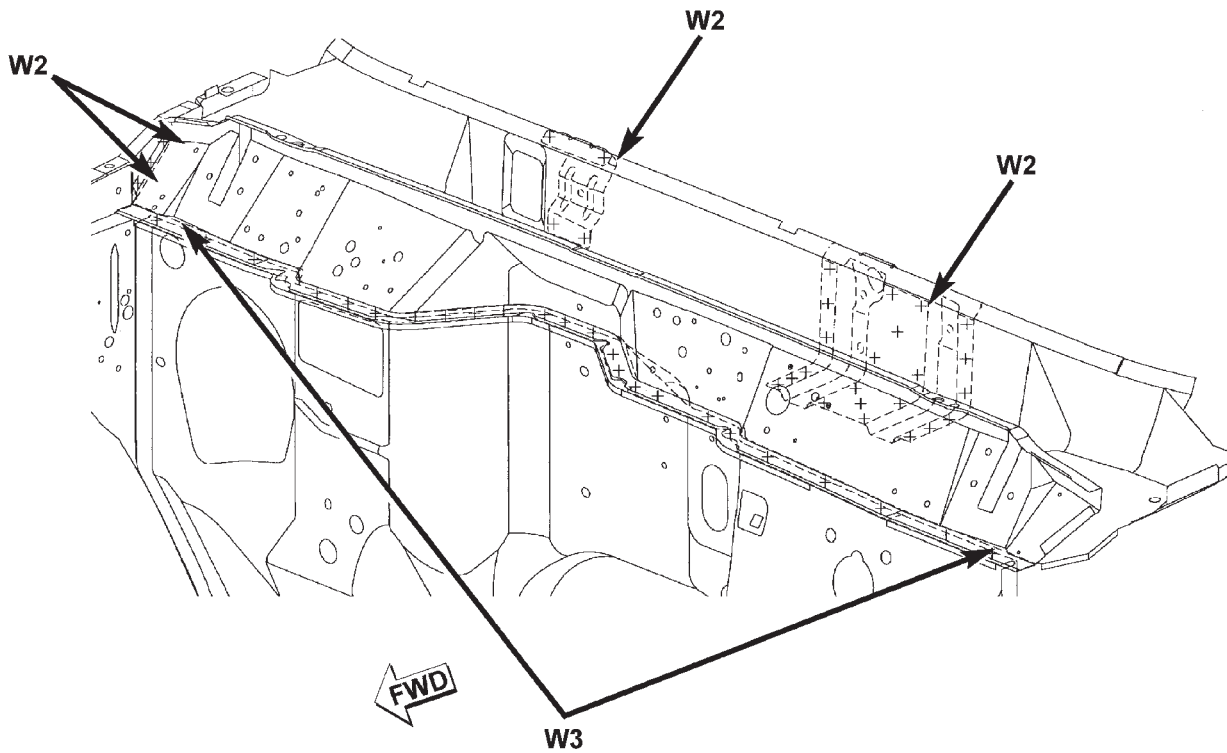

W2 - WELDING OF 2 PARTS
W3 - WELDING OF 3 PARTS
W4 - WELDING OF 4 PARTS

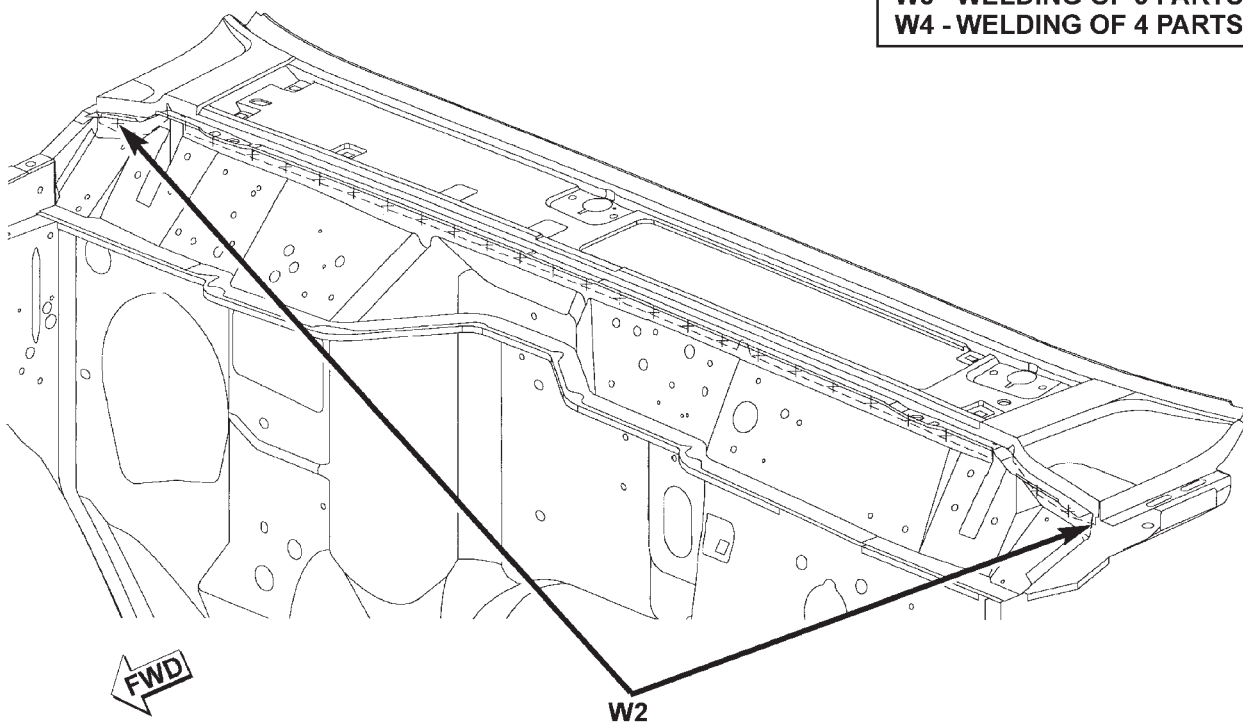

SPECIFICATIONS (Continued)

UPPER COWL

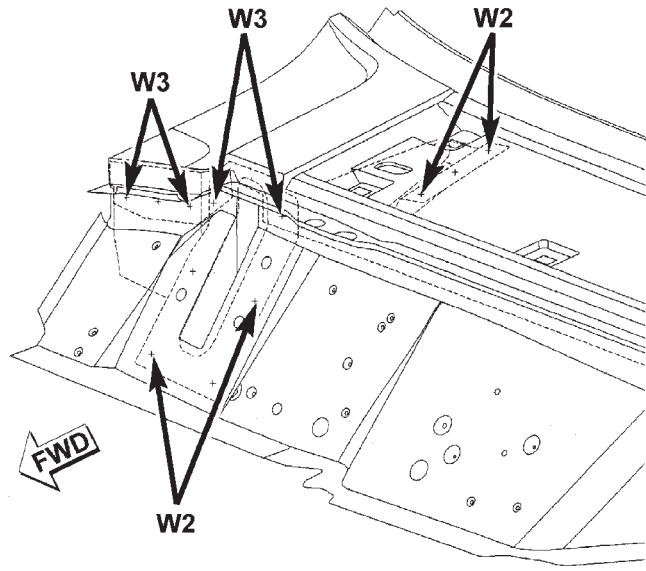

W2 - WELDING OF 2 PARTS
W3 - WELDING OF 3 PARTS
W4 - WELDING OF 4 PARTS

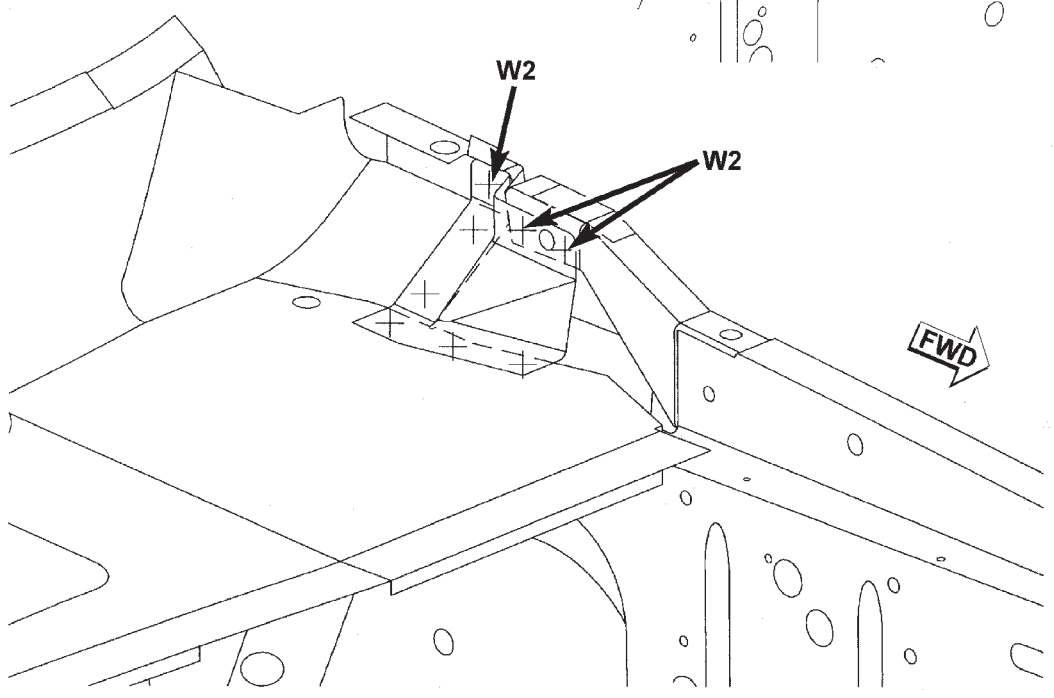
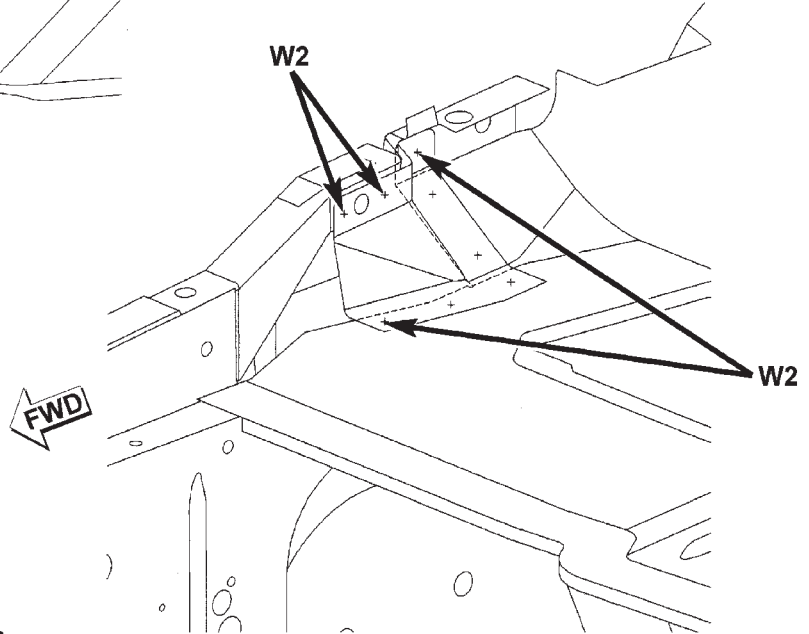

SPECIFICATIONS (Continued)

COWL

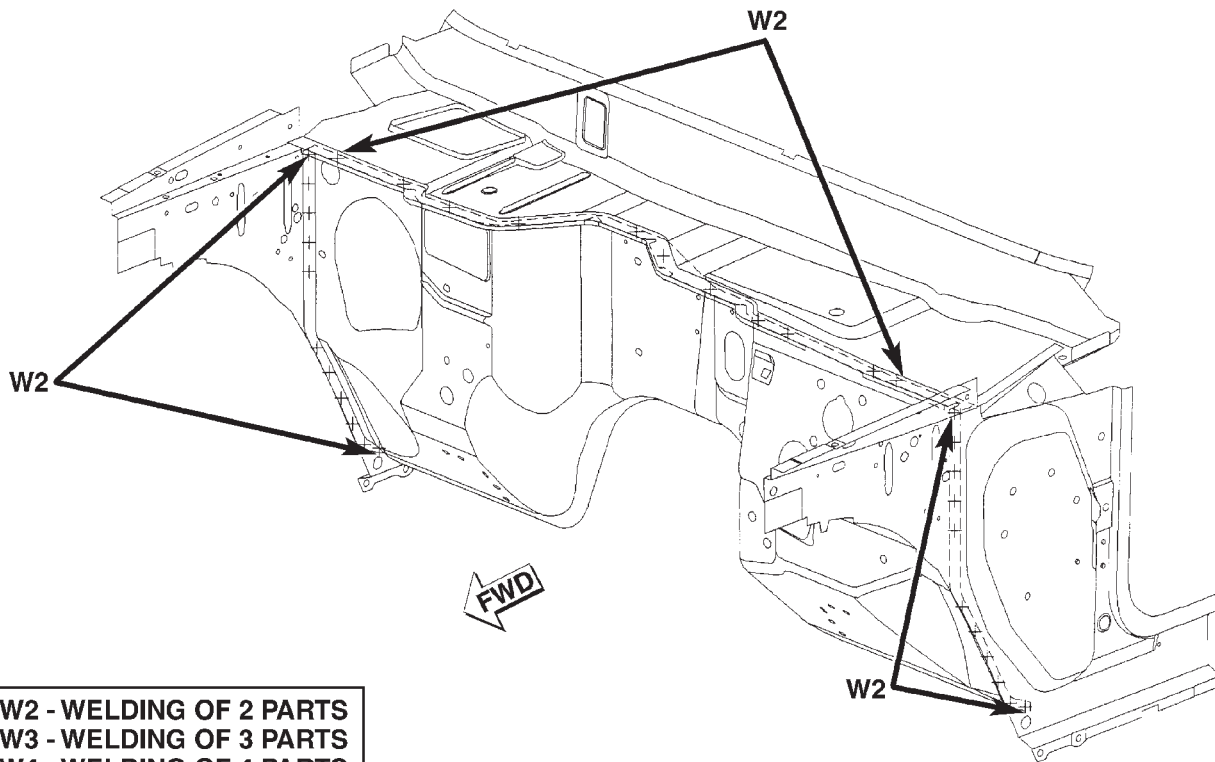
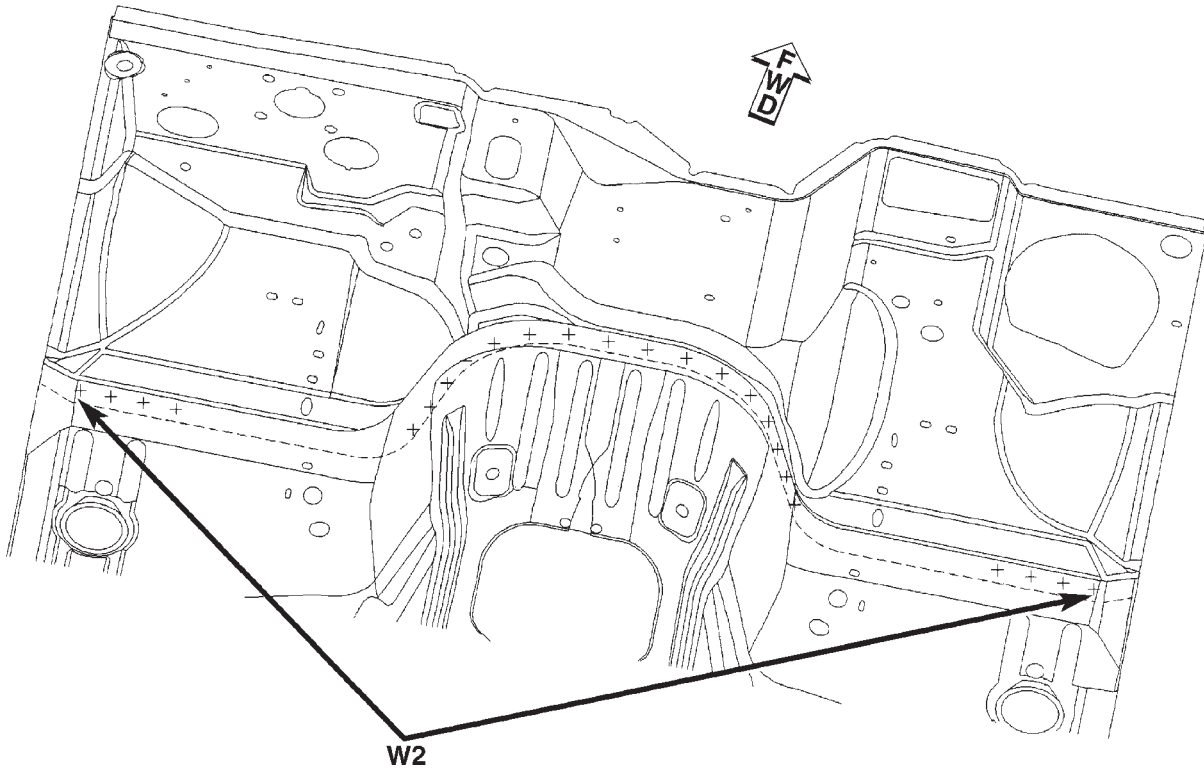

W2 - WELDING OF 2 PARTS
W3 - WELDING OF 3 PARTS
W4 - WELDING OF 4 PARTS

SPECIFICATIONS (Continued)

A—PILLAR

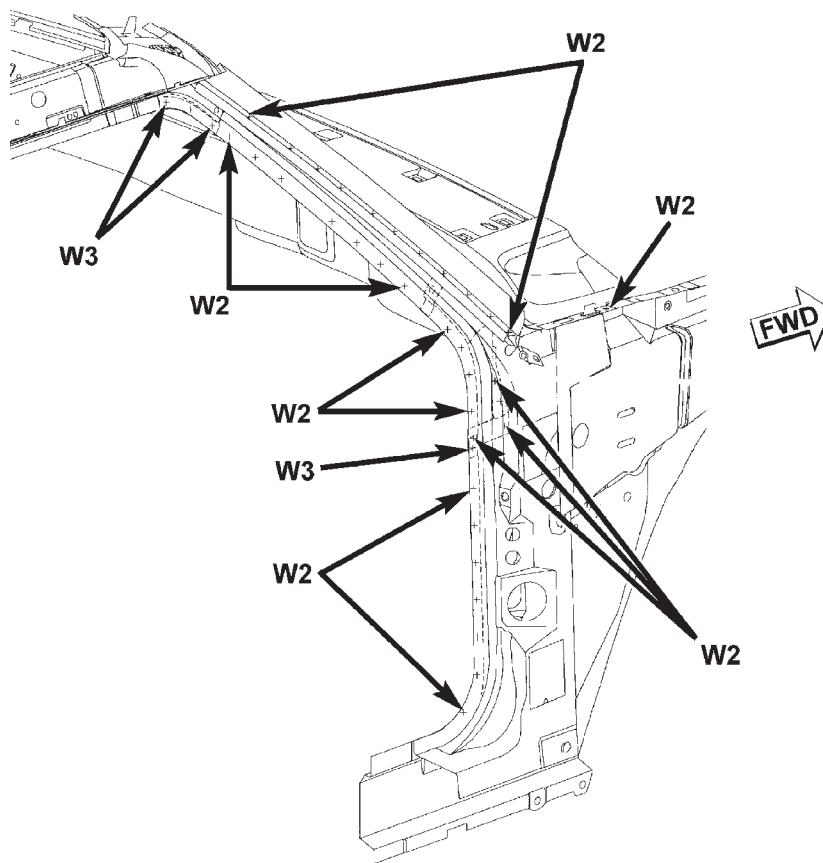

W2 - WELDING OF 2 PARTS
W3 - WELDING OF 3 PARTS
W4 - WELDING OF 4 PARTS

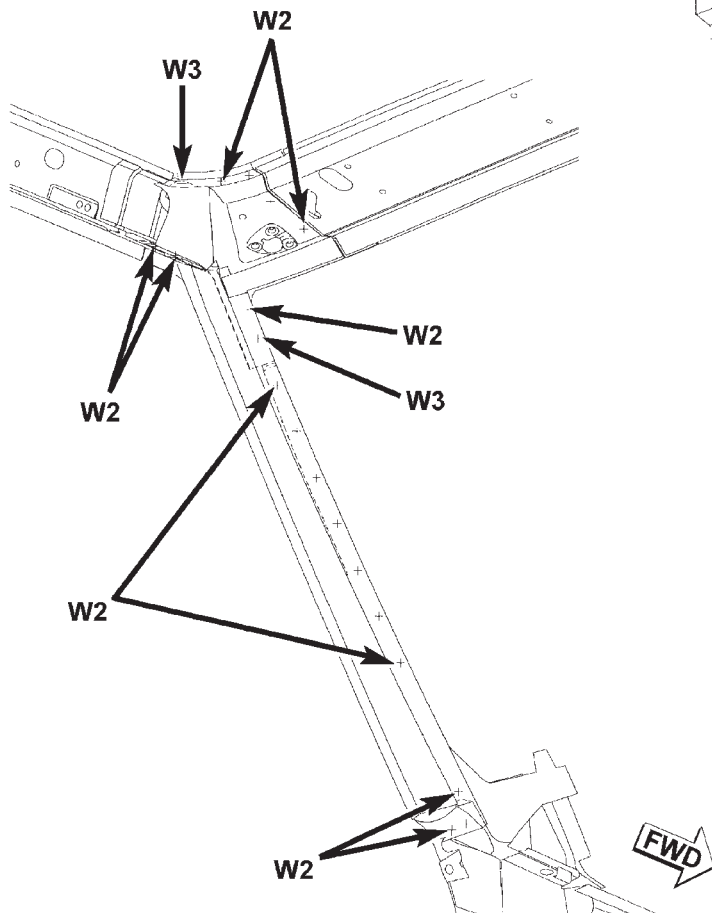

SPECIFICATIONS (Continued)

A—PILLAR

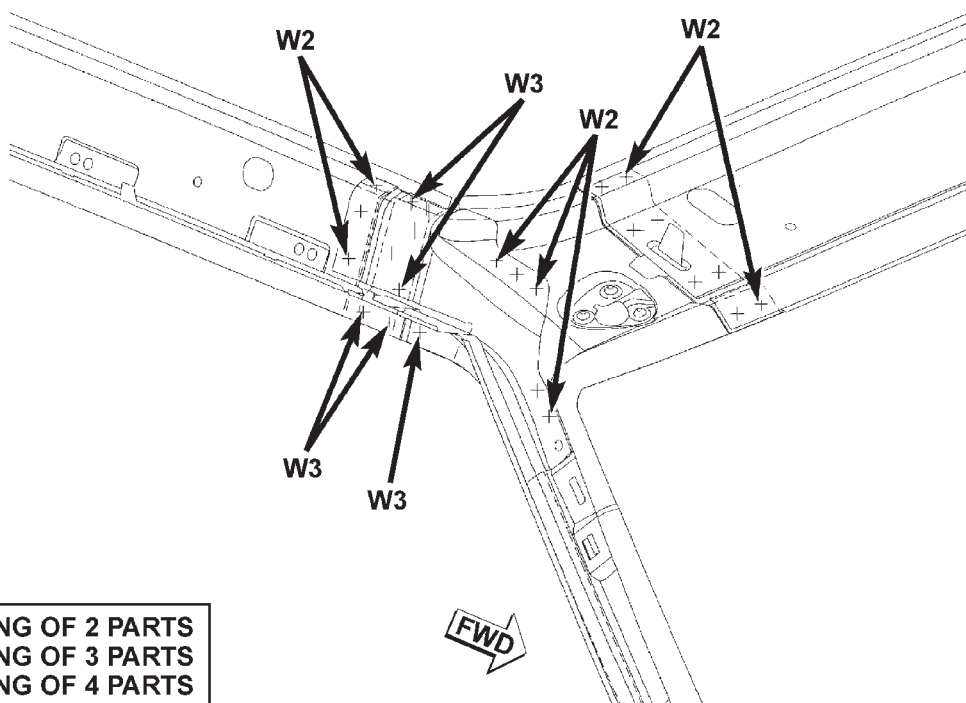
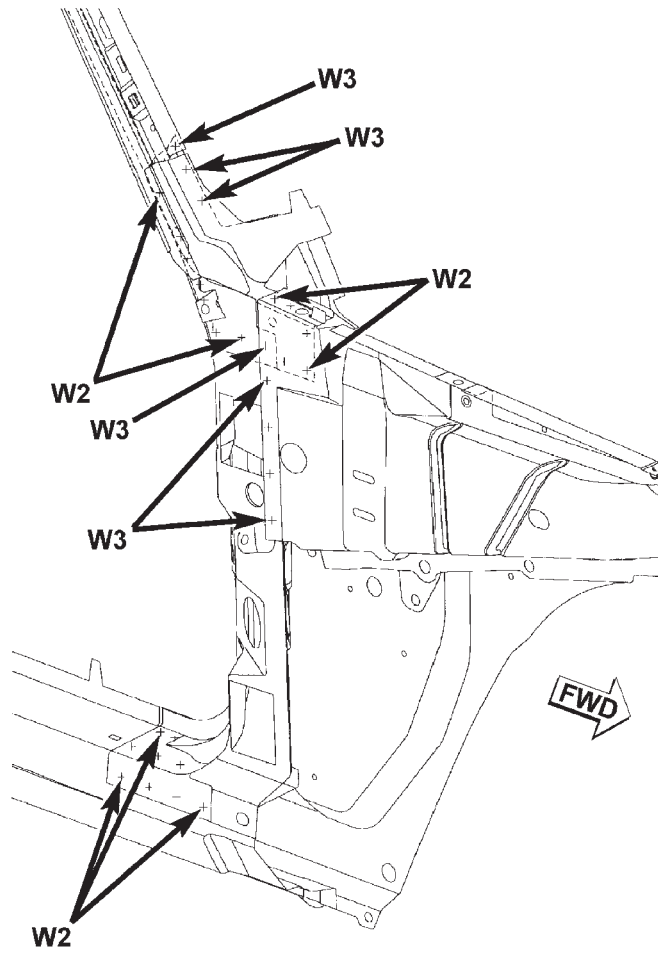

W2 - WELDING OF 2 PARTS
W3 - WELDING OF 3 PARTS
W4 - WELDING OF 4 PARTS

SPECIFICATIONS (Continued)

A—PILLAR

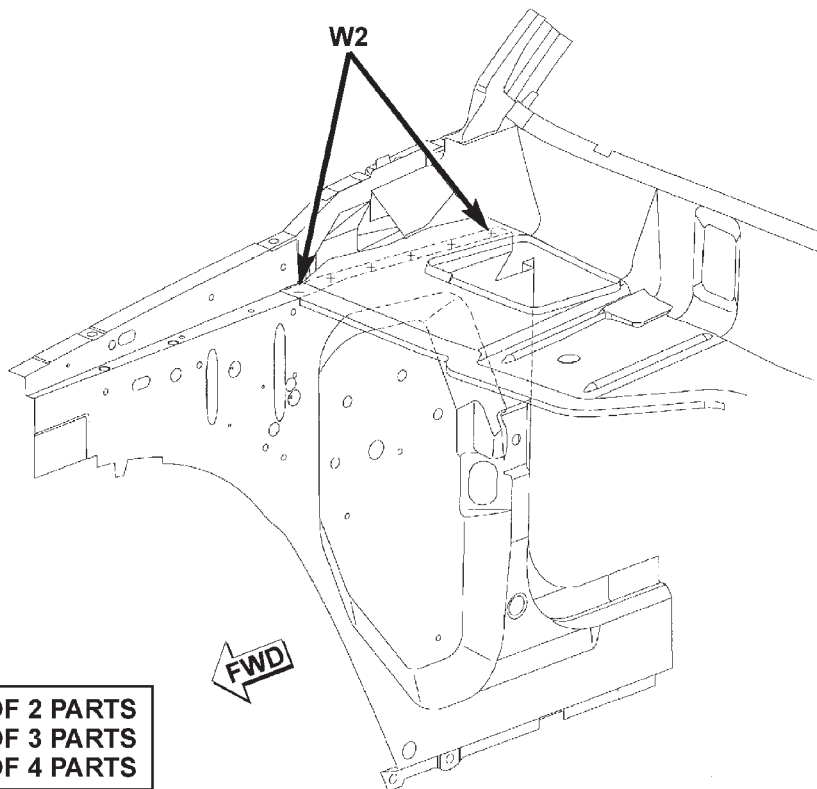
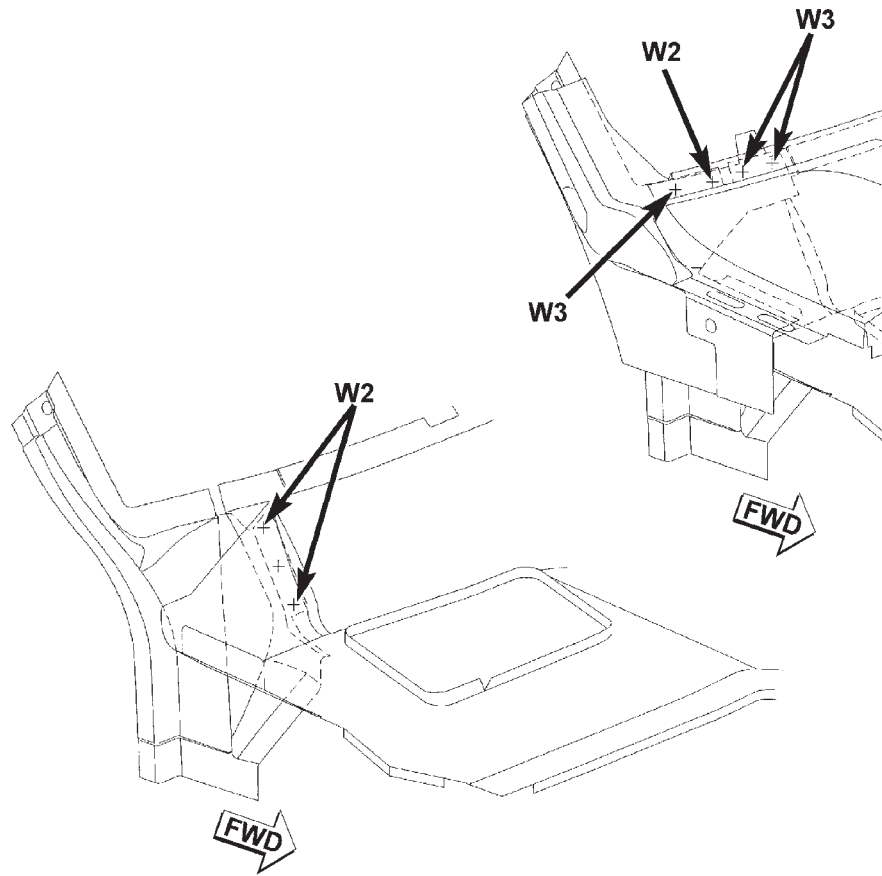

W2 - WELDING OF 2 PARTS
W3 - WELDING OF 3 PARTS
W4 - WELDING OF 4 PARTS

SPECIFICATIONS (Continued)

A—PILLAR

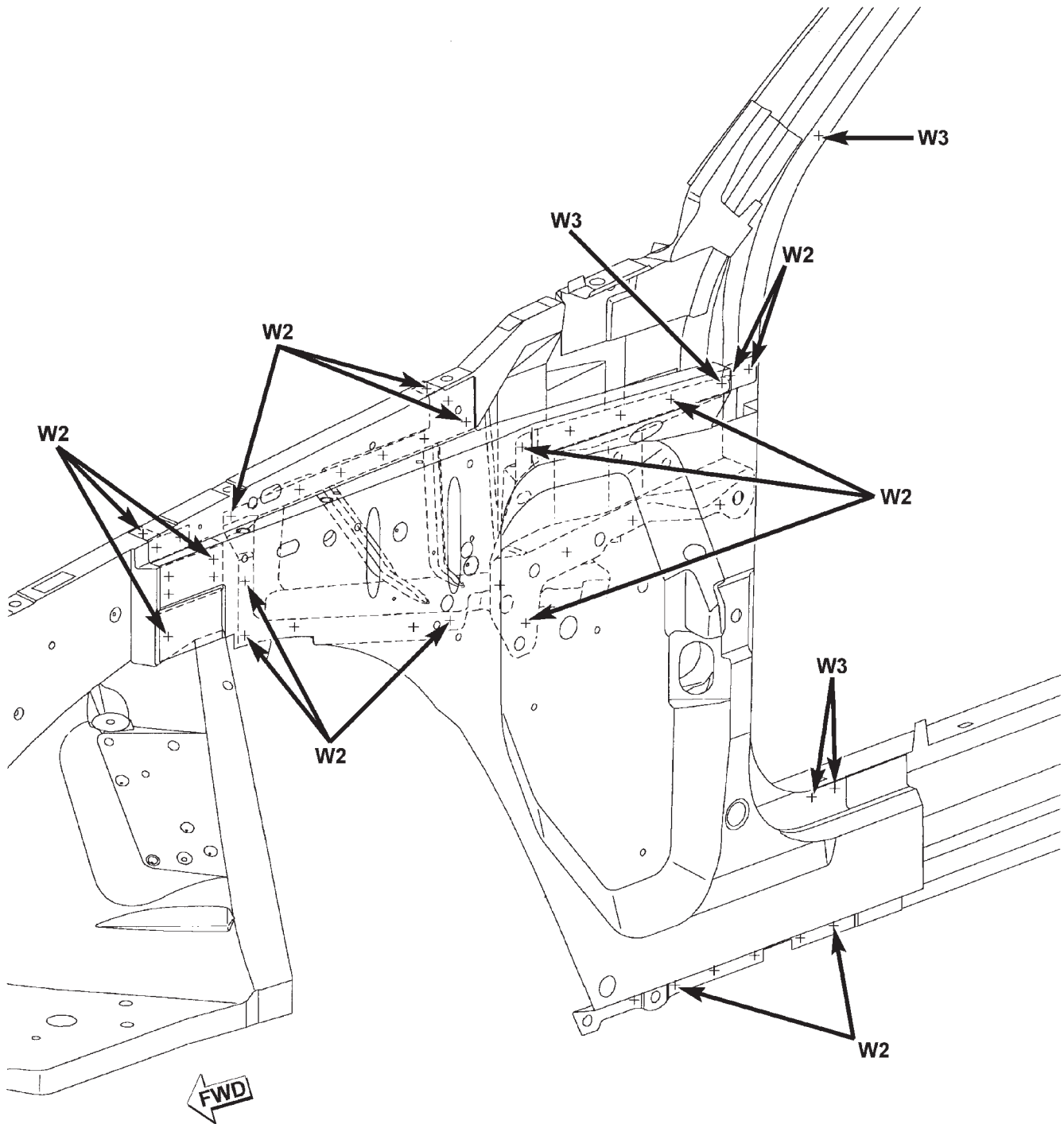

W2 - WELDING OF 2 PARTS
W3 - WELDING OF 3 PARTS
W4 - WELDING OF 4 PARTS

SPECIFICATIONS (Continued)

B—PILLAR

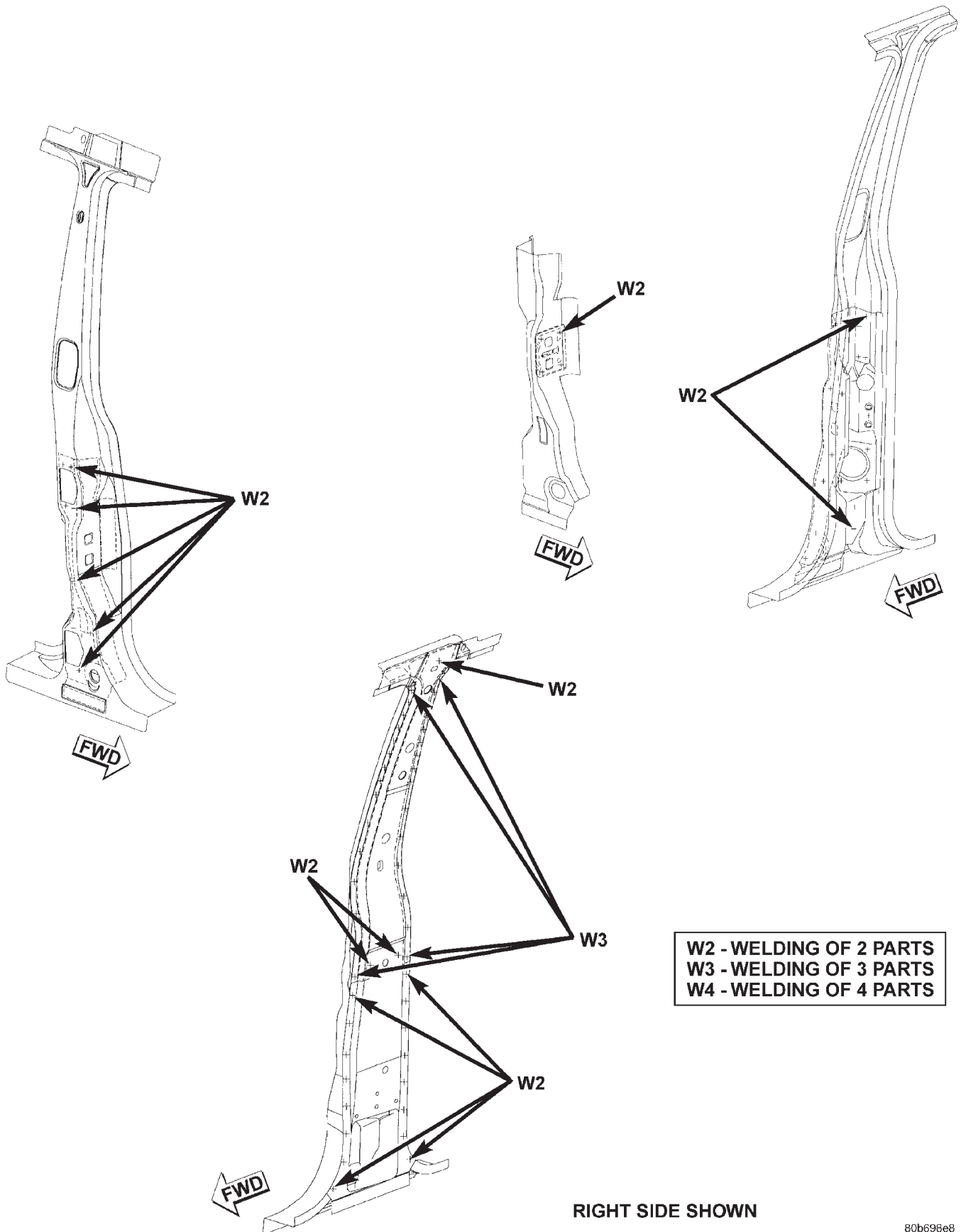

W2 - WELDING OF 2 PARTS
W3 - WELDING OF 3 PARTS
W4 - WELDING OF 4 PARTS

RIGHT SIDE SHOWN

SPECIFICATIONS (Continued)

D—PILLAR

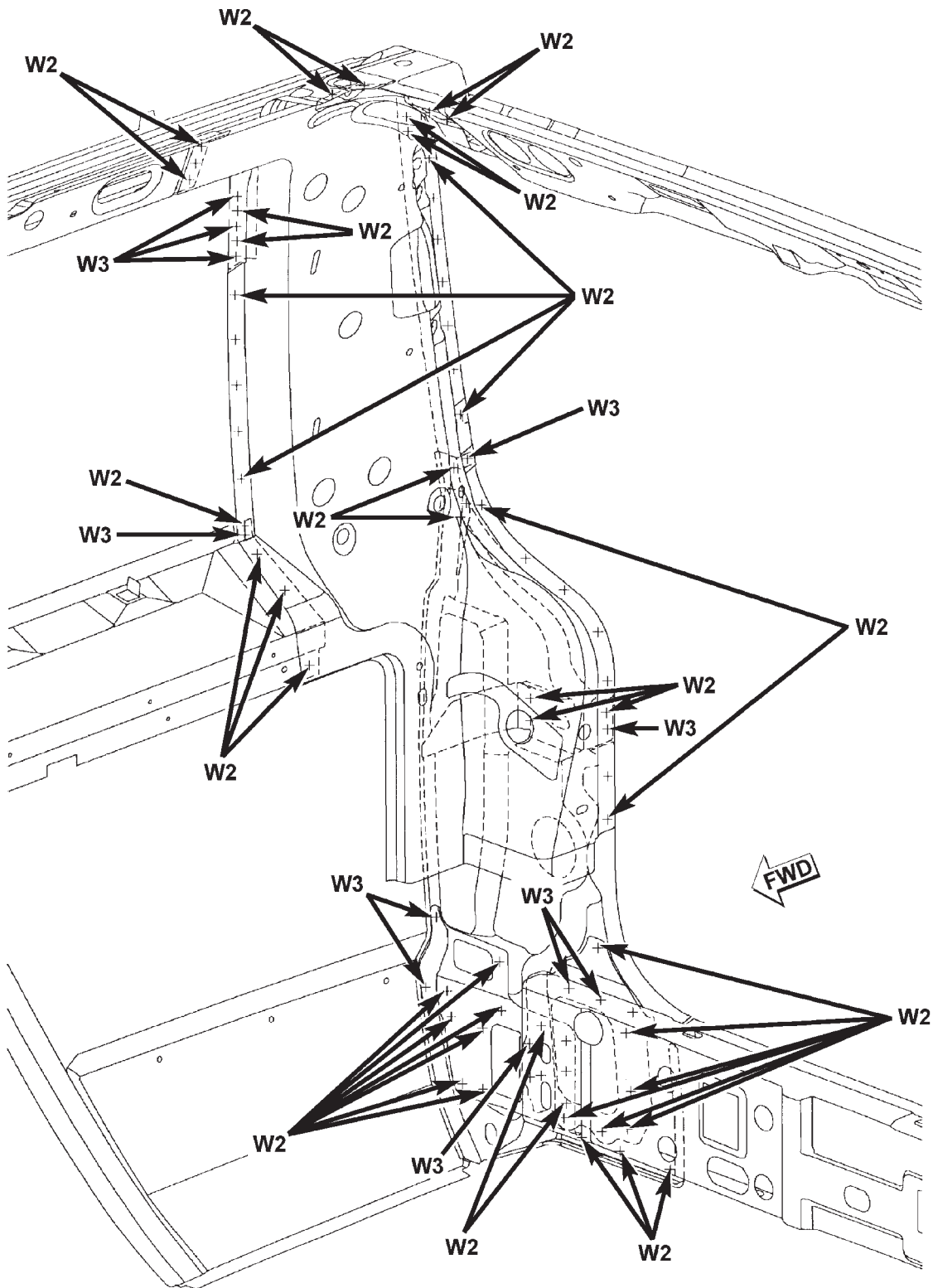

W2 - WELDING OF 2 PARTS
W3 - WELDING OF 3 PARTS
W4 - WELDING OF 4 PARTS

SPECIFICATIONS (Continued)

FUEL FILLER OPENING

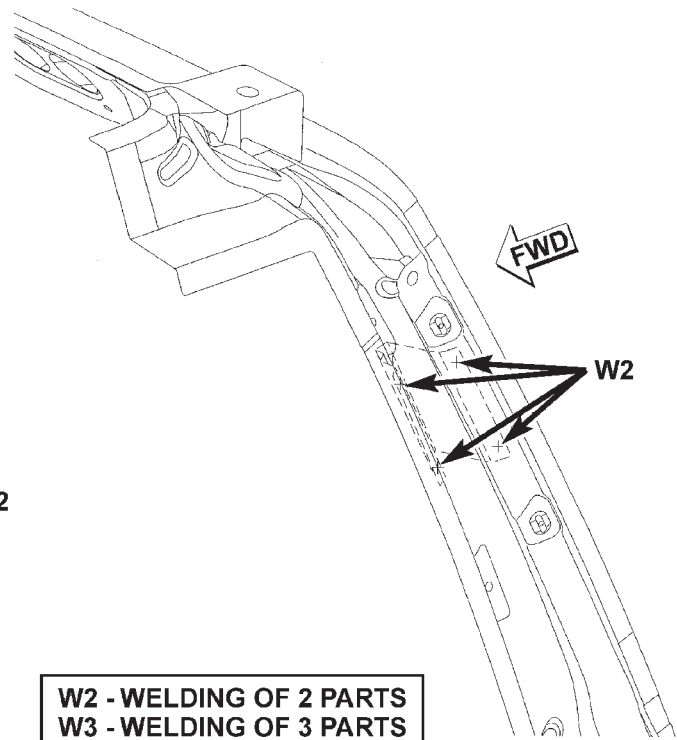
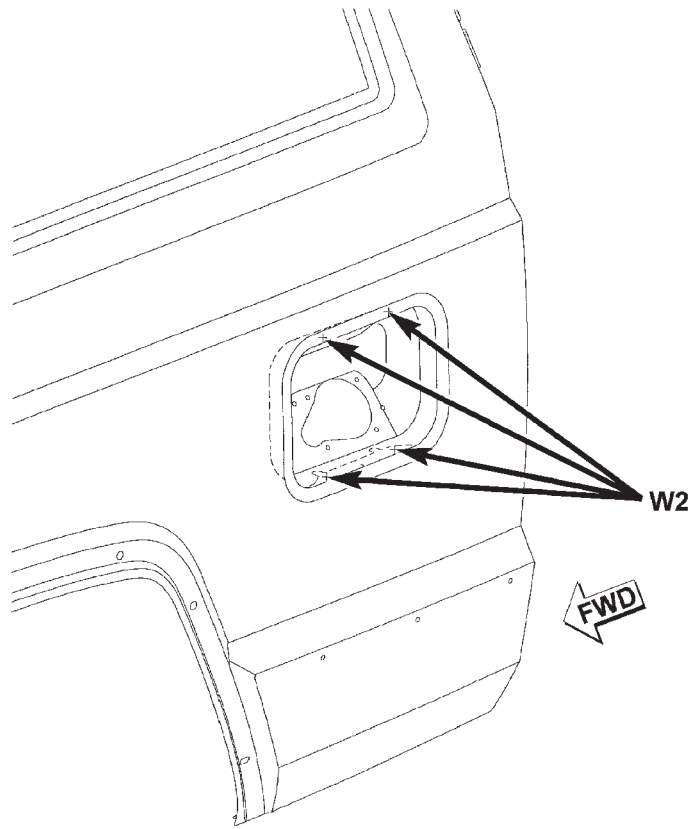

W2 - WELDING OF 2 PARTS
W3 - WELDING OF 3 PARTS
W4 - WELDING OF 4 PARTS

SPECIFICATIONS (Continued)

CARGO AREA FLOOR PAN

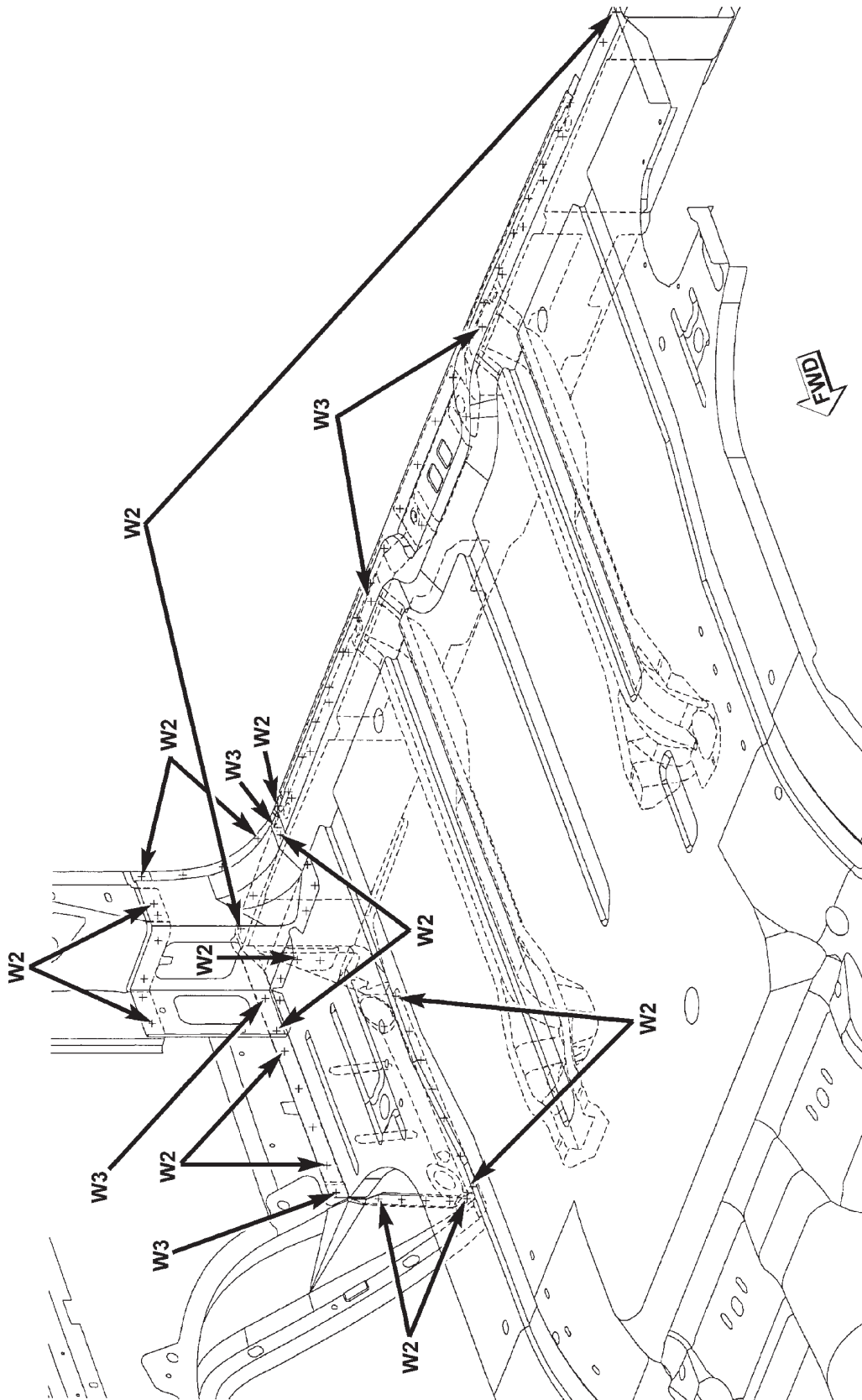

80b698eb

W2 - WELDING OF 2 PARTS
W3 - WELDING OF 3 PARTS
W4 - WELDING OF 4 PARTS

SPECIFICATIONS (Continued)

ROOF AND D—PILLAR

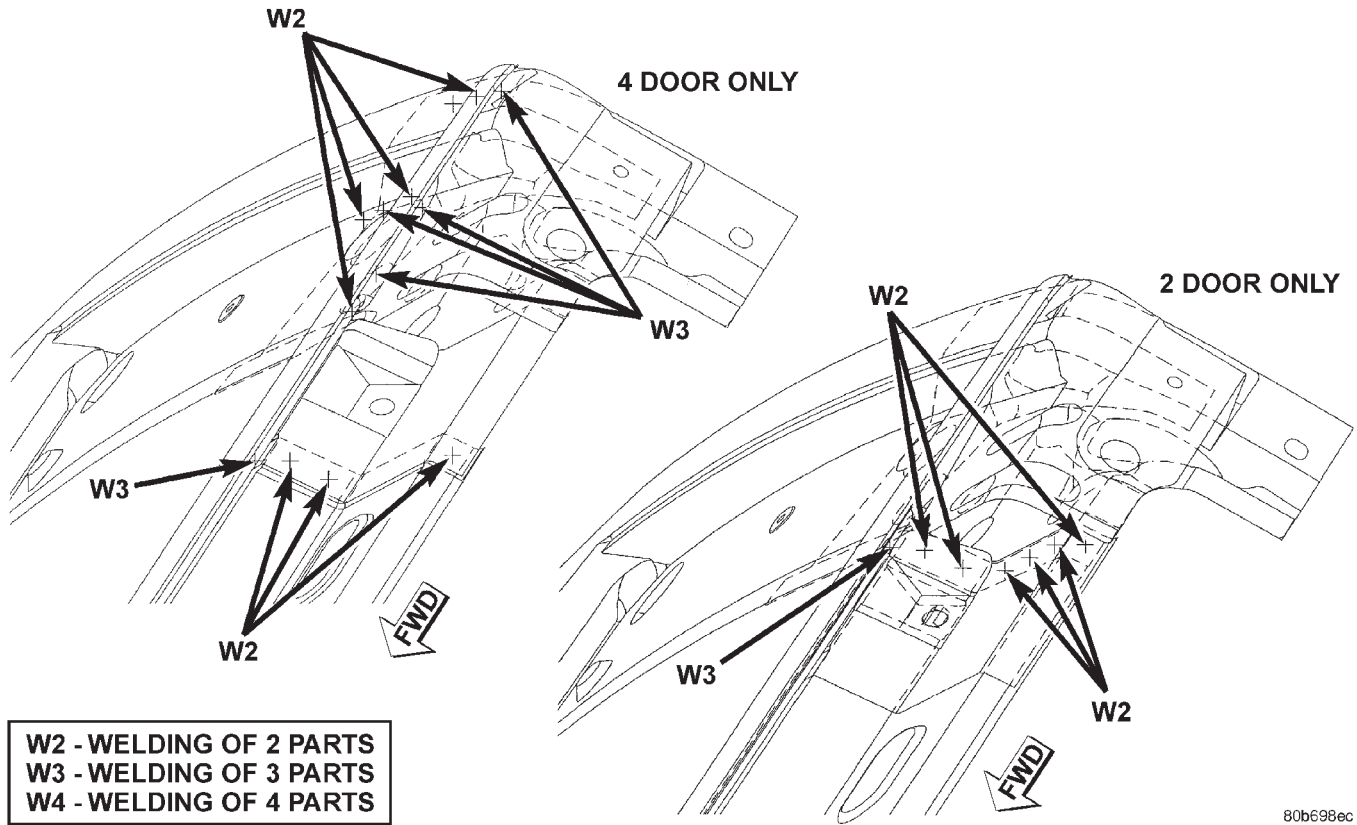

SPECIFICATIONS (Continued)

LIFTGATE OPENING

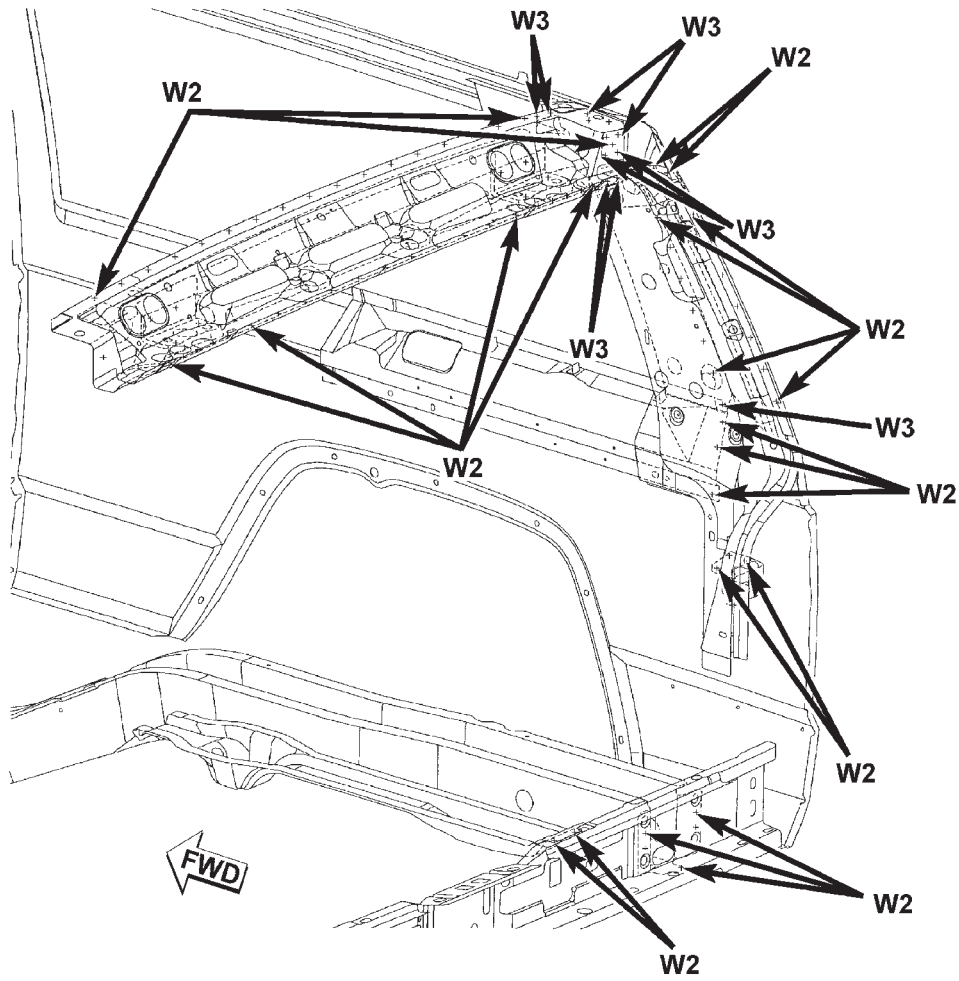

W2 - WELDING OF 2 PARTS
W3 - WELDING OF 3 PARTS
W4 - WELDING OF 4 PARTS

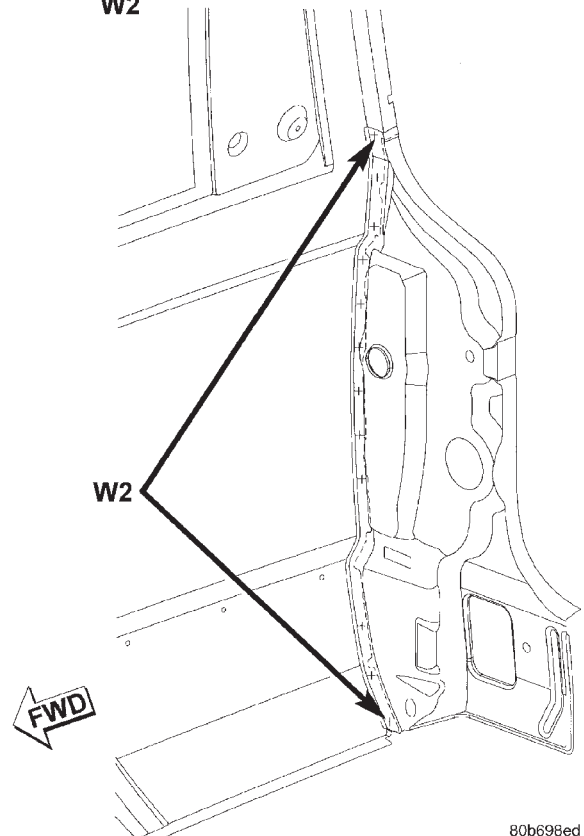

SPECIFICATIONS (Continued)

ROOF

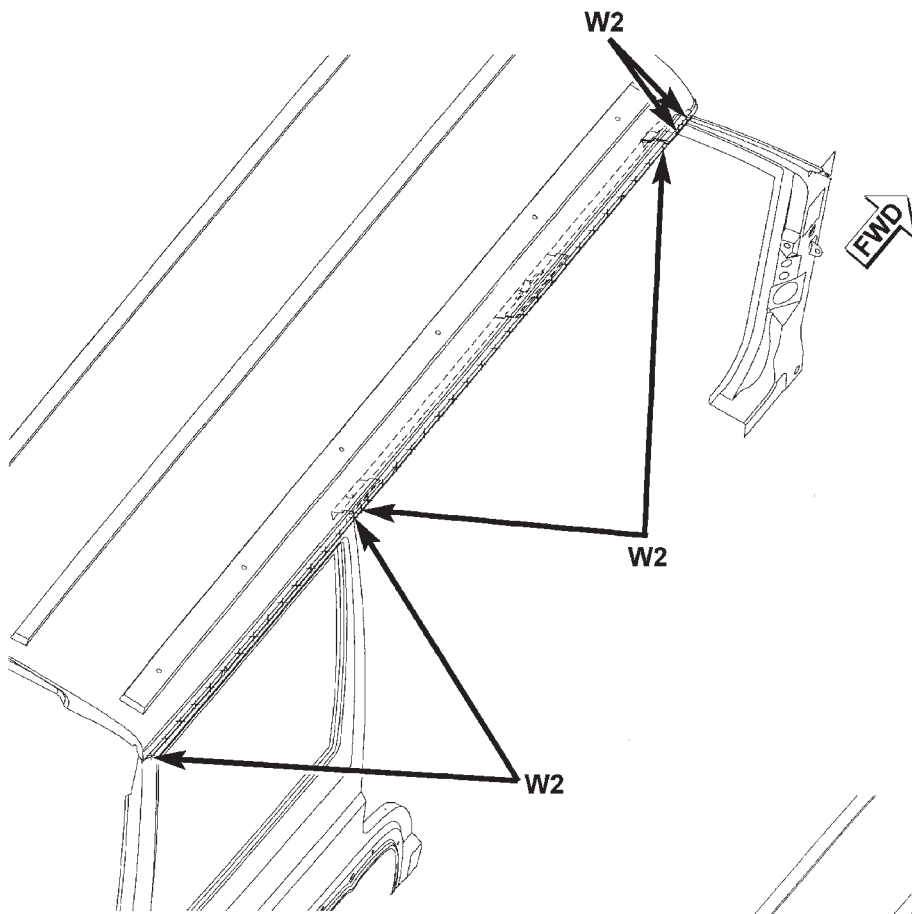

4 DOOR

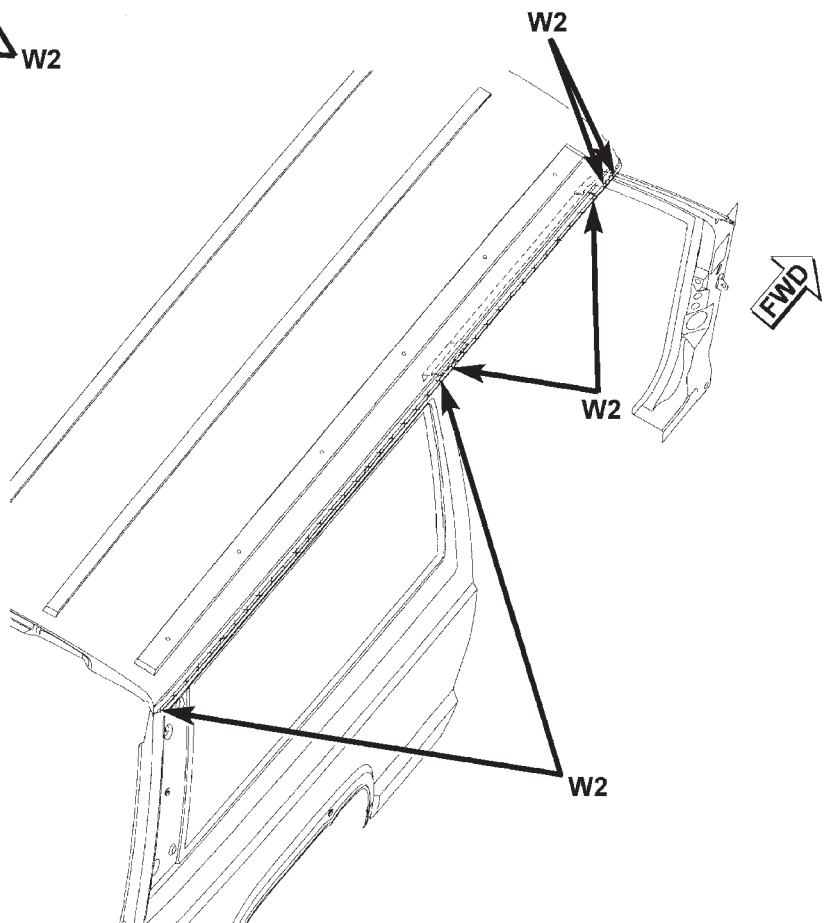

2 DOOR

W2 - WELDING OF 2 PARTS
W3 - WELDING OF 3 PARTS
W4 - WELDING OF 4 PARTS

SPECIFICATIONS (Continued)

ROOF

W2 - WELDING OF 2 PARTS
W3 - WELDING OF 3 PARTS
W4 - WELDING OF 4 PARTS

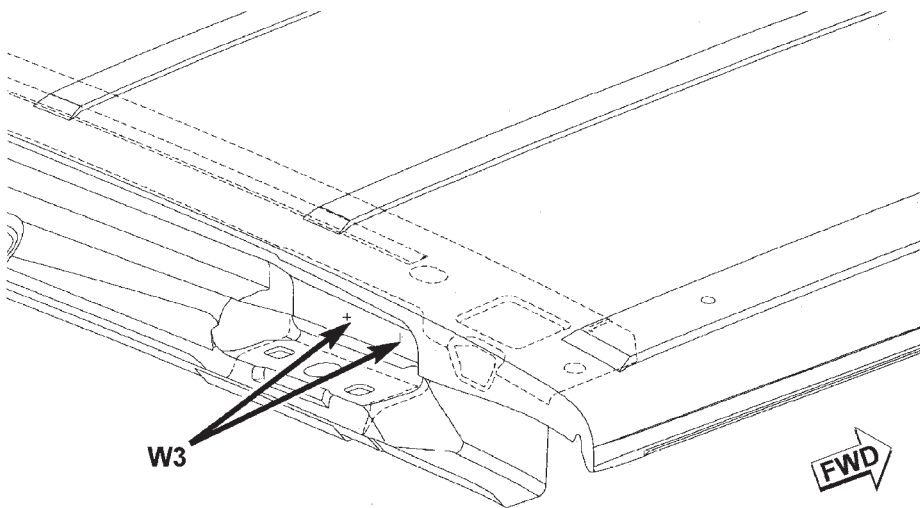
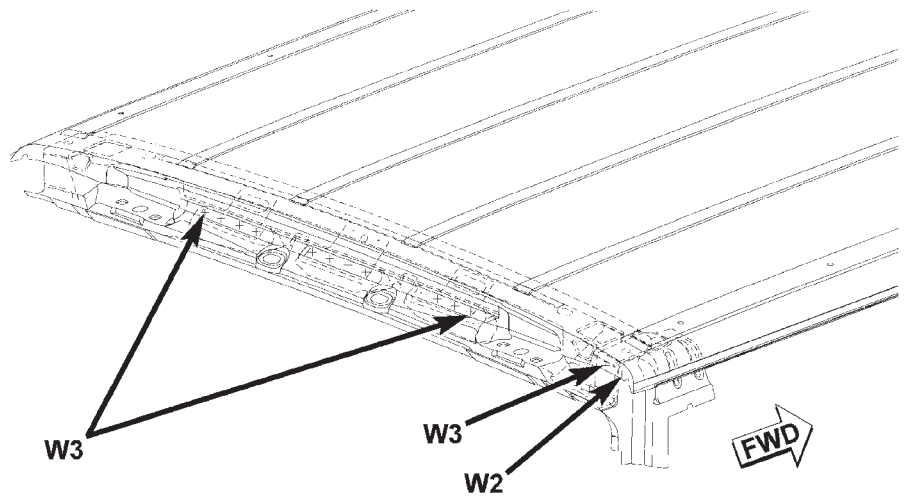
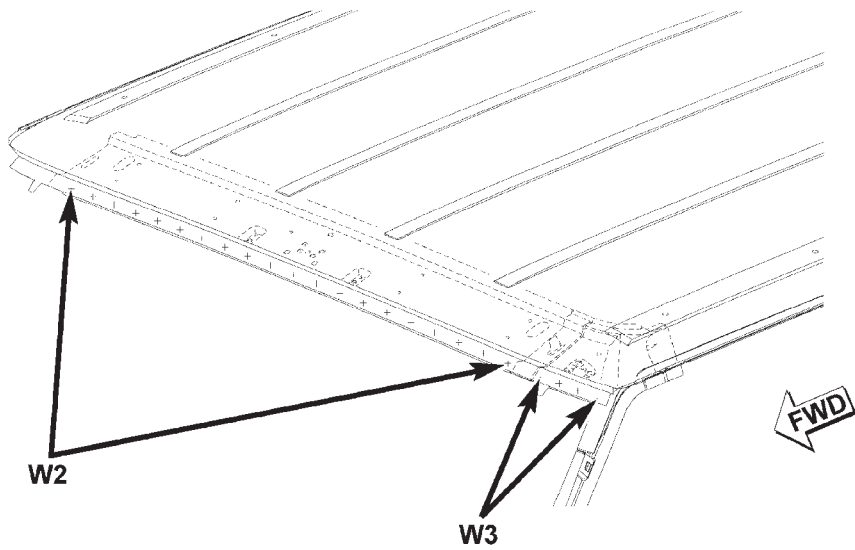

SPECIFICATIONS (Continued)

FRAME RAIL

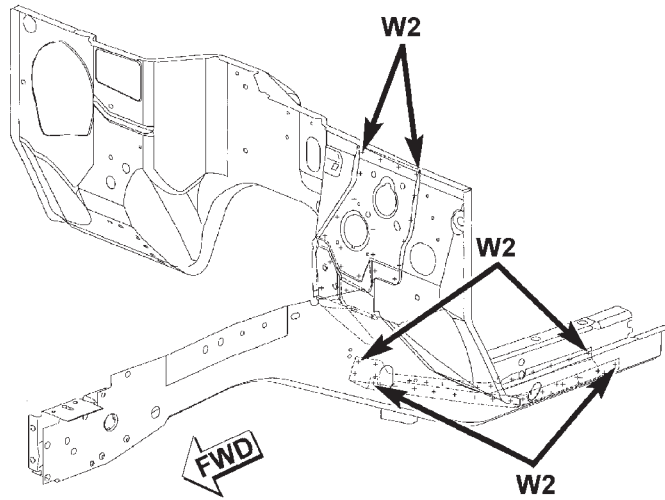

W2 - WELDING OF 2 PARTS
W3 - WELDING OF 3 PARTS
W4 - WELDING OF 4 PARTS

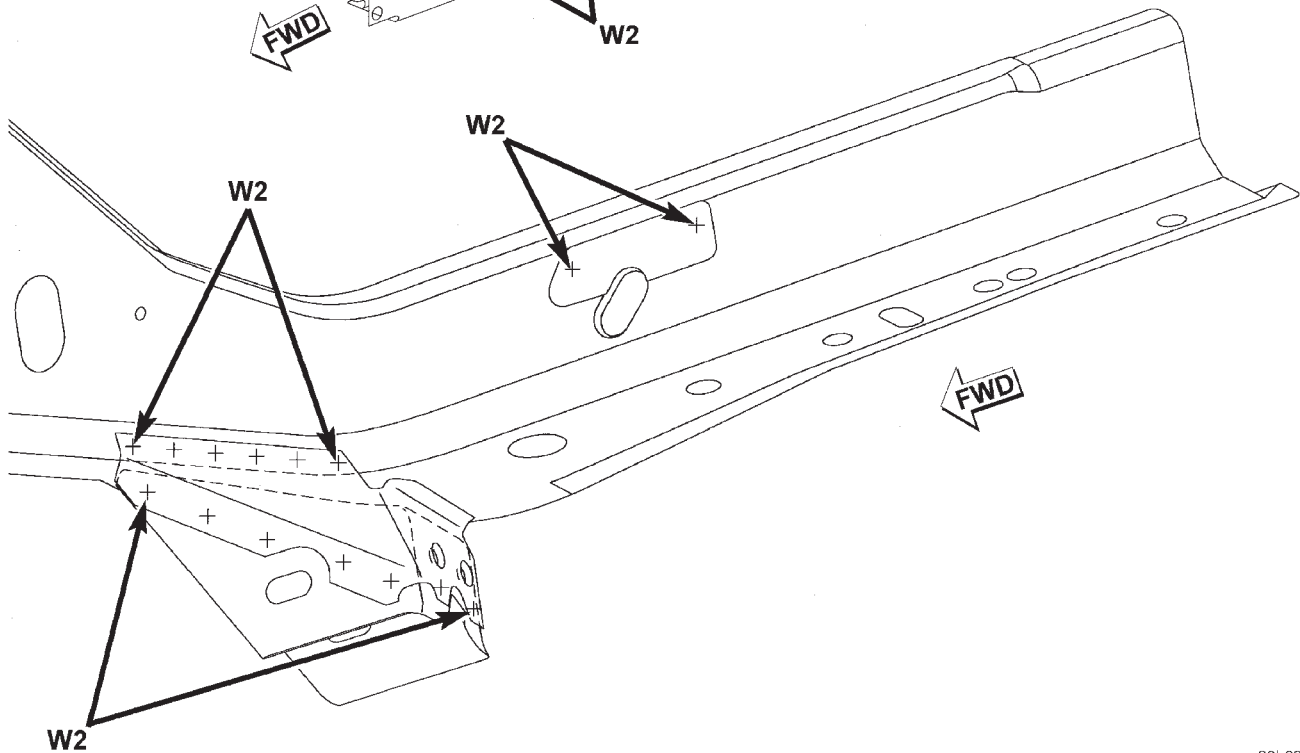
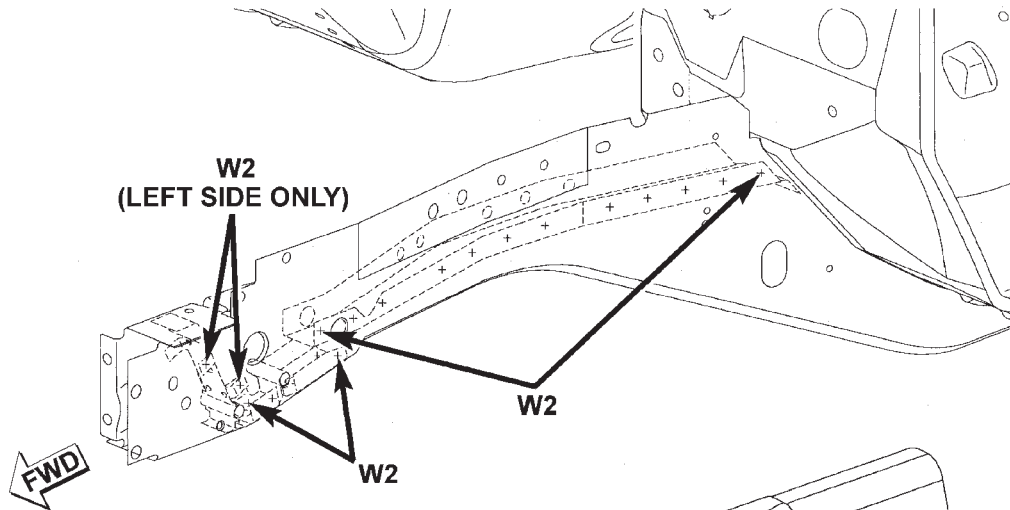

SPECIFICATIONS (Continued)

FRAME RAIL

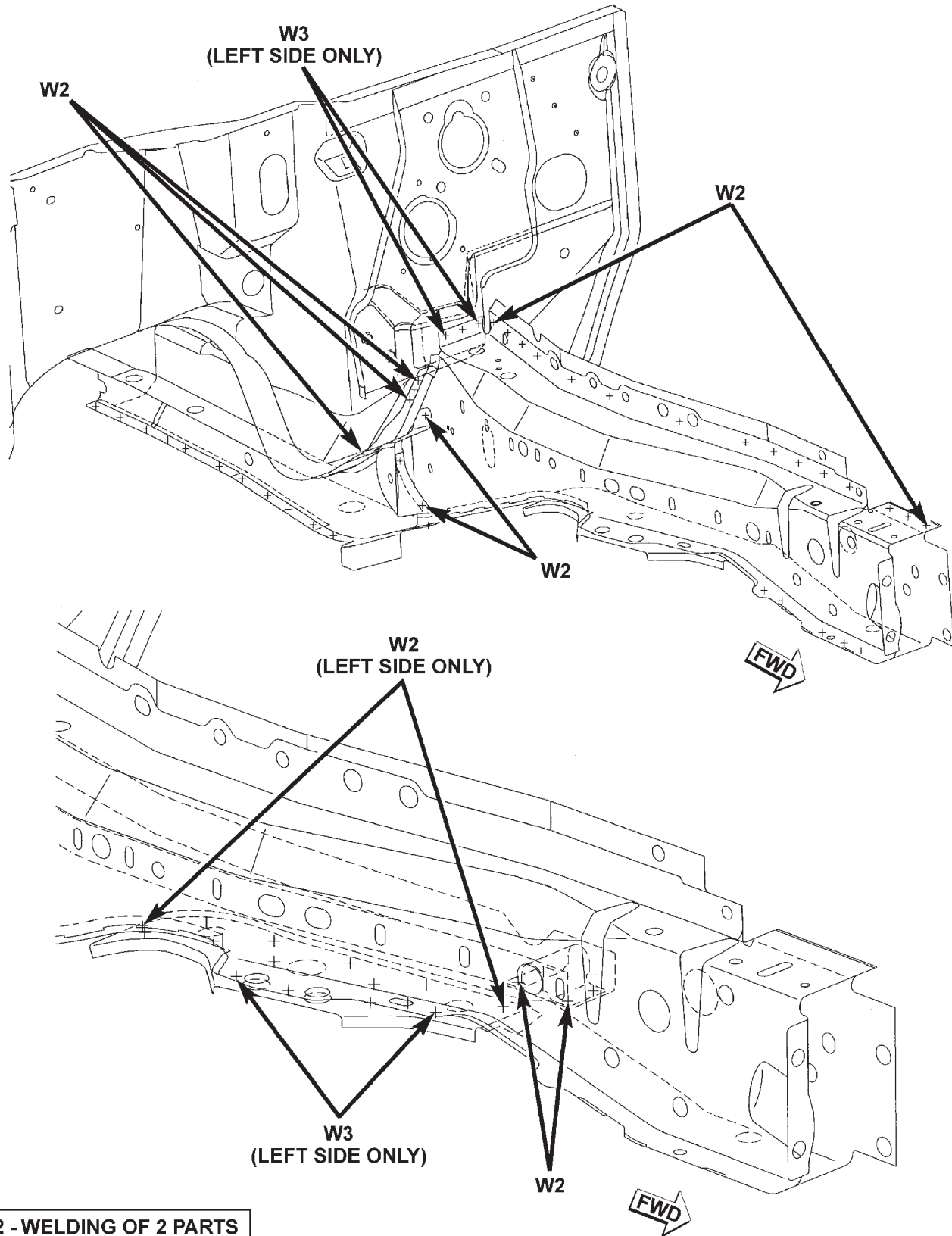

W2 - WELDING OF 2 PARTS
W3 - WELDING OF 3 PARTS
W4 - WELDING OF 4 PARTS

SPECIFICATIONS (Continued)

FRAME RAIL

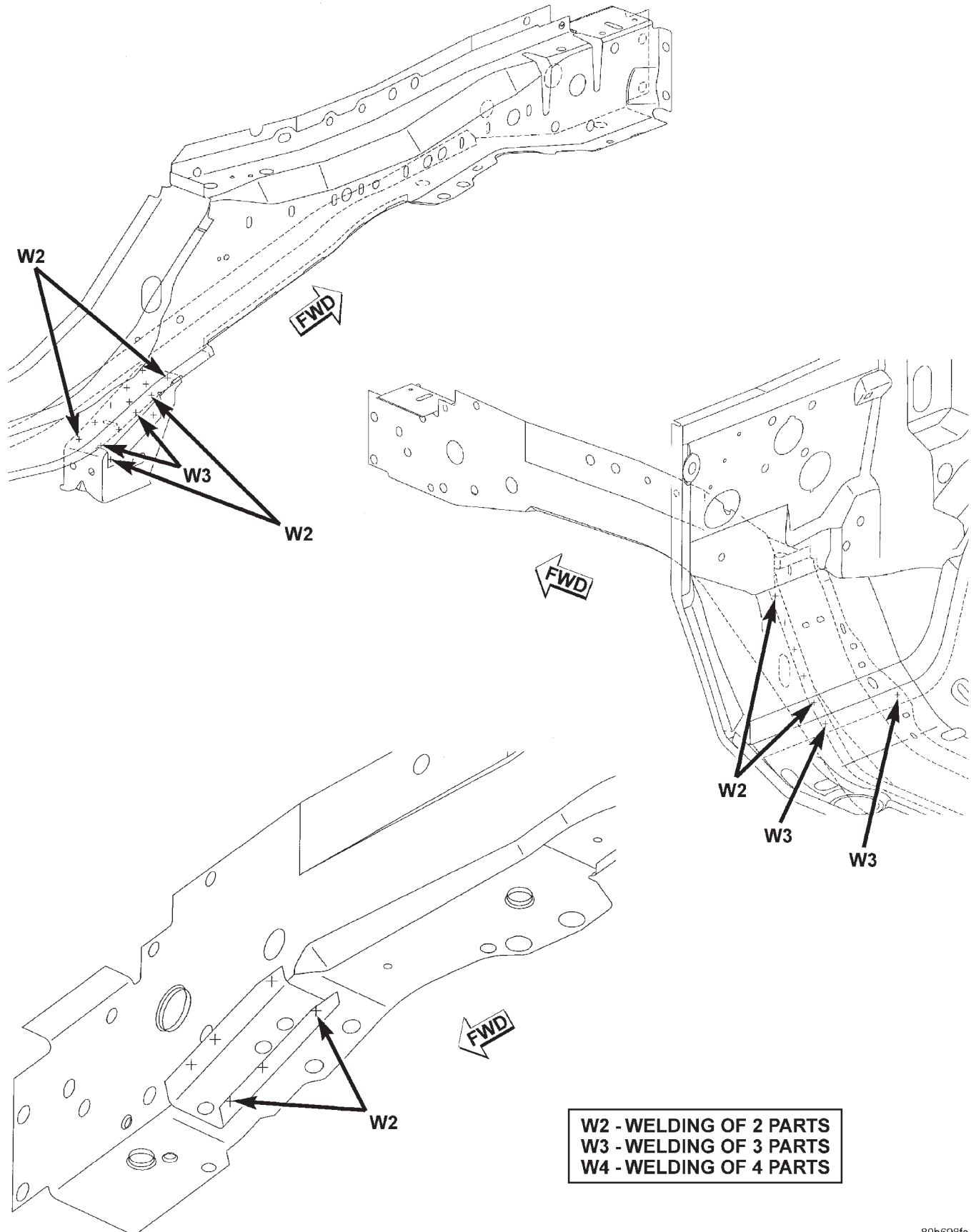

SPECIFICATIONS (Continued)

FRAME RAIL

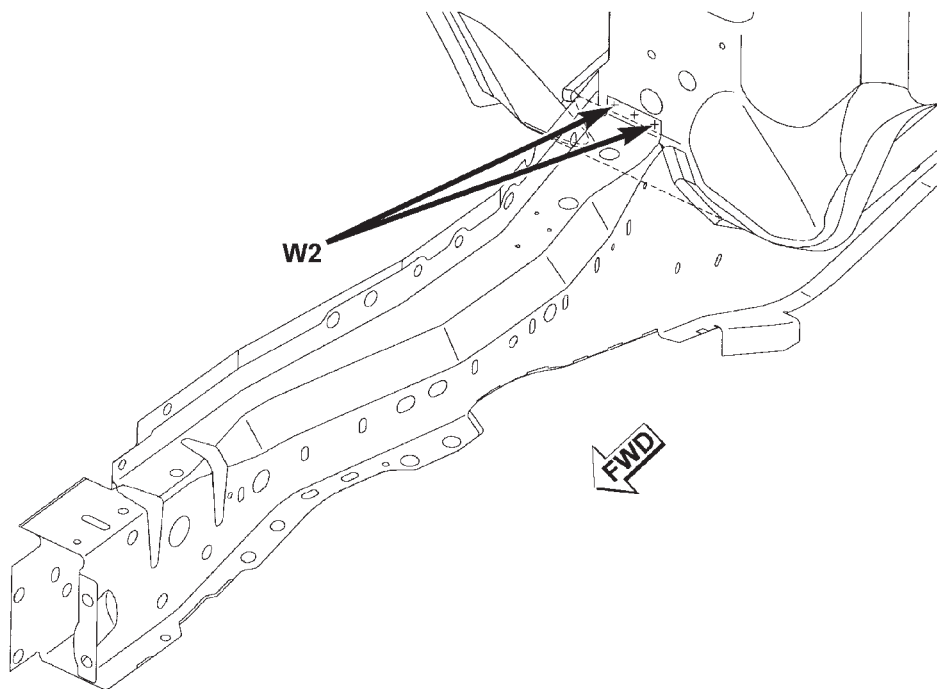
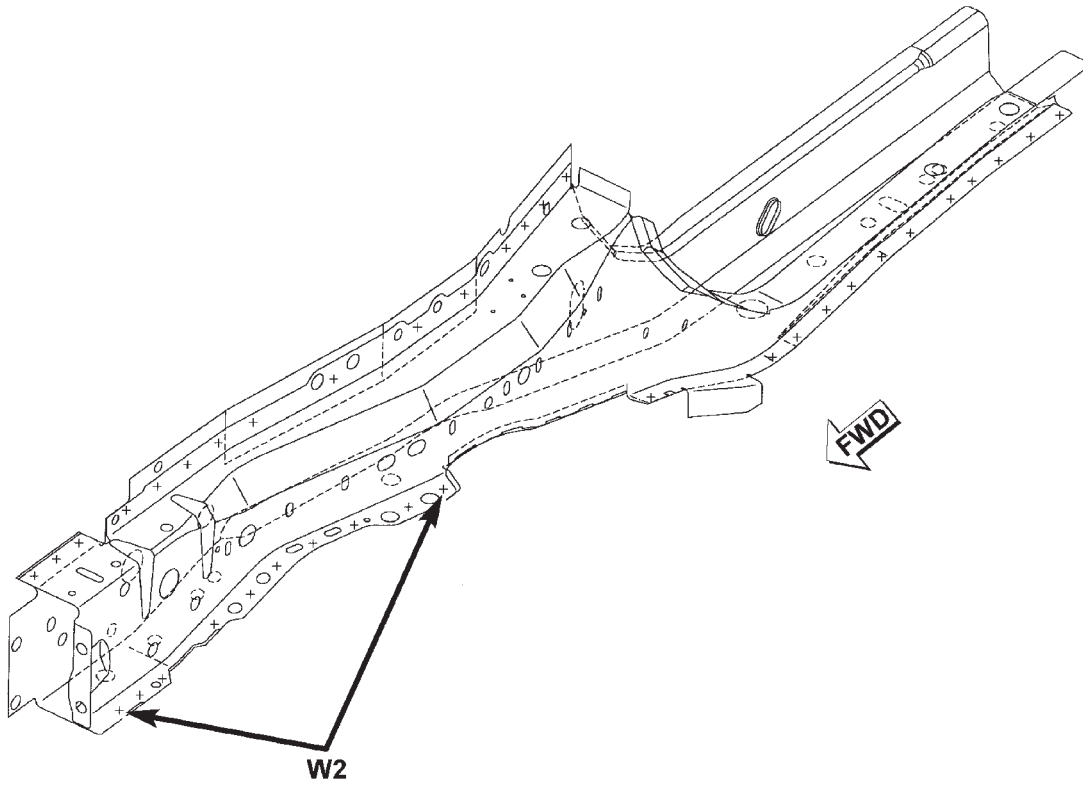

W2 - WELDING OF 2 PARTS
W3 - WELDING OF 3 PARTS
W4 - WELDING OF 4 PARTS

SPECIFICATIONS (Continued)

REINFORCEMENT

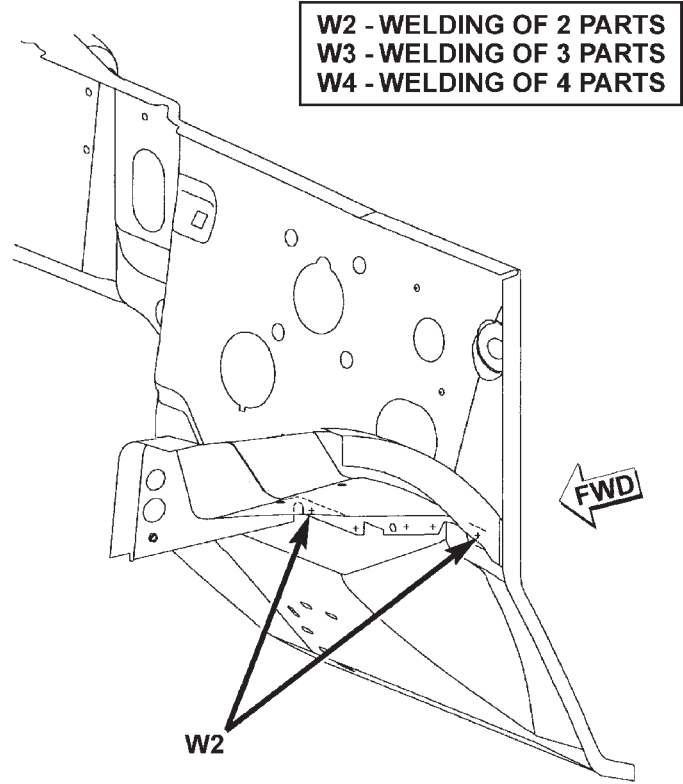
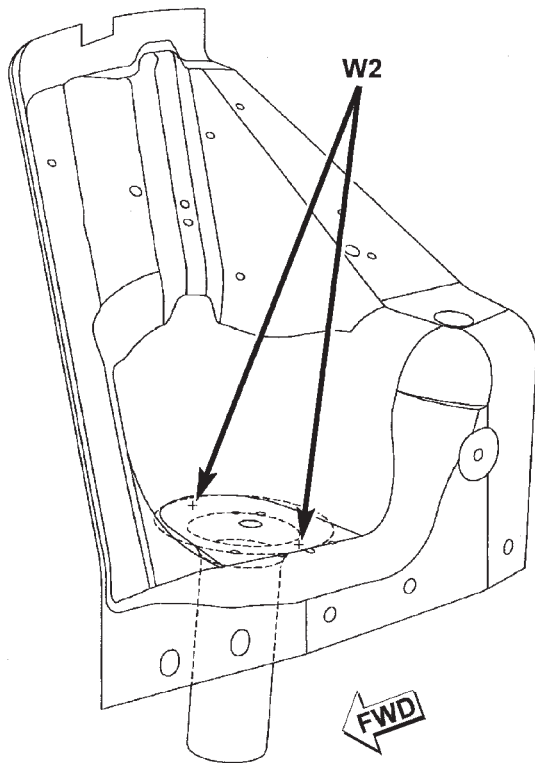

80b69900

SPECIFICATIONS (Continued)

FRONT INNER FENDER

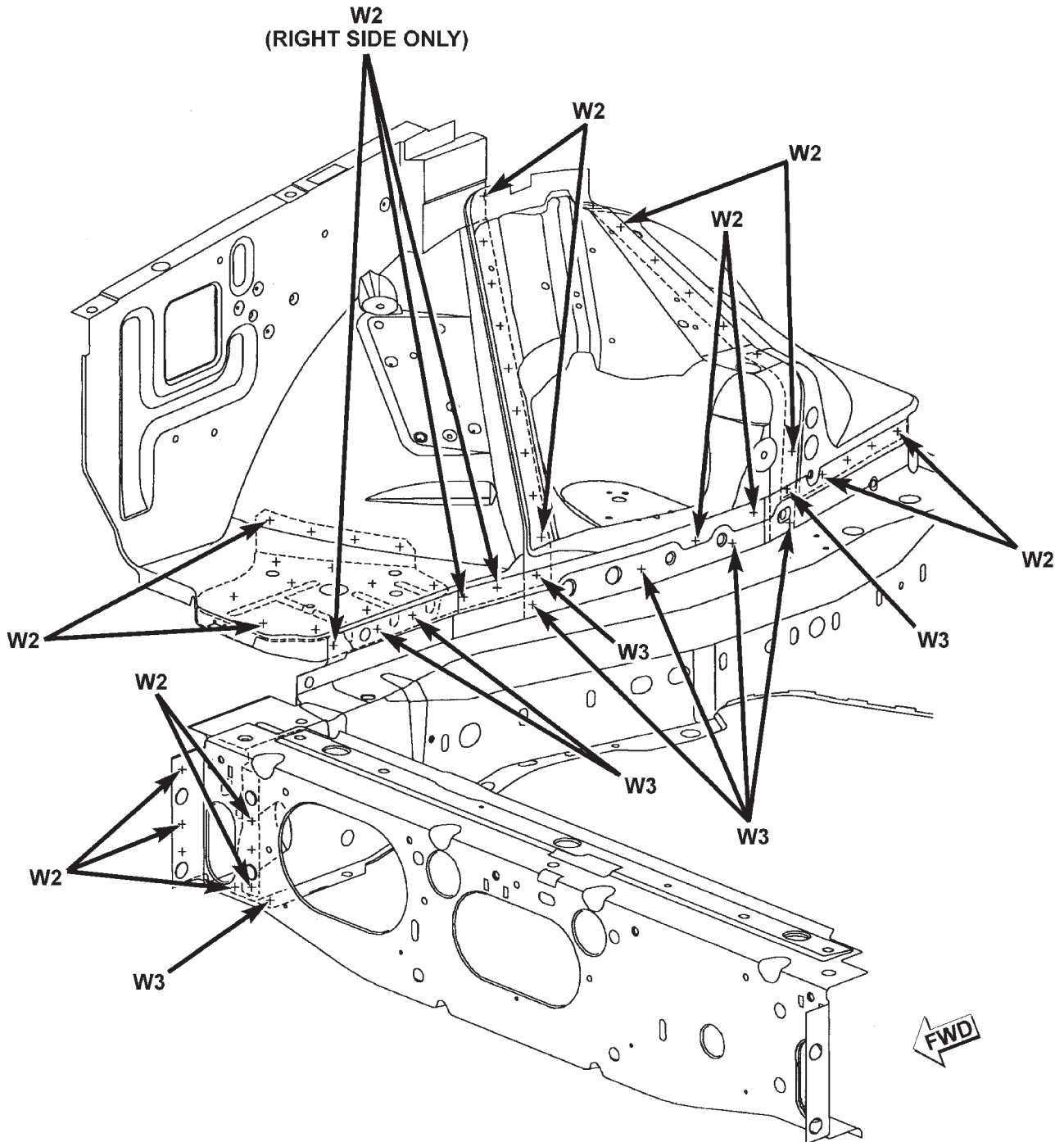

W2 - WELDING OF 2 PARTS
W3 - WELDING OF 3 PARTS
W4 - WELDING OF 4 PARTS

SPECIFICATIONS (Continued)

FRONT INNER FENDER AND RADIATOR CLOSURE
PANEL

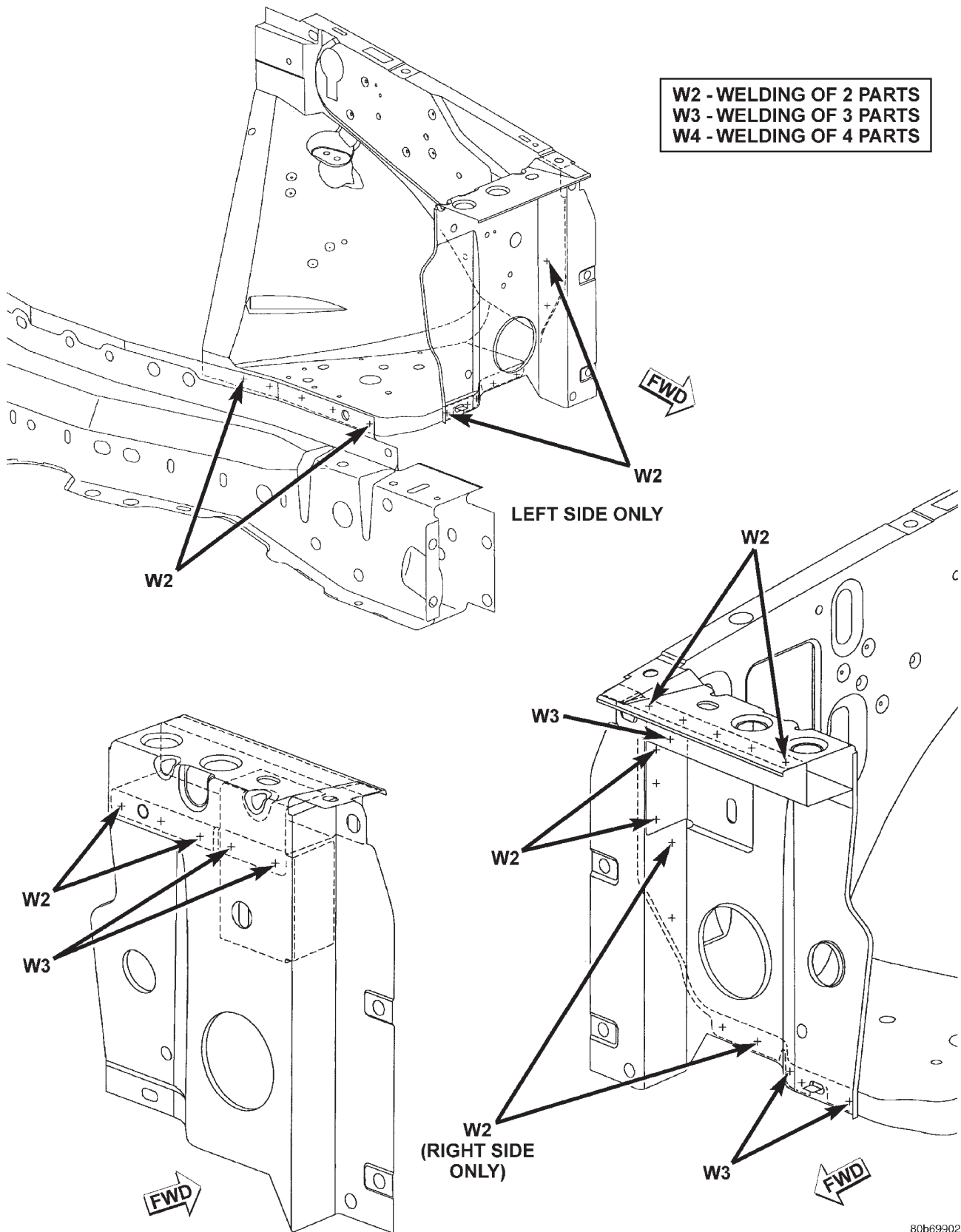

SPECIFICATIONS (Continued)

REINFORCEMENT

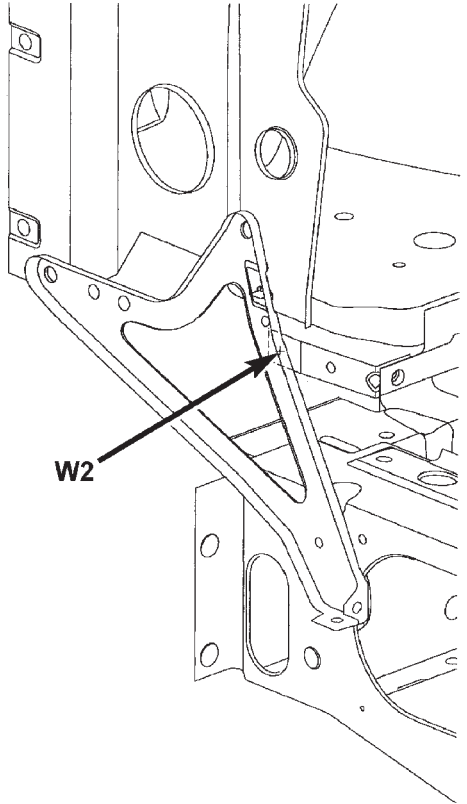

W2 - WELDING OF 2 PARTS
W3 - WELDING OF 3 PARTS
W4 - WELDING OF 4 PARTS

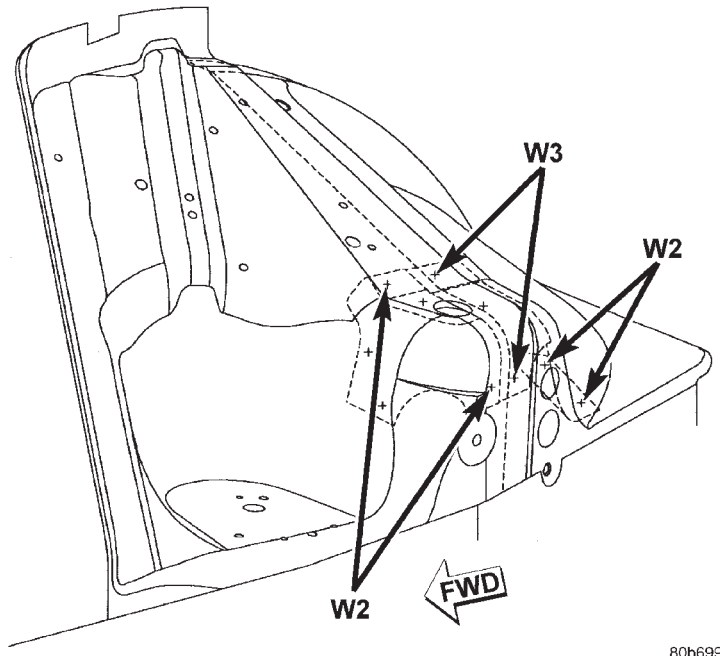

SPECIFICATIONS (Continued)

FRONT FENDER

W2 - WELDING OF 2 PARTS
W3 - WELDING OF 3 PARTS
W4 - WELDING OF 4 PARTS

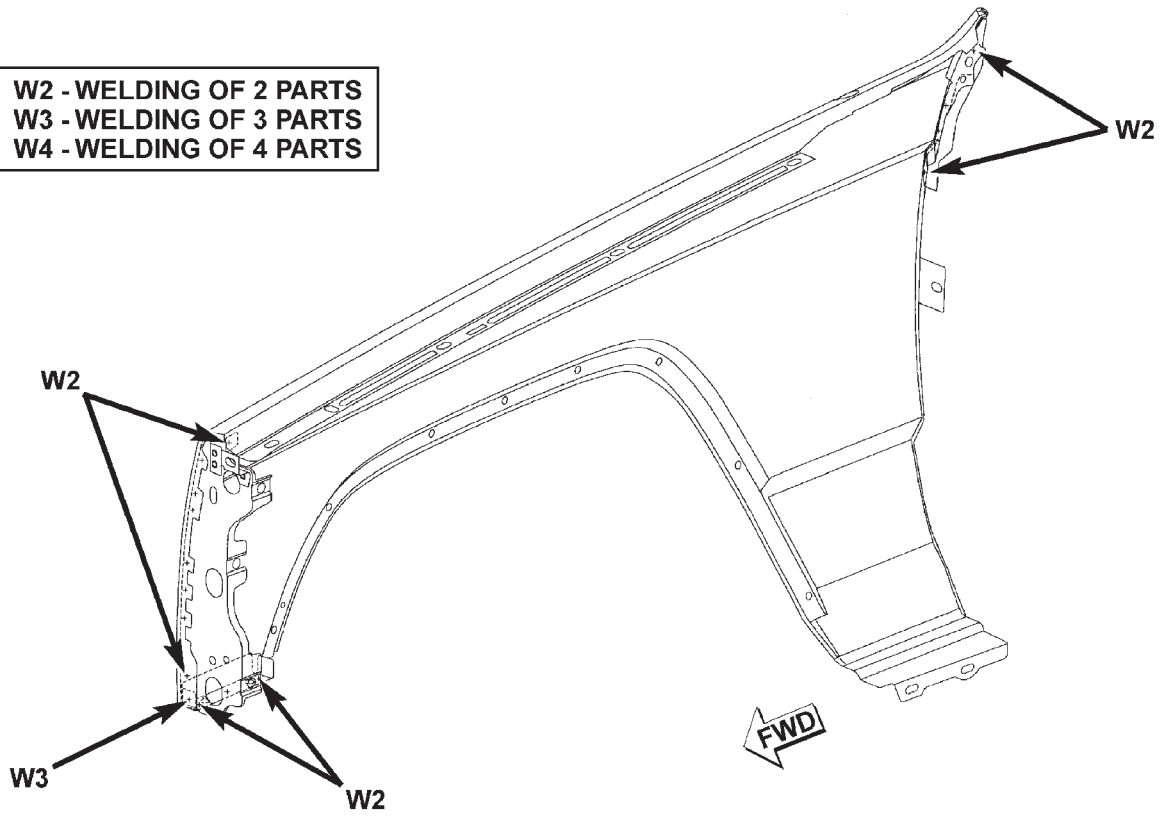

SPECIFICATIONS (Continued)

BODY SIDE

W2 - WELDING OF 2 PARTS
W3 - WELDING OF 3 PARTS
W4 - WELDING OF 4 PARTS

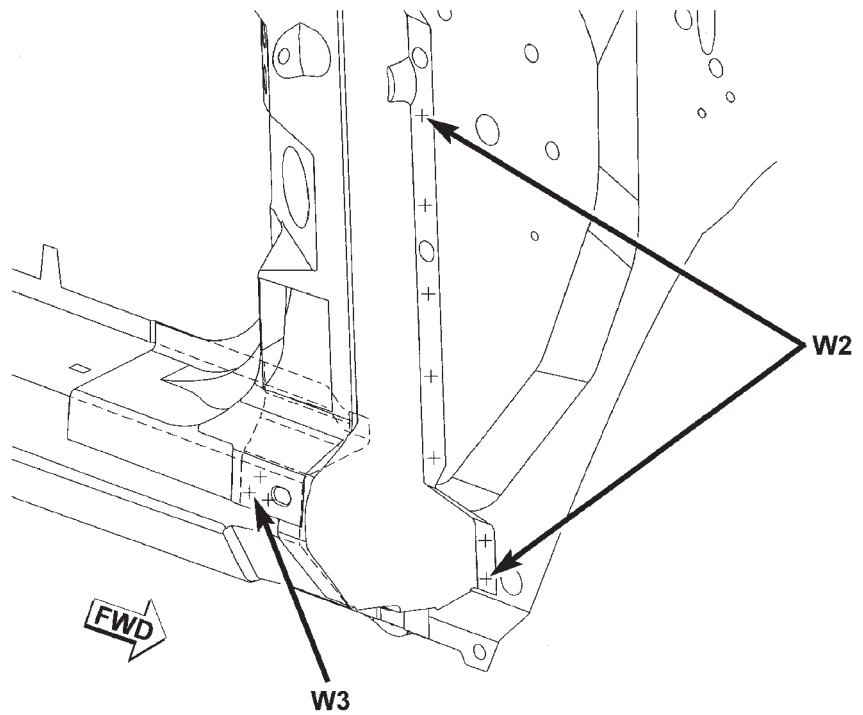
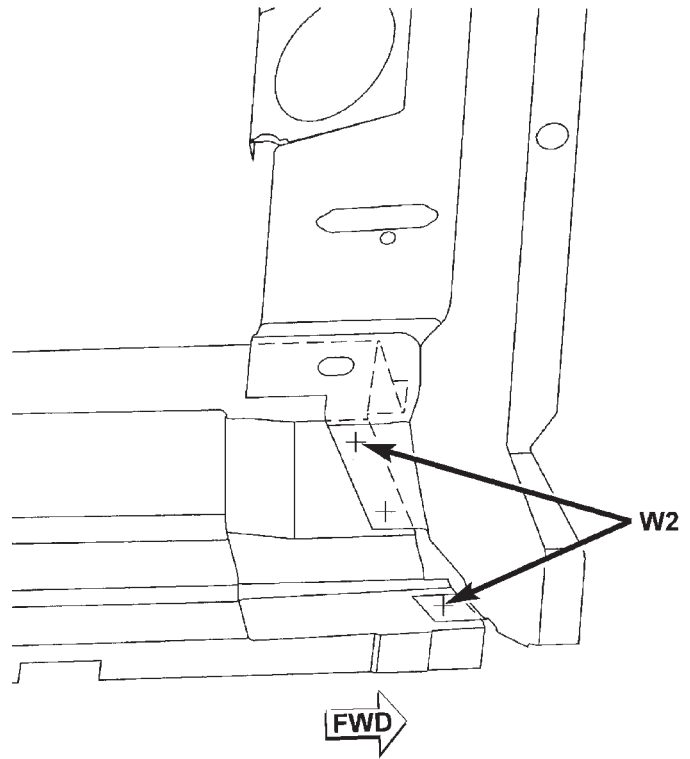
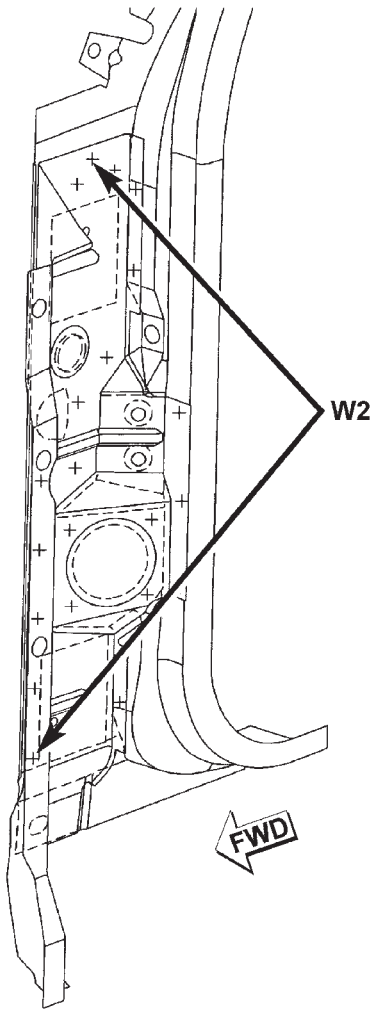

RIGHT SIDE SHOWN

SPECIFICATIONS (Continued)

REAR WHEELHOUSE

W2 - WELDING OF 2 PARTS
W3 - WELDING OF 3 PARTS
W4 - WELDING OF 4 PARTS

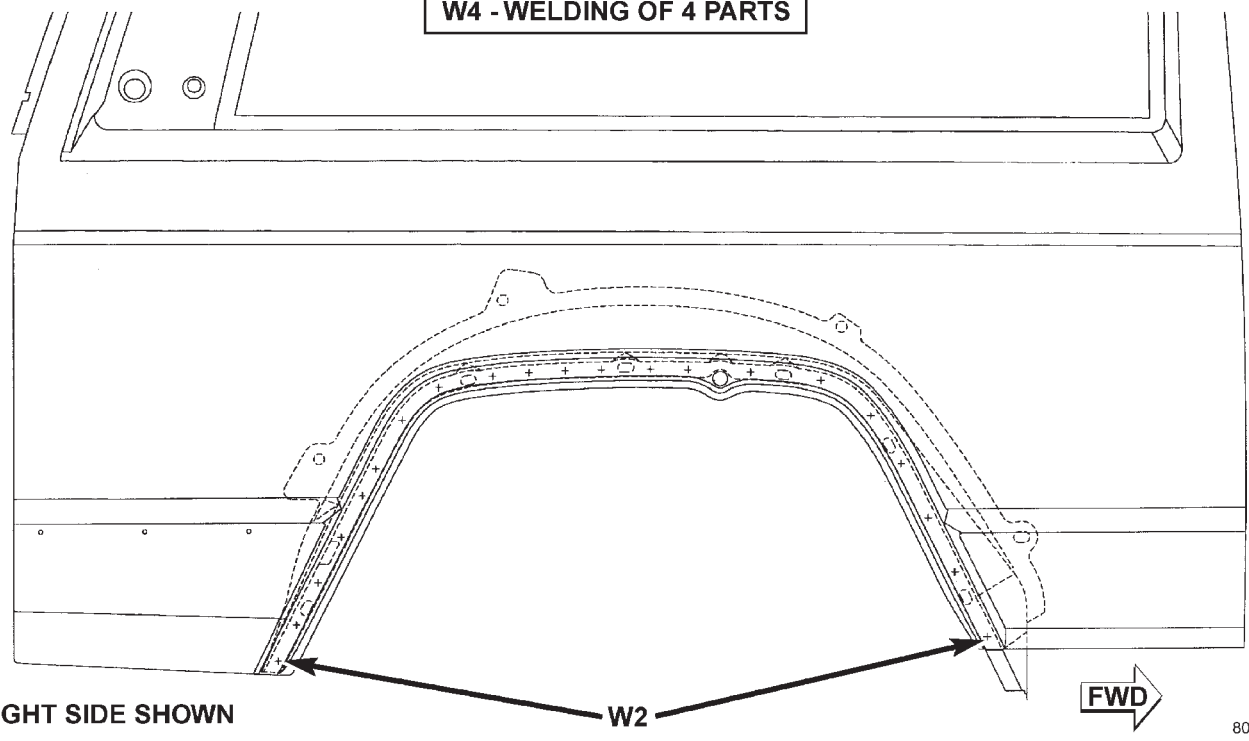

RIGHT SIDE SHOWN

W2



80b69906

SPECIFICATIONS (Continued)

REAR INNER WHEELHOUSE

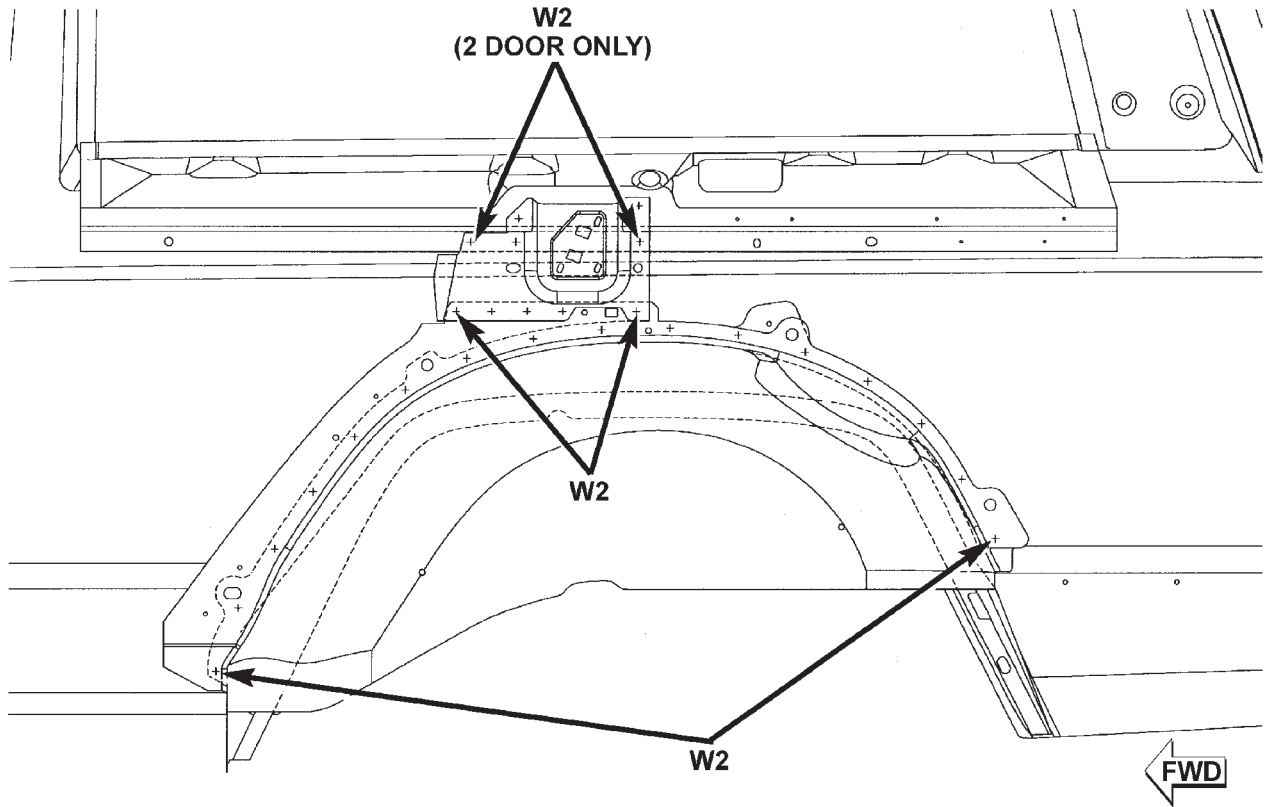

W2
(2 DOOR ONLY)

W2

W2

FWD

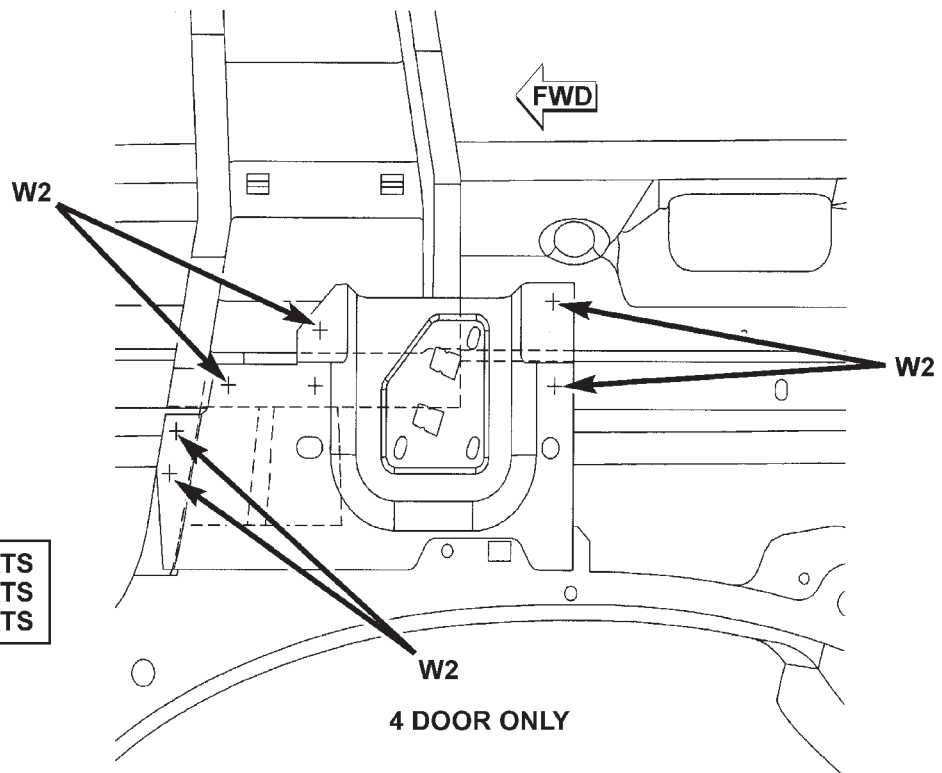

FWD

W2

W2

W2

4 DOOR ONLY

W2 - WELDING OF 2 PARTS
W3 - WELDING OF 3 PARTS
W4 - WELDING OF 4 PARTS

RIGHT SIDE SHOWN

SPECIFICATIONS (Continued)

BODY SIDE

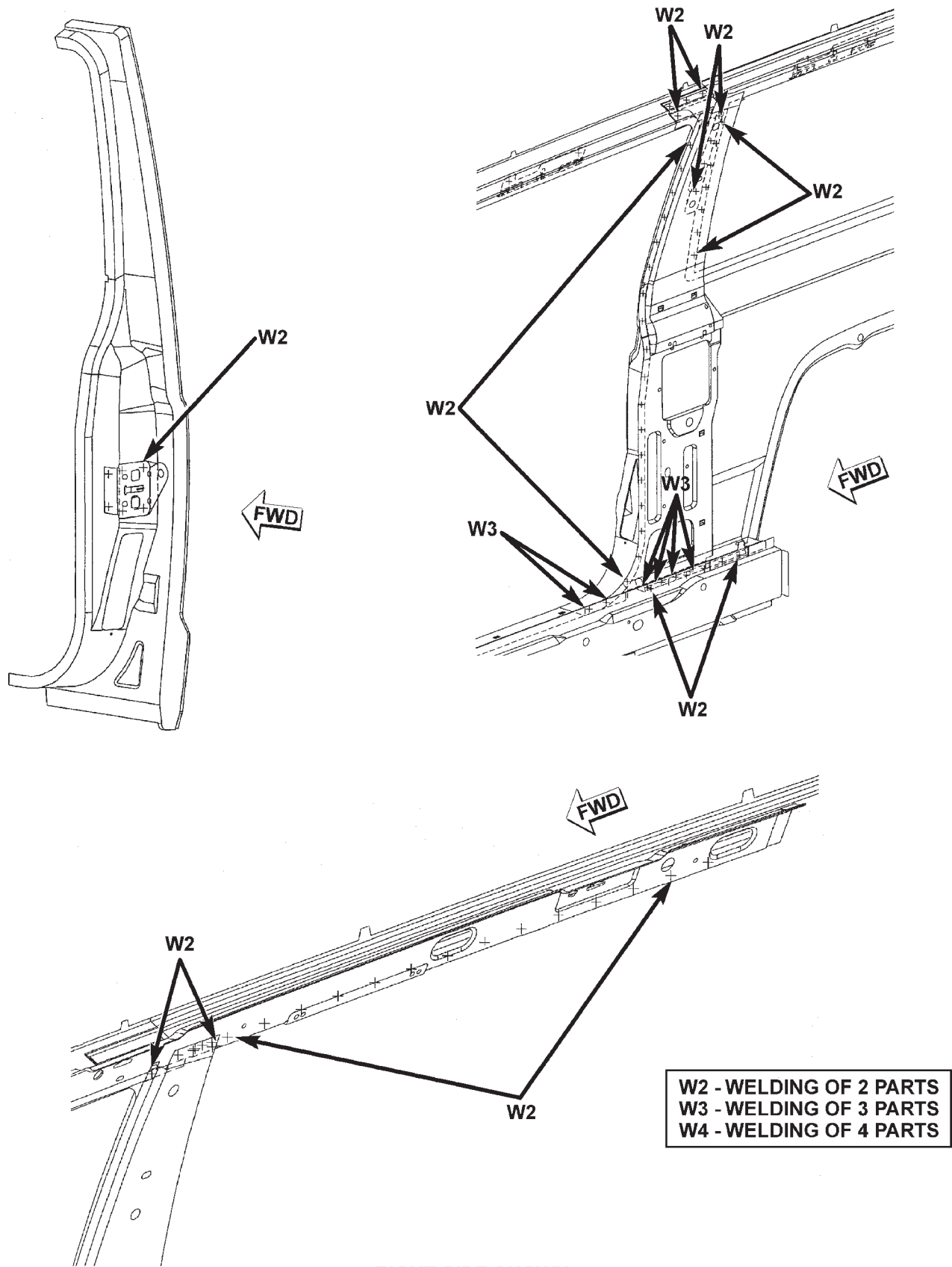

RIGHT SIDE SHOWN

SPECIFICATIONS (Continued)

BODY SIDE

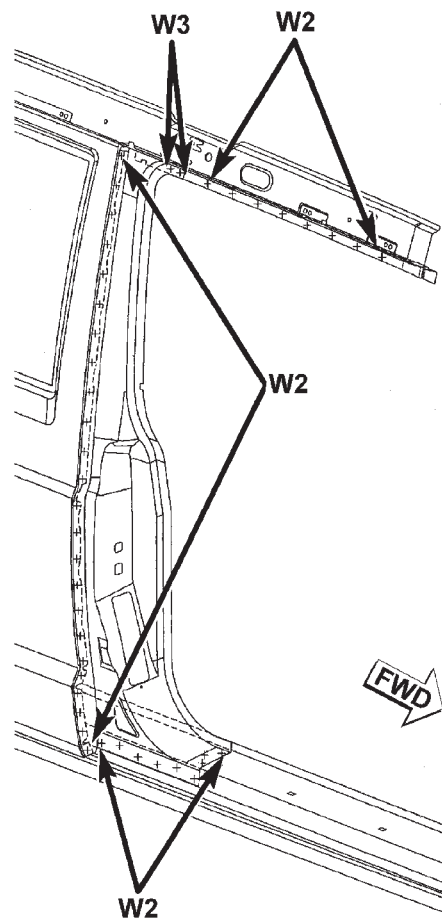
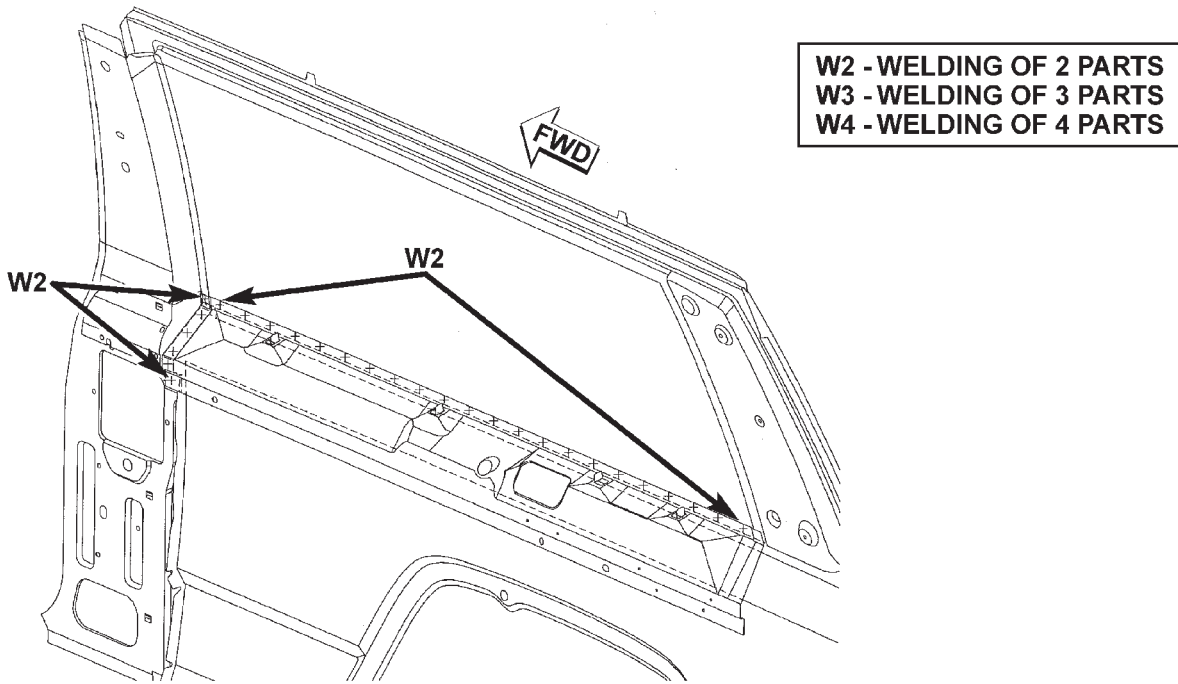

RIGHT SIDE SHOWN

SPECIFICATIONS (Continued)

BODY SIDE

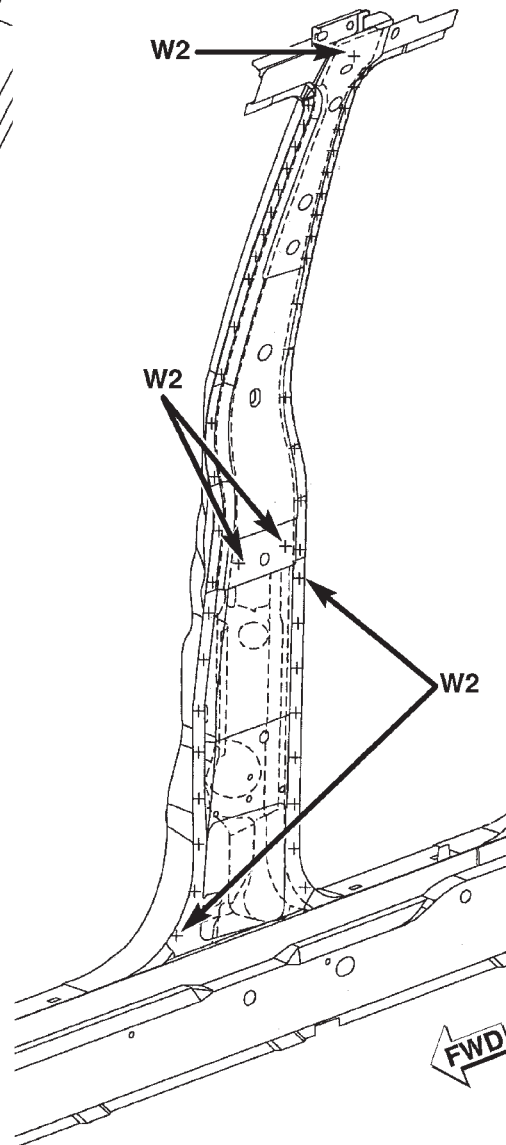
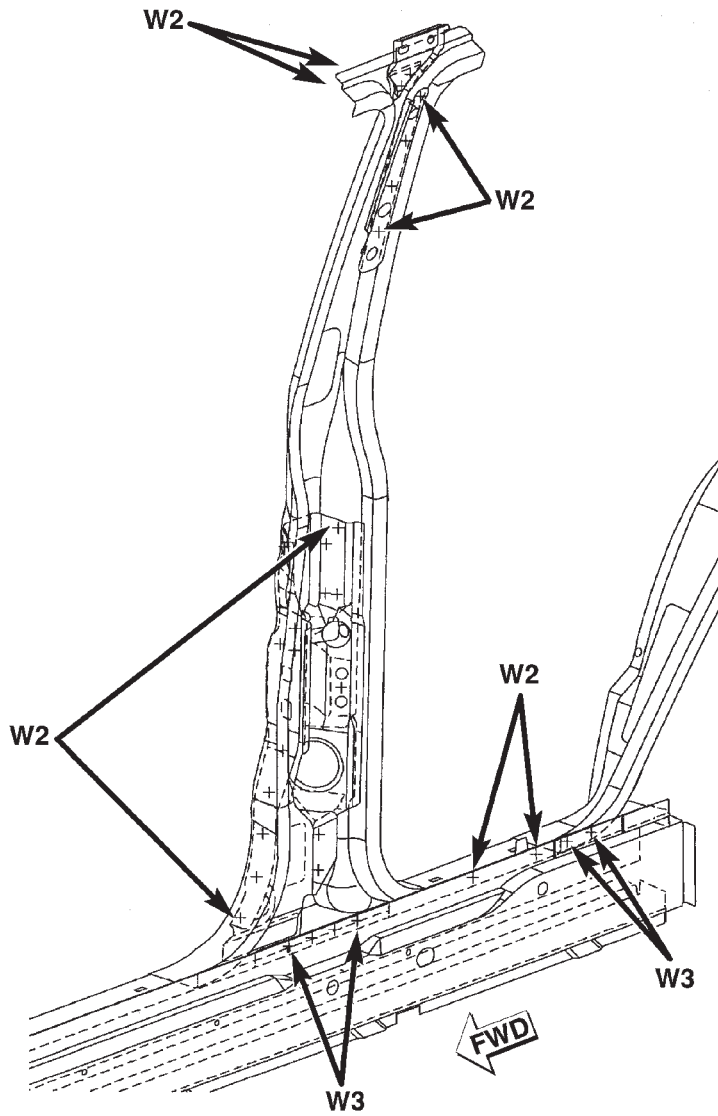

W2 - WELDING OF 2 PARTS
W3 - WELDING OF 3 PARTS
W4 - WELDING OF 4 PARTS

SPECIFICATIONS (Continued)

BODY SIDE

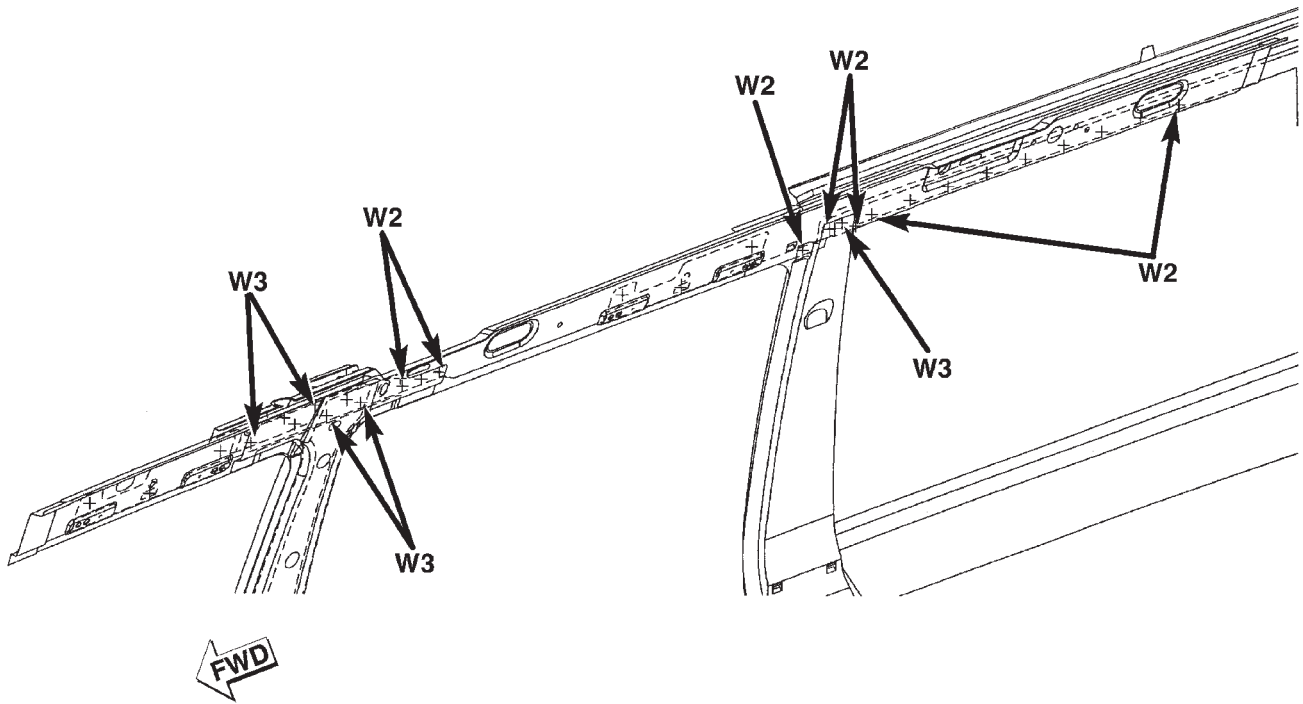

W2 - WELDING OF 2 PARTS
W3 - WELDING OF 3 PARTS
W4 - WELDING OF 4 PARTS

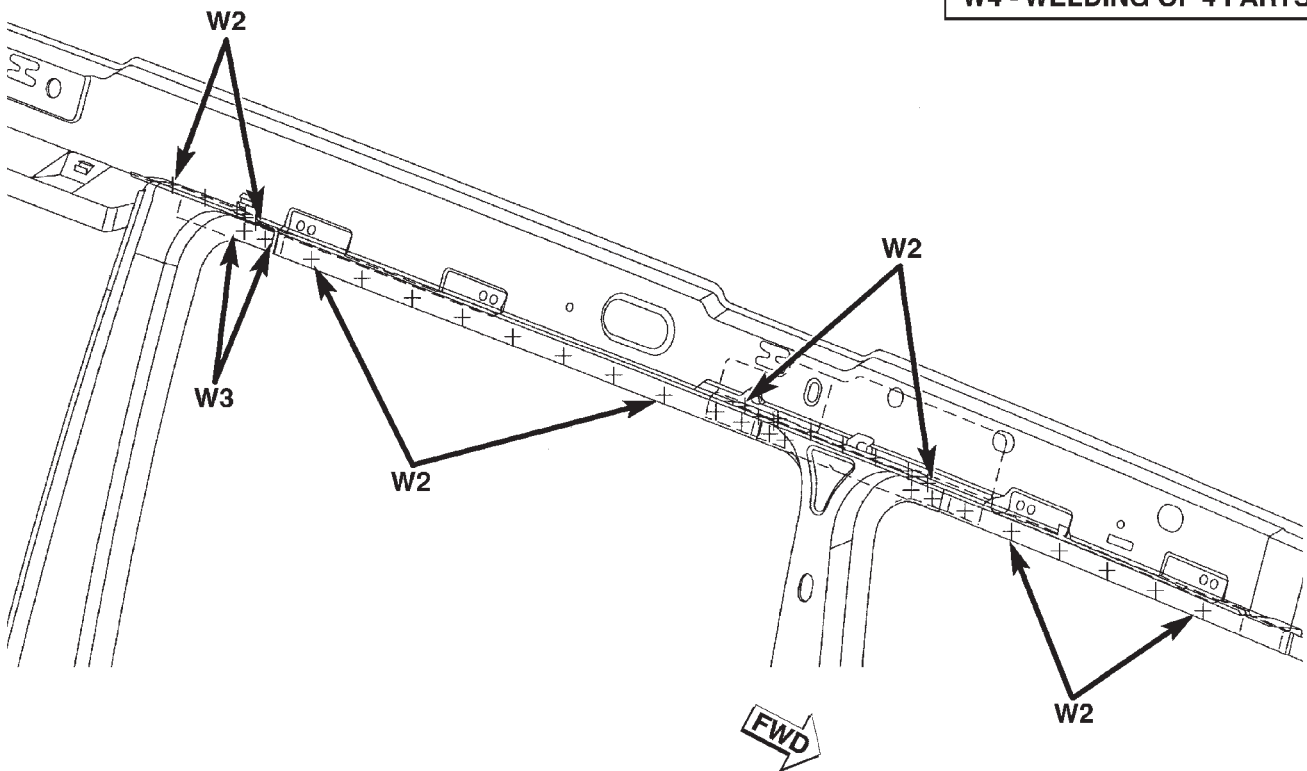

SPECIFICATIONS (Continued)

BODY SIDE

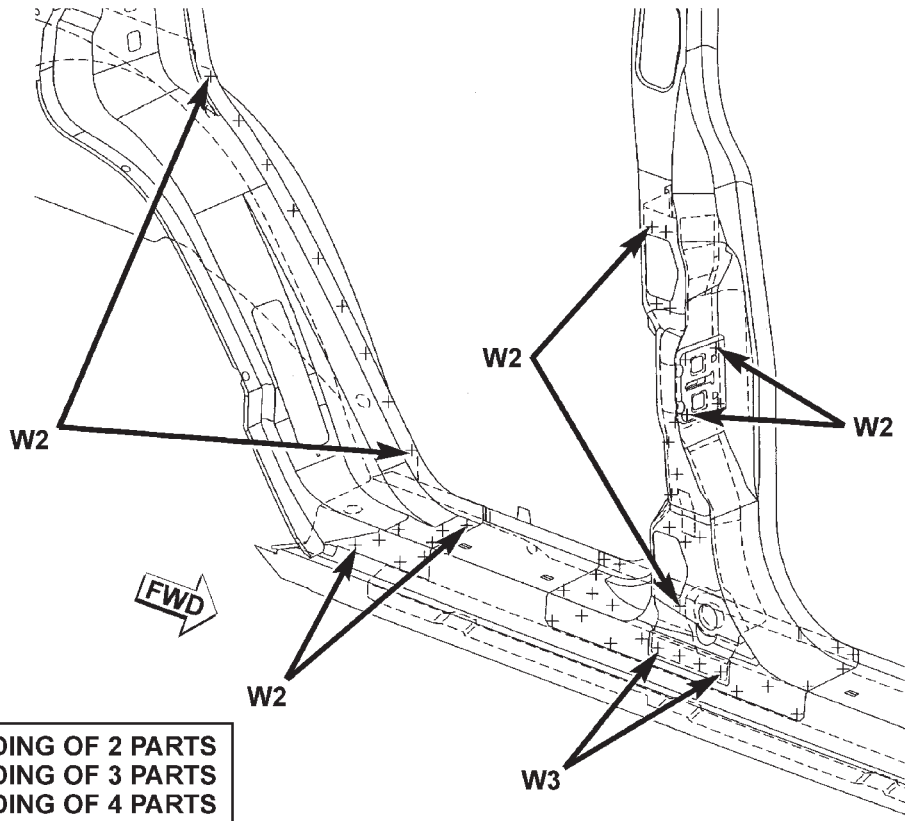

SPECIFICATIONS (Continued)

BODY SIDE

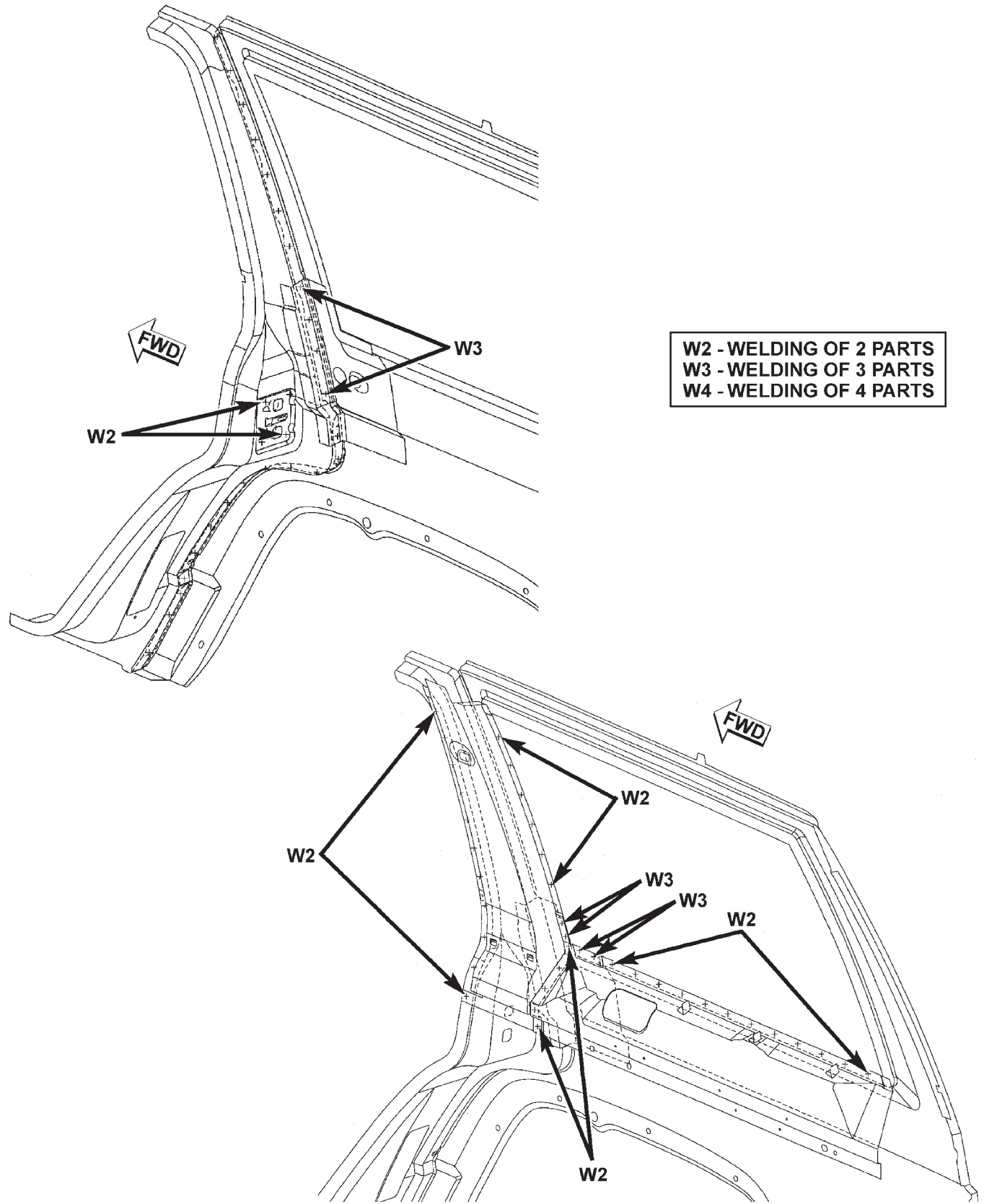

SPECIFICATIONS (Continued)

UNDERBODY

W2 - WELDING OF 2 PARTS
W3 - WELDING OF 3 PARTS
W4 - WELDING OF 4 PARTS

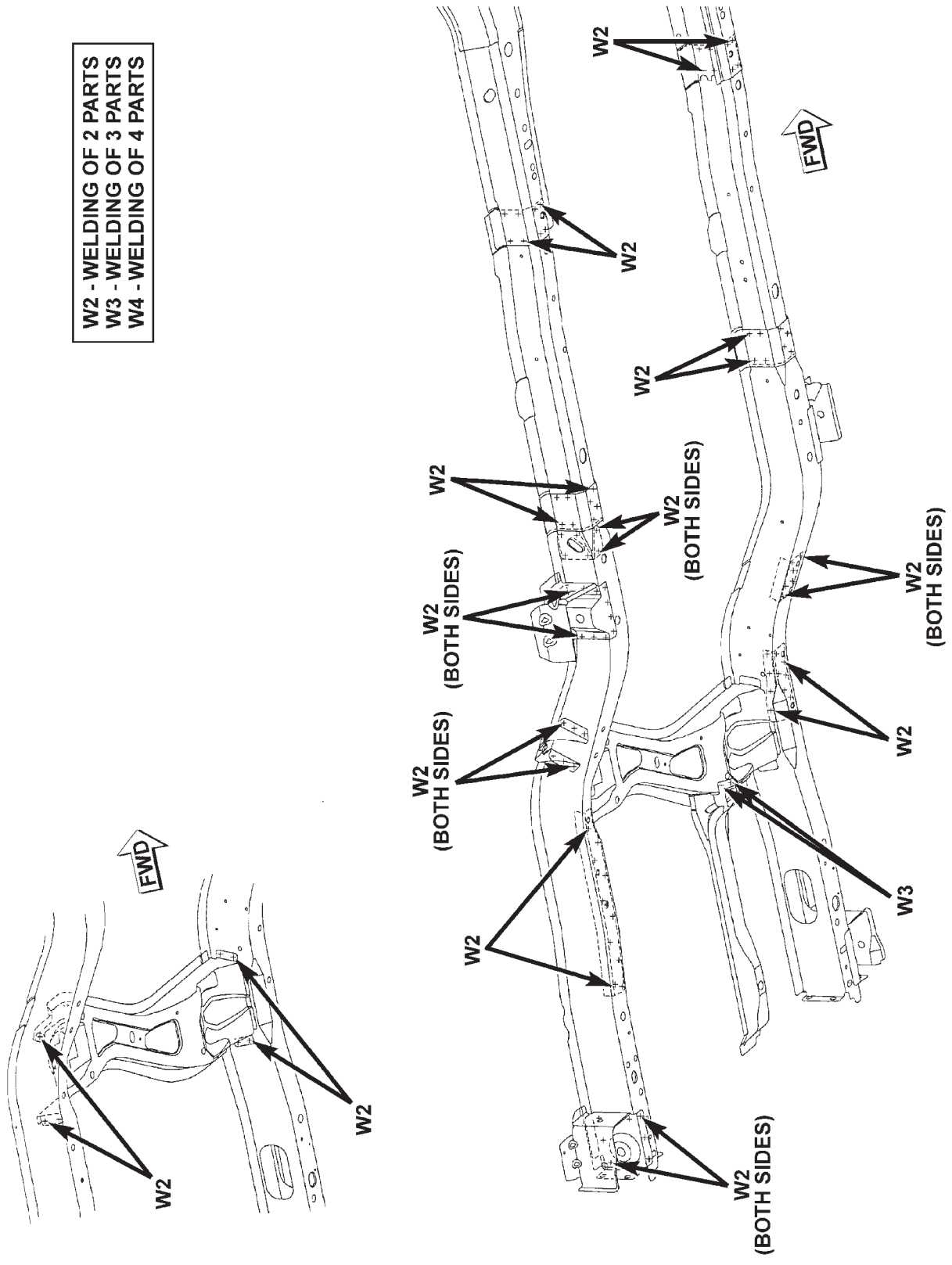

80b698ef

SPECIFICATIONS (Continued)

UNDERBODY

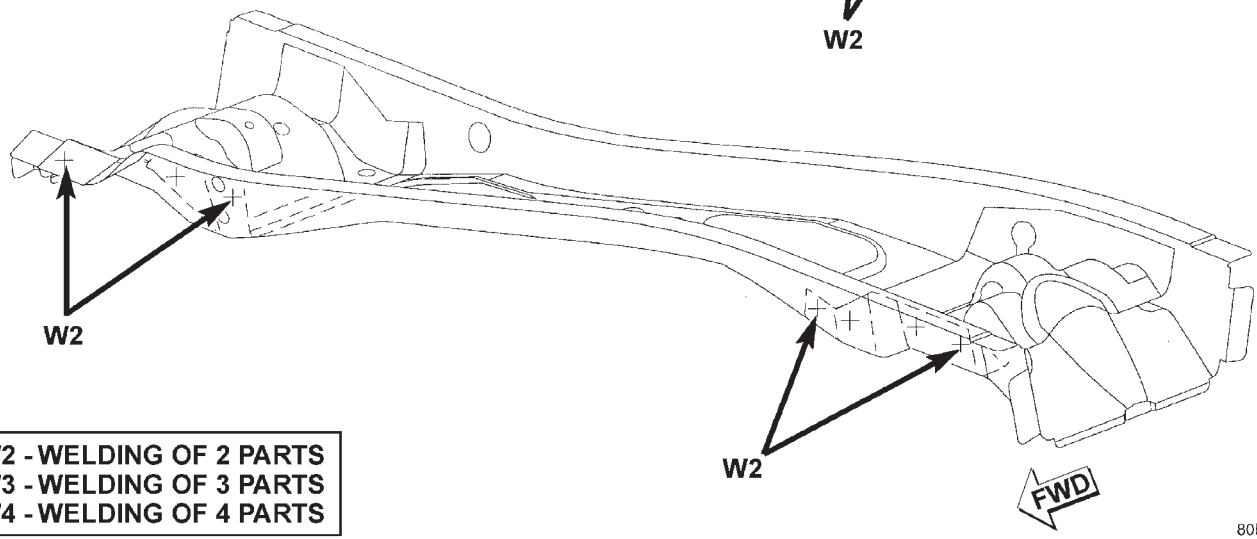
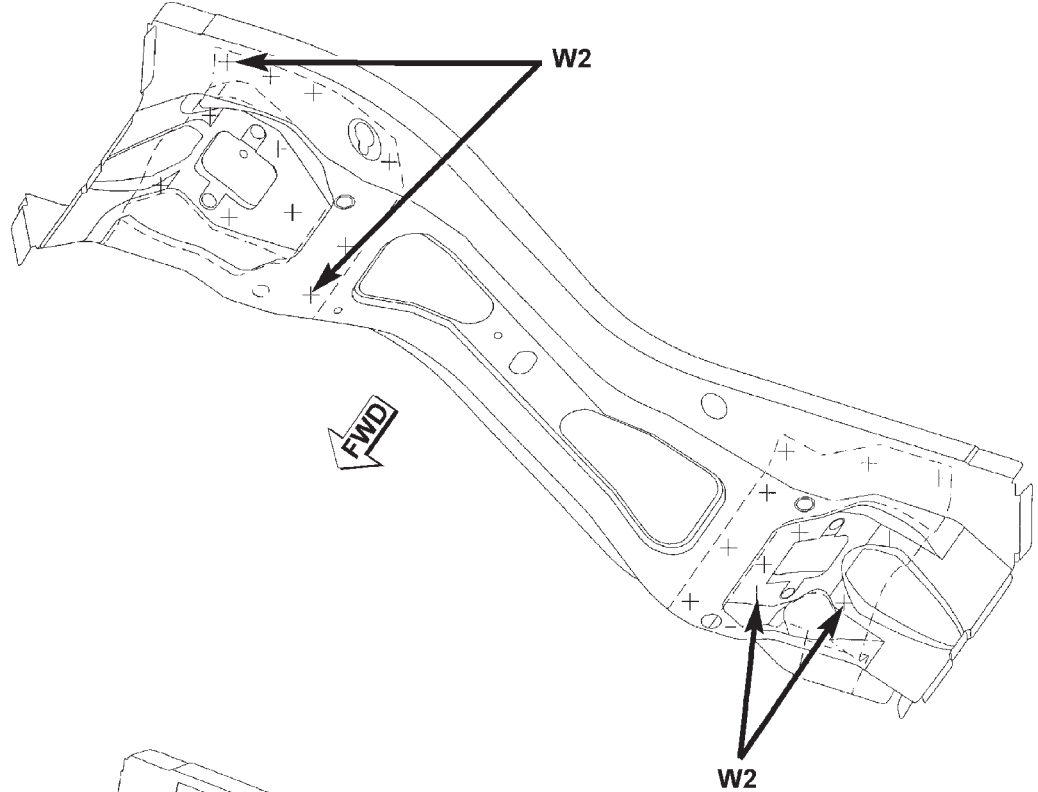
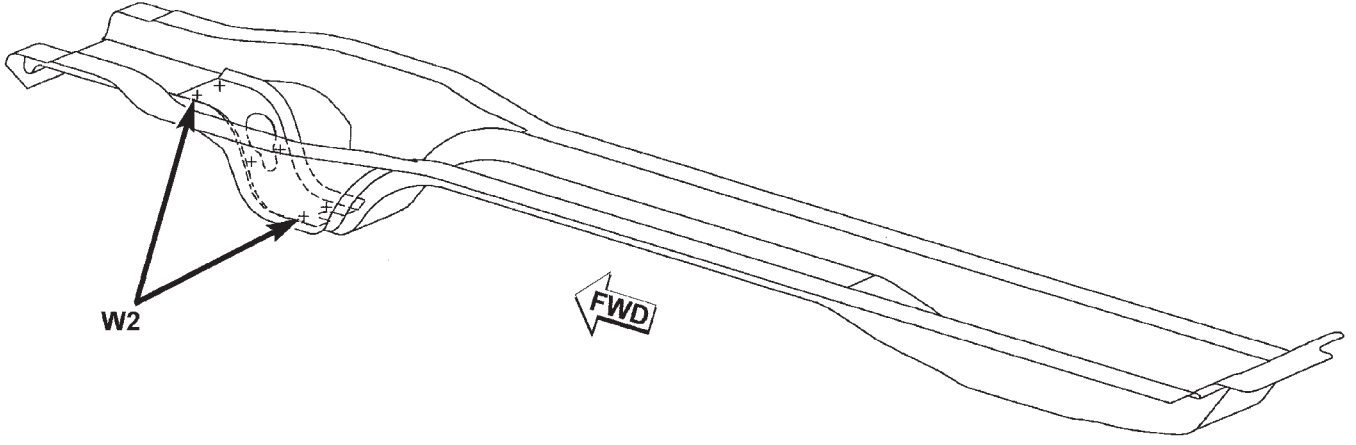

W2 - WELDING OF 2 PARTS
W3 - WELDING OF 3 PARTS
W4 - WELDING OF 4 PARTS

SPECIFICATIONS (Continued)

UNDERBODY

W2 - WELDING OF 2 PARTS
W3 - WELDING OF 3 PARTS
W4 - WELDING OF 4 PARTS

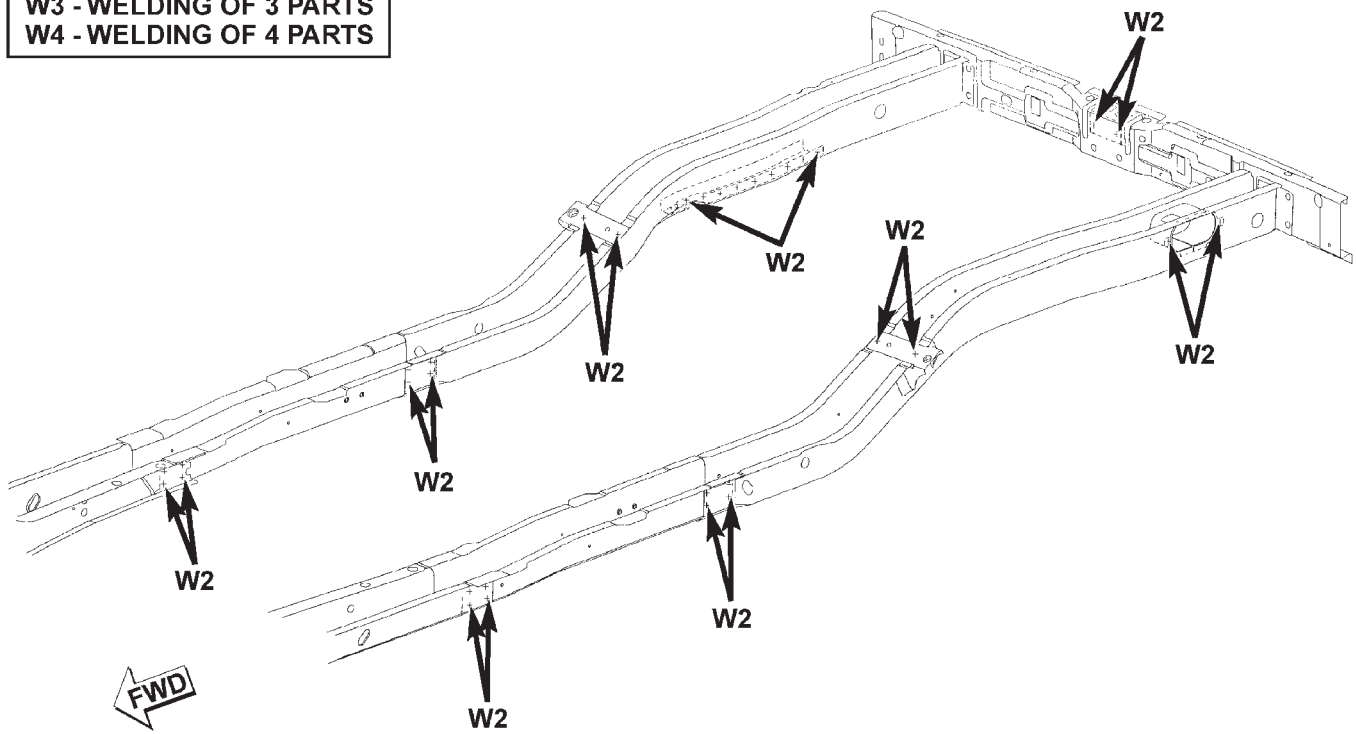

SPECIFICATIONS (Continued)

UNDERBODY

80c69812

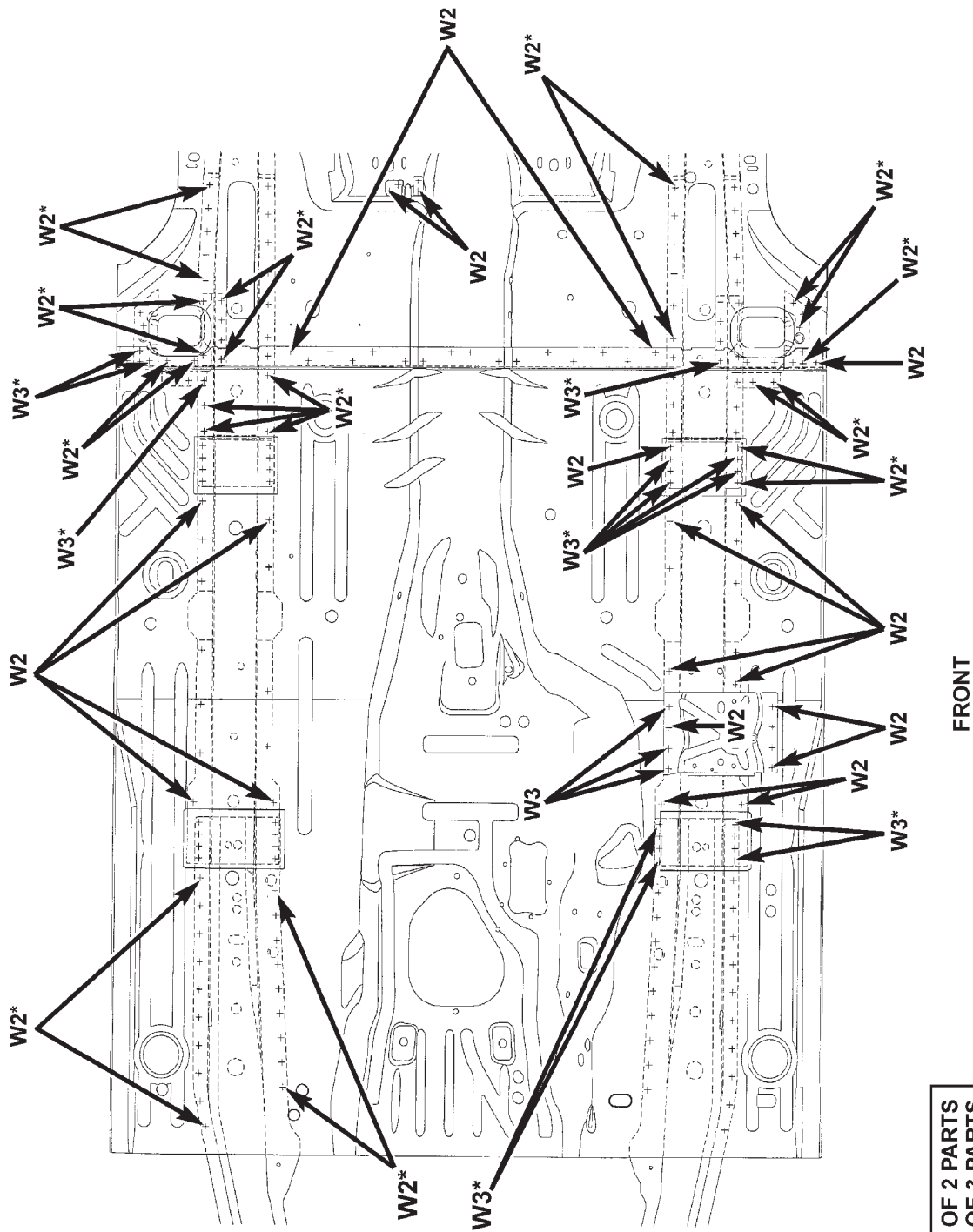

*BOTH SIDES

- W2 - WELDING OF 2 PARTS
- W3 - WELDING OF 3 PARTS
- W4 - WELDING OF 4 PARTS

SPECIFICATIONS (Continued)

UNDERBODY

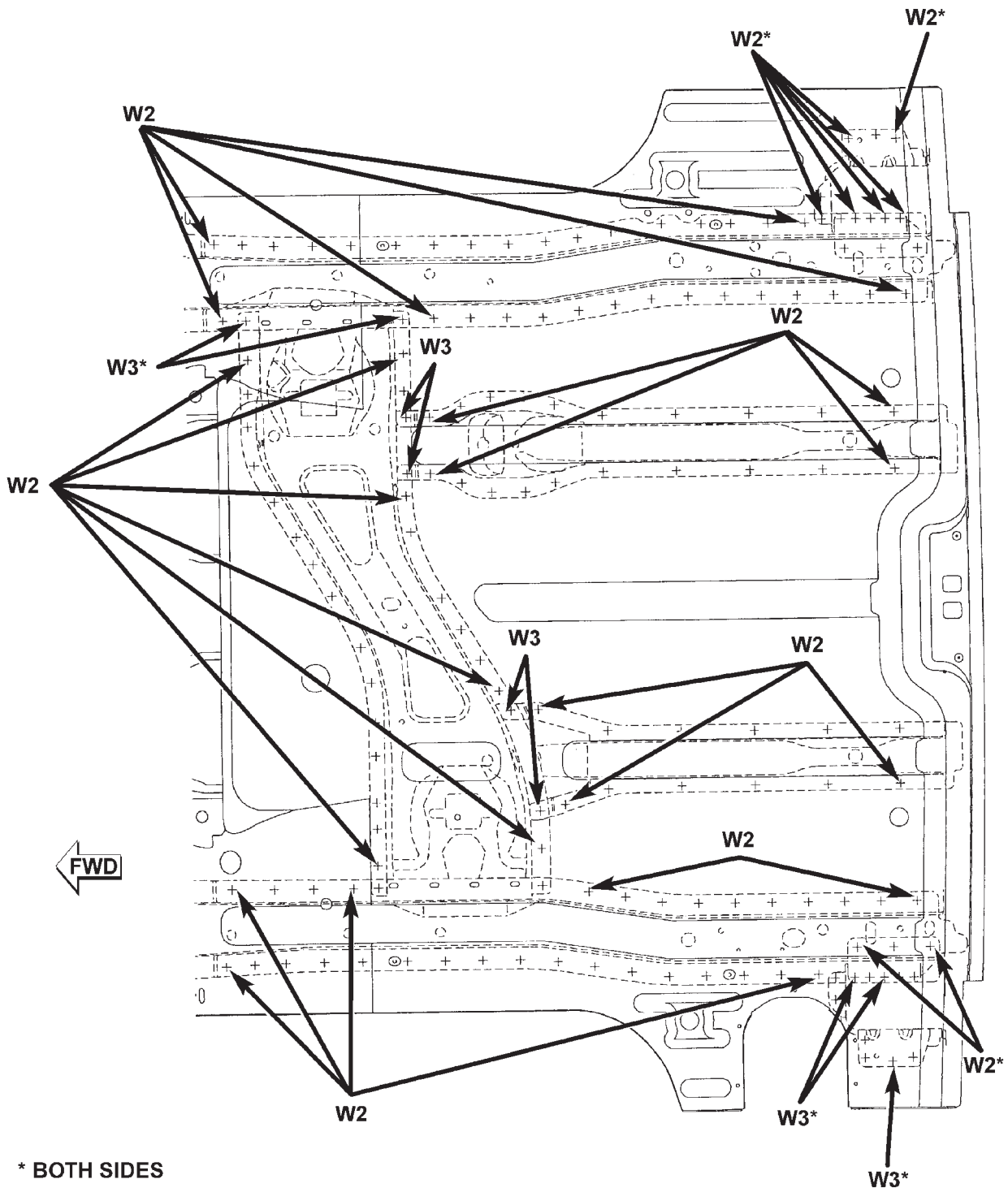

* BOTH SIDES

W2 - WELDING OF 2 PARTS
W3 - WELDING OF 3 PARTS
W4 - WELDING OF 4 PARTS

REAR

SPECIFICATIONS (Continued)

UNDERBODY

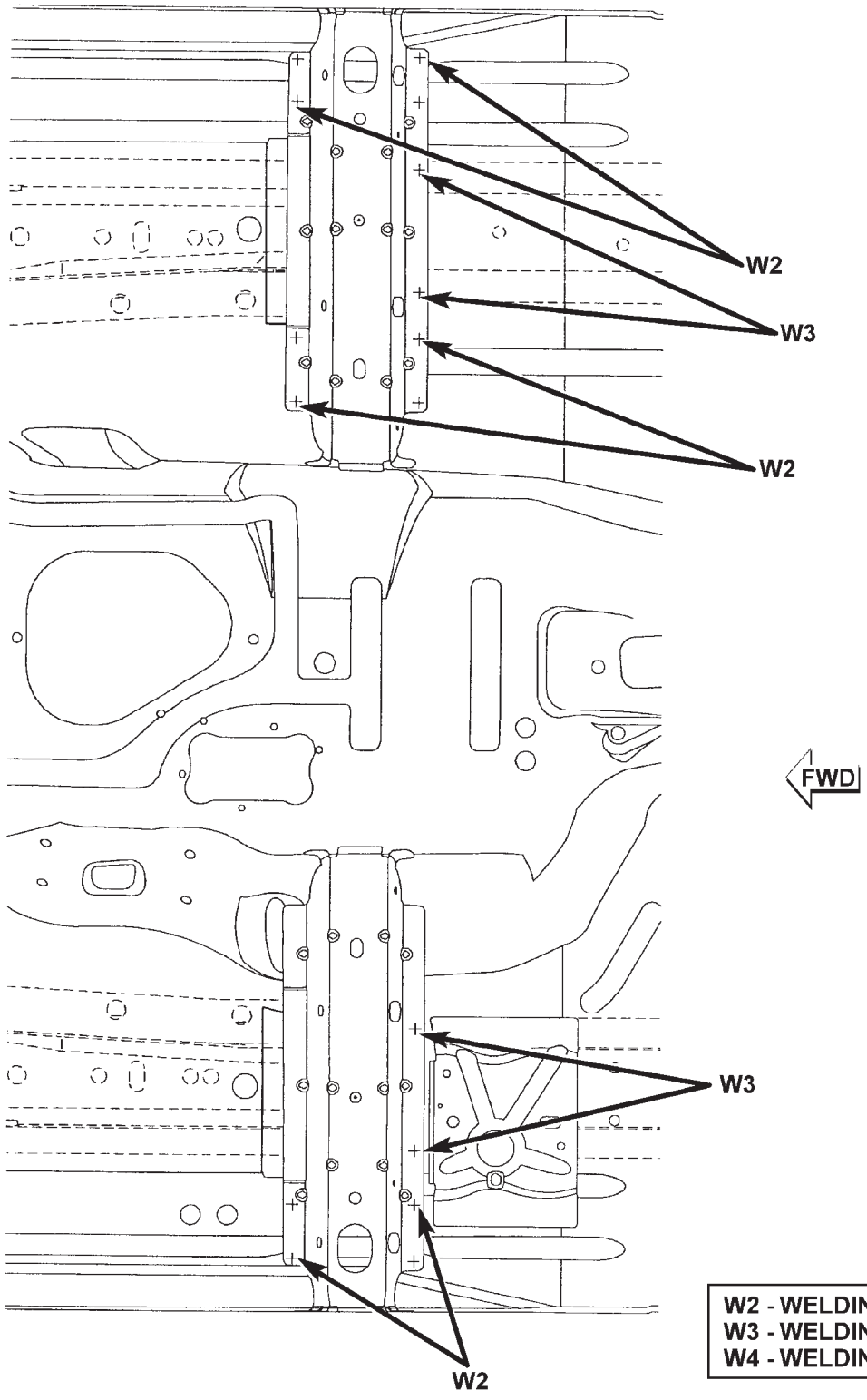

W2 - WELDING OF 2 PARTS
W3 - WELDING OF 3 PARTS
W4 - WELDING OF 4 PARTS

SPECIFICATIONS (Continued)

UNDERBODY

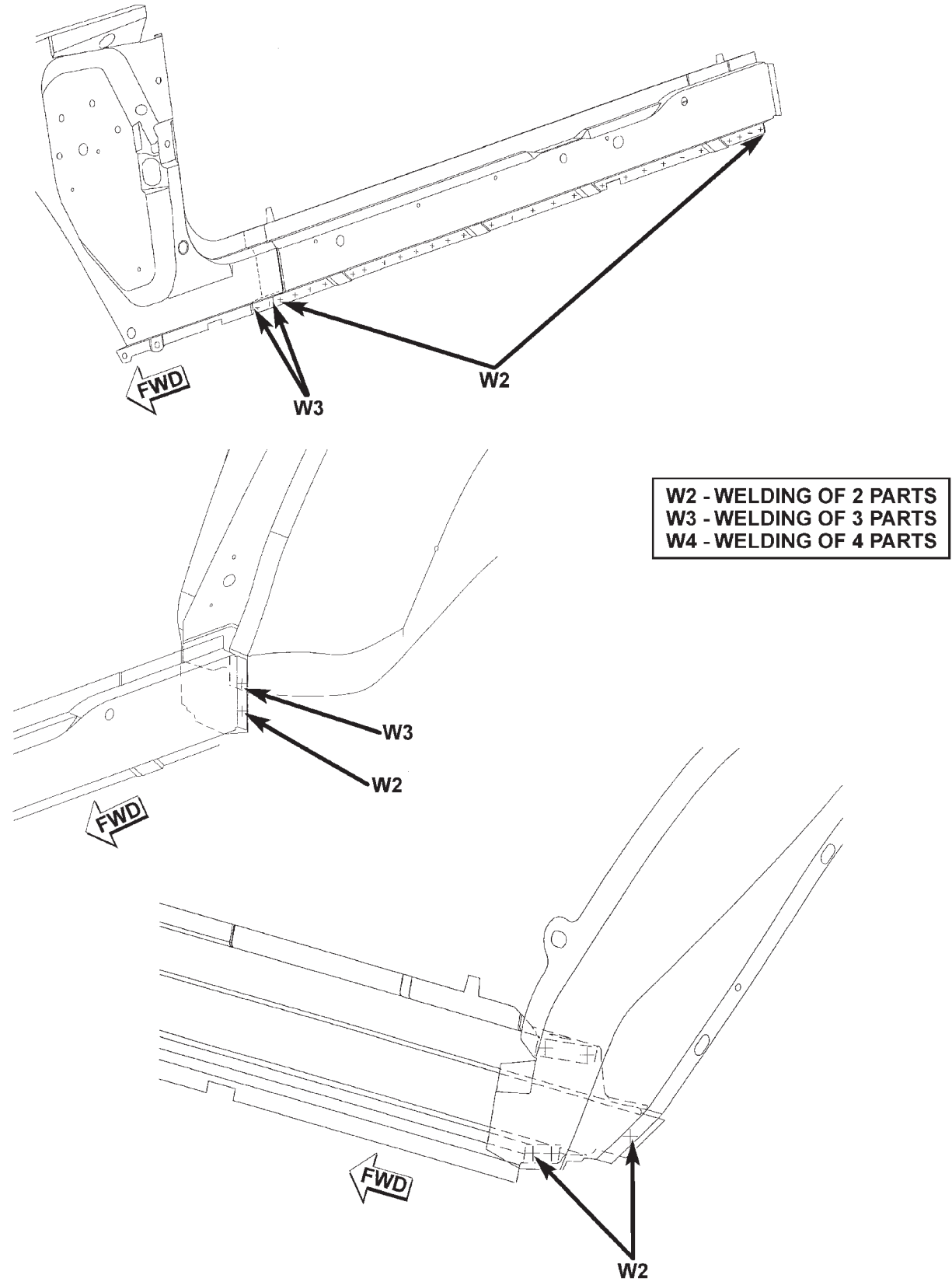

SPECIFICATIONS (Continued)

UNDERBODY

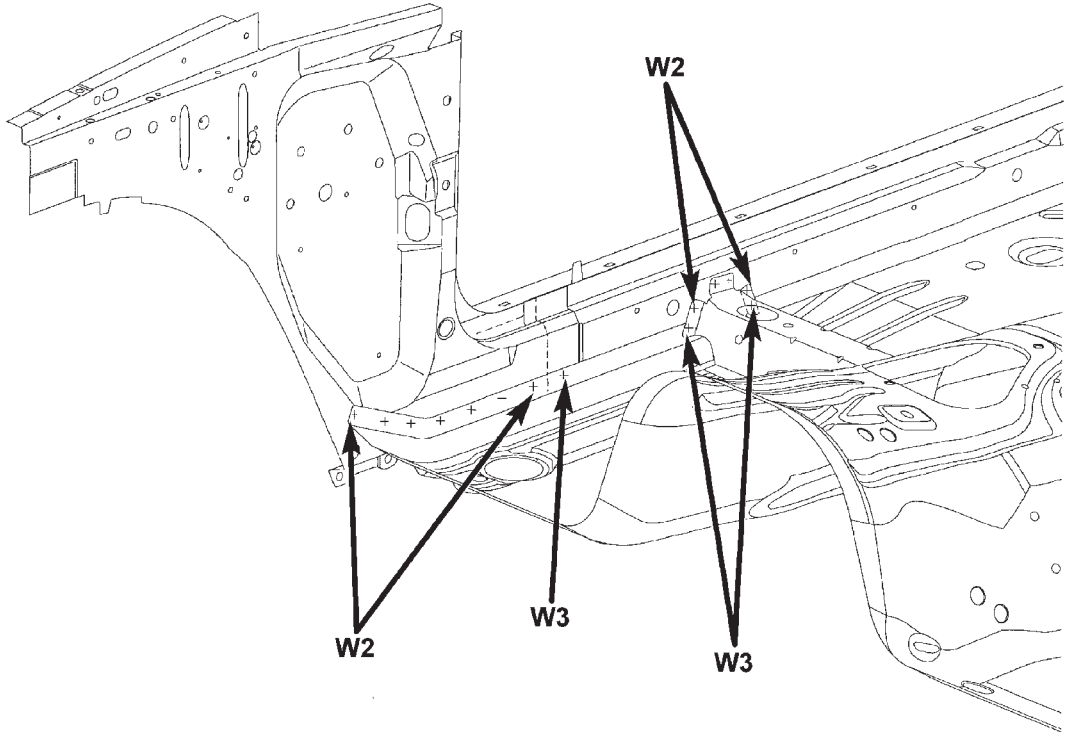

W2 - WELDING OF 2 PARTS
W3 - WELDING OF 3 PARTS
W4 - WELDING OF 4 PARTS

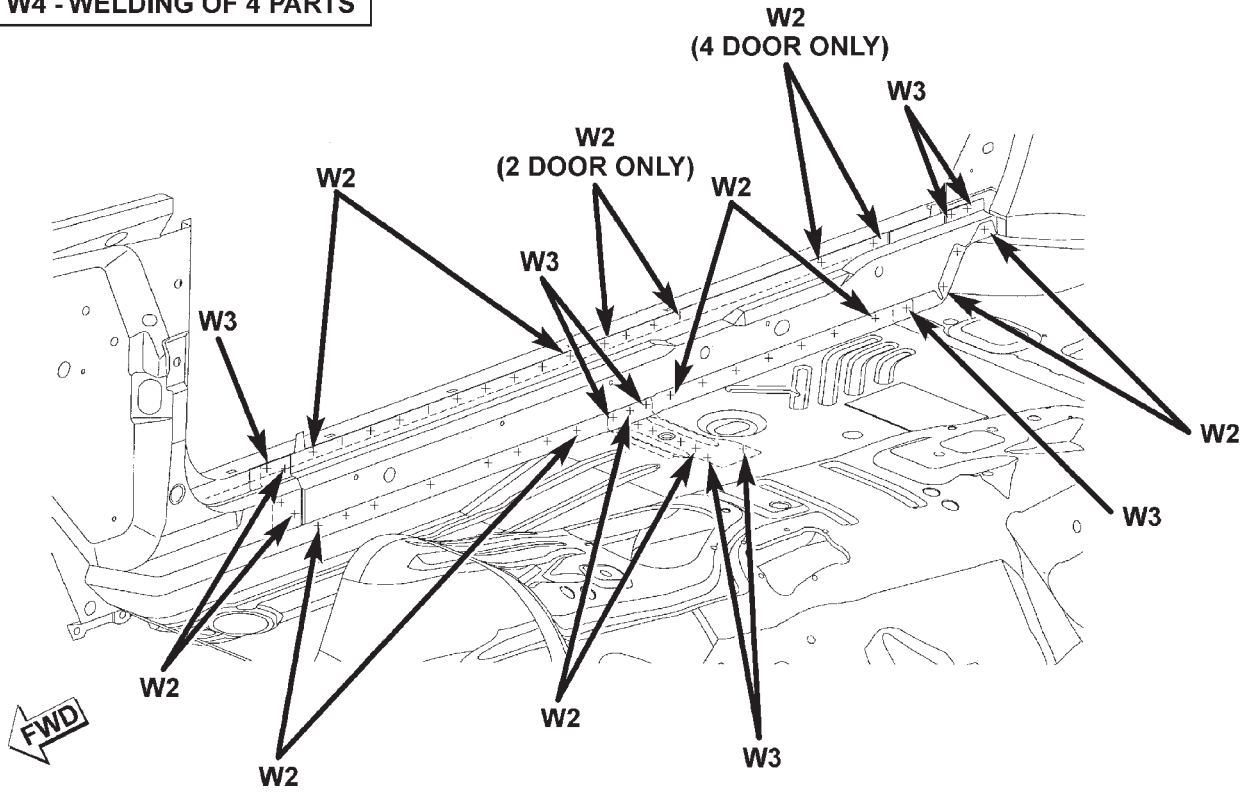

SPECIFICATIONS (Continued)

UNDERBODY

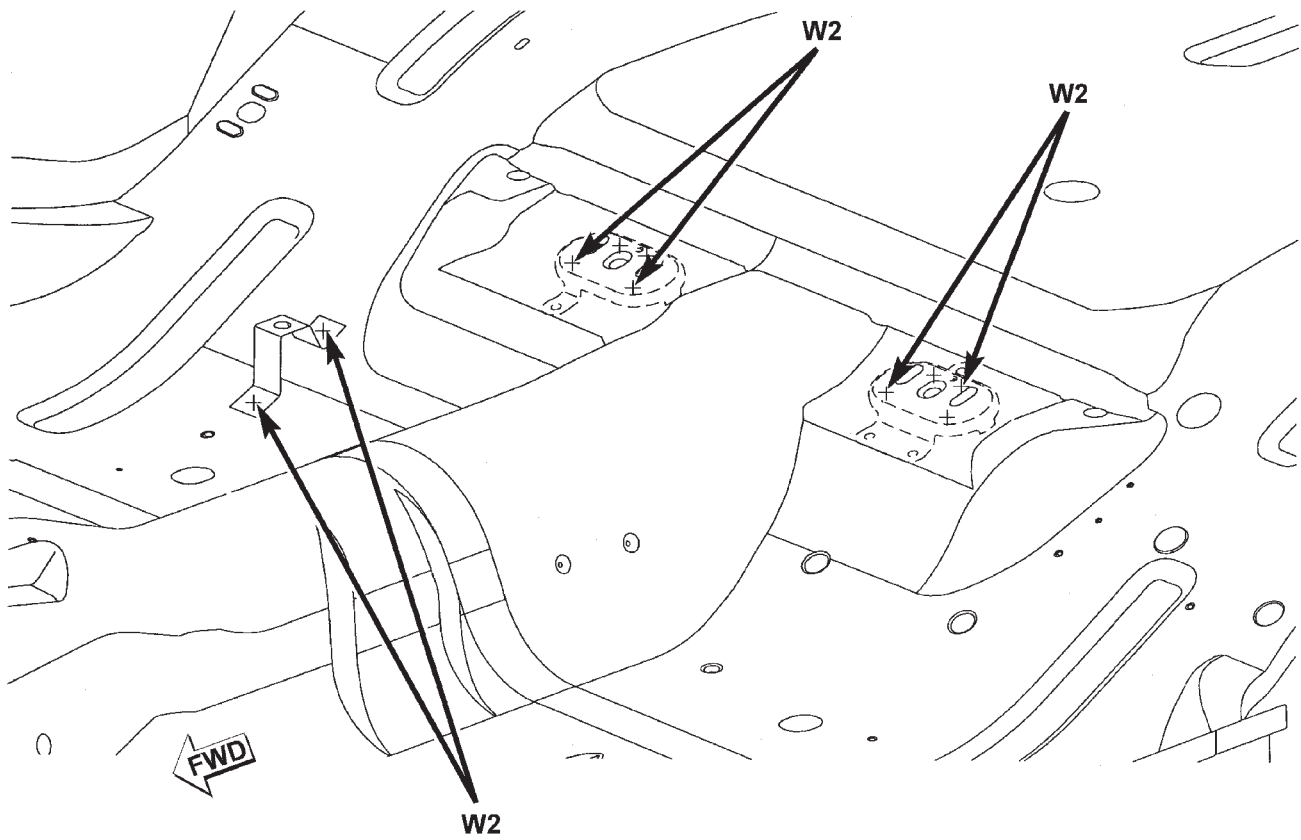
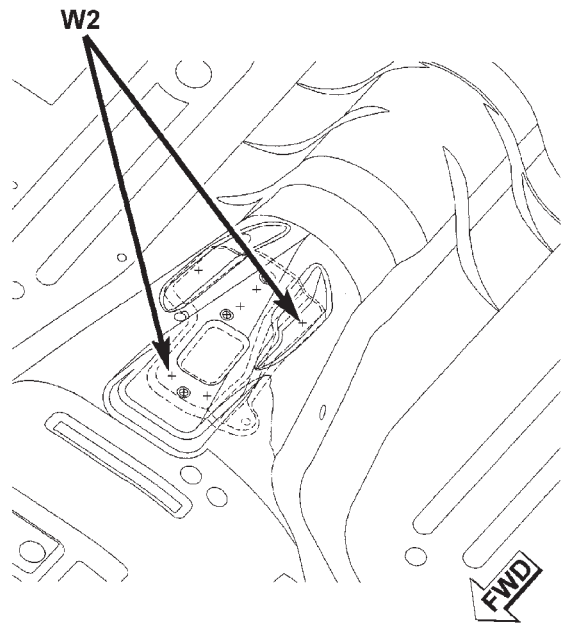
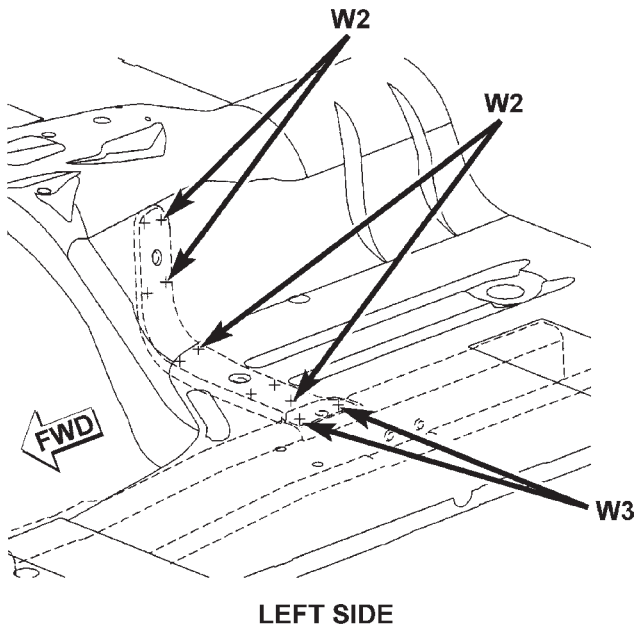

W2 - WELDING OF 2 PARTS
W3 - WELDING OF 3 PARTS
W4 - WELDING OF 4 PARTS

SPECIFICATIONS (Continued)

UNDERBODY

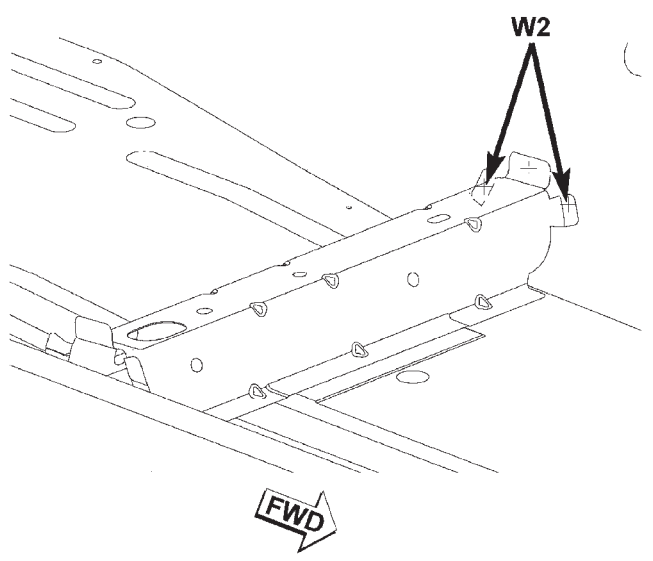
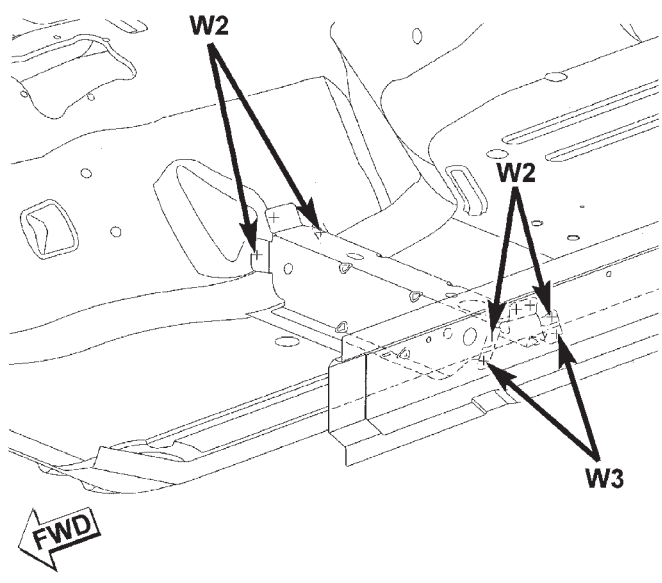

W2 - WELDING OF 2 PARTS
W3 - WELDING OF 3 PARTS
W4 - WELDING OF 4 PARTS

SPECIFICATIONS (Continued)

UNDERBODY

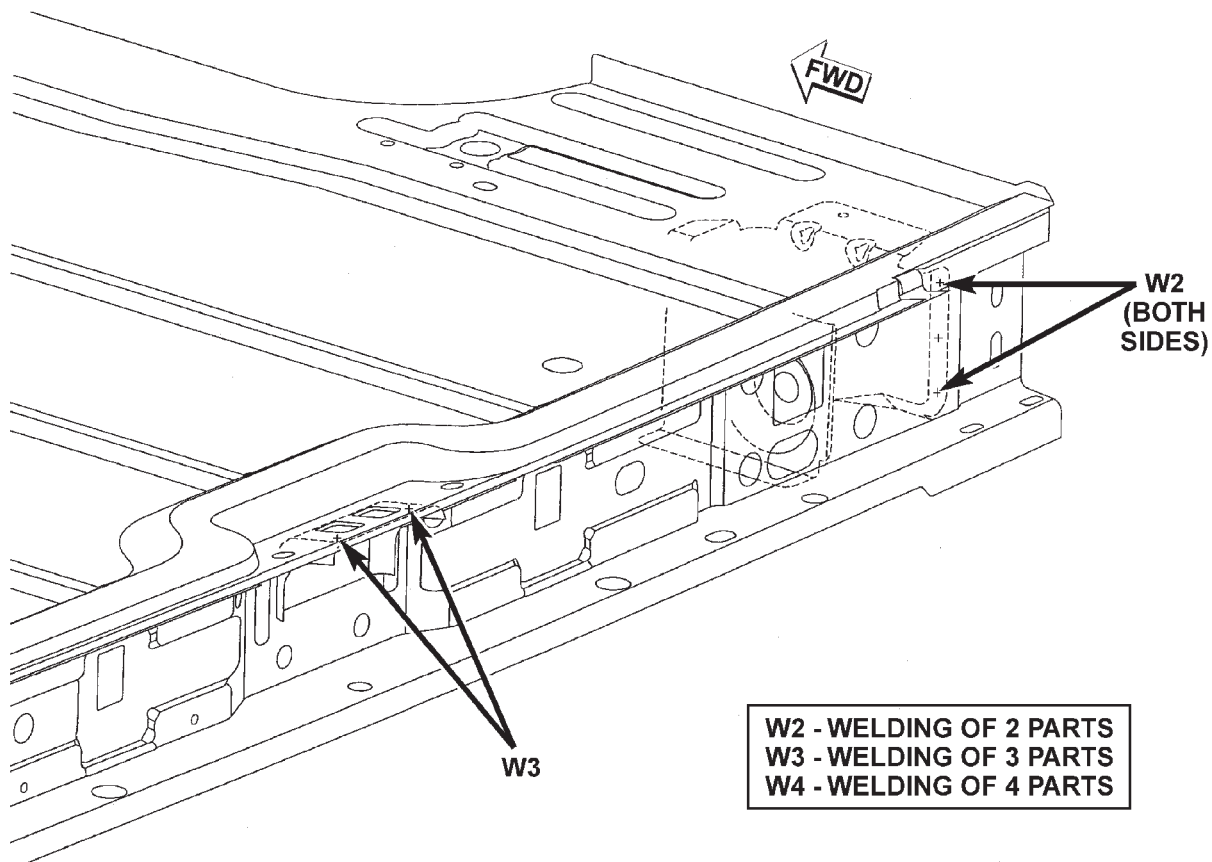
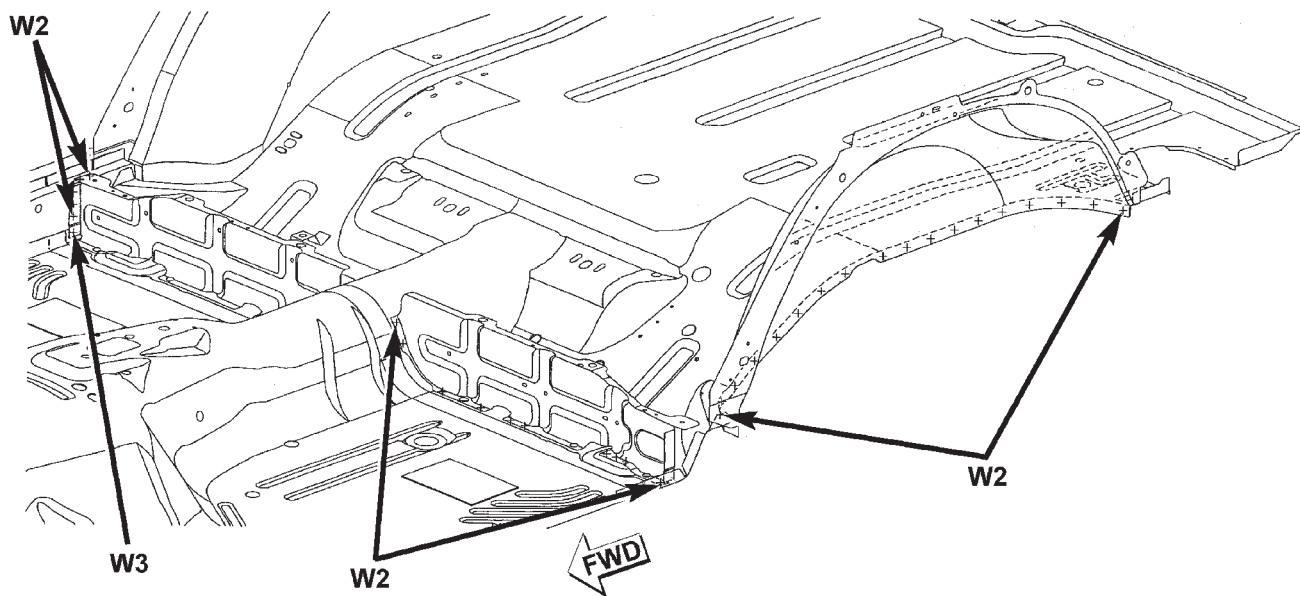

SPECIFICATIONS (Continued)

BODY SEALING LOCATIONS

APPLICATION METHODS

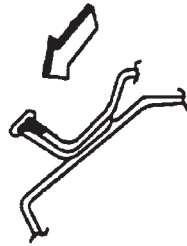

HOLD GUN NOZZLE IN DIRECTION OF ARROW IN ORDER TO EFFECTIVELY SEAL METAL JOINTS.

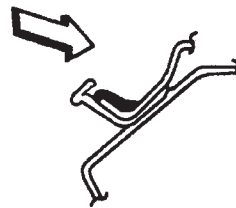

DO NOT HOLD GUN NOZZLE IN DIRECTION OF ARROW. SEALER APPLIED AS SHOWN IN INEFFECTIVE.

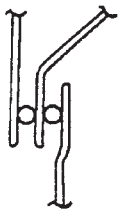

3 METAL THICKNESS

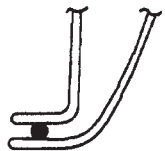

2 METAL THICKNESS

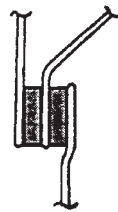

3 METAL THICKNESS

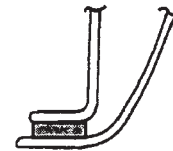

2 METAL THICKNESS

EXPOSED SURFACE
WORK SEAL ON METAL SURFACE TO GET GOOD ADHESIVE. EDGE MUST BE FEATHERED AS SHOWN.

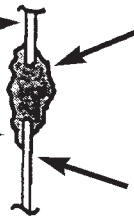

SEALER MUST BE APPLIED AS ILLUSTRATED. TO LOCK SEAL IN PLACE, FORCE SEAL BEYOND HOLE.

HIDDEN SURFACE

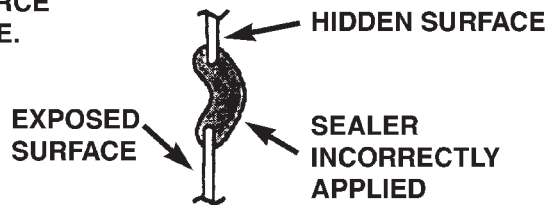

SEALER INCORRECTLY APPLIED

| SYMBOLS | |
|---------|-------------------------------|
| | THUMBGRADEABLE SEALER |
| | EXTRUDABLE THERMOPLASTIC |
| | EXPOSED THERMOPLASTIC SEALANT |
| | HIDDEN SEALANT |

SPECIFICATIONS (Continued)

COWL AND DASH PANEL

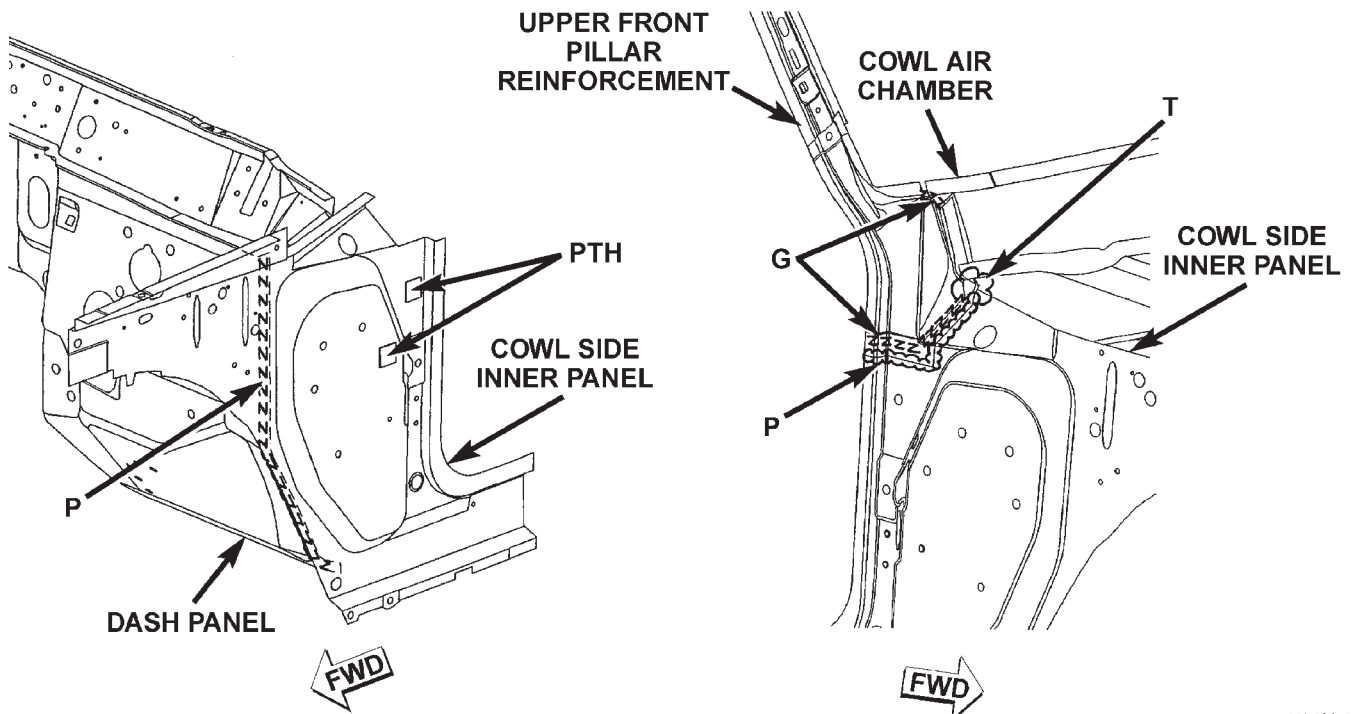
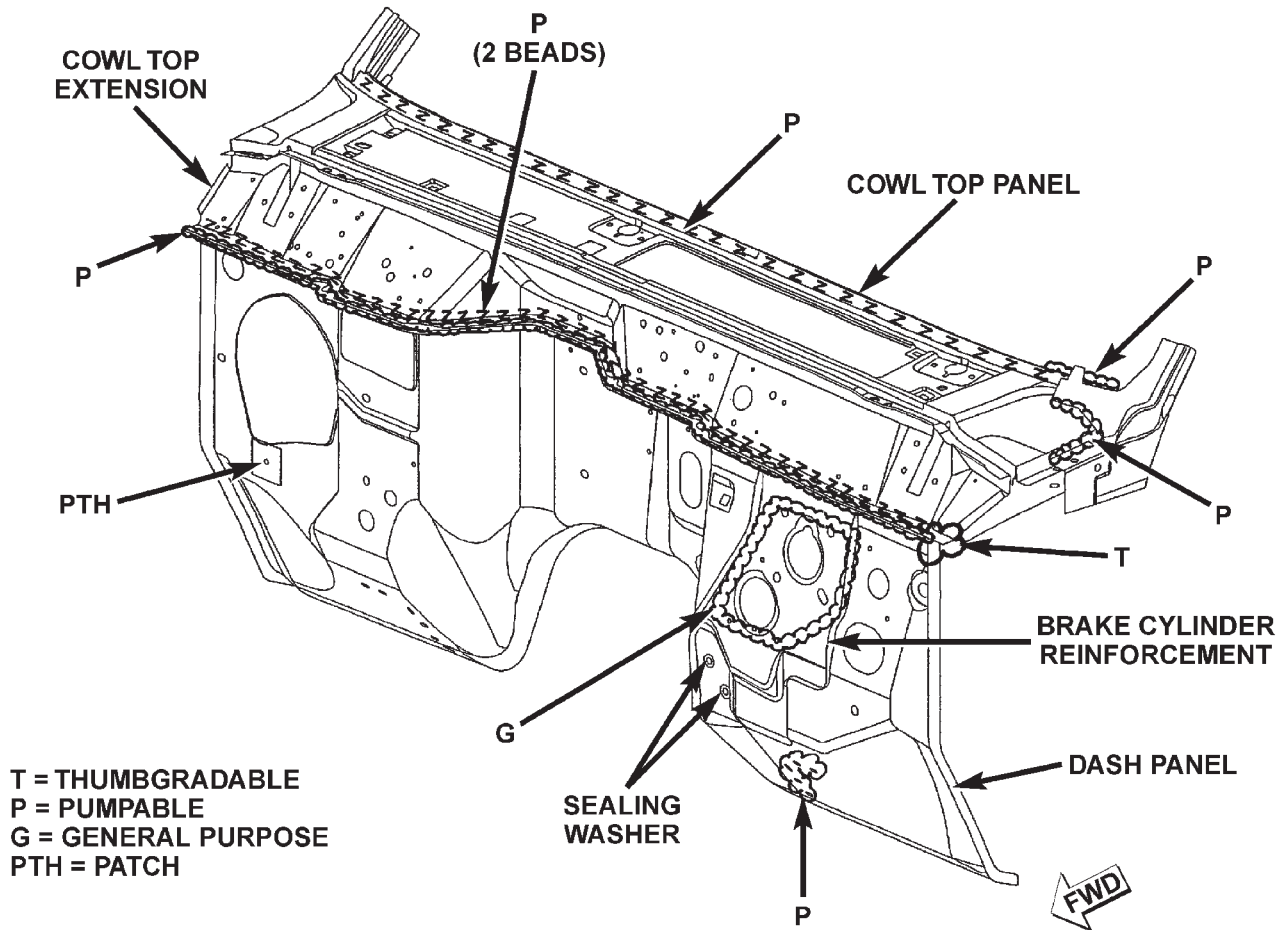

SPECIFICATIONS (Continued)

DASH PANEL AND FLOOR PAN

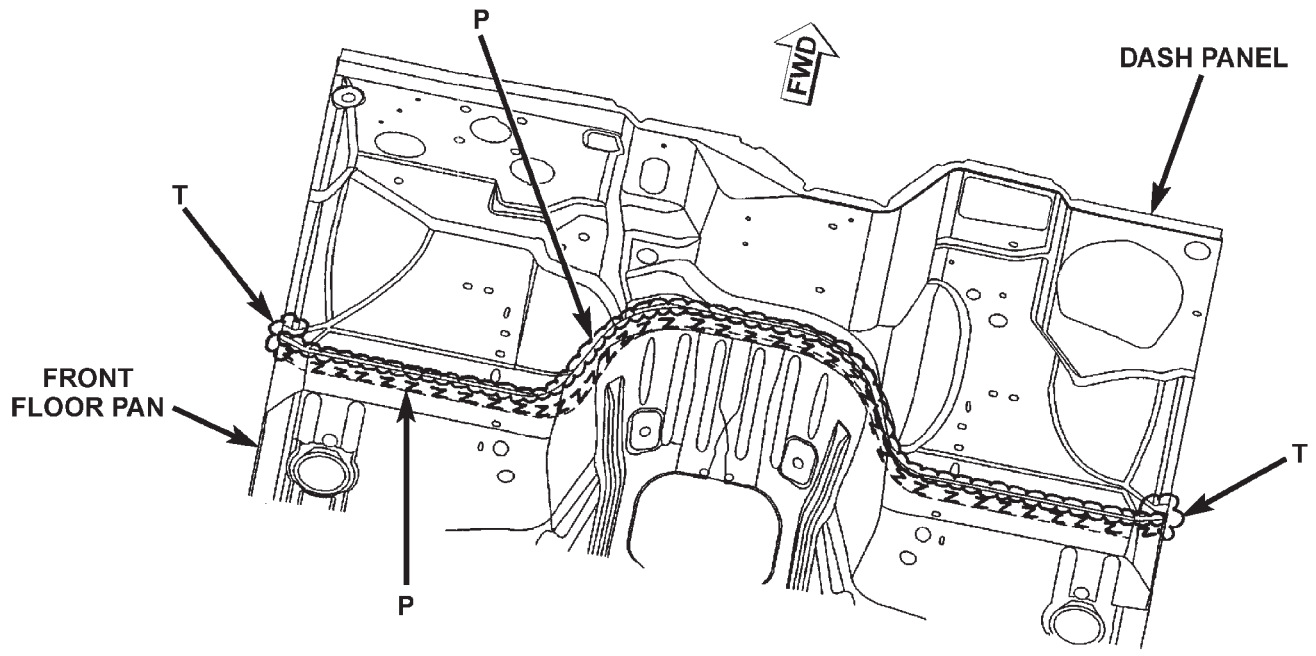

T = THUMBGRADABLE
P = PUMPABLE

SPECIFICATIONS (Continued)

FLOOR PAN

P = PUMPABLE
G = GENERAL PURPOSE

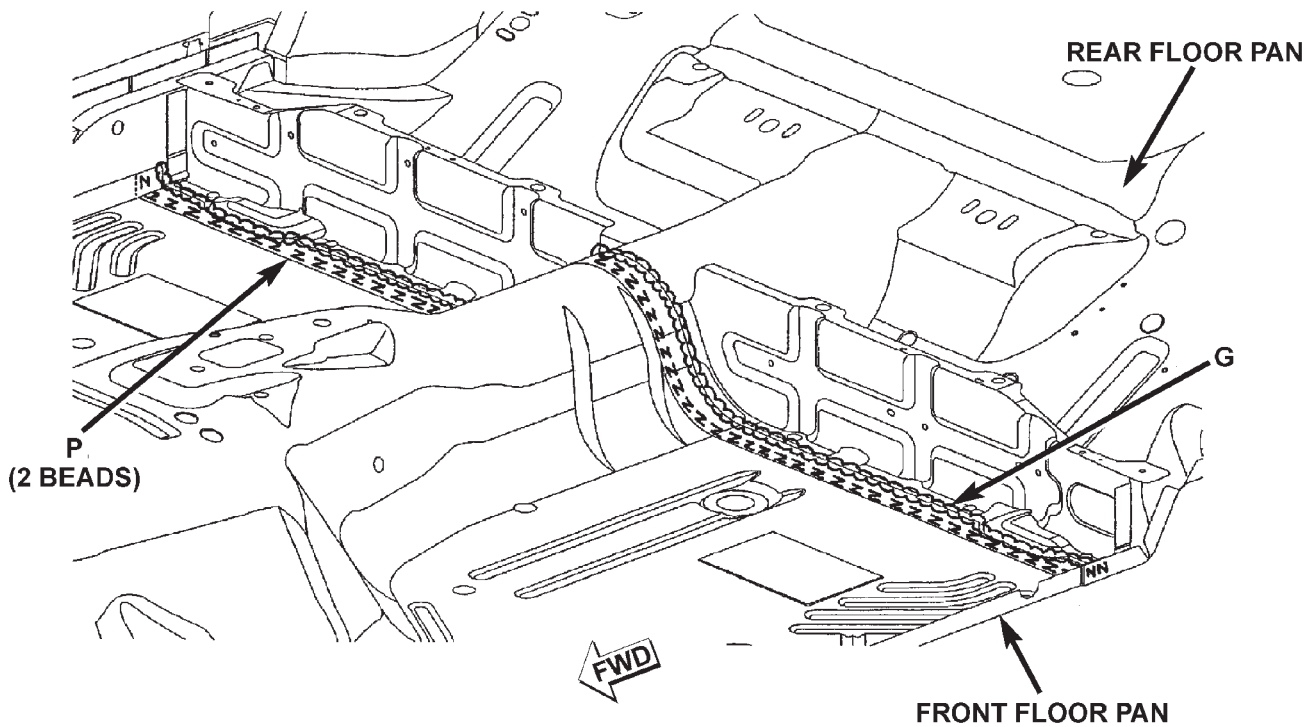
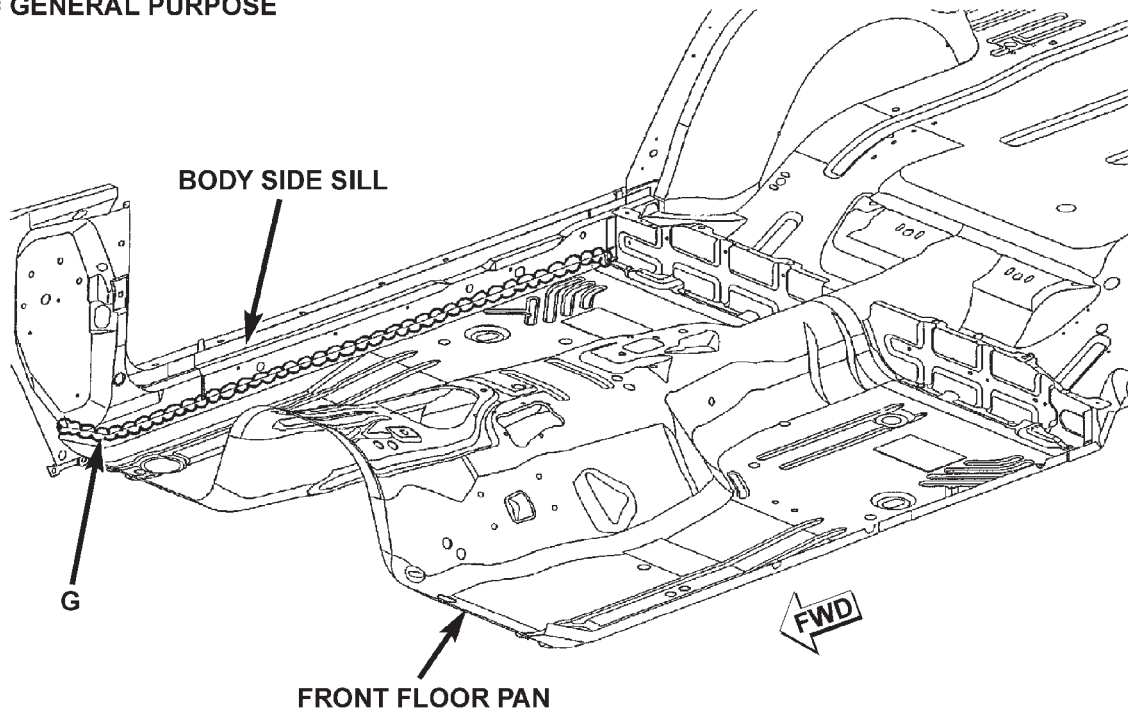

SPECIFICATIONS (Continued)

REAR INNER WHEELHOUSE

T = THUMBGRADABLE
P = PUMPABLE
G = GENERAL PURPOSE

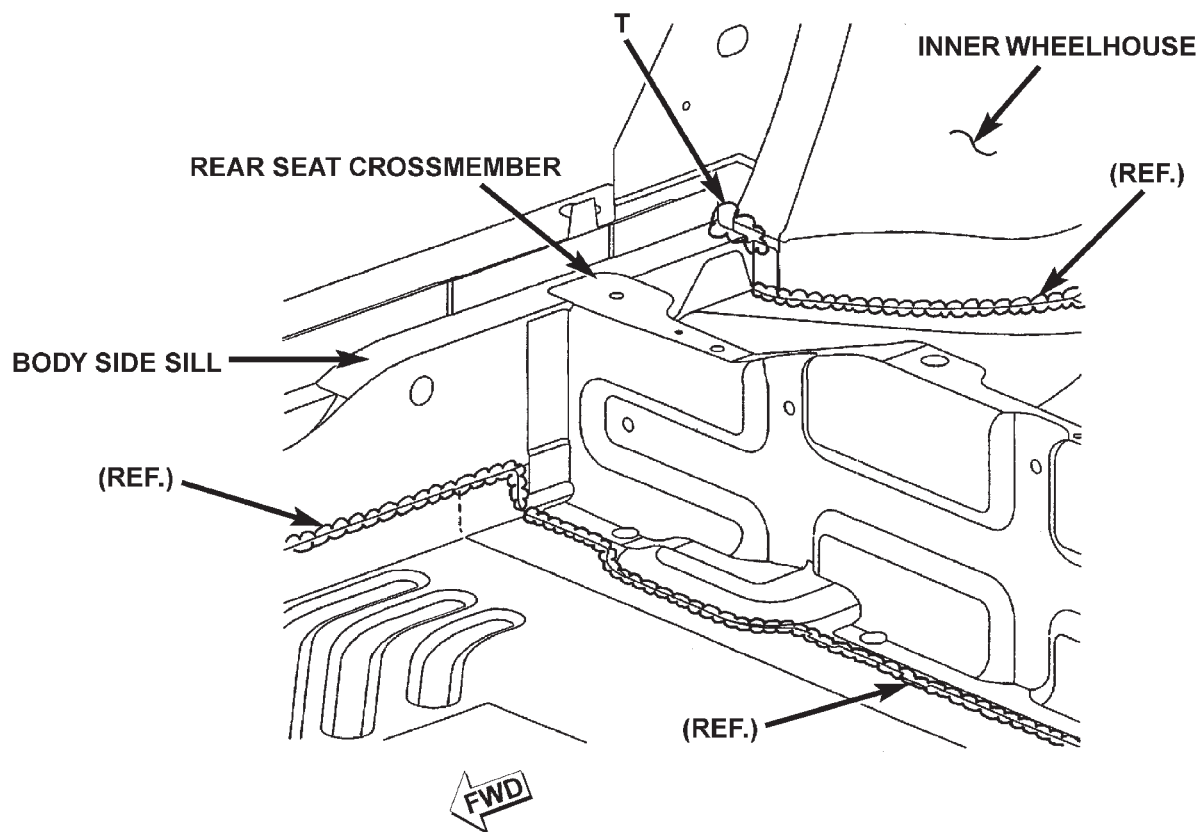
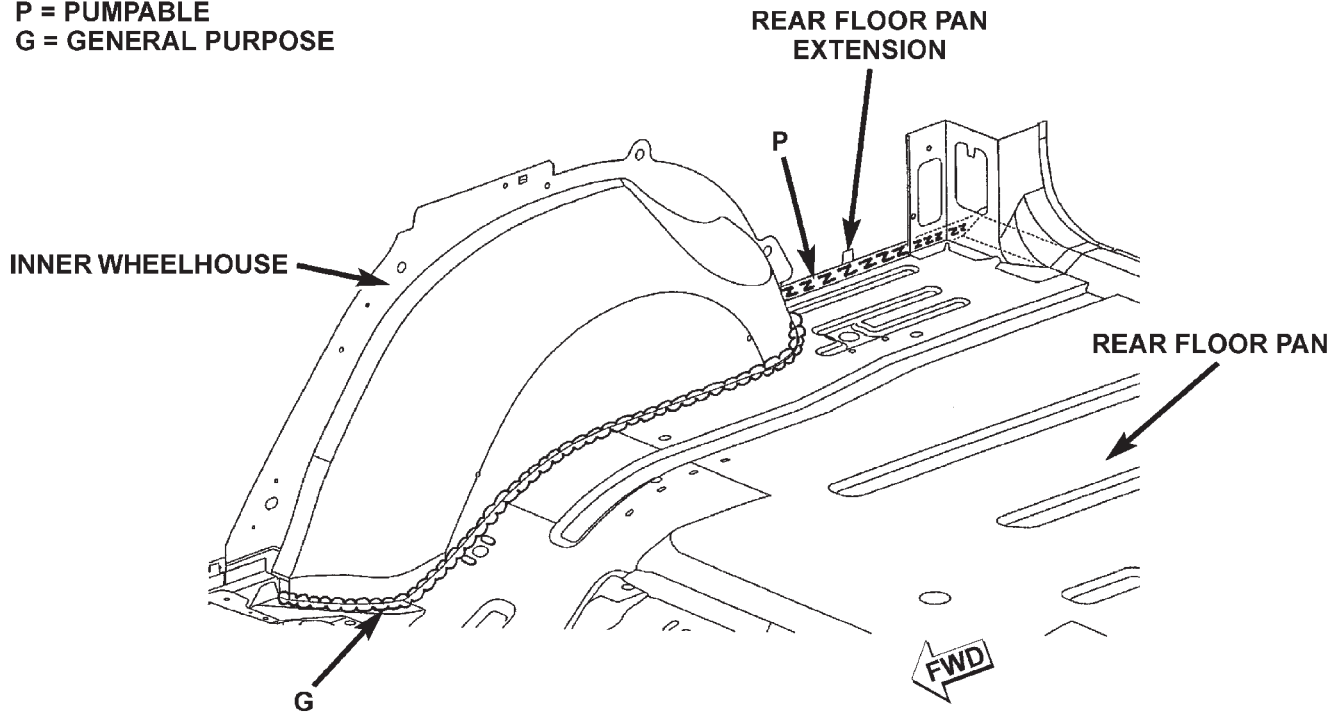

SPECIFICATIONS (Continued)

FRONT INNER WHEELHOUSE

T = THUMBGRADABLE
P = PUMPABLE

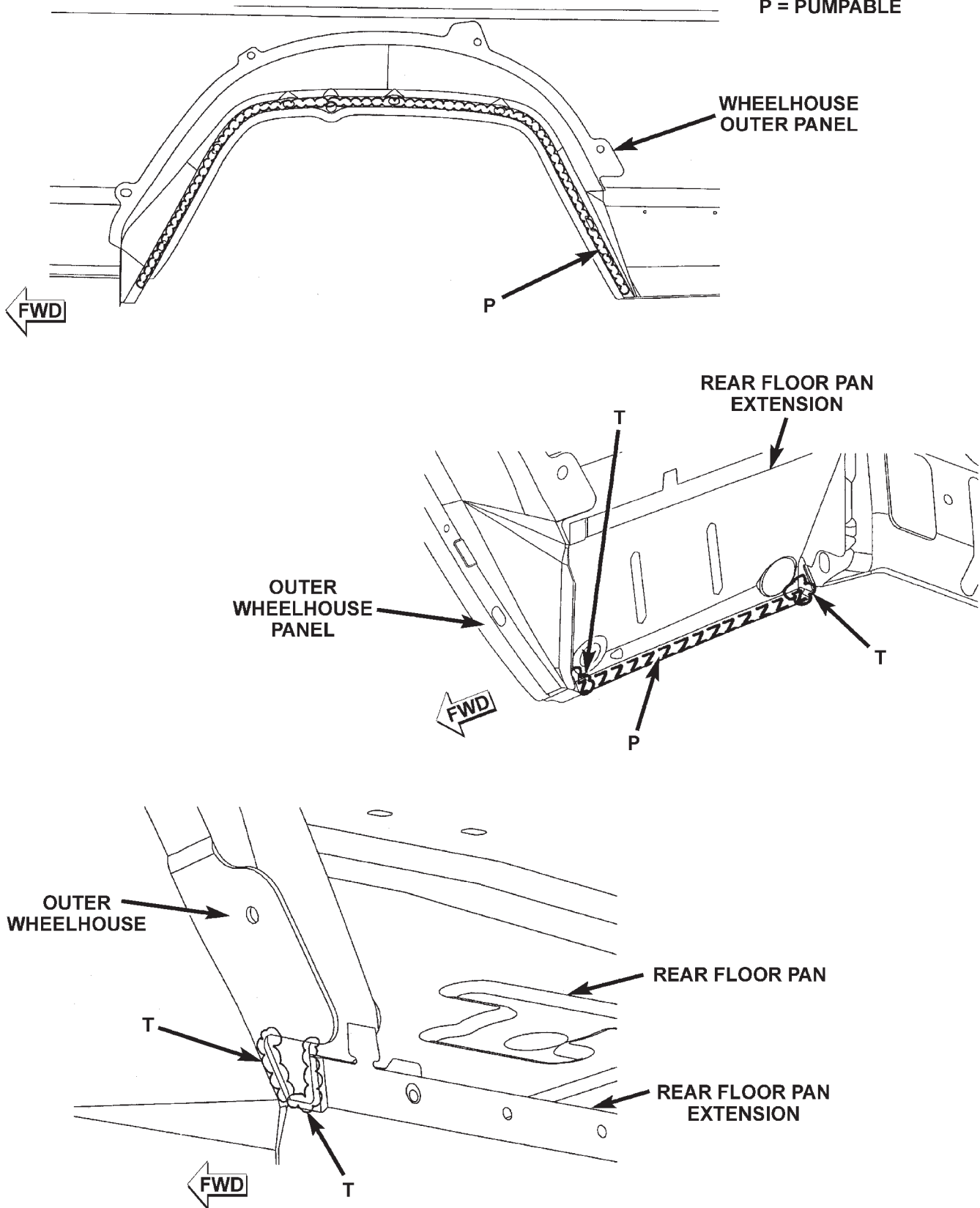

SPECIFICATIONS (Continued)

BODY SIDE

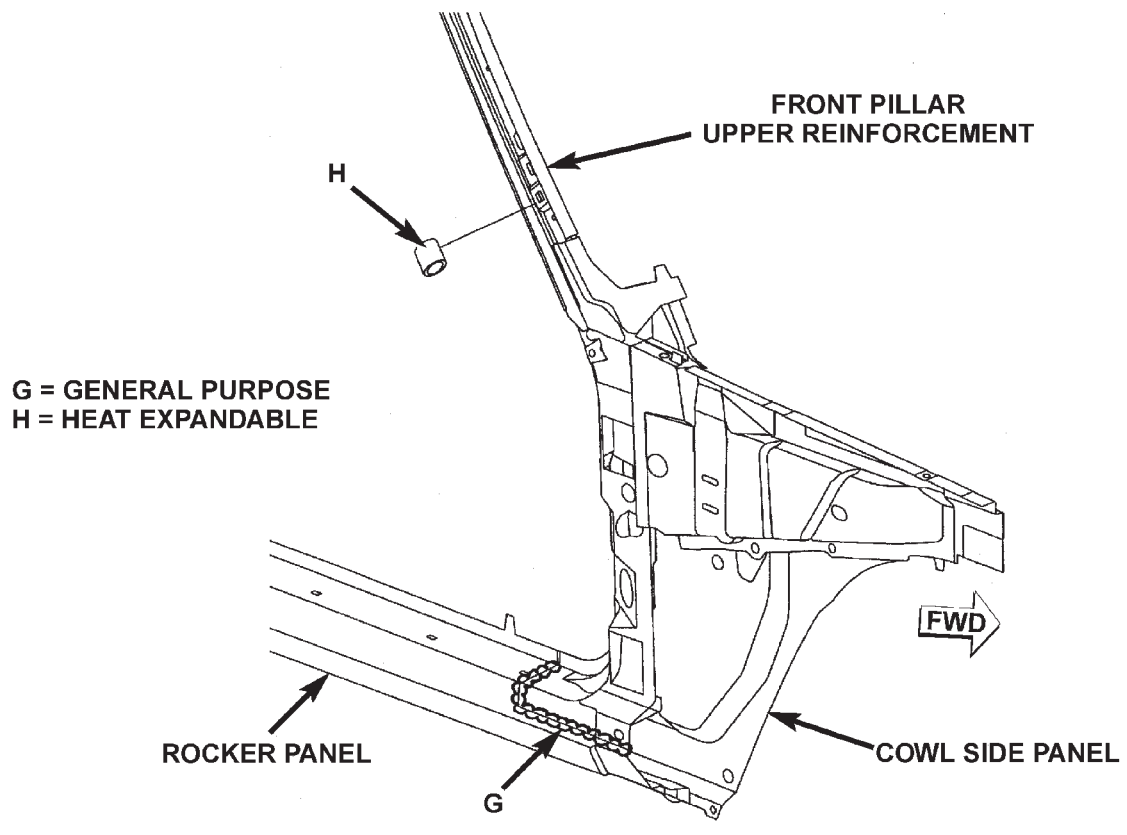

80b6fdeb

SPECIFICATIONS (Continued)

BODY SIDE

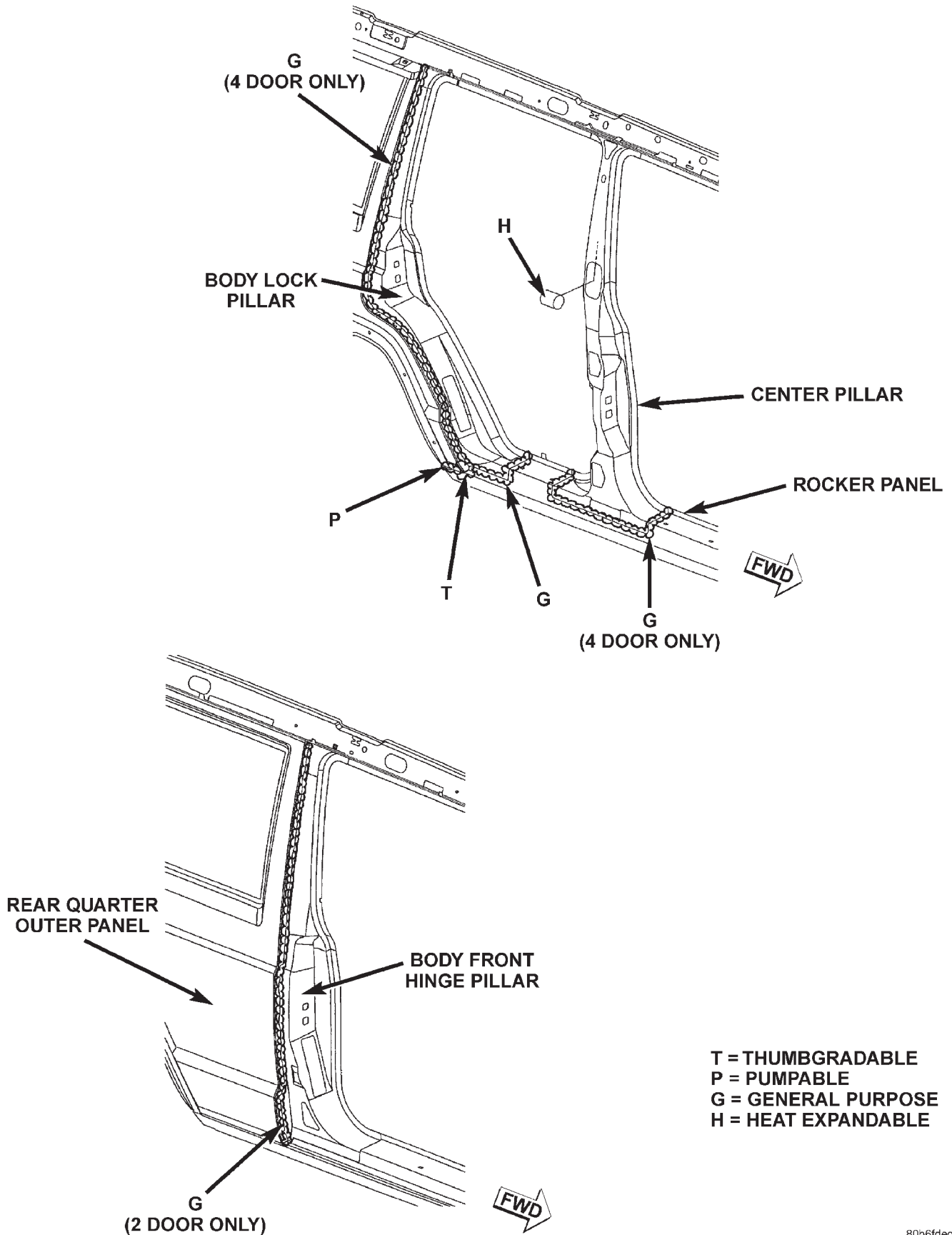

T = THUMBGRADABLE
P = PUMPABLE
G = GENERAL PURPOSE
H = HEAT EXPANDABLE

SPECIFICATIONS (Continued)

BODY SIDE

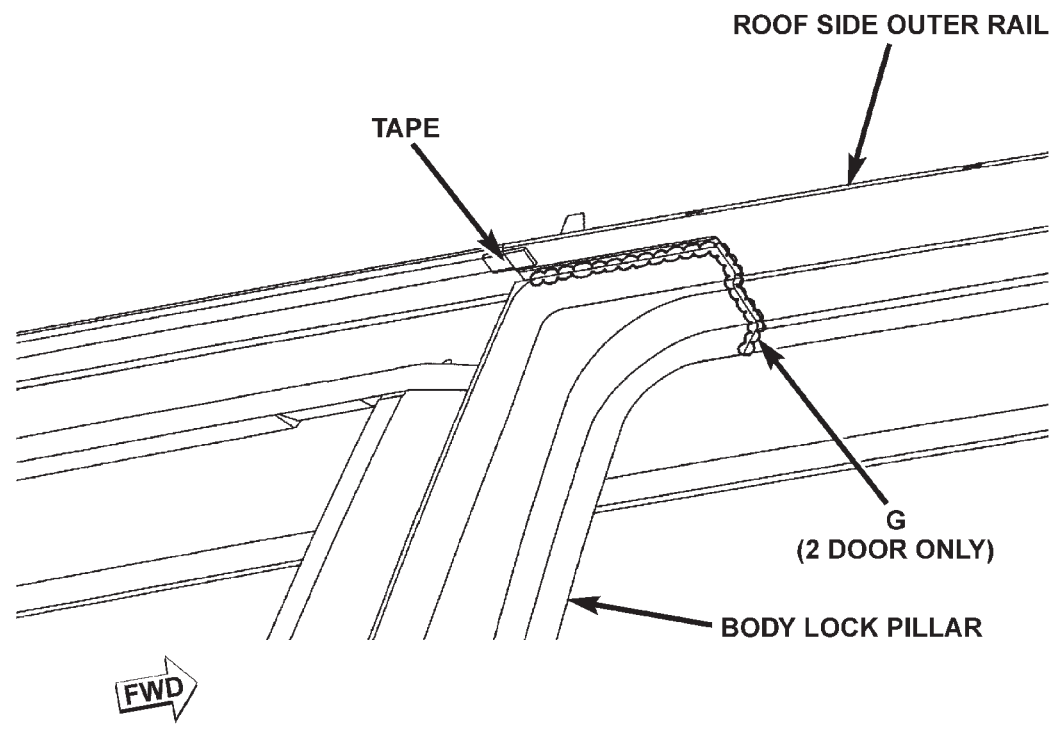
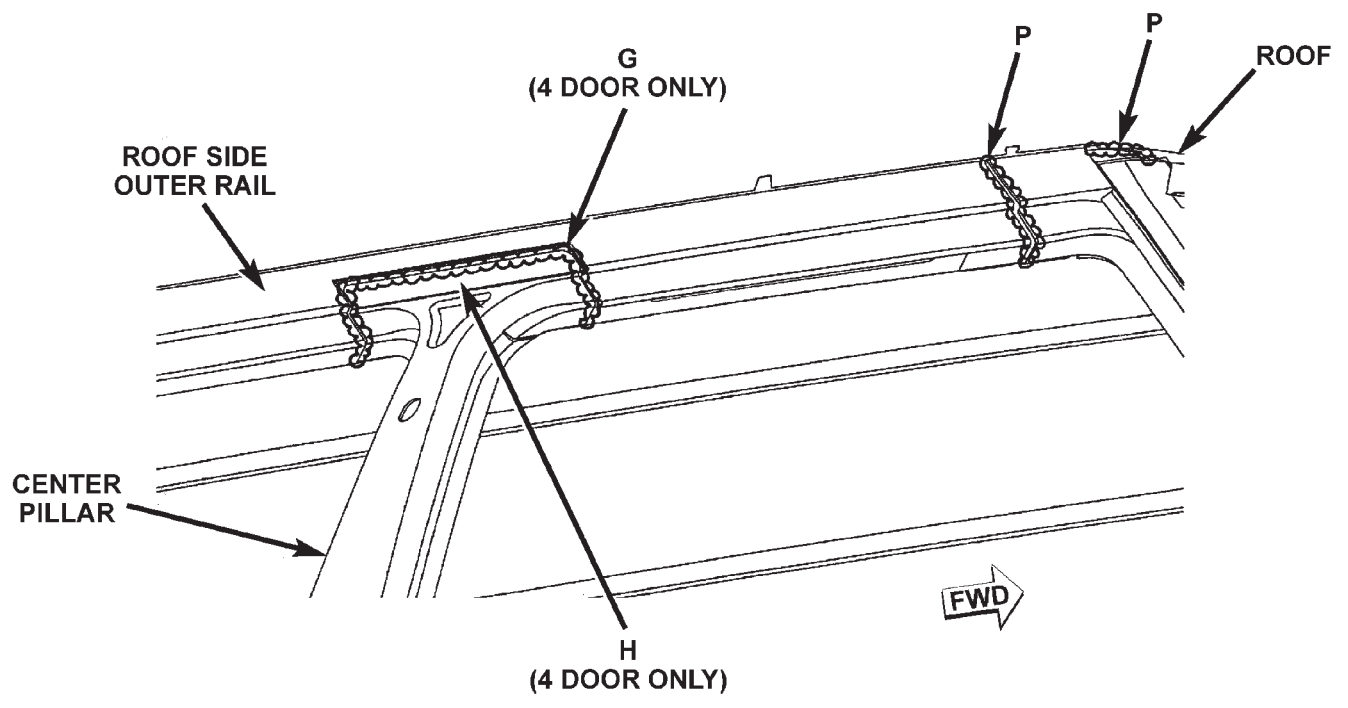

P = PUMPABLE
 G = GENERAL PURPOSE
 H = HEAT EXPANDABLE

SPECIFICATIONS (Continued)

ROOF PANEL

P = PUMPABLE

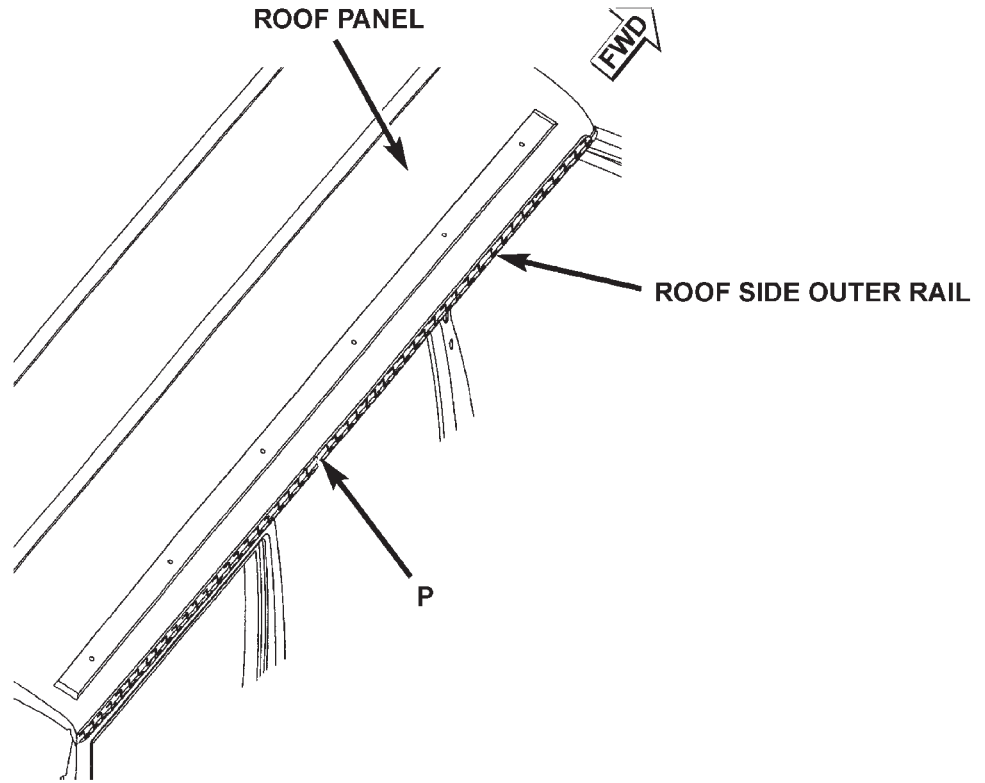

80b6fdee

SPECIFICATIONS (Continued)

FUEL FILLER HOUSING

T = THUMBGRADABLE
P = PUMPABLE

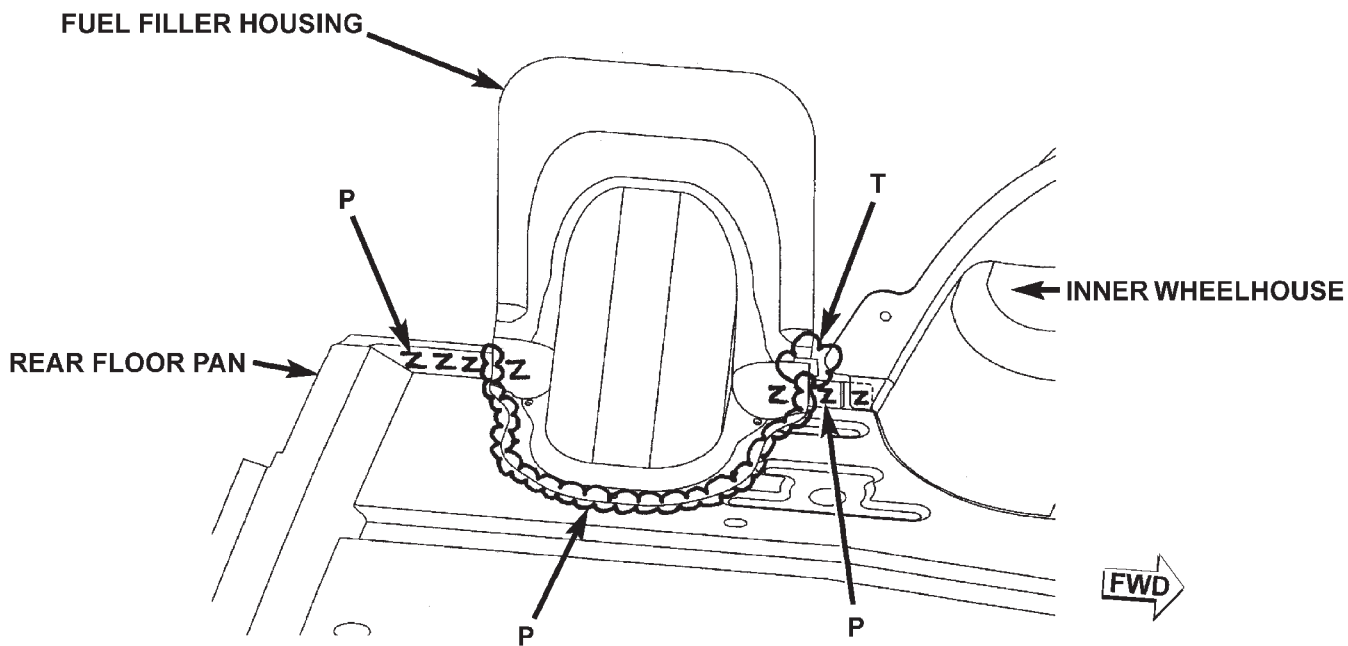
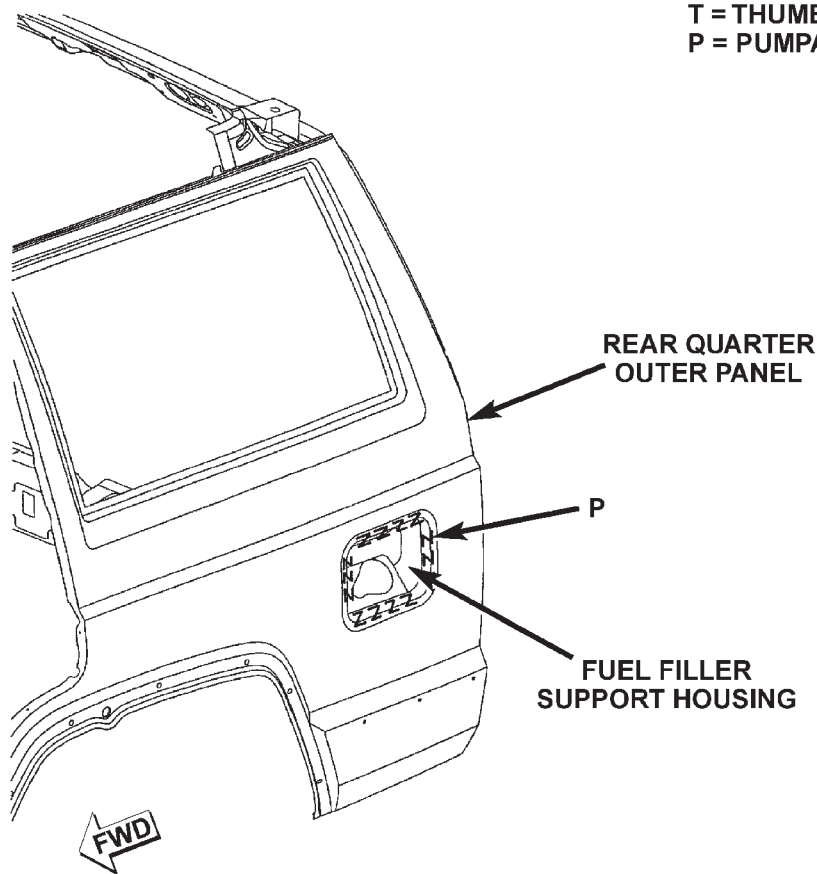

SPECIFICATIONS (Continued)

LIFTGATE OPENING

LIFTGATE HEADER
PANEL

T = THUMBGRADABLE
P = PUMPABLE

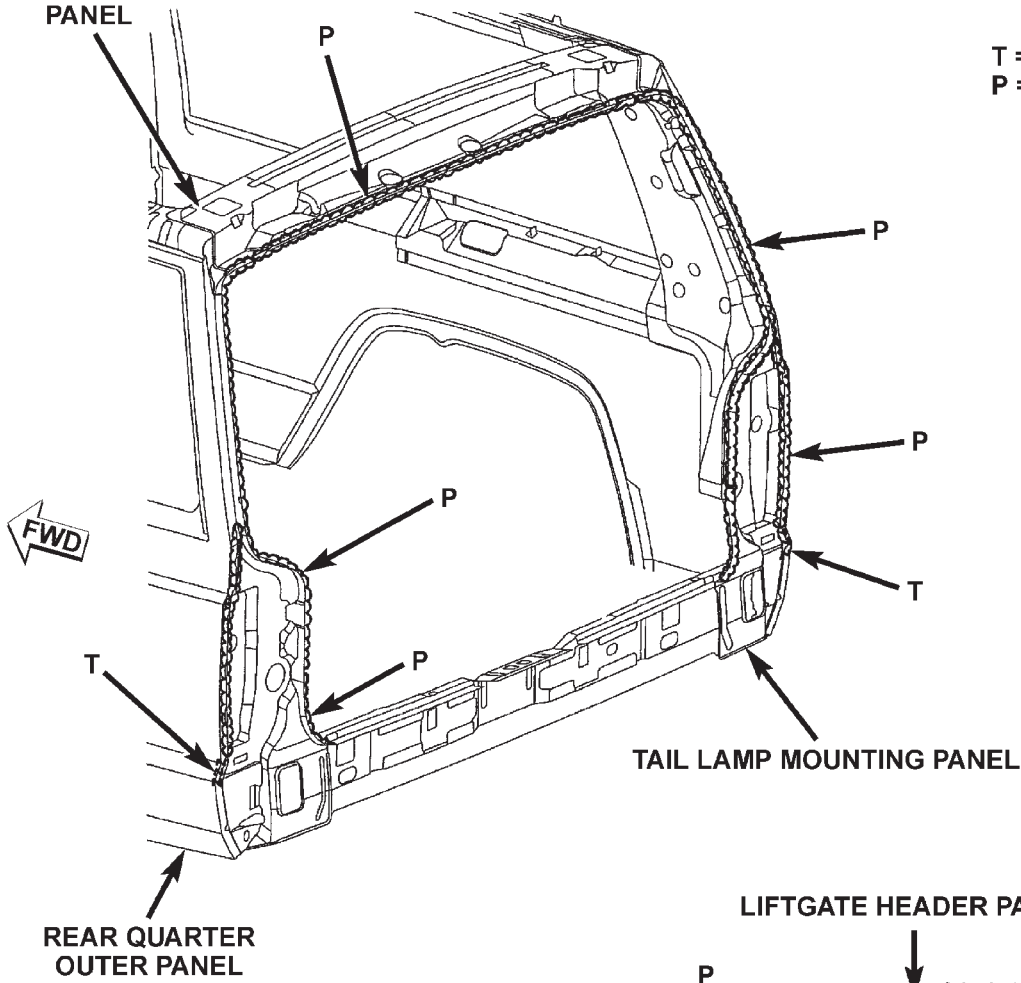

TAIL LAMP MOUNTING PANEL

REAR QUARTER
OUTER PANEL

LIFTGATE HEADER
PANEL

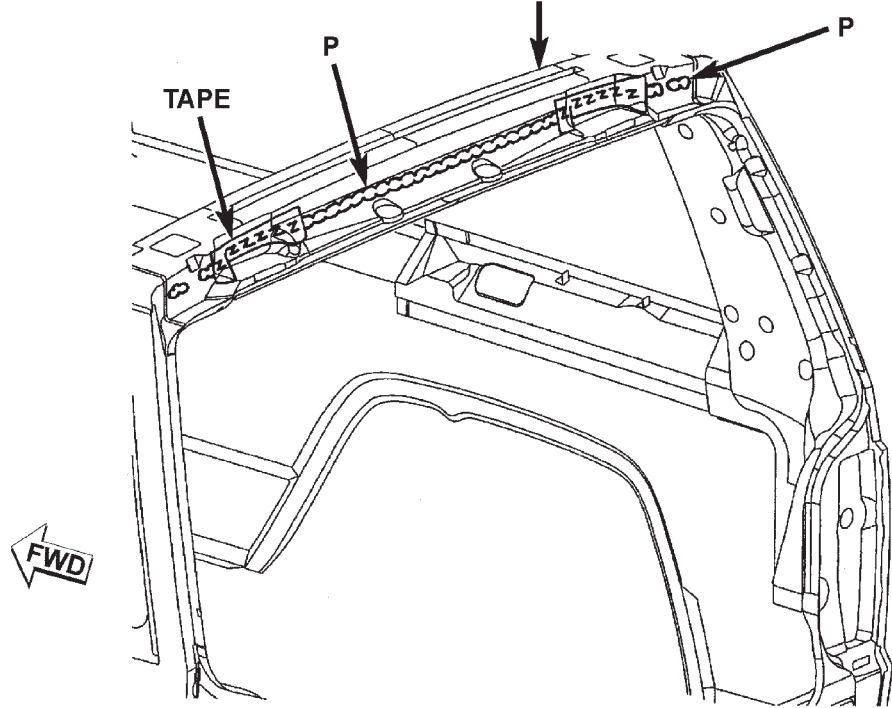

TAPE

SPECIFICATIONS (Continued)

STRUCTURAL ADHESIVE LOCATIONS

LEFT QUARTER PANEL

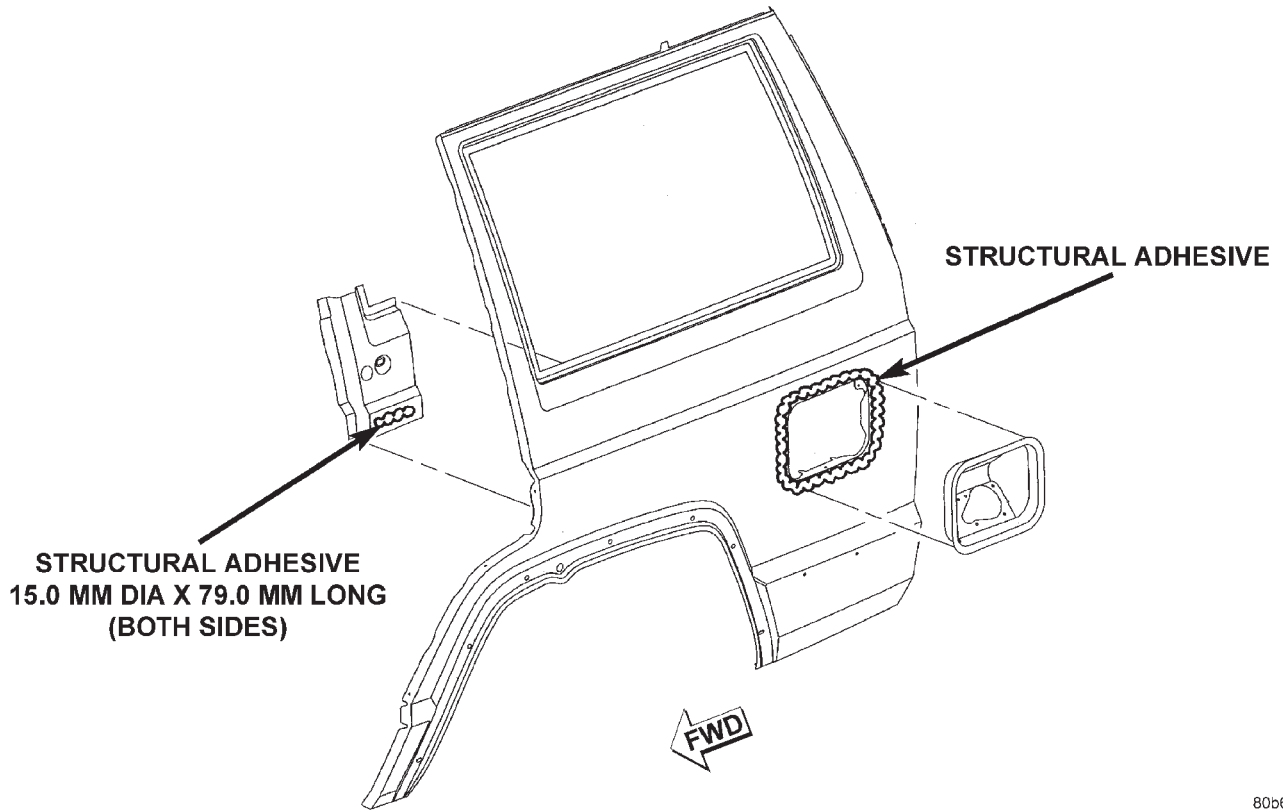

SPECIFICATIONS (Continued)

REAR WHEELHOUSE

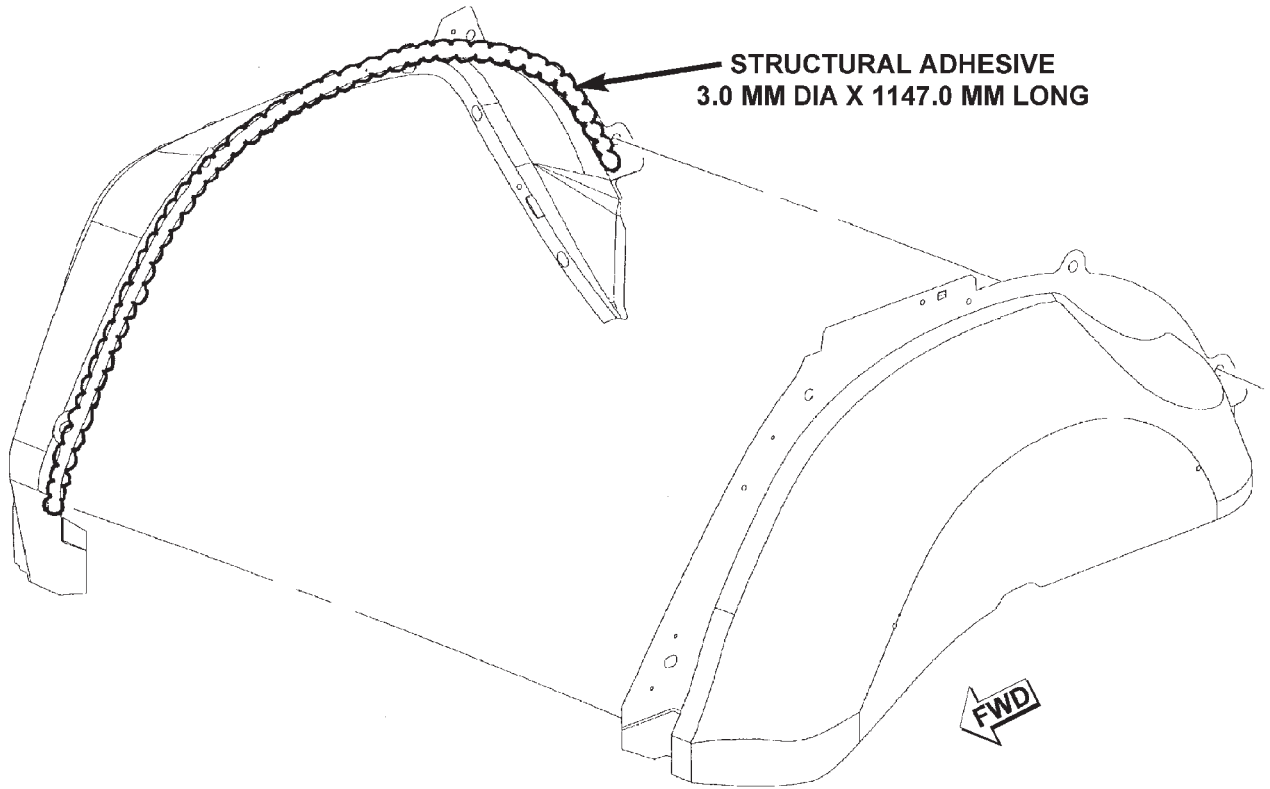

80b6fde4

SPECIFICATIONS (Continued)

ROOF BOWS

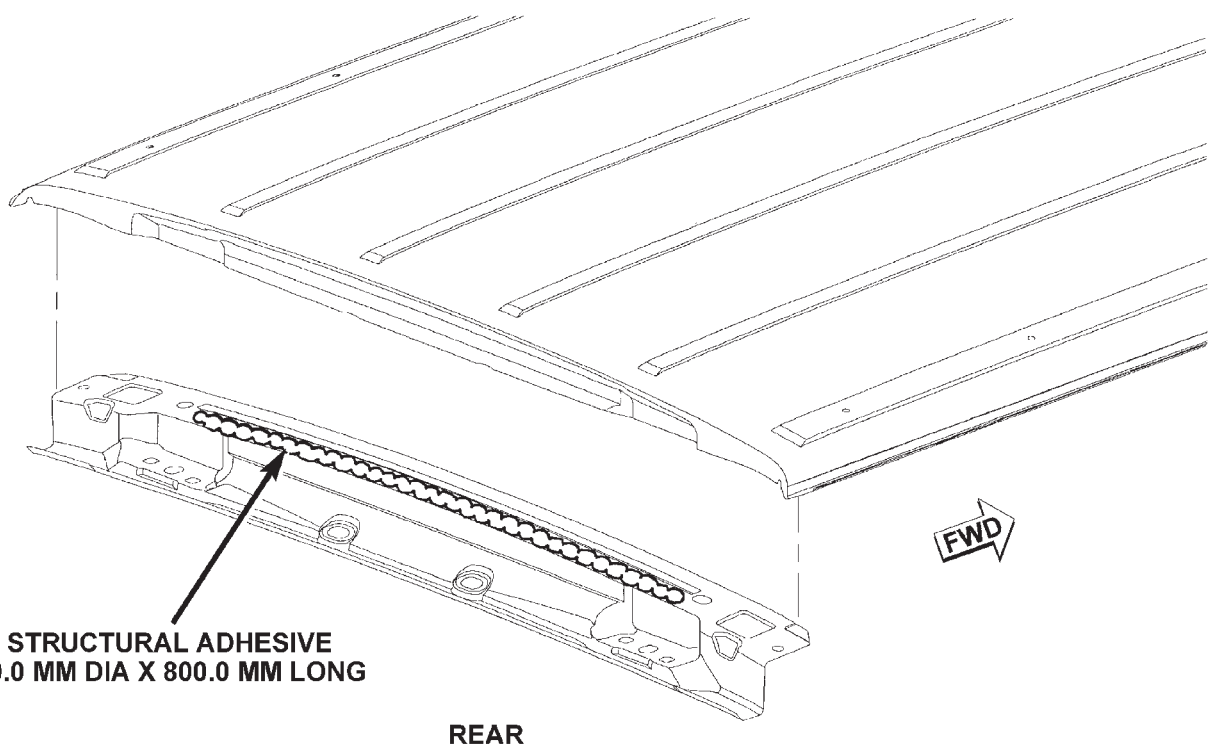
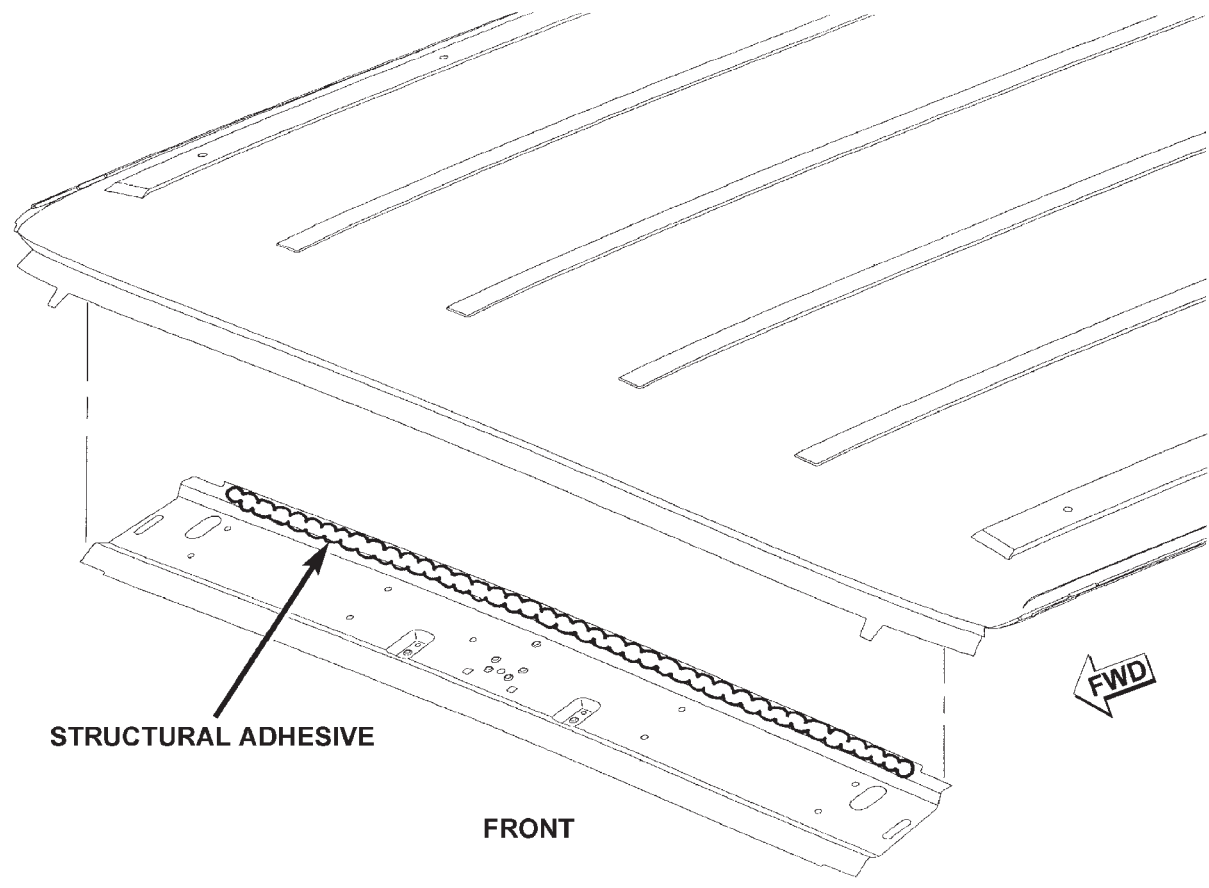

SPECIFICATIONS (Continued)

BODY GAP AND FLUSH MEASUREMENTS

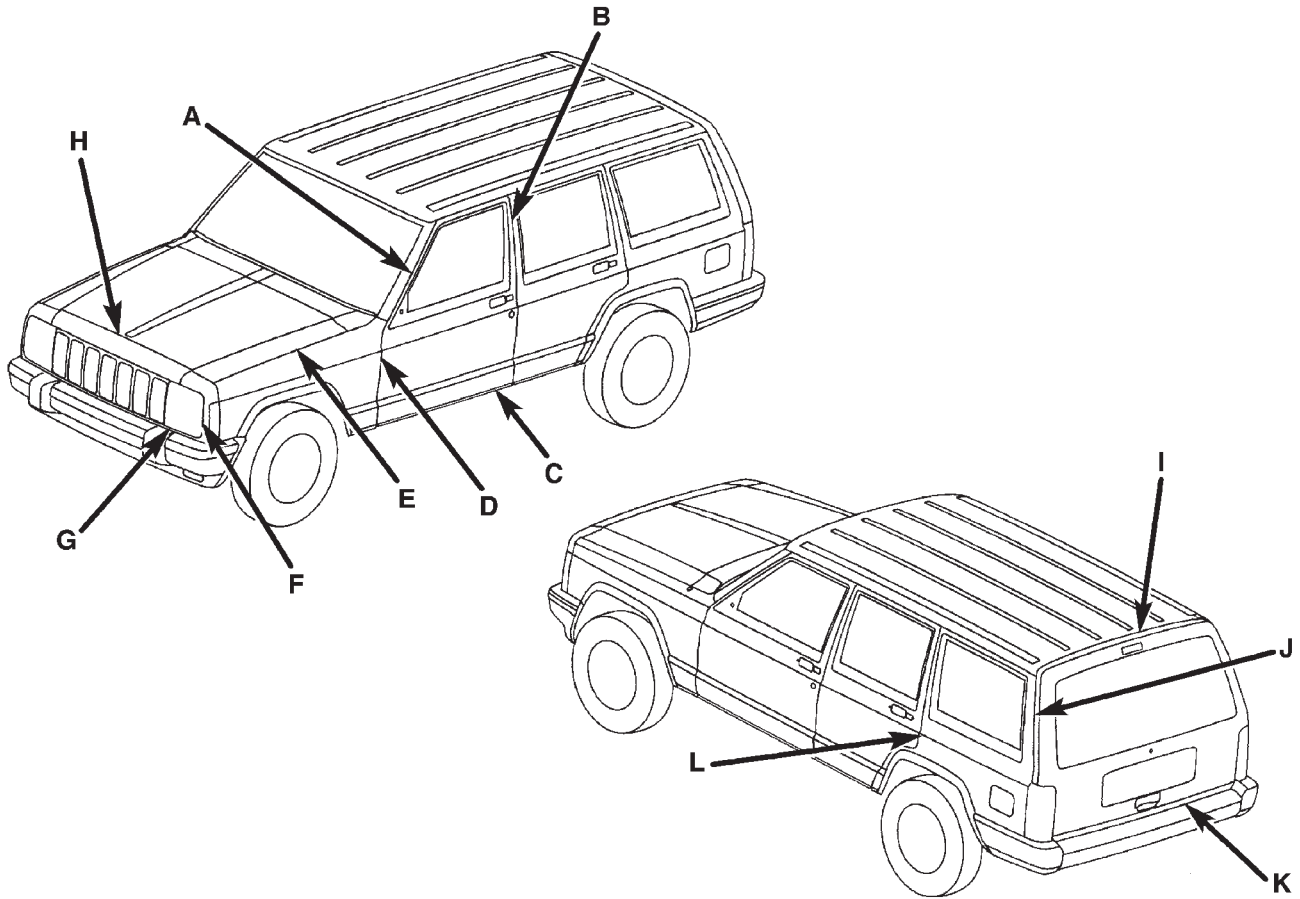

| | LOCATION | GAP | FLUSH |
|---|---------------------------------|--------------|--------------|
| A | Front Door to Windshield Pillar | 6.4 +/- 2.0 | 1.6 +/- 2.0 |
| B | Front Door to REar Door | 6.4 +/- 1.5 | 0.0 +/- 1.5 |
| C | Front Door to Aperture at Sill | 8.1 +/- 1.5 | 0.0 +/- 1.5 |
| D | Front Door to Fender | 6.4 +/- 1.5 | 0.0 +/- 1.5 |
| E | Hood to Fender | 5.6 +/- 1.5 | 0.5 +/- 1.5 |
| F | Headlamp to Fender | 5.6 +/- 1.5 | 0.5 +/- 1.5 |
| G | Headlamp to Roof | N/A | 0.74 +/- 1.0 |
| H | Grille to Hood | 6.0 +/- 1.5 | 0.24 +/- 1.5 |
| I | Liftgate to Roof | 7.5 +/- 1.5 | 0.5 +/- 1.5 |
| J | Liftgate to Aperture | 6.5 +/- 1.5 | 0.0 +/- 1.5 |
| K | Liftgate to Fascia | X. X +/- 2.0 | N/A |
| L | Rear Door to Quarter Panel | 6.4 +/- 1.5 | 0.0 +/- 1.5 |

NOTE: ALL MEASUREMENTS ARE IN MM.

SPECIFICATIONS (Continued)

BODY OPENING DIMENSIONS

WINDSHIELD OPENING

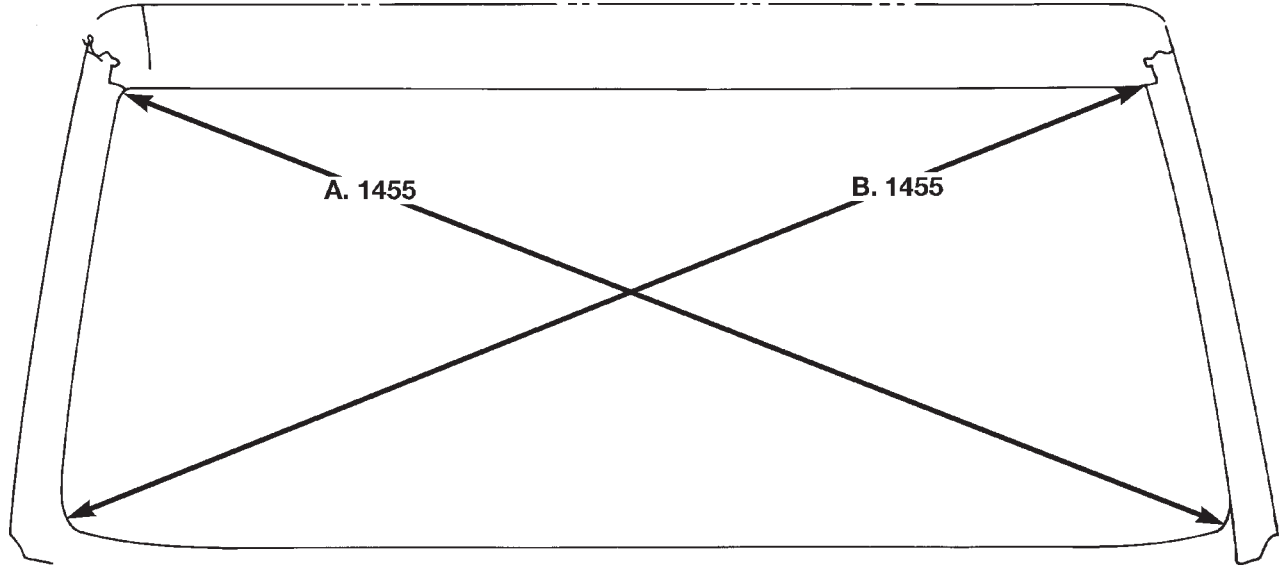

80ae834e

- A. & B. Center of radius at bottom to center of radius at top

SPECIFICATIONS (Continued)

FRONT DOOR OPENING 2-DOOR

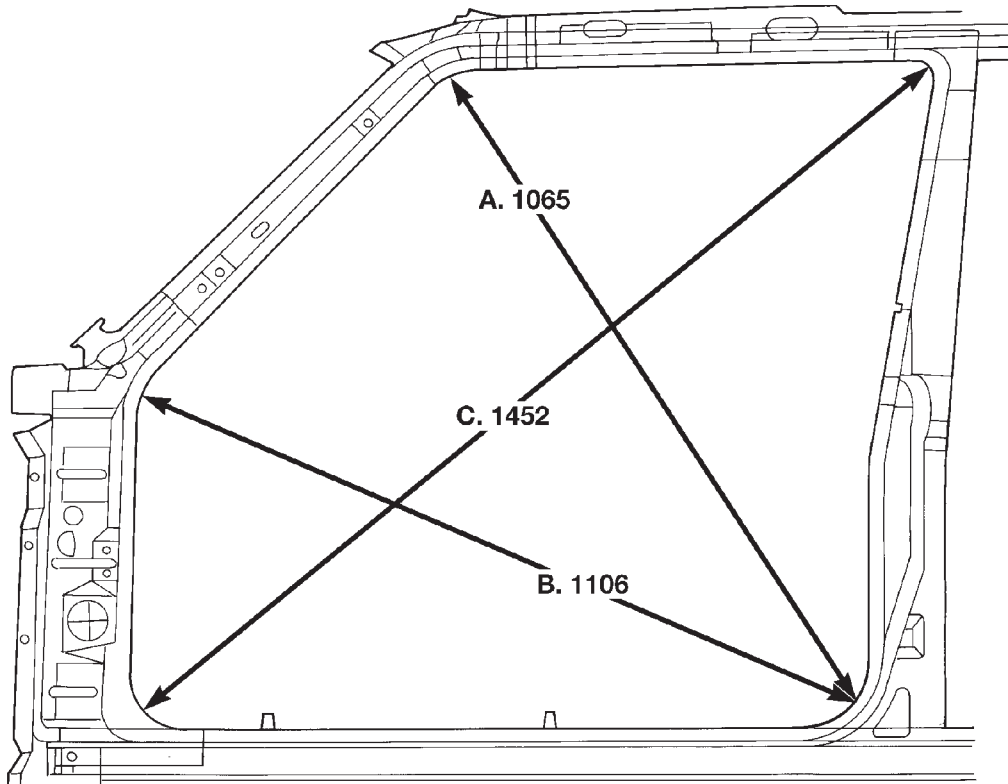

80ae834f

- A. Center of front door lower rear radius to center of A-pillar radius
- B. Center of radius at bottom rear to center of radius at lower A-pillar

- C. Center of radius at bottom front to center of radius at top rear

SPECIFICATIONS (Continued)

FRONT DOOR OPENING 4-DOOR

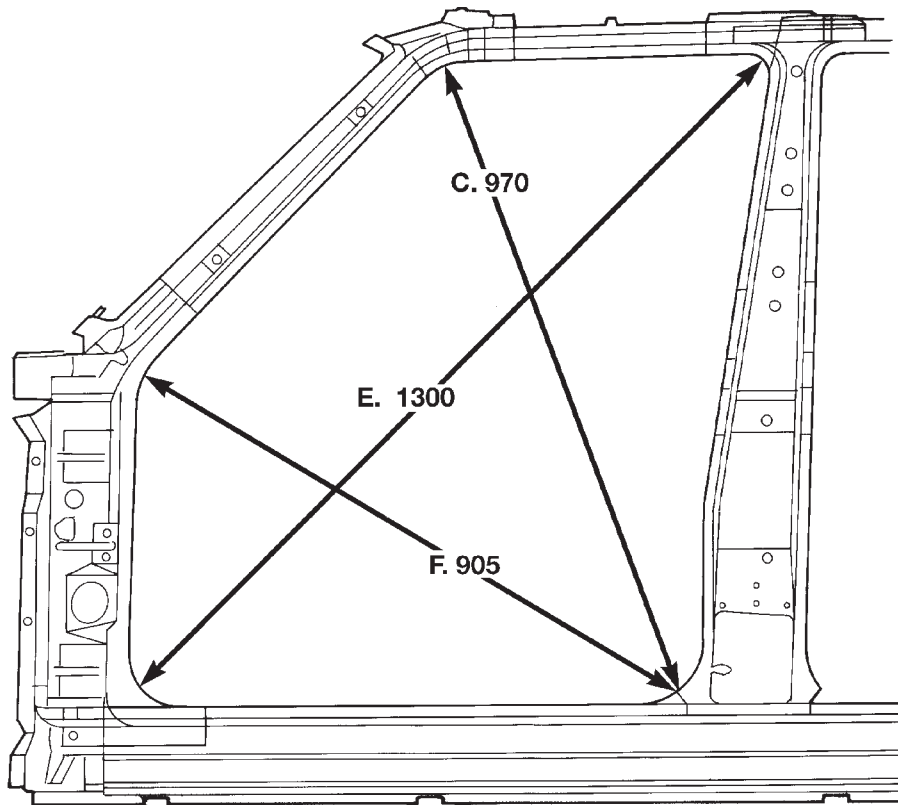

80ae8351

- C. Center of front door lower rear radius to center of A-pillar radius
- E. Center of radius at bottom rear to center of radius at lower A-pillar

- F. Center of radius at bottom front to center of radius at top rear

SPECIFICATIONS (Continued)

REAR DOOR OPENING

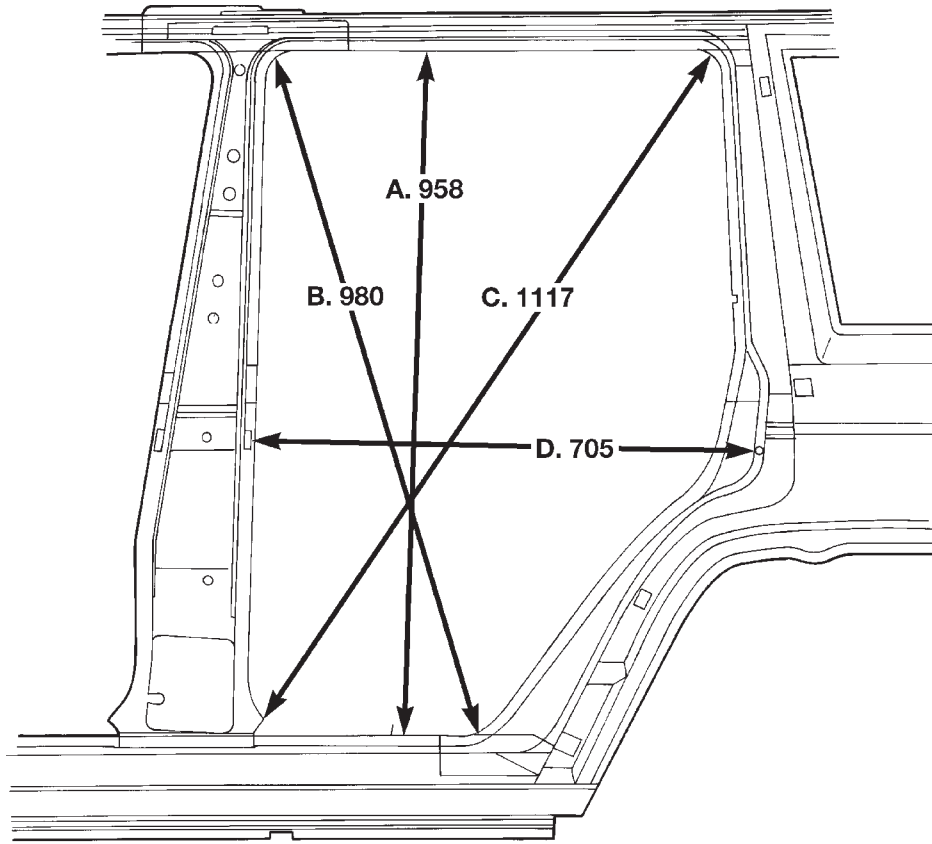

80ae8352

- A. Quarter panel to front outer body side upper and lower seam
- B. Center of front upper door radius to center of rear lower door radius
- C. Center of front lower door radius to center of rear upper door radius
- D. Flange to rear door striker mount

SPECIFICATIONS (Continued)

QUARTER WINDOW OPENING 2-DOOR

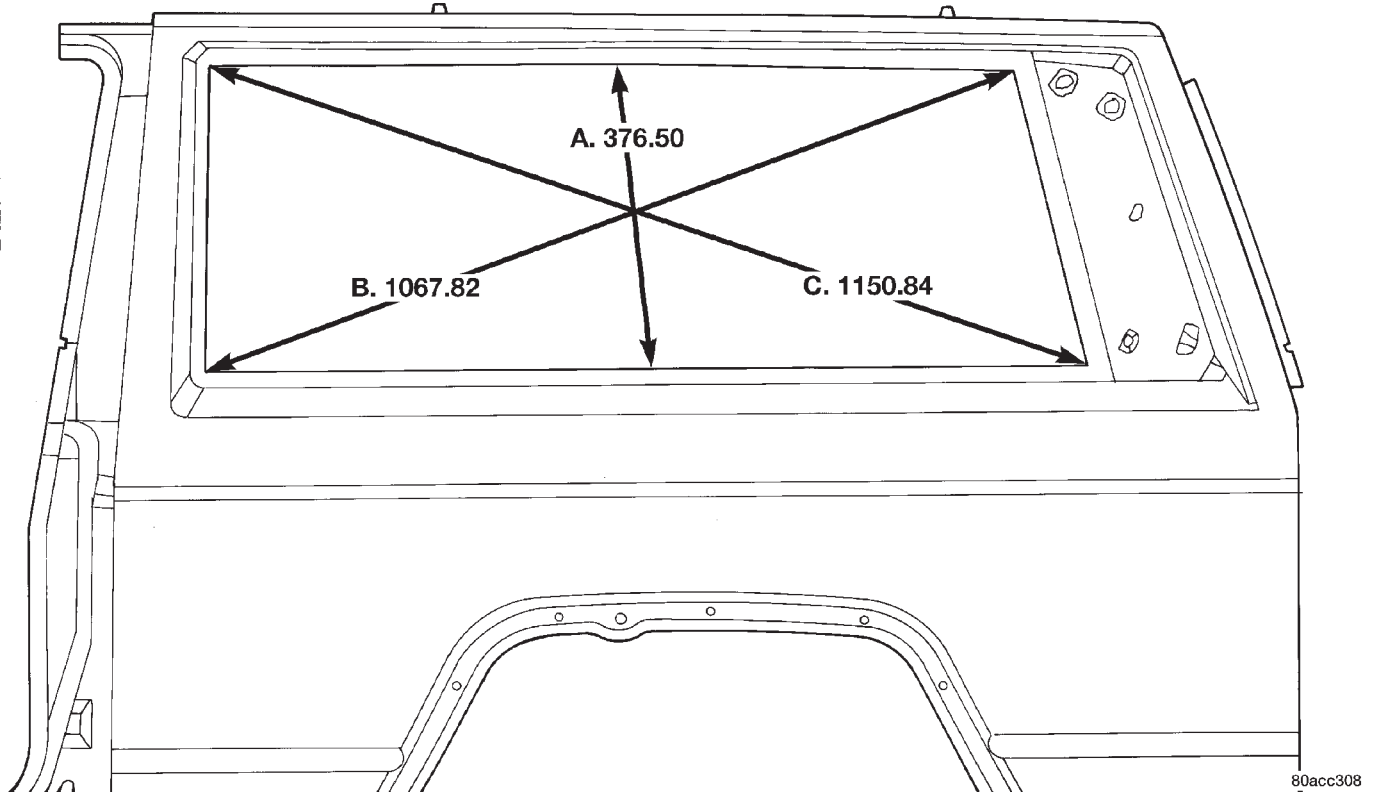

- A. Center of upper and lower rear quarter window opening
- B. Center of radius front lower corner to center of radius rear upper corner

- C. Center of radius front upper corner to center of radius rear lower corner

SPECIFICATIONS (Continued)

QUARTER WINDOW OPENING 4-DOOR

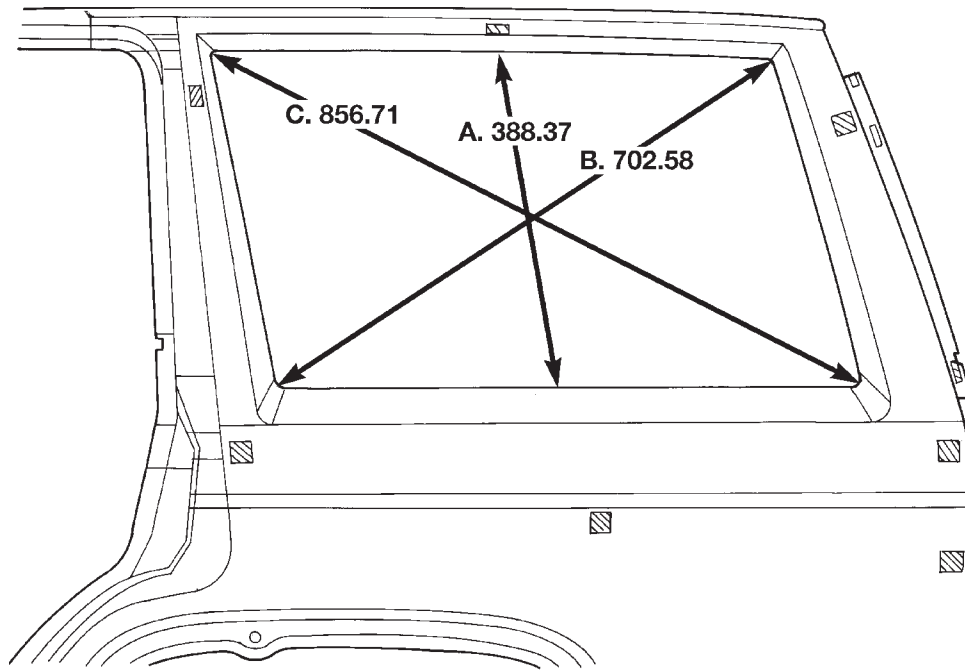

80a9f0f9

- A. Center of upper and lower rear quarter window opening
- B. Center of radius front lower corner to center of radius rear upper corner

- C. Center of radius front upper corner to center of radius rear lower corner

SPECIFICATIONS (Continued)

ENGINE COMPARTMENT

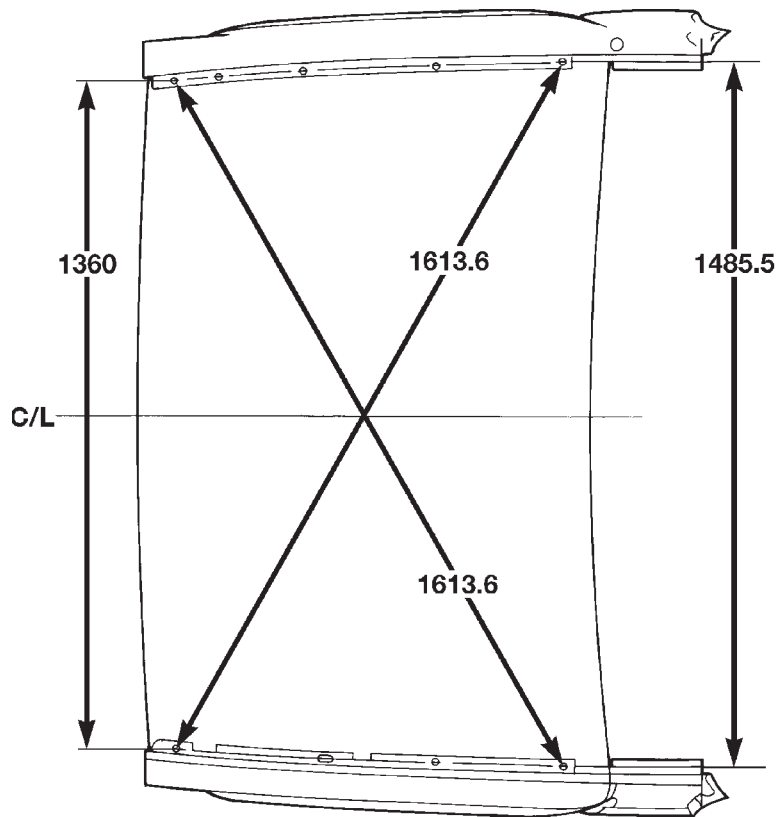

80ae8354

LIFTGATE OPENING

- A. Center of upper liftgate opening to liftgate striker mount
- B. & C. Center of radius upper corner to center of radius lower corner

- D. Distance between outer quarter panel to tail lamp mounting panel to inner quarter panel seams

SPECIFICATIONS (Continued)

LIFTGATE OPENING

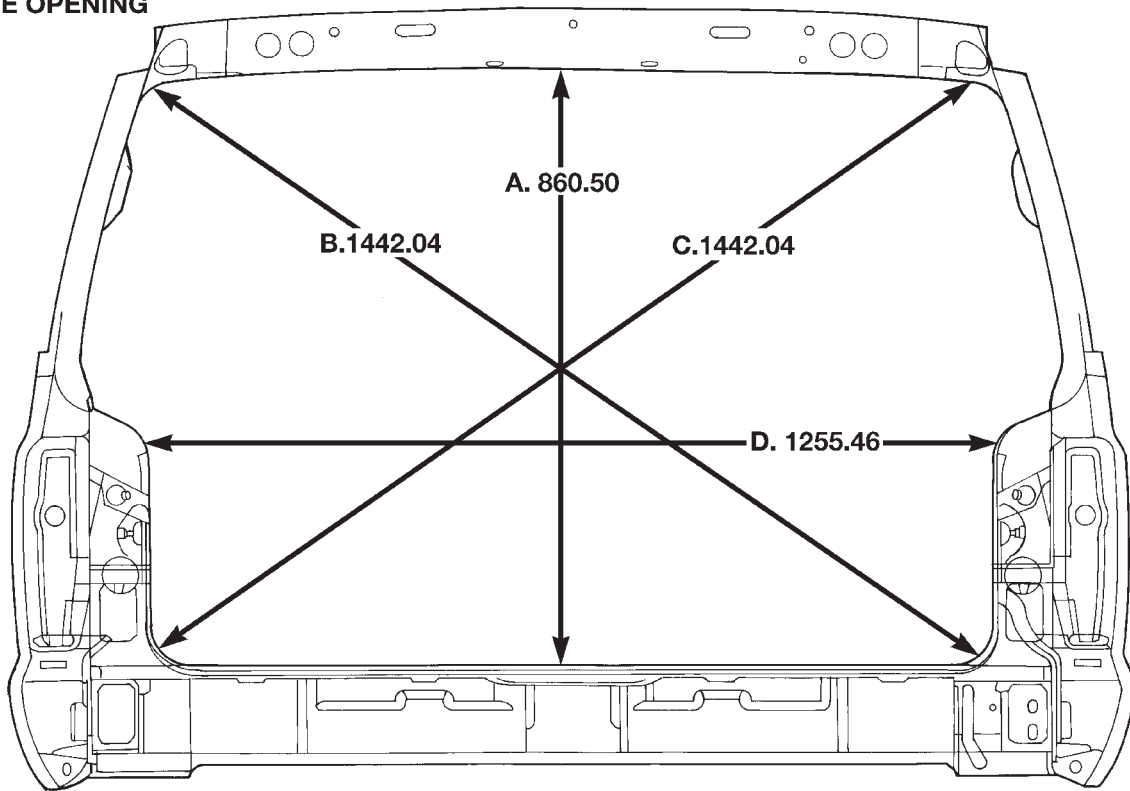

80b3c727

TORQUE SPECIFICATIONS

| DESCRIPTION | TORQUE |
|--|-------------------------|
| Bucket Seat to Floor Pan Bolt . . . | 27 N·m (20 ft. lbs.) |
| Bucket Seat to Floor Pan Nut . . . | 40 N·m (30 ft. lbs.) |
| Front Door Hinge Bolts | 3 N·m (2 ft. lbs.) |
| Front Door Latch Screw | 11 N·m (8 ft. lbs.) |
| Front Door Latch Striker Screw | 28 N·m (20 ft. lbs.) |
| Front Seat Belt Anchor Bolt . . . | 43 N·m (32 ft. lbs.) |
| Front Retractor Anchor Bolt . . . | 43 N·m (32 ft. lbs.) |
| Front Seat Belt Buckle Anchor Bolt | 43 N·m (32 ft. lbs.) |
| GOP to Support Bracket Nut . . . | 4 N·m (38 in. lbs.) |
| GOP to Fender Nut | 4 N·m (38 in. lbs.) |
| Liftgate Hinge to Body and/or Liftgate Bolt | 26 N·m (19 ft. lbs.) |
| Liftgate Latch Screw | 13 N·m (9 ft. lbs.) |
| Liftgate Latch Striker Nut | 54 N·m (40 ft. lbs.) |
| Rear Door Hinge Bolt | 3 N·m (2 ft. lbs.) |
| Rear Door Latch Screw | 11 N·m (8 ft. lbs.) |
| Rear Door Latch Striker Screw . | 28 N·m (20 ft. lbs.) |
| Rear Shoulder Belt Lower Anchor Bolt | 43 N·m (32 ft. lbs.) |

| DESCRIPTION | TORQUE |
|--|-------------------------|
| Rear Seatback Pivot Bolt | 33 N·m (25 ft. lbs.) |
| Rear Seat Belt/Buckle Anchor Bolt | 43 N·m (32 ft. lbs.) |
| Rear Shoulder Belt Upper Anchor Bolt | 43 N·m (32 ft. lbs.) |

SPECIAL TOOLS

BODY

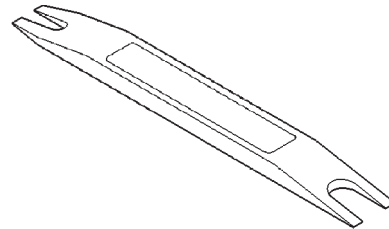

Remover, Moldings C-4829

HEATING AND AIR CONDITIONING

TABLE OF CONTENTS

| | page | | page |
|--|------|--|------|
| DESCRIPTION AND OPERATION | | REFRIGERANT SYSTEM LEAKS | 17 |
| ACCUMULATOR | 2 | VACUUM SYSTEM | 18 |
| BLOWER MOTOR | 2 | SERVICE PROCEDURES | |
| BLOWER MOTOR RELAY | 2 | REFRIGERANT OIL LEVEL | 19 |
| BLOWER MOTOR RESISTOR | 3 | REFRIGERANT RECOVERY | 22 |
| BLOWER MOTOR SWITCH | 3 | REFRIGERANT SYSTEM EVACUATE | 22 |
| COMPRESSOR | 3 | REFRIGERANT SYSTEM CHARGE | 22 |
| COMPRESSOR CLUTCH | 3 | REFRIGERANT SYSTEM SERVICE | |
| COMPRESSOR CLUTCH RELAY | 4 | EQUIPMENT | 22 |
| CONDENSER | 4 | REMOVAL AND INSTALLATION | |
| DUAL FUNCTION HIGH PRESSURE SWITCH | | SERVICE WARNINGS AND PRECAUTIONS | 23 |
| (4.0 L) | 4 | ACCUMULATOR | 25 |
| EVAPORATOR COIL | 4 | BLEND-AIR DOOR MOTOR | 26 |
| FIXED ORIFICE TUBE | 5 | BLOWER MOTOR | 26 |
| HEATER AND AIR CONDITIONER | 5 | BLOWER MOTOR RELAY | 27 |
| HEATER AND AIR CONDITIONER CONTROL | 6 | BLOWER MOTOR RESISTOR | 27 |
| HEATER CORE | 6 | COMPRESSOR | 28 |
| HIGH PRESSURE CUT-OFF SWITCH | 6 | COMPRESSOR CLUTCH | 29 |
| HIGH PRESSURE RELIEF VALVE | 7 | COMPRESSOR CLUTCH RELAY | 31 |
| LOW PRESSURE CYCLING CLUTCH SWITCH | 7 | CONDENSER | 32 |
| REFRIGERANT | 7 | DUAL FUNCTION HIGH PRESSURE | |
| REFRIGERANT LINES | 7 | SWITCH/HIGH PRESSURE CUT-OFF | |
| REFRIGERANT LINE COUPLERS | 8 | SWITCH | 33 |
| REFRIGERANT OIL | 8 | DUCTS AND OUTLETS | 33 |
| REFRIGERANT SYSTEM SERVICE PORT | 9 | EVAPORATOR COIL | 35 |
| VACUUM CHECK VALVE | 9 | FIXED ORIFICE TUBE | 35 |
| VACUUM RESERVOIR | 9 | HEATER-A/C CONTROL | 35 |
| DIAGNOSIS AND TESTING | | HEATER-A/C HOUSING | 36 |
| A/C PERFORMANCE | 9 | HEATER-A/C HOUSING DOOR | 39 |
| BLOWER MOTOR | 12 | HEATER CORE | 41 |
| BLOWER MOTOR RELAY | 13 | LIQUID LINE | 41 |
| BLOWER MOTOR RESISTOR | 14 | LOW PRESSURE CYCLING CLUTCH SWITCH | 42 |
| BLOWER MOTOR SWITCH | 14 | KICK COVER | 42 |
| COMPRESSOR | 14 | MODE DOOR VACUUM ACTUATOR | 43 |
| COMPRESSOR CLUTCH COIL | 15 | REFRIGERANT LINE COUPLER | 45 |
| COMPRESSOR CLUTCH RELAY | 15 | SUCTION AND DISCHARGE LINE | 45 |
| DUAL FUNCTION HIGH PRESSURE | | VACUUM CHECK VALVE | 46 |
| SWITCH/HIGH PRESSURE CUT-OFF | | VACUUM RESERVOIR | 47 |
| SWITCH | 16 | SPECIFICATIONS | |
| HEATER PERFORMANCE | 16 | A/C APPLICATION TABLE | 47 |
| LOW PRESSURE CYCLING CLUTCH SWITCH | 17 | | |

DESCRIPTION AND OPERATION

ACCUMULATOR

DESCRIPTION

The accumulator is mounted in the engine compartment between the evaporator coil outlet tube and the compressor inlet.

OPERATION

Refrigerant enters the accumulator canister as a low pressure vapor through the inlet tube. Any liquid, oil-laden refrigerant falls to the bottom of the canister, which acts as a separator. A desiccant bag is mounted inside the accumulator canister to absorb any moisture which may have entered and become trapped within the refrigerant system (Fig. 1).

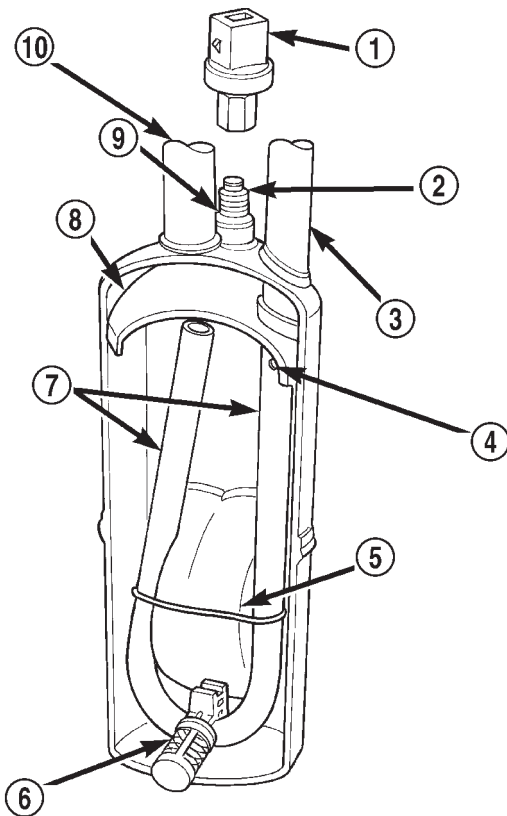

80add30t

Fig. 1 Accumulator - Typical

- 1 - LOW PRESSURE CYCLING CLUTCH SWITCH
- 2 - PRESSURE SWITCH FITTING
- 3 - OUTLET TO COMPRESSOR
- 4 - ANTI-SIPHON HOLE
- 5 - DESICCANT BAG
- 6 - OIL RETURN ORIFICE FILTER
- 7 - VAPOR RETURN TUBE
- 8 - ACCUMULATOR DOME
- 9 - O-RING SEAL
- 10 - INLET FROM EVAPORATOR

BLOWER MOTOR

DESCRIPTION

The blower motor and blower wheel are located in the passenger side end of the heater-A/C housing, below the glove box. The blower motor controls the velocity of air flowing through the heater-A/C housing by spinning a squirrel cage-type blower wheel within the housing at the selected speed. The blower motor and wheel can be removed through an opening in the engine compartment side of the dash panel without heater-A/C housing removal.

OPERATION

The blower motor will only operate when the ignition switch is in the On position, and the heater-A/C mode control switch knob is in any position, except Off. The blower motor receives a fused battery feed through the blower motor relay whenever the ignition switch is in the On position. The blower motor battery feed circuit is protected by a fuse in the Power Distribution Center (PDC). Blower motor speed is controlled by regulating the ground path through the heater-A/C control blower motor switch and the blower motor resistor.

The blower motor and blower motor wheel cannot be repaired and, if faulty or damaged, they must be replaced. The blower motor and blower wheel are serviced only as a unit.

BLOWER MOTOR RELAY

DESCRIPTION

The blower motor relay is a International Standards Organization (ISO)-type relay. The relay is an electromechanical device that switches battery current from a fuse in the Power Distribution Center (PDC) directly to the blower motor. The relay is energized when the relay coil is provided a voltage signal by the ignition switch. See Blower Motor Relay in the Diagnosis and Testing section of this group for more information.

OPERATION

The blower motor relay is installed in a wire harness connector that is secured to the passenger side outboard end of the heater-A/C housing in the passenger compartment, next to the heater-A/C wire harness connector.

The blower motor relay cannot be repaired and, if faulty or damaged, it must be replaced.

DESCRIPTION AND OPERATION (Continued)

BLOWER MOTOR RESISTOR**DESCRIPTION**

The blower motor resistor is mounted to the bottom of the heater-A/C housing on the passenger side of the vehicle under the instrument panel. It can be accessed for service by removing the heater-A/C housing kick cover.

OPERATION

The resistor has multiple resistor wires, each of which reduce the current flow to the blower motor, to change the blower motor speed. The blower motor switch directs the ground path through the correct resistor wire to obtain the selected speed. When the highest blower speed is selected, the blower motor switch connects the blower motor directly to ground, bypassing the blower motor resistor.

The blower motor resistor cannot be repaired and, if faulty or damaged, it must be replaced.

BLOWER MOTOR SWITCH**DESCRIPTION**

The heater-only or heater-A/C blower motor is controlled by a four position rotary-type blower motor switch, mounted in the heater-A/C control panel. The switch allows the selection of one of four blower motor speeds, but can only be turned off by selecting the Off position with the heater-A/C mode control switch knob.

OPERATION

The blower motor switch directs the blower motor ground path through the mode control switch to the blower motor resistor, or directly to ground, as required to achieve the selected blower motor speed.

The blower motor switch cannot be repaired and, if faulty or damaged, the entire heater-only or heater-A/C control unit must be replaced.

COMPRESSOR**DESCRIPTION**

The air conditioning system uses a Sanden SD7H15 seven cylinder, reciprocating wobble plate-type compressor on all models. This compressor has a fixed displacement of 150 cubic centimeters (9.375 cubic inches), and has both the suction and discharge ports located on the cylinder head. A label identifying the use of R-134a refrigerant is located on the compressor.

OPERATION

The compressor is driven by the engine through an electric clutch, drive pulley and belt arrangement.

The compressor is lubricated by refrigerant oil that is circulated throughout the refrigerant system with the refrigerant.

The compressor draws in low-pressure refrigerant vapor from the evaporator through its suction port. It then compresses the refrigerant into a high-pressure, high-temperature refrigerant vapor, which is then pumped to the condenser through the compressor discharge port.

The compressor cannot be repaired. If faulty or damaged, the entire compressor assembly must be replaced. The compressor clutch, pulley and clutch coil are available for service.

COMPRESSOR CLUTCH**DESCRIPTION**

The compressor clutch assembly consists of a stationary electromagnetic coil, a hub bearing and pulley assembly, and a clutch plate (Fig. 2). The electromagnetic coil unit and the hub bearing and pulley assembly are each retained on the nose of the compressor front housing with snap rings. The clutch plate is keyed to the compressor shaft and secured with a nut. These components provide the means to engage and disengage the compressor from the engine serpentine accessory drive belt.

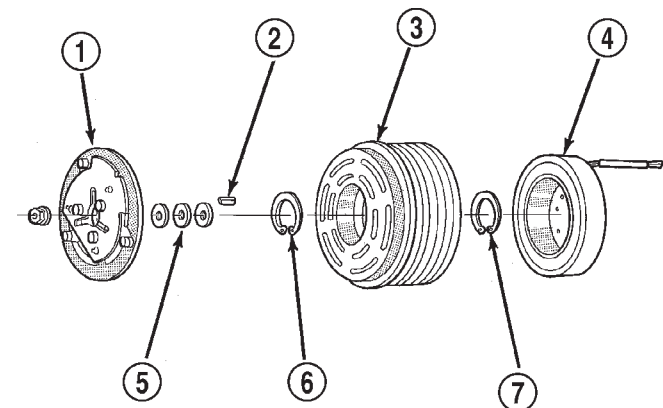

J9524-33

Fig. 2 Compressor Clutch - Typical

- 1 - CLUTCH PLATE
- 2 - SHAFT KEY
- 3 - PULLEY
- 4 - COIL
- 5 - CLUTCH SHIMS
- 6 - SNAP RING
- 7 - SNAP RING

OPERATION

When the clutch coil is energized, it magnetically draws the clutch into contact with the pulley and drives the compressor shaft. When the coil is not energized, the pulley freewheels on the clutch hub.

DESCRIPTION AND OPERATION (Continued)

bearing, which is part of the pulley. The compressor clutch and coil are the only serviced parts on the compressor.

The compressor clutch engagement is controlled by several components: the heater-A/C mode control switch, the low pressure cycling clutch switch, the high pressure cut-off switch, the compressor clutch relay, and the Powertrain Control Module (PCM). The PCM may delay compressor clutch engagement for up to thirty seconds. Refer to Group 14 - Fuel System for more information on the PCM controls.

COMPRESSOR CLUTCH RELAY

DESCRIPTION

The compressor clutch relay is a International Standards Organization (ISO) micro-relay. The terminal designations and functions are the same as a conventional ISO relay. However, the micro-relay terminal orientation (footprint) is different, the current capacity is lower, and the relay case dimensions are smaller than those of the conventional ISO relay.

The compressor clutch relay is located in the Power Distribution Center (PDC) in the engine compartment. Refer to the PDC label for relay identification and location.

OPERATION

The compressor clutch relay is a electromechanical device that switches battery current to the compressor clutch coil when the Powertrain Control Module (PCM) grounds the coil side of the relay. The PCM responds to inputs from the heater-A/C mode control switch, the low pressure cycling clutch switch, and the high pressure cut-off switch. See Compressor Clutch Relay in the Diagnosis and Testing section of this group for more information.

The compressor clutch relay cannot be repaired and, if faulty or damaged, it must be replaced.

CONDENSER

DESCRIPTION

The condenser is located in the air flow in front of the engine cooling radiator. The condenser is a heat exchanger that allows the high-pressure refrigerant gas being discharged by the compressor to give up its heat to the air passing over the condenser fins.

OPERATION

When the refrigerant gas gives up its heat, it condenses. When the refrigerant leaves the condenser, it has become a high-pressure liquid refrigerant. The volume of air flowing over the condenser fins is critical to the proper cooling performance of the air conditioning system. Therefore, it is important that

there are no objects placed in front of the radiator grille openings in the front of the vehicle or foreign material on the condenser fins that might obstruct proper air flow. Also, any factory-installed air seals or shrouds must be properly reinstalled following radiator or condenser service.

The condenser cannot be repaired and, if faulty or damaged, it must be replaced.

DUAL FUNCTION HIGH PRESSURE SWITCH (4.0 L)

DESCRIPTION

The Dual Function High Pressure Switch controls both A/C clutch engagement/disengagement, and electric cooling fan operations. The switch is located on the discharge line near the compressor. The switch is screwed onto a fitting that contains a Schrader-type valve, which allows the switch to be serviced without discharging the refrigerant system. The discharge line fitting is equipped with an O-ring to seal the switch connection.

OPERATION

The dual function switch is connected in series electrically with the low pressure cycling clutch switch between ground and the Powertrain Control Module (PCM). The switch contacts open and close causing the PCM to turn the compressor clutch on and off. This prevents compressor operation when the discharge line pressure approaches high levels, and also reduces electrical surging from compressor clutch engagement.

The dual function switch controls the electric cooling fan operation by monitoring refrigerant line pressures. When the discharge line pressure rises above 1900 to 2200 kPa (280 to 320 psi) the fan will turn on. The cooling fan will turn off when the discharge line pressure drops to 1600 kPa (235 psi).

The dual function switch controls the A/C clutch operation by disengaging the clutch when the discharge line pressure rises above 3100 to 3375 kPa (450 to 490 psi). The switch contacts will close and allow A/C clutch engagement when the discharge line pressure drops to 1860 to 2275 kPa (270 to 330 psi).

The Dual Function High Pressure Switch is a factory-calibrated unit. The switch cannot be adjusted or repaired and, if faulty or damaged, it must be replaced.

EVAPORATOR COIL

DESCRIPTION

The evaporator coil is located in the heater-A/C housing, under the instrument panel. The evaporator coil is positioned in the heater-A/C housing so that

DESCRIPTION AND OPERATION (Continued)

all air that enters the housing must pass over the fins of the evaporator before it is distributed through the system ducts and outlets. However, air passing over the evaporator coil fins will only be conditioned when the compressor is engaged and circulating refrigerant through the evaporator coil tubes.

OPERATION

Refrigerant enters the evaporator from the fixed orifice tube as a low-temperature, low-pressure liquid. As air flows over the fins of the evaporator, the humidity in the air condenses on the fins, and the heat from the air is absorbed by the refrigerant. Heat absorption causes the refrigerant to boil and vaporize. The refrigerant becomes a low-pressure gas when it leaves the evaporator.

The evaporator coil cannot be repaired and, if faulty or damaged, it must be replaced.

FIXED ORIFICE TUBE

DESCRIPTION

The fixed orifice tube is installed in the liquid line (left-hand drive) or liquid line jumper (right-hand drive) between the outlet of the condenser and the inlet of the evaporator. The fixed orifice tube is located in the end of the liquid line or liquid line jumper that is closest to the condenser outlet tube.

The inlet end of the fixed orifice tube has a nylon mesh filter screen, which filters the refrigerant and helps to reduce the potential for blockage of the metering orifice by refrigerant system contaminants (Fig. 3). The outlet end of the tube has a nylon mesh diffuser screen. The O-rings on the plastic body of the fixed orifice tube seal the tube to the inside of the liquid line and prevent the refrigerant from bypassing the fixed metering orifice.

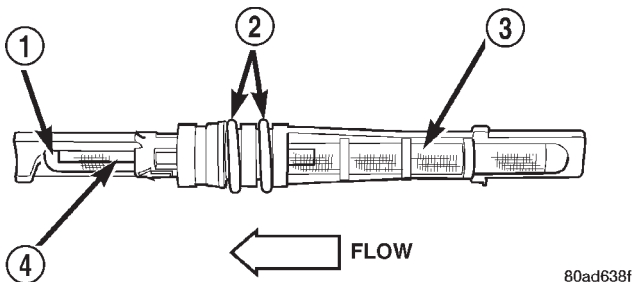

Fig. 3 Fixed Orifice Tube - Typical

- 1 - DIFFUSER SCREEN
- 2 - "O" RINGS
- 3 - INLET FILTER SCREEN
- 4 - ORIFICE

OPERATION

The fixed orifice tube is used to meter the flow of liquid refrigerant into the evaporator coil. The high-

pressure liquid refrigerant from the condenser expands into a low-pressure liquid as it passes through the metering orifice and diffuser screen of the fixed orifice tube.

The fixed orifice tube cannot be repaired and, if faulty or plugged, the liquid line and fixed orifice tube unit or liquid line jumper and fixed orifice tube unit must be replaced.

HEATER AND AIR CONDITIONER

DESCRIPTION

All vehicles are equipped with a common heater-A/C housing assembly (Fig. 4). The system combines air conditioning, heating, and ventilating capabilities in a single unit housing mounted under the instrument panel. On heater-only systems, the evaporator coil and recirculating air door are omitted from the housing.

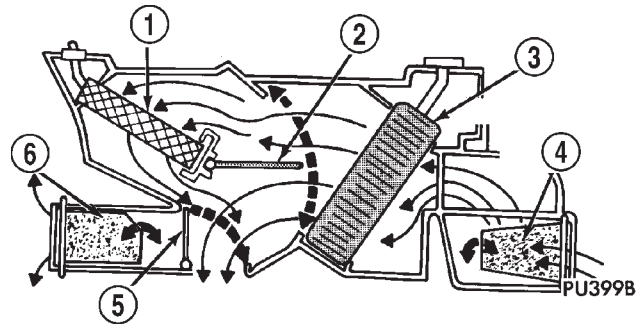

Fig. 4 Common Blend-Air Heater-Air Conditioner System - Typical

- 1 - HEATER CORE
- 2 - BLEND-AIR DOOR
- 3 - EVAPORATOR A/C ONLY
- 4 - RECIRCULATING AIR DOOR A/C ONLY
- 5 - FLOOR/PANEL DOOR
- 6 - FLOOR/DEFROST DOOR

Outside fresh air enters the vehicle through the cowl top opening at the base of the windshield, and passes through a plenum chamber to the heater-A/C system blower housing. Air flow velocity can then be adjusted with the blower motor speed selector switch on the heater-A/C control panel. The air intake openings must be kept free of snow, ice, leaves, and other obstructions for the heater-A/C system to receive a sufficient volume of outside air.

It is also important to keep the air intake openings clear of debris because leaf particles and other debris that is small enough to pass through the cowl plenum screen can accumulate within the heater-A/C housing. The closed, warm, damp and dark environment created within the heater-A/C housing is ideal for the growth of certain molds, mildews and other fungi. Any accumulation of decaying plant matter

DESCRIPTION AND OPERATION (Continued)

provides an additional food source for fungal spores, which enter the housing with the fresh air. Excess debris, as well as objectionable odors created by decaying plant matter and growing fungi can be discharged into the passenger compartment during heater-A/C system operation.

OPERATION

The heater and optional air conditioner are blend-air type systems. In a blend-air system, a blend-air door controls the amount of unconditioned air (or cooled air from the evaporator on models with air conditioning) that is allowed to flow through, or around, the heater core. A temperature control knob on the heater-A/C control panel determines the discharge air temperature by controlling an electric motor, which moves the blend-air door. This allows an almost immediate control of the output air temperature of the system.

The mode control knob on the heater-only or heater-A/C control panel is used to direct the conditioned air to the selected system outlets. Both mode control switches use engine vacuum to control the mode doors, which are operated by vacuum actuator motors.

On air conditioned vehicles, the outside air intake can be shut off by selecting the Recirculation Mode with the mode control knob. This will operate a vacuum actuated recirculating air door that closes off the outside fresh air intake and recirculates the air that is already inside the vehicle.

The optional air conditioner for all models is designed for the use of non-CFC, R-134a refrigerant. The air conditioning system has an evaporator to cool and dehumidify the incoming air prior to blending it with the heated air. This air conditioning system uses a fixed orifice tube in the liquid line near the condenser outlet tube to meter refrigerant flow to the evaporator coil. To maintain minimum evaporator temperature and prevent evaporator freezing, a fixed pressure setting switch on the accumulator cycles the compressor clutch.

HEATER AND AIR CONDITIONER CONTROL**DESCRIPTION**

Both the heater-only and heater-A/C systems use a combination of mechanical, electrical, and vacuum controls. These controls provide the vehicle operator with a number of setting options to help control the climate and comfort within the vehicle. Refer to the owner's manual in the vehicle glove box for more information on the features, use, and suggested operation of these controls.

OPERATION

The heater-only or heater-A/C control panel is located to the right of the instrument cluster on the instrument panel. The control panel contains a rotary-type temperature control knob, a rotary-type mode control switch knob, and a rotary-type blower motor speed switch knob.

The heater-only or heater-A/C control panel cannot be repaired. If faulty or damaged, the entire unit must be replaced. The illumination lamps are available for service replacement.

HEATER CORE**DESCRIPTION**

The heater core is located in the heater-A/C housing, under the instrument panel. It is a heat exchanger made of rows of tubes and fins.

OPERATION

Engine coolant is circulated through heater hoses to the heater core at all times. As the coolant flows through the heater core, heat removed from the engine is transferred to the heater core fins and tubes. Air directed through the heater core picks up the heat from the heater core fins. The blend air door allows control of the heater output air temperature by controlling how much of the air flowing through the heater-A/C housing is directed through the heater core. The blower motor speed controls the volume of air flowing through the heater-A/C housing.

The heater core cannot be repaired and, if faulty or damaged, it must be replaced. Refer to Group 7 - Cooling System for more information on the engine cooling system, the engine coolant and the heater hoses.

HIGH PRESSURE CUT-OFF SWITCH**DESCRIPTION**

The high pressure cut-off switch is located on the discharge line between the compressor and the condenser inlet. The switch is screwed onto a fitting that contains a Schrader-type valve, which allows the switch to be serviced without discharging the refrigerant system. The discharge line fitting is equipped with an O-ring to seal the switch connection.

OPERATION

The high pressure cut-off switch is connected in series electrically with the low pressure cycling clutch switch between ground and the Powertrain Control Module (PCM). The switch contacts open and close causing the PCM to turn the compressor clutch on and off. This prevents compressor operation when the discharge line pressure approaches high levels.

DESCRIPTION AND OPERATION (Continued)

The high pressure cut-off switch contacts are open when the discharge line pressure rises above 3100 to 3375 kPa (450 to 490 psi). The switch contacts will close when the discharge line pressure drops to 1860 to 2275 kPa (270 to 330 psi).

The high pressure cut-off switch is a factory-calibrated unit. The switch cannot be adjusted or repaired and, if faulty or damaged, it must be replaced.

HIGH PRESSURE RELIEF VALVE

DESCRIPTION

A high pressure relief valve is located on the compressor manifold, which is on the side of the compressor. This mechanical valve is designed to vent refrigerant from the system to protect against damage to the compressor and other system components, caused by condenser air flow restriction or an over-charge of refrigerant.

OPERATION

The high pressure relief valve vents the system when a discharge pressure of 3445 to 4135 kPa (500 to 600 psi) or above is reached. The valve closes when a minimum discharge pressure of 2756 kPa (400 psi) is reached.

The high pressure relief valve vents only enough refrigerant to reduce the system pressure, and then re-seats itself. The majority of the refrigerant is conserved in the system. If the valve vents refrigerant, it does not mean that the valve is faulty.

The high pressure relief valve is a factory-calibrated unit. The valve cannot be adjusted or repaired, and must not be removed or otherwise disturbed. The valve is only serviced as a part of the compressor assembly.

LOW PRESSURE CYCLING CLUTCH SWITCH

DESCRIPTION

The low pressure cycling clutch switch is located on the top of the accumulator. The switch is screwed onto an accumulator fitting that contains a Schrader-type valve, which allows the switch to be serviced without discharging the refrigerant system. The accumulator fitting is equipped with an O-ring to seal the switch connection.

OPERATION

The low pressure cycling clutch switch is connected in series electrically with the high pressure cut-off switch, between ground and the Powertrain Control Module (PCM). The switch contacts open and close causing the PCM to turn the compressor clutch on and off. This regulates the refrigerant system pres-

sure and controls evaporator temperature. Controlling the evaporator temperature prevents condensate water on the evaporator fins from freezing and obstructing air conditioning system air flow.

The low pressure cycling clutch switch contacts are open when the suction pressure is approximately 141 kPa (20.5 psi) or lower. The switch contacts will close when the suction pressure rises to approximately 234 to 262 kPa (34 to 38 psi) or above. Lower ambient temperatures, below approximately -1° C (30° F), will also cause the switch contacts to open. This is due to the pressure/temperature relationship of the refrigerant in the system.

The low pressure cycling clutch switch is a factory-calibrated unit. It cannot be adjusted or repaired and, if faulty or damaged, it must be replaced.

REFRIGERANT

DESCRIPTION

The refrigerant used in this air conditioning system is a HydroFluoroCarbon (HFC), type R-134a. Unlike R-12, which is a ChloroFluoroCarbon (CFC), R-134a refrigerant does not contain ozone-depleting chlorine. R-134a refrigerant is a non-toxic, non-flammable, clear, and colorless liquefied gas.

Even though R-134a does not contain chlorine, it must be reclaimed and recycled just like CFC-type refrigerants. This is because R-134a is a greenhouse gas and can contribute to global warming.

OPERATION

R-134a refrigerant is not compatible with R-12 refrigerant in an air conditioning system. Even a small amount of R-12 added to an R-134a refrigerant system will cause compressor failure, refrigerant oil sludge or poor air conditioning system performance. In addition, the PolyAlkylene Glycol (PAG) synthetic refrigerant oils used in an R-134a refrigerant system are not compatible with the mineral-based refrigerant oils used in an R-12 refrigerant system.

R-134a refrigerant system service ports, service tool couplers and refrigerant dispensing bottles have all been designed with unique fittings to ensure that an R-134a system is not accidentally contaminated with the wrong refrigerant (R-12). There are also labels posted in the engine compartment of the vehicle and on the compressor identifying to service technicians that the air conditioning system is equipped with R-134a.

REFRIGERANT LINES

DESCRIPTION

The refrigerant lines and hoses are used to carry the refrigerant between the various air conditioning

DESCRIPTION AND OPERATION (Continued)

system components. A barrier hose design with a nylon tube, which is sandwiched between rubber layers, is used for the R-134a air conditioning system on this vehicle. This nylon tube helps to further contain the R-134a refrigerant, which has a smaller molecular structure than R-12 refrigerant. The ends of the refrigerant hoses are made from lightweight aluminum or steel, and commonly use braze-less fittings.

Any kinks or sharp bends in the refrigerant plumbing will reduce the capacity of the entire air conditioning system. Kinks and sharp bends reduce the flow of refrigerant in the system. A good rule for the flexible hose refrigerant lines is to keep the radius of all bends at least ten times the diameter of the hose. In addition, the flexible hose refrigerant lines should be routed so they are at least 80 millimeters (3 inches) from the exhaust manifold.

OPERATION

High pressures are produced in the refrigerant system when the air conditioning compressor is operating. Extreme care must be exercised to make sure that each of the refrigerant system connections is pressure-tight and leak free. It is a good practice to inspect all flexible hose refrigerant lines at least once a year to make sure they are in good condition and properly routed.

The refrigerant lines and hoses are coupled with other components of the HVAC system with peanut-block style fittings. A stat-O seal type flat steel gasket with a captured compressible O-ring, is used to mate plumbing lines with A/C components to ensure the integrity of the refrigerant system.

The refrigerant lines and hoses cannot be repaired and, if faulty or damaged, they must be replaced.

REFRIGERANT LINE COUPLERS

DESCRIPTION

Spring-lock type refrigerant line couplers are used to connect many of the refrigerant lines and other components to the refrigerant system. These couplers require a special tool for disengaging the two coupler halves.

OPERATION

The spring-lock coupler is held together by a garter spring inside a circular cage on the male half of the fitting (Fig. 5). When the two coupler halves are connected, the flared end of the female fitting slips behind the garter spring inside the cage on the male fitting. The garter spring and cage prevent the flared end of the female fitting from pulling out of the cage.

Two O-rings on the male half of the fitting are used to seal the connection. These O-rings are com-

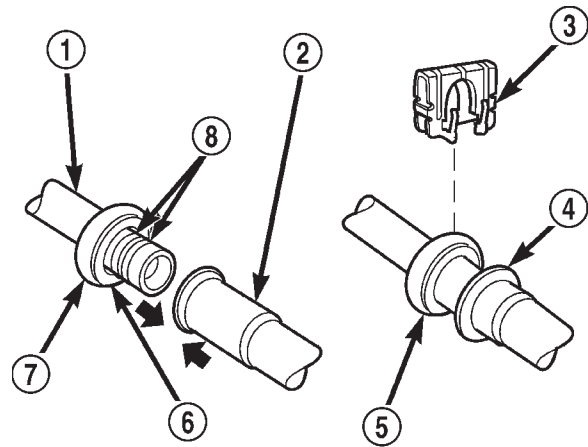

80a7e303

Fig. 5 Spring-Lock Coupler - Typical

- 1 - MALE HALF SPRING-LOCK COUPLER
- 2 - FEMALE HALF SPRING-LOCK COUPLER
- 3 - SECONDARY CLIP
- 4 - CONNECTION INDICATOR RING
- 5 - COUPLER CAGE
- 6 - GARTER SPRING
- 7 - COUPLER CAGE
- 8 - "O" RINGS

patible with R-134a refrigerant and must be replaced with O-rings made of the same material.

Secondary clips are installed over the two connected coupler halves at the factory for added blowoff protection. In addition, some models have a plastic ring that is used at the factory as a visual indicator to confirm that these couplers are connected. After the coupler is connected, the plastic indicator ring is no longer needed; however, it will remain on the refrigerant line near the coupler cage.

REFRIGERANT OIL

DESCRIPTION

The refrigerant oil used in R-134a refrigerant systems is a synthetic-based, PolyAlkylene Glycol (PAG), wax-free lubricant. Mineral-based R-12 refrigerant oils are not compatible with PAG oils, and should never be introduced to an R-134a refrigerant system.

There are different PAG oils available, and each contains a different additive package. The 10PA17 compressor used in this vehicle is designed to use an ND-8 PAG refrigerant oil. Use only refrigerant oil of this same type to service the refrigerant system.

OPERATION

After performing any refrigerant recovery or recycling operation, always replenish the refrigerant system with the same amount of the recommended refrigerant oil as was removed. Too little refrigerant

DESCRIPTION AND OPERATION (Continued)

oil can cause compressor damage, and too much can reduce air conditioning system performance.

PAG refrigerant oil is much more hygroscopic than mineral oil, and will absorb any moisture it comes into contact with, even moisture in the air. The PAG oil container should always be kept tightly capped until it is ready to be used. After use, recap the oil container immediately to prevent moisture contamination.

REFRIGERANT SYSTEM SERVICE PORT**DESCRIPTION**

The two refrigerant system service ports are used to charge, recover/recycle, evacuate, and test the air conditioning refrigerant system. Unique service port coupler sizes are used on the R-134a system, to ensure that the refrigerant system is not accidentally contaminated by the use of the wrong refrigerant (R-12), or refrigerant system service equipment.

OPERATION

The high pressure service port is located on the refrigerant line, near the discharge port of the compressor. The low pressure service port is located on the liquid line at the rear of the engine compartment, near the evaporator inlet tube.

Each of the service ports has a threaded plastic protective cap installed over it from the factory. After servicing the refrigerant system, always reinstall both of the service port caps.

VACUUM CHECK VALVE**DESCRIPTION**

A vacuum check valve is installed in the accessory vacuum supply line in the engine compartment, near the vacuum tap on the engine intake manifold, and at the HVAC unit takeout. The vacuum check valve is designed to allow vacuum to flow in only one direction through the accessory vacuum supply circuits.

OPERATION

The use of a vacuum check valve helps to maintain the system vacuum needed to retain the selected heater-A/C mode settings. The check valve will prevent the engine from bleeding down system vacuum through the intake manifold during extended heavy engine load (low engine vacuum) operation.

The vacuum check valve cannot be repaired and, if faulty or damaged, it must be replaced.

VACUUM RESERVOIR**DESCRIPTION**

The vacuum reservoir is mounted to the front bumper bar behind the passenger side bumper end cap. The bumper end cap must be removed from the vehicle to access the vacuum reservoir for service.

OPERATION

Engine vacuum is stored in the vacuum reservoir. The stored vacuum is used to operate the vacuum-controlled vehicle accessories during periods of low engine vacuum such as when the vehicle is climbing a steep grade, or under other high engine load operating conditions.

The vacuum reservoir cannot be repaired and, if faulty or damaged, it must be replaced.

DIAGNOSIS AND TESTING**A/C PERFORMANCE**

The air conditioning system is designed to provide the passenger compartment with low temperature and low humidity air. The evaporator, located in the heater-A/C housing on the dash panel below the instrument panel, is cooled to temperatures near the freezing point. As warm damp air passes through the cooled evaporator, the air transfers its heat to the refrigerant in the evaporator and the moisture in the air condenses on the evaporator fins. During periods of high heat and humidity, an air conditioning system will be more effective in the Recirculation Mode. With the system in the Recirculation Mode, only air from the passenger compartment passes through the evaporator. As the passenger compartment air dehumidifies, the air conditioning system performance levels improve.

Humidity has an important bearing on the temperature of the air delivered to the interior of the vehicle. It is important to understand the effect that humidity has on the performance of the air conditioning system. When humidity is high, the evaporator has to perform a double duty. It must lower the air temperature, and it must lower the temperature of the moisture in the air that condenses on the evaporator fins. Condensing the moisture in the air transfers heat energy into the evaporator fins and tubing. This reduces the amount of heat the evaporator can absorb from the air. High humidity greatly reduces the ability of the evaporator to lower the temperature of the air.

DIAGNOSIS AND TESTING (Continued)

However, evaporator capacity used to reduce the amount of moisture in the air is not wasted. Wringing some of the moisture out of the air entering the vehicle adds to the comfort of the passengers. Although, an owner may expect too much from their air conditioning system on humid days. A performance test is the best way to determine whether the system is performing up to standard. This test also provides valuable clues as to the possible cause of trouble with the air conditioning system.

Review the Service Warnings and Precautions in the front of this group before performing this procedure. The air temperature in the test room and in the vehicle must be a minimum of 21° C (70° F) for this test.

(1) Connect a tachometer and a manifold gauge set.

(2) Set the heater-A/C mode control switch knob in the Recirculation Mode position, the temperature control knob in the full cool position, and the blower motor switch knob in the highest speed position.

(3) Start the engine and hold the idle at 1,000 rpm with the compressor clutch engaged.

(4) The engine should be at operating temperature. The doors and windows must be open.

(5) Insert a thermometer in the driver side center A/C (panel) outlet. Operate the engine for five minutes.

(6) The compressor clutch may cycle, depending upon the ambient temperature and humidity. If the clutch cycles, unplug the low pressure cycling clutch switch wire harness connector from the switch

located on the accumulator (Fig. 6). Place a jumper wire across the terminals of the low pressure cycling clutch switch wire harness connector.

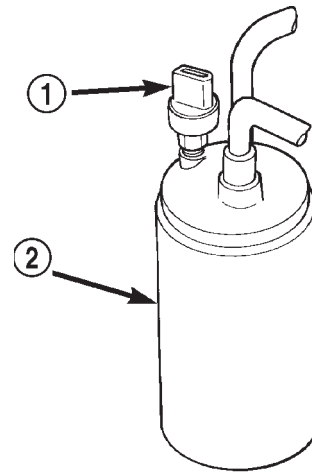

80add30d

Fig. 6 Low Pressure Cycling Clutch Switch - Typical

- 1 - LOW PRESSURE CYCLING CLUTCH SWITCH
- 2 - ACCUMULATOR

(7) With the compressor clutch engaged, record the discharge air temperature and the compressor discharge pressure.

(8) Compare the discharge air temperature to the Performance Temperature and Pressure chart. If the discharge air temperature is high, see Refrigerant System Leaks and Refrigerant System Charge in this group.

| Performance Temperature and Pressure | | | | | |
|--|--------------------------------------|--------------------------------------|--------------------------------------|--------------------------------------|--------------------------------------|
| Ambient Air Temperature | 21° C (70° F) | 27° C (80° F) | 32° C (90° F) | 38° C (100° F) | 43° C (110° F) |
| Air Temperature at Center Panel Outlet | -3 to 3° C (27 to 38° F) | 1 to 7° C (33 to 44° F) | 3 to 9° C (37 to 48° F) | 6 to 13° C (43 to 55° F) | 10 to 18° C (50 to 64° F) |
| Evaporator Inlet Pressure at Charge Port | 179 to 241 kPa (26 to 35 psi) | 221 to 283 kPa (32 to 41 psi) | 262 to 324 kPa (38 to 47 psi) | 303 to 365 kPa (44 to 53 psi) | 345 to 414 kPa (50 to 60 psi) |
| Compressor Discharge Pressure | 1240 to 1655 kPa (180 to 240 psi) | 1380 to 1790 kPa (200 to 260 psi) | 1720 to 2070 kPa (250 to 300 psi) | 1860 to 2345 kPa (270 to 340 psi) | 2070 to 2690 kPa (300 to 390 psi) |

(9) Compare the compressor discharge pressure to the Performance Temperature and Pressure chart. If the compressor discharge pressure is high, see the Pressure Diagnosis chart.

DIAGNOSIS AND TESTING (Continued)

| Pressure Diagnosis | | |
|--|--|---|
| Condition | Possible Causes | Correction |
| Rapid compressor clutch cycling (ten or more cycles per minute). | 1. Low refrigerant system charge. | 1. See Refrigerant System Leaks in this group. Test the refrigerant system for leaks. Repair, evacuate and charge the refrigerant system, if required. |
| Equal pressures, but the compressor clutch does not engage. | 1. No refrigerant in the refrigerant system. 2. Faulty fuse. 3. Faulty compressor clutch coil. 4. Faulty compressor clutch relay. 5. Improperly installed or faulty low pressure cycling clutch switch. 6. Faulty high pressure cut-off switch. 7. Faulty Powertrain Control Module (PCM). | 1. See Refrigerant System Leaks in this group. Test the refrigerant system for leaks. Repair, evacuate and charge the refrigerant system, if required. 2. Check the fuses in the Power Distribution Center and the junction block. Repair the shorted circuit or component and replace the fuses, if required. 3. See Compressor Clutch Coil in this group. Test the compressor clutch coil and replace, if required. 4. See Compressor Clutch Relay in this group. Test the compressor clutch relay and relay circuits. Repair the circuits or replace the relay, if required. 5. See Low Pressure Cycling Clutch Switch in this group. Test the low pressure cycling clutch switch and tighten or replace, if required. 6. See High Pressure Cut-Off Switch in this group. Test the high pressure cut-off switch and replace, if required. 7. Refer to the proper Diagnostic Procedures manual for testing of the PCM. Test the PCM and replace, if required. |
| Normal pressures, but A/C Performance Test air temperatures at center panel outlet are too high. | 1. Excessive refrigerant oil in system. 2. Blend-Air door inoperative or sealing improperly. 3. Blend-Air door motor faulty or inoperative. | 1. See Refrigerant Oil Level in this group. Recover the refrigerant from the refrigerant system and inspect the refrigerant oil content. Restore the refrigerant oil to the proper level, if required. 2. See Blend-Air Door under Heater-A/C Housing Door in this group. Inspect the blend-air door for proper operation and sealing and correct, if required. 3. Perform Blend-Air door motor diagnosis, replace if faulty. |
| The low side pressure is normal or slightly low, and the high side pressure is too low. | 1. Low refrigerant system charge. 2. Refrigerant flow through the accumulator is restricted. 3. Refrigerant flow through the evaporator coil is restricted. 4. Faulty compressor. | 1. See Refrigerant System Leaks in this group. Test the refrigerant system for leaks. Repair, evacuate and charge the refrigerant system, if required. 2. See Accumulator in this group. Replace the restricted accumulator, if required. 3. See Evaporator Coil in this group. Replace the restricted evaporator coil, if required. 4. See Compressor in this group. Replace the compressor, if required. |

DIAGNOSIS AND TESTING (Continued)

| Pressure Diagnosis | | |
|---|--|---|
| Condition | Possible Causes | Correction |
| The low side pressure is normal or slightly high, and the high side pressure is too high. | <ol style="list-style-type: none"> 1. Condenser air flow restricted. 2. Inoperative cooling fan. 3. Refrigerant system overcharged. 4. Air in the refrigerant system. 5. Engine overheating. | <ol style="list-style-type: none"> 1. Check the condenser for damaged fins, foreign objects obstructing air flow through the condenser fins, and missing or improperly installed air seals. Refer to Group 7 - Cooling System for more information on air seals. Clean, repair, or replace components as required. 2. Refer to Group 7 - Cooling System for more information. Test the cooling fan and replace, if required. 3. See Refrigerant System Charge in this group. Recover the refrigerant from the refrigerant system. Charge the refrigerant system to the proper level, if required. 4. See Refrigerant System Leaks in this group. Test the refrigerant system for leaks. Repair, evacuate and charge the refrigerant system, if required. 5. Refer to Group 7 - Cooling System for more information. Test the cooling system and repair, if required. |
| The low side pressure is too high, and the high side pressure is too low. | <ol style="list-style-type: none"> 1. Accessory drive belt slipping. 2. Fixed orifice tube not installed. 3. Faulty compressor. | <ol style="list-style-type: none"> 1. Refer to Group 7 - Cooling System for more information. Inspect the accessory drive belt condition and tension. Tighten or replace the accessory drive belt, if required. 2. See Fixed Orifice Tube in this group. Install the missing fixed orifice tube, if required. 3. See Compressor in this group. Replace the compressor, if required. |
| The low side pressure is too low, and the high side pressure is too high. | <ol style="list-style-type: none"> 1. Restricted refrigerant flow through the refrigerant lines. 2. Restricted refrigerant flow through the fixed orifice tube. 3. Restricted refrigerant flow through the condenser. | <ol style="list-style-type: none"> 1. See Liquid Line and Suction and Discharge Line in this group. Inspect the refrigerant lines for kinks, tight bends or improper routing. Correct the routing or replace the refrigerant line, if required. 2. See Fixed Orifice Tube in this group. Replace the restricted fixed orifice tube, if required. 3. See Condenser in this group. Replace the restricted condenser, if required. |

BLOWER MOTOR

WARNING: ON VEHICLES EQUIPPED WITH AIRBAGS, REFER TO GROUP 8M - PASSIVE RESTRAINT SYSTEMS BEFORE ATTEMPTING ANY STEERING WHEEL, STEERING COLUMN, OR INSTRUMENT PANEL COMPONENT DIAGNOSIS OR SERVICE. FAILURE TO TAKE THE PROPER PRECAUTIONS COULD RESULT IN ACCIDENTAL AIRBAG DEPLOYMENT AND POSSIBLE PERSONAL INJURY.

For circuit descriptions and diagrams, refer to 8W-42 - Air Conditioning/Heater in Group 8W - Wiring Diagrams. Possible causes of an inoperative blower motor include:

- Faulty fuse
- Faulty blower motor circuit wiring or wire harness connectors
- Faulty blower motor resistor
- Faulty blower motor relay
- Faulty blower motor switch
- Faulty heater-A/C mode control switch
- Faulty blower motor.

Possible causes of the blower motor not operating in all speeds include:

- Faulty fuse
- Faulty blower motor switch
- Faulty blower motor resistor
- Faulty blower motor circuit wiring or wire harness connectors.

DIAGNOSIS AND TESTING (Continued)

VIBRATION

Possible causes of blower motor vibration include:

- Improper blower motor mounting
- Improper blower wheel mounting
- Blower wheel out of balance or bent
- Blower motor faulty.

NOISE

To verify that the blower is the source of the noise, unplug the blower motor wire harness connector and operate the heater-A/C system. If the noise goes away, possible causes include:

- Foreign material in the heater-A/C housing
- Improper blower motor mounting
- Improper blower wheel mounting
- Blower motor faulty.

BLOWER MOTOR RELAY

WARNING: ON VEHICLES EQUIPPED WITH AIR-BAGS, REFER TO GROUP 8M - PASSIVE RESTRAINT SYSTEMS BEFORE ATTEMPTING ANY STEERING WHEEL, STEERING COLUMN, OR INSTRUMENT PANEL COMPONENT DIAGNOSIS OR SERVICE. FAILURE TO TAKE THE PROPER PRECAUTIONS COULD RESULT IN ACCIDENTAL AIR-BAG DEPLOYMENT AND POSSIBLE PERSONAL INJURY.

RELAY TEST

The blower motor relay (Fig. 7) is located in a wire harness connector that is secured to the heater-A/C housing behind the glove box on the passenger side of the vehicle, next to the heater-A/C wire harness connector in the passenger compartment. Remove the relay from its connector to perform the following tests:

- (1) A relay in the de-energized position should have continuity between terminals 87A and 30, and no continuity between terminals 87 and 30. If OK, go to Step 2. If not OK, replace the faulty relay.
- (2) Resistance between terminals 85 and 86 (electromagnet) should be 75 ± 5 ohms. If OK, go to Step 3. If not OK, replace the faulty relay.
- (3) Connect a battery to terminals 85 and 86. There should now be continuity between terminals 30 and 87, and no continuity between terminals 87A and 30. If OK, see the Relay Circuit Test procedure in this group. If not OK, replace the faulty relay.

RELAY CIRCUIT TEST

For circuit descriptions and diagrams, refer to 8W-42 - Air Conditioning/Heater in Group 8W - Wiring Diagrams.

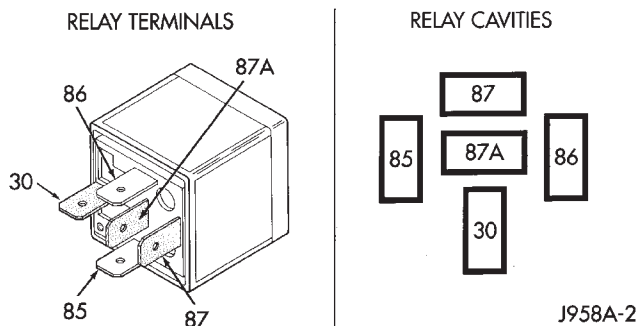

| TERMINAL LEGEND | |
|-----------------|-----------------|
| NUMBER | IDENTIFICATION |
| 30 | COMMON FEED |
| 85 | COIL GROUND |
| 86 | COIL BATTERY |
| 87 | NORMALLY OPEN |
| 87A | NORMALLY CLOSED |

Fig. 7 Blower Motor Relay

(1) The relay common feed terminal cavity (30) is connected to fused battery feed directly from a fuse in the Power Distribution Center (PDC), and should be hot at all times. Check for battery voltage at the connector cavity for relay terminal 30. If OK, go to Step 2. If not OK, repair the open circuit to the PDC fuse as required.

(2) The relay normally closed terminal cavity (87A) is not used for this application. Go to Step 3.

(3) The relay normally open terminal cavity (87) is connected to the blower motor. When the relay is energized, terminal 87 is connected to terminal 30 and provides full battery current to the blower motor relay output circuit cavity of the blower motor wire harness connector at all times. If OK, go to Step 4. If not OK, repair the open circuit to the blower motor as required.

(4) The coil battery terminal cavity (86) is connected to the ignition switch. When the ignition switch is placed in the On position, fused ignition switch output is directed from a fuse in the junction block to the relay electromagnetic coil to energize the relay. There should be battery voltage at the connector cavity for relay terminal 86 with the ignition switch in the On position. If OK, go to Step 5. If not OK, repair the open circuit to the junction block fuse as required.

(5) The coil ground terminal cavity (85) is connected to ground. This terminal supplies the ground for the relay electromagnetic coil. There should be continuity between the connector cavity for relay termi-

DIAGNOSIS AND TESTING (Continued)

nal 85 and a good ground at all times. If not OK, repair the open circuit as required.

BLOWER MOTOR RESISTOR

For circuit descriptions and diagrams, refer to 8W-42 - Air Conditioning/Heater in Group 8W - Wiring Diagrams.

WARNING: ON VEHICLES EQUIPPED WITH AIR-BAGS, REFER TO GROUP 8M - PASSIVE RESTRAINT SYSTEMS BEFORE ATTEMPTING ANY STEERING WHEEL, STEERING COLUMN, OR INSTRUMENT PANEL COMPONENT DIAGNOSIS OR SERVICE. FAILURE TO TAKE THE PROPER PRECAUTIONS COULD RESULT IN ACCIDENTAL AIR-BAG DEPLOYMENT AND POSSIBLE PERSONAL INJURY.

(1) Disconnect and isolate the battery negative cable.

(2) Remove the kick cover from the heater-A/C housing and unplug the wire harness connector from the blower motor resistor.

(3) Check for continuity between each of the blower motor switch input terminals of the resistor and the resistor output terminal. In each case there should be continuity. If OK, repair the wire harness circuits between the blower motor switch and the blower motor resistor or blower motor relay as required. If not OK, replace the faulty blower motor resistor.

BLOWER MOTOR SWITCH

For circuit descriptions and diagrams, refer to 8W-42 - Air Conditioning/Heater in Group 8W - Wiring Diagrams.

WARNING: ON VEHICLES EQUIPPED WITH AIR-BAGS, REFER TO GROUP 8M - PASSIVE RESTRAINT SYSTEMS BEFORE ATTEMPTING ANY STEERING WHEEL, STEERING COLUMN, OR INSTRUMENT PANEL COMPONENT DIAGNOSIS OR SERVICE. FAILURE TO TAKE THE PROPER PRECAUTIONS COULD RESULT IN ACCIDENTAL AIR-BAG DEPLOYMENT AND POSSIBLE PERSONAL INJURY.

(1) Check for battery voltage at the fuse in the Power Distribution Center (PDC). If OK, go to Step 2. If not OK, repair the shorted circuit or component as required and replace the faulty fuse.

(2) Turn the ignition switch to the Off position. Disconnect and isolate the battery negative cable. Remove the heater-A/C control from the instrument panel. Check for continuity between the ground circuit cavity of the heater-A/C control wire harness connector and a good ground. There should be conti-

nunity. If OK, go to Step 3. If not OK, repair the open circuit to ground as required.

(3) With the heater-A/C control wire harness connector unplugged, place the heater-A/C mode control switch knob in any position except the Off position. Check for continuity between the ground circuit terminal and each of the blower motor driver circuit terminals of the heater-A/C control as you move the blower motor switch knob to each of the four speed positions. There should be continuity at each driver circuit terminal in only one blower motor switch speed position. If OK, test and repair the blower driver circuits between the heater-A/C control connector and the blower motor resistor as required. If not OK, replace the faulty heater-A/C control unit.

COMPRESSOR

When investigating an air conditioning related noise, you must first know the conditions under which the noise occurs. These conditions include: weather, vehicle speed, transmission in gear or neutral, engine speed, engine temperature, and any other special conditions. Noises that develop during air conditioning operation can often be misleading. For example: What sounds like a failed front bearing or connecting rod, may be caused by loose bolts, nuts, mounting brackets, or a loose compressor clutch assembly.

Drive belts are speed sensitive. At different engine speeds and depending upon belt tension, belts can develop noises that are mistaken for a compressor noise. Improper belt tension can cause a misleading noise when the compressor clutch is engaged, which may not occur when the compressor clutch is disengaged. Check the serpentine drive belt condition and tension as described in Group 7 - Cooling System before beginning this procedure.

(1) Select a quiet area for testing. Duplicate the complaint conditions as much as possible. Switch the compressor on and off several times to clearly identify the compressor noise. Listen to the compressor while the clutch is engaged and disengaged. Probe the compressor with an engine stethoscope or a long screwdriver with the handle held to your ear to better localize the source of the noise.

(2) Loosen all of the compressor mounting hardware and retighten. Tighten the compressor clutch mounting nut. Be certain that the clutch coil is mounted securely to the compressor, and that the clutch plate and pulley are properly aligned and have the correct air gap. See Compressor and Compressor Clutch in the Removal and Installation section of this group for the procedures.

(3) To duplicate a high-ambient temperature condition (high head pressure), restrict the air flow through the condenser. Install a manifold gauge set

DIAGNOSIS AND TESTING (Continued)

to be certain that the discharge pressure does not exceed 2760 kPa (400 psi).

(4) Check the refrigerant system plumbing for incorrect routing, rubbing or interference, which can cause unusual noises. Also check the refrigerant lines for kinks or sharp bends that will restrict refrigerant flow, which can cause noises. See Suction and Discharge Line in the Removal and Installation section of this group for more information.

(5) If the noise is from opening and closing of the high pressure relief valve, evacuate and recharge the refrigerant system. See Refrigerant System Evacuate and Refrigerant System Charge in the Service Procedures section of this group. If the high pressure relief valve still does not seat properly, replace the compressor.

(6) If the noise is from liquid slugging on the suction line, replace the accumulator. See Accumulator in the Removal and Installation section of this group for the procedures. Check the refrigerant oil level and the refrigerant system charge. See Refrigerant Oil Level and Refrigerant System Charge in the Service Procedures section of this group. If the liquid slugging condition continues following accumulator replacement, replace the compressor.

(7) If the noise continues, replace the compressor and repeat Step 1.

COMPRESSOR CLUTCH COIL

For circuit descriptions and diagrams, refer to 8W-42 - Air Conditioning/Heater in Group 8W - Wiring Diagrams. The battery must be fully-charged before performing the following tests. Refer to Group 8A - Battery for more information.

(1) Connect an ammeter (0 to 10 ampere scale) in series with the clutch coil terminal. Use a voltmeter (0 to 20 volt scale) with clip-type leads for measuring the voltage across the battery and the compressor clutch coil.

(2) With the heater-A/C mode control switch in any A/C mode, and the blower motor switch in the lowest speed position, start the engine and run it at normal idle.

(3) The compressor clutch coil voltage should read within two volts of the battery voltage. If there is voltage at the clutch coil, but the reading is not within two volts of the battery voltage, test the clutch coil feed circuit for excessive voltage drop and repair as required. If there is no voltage reading at the clutch coil, use a DRB scan tool and the proper Diagnostic Procedures manual for testing of the compressor clutch circuit. The following components must be checked and repaired as required before you can complete testing of the clutch coil:

- Fuses in the junction block and the Power Distribution Center (PDC)

- Heater-A/C mode control switch
- Compressor clutch relay
- High pressure cut-off switch
- Low pressure cycling clutch switch
- Powertrain Control Module (PCM).

(4) The compressor clutch coil is acceptable if the current draw measured at the clutch coil is 2.0 to 3.9 amperes with the electrical system voltage at 11.5 to 12.5 volts. This should only be checked with the work area temperature at 21° C (70° F). If system voltage is more than 12.5 volts, add electrical loads by turning on electrical accessories until the system voltage drops below 12.5 volts.

(a) If the clutch coil current reading is four amperes or more, the coil is shorted and should be replaced.

(b) If the clutch coil current reading is zero, the coil is open and should be replaced.

COMPRESSOR CLUTCH RELAY

RELAY TEST

The compressor clutch relay (Fig. 8) is located in the Power Distribution Center (PDC). Refer to the PDC label for relay identification and location. Remove the relay from the PDC to perform the following tests:

(1) A relay in the de-energized position should have continuity between terminals 87A and 30, and no continuity between terminals 87 and 30. If OK, go to Step 2. If not OK, replace the faulty relay.

(2) Resistance between terminals 85 and 86 (electromagnet) should be 75 ± 5 ohms. If OK, go to Step 3. If not OK, replace the faulty relay.

(3) Connect a battery to terminals 85 and 86. There should now be continuity between terminals 30 and 87, and no continuity between terminals 87A and 30. If OK, see Relay Circuit Test in the Diagnosis and Testing section of this group. If not OK, replace the faulty relay.

RELAY CIRCUIT TEST

For circuit descriptions and diagrams, refer to 8W-42 - Air Conditioning/Heater in Group 8W - Wiring Diagrams.

(1) The relay common feed terminal cavity (30) is connected to fused battery feed. There should be battery voltage at the cavity for relay terminal 30 at all times. If OK, go to Step 2. If not OK, repair the open circuit to the fuse in the PDC as required.

(2) The relay normally closed terminal (87A) is not used in this application. Go to Step 3.

(3) The relay normally open terminal cavity (87) is connected to the compressor clutch coil. There should be continuity between this cavity and the A/C compressor clutch relay output circuit cavity of the com-

DIAGNOSIS AND TESTING (Continued)

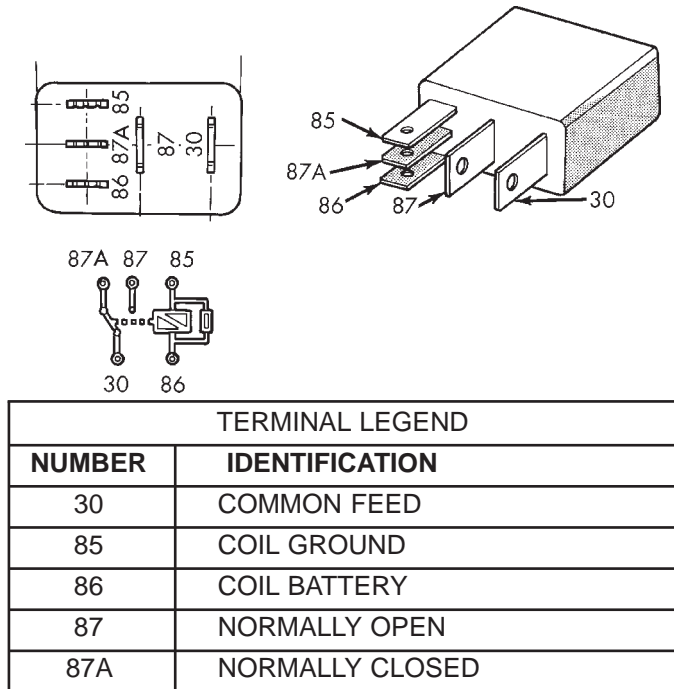

Fig. 8 Compressor Clutch Relay

pressor clutch coil wire harness connector. If OK, go to Step 4. If not OK, repair the open circuit as required.

(4) The relay coil battery terminal (86) is connected to the fused ignition switch output (run/start) circuit. There should be battery voltage at the cavity for relay terminal 86 with the ignition switch in the On position. If OK, go to Step 5. If not OK, repair the open circuit to the fuse in the junction block as required.

(5) The coil ground terminal cavity (85) is switched to ground through the Powertrain Control Module (PCM). There should be continuity between this cavity and the A/C compressor clutch relay control circuit cavity of the PCM wire harness connector C (gray) at all times. If not OK, repair the open circuit as required.

**DUAL FUNCTION HIGH PRESSURE SWITCH/
HIGH PRESSURE CUT-OFF SWITCH**

Before performing diagnosis of the dual function high pressure switch, or the high pressure cut-off switch, verify that the refrigerant system has the correct refrigerant charge. See Refrigerant System Charge in the Service Procedures section of this group for more information.

For circuit descriptions and diagrams, refer to 8W-42 - Air Conditioning/Heater in Group 8W - Wiring Diagrams.

(1) Disconnect and isolate the battery negative cable.

(2) Unplug the high pressure switch wire harness connector from the switch on the refrigerant system fitting.

(3) On the dual function high pressure switch, check for continuity between terminals C and D. On the two terminal switch, check for continuity between both terminals of the high pressure cut-off switch. There should be continuity. If OK, test and repair the A/C switch sense circuit as required. If not OK, replace the faulty switch.

HEATER PERFORMANCE

Before performing the following tests, refer to Group 7 - Cooling System for the procedures to check the radiator coolant level, serpentine drive belt tension, radiator air flow and the radiator fan operation. Also be certain that the accessory vacuum supply line is connected at the engine intake manifold.

MAXIMUM HEATER OUTPUT

Engine coolant is delivered to the heater core through two heater hoses. With the engine idling at normal operating temperature, set the temperature control knob in the full hot position, the mode control switch knob in the floor heat position, and the blower motor switch knob in the highest speed position. Using a test thermometer, check the temperature of the air being discharged at the heater-A/C housing floor outlets. Compare the test thermometer reading to the Temperature Reference chart.

| Temperature Reference | | | | |
|---|---------------------|---------------------|---------------------|---------------------|
| Ambient Air Temperature | 15.5° C (60° F) | 21.1° C (70° F) | 26.6° C (80° F) | 32.2° C (90° F) |
| Minimum Air Temperature at Floor Outlet | 62.2° C (144° F) | 63.8° C (147° F) | 65.5° C (150° F) | 67.2° C (153° F) |

DIAGNOSIS AND TESTING (Continued)

If the floor outlet air temperature is too low, refer to Group 7 - Cooling System to check the engine coolant temperature specifications. Both of the heater hoses should be hot to the touch. The coolant return heater hose should be slightly cooler than the coolant supply heater hose. If the return hose is much cooler than the supply hose, locate and repair the engine coolant flow obstruction in the cooling system. Refer to Group 7 - Cooling System for the procedures.

OBSTRUCTED COOLANT FLOW Possible locations or causes of obstructed coolant flow:

- Pinched or kinked heater hoses.
- Improper heater hose routing.
- Plugged heater hoses or supply and return ports at the cooling system connections.
- A plugged heater core.

If proper coolant flow through the cooling system is verified, and heater outlet air temperature is still low, a mechanical problem may exist.

MECHANICAL PROBLEMS Possible locations or causes of insufficient heat:

- An obstructed cowl air intake.
- Obstructed heater system outlets.
- A blend-air door not functioning properly.

TEMPERATURE CONTROL

If the heater outlet air temperature cannot be adjusted with the temperature control knob on the heater-A/C control panel, the following could require service:

- The heater-A/C control.
- The temperature control motor.
- The blend-air door.
- Improper engine coolant temperature.

LOW PRESSURE CYCLING CLUTCH SWITCH

Before performing diagnosis of the low pressure cycling clutch switch, be certain that the switch is properly installed on the accumulator fitting. If the switch is too loose it may not open the Schrader-type valve in the accumulator fitting, which will prevent the switch from correctly monitoring the refrigerant system pressure. Remember that lower ambient temperatures, below about -1°C (30°F), during cold weather will open the switch contacts and prevent compressor operation due to the pressure/temperature relationship of the refrigerant.

Also verify that the refrigerant system has the correct refrigerant charge. See Refrigerant System Charge in the Service Procedures section of this group for more information.

For circuit descriptions and diagrams, refer to 8W-42 - Air Conditioning/Heater in Group 8W - Wiring Diagrams.

(1) Disconnect and isolate the battery negative cable.

(2) Unplug the low pressure cycling clutch switch wire harness connector from the switch on the accumulator fitting.

(3) Install a jumper wire between the two cavities of the low pressure cycling clutch switch wire harness connector.

(4) Connect a manifold gauge set to the refrigerant system service ports. See Refrigerant System Service Equipment and Refrigerant System Service Ports in the Description and Operation section of this group for more information.

(5) Connect the battery negative cable.

(6) Place the heater-A/C mode control switch knob in any A/C position and start the engine.

(7) Check for continuity between the two terminals of the low pressure cycling clutch switch. There should be continuity with a suction pressure reading of 262 kPa (38 psi) or above, and no continuity with a suction pressure reading of 141 kPa (20.5 psi) or below. If OK, test and repair the A/C switch sense circuit as required. If not OK, replace the faulty switch.

REFRIGERANT SYSTEM LEAKS

WARNING: REVIEW THE WARNINGS AND CAUTIONS IN THE FRONT OF THIS GROUP BEFORE LEAK TESTING THE SYSTEM.

If the air conditioning system is not cooling properly, determine if the refrigerant system is fully-charged. See A/C Performance in this group for the procedures. If the refrigerant system is low or empty; a leak at a refrigerant line, connector fitting, component, or component seal is likely.

An electronic leak detector designed for R-134a refrigerant, or a fluorescent R-134a leak detection dye and a black light are recommended for locating and confirming refrigerant system leaks. Refer to the operating instructions supplied by the equipment manufacturer for proper care and use of this equipment.

An oily residue on or near refrigerant system lines, connector fittings, components, or component seals can indicate the general location of a possible refrigerant leak. However, the exact leak location should be confirmed with an electronic leak detector prior to component repair or replacement.

To detect a leak in the refrigerant system with an electronic leak detector, perform one of the following procedures:

SYSTEM EMPTY

(1) Evacuate the refrigerant system. See Refrigerant System Evacuate in this group for the procedures.

DIAGNOSIS AND TESTING (Continued)

(2) Connect and dispense 0.283 kilograms (0.625 pounds or 10 ounces) of R-134a refrigerant into the evacuated refrigerant system. See Refrigerant System Charge in this group for the procedures.

(3) Position the vehicle in a wind-free work area. This will aid in detecting small leaks.

(4) With the engine not running, use a electronic R-134a leak detector and search for leaks. Because R-134a refrigerant is heavier than air, the leak detector probe should be moved slowly along the bottom side of all refrigerant lines, connector fittings and components.

(5) To inspect the evaporator coil for leaks, insert the electronic leak detector probe into the center instrument panel outlet. Set the blower motor switch to the lowest speed position, and the mode control switch in the recirculation mode.

SYSTEM LOW

(1) Position the vehicle in a wind-free work area. This will aid in detecting small leaks.

(2) Bring the refrigerant system up to operating temperature and pressure. This is done by allowing the engine to run with the air conditioning system turned on for five minutes.

(3) With the engine not running, use a electronic R-134a leak detector and search for leaks. Because R-134a refrigerant is heavier than air, the leak detector probe should be moved slowly along the bottom side of all refrigerant lines, connector fittings and components.

(4) To inspect the evaporator coil for leaks, insert the electronic leak detector probe into the center instrument panel outlet. Set the blower motor switch to the lowest speed position, and the mode control switch in the recirculation mode.

VACUUM SYSTEM

Vacuum control is used to operate the mode doors in the heater-only and heater-A/C housings. Testing of the heater-only and heater-A/C mode control switch operation will determine if the vacuum, electrical, and mechanical controls are functioning. However, it is possible that a vacuum control system that operates perfectly at engine idle (high engine vacuum) may not function properly at high engine speeds or loads (low engine vacuum). This can be caused by leaks in the vacuum system, or a faulty vacuum check valve.

A vacuum system test will help to identify the source of poor vacuum system performance or vacuum system leaks. Before starting this test, stop the engine and make certain that the problem is not a disconnected vacuum supply tube at the engine intake manifold vacuum tap or at the vacuum reservoir.

Use an adjustable vacuum test set (Special Tool C-3707-B) and a suitable vacuum pump to test the heater-A/C vacuum control system. With a finger placed over the end of the vacuum test hose probe (Fig. 9), adjust the bleed valve on the test set gauge to obtain a vacuum of exactly 27 kPa (8 in. Hg.). Release and block the end of the probe several times to verify that the vacuum reading returns to the exact 27 kPa (8 in. Hg.) setting. Otherwise, a false reading will be obtained during testing.

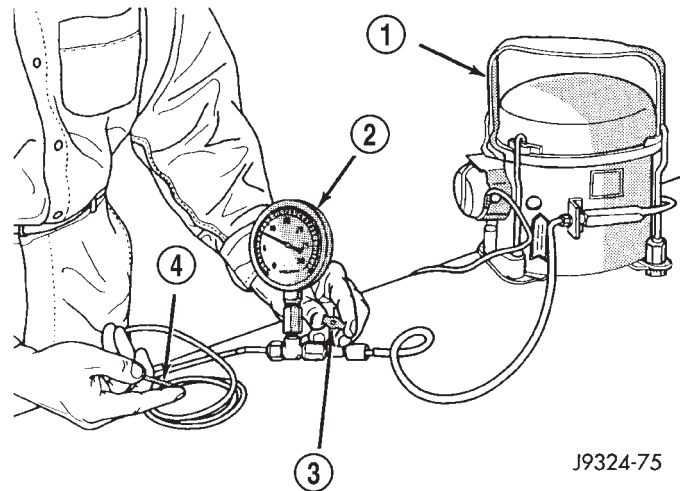

Fig. 9 Adjust Vacuum Test Bleed Valve

- 1 - VACUUM PUMP TOOL C-4289
- 2 - VACUUM TEST SET C-3707
- 3 - BLEED VALVE
- 4 - PROBE

VACUUM CHECK VALVE

(1) Remove the vacuum check valve. The valve is located in the vacuum supply tube (black) at the heater-A/C system vacuum tee.

(2) Connect the test set vacuum supply hose to the heater-A/C control side of the valve. When connected to this side of the check valve, no vacuum should pass and the test set gauge should return to the 27 kPa (8 in. Hg.) setting. If OK, go to Step 3. If not OK, replace the faulty valve.

(3) Connect the test set vacuum supply hose to the engine vacuum side of the valve. When connected to this side of the check valve, vacuum should flow through the valve without restriction. If not OK, replace the faulty valve.

HEATER-A/C CONTROLS

(1) Connect the test set vacuum probe to the heater-A/C vacuum supply (black) tube at the tee in the engine compartment. Position the test set gauge so that it can be viewed from the passenger compartment.

DIAGNOSIS AND TESTING (Continued)

(2) Place the heater-A/C mode control switch knob in each mode position, one position at a time, and pause after each selection. The test set gauge should return to the 27 kPa (8 in. Hg.) setting shortly after each selection is made. If not OK, a component or vacuum line in the vacuum circuit of the selected mode has a leak. See the procedure in Locating Vacuum Leaks.

CAUTION: Do not use lubricant on the switch ports or in the holes in the plug, as lubricant will ruin the vacuum valve in the switch. A drop of clean water in the connector plug holes will help the connector slide onto the switch ports.

LOCATING VACUUM LEAKS

WARNING: ON VEHICLES EQUIPPED WITH AIR-BAGS, REFER TO GROUP 8M - PASSIVE RESTRAINT SYSTEMS BEFORE ATTEMPTING ANY STEERING WHEEL, STEERING COLUMN, OR INSTRUMENT PANEL COMPONENT DIAGNOSIS OR SERVICE. FAILURE TO TAKE THE PROPER PRECAUTIONS COULD RESULT IN ACCIDENTAL AIR-BAG DEPLOYMENT AND POSSIBLE PERSONAL INJURY.

(1) Disconnect the vacuum harness connector behind the glove box and inboard of the glove box opening on the heater-A/C housing.

(2) Connect the test set vacuum hose probe to each port in the heater-A/C housing half of the vacuum harness connector, one port at a time, and pause after each connection (Fig. 10). The test set gauge should return to the 27 kPa (8 in. Hg.) setting shortly after each connection is made. If OK, replace the faulty heater-A/C control. If not OK, go to Step 3.

(3) Determine the vacuum line color of the vacuum circuit that is leaking. To determine the vacuum line colors, refer to the Vacuum Circuits chart (Fig. 11) or (Fig. 12).

(4) Disconnect and plug the vacuum line from the component (fitting, actuator, valve, switch, or reservoir) on the other end of the leaking circuit. Instrument panel disassembly or removal may be necessary to gain access to some components. See the service procedures in this group.

(5) Connect the test set hose or probe to the open end of the leaking circuit. The test set gauge should return to the 27 kPa (8 in. Hg.) setting shortly after each connection is made. If OK, replace the faulty disconnected component. If not OK, go to Step 6.

(6) To locate a leak in a vacuum line, leave one end of the line plugged and connect the test set hose or probe to the other end of the line. Run your fingers slowly along the line while watching the test set

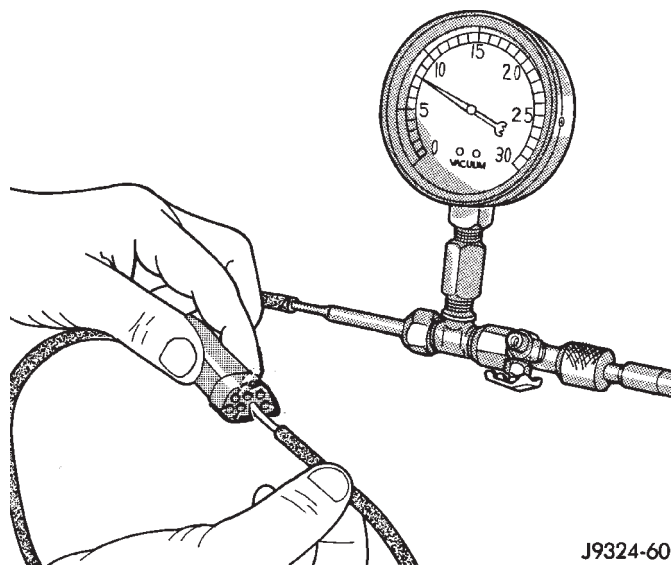

Fig. 10 Vacuum Circuit Test

gauge. The vacuum reading will fluctuate when your fingers contact the source of the leak. To repair the vacuum line, cut out the leaking section of the line. Then, insert the loose ends of the line into a suitable length of 3 millimeter (0.125 inch) inside diameter rubber hose.

SERVICE PROCEDURES

REFRIGERANT OIL LEVEL

When an air conditioning system is assembled at the factory, all components except the compressor are refrigerant oil free. After the refrigerant system has been charged and operated, the refrigerant oil in the compressor is dispersed throughout the refrigerant system. The accumulator, evaporator, condenser, and compressor will each retain a significant amount of the needed refrigerant oil.

It is important to have the correct amount of oil in the refrigerant system. This ensures proper lubrication of the compressor. Too little oil will result in damage to the compressor. Too much oil will reduce the cooling capacity of the air conditioning system.

It will not be necessary to check the oil level in the compressor or to add oil, unless there has been an oil loss. An oil loss may occur due to a rupture or leak from a refrigerant line, a connector fitting, a component, or a component seal. If a leak occurs, add 30 milliliters (1 fluid ounce) of refrigerant oil to the refrigerant system after the repair has been made. Refrigerant oil loss will be evident at the leak point by the presence of a wet, shiny surface around the leak.

Refrigerant oil must be added when an accumulator, evaporator coil, or condenser are replaced. See the Refrigerant Oil Capacities chart. When a compressor

SERVICE PROCEDURES (Continued)

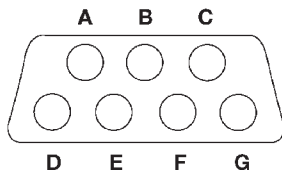

| VACUUM CIRCUIT LEGEND | | |
|-----------------------|----------------------------------|--------|
| I. D. | Function | Color |
| A | Not Used | N/A |
| B | Defrost Actuator (Full Position) | Yellow |
| C | Floor Actuator | Brown |
| D | Defrost Actuator (Mid-Position) | Blue |
| E | Vacuum Supply (Reservoir) | Black |
| F | Panel Actuator | Red |
| G | Not Used | N/A |

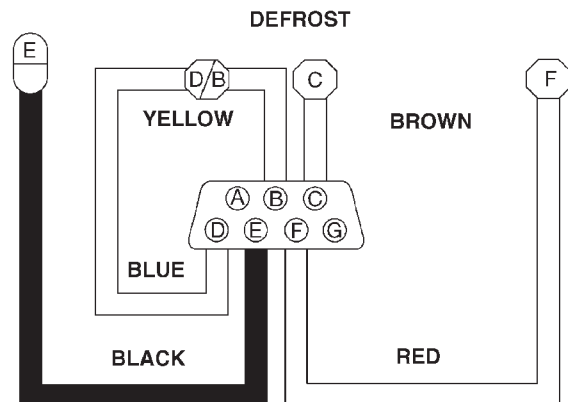
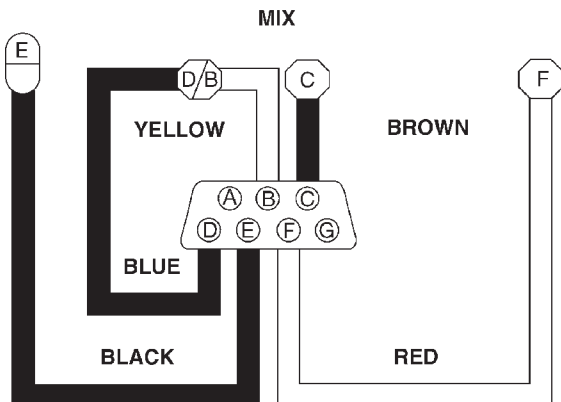
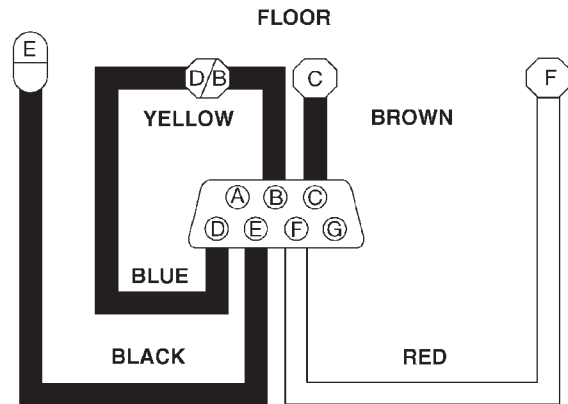
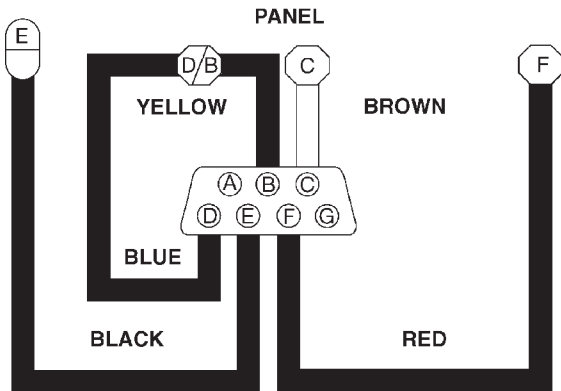
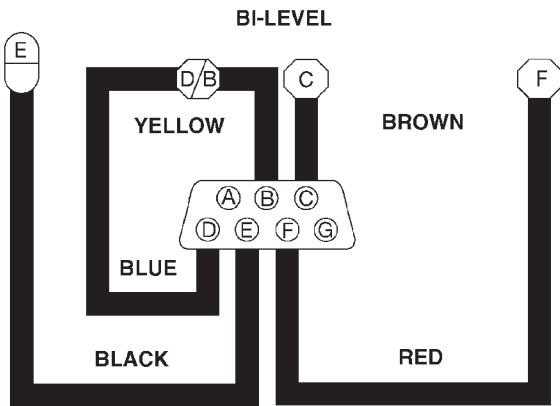
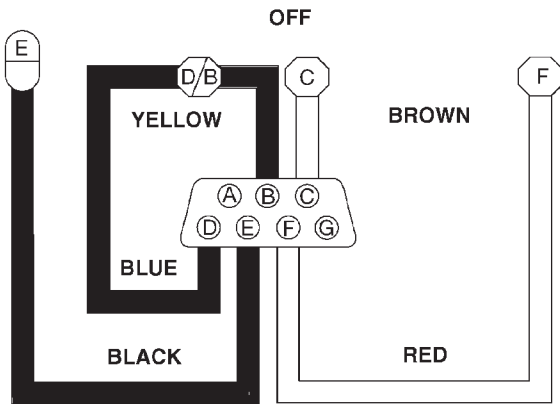

80aac2d2

Fig. 11 Vacuum Circuits - Heater Only

SERVICE PROCEDURES (Continued)

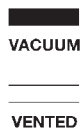
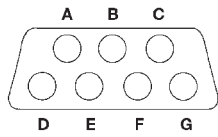

| VACUUM CIRCUIT LEGEND | | |
|-----------------------|----------------------------------|--------|
| I. D. | Function | Color |
| A | Not Used | N/A |
| B | Defrost Actuator (Full Position) | Yellow |
| C | Floor Actuator | Brown |
| D | Defrost Actuator (Mid-Position) | Blue |
| E | Vacuum Supply (Reservoir) | Black |
| F | Panel Actuator | Red |
| G | Recirculation Actuator | Green |

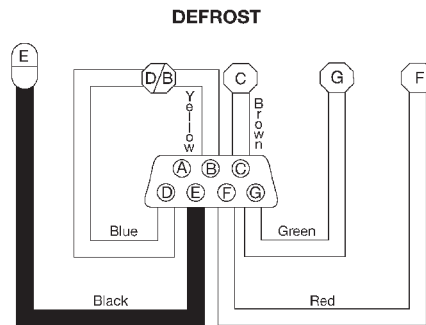
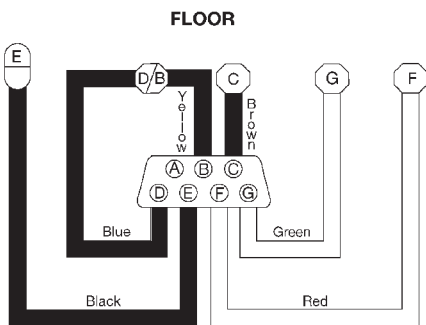
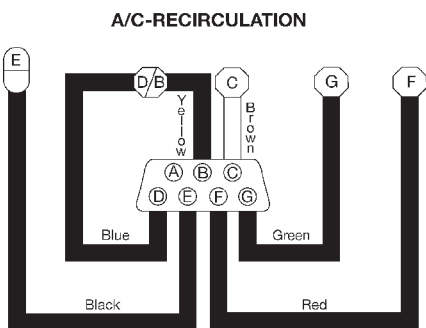
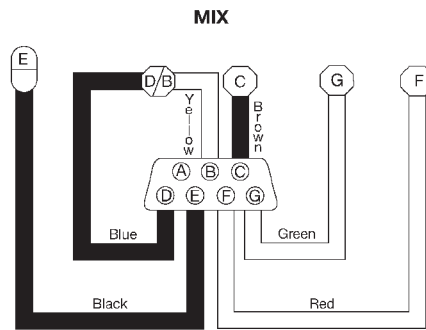
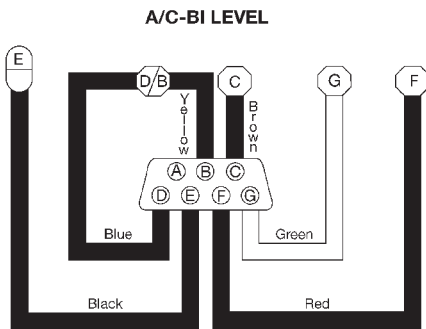
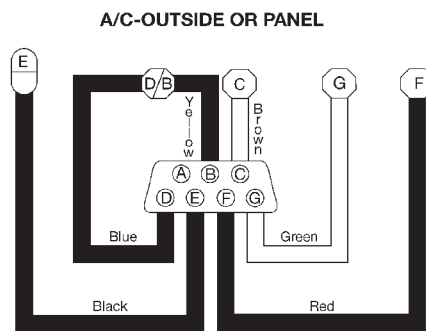
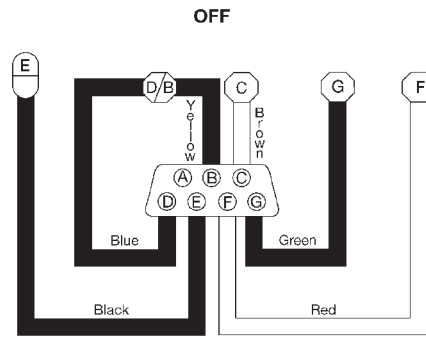

Fig. 12 Vacuum Circuits - Heater-A/C

SERVICE PROCEDURES (Continued)

is replaced, the refrigerant oil must be drained from the old compressor and measured. Drain all of the refrigerant oil from the new compressor, then fill the new compressor with the same amount of refrigerant oil that was drained out of the old compressor.

| Refrigerant Oil Capacities | | |
|----------------------------|--|-------|
| Component | ml | fl oz |
| A/C System | 180 | 6.1 |
| Accumulator | 90 | 3 |
| Condenser | 22 | .75 |
| Evaporator | 45 | 1.5 |
| Compressor | drain and measure the oil from the old compressor as noted | |

REFRIGERANT RECOVERY

WARNING: REVIEW THE WARNINGS AND CAUTIONS IN THE GENERAL INFORMATION SECTION NEAR THE FRONT OF THIS GROUP BEFORE RECOVERING REFRIGERANT.

A R-134a refrigerant recovery/recycling/charging station that meets SAE Standard J2210 must be used to recover the refrigerant from an R-134a refrigerant system. Refer to the operating instructions supplied by the equipment manufacturer for the proper care and use of this equipment.

REFRIGERANT SYSTEM EVACUATE

WARNING: REVIEW THE WARNINGS AND CAUTIONS IN THE GENERAL INFORMATION SECTION NEAR THE FRONT OF THIS GROUP BEFORE EVACUATING THE SYSTEM.

If the refrigerant system has been open to the atmosphere, it must be evacuated before the system can be charged. If moisture and air enters the system and becomes mixed with the refrigerant, the compressor head pressure will rise above acceptable operating levels. This will reduce the performance of the air conditioner and damage the compressor. Evacuating the refrigerant system will remove the air and boil the moisture out of the system at near room temperature. To evacuate the refrigerant system, use the following procedure:

(1) Connect a R-134a refrigerant recovery/recycling/charging station that meets SAE Standard J2210 and a manifold gauge set to the refrigerant system of the vehicle.

(2) Open the low and high side valves and start the charging station vacuum pump. When the suction gauge reads 88 kPa (26 in. Hg.) vacuum or

greater, close all of the valves and turn off the vacuum pump.

(a) If the refrigerant system fails to reach the specified vacuum, the system has a leak that must be corrected. See Refrigerant System Leaks in the Diagnosis and Testing section of this group for the procedures.

(b) If the refrigerant system maintains the specified vacuum for five minutes, restart the vacuum pump, open the suction and discharge valves and evacuate the system for an additional ten minutes.

(3) Close all of the valves, and turn off the charging station vacuum pump.

(4) The refrigerant system is now ready to be charged with R-134a refrigerant. See Refrigerant System Charge in the Service Procedures section of this group.

REFRIGERANT SYSTEM CHARGE

WARNING: REVIEW THE WARNINGS AND CAUTIONS IN THE FRONT OF THIS GROUP BEFORE CHARGING THE REFRIGERANT SYSTEM.

After the refrigerant system has been tested for leaks and evacuated, a refrigerant charge can be injected into the system. See Refrigerant Charge Capacity for the proper amount of the refrigerant charge.

A R-134a refrigerant recovery/recycling/charging station that meets SAE Standard J2210 must be used to charge the refrigerant system with R-134a refrigerant. Refer to the operating instructions supplied by the equipment manufacturer for proper care and use of this equipment.

REFRIGERANT CHARGE CAPACITY

The R-134a refrigerant system charge capacity for this vehicle is 0.567 kilograms (1.25 pounds).

REFRIGERANT SYSTEM SERVICE EQUIPMENT

WARNING: EYE PROTECTION MUST BE WORN WHEN SERVICING AN AIR CONDITIONING REFRIGERANT SYSTEM. TURN OFF (ROTATE CLOCKWISE) ALL VALVES ON THE EQUIPMENT BEING USED, BEFORE CONNECTING TO OR DISCONNECTING FROM THE REFRIGERANT SYSTEM. FAILURE TO OBSERVE THESE WARNINGS MAY RESULT IN PERSONAL INJURY.

When servicing the air conditioning system, a R-134a refrigerant recovery/recycling/charging station that meets SAE Standard J2210 must be used. Contact an automotive service equipment supplier for refrigerant recovery/recycling/charging equipment. Refer to the operating instructions supplied by the

SERVICE PROCEDURES (Continued)

equipment manufacturer for proper care and use of this equipment.

A manifold gauge set may be needed with some recovery/recycling/charging equipment (Fig. 13). The service hoses on the gauge set being used should have manual (turn wheel), or automatic back-flow valves at the service port connector ends. This will prevent refrigerant from being released into the atmosphere.

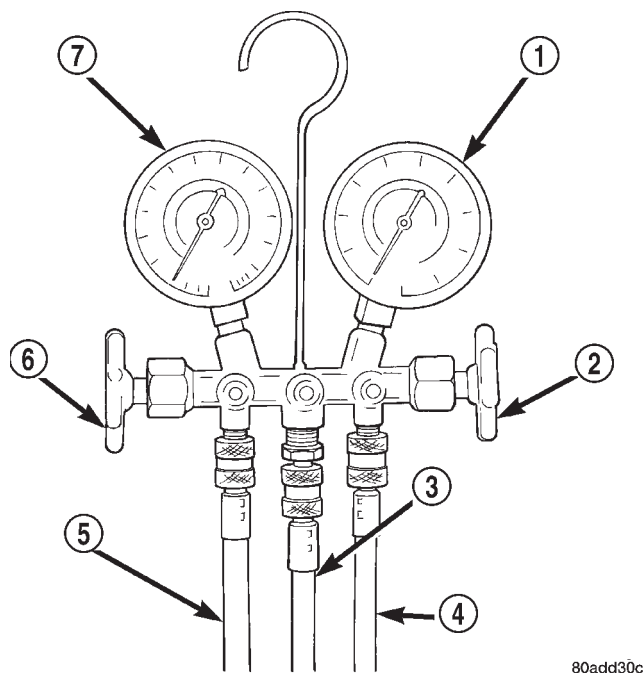

80add30c

Fig. 13 Manifold Gauge Set - Typical

- 1 - HIGH PRESSURE GAUGE
- 2 - VALVE
- 3 - VACUUM/REFRIGERANT HOSE (YELLOW W/BLACK STRIPE)
- 4 - HIGH PRESSURE HOSE (RED W/BLACK STRIPE)
- 5 - LOW PRESSURE HOSE (BLUE W/BLACK STRIPE)
- 6 - VALVE
- 7 - LOW PRESSURE GAUGE

MANIFOLD GAUGE SET CONNECTIONS

CAUTION: Do not use an R-12 manifold gauge set on an R-134a system. The refrigerants are not compatible and system damage will result.

LOW PRESSURE GAUGE HOSE The low pressure hose (Blue with Black stripe) attaches to the suction service port. This port is located on the suction line between the accumulator outlet and the compressor.

HIGH PRESSURE GAUGE HOSE The high pressure hose (Red with Black stripe) attaches to the discharge service port. This port is located on the discharge line between the compressor and the condenser inlet.

RECOVERY/RECYCLING/EVACUATION/CHARGING HOSE The center manifold hose (Yellow, or White, with Black stripe) is used to recover, evacuate, and charge the refrigerant system. When the low or high pressure valves on the manifold gauge set are opened, the refrigerant in the system will escape through this hose.

REMOVAL AND INSTALLATION

SERVICE WARNINGS AND PRECAUTIONS

WARNING:

- **THE AIR CONDITIONING SYSTEM CONTAINS REFRIGERANT UNDER HIGH PRESSURE. SEVERE PERSONAL INJURY MAY RESULT FROM IMPROPER SERVICE PROCEDURES. REPAIRS SHOULD ONLY BE PERFORMED BY QUALIFIED SERVICE PERSONNEL.**

- **AVOID BREATHING THE REFRIGERANT AND REFRIGERANT OIL VAPOR OR MIST. EXPOSURE MAY IRRITATE THE EYES, NOSE, AND/OR THROAT. WEAR EYE PROTECTION WHEN SERVICING THE AIR CONDITIONING REFRIGERANT SYSTEM. SERIOUS EYE INJURY CAN RESULT FROM DIRECT CONTACT WITH THE REFRIGERANT. IF EYE CONTACT OCCURS, SEEK MEDICAL ATTENTION IMMEDIATELY.**

- **DO NOT EXPOSE THE REFRIGERANT TO OPEN FLAME. POISONOUS GAS IS CREATED WHEN REFRIGERANT IS BURNED. AN ELECTRONIC LEAK DETECTOR IS RECOMMENDED.**

- **IF ACCIDENTAL SYSTEM DISCHARGE OCCURS, VENTILATE THE WORK AREA BEFORE RESUMING SERVICE. LARGE AMOUNTS OF REFRIGERANT RELEASED IN A CLOSED WORK AREA WILL DISPLACE THE OXYGEN AND CAUSE SUFFOCATION.**

- **THE EVAPORATION RATE OF R-134a REFRIGERANT AT AVERAGE TEMPERATURE AND ALTITUDE IS EXTREMELY HIGH. AS A RESULT, ANYTHING THAT COMES IN CONTACT WITH THE REFRIGERANT WILL FREEZE. ALWAYS PROTECT THE SKIN OR DELICATE OBJECTS FROM DIRECT CONTACT WITH THE REFRIGERANT.**

- **THE R-134a SERVICE EQUIPMENT OR THE VEHICLE REFRIGERANT SYSTEM SHOULD NOT BE PRESSURE TESTED OR LEAK TESTED WITH COMPRESSED AIR. SOME MIXTURES OF AIR AND R-134a HAVE BEEN SHOWN TO BE COMBUSTIBLE AT ELEVATED PRESSURES. THESE MIXTURES ARE POTENTIALLY DANGEROUS, AND MAY RESULT IN FIRE OR EXPLOSION CAUSING INJURY OR PROPERTY DAMAGE.**

REMOVAL AND INSTALLATION (Continued)

CAUTION:

- Liquid refrigerant is corrosive to metal surfaces. Follow the operating instructions supplied with the service equipment being used.
- Never add R-12 to a refrigerant system designed to use R-134a. Damage to the system will result.
- R-12 refrigerant oil must not be mixed with R-134a refrigerant oil. They are not compatible.
- Do not use R-12 equipment or parts on the R-134a system. Damage to the system will result.
- Do not overcharge the refrigerant system. This will cause excessive compressor head pressure and can cause noise and system failure.
- Recover the refrigerant before opening any fitting or connection. Open the fittings with caution, even after the system has been discharged. Never open or loosen a connection before recovering the refrigerant.
- Do not remove the secondary retention clip from any spring-lock coupler connection while the refrigerant system is under pressure. Recover the refrigerant before removing the secondary retention clip. Open the fittings with caution, even after the system has been discharged. Never open or loosen a connection before recovering the refrigerant.
- The refrigerant system must always be evacuated before charging.
- Do not open the refrigerant system or uncap a replacement component until you are ready to service the system. This will prevent contamination in the system.
- Before disconnecting a component, clean the outside of the fittings thoroughly to prevent contamination from entering the refrigerant system.
- Immediately after disconnecting a component from the refrigerant system, seal the open fittings with a cap or plug.
- Before connecting an open refrigerant fitting, always install a new seal or gasket. Coat the fitting and seal with clean refrigerant oil before connecting.
- Do not remove the sealing caps from a replacement component until it is to be installed.
- When installing a refrigerant line, avoid sharp bends that may restrict refrigerant flow. Position the refrigerant lines away from exhaust system components or any sharp edges, which may damage the line.
- Tighten refrigerant fittings only to the specified torque. The aluminum fittings used in the refrigerant system will not tolerate overtightening.
- When disconnecting a refrigerant fitting, use a wrench on both halves of the fitting. This will prevent twisting of the refrigerant lines or tubes.

- Refrigerant oil will absorb moisture from the atmosphere if left uncapped. Do not open a container of refrigerant oil until you are ready to use it. Replace the cap on the oil container immediately after using. Store refrigerant oil only in a clean, airtight, and moisture-free container.

- Keep service tools and the work area clean. Contamination of the refrigerant system through careless work habits must be avoided.

COOLING SYSTEM REQUIREMENTS

To maintain the performance level of the heating-air conditioning system, the engine cooling system must be properly maintained. The use of a bug screen is not recommended. Any obstructions in front of the radiator or condenser will reduce the performance of the air conditioning and engine cooling systems.

The engine cooling system includes the heater core and the heater hoses. Refer to Group 7 - Cooling System for more information before the opening of, or attempting any service to the engine cooling system.

REFRIGERANT HOSES/LINES/TUBES PRECAUTIONS

Kinks or sharp bends in the refrigerant plumbing will reduce the capacity of the entire system. High pressures are produced in the system when it is operating. Extreme care must be exercised to make sure that all refrigerant system connections are pressure tight.

A good rule for the flexible hose refrigerant lines is to keep the radius of all bends at least ten times the diameter of the hose. Sharp bends will reduce the flow of refrigerant. The flexible hose lines should be routed so they are at least 80 millimeters (3 inches) from the exhaust manifold. It is a good practice to inspect all flexible refrigerant system hose lines at least once a year to make sure they are in good condition and properly routed.

There are two types of refrigerant fittings:

- All fittings with O-rings need to be coated with refrigerant oil before installation. Use only O-rings that are the correct size and approved for use with R-134a refrigerant. Failure to do so may result in a leak.

- Unified plumbing connections with gaskets cannot be serviced with O-rings. The gaskets are not reusable and new gaskets do not require lubrication before installing.

Using the proper tools when making a refrigerant plumbing connection is very important. Improper tools or improper use of the tools can damage the refrigerant fittings. Always use two wrenches when loosening or tightening tube fittings. Use one wrench

REMOVAL AND INSTALLATION (Continued)

to hold one side of the connection stationary, while loosening or tightening the other side of the connection with a second wrench.

The refrigerant must be recovered completely from the system before opening any fitting or connection. Open the fittings with caution, even after the refrigerant has been recovered. If any pressure is noticed as a fitting is loosened, tighten the fitting and recover the refrigerant from the system again.

Do not discharge refrigerant into the atmosphere. Use an R-134a refrigerant recovery/recycling device that meets SAE Standard J2210.

The refrigerant system will remain chemically stable as long as pure, moisture-free R-134a refrigerant and refrigerant oil is used. Dirt, moisture, or air can upset this chemical stability. Operational troubles or serious damage can occur if foreign material is present in the refrigerant system.

When it is necessary to open the refrigerant system, have everything needed to service the system ready. The refrigerant system should not be left open to the atmosphere any longer than necessary. Cap or plug all lines and fittings as soon as they are opened to prevent the entrance of dirt and moisture. All lines and components in parts stock should be capped or sealed until they are to be installed.

All tools, including the refrigerant recycling equipment, the manifold gauge set, and test hoses should be kept clean and dry. All tools and equipment must be designed for R-134a refrigerant.

ACCUMULATOR

WARNING: REVIEW THE WARNINGS AND CAUTIONS IN THE FRONT OF THIS GROUP BEFORE PERFORMING THE FOLLOWING OPERATION.

REMOVAL

(1) Disconnect and isolate the battery negative cable.

(2) Recover the refrigerant from the refrigerant system. See Refrigerant Recovery in this group for the procedures.

(3) Unplug the wire harness connector from the low pressure cycling clutch switch.

(4) Loosen the screw that secures the accumulator retaining band to the support bracket on the dash panel (Fig. 14).

(5) Disconnect the suction line from the accumulator outlet tube refrigerant line fitting. See Refrigerant Line Coupler in this group for the procedures. Install plugs in, or tape over all of the opened refrigerant line fittings.

(6) Disconnect the accumulator inlet tube refrigerant line fitting from the evaporator outlet tube. See Refrigerant Line Coupler in this group for the proce-

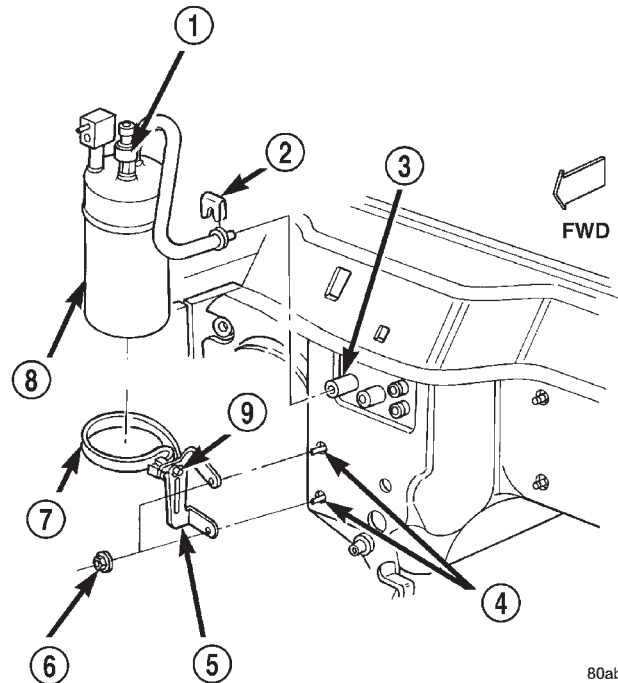

80abd2a5

Fig. 14 Accumulator Remove/Install

- 1 - LOW PRESSURE CYCLING CLUTCH SWITCH
- 2 - CLIP
- 3 - EVAPORATOR
- 4 - STUDS
- 5 - BRACKET
- 6 - NUTS
- 7 - BAND
- 8 - ACCUMULATOR
- 9 - SCREW

dures. Install plugs in, or tape over all of the opened refrigerant line fittings.

(7) Pull the accumulator and retaining band unit forward until the screw in the band is clear of the slotted hole in the support bracket on the dash panel.

(8) Remove the accumulator from the vehicle.

INSTALLATION

(1) Install the accumulator and retaining band as a unit by sliding the screw in the band into the slotted hole in the support bracket on the dash panel.

(2) Remove the tape or plugs from the refrigerant line fittings on the accumulator inlet tube and the evaporator outlet tube. Connect the accumulator inlet tube refrigerant line coupler to the evaporator outlet tube. See Refrigerant Line Coupler in this group for the procedures.

(3) Tighten the accumulator retaining band screw to 5 N·m (45 in. lbs.).

(4) Remove the tape or plugs from the refrigerant line fittings on the suction line and the accumulator outlet tube. Connect the suction line to the accumu-

REMOVAL AND INSTALLATION (Continued)

lator outlet tube refrigerant line coupler. See Refrigerant Line Coupler in this group for the procedures.

(5) Plug the wire harness connector into the low pressure cycling clutch switch.

(6) Connect the battery negative cable.

(7) Evacuate the refrigerant system. See Refrigerant System Evacuate in this group for the procedures.

(8) Charge the refrigerant system. See Refrigerant System Charge in this group for the procedures.

NOTE: If the accumulator is replaced, add 120 milliliters (4 fluid ounces) of refrigerant oil to the refrigerant system. Use only refrigerant oil of the type recommended for the compressor in the vehicle.

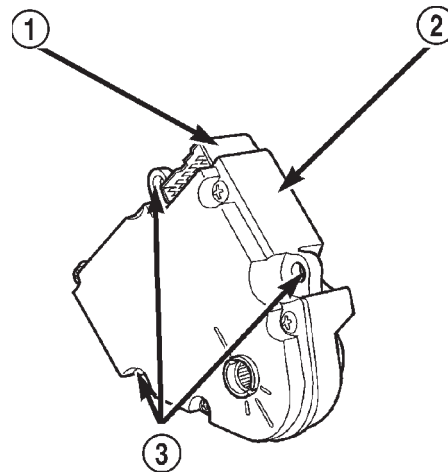

Fig. 15 Blend-Air Door Motor

- 1 - ELECTRICAL CONNECTOR
- 2 - BLEND-AIR DOOR MOTOR
- 3 - SCREW MOUNTING POINTS

80c073d9

BLEND-AIR DOOR MOTOR

WARNING: ON VEHICLES EQUIPPED WITH AIR-BAGS, REFER TO GROUP 8M - PASSIVE RESTRAINT SYSTEMS BEFORE ATTEMPTING ANY STEERING WHEEL, STEERING COLUMN, OR INSTRUMENT PANEL COMPONENT DIAGNOSIS OR SERVICE. FAILURE TO TAKE THE PROPER PRECAUTIONS COULD RESULT IN ACCIDENTAL AIR-BAG DEPLOYMENT AND POSSIBLE PERSONAL INJURY.

REMOVAL

(1) Disconnect and isolate the battery negative cable.

(2) Disconnect the wire connector from the blend-air door motor.

(3) Remove the screws that secure the blend-air door motor to the housing (Fig. 15).

(4) Remove the blend-air door motor.

INSTALLATION

(1) Reverse the removal procedures for installation.

(2) Install and tighten the screws that secures the blend-air door motor to the housing. Tighten the mounting screws to 1 N·m (10 in. lbs.).

(3) Connect the battery negative cable.

BLOWER MOTOR

REMOVAL

(1) If the vehicle is equipped with air conditioning, recover the refrigerant from the refrigerant system. See Refrigerant Recovery in this group for the procedures.

(2) Disconnect and isolate the battery negative cable.

(3) If the vehicle is equipped with air conditioning, the accumulator must be relocated in order to service the blower motor. This is done by loosening the accumulator retaining band screw and disconnecting the accumulator inlet tube from the evaporator outlet tube. The accumulator can then be moved far enough to access and remove the blower motor. See Accumulator in this group for the procedures.

(4) Unplug the blower motor wire harness connector (Fig. 16).

(5) Remove the three screws that secure the blower motor and wheel assembly to the heater-A/C housing.

(6) Rotate and tilt the blower motor unit as needed for clearance to remove the blower motor and wheel from the heater-A/C housing.

INSTALLATION

(1) Align and install the blower motor and wheel assembly into the heater-A/C housing.

(2) Install and tighten the three screws that secure the blower motor and wheel assembly to the heater-A/C housing. Tighten the mounting screws to 2.2 N·m (20 in. lbs.).

(3) Plug in the blower motor wire harness connector.

(4) If the vehicle is equipped with air conditioning, connect the accumulator inlet tube to the evaporator outlet tube and tighten the accumulator retaining band screw. See Accumulator in this group for the procedures.

(5) Connect the battery negative cable.

REMOVAL AND INSTALLATION (Continued)

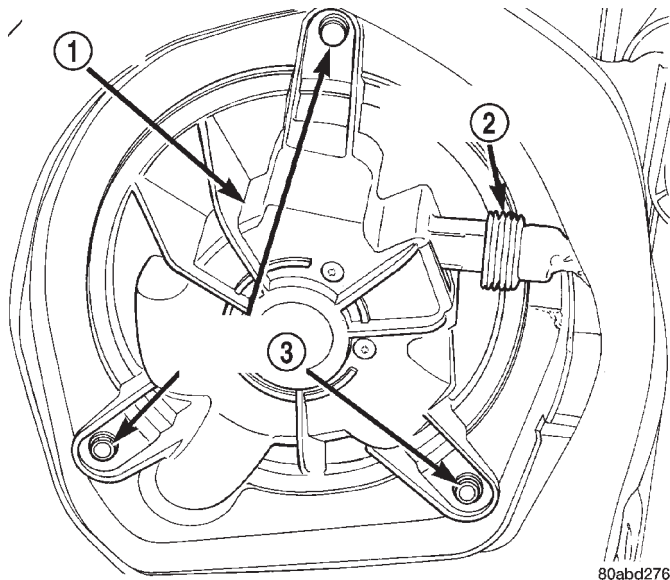
**Fig. 16 Blower Motor Remove/Install**

- 1 - BLOWER MOTOR
- 2 - WIRE HARNESS CONNECTOR
- 3 - MOUNTING SCREWS

(6) If the vehicle is equipped with air conditioning, evacuate the refrigerant system. See Refrigerant System Evacuate in this group for the procedures.

(7) If the vehicle is equipped with air conditioning, charge the refrigerant system. See Refrigerant System Charge in this group for the procedures.

BLOWER MOTOR RELAY

WARNING: ON VEHICLES EQUIPPED WITH AIR-BAGS, REFER TO GROUP 8M - PASSIVE RESTRAINT SYSTEMS BEFORE ATTEMPTING ANY STEERING WHEEL, STEERING COLUMN, OR INSTRUMENT PANEL COMPONENT DIAGNOSIS OR SERVICE. FAILURE TO TAKE THE PROPER PRECAUTIONS COULD RESULT IN ACCIDENTAL AIR-BAG DEPLOYMENT AND POSSIBLE PERSONAL INJURY.

(1) Disconnect and isolate the battery negative cable.

(2) Roll the glove box down from the instrument panel. Refer to Glove Box in Group 8E - Instrument Panel Systems for the procedures.

(3) Reach through the instrument panel glove box opening to locate the blower motor relay (Fig. 17).

(4) Unplug the blower motor relay from its wire harness connector.

(5) Install the blower motor relay by aligning the relay terminals with the cavities in the wire harness connector and pushing the relay firmly into place.

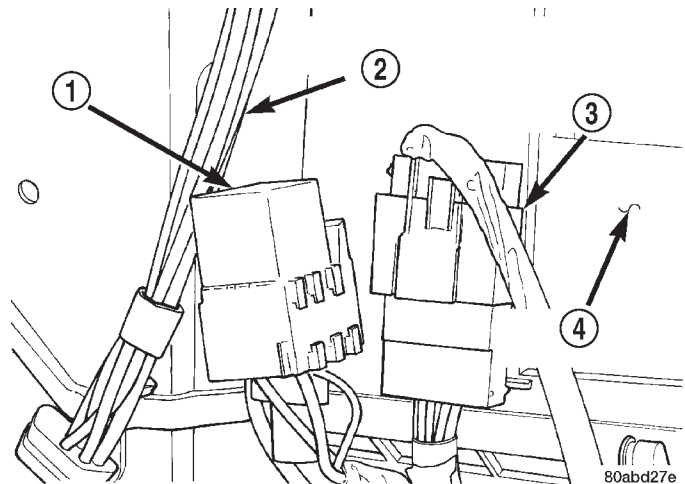
**Fig. 17 Blower Motor Relay Remove/Install**

- 1 - BLOWER MOTOR RELAY
- 2 - VACUUM HARNESS
- 3 - HEATER-A/C WIRE HARNESS CONNECTOR
- 4 - HEATER-A/C HOUSING

(6) Roll the glove box back up into the instrument panel. Refer to Glove Box in Group 8E - Instrument Panel Systems for the procedures.

(7) Connect the battery negative cable.

(8) Test the relay operation.

BLOWER MOTOR RESISTOR

WARNING: ON VEHICLES EQUIPPED WITH AIR-BAGS, REFER TO GROUP 8M - PASSIVE RESTRAINT SYSTEMS BEFORE ATTEMPTING ANY STEERING WHEEL, STEERING COLUMN, OR INSTRUMENT PANEL COMPONENT DIAGNOSIS OR SERVICE. FAILURE TO TAKE THE PROPER PRECAUTIONS COULD RESULT IN ACCIDENTAL AIR-BAG DEPLOYMENT AND POSSIBLE PERSONAL INJURY.

(1) Disconnect and isolate the battery negative cable.

(2) Remove the kick cover from the heater-A/C housing. See Kick Cover in this group for the procedures.

(3) Pull out the lock on the blower motor resistor wire harness connector to unlock the connector latch (Fig. 18).

(4) Depress the latch on the blower motor resistor wire harness connector and unplug the connector from the resistor.

(5) Remove the two screws that secure the resistor to the heater-A/C housing.

(6) Remove the resistor from the heater-A/C housing.

(7) Reverse the removal procedures to install. Tighten the mounting screws to 2.2 N·m (20 in lbs.).

REMOVAL AND INSTALLATION (Continued)

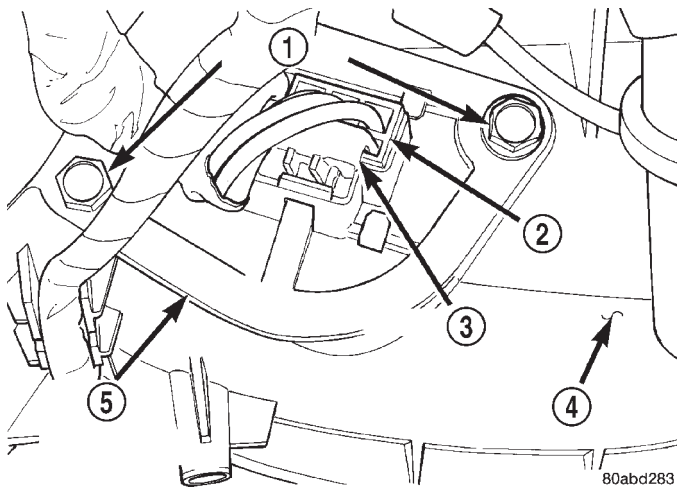

Fig. 18 Blower Motor Resistor Remove/Install

- 1 - SCREWS
- 2 - WIRE HARNESS CONNECTOR
- 3 - CONNECTOR LOCK
- 4 - HEATER-A/C HOUSING
- 5 - BLOWER MOTOR RESISTOR

COMPRESSOR

The compressor may be removed and repositioned without disconnecting the refrigerant lines or discharging the refrigerant system. Discharging is not necessary if servicing the compressor clutch or clutch coil, the engine, the cylinder head, or the generator.

WARNING: REVIEW THE WARNINGS AND CAUTIONS IN THE FRONT OF THIS GROUP BEFORE PERFORMING THE FOLLOWING OPERATION.

REMOVAL

(1) Recover the refrigerant from the refrigerant system. See Refrigerant Recovery in this group for the procedures.

(2) Disconnect and isolate the battery negative cable.

(3) Remove the serpentine drive belt. Refer to Group 7 - Cooling System for the procedures.

(4) Unplug the compressor clutch coil wire harness connector.

(5) Remove the suction and discharge refrigerant line manifold from the compressor. See Suction and Discharge Line in this group for the procedures. Install plugs in, or tape over all of the opened refrigerant fittings.

(6) Remove the four bolts that secure the compressor to the mounting bracket (Fig. 19).

(7) Remove the compressor from the mounting bracket.

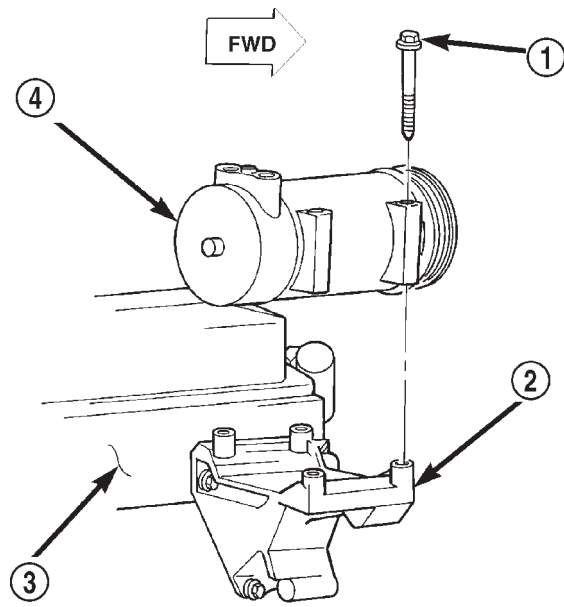

Fig. 19 Compressor Remove/Install - All 2.5L/4.0L Engines

- 1 - BOLT
- 2 - MOUNTING BRACKET
- 3 - ENGINE
- 4 - COMPRESSOR

INSTALLATION

NOTE: If a replacement compressor is being installed, be certain to check the refrigerant oil level. See Refrigerant Oil Level in this group for the procedures. Use only refrigerant oil of the type recommended for the compressor in the vehicle.

(1) Install the compressor to the mounting bracket. Tighten the four mounting bolts as follows:

- All 2.5L and 4.0L engines - 27 N·m (20 ft. lbs.)

(2) Remove the tape or plugs from all of the opened refrigerant line fittings. Install the suction and discharge line manifold to the compressor. See Suction and Discharge Line in this group for the procedures.

(3) Install the serpentine drive belt. Refer to Group 7 - Cooling System for the procedures.

(4) Plug in the compressor clutch coil wire harness connector.

(5) Connect the battery negative cable.

(6) Evacuate the refrigerant system. See Refrigerant System Evacuate in this group for the procedures.

(7) Charge the refrigerant system. See Refrigerant System Charge in this group for the procedures.

REMOVAL AND INSTALLATION (Continued)

COMPRESSOR CLUTCH

The refrigerant system can remain fully-charged during compressor clutch, pulley, or coil replacement. The compressor clutch can be serviced in the vehicle.

REMOVAL

(1) Disconnect and isolate the battery negative cable.

(2) Remove the serpentine drive belt. Refer to Group 7 - Cooling System for the procedures.

(3) Unplug the compressor clutch coil wire harness connector.

(4) Remove the four bolts that secure the compressor to the mounting bracket.

(5) Remove the compressor from the mounting bracket. Support the compressor in the engine compartment while servicing the clutch.

(6) Insert the two pins of the spanner wrench (Special Tool C-4489) into the holes of the clutch plate. Hold the clutch plate stationary and remove the hex nut (Fig. 20).

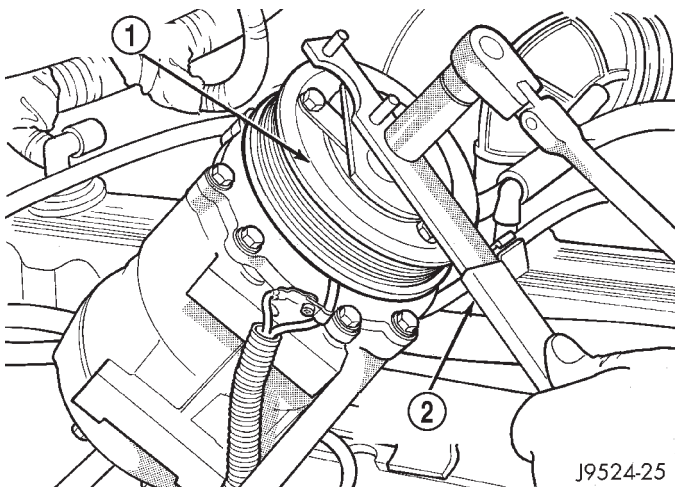

Fig. 20 Clutch Nut Remove

- 1 - CLUTCH PLATE
2 - SPANNER

(7) Remove the clutch plate with a puller (Special Tool C-6461) (Fig. 21).

(8) Remove the compressor shaft key and the clutch shims.

(9) Remove the external front housing snap ring with snap ring pliers (Fig. 22).

(10) Install the lip of the rotor puller (Special Tool C-6141-1) into the snap ring groove exposed in the previous step, and install the shaft protector (Special Tool C-6141-2) (Fig. 23).

(11) Install the puller through-bolts (Special Tool C-6461) through the puller flange and into the jaws of the rotor puller and tighten (Fig. 24). Turn the

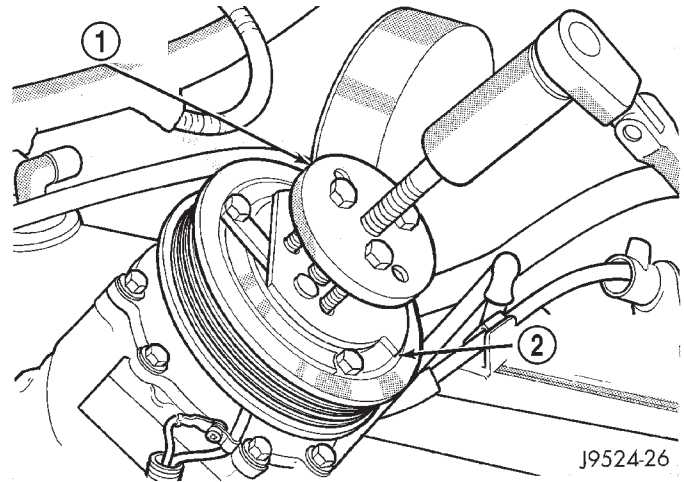

Fig. 21 Clutch Plate Remove

- 1 - CLUTCH PLATE PULLER
2 - CLUTCH PLATE

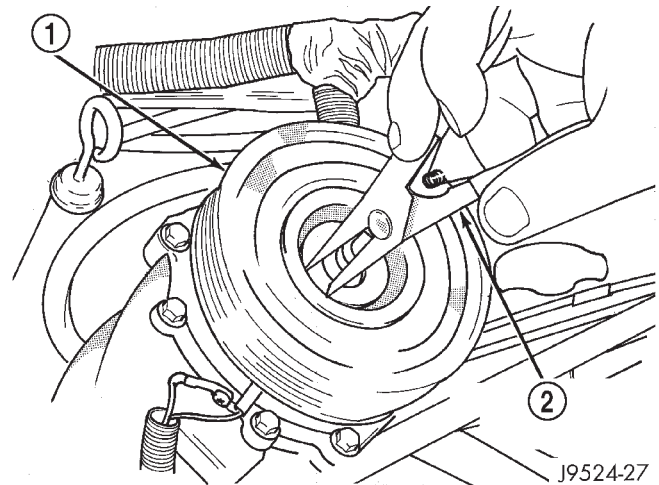

Fig. 22 External Snap Ring Remove

- 1 - PULLEY
2 - SNAP RING PLIERS

puller center bolt clockwise until the rotor pulley is free.

(12) Remove the screw and retainer from the clutch coil lead wire harness on the compressor front housing (Fig. 25).

(13) Remove the snap ring from the compressor hub and remove the clutch field coil (Fig. 26). Slide the clutch field coil off of the compressor hub.

INSPECTION

Examine the friction surfaces of the clutch pulley and the front plate for wear. The pulley and front plate should be replaced if there is excessive wear or scoring.

If the friction surfaces are oily, inspect the shaft and nose area of the compressor for oil. Remove the

REMOVAL AND INSTALLATION (Continued)

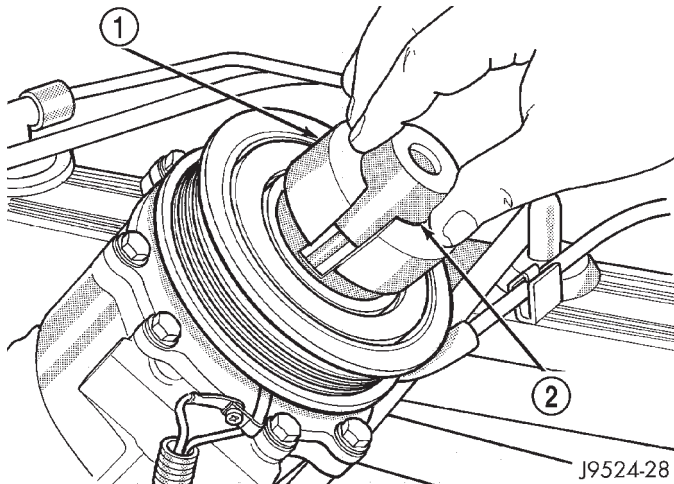
**Fig. 23 Shaft Protector and Puller**

- 1 - PULLER JAW
- 2 - SHAFT PROTECTOR

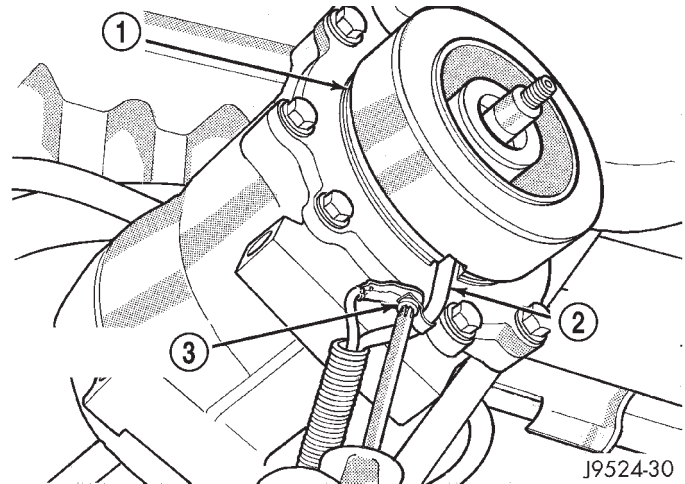
**Fig. 25 Clutch Coil Lead Wire Harness**

- 1 - COIL
- 2 - COIL WIRE
- 3 - RETAINER SCREW

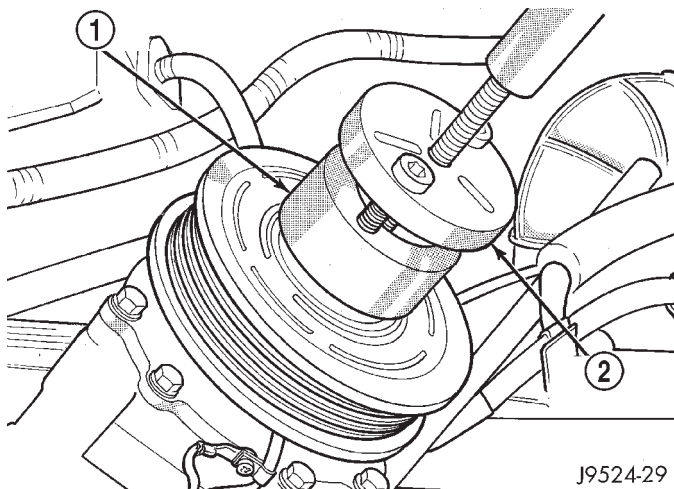
**Fig. 24 Install Puller Plate**

- 1 - PULLER JAW
- 2 - PULLER

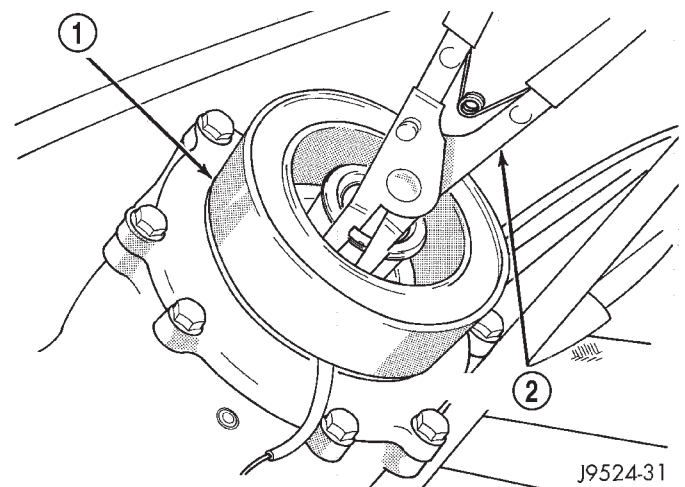
**Fig. 26 Clutch Field Coil Snap Ring Remove**

- 1 - COIL
- 2 - SNAP RING PLIERS

felt from the front cover. If the felt is saturated with oil, the shaft seal is leaking and the compressor must be replaced.

Check the clutch pulley bearing for roughness or excessive leakage of grease. Replace the bearing, if required.

INSTALLATION

- (1) Install the clutch field coil and snap ring.
- (2) Install the clutch coil lead wire harness retaining clip on the compressor front housing and tighten the retaining screw.
- (3) Align the rotor assembly squarely on the front compressor housing hub.
- (4) Install the pulley bearing assembly with the installer (Special Tool C-6871) (Fig. 27). Thread the

installer on the shaft, then turn the nut until the pulley assembly is seated.

- (5) Install the external front snap ring with snap ring pliers. The bevel side of the snap ring must be facing outward. Press the snap ring to make sure it is properly seated in the groove.

CAUTION: If the snap ring is not fully seated in the groove it will vibrate out, resulting in a clutch failure and severe damage to the front housing of the compressor.

- (6) Install the compressor shaft key and the original clutch shims on the compressor shaft.

REMOVAL AND INSTALLATION (Continued)

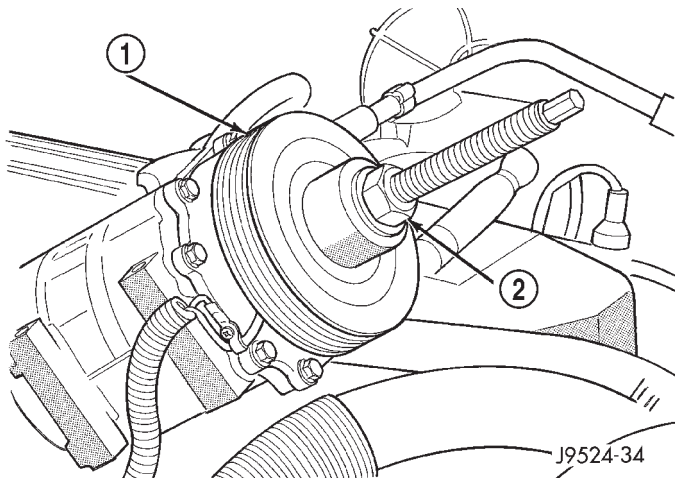
**Fig. 27 Clutch Pulley Install**

- 1 - PULLEY BEARING ASSEMBLY
2 - INSTALLER

(7) Install the clutch plate with the driver (Special Tool C-6463) (Fig. 28). Install the shaft hex nut and tighten to 14.4 N·m (10.5 ft. lbs.).

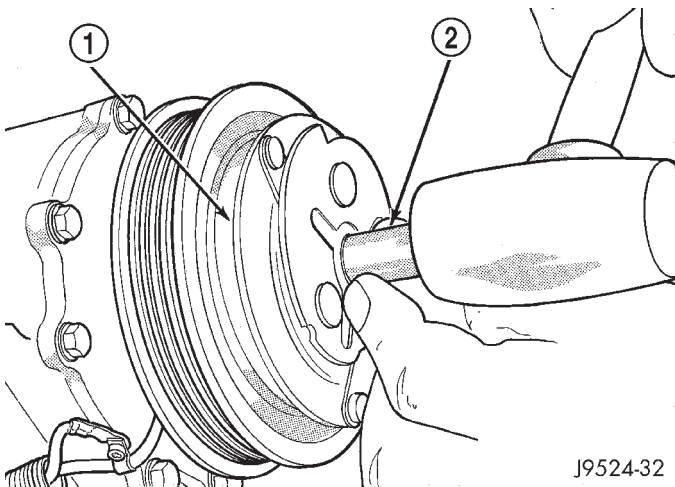
**Fig. 28 Clutch Plate Driver**

- 1 - CLUTCH PLATE
2 - DRIVER

(8) Check the clutch air gap with a feeler gauge (Fig. 29). If the air gap does not meet the specification, add or subtract shims as required. The air gap specification is 0.41 to 0.79 millimeter (0.016 to 0.031 inch). If the air gap is not consistent around the circumference of the clutch, lightly pry up at the minimum variations. Lightly tap down at the points of maximum variation.

NOTE: The air gap is determined by the spacer shims. When installing an original, or a new clutch assembly, try the original shims first. When installing a new clutch onto a compressor that previously

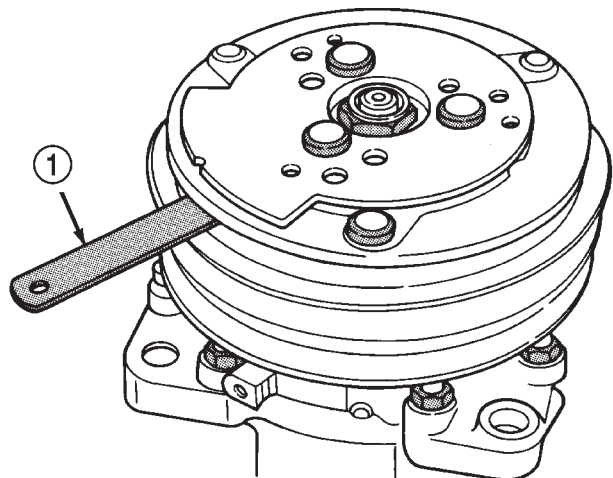
**Fig. 29 Check Clutch Air Gap**

- 1 - FEELER GAUGE

did not have a clutch, use 1.0, 0.50, and 0.13 millimeter (0.040, 0.020, and 0.005 inch) shims from the clutch hardware package that is provided with the new clutch.

(9) Reverse the remaining removal procedures to complete the installation.

CLUTCH BREAK-IN

After a new compressor clutch has been installed, cycle the compressor clutch approximately twenty times (five seconds on, then five seconds off). During this procedure, set the heater-A/C control to the Recirculation Mode, the blower motor switch in the highest speed position, and the engine speed at 1500 to 2000 rpm. This procedure (burnishing) will seat the opposing friction surfaces and provide a higher compressor clutch torque capability.

COMPRESSOR CLUTCH RELAY

(1) Disconnect and isolate the battery negative cable.

(2) Remove the cover from the Power Distribution Center (PDC) (Fig. 30).

(3) Refer to the label on the PDC for compressor clutch relay identification and location.

(4) Unplug the compressor clutch relay from the PDC.

(5) Install the compressor clutch relay by aligning the relay terminals with the cavities in the PDC and pushing the relay firmly into place.

(6) Install the PDC cover.

(7) Connect the battery negative cable.

(8) Test the relay operation.

REMOVAL AND INSTALLATION (Continued)

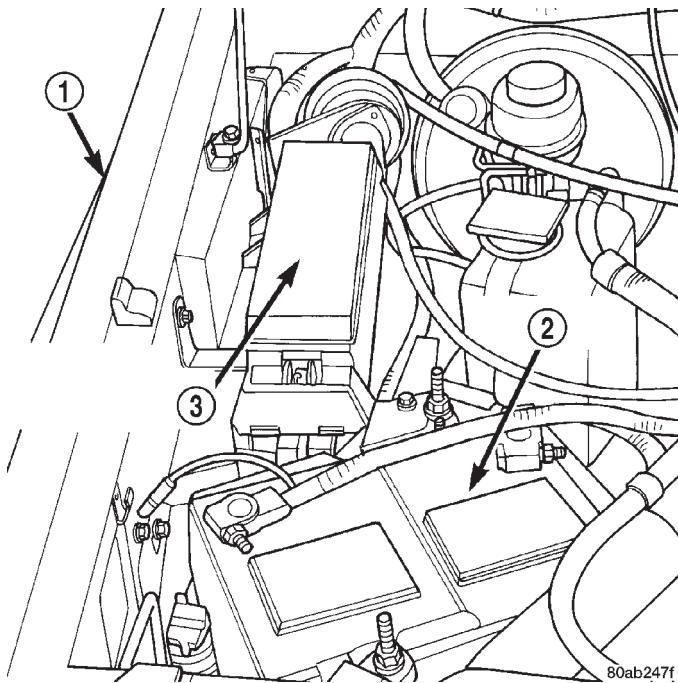
**Fig. 30 Power Distribution Center**

- 1 - RIGHT FENDER
- 2 - BATTERY
- 3 - POWER DISTRIBUTION CENTER

CONDENSER

WARNING: REVIEW THE WARNINGS AND CAUTIONS IN THE FRONT OF THIS GROUP BEFORE PERFORMING THE FOLLOWING OPERATION.

CAUTION: Before removing the condenser, note the location of each of the radiator and condenser air seals. These seals are used to direct air through the condenser and radiator. The air seals must be reinstalled in their proper locations in order for the air conditioning and engine cooling systems to perform as designed.

REMOVAL

- (1) Disconnect and isolate the battery negative cable.
- (2) Recover the refrigerant from the refrigerant system. See Refrigerant Recovery in this group for the procedures.
- (3) Disconnect the discharge line refrigerant line fitting at the condenser inlet. See Refrigerant Line Coupler in this group for the procedures. Install plugs in, or tape over all of the opened refrigerant line fittings.
- (4) Disconnect the liquid line (Left-Hand Drive) or liquid line jumper (Right-Hand Drive) refrigerant

line fitting at the condenser outlet. See Refrigerant Line Coupler in this group for the procedures. Install plugs in, or tape over all of the opened refrigerant line fittings.

(5) Remove the radiator and the condenser from the vehicle as a unit. Refer to Group 7 - Cooling System for the procedures.

(6) Remove the two nuts that secure the condenser studs to the upper brackets of the radiator (Fig. 31).

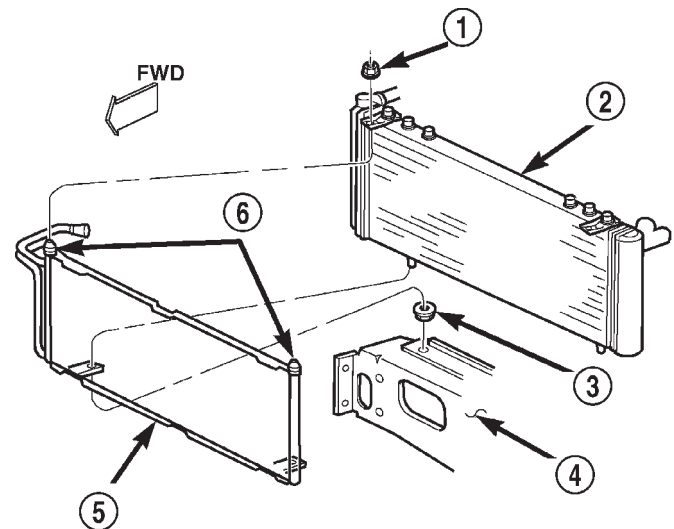
**Fig. 31 Condenser Remove/Install**

- 1 - NUT
- 2 - RADIATOR
- 3 - GROMMET
- 4 - LOWER CROSSMEMBER
- 5 - CONDENSER
- 6 - STUDS

(7) Slide the condenser down from the radiator far enough for the condenser studs to clear the upper radiator bracket holes, and for the lower condenser bracket holes to clear the dowel pins on the bottom of the radiator.

(8) Remove the condenser from the radiator.

INSTALLATION

- (1) Install the holes of the condenser lower brackets over the dowel pins on the bottom of the radiator.
- (2) Slide the condenser upwards until both of the condenser studs are installed through the holes in the radiator upper brackets. Tighten the mounting nuts to 5.3 N·m (47 in. lbs.).
- (3) Reinstall the radiator and condenser unit in the vehicle. Refer to Group 7 - Cooling System for the procedures.
- (4) Remove the tape or plugs from the refrigerant line fittings on the condenser outlet and the liquid line (Left-Hand Drive) or the liquid line jumper (Right-Hand Drive). Install the liquid line or the liq-

80b0d766

REMOVAL AND INSTALLATION (Continued)

uid line jumper to the condenser outlet. See Refrigerant Line Coupler in this group for the procedures.

(5) Remove the tape or plugs from the refrigerant line fittings on the condenser inlet and the discharge line. Connect the discharge line to the condenser inlet. See Refrigerant Line Coupler in this group for the procedures.

(6) Connect the battery negative cable.

(7) Evacuate the refrigerant system. See Refrigerant System Evacuate in this group for the procedures.

(8) Charge the refrigerant system. See Refrigerant System Charge in this group for the procedures.

NOTE: If the condenser is replaced, add 30 milliliters (1 fluid ounce) of refrigerant oil to the refrigerant system. Use only refrigerant oil of the type recommended for the compressor in the vehicle.

DUAL FUNCTION HIGH PRESSURE SWITCH/ HIGH PRESSURE CUT-OFF SWITCH

REMOVAL

(1) Disconnect and isolate the battery negative cable.

(2) Unplug the wire harness connector from the dual function high pressure switch or the high pressure cut-off switch, which is mounted to a fitting on the non-flexible section of the discharge line nearest the compressor.

(3) Unscrew the high pressure switch from the discharge line fitting.

(4) Remove the high pressure switch from the vehicle.

(5) Remove the O-ring seal from the discharge line fitting and discard.

INSTALLATION

(1) Lubricate a new O-ring seal with clean refrigerant oil and install it on the discharge line fitting. Use only the specified O-rings as they are made of a special material for the R-134a system. Use only refrigerant oil of the type recommended for the compressor in the vehicle.

(2) Install and tighten the high pressure switch on the discharge line fitting.

(3) Plug the wire harness connector into the high pressure cut-off switch.

(4) Connect the battery negative cable.

DUCTS AND OUTLETS

WARNING: ON VEHICLES EQUIPPED WITH AIRBAGS, REFER TO GROUP 8M - PASSIVE RESTRAINT SYSTEMS BEFORE ATTEMPTING ANY

STEERING WHEEL, STEERING COLUMN, OR INSTRUMENT PANEL COMPONENT DIAGNOSIS OR SERVICE. FAILURE TO TAKE THE PROPER PRECAUTIONS COULD RESULT IN ACCIDENTAL AIRBAG DEPLOYMENT AND POSSIBLE PERSONAL INJURY.

PANEL OUTLET DUCTS

The panel outlet ducts are integral to the instrument panel assembly. Refer to Instrument Panel Assembly in Group 8E - Instrument Panel Systems for the procedures.

PANEL OUTLET BARRELS

(1) Use a trim stick or another suitable wide flat-bladed tool to gently pry the panel outlet barrel out of the panel outlet housing (Fig. 32). The barrel is retained by a light snap fit.

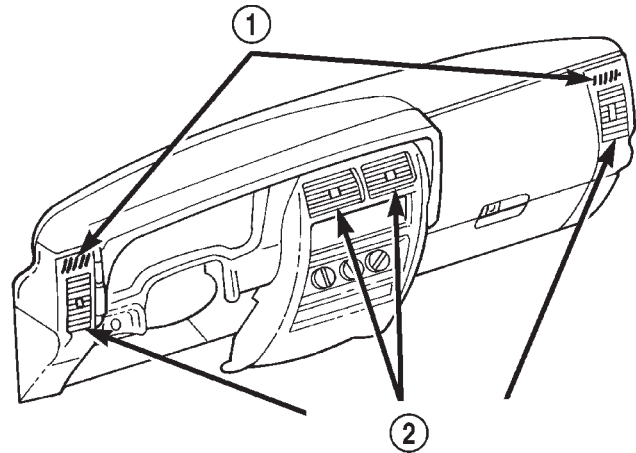

80abd29e

Fig. 32 Panel Outlet Barrels

- 1 - DEMISTER OUTLETS
2 - PANEL OUTLET BARRELS

(2) To install, position the barrel in the panel outlet housing and press firmly until the barrel snaps into place.

DEMISTER OUTLETS

The side window demister outlets are integral to the instrument panel end caps. Refer to Instrument Panel End Cap in Group 8E - Instrument Panel Systems for the procedures.

DEFROST DUCT/DEMISTER ADAPTER

(1) Remove the instrument panel assembly from the vehicle. Refer to Instrument Panel Assembly in Group 8E - Instrument Panel Systems for the procedures.

(2) Disconnect the demister hoses from the defrost duct/demister adapter (Fig. 33).

REMOVAL AND INSTALLATION (Continued)

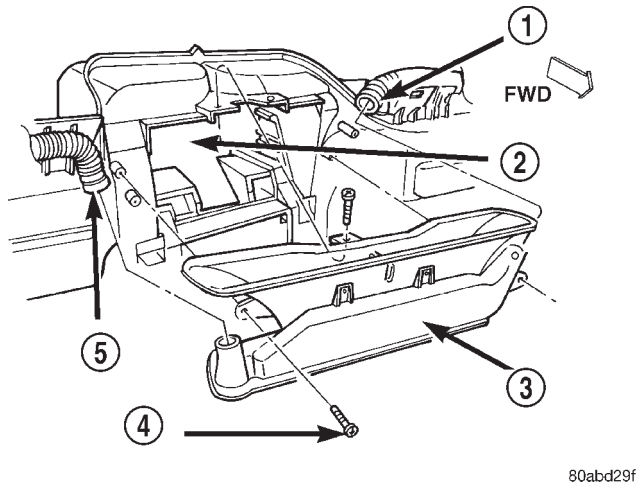
**Fig. 33 Defrost Duct/Demister Adapter**

- 1 - HOSE
- 2 - INSTRUMENT PANEL
- 3 - DEFROST DUCT/DEMISTER ADAPTER
- 4 - SCREW
- 5 - HOSE

(3) Remove the three screws that secure the defrost duct/demister adapter to the instrument panel.

(4) Remove the defrost duct/demister adapter from the instrument panel.

(5) Reverse the removal procedures to install. Tighten the mounting screws to 2.2 N·m (20 in. lbs.).

DEMISTER HOSES

(1) Remove the instrument panel assembly from the vehicle. Refer to Instrument Panel Assembly in Group 8E - Instrument Panel Systems for the procedures.

(2) Disconnect the ends of the demister hose from the demister duct (Fig. 34) and the defrost duct/demister adapter (Fig. 33).

(3) Reverse the removal procedures to install.

DEMISTER DUCTS

(1) Remove the instrument panel assembly from the vehicle. Refer to Instrument Panel Assembly in Group 8E - Instrument Panel Systems for the procedures.

(2) Remove the end cap from the instrument panel. Refer to Instrument Panel End Cap in Group 8E - Instrument Panel Systems for the procedures.

(3) Disconnect the demister hoses from the demister duct (Fig. 34).

(4) Remove the two screws that secure the demister duct to the top of the instrument panel.

(5) Remove the demister duct from the instrument panel.

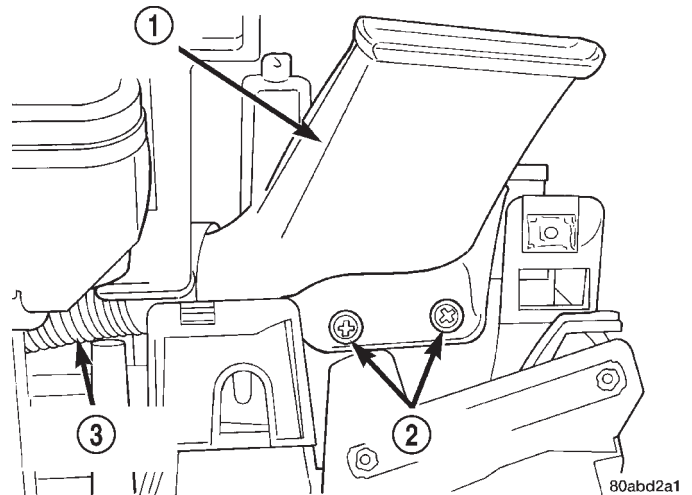
**Fig. 34 Demister Duct Remove/Install**

- 1 - DEMISTER DUCT
- 2 - SCREWS
- 3 - DEMISTER HOSE

(6) Reverse the removal procedures to install. Tighten the mounting screws to 2.2 N·m (20 in. lbs.).

CONSOLE REAR DUCT

(1) Disconnect and isolate the battery negative cable.

(2) Remove the floor console from the floor panel transmission tunnel (Fig. 35). Refer to Group 23 - Body for the procedures.

(3) Lift the rear of the console rear duct out of the console rear mounting bracket on the floor panel transmission tunnel and slide the duct rearward to disengage it from the floor duct and adapter.

(4) Remove the console rear duct from the vehicle.

(5) Reverse the removal procedures to install.

FLOOR DUCT AND ADAPTER

(1) Remove the instrument panel from the vehicle. Refer to Instrument Panel Assembly in Group 8E - Instrument Panel Systems for the procedures.

(2) Remove the heater-A/C housing from the vehicle. See Heater-A/C Housing in this group for the procedures.

(3) Remove the three screws that secure the floor duct and adapter to the heater-A/C housing (Fig. 35).

(4) Remove the floor duct and adapter from the heater-A/C housing.

(5) Reverse the removal procedures to install. Tighten the mounting screws to 2.2 N·m (20 in. lbs.).

REMOVAL AND INSTALLATION (Continued)

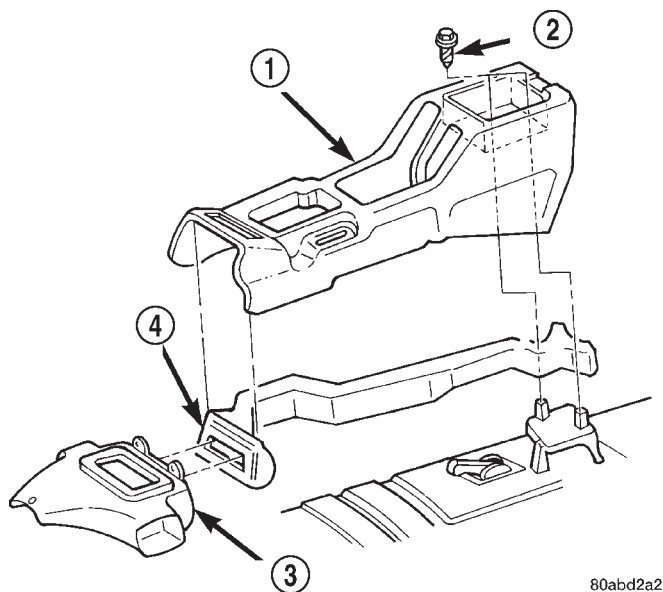

80abd2a2

Fig. 35 Floor Duct and Console Rear Duct Remove/Install

- 1 - FLOOR CONSOLE
- 2 - SCREW
- 3 - FLOOR DUCT AND ADAPTER
- 4 - CONSOLE REAR DUCT

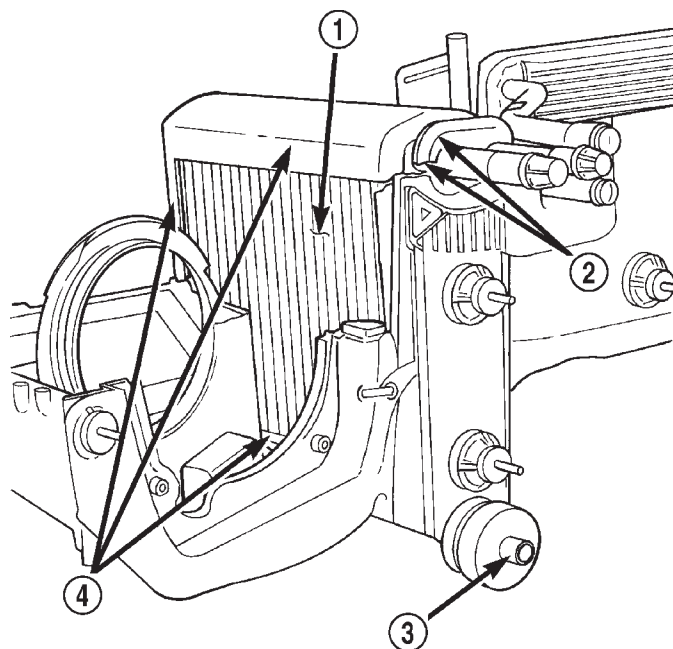

80abd29a

Fig. 36 Evaporator Coil Remove/Install

- 1 - EVAPORATOR COIL
- 2 - TUBE SEAL
- 3 - CONDENSATE DRAIN TUBE
- 4 - FOAM INSULATOR WRAP

EVAPORATOR COIL

WARNING: ON VEHICLES EQUIPPED WITH AIR-BAGS, REFER TO GROUP 8M - PASSIVE RESTRAINT SYSTEMS BEFORE ATTEMPTING ANY STEERING WHEEL, STEERING COLUMN, OR INSTRUMENT PANEL COMPONENT DIAGNOSIS OR SERVICE. FAILURE TO TAKE THE PROPER PRECAUTIONS COULD RESULT IN ACCIDENTAL AIR-BAG DEPLOYMENT AND POSSIBLE PERSONAL INJURY.

(1) Remove and disassemble the heater-A/C housing. See Heater-A/C Housing in this group for the procedures.

(2) Lift the evaporator coil unit out of the lower half of the heater-A/C housing (Fig. 36).

(3) Reverse the removal procedures to install. Be certain that the evaporator foam insulator wrap and rubber tube seal are reinstalled.

NOTE: If the evaporator is replaced, add 60 milliliters (2 fluid ounces) of refrigerant oil to the refrigerant system. Use only refrigerant oil of the type recommended for the compressor in the vehicle.

FIXED ORIFICE TUBE

The fixed orifice tube is located in the liquid line (Left-Hand Drive) or the liquid line jumper (Right-

Hand Drive) near the condenser. The orifice has filter screens on the inlet and outlet ends of the tube body. If the fixed orifice tube is faulty or plugged, the liquid line unit or liquid line jumper unit must be replaced. See Liquid Line in this group for the service procedures.

HEATER-A/C CONTROL

WARNING: ON VEHICLES EQUIPPED WITH AIR-BAGS, REFER TO GROUP 8M - PASSIVE RESTRAINT SYSTEMS BEFORE ATTEMPTING ANY STEERING WHEEL, STEERING COLUMN, OR INSTRUMENT PANEL COMPONENT DIAGNOSIS OR SERVICE. FAILURE TO TAKE THE PROPER PRECAUTIONS COULD RESULT IN ACCIDENTAL AIR-BAG DEPLOYMENT AND POSSIBLE PERSONAL INJURY.

REMOVAL

(1) Disconnect and isolate the battery negative cable.

(2) Roll down the glove box from the instrument panel. Refer to Glove Box in Group 8E - Instrument Panel Systems for the procedures.

(3) Reach through the instrument panel glove box opening to access and unplug the two halves of the heater-A/C vacuum harness connector.

REMOVAL AND INSTALLATION (Continued)

(4) Remove the center bezel from the instrument panel. Refer to Instrument Panel Center Bezel in Group 8E - Instrument Panel Systems for the procedures.

(5) Release the vacuum harness push-in retainer from the instrument panel directly beneath the heater-A/C control.

(6) Remove the four screws that secure the heater-A/C control to the instrument panel (Fig. 37).

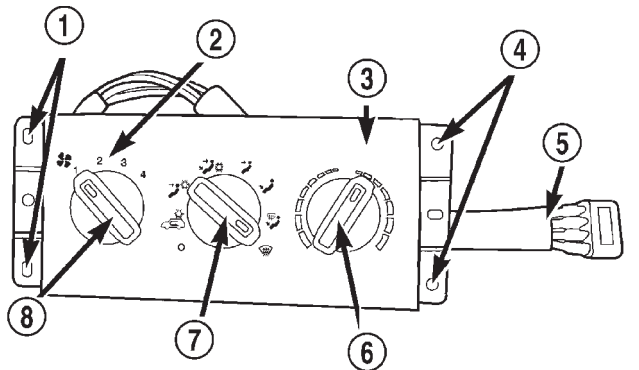

80ba777C

Fig. 37 Heater-A/C Control Remove/Install

- 1 - MOUNTING HOLES
- 2 - CONTROL HEAD
- 3 - HEATER-A/C CONTROL HEAD
- 4 - MOUNTING HOLES
- 5 - VACUUM HARNESS
- 6 - TEMPERATURE SELECT CONTROL
- 7 - MODE SELECT CONTROL
- 8 - BLOWER SPEED CONTROL

(7) Pull the heater-A/C control assembly away from the instrument panel far enough to access the connections on the back of the control.

(8) Unplug the wire harness connectors from the back of the heater-A/C control (Fig. 38).

(9) Reach through the instrument panel glove box opening to guide the heater-A/C control half of the vacuum harness around any obstacles while pulling the heater-A/C control out from the front of the instrument panel.

INSTALLATION

(1) Plug the wire harness connectors into the back of the heater-A/C control.

(2) Route the vacuum harness through the instrument panel opening and reinstall the vacuum harness push-in retainer.

(3) Reach through the instrument panel glove box opening to reconnect the two halves of the heater-A/C vacuum harness connector.

(4) Roll the glove box back up into the instrument panel. Refer to Glove Box in Group 8E - Instrument Panel Systems for the procedures.

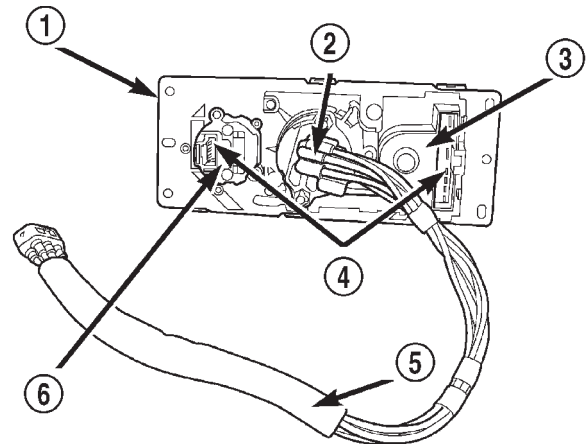

80ba7771

Fig. 38 Heater-A/C Control Connections

- 1 - HEATER-A/C CONTROL HEAD
- 2 - MODE SELECT CONTROL
- 3 - BLOWER SPEED CONTROL
- 4 - ELECTRICAL CONNECTORS
- 5 - VACUUM HARNESS
- 6 - TEMPERATURE SELECT CONTROL

(5) Position the heater-A/C control in the instrument panel and secure it with four screws. Tighten the screws to 2.2 N·m (20 in. lbs.).

(6) Reinstall the center bezel onto the instrument panel. Refer to Instrument Panel Center Bezel in Group 8E - Instrument Panel Systems for the procedures.

(7) Connect the battery negative cable.

HEATER-A/C HOUSING

The heater-A/C housing assembly must be removed from the vehicle and the two halves of the housing separated for service access of the heater core, evaporator coil, blend-air door, and each of the various mode control doors.

WARNING: ON VEHICLES EQUIPPED WITH AIR-BAGS, REFER TO GROUP 8M - PASSIVE RESTRAINT SYSTEMS BEFORE ATTEMPTING ANY STEERING WHEEL, STEERING COLUMN, OR INSTRUMENT PANEL COMPONENT DIAGNOSIS OR SERVICE. FAILURE TO TAKE THE PROPER PRECAUTIONS COULD RESULT IN ACCIDENTAL AIR-BAG DEPLOYMENT AND POSSIBLE PERSONAL INJURY.

REMOVAL

(1) Disconnect and isolate the battery negative cable.

(2) Remove the instrument panel from the vehicle. Refer to Instrument Panel Assembly in Group 8E - Instrument Panel Systems for the procedures.

REMOVAL AND INSTALLATION (Continued)

(3) If the vehicle is not equipped with air conditioning, go to Step 6. If the vehicle is equipped with air conditioning, recover the refrigerant from the refrigerant system. See Refrigerant Recovery in this group for the procedures.

(4) Disconnect the liquid line refrigerant line fitting from the evaporator inlet tube. See Refrigerant Line Coupler in this group for the procedures. Install plugs in, or tape over all of the opened refrigerant line fittings.

(5) Disconnect the accumulator inlet tube refrigerant line fitting from the evaporator outlet tube. See Refrigerant Line Coupler in this group for the procedures. Install plugs in, or tape over all of the opened refrigerant line fittings.

(6) Drain the engine cooling system. Refer to Group 7 - Cooling System for the procedures.

(7) Disconnect the heater hoses from the heater core tubes. Refer to Group 7 - Cooling System for the procedures. Install plugs in, or tape over the opened heater core tubes.

(8) Unplug the heater-A/C system vacuum supply line connector from the tee fitting near the heater core tubes.

(9) Unplug the heater-A/C unit wire harness connector, which is fastened to the heater-A/C housing next to the blower motor relay (Fig. 39).

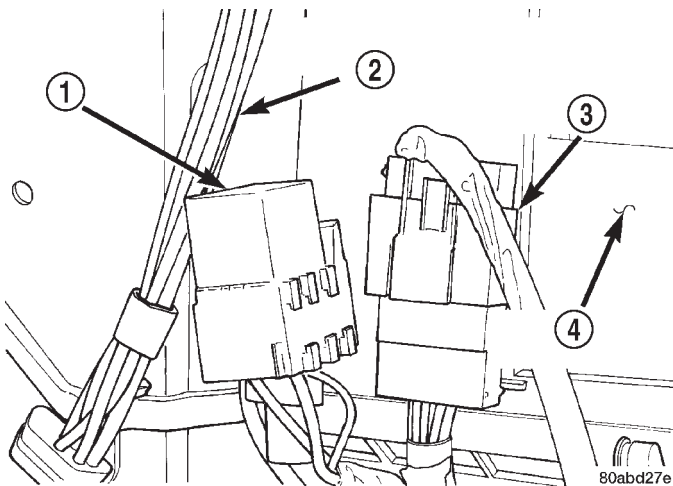

Fig. 39 Heater-A/C Unit Connector

- 1 - BLOWER MOTOR RELAY
- 2 - VACUUM HARNESS
- 3 - HEATER-A/C WIRE HARNESS CONNECTOR
- 4 - HEATER-A/C HOUSING

(10) Remove the five nuts from the heater-A/C housing mounting studs on the engine compartment side of the dash panel (Fig. 40). Remove or reposition the evaporation canister for additional access, if required.

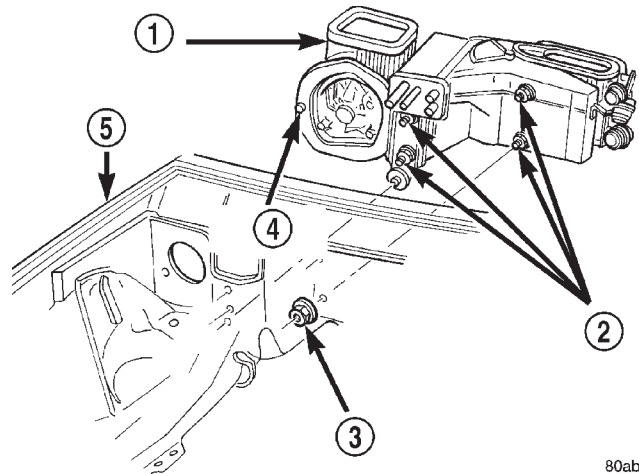

Fig. 40 Heater-A/C Housing Remove/Install

- 1 - HEATER-A/C HOUSING
- 2 - STUD
- 3 - NUT
- 4 - STUD
- 5 - RIGHT FRONT FENDER

(11) Pull the heater-A/C housing rearward far enough for the mounting studs and the evaporator condensate drain tube to clear the dash panel holes.

(12) Remove the heater-A/C housing from the vehicle.

DISASSEMBLY

(1) Remove the heater-A/C housing from the vehicle and place it on a work bench.

(2) Unplug the vacuum harness connectors from the floor door actuator and, if the unit is so equipped, the recirculation air door actuator.

(3) Disengage the vacuum harness from any routing clips located on the lower half of the heater-A/C housing.

(4) Disengage the heater-A/C wire harness connector and the blower motor relay wire harness connector push-in retainers from their mounting holes on the heater-A/C housing.

(5) Remove the blower motor and blower wheel unit from the heater-A/C housing. See Blower Motor in this group for the procedures.

(6) Carefully remove the foam seal from the flange around the blower motor opening in the heater-A/C housing. If the seal is deformed or damaged, it must be replaced.

(7) Pull the vacuum supply line and connector through the foam seal on the heater core and evaporator coil tube mounting flange of the heater-A/C housing (Fig. 41).

(8) If the unit is equipped with air conditioning, remove the screw that secures the clamp to the evaporator coil tubes and remove the clamp.

REMOVAL AND INSTALLATION (Continued)

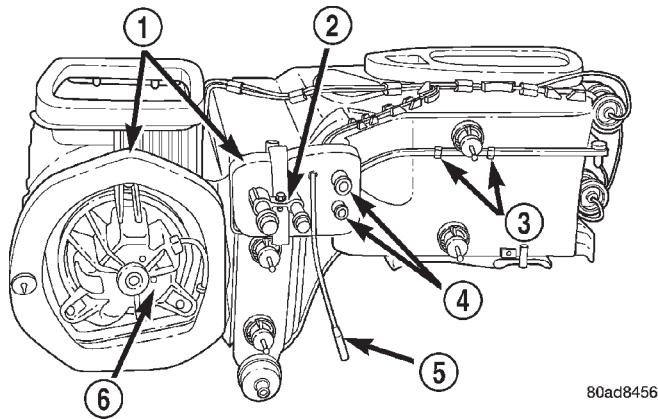
**Fig. 41 Heater-A/C Housing Disassembly**

- 1 - SEALS
- 2 - EVAPORATOR TUBE CLAMP
- 3 - CLIPS
- 4 - HEATER CORE TUBES
- 5 - VACUUM SUPPLY LINE
- 6 - BLOWER MOTOR

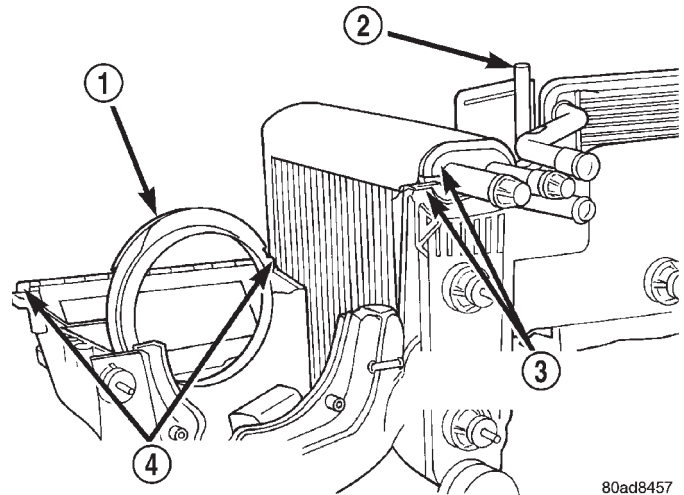
**Fig. 42 Heater-A/C Housing Assembly**

- 1 - BLOWER MOTOR VENTURI RING
- 2 - BLEND-AIR DOOR PIVOT
- 3 - EVAPORATOR COIL TUBE RUBBER SEAL
- 4 - RECIRCULATION AIR DOOR PIVOTS

(9) Carefully remove the foam seal from the heater core and evaporator coil tube mounting flange of the heater-A/C housing. If the seal is deformed or damaged, it must be replaced.

(10) Use a screwdriver to pry off the two snap clips that help secure the upper and lower heater-A/C housing halves to each other.

(11) Remove the 14 screws that secure the upper and lower heater-A/C housing halves to each other.

(12) Carefully separate the upper heater-A/C housing half from the lower half.

ASSEMBLY

(1) Assemble the upper heater-A/C housing half to the lower half. During assembly, be certain of the following:

(a) That each of the mode door pivot shaft ends is properly engaged in its pivot hole (Fig. 42).

(b) That the blower motor venturi ring is properly indexed and installed.

(c) If the unit is equipped with air conditioning, that the evaporator coil tube rubber seal is properly positioned in the grooves in both the upper and lower heater-A/C housing halves.

(2) Install the 14 screws and two snap clips that secure the upper and lower heater-A/C housing halves to each other. Tighten the screws to 2.2 N·m (20 in. lbs.).

(3) Install the blower motor and wheel unit in the heater-A/C housing. See Blower Motor in this group for the procedures.

(4) Install the foam seals on the flanges around the blower motor opening and the heater core and evaporator coil tube mounting flange of the heater-A/C housing.

(5) Insert the vacuum supply line and connector through the foam seal on the heater core and evaporator coil tube mounting flange of the heater-A/C housing.

(6) If the unit is equipped with air conditioning, reinstall the evaporator coil tube clamp. Tighten the mounting screw to 2.2 N·m (20 in. lbs.).

(7) Engage the heater-A/C wire harness connector and blower motor relay wire harness connector push-in retainers with their mounting holes in the heater-A/C housing.

(8) Engage the vacuum harness to the routing clips and plug in the vacuum harness connector at the floor door actuator and, if the unit is so equipped, at the recirculation air door actuator.

(9) Install the heater-A/C housing in the vehicle.

INSTALLATION

(1) Position the heater-A/C housing to the dash panel. Be certain that the evaporator condensate drain tube and the housing mounting studs are inserted into their correct mounting holes.

(2) Install and tighten the five nuts onto the heater-A/C housing mounting studs on the engine compartment side of the dash panel. Tighten the nuts to 6.2 N·m (55 in. lbs.).

(3) If the evaporation canister was repositioned during the removal procedure, reinstall it to its proper position.

(4) Connect the heater-A/C system vacuum supply line connector to the tee fitting near the heater core tubes.

(5) Unplug or remove the tape from the heater core tubes. Connect the heater hoses to the heater

REMOVAL AND INSTALLATION (Continued)

core tubes and fill the engine cooling system. Refer to Group 7 - Cooling System for the procedures.

(6) If the vehicle is not equipped with air conditioning, go to Step 10. If the vehicle is equipped with air conditioning, unplug or remove the tape from the accumulator inlet tube and the evaporator outlet tube fittings. Connect the accumulator inlet tube coupler to the evaporator outlet tube. See Refrigerant Line Coupler in this group for the procedures.

(7) Unplug or remove the tape from the liquid line and the evaporator inlet tube fittings. Connect the liquid line coupler to the evaporator inlet tube. See Refrigerant Line Coupler in this group for the procedures.

(8) Evacuate the refrigerant system. See Refrigerant System Evacuate in this group for the procedures.

(9) Charge the refrigerant system. See Refrigerant System Charge in this group for the procedures.

(10) Install the instrument panel in the vehicle. Refer to Instrument Panel Assembly in Group 8E - Instrument Panel Systems for the procedures.

(11) Connect the battery negative cable.

(12) Start the engine and check for proper operation of the heating and air conditioning systems.

HEATER-A/C HOUSING DOOR

WARNING: ON VEHICLES EQUIPPED WITH AIR-BAGS, REFER TO GROUP 8M - PASSIVE RESTRAINT SYSTEMS BEFORE ATTEMPTING ANY STEERING WHEEL, STEERING COLUMN, OR INSTRUMENT PANEL COMPONENT DIAGNOSIS OR SERVICE. FAILURE TO TAKE THE PROPER PRECAUTIONS COULD RESULT IN ACCIDENTAL AIR-BAG DEPLOYMENT AND POSSIBLE PERSONAL INJURY.

BLEND-AIR DOOR

(1) Remove and disassemble the heater-A/C housing. See Heater-A/C Housing in this group for the procedures.

(2) Lift the blend-air door pivot shaft out of the pivot hole in the bottom of the lower half of the heater-A/C housing (Fig. 43).

(3) Reverse the removal procedures to install.

PANEL/DEMIST DOOR AND LEVER

(1) Remove and disassemble the heater-A/C housing. See Heater-A/C Housing in this group for the procedures.

(2) Remove the defrost and panel/demist door vacuum actuators from the heater-A/C housing. See Mode Door Vacuum Actuator in this group for the procedures.

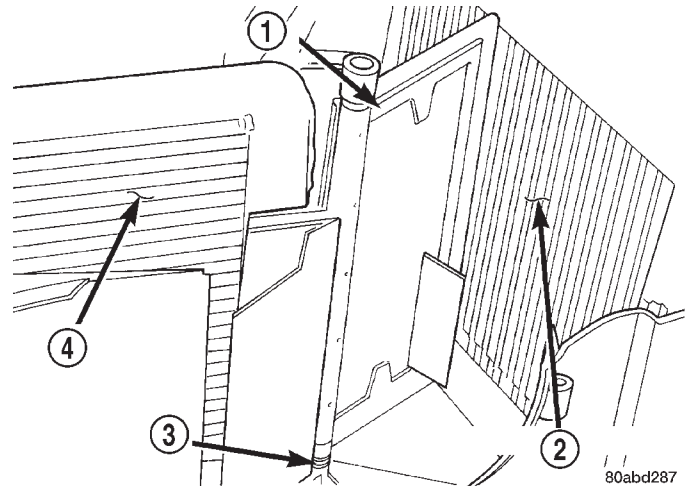

Fig. 43 Blend-Air Door

- 1 - BLEND-AIR DOOR
- 2 - EVAPORATOR COIL
- 3 - PIVOT HOLE
- 4 - HEATER CORE

(3) Insert a screwdriver into the latch hole (Fig. 44) of the panel/demist door pivot shaft to release the latch of the panel/demist door lever, and pull the lever out of the pivot shaft from the outside of the upper half of the heater-A/C housing.

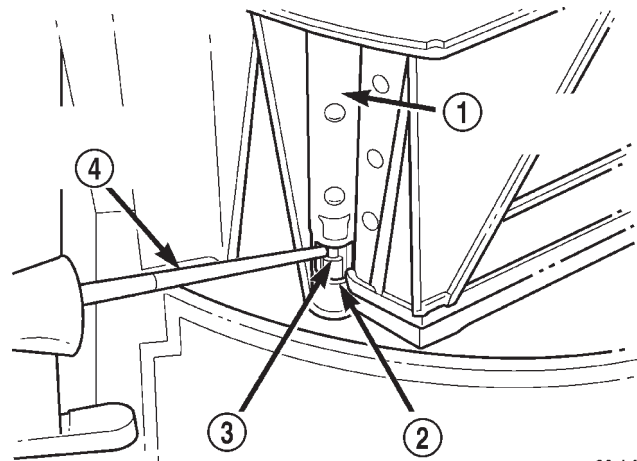

Fig. 44 Mode Door Lever Remove/Install - Typical

- 1 - DOOR PIVOT SHAFT
- 2 - LATCH HOLE
- 3 - CRANK ARM LATCH
- 4 - FLAT BLADE PRY TOOL

(4) Reach inside the upper half of the heater-A/C housing and carefully flex the panel/defrost door (Fig. 45) enough so that the door pivot clears the pivot hole in the housing.

(5) Remove the panel/demist door from the heater-A/C housing.

(6) Reverse the removal procedures to install.

REMOVAL AND INSTALLATION (Continued)

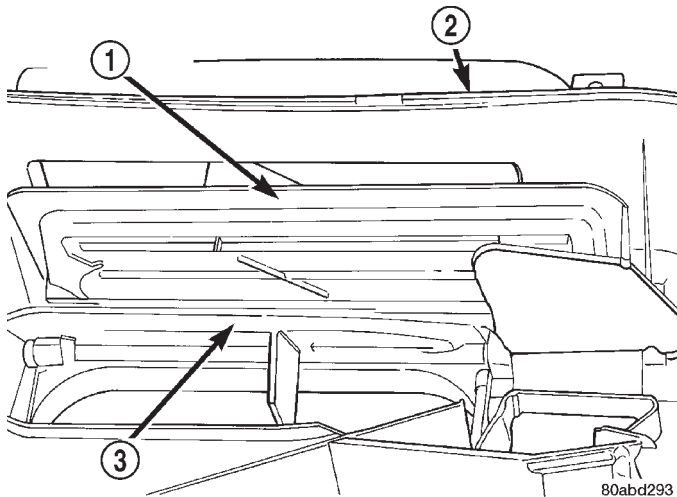
**Fig. 45 Panel/Demist and Defrost Doors**

- 1 - PANEL/DEMIST DOOR
- 2 - UPPER HEATER-A/C HOUSING
- 3 - DEFROST DOOR

DEFROST DOOR AND LEVER

(1) Remove and disassemble the heater-A/C housing. See Heater-A/C Housing in this group for the procedures.

(2) Remove the panel/demist door and lever from the upper heater-A/C housing. See Panel/Demist Door and Lever in this group for the procedures.

(3) Insert a screwdriver into the latch hole (Fig. 44) of the defrost door pivot shaft to release the latch of the defrost door lever, and pull the lever out of the pivot shaft from the outside of the upper half of the heater-A/C housing.

(4) Reach inside the upper half of the heater-A/C housing and carefully flex the defrost door (Fig. 45) enough so that the door pivot clears the pivot hole in the housing.

(5) Remove the defrost door from the heater-A/C housing.

(6) Reverse the removal procedures to install.

FLOOR DOOR AND LEVER

(1) Remove and disassemble the heater-A/C housing. See Heater-A/C Housing in this group for the procedures.

(2) Remove the floor door vacuum actuator from the lower heater-A/C housing. See Mode Door Vacuum Actuator in this group for the procedures.

(3) Insert a screwdriver into the latch hole (Fig. 44) of the floor door pivot shaft to release the latch of the floor door lever, and pull the lever out of the pivot shaft from the outside of the lower half of the heater-A/C housing.

(4) Reach inside the lower half of the heater-A/C housing and carefully flex the floor door (Fig. 46)

enough so that the door pivot clears the pivot hole in the housing.

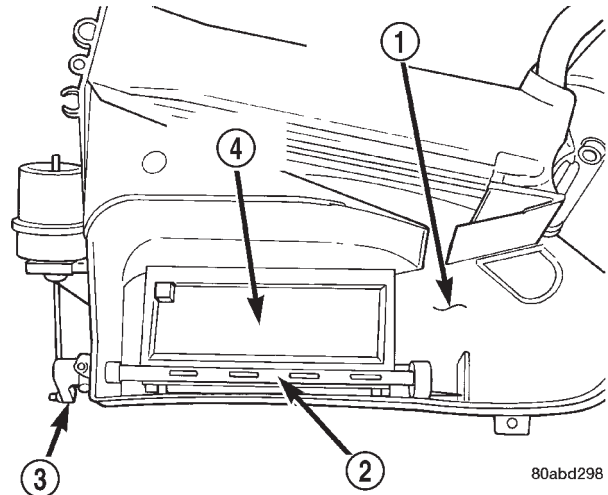
**Fig. 46 Floor Door**

- 1 - LOWER HEATER-A/C HOUSING
- 2 - PIVOT SHAFT
- 3 - CRANK ARM
- 4 - FLOOR DOOR

(5) Remove the floor door from the heater-A/C housing.

(6) Reverse the removal procedures to install.

RECIRCULATION AIR DOOR

A recirculation air door and vacuum actuator are used only on models with the optional air conditioning system.

(1) Remove and disassemble the heater-A/C housing. See Heater-A/C Housing in this group for the procedures.

(2) Remove the recirculation air door vacuum actuator from the lower heater-A/C housing. See Mode Door Vacuum Actuator in this group for the procedures.

(3) Reach inside the lower half of the heater-A/C housing and lift the bottom edge of the recirculation air door upwards (Fig. 47).

(4) Guide the recirculation air door lever through the air intake grille of the heater-A/C housing while removing the door from the housing.

(5) Reverse the removal procedures to install.

REMOVAL AND INSTALLATION (Continued)

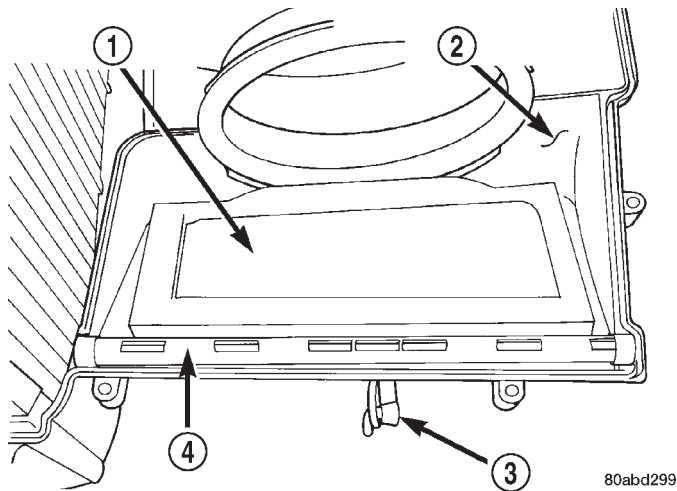
**Fig. 47 Recirculation Air Door**

- 1 - RECIRCULATION AIR DOOR
- 2 - LOWER HEATER-A/C HOUSING
- 3 - LEVER
- 4 - PIVOT SHAFT

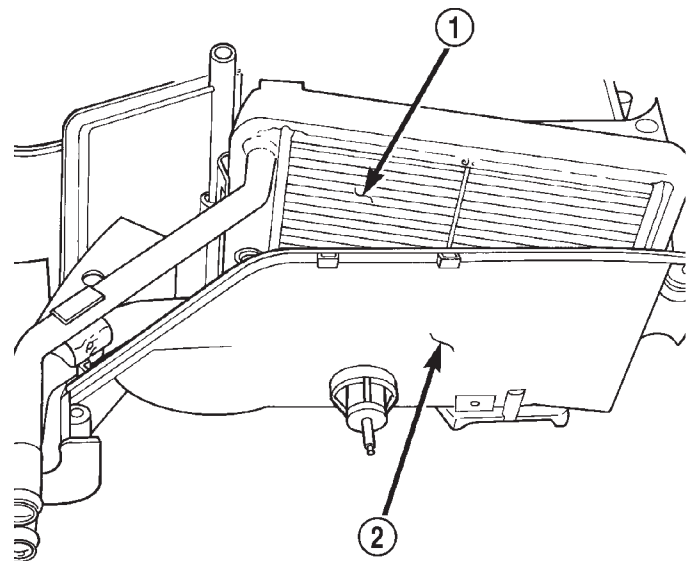
**Fig. 48 Heater Core Remove/Install**

- 1 - HEATER CORE
- 2 - LOWER HEATER-A/C HOUSING

HEATER CORE

WARNING: ON VEHICLES EQUIPPED WITH AIR-BAGS, REFER TO GROUP 8M - PASSIVE RESTRAINT SYSTEMS BEFORE ATTEMPTING ANY STEERING WHEEL, STEERING COLUMN, OR INSTRUMENT PANEL COMPONENT DIAGNOSIS OR SERVICE. FAILURE TO TAKE THE PROPER PRECAUTIONS COULD RESULT IN ACCIDENTAL AIR-BAG DEPLOYMENT AND POSSIBLE PERSONAL INJURY.

(1) Remove and disassemble the heater-A/C housing. See Heater-A/C Housing in this group for the procedures.

(2) Lift the heater core out of the lower half of the heater-A/C housing (Fig. 48).

(3) Reverse the removal procedures to install. Be certain that the heater core foam insulator is reinstalled.

LIQUID LINE

Any kinks or sharp bends in the refrigerant plumbing will reduce the capacity of the entire air conditioning system. Kinks and sharp bends reduce the flow of refrigerant in the system. A good rule for the flexible hose refrigerant lines is to keep the radius of all bends at least ten times the diameter of the hose. In addition, the flexible hose refrigerant lines should be routed so they are at least 80 millimeters (3 inches) from the exhaust manifold.

High pressures are produced in the refrigerant system when the air conditioning compressor is operating. Extreme care must be exercised to make sure

that each of the refrigerant system connections is pressure-tight and leak free. It is a good practice to inspect all flexible hose refrigerant lines at least once a year to make sure they are in good condition and properly routed.

WARNING: REVIEW THE WARNINGS AND CAUTIONS IN THE FRONT OF THIS GROUP BEFORE PERFORMING THE FOLLOWING OPERATION.

REMOVAL

(1) Disconnect and isolate the battery negative cable.

(2) Recover the refrigerant from the refrigerant system. See Refrigerant Recovery in this group for the procedures.

(3) Disconnect the liquid line refrigerant line couplers at the evaporator inlet and the condenser outlet (Fig. 49). See Refrigerant Line Coupler in this group for the procedures. Install plugs in, or tape over all of the opened refrigerant line fittings.

(4) Remove the liquid line from the vehicle.

INSTALLATION

(1) Remove the tape or plugs from the refrigerant line fittings on the liquid line, the evaporator inlet and the condenser outlet. Connect the liquid line to the evaporator inlet and condenser outlet refrigerant line couplers. See Refrigerant Line Coupler in this group for the procedures.

(2) Connect the battery negative cable.

REMOVAL AND INSTALLATION (Continued)

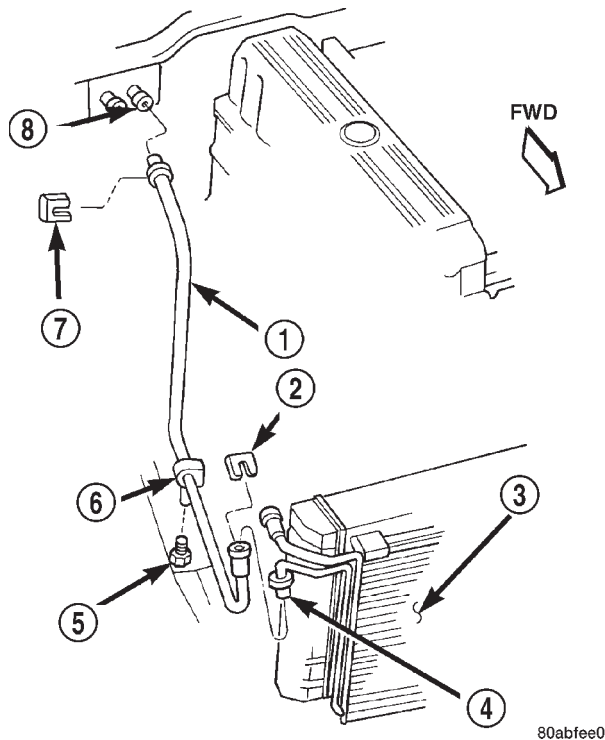
**Fig. 49 Liquid Line Remove/Install**

- 1 - LIQUID LINE WITH ORIFICE TUBE
- 2 - CLIP
- 3 - CONDENSER
- 4 - OUTLET TUBE
- 5 - STUD
- 6 - CLIP
- 7 - CLIP
- 8 - EVAPORATOR INLET

(3) Evacuate the refrigerant system. See Refrigerant System Evacuate in this group for the procedures.

(4) Charge the refrigerant system. See Refrigerant System Charge in this group for the procedures.

LOW PRESSURE CYCLING CLUTCH SWITCH**REMOVAL**

(1) Disconnect and isolate the battery negative cable.

(2) Unplug the wire harness connector from the low pressure cycling clutch switch on the top of the accumulator (Fig. 50).

(3) Unscrew the low pressure cycling clutch switch from the fitting on the top of the accumulator.

(4) Remove the O-ring seal from the accumulator fitting and discard.

INSTALLATION

(1) Lubricate a new O-ring seal with clean refrigerant oil and install it on the accumulator fitting. Use only the specified O-rings as they are made of a

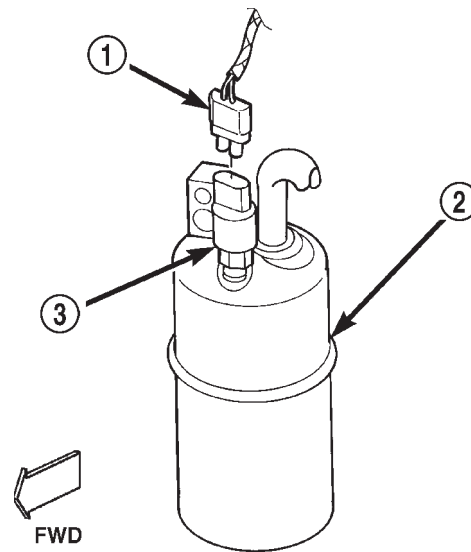

80abd2a4

Fig. 50 Low Pressure Cycling Clutch Switch Remove/Install - Typical

- 1 - WIRE HARNESS CONNECTOR
- 2 - ACCUMULATOR
- 3 - LOW PRESSURE CYCLING CLUTCH SWITCH

special material for the R-134a system. Use only refrigerant oil of the type recommended for the compressor in the vehicle.

(2) Install and tighten the low pressure cycling clutch switch on the accumulator fitting. The switch should be hand-tightened onto the accumulator fitting.

(3) Plug the wire harness connector into the low pressure cycling clutch switch.

(4) Connect the battery negative cable.

KICK COVER

WARNING: ON VEHICLES EQUIPPED WITH AIRBAGS, REFER TO GROUP 8M - PASSIVE RESTRAINT SYSTEMS BEFORE ATTEMPTING ANY STEERING WHEEL, STEERING COLUMN, OR INSTRUMENT PANEL COMPONENT DIAGNOSIS OR SERVICE. FAILURE TO TAKE THE PROPER PRECAUTIONS COULD RESULT IN ACCIDENTAL AIRBAG DEPLOYMENT AND POSSIBLE PERSONAL INJURY.

REMOVAL

(1) Disconnect and isolate the battery negative cable.

(2) Loosen the two screws that secure the upper half of the kick cover to the heater-A/C housing

REMOVAL AND INSTALLATION (Continued)

under the passenger side end of the instrument panel (Fig. 51).

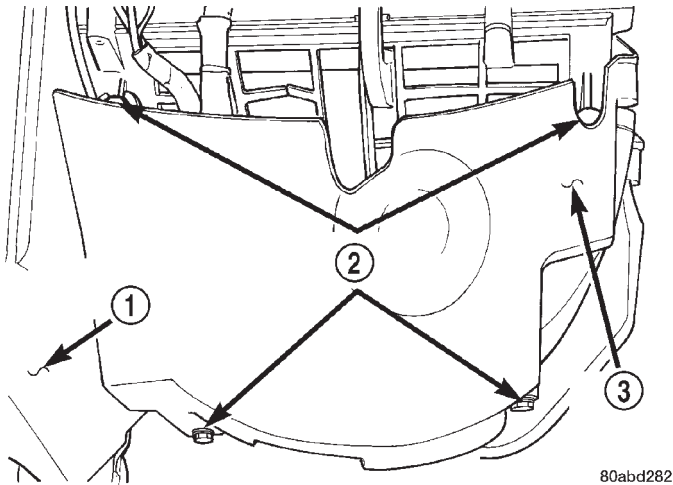

Fig. 51 Kick Cover Remove/Install

- 1 - HEATER-A/C HOUSING
- 2 - MOUNTING SCREWS
- 3 - KICK COVER

(3) Remove the two screws that secure the lower half of the kick cover to the heater-A/C housing.

(4) Pull the kick cover down towards the floor panel to disengage the slotted upper mounting tabs from under the two loosened heater-A/C housing screws.

(5) Remove the kick cover from the heater-A/C housing.

INSTALLATION

(1) Position the slotted upper kick cover mounting tabs under the heads of the two loosened heater-A/C housing screws. Tighten the screws to 2.2 N·m (20 in. lbs.).

(2) Install the two screws that secure the lower kick cover to the heater-A/C housing. Tighten the screws to 2.2 N·m (20 in. lbs.).

(3) Connect the battery negative cable.

MODE DOOR VACUUM ACTUATOR

WARNING: ON VEHICLES EQUIPPED WITH AIR-BAGS, REFER TO GROUP 8M - PASSIVE RESTRAINT SYSTEMS BEFORE ATTEMPTING ANY STEERING WHEEL, STEERING COLUMN, OR INSTRUMENT PANEL COMPONENT DIAGNOSIS OR SERVICE. FAILURE TO TAKE THE PROPER PRECAUTIONS COULD RESULT IN ACCIDENTAL AIR-BAG DEPLOYMENT AND POSSIBLE PERSONAL INJURY.

DEFROST DOOR ACTUATOR

(1) Disconnect and isolate the battery negative cable.

(2) Remove the instrument panel assembly from the vehicle. Refer to Instrument Panel Assembly in Group 8E - Instrument Panel Systems for the procedures.

(3) Unplug the two vacuum harness connectors from the defrost door actuator (Fig. 52).

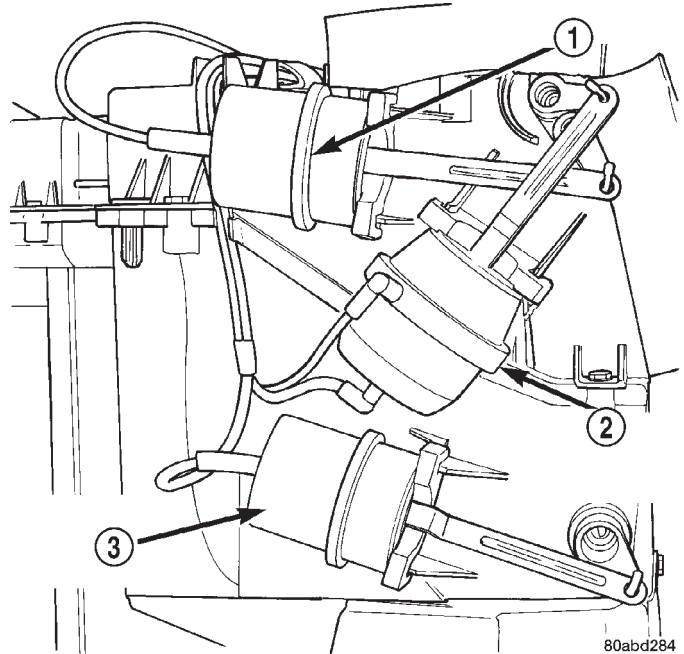

Fig. 52 Defrost, Floor, and Panel/Demist Door Vacuum Actuators

- 1 - PANEL/DEMIST DOOR ACTUATOR
- 2 - DEFROST DOOR ACTUATOR
- 3 - FLOOR DOOR ACTUATOR

(4) Insert a trim stick or another suitable wide flat-bladed tool into the latch hole on the heater-A/C housing actuator mount (Fig. 53). Gently pry the actuator latch while pulling firmly outwards on the actuator to remove the actuator from the mount.

(5) Rotate and tilt the vacuum actuator as required to disengage the hole on the end of the actuator link from the hooked pin on the end of the defrost door lever.

(6) Remove the defrost door vacuum actuator from the vehicle.

(7) Reverse the removal procedures to install.

FLOOR DOOR ACTUATOR

(1) Disconnect and isolate the battery negative cable.

(2) Remove the instrument panel assembly from the vehicle. Refer to Instrument Panel Assembly in

REMOVAL AND INSTALLATION (Continued)

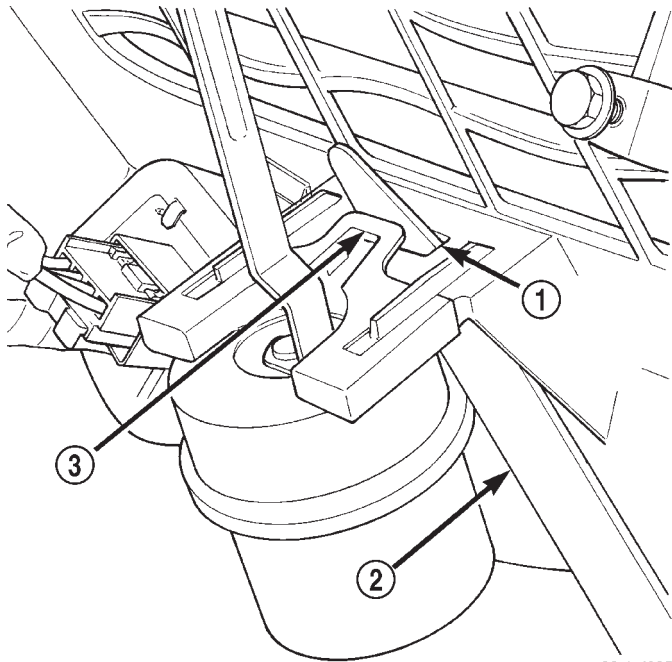

80abd285

Fig. 53 Vacuum Actuator Remove/Install - Typical

- 1 - ACTUATOR MOUNT LATCH HOLE
- 2 - TRIM STICK
- 3 - ACTUATOR LATCH

Group 8E - Instrument Panel Systems for the procedures.

(3) Unplug the vacuum harness connector from the floor door actuator (Fig. 52).

(4) Insert a trim stick or another suitable wide flat-bladed tool into the latch hole on the heater-A/C housing actuator mount (Fig. 53). Gently pry the actuator latch while pulling firmly outwards on the actuator to remove the actuator from the mount.

(5) Rotate and tilt the vacuum actuator as required to disengage the hole on the end of the actuator link from the hooked pin on the end of the floor door lever.

(6) Remove the floor door vacuum actuator from the vehicle.

(7) Reverse the removal procedures to install.

PANEL/DEMIST DOOR ACTUATOR

(1) Remove the defrost door actuator from the heater-A/C housing. See Defrost Door Actuator in this group for the procedures.

(2) Unplug the vacuum harness connector from the panel/demist door actuator (Fig. 52).

(3) Insert a trim stick or another suitable wide flat-bladed tool into the latch hole on the heater-A/C housing actuator mount (Fig. 53). Gently pry the actuator latch while pulling firmly outwards on the actuator to remove the actuator from the mount.

(4) Rotate and tilt the vacuum actuator as required to disengage the hole on the end of the actuator link from the hooked pin on the end of the panel/demist door lever.

(5) Remove the panel/demist door vacuum actuator from the vehicle.

(6) Reverse the removal procedures to install.

RECIRCULATION AIR DOOR ACTUATOR

A recirculation air door and vacuum actuator are used only on models with the optional air conditioning system.

(1) Disconnect and isolate the battery negative cable.

(2) Remove the kick cover from the heater-A/C housing. See Kick Cover in this group for the procedures.

(3) Unplug the vacuum harness connector from the recirculation air door actuator (Fig. 54).

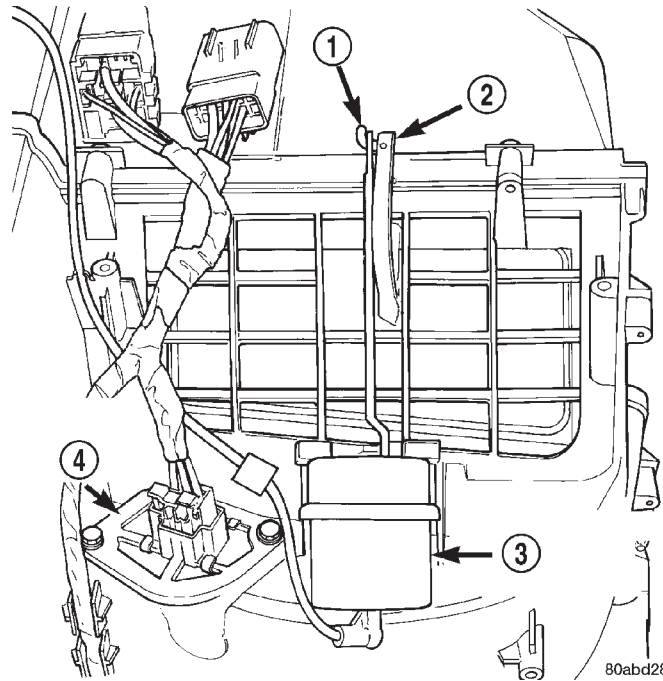

80abd286

Fig. 54 Recirculation Air Door Vacuum Actuator Remove/Install

- 1 - HOOK
- 2 - LEVER
- 3 - RECIRCULATION AIR DOOR ACTUATOR
- 4 - BLOWER MOTOR RESISTOR

(4) Insert a trim stick or another suitable wide flat-bladed tool into the latch hole on the heater-A/C housing actuator mount (Fig. 53). Gently pry the actuator latch while pulling firmly outwards on the actuator to remove the actuator from the mount.

(5) Rotate and tilt the vacuum actuator as required to disengage the hole on the end of the

REMOVAL AND INSTALLATION (Continued)

actuator link from the hooked pin on the end of the recirculation air door lever.

(6) Remove the recirculation air door vacuum actuator from the vehicle.

(7) Reverse the removal procedures to install.

REFRIGERANT LINE COUPLER

WARNING: REVIEW THE WARNINGS AND CAUTIONS IN THE GENERAL INFORMATION SECTION NEAR THE FRONT OF THIS GROUP BEFORE PERFORMING THE FOLLOWING OPERATION.

REMOVAL

(1) Recover the refrigerant from the refrigerant system. See Refrigerant Recovery in the Service Procedures section of this group.

(2) Remove the secondary clip from the spring-lock coupler.

(3) Fit the proper size A/C line disconnect tool (Special Tool Kit 7193) over the spring-lock coupler cage (Fig. 55).

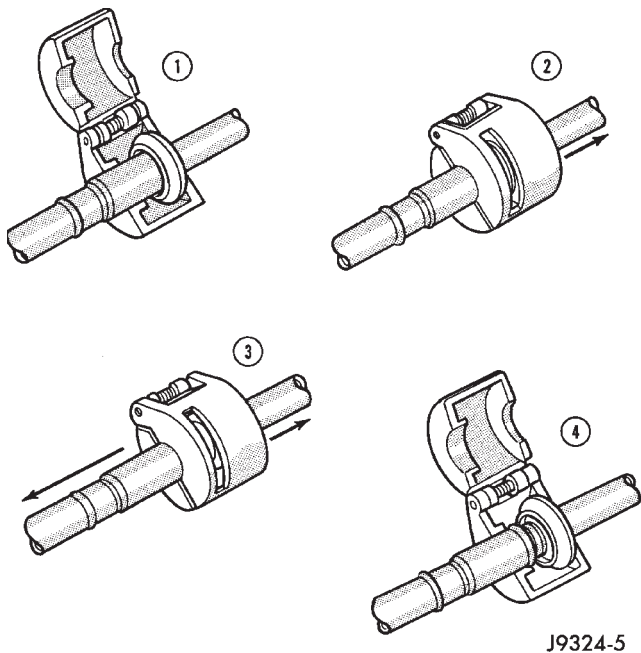

Fig. 55 Refrigerant Line Spring-Lock Coupler Disconnect

(4) Close the two halves of the A/C line disconnect tool around the spring-lock coupler.

(5) Push the A/C line disconnect tool into the open side of the coupler cage to expand the garter spring. Once the garter spring is expanded and while still pushing the disconnect tool into the open side of the coupler cage, pull on the refrigerant line attached to the female half of the coupler fitting until the flange on the female fitting is separated from the garter

spring and cage on the male fitting within the disconnect tool.

NOTE: The garter spring may not release if the A/C line disconnect tool is cocked while pushing it into the coupler cage opening.

(6) Open and remove the A/C line disconnect tool from the disconnected spring-lock coupler.

(7) Complete the separation of the two halves of the coupler fitting.

INSTALLATION

(1) Check to ensure that the garter spring is located within the cage of the male coupler fitting, and that the garter spring is not damaged.

(a) If the garter spring is missing, install a new spring by pushing it into the coupler cage opening.

(b) If the garter spring is damaged, remove it from the coupler cage with a small wire hook (DO NOT use a screwdriver) and install a new garter spring.

(2) Clean any dirt or foreign material from both halves of the coupler fitting.

(3) Install new O-rings on the male half of the coupler fitting.

CAUTION: Use only the specified O-rings as they are made of a special material for the R-134a system. The use of any other O-rings may allow the connection to leak intermittently during vehicle operation.

(4) Lubricate the male fitting and O-rings, and the inside of the female fitting with clean R-134a refrigerant oil. Use only refrigerant oil of the type recommended for the compressor in the vehicle.

(5) Fit the female half of the coupler fitting over the male half of the fitting.

(6) Push together firmly on the two halves of the coupler fitting until the garter spring in the cage on the male half of the fitting snaps over the flanged end on the female half of the fitting.

(7) Ensure that the spring-lock coupler is fully engaged by trying to separate the two coupler halves. This is done by pulling the refrigerant lines on either side of the coupler away from each other.

(8) Reinstall the secondary clip over the spring-lock coupler cage.

SUCTION AND DISCHARGE LINE

Any kinks or sharp bends in the refrigerant plumbing will reduce the capacity of the entire air conditioning system. Kinks and sharp bends reduce the flow of refrigerant in the system. A good rule for the flexible hose refrigerant lines is to keep the radius of all bends at least ten times the diameter of the hose.

REMOVAL AND INSTALLATION (Continued)

In addition, the flexible hose refrigerant lines should be routed so they are at least 80 millimeters (3 inches) from the exhaust manifold.

High pressures are produced in the refrigerant system when the air conditioning compressor is operating. Extreme care must be exercised to make sure that each of the refrigerant system connections is pressure-tight and leak free. It is a good practice to inspect all flexible hose refrigerant lines at least once a year to make sure they are in good condition and properly routed.

WARNING: REVIEW THE WARNINGS AND CAUTIONS IN THE FRONT OF THIS GROUP BEFORE PERFORMING THE FOLLOWING OPERATION.

REMOVAL

(1) Disconnect and isolate the battery negative cable.

(2) Recover the refrigerant from the refrigerant system. See Refrigerant Recovery in this group for the procedures.

(3) Unplug the wire harness connector from the high pressure cut-off switch.

(4) Disconnect the discharge line refrigerant line fitting from the condenser inlet tube (Fig. 56). See Refrigerant Line Coupler in this group for the procedures. Install plugs in, or tape over all of the opened refrigerant line fittings.

(5) Remove the nut that secures the suction line block fitting to the accumulator outlet. Install plugs in, or tape over all of the opened refrigerant line fittings.

(6) Remove the screw that secures the suction and discharge line manifold to the compressor. Install plugs in, or tape over all of the opened refrigerant line fittings.

(7) Remove the suction and discharge line assembly from the vehicle.

INSTALLATION

(1) Remove the tape or plugs from the suction and discharge line manifold and the compressor. Install the suction and discharge line manifold to the compressor. Tighten the mounting screw to 28 N·m (250 in. lbs.).

(2) Remove the tape or plugs from the suction line and the accumulator outlet block fittings. Install the suction line to the accumulator outlet and tighten the mounting nut to 9 N·m (80 in. lbs.).

(3) Remove the tape or plugs from the refrigerant line fittings on the discharge line and the condenser inlet tube. Connect the discharge line refrigerant line coupler to the condenser inlet tube. See Refrigerant Line Coupler in this group for the procedures.

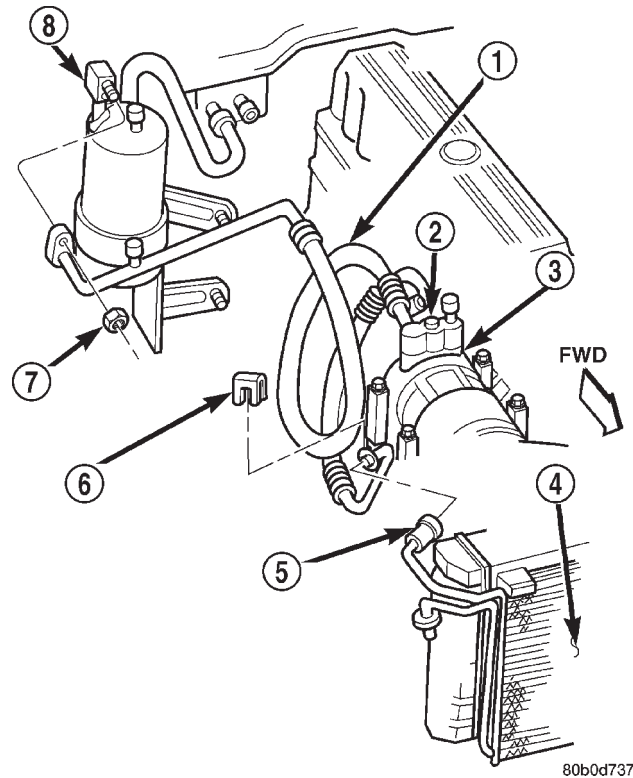

Fig. 56 Suction and Discharge Line

- 1 - SUCTION AND DISCHARGE LINE
- 2 - SCREW
- 3 - COMPRESSOR
- 4 - CONDENSER
- 5 - INLET
- 6 - CLIP
- 7 - HEX NUT
- 8 - ACCUMULATOR

(4) Plug in the wire harness connector to the high pressure cut-off switch.

(5) Connect the battery negative cable.

(6) Evacuate the refrigerant system. See Refrigerant System Evacuate in this group for the procedures.

(7) Charge the refrigerant system. See Refrigerant System Charge in this group for the procedures.

VACUUM CHECK VALVE

(1) Unplug the heater-A/C vacuum supply line connector at the vacuum check valve (Fig. 57).

(2) Note the orientation of the check valve in the vacuum supply line for correct reinstallation.

(3) Unplug the vacuum check valve from the vacuum supply line fittings.

(4) Reverse the removal procedures to install.

REMOVAL AND INSTALLATION (Continued)

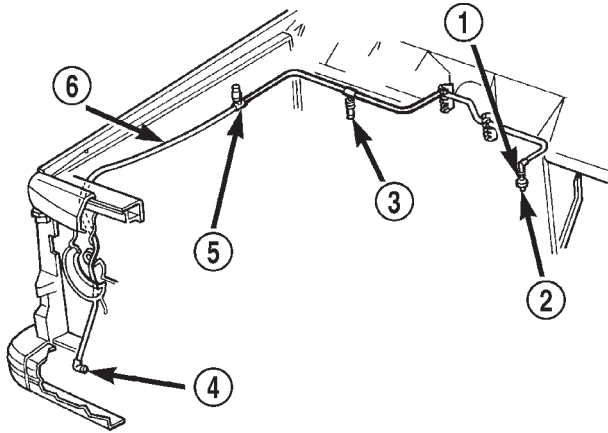

80abd2a3

Fig. 57 Vacuum Supply

- 1 - VACUUM CHECK VALVE
- 2 - TO ENGINE INTAKE MANIFOLD
- 3 - TO HEATER-A/C CONTROLS
- 4 - TO VACUUM RESERVOIR
- 5 - TO SPEED CONTROL SERVO
- 6 - VACUUM SUPPLY LINE

VACUUM RESERVOIR

(1) Remove the passenger side bumper end cap from the front bumper. Refer to Group 23 - Body for the procedures.

(2) Unplug the vacuum supply line connector from the vacuum reservoir (Fig. 58).

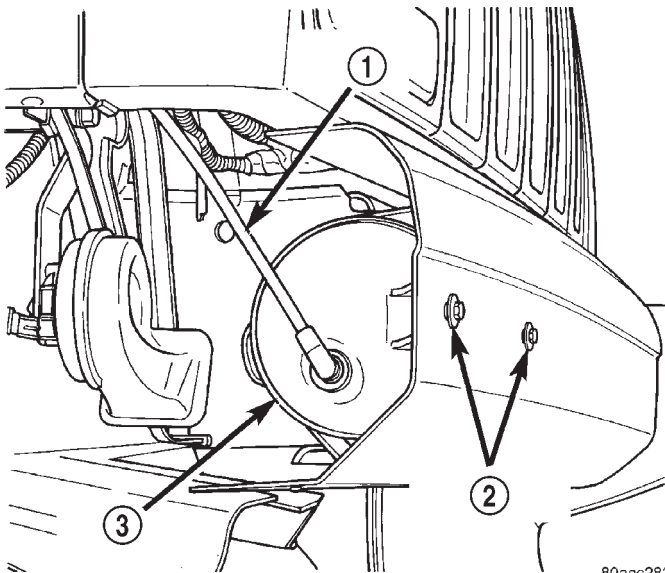

80aac282

Fig. 58 Vacuum Reservoir Remove/Install

- 1 - VACUUM LINE
- 2 - RESERVOIR SCREWS
- 3 - VACUUM RESERVOIR

(3) Remove the two screws that secure the vacuum reservoir to the front bumper.

(4) Remove the vacuum reservoir from behind the front bumper.

(5) Reverse the removal procedures to install. Tighten the mounting screws to 2.2 N-m (20 in. lbs.).

SPECIFICATIONS

A/C APPLICATION TABLE

| Item | Description | Notes |
|----------------------|--|------------------------|
| Vehicle | XJ Cherokee/ Laredo | |
| System | R134a w/orifice tube | |
| Compressor | Sanden SD7H15 | SP-20 PAG oil |
| Freeze-up Control | Low Pressure cycling cutout switch | accumulator mounted |
| Low psi Control | opens < 25 psi - resets > 43 psi | |
| High psi Control | switch - opens > 450-490 psi - resets < 270-330 psi | discharge line |
| Control Head | manual type | |
| Mode Door | vacuum | |
| Blend-Air Door | electric | |
| Fresh/Recirc door | vacuum | |
| Blower Motor | hardwired to control head | resistor block |
| Cooling Fan | viscous for cooling, single speed electric for A/C | |
| Clutch | | |
| Control | relay | PCM |
| Draw | 2 - 3.7 amps @ 12V | ± 0.5V @ 70° F |
| Gap | 0.016" - 0.031" | |
| DRB III® | | |
| Reads | TPS, RPM, A/C switch test | |
| Actuators | clutch and fan relay | |

HEATING AND AIR CONDITIONING

TABLE OF CONTENTS

| | page | | page |
|--|------|--|------|
| DESCRIPTION AND OPERATION | | REMOVAL AND INSTALLATION | |
| SERVICE WARNINGS AND PRECAUTIONS | 1 | SUCTION AND DISCHARGE LINE | 4 |
| COMPRESSOR - 2.5L VM DIESEL | 3 | COMPRESSOR - 2.5L VM DIESEL | 6 |
| COMPRESSOR CLUTCH - 2.5L VM DIESEL | 3 | COMPRESSOR CLUTCH - 2.5L VM DIESEL | 8 |

DESCRIPTION AND OPERATION

SERVICE WARNINGS AND PRECAUTIONS

WARNING:

- THE AIR CONDITIONING SYSTEM CONTAINS REFRIGERANT UNDER HIGH PRESSURE. SEVERE PERSONAL INJURY MAY RESULT FROM IMPROPER SERVICE PROCEDURES. REPAIRS SHOULD ONLY BE PERFORMED BY QUALIFIED SERVICE PERSONNEL.

- AVOID BREATHING THE REFRIGERANT AND REFRIGERANT OIL VAPOR OR MIST. EXPOSURE MAY IRRITATE THE EYES, NOSE, AND/OR THROAT. WEAR EYE PROTECTION WHEN SERVICING THE AIR CONDITIONING REFRIGERANT SYSTEM. SERIOUS EYE INJURY CAN RESULT FROM DIRECT CONTACT WITH THE REFRIGERANT. IF EYE CONTACT OCCURS, SEEK MEDICAL ATTENTION IMMEDIATELY.

- DO NOT EXPOSE THE REFRIGERANT TO OPEN FLAME. POISONOUS GAS IS CREATED WHEN REFRIGERANT IS BURNED. AN ELECTRONIC LEAK DETECTOR IS RECOMMENDED.

- IF ACCIDENTAL SYSTEM DISCHARGE OCCURS, VENTILATE THE WORK AREA BEFORE RESUMING SERVICE. LARGE AMOUNTS OF REFRIGERANT RELEASED IN A CLOSED WORK AREA WILL DISPLACE THE OXYGEN AND CAUSE SUFFOCATION.

- THE EVAPORATION RATE OF R-134a REFRIGERANT AT AVERAGE TEMPERATURE AND ALTITUDE IS EXTREMELY HIGH. AS A RESULT, ANYTHING THAT COMES IN CONTACT WITH THE REFRIGERANT WILL FREEZE. ALWAYS PROTECT THE SKIN OR DELICATE OBJECTS FROM DIRECT CONTACT WITH THE REFRIGERANT.

- THE R-134a SERVICE EQUIPMENT OR THE VEHICLE REFRIGERANT SYSTEM SHOULD NOT BE PRESSURE TESTED OR LEAK TESTED WITH COMPRESSED AIR. SOME MIXTURES OF AIR AND R-134a HAVE BEEN SHOWN TO BE COMBUSTIBLE AT ELEVATED PRESSURES. THESE MIXTURES ARE POTENTIALLY DANGEROUS, AND MAY RESULT IN FIRE OR EXPLOSION CAUSING INJURY OR PROPERTY DAMAGE.

DESCRIPTION AND OPERATION (Continued)

CAUTION:

- Liquid refrigerant is corrosive to metal surfaces. Follow the operating instructions supplied with the service equipment being used.

- Never add R-12 to a refrigerant system designed to use R-134a. Damage to the system will result.

- R-12 refrigerant oil must not be mixed with R-134a refrigerant oil. They are not compatible.

- Do not use R-12 equipment or parts on the R-134a system. Damage to the system will result.

- Do not overcharge the refrigerant system. This will cause excessive compressor head pressure and can cause noise and system failure.

- Recover the refrigerant before opening any fitting or connection. Open the fittings with caution, even after the system has been discharged. Never open or loosen a connection before recovering the refrigerant.

- Do not remove the secondary retention clip from any spring-lock coupler connection while the refrigerant system is under pressure. Recover the refrigerant before removing the secondary retention clip. Open the fittings with caution, even after the system has been discharged. Never open or loosen a connection before recovering the refrigerant.

- The refrigerant system must always be evacuated before charging.

- Do not open the refrigerant system or uncap a replacement component until you are ready to service the system. This will prevent contamination in the system.

- Before disconnecting a component, clean the outside of the fittings thoroughly to prevent contamination from entering the refrigerant system.

- Immediately after disconnecting a component from the refrigerant system, seal the open fittings with a cap or plug.

- Before connecting an open refrigerant fitting, always install a new seal or gasket. Coat the fitting and seal with clean refrigerant oil before connecting.

- Do not remove the sealing caps from a replacement component until it is to be installed.

- When installing a refrigerant line, avoid sharp bends that may restrict refrigerant flow. Position the refrigerant lines away from exhaust system components or any sharp edges, which may damage the line.

- Tighten refrigerant fittings only to the specified torque. The aluminum fittings used in the refrigerant system will not tolerate overtightening.

- When disconnecting a refrigerant fitting, use a wrench on both halves of the fitting. This will prevent twisting of the refrigerant lines or tubes.

- Refrigerant oil will absorb moisture from the atmosphere if left uncapped. Do not open a container of refrigerant oil until you are ready to use it. Replace the cap on the oil container immediately after using. Store refrigerant oil only in a clean, airtight, and moisture-free container.

- Keep service tools and the work area clean. Contamination of the refrigerant system through careless work habits must be avoided.

COOLING SYSTEM REQUIREMENTS

To maintain the performance level of the heating-air conditioning system, the engine cooling system must be properly maintained. The use of a bug screen is not recommended. Any obstructions in front of the radiator or condenser will reduce the performance of the air conditioning and engine cooling systems.

The engine cooling system includes the heater core and the heater hoses. Refer to Group 7 - Cooling System for more information before the opening of, or attempting any service to the engine cooling system.

REFRIGERANT HOSES/LINES/TUBES**PRECAUTIONS**

Kinks or sharp bends in the refrigerant plumbing will reduce the capacity of the entire system. High pressures are produced in the system when it is operating. Extreme care must be exercised to make sure that all refrigerant system connections are pressure tight.

A good rule for the flexible hose refrigerant lines is to keep the radius of all bends at least ten times the diameter of the hose. Sharp bends will reduce the flow of refrigerant. The flexible hose lines should be routed so they are at least 80 millimeters (3 inches) from the exhaust manifold. It is a good practice to inspect all flexible refrigerant system hose lines at least once a year to make sure they are in good condition and properly routed.

There are two types of refrigerant fittings:

- All fittings with O-rings need to be coated with refrigerant oil before installation. Use only O-rings that are the correct size and approved for use with R-134a refrigerant. Failure to do so may result in a leak.

- Unified plumbing connections with gaskets cannot be serviced with O-rings. The gaskets are not reusable and new gaskets do not require lubrication before installing.

Using the proper tools when making a refrigerant plumbing connection is very important. Improper tools or improper use of the tools can damage the refrigerant fittings. Always use two wrenches when loosening or tightening tube fittings. Use one wrench

DESCRIPTION AND OPERATION (Continued)

to hold one side of the connection stationary, while loosening or tightening the other side of the connection with a second wrench.

The refrigerant must be recovered completely from the system before opening any fitting or connection. Open the fittings with caution, even after the refrigerant has been recovered. If any pressure is noticed as a fitting is loosened, tighten the fitting and recover the refrigerant from the system again.

Do not discharge refrigerant into the atmosphere. Use an R-134a refrigerant recovery/recycling device that meets SAE Standard J2210.

The refrigerant system will remain chemically stable as long as pure, moisture-free R-134a refrigerant and refrigerant oil is used. Dirt, moisture, or air can upset this chemical stability. Operational troubles or serious damage can occur if foreign material is present in the refrigerant system.

When it is necessary to open the refrigerant system, have everything needed to service the system ready. The refrigerant system should not be left open to the atmosphere any longer than necessary. Cap or plug all lines and fittings as soon as they are opened to prevent the entrance of dirt and moisture. All lines and components in parts stock should be capped or sealed until they are to be installed.

All tools, including the refrigerant recycling equipment, the manifold gauge set, and test hoses should be kept clean and dry. All tools and equipment must be designed for R-134a refrigerant.

COMPRESSOR - 2.5L VM DIESEL

DESCRIPTION

The 2.5L diesel engine uses a Denso 10PA17 seven cylinder, reciprocating wobble plate-type compressor. This compressor has a fixed displacement of 150 cubic centimeters (9.375 cubic inches), and has both the suction and discharge ports located on the compressor cylinder head. A label identifying the use of R-134a refrigerant is located on the compressor.

OPERATION

The compressor is driven by the engine through the power steering pump main shaft. The power steering pump is driven by the accessory drive belt.

The compressor is lubricated by refrigerant oil that is circulated throughout the refrigerant system with the refrigerant. The compressor draws in low-pressure refrigerant vapor from the evaporator through its suction port. It then compresses the refrigerant into a high-pressure, high-temperature refrigerant vapor, which is then pumped to the condenser through the compressor discharge port.

The compressor cannot be repaired. If faulty or damaged, the entire compressor assembly must be

replaced. The compressor clutch, pulley and clutch coil are available for service.

COMPRESSOR CLUTCH - 2.5L VM DIESEL

DESCRIPTION

The compressor clutch assembly used on the diesel engine is the same clutch used on most compressors however, due to the different drive arrangement it utilizes a drive cup that threads onto the clutch drive pulley. The basic compressor clutch assembly consists of a stationary electromagnetic coil, a hub bearing and pulley assembly, and a clutch plate (Fig. 1). The electromagnetic coil unit and the hub bearing and pulley assembly are each retained on the nose of the compressor front housing with snap rings. The clutch plate is keyed to the compressor shaft and secured with a nut. These components provide the means to engage and disengage the compressor from the engine serpentine accessory drive belt.

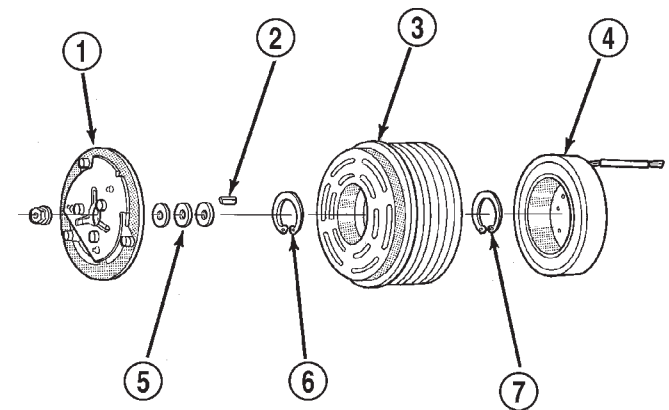

J9524-33

Fig. 1 Compressor Clutch – Drive Cup Not Shown

- 1 - CLUTCH PLATE
- 2 - SHAFT KEY
- 3 - PULLEY
- 4 - COIL
- 5 - CLUTCH SHIMS
- 6 - SNAP RING
- 7 - SNAP RING

OPERATION

When the clutch coil is energized, it magnetically draws the clutch into contact with the pulley and drives the compressor shaft. When the coil is not energized, the pulley freewheels on the clutch hub bearing, which is part of the pulley. The compressor clutch and coil are the only serviced parts on the compressor.

The compressor clutch engagement is controlled by several components: the heater-A/C mode control switch, the low pressure cycling clutch switch, the dual function high pressure switch, the compressor

DESCRIPTION AND OPERATION (Continued)

clutch relay, and the Powertrain Control Module (PCM). The PCM may delay compressor clutch engagement for up to thirty seconds. Refer to Group 14 - Fuel System for more information on the PCM controls.

REMOVAL AND INSTALLATION

SUCTION AND DISCHARGE LINE

Any kinks or sharp bends in the refrigerant plumbing will reduce the capacity of the entire air conditioning system. Kinks and sharp bends reduce the flow of refrigerant in the system. A good rule for the flexible hose refrigerant lines is to keep the radius of all bends at least ten times the diameter of the hose. In addition, the flexible hose refrigerant lines should be routed so they are at least 80 millimeters (3 inches) from the exhaust manifold.

High pressures are produced in the refrigerant system when the air conditioning compressor is operating. Extreme care must be exercised to make sure that each of the refrigerant system connections is pressure-tight and leak free. It is a good practice to inspect all flexible hose refrigerant lines at least once a year to make sure they are in good condition and properly routed.

WARNING: REVIEW THE WARNINGS AND CAUTIONS IN THE FRONT OF THIS GROUP BEFORE PERFORMING THE FOLLOWING OPERATION.

LEFT-HAND DRIVE

REMOVAL

(1) Disconnect and isolate the battery negative cable.

(2) Recover the refrigerant from the refrigerant system. See Refrigerant Recovery in this group for the procedures.

(3) Unplug the wire harness connector from the high pressure cut-off switch.

(4) Disconnect the discharge line refrigerant line fitting from the condenser inlet tube (Fig. 2). See Refrigerant Line Coupler in this group for the procedures. Install plugs in, or tape over all of the opened refrigerant line fittings.

(5) Remove the nut that secures the suction line block fitting to the accumulator outlet. Install plugs in, or tape over all of the opened refrigerant line fittings.

(6) Remove the screw that secures the suction and discharge line manifold to the compressor. Install plugs in, or tape over all of the opened refrigerant line fittings.

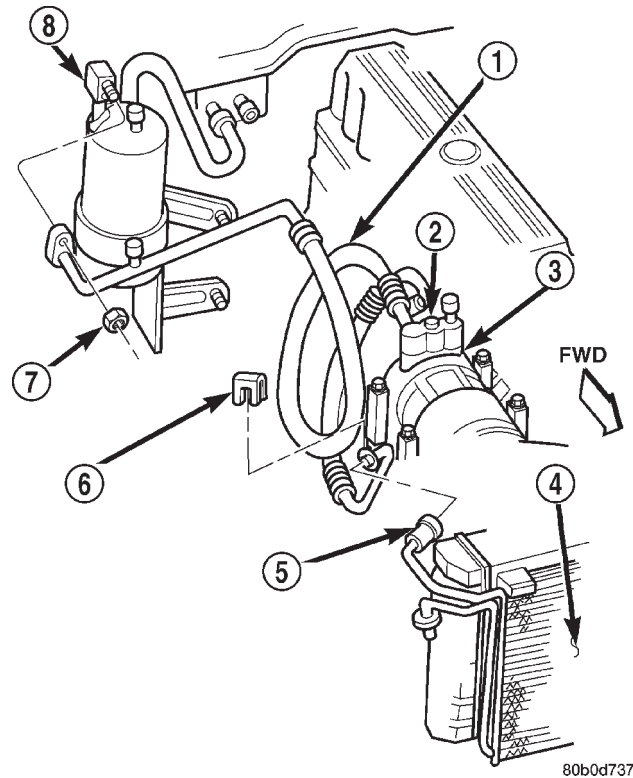

Fig. 2 Suction and Discharge Line Remove/Install - Left-Hand Drive

- 1 - SUCTION AND DISCHARGE LINE
- 2 - SCREW
- 3 - COMPRESSOR
- 4 - CONDENSER
- 5 - INLET
- 6 - CLIP
- 7 - HEX NUT
- 8 - ACCUMULATOR

(7) Remove the suction and discharge line assembly from the vehicle.

INSTALLATION

(1) Remove the tape or plugs from the suction and discharge line manifold and the compressor. Install the suction and discharge line manifold to the compressor. Tighten the mounting screw to 28 N·m (250 in. lbs.).

(2) Remove the tape or plugs from the suction line and the accumulator outlet block fittings. Install the suction line to the accumulator outlet and tighten the mounting nut to 9 N·m (80 in. lbs.).

(3) Remove the tape or plugs from the refrigerant line fittings on the discharge line and the condenser inlet tube. Connect the discharge line refrigerant line coupler to the condenser inlet tube. See Refrigerant Line Coupler in this group for the procedures.

(4) Plug in the wire harness connector to the high pressure cut-off switch.

(5) Connect the battery negative cable.

REMOVAL AND INSTALLATION (Continued)

(6) Evacuate the refrigerant system. See Refrigerant System Evacuate in this group for the procedures.

(7) Charge the refrigerant system. See Refrigerant System Charge in this group for the procedures.

RIGHT-HAND DRIVE - 2.5L ENGINE

REMOVAL

(1) Disconnect and isolate the battery negative cable.

(2) Recover the refrigerant from the refrigerant system. See Refrigerant Recovery in this group for the procedures.

(3) Unplug the wire harness connector from the high pressure cut-off switch.

(4) Disconnect the discharge line refrigerant line fitting from the condenser inlet tube (Fig. 3). See Refrigerant Line Coupler in this group for the procedures. Install plugs in, or tape over all of the opened refrigerant line fittings.

(5) Remove the nut that secures the suction line block fitting to the accumulator outlet. Install plugs in, or tape over all of the opened refrigerant line fittings.

(6) Remove the screw that secures the suction and discharge line manifold to the compressor. Install plugs in, or tape over all of the opened refrigerant line fittings.

(7) Remove the suction and discharge line assembly from the vehicle.

INSTALLATION

(1) Remove the tape or plugs from the suction and discharge line manifold and the compressor. Install the suction and discharge line manifold to the compressor. Tighten the mounting screw to 28 N·m (250 in. lbs.).

(2) Remove the tape or plugs from the suction line and the accumulator outlet block fittings. Install the suction line to the accumulator outlet and tighten the mounting nut to 9 N·m (80 in. lbs.).

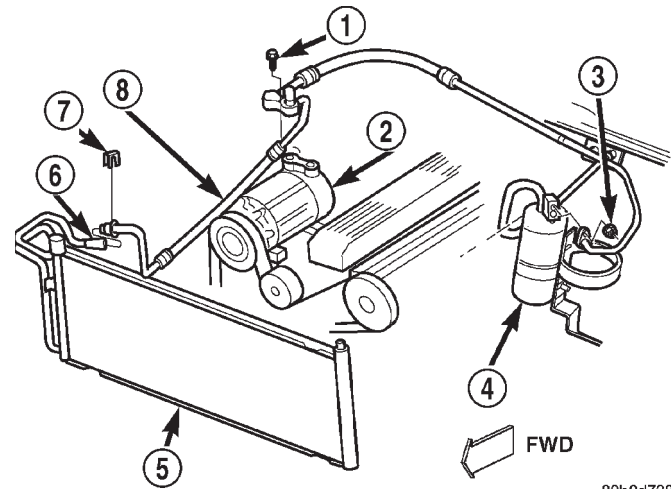

80b0d738

Fig. 3 Suction and Discharge Line Remove/Install - Right-Hand Drive 2.5L Engine

- 1 - SCREW
- 2 - COMPRESSOR
- 3 - HEX NUT
- 4 - ACCUMULATOR
- 5 - CONDENSER
- 6 - INLET
- 7 - CLIP
- 8 - SUCTION AND DISCHARGE LINE

(3) Remove the tape or plugs from the refrigerant line fittings on the discharge line and the condenser inlet tube. Connect the discharge line refrigerant line coupler to the condenser inlet tube. See Refrigerant Line Coupler in this group for the procedures.

(4) Plug in the wire harness connector to the high pressure cut-off switch.

(5) Connect the battery negative cable.

(6) Evacuate the refrigerant system. See Refrigerant System Evacuate in this group for the procedures.

(7) Charge the refrigerant system. See Refrigerant System Charge in this group for the procedures.

REMOVAL AND INSTALLATION (Continued)

RIGHT-HAND DRIVE - 4.0L ENGINE

The suction and discharge lines for this model are individual components and are secured to a manifold block on the compressor with block fittings (Fig. 4). There is also a jumper line installed between the discharge line and the condenser inlet that is secured with refrigerant line couplers at each end. Each of these components is available as a separate service part.

The suction and discharge line components can be removed from or installed on the vehicle individually, or as a unit. Otherwise, the service procedures are the same as those for the other applications. Tighten the additional mounting hardware as follows:

- Suction line to manifold block nut - 9 N-m (80 in. lbs.)
- Discharge line to manifold block nut - 9 N-m (80 in. lbs.)

- Manifold block to compressor screw - 28 N-m (250 in. lbs.).

COMPRESSOR - 2.5L VM DIESEL**REMOVAL**

- (1) Disconnect the negative battery cable.
- (2) Recover the refrigerant. See Refrigerant Recovery in this group for the procedure.
- (3) Disconnect the A/C compressor clutch electrical connector (Fig. 5).
- (4) Remove the suction and discharge refrigerant line retaining bolts from the compressor and plug the openings.
- (5) Raise the vehicle on a hoist.
- (6) Loosen all (4) H-block retaining bolts. Do not remove at this time.

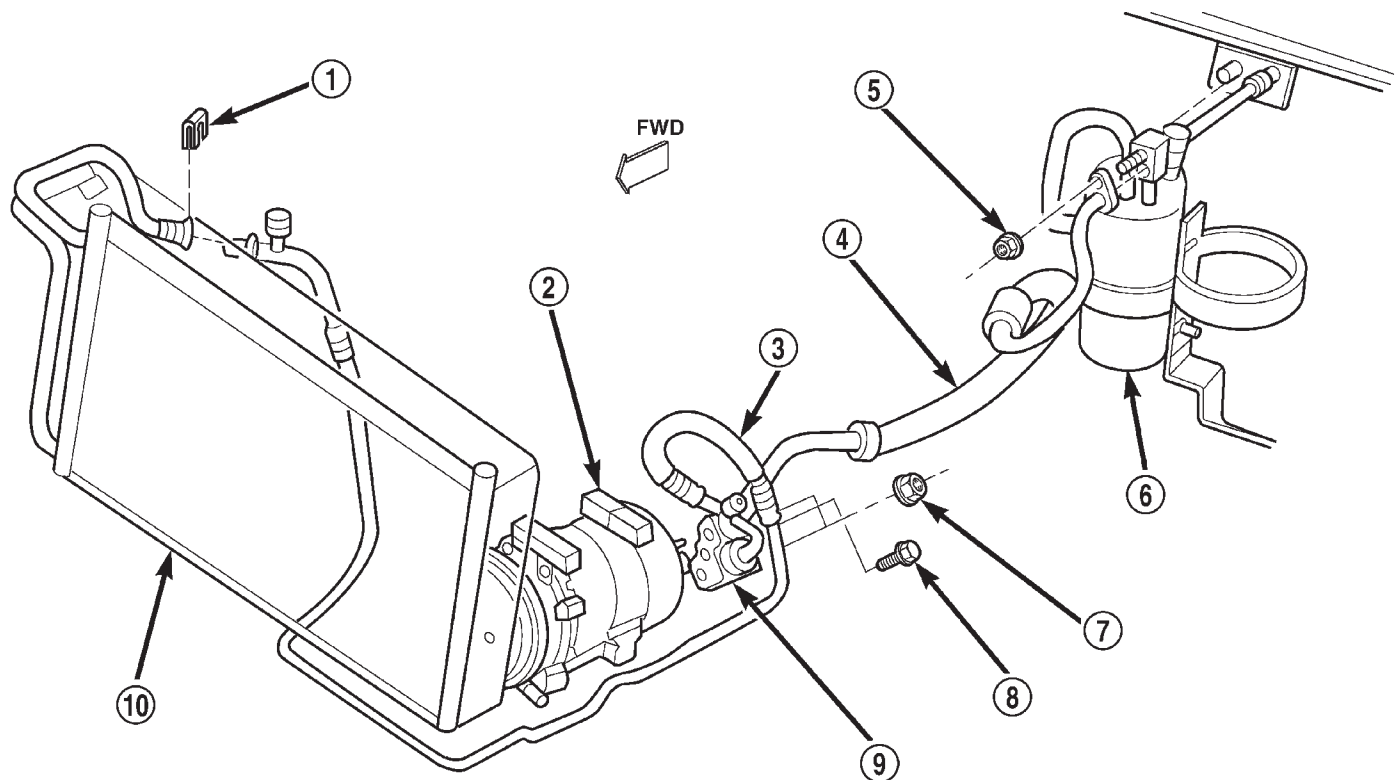

80ae839c

Fig. 4 Suction and Discharge Line Remove/Install - Right-Hand Drive 4.0L Engine

- | | |
|--------------------|--------------------|
| 1 - CLIP | 6 - ACCUMULATOR |
| 2 - COMPRESSOR | 7 - NUT |
| 3 - DISCHARGE LINE | 8 - SCREW |
| 4 - SUCTION LINE | 9 - MANIFOLD BLOCK |
| 5 - NUT | 10 - CONDENSER |

REMOVAL AND INSTALLATION (Continued)

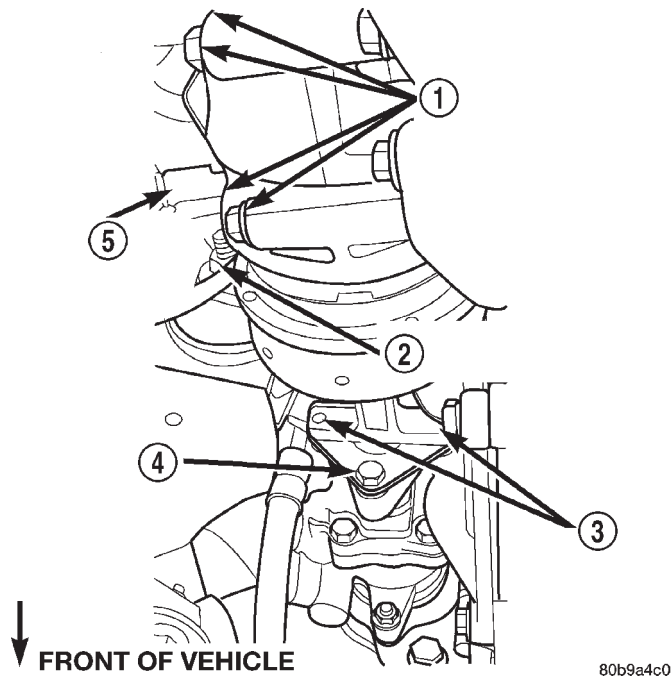
**Fig. 5 A/C Compressor Position & Orientation**

- 1 - A/C COMPRESSOR MOUNTING BOLTS
- 2 - LEFT ENGINE MOUNT THROUGHBOLT NUT
- 3 - H BLOCK BOLTS
- 4 - COUPLER PINCH BOLT
- 5 - COMPRESSOR ELECTRICAL CONNECTOR

NOTE: Mark the H-Block position in relation to the power steering pump so it may be reinstalled in the same position.

(7) Remove the (2) H-block bolts from the power steering pump side of the block (Fig. 5).

(8) Remove the serpentine drive belt. Refer to Group 7, Cooling System for the procedure.

(9) Loosen, but do not remove, the coupler pinch bolt and slide the coupler towards the pump (Fig. 5).

NOTE: There are 4 spacers located between the engine block and the A/C compressor. The doweled spacers are located in the front, undoweled in the rear.

(10) Remove the (4) A/C compressor retaining bolts (Fig. 5).

(11) Remove the compressor assembly from the vehicle with H-Block attached.

CAUTION: Check the refrigerant oil level in the new compressor prior to installation. See compressor oil level in this group for a detailed procedure.

INSTALLATION

(1) Transfer the H-Block to the new compressor and leave the bolts loose at this time.

(2) Lift the A/C compressor in position and install the (4) spacers and retaining bolts (Fig. 6). Torque the bolts to 33 N·m (25 ft. lbs.).

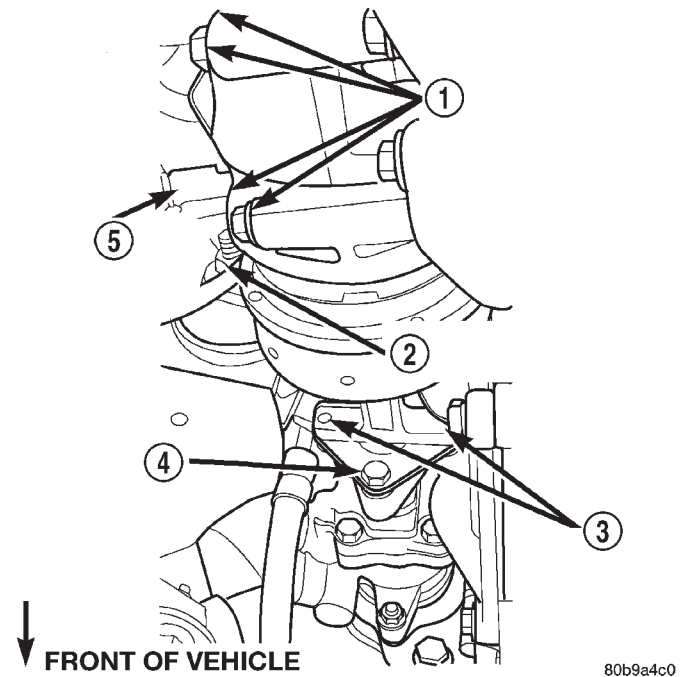
**Fig. 6 A/C Compressor Position & Orientation**

- 1 - A/C COMPRESSOR MOUNTING BOLTS
- 2 - LEFT ENGINE MOUNT THROUGHBOLT NUT
- 3 - H BLOCK BOLTS
- 4 - COUPLER PINCH BOLT
- 5 - COMPRESSOR ELECTRICAL CONNECTOR

(3) Slide the drive coupler into its original position and start the remaining (2) H-Block bolts (Fig. 6).

(4) Install the serpentine drive belt. See Group 7, Cooling System for the procedure.

(5) Torque all H-Block retaining bolts to 33 N·m (25 ft. lbs.).

(6) Lower the vehicle from the hoist.

(7) Install the suction and discharge refrigerant lines on the compressor, making sure the o-rings are well lubricated with refrigerant oil and free of tears.

(8) Connect the A/C compressor electrical connector (Fig. 6).

(9) Connect the negative battery cable.

(10) Charge the refrigerant system. See Refrigerant System Charge in this group for procedure.

REMOVAL AND INSTALLATION (Continued)

COMPRESSOR CLUTCH - 2.5L VM DIESEL

REMOVAL

(1) Disconnect and isolate the battery negative cable.

(2) Remove the compressor from the vehicle. Refer to the procedure in this group.

(3) Unscrew the compressor drive cup from the clutch pulley.

(4) Insert the two pins of the spanner wrench (Special Tool C-4489) into the holes of the clutch plate. Hold the clutch plate stationary and remove the hex nut (Fig. 7).

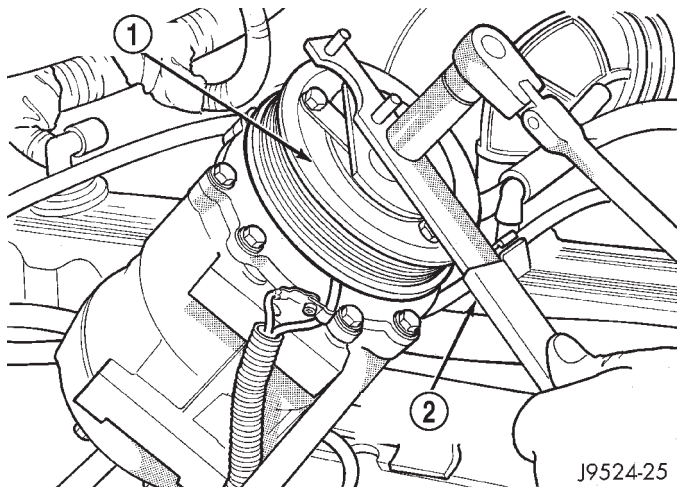

Fig. 7 Clutch Nut Remove

- 1 - CLUTCH PLATE
- 2 - SPANNER

(5) Remove the clutch plate with a puller (Special Tool C-6461) (Fig. 8).

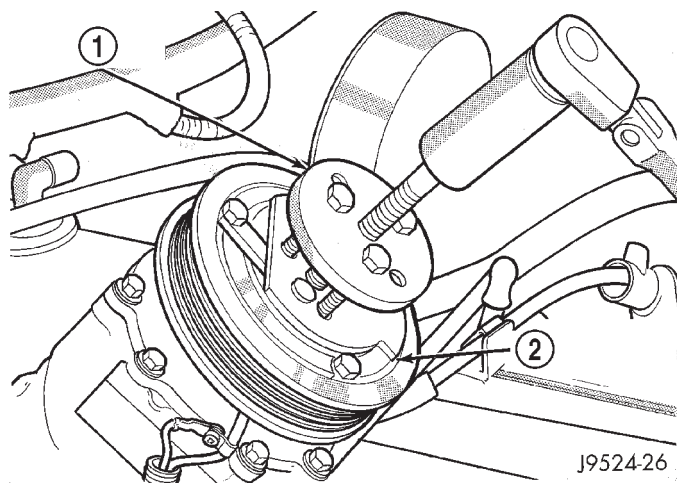

Fig. 8 Clutch Plate Remove

- 1 - CLUTCH PLATE PULLER
- 2 - CLUTCH PLATE

(6) Remove the compressor shaft key and the clutch shims.

(7) Remove the external front housing snap ring with snap ring pliers (Fig. 9).

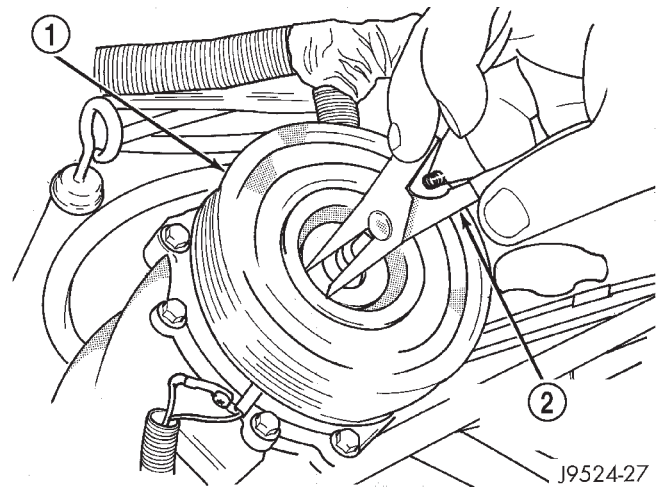

Fig. 9 External Snap Ring Remove

- 1 - PULLEY
- 2 - SNAP RING PLIERS

(8) Install the lip of the rotor puller (Special Tool C-6141-1) into the snap ring groove exposed in the previous step, and install the shaft protector (Special Tool C-6141-2) (Fig. 10).

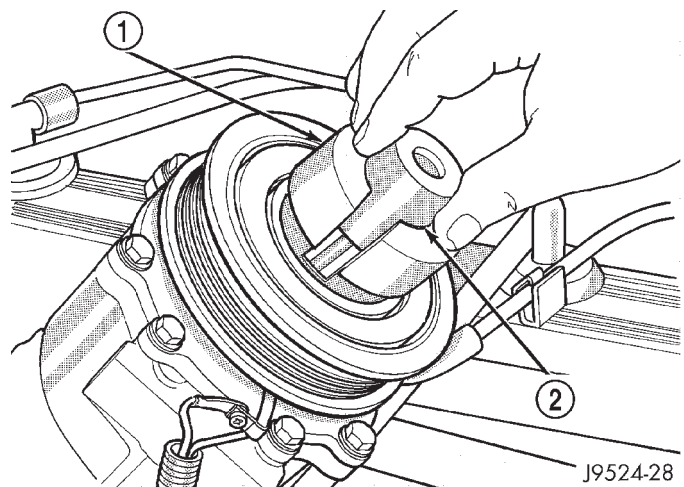

Fig. 10 Shaft Protector and Puller

- 1 - PULLER JAW
- 2 - SHAFT PROTECTOR

REMOVAL AND INSTALLATION (Continued)

(9) Install the puller through-bolts (Special Tool C-6461) through the puller flange and into the jaws of the rotor puller and tighten (Fig. 11). Turn the puller center bolt clockwise until the rotor pulley is free.

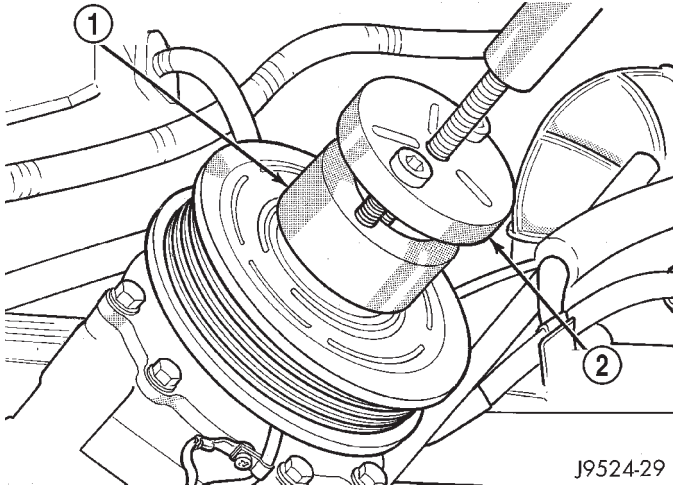

Fig. 11 Install Puller Plate

- 1 - PULLER JAW
- 2 - PULLER

(10) Remove the screw and retainer from the clutch coil lead wire harness on the compressor front housing (Fig. 12).

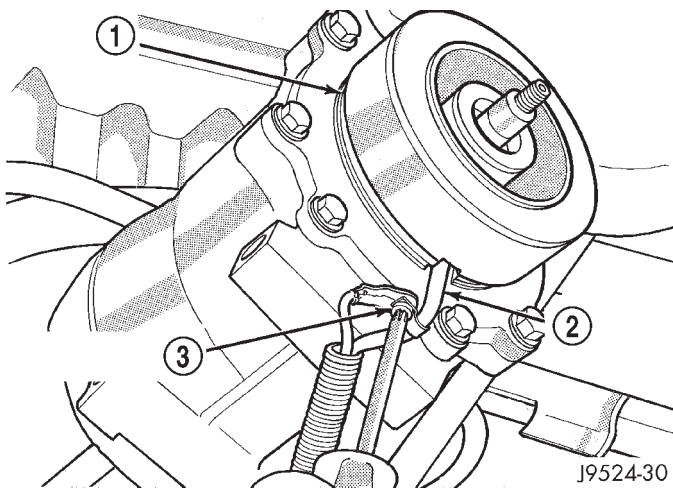

Fig. 12 Clutch Coil Lead Wire Harness

- 1 - COIL
- 2 - COIL WIRE
- 3 - RETAINER SCREW

(11) Remove the snap ring from the compressor hub and remove the clutch field coil (Fig. 13). Slide the clutch field coil off of the compressor hub.

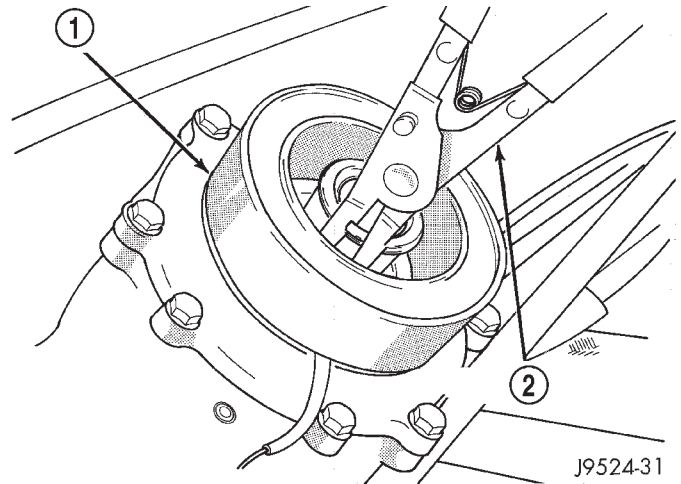

Fig. 13 Clutch Field Coil Snap Ring Remove

- 1 - COIL
- 2 - SNAP RING PLIERS

INSPECTION

Examine the friction surfaces of the clutch pulley and the front plate for wear. The pulley and front plate should be replaced if there is excessive wear or scoring.

If the friction surfaces are oily, inspect the shaft and nose area of the compressor for oil. Remove the felt from the front cover. If the felt is saturated with oil, the shaft seal is leaking and the compressor must be replaced.

Check the clutch pulley bearing for roughness or excessive leakage of grease. Replace the bearing, if required.

INSTALLATION

- (1) Install the clutch field coil and snap ring.
- (2) Install the clutch coil lead wire harness retaining clip on the compressor front housing and tighten the retaining screw.
- (3) Align the rotor assembly squarely on the front compressor housing hub.
- (4) Install the pulley bearing assembly with the installer (Special Tool C-6871) (Fig. 14). Thread the installer on the shaft, then turn the nut until the pulley assembly is seated.
- (5) Install the external front snap ring with snap ring pliers. The bevel side of the snap ring must be facing outward. Press the snap ring to make sure it is properly seated in the groove.

REMOVAL AND INSTALLATION (Continued)

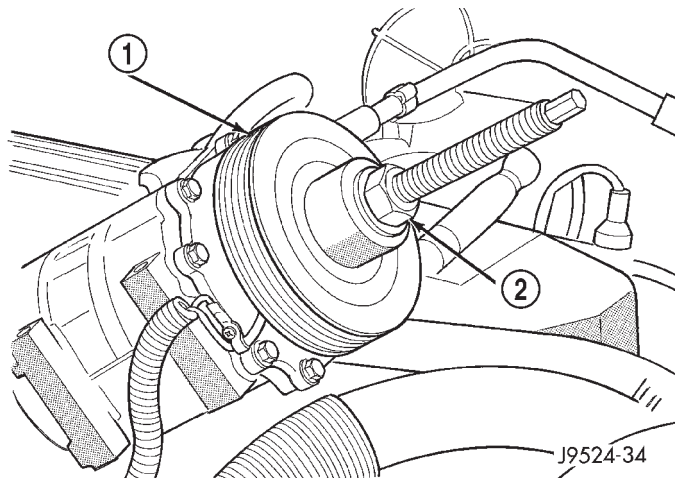
**Fig. 14 Clutch Pulley Install**

- 1 - PULLEY BEARING ASSEMBLY
2 - INSTALLER

CAUTION: If the snap ring is not fully seated in the groove it will vibrate out, resulting in a clutch failure and severe damage to the front housing of the compressor.

(6) Install the compressor shaft key and the original clutch shims on the compressor shaft.

(7) Install the clutch plate with the driver (Special Tool C-6463) (Fig. 15). Install the shaft hex nut and tighten to 14.4 N·m (10.5 ft. lbs.).

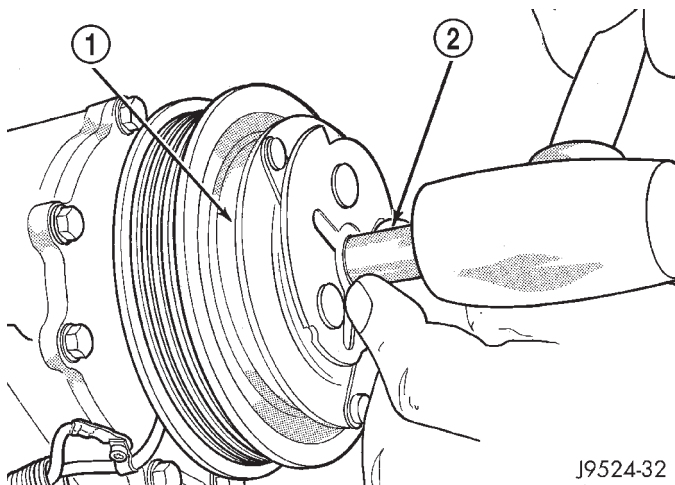
**Fig. 15 Clutch Plate Driver**

- 1 - CLUTCH PLATE
2 - DRIVER

(8) Check the clutch air gap with a feeler gauge (Fig. 16). If the air gap does not meet the specification, add or subtract shims as required. The air gap specification is 0.41 to 0.79 millimeter (0.016 to 0.031 inch). If the air gap is not consistent around the circumference of the clutch, lightly pry up at the minimum variations. Lightly tap down at the points of maximum variation.

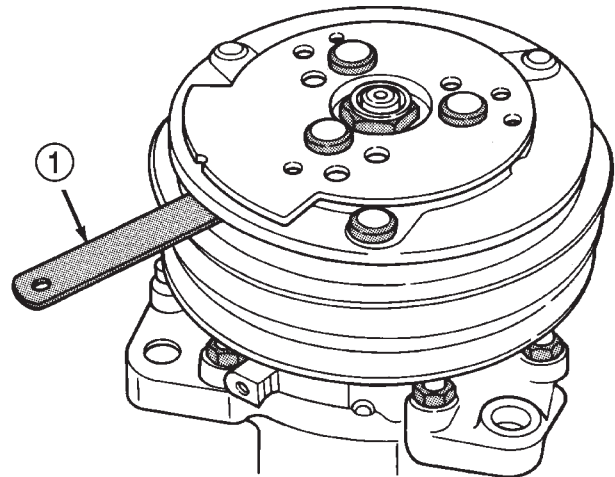

J8924-28

Fig. 16 Check Clutch Air Gap

- 1 - FEELER GAUGE

NOTE: The air gap is determined by the spacer shims. When installing an original, or a new clutch assembly, try the original shims first. When installing a new clutch onto a compressor that previously did not have a clutch, use 1.0, 0.50, and 0.13 millimeter (0.040, 0.020, and 0.005 inch) shims from the clutch hardware package that is provided with the new clutch.

(9) Reverse the remaining removal procedures to complete the installation.

CLUTCH BREAK-IN

After a new compressor clutch has been installed, cycle the compressor clutch approximately twenty times (five seconds on, then five seconds off). During this procedure, set the heater-A/C control to the Recirculation Mode, the blower motor switch in the highest speed position, and the engine speed at 1500 to 2000 rpm. This procedure (burnishing) will seat the opposing friction surfaces and provide a higher compressor clutch torque capability.

EMISSION CONTROL SYSTEMS

TABLE OF CONTENTS

| | page | | page |
|----------------------------|------|-------------------------------------|------|
| ON-BOARD DIAGNOSTICS | 1 | EVAPORATIVE EMISSION CONTROLS | 23 |

ON-BOARD DIAGNOSTICS

TABLE OF CONTENTS

| | page | | page |
|--|------|------------------------------|-----------|
| DESCRIPTION AND OPERATION | | TASK MANAGER | 16 |
| EMISSION SYSTEM..... | 1 | MONITORED SYSTEMS..... | 19 |
| MALFUNCTION INDICATOR LAMP (MIL) | 2 | TRIP DEFINITION | 21 |
| STATE DISPLAY TEST MODE | 2 | COMPONENT MONITORS..... | 21 |
| CIRCUIT ACTUATION TEST MODE | 2 | NON-MONITORED CIRCUITS | 22 |
| DIAGNOSTIC TROUBLE CODES..... | 2 | HIGH AND LOW LIMITS..... | 22 |
| DIAGNOSTIC TROUBLE CODE | | LOAD VALUE..... | 22 |
| DESCRIPTIONS | 3 | | |

DESCRIPTION AND OPERATION

EMISSION SYSTEM

OPERATION

The Powertrain Control Module (PCM) monitors many different circuits in the fuel injection, ignition, emission and engine systems. If the PCM senses a problem with a monitored circuit often enough to indicate an actual problem, it stores a Diagnostic Trouble Code (DTC) in the PCM's memory. If the code applies to a non-emissions related component or system, and the problem is repaired or ceases to exist, the PCM cancels the code after 40 warm-up cycles. Diagnostic trouble codes that affect vehicle emissions illuminate the Malfunction Indicator Lamp (MIL). The MIL is displayed as an engine icon on the instrument panel. Refer to Malfunction Indicator Lamp (MIL) in this section.

Certain criteria must be met before the PCM stores a DTC in memory. The criteria may be a specific range of engine RPM, engine temperature, and/or input voltage to the PCM.

The PCM might not store a DTC for a monitored circuit even though a malfunction has occurred. This may happen because one of the DTC criteria for the circuit has not been met. **For example**, assume the

diagnostic trouble code criteria requires the PCM to monitor the circuit only when the engine operates between 750 and 2000 RPM. Suppose the sensor's output circuit shorts to ground when engine operates above 2400 RPM (resulting in 0 volt input to the PCM). Because the condition happens at an engine speed above the maximum threshold (2000 rpm), the PCM will not store a DTC.

There are several operating conditions for which the PCM monitors and sets DTC's. Refer to Monitored Systems, Components, and Non-Monitored Circuits in this section.

Technicians must retrieve stored DTC's by connecting the DRB scan tool (or an equivalent scan tool) to the 16-way data link connector (Fig. 1).

NOTE: Various diagnostic procedures may actually cause a diagnostic monitor to set a DTC. For instance, pulling a spark plug wire to perform a spark test may set the misfire code. When a repair is completed and verified, connect the DRB scan tool to the 16-way data link connector to erase all DTC's and extinguish the MIL.

DESCRIPTION AND OPERATION (Continued)

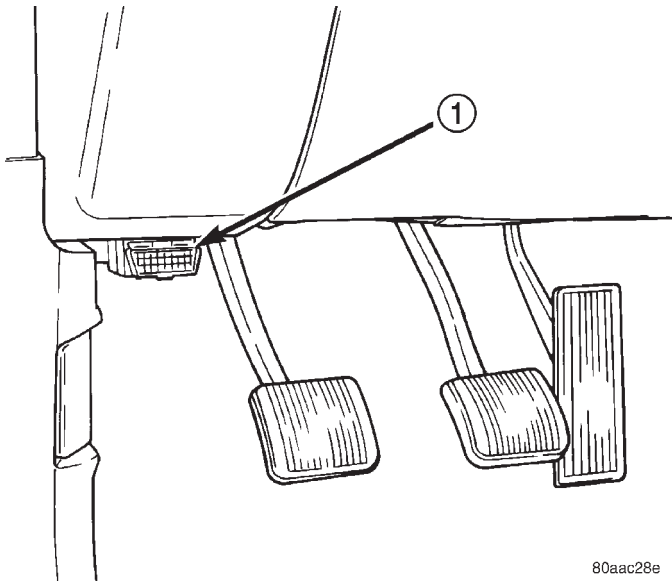

Fig. 1 Data Link (Diagnostic) Connector Location

1 - 16-WAY DATA LINK CONNECTOR

MALFUNCTION INDICATOR LAMP (MIL)

DESCRIPTION

The Malfunction Indicator Lamp (MIL) is located on the instrument panel. It is displayed as an engine icon (graphic).

OPERATION

As a functional test, the MIL illuminates at key-on before engine cranking. Whenever the Powertrain Control Module (PCM) sets a Diagnostic Trouble Code (DTC) that affects vehicle emissions, it illuminates the MIL. If a problem is detected, the PCM sends a message to the instrument cluster to illuminate the lamp. The PCM illuminates the MIL only for DTC's that affect vehicle emissions. There are some monitors that may take two consecutive trips, with a detected fault, before the MIL is illuminated. The MIL stays on continuously when the PCM has entered a Limp-In mode or identified a failed emission component. Refer to the Diagnostic Trouble Code charts in this group for emission related codes.

Also, the MIL either flashes or illuminates continuously when the PCM detects active engine misfire. Refer to Misfire Monitoring in this section.

Additionally, the PCM may reset (turn off) the MIL when one of the following occur:

- PCM does not detect the malfunction for 3 consecutive trips (except misfire and Fuel system Monitors).
- PCM does not detect a malfunction while performing three successive engine misfire or fuel system tests. The PCM performs these tests while the engine is operating within ± 375 RPM of and within

10 % of the load of the operating condition at which the malfunction was first detected.

STATE DISPLAY TEST MODE

OPERATION

The switch inputs to the Powertrain Control Module (PCM) have two recognized states; HIGH and LOW. For this reason, the PCM cannot recognize the difference between a selected switch position versus an open circuit, a short circuit, or a defective switch. If the State Display screen shows the change from HIGH to LOW or LOW to HIGH, assume the entire switch circuit to the PCM functions properly. Connect the DRB scan tool to the data link connector and access the state display screen. Then access either State Display Inputs and Outputs or State Display Sensors.

CIRCUIT ACTUATION TEST MODE

OPERATION

The Circuit Actuation Test Mode checks for proper operation of output circuits or devices the Powertrain Control Module (PCM) may not internally recognize. The PCM attempts to activate these outputs and allow an observer to verify proper operation. Most of the tests provide an audible or visual indication of device operation (click of relay contacts, fuel spray, etc.). Except for intermittent conditions, if a device functions properly during testing, assume the device, its associated wiring, and driver circuit work correctly. Connect the DRB scan tool to the data link connector and access the Actuators screen.

DIAGNOSTIC TROUBLE CODES

OPERATION

A Diagnostic Trouble Code (DTC) indicates that the Powertrain Control Module (PCM) has recognized an abnormal condition in the system.

DTC's are the results of a system or circuit failure, but do not directly identify the failed component or components.

Technicians must retrieve stored DTC's by connecting the DRB III scan tool (or an equivalent scan tool) to the 16-way data link connector. This connector is located on the lower edge of the instrument panel near the steering column.

OBTAINING DTC's

WARNING: APPLY PARKING BRAKE AND/OR BLOCK WHEELS BEFORE PERFORMING ANY TEST ON AN OPERATING ENGINE.

DESCRIPTION AND OPERATION (Continued)

- (1) Connect the DRB scan tool to data link (diagnostic) connector.
- (2) Turn the ignition switch on, access Read Fault Screen. Record all the DTC's shown on the DRB scan tool.

- (3) To erase DTC's, use the Erase Trouble Code data screen on the DRB scan tool.

NOTE: For a list of DTC's, refer to the following charts.

DIAGNOSTIC TROUBLE CODE DESCRIPTIONS

| (M) Malfunction Indicator Lamp (MIL) illuminated during engine operation if this DTC was recorded (depending if required by CARB and/or EPA). MIL is displayed as an engine icon on instrument panel. | | |
|--|--|---|
| (G) Generator lamp illuminated | | |
| Generic Scan Tool P-Code | DRB Scan Tool Display | Brief Description of DTC |
| P0030 (M) | 1/1 O2 Sensor Heater Relay Circuit | Problem detected in oxygen sensor heater relay circuit. |
| P0036 (M) | 1/2 O2 Sensor Heater Relay Circuit | Problem detected in oxygen sensor heater relay circuit. |
| P0106 | Barometric Pressure Out of Range | MAP sensor input voltage out of an acceptable range detected during reading of barometric pressure at key-on. |
| P0107 (M) | Map Sensor Voltage Too Low | MAP sensor input below minimum acceptable voltage. |
| P0108 (M) | Map Sensor Voltage Too High | MAP sensor input above maximum acceptable voltage. |
| P0112 (M) | Intake Air Temp Sensor Voltage Low | Intake air (charge) temperature sensor input below the minimum acceptable voltage. |
| P0113 (M) | Intake Air Temp Sensor Voltage High | Intake air (charge) temperature sensor input above the maximum acceptable voltage. |
| P0116 | | A rationatilty error has been detected in the coolant temp sensor. |
| P0117 (M) | ECT Sensor Voltage Too Low | Engine coolant temperature sensor input below the minimum acceptable voltage. |
| P0118 (M) | ECT Sensor Voltage Too High | Engine coolant temperature sensor input above the maximum acceptable voltage. |
| P0121 (M) | TPS Voltage Does Not Agree With MAP | TPS signal does not correlate to MAP sensor signal. |
| P0121 (M) | Accelerator Position Sensor (APPS) Signal Voltage Too Low | APPS voltage input below the minimum acceptable voltage. |
| P0122 (M) | Throttle Position Sensor Voltage Low | Throttle position sensor input below the acceptable voltage range. |
| P0122 (M) | Accelerator Position Sensor (APPS) Signal Voltage Too Low | APPS voltage input below the minimum acceptable voltage. |
| P0123 (M) | Throttle Position Sensor Voltage High | Throttle position sensor input above the maximum acceptable voltage. |
| P0123 (M) | Accelerator Position Sensor (APPS) Signal Voltage Too High | APPS voltage input above the maximum acceptable voltage. |
| P0125 (M) | Closed Loop Temp Not Reached | Time to enter Closed Loop Operation (Fuel Control) is excessive. |
| P0125 (M) | Engine is Cold Too Long | Engine does not reach operating temperature. |
| P0130 (M) | 1/1 O2 Sensor Heater Circuit Malfunction | Oxygen sensor heater element malfunction. |

DESCRIPTION AND OPERATION (Continued)

| (M) Malfunction Indicator Lamp (MIL) illuminated during engine operation if this DTC was recorded (depending if required by CARB and/or EPA). MIL is displayed as an engine icon on instrument panel. | | |
|--|--|--|
| P0131 (M) | 1/1 O2 Sensor Shorted To Ground | Oxygen sensor input voltage maintained below normal operating range. |
| P0132 (M) | 1/1 O2 Sensor Shorted To Voltage | Oxygen sensor input voltage maintained above normal operating range. |
| P0133 (M) | 1/1 O2 Sensor Slow Response | Oxygen sensor response slower than minimum required switching frequency. |
| P0134 (M) | 1/1 O2 Sensor Stays at Center | Neither rich or lean condition is detected from the oxygen sensor input. |
| P0135 (M) | 1/1 O2 Sensor Heater Failure | Oxygen sensor heater element malfunction. |
| P0136 (M) | 1/2 O2 Sensor Heater Circuit Malfunction | Oxygen sensor heater element malfunction. |
| P0137 (M) | 1/2 O2 Sensor Shorted To Ground | Oxygen sensor input voltage maintained below normal operating range. |
| P0138 (M) | 1/2 O2 Sensor Shorted To Voltage | Oxygen sensor input voltage maintained above normal operating range. |
| P0139 (M) | 1/2 O2 Sensor Slow Response | Oxygen sensor response not as expected. |
| P0140 (M) | 1/2 O2 Sensor Stays at Center | Neither rich or lean condition is detected from the oxygen sensor. |
| P0141 (M) | 1/2 O2 Sensor Heater Failure | Oxygen sensor heater element malfunction. |
| P0143 (M) | 1/3 O2 Sensor Shorted To Ground | Oxygen sensor input voltage maintained below normal operating range. |
| P0144 (M) | 1/3 O2 Sensor Shorted To Voltage | Oxygen sensor input voltage maintained above normal operating range. |
| P0145 (M) | 1/3 O2 Sensor Slow Response | Oxygen sensor response slower than minimum required switching frequency. |
| P0146 (M) | 1/3 O2 Sensor Stays at Center | Neither rich or lean condition is detected from the oxygen sensor. |
| P0147 (M) | 1/3 O2 Sensor Heater Failure | Oxygen sensor heater element malfunction. |
| P0151 (M) | 2/1 O2 Sensor Shorted To Ground | Oxygen sensor input voltage maintained below normal operating range. |
| P0152 (M) | 2/1 O2 Sensor Shorted To Voltage | Oxygen sensor input voltage sustained above normal operating range. |
| P0153 (M) | 2/1 O2 Sensor Slow Response | Oxygen sensor response slower than minimum required switching frequency. |
| P0154 (M) | 2/1 O2 Sensor Stays at Center | Neither rich or lean condition is detected from the oxygen sensor. |
| P0155 (M) | 2/1 O2 Sensor Heater Failure | Oxygen sensor heater element malfunction. |
| P0157 (M) | 2/2 O2 Sensor Shorted To Ground | Oxygen sensor input voltage maintained below normal operating range. |
| P0158 (M) | 2/2 O2 Sensor Shorted To Voltage | Oxygen sensor input voltage maintained above normal operating range. |
| P0159 | 2/2 O2 Sensor Slow Response | Oxygen sensor response slower than minimum required switching frequency. |
| P0160 (M) | 2/2 O2 Sensor Stays at Center | Neither rich or lean condition is detected from the oxygen sensor. |

DESCRIPTION AND OPERATION (Continued)

| (M) Malfunction Indicator Lamp (MIL) illuminated during engine operation if this DTC was recorded (depending if required by CARB and/or EPA). MIL is displayed as an engine icon on instrument panel. | | |
|--|---|---|
| P0161 (M) | 2/2 O2 Sensor Heater Failure | Oxygen sensor heater element malfunction. |
| P0168 | Decreased Engine Performance Due To High Injection Pump Fuel Temp | Fuel temperature is above the engine protection limit. Engine power will be derated. |
| P0171 (M) | 1/1 Fuel System Lean | A lean air/fuel mixture has been indicated by an abnormally rich correction factor. |
| P0172 (M) | 1/1 Fuel System Rich | A rich air/fuel mixture has been indicated by an abnormally lean correction factor. |
| P0174 (M) | 2/1 Fuel System Lean | A lean air/fuel mixture has been indicated by an abnormally rich correction factor. |
| P0175 (M) | 2/1 Fuel System Rich | A rich air/fuel mixture has been indicated by an abnormally lean correction factor. |
| P0176 | Loss of Flex Fuel Calibration Signal | No calibration voltage present from flex fuel sensor. |
| P0177 | Water In Fuel | Excess water found in fuel by water-in-fuel sensor. |
| P0178 | Flex Fuel Sensor Volts Too Low | Flex fuel sensor input below minimum acceptable voltage. |
| P0178 | Water In Fuel Sensor Voltage Too Low | Loss of water-in-fuel circuit or sensor. |
| P0179 | Flex Fuel Sensor Volts Too High | Flex fuel sensor input above maximum acceptable voltage. |
| P0181 | Fuel Injection Pump Failure | Low power, engine derated, or engine stops. |
| P0182 (M) | CNG Temp Sensor Voltage Too Low | Compressed natural gas temperature sensor voltage below acceptable voltage. |
| P0183 (M) | CNG Temp Sensor Voltage Too High | Compressed natural gas temperature sensor voltage above acceptable voltage. |
| P0201 (M) | Injector #1 Control Circuit | An open or shorted condition detected in control circuit for injector #1 or the INJ 1 injector bank. |
| P0202 (M) | Injector #2 Control Circuit | An open or shorted condition detected in control circuit for injector #2 or the INJ 2 injector bank. |
| P0203 (M) | Injector #3 Control Circuit | An open or shorted condition detected in control circuit for injector #3 or the INJ 3 injector bank. |
| P0204 (M) | Injector #4 Control Circuit | Injector #4 or INJ 4 injector bank output driver stage does not respond properly to the control signal. |
| P0205 (M) | Injector #5 Control Circuit | Injector #5 output driver stage does not respond properly to the control signal. |
| P0206 (M) | Injector #6 Control Circuit | Injector #6 output driver stage does not respond properly to the control signal. |
| P0207 (M) | Injector #7 Control Circuit | Injector #7 output driver stage does not respond properly to the control signal. |
| P0208 (M) | Injector #8 Control Circuit | Injector #8 output driver stage does not respond properly to the control signal. |
| P0209 (M) | Injector #9 Control Circuit | Injector #9 output driver stage does not respond properly to the control signal. |
| P0210 (M) | Injector #10 Control Circuit | Injector #10 output driver stage does not respond properly to the control signal. |
| P0215 | Fuel Injection Pump Control Circuit | Failure in fuel pump relay control circuit. |

DESCRIPTION AND OPERATION (Continued)

| (M) Malfunction Indicator Lamp (MIL) illuminated during engine operation if this DTC was recorded (depending if required by CARB and/or EPA). MIL is displayed as an engine icon on instrument panel. | | |
|--|--|---|
| P0216 (M) | Fuel Injection Pump Timing Failure | High fuel supply restriction, low fuel pressure or possible wrong or incorrectly installed pump keyway. |
| P0217 | Decreased Engine Performance Due To Engine Overheat Condition | Engine overheating. ECM will derate engine performance. |
| P0219 | Crankshaft Position Sensor Overspeed Signal | Engine has exceeded rpm limits. |
| P0222 (M) | Idle Validation Signals Both Low | Problem detected with idle validation circuits within APPS. |
| P0223 (M) | Idle Validation Signals Both High (Above 5 Volts) | Problem detected with idle validation circuits within APPS. |
| P0230 | Transfer Pump (Lift Pump) Circuit Out of Range | Problem detected in fuel transfer pump circuits. |
| P0232 | Fuel Shutoff Signal Voltage Too High | Fuel shut-off signal voltage too high from ECM to fuel injection pump. |
| P0234 (M) | Turbo Boost Limit Exceeded | Problem detected in turbocharger wastegate. |
| P0236 (M) | Map Sensor Too High Too Long | Problem detected in turbocharger wastegate. |
| P0237 (M) | Map Sensor Voltage Too Low | MAP sensor voltage input below the minimum acceptable voltage. |
| P0238 (M) | Map Sensor Voltage Too High | MAP sensor voltage input above the maximum acceptable voltage. |
| P0251 (M) | Fuel Inj. Pump Mech. Failure Fuel Valve Feedback Circuit | Problem sensed with fuel circuit internal to fuel injection pump. |
| P0253 (M) | Fuel Injection Pump Fuel Valve Open Circuit | Problem sensed with fuel circuit internal to fuel injection pump. |
| P0254 | Fuel Injection Pump Fuel Valve Current Too High | Problem caused by internal fuel injection pump failure. |
| P0300 (M) | Multiple Cylinder Mis-fire | Misfire detected in multiple cylinders. |
| P0301 (M) | CYLINDER #1 MISFIRE | Misfire detected in cylinder #1. |
| P0302 (M) | CYLINDER #2 MISFIRE | Misfire detected in cylinder #2. |
| P0303 (M) | CYLINDER #3 MISFIRE | Misfire detected in cylinder #3. |
| P0304 (M) | CYLINDER #4 MISFIRE | Misfire detected in cylinder #4. |
| P0305 (M) | CYLINDER #5 MISFIRE | Misfire detected in cylinder #5. |
| P0306 (M) | CYLINDER #6 MISFIRE | Misfire detected in cylinder #6. |
| P0307 (M) | CYLINDER #7 MISFIRE | Misfire detected in cylinder #7. |
| P0308 (M) | CYLINDER #8 MISFIRE | Misfire detected in cylinder #8. |
| P0309 (M) | CYLINDER #9 MISFIRE | Misfire detected in cylinder #9. |
| P0310 (M) | CYLINDER #10 MISFIRE | Misfire detected in cylinder #10. |
| P0320 (M) | No Crank Referance Signal at PCM | No reference signal (crankshaft position sensor) detected during engine cranking. |
| P0320 (M) | No RPM Signal to PCM (Crankshaft Position Sensor Signal to JTEC) | A CKP signal has not been detected at the PCM. |
| P0325 | Knock Sensor #1 Circuit | Knock sensor (#1) signal above or below minimum acceptable threshold voltage at particular engine speeds. |

DESCRIPTION AND OPERATION (Continued)

| | | |
|--|--|---|
| (M) Malfunction Indicator Lamp (MIL) illuminated during engine operation if this DTC was recorded (depending if required by CARB and/or EPA). MIL is displayed as an engine icon on instrument panel. | | |
| P0330 | Knock Sensor #2 Circuit | Knock sensor (#2) signal above or below minimum acceptable threshold voltage at particular engine speeds. |
| P0336 (M) | Crankshaft Position (CKP) Sensor Signal | Problem with voltage signal from CKP. |
| P0340 (M) | No Cam Signal At PCM | No fuel sync |
| P0341 (M) | Camshaft Position (CMP) Sensor Signal | Problem with voltage signal from CMP. |
| P0350 | Ignition Coil Draws Too Much Current | A coil (1-5) is drawing too much current. |
| P0351 (M) | Ignition Coil # 1 Primary Circuit | Peak primary circuit current not achieved with maximum dwell time. |
| P0352 (M) | Ignition Coil # 2 Primary Circuit | Peak primary circuit current not achieved with maximum dwell time. |
| P0353 (M) | Ignition Coil # 3 Primary Circuit | Peak primary circuit current not achieved with maximum dwell time. |
| P0354 (M) | Ignition Coil # 4 Primary Circuit | Peak primary circuit current not achieved with maximum dwell time (High Impedance). |
| P0355 (M) | Ignition Coil # 5 Primary Circuit | Peak primary circuit current not achieved with maximum dwell time (High Impedance). |
| P0356 (M) | Ignition Coil # 6 Primary Circuit | Peak primary circuit current not achieved with maximum dwell time (high impedance). |
| P0357 (M) | Ignition Coil # 7 Primary Circuit | Peak primary circuit current not achieved with maximum dwell time (high impedance). |
| P0358 (M) | Ignition Coil # 8 Primary Circuit | Peak primary circuit current not achieved with maximum dwell time (high impedance). |
| P0370 | Fuel Injection Pump Speed/Position Sensor Sig Lost | Problem caused by internal fuel injection pump failure. |
| P0380 (M) | Intake Air Heater Relay #1 Control Circuit | Problem detected in #1 air heater solenoid/relay circuit (not heater element) |
| P0381 (M) | Wait To Start Lamp Inoperative | Problem detected in wait-to-start bulb circuit. |
| P0382 (M) | Intake Air Heater Relay #2 Control Circuit | Problem detected in #2 air heater solenoid/relay circuit (not heater element) |
| P0387 | Crankshaft Position Sensor Supply Voltage Too Low | CKP sensor voltage input below the minimum acceptable voltage. |
| P0388 | Crankshaft Position Sensor Supply Voltage Too High | CKP sensor voltage input above the maximum acceptable voltage. |
| P0401 | EGR System Failure | Required change in air/fuel ration not detected during diagnostic test. |
| P0403 | EGR Solenoid Circuit | An open or shorted condition detected in the EGR solenoid control circuit. |
| P0404 | EGR Position Sensor Rationality | EGR position sensor signal does not correlate to EGR duty cycle. |
| P0405 | EGR Position Sensor Volts Too Low | EGR position sensor input below the acceptable voltage range. |

DESCRIPTION AND OPERATION (Continued)

| (M) Malfunction Indicator Lamp (MIL) illuminated during engine operation if this DTC was recorded (depending if required by CARB and/or EPA). MIL is displayed as an engine icon on instrument panel. | | |
|--|--|--|
| P0406 | EGR Position Sensor Volts Too High | EGR position sensor input above the acceptable voltage range. |
| P0412 | Secondary Air Solenoid Circuit | An open or shorted condition detected in the secondary air (air switching/aspirator) solenoid control circuit. |
| P0420 (M) | 1/1 Catalytic Converter Efficiency | Catalyst 1/1 efficiency below required level. |
| P0432 (M) | 1/2 Catalytic Converter Efficiency | Catalyst 2/1 efficiency below required level. |
| P0441 (M) | Evap Purge Flow Monitor | Insufficient or excessive vapor flow detected during evaporative emission system operation. |
| P0442 (M) | Evap Leak Monitor Medium Leak Detected | A small leak has been detected in the evaporative system. |
| P0443 (M) | Evap Purge Solenoid Circuit | An open or shorted condition detected in the EVAP purge solenoid control circuit. |
| P0455 (M) | Evap Leak Monitor Large Leak Detected | A large leak has been detected in the evaporative system. |
| P0456 (M) | Evap Leak Monitor Small Leak Detected | Leak has been detected in the evaporative system. |
| P0460 | Fuel Level Unit No Change Over Miles | During low fuel |
| P0460 | Fuel Level Unit No Change Over Miles | Fuel level sending unit voltage does not change for more than 40 miles. |
| P0462 | Fuel Level Sending Unit Volts Too Low | Fuel level sensor input below acceptable voltage. |
| P0462 (M) | Fuel Level Sending Unit Volts Too Low | Open circuit between PCM and fuel gauge sending unit. |
| P0463 | Fuel Level Sending Unit Volts Too High | Fuel level sensor input above acceptable voltage. |
| P0463 (M) | Fuel Level Sending Unit Volts Too High | Circuit shorted to voltage between PCM and fuel gauge sending unit. |
| P0500 (M) | No Vehicle Speed Sensor Signal | No vehicle speed sensor signal detected during road load conditions. |
| P0500 (M) | No Vehicle Speed Sensor Signal | A vehicle speed signal was not detected. |
| P0505 (M) | Idle Air Control Motor Circuits | SBEC II |
| P0522 | Oil Pressure Voltage Too Low | Oil pressure sending unit (sensor) voltage input below the minimum acceptable voltage. |
| P0523 | Oil Pressure Voltage Too High | Oil pressure sending unit (sensor) voltage input above the maximum acceptable voltage. |
| P0524 | Oil Pressure Too Low | Engine oil pressure is low. Engine power derated. |
| P0545 | A/C Clutch Relay Circuit | Problem detected in air conditioning clutch relay control circuit. |
| P0551 | Power Steering Switch Failure | Incorrect input state detected for the power steering switch circuit. PL: High pressure seen at high speed. |
| P0562 | Charging System Voltage Too Low | Supply voltage sensed at ECM too low. |
| P0563 | Charging System Voltage Too High | Supply voltage sensed at ECM too high. |

DESCRIPTION AND OPERATION (Continued)

| (M) Malfunction Indicator Lamp (MIL) illuminated during engine operation if this DTC was recorded (depending if required by CARB and/or EPA). MIL is displayed as an engine icon on instrument panel. | | |
|--|--|--|
| P0600 | PCM Failure SPI Communications | No communication detected between co-processors in the control module. |
| P0601 (M) | Internal Controller Failure | Internal control module fault condition (check sum) detected. |
| P0602 (M) | ECM Fueling Calibration Error | ECM Internal fault condition detected. |
| P0604 | RAM Check Failure | Transmission control module RAM self test fault detected. -Aisin transmission |
| P0605 | ROM Check Failure | Transmission control module ROM self test fault detected -Aisin transmission |
| P0606 (M) | ECM Failure | ECM Internal fault condition detected. |
| P0615 | Starter Relay Control Circuit | An open or shorted condition detected in the starter relay control circuit. |
| P0622 (G) | Generator Field Not Switching Properly | An open or shorted condition detected in the generator field control circuit. |
| P0645 | A/C Clutch Relay Circuit | An open or shorted condition detected in the A/C clutch relay control circuit. |
| P0700 | EATX Controller DTC Present | This SBEC III or JTEC DTC indicates that the EATX or Aisin controller has an active fault and has illuminated the MIL via a CCD (EATX) or SCI (Aisin) message. The specific fault must be acquired from the EATX via CCD or from the Aisin via ISO-9141. |
| P0703 | Brake Switch Stuck Pressed or Released | Incorrect input state detected in the brake switch circuit. (Changed from P1595) |
| P0711 (M) | Trans Temp Sensor, No Temp Rise After Start | Relationship between the transmission temperature and overdrive operation and/or TCC operation indicates a failure of the Transmission Temperature Sensor. OBD II Rationality. Was MIL code 37. |
| P0712 | Trans Temp Sensor Voltage Too Low | Transmission fluid temperature sensor input below acceptable voltage. Was MIL code 37. |
| P0712 (M) | Trans Temp Sensor Voltage Too Low | Voltage less than 1.55 volts (4-speed auto. trans. only). |
| P0713 | Trans Temp Sensor Voltage Too High | Transmission fluid temperature sensor input above acceptable voltage. Was MIL code 37. |
| P0713 (M) | Trans Temp Sensor Voltage Too High | Voltage greater than 3.76 volts (4-speed auto. trans. only). |
| P0720 (M) | Low Output SPD Sensor RPM, Above 15 MPH | The relationship between the Output Shaft Speed Sensor and vehicle speed is not within acceptable limits. |
| P0720 (M) | Low Output Spd Sensor RPM Above 15 mph | Output shaft speed is less than 60 rpm with vehicle speed above 15 mph (4-speed auto. trans. only). |
| P0740 (M) | Torq Con Clu, No RPM Drop at Lockup | Relationship between engine and vehicle speeds indicated failure of torque convertor clutch lock-up system (TCC/PTU solenoid) |
| P0743 (M) | Torque Converter Clutch Solenoid/ Trans Relay Circuits | An open or shorted condition detected in the torque converter clutch (part throttle unlock) solenoid control circuit. Shift solenoid C electrical fault - Aisin transmission |

DESCRIPTION AND OPERATION (Continued)

| (M) Malfunction Indicator Lamp (MIL) illuminated during engine operation if this DTC was recorded (depending if required by CARB and/or EPA). MIL is displayed as an engine icon on instrument panel. | | |
|--|--|---|
| P0743 (M) | Torque Converter Clutch Solenoid/ Trans Relay Circuits | An open or shorted condition detected in the torque converter part throttle unlock solenoid control circuit (3 or 4-speed auto. trans. only). |
| P0748 (M) | Governor Pressur Sol Control/Trans Relay Circuits | An open or shorted condition detected in the Governor Pressure Solenoid circuit or Trans Relay Circuit in JTEC RE transmissions. |
| P0748 (M) | Governor Pressure Sol Control/Trans Relay Circuits | An open or shorted condition detected in the governor pressure solenoid or relay circuits (4-speed auto. trans. only). |
| P0751 (M) | O/D Switch Pressed (Lo) More Than 5 Minutes | Overdrive override switch input is in a prolonged depressed state. |
| P0751 (M) | O/D Switch Pressed (LO) More Than 5 Min | Overdrive Off switch input too low for more than 5 minutes (4-speed auto. trans. only). |
| P0753 (M) | Trans 3-4 Shift Sol/Trans Relay Circuits | An open or shorted condition detected in the overdrive solenoid control circuit or Trans Relay Circuit in JTEC RE transmissions. Was MIL code 45. |
| P0753 (M) | Trans 3-4 Shift Sol/Trans Relay Circuits | An open or shorted condition detected in the transmission 2-4 shift solenoid circuit (4-speed auto. trans. only). |
| P0756 | AW4 Shift Sol B (2-3) Functional Failure | Shift solenoid B (2-3) functional fault - Aisin transmission |
| P0783 (M) | 3-4 Shift Sol, No RPM Drop at Lockup | The overdrive solenoid is unable to engage the gear change from 3rd gear to the overdrive gear. |
| P0801 | Reverse Gear Lockout Circuit Open or Short | An open or shorted condition detected in the transmission reverse gear lock-out solenoid control circuit. |
| P0830 | Clutch Depressed Switch Circuit | Problem detected in clutch switch circuit. |
| P0833 | Clutch Released Switch Circuit | Problem detected in clutch switch circuit. |
| P1110 | Decrease Engine Performance Due To High Intake Air Temperature | Intake manifold air temperature is above the engine protection limit. Engine power will be derated. |
| P1180 | Decreased Engine Performance Due To High Injection Pump Fuel Temp | Fuel temperature is above the engine protection limit. Engine power will be derated. |
| P1195 (M) | 1/1 O2 Sensor Slow During Catalyst Monitor | A slow switching oxygen sensor has been detected in bank 1/1 during catalyst monitor test. (Also see SCI DTC \$66) (was P0133) |
| P1196 (M) | 2/1 O2 Sensor Slow During Catalyst Monitor | A slow switching oxygen sensor has been detected in bank 2/1 during catalyst monitor test. (Also see SCI DTC \$7A) (was P0153) |
| P1197 | 1/2 O2 Sensor Slow During Catalyst Monitor | A slow switching oxygen sensor has been detected in bank 1/2 during catalyst monitor test. (Also see SCI DTC \$68) (was P0139) |
| P1198 | Radiator Temperature Sensor Volts Too High | Radiator coolant temperature sensor input above the maximum acceptable voltage. |
| P1199 | Radiator Temperature Sensor Volts Too Low | Radiator coolant temperature sensor input below the minimum acceptable voltage. |
| P1281 | Engine is Cold Too Long | Engine coolant temperature remains below normal operating temperatures during vehicle travel (Thermostat). |

DESCRIPTION AND OPERATION (Continued)

| | | |
|--|--|--|
| (M) Malfunction Indicator Lamp (MIL) illuminated during engine operation if this DTC was recorded (depending if required by CARB and/or EPA). MIL is displayed as an engine icon on instrument panel. | | |
| P1282 | Fuel Pump Relay Control Circuit | An open or shorted condition detected in the fuel pump relay control circuit. |
| P1283 | Idle Select Signal Invalid | ECM or fuel injection pump module internal fault condition detected. |
| P1284 (M) | Fuel Injection Pump Battery Voltage Out-Of-Range | Fuel injection pump module internal fault condition detected. Engine power will be derated. |
| P1285 (M) | Fuel Injection Pump Controller Always On | Fuel injection pump module relay circuit failure detected. Engine power will be derated. |
| P1286 | Accelerator Position Sensor (APPS) Supply Voltage Too High | High voltage detected at APPS. |
| P1287 | Fuel Injection Pump Controller Supply Voltage Low | ECM or fuel injection pump module internal fault condition detected. Engine power will be derated. |
| P1288 | Intake Manifold Short Runner Solenoid Circuit | An open or shorted condition detected in the short runner tuning valve circuit. |
| P1289 | Manifold Tune Valve Solenoid Circuit | An open or shorted condition detected in the manifold tuning valve solenoid control circuit. |
| P1290 | CNG Fuel System Pressure Too High | Compressed natural gas system pressure above normal operating range. |
| P1291 | No Temp Rise Seen From Intake Heaters | Energizing Heated Air Intake does not change intake air temperature sensor an acceptable amount. |
| P1291 (M) | No Temperature Rise Seen From Intake Air Heaters | Problem detected in intake manifold air heating system. |
| P1292 | CNG Pressure Sensor Voltage Too High | Compressed natural gas pressure sensor reading above acceptable voltage. |
| P1293 | CNG Pressure Sensor Voltage Too Low | Compressed natural gas pressure sensor reading below acceptable voltage. |
| P1294 (M) | Target Idle Not Reached | Target RPM not achieved during drive idle condition. Possible vacuum leak or IAC (AIS) lost steps. |
| P1295 (M) | No 5 Volts to TP Sensor | Loss of a 5 volt feed to the Throttle Position Sensor has been detected. |
| P1295 (M) | Accelerator Position Sensor (APPS) Supply Voltage Too Low | APPS supply voltage input below the minimum acceptable voltage. |
| P1296 | No 5 Volts to MAP Sensor | Loss of a 5 volt feed to the MAP Sensor has been detected. |
| P1297 (M) | No Change in MAP From Start To Run | No difference is recognized between the MAP reading at engine idle and the stored barometric pressure reading. |
| P1298 | Lean Operation at Wide Open Throttle | A prolonged lean condition is detected during Wide Open Throttle |
| P1299 | Vacuum Leak Found (IAC Fully Seated) | MAP Sensor signal does not correlate to Throttle Position Sensor signal. Possible vacuum leak. |
| P1388 | Auto Shutdown Relay Control Circuit | An open or shorted condition detected in the ASD or CNG shutoff relay control ckt. |
| P1388 | Auto Shutdown Relay Control Circuit | An open or shorted condition detected in the auto shutdown relay circuit. |

DESCRIPTION AND OPERATION (Continued)

| (M) Malfunction Indicator Lamp (MIL) illuminated during engine operation if this DTC was recorded (depending if required by CARB and/or EPA). MIL is displayed as an engine icon on instrument panel. | | |
|--|---|--|
| P1389 | No ASD Relay Output Voltage At PCM | No Z1 or Z2 voltage sensed when the auto shutdown relay is energized. |
| P1389 (M) | No ASD Relay Output Voltage at PCM | An open condition detected in the ASD relay output circuit. |
| P1390 | Timing Belt Skipped 1 Tooth or More | Relationship between Cam and Crank signals not correct |
| P1391 (M) | Intermittent Loss of CMP or CKP | Loss of the Cam Position Sensor or Crank Position sensor has occurred. For PL 2.0L |
| P1398 (M) | Mis-Fire Adaptive Numerator at Limit | PCM is unable to learn the Crank Sensor's signal in preparation for Misfire Diagnostics. Probable defective Crank Sensor |
| P1399 | Wait To Start Lamp Circuit | An open or shorted condition detected in the Wait to Start Lamp circuit. |
| P1403 | No 5V to EGR Sens | Loss of 5v feed to the EGR position sensor. |
| P01475 | Aux 5 Volt Supply Voltage High | Sensor supply voltage for ECM sensors is too high. |
| P1476 | Too Little Secondary Air | Insufficient flow of secondary air injection detected during aspirator test (was P0411) |
| P1477 | Too Much Secondary Air | Excessive flow of secondary air injection detected during aspirator test (was P0411). |
| P1478 | Battery Temp Sensor Volts Out of Limit | Internal temperature sensor input voltage out of an acceptable range. |
| P1479 | Transmission Fan Relay Circuit | An open or shorted condition detected in the transmission fan relay circuit. |
| P1480 | PCV Solenoid Circuit | An open or shorted condition detected in the PCV solenoid circuit. |
| P1481 | EATX RPM Pulse Perf | EATX RPM pulse generator signal for misfire detection does not correlate with expected value. |
| P1482 | Catalyst Temperature Sensor Circuit Shorted Low | Catalyst temperature sensor circuit shorted low. |
| P1483 | Catalyst Temperature Sensor Circuit Shorted High. | Catalyst temperature sensor circuit shorted high. |
| P1484 | Catalytic Converter Overheat Detected | A catalyst overheat condition has been detected by the catalyst temperature sensor. |
| P1485 | Air Injection Solenoid Circuit | An open or shorted condition detected in the air assist solenoid circuit. |
| P1486 | Evap Leak Monitor Pinched Hose Found | LDP has detected a pinched hose in the evaporative hose system. |
| P1487 | Hi Speed Rad Fan CTRL Relay Circuit | An open or shorted condition detected in the control circuit of the #2 high speed radiator fan control relay. |
| P1488 | Auxiliary 5 Volt Supply Output Too Low | Auxiliary 5 volt sensor feed is sensed to be below an acceptable limit. |
| P1488 | 5 Volt Supply Voltage Low | Sensor supply voltage for ECM sensors is too low. |
| P1489 | High Speed Fan CTRL Relay Circuit | An open or shorted condition detected in the control circuit of the high speed radiator fan control relay. |
| P1490 | Low Speed Fan CTRL Relay Circuit | An open or shorted condition detected in control circuit of the low speed radiator fan control relay. |

DESCRIPTION AND OPERATION (Continued)

| (M) Malfunction Indicator Lamp (MIL) illuminated during engine operation if this DTC was recorded (depending if required by CARB and/or EPA). MIL is displayed as an engine icon on instrument panel. | | |
|--|--|--|
| P1491 | Rad Fan Control Relay Circuit | An open or shorted condition detected in the radiator fan control relay control circuit. This includes PWM solid state relays. |
| P1492 | Ambient/Batt Temp Sen Volts Too High | External temperature sensor input above acceptable voltage. |
| P1492 (M) | Ambient/Batt Temp Sensor Volts Too High | Battery temperature sensor input voltage above an acceptable range. |
| P1493 (M) | Ambient/Batt Temp Sen Volts Too Low | External temperature sensor input below acceptable voltage. |
| P1493 (M) | Ambient/Batt Temp Sen Volts Too Low | Battery temperature sensor input voltage below an acceptable range. |
| P1494 (M) | Leak Detection Pump Sw or Mechanical Fault | Incorrect input state detected for the Leak Detection Pump (LDP) pressure switch. |
| P1495 | Leak Detection Pump Solenoid Circuit | An open or shorted condition detected in the Leak Detection Pump (LDP) solenoid circuit. |
| P1496 | 5 Volt Supply, Output Too Low | 5 volt sensor feed is sensed to be below an acceptable limit. (less than 4v for 4 sec) |
| P1498 | High Speed Rad Fan Ground CTRL Rly Circuit | An open or shorted condition detected in the control circuit of the #3 high speed radiator fan control relay. |
| P1594 (G) | Charging System Voltage Too High | Battery voltage sense input above target charging voltage during engine operation. |
| P1594 | Charging System Voltage Too High | Battery voltage sense input above target charging voltage during engine operation. |
| P1595 | Speed Control Solenoid Circuits | An open or shorted condition detected in either of the speed control vacuum or vent solenoid control circuits. |
| P1595 | Speed Control Solenoid Circuits | An open or shorted condition detected in the speed control vacuum or vent solenoid circuits. |
| P1596 | Speed Control Switch Always High | Speed control switch input above maximum acceptable voltage. |
| P1597 | Speed Control Switch Always Low | Speed control switch input below minimum acceptable voltage. |
| P1597 | Speed Control Switch Always Low | Speed control switch input below the minimum acceptable voltage. |
| P1598 | A/C Pressure Sensor Volts Too High | A/C pressure sensor input above maximum acceptable voltage. |
| P1598 | A/C Sensor Input Hi | Problem detected in air conditioning electrical circuit. |
| P1599 | A/C Pressure Sensor Volts Too Low | A/C pressure sensor input below minimum acceptable voltage. |
| P1599 | A/C Sensor Input Lo | Problem detected in air conditioning electrical circuit. |
| P1680 | Clutch Released Switch Circuit | Problem detected in clutch switch electrical circuit. |
| P1681 | No I/P Cluster CCD/J1850 Messages Received | No CCD/J1850 messages received from the cluster control module. |

DESCRIPTION AND OPERATION (Continued)

| (M) Malfunction Indicator Lamp (MIL) illuminated during engine operation if this DTC was recorded (depending if required by CARB and/or EPA). MIL is displayed as an engine icon on instrument panel. | | |
|--|---|---|
| P1682 (G) | Charging System Voltage Too Low | Battery voltage sense input below target charging voltage during engine operation and no significant change in voltage detected during active test of generator output circuit. |
| P1682 | Charging System Voltage Too Low | Charging system output voltage low. |
| P1683 | SPD CTRL PWR Relay; or S/C 12v Driver CKT | An open or shorted condition detected in the speed control servo power control circuit. |
| P1683 | Spd ctrl pwr rly, or s/c 12v driver circuit | An open or shorted condition detected in the speed control servo power control circuit. |
| P1684 | Batt Loss in 50 Star | The battery has been disconnected within the last 50 starts |
| P1685 | SKIM Invalid Key | The engine controller has received an invalid key from the SKIM. |
| P1686 | No SKIM BUS Messages Received | No CCD/J1850 messages received from the Smart Key Immobilizer Module (SKIM). |
| P1687 | No MIC BUS Message | No CCD/J1850 messages received from the Mechanical Instrument Cluster (MIC) module. |
| P1688 (M) | Internal Fuel Injection Pump Controller Failure | Internal problem within the fuel injection pump. Low power, engine derated, or engine stops. |
| P1689 (M) | No Communication Between ECM and Injection Pump Module | Data link circuit failure between ECM and fuel injection pump. Low power, engine derated, or engine stops. |
| P1690 (M) | Fuel Injection Pump CKP Sensor Does Not Agree With ECM CKP Sensor | Problem in fuel sync signal. Possible injection pump timing problem. Low power, engine derated, or engine stops. |
| P1691 | Fuel Injection Pump Controller Calibration Error | Internal fuel injection pump failure. Low power, engine derated, or engine stops. |
| P1692 | DTC Set In ECM | A "Companion DTC" was set in both the ECM and PCM. |
| P1693 (M) | DTC Detected in Companion Module | A fault has been generated in the companion engine control module. |
| P1693 (M) | DTC Detected in PCM/ECM or DTC Detected in ECM | A "Companion DTC" was set in both the ECM and PCM. |
| P1694 | Fault In Companion Module | No CCD/J1850 messages received from the powertrain control module-Aisin transmission |
| P1694 (M) | No CCD Messages received from ECM | Bus communication failure to PCM. |
| P1695 | No CCD/J1850 Message From Body Control Module | No CCD/J1850 messages received from the body control module. |
| P1696 | PCM Failure EEPROM Write Denied | Unsuccessful attempt to write to an EEPROM location by the control module. |
| P1697 | PCM Failure SRI Mile Not Stored | Unsuccessful attempt to update Service Reminder Indicator (SRI or EMR) mileage in the control module EEPROM. |
| P1698 | No CCD/J1850 Message From TCM | No CCD/J1850 messages received from the electronic transmission control module (EATX) or the Aisin transmission controller. |

DESCRIPTION AND OPERATION (Continued)

| (M) Malfunction Indicator Lamp (MIL) illuminated during engine operation if this DTC was recorded (depending if required by CARB and/or EPA). MIL is displayed as an engine icon on instrument panel. | | |
|--|---|---|
| P1698 | No CCD Messages received from PCM | Bus communication failure to PCM. A "Companion DTC" was set in both the ECM and PCM. |
| P1719 | Skip Shift Solenoid Circuit | An open or shorted condition detected in the transmission 2-3 gear lock-out solenoid control circuit. |
| P1740 | TCC or OD Sol Perf | A rationality error has been detected in either the TCC solenoid or overdrive solenoid systems. |
| P1740 (M) | TCC OR O/D Solenoid Performance | Problem detected in transmission convertor clutch and/or overdrive circuits (diesel engine with 4-speed auto. trans. only). |
| P1756 (M) | GOV Press Not Equal to Target @ 15-20 PSI | The requested pressure and the actual pressure are not within a tolerance band for the Governor Control System which is used to regulate governor pressure to control shifts for 1st, 2nd, and 3rd gear. (Mid Pressure Malfunction) |
| P1756 (M) | Governor Pressure Not Equal to Target @ 15-20 PSI | Governor sensor input not between 10 and 25 psi when requested (4-speed auto. trans. only). |
| P1757 | GOV Press Not Equal to Target @ 15-20 PSI | The requested pressure and the actual pressure are not within a tolerance band for the Governor Control System which is used to regulate governor pressure to control shifts for 1st, 2nd, and 3rd gear (Zero Pressure Malfunction) |
| P1757 (M) | Governor Pressure Above 3 PSI In Gear With 0 MPH | Governor pressure greater than 3 psi when requested to be 0 psi (4-speed auto. trans. only). |
| P1762 (M) | Gov Press Sen Offset Volts Too Low or High | The Governor Pressure Sensor input is greater than a calibration limit or is less than a calibration limit for 3 consecutive park/neutral calibrations. |
| P1762 (M) | Governor Press Sen Offset Volts Too Low or High | Sensor input greater or less than calibration for 3 consecutive Neutral/Park occurrences (4-speed auto. trans. only). |
| P1763 | Governor Pressure Sensor Volts Too Hi | The Governor Pressure Sensor input is above an acceptable voltage level. |
| P1763 (M) | Governor Pressure Sensor Volts Too HI | Voltage greater than 4.89 volts (4-speed auto. trans. only). |
| P1764 (M) | Governor Pressure Sensor Volts Too Low | The Governor Pressure Sensor input is below an acceptable voltage level. |
| P1764 (M) | Governor Pressure Sensor Volts Too Low | Voltage less than .10 volts (4-speed auto. trans. only). |
| P1765 (M) | Trans 12 Volt Supply Relay CTRL Circuit | An open or shorted condition is detected in the Transmission Relay control circuit. This relay supplies power to the TCC |
| P1765 (M) | Trans 12 Volt Supply Relay Ctrl Circuit | Current state of solenoid output port is different than expected (4-speed auto. trans. only). |
| P1899 (M) | P/N Switch Stuck in Park or in Gear | Incorrect input state detected for the Park/Neutral switch. |
| P1899 (M) | P/N Switch Stuck in Park or in Gear | Incorrect input state detected for the Park/Neutral switch (3 or 4-speed auto. trans. only). |

DESCRIPTION AND OPERATION (Continued)

TASK MANAGER

DESCRIPTION

The PCM is responsible for efficiently coordinating the operation of all the emissions-related components. The PCM is also responsible for determining if the diagnostic systems are operating properly. The software designed to carry out these responsibilities is called the 'Task Manager'.

OPERATION

The Task Manager determines which tests happen when and which functions occur when. Many of the diagnostic steps required by OBD II must be performed under specific operating conditions. The Task Manager software organizes and prioritizes the diagnostic procedures. The job of the Task Manager is to determine if conditions are appropriate for tests to be run, monitor the parameters for a trip for each test, and record the results of the test. Following are the responsibilities of the Task Manager software:

- Test Sequence
- MIL Illumination
- Diagnostic Trouble Codes (DTCs)
- Trip Indicator
- Freeze Frame Data Storage
- Similar Conditions Window

Test Sequence

In many instances, emissions systems must fail diagnostic tests more than once before the PCM illuminates the MIL. These tests are known as 'two trip monitors.' Other tests that turn the MIL lamp on after a single failure are known as 'one trip monitors.' A trip is defined as 'start the vehicle and operate it to meet the criteria necessary to run the given monitor.'

Many of the diagnostic tests must be performed under certain operating conditions. However, there are times when tests cannot be run because another test is in progress (conflict), another test has failed (pending) or the Task Manager has set a fault that may cause a failure of the test (suspend).

- Pending

Under some situations the Task Manager will not run a monitor if the MIL is illuminated and a fault is stored from another monitor. In these situations, the Task Manager postpones monitors **pending** resolution of the original fault. The Task Manager does not run the test until the problem is remedied.

For example, when the MIL is illuminated for an Oxygen Sensor fault, the Task Manager does not run the Catalyst Monitor until the Oxygen Sensor fault is remedied. Since the Catalyst Monitor is based on signals from the Oxygen Sensor, running the test would produce inaccurate results.

- Conflict

There are situations when the Task Manager does not run a test if another monitor is in progress. In these situations, the effects of another monitor running could result in an erroneous failure. If this **conflict** is present, the monitor is not run until the conflicting condition passes. Most likely the monitor will run later after the conflicting monitor has passed.

For example, if the Fuel System Monitor is in progress, the Task Manager does not run the EGR Monitor. Since both tests monitor changes in air/fuel ratio and adaptive fuel compensation, the monitors will conflict with each other.

- Suspend

Occasionally the Task Manager may not allow a two trip fault to mature. The Task Manager will **suspend** the maturing of a fault if a condition exists that may induce an erroneous failure. This prevents illuminating the MIL for the wrong fault and allows more precise diagnosis.

For example, if the PCM is storing a one trip fault for the Oxygen Sensor and the EGR monitor, the Task Manager may still run the EGR Monitor but will suspend the results until the Oxygen Sensor Monitor either passes or fails. At that point the Task Manager can determine if the EGR system is actually failing or if an Oxygen Sensor is failing.

MIL Illumination

The PCM Task Manager carries out the illumination of the MIL. The Task Manager triggers MIL illumination upon test failure, depending on monitor failure criteria.

The Task Manager Screen shows both a Requested MIL state and an Actual MIL state. When the MIL is illuminated upon completion of a test for a third trip, the Requested MIL state changes to OFF. However, the MIL remains illuminated until the next key cycle. (On some vehicles, the MIL will actually turn OFF during the third key cycle) During the key cycle for the third good trip, the Requested MIL state is OFF, while the Actual MIL state is ON. After the next key cycle, the MIL is not illuminated and both MIL states read OFF.

Diagnostic Trouble Codes (DTCs)

With OBD II, different DTC faults have different priorities according to regulations. As a result, the priorities determine MIL illumination and DTC erasure. DTCs are entered according to individual priority. DTCs with a higher priority overwrite lower priority DTCs.

Priorities

- Priority 0 —Non-emissions related trouble codes

DESCRIPTION AND OPERATION (Continued)

- Priority 1 — One trip failure of a two trip fault for non-fuel system and non-misfire.
- Priority 2 — One trip failure of a two trip fault for fuel system (rich/lean) or misfire.
- Priority 3 — Two trip failure for a non-fuel system and non-misfire or matured one trip comprehensive component fault.
- Priority 4 — Two trip failure or matured fault for fuel system (rich/lean) and misfire or one trip catalyst damaging misfire.

Non-emissions related failures have no priority. One trip failures of two trip faults have low priority. Two trip failures or matured faults have higher priority. One and two trip failures of fuel system and misfire monitor take precedence over non-fuel system and non-misfire failures.

DTC Self Erasure

With one trip components or systems, the MIL is illuminated upon test failure and DTCs are stored.

Two trip monitors are components requiring failure in two consecutive trips for MIL illumination. Upon failure of the first test, the Task Manager enters a maturing code. If the component fails the test for a second time the code matures and a DTC is set.

After three good trips the MIL is extinguished and the Task Manager automatically switches the trip counter to a warm-up cycle counter. DTCs are automatically erased following 40 warm-up cycles if the component does not fail again.

For misfire and fuel system monitors, the component must pass the test under a Similar Conditions Window in order to record a good trip. A Similar Conditions Window is when engine RPM is within ± 375 RPM and load is within $\pm 10\%$ of when the fault occurred.

NOTE: It is important to understand that a component does not have to fail under a similar window of operation to mature. It must pass the test under a Similar Conditions Window when it failed to record a Good Trip for DTC erasure for misfire and fuel system monitors.

DTCs can be erased anytime with a DRB III. Erasing the DTC with the DRB III erases all OBD II information. The DRB III automatically displays a warning that erasing the DTC will also erase all OBD II monitor data. This includes all counter information for warm-up cycles, trips and Freeze Frame.

Trip Indicator

The **Trip** is essential for running monitors and extinguishing the MIL. In OBD II terms, a trip is a set of vehicle operating conditions that must be met for a specific monitor to run. All trips begin with a key cycle.

Good Trip

The Good Trip counters are as follows:

- Specific Good Trip
- Fuel System Good Trip
- Misfire Good Trip
- Alternate Good Trip (appears as a Global Good Trip on DRB III)
- Comprehensive Components
- Major Monitor
- Warm-Up Cycles

Specific Good Trip

The term Good Trip has different meanings depending on the circumstances:

- If the MIL is OFF, a trip is defined as when the Oxygen Sensor Monitor and the Catalyst Monitor have been completed in the same drive cycle.
- If the MIL is ON and a DTC was set by the Fuel Monitor or Misfire Monitor (both continuous monitors), the vehicle must be operated in the Similar Condition Window for a specified amount of time.
- If the MIL is ON and a DTC was set by a Task Manager commanded once-per-trip monitor (such as the Oxygen Sensor Monitor, Catalyst Monitor, Purge Flow Monitor, Leak Detection Pump Monitor, EGR Monitor or Oxygen Sensor Heater Monitor), a good trip is when the monitor is passed on the next start-up.
- If the MIL is ON and any other emissions DTC was set (not an OBD II monitor), a good trip occurs when the Oxygen Sensor Monitor and Catalyst Monitor have been completed, or two minutes of engine run time if the Oxygen Sensor Monitor and Catalyst Monitor have been stopped from running.

Fuel System Good Trip

To count a good trip (three required) and turn off the MIL, the following conditions must occur:

- Engine in closed loop
- Operating in Similar Conditions Window
- Short Term multiplied by Long Term less than threshold
- Less than threshold for a predetermined time

If all of the previous criteria are met, the PCM will count a good trip (three required) and turn off the MIL.

Misfire Good Trip

If the following conditions are met the PCM will count one good trip (three required) in order to turn off the MIL:

- Operating in Similar Condition Window
- 1000 engine revolutions with no misfire

Warm-Up Cycles

Once the MIL has been extinguished by the Good Trip Counter, the PCM automatically switches to a Warm-Up Cycle Counter that can be viewed on the DRB III. Warm-Up Cycles are used to erase DTCs and Freeze Frames. Forty Warm-Up cycles must

DESCRIPTION AND OPERATION (Continued)

occur in order for the PCM to self-erase a DTC and Freeze Frame. A Warm-Up Cycle is defined as follows:

- Engine coolant temperature must start below and rise above 160° F
- Engine coolant temperature must rise by 40° F
- No further faults occur

Freeze Frame Data Storage

Once a failure occurs, the Task Manager records several engine operating conditions and stores it in a Freeze Frame. The Freeze Frame is considered one frame of information taken by an on-board data recorder. When a fault occurs, the PCM stores the input data from various sensors so that technicians can determine under what vehicle operating conditions the failure occurred.

The data stored in Freeze Frame is usually recorded when a system fails the first time for two trip faults. Freeze Frame data will only be overwritten by a different fault with a higher priority.

CAUTION: Erasing DTCs, either with the DRB III or by disconnecting the battery, also clears all Freeze Frame data.

Similar Conditions Window

The Similar Conditions Window displays information about engine operation during a monitor. Absolute MAP (engine load) and Engine RPM are stored in this window when a failure occurs. There are two different Similar conditions Windows: Fuel System and Misfire.

FUEL SYSTEM

- **Fuel System Similar Conditions Window** — An indicator that 'Absolute MAP When Fuel Sys Fail' and 'RPM When Fuel Sys Failed' are all in the same range when the failure occurred. Indicated by switching from 'NO' to 'YES'.

- **Absolute MAP When Fuel Sys Fail** — The stored MAP reading at the time of failure. Informs the user at what engine load the failure occurred.

- **Absolute MAP** — A live reading of engine load to aid the user in accessing the Similar Conditions Window.

- **RPM When Fuel Sys Fail** — The stored RPM reading at the time of failure. Informs the user at what engine RPM the failure occurred.

- **Engine RPM** — A live reading of engine RPM to aid the user in accessing the Similar Conditions Window.

- **Adaptive Memory Factor** — The PCM utilizes both Short Term Compensation and Long Term Adaptive to calculate the Adaptive Memory Factor for total fuel correction.

- **Upstream O₂S Volts** — A live reading of the Oxygen Sensor to indicate its performance. For example, stuck lean, stuck rich, etc.

- **SCW Time in Window (Similar Conditions Window Time in Window)** — A timer used by the PCM that indicates that, after all Similar Conditions have been met, if there has been enough good engine running time in the SCW without failure detected. This timer is used to increment a Good Trip.

- **Fuel System Good Trip Counter** — A Trip Counter used to turn OFF the MIL for Fuel System DTCs. To increment a Fuel System Good Trip, the engine must be in the Similar Conditions Window, Adaptive Memory Factor must be less than calibrated threshold and the Adaptive Memory Factor must stay below that threshold for a calibrated amount of time.

- **Test Done This Trip** — Indicates that the monitor has already been run and completed during the current trip.

MISFIRE

- **Same Misfire Warm-Up State** — Indicates if the misfire occurred when the engine was warmed up (above 160° F).

- **In Similar Misfire Window** — An indicator that 'Absolute MAP When Misfire Occurred' and 'RPM When Misfire Occurred' are all in the same range when the failure occurred. Indicated by switching from 'NO' to 'YES'.

- **Absolute MAP When Misfire Occurred** — The stored MAP reading at the time of failure. Informs the user at what engine load the failure occurred.

- **Absolute MAP** — A live reading of engine load to aid the user in accessing the Similar Conditions Window.

- **RPM When Misfire Occurred** — The stored RPM reading at the time of failure. Informs the user at what engine RPM the failure occurred.

- **Engine RPM** — A live reading of engine RPM to aid the user in accessing the Similar Conditions Window.

- **Adaptive Memory Factor** — The PCM utilizes both Short Term Compensation and Long Term Adaptive to calculate the Adaptive Memory Factor for total fuel correction.

- **200 Rev Counter** — Counts 0–100 720 degree cycles.

- **SCW Cat 200 Rev Counter** — Counts when in similar conditions.

- **SCW FTP 1000 Rev Counter** — Counts 0–4 when in similar conditions.

- **Misfire Good Trip Counter** — Counts up to three to turn OFF the MIL.

- **Misfire Data** — Data collected during test.

DESCRIPTION AND OPERATION (Continued)

- **Test Done This Trip** — Indicates YES when the test is done.

MONITORED SYSTEMS**OPERATION**

There are new electronic circuit monitors that check fuel, emission, engine and ignition performance. These monitors use information from various sensor circuits to indicate the overall operation of the fuel, engine, ignition and emission systems and thus the emissions performance of the vehicle.

The fuel, engine, ignition and emission systems monitors do not indicate a specific component problem. They do indicate that there is an implied problem within one of the systems and that a specific problem must be diagnosed.

If any of these monitors detect a problem affecting vehicle emissions, the Malfunction Indicator Lamp (MIL) will be illuminated. These monitors generate Diagnostic Trouble Codes that can be displayed with the MIL or a scan tool.

The following is a list of the system monitors:

- Misfire Monitor
- Fuel System Monitor
- Oxygen Sensor Monitor
- Oxygen Sensor Heater Monitor
- Catalyst Monitor
- Leak Detection Pump Monitor (if equipped)

All these system monitors require two consecutive trips with the malfunction present to set a fault.

Refer to the appropriate Powertrain Diagnostics Procedures manual for diagnostic procedures.

The following is an operation and description of each system monitor :

OXYGEN SENSOR (O2S) MONITOR

Effective control of exhaust emissions is achieved by an oxygen feedback system. The most important element of the feedback system is the O2S. The O2S is located in the exhaust path. Once it reaches operating temperature 300° to 350°C (572° to 662°F), the sensor generates a voltage that is inversely proportional to the amount of oxygen in the exhaust. The information obtained by the sensor is used to calculate the fuel injector pulse width. This maintains a 14.7 to 1 Air Fuel (A/F) ratio. At this mixture ratio, the catalyst works best to remove hydrocarbons (HC), carbon monoxide (CO) and nitrogen oxide (NOx) from the exhaust.

The O2S is also the main sensing element for the Catalyst and Fuel Monitors.

The O2S can fail in any or all of the following manners:

- slow response rate

- reduced output voltage
- dynamic shift
- shorted or open circuits

Response rate is the time required for the sensor to switch from lean to rich once it is exposed to a richer than optimum A/F mixture or vice versa. As the sensor starts malfunctioning, it could take longer to detect the changes in the oxygen content of the exhaust gas.

The output voltage of the O2S ranges from 0 to 1 volt. A good sensor can easily generate any output voltage in this range as it is exposed to different concentrations of oxygen. To detect a shift in the A/F mixture (lean or rich), the output voltage has to change beyond a threshold value. A malfunctioning sensor could have difficulty changing beyond the threshold value.

OXYGEN SENSOR HEATER MONITOR

If there is an oxygen sensor (O2S) shorted to voltage DTC, as well as a O2S heater DTC, the O2S fault **MUST** be repaired first. Before checking the O2S fault, verify that the heater circuit is operating correctly.

Effective control of exhaust emissions is achieved by an oxygen feedback system. The most important element of the feedback system is the O2S. The O2S is located in the exhaust path. Once it reaches operating temperature 300° to 350°C (572° to 662°F), the sensor generates a voltage that is inversely proportional to the amount of oxygen in the exhaust. The information obtained by the sensor is used to calculate the fuel injector pulse width. This maintains a 14.7 to 1 Air Fuel (A/F) ratio. At this mixture ratio, the catalyst works best to remove hydrocarbons (HC), carbon monoxide (CO) and nitrogen oxide (NOx) from the exhaust.

The voltage readings taken from the O2S sensor are very temperature sensitive. The readings are not accurate below 300°C. Heating of the O2S sensor is done to allow the engine controller to shift to closed loop control as soon as possible. The heating element used to heat the O2S sensor must be tested to ensure that it is heating the sensor properly.

The O2S sensor circuit is monitored for a drop in voltage. The sensor output is used to test the heater by isolating the effect of the heater element on the O2S sensor output voltage from the other effects.

LEAK DETECTION PUMP MONITOR (IF EQUIPPED)

The leak detection assembly incorporates two primary functions: it must detect a leak in the evaporative system and seal the evaporative system so the leak detection test can be run.

The primary components within the assembly are: A three port solenoid that activates both of the func-

DESCRIPTION AND OPERATION (Continued)

tions listed above; a pump which contains a switch, two check valves and a spring/diaphragm, a canister vent valve (CVV) seal which contains a spring loaded vent seal valve.

Immediately after a cold start, between predetermined temperature thresholds limits, the three port solenoid is briefly energized. This initializes the pump by drawing air into the pump cavity and also closes the vent seal. During non test conditions the vent seal is held open by the pump diaphragm assembly which pushes it open at the full travel position. The vent seal will remain closed while the pump is cycling due to the reed switch triggering of the three port solenoid that prevents the diaphragm assembly from reaching full travel. After the brief initialization period, the solenoid is de-energized allowing atmospheric pressure to enter the pump cavity, thus permitting the spring to drive the diaphragm which forces air out of the pump cavity and into the vent system. When the solenoid is energized and de energized, the cycle is repeated creating flow in typical diaphragm pump fashion. The pump is controlled in 2 modes:

Pump Mode: The pump is cycled at a fixed rate to achieve a rapid pressure build in order to shorten the overall test length.

Test Mode: The solenoid is energized with a fixed duration pulse. Subsequent fixed pulses occur when the diaphragm reaches the Switch closure point.

The spring in the pump is set so that the system will achieve an equalized pressure of about 7.5" H₂O. The cycle rate of pump strokes is quite rapid as the system begins to pump up to this pressure. As the pressure increases, the cycle rate starts to drop off. If there is no leak in the system, the pump would eventually stop pumping at the equalized pressure. If there is a leak, it will continue to pump at a rate representative of the flow characteristic of the size of the leak. From this information we can determine if the leak is larger than the required detection limit (currently set at .040" orifice by CARB). If a leak is revealed during the leak test portion of the test, the test is terminated at the end of the test mode and no further system checks will be performed.

After passing the leak detection phase of the test, system pressure is maintained by turning on the LDP's solenoid until the purge system is activated. Purge activation in effect creates a leak. The cycle rate is again interrogated and when it increases due to the flow through the purge system, the leak check portion of the diagnostic is complete.

The canister vent valve will unseal the system after completion of the test sequence as the pump diaphragm assembly moves to the full travel position.

Evaporative system functionality will be verified by using the stricter evap purge flow monitor. At an

appropriate warm idle the LDP will be energized to seal the canister vent. The purge flow will be clocked up from some small value in an attempt to see a shift in the O₂ control system. If fuel vapor, indicated by a shift in the O₂ control, is present the test is passed. If not, it is assumed that the purge system is not functioning in some respect. The LDP is again turned off and the test is ended.

MISFIRE MONITOR

Excessive engine misfire results in increased catalyst temperature and causes an increase in HC emissions. Severe misfires could cause catalyst damage. To prevent catalytic convertor damage, the PCM monitors engine misfire.

The Powertrain Control Module (PCM) monitors for misfire during most engine operating conditions (positive torque) by looking at changes in the crankshaft speed. If a misfire occurs the speed of the crankshaft will vary more than normal.

FUEL SYSTEM MONITOR

To comply with clean air regulations, vehicles are equipped with catalytic converters. These converters reduce the emission of hydrocarbons, oxides of nitrogen and carbon monoxide. The catalyst works best when the Air Fuel (A/F) ratio is at or near the optimum of 14.7 to 1.

The PCM is programmed to maintain the optimum air/fuel ratio of 14.7 to 1. This is done by making short term corrections in the fuel injector pulse width based on the O₂S sensor output. The programmed memory acts as a self calibration tool that the engine controller uses to compensate for variations in engine specifications, sensor tolerances and engine fatigue over the life span of the engine. By monitoring the actual fuel-air ratio with the O₂S sensor (short term) and multiplying that with the program long-term (adaptive) memory and comparing that to the limit, it can be determined whether it will pass an emissions test. If a malfunction occurs such that the PCM cannot maintain the optimum A/F ratio, then the MIL will be illuminated.

CATALYST MONITOR

To comply with clean air regulations, vehicles are equipped with catalytic converters. These converters reduce the emission of hydrocarbons, oxides of nitrogen and carbon monoxide.

Normal vehicle miles or engine misfire can cause a catalyst to decay. A meltdown of the ceramic core can cause a reduction of the exhaust passage. This can increase vehicle emissions and deteriorate engine performance, driveability and fuel economy.

The catalyst monitor uses dual oxygen sensors (O₂S's) to monitor the efficiency of the converter. The dual O₂S's sensor strategy is based on the fact that

DESCRIPTION AND OPERATION (Continued)

as a catalyst deteriorates, its oxygen storage capacity and its efficiency are both reduced. By monitoring the oxygen storage capacity of a catalyst, its efficiency can be indirectly calculated. The upstream O₂S is used to detect the amount of oxygen in the exhaust gas before the gas enters the catalytic converter. The PCM calculates the A/F mixture from the output of the O₂S. A low voltage indicates high oxygen content (lean mixture). A high voltage indicates a low content of oxygen (rich mixture).

When the upstream O₂S detects a lean condition, there is an abundance of oxygen in the exhaust gas. A functioning converter would store this oxygen so it can use it for the oxidation of HC and CO. As the converter absorbs the oxygen, there will be a lack of oxygen downstream of the converter. The output of the downstream O₂S will indicate limited activity in this condition.

As the converter loses the ability to store oxygen, the condition can be detected from the behavior of the downstream O₂S. When the efficiency drops, no chemical reaction takes place. This means the concentration of oxygen will be the same downstream as upstream. The output voltage of the downstream O₂S copies the voltage of the upstream sensor. The only difference is a time lag (seen by the PCM) between the switching of the O₂S's.

To monitor the system, the number of lean-to-rich switches of upstream and downstream O₂S's is counted. The ratio of downstream switches to upstream switches is used to determine whether the catalyst is operating properly. An effective catalyst will have fewer downstream switches than it has upstream switches i.e., a ratio closer to zero. For a totally ineffective catalyst, this ratio will be one-to-one, indicating that no oxidation occurs in the device.

The system must be monitored so that when catalyst efficiency deteriorates and exhaust emissions increase to over the legal limit, the MIL will be illuminated.

TRIP DEFINITION

OPERATION

The term "Trip" has different meanings depending on what the circumstances are. If the MIL (Malfunction Indicator Lamp) is OFF, a Trip is defined as when the Oxygen Sensor Monitor and the Catalyst Monitor have been completed in the same drive cycle.

When any Emission DTC is set, the MIL on the dash is turned ON. When the MIL is ON, it takes 3 good trips to turn the MIL OFF. In this case, it depends on what type of DTC is set to know what a "Trip" is.

For the Fuel Monitor or Mis-Fire Monitor (continuous monitor), the vehicle must be operated in the

"Similar Condition Window" for a specified amount of time to be considered a Good Trip.

If a Non-Continuous OBDII Monitor, such as:

- Oxygen Sensor
- Catalyst Monitor
- Purge Flow Monitor
- Leak Detection Pump Monitor (if equipped)
- EGR Monitor (if equipped)
- Oxygen Sensor Heater Monitor

fails twice in a row and turns ON the MIL, re-running that monitor which previously failed, on the next start-up and passing the monitor is considered to be a Good Trip.

If any other Emission DTC is set (not an OBDII Monitor), a Good Trip is considered to be when the Oxygen Sensor Monitor and Catalyst Monitor have been completed; or 2 Minutes of engine run time if the Oxygen Sensor Monitor or Catalyst Monitor have been stopped from running.

It can take up to 2 Failures in a row to turn on the MIL. After the MIL is ON, it takes 3 Good Trips to turn the MIL OFF. After the MIL is OFF, the PCM will self-erase the DTC after 40 Warm-up cycles. A Warm-up cycle is counted when the ECT (Engine Coolant Temperature Sensor) has crossed 160°F and has risen by at least 40°F since the engine has been started.

COMPONENT MONITORS

OPERATION

There are several components that will affect vehicle emissions if they malfunction. If one of these components malfunctions the Malfunction Indicator Lamp (MIL) will illuminate.

Some of the component monitors are checking for proper operation of the part. Electrically operated components now have input (rationality) and output (functionality) checks. Previously, a component like the Throttle Position sensor (TPS) was checked by the PCM for an open or shorted circuit. If one of these conditions occurred, a DTC was set. Now there is a check to ensure that the component is working. This is done by watching for a TPS indication of a greater or lesser throttle opening than MAP and engine rpm indicate. In the case of the TPS, if engine vacuum is high and engine rpm is 1600 or greater and the TPS indicates a large throttle opening, a DTC will be set. The same applies to low vacuum if the TPS indicates a small throttle opening.

All open/short circuit checks or any component that has an associated limp in will set a fault after 1 trip with the malfunction present. Components without an associated limp in will take two trips to illuminate the MIL.

DESCRIPTION AND OPERATION (Continued)

Refer to the Diagnostic Trouble Codes Description Charts in this section and the appropriate Powertrain Diagnostic Procedure Manual for diagnostic procedures.

NON-MONITORED CIRCUITS

The PCM does not monitor the following circuits, systems and conditions that could have malfunctions causing driveability problems. The PCM might not store diagnostic trouble codes for these conditions. However, problems with these systems may cause the PCM to store diagnostic trouble codes for other systems or components. For example, a fuel pressure problem will not register a fault directly, but could cause a rich/lean condition or misfire. This could cause the PCM to store an oxygen sensor or misfire diagnostic trouble code.

OPERATION**FUEL PRESSURE**

The fuel pressure regulator controls fuel system pressure. The PCM cannot detect a clogged fuel pump inlet filter, clogged in-line fuel filter, or a pinched fuel supply or return line. However, these could result in a rich or lean condition causing the PCM to store an oxygen sensor or fuel system diagnostic trouble code.

SECONDARY IGNITION CIRCUIT

The PCM cannot detect an inoperative ignition coil, fouled or worn spark plugs, ignition cross firing, or open spark plug cables.

CYLINDER COMPRESSION

The PCM cannot detect uneven, low, or high engine cylinder compression.

EXHAUST SYSTEM

The PCM cannot detect a plugged, restricted or leaking exhaust system, although it may set a fuel system fault.

FUEL INJECTOR MECHANICAL MALFUNCTIONS

The PCM cannot determine if a fuel injector is clogged, the needle is sticking or if the wrong injector is installed. However, these could result in a rich or lean condition causing the PCM to store a diagnostic trouble code for either misfire, an oxygen sensor, or the fuel system.

EXCESSIVE OIL CONSUMPTION

Although the PCM monitors engine exhaust oxygen content when the system is in closed loop, it cannot determine excessive oil consumption.

THROTTLE BODY AIR FLOW

The PCM cannot detect a clogged or restricted air cleaner inlet or filter element.

VACUUM ASSIST

The PCM cannot detect leaks or restrictions in the vacuum circuits of vacuum assisted engine control system devices. However, these could cause the PCM to store a MAP sensor diagnostic trouble code and cause a high idle condition.

PCM SYSTEM GROUND

The PCM cannot determine a poor system ground. However, one or more diagnostic trouble codes may be generated as a result of this condition. The module should be mounted to the body at all times, also during diagnostic.

PCM CONNECTOR ENGAGEMENT

The PCM may not be able to determine spread or damaged connector pins. However, it might store diagnostic trouble codes as a result of spread connector pins.

HIGH AND LOW LIMITS**OPERATION**

The PCM compares input signal voltages from each input device with established high and low limits for the device. If the input voltage is not within limits and other criteria are met, the PCM stores a diagnostic trouble code in memory. Other diagnostic trouble code criteria might include engine RPM limits or input voltages from other sensors or switches that must be present before verifying a diagnostic trouble code condition.

LOAD VALUE**OPERATION**

| ENGINE | IDLE/NEUTRAL | 2500 RPM/ NEUTRAL |
|-------------|-----------------------------|------------------------------|
| All Engines | 2% to 8% of Maximum Load | 9% to 17% of Maximum Load |

EVAPORATIVE EMISSION CONTROLS

TABLE OF CONTENTS

| | page | | page |
|------------------------------------|------|------------------------------------|------|
| DESCRIPTION AND OPERATION | | LEAK DETECTION PUMP (LDP)..... | 27 |
| EVAPORATION CONTROL SYSTEM | 23 | CRANKCASE VENTILATION SYSTEM | 27 |
| ROLLOVER VALVE | 23 | REMOVAL AND INSTALLATION | |
| EVAP CANISTER | 24 | EVAP CANISTER | 27 |
| DUTY CYCLE EVAP CANISTER PURGE | | DUTY CYCLE EVAP CANISTER PURGE | |
| SOLENOID | 24 | SOLENOID | 27 |
| LEAK DETECTION PUMP (LDP)..... | 24 | ROLLOVER VALVE(S) | 27 |
| CRANKCASE VENTILATION SYSTEM | 25 | LEAK DETECTION PUMP (LDP)..... | 28 |
| VEHICLE EMISSION CONTROL | | SPECIFICATIONS | |
| INFORMATION (VECI) LABEL..... | 26 | TORQUE CHART..... | 28 |
| DIAGNOSIS AND TESTING | | | |
| VACUUM SCHEMATICS..... | 26 | | |

DESCRIPTION AND OPERATION

EVAPORATION CONTROL SYSTEM

OPERATION

The evaporation control system prevents the emission of fuel tank vapors into the atmosphere. When fuel evaporates in the fuel tank, the vapors pass through vent hoses or tubes to a charcoal filled evaporative canister. The canister temporarily holds the vapors. The Powertrain Control Module (PCM) allows intake manifold vacuum to draw vapors into the combustion chambers during certain operating conditions.

All engines use a duty cycle purge system. The PCM controls vapor flow by operating the duty cycle EVAP purge solenoid. Refer to Duty Cycle EVAP Canister Purge Solenoid.

When equipped with certain emissions packages, a Leak Detection Pump (LDP) will be used as part of the evaporative system for OBD II requirements. Also refer to Leak Detection Pump.

NOTE: The evaporative system uses specially manufactured lines/hoses. If replacement becomes necessary, only use fuel resistant hose.

ROLLOVER VALVE

DESCRIPTION

The fuel tank is equipped with a rollover valve. The valve is located on the top of the fuel tank (Fig. 1).

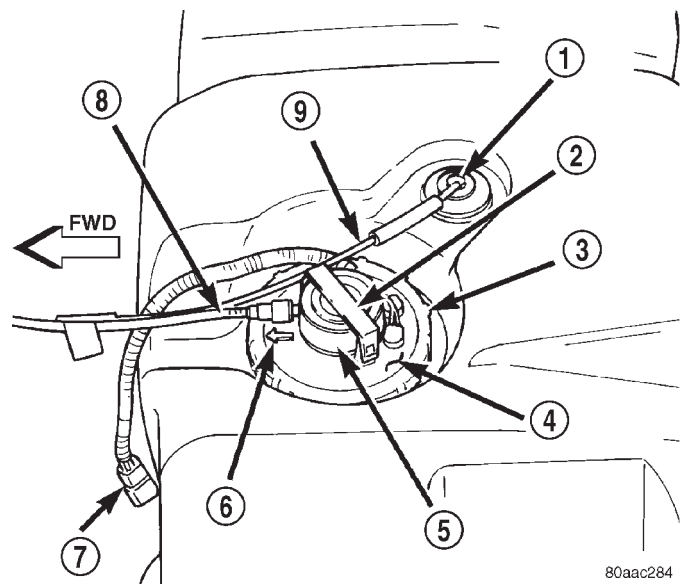

Fig. 1 Rollover Valve Location

- 1 - ROLLOVER VALVE
- 2 - RETAINER CLAMP
- 3 - LOCKNUT
- 4 - FUEL PUMP MODULE
- 5 - FUEL FILTER/FUEL PRESSURE REGULATOR
- 6 - ALIGNMENT ARROW
- 7 - PIGTAIL HARNESS
- 8 - FUEL SUPPLY TUBE
- 9 - EVAP CANISTER VENT LINE

OPERATION

The rollover valve will prevent fuel flow through the fuel tank vent (EVAP) hoses in the event of an accidental vehicle rollover. The EVAP canister draws fuel vapors from the fuel tank through this valve.

DESCRIPTION AND OPERATION (Continued)

The valve cannot be serviced separately. If replacement is necessary, the fuel tank must be replaced.

EVAP CANISTER

DESCRIPTION

A maintenance free, EVAP canister is used on all vehicles. The EVAP canister is located under the left side of vehicle near the front of the rear axle (Fig. 2).

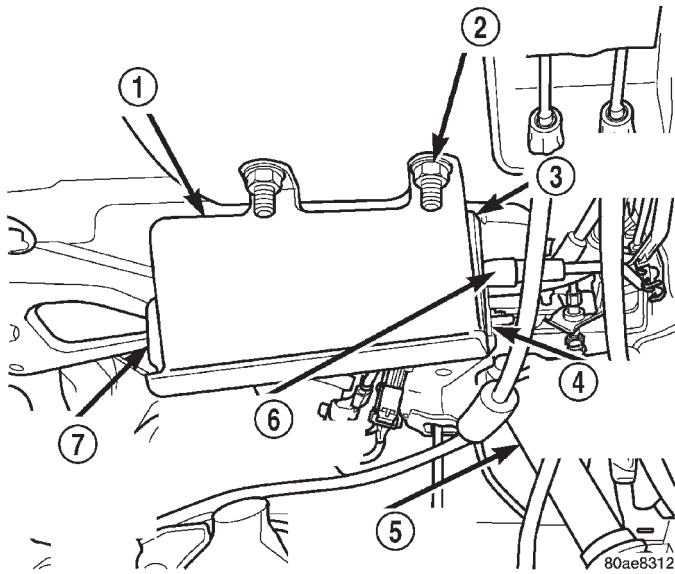

Fig. 2 EVAP Canister Location

- 1 - CANISTER MOUNTING BRACKET
- 2 - BRACKET NUTS (3)
- 3 - EVAP CANISTER
- 4 - CANISTER MOUNTING NUTS (2)
- 5 - L. R. SHOCK ABSORBER
- 6 - EVAP LINES/HOSES
- 7 - DOWEL PINS AND BUSHINGS (2)

OPERATION

The EVAP canister is filled with granules of an activated carbon mixture. Fuel vapors entering the EVAP canister are absorbed by the charcoal granules.

Fuel tank pressure vents into the EVAP canister. Fuel vapors are temporarily held in the canister until they can be drawn into the intake manifold. The duty cycle EVAP canister purge solenoid allows the EVAP canister to be purged at predetermined times and at certain engine operating conditions.

DUTY CYCLE EVAP CANISTER PURGE SOLENOID

OPERATION

The duty cycle EVAP canister purge solenoid (DCP) regulates the rate of vapor flow from the EVAP canister to the intake manifold. The Powertrain Control Module (PCM) operates the solenoid.

During the cold start warm-up period and the hot start time delay, the PCM does not energize the solenoid. When de-energized, no vapors are purged. The PCM de-energizes the solenoid during open loop operation.

The engine enters closed loop operation after it reaches a specified temperature and the time delay ends. During closed loop operation, the PCM cycles (energizes and de-energizes) the solenoid 5 or 10 times per second, depending upon operating conditions. The PCM varies the vapor flow rate by changing solenoid pulse width. Pulse width is the amount of time that the solenoid is energized. The PCM adjusts solenoid pulse width based on engine operating condition.

LEAK DETECTION PUMP (LDP)

OPERATION

The Leak Detection Pump (LDP) is used only with certain emission packages.

The LDP is a device used to detect a leak in the evaporative system.

The pump contains a 3 port solenoid, a pump that contains a switch, a spring loaded canister vent valve seal, 2 check valves and a spring/diaphragm.

Immediately after a cold start, engine temperature between 40°F and 86°F, the 3 port solenoid is briefly energized. This initializes the pump by drawing air into the pump cavity and also closes the vent seal. During non-test conditions, the vent seal is held open by the pump diaphragm assembly which pushes it open at the full travel position. The vent seal will remain closed while the pump is cycling. This is due to the operation of the 3 port solenoid which prevents the diaphragm assembly from reaching full travel. After the brief initialization period, the solenoid is de-energized, allowing atmospheric pressure to enter the pump cavity. This permits the spring to drive the diaphragm which forces air out of the pump cavity and into the vent system. When the solenoid is energized and de-energized, the cycle is repeated creating flow in typical diaphragm pump fashion. The pump is controlled in 2 modes:

PUMP MODE: The pump is cycled at a fixed rate to achieve a rapid pressure build in order to shorten the overall test time.

TEST MODE: The solenoid is energized with a fixed duration pulse. Subsequent fixed pulses occur when the diaphragm reaches the switch closure point.

The spring in the pump is set so that the system will achieve an equalized pressure of about 7.5 inches of water.

When the pump starts, the cycle rate is quite high. As the system becomes pressurized pump rate drops.

DESCRIPTION AND OPERATION (Continued)

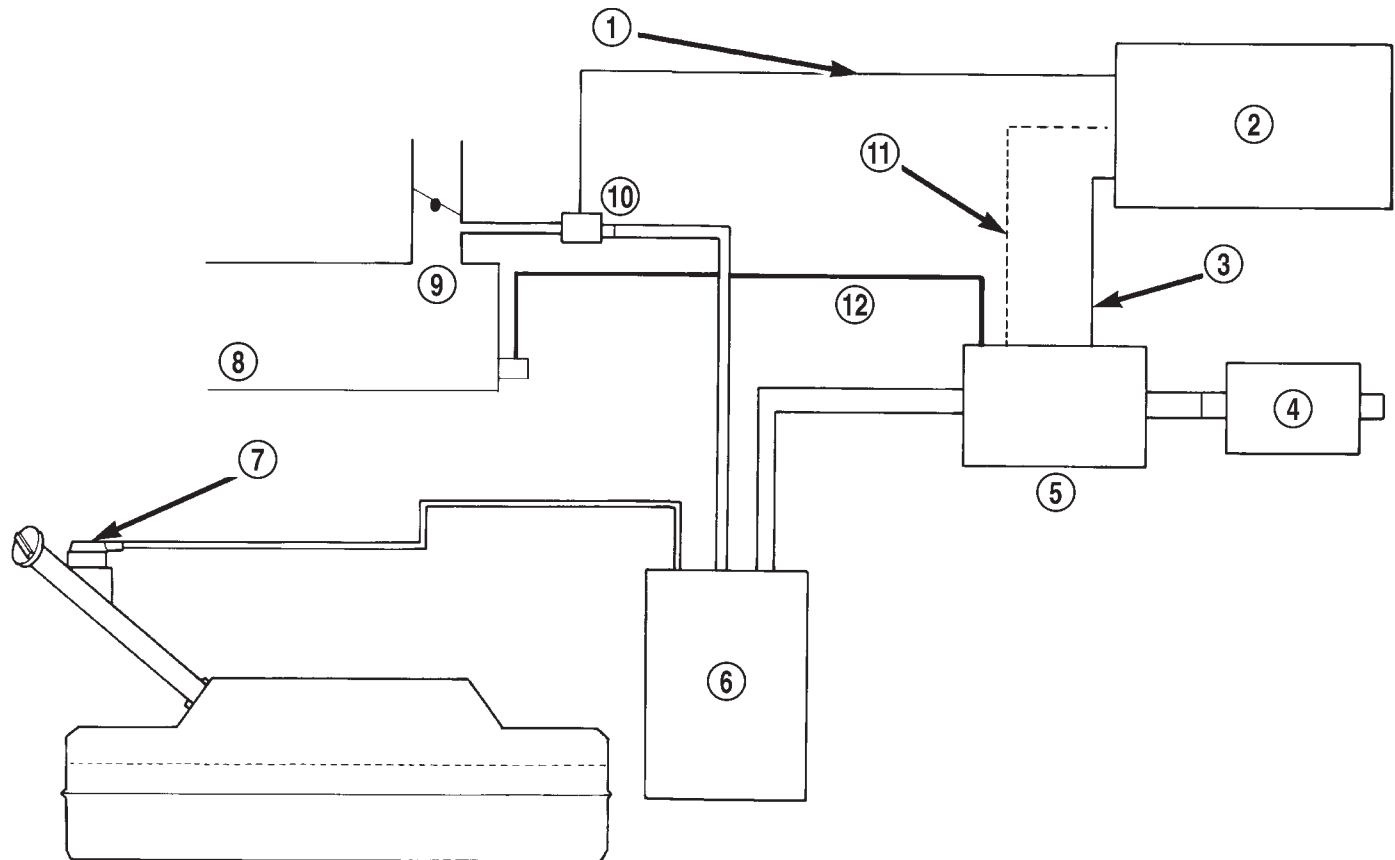

80004293

Fig. 3 Evaporative System Monitor Schematic—Typical

- | | |
|--|--|
| 1 - DUTY CYCLE PURGE SOLENOID (DCPS) DRIVER | 7 - TANK ROLLOVER VALVE & VAPOR FLOW CONTROL ORIFICE |
| 2 - POWERTRAIN CONTROL MODULE (PCM) | 8 - INTAKE MANIFOLD |
| 3 - 3-PORT SOLENOID DRIVER | 9 - THROTTLE BODY |
| 4 - REMOTE FILTER | 10 - DCPS |
| 5 - COMBINED CANISTER VENT VALVE & LEAK DETECTION PUMP | 11 - SWITCH SIGNAL INPUT TO THE PCM |
| 6 - CANISTER | 12 - ENGINE VACUUM LINE |

If there is no leak the pump will quit. If there is a leak, the test is terminated at the end of the test mode.

If there is no leak, the purge monitor is run. If the cycle rate increases due to the flow through the purge system, the test is passed and the diagnostic is complete.

The canister vent valve will unseal the system after completion of the test sequence as the pump diaphragm assembly moves to the full travel position.

A typical system schematic is shown in (Fig. 3).

CRANKCASE VENTILATION SYSTEM

DESCRIPTION

All 2.5L 4-cylinder and 4.0L 6-cylinder engines are equipped with a Closed Crankcase Ventilation (CCV) system (Fig. 4) or (Fig. 5).

OPERATION

The CCV system performs the same function as a conventional PCV system, but does not use a vacuum controlled valve.

On 4.0L 6 cylinder engines, a molded vacuum tube connects manifold vacuum to top of cylinder head (valve) cover at dash panel end. The vacuum fitting contains a fixed orifice of a calibrated size. It meters the amount of crankcase vapors drawn out of the engine.

On 2.5L 4 cylinder engines, a fitting on drivers side of cylinder head (valve) cover contains the metered orifice. It is connected to manifold vacuum.

A fresh air supply hose from the air cleaner is connected to front of cylinder head cover on 4.0L engines. It is connected to rear of cover on 2.5L engines.

DESCRIPTION AND OPERATION (Continued)

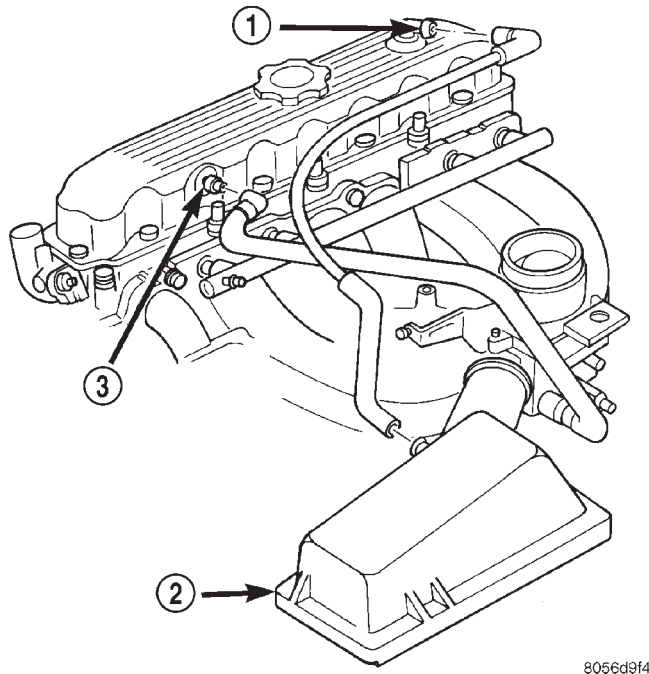

8056d9f4

Fig. 4 CCV System—2.5L Engine—Typical

- 1 - AIR INLET FITTING
- 2 - AIR FILTER COVER
- 3 - FIXED ORIFICE FITTING

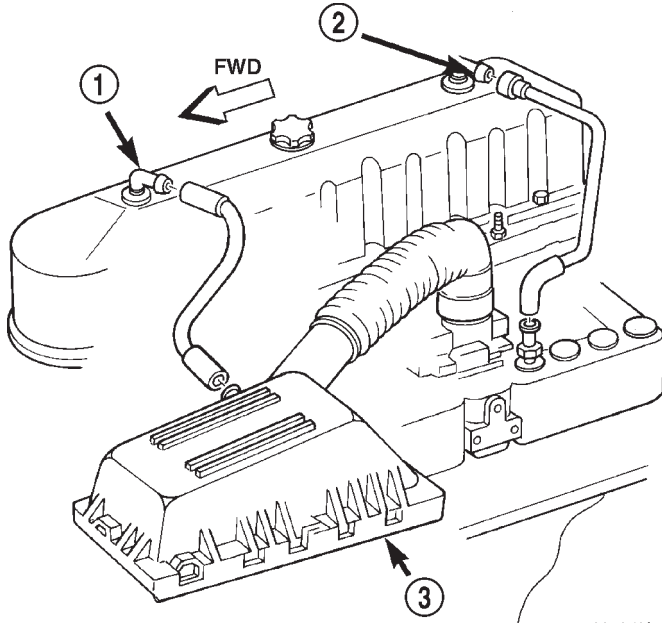

8056d9f5

Fig. 5 CCV System—4.0L Engine—Typical

- 1 - AIR INLET FITTING
- 2 - FIXED ORIFICE FITTING
- 3 - AIR FILTER COVER

When the engine is operating, fresh air enters the engine and mixes with crankcase vapors. Manifold vacuum draws the vapor/air mixture through the

fixed orifice and into the intake manifold. The vapors are then consumed during combustion.

VEHICLE EMISSION CONTROL INFORMATION (VECI) LABEL**DESCRIPTION**

All vehicles are equipped with a combined VECI label. This label is located in the engine compartment (Fig. 6).

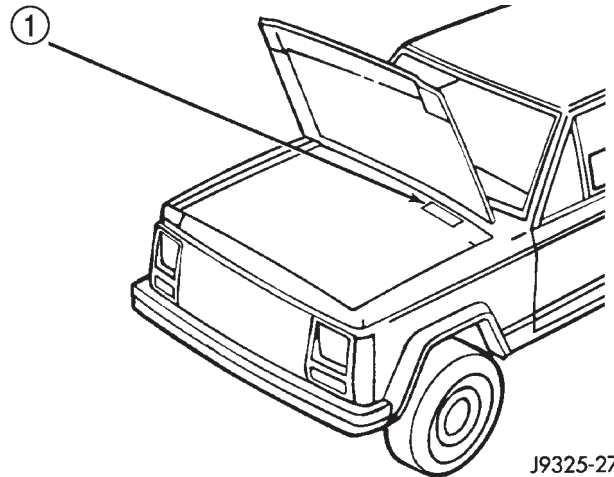

J9325-27

Fig. 6 VECI Label Location—Typical

- 1 - VECI LABEL

OPERATION

The VECI label contains the following:

- Engine family and displacement
- Evaporative family
- Emission control system schematic
- Certification application
- Engine timing specifications (if adjustable)
- Idle speeds (if adjustable)
- Spark plug and gap

The label also contains an engine vacuum schematic. There are unique labels for vehicles built for sale in the state of California and the country of Canada. Canadian labels are written in both the English and French languages. These labels are permanently attached and cannot be removed without defacing information and destroying label.

DIAGNOSIS AND TESTING**VACUUM SCHEMATICS**

A vacuum schematic for emission related items can be found on the Vehicle Emission Control Information (VECI) label. For label location, refer to Vehicle Emission Control Information (VECI) Label.

DIAGNOSIS AND TESTING (Continued)

LEAK DETECTION PUMP (LDP)

Refer to the appropriate Powertrain Diagnostic Procedures service manual for LDP testing procedures.

CRANKCASE VENTILATION SYSTEM

TESTING/CLEANING

The Crankcase Ventilation (CCV) system performs the same function as a conventional PCV system, but does not use a vacuum controlled valve. A vacuum fitting containing a fixed orifice of a calibrated size is used. It meters the amount of crankcase vapors drawn out of the engine.

- (1) Check each CCV system tube (line) for leaks, cracks, kinks or bends. Replace as necessary
- (2) Disconnect each CCV tube..
- (3) Blow compressed air through each tube and check for blockage or restrictions. If cleaning is necessary, spray a soapy-type all-purpose cleaner into each component and blow out. After restriction is cleared, rinse out component with clear water. Blow water from component and install to vehicle. **To prevent damage to plastic components, never spray carburetor-type cleaner into any of the plastic tubes or the fixed orifice fitting. Never attempt to clean the fixed orifice fitting with a metal object as calibration could be affected. If fixed fitting cannot be cleared, replace it.**

REMOVAL AND INSTALLATION

EVAP CANISTER

The EVAP canister is located under left side of vehicle near front of rear axle (Fig. 7).

REMOVAL

- (1) Disconnect vacuum hoses/lines at EVAP canister. Note location of lines before removal.
- (2) Remove EVAP canister and mounting bracket assembly from body (3 nuts).
- (3) Remove canister from mounting bracket (2 nuts).

INSTALLATION

- (1) Position canister into canister mounting bracket. Align 2 canister dowel pins into rubber bushings.
- (2) Install 2 canister nuts and tighten to 5 N·m (45 in. lbs.) torque.
- (3) Position canister and bracket assembly to body.
- (4) Install 3 nuts and tighten to 43 N·m (32 ft. lbs.) torque.
- (5) Connect vacuum hoses/lines at EVAP canister.

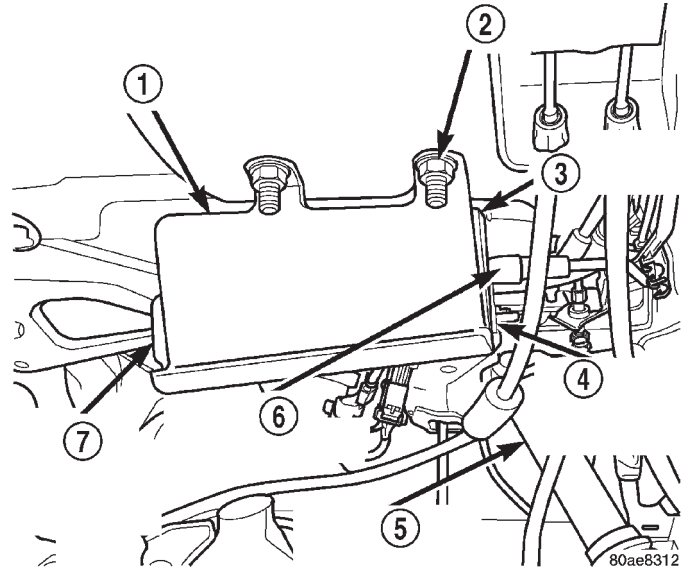

Fig. 7 EVAP Canister Location

- 1 - CANISTER MOUNTING BRACKET
- 2 - BRACKET NUTS (3)
- 3 - EVAP CANISTER
- 4 - CANISTER MOUNTING NUTS (2)
- 5 - L. R. SHOCK ABSORBER
- 6 - EVAP LINES/HOSES
- 7 - DOWEL PINS AND BUSHINGS (2)

DUTY CYCLE EVAP CANISTER PURGE SOLENOID

REMOVAL

The solenoid attaches to a bracket located in right-rear side of engine compartment (Fig. 8) or (Fig. 9). The top of the solenoid has the word UP or TOP on it. The solenoid will not operate properly unless it is installed correctly.

- (1) Disconnect electrical wiring connector at solenoid.
- (2) Disconnect vacuum harness at solenoid.
- (3) Remove solenoid and its support bracket.

INSTALLATION

- (1) Install EVAP canister purge solenoid and its mounting bracket to cowl panel.
- (2) Tighten bolt to 5 N·m (45 in. lbs.) torque.
- (3) Connect vacuum harness and wiring connector.

ROLLOVER VALVE(S)

The rollover valve(s) are/is molded into the fuel tank and are not serviced separately. If replacement is necessary, the fuel tank must be replaced. Refer to Fuel Tank Removal/Installation.

REMOVAL AND INSTALLATION (Continued)

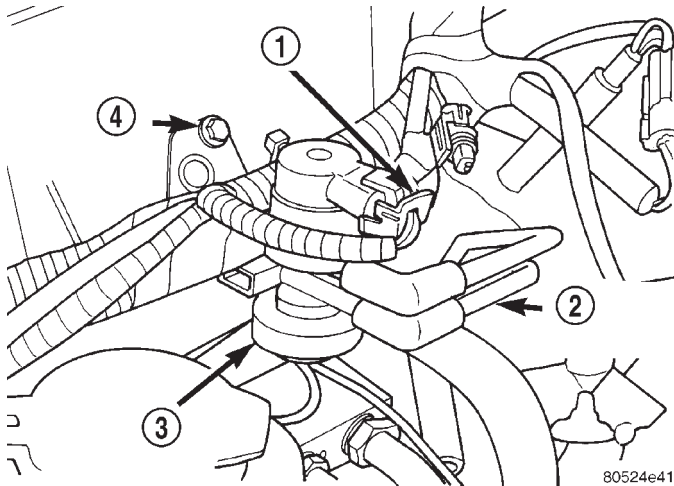

Fig. 8 EVAP Canister Purge Solenoid (Without LDP)

- 1 - ELECTRICAL CONNECTOR
- 2 - VACUUM HARNESS
- 3 - PURGE SOLENOID
- 4 - MOUNTING BOLT

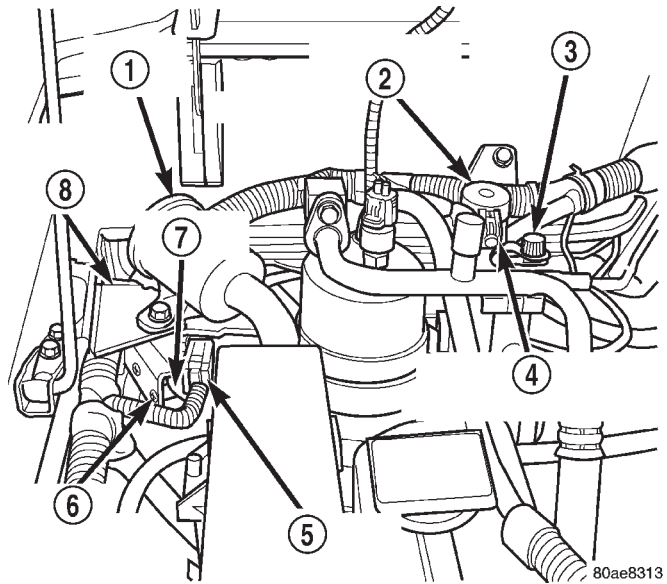

Fig. 9 EVAP Canister Purge Solenoid (With LDP)

- 1 - LDP FILTER
- 2 - EVAP SOLENOID
- 3 - EVAP SYSTEM TEST PORT
- 4 - EVAP SOLENOID ELEC. CONNECTOR
- 5 - LDP ELEC. CONNECTOR
- 6 - LDP MOUNTING SCREWS (2)
- 7 - LDP
- 8 - LDP MOUNTING BRACKET

LEAK DETECTION PUMP (LDP)

The LDP is located in the right-rear side of engine compartment (Fig. 9). The LDP filter is located above the LDP (Fig. 9). The LDP and LDP filter are replaced (serviced) as one unit.

REMOVAL

- (1) Carefully remove hose at LDP filter.
- (2) Remove LDP filter mounting bolt and remove from vehicle.
- (3) Carefully remove vapor/vacuum lines at LDP.
- (4) Disconnect electrical connector at LDP.
- (5) Remove 2 LDP mounting screws (Fig. 9) and remove from vehicle.

INSTALLATION

- (1) Install LDP to mounting bracket. Tighten screws to 1 N·m (11 in. lbs.) torque.
- (2) Install LDP filter to mounting bracket. Tighten bolt to 7 N·m (65 in. lbs.) torque.
- (3) Carefully install vapor/vacuum lines to LDP, and install hose to LDP filter. **The vapor/vacuum lines and hoses must be firmly connected. Check the vapor/vacuum lines at the LDP, LDP filter and EVAP canister purge solenoid for damage or leaks. If a leak is present, a Diagnostic Trouble Code (DTC) may be set.**
- (4) Connect electrical connector to LDP.

SPECIFICATIONS

TORQUE CHART

| Description | Torque |
|--|----------------------|
| EVAP Canister Mounting Nuts (canister-to-mounting bracket) | 5 N·m (45 in. lbs.) |
| EVAP Canister Mounting Bracket Nuts (mounting bracket-to-body) | 43 N·m (32 in. lbs.) |
| EVAP Canister Purge Solenoid Bracket-to-Body Mounting Bolt | 5 N·m (45 in. lbs.) |
| LDP Mounting Screws | 1 N·m (11 in. lbs.) |

EMISSION CONTROL SYSTEM

TABLE OF CONTENTS

| | page | | page |
|--|------|---|------|
| ON-BOARD DIAGNOSTICS—2.5L DIESEL ENGINE..... | 1 | EXHAUST EMISSION CONTROLS—2.5L DIESEL ENGINE..... | 6 |

ON-BOARD DIAGNOSTICS—2.5L DIESEL ENGINE

TABLE OF CONTENTS

| | page | | page |
|---|------|-------------------------------|------|
| DESCRIPTION AND OPERATION EMISSION CONTROL SYSTEM—2.5L DIESEL ENGINE..... | 1 | DIAGNOSTIC TROUBLE CODES..... | 2 |

DESCRIPTION AND OPERATION

EMISSION CONTROL SYSTEM—2.5L DIESEL ENGINE

DESCRIPTION

The 2.5L diesel Engine Control Module (ECM) and Powertrain Control Module (PCM) monitor and control many different circuits in the fuel injection pump and engine systems. If the ECM senses a problem with a monitored circuit that indicates an actual problem, a Diagnostic Trouble Code (DTC) will be stored in the PCM's memory, and eventually may illuminate the Check Engine Lamp constantly while the key is on. If the problem is repaired, or is intermittent, the ECM will erase the DTC after 40 warm-up cycles without the the fault detected. A warm-up cycle consists of starting the vehicle when the engine is cold, then the engine is warmed up to a certain temperature, and finally, the engine temperature falls to a normal operating temperature, then the key is turned off.

Certain criteria must be met for a DTC to be entered into ECM memory. The criteria may be a specific range of engine rpm, engine or fuel temperature and/or input voltage to the ECM. A DTC indicates that the ECM has identified an abnormal signal in a circuit or the system. A DTC may indicate the result of a failure, but never identify the failed component directly.

There are several operating conditions that the ECM does not monitor and set a DTC for. Refer to the following Monitored Circuits and Non-Monitored Circuits in this section.

ECM MONITORED SYSTEMS

The ECM can detect certain problems in the electrical system.

Open or Shorted Circuit – The ECM will not distinguish between an open or a short to ground, however the ECM can determine if the circuit is shorted to voltage.

Output Device Current Flow – The ECM senses whether the output devices are electrically connected.

If there is a problem with the circuit, the ECM senses whether the circuit is open, shorted to ground (-), or shorted to (+) voltage.

ECM NON-MONITORED SYSTEMS

The ECM does not monitor the following circuits, systems or conditions that could have malfunctions that result in driveability problems. A DTC will not be displayed for these conditions.

Fuel Pressure: Fuel pressure is controlled by the fuel injection pump. The ECM cannot detect fuel pressure problems in this component. The ECM does a comparison analysis of fuel quantity, fuel timing, fuel temperature, and control sleeve sensor inputs to determine if a fuel problem exists.

Cylinder Compression: The ECM cannot detect uneven, low, or high engine cylinder compression.

DESCRIPTION AND OPERATION (Continued)

Exhaust System: The ECM cannot detect a plugged, restricted or leaking exhaust system.

Fuel Injector Malfunctions: The ECM cannot determine if the fuel injector is clogged, or the wrong injector is installed. The fuel injectors on the diesel engine are **not controlled** by the ECM, although a defective needle movement sensor in the #1 injector **is monitored** by the ECM.

Vacuum Assist: Leaks or restrictions in the vacuum circuits of the Exhaust Gas Recirculation System (EGR) are not monitored by the ECM.

ECM System Ground: The ECM cannot determine a poor system ground. However, a DTC may be generated as a result of this condition.

ECM/PCM Connector Engagement: The ECM cannot determine spread or damaged connector pins. However, a DTC may be generated as a result of this condition.

HIGH AND LOW LIMITS

The ECM compares input signals from each input device. It has high and low limits that are programmed into it for that device. If the inputs are not within specifications and other DTC criteria are met, a DTC will be stored in memory. Other DTC criteria might include engine rpm limits or input voltages from other sensors or switches. The other inputs might have to be sensed by the ECM when it senses a high or low input voltage from the control system device in question.

DIAGNOSTIC TROUBLE CODES

DESCRIPTION

On the following pages, a list of DTC's is provided for the 2.5L diesel engine. A DTC indicates that the ECM has recognized an abnormal signal in a circuit or the system. A DTC may indicate the result of a failure, but most likely will not identify the failed component directly.

ACCESSING DIAGNOSTIC TROUBLE CODES

A stored DTC can be displayed through the use of the DRB III® scan tool. The DRB III® connects to the data link connector. The data link connector is located under the instrument panel near bottom of the steering column (Fig. 1) (Fig. 2).

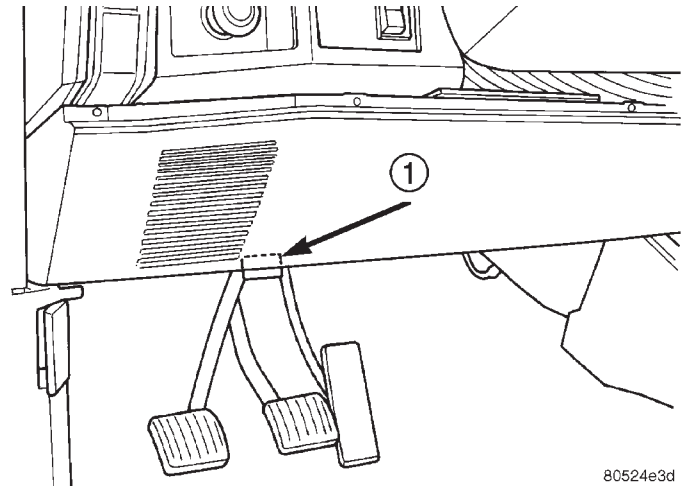

Fig. 1 Data Link Connector Location—LHD

1 - 16-WAY DATA LINK CONNECTOR

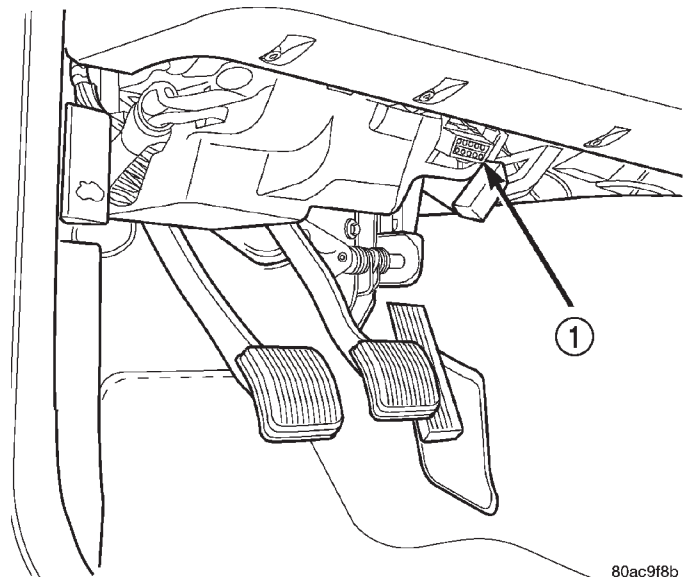

Fig. 2 Data Link Connector Location—RHD

1 - DATA LINK CONNECTOR

ERASING TROUBLE CODES

After the problem has been repaired, use the DRB III® scan tool to erase a DTC.

DESCRIPTION AND OPERATION (Continued)

MSA CONTROLLER DRBIII® CODES

| Generic Scan Tool Code | DRB III® Scan Tool Display |
|------------------------|---|
| P0115 | Temperature of Engine Coolant SRC High Exceeded Temperature of Engine Coolant SRC Low Exceeded |
| P0180 | Fuel Temperature Sensor SRC High Exceeded Fuel Temperature Sensor SRC Low Exceeded |
| P0235 | Turbocharger Boost Sensor Signal High Exceeded Turbocharger Boost Sensor Signal Low Exceeded Turbocharger Boost Sensor Supply High Exceeded Turbocharger Boost Sensor Supply High Exceeded Turbocharger Boost Sensor Plausibility |
| P0400 | EGR Open Circuit EGR Short Circuit |
| P0500 | Veh. Speed Sensor PEC Frequency Too High Veh. Speed Sensor SRC High Exceeded Veh. Speed Sensor Plausibility |
| P0725 | Engine Speed Sensor Dyn. Plausibility Engine Speed Sensor Over Speed Recognition Engine Speed Sensor Static Plausibility |
| P1105 | Atmosphere Pressure Sensor SRC High Exceeded Atmosphere Pressure Sensor SRC Low Exceeded |
| P1110 | Air Temp. Sensor SRC High Exceeded Air Temp. Sensor SRC Low Exceeded |
| P1201 | Needle Movement Sensor SRC High Exceeded Needle Movement Sensor SRC Low Exceeded |
| P1220 | Fuel Quantity Actuator Neg Gov Deviation Cold Fuel Quantity Actuator Neg Gov Deviation Warm Fuel Quantity Actuator Pos Gov Deviation Cold Fuel Quantity Actuator Pos Gov Deviation Warm |
| P1225 | Control Sleeve Sensor Signal High Exceeded Control Sleeve Sensor Start End Pos. Not Attained Control Sleeve Sensor Stop End Pos. Not Attained |
| P1230 | Timing Governing Negative Governor Deviation Timing Governing Positive Governor Deviation |
| P1515 | Accel. Pedal Sensor Signal High Exceeded Accel. Pedal Sensor Supply SRC High Exceeded Accel. Pedal Sensor Supply SRC Low Exceeded Accel. Pedal Sensor Plausibility |

DESCRIPTION AND OPERATION (Continued)

| Generic Scan Tool Code | DRB III® Scan Tool Display |
|------------------------|--|
| P1520 | Vehicle Speed Gov Analog Ctrl Control Contact Alone |
| P1600 | Battery Voltage SRC High Exceeded |
| P1605 | Terminal #15 Plausibility After Startup |
| P1610 | Regulator Lower Regulator Limit Regulator Upper Regulator Limit |
| P1615 | Microcontroller Gate-Array Monitoring Microcontroller Gate-Array Watchdog Microcontroller Prepare Fuel Quantity Stop Microcontroller Recovery Was Occurred Microcontrller Redundant Overrun Monitoring |
| P1620 | U_REF (2.5V) |
| P1630 | Solenoid Valve Controller Open Circuit Solenoid Valve Controller Short Circuit |
| P1635 | Glow Relay Controller Open Circuit Glow Relay Controller Short Circuit |
| P1660 | Redundant Emer. Stop Plausibility In After-Run Redundant Emer. Stop Powerstage Defective |
| P1680 | EEPROM Plausibility Checksum Error for Adj. EEPROM Plausibility Checksum Error in CC212 EEPROM Plausibility Communication With EEPROM EEPROM Plausibility Func. Switch Wrong or Missing EEPROM Plausibility VIN Checksum Error |
| P1685 | Vehicle Theft Alarm Immobilizer Signal Lost Vehicle Theft Alarm Invalid SKIM Message |
| P1690 | Fan Control Open Circuit Fan Control Short Circuit |
| P1695 | AC Control Short Circuit AC Control OpenCircuit |
| P1703 | Brake Signal Plaus With Redundant Contact |
| P1725 | Inductive Aux. Speed Sensor Dynamic Plausibility Inductive Aux. Speed Sensor Overspeed Recognition Inductive Aux Speed Sensor Plausibility Inductive Aux. Speed Sensor Static Plausibility |

DESCRIPTION AND OPERATION (Continued)

PCM DRBIII® CODES

| Generic Scan Tool Code | DRBIII Scan Tool Display |
|------------------------|--|
| P0117 | Engine Coolant Volts Low |
| P0118 | Engine Coolant Volts High |
| P0462 | Fuel Level Sending Unit volts Too Low |
| P0463 | Fuel Level Sending Unit volts Too High |
| P0500 | Vehicle Speed Signal |
| P0522 | Oil Pressure Sense Low |
| P0523 | Oil Pressure Sense High |
| P0601 | Internal Controller Failure |
| P0622 | Generator Field Not Switching Properly |
| P1296 | 5 VDC Output |
| P1391 | Loss of Cam or Crank |
| P1492 | Ambient/Batt temp Sen Volts Too High |
| P1493 | Ambient/Batt temp Sen Volts Too Low |
| P1594 | Charging System Voltage Too High |
| P1682 | Charge Output Low |
| P1685 | SKIM Invalid Key |
| P1686 | No SKIM Bus Message Recieved |
| P1687 | No MIC Bus Message |
| P1696 | PCM Failure EEPROM Write Denied |

EXHAUST EMISSION CONTROLS—2.5L DIESEL ENGINE

TABLE OF CONTENTS

| | page | page |
|---|------|------|
| DESCRIPTION AND OPERATION | | |
| VACUUM HOSE ROUTING SCHEMATIC | 6 | |
| EXHAUST GAS RECIRCULATION (EGR) SYSTEM..... | 6 | |
| DIAGNOSIS AND TESTING | | |
| EGR GAS FLOW TEST | 7 | |
| EGR SOLENOID TEST | 7 | |
| REMOVAL AND INSTALLATION | | |
| EGR VALVE..... | | 7 |
| EGR TUBE..... | | 7 |
| ELECTRIC VACUUM MODULATOR (EVM)..... | | 8 |
| SPECIFICATIONS | | |
| TORQUE CHART—2.5L DIESEL | | 8 |

DESCRIPTION AND OPERATION

VACUUM HOSE ROUTING SCHEMATIC

DESCRIPTION

Vacuum for the EGR system is supplied by the internal engine mounted vacuum pump. Refer to EGR System Operation for vacuum pump information. Vacuum harness routing for emission related components is displayed in (Fig. 1).

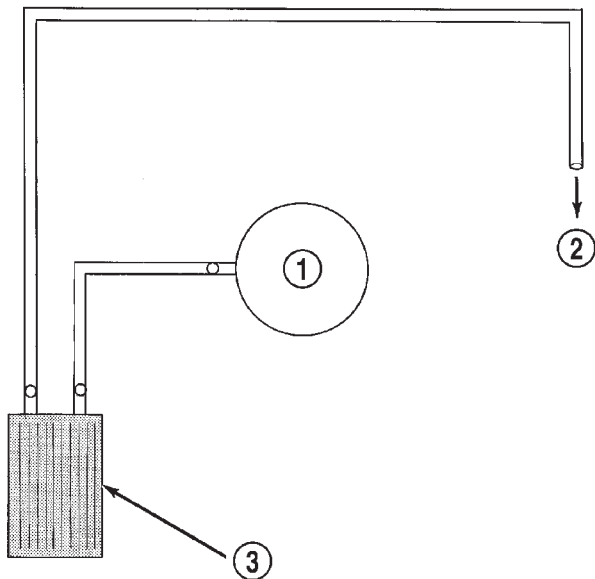

J9525-27

Fig. 1 Typical Hose Routing

- 1 - EGR VALVE
- 2 - TO VACUUM PUMP
- 3 - ELECTRIC VACUUM MODULATOR (EVM)

EXHAUST GAS RECIRCULATION (EGR) SYSTEM

DESCRIPTION

The EGR system reduces oxides of nitrogen (NO_x) in the engine exhaust. This is accomplished by allowing a predetermined amount of hot exhaust gas to recirculate and dilute the incoming fuel/air mixture.

A malfunctioning EGR system can cause engine stumble, sags or hesitation, rough idle, engine stalling and poor driveability.

OPERATION

The system consists of:

- An EGR valve assembly. The valve is located on the side of the intake manifold.
- An Electric Vacuum Modulator (EVM). The EVM is sometimes referred to as the EGR control solenoid or EGR duty cycle solenoid. The EVM controls the "on time" of the EGR valve.
- The ECM operates the EVM. The ECM is located inside the vehicle under the instrument panel.
- An EGR tube connects a passage in the EGR valve to the rear of the exhaust manifold.
- The vacuum pump supplies vacuum for the EVM and the EGR valve. This pump also supplies vacuum for operation of the power brake booster and the heating and air conditioning system. The pump is located internally in the front of the engine block (Fig. 2) and is driven by the crankshaft gear.
- Vacuum lines and hoses connect the various components.

When the ECM supplies a variable ground signal to the EVM, EGR system operation starts to occur. The ECM will monitor and determine when to supply and remove this variable ground signal. This will depend on inputs from the engine coolant temperature, throttle position and engine speed sensors.

DESCRIPTION AND OPERATION (Continued)

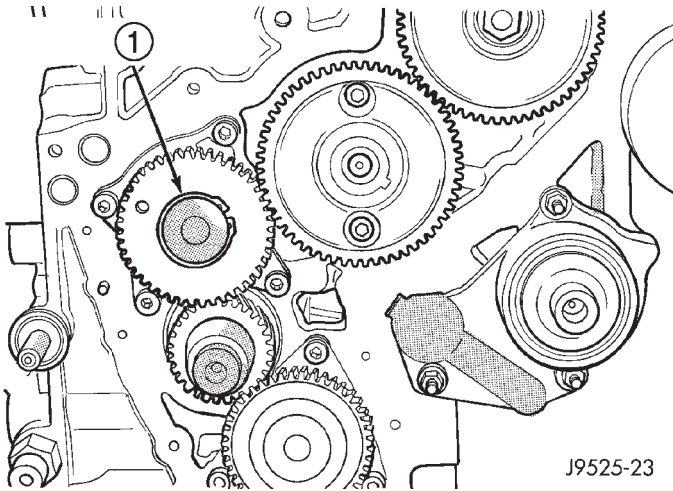
**Fig. 2 Internal Vacuum Pump**

1 - INTERNAL VACUUM PUMP AND DRIVE GEAR

When the variable ground signal is supplied to the EVM, vacuum from the vacuum pump will be allowed to pass through the EVM and on to the EGR valve with a connecting hose.

Exhaust gas recirculation will begin in this order when:

- The ECM determines that EGR system operation is necessary.
- The engine is running to operate the vacuum pump.
- A variable ground signal is supplied to the EVM.
- Variable vacuum passes through the EVM to the EGR valve.
- The inlet seat (poppet valve) at the bottom of the EGR valve opens to dilute and recirculate exhaust gas back into the intake manifold.

The EGR system will be shut down by the ECM after 60 seconds of continuous engine idling to improve idle quality.

DIAGNOSIS AND TESTING**EGR GAS FLOW TEST**

Refer to the 2000 XJ Diesel Powertrain Diagnostic Manual for complete test procedure.

EGR SOLENOID TEST**VACUUM TEST**

With the engine running, disconnect the vacuum supply line at the fitting on the Electric Vacuum Modulator (EVM). Vacuum should be no less than 20 inches. If vacuum is lower, check for leaks in vacuum supply line. If leaks cannot be found, check for low vacuum at vacuum pump.

REMOVAL AND INSTALLATION**EGR VALVE****REMOVAL**

- (1) Disconnect vacuum line at EGR valve vacuum supply fitting.
- (2) Loosen the tube fitting at exhaust manifold end of EGR tube.
- (3) Remove the two bolts retaining the EGR tube to the EGR valve and remove the EGR tube.
- (4) Remove the two bolts retaining the EGR valve to the intake manifold elbow and remove EGR valve.
- (5) Discard both of the old EGR mounting gaskets.

INSTALLATION

- (1) Clean the intake manifold of any old gasket material.
- (2) Clean the end of EGR tube of any old gasket material.
- (3) Position the EGR valve and new gasket to the intake manifold elbow.
- (4) Install two EGR valve mounting bolts. Do not tighten bolts at this time.
- (5) Position new gasket between EGR valve and EGR tube.
- (6) Install two EGR tube bolts. Tighten all four mounting bolts to 23 N·m (204 in. lbs.).
- (7) Tighten EGR tube fitting at exhaust manifold.
- (8) Connect vacuum line to EGR valve.

EGR TUBE

The EGR tube connects the EGR valve to the rear of the exhaust manifold.

REMOVAL

- (1) Remove two EGR tube mounting bolts at EGR valve end of tube.
- (2) Loosen fitting at exhaust manifold end of tube.
- (3) Remove EGR tube and discard old gasket.
- (4) Clean gasket mating surfaces and EGR tube flange gasket surfaces.
- (5) Check for signs of leakage or cracked surfaces at both ends of tube, exhaust manifold and EGR valve.

INSTALLATION

- (1) Install a new gasket to EGR valve end of EGR tube.
- (2) Position EGR tube to engine.
- (3) Loosely tighten fitting at exhaust manifold end of tube.
- (4) Install 2 mounting bolts at EGR valve end of tube. Tighten bolts to 23 N·m (204 in. lbs.) torque.
- (5) Tighten fitting at exhaust manifold end of tube.

REMOVAL AND INSTALLATION (Continued)

ELECTRIC VACUUM MODULATOR (EVM)

The EVM (EGR Duty Cycle Solenoid) is mounted behind the PCM.

REMOVAL

- (1) Disconnect the negative battery cable.
- (2) Disconnect two vacuum hoses at EVM (Fig. 3).
- (3) Remove mounting screws of EVM (Fig. 3).
- (4) Remove the EVM to gain access to the EVM electrical connector.
- (5) Remove electrical connector at EVM.

INSTALLATION

- (1) Install electrical connector to EVM.
- (2) Install EVM and tighten mounting screws (Fig. 3).
- (3) Connect vacuum hoses (Fig. 3).
- (4) Connect the negative battery cable.

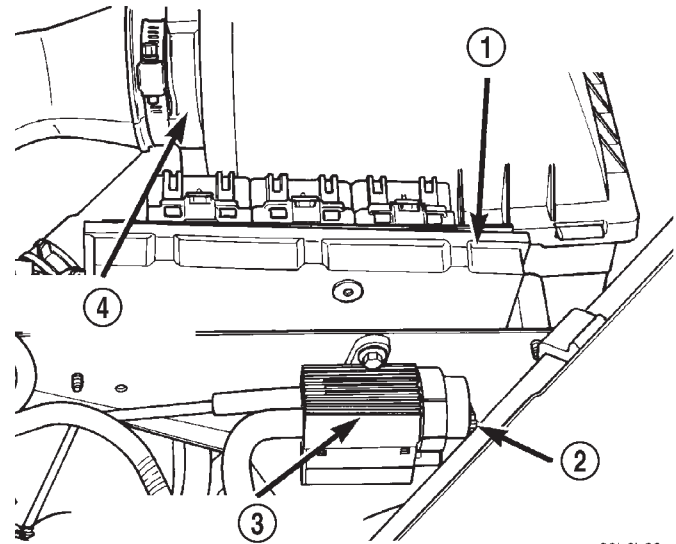

80b6b23c

Fig. 3 Electric Vacuum Modulator (EVM)

- 1 - POWERTRAIN CONTROL MODULE (PCM)
- 2 - EVM HARNESS CONNECTOR
- 3 - ELECTRIC VACUUM MODULATOR (EVM)
- 4 - AIR CLEANER HOUSING

SPECIFICATIONS

TORQUE CHART—2.5L DIESEL

| Description | Torque |
|--------------------------------|-----------------------|
| EGR Valve Mounting Bolts . . . | 23 N·m (204 in. lbs.) |
| EGR Tube Mounting Bolts . . . | 23 N·m (204 in. lbs.) |
| EVM Mounting Bolt | 2 N·m (20 in. lbs.) |

DIFFERENTIAL AND DRIVELINE

TABLE OF CONTENTS

| | page | | page |
|-----------------------------------|------|-----------------------|------|
| PROPELLER SHAFTS | 1 | 194 RBI AXLE | 65 |
| TUBE, 181, AND 186 FBI AXLE | 16 | 8 1/4 REAR AXLE | 103 |

PROPELLER SHAFTS

TABLE OF CONTENTS

| | page | | page |
|---|------|-------------------------------------|------|
| DESCRIPTION AND OPERATION | | REAR PROPELLER SHAFT | 8 |
| PROPELLER SHAFT | 1 | DISASSEMBLY AND ASSEMBLY | |
| PROPELLER SHAFT JOINTS | 2 | SINGLE CARDAN UNIVERSAL JOINT | 9 |
| PROPELLER SHAFT JOINT ANGLE | 3 | DOUBLE CARDAN JOINT | 11 |
| DIAGNOSIS AND TESTING | | CLEANING AND INSPECTION | |
| VIBRATION | 4 | PROPELLER SHAFT | 14 |
| UNBALANCE | 5 | ADJUSTMENTS | |
| RUNOUT | 5 | REAR AXLE PINION INPUT ANGLE | 15 |
| SERVICE PROCEDURES | | FRONT AXLE PINION INPUT ANGLE | 15 |
| DRIVELINE ANGLE MEASUREMENT | | SPECIFICATIONS | |
| PREPARATION | 6 | PROPELLER SHAFTS AND U-JOINTS | 15 |
| PROPELLER SHAFT ANGLE MEASUREMENT | 6 | SPECIAL TOOLS | |
| REMOVAL AND INSTALLATION | | PROPELLER SHAFT | 15 |
| FRONT PROPELLER SHAFT | 8 | | |

DESCRIPTION AND OPERATION

PROPELLER SHAFT

DESCRIPTION

A propeller shaft (Fig. 2) is the shaft which connects the transmission/transfer case to the axle differential. This is the link through which the engine power is transmitted to the axle.

The propeller shaft is designed and built with the yoke lugs in line with each other which is called zero phasing. This design produces the smoothest running condition, an out-of-phase shaft can cause a vibration.

Tubular propeller shafts are balanced by the manufacturer with weights spot welded to the tube.

PRECAUTIONS

Use the exact replacement parts when installing the propeller shafts. The use of the correct replace-

ment parts helps to ensure safe operation. All fasteners must be torqued to the specified values for safe operation.

Also make alignment reference marks (Fig. 1) on the propeller shaft yoke and axle, or transmission, yoke prior to servicing. This helps to eliminate possible vibration.

CAUTION: Do not allow the propeller shaft to drop or hang from any propeller shaft joint during removal. Attach the propeller shaft to the vehicle underside with wire to prevent damage to the joints.

OPERATION

The propeller shaft must operate through constantly changing relative angles between the transmission and axle when going over various road surfaces. It must also be capable of changing length while transmitting torque. The axle rides suspended by springs in a floating motion. This is accomplished through universal joints, which permit the propeller

DESCRIPTION AND OPERATION (Continued)

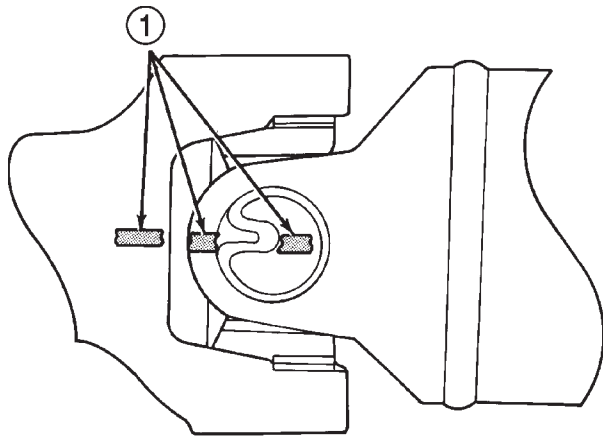

J9316-2

Fig. 1 Reference Marks on Yokes

1 - REFERENCE MARKS

shaft to operate at different angles. The slip joints (or yokes) permit contraction or expansion (Fig. 2).

Before undercoating a vehicle, the propeller shaft and the U-joints should be covered to prevent an out-of-balance condition and driveline vibration.

CAUTION: Use original equipment replacement parts for attaching the propeller shafts. The specified torque must always be applied when tightening the fasteners.

PROPELLER SHAFT JOINTS

DESCRIPTION

Two different types of propeller shaft joints are used:

- Single cardan universal joint (Fig. 3)
- Double cardan (CV) universal joint (Fig. 4)

None of the universal joints are serviceable. If one becomes worn or damaged, the complete universal joint assembly must be replaced.

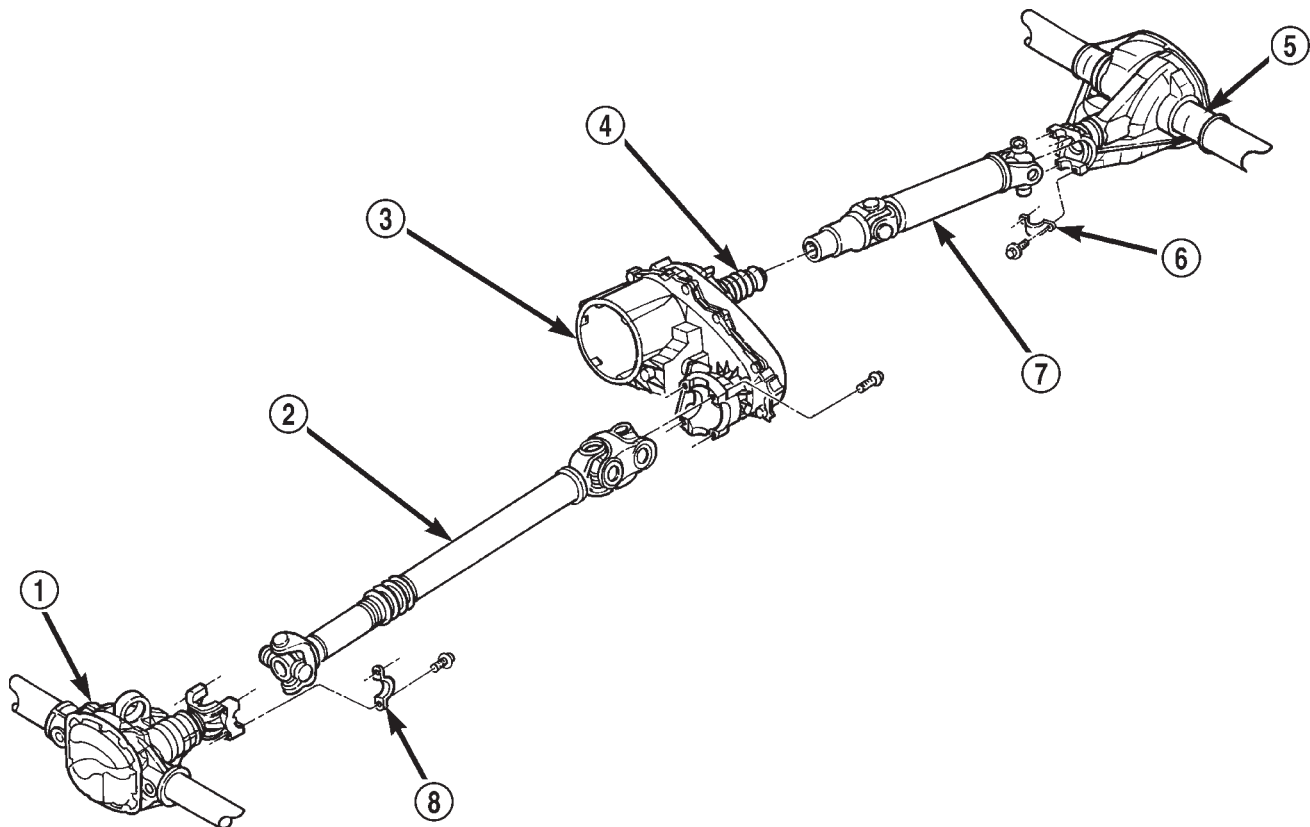

80a53ac2

Fig. 2 Propeller Shafts

- 1 - FRONT AXLE
- 2 - FRONT PROPELLER SHAFT
- 3 - TRANSFER CASE
- 4 - BOOT

- 5 - REAR AXLE
- 6 - STRAP
- 7 - REAR PROPELLER SHAFT
- 8 - STRAP

DESCRIPTION AND OPERATION (Continued)

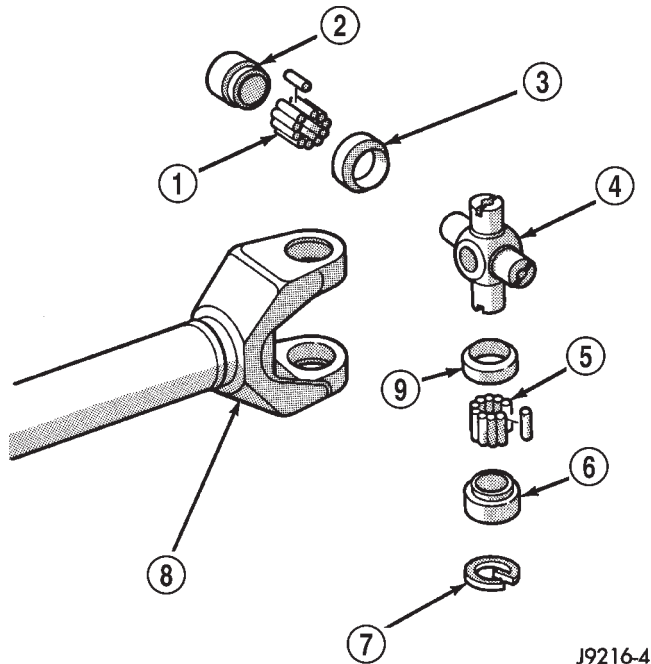

Fig. 3 Single Cardan Universal Joint

J9216-4

- | | |
|--------------------|--------------------|
| 1 - NEEDLE BEARING | 6 - BEARING CAP |
| 2 - BEARING CAP | 7 - RETAINING CLIP |
| 3 - SEAL | 8 - YOKE |
| 4 - SPIDER | 9 - SEAL |
| 5 - NEEDLE BEARING | |

PROPELLER SHAFT JOINT ANGLE

DESCRIPTION

When two shafts come together at a common joint, the bend that is formed is called the operating angle. The larger the angle, the larger the amount of angular acceleration and deceleration of the joint. This speeding up and slowing down of the joint must be cancelled to produce a smooth power flow.

OPERATION

This cancellation is done through the phasing of a propeller shaft and ensuring that the proper propeller shaft joint working angles are maintained.

A propeller shaft is properly phased when the yoke ends are in the same plane, or in line. A twisted shaft will make the yokes out of phase and cause a noticeable vibration.

When taking propeller shaft joint angle measurements, or checking the phasing, of two piece shafts, consider each shaft separately.

Ideally the driveline system should have;

- Angles that are equal or opposite within 1 degree of each other.
- Have a 3 degree maximum operating angle.
- Have at least a 1/2 degree continuous operating (propeller shaft) angle.

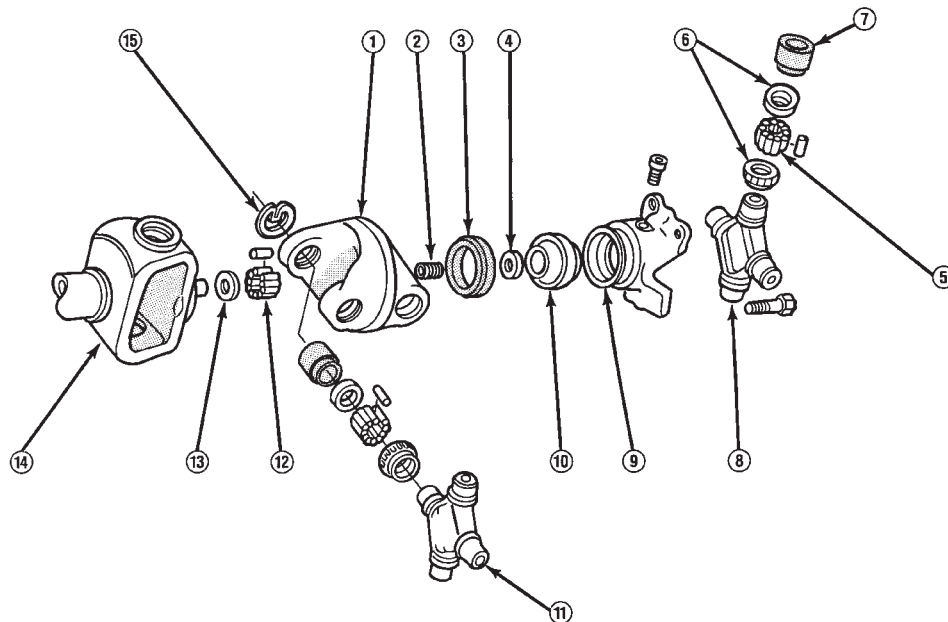

- | | | |
|-------------------------|-----------------|----------------------|
| 1. LINK YOKE | 6. SEAL | 11. FRONT SPIDER |
| 2. SOCKET SPRING | 7. BEARING CAP | 12. NEEDLE BEARINGS |
| 3. SOCKET BALL RETAINER | 8. REAR SPIDER | 13. THRUST WASHER |
| 4. THRUST WASHER | 9. SOCKET YOKE | 14. DRIVE SHAFT YOKE |
| 5. NEEDLE BEARINGS | 10. SOCKET BALL | 15. RETAINING CLIP |

Fig. 4 Double Cardan (CV) Universal Joint

J9216-21

DESCRIPTION AND OPERATION (Continued)

Propeller shaft speed (rpm) is the main factor in determining the maximum allowable operating angle. As a guide to the maximum normal operating angles refer to (Fig. 5).

| PROPELLER SHAFT R.P.M. | MAX. NORMAL OPERATING ANGLES |
|---------------------------|---------------------------------|
| 5000 | 3° |
| 4500 | 3° |
| 4000 | 4° |
| 3500 | 5° |
| 3000 | 5° |
| 2500 | 7° |
| 2000 | 8° |
| 1500 | 11° |

Fig. 5 Maximum Angles And Propeller Shaft Speed

DIAGNOSIS AND TESTING

VIBRATION

Tires that are out-of-round, or wheels that are unbalanced, will cause a low frequency vibration. Refer to Group 22, Tires and Wheels, for additional information.

Brake drums that are unbalanced will cause a harsh, low frequency vibration. Refer to Group 5, Brakes, for additional information.

Driveline vibration can also result from loose or damaged engine mounts. Refer to Group 9, Engines, for additional information.

Propeller shaft vibration increases as the vehicle speed is increased. A vibration that occurs within a specific speed range is not usually caused by a propeller shaft being unbalanced. Defective universal joints, or an incorrect propeller shaft angle, are usually the cause of such a vibration.

DRIVELINE VIBRATION

| Drive Condition | Possible Cause | Correction |
|-----------------------|---|--|
| Propeller Shaft Noise | 1) Undercoating or other foreign material on shaft. 2) Loose U-joint clamp screws. 3) Loose or bent U-joint yoke or excessive runout. 4) Incorrect driveline angularity. 5) Rear spring center bolt not in seat. 6) Worn U-joint bearings. 7) Propeller shaft damaged or out of balance. 8) Broken rear spring. 9) Excessive runout or unbalanced condition. 10) Excessive drive pinion gear shaft runout. 11) Excessive axle yoke deflection. 12) Excessive transfer case runout. | 1) Clean exterior of shaft and wash with solvent. 2) Install new clamps and screws and tighten to proper torque. 3) Install new yoke. 4) Measure and correct driveline angles. 5) Loosen spring u-bolts and seat center bolt. 6) Install new U-joint. 7) Install new propeller shaft. 8) Install new rear spring. 9) Re-index propeller shaft, test, and evaluate. 10) Re-index propeller shaft and evaluate. 11) Inspect and replace yoke if necessary. 12) Inspect and repair as necessary. |
| Universal Joint Noise | 1) Loose U-joint clamp screws. 2) Lack of lubrication. | 1) Install new clamps and screws and tighten to proper torque. 2) Replace as U-joints as necessary. |

DIAGNOSIS AND TESTING (Continued)

UNBALANCE

NOTE: Removing and re-indexing the propeller shaft 180° relative to the yoke may eliminate some vibrations.

If propeller shaft is suspected of being unbalanced, it can be verified with the following procedure:

- (1) Raise the vehicle.
- (2) Clean all the foreign material from the propeller shaft and the universal joints.
- (3) Inspect the propeller shaft for missing balance weights, broken welds, and bent areas. **If the propeller shaft is bent, it must be replaced.**
- (4) Inspect the universal joints to ensure that they are not worn, are properly installed, and are correctly aligned with the shaft.
- (5) Check the universal joint clamp screws torque.
- (6) Remove the wheels and tires. Install the wheel lug nuts to retain the brake drums or rotors.
- (7) Mark and number the shaft six inches from the yoke end at four positions 90° apart.
- (8) Run and accelerate the vehicle until vibration occurs. Note the intensity and speed the vibration occurred. Stop the engine.
- (9) Install a screw clamp at position 1 (Fig. 6).

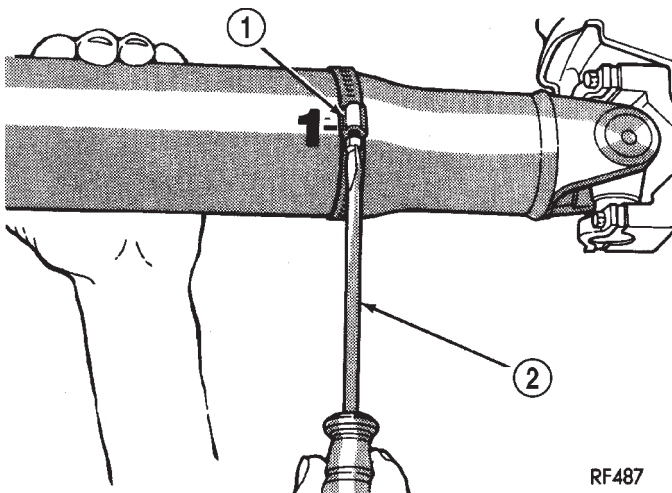

Fig. 6 Clamp Screw At Position 1

- 1 - CLAMP
- 2 - SCREWDRIVER

(10) Start the engine and re-check for vibration. If there is little or no change in vibration, move the clamp to one of the other three positions. Repeat the vibration test.

(11) If there is no difference in vibration at the other positions, the source of the vibration may not be propeller shaft.

(12) If the vibration decreased, install a second clamp (Fig. 7) and repeat the test.

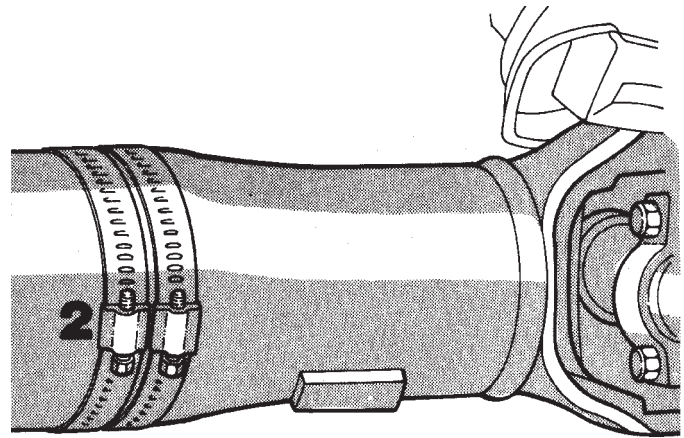

RF488

Fig. 7 Two Clamp Screws At The Same Position

(13) If the additional clamp causes an additional vibration, separate the clamps (1/4 inch above and below the mark). Repeat the vibration test (Fig. 8).

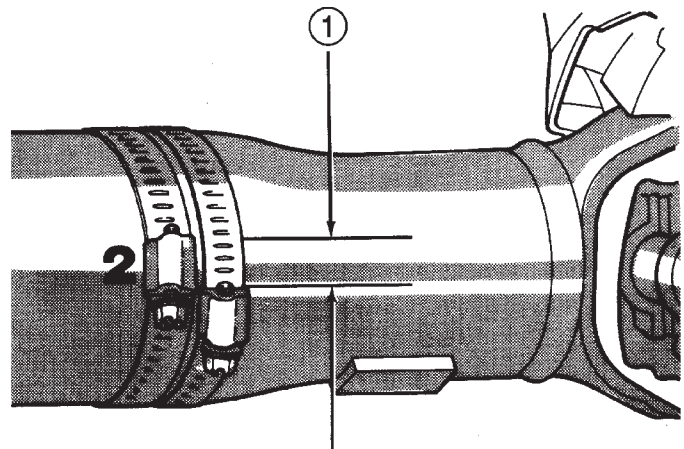

RF489

Fig. 8 Clamp Screws Separated

1 - 1/2 INCH

(14) Increase distance between the clamp screws and repeat the test until the amount of vibration is at the lowest level. Bend the slack end of the clamps so the screws will not loosen.

(15) If the vibration remains unacceptable, apply the same steps to the front end of the propeller shaft.

(16) Install the wheel and tires. Lower the vehicle.

RUNOUT

(1) Remove dirt, rust, paint, and undercoating from the propeller shaft surface where the dial indicator will contact the shaft.

(2) The dial indicator must be installed perpendicular to the shaft surface.

(3) Measure runout at the center and ends of the shaft sufficiently far away from weld areas to ensure that the effects of the weld process will not enter into the measurements.

DIAGNOSIS AND TESTING (Continued)

(4) Refer to Runout Specifications chart.

(5) If the propeller shaft runout is out of specification, remove the propeller shaft, index the shaft 180°, and re-install the propeller shaft. Measure shaft runout again.

(6) If the propeller shaft runout is now within specifications, mark the shaft and yokes for proper orientation.

(7) If the propeller shaft runout is not within specifications, verify that the runout of the transmission/transfer case and axle are within specifications. Correct as necessary and re-measure propeller shaft runout.

(8) Replace the propeller shaft if the runout still exceeds the limits.

RUNOUT SPECIFICATIONS

| | |
|---|---------------------|
| Front of Shaft | 0.020 in. (0.50 mm) |
| Center of Shaft | 0.025 in. (0.63 mm) |
| Rear of Shaft | 0.020 in. (0.50 mm) |
| Measure front/rear runout approximately 3 inches (76 mm) from the weld seam at each end of the shaft tube for tube lengths over 30 inches. For tube lengths under 30 inches, the maximum allowed runout is 0.020 in. (0.50 mm) for the full length of the tube. | |

SERVICE PROCEDURES

DRIVELINE ANGLE MEASUREMENT
PREPARATION

Before measuring universal joint angles, the following must be done;

- Inflate all tires to correct pressure.
- Check the angles in the same loaded or unloaded condition as when the vibration occurred. Propeller shaft angles change according to the amount of load in the vehicle.
- Check the condition of all suspension components and verify all fasteners are torqued to specifications.
- Check the condition of the engine and transmission mounts and verify all fasteners are torqued to specifications.

PROPELLER SHAFT ANGLE MEASUREMENT

To accurately check driveline alignment, raise and support the vehicle at the axles as level as possible. Allow the wheels and propeller shaft to turn.

(1) Remove any external bearing snap rings, if equipped, from universal joint so protractor base sits flat.

(2) Rotate the shaft until transmission/transfer case output yoke bearing is facing downward.

Always make measurements from front to rear. Also, be sure to take all measurements while working from the same side of the vehicle.

(3) Place Inclinator on yoke bearing (A) parallel to the shaft (Fig. 9). Center bubble in sight glass and record measurement.

This measurement will give you the transmission or Output Yoke Angle (A).

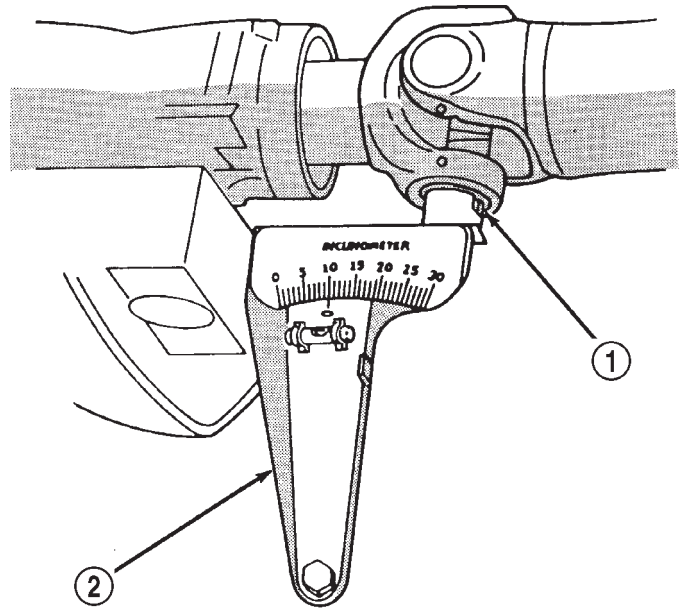

J9216-13

Fig. 9 Front (Output) Angle Measurement (A)

- 1 - SLIP YOKE BEARING CAP
2 - SPECIAL TOOL 7663 (J-23498A)

(4) Rotate propeller shaft 90 degrees and place Inclinator on yoke bearing parallel to the shaft (Fig. 10). Center bubble in sight glass and record measurement. This measurement can also be taken at the rear end of the shaft.

This measurement will give you the Propeller Shaft Angle (C).

(5) Subtract smaller figure from larger (C minus A) to obtain Transmission Output Operating Angle.

(6) Rotate propeller shaft 90 degrees and place Inclinator on pinion yoke bearing parallel to the shaft (Fig. 11). Center bubble in sight glass and record measurement.

SERVICE PROCEDURES (Continued)

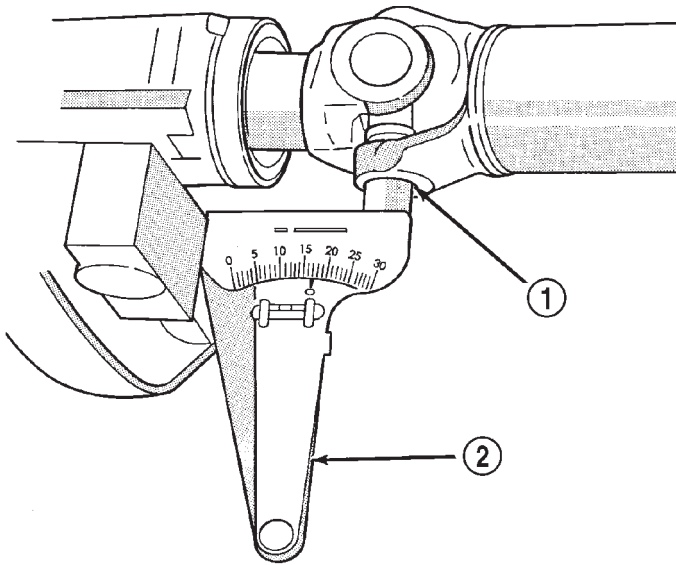

J9216-9

Fig. 10 Propeller Shaft Angle Measurement (C)

- 1 - SHAFT YOKE BEARING CAP
- 2 - SPECIAL TOOL 7663 (J23498-A)

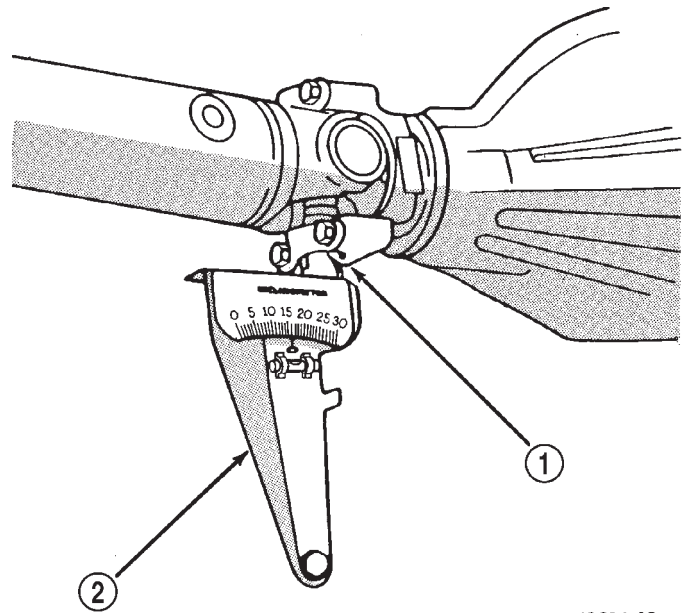

J9216-12

Fig. 11 Rear (Input) Angle Measurement (B)

- 1 - PINION YOKE BEARING CAP
- 2 - SPECIAL TOOL 7663 (J-23498A)

This measurement will give you the pinion shaft or Input Yoke Angle (B).

(7) Subtract smaller figure from larger (C minus B) to obtain axle Input Operating Angle.

Refer to rules given below and the example in (Fig. 12) for additional information.

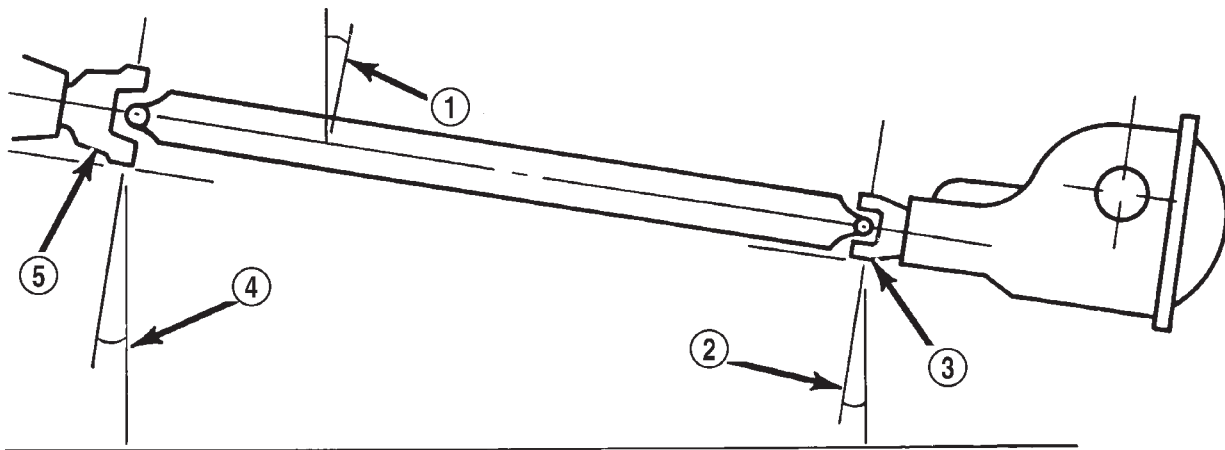

Horizontal Level

(A) Output Yoke = 3.0° or 4.9°
 (C) Prop. Shaft = 4.9° or -3.0°

(B) Axle Input Yoke = 3.2° or 4.9°
 (C) Prop. Shaft = 4.9° or -3.2°

Transmission Output Operating Angle 1.9°

Axle Input Operating Angle 1.7°

Trans. Output Operating Angle 1.9°
 Axle Input Operating Angle -1.7°

Amount of U-Joint Cancellation 0.2°

Fig. 12 Universal Joint Angle Example

J9316-3

- 1 - 4.9° Angle (C)
- 2 - 3.2° Angle (B)
- 3 - Input Yoke

- 4 - 3.0° Angle (A)
- 5 - Output Yoke

SERVICE PROCEDURES (Continued)

- Good cancellation of U-joint operating angles (within 1°).
- Operating angles less than 3°.
- At least 1/2 of one degree continuous operating (propeller shaft) angle.

REMOVAL AND INSTALLATION

FRONT PROPELLER SHAFT

REMOVAL

- (1) Hoist and support vehicle on safety stands.
- (2) Remove the crossmember/skid plate as necessary to gain access to the propeller shaft.
- (3) Shift the transmission and transfer case, if necessary, into the Neutral position.
- (4) Using a suitable marker, mark a line across the yoke at the transfer case, the link yoke, and propeller shaft yoke at the rear of the front propeller shaft for installation reference (Fig. 13).
- (5) Mark a line across the propeller shaft yoke and the pinion shaft yoke for installation reference.

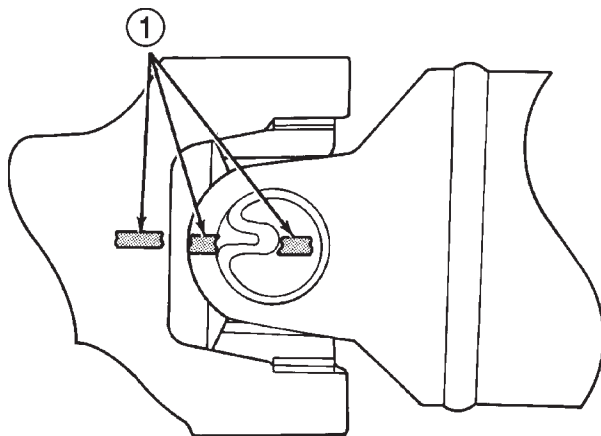

J9316-2

Fig. 13 Reference Marks on Yokes

1 - REFERENCE MARKS

- (6) Remove the U-joint strap bolts at the pinion shaft yoke (Fig. 14).
- (7) Remove bolts holding rear universal joint to the transfer case yoke.
- (8) Separate the rear universal joint from the transfer case yoke.
- (9) Push rear of propeller shaft upward to clear transfer case yoke.
- (10) Separate front universal joint from front axle.
- (11) Separate propeller shaft from vehicle.

INSTALLATION

- (1) Position front propeller shaft under vehicle with rear universal joint over the transfer case yoke.

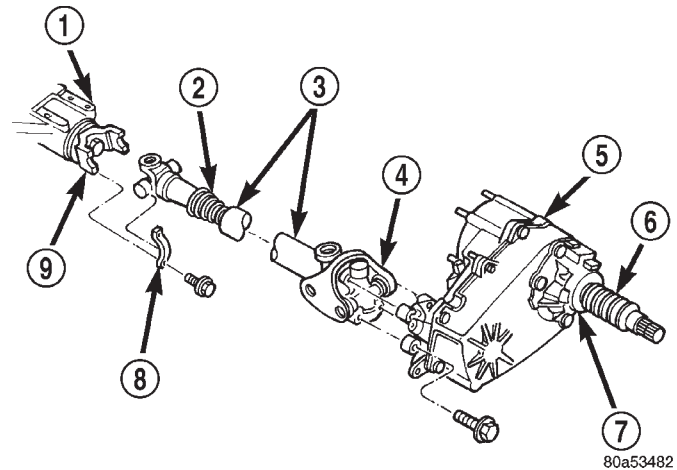

80a53482

Fig. 14 Front Propeller Shaft

- 1 - FRONT AXLE
- 2 - BOOT
- 3 - PROPELLER SHAFT
- 4 - CV-JOINT
- 5 - TRANSFER CASE
- 6 - BOOT
- 7 - SLINGER
- 8 - CLAMP
- 9 - YOKE

- (2) Place front universal joint into the axle pinion yoke.
- (3) Align mark on the rear link yoke and universal joint to the mark on the transfer case yoke (Fig. 13).
- (4) Loosely install bolts to hold universal joint to transfer case yoke.
- (5) Align mark on front universal joint to the mark on the axle pinion yoke.
- (6) Tighten the U-joint strap/clamp bolts at the axle yoke to 19 N·m (14 ft. lbs.) torque.
- (7) Tighten the universal joint to transfer case bolts to 27 N·m (20 ft. lbs.) torque.
- (8) Lower the vehicle.

REAR PROPELLER SHAFT

REMOVAL

- (1) Shift the transmission and transfer case into Neutral.
- (2) Hoist and support vehicle on safety stands.
- (3) Scribe alignment marks at the pinion shaft and at each end of the propeller shaft. These marks will be used for installation reference.
- (4) Remove the U-joint strap bolts at the pinion shaft yoke.
- (5) Pry open clamp holding the dust boot to propeller shaft yoke (Fig. 15).
- (6) Slide the slip yoke off of the transmission/transfer case output shaft and remove the propeller shaft (Fig. 16).

REMOVAL AND INSTALLATION (Continued)

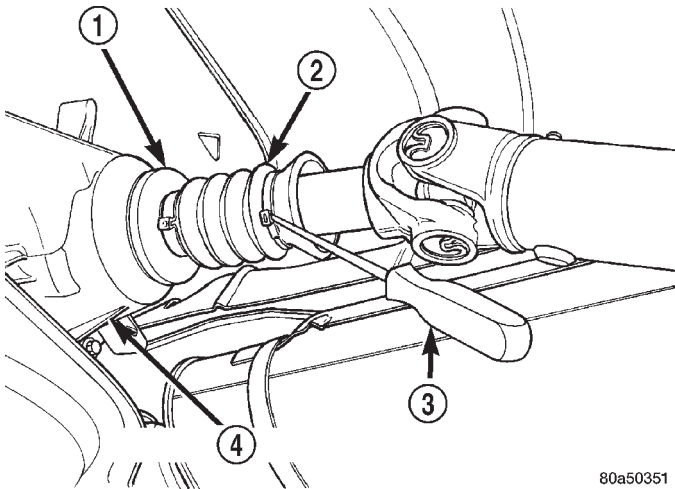

Fig. 15 Dust Boot Clamp

- 1 - SLINGER
- 2 - BOOT
- 3 - AWL
- 4 - TRANSFER CASE

80a50351

(4) Lower the vehicle.

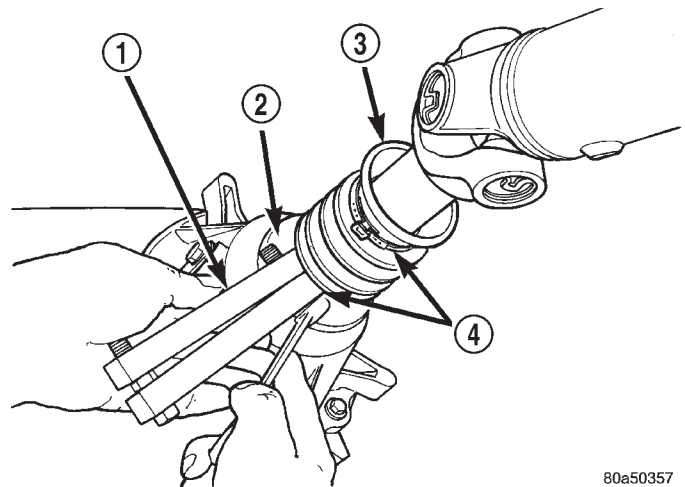

Fig. 17 Crimping Dust Boot Clamp

- 1 - SPECIAL TOOL C-4975-A
- 2 - SLINGER
- 3 - BOOT
- 4 - CLAMP

80a50357

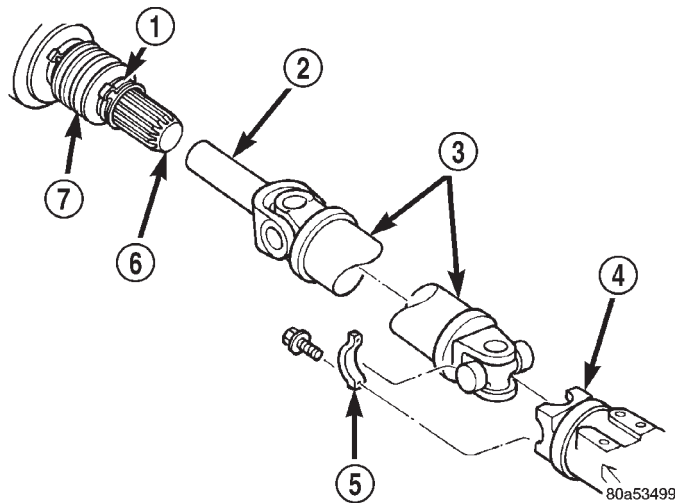

Fig. 16 Rear Propeller Shaft

- 1 - CLAMP
- 2 - YOKE
- 3 - PROPELLER SHAFT
- 4 - AXLE YOKE
- 5 - CLAMP
- 6 - OUTPUT SHAFT
- 7 - BOOT

80a53499

DISASSEMBLY AND ASSEMBLY

SINGLE CARDAN UNIVERSAL JOINT

DISASSEMBLY

Individual components of cardan universal joints are not serviceable. If worn or leaking, they must be replaced as an assembly.

- (1) Remove the propeller shaft.
- (2) Using a soft drift, tap the outside of the bearing cap assembly to loosen snap ring.
- (3) Remove snap rings from both sides of yoke (Fig. 18).

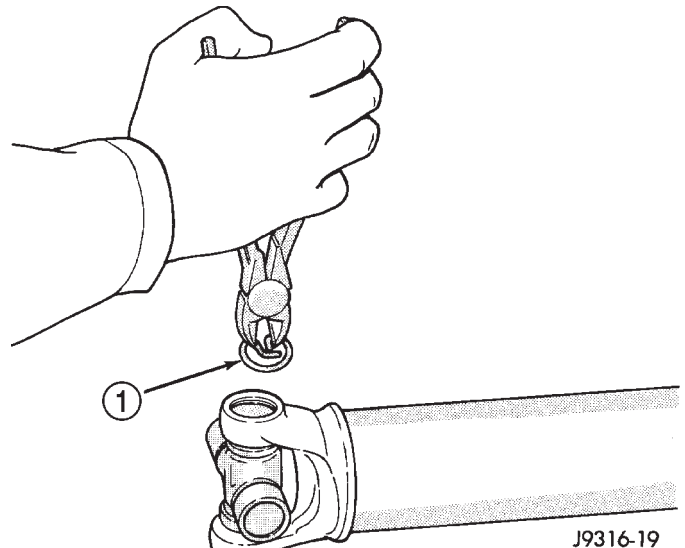

Fig. 18 Remove Snap Ring

- 1 - SNAP RING

J9316-19

INSTALLATION

- (1) Slide the slip yoke on the transmission/transfer case output shaft. Align the installation reference marks at the axle yoke and install the propeller shaft (Fig. 16).
- (2) Tighten the U-joint strap/clamp bolts at the axle yoke to 19 N·m (14 ft. lbs.) torque.
- (3) Crimp clamp to hold dust boot to propeller shaft yoke (Fig. 17).

DISASSEMBLY AND ASSEMBLY (Continued)

(4) Set the yoke in an arbor press or vise with a socket whose inside diameter is large enough to receive the bearing cap positioned beneath the yoke.

(5) Position the yoke with the grease fitting, if equipped, pointing up.

(6) Place a socket with an outside diameter smaller than the upper bearing cap on the upper bearing cap and press the cap through the yoke to release the lower bearing cap (Fig. 19).

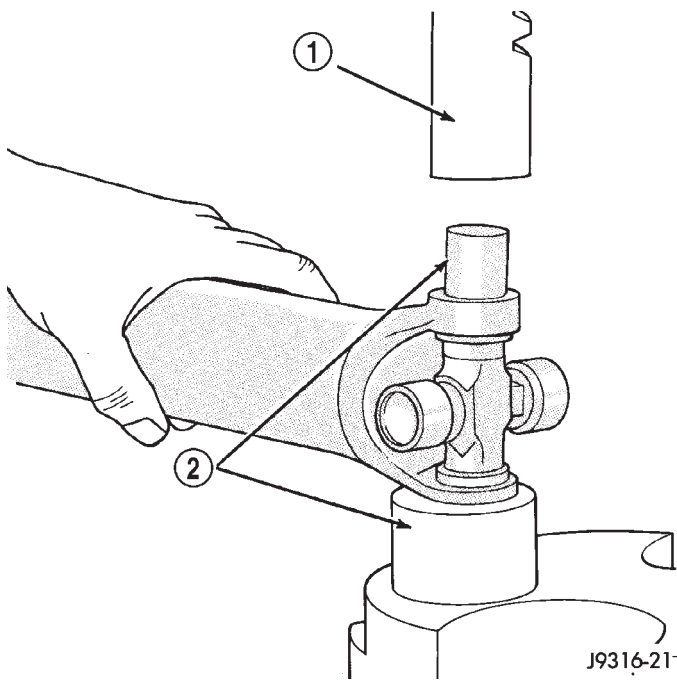

Fig. 19 Press Out Bearing

- 1 - PRESS
2 - SOCKET

(7) If the bearing cap will not pull out of the yoke by hand after pressing, tap the yoke ear near the bearing cap to dislodge the cap.

(8) To remove the opposite bearing cap, turn the yoke over and straighten the cross in the open hole. Then, carefully press the end of the cross until the remaining bearing cap can be removed (Fig. 20).

CAUTION: If the cross or bearing cap are not straight during installation, the bearing cap will score the walls of the yoke bore and damage can occur.

ASSEMBLY

(1) Apply extreme pressure (EP) N.L.G.I. Grade 1 or 2 grease to inside of yoke bores to aid in installation.

(2) Position the cross in the yoke with its lube fitting, if equipped, pointing up (Fig. 21).

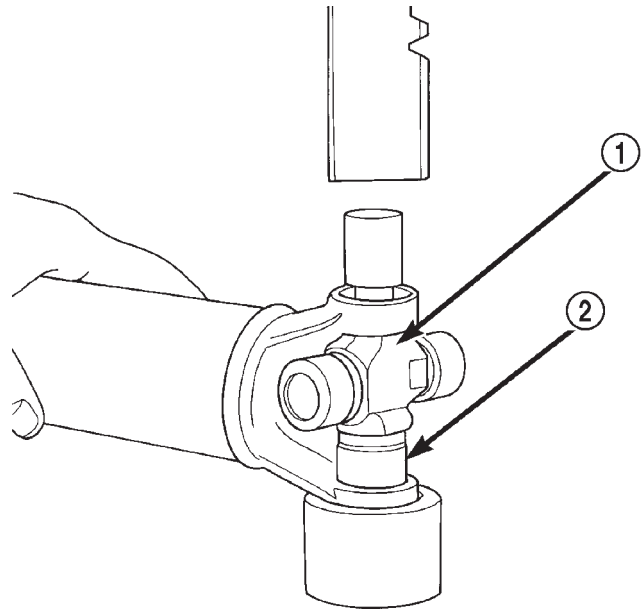

Fig. 20 Press Out Remaining Bearing

- 1 - CROSS
2 - BEARING CAP

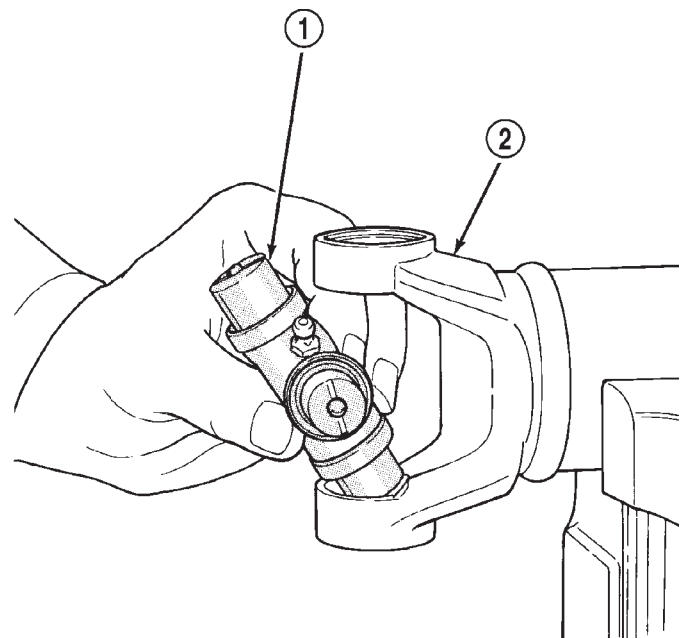
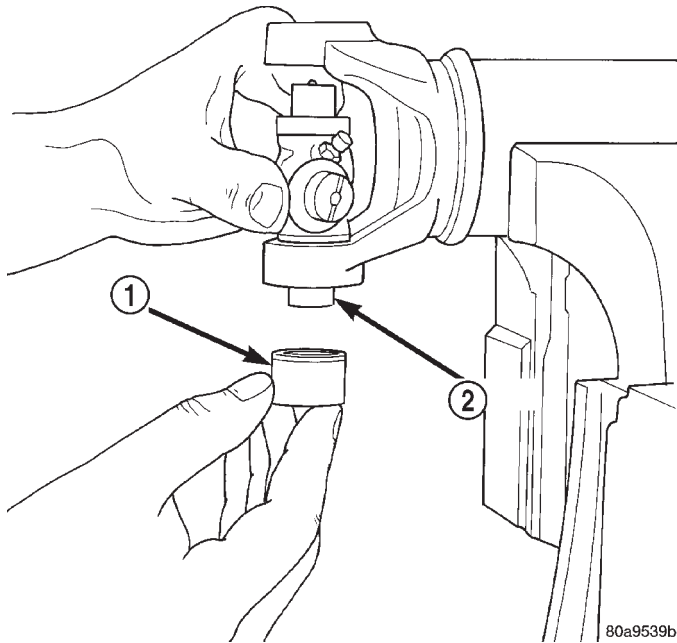

Fig. 21 Install Cross In Yoke

- 1 - CROSS
2 - YOKE

(3) Place a bearing cap over the trunnion and align the cap with the yoke bore (Fig. 22). Keep the needle bearings upright in the bearing assembly. A needle bearing lying at the bottom of the cap will prevent proper assembly.

DISASSEMBLY AND ASSEMBLY (Continued)

**Fig. 22 Install Bearing On Trunnion**

- 1 - BEARING CAP
2 - TRUNNION

(4) Press the bearing cap into the yoke bore enough to install a snap ring.

(5) Install a snap ring.

(6) Repeat Step 3 and Step 4 to install the opposite bearing cap. If the joint is stiff or binding, strike the yoke with a soft hammer to seat the needle bearings.

(7) Add grease to lube fitting, if equipped.

(8) Install the propeller shaft.

DOUBLE CARDAN JOINT**DISASSEMBLY**

Individual components of cardan universal joints are not serviceable. If worn or leaking, they must be replaced as an assembly.

(1) Remove the propeller shaft.

(2) Using a soft drift, tap the outside of the bearing cap assembly to loosen snap ring.

(3) Remove all the bearing cap snap rings (Fig. 23).

(4) Set the joint in an arbor press or vise with a socket whose inside diameter is large enough to receive the bearing cap positioned beneath the link yoke.

(5) Place a socket with an outside diameter smaller than the upper bearing cap on the upper bearing cap and partially press one bearing cap from the outboard side of the link yoke enough to grasp the bearing cap with vise jaws (Fig. 24). Be sure to remove grease fittings that interfere with removal.

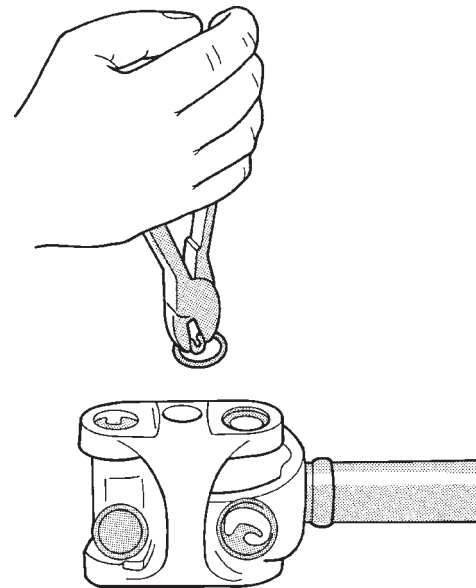
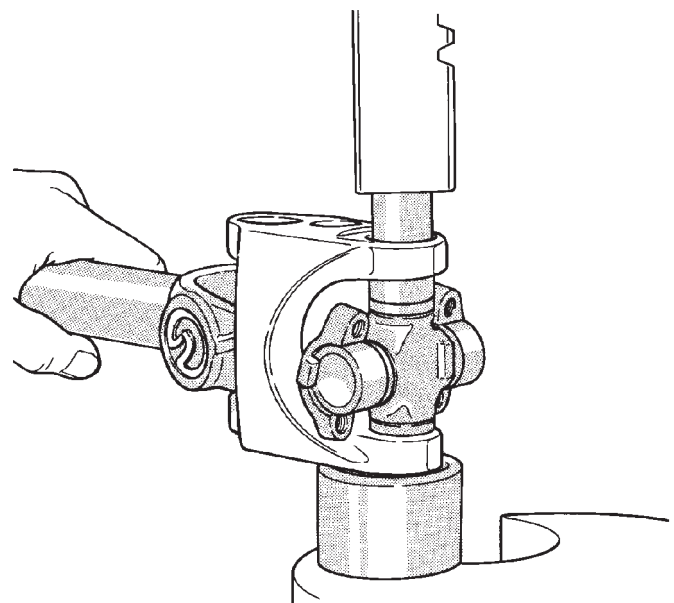
**Fig. 23 Remove Snap Rings****Fig. 24 Press Out Bearing**

(6) Grasp the protruding bearing by vise jaws. Tap the link yoke with a mallet and drift to dislodge the bearing cap from the yoke (Fig. 25).

(7) Flip assembly and repeat Step 4, Step 5, and Step 6 to remove the opposite bearing cap. This will then allow removal of the cross centering kit assembly and spring (Fig. 26).

(8) Press the remaining bearing caps out the other end of the link yoke as described above to complete the disassembly.

DISASSEMBLY AND ASSEMBLY (Continued)

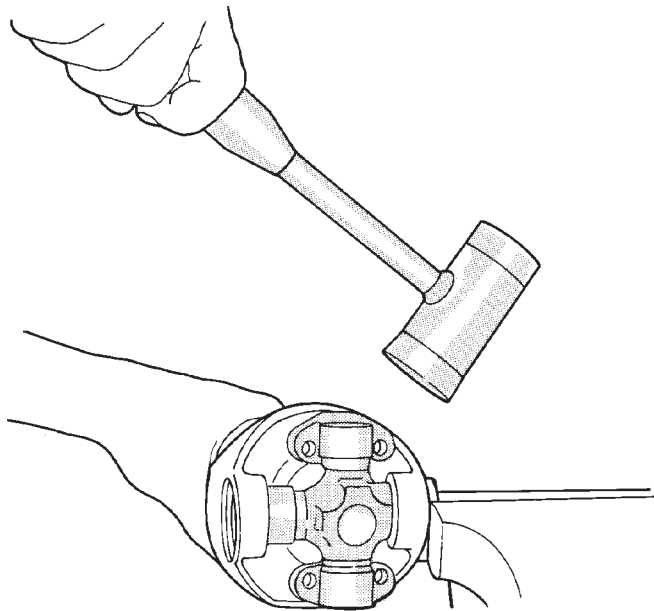

J9316-7

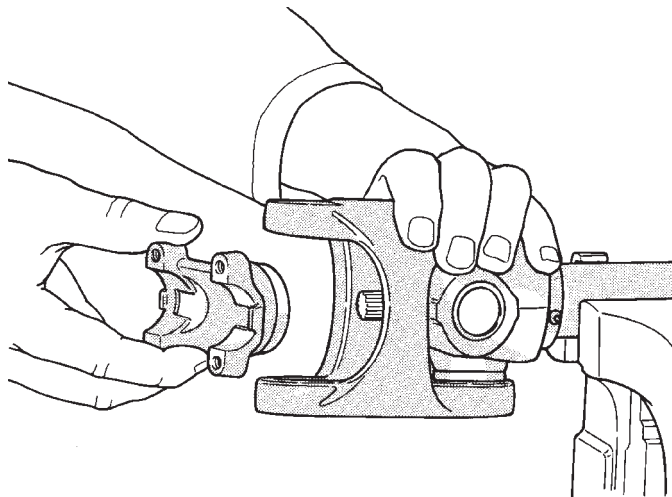
Fig. 25 Remove Bearing From Yoke

J9316-8

Fig. 26 Remove Centering Kit**ASSEMBLY**

During assembly, ensure that the alignment marks on the link yoke and propeller shaft yoke are aligned.

(1) Apply extreme pressure (EP) N.L.G.I. Grade 1 or 2 grease to inside of yoke bores to aid in installation.

(2) Fit a cross into the propeller shaft yoke (Fig. 27).

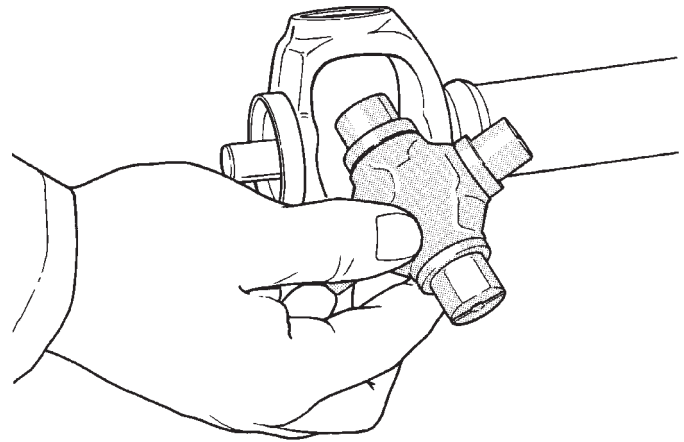

J9316-9

Fig. 27 Install Cross In Yoke

(3) Place a bearing cap over the trunnion and align the cap with the yoke bore (Fig. 28). Keep the needle bearings upright in the bearing assembly. A needle bearing lying at the bottom of the cap will prevent proper assembly.

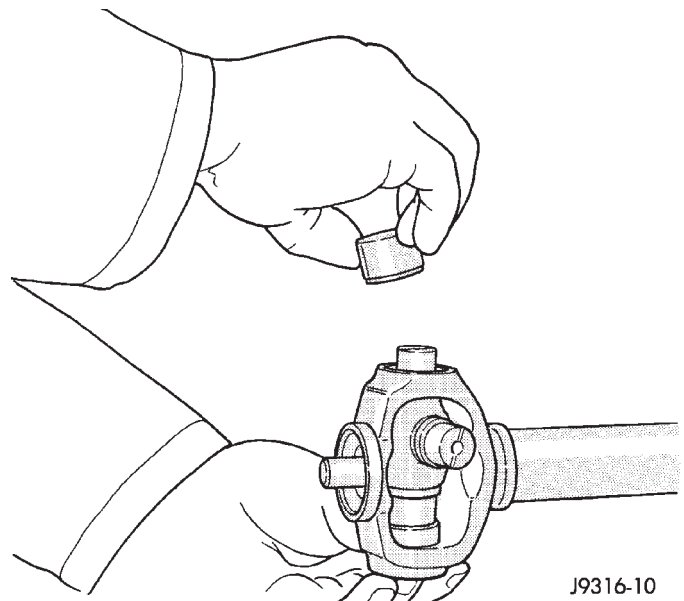

J9316-10

Fig. 28 Install Bearing Cap

(4) Press the bearing cap into the yoke bore enough to install a snap ring (Fig. 29).

(5) Install a snap ring.

DISASSEMBLY AND ASSEMBLY (Continued)

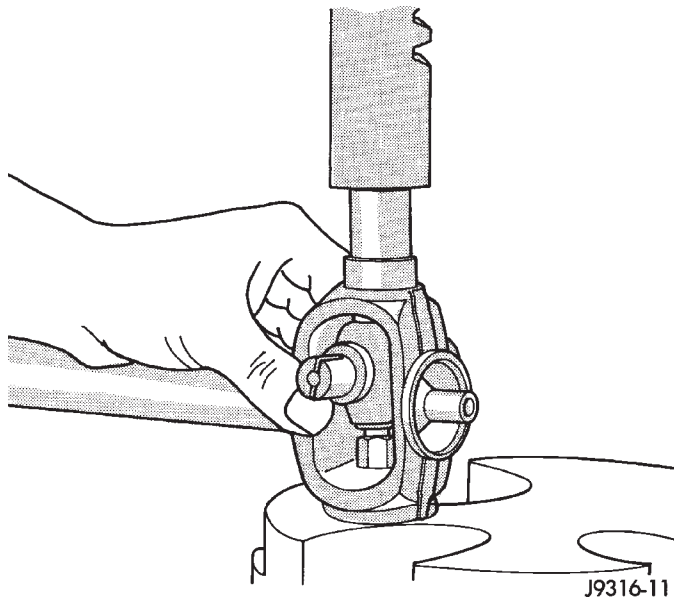

Fig. 29 Press In Bearing Cap

(6) Flip the propeller shaft yoke and install the bearing cap onto the opposite trunnion. Install a snap ring (Fig. 30).

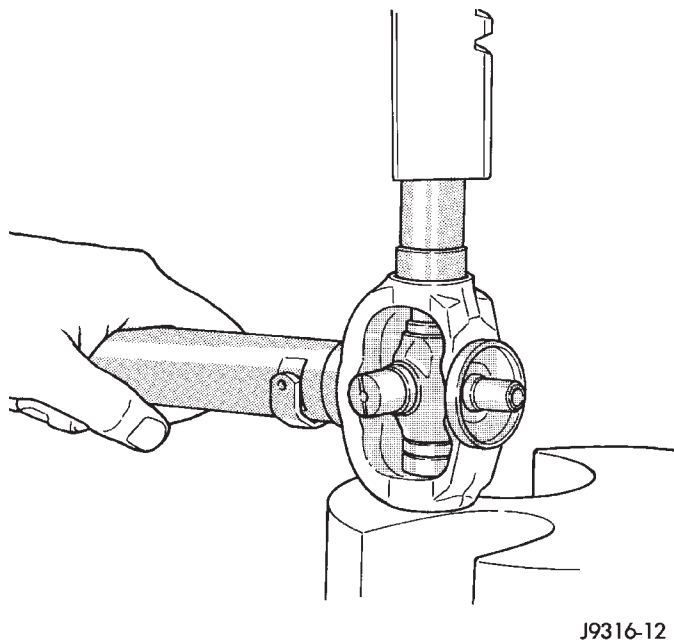

Fig. 30 Press In Bearing Cap

(7) Fit the link yoke on the remaining two trunnions and press both bearing caps into place (Fig. 31).

(8) Install snap rings.

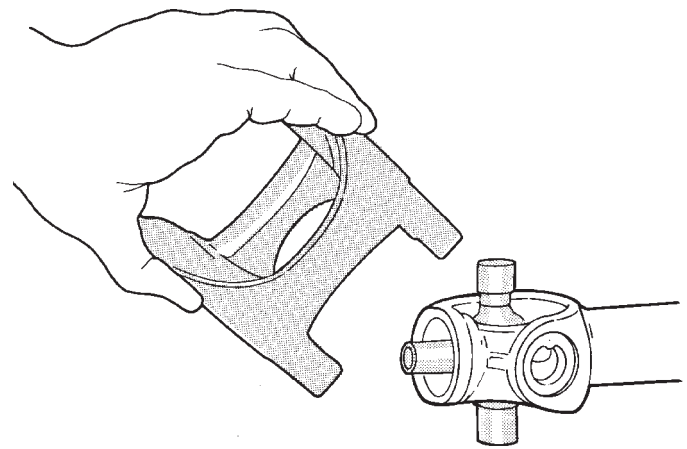

Fig. 31 Install Link Yoke

(9) Install the centering kit assembly inside the link yoke making sure the spring is properly positioned (Fig. 32).

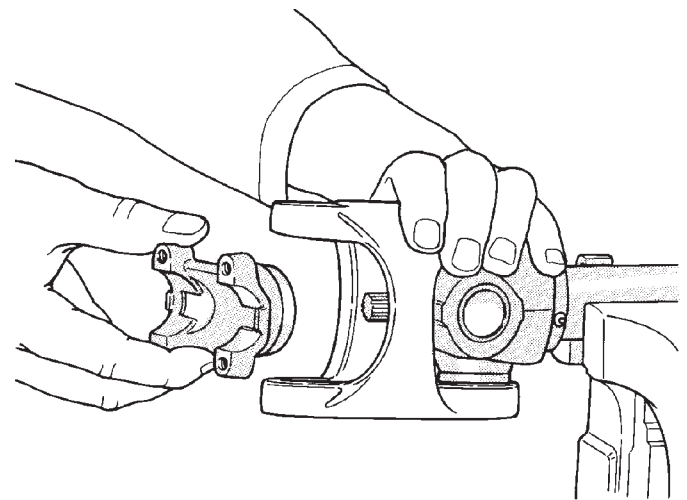
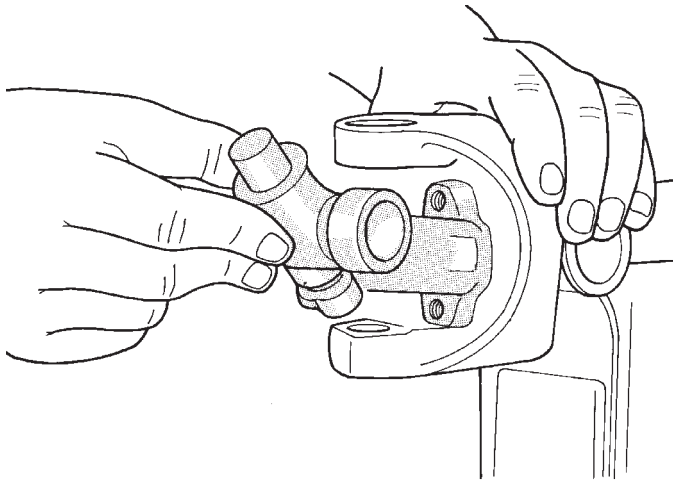

Fig. 32 Install Centering Kit

DISASSEMBLY AND ASSEMBLY (Continued)

(10) Place two bearing caps on opposite trunnions of the remaining cross. Fit the open trunnions into the link yoke bores and the bearing caps into the centering kit (Fig. 33).



J9316-15

Fig. 33 Install Remaining Cross

(11) Press the remaining two bearing caps into place and install snap rings (Fig. 34).

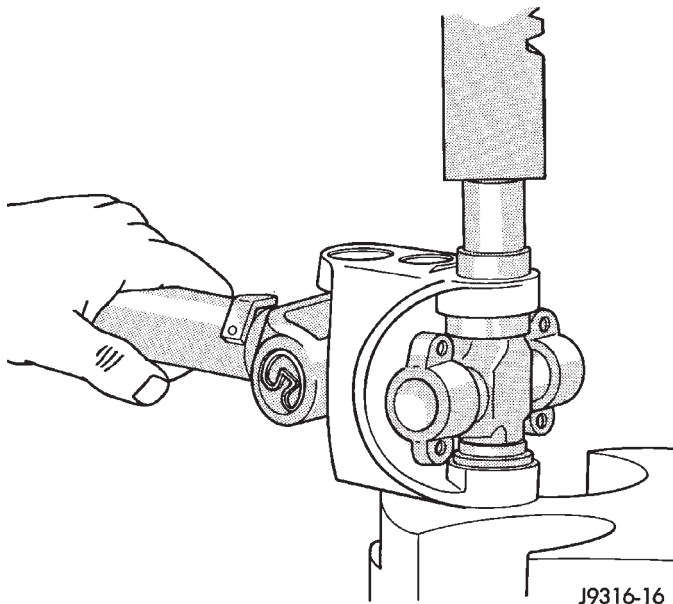

J9316-16

Fig. 34 Press In Bearing Cap

(12) Tap the snap rings to allow them to seat into the grooves (Fig. 35).

(13) Check for proper assembly. Flex the joint beyond center, it should snap over-center in both directions when correctly assembled (Fig. 36).

(14) Install the propeller shaft.

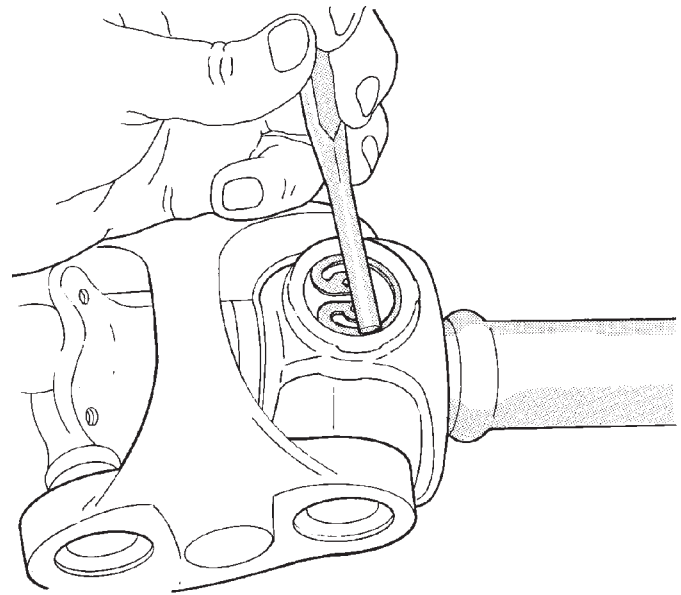

J9316-17

Fig. 35 Seat Snap Rings In Groove

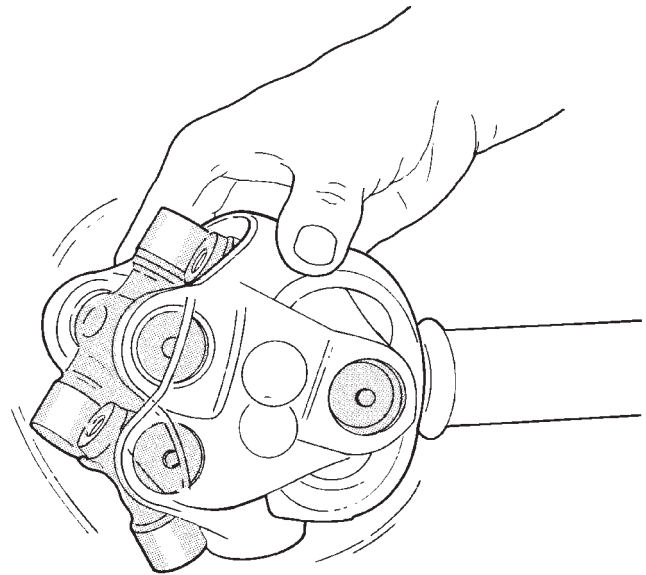

J9316-18

Fig. 36 Check Assembly

CLEANING AND INSPECTION

PROPELLER SHAFT

(1) Clean all universal joint bores with cleaning solvent and a wire brush.

(2) Inspect the yokes for distortion, cracks, and worn bearing cap bores.

ADJUSTMENTS

REAR AXLE PINION INPUT ANGLE

Adjust the rear axle pinion input angle on vehicles equipped with leaf springs with tapered shims (Fig. 37). Install tapered shims between the springs and axle pad to correct the angle. Refer to Group 2, Suspension, for additional information.

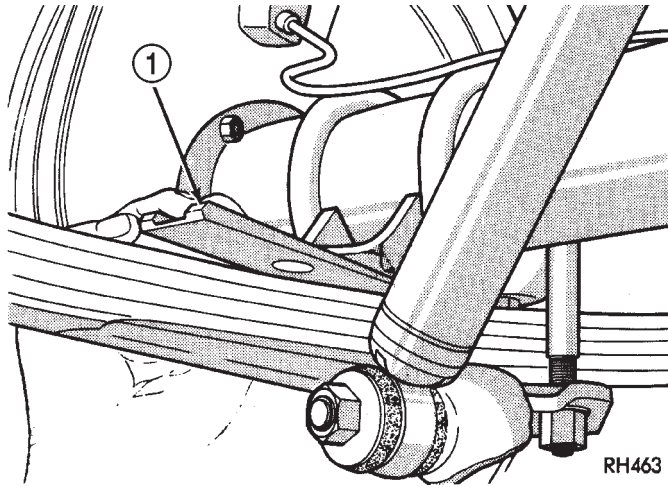
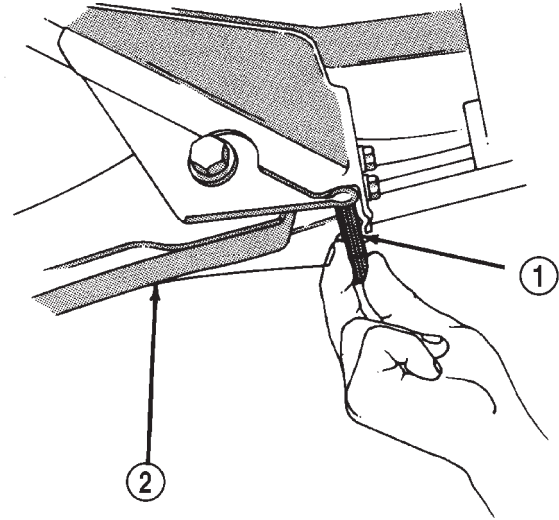

Fig. 37 Pinion Angle Adjustment at Leaf Springs

1 - WEDGE



J8916-22

Fig. 38 Front Axle Angle Adjustment

1 - SHIM
2 - SUSPENSION ARM

FRONT AXLE PINION INPUT ANGLE

Adjust the front axle pinion input angle at the lower suspension arms with shims (Fig. 38). Adding shims will decrease the pinion shaft angle but will also increase the caster angle. The pinion shaft angle has priority over the caster angle. Refer to Group 2, Suspension, for additional information.

SPECIFICATIONS

PROPELLER SHAFTS AND U-JOINTS

| DESCRIPTION | TORQUE |
|-------------------------------------|----------------------|
| Bolts, Transfer Case Yoke | 27 N·m (20 ft. lbs.) |
| Bolts, Axle Yoke | 19 N·m (14 ft. lbs.) |
| Bolts, Axle Yoke | 19 N·m (14 ft. lbs.) |

SPECIAL TOOLS

PROPELLER SHAFT

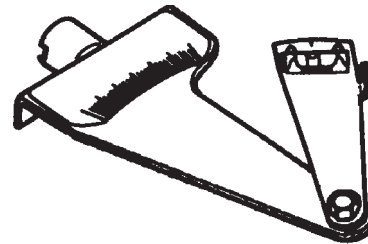

Inclinometer—7663

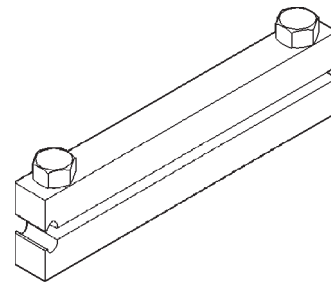

Boot Clamp Installer—C-4975-A

TUBE, 181, AND 186 FBI AXLE

TABLE OF CONTENTS

| | page | page |
|--|------|------|
| DESCRIPTION AND OPERATION | | |
| 181 FBI AXLE..... | 16 | |
| 186 FBI AXLE..... | 17 | |
| LUBRICANT..... | 17 | |
| STANDARD DIFFERENTIAL..... | 18 | |
| DIAGNOSIS AND TESTING | | |
| GENERAL INFORMATION..... | 19 | |
| GEAR NOISE..... | 21 | |
| BEARING NOISE..... | 21 | |
| LOW SPEED KNOCK..... | 21 | |
| VIBRATION..... | 21 | |
| DRIVELINE SNAP..... | 21 | |
| SERVICE PROCEDURES | | |
| LUBRICANT CHANGE..... | 21 | |
| REMOVAL AND INSTALLATION | | |
| DRIVE AXLE ASSEMBLY..... | 22 | |
| TUBE AXLE ASSEMBLY..... | 23 | |
| AXLE SHAFT—CARDAN U-JOINT..... | 23 | |
| 181 FBI PINION SHAFT SEAL..... | 24 | |
| 186 FBI PINION SHAFT SEAL..... | 26 | |
| COLLAPSIBLE SPACER..... | 27 | |
| HUB BEARING AND AXLE SHAFT..... | 30 | |
| STEERING KNUCKLE AND BALL STUDS..... | 31 | |
| AXLE BUSHING REPLACEMENT..... | 33 | |
| DIFFERENTIAL..... | 33 | |
| | | 36 |
| DIFFERENTIAL SIDE BEARINGS..... | | 36 |
| AXLE SHAFT OIL SEAL..... | | 36 |
| 181 FBI PINION..... | | 36 |
| 186 FBI PINION..... | | 41 |
| RING GEAR..... | | 45 |
| DISASSEMBLY AND ASSEMBLY | | |
| STANDARD DIFFERENTIAL..... | | 46 |
| FINAL ASSEMBLY..... | | 47 |
| CLEANING AND INSPECTION | | |
| CARDAN U-JOINT..... | | 47 |
| AXLE COMPONENTS..... | | 47 |
| ADJUSTMENTS | | |
| 181 FBI PINION GEAR DEPTH..... | | 48 |
| 186 FBI PINION GEAR DEPTH..... | | 50 |
| 181 FBI DIFFERENTIAL BEARING PRELOAD AND GEAR BACKLASH..... | | 52 |
| 186 FBI DIFFERENTIAL BEARING PRELOAD AND GEAR BACKLASH..... | | 56 |
| GEAR CONTACT PATTERN ANALYSIS..... | | 59 |
| SPECIFICATIONS | | |
| 181 FBI AXLE..... | | 61 |
| 186 FBI AXLE..... | | 61 |
| TORQUE..... | | 61 |
| SPECIAL TOOLS | | |
| 181 and 186 FBI AXLE..... | | 61 |

DESCRIPTION AND OPERATION

181 FBI AXLE

DESCRIPTION

The 181 Front Beam-design Iron (FBI) axle consists of a cast iron differential housing with axle shaft tubes extending from either side. The tubes are pressed into the differential housing and welded.

The integral type housing, hypoid gear design has the centerline of the pinion set above the centerline of the ring gear.

The axle has a fitting for a vent hose used to relieve internal pressure caused by lubricant vaporization and internal expansion.

The axles are equipped with semi-floating axle shafts, meaning that loads are supported by the hub bearings. The axle shafts are retained by nuts at the hub bearings. The hub bearings are bolted to the steering knuckle at the outboard end of the axle tube yoke. The hub bearings are serviced as an assembly.

For vehicles with ABS brakes, the ABS wheel speed sensors are attached to the knuckle assemblies. The tone rings for the ABS system are pressed onto the axle shaft. **Do not damage ABS tone wheel or the sensor when removing axle shafts.**

The stamped steel cover provides a means for inspection and servicing the differential.

The 181 FBI axle has the assembly part number and gear ratio listed on a tag. The tag is attached to the housing cover by a cover bolt. Build date identification codes are stamped on the cover side of the axle shaft tube.

The differential case is a one-piece design. The differential pinion mate shaft is retained with a roll pin. Differential bearing preload and ring gear backlash is adjusted by the use of shims (select thickness). The shims are located between the differential bearing cones and case. Pinion bearing preload is set and maintained by the use of shims (select thickness).

DESCRIPTION AND OPERATION (Continued)

OPERATION

The axle receives power from the transfer case through the front propeller shaft. The front propeller shaft is connected to the pinion gear which rotates the differential through the gear mesh with the ring gear bolted to the differential case. The engine power is transmitted to the axle shafts through the pinion mate and side gears. The side gears are splined to the axle shafts.

186 FBI AXLE**DESCRIPTION**

The 186 Front Beam-design Iron (FBI) axle consists of a cast iron differential housing with axle shaft tubes extending from either side. The tubes are pressed into the differential housing and welded.

The integral type housing, hypoid gear design has the centerline of the pinion set below the centerline of the ring gear.

The axle has a fitting for a vent hose used to relieve internal pressure caused by lubricant vaporization and internal expansion.

The axles are equipped with semi-floating axle shafts, meaning that loads are supported by the hub bearings. The axle shafts are retained by nuts at the hub bearings. The hub bearings are bolted to the steering knuckle at the outboard end of the axle tube yoke. The hub bearings are serviced as an assembly.

For vehicles with ABS brakes, the ABS wheel speed sensors are attached to the knuckle assemblies. The tone rings for the ABS system are pressed onto the axle shaft. **Do not damage ABS tone wheel or the sensor when removing axle shafts.**

The stamped steel cover provides a means for inspection and servicing the differential.

The 186 FBI axle has the assembly part number and gear ratio listed on a tag. The tag is attached to the housing cover by a cover bolt. Build date identification codes are stamped on the cover side of the axle shaft tube.

The differential case is a one-piece design. The differential pinion mate shaft is retained with a roll pin. Differential bearing preload and ring gear backlash is adjusted by the use of shims (select thickness). The shims are located between the differential bearing cones and case. Pinion bearing preload is set and maintained by the use of a collapsible spacer.

OPERATION

The axle receives power from the transfer case through the front propeller shaft. The front propeller shaft is connected to the pinion gear which rotates the differential through the gear mesh with the ring gear bolted to the differential case. The engine power is transmitted to the axle shafts through the pinion mate and side gears. The side gears are splined to the axle shafts.

LUBRICANT**DESCRIPTION**

A multi-purpose, hypoid gear lubricant which conforms to the following specifications should be used. Mopar® Hypoid Gear Lubricant conforms to all of these specifications.

- The lubricant should have MIL-L-2105C and API GL 5 quality specifications.
- Lubricant is a thermally stable SAE 80W-90 gear lubricant.
- Lubricant for axles intended for heavy-duty or trailer tow use is SAE 75W-140 SYNTHETIC gear lubricant.

The 181 FBI axle lubricant capacity is 1.2 L (2.5 pts.). The 186 FBI axle lubricant capacity is 1.18 L (2.5 pts.).

CAUTION: If axle is submerged in water, lubricant must be replaced immediately to avoid possible premature axle failure.

DESCRIPTION AND OPERATION (Continued)

STANDARD DIFFERENTIAL

DESCRIPTION

The differential gear system divides the torque between the axle shafts. It allows the axle shafts to rotate at different speeds when turning corners.

Each differential side gear is splined to an axle shaft. The pinion gears are mounted on a pinion mate shaft and are free to rotate on the shaft. The pinion gear is fitted in a bore in the differential case and is positioned at a right angle to the axle shafts.

OPERATION

In operation, power flow occurs as follows:

- The pinion gear rotates the ring gear
- The ring gear (bolted to the differential case) rotates the case
- The differential pinion gears (mounted on the pinion mate shaft in the case) rotate the side gears
- The side gears (splined to the axle shafts) rotate the shafts

During straight-ahead driving, the differential pinion gears do not rotate on the pinion mate shaft. This occurs because input torque applied to the gears is divided and distributed equally between the two side gears. As a result, the pinion gears revolve with the pinion mate shaft but do not rotate around it (Fig. 1).

When turning corners, the outside wheel must travel a greater distance than the inside wheel to complete a turn. The difference must be compensated for to prevent the tires from scuffing and skidding through turns. To accomplish this, the differential allows the axle shafts to turn at unequal speeds (Fig. 2). In this instance, the input torque applied to the pinion gears is not divided equally. The pinion gears now rotate around the pinion mate shaft in opposite directions. This allows the side gear and axle shaft attached to the outside wheel to rotate at a faster speed.

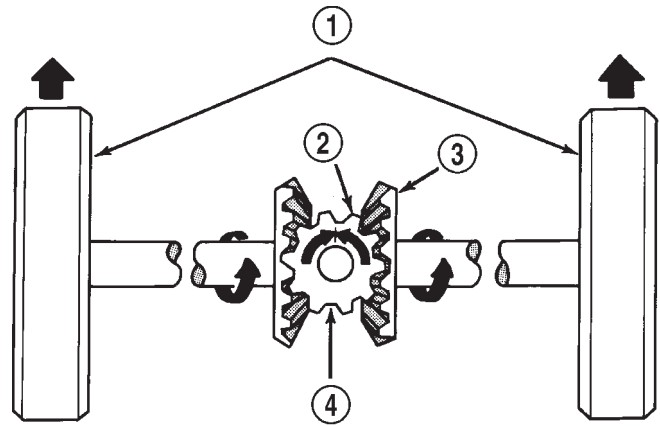

J9303-13

Fig. 1 Differential Operation—Straight Ahead Driving

- 1 - IN STRAIGHT AHEAD DRIVING EACH WHEEL ROTATES AT 100% OF CASE SPEED
- 2 - PINION GEAR
- 3 - SIDE GEAR
- 4 - PINION GEARS ROTATE WITH CASE

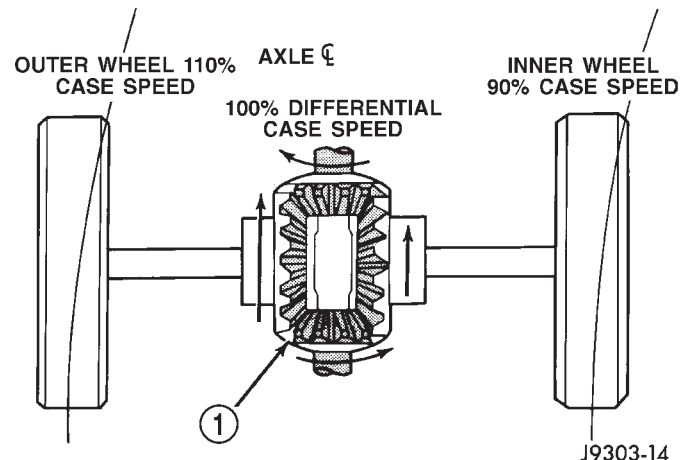

J9303-14

Fig. 2 Differential Operation—On Turns

- 1 - PINION GEARS ROTATE ON PINION SHAFT

DIAGNOSIS AND TESTING

GENERAL INFORMATION

Axle bearing problem conditions are usually caused by:

- Insufficient or incorrect lubricant.
- Foreign matter/water contamination.
- Incorrect bearing preload torque adjustment.
- Incorrect backlash.

Axle gear problem conditions are usually the result of:

- Insufficient lubrication.

- Incorrect or contaminated lubricant.
- Overloading (excessive engine torque) or exceeding vehicle weight capacity.

- Incorrect clearance or backlash adjustment.

Axle component breakage is most often the result of:

- Severe overloading.
- Insufficient lubricant.
- Incorrect lubricant.
- Improperly tightened components.
- Differential housing bores not square to each other.

DIAGNOSTIC CHART

| Condition | Possible Causes | Correction |
|----------------------|---|--|
| Wheel Noise | <ol style="list-style-type: none"> 1. Wheel loose. 2. Faulty, brinelled wheel bearing. | <ol style="list-style-type: none"> 1. Tighten loose nuts. 2. Replace bearing. |
| Axle Shaft Noise | <ol style="list-style-type: none"> 1. Misaligned axle tube. 2. Bent or sprung axle shaft. 3. End-play in pinion bearings. 4. Excessive gear backlash between the ring gear and pinion. 5. Improper adjustment of pinion gear bearings. 6. Loose pinion yoke nut. 7. Scuffed gear tooth contact surfaces. | <ol style="list-style-type: none"> 1. Inspect axle tube alignment. Correct as necessary. 2. Inspect and correct as necessary. 3. Refer to pinion pre-load information and correct as necessary. 4. Check adjustment of the ring gear and pinion backlash. Correct as necessary. 5. Adjust the pinion bearings pre-load. 6. Tighten the pinion yoke nut. 7. Inspect and replace as necessary. |
| Axle Shaft Broke | <ol style="list-style-type: none"> 1. Misaligned axle tube. 2. Vehicle overloaded. 3. Erratic clutch operation. 4. Grabbing clutch. | <ol style="list-style-type: none"> 1. Replace the broken shaft after correcting tube mis-alignment. 2. Replace broken shaft and avoid excessive weight on vehicle. 3. Replace broken shaft and avoid or correct erratic clutch operation. 4. Replace broken shaft and inspect and repair clutch as necessary. |
| Differential Cracked | <ol style="list-style-type: none"> 1. Improper adjustment of the differential bearings. 2. Excessive ring gear backlash. 3. Vehicle overloaded. 4. Erratic clutch operation. | <ol style="list-style-type: none"> 1. Replace case and inspect gears and bearings for further damage. Set differential bearing pre-load properly. 2. Replace case and inspect gears and bearings for further damage. Set ring gear backlash properly. 3. Replace case and inspect gears and bearings for further damage. Avoid excessive vehicle weight. 4. Replace case and inspect gears and bearings for further damage. Avoid erratic use of clutch. |

DIAGNOSIS AND TESTING (Continued)

| Condition | Possible Causes | Correction |
|---------------------------|---|--|
| Differential Gears Scored | <ol style="list-style-type: none"> 1. Insufficient lubrication. 2. Improper grade of lubricant. 3. Excessive spinning of one wheel/tire. | <ol style="list-style-type: none"> 1. Replace scored gears. Fill differential with the correct fluid type and quantity. 2. Replace scored gears. Fill differential with the correct fluid type and quantity. 3. Replace scored gears. Inspect all gears, pinion bores, and shaft for damage. Service as necessary. |
| Loss Of Lubricant | <ol style="list-style-type: none"> 1. Lubricant level too high. 2. Worn axle shaft seals. 3. Cracked differential housing. 4. Worn pinion seal. 5. Worn/scored yoke. 6. Axle cover not properly sealed. | <ol style="list-style-type: none"> 1. Drain lubricant to the correct level. 2. Replace seals. 3. Repair as necessary. 4. Replace seal. 5. Replace yoke and seal. 6. Remove, clean, and re-seal cover. |
| Axle Overheating | <ol style="list-style-type: none"> 1. Lubricant level low. 2. Improper grade of lubricant. 3. Bearing pre-loads too high. 4. Insufficient ring gear backlash. | <ol style="list-style-type: none"> 1. Fill differential to correct level. 2. Fill differential with the correct fluid type and quantity. 3. Re-adjust bearing pre-loads. 4. Re-adjust ring gear backlash. |
| Gear Teeth Broke | <ol style="list-style-type: none"> 1. Overloading. 2. Erratic clutch operation. 3. Ice-spotted pavement. 4. Improper adjustments. | <ol style="list-style-type: none"> 1. Replace gears. Examine other gears and bearings for possible damage. 2. Replace gears and examine the remaining parts for damage. Avoid erratic clutch operation. 3. Replace gears and examine remaining parts for damage. 4. Replace gears and examine remaining parts for damage. Ensure ring gear backlash is correct. |
| Axle Noise | <ol style="list-style-type: none"> 1. Insufficient lubricant. 2. Improper ring gear and pinion adjustment. 3. Unmatched ring gear and pinion. 4. Worn teeth on ring gear and/or pinion. 5. Loose pinion bearings. 6. Loose differential bearings. 7. Mis-aligned or sprung ring gear. 8. Loose differential bearing cap bolts. 9. Housing not machined properly. | <ol style="list-style-type: none"> 1. Fill differential with the correct fluid type and quantity. 2. Check ring gear and pinion contact pattern. 3. Replace gears with a matched ring gear and pinion. 4. Replace ring gear and pinion. 5. Adjust pinion bearing pre-load. 6. Adjust differential bearing pre-load. 7. Measure ring gear run-out. Replace components as necessary. 8. Inspect differential components and replace as necessary. Ensure that the bearing caps are torqued to the proper specification. 9. Replace housing. |

DIAGNOSIS AND TESTING (Continued)

GEAR NOISE

Axle gear noise can be caused by insufficient lubricant, incorrect backlash, tooth contact, worn/damaged gears, or the carrier housing not having the proper offset and squareness.

Gear noise usually happens at a specific speed range. The noise can also occur during a specific type of driving condition. These conditions are acceleration, deceleration, coast, or constant load.

When road testing, first warm-up the axle fluid by driving the vehicle at least 5 miles and then accelerate the vehicle to the speed range where the noise is the greatest. Shift out-of-gear and coast through the peak-noise range. If the noise stops or changes greatly:

- Check for insufficient lubricant.
- Incorrect ring gear backlash.
- Gear damage.

Differential side gears and pinions can be checked by turning the vehicle. They usually do not cause noise during straight-ahead driving when the gears are unloaded. The side gears are loaded during vehicle turns. A worn pinion mate shaft can also cause a snapping or a knocking noise.

BEARING NOISE

The axle shaft, differential and pinion bearings can all produce noise when worn or damaged. Bearing noise can be either a whining, or a growling sound.

Pinion bearings have a constant-pitch noise. This noise changes only with vehicle speed. Pinion bearing noise will be higher pitched because it rotates at a faster rate. Drive the vehicle and load the differential. If bearing noise occurs, the rear pinion bearing is the source of the noise. If the bearing noise is heard during a coast, the front pinion bearing is the source.

Worn or damaged differential bearings usually produce a low pitch noise. Differential bearing noise is similar to pinion bearing noise. The pitch of differential bearing noise is also constant and varies only with vehicle speed.

Axle shaft bearings produce noise and vibration when worn or damaged. The noise generally changes when the bearings are loaded. Road test the vehicle. Turn the vehicle sharply to the left and to the right. This will load the bearings and change the noise level. Where axle bearing damage is slight, the noise is usually not noticeable at speeds above 30 mph.

LOW SPEED KNOCK

Low speed knock is generally caused by a worn U-joint or by worn side-gear thrust washers. A worn pinion shaft bore will also cause low speed knock.

VIBRATION

Vibration at the rear of the vehicle is usually caused by a:

- Damaged drive shaft.
- Missing drive shaft balance weight(s).
- Worn or out-of-balance wheels.
- Loose wheel lug nuts.
- Worn U-joint(s).
- Loose/broken springs.
- Damaged axle shaft bearing(s).
- Loose pinion gear nut.
- Excessive pinion yoke run out.
- Bent axle shaft(s).

Check for loose or damaged front-end components or engine/transmission mounts. These components can contribute to what appears to be a rear-end vibration. Do not overlook engine accessories, brackets and drive belts.

All driveline components should be examined before starting any repair.

Refer to Group 22, Wheels and Tires, for additional vibration information.

DRIVELINE SNAP

A snap or clunk noise when the vehicle is shifted into gear (or the clutch engaged), can be caused by:

- High engine idle speed.
- Transmission shift operation.
- Loose engine/transmission/transfer case mounts.
- Worn U-joints.
- Loose spring mounts.
- Loose pinion gear nut and yoke.
- Excessive ring gear backlash.
- Excessive side gear to case clearance.

The source of a snap or a clunk noise can be determined with the assistance of a helper. Raise the vehicle on a hoist with the wheels free to rotate. Instruct the helper to shift the transmission into gear. Listen for the noise, a mechanics stethoscope is helpful in isolating the source of a noise.

SERVICE PROCEDURES**LUBRICANT CHANGE**

- (1) Raise and support the vehicle.
- (2) Remove the lubricant fill hole plug from the differential housing cover.
- (3) Remove the differential housing cover and drain the lubricant from the housing.
- (4) Clean the housing cavity with a flushing oil, light engine oil or lint free cloth. **Do not use water, steam, kerosene or gasoline for cleaning.**
- (5) Remove the sealant from the housing and cover surfaces. Use solvent to clean the mating surfaces.

SERVICE PROCEDURES (Continued)

(6) Apply a bead of Mopar® Silicone Rubber Sealant, or equivalent, to the housing cover (Fig. 3).

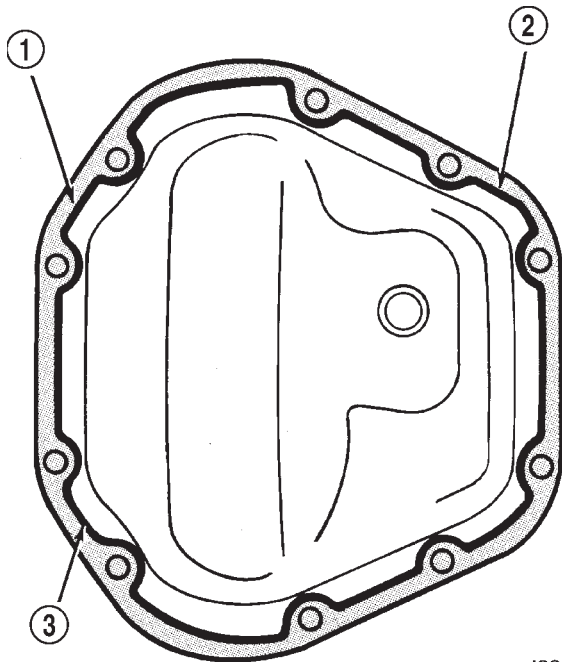

J9302-30

Fig. 3 Typical Housing Cover With Sealant

- 1 - SEALING SURFACE
2 - CONTOUR OF BEAD
3 - BEAD THICKNESS 6.35mm (1/4")

Install the housing cover within 5 minutes after applying the sealant.

(7) Install the cover and any identification tag. Tighten the cover bolts in a criss-cross pattern to 41 N·m (30 ft. lbs.) torque.

(8) Refill the differential with Mopar® Hypoid Gear Lubricant, or equivalent, to bottom of the fill plug hole. Refer to the Lubricant Specifications in this group for the quantity necessary.

(9) Install the fill hole plug and lower the vehicle. Tighten fill plug to 34 N·m (25 ft. lbs.).

REMOVAL AND INSTALLATION

DRIVE AXLE ASSEMBLY

REMOVAL

- (1) Raise and support the vehicle.
- (2) Position a suitable lifting device under the axle.
- (3) Secure axle to device.
- (4) Remove the wheels and tires.
- (5) Remove the brake rotors and calipers from the axle. Refer to Group 5, Brakes, for proper procedures.
- (6) Disconnect the wheel sensor wiring harness from the vehicle wiring harness, if necessary.

(7) Disconnect the vent hose from the axle shaft tube.

(8) Mark the propeller shaft and yoke for installation alignment reference.

(9) Remove propeller shaft.

(10) Disconnect stabilizer bar links at the axle.

(11) Disconnect shock absorbers from axle brackets.

(12) Disconnect track bar.

(13) Disconnect the tie rod and drag link from the steering knuckle. Refer to Group 2, Suspension, for proper procedures.

(14) Disconnect the steering damper from the axle bracket.

(15) Disconnect the upper and lower suspension arms from the axle brackets.

(16) Lower the lifting device enough to remove the axle. The coil springs will drop with the axle.

(17) Remove the coil springs from the axle.

INSTALLATION

CAUTION: The weight of the vehicle must be supported by the springs before suspension arms and track bar fasteners can be tightened. If the springs are not at their normal ride position, ride height and handling could be affected.

(1) Install the springs and retainer clips. Tighten the retainer bolts to 21 N·m (16 ft. lbs.) torque.

(2) Support the axle on a suitable lifting device and position axle under the vehicle.

(3) Raise the axle and align it with the spring pads.

(4) Position the upper and lower suspension arms in the axle brackets. Loosely install bolts and nuts to hold suspension arms to the axle brackets.

(5) Connect the vent hose to the axle shaft tube.

(6) Connect the track bar to the axle bracket. Loosely install the bolt to hold the track bar to the axle bracket.

(7) Install the shock absorbers and tighten the bolts to 23 N·m (17 ft. lbs.) torque.

(8) Install the stabilizer bar links to the axle brackets. Tighten the nut to 95 N·m (70 ft. lbs.) torque.

(9) Install the drag link and tie rod to the steering knuckles. Refer to Group 2, Suspension, for proper procedures.

(10) Install the steering damper to the axle bracket and tighten the nut to 75 N·m (55 ft. lbs.) torque.

(11) Install the brake rotors and calipers. Refer to Group 5, Brakes, for the proper procedures.

(12) Connect the wheel speed sensor wiring harness to the vehicle wiring harness, if necessary.

REMOVAL AND INSTALLATION (Continued)

(13) Align the previously made marks on the propeller shaft and the yoke.

(14) Install the straps and bolts to hold the propeller shaft to the yoke.

(15) Check and fill axle lubricant. Refer to the Lubricant Specifications in this group for the quantity necessary.

(16) Install the wheel and tire assemblies.

(17) Remove the lifting device from the axle and lower the vehicle.

(18) Tighten the upper suspension arm nuts to 75 N·m (55 ft. lbs.) torque. Tighten the lower suspension arm nuts to 115 N·m (85 ft. lbs.) torque.

(19) Tighten the track bar bolt at the axle bracket to 100 N·m (74 ft. lbs.) torque.

(20) Check the front wheel alignment.

TUBE AXLE ASSEMBLY

REMOVAL

(1) Raise and support the vehicle.

(2) Position a suitable lifting device under the axle.

(3) Secure axle to device.

(4) Remove the wheels and tires.

(5) Remove the brake rotors and calipers from the axle. Refer to Group 5, Brakes, for proper procedures.

(6) Disconnect the wheel sensor wiring harness from the vehicle wiring harness, if necessary.

(7) Disconnect stabilizer bar links at the axle.

(8) Disconnect shock absorbers from axle brackets.

(9) Disconnect track bar.

(10) Disconnect the tie rod and drag link from the steering knuckle. Refer to Group 2, Suspension, for proper procedures.

(11) Disconnect the steering damper from the axle bracket.

(12) Disconnect the upper and lower suspension arms from the axle brackets.

(13) Lower the lifting device enough to remove the axle. The coil springs will drop with the axle.

(14) Remove the coil springs from the axle.

INSTALLATION

CAUTION: The weight of the vehicle must be supported by the springs before suspension arms and track bar fasteners can be tightened. If the springs are not at their normal ride position, ride height and handling could be affected.

(1) Install the springs and retainer clips. Tighten the retainer bolts to 21 N·m (16 ft. lbs.) torque.

(2) Support the axle on a suitable lifting device and position axle under the vehicle.

(3) Raise the axle and align it with the spring pads.

(4) Position the upper and lower suspension arms in the axle brackets. Loosely install bolts and nuts to hold suspension arms to the axle brackets.

(5) Connect the track bar to the axle bracket. Loosely install the bolt to hold the track bar to the axle bracket.

(6) Install the shock absorbers and tighten the bolts to 23 N·m (17 ft. lbs.) torque.

(7) Install the stabilizer bar links to the axle brackets. Tighten the nut to 95 N·m (70 ft. lbs.) torque.

(8) Install the drag link and tie rod to the steering knuckles. Refer to Group 2, Suspension, for proper procedures.

(9) Install the steering damper to the axle bracket and tighten the nut to 75 N·m (55 ft. lbs.) torque.

(10) Install the brake rotors and calipers. Refer to Group 5, Brakes, for the proper procedures.

(11) Connect the wheel speed sensor wiring harness to the vehicle wiring harness, if necessary.

(12) Install the wheel and tire assemblies.

(13) Remove the lifting device from the axle and lower the vehicle.

(14) Tighten the upper suspension arm nuts to 75 N·m (55 ft. lbs.) torque. Tighten the lower suspension arm nuts to 115 N·m (85 ft. lbs.) torque.

(15) Tighten the track bar bolt at the axle bracket to 100 N·m (74 ft. lbs.) torque.

(16) Check the front wheel alignment.

AXLE SHAFT—CARDAN U-JOINT

Single cardan U-joint components are not serviceable. If defective, they must be replaced as a unit. If the bearings, seals, spider, or bearing caps are damaged or worn, replace the complete U-joint.

REMOVAL

CAUTION: Clamp only the narrow forged portion of the yoke in the vise. Also, to avoid distorting the yoke, do not over tighten the vise jaws.

(1) Remove axle shaft.

(2) Remove the bearing cap retaining snap rings (Fig. 4).

It can be helpful to saturate the bearing caps with penetrating oil prior to removal.

(3) Locate a socket where the inside diameter is larger in diameter than the bearing cap. Place the socket (receiver) against the yoke and around the perimeter of the bearing cap to be removed.

(4) Locate a socket where the outside diameter is smaller in diameter than the bearing cap. Place the socket (driver) against the opposite bearing cap.

(5) Position the yoke with the sockets in a vise (Fig. 5).

REMOVAL AND INSTALLATION (Continued)

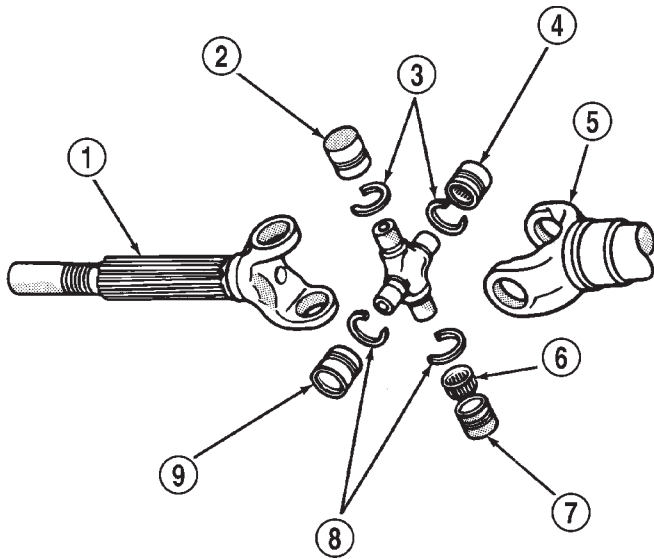

J8902-15

Fig. 4 Axle Shaft Outer U-Joint

- 1 - SHAFT YOKE
- 2 - BEARING CAP
- 3 - SNAP RINGS
- 4 - BEARING CAP
- 5 - SPINDLE YOKE
- 6 - BEARING
- 7 - BEARING CAP
- 8 - SNAP RINGS
- 9 - BEARING CAP

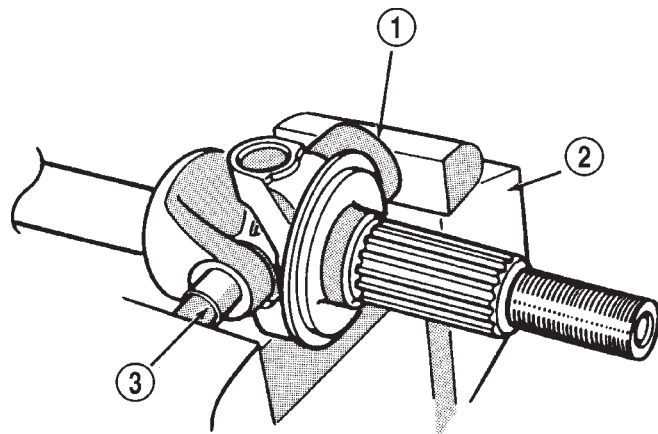

J8902-16

Fig. 5 Yoke Bearing Cap Removal

- 1 - LARGE-DIAMETER SOCKET WRENCH
- 2 - VISE
- 3 - SMALL-DIAMETER SOCKET WRENCH

(6) Compress the vise jaws to force the bearing cap into the larger socket (receiver).

(7) Release the vise jaws. Remove the sockets and bearing cap that was partially forced out of the yoke.

(8) Repeat the above procedure for the remaining bearing cap.

(9) Remove the remaining bearing cap, bearings, seals and spider from the propeller shaft yoke.

INSTALLATION

(1) Pack the bearing caps 1/3 full of wheel bearing lubricant. Apply extreme pressure (EP), lithium-base lubricant to aid in installation.

(2) Position the spider in the yoke. Insert the seals and bearings. Tap the bearing caps into the yoke bores far enough to hold the spider in position.

(3) Place the socket (driver) against one bearing cap. Position the yoke with the socket wrench in a vise.

(4) Compress the vise to force the bearing caps into the yoke. Force the caps enough to install the retaining clips.

(5) Install the bearing cap retaining clips.

(6) Install axle shaft.

181 FBI PINION SHAFT SEAL**REMOVAL**

(1) Raise and support the vehicle.

(2) Remove wheel and tire assemblies.

(3) Remove brake rotors and calipers. Refer to Group 5, Brakes, for proper procedures.

(4) Mark the propeller shaft and pinion yoke for installation reference.

(5) Remove the propeller shaft from the yoke.

(6) Rotate the pinion gear three or four times.

(7) Measure the amount of torque necessary to rotate the pinion gear with a (in. lbs.) dial-type torque wrench. Record the torque reading for installation reference.

(8) Using Holder 6958 to hold the pinion yoke, remove the pinion nut and washer.

(9) Use Remover C-452 and Wrench C-3281 to remove the pinion yoke (Fig. 6).

(10) Use a suitable pry tool or a slide hammer mounted screw to remove the pinion shaft seal.

INSTALLATION

(1) Apply a light coating of gear lubricant on the lip of pinion seal. Install seal with Installer C-3972-A and Handle C-4171 (Fig. 7).

(2) Install yoke on the pinion gear with Installer W-162-D, Cup 8109, and Holder 6958 (Fig. 8).

REMOVAL AND INSTALLATION (Continued)

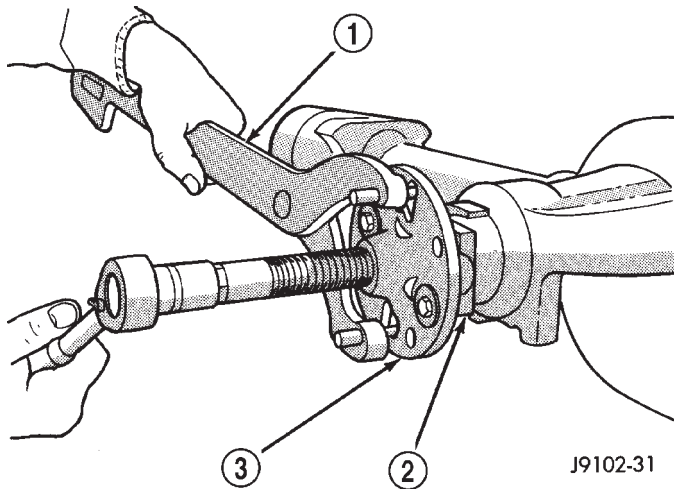

Fig. 6 Pinion Yoke Removal

- 1 - SPECIAL TOOL C-3281
- 2 - YOKE
- 3 - SPECIAL TOOL C-452

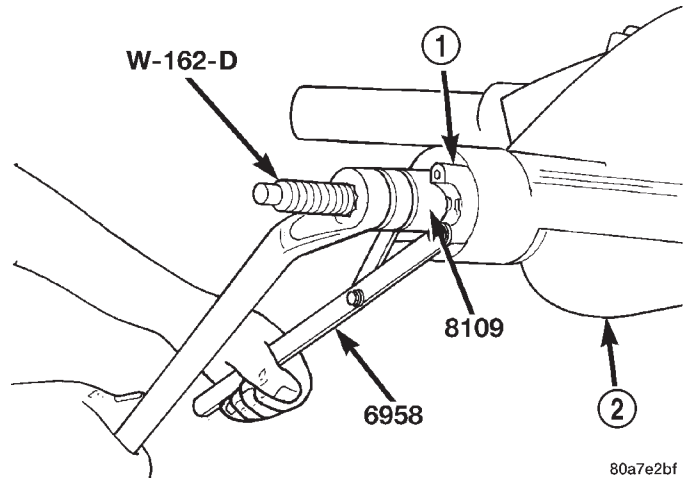

Fig. 8 Pinion Yoke Installation

- 1 - PINION YOKE
- 2 - AXLE HOUSING

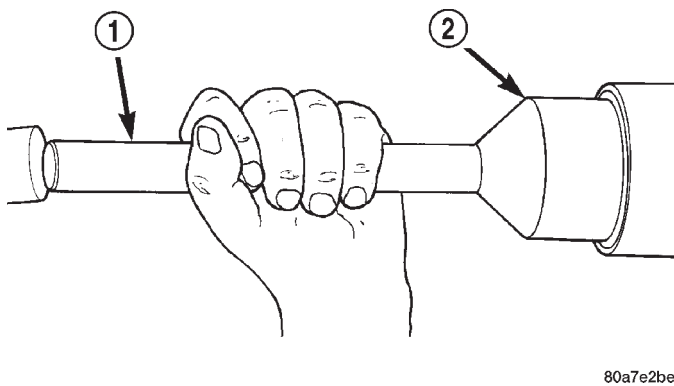

Fig. 7 Pinion Seal Installation

- 1 - SPECIAL TOOL C-4171
- 2 - SPECIAL TOOL C-3972-A

CAUTION: Do not exceed the minimum tightening torque when installing the pinion yoke retaining nut at this point. Damage to the pinion bearings may result.

(3) Install the pinion washer and a new nut on the pinion gear. **Tighten the nut only enough to remove the shaft end play.**

(4) Tighten pinion nut to 217 N·m (160 ft. lbs.).

(5) Rotate the pinion shaft using a (in. lbs.) torque wrench. Rotating torque should be equal to the reading recorded during removal, plus an additional 0.56 N·m (5 in. lbs.) (Fig. 9).

(6) If the rotating torque is low, use Holder 6958 to hold the pinion yoke, and tighten the pinion shaft nut in 6.8 N·m (5 ft. lbs.) increments until proper rotating torque is achieved.

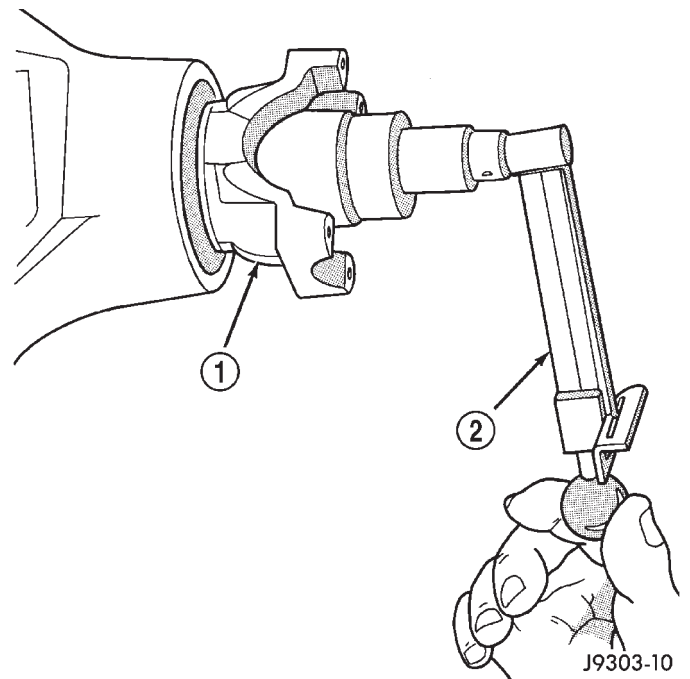

Fig. 9 Check Pinion Rotation Torque

- 1 - PINION YOKE
- 2 - INCH POUND TORQUE WRENCH

(7) Align the installation reference marks on the propeller shaft and yoke, and install the propeller shaft.

(8) Check and fill the gear lubricant. Refer to the Lubricant Specifications for gear lubricant requirements.

(9) Install the brake rotors and calipers. Refer to Group 5, Brakes, for proper procedures.

(10) Install wheel and tire assemblies.

(11) Lower the vehicle.

REMOVAL AND INSTALLATION (Continued)

186 FBI PINION SHAFT SEAL

REMOVAL

- (1) Raise and support the vehicle.
- (2) Remove wheel and tire assemblies.
- (3) Remove brake rotors and calipers. Refer to Group 5, Brakes, for proper procedures.
- (4) Mark the propeller shaft and pinion yoke for installation reference.
- (5) Remove the propeller shaft from the yoke.
- (6) Rotate the pinion gear three or four times.
- (7) Measure the amount of torque necessary to rotate the pinion gear with a (in. lbs.) dial-type torque wrench. Record the torque reading for installation reference.
- (8) Using Holder 6958 to hold the pinion yoke, remove the pinion nut and washer.
- (9) Use Remover C-452 and Wrench C-3281 to remove the pinion yoke (Fig. 10).

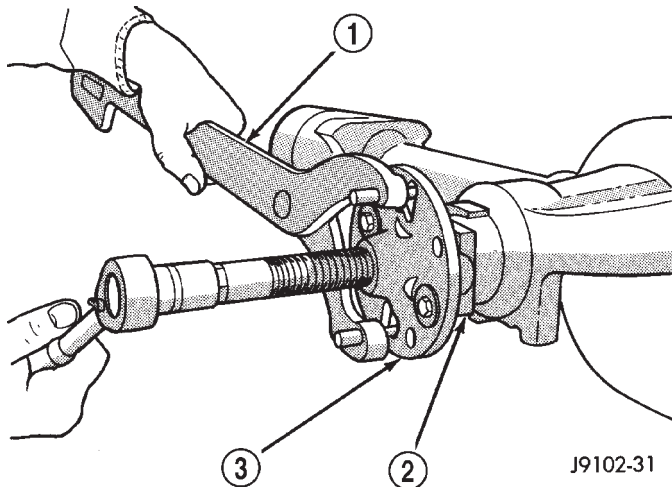

Fig. 10 Pinion Yoke Removal

- 1 - SPECIAL TOOL C-3281
- 2 - YOKE
- 3 - SPECIAL TOOL C-452

- (10) Use a suitable pry tool or a slide hammer mounted screw to remove the pinion seal.

INSTALLATION

- (1) Apply a light coating of gear lubricant on the lip of pinion seal. Install seal with Installer C-3972-A and Handle C-4171 (Fig. 11).
- (2) Install yoke on the pinion gear with Installer W-162-D, Cup 8109, and Holder 6958 (Fig. 12).

CAUTION: Do not exceed the minimum tightening torque when installing the pinion yoke retaining nut at this point. Damage to collapsible spacer or bearings may result.

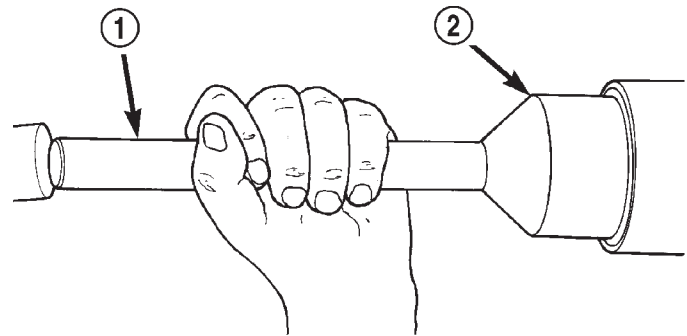

80a7e2be

Fig. 11 Pinion Seal Installation

- 1 - SPECIAL TOOL C-4171
- 2 - SPECIAL TOOL C-3972-A

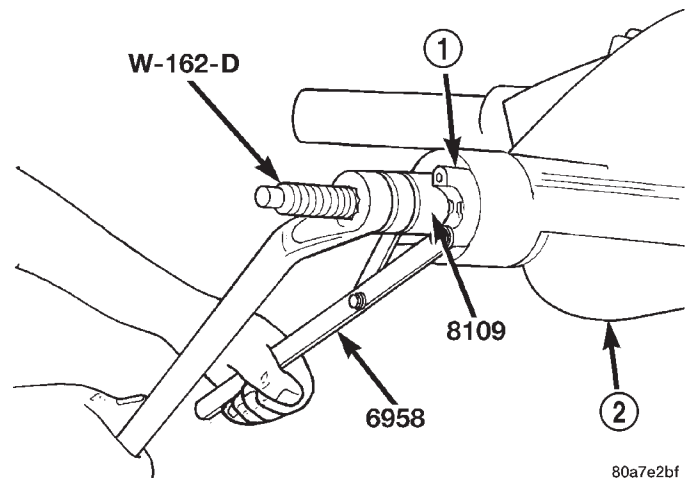

80a7e2bf

Fig. 12 Pinion Yoke Installation

- 1 - PINION YOKE
- 2 - AXLE HOUSING

- (3) Install the pinion washer and a new nut on the pinion gear. **Tighten the nut only enough to remove the shaft end play.**

- (4) Rotate the pinion shaft using a (in. lbs.) torque wrench. Rotating torque should be equal to the reading recorded during removal, plus an additional 0.56 N·m (5 in. lbs.) (Fig. 13).

- (5) If the rotating torque is low, use Holder 6958 to hold the pinion yoke (Fig. 14), and tighten the pinion shaft nut in 6.8 N·m (5 ft. lbs.) increments until proper rotating torque is achieved.

CAUTION: If the maximum tightening torque is reached prior to reaching the required rotating torque, the collapsible spacer may have been damaged. Replace the collapsible spacer.

- (6) Align the installation reference marks on the propeller shaft and yoke and install the propeller shaft.

REMOVAL AND INSTALLATION (Continued)

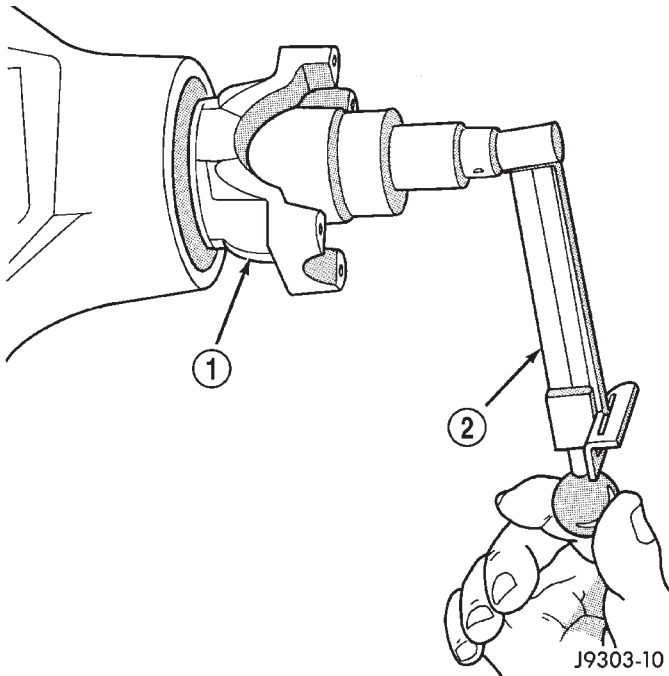

Fig. 13 Check Pinion Rotation Torque

- 1 - PINION YOKE
- 2 - INCH POUND TORQUE WRENCH

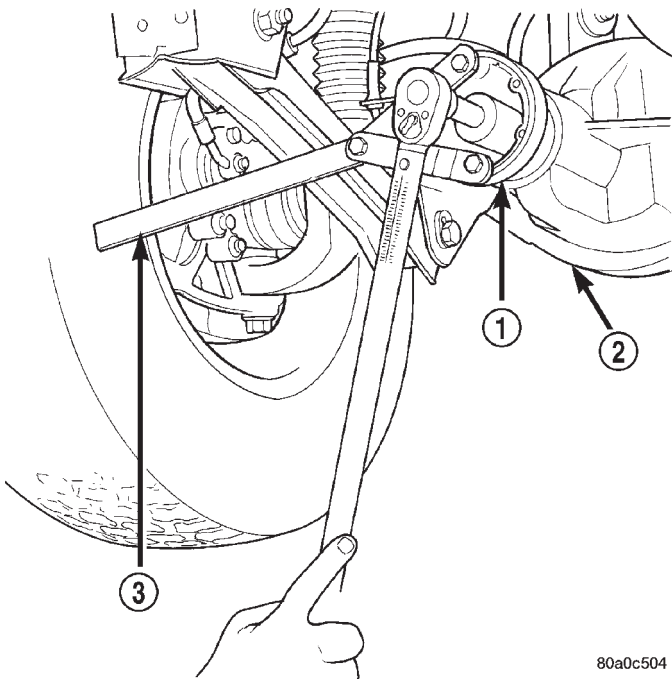

Fig. 14 Tightening Pinion Shaft Nut—Typical

- 1 - PINION FLANGE
- 2 - FRONT AXLE
- 3 - TOOL 6958

(7) Check and fill the gear lubricant. Refer to the Lubricant Specifications for gear lubricant requirements.

- (8) Install the brake rotors and calipers. Refer to Group 5, Brakes, for proper procedures.
- (9) Install wheel and tire assemblies.
- (10) Lower the vehicle.

COLLAPSIBLE SPACER

REMOVAL W/PINION INSTALLED

- (1) Raise and support the vehicle.
- (2) Remove wheel and tire assemblies.
- (3) Remove brake rotors and calipers. Refer to Group 5, Brakes, for proper procedures.
- (4) Mark the propeller shaft and pinion yoke for installation reference.
- (5) Remove the propeller shaft from the yoke.
- (6) Rotate the pinion gear three or four times.
- (7) Measure the amount of torque necessary to rotate the pinion gear with a (in. lbs.) dial-type torque wrench. Record the torque reading for installation reference.
- (8) Using Holder 6958 to hold the pinion yoke, remove the pinion nut and washer.
- (9) Use Remover C-452 and Wrench C-3281 to remove the pinion yoke (Fig. 15).
- (10) Use a suitable pry tool or a slide hammer mounted screw, remove the pinion seal.
- (11) Remove the front pinion bearing using a pair of suitable pick tools to pull the bearing straight off the pinion gear shaft. It may be necessary to lightly tap the end of the pinion gear with a rawhide or rubber mallet if the bearing becomes bound on the pinion shaft.
- (12) Remove the collapsible spacer.

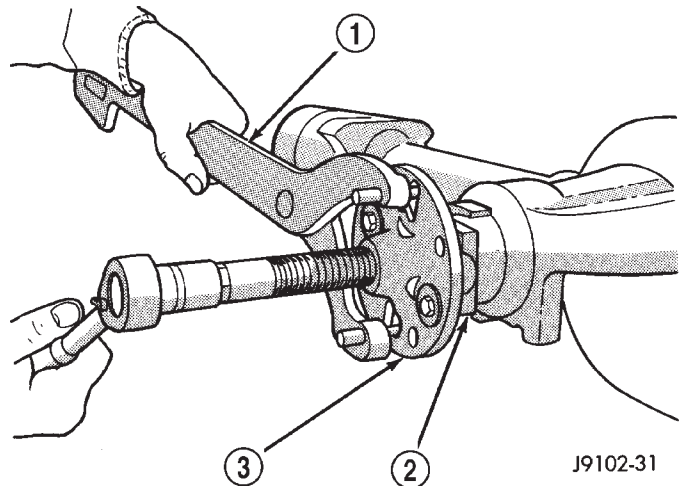

Fig. 15 Pinion Yoke Removal

- 1 - SPECIAL TOOL C-3281
- 2 - YOKE
- 3 - SPECIAL TOOL C-452

REMOVAL AND INSTALLATION (Continued)

REMOVAL W/PINION REMOVED

- (1) Raise and support the vehicle.
- (2) Remove wheel and tire assemblies.
- (3) Remove brake rotors and calipers. Refer to Group 5, Brakes, for proper procedures.
- (4) Mark the propeller shaft and pinion yoke for installation reference.
- (5) Remove the propeller shaft from the yoke.
- (6) Rotate the pinion gear three or four times.
- (7) Measure the amount of torque necessary to rotate the pinion gear with a (in. lbs.) dial-type torque wrench. Record the torque reading for installation reference.
- (8) Remove differential assembly from axle housing.
- (9) Using Holder 6958 to hold yoke, remove the pinion nut and washer.
- (10) Using Remover C-452 and Wrench C-3281, remove the pinion yoke from pinion shaft (Fig. 15).
- (11) Remove the pinion gear from housing (Fig. 16). Catch the pinion with your hand to prevent it from falling and being damaged.
- (12) Remove collapsible spacer from pinion shaft.

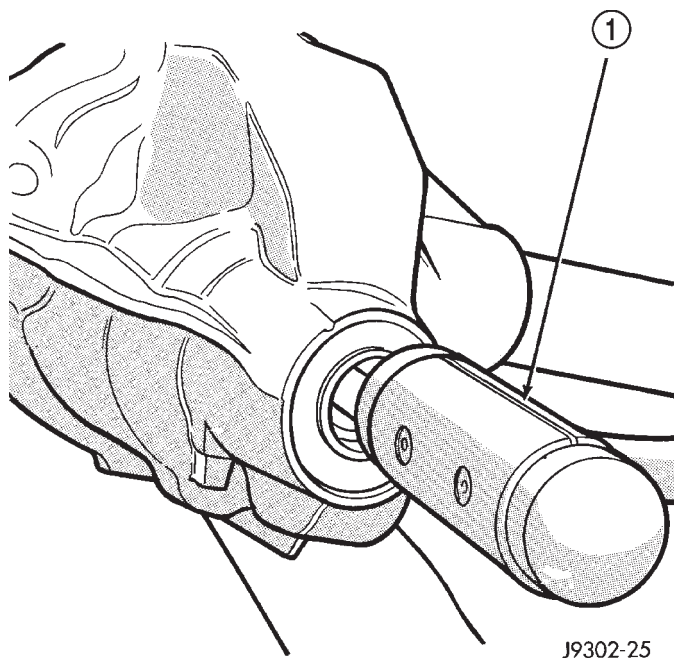

J9302-25

Fig. 16 Remove Pinion Gear

- 1 - RAWHIDE HAMMER

INSTALLATION

- (1) Install a new collapsible preload spacer on pinion shaft (Fig. 17).
- (2) If pinion gear was removed, install pinion gear in housing.
- (3) Install pinion front bearing, if necessary.

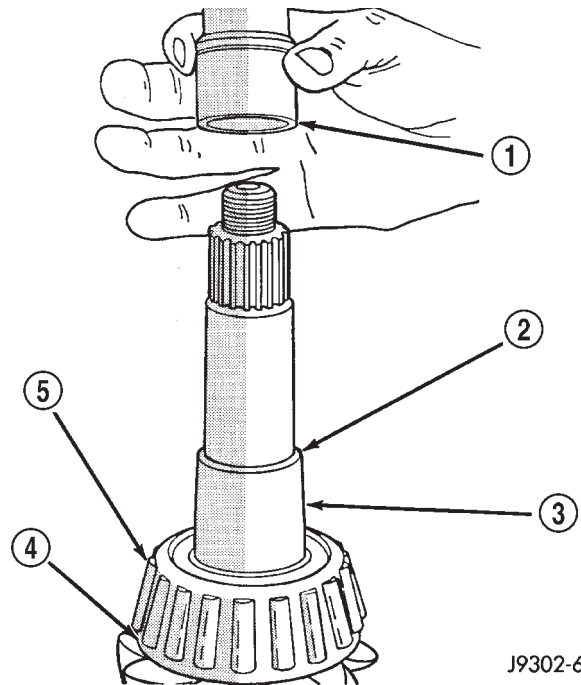

J9302-66

Fig. 17 Collapsible Preload Spacer

- 1 - COLLAPSIBLE SPACER
 2 - SHOULDER
 3 - PINION GEAR
 4 - OIL SLINGER
 5 - REAR BEARING

- (4) Apply a light coating of gear lubricant on the lip of pinion seal. Install seal with Installer C-3972-A and Handle C-4171 (Fig. 18), if necessary.

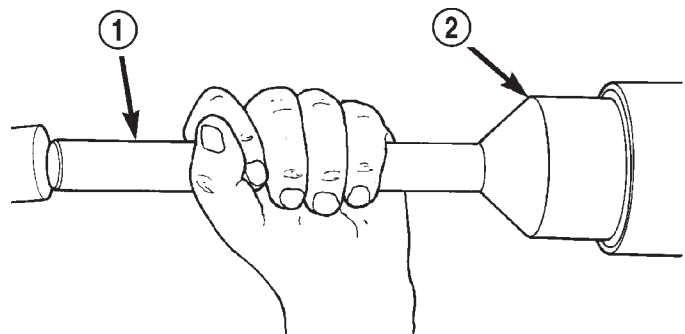

80a7e2be

Fig. 18 Pinion Seal Installation

- 1 - SPECIAL TOOL C-4171
 2 - SPECIAL TOOL C-3972-A

- (5) Install yoke with Installer W-162-D, Cup 8109, and holder 6958 (Fig. 19).

- (6) If the original pinion bearings are being used, install differential assembly and axle shafts, if necessary.

REMOVAL AND INSTALLATION (Continued)

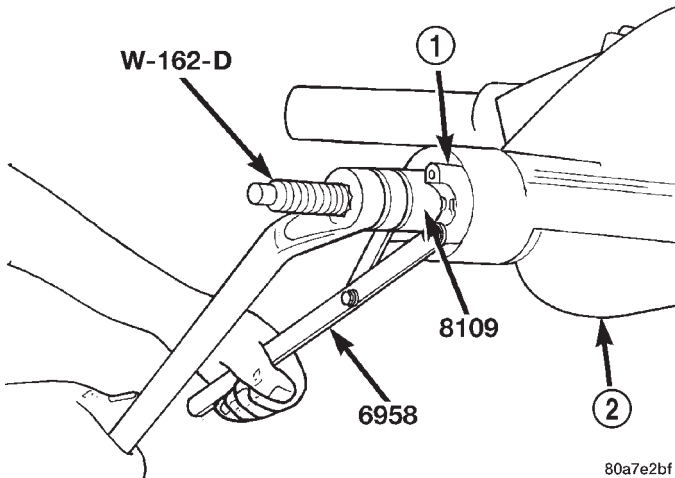

Fig. 19 Pinion Yoke Installation

- 1 - PINION YOKE
- 2 - AXLE HOUSING

NOTE: If new pinion bearings were installed, do not install the differential assembly and axle shafts until after the pinion bearing preload and rotating torque are set.

(7) Install the pinion washer and a new nut on the pinion gear. Tighten the nut to 217 N·m (160 ft. lbs.) minimum. **Do not over-tighten.** Maximum torque is 353 N·m (260 ft. lbs.).

CAUTION: Never loosen pinion gear nut to decrease pinion gear bearing rotating torque and never exceed specified preload torque. If preload torque is exceeded, a new collapsible spacer must be installed. The torque sequence will then have to be repeated.

(8) Using yoke holder 6958 and a torque wrench set at 353 N·m (260 ft. lbs.), crush collapsible spacer until bearing end play is taken up (Fig. 20). If more than 353 N·m (260 ft. lbs.) is needed to begin to collapse the spacer, the spacer is defective and must be replaced.

(9) Slowly tighten the nut in 6.8 N·m (5 ft. lbs.) increments until the rotating torque is achieved. Measure the rotating torque frequently to avoid over crushing the collapsible spacer (Fig. 21).

(10) Check rotating torque with an inch pound torque wrench (Fig. 21). The torque necessary to rotate the pinion gear should be:

- Original Bearings — The reading recorded during removal, plus an additional 0.56 N·m (5 in. lbs.).
- New Bearings — 1.5 to 4 N·m (15 to 35 in. lbs.).

(11) Install differential assembly and axle shafts, if necessary.

(12) Align marks made previously on yoke and propeller shaft and install propeller shaft.

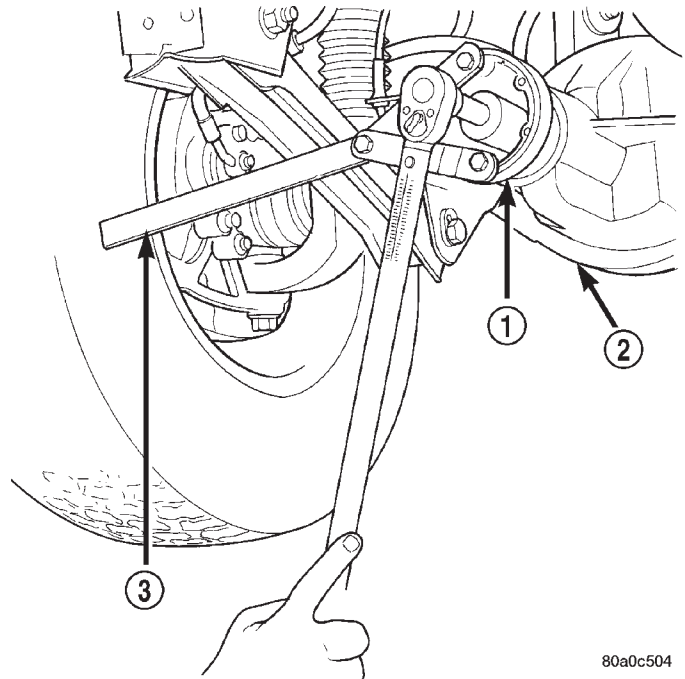

Fig. 20 Tightening Pinion Nut

- 1 - PINION FLANGE
- 2 - FRONT AXLE
- 3 - TOOL 6958

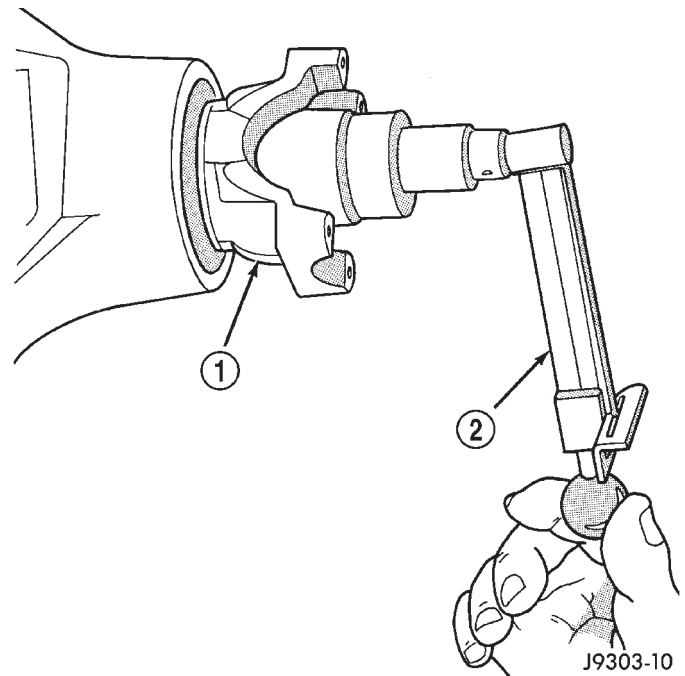
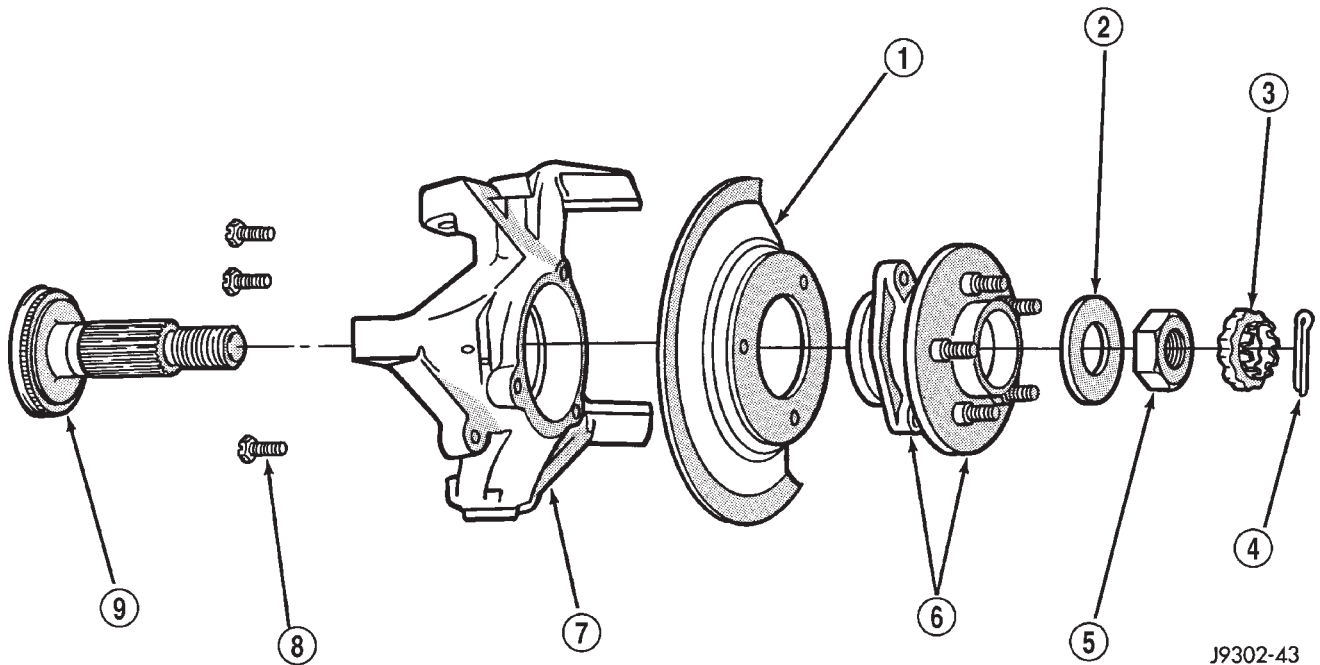

Fig. 21 Check Pinion Gear Rotation Torque—Typical

- 1 - PINION YOKE
- 2 - INCH POUND TORQUE WRENCH

(13) Install brake rotors and calipers. Refer to Group 5, Brakes, for proper procedures.

REMOVAL AND INSTALLATION (Continued)



J9302-43

Fig. 22 Hub, Knuckle and Axle Shaft

- 1 - BRAKE SHIELD
- 2 - WASHER
- 3 - RETAINER
- 4 - COTTER PIN
- 5 - NUT

- 6 - HUB AND BEARING ASSEMBLY
- 7 - STEERING KNUCKLE
- 8 - BOLT
- 9 - TONE WHEEL (ABS)

(14) Add gear lubricant, if necessary. Refer to Lubricant Specifications of this section for lubricant requirements.

(15) Install wheel and tire assemblies.

(16) Lower vehicle.

HUB BEARING AND AXLE SHAFT

If the axle shaft and hub bearing are being removed in order to service another component, the axle shaft and hub bearing can be removed as an assembly.

REMOVAL

- (1) Raise and support the vehicle.
- (2) Remove the wheel and tire assembly.
- (3) Remove the brake caliper and rotor. Refer to Group 5, Brakes, for proper procedures.
- (4) Remove ABS wheel speed sensor, if necessary. Refer to Group 5, Brakes, for proper procedures.
- (5) Remove the cotter pin, nut retainer, and axle hub nut (Fig. 22), if necessary.
- (6) Remove the hub to knuckle bolts (Fig. 23).
- (7) Remove the hub from the steering knuckle and axle shaft, if necessary.
- (8) Remove hub bearing and axle shaft assembly (Fig. 24), or axle shaft from axle. **Avoid damaging the axle shaft oil seals in the axle housing.**

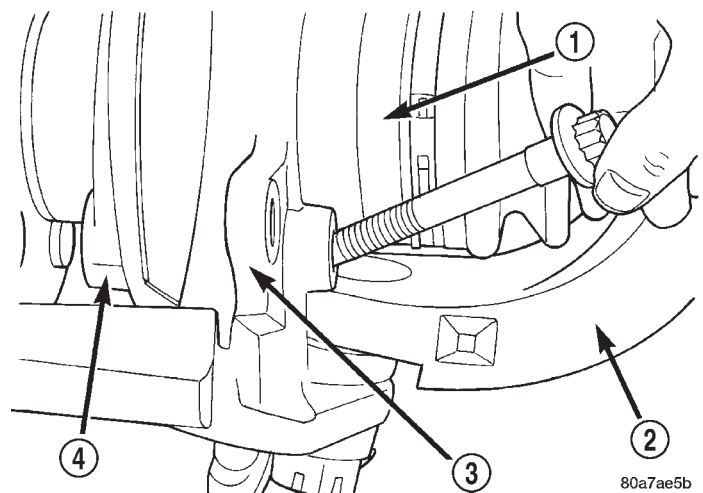

80a7ae5b

Fig. 23 Hub Bearing Bolts

- 1 - AXLE SHAFT
- 2 - AXLE
- 3 - KNUCKLE
- 4 - HUB BEARING

(9) Remove the brake rotor shield from the hub bearing or knuckle (Fig. 22).

REMOVAL AND INSTALLATION (Continued)

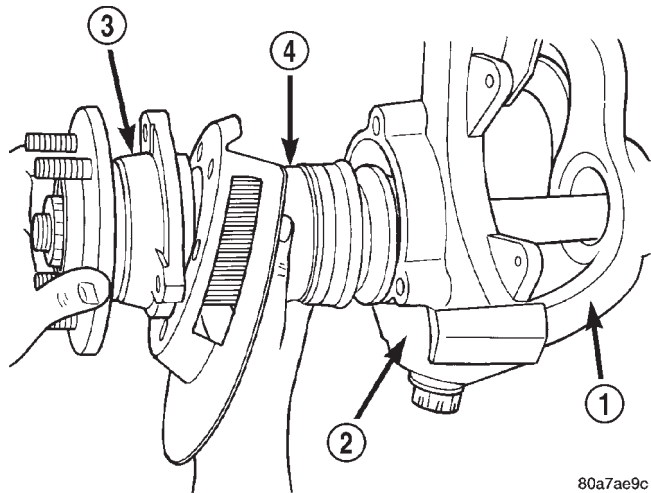

80a7ae9c

Fig. 24 Hub Bearing and Axle Assembly

- 1 - AXLE
- 2 - KNUCKLE
- 3 - HUB BEARING
- 4 - AXLE SHAFT

INSTALLATION

(1) Thoroughly clean the axle shaft (Fig. 22) and apply a thin film of Mopar® Wheel Bearing Grease, or equivalent, to the shaft splines, seal contact surface, and hub bore.

(2) Install the brake rotor shield to the knuckle.

(3) Install the hub bearing and axle shaft assembly, or axle shaft, into the housing and differential side gears. Avoid damaging the axle shaft oil seals in the axle housing.

(4) Install the hub bearing, if necessary.

(5) Install the hub to knuckle bolts and tighten to 102 N·m (75 ft. lbs.) torque.

(6) Install the hub washer and nut, if necessary. Tighten the hub nut to 237 N·m (175 ft. lbs.) torque. Install the nut retainer and a new cotter pin (Fig. 22).

(7) Install ABS wheel speed sensor, if necessary. Refer to Group 5, Brakes, for proper procedures.

(8) Install the brake rotor and caliper. Refer to Group 5, Brakes, for proper procedures.

(9) Install the wheel and tire assembly.

(10) Remove support and lower the vehicle.

STEERING KNUCKLE AND BALL STUDS

Ball stud service procedures below require removal of the hub bearing and axle shaft. Removal and installation of upper and lower ball studs require the use of Tool Kit 6289.

KNUCKLE REMOVAL

(1) Remove hub bearing and axle shaft.

(2) Disconnect the tie-rod or drag link from the steering knuckle arm. Refer to Group 2, Suspension, for proper procedures.

(3) Remove the cotter pins from the upper and lower ball studs.

(4) Remove the upper and lower ball stud nuts.

(5) Strike the steering knuckle with a brass hammer to loosen knuckle from the ball studs. Remove knuckle from ball studs (Fig. 25).

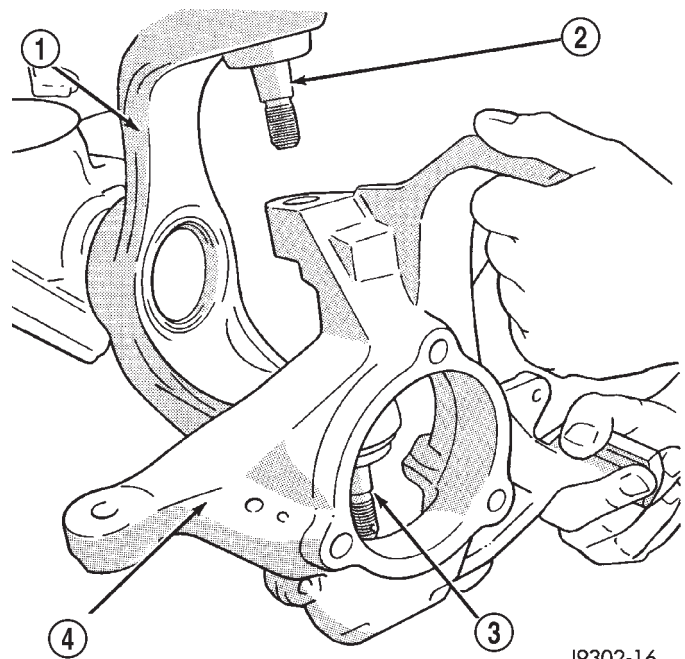

J9302-16

Fig. 25 Steering Knuckle Removal/Installation

- 1 - AXLE YOKE
- 2 - UPPER BALL STUD
- 3 - LOWER BALL STUD
- 4 - STEERING KNUCKLE

REMOVAL AND INSTALLATION (Continued)

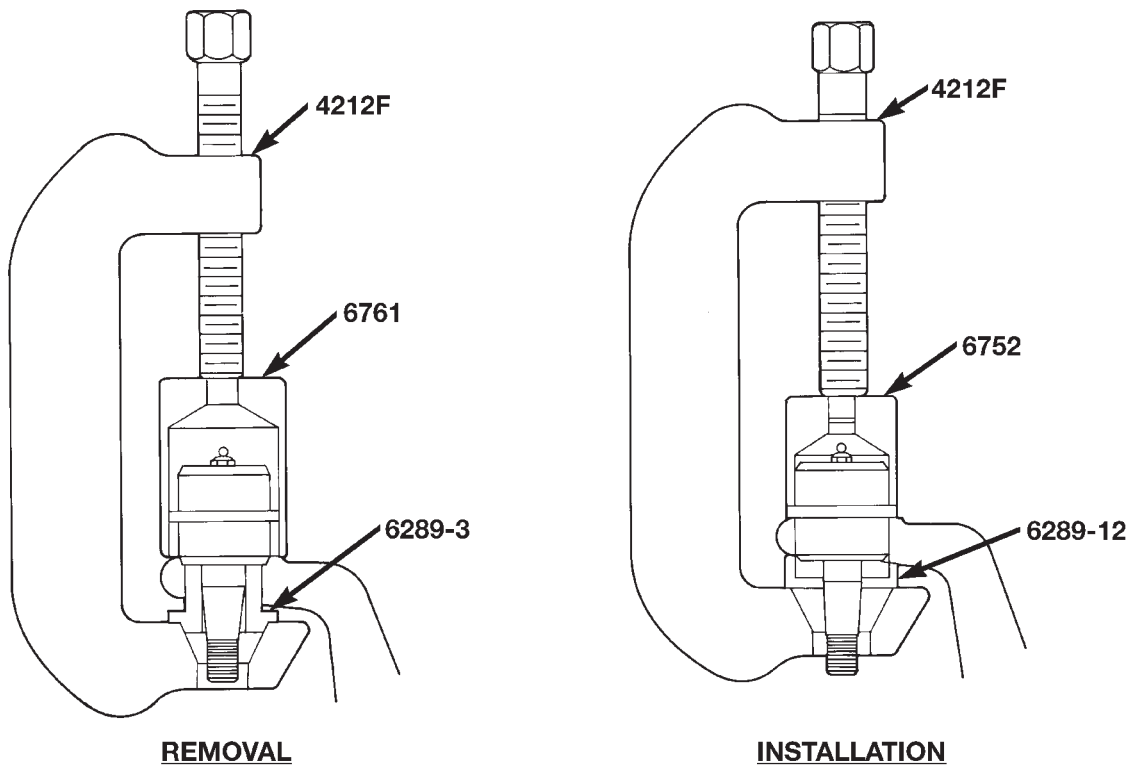
**Fig. 26 Upper Ball Stud Remove/Install**

80a7e2a7

UPPER BALL STUD REPLACEMENT

(1) Position tools as shown to remove and install ball stud (Fig. 26).

LOWER BALL STUD REPLACEMENT

(1) Position tools as shown to remove and install ball stud (Fig. 27).

KNUCKLE INSTALLATION

(1) Position the steering knuckle on the ball studs.

(2) Install and tighten the bottom retaining nut to 109 N·m (80 ft. lbs.) torque. Install new cotter pin.

(3) Install and tighten the top retaining nut to 101 N·m (75 ft. lbs.) torque. Install new cotter pin.

(4) Install the hub bearing and axle shaft.

(5) Connect the tie-rod or drag link end to the steering knuckle arm. Refer to Group 2, Suspension, for proper procedures.

REMOVAL AND INSTALLATION (Continued)

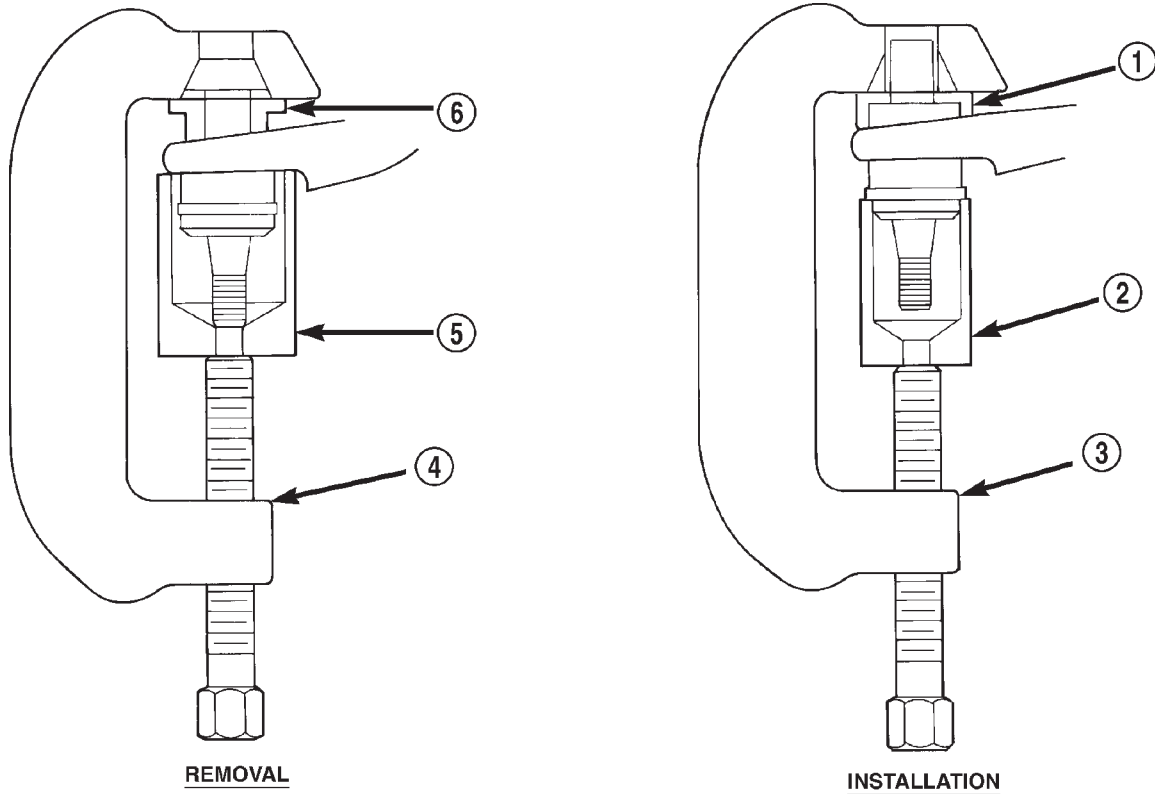

Fig. 27 Lower Ball Stud Remove/Install

80a7e2a8

- 1 - SPECIAL TOOL 6289-12
- 2 - SPECIAL TOOL 6289-4
- 3 - SPECIAL TOOL 4212F

- 4 - SPECIAL TOOL 4212F
- 5 - SPECIAL TOOL 6289-1
- 6 - SPECIAL TOOL 6289-3

AXLE BUSHING REPLACEMENT

Refer to Group 2, Suspension, for the proper axle bushing procedures.

DIFFERENTIAL

REMOVAL

- (1) Raise and support vehicle.
- (2) Remove the lubricant fill hole plug from the differential housing cover.
- (3) Remove the differential housing cover and allow fluid to drain.
- (4) Remove hub bearings and axle shafts.
- (5) Note the installation reference letters stamped on the bearing caps and housing machined sealing surface (Fig. 28).
- (6) Loosen the differential bearing cap bolts.
- (7) Position Spreader W-129-B, utilizing some items from Adapter Kit 6987, with the tool dowel pins seated in the locating holes (Fig. 29). Install the holddown clamps and tighten the tool turnbuckle finger-tight.

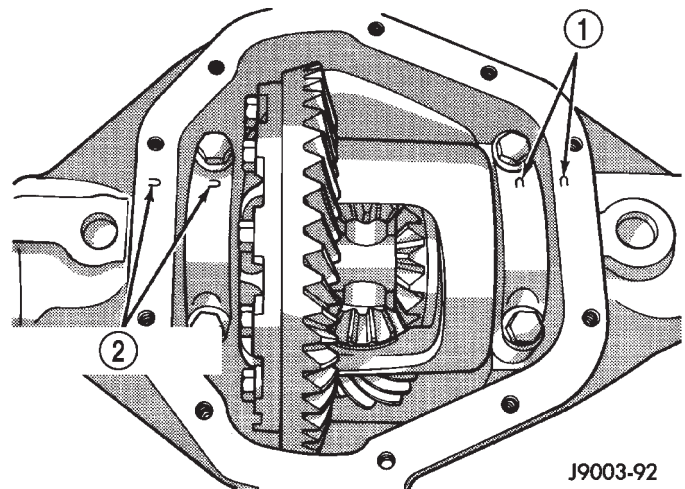

J9003-92

Fig. 28 Bearing Cap Identification

- 1 - INSTALLATION REFERENCE LETTERS
- 2 - INSTALLATION REFERENCE LETTERS

REMOVAL AND INSTALLATION (Continued)

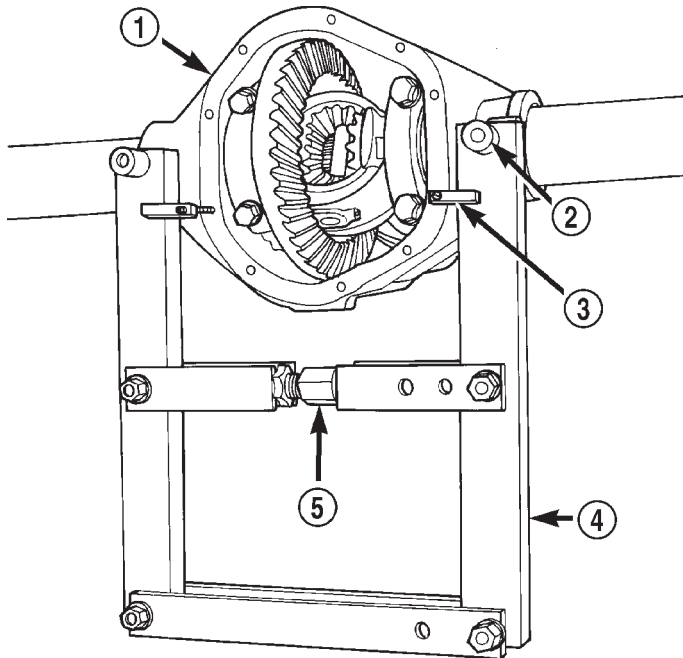
**Fig. 29 Install Axle Housing Spreader**

80a534c5

- 1 - AXLE HOUSING
- 2 - DOWEL
- 3 - SAFETY HOLD DOWN
- 4 - SPECIAL TOOL
W-129-B
- 5 - TURNBUCKLE

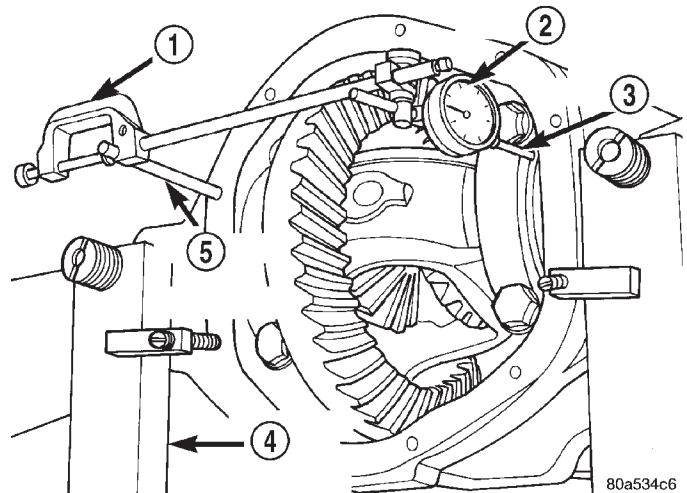

80a534c6

Fig. 30 Install Dial Indicator

- 1 - SPECIAL TOOL
C-3339
- 2 - DIAL INDICATOR
- 3 - LEVER ADAPTER
- 4 - SPECIAL TOOL
W-129-B
- 5 - SPECIAL TOOL
C-3288-B

(8) Install a Guide Pin C-3288-B at the left side of the differential housing. Attach Dial Indicator C-3339 to guide pin. Load the lever adapter against the opposite side of the housing (Fig. 30) and zero the indicator.

CAUTION: Do not spread over 0.50 mm (0.020 in). If the housing is over-spread, it could be distorted or damaged.

(9) Spread the housing enough to remove the differential case from the housing. Measure the distance with the dial indicator (Fig. 31).

(10) Remove the dial indicator.

(11) While holding the differential case in position, remove the differential bearing cap bolts and caps.

(12) Remove the differential, and the differential preload shims for the 181FBI axles, from the housing. Ensure that the differential bearing cups remain in position on the differential bearings (Fig. 32).

(13) Mark or tag the differential bearing cups, and the differential preload shims for the 181FBI axles, to indicate which side of the differential they were removed from.

(14) Remove spreader from housing.

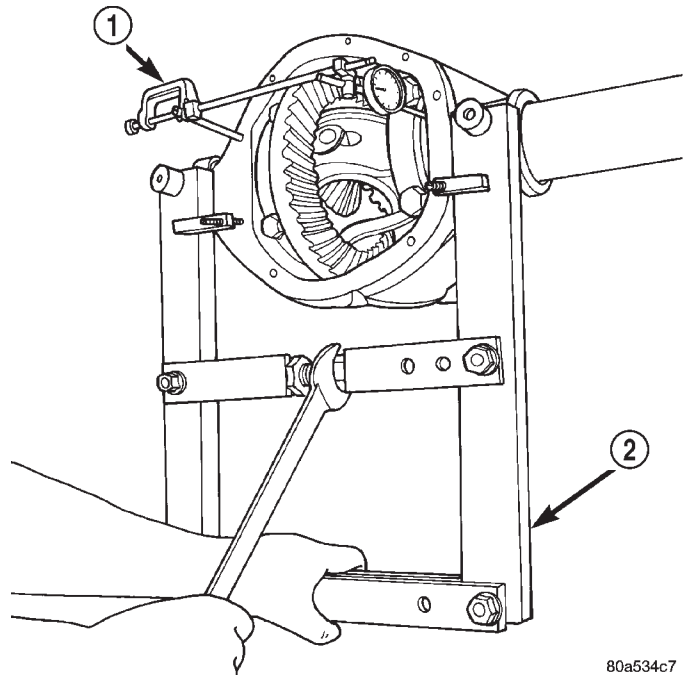

80a534c7

Fig. 31 Spread Axle Housing

- 1 - SPECIAL TOOL
C-3339
- 2 - SPECIAL TOOL
W-129-B

REMOVAL AND INSTALLATION (Continued)

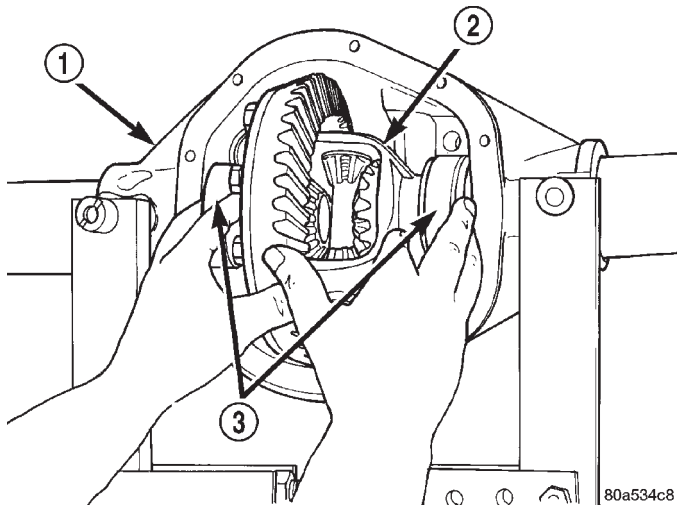

Fig. 32 Differential Case Removal

- 1 - AXLE HOUSING
- 2 - DIFFERENTIAL CASE
- 3 - BEARING CUPS

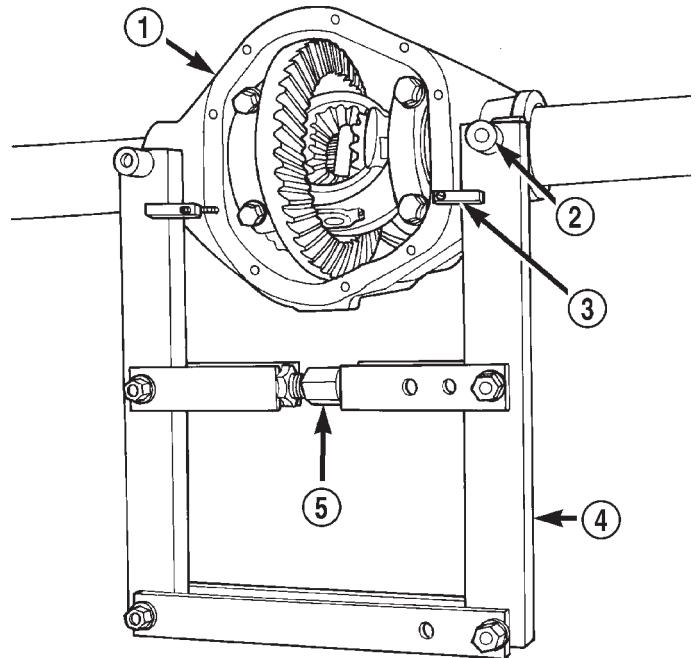

Fig. 33 Install Axle Housing Spreader

- 1 - AXLE HOUSING
- 2 - DOWEL
- 3 - SAFETY HOLD DOWN
- 4 - SPECIAL TOOL W-129-B
- 5 - TURNBUCKLE

INSTALLATION

If replacement differential bearings or differential case are being installed, differential side bearing shim requirements may change. Refer to the Differential Bearing Preload and Gear Backlash procedures in this section to determine the proper shim selection.

(1) Position Spreader W-129-B, utilizing some items from Adapter Kit 6987, with the tool dowel pins seated in the locating holes (Fig. 33). Install the holddown clamps and tighten the tool turnbuckle finger-tight.

(2) Install a Guide Pin C-3288-B at the left side of the differential housing. Attach Dial Indicator C-3339 to guide pin. Load the lever adapter against the opposite side of the housing (Fig. 30) and zero the indicator.

CAUTION: Do not spread over 0.50 mm (0.020 in). If the housing is over-spread, it could be distorted or damaged.

(3) Spread the housing enough to install the case in the housing. Measure the distance with the dial indicator (Fig. 31).

(4) Remove the dial indicator.

(5) Install differential case, and the differential preload shims for the 181FBI axles, in the housing. Ensure that the differential bearing cups remain in position on the differential bearings. Tap the differential case to ensure the bearings cups are fully seated in the housing.

(6) Install the bearing caps at their original locations (Fig. 34).

(7) Loosely install differential bearing cap bolts.

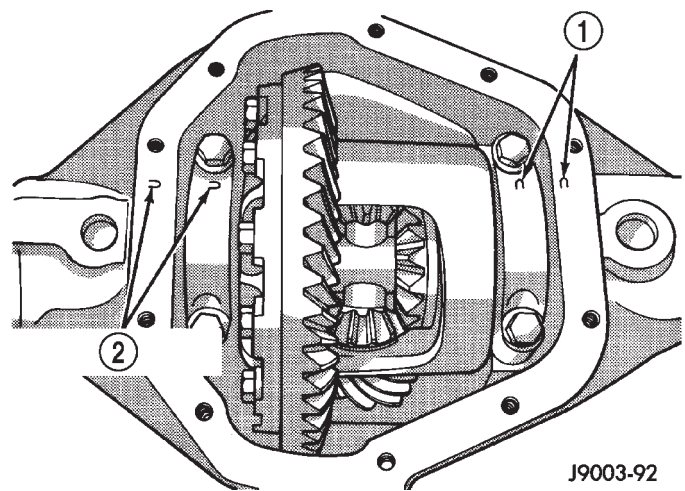

Fig. 34 Differential Bearing Cap Reference Letters

- 1 - INSTALLATION REFERENCE LETTERS
- 2 - INSTALLATION REFERENCE LETTERS

- (8) Remove axle housing spreader.
- (9) Tighten the bearing cap bolts to 61 N·m (45 ft. lbs.) torque.
- (10) Install the hub bearings and axle shafts.

REMOVAL AND INSTALLATION (Continued)

DIFFERENTIAL SIDE BEARINGS

REMOVAL

- (1) Remove differential case from axle housing.
- (2) Remove the bearings from the differential case with Puller/Press C-293-PA, C-293-39 Adapter Blocks, and Plug SP-3289 (Fig. 35).

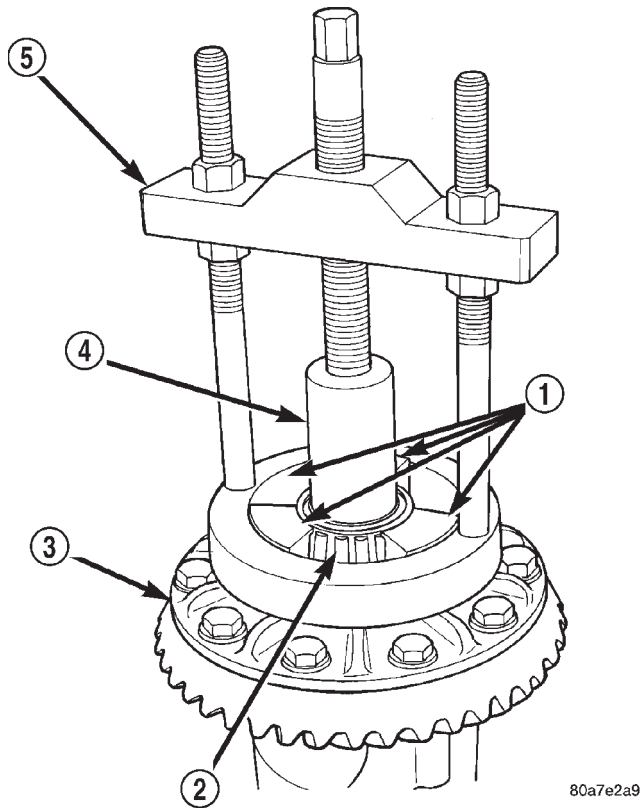

Fig. 35 Differential Bearing Removal

- 1 - SPECIAL TOOL C-293-39
- 2 - BEARING
- 3 - DIFFERENTIAL
- 4 - SPECIAL TOOL SP-3289
- 5 - SPECIAL TOOL C-293-PA

INSTALLATION

If replacement differential side bearings or differential case are being installed, differential side bearing shim requirements may change. Refer to the Differential Bearing Preload and Gear Backlash procedures in this section to determine the proper shim selection.

- (1) Install differential side bearing shims onto differential case hubs, for 186FBI axles.
- (2) Using Installer C-3716-A and Handle C-4171, install differential side bearings (Fig. 36).
- (3) Install differential in axle housing.

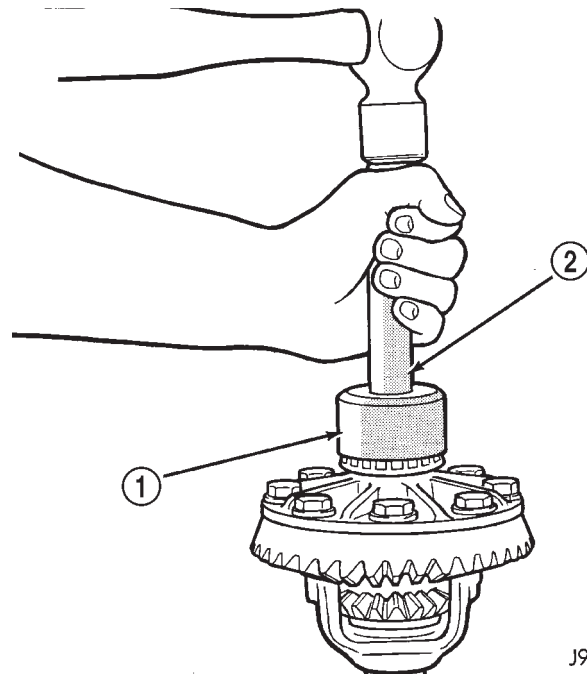

Fig. 36 Differential Side Bearing Installation

- 1 - SPECIAL TOOL C-3716-A
- 2 - SPECIAL TOOL C-4171

AXLE SHAFT OIL SEAL

REMOVAL

- (1) Raise and support vehicle.
- (2) Remove differential assembly.
- (3) Remove the inner axle shaft seals with a pry bar.

INSTALLATION

- (1) Remove any sealer remaining from original seals.
- (2) Remove sealer from axle tube to housing junction, if necessary.
- (3) Install oil seals with Discs 8110 and Turnbuckle 6797 (Fig. 37). Tighten tool until disc bottoms in housing.
- (4) Install differential assembly.

181 FBI PINION

The ring gear and pinion are serviced as a matched set. Do not replace the pinion without replacing the ring gear.

REMOVAL

- (1) Remove differential assembly from axle housing.
- (2) Mark pinion yoke and propeller shaft for installation alignment.
- (3) Disconnect propeller shaft from pinion yoke. Using suitable wire, tie propeller shaft to underbody.

REMOVAL AND INSTALLATION (Continued)

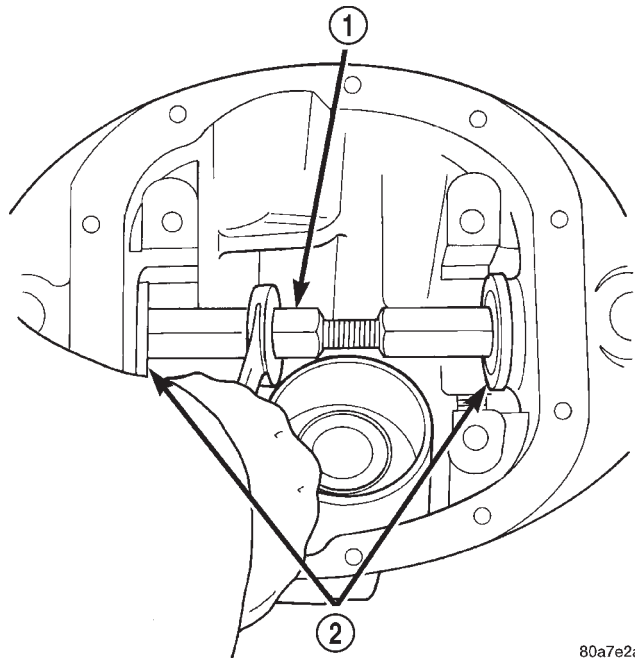

80a7e2aa

Fig. 37 Axle Seal Installation

- 1 - TURNBUCKLE 6797
- 2 - DISCS 8110

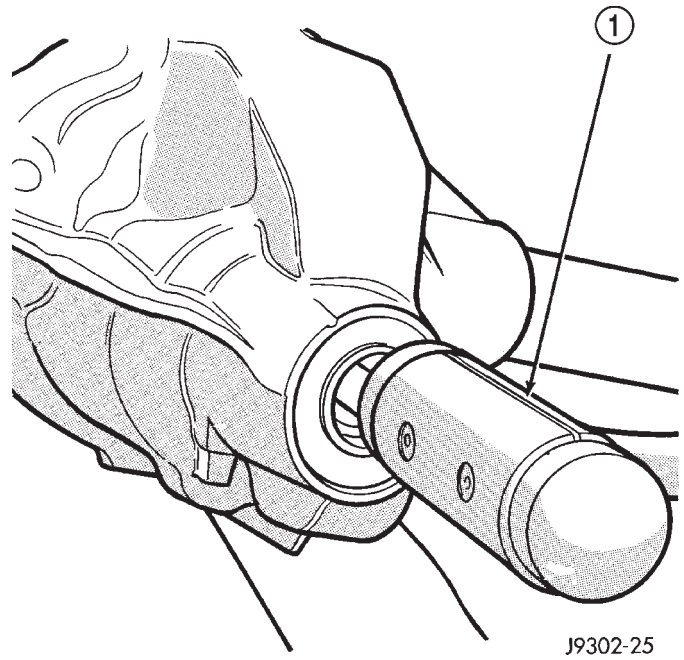

J9302-25

Fig. 39 Remove Pinion Gear

- 1 - RAWHIDE HAMMER

(4) Using Holder 6958 to hold yoke, remove the pinion nut and washer.

(5) Using Remover C-452 and Holder C-3281, remove the pinion yoke from pinion shaft (Fig. 38).

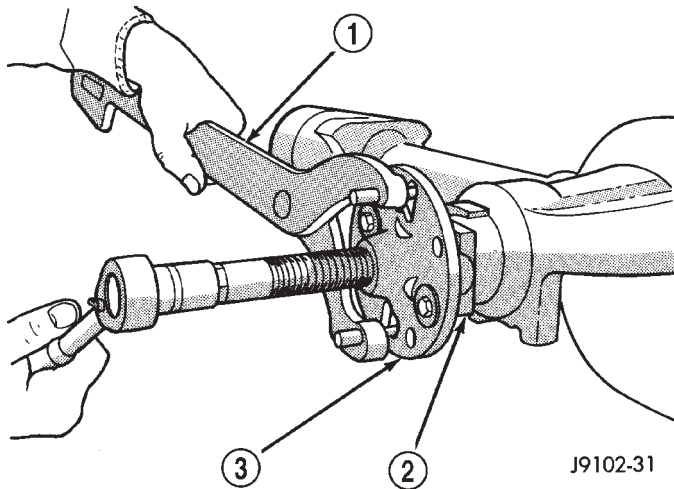

J9102-31

Fig. 38 Pinion Yoke Removal

- 1 - SPECIAL TOOL C-3281
- 2 - YOKE
- 3 - SPECIAL TOOL C-452

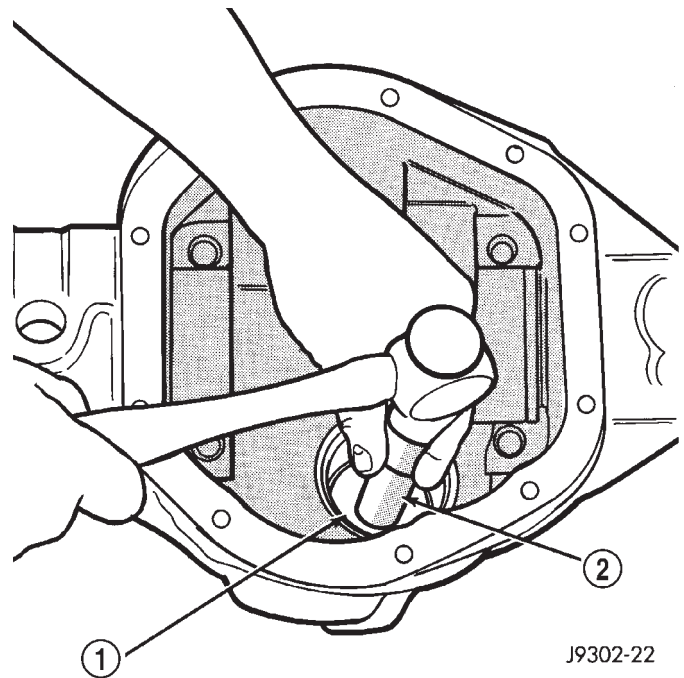

J9302-22

Fig. 40 Front Bearing Cup Removal

- 1 - REMOVER
- 2 - HANDLE

(6) Remove the pinion gear and preload shims from housing (Fig. 39). Catch the pinion with your hand to prevent it from falling and being damaged.

REMOVAL AND INSTALLATION (Continued)

(8) Remove the rear pinion bearing cup and oil slinger from the axle housing (Fig. 41). Use Remover D-149 and Handle C-4171. Record the thickness of the oil slinger for future reference.

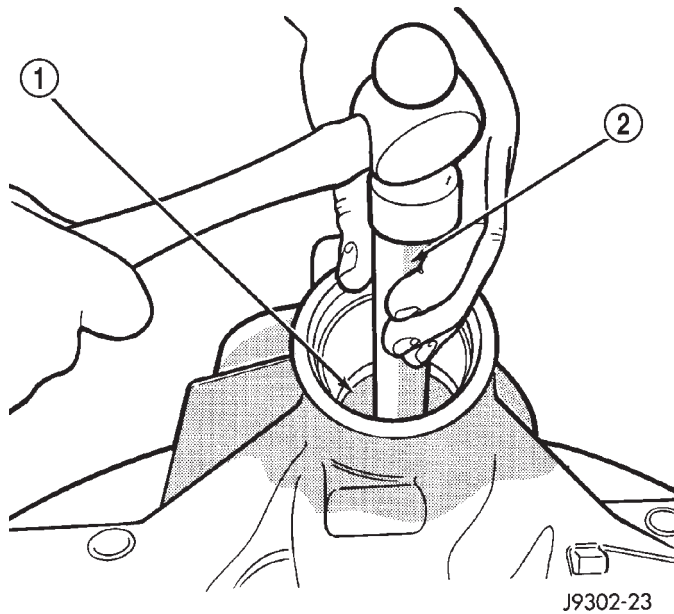

Fig. 41 Rear Bearing Cup Removal

- 1 - DRIVER
2 - HANDLE

(9) Remove the rear pinion bearing from the pinion with Puller/Press C-293-PA and Adapters C-293-39 (Fig. 42).

Place 4 adapter blocks so they do not damage the bearing cage.

(10) Remove the pinion depth shim/oil baffle from the pinion shaft. Record the thickness of the depth shim/oil baffle.

INSTALLATION

NOTE: A pinion depth shim/oil baffle is placed between the rear pinion bearing cone and pinion gear. If the factory installed ring and pinion gears are reused, the pinion depth shim/oil baffle should not require replacement. Refer to Pinion Gear Depth to select the proper thickness shim before installing pinion gear.

(1) Install a new oil slinger of the same thickness as the original into the rear pinion bearing bore of the axle housing.

(2) Apply Mopar® Door Ease, or equivalent, stick lubricant to outside surface of rear pinion bearing cup. Install the bearing cup with Installer D-146 and Handle C-4171 (Fig. 43). Verify cup is correctly seated.

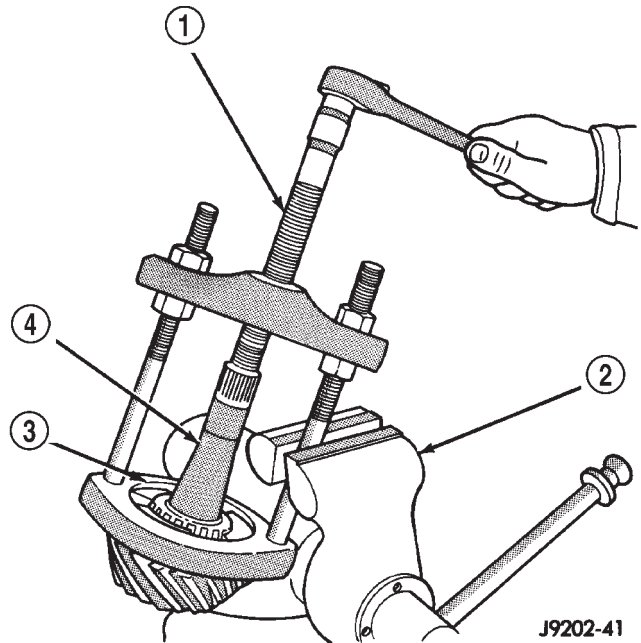

Fig. 42 Rear Bearing Removal

- 1 - SPECIAL TOOL C-293-PA
2 - VISE
3 - ADAPTERS
4 - DRIVE PINION GEAR SHAFT

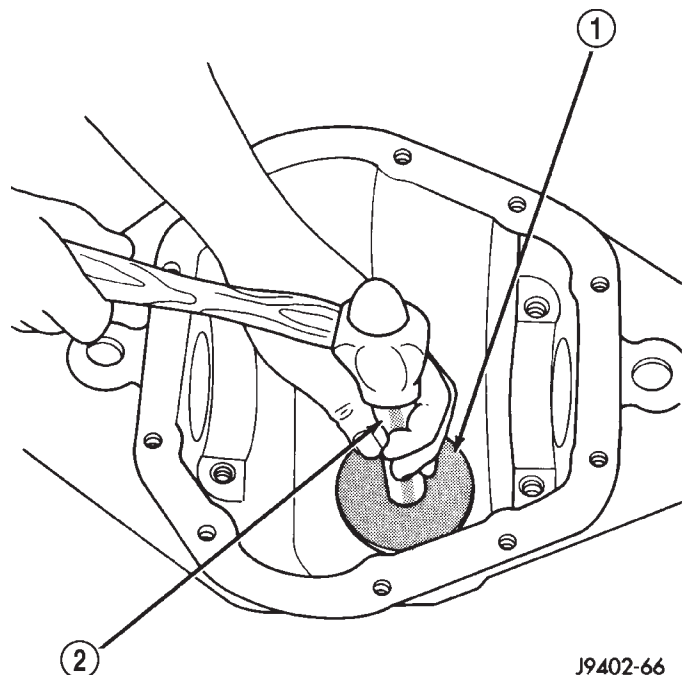
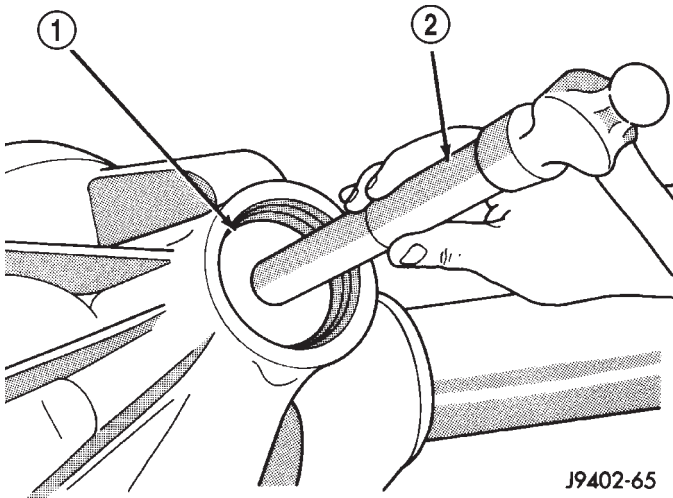

Fig. 43 Rear Pinion Bearing Cup Installation

- 1 - INSTALLER
2 - HANDLE

REMOVAL AND INSTALLATION (Continued)

(3) Apply Mopar® Door Ease, or equivalent, stick lubricant to outside surface of front pinion bearing cup. Install the bearing cup with Installer D-144 and Handle C-4171 (Fig. 44).



J9402-65

Fig. 44 Pinion Outer Bearing Cup Installation

- 1 - INSTALLER
- 2 - HANDLE

(4) Install front pinion bearing, and oil slinger, if equipped.

(5) Apply a light coating of gear lubricant on the lip of pinion seal. Install seal with Installer C-3972-A and Handle C-4171 (Fig. 45).

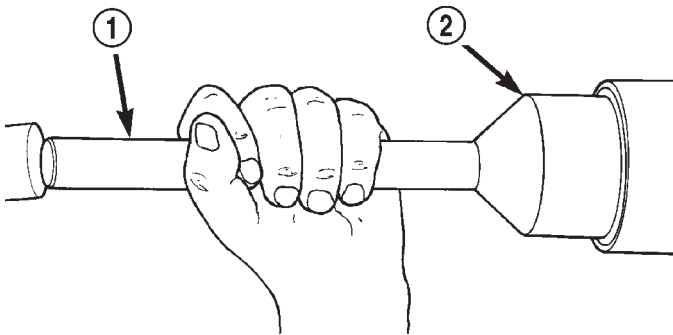

80a7e2be

Fig. 45 Pinion Seal Installation

- 1 - SPECIAL TOOL C-4171
- 2 - SPECIAL TOOL C-3972-A

(6) Install the rear pinion bearing and pinion depth shim/oil baffle onto the pinion gear with Installer W-262 and a shop press (Fig. 46).

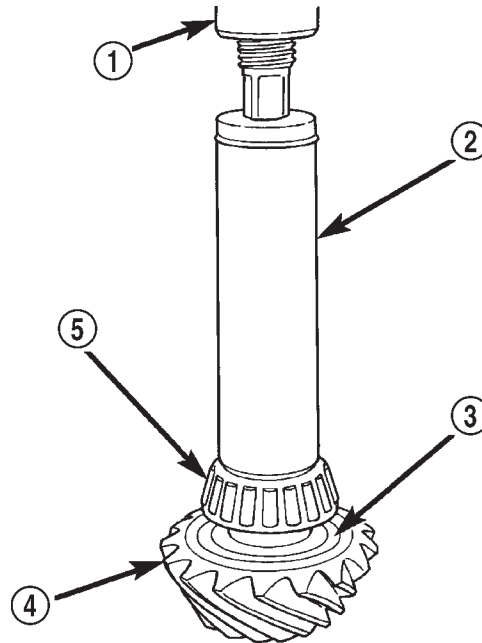

80be45fe

Fig. 46 Rear Pinion Bearing Installation

- 1 - PRESS
- 2 - INSTALLATION TOOL
- 3 - PINION DEPTH SHIM/OIL BAFFLE
- 4 - DRIVE PINION
- 5 - DRIVE PINION SHAFT REAR BEARING

(7) Install pinion bearing preload shims onto the pinion gear (Fig. 47).

(8) Install pinion gear in housing.

(9) Install yoke with Installer W-162-B, Cup 8109, and Holder 6958 (Fig. 48).

REMOVAL AND INSTALLATION (Continued)

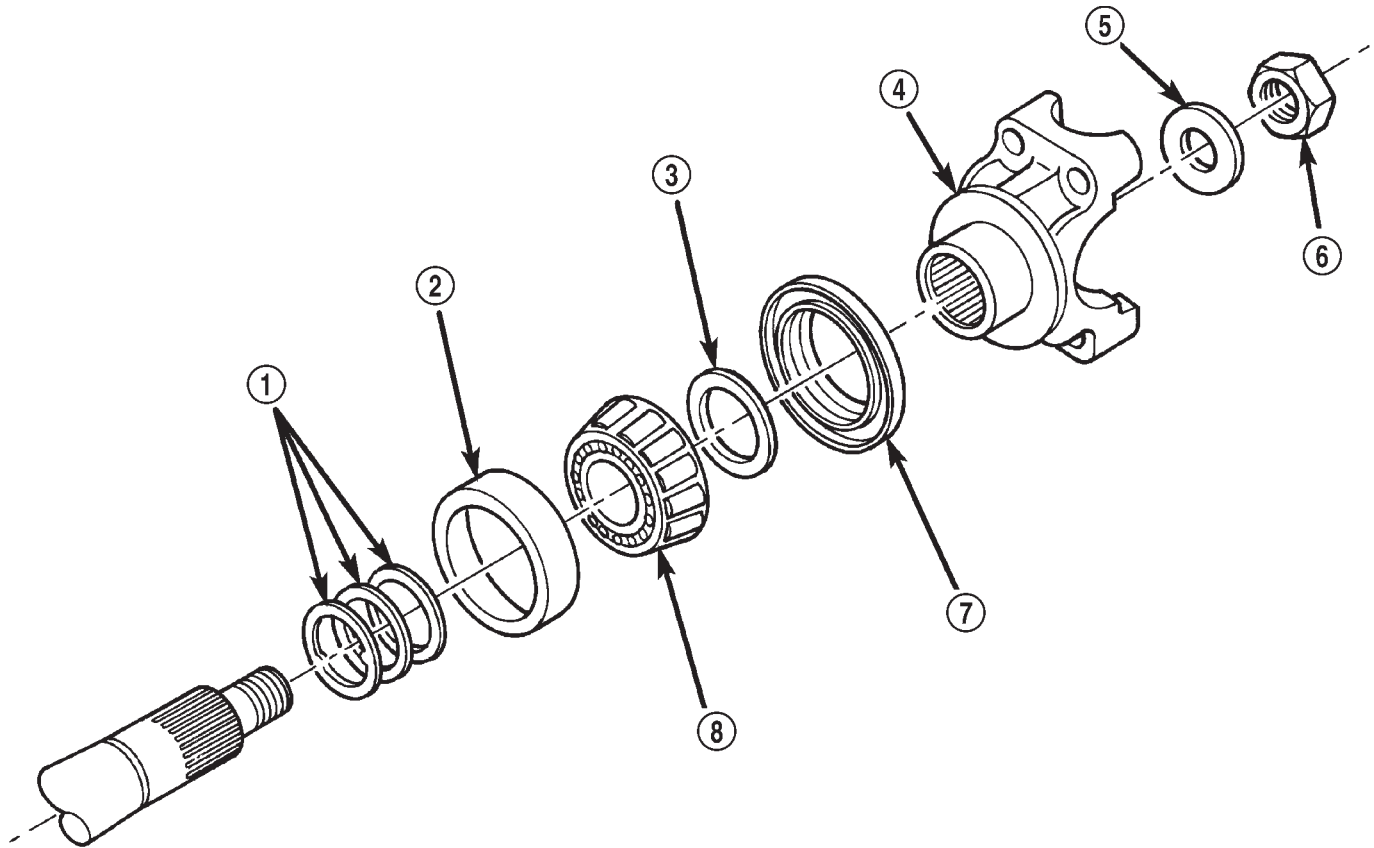
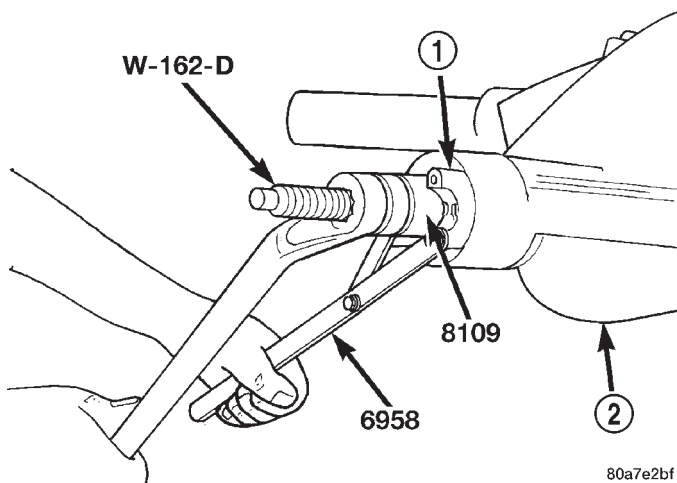

Fig. 47 Pinion Preload Shims—Typical

80ba45fc

- 1 - PINION PRELOAD SHIMS
- 2 - FRONT BEARING CUP
- 3 - SLINGER
- 4 - PINION YOKE

- 5 - WASHER
- 6 - PINION NUT
- 7 - PINION OIL SEAL
- 8 - FRONT BEARING CONE



80a7e2bf

Fig. 48 Pinion Yoke Installation

- 1 - PINION YOKE
- 2 - AXLE HOUSING

(10) Install the pinion washer and a new nut on the pinion gear. Tighten the nut to 217 N·m (160 ft. lbs.).

CAUTION: Never loosen pinion gear nut to decrease pinion gear bearing rotating torque and never exceed specified preload rotating torque.

(11) Check bearing preload torque with an inch pound torque wrench (Fig. 49). The torque necessary to rotate the pinion gear should be:

- Original Bearings—1 to 2 N·m (10 to 20 in. lbs.).
- New Bearings—1.5 to 4 N·m (15 to 35 in. lbs.).

(12) If rotating torque is above the desired amount, remove the pinion yoke and increase the preload shim pack thickness. Increasing the shim pack thickness 0.025 mm (0.001 in.) will decrease the rotating torque approximately 0.9 N·m (8 in. lbs.).

(13) Tighten pinion shaft nut in 6.8 N·m (5 ft. lbs.) increments until the maximum tightening or desired rotating torque is reached. Maximum tightening torque is 271 N·m (200 ft.lbs.).

REMOVAL AND INSTALLATION (Continued)

(14) If the maximum tightening torque is reached prior to achieving the desired rotating torque, remove the pinion yoke and decrease the thickness of the preload shim pack. Decreasing the shim pack thickness 0.025 mm (0.001 in.) will increase the rotating torque approximately 0.9 N·m (8 in. lbs.).

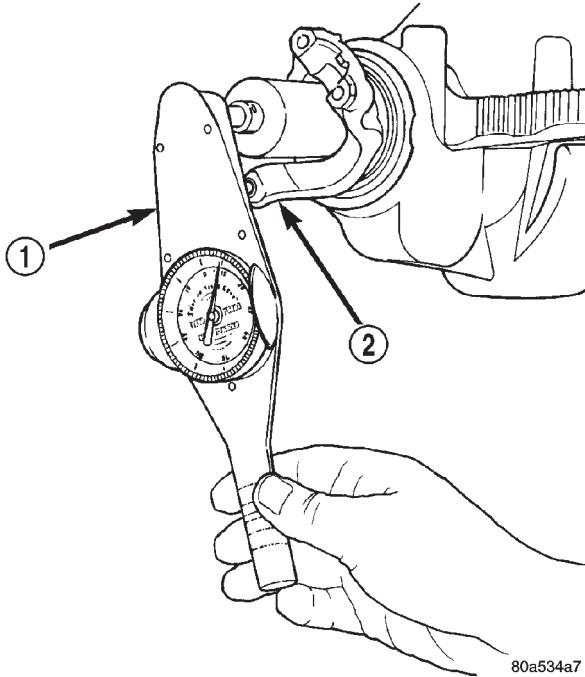

Fig. 49 Check Pinion Gear Rotating Torque

- 1 - in. lbs. TORQUE WRENCH
- 2 - PINION YOKE

(15) Install differential assembly.

186 FBI PINION

The ring gear and pinion are serviced as a matched set. Do not replace the pinion without replacing the ring gear.

REMOVAL

- (1) Remove differential assembly from axle housing.
- (2) Mark pinion yoke and propeller shaft for installation alignment.
- (3) Disconnect propeller shaft from pinion yoke. Using suitable wire, tie propeller shaft to underbody.

(4) Using Holder 6958 to the hold yoke, remove the pinion nut and washer (Fig. 50).

(5) Using Remover C-452 and Holder C-3281, remove the pinion yoke from pinion shaft (Fig. 51).

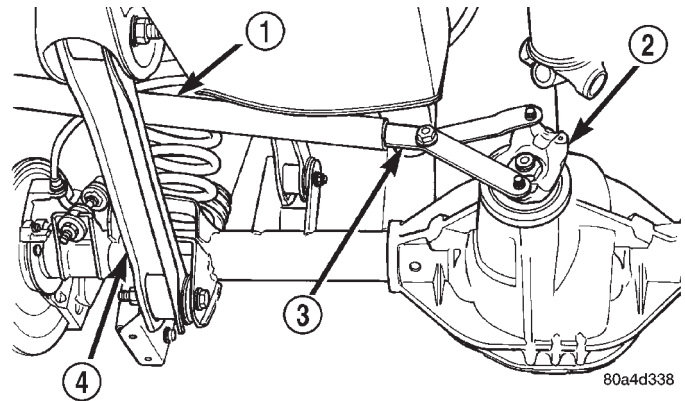

Fig. 50 Pinion Yoke Holder—Typical

- 1 - 1 in. PIPE
- 2 - PINION YOKE
- 3 - SPECIAL TOOL 6958
- 4 - LOWER CONTROL ARM

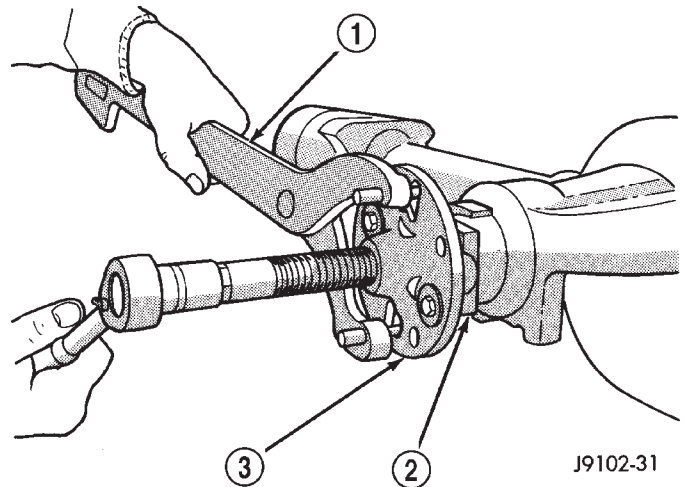
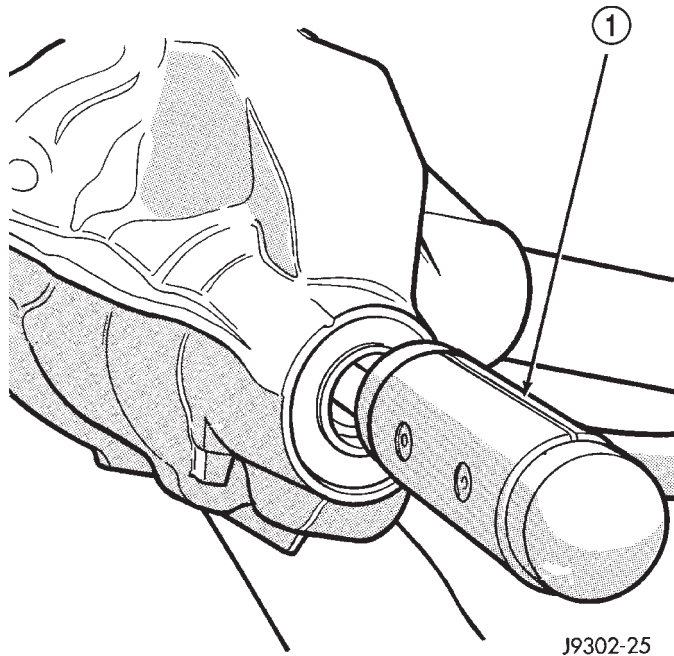

Fig. 51 Pinion Yoke Removal

- 1 - SPECIAL TOOL C-3281
- 2 - YOKE
- 3 - SPECIAL TOOL C-452

REMOVAL AND INSTALLATION (Continued)

(6) Remove the pinion and collapsible spacer from housing (Fig. 52). Catch the pinion with your hand to prevent it from falling and being damaged.



J9302-25

Fig. 52 Remove Pinion

- 1 - RAWHIDE HAMMER

(7) Remove the front pinion bearing cup, bearing, oil slinger, if equipped, and pinion seal with Remover C-4345 and Handle C-4171 (Fig. 53).

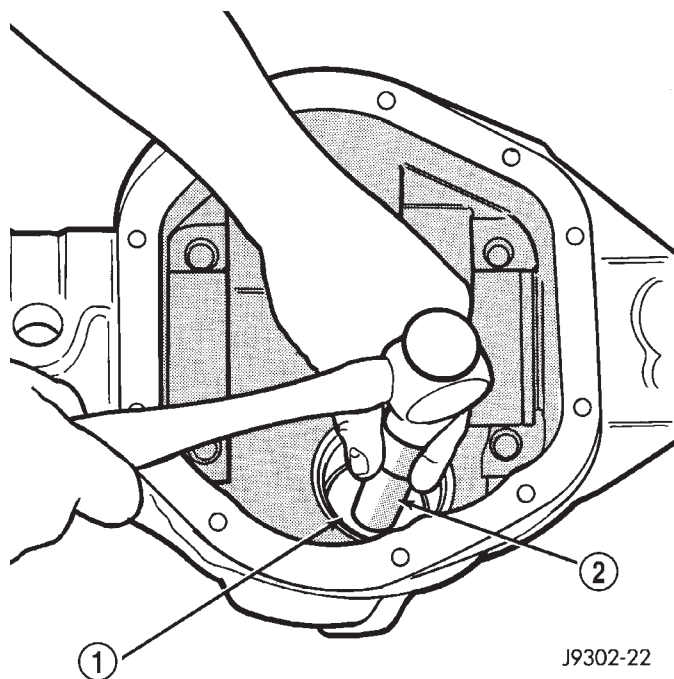

J9302-22

Fig. 53 Front Bearing Cup Removal

- 1 - REMOVER
- 2 - HANDLE

(8) Remove the rear pinion bearing cup from axle housing (Fig. 54). Use Remover D-149 and Handle C-4171.

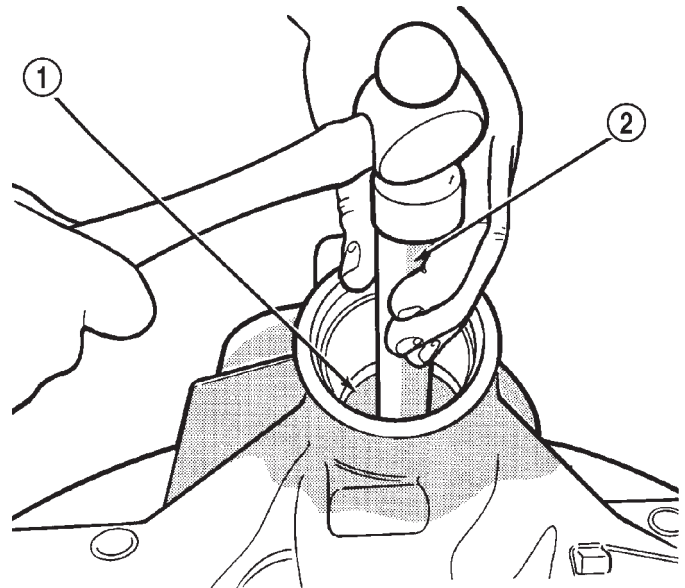

J9302-23

Fig. 54 Rear Bearing Cup Removal

- 1 - DRIVER
- 2 - HANDLE

(9) Remove the collapsible preload spacer from pinion gear (Fig. 55).

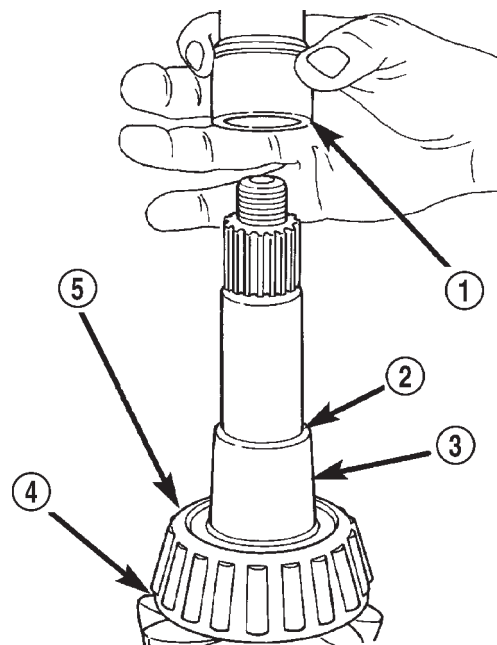

80be4606

Fig. 55 Collapsible Spacer

- 1 - COLLAPSIBLE SPACER
- 2 - SHOULDER
- 3 - PINION
- 4 - PINION DEPTH SHIM
- 5 - REAR BEARING

REMOVAL AND INSTALLATION (Continued)

(10) Remove the rear pinion bearing from the pinion with Puller/Press C-293-PA and Adapters C-293-39 (Fig. 56).

Place 4 adapter blocks so they do not damage the bearing cage.

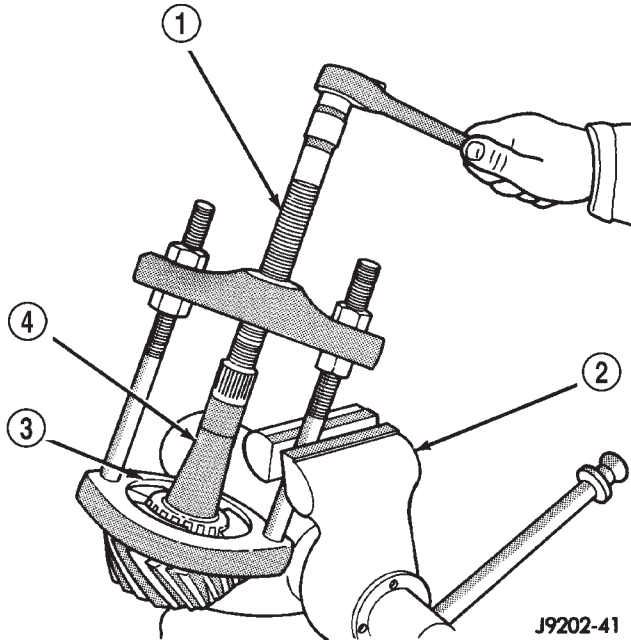

Fig. 56 Inner Bearing Removal

- 1 - SPECIAL TOOL C-293-PA
- 2 - VISE
- 3 - ADAPTERS
- 4 - DRIVE PINION GEAR SHAFT

(11) Remove the depth shim/oil slinger from the pinion shaft. Record the thickness of the depth shim/oil slinger.

INSTALLATION

NOTE: A pinion depth shim/oil slinger is placed between the rear pinion bearing cone and the pinion head to achieve proper ring gear and pinion mesh. If the factory installed ring gear and pinion are reused, the pinion depth shim/oil slinger should not require replacement. Refer to Pinion Gear Depth to select the proper thickness shim/oil slinger before installing pinion.

(1) Apply Mopar® Door Ease, or equivalent, stick lubricant to outside surface of rear pinion bearing cup. Install the bearing cup with Installer D-146 and Driver Handle C-4171 (Fig. 57). Verify cup is correctly seated.

(2) Apply Mopar® Door Ease, or equivalent, stick lubricant to outside surface of front pinion bearing cup. Install the bearing cup with Installer D-130 and Handle C-4171 (Fig. 58).

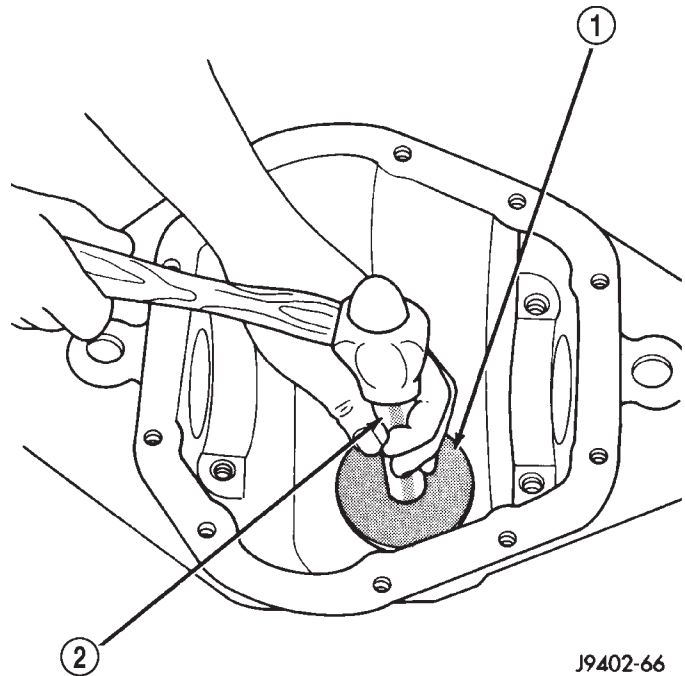

Fig. 57 Rear Pinion Bearing Cup Installation

- 1 - INSTALLER
- 2 - HANDLE

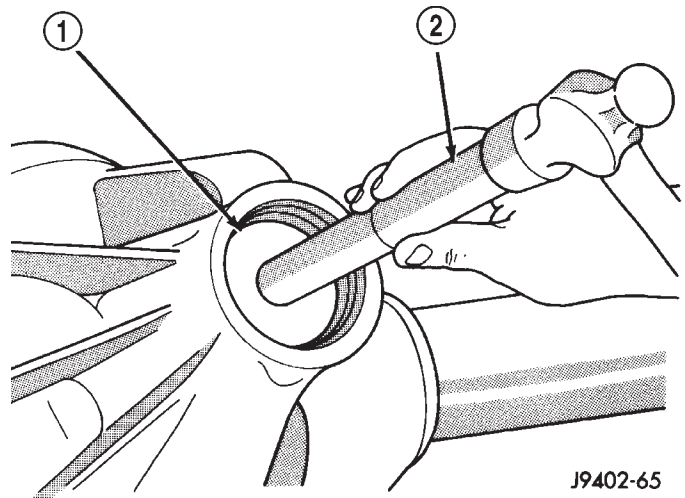

Fig. 58 Pinion Outer Bearing Cup Installation

- 1 - INSTALLER
- 2 - HANDLE

(3) Install front pinion bearing, and oil slinger, if equipped.

(4) Apply a light coating of gear lubricant on the lip of pinion seal. Install seal with Installer C-3972-A and Handle C-4171 (Fig. 59).

(5) Install the rear pinion bearing and the pinion depth shim/oil slinger onto the pinion with Installer W-262 and a shop press (Fig. 60).

REMOVAL AND INSTALLATION (Continued)

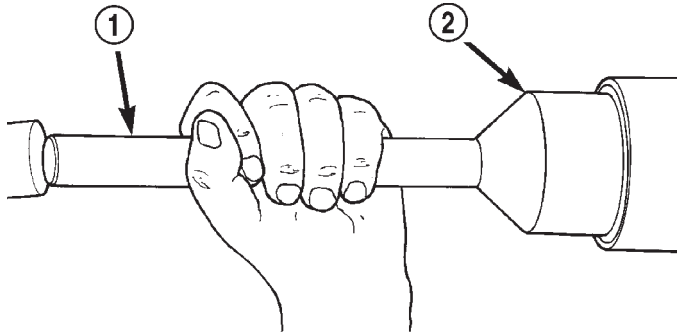

80a7e2be

Fig. 59 Pinion Seal Installation

- 1 - SPECIAL TOOL C-4171
- 2 - SPECIAL TOOL C-3972-A

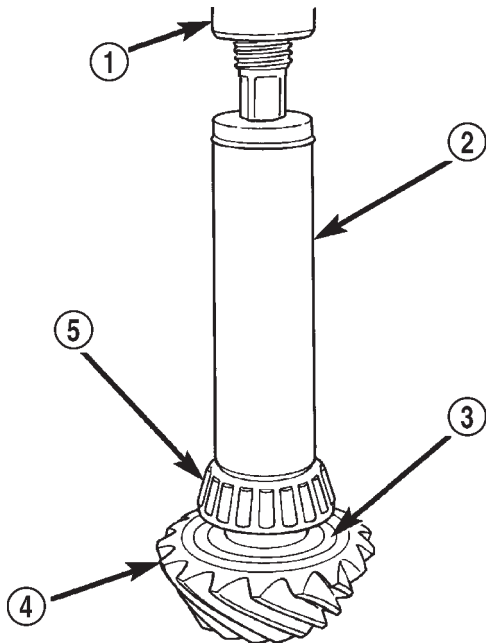

80be45fe

Fig. 60 Rear Pinion Bearing Installation

- 1 - PRESS
- 2 - INSTALLATION TOOL
- 3 - PINION DEPTH SHIM/OIL BAFFLE
- 4 - DRIVE PINION
- 5 - DRIVE PINION SHAFT REAR BEARING

(6) Install a new collapsible preload spacer on pinion shaft and install pinion in housing (Fig. 61).

(7) Install yoke with Installer W-162-B, Cup 8109, and Holder 6958 (Fig. 62).

(8) Install the pinion washer and a new nut onto the pinion. Tighten the nut to 216 N·m (160 ft. lbs.) minimum. **Do not over-tighten.** Maximum torque is 352 N·m (260 ft. lbs.).

CAUTION: Never loosen the pinion nut to decrease pinion bearing rotating torque and never exceed

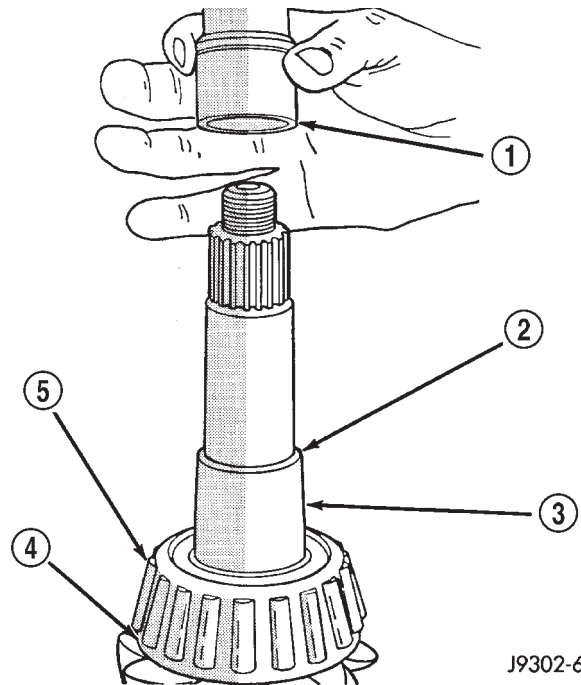

J9302-66

Fig. 61 Collapsible Preload Spacer

- 1 - COLLAPSIBLE SPACER
- 2 - SHOULDER
- 3 - PINION GEAR
- 4 - OIL SLINGER
- 5 - REAR BEARING

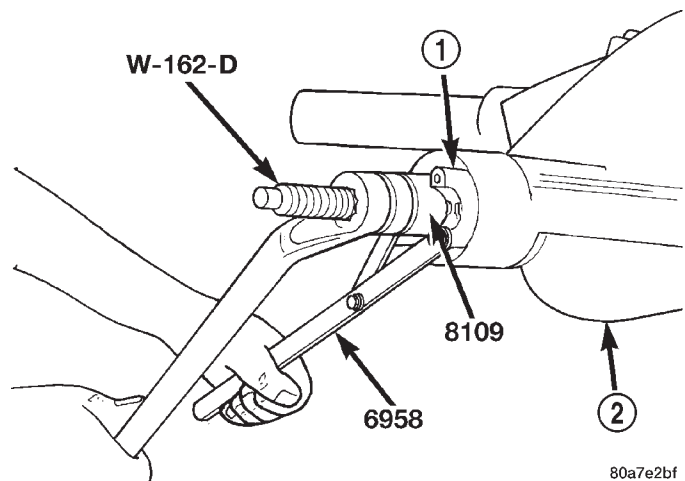

80a7e2bf

Fig. 62 Pinion Yoke Installation

- 1 - PINION YOKE
- 2 - AXLE HOUSING

specified preload torque. If preload torque is exceeded a new collapsible spacer must be installed. The torque sequence will then have to be repeated.

(9) Using Holder 6958 and torque wrench (set at 352 N·m (260 ft. lbs.)), crush collapsible spacer until

REMOVAL AND INSTALLATION (Continued)

bearing end play is taken up (Fig. 63). If more than 353 N·m (260 ft. lbs.) is needed to begin to collapse the spacer, the spacer is defective and must be replaced.

(10) Slowly tighten the nut in 6.8 N·m (5 ft. lb.) increments until the rotating torque is achieved. Measure the rotating torque frequently to avoid over crushing the collapsible spacer (Fig. 64).

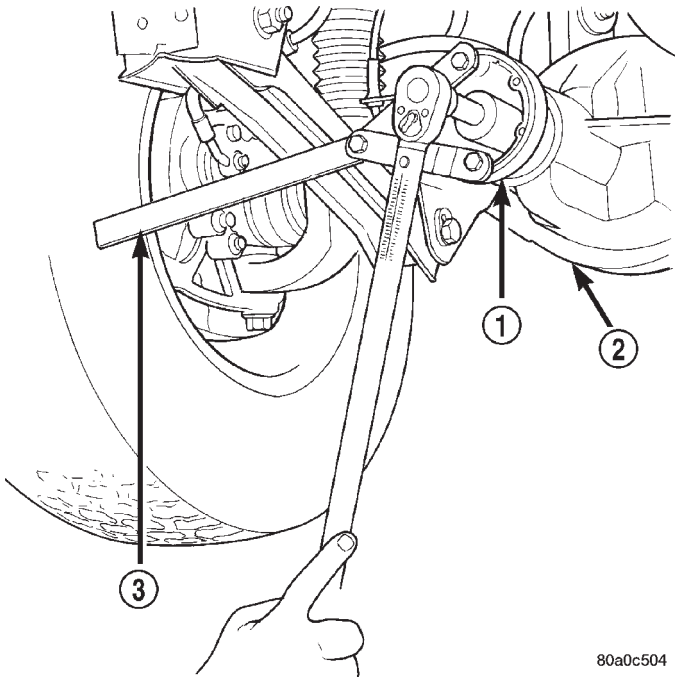

Fig. 63 Tightening Pinion Nut—Typical

- 1 - PINION FLANGE
- 2 - FRONT AXLE
- 3 - TOOL 6958

(11) Check bearing rotating torque with an inch pound torque wrench (Fig. 64). The torque necessary to rotate the pinion should be:

- Original Bearings — 1 to 2 N·m (10 to 20 in. lbs.).
 - New Bearings — 1.5 to 4 N·m (15 to 35 in. lbs.).
- (12) Install differential assembly.

RING GEAR

NOTE: The ring gear and pinion are serviced as a matched set. Do not replace the ring gear without replacing the pinion.

REMOVAL

- (1) Remove differential from axle housing.
- (2) Place differential case in a suitable vise with soft metal jaw protectors. (Fig. 65)
- (3) Remove bolts holding ring gear to differential case.

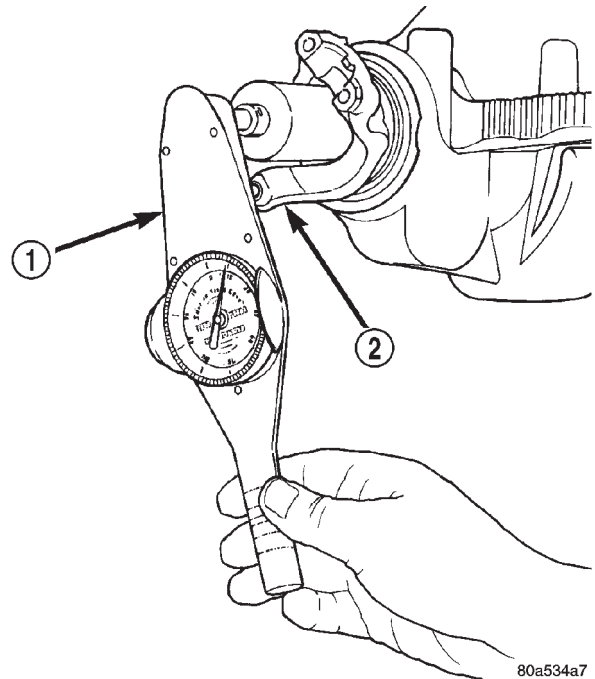

Fig. 64 Check Pinion Rotation Torque

- 1 - in. lbs. TORQUE WRENCH
- 2 - PINION YOKE

(4) Using a soft hammer, drive ring gear from differential case (Fig. 65).

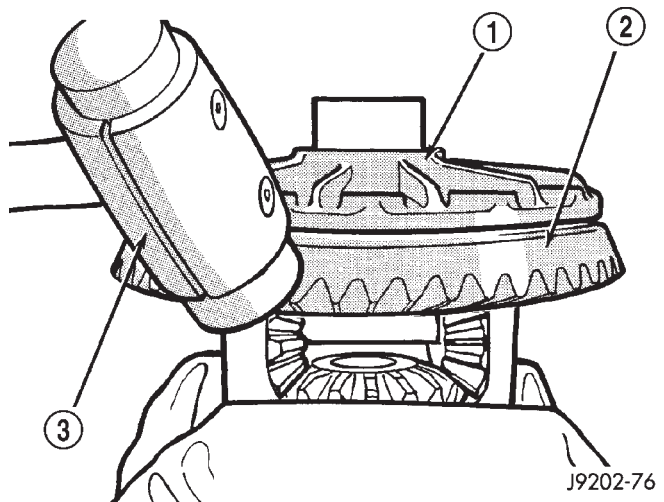

Fig. 65 Ring Gear Removal

- 1 - CASE
- 2 - RING GEAR
- 3 - RAWHIDE HAMMER

INSTALLATION

CAUTION: Do not reuse the bolts that held the ring gear to the differential case. The bolts can fracture causing extensive damage.

REMOVAL AND INSTALLATION (Continued)

(1) Invert the differential case and start two ring gear bolts. This will provide case-to-ring gear bolt hole alignment.

(2) Invert the differential case in the vise.

(3) Install new ring gear bolts and alternately tighten to 95–122 N·m (70–90 ft. lbs.) torque (Fig. 66).

(4) Install differential in axle housing and verify gear mesh and contact pattern.

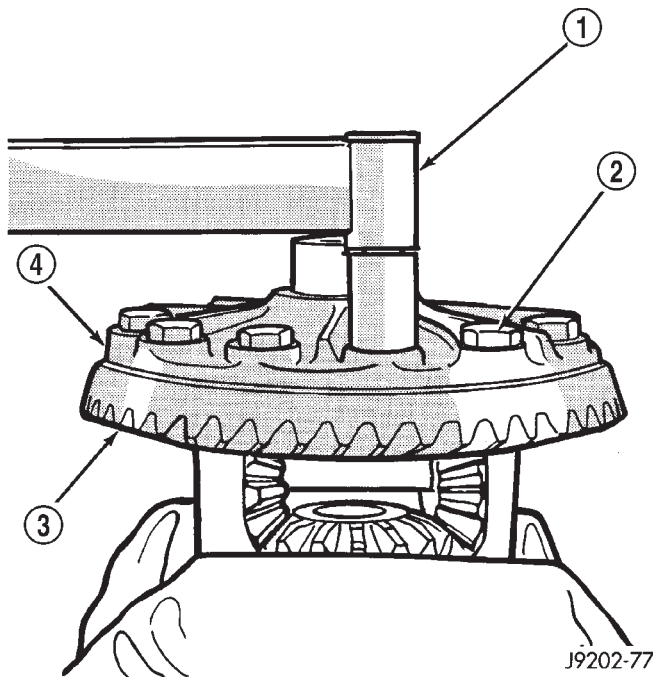

Fig. 66 Ring Gear Bolt Installation

- 1 - TORQUE WRENCH
- 2 - RING GEAR BOLT
- 3 - RING GEAR
- 4 - CASE

DISASSEMBLY AND ASSEMBLY

STANDARD DIFFERENTIAL

DISASSEMBLY

(1) Remove the ring gear.

(2) Using a suitable roll pin punch, drive out the roll pin holding pinion gear mate shaft in the differential case (Fig. 67).

(3) Remove the pinion gear mate shaft from the differential case and the pinion mate gears.

(4) Rotate differential side gears and remove the pinion mate gears and thrust washers (Fig. 68).

(5) Remove the differential side gears and thrust washers.

ASSEMBLY

(1) Install the differential side gears and thrust washers.

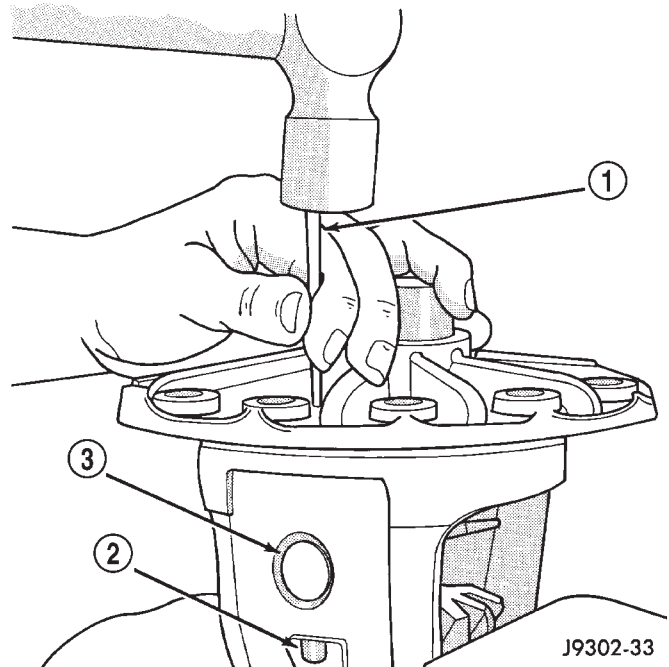

Fig. 67 Mate Shaft Roll Pin Removal

- 1 - DRIFT
- 2 - LOCKPIN
- 3 - MATE SHAFT

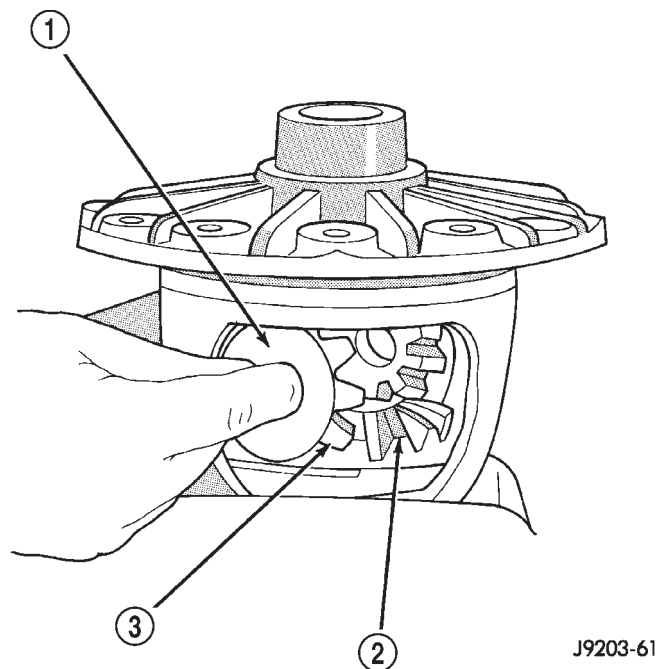

Fig. 68 Pinion Mate Gear Removal

- 1 - THRUST WASHER
- 2 - SIDE GEAR
- 3 - PINION MATE GEAR

(2) Install the pinion mate gears and thrust washers.

DISASSEMBLY AND ASSEMBLY (Continued)

(3) Install the pinion gear mate shaft. Align the roll pin holes in shaft and the differential case.

(4) Install the roll pin to hold the pinion mate shaft in the differential case (Fig. 69).

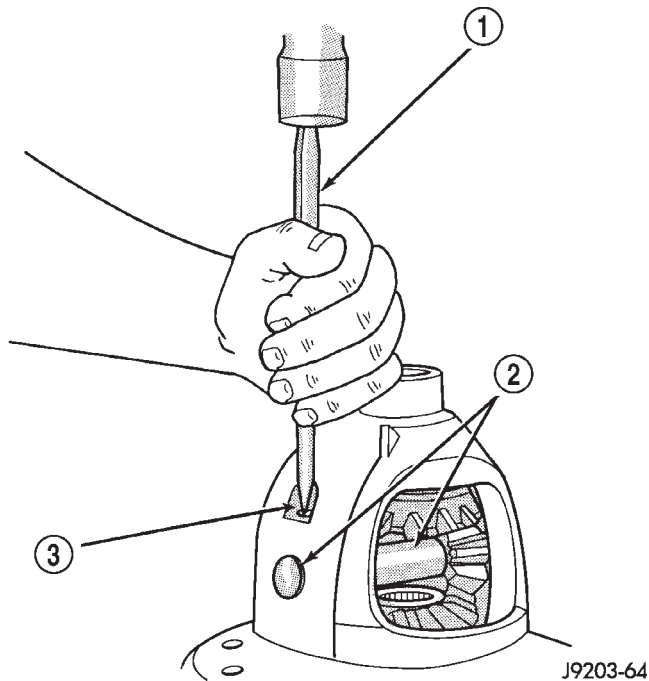

Fig. 69 Mate Shaft Roll Pin Installation

- 1 - PUNCH
2 - PINION MATE SHAFT
3 - MATE SHAFT LOCKPIN

(5) Install the ring gear.

(6) Lubricate all differential components with hypoid gear lubricant.

FINAL ASSEMBLY

(1) Scrape the residual sealant from the housing and cover mating surfaces. Clean the mating surfaces with mineral spirits. Apply a bead of Mopar® Silicone Rubber Sealant, or equivalent, on the housing cover (Fig. 70).

Install the housing cover within 5 minutes after applying the sealant.

(2) Install the cover on the differential with the attaching bolts. Install the identification tag. Tighten the cover bolts to 41 N·m (30 ft. lbs.) torque.

CAUTION: Overfilling the differential can result in lubricant foaming and overheating.

(3) Refill the differential housing with gear lubricant. Refer to the Lubricant Specifications section of this group for the gear lubricant requirements.

(4) Install the fill hole plug.

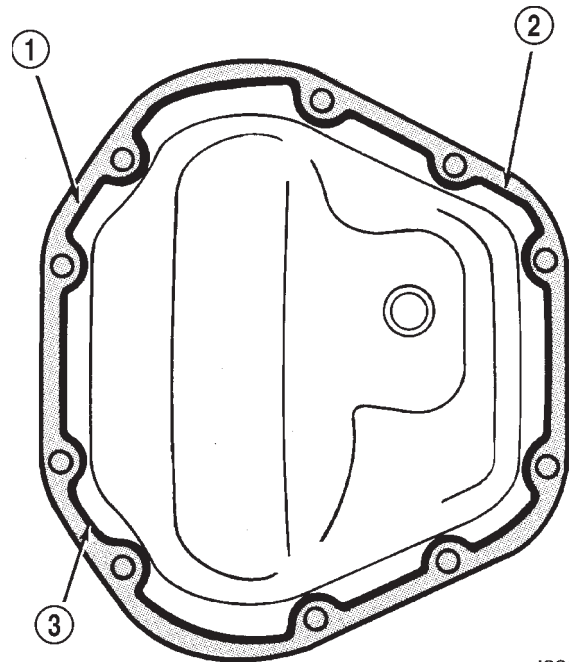

J9302-30

Fig. 70 Typical Housing Cover With Sealant

- 1 - SEALING SURFACE
2 - CONTOUR OF BEAD
3 - BEAD THICKNESS 6.35mm (1/4")

CLEANING AND INSPECTION

CARDAN U-JOINT

Clean all the U-joint yoke bores with cleaning solvent and a wire brush. Ensure that all the rust and foreign matter are removed from the bores.

Inspect the yokes for distortion, cracks and worn bearing cap bores.

Replace the complete U-joint if any of the components are defective.

AXLE COMPONENTS

Wash differential components with cleaning solvent and dry with compressed air. **Do not steam clean the differential components.**

Wash bearings with solvent and towel dry, or dry with compressed air. **DO NOT spin bearings with compressed air. Cup and bearing must be replaced as matched sets only.**

Clean axle shaft tubes and oil channels in housing. Inspect for;

- Smooth appearance with no broken/dented surfaces on the bearing rollers or the roller contact surfaces.
- Bearing cups must not be distorted or cracked.
- Machined surfaces should be smooth and without any raised edges.
- Raised metal on shoulders of cup bores should be removed with a hand stone.

CLEANING AND INSPECTION (Continued)

- Wear and damage to pinion gear mate shaft, pinion gears, side gears and thrust washers. Replace as a matched set only.
- Ring and pinion gear for worn and chipped teeth.
- Ring gear for damaged bolt threads. Replaced as a matched set only.
- Pinion yoke for cracks, worn splines, pitted areas, and a rough/corroded seal contact surface. Repair or replace as necessary.
- Preload shims for damage and distortion. Install new shims, if necessary.

ADJUSTMENTS

181 FBI PINION GEAR DEPTH

GENERAL INFORMATION

Ring and pinion gears are supplied as matched sets only. The identifying numbers for the ring and pinion gear are etched into the face of each gear (Fig. 71). A plus (+) number, minus (-) number or zero (0) is etched into the face of the pinion gear. This number is the amount (in thousandths of an inch) the depth varies from the standard depth setting of a pinion etched with a (0). The standard setting from the center line of the ring gear to the back face of the pinion is 92.08 mm (3.625 in.). The standard depth provides the best gear tooth contact pattern. Refer to Backlash and Contact Pattern Analysis paragraph in this section for additional information.

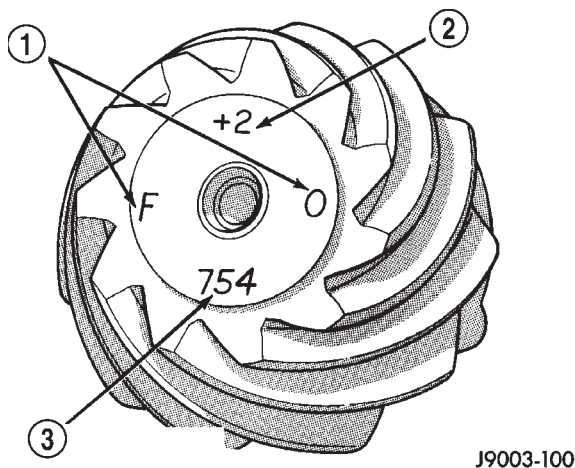
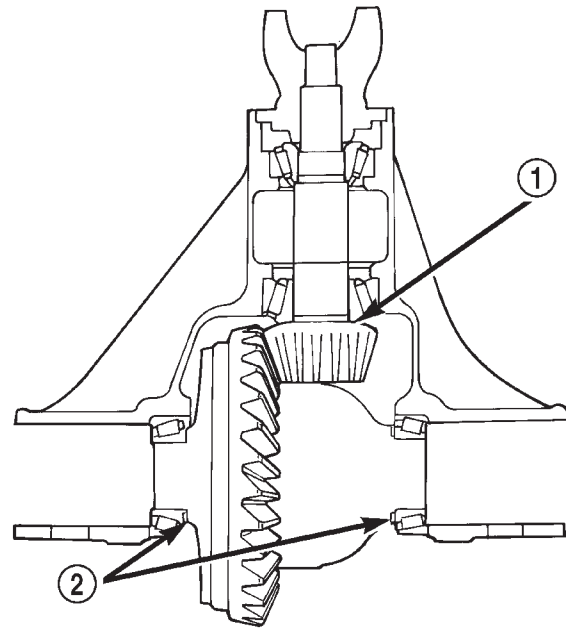

Fig. 71 Pinion Gear ID Numbers

- 1 - PRODUCTION NUMBERS
- 2 - DRIVE PINION GEAR DEPTH VARIANCE
- 3 - GEAR MATCHING NUMBER (SAME AS RING GEAR NUMBER)

Compensation for pinion depth variance is achieved with a select shim/oil baffle. The shims are placed between the rear pinion bearing and the pinion gear head (Fig. 72).



80c07134

Fig. 72 Shim Locations

- 1 - PINION GEAR DEPTH SHIM/OIL BAFFLE
- 2 - DIFFERENTIAL BEARING SHIM

If a new gear set is being installed, note the depth variance etched into both the original and replacement pinion. Add or subtract this number from the thickness of the original depth shim/oil slinger to compensate for the difference in the depth variances. Refer to the Depth Variance chart.

Note where Old and New Pinion Marking columns intersect. Intersecting figure represents plus or minus the amount needed.

Note the etched number on the face of the pinion gear head (-1, -2, 0, +1, +2, etc.). The numbers represent thousands of an inch deviation from the standard. If the number is negative, add that value to the required thickness of the depth shims. If the number is positive, subtract that value from the thickness of the depth shim. If the number is 0 no change is necessary.

ADJUSTMENTS (Continued)

PINION GEAR DEPTH VARIANCE

| Original Pinion Gear Depth Variance | Replacement Pinion Gear Depth Variance | | | | | | | | |
|-------------------------------------|--|--------|--------|--------|--------|--------|--------|--------|--------|
| | -4 | -3 | -2 | -1 | 0 | +1 | +2 | +3 | +4 |
| +4 | +0.008 | +0.007 | +0.006 | +0.005 | +0.004 | +0.003 | +0.002 | +0.001 | 0 |
| +3 | +0.007 | +0.006 | +0.005 | +0.004 | +0.003 | +0.002 | +0.001 | 0 | -0.001 |
| +2 | +0.006 | +0.005 | +0.004 | +0.003 | +0.002 | +0.001 | 0 | -0.001 | -0.002 |
| +1 | +0.005 | +0.004 | +0.003 | +0.002 | +0.001 | 0 | -0.001 | -0.002 | -0.003 |
| 0 | +0.004 | +0.003 | +0.002 | +0.001 | 0 | -0.001 | -0.002 | -0.003 | -0.004 |
| -1 | +0.003 | +0.002 | +0.001 | 0 | -0.001 | -0.002 | -0.003 | -0.004 | -0.005 |
| -2 | +0.002 | +0.001 | 0 | -0.001 | -0.002 | -0.003 | -0.004 | -0.005 | -0.006 |
| -3 | +0.001 | 0 | -0.001 | -0.002 | -0.003 | -0.004 | -0.005 | -0.006 | -0.007 |
| -4 | 0 | -0.001 | -0.002 | -0.003 | -0.004 | -0.005 | -0.006 | -0.007 | -0.008 |

PINION DEPTH MEASUREMENT AND ADJUSTMENT

Measurements are taken with pinion bearing cups and pinion bearings installed in the axle housing. Take measurements with Pinion Gauge Set and Dial Indicator C-3339 (Fig. 73).

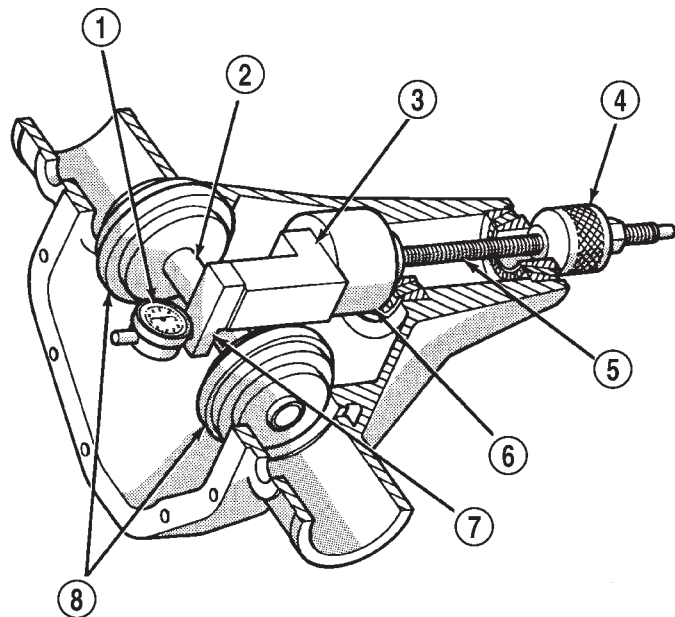

J9403-45

Fig. 73 Pinion Gear Depth Gauge Tools—Typical

- 1 - DIAL INDICATOR
- 2 - ARBOR
- 3 - PINION HEIGHT BLOCK
- 4 - CONE
- 5 - SCREW
- 6 - PINION BLOCK
- 7 - SCOOTER BLOCK
- 8 - ARBOR DISC

(1) Assemble Pinion Height Block 6739, Pinion Block 6733, and rear pinion bearing onto Screw 6741 (Fig. 73).

(2) Insert assembled height gauge components, rear bearing and screw into axle housing through pinion bearing cups (Fig. 74).

(3) Install front pinion bearing and Cone-nut 6740 hand tight (Fig. 73).

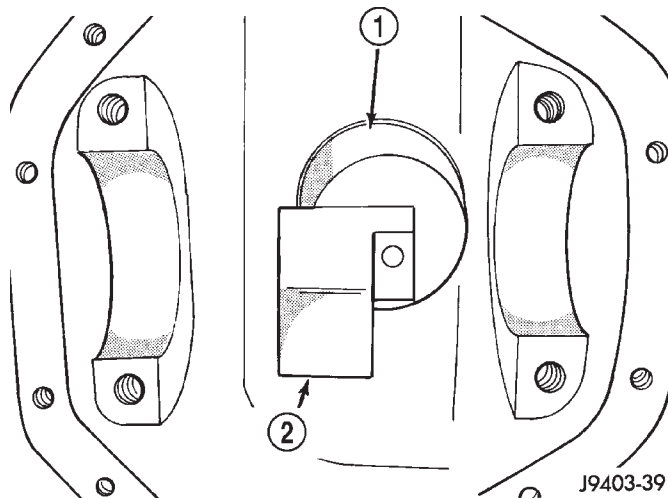

Fig. 74 Pinion Height Block—Typical

- 1 - PINION BLOCK
- 2 - PINION HEIGHT BLOCK

(4) Place Arbor Disc 6732 on Arbor D-115-3 in position in axle housing side bearing cradles (Fig. 75). Install differential bearing caps on Arbor Discs and tighten cap bolts to 41 N·m (30 ft. lbs.).

NOTE: Arbor Discs 6732 has different step diameters to fit other axles. Choose proper step for axle being serviced.

(5) Assemble Dial Indicator C-3339 into Scooter Block D-115-2 and secure set screw.

(6) Place Scooter Block/Dial Indicator in position in axle housing so dial probe and scooter block are flush against the rearward surface of the pinion

ADJUSTMENTS (Continued)

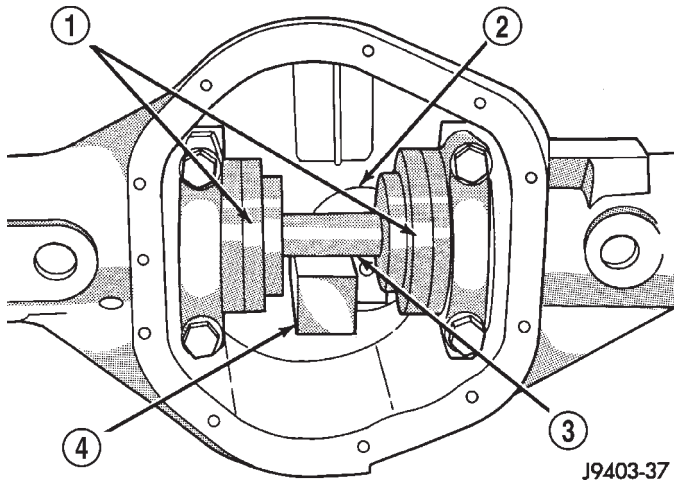

J9403-37

Fig. 75 Gauge Tools In Housing—Typical

- 1 - ARBOR DISC
- 2 - PINION BLOCK
- 3 - ARBOR
- 4 - PINION HEIGHT BLOCK

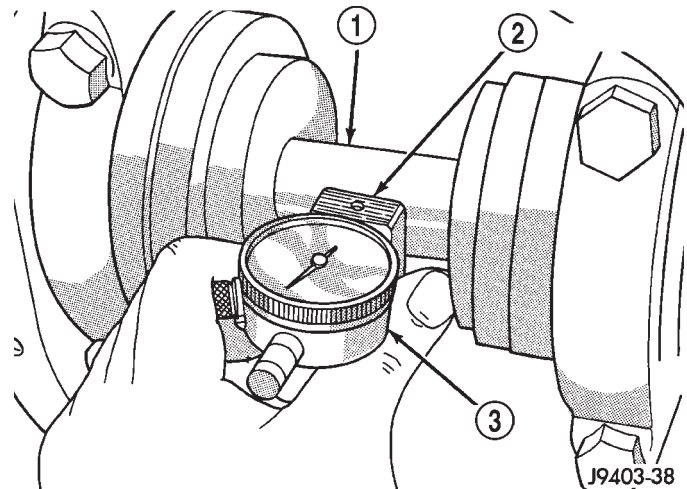

J9403-38

Fig. 76 Pinion Gear Depth Measurement—Typical

- 1 - ARBOR
- 2 - SCOOTER BLOCK
- 3 - DIAL INDICATOR

height block (Fig. 73). Hold scooter block in place and zero the dial indicator face to the pointer. Tighten dial indicator face lock screw.

(7) With scooter block still in position against the pinion height block, slowly slide the dial indicator probe over the edge of the pinion height block.

(8) Slide the dial indicator probe across the gap between the pinion height block and the arbor bar with the scooter block against the pinion height block (Fig. 76). When the dial probe contacts the arbor bar, the dial pointer will turn clockwise. Bring dial pointer back to zero against the arbor bar, do not turn dial face. Continue moving the dial probe to the crest of the arbor bar and record the highest reading. If the dial indicator can not achieve the zero reading, the rear bearing cup or the pinion depth gauge set is not installed correctly.

(9) Select a shim/oil baffle equal to the dial indicator reading plus the pinion depth variance number etched in the face of the pinion (Fig. 71). For example, if the depth variance is -2 , add $+0.002$ in. to the dial indicator reading.

pinion is 92.08 mm (3.625 in.). The standard depth provides the best gear tooth contact pattern. Refer to Backlash and Contact Pattern Analysis paragraph in this section for additional information.

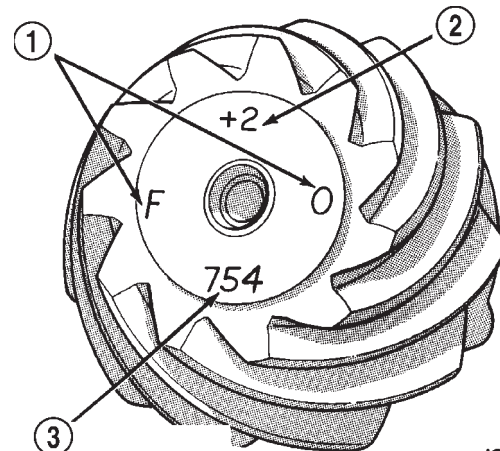

J9003-100

Fig. 77 Pinion Gear ID Numbers

- 1 - PRODUCTION NUMBERS
- 2 - DRIVE PINION GEAR DEPTH VARIANCE
- 3 - GEAR MATCHING NUMBER (SAME AS RING GEAR NUMBER)

186 FBI PINION GEAR DEPTH**GENERAL INFORMATION**

Ring gear and pinion are supplied as matched sets only. The identifying numbers for the ring gear and pinion are etched into the face of each gear (Fig. 77). A plus (+) number, minus (-) number or zero (0) is etched into the face of the pinion gear head. This number is the amount (in thousandths of an inch) the depth varies from the standard depth setting of a pinion etched with a (0). The standard setting from the center line of the ring gear to the back face of the

Compensation for pinion depth variance is achieved with a select shim/oil slinger. The shim/oil slinger is placed between the rear pinion bearing and the pinion gear head (Fig. 78).

If a new gear set is being installed, note the depth variance etched into both the original and replacement pinion. Add or subtract the thickness of the original depth shims to compensate for the difference in the depth variances. Refer to the Depth Variance chart.

ADJUSTMENTS (Continued)

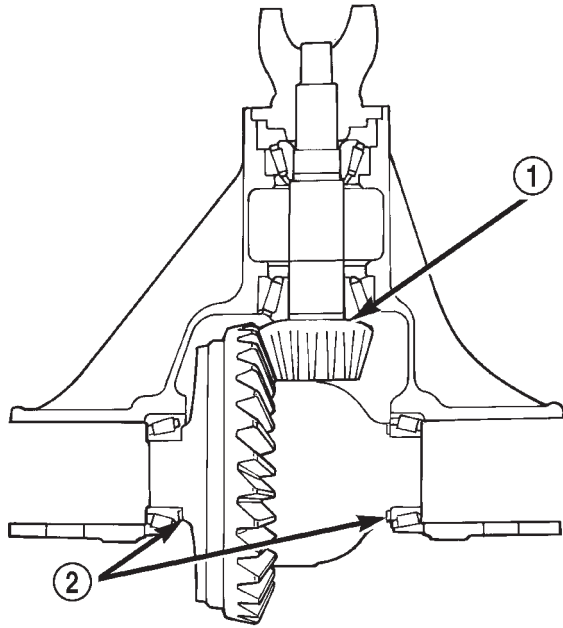

Fig. 78 Shim Locations

80c07134

- 1 - PINION GEAR DEPTH SHIM/OIL BAFFLE
- 2 - DIFFERENTIAL BEARING SHIM

Note where Old and New Pinion Marking columns intersect. Intersecting figure represents plus or minus the amount needed.

Note the etched number on the face of the drive pinion (-1, -2, 0, +1, +2, etc.). The numbers represent thousands of an inch deviation from the standard. If the number is negative, add that value to the required thickness of the depth shim/oil slinger. If the number is positive, subtract that value from the thickness of the depth shim/oil slinger. If the number is 0 no change is necessary.

PINION DEPTH MEASUREMENT AND ADJUSTMENT

Measurements are taken with pinion bearing cups and pinion bearings installed in the axle housing. Take measurements with Pinion Gauge Set 6774 and Dial Indicator C-3339 (Fig. 79).

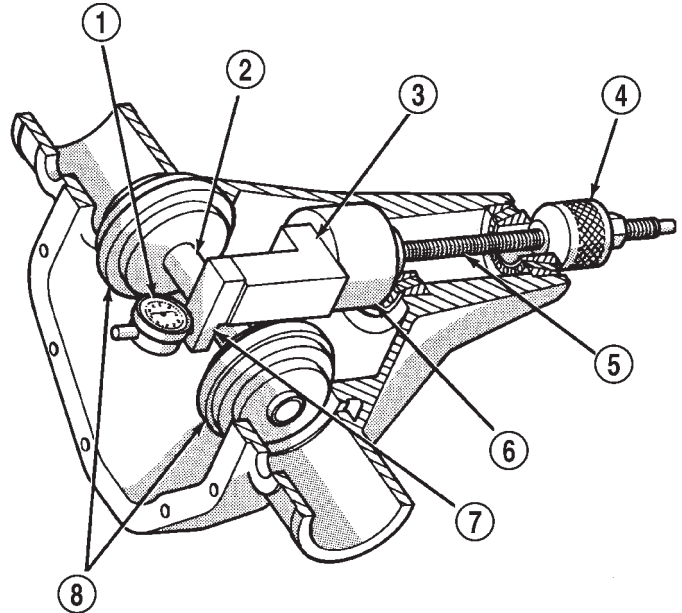

J9403-45

Fig. 79 Pinion Gear Depth Gauge Tools—Typical

- 1 - DIAL INDICATOR
- 2 - ARBOR
- 3 - PINION HEIGHT BLOCK
- 4 - CONE
- 5 - SCREW
- 6 - PINION BLOCK
- 7 - SCOOTER BLOCK
- 8 - ARBOR DISC

PINION GEAR DEPTH VARIANCE

| Original Pinion Gear Depth Variance | Replacement Pinion Gear Depth Variance | | | | | | | | | |
|-------------------------------------|--|--------|--------|--------|--------|--------|--------|--------|--------|--|
| | -4 | -3 | -2 | -1 | 0 | +1 | +2 | +3 | +4 | |
| +4 | +0.008 | +0.007 | +0.006 | +0.005 | +0.004 | +0.003 | +0.002 | +0.001 | 0 | |
| +3 | +0.007 | +0.006 | +0.005 | +0.004 | +0.003 | +0.002 | +0.001 | 0 | -0.001 | |
| +2 | +0.006 | +0.005 | +0.004 | +0.003 | +0.002 | +0.001 | 0 | -0.001 | -0.002 | |
| +1 | +0.005 | +0.004 | +0.003 | +0.002 | +0.001 | 0 | -0.001 | -0.002 | -0.003 | |
| 0 | +0.004 | +0.003 | +0.002 | +0.001 | 0 | -0.001 | -0.002 | -0.003 | -0.004 | |
| -1 | +0.003 | +0.002 | +0.001 | 0 | -0.001 | -0.002 | -0.003 | -0.004 | -0.005 | |
| -2 | +0.002 | +0.001 | 0 | -0.001 | -0.002 | -0.003 | -0.004 | -0.005 | -0.006 | |
| -3 | +0.001 | 0 | -0.001 | -0.002 | -0.003 | -0.004 | -0.005 | -0.006 | -0.007 | |
| -4 | 0 | -0.001 | -0.002 | -0.003 | -0.004 | -0.005 | -0.006 | -0.007 | -0.008 | |

ADJUSTMENTS (Continued)

(1) Assemble Pinion Height Block 6739, Pinion Block 6733, and rear pinion bearing onto Screw 6741 (Fig. 79).

(2) Insert assembled height gauge components, rear bearing and screw into axle housing through pinion bearing cups (Fig. 80).

(3) Install front pinion bearing and Cone-nut 6740 hand tight (Fig. 79).

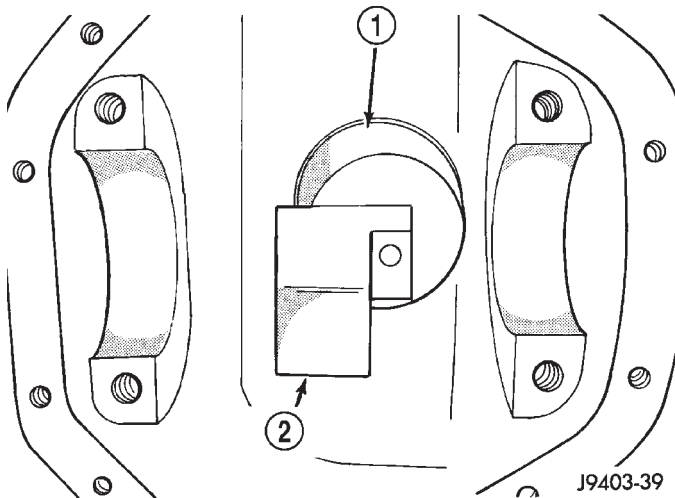

Fig. 80 Pinion Height Block—Typical

- 1 - PINION BLOCK
- 2 - PINION HEIGHT BLOCK

(4) Place Arbor Disc 6732 on Arbor D-115-3 in position in axle housing side bearing cradles (Fig. 81). Install differential bearing caps on Arbor Discs and tighten cap bolts to 41 N·m (30 ft. lbs.).

NOTE: Arbor Discs 6732 has different step diameters to fit other axles. Choose proper step for axle being serviced.

(5) Assemble Dial Indicator C-3339 into Scooter Block D-115-2 and secure set screw.

(6) Place Scooter Block/Dial Indicator in position in axle housing so dial probe and scooter block are flush against the rearward surface of the pinion height block (Fig. 79). Hold scooter block in place and zero the dial indicator face to the pointer. Tighten dial indicator face lock screw.

(7) With scooter block still in position against the pinion height block, slowly slide the dial indicator probe over the edge of the pinion height block.

(8) Slide the dial indicator probe across the gap between the pinion height block and the arbor bar with the scooter block against the pinion height block (Fig. 82). When the dial probe contacts the arbor bar, the dial pointer will turn clockwise. Bring dial pointer back to zero against the arbor bar, do not turn dial face. Continue moving the dial probe to the crest of the arbor bar and record the highest reading.

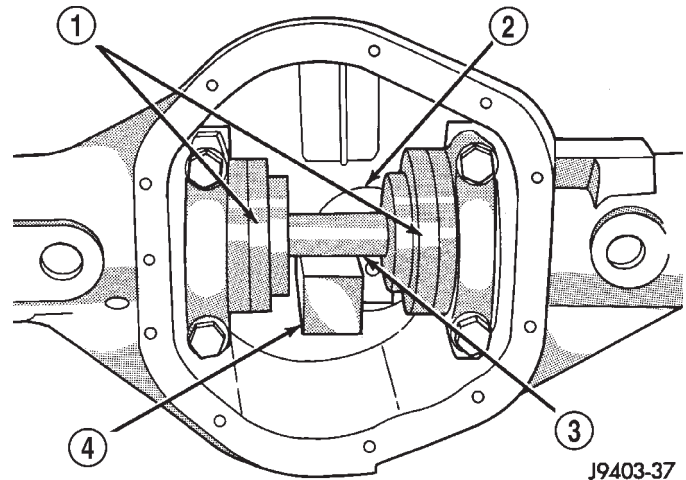

Fig. 81 Gauge Tools In Housing—Typical

- 1 - ARBOR DISC
- 2 - PINION BLOCK
- 3 - ARBOR
- 4 - PINION HEIGHT BLOCK

If the dial indicator can not achieve the zero reading, the rear bearing cup or the pinion depth gauge set is not installed correctly.

(9) Select a shim/oil slinger equal to the dial indicator reading plus the drive pinion depth variance number etched in the face of the pinion (Fig. 77). For example, if the depth variance is -2 , add $+0.002$ in. to the dial indicator reading.

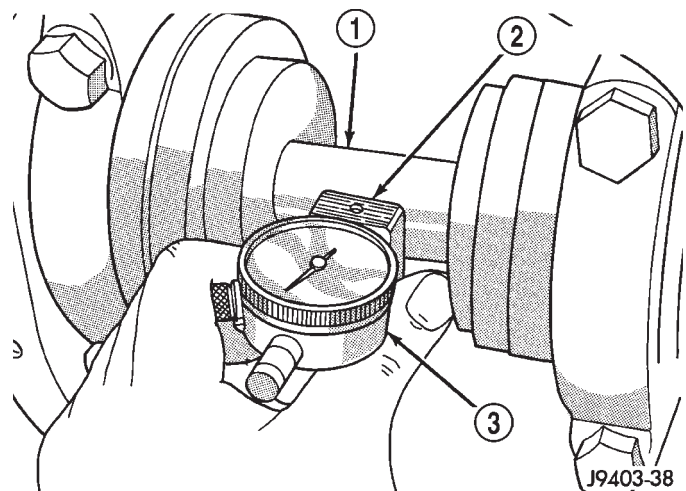

Fig. 82 Pinion Gear Depth Measurement—Typical

- 1 - ARBOR
- 2 - SCOOTER BLOCK
- 3 - DIAL INDICATOR

181 FBI DIFFERENTIAL BEARING PRELOAD AND GEAR BACKLASH

INTRODUCTION

Differential side bearing preload and gear backlash is achieved by selective shims positioned behind the

ADJUSTMENTS (Continued)

differential side bearing cones. The proper shim thickness can be determined using slip-fit dummy bearings D-348 in place of the differential side bearings and a dial indicator C-3339. Before proceeding with the differential bearing preload and gear backlash measurements, measure the pinion gear depth and prepare the pinion for installation. Establishing proper pinion gear depth is essential to establishing gear backlash and tooth contact patterns. After the overall shim thickness to take up differential side play is measured, the pinion is installed, and the gear backlash shim thickness is measured. The overall shim thickness is the total of the dial indicator reading and the preload specification added together. The gear backlash measurement determines the thickness of the shim used on the ring gear side of the differential case. Subtract the gear backlash shim thickness from the total overall shim thickness and select that amount for the pinion gear side of the differential (Fig. 83). Differential shim measurements are performed with axle spreader W-129-B removed.

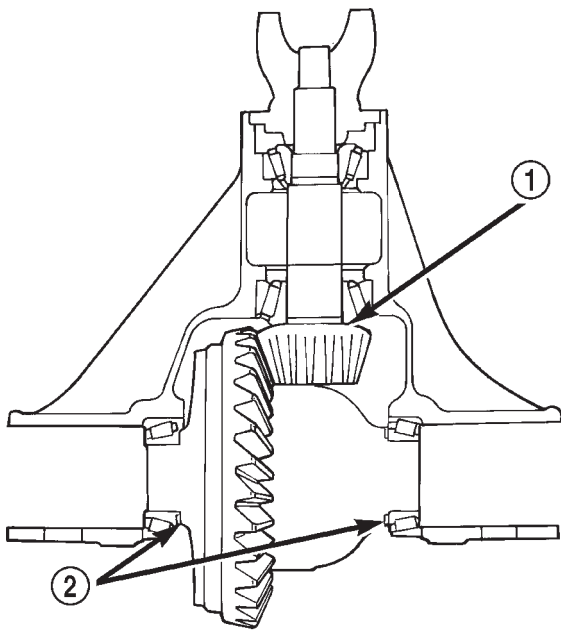

80c07134

Fig. 83 Axle Adjustment Shim Locations

- 1 - PINION GEAR DEPTH SHIM/OIL BAFFLE
- 2 - DIFFERENTIAL BEARING SHIM

SHIM SELECTION

NOTE: It is difficult to salvage the differential side bearings during the removal procedure. Install replacement bearings if necessary.

(1) Remove differential side bearings from differential case.

(2) Remove factory installed shims from differential case.

(3) Install ring gear on differential case and tighten bolts to specification.

(4) Install dummy side bearings D-348 on differential case.

(5) Install differential case in axle housing.

(6) Install the marked bearing caps in their correct positions. Install and snug the bolts (Fig. 84).

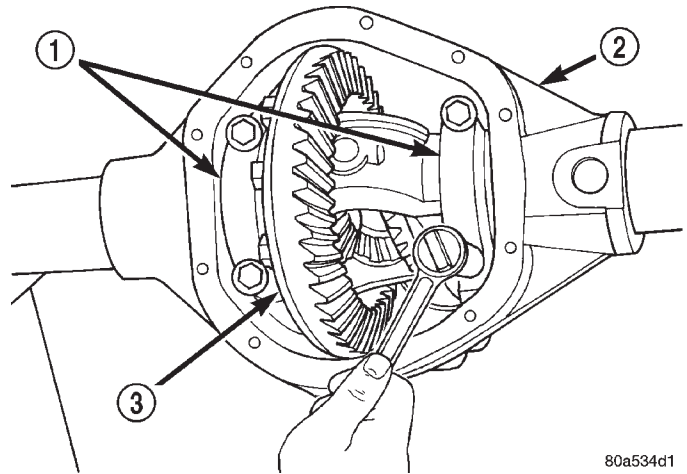

80a534c1

Fig. 84 Tighten Bolts Holding Bearing Caps

- 1 - BEARING CAP
- 2 - AXLE HOUSING
- 3 - DIFFERENTIAL CASE

(7) Using a dead-blow type mallet, seat the differential dummy bearings to each side of the axle housing (Fig. 85) and (Fig. 86).

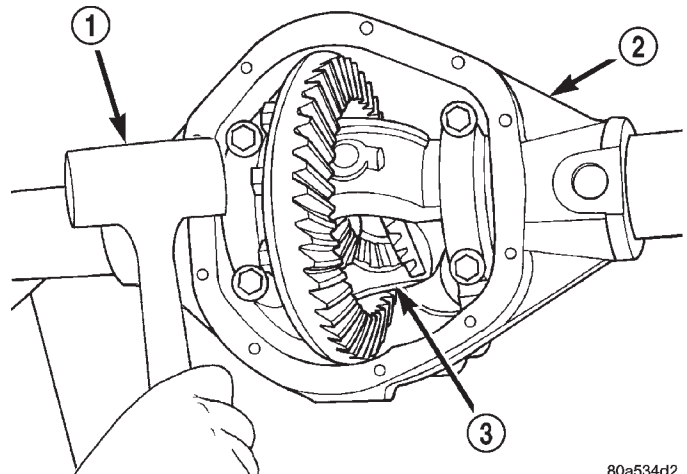

80a534d2

Fig. 85 Seat Pinion Gear Side Differential Dummy Side Bearing

- 1 - MALLET
- 2 - AXLE HOUSING
- 3 - DIFFERENTIAL CASE

(8) Thread guide stud C-3288-B into rear cover bolt hole below ring gear (Fig. 87).

ADJUSTMENTS (Continued)

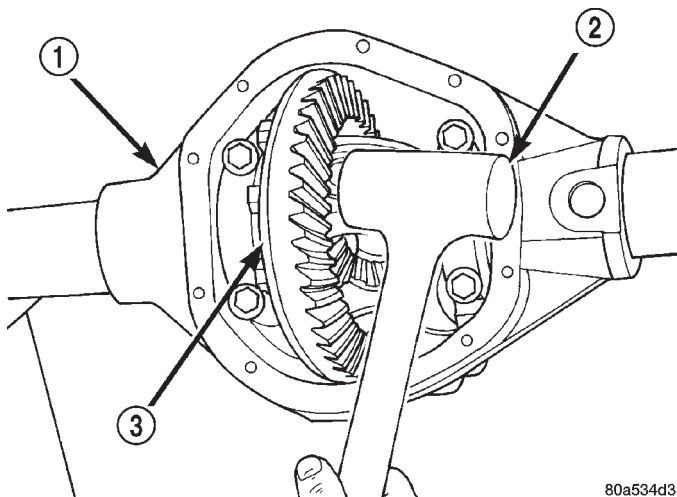

80a534d3

Fig. 86 Seat Ring Gear Side Differential Dummy Side Bearing

- 1 - AXLE HOUSING
- 2 - MALLET
- 3 - DIFFERENTIAL CASE

(9) Attach a dial indicator C-3339 to guide stud. Position the dial indicator plunger on a flat surface between the ring gear bolt heads (Fig. 87).

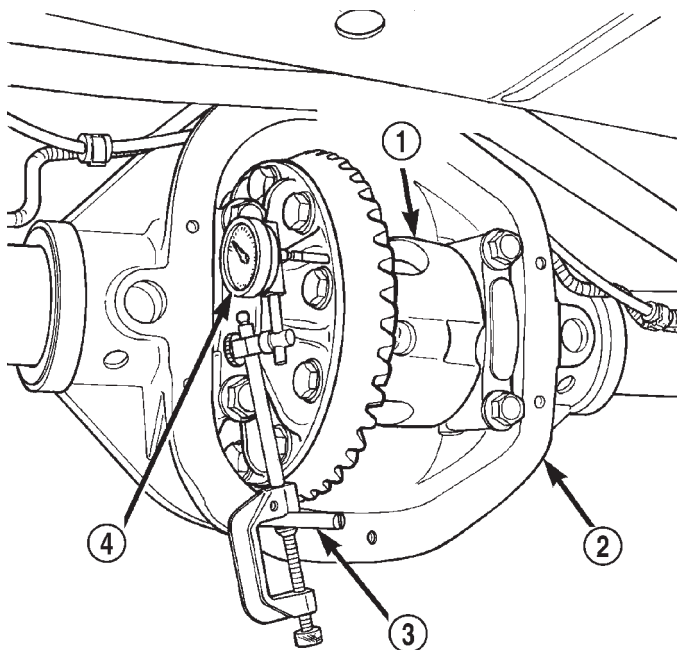

80a7e2cf

Fig. 87 Differential Side play Measurement

- 1 - DIFFERENTIAL CASE
- 2 - AXLE HOUSING
- 3 - SPECIAL TOOL C-3288-B
- 4 - SPECIAL TOOL C-3339

(10) Push and hold differential case to pinion gear side of axle housing (Fig. 88).

(11) Zero dial indicator face to pointer (Fig. 88).

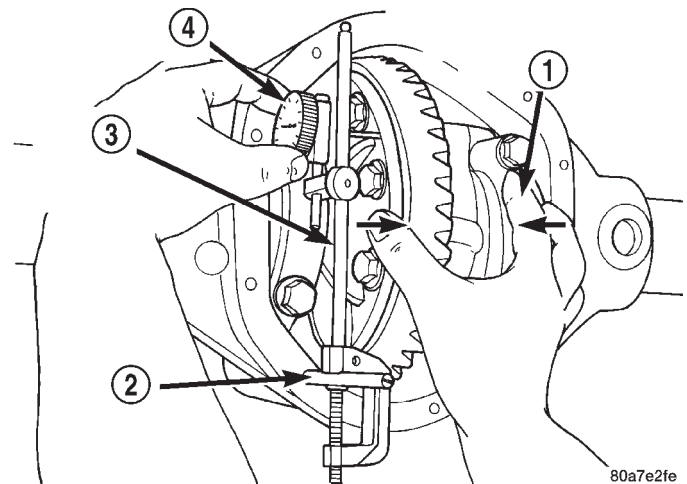

80a7e2fe

Fig. 88 Hold Differential Case and Zero Dial Indicator

- 1 - FORCE DIFFERENTIAL CASE TO PINION GEAR SIDE
- 2 - SPECIAL TOOL C-3288-B
- 3 - SPECIAL TOOL C-3339
- 4 - ZERO DIAL INDICATOR FACE

(12) Push and hold differential case to ring gear side of the axle housing (Fig. 89).

(13) Record dial indicator reading (Fig. 89).

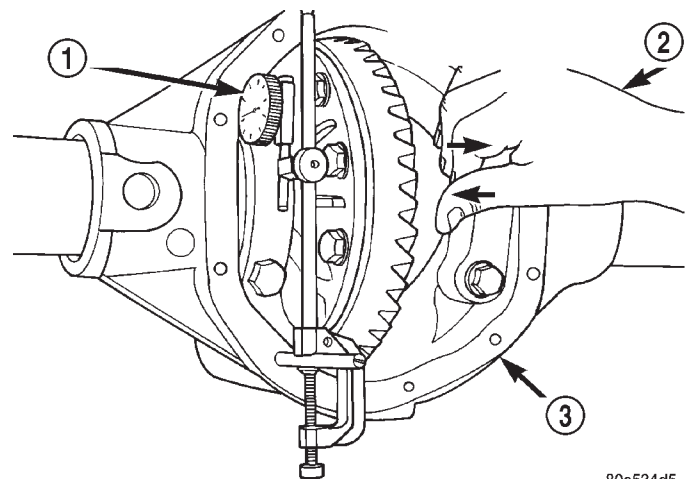

80a534d5

Fig. 89 Hold Differential Case and Read Dial Indicator

- 1 - READ DIAL INDICATOR
- 2 - FORCE DIFFERENTIAL CASE TO RING GEAR SIDE
- 3 - AXLE HOUSING

(14) Add 0.008 in. (0.2 mm) to the zero end play total. This new total represents the thickness of shims to compress, or preload the new bearings when the differential is installed.

(15) Rotate dial indicator out of the way on the guide stud.

(16) Remove differential case and dummy bearings from axle housing.

ADJUSTMENTS (Continued)

(17) Install the pinion gear in axle housing. Install the pinion yoke and establish the correct pinion rotating torque.

(18) Install differential case and dummy bearings D-348 in axle housing (without shims), install bearing caps and tighten bolts snug.

(19) Seat ring gear side dummy bearing (Fig. 86).

(20) Position the dial indicator plunger on a flat surface between the ring gear bolt heads. (Fig. 87).

(21) Push and hold differential case toward pinion gear (Fig. 90).

(22) Zero dial indicator face to pointer (Fig. 90).

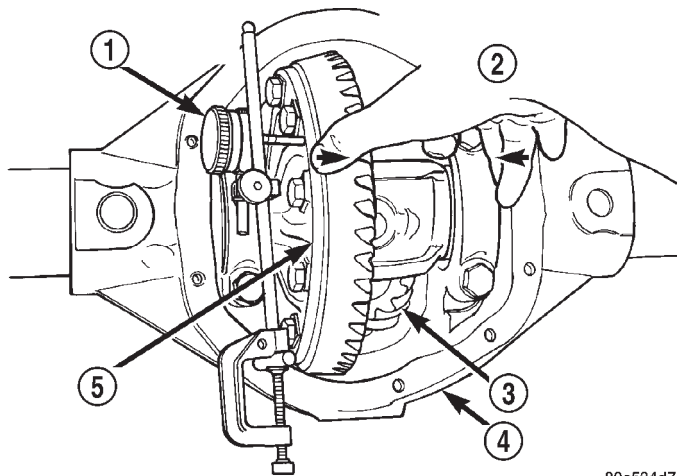

80a534d7

Fig. 90 Hold Differential Case and Zero Dial Indicator

- 1 - ZERO DIAL INDICATOR FACE
- 2 - FORCE DIFFERENTIAL CASE TO PINION GEAR SIDE
- 3 - PINION GEAR
- 4 - AXLE HOUSING
- 5 - DIFFERENTIAL CASE

(23) Push and hold differential case to ring gear side of the axle housing (Fig. 91).

(24) Record dial indicator reading (Fig. 91).

(25) Subtract 0.002 in. (0.05 mm) from the dial indicator reading to compensate for backlash between ring and pinion gears. This total is the thickness shim required to achieve proper backlash.

(26) Subtract the backlash shim thickness from the total preload shim thickness. The remainder is the shim thickness required on the pinion side of the axle housing.

(27) Rotate dial indicator out of the way on guide stud.

(28) Remove differential case and dummy bearings from axle housing.

(29) Install the selected side bearing shims onto the differential case hubs.

(30) Install side bearings and cups on differential case.

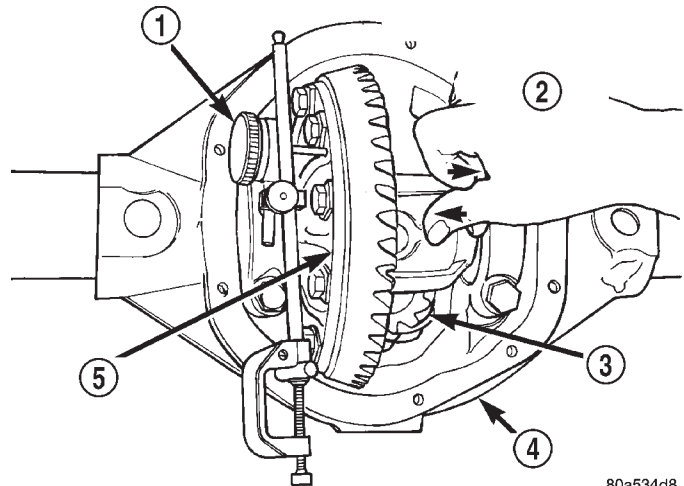

80a534d8

Fig. 91 Hold Differential Case and Read Dial Indicator

- 1 - READ DIAL INDICATOR
- 2 - FORCE DIFFERENTIAL CASE TO RING GEAR SIDE
- 3 - PINION GEAR
- 4 - AXLE HOUSING
- 5 - DIFFERENTIAL CASE

(31) Install spreader W-129-B, utilizing some items from Adapter Set 6987, on axle housing and spread axle opening enough to receive differential case.

(32) Install differential case into the axle housing.

(33) Remove spreader from axle housing.

(34) Rotate the differential case several times to seat the side bearings.

(35) Position the indicator plunger against a ring gear tooth (Fig. 92).

(36) Push and hold ring gear upward while not allowing the pinion gear to rotate.

(37) Zero dial indicator face to pointer.

(38) Push and hold ring gear downward while not allowing the pinion gear to rotate. Dial indicator reading should be between 0.12 mm (0.005 in.) and 0.20 mm (0.008 in.). If backlash is not within specifications transfer the necessary amount of shim thickness from one side of the axle housing to the other (Fig. 93).

(39) Verify differential case and ring gear runout by measuring ring to pinion gear backlash at eight locations around the ring gear. Readings should not vary more than 0.05 mm (0.002 in.). If readings vary more than specified, the ring gear or the differential case is defective.

(39) Verify differential case and ring gear runout by measuring ring to pinion gear backlash at eight locations around the ring gear. Readings should not vary more than 0.05 mm (0.002 in.). If readings vary more than specified, the ring gear or the differential case is defective.

After the proper backlash is achieved, perform Gear Contact Pattern Analysis procedure.

ADJUSTMENTS (Continued)

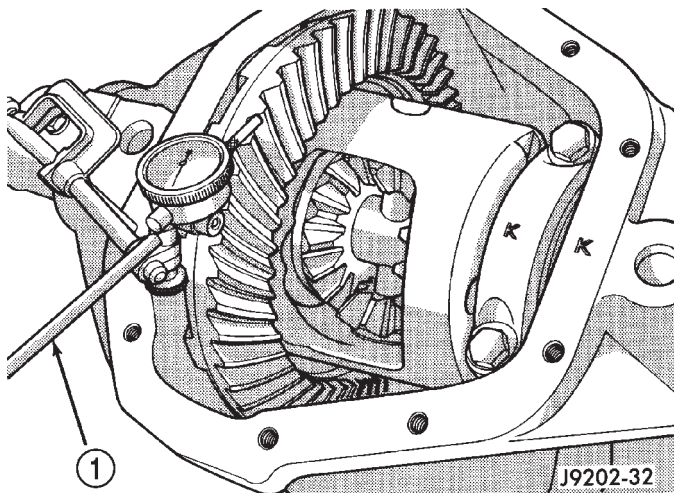

Fig. 92 Ring Gear Backlash Measurement

1 - DIAL INDICATOR

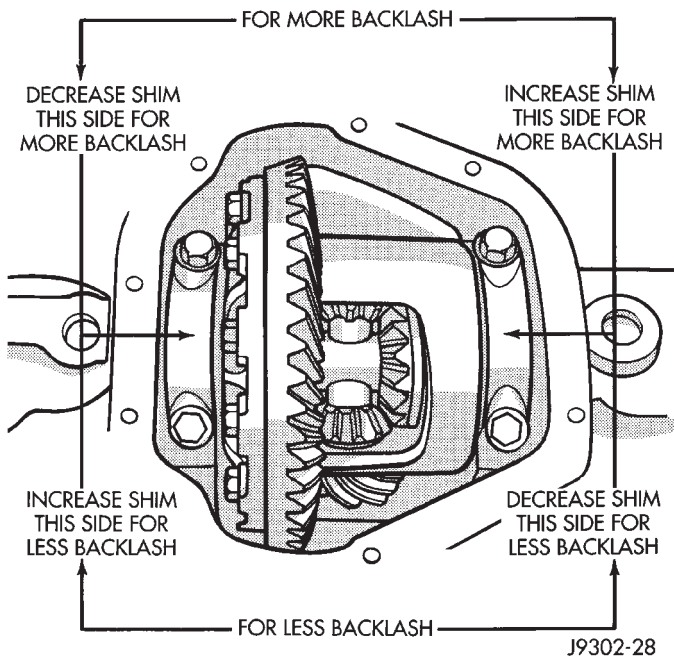

Fig. 93 Backlash Shim Adjustment

186 FBI DIFFERENTIAL BEARING PRELOAD AND GEAR BACKLASH

INTRODUCTION

Differential side bearing preload and gear backlash is achieved by selective shims positioned behind the differential side bearing cones. The proper shim thickness can be determined using slip-fit dummy bearings D-348 in place of the differential side bearings and a dial indicator C-3339. Before proceeding with the differential bearing preload and gear backlash measurements, measure the pinion gear depth and prepare the pinion for installation. Establishing

proper pinion gear depth is essential to establishing gear backlash and tooth contact patterns. After the overall shim thickness to take up differential side play is measured, the pinion is installed, and the gear backlash shim thickness is measured. The overall shim thickness is the total of the dial indicator reading and the preload specification added together. The gear backlash measurement determines the thickness of the shim used on the ring gear side of the differential case. Subtract the gear backlash shim thickness from the total overall shim thickness and select that amount for the pinion gear side of the differential (Fig. 94). Differential shim measurements are performed with axle spreader W-129-B removed.

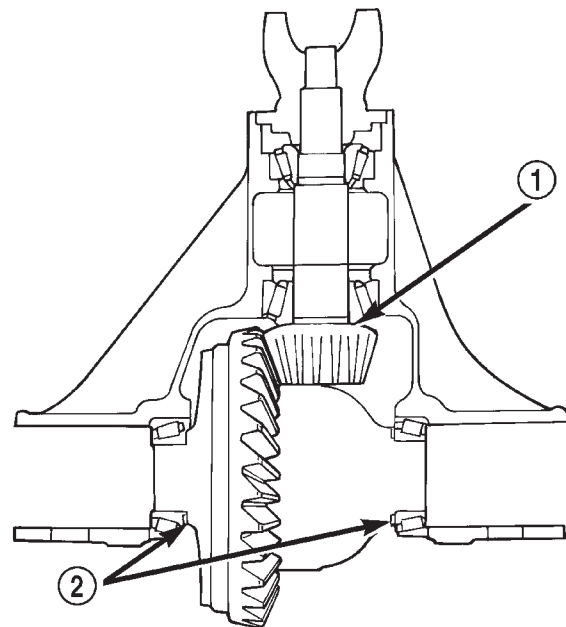

Fig. 94 Axle Adjustment Shim Locations

1 - PINION GEAR DEPTH SHIM/OIL BAFFLE
2 - DIFFERENTIAL BEARING SHIM

SHIM SELECTION

NOTE: It is difficult to salvage the differential side bearings during the removal procedure. Install replacement bearings if necessary.

- (1) Remove differential side bearings from differential case.
- (2) Remove factory installed shims from differential case.
- (3) Install ring gear on differential case and tighten bolts to specification.
- (4) Install dummy side bearings D-348 on differential case.
- (5) Install differential case in axle housing.

ADJUSTMENTS (Continued)

(6) Install the marked bearing caps in their correct positions. Install and snug the bolts (Fig. 95).

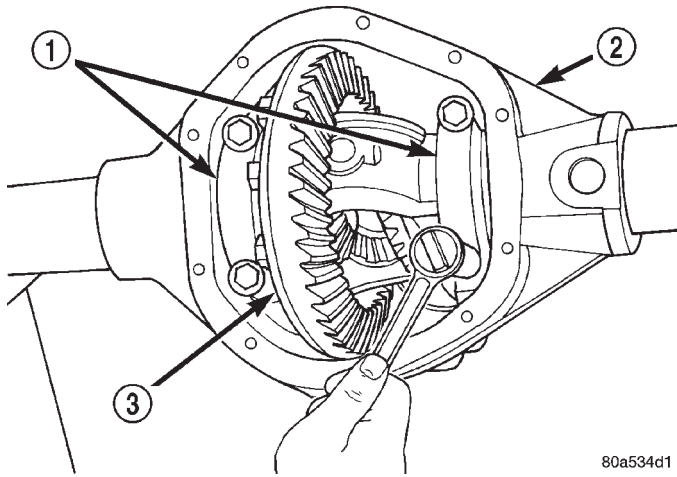

80a534d1

Fig. 95 Tighten Bolts Holding Bearing Caps

- 1 - BEARING CAP
- 2 - AXLE HOUSING
- 3 - DIFFERENTIAL CASE

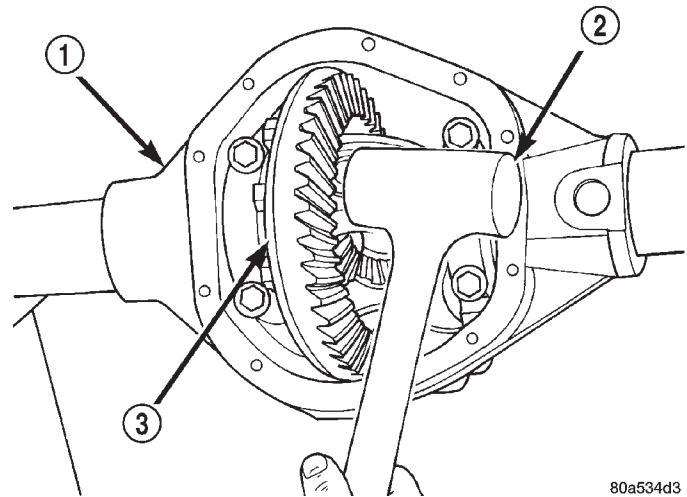

80a534d3

Fig. 97 Seat Ring Gear Side Differential Dummy Side Bearing

- 1 - AXLE HOUSING
- 2 - MALLET
- 3 - DIFFERENTIAL CASE

(7) Using a dead-blow type mallet, seat the differential dummy bearings to each side of the axle housing (Fig. 96) and (Fig. 97).

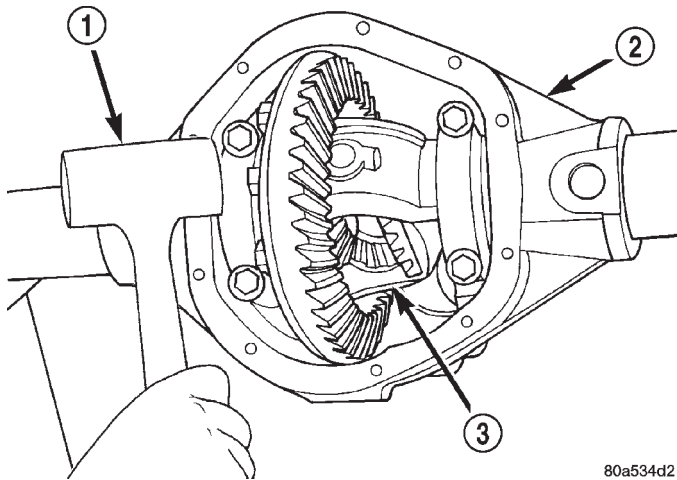

80a534d2

Fig. 96 Seat Pinion Gear Side Differential Dummy Side Bearing

- 1 - MALLET
- 2 - AXLE HOUSING
- 3 - DIFFERENTIAL CASE

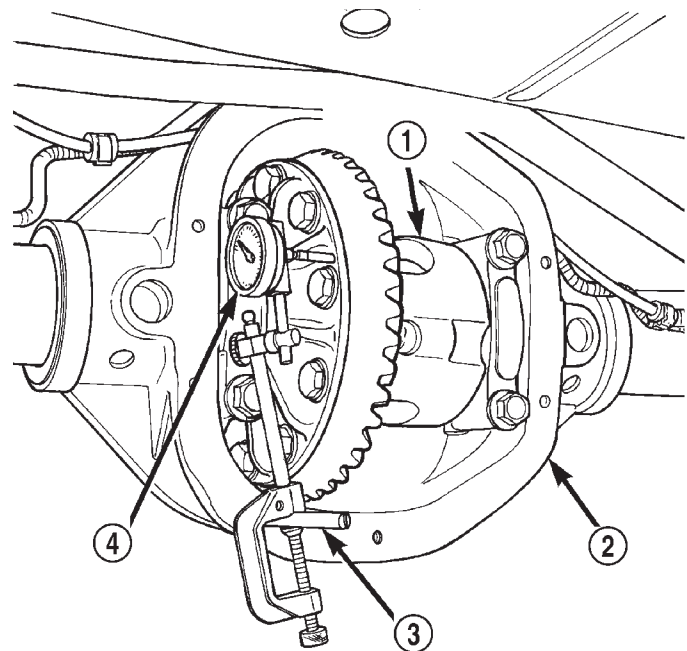

80a7e2cf

Fig. 98 Differential Side play Measurement

- 1 - DIFFERENTIAL CASE
- 2 - AXLE HOUSING
- 3 - SPECIAL TOOL C-3288-B
- 4 - SPECIAL TOOL C-3339

(8) Thread guide stud C-3288-B into rear cover bolt hole below ring gear (Fig. 98).

(9) Attach a dial indicator C-3339 to guide stud. Position the dial indicator plunger on a flat surface between the ring gear bolt heads (Fig. 98).

(10) Push and hold differential case to pinion gear side of axle housing (Fig. 99).

(11) Zero dial indicator face to pointer (Fig. 99).

(12) Push and hold differential case to ring gear side of the axle housing (Fig. 100).

(13) Record dial indicator reading (Fig. 100).

(14) Add 0.008 in. (0.2 mm) to the zero end play total. This new total represents the thickness of

ADJUSTMENTS (Continued)

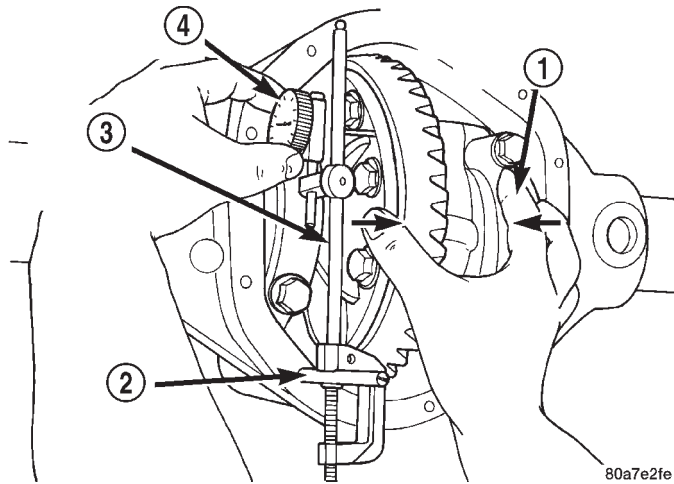

Fig. 99 Hold Differential Case and Zero Dial Indicator

- 1 - FORCE DIFFERENTIAL CASE TO PINION GEAR SIDE
- 2 - SPECIAL TOOL C-3288-B
- 3 - SPECIAL TOOL C-3339
- 4 - ZERO DIAL INDICATOR FACE

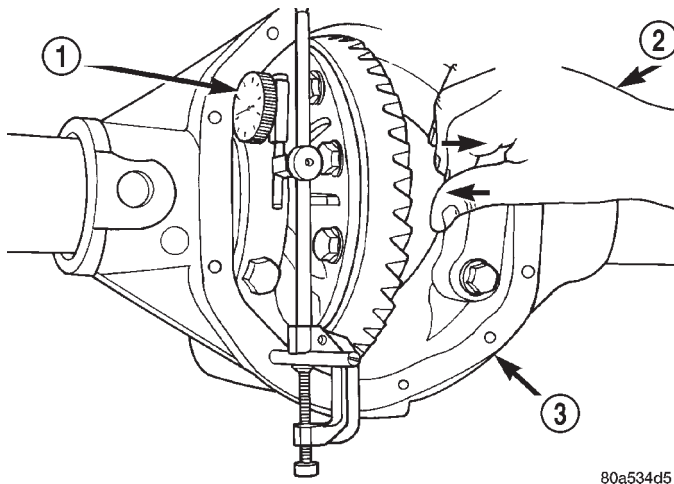

Fig. 100 Hold Differential Case and Read Dial Indicator

- 1 - READ DIAL INDICATOR
- 2 - FORCE DIFFERENTIAL CASE TO RING GEAR SIDE
- 3 - AXLE HOUSING

shims to compress, or preload the new bearings when the differential is installed.

(15) Rotate dial indicator out of the way on the guide stud.

(16) Remove differential case and dummy bearings from axle housing.

(17) Install the pinion in the axle housing. Install the pinion yoke and establish the correct pinion rotating torque.

(18) Install differential case and dummy bearings D-348 in axle housing (without shims), install bearing caps and tighten bolts snug.

- (19) Seat ring gear side dummy bearing (Fig. 97).
- (20) Position the dial indicator plunger on a flat surface between the ring gear bolt heads. (Fig. 98).
- (21) Push and hold differential case toward pinion gear (Fig. 101).
- (22) Zero dial indicator face to pointer (Fig. 101).

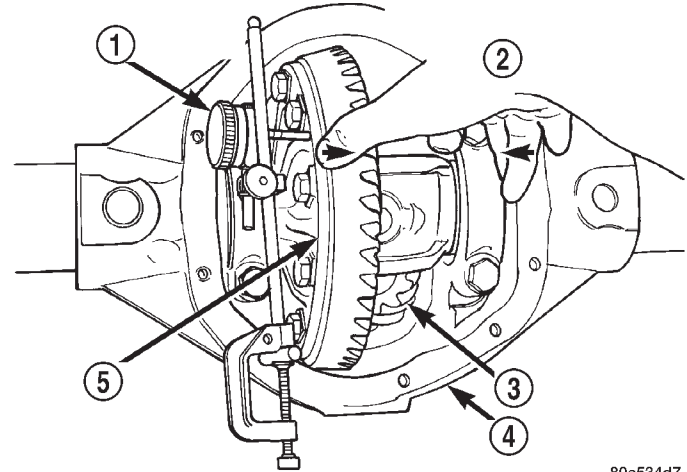

Fig. 101 Hold Differential Case and Zero Dial Indicator

- 1 - ZERO DIAL INDICATOR FACE
- 2 - FORCE DIFFERENTIAL CASE TO PINION GEAR SIDE
- 3 - PINION GEAR
- 4 - AXLE HOUSING
- 5 - DIFFERENTIAL CASE

(23) Push and hold differential case to ring gear side of the axle housing (Fig. 102).

(24) Record dial indicator reading (Fig. 102).

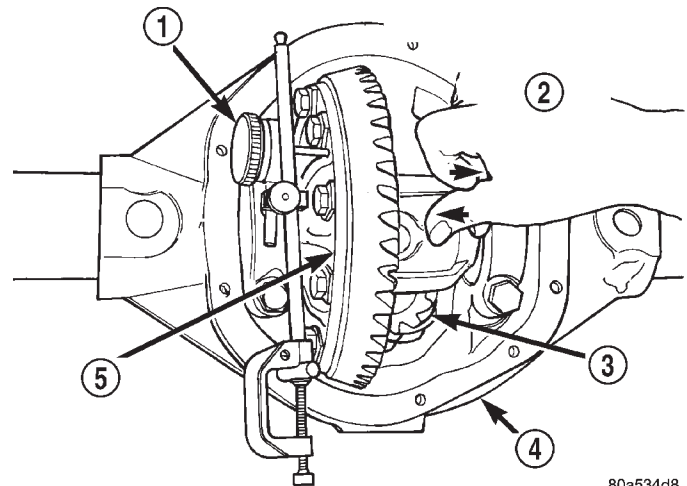

Fig. 102 Hold Differential Case and Read Dial Indicator

- 1 - READ DIAL INDICATOR
- 2 - FORCE DIFFERENTIAL CASE TO RING GEAR SIDE
- 3 - PINION GEAR
- 4 - AXLE HOUSING
- 5 - DIFFERENTIAL CASE

ADJUSTMENTS (Continued)

(25) Subtract 0.002 in. (0.05 mm) from the dial indicator reading to compensate for backlash between ring and pinion gears. This total is the thickness shim required to achieve proper backlash.

(26) Subtract the backlash shim thickness from the total preload shim thickness. The remainder is the shim thickness required on the pinion side of the axle housing.

(27) Rotate dial indicator out of the way on guide stud.

(28) Remove differential case and dummy bearings from axle housing.

(29) Install side bearing shims on differential case hubs.

(30) Install side bearings and cups on differential case.

(31) Install spreader W-129-B, utilizing some items from Adapter Set 6987, on axle housing and spread axle opening enough to receive differential case.

(32) Install differential case in axle housing.

(33) Remove spreader from axle housing.

(34) Rotate the differential case several times to seat the side bearings.

(35) Position the indicator plunger against a ring gear tooth (Fig. 103).

(36) Push and hold ring gear upward while not allowing the pinion gear to rotate.

(37) Zero dial indicator face to pointer.

(38) Push and hold ring gear downward while not allowing the pinion gear to rotate. Dial indicator reading should be between 0.12 mm (0.005 in.) and 0.20 mm (0.008 in.). If backlash is not within specifications transfer the necessary amount of shim thickness from one side of the axle housing to the other (Fig. 104).

(39) Verify differential case and ring gear runout by measuring ring to pinion gear backlash at eight locations around the ring gear. Readings should not vary more than 0.05 mm (0.002 in.). If readings vary more than specified, the ring gear or the differential case is defective.

After the proper backlash is achieved, perform Gear Contact Pattern Analysis procedure.

GEAR CONTACT PATTERN ANALYSIS

The ring gear and pinion teeth contact patterns will show if the pinion depth is correct in the axle housing. It will also show if the ring gear backlash has been adjusted correctly. The backlash can be adjusted within specifications to achieve desired tooth contact patterns.

(1) Apply a thin coat of hydrated ferric oxide, or equivalent, to the drive and coast side of the ring gear teeth.

(2) Wrap, twist, and hold a shop towel around the pinion yoke to increase the turning resistance of the

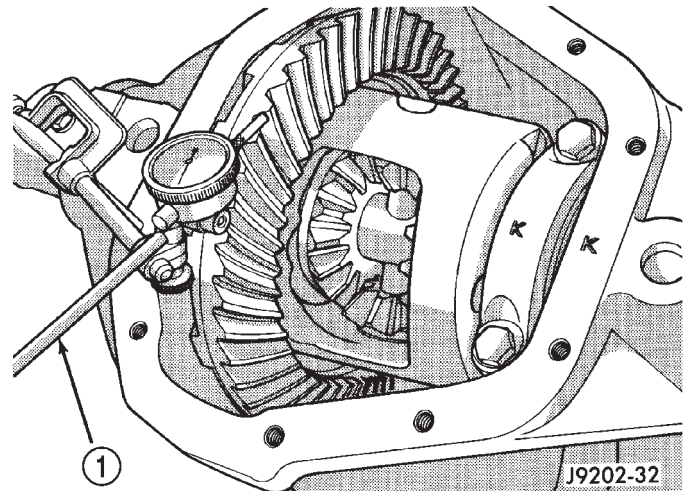

Fig. 103 Ring Gear Backlash Measurement

1 - DIAL INDICATOR

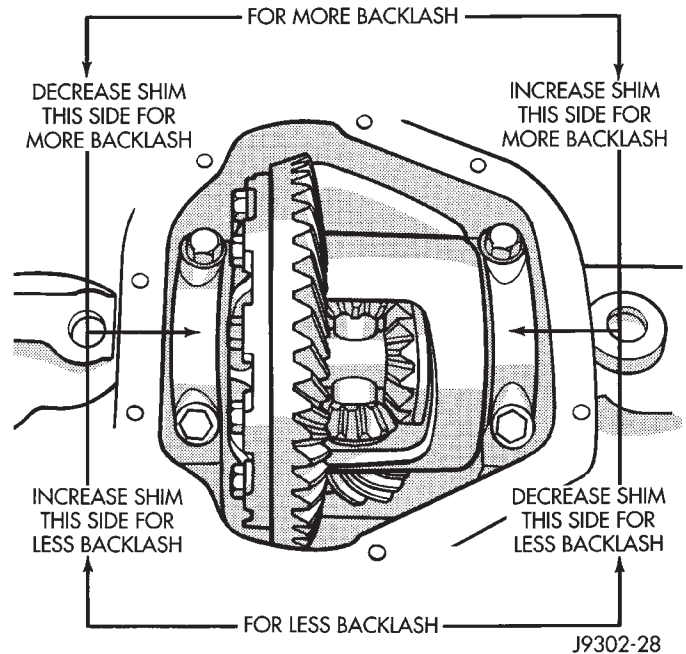

Fig. 104 Backlash Shim Adjustment

pinion. This will provide a more distinct contact pattern.

(3) Using a boxed end wrench on a ring gear bolt, Rotate the differential case one complete revolution in both directions while a load is being applied from shop towel.

The areas on the ring gear teeth with the greatest degree of contact against the pinion teeth will squeegee the compound to the areas with the least amount of contact. Note and compare patterns on the ring gear teeth to Gear Tooth Contact Patterns chart (Fig. 105) and adjust pinion depth and gear backlash as necessary.

ADJUSTMENTS (Continued)

| <p>DRIVE SIDE OF RING GEAR TEETH</p> <p>HEEL TOE</p>  | <p>COAST SIDE OF RING GEAR TEETH</p> <p>TOE HEEL</p>  | <p>DESIRABLE CONTACT PATTERN. PATTERN SHOULD BE CENTERED ON THE DRIVE SIDE OF TOOTH. PATTERN SHOULD BE CENTERED ON THE COAST SIDE OF TOOTH, BUT MAY BE SLIGHTLY TOWARD THE TOE. THERE SHOULD ALWAYS BE SOME CLEARANCE BETWEEN CONTACT PATTERN AND TOP OF THE TOOTH.</p> |
|--|--|---|
|  |  | <p>RING GEAR BACKLASH CORRECT. THINNER PINION GEAR DEPTH SHIM REQUIRED.</p> |
|  |  | <p>RING GEAR BACKLASH CORRECT. THICKER PINION GEAR DEPTH SHIM REQUIRED.</p> |
|  |  | <p>PINION GEAR DEPTH SHIM CORRECT. DECREASE RING GEAR BACKLASH.</p> |
|  |  | <p>PINION GEAR DEPTH SHIM CORRECT. INCREASE RING GEAR BACKLASH.</p> |

Fig. 105 Gear Tooth Contact Patterns

SPECIFICATIONS

181 FBI AXLE

Axle Type Hypoid
 Lubricant-Std. SAE Thermally Stable 80W-90
 Lubricant-Heavy Duty ... SAE 75W-140 Synthetic
 Lube Capacity 1.48 L (3.13 pts.)
 Axle Ratio 3.07, 3.55, 3.73, 4.10
 Differential Side Gear Clearance ... 0.12-0.20 mm
 (0.005-0.008 in.)
 Ring Gear Diameter 18.09 cm (7.125 in.)
 Backlash 0-0.15 mm (0.005-0.008 in.)
 Pinion Std. Depth 92.1 mm (3.625 in.)
 Pinion Bearing Rotating Torque
 Original Bearings 1-2 N·m (10-20 in. lbs.)
 New Bearings 1.5-4 N·m (15-35 in. lbs.)

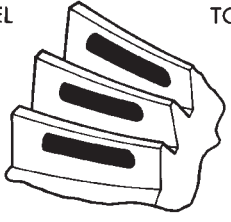
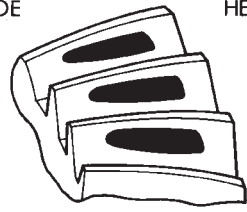
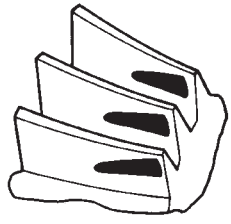
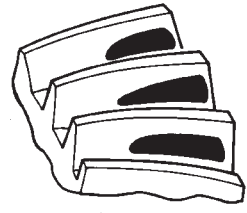
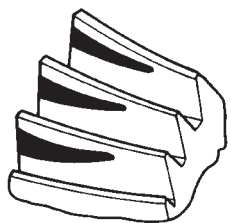
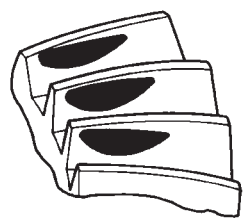
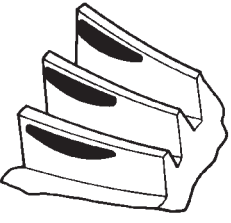
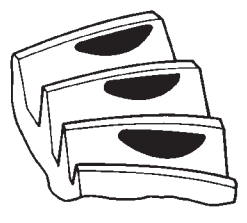
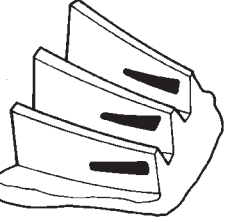
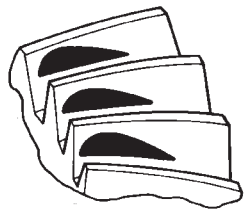
186 FBI AXLE

Axle Type Hypoid
 Lubricant-Std. SAE Thermally Stable 80W-90
 Lubricant-Heavy Duty ... SAE 75W-140 Synthetic
 Lube Capacity 1.18 L (2.5 pts.)
 Axle Ratio 3.07, 3.55, 3.73, 4.10
 Differential Side Gear Clearance ... 0.12-0.20 mm
 (0.005-0.008 in.)
 Ring Gear Diameter 18.59 cm (7.33 in.)
 Backlash 0-0.15 mm (0.005-0.008 in.)
 Pinion Std. Depth 92.1 mm (3.625 in.)
 Pinion Bearing Rotating Torque
 Original Bearings 1-2 N·m (10-20 in. lbs.)
 New Bearings 1.5-4 N·m (15-35 in. lbs.)

TORQUE

| DESCRIPTION | TORQUE |
|------------------------|-----------------------------|
| Fill Hole Plug | 34 N·m (25 ft. lbs.) |
| Diff. Cover Bolt | 41 N·m (30 ft. lbs.) |
| Bearing Cap Bolt | 61 N·m (45 ft. lbs.) |
| Ring Gear Bolt | 95-122 N·m (70-90 ft. lbs.) |
| Axle Nut | 237 N·m (175 ft. lbs.) |
| Hub Brg. Bolt | 102 N·m (75 ft. lbs.) |
| Lower Ball Stud | 108 N·m (80 ft. lbs.) |
| Upper Ball Stud | 101 N·m (75 ft. lbs.) |

SPECIAL TOOLS

181 and 186 FBI AXLE

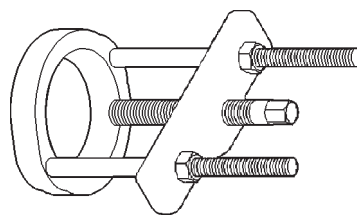

Puller—C-293-PA

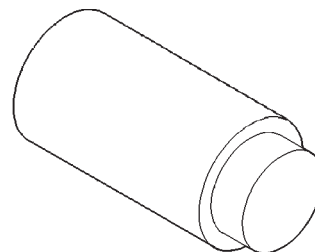

Plug—SP-3289

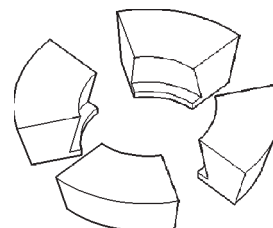

Adapter—C-293-39

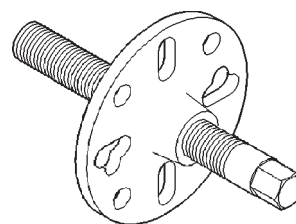

Puller—C-452

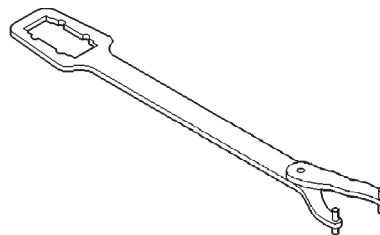

Wrench—C-3281

SPECIAL TOOLS (Continued)

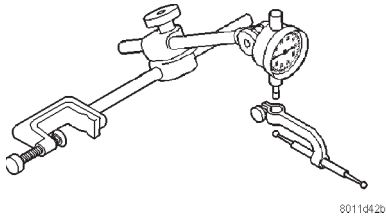

Dial Indicator—C-3339

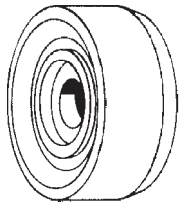

Driver—C-3716-A

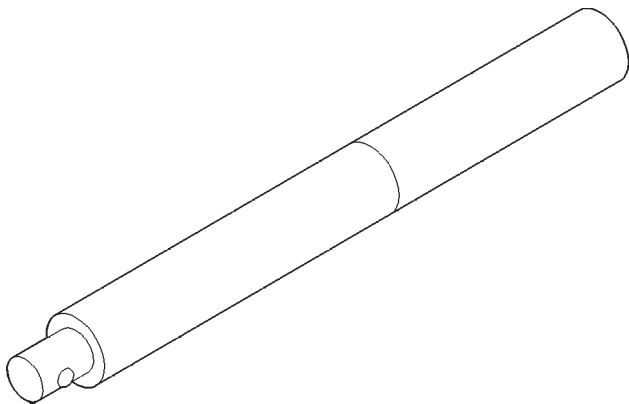

Handle—C-4171

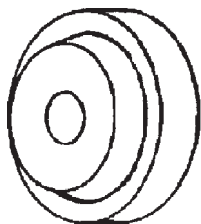

Installer—D-146

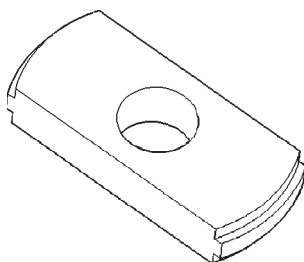

Remover—D-149

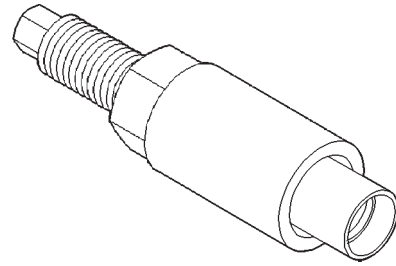

Installer—W-162-D

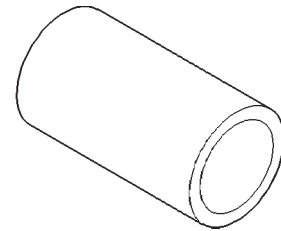

Cup—8109

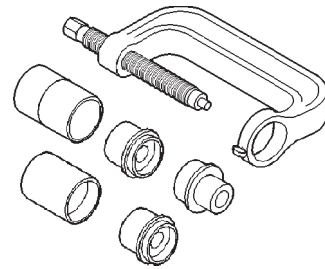

Remover/Installer—6289

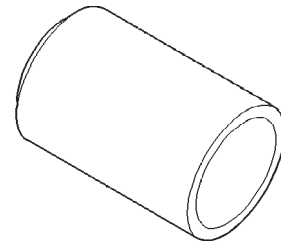

Installer—6761

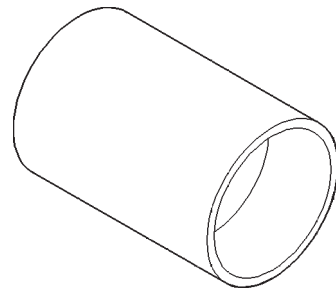

Installer—6752

SPECIAL TOOLS (Continued)

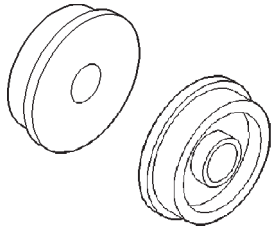

Installer Discs—8110

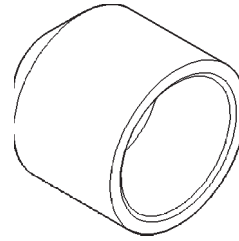

Installer—C-3972-A

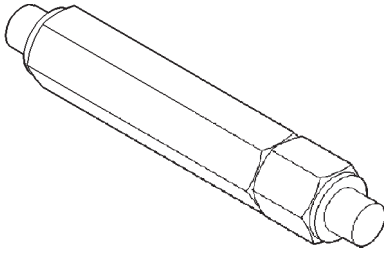

Turnbuckle—6797

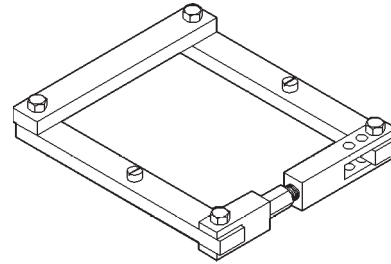

Spreader—W-129-B

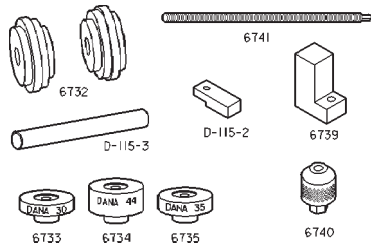

Tool Set, Pinion Depth—6774

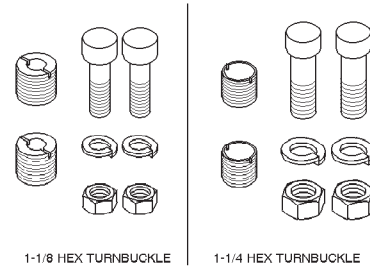

Adapter Kit—6987

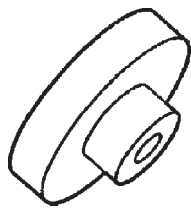

Gauge Block—6733

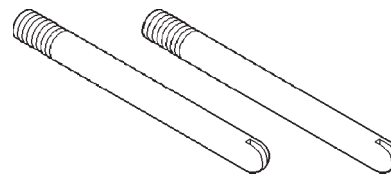

Pilot Stud—C-3288-B

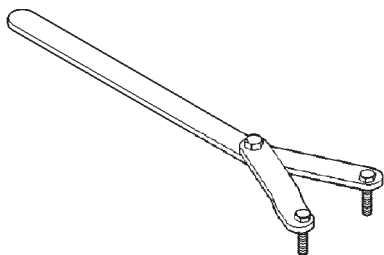

Spanner—6958

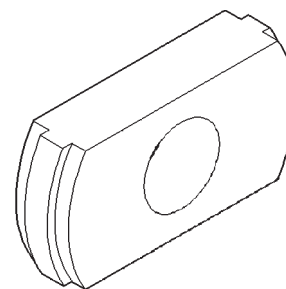

Remover—D-147

SPECIAL TOOLS (Continued)

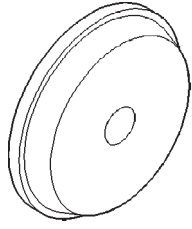

Installer—D-144

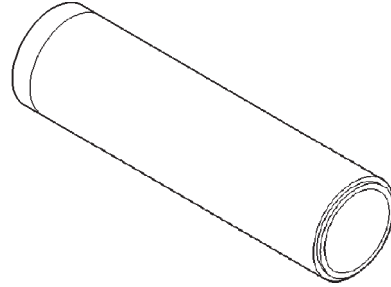

Installer—W-262

194 RBI AXLE

TABLE OF CONTENTS

| | page | | page |
|------------------------------------|------|---|------|
| DESCRIPTION AND OPERATION | | | |
| 194 RBI AXLE | 65 | DIFFERENTIAL | 78 |
| LUBRICANT | 66 | DIFFERENTIAL SIDE BEARINGS | 80 |
| STANDARD DIFFERENTIAL | 66 | RING GEAR | 80 |
| TRAC-LOK™ DIFFERENTIAL | 66 | PINION GEAR | 81 |
| DIAGNOSIS AND TESTING | | | |
| GENERAL INFORMATION | 67 | FINAL ASSEMBLY | 85 |
| GEAR NOISE | 70 | DISASSEMBLY AND ASSEMBLY | |
| BEARING NOISE | 70 | STANDARD DIFFERENTIAL | 86 |
| LOW SPEED KNOCK | 70 | TRAC-LOK™ DIFFERENTIAL | 87 |
| VIBRATION | 70 | CLEANING AND INSPECTION | |
| DRIVELINE SNAP | 70 | AXLE COMPONENTS | 91 |
| TRAC-LOK™ DIFFERENTIAL NOISE | 70 | TRAC-LOK™ | 91 |
| TRAC-LOK™ TEST | 71 | ADJUSTMENTS | |
| SERVICE PROCEDURES | | | |
| LUBRICANT CHANGE | 71 | PINION GEAR DEPTH | 91 |
| REMOVAL AND INSTALLATION | | | |
| REAR AXLE | 72 | DIFFERENTIAL BEARING PRELOAD AND GEAR BACKLASH | 94 |
| PINION SHAFT SEAL | 72 | GEAR CONTACT PATTERN ANALYSIS | 97 |
| COLLAPSIBLE SPACER | 74 | SPECIFICATIONS | |
| AXLE SHAFT | 76 | 194 RBI AXLE | 99 |
| AXLE SHAFT SEAL AND BEARING | 77 | 194 RBI AXLE | 99 |
| | | SPECIAL TOOLS | |
| | | 194 RBI AXLE | 99 |

DESCRIPTION AND OPERATION

194 RBI AXLE

DESCRIPTION

The 194 Rear Beam-design Iron (RBI) axle housing has an iron center casting (differential housing) with axle shaft tubes extending from either side. The tubes are pressed into and welded to the differential housing to form a one-piece axle housing.

The integral type, hypoid gear design, housing has the centerline of the pinion set below the centerline of the ring gear.

The axle has a vent hose to relieve internal pressure caused by lubricant vaporization and internal expansion.

The axles are equipped with semi-floating axle shafts, meaning that loads are supported by the axle shaft and bearings. The axle shafts are retained by C-clips in the differential side gears.

The cover provides a means for servicing the differential without removing the axle.

For vehicles equipped with ABS brakes, the axles have a tone ring pressed onto the axle shaft. Use care when removing axle shafts to ensure that the tone wheel or the wheel speed sensor are not damaged.

The 194 RBI axle has the assembly part number and gear ratio listed on a tag. The tag is attached to the differential housing by a cover bolt. Build date identification codes are stamped on the cover side of an axle shaft tube.

The differential case is a one-piece design. The differential pinion mate shaft is retained with a threaded pin. Differential bearing preload and ring gear backlash is adjusted by the use of selective spacer shims. Pinion bearing preload is set and maintained by the use of a collapsible spacer (Fig. 1).

Axles equipped with a Trac-Lok™ differential are optional. A Trac-Lok differential has a one-piece differential case, and the same internal components as a standard differential, plus two clutch disc packs.

OPERATION

The axle receives power from the transmission/transfer case through the rear propeller shaft. The rear propeller shaft is connected to the pinion gear which rotates the differential through the gear mesh with the ring gear bolted to the differential case. The engine power is transmitted to the axle shafts through the pinion mate and side gears. The side gears are splined to the axle shafts.

DESCRIPTION AND OPERATION (Continued)

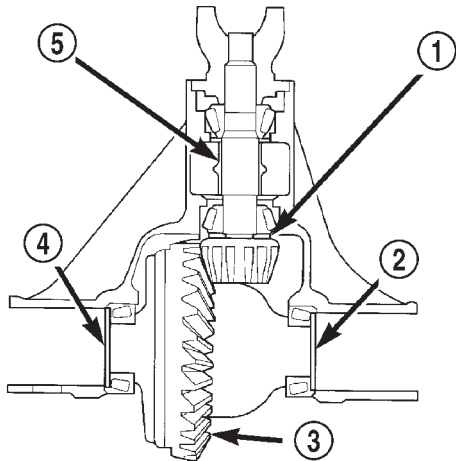

Fig. 1 Shim Locations

80a5037a

- 1 - PINION GEAR DEPTH SHIM
- 2 - DIFFERENTIAL BEARING SHIM-PINION GEAR SIDE
- 3 - RING GEAR
- 4 - DIFFERENTIAL BEARING SHIM-RING GEAR SIDE
- 5 - COLLAPSIBLE SPACER

LUBRICANT

DESCRIPTION

A multi-purpose, hypoid gear lubricant which conforms to the following specifications should be used. Mopar® Hypoid Gear Lubricant conforms to all of these specifications.

- The lubricant should have MIL-L-2105C and API GL 5 quality specifications.
- Lubricant is a thermally stable SAE 80W-90 gear lubricant.
- Lubricant for axles intended for heavy-duty or trailer tow use is SAE 75W-140 SYNTHETIC gear lubricant.

Trac-lok differentials require the addition of 3.5 oz. of friction modifier to the axle lubricant. The 194 RBI axle lubricant capacity is 1.66L (3.50 pts.) total, including the friction modifier if necessary.

CAUTION: If axle is submerged in water, lubricant must be replaced immediately to avoid possible premature axle failure.

STANDARD DIFFERENTIAL

DESCRIPTION

The differential gear system divides the torque between the axle shafts. It allows the axle shafts to rotate at different speeds when turning corners.

Each differential side gear is splined to an axle shaft. The pinion gears are mounted on a pinion mate shaft and are free to rotate on the shaft. The pinion gear is fitted in a bore in the differential case and is positioned at a right angle to the axle shafts.

OPERATION

In operation, power flow occurs as follows:

- The pinion gear rotates the ring gear
- The ring gear (bolted to the differential case) rotates the case
- The differential pinion gears (mounted on the pinion mate shaft in the case) rotate the side gears
- The side gears (splined to the axle shafts) rotate the shafts

During straight-ahead driving, the differential pinion gears do not rotate on the pinion mate shaft. This occurs because input torque applied to the gears is divided and distributed equally between the two side gears. As a result, the pinion gears revolve with the pinion mate shaft but do not rotate around it (Fig. 2).

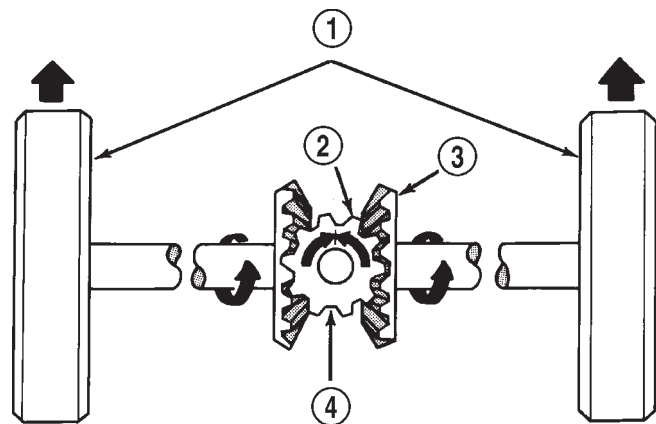

J9303-13

Fig. 2 Differential Operation—Straight Ahead Driving

- 1 - IN STRAIGHT AHEAD DRIVING EACH WHEEL ROTATES AT 100% OF CASE SPEED
- 2 - PINION GEAR
- 3 - SIDE GEAR
- 4 - PINION GEARS ROTATE WITH CASE

When turning corners, the outside wheel must travel a greater distance than the inside wheel to complete a turn. The difference must be compensated for to prevent the tires from scuffing and skidding through turns. To accomplish this, the differential allows the axle shafts to turn at unequal speeds (Fig. 3). In this instance, the input torque applied to the pinion gears is not divided equally. The pinion gears now rotate around the pinion mate shaft in opposite directions. This allows the side gear and axle shaft attached to the outside wheel to rotate at a faster speed.

TRAC-LOK™ DIFFERENTIAL

DESCRIPTION

In a standard differential, if one wheel spins, the opposite wheel will generate only as much torque as the spinning wheel.

DESCRIPTION AND OPERATION (Continued)

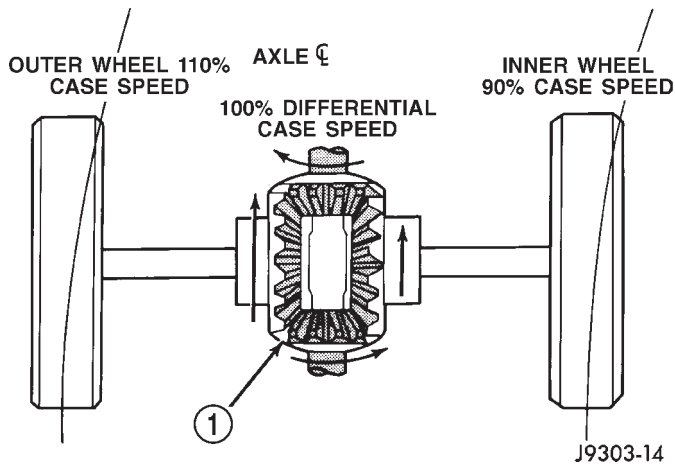

Fig. 3 Differential Operation—On Turns

1 - PINION GEARS ROTATE ON PINION SHAFT

In the Trac-lok™ differential, part of the ring gear torque is transmitted through clutch packs which contain multiple discs. The clutches will have radial grooves on the plates, and concentric grooves on the discs or bonded fiber material that is smooth in appearance.

OPERATION

In operation, the Trac-lok™ clutches are engaged by two concurrent forces. The first being the preload force exerted through Belleville spring washers within the clutch packs. The second is the separating forces generated by the side gears as torque is applied through the ring gear (Fig. 4).

The Trac-lok™ design provides the differential action needed for turning corners and for driving straight ahead during periods of unequal traction. When one wheel loses traction, the clutch packs transfer additional torque to the wheel having the most traction. Trac-lok™ differentials resist wheel spin on bumpy roads and provide more pulling power when one wheel loses traction. Pulling power is provided continuously until both wheels loose traction. If both wheels slip due to unequal traction, Trac-lok™ operation is normal. In extreme cases of differences of traction, the wheel with the least traction may spin.

DIAGNOSIS AND TESTING

GENERAL INFORMATION

Axle bearing problem conditions are usually caused by:

- Insufficient or incorrect lubricant.
- Foreign matter/water contamination.
- Incorrect bearing preload torque adjustment.

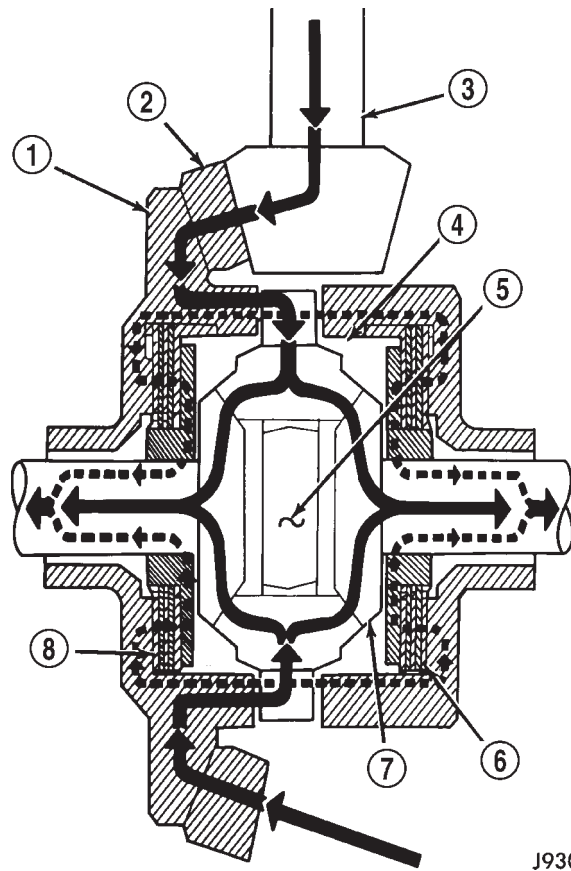

Fig. 4 Trac-lok™ Limited Slip Differential Operation

- 1 - CASE
- 2 - RING GEAR
- 3 - DRIVE PINION
- 4 - PINION GEAR
- 5 - MATE SHAFT
- 6 - CLUTCH PACK
- 7 - SIDE GEAR
- 8 - CLUTCH PACK

• Incorrect backlash.
Axle gear problem conditions are usually the result of:

- Insufficient lubrication.
- Incorrect or contaminated lubricant.
- Overloading (excessive engine torque) or exceeding vehicle weight capacity.

• Incorrect clearance or backlash adjustment.
Axle component breakage is most often the result of:

- Severe overloading.
- Insufficient lubricant.
- Incorrect lubricant.
- Improperly tightened components.
- Differential housing bores not square to each other.

DIAGNOSIS AND TESTING (Continued)

DIAGNOSTIC CHART

| Condition | Possible Causes | Correction |
|---------------------------|---|--|
| Wheel Noise | <ol style="list-style-type: none"> 1. Wheel loose. 2. Faulty, brinelled wheel bearing. | <ol style="list-style-type: none"> 1. Tighten loose nuts. 2. Replace bearing. |
| Axle Shaft Noise | <ol style="list-style-type: none"> 1. Misaligned axle tube. 2. Bent or sprung axle shaft. 3. End-play in pinion bearings. 4. Excessive gear backlash between the ring gear and pinion. 5. Improper adjustment of pinion gear bearings. 6. Loose pinion yoke nut. 7. Scuffed gear tooth contact surfaces. | <ol style="list-style-type: none"> 1. Inspect axle tube alignment. Correct as necessary. 2. Inspect and correct as necessary. 3. Refer to pinion pre-load information and correct as necessary. 4. Check adjustment of the ring gear and pinion backlash. Correct as necessary. 5. Adjust the pinion bearings pre-load. 6. Tighten the pinion yoke nut. 7. Inspect and replace as necessary. |
| Axle Shaft Broke | <ol style="list-style-type: none"> 1. Misaligned axle tube. 2. Vehicle overloaded. 3. Erratic clutch operation. 4. Grabbing clutch. | <ol style="list-style-type: none"> 1. Replace the broken shaft after correcting tube mis-alignment. 2. Replace broken shaft and avoid excessive weight on vehicle. 3. Replace broken shaft and avoid or correct erratic clutch operation. 4. Replace broken shaft and inspect and repair clutch as necessary. |
| Differential Cracked | <ol style="list-style-type: none"> 1. Improper adjustment of the differential bearings. 2. Excessive ring gear backlash. 3. Vehicle overloaded. 4. Erratic clutch operation. | <ol style="list-style-type: none"> 1. Replace case and inspect gears and bearings for further damage. Set differential bearing pre-load properly. 2. Replace case and inspect gears and bearings for further damage. Set ring gear backlash properly. 3. Replace case and inspect gears and bearings for further damage. Avoid excessive vehicle weight. 4. Replace case and inspect gears and bearings for further damage. Avoid erratic use of clutch. |
| Differential Gears Scored | <ol style="list-style-type: none"> 1. Insufficient lubrication. 2. Improper grade of lubricant. 3. Excessive spinning of one wheel/tire. | <ol style="list-style-type: none"> 1. Replace scored gears. Fill differential with the correct fluid type and quantity. 2. Replace scored gears. Fill differential with the correct fluid type and quantity. 3. Replace scored gears. Inspect all gears, pinion bores, and shaft for damage. Service as necessary. |

DIAGNOSIS AND TESTING (Continued)

| Condition | Possible Causes | Correction |
|-------------------|---|--|
| Loss Of Lubricant | <ol style="list-style-type: none"> 1. Lubricant level too high. 2. Worn axle shaft seals. 3. Cracked differential housing. 4. Worn pinion seal. 5. Worn/scored yoke. 6. Axle cover not properly sealed. | <ol style="list-style-type: none"> 1. Drain lubricant to the correct level. 2. Replace seals. 3. Repair as necessary. 4. Replace seal. 5. Replace yoke and seal. 6. Remove, clean, and re-seal cover. |
| Axle Overheating | <ol style="list-style-type: none"> 1. Lubricant level low. 2. Improper grade of lubricant. 3. Bearing pre-loads too high. 4. Insufficient ring gear backlash. | <ol style="list-style-type: none"> 1. Fill differential to correct level. 2. Fill differential with the correct fluid type and quantity. 3. Re-adjust bearing pre-loads. 4. Re-adjust ring gear backlash. |
| Gear Teeth Broke | <ol style="list-style-type: none"> 1. Overloading. 2. Erratic clutch operation. 3. Ice-spotted pavement. 4. Improper adjustments. | <ol style="list-style-type: none"> 1. Replace gears. Examine other gears and bearings for possible damage. 2. Replace gears and examine the remaining parts for damage. Avoid erratic clutch operation. 3. Replace gears and examine remaining parts for damage. 4. Replace gears and examine remaining parts for damage. Ensure ring gear backlash is correct. |
| Axle Noise | <ol style="list-style-type: none"> 1. Insufficient lubricant. 2. Improper ring gear and pinion adjustment. 3. Unmatched ring gear and pinion. 4. Worn teeth on ring gear and/or pinion. 5. Loose pinion bearings. 6. Loose differential bearings. 7. Mis-aligned or sprung ring gear. 8. Loose differential bearing cap bolts. 9. Housing not machined properly. | <ol style="list-style-type: none"> 1. Fill differential with the correct fluid type and quantity. 2. Check ring gear and pinion contact pattern. 3. Replace gears with a matched ring gear and pinion. 4. Replace ring gear and pinion. 5. Adjust pinion bearing pre-load. 6. Adjust differential bearing pre-load. 7. Measure ring gear run-out. Replace components as necessary. 8. Inspect differential components and replace as necessary. Ensure that the bearing caps are torqued to the proper specification. 9. Replace housing. |

DIAGNOSIS AND TESTING (Continued)

GEAR NOISE

Axle gear noise can be caused by insufficient lubricant, incorrect backlash, tooth contact, worn/damaged gears, or the carrier housing not having the proper offset and squareness.

Gear noise usually happens at a specific speed range. The noise can also occur during a specific type of driving condition. These conditions are acceleration, deceleration, coast, or constant load.

When road testing, first warm-up the axle fluid by driving the vehicle at least 5 miles and then accelerate the vehicle to the speed range where the noise is the greatest. Shift out-of-gear and coast through the peak-noise range. If the noise stops or changes greatly:

- Check for insufficient lubricant.
- Incorrect ring gear backlash.
- Gear damage.

Differential side gears and pinions can be checked by turning the vehicle. They usually do not cause noise during straight-ahead driving when the gears are unloaded. The side gears are loaded during vehicle turns. A worn pinion mate shaft can also cause a snapping or a knocking noise.

BEARING NOISE

The axle shaft, differential and pinion bearings can all produce noise when worn or damaged. Bearing noise can be either a whining, or a growling sound.

Pinion bearings have a constant-pitch noise. This noise changes only with vehicle speed. Pinion bearing noise will be higher pitched because it rotates at a faster rate. Drive the vehicle and load the differential. If bearing noise occurs, the rear pinion bearing is the source of the noise. If the bearing noise is heard during a coast, the front pinion bearing is the source.

Worn or damaged differential bearings usually produce a low pitch noise. Differential bearing noise is similar to pinion bearing noise. The pitch of differential bearing noise is also constant and varies only with vehicle speed.

Axle shaft bearings produce noise and vibration when worn or damaged. The noise generally changes when the bearings are loaded. Road test the vehicle. Turn the vehicle sharply to the left and to the right. This will load the bearings and change the noise level. Where axle bearing damage is slight, the noise is usually not noticeable at speeds above 30 mph.

LOW SPEED KNOCK

Low speed knock is generally caused by a worn U-joint or by worn side-gear thrust washers. A worn pinion shaft bore will also cause low speed knock.

VIBRATION

Vibration at the rear of the vehicle is usually caused by a:

- Damaged drive shaft.
- Missing drive shaft balance weight(s).
- Worn or out-of-balance wheels.
- Loose wheel lug nuts.
- Worn U-joint(s).
- Loose/broken springs.
- Damaged axle shaft bearing(s).
- Loose pinion gear nut.
- Excessive pinion yoke run out.
- Bent axle shaft(s).

Check for loose or damaged front-end components or engine/transmission mounts. These components can contribute to what appears to be a rear-end vibration. Do not overlook engine accessories, brackets and drive belts.

All driveline components should be examined before starting any repair.

Refer to Group 22, Wheels and Tires, for additional vibration information.

DRIVELINE SNAP

A snap or clunk noise when the vehicle is shifted into gear (or the clutch engaged), can be caused by:

- High engine idle speed.
- Transmission shift operation.
- Loose engine/transmission/transfer case mounts.
- Worn U-joints.
- Loose spring mounts.
- Loose pinion gear nut and yoke.
- Excessive ring gear backlash.
- Excessive side gear to case clearance.

The source of a snap or a clunk noise can be determined with the assistance of a helper. Raise the vehicle on a hoist with the wheels free to rotate. Instruct the helper to shift the transmission into gear. Listen for the noise, a mechanics stethoscope is helpful in isolating the source of a noise.

TRAC-LOK™ DIFFERENTIAL NOISE

The most common problem is a chatter noise when turning corners. Before removing a Trac-lok™ unit for repair, drain, flush and refill the axle with the specified lubricant. Refer to Lubricant change in this Group.

A container of Mopar® Trac-lok™ Lubricant (friction modifier) should be added after repair service or during a lubricant change.

After changing the lubricant, drive the vehicle and make 10 to 12 slow, figure-eight turns. This maneuver will pump lubricant through the clutches. This will correct the condition in most instances. If the chatter persists, clutch damage could have occurred.

DIAGNOSIS AND TESTING (Continued)

TRAC-LOK™ TEST

WARNING: WHEN SERVICING VEHICLES WITH A TRAC-LOK™ DIFFERENTIAL DO NOT USE THE ENGINE TO TURN THE AXLE AND WHEELS. BOTH REAR WHEELS MUST BE RAISED AND THE VEHICLE SUPPORTED. A TRAC-LOK™ AXLE CAN EXERT ENOUGH FORCE IF ONE WHEEL IS IN CONTACT WITH A SURFACE TO CAUSE THE VEHICLE TO MOVE.

The differential can be tested without removing the differential case by measuring rotating torque. Make sure brakes are not dragging during this measurement.

- (1) Place blocks in front and rear of both front wheels.
- (2) Raise one rear wheel until it is completely off the ground.
- (3) Engine off, transmission in neutral, and parking brake off.
- (4) Remove wheel and bolt Special Tool 6790 to studs.
- (5) Use torque wrench on special tool to rotate wheel and read rotating torque (Fig. 5).

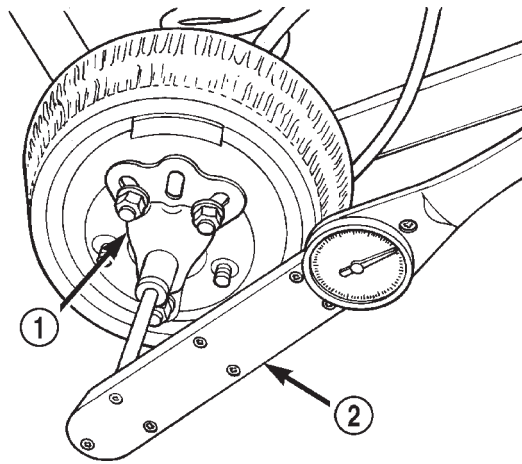

80a4d327

Fig. 5 Trac-lok™ Test —Typical

- 1 - SPECIAL TOOL 6790 WITH BOLT IN CENTER HOLE
- 2 - TORQUE WRENCH

(6) If rotating torque is less than 22 N·m (30 ft. lbs.) or more than 271 N·m (200 ft. lbs.) on either wheel the unit should be serviced.

SERVICE PROCEDURES

LUBRICANT CHANGE

- (1) Raise and support the vehicle.
- (2) Remove the lubricant fill hole plug from the differential housing cover.

- (3) Remove the differential housing cover and drain the lubricant from the housing.
- (4) Clean the housing cavity with a flushing oil, light engine oil, or lint free cloth. **Do not use water, steam, kerosene, or gasoline for cleaning.**
- (5) Remove the original sealant from the housing and cover surfaces.
- (6) Apply a bead of Mopar® Silicone Rubber Sealant, or equivalent, to the housing cover (Fig. 6).

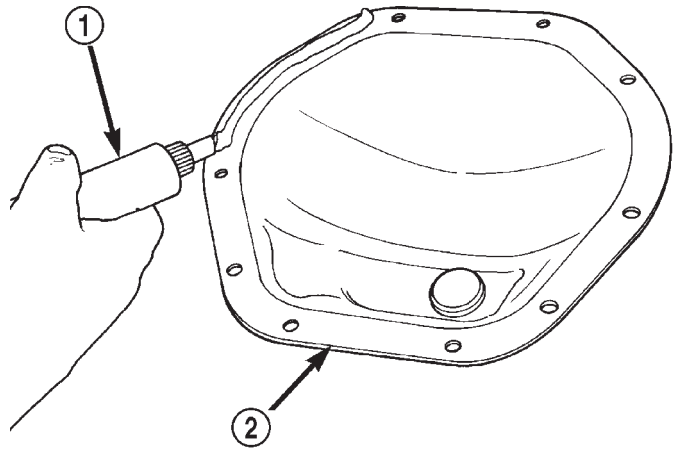

80a534a8

Fig. 6 Apply Sealant

- 1 - SEALANT
- 2 - AXLE HOUSING COVER

Install the housing cover within 5 minutes after applying the sealant.

- (7) Install the cover and any identification tag. Tighten the cover bolts to 41 N·m (30 ft. lbs.) torque.
- (8) For Trac-lok™ differentials, a quantity of Mopar® Trac-lok™ lubricant (friction modifier), or equivalent, must be added after repair service or a lubricant change. Refer to the Lubricant Specifications section of this group for the quantity necessary.
- (9) Fill differential with Mopar® Hypoid Gear Lubricant, or equivalent, to bottom of the fill plug hole. Refer to the Lubricant Specifications section of this group for the quantity necessary.

CAUTION: Overfilling the differential can result in lubricant foaming and overheating.

- (10) Install the fill hole plug and lower the vehicle.
- (11) Trac-lok™ differential equipped vehicles should be road tested by making 10 to 12 slow figure-eight turns. This maneuver will pump the lubricant through the clutch discs to eliminate a possible chatter noise complaint.

REMOVAL AND INSTALLATION

REAR AXLE

REMOVAL

- (1) Raise and support the vehicle.
- (2) Position a suitable lifting device under the axle.
- (3) Secure axle to device.
- (4) Remove the wheels and tires.
- (5) Remove the brake drums from the axle. Refer to Group 5, Brakes, for proper procedures.
- (6) Disconnect parking brake cables from brackets and lever.
- (7) Remove wheel speed sensors, if necessary. Refer to Group 5, Brakes, for proper procedures.
- (8) Disconnect the brake hose at the axle junction block. Do not disconnect the brake hydraulic lines at the wheel cylinders. Refer to Group 5, Brakes, for proper procedures.
- (9) Disconnect the vent hose from the axle shaft tube.
- (10) Mark the propeller shaft and yokes for installation alignment reference.
- (11) Remove propeller shaft.
- (12) Disconnect stabilizer bar links.
- (13) Disconnect shock absorbers from axle.
- (14) Remove the U-bolts which hold the axle to the spring brackets.
- (15) Separate the axle from the vehicle.

INSTALLATION

NOTE: The weight of the vehicle must be supported by the springs before suspension arms and track bar fasteners can be tightened. If the springs are not at their normal ride position, vehicle ride height and handling could be affected.

- (1) Raise the axle with lifting device and align the spring centering bolts with the mating holes in the axle spring perch.
- (2) Install the U-bolts which hold the axle to the spring brackets. Tighten nuts to 70 N·m (52 ft. lbs.).
- (3) Install shock absorbers and tighten nuts to 60 N·m (44 ft. lbs.) torque.
- (4) Install stabilizer bar links and tighten nuts to 74 N·m (55 ft. lbs.) torque.
- (5) Install the wheel speed sensors, if necessary. Refer to Group 5, Brakes, for proper procedures.
- (6) Connect parking brake cable to brackets and lever.
- (7) Install the brake drums. Refer to Group 5, Brakes, for proper procedures.

(8) Connect the brake hose to the axle junction block. Refer to Group 5, Brakes, for proper procedures.

(9) Install axle vent hose.

(10) Align propeller shaft and pinion yoke reference marks. Install U-joint straps and bolts. Tighten to 19 N·m (14 ft. lbs.) torque.

(11) Install the wheels and tires.

(12) Add gear lubricant, if necessary. Refer to Lubricant Specifications in this section for lubricant requirements.

(13) Remove lifting device from axle and lower the vehicle.

PINION SHAFT SEAL

REMOVAL

- (1) Raise and support the vehicle.
- (2) Remove wheel and tire assemblies.
- (3) Remove the brake drums. Refer to Group 5, Brakes, for proper procedures.
- (4) Mark the propeller shaft and pinion yoke for installation alignment reference.
- (5) Remove the propeller shaft from the yoke.
- (6) Rotate the pinion gear three or four times.
- (7) Measure the amount of torque necessary to rotate the pinion gear with a (in. lbs.) dial-type torque wrench. Record the torque reading for installation reference.
- (8) Using Holder 6958 to hold the pinion yoke, remove the pinion nut and washer.
- (9) Use Remover C-452 and Wrench C-3281 to remove the pinion yoke (Fig. 7).

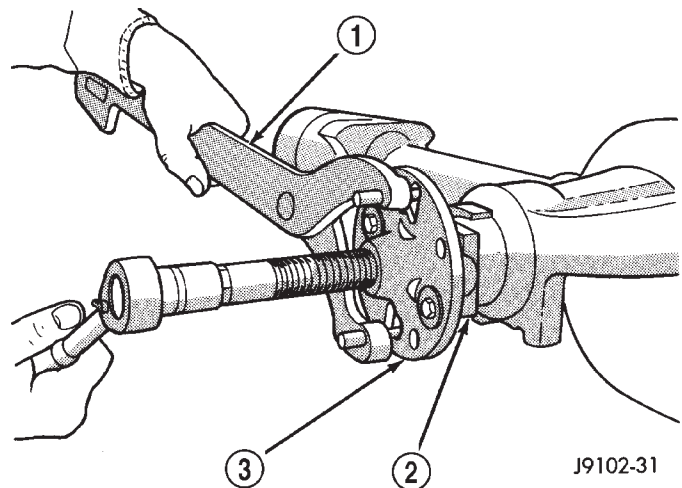

Fig. 7 Pinion Yoke Removal

- 1 - SPECIAL TOOL C-3281
- 2 - YOKE
- 3 - SPECIAL TOOL C-452

J9102-31

REMOVAL AND INSTALLATION (Continued)

(10) Use a suitable pry tool or slide hammer mounted screw to remove the pinion gear seal.

INSTALLATION

(1) Apply a light coating of gear lubricant on the lip of pinion seal. Install seal with Installer C-3972-A and Handle C-4171 (Fig. 8).

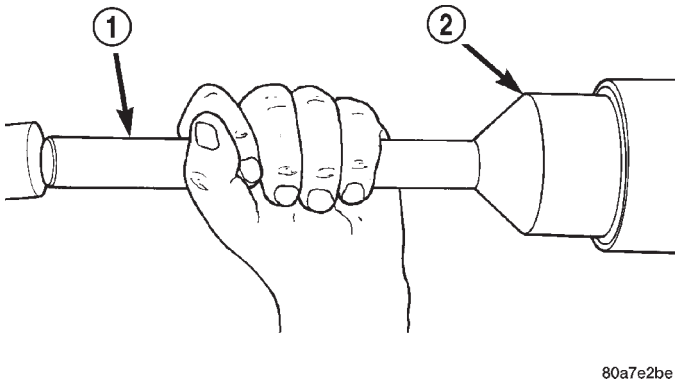

Fig. 8 Pinion Seal Installation

- 1 - SPECIAL TOOL C-4171
- 2 - SPECIAL TOOL C-3972-A

(2) Install yoke on the pinion gear with Screw 8112, Cup 8109, and Holder 6958 (Fig. 9).

CAUTION: Do not exceed the minimum tightening torque when installing the pinion yoke at this point. Damage to the collapsible spacer or bearings may result.

(3) Install the yoke washer and a new nut on the pinion gear and tighten the pinion nut until there is zero bearing end-play.

(4) Tighten the nut to 271 N·m (200 ft. lbs.).

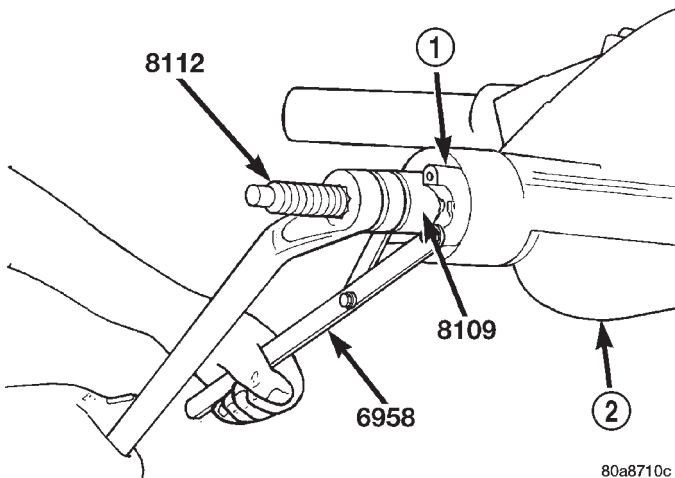

Fig. 9 Pinion Yoke Installation

- 1 - PINION YOKE
- 2 - AXLE HOUSING

CAUTION: Never loosen pinion gear nut to decrease pinion gear bearing rotating torque and never exceed specified preload torque. If preload torque or rotating torque is exceeded a new collapsible spacer must be installed. The torque sequence will then have to be repeated.

(5) Rotate the pinion shaft using a (in. lbs.) torque wrench. Rotating torque should be equal to the reading recorded during removal plus an additional 0.56 N·m (5 in. lbs.) (Fig. 10).

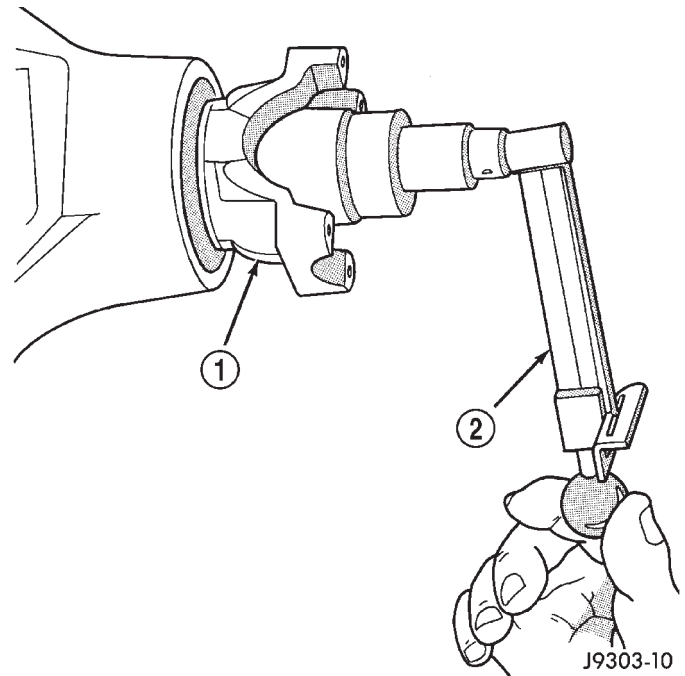

Fig. 10 Check Pinion Rotation Torque

- 1 - PINION YOKE
- 2 - INCH POUND TORQUE WRENCH

(6) If the rotating torque is low, use Holder 6958 to hold the pinion yoke (Fig. 11), and tighten the pinion shaft nut in 6.8 N·m (5 ft. lbs.) increments until the proper rotating torque is achieved.

CAUTION: If the maximum tightening torque is reached prior to reaching the required rotating torque, the collapsible spacer may have been damaged. Replace the collapsible spacer.

(7) Align the installation reference marks on the propeller shaft and yoke and install the propeller shaft.

(8) Add gear lubricant to the differential housing, if necessary. Refer to the Lubricant Specifications for gear lubricant requirements.

(9) Install the brake drums. Refer to Group 5, Brakes, for proper procedures.

(10) Install wheel and tire assemblies.

REMOVAL AND INSTALLATION (Continued)

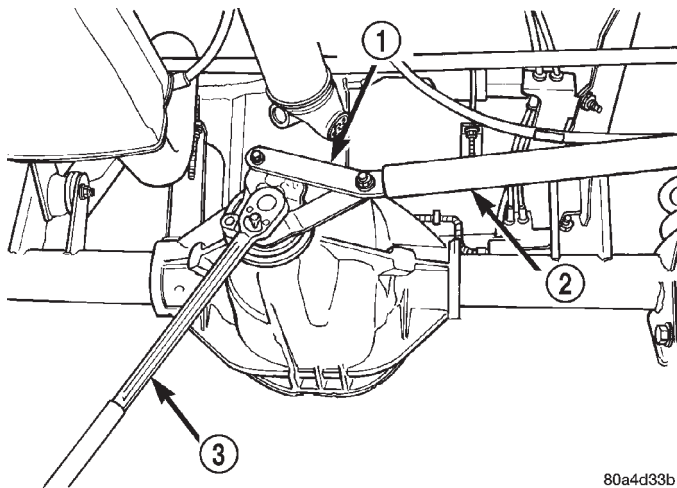
**Fig. 11 Tightening Pinion Shaft Nut—Typical**

- 1 - SPECIAL TOOL 6958
- 2 - 1 in. PIPE
- 3 - 3/4 DRIVE TORQUE WRENCH

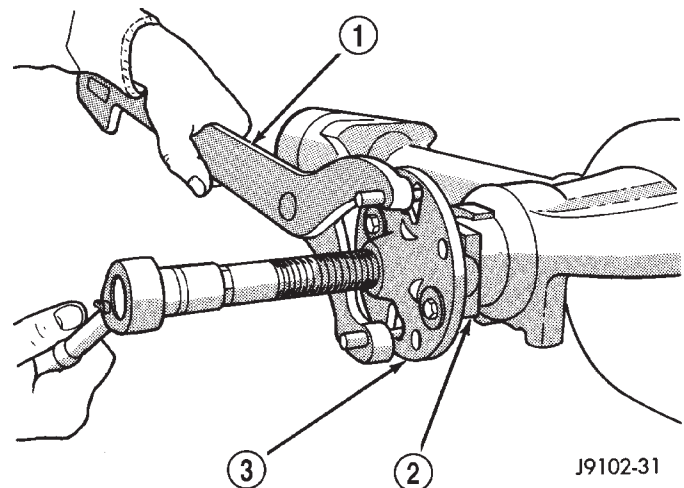
**Fig. 12 Pinion Yoke Removal**

- 1 - SPECIAL TOOL C-3281
- 2 - YOKE
- 3 - SPECIAL TOOL C-452

(11) Lower the vehicle.

COLLAPSIBLE SPACER**REMOVAL W/PINION INSTALLED**

- (1) Raise and support the vehicle.
- (2) Remove wheel and tire assemblies.
- (3) Remove rear brake drums. Refer to Group 5, Brakes, for proper procedures.
- (4) Mark the propeller shaft and pinion yoke for installation reference.
- (5) Remove the propeller shaft from the yoke.
- (6) Rotate the pinion gear three or four times.
- (7) Measure the amount of torque necessary to rotate the pinion gear with a (in. lbs.) dial-type torque wrench. Record the torque reading for installation reference.
- (8) Using Holder 6958 to hold the pinion yoke, remove the pinion nut and washer.
- (9) Use Remover C-452 and Wrench C-3281 to remove the pinion yoke (Fig. 12).
- (10) Use a suitable pry tool or a slide hammer mounted screw to remove the pinion shaft seal.
- (11) Remove the front pinion bearing using a pair of suitable pick tools to pull the bearing straight off the pinion gear shaft. It may be necessary to lightly tap the end of the pinion gear with a rawhide or rubber mallet if the bearing becomes bound on the pinion shaft.
- (12) Remove the collapsible spacer.

REMOVAL W/PINION REMOVED

- (1) Raise and support the vehicle.
- (2) Remove wheel and tire assemblies.
- (3) Remove rear brake drums. Refer to Group 5, Brakes, for proper procedures.

(4) Mark the propeller shaft and pinion yoke for installation reference.

- (5) Remove the propeller shaft from the yoke.
- (6) Rotate the pinion gear three or four times.
- (7) Measure the amount of torque necessary to rotate the pinion gear with a (in. lbs.) dial-type torque wrench. Record the torque reading for installation reference.
- (8) Remove differential assembly from axle housing.
- (9) Using Holder 6958 to hold yoke, remove the pinion yoke nut and washer.
- (10) Using Remover C-452 and Wrench C-3281, remove the pinion yoke from pinion shaft (Fig. 12).
- (11) Remove the pinion gear from housing (Fig. 13). Catch the pinion with your hand to prevent it from falling and being damaged.
- (12) Remove collapsible spacer from pinion shaft.

INSTALLATION

- (1) Install a new collapsible preload spacer on pinion shaft (Fig. 14).
- (2) If pinion gear was removed, install pinion gear in housing.
- (3) Install pinion front bearing, if necessary.
- (4) Apply a light coating of gear lubricant on the lip of pinion seal. Install seal with Installer C-3972-A and Handle C-4171 (Fig. 15).
- (5) Install yoke with Screw 8112, Cup 8109, and Holder 6958 (Fig. 16).
- (6) If the original pinion bearings are being used, install differential assembly and axle shafts, if necessary.

REMOVAL AND INSTALLATION (Continued)

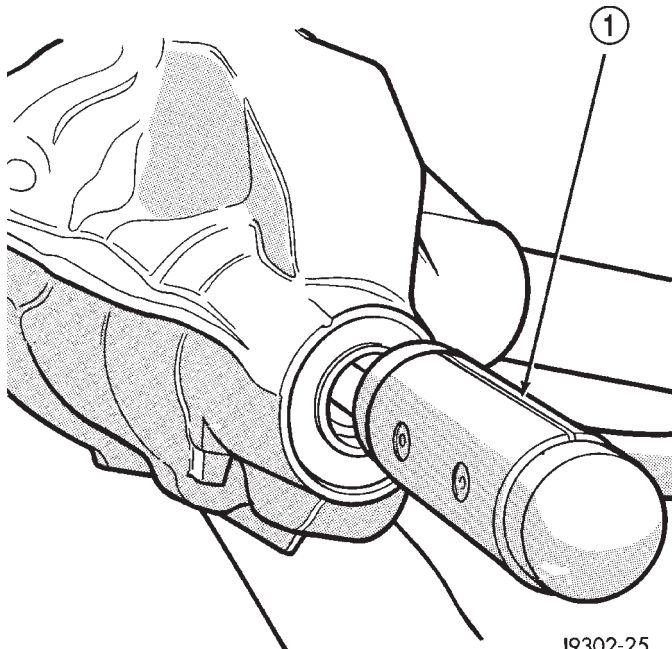
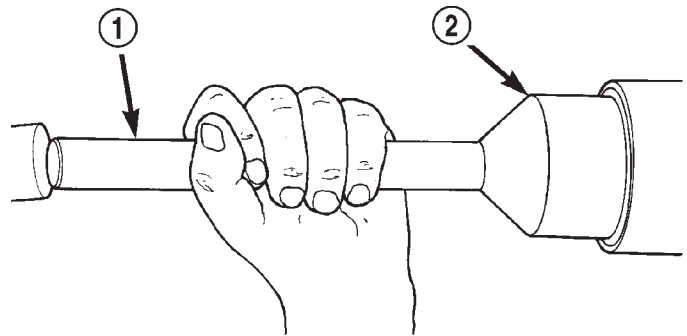

Fig. 13 Remove Pinion Gear

J9302-25

- 1 - RAWHIDE HAMMER



80a7e2be

Fig. 15 Pinion Seal Installation

- 1 - SPECIAL TOOL C-4171
- 2 - SPECIAL TOOL C-3972-A

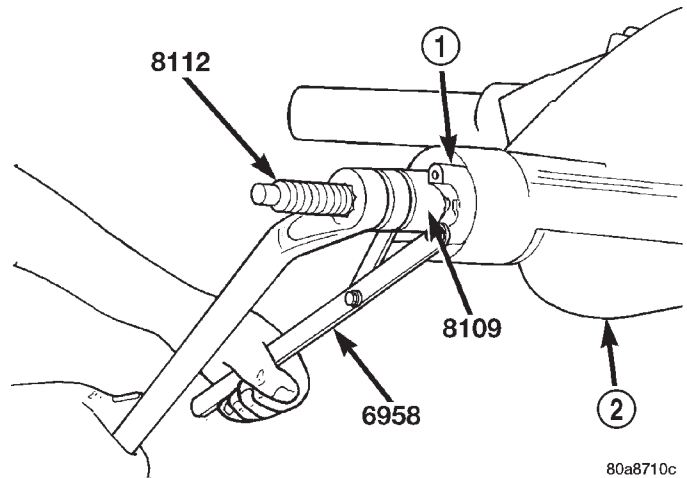

80a8710c

Fig. 16 Pinion Yoke Installation

- 1 - PINION YOKE
- 2 - AXLE HOUSING

(7) Install the yoke washer and a new nut on the pinion gear. Tighten the pinion nut until there is zero bearing end-play.

(8) Tighten the nut to 271 N·m (200 ft. lbs.).

CAUTION: Never loosen pinion gear nut to decrease pinion gear bearing rotating torque and never exceed specified preload torque. If preload torque or rotating torque is exceeded a new collapsible spacer must be installed. The torque sequence will then have to be repeated.

(9) Using yoke holder 6958 and a torque wrench set at 474 N·m (350 ft. lbs.), crush collapsible spacer until bearing end play is taken up (Fig. 17).

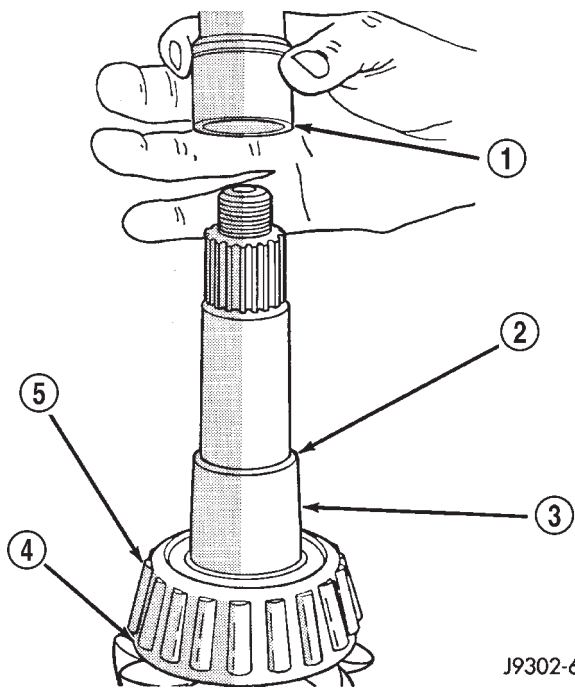

J9302-66

Fig. 14 Collapsible Preload Spacer

- 1 - COLLAPSIBLE SPACER
- 2 - SHOULDER
- 3 - PINION GEAR
- 4 - OIL SLINGER
- 5 - REAR BEARING

NOTE: If new pinion bearings were installed, do not install the differential assembly and axle shafts until after the pinion bearing preload and rotating torque are set.

NOTE: If more than 474 N·m (350 ft. lbs.) of torque is necessary to remove the bearing end play, the collapsible spacer is defective and must be replaced.

REMOVAL AND INSTALLATION (Continued)

(10) Slowly tighten the nut in 6.8 N·m (5 ft. lbs.) increments until the rotating torque is achieved. Measure the rotating torque frequently to avoid over crushing the collapsible spacer (Fig. 18).

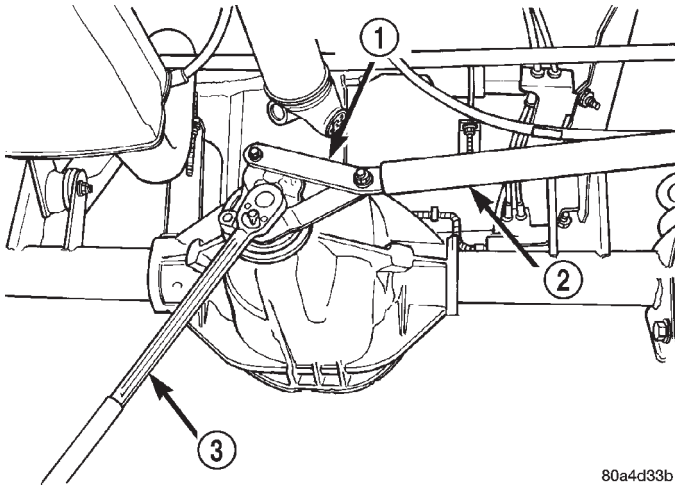

80a4d33b

Fig. 17 Tightening Pinion Nut—Typical

- 1 - SPECIAL TOOL 6958
2 - 1 in. PIPE
3 - 3/4 DRIVE TORQUE WRENCH

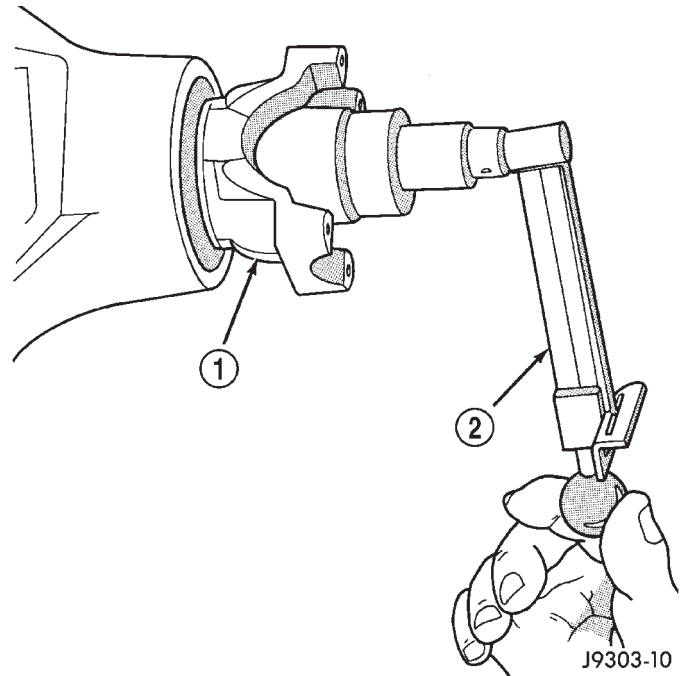

J9303-10

Fig. 18 Check Pinion Gear Rotation Torque

- 1 - PINION YOKE
2 - INCH POUND TORQUE WRENCH

(11) Check rotating torque with a (in. lbs.) torque wrench (Fig. 18). The torque necessary to rotate the pinion gear should be:

- Original Bearings — The reading recorded during removal, plus an additional 0.56 N·m (5 in. lbs.).
- New Bearings — 1.5 to 4 N·m (15 to 35 in. lbs.).

(12) Install differential assembly and axle shafts, if necessary.

(13) Align marks made previously on yoke and propeller shaft and install propeller shaft.

(14) Install rear brake drums. Refer to Group 5, Brakes, for proper procedures.

(15) Add gear lubricant, if necessary. Refer to Lubricant Specifications of this section for lubricant requirements.

(16) Install wheel and tire assemblies.

(17) Lower vehicle.

AXLE SHAFT

REMOVAL

(1) Raise and support vehicle. Ensure that the transmission is in neutral.

(2) Remove wheel and tire assembly.

(3) Remove brake drum. Refer to Group 5, Brakes, for proper procedure.

(4) Clean all foreign material from housing cover area.

(5) Loosen housing cover bolts. Drain lubricant from the housing and axle shaft tubes. Remove housing cover.

(6) Rotate differential case so that pinion mate gear shaft lock screw is accessible. Remove lock screw and pinion mate gear shaft from differential case (Fig. 19).

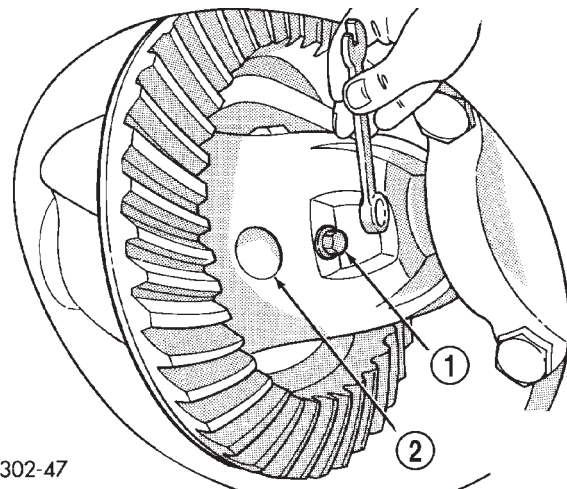

J9302-47

Fig. 19 Mate Shaft Lock Screw

- 1 - LOCK SCREW
2 - PINION GEAR MATE SHAFT

(7) Push axle shaft inward and remove axle shaft C-clip lock from the axle shaft (Fig. 20).

(8) Remove axle shaft. Use care to prevent damage to axle shaft bearing and seal, which will remain in axle shaft tube. Also, exercise care not to damage the

REMOVAL AND INSTALLATION (Continued)

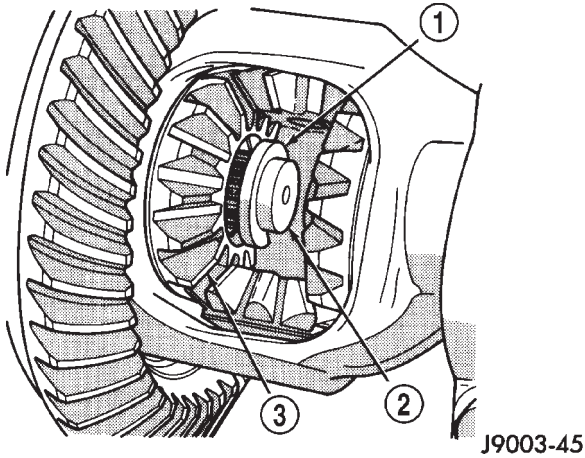

Fig. 20 Axle Shaft C-Clip Lock

- 1 - C-CLIP LOCK
- 2 - AXLE SHAFT
- 3 - SIDE GEAR

wheel speed sensor on vehicles equipped with ABS brakes.

(9) Inspect axle shaft seal for leakage or damage.

(10) Inspect roller bearing contact surface on axle shaft for signs of brinelling, galling and pitting. If any of these conditions exist, the axle shaft and/or bearing and seal must be replaced.

INSTALLATION

(1) Lubricate bearing bore and seal lip with gear lubricant. Insert axle shaft through seal, bearing, and engage it into side gear splines.

NOTE: Use care to prevent shaft splines from damaging axle shaft seal lip. Also, exercise care not to damage the wheel speed sensor on vehicles equipped with ABS brakes

(2) Insert C-clip lock in end of axle shaft. Push axle shaft outward to seat C-clip lock in side gear.

(3) Insert pinion mate shaft into differential case and through thrust washers and pinion gears.

(4) Align hole in shaft with hole in the differential case and install lock screw with Loctite® on the threads. Tighten lock screw to 19 N·m (14 ft. lbs.) torque.

(5) Install cover and add fluid. Refer to Lubricant Change procedure in this section for procedure and lubricant requirements.

(6) Install brake drum. Refer to Group 5, Brakes, for proper procedures.

(7) Install wheel and tire.

(8) Lower vehicle.

AXLE SHAFT SEAL AND BEARING

REMOVAL

(1) Remove the axle shaft.

(2) Remove the axle shaft seal from the end of the axle shaft tube with a small pry bar.

NOTE: The seal and bearing can be removed at the same time with the bearing removal tool.

(3) Remove the axle shaft bearing from the axle tube with Bearing Removal Tool Set 6310 using Adapter Foot 6310-5 (Fig. 21).

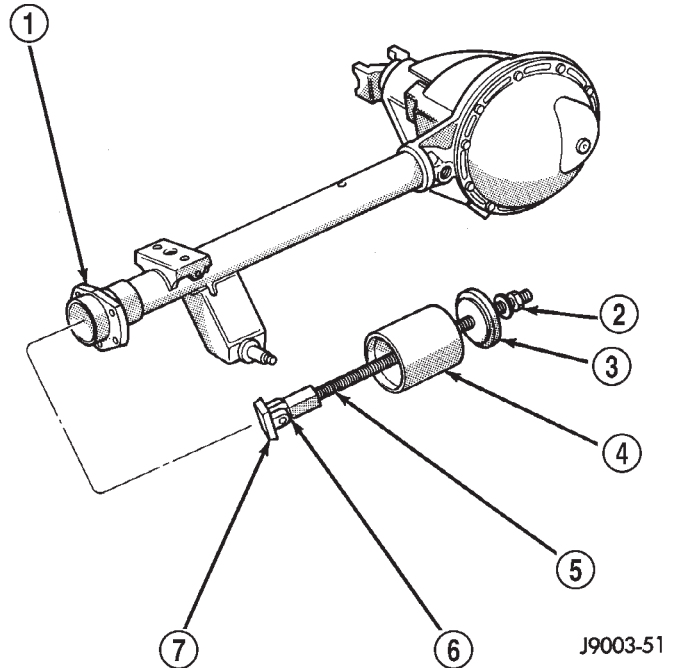

Fig. 21 Axle Shaft Bearing Removal

- 1 - AXLE SHAFT TUBE
- 2 - NUT
- 3 - GUIDE PLATE
- 4 - GUIDE
- 5 - THREADED ROD
- 6 - ADAPTER
- 7 - FOOT

(4) Inspect the axle shaft tube bore for roughness and burrs. Remove as necessary.

INSTALLATION

Do not install the original axle shaft seal. Always install a new seal.

(1) Wipe the axle shaft tube bore clean.

(2) Install axle shaft bearing with Installer 6436 and Handle C-4171. Ensure that the part number on the bearing is against the installer.

(3) Install the new axle shaft seal with Installer 6437 and Handle C-4171 (Fig. 22).

REMOVAL AND INSTALLATION (Continued)

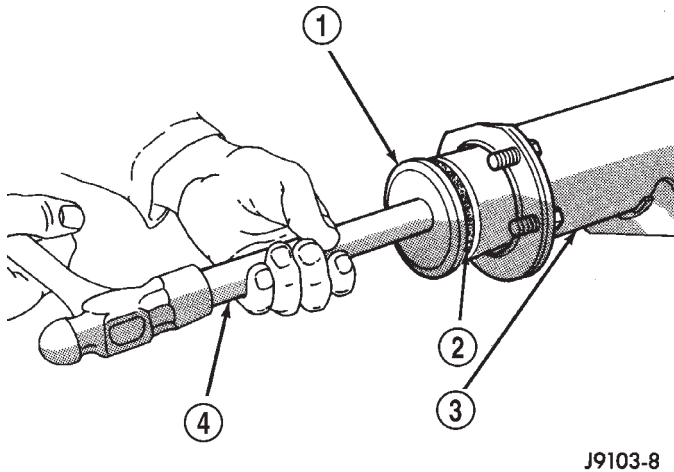
**Fig. 22 Axle Shaft Seal Installation**

- 1 - SPECIAL TOOL 6437
- 2 - SEAL
- 3 - AXLE SHAFT TUBE
- 4 - SPECIAL TOOL C-4171

(4) Install the axle shaft.

DIFFERENTIAL**REMOVAL**

- (1) Raise and support vehicle.
- (2) Remove the lubricant fill hole plug from the differential housing cover.
- (3) Remove the differential housing cover and allow fluid to drain.
- (4) Remove axle shafts.
- (5) Note the installation reference letters stamped on the bearing caps and housing machined sealing surface (Fig. 23).

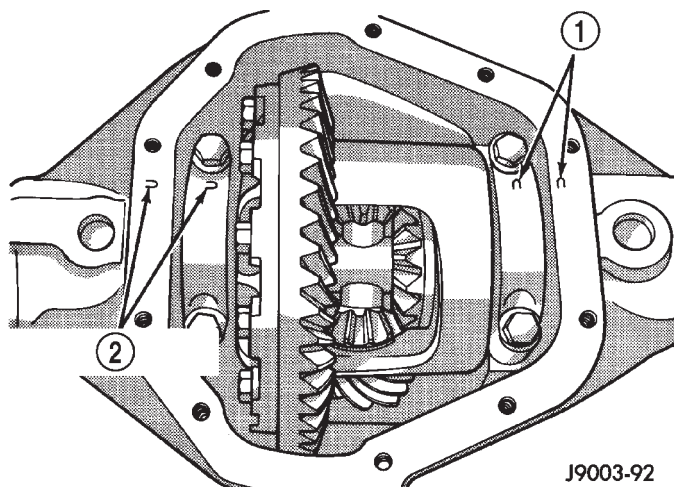
**Fig. 23 Bearing Cap Identification**

- 1 - INSTALLATION REFERENCE LETTERS
- 2 - INSTALLATION REFERENCE LETTERS

- (6) Loosen the differential bearing cap bolts.
- (7) Position Spreader W-129-B, utilizing some items from Adapter set 6987, with the tool dowel pins seated in the locating holes (Fig. 24). Install the hold-down clamps and tighten the tool turnbuckle finger-tight.

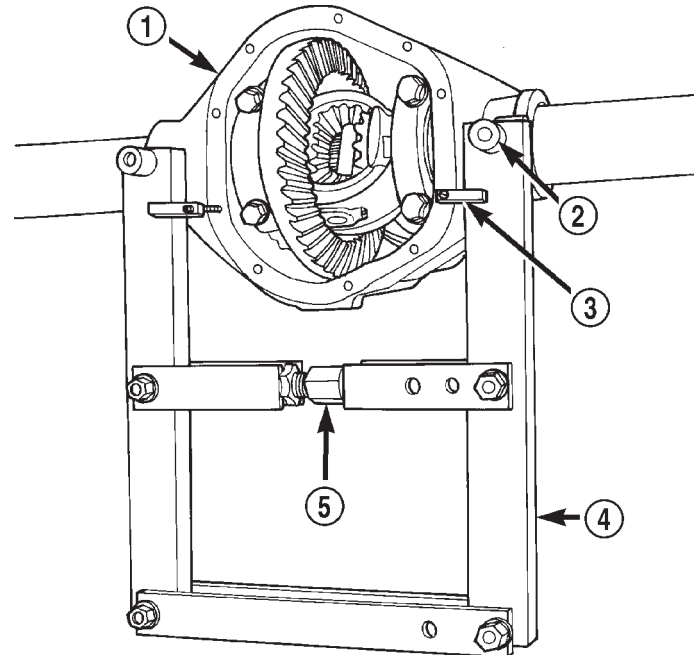
**Fig. 24 Install Axle Housing Spreader**

- 1 - AXLE HOUSING
- 2 - DOWEL
- 3 - SAFETY HOLD DOWN
- 4 - SPECIAL TOOL W-129-B
- 5 - TURNBUCKLE

- (8) Install a Pilot Stud C-3288-B at the left side of the differential housing. Attach Dial Indicator C-3339 to pilot stud. Load the indicator plunger against the opposite side of the housing (Fig. 25) and zero the indicator.

CAUTION: Do not spread over 0.38 mm (0.015 in). If the housing is over-spread, it could be distorted or damaged.

- (9) Spread the housing enough to remove the differential case from the housing. Measure the distance with the dial indicator (Fig. 26).
- (10) Remove the dial indicator.
- (11) While holding the differential case in position, remove the differential bearing cap bolts and caps.
- (12) Remove the differential from the housing. Ensure that the differential bearing cups remain in position on the differential bearings (Fig. 27).
- (13) Mark or tag the differential bearing cups to indicate which side of the differential they were removed from.

REMOVAL AND INSTALLATION (Continued)

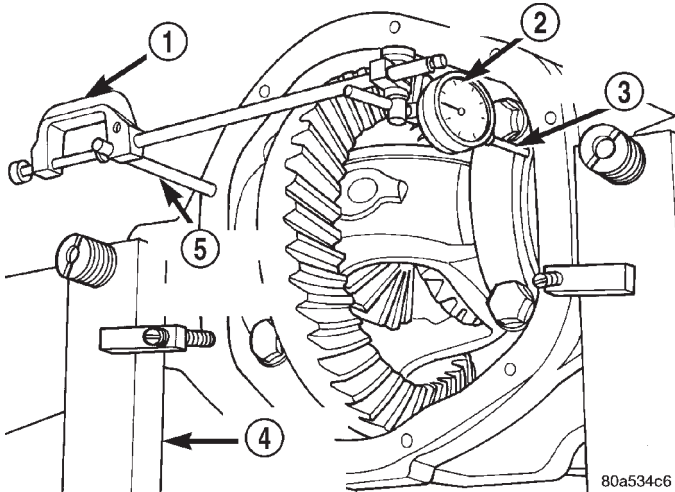

Fig. 25 Install Dial Indicator

- 1 - SPECIAL TOOL C-3339
- 2 - DIAL INDICATOR
- 3 - LEVER ADAPTER
- 4 - SPECIAL TOOL W-129-B
- 5 - SPECIAL TOOL C-3288-B

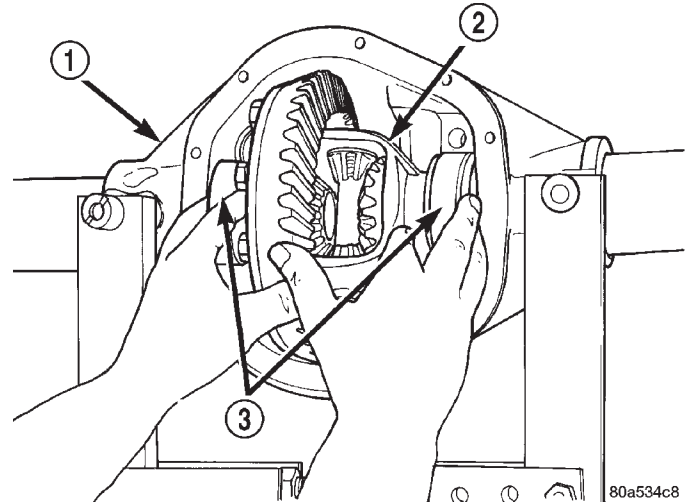

Fig. 27 Differential Case Removal

- 1 - AXLE HOUSING
- 2 - DIFFERENTIAL CASE
- 3 - BEARING CUPS

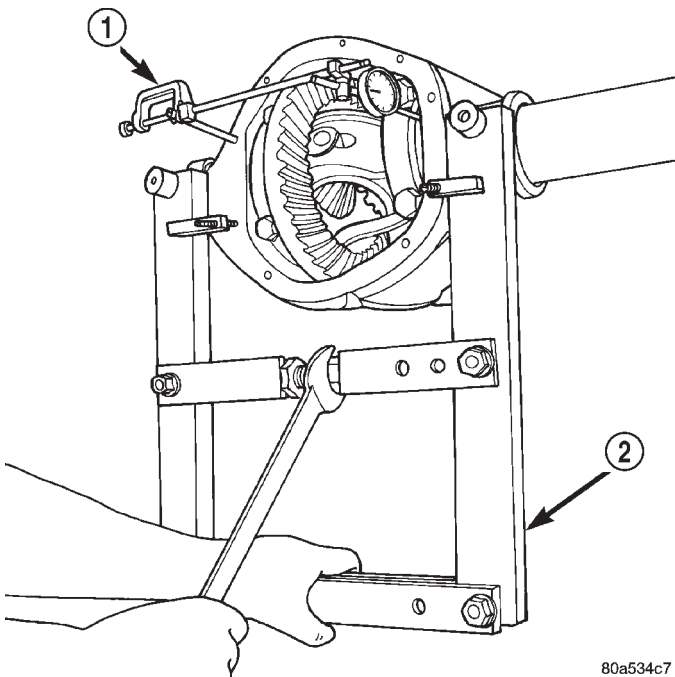

Fig. 26 Spread Axle Housing

- 1 - SPECIAL TOOL C-3339
- 2 - SPECIAL TOOL W-129-B

(14) Retrieve differential case preload shims from axle housing. Mark or tag the differential case preload shims to indicate which side of the differential they were removed from.

(15) Remove spreader from housing.

INSTALLATION

If replacement differential bearings or differential case are being installed, differential side bearing shim requirements may change. Refer to the Differential Bearing Preload and Gear Backlash procedures in this section to determine the proper shim selection.

(1) Position Spreader W-129-B, utilizing some items from Adapter set 6987, with the tool dowel pins seated in the locating holes (Fig. 28). Install the holddown clamps and tighten the tool turnbuckle finger-tight.

(2) Install a Pilot Stud C-3288-B at the left side of the differential housing. Attach Dial Indicator C-3339 to pilot stud. Load the indicator plunger against the opposite side of the housing (Fig. 25) and zero the indicator.

CAUTION: Do not spread over 0.38 mm (0.015 in). If the housing is over-spread, it could be distorted or damaged.

(3) Spread the housing enough to install the case in the housing. Measure the distance with the dial indicator (Fig. 26).

(4) Remove the dial indicator.

(5) Install differential case in the housing. Ensure that the differential bearing cups remain in position on the differential bearings and that the preload shims remain between the face of the bearing cup and the housing. Tap the differential case to ensure the bearings cups and shims are fully seated in the housing.

(6) Install the bearing caps at their original locations (Fig. 29).

(7) Loosely install differential bearing cap bolts.

(8) Remove axle housing spreader.

REMOVAL AND INSTALLATION (Continued)

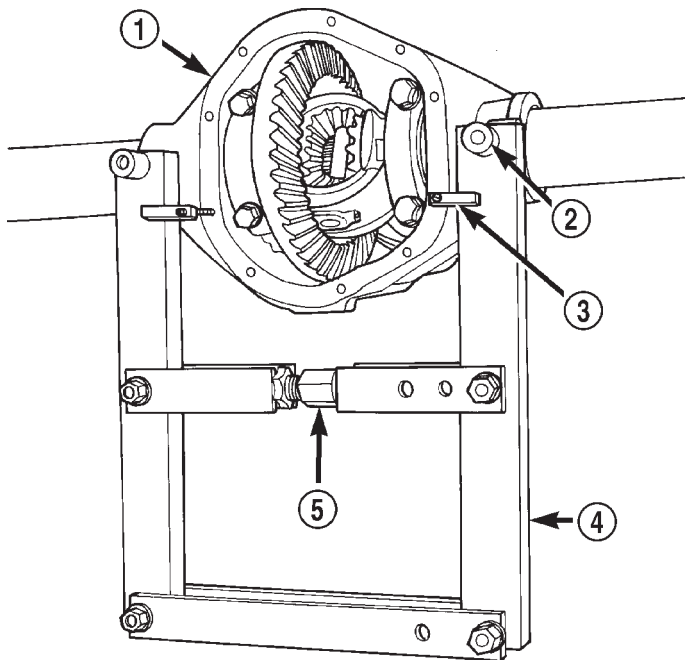

Fig. 28 Install Axle Housing Spreader

80a534c5

- 1 - AXLE HOUSING
- 2 - DOWEL
- 3 - SAFETY HOLD DOWN
- 4 - SPECIAL TOOL W-129-B
- 5 - TURNBUCKLE

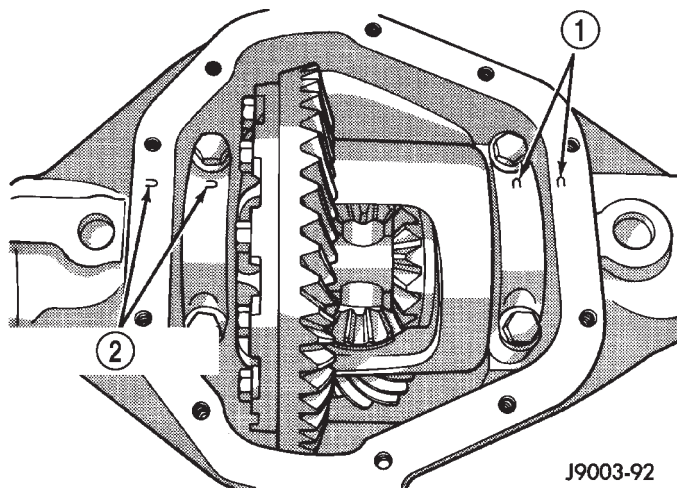

Fig. 29 Differential Bearing Cap Reference Letters

J9003-92

- 1 - INSTALLATION REFERENCE LETTERS
- 2 - INSTALLATION REFERENCE LETTERS

(9) Tighten the bearing cap bolts to 77 N·m (57 ft. lbs.) torque.

(10) Install the axle shafts.

DIFFERENTIAL SIDE BEARINGS

REMOVAL

(1) Remove differential from axle housing.

(2) Remove the bearings from the differential case with Puller/Press C-293-PA, C-293-39 Blocks, and Plug SP-3289 (Fig. 30).

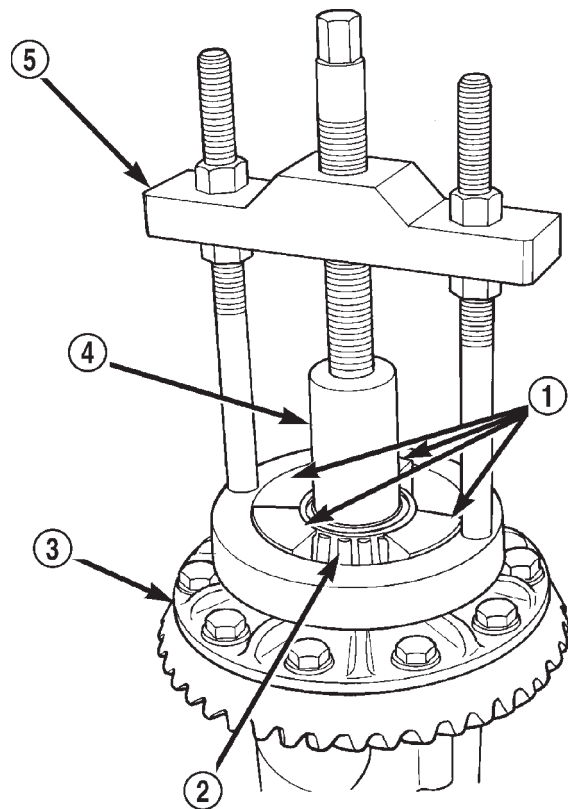

Fig. 30 Differential Bearing Removal

80a7e2a9

- 1 - SPECIAL TOOL C-293-39
- 2 - BEARING
- 3 - DIFFERENTIAL
- 4 - SPECIAL TOOL SP-3289
- 5 - SPECIAL TOOL C-293-PA

INSTALLATION

(1) Using tool C-3716-A with handle C-4171, install differential side bearings (Fig. 31).

(2) Install differential in axle housing.

RING GEAR

NOTE: The ring gear and pinion are serviced as a matched set. Do not replace the ring gear without replacing the pinion.

REMOVAL

(1) Remove differential from axle housing.

(2) Place differential case in a suitable vise with soft metal jaw protectors. (Fig. 32)

(3) Remove bolts holding ring gear to differential case.

(4) Using a soft hammer, drive ring gear from differential case (Fig. 32).

REMOVAL AND INSTALLATION (Continued)

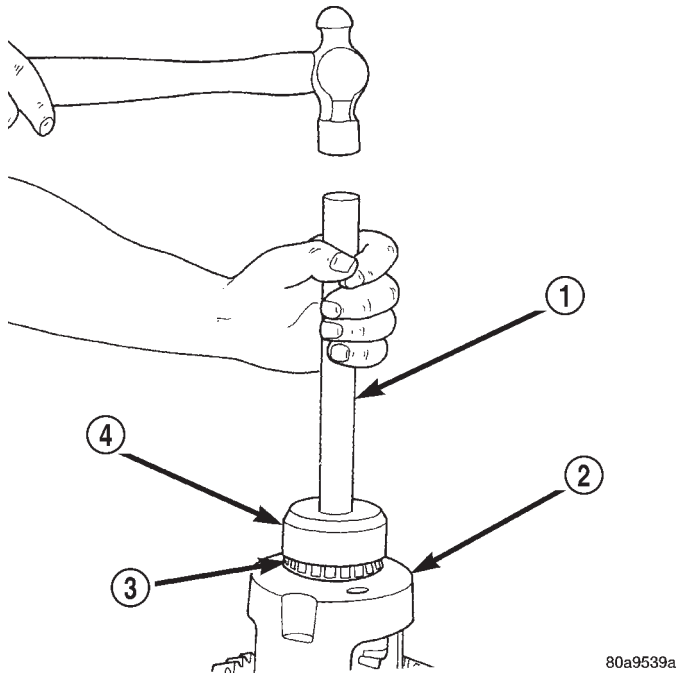

80a9539a

Fig. 31 Install Differential Side Bearings

- 1 - HANDLE C-4171
- 2 - DIFFERENTIAL
- 3 - BEARING
- 4 - TOOL C-3716-A

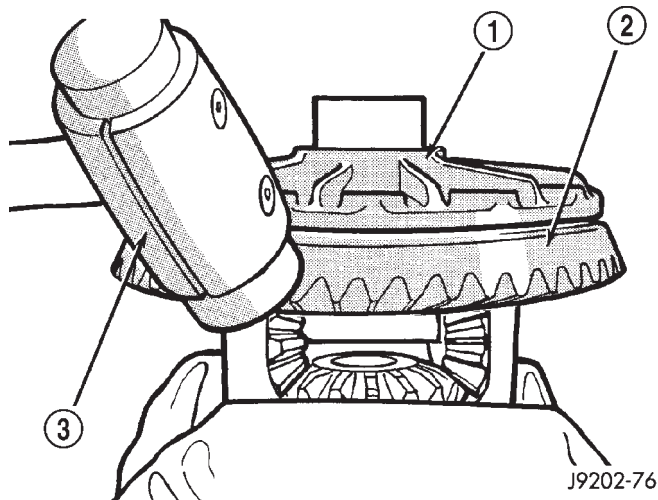

J9202-76

Fig. 32 Ring Gear Removal

- 1 - CASE
- 2 - RING GEAR
- 3 - RAWHIDE HAMMER

INSTALLATION

CAUTION: Do not reuse the bolts that held the ring gear to the differential case. The bolts can fracture causing extensive damage.

(1) Invert the differential case and start two ring gear bolts. This will provide case-to-ring gear bolt hole alignment.

(2) Invert the differential case in the vise.

(3) Install new ring gear bolts and alternately tighten to 95-122 N·m (70-90 ft. lbs.) torque (Fig. 33).

(4) Install differential in axle housing and verify gear mesh and contact pattern.

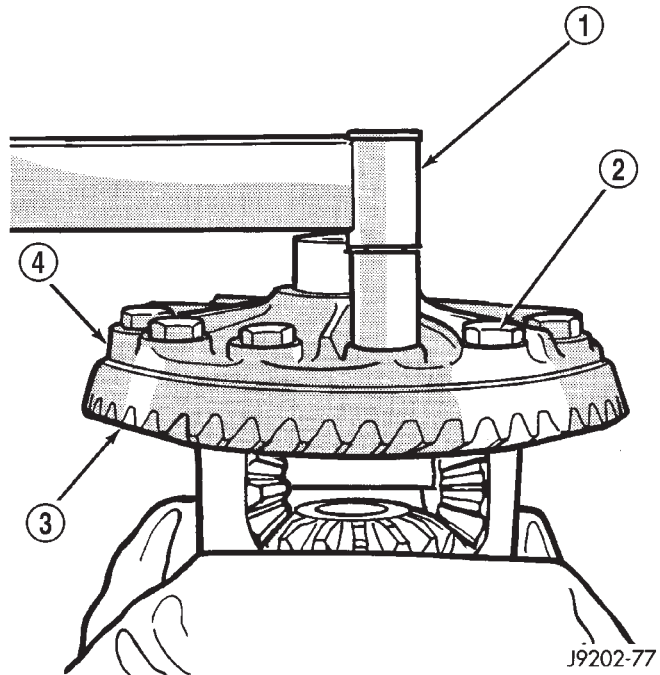

J9202-77

Fig. 33 Ring Gear Bolt Installation

- 1 - TORQUE WRENCH
- 2 - RING GEAR BOLT
- 3 - RING GEAR
- 4 - CASE

PINION GEAR

The ring and pinion gears are serviced in a matched set. Do not replace the pinion gear without replacing the ring gear.

REMOVAL

(1) Remove differential from the axle housing.

(2) Mark pinion yoke and propeller shaft for installation alignment.

(3) Disconnect propeller shaft from pinion yoke. Using suitable wire, tie propeller shaft to underbody.

(4) Using Holder 6958 to hold yoke, remove the pinion yoke nut and washer.

(5) Using Remover C-452 and Wrench C-3281, remove the pinion yoke from pinion shaft (Fig. 34).

(6) Remove the pinion gear from housing (Fig. 35). Catch the pinion with your hand to prevent it from falling and being damaged.

REMOVAL AND INSTALLATION (Continued)

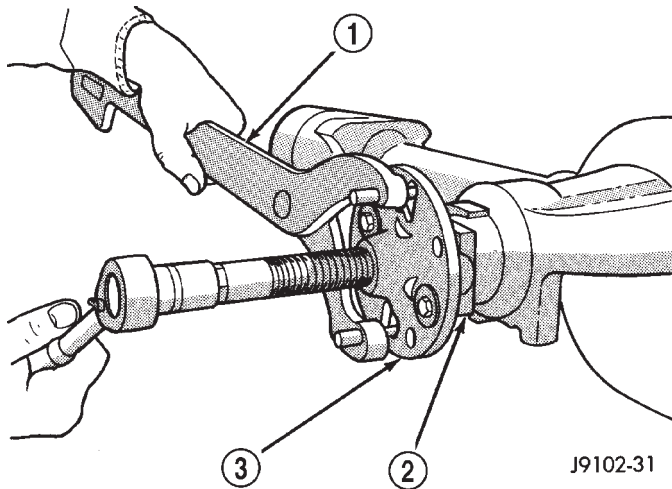
**Fig. 34 Pinion Yoke Removal**

- 1 - SPECIAL TOOL C-3281
- 2 - YOKE
- 3 - SPECIAL TOOL C-452

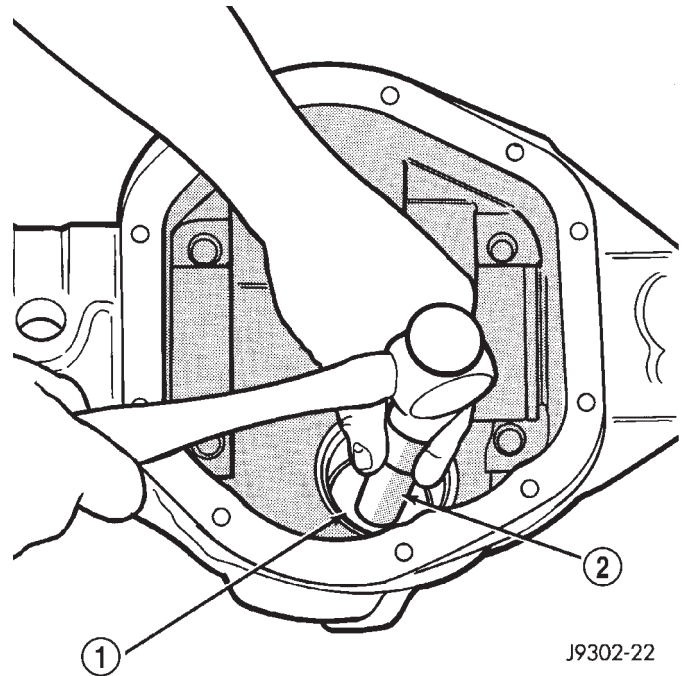
**Fig. 36 Front Bearing Cup Removal**

- 1 - REMOVER
- 2 - HANDLE

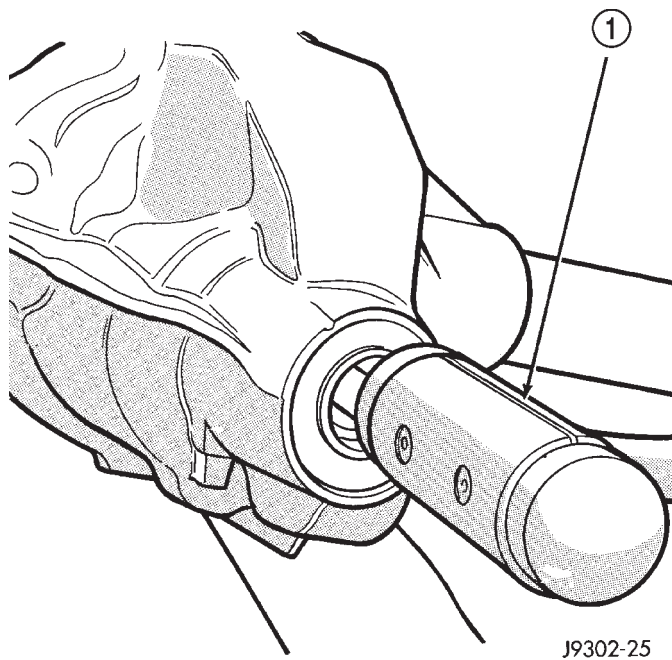
**Fig. 35 Remove Pinion Gear**

- 1 - RAWHIDE HAMMER

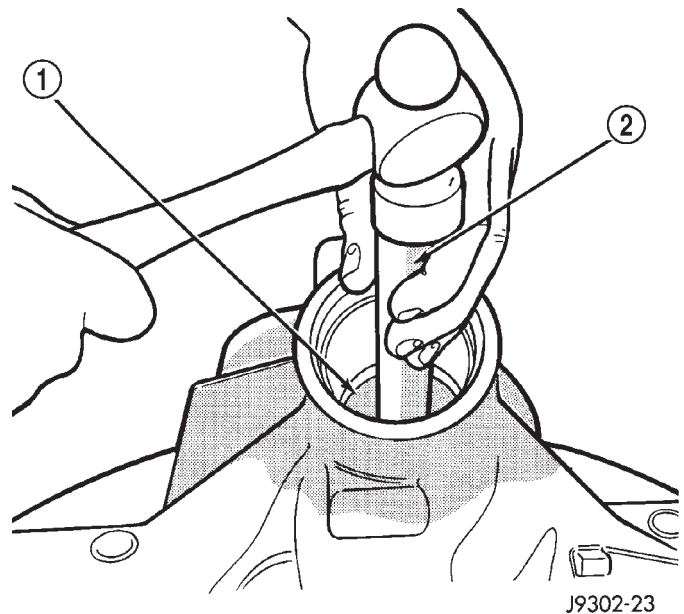
**Fig. 37 Rear Bearing Cup Removal**

- 1 - DRIVER
- 2 - HANDLE

(7) Use a suitable pry tool or a slide hammer mounted screw to remove the pinion shaft seal.

(8) Remove oil slinger, if equipped, and front pinion bearing.

(9) Remove the front pinion bearing cup with Remover C-4345 and Handle C-4171 (Fig. 36).

(10) Remove the rear bearing cup from housing (Fig. 37). Use Remover D-149 and Handle C-4171.

(11) Remove the collapsible preload spacer (Fig. 38).

(12) Remove the rear bearing from the pinion with Puller/Press C-293-PA and Adapters C-293-40 (Fig. 39).

Place 4 adapter blocks so they do not damage the bearing cage.

REMOVAL AND INSTALLATION (Continued)

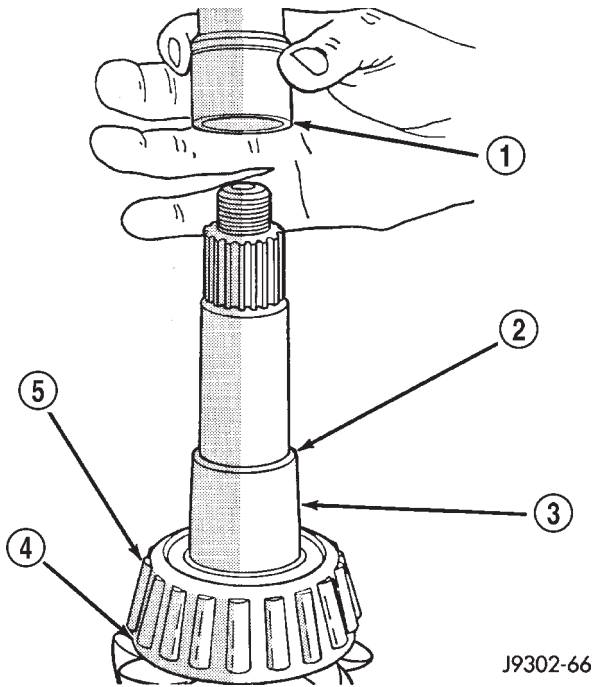

Fig. 38 Collapsible Spacer

- 1 - COLLAPSIBLE SPACER
- 2 - SHOULDER
- 3 - PINION GEAR
- 4 - OIL SLINGER
- 5 - REAR BEARING

(13) Remove the depth shims from the pinion gear shaft. Record the thickness of the depth shims.

INSTALLATION

(1) Apply Mopar® Door Ease, or equivalent, stick lubricant to outside surface of bearing cup.

(2) Install the pinion rear bearing cup with Installer D-146 and Driver Handle C-4171 (Fig. 40). Ensure cup is correctly seated.

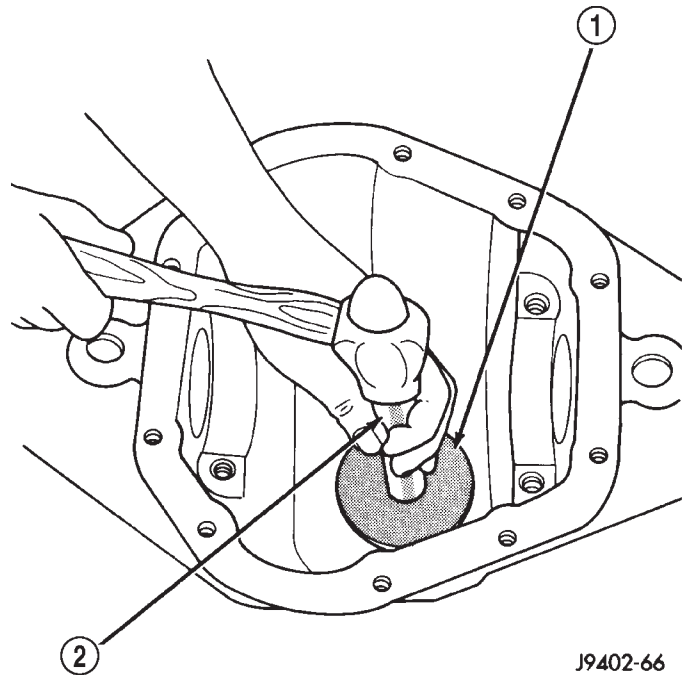

Fig. 40 Pinion Rear Bearing Cup Installation

- 1 - INSTALLER
- 2 - HANDLE

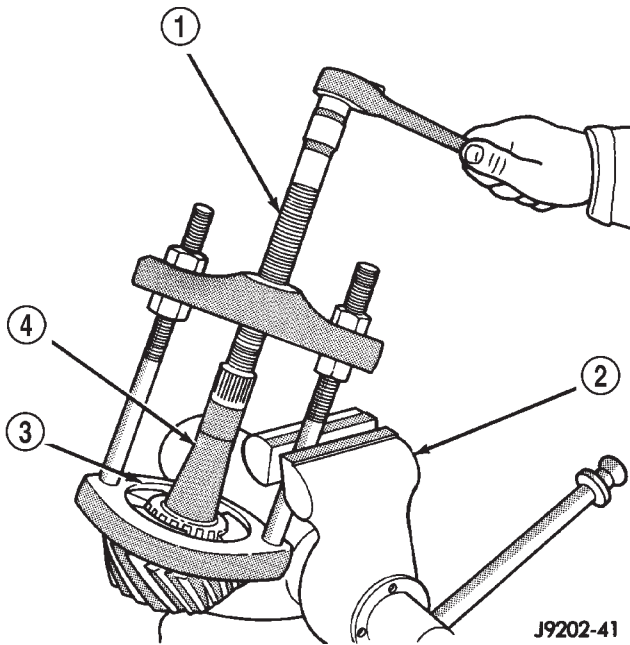

Fig. 39 Rear Bearing Removal

- 1 - SPECIAL TOOL C-293-PA
- 2 - VISE
- 3 - ADAPTERS
- 4 - DRIVE PINION GEAR SHAFT

(3) Apply Mopar® Door Ease, or equivalent, stick lubricant to outside surface of bearing cup.

(4) Install the pinion front bearing cup with Installer D-130 and Handle C-4171 (Fig. 41).

(5) Install pinion front bearing, and oil slinger, if equipped.

(6) Apply a light coating of gear lubricant on the lip of pinion seal. Install seal with Installer C-3972-A and Handle C-4171 (Fig. 42).

NOTE: Pinion depth shims are placed between the rear pinion bearing cone and pinion gear to achieve proper ring and pinion gear mesh. If the factory installed ring and pinion gears are reused, the pinion depth shim should not require replacement. If required, refer to Pinion Gear Depth to select the proper thickness shim before installing rear pinion bearing.

(7) Place the proper thickness depth shim on the pinion gear.

REMOVAL AND INSTALLATION (Continued)

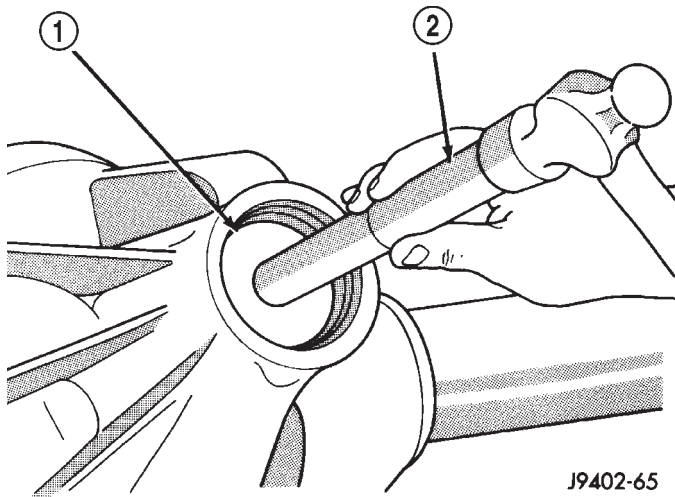

J9402-65

Fig. 41 Pinion Front Bearing Cup Installation

- 1 - INSTALLER
- 2 - HANDLE

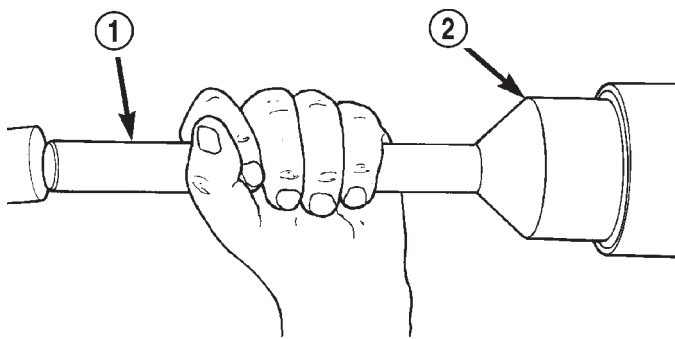

80a7e2be

Fig. 42 Pinion Seal Installation

- 1 - SPECIAL TOOL C-4171
- 2 - SPECIAL TOOL C-3972-A

(8) Install the rear bearing and slinger, if equipped, on the pinion gear with Installer W-262 (Fig. 43).

(9) Install a new collapsible preload spacer on pinion shaft and install pinion gear in housing (Fig. 44).

(10) Install pinion gear in housing.

(11) Install yoke with Installer Screw 8112, Cup 8109, and holder 6958 (Fig. 45).

(12) Install the yoke washer and a new nut on the pinion gear and tighten the pinion nut until there is zero bearing end-play.

(13) Tighten the nut to 271 N·m (200 ft. lbs.).

CAUTION: Never loosen pinion gear nut to decrease pinion gear bearing rotating torque and never exceed specified preload torque. If preload torque or rotating torque is exceeded a new collapsible spacer must be installed. The torque sequence will then have to be repeated.

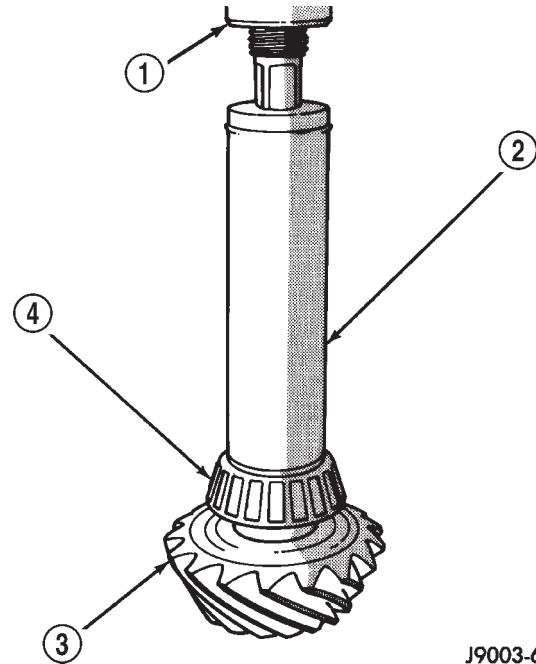

J9003-67

Fig. 43 Shaft Rear Bearing Installation

- 1 - PRESS
- 2 - INSTALLATION TOOL
- 3 - DRIVE PINION GEAR
- 4 - DRIVE PINION GEAR SHAFT REAR BEARING

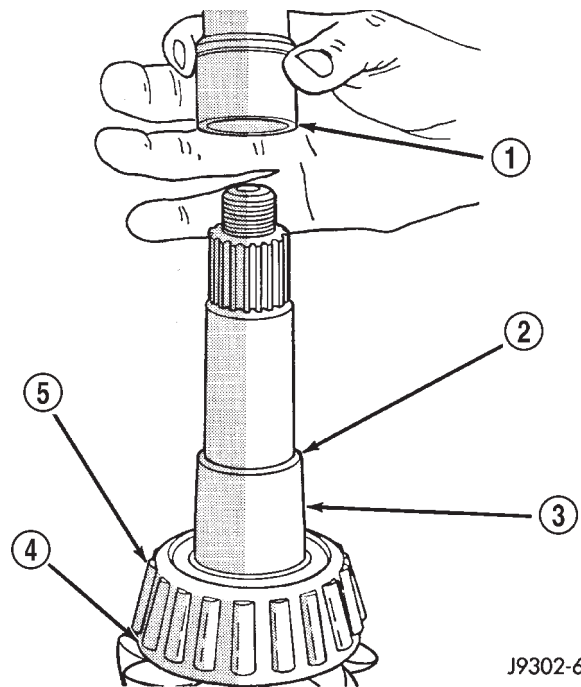

J9302-66

Fig. 44 Collapsible Preload Spacer

- 1 - COLLAPSIBLE SPACER
- 2 - SHOULDER
- 3 - PINION GEAR
- 4 - OIL SLINGER
- 5 - REAR BEARING

REMOVAL AND INSTALLATION (Continued)

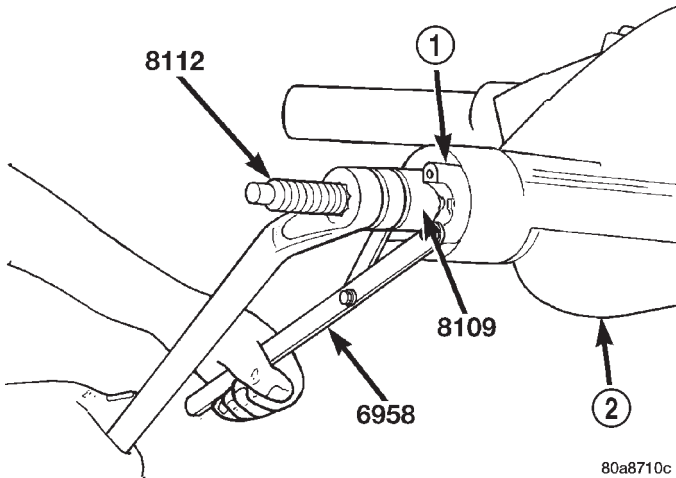

Fig. 45 Pinion Yoke Installation

- 1 - PINION YOKE
- 2 - AXLE HOUSING

(14) Using yoke holder 6958 and a torque wrench set at 474 N·m (350 ft. lbs.), crush collapsible spacer until bearing end play is taken up (Fig. 46).

NOTE: If the spacer requires more than 474 N·m (350 ft. lbs.) torque to crush, the collapsible spacer is defective and must be replaced.

(15) Slowly tighten the nut in 6.8 N·m (5 ft. lbs.) increments until the rotating torque is achieved. Measure the rotating torque frequently to avoid over crushing the collapsible spacer (Fig. 47).

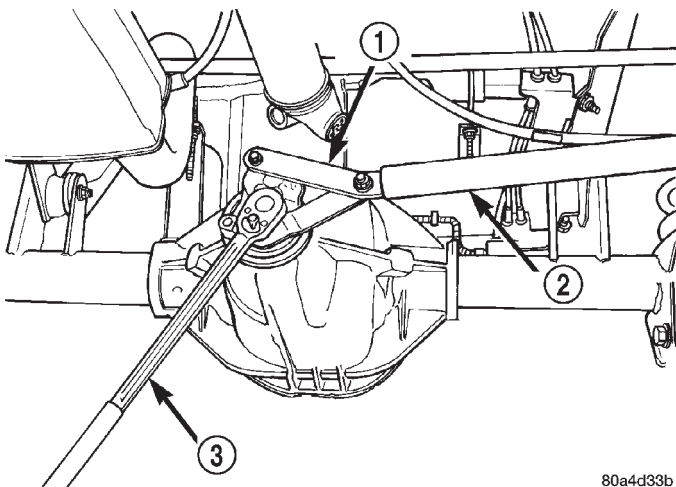

Fig. 46 Tightening Pinion Nut—Typical

- 1 - SPECIAL TOOL 6958
- 2 - 1 in. PIPE
- 3 - 3/4 DRIVE TORQUE WRENCH

(16) Check bearing rotating torque with a (in. lbs.) torque wrench (Fig. 47). The torque necessary to rotate the pinion gear should be:

- Original Bearings — 1 to 2 N·m (10 to 20 in. lbs.).
- New Bearings — 1.5 to 4 N·m (15 to 35 in. lbs.).

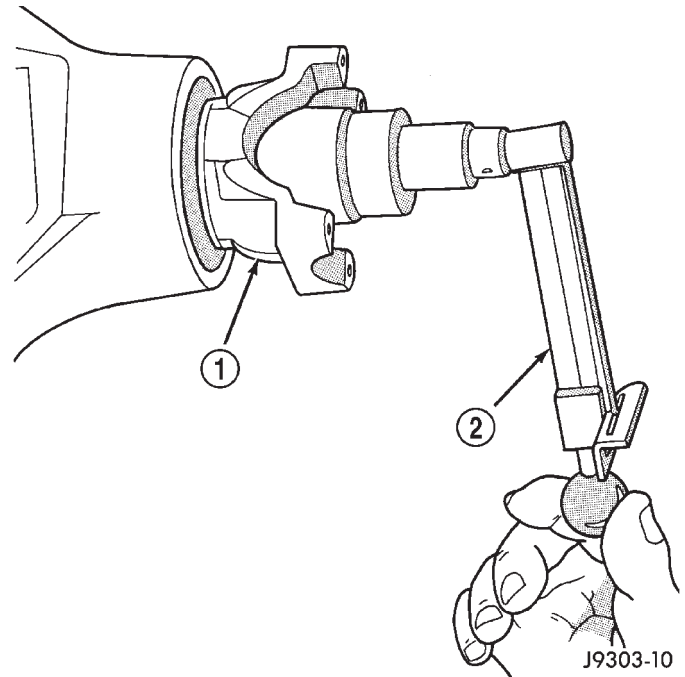

Fig. 47 Check Pinion Gear Rotating Torque

- 1 - PINION YOKE
- 2 - INCH POUND TORQUE WRENCH

(17) Install differential in housing.

FINAL ASSEMBLY

(1) Scrape the residual sealant from the housing and cover mating surfaces. Clean the mating surfaces with mineral spirits. Apply a bead of Mopar® Silicone Rubber Sealant, or equivalent, on the housing cover (Fig. 48).

Install the housing cover within 5 minutes after applying the sealant.

(2) Install the cover on the differential with the attaching bolts. Install the identification tag. Tighten the cover bolts to 41 N·m (30 ft. lbs.) torque.

CAUTION: Overfilling the differential can result in lubricant foaming and overheating.

(3) Refill the differential housing with gear lubricant. Refer to the Lubricant Specifications section of this group for the gear lubricant requirements.

(4) Install the fill hole plug.

REMOVAL AND INSTALLATION (Continued)

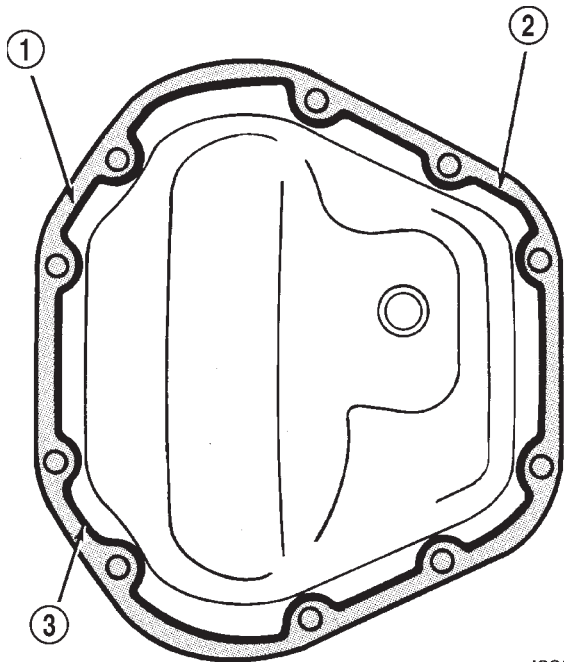

J9302-30

Fig. 48 Typical Housing Cover With Sealant

- 1 - SEALING SURFACE
- 2 - CONTOUR OF BEAD
- 3 - BEAD THICKNESS 6.35mm (1/4")

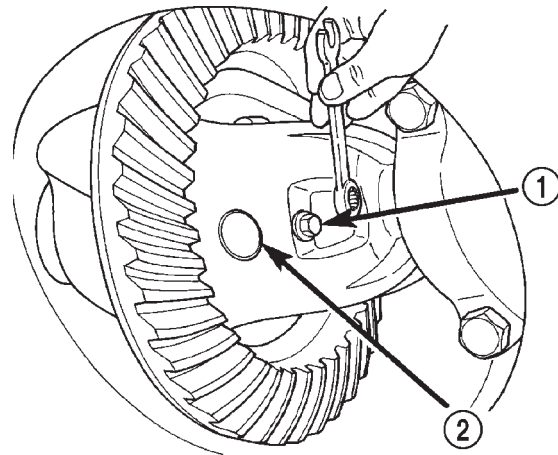

80be4604

Fig. 49 Pinion Mate Shaft Lock Screw

- 1 - LOCK SCREW
- 2 - PINION MATE SHAFT

DISASSEMBLY AND ASSEMBLY

STANDARD DIFFERENTIAL

DISASSEMBLY

- (1) Remove pinion mate shaft lock screw (Fig. 49).
- (2) Remove pinion mate shaft.
- (3) Rotate the differential side gears and remove the differential pinion gears and thrust washers (Fig. 50).
- (4) Remove the differential side gears and thrust washers.

ASSEMBLY

- (1) Install the differential side gears and thrust washers.
- (2) Install the differential pinion gears and thrust washers.
- (3) Install the pinion mate shaft.
- (4) Align the hole in the pinion mate shaft with the hole in the differential case and install the pinion mate shaft lock screw.
- (5) Lubricate all differential components with hypoid gear lubricant.

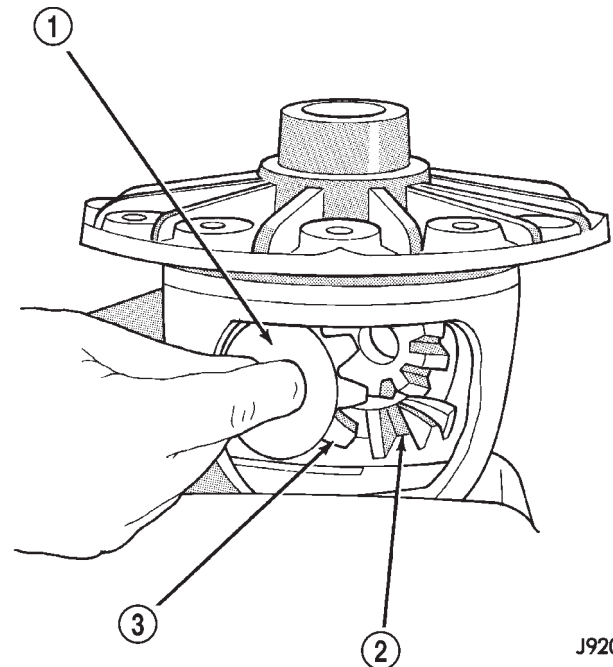

J9203-61

Fig. 50 Pinion Mate Gear Removal

- 1 - THRUST WASHER
- 2 - SIDE GEAR
- 3 - PINION MATE GEAR

DISASSEMBLY AND ASSEMBLY (Continued)

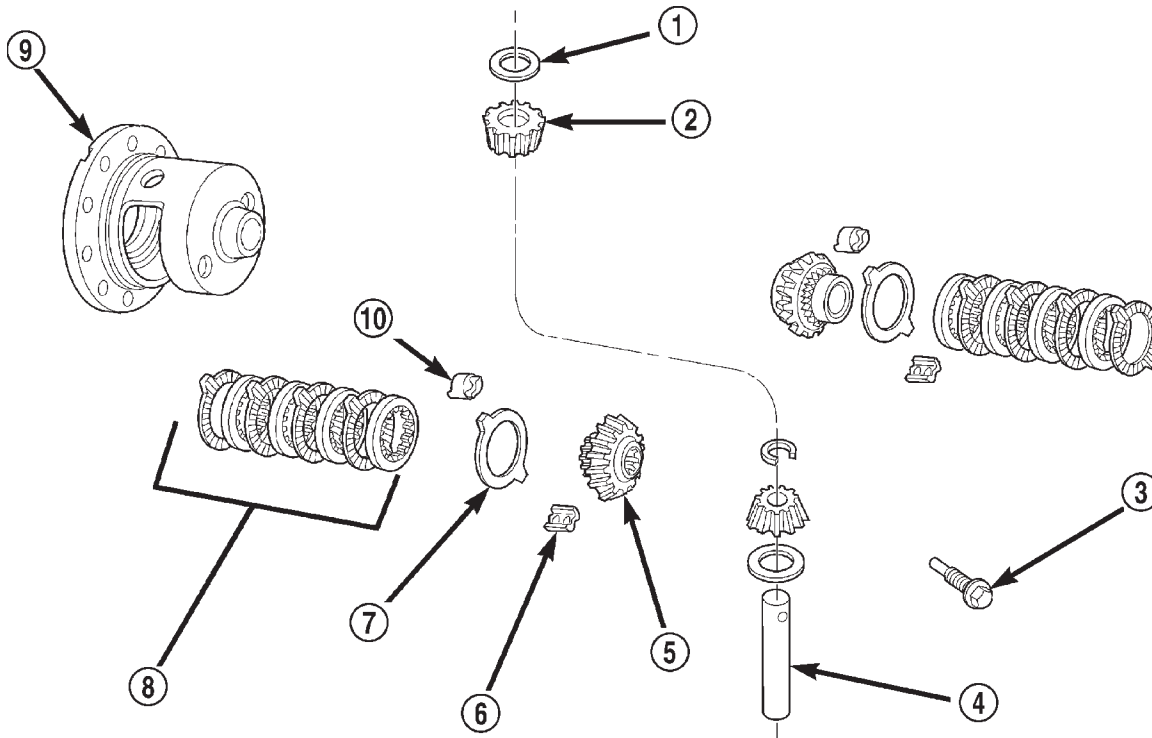

Fig. 51 Trac-lok™ Differential Components

80a77404

- | | |
|-----------------------|-----------------------|
| 1 - THRUST WASHER | 6 - RETAINER |
| 2 - PINION | 7 - DISC |
| 3 - SHAFT LOCK SCREW | 8 - CLUTCH PACK |
| 4 - PINION MATE SHAFT | 9 - DIFFERENTIAL CASE |
| 5 - SIDE GEAR | 10 - RETAINER |

TRAC-LOK™ DIFFERENTIAL

The Trac-lok™ differential components are illustrated in (Fig. 51). Refer to this illustration during repair service.

DISASSEMBLY

- (1) Clamp Side Gear Holding Tool 6965 in a vise.
- (2) Position the differential case on Side Gear Holding Tool 6965 (Fig. 52).
- (3) Remove ring gear, if necessary. Ring gear removal is necessary only if the ring gear is to be replaced. The Trac-lok™ differential can be serviced with the ring gear installed.
- (4) Remove the pinion gear mate shaft lock screw (Fig. 53).
- (5) Remove the pinion gear mate shaft. If necessary, use a drift and hammer (Fig. 54).
- (6) Install and lubricate Step Plate C-6960-3 (Fig. 55).

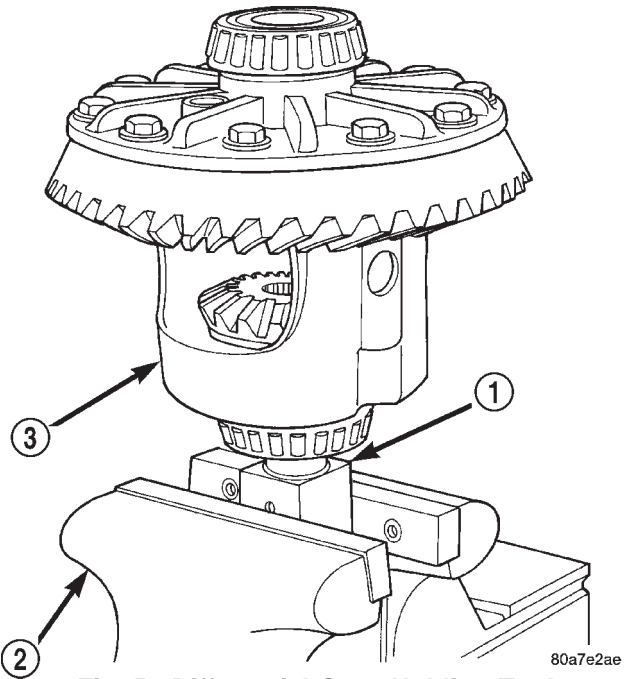
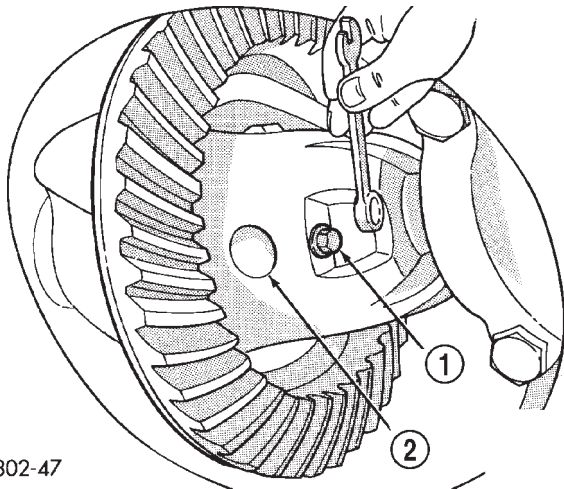

Fig. 52 Differential Case Holding Tool

- | |
|-----------------------|
| 1 - SPECIAL TOOL 6965 |
| 2 - VISE |
| 3 - DIFFERENTIAL |

DISASSEMBLY AND ASSEMBLY (Continued)



J9302-47

Fig. 53 Mate Shaft Lock Screw

- 1 - LOCK SCREW
- 2 - PINION GEAR MATE SHAFT

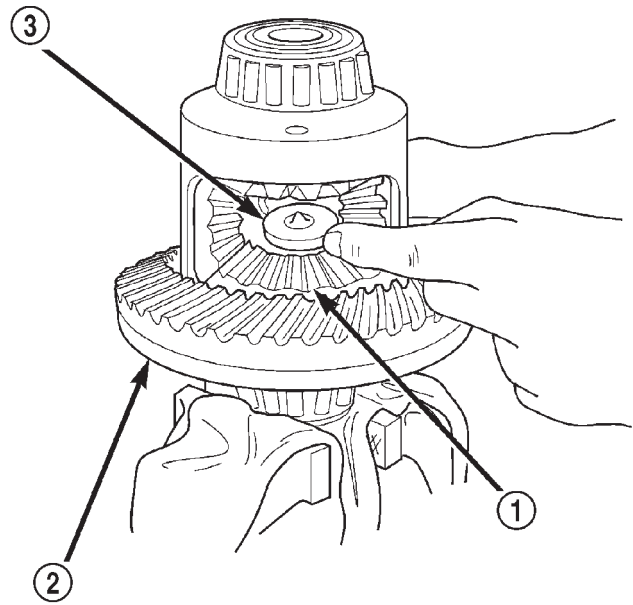
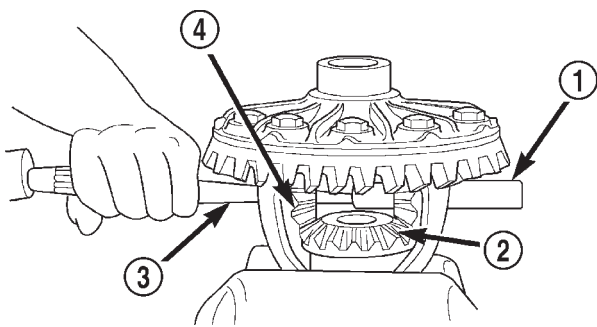

Fig. 55 Step Plate Tool Installation

80a83886

- 1 - LOWER SIDE GEAR
- 2 - DIFFERENTIAL CASE
- 3 - SPECIAL TOOL C-6960-3



80a773e1

Fig. 54 Mate Shaft Removal

- 1 - PINION MATE SHAFT
- 2 - SIDE GEAR
- 3 - DRIFT
- 4 - PINION MATE GEAR

(7) Assemble Threaded Adapter C-6960-1 into top side gear. Thread Forcing Screw C-6960-4 into adapter until it becomes centered in adapter plate.

(8) Position a small screw driver in slot of Threaded Adapter C-6960-1 (Fig. 56) to prevent adapter from turning.

(9) Tighten forcing screw tool 122 N·m (90 ft. lbs.) maximum to compress Belleville springs in clutch packs (Fig. 57).

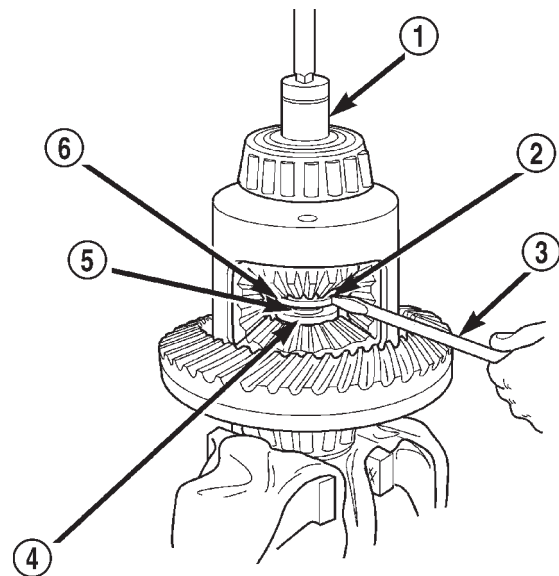

Fig. 56 Threaded Adapter Installation

80a8387f

- 1 - SOCKET
- 2 - SLOT IN ADAPTER
- 3 - SCREWDRIVER
- 4 - DISC C-6960-3
- 5 - THREADED ROD C-6960-4
- 6 - THREADED ADAPTER DISC C-6960-1

DISASSEMBLY AND ASSEMBLY (Continued)

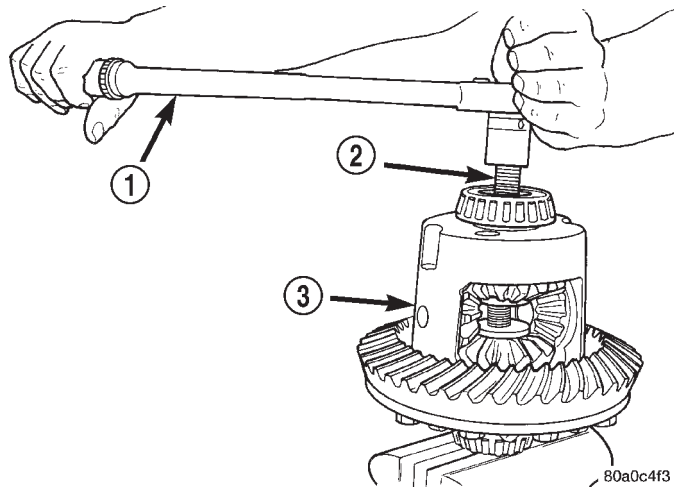

Fig. 57 Tighten Belleville Spring Compressor Tool

- 1 - TORQUE WRENCH
- 2 - TOOL ASSEMBLED
- 3 - DIFFERENTIAL CASE

(10) Using an appropriate size feeler gauge, remove thrust washers from behind the pinion gears (Fig. 58).

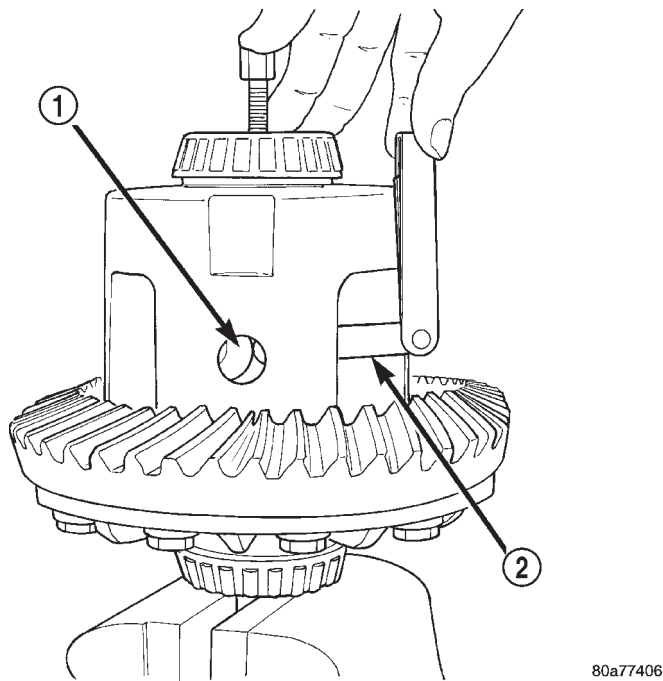

Fig. 58 Remove Pinion Gear Thrust Washer

- 1 - THRUST WASHER
- 2 - FEELER GAUGE

(11) Insert Turning Bar C-6960-2 in case (Fig. 59).
 (12) Loosen the Forcing Screw C-6960-4 in small increments until the clutch pack tension is relieved and the differential case can be turned using Turning Bar C-6960-2.

(13) Rotate differential case until the pinion gears can be removed.
 (14) Remove pinion gears from differential case.

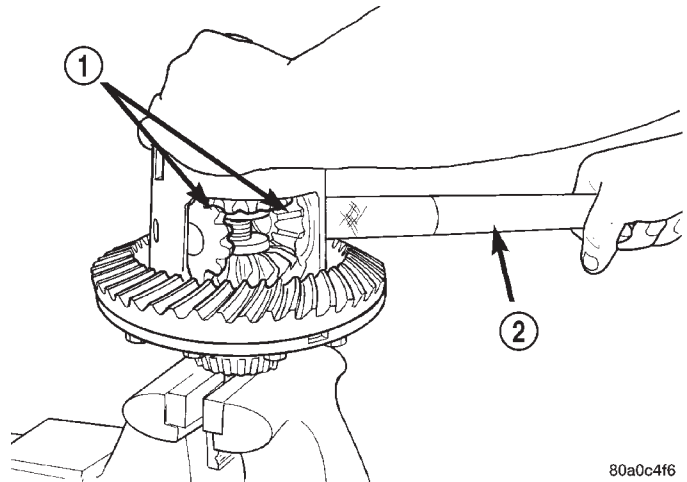

Fig. 59 Pinion Gear Removal

- 1 - PINION GEARS
- 2 - TOOL

(15) Remove Forcing Screw C-6960-4, Step Plate C-6960-3, and Threaded Adapter C-6960-1.

(16) Remove top side gear, clutch pack retainer, and clutch pack. Keep plates in correct order during removal (Fig. 60).

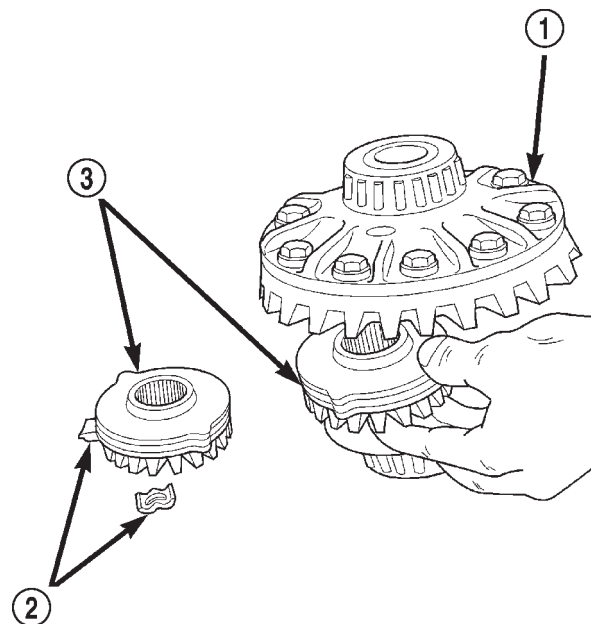

Fig. 60 Side Gear & Clutch Disc Removal

- 1 - DIFFERENTIAL CASE
- 2 - RETAINER
- 3 - SIDE GEAR AND CLUTCH DISC PACK

80a98362

DISASSEMBLY AND ASSEMBLY (Continued)

(17) Remove differential case from Side Gear Holding Tool 6965. Remove side gear, clutch pack retainer, and clutch pack. Keep plates in correct order during removal.

ASSEMBLY

NOTE: The clutch discs are replaceable as complete sets only. If one clutch disc pack is damaged, both packs must be replaced.

Lubricate each component with gear lubricant before assembly.

(1) Assemble the clutch discs into packs and secure disc packs with retaining clips (Fig. 61).

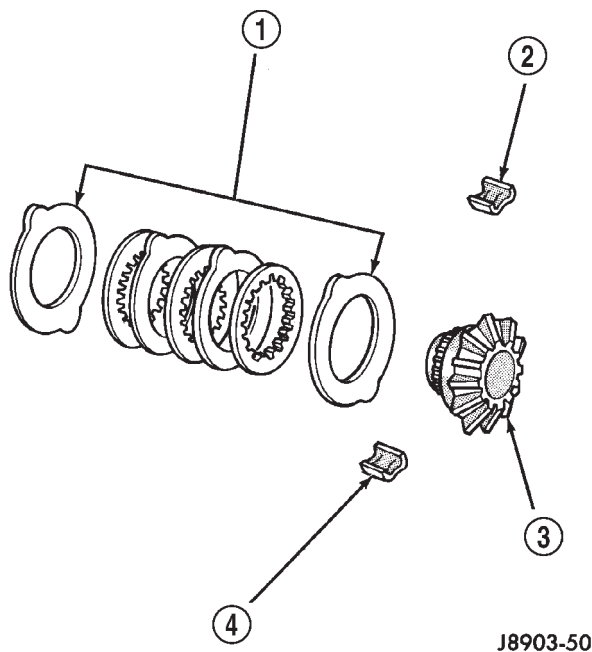

J8903-50

Fig. 61 Clutch Disc Pack

- 1 - CLUTCH PACK
- 2 - RETAINER
- 3 - SIDE GEAR
- 4 - RETAINER

(2) Position assembled clutch disc packs on the side gear hubs.

(3) Install clutch pack and side gear in the ring gear side of the differential case (Fig. 62). **Be sure clutch pack retaining clips remain in position and are seated in the case pockets.**

(4) Position the differential case on Side Gear Holding Tool 6965.

(5) Install lubricated Step Plate C-6960-3 in lower side gear (Fig. 63).

(6) Install the upper side gear and clutch disc pack (Fig. 63).

(7) Hold assembly in position. Insert Threaded Adapter C-6960-1 into top side gear.

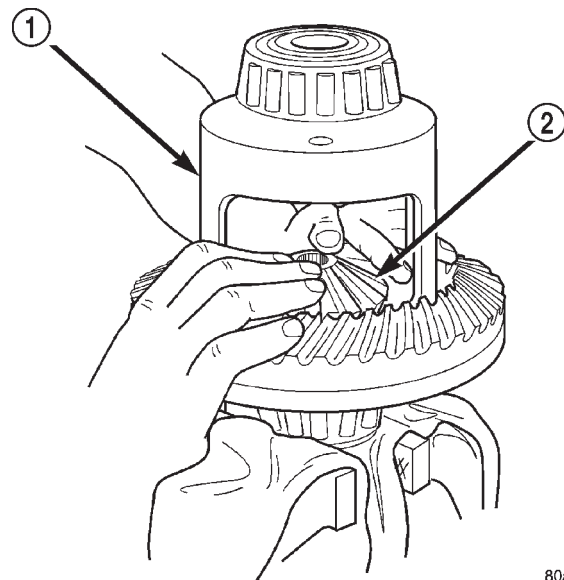

80a7739c

Fig. 62 Clutch Discs & Lower Side Gear Installation

- 1 - DIFFERENTIAL CASE
- 2 - LOWER SIDE GEAR AND CLUTCH DISC PACK

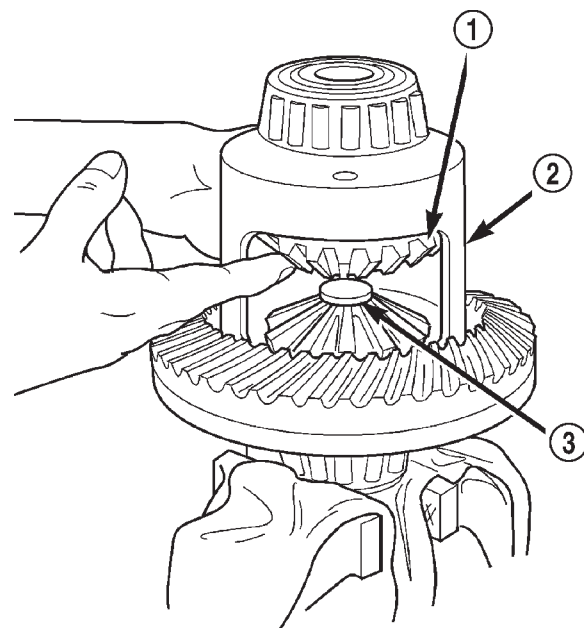

80a83887

Fig. 63 Upper Side Gear & Clutch Disc Pack Installation

- 1 - UPPER SIDE GEAR AND CLUTCH DISC PACK
- 2 - DIFFERENTIAL CASE
- 3 - SPECIAL TOOL C-6960-3

(8) Insert Forcing Screw C-6960-4.

(9) Tighten forcing screw tool to slightly compress clutch discs.

(10) Place pinion gears in position in side gears and verify that the pinion mate shaft hole is aligned.

DISASSEMBLY AND ASSEMBLY (Continued)

(11) Rotate case with Turning Bar C-6960-2 until the pinion mate shaft holes in pinion gears align with holes in case. It may be necessary to slightly tighten the forcing screw in order to install the pinion gears.

(12) Tighten forcing screw to 122 N·m (90 ft. lbs.) maximum to compress the Belleville springs.

(13) Lubricate and install thrust washers behind pinion gears and align washers with a small screw driver. Insert mate shaft into each pinion gear to verify alignment.

(14) Remove Forcing Screw C-6960-4, Step Plate C-6960-3, and Threaded Adapter C-6960-1.

(15) Install pinion gear mate shaft and align holes in shaft and case.

(16) Install the pinion mate shaft lock screw finger tight to hold shaft during differential installation.

If replacement gears and thrust washers were installed, it is not necessary to measure the gear backlash. Correct fit is due to close machining tolerances during manufacture.

(17) Lubricate all differential components with hypoid gear lubricant.

CLEANING AND INSPECTION

AXLE COMPONENTS

Wash differential components with cleaning solvent and dry with compressed air. **Do not steam clean the differential components.**

Wash bearings with solvent and towel dry, or dry with compressed air. **DO NOT** spin bearings with compressed air. **Cup and bearing must be replaced as matched sets only.**

Clean axle shaft tubes and oil channels in housing. Inspect for;

- Smooth appearance with no broken/dented surfaces on the bearing rollers or the roller contact surfaces.
- Bearing cups must not be distorted or cracked.
- Machined surfaces should be smooth and without any raised edges.
- Raised metal on shoulders of cup bores should be removed with a hand stone.
- Wear and damage to pinion gear mate shaft, pinion gears, side gears and thrust washers. Replace as a matched set only.
- Ring and pinion gear for worn and chipped teeth.
- Ring gear for damaged bolt threads. Replaced as a matched set only.
- Pinion yoke for cracks, worn splines, pitted areas, and a rough/corroded seal contact surface. Repair or replace as necessary.
- Preload shims for damage and distortion. Install new shims, if necessary.

TRAC-LOK™

Clean all components in cleaning solvent. Dry components with compressed air. Inspect clutch pack plates for wear, scoring or damage. Replace both clutch packs if any one component in either pack is damaged. Inspect side gears and pinions. Replace any gear that is worn, cracked, chipped or damaged. Inspect differential case and pinion shaft. Replace if worn or damaged.

PRESOAK PLATES AND DISC

Plates and discs with fiber coating (no grooves or lines) must be presoaked in Friction Modifier before assembly. Soak plates and discs for a minimum of 20 minutes.

ADJUSTMENTS

PINION GEAR DEPTH

GENERAL INFORMATION

Ring and pinion gears are supplied as matched sets only. The identifying numbers for the ring and pinion gear are etched into the face of each gear (Fig. 64). A plus (+) number, minus (-) number or zero (0) is etched into the face of the pinion gear. This number is the amount (in thousandths of an inch) the depth varies from the standard depth setting of a pinion etched with a (0). The standard setting from the center line of the ring gear to the back face of the pinion is 96.850 mm (3.813 in.). The standard depth provides the best teeth contact pattern. Refer to Backlash and Contact Pattern Analysis Paragraph in this section for additional information.

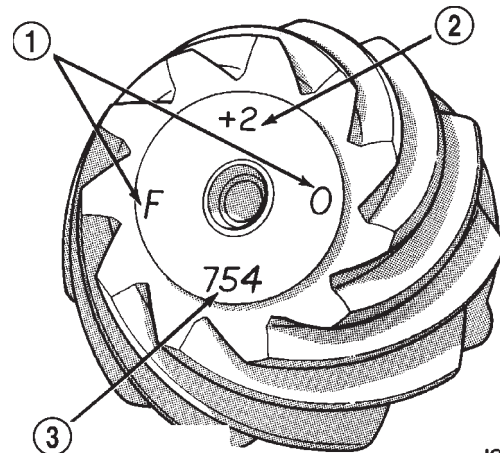

J9003-100

Fig. 64 Pinion Gear ID Numbers

- 1 - PRODUCTION NUMBERS
- 2 - DRIVE PINION GEAR DEPTH VARIANCE
- 3 - GEAR MATCHING NUMBER (SAME AS RING GEAR NUMBER)

ADJUSTMENTS (Continued)

Compensation for pinion depth variance is achieved with select shims. The shims are placed under the inner pinion bearing cone (Fig. 65).

If a new gear set is being installed, note the depth variance etched into both the original and replacement pinion gear. Add or subtract the thickness of the original depth shims to compensate for the difference in the depth variances. Refer to the Depth Variance charts.

Note where Old and New Pinion Marking columns intersect. Intersecting figure represents plus or minus amount needed.

Note the etched number on the face of the drive pinion gear (-1, -2, 0, +1, +2, etc.). The numbers represent thousands of an inch deviation from the standard. If the number is negative, add that value to the required thickness of the depth shim(s). If the number is positive, subtract that value from the thickness of the depth shim(s). If the number is 0 no change is necessary. Refer to the Pinion Gear Depth Variance Chart.

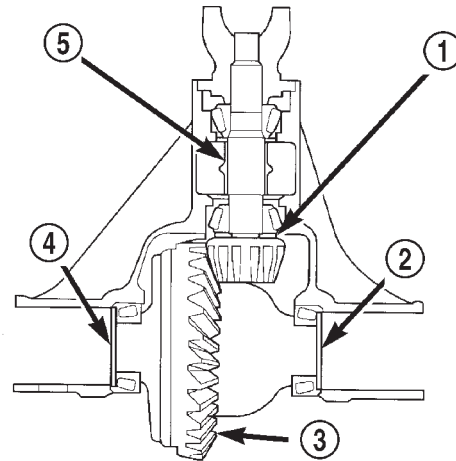

Fig. 65 Shim Locations

80a5037a

- 1 - PINION GEAR DEPTH SHIM
- 2 - DIFFERENTIAL BEARING SHIM-PINION GEAR SIDE
- 3 - RING GEAR
- 4 - DIFFERENTIAL BEARING SHIM-RING GEAR SIDE
- 5 - COLLAPSIBLE SPACER

PINION GEAR DEPTH VARIANCE

| Original Pinion Gear Depth Variance | Replacement Pinion Gear Depth Variance | | | | | | | | |
|-------------------------------------|--|--------|--------|--------|--------|--------|--------|--------|--------|
| | -4 | -3 | -2 | -1 | 0 | +1 | +2 | +3 | +4 |
| +4 | +0.008 | +0.007 | +0.006 | +0.005 | +0.004 | +0.003 | +0.002 | +0.001 | 0 |
| +3 | +0.007 | +0.006 | +0.005 | +0.004 | +0.003 | +0.002 | +0.001 | 0 | -0.001 |
| +2 | +0.006 | +0.005 | +0.004 | +0.003 | +0.002 | +0.001 | 0 | -0.001 | -0.002 |
| +1 | +0.005 | +0.004 | +0.003 | +0.002 | +0.001 | 0 | -0.001 | -0.002 | -0.003 |
| 0 | +0.004 | +0.003 | +0.002 | +0.001 | 0 | -0.001 | -0.002 | -0.003 | -0.004 |
| -1 | +0.003 | +0.002 | +0.001 | 0 | -0.001 | -0.002 | -0.003 | -0.004 | -0.005 |
| -2 | +0.002 | +0.001 | 0 | -0.001 | -0.002 | -0.003 | -0.004 | -0.005 | -0.006 |
| -3 | +0.001 | 0 | -0.001 | -0.002 | -0.003 | -0.004 | -0.005 | -0.006 | -0.007 |
| -4 | 0 | -0.001 | -0.002 | -0.003 | -0.004 | -0.005 | -0.006 | -0.007 | -0.008 |

PINION DEPTH MEASUREMENT AND ADJUSTMENT

Measurements are taken with pinion cups and pinion bearings installed in housing. Take measurements with a Pinion Gauge Set, Pinion Block 6735, Arbor Discs 6732, and Dial Indicator C-3339 (Fig. 66).

(1) Assemble Pinion Height Block 6739, Pinion Block 6735, and rear pinion bearing onto Screw 6741 (Fig. 66).

(2) Insert assembled height gauge components, rear bearing and screw into axle housing through pinion bearing cups (Fig. 67).

(3) Install front pinion bearing and Cone 6740 hand tight (Fig. 66).

(4) Place Arbor Disc 6732 on Arbor D-115-3 in position in axle housing side bearing cradles (Fig. 68). Install differential bearing caps on Arbor Discs and tighten cap bolts. Refer to the Torque Specifications in this section.

NOTE: Arbor Discs 6732 have different step diameters to fit other axle sizes. Pick correct size step for axle being serviced.

(5) Assemble Dial Indicator C-3339 into Scooter Block D-115-2 and secure set screw.

ADJUSTMENTS (Continued)

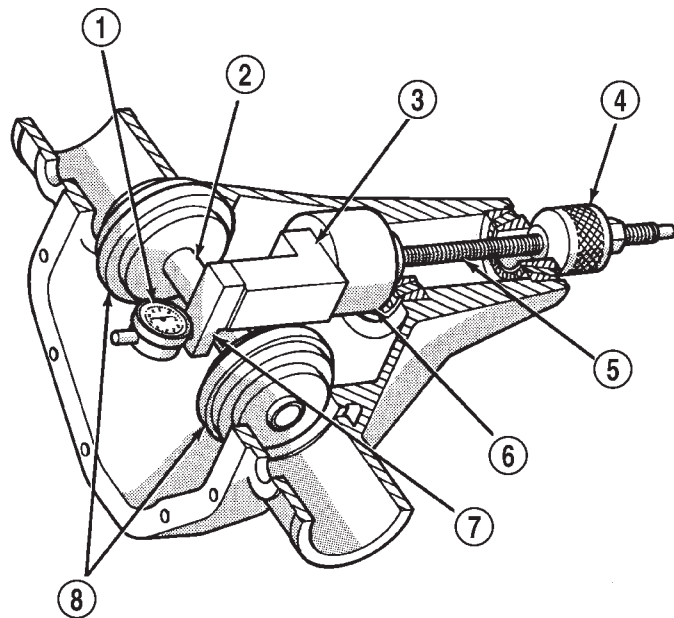

J9403-45

Fig. 66 Pinion Gear Depth Gauge Tools—Typical

- 1 - DIAL INDICATOR
- 2 - ARBOR
- 3 - PINION HEIGHT BLOCK
- 4 - CONE
- 5 - SCREW
- 6 - PINION BLOCK
- 7 - SCOOTER BLOCK
- 8 - ARBOR DISC

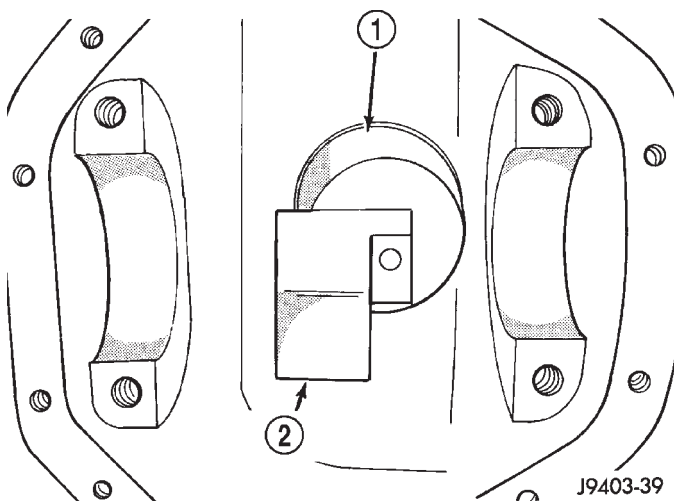

J9403-39

Fig. 67 Pinion Height Block—Typical

- 1 - PINION BLOCK
- 2 - PINION HEIGHT BLOCK

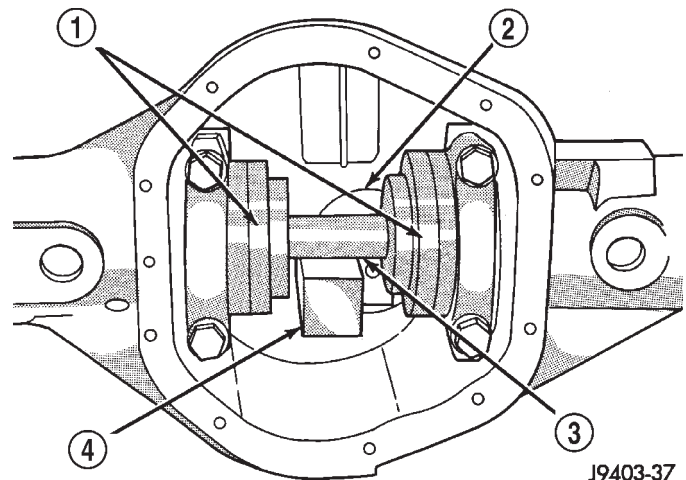

J9403-37

Fig. 68 Gauge Tools In Housing—Typical

- 1 - ARBOR DISC
- 2 - PINION BLOCK
- 3 - ARBOR
- 4 - PINION HEIGHT BLOCK

(6) Place Scooter Block/Dial Indicator in position in axle housing so dial probe and scooter block are flush against the surface of the pinion height block. Hold scooter block in place and zero the dial indicator face to the pointer. Tighten dial indicator face lock screw.

(7) With scooter block still in position against the pinion height block, slowly slide the dial indicator probe over the edge of the pinion height block. Observe how many revolutions counterclockwise the dial pointer travels (approximately 0.125 in.) to the out-stop of the dial indicator.

(8) Slide the dial indicator probe across the gap between the pinion height block and the arbor bar with the scooter block against the pinion height block (Fig. 69). When the dial probe contacts the arbor bar, the dial pointer will turn clockwise. Bring dial pointer back to zero against the arbor bar, do not turn dial face. Continue moving the dial probe to the crest of the arbor bar and record the highest reading. If the dial indicator can not achieve the zero reading, the rear bearing cup or the pinion depth gauge set is not installed correctly.

(9) Select a shim equal to the dial indicator reading plus the drive pinion gear depth variance number etched in the face of the pinion gear (Fig. 64) using the opposite sign on the variance number. For example, if the depth variance is -2 , add $+0.002$ in. to the dial indicator reading.

(10) Remove the pinion depth gauge components from the axle housing

ADJUSTMENTS (Continued)

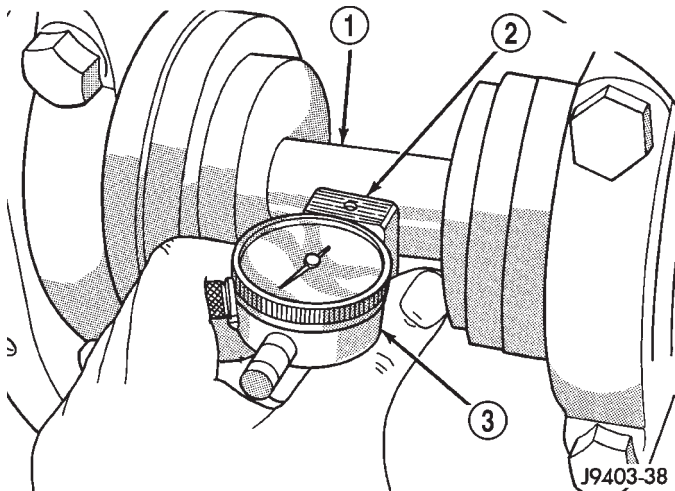
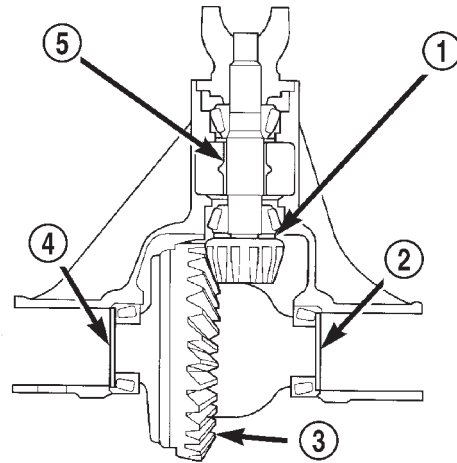

Fig. 69 Pinion Gear Depth Measurement—Typical

- 1 - ARBOR
- 2 - SCOOTER BLOCK
- 3 - DIAL INDICATOR



80a5037a

Fig. 70 Axle Adjustment Shim Locations

- 1 - PINION GEAR DEPTH SHIM
- 2 - DIFFERENTIAL BEARING SHIM-PINION GEAR SIDE
- 3 - RING GEAR
- 4 - DIFFERENTIAL BEARING SHIM-RING GEAR SIDE
- 5 - COLLAPSIBLE SPACER

DIFFERENTIAL BEARING PRELOAD AND GEAR BACKLASH

Differential side bearing preload and gear backlash is achieved by selective shims inserted between the bearing cup and the axle housing. The proper shim thickness can be determined using slip-fit dummy bearings D-348 in place of the differential side bearings and a dial indicator C-3339. Before proceeding with the differential bearing preload and gear backlash measurements, measure the pinion gear depth and prepare the pinion gear for installation. Establishing proper pinion gear depth is essential to establishing gear backlash and tooth contact patterns. After the overall shim thickness to take up differential side play is measured, the pinion gear is installed, and the gear backlash shim thickness is measured. The overall shim thickness is the total of the dial indicator reading, starting point shim thickness, and the preload specification added together. The gear backlash measurement determines the thickness of the shim used on the ring gear side of the differential case. Subtract the gear backlash shim thickness from the total overall shim thickness and select that amount for the pinion gear side of the differential (Fig. 70).

SHIM SELECTION

NOTE: It is difficult to salvage the differential side bearings during the removal procedure. Install replacement bearings if necessary.

- (1) Remove side bearings from differential case.
- (2) Install ring gear, if necessary, on differential case and tighten bolts to specification.

- (3) Install dummy side bearings D-348 on differential case.

- (4) Install differential case in axle housing.

- (5) Insert Dummy Shims 8107 (0.118 in. (3.0 mm)) starting point shims between the dummy bearing and the axle housing (Fig. 71).

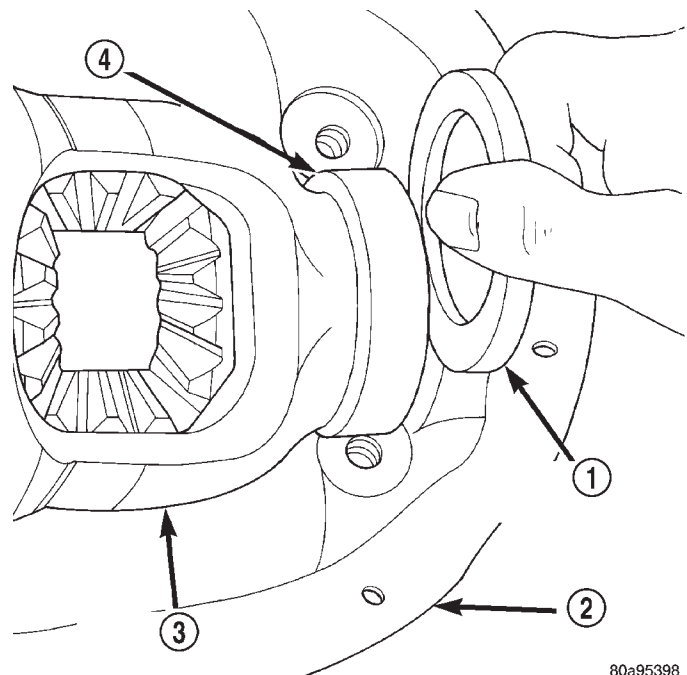

80a95398

Fig. 71 Insert Starting Point Shims

- 1 - SPECIAL TOOL 8107
- 2 - AXLE HOUSING
- 3 - DIFFERENTIAL CASE
- 4 - SPECIAL TOOL D-348

ADJUSTMENTS (Continued)

(6) Install the marked bearing caps in their correct positions. Install and snug the bolts.

(7) Using a dead-blow type mallet, seat the differential dummy bearings to each side of the axle housing (Fig. 72) and (Fig. 73).

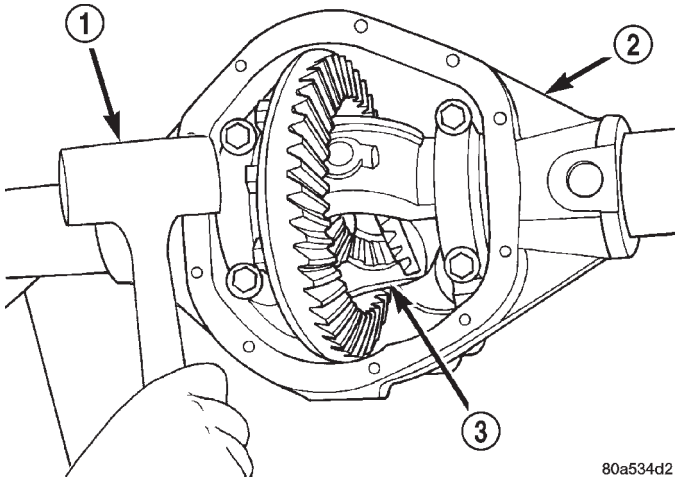

Fig. 72 Seat Pinion Gear Dummy Side Bearing

- 1 - MALLET
- 2 - AXLE HOUSING
- 3 - DIFFERENTIAL CASE

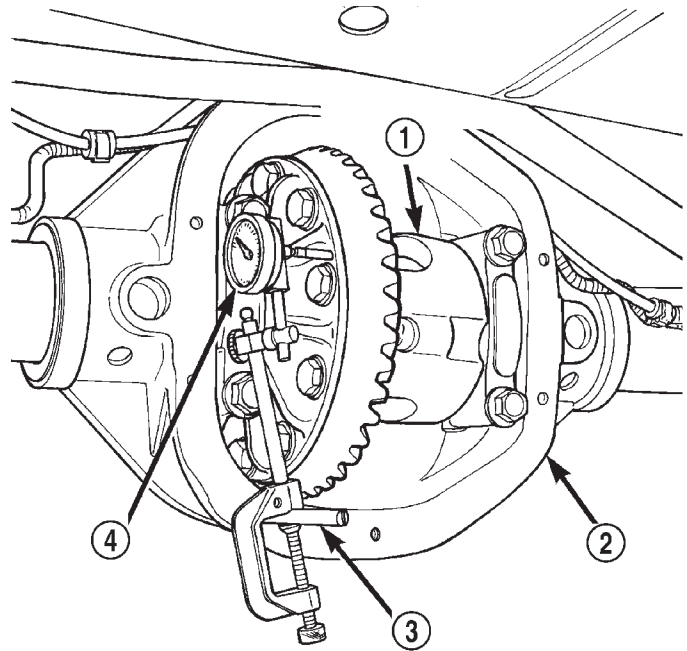

Fig. 74 Differential Side play Measurement

- 1 - DIFFERENTIAL CASE
- 2 - AXLE HOUSING
- 3 - SPECIAL TOOL C-3288-B
- 4 - SPECIAL TOOL C-3339

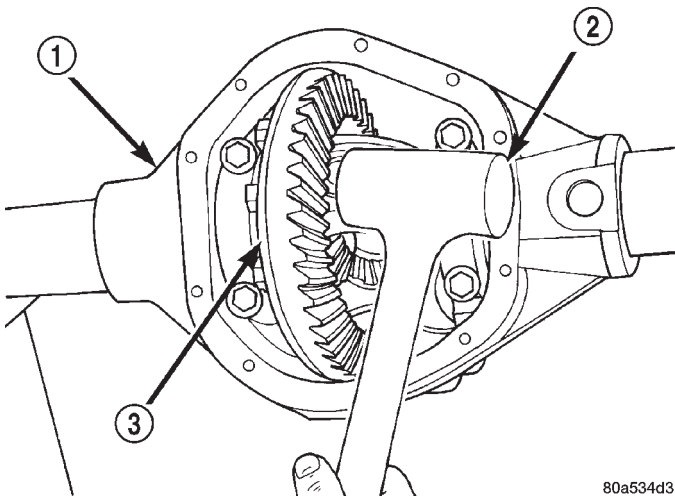

Fig. 73 Seat Ring Gear Side Dummy Bearing

- 1 - AXLE HOUSING
- 2 - MALLET
- 3 - DIFFERENTIAL CASE

(12) Push firmly and hold differential case to ring gear side of the axle housing (Fig. 76).

(13) Record dial indicator reading.

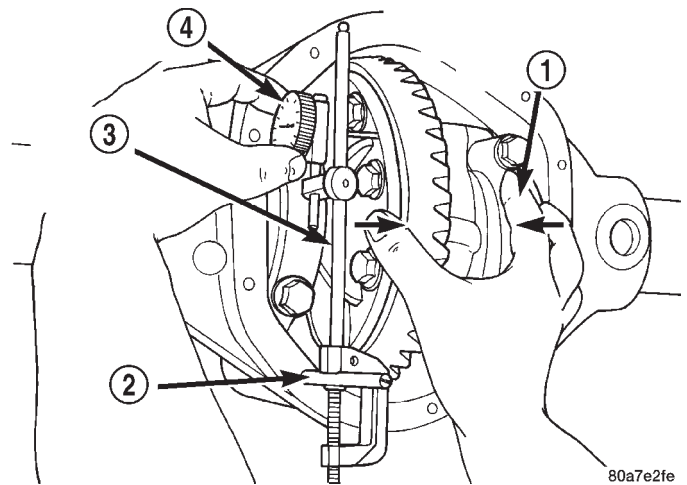

Fig. 75 Hold Differential Case and Zero Dial Indicator

- 1 - FORCE DIFFERENTIAL CASE TO PINION GEAR SIDE
- 2 - SPECIAL TOOL C-3288-B
- 3 - SPECIAL TOOL C-3339
- 4 - ZERO DIAL INDICATOR FACE

(8) Thread guide stud C-3288-B into rear cover bolt hole below ring gear (Fig. 74).

(9) Attach dial indicator C-3339 to guide stud. Position the dial indicator plunger on a flat surface on a ring gear bolt head (Fig. 74).

(10) Push firmly and hold differential case to pinion gear side of axle housing (Fig. 75).

(11) Zero dial indicator face to pointer.

ADJUSTMENTS (Continued)

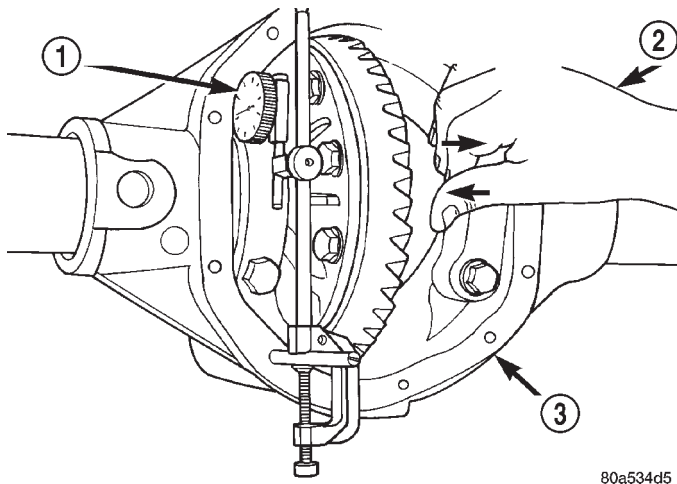

80a534d5

Fig. 76 Hold Differential Case and Read Dial Indicator

- 1 - READ DIAL INDICATOR
 2 - FORCE DIFFERENTIAL CASE TO RING GEAR SIDE
 3 - AXLE HOUSING

(14) Add the dial indicator reading to the starting point shim thickness to determine total shim thickness to achieve zero differential end play.

(15) Add 0.008 in. (0.2 mm) to the zero end play total. This new total represents the thickness of shims to compress, or preload the new bearings when the differential is installed.

(16) Rotate dial indicator out of the way on guide stud.

(17) Remove differential case, dummy bearings, and starting point shims from axle housing.

(18) Install pinion gear in axle housing. Install the yoke and establish the correct pinion rotating torque.

(19) Install differential case and dummy bearings in axle housing (without shims) and tighten retaining cap bolts.

(20) Position the dial indicator plunger on a flat surface between the ring gear bolt heads (Fig. 74).

(21) Push and hold differential case toward pinion gear.

(22) Zero dial indicator face to pointer.

(23) Push and hold differential case to ring gear side of the axle housing.

(24) Record dial indicator reading.

(25) Subtract 0.002 in. (0.05 mm) from the dial indicator reading to compensate for backlash between ring and pinion gears. This total is the thickness of shim required to achieve proper backlash.

(26) Subtract the backlash shim thickness from the total preload shim thickness. The remainder is the shim thickness required on the pinion side of the axle housing.

(27) Rotate dial indicator out of the way on guide stud.

(28) Remove differential case and dummy bearings from axle housing.

(29) Install new side bearing cones and cups on differential case.

(30) Install spreader W-129-B, utilizing some components of Adapter Set 6987, on axle housing and spread axle opening enough to receive differential case.

(31) Place side bearing shims in axle housing against axle tubes.

(32) Install differential case in axle housing.

(33) Rotate the differential case several times to seat the side bearings.

(34) Position the indicator plunger against a ring gear tooth (Fig. 77).

(35) Push and hold ring gear upward while not allowing the pinion gear to rotate.

(36) Zero dial indicator face to pointer.

(37) Push and hold ring gear downward while not allowing the pinion gear to rotate. Dial indicator reading should be between 0.12 mm (0.005 in.) and 0.20 mm (0.008 in.). If backlash is not within specifications transfer the necessary amount of shim thickness from one side of the differential housing to the other (Fig. 78).

ADJUSTMENTS (Continued)

(38) Verify differential case and ring gear runout by measuring ring to pinion gear backlash at eight locations around the ring gear. Readings should not vary more than 0.05 mm (0.002 in.). If readings vary more than specified, the ring gear or the differential case is defective.

After the proper backlash is achieved, perform the Gear Contact Pattern Analysis procedure.

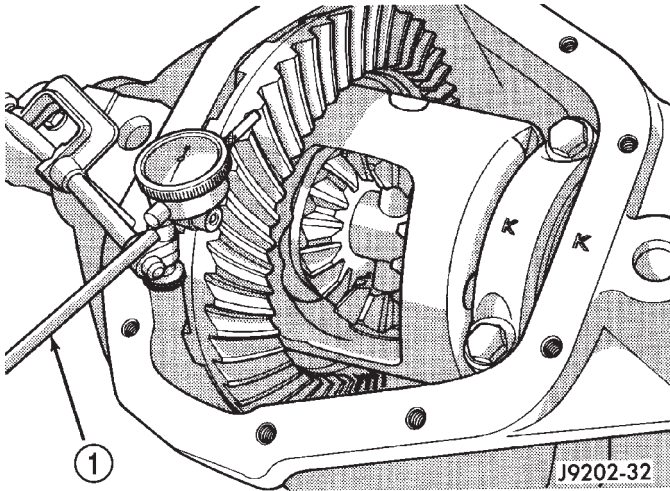

Fig. 77 Ring Gear Backlash Measurement

1 - DIAL INDICATOR

GEAR CONTACT PATTERN ANALYSIS

The ring gear and pinion teeth contact patterns will show if the pinion depth is correct in the axle housing. It will also show if the ring gear backlash has been adjusted correctly. The backlash can be adjusted within specifications to achieve desired tooth contact patterns.

(1) Apply a thin coat of hydrated ferric oxide, or equivalent, to the drive and coast side of the ring gear teeth.

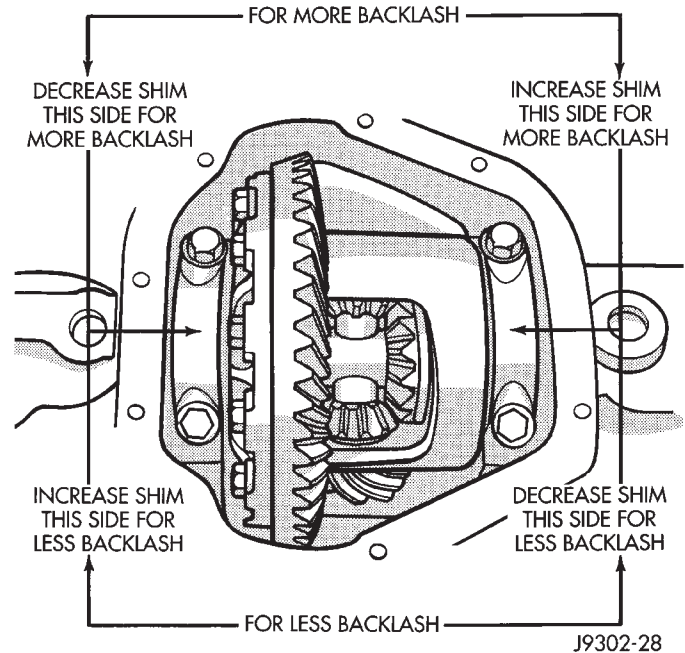

Fig. 78 Backlash Shim Adjustment

(2) Wrap, twist, and hold a shop towel around the pinion yoke to increase the turning resistance of the pinion. This will provide a more distinct contact pattern.

(3) Using a boxed end wrench on a ring gear bolt, Rotate the differential case one complete revolution in both directions while a load is being applied from shop towel.

The areas on the ring gear teeth with the greatest degree of contact against the pinion teeth will squeegee the compound to the areas with the least amount of contact. Note and compare patterns on the ring gear teeth to Gear Tooth Contact Patterns chart (Fig. 79) and adjust pinion depth and gear backlash as necessary.

ADJUSTMENTS (Continued)



| <p>DRIVE SIDE OF RING GEAR TEETH</p> <p>HEEL TOE</p>  | <p>COAST SIDE OF RING GEAR TEETH</p> <p>TOE HEEL</p>  | <p>DESIRABLE CONTACT PATTERN. PATTERN SHOULD BE CENTERED ON THE DRIVE SIDE OF TOOTH. PATTERN SHOULD BE CENTERED ON THE COAST SIDE OF TOOTH, BUT MAY BE SLIGHTLY TOWARD THE TOE. THERE SHOULD ALWAYS BE SOME CLEARANCE BETWEEN CONTACT PATTERN AND TOP OF THE TOOTH.</p> |
|--|--|---|
|  |  | <p>RING GEAR BACKLASH CORRECT. THINNER PINION GEAR DEPTH SHIM REQUIRED.</p> |
|  |  | <p>RING GEAR BACKLASH CORRECT. THICKER PINION GEAR DEPTH SHIM REQUIRED.</p> |
|  |  | <p>PINION GEAR DEPTH SHIM CORRECT. DECREASE RING GEAR BACKLASH.</p> |
|  |  | <p>PINION GEAR DEPTH SHIM CORRECT. INCREASE RING GEAR BACKLASH.</p> |

Fig. 79 Gear Tooth Contact Patterns

SPECIFICATIONS

194 RBI AXLE

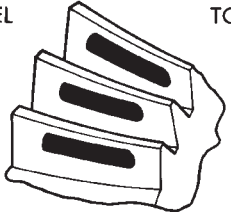
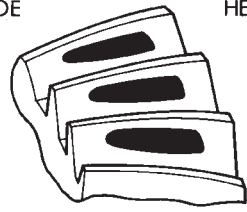
| DESCRIPTION | SPECIFICATION |
|---|-------------------------------|
| Axle Type | Semi-Floating Hypoid |
| Lubricant | SAE Thermally Stable 80W-90 |
| Lubricant Trailer Tow | Synthetic 75W-140 |
| Lube Capacity | 1.66 L (3.50 pts.) |
| Friction Modifier | 0.12 L (3.50 ozs.) |
| Axle Ratios | 3.07, 3.55, 3.73 |
| Differential Bearing Preload ... | 0.1 mm (0.008 in.) |
| Differential Side Gear Clearance | 0-0.15 mm (0-0.006 in.) |
| Ring Gear Diameter | 19.2 cm (7.562 in.) |
| Ring Gear Backlash .. | 0-0.15 mm (0.005-0.008 in.) |
| Pinion Std. Depth | 96.85 mm (3.813 in.) |
| Pinion Bearing Preload-Original Bearings | 1-2 N·m (10-20 in. lbs.) |
| Pinion Bearing Preload-New Bearings .. | 1.5-4 N·m (15-35 in. lbs.) |

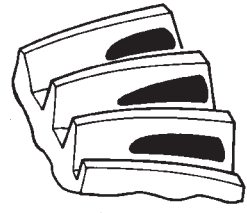
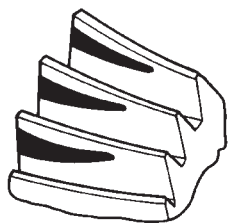
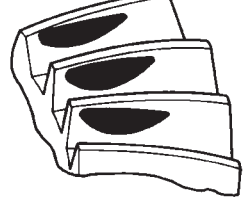
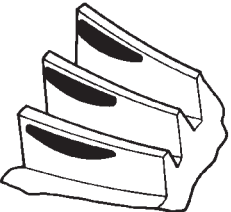
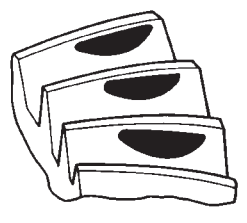
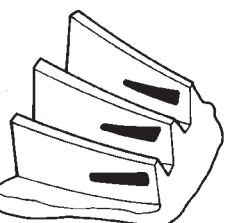
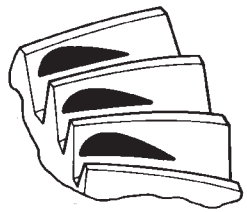
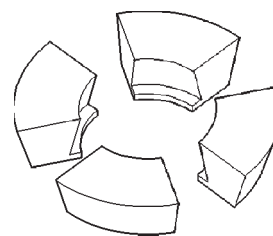

Adapter—C-293-40

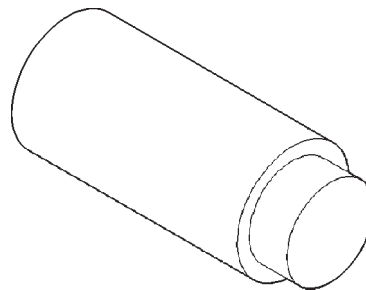

Plug—SP-3289

194 RBI AXLE

| DESCRIPTION | TORQUE |
|-------------------------------------|--------------------------------|
| Bolt, Diff. Cover | 41 N·m (30 ft. lbs.) |
| Bolt, Bearing Cap | 77 N·m (57 ft. lbs.) |
| Nut, Pinion | 271-474 N·m (200-350 ft. lbs.) |
| Screw, Pinion Mate Shaft Lock | 16.25 N·m (12 ft. lbs.) |
| Bolt, Ring Gear | 95-122 N·m (70-90 ft. lbs.) |
| Bolt, RWAL/ABS Sensor | 8 N·m (70 in. lbs.) |

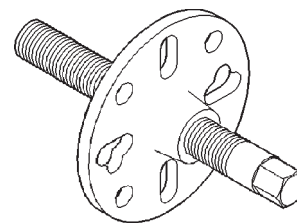

Puller—C-452

SPECIAL TOOLS

194 RBI AXLE

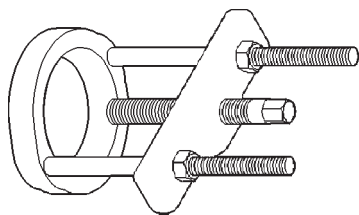

Puller—C-293-PA

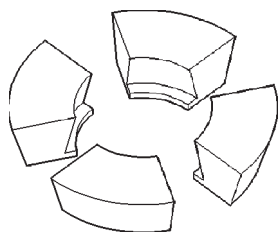

Adapter—C-293-39

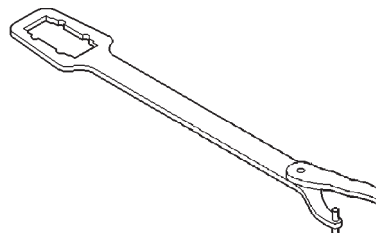

Wrench—C-3281

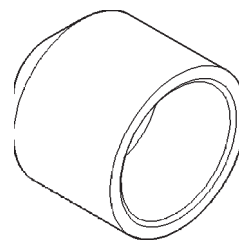

Installer—C-3972-A

SPECIAL TOOLS (Continued)

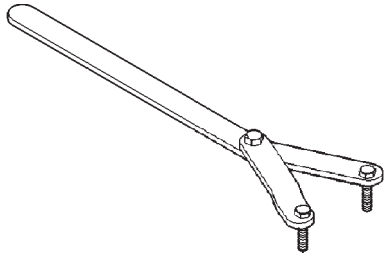

Spanner—6958

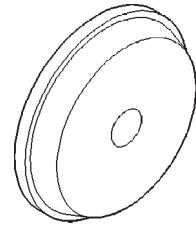

Installer—D-130

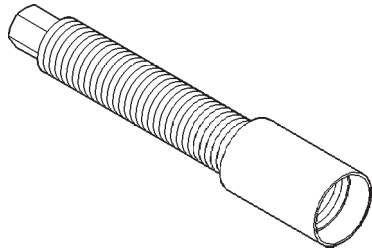

Installer Screw—8112

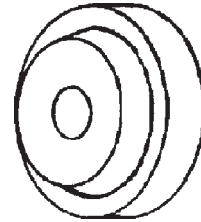

Installer—D-146

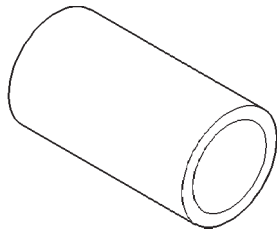

Cup—8109

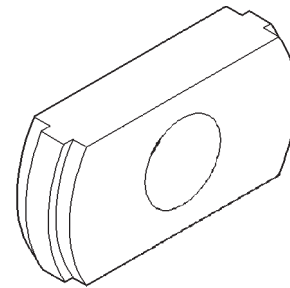

Remover—C-4345

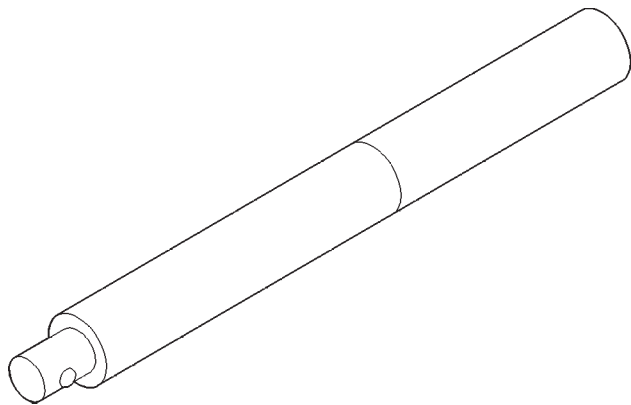

Handle—C-4171

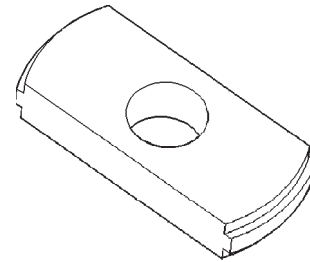

Remover—D-149

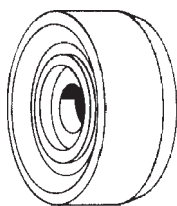

Driver—C-3716-A

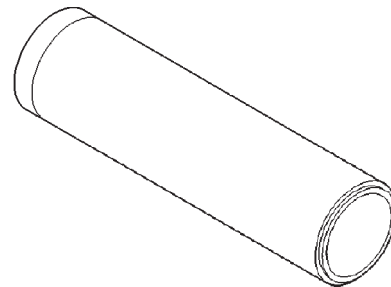

Installer—W-262

SPECIAL TOOLS (Continued)

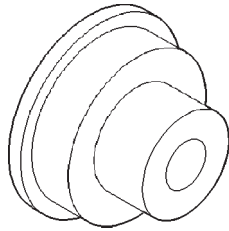

Installer—6436

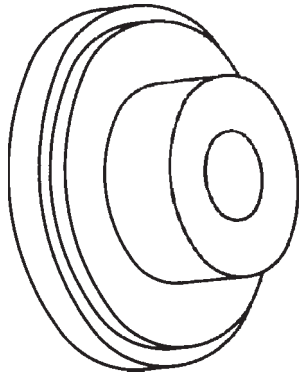

Installer—6437

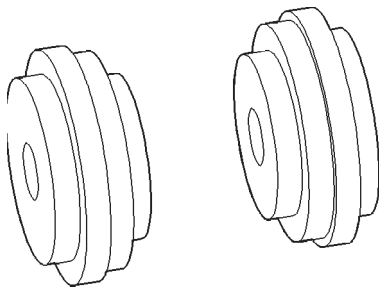

Disc, Axle Arbor—6732

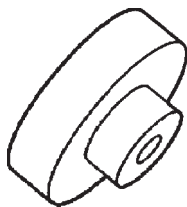

Gauge Block—6735

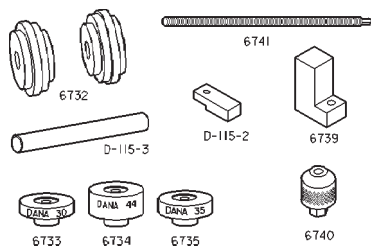

Tool Set, Pinion Depth—6774

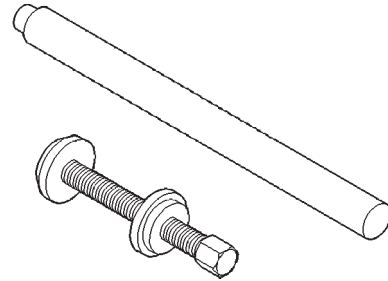

Trac-lok Tool Set—6960

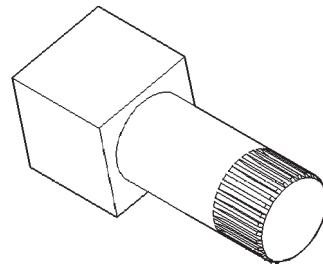

Holder—6965

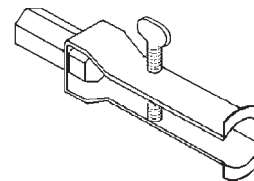

Puller—7794-A

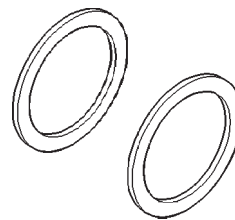

Starting Point Shim—8107

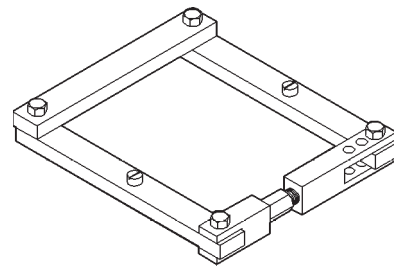

Spreader—W-129-B

SPECIAL TOOLS (Continued)

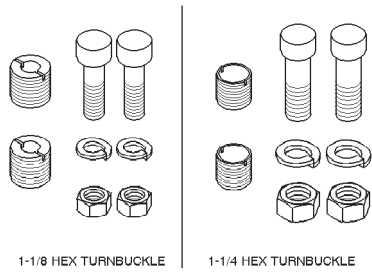

Adapter Kit—6987

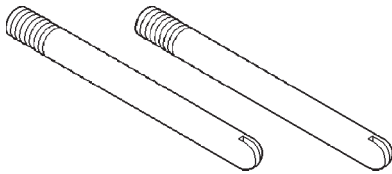

Guide Pin—C-3288-B

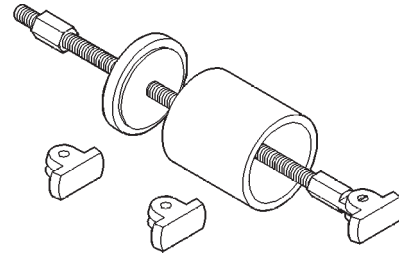

Bearing Remover Tool Set—6310

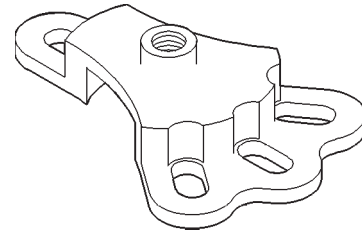

Hub Puller—6790

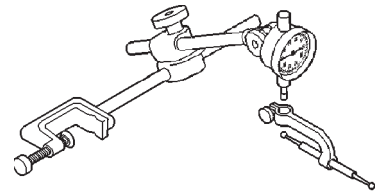

8011d42b

Dial Indicator—C-3339

8 1/4 REAR AXLE

TABLE OF CONTENTS

| | page | | page |
|--|------|---|------|
| DESCRIPTION AND OPERATION | | DIFFERENTIAL | 114 |
| 8 1/4 AXLE | 103 | DIFFERENTIAL SIDE BEARINGS | 115 |
| LUBRICANT | 104 | RING GEAR | 116 |
| STANDARD DIFFERENTIAL | 105 | PINION GEAR | 117 |
| TRAC-LOK™ DIFFERENTIAL | 105 | DISASSEMBLY AND ASSEMBLY | |
| DIAGNOSIS AND TESTING | | STANDARD DIFFERENTIAL | 120 |
| GENERAL INFORMATION | 106 | TRAC-LOK™ DIFFERENTIAL | 121 |
| GEAR NOISE | 109 | CLEANING AND INSPECTION | |
| BEARING NOISE | 109 | 8 1/4 AXLE | 125 |
| LOW SPEED KNOCK | 109 | TRAC-LOK™ | 125 |
| VIBRATION | 109 | ADJUSTMENTS | |
| DRIVELINE SNAP | 109 | 8 1/4 AXLE PINION GEAR DEPTH | 126 |
| TRAC-LOK™ DIFFERENTIAL NOISE | 109 | DIFFERENTIAL BEARING PRELOAD AND | |
| TRAC-LOK™ TEST | 110 | GEAR BACKLASH | 127 |
| SERVICE PROCEDURES | | GEAR CONTACT PATTERN ANALYSIS | 129 |
| LUBRICANT CHANGE | 110 | SIDE GEAR CLEARANCE | 129 |
| REMOVAL AND INSTALLATION | | SPECIFICATIONS | |
| REAR AXLE | 111 | 8 1/4 INCH AXLE | 131 |
| AXLE SHAFT | 111 | 8 1/4 INCH AXLE | 131 |
| AXLE SEAL AND BEARING | 112 | SPECIAL TOOLS | |
| PINION SEAL | 113 | 8 1/4 AXLES | 131 |

DESCRIPTION AND OPERATION

8 1/4 AXLE

DESCRIPTION

The 8 1/4 inch axle housings consist of a cast iron center section with axle tubes extending from either side. The tubes are pressed into and welded to the differential housing to form a one-piece axle housing (Fig. 1).

The axles have a vent hose to relieve internal pressure caused by lubricant vaporization and internal expansion.

The axles are equipped with semi-floating axle shafts, meaning vehicle loads are supported by the axle shaft and bearings. The axle shafts are retained by C-locks in the differential side gears.

The removable, stamped steel cover provides a means for inspection and service without removing the complete axle from the vehicle.

The 8 1/4 axle have a date tag and a gear ratio tag. The tags are attached to the differential housing by a cover bolt.

The differential case is a one-piece design. The differential pinion mate shaft is retained with a

threaded pin. Differential bearing preload and ring gear backlash are set and maintained by threaded adjusters at the outside of the differential housing. Pinion bearing preload is set and maintained by the use of a collapsible spacer.

Axles equipped with a Trac-Lok™ differential are optional. A Trac-Lok differential has a one-piece differential case, and the same internal components as a standard differential, plus two clutch disc packs.

AXLE IDENTIFICATION

The axle differential cover can be used for identification of the axle (Fig. 2). A tag is also attached to the cover.

OPERATION

The axle receives power from the transmission/transfer case through the rear propeller shaft. The rear propeller shaft is connected to the pinion gear which rotates the differential through the gear mesh with the ring gear bolted to the differential case. The engine power is transmitted to the axle shafts through the pinion mate and side gears. The side gears are splined to the axle shafts.

DESCRIPTION AND OPERATION (Continued)

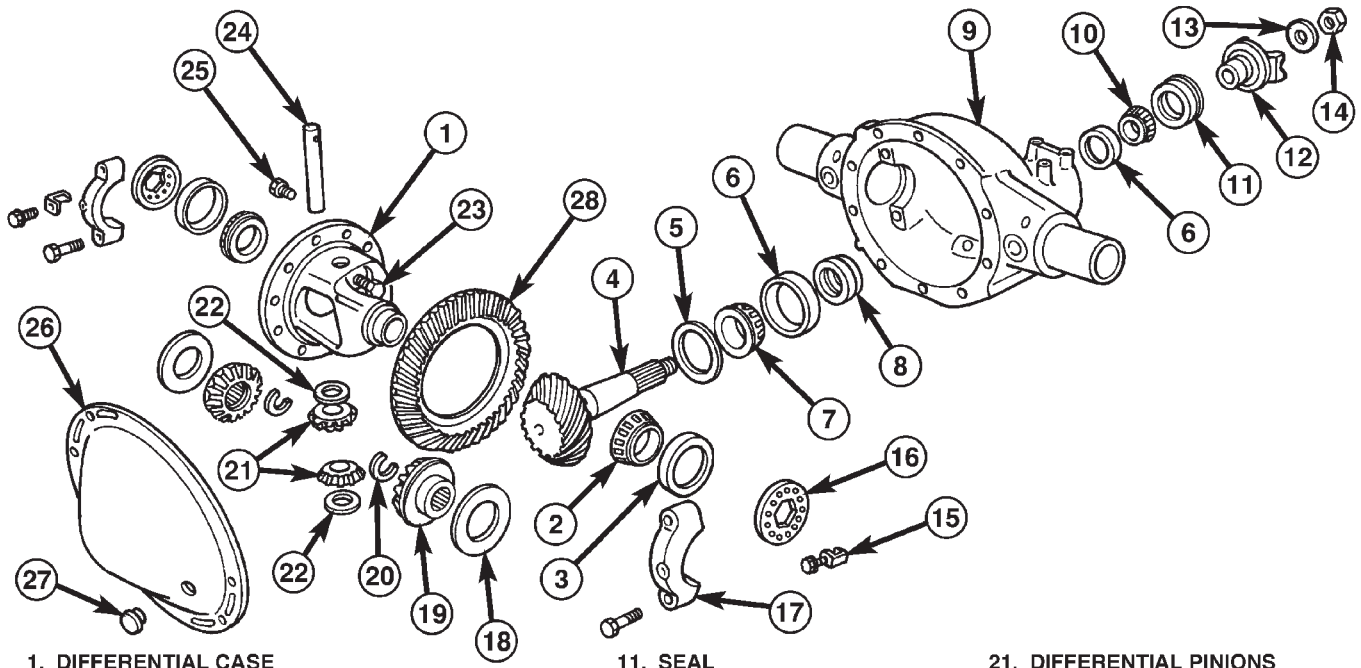

- 1. DIFFERENTIAL CASE
- 2. DIFFERENTIAL BEARING CONE
- 3. BEARING CUP
- 4. PINION
- 5. PINION GEAR DEPTH SHIMS
- 6. BEARING CUP
- 7. PINION REAR BEARING CONE
- 8. BEARING PRELOAD COLLAPSIBLE SPACER
- 10. PINION FRONT BEARING CONE

- 11. SEAL
- 12. YOKE
- 13. WASHER
- 14. NUT
- 15. LOCK
- 16. ADJUSTER
- 17. BEARING CAP
- 18. THRUST WASHER
- 19. SIDE GEAR
- 20. C-LOCK

- 21. DIFFERENTIAL PINIONS
- 22. THRUST WASHERS
- 23. PINION SHAFT LOCK BOLT
- 24. PINION MATE SHAFT
- 25. RING GEAR BOLT
- 26. COVER
- 27. PLUG
- 28. RING GEAR

80be4601

Fig. 1 8 1/4 Axle

LUBRICANT

DESCRIPTION

Multi-purpose, hypoid gear lubricant should be used for rear axles with a standard differential. The lubricant should have a MIL-L-2105C and API GL 5 quality specifications.

Trac-Lok differentials require the addition of 4 oz. of friction modifier to the axle lubricant after service. The 8 1/4 axle lubricant capacity is 2.08 L (4.4 pts.) total, including the friction modifier, if necessary.

CAUTION: If the rear axle is submerged in water, the lubricant must be replaced immediately. Avoid the possibility of premature axle failure resulting from water contamination of the lubricant.

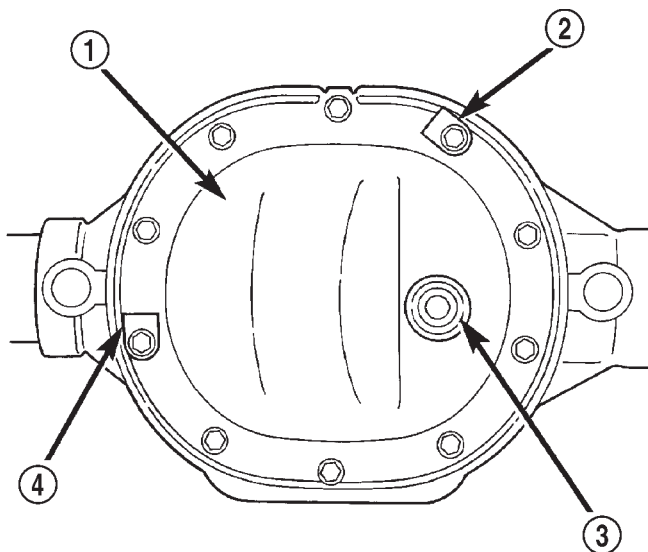

80be4602

Fig. 2 Differential Cover 8 1/4 Inch Axle

- 1 - DIFFERENTIAL COVER
- 2 - IDENTIFICATION TAG
- 3 - PUSH-IN FILL PLUG
- 4 - DATE TAG

DESCRIPTION AND OPERATION (Continued)

STANDARD DIFFERENTIAL

DESCRIPTION

The differential gear system divides the torque between the axle shafts. It allows the axle shafts to rotate at different speeds when turning corners.

Each differential side gear is splined to an axle shaft. The pinion gears are mounted on a pinion mate shaft and are free to rotate on the shaft. The pinion gear is fitted in a bore in the differential case and is positioned at a right angle to the axle shafts.

OPERATION

In operation, power flow occurs as follows:

- The pinion gear rotates the ring gear
- The ring gear (bolted to the differential case) rotates the case
- The differential pinion gears (mounted on the pinion mate shaft in the case) rotate the side gears
- The side gears (splined to the axle shafts) rotate the shafts

During straight-ahead driving, the differential pinion gears do not rotate on the pinion mate shaft. This occurs because input torque applied to the gears is divided and distributed equally between the two side gears. As a result, the pinion gears revolve with the pinion mate shaft but do not rotate around it (Fig. 3).

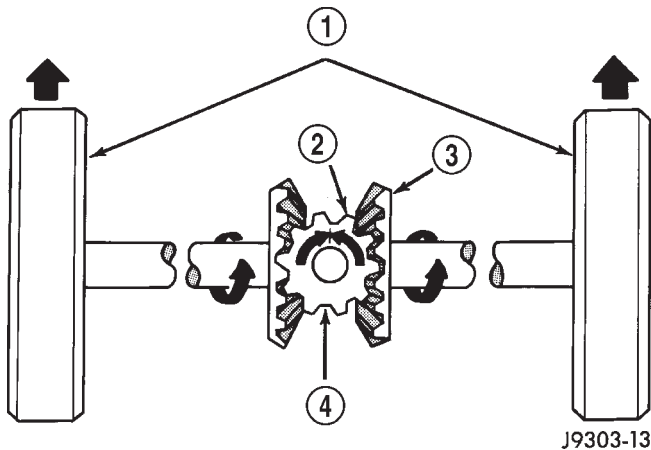

Fig. 3 Differential Operation—Straight Ahead Driving

- 1 - IN STRAIGHT AHEAD DRIVING EACH WHEEL ROTATES AT 100% OF CASE SPEED
- 2 - PINION GEAR
- 3 - SIDE GEAR
- 4 - PINION GEARS ROTATE WITH CASE

When turning corners, the outside wheel must travel a greater distance than the inside wheel to complete a turn. The difference must be compensated for to prevent the tires from scuffing and skidding through turns. To accomplish this, the differential allows the axle shafts to turn at unequal speeds (Fig. 4). In this instance, the input torque applied to the pinion gears is not divided equally. The pinion gears now rotate around the pinion mate shaft in opposite directions. This allows the side gear and axle shaft attached to the outside wheel to rotate at a faster speed.

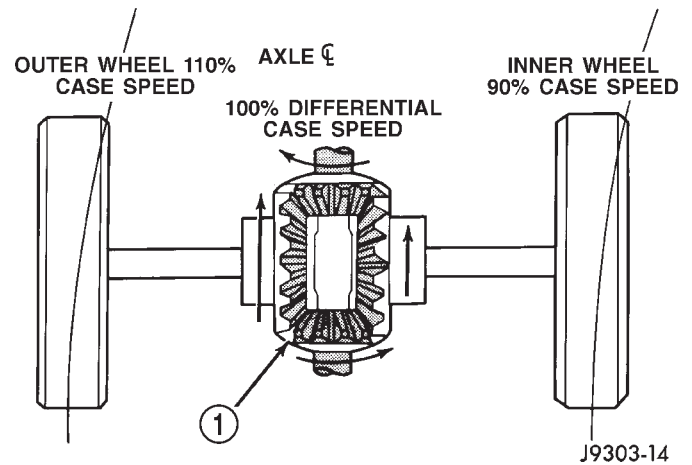

Fig. 4 Differential Operation—On Turns

- 1 - PINION GEARS ROTATE ON PINION SHAFT

TRAC-LOK™ DIFFERENTIAL

DESCRIPTION

In a standard differential, if one wheel spins, the opposite wheel will generate only as much torque as the spinning wheel.

In the Trac-lok™ differential, part of the ring gear torque is transmitted through clutch packs which contain multiple discs. The clutches will have radial grooves on the plates, and concentric grooves on the discs or bonded fiber material that is smooth in appearance.

OPERATION

In operation, the Trac-lok™ clutches are engaged by two concurrent forces. The first being the preload force exerted through Belleville spring washers within the clutch packs. The second is the separating forces generated by the side gears as torque is applied through the ring gear (Fig. 5).

DESCRIPTION AND OPERATION (Continued)

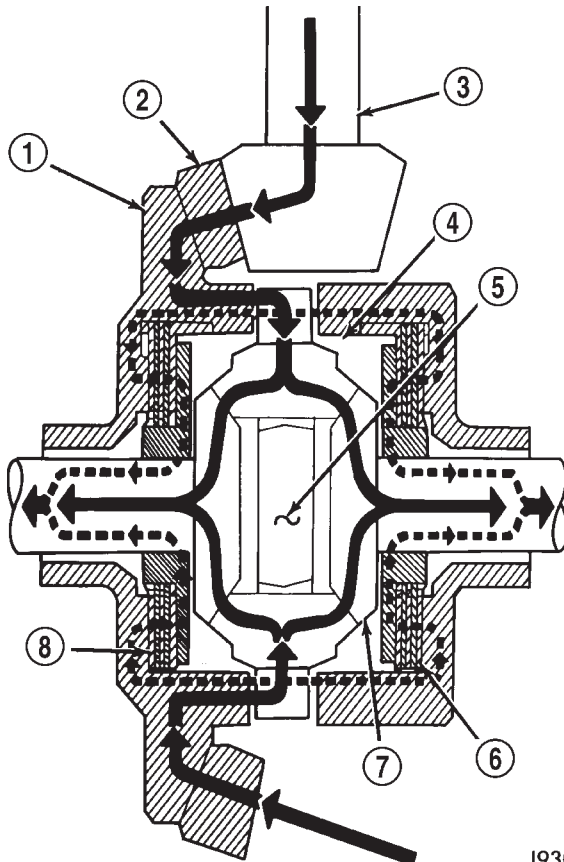

J9303-15

Fig. 5 Trac-lok™ Limited Slip Differential Operation

- 1 - CASE
- 2 - RING GEAR
- 3 - DRIVE PINION
- 4 - PINION GEAR
- 5 - MATE SHAFT
- 6 - CLUTCH PACK
- 7 - SIDE GEAR
- 8 - CLUTCH PACK

The Trac-lok™ design provides the differential action needed for turning corners and for driving

straight ahead during periods of unequal traction. When one wheel loses traction, the clutch packs transfer additional torque to the wheel having the most traction. Trac-lok™ differentials resist wheel spin on bumpy roads and provide more pulling power when one wheel loses traction. Pulling power is provided continuously until both wheels lose traction. If both wheels slip due to unequal traction, Trac-lok™ operation is normal. In extreme cases of differences of traction, the wheel with the least traction may spin.

DIAGNOSIS AND TESTING

GENERAL INFORMATION

Axle bearing problem conditions are usually caused by:

- Insufficient or incorrect lubricant.
- Foreign matter/water contamination.
- Incorrect bearing preload torque adjustment.
- Incorrect backlash.

Axle gear problem conditions are usually the result of:

- Insufficient lubrication.
- Incorrect or contaminated lubricant.
- Overloading (excessive engine torque) or exceeding vehicle weight capacity.
- Incorrect clearance or backlash adjustment.

Axle component breakage is most often the result of:

- Severe overloading.
- Insufficient lubricant.
- Incorrect lubricant.
- Improperly tightened components.
- Differential housing bores not square to each other.

DIAGNOSIS AND TESTING (Continued)

DIAGNOSTIC CHART

| Condition | Possible Causes | Correction |
|---------------------------|---|--|
| Wheel Noise | <ol style="list-style-type: none"> 1. Wheel loose. 2. Faulty, brinelled wheel bearing. | <ol style="list-style-type: none"> 1. Tighten loose nuts. 2. Replace bearing. |
| Axle Shaft Noise | <ol style="list-style-type: none"> 1. Misaligned axle tube. 2. Bent or sprung axle shaft. 3. End-play in pinion bearings. 4. Excessive gear backlash between the ring gear and pinion. 5. Improper adjustment of pinion gear bearings. 6. Loose pinion yoke nut. 7. Scuffed gear tooth contact surfaces. | <ol style="list-style-type: none"> 1. Inspect axle tube alignment. Correct as necessary. 2. Inspect and correct as necessary. 3. Refer to pinion pre-load information and correct as necessary. 4. Check adjustment of the ring gear and pinion backlash. Correct as necessary. 5. Adjust the pinion bearings pre-load. 6. Tighten the pinion yoke nut. 7. Inspect and replace as necessary. |
| Axle Shaft Broke | <ol style="list-style-type: none"> 1. Misaligned axle tube. 2. Vehicle overloaded. 3. Erratic clutch operation. 4. Grabbing clutch. | <ol style="list-style-type: none"> 1. Replace the broken shaft after correcting tube mis-alignment. 2. Replace broken shaft and avoid excessive weight on vehicle. 3. Replace broken shaft and avoid or correct erratic clutch operation. 4. Replace broken shaft and inspect and repair clutch as necessary. |
| Differential Cracked | <ol style="list-style-type: none"> 1. Improper adjustment of the differential bearings. 2. Excessive ring gear backlash. 3. Vehicle overloaded. 4. Erratic clutch operation. | <ol style="list-style-type: none"> 1. Replace case and inspect gears and bearings for further damage. Set differential bearing pre-load properly. 2. Replace case and inspect gears and bearings for further damage. Set ring gear backlash properly. 3. Replace case and inspect gears and bearings for further damage. Avoid excessive vehicle weight. 4. Replace case and inspect gears and bearings for further damage. Avoid erratic use of clutch. |
| Differential Gears Scored | <ol style="list-style-type: none"> 1. Insufficient lubrication. 2. Improper grade of lubricant. 3. Excessive spinning of one wheel/tire. | <ol style="list-style-type: none"> 1. Replace scored gears. Fill differential with the correct fluid type and quantity. 2. Replace scored gears. Fill differential with the correct fluid type and quantity. 3. Replace scored gears. Inspect all gears, pinion bores, and shaft for damage. Service as necessary. |

DIAGNOSIS AND TESTING (Continued)

| Condition | Possible Causes | Correction |
|-------------------|---|--|
| Loss Of Lubricant | <ol style="list-style-type: none"> 1. Lubricant level too high. 2. Worn axle shaft seals. 3. Cracked differential housing. 4. Worn pinion seal. 5. Worn/scored yoke. 6. Axle cover not properly sealed. | <ol style="list-style-type: none"> 1. Drain lubricant to the correct level. 2. Replace seals. 3. Repair as necessary. 4. Replace seal. 5. Replace yoke and seal. 6. Remove, clean, and re-seal cover. |
| Axle Overheating | <ol style="list-style-type: none"> 1. Lubricant level low. 2. Improper grade of lubricant. 3. Bearing pre-loads too high. 4. Insufficient ring gear backlash. | <ol style="list-style-type: none"> 1. Fill differential to correct level. 2. Fill differential with the correct fluid type and quantity. 3. Re-adjust bearing pre-loads. 4. Re-adjust ring gear backlash. |
| Gear Teeth Broke | <ol style="list-style-type: none"> 1. Overloading. 2. Erratic clutch operation. 3. Ice-spotted pavement. 4. Improper adjustments. | <ol style="list-style-type: none"> 1. Replace gears. Examine other gears and bearings for possible damage. 2. Replace gears and examine the remaining parts for damage. Avoid erratic clutch operation. 3. Replace gears and examine remaining parts for damage. 4. Replace gears and examine remaining parts for damage. Ensure ring gear backlash is correct. |
| Axle Noise | <ol style="list-style-type: none"> 1. Insufficient lubricant. 2. Improper ring gear and pinion adjustment. 3. Unmatched ring gear and pinion. 4. Worn teeth on ring gear and/or pinion. 5. Loose pinion bearings. 6. Loose differential bearings. 7. Mis-aligned or sprung ring gear. 8. Loose differential bearing cap bolts. 9. Housing not machined properly. | <ol style="list-style-type: none"> 1. Fill differential with the correct fluid type and quantity. 2. Check ring gear and pinion contact pattern. 3. Replace gears with a matched ring gear and pinion. 4. Replace ring gear and pinion. 5. Adjust pinion bearing pre-load. 6. Adjust differential bearing pre-load. 7. Measure ring gear run-out. Replace components as necessary. 8. Inspect differential components and replace as necessary. Ensure that the bearing caps are torqued to the proper specification. 9. Replace housing. |

DIAGNOSIS AND TESTING (Continued)

GEAR NOISE

Axle gear noise can be caused by insufficient lubricant, incorrect backlash, tooth contact, worn/damaged gears, or the carrier housing not having the proper offset and squareness.

Gear noise usually happens at a specific speed range. The noise can also occur during a specific type of driving condition. These conditions are acceleration, deceleration, coast, or constant load.

When road testing, first warm-up the axle fluid by driving the vehicle at least 5 miles and then accelerate the vehicle to the speed range where the noise is the greatest. Shift out-of-gear and coast through the peak-noise range. If the noise stops or changes greatly:

- Check for insufficient lubricant.
- Incorrect ring gear backlash.
- Gear damage.

Differential side gears and pinions can be checked by turning the vehicle. They usually do not cause noise during straight-ahead driving when the gears are unloaded. The side gears are loaded during vehicle turns. A worn pinion mate shaft can also cause a snapping or a knocking noise.

BEARING NOISE

The axle shaft, differential and pinion bearings can all produce noise when worn or damaged. Bearing noise can be either a whining, or a growling sound.

Pinion bearings have a constant-pitch noise. This noise changes only with vehicle speed. Pinion bearing noise will be higher pitched because it rotates at a faster rate. Drive the vehicle and load the differential. If bearing noise occurs, the rear pinion bearing is the source of the noise. If the bearing noise is heard during a coast, the front pinion bearing is the source.

Worn or damaged differential bearings usually produce a low pitch noise. Differential bearing noise is similar to pinion bearing noise. The pitch of differential bearing noise is also constant and varies only with vehicle speed.

Axle shaft bearings produce noise and vibration when worn or damaged. The noise generally changes when the bearings are loaded. Road test the vehicle. Turn the vehicle sharply to the left and to the right. This will load the bearings and change the noise level. Where axle bearing damage is slight, the noise is usually not noticeable at speeds above 30 mph.

LOW SPEED KNOCK

Low speed knock is generally caused by a worn U-joint or by worn side-gear thrust washers. A worn pinion shaft bore will also cause low speed knock.

VIBRATION

Vibration at the rear of the vehicle is usually caused by a:

- Damaged drive shaft.
- Missing drive shaft balance weight(s).
- Worn or out-of-balance wheels.
- Loose wheel lug nuts.
- Worn U-joint(s).
- Loose/broken springs.
- Damaged axle shaft bearing(s).
- Loose pinion gear nut.
- Excessive pinion yoke run out.
- Bent axle shaft(s).

Check for loose or damaged front-end components or engine/transmission mounts. These components can contribute to what appears to be a rear-end vibration. Do not overlook engine accessories, brackets and drive belts.

All driveline components should be examined before starting any repair.

Refer to Group 22, Wheels and Tires, for additional vibration information.

DRIVELINE SNAP

A snap or clunk noise when the vehicle is shifted into gear (or the clutch engaged), can be caused by:

- High engine idle speed.
- Transmission shift operation.
- Loose engine/transmission/transfer case mounts.
- Worn U-joints.
- Loose spring mounts.
- Loose pinion gear nut and yoke.
- Excessive ring gear backlash.
- Excessive side gear to case clearance.

The source of a snap or a clunk noise can be determined with the assistance of a helper. Raise the vehicle on a hoist with the wheels free to rotate. Instruct the helper to shift the transmission into gear. Listen for the noise, a mechanics stethoscope is helpful in isolating the source of a noise.

TRAC-LOK™ DIFFERENTIAL NOISE

The most common problem is a chatter noise when turning corners. Before removing a Trac-lok™ unit for repair, drain, flush and refill the axle with the specified lubricant. Refer to Lubricant change in this Group.

A container of Mopar® Trac-lok™ Lubricant (friction modifier) should be added after repair service or during a lubricant change.

After changing the lubricant, drive the vehicle and make 10 to 12 slow, figure-eight turns. This maneuver will pump lubricant through the clutches. This will correct the condition in most instances. If the chatter persists, clutch damage could have occurred.

DIAGNOSIS AND TESTING (Continued)

TRAC-LOK™ TEST

WARNING: WHEN SERVICING VEHICLES WITH A TRAC-LOK™ DIFFERENTIAL DO NOT USE THE ENGINE TO TURN THE AXLE AND WHEELS. BOTH REAR WHEELS MUST BE RAISED AND THE VEHICLE SUPPORTED. A TRAC-LOK™ AXLE CAN EXERT ENOUGH FORCE IF ONE WHEEL IS IN CONTACT WITH A SURFACE TO CAUSE THE VEHICLE TO MOVE.

The differential can be tested without removing the differential case by measuring rotating torque. Make sure brakes are not dragging during this measurement.

(1) Place blocks in front and rear of both front wheels.

(2) Raise one rear wheel until it is completely off the ground.

(3) Engine off, transmission in neutral, and parking brake off.

(4) Remove wheel and bolt Special Tool 6790 to studs.

(5) Use torque wrench on special tool to rotate wheel and read rotating torque (Fig. 6).

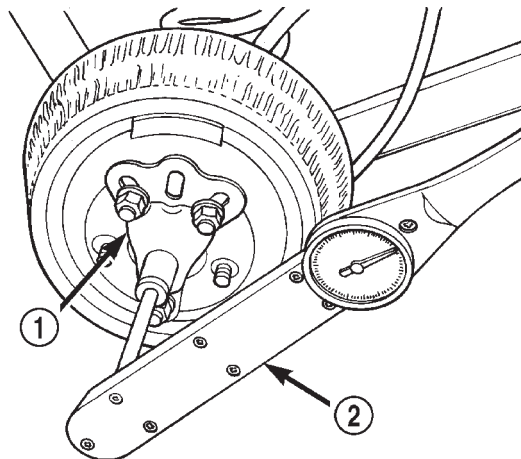

80a4d327

Fig. 6 Trac-lok™ Test — Typical

- 1 - SPECIAL TOOL 6790 WITH BOLT IN CENTER HOLE
2 - TORQUE WRENCH

(6) If rotating torque is less than 22 N·m (30 ft. lbs.) or more than 271 N·m (200 ft. lbs.) on either wheel the unit should be serviced.

SERVICE PROCEDURES

LUBRICANT CHANGE

(1) Raise and support the vehicle.

(2) Remove the lubricant fill hole plug from the differential housing cover.

(3) Remove the differential housing cover and drain the lubricant from the housing.

(4) Clean the housing cavity with a flushing oil, light engine oil, or lint free cloth. **Do not use water, steam, kerosene, or gasoline for cleaning.**

(5) Remove the original sealant from the housing and cover surfaces.

(6) Apply a bead of Mopar® Silicone Rubber Sealant, or equivalent, to the housing cover (Fig. 7).

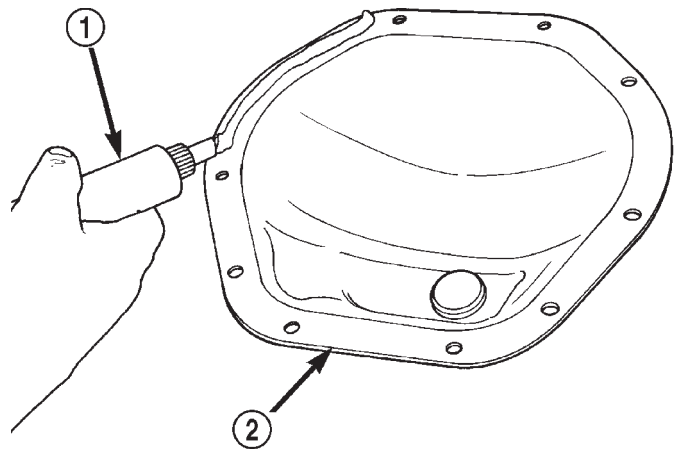

80a534a8

Fig. 7 Apply Sealant

- 1 - SEALANT
2 - AXLE HOUSING COVER

Install the housing cover within 5 minutes after applying the sealant.

(7) Install the cover and any identification tag. Tighten the cover bolts to 41 N·m (30 ft. lbs.) torque.

(8) For Trac-lok™ differentials, a quantity of Mopar® Trac-lok™ lubricant (friction modifier), or equivalent, must be added after repair service or a lubricant change. Refer to the Lubricant Specifications section of this group for the quantity necessary.

(9) Fill differential with Mopar® Hypoid Gear Lubricant, or equivalent, to bottom of the fill plug hole. Refer to the Lubricant Specifications section of this group for the quantity necessary.

CAUTION: Overfilling the differential can result in lubricant foaming and overheating.

(10) Install the fill hole plug and lower the vehicle.

(11) Trac-lok™ differential equipped vehicles should be road tested by making 10 to 12 slow figure-eight turns. This maneuver will pump the lubricant through the clutch discs to eliminate a possible chatter noise complaint.

REMOVAL AND INSTALLATION

REAR AXLE

REMOVAL

- (1) Raise and support the vehicle.
- (2) Position a suitable lifting device under the axle.
- (3) Secure axle to device.
- (4) Remove the wheels and tires.
- (5) Secure brake drums to the axle shaft.
- (6) Disconnect the brake hose at the axle junction block. Do not disconnect the brake hydraulic lines at the wheel cylinders. Refer to Group 5, Brakes, for proper procedures.
- (7) Disconnect the parking brake cables and cable brackets.
- (8) Disconnect the vent hose from the axle tube.
- (9) Mark the propeller shaft and yoke for installation alignment reference.
- (10) Remove propeller shaft.
- (11) Disconnect shock absorbers from axle.
- (12) Remove the stabilizer links.
- (13) Remove the spring clamps and spring brackets. Refer to Group 2, Suspension, for proper procedures.
- (14) Separate the axle from the vehicle.

INSTALLATION

- (1) Raise the axle with lifting device and align to the leaf spring centering bolts.
- (2) Install the spring clamps and spring brackets. Refer to Group 2, Suspension, for proper procedures.
- (3) Install shock absorbers and tighten nuts to 60 N·m (44 ft. lbs.) torque.
- (4) Install the stabilizer links. Tighten sway bar links to 74 N·m (55 ft. lbs.).
- (5) Connect the parking brake cables and cable brackets.
- (6) Install the brake drums. Refer to Group 5, Brakes, for proper procedures.
- (7) Connect the brake hose to the axle junction block. Refer to Group 5, Brakes, for proper procedures.
- (8) Install axle vent hose.
- (9) Align propeller shaft and pinion yoke reference marks. Install universal joint straps and bolts. Tighten to 19 N·m (14 ft. lbs.) torque.
- (10) Install the wheels and tires.
- (11) Add gear lubricant, if necessary. Refer to Lubricant Specifications in this section for lubricant requirements.
- (12) Remove lifting device from axle and lower the vehicle.

AXLE SHAFT

REMOVAL

- (1) Raise and support vehicle. Ensure that the transmission is in neutral.
- (2) Remove wheel and tire assembly.
- (3) Remove brake drum. Refer to Group 5, Brakes, for proper procedure.
- (4) Clean all foreign material from housing cover area.
- (5) Loosen housing cover bolts. Drain lubricant from the housing and axle tubes. Remove housing cover.
- (6) Rotate differential case so that pinion mate shaft lock screw is accessible. Remove lock screw and pinion mate shaft from differential case (Fig. 8).

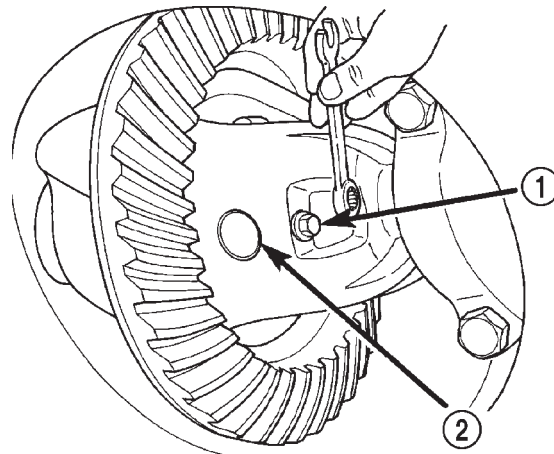

80be4604

Fig. 8 Pinion Mate Shaft Lock Screw

- 1 - LOCK SCREW
2 - PINION MATE SHAFT

- (7) Push axle shaft inward and remove axle shaft C-lock from the axle shaft (Fig. 9).
- (8) Remove axle shaft. Use care to prevent damage to axle shaft bearing and seal, which will remain in axle tube.
- (9) Inspect axle shaft seal for leakage or damage.
- (10) Inspect roller bearing contact surface on axle shaft for signs of brinelling, galling and pitting. If any of these conditions exist, the axle shaft and/or bearing and seal must be replaced.

INSTALLATION

- (1) Lubricate bearing bore and seal lip with gear lubricant. Insert axle shaft through seal, bearing, and engage it into side gear splines.

NOTE: Use care to prevent shaft splines from damaging axle shaft seal lip.

REMOVAL AND INSTALLATION (Continued)

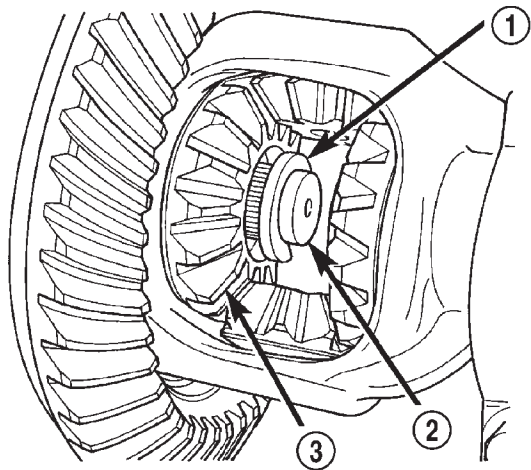

Fig. 9 Axle Shaft C-Lock

80be4603

- 1 - C-LOCK
- 2 - AXLE SHAFT
- 3 - SIDE GEAR

(2) Insert C-lock in end of axle shaft. Push axle shaft outward to seat C-lock in side gear.

(3) Insert pinion shaft into differential case and through thrust washers and differential pinions.

(4) Align hole in shaft with hole in the differential case and install lock screw with Loctite® on the threads. Tighten lock screw to 11 N·m (8 ft. lbs.) torque.

(5) Install cover and add fluid. Refer to Lubricant Change procedure in this section for procedure and lubricant requirements.

(6) Install brake drum. Refer to Group 5, Brakes, for proper procedures.

(7) Install wheel and tire.

(8) Lower vehicle.

AXLE SEAL AND BEARING

REMOVAL

(1) Remove axle shaft.

(2) Remove axle shaft seal from the end of the axle tube with a small pry bar (Fig. 10).

NOTE: The seal and bearing can be removed at the same time with the bearing removal tool.

(3) Remove the axle shaft bearing from the axle tube with Bearing Removal Tool Set 6310, using Adapter Foot 6310-9 (Fig. 11).

INSTALLATION

NOTE: Do not install the original axle shaft seal. Always install a new seal.

(1) Wipe the axle tube bore clean. Remove any old sealer or burrs from the tube.

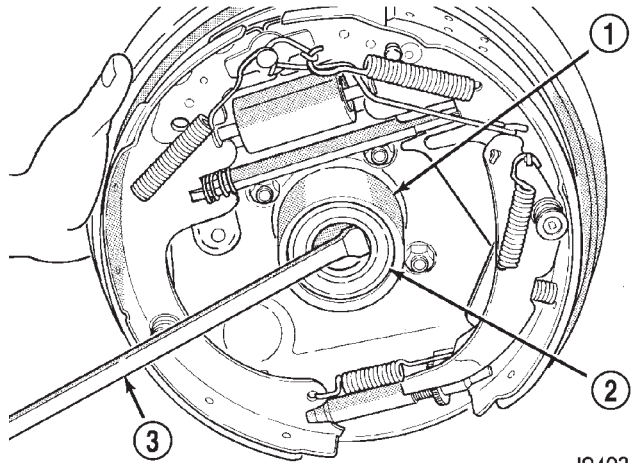

Fig. 10 Axle Seal Removal

J9403-16

- 1 - AXLE TUBE
- 2 - AXLE SEAL
- 3 - PRY BAR

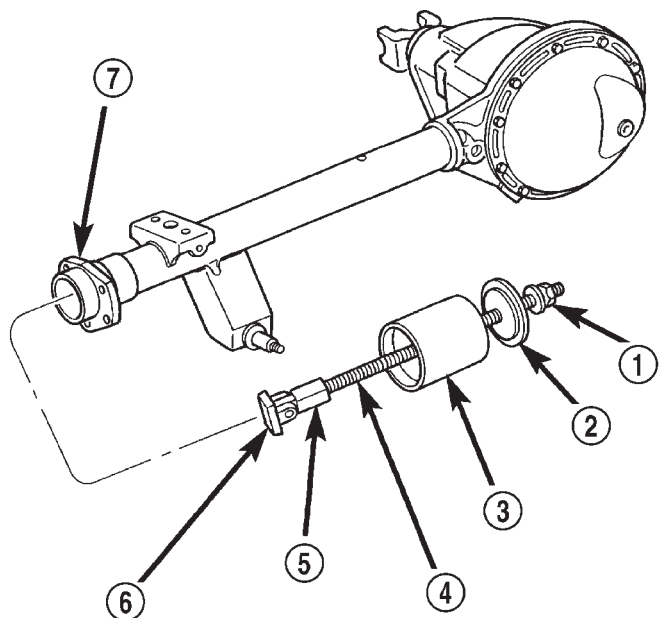

Fig. 11 Axle Shaft Bearing Removal Tool

80be4605

- 1 - NUT
- 2 - GUIDE PLATE
- 3 - GUIDE
- 4 - THREADED ROD
- 5 - ADAPTER
- 6 - FOOT
- 7 - AXLE TUBE

(2) Install the axle shaft bearing with Installer C-4198 and Handle C-4171 (Fig. 12). Ensure that the bearing part number is against the installer. Verify that the bearing is installed straight and the tool fully contacts the axle tube when seating the bearing.

REMOVAL AND INSTALLATION (Continued)

(3) Install a new axle seal with Installer C-4076-B and Handle C-4735-1. When the tool contacts the axle tube, the seal is installed to the correct depth.

(4) Coat the lip of the seal with axle lubricant for protection prior to installing the axle shaft.

(5) Install the axle shaft.

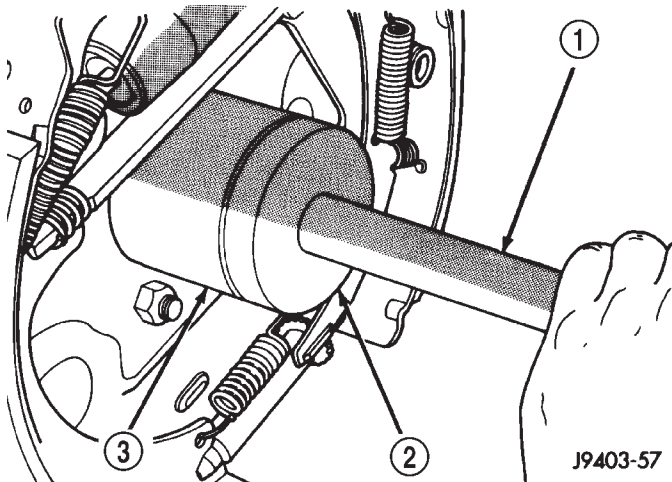

Fig. 12 Axle Shaft Seal and Bearing Installation

- 1 - HANDLE
- 2 - INSTALLER
- 3 - AXLE TUBE

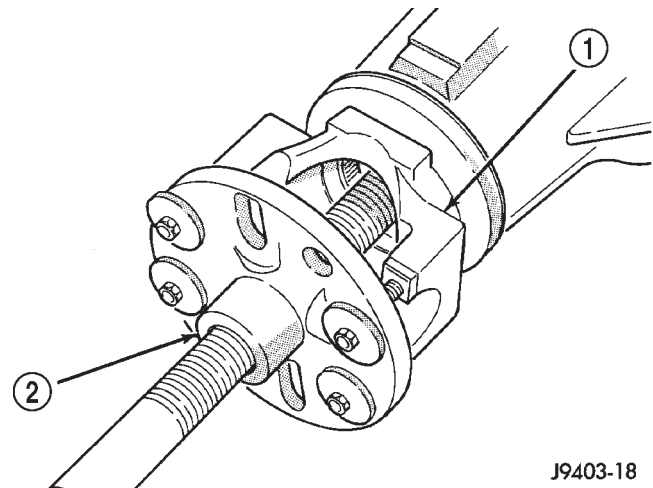

Fig. 13 Yoke Removal

- 1 - PINION YOKE
- 2 - TOOL C452

(3) Inspect pinion yoke for cracks, worn splines and worn seal contact surface. Replace yoke if necessary.

NOTE: The outer perimeter of the seal is pre-coated with a special sealant. An additional application of sealant is not required.

(4) Apply a light coating of gear lubricant on the lip of pinion seal.

(5) Install the new pinion seal with Installer C-4076-B and Handle C-4735-1 (Fig. 14).

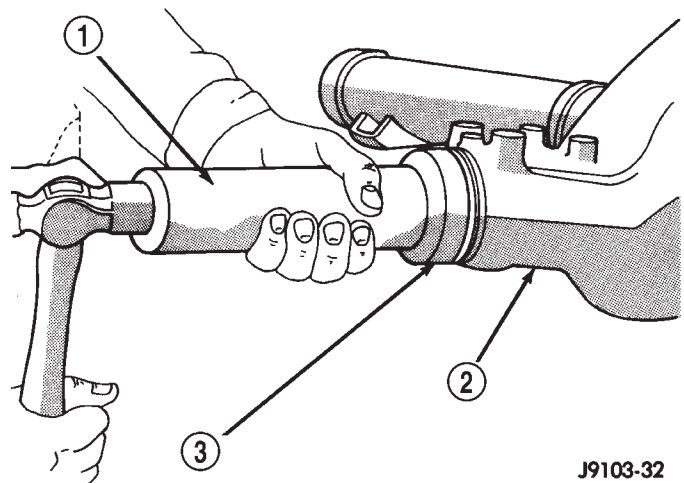

Fig. 14 8 1/4 Axle Pinion Seal Installation

- 1 - SPECIAL TOOL C-4735
- 2 - DIFFERENTIAL HOUSING
- 3 - SPECIAL TOOL C-4076-A

PINION SEAL

REMOVAL

- (1) Raise and support the vehicle.
- (2) Scribe a mark on the universal joint, pinion yoke, and pinion shaft for reference.
- (3) Disconnect the propeller shaft from the pinion yoke. Secure the propeller shaft in an upright position to prevent damage to the rear universal joint.
- (4) Remove the wheel and tire assemblies.
- (5) Remove the brake drums to prevent any drag. The drag may cause a false bearing preload torque measurement.
- (6) Rotate the pinion yoke three or four times.
- (7) Measure the amount of torque necessary to rotate the pinion gear with a (in. lbs.) dial-type torque wrench. Record the torque reading for installation reference.
- (8) Hold the yoke with Wrench 6719. Remove the pinion nut and washer.
- (9) Remove the yoke with Remover C-452 (Fig. 13).
- (10) Remove the pinion seal with suitable pry tool or slide-hammer mounted screw.

INSTALLATION

- (1) Clean the seal contact surface in the housing bore.
- (2) Examine the splines on the pinion shaft for burrs or wear. Remove any burrs and clean the shaft.

NOTE: The seal is correctly installed when the seal flange contacts the face of the differential housing flange.

REMOVAL AND INSTALLATION (Continued)

(6) Position the pinion yoke on the end of the shaft with the reference marks aligned.

(7) Seat yoke on pinion shaft with Installer C-3718 and Wrench 6719.

(8) Remove the tools and install the pinion yoke washer. The convex side of the washer must face outward.

CAUTION: Do not exceed the minimum tightening torque when installing the pinion yoke retaining nut at this point. Damage to collapsible spacer or bearings may result.

(9) Hold pinion yoke with Yoke Holder 6719 and tighten shaft nut to 285 N·m (210 ft. lbs.) (Fig. 15). Rotate the pinion several revolutions to ensure the bearing rollers are seated.

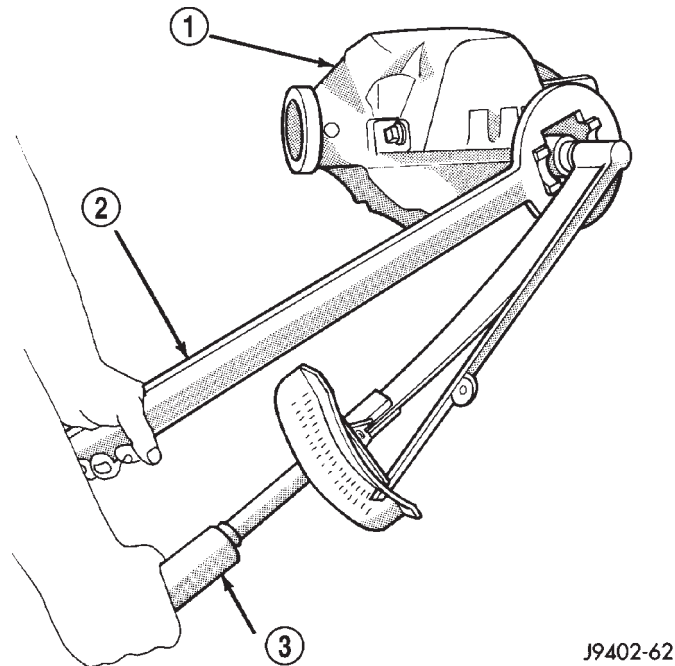

Fig. 15 Tightening Pinion Nut

- 1 - DIFFERENTIAL HOUSING
2 - YOKE HOLDER
3 - TORQUE WRENCH

(10) Rotate the pinion using an (in. lbs.) torque wrench. Rotating torque should be equal to the reading recorded during removal, plus an additional 0.56 N·m (5 in. lbs.) (Fig. 16).

CAUTION: Never loosen pinion nut to decrease pinion gear bearing rotating torque and never exceed specified preload torque. If preload torque is exceeded a new collapsible spacer must be installed. The torque sequence will then have to be repeated.

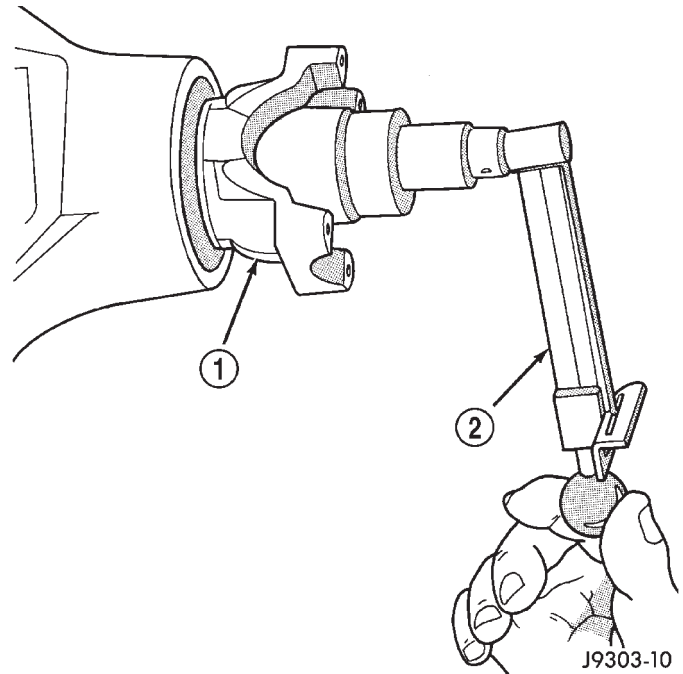

Fig. 16 Check Pinion Rotation Torque

- 1 - PINION YOKE
2 - INCH POUND TORQUE WRENCH

(11) If the rotating torque is low, use Yoke Holder 6719 to hold the pinion yoke (Fig. 15) and tighten the pinion nut in 6.8 N·m (5 ft. lbs.) increments until proper rotating torque is achieved.

NOTE: The bearing rotating torque should be constant during a complete revolution of the pinion. If the rotating torque varies, this indicates a binding condition.

(12) The seal replacement is unacceptable if the final pinion nut torque is less than 285 N·m (210 ft. lbs.).

(13) Install the propeller shaft with the installation reference marks aligned.

(14) Tighten the universal joint yoke clamp screws to 19 N·m (14 ft. lbs.).

(15) Install the brake drums.

(16) Install wheel and tire assemblies and lower the vehicle.

(17) Check the differential housing lubricant level.

DIFFERENTIAL

REMOVAL

(1) Remove the axle shafts.

NOTE: Side play resulting from bearing races being loose on case hubs requires replacement of the differential case.

REMOVAL AND INSTALLATION (Continued)

(2) Mark the differential housing and the differential bearing caps for installation reference (Fig. 17).

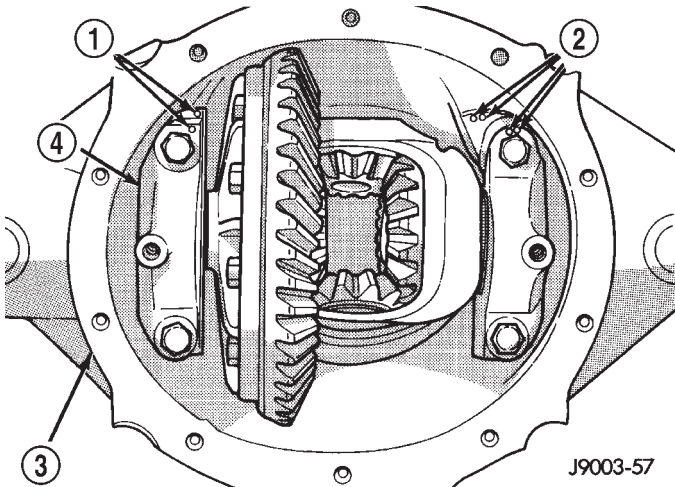

Fig. 17 Mark For Installation Reference

- 1 - INSTALLATION REFERENCE MARKS
- 2 - INSTALLATION REFERENCE MARKS
- 3 - DIFFERENTIAL HOUSING
- 4 - BEARING CAP

(3) Remove bearing threaded adjuster lock from each bearing cap. Loosen the bolts, but do not remove the bearing caps.

(4) Loosen the threaded adjusters with Wrench C-4164 (Fig. 18).

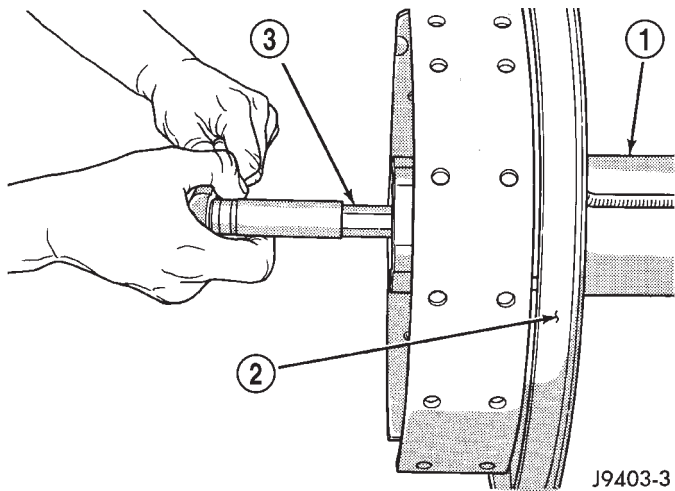

Fig. 18 Threaded Adjuster Tool

- 1 - AXLE TUBE
- 2 - BACKING PLATE
- 3 - TOOL C-4164

(5) Hold the differential case while removing bearing caps and adjusters.

(6) Remove the differential case.

NOTE: Each differential bearing cup and threaded adjuster must be kept with their respective bearing.

INSTALLATION

(1) Apply a coating of hypoid gear lubricant to the differential bearings, bearing cups, and threaded adjusters. A dab of grease can be used to keep the adjusters in position. Carefully position the assembled differential case in the housing.

(2) Observe the reference marks and install the differential bearing caps at their original locations (Fig. 19).

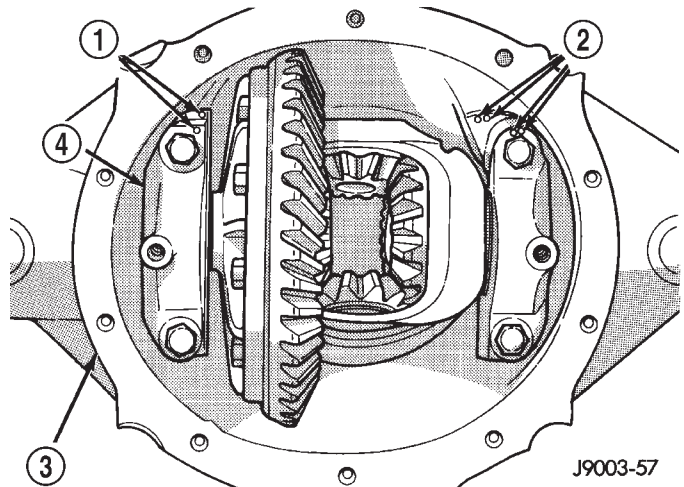

Fig. 19 Bearing Caps & Bolts

- 1 - INSTALLATION REFERENCE MARKS
- 2 - INSTALLATION REFERENCE MARKS
- 3 - DIFFERENTIAL HOUSING
- 4 - BEARING CAP

(3) Install bearing cap bolts and tighten the upper bolts to 14 N·m (10 ft. lbs.). Tighten the lower bolts finger-tight until the bolt head is seated.

(4) Perform the differential bearing preload and adjustment procedure.

NOTE: Be sure that all bearing cap bolts are tightened to the final torque of 95 N·m (70 ft.lbs) before proceeding.

(5) Install axle shafts and differential housing cover.

DIFFERENTIAL SIDE BEARINGS

REMOVAL

(1) Remove differential case from axle housing.

(2) Remove the bearings from the differential case with Puller/Press C-293-PA and Adapters C-293-48 and Plug SP-3289 (Fig. 20).

INSTALLATION

(1) Install differential side bearings. Use Installer C-4340 with handle C-4171 (Fig. 21).

(2) Install differential case in axle housing.

REMOVAL AND INSTALLATION (Continued)

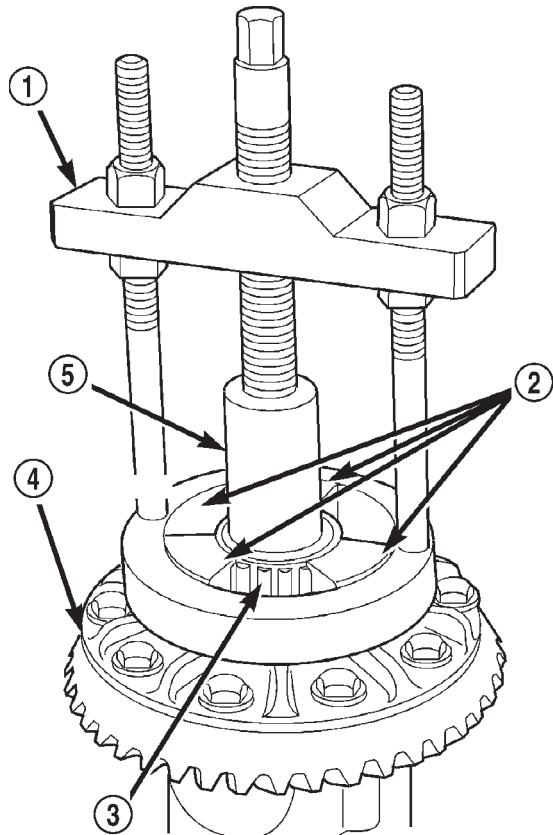
**Fig. 20 Differential Bearing Removal**

80a982f2

- 1 - SPECIAL TOOL C-293-PA
- 2 - SPECIAL TOOL C-293-48
- 3 - BEARING
- 4 - DIFFERENTIAL
- 5 - SPECIAL TOOL SP-3289

RING GEAR

The ring gear and pinion are serviced in a matched set. Do not replace the ring gear without replacing the pinion.

REMOVAL

- (1) Remove differential from axle housing.
- (2) Place differential case in a suitable vise with soft metal jaw protectors. (Fig. 22).
- (3) Remove bolts holding ring gear to differential case.
- (4) Using a soft hammer, drive ring gear from differential case (Fig. 22).

INSTALLATION

CAUTION: Do not reuse the bolts that held the ring gear to the differential case. The bolts can fracture causing extensive damage.

- (1) Invert the differential case.

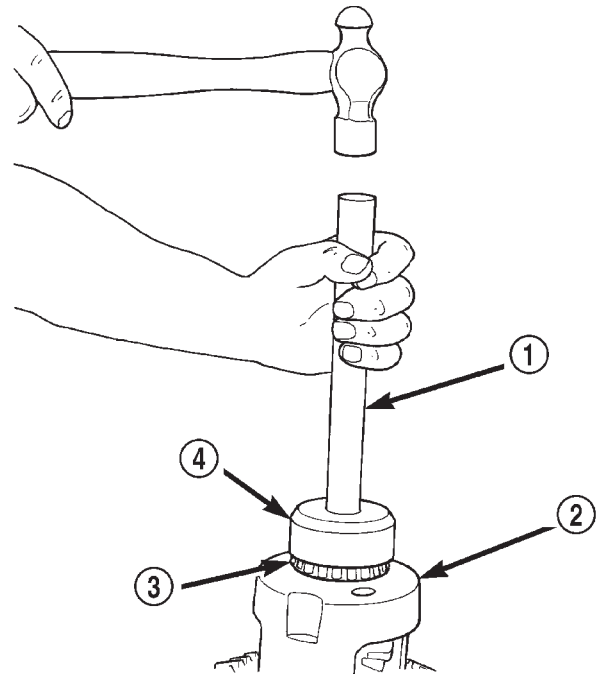

80a0c4fe

Fig. 21 Install Differential Side Bearings

- 1 - HANDLE C-4171
- 2 - DIFFERENTIAL
- 3 - BEARING
- 4 - TOOL C-4340

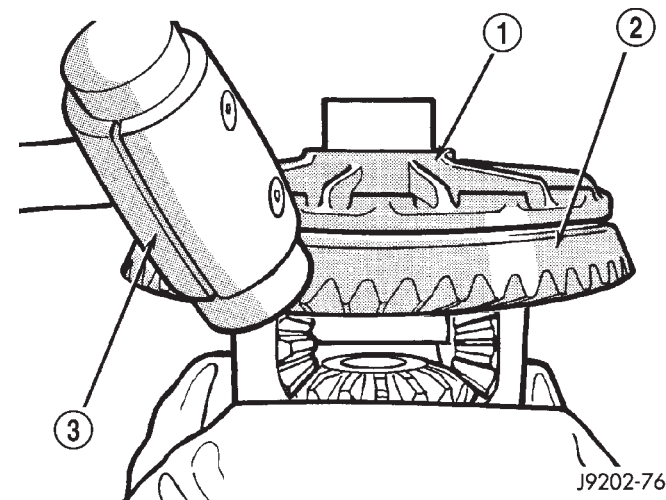

J9202-76

Fig. 22 Ring Gear Removal

- 1 - CASE
- 2 - RING GEAR
- 3 - RAWHIDE HAMMER

- (2) Position ring gear on the differential case and start two ring gear bolts. This will provide case-to-ring gear bolt hole alignment.

- (3) Invert the differential case in the vise.

- (4) Install new ring gear bolts and alternately tighten to 102 N·m (75 ft. lbs.) torque (Fig. 23).

- (5) Install differential in axle housing and verify gear mesh and contact pattern.

REMOVAL AND INSTALLATION (Continued)

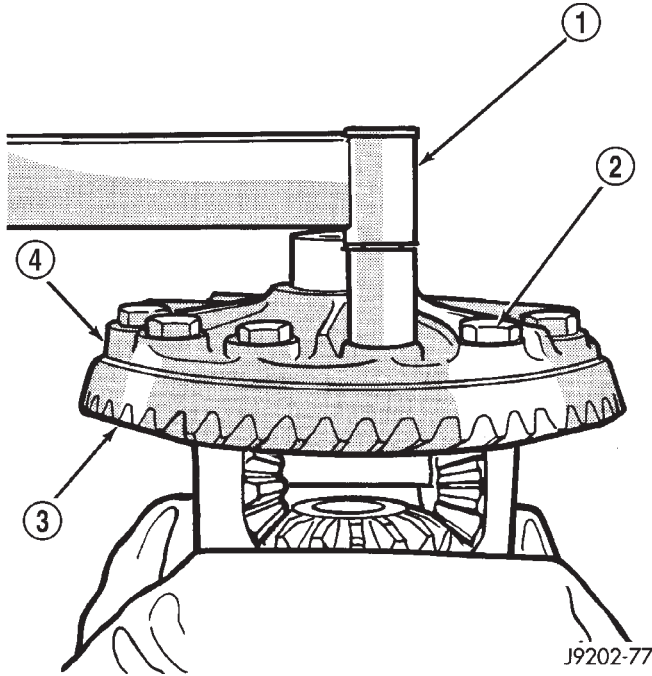

Fig. 23 Ring Gear Bolt Installation

- 1 - TORQUE WRENCH
- 2 - RING GEAR BOLT
- 3 - RING GEAR
- 4 - CASE

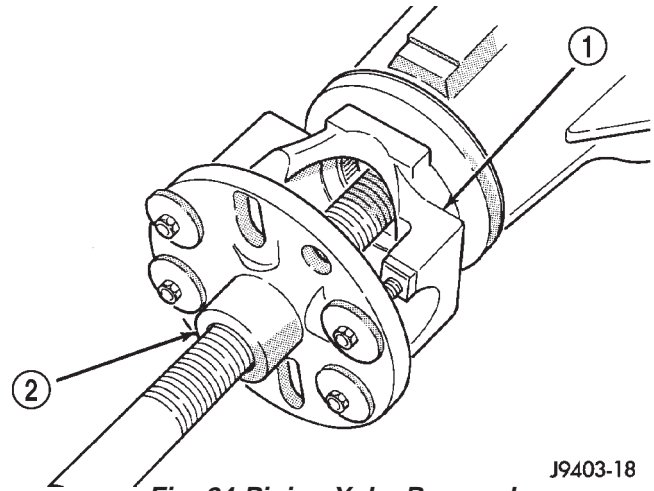

Fig. 24 Pinion Yoke Removal

J9403-18

- 1 - PINION YOKE
- 2 - TOOL C452

PINION GEAR

The ring gear and pinion are serviced in a matched set. Do not replace the pinion without replacing the ring gear.

REMOVAL

- (1) Remove differential from the axle housing.
- (2) Mark pinion yoke and propeller shaft for installation alignment.
- (3) Disconnect propeller shaft from pinion yoke. Using suitable wire, tie propeller shaft to underbody.
- (4) Using Yoke Holder 6719 to hold yoke and remove the pinion yoke nut and washer.
- (5) Using Remover C-452, remove the pinion yoke from pinion shaft (Fig. 24).
- (6) Partially install pinion nut onto pinion to protect the threads.
- (7) Remove the pinion from housing (Fig. 25). Catch the pinion with your hand to prevent it from falling and being damaged.
- (8) Remove the pinion shaft seal with suitable pry tool or slide-hammer mounted screw.
- (9) Remove oil slinger, if equipped, and front pinion bearing.
- (10) Remove the front pinion bearing cup with Remover C-4345 and Handle C-4171 (Fig. 26).
- (11) Remove the rear bearing cup from housing (Fig. 27). Use Remover C-4307 and Handle C-4171.

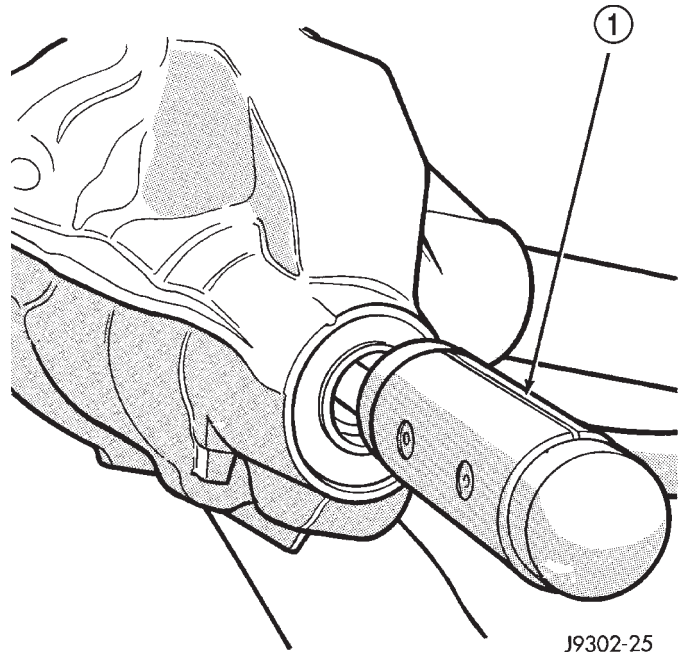

Fig. 25 Remove Pinion Gear

J9302-25

- 1 - RAWHIDE HAMMER

- (12) Remove the collapsible preload spacer (Fig. 28).
- (13) Remove the rear bearing from the pinion (Fig. 29) with Puller/Press C-293-PA and Adapters C-293-47.
- Place 4 adapter blocks so they do not damage the bearing cage.**
- (14) Remove the depth shims from the pinion shaft. Record the thickness of the depth shims.

INSTALLATION

- (1) Apply Mopar® Door Ease, or equivalent, stick lubricant to outside surface of bearing cup.
- (2) Install the pinion rear bearing cup (Fig. 30) with Installer C-4308 and Driver Handle C-4171.

REMOVAL AND INSTALLATION (Continued)

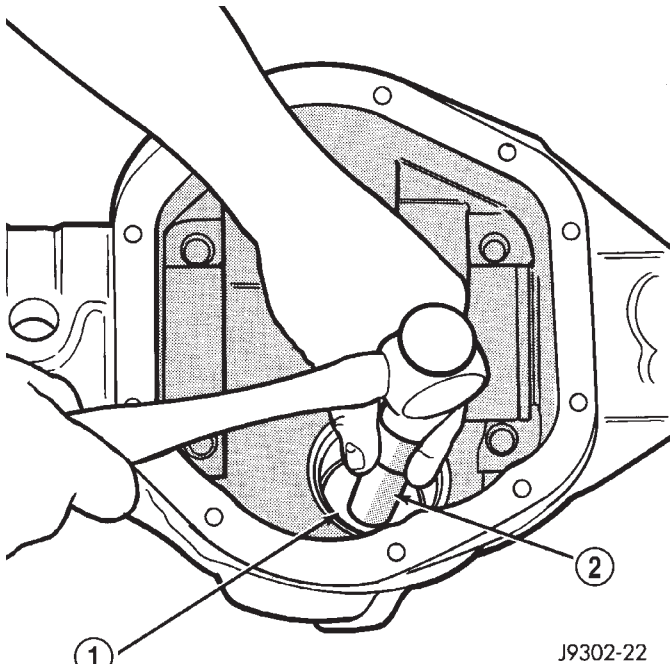

Fig. 26 Front Bearing Cup Removal

- 1 - REMOVER
- 2 - HANDLE

J9302-22

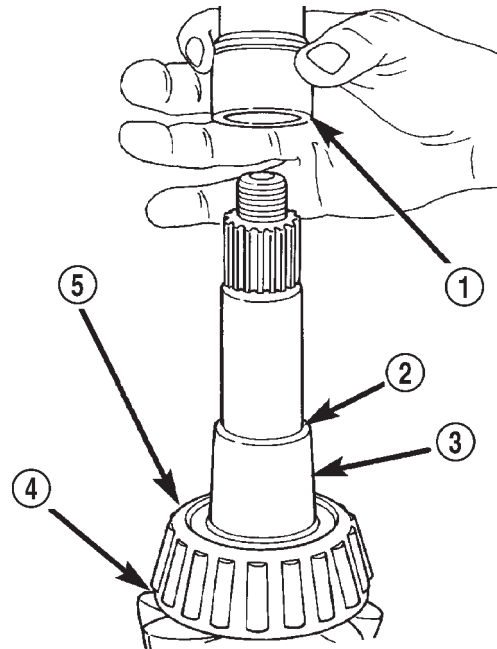

Fig. 28 Collapsible Spacer

80be4606

- 1 - COLLAPSIBLE SPACER
- 2 - SHOULDER
- 3 - PINION
- 4 - PINION DEPTH SHIM
- 5 - REAR BEARING

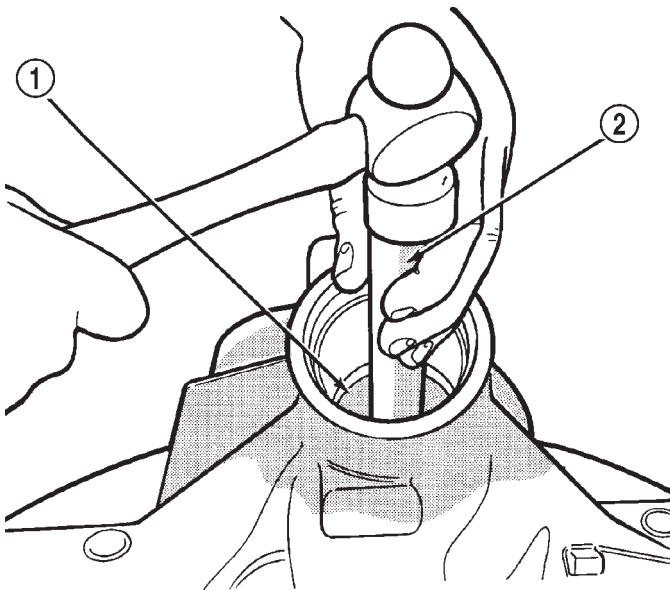

Fig. 27 Rear Bearing Cup Removal

- 1 - DRIVER
- 2 - HANDLE

J9302-23

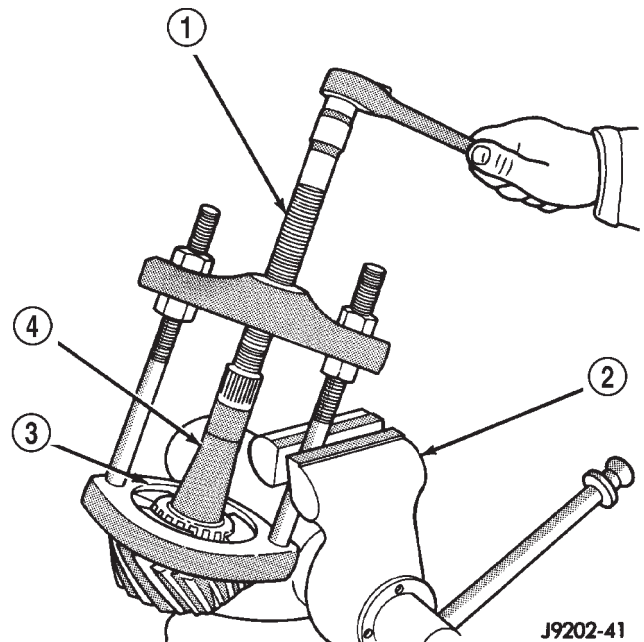

Fig. 29 Rear Bearing Removal

J9202-41

- 1 - SPECIAL TOOL C-293-PA
- 2 - VISE
- 3 - ADAPTERS
- 4 - DRIVE PINION GEAR SHAFT

- (2) Ensure cup is correctly seated.
- (3) Apply Mopar® Door Ease, or equivalent, stick lubricant to outside surface of bearing cup.
- (4) Install the pinion front bearing cup (Fig. 31) with Installer D-130 and Handle C-4171.
- (5) Install pinion front bearing, and oil slinger, if equipped.

- (6) Apply a light coating of gear lubricant on the lip of pinion seal. Install seal with Installer C-4076-B and Handle C-4735-1 (Fig. 32).

REMOVAL AND INSTALLATION (Continued)

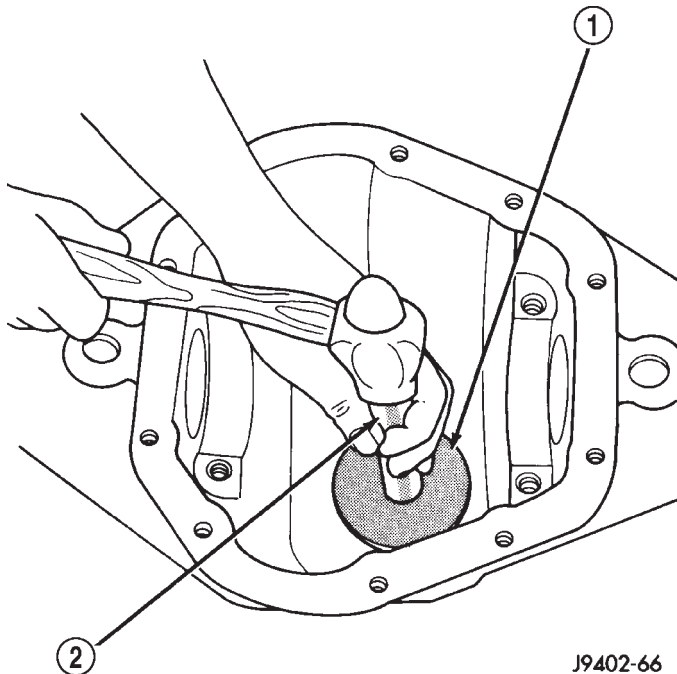

Fig. 30 Pinion Rear Bearing Cup Installation J9402-66

- 1 - INSTALLER
- 2 - HANDLE

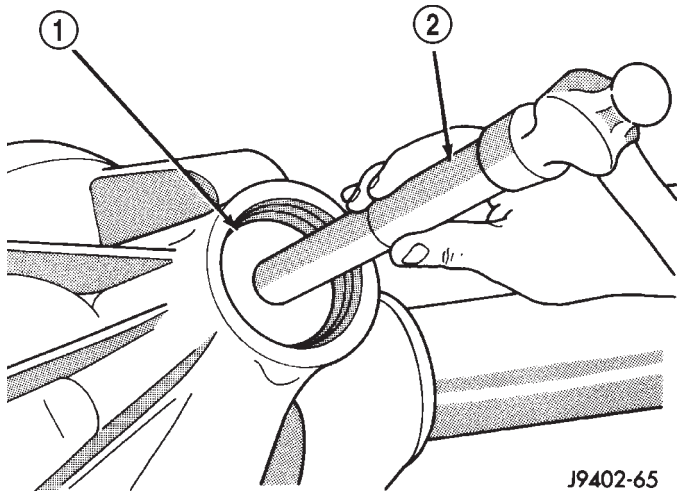

Fig. 31 Pinion Front Bearing Cup Installation J9402-65

- 1 - INSTALLER
- 2 - HANDLE

NOTE: Pinion depth shims are placed between the rear pinion bearing cone and pinion head to achieve proper ring and pinion gear mesh. If the factory installed ring gear and pinion are reused, the pinion depth shim should not require replacement. If required, refer to Pinion Gear Depth to select the proper thickness shim before installing rear pinion bearing.

(7) Place the proper thickness depth shim on the pinion.

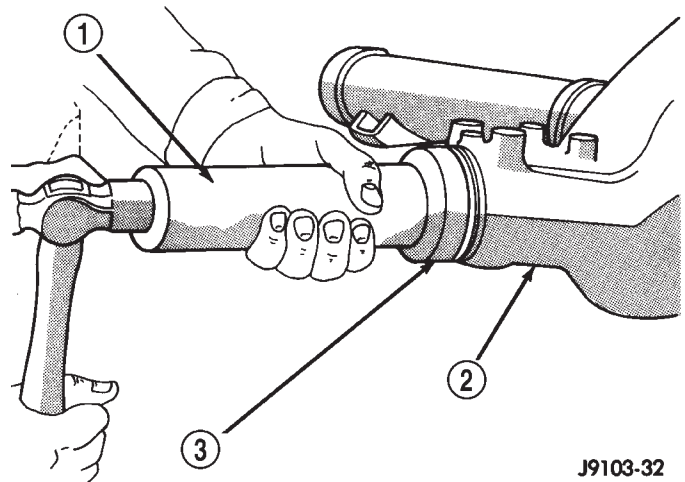

Fig. 32 Pinion Seal Installation J9103-32

- 1 - SPECIAL TOOL C-4735
- 2 - DIFFERENTIAL HOUSING
- 3 - SPECIAL TOOL C-4076-A

(8) Install the rear bearing and slinger, if equipped, on the pinion (Fig. 33) with Installer 6448.

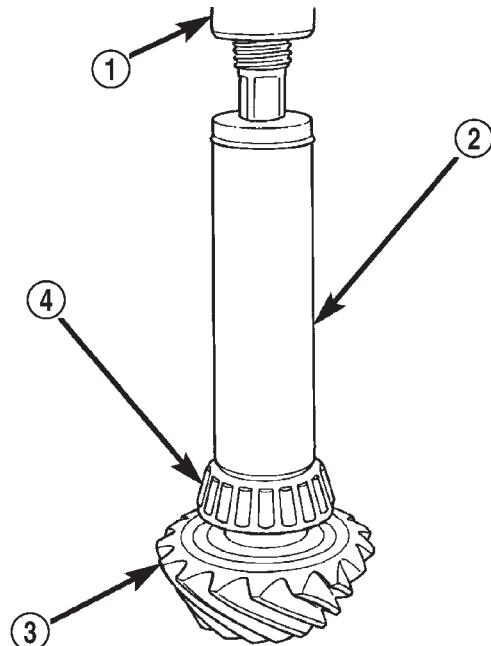

Fig. 33 Shaft Rear Bearing Installation 80be4607

- 1 - PRESS
- 2 - INSTALLATION TOOL
- 3 - DRIVE PINION
- 4 - DRIVE PINION SHAFT REAR BEARING

(9) Install a new collapsible preload spacer on pinion shaft and install pinion in housing (Fig. 34).

(10) Install pinion in housing.

(11) Install yoke with Installer C-3718 and Yoke Holder 6719.

(12) Install the yoke washer and a new nut on the pinion and tighten the pinion nut until there is zero

REMOVAL AND INSTALLATION (Continued)

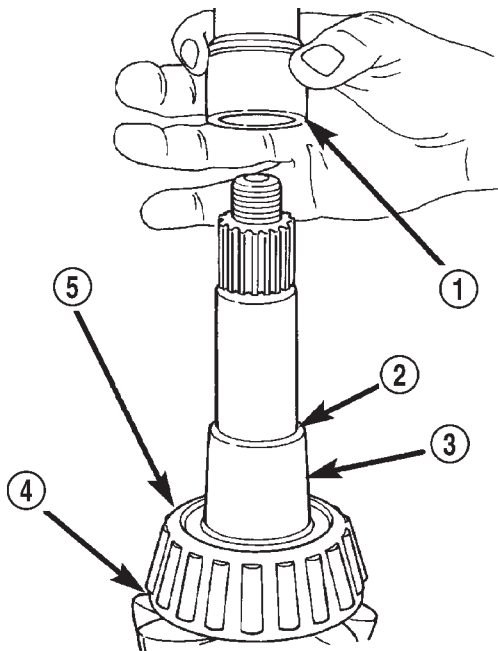

80be4606

Fig. 34 Collapsible Preload Spacer

- 1 - COLLAPSIBLE SPACER
- 2 - SHOULDER
- 3 - PINION
- 4 - PINION DEPTH SHIM
- 5 - REAR BEARING

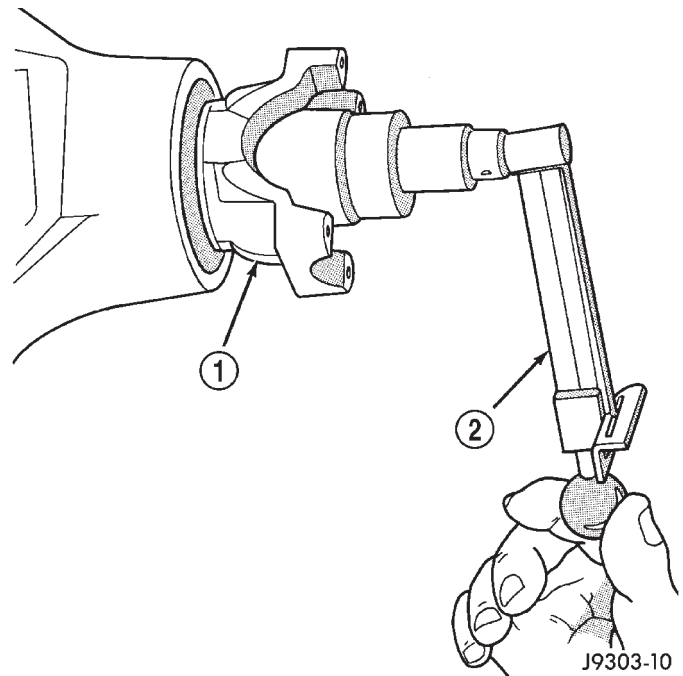

J9303-10

Fig. 35 Check Pinion Rotating Torque

- 1 - PINION YOKE
- 2 - INCH POUND TORQUE WRENCH

bearing end-play. It will not be possible at this point to achieve zero bearing end-play if a new collapsible spacer was installed.

(13) Tighten the nut to 285 N·m (210 ft. lbs.).

CAUTION: Never loosen pinion nut to decrease pinion bearing rotating torque and never exceed specified preload torque. If preload torque or rotating torque is exceeded a new collapsible spacer must be installed. The torque sequence will then have to be repeated.

(14) Using Yoke Holder 6719, crush collapsible spacer until bearing end play is taken up.

(15) Slowly tighten the nut in 6.8 N·m (5 ft. lbs.) increments until the desired rotating torque is achieved. Measure the rotating torque frequently to avoid over crushing the collapsible spacer (Fig. 35).

(16) Check bearing rotating torque with an inch pound torque wrench (Fig. 35). The torque necessary to rotate the pinion gear should be:

- Original Bearings — 1 to 2 N·m (10 to 20 in. lbs.).
- New Bearings — 1 to 5 N·m (10 to 30 in. lbs.).

(17) Install propeller shaft.

(18) Install differential in housing.

DISASSEMBLY AND ASSEMBLY

STANDARD DIFFERENTIAL

DISASSEMBLY

- (1) Remove pinion mate shaft lock screw (Fig. 36).
- (2) Remove pinion mate shaft.
- (3) Rotate the differential side gears and remove the differential pinion gears and thrust washers (Fig. 37).

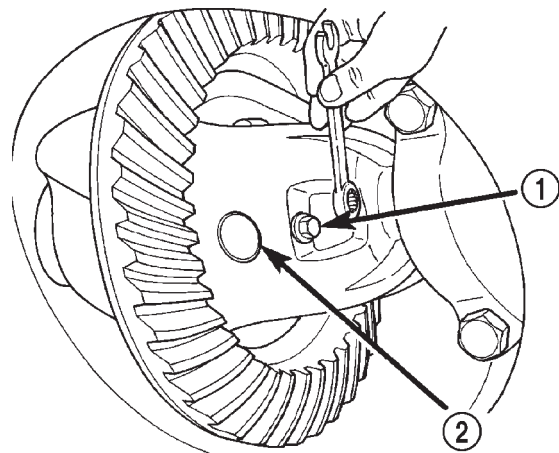

80be4604

Fig. 36 Pinion Mate Shaft Lock Screw

- 1 - LOCK SCREW
- 2 - PINION MATE SHAFT

(4) Remove the differential side gears and thrust washers.

DISASSEMBLY AND ASSEMBLY (Continued)

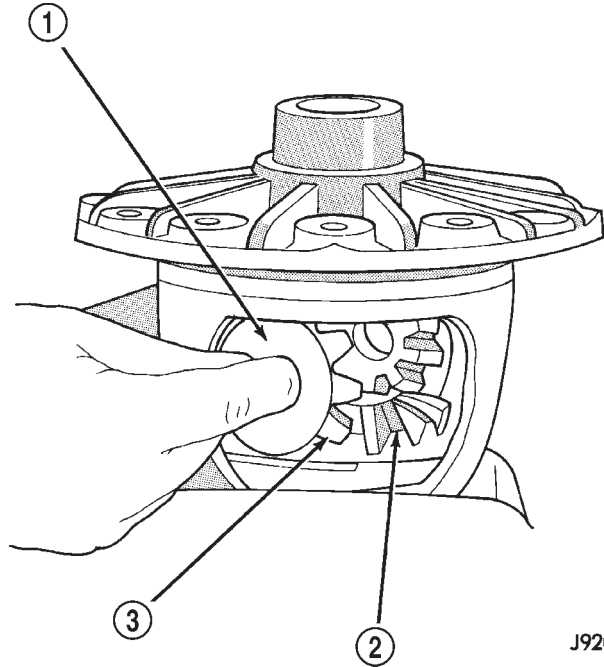

J9203-61

Fig. 37 Pinion Mate Gear Removal

- 1 - THRUST WASHER
- 2 - SIDE GEAR
- 3 - PINION MATE GEAR

ASSEMBLY

- (1) Install the differential side gears and thrust washers.
- (2) Install the differential pinion gears and thrust washers.
- (3) Install the pinion mate shaft.
- (4) Align the hole in the pinion mate shaft with the hole in the differential case and install the pinion mate shaft lock screw.
- (5) Lubricate all differential components with hypoid gear lubricant.

TRAC-LOK™ DIFFERENTIAL

The Trac-*lok*™ differential components are illustrated in (Fig. 38). Refer to this illustration during repair service.

DISASSEMBLY

- (1) Clamp Side Gear Holding Tool 8138 in a vise.
- (2) Position the differential case on Side Gear Holding Tool 8138 (Fig. 39).
- (3) Remove ring gear, if necessary. Ring gear removal is necessary only if the ring gear is to be replaced. The Trac-*lok*™ differential can be serviced with the ring gear installed.

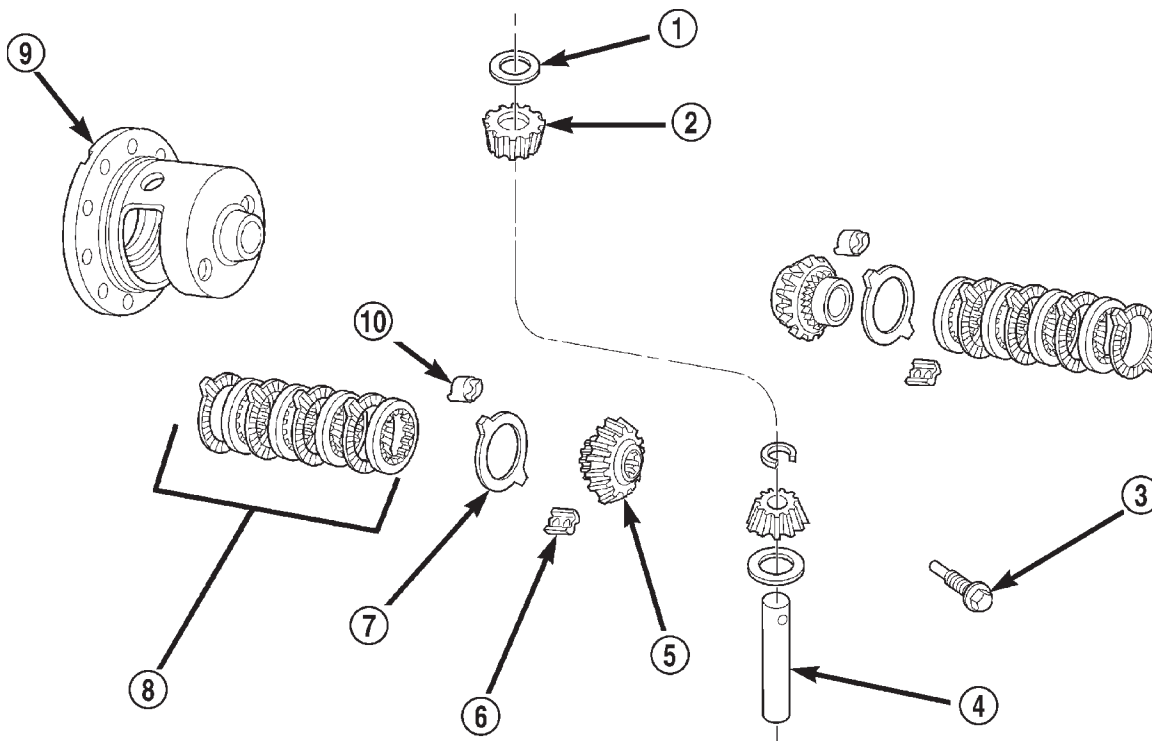

Fig. 38 Trac-*lok*™ Differential Components

80a77404

- | | |
|---|---|
| <ul style="list-style-type: none"> 1 - THRUST WASHER 2 - PINION 3 - SHAFT LOCK SCREW 4 - PINION MATE SHAFT 5 - SIDE GEAR | <ul style="list-style-type: none"> 6 - RETAINER 7 - DISC 8 - CLUTCH PACK 9 - DIFFERENTIAL CASE 10 - RETAINER |
|---|---|

DISASSEMBLY AND ASSEMBLY (Continued)

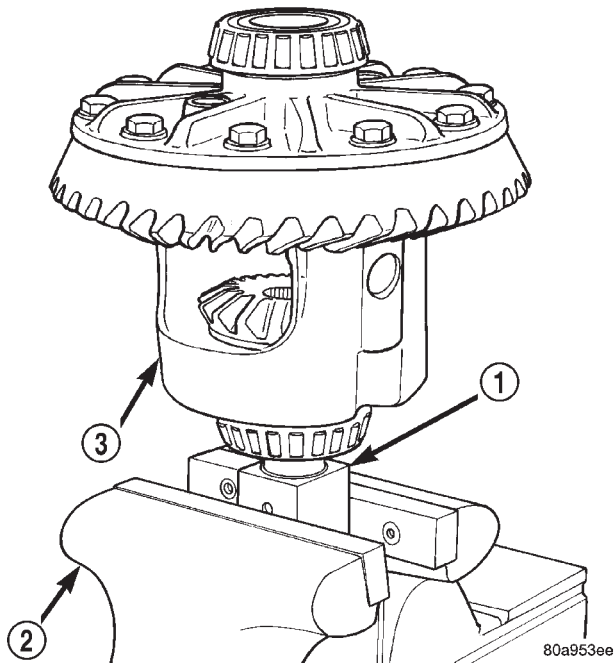

Fig. 39 Differential Case Holding Tool

- 1 - SIDE GEAR HOLDING TOOL
- 2 - VISE
- 3 - DIFFERENTIAL

(4) Remove the pinion mate shaft lock screw (Fig. 40).

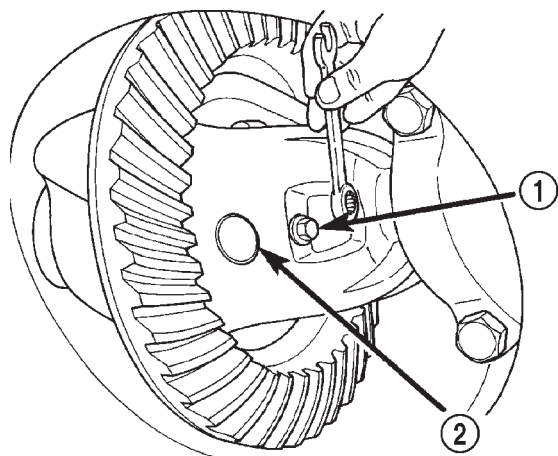

Fig. 40 Mate Shaft Lock Screw

- 1 - LOCK SCREW
- 2 - PINION MATE SHAFT

(5) Remove the pinion mate shaft. If necessary, use a drift and hammer (Fig. 41).

(6) Install and lubricate Step Plate 8140-2 (Fig. 42).

(7) Assemble Threaded Adapter 8140-1 into top side gear. Thread Forcing Screw 6960-4 into adapter until it becomes centered in adapter plate.

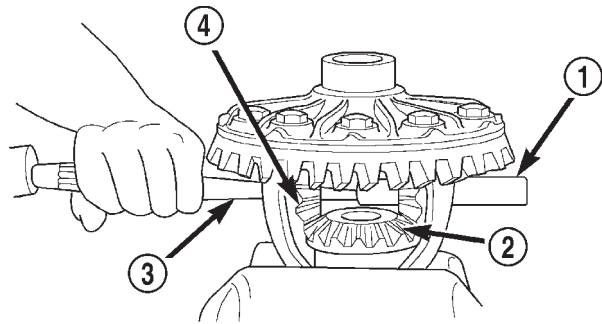

Fig. 41 Mate Shaft Removal

- 1 - PINION MATE SHAFT
- 2 - SIDE GEAR
- 3 - DRIFT
- 4 - PINION MATE GEAR

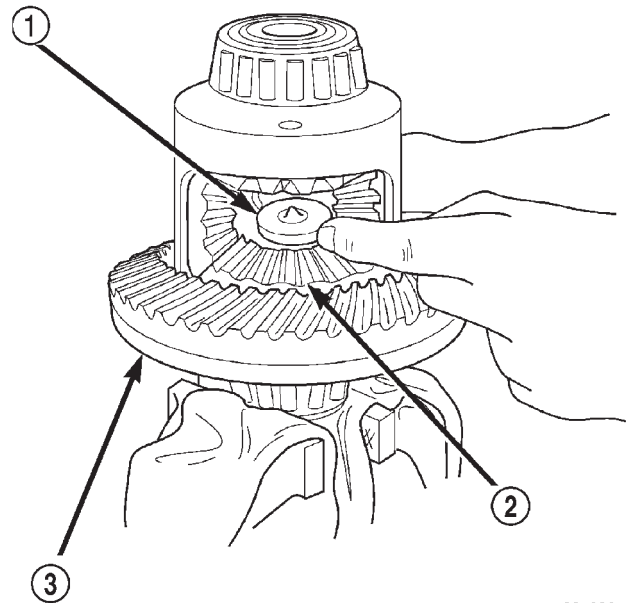

Fig. 42 Step Plate Tool Installation

- 1 - SPECIAL TOOL 8140-2
- 2 - LOWER SIDE GEAR
- 3 - DIFFERENTIAL CASE

(8) Position a small screw driver in slot of Threaded Adapter 8140-1 (Fig. 43) to prevent adapter from turning.

(9) Tighten forcing screw tool 122 N·m (90 ft. lbs.) maximum to compress Belleville springs in clutch packs (Fig. 44).

(10) Using an appropriate size feeler gauge, remove thrust washers from behind the differential pinions (Fig. 45).

(11) Insert Turning Bar 6960-2 in case (Fig. 46).

DISASSEMBLY AND ASSEMBLY (Continued)

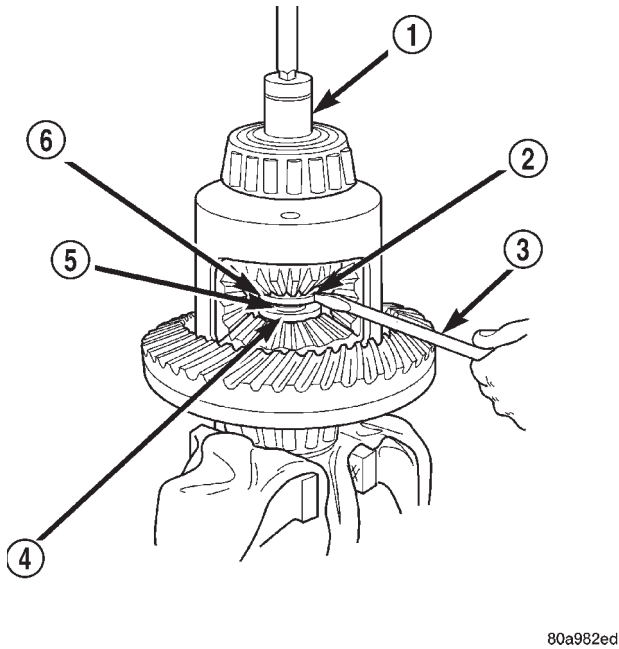

80a982ed

Fig. 43 Threaded Adapter Installation

- 1 - SOCKET
- 2 - SLOT IN ADAPTER
- 3 - SCREWDRIVER
- 4 - DISC 8140-2
- 5 - THREADED ROD C-6960-4
- 6 - THREADED ADAPTER DISC 8140-1

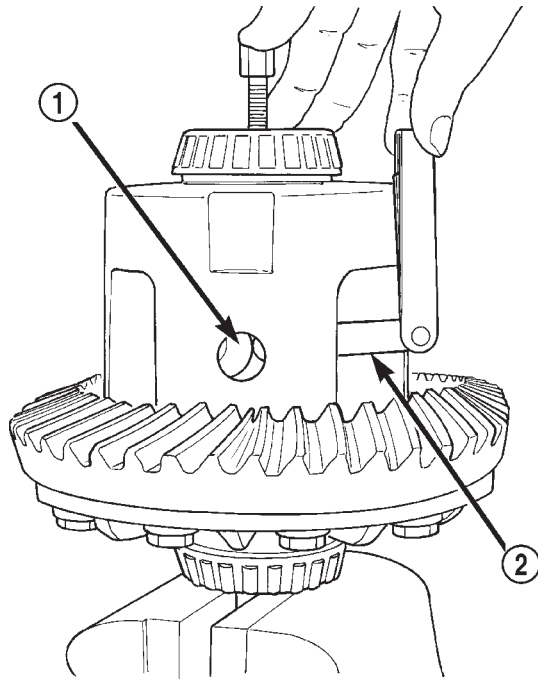

80a77406

Fig. 45 Remove Pinion Thrust Washer

- 1 - THRUST WASHER
- 2 - FEELER GAUGE

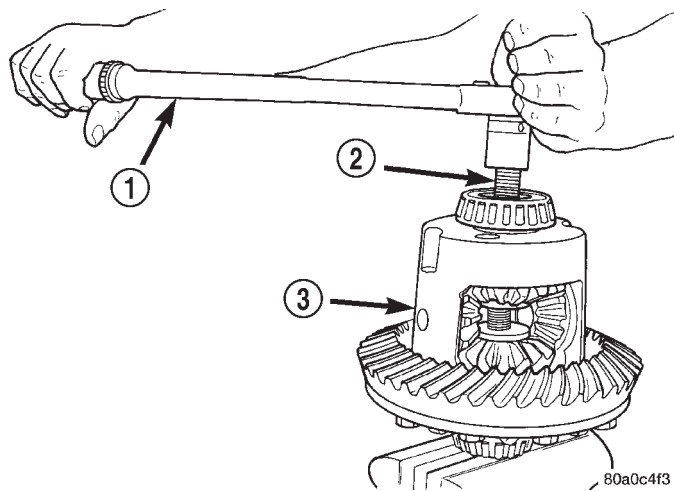

80a0c4f3

Fig. 44 Tighten Belleville Spring Compressor Tool

- 1 - TORQUE WRENCH
- 2 - TOOL ASSEMBLED
- 3 - DIFFERENTIAL CASE

(12) Loosen the Forcing Screw 6960-4 in small increments until the clutch pack tension is relieved and the differential case can be turned using Turning Bar 6960-2.

(13) Rotate differential case until the differential pinions can be removed.

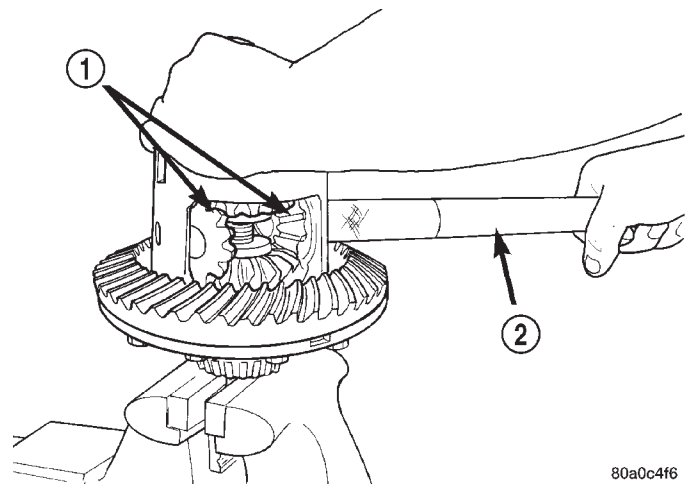

80a0c4f6

Fig. 46 Pinion Gear Removal

- 1 - PINION GEARS
- 2 - TOOL

(15) Remove Forcing Screw 6960-4, Step Plate 8140-2, and Threaded Adapter 8140-1.

(16) Remove top side gear, clutch pack retainer, and clutch pack. Keep plates in correct order during removal (Fig. 47).

(17) Remove differential case from Side Gear Holding Tool 8138. Remove side gear, clutch pack retainer,

DISASSEMBLY AND ASSEMBLY (Continued)

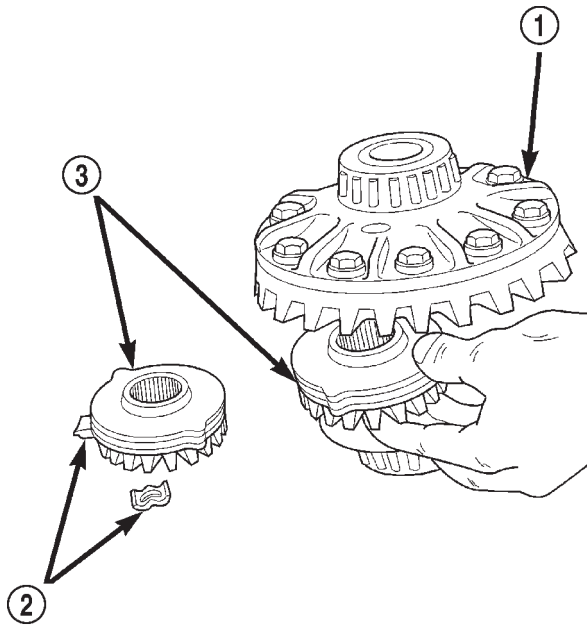

80a98382

Fig. 47 Side Gear & Clutch Disc Removal

- 1 - DIFFERENTIAL CASE
- 2 - RETAINER
- 3 - SIDE GEAR AND CLUTCH DISC PACK

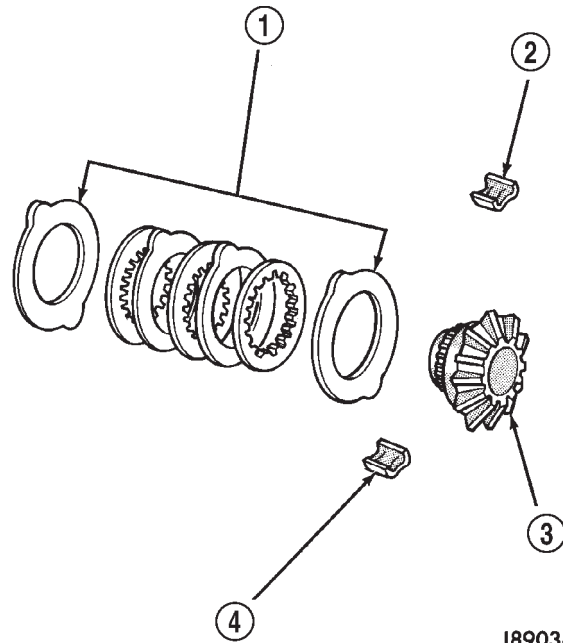

J8903-50

Fig. 48 Clutch Disc Pack

- 1 - CLUTCH PACK
- 2 - RETAINER
- 3 - SIDE GEAR
- 4 - RETAINER

and clutch pack. Keep plates in correct order during removal.

ASSEMBLY

NOTE: The clutch discs are replaceable as complete sets only. If one clutch disc pack is damaged, both packs must be replaced.

Lubricate each component with gear lubricant before assembly.

(1) Assemble the clutch discs into packs and secure disc packs with retaining clips (Fig. 48).

(2) Position assembled clutch disc packs on the side gear hubs.

(3) Install clutch pack and side gear in the ring gear side of the differential case (Fig. 49). **Be sure clutch pack retaining clips remain in position and are seated in the case pockets.**

(4) Position the differential case on Side Gear Holding Tool 8138.

(5) Install lubricated Step Plate 8140-2 in lower side gear (Fig. 50).

(6) Install the upper side gear and clutch disc pack (Fig. 50).

(7) Hold assembly in position. Insert Threaded Adapter 8140-1 into top side gear.

(8) Insert Forcing Screw 6960-4.

(9) Tighten forcing screw tool to slightly compress clutch discs.

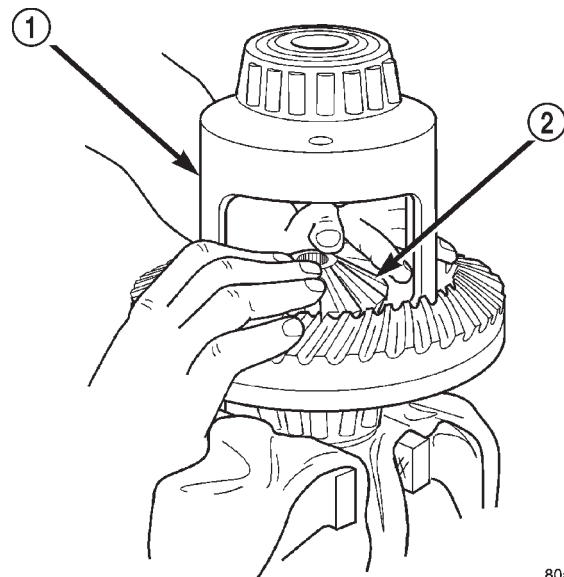

80a7739c

Fig. 49 Clutch Discs & Lower Side Gear Installation

- 1 - DIFFERENTIAL CASE
- 2 - LOWER SIDE GEAR AND CLUTCH DISC PACK

(10) Place differential pinions in position in side gears and verify that the pinion mate shaft holes are aligned.

(11) Rotate case with Turning Bar 6960-2 until the pinion mate shaft holes in the differential pinions align with holes in case. It may be necessary to

DISASSEMBLY AND ASSEMBLY (Continued)

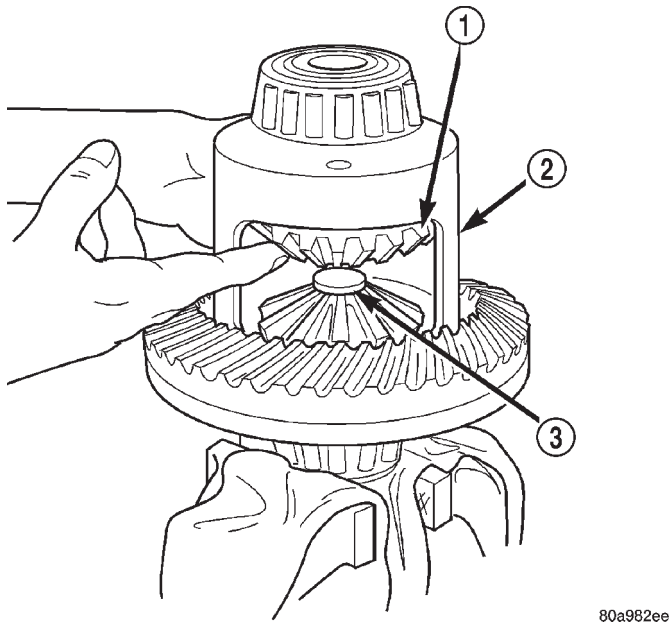

Fig. 50 Upper Side Gear & Clutch Disc Pack Installation

- 1 - UPPER SIDE GEAR AND CLUTCH DISC PACK
 2 - DIFFERENTIAL CASE
 3 - SPECIAL TOOL 8140-2

slightly tighten the forcing screw in order to install the pinions.

(12) Tighten forcing screw to 122 N·m (90 ft. lbs.) maximum to compress the Belleville springs.

(13) Lubricate and install thrust washers behind pinions and align washers with a small screw driver. Insert mate shaft into each pinion to verify alignment.

(14) Remove Forcing Screw 6960-4, Step Plate 8140-2, and Threaded Adapter 8140-1.

(15) Install pinion mate shaft and align holes in shaft and case.

(16) Install the pinion mate shaft lock screw finger tight to hold shaft during differential installation.

(17) Lubricate all differential components with hypoid gear lubricant.

CLEANING AND INSPECTION

8 1/4 AXLE

Wash differential components with cleaning solvent and dry with dry compressed air. **Do not steam clean the differential components.**

Wash bearings with solvent and towel dry, or dry with compressed air. **DO NOT** spin bearings with compressed air. **Cup and bearing must be replaced as matched sets only.**

Be sure that the axle tubes and oil channels are thoroughly cleaned in the housing.

Inspect for:

- Smooth appearance with no broken/dented surfaces on the bearing rollers or the roller contact surfaces.
- Bearing cups must not be distorted or cracked.
- Machined surfaces should be smooth and without any raised edges.
- Raised metal on shoulders of cup bores should be removed with a hand stone.
- Wear and damage to pinion mate shaft, pinions, side gears and thrust washers. Replace as a matched set only.
- Ring gear and pinion for worn and chipped teeth.
- Ring gear for damaged bolt threads. Replaced as a matched set only.
- Pinion yoke for cracks, worn splines, pitted areas, and a rough/corroded seal contact surface. Repair or replace as necessary.
- Pinion depth shims for damage and distortion. Install new shims if necessary.
- The differential case. Replace the case if cracked or damaged.

• The axle shaft C-locks for cracks and excessive wear. Replace them if necessary.

• Each threaded adjuster to determine if it rotates freely. If an adjuster binds, repair the damaged threads or replace the adjuster.

Polish each axle shaft sealing surface with No. 600 crocus cloth. This can remove slight surface damage. Do not reduce the diameter of the axle shaft seal contact surface. When polishing, the crocus cloth should be moved around the circumference of the shaft (not in-line with the shaft).

TRAC-LOK™

Clean all components in cleaning solvent. Dry components with compressed air. Inspect clutch pack plates for wear, scoring or damage. Replace both clutch packs if any one component in either pack is damaged. Inspect side gears and pinions. Replace any gear that is worn, cracked, chipped or damaged. Inspect differential case and pinion shaft. Replace if worn or damaged.

PRESOAK PLATES AND DISC

Plates and discs with fiber coating (no grooves or lines) must be presoaked in Friction Modifier before assembly. Soak plates and discs for a minimum of 20 minutes.

ADJUSTMENTS

8 1/4 AXLE PINION GEAR DEPTH

GENERAL INFORMATION

Ring gears and pinions are supplied as matched sets only. The identifying numbers for the ring gear and pinion are etched into the face of each gear (Fig. 51). A plus (+) number, minus (-) number or zero (0) is etched into the face of the pinion. This number is the amount (in thousandths of an inch) the depth varies from the standard depth setting of a pinion etched with a (0). The standard depth provides the best gear tooth contact pattern. Refer to Backlash and Contact Pattern Analysis paragraph in this section for additional information.

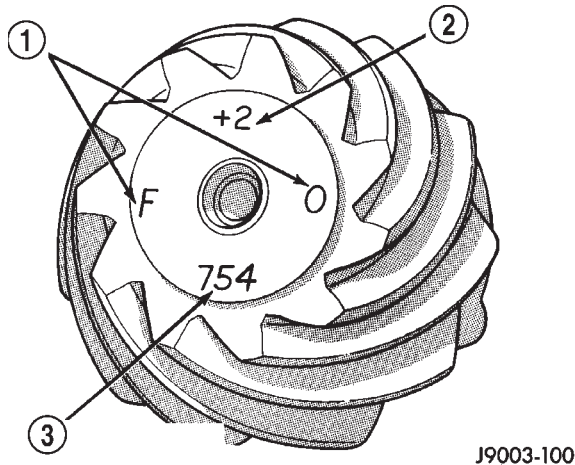

Fig. 51 Pinion Gear ID Numbers

- 1 - PRODUCTION NUMBERS
- 2 - DRIVE PINION GEAR DEPTH VARIANCE
- 3 - GEAR MATCHING NUMBER (SAME AS RING GEAR NUMBER)

Compensation for pinion depth variance is achieved with select shims. The shims are placed behind the rear pinion bearing (Fig. 52).

If a new gear set is being installed, note the depth variance etched into both the original and replacement pinion. Add or subtract the thickness of the original depth shims to compensate for the difference in the depth variances. Refer to the Depth Variance chart.

Note where Old and New Pinion Marking columns intersect. Intersecting figure represents plus or minus the amount needed.

Note the etched number on the face of the pinion gear head (-1, -2, 0, +1, +2, etc.). The numbers represent thousands of an inch deviation from the standard. If the number is negative, add that value to the required thickness of the depth shims. If the number is positive, subtract that value from the thickness of

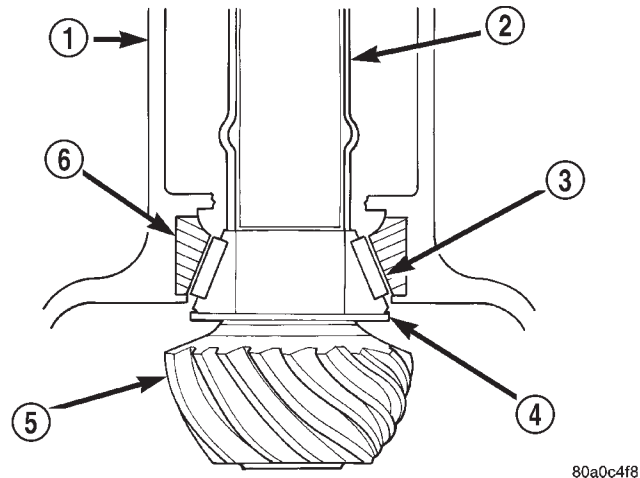

80a0c4f8

Fig. 52 Shim Locations

- 1 - AXLE HOUSING
- 2 - COLLAPSIBLE SPACER
- 3 - PINION BEARING
- 4 - PINION DEPTH SHIM
- 5 - PINION GEAR
- 6 - BEARING CUP

the depth shim. If the number is 0 no change is necessary.

PINION DEPTH MEASUREMENT AND ADJUSTMENT

Measurements are taken with pinion bearing cups and pinion bearings installed in the axle housing. Take measurements with Pinion Gauge Set and Dial Indicator C-3339 (Fig. 53).

(1) Assemble Pinion Height Block 6739, Pinion Block 8540, and rear pinion bearing onto Screw 6741 (Fig. 53).

(2) Insert assembled height gauge components, rear bearing, and screw into axle housing through pinion bearing cups (Fig. 54).

(3) Install front pinion bearing and Cone-Nut 6740 hand tight (Fig. 53).

(4) Place Arbor Disc 8541 on Arbor D-115-3 in position in axle housing side bearing cradles (Fig. 55). Install differential bearing caps on Arbor Discs and tighten cap bolts to 41 N·m (30 ft. lbs.).

NOTE: Arbor Discs 8541 has different step diameters to fit other axles. Choose proper step for axle being serviced.

(5) Assemble Dial Indicator C-3339 into Scooter Block D-115-2 and secure set screw.

(6) Place Scooter Block/Dial Indicator in position in axle housing so dial probe and scooter block are flush against the rearward surface of the pinion height block (Fig. 53). Hold scooter block in place and zero the dial indicator face to the pointer. Tighten dial indicator face lock screw.

ADJUSTMENTS (Continued)

PINION GEAR DEPTH VARIANCE

| Original Pinion Gear Depth Variance | Replacement Pinion Gear Depth Variance | | | | | | | | |
|-------------------------------------|--|--------|--------|--------|--------|--------|--------|--------|--------|
| | -4 | -3 | -2 | -1 | 0 | +1 | +2 | +3 | +4 |
| +4 | +0.008 | +0.007 | +0.006 | +0.005 | +0.004 | +0.003 | +0.002 | +0.001 | 0 |
| +3 | +0.007 | +0.006 | +0.005 | +0.004 | +0.003 | +0.002 | +0.001 | 0 | -0.001 |
| +2 | +0.006 | +0.005 | +0.004 | +0.003 | +0.002 | +0.001 | 0 | -0.001 | -0.002 |
| +1 | +0.005 | +0.004 | +0.003 | +0.002 | +0.001 | 0 | -0.001 | -0.002 | -0.003 |
| 0 | +0.004 | +0.003 | +0.002 | +0.001 | 0 | -0.001 | -0.002 | -0.003 | -0.004 |
| -1 | +0.003 | +0.002 | +0.001 | 0 | -0.001 | -0.002 | -0.003 | -0.004 | -0.005 |
| -2 | +0.002 | +0.001 | 0 | -0.001 | -0.002 | -0.003 | -0.004 | -0.005 | -0.006 |
| -3 | +0.001 | 0 | -0.001 | -0.002 | -0.003 | -0.004 | -0.005 | -0.006 | -0.007 |
| -4 | 0 | -0.001 | -0.002 | -0.003 | -0.004 | -0.005 | -0.006 | -0.007 | -0.008 |

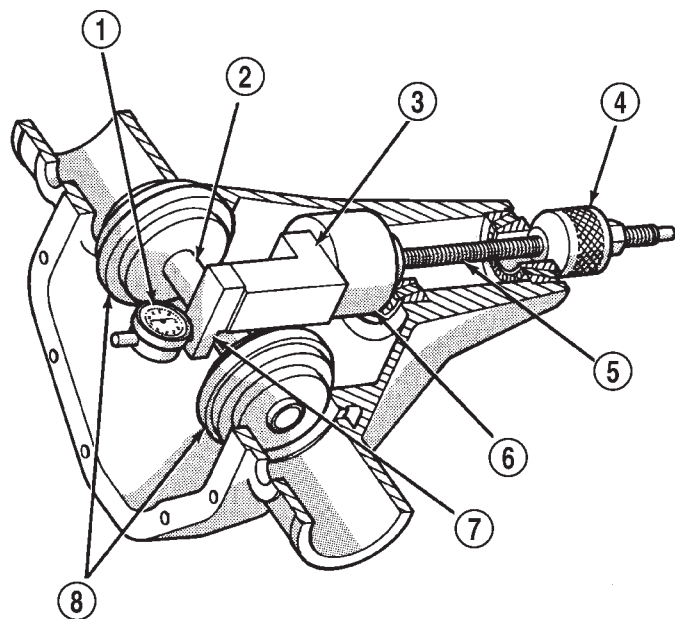

J9403-45

Fig. 53 Pinion Gear Depth Gauge Tools—Typical

- 1 - DIAL INDICATOR
- 2 - ARBOR
- 3 - PINION HEIGHT BLOCK
- 4 - CONE
- 5 - SCREW
- 6 - PINION BLOCK
- 7 - SCOOTER BLOCK
- 8 - ARBOR DISC

(7) With scooter block still in position against the pinion height block, slowly slide the dial indicator probe over the edge of the pinion height block.

(8) Slide the dial indicator probe across the gap between the pinion height block and the arbor bar with the scooter block against the pinion height block (Fig. 56). When the dial probe contacts the arbor bar, the dial pointer will turn clockwise. Bring dial

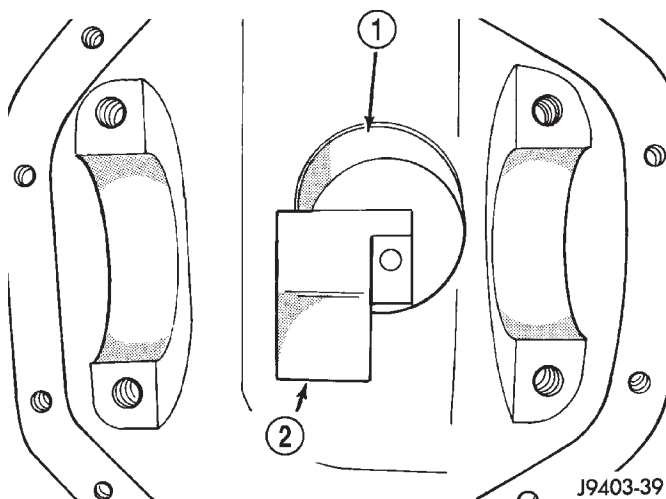

Fig. 54 Pinion Height Block—Typical

- 1 - PINION BLOCK
- 2 - PINION HEIGHT BLOCK

pointer back to zero against the arbor bar, do not turn dial face. Continue moving the dial probe to the crest of the arbor bar and record the highest reading. If the dial indicator can not achieve the zero reading, the rear bearing cup or the pinion depth gauge set is not installed correctly.

(9) Select a shim equal to the dial indicator reading plus the drive pinion gear depth variance etched in the face of the pinion (Fig. 51). For example, if the depth variance is -2, add +0.002 in. to the dial indicator reading.

DIFFERENTIAL BEARING PRELOAD AND GEAR BACKLASH

The following must be considered when adjusting bearing preload and gear backlash:

- The maximum ring gear backlash variation is 0.003 inch (0.076 mm).

ADJUSTMENTS (Continued)

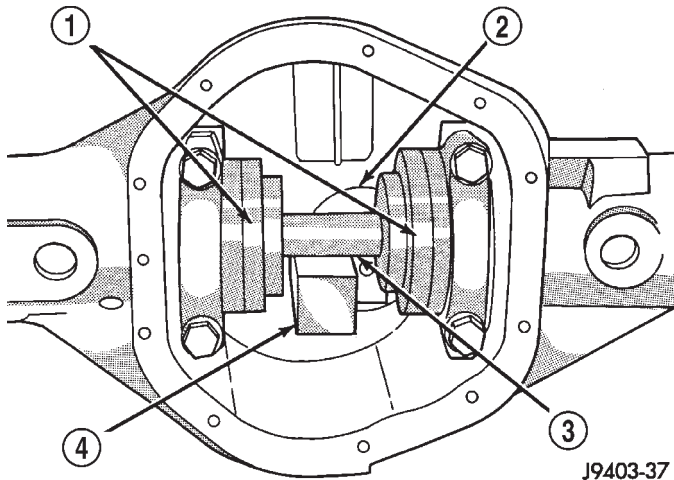

J9403-37

Fig. 55 Gauge Tools In Housing—Typical

- 1 - ARBOR DISC
- 2 - PINION BLOCK
- 3 - ARBOR
- 4 - PINION HEIGHT BLOCK

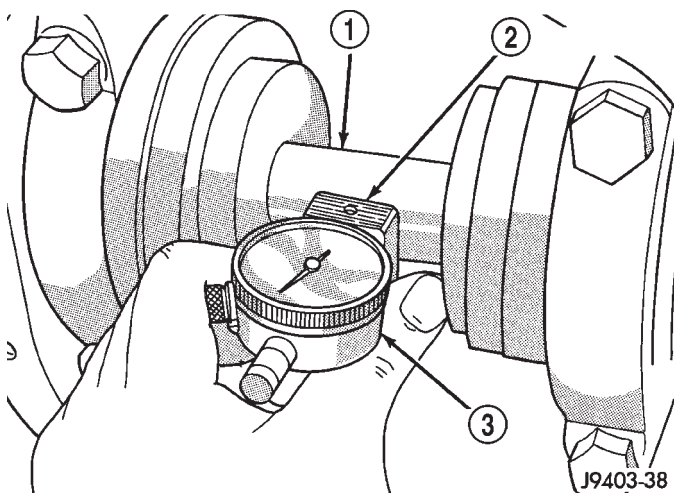

J9403-38

Fig. 56 Pinion Gear Depth Measurement—Typical

- 1 - ARBOR
- 2 - SCOOTER BLOCK
- 3 - DIAL INDICATOR

- Mark the gears so the same teeth are meshed during all backlash measurements.
- Maintain the torque while adjusting the bearing preload and ring gear backlash.
- Excessive adjuster torque will introduce a high bearing load and cause premature bearing failure. Insufficient adjuster torque can result in excessive differential case free-play and ring gear noise.
- Insufficient adjuster torque will not support the ring gear correctly and can cause excessive differential case free-play and ring gear noise.

NOTE: The differential bearing cups will not always immediately follow the threaded adjusters as they are moved during adjustment. To ensure accurate bearing cup responses to the adjustments:

- Maintain the gear teeth engaged (meshed) as marked.
- The bearings must be seated by rapidly rotating the pinion gear a half turn back and forth.
- Do this five to ten times each time the threaded adjusters are adjusted.

(1) Use Wrench C-4164 to adjust each threaded adjuster inward until the differential bearing free-play is eliminated (Fig. 57). Allow some ring gear backlash (approximately 0.01 inch/0.25 mm) between the ring and pinion gear. Seat the bearing cups with the procedure described above.

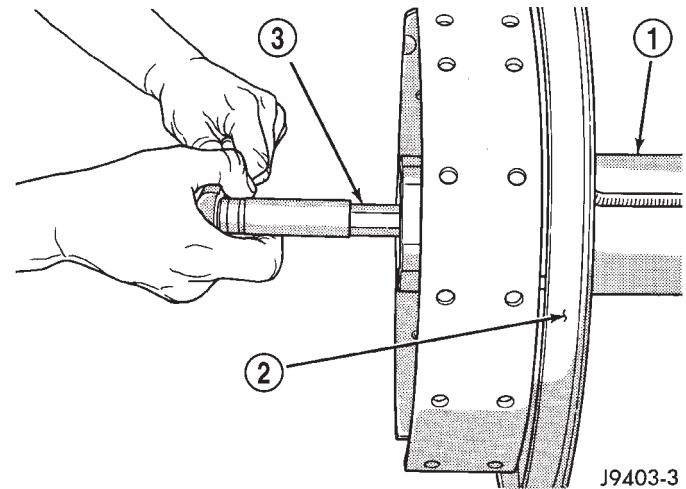

J9403-3

Fig. 57 Threaded Adjuster Tool

- 1 - AXLE TUBE
- 2 - BACKING PLATE
- 3 - TOOL C-4164

(2) Install dial indicator and position the plunger against the drive side of a ring gear tooth (Fig. 58). Measure the backlash at 4 positions (90 degrees apart) around the ring gear. Locate and mark the area of minimum backlash.

(3) Rotate the ring gear to the position of the least backlash. Mark the gear so that all future backlash measurements will be taken with the same gear teeth meshed.

(4) Loosen the right-side, tighten the left-side threaded adjuster. Obtain backlash of 0.003 to 0.004 inch (0.076 to 0.102 mm) with each adjuster tightened to 14 N·m (10 ft. lbs.). Seat the bearing cups with the procedure described above.

(5) Tighten the differential bearing cap bolts 95 N·m (70 ft. lbs.).

(6) Tighten the right-side threaded adjuster to 102 N·m (75 ft. lbs.). Seat the bearing cups with the pro-

ADJUSTMENTS (Continued)

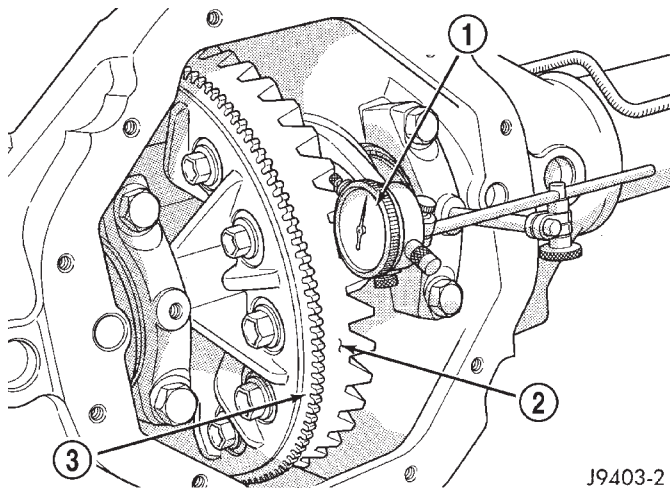

Fig. 58 Ring Gear Backlash Measurement

- 1 - DIAL INDICATOR
2 - RING GEAR
3 - EXCITER RING

cedure described above. Continue to tighten the right-side adjuster and seat bearing cups until the torque remains constant at 102 N·m (75 ft. lbs.)

(7) Measure the ring gear backlash. The range of backlash is 0.006 to 0.008 inch (0.15 to 0.203 mm).

(8) Continue increasing the torque at the right-side threaded adjuster until the specified backlash is obtained.

NOTE: The left-side threaded adjuster torque should have approximately 102 N·m (75 ft. lbs.). If the torque is considerably less, the complete adjustment procedure must be repeated.

(9) Tighten the left-side threaded adjuster until 102 N·m (75 ft. lbs.) torque is indicated. Seat the bearing rollers with the procedure described above. Do this until the torque remains constant.

(10) Install the threaded adjuster locks and tighten the lock screws to 10 N·m (90 in. lbs.).

After the proper backlash is achieved, perform the Gear Contact Analysis procedure.

GEAR CONTACT PATTERN ANALYSIS

The ring gear and pinion teeth contact patterns will show if the pinion depth is correct in the axle housing. It will also show if the ring gear backlash has been adjusted correctly. The backlash can be adjusted within specifications to achieve desired tooth contact patterns.

(1) Apply a thin coat of hydrated ferric oxide, or equivalent, to the drive and coast side of the ring gear teeth.

(2) Wrap, twist, and hold a shop towel around the pinion yoke to increase the turning resistance of the

pinion. This will provide a more distinct contact pattern.

(3) Using a boxed end wrench on a ring gear bolt, Rotate the differential case one complete revolution in both directions while a load is being applied from shop towel.

The areas on the ring gear teeth with the greatest degree of contact against the pinion teeth will squeeze the compound to the areas with the least amount of contact. Note and compare patterns on the ring gear teeth to Gear Tooth Contact Patterns chart (Fig. 59) and adjust pinion depth and gear backlash as necessary.

SIDE GEAR CLEARANCE

When measuring side gear clearance, check each gear independently. If it necessary to replace a side gear, replace both gears as a matched set.

(1) Install the axle shafts and C-locks and pinion mate shaft.

(2) Measure each side gear clearance. Insert a matched pair of feeler gauge blades between the gear and differential housing on opposite sides of the hub (Fig. 60).

(3) If side gear clearances is no more than 0.005 inch. Determine if the axle shaft is contacting the pinion mate shaft. **Do not remove the feeler gauges, inspect the axle shaft with the feeler gauge inserted behind the side gear.** If the end of the axle shaft is not contacting the pinion mate shaft, the side gear clearance is acceptable.

(4) If clearance is more than 0.005 inch (axle shaft not contacting mate shaft), record the side gear clearance. Remove the thrust washer and measure its thickness with a micrometer. Add the washer thickness to the recorded side gear clearance. The sum of gear clearance and washer thickness will determine required thickness of replacement thrust washer (Fig. 61).

In some cases, the end of the axle shaft will move and contact the mate shaft when the feeler gauge is inserted. The C-lock is preventing the side gear from sliding on the axle shaft.

(5) If there is no side gear clearance, remove the C-lock from the axle shaft. Use a micrometer to measure the thrust washer thickness. Record the thickness and re-install the thrust washer. Assemble the differential case without the C-lock installed and re-measure the side gear clearance.

(6) Compare both clearance measurements. If the difference is less than 0.012 inch (0.305 mm), add clearance recorded when the C-lock was installed to thrust washer thickness measured. The sum will determine the required thickness of the replacement thrust washer.

ADJUSTMENTS (Continued)

| <p>DRIVE SIDE OF RING GEAR TEETH</p> <p>HEEL TOE</p>  | <p>COAST SIDE OF RING GEAR TEETH</p> <p>TOE HEEL</p>  | <p>DESIRABLE CONTACT PATTERN. PATTERN SHOULD BE CENTERED ON THE DRIVE SIDE OF TOOTH. PATTERN SHOULD BE CENTERED ON THE COAST SIDE OF TOOTH, BUT MAY BE SLIGHTLY TOWARD THE TOE. THERE SHOULD ALWAYS BE SOME CLEARANCE BETWEEN CONTACT PATTERN AND TOP OF THE TOOTH.</p> |
|--|--|---|
|  |  | <p>RING GEAR BACKLASH CORRECT. THINNER PINION GEAR DEPTH SHIM REQUIRED.</p> |
|  |  | <p>RING GEAR BACKLASH CORRECT. THICKER PINION GEAR DEPTH SHIM REQUIRED.</p> |
|  |  | <p>PINION GEAR DEPTH SHIM CORRECT. DECREASE RING GEAR BACKLASH.</p> |
|  |  | <p>PINION GEAR DEPTH SHIM CORRECT. INCREASE RING GEAR BACKLASH.</p> |

Fig. 59 Gear Tooth Contact Patterns

ADJUSTMENTS (Continued)

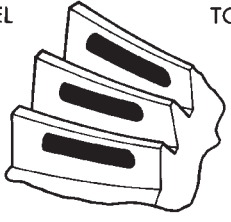
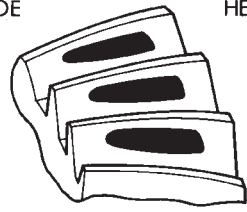
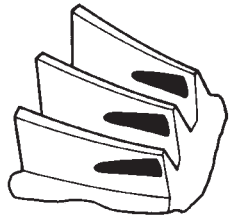
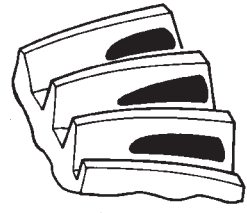
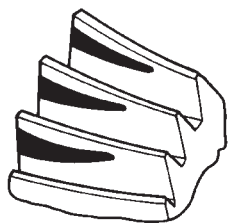
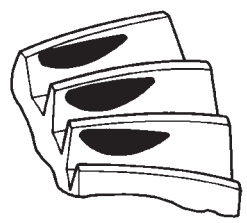
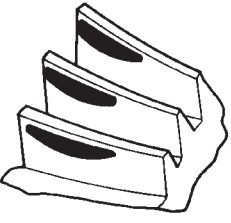
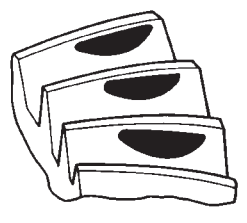
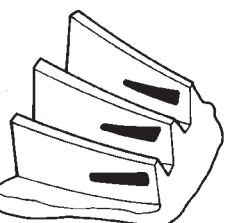
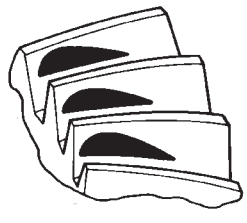
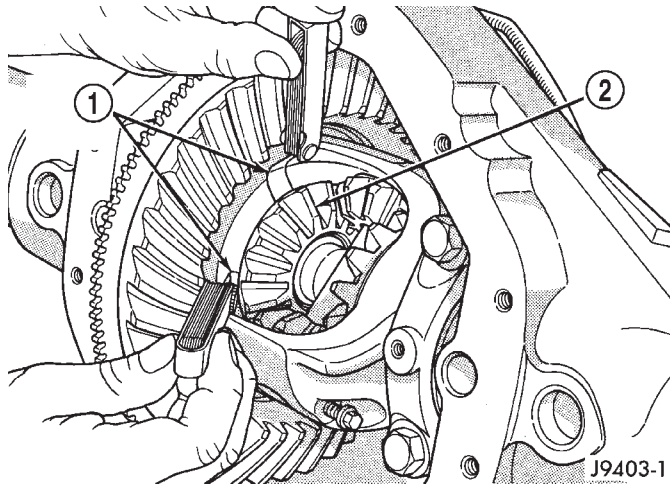

Fig. 60 Side Gear Clearance Measurement

- 1 - FEELER GAUGE BLADES
- 2 - SIDE GEAR

| | |
|------------------------------|----------|
| SIDE GEAR CLEARANCE | 0.007 |
| THRUST WASHER THICKNESS | +0.033 |
| TOTAL | 0.040 |
| | |
| REPLACEMENT WASHER THICKNESS | 0.040 |
| NEW SIDE GEAR CLEARANCE | -0.037 |
| | 0.003 |
| | J9203-31 |

Fig. 61 Side Gear Calculations

(7) If clearance is 0.012 inch (0.305 mm) or greater, both side gears must be replaced (matched set) and the clearance measurements repeated.

(8) If clearance (above) continues to be 0.012 inch (0.305 mm) or greater, the case must be replaced.

SPECIFICATIONS

8 1/4 INCH AXLE

- Axle Type Semi-floating, hypoid
- Lubricant SAE 80W-90
- Lube Capacity 2.08 L (4.4 pts.)
- Trac-Lok Additive 118 ml (4 oz.)
- Axle Ratio 3.07, 3.55, 4.10

Differential

- Case Clearance 0.12 mm (0.005 in.)
- Case Flange Runout 0.076 mm (0.003 in.)

Ring Gear

- Diameter 20.95 cm (8.25 in.)
- Backlash 0.12-0.20 mm (0.005-0.008 in.)
- Runout 0.127 mm (0.005 in.)

Pinion Bearing

- Preload-Used Bearings 1-2 N·m (10-20 in.lbs.)
- Preload-New Bearings 1-5 N·m (10-30 in.lbs.)

8 1/4 INCH AXLE

DESCRIPTION

TORQUE

- Diff. Cover Bolt 41 N·m (30 ft. lbs.)
- Bearing Cap Bolt 136 N·m (100 ft. lbs.)
- Pinion Nut-Minimum 285 N·m (210 ft. lbs.)
- Ring Gear Bolt 95 N·m (70 ft. lbs.)
- Backing Plate Bolt 614 N·m (45 ft. lbs.)
- RWAL/ABS Sensor Bolt 24 N·m (18. ft. lbs.)

SPECIAL TOOLS

8 1/4 AXLES

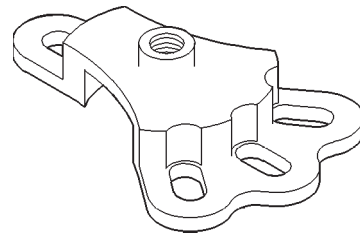

Puller, Hub—6790

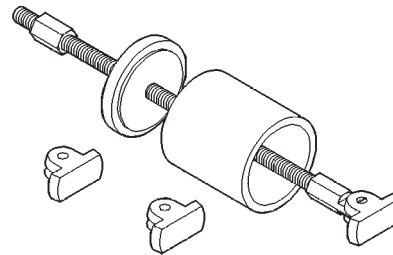

Remover, Bearing—6310

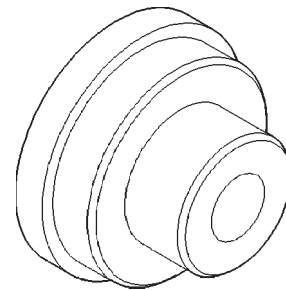

Installer—C-4198

SPECIAL TOOLS (Continued)

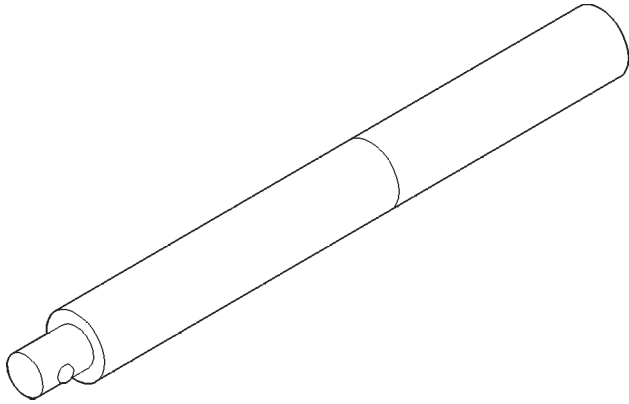

Handle—C-4171

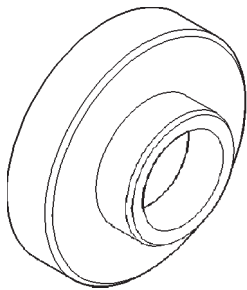

Installer—C-4076-B

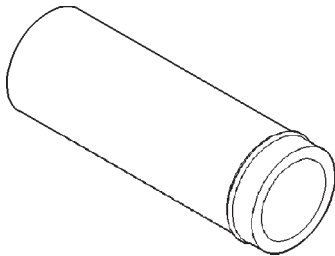

Handle—C-4735-1

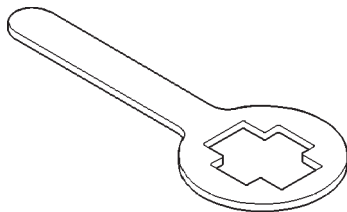

Holder—6719

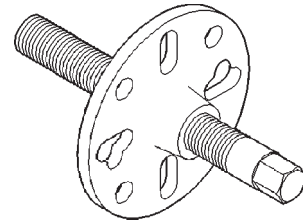

Puller—C-452

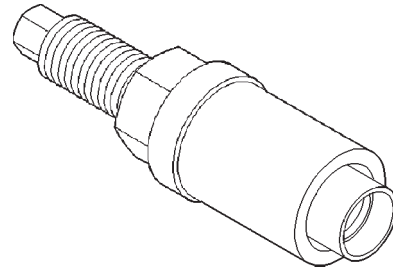

Installer—C-3718

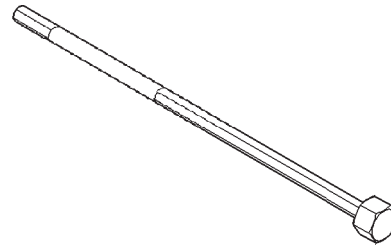

Adjustment Rod—C-4164

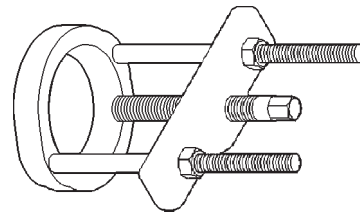

Puller/Press—C-293-PA

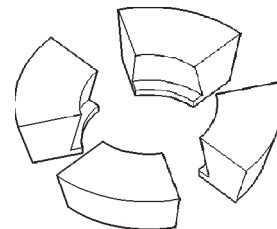

Adapters—C-293-48

SPECIAL TOOLS (Continued)

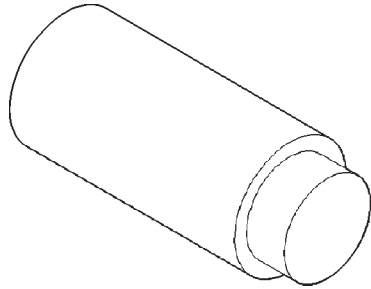

Plug—SP-3289

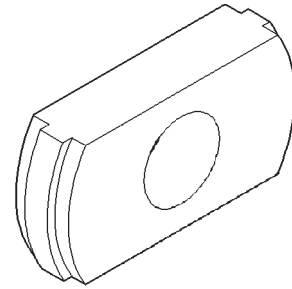

Installer—C-4345

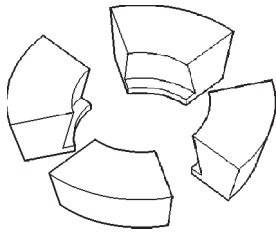

Adapters—C-293-47

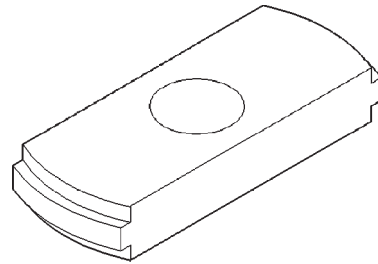

Remover—C-4307

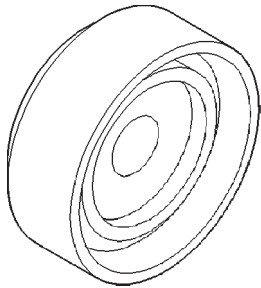

Installer—C-4340

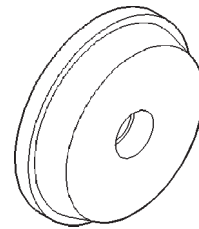

Installer—C-4308

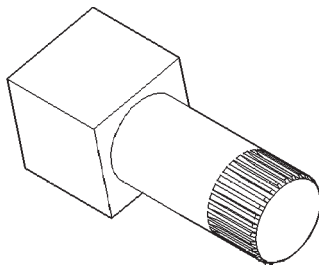

Holder—8138

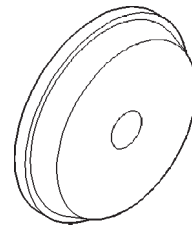

Installer—D-130

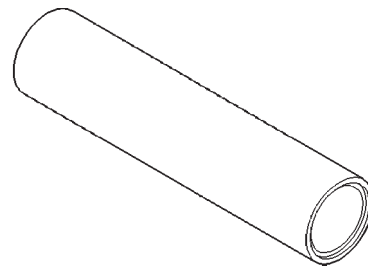

Installer—6448

SPECIAL TOOLS (Continued)

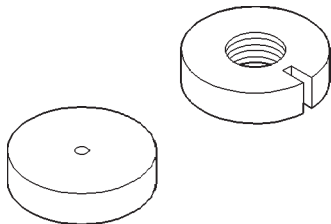

Trac-lok™ Tools—8140

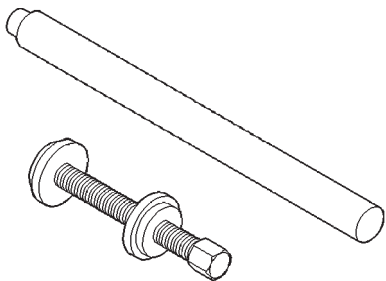

Trac-lok™ Tools—6960

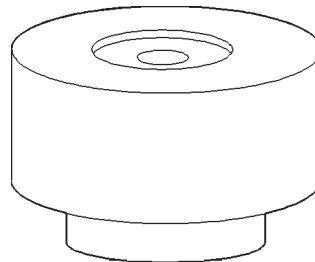

Pinion Gauge Block—8540

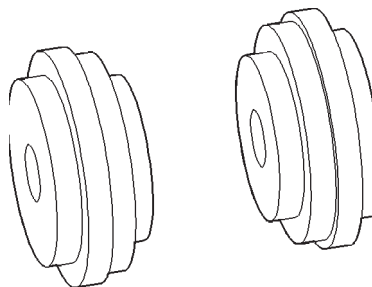

Arbor Discs—8541

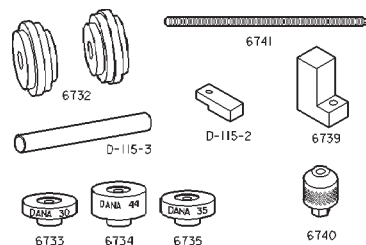

Pinion Gauge Set

BRAKES

TABLE OF CONTENTS

| | page | | page |
|-------------------------|------|-----------------------|------|
| BASE BRAKE SYSTEM | 1 | ANTILOCK BRAKES | 33 |

BASE BRAKE SYSTEM

TABLE OF CONTENTS

| | page | | page |
|-------------------------------------|------|-------------------------------------|------|
| DESCRIPTION AND OPERATION | | | |
| BRAKE SYSTEM | 2 | BRAKE PEDAL | 15 |
| SERVICE WARNINGS & CAUTIONS | 2 | COMBINATION VALVE | 16 |
| BRAKE PEDAL | 2 | MASTER CYLINDER | 16 |
| BRAKE LAMP SWITCH | 2 | POWER BRAKE BOOSTER | 17 |
| RED BRAKE WARNING LAMP | 3 | FRONT DISC BRAKE CALIPER | 18 |
| POWER BRAKE BOOSTER | 3 | FRONT DISC BRAKE SHOES | 20 |
| MASTER CYLINDER | 3 | DISC BRAKE ROTOR | 21 |
| COMBINATION VALVE | 3 | DRUM BRAKE SHOES | 21 |
| FRONT DISC BRAKES | 4 | WHEEL CYLINDER | 21 |
| REAR DRUM BRAKE | 5 | BRAKE SUPPORT PLATE | 22 |
| PARKING BRAKE | 5 | REAR PARKING BRAKE CABLES | 23 |
| BRAKE HOSES AND LINES | 7 | PARKING BRAKE LEVER | 23 |
| DIAGNOSIS AND TESTING | | | |
| BASE BRAKE SYSTEM | 7 | DISASSEMBLY AND ASSEMBLY | |
| BRAKE LAMP SWITCH | 9 | MASTER CYLINDER RESERVOIR | 24 |
| RED BRAKE WARNING LAMP | 9 | DISC BRAKE CALIPER | 25 |
| MASTER CYLINDER/POWER BOOSTER | 10 | WHEEL CYLINDER | 28 |
| COMBINATION VALVE | 11 | CLEANING AND INSPECTION | |
| DISC BRAKE ROTOR | 11 | CALIPER | 28 |
| BRAKE DRUM | 11 | REAR DRUM BRAKE | 29 |
| BRAKE LINE AND HOSES | 12 | WHEEL CYLINDER | 29 |
| BRAKE FLUID CONTAMINATION | 12 | ADJUSTMENTS | |
| SERVICE PROCEDURES | | | |
| BRAKE FLUID LEVEL | 12 | BRAKE LAMP SWITCH | 30 |
| MASTER CYLINDER BLEEDING | 12 | REAR DRUM BRAKE | 30 |
| BASE BRAKE BLEEDING | 13 | PARKING BRAKE CABLE TENSIONER | 31 |
| DISC ROTOR MACHINING | 13 | SPECIFICATIONS | |
| BRAKE DRUM MACHINING | 14 | BRAKE FLUID | 31 |
| BRAKE TUBE FLARING | 14 | BRAKE COMPONENTS | 32 |
| REMOVAL AND INSTALLATION | | | |
| BRAKE LAMP SWITCH | 15 | TORQUE CHART | 32 |
| | | SPECIAL TOOLS | |
| | | BASE BRAKES | 32 |

DESCRIPTION AND OPERATION

BRAKE SYSTEM

DESCRIPTION

Power assist front disc and rear drum brakes are standard equipment. Disc brake components consist of single piston calipers and ventilated rotors. Rear drum brakes are dual shoe units with cast brake drums.

The parking brake mechanism is lever and cable operated. The cables are attached to levers on the rear drum brake secondary shoes. The parking brakes are operated by a hand lever.

A dual diaphragm vacuum power brake booster is used for all applications. All models have an aluminum master cylinder with plastic reservoir.

All models are equipped with a combination valve. The valve contains a pressure differential valve and switch and a fixed rate rear proportioning valve.

Factory brake lining on all models consists of an organic base material combined with metallic particles. The original equipment linings do not contain asbestos.

SERVICE WARNINGS & CAUTIONS

DESCRIPTION

WARNING: DUST AND DIRT ACCUMULATING ON BRAKE PARTS DURING NORMAL USE MAY CONTAIN ASBESTOS FIBERS FROM AFTERMARKET LININGS. BREATHING EXCESSIVE CONCENTRATIONS OF ASBESTOS FIBERS CAN CAUSE SERIOUS BODILY HARM. EXERCISE CARE WHEN SERVICING BRAKE PARTS. DO NOT CLEAN BRAKE PARTS WITH COMPRESSED AIR OR BY DRY BRUSHING. USE A VACUUM CLEANER SPECIFICALLY DESIGNED FOR THE REMOVAL OF ASBESTOS FIBERS FROM BRAKE COMPONENTS. IF A SUITABLE VACUUM CLEANER IS NOT AVAILABLE, CLEANING SHOULD BE DONE WITH A WATER DAMPENED CLOTH. DO NOT SAND, OR GRIND BRAKE LINING UNLESS EQUIPMENT USED IS DESIGNED TO CONTAIN THE DUST RESIDUE. DISPOSE OF ALL RESIDUE CONTAINING ASBESTOS FIBERS IN SEALED BAGS OR CONTAINERS TO MINIMIZE EXPOSURE TO YOURSELF AND OTHERS. FOLLOW PRACTICES PRESCRIBED BY THE OCCUPATIONAL SAFETY AND HEALTH ADMINISTRATION AND THE ENVIRONMENTAL PROTECTION AGENCY FOR THE HANDLING, PROCESSING, AND DISPOSITION OF DUST OR DEBRIS THAT MAY CONTAIN ASBESTOS FIBERS.

CAUTION: Never use gasoline, kerosene, alcohol, motor oil, transmission fluid, or any fluid containing mineral oil to clean the system components. These fluids damage rubber cups and seals. Use only fresh brake fluid or Mopar brake cleaner to clean or flush brake system components. These are the only cleaning materials recommended. If system contamination is suspected, check the fluid for dirt, discoloration, or separation into distinct layers. Also check the reservoir cap seal for distortion. Drain and flush the system with new brake fluid if contamination is suspected.

CAUTION: Use Mopar brake fluid, or an equivalent quality fluid meeting SAE/DOT standards J1703 and DOT 3. Brake fluid must be clean and free of contaminants. Use fresh fluid from sealed containers only to ensure proper antilock component operation.

CAUTION: Use Mopar multi-mileage or high temperature grease to lubricate caliper slide surfaces, drum brake pivot pins, and shoe contact points on the backing plates. Use multi-mileage grease or GE 661 or Dow 111 silicone grease on caliper slide pins to ensure proper operation.

BRAKE PEDAL

DESCRIPTION

A suspended-type brake pedal is used, the pedal pivots on a shaft mounted in the pedal support bracket. The bracket is attached to the dash panel and steering support bracket. The unit is serviced as an assembly, except for the pedal pad.

OPERATION

The brake pedal is attached to the booster push rod. When the pedal is depressed, the primary booster push rod is depressed which move the booster secondary rod. The booster secondary rod depress the master cylinder piston.

BRAKE LAMP SWITCH

DESCRIPTION

The plunger type brake lamp switch is mounted on a bracket attached to the brake pedal support. The switch can be adjusted when necessary.

OPERATION

The brake lamp switch is used to for the brake lamp, speed control and brake sensor circuits.

DESCRIPTION AND OPERATION (Continued)

RED BRAKE WARNING LAMP**DESCRIPTION**

A red warning lamp is used for the service brake portion of the hydraulic system. The lamp is located in the instrument cluster.

OPERATION

The red warning light alerts the driver if a pressure differential exists between the front and rear hydraulic systems or the parking brakes are applied. The lamp is turned on momentarily when the ignition switch is turned to the on position. This is a self test to verify the lamp is operational.

POWER BRAKE BOOSTER**DESCRIPTION**

The booster assembly consists of a housing divided into separate chambers by two internal diaphragms. The outer edge of each diaphragm is attached to the booster housing. The diaphragms are connected to the booster primary push rod.

Two push rods are used in the booster. The primary push rod connects the booster to the brake pedal. The secondary push rod connects the booster to the master cylinder to stroke the cylinder pistons.

OPERATION

The atmospheric inlet valve is opened and closed by the primary push rod. Booster vacuum supply is through a hose attached to an intake manifold fitting at one end and to the booster check valve at the other. The vacuum check valve in the booster housing is a one-way device that prevents vacuum leak back.

Power assist is generated by utilizing the pressure differential between normal atmospheric pressure and a vacuum. The vacuum needed for booster operation is taken directly from the engine intake manifold. The entry point for atmospheric pressure is through a filter and inlet valve at the rear of the housing (Fig. 1).

The chamber areas forward of the booster diaphragms are exposed to vacuum from the intake manifold. The chamber areas to the rear of the diaphragms, are exposed to normal atmospheric pressure of 101.3 kilopascals (14.7 pounds/square in.).

Brake pedal application causes the primary push rod to open the atmospheric inlet valve. This exposes the area behind the diaphragms to atmospheric pressure. The resulting pressure differential provides the extra apply force for power assist.

The booster check valve, check valve grommet and booster seals are serviceable.

MASTER CYLINDER**DESCRIPTION**

The master cylinder has a removable nylon reservoir. The cylinder body is made of aluminum and contains a primary and secondary piston assembly. The cylinder body including the piston assemblies are not serviceable. If diagnosis indicates an internal problem with the cylinder body, it must be replaced as an assembly. The reservoir and grommets are the only replaceable parts on the master cylinder.

OPERATION

The master cylinder bore contains a primary and secondary piston. The primary piston supplies hydraulic pressure to the front brakes. The secondary piston supplies hydraulic pressure to the rear brakes. The master cylinder reservoir stores reserve brake fluid for the hydraulic brake circuits.

COMBINATION VALVE**DESCRIPTION**

The combination valve contains a pressure differential valve and switch and a rear brake proportioning valve. The valve is not repairable and must be replaced as an assembly if diagnosis indicates this is necessary.

OPERATION**PRESSURE DIFFERENTIAL VALVE**

The pressure differential switch is connected to the brake warning light. The switch is actuated by movement of the switch valve. The switch monitors fluid pressure in the separate front/rear brake hydraulic circuits.

A decrease or loss of fluid pressure in either hydraulic circuit will cause the switch valve to shuttle to the low pressure side. Movement of the valve pushes the switch plunger upward. This action closes the switch internal contacts completing the electrical circuit to the red warning light. The switch valve will remain in an actuated position until repairs to the brake system are made.

PROPORTIONING VALVE

The proportioning valve is used to balance front-rear brake action at high decelerations. The valve allows normal fluid flow during moderate braking. The valve only controls fluid flow during high decelerations brake stops.

DESCRIPTION AND OPERATION (Continued)

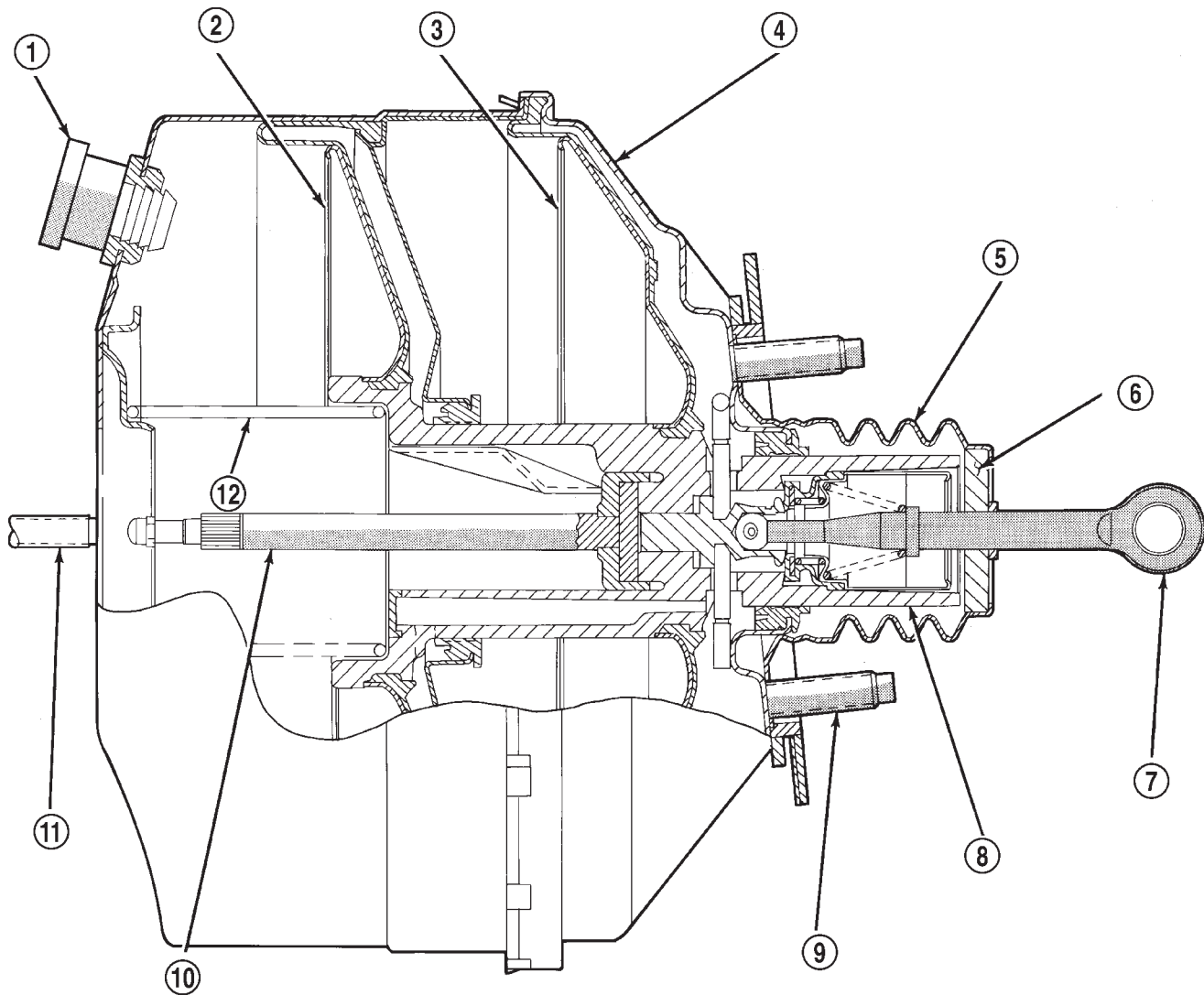

J9505-58

Fig. 1 Power Brake Booster—Typical

- | | |
|------------------------|--|
| 1 - VACUUM CHECK VALVE | 7 - PRIMARY PUSH ROD (TO BRAKE PEDAL) |
| 2 - FRONT DIAPHRAGM | 8 - ATMOSPHERIC INLET VALVE ASSEMBLY |
| 3 - REAR DIAPHRAGM | 9 - BOOSTER MOUNTING STUDS (4) |
| 4 - HOUSING | 10 - SECONDARY PUSH ROD (TO MASTER CYLINDER) |
| 5 - SEAL | 11 - MASTER CYLINDER MOUNTING STUD (2) |
| 6 - AIR FILTER | 12 - SPRING |

FRONT DISC BRAKES**DESCRIPTION**

The calipers are a single piston type. The calipers are free to slide laterally, this allows continuous compensation for lining wear.

OPERATION

When the brakes are applied fluid pressure is exerted against the caliper piston. The fluid pressure is exerted equally and in all directions. This means

pressure exerted against the caliper piston and within the caliper bore will be equal (Fig. 2).

Fluid pressure applied to the piston is transmitted directly to the inboard brake shoe. This forces the shoe lining against the inner surface of the disc brake rotor. At the same time, fluid pressure within the piston bore forces the caliper to slide inward on the mounting bolts. This action brings the outboard brake shoe lining into contact with the outer surface of the disc brake rotor.

DESCRIPTION AND OPERATION (Continued)

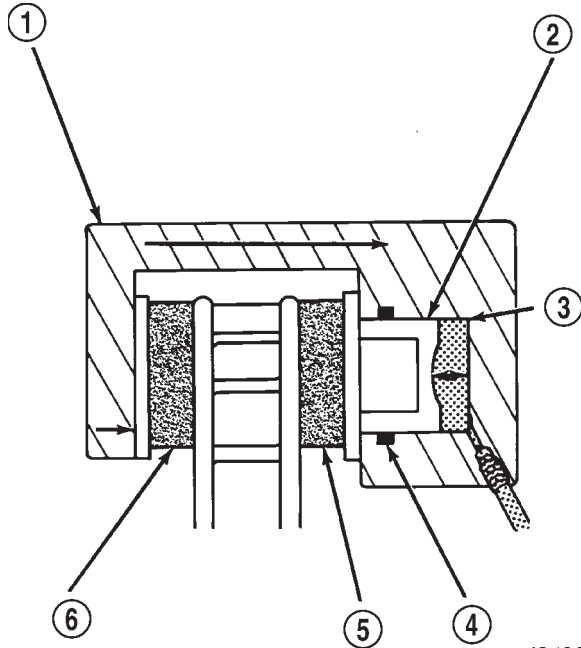

J9405-102

Fig. 2 Brake Caliper Operation

- 1 - CALIPER
- 2 - PISTON
- 3 - PISTON BORE
- 4 - SEAL
- 5 - INBOARD SHOE
- 6 - OUTBOARD SHOE

In summary, fluid pressure acting simultaneously on both piston and caliper, produces a strong clamping action. When sufficient force is applied, friction will attempt to stop the rotors from turning and bring the vehicle to a stop.

Application and release of the brake pedal generates only a very slight movement of the caliper and piston. Upon release of the pedal, the caliper and piston return to a rest position. The brake shoes do not retract an appreciable distance from the rotor. In fact, clearance is usually at, or close to zero. The reasons for this are to keep road debris from getting between the rotor and lining and in wiping the rotor surface clear each revolution.

The caliper piston seal controls the amount of piston extension needed to compensate for normal lining wear.

During brake application, the seal is deflected outward by fluid pressure and piston movement (Fig. 3). When the brakes (and fluid pressure) are released, the seal relaxes and retracts the piston.

The amount of piston retraction is determined by the amount of seal deflection. Generally the amount is just enough to maintain contact between the piston and inboard brake shoe.

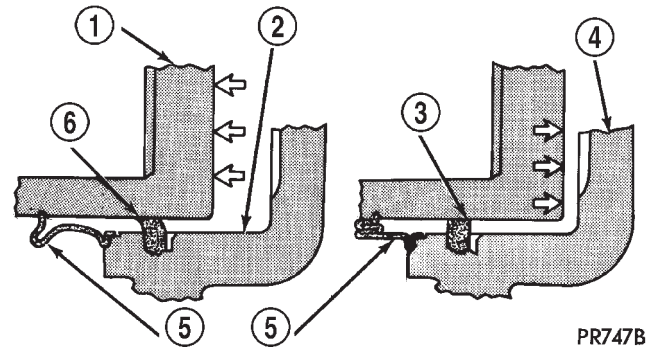

PR747B

Fig. 3 Lining Wear Compensation By Piston Seal

- 1 - PISTON
- 2 - CYLINDER BORE
- 3 - PISTON SEAL BRAKE PRESSURE OFF
- 4 - CALIPER HOUSING
- 5 - DUST BOOT
- 6 - PISTON SEAL BRAKE PRESSURE ON

REAR DRUM BRAKE**DESCRIPTION**

The rear brakes use a leading shoe (primary) and trailing shoe (secondary) design (Fig. 4).

OPERATION

When the brake pedal is depressed hydraulic pressure pushes the rear brake wheel cylinder pistons outward. The wheel cylinder push rods then push the brake shoes outward against the brake drum. When the brake pedal is released return springs attached to the brake shoes pull the shoes back to their original position.

PARKING BRAKE**DESCRIPTION**

The parking brake is a hand lever and cable operated system used to apply the rear brakes.

OPERATION

A hand operated lever in the passenger compartment is the main application device. The front cable is connected between the hand lever and the tensioner. The tensioner rod is attached to the equalizer which is the connecting point for the rear cables (Fig. 5).

The rear cables are connected to the actuating lever on each secondary brake shoe. The levers are attached to the brake shoes by a pin either pressed into, or welded to the lever. A clip is used to secure the pin in the brake shoe. The pin allows each lever to pivot independently of the brake shoe.

To apply the parking brakes, the hand lever is pulled upward. This pulls the rear brake shoe actu-

DESCRIPTION AND OPERATION (Continued)

**RIGHT REAR
BRAKE ASSEMBLY**

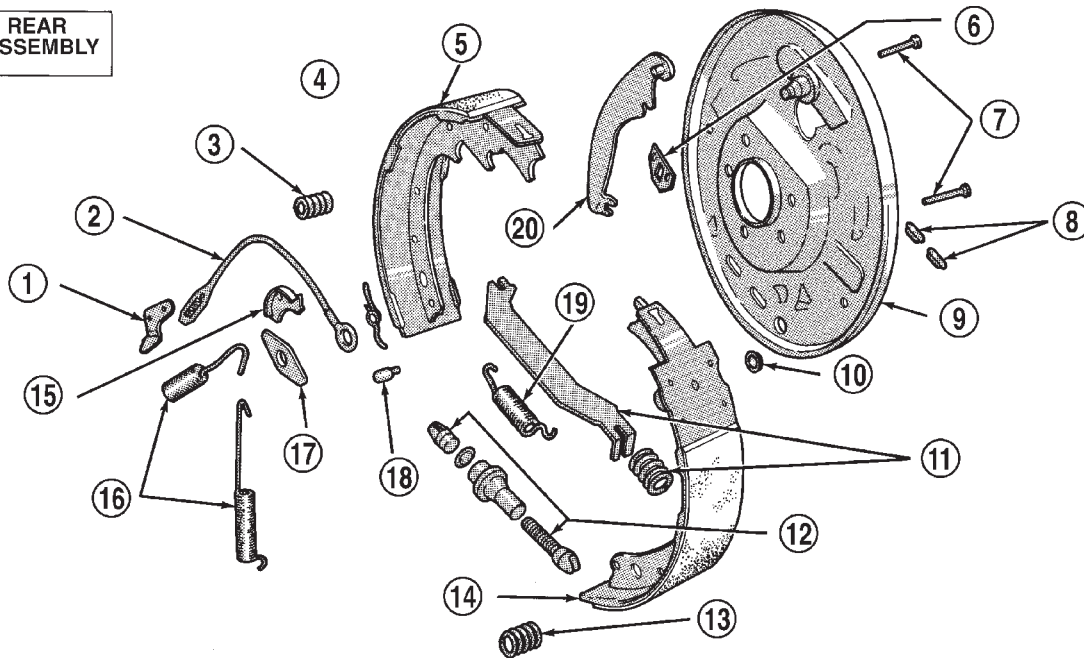

J9005-13

Fig. 4 Brake Components

- | | |
|-----------------------------------|------------------------------------|
| 1 - ADJUSTER LEVER | 11 - PARK BRAKE STRUT AND SPRING |
| 2 - ADJUSTER CABLE | 12 - ADJUSTER SCREW ASSEMBLY |
| 3 - HOLDDOWN SPRING AND RETAINERS | 13 - HOLDDOWN SPRING AND RETAINERS |
| 4 - ADJUSTER LEVER SPRING | 14 - LEADING SHOE |
| 5 - TRAILING SHOE | 15 - CABLE GUIDE |
| 6 - CYLINDER-TO-SUPPORT SEAL | 16 - SHOE RETURN SPRINGS |
| 7 - HOLDDOWN PINS | 17 - SHOE GUIDE PLATE |
| 8 - ACCESS PLUGS | 18 - PIN |
| 9 - SUPPORT PLATE | 19 - SHOE SPRING |
| 10 - CABLE HOLE PLUG | 20 - PARK BRAKE LEVER |

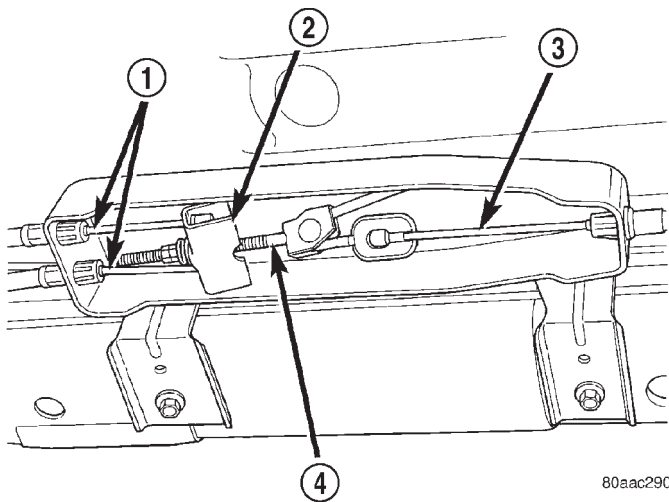

80aac29C

Fig. 5 Parking Brake Components

- | |
|-------------------|
| 1 - REAR CABLES |
| 2 - EQUALIZER |
| 3 - FRONT CABLE |
| 4 - TENSIONER ROD |

ating levers forward, by means tensioner and cables. As the actuating lever is pulled forward, the parking brake strut (which is connected to both shoes), exerts a linear force against the primary brake shoe. This action presses the primary shoe into contact with the drum. Once the primary shoe contacts the drum, force is exerted through the strut. This force is transferred through the strut to the secondary brake shoe causing it to pivot into the drum as well.

A gear type ratcheting mechanism is used to hold the lever in an applied position. Parking brake release is accomplished by the hand lever release button.

A parking brake switch is mounted on the parking brake lever and is actuated by movement of the lever. The switch, which is in circuit with the red warning light in the dash, will illuminate the warning light whenever the parking brakes are applied.

Parking brake adjustment is controlled by a cable tensioner mechanism. The cable tensioner, once adjusted at the factory, should not need further adjustment under normal circumstances. Adjustment

DESCRIPTION AND OPERATION (Continued)

may be required if a new tensioner, or cables are installed, or disconnected.

BRAKE HOSES AND LINES

DESCRIPTION

Flexible rubber hose is used at both front brakes and at the rear axle junction block. Double walled steel tubing is used to connect the master cylinder to the major hydraulic braking components and then to the flexible rubber hoses. Double inverted style and ISO style flares are used on the brake lines.

DIAGNOSIS AND TESTING

BASE BRAKE SYSTEM

Base brake components consist of the brake shoes, calipers, wheel cylinders, brake drums, rotors, brake lines, master cylinder, booster, and parking brake components.

Brake diagnosis involves determining if the problem is related to a mechanical, hydraulic, or vacuum operated component.

The first diagnosis step is the preliminary check.

PRELIMINARY BRAKE CHECK

(1) Check condition of tires and wheels. Damaged wheels and worn, damaged, or underinflated tires can cause pull, shudder, vibration, and a condition similar to grab.

(2) If complaint was based on noise when braking, check suspension components. Jounce front and rear of vehicle and listen for noise that might be caused by loose, worn or damaged suspension or steering components.

(3) Inspect brake fluid level and condition. Note that the brake reservoir fluid level will decrease in proportion to normal lining wear. **Also note that brake fluid tends to darken over time. This is normal and should not be mistaken for contamination.**

(a) If fluid level is abnormally low, look for evidence of leaks at calipers, wheel cylinders, brake lines, and master cylinder.

(b) If fluid appears contaminated, drain out a sample to examine. System will have to be flushed if fluid is separated into layers, or contains a substance other than brake fluid. The system seals and cups will also have to be replaced after flushing. Use clean brake fluid to flush the system.

(4) Check parking brake operation. Verify free movement and full release of cables and pedal. Also note if vehicle was being operated with parking brake partially applied.

(5) Check brake pedal operation. Verify that pedal does not bind and has adequate free play. If pedal lacks free play, check pedal and power booster for being loose or for bind condition. Do not road test until condition is corrected.

(6) Check booster vacuum check valve and hose.

(7) If components checked appear OK, road test the vehicle.

ROAD TESTING

(1) If complaint involved low brake pedal, pump pedal and note if it comes back up to normal height.

(2) Check brake pedal response with transmission in Neutral and engine running. Pedal should remain firm under constant foot pressure.

(3) During road test, make normal and firm brake stops in 25-40 mph range. Note faulty brake operation such as low pedal, hard pedal, fade, pedal pulsation, pull, grab, drag, noise, etc.

(4) Attempt to stop the vehicle with the parking brake only and note grab, drag, noise, etc.

PEDAL FALLS AWAY

A brake pedal that falls away under steady foot pressure is generally the result of a system leak. The leak point could be at a brake line, fitting, hose, or caliper/wheel cylinder. If leakage is severe, fluid will be evident at or around the leaking component.

Internal leakage (seal by-pass) in the master cylinder caused by worn or damaged piston cups, may also be the problem cause.

An internal leak in the ABS or RWAL system may also be the problem with no physical evidence.

LOW PEDAL

If a low pedal is experienced, pump the pedal several times. If the pedal comes back up worn linings, rotors, drums, or rear brakes out of adjustment are the most likely causes. The proper course of action is to inspect and replace all worn component and make the proper adjustments.

SPONGY PEDAL

A spongy pedal is most often caused by air in the system. However, thin brake drums or substandard brake lines and hoses can also cause a spongy pedal. The proper course of action is to bleed the system, and replace thin drums and substandard quality brake hoses if suspected.

HARD PEDAL OR HIGH PEDAL EFFORT

A hard pedal or high pedal effort may be due to lining that is water soaked, contaminated, glazed, or badly worn. The power booster or check valve could also be faulty.

DIAGNOSIS AND TESTING (Continued)

PEDAL PULSATION

Pedal pulsation is caused by components that are loose, or beyond tolerance limits.

The primary cause of pulsation are disc brake rotors with excessive lateral runout or thickness variation, or out of round brake drums. Other causes are loose wheel bearings or calipers and worn, damaged tires.

NOTE: Some pedal pulsation may be felt during ABS activation.

BRAKE DRAG

Brake drag occurs when the lining is in constant contact with the rotor or drum. Drag can occur at one wheel, all wheels, fronts only, or rears only.

Drag is a product of incomplete brake shoe release. Drag can be minor or severe enough to overheat the linings, rotors and drums.

Minor drag will usually cause slight surface charring of the lining. It can also generate hard spots in rotors and drums from the overheat-cool down process. In most cases, the rotors, drums, wheels and tires are quite warm to the touch after the vehicle is stopped.

Severe drag can char the brake lining all the way through. It can also distort and score rotors and drums to the point of replacement. The wheels, tires and brake components will be extremely hot. In severe cases, the lining may generate smoke as it chars from overheating.

Common causes of brake drag are:

- Seized or improperly adjusted parking brake cables.
- Loose/worn wheel bearing.
- Seized caliper or wheel cylinder piston.
- Caliper binding on corroded bushings or rusted slide surfaces.
- Loose caliper mounting.
- Drum brake shoes binding on worn/damaged support plates.
- Mis-assembled components.
- Long booster output rod.

If brake drag occurs at all wheels, the problem may be related to a blocked master cylinder return port, or faulty power booster (binds-does not release).

BRAKE FADE

Brake fade is usually a product of overheating caused by brake drag. However, brake overheating and resulting fade can also be caused by riding the brake pedal, making repeated high deceleration stops in a short time span, or constant braking on steep mountain roads. Refer to the Brake Drag information in this section for causes.

BRAKE PULL

Front brake pull condition could result from:

- Contaminated lining in one caliper
- Seized caliper piston
- Binding caliper
- Loose caliper
- Rusty caliper slide surfaces
- Improper brake shoes
- Damaged rotor

A worn, damaged wheel bearing or suspension component are further causes of pull. A damaged front tire (bruised, ply separation) can also cause pull.

A common and frequently misdiagnosed pull condition is where direction of pull changes after a few stops. The cause is a combination of brake drag followed by fade at one of the brake units.

As the dragging brake overheats, efficiency is so reduced that fade occurs. Since the opposite brake unit is still functioning normally, its braking effect is magnified. This causes pull to switch direction in favor of the normally functioning brake unit.

An additional point when diagnosing a change in pull condition concerns brake cool down. Remember that pull will return to the original direction, if the dragging brake unit is allowed to cool down (and is not seriously damaged).

REAR BRAKE GRAB OR PULL

Rear grab or pull is usually caused by improperly adjusted or seized parking brake cables, contaminated lining, bent or binding shoes and support plates, or improperly assembled components. This is particularly true when only one rear wheel is involved. However, when both rear wheels are affected, the master cylinder or proportioning valve could be at fault.

BRAKES DO NOT HOLD AFTER DRIVING THROUGH DEEP WATER PUDDLES

This condition is generally caused by water soaked lining. If the lining is only wet, it can be dried by driving with the brakes very lightly applied for a mile or two. However, if the lining is both soaked and dirt contaminated, cleaning and/or replacement will be necessary.

BRAKE LINING CONTAMINATION

Brake lining contamination is mostly a product of leaking calipers or wheel cylinders, worn seals, driving through deep water puddles, or lining that has become covered with grease and grit during repair. Contaminated lining should be replaced to avoid further brake problems.

DIAGNOSIS AND TESTING (Continued)

WHEEL AND TIRE PROBLEMS

Some conditions attributed to brake components may actually be caused by a wheel or tire problem.

A damaged wheel can cause shudder, vibration and pull. A worn or damaged tire can also cause pull.

Severely worn tires with very little tread left can produce a grab-like condition as the tire loses and recovers traction. Flat-spotted tires can cause vibration and generate shudder during brake operation. A tire with internal damage such as a severe bruise, cut, or ply separation can cause pull and vibration.

BRAKE NOISES

Some brake noise is common with rear drum brakes and on some disc brakes during the first few stops after a vehicle has been parked overnight or stored. This is primarily due to the formation of trace corrosion (light rust) on metal surfaces. This light corrosion is typically cleared from the metal surfaces after a few brake applications causing the noise to subside.

BRAKE SQUEAK/SQUEAL

Brake squeak or squeal may be due to linings that are wet or contaminated with brake fluid, grease, or oil. Glazed linings and rotors with hard spots can also contribute to squeak. Dirt and foreign material embedded in the brake lining will also cause squeak/squeal.

A very loud squeak or squeal is frequently a sign of severely worn brake lining. If the lining has worn through to the brake shoes in spots, metal-to-metal contact occurs. If the condition is allowed to continue, rotors and drums can become so scored that replacement is necessary.

BRAKE CHATTER

Brake chatter is usually caused by loose or worn components, or glazed/burnt lining. Rotors with hard spots can also contribute to chatter. Additional causes of chatter are out-of-tolerance rotors, brake lining not securely attached to the shoes, loose wheel bearings and contaminated brake lining.

THUMP/CLUNK NOISE

Thumping or clunk noises during braking are frequently **not** caused by brake components. In many cases, such noises are caused by loose or damaged steering, suspension, or engine components. However, calipers that bind on the slide surfaces can generate a thump or clunk noise. In addition, worn out, improperly adjusted, or improperly assembled rear brake shoes can also produce a thump noise.

BRAKE LAMP SWITCH

The brake lamp switch operation can be tested with an ohmmeter. The ohmmeter is used to check continuity between the pin terminals (Fig. 6).

SWITCH CIRCUIT IDENTIFICATION

- Terminals 1 and 2: brake sensor circuit
- Terminals 3 and 4: speed control circuit if equipped
- Terminals 5 and 6: brake lamp circuit

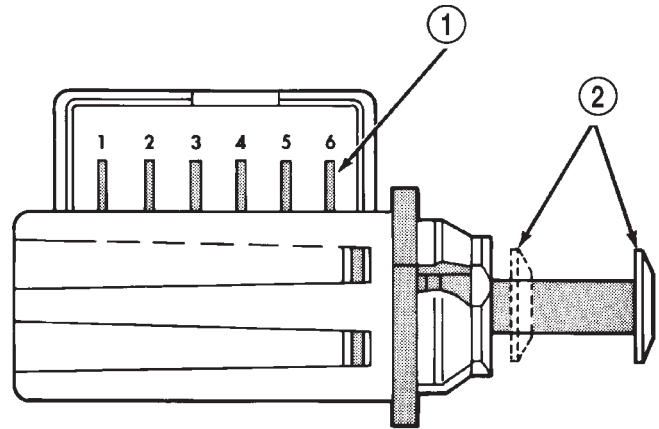

J9405-88

Fig. 6 Brake Lamp Switch Terminal Identification

- 1 - TERMINAL PINS
2 - PLUNGER TEST POSITIONS

SWITCH CONTINUITY TEST

NOTE: Disconnect switch harness before testing switch continuity.

With the switch plunger retracted, attach test leads to terminal pins 1 and 2. Replace switch if meter indicates no continuity.

With the switch plunger retracted, attach test leads to terminal pins 3 and 4. Replace switch if meter indicates no continuity.

With the switch plunger extended, attach test leads to terminal pins 5 and 6. Replace switch if meter indicates no continuity.

RED BRAKE WARNING LAMP

The red brake warning lamp will illuminate under the following conditions:

- Self test at start-up.
- Parking brakes are applied.
- Leak in front/rear brake hydraulic circuit.

If the red light remains on after start-up, first verify that the parking brakes are fully released. Then check pedal action and fluid level. If the lamp on and the brake pedal is low this indicates the pressure dif-

DIAGNOSIS AND TESTING (Continued)

ferential switch and valve have been actuated due to a leak in the hydraulic system.

On models with ABS brakes, the amber warning lamp only illuminates during the self test and when an ABS malfunction has occurred. The ABS lamp operates independently of the red warning lamp.

For additional information refer to Group 8W.

MASTER CYLINDER/POWER BOOSTER

(1) Start engine and check booster vacuum hose connections. A hissing noise indicates vacuum leak. Correct any vacuum leak before proceeding.

(2) Stop engine and shift transmission into Neutral.

(3) Pump brake pedal until all vacuum reserve in booster is depleted.

(4) Press and hold brake pedal under light foot pressure. The pedal should hold firm, if the pedal falls away master cylinder is faulty (internal leakage).

(5) Start engine and note pedal action. It should fall away slightly under light foot pressure then hold firm. If no pedal action is discernible, power booster, vacuum supply, or vacuum check valve is faulty. Proceed to the POWER BOOSTER VACUUM TEST.

(6) If the POWER BOOSTER VACUUM TEST passes, rebuild booster vacuum reserve as follows: Release brake pedal. Increase engine speed to 1500 rpm, close the throttle and immediately turn off ignition to stop engine.

(7) Wait a minimum of 90 seconds and try brake action again. Booster should provide two or more vacuum assisted pedal applications. If vacuum assist is not provided, booster is faulty.

POWER BOOSTER VACUUM TEST

(1) Connect vacuum gauge to booster check valve with short length of hose and T-fitting (Fig. 7).

(2) Start and run engine at curb idle speed for one minute.

(3) Observe the vacuum supply. If vacuum supply is not adequate, repair vacuum supply.

(4) Clamp hose shut between vacuum source and check valve.

(5) Stop engine and observe vacuum gauge.

(6) If vacuum drops more than one inch HG (33 millibars) within 15 seconds, booster diaphragm or check valve is faulty.

POWER BOOSTER CHECK VALVE TEST

(1) Disconnect vacuum hose from check valve.

(2) Remove check valve and valve seal from booster.

(3) Use a hand operated vacuum pump for test.

(4) Apply 15-20 inches vacuum at large end of check valve (Fig. 8).

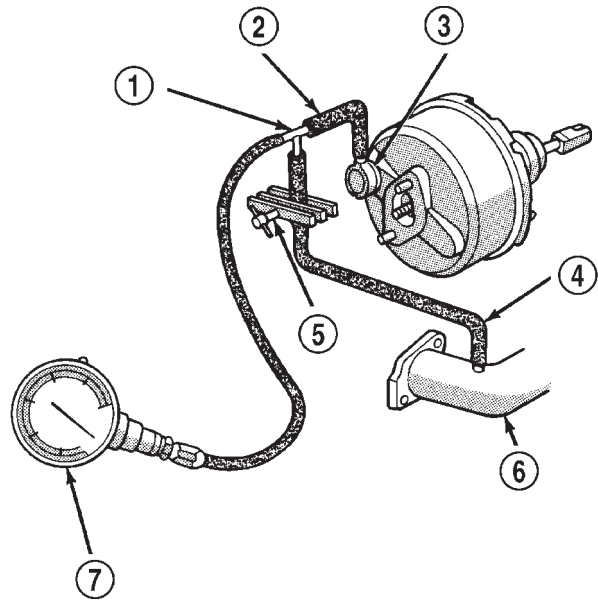

J9005-81

Fig. 7 Typical Booster Vacuum Test Connections

- 1 - TEE FITTING
- 2 - SHORT CONNECTING HOSE
- 3 - CHECK VALVE
- 4 - CHECK VALVE HOSE
- 5 - CLAMP TOOL
- 6 - INTAKE MANIFOLD
- 7 - VACUUM GAUGE

(5) Vacuum should hold steady. If gauge on pump indicates vacuum loss, check valve is faulty and should be replaced.

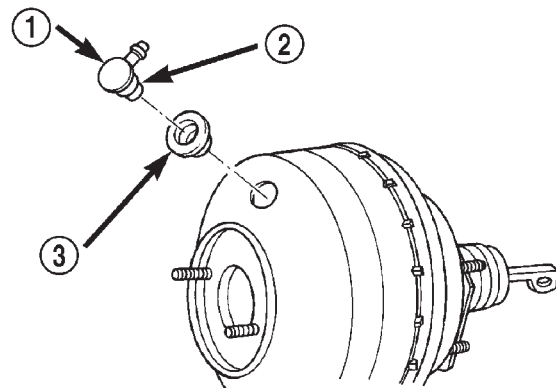

8031e866

Fig. 8 Vacuum Check Valve And Seal

- 1 - BOOSTER CHECK VALVE
- 2 - APPLY TEST VACUUM HERE
- 3 - VALVE SEAL

DIAGNOSIS AND TESTING (Continued)

COMBINATION VALVE

PRESSURE DIFFERENTIAL SWITCH

(1) Have helper sit in drivers seat to apply brake pedal and observe red brake warning light.

(2) Raise vehicle on hoist.

(3) Connect bleed hose to a rear wheel cylinder and immerse hose end in container partially filled with brake fluid.

(4) Have helper press and hold brake pedal to floor and observe warning light.

(a) If warning light illuminates, switch is operating correctly.

(b) If light fails to illuminate, check circuit fuse, bulb, and wiring. The parking brake switch can be used to aid in identifying whether or not the brake light bulb and fuse is functional. Repair or replace parts as necessary and test differential pressure switch operation again.

(5) If warning light still does not illuminate, switch is faulty. Replace combination valve assembly, bleed brake system and verify proper switch and valve operation.

REAR PROPORTIONING VALVE

The valve controls fluid flow. If fluid enters the valve and does not exit the valve the combination valve must be replaced.

DISC BRAKE ROTOR

The rotor braking surfaces should not be refinished unless necessary.

Light surface rust and scale can be removed with a lathe equipped with dual sanding discs. The rotor surfaces can be restored by machining in a disc brake lathe if surface scoring and wear are light.

Replace the rotor under the following conditions:

- severely scored
- tapered
- hard spots
- cracked
- below minimum thickness

ROTOR MINIMUM THICKNESS

Measure rotor thickness at the center of the brake shoe contact surface. Replace the rotor if worn below minimum thickness, or if machining would reduce thickness below the allowable minimum.

Rotor minimum thickness is usually specified on the rotor hub. The specification is either stamped or cast into the hub surface.

ROTOR RUNOUT

Check rotor lateral runout with dial indicator C-3339 (Fig. 9). Excessive lateral runout will cause brake pedal pulsation and rapid, uneven wear of the

brake shoes. Position the dial indicator plunger approximately 25.4 mm (1 in.) inward from the rotor edge. Maximum allowable rotor runout is 0.102 mm (0.004 in.).

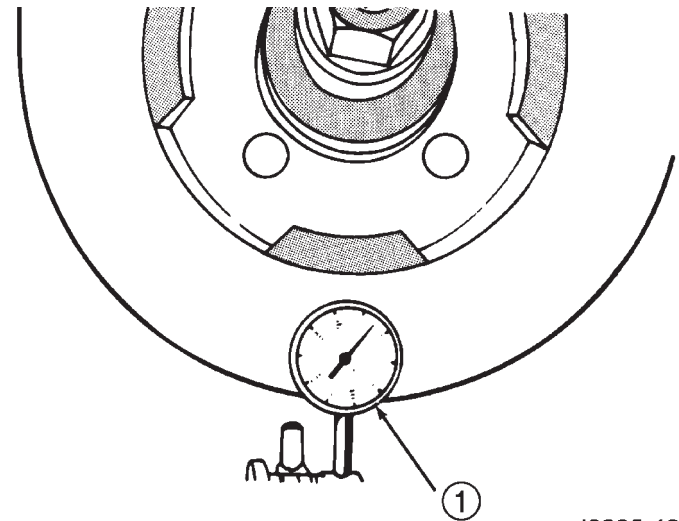

J8905-68

Fig. 9 Checking Rotor Runout And Thickness Variation

1 - DIAL INDICATOR

ROTOR THICKNESS VARIATION

Variations in rotor thickness will cause pedal pulsation, noise and shudder.

Measure rotor thickness at 6 to 12 points around the rotor face (Fig. 10).

Position the micrometer approximately 25.4 mm (1 in.) from the rotor outer circumference for each measurement.

Thickness should not vary by more than 0.013 mm (0.0005 in.) from point-to-point on the rotor. Machine or replace the rotor if necessary.

BRAKE DRUM

The maximum allowable diameter of the drum braking surface is indicated on the drum outer edge. Generally, a drum can be machined to a maximum of 1.52 mm (0.060 in.) oversize. Always replace the drum if machining would cause drum diameter to exceed the size limit indicated on the drum.

BRAKE DRUM RUNOUT

Measure drum diameter and runout with an accurate gauge. The most accurate method of measurement involves mounting the drum in a brake lathe and checking variation and runout with a dial indicator.

Variations in drum diameter should not exceed 0.076 mm (0.003 in.). Drum runout should not exceed 0.20 mm (0.008 in.) out of round. Machine the drum if runout or variation exceed these values. Replace

DIAGNOSIS AND TESTING (Continued)

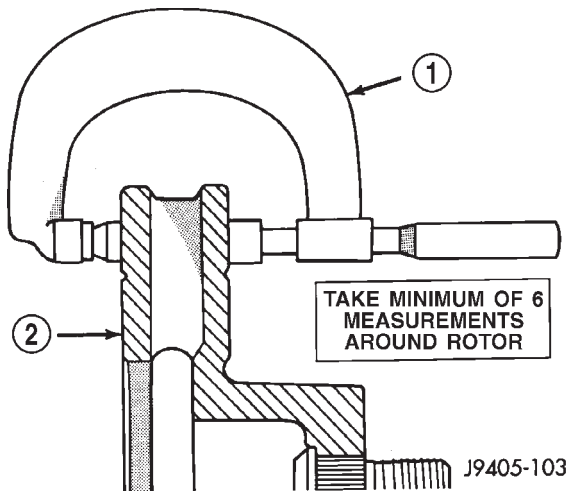

Fig. 10 Measuring Rotor Thickness

- 1 - MICROMETER
2 - ROTOR

the drum if machining causes the drum to exceed the maximum allowable diameter.

BRAKE LINE AND HOSES

Flexible rubber hose is used at both front brakes and at the rear axle junction block. Inspect the hoses whenever the brake system is serviced, at every engine oil change, or whenever the vehicle is in for service.

Inspect the hoses for surface cracking, scuffing, or worn spots. Replace any brake hose immediately if the fabric casing of the hose is exposed due to cracks or abrasions.

Also check brake hose installation. Faulty installation can result in kinked, twisted hoses, or contact with the wheels and tires or other chassis components. All of these conditions can lead to scuffing, cracking and eventual failure.

The steel brake lines should be inspected periodically for evidence of corrosion, twists, kinks, leaks, or other damage. Heavily corroded lines will eventually rust through causing leaks. In any case, corroded or damaged brake lines should be replaced.

Factory replacement brake lines and hoses are recommended to ensure quality, correct length and superior fatigue life. Care should be taken to make sure that brake line and hose mating surfaces are clean and free from nicks and burrs. Also remember that right and left brake hoses are not interchangeable.

Use new copper seal washers at all caliper connections. Be sure brake line connections are properly made (not cross threaded) and tightened to recommended torque.

BRAKE FLUID CONTAMINATION

Indications of fluid contamination are swollen or deteriorated rubber parts.

Swollen rubber parts indicate the presence of petroleum in the brake fluid.

To test for contamination, put a small amount of drained brake fluid in clear glass jar. If fluid separates into layers, there is mineral oil or other fluid contamination of the brake fluid.

If brake fluid is contaminated, drain and thoroughly flush system. Replace master cylinder, proportioning valve, caliper seals, wheel cylinder seals, Antilock Brakes hydraulic unit and all hydraulic fluid hoses.

SERVICE PROCEDURES

BRAKE FLUID LEVEL

Always clean the master cylinder reservoir and cap before adding fluid. This will prevent dirt from falling in the reservoir and contaminating the brake fluid.

The reservoir has a ADD and a FULL mark on the side (Fig. 11) fill to the FULL mark.

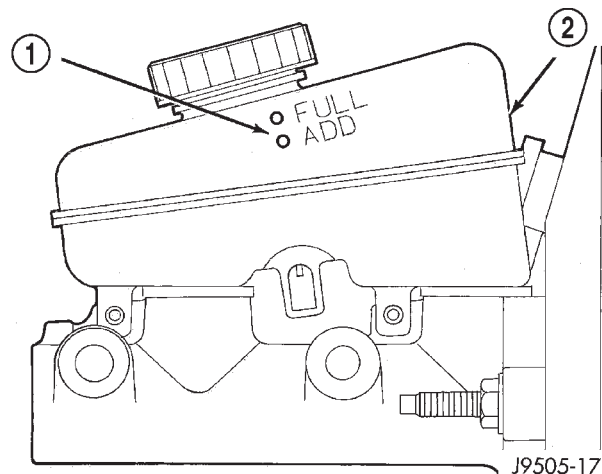

Fig. 11 Master Cylinder Fluid Level

- 1 - FLUID LEVEL MARKS
2 - RESERVOIR

MASTER CYLINDER BLEEDING

A new master cylinder should be bled before installation on the vehicle. Required bleeding tools include bleed tubes and a wood dowel to stroke the pistons. Bleed tubes can be fabricated from brake line.

BLEEDING PROCEDURE

- (1) Mount master cylinder in vise.
- (2) Attach bleed tubes to cylinder outlet ports. Then position each tube end into reservoir (Fig. 12).

SERVICE PROCEDURES (Continued)

(3) Fill reservoir with fresh brake fluid.

(4) Press cylinder pistons inward with wood dowel. Then release pistons and allow them to return under spring pressure. Continue bleeding operations until air bubbles are no longer visible in fluid.

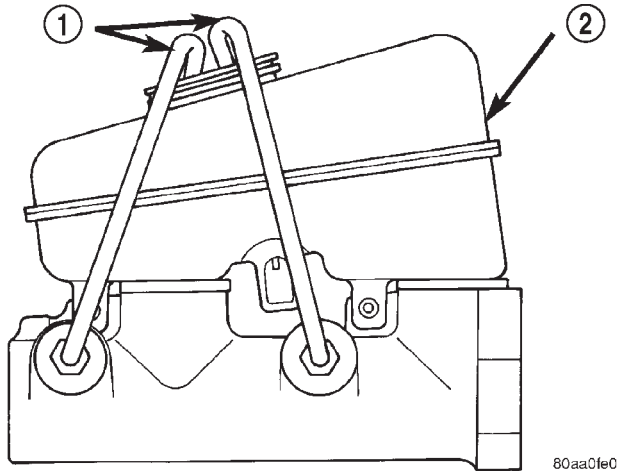

Fig. 12 Master Cylinder Bleeding—Typical

- 1 - BLEEDING TUBES
2 - RESERVOIR

BASE BRAKE BLEEDING

Use Mopar brake fluid, or an equivalent quality fluid meeting SAE J1703-F and DOT 3 standards only. Use fresh, clean fluid from a sealed container at all times.

Do not pump the brake pedal at any time while bleeding. Air in the system will be compressed into small bubbles that are distributed throughout the hydraulic system. This will make additional bleeding operations necessary.

Do not allow the master cylinder to run out of fluid during bleed operations. An empty cylinder will allow additional air to be drawn into the system. Check the cylinder fluid level frequently and add fluid as needed.

Bleed only one brake component at a time in the following sequence:

- Master Cylinder
- Combination Valve
- Right Rear Wheel
- Left Rear Wheel
- Right Front Wheel
- Left Front Wheel

MANUAL BLEEDING

(1) Remove reservoir filler caps and fill reservoir.

(2) If calipers, or wheel cylinders were overhauled, open all caliper and wheel cylinder bleed screws. Then close each bleed screw as fluid starts to drip from it. Top off master cylinder reservoir once more before proceeding.

(3) Attach one end of bleed hose to bleed screw and insert opposite end in glass container partially filled with brake fluid (Fig. 13). Be sure end of bleed hose is immersed in fluid.

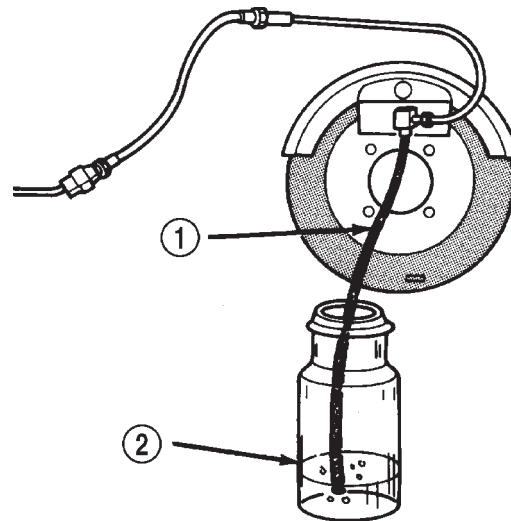

Fig. 13 Bleed Hose Setup

- 1 - BLEED HOSE
2 - FLUID CONTAINER PARTIALLY FILLED WITH FLUID

J8905-18

(4) Open up bleeder, then have a helper press down the brake pedal. Once the pedal is down close the bleeder. Repeat bleeding until fluid stream is clear and free of bubbles. Then move to the next wheel.

PRESSURE BLEEDING

Follow the manufacturers instructions carefully when using pressure equipment. Do not exceed the tank manufacturers pressure recommendations. Generally, a tank pressure of 15-20 psi is sufficient for bleeding.

Fill the bleeder tank with recommended fluid and purge air from the tank lines before bleeding.

Do not pressure bleed without a proper master cylinder adapter. The wrong adapter can lead to leakage, or drawing air back into the system. Use adapter provided with the equipment or Adapter 6921.

DISC ROTOR MACHINING

The disc brake rotor can be machined if scored or worn. The lathe must machine both sides of the rotor simultaneously with dual cutter heads. The rotor mounting surface must be clean before placing on the lathe. Equipment capable of machining only one side at a time may produce a tapered rotor. A hub

SERVICE PROCEDURES (Continued)

mounted on-vehicle lathe is recommended. This type of lathe trues the rotor to the vehicles hub/bearing.

CAUTION: Brake rotors that do not meet minimum thickness specifications before or after machining must be replaced.

BRAKE DRUM MACHINING

The brake drums can be machined on a drum lathe when necessary. Initial machining cuts should be limited to 0.12 - 0.20 mm (0.005 - 0.008 in.) at a time as heavier feed rates can produce taper and surface variation. Final finish cuts of 0.025 to 0.038 mm (0.001 to 0.0015 in.) are recommended and will generally provide the best surface finish.

Be sure the drum is securely mounted in the lathe before machining operations. A damper strap should always be used around the drum to reduce vibration and avoid chatter marks.

The maximum allowable diameter of the drum braking surface is stamped or cast into the drum outer edge.

CAUTION: Replace the drum if machining will cause the drum to exceed the maximum allowable diameter.

BRAKE TUBE FLARING

A preformed metal brake tube is recommended and preferred for all repairs. However, double-wall steel tube can be used for emergency repair when factory replacement parts are not readily available.

Special bending tools are needed to avoid kinking or twisting of metal brake tubes. Special flaring tools are needed to make a double inverted flare or ISO flare (Fig. 14).

DOUBLE INVERTED FLARING

- (1) Cut off damaged tube with Tubing Cutter.
- (2) Ream cut edges of tubing to ensure proper flare.
- (3) Install replacement tube nut on the tube.
- (4) Insert tube in flaring tool.
- (5) Place gauge form over the end of the tube.
- (6) Push tubing through flaring tool jaws until tube contacts recessed notch in gauge that matches tube diameter.
- (7) Tighten the tool bar on the tube
- (8) Insert plug on gauge in the tube. Then swing compression disc over gauge and center tapered flaring screw in recess of compression disc (Fig. 15).
- (9) Tighten tool handle until plug gauge is squarely seated on jaws of flaring tool. This will start the inverted flare.

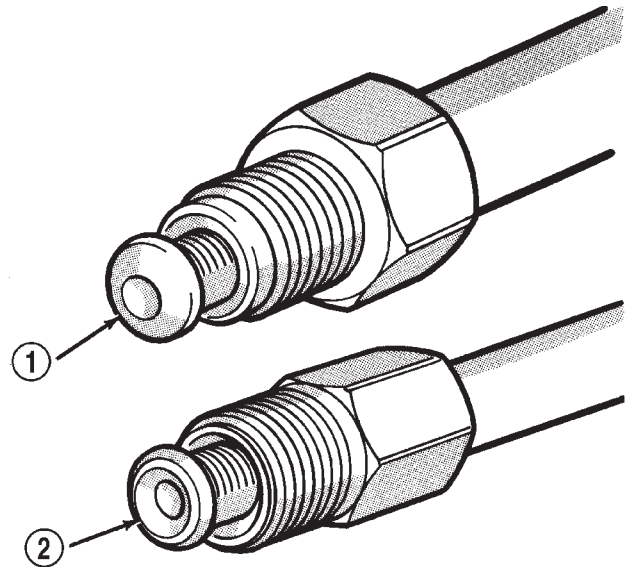

9205-174

Fig. 14 Inverted Flare And ISO Flare

- 1 - ISO-STYLE FLARE
2 - DOUBLE INVERTED-STYLE FLARE

(10) Remove the plug gauge and complete the inverted flare.

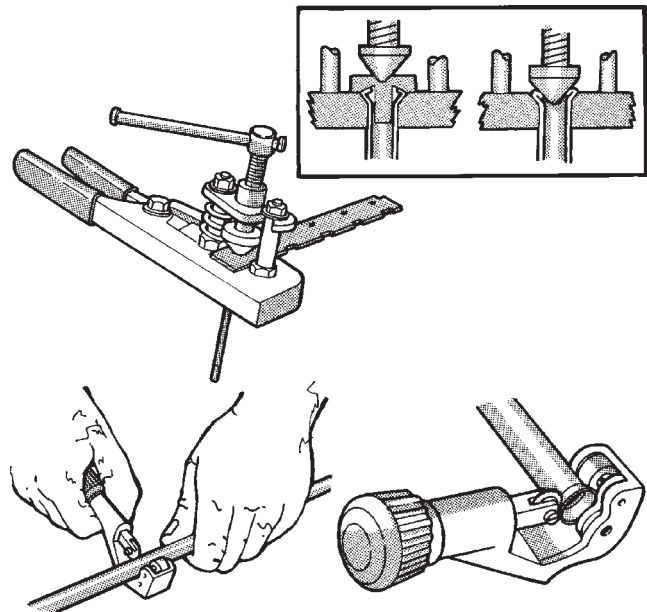

RH222

Fig. 15 Inverted Flare Tools

ISO FLARING

To make a ISO flare use Snap-On® Flaring Tool TFM-428 or equivalent.

- (1) Cut off damaged tube with Tubing Cutter.
- (2) Remove any burrs from the inside of the tube.
- (3) Install tube nut on the tube.

SERVICE PROCEDURES (Continued)

(4) Position the tube in the flaring tool flush with the top of the tool bar (Fig. 16). Then tighten the tool bar on the tube.

(5) Install the correct size adaptor on the flaring tool yoke screw.

(6) Lubricate the adaptor.

(7) Align the adaptor and yoke screw over the tube (Fig. 16).

(8) Turn the yoke screw in until the adaptor is squarely seated on the tool bar.

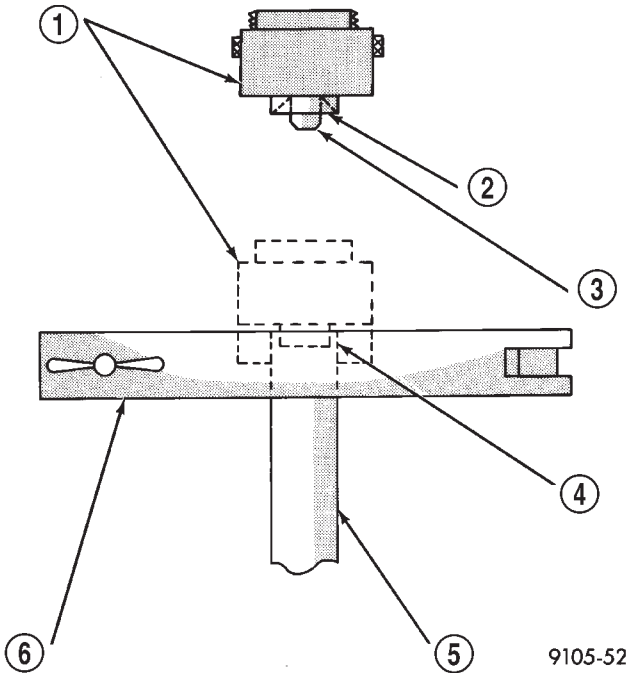

Fig. 16 ISO Flaring

- 1 - ADAPTER
- 2 - LUBRICATE HERE
- 3 - PILOT
- 4 - FLUSH WITH BAR
- 5 - TUBING
- 6 - BAR ASSEMBLY

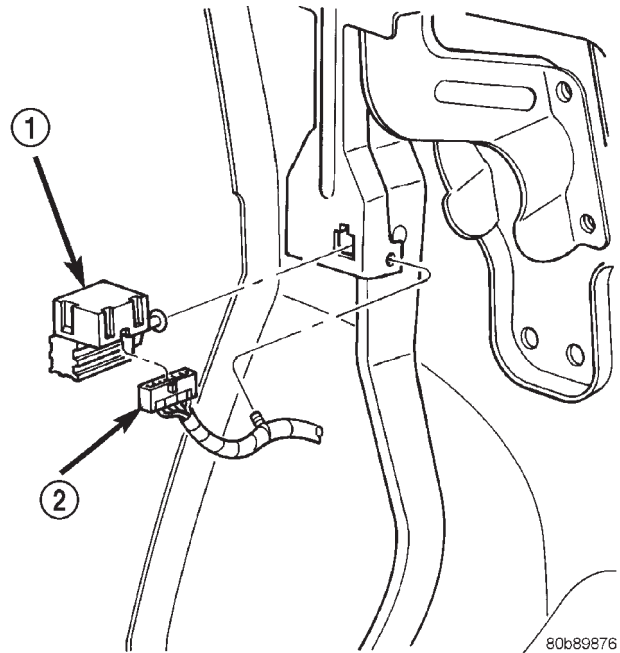

Fig. 17 Brake Lamp Switch

- 1 - SWITCH
- 2 - HARNESS CONNECTOR

INSTALLATION

(1) Pull switch plunger all the way out to fully extended position.

(2) Connect harness wires to switch.

(3) Press and hold brake pedal in applied position.

(4) Install switch as follows: Align tab on switch with notch in switch bracket. Then insert switch in bracket and turn it clockwise about 30° to lock it in place.

(5) Release brake pedal. Then pull pedal lightly rearward. Pedal will set plunger to correct position as pedal pushes plunger into switch body. Switch will make ratcheting sound as it self adjusts.

CAUTION: Booster damage may occur if the pedal pull exceeds 20 lbs..

REMOVAL AND INSTALLATION

BRAKE LAMP SWITCH

REMOVAL

(1) Remove steering column cover and lower trim panel for switch access (if necessary).

(2) Press brake pedal downward to fully applied position.

(3) Rotate switch approximately 30° in counter-clockwise direction to unlock switch retainer. Then pull switch rearward and out of bracket.

(4) Disconnect switch harness and remove switch from vehicle (Fig. 17).

BRAKE PEDAL

REMOVAL

(1) Remove knee blocker under the steering column.

(2) Remove retainer clip securing booster push rod to pedal (Fig. 18).

(3) Remove brake lamp switch.

(4) Remove nuts securing the booster to the pedal support bracket and nuts to the column bracket.

(5) Remove pedal and support bracket as an assembly from the vehicle.

REMOVAL AND INSTALLATION (Continued)

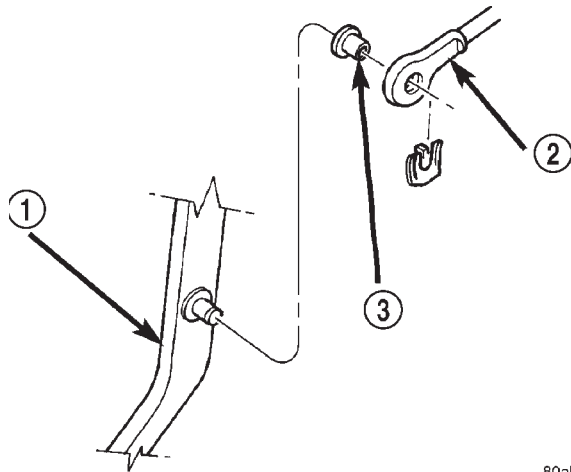

80ab88a7

Fig. 18 Booster Push Rod

- 1 - BRAKE PEDAL
- 2 - BOOSTER ROD
- 3 - BUSHING

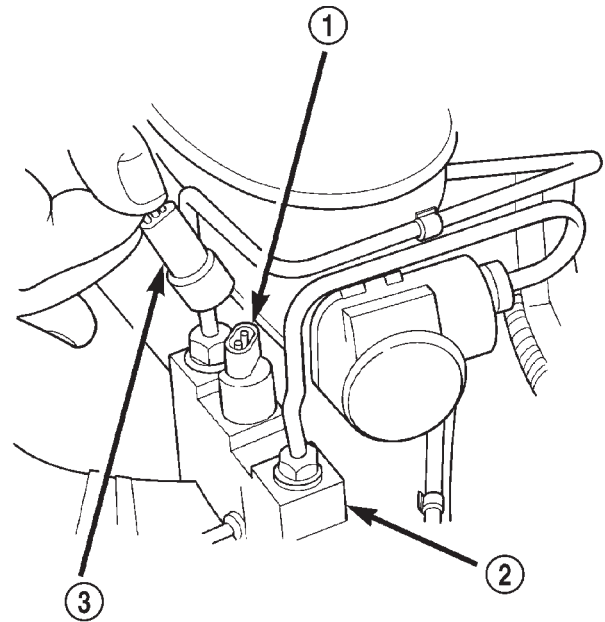

8031e88c

Fig. 19 Differential Pressure Switch

- 1 - SWITCH TERMINAL
- 2 - COMBINATION VALVE
- 3 - WIRE HARNESS CONNECTOR

INSTALLATION

- (1) Install pedal and support bracket as an assembly into the vehicle.
- (2) Install nuts securing the booster to the pedal support bracket and nuts to the column bracket.
- (3) Tighten nuts to 39 N·m (29 ft. lbs.).
- (4) Lubricate the brake pedal pin and bushings with Mopar multi-mileage grease.
- (5) Install booster push rod on pedal pin and install new retainer clip.
- (6) Install knee blocker.

COMBINATION VALVE

NOTE: The combination valve is not repairable. The valve is serviced as an assembly only.

REMOVAL

- (1) Remove air cleaner cover and hose for access to valve.
- (2) Unsnap connector lock tabs and disconnect differential pressure switch wire at combination valve (Fig. 19). Do not pull switch wire to disconnect.
- (3) Disconnect brake lines at combination valve (Fig. 20).
- (4) Remove mounting nut and remove valve.

INSTALLATION

- (1) Install valve and tighten mounting nut to 17 N·m (155 in. lbs.).
- (2) Connect brake lines to replacement valve. Start line fittings by hand to avoid cross threading.
- (3) Tighten brake line fittings to 14 N·m (124 in. lbs.).

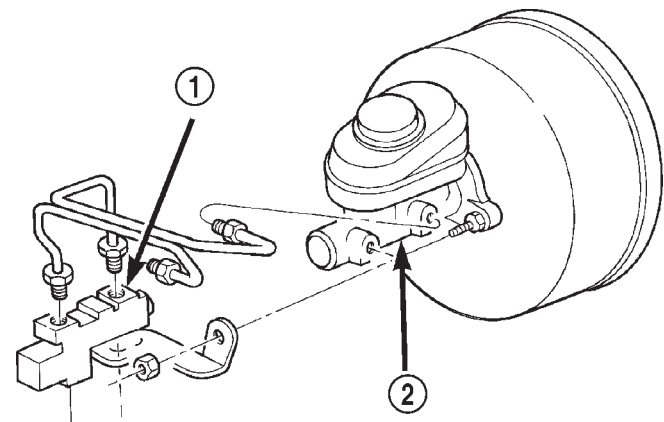

8031e88d

Fig. 20 Combination Valve

- 1 - COMBINATION VALVE
- 2 - MASTER CYLINDER

- (4) Connect wire to pressure differential switch.
- (5) Bleed base brakes.

MASTER CYLINDER**REMOVAL**

- (1) Remove brake lines at master cylinder and combination valve (Fig. 20).
- (2) Disconnect differential pressure switch wire from the combination valve.

REMOVAL AND INSTALLATION (Continued)

- (3) Remove mounting nuts from the combination valve bracket and remove the valve (Fig. 20).
- (4) Remove mounting nuts from the master cylinder (Fig. 21).
- (5) Remove master cylinder.
- (6) Remove cylinder cover and drain fluid.
- (7) If master cylinder reservoir requires service, refer to reservoir replacement procedure in this section.

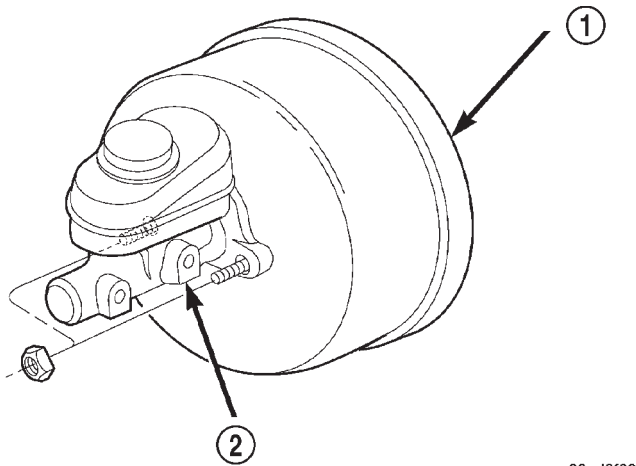
**Fig. 21 Master Cylinder**

- 1 - BOOSTER
2 - MASTER CYLINDER

INSTALLATION

NOTE: If master cylinder is replaced, bleed cylinder before installation.

- (1) Remove protective sleeve from primary piston shank on new master cylinder.
- (2) Clean cylinder mounting surface of brake booster.
- (3) Install master cylinder onto brake booster studs.
- (4) Install mounting nuts and tighten to 17 N·m (155 in. lbs.).
- (5) Install combination valve and install mounting nuts.
- (6) Connect brake lines to master cylinder and combination valve and tighten to 14 N·m (124 in. lbs.).
- (7) Connect differential pressure switch wire to the combination valve.
- (8) On RHD vehicles install the coolant reserve/overflow tank. Refer to Group 7 Cooling System.
- (9) Fill and bleed base brake system.

POWER BRAKE BOOSTER

REMOVAL

- (1) On RHD vehicles remove the coolant reserve/overflow tank. Refer to Group 7 Cooling System.
- (2) Disconnect brake lines at master cylinder.
- (3) Disconnect wire at combination valve differential pressure switch.
- (4) Remove nut mounting combination valve bracket to booster studs and remove valve.
- (5) Remove nuts mounting master cylinder to booster studs and remove cylinder.
- (6) Disconnect vacuum hose from booster check valve.
- (7) Remove knee blocker under the steering column.
- (8) Remove retaining clip that secures booster push rod to brake pedal (Fig. 22).
- (9) Remove nuts attaching booster to passenger compartment side of dash panel (Fig. 23).

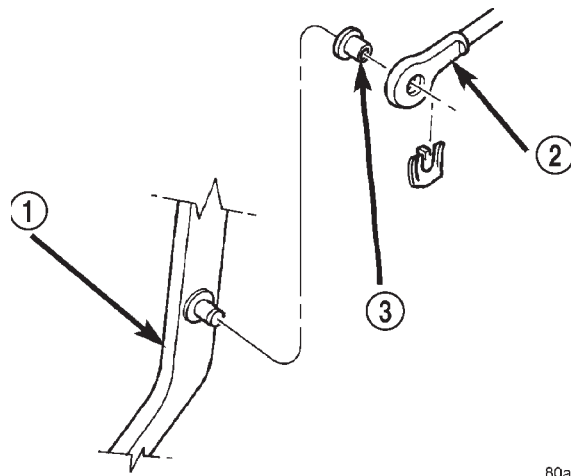
**Fig. 22 Booster Push Rod**

- 1 - BRAKE PEDAL
2 - BOOSTER ROD
3 - BUSHING

- (10) In engine compartment, slide booster studs out of dash panel, tilt booster upward, and remove booster from engine compartment.

- (11) Remove dash seal from booster.

INSTALLATION

- (1) Install dash seal on booster.
- (2) Align and position booster on dash panel.
- (3) In passenger compartment, install booster mounting nuts. Tighten nuts just enough to hold booster in place.
- (4) Slide booster push rod onto the brake pedal. Then secure push rod to pedal pin with retaining clip.

REMOVAL AND INSTALLATION (Continued)

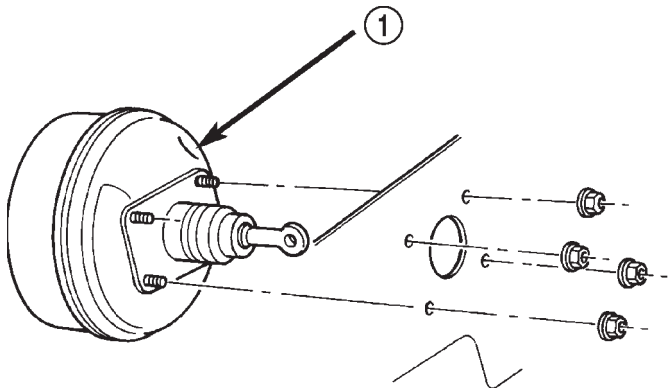

80ab88a8

Fig. 23 Booster Mounting

1 - BOOSTER

NOTE: Lubricate the pedal pin and bushing with Mopar multi-mileage grease before installation.

(5) Tighten booster mounting nuts to 39 N·m (29 ft. lbs.).

(6) Install the knee blocker.

(7) If original master cylinder is being installed, check condition of seal at rear of master cylinder. Replace seal if cut, or torn.

(8) Clean cylinder mounting surface of brake booster. Use shop towel wetted with brake cleaner for this purpose. Dirt, grease, or similar materials will prevent proper cylinder seating and could result in vacuum leak.

(9) Align and install master cylinder on booster studs. Install mounting nuts and tighten to 17.5 N·m (155 in. lbs.).

(10) Connect vacuum hose to booster check valve.

(11) Connect and secure brake lines to combination valve and master cylinder. Start all brake line fittings by hand to avoid cross threading.

(12) Install combination valve on booster studs. Tighten bracket mounting nuts to 17.5 N·m (155 in. lbs.).

(13) Connect wire to combination valve switch.

(14) On RHD vehicles install the coolant reserve/overflow tank. Refer to Group 7 Cooling System.

(15) Fill and bleed base brake system.

(16) Verify proper brake operation before moving vehicle.

FRONT DISC BRAKE CALIPER**REMOVAL**

- (1) Raise and support vehicle.
- (2) Remove front wheel and tire assembly.

(3) Drain small amount of fluid from master cylinder brake reservoir with suction gun.

(4) Bottom caliper piston in bore with C-clamp. Position clamp screw on outboard brake shoe and clamp frame on rear of caliper (Fig. 24). **Do not allow clamp screw to bear directly on outboard shoe retainer spring. Use wood or metal spacer between shoe and clamp screw.**

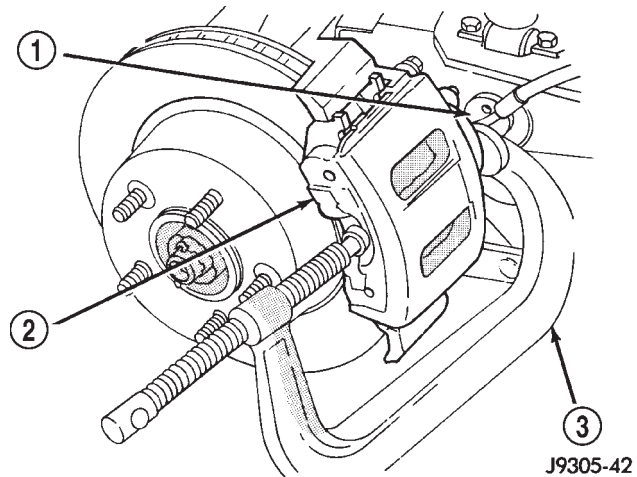
**Fig. 24 Bottoming Caliper Piston With C-Clamp**

- 1 - CALIPER BOSS
- 2 - OUTBOARD BRAKESHOE
- 3 - C-CLAMP

(5) Remove brake hose mounting bolt and discard washers (Fig. 25).

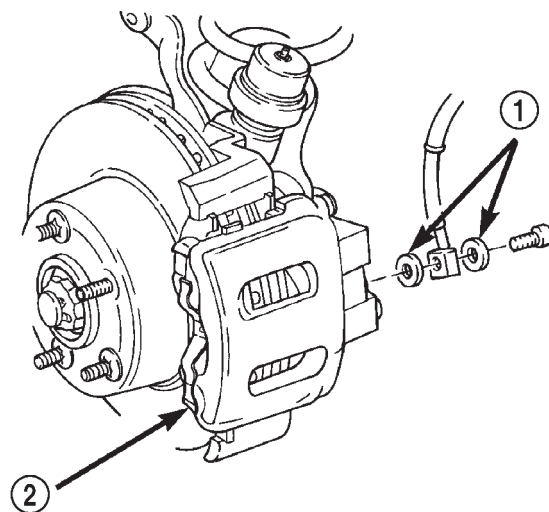

8031e88f

Fig. 25 Brake Hose And Bolt

- 1 - FITTING WASHERS
- 2 - CALIPERS

(6) Remove caliper mounting bolts (Fig. 26).

REMOVAL AND INSTALLATION (Continued)

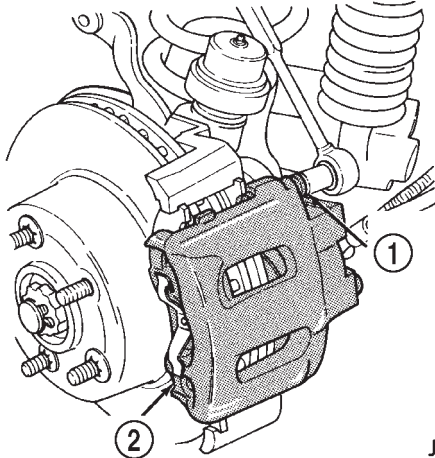

J9105-31

Fig. 26 Caliper Mounting Bolts

- 1 - CALIPER MOUNTING BOLT (2)
- 2 - CALIPER

(7) Tilt top of caliper outward with pry tool if necessary (Fig. 27) and remove caliper.

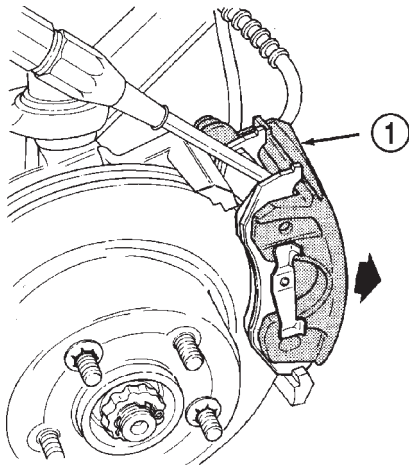

J9005-30

Fig. 27 Caliper Removal

- 1 - TILT CALIPER OUTBOARD TO REMOVE

(8) Remove caliper from vehicle.

INSTALLATION

(1) Clean brake shoe mounting ledges with wire brush and apply light coat of Mopar multi-mileage grease to surfaces (Fig. 28).

(2) Install caliper by position notches at lower end of brake shoes on bottom mounting ledge. Then rotate caliper over rotor and seat notches at upper end of shoes on top mounting ledge (Fig. 29).

(3) Coat caliper mounting bolts with silicone grease. Then install and tighten bolts to 15 N·m (11 ft. lbs.).

CAUTION: If new caliper bolts are being installed, or if the original reason for repair was a drag/pull

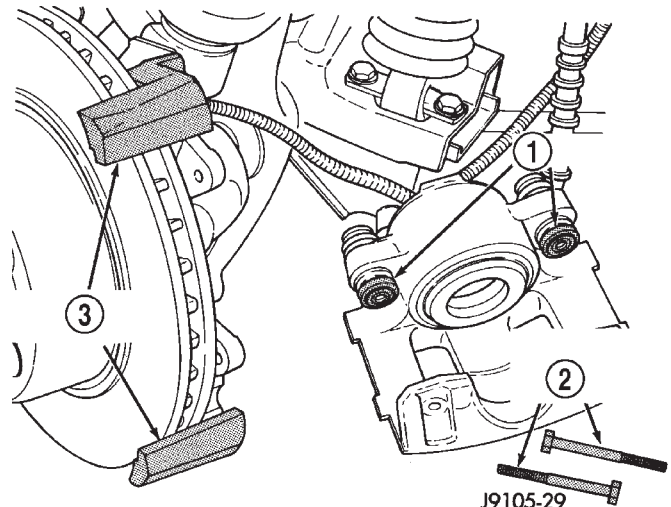

J9105-29

Fig. 28 Caliper Lubrication Points

- 1 - BUSHINGS
- 2 - CALIPER MOUNTING BOLTS
- 3 - MOUNTING LEDGES

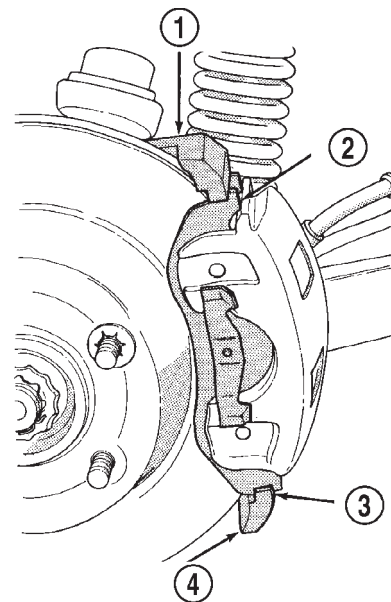

J9005-35

Fig. 29 Caliper Installation

- 1 - TOP LEDGE
- 2 - BRAKESHOE TAB ON LEDGE OUTER SURFACE
- 3 - LEDGE SEATED IN BRAKESHOE NOTCH
- 4 - BOTTOM LEDGE

condition, check caliper bolt length before proceeding. Bolts must not have a shank length greater than 67.6 mm (2.66 in.) (Fig. 30).

(4) Install brake hose to caliper with **new seal washers** and tighten fitting bolt to 31 N·m (23 ft. lbs.).

REMOVAL AND INSTALLATION (Continued)

CORRECT SHANK LENGTH:

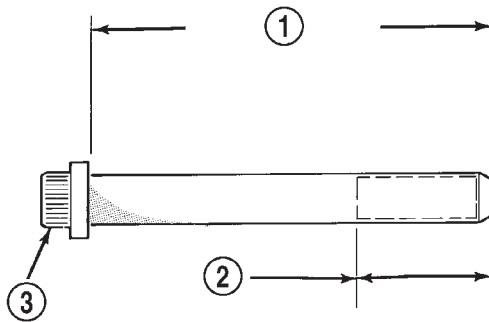

J9405-154

Fig. 30 Mounting Bolt Dimensions

- 1 - 67 mm (± 0.6 mm) 2.637 in. (± 0.0236 in.)
- 2 - 22 mm (0.866 in.) THREAD LENGTH
- 3 - CALIPER BOLT

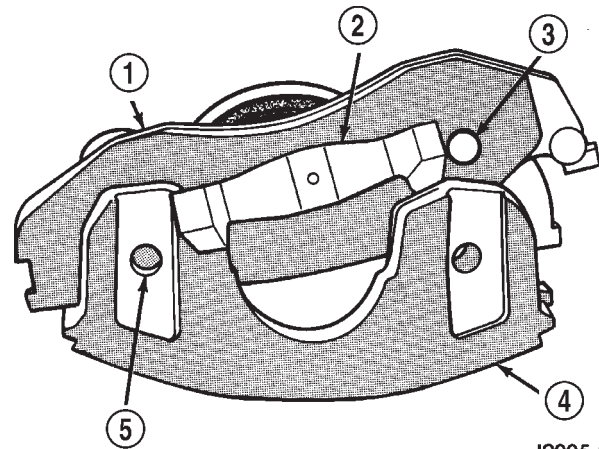

J9005-83

Fig. 31 Outboard Brake Shoe Removal

- 1 - OUTBOARD BRAKESHOE
- 2 - SHOE SPRING
- 3 - LOCATING LUG
- 4 - CALIPER
- 5 - LOCATING LUG

CAUTION: Verify brake hose is not twisted or kinked before tightening fitting bolt.

- (5) Bleed base brake system.
- (6) Install wheel and tire assemblies.
- (7) Remove supports and lower vehicle.
- (8) Verify firm pedal before moving vehicle.

FRONT DISC BRAKE SHOES

REMOVAL

- (1) Raise and support vehicle.
- (2) Remove wheel and tire assembly.
- (3) Remove caliper.
- (4) Pressing one end of outboard shoe inward to disengage shoe lug. Then rotate shoe upward until retainer spring clears caliper. Press opposite end of shoe inward to disengage shoe lug and rotate shoe up and out of caliper (Fig. 31).
- (5) Grasp ends of inboard shoe and tilt shoe outward to release springs from caliper piston (Fig. 32) and remove shoe from caliper.

NOTE: If original brake shoes will be used, keep them in sets left and right. They are not interchangeable.

(6) Secure caliper to nearby suspension part with wire. **Do not allow brake hose to support caliper weight.**

- (7) Wipe caliper off with shop rags or towels.

CAUTION: Do not use compressed air, this can unseat dust boot and force dirt into piston bore.

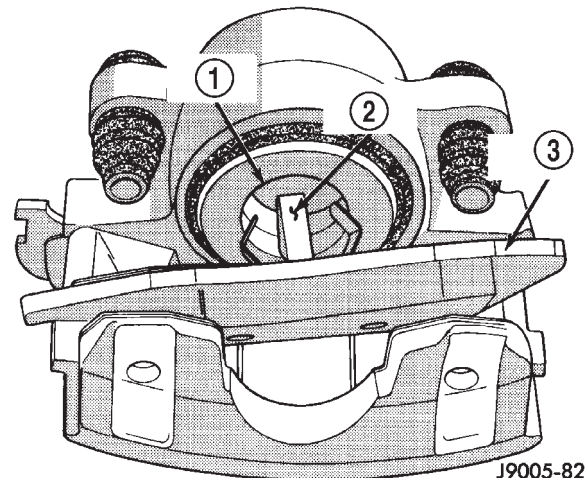

J9005-82

Fig. 32 Inboard Brake Shoe Removal

- 1 - CALIPER PISTON
- 2 - SHOE SPRINGS
- 3 - INBOARD BRAKESHOE

INSTALLATION

- (1) Install inboard shoe in caliper and verify shoe retaining is fully seated into the piston.
- (2) Starting one end of outboard shoe in caliper and rotating shoe downward into place. Verify shoe locating lugs and shoe spring are seated.
- (3) Install caliper.
- (4) Install wheel and tire assembly.
- (5) Remove support and lower vehicle.
- (6) Pump brake pedal until caliper pistons and brake shoes are seated.
- (7) Top off brake fluid level if necessary.

REMOVAL AND INSTALLATION (Continued)

DISC BRAKE ROTOR

REMOVAL

- (1) Remove wheel and tire assemble.
- (2) Remove caliper.
- (3) Remove retainers securing rotor to hub studs (Fig. 33).
- (4) Remove rotor from hub.
- (5) If rotor shield requires service, remove front hub and bearing assembly.

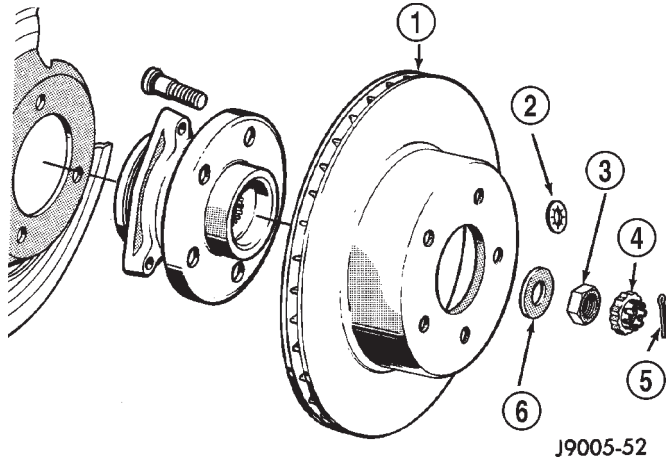

Fig. 33 Rotor & Hub

- 1 - ROTOR
- 2 - RETAINER
- 3 - BEARING NUT
- 4 - NUT LOCK
- 5 - COTTER PIN
- 6 - WASHER

INSTALLATION

- (1) If new rotor is being installed, remove protective coating from rotor surfaces with carburetor cleaner.
- (2) Install rotor on hub.
- (3) Install caliper.
- (4) Install wheel and tire assembly.

DRUM BRAKE SHOES

REMOVAL

- (1) Raise vehicle and remove rear wheels.
- (2) Remove and discard spring nuts securing drums to wheel studs.
- (3) Remove brake drums. If drums prove difficult to remove, retract brake shoes. Remove access plug at the rear of backing plate and back off adjuster screw with brake tool and screwdriver.
- (4) Remove U-clip and washer securing adjuster cable to parking brake lever (Fig. 34).
- (5) Remove primary and secondary return springs from anchor pin with brake spring pliers.

- (6) Remove hold-down springs, retainers and pins with standard retaining spring tool.
- (7) Install spring clamps on wheel cylinders to hold pistons in place.
- (8) Remove adjuster lever, adjuster screw and spring.
- (9) Remove adjuster cable and cable guide.
- (10) Remove brake shoes and parking brake strut.
- (11) Disconnect cable from parking brake lever and remove lever.

INSTALLATION

- (1) Clean support plate with brake cleaner.
- (2) If new drums are being installed, remove protective coating with carburetor cleaner followed by final rinse with brake cleaner.
- (3) Clean and lubricate anchor pin with light coat of Mopar multi-mileage grease.
- (4) Apply Mopar multi-mileage grease to brake shoe contact surfaces of support plate (Fig. 35).
- (5) Lubricate adjuster screw threads and pivot with spray lube.
- (6) Attach parking brake lever to secondary brake shoe. Use new washer and U-clip to secure lever.
- (7) Remove wheel cylinder clamps.
- (8) Attach parking brake cable to lever.
- (9) Install brake shoes on support plate. Secure shoes with new hold-down springs, pins and retainers.
- (10) Install parking brake strut and spring.
- (11) Install guide plate and adjuster cable on anchor pin.
- (12) Install primary and secondary return springs.
- (13) Install adjuster cable guide on secondary shoe.
- (14) Lubricate and assemble adjuster screw.
- (15) Install adjuster screw, spring and lever and connect to adjuster cable.
- (16) Adjust shoes to drum.
- (17) Install wheel/tire assemblies and lower vehicle.
- (18) Verify firm brake pedal before moving vehicle.

WHEEL CYLINDER

REMOVAL

- (1) Remove wheel and tire assembly.
- (2) Remove brake drum.
- (3) Disconnect wheel cylinder brake line.
- (4) Remove brake shoe return springs and move shoes out of engagement with cylinder push rods.
- (5) Remove cylinder attaching bolts and remove cylinder from support plate.

REMOVAL AND INSTALLATION (Continued)

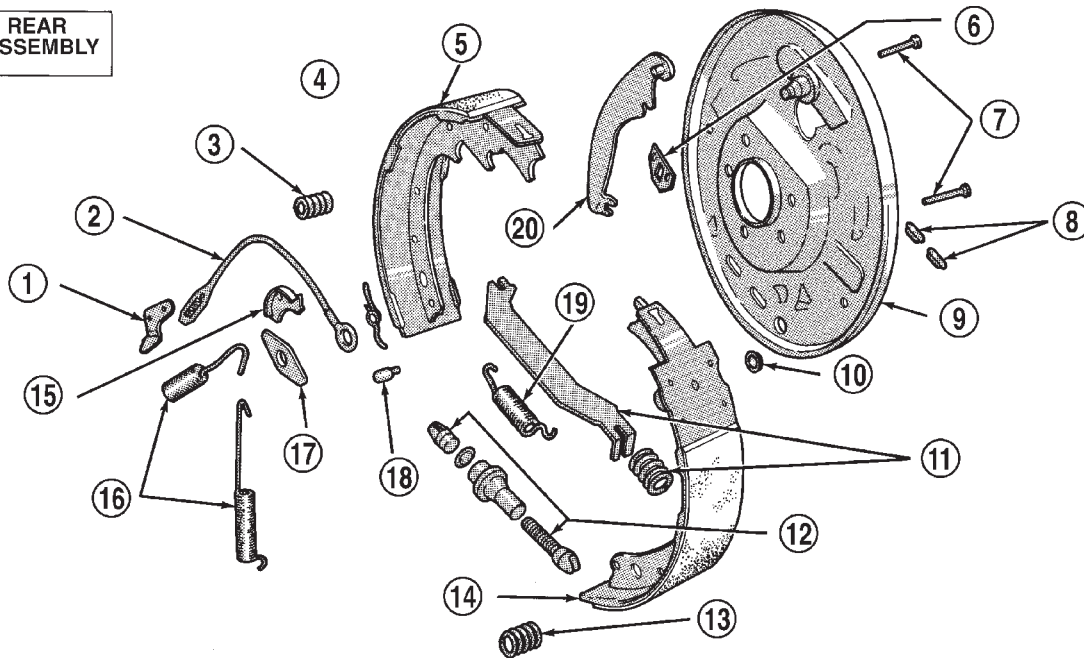
RIGHT REAR
BRAKE ASSEMBLY

J9005-13

Fig. 34 Drum Brake Components—Typical

- | | |
|-----------------------------------|------------------------------------|
| 1 - ADJUSTER LEVER | 11 - PARK BRAKE STRUT AND SPRING |
| 2 - ADJUSTER CABLE | 12 - ADJUSTER SCREW ASSEMBLY |
| 3 - HOLDDOWN SPRING AND RETAINERS | 13 - HOLDDOWN SPRING AND RETAINERS |
| 4 - ADJUSTER LEVER SPRING | 14 - LEADING SHOE |
| 5 - TRAILING SHOE | 15 - CABLE GUIDE |
| 6 - CYLINDER-TO-SUPPORT SEAL | 16 - SHOE RETURN SPRINGS |
| 7 - HOLDDOWN PINS | 17 - SHOE GUIDE PLATE |
| 8 - ACCESS PLUGS | 18 - PIN |
| 9 - SUPPORT PLATE | 19 - SHOE SPRING |
| 10 - CABLE HOLE PLUG | 20 - PARK BRAKE LEVER |

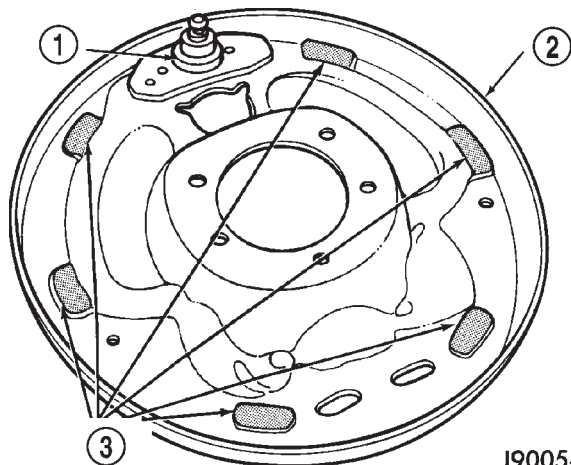

J9005-14

Fig. 35 Shoe Contact Surfaces

- 1 - ANCHOR PIN
2 - SUPPORT PLATE
3 - SHOE CONTACT SURFACES

INSTALLATION

- (1) Apply bead of silicone sealer around cylinder mounting surface of support plate.
- (2) Install cylinder mounting bolts and tighten to 20 N·m (15 ft. lbs.).
- (3) Connect brake line to cylinder.
- (4) Install brake shoe return spring.
- (5) Install brake drum.
- (6) Install wheel and tire assembly.
- (7) Bleed base brake system.

BRAKE SUPPORT PLATE**REMOVAL**

- (1) Remove wheel and tire assembly and brake drum.
- (2) Remove brake shoe assembly.
- (3) Remove parking brake cable from parking brake lever.
- (4) Compress parking brake cable retainer tabs. Then push retainer and cable through and out of support plate.

REMOVAL AND INSTALLATION (Continued)

- (5) Disconnect brake line at wheel cylinder.
- (6) Remove wheel cylinder from support plate.
- (7) Remove axle shaft, refer to Group 3 for procedures.
- (8) Remove bolts attaching support plate to axle and remove support plate.

INSTALLATION

- (1) Apply bead of silicone sealer around axle mounting surface of support plate.
- (2) Install support plate on axle flange. Tighten attaching bolts to 115 N·m (85 ft. lbs.).
- (3) Apply bead of silicone sealer around wheel cylinder mounting surface and install wheel cylinder.
- (4) Install brake line in wheel cylinder.
- (5) Install parking brake cable in support plate.
- (6) Install axle shaft, refer to Group 3 for procedure.
- (7) Connect parking brake cable to lever on secondary shoe and install brake shoes on support plate.
- (8) Adjust brake shoes to drum with brake gauge.
- (9) Install brake drum and wheel and tire assembly.
- (10) Bleed brake system.

REAR PARKING BRAKE CABLES

REMOVAL

- (1) Raise vehicle and loosen equalizer nuts until rear cables are slack.
- (2) Disengage cables from equalizer and compress cable retainers with a worm drive hose clamp.
- (3) Remove cables from the cable bracket (Fig. 36).
- (4) Remove rear wheel and brake drums.
- (5) Remove secondary brake shoe and disconnect cable from lever on brake shoe.
- (6) Compress cables retainer with worm drive hose clamp (Fig. 37) and remove cables from backing plates.

INSTALLATION

- (1) Install new cables in backing plates. Be sure cable retainer is seated.
- (2) Attach cable to lever on brake shoe and install brake shoe on backing plate.
- (3) Adjust brake shoes to drum with brake gauge.
- (4) Install brake drums and wheels.
- (5) Install cables into the cable bracket and insure retainers are seated in the bracket.
- (6) Engage the cable ends into the equalizer and install equalizer nut.
- (7) Adjust parking brakes.

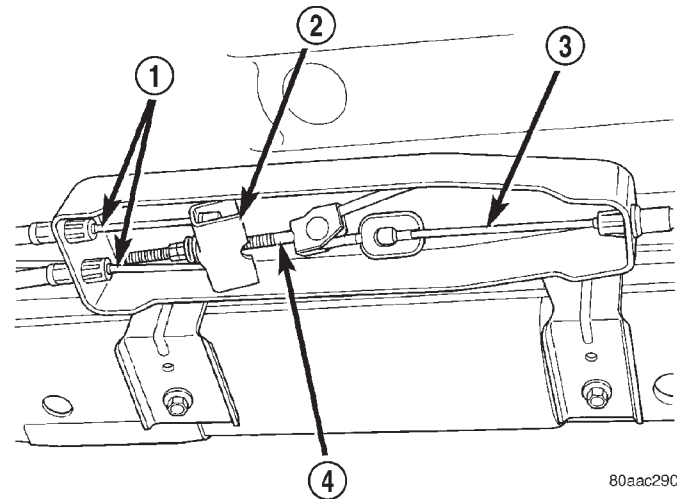

Fig. 36 Parking Brake Cables

- 1 - REAR CABLES
- 2 - EQUALIZER
- 3 - FRONT CABLE
- 4 - TENSIONER ROD

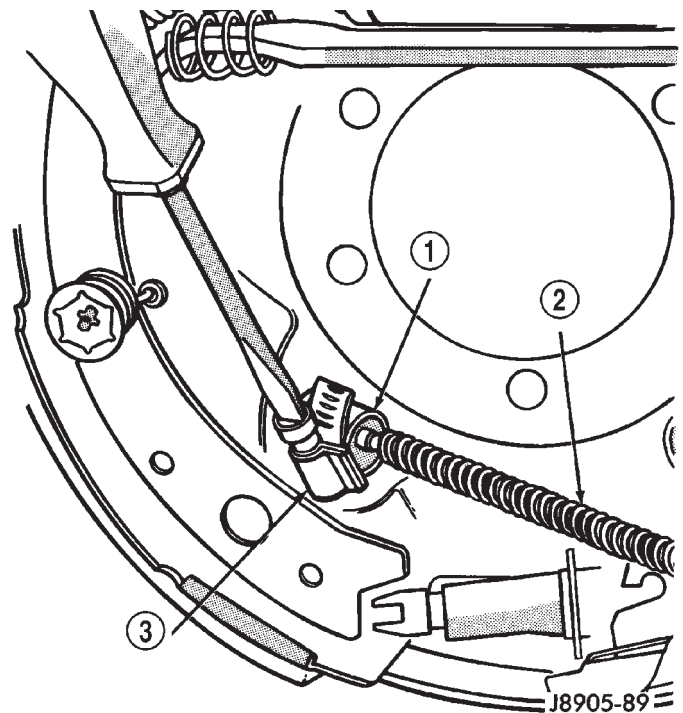

Fig. 37 Cable Retainer

- 1 - CABLE RETAINER
- 2 - REAR CABLE
- 3 - WORM DRIVE HOSE CLAMP

PARKING BRAKE LEVER

The center console must be removed to service the parking brake lever. Refer to Group 23 Interior Components for service procedures.

REMOVAL AND INSTALLATION (Continued)

REMOVAL

- (1) Release parking brakes.
- (2) Raise vehicle.
- (3) Remove adjusting nut from tensioner rod at the equalizer (Fig. 38).

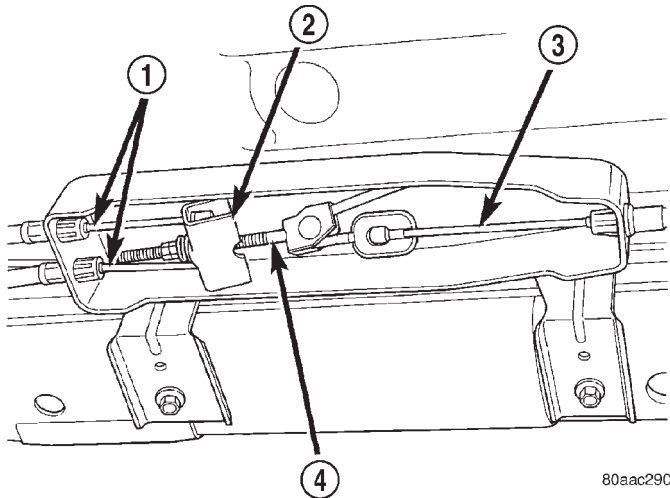

Fig. 38 Parking Brake Equalizer

- 1 - REAR CABLES
- 2 - EQUALIZER
- 3 - FRONT CABLE
- 4 - TENSIONER ROD

- (4) Lower vehicle.
- (5) Disengage front cable from the cable lever.
- (6) Compress cable retainer with worm drive hose clamp and remove the cable from the parking brake lever base.
- (7) Disconnect parking brake lamp switch wire (Fig. 39).
- (8) Remove parking brake lever assembly mounting bolts (Fig. 39).
- (9) Remove lever assembly.
- (10) Remove parking brake lamp switch.

INSTALLATION

- (1) Install parking brake lamp switch.
- (2) Position lever assembly on floorpan and install lever mounting bolts.
- (3) Tighten lever mounting bolts to 10 to 14 N·m (7 to 10 ft. lbs.).
- (4) Insert front cable through the parking brake lever base. Insure the cable retainer is seated into the base.
- (5) Attach the front cable to the cable lever (Fig. 39).
- (6) Connect parking brake lamp switch wire.
- (7) Raise vehicle.
- (8) Install adjusting nut to the tensioner rod and adjust parking brakes.
- (9) Lower vehicle.

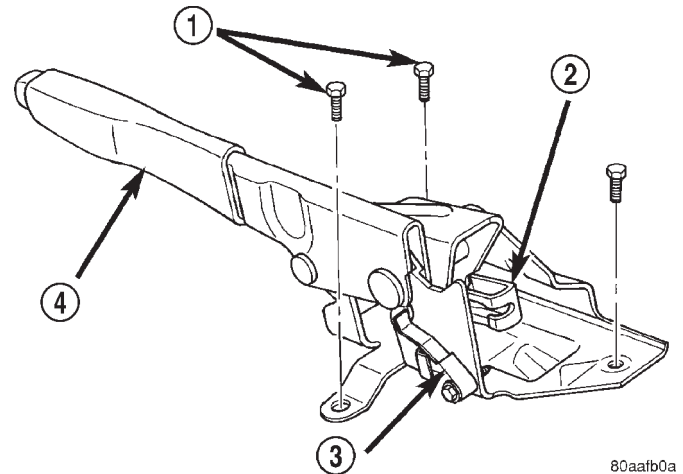

Fig. 39 Parking Brake Lever Assembly

- 1 - MOUNTING BOLTS
- 2 - FRONT CABLE LEVER
- 3 - PARKING BRAKE SWITCH
- 4 - PARKING BRAKE LEVER

- (10) Verify correct parking brake operation.

DISASSEMBLY AND ASSEMBLY

MASTER CYLINDER RESERVOIR

REMOVAL

- (1) Remove reservoir cap and empty fluid into drain container.
- (2) Remove pins that retain reservoir to master cylinder. Use hammer and pin punch to remove pins (Fig. 40).

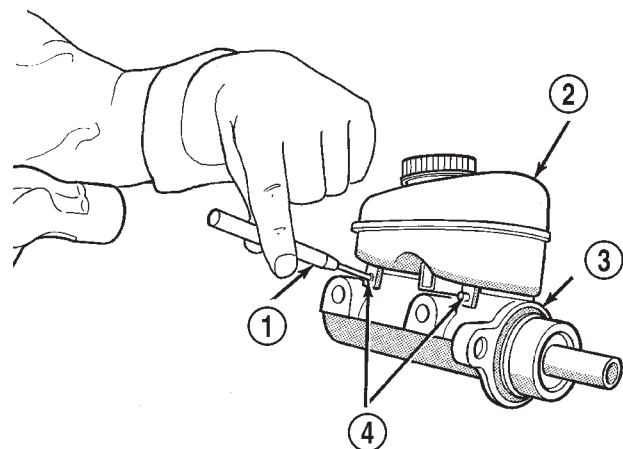

Fig. 40 Reservoir Retaining Pins

- 1 - PIN PUNCH
- 2 - RESERVOIR
- 3 - BODY
- 4 - ROLL PINS

DISASSEMBLY AND ASSEMBLY (Continued)

(3) Clamp cylinder body in vise with brass protective jaws.

(4) Loosen reservoir from grommets with pry tool (Fig. 41).

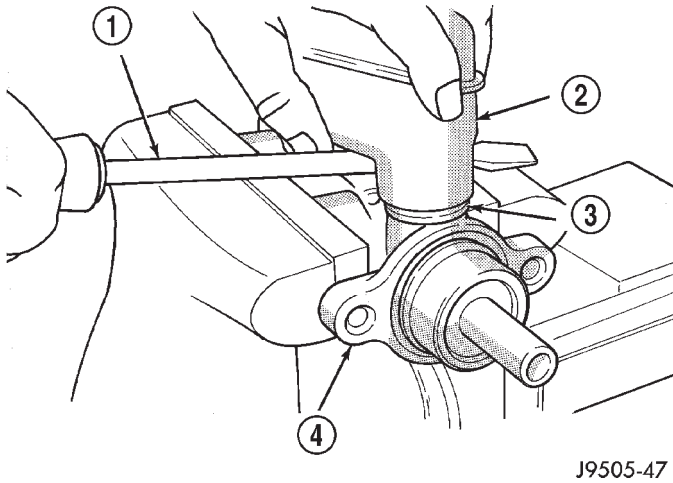

Fig. 41 Loosening Reservoir

- 1 - PRY TOOL
- 2 - RESERVOIR
- 3 - GROMMET
- 4 - MASTER CYLINDER BODY

(5) Remove reservoir by rocking it to one side and pulling free of grommets (Fig. 42).

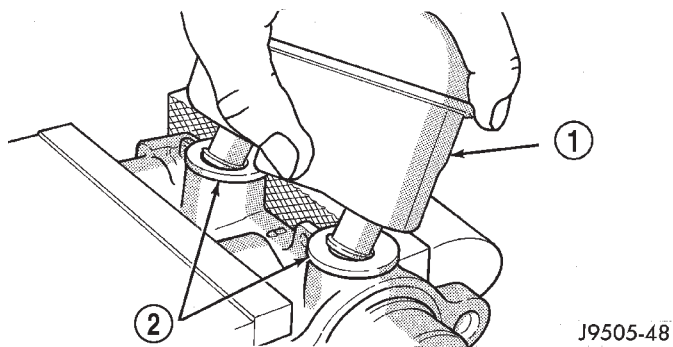

Fig. 42 Reservoir Removal

- 1 - RESERVOIR
- 2 - GROMMETS

(6) Remove old grommets from cylinder body (Fig. 43).

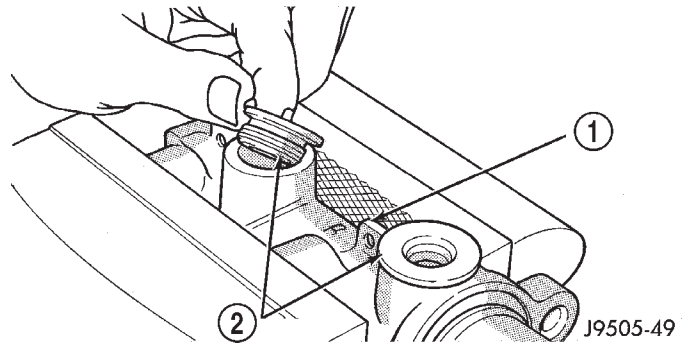

Fig. 43 Grommet Removal

- 1 - MASTER CYLINDER BODY
- 2 - GROMMETS

(1) Lubricate new grommets with clean brake fluid and install new grommets in cylinder body (Fig. 44). Use finger pressure to install and seat grommets.

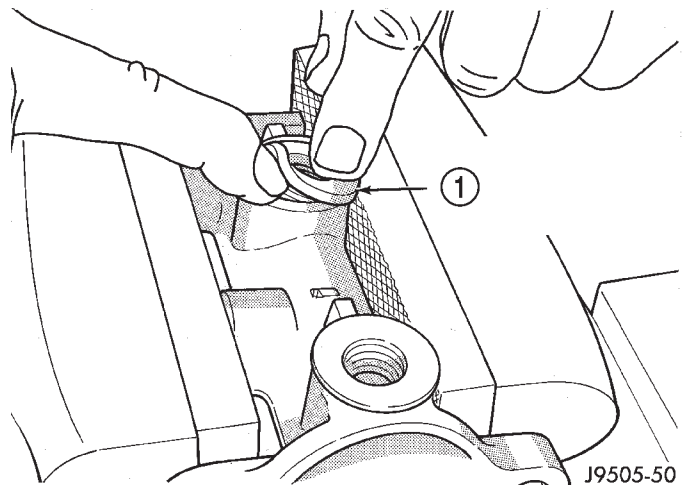

Fig. 44 Grommet Installation

- 1 - WORK NEW GROMMETS INTO PLACE USING FINGER PRESSURE ONLY

(2) Start reservoir in grommets. Then rock reservoir back and forth while pressing downward to seat it in grommets.

(3) Install pins that retain reservoir to cylinder body.

(4) Fill and bleed master cylinder on bench before installation in vehicle.

INSTALLATION

CAUTION: Do not use any type of tool to install the grommets. Tools may cut, or tear the grommets creating a leak problem after installation. Install the grommets using finger pressure only.

DISC BRAKE CALIPER

DISASSEMBLY

- (1) Remove brake shoes from caliper.
- (2) Drain brake fluid out of caliper.
- (3) Take a piece of wood and pad it with one-inch thickness of shop towels. Place this piece in the out-board shoe side of the caliper in front of the piston.

DISASSEMBLY AND ASSEMBLY (Continued)

This will cushion and protect caliper piston during removal (Fig. 45).

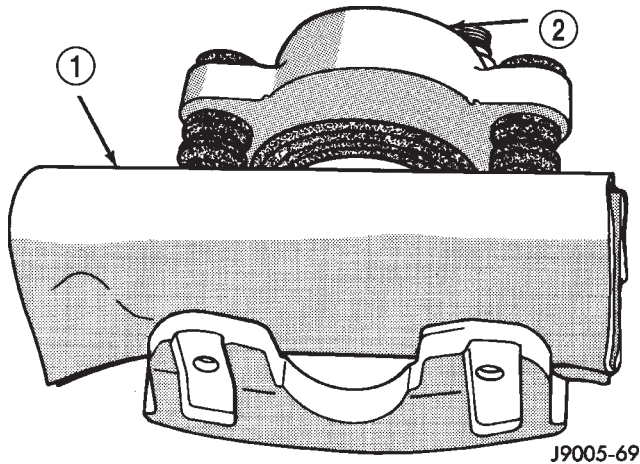

J9005-69

Fig. 45 Padding Caliper Interior

- 1 - SHOP TOWELS OR CLOTHS
2 - CALIPER

(4) Remove caliper piston with **short bursts** of low pressure compressed air. Direct air through fluid inlet port and ease piston out of bore (Fig. 46).

CAUTION: Do not blow the piston out of the bore with sustained air pressure. This could result in a cracked piston. Use only enough air pressure to ease the piston out.

WARNING: NEVER ATTEMPT TO CATCH THE PISTON AS IT LEAVES THE BORE. THIS MAY RESULT IN PERSONAL INJURY.

(5) Remove caliper piston dust boot with suitable pry tool (Fig. 47).

(6) Remove caliper piston seal with wood or plastic tool (Fig. 48). Do not use metal tools as they will scratch piston bore.

(7) Remove caliper mounting bolt bushings and boots (Fig. 49).

ASSEMBLY

CAUTION: Dirt, oil, and solvents can damage caliper seals. Insure assembly area is clean and dry.

(1) Lubricate caliper piston bore, new piston seal and piston with clean brake fluid.

(2) Lubricate caliper bushings and interior of bushing boots with silicone grease.

(3) Install bushing boots in caliper, then insert bushing into boot and push bushing into place (Fig. 50).

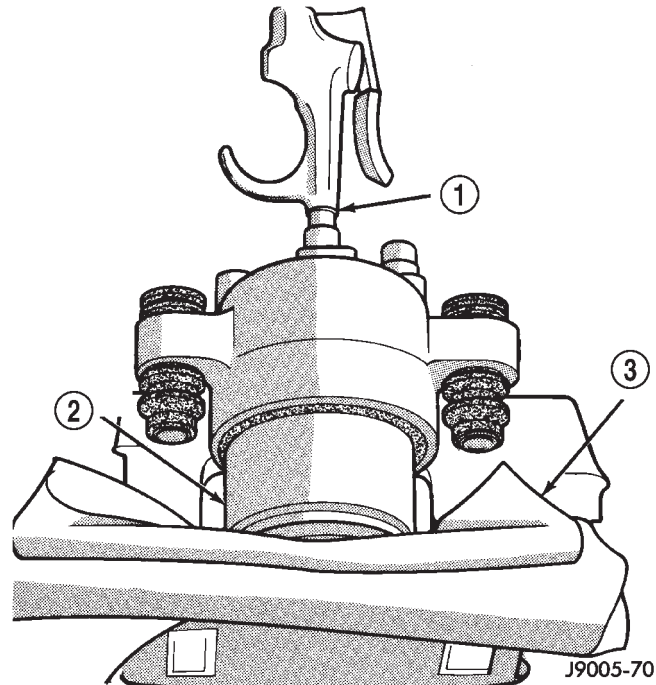

J9005-70

Fig. 46 Caliper Piston Removal

- 1 - AIR GUN
2 - CALIPER PISTON
3 - PADDING MATERIAL

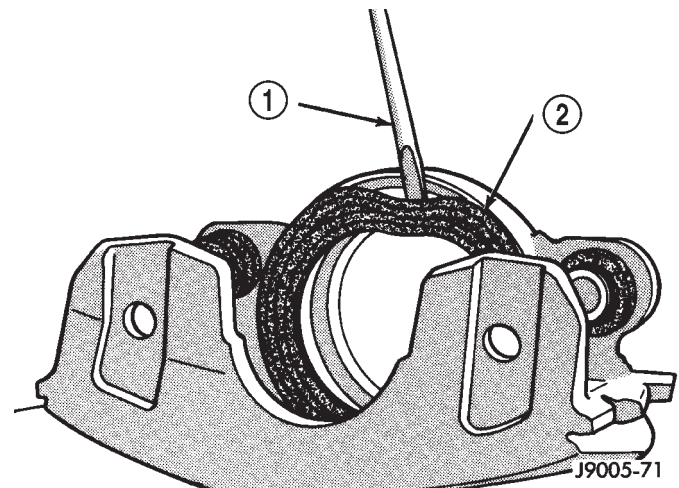

J9005-71

Fig. 47 Caliper Piston Dust Boot Removal

- 1 - COLLAPSE BOOT WITH PUNCH OR SCREWDRIVER
2 - PISTON DUST BOOT

(4) Install new piston seal into seal groove with finger (Fig. 51).

(5) Install new dust boot on caliper piston and seat boot in piston groove (Fig. 52).

(6) Press piston into caliper bore by hand, use a turn and push motion to work piston into seal (Fig. 53).

(7) Press caliper piston to bottom of bore.

DISASSEMBLY AND ASSEMBLY (Continued)

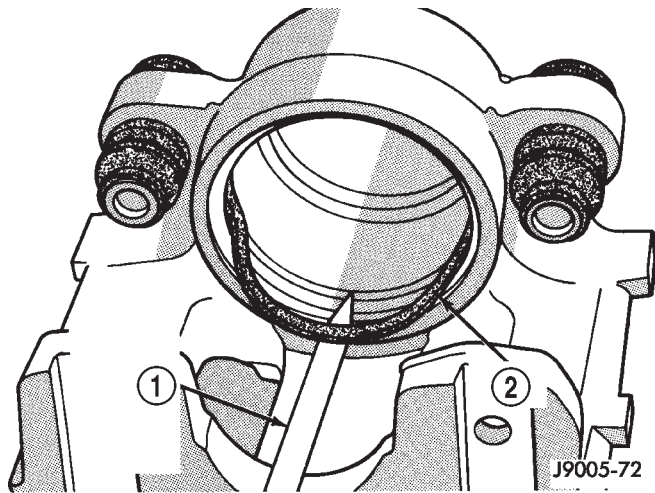

Fig. 48 Piston Seal Removal

- 1 - REMOVE SEAL WITH WOOD PENCIL OR SIMILAR TOOL
- 2 - PISTON SEAL

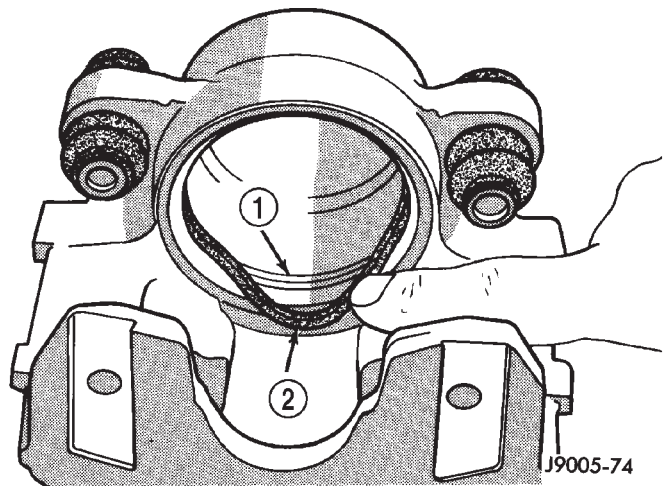

Fig. 51 Piston Seal Installation

- 1 - SEAL GROOVE
- 2 - PISTON SEAL

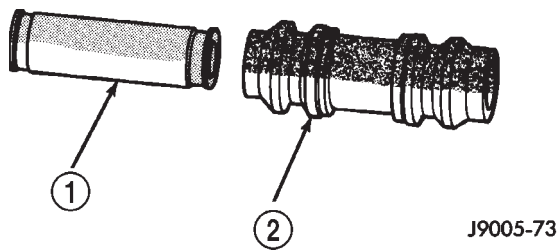

Fig. 49 Mounting Bolt Bushing And Boot

- 1 - CALIPER SLIDE BUSHING
- 2 - BOOT

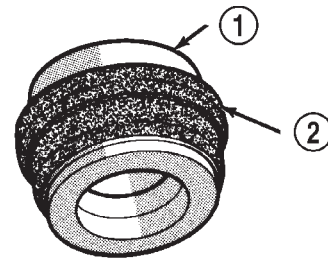

Fig. 52 Dust Boot On Piston

- 1 - PISTON
- 2 - DUST BOOT

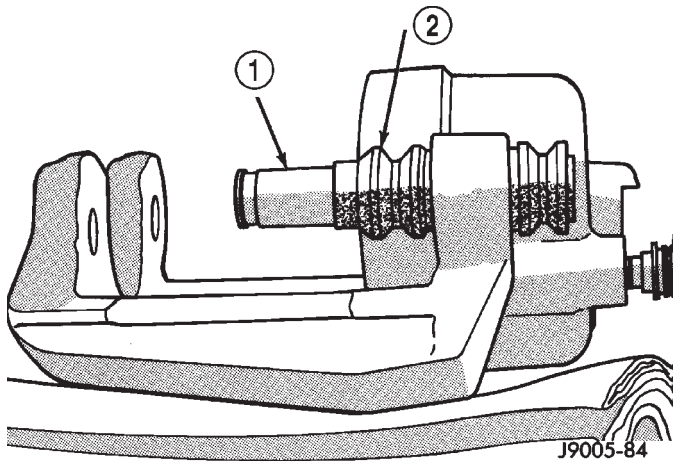

Fig. 50 Bushings And Boots Installation

- 1 - BUSHING
- 2 - BOOT

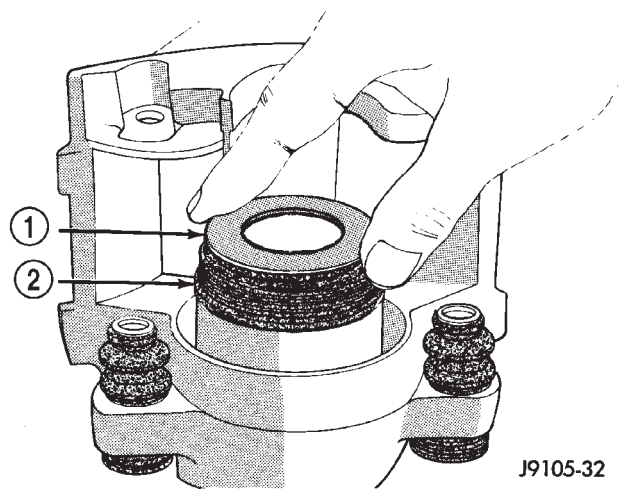

Fig. 53 Caliper Piston Installation

- 1 - PISTON
- 2 - BOOT

DISASSEMBLY AND ASSEMBLY (Continued)

(8) Seat dust boot in caliper with Installer Tool C-4842 and Tool Handle C-4171 (Fig. 54).

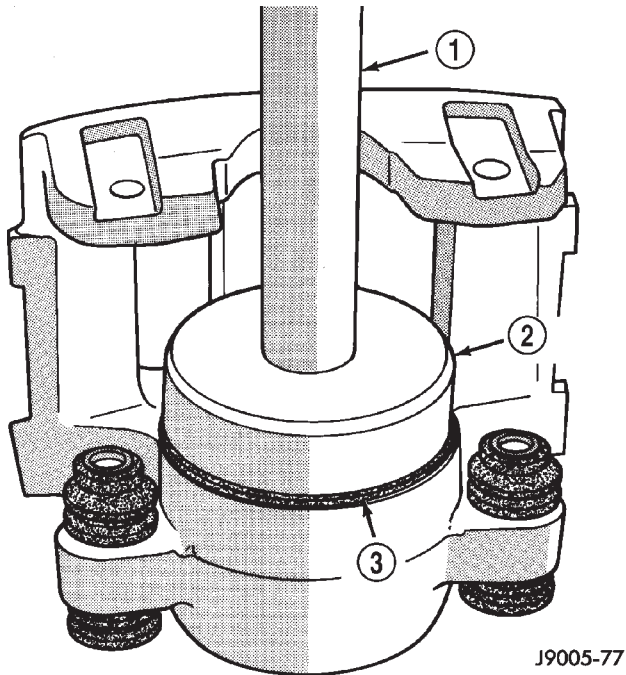

Fig. 54 Piston Dust Boot Installation

- 1 - HANDLE C-4171
- 2 - INSTALLER C-4842
- 3 - DUST BOOT

(9) Replace caliper bleed screw if removed.

WHEEL CYLINDER

DISASSEMBLY

- (1) Remove push rods and boots (Fig. 55).
- (2) Press pistons, cups and spring and expander out of cylinder bore.
- (3) Remove bleed screw.

ASSEMBLY

- (1) Lubricate wheel cylinder bore, pistons, piston cups and spring and expander with clean brake fluid.
- (2) Install first piston in cylinder bore. Then install first cup in bore and against piston. **Be sure lip of piston cup is facing inward (toward spring and expander) and flat side is against piston.**
- (3) Install spring and expander followed by remaining piston cup and piston.
- (4) Install boots on each end of cylinder and insert push rods in boots.
- (5) Install cylinder bleed screw.

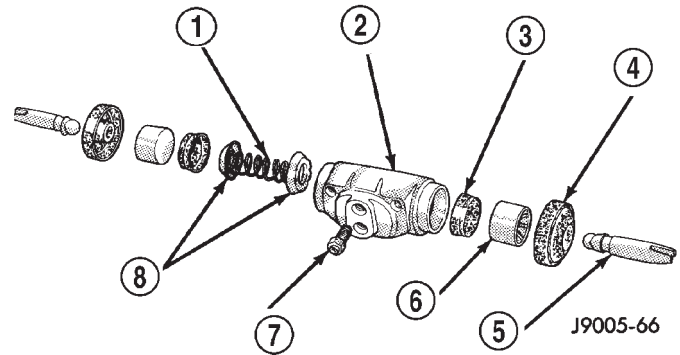

Fig. 55 Wheel Cylinder Components—Typical

- 1 - SPRING
- 2 - CYLINDER
- 3 - PISTON CLIP
- 4 - BOOT
- 5 - PUSH ROD
- 6 - PISTON
- 7 - BLEED SCREW
- 8 - CUP EXPANDERS

CLEANING AND INSPECTION

CALIPER

CLEANING

Clean the caliper components with clean brake fluid or brake clean only. Wipe the caliper and piston dry with lint free towels or use low pressure compressed air.

CAUTION: Do not use gasoline, kerosene, thinner, or similar solvents. These products may leave a residue that could damage the piston and seal.

INSPECTION

The piston is made from a phenolic resin (plastic material) and should be smooth and clean.

The piston must be replaced if cracked or scored. Do not attempt to restore a scored piston surface by sanding or polishing.

CAUTION: If the caliper piston is replaced, install the same type of piston in the caliper. Never interchange phenolic resin and steel caliper pistons. The pistons, seals, seal grooves, caliper bore and piston tolerances are different.

The bore can be **lightly** polished with a brake hone to remove very minor surface imperfections (Fig. 56). The caliper should be replaced if the bore is severely corroded, rusted, scored, or if polishing would increase bore diameter more than 0.025 mm (0.001 inch).

CLEANING AND INSPECTION (Continued)

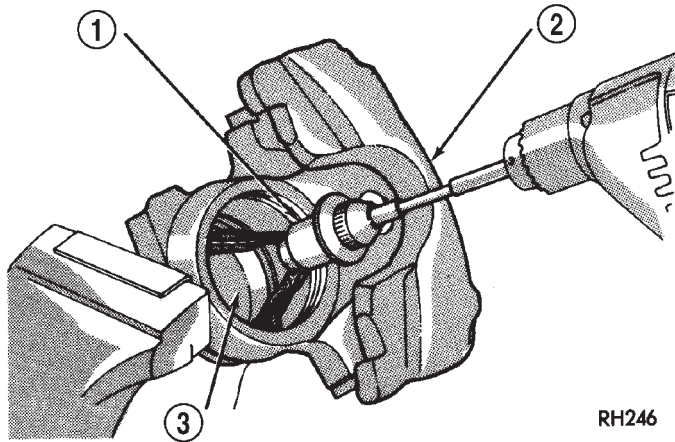

RH246

Fig. 56 Polishing Piston Bore

- 1 - SPECIAL HONE
- 2 - CALIPER
- 3 - PISTON BORE

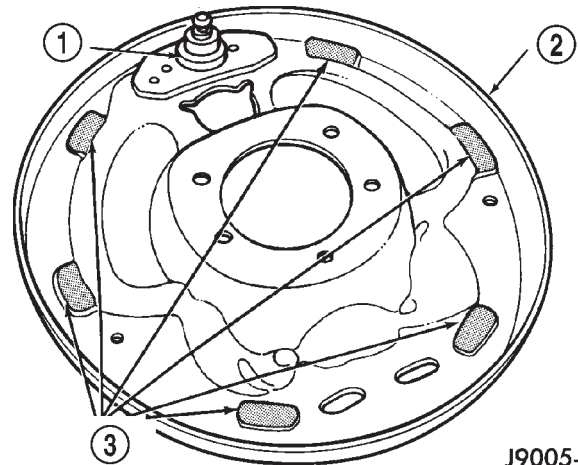

J9005-14

Fig. 57 Shoe Contact Surfaces

- 1 - ANCHOR PIN
- 2 - SUPPORT PLATE
- 3 - SHOE CONTACT SURFACES

REAR DRUM BRAKE**CLEANING**

Clean the individual brake components, including the support plate and wheel cylinder exterior, with a water dampened cloth or with brake cleaner. Do not use any other cleaning agents. Remove light rust and scale from the brake shoe contact pads on the support plate with fine sandpaper.

INSPECTION

As a general rule, riveted brake shoes should be replaced when worn to within 0.78 mm (1/32 in.) of the rivet heads. Bonded lining should be replaced when worn to a thickness of 1.6 mm (1/16 in.).

Examine the lining contact pattern to determine if the shoes are bent or the drum is tapered. The lining should exhibit contact across its entire width. Shoes exhibiting contact only on one side should be replaced and the drum checked for runout or taper.

Inspect the adjuster screw assembly. Replace the assembly if the star wheel or threads are damaged, or the components are severely rusted or corroded.

Discard the brake springs and retainer components if worn, distorted or collapsed. Also replace the springs if a brake drag condition had occurred. Overheating will distort and weaken the springs.

Inspect the brake shoe contact pads on the support plate, replace the support plate if any of the pads are worn or rusted through. Also replace the plate if it is bent or distorted (Fig. 57).

WHEEL CYLINDER**CLEANING**

Clean the cylinder and pistons with clean brake fluid or brake cleaner only. Do not use any other cleaning agents.

Dry the cylinder and pistons with compressed air. Do not use rags or shop towels to dry the cylinder components. Lint from cloth material will adhere to the cylinder bores and pistons.

INSPECTION

Inspect the cylinder bore. Light discoloration and dark stains in the bore are normal and will not impair cylinder operation.

The cylinder bore can be lightly polished but only with crocus cloth. Replace the cylinder if the bore is scored, pitted or heavily corroded. Honing the bore to restore the surface is not recommended.

Inspect the cylinder pistons. The piston surfaces should be smooth and free of scratches, scoring and corrosion. Replace the pistons if worn, scored, or corroded. Do attempt to restore the surface by sanding or polishing.

Discard the old piston cups and the spring and expander. These parts are not reusable. The original dust boots may be reused but only if they are in good condition.

ADJUSTMENTS

BRAKE LAMP SWITCH

- (1) Press and hold brake pedal in applied position.
- (2) Pull switch plunger all the way out to fully extended position.
- (3) Release brake pedal. Then pull pedal lightly rearward. Pedal will set plunger to correct position as pedal pushes plunger into switch body. Switch will make ratcheting sound as it self adjusts.

CAUTION: Booster damage may occur if the pedal pull exceeds 20 lbs..

REAR DRUM BRAKE

The rear drum brakes are equipped with a self-adjusting mechanism. Under normal circumstances, the only time adjustment is required is when the shoes are replaced, removed for access to other parts, or when one or both drums are replaced.

Adjustment can be made with a standard brake gauge or with adjusting tool. Adjustment is performed with the complete brake assembly installed on the backing plate.

ADJUSTMENT WITH BRAKE GAUGE

- (1) Be sure parking brakes are fully released.
- (2) Raise rear of vehicle and remove wheels and brake drums.
- (3) Verify that left and right automatic adjuster levers and cables are properly connected.
- (4) Insert brake gauge in drum. Expand gauge until gauge inner legs contact drum braking surface. Then lock gauge in position (Fig. 58).

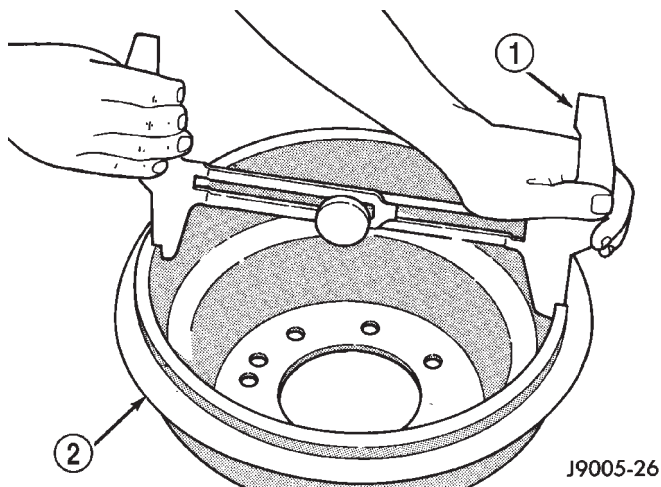

Fig. 58 Adjusting Gauge On Drum

- 1 - BRAKE GAUGE
2 - BRAKE DRUM

- (5) Reverse gauge and install it on brake shoes. Position gauge legs at shoe centers as shown (Fig. 59). If gauge does not fit (too loose/too tight), adjust shoes.

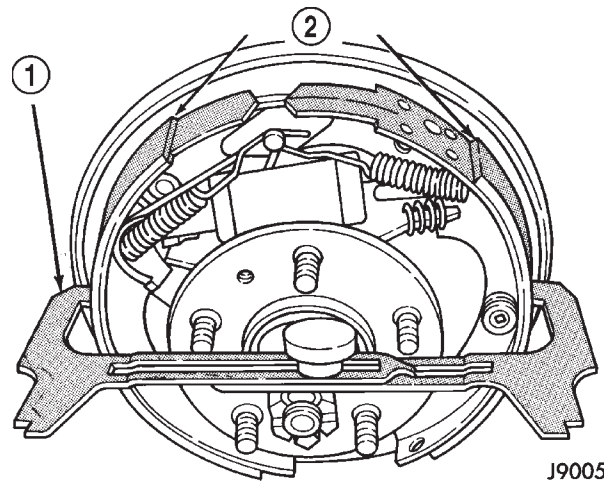

Fig. 59 Adjusting Gauge On Brake Shoes

- 1 - BRAKE GAUGE
2 - BRAKE SHOES

- (6) Pull shoe adjuster lever away from adjuster screw star wheel.

- (7) Turn adjuster screw star wheel (by hand) to expand or retract brake shoes. Continue adjustment until gauge outside legs are light drag-fit on shoes.

- (8) Install brake drums and wheels and lower vehicle.

- (9) Drive vehicle and make one forward stop followed by one reverse stop. Repeat procedure 8-10 times to operate automatic adjusters and equalize adjustment.

NOTE: Bring vehicle to complete standstill at each stop. Incomplete, rolling stops will not activate automatic adjusters.

ADJUSTMENT WITH ADJUSTING TOOL

- (1) Be sure parking brake lever is fully released.
- (2) Raise vehicle so rear wheels can be rotated freely.
- (3) Remove plug from each access hole in brake support plates.
- (4) Loosen parking brake cable adjustment nut until there is slack in front cable.
- (5) Insert adjusting tool through support plate access hole and engage tool in teeth of adjusting screw star wheel (Fig. 60).
- (6) Rotate adjuster screw star wheel (move tool handle upward) until slight drag can be felt when wheel is rotated.

ADJUSTMENTS (Continued)

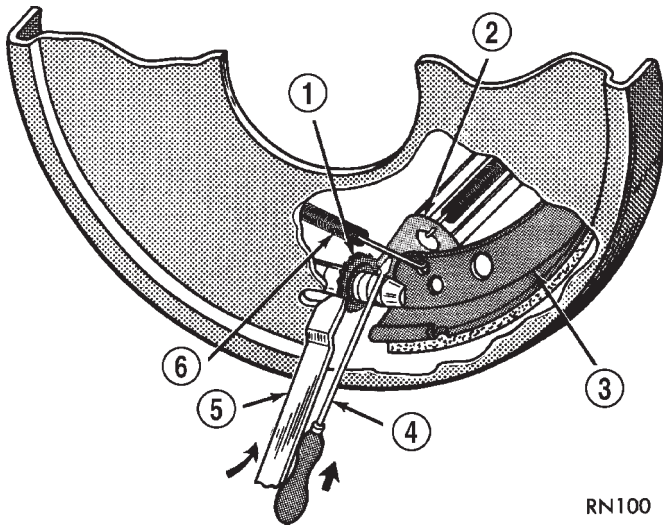

Fig. 60 Brake Adjustment

- 1 - STAR WHEEL
- 2 - LEVER
- 3 - BRAKE SHOE WEB
- 4 - SCREWDRIVER
- 5 - ADJUSTING TOOL
- 6 - ADJUSTER SPRING

- (7) Push and hold adjuster lever away from star wheel with thin screwdriver.
- (8) Back off adjuster screw star wheel until brake drag is eliminated.
- (9) Repeat adjustment at opposite wheel. Be sure adjustment is equal at both wheels.
- (10) Install support plate access hole plugs.
- (11) Adjust parking brake cable and lower vehicle.
- (12) Drive vehicle and make one forward stop followed by one reverse stop. Repeat procedure 8-10 times to operate automatic adjusters and equalize adjustment.

NOTE: Bring vehicle to complete standstill at each stop. Incomplete, rolling stops will not activate automatic adjusters.

PARKING BRAKE CABLE TENSIONER

NOTE: Parking brake adjustment is only necessary when the tensioner, or a cable has been replaced or disconnected.

ADJUSTMENT

- (1) Raise vehicle.
- (2) Back off tensioner adjusting nut to create slack in cables.
- (3) Remove rear wheel/tire assemblies and remove brake drums.

- (4) Check rear brake shoe adjustment with standard brake gauge.

CAUTION: Excessive shoe-to-drum clearance, or worn brake components will result in faulty parking brake adjustment and operation.

- (5) Verify that parking brake cables operate freely and are not binding, or seized. Replace faulty cables, before proceeding.

- (6) Reinstall brake drums and wheel/tire assemblies after brake shoe adjustment is complete.

- (7) Lower vehicle enough for access to parking brake lever. Then **fully** apply parking brakes. Leave brakes applied until adjustment is complete.

- (8) Raise vehicle and mark tensioner rod 6.5 mm (1/4 in.) from tensioner bracket (Fig. 61).

- (9) Tighten adjusting nut at equalizer until mark on tensioner rod moves into alignment with tensioner bracket.

- (10) Lower vehicle until rear wheels are 15-20 cm (6-8 in.) off shop floor.

- (11) Release parking brake lever and verify that rear wheels rotate freely without drag.

- (12) Lower vehicle.

NOTE: Do not loosen/tighten equalizer adjusting nut for any reason after completing adjustment.

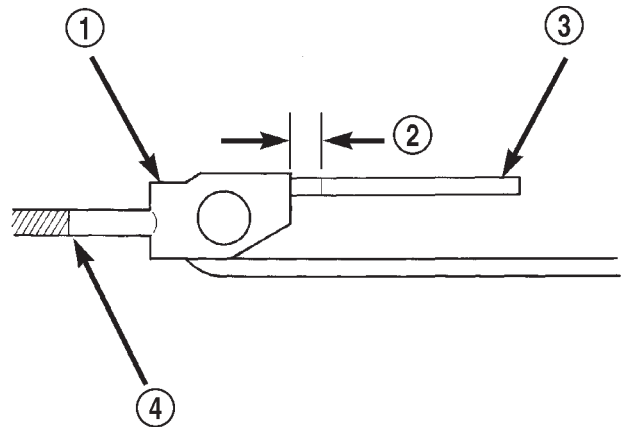

80add400

Fig. 61 Tensioner Rod Measurement

- 1 - TENSIONER BRACKET
- 2 - 6.5 mm (1/4 in.)
- 3 - TENSIONER ROD
- 4 - ROD TO EQUALIZER

SPECIFICATIONS

BRAKE FLUID

The brake fluid used in this vehicle must conform to DOT 3 specifications and SAE J1703 standards. No other type of brake fluid is recommended or approved for usage in the vehicle brake system. Use

SPECIFICATIONS (Continued)

only Mopar brake fluid or an equivalent from a tightly sealed container.

CAUTION: Never use reclaimed brake fluid or fluid from an container which has been left open. An open container will absorb moisture from the air and contaminate the fluid.

CAUTION: Never use any type of a petroleum-based fluid in the brake hydraulic system. Use of such type fluids will result in seal damage of the vehicle brake hydraulic system causing a failure of the vehicle brake system. Petroleum based fluids would be items such as engine oil, transmission fluid, power steering fluid, etc.

BRAKE COMPONENTS

Disc Brake Caliper

Type Sliding

Disc Brake Rotor

Type Ventilated

Max. Runout 0.12 mm (0.005 in.)

Max. Thickness Variation .. 0.013 mm (0.0005 in.)

Min. Thickness 22.7 mm (0.8937 in.)

Brake Drum

Size 9 in. or 10 in.

Brake Booster

Type Dual Diaphragm

TORQUE CHART

| | |
|--------------------|---------------|
| DESCRIPTION | TORQUE |
|--------------------|---------------|

Brake Pedal

Pivot Bolt/Nut 35 N·m (26 ft. lbs.)

Brake Booster

Mounting Nuts 39 N·m (29 ft. lbs.)

Master Cylinder

Mounting Nuts 17.5 N·m (155 in. lbs.)

Brake Lines 14 N·m (124 in. lbs.)

Combination Valve

Mounting Nuts 17.5 N·m (155 in. lbs.)

Brake Lines 14 N·m (124 in. lbs.)

Caliper

Mounting Bolts 15 N·m (11 ft. lbs.)

Brake Hose Bolt 31 N·m (23 ft. lbs.)

Wheel Cylinder

Mounting Bolts 10 N·m (7 ft. lbs.)

Brake Line 14 N·m (124 in. lbs.)

Parking Brake

Lever Screws 10-14 N·m (7-10 ft. lbs.)

Lever Bracket Screws .. 10-14 N·m (7-10 ft. lbs.)

Cable Retainer Nut 1.5 N·m (14 in. lbs.)

SPECIAL TOOLS

BASE BRAKES

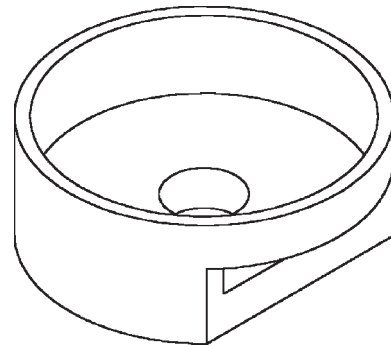

Installer Caliper Dust Boot 8280

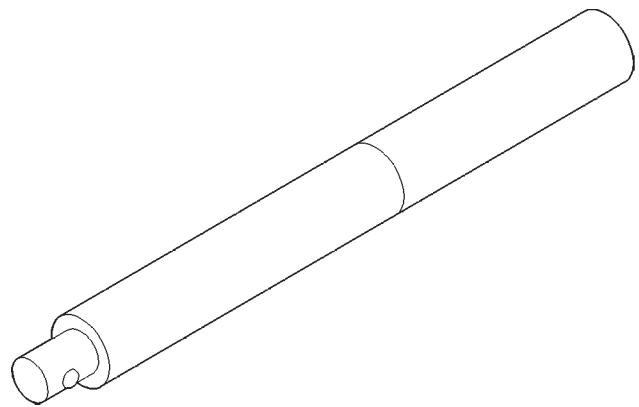

Handle C-4171

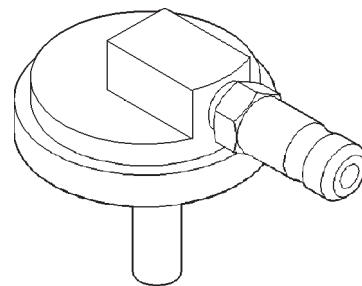

Adapter Pressure Bleeder 6921

ANTILOCK BRAKES

TABLE OF CONTENTS

| | page | page |
|--|------|------|
| DESCRIPTION AND OPERATION | | |
| ANTILOCK BRAKE SYSTEM | 33 | |
| CONTROLLER ANTILOCK BRAKES | 33 | |
| HYDRAULIC CONTROL UNIT | 34 | |
| WHEEL SPEED SENSORS AND TONE WHEEL | 34 | |
| COMBINATION VALVE | 35 | |
| G-SWITCH | 35 | |
| ABS WARNING LAMP | 35 | |
| DIAGNOSIS AND TESTING | | |
| ANTILOCK BRAKES | 36 | |
| SERVICE PROCEDURES | | |
| BLEEDING ABS BRAKE SYSTEM | 36 | |
| REMOVAL AND INSTALLATION | | |
| HYDRAULIC CONTROL UNIT/CONTROLLER | | |
| ANTILOCK BRAKES | | 36 |
| FRONT WHEEL SPEED SENSOR | | 37 |
| REAR WHEEL SPEED SENSOR | | 37 |
| G-SWITCH | | 38 |
| DISASSEMBLY AND ASSEMBLY | | |
| HYDRAULIC CONTROL UNIT/CONTROLLER | | |
| ANTILOCK BRAKE | | 39 |
| SPECIFICATIONS | | |
| TORQUE CHART | | 40 |

DESCRIPTION AND OPERATION

ANTILOCK BRAKE SYSTEM

DESCRIPTION

The purpose of the antilock system is to prevent wheel lockup during periods of high wheel slip. Preventing lockup helps maintain vehicle braking action and steering control.

The antilock CAB activates the system whenever sensor signals indicate periods of high wheel slip. High wheel slip can be described as the point where wheel rotation begins approaching 20 to 30 percent of actual vehicle speed during braking. Periods of high wheel slip occur when brake stops involve high pedal pressure and rate of vehicle deceleration.

Battery voltage is supplied to the CAB ignition terminal when the ignition switch is turned to Run position. The CAB performs a system initialization procedure at this point. Initialization consists of a static and dynamic self check of system electrical components.

The static check occurs after the ignition switch is turned to Run position. The dynamic check occurs when vehicle road speed reaches approximately 30 kph (18 mph). During the dynamic check, the CAB briefly cycles the pump and solenoids to verify operation.

If an ABS component exhibits a fault during initialization, the CAB illuminates the amber warning light and registers a fault code in the microprocessor memory.

OPERATION

During normal braking, the master cylinder, power booster and wheel brake units all function as they

would in a vehicle without ABS. The HCU components are not activated.

During antilock braking fluid pressure is modulated according to wheel speed, degree of slip and rate of deceleration. A sensor at each wheel converts wheel speed into electrical signals. These signals are transmitted to the CAB for processing and determination of wheel slip and deceleration rate.

The ABS system has three fluid pressure control channels. The front brakes are controlled separately and the rear brakes in tandem. A speed sensor input signal indicating a high slip condition activates the CAB antilock program. Two solenoid valves are used in each antilock control channel. The valves are all located within the HCU valve body and work in pairs to either increase, hold, or decrease apply pressure as needed in the individual control channels. The solenoid valves are not static during antilock braking. They are cycled continuously to modulate pressure. Solenoid cycle time in antilock mode can be measured in milliseconds.

CONTROLLER ANTILOCK BRAKES

DESCRIPTION

The CAB is mounted to the HCU and operates the ABS system (Fig. 1) separate from other vehicle electrical circuits.

OPERATION

The CAB voltage source is through the ignition switch in the RUN position. The CAB contains dual

DESCRIPTION AND OPERATION (Continued)

microprocessors. A logic block in each microprocessor receives identical sensor signals. These signals are processed and compared simultaneously. The CAB contains a self check program that illuminates the ABS warning light when a system fault is detected. Faults are stored in a diagnostic program memory and are accessible with the DRB scan tool. ABS faults remain in memory until cleared, or until after the vehicle is started approximately 50 times. Stored faults are **not** erased if the battery is disconnected.

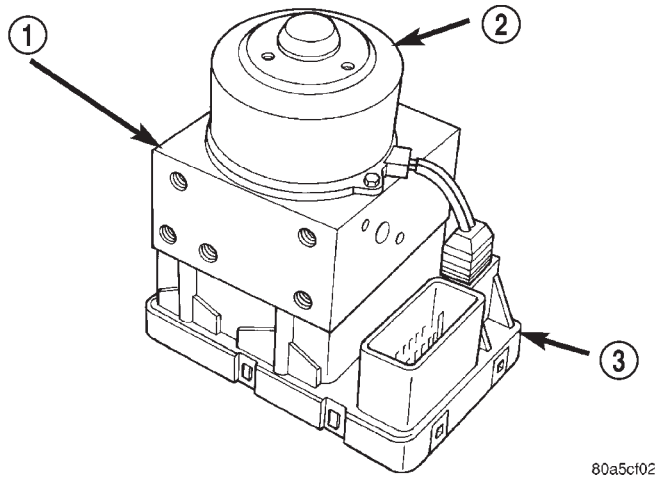

Fig. 1 Controller Antilock Brakes

- 1 - HCU
- 2 - MOTOR
- 3 - CAB

HYDRAULIC CONTROL UNIT

DESCRIPTION

The HCU consists of a valve body, pump motor, and wire harness (Fig. 1).

OPERATION

Accumulators in the valve body store extra fluid released to the system for ABS mode operation. The pump provides the fluid volume needed and is operated by a DC type motor. The motor is controlled by the CAB.

The valves modulate brake pressure during antilock braking and are controlled by the CAB.

The HCU provides three channel pressure control to the front and rear brakes. One channel controls the rear wheel brakes in tandem. The two remaining channels control the front wheel brakes individually.

During antilock braking, the solenoid valves are opened and closed as needed. The valves are not static. They are cycled rapidly and continuously to modulate pressure and control wheel slip and deceleration.

During normal braking, the HCU solenoid valves and pump are not activated. The master cylinder and

power booster operate the same as a vehicle without an ABS brake system.

During antilock braking, solenoid valve pressure modulation occurs in three stages, pressure increase, pressure hold, and pressure decrease. The valves are all contained in the valve body portion of the HCU.

PRESSURE DECREASE

The outlet valve is opened and the inlet valve is closed during the pressure decrease cycle.

A pressure decrease cycle is initiated when speed sensor signals indicate high wheel slip at one or more wheels. At this point, the CAB closes the inlet then opens the outlet valve, which also opens the return circuit to the accumulators. Fluid pressure is allowed to bleed off (decrease) as needed to prevent wheel lock.

Once the period of high wheel slip has ended, the CAB closes the outlet valve and begins a pressure increase or hold cycle as needed.

PRESSURE HOLD

Both solenoid valves are closed in the pressure hold cycle. Fluid apply pressure in the control channel is maintained at a constant rate. The CAB maintains the hold cycle until sensor inputs indicate a pressure change is necessary.

PRESSURE INCREASE

The inlet valve is open and the outlet valve is closed during the pressure increase cycle. The pressure increase cycle is used to counteract unequal wheel speeds. This cycle controls re-application of fluid apply pressure due to changing road surfaces or wheel speed.

WHEEL SPEED SENSORS AND TONE WHEEL

DESCRIPTION

A speed sensor is used at each wheel. The front sensors are mounted to the steering knuckles. The rear sensors at the outboard end of the axle.

OPERATION

The sensors convert wheel speed into a small AC electrical signal. This signal is transmitted to the CAB. The CAB converts the AC signal into a digital signal for each wheel. This voltage is generated by magnetic induction when a tone wheel passes by the stationary magnet of the wheel speed sensor.

A gear type tone ring serves as the trigger mechanism for each sensor. The tone rings are mounted at the outboard ends of the front and rear axle shafts.

Different sensors are used at the front and rear wheels (Fig. 2). The front/rear sensors have the same electrical values but are not interchangeable. The

DESCRIPTION AND OPERATION (Continued)

sensors have a resistance between 900 and 1300 ohms.

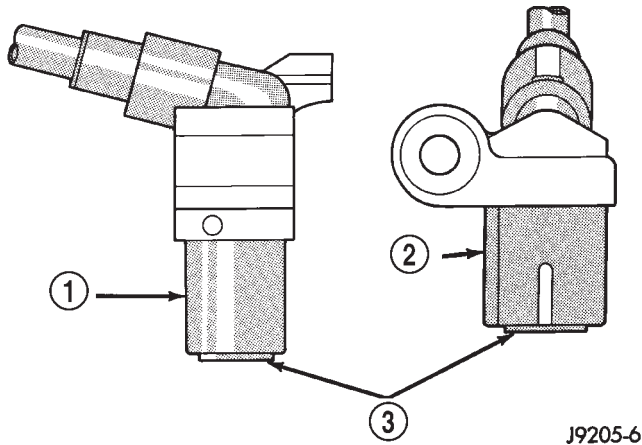

Fig. 2 Wheel Speed Sensors

- 1 - FRONT SENSOR
- 2 - REAR SENSOR
- 3 - PICKUP FACE

FRONT SENSOR AIR GAP

Front sensor air gap is fixed and not adjustable. Only rear sensor air gap is adjustable.

Although front air gap is not adjustable, it can be checked if diagnosis indicates this is necessary. Front air gap should be 0.36 to 1.5 mm (0.014 to 0.059 in.). If gap is incorrect, the sensor is either loose, or damaged.

REAR SENSOR AIR GAP

A rear sensor air gap adjustment is only needed when reinstalling an original sensor. Replacement sensors have an air gap spacer attached to the sensor pickup face. The spacer establishes correct air gap when pressed against the tone ring during installation. As the tone ring rotates, it peels the spacer off the sensor to create the required air gap. Rear sensor air gap is 0.92-1.275 mm (0.036-0.05 in.).

Sensor air gap measurement, or adjustment procedures are provided in this section. Refer to the front, or rear sensor removal and installation procedures as required.

COMBINATION VALVE

DESCRIPTION

The combination valve contains a pressure differential valve and switch and a rear brake proportioning valve. The valve is not repairable and must be replaced as an assembly if diagnosis indicates this is necessary.

OPERATION

PRESSURE DIFFERENTIAL VALVE

The pressure differential switch is connected to the brake warning light. The switch is actuated by movement of the switch valve. The switch monitors fluid pressure in the separate front/rear brake hydraulic circuits.

A decrease or loss of fluid pressure in either hydraulic circuit will cause the switch valve to shuttle to the low pressure side. Movement of the valve pushes the switch plunger upward. This action closes the switch internal contacts completing the electrical circuit to the red warning light. The switch valve will remain in an actuated position until repairs to the brake system are made.

PROPORTIONING VALVE

The proportioning valve is used to balance front-rear brake action at high decelerations. The valve allows normal fluid flow during moderate braking. The valve only controls fluid flow during high decelerations brake stops.

G-SWITCH

DESCRIPTION

The G-switch is located under the rear seat. The switch has directional arrow and must be mounted with the arrow pointing towards the front of the vehicle.

OPERATION

The switch (Fig. 3), provides an additional vehicle deceleration reference during 4x4 operation. The switch is monitored by the CAB at all times. The switch reference signal is utilized by the CAB when all wheels are decelerating at the same speed.

ABS WARNING LAMP

DESCRIPTION

The amber ABS warning lamp is located in the instrument cluster. The lamp illuminates at start-up to perform a self check. The lamp goes out when the self check program determines the system is operating normal.

OPERATION

If an ABS component exhibits a fault the CAB will illuminate the lamp and register a trouble code in the microprocessor. The lamp is controlled by the CAB. The lamp is illuminated when the CAB sends a ground signal to the ABS relay. The ABS relay then grounds the lamp circuit and illuminates the lamp.

DESCRIPTION AND OPERATION (Continued)

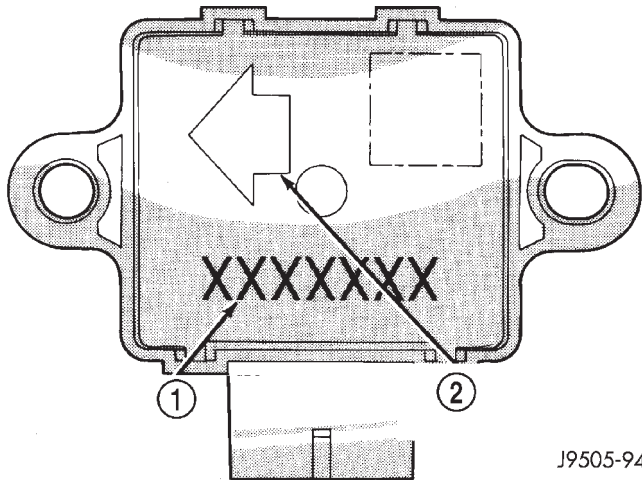

J9505-94

Fig. 3 G-Switch

- 1 - SWITCH PART NUMBER
2 - ARROW INDICATES FRONT OF SWITCH FOR PROPER MOUNTING

DIAGNOSIS AND TESTING

ANTILOCK BRAKES

The ABS brake system performs several self-tests every time the ignition switch is turned on and the vehicle is driven. The CAB monitors the systems input and output circuits to verify the system is operating correctly. If the on board diagnostic system senses that a circuit is malfunctioning the system will set a trouble code in its memory.

NOTE: An audible noise may be heard during the self-test. This noise should be considered normal.

NOTE: The MDS or DRB III scan tool is used to diagnose the ABS system. For additional information refer to the Antilock Brake section in Group 8W. For test procedures refer to the Chassis Diagnostic Manual.

SERVICE PROCEDURES

BLEEDING ABS BRAKE SYSTEM

ABS system bleeding requires conventional bleeding methods plus use of the DRB scan tool. The procedure involves performing a base brake bleeding, followed by use of the scan tool to cycle and bleed the HCU pump and solenoids. A second base brake bleeding procedure is then required to remove any air remaining in the system.

- (1) Perform base brake bleeding. Refer to base brake section for procedure.
- (2) Connect scan tool to the Data Link Connector.

- (3) Select ANTILOCK BRAKES, followed by MISCELLANEOUS, then ABS BRAKES. Follow the instructions displayed. When scan tool displays TEST COMPLETE, disconnect scan tool and proceed.

- (4) Perform base brake bleeding a second time. Refer to base brake section for procedure.

- (5) Top off master cylinder fluid level and verify proper brake operation before moving vehicle.

REMOVAL AND INSTALLATION

HYDRAULIC CONTROL UNIT/CONTROLLER
ANTILOCK BRAKES

REMOVAL

- (1) Remove negative battery cable from the battery.
- (2) Pull up on the CAB harness connector release (Fig. 4) and remove connector.
- (3) Remove brake lines from the HCU.
- (4) Remove HCU/CAB mounting nuts and bolt (Fig. 5) and remove HCU/CAB.

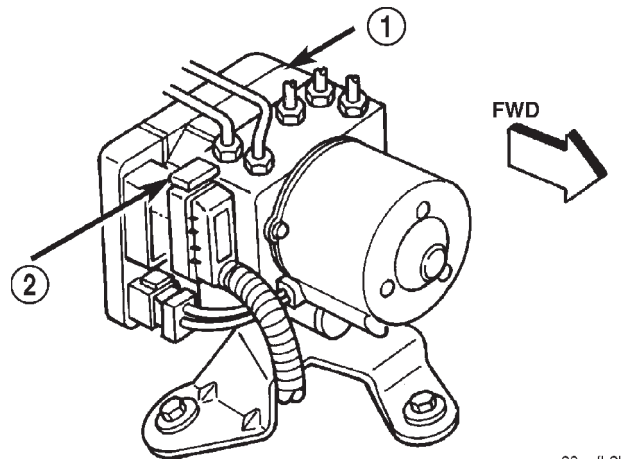

80aatb2b

Fig. 4 CAB Harness Connector Release

- 1 - CAB
2 - CAB HARNESS RELEASE

INSTALLATION

- (1) Install HCU/CAB on the mounting studs.
- (2) Install mounting nuts and bolt. Tighten to 11.5 N·m (102 in. lbs.).
- (3) Install brake lines to the HCU and tighten to 19 N·m (170 in. lbs.).
- (4) Install wiring harness connector to the CAB and push down on the release to secure the connector.
- (5) Install negative battery cable to the battery.
- (6) Bleed ABS brake system.

REMOVAL AND INSTALLATION (Continued)

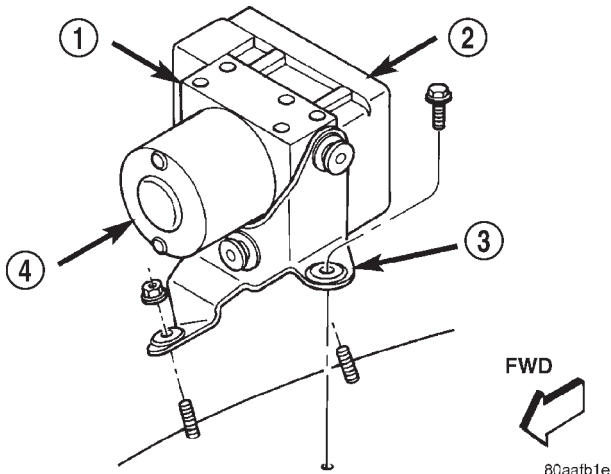
**Fig. 5 HCU/CAB Mounting**

- 1 - HCU
- 2 - CAB
- 3 - HCU/CAB BRACKET
- 4 - MOTOR

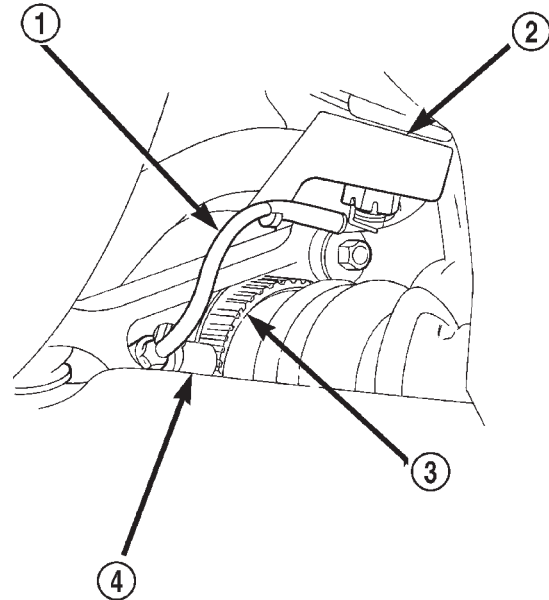
**Fig. 6 Front Wheel Speed Sensor**

- 1 - WHEEL SPEED SENSOR PIGTAIL
- 2 - STEERING KNUCKLE
- 3 - TONE WHEEL
- 4 - FRONT WHEEL SPEED SENSOR

8031e865

FRONT WHEEL SPEED SENSOR**REMOVAL**

- (1) Raise vehicle and turn wheel outward for easier access to sensor.
- (2) Remove sensor wire from mounting brackets.
- (3) Clean sensor and surrounding area with shop towel before removal.
- (4) Remove bolt attaching sensor to steering knuckle and remove sensor (Fig. 6).
- (5) Remove sensor wire from brackets on body and steering knuckle.
- (6) Unseat sensor wire grommet in wheel house panel.
- (7) In engine compartment, disconnect sensor wire connector at harness plug. Then remove sensor and wire.

INSTALLATION

- (1) If **original** sensor will be installed, wipe all traces of old spacer material off sensor pickup face. Use a dry shop towel for this purpose.
- (2) Apply Mopar Lock N' Seal or Loctite[®] 242 to bolt that secures sensor in steering knuckle. Use new sensor bolt if original bolt is worn or damaged.
- (3) Position sensor on steering knuckle. Seat sensor locating tab in hole in knuckle and install sensor attaching bolt finger tight.
- (4) Tighten sensor attaching bolt to 4.7 N·m (42 in. lbs.).
- (5) If original sensor has been installed, check sensor air gap. Air gap should be 0.36 to 1.5 mm (0.014 to 0.059 in.). If gap is incorrect, sensor is either loose, or damaged.

- (6) Secure sensor wire to steering knuckle and body brackets.
- (7) Route sensor wire forward and behind shock absorber. Then attach sensor wire to spring seat bracket with grommets on sensor wire.
- (8) Route sensor wire to outer sill bracket. Remove all twists or kinks from wire.
- (9) Attach sensor wire to sill bracket with grommet. Be sure wire is free of twists and kinks.
- (10) Verify sensor wire routing. Wire should loop forward and above sill bracket. Loose end of wire should be below sill bracket and towards brake hose.
- (11) Seat sensor wire grommet in body panel and clip wire to brake line at grommet location.
- (12) Connect sensor wire to harness in engine compartment.

REAR WHEEL SPEED SENSOR**REMOVAL**

- (1) Raise and fold rear seat forward for access to rear sensor connectors (Fig. 7).
- (2) Disconnect sensors at rear harness connectors.
- (3) Push sensor grommets and sensor wires through floorpan.
- (4) Raise vehicle.
- (5) Disconnect sensor wires at rear axle connectors.
- (6) Remove wheel and tire assembly.

REMOVAL AND INSTALLATION (Continued)

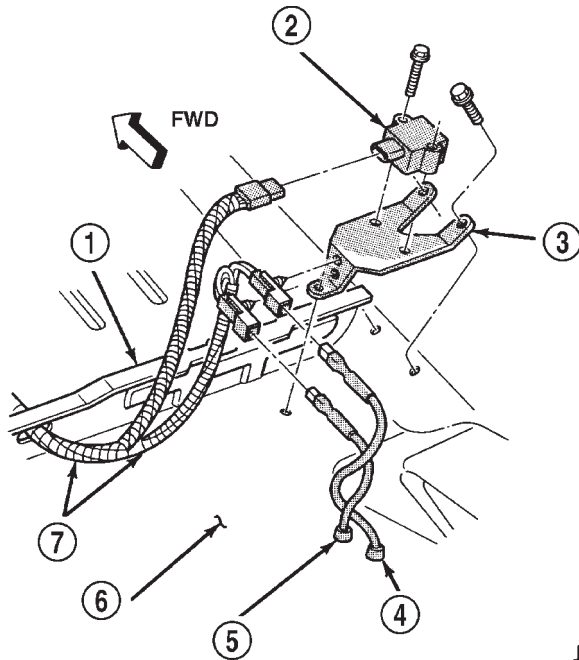

J9205-19

Fig. 7 Acceleration Switch And Rear Sensor Connections

- 1 - REAR SEAT CROSSMEMBER
- 2 - ACCELERATION SENSOR
- 3 - SENSOR MOUNTING BRACKET
- 4 - TO R. R. WHEEL SENSOR
- 5 - TO L. R. WHEEL SENSOR
- 6 - FLOORPAN
- 7 - SENSOR HARNESS

- (7) Remove brake drum.
- (8) Remove clips securing sensor wires to brake lines, rear axle and, brake hose.
- (9) Unseat sensor wire support plate grommet.
- (10) Remove bolt attaching sensor to bracket and remove sensor (Fig. 8).

INSTALLATION

- (1) If **original sensor** is being installed, remove any remaining pieces of cardboard spacer from sensor pickup face. Use dry shop towel only to remove old spacer material.
- (2) Insert sensor wire through support plate hole. Then seat sensor grommet in support plate.
- (3) Apply Mopar Lock N' Seal or Loctite® 242 to original sensor bolt. Use new bolt if original is worn or damaged.
- (4) Install sensor bolt finger tight only at this time.
- (5) If **original** rear sensor was installed, adjust sensor air gap to 0.92-1.275 mm (0.036-0.05 in.). Use feeler gauge to measure air gap (Fig. 9). Tighten sensor bolt to 13 N·m (115 in. lbs.).
- (6) If **new** sensor was installed, push cardboard spacer on sensor face against tone ring (Fig. 10).

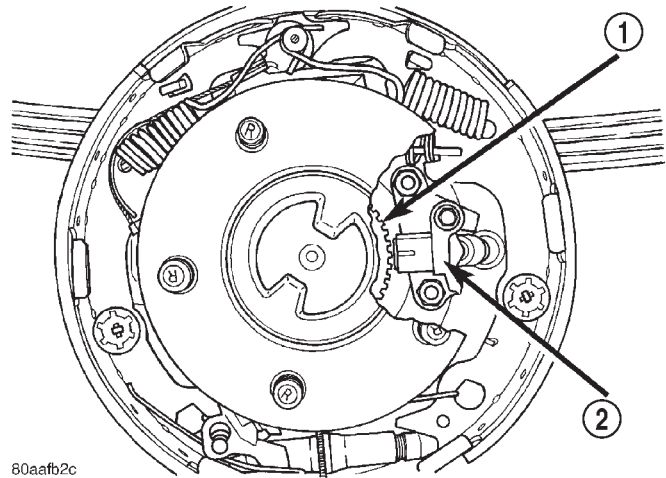

80aafb2c

Fig. 8 Rear Wheel Speed Sensor

- 1 - TONE WHEEL
- 2 - WHEEL SPEED SENSOR

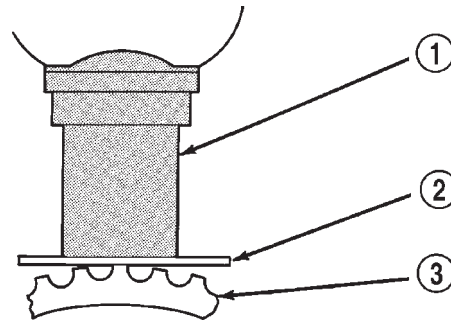

J9205-17

Fig. 9 Setting Air Gap On Original Rear Sensor

- 1 - WHEEL SPEED SENSOR
- 2 - BRASS FEELER GAUGE
- 3 - TONE RING

Then tighten sensor bolt to 13 N·m (115 in. lbs.). Correct air gap will be established as tone ring rotates and peels spacer off sensor face.

- (7) Route sensor wires to rear seat area.
- (8) Feed sensor wires through floorpan access hole and seat sensor grommets in floorpan.
- (9) Verify that rear sensor wires are secured to rear brake hose and axle with clips. Verify that wire is clear of rotating components.
- (10) Install brake drum and wheel and tire assembly.
- (11) Lower vehicle.
- (12) Connect sensor wire to harness connector. Then reposition carpet and fold rear seat down.

G-SWITCH

REMOVAL

- (1) Raise and fold rear seat assembly forward for access to sensor.

REMOVAL AND INSTALLATION (Continued)

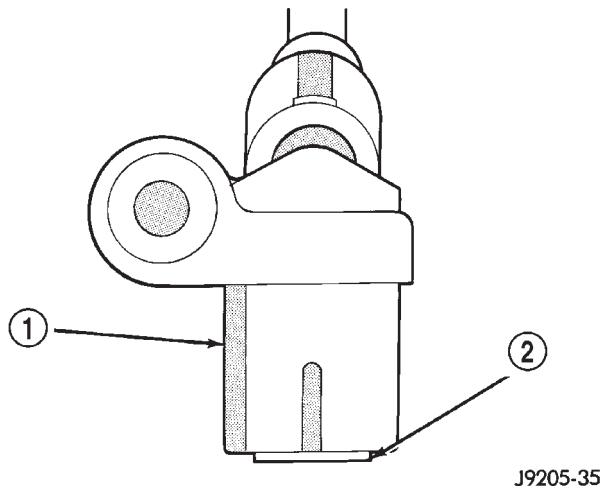

Fig. 10 New Rear Sensor

- 1 - REAR SENSOR
- 2 - AIR GAP SPACER ATTACHED TO SENSOR FACE

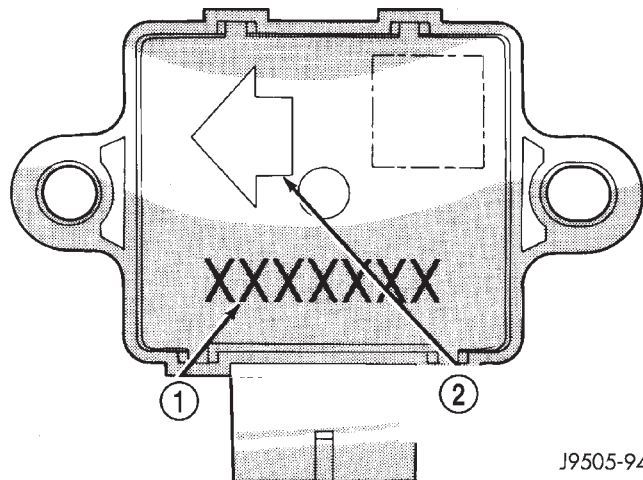

Fig. 12 G-Switch

- 1 - SWITCH PART NUMBER
- 2 - ARROW INDICATES FRONT OF SWITCH FOR PROPER MOUNTING

- (2) Disconnect switch harness.
- (3) Remove switch mounting screws (Fig. 11)
- (4) Remove the acceleration switch.

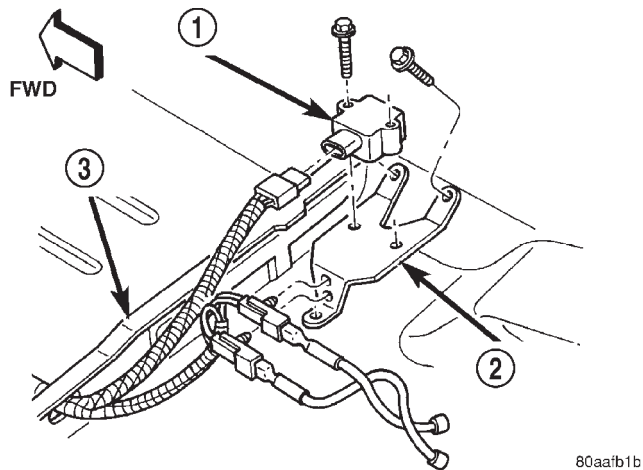

Fig. 11 G-Switch Mounting

- 1 - ACCELERATION SWITCH
- 2 - SWITCH BRACKET
- 3 - REAR SEAT CROSSMEMBER

INSTALLATION

CAUTION: The mercury switch (inside the G-switch), will not function properly if the switch is installed incorrectly. Verify that the switch locating arrow is pointing to the front of the vehicle (Fig. 12).

- (1) Position switch in mounting bracket.
- (2) Install switch mounting bolts and tighten to 3 N·m (27.5 in. lbs.).

- (3) Connect harness to switch. Be sure harness connector is firmly seated.
- (4) Move seat back to normal position.

**DISASSEMBLY AND ASSEMBLY
HYDRAULIC CONTROL UNIT/CONTROLLER
ANTILOCK BRAKE**

DISASSEMBLY

- (1) Remove pump motor connector from the CAB.
- (2) Remove CAB mounting screws from the HCU (Fig. 13).
- (3) Remove CAB from the HCU.

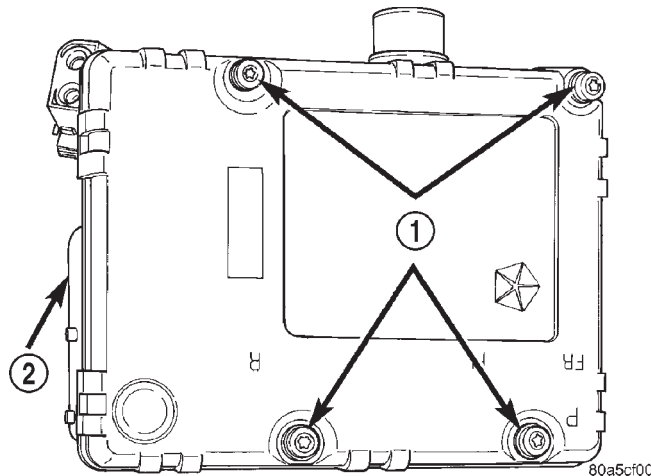

Fig. 13 CAB Mounting Screws

- 1 - MOUNTING SCREWS
- 2 - CAB

DISASSEMBLY AND ASSEMBLY (Continued)

ASSEMBLY

- (1) Install the CAB onto the HCU.
- (2) Install the CAB mounting screws and tighten to 1.8 N·m (16 in. lbs.).
- (3) Install pump motor connector to the CAB.

SPECIFICATIONS**TORQUE CHART**

| DESCRIPTION | TORQUE |
|--|-------------------------|
| G-Sensor | |
| Sensor Bolt | 3 N·m (27.5 in. lbs.) |
| Bracket Bolt | 2.7 N·m (24 in. lbs.) |
| Hydraulic Control Unit/Controller Antilock Brakes | |
| Mounting Nuts | 11.5 N·m (102 in. lbs.) |
| Brake Lines | 19 N·m (170 in. lbs.) |
| Controller Antilock Brakes | |
| Mounting Screws | 1.8 N·m (16 in. lbs.) |
| Wheel Speed Sensors | |
| Front Mounting Bolt | 4.7 N·m (42 in. lbs.) |
| Rear Mounting Bolt | 13 N·m (115 in. lbs.) |

BRAKES

TABLE OF CONTENTS

| | page | page |
|--|------|------|
| REMOVAL AND INSTALLATION | | |
| BRAKE BOOSTER – RHD DIESEL | 1 | |
| MASTER CYLINDER – RHD DIESEL | 3 | |
| SPECIFICATIONS | | |
| TORQUE SPECIFICATIONS | | 4 |

REMOVAL AND INSTALLATION

BRAKE BOOSTER – RHD DIESEL

REMOVAL

(1) Open hood and disconnect the negative battery cable

NOTE: Pump the brake pedal several times to relieve vacuum in the brake booster. This will prevent booster from sucking any contaminants when master cylinder is removed.

(2) Remove the short brake lines leading from the master cylinder to the combination valve (Fig. 1).

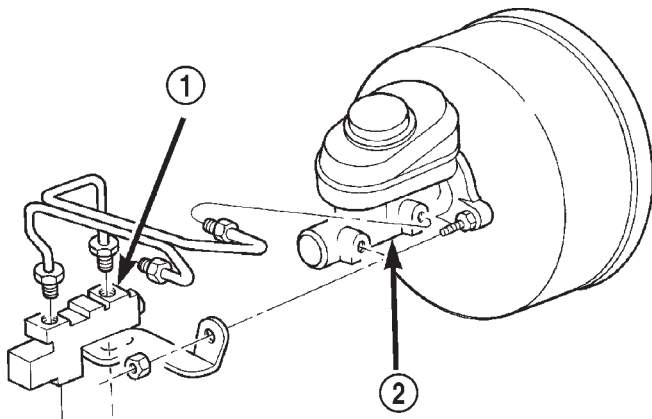

Fig. 1 Brake Line Orientation

- 1 – COMBINATION VALVE
2 – MASTER CYLINDER

(3) Disconnect differential pressure switch wire from the combination valve. Lift the release tab on the underside of the electrical connector and pull straight off (Fig. 2).

(4) Remove the combination valve support bracket retaining nuts and remove the valve and bracket assembly from the vehicle.

(5) Remove the master cylinder retaining nuts (Fig. 8) and remove the master cylinder from the brake booster by sliding straight off mounting studs.

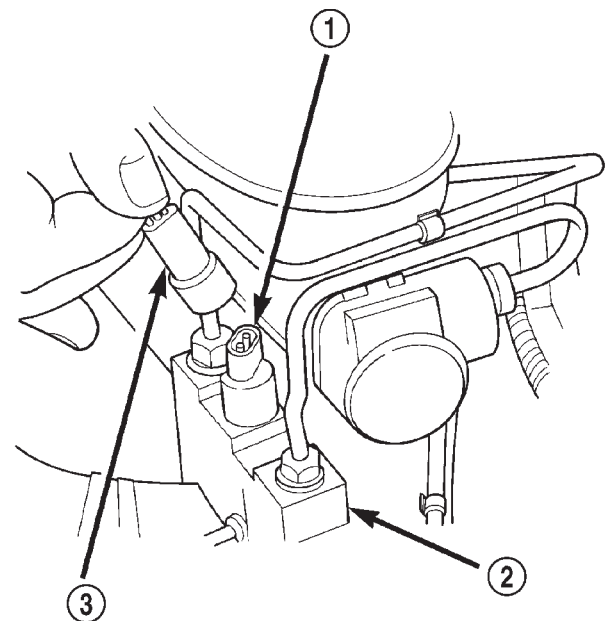

8031e88c

Fig. 2 Differential Pressure Switch Electrical

- 1 – SWITCH TERMINAL
2 – COMBINATION VALVE
3 – WIRE HARNESS CONNECTOR

(6) Disconnect the vacuum supply hose from the brake booster.

(7) Disconnect the coolant level switch electrical connector. Located on the side of the coolant reservoir.

NOTE: It is not necessary to drain the cooling system to perform this procedure.

(8) Remove the coolant reservoir retaining screws so reservoir can be positioned out of the way.

(9) Working inside the vehicle, remove the hood release cable handle retaining screws from the underside of the instrument panel.

(10) Remove the plastic and steel knee blockers from the vehicle. Refer to Group 23, Body for the procedure.

REMOVAL AND INSTALLATION (Continued)

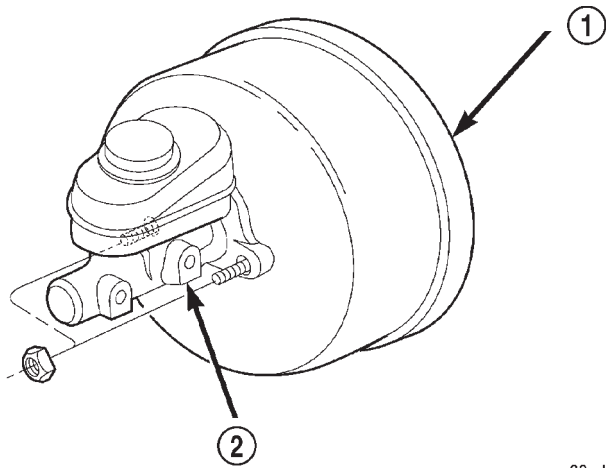

80ad2f20

Fig. 3 Master Cylinder

- 1 - BOOSTER
2 - MASTER CYLINDER

(11) Remove the retaining clip that secures the booster push rod to the brake pedal (Fig. 4).

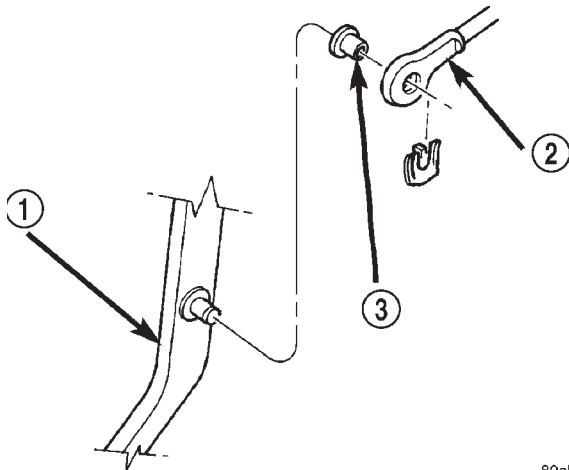

80ab88a7

Fig. 4 Booster Push Rod

- 1 - BRAKE PEDAL
2 - BOOSTER ROD
3 - BUSHING

(12) Remove nuts attaching booster to passenger compartment side of dash panel (Fig. 5).

(13) Working inside the engine compartment, position the coolant reservoir out of the way and remove the brake booster by pulling straight out.

INSTALLATION

NOTE: Be certain rubber o-ring vacuum seal is installed in the master cylinder mounting flange prior to installation.

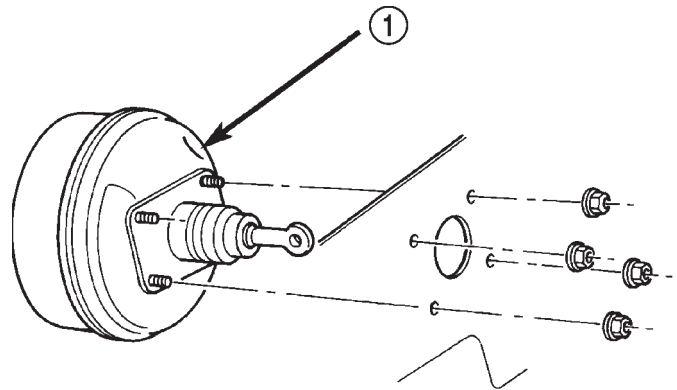

80ab88a8

Fig. 5 Booster Mounting

- 1 - BOOSTER

NOTE: If a new master cylinder is being installed, cylinder must be bench bleed prior to installation.

(1) Install the brake booster on the bulkhead, be certain dash seal is installed on booster studs prior to installation.

(2) From under the instrument panel, install booster mounting nuts. Tighten nuts just enough to hold booster in place.

NOTE: Lubricate the pedal pin and bushing with Mopar multi-mileage grease before installation.

(3) Slide booster push rod onto the brake pedal pin. Then secure push rod to pedal pin with retaining clip.

(4) Torque booster mounting nuts to 39 N·m (29 ft. lbs.).

(5) Install the steel and plastic knee blocker in the vehicle. Refer to Group 23, Body for the procedure.

(6) Install the hood release cable handle.

(7) Install the coolant reservoir bottle retaining screws and connect the coolant level switch.

(8) Connect the vacuum supply hose on the brake booster.

(9) Install master cylinder on brake booster and install retaining nuts. Torque the nuts to 17.5 N·m (155 in. lbs.).

(10) Install combination valve/bracket and retaining nuts.

(11) Install brake lines on cylinder and valve. Torque brake lines to 19 N·m (170 in. lbs.).

(12) Connect differential pressure switch wire on the combination valve.

(13) Fill and bleed the brake system. Refer to the procedure in this group.

(14) Connect the negative battery cable.

REMOVAL AND INSTALLATION (Continued)

(15) Adjust the brake lamp switch. Refer to the procedure in this group.

WARNING: Be certain a firm brake pedal is achieved prior to attempting to operate the vehicle.

MASTER CYLINDER – RHD DIESEL

REMOVAL

(1) Open hood and disconnect the negative battery cable

NOTE: Pump the brake pedal several times to relieve vacuum in the brake booster. This will prevent booster from sucking any contaminants when master cylinder is removed.

(2) Remove the short brake lines leading from the master cylinder to the combination valve (Fig. 6).

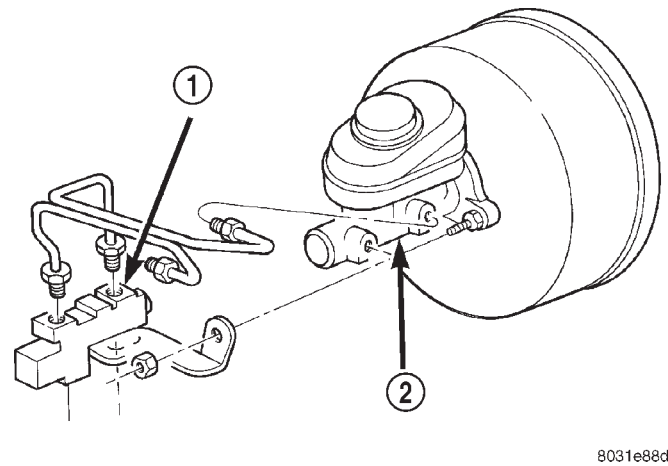

Fig. 6 Brake Line Orientation

- 1 - COMBINATION VALVE
- 2 - MASTER CYLINDER

(3) Disconnect differential pressure switch wire from the combination valve. Lift the release tab on the underside of the electrical connector and pull straight off (Fig. 7).

(4) Remove the combination valve support bracket retaining nuts and remove the valve and bracket assembly from the vehicle.

(5) Remove the master cylinder retaining nuts (Fig. 8) and remove the master cylinder from the brake booster by sliding straight off mounting studs.

INSTALLATION

NOTE: Be certain rubber o-ring vacuum seal is installed in the master cylinder mounting flange prior to installation.

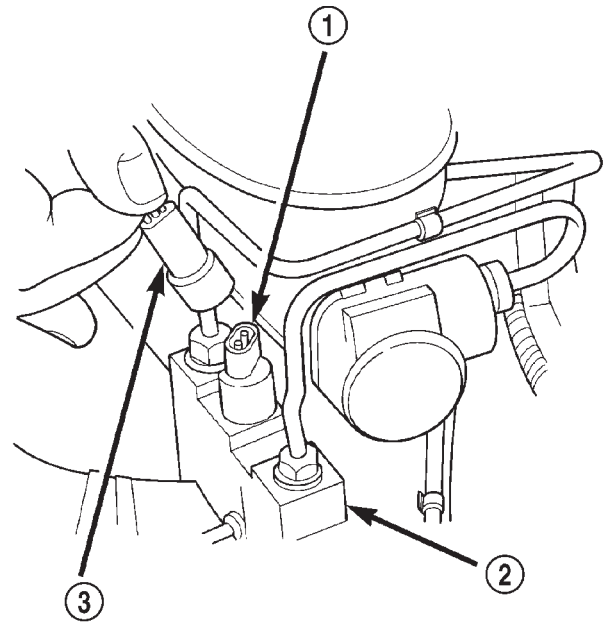

Fig. 7 Differential Pressure Switch Electrical

- 1 - SWITCH TERMINAL
- 2 - COMBINATION VALVE
- 3 - WIRE HARNESS CONNECTOR

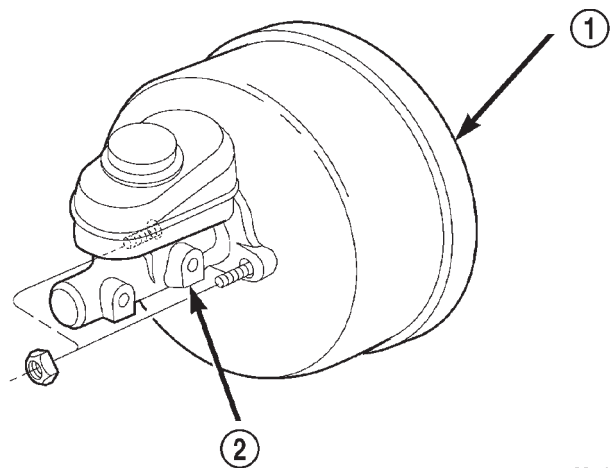

Fig. 8 Master Cylinder

- 1 - BOOSTER
- 2 - MASTER CYLINDER

NOTE: If a new master cylinder is being installed, cylinder must be bench bleed prior to installation.

(1) If equipped, remove protective sleeve from primary piston shank on new master cylinder.

(2) Clean cylinder mounting surface of brake booster.

(3) Install master cylinder on brake booster and install retaining nuts. Torque the nuts to 17.5 N-m (155 in. lbs.).

REMOVAL AND INSTALLATION (Continued)

(4) Install combination valve/bracket and retaining nuts.

(5) Install brake lines on cylinder and valve. Torque brake lines to 19 N·m (170 in. lbs.).

(6) Connect differential pressure switch wire on the combination valve.

(7) Fill and bleed the brake system. Refer to the procedure in this group.

(8) Connect the negative battery cable.

(9) Adjust the brake lamp switch. Refer to the procedure in this group.

WARNING: Be certain a firm brake pedal is achieved prior to attempting to operate the vehicle.

SPECIFICATIONS

TORQUE SPECIFICATIONS

| DESCRIPTION | TORQUE |
|---|-------------------------|
| Brake Booster to Cowl Panel | |
| Nuts | 39 N·m (29 ft. lbs.) |
| Brake Lines at Master Cylinder and Combination Valve | |
| Tube Nuts | 19 N·m (170 in. lbs.) |
| Master Cylinder to Vacuum Booster | |
| Nuts | 17.5 N·m (155 in. lbs.) |

CLUTCH

TABLE OF CONTENTS

| | page | | page |
|---|------|---|------|
| DESCRIPTION AND OPERATION | | CLUTCH FLYWHEEL RUNOUT | 6 |
| CLUTCH | 1 | CLUTCH COVER AND DISC RUNOUT | 7 |
| FLYWHEEL | 2 | CLUTCH DIAGNOSIS CHARTS | 7 |
| CLUTCH DISC | 2 | SERVICE PROCEDURES | |
| CLUTCH PRESSURE PLATE | 2 | CLUTCH COMPONENT LUBRICATION | 9 |
| CLUTCH RELEASE BEARING | 3 | CLUTCH LINKAGE FLUID | 9 |
| HYDRAULIC CLUTCH LINKAGE | 4 | CLUTCH FLUID LEVEL | 10 |
| DIAGNOSIS AND TESTING | | FLYWHEEL | 10 |
| SAFETY PRECAUTIONS | 4 | REMOVAL AND INSTALLATION | |
| INSTALLATION METHODS AND PARTS | | CLUTCH COVER AND DISC | 11 |
| USAGE | 4 | RELEASE BEARING | 12 |
| CLUTCH DIAGNOSTIC INFORMATION | 4 | PILOT BEARING | 12 |
| CLUTCH CONTAMINATION | 6 | CLUTCH HOUSING | 13 |
| IMPROPER CLUTCH RELEASE OR | | CLUTCH HYDRAULIC LINKAGE | 13 |
| ENGAGEMENT | 6 | SPECIFICATIONS | |
| CLUTCH MISALIGNMENT | 6 | TORQUE | 15 |
| CLUTCH HOUSING MISALIGNMENT | 6 | | |

DESCRIPTION AND OPERATION

CLUTCH

DESCRIPTION

The clutch mechanism consists of a flywheel, a single, dry-type disc, and a diaphragm style clutch cover (Fig. 1). A hydraulic linkage is used to operate the clutch release bearing and fork. The flywheel is bolted to the rear flange of the crankshaft. The clutch pressure plate is bolted to the flywheel with the clutch disc located between these two components. The clutch system provides the mechanical, but still easily detachable, link between the engine and the transmission. The system is designed to ensure that the full torque output of the engine is transferred to the transmission while isolating the transmission from the engine firing pulses to minimize concerns such as gear rattle.

OPERATION

Leverage, clamping force, and friction are what make the clutch work. The disc serves as the friction element and a diaphragm spring and pressure plate provide the clamping force. The clutch pedal, hydraulic linkage, release lever and bearing provide the leverage.

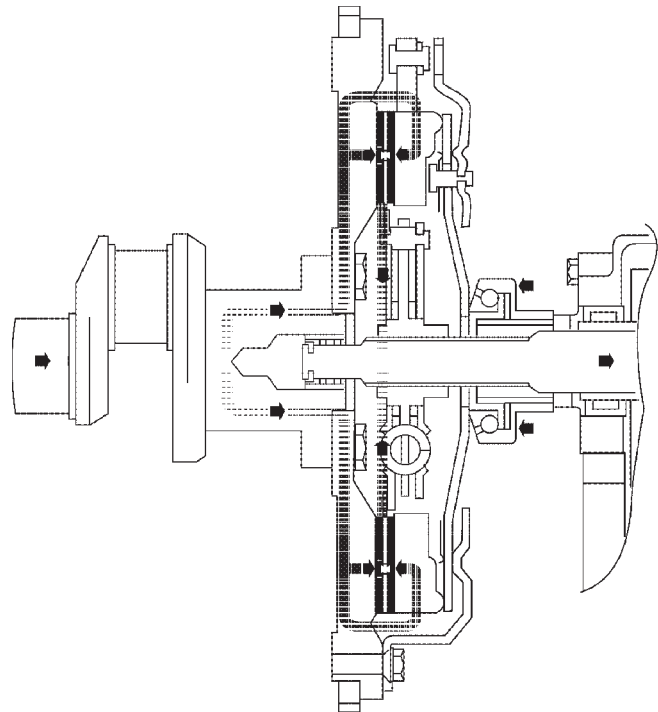

80be45e9

Fig. 1 Engine Powerflow

DESCRIPTION AND OPERATION (Continued)

The clutch master cylinder push rod is connected to the clutch pedal. When the clutch pedal is depressed, the slave cylinder is operated by the clutch master cylinder mounted on the dash panel. The release fork is actuated by the hydraulic slave cylinder mounted on the transmission housing. The release bearing is operated by a release fork pivoting on a ball stud mounted in the transmission housing. The release bearing then depresses the pressure plate spring fingers, thereby releasing pressure on the clutch disc and allowing the engine crankshaft to spin independently of the transmission input shaft (Fig. 2).

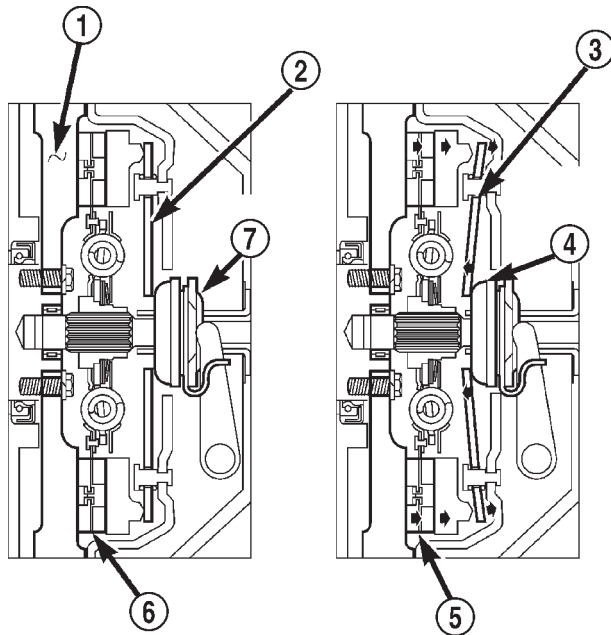

Fig. 2 Clutch Operation

- 1 - FLYWHEEL
- 2 - PRESSURE PLATE FINGERS
- 3 - PIVOT POINT
- 4 - RELEASE BEARING PUSHED IN
- 5 - CLUTCH DISC ENGAGED
- 6 - CLUTCH DISC ENGAGED
- 7 - RELEASE BEARING

80be45ea

FLYWHEEL

DESCRIPTION

The flywheel (Fig. 3) is a heavy plate bolted to the rear of the crankshaft. The flywheel incorporates the ring gear around the outer circumference to mesh with the starter to permit engine cranking. The rear face of the flywheel serves as the driving member to the clutch disc.

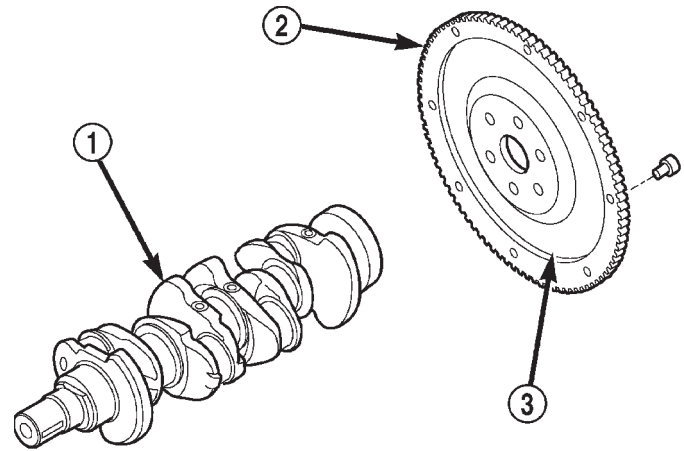

Fig. 3 Flywheel

80be45ee

- 1 - CRANKSHAFT
- 2 - RING GEAR
- 3 - FLYWHEEL

OPERATION

The flywheel serves to dampen the engine firing pulses. The heavy weight of the flywheel relative to the rotating mass of the engine components serves to stabilize the flow of power to the remainder of the drivetrain. The crankshaft has the tendency to attempt to speed up and slow down in response to the cylinder firing pulses. The flywheel dampens these impulses by absorbing energy when the crankshaft speeds and releasing the energy back into the system when the crankshaft slows down.

CLUTCH DISC

DESCRIPTION

The clutch disc friction material is riveted to the disc hub (Fig. 4). The hub bore is splined for installation on the transmission input shaft. The clutch disc has cushion springs in the disc hub to dampen disc vibrations during application and release of the clutch.

OPERATION

The clutch disc is held onto the surface of the flywheel by the force exerted by the pressure plate's diaphragm spring. The friction material of the clutch disc then transfers the engine torque from the flywheel and pressure plate to the input shaft of the transmission.

CLUTCH PRESSURE PLATE

DESCRIPTION

The clutch pressure plate assembly is a diaphragm type with a one-piece spring and multiple release fingers (Fig. 5). The pressure plate release fingers are preset during manufacture and are not adjustable. The assembly also contains the cover, pressure plate, and fulcrum components.

DESCRIPTION AND OPERATION (Continued)

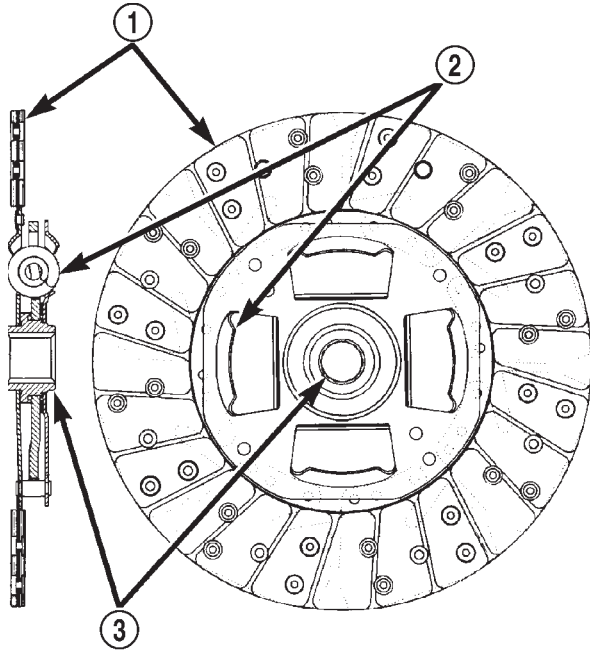

80be45eb

Fig. 4 Clutch Disc-Typical

- 1 - FACING MATERIAL
- 2 - DAMPER SPRINGS
- 3 - HUB

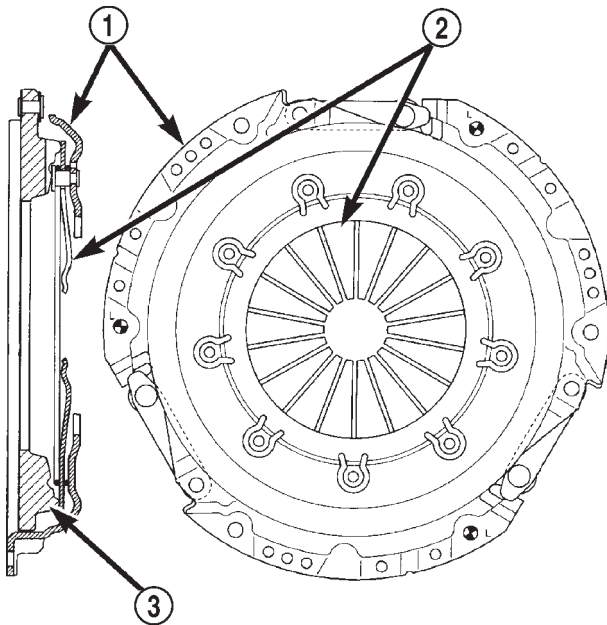

80be45ec

Fig. 5 Clutch Pressure Plate-Typical

- 1 - COVER
- 2 - RELEASE FINGERS
- 3 - PRESSURE PLATE

OPERATION

The clutch pressure plate assembly clamps the clutch disc against the flywheel. When the release bearing is depressed by the shift fork, the pressure exerted on the clutch disc by the pressure plate spring is decreased. As additional force is applied, the bearing presses the diaphragm spring fingers inward on the fulcrums. This action moves the pressure plate rearward relieving clamp force on the disc. The clutch disc is disengaged and freewheeling at this point.

CLUTCH RELEASE BEARING

DESCRIPTION

A conventional release bearing (Fig. 6) is used to engage and disengage the clutch pressure plate assembly. The clutch release bearing is mounted on the transmission front bearing retainer. The bearing is attached to the release fork, which moves the bearing into contact with the clutch cover diaphragm spring.

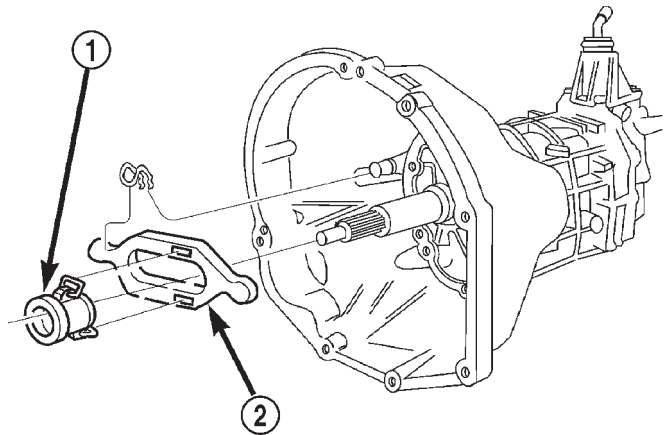

80be45ed

Fig. 6 Clutch Release Bearing

- 1 - RELEASE BEARING
- 2 - RELEASE FORK

OPERATION

The release bearing is operated by a release fork in the clutch housing. Slave cylinder force causes the release lever to move the release bearing into contact with the diaphragm spring. As additional force is applied, the bearing presses the diaphragm spring fingers inward on the fulcrums. This action moves the pressure plate rearward relieving clamp force on the disc. Releasing pedal pressure removes clutch hydraulic pressure. The release bearing then moves away from the diaphragm spring which allows the pressure plate to exert clamping force on the clutch disc.

DESCRIPTION AND OPERATION (Continued)

HYDRAULIC CLUTCH LINKAGE

DESCRIPTION

The hydraulic linkage consists of a clutch master cylinder with integral reservoir, a clutch slave cylinder and an interconnecting fluid line (Fig. 7).

The clutch master cylinder push rod is connected to the clutch pedal. The slave cylinder push rod is connected to the clutch release fork. The master cylinder is mounted on the driver side of the dash panel adjacent to the brake master cylinder and booster assembly.

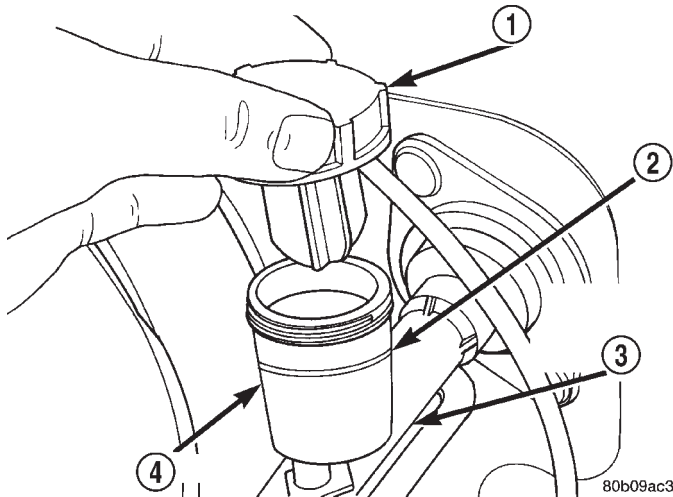

Fig. 7 Clutch Master Cylinder

- 1 - CAP
- 2 - FILL LINE
- 3 - CLUTCH MASTER CYLINDER
- 4 - RESERVOIR

OPERATION

The clutch linkage uses hydraulic pressure to operate the clutch. Depressing the clutch pedal develops fluid pressure in the clutch master cylinder. This pressure is transmitted to the slave cylinder through a connecting line. In turn, the slave cylinder operates the clutch release lever.

Slave cylinder force causes the release lever to move the release bearing into contact with the diaphragm spring. As additional force is applied, the bearing presses the diaphragm spring fingers inward on the fulcrums. This action moves the pressure plate rearward relieving clamp force on the disc.

DIAGNOSIS AND TESTING

SAFETY PRECAUTIONS

WARNING: EXERCISE CARE WHEN SERVICING CLUTCH COMPONENTS. FACTORY INSTALLED CLUTCH DISCS DO NOT CONTAIN ASBESTOS FIBERS. DUST AND DIRT ON CLUTCH PARTS MAY CONTAIN ASBESTOS FIBERS FROM AFTERMARKET

COMPONENTS. BREATHING EXCESSIVE CONCENTRATIONS OF THESE FIBERS CAN CAUSE SERIOUS BODILY HARM. WEAR A RESPIRATOR DURING SERVICE AND NEVER CLEAN CLUTCH COMPONENTS WITH COMPRESSED AIR OR WITH A DRY BRUSH. EITHER CLEAN THE COMPONENTS WITH A WATER DAMPENED RAGS OR USE A VACUUM CLEANER SPECIFICALLY DESIGNED FOR REMOVING ASBESTOS FIBERS AND DUST. DO NOT CREATE DUST BY SANDING A CLUTCH DISC. REPLACE THE DISC IF THE FRICTION MATERIAL IS DAMAGED OR CONTAMINATED. DISPOSE OF ALL DUST AND DIRT CONTAINING ASBESTOS FIBERS IN SEALED BAGS OR CONTAINERS. THIS WILL HELP MINIMIZE EXPOSURE TO YOURSELF AND TO OTHERS. FOLLOW ALL RECOMMENDED SAFETY PRACTICES PRESCRIBED BY THE OCCUPATIONAL SAFETY AND HEALTH ADMINISTRATION (OSHA) AND THE ENVIRONMENTAL SAFETY AGENCY (EPA), FOR THE HANDLING AND DISPOSAL OF PRODUCTS CONTAINING ASBESTOS.

INSTALLATION METHODS AND PARTS USAGE

Distortion of clutch components during installation and the use of non-standard components are common causes of clutch malfunction.

Improper clutch cover bolt tightening can distort the cover. The usual result is clutch grab, chatter and rapid wear. Tighten the cover bolts as described in Removal and Installation section.

An improperly seated flywheel and/or clutch housing are additional causes of clutch failure. Improper seating will produce misalignment and additional clutch problems.

The use of non-standard or low quality parts will also lead to problems and wear. Use recommended factory quality parts to avoid comebacks.

A cocked pilot bearing is another cause of clutch noise, drag, hard shifting, and rapid bearing wear. Always use an alignment tool to install a new bearing. This practice helps avoid cocking the bearing during installation.

CLUTCH DIAGNOSTIC INFORMATION

Unless the cause of a clutch problem is obvious, accurate problem diagnosis will usually require a road test to confirm a problem. Component inspection (Fig. 8) will then be required to determine the actual problem cause.

During a road test, drive the vehicle at normal speeds. Shift the transmission through all gear ranges and observe clutch action. If chatter, grab, slip, or improper release is experienced, remove and inspect the clutch components. However, if the problem is noise or hard shifting, further diagnosis may be needed as the transmission or another driveline component may be at fault. Careful observation during the test will help narrow the problem area.

DIAGNOSIS AND TESTING (Continued)

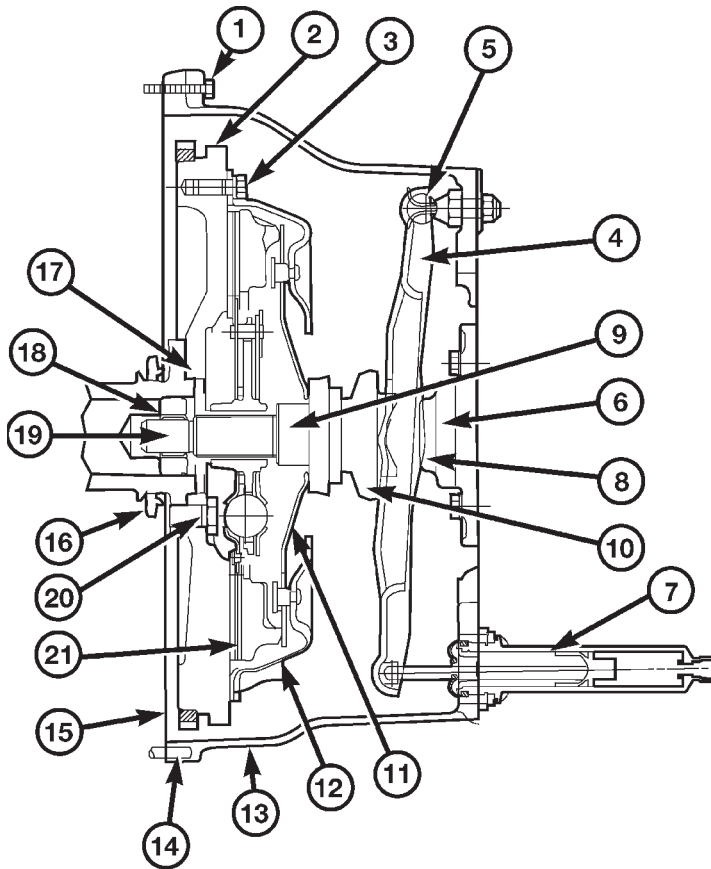

1 Check clutch housing bolts. Tighten if loose. Be sure housing is fully seated on engine block.

2 Check flywheel. Scuff sand face to remove glaze. Clean surface with wax and grease remover. Replace flywheel if severely scored, worn or cracked. Secure flywheel with new bolts (if removed). Do not reuse old bolts. Use Mopar Lock N'Seal on bolts.

3 Tighten clutch cover bolts 2-3 threads at a time, alternately and evenly (in a star pattern) to specified torque. Failure to do so could warp the cover.

4 Check release fork. Replace fork if bent or worn. Make sure pivot and bearing contact surfaces are lubricated.

5 Check release fork pivot (in housing). Be sure pivot is secure and ball end is lubricated.

6 Transmission input shaft bearing will cause noise, chatter, or improper release if damaged. Check condition before installing transmission.

7 Check slave cylinder. Replace it if leaking. Be sure cylinder is properly secured in housing and cylinder piston is seated in release fork.

8 Check input shaft seal if clutch cover and disc were oil covered. Replace seal if worn, or cut.

9 Inspect release bearing slide surface of trans. front bearing retainer. Surface should be smooth, free of nicks, scores. Replace retainer if necessary. Lubricate slide surface before installing release bearing.

10 Do not replace release bearing unless actually faulty. Replace bearing only if seized, noisy, or damaged.

11 Check clutch cover diaphragm spring and release fingers. Replace cover if spring or fingers are bent, warped, broken, cracked. Do not tamper with factory spring setting as clutch problems will result.

12 Check condition of clutch cover. Replace clutch cover if plate surface is deeply scored, warped, worn, or cracked. Be sure cover is correct size and properly aligned on disc and flywheel.

13 Inspect clutch housing. Be sure bolts are tight. Replace housing if damaged.

14 Verify that housing alignment dowels are in position before installing housing.

15 Clean engine block surface before installing clutch housing. Dirt, grime can produce misalignment.

16 Check rear main seal if clutch disc and cover were oil covered. Replace seal if necessary.

17 Check crankshaft flange (if flywheel is removed). Be sure flange is clean and flywheel bolt threads are in good condition.

18 Check pilot bearing. Replace bearing if damaged. Lube with Mopar high temp. bearing grease before installation.

19 Check transmission input shaft. Disc must slide freely on shaft splines. Lightly grease splines before installation. Replace shaft if splines or pilot bearing hub are damaged.

20 Check flywheel bolt torque. If bolts are loose, replace them. Use Mopar Lock N'Seal to secure new bolts.

21 Check clutch disc facing. Replace disc if facing is charred, scored, flaking off, or worn. Also check runout of new disc. Runout should not exceed 0.5 mm (0.02 in.).

Fig. 8 Clutch Components And Inspection

DIAGNOSIS AND TESTING (Continued)

CLUTCH CONTAMINATION

Fluid contamination is a frequent cause of clutch malfunctions. Oil, water, or clutch fluid on the clutch disc and pressure plate surfaces will cause chatter, slip and grab.

During inspection, note if any components are contaminated with oil, hydraulic fluid, or water/road splash.

Oil contamination indicates a leak at either the rear main seal or transmission input shaft. Oil leakage produces a residue of oil on the housing interior and on the clutch cover and flywheel. Heat buildup caused by slippage between the cover, disc and flywheel, can sometimes bake the oil residue onto the components. The glaze-like residue ranges in color from amber to black.

Road splash contamination means dirt/water is entering the clutch housing due to loose bolts, housing cracks, or through hydraulic line openings. Driving through deep water puddles can force water/road splash into the housing through such openings.

Clutch fluid leaks are usually from damaged slave cylinder push rod seals. This type of leak can only be confirmed by visual inspection.

IMPROPER CLUTCH RELEASE OR ENGAGEMENT

Clutch release or engagement problems are caused by wear, or damage to one or more clutch components. A visual inspection of the release components will usually reveal the problem part.

Release problems can result in hard shifting and noise. Items to look for are: leaks at the clutch cylinders and interconnecting line; loose slave cylinder bolts; worn/loose release fork and pivot stud; damaged release bearing; and a worn clutch disc, or pressure plate.

Normal condensation in vehicles that are stored or out of service for long periods of time can generate enough corrosion to make the disc stick to the flywheel, or pressure plate. If this condition is experienced, correction only requires that the disc be loosened manually through the inspection plate opening.

Engagement problems usually result in slip, chatter/shudder, and noisy operation. The primary causes are clutch disc contamination; clutch disc wear; misalignment, or distortion; flywheel damage; or a combination of the foregoing. A visual inspection is required to determine the part actually causing the problem.

CLUTCH MISALIGNMENT

Clutch components must be in proper alignment with the crankshaft and transmission input shaft. Misalignment caused by excessive runout or warpage

of any clutch component will cause grab, chatter and improper clutch release.

CLUTCH HOUSING MISALIGNMENT

Clutch housing alignment is important to proper clutch operation. The housing maintains alignment between the crankshaft and transmission input shaft. Misalignment can cause clutch noise, hard shifting, incomplete release and chatter. It can also result in premature wear of the pilot bearing, cover release fingers and clutch disc. In severe cases, misalignment can also cause premature wear of the transmission input shaft and front bearing.

Housing misalignment is generally caused by incorrect seating on the engine or transmission, loose housing bolts, missing alignment dowels, or housing damage. Infrequently, misalignment may also be caused by housing mounting surfaces that are not completely parallel. Misalignment can be corrected with shims.

CLUTCH FLYWHEEL RUNOUT

Check flywheel runout whenever misalignment is suspected. Flywheel runout should not exceed 0.08 mm (0.003 in.). Measure runout at the outer edge of the flywheel face with a dial indicator. Mount the indicator on a stud installed in place of one of the flywheel bolts.

Common causes of runout are:

- heat warpage
- improper machining
- incorrect bolt tightening
- improper seating on crankshaft flange shoulder
- foreign material on crankshaft flange

Flywheel machining is not recommended. The flywheel clutch surface is machined to a unique contour and machining will negate this feature. However, minor flywheel scoring can be cleaned up by hand with 180 grit emery, or with surface grinding equipment. Remove only enough material to reduce scoring (approximately 0.001 - 0.003 in.). Heavy stock removal is **not recommended**. Replace the flywheel if scoring is severe and deeper than 0.076 mm (0.003 in.). Excessive stock removal can result in flywheel cracking or warpage after installation; it can also weaken the flywheel and interfere with proper clutch release.

Clean the crankshaft flange before mounting the flywheel. Dirt and grease on the flange surface may cock the flywheel causing excessive runout. Use new bolts when remounting a flywheel and secure the bolts with Mopar® Lock And Seal. Tighten flywheel bolts to specified torque only. Overtightening can distort the flywheel hub causing runout.

DIAGNOSIS AND TESTING (Continued)

CLUTCH COVER AND DISC RUNOUT

Check the clutch disc before installation. Axial (face) runout of a **new** disc should not exceed 0.50 mm (0.020 in.). Measure runout about 6 mm (1/4 in.) from the outer edge of the disc facing. Obtain another disc if runout is excessive.

Check condition of the clutch before installation. A warped cover or diaphragm spring will cause grab and incomplete release or engagement. Be careful when handling the cover and disc. Impact can distort the cover, diaphragm spring, release fingers and the hub of the clutch disc.

Use an alignment tool when positioning the disc on the flywheel. The tool prevents accidental misalignment which could result in cover distortion and disc damage.

A frequent cause of clutch cover distortion (and consequent misalignment) is improper bolt tightening.

CLUTCH DIAGNOSIS CHARTS

The clutch inspection chart (Fig. 8) outlines items to be checked before and during clutch installation. Use the chart as a check list to help avoid overlooking potential problem sources during service operations.

The diagnosis charts describe common clutch problems, causes and correction. Fault conditions are listed at the top of each chart. Conditions, causes and corrective action are outlined in the indicated columns.

The charts are provided as a convenient reference when diagnosing faulty clutch operation.

DIAGNOSIS CHART

| CONDITION | POSSIBLE CAUSES | CORRECTION |
|--|--|--|
| Disc facing worn out | <ol style="list-style-type: none"> 1. Normal wear. 2. Driver frequently rides (slips) the clutch. Results in rapid overheating and wear. 3. Insufficient clutch cover diaphragm spring tension. | <ol style="list-style-type: none"> 1. Replace cover and disc. 2. Replace cover and disc. 3. Replace cover and disc. |
| Clutch disc facing contaminated with oil, grease, or clutch fluid. | <ol style="list-style-type: none"> 1. Leak at rear main engine seal or transmission input shaft seal. 2. Excessive amount of grease applied to the input shaft splines. 3. Road splash, water entering housing. 4. Slave cylinder leaking. | <ol style="list-style-type: none"> 1. Replace appropriate seal. 2. Remove grease and apply the correct amount of grease. 3. Replace clutch disc. Clean clutch cover and reuse if in good condition. 4. Replace hydraulic clutch linkage. |
| Clutch is running partially disengaged. | <ol style="list-style-type: none"> 1. Release bearing sticking or binding and does not return to the normal running position. | <ol style="list-style-type: none"> 1. Verify failure. Replace the release bearing and transmission front bearing retainer as necessary. |
| Flywheel below minimum thickness specification. | <ol style="list-style-type: none"> 1. Improper flywheel machining. Flywheel has excessive taper or excessive material removal. | <ol style="list-style-type: none"> 1. Replace flywheel. |
| Clutch disc, cover and/or diaphragm spring warped or distorted. | <ol style="list-style-type: none"> 1. Rough handling. Impact bent cover, spring, or disc. 2. Improper bolt tightening procedure. | <ol style="list-style-type: none"> 1. Replace disc or cover as necessary. 2. Tighten clutch cover using proper procedure. |

DIAGNOSIS AND TESTING (Continued)

| CONDITION | POSSIBLE CAUSES | CORRECTION |
|--|---|--|
| Facing on flywheel side of disc torn, gouged, or worn. | <ol style="list-style-type: none"> 1. Flywheel surface scored or nicked. 2. Clutch disc sticking or binding on transmission input shaft. | <ol style="list-style-type: none"> 2. Correct surface condition if possible. Replace flywheel and disc as necessary. 2. Inspect components and correct/replace as necessary. |
| Clutch disc facing burnt. Flywheel and cover pressure plate surfaces heavily glazed. | <ol style="list-style-type: none"> 1. Frequent operation under high loads or hard acceleration conditions. 2. Driver frequently rides (slips) clutch. Results in rapid wear and overheating of disc and cover. | <ol style="list-style-type: none"> 1. Correct condition of flywheel and pressure plate surface. Replace clutch cover and disc. Alert driver to problem cause. 2. Correct condition of flywheel and pressure plate surface. Replace clutch cover and disc. Alert driver to problem cause. |
| Clutch disc binds on input shaft splines. | <ol style="list-style-type: none"> 1. Clutch disc hub splines damaged during installation. 2. Input shaft splines rough, damaged, or corroded. | <ol style="list-style-type: none"> 1. Clean, smooth, and lubricate hub splines if possible. Replace disc if necessary. 2. Clean, smooth, and lubricate shaft splines if possible. Replace input shaft if necessary. |
| Clutch disc rusted to flywheel and/or pressure plate. | <ol style="list-style-type: none"> 1. Clutch not used for and extended period of time (e.g. long term vehicle storage). | <ol style="list-style-type: none"> 1. Sand rusted surfaces with 180 grit sanding paper. Replace clutch cover and flywheel if necessary. |
| Pilot bearing seized, loose, or rollers are worn. | <ol style="list-style-type: none"> 1. Bearing cocked during installation. 2. Bearing defective. 3. Bearing not lubricated. 4. Clutch misalignment. | <ol style="list-style-type: none"> 1. Install and lubricate a new bearing. 2. Install and lubricate a new bearing. 3. Install and lubricate a new bearing. 4. Inspect clutch and correct as necessary. Install and lubricate a new bearing. |
| Clutch will not disengage properly. | <ol style="list-style-type: none"> 1. Low clutch fluid level. 2. Clutch cover loose. 3. Clutch disc bent or distorted. 4. Clutch cover diaphragm spring bent or warped. 5. Clutch disc installed backwards. 6. Release fork bent or fork pivot loose or damaged. 7. Clutch master or slave cylinder failure. | <ol style="list-style-type: none"> 1. Replace hydraulic linkage assembly. 2. Follow proper bolt tightening procedure. 3. Replace clutch disc. 4. Replace clutch cover. 5. Remove and install clutch disc correctly. 6. Replace fork or pivot as necessary. 7. Replace hydraulic linkage assembly. |

DIAGNOSIS AND TESTING (Continued)

| CONDITION | POSSIBLE CAUSES | CORRECTION |
|--|---|--|
| Clutch pedal squeak. | 1. Pivot pin loose. 2. Master cylinder bushing not lubricated. 3. Pedal bushings worn out or cracked. | 1. Tighten pivot pin if possible. Replace clutch pedal if necessary. 2. Lubricate master cylinder bushing. 3. Replace and lubricate bushings. |
| Clutch master or slave cylinder plunger dragging and/or binding | 1. Master or slave cylinder components worn or corroded. | 1. Replace clutch hydraulic linkage assembly. |
| Release bearing is noisy. | 1. Release bearing defective or damaged. | 1. Replace release bearing. |
| Contact surface of release bearing damaged. | 1. Clutch cover incorrect or release fingers bent or distorted. 2. Release bearing defective or damaged. 3. Release bearing misaligned. | 1. Replace clutch cover and release bearing. 2. Replace the release bearing. 3. Check and correct runout of clutch components. Check front bearing sleeve for damage/alignment. Repair as necessary. |
| Partial engagement of clutch disc. One side of disc is worn and the other side is glazed and lightly worn. | 1. Clutch pressure plate position incorrect. 2. Clutch cover, spring, or release fingers bent or distorted. 3. Clutch disc damaged or distorted. 4. Clutch misalignment. | 1. Replace clutch disc and cover. 2. Replace clutch disc and cover. 2. Replace clutch disc. 4. Check alignment and runout of flywheel, disc, pressure plate, and/or clutch housing. Correct as necessary. |

SERVICE PROCEDURES

CLUTCH COMPONENT LUBRICATION

Proper clutch component lubrication is important to satisfactory operation. Using the correct lubricant and not over lubricating are equally important. Apply recommended lubricant sparingly to avoid disc and pressure plate contamination.

Clutch and transmission components requiring lubrication are:

- Pilot bearing.
- Release lever pivot ball stud.
- Release lever contact surfaces.
- Release bearing bore.
- Clutch disc hub splines.
- Clutch pedal pivot shaft bore.
- Clutch pedal bushings.
- Input shaft splines.

- Input shaft pilot hub.
- Transmission front bearing retainer slide surface.

NOTE: Never apply grease to any part of the clutch cover, or disc.

RECOMMENDED LUBRICANTS

Use Mopar® multi-purpose grease for the clutch pedal bushings and pivot shaft. Use Mopar® high temperature grease (or equivalent) for all other lubrication requirements. Apply recommended amounts and do not over lubricate.

CLUTCH LINKAGE FLUID

If inspection or diagnosis indicates additional fluid may be needed, use Mopar® brake fluid, or an equiv-

SERVICE PROCEDURES (Continued)

alent meeting standards SAE J1703 and DOT 3. Do not use any other type of fluid.

CLUTCH FLUID LEVEL

The clutch fluid reservoir, master cylinder, slave cylinder and fluid lines are pre-filled with fluid at the factory during assembly operations.

The hydraulic system should not require additional fluid under normal circumstances. In fact, **the reservoir fluid level will actually increase as normal clutch wear occurs. For this reason, it is important to avoid overfilling, or removing fluid from the reservoir.**

Clutch fluid level is checked at the master cylinder reservoir (Fig. 9). An indicator ring is provided on the outside rim of the reservoir.

Be sure to wipe the reservoir and cover clean before removing the cover. This will avoid having dirt or foreign material fall into the reservoir during a fluid level check.

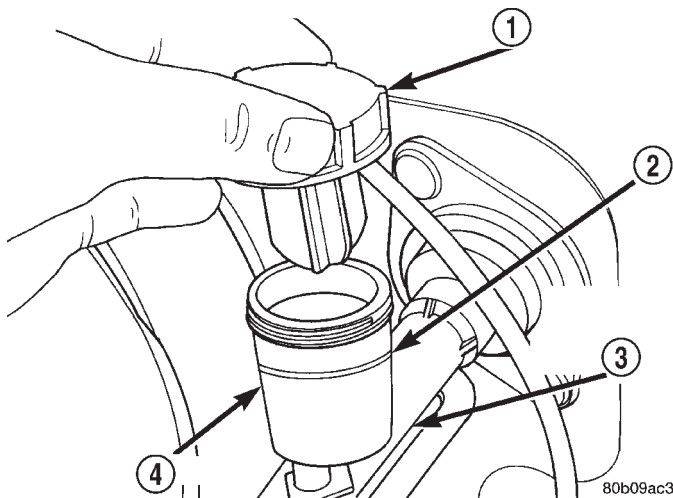

Fig. 9 Clutch Master Cylinder Reservoir And Cap

- 1 - CAP
- 2 - FILL LINE
- 3 - CLUTCH MASTER CYLINDER
- 4 - RESERVOIR

FLYWHEEL

Inspect the flywheel whenever the clutch disc, cover and housing are removed for service. Check condition of the flywheel face, hub, ring gear teeth, and flywheel bolts.

Minor scratches, burrs, or glazing on the flywheel face can be reduced with 180 grit emery cloth. However, the flywheel should be replaced if the disc contact surface is severely scored, heat checked, cracked, or obviously worn.

Flywheel machining is not recommended. The flywheel surface is manufactured with a unique contour that would be negated by machining. However,

cleanup of minor flywheel scoring can be performed by hand with 180 grit emery, or with surface grinding equipment. Replace the flywheel if scoring is deeper than 0.0762 mm (0.003 in.).

Heavy stock removal by grinding is **not recommended**. Excessive stock removal can result in flywheel cracking or warpage after installation. It can also weaken the flywheel and interfere with proper clutch release.

Check flywheel runout if misalignment is suspected. Runout should not exceed 0.08 mm (0.003 in.). Measure runout at the outer edge of the flywheel face with a dial indicator. Mount the dial indicator on a stud installed in place of one of the clutch housing attaching bolts.

Clean the crankshaft flange before mounting the flywheel. Dirt and grease on the flange surface may cock the flywheel causing excessive runout.

Check condition of the flywheel hub and attaching bolts. Replace the flywheel if the hub exhibits cracks in the area of the attaching bolt holes.

Install new attaching bolts whenever the flywheel is replaced and use Mopar® Lock N' Seal, or Loctite 242 on the replacement bolt threads.

Recommended flywheel bolt torques are:

- 142 N·m (105 ft. lbs.) for 6-cylinder flywheels
- 95 N·m (70 ft. lbs.) for 4-cylinder flywheels

Inspect the teeth on the starter ring gear. **If the teeth are worn or damaged, the flywheel should be replaced as an assembly. This is the recommended and preferred method of repair.**

In cases where a new flywheel is not readily available, a replacement ring gear can be installed. However, the following precautions must be observed to avoid damaging the flywheel and replacement gear.

(1) Mark position of the old gear for alignment reference on the flywheel. Use a scribe for this purpose.

(2) Wear protective goggles or approved safety glasses. Also wear heat resistant gloves when handling a heated ring gear.

(3) Remove the old gear by cutting most of the way through it (at one point) with an abrasive cut-off wheel. Then complete removal with a cold chisel or punch.

(4) The ring gear is a shrink fit on the flywheel. This means the gear must be expanded by heating in order to install it. **The method of heating and expanding the gear is extremely important.** Every surface of the gear must be heated at the same time to produce uniform expansion. An oven or similar enclosed heating device must be used. Temperature required for uniform expansion is approximately 375° F.

SERVICE PROCEDURES (Continued)

CAUTION: Do not use an oxy/acetylene torch to remove the old gear, or to heat and expand a new gear. The high temperature of the torch flame can cause localized heating that will damage the flywheel. In addition, using the torch to heat a replacement gear will cause uneven heating and expansion. The torch flame can also anneal the gear teeth resulting in rapid wear and damage after installation.

(5) The heated gear must be installed evenly to avoid misalignment or distortion. A shop press and suitable press plates should be used to install the gear if at all possible.

(6) Be sure to wear eye and hand protection. Heat resistant gloves and safety goggles are needed for personal safety. Also use metal tongs, vise grips, or similar tools to position the gear as necessary for installation.

(7) Allow the flywheel and ring gear to cool down before installation. Set the assembly on a workbench and let it cool in normal shop air.

CAUTION: Do not use water, or compressed air to cool the flywheel. The rapid cooling produced by water or compressed air can distort, or crack the gear and flywheel.

REMOVAL AND INSTALLATION

CLUTCH COVER AND DISC

REMOVAL

(1) Remove transmission. Refer to procedures in Group 21.

(2) If original clutch cover will be reinstalled, mark position of cover on flywheel for assembly reference. Use paint or a scribe for this purpose.

(3) If clutch cover is to be replaced, cover bolts can be removed in any sequence. However, if original cover will be reinstalled, loosen cover bolts evenly and in rotation to relieve spring tension equally. This is necessary to avoid warping cover.

(4) Remove cover bolts and remove cover and disc (Fig. 10).

INSTALLATION

(1) Lightly scuff sand flywheel face with 180 grit emery cloth. Then clean surface with a wax and grease remover.

(2) Lubricate pilot bearing with Mopar high temperature bearing grease.

(3) Check runout and free operation of new clutch disc as follows:

(a) Slide disc onto transmission input shaft splines. Disc should slide freely on splines.

(b) Leave disc on shaft and check face runout with dial indicator. Check runout at disc hub and about 6 mm (1/4 in.) from outer edge of facing.

(c) Face runout should not exceed 0.5 mm (0.020 in.). Obtain another clutch disc if runout exceeds this limit.

(4) Position clutch disc on flywheel. Be sure side of disc marked flywheel side is positioned against flywheel (Fig. 10). If disc is not marked, be sure flat side of disc hub is toward flywheel.

(5) Inspect condition of pressure plate surface of clutch cover (Fig. 10). Replace cover if this surface is worn, heat checked, cracked, or scored.

(6) Insert clutch alignment tool in clutch disc (Fig. 11).

(7) Insert alignment tool in pilot bearing and position disc on flywheel. Be sure disc hub is positioned correctly. Side of hub marked Flywheel Side should face flywheel (Fig. 10). If disc is not marked, place flat side of disc against flywheel.

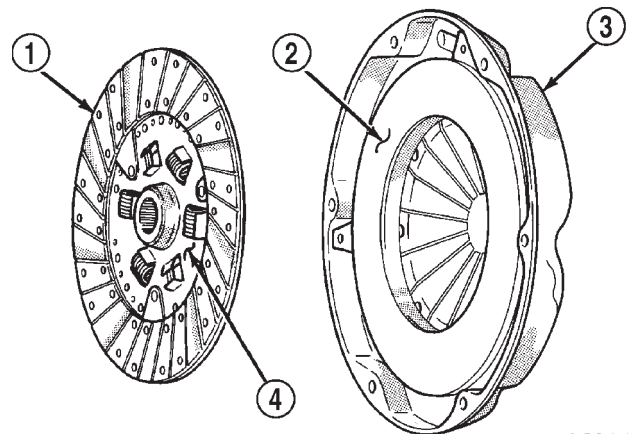

Fig. 10 Clutch Disc And Pressure Plate Inspection

- 1 - DISC
2 - INSPECT THIS SURFACE
3 - CLUTCH COVER
4 - "FLYWHEEL SIDE" STAMPED ON THIS SURFACE

(8) Position clutch cover over disc and on flywheel (Fig. 11).

(9) Install clutch cover bolts finger tight.

(10) Tighten cover bolts evenly and in rotation a few threads at a time. **Cover bolts must be tightened evenly and to specified torque to avoid distorting cover. Tightening torques are 31 N·m (23 ft. lbs.) on 2.5L engines and 50N·m (37ft. lbs.) on 4.0 L engines.**

(a) Start all 6 bolts by hand.

(b) Tighten 3 pilot hole bolts 3/4s of the way (any sequence).

REMOVAL AND INSTALLATION (Continued)

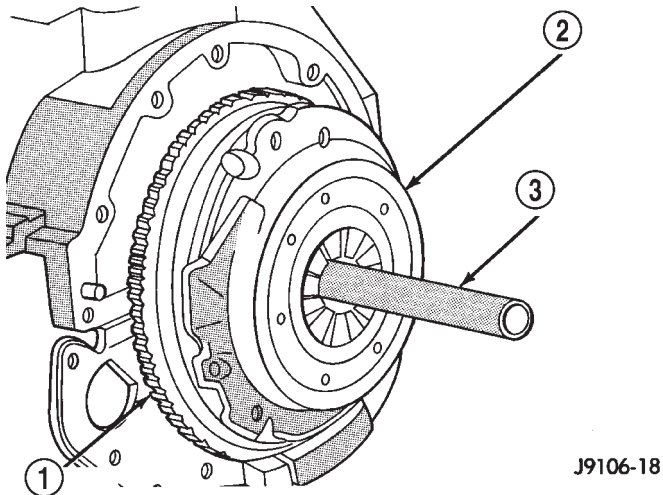

J9106-18

Fig. 11 Typical Method Of Aligning Clutch Disc

- 1 - FLYWHEEL
2 - CLUTCH COVER AND DISC
3 - CLUTCH DISC ALIGNMENT TOOL

(c) Starting 180 degrees from the last pilot bolt, tighten 3 large hole bolts 3/4s of the way (any sequence).

(d) Tighten 3 pilot hole bolts all the way (any sequence).

(e) Starting 180 degrees from last pilot bolt, tighten 3 large bolts all the way (any sequence).

(11) Apply light coat of Mopar® high temperature bearing grease to clutch disc hub and splines of transmission input shaft. **Do not over lubricate shaft splines. This will result in grease contamination of disc.**

(12) Install transmission.

RELEASE BEARING

REMOVAL

- (1) Remove transmission.
- (2) Disconnect release bearing from release lever and remove bearing (Fig. 12).
- (3) Inspect bearing slide surface of transmission front bearing retainer. Replace retainer if slide surface is scored, worn, or cracked.
- (4) Inspect release fork and fork pivot. Be sure pivot is secure and in good condition. Be sure fork is not distorted or worn. Replace release fork retainer spring if bent or damaged.

INSTALLATION

- (1) Lubricate crankshaft pilot bearing with Mopar® high temperature bearing grease. Apply grease to end of long shank, small diameter flat blade screwdriver. Then insert tool through clutch disc hub to reach bearing.

(2) Lubricate input shaft splines, bearing retainer slide surface, fork pivot and release fork pivot surface with Mopar® high temperature grease.

(3) Install new release bearing. Be sure bearing is properly secured to release fork.

(4) Install transmission.

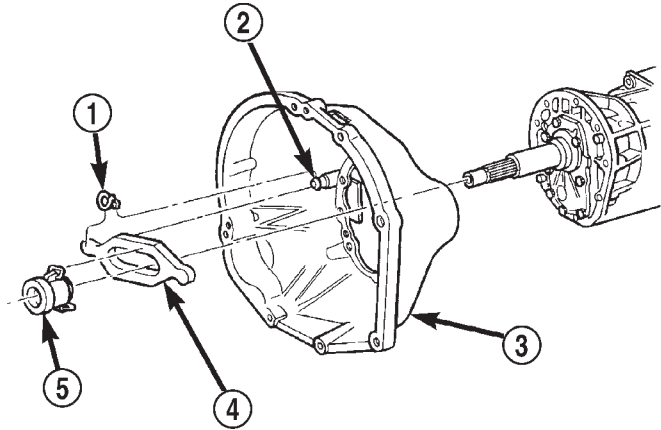

80a5570d

Fig. 12 Release Bearing Attachment

- 1 - RETURN SPRING
2 - PIVOT BALL STUD
3 - CLUTCH HOUSING
4 - RELEASE FORK
5 - RELEASE BEARING

PILOT BEARING

REMOVAL

- (1) Remove transmission. Refer to Group 21, Transmission and Transfer Case, for proper procedures.
- (2) Remove clutch cover and disc.
- (3) Use a suitable blind hole puller to remove pilot bearing.

INSTALLATION

- (1) Clean bearing bore with solvent and wipe dry with shop towel.
- (2) Lubricate new pilot bearing with Mopar® high temperature grease.
- (3) Position and start new bearing in bearing bore by hand. Note that pilot bearing has seal at one end. Install bearing so seal is facing outward toward transmission.
- (4) Seat pilot bearing with clutch alignment tool (Fig. 13). Keep bearing straight during installation. Do not allow bearing to become cocked. Tap bearing into place until flush with edge of bearing bore. Do not recess bearing.
- (5) Install transmission. Refer to Group 21, Transmission and Transfer Case, for proper procedures.

REMOVAL AND INSTALLATION (Continued)

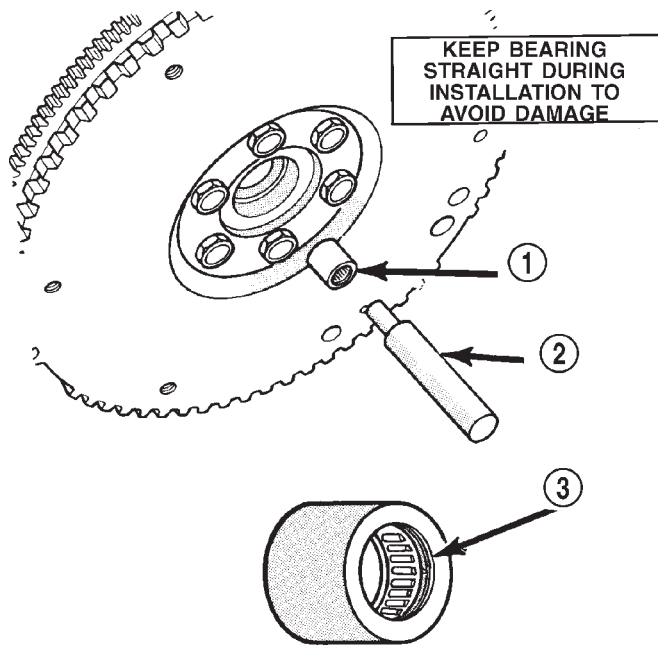

J9206-8

Fig. 13 Typical Method Of Installing Pilot Bearing

- 1 - PILOT BEARING
- 2 - ALIGNMENT TOOL
- 3 - BEARING SEAL MUST FACE TRANSMISSION

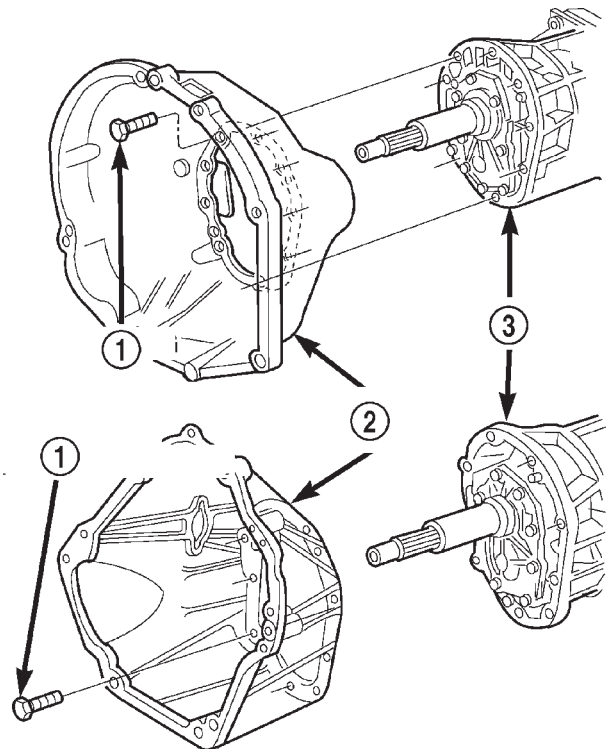

80be4510

Fig. 14 Clutch Housing Attachment

- 1 - HOUSING-TO-TRANSMISSION BOLTS (46 N·m/34 ft. lbs.)
- 2 - CLUTCH HOUSING
- 3 - TRANSMISSION

CLUTCH HOUSING

The clutch housing is removable and can be replaced when the transmission is out of the vehicle.

The bolts attaching the housing to the transmission case are located inside the housing (Fig. 14). Recommended tightening torque for the clutch housing-to-transmission bolts is 46 N·m (34 ft. lbs.).

NOTE: Be sure the transmission and housing mating surfaces are clean before installing an original, or replacement clutch housing. Dirt/foreign material trapped between the housing and transmission will cause misalignment. If misalignment is severe enough, the result will be clutch drag, incomplete release and hard shifting.

CLUTCH HYDRAULIC LINKAGE

The clutch master cylinder, slave cylinder and connecting line are serviced as an assembly only. The linkage components cannot be overhauled or serviced separately. The cylinders and connecting line are sealed units. Also note that removal/installation procedures for right and left hand drive models are basically the same. Only master cylinder location is different.

REMOVAL

- (1) Raise vehicle.
- (2) Remove fasteners attaching slave cylinder to clutch housing.
- (3) Remove slave cylinder from clutch housing (Fig. 15).
- (4) Disengage clutch fluid line from body clips, if applicable.
- (5) Lower vehicle.
- (6) Verify that cap on clutch master cylinder reservoir is tight. This is necessary to avoid spilling fluid during removal.
- (7) Remove clutch master cylinder attaching nuts (Fig. 16) or (Fig. 17).
- (8) Disengage captured bushing on clutch master cylinder actuator from pivot pin on pedal arm (Fig. 18).
- (9) Slide actuator off pivot pin.
- (10) Disconnect clutch interlock safety switch wires.
- (11) Remove clutch hydraulic linkage through engine compartment.

REMOVAL AND INSTALLATION (Continued)

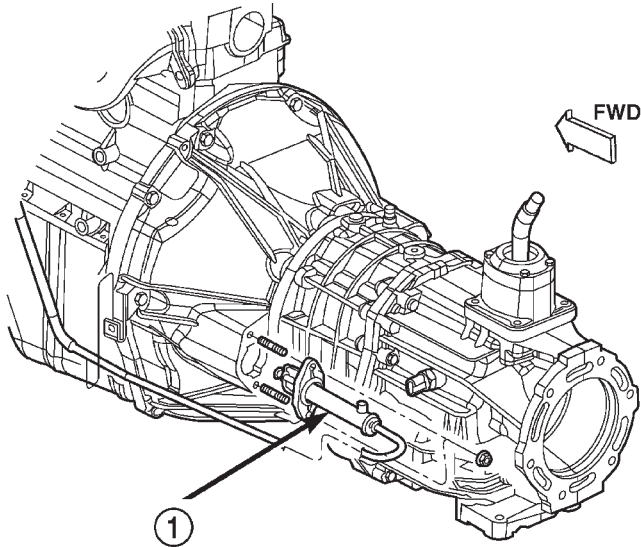

80be45f3

Fig. 15 Slave Cylinder

1 - CLUTCH SLAVE CYLINDER

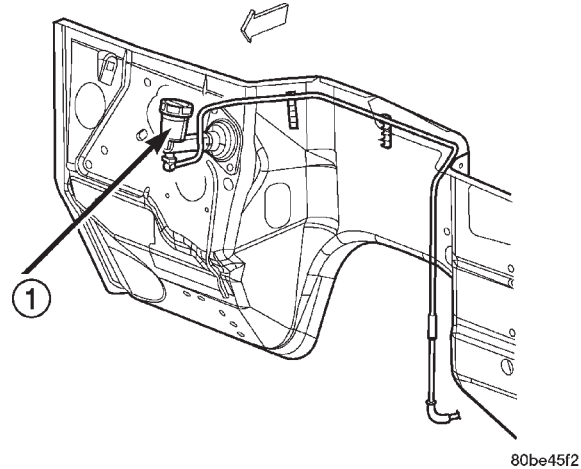

80be45f2

Fig. 17 Right Hand Drive Clutch Master Cylinder

1 - CLUTCH MASTER CYLINDER

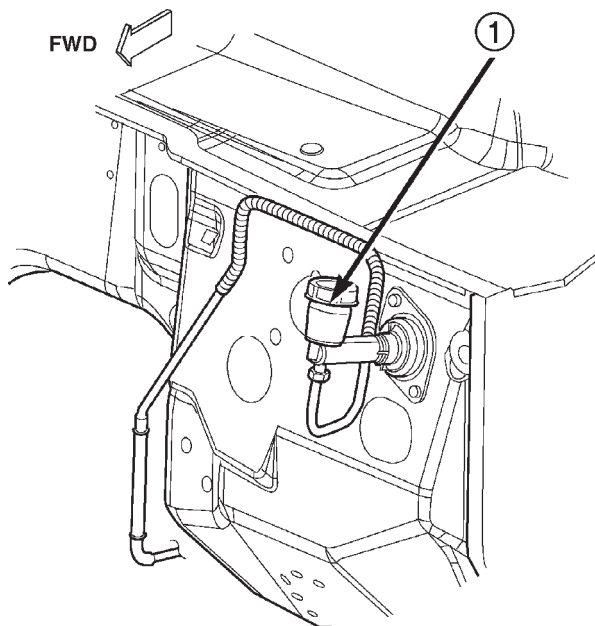

80be45f1

Fig. 16 Left Hand Drive Clutch Master Cylinder

1 - CLUTCH MASTER CYLINDER

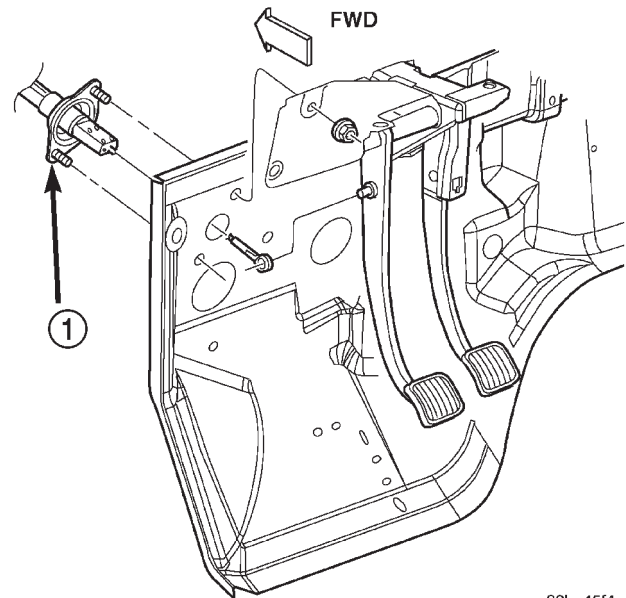

80be45f4

Fig. 18 Clutch Pedal Attachment

1 - CLUTCH MASTER CYLINDER

INSTALLATION

(1) Be sure reservoir cover on clutch master cylinder is tight to avoid spills.

(2) Position clutch linkage components in vehicle. Work connecting line and slave cylinder downward past engine and adjacent to clutch housing (Fig. 16) or (Fig. 17).

(3) Position clutch master cylinder on dash panel (Fig. 16) or (Fig. 17).

(4) Attach clutch master cylinder actuator to pivot pin on clutch pedal (Fig. 18).

(5) Install and tighten clutch master cylinder attaching nuts to 38 N·m (28 ft. lbs.) torque.

(6) Raise vehicle.

(7) Insert slave cylinder push rod through clutch housing opening and into release lever. Be sure cap on end of rod is securely engaged in lever. Check this before installing cylinder attaching nuts.

(8) Install and tighten slave cylinder attaching nuts to 23 N·m (17 ft. lbs.) torque.

REMOVAL AND INSTALLATION (Continued)

- (9) Secure clutch fluid line in body and transmission clips.
- (10) Lower vehicle.
- (11) Connect clutch interlock safety switch wires.

SPECIFICATIONS

TORQUE

| DESCRIPTION | TORQUE |
|---------------------------------------|-----------------------|
| Bolts, clutch cover 2.5 L | 31 N·m (23 ft. lbs) |
| Bolts, clutch cover 4.0 L | 50 N·m (37 ft. lbs) |
| Bolt/Nut, clutch cyl. mount | 23 N·m (200 in. lbs) |
| Bolt, clutch housing M12 | 75 N·m (55 ft. lbs) |
| Bolt, clutch housing 3/8 | 37 N·m (27 ft. lbs) |
| Bolt, clutch housing 7/16 | 58 N·m (43 ft. lbs) |
| Bolt, clutch housing/trans. | 46 N·m (34 ft. lbs) |
| Bolt, dust shield M8 | 8 N·m (72 in. lbs) |
| Bolt, dust shield lower | 50 N·m (37 ft. lbs) |
| Bolt, X-member/frame | 41 N·m (30 ft. lbs) |
| Bolt, X-member/rear support | 45 N·m (33 ft. lbs.) |
| Bolts, flywheel 4.0 L | 142 N·m (105 ft. lbs) |
| Bolts, flywheel 2.5 L | 95 N·m (70 ft. lbs) |
| Bolt, starter motor | 45 N·m (33 ft. lbs) |
| Bolts, U-joints | 19 N·m (170 in. lbs.) |

CLUTCH

TABLE OF CONTENTS

| | page | | page |
|----------------------------------|------|---------------------------------|------|
| DESCRIPTION AND OPERATION | | FLYWHEEL | 5 |
| CLUTCH COMPONENTS | 1 | FLYWHEEL RING GEAR | 7 |
| CLUTCH HYDRAULIC SYSTEM | 1 | SPECIFICATIONS | |
| REMOVAL AND INSTALLATION | | SPECIFICATIONS | 8 |
| CLUTCH COVER AND DISC | 1 | SPECIAL TOOLS | |
| PILOT BEARING | 3 | SPECIAL TOOLS | 8 |

DESCRIPTION AND OPERATION

CLUTCH COMPONENTS

The clutch mechanism consists of a single, dry-type clutch disc and a diaphragm style clutch cover. A hydraulic linkage is used to operate the clutch disc and cover. The clutch components are very similar to those used in gas engine models.

A pilot bearing is used to support the transmission input shaft. The bearing is seated in a separate, removable housing bolted to the flywheel hub.

CLUTCH HYDRAULIC SYSTEM

The clutch hydraulic system should not require additional fluid under normal circumstances.

NOTE: The reservoir fluid level will actually increase as normal clutch wear occurs. For this reason, it is important to avoid over filling, or removing fluid from the reservoir.

If inspection indicates additional fluid is needed, add fluid from a sealed container only. Use Mopar® brake fluid, or an equivalent meeting standards SAE J1703 and DOT 3. Do not use any other type of fluid.

REMOVAL AND INSTALLATION

CLUTCH COVER AND DISC

REMOVAL

(1) Remove the transmission. Refer to Group 21, Transmission and Transfer Case for procedure.

(2) If the original clutch cover will be reinstalled, mark position of cover on flywheel for assembly reference. Use paint or scribe for this purpose.

(3) If the clutch cover is to be replaced, cover bolts can be removed in any sequence. However, if original cover will be reinstalled, loosen cover bolts evenly in

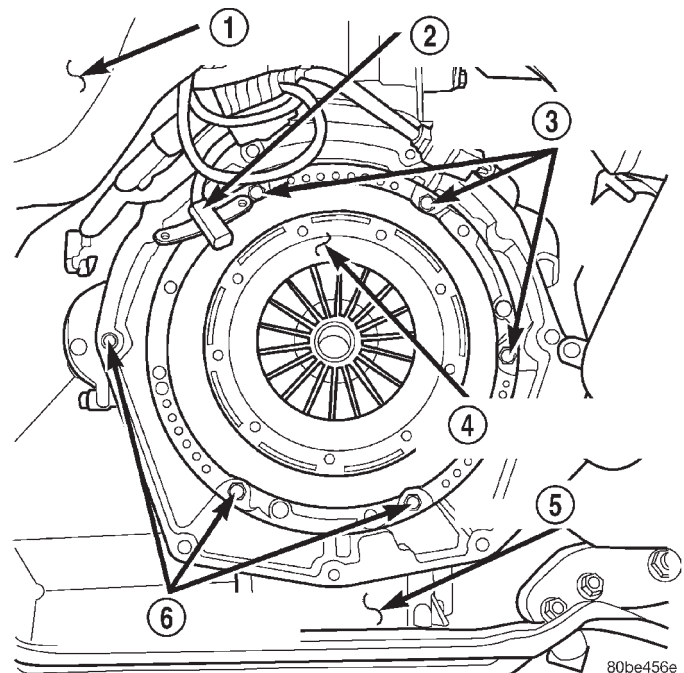

Fig. 1 Clutch Cover (Pressure Plate) View

- 1 - VEHICLE UNDERBODY
- 2 - ENGINE SPEED SENSOR
- 3 - PRESSURE PLATE RETAINING BOLTS
- 4 - CLUTCH COVER (PRESSURE PLATE)
- 5 - ENGINE OIL PAN
- 6 - PRESSURE PLATE RETAINING BOLTS

a star pattern to relieve spring tension equally. This is necessary to avoid warping the cover.

(4) Remove the clutch cover bolts and remove cover and disc (Fig. 1).

INSTALLATION

(1) Lightly scuff sand flywheel face with 180 grit emery cloth. Then clean surface with brake cleaner.

(2) Lightly lubricate the pilot bearing with Mopar® high temperature bearing grease.

REMOVAL AND INSTALLATION (Continued)

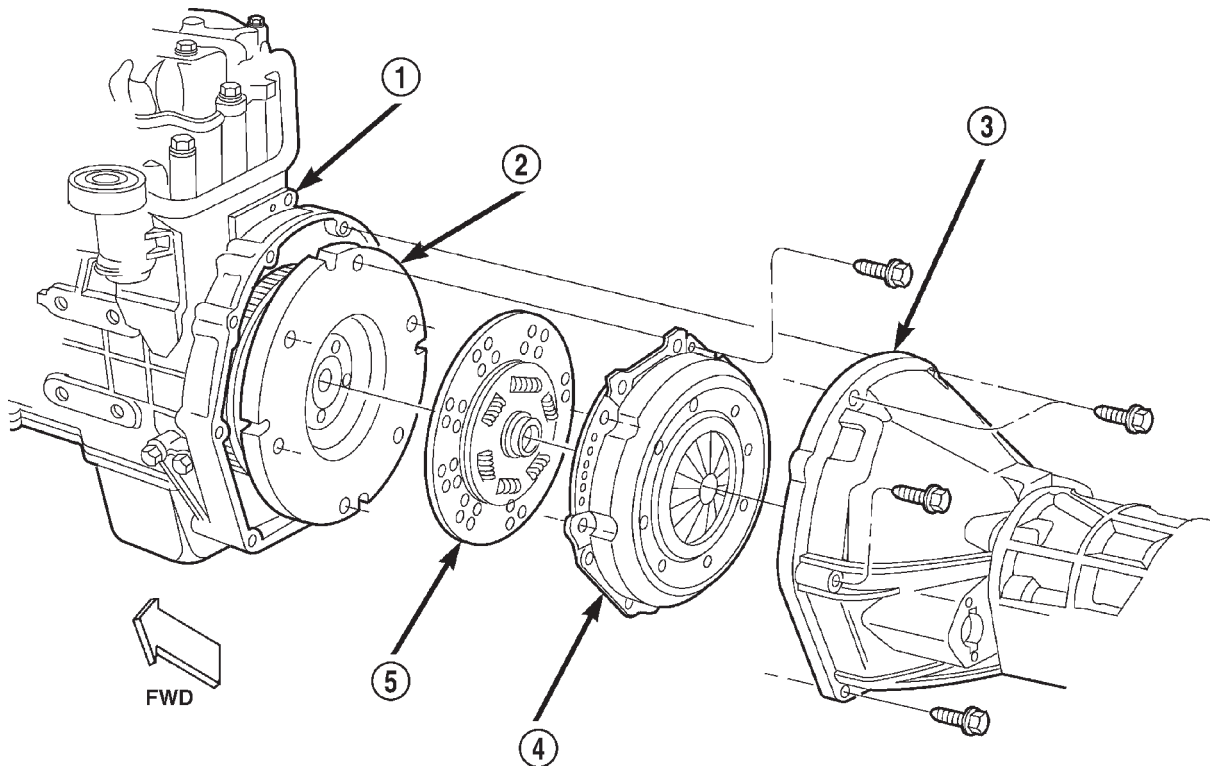

80abfe70

Fig. 2 Clutch Components (VM Diesel)

- | | |
|-------------------------------------|------------------|
| 1 - ENGINE BLOCK | 4 - CLUTCH COVER |
| 2 - FLYWHEEL | 5 - CLUTCH DISC |
| 3 - CLUTCH HOUSING AND TRANSMISSION | |

(3) Check free operation of clutch disc by sliding disc onto transmission output shaft splines. Disc should slide onto splines freely without binding.

(4) Position the clutch disc on flywheel. Be sure side of disc marked "flywheel side" is positioned against flywheel (Fig. 3). If disc is not marked, be sure flat side of disc hub is placed toward the flywheel.

(5) Insert the clutch alignment tool (Fig. 4) in clutch disc and pilot bearing.

(6) Position the clutch cover over the disc and on the flywheel (Fig. 5).

(7) Install the clutch cover bolts finger tight (Fig. 5).

(8) Starting with the bolts marked "P" on the cover first, tighten clutch cover bolts in a star pattern to 50 N·m torque (37 ft. lbs.).

(9) Apply light coat of Mopar® high temperature bearing grease to pilot bearing and splines of transmission input shaft.

CAUTION: Do not over-lubricate as this will result in grease contamination of the disc.

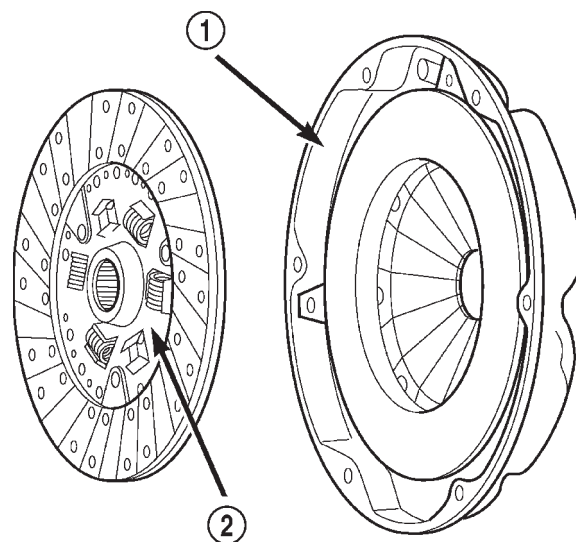

80accfc1

Fig. 3 Clutch Disc Position

- | |
|---|
| 1 - INSPECT THIS SURFACE |
| 2 - "FLYWHEEL SIDE" STAMPED ON THIS SURFACE |

REMOVAL AND INSTALLATION (Continued)

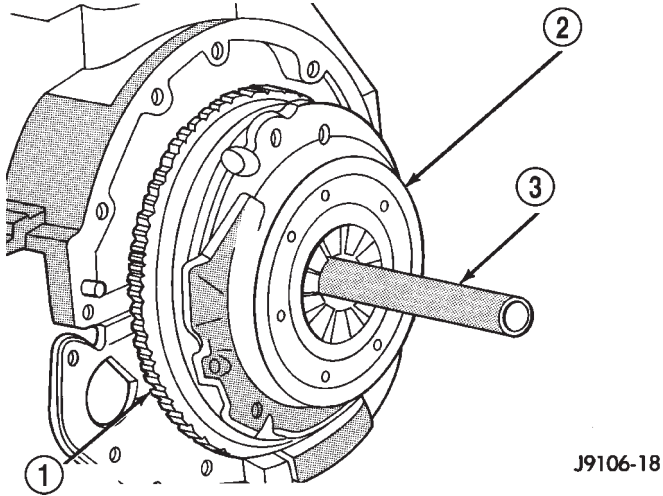

Fig. 4 Clutch Disc Alignment – Typical

- 1 – FLYWHEEL
- 2 – CLUTCH COVER AND DISC
- 3 – CLUTCH DISC ALIGNMENT TOOL

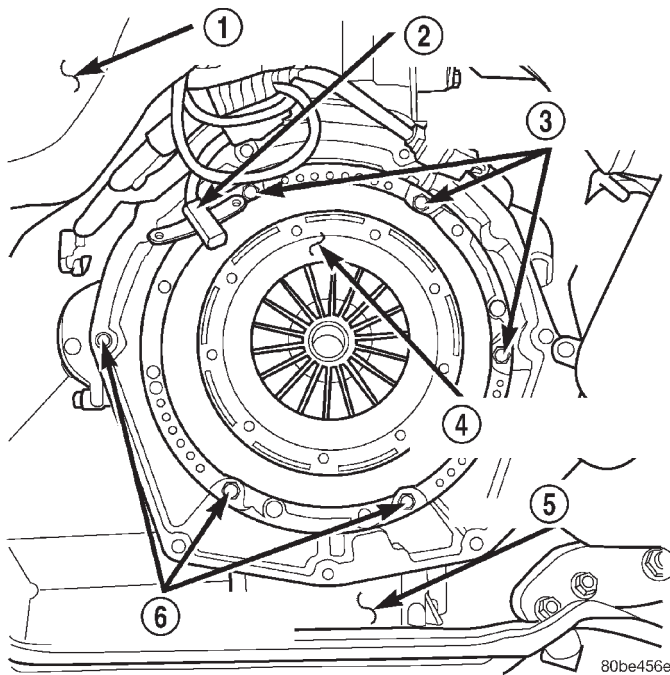

Fig. 5 Clutch Cover (Pressure Plate) View

- 1 – VEHICLE UNDERBODY
- 2 – ENGINE SPEED SENSOR
- 3 – PRESSURE PLATE RETAINING BOLTS
- 4 – CLUTCH COVER (PRESSURE PLATE)
- 5 – ENGINE OIL PAN
- 6 – PRESSURE PLATE RETAINING BOLTS

PILOT BEARING

REMOVAL

(1) Remove the transmission and transfer case. Refer to Group 21, Transmission and Transfer Case for procedures.

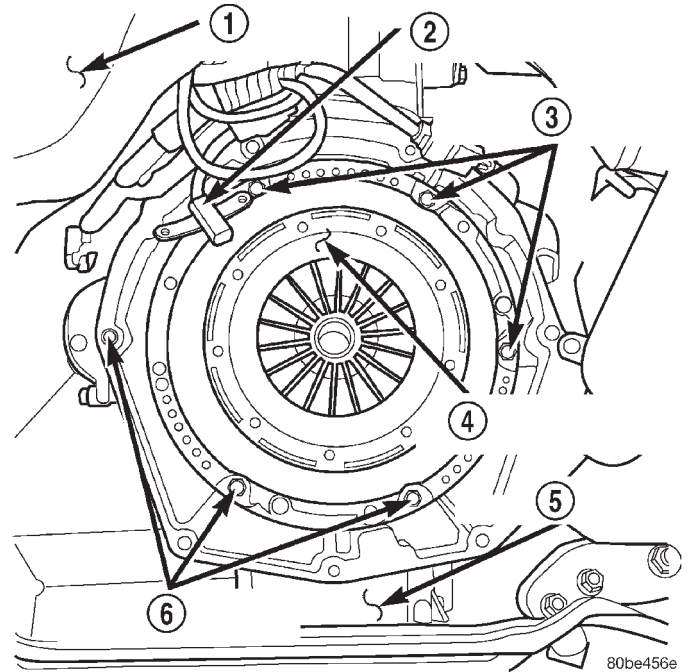

Fig. 6 Clutch Cover (Pressure Plate) View

- 1 – VEHICLE UNDERBODY
- 2 – ENGINE SPEED SENSOR
- 3 – PRESSURE PLATE RETAINING BOLTS
- 4 – CLUTCH COVER (PRESSURE PLATE)
- 5 – ENGINE OIL PAN
- 6 – PRESSURE PLATE RETAINING BOLTS

(2) Remove the clutch cover and disc (Fig. 6). Refer to clutch cover and disc removal and installation in this group.

(3) Remove the four bolts that attach the pilot bearing retainer to the flywheel (Fig. 7).

(4) Remove the pilot bearing retainer.

(5) Support the bearing retainer on two wood blocks.

(6) Remove the pilot bearing with a suitable sized socket and extension (Fig. 8). Use mallet to tap bearing out of retainer.

(10) Install the transmission and transfer case. Refer to Group 21, Transmission and Transfer Case for procedure.

REMOVAL AND INSTALLATION (Continued)

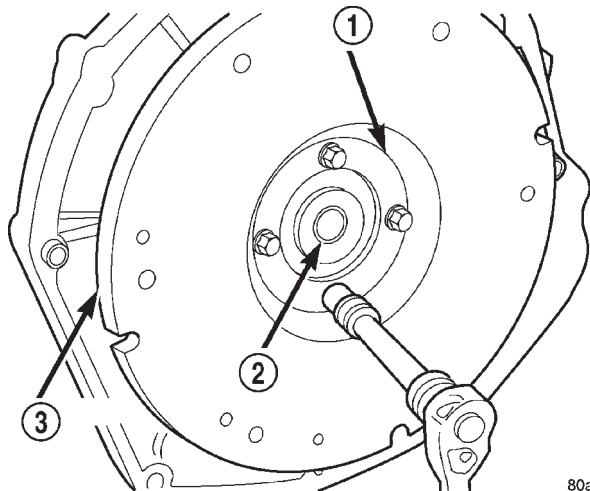

80accfc2

Fig. 7 Pilot Bearing Retainer Bolt Removal/Installation

- 1 - RETAINER
- 2 - PILOT BEARING
- 3 - FLYWHEEL

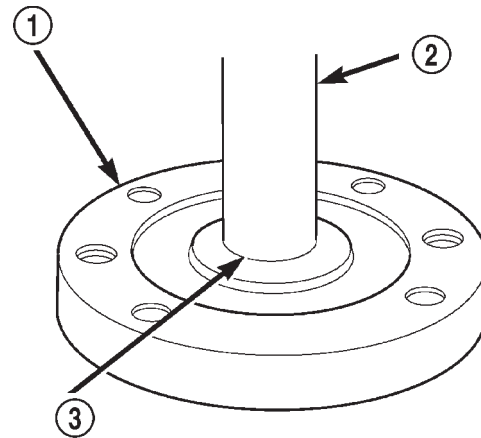

80accfc4

Fig. 9 Pilot Bearing Installation

- 1 - HOUSING
- 2 - SPECIAL TOOL C-4171
- 3 - BEARING

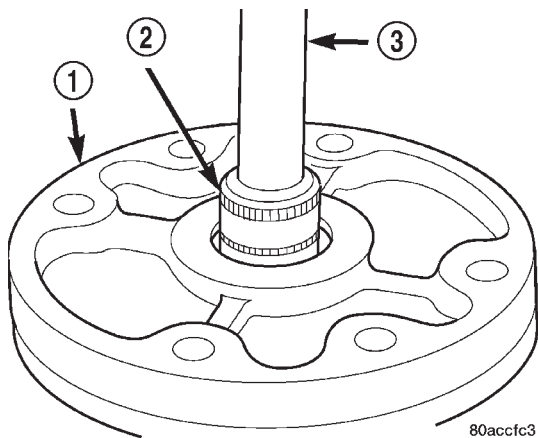

80accfc3

Fig. 8 Pilot Bearing Removal

- 1 - HOUSING
- 2 - SUITABLE SIZE SOCKET
- 3 - EXTENSION

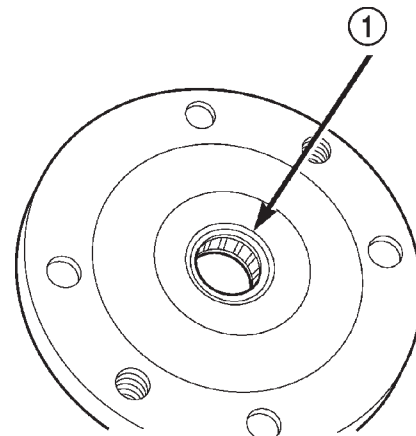

80accfc5

Fig. 10 Pilot Bearing Seated In Retainer

- 1 - SEAT PILOT BEARING FLUSH WITH LOWER EDGE OF CHAMFER (IN BORE)

INSTALLATION

CAUTION: The bearing can be installed incorrectly if care is not exercised. Make sure the stamped letters on the bearing will be facing out (toward rear of vehicle) after installation.

(1) Lightly scuff sand the flywheel surface with 180 grit emery cloth. Clean the surface with Mopar® brake or carburetor cleaner.

(2) Install the new pilot bearing with hammer and tool handle C-4171. (Fig. 9). Seat the bearing flush with lower edge of chamfer in retainer bore (Fig. 10). Reposition the bearing if necessary.

(3) Install the bearing retainer. Torque bolts to 28 N·m (20 ft. lbs.)

(4) Lubricate the pilot bearing with Mopar® high temperature wheel bearing grease.

REMOVAL AND INSTALLATION (Continued)

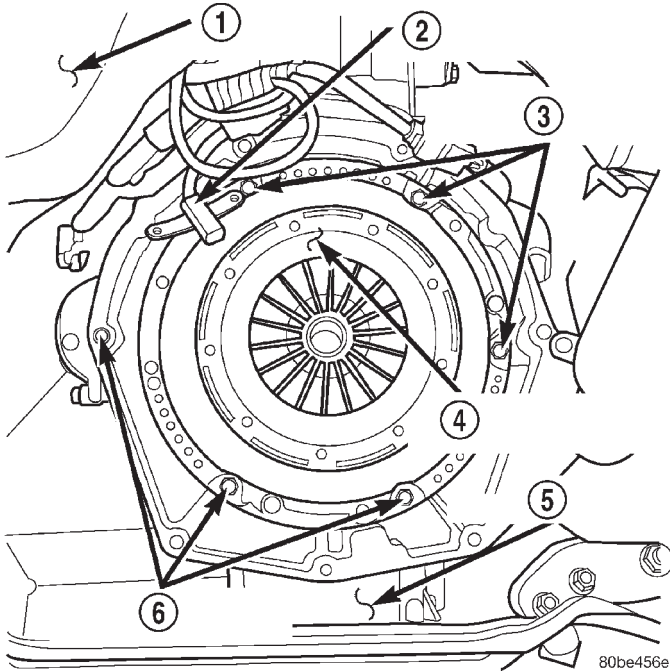
**Fig. 11 Clutch Cover (Pressure Plate) View**

- 1 - VEHICLE UNDERBODY
- 2 - ENGINE SPEED SENSOR
- 3 - PRESSURE PLATE RETAINING BOLTS
- 4 - CLUTCH COVER (PRESSURE PLATE)
- 5 - ENGINE OIL PAN
- 6 - PRESSURE PLATE RETAINING BOLTS

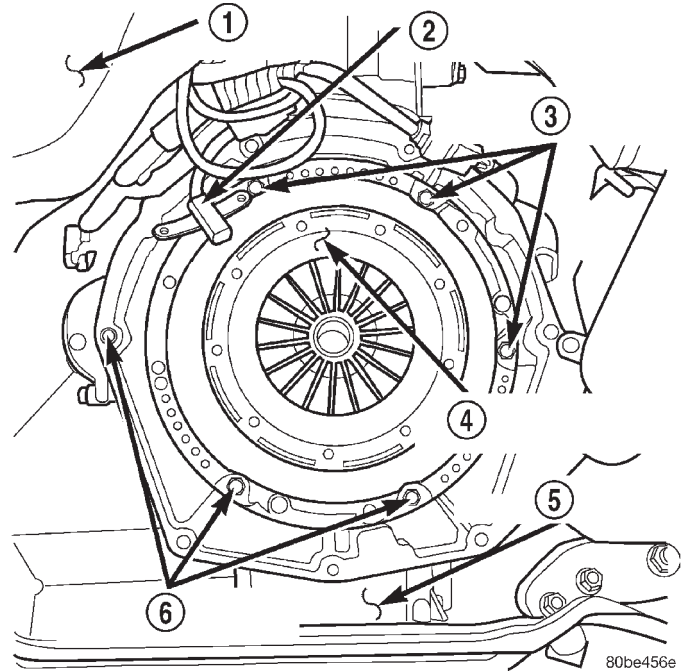
**Fig. 12 Clutch Cover (Pressure Plate) View**

- 1 - VEHICLE UNDERBODY
- 2 - ENGINE SPEED SENSOR
- 3 - PRESSURE PLATE RETAINING BOLTS
- 4 - CLUTCH COVER (PRESSURE PLATE)
- 5 - ENGINE OIL PAN
- 6 - PRESSURE PLATE RETAINING BOLTS

(5) Install the clutch disc and cover (Fig. 11). Refer to clutch cover and disc removal and installation in this group.

(6) Install the transmission and transfer case. Refer to Group 21, Transmission and Transfer Case for procedures.

FLYWHEEL**REMOVAL**

(1) Remove the transmission and clutch housing. Refer to Group 21, Transmission and Transfer Case for procedure.

(2) Remove the clutch cover and disc (Fig. 12) as described in this section.

(3) Remove the bolts that attach pilot bearing retainer to flywheel.

(4) Remove the pilot bearing and retainer.

(5) Remove the flywheel bolts.

(6) Grasp the flywheel firmly and work it off the crankshaft flange.

(7) Remove the o-ring from the crankshaft flange, or the mounting shoulder of the flywheel (Fig. 14).

(8) Clean the flywheel in solvent.

INSPECTION

Examine the flywheel mounting surfaces, clutch contact surface, and ring gear. Check condition of flywheel hub and attaching bolts. Replace flywheel if hub exhibits cracks in the area of attaching bolt holes. Replace ring gear if the teeth are damaged. Resurface the flywheel if the clutch contact surface is scored or rough (refer to flywheel finishing and ring gear replacement information in this section).

Check flywheel runout if misalignment is suspected. Runout should not exceed 0.08 mm. Measure flywheel face runout with a dial indicator (Fig. 13). Mount the indicator on a stud installed in the engine block or in one of the flywheel attaching bolt holes. Face runout can be corrected by resurfacing if necessary. Surface grinding equipment is recommended for this purpose. Stock removal should not exceed 0.25 mm.

INSTALLATION

CAUTION: Use **NEW** flywheel bolts for the following procedure.

(1) Clean the crankshaft flange before mounting the flywheel. Dirt or grease on flange surface may cock flywheel causing run-out.

REMOVAL AND INSTALLATION (Continued)

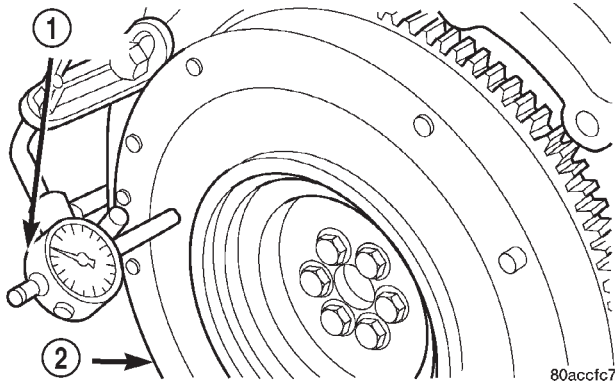

Fig. 13 Checking Flywheel Runout

- 1 - DIAL INDICATOR
2 - FLYWHEEL FACE

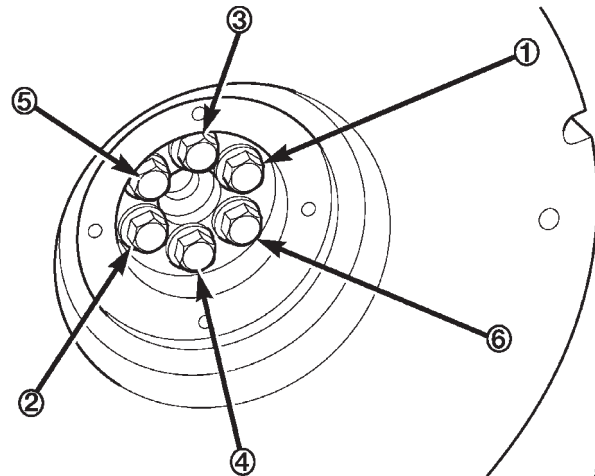

Fig. 15 Cross Tightening Method

(c) Loosen one bolt at a time and tighten to 19.6 N•m (14 ft. lbs.) plus 75° using the cross tightening method until completion.

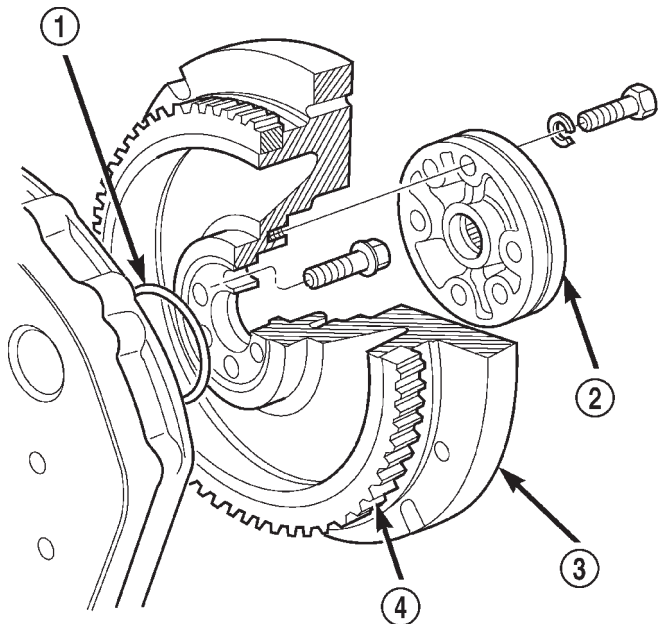

Fig. 14 Flywheel Mounting (VM Diesel)

- 1 - O-RING
2 - PILOT BEARING HOUSING
3 - FLYWHEEL
4 - STARTER RING GEAR

(2) Install new o-ring in the flywheel mounting flange (Fig. 14). Use grease to hold the ring in place.

(3) Install the flywheel on the crankshaft and align the bolt holes.

(4) Install and tighten the new flywheel bolts as follows:

(a) Lubricate and install the 6 new flywheel bolts.

(b) Torque the 6 flywheel bolts to 49 N•m (36 ft. lbs.) starting with one bolt and following with the opposite one (cross tightening) until completion, in a clockwise direction (Fig. 15).

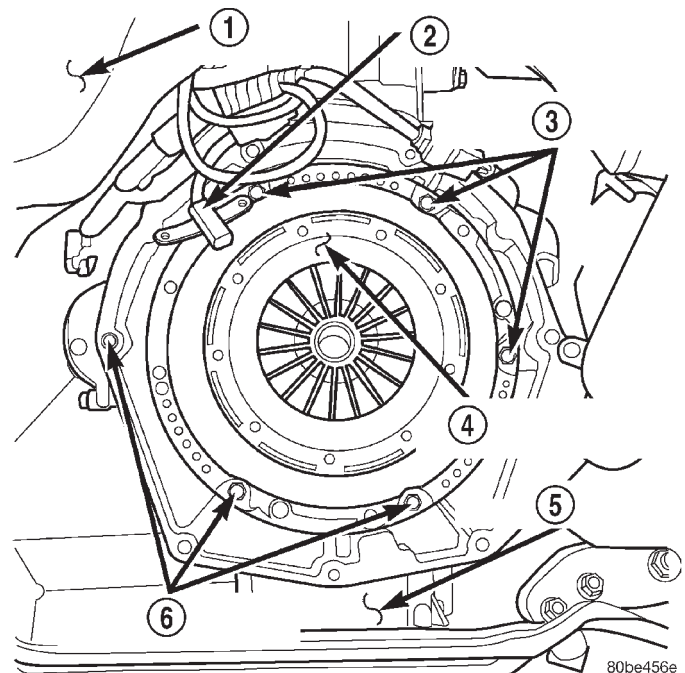

Fig. 16 Clutch Cover (Pressure Plate) View

- 1 - VEHICLE UNDERBODY
2 - ENGINE SPEED SENSOR
3 - PRESSURE PLATE RETAINING BOLTS
4 - CLUTCH COVER (PRESSURE PLATE)
5 - ENGINE OIL PAN
6 - PRESSURE PLATE RETAINING BOLTS

(5) Install the clutch cover and disc (Fig. 16). Refer to clutch cover and disc removal and installation procedure in this section.

(6) Install the transmission and transfer case. Refer to Group 21, Transmission and Transfer Case for removal and installation procedure.

REMOVAL AND INSTALLATION (Continued)

FLYWHEEL RING GEAR

REMOVAL

(1) Remove the transmission and transfer case. Refer to Group 21, Transmission and Transfer Case for removal and installation procedures.

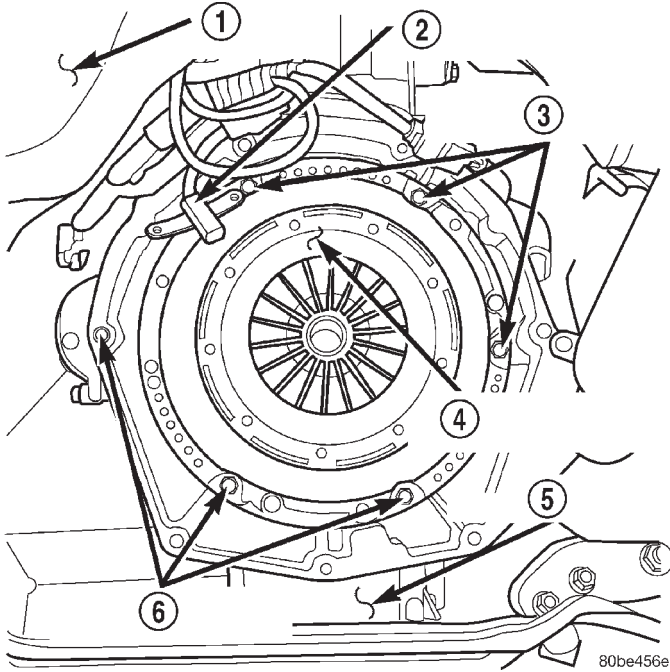

Fig. 17 Clutch Cover (Pressure Plate) View

- 1 - VEHICLE UNDERBODY
- 2 - ENGINE SPEED SENSOR
- 3 - PRESSURE PLATE RETAINING BOLTS
- 4 - CLUTCH COVER (PRESSURE PLATE)
- 5 - ENGINE OIL PAN
- 6 - PRESSURE PLATE RETAINING BOLTS

(2) Remove the clutch cover and disc (Fig. 17). Refer to clutch cover and disc removal and installation in this group.

(3) Remove the flywheel. Refer to flywheel removal and installation in this group.

(4) Mark position of the old gear for alignment reference. Use a carbide tipped scribe to mark gear location on flywheel.

(5) Wear protective goggles or approved safety glasses.

(6) Remove the old gear by cutting most of the way through it at one point. Use an abrasive cut off wheel for this purpose. Break the ring gear at cut with a hammer and a cold chisel or punch

(7) Ring gear is shrink fit on flywheel. This means the gear must be expanded by heating in order to install it.

NOTE: The method of heating and expanding the new ring gear is extremely important. Every surface of the gear must be heated at the same time to produce uniform expansion. An oven or similar enclosed heating device must be used. Temperature required for uniform expansion is approximately 350°-375°.

CAUTION: Do not use an oxy/acetylene torch to remove the old gear, or to heat and expand a new gear. The high temperature of the torch flame can cause localized heating that will damage the flywheel. In addition, using the torch to heat a replacement gear will cause uneven heating and expansion. The torch flame can also anneal the gear teeth resulting in rapid wear and damage after installation.

INSTALLATION

(1) Position and install the heated ring gear on the flywheel:

- (a) Wear heat resistant gloves to handle the hot ring gear.
- (b) Align the ring gear on the flywheel evenly.
- (c) Use hammer and brass drift to tap ring gear onto the flywheel.
- (d) Seat the ring gear on flywheel

(2) Allow the ring gear to cool down before installation on the engine. Place flywheel on work bench and let it cool in normal shop air.

(3) Install the flywheel and torque bolts. Refer to flywheel removal and installation in this group.

(4) Install the clutch cover and disc (Fig. 18). Refer to clutch cover and disc removal and installation in this group.

(5) Install the transmission and transfer case. Refer to Group 21, Transmission and Transfer Case for removal and installation procedures.

CAUTION: Do not use water or compressed air to cool the flywheel. The rapid cooling produced by water or compressed air will distort or crack the new gear.

REMOVAL AND INSTALLATION (Continued)

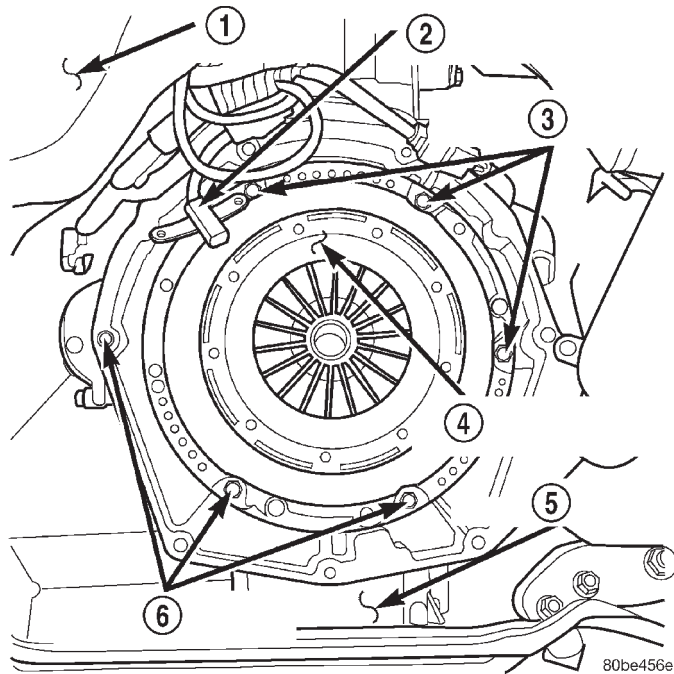

Fig. 18 Clutch Cover (Pressure Plate) View

- 1 - VEHICLE UNDERBODY
- 2 - ENGINE SPEED SENSOR
- 3 - PRESSURE PLATE RETAINING BOLTS
- 4 - CLUTCH COVER (PRESSURE PLATE)
- 5 - ENGINE OIL PAN
- 6 - PRESSURE PLATE RETAINING BOLTS

SPECIFICATIONS

SPECIFICATIONS

| DESCRIPTION | TORQUE |
|--|---|
| Clutch Cover to Flywheel | |
| Bolts | 50 N·m (37 ft. lbs.) |
| Clutch Housing to Transmission | |
| Bolts | 46 N·m (34 ft. lbs.) |
| Flywheel to Crankshaft | |
| Bolts | See removal and installation procedure. |
| Pilot Bearing Retainer to Flywheel/Crankshaft | |
| Bolts | 28 N·m (20 ft. lbs.) |
| Clutch Housing to Engine | |
| Top (2) Bolts | 37 N·m (27 ft. lbs.) |
| Middle (2) Bolts | 58 N·m (43 ft. lbs.) |
| Bottom (2) Bolts | 75 N·m (55 ft. lbs.) |

SPECIAL TOOLS

SPECIAL TOOLS

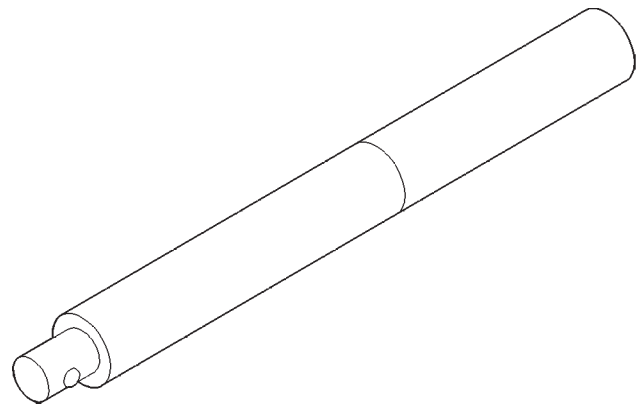

Universal Handle—C-4171

COOLING SYSTEM

TABLE OF CONTENTS

| | page | page |
|---|------|---|
| DESCRIPTION AND OPERATION | | |
| COOLING SYSTEM | 1 | |
| AUTOMATIC TRANSMISSION OIL COOLER | 2 | |
| COOLANT RESERVE/OVERFLOW SYSTEM | 2 | |
| COOLING SYSTEM FANS | 3 | |
| BLOCK HEATER | 4 | |
| THERMOSTAT | 4 | |
| RADIATOR | 5 | |
| RADIATOR PRESSURE CAP | 5 | |
| WATER PUMP | 6 | |
| HOSE CLAMPS | 6 | |
| VISCOUS FAN DRIVE | 7 | |
| ELECTRIC COOLING FAN | 8 | |
| DIAGNOSIS AND TESTING | | |
| ON-BOARD DIAGNOSTICS (OBD) | 9 | |
| DRB SCAN TOOL | 9 | |
| ACCESSORY DRIVE BELT DIAGNOSIS | 9 | |
| PRELIMINARY CHECKS | 11 | |
| RADIATOR COOLANT FLOW CHECK | 17 | |
| COOLING SYSTEM—TESTING FOR LEAKS | 17 | |
| VISCOUS FAN DRIVE | 19 | |
| ELECTRIC COOLING FAN | 19 | |
| RADIATOR CAP-TO-FILLER NECK SEAL—PRESSURE RELIEF CHECK | 20 | |
| RADIATOR CAP—PRESSURE TESTING | 20 | |
| COOLANT—LOW LEVEL AERATION | 21 | |
| DEAERATION | 21 | |
| SERVICE PROCEDURES | | |
| COOLANT—ROUTINE LEVEL CHECK | 21 | |
| COOLANT—ADDING ADDITIONAL | 21 | |
| | | COOLANT—LEVEL CHECK 21 |
| | | COOLING SYSTEM—DRAINING AND FILLING 21 |
| | | COOLING SYSTEM—REVERSE FLUSHING 22 |
| | | REMOVAL AND INSTALLATION |
| | | TRANSMISSION OIL COOLERS 23 |
| | | COOLANT RESERVE TANK 23 |
| | | WATER PUMP 24 |
| | | THERMOSTAT 28 |
| | | RADIATOR—2.5L 29 |
| | | RADIATOR—4.0L 31 |
| | | ELECTRIC COOLING FAN—2.5L 33 |
| | | ELECTRIC COOLING FAN—4.0L 34 |
| | | BLOCK HEATER 35 |
| | | ENGINE ACCESSORY DRIVE BELTS 35 |
| | | COOLING SYSTEM FANS 38 |
| | | VISCOUS FAN DRIVE REMOVAL/ INSTALLATION 39 |
| | | CLEANING AND INSPECTION |
| | | RADIATOR PRESSURE CAP 39 |
| | | RADIATOR 39 |
| | | WATER PUMP 39 |
| | | FAN BLADE 39 |
| | | COOLING SYSTEM HOSES 40 |
| | | SPECIFICATIONS |
| | | BELT TENSION 40 |
| | | TORQUE SPECIFICATIONS 40 |
| | | SPECIAL TOOLS |
| | | COOLING 40 |

DESCRIPTION AND OPERATION

COOLING SYSTEM

DESCRIPTION

The cooling system regulates engine operating temperature. It allows the engine to reach normal operating temperature as quickly as possible, maintains normal operating temperature and prevents overheating.

The cooling system also provides a means of heating the passenger compartment and cooling the auto-

matic transmission fluid (if equipped). The cooling system is pressurized and uses a centrifugal water pump to circulate coolant throughout the system.

An optional factory installed heavy duty cooling package is available on most models. The package consists of a radiator that has an increased number of cooling fins. Vehicles equipped with a 2.5L/4.0L engine and heavy duty cooling and/or air conditioning also have an auxiliary electric cooling fan.

The cooling system consists of:

- A radiator
- Cooling fan (mechanical and/or electrical)
- Thermal viscous fan drive

DESCRIPTION AND OPERATION (Continued)

- Fan shroud
- Radiator pressure cap
- Thermostat
- Coolant reserve/overflow system
- Transmission oil cooler (if equipped with an automatic transmission)
 - Coolant
 - Water pump
 - Hoses and hose clamps

Cooling system circulation for 2.5L/4.0L models is shown in (Fig. 1).

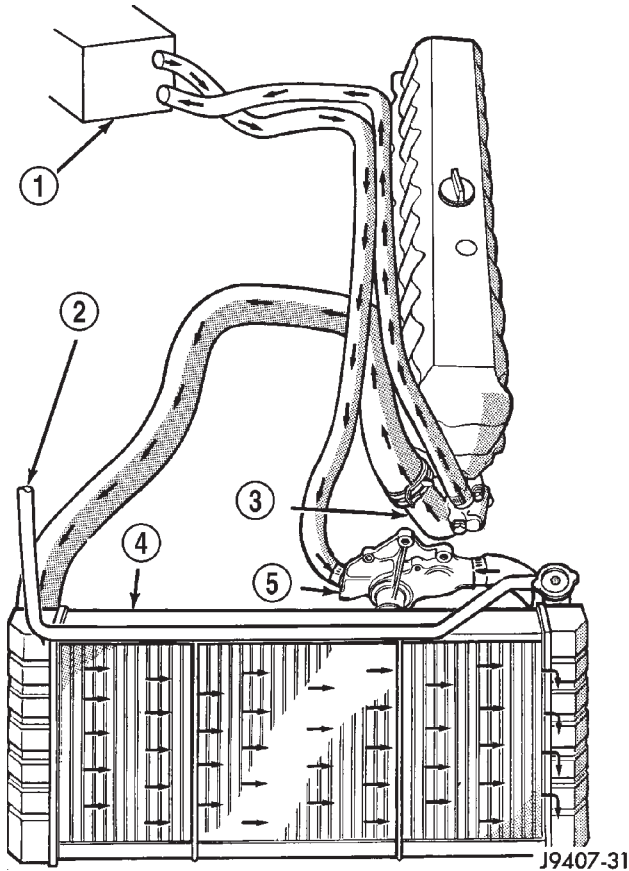

Fig. 1 Coolant Circulation—2.5L/4.0L Engines

- 1 - HEATER CORE
- 2 - TO COOLANT RESERVE/OVERFLOW TANK
- 3 - THERMOSTAT HOUSING
- 4 - RADIATOR
- 5 - WATER PUMP

AUTOMATIC TRANSMISSION OIL COOLER

DESCRIPTION

All models equipped with an automatic transmission are equipped with a transmission oil cooler mounted internally within the radiator tank. This internal cooler is supplied as standard equipment on all models equipped with an automatic transmission.

Transmission oil is cooled when it passes through this separate cooler. In case of a leak in the internal radiator mounted transmission oil cooler, engine coolant may become mixed with transmission fluid or transmission fluid may enter engine cooling system. Both cooling system and transmission should be drained and inspected if the internal radiator mounted transmission cooler is leaking.

An auxiliary air-to-oil transmission oil cooler is available with most engine packages.

The auxiliary air-to-oil transmission oil cooler is located in front of the radiator or A/C condenser (if equipped) and behind the grill. It is mounted to the front frame crossmember.

The auxiliary oil coolers on all models operate in conjunction with the internal radiator mounted main oil cooler. The transmission oil is routed through the main cooler first, then the auxiliary cooler, before returning to the transmission.

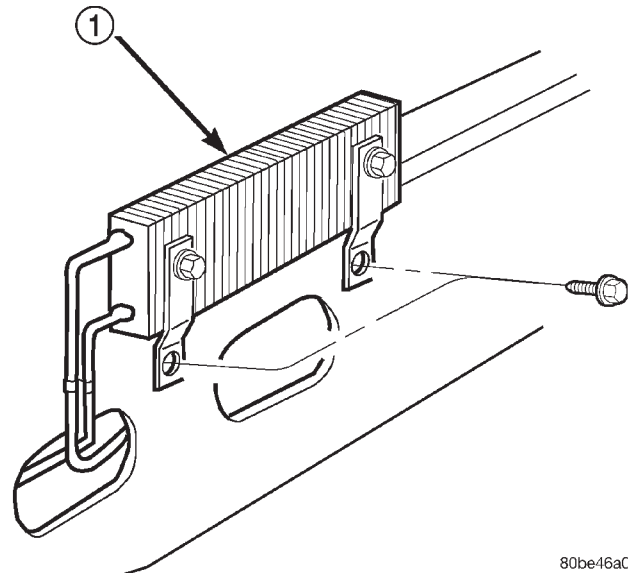

Fig. 2 Auxiliary Transmission Oil Cooler

- 1 - AUXILIARY TRANSMISSION OIL COOLER

COOLANT RESERVE/OVERFLOW SYSTEM

DESCRIPTION

The system works along with the radiator pressure cap. This is done by using thermal expansion and contraction of the coolant to keep the coolant free of trapped air. It provides:

- A volume for coolant expansion and contraction.
- A convenient and safe method for checking/adjusting coolant level at atmospheric pressure. This is done without removing the radiator pressure cap.
- Some reserve coolant to the radiator to cover minor leaks and evaporation or boiling losses.

DESCRIPTION AND OPERATION (Continued)

The coolant reserve/overflow system consists of a radiator mounted pressurized cap, a plastic reserve/overflow tank (Fig. 3) (Fig. 4), a tube (hose) connecting the radiator and tank, and an overflow tube on the side of the tank.

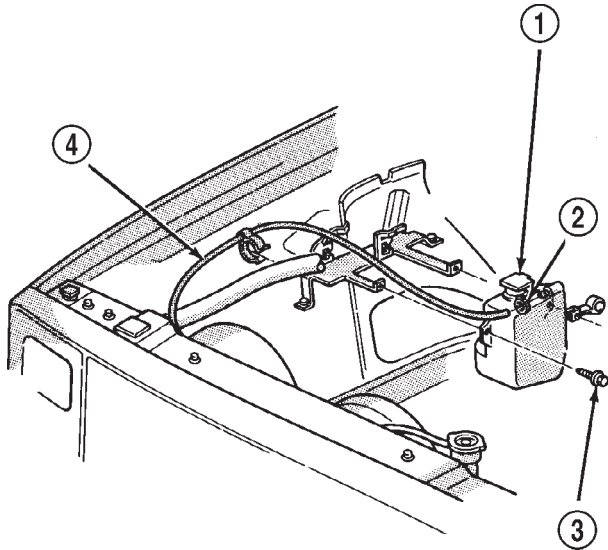

J9407-26

Fig. 3 Reserve/Overflow Tank—Except Right Hand Drive

- 1 - COOLANT RESERVE/OVERFLOW TANK
- 2 - CLAMP
- 3 - MOUNTING BOLTS
- 4 - TUBE TO RADIATOR

OPERATION

As the engine cools, a vacuum is formed in the cooling system of both the radiator and engine. Coolant will then be drawn from the coolant tank and returned to a proper level in the radiator.

COOLING SYSTEM FANS

DESCRIPTION

All models are equipped with a viscous fan. This thermal viscous fan drive is a torque-and-temperature-sensitive clutch unit. It automatically increases or decreases fan speed to provide proper engine cooling. Vehicles with a 2.5L/4.0L engine with air conditioning, or 4.0L with "max" cooling also have an auxiliary electrical cooling fan.

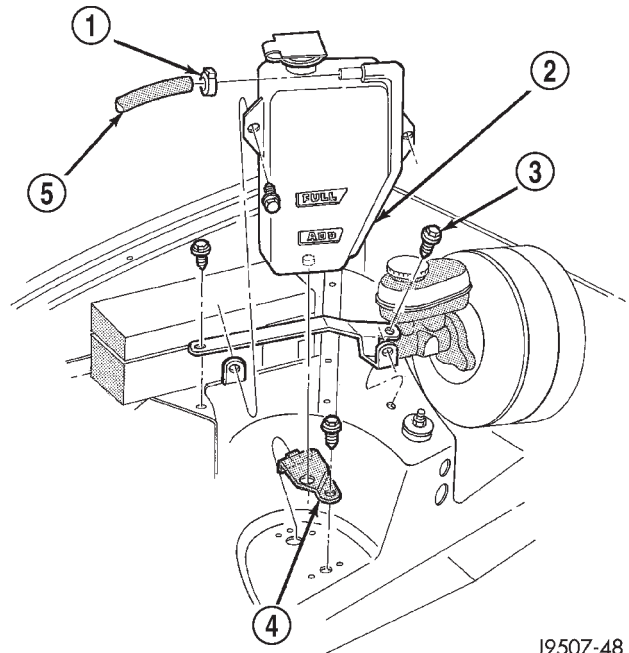

J9507-48

Fig. 4 Reserve/Overflow Tank—With Right Hand Drive

- 1 - CLAMP
- 2 - COOLANT RESERVE/OVERFLOW TANK
- 3 - MOUNTING BOLTS
- 4 - LOWER BRACKET
- 5 - TUBE TO RADIATOR

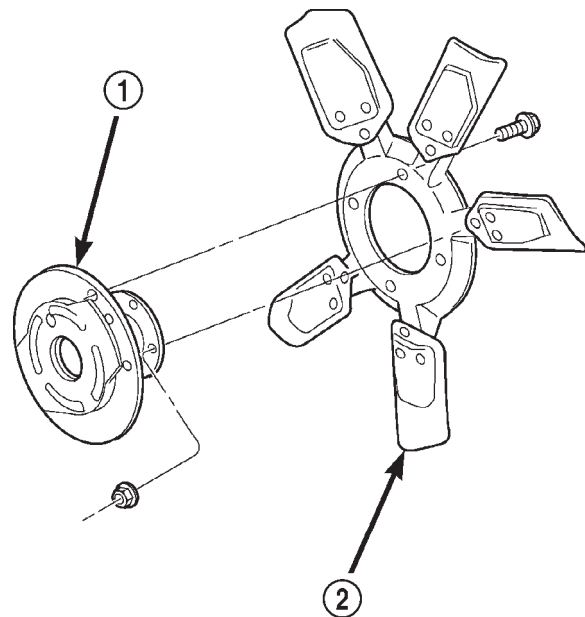

80be46a2

Fig. 5 Viscous Fan Drive and Fan Blade Assembly

- 1 - VISCIOUS FAN DRIVE
- 2 - FAN BLADE ASSEMBLY

DESCRIPTION AND OPERATION (Continued)

BLOCK HEATER

DESCRIPTION

WARNING: DO NOT OPERATE ENGINE UNLESS BLOCK HEATER CORD HAS BEEN DISCONNECTED FROM POWER SOURCE AND SECURED IN PLACE.

An optional engine block heater is available for all models. The heater is equipped with a power cord. The cord is attached to an engine compartment component with tie-straps. The heater warms the engine providing easier engine starting and faster warm-up in low temperatures. The heater is mounted in a core hole of the engine cylinder block (in place of a freeze plug) with the heating element immersed in engine coolant.

BLOCK HEATER SPECIFICATIONS

- 2.5L 4-Cylinder Engine: 115 Volts 400 Watts
- 4.0L 6-Cylinder Engine: 120 Volts 600 Watts

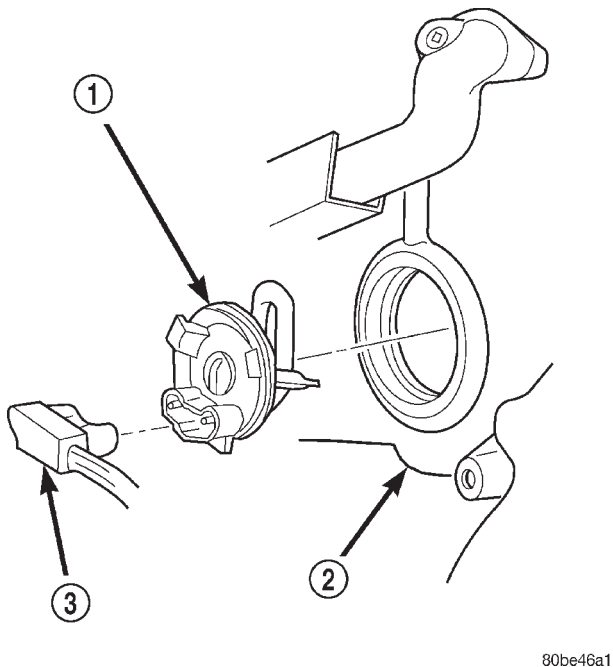

80be46a1

Fig. 6 Engine Block Heater

- 1 - BLOCK HEATER
- 2 - CYLINDER BLOCK
- 3 - BLOCK HEATER POWER CORD

OPERATION

Connecting the power cord to a grounded 110-120 volt AC electrical outlet with a grounded, three-wire extension cord activates the block heater.

THERMOSTAT

DESCRIPTION

CAUTION: Do not operate an engine without a thermostat, except for servicing or testing.

A pellet-type thermostat controls the operating temperature of the engine by controlling the amount of coolant flow to the radiator. On all engines the thermostat is closed below 195°F (90°C). Above this temperature, coolant is allowed to flow to the radiator. This provides quick engine warm-up and overall temperature control.

An arrow plus the word **UP** is stamped on the front flange next to the air bleed. The words **TO RAD** are stamped on one arm of the thermostat. They indicate the proper installed position.

The same thermostat is used for winter and summer seasons. An engine should not be operated without a thermostat, except for servicing or testing. Operating without a thermostat causes other problems. These are: A 'check engine' light and a DTC will eventually be set, longer engine warm-up time, unreliable warm-up performance, increased exhaust emissions and crankcase condensation. This condensation can result in sludge formation.

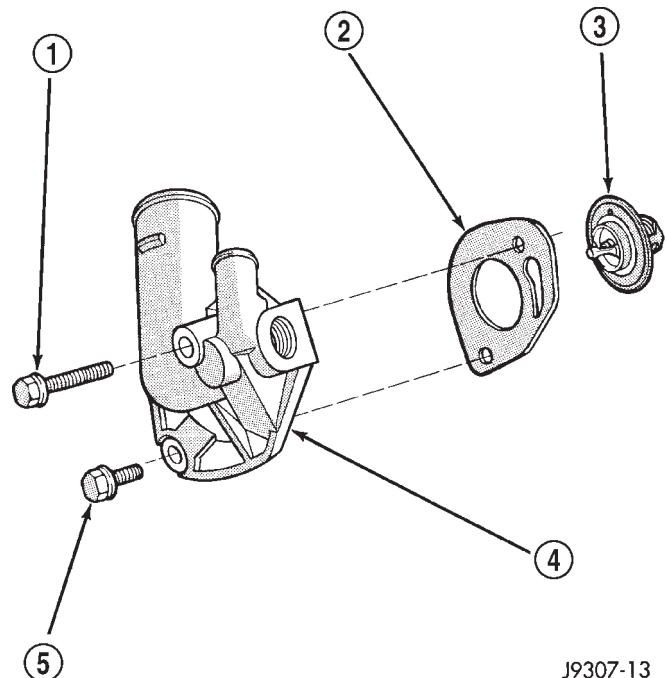

J9307-13

Fig. 7 Thermostat and Housing

- 1 - LONG BOLT
- 2 - GASKET
- 3 - THERMOSTAT
- 4 - THERMOSTAT HOUSING
- 5 - SHORT BOLT

DESCRIPTION AND OPERATION (Continued)

RADIATOR

DESCRIPTION

CAUTION: Plastic tanks, while stronger than brass, are subject to damage by impact, such as wrenches.

Radiators for both engines are the cross flow type. Plastic tanks are used on all radiators.

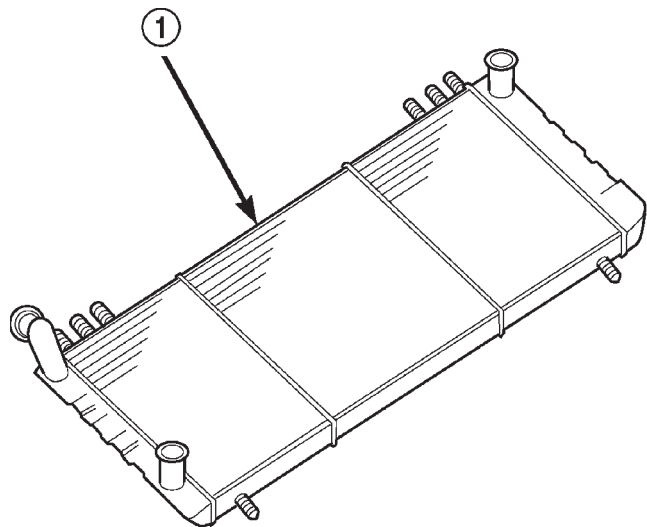

80be469f

Fig. 8 Cross Flow Radiator

1 - RADIATOR

A rubber gasket seals radiator filler neck. This is done to maintain vacuum during coolant cool-down and to prevent leakage when system is under pressure.

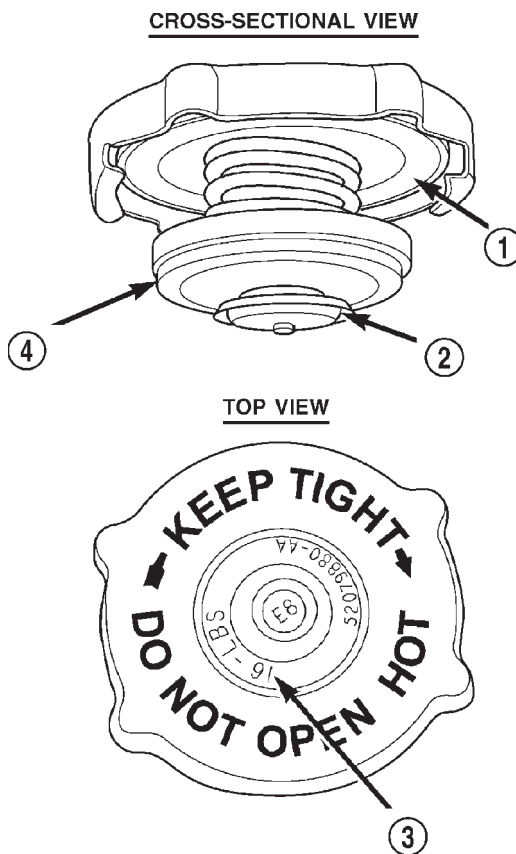

80bfe12f

Fig. 9 Radiator Pressure Cap and Filler Neck—Typical

- 1 - FILLER NECK SEAL
- 2 - VACUUM VENT VALVE
- 3 - PRESSURE RATING
- 4 - PRESSURE VALVE

RADIATOR PRESSURE CAP

DESCRIPTION

All radiators are equipped with a pressure cap. This cap releases pressure at some point within a range of 83-110 kPa (12-16 psi). The pressure relief point (in pounds) is engraved on top of the cap (Fig. 9).

The cooling system will operate at pressures slightly above atmospheric pressure. This results in a higher coolant boiling point allowing increased radiator cooling capacity. The cap contains a spring-loaded pressure relief valve that opens when system pressure reaches release range of 83-110 kPa (12-16 psi).

OPERATION

A vent valve in the center of cap allows a small coolant flow through cap when coolant is below boiling temperature. The valve is completely closed when boiling point is reached. As the coolant cools, it contracts and creates a vacuum in the cooling system. This causes the vacuum valve to open and coolant in the reserve/overflow tank to be drawn through its connecting hose into radiator. If the vacuum valve is stuck shut, the radiator hoses will collapse on cool-down.

DESCRIPTION AND OPERATION (Continued)

WATER PUMP

DESCRIPTION

CAUTION: All engines are equipped with a reverse (counter-clockwise) rotating water pump and viscous fan drive assembly. REVERSE is stamped or imprinted on the cover of the viscous fan drive and inner side of the fan. The letter R is stamped into the back of the water pump impeller (Fig. 10).

A centrifugal water pump circulates coolant through the water jackets, passages, intake manifold, radiator core, cooling system hoses and heater core. The pump is driven from the engine crankshaft by a drive belt on all engines.

The water pump impeller is pressed onto the rear of a shaft that rotates in bearings pressed into the housing. The housing has a small hole to allow seepage to escape. The water pump seals are lubricated by the antifreeze in the coolant mixture. No additional lubrication is necessary.

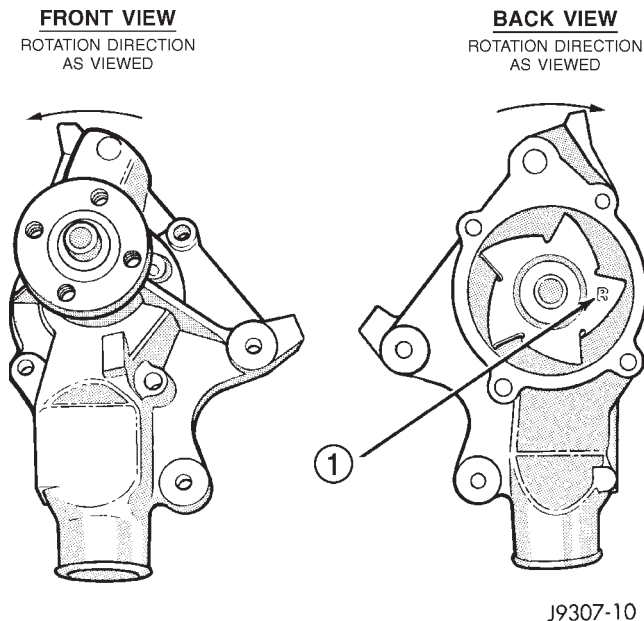

J9307-10

Fig. 10 Reverse Rotating Water Pump—Typical

1 - R STAMPED INTO IMPELLER

HOSE CLAMPS

DESCRIPTION

The cooling system utilizes both worm drive and spring type hose clamps. If a spring type clamp replacement is necessary, replace with the original Mopar® equipment spring type clamp.

CAUTION: A number or letter is stamped into the tongue of constant tension clamps. If replacement is necessary, use only a original equipment clamp with matching number or letter (Fig. 11).

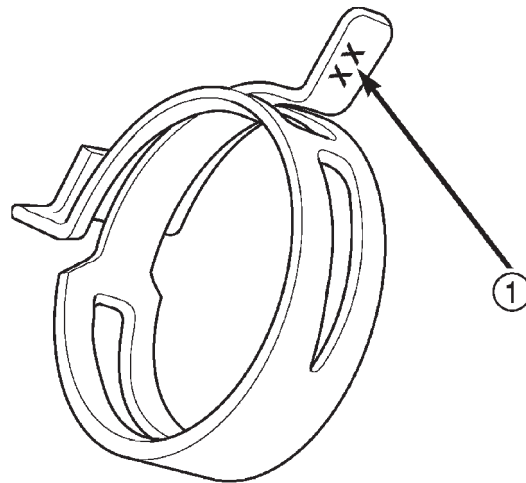

80b76ee

Fig. 11 Spring Clamp Size Location

1 - SPRING CLAMP SIZE LOCATION

OPERATION

The worm type hose clamp uses a specified torque value to maintain proper tension on a hose connection.

The spring type hose clamp applies constant tension on a hose connection. To remove a spring type hose clamp, use Special Tool 6094 or equivalent, constant tension clamp pliers (Fig. 12) to compress the hose clamp.

DESCRIPTION AND OPERATION (Continued)

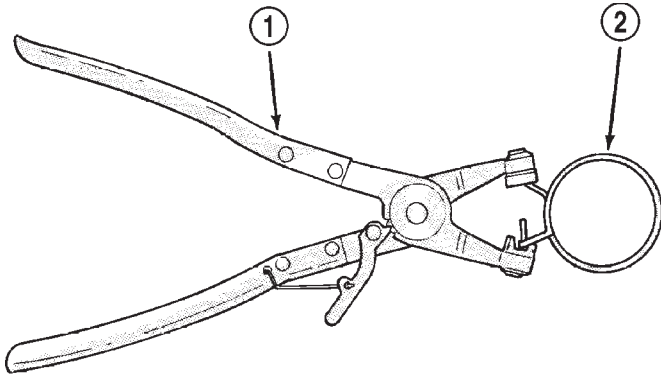

J9207-36

Fig. 12 Hose Clamp Tool

- 1 - HOSE CLAMP TOOL 6094
- 2 - HOSE CLAMP

VISCOUS FAN DRIVE

DESCRIPTION

CAUTION: Engines equipped with poly-V drive belts have reverse rotating fans and viscous fan drives. They are marked with the word REVERSE to designate their usage. Installation of the wrong fan or viscous fan drive can result in engine overheating.

The thermal viscous fan drive is a silicone-fluid-filled coupling used to connect the fan blades to either the engine or the water pump shaft. The coupling allows the fan to be driven in a normal manner. This is done at low engine speeds while limiting the top speed of the fan to a predetermined maximum level at higher engine speeds.

2.5L vehicles with A/C are equipped with a viscous fan drive which is designed to "free wheel" during most of the ambient conditions encountered by the vehicle and will only engage during high heat loads as seen in trailer towing or high ambient temperatures.

A thermostatic bimetallic spring coil is located on the front face of the viscous fan drive unit. A typical viscous unit is shown in (Fig. 13). This spring coil reacts to the temperature of the radiator discharge air. It engages the viscous fan drive for higher fan speed if the air temperature from the radiator rises above a certain point. Until additional engine cooling is necessary, the fan will remain at a reduced rpm regardless of engine speed.

Vehicles equipped with 2.5L engines have what is known as a hybrid cooling fan system. This means that not only do they have a viscous fan but they also have an electric fan as well. The hybrid viscous fan drive has a low speed characteristic. This causes the mechanical fan speeds to be very low 200-400 rpm range when not engaged allowing the engine to have additional performance and horsepower gains.

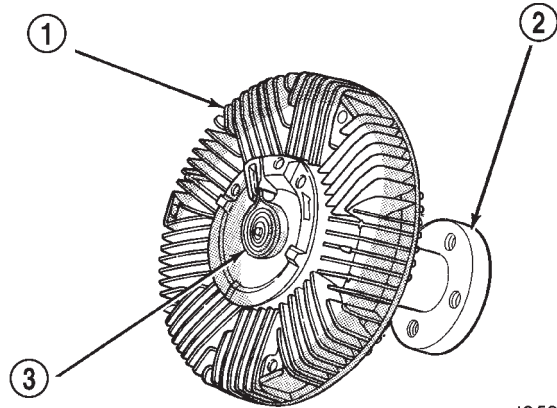

J9507-37

Fig. 13 Typical Viscous Fan Drive

- 1 - VISCOUS FAN DRIVE
- 2 - MOUNTING HUB
- 3 - THERMOSTATIC SPRING

OPERATION

Only when sufficient heat is present, will the viscous fan drive engage. This is when the air flowing through the radiator core causes a reaction to the bimetallic coil. It then increases fan speed to provide the necessary additional engine cooling.

Once the engine has cooled, the radiator discharge temperature will drop. The bimetallic coil again reacts and the fan speed is reduced to the previous disengaged speed.

DESCRIPTION AND OPERATION (Continued)

ELECTRIC COOLING FAN

DESCRIPTION

Vehicles equipped with a 2.5L/4.0L engine and air conditioning and 4.0L vehicles equipped with the "max" cooling package also have an electrical cooling fan. The fan is controlled by the cooling fan relay, which is located in the power distribution center (PDC) (Fig. 15). For the location of relay within the PDC, refer to the label on PDC cover.

The electric fan on the 2.5L engine equipped vehicles is considered the primary fan (low to moderate ambient conditions) and is energized when the JTEC receives input from the coolant temperature sensor or the a/c system and supplies ground to the cooling fan relay.

The cooling fan motor is protected by a 40 amp maxi-fuse located in the PDC. The fan relay is protected by a 15 amp fuse located in the junction block.

OPERATION

Electric cooling fan 2.5L: When air conditioning is not requested, the electric fan will not come on unless the coolant temperature is at least 103° C (218° F), at which time the fan will come on and remain on until the coolant temperature drops to 99° C (210° F) or below. When air conditioning is requested (including defroster operation), the fan will cycle on and off in conjunction with the A/C compressor unless the coolant temperature is at least 97° C (207° F), at which time the fan will come on and remain on until the coolant temperature drops to 93° C (199° F) or below. Then, the cycle fan operation will resume. When the fan is scheduled to be on, the powertrain control module (PCM) provides a ground path for the fan relay. This ground is provided to the cooling fan relay through pin C2 of PCM connector C3. Battery voltage is then applied to the fan through the relay. When the fan is scheduled to be off, the PCM opens the ground path to the relay. This will prevent the cooling fan from being energized.

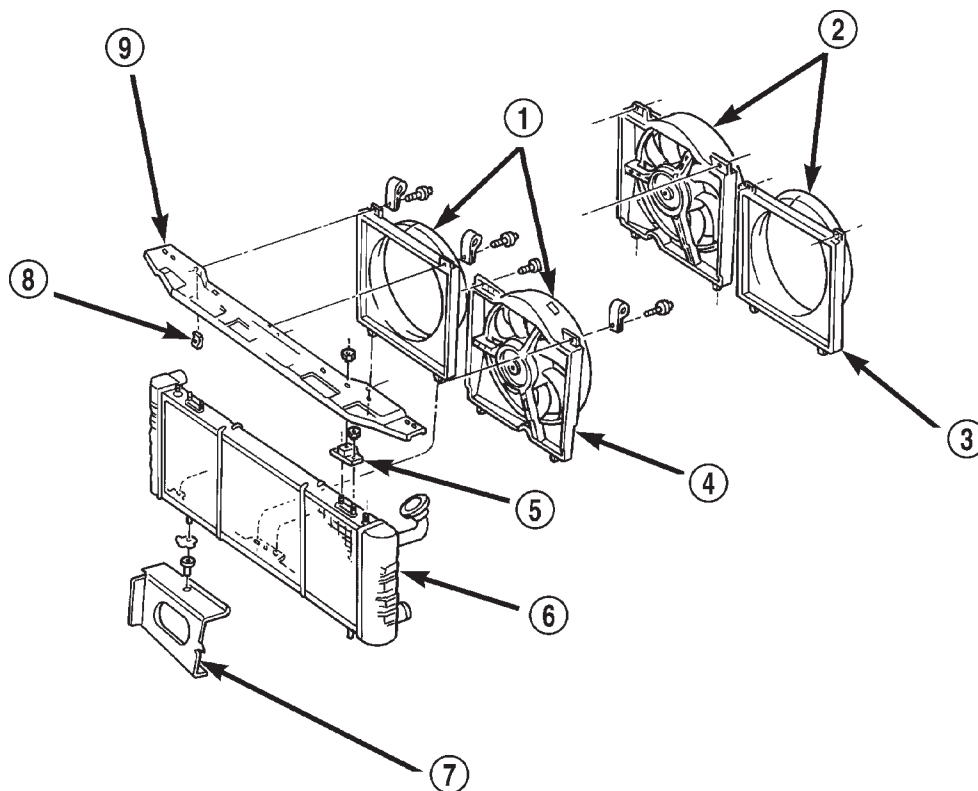

80ae8364

Fig. 14 Electric Cooling Fan

- | | |
|-------------------------|-----------------------|
| 1 - (LHD) | 6 - RADIATOR |
| 2 - (RHD) | 7 - LOWER CROSSMEMBER |
| 3 - VISCOUS FAN SHROUD | 8 - U-NUT |
| 4 - ELECTRIC FAN MODULE | 9 - UPPER CROSSMEMBER |
| 5 - ISOLATOR | |

DESCRIPTION AND OPERATION (Continued)

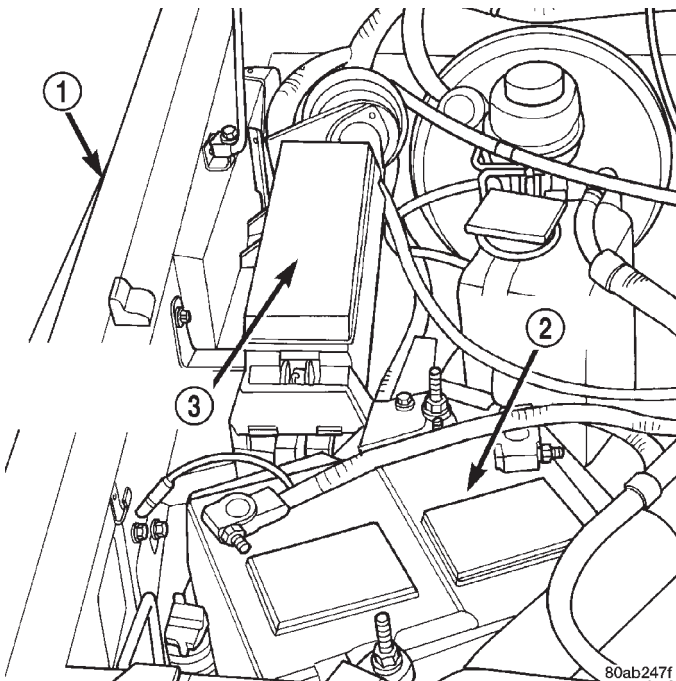

Fig. 15 Power Distribution Center (PDC)

- 1 - RIGHT FENDER
- 2 - BATTERY
- 3 - POWER DISTRIBUTION CENTER

Electric cooling fan 4.0L: With or without A/C request the electric fan will come on only when the coolant temperature is at least 106° C (223° F), and will remain on until the coolant temperature drops to 103° C (217° F) or below. Regardless of coolant temperature, When air conditioning system pressures reach 2068.5 ± 138 kPa (300 ± 20 psi) the electric fan will engage and continue to run until the A/C system pressure drops to 1620.3 kPa (235 psi) minimum, then the electric fan will shut off.

DIAGNOSIS AND TESTING

ON-BOARD DIAGNOSTICS (OBD)

COOLING SYSTEM RELATED DIAGNOSTICS

The Powertrain Control Module (PCM) has been programmed to monitor the certain following cooling system components:

- If the engine has remained cool for too long a period, such as with a stuck open thermostat, a Diagnostic Trouble Code (DTC) can be set.
- If an open or shorted condition has developed in the relay circuit controlling the electric radiator fan, a Diagnostic Trouble Code (DTC) can be set.

If the problem is sensed in a monitored circuit often enough to indicate an actual problem, a DTC is stored. The DTC will be stored in the PCM memory for eventual display to the service technician. (Refer

to Group 25, Emission Control Systems for proper procedures)

ACCESSING DIAGNOSTIC TROUBLE CODES

To read DTC's and to obtain cooling system data, refer to Group 25, Emission Control Systems for proper procedures.

DRB SCAN TOOL

For operation of the DRB scan tool, refer to the appropriate Powertrain Diagnostic Procedures service manual.

ACCESSORY DRIVE BELT DIAGNOSIS

VISUAL DIAGNOSIS

When diagnosing serpentine accessory drive belts, small cracks that run across the ribbed surface of the belt from rib to rib (Fig. 16), are considered normal. These are not a reason to replace the belt. However, cracks running along a rib (not across) are **not** normal. Any belt with cracks running along a rib must be replaced (Fig. 16). Also replace the belt if it has excessive wear, frayed cords or severe glazing.

Refer to the Accessory Drive Belt Diagnosis charts for further belt diagnosis.

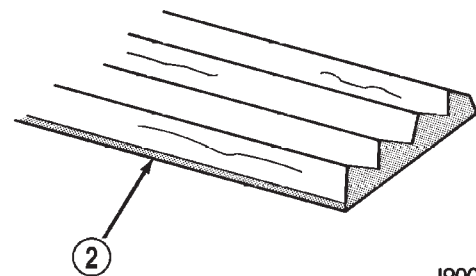
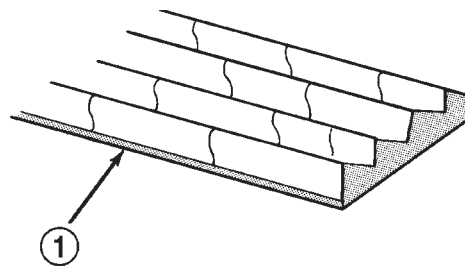

Fig. 16 Belt Wear Patterns

J9007-44

- 1 - NORMAL CRACKS BELT OK
- 2 - NOT NORMAL CRACKS REPLACE BELT

NOISE DIAGNOSIS

Noises generated by the accessory drive belt are most noticeable at idle. Before replacing a belt to resolve a noise condition, inspect all of the accessory drive pulleys for alignment, glazing, or excessive end play.

DIAGNOSIS AND TESTING (Continued)

ACCESSORY DRIVE BELT DIAGNOSIS CHART

| CONDITION | POSSIBLE CAUSES | CORRECTION |
|--|--|--|
| RIB CHUNKING (One or more ribs has separated from belt body) | <ol style="list-style-type: none"> 1. Foreign objects imbedded in pulley grooves. 2. Installation damage | <ol style="list-style-type: none"> 1. Remove foreign objects from pulley grooves. Replace belt. 2. Replace belt |
| RIB OR BELT WEAR | <ol style="list-style-type: none"> 1. Pulley misaligned 2. Abrasive environment 3. Rusted pulley(s) 4. Sharp or jagged pulley groove tips 5. Belt rubber deteriorated | <ol style="list-style-type: none"> 1. Align pulley(s) 2. Clean pulley(s). Replace belt if necessary 3. Clean rust from pulley(s) 4. Replace pulley. Inspect belt. 5. Replace belt |
| BELT SLIPS | <ol style="list-style-type: none"> 1. Belt slipping because of insufficient tension 2. Belt or pulley exposed to substance that has reduced friction (belt dressing, oil, ethylene glycol) 3. Driven component bearing failure (seizure) 4. Belt glazed or hardened from heat and excessive slippage | <ol style="list-style-type: none"> 1. Adjust tension (2.5L) 2. Replace belt and clean pulleys 3. Replace faulty component or bearing 4. Replace belt. |
| LONGITUDINAL BELT CRACKING | <ol style="list-style-type: none"> 1. Belt has mistracked from pulley groove 2. Pulley groove tip has worn away rubber to tensile member | <ol style="list-style-type: none"> 1. Replace belt 2. Replace belt |
| "GROOVE JUMPING" (Belt does not maintain correct position on pulley) | <ol style="list-style-type: none"> 1. Belt tension either too low or too high 2. Pulley(s) not within design tolerance 3. Foreign object(s) in grooves 4. Pulley misalignment 5. Belt cordline is broken | <ol style="list-style-type: none"> 1. Adjust belt tension (2.5L) 2. Replace pulley(s) 3. Remove foreign objects from grooves 4. Align component 5. Replace belt |
| BELT BROKEN (Note: Identify and correct problem before new belt is installed) | <ol style="list-style-type: none"> 1. Excessive tension 2. Tensile member damaged during belt installation 3. Severe misalignment 4. Bracket, pulley, or bearing failure | <ol style="list-style-type: none"> 1. Replace belt and adjust tension to specification 2. Replace belt 3. Align pulley(s) 4. Replace defective component and belt |

DIAGNOSIS AND TESTING (Continued)

| CONDITION | POSSIBLE CAUSES | CORRECTION |
|--|---|---|
| NOISE (Objectionable squeal, squeak, or rumble is heard or felt while drive belt is in operation) | <ol style="list-style-type: none"> 1. Belt slippage 2. Bearing noise 3. Belt misalignment 4. Belt to pulley mismatch 5. Driven component induced vibration 6. System resonant frequency induced vibration | <ol style="list-style-type: none"> 1. Adjust belt tension (2.5L) 2. Locate and repair 3. Align belt/pulley(s) 4. Install correct belt 5. Locate defective driven component and repair 6. Vary belt tension within specifications. |
| TENSION SHEETING FABRIC FAILURE (Woven fabric on outside, circumference of belt has cracked or separated from body of belt) | <ol style="list-style-type: none"> 1. Tension sheeting contacting stationary object 2. Excessive heat causing woven fabric to age 3. Tension sheeting splice has fractured | <ol style="list-style-type: none"> 1. Correct rubbing condition 2. Replace belt 3. Replace belt |
| CORD EDGE FAILURE (Tensile member exposed at edges of belt or separated from belt body) | <ol style="list-style-type: none"> 1. Excessive tension 2. Belt contacting stationary object 3. Pulley(s) out of tolerance 4. Insufficient adhesion between tensile member and rubber matrix | <ol style="list-style-type: none"> 1. Adjust belt tension (2.5L) 2. Replace belt 3. Replace pulley 4. Replace belt and adjust tension to specifications |

PRELIMINARY CHECKS

ENGINE COOLING SYSTEM OVERHEATING

Establish what driving conditions caused the complaint. Abnormal loads on the cooling system such as the following may be the cause:

PROLONGED IDLE, VERY HIGH AMBIENT TEMPERATURE, SLIGHT TAIL WIND AT IDLE, SLOW TRAFFIC, TRAFFIC JAMS, HIGH SPEED OR STEEP GRADES.

Driving techniques that avoid overheating are:

- Idle with A/C off when temperature gauge is at end of normal range.
- Increasing engine speed for more air flow is recommended.

TRAILER TOWING:

Consult Trailer Towing section of owners manual. Do not exceed limits.

AIR CONDITIONING; ADD-ON OR AFTER MARKET:

A maximum cooling package should have been ordered with vehicle if add-on or after market A/C is installed. If not, maximum cooling system components should be installed for model involved per manufacturer's specifications.

RECENT SERVICE OR ACCIDENT REPAIR:

Determine if any recent service has been performed on vehicle that may effect cooling system. This may be:

- Engine adjustments (incorrect timing)
- Slipping engine accessory drive belt(s)
- Brakes (possibly dragging)
- Changed parts. Incorrect water pump or pump rotating in wrong direction due to belt not correctly routed
- Reconditioned radiator or cooling system refilling (possibly under filled or air trapped in system).

NOTE: If investigation reveals none of the previous items as a cause for an engine overheating complaint, refer to following Cooling System Diagnosis charts.

These charts are to be used as a quick-reference only. Refer to the group text for information.

DIAGNOSIS AND TESTING (Continued)

COOLING SYSTEM DIAGNOSIS CHART

| CONDITION | POSSIBLE CAUSES | CORRECTION |
|---|--|---|
| TEMPERATURE GAUGE READS LOW | <ol style="list-style-type: none"> 1. Has a Diagnostic Trouble Code (DTC) been set indicating a stuck open thermostat? 2. Is the temperature sending unit connected? 3. Is the temperature gauge operating OK? 4. Coolant level low in cold ambient temperatures accompanied with poor heater performance. 5. Improper operation of internal heater doors or heater controls. | <ol style="list-style-type: none"> 1. Refer to Group 25, Emission Systems for On-Board Diagnostics and DTC information. Replace thermostat if necessary. 2. Check the temperature sensor connector. Refer to Group 8E. Repair connector if necessary. 3. Check gauge operation. Refer to Group 8E. Repair as necessary. 4. Check coolant level in the coolant reserve/overflow tank and the radiator. Inspect system for leaks. Repair leaks as necessary. Refer to the Coolant section of the manual text for WARNINGS and CAUTIONS associated with removing the radiator cap. 5. Inspect heater and repair as necessary. Refer to Group 24, Heating and Air Conditioning for procedures. |
| TEMPERATURE GAUGE READS HIGH OR THE COOLANT WARNING LAMP ILLUMINATES. COOLANT MAY OR MAY NOT BE LOST OR LEAKING FROM THE COOLING SYSTEM | <ol style="list-style-type: none"> 1. Trailer is being towed, a steep hill is being climbed, vehicle is operated in slow moving traffic, or engine is being idled with very high ambient (outside) temperatures and the air conditioning is on. Higher altitudes could aggravate these conditions. 2. Is the temperature gauge reading correctly? 3. Is the temperature warning illuminating unnecessarily? 4. Coolant low in coolant reserve/overflow tank and radiator? 5. Pressure cap not installed tightly. If cap is loose, boiling point of coolant will be lowered. Also refer to the following Step 6. | <ol style="list-style-type: none"> 1. This may be a temporary condition and repair is not necessary. Turn off the air conditioning and attempt to drive the vehicle without any of the previous conditions. Observe the temperature gauge. The gauge should return to the normal range. If the gauge does not return to the normal range, determine the cause for overheating and repair. Refer to Possible Causes (2-20). 2. Check gauge. Refer to Group 8E. Repair as necessary. 3. Check warning lamp operation. Refer to Group 8E. Repair as necessary. 4. Check for coolant leaks and repair as necessary. Refer to Testing Cooling System for Leaks in this Group. 5. Tighten cap |

DIAGNOSIS AND TESTING (Continued)

| CONDITION | POSSIBLE CAUSES | CORRECTION |
|--|--|--|
| <p>TEMPERATURE GAUGE READS HIGH OR THE COOLANT WARNING LAMP ILLUMINATES. COOLANT MAY OR MAY NOT BE LOST OR LEAKING FROM THE COOLING SYSTEM (CONTINUED)</p> | <p>6. Poor seals at the radiator cap.</p> <p>7. Coolant level low in radiator but not in coolant reserve/overflow tank. This means the radiator is not drawing coolant from the coolant reserve/overflow tank as the engine cools</p> <p>8. Incorrect coolant concentration</p> <p>9. Coolant not flowing through system</p> <p>10. Radiator or A/C condenser fins are dirty or clogged.</p> <p>11. Radiator core is corroded or plugged.</p> <p>12. Aftermarket A/C installed without proper radiator.</p> <p>13. Fuel or ignition system problems.</p> <p>14. Dragging brakes.</p> <p>15. Bug screen or cardboard is being used, reducing airflow.</p> <p>16. Thermostat partially or completely shut.</p> | <p>6. (a) Check condition of cap and cap seals. Refer to Radiator Cap. Replace cap if necessary. (b) Check condition of radiator filler neck. If neck is bent or damaged, replace radiator.</p> <p>7. (a) Check condition of radiator cap and cap seals. Refer to Radiator Cap in this Group. Replace cap if necessary. (b) Check condition of radiator filler neck. If neck is bent or damaged, replace radiator. (c) Check condition of the hose from the radiator to the coolant tank. It should fit tight at both ends without any kinks or tears. Replace hose if necessary. (d) Check coolant reserve/overflow tank and tanks hoses for blockage. Repair as necessary.</p> <p>8. Check coolant. Refer to Coolant section in this Group for correct coolant/water mixture ratio.</p> <p>9. Check for coolant flow at radiator filler neck with some coolant removed, engine warm and thermostat open. Coolant should be observed flowing through radiator. If flow is not observed, determine area of obstruction and repair as necessary.</p> <p>10. Remove insects and debris. Refer to Radiator Cleaning in this Group.</p> <p>11. Have radiator re-cored or replaced.</p> <p>12. Install proper radiator.</p> <p>13. Refer to Fuel and Ignition System Groups for diagnosis.</p> <p>14. Check and correct as necessary. Refer to Group 5, Brakes for correct procedures.</p> <p>15. Remove bug screen or cardboard.</p> <p>16. Check thermostat operation and replace as necessary. Refer to Thermostats in this Group.</p> |

DIAGNOSIS AND TESTING (Continued)

| CONDITION | POSSIBLE CAUSES | CORRECTION |
|---|--|--|
| TEMPERATURE GAUGE READS HIGH OR THE COOLANT WARNING LAMP ILLUMINATES. COOLANT MAY OR MAY NOT BE LOST OR LEAKING FROM THE COOLING SYSTEM (CONTINUED) | <p>17. Viscous fan drive not operating properly.</p> <p>18. Electric cooling fan not operating properly (vehicles equipped with 2.5L/4.0L and air conditioning)</p> <p>19. Cylinder head gasket leaking.</p> <p>20. Heater core leaking.</p> | <p>17. Check fan drive operation and replace as necessary. Refer to Viscous Fan Drive in this Group.</p> <p>18. Check electric fan operation and repair as necessary. Refer to Electric Cooling Fan in this Group.</p> <p>19. Check for cylinder head gasket leaks. Refer to Cooling System-Testing For Leaks in this Group. For repair, refer to Group 9, Engines.</p> <p>20. Check heater core for leaks. Refer to Group 24, Heating and Air Conditioning. Repair as necessary.</p> |
| TEMPERATURE GAUGE READING IS INCONSISTENT (FLUCTUATES, CYCLES OR IS ERRATIC) | <p>1. On vehicles equipped with an electric fan, the gauge may cycle up and down. This is due to the cycling of the electric radiator fan.</p> <p>2. During cold weather operation, with the heater blower in the high position, the gauge reading may drop slightly.</p> <p>3. Temperature gauge or engine mounted gauge sensor defective or shorted. Also, corroded or loose wiring in this circuit.</p> <p>4. Gauge reading rises when vehicle is brought to a stop after heavy use (engine still running)</p> <p>5. Gauge reading high after re-starting a warmed up (hot) engine.</p> <p>6. Coolant level low in radiator (air will build up in the cooling system causing the thermostat to open late).</p> <p>7. Cylinder head gasket leaking allowing exhaust gas to enter cooling system causing a thermostat to open late.</p> | <p>1. This is a normal condition. No correction is necessary unless the gauge cycles into the red (overheat) zone. Refer to Electric Cooling Fan Diagnosis and Testing in this group.</p> <p>2. A normal condition. No correction is necessary.</p> <p>3. Check operation of gauge and repair if necessary. Refer to Group 8E, Instrument Panel and Gauges.</p> <p>4. A normal condition. No correction is necessary. Gauge should return to normal range after vehicle is driven.</p> <p>5. A normal condition. No correction is necessary. The gauge should return to normal range after a few minutes of engine operation.</p> <p>6. Check and correct coolant leaks. Refer to Cooling System-Testing for leaks in this group.</p> <p>7. (a) Check for cylinder head gasket leaks. Refer to Cooling System-Testing for Leaks in this group. (b) Check for coolant in the engine oil. Inspect for white steam emitting from the exhaust system. Repair as necessary.</p> |

DIAGNOSIS AND TESTING (Continued)

| CONDITION | POSSIBLE CAUSES | CORRECTION |
|--|--|--|
| TEMPERATURE GAUGE READING IS INCONSISTENT (FLUCTUATES, CYCLES OR IS ERRATIC) (CONTINUED) | 8. Water pump impeller loose on shaft. 9. Loose accessory drive belt. (water pump slipping) 10. Air leak on the suction side of the water pump allows air to build up in cooling system causing thermostat to open late. | 8. Check water pump and replace as necessary. Refer to water Pumps in this group. 9. Refer to Accessory Drive Belts in this group. Check and correct as necessary. 10. Locate leak and repair as necessary. |
| PRESSURE CAP IS BLOWING OFF STEAM AND/OR COOLANT TO COOLANT TANK. TEMPERATURE GAUGE READING MAY BE ABOVE NORMAL BUT NOT HIGH. COOLANT LEVEL MAY BE HIGH IN COOLANT RESERVE/OVERFLOW TANK | 1. Pressure relief valve in radiator cap is defective. | 1. Check condition of radiator cap and cap seals. Refer to Radiator Caps in this group. Replace cap as necessary. |
| COOLANT LOSS TO THE GROUND WITHOUT PRESSURE CAP BLOWOFF. GAUGE READING HIGH OR HOT | 1. Coolant leaks in radiator, cooling system hoses, water pump or engine. | 1. Pressure test and repair as necessary. Refer to Cooling System-Testing For Leaks in this group. |
| DETONATION OR PRE-IGNITION (NOT CAUSED BY IGNITION SYSTEM). GAUGE MAY OR MAY NOT BE READING HIGH | 1. engine overheating. 2. Freeze point of coolant not correct. Mixture is too rich or too lean. | 1. Check reason for overheating and repair as necessary. 2. Check coolant concentration. Refer to the Coolant section of this group and adjust ratio as required. |
| HOSE OR HOSES COLLAPSE WHILE ENGINE IS RUNNING | 1. Vacuum created in cooling system on engine cool-down is not being relieved through coolant reserve/overflow system. | 1. (a) Radiator cap relief valve stuck. Refer to Radiator Cap in this group. Replace if necessary (b) Hose between coolant reserve/overflow tank and radiator is kinked. Repair as necessary. (c) Vent at coolant reserve/overflow tank is plugged. Clean vent and repair as necessary. (d) Reserve/overflow tank is internally blocked or plugged. Check for blockage and repair as necessary. |
| ELECTRIC RADIATOR FAN RUNS ALL OF THE TIME (2.5L/4.0L MODELS EQUIPPED WITH A/C AND 4.0L MODELS EQUIPPED WITH MAX COOLING) | 1. Fan relay, powertrain control module (PCM) or coolant temperature sensor defective. | 1. Refer to Electric Cooling Fan Diagnosis and Testing. Also refer to Group 8W, Wiring Diagrams. Repair as necessary. |

DIAGNOSIS AND TESTING (Continued)

| CONDITION | POSSIBLE CAUSES | CORRECTION |
|---|---|--|
| ELECTRIC RADIATOR FAN WILL NOT RUN AT ALL. GAUGE READING HIGH OR HOT (2.5L/4.0L MODELS EQUIPPED WITH A/C AND 4.0L MODELS EQUIPPED WITH MAX COOLING) | <ol style="list-style-type: none"> 1. Blown Fuse in Power Distribution Center (PDC) 2. Fan relay, powertrain control module (PCM) or coolant temperature sensor defective. 3. Fan Motor Defective | <ol style="list-style-type: none"> 1. Determine reason for blown fuse and repair as necessary. 2. Refer to Electric Cooling Fan Diagnosis and Testing. Also refer to Group 8W, Wiring Diagrams. Repair as necessary. 3. Refer to Electric Cooling Fan Diagnosis and Testing. Also refer to Group 8W, Wiring Diagrams. Repair as necessary. |
| NOISY VISCOUS FAN/DRIVE | <ol style="list-style-type: none"> 1. Fan blades loose. 2. Fan blades striking a surrounding object. 3. Air obstructions at radiator or air conditioning condenser. 4. Thermal viscous fan drive has defective bearing. 5. A certain amount of fan noise may be evident on models equipped with a thermal viscous fan drive. Some of this noise is normal. | <ol style="list-style-type: none"> 1. Replace fan blade assembly. Refer to Cooling System Fans in this Group 2. Locate point of fan blade contact and repair as necessary. 3. Remove obstructions and/or clean debris or insects from radiator or A/C condenser. 4. Replace fan drive. Bearing is not serviceable. Refer to Viscous Fan Drive in this group. 5. Refer to Viscous Fan Drive in this group for an explanation of normal fan noise. |
| INADEQUATE HEATER PERFORMANCE. THERMOSTAT FAILED IN OPEN POSITION | <ol style="list-style-type: none"> 1. Has a Diagnostic trouble Code (DTC) been set? 2. Coolant level low 3. Obstructions in heater hose/ fittings 4. Heater hose kinked 5. Water pump is not pumping water to/through the heater core. When the engine is fully warmed up, both heater hoses should be hot to the touch. If only one of the hoses is hot, the water pump may not be operating correctly or the heater core may be plugged. Accessory drive belt may be slipping causing poor water pump operation. | <ol style="list-style-type: none"> 1. Refer to Group 25, Emissions for correct procedures and replace thermostat if necessary 2. Refer to Cooling System-Testing For Leaks in this group. 3. Remove heater hoses at both ends and check for obstructions 4. Locate kinked area and repair as necessary 5. Refer to Water Pump in this group. If a slipping belt is detected, refer to Accessory Drive Belts in this group. If heater core obstruction is detected, refer to Group 24, Heating and Air Conditioning. |

DIAGNOSIS AND TESTING (Continued)

| CONDITION | POSSIBLE CAUSES | CORRECTION |
|---|---|---|
| STEAM IS COMING FROM THE FRONT OF VEHICLE NEAR THE GRILL AREA WHEN WEATHER IS WET, ENGINE IS WARMED UP AND RUNNING, AND VEHICLE IS STATIONARY. TEMPERATURE GAUGE IS IN NORMAL RANGE | 1. During wet weather, moisture (snow, ice or rain condensation) on the radiator will evaporate when the thermostat opens. This opening allows heated water into the radiator. When the moisture contacts the hot radiator, steam may be emitted. This usually occurs in cold weather with no fan or airflow to blow it away. | 1. Occasional steam emitting from this area is normal. No repair is necessary. |
| COOLANT COLOR | 1. Coolant color is not necessarily an indication of adequate corrosion or temperature protection. Do not rely on coolant color for determining condition of coolant. | 1. Refer to Coolant in this group for coolant concentration information. Adjust coolant mixture as necessary. |
| COOLANT LEVEL CHANGES IN COOLANT RESERVE/OVERFLOW TANK. TEMPERATURE GAUGE IS IN NORMAL RANGE | 1. Level changes are to be expected as coolant volume fluctuates with engine temperature. If the level in the tank was between the FULL and ADD marks at normal operating temperature, the level should return to within that range after operation at elevated temperatures. | 1. A normal condition. No repair is necessary. |

RADIATOR COOLANT FLOW CHECK

The following procedure will determine if coolant is flowing through the cooling system.

If engine is cold, idle engine until normal operating temperature is reached. Then feel the upper radiator hose. If hose is hot, the thermostat is open and water is circulating through cooling system.

COOLING SYSTEM—TESTING FOR LEAKS

ULTRAVIOLET LIGHT METHOD

All Jeep models have a leak detection additive added to the cooling system before they leave the factory. The additive is highly visible under ultraviolet light (black light). If the factory original coolant has been drained, pour one ounce of additive into the cooling system. The additive is available through the part's department. Place the heater control unit in HEAT position. Start and operate the engine until the radiator upper hose is warm to the touch. Aim the commercially available black light tool at the components to be checked. If leaks are present, the black light will cause the additive to glow a bright green color.

The black light can be used along with a pressure tester to determine if any external leaks exist (Fig. 17).

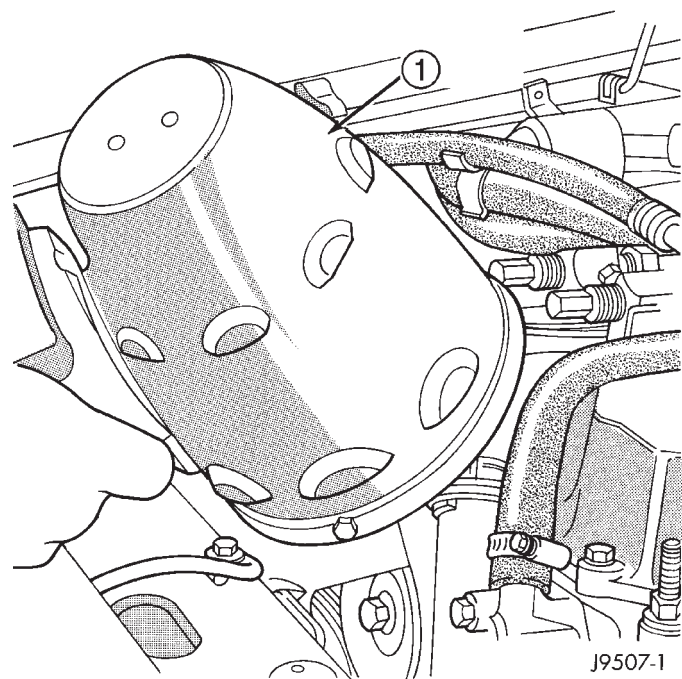

J9507-1

Fig. 17 Leak Detection Using Black Light—Typical
1 – TYPICAL BLACK LIGHT TOOL

DIAGNOSIS AND TESTING (Continued)

PRESSURE TESTER METHOD

The engine should be at the normal operating temperature. Recheck the system cold if the cause of coolant loss is not located during warm engine examination.

WARNING: HOT, PRESSURIZED COOLANT CAN CAUSE INJURY BY SCALDING.

Carefully remove the radiator pressure cap from the filler neck and check the coolant level. Push down on the cap to disengage it from the stop tabs. Wipe the inner part of the filler neck and examine the lower inside sealing seat for nicks, cracks, paint, dirt and solder residue. Inspect the reserve/overflow tank tube for internal obstructions. Insert a wire through the tube to be sure it is not obstructed.

Inspect the cams on the outside part of the filler neck. If the cams are bent, seating of pressure cap valve and tester seal will be affected. Replace cap if cams are bent.

Attach pressure tester 7700 (or an equivalent) to the radiator filler neck (Fig. 18).

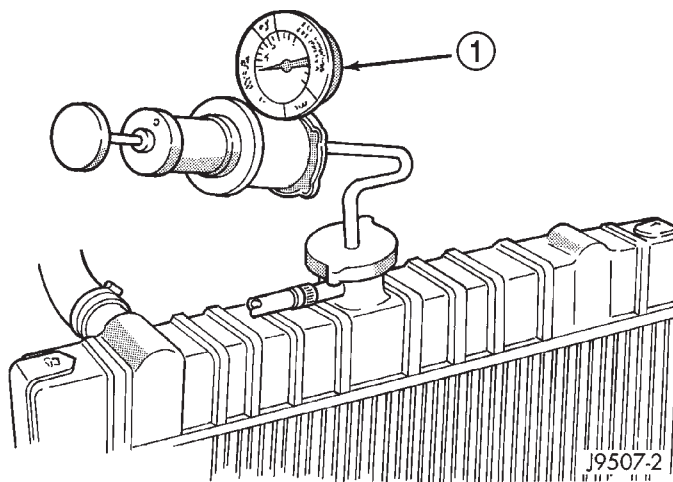

Fig. 18 Pressurizing System—Typical

1 - TYPICAL COOLING SYSTEM PRESSURE TESTER

Operate the tester pump to apply 124 kPa (18 psi) pressure to the system. If the hoses enlarge excessively or bulge while testing, replace as necessary. Observe the gauge pointer and determine the condition of the cooling system according to the following criteria:

- **Holds Steady:** If the pointer remains steady for two minutes, there are no serious coolant leaks in the system. However, there could be an internal leak that does not appear with normal system test pressure. Inspect for interior leakage or do the Internal Leakage Test. Do this if it is certain that coolant is being lost and no leaks can be detected.

- **Drops Slowly:** Shows a small leak or seepage is occurring. Examine all connections for seepage or slight leakage with a flashlight. Inspect the radiator, hoses, gasket edges and heater. Seal any small leak holes with a Sealer Lubricant or equivalent. Repair leak holes and reinspect the system with pressure applied.

- **Drops Quickly:** Shows that a serious leakage is occurring. Examine the system for serious external leakage. If no leaks are visible, inspect for internal leakage. Large radiator leak holes should be repaired by a reputable radiator repair shop.

INTERNAL LEAKAGE INSPECTION

Remove the engine oil pan drain plug and drain a small amount of engine oil. Coolant, being heavier than engine oil, will drain first. Another way of testing is to operate the engine and check for water globules on the engine oil dipstick. Also inspect the automatic transmission oil dipstick for water globules. Inspect the automatic transmission fluid cooler for leakage. Operate the engine without the pressure cap on the radiator until thermostat opens.

Attach a pressure tester to the filler neck. If pressure builds up quickly, a leak exists as a result of a faulty cylinder head gasket or crack in the engine. Repair as necessary.

WARNING: DO NOT ALLOW PRESSURE TO EXCEED 124 KPA (18 PSI). TURN THE ENGINE OFF. TO RELEASE THE PRESSURE, ROCK THE TESTER FROM SIDE TO SIDE. WHEN REMOVING THE TESTER, DO NOT TURN THE TESTER MORE THAN 1/2 TURN IF THE SYSTEM IS UNDER PRESSURE.

If there is no immediate pressure increase, pump the pressure tester until the indicated pressure is within the system range. Vibration of the gauge pointer indicates compression or combustion leakage into the cooling system.

WARNING: DO NOT DISCONNECT THE SPARK PLUG WIRES WHILE THE ENGINE IS OPERATING.

CAUTION: Do not operate the engine with a spark plug shorted for more than a minute. The catalytic converter may be damaged.

Isolate the compression leak by shorting each spark plug to the cylinder block. The gauge pointer should stop or decrease vibration when spark plug for leaking cylinder is shorted. This happens because of the absence of combustion pressure.

DIAGNOSIS AND TESTING (Continued)

COMBUSTION LEAKAGE TEST (WITHOUT PRESSURE TESTER)

DO NOT WASTE reusable coolant. If the solution is clean, drain the coolant into a clean container for reuse.

WARNING: DO NOT REMOVE THE CYLINDER BLOCK DRAIN PLUGS OR LOOSEN THE RADIATOR DRAINCOCK WITH THE SYSTEM HOT AND UNDER PRESSURE. SERIOUS BURNS FROM COOLANT CAN OCCUR.

Drain sufficient coolant to allow for thermostat removal. Refer to Thermostat Replacement. Disconnect the water pump drive belt.

Disconnect the upper radiator hose from the thermostat housing. Remove the housing and thermostat. Install the thermostat housing.

Add coolant to the radiator to bring the level to within 6.3 mm (1/4 in) of the top of the thermostat housing.

CAUTION: Avoid overheating. Do not operate the engine for an excessive period of time. Open the draincock immediately after the test to eliminate boil over of coolant.

Start the engine and accelerate rapidly three times (to approximately 3000 rpm) while observing the coolant. If internal engine combustion gases are leaking into the cooling system, bubbles will appear in the coolant. If bubbles do not appear, there is no internal combustion gas leakage.

VISCOUS FAN DRIVE**LEAKS**

Viscous fan drive operation is not affected by small oil stains near the drive bearing. If leakage appears excessive, replace the fan drive unit.

TESTING

If the fan assembly free-wheels without drag (the fan blades will revolve more than five turns when spun by hand), replace the fan drive. This spin test must be performed when the engine is cool.

For the following test, the cooling system must be in good condition. It also will ensure against excessively high coolant temperature.

WARNING: BE SURE THAT THERE IS ADEQUATE FAN BLADE CLEARANCE BEFORE DRILLING.

(1) Drill a 3.18-mm (1/8-in) diameter hole in the top center of the fan shroud.

(2) Obtain a dial thermometer with an 8 inch stem (or equivalent). It should have a range of -18°-to-

105°C (0°-to-220° F). Insert thermometer through the hole in the shroud. Be sure that there is adequate clearance from the fan blades.

(3) Connect a tachometer and an engine ignition timing light (timing light is to be used as a strobe light).

(4) Block the air flow through the radiator. Secure a sheet of plastic in front of the radiator (or air conditioner condenser). Use tape at the top to secure the plastic and be sure that the air flow is blocked.

(5) Be sure that the air conditioner (if equipped) is turned off.

WARNING: USE EXTREME CAUTION WHEN THE ENGINE IS OPERATING. DO NOT STAND IN A DIRECT LINE WITH THE FAN. DO NOT PUT YOUR HANDS NEAR THE PULLEYS, BELTS OR FAN. DO NOT WEAR LOOSE CLOTHING.

(6) Start the engine and operate at 2400 rpm. Within ten minutes the air temperature (indicated on the dial thermometer) should be up to 88° C (190° F). Fan drive **engagement** should have started to occur at between 74° to 82° C (165° to 180° F). Engagement is distinguishable by a definite **increase** in fan flow noise (roaring). The timing light also will indicate an increase in the speed of the fan.

(7) When the air temperature reaches 88° C (190° F), remove the plastic sheet. Fan drive **disengagement** should have started to occur at between 57° to 79° C (135° to 175° F). A definite **decrease** of fan flow noise (roaring) should be noticed. If not, replace the defective viscous fan drive unit.

ELECTRIC COOLING FAN**ELECTRIC COOLING FAN AND RELAY DIAGNOSIS**

NOTE: Refer to Electrical Group 8W for electric cooling fan and relay circuit schematic.

The powertrain control module (PCM) will enter a diagnostic trouble code (DTC) in memory if it detects a problem in the auxiliary cooling fan relay or circuit. Refer to Group 25, Emission Control Systems for correct DTC retrieval procedures.

If the electric cooling fan is inoperative, check the 15A fuse in the junction block and the 40A fuse in the Power Distribution Center (PDC) with a 12 volt test lamp or DVOM. Refer to the inside of the PDC cover for the exact location of the fuse. If fuses are o.k., refer to Group 8W for electric cooling fan and relay circuit schematic.

DIAGNOSIS AND TESTING (Continued)

**RADIATOR CAP-TO-FILLER NECK SEAL—
PRESSURE RELIEF CHECK**

With radiator cap installed on filler neck, remove coolant reserve/ overflow tank hose from nipple on filler neck. Connect a hand operated vacuum pump to nipple. Operate pump until a reading of 47-to-61 kPa (14- to-18 in. Hg) appears on gauge. If the reading stays steady, or drops slightly and then remains steady, the pressure valve seal is good. Replace radiator cap if reading does not hold.

WARNING: THE WARNING WORDS -DO NOT OPEN HOT- ON THE RADIATOR PRESSURE CAP (Fig. 19) ARE A SAFETY PRECAUTION. WHEN HOT, PRESSURE BUILDS UP IN COOLING SYSTEM. TO PREVENT SCALDING OR INJURY, THE RADIATOR CAP SHOULD NOT BE REMOVED WHILE THE SYSTEM IS HOT AND/OR UNDER PRESSURE.

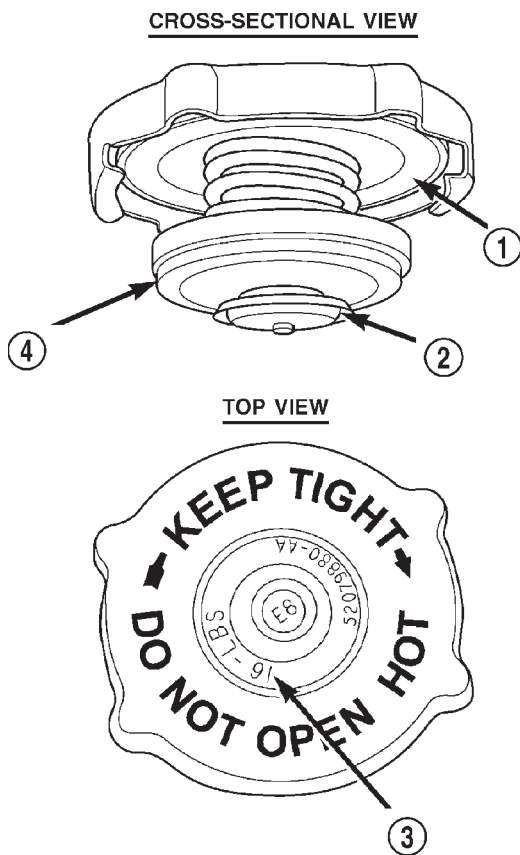

80bfe12f

Fig. 19 Radiator Pressure Cap

- 1 - FILLER NECK SEAL
- 2 - VACUUM VENT VALVE
- 3 - PRESSURE RATING
- 4 - PRESSURE VALVE

There is no need to remove the radiator cap **except** for the following purposes:

- (1) To check and adjust antifreeze freeze point.
- (2) To refill system with new antifreeze.
- (3) For conducting service procedures.
- (4) When checking for vacuum leaks.

WARNING: IF VEHICLE HAS BEEN RUN RECENTLY, WAIT AT LEAST 15 MINUTES BEFORE REMOVING RADIATOR CAP. WITH A RAG, SQUEEZE RADIATOR UPPER HOSE TO CHECK IF SYSTEM IS UNDER PRESSURE. PLACE A RAG OVER THE CAP AND WITHOUT PUSHING DOWN, ROTATE CAP COUNTER-CLOCKWISE TO THE FIRST STOP. ALLOW FLUID TO ESCAPE THROUGH OVERFLOW HOSE INTO COOLANT RESERVE/OVERFLOW TANK. SQUEEZE RADIATOR UPPER HOSE TO DETERMINE WHEN PRESSURE HAS BEEN RELEASED. WHEN COOLANT AND STEAM STOP BEING PUSHED INTO TANK AND SYSTEM PRESSURE DROPS, REMOVE RADIATOR CAP COMPLETELY.

RADIATOR CAP—PRESSURE TESTING

Remove cap from radiator. Be sure that sealing surfaces are clean. Moisten rubber gasket with water and install the cap on pressure tester (tool 7700 or an equivalent) (Fig. 20).

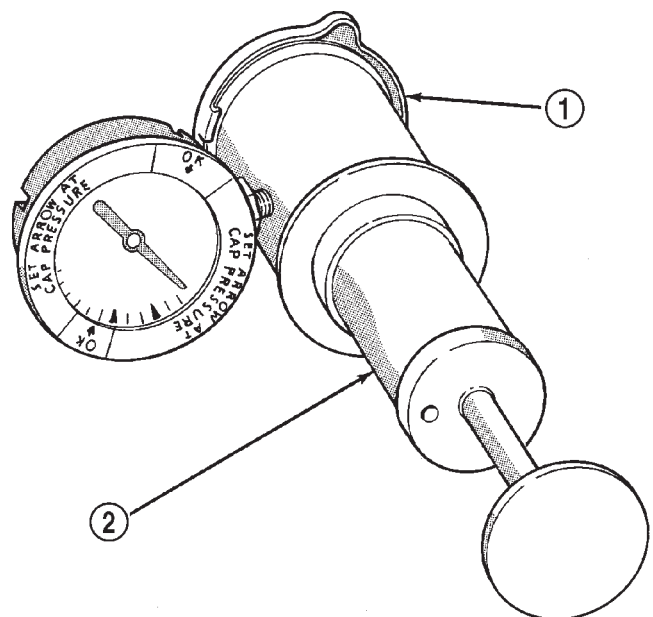

J9507-3

**Fig. 20 Pressure Testing Radiator Pressure
Cap—Typical**

- 1 - PRESSURE CAP
- 2 - TYPICAL COOLING SYSTEM PRESSURE TESTER

DIAGNOSIS AND TESTING (Continued)

Operate the tester pump and observe the gauge pointer at its highest point. The cap release pressure should be 83-to-110 kPa (12-to-16 psi). The cap is satisfactory when the pressure holds steady. It is also good if it holds pressure within the 83-to-110 kPa (12-to-16 psi) range for 30 seconds or more. If the pointer drops quickly, replace the cap.

CAUTION: Radiator pressure testing tools are very sensitive to small air leaks, which will not cause cooling system problems. A pressure cap that does not have a history of coolant loss should not be replaced just because it leaks slowly when tested with this tool. Add water to tool. Turn tool upside down and recheck pressure cap to confirm that cap needs replacement.

CAP INSPECTION

Visually inspect the pressure valve gasket on the cap. Replace cap if the gasket is swollen, torn or worn. Inspect the area around radiator filler neck for white deposits that indicate a leaking cap.

COOLANT—LOW LEVEL AERATION

If the coolant level in radiator drops below top of radiator core tubes, air will enter cooling system.

Low coolant level can cause thermostat pellet to be suspended in air instead of coolant. This will cause thermostat to open later, which in turn causes higher coolant temperature. Air trapped in cooling system also reduces amount of coolant circulating in heater core resulting in low heat output.

DEAERATION

As the engine operates, any air trapped in cooling system gathers under the radiator cap. The next time the engine is operated, thermal expansion of coolant will push any trapped air past radiator cap into the coolant reserve/overflow tank. Here it escapes to the atmosphere into the tank. When the engine cools down the coolant, it will be drawn from the reserve/overflow tank into the radiator to replace any removed air.

SERVICE PROCEDURES

COOLANT—ROUTINE LEVEL CHECK

NOTE: Do not remove radiator cap for routine coolant level inspections. The coolant level can be checked at coolant reserve/overflow tank.

The coolant reserve/overflow system provides a quick visual method for determining coolant level without removing radiator pressure cap. With engine cold and not running, observe coolant level in reserve/overflow tank. The coolant level should be between ADD and FULL marks.

COOLANT—ADDING ADDITIONAL

Do not remove radiator cap to add coolant to system. When adding coolant to maintain correct level, do so at coolant reserve/overflow tank. Use a 50/50 mixture of ethylene-glycol antifreeze containing Alugard 340-2 [™] and low mineral content water. Remove radiator cap only for testing or when refilling system after service. Removing cap unnecessarily can cause loss of coolant and allow air to enter system, which produces corrosion.

COOLANT—LEVEL CHECK

The cooling system is closed and designed to maintain coolant level to top of radiator.

WARNING: DO NOT OPEN RADIATOR DRAINCOCK WITH ENGINE RUNNING OR WHILE ENGINE IS HOT AND COOLING SYSTEM IS UNDER PRESSURE.

When vehicle servicing requires a coolant level check in radiator, drain several ounces of coolant from radiator drain cock. Do this while observing coolant reserve/overflow system tank. The coolant level in reserve/overflow tank should drop slightly. If not, inspect for a leak between radiator and coolant reserve/overflow system connection. Remove radiator cap. The coolant level should be to top of radiator. If not and if coolant level in reserve/overflow tank is at ADD mark, check for:

- An air leak in coolant reserve/overflow tank or its hose
- An air leak in radiator filler neck
- Leak in pressure cap seal to radiator filler neck

COOLING SYSTEM—DRAINING AND FILLING

DRAINING

WARNING: DO NOT REMOVE THE CYLINDER BLOCK DRAIN PLUGS OR LOOSEN THE RADIATOR DRAINCOCK WITH SYSTEM HOT AND UNDER PRESSURE. SERIOUS BURNS FROM COOLANT CAN OCCUR.

DO NOT WASTE reusable coolant. If the solution is clean, drain the coolant into a clean container for reuse.

- (1) Remove radiator pressure cap.

SERVICE PROCEDURES (Continued)

(2) For access to radiator draincock (Fig. 21), remove radiator grille mounting screws and remove grille. Refer to Group 23, Body for correct procedure.

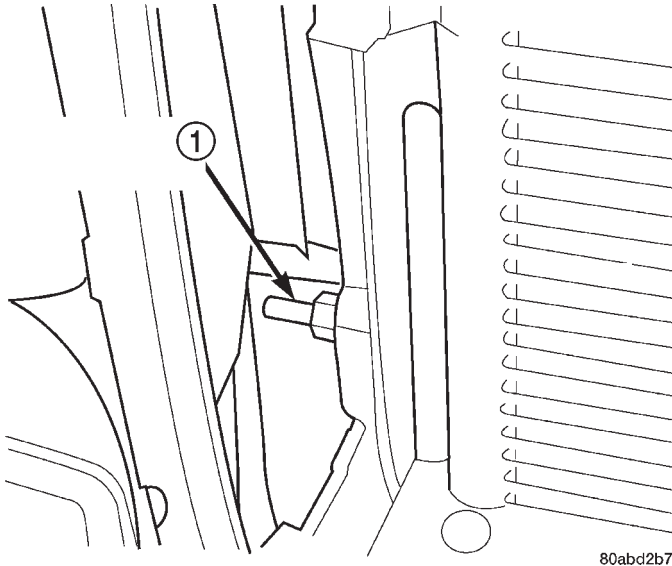

80abd2b7

Fig. 21 Radiator Petcock—2.5L/4.0L (LHD/RHD)

1 - RADIATOR PETCOCK

(3) Attach one end of a 24 inch long X 1/4 inch ID hose to the radiator draincock. Put the other end into a clean container. Open draincock and drain coolant from radiator.

(4) Drain coolant from engine by removing the drain plug and coolant temperature sensor on left side of block.

REFILLING

(1) Tighten the radiator petcock and the cylinder block drain plug(s).

(2) Install grille.

(3) Fill system using a 50/50 mixture of water and antifreeze as described in the Coolant section of this group. Fill radiator to top and install radiator cap. Add sufficient coolant to reserve/overflow tank to raise level to FULL mark.

(4) With heater control unit in the HEAT position, operate engine with radiator cap in place.

(5) After engine has reached normal operating temperature, shut engine off and allow it to cool.

(6) Add coolant to reserve/overflow tank as necessary. **Only add coolant when the engine is cold. Coolant level in a warm engine will be higher due to thermal expansion.**

COOLING SYSTEM—REVERSE FLUSHING

CAUTION: The cooling system normally operates at 97-to-124 kPa (14- to-18 psi) pressure. Exceeding this pressure may damage the radiator or hoses.

Reverse flushing of the cooling system is the forcing of water through the cooling system. This is done using air pressure in the opposite direction of normal coolant flow. It is usually only necessary with very dirty systems with evidence of partial plugging.

CHEMICAL CLEANING

If visual inspection indicates the formation of sludge or scaly deposits, use a radiator cleaner (Mopar Radiator Kleen or equivalent) before flushing. This will soften scale and other deposits and aid the flushing operation.

CAUTION: Be sure instructions on the container are followed.

REVERSE FLUSHING RADIATOR

Disconnect the radiator hoses from the radiator fittings. Attach a section of radiator hose to the radiator bottom outlet fitting and insert the flushing gun. Connect a water supply hose and air supply hose to the flushing gun.

CAUTION: The cooling system normally operates at 97-to-124 kPa (14- to-18 psi) pressure. Exceeding this pressure may damage the radiator or hoses.

Allow the radiator to fill with water. When radiator is filled, apply air in short blasts allowing radiator to refill between blasts. Continue this reverse flushing until clean water flows out through rear of radiator cooling tube passages. For more information, refer to operating instructions supplied with flushing equipment. Have radiator cleaned more extensively by a radiator repair shop.

REVERSE FLUSHING ENGINE

Drain the cooling system. Remove the thermostat housing and thermostat. Install the thermostat housing. Disconnect the radiator upper hose from the radiator and attach the flushing gun to the hose. Disconnect the radiator lower hose from the water pump. Attach a lead away hose to the water pump inlet fitting.

CAUTION: Be sure that the heater control valve is closed (heat off). This is done to prevent coolant flow with scale and other deposits from entering the heater core.

Connect the water supply hose and air supply hose to the flushing gun. Allow the engine to fill with water. When the engine is filled, apply air in short blasts, allowing the system to fill between air blasts. Continue until clean water flows through the lead away hose. For more information, refer to operating instructions supplied with flushing equipment.

SERVICE PROCEDURES (Continued)

Remove the lead away hose, flushing gun, water supply hose and air supply hose. Remove the thermostat housing and install thermostat. Install the thermostat housing with a replacement gasket. Refer to Thermostat Replacement. Connect the radiator hoses. Refill the cooling system with the correct anti-freeze/water mixture.

REMOVAL AND INSTALLATION

TRANSMISSION OIL COOLERS

WATER-TO-OIL COOLER

The internal transmission oil cooler located within the radiator is not serviceable. If it requires service, the radiator must be replaced.

Once the repaired or replacement radiator has been installed, fill the cooling system and inspect for leaks. Refer to the Refilling Cooling System and Testing Cooling System For Leaks sections in this group. If the transmission operates properly after repairing the leak, drain the transmission and remove the transmission oil pan. Inspect for sludge and/or rust. Inspect for a dirty or plugged inlet filter. If none of these conditions are found, the transmission and torque convertor may not require reconditioning. Refer to Group 21 for automatic transmission servicing.

AIR-TO-OIL COOLER

REMOVAL

- (1) Remove the grill mounting screws and remove the grill. Refer to Group 23, Body for procedures.
- (2) Place a drain pan below the transmission oil cooler.
- (3) Remove the two constant tension clamps at oil cooler inlet and outlet tubes.
- (4) Remove the two oil cooler mounting bolts (Fig. 22).
- (5) Remove the oil cooler from vehicle.

INSTALLATION

- (1) Position and secure oil cooler to vehicle. Tighten mounting bolts to 8 N·m (72 in. lbs.) torque.
 - (2) Secure inlet and outlet tubes with constant tension clamps.
- Install the grill.
- (3) Start engine and check transmission fluid level. Add fluid if necessary.

COOLANT RESERVE TANK

REMOVAL

- (1) Remove the tube clamp at the tank and remove tube.

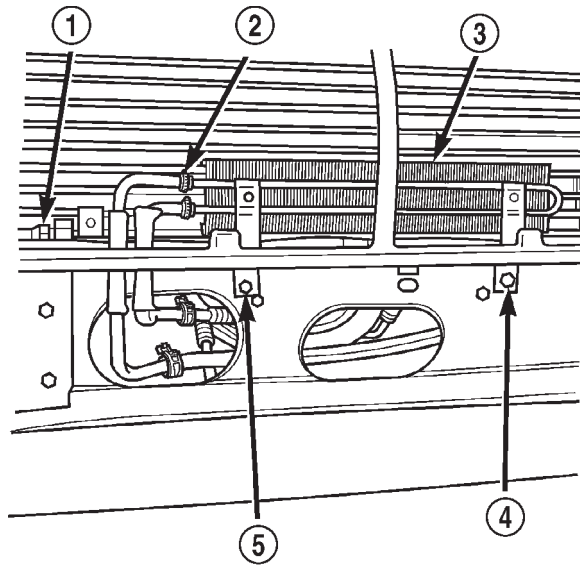

Fig. 22 Auxiliary Air-To-Oil Cooler

80be4561

- 1 - AIR CONDITIONING CONDENSER
- 2 - HOSE CLAMPS (2)
- 3 - AUXILIARY AUTOMATIC TRANSMISSION OIL COOLER
- 4 - MOUNTING BOLT
- 5 - MOUNTING BOLT

(2) Remove the tank mounting bolts and remove tank (Fig. 23) (Fig. 24).

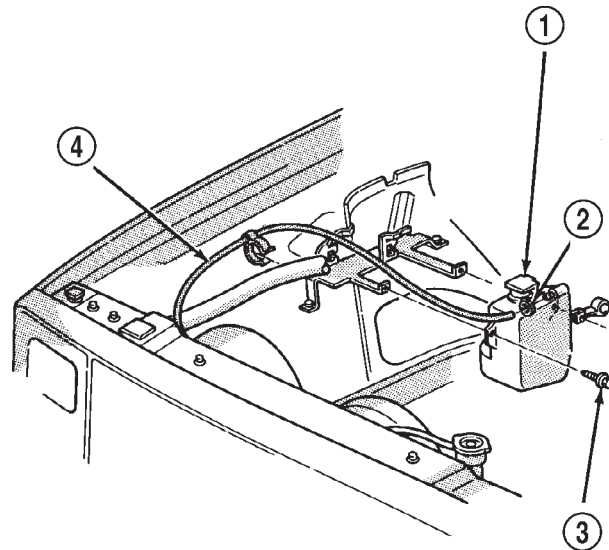
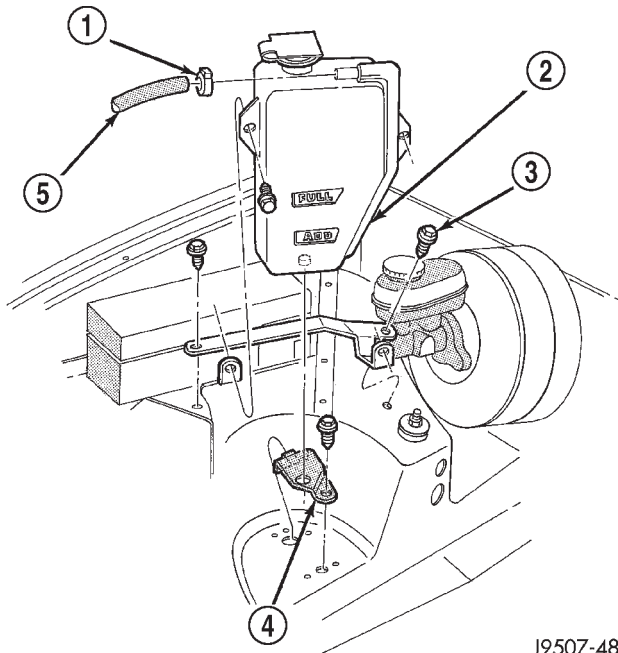

Fig. 23 Reserve/Overflow Tank—Except Right Hand Drive

J9407-26

- 1 - COOLANT RESERVE/OVERFLOW TANK
- 2 - CLAMP
- 3 - MOUNTING BOLTS
- 4 - TUBE TO RADIATOR

REMOVAL AND INSTALLATION (Continued)



J9507-48

Fig. 24 Reserve/Overflow Tank—With Right Hand Drive

- 1 - CLAMP
- 2 - COOLANT RESERVE/OVERFLOW TANK
- 3 - MOUNTING BOLTS
- 4 - LOWER BRACKET
- 5 - TUBE TO RADIATOR

INSTALLATION

(1) Position tank and tighten to 2 N·m (17 in. lbs.) torque.

(2) Position tube and secure clamp.

WATER PUMP

CAUTION: If the water pump is replaced because of mechanical damage, the fan blades and viscous fan drive should also be inspected. These components could have been damaged due to excessive vibration.

The water pump can be removed without discharging the air conditioning system (if equipped).

CAUTION: All engines have a reverse (counter-clockwise) rotating water pump. The letter R is stamped into the back of the water pump impeller (Fig. 25) to identify. Engines from previous model years, depending upon application, may be equipped with a forward (clockwise) rotating water pump. Installation of the wrong water pump will cause engine over heating.

FRONT VIEW
ROTATION DIRECTION
AS VIEWED

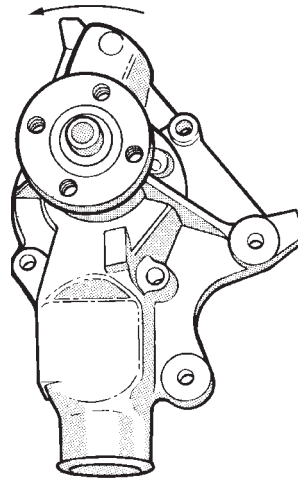

BACK VIEW
ROTATION DIRECTION
AS VIEWED

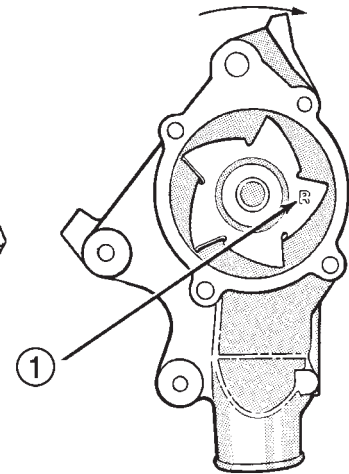

J9307-10

Fig. 25 Reverse Rotating Water Pump—Typical

1 - R STAMPED INTO IMPELLER

The water pump impeller is pressed on the rear of the pump shaft and bearing assembly. The water pump is serviced only as a complete assembly.

WARNING: DO NOT REMOVE THE BLOCK DRAIN PLUG(S) OR LOOSEN RADIATOR DRAINCOCK WITH THE SYSTEM HOT AND UNDER PRESSURE. SERIOUS BURNS FROM COOLANT CAN OCCUR.

DO NOT WASTE reusable coolant. If the solution is clean, drain coolant into a clean container for reuse.

REMOVAL-2.5L ENGINE (LHD/RHD)

- (1) Disconnect battery negative cable.
- (2) Drain cooling system. Refer to Cooling System-Draining and Filling in this group.
- (3) Remove upper radiator hose.
- (4) Loosen (but do not remove at this time) the four fan hub-to-water pump pulley mounting nuts (Fig. 26).
- (5) Remove accessory drive belt. (Refer to Accessory Drive Belt, Removal and Installation in this group)
- (6) Disconnect electric cooling fan connector (if equipped).
- (7) Unbolt fan shroud.
- (8) Remove the four fan hub-to-water pump pulley nuts and remove fan and shroud together.

REMOVAL AND INSTALLATION (Continued)

CAUTION: After removing fan blade/viscous fan drive assembly, do not place thermal viscous fan drive in horizontal position. If stored horizontally, silicone fluid in viscous fan drive could drain into its bearing assembly and contaminate lubricant.

(9) Remove power steering pump and bracket (Fig. 27), refer to Group 19 Steering for correct procedure.

(10) Remove lower radiator hose from water pump. Remove heater hose from water pump pipe.

(11) Remove the four pump mounting bolts (Fig. 28) and remove pump from vehicle. Discard old gasket. Note that one of the four bolts is longer than the other bolts.

(12) If pump is to be replaced, the heater hose fitting must be removed. Note position of fitting before removal.

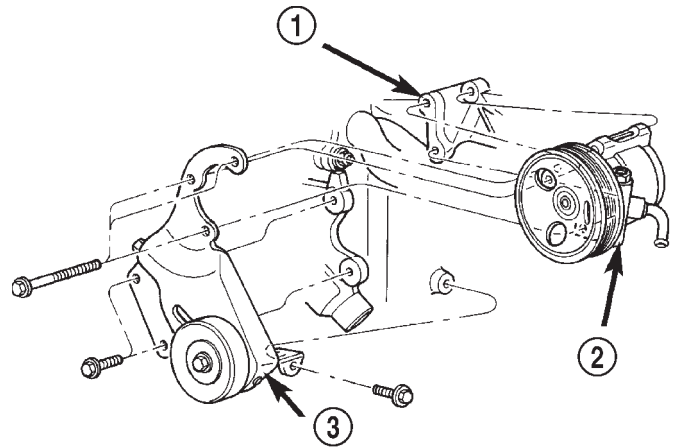

Fig. 27 Power Steering Pump Attachment-2.5L

- 80a871e2
- 1 - INTAKE MANIFOLD
 - 2 - PUMP ASSEMBLY 2.5L
 - 3 - PUMP BRACKET

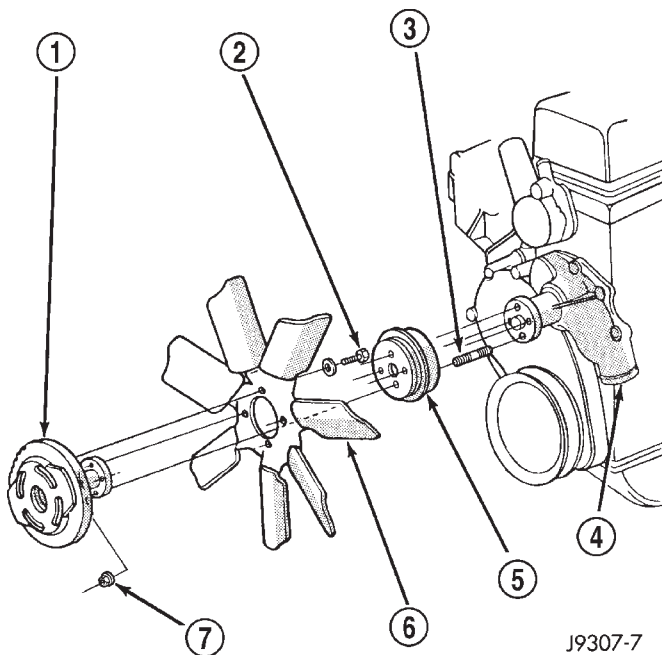

Fig. 26 Fan Mounting Nuts

- J9307-7
- 1 - THERMAL VISCOUS FAN DRIVE
 - 2 - (4) FAN BLADE-TO-VISCOUS DRIVE BOLTS
 - 3 - (4) FAN HUB-TO-PUMP PULLEY STUDS
 - 4 - WATER PUMP
 - 5 - WATER PUMP PULLEY
 - 6 - FAN BLADE
 - 7 - (4) FAN HUB-TO-PUMP PULLEY NUTS

INSTALLATION-2.5L ENGINE (LHD/RHD)

(1) If pump is being replaced, install the heater hose pipe to the pump. Use a sealant on the fitting such as Mopar® Thread Sealant With Teflon. Refer to the directions on the package.

(2) Clean the gasket mating surfaces. If the original pump is used, remove any deposits or other foreign material. Inspect the cylinder block and water

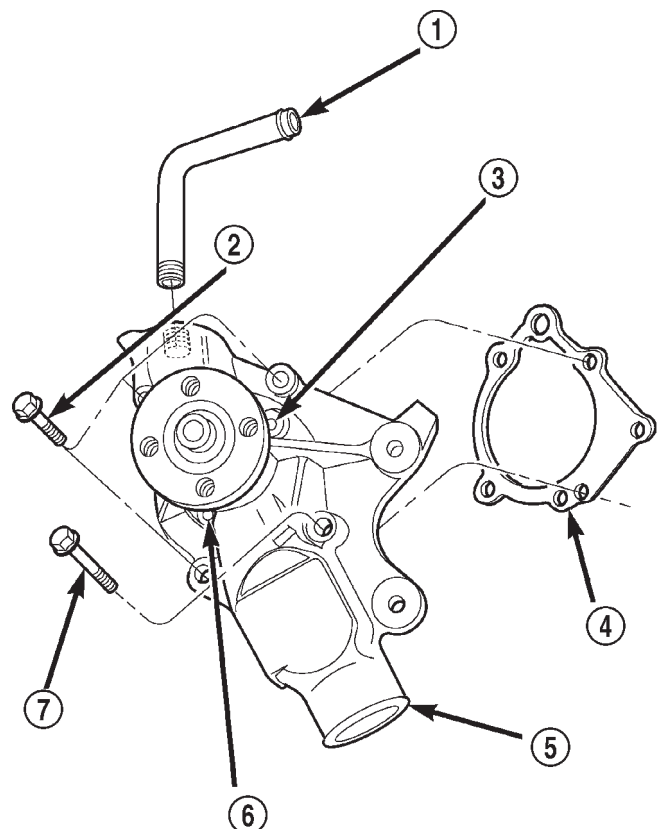

Fig. 28 Water Pump Remove/Install—Typical

- 80bcea54
- 1 - HEATER HOSE FITTING
 - 2 - UPPER VENT HOLE
 - 3 - PUMP GASKET
 - 4 - WATER PUMP
 - 5 - LOWER VENT HOLE
 - 6 - LONG BOLT
 - 7 - BOLTS (3) SHORT

REMOVAL AND INSTALLATION (Continued)

pump mating surfaces for erosion or damage from cavitation.

(3) Install the gasket and water pump. The silicone bead on the gasket should be facing the water pump. Also, the gasket is installed dry. Tighten mounting bolts to 23 N·m (17 ft. lbs.) torque. Rotate the shaft by hand to be sure it turns freely.

(4) Connect the radiator and heater hoses to the water pump.

(5) Install power steering pump and bracket. Refer to Group 19, Steering.

(6) Position water pump pulley to water pump hub.

(7) Install shroud and fan together and install four nuts to water pump hub studs. Tighten nuts to 27 N·m (20 ft. lbs.) torque.

(8) Install and tighten upper fan shroud nuts to 4 N·m (31 in. lbs.).

(9) Connect electric fan connector (if equipped).

CAUTION: When installing the accessory drive belt, the belt **MUST** be routed correctly. If not, the engine may overheat due to the water pump rotating in the wrong direction. Refer to the Belt Removal and Installation in this group for appropriate belt routing. You may also refer to the Belt Routing Label in the vehicle engine compartment.

(10) Install and tension accessory drive belt, refer to Accessory Drive Belt removal and installation in this group.

(11) Install upper radiator hose.

(12) Fill cooling system with coolant and check for leaks. Refer to Refilling Cooling System in this group.

(13) Connect battery negative cable.

(14) Start and warm the engine. Check for leaks.

REMOVAL-4.0L ENGINE (LHD/RHD)

(1) Disconnect battery negative cable.

(2) Drain the cooling system. (Refer to Cooling System-Draining and Filling in this group.)

(3) Disconnect electric cooling fan connector.

(4) Remove electric cooling fan/shroud assembly (if equipped).

(5) Remove viscous fan shroud bolts (2).

(6) Loosen (but do not remove at this time) the four water pump pulley-to-water pump hub mounting bolts (Fig. 29) and the four viscous fan to idler pulley nuts.

NOTE: The accessory drive belt must be removed prior to removing the fan (if installed at pump) or fan pulley.

(7) Remove accessory drive belt (refer to Accessory Drive Belt, Removal and Installation in this group)

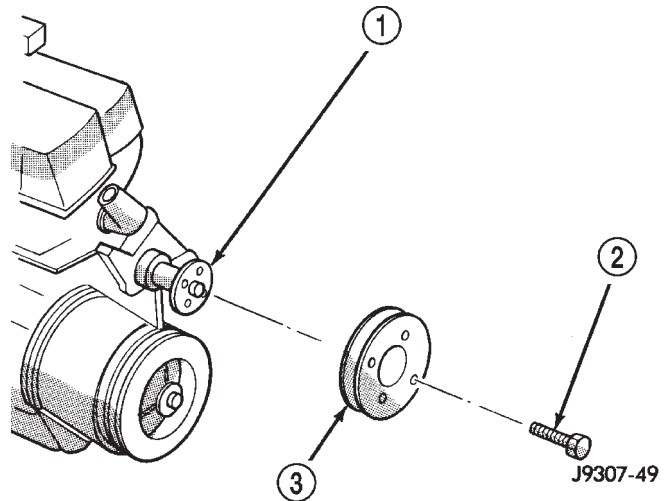

Fig. 29 Water Pump Pulley Bolts

1 - WATER PUMP HUB

2 - BOLTS (4)

3 - PUMP PULLEY

(8) Remove the four viscous fan to idler pulley nuts and remove the fan and shroud together.

CAUTION: After removing fan blade/viscous fan drive assembly, do not place thermal viscous fan drive in horizontal position. If stored horizontally, silicone fluid in viscous fan drive could drain into its bearing assembly and contaminate lubricant.

(9) Remove the four water pump pulley bolts and remove the pulley.

(10) Remove power steering pump and bracket (Fig. 30), refer to Group 19 Steering.

(11) Remove lower radiator hose from water pump. Remove heater hose from water pump fitting.

(12) Remove the four pump mounting bolts (Fig. 31) and remove pump from vehicle. Discard old gasket. Note that one of the four bolts is longer than the other bolts.

(13) If pump is to be replaced, the heater hose fitting must be removed. Note position of fitting before removal.

INSTALLATION-4.0L ENGINE (LHD/RHD)

(1) If pump is being replaced, install the heater hose fitting to the pump. Use a sealant on the fitting such as Mopar® Thread Sealant With Teflon. Refer to the directions on the package.

(2) Clean the gasket mating surfaces. If the original pump is used, remove any deposits or other foreign material. Inspect the cylinder block and water pump mating surfaces for erosion or damage from cavitation.

(3) Install the gasket and water pump. The silicone bead on the gasket should be facing the water

REMOVAL AND INSTALLATION (Continued)

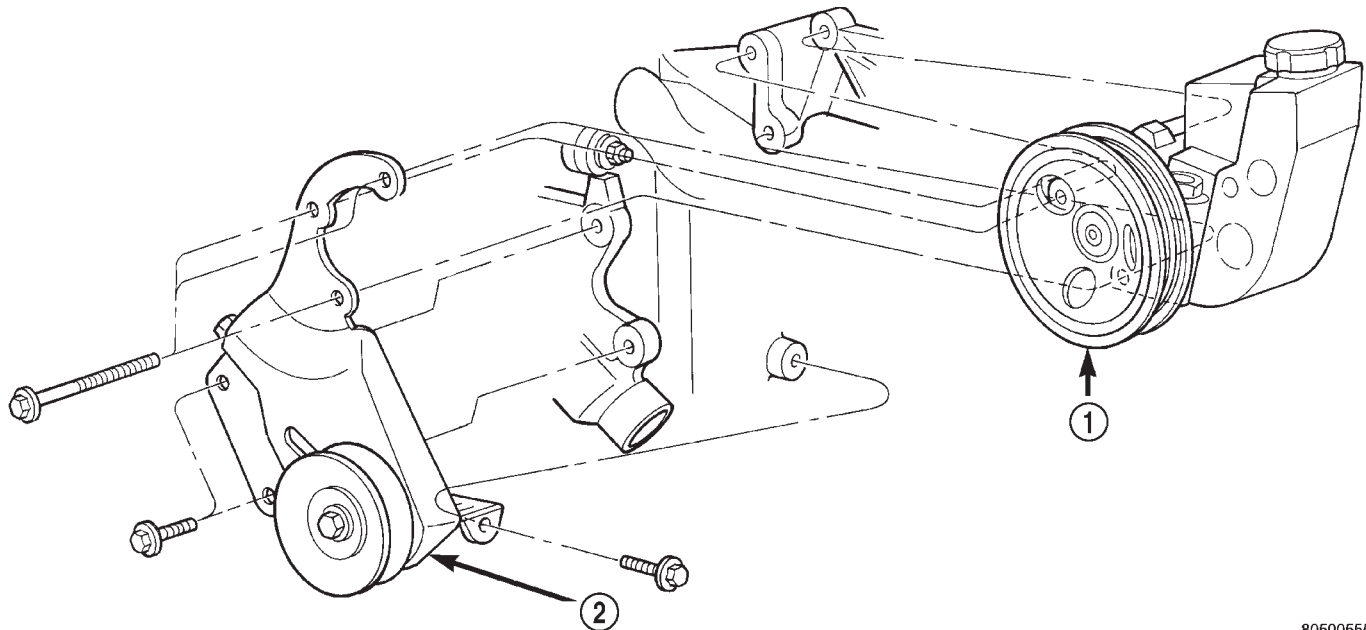

Fig. 30 Power Steering Pump Attachment-4.0L

80500555

- 1 - PUMP ASSEMBLY
- 2 - PUMP BRACKET

pump. Also, the gasket is installed dry. Tighten mounting bolts to 23 N·m (17 ft. lbs.) torque. Rotate the shaft by hand to be sure it turns freely.

(4) Connect the radiator and heater hoses to the water pump.

(5) Position water pump pulley to water pump hub.

(6) Install four pump pulley bolts. Tighten bolts (or nuts) to 27 N·m (20 ft. lbs.) torque.

(7) Install power steering pump. Refer to Group 19, Steering for proper procedure and torque values.

(8) Install the viscous fan and shroud together. Install the four fan to idler pulley nuts and tighten to 27 N·m (20 ft. lbs.).

CAUTION: When installing the accessory drive belt, the belt **MUST** be routed correctly. If not, the engine may overheat due to the water pump rotating in the wrong direction. Refer to the Belt Removal and Installation in this group for appropriate belt routing. You may also refer to the Belt Routing Label in the vehicle engine compartment.

(9) Install and tighten viscous fan shroud bolts to 4 N·m (31 in. lbs.).

(10) Install and tension the accessory drive belt, refer to Accessory Drive Belt removal and installation in this group.

(11) Install the electric cooling fan/shroud assy.

(12) Install and tighten electric fan shroud bolts to 4 N·m (31 in. lbs.). Connect fan connector.

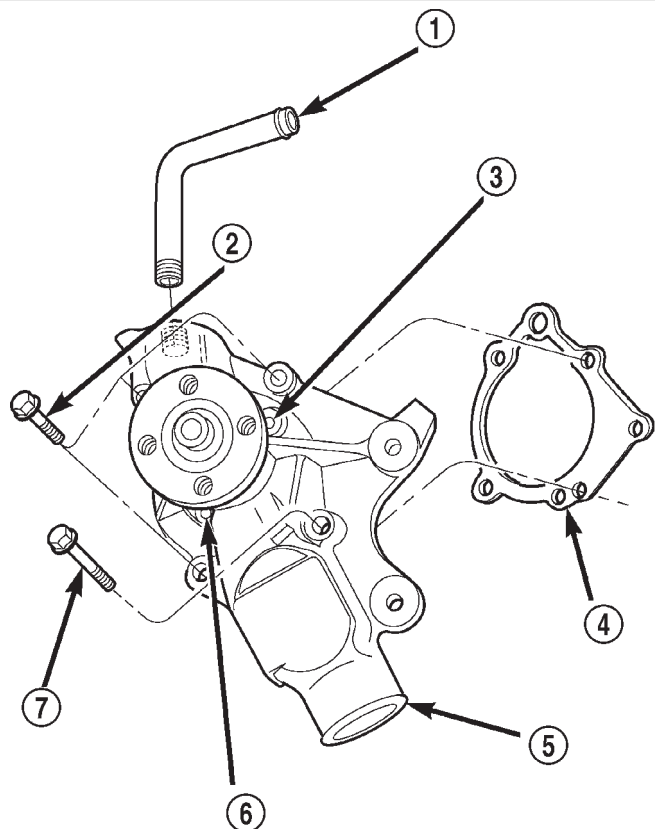

Fig. 31 Water Pump Remove/Install—Typical

80bcea54

- 1 - HEATER HOSE FITTING
- 2 - UPPER VENT HOLE
- 3 - PUMP GASKET
- 4 - WATER PUMP
- 5 - LOWER VENT HOLE
- 6 - LONG BOLT
- 7 - BOLTS (3) SHORT

REMOVAL AND INSTALLATION (Continued)

(13) Fill cooling system with coolant and check for leaks. Refer to Refilling Cooling System in this group.

(14) Connect battery negative cable.

(15) Start and warm the engine. Check for leaks.

THERMOSTAT

REMOVAL

WARNING: DO NOT LOOSEN THE RADIATOR DRAINCOCK WITH THE SYSTEM HOT AND PRESSURIZED. SERIOUS BURNS FROM THE COOLANT CAN OCCUR.

DO NOT WASTE reusable coolant. If the solution is clean, drain the coolant into a clean container for reuse.

(1) Drain the coolant from the radiator until the level is below the thermostat housing.

WARNING: CONSTANT TENSION HOSE CLAMPS ARE USED ON MOST COOLING SYSTEM HOSES. WHEN REMOVING OR INSTALLING, USE ONLY TOOLS DESIGNED FOR SERVICING THIS TYPE OF CLAMP, SUCH AS SPECIAL CLAMP TOOL (NUMBER 6094) (Fig. 12). SNAP-ON CLAMP TOOL (NUMBER HPC-20) MAY BE USED FOR LARGER CLAMPS. ALWAYS WEAR SAFETY GLASSES WHEN SERVICING CONSTANT TENSION CLAMPS.

CAUTION: A number or letter is stamped into the tongue of constant tension clamps (Fig. 11). If replacement is necessary, use only an original equipment clamp with matching number or letter.

(2) Remove radiator upper hose and heater hose at thermostat housing.

(3) Disconnect wiring connector at engine coolant temperature sensor.

(4) Remove thermostat housing mounting bolts, thermostat housing, gasket and thermostat (Fig. 32). Discard old gasket.

(5) Clean the gasket mating surfaces.

INSTALLATION

(1) Install the replacement thermostat so that the pellet, which is encircled by a coil spring, faces the engine. All thermostats are marked on the outer flange to indicate the proper installed position.

(a) Observe the recess groove in the engine cylinder head (Fig. 33).

(b) Position thermostat into this groove with arrow and air bleed hole on outer flange pointing up.

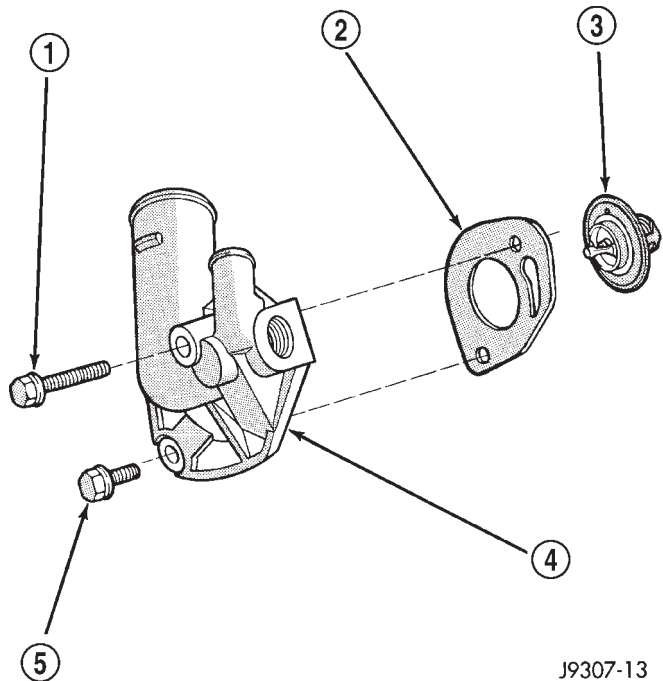

J9307-13

Fig. 32 Thermostat Removal/Installation

- 1 - LONG BOLT
- 2 - GASKET
- 3 - THERMOSTAT
- 4 - THERMOSTAT HOUSING
- 5 - SHORT BOLT

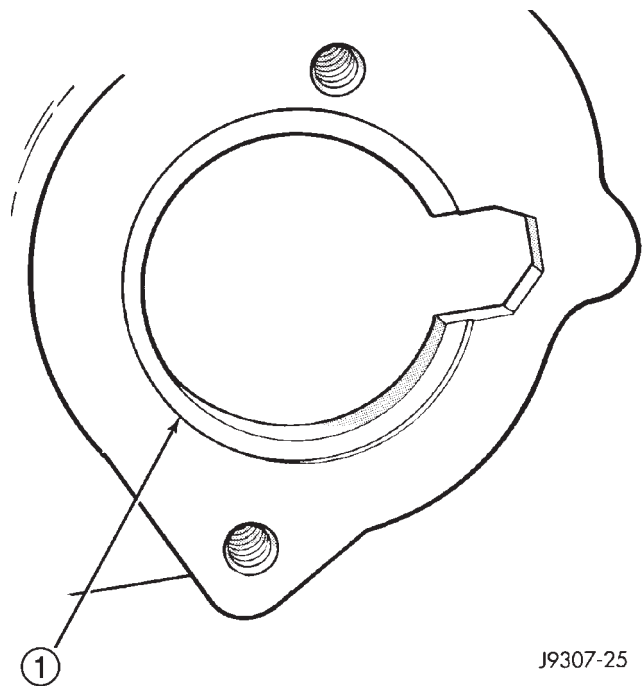

J9307-25

Fig. 33 Thermostat Recess

- 1 - GROOVE

(2) Install replacement gasket and thermostat housing.

REMOVAL AND INSTALLATION (Continued)

CAUTION: Tightening the thermostat housing unevenly or with the thermostat out of its recess may result in a cracked housing.

- (3) Tighten the housing bolts to 20 N·m (15 ft. lbs.) torque.
- (4) Install hoses to thermostat housing.
- (5) Install electrical connector to coolant temperature sensor.
- (6) Be sure that the radiator draincock is tightly closed. Fill the cooling system to the correct level with the required coolant mixture. Refer to Refilling Cooling System in this group.
- (7) Start and warm the engine. Check for leaks.

RADIATOR—2.5L

WARNING: DO NOT REMOVE THE CYLINDER BLOCK DRAIN PLUGS OR LOOSEN THE RADIATOR DRAINCOCK WITH THE SYSTEM HOT AND PRESSURIZED. SERIOUS BURNS FROM THE COOLANT CAN OCCUR.

DO NOT WASTE reusable coolant. If solution is clean, drain coolant into a clean container for reuse.

WARNING: CONSTANT TENSION HOSE CLAMPS ARE USED ON MOST COOLING SYSTEM HOSES. WHEN REMOVING OR INSTALLING, USE ONLY TOOLS DESIGNED FOR SERVICING THIS TYPE OF CLAMP, SUCH AS SPECIAL CLAMP TOOL (NUMBER 6094) (Fig. 12). SNAP-ON CLAMP TOOL (NUMBER HPC-20) MAY BE USED FOR LARGER CLAMPS. ALWAYS WEAR SAFETY GLASSES WHEN SERVICING CONSTANT TENSION CLAMPS.

CAUTION: A number or letter is stamped into the tongue of constant tension clamps (Fig. 11). If replacement is necessary, use only an original equipment clamp with matching number or letter.

REMOVAL

- (1) Disconnect battery negative cable.
- (2) Observe the previous **WARNINGS**.
- (3) Remove radiator pressure cap.
- (4) For access to radiator draincock, remove radiator grill mounting screws and remove grill. Refer to Group 23, Body for procedures.
- (5) Attach one end of a 24 inch long X 1/4 inch ID hose to the radiator petcock (Fig. 34). Put the other end into a clean container. Open petcock and drain radiator.
- (6) Detach power steering fluid reservoir from fan shroud and lay aside.

- (7) Disconnect electric cooling fan electrical connector, if equipped.

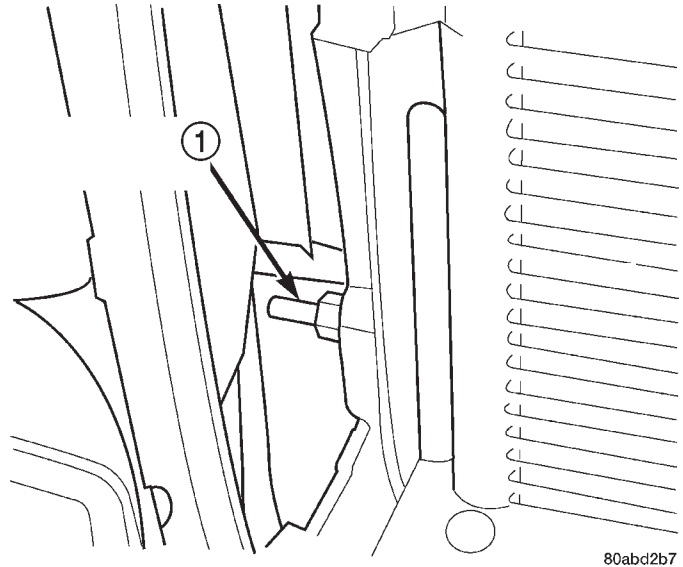

80abd2b7

Fig. 34 Radiator Petcock—Typical

1 - RADIATOR PETCOCK

- (8) Disconnect CRS hose from radiator filler neck and remove from shroud retaining loops.
- (9) Remove the four (4) viscous fan/drive assembly nuts from the water pump pulley and remove fan/drive assy.
- (10) Remove the four (4) fan shroud to core support mounting screws.
- (11) Remove the electric fan (if equipped) and shroud assembly from the vehicle (Fig. 36).
- (12) Remove radiator upper crossmember (Fig. 36).
- (13) If equipped with air conditioning, separate radiator from condenser by removing condenser-to-radiator mounting brackets (Fig. 35).
- (14) Disconnect upper and lower radiator hoses.
- (15) If equipped, disconnect and plug automatic transmission fluid cooler lines. Quick Connect Fitting Release Tool 6935 may be needed. If equipped with remote transmission cooler, remove line to cooler from bracket at bottom of radiator.
- (16) Lift radiator straight up and out of engine compartment taking care not to damage fins.
- (17) If radiator is to be replaced, be sure to remove and transfer any components not included with replacement radiator.

INSTALLATION

The radiator is supplied with two alignment dowels (Fig. 41). They are located on the bottom tank and fit into rubber grommets in the radiator lower crossmember.

REMOVAL AND INSTALLATION (Continued)

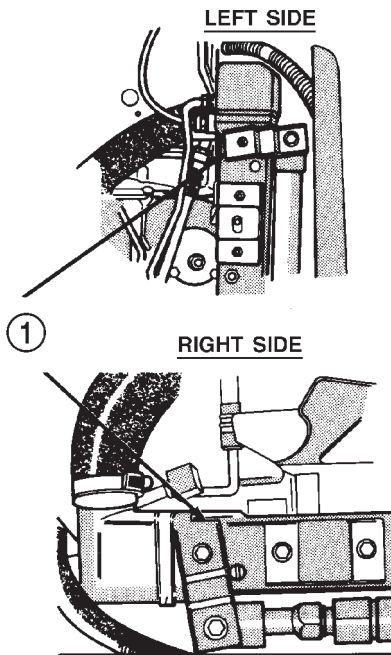

J-8907-26

Fig. 35 Condenser-to-Radiator Mounting Brackets

1 - CONDENSER TO RADIATOR MOUNTING BRACKETS

(1) Lower radiator into engine compartment. Position alignment dowels into rubber grommets in radiator lower crossmember (Fig. 41).

(2) If equipped with air conditioning, attach condenser to radiator with mounting brackets (Fig. 35).

(3) Install radiator upper crossmember and four mounting bolts.

(4) Install radiator upper crossmember-to-isolator nuts. Tighten nuts to 10 N·m (86 in. lbs.) torque. If isolator-to-radiator nuts had been removed, tighten them to 5 N·m (47 in. lbs.) torque.

(5) Connect radiator upper and lower hoses.

(6) If equipped, connect automatic transmission fluid cooler lines. If equipped with remote cooler, attach cooler line to bracket at bottom of radiator.

(7) Install electric fan (if equipped) and shroud assembly. Insert alignment tabs at bottom of fan shroud into slots in bracket at bottom of radiator. Tighten mounting bolts to 3 N·m (31 in. lbs.) torque.

(8) Connect electric cooling fan electrical connector.

(9) Install power steering reservoir to fan shroud.

(10) Install grill.

(11) Connect battery negative cable.

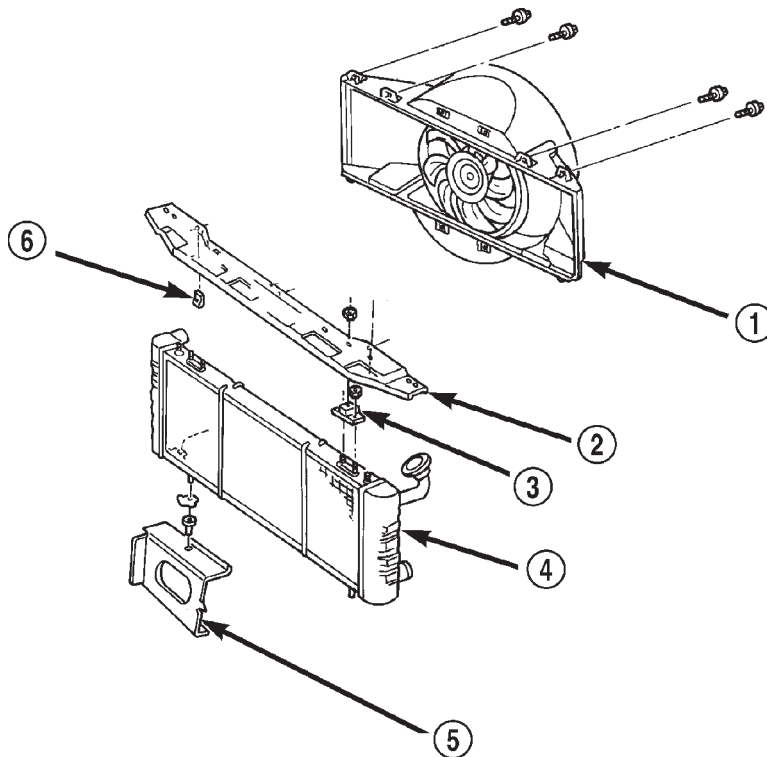
**Fig. 36 Radiator Removal/Installation—2.5L Engines**

80ae8363

1 - ELECTRIC FAN/SHROUD ASSEMBLY
2 - UPPER CROSSMEMBER
3 - ISOLATOR

4 - RADIATOR
5 - LOWER CROSSMEMBER
6 - U-NUT

REMOVAL AND INSTALLATION (Continued)

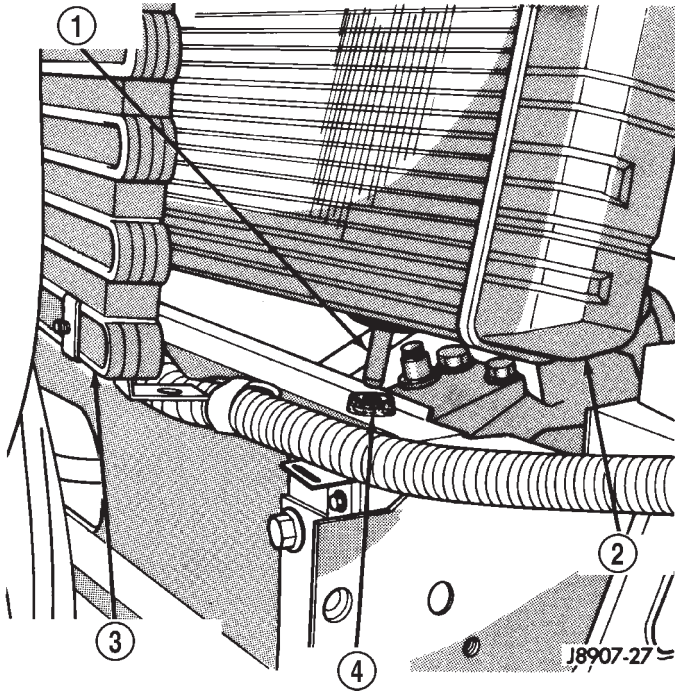

Fig. 37 Radiator Alignment Dowels—Typical

- 1 - ALIGNMENT DOWEL
- 2 - RADIATOR
- 3 - AIR CONDITIONING CONDENSER
- 4 - GROMMET

- (12) Fill cooling system with correct coolant. Refer to the Coolant section of this group.
- (13) Install pressure cap.
- (14) Check and adjust automatic transmission fluid level (if equipped).
- (15) Start engine and visually check for leaks.

RADIATOR—4.0L

WARNING: DO NOT REMOVE THE CYLINDER BLOCK DRAIN PLUGS OR LOOSEN THE RADIATOR DRAINCOCK WITH THE SYSTEM HOT AND PRESSURIZED. SERIOUS BURNS FROM THE COOLANT CAN OCCUR.

DO NOT WASTE reusable coolant. If solution is clean, drain coolant into a clean container for reuse.

WARNING: CONSTANT TENSION HOSE CLAMPS ARE USED ON MOST COOLING SYSTEM HOSES. WHEN REMOVING OR INSTALLING, USE ONLY TOOLS DESIGNED FOR SERVICING THIS TYPE OF CLAMP, SUCH AS SPECIAL CLAMP TOOL (NUMBER 6094) (Fig. 12). SNAP-ON CLAMP TOOL (NUMBER HPC-20) MAY BE USED FOR LARGER CLAMPS. ALWAYS WEAR SAFETY GLASSES WHEN SERVICING CONSTANT TENSION CLAMPS.

CAUTION: A number or letter is stamped into the tongue of constant tension clamps (Fig. 11). If replacement is necessary, use only an original equipment clamp with matching number or letter.

REMOVAL

- (1) Disconnect battery negative cable.
- (2) Observe the previous **WARNINGS**.
- (3) Remove radiator pressure cap.
- (4) For access to radiator draincock, remove radiator grill mounting screws and remove grill. Refer to Group 23, Body for procedures.
- (5) Attach one end of a 24 inch long X 1/4 inch ID hose to the radiator petcock (Fig. 38). Put the other end into a clean container. Open petcock and drain radiator.
- (6) Disconnect electric cooling fan electrical connector, if equipped.

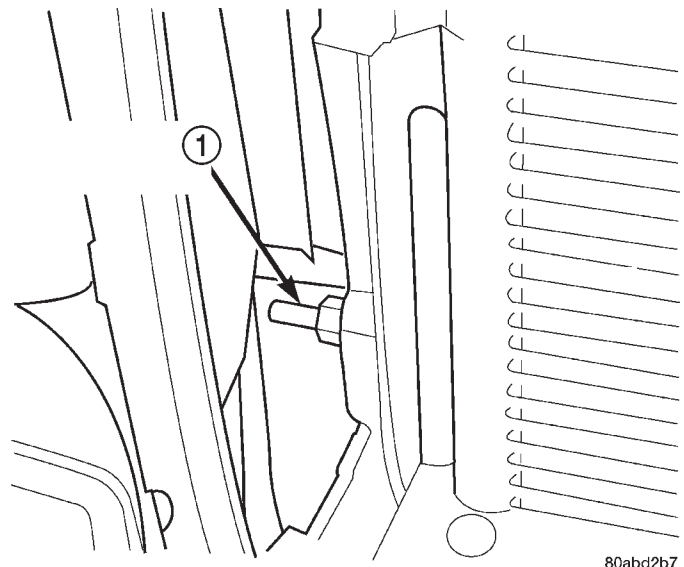

Fig. 38 Radiator Petcock—Typical

- 1 - RADIATOR PETCOCK

(7) If equipped, remove two electric cooling fan mounting bolts. Lift cooling fan straight up until alignment tabs at the bottom are clear of slots in bracket at bottom of radiator (Fig. 39).

(8) Remove the two mechanical (non-electrical) fan shroud mounting bolts. Lift shroud straight up until alignment tabs at the bottom are clear of slots in bracket at bottom of radiator (Fig. 39). Place shroud over mechanical fan.

(9) If equipped, disconnect and plug automatic transmission fluid cooler lines. Quick Connect Fitting Release Tool 6935 may be needed. If equipped with remote transmission cooler, remove line to cooler from bracket at bottom of radiator.

REMOVAL AND INSTALLATION (Continued)

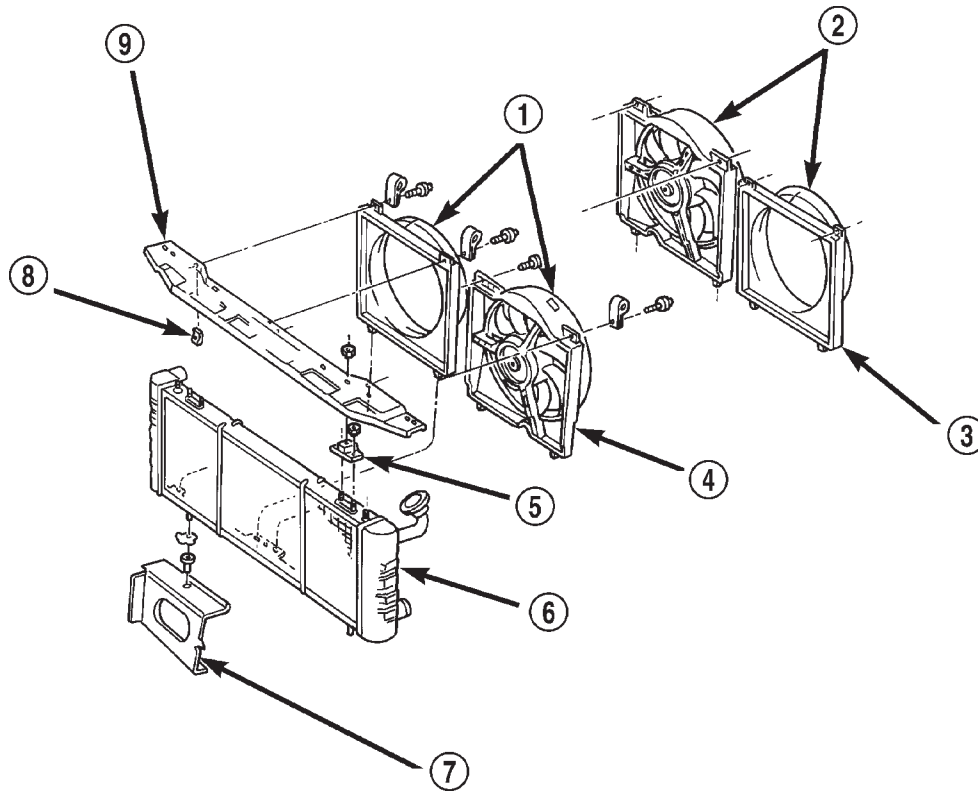

80ae8364

Fig. 39 Radiator Removal/Installation—4.0L Engines

- | | |
|-------------------------|-----------------------|
| 1 - (LHD) | 6 - RADIATOR |
| 2 - (RHD) | 7 - LOWER CROSSMEMBER |
| 3 - VISCOUS FAN SHROUD | 8 - U-NUT |
| 4 - ELECTRIC FAN MODULE | 9 - UPPER CROSSMEMBER |
| 5 - ISOLATOR | |

(10) Disconnect radiator upper and lower hoses clamps. Disconnect radiator upper and lower hoses.

(11) Mark the position of the hood latch striker on the radiator crossmember and remove hood latch striker.

(12) Remove two radiator upper crossmember to isolator nuts (Fig. 39).

(13) Remove four radiator upper crossmember bolts and remove upper crossmember.

(14) If equipped with air conditioning, separate radiator from condenser by removing condenser-to-radiator mounting brackets (Fig. 40).

(15) Lift radiator straight up and out of engine compartment taking care not to damage fins.

INSTALLATION

The radiator is supplied with two alignment dowels (Fig. 41). They are located on the bottom tank and fit into rubber grommets in the radiator lower crossmember.

(1) Lower radiator into engine compartment. Position alignment dowels into rubber grommets in radiator lower crossmember (Fig. 41)

(2) If equipped with air conditioning, attach condenser to radiator with mounting brackets (Fig. 40).

(3) Install radiator upper crossmember and four mounting bolts.

(4) Install radiator upper crossmember-to-isolator nuts. Tighten nuts to 10 N·m (86 in. lbs.) torque. If isolator-to-radiator nuts had been removed, tighten them to 5 N·m (47 in. lbs.) torque.

(5) Install hood latch striker. Note previously marked position.

(6) Connect radiator upper and lower hoses.

(7) If equipped, connect automatic transmission fluid cooler lines. Refer to Group 21, Transmissions for procedures. If equipped with remote cooler, attach cooler line to bracket at bottom of radiator.

REMOVAL AND INSTALLATION (Continued)

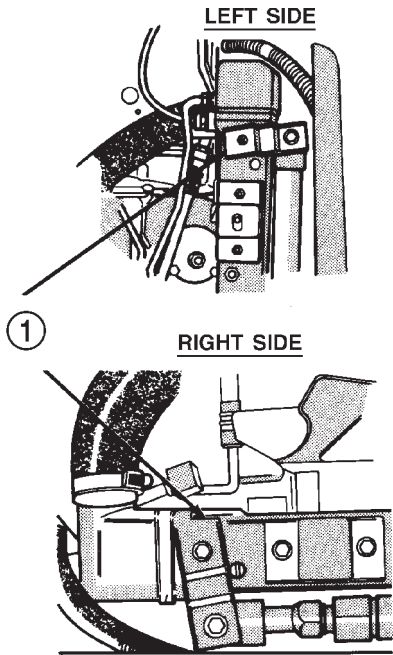

Fig. 40 Condenser to Radiator Mounting Brackets—4.0L Engine

1 - CONDENSER TO RADIATOR MOUNTING BRACKETS

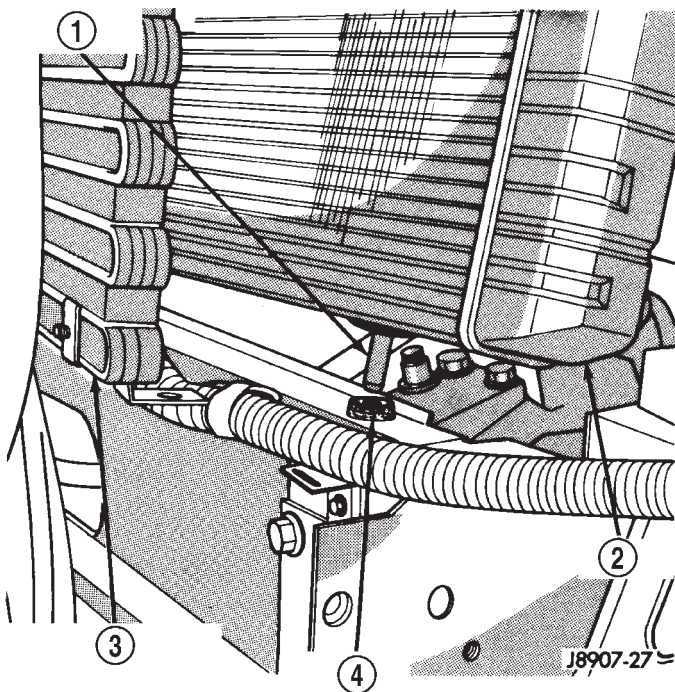

Fig. 41 Radiator Alignment Dowels—Typical

1 - ALIGNMENT DOWEL
 2 - RADIATOR
 3 - AIR CONDITIONING CONDENSER
 4 - GROMMET

(8) Install electric cooling fan (if equipped). Insert alignment tabs at bottom of fan shroud into slots in bracket at bottom of radiator. Tighten mounting bolts to 3 N·m (31 in. lbs.) torque.

(9) Connect electric cooling fan electrical connector.

(10) Install mechanical cooling fan shroud. Insert alignment tabs at bottom of shroud into slots in bracket at bottom of radiator. Tighten mounting bolts to 3 N·m (31 in. lbs.) torque.

(11) Close radiator draincock.

(12) Install grill.

(13) Connect negative battery cable.

(14) Fill cooling system with correct coolant. Refer to the Coolant section of this group.

(15) Install pressure cap.

(16) Check and adjust automatic transmission fluid level (if equipped).

ELECTRIC COOLING FAN—2.5L

The electric fan module is only to be serviced as an assembly.

REMOVAL

(1) Disconnect battery negative cable.

(2) Disconnect CRS hose from radiator filler neck and pull through (remove) the shroud retaining loops.

(3) Detach power steering reservoir from fan shroud and lay aside.

(4) Remove the four viscous fan/drive assembly mounting nuts from the water pump studs and remove viscous fan assembly.

(5) Disconnect cooling fan electrical connector.

(6) Remove the four upper fan shroud to radiator crossmember mounting screws (Fig. 42).

(7) Lift fan and shroud assy. from vehicle

(8) Detach fan harness from shroud.

(9) Remove four fan module to shroud phillips head screws (Fig. 43) and remove module from shroud.

INSTALLATION

(1) Position fan module in shroud so that the harness exits the motor at the 12 o'clock position (Fig. 43).

(2) Install and tighten fan module to shroud screws to 3 N·m (31 in. lbs.).

(3) Route fan harness through the shroud and attach to shroud at correct position.

(4) Lower fan and shroud assembly into place, making sure the shroud alignment tabs rest in their corresponding lower radiator slots.

(5) Install upper fan shroud screws and tighten to 3 N·m (31 in. lbs.).

REMOVAL AND INSTALLATION (Continued)

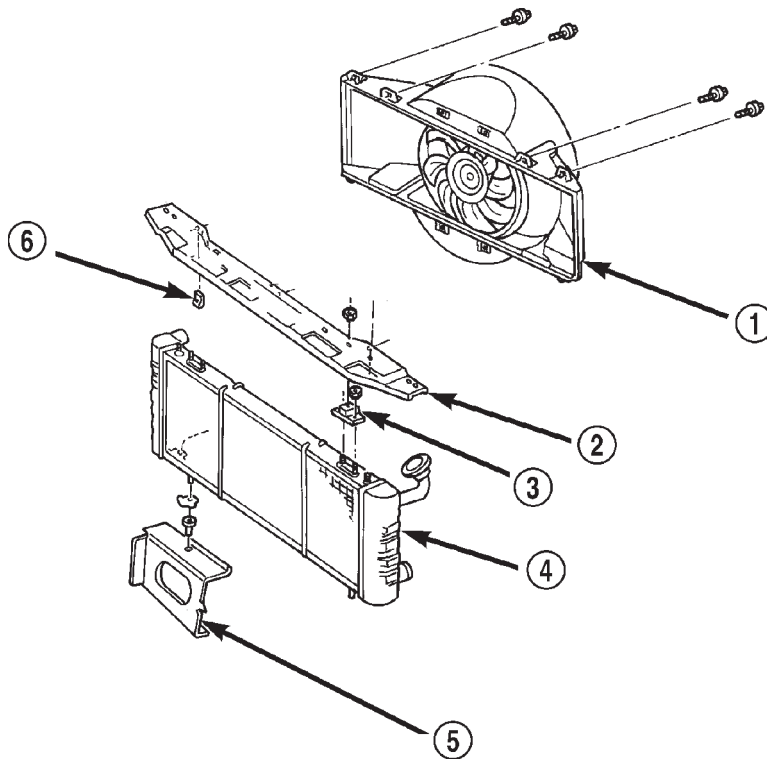

80ae8363

Fig. 42 Fan Shroud Removal/Installation

- 1 - ELECTRIC FAN/SHROUD ASSEMBLY
 2 - UPPER CROSSMEMBER
 3 - ISOLATOR

- 4 - RADIATOR
 5 - LOWER CROSSMEMBER
 6 - U-NUT

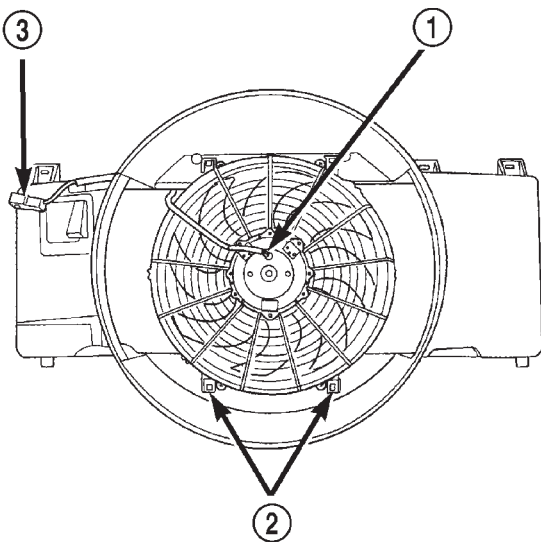

80b04ff0

Fig. 43 Fan Module Orientation and Mounting

- 1 - FAN MOTOR HARNESS AT 12 O'CLOCK POSITION
 2 - MOUNTING SCREWS (4)
 3 - FAN CONNECTOR

- (6) Connect fan electrical connector.
 (7) Install power steering reservoir to shroud.
 (8) Install viscous fan drive assy. to water pump hub and tighten nuts to 27 N·m (20 ft. lbs.)
 (9) Connect battery negative cable.

ELECTRIC COOLING FAN—4.0L**REMOVAL**

The auxiliary cooling fan is attached to the radiator upper crossmember behind the radiator.

- (1) Remove the two fan mounting bolts from radiator upper crossmember (Fig. 44).
 (2) Disconnect the electric fan connector.
 (3) Lift fan straight up and out of vehicle.

INSTALLATION

- (1) Align lower retaining tabs of fan shroud with slots in bracket at bottom of radiator. Push fan down into position.
 (2) Tighten the mounting bolts to 4 N·m (31 in. lbs.) torque.

REMOVAL AND INSTALLATION (Continued)

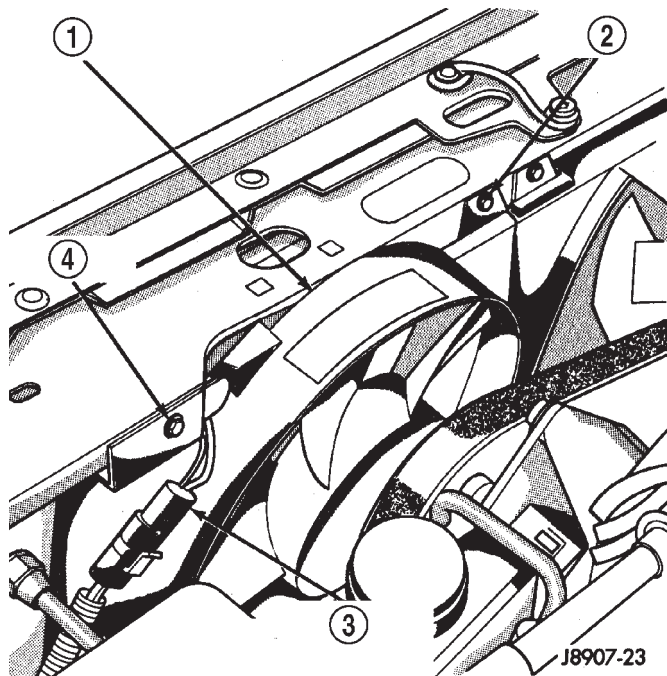

Fig. 44 Auxiliary Cooling Fan—Remove/Install—Typical

- 1 - ELECTRIC COOLING FAN
- 2 - MOUNTING BOLT
- 3 - ELECTRIC COOLING FAN CONNECTOR
- 4 - MOUNTING BOLT

(3) Connect auxiliary cooling fan electrical connector.

BLOCK HEATER

REMOVAL

Refer to correct illustration (Fig. 45) (Fig. 46) when servicing block heater.

WARNING: DO NOT REMOVE THE CYLINDER BLOCK DRAIN PLUGS OR LOOSEN THE RADIATOR DRAINCOCK WITH THE SYSTEM HOT AND PRESSURIZED. SERIOUS BURNS FROM THE COOLANT CAN OCCUR.

DO NOT WASTE reusable coolant. If solution is clean, drain coolant into a clean container for reuse.

- (1) Drain coolant from radiator and engine cylinder block.
- (2) Unplug power cord from block heater.
- (3) Loosen screw in center of block heater (Fig. 45) (Fig. 46).
- (4) Remove block heater from cylinder block.

INSTALLATION

- (1) Thoroughly clean the engine core hole and the block heater seat.

(2) Insert block heater assembly into core hole with element loop pointing **Up**.

(3) Seat block heater flush against block face. Tighten mounting screw to 3.6 N-m (32 in. lbs.) torque.

(4) Fill cooling system with coolant. Pressurize system and inspect for leaks.

(5) Plug power cord into block heater. Route cord away from moving parts, linkages and exhaust system components. Secure cord in place with tie-straps.

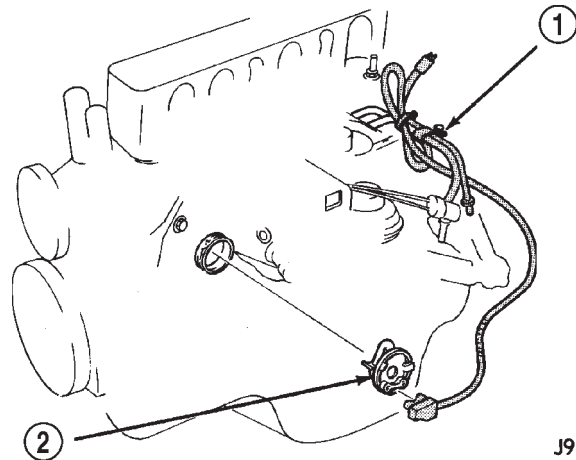

Fig. 45 Heater and Cord—2.5L 4-Cylinder Engine

- 1 - POWER CORD LOCATION
- 2 - BLOCK HEATER

ENGINE ACCESSORY DRIVE BELTS

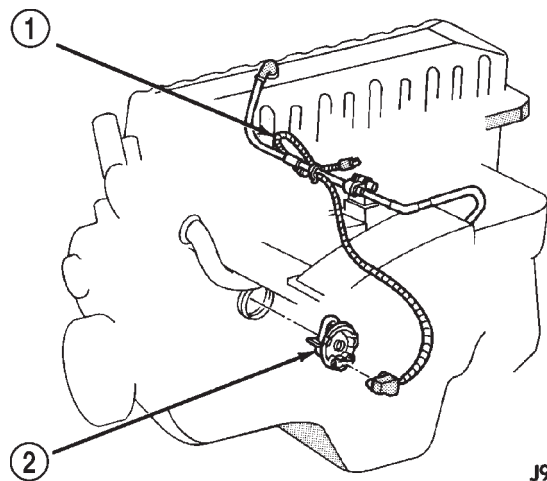

Fig. 46 Heater and Cord—4.0L 6-Cylinder Engine

- 1 - POWER CORD LOCATION
- 2 - BLOCK HEATER

Correct drive belt tension is required to ensure optimum performance of the belt driven engine accessories. There are different types of adjustment gauges for checking either a serpentine or a V-type belt. Refer to the instructions supplied with the

REMOVAL AND INSTALLATION (Continued)

gauge. Use the correct gauge when checking belt tension. Place gauge in the middle of the section of belt being tested (between two pulleys) to check tension. Do not allow the gauge (or gauge adapter) to contact anything but the belt.

BELT SCHEMATICS

The belt routing schematics are published from the latest information available at the time of publication. **If anything differs between these schematics and the Belt Routing Label, use the schematics on Belt Routing Label.** This label is located in the engine compartment.

Refer to (Fig. 47) (Fig. 48) (Fig. 49) (Fig. 50) for proper belt routing on vehicles with conventional left hand drive. Refer to (Fig. 51) (Fig. 52) for proper belt routing on vehicles with right hand drive (RHD). Or, refer to the Belt Routing Label located in the vehicle engine compartment.

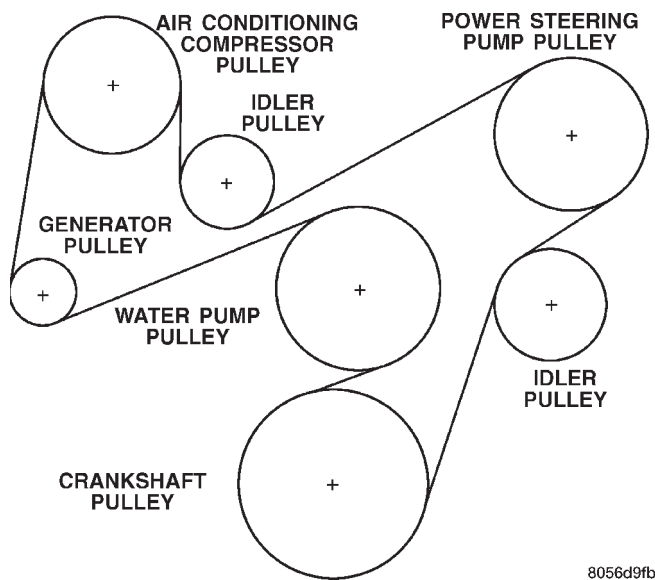

Fig. 47 Models with 2.5L Engine—With A/C

BELT REPLACEMENT OR ADJUSTMENT—LEFT HAND DRIVE

Belt tension is adjusted at the power steering pump bracket and idler pulley assembly.

- (1) Disconnect negative battery cable from battery.
- (2) Loosen idler pulley bolt at the power steering pump bracket (Fig. 53).
- (3) Loosen adjusting bolt until belt can be removed from pulleys.
- (4) Remove belt.

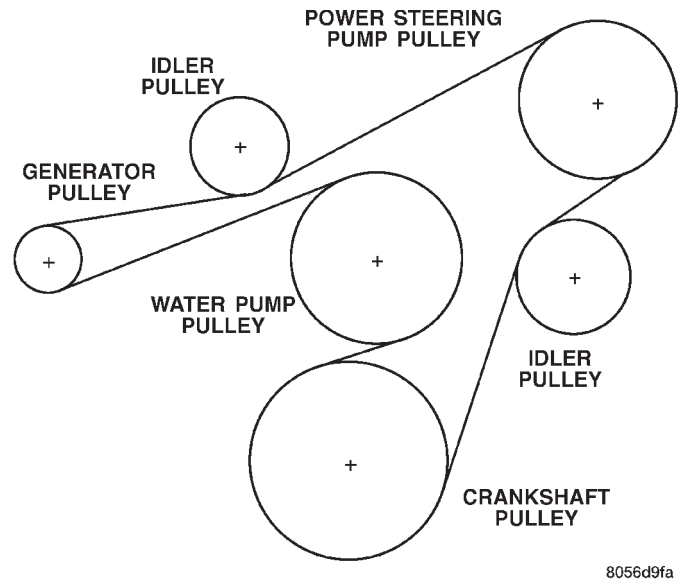

Fig. 48 Models with 2.5L Engine—Without A/C

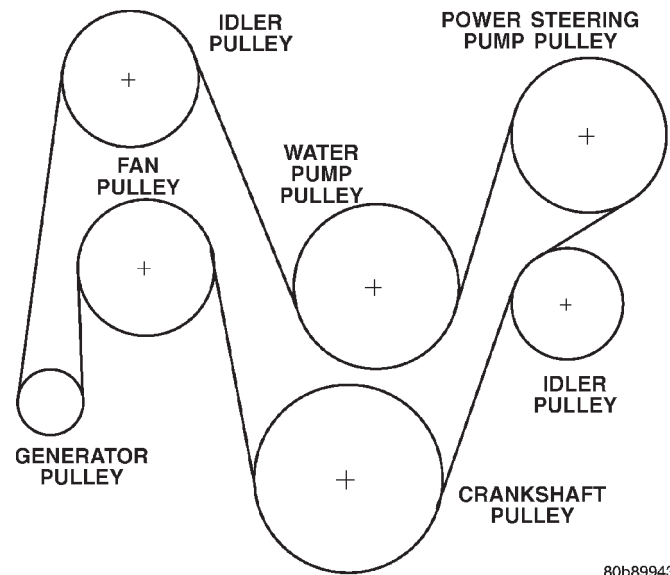

Fig. 49 Models with 4.0L Engine—Without A/C—Except RHD

INSTALLATION

- (1) Check condition of all pulleys.

CAUTION: When installing the serpentine accessory drive belt, the belt **MUST** be routed correctly. If not, the engine may overheat due to the water pump rotating in the wrong direction. Refer to (Fig. 47) (Fig. 48) (Fig. 49) (Fig. 50) for correct belt routing.

REMOVAL AND INSTALLATION (Continued)

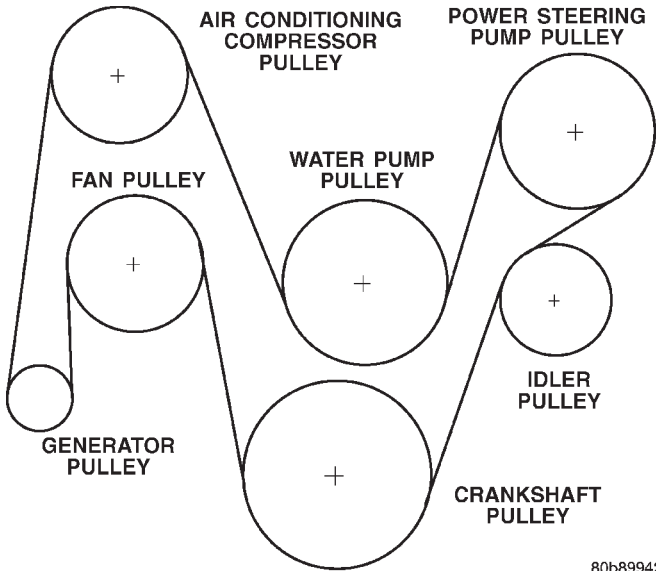

80b89942

Fig. 50 Models With 4.0L Engine—With A/C—Except RHD

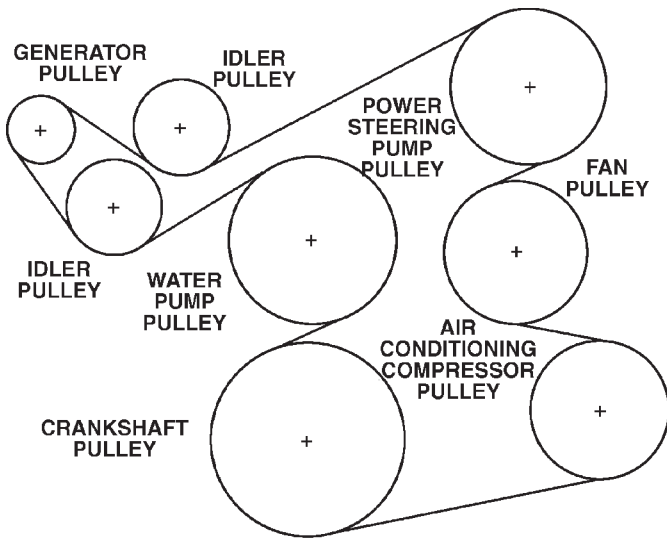

80570e04

Fig. 51 Models With 4.0L Engine—With A/C—With RHD

- (2) Install new belt.
- (3) Using serpentine belt tension gauge, tighten adjusting bolt until belt reaches proper tension. Refer to Belt Tension at the rear of this section for proper belt tension.
- (4) After belt is tensioned correctly, tighten idler pulley bolt to 47 N·m (35 ft. lbs.)
- (5) After idler pulley has been tightened into position, recheck belt tension. Adjust if necessary.

BELT REPLACEMENT OR ADJUSTMENT—RIGHT HAND DRIVE (4.0L)

- (1) Disconnect negative battery cable from battery.
- (2) Loosen lower alternator mounting bolt and nut.

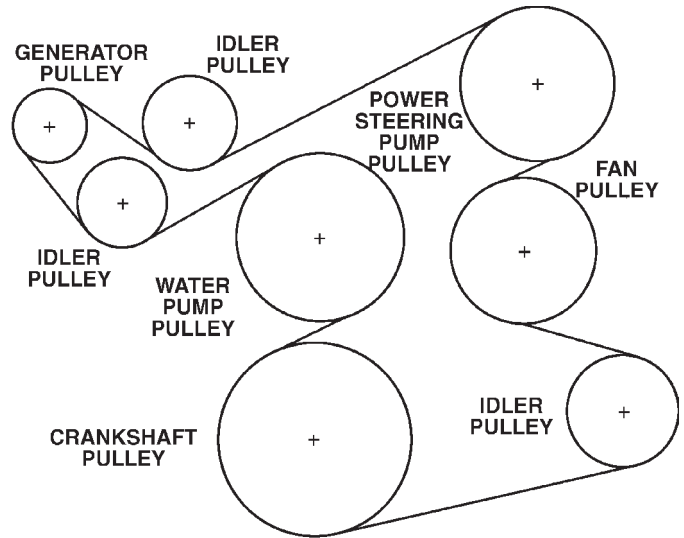

80570e03

Fig. 52 Models With 4.0L Engine—Without A/C—With RHD

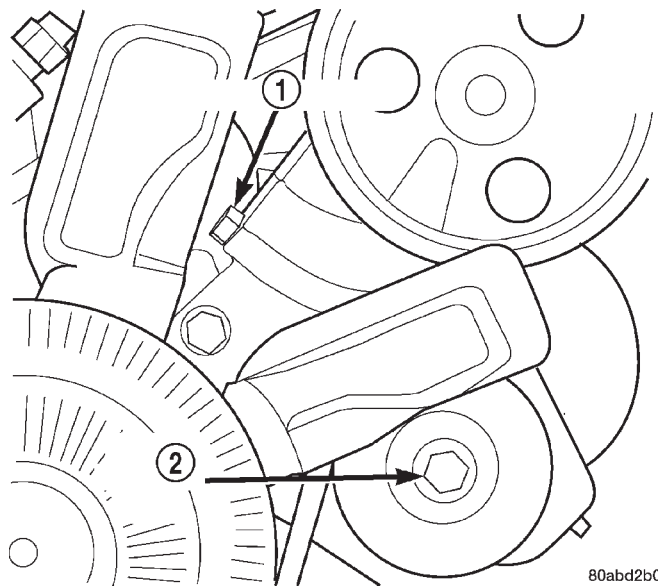

80abd2b0

Fig. 53 Power Steering Pump Bracket and Idler Pulley

- 1 - ADJUSTING BOLT
- 2 - IDLER PULLEY BOLT

- (3) Loosen upper alternator mounting nut.
- (4) Loosen adjusting bolt at upper alternator bracket (Fig. 54) until belt can be removed from pulleys.
- (5) Remove belt.

INSTALLATION

- (1) Check condition of all pulleys.

REMOVAL AND INSTALLATION (Continued)

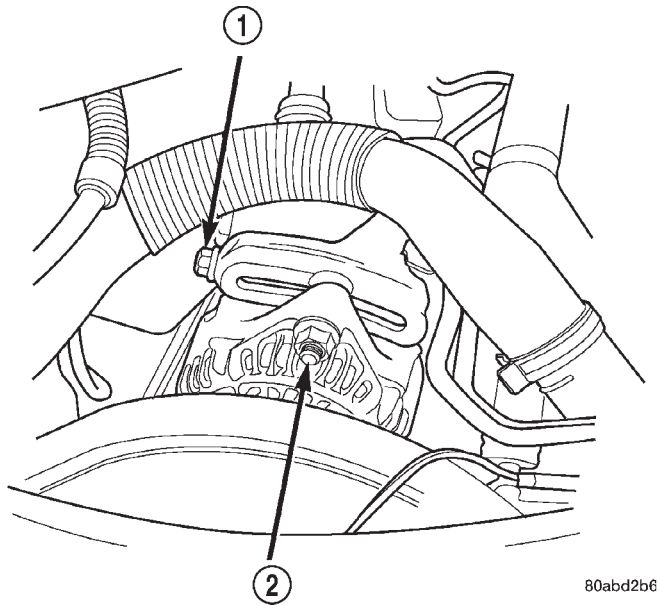

Fig. 54 Generator Belt Tension Adjust Bracket

- 1 - TENSION ADJUSTMENT BOLT
2 - UPPER ALTERNATOR NUT

CAUTION: When installing the serpentine accessory drive belt, the belt **MUST** be routed correctly. If not, the engine may overheat due to the water pump rotating in the wrong direction. Refer to (Fig. 51) (Fig. 52) for correct belt routing.

- (2) Install new belt.
- (3) Using serpentine belt tension gauge, tighten adjusting bolt until belt reaches proper tension. Refer to Belt Tension at the rear of this section for proper belt tension.
- (4) Tighten alternator upper and lower mounting bolts.
- (5) After generator and adjust bracket have been tightened into position, recheck belt tension. Adjust if necessary.

COOLING SYSTEM FANS

REMOVAL

Some engines have the mechanical fan/viscous fan drive assembly mounted directly to the water pump hub (Fig. 55). It may also be mounted to a hub/bearing attached to an aluminum bracket on the right front side of engine (Fig. 56).

- (1) Loosen but do not remove at this time, the four fan hub mounting nuts (Fig. 55) (Fig. 56).
- (2) Remove accessory serpentine drive belt. Refer to Belt Service in the Engine Accessory Drive Belt section of this group.
- (3) Some models with certain engines may require the removal of the fan shroud to remove the viscous fan drive. The fan shroud and fan blade/viscous fan

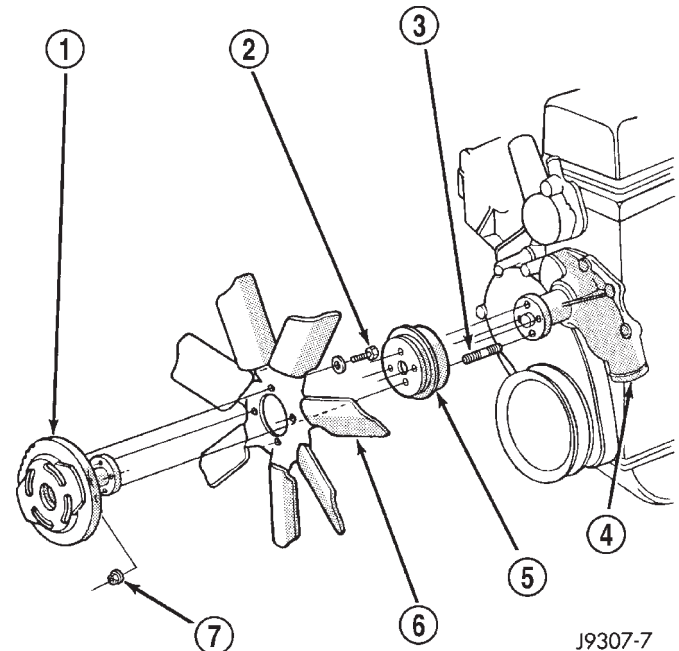

Fig. 55 Water Pump Mounted Cooling Fan

- 1 - THERMAL VISCOUS FAN DRIVE
2 - (4) FAN BLADE-TO-VISCOUS DRIVE BOLTS
3 - (4) FAN HUB-TO-PUMP PULLEY STUDS
4 - WATER PUMP
5 - WATER PUMP PULLEY
6 - FAN BLADE
7 - (4) FAN HUB-TO-PUMP PULLEY NUTS

drive should be removed from the vehicle as one assembly.

(4) Remove four fan hub mounting nuts (Fig. 55) (Fig. 56) and remove fan/viscous fan drive assembly from vehicle.

(5) After removing fan blade/viscous fan drive assembly, **do not** place thermal viscous fan drive in horizontal position. If stored horizontally, silicone fluid in viscous fan drive could drain into its bearing assembly and contaminate lubricant.

INSTALLATION

(1) Assemble fan blade to viscous fan drive. Tighten mounting bolts to 27 N·m (20 ft. lbs.) torque.

(2) Position mounting flange of fan blade/viscous fan drive assembly onto hub. Install four nuts and tighten to 24 N·m (18 ft. lbs.) torque. Tighten the first two nuts 180 degrees apart. Then tighten last two nuts.

CAUTION: When installing a serpentine accessory drive belt, the belt **MUST** be routed correctly. If not, the engine may overheat due to the water pump rotating in the wrong direction. Refer to appropriate Engine Accessory Drive Belt Schematic in this group for correct belt routing.

REMOVAL AND INSTALLATION (Continued)

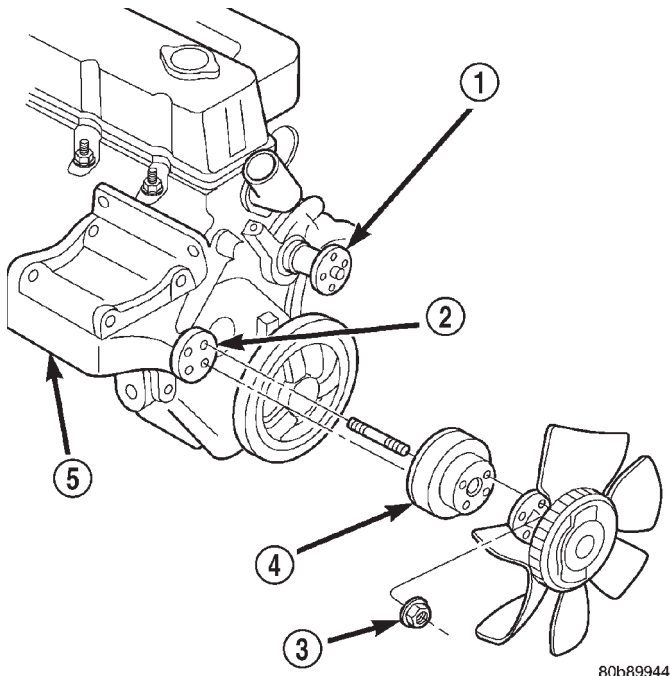

Fig. 56 Bracket Mounted Cooling Fan

- 1 - WATER PUMP (2.5L ENGINE)
- 2 - HUB/BEARING (4.0L ENGINE)
- 3 - PULLEY NUTS
- 4 - PULLEY
- 5 - BRACKET

(3) Install accessory drive belts. Tension belts to specifications. Refer to the Specifications section at the end of this group.

VISCOUS FAN DRIVE REMOVAL/INSTALLATION

Refer to Cooling System Fan for removal and installation procedures of the viscous drive unit.

Viscous Fan Drive Fluid Pump Out Requirement:

After installing a **new** viscous fan drive, bring the engine speed up to approximately 2000 rpm and hold for approximately two minutes. This will ensure proper fluid distribution within the drive.

CLEANING AND INSPECTION

RADIATOR PRESSURE CAP

CLEANING

Clean the radiator pressure cap using a mild soap and water only.

INSPECTION

Visually inspect the pressure valve gasket on the cap. Replace cap if the gasket is swollen, torn or worn. Inspect the area around radiator filler neck for white deposits that indicate a leaking cap.

RADIATOR

CLEANING

Clean radiator fins With the engine cold, apply cold water and compressed air to the back (engine side) of the radiator to flush the radiator and/or A/C condenser of debris.

INSPECTION

The radiator cooling fins should be checked for damage or deterioration. Inspect cooling fins to make sure they are not bent or crushed, these areas result in reduced heat exchange causing the cooling system to operate at higher temperatures. Inspect the plastic end tanks for cracks, damage or leaks.

Inspect the radiator neck for damage or distortion.

WATER PUMP

CLEANING

Clean the gasket mating surface. Use caution not to damage the gasket sealing surface.

INSPECTION

Inspect the water pump assembly for cracks in the housing, Water leaks from shaft seal, Loose or rough turning bearing or Impeller rubbing either the pump body or timing chain case/cover.

FAN BLADE

CLEANING

Clean the fan blades using a mild soap and water. Do not use an abrasive to clean the blades.

INSPECTION

WARNING: DO NOT ATTEMPT TO BEND OR STRAIGHTEN FAN BLADES IF FAN IS NOT WITHIN SPECIFICATIONS.

CAUTION: If fan blade assembly is replaced because of mechanical damage, water pump and viscous fan drive should also be inspected. These components could have been damaged due to excessive vibration.

(1) Remove fan blade assembly from viscous fan drive unit (four bolts).

(2) Lay fan on a flat surface with leading edge facing down. With tip of blade touching flat surface, replace fan if clearance between opposite blade and surface is greater than 2.0 mm (.090 inch). Rocking motion of opposite blades should not exceed 2.0 mm (.090 inch). Test all blades in this manner.

CLEANING AND INSPECTION (Continued)

(3) Inspect fan assembly for cracks, bends, loose rivets or broken welds. Replace fan if any damage is found.

COOLING SYSTEM HOSES

INSPECTION

Inspect the hoses at regular intervals. Replace hoses that are cracked, feel brittle when squeezed or swell excessively when the system is pressurized. The use of molded replacement hoses is recommended. When performing a hose inspection, inspect the radiator lower hose for proper position and condition of the spring.

SPECIFICATIONS

BELT TENSION

Belt tension must be adjusted. Refer to the following Belt Tension chart for specifications.

| DESCRIPTION | N·f | Lbs. ft. |
|--|---------|----------|
| New Serpentine Belt* | 800-900 | 180-200 |
| Used Serpentine Belt | 623-712 | 140-160 |
| * Belt is considered new if it has been used 15 minutes or less. | | |

TORQUE SPECIFICATIONS

| DESCRIPTION | N·m | Ft. Lbs. | In. Lbs. |
|---|-----|----------|----------|
| Trans. Auxiliary Oil Cooler—Screws | 2 | — | 18 |
| Block Heater—Screw | 4 | — | 20 |
| Condenser-to-Radiator—Bolts | 6 | — | 55 |
| Electric Cooling Fan—Bolts | 3 | — | 31 |
| Fan Blade Assy to Viscous Fan Drive—Bolts | 24 | 18 | — |
| Fan Shroud—Bolts | 3 | — | 31 |
| Isolator-to-Crossmember—Nuts | 10 | — | 86 |
| Isolator-to-Radiator—Nuts | 5 | — | 47 |
| Radiator—Bolts | | | |
| 4.0L Engine | 8 | — | 70 |
| 2.5L Engine | 6 | — | 55 |
| Thermostat Housing—Bolts | 20 | 15 | — |
| Viscous Fan Drive Assy. to | | | |

| DESCRIPTION | N·m | Ft. Lbs. | In. Lbs. |
|--------------------------------|-----|----------|----------|
| Water Pump or Hub Bearing—Nuts | 27 | 20 | — |
| Water Pump—Bolts | 23 | 17 | — |

SPECIAL TOOLS

COOLING

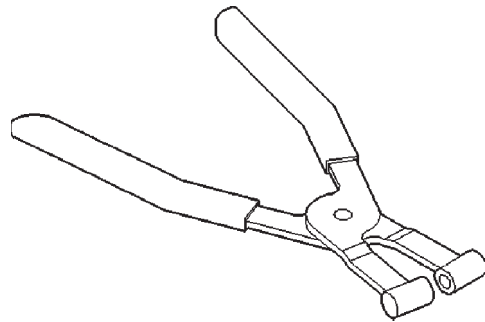

Hose Clamp Tool—6094

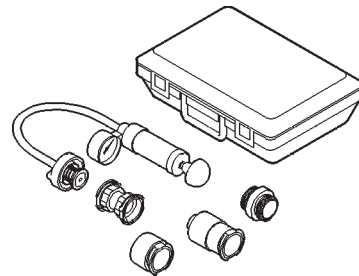

Cooling System Pressure Tester—7700A

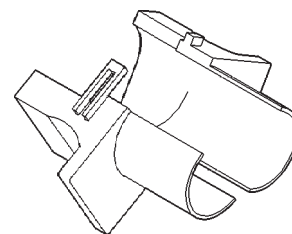

3/8" Quick Connect Release Tool—6935

COOLING SYSTEM

TABLE OF CONTENTS

| | page | | page |
|--|------|---|------|
| DESCRIPTION AND OPERATION | | SERVICE PROCEDURES | |
| COOLING SYSTEM | 1 | COOLANT LEVEL CHECK | 18 |
| RADIATOR | 3 | DRAINING COOLING SYSTEM | 19 |
| ENGINE ACCESSORY DRIVE BELT | 3 | REFILLING COOLING SYSTEM | 19 |
| COOLANT TANK | 3 | COOLANT REPLACEMENT | 20 |
| WATER PUMP | 3 | REMOVAL AND INSTALLATION | |
| COOLANT | 3 | RADIATOR | 20 |
| LOW COOLANT LEVEL SENSOR | 3 | FAN BLADE REMOVAL | 21 |
| THERMOSTAT | 4 | VISCOUS FAN DRIVE | 22 |
| PRESSURE/VENT CAP | 4 | THERMOSTAT | 22 |
| COOLANT PERFORMANCE | 5 | DRIVE BELT | 23 |
| COOLING SYSTEM HOSES | 5 | AUTOMATIC BELT TENSIONER | 23 |
| VISCOUS FAN DRIVE | 6 | WATER PUMP | 23 |
| BELT TENSION | 7 | CLEANING AND INSPECTION | |
| AUTOMATIC BELT TENSIONER | 7 | WATER PUMP | 26 |
| DIAGNOSIS AND TESTING | | RADIATOR CLEANING | 26 |
| PRELIMINARY CHECKS | 8 | FAN BLADE | 26 |
| THERMOSTAT | 14 | PRESSURE/VENT CAP | 27 |
| VISCOUS FAN DRIVE | 14 | COOLING SYSTEM CLEANING/REVERSE FLUSHING | 27 |
| RADIATOR COOLANT FLOW CHECK | 15 | SPECIFICATIONS | |
| TESTING COOLING SYSTEM FOR LEAKS | 15 | COOLING SYSTEM CAPACITY | 28 |
| PRESSURE/VENT CAP | 16 | THERMOSTAT | 28 |
| LOW COOLANT LEVEL- AERATION | 16 | TORQUE SPECIFICATIONS | 28 |
| BELT DIAGNOSIS | 17 | | |

DESCRIPTION AND OPERATION

COOLING SYSTEM

DESCRIPTION

The cooling system regulates engine operating temperature. It allows the engine to reach normal operating temperature as quickly as possible, maintains normal operating temperature and prevents overheating.

The cooling system also provides a means of heating the passenger compartment. The cooling system is pressurized and uses a centrifugal water pump to circulate coolant throughout the system. A water manifold collects coolant from the cylinder heads. A separate and remotely mounted, pressurized coolant tank using a pressure/vent cap is used.

COOLING SYSTEM COMPONENTS

The cooling system consists of:

- Charge Air Cooler
- Electric Cooling Fan
- An aluminum radiator with plastic side tanks
- A radiator mounted fill vent valve
- A separate pressurized coolant tank
- A threaded-on, pressure/vent cap mounted to the coolant tank
- Cooling fan (mechanical)
- Thermal viscous fan drive
- Fan shroud
- Thermostat
- Coolant
- Low coolant level sensor
- Low coolant warning lamp
- Coolant temperature gauge
- Water pump
- Hoses and hose clamps

DESCRIPTION AND OPERATION (Continued)

COOLANT ROUTING

For cooling system flow routing, refer to (Fig. 1)

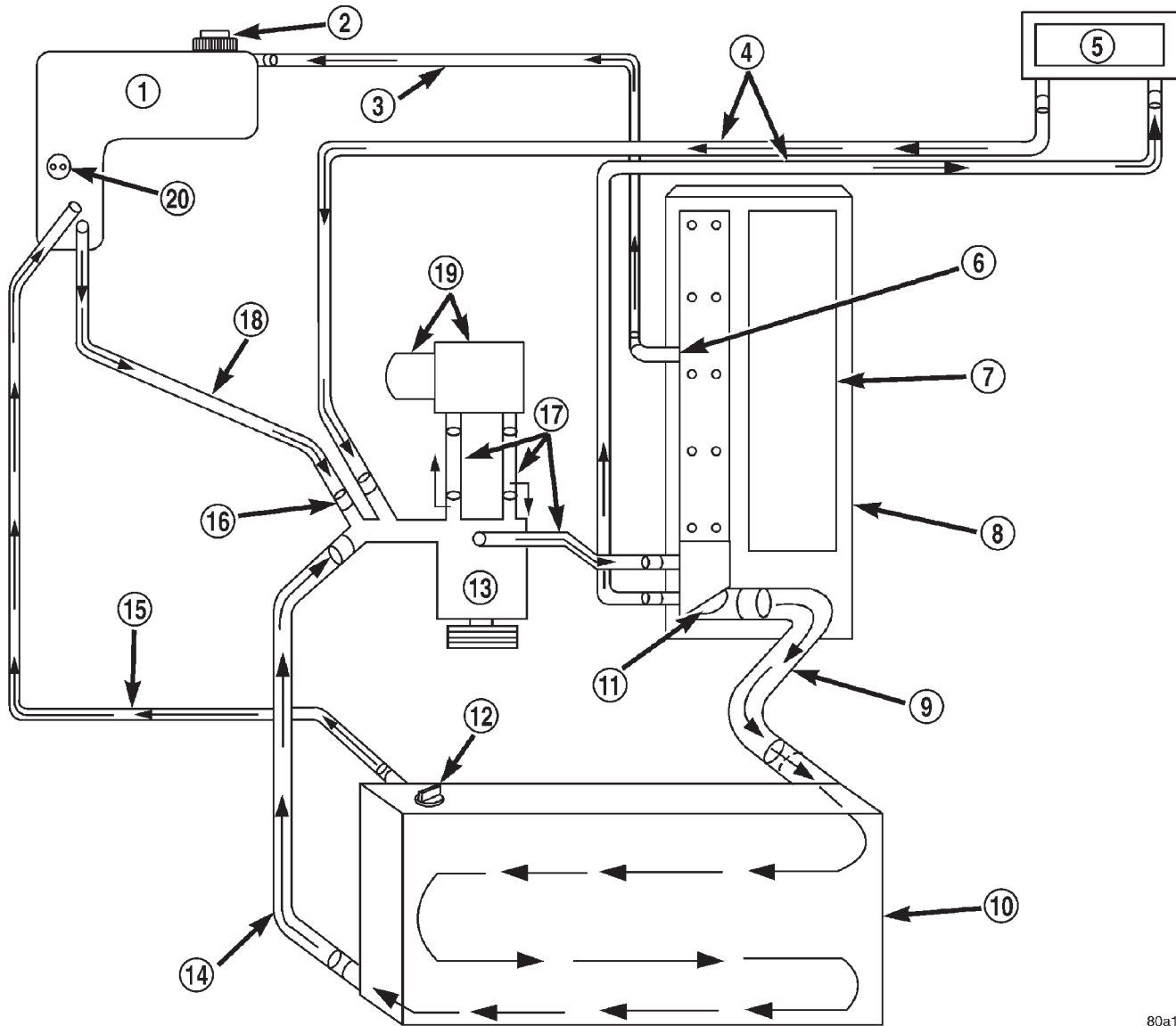

80a1386c

Fig. 1 Coolant Flow—2.5L Diesel Engine—Typical

- | | |
|---|-------------------------------------|
| 1 - PRESSURIZED COOLANT TANK | 11 - THERMOSTAT |
| 2 - PRESSURE/VENT CAP | 12 - FILL VENT CAP |
| 3 - HOSE | 13 - WATER PUMP |
| 4 - HEATER HOSES | 14 - LOWER RADIATOR HOSE |
| 5 - HEATER CORE | 15 - VENT HOSE |
| 6 - WATER MANIFOLD FITTING | 16 - LARGER FITTING TO COOLANT TANK |
| 7 - WATER MANIFOLD (TOP OF CYLINDER HEAD) | 17 - HOSES |
| 8 - ENGINE (TOP VIEW) | 18 - HOSE |
| 9 - UPPER RADIATOR HOSE | 19 - ENGINE OIL COOLER |
| 10 - RADIATOR | 20 - LOW COOLANT LEVEL SENSOR |

DESCRIPTION AND OPERATION (Continued)

RADIATOR**DESCRIPTION**

The radiator used with the 2.5L diesel is constructed of a horizontal flow aluminum core with plastic side tanks.

CAUTION: Plastic tanks, while stronger than brass, are subject to damage by impact, such as wrenches.

ENGINE ACCESSORY DRIVE BELT**DESCRIPTION**

The accessory drive components are operated by a single, crankshaft driven, serpentine drive belt. An automatic belt tensioner is used to maintain correct belt tension at all times.

CAUTION: When installing a serpentine accessory drive belt, the belt **MUST** be routed correctly. If not, the engine may overheat due to water pump rotating in wrong direction.

COOLANT TANK**DESCRIPTION**

A pressurized, plastic coolant tank is used with this cooling system (Fig. 2). The tank is located at the right-rear side of the engine compartment and is mounted as the highest point of the cooling system. This allows any air or vapor exceeding the pressure/vent cap rating to escape through the cap. Coolant flows through the tank at all times during engine operation whether the engine is cold or at normal operating temperature. The coolant tank is equipped with a threaded pressure/vent cap. Refer to Pressure/Vent Cap for additional information.

The low coolant level sensor is located near the bottom of the tank (Fig. 2).

WATER PUMP**DESCRIPTION**

A centrifugal water pump circulates coolant through the water jackets, passages, water manifold, radiator core, pressurized coolant tank, cooling system hoses and heater core. The pump is driven from the engine crankshaft by a drive belt. The water pump is bolted to the water pump adapter (Fig. 3). The water pump adapter is bolted to the engine.

The water pump impeller is pressed onto the rear of a shaft that rotates in bearings pressed into the housing. The bottom of the housing is equipped with a small vent tube (Fig. 3) to allow seepage to escape.

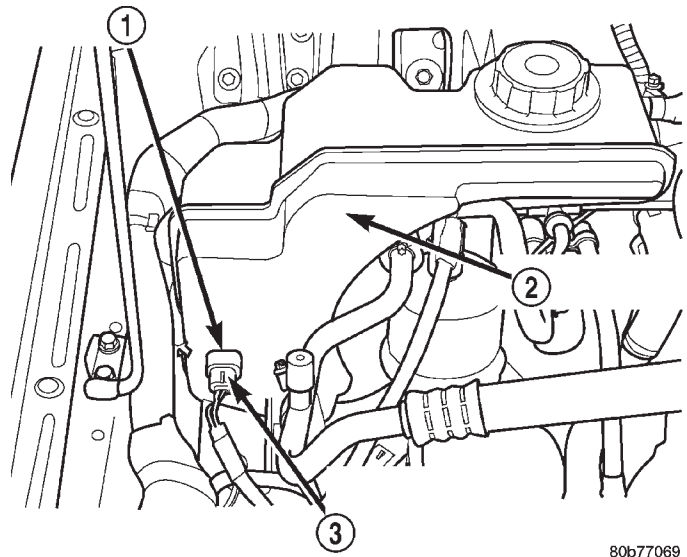

80b77069

Fig. 2 Pressurized Coolant Tank

- 1 - LOW COOLANT LEVEL SWITCH
- 2 - COOLANT RESERVOIR
- 3 - LOW COOLANT LEVEL SWITCH HARNESS CONNECTOR

A drain hose is attached to this tube. The water pump seals is lubricated by the antifreeze in the coolant mixture. No additional lubrication is necessary.

A rubber o-ring (instead of a gasket) is used as a seal between the water pump and the water pump adapter (Fig. 3).

A quick test to determine if the pump is working is to check if the heater warms properly. A defective water pump will not be able to circulate heated coolant through the heater hoses and the heater core.

COOLANT**DESCRIPTION**

Coolant flows through the engine water jackets and cylinder heads absorbing heat produced by the engine during operation. The coolant carries heat to the radiator and heater core. Here it is transferred to the ambient air passing through the radiator and heater core fins.

LOW COOLANT LEVEL SENSOR**DESCRIPTION**

The low coolant level sensor checks for low coolant level in the coolant tank (Fig. 4).

OPERATION

When the coolant level gets low a signal will be sent from this sensor to the powertrain control module (PCM). When the PCM determines low coolant level, the instrument panel mounted low coolant level warning lamp is illuminated. The sensor is located

DESCRIPTION AND OPERATION (Continued)

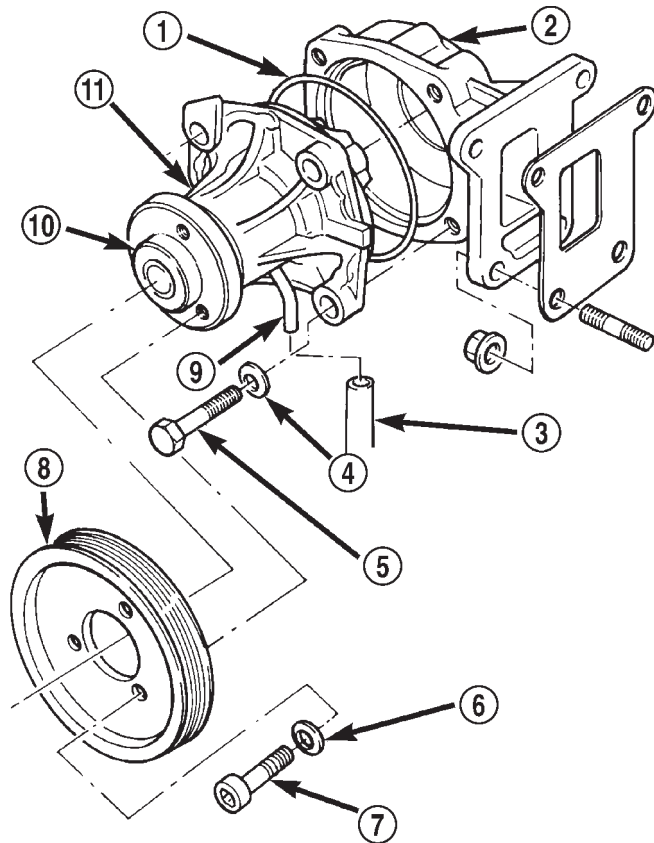

Fig. 3 Water Pump— Typical

- 1 - O-RING SEAL
- 2 - WATER PUMP ADAPTER
- 3 - DRAIN HOSE
- 4 - WASHER
- 5 - PUMP MOUNTING BOLTS (4)
- 6 - WASHER
- 7 - WATER PUMP PULLEY BOLTS (3)
- 8 - WATER PUMP PULLEY
- 9 - VENT TUBE
- 10 - PUMP HUB
- 11 - WATER PUMP

on the front of the coolant tank (Fig. 4). For information, refer to Group 8E, Instrument Panel and Gauges.

If this lamp is illuminated, it indicates the need for service.

THERMOSTAT

DESCRIPTION

A pellet-type thermostat controls the operating temperature of the engine by controlling the amount of coolant flow to the radiator.

OPERATION

The thermostat starts to open at 80°C (176°F). Above this temperature, coolant is allowed to flow to

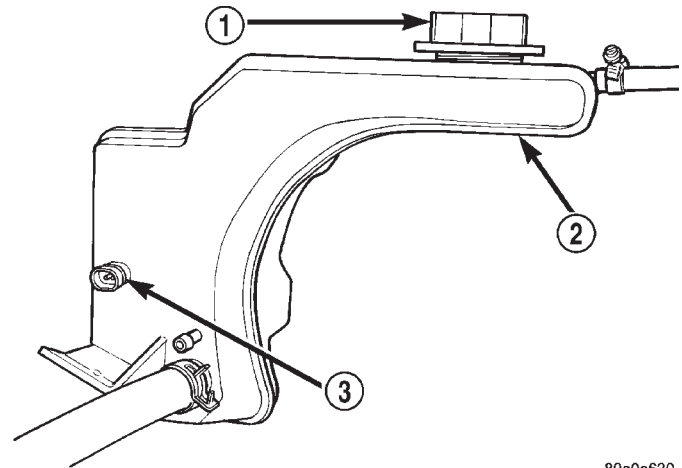

Fig. 4 Low Coolant Level Sensor

- 1 - PRESSURE/VENT CAP
- 2 - PRESSURIZED COOLANT TANK
- 3 - LOW COOLANT LEVEL SENSOR

the radiator. This provides quicker engine warmup and overall temperature control.

The same thermostat is used for winter and summer seasons. An engine should not be operated without a thermostat, except for servicing or testing. Operating without a thermostat causes other problems. These are: longer engine warmup time, unreliable warmup performance, increased exhaust emissions and crankcase condensation. This condensation can result in sludge formation.

CAUTION: Do not operate an engine without a thermostat, except for servicing or testing.

PRESSURE/VENT CAP

DESCRIPTION

The pressure/vent cap is threaded-on to the coolant tank. This cap releases excess pressure at some point within a range of 90-117 kPa (13- 17 psi). The actual pressure relief point (in pounds) is labeled on top of the cap (Fig. 5).

OPERATION

The cooling system will operate at pressures up to 103 kPa (15 psi). This results in a higher coolant boiling point allowing increased radiator cooling capacity. The cap (Fig. 5) contains a spring-loaded pressure relief valve. This valve opens when system pressure reaches approximately 103 kPa (15 psi).

When the engine is cooling down, vacuum is formed within the cooling system. To prevent collapse of the radiator and coolant hoses from this vacuum, a vacuum valve is used within the cap. This valve prevents excessive pressure differences from occurring

DESCRIPTION AND OPERATION (Continued)

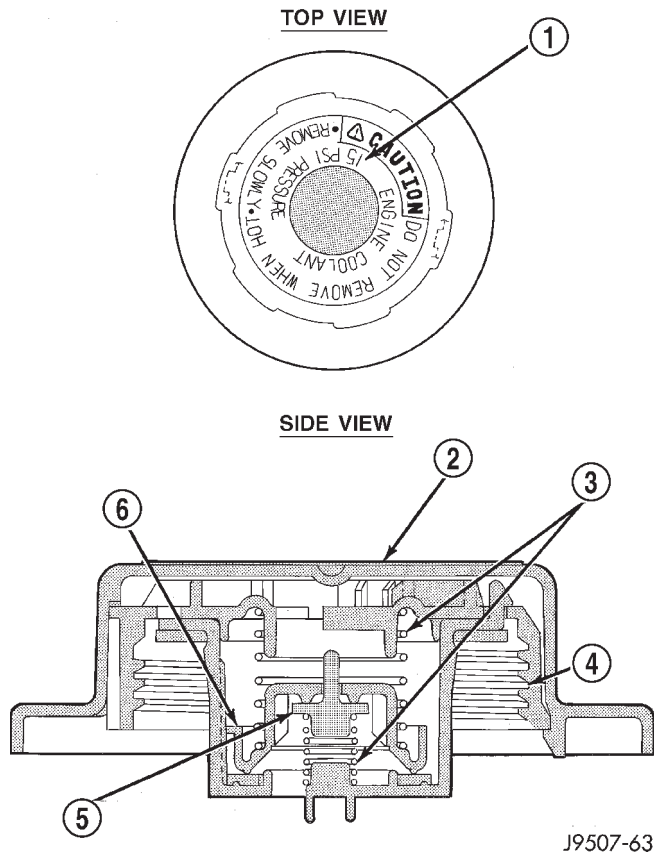

Fig. 5 Coolant Tank Pressure/Vent Cap

- 1 - RELEASE PRESSURE
- 2 - CAP COVER
- 3 - SPRING
- 4 - GASKET
- 5 - RUBBER VACUUM VALVE
- 6 - PRESSURE VALVE

between the closed cooling system and the atmosphere. If the vacuum valve is stuck shut, the radiator and/or cooling system hoses will collapse on cool-down.

NOTE: Do not use any type of tool when tightening the cap. Hand tighten only.

COOLANT PERFORMANCE

DESCRIPTION

The required ethylene-glycol (antifreeze) and water mixture depends upon the climate and vehicle operating conditions. The recommended mixture of 50/50 ethylene-glycol and water will provide protection against freezing to -37 deg. C (-35 deg. F). The antifreeze concentration **must always** be a minimum of 44 percent, year-round in all climates. **If percentage is lower than 44 percent, engine parts may be eroded by cavitation, and cooling system com-**

ponents may be severely damaged by corrosion. Maximum protection against freezing is provided with a 68 percent antifreeze concentration, which prevents freezing down to -67.7 deg. C (-90 deg. F). A higher percentage will freeze at a warmer temperature. Also, a higher percentage of antifreeze can cause the engine to overheat because the specific heat of antifreeze is lower than that of water.

100 Percent Ethylene-Glycol—Should Not Be Used in DaimlerChrysler Corporation Vehicles

Use of 100 percent ethylene-glycol will cause formation of additive deposits in the system, as the corrosion inhibitive additives in ethylene-glycol require the presence of water to dissolve. The deposits act as insulation, causing temperatures to rise to as high as 149 deg. C (300 deg. F). This temperature is hot enough to melt plastic and soften solder. The increased temperature can result in engine detonation. In addition, 100 percent ethylene-glycol freezes at 22 deg. C (-8 deg. F).

Propylene-glycol Formulations—Should Not Be Used in DaimlerChrysler Corporation Vehicles

Propylene-glycol formulations do not meet Chrysler coolant specifications. Its overall effective temperature range is smaller than that of ethylene-glycol. The freeze point of 50/50 propylene-glycol and water is -32 deg. C (-26 deg. F). 5 deg. C higher than ethylene-glycol's freeze point. The boiling point (protection against summer boil-over) of propylene-glycol is 125 deg. C (257 deg. F) at 96.5 kPa (14 psi), compared to 128 deg. C (263 deg. F) for ethylene-glycol. Use of propylene-glycol can result in boil-over or freeze-up in Chrysler vehicles, which are designed for ethylene-glycol. Propylene glycol also has poorer heat transfer characteristics than ethylene glycol. This can increase cylinder head temperatures under certain conditions.

Propylene-glycol/Ethylene-glycol Mixtures—Should Not Be Used in DaimlerChrysler Corporation Vehicles

Propylene-glycol/ethylene-glycol Mixtures can cause the destabilization of various corrosion inhibitors, causing damage to the various cooling system components. Also, once ethylene-glycol and propylene-glycol based coolants are mixed in the vehicle, conventional methods of determining freeze point will not be accurate. Both the refractive index and specific gravity differ between ethylene glycol and propylene glycol.

COOLING SYSTEM HOSES

DESCRIPTION

Rubber hoses route coolant to and from the radiator, and heater core.

DESCRIPTION AND OPERATION (Continued)

The radiator lower hose is spring-reinforced to prevent collapse from water pump suction at high engine speeds.

WARNING: CONSTANT TENSION HOSE CLAMPS ARE USED ON MOST COOLING SYSTEM HOSES. WHEN REMOVING OR INSTALLING, USE ONLY TOOLS DESIGNED FOR SERVICING THIS TYPE OF CLAMP (Fig. 6). ALWAYS WEAR SAFETY GLASSES WHEN SERVICING CONSTANT TENSION CLAMPS.

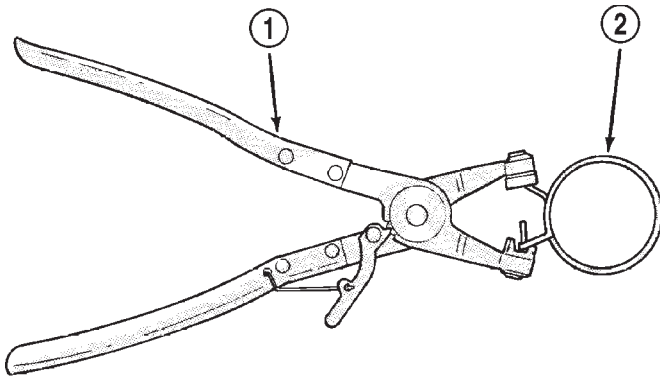

J9207-36

Fig. 6 Hose Clamp Tool

- 1 - HOSE CLAMP TOOL 6094
- 2 - HOSE CLAMP

CAUTION: A number or letter is stamped into the tongue of constant tension clamps (Fig. 7). If replacement is necessary, use only an original equipment clamp with matching number or letter.

Inspect the hoses at regular intervals. Replace hoses that are cracked, feel brittle when squeezed, or swell excessively when the system is pressurized.

For all vehicles: Be sure that hoses are positioned with sufficient clearance. Check clearance from exhaust manifolds and pipe, fan blades, drive belts and sway bars. Improperly positioned hoses can be damaged, resulting in coolant loss and engine overheating.

Ordinary worm gear type hose clamps (when equipped) can be removed with a straight screwdriver or a hex socket. **To prevent damage to hoses or clamps, the hose clamps should be tightened to 4 N·m (34 in. lbs.) torque. Do not over tighten hose clamps.**

When performing a hose inspection, inspect the radiator lower hose for proper position and condition of the internal spring.

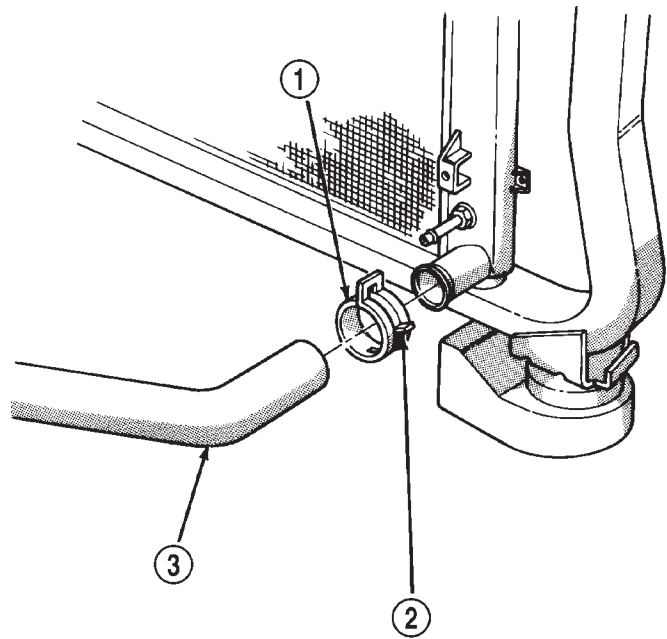

J9407-39

Fig. 7 Clamp Number/Letter Location

- 1 - TYPICAL CONSTANT TENSION HOSE CLAMP
- 2 - CLAMP NUMBER/LETTER LOCATION
- 3 - TYPICAL HOSE

VISCOUS FAN DRIVE

DESCRIPTION

The thermal viscous fan drive (Fig. 8) is a silicone-fluid-filled coupling. It connects the fan blade assembly to the fan pulley.

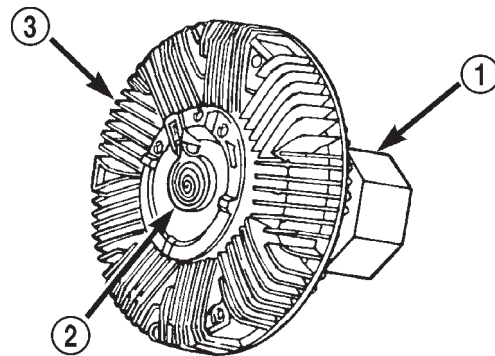

80a243e4

Fig. 8 Viscous Fan Drive

- 1 - MOUNTING NUT TO FAN PULLEY SHAFT
- 2 - THERMOSTATIC SPRING
- 3 - VISCOUS FAN DRIVE

OPERATION

The coupling allows the fan to be driven in a normal manner. This is done at low engine speeds while limiting the top speed of the fan to a predetermined maximum level at higher engine speeds. A bimetallic

DESCRIPTION AND OPERATION (Continued)

coil spring is located on the front face. This spring coil reacts to the temperature of the radiator discharge air. It engages the viscous fan drive for higher fan speed if the air temperature from the radiator rises above a certain point. Until additional engine cooling is necessary, the fan will remain at a reduced rpm regardless of engine speed.

The viscous fan drive will only engage when sufficient heat is present. This is when the air flowing through the radiator core causes a reaction from the bimetallic coil. It then increases fan speed to provide the necessary additional engine cooling.

Once the engine has cooled, the radiator discharge temperature will drop. The bimetallic coil again reacts and the fan speed is reduced to the previous disengaged speed.

CAUTION: Some engines equipped with serpentine drive belts have reverse rotating fans and viscous fan drives. They are marked with the word **REVERSE** to designate their usage. Installation of the wrong fan or viscous fan drive can result in engine overheating.

NOISE

NOTE: It is normal for fan noise to be louder (roaring) when:

- The underhood temperature is above the engagement point for the viscous drive coupling. This may occur when ambient (outside air temperature) is very high.
- Engine loads and temperatures are high such as when towing a trailer.
- Cool silicone fluid within the fan drive unit is being redistributed back to its normal disengaged (warm) position. This can occur during the first 15 seconds to one minute after engine start-up on a cold engine.

LEAKS

Viscous fan drive operation is not affected by small oil stains near the drive bearing. If leakage appears excessive, replace the fan drive unit.

BELT TENSION

DESCRIPTION

Correct accessory drive belt tension is required to be sure of optimum performance of belt driven engine accessories. If specified tension is not maintained, belt slippage may cause; engine overheating, lack of power steering assist, loss of air conditioning capacity, reduced generator output rate and greatly reduced belt life.

An automatic belt tensioner is used to maintain correct belt tension at all times. Do not attempt to check belt tension with a belt tension gauge on vehicles equipped with an automatic belt tensioner.

AUTOMATIC BELT TENSIONER

DESCRIPTION

Drive belt tension is controlled by a spring loaded automatic belt tensioner located below and to the front of the engine oil filter (Fig. 9).

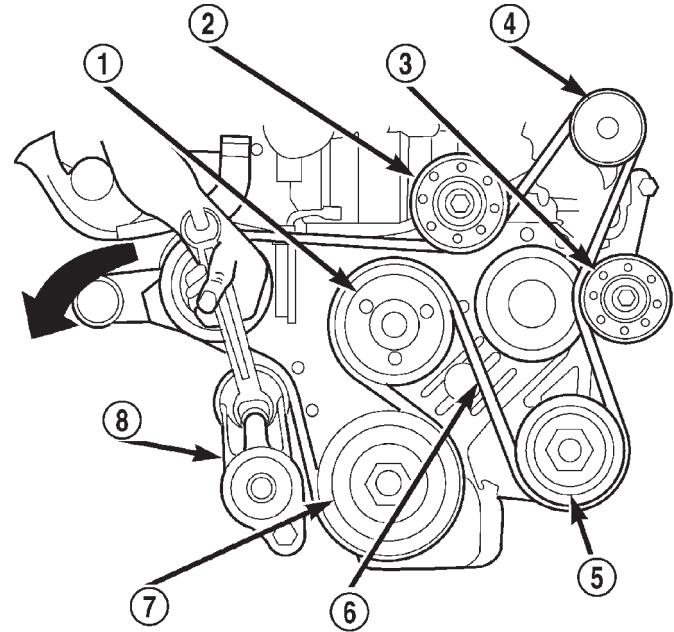

80bfe1c0

Fig. 9 Automatic Belt Tensioner Assembly

- 1 - FAN PULLEY
- 2 - IDLER PULLEY
- 3 - IDLER PULLEY
- 4 - GENERATOR
- 5 - POWER STEERING PUMP
- 6 - DRIVE BELT
- 7 - CRANKSHAFT PULLEY
- 8 - AUTOMATIC BELT TENSIONER

WARNING: BECAUSE OF HIGH SPRING PRESSURE, DO NOT ATTEMPT TO DISASSEMBLE THE AUTOMATIC BELT TENSIONER. UNIT IS SERVICED AS AN ASSEMBLY.

DIAGNOSIS AND TESTING

PRELIMINARY CHECKS

ENGINE COOLING SYSTEM OVERHEATING

Establish what driving conditions caused the complaint. Abnormal loads on the cooling system such as the following may be the cause:

(1) PROLONGED IDLE, VERY HIGH AMBIENT TEMPERATURE, SLIGHT TAIL WIND AT IDLE, SLOW TRAFFIC, TRAFFIC JAMS, HIGH SPEED OR STEEP GRADES.

Driving techniques that avoid overheating are:

- Idle with A/C off when temperature gauge is at end of normal range.
- Increasing engine speed for more air flow is recommended.

(2) TRAILER TOWING:

Consult Trailer Towing section of owners manual. Do not exceed limits.

(3) RECENT SERVICE OR ACCIDENT REPAIR:
Determine if any recent service has been performed on vehicle that may effect cooling system. This may be:

- Engine adjustments (incorrect timing)
- Slipping engine accessory drive belt
- Brakes (possibly dragging)
- Changed parts (incorrect water pump)
- Reconditioned radiator or cooling system refilling (possibly under filled or air trapped in system).

NOTE: If investigation reveals none of the previous items as a cause for an engine overheating complaint, refer to following Cooling System Diagnosis charts.

These charts are to be used as a quick-reference only. Refer to the group text for information.

COOLING SYSTEM DIAGNOSIS—DIESEL ENGINE

| CONDITION | POSSIBLE CAUSES | CORRECTION |
|-----------------------------|---|--|
| TEMPERATURE GAUGE READS LOW | <ol style="list-style-type: none"> 1. Diesel engines, due to their inherent efficiency are slower to warm up than gasoline powered engines, and will operate at lower temperatures when the vehicle is unloaded. 2. Is the temperature gauge connected to the temperature gauge coolant sensor on the engine? 3. Is the temperature gauge operating OK? 4. Coolant level low in cold ambient temperatures accompanied with poor heater performance. 5. Improper operation of internal heater doors or heater controls. | <ol style="list-style-type: none"> 1. The low gauge reading may be normal. Refer to thermostats in the manual text for information. See Thermostat Diagnosis - Diesel Engine. 2. Check, the engine temperature sensor connector in the engine compartment. Refer to Group 8E. Repair as necessary. 3. Check gauge operation. Refer to Group 8E. Repair as necessary. 4. Check coolant level in the coolant tank. Inspect system for leaks. Repair leaks as necessary. Refer to the Coolant section of the manual text for WARNINGS and precautions before removing the pressure cap. 5. Inspect heater and repair as necessary. Refer to Group 24, Heating and Air Conditioning for procedures. |

DIAGNOSIS AND TESTING (Continued)

| CONDITION | POSSIBLE CAUSES | CORRECTION |
|--|--|--|
| <p>TEMPERATURE GAUGE READS HIGH. COOLANT MAY OR MAY NOT BE LOST OR LEAKING FROM COOLING SYSTEM</p> | <ol style="list-style-type: none"> 1. Trailer is being towed, a steep hill is being climbed, vehicle is operated in slow moving traffic, or engine is being idled with very high ambient (outside) temperatures and the air conditioning is on. Higher altitudes could aggravate these conditions. 2. Is temperature gauge reading correctly? 3. Coolant low in coolant tank and radiator? 4. Pressure cap not installed tightly. If cap is loose, boiling point of coolant will be lowered. Also refer to the following step 5. 5. Poor seals at pressure/vent cap. 6. Freeze point of antifreeze not correct. Mixture may be too rich. | <ol style="list-style-type: none"> 1. This may be a temporary condition and repair is not necessary. Turn off the air conditioning and attempt to drive the vehicle without any of the previous conditions. Observe the temperature gauge. The gauge should return to the normal range. If the gauge does not return to normal range, determine the cause for overheating and repair. Refer to POSSIBLE CAUSES (numbers 2 through 16). 2. Check gauge. Refer to Group 8E. Repair as necessary. 3. Check for coolant leaks and repair as necessary. Refer to Testing Cooling System For Leaks in this group. 4. Tighten cap. 5. (a) Check condition of cap and cap seals. Refer to Pressure/Vent Cap. (b) Check condition of coolant tank filler neck. Make sure it does not leak pressure. 6. Check antifreeze. Refer to Coolant section of this group. Adjust antifreeze -to-water ratio as required. |

DIAGNOSIS AND TESTING (Continued)

| CONDITION | POSSIBLE CAUSES | CORRECTION |
|---|---|---|
| TEMPERATURE GAUGE READS HIGH. COOLANT MAY OR MAY NOT BE LOST OR LEAKING FROM COOLING SYSTEM - CONT. | 7. Coolant not flowing through system. 8. Radiator or A/C condenser fins are dirty or clogged. 9. Radiator core is corroded or plugged. 10. Aftermarket A/C installed without proper A/C condenser. 11. Dragging brakes. 12. Non-factory bug screen is being used reducing airflow. 13. Thermostat partially or completely shut. This is more prevalent on high mileage vehicles. 14. Thermal viscous fan drive not operating properly. 15. Cylinder head gasket leaking. 16. Heater core leaking. | 7. Check for coolant flow in coolant tank with engine warm and thermostat open. Coolant should be observed flowing through tank. If flow is not observed, determine reason for lack of flow and repair as necessary. 8. Clean insects or debris. Refer to Radiator Cleaning in this group. 9. Have radiator re-cored or replaced. 10. Install proper A/C condenser. 11. Check and correct as necessary. Refer to Group 5, Brakes in the manual text. 12. Only a factory approved screen may be used. 13. Check thermostat operation and replace as necessary. Refer to Thermostats in this group. 14. Check fan drive operation and replace if necessary. Refer to Viscous Fan Drive in this group. 15. Check for cylinder head gasket leaks. Refer to Testing Cooling System For Leaks in this group. For repair, refer to Group 9, Engines. 16. Check heater core for leaks. Refer to Group 24, Heating and Air Conditioning. Repair as necessary. |

DIAGNOSIS AND TESTING (Continued)

| CONDITION | POSSIBLE CAUSES | CORRECTION |
|---|--|--|
| <p>TEMPERATURE GAUGE READING IS INCONSISTENT (FLUCTUATES, CYCLES OR IS ERRATIC)</p> | <ol style="list-style-type: none"> 1. During cold weather operation, with the heater blower in the high position, the gauge reading may drop slightly. Fluctuation is also influenced by loads, outside temperature and extended idle time with diesel engines. 2. Temperature gauge or engine mounted gauge sensor defective or shorted. Also, corroded or loose wiring in this circuit. 3. Gauge reading rises when vehicle is brought to a stop after heavy use (engine still running). 4. Gauge reading high after restarting a warmed-up (hot) engine. 5. Coolant level low in coolant tank (air will build up in the cooling system causing the thermostat to open late). 6. Cylinder head gasket leaking allowing exhaust gas to enter cooling system causing thermostat to open late. 7. Water pump impeller loose on shaft. 8. Loose accessory drive belt (water pump slipping). 9. Air leak on the suction side of water pump allows air to build up in cooling system causing thermostat to open late. | <ol style="list-style-type: none"> 1. A normal condition. No correction is necessary. 2. Check operation of gauge and repair if necessary. Refer to Group 8E, Instrument Panel And Gauges. 3. A normal condition. No correction is necessary. Gauge reading should return to normal range after vehicle is driven. 4. A normal condition. No correction is necessary. The gauge should return to normal range after a few minutes of engine operation. 5. Check and correct coolant leaks. Refer to Testing Cooling System For Leaks in this group. 6. (a) Check for cylinder head gasket leaks with a commercially available Block Leak Tester. Repair as necessary. (b) Check for coolant in the engine oil. Inspect for white steam emitting from exhaust system. Repair as necessary. 7. Check water pump and replace as necessary. Refer to Water Pumps in this group. 8. Refer to Engine Accessory Drive Belts in this group. Check and correct as necessary. Locate leak and repair as necessary. |
| <p>PRESSURE CAP IS BLOWING OFF STEAM AND/OR COOLANT. TEMPERATURE GAUGE READING MAY BE ABOVE NORMAL BUT NOT HIGH. COOLANT LEVEL MAY BE HIGH IN COOLANT TANK.</p> | <ol style="list-style-type: none"> 1. Pressure relief valve in pressure/vent cap is defective. 2. Major head gasket leak or cracked cylinder head. | <ol style="list-style-type: none"> 1. Check condition of pressure/vent cap and cap seals. Refer to Pressure/Vent Caps in this group. Replace cap as necessary. 2. Refer to Engine group and repair as necessary. |

DIAGNOSIS AND TESTING (Continued)

| CONDITION | POSSIBLE CAUSES | CORRECTION |
|---|--|--|
| COOLANT LOSS TO THE GROUND WITHOUT PRESSURE CAP BLOWOFF. GAUGE IS READING HIGH OR HOT | 1. Coolant leaks in radiator, cooling system hoses, water pump or engine. | 1. Pressure test and repair as necessary. Refer to Testing Cooling System For Leaks in this group. |
| HOSE OR HOSES COLLAPSE WHEN ENGINE IS COOLING | 1. Vacuum created in cooling system on engine cool-down is not being relieved through pressure/vent cap. | 1. Cap relief valve stuck. Refer to Pressure/Vent Cap in this group. Replace if necessary. |
| NOISY FAN | 1. Fan blades loose. 2. Fan blades striking a surrounding object. 3. Air obstructions at radiator or air conditioning condenser. 4. Thermal viscous fan drive has defective bearing. 5. A certain amount of fan noise (roaring) may be evident on models equipped with a thermal viscous fan drive. Some of this noise is normal. | 1. Replace fan blade assembly. Refer to Cooling System Fans in this group. 2. Locate point of fan blade contact and repair as necessary. 3. Remove obstructions and/or clean debris or insects from radiator or A/C condenser. 4. Replace fan drive. Bearing is not serviceable. Refer to Viscous Fan Drive in this group. 5. Refer to Viscous Fan Drive in this group for an explanation of normal fan noise. |
| INADEQUATE AIR CONDITIONER PERFORMANCE (COOLING SYSTEM SUSPECTED) | 1. Radiator and/or A/C condenser is restricted, obstructed or dirty (insects, leaves etc.). 2. Thermal viscous fan drive is freewheeling. 3. Engine is overheating (heat may be transferred from radiator to A/C condenser. High underhood temperatures due to engine overheating may also transfer heat to A/C components). 4. The cooling system is equipped with air seals at the radiator and/or A/C condenser. If these seals are missing or damaged, not enough air flow will be pulled through the radiator and A/C condenser. | 1. Remove restriction and/or clean as necessary. Refer to Radiator Cleaning in this group. 2. Refer to Viscous Fan Drive for diagnosis. Repair as necessary. 3. Correct overheating condition. Refer to text in Group 7, Cooling. 4. Check for missing or damaged air seals and repair as necessary. |

DIAGNOSIS AND TESTING (Continued)

| CONDITION | POSSIBLE CAUSES | CORRECTION |
|--|---|--|
| <p>INADEQUATE HEATER PERFORMANCE. MAY BE ACCOMPANIED BY LOW GAUGE READING</p> | <ol style="list-style-type: none"> 1. Diesel engines, due to their inherent efficiency are slower to warm up than gasoline powered engines, and will operate at lower temperatures when the vehicle is unloaded. 2. Coolant level low. 3. Obstructions in heater hose fittings at engine. 4. Heater hose kinked. 5. Water pump is not pumping water to heater core. When the engine is fully warmed up, both heater hoses should be hot to the touch. If only one of the hoses is hotk the water pump may not be operating correctly. The accessory drive belt may also be slipping causing poor water pump operation. | <ol style="list-style-type: none"> 1. The low gauge reading may be normal. Refer to Thermostats in the manual text for information. See Thermostat Diagnosis - Diesel Engine. 2. Refer to Testing Cooling System For Leaks in the manual text. Repair as necessary. 3. Remove heater hoses at both ends and check for obstructions. Repair as neccessary. 4. Located kinked area and repair as necessary. 5. Refer to Water Pumps in this group. Repair as necessary. If a slipping belt is detected, refer to Engine Accessory Drive Belts in this group. Repair as necessary. |
| <p>HEAT ODOR</p> | <ol style="list-style-type: none"> 1. Various heat shields are used at certain drive line components. One or more of these shields may be missing. 2. Is temperature gauge reading above the normal range? 3. Is cooling fan operating correctly? 4. Has undercoating been applied to any unnecessary component? | <ol style="list-style-type: none"> 1. Locate missing shields and replace or repair as necessary. 2. Refer to the previous Temperature Gauge Reads High in these Diagnosis Charts. Repair as necessary. 3. Refer to Cooling System Fan in this group for diagnosis. Repair as necessary. 4. Clean undercoating as necessary. |
| <p>STEAM IS COMING FROM FRONT OF VEHICLE NEAR GRILL AREA WHEN WEATHER IS WET, ENGINE IS WARMED UP AND RUNNING, AND VEHICLE IS STATIONARY. TEMPERATURE GAUGE IS IN NORMAL RANGE</p> | <ol style="list-style-type: none"> 1. During wet weather, moisture (snow, ice or rain condensation) on the radiator will evaporate when the thermostat opens. This opening allows heated water into the radiator. When the moisture contacts the hot radiator, steam may be emitted. This usually occurs in cold weather with no fan or airflow to blow it away. | <ol style="list-style-type: none"> 1. Occasional steam emitting from this area is normal. No repair is necessary. |
| <p>COOLANT COLOR</p> | <ol style="list-style-type: none"> 1. Coolant color is not necessarily an indication of adequate corrosion or temperatue protection. Do not rely on coolant color for determining condition of coolant. | <ol style="list-style-type: none"> 1. Refer to Coolant in this group for antifreeze tests. Adjust antifreeze-to-water ratio as necessary. |

DIAGNOSIS AND TESTING (Continued)

| CONDITION | POSSIBLE CAUSES | CORRECTION |
|--|--|--|
| COOLANT LEVEL CHANGES IN COOLANT TANK. TEMPERATURE GAUGE IS IN NORMAL RANGE | 1. Level changes are to be expected as coolant volume fluctuates with engine temperature. If the level in the tank was between the HOT and COLD marks at normal engine operating temperature, the level should return to within that range after operation at elevated temperatures. | 1. A normal condition. No repair is necessary. |

THERMOSTAT

DIAGNOSIS

Diesel engines, due to their inherent efficiency are slower to warm up than gasoline powered engines, and will operate at lower temperatures when the vehicle is unloaded. Because of this, lower temperature gauge readings for diesel versus gasoline engines may, at times be normal.

TESTING

NOTE: The DRB scan tool cannot be used to monitor engine coolant temperature on the diesel engine.

(1) To determine if the thermostat is defective, it must be removed from the vehicle. Refer to Thermostats for removal and installation procedures.

(2) After the thermostat has been removed, examine the thermostat and inside of thermostat housing for contaminants. If contaminants are found, the thermostat may already be in a "stuck open" position. Flush the cooling system before replacing thermostat. Refer to Cooling System Cleaning/Reverse Flushing in this group for additional information.

(3) Place the thermostat into a container filled with water.

(4) Place the container on a hot plate or other suitable heating device.

(5) Place a commercially available radiator thermometer into the water.

(6) Apply heat to the water while observing the thermostat and thermometer.

(7) When the water temperature reaches 80°C (176°F) the thermostat should start to open (valve will start to move). If the valve starts to move before this temperature is reached, it is opening too early. Replace thermostat. The thermostat should be fully open (valve will stop moving) at approximately 89°C (192°F). If the valve is still moving after the water temperature reaches this temperature, it is opening too late. Replace thermostat.

(8) If the valve refuses to move at any time, replace thermostat.

VISCOUS FAN DRIVE

TESTING

If the fan assembly free-wheels without drag (the fan blades will revolve more than five turns when spun by hand), replace the fan drive. This spin test must be performed when the engine is cool.

The cooling system must be in good condition. This is checked prior to performing the following test. It also will ensure against excessively high coolant temperature.

WARNING: BE SURE OF ADEQUATE FAN BLADE CLEARANCE BEFORE DRILLING.

(1) Drill a 3.12-mm (1/8-in) diameter hole in the top center of the fan shroud.

(2) Obtain a dial thermometer with an 8 inch stem (or equivalent). It should have a range of -18° to 105°C (0° to 220° F). Insert thermometer through the hole in the shroud. Be sure that there is adequate clearance from the fan blades.

(3) Block the air flow through the radiator. Secure a sheet of plastic in front of the radiator (or air conditioner condenser). Use tape at the top to secure the plastic and be sure that the air flow is blocked.

(4) Be sure that the air conditioner (if equipped) is turned off.

WARNING: USE EXTREME CAUTION WHEN THE ENGINE IS OPERATING. DO NOT STAND IN A DIRECT LINE WITH THE FAN. DO NOT PUT YOUR HANDS NEAR THE PULLEYS, BELTS OR FAN. DO NOT WEAR LOOSE CLOTHING.

(5) Start the engine and operate at 2400 rpm. Within ten minutes the air temperature (indicated on the dial thermometer) should be up to 93° C (200° F). Fan drive **engagement** should have started to occur at between 82° to 91° C (180° to 195° F). Engagement is distinguishable by a definite **increase** in fan flow noise (roaring).

(6) When the air temperature reaches 93° C (200° F), remove the plastic sheet. Fan drive **disengagement** should have started to occur at between 57° to 79° C (135° to 175° F). A definite **decrease** of fan

DIAGNOSIS AND TESTING (Continued)

flow noise (roaring) should be noticed. If not, replace the defective viscous fan drive unit.

RADIATOR COOLANT FLOW CHECK

There is coolant flow through the coolant tank (bottle) before and after the thermostat opens.

CAUTION: Do not remove the vent valve to insert a temperature gauge through the opening, coolant will spill out of the system and the engine will not be filled with coolant up to the heads. Major damage could happen if you run the engine in this condition.

TESTING COOLING SYSTEM FOR LEAKS

ULTRAVIOLET LIGHT METHOD

All Jeep[™] models have a leak detection additive added to the cooling system before they leave the factory. The additive is highly visible under ultraviolet light (black light). If the factory original coolant has been drained, pour one ounce of additive into the cooling system. The additive is available through the parts department. Place the heater control unit in HEAT position. Start and operate the engine until the radiator upper hose is warm to the touch. Aim the commercially available black light tool at the components to be checked. If leaks are present, the black light will cause the additive to glow a bright green color.

The black light can be used along with a radiator pressure tester to determine if any external leaks exist (Fig. 10).

PRESSURE TESTER METHOD

WARNING: HOT, PRESSURIZED COOLANT CAN CAUSE SERIOUS INJURY BY SCALDING. NEVER REMOVE THE PRESSURE/VENT CAP OR PRESSURE TESTER WHEN THE COOLING SYSTEM IS HOT OR UNDER PRESSURE!

Allow the engine to cool sufficiently so that the system is not under pressure and carefully remove the pressure/vent cap from the filler neck. Warm the engine with the pressure/vent cap off to normal operating temperature. With the engine turned off attach the cooling system pressure tester and test the system as described below.

Recheck the system cold if the cause of coolant loss is not located during warm engine examination.

A two-piece, threaded adapter set (Fig. 11) must be used to adapt a standard pressure-type tester (Fig. 12) when testing either the coolant tank or pressure cap. Use Kent-Moore[®] adapter set number J-24460-92 or Snap-On[®] numbers TA-32 and TA-33.

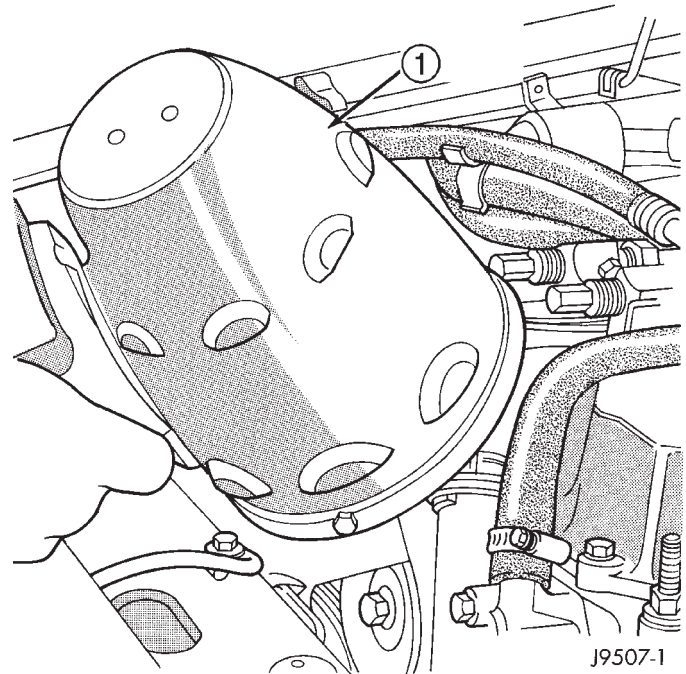

Fig. 10 Leak Detection Using Black Light—Typical
1 – TYPICAL BLACK LIGHT TOOL

Attach one of the adapters to the coolant pressure tank neck. Adapter must first be threaded to tank. Attach pressure tester to adapter.

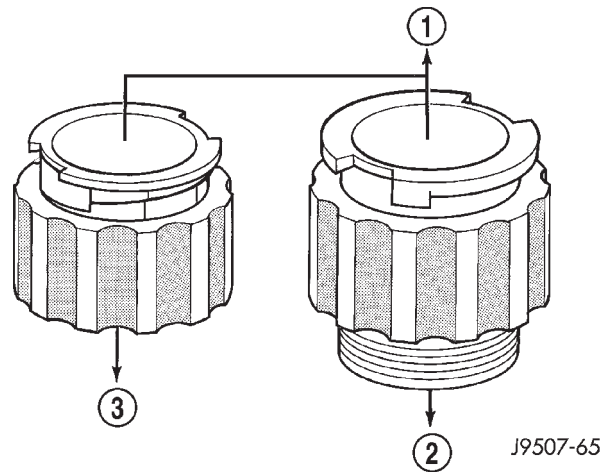
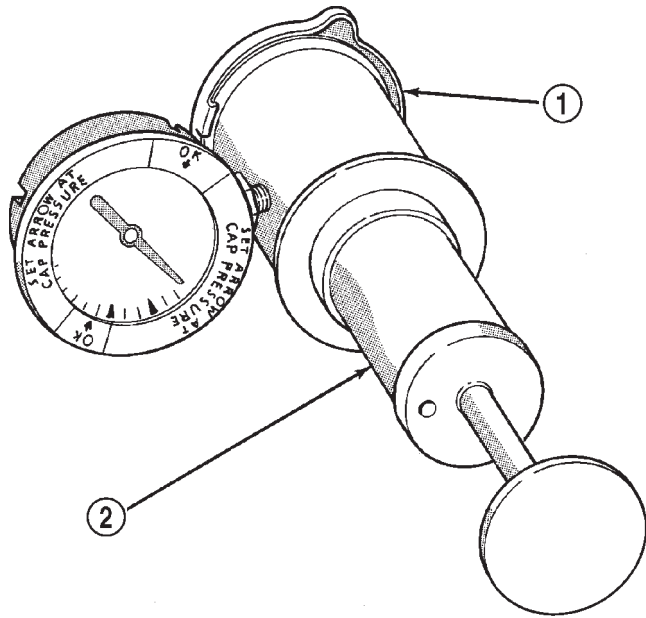

Fig. 11 Typical Pressure Tester Adapters

- 1 – TO PRESSURE TESTER
- 2 – TO CAP
- 3 – TO TANK

Operate the tester pump to apply 103 kPa (15 psi) pressure to the system. If the hoses enlarge excessively or bulge while testing, replace as necessary. Observe the gauge pointer and determine the condition of the cooling system according to the following criteria:

DIAGNOSIS AND TESTING (Continued)



J9507-3

Fig. 12 Typical Cooling System Pressure Tester

- 1 - PRESSURE CAP
2 - TYPICAL COOLING SYSTEM PRESSURE TESTER

- **Holds Steady:** If the pointer remains steady for two minutes, there are no serious coolant leaks in the system. However, there could be an internal leak that does not appear with normal system test pressure. Inspect for interior leakage or do the Internal Leakage Test. Do this if it is certain that coolant is being lost and no leaks can be detected.

- **Drops Slowly:** Shows a small leak or seepage is occurring. Examine all connections for seepage or slight leakage with a flashlight. Inspect the radiator, hoses, gasket edges and heater. Seal any small leak holes with a Sealer Lubricant or equivalent. Repair leak holes and reinspect the system with pressure applied.

- **Drops Quickly:** Shows that a serious leakage is occurring. Examine the system for serious external leakage. If no leaks are visible, inspect for internal leakage. Large radiator leak holes should be repaired by a reputable radiator repair shop.

INTERNAL LEAKAGE INSPECTION

Remove the oil pan drain-plug and drain a small amount of engine oil. Coolant, being heavier will drain first, or operate engine to churn oil, then examine dipstick for water globules. Operate the engine without the pressure/vent cap on the coolant tank until thermostat opens.

Attach a radiator pressure tester to the tank filler neck. If pressure builds up quickly, a leak exists as

result of a faulty cylinder head gasket or crack in the engine. Repair as necessary.

WARNING: DO NOT ALLOW PRESSURE TO EXCEED 117 KPA (17 PSI). TURN THE ENGINE OFF. TO RELEASE THE PRESSURE, ROCK THE TESTER FROM SIDE TO SIDE. WHEN REMOVING THE TESTER, DO NOT TURN THE TESTER MORE THAN 1/2 TURN IF THE SYSTEM IS UNDER PRESSURE.

If there is no immediate pressure increase, pump the pressure tester until the indicated pressure is within the system range. Vibration of the gauge pointer indicates compression or combustion leakage into the cooling system.

PRESSURE/VENT CAP

PRESSURE TESTING

Remove the cap from the coolant tank. Be sure that sealing surfaces are clean. Moisten rubber gasket with water.

A two-piece, threaded adapter set (Fig. 11) must be used to adapt a standard pressure-type tester (Fig. 12) when testing either the coolant tank or pressure cap. Use Kent-Moore® adapter set number J-24460-92 or Snap-On® numbers TA-32 and TA-33. Attach the adapter to the cap. Adapter must first be threaded to cap. Attach pressure tester to adapter.

Operate the tester pump and observe the gauge pointer at its highest point. The cap release pressure should be 90-to-117 kPa (13-to-17 psi). The cap is satisfactory when the pressure holds steady. It is also good if it holds pressure within the 90-to-117 kPa (13-to-17 psi) range for 30 seconds or more. If the pointer drops quickly, replace the cap.

CAUTION: Radiator pressure testing tools are very sensitive to small air leaks, which will not cause cooling system problems. A pressure cap that does not have a history of coolant loss should not be replaced just because it leaks slowly when tested with this tool. Add water to tool. Turn tool upside down and recheck pressure/vent cap to confirm that cap needs replacement.

LOW COOLANT LEVEL- AERATION

CAUTION: Engine damage could occur if the coolant level is allowed to get this low. Always ensure that the coolant level is not below the full mark. For better visibility of the coolant level use a shop lamp to light the pressurized coolant tank and look through the pressurized coolant tank.

DIAGNOSIS AND TESTING (Continued)

BELT DIAGNOSIS

When diagnosing serpentine accessory drive belts, small cracks that run across the ribbed surface of the belt from rib to rib (Fig. 13), are considered normal. These are not a reason to replace the belt. However, cracks running along a rib (not across) are **not** normal. Any belt with cracks running along a rib must be replaced (Fig. 13). Also replace the belt if it has excessive wear, frayed cords or severe glazing.

Refer to the Serpentine Drive Belt Diagnosis chart for further belt diagnosis.

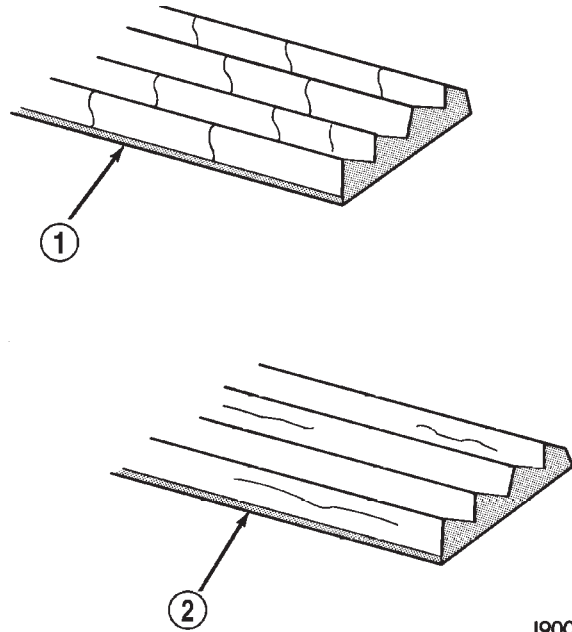

J9007-44

Fig. 13 Serpentine Belt Wear Patterns

- 1 - NORMAL CRACKS BELT OK
- 2 - NOT NORMAL CRACKS RELACE BELT

| CONDITION | POSSIBLE CAUSES | CORRECTION |
|--|---|--|
| RIB CHUNKING (ONE OR MORE RIBS HAS SEPARATED FROM BELT BODY) | <ol style="list-style-type: none"> 1. Foreign objects imbedded in pulley grooves. 2. Installation damage. | <ol style="list-style-type: none"> 1. Remove foreign objects from pulley grooves. Replace belt. 2. Replace belt. |
| RIB OR BELT WEAR | <ol style="list-style-type: none"> 1. Pulley(s) misaligned. 2. Abrasive environment. 3. Rusted pulley(s). 4. Sharp or jagged pulley groove tips. 5. Rubber deteriorated. | <ol style="list-style-type: none"> 1. Align pulley(s). 2. Clean pulley(s). Replace belt if necessary. 3. Clean rust from pulley(s). 4. Replace pulley. 5. Replace belt. |
| LONGITUDINAL BELT CRACKING (CRACKS BETWEEN TWO RIBS) | <ol style="list-style-type: none"> 1. Belt has mistracked from pulley groove. 2. Pulley groove tip has worn away rubber to tensile member | <ol style="list-style-type: none"> 1. Replace belt. 2. Replace belt. |

DIAGNOSIS AND TESTING (Continued)

| CONDITION | POSSIBLE CAUSES | CORRECTION |
|---|---|---|
| BELT SLIPS | <ol style="list-style-type: none"> 1. Belt slipping because of insufficient tension. 2. Incorrect belt. 3. Belt or pulley subjected to substance (belt dressing, oil, ethylene glycol) that has reduced friction. 4. Driven component bearing failure. 5. Belt glazed and hardened from heat and excessive slippage. | <ol style="list-style-type: none"> 1. Replace automatic belt tensioner. 2. Replace belt. 3. Replace belt and clean pulleys. 4. Replace faulty component bearing. 5. Replace belt. |
| "GROOVE JUMPING" (BELT DOES NOT MAINTAIN CORRECT POSITION ON PULLEY) | <ol style="list-style-type: none"> 1. Belt tension either too high or too low. 2. Incorrect belt. 3. Pulley(s) not within design tolerance. 4. Foreign object(s) in grooves. 4. Pulley misalignment. 5. Belt cordline is broken. | <ol style="list-style-type: none"> 1. Replace automatic belt tensioner. 2. Replace belt. Replace pulley(s). 4 Remove foreign objects from grooves. 4. Check and replace. 5. Replace belt. |
| BELT BROKEN (NOTE: IDENTIFY AND CORRECT PROBLEM BEFORE NEW BELT IS INSTALLED) | <ol style="list-style-type: none"> 1. Excessive tension. 2. Incorrect belt. 3. Tensile member damaged during belt installation. 4. Severe misalignment. 5. Bracket, pulley, or bearing failure. | <ol style="list-style-type: none"> 1. Replace belt and automatic belt tensioner. 2. Replace belt. 3. Replace belt. 4. Check and replace. 5. Replace defective component and belt. |
| NOISE (OBJECTIONAL SQUEAL, SQUEAK, OR RUMBLE IS HEARD OR FELT WHILE DRIVE BELT IS IN OPERATION) | <ol style="list-style-type: none"> 1. Belt slippage. 2. Bearing noise. 3. Belt misalignment. 4. Belt-to-pulley mismatch. | <ol style="list-style-type: none"> 1. Replace belt or automatic belt tensioner. 2. Locate and repair. 3. Replace belt. 4. Install correct belt. |

SERPENTINE DRIVE BELT DIAGNOSIS

SERVICE PROCEDURES

COOLANT LEVEL CHECK

The coolant level is checked and adjusted at the pressurized coolant tank (Fig. 14). The tank is located at the right-rear side of the engine compartment and is mounted as the highest point of the cooling system. This will allow any air or vapor exceeding the pressure/vent cap rating to escape through the cap. The coolant tank is equipped with a

threaded-on pressure/vent cap. Refer to Pressure/Vent Cap for additional information.

A coolant reserve/overflow system with a separate tank is not used with the 2.5L diesel engine.

NOTE: The coolant level should be checked after the engine has been operated at normal operating temperature for approximately 5–10 minutes.

(1) Add coolant into the coolant tank up to the FULL mark. **If possible, only add coolant when the engine is cold. Coolant level in a warm**

SERVICE PROCEDURES (Continued)

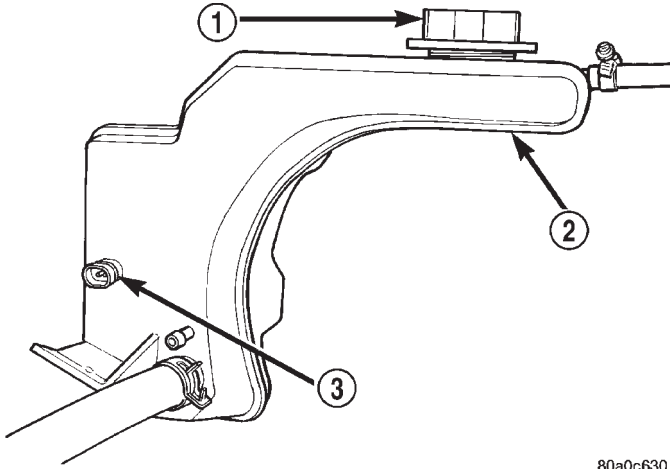

80a0c630

Fig. 14 Coolant Tank and Pressure/Vent Cap

- 1 - PRESSURE/VENT CAP
- 2 - PRESSURIZED COOLANT TANK
- 3 - LOW COOLANT LEVEL SENSOR

engine will be higher in the tank due to thermal expansion.

(2) After the engine has been operated through a few heat-up and cool-down cycles, recheck the coolant level in the tank.

DRAINING COOLING SYSTEM

The cooling system is equipped with a pressurized coolant tank using a pressure/vent cap.

WARNING: DO NOT REMOVE THE CYLINDER BLOCK DRAIN-PLUG, THE COOLANT TANK CAP, THE RADIATOR FILL VENT VALVE, OR LOOSEN THE RADIATOR DRAINCOCK WITH THE SYSTEM HOT AND PRESSURIZED. SERIOUS BURNS FROM THE COOLANT CAN OCCUR.

WARNING: IF VEHICLE HAS BEEN RUN RECENTLY, WAIT AT LEAST 15 MINUTES BEFORE REMOVING COOLANT TANK CAP. WITH A RAG, SQUEEZE THE UPPER RADIATOR HOSE TO CHECK IF SYSTEM IS UNDER PRESSURE. PLACE A RAG OVER THE CAP. VERY SLOWLY ROTATE THE CAP COUNTER-CLOCKWISE ALLOWING PRESSURE TO SLOWLY RELEASE. AFTER ALL PRESSURE HAS BEEN RELEASED, REMOVE THE COOLANT TANK CAP COMPLETELY.

DO NOT WASTE reusable coolant. If the solution is clean, drain the coolant into a clean container for reuse.

- (1) Observe the previous **WARNINGS** and remove the coolant tank pressure/vent cap.
- (2) The plastic radiator draincock is located on the bottom of the left radiator tank. It can be accessed by

removing the left front headlamp bezel and the radiator grille assembly from the bottom of vehicle.

(a) Attach one end of a 24 inch long X 1/4 inch ID drain-hose to the nipple below the radiator draincock.

(b) Put the other end of drain-hose into a clean container.

(c) Open the draincock (counterclockwise as viewed from left side of vehicle) and drain coolant from radiator.

(3) If the complete cooling system must be drained, raise the vehicle and remove the cylinder block drain-plug. This hex-headed plug is located on the right/rear side of the engine above the starter motor.

REFILLING COOLING SYSTEM

The cooling system is equipped with a pressurized coolant tank using a pressure/vent cap. Refilling of the system is done through this tank.

NOTE: The radiator draincock is equipped with a rubber o-ring. Do not over tighten draincock.

(1) Tighten the radiator draincock and (if removed), the cylinder block drain-plug.

(2) Open the plastic radiator fill vent valve (unscrews counter-clockwise) from the radiator. The fill vent valve is located on the top of the right radiator tank.

(3) With the fill vent valve open, proceed to fill the system using a 50/50 mixture of water and antifreeze as described in the Coolant section of this group.

(4) Continue to fill the cooling system until coolant is observed escaping from the fill vent opening. When this occurs, close the fill vent valve. **The plastic fill vent valve is equipped with a rubber o-ring. Do not over tighten the fill vent valve.**

(5) Continue to fill the system until the coolant tank is full.

(6) Install and tighten the coolant tank pressure/vent cap. **Do not use any type of tool when tightening the cap. Hand tighten only.**

(7) Operate engine with coolant tank cap tightened.

(8) After engine has reached normal operating temperature, shut engine off and allow it to cool.

(9) Remove coolant tank cap.

(10) Add coolant into the coolant tank up to the FULL mark. **If possible, only add coolant when the engine is cold. Coolant level in a warm engine will be higher in the tank due to thermal expansion.**

(11) After the engine has been operated through a few heat-up and cool-down cycles, recheck the coolant level in the tank.

SERVICE PROCEDURES (Continued)

COOLANT REPLACEMENT

It is recommended that the cooling system be drained and flushed at 84,000 kilometers (52,500 miles), or 3 years, whichever occurs first. Then every two years, or 48,000 kilometers (30,000 miles), whichever occurs first.

REMOVAL AND INSTALLATION

RADIATOR

WARNING: DO NOT REMOVE THE CYLINDER BLOCK DRAIN-PLUG, THE COOLANT TANK CAP, THE RADIATOR FILL VENT VALVE, OR LOOSEN THE RADIATOR DRAINCOCK WITH THE SYSTEM HOT AND PRESSURIZED. SERIOUS BURNS FROM THE COOLANT CAN OCCUR.

DO NOT WASTE reusable coolant. If solution is clean, drain coolant into a clean container for reuse.

WARNING: CONSTANT TENSION HOSE CLAMPS ARE USED ON MOST COOLING SYSTEM HOSES. WHEN REMOVING OR INSTALLING, USE ONLY TOOLS DESIGNED FOR SERVICING THIS TYPE OF CLAMP (Fig. 15). ALWAYS WEAR SAFETY GLASSES WHEN SERVICING CONSTANT TENSION CLAMPS.

CAUTION: A number or letter is stamped into the tongue of constant tension clamps (Fig. 16). If replacement is necessary, use only an original equipment clamp with matching number or letter.

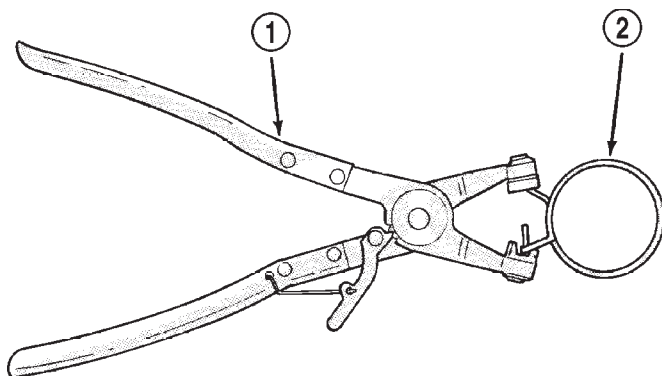

J9207-36

Fig. 15 Hose Clamp Tool

- 1 - HOSE CLAMP TOOL 6094
2 - HOSE CLAMP

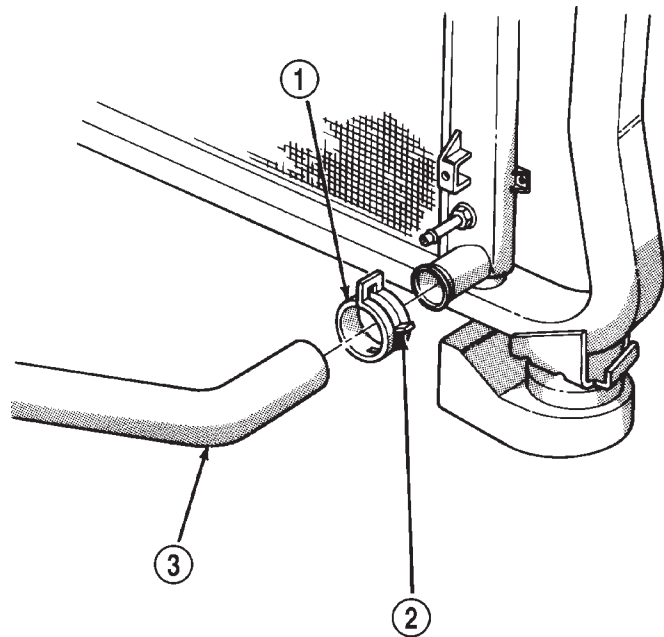

J9407-39

Fig. 16 Clamp Number/Letter Location

- 1 - TYPICAL CONSTANT TENSION HOSE CLAMP
2 - CLAMP NUMBER/LETTER LOCATION
3 - TYPICAL HOSE

REMOVAL

- (1) Disconnect negative battery cable at battery.
- (2) Observe the previous **WARNINGS**.
- (3) Drain cooling system. Refer to Draining Cooling System in this group.
- (4) Remove the upper fan shroud-to-upper cross-member mounting bolts. One of the bolts is mounted vertically at the bottom of the fan shroud.
- (5) Lift the fan shroud up until alignment tabs at the bottom are clear of slots in bracket at bottom of radiator. Slip the fan shroud rearward and position it over the fan blades.
- (6) Remove radiator hose clamps and remove radiator hoses.
- (7) Mark the position of the hood latch striker on the radiator crossmember and remove hood latch striker.
- (8) Remove radiator upper crossmember.
- (9) If equipped with air conditioning, separate the radiator from the A/C condenser by removing the condenser-to-radiator mounting brackets.
- (10) Lift radiator straight up and out of engine compartment taking care not to damage radiator or A/C condenser fins.

INSTALLATION

The radiator is equipped with two alignment dowels (Fig. 17). They are located on the bottom of the

REMOVAL AND INSTALLATION (Continued)

plastic side tanks and fit into rubber grommets located in the front lower crossmember.

(1) Carefully lower the radiator into engine compartment. Position the alignment dowels on the bottom of radiator into the rubber grommets in front lower crossmember (Fig. 17).

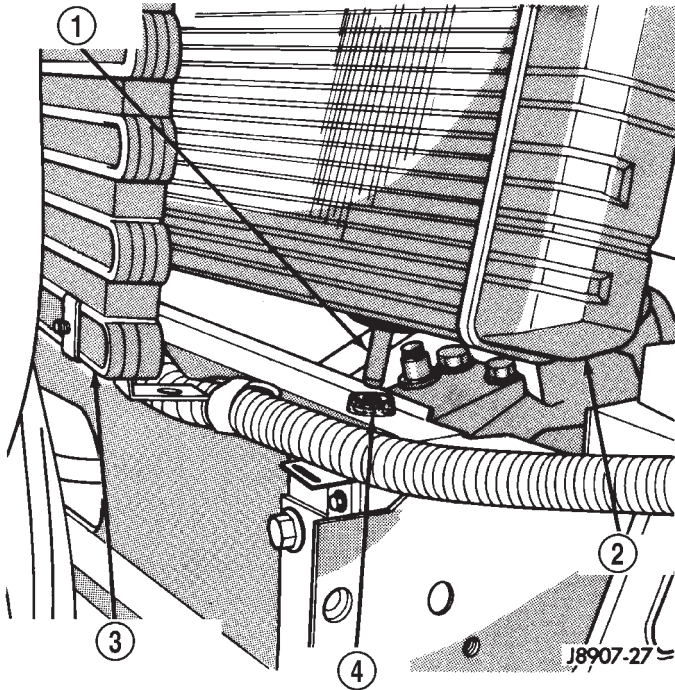

Fig. 17 Radiator Alignment Dowels—Typical

- 1 - ALIGNMENT DOWEL
- 2 - RADIATOR
- 3 - AIR CONDITIONING CONDENSER
- 4 - GROMMET

(2) If equipped with air conditioning, attach condenser to radiator with mounting brackets.

- (3) Install radiator upper crossmember.
- (4) Install hood latch striker.
- (5) Connect radiator upper and lower hoses.
- (6) Insert alignment tabs at bottom of fan shroud into slots in bracket at bottom of radiator. Install and tighten fan shroud bolts to 3 N·m (31 in. lbs.) torque.
- (7) Connect negative battery cable.
- (8) Fill cooling system with correct coolant. Refer to Refilling Cooling System in this group.
- (9) Start and warm the engine. Check for coolant leaks.

FAN BLADE REMOVAL

FAN BLADE REMOVAL

Accessory drive belt removal is not necessary for fan blade or viscous fan drive removal.

(1) Disconnect negative battery cable from battery.

(2) The thermal viscous fan drive/fan blade assembly is attached (threaded) to the fan pulley shaft (Fig. 18). Remove fan blade/viscous fan drive assembly from fan pulley by turning mounting nut counterclockwise as viewed from front. Threads on viscous fan drive are **RIGHT HAND**. Snap-On® 36 MM Fan Wrenches (number SP346) can be used to turn the mounting nut and to hold the fan pulley from rotating.

(3) Do not attempt to remove fan/viscous fan drive assembly from vehicle at this time.

(4) Do not unbolt fan blade assembly from viscous fan drive at this time.

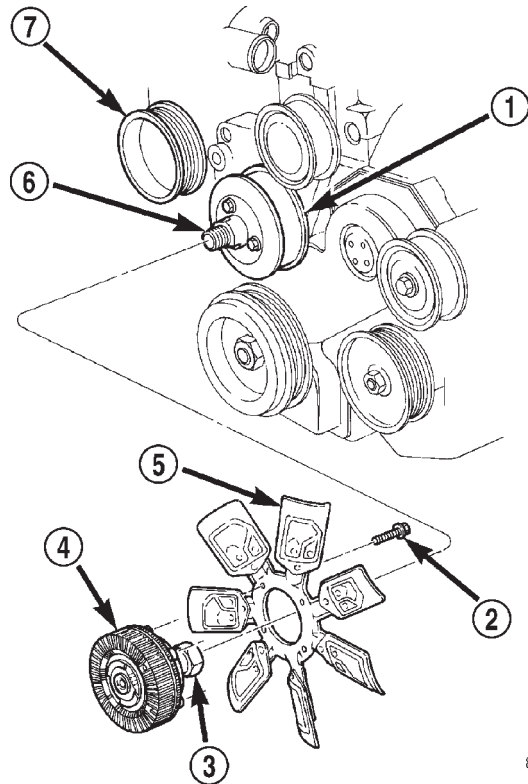

Fig. 18 Thermal Viscous Fan Drive and Blade Assembly

- 1 - FAN PULLEY
- 2 - FAN DRIVE-TO-FAN BLADE BOLTS (4)
- 3 - MOUNTING NUT
- 4 - THERMAL VISCIOUS FAN DRIVE
- 5 - FAN BLADES
- 6 - FAN PULLEY SHAFT
- 7 - WATER PUMP

80b89817

- (5) Remove the fan shroud mounting bolts.
- (6) Remove the fan shroud and fan blade/viscous fan drive assembly as a complete unit from vehicle.

(7) After removing fan blade/viscous fan drive assembly, **do not** place viscous fan drive in horizontal position. If stored horizontally, silicone fluid in the viscous fan drive could drain into its bearing assembly and contaminate lubricant.

REMOVAL AND INSTALLATION (Continued)

CAUTION: Do not attempt to remove the fan pulley bolts. The fan pulley is under tension from the drive belt.

(7) Remove four bolts securing fan blade assembly to viscous fan drive (Fig. 18).

FAN BLADE INSTALLATION

(1) Install fan blade assembly to viscous fan drive. Tighten bolts (Fig. 18) to 23 N·m (200 in. lbs.) torque.

(2) Position fan shroud and fan blade/viscous fan drive assembly to vehicle as a complete unit.

(3) Install and tighten fan shroud bolts to 3 N·m (31 in. lbs.) torque.

(4) Install fan blade/viscous fan drive assembly to fan pulley shaft (Fig. 18).

(5) Connect the negative battery cable.

VISCOUS FAN DRIVE

Refer to the FAN BLADE removal and installation procedure for replacement of the viscous fan drive.

The thermal viscous fan drive (Fig. 19) is a silicone-fluid-filled coupling. It connects the fan blade assembly to the fan pulley. The coupling allows the fan to be driven in a normal manner. This is done at low engine speeds while limiting the top speed of the fan to a predetermined maximum level at higher engine speeds. A bimetallic spring coil is located on the front face. This spring coil reacts to the temperature of the radiator discharge air. It engages the viscous fan drive for higher fan speed if the air temperature from the radiator rises above a certain point. Until additional engine cooling is necessary, the fan will remain at a reduced rpm regardless of engine speed.

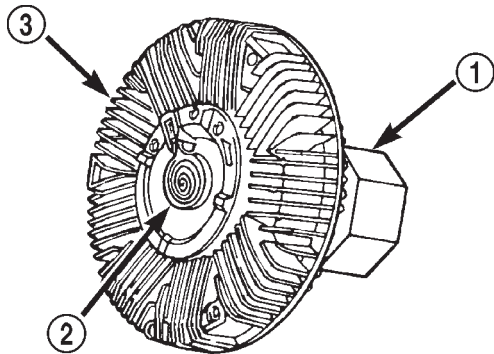

80a243e4

Fig. 19 Viscous Fan Drive

- 1 - MOUNTING NUT TO FAN PULLEY SHAFT
2 - THERMOSTATIC SPRING
3 - VISCOUS FAN DRIVE

The viscous fan drive will only engage when sufficient heat is present. This is when the air flowing through the radiator core causes a reaction from the

bimetallic coil. It then increases fan speed to provide the necessary additional engine cooling.

Once the engine has cooled, the radiator discharge temperature will drop. The bimetallic coil again reacts and the fan speed is reduced to the previous disengaged speed.

NOISE

NOTE: It is normal for fan noise to be louder (roaring) when:

- The underhood temperature is above the engagement point for the viscous drive coupling. This may occur when ambient (outside air temperature) is very high.
- Engine loads and temperatures are high such as when towing a trailer.
- Cool silicone fluid within the fan drive unit is being redistributed back to its normal disengaged (warm) position. This can occur during the first 15 seconds to one minute after engine start-up on a cold engine.

LEAKS

Viscous fan drive operation is not affected by small oil stains near the drive bearing. If leakage appears excessive, replace the fan drive unit.

THERMOSTAT

REMOVAL

WARNING: DO NOT REMOVE THE CYLINDER BLOCK DRAIN-PLUG, THE COOLANT TANK CAP, THE RADIATOR FILL VENT VALVE, OR LOOSEN THE RADIATOR DRAINCOCK WITH THE SYSTEM HOT AND PRESSURIZED. SERIOUS BURNS FROM THE COOLANT CAN OCCUR.

DO NOT WASTE reusable coolant. If the solution is clean, drain the coolant into a clean container for reuse.

(1) Drain the coolant from the radiator until the level is below the thermostat housing. Refer to Draining Cooling System for procedures.

WARNING: CONSTANT TENSION HOSE CLAMPS ARE USED ON MOST COOLING SYSTEM HOSES. WHEN REMOVING OR INSTALLING, USE ONLY TOOLS DESIGNED FOR SERVICING THIS TYPE OF CLAMP (Fig. 15). ALWAYS WEAR SAFETY GLASSES WHEN SERVICING CONSTANT TENSION CLAMPS.

REMOVAL AND INSTALLATION (Continued)

CAUTION: A number or letter is stamped into the tongue of constant tension clamps (Fig. 16). If replacement is necessary, use only an original equipment clamp with matching number or letter.

(2) Remove the upper radiator hose at the thermostat housing.

(3) Remove the four thermostat housing bolts (Fig. 20)

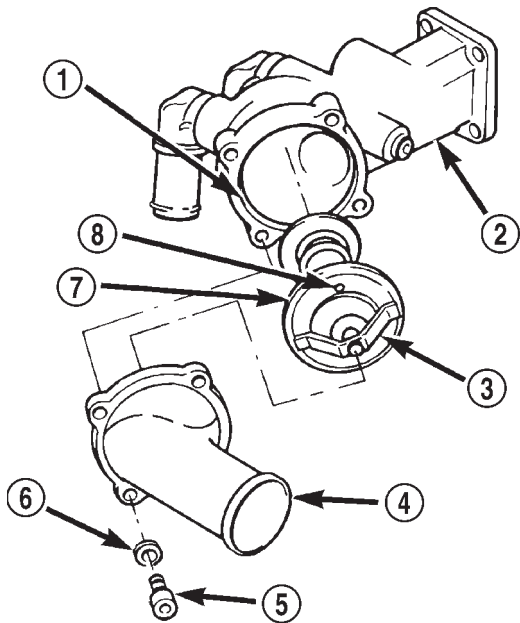

80a243e2

Fig. 20 Thermostat Removal/Installation

- 1 - THERMOSTAT RECESS GROOVE
- 2 - WATER MANIFOLD ADAPTER
- 3 - THERMOSTAT
- 4 - THERMOSTAT HOUSING
- 5 - HOUSING BOLTS (4)
- 6 - WASHER
- 7 - RUBBER SEAL
- 8 - VENT

(4) Remove the thermostat housing from the water manifold.

(5) Remove the thermostat and rubber seal from the water manifold.

(6) Thoroughly clean the rubber seal mating surfaces.

INSTALLATION

(1) Install a new rubber seal around the outer lip of the thermostat (a notch is provided in the rubber seal). Do not apply any adhesive to this seal.

(2) Install the replacement thermostat and rubber seal as one assembly into the water manifold adapter (the pointed end of the thermostat should be facing towards the front of engine (Fig. 20). Observe the recess groove in the water manifold adapter. Be sure

the thermostat vent is in the 12 o'clock position (Fig. 20).

(3) Position the thermostat housing and four bolts to the water manifold.

CAUTION: Tightening the thermostat housing unevenly or with the thermostat out of its recess groove, may result in a cracked housing.

(4) Tighten the four housing bolts to 11 N·m (98 in. lbs.) torque.

(5) Install radiator hose to thermostat housing.

(6) Be sure that the radiator drain is tightly closed. Fill the cooling system to the correct level with the required coolant mixture. Refer to Refilling Cooling System in this group for procedures.

(7) Start and warm the engine. Check thermostat and hose for leaks.

DRIVE BELT

CAUTION: The drive belt on the 2.5L diesel engine is equipped with a spring loaded automatic belt tensioner. After belt installation, do not attempt to check belt tension with a belt tension gauge.

AUTOMATIC BELT TENSIONER

WATER PUMP

REMOVAL

The water pump can be removed without discharging the air conditioning system (if equipped).

The water pump is serviced by replacing the pump and its impeller only. The water pump adapter (Fig. 22) does not have to be removed. The pump impeller is pressed on the rear of the pump shaft and bearing assembly. The pump is serviced only as a complete assembly with the impeller, housing, hub and bearing.

A rubber o-ring seal (instead of a gasket) is used as a seal between the water pump and the water pump adapter.

WARNING: DO NOT REMOVE THE CYLINDER BLOCK DRAIN-PLUG, THE COOLANT TANK CAP, THE RADIATOR FILL VENT VALVE, OR LOOSEN THE RADIATOR DRAINCOCK WITH THE SYSTEM HOT AND PRESSURIZED. SERIOUS BURNS FROM THE COOLANT CAN OCCUR.

DO NOT WASTE reusable coolant. If the solution is clean, drain coolant into a clean container for reuse.

(1) Disconnect the negative battery cable.

REMOVAL AND INSTALLATION (Continued)

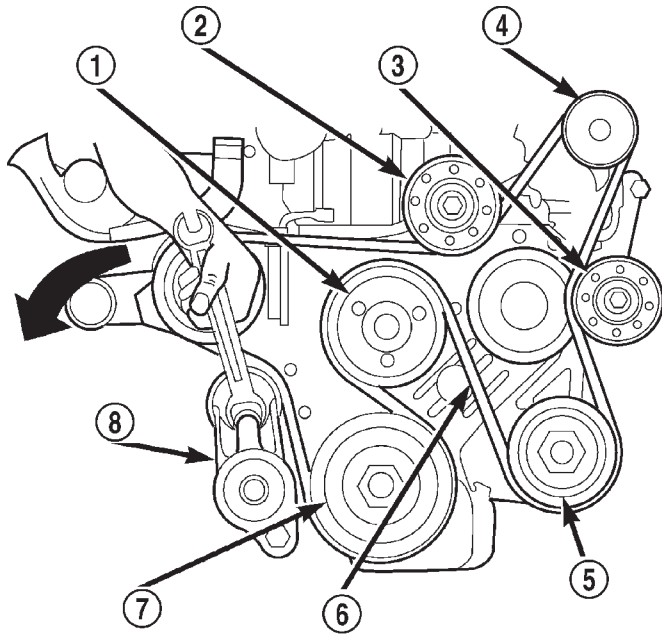

80bfe1c0

Fig. 21 Automatic Belt Tensioner Assembly

- 1 - FAN PULLEY
- 2 - IDLER PULLEY
- 3 - IDLER PULLEY
- 4 - GENERATOR
- 5 - POWER STEERING PUMP
- 6 - DRIVE BELT
- 7 - CRANKSHAFT PULLEY
- 8 - AUTOMATIC BELT TENSIONER

(2) Drain the cooling system. Refer to Draining Cooling System in this group.

(3) The thermal viscous fan drive and the fan blade assembly are attached (threaded) to the fan pulley shaft (Fig. 23). Remove the fan/fan drive assembly from the fan pulley by turning the mounting nut counterclockwise (as viewed from front). Threads on the fan drive are **RIGHT HAND**. Snap-On® 36 MM Fan Wrenches (number SP346) can be used to turn the mounting nut and to hold the fan pulley from rotating.

(4) If the water pump is being replaced, do not unbolt the fan blade assembly (Fig. 23) from the thermal viscous fan drive.

(5) Remove the upper fan shroud-to-upper cross-member mounting bolts. One of the bolts is mounted vertically at the bottom of the fan shroud.

(6) Slip the fan shroud rearward. Remove the fan shroud and viscous drive/fan blade together as one assembly from the engine compartment.

(7) Loosen **but do not remove** the 3 water pump pulley bolts (Fig. 22).

(8) Remove the drive belt by relieving the tension on the belt tensioner. For procedures, refer to Belt

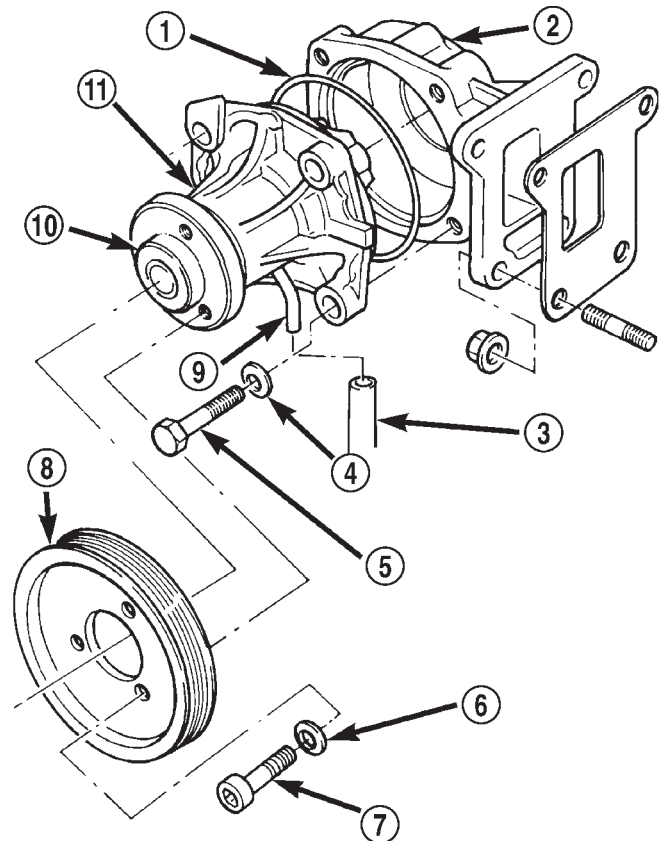

80a0c4e0

Fig. 22 WATER PUMP REMOVAL/INSTALL—TYPICAL

- 1 - O-RING SEAL
- 2 - WATER PUMP ADAPTER
- 3 - DRAIN HOSE
- 4 - WASHER
- 5 - PUMP MOUNTING BOLTS (4)
- 6 - WASHER
- 7 - WATER PUMP PULLEY BOLTS (3)
- 8 - WATER PUMP PULLEY
- 9 - VENT TUBE
- 10 - PUMP HUB
- 11 - WATER PUMP

Removal/Installation in the Engine Accessory Drive Belt section of this group.

WARNING: CONSTANT TENSION HOSE CLAMPS ARE USED ON MOST COOLING SYSTEM HOSES. WHEN REMOVING OR INSTALLING, USE ONLY TOOLS DESIGNED FOR SERVICING THIS TYPE OF CLAMP (Fig. 24). ALWAYS WEAR SAFETY GLASSES WHEN SERVICING CONSTANT TENSION CLAMPS.

CAUTION: A number or letter is stamped into the tongue of constant tension clamps (Fig. 25). If replacement is necessary, use only an original equipment clamp with matching number or letter.

REMOVAL AND INSTALLATION (Continued)

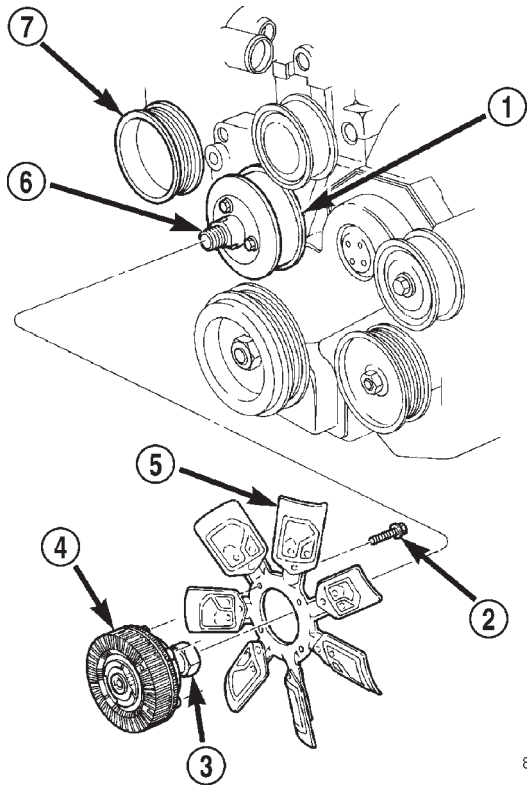
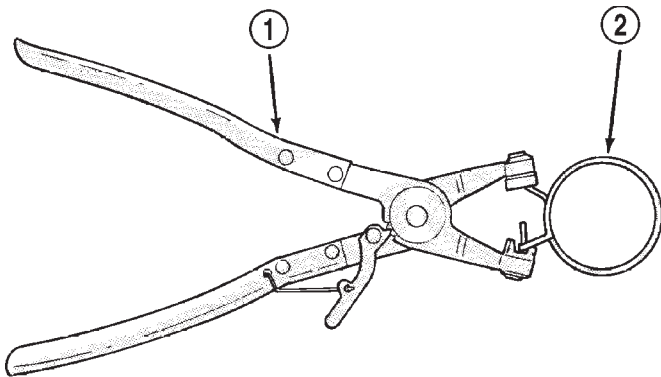

Fig. 23 Thermal Viscous Fan Drive and Blade Assembly

- 1 - FAN PULLEY
- 2 - FAN DRIVE-TO-FAN BLADE BOLTS (4)
- 3 - MOUNTING NUT
- 4 - THERMAL VISCOUS FAN DRIVE
- 5 - FAN BLADES
- 6 - FAN PULLEY SHAFT
- 7 - WATER PUMP

80b89817



J9207-36

Fig. 24 Hose Clamp Tool

- 1 - HOSE CLAMP TOOL 6094
- 2 - HOSE CLAMP

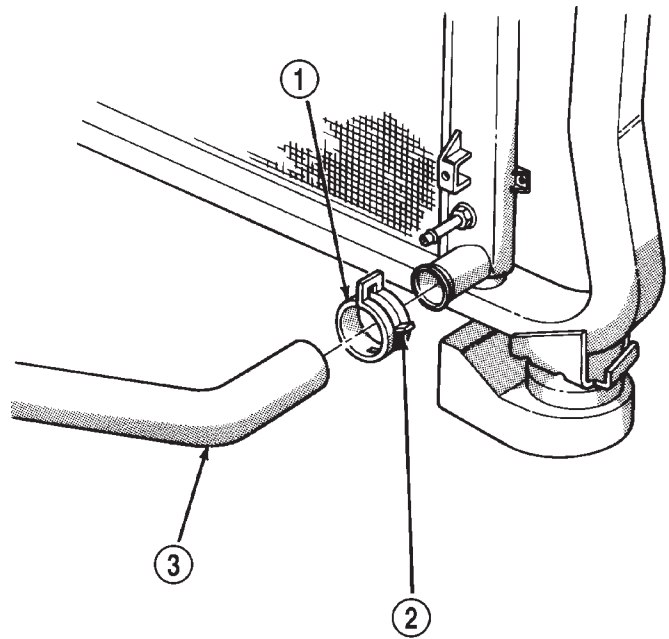

J9407-39

Fig. 25 Clamp Number/Letter Location

- 1 - TYPICAL CONSTANT TENSION HOSE CLAMP
- 2 - CLAMP NUMBER/LETTER LOCATION
- 3 - TYPICAL HOSE

(9) A metal coolant tube (used to connect rubber coolant hoses), and its mounting bracket are attached to the front of the water pump (Fig. 26). A rubber hose connects this tube to the engine. Disconnect the hose clamp and rubber hose at the back of the thermostat. Position the hose to the side.

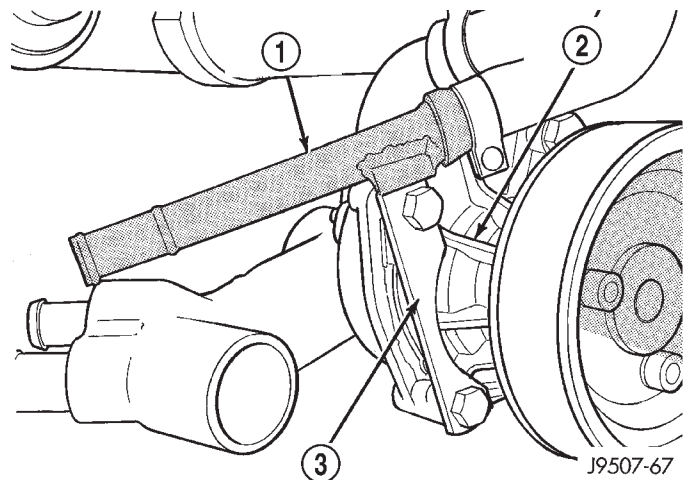

J9507-67

Fig. 26 Coolant Tube at Water Pump

- 1 - COOLANT TUBE
- 2 - WATER PUMP
- 3 - BRACKET

(10) Remove the 3 water pump pulley bolts (Fig. 22).

REMOVAL AND INSTALLATION (Continued)

- (11) Remove the water pump pulley from the water pump.
- (12) Disconnect the drain hose from the vent tube at the bottom of water pump (Fig. 22).
- (13) Remove the 4 water pump mounting bolts (Fig. 22).
- (14) Remove water pump from engine.

INSTALLATION

- (1) Clean the o-ring mating surfaces. If the original pump is to be reinstalled, remove any deposits or other foreign material. Inspect the water pump, water pump adapter and water pump mating surfaces for erosion or damage from cavitation.
- (2) Position a new rubber o-ring seal (Fig. 22) between the pump and pump adapter. Hold the seal with petroleum jelly.
- (3) Position the pump on the engine.
- (4) Position the metal coolant tube and its mounting bracket on the pump.
- (5) Install the four water pump mounting bolts. Torque bolts to 24 N·m (18 ft. lbs.).
- (6) Install drain hose to vent tube at bottom of pump.
- (7) Position the water pump pulley to the water pump.
- (8) Install the water pump pulley bolts finger tight.
- (9) Install the rubber coolant hose near the thermostat.
- (10) Install the accessory drive belt. For procedures, refer to Belt Removal/Installation in the Engine Accessory Drive Belt section of this group.
- (11) Torque the water pump pulley bolts to 24 N·m (18 ft. lbs.).
- (12) Position the viscous drive/fan blade and fan shroud to the engine compartment as one assembly.
- (13) Install the thermal viscous fan drive and fan blade to fan pulley. Torque to 56 N·m (41 ft. lbs.).
- (14) Install the fan shroud mounting bolts. Torque bolts to 3 N·m (31 in. lbs.).
- (15) Fill the cooling system with coolant and check for leaks. Refer to Refilling Cooling System in this group.
- (16) Connect the negative battery cable.
- (17) Start and warm the engine. Check for leaks.

CLEANING AND INSPECTION

WATER PUMP

INSPECTION

Replace the water pump assembly if it has any of the following conditions:

- The body is cracked or damaged

- Water leaks from the shaft seal. This is evident by traces of coolant below the vent tube drain hose
- Loose or rough turning bearing.
- Impeller rubs either the water pump body or water pump adapter.

RADIATOR CLEANING

The radiator and air conditioning fins should be cleaned when an accumulation of bugs, leaves etc. has occurred. Clean radiator fins are necessary for good heat transfer. With the engine cold, apply cold water and compressed air to the back (engine side) of the radiator to flush the radiator and/or A/C condenser of debris.

FAN BLADE

INSPECTION

The fan cannot be repaired. If fan is damaged, it must be replaced. Inspect fan as follows:

- (1) Remove fan blade and viscous fan drive as an assembly from the engine.
- (2) Remove fan blade assembly from viscous fan drive unit (four bolts) (Fig. 27).
- (3) Lay fan on a flat surface with leading edge facing down. With tip of blade touching flat surface, replace fan if clearance between opposite blade and surface is greater than 2.0 mm (.090 inch). Rocking motion of opposite blades should not exceed 2.0 mm (.090 inch). Test all blades in this manner.

WARNING: DO NOT ATTEMPT TO BEND OR STRAIGHTEN FAN BLADES IF NOT WITHIN SPECIFICATIONS.

- (4) Inspect fan assembly for cracks, bends, loose rivets or broken welds. Replace fan if any damage is found.

CAUTION: If fan blade assembly is replaced because of mechanical damage, the fan pulley bearing and viscous fan drive should also be inspected. These components could have been damaged due to excessive vibration.

CAUTION: Some engines equipped with serpentine drive belts have reverse rotating fans and viscous fan drives. They are marked with the word REVERSE to designate their usage. Installation of the wrong fan or viscous fan drive can result in engine overheating.

CLEANING AND INSPECTION (Continued)

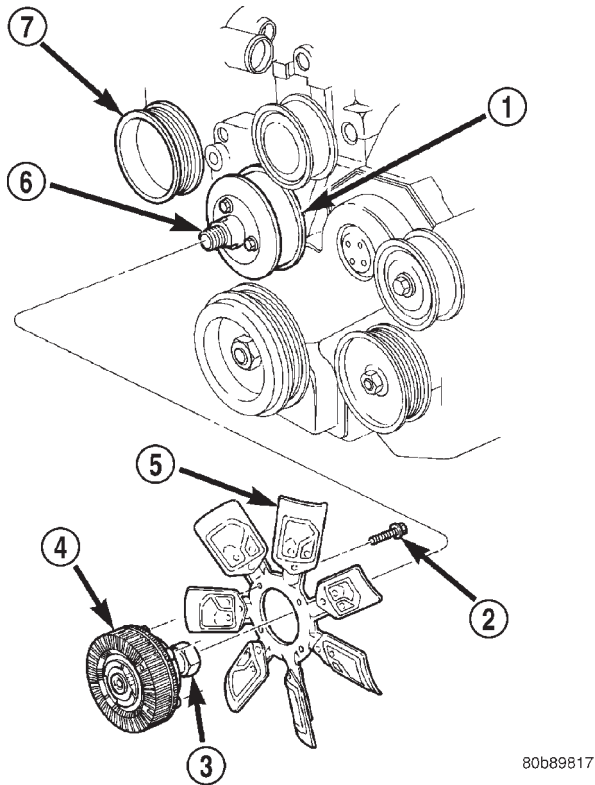

Fig. 27 Thermal Viscous Fan Drive and Blade Assembly

- 1 – FAN PULLEY
- 2 – FAN DRIVE-TO-FAN BLADE BOLTS (4)
- 3 – MOUNTING NUT
- 4 – THERMAL VISCOUS FAN DRIVE
- 5 – FAN BLADES
- 6 – FAN PULLEY SHAFT
- 7 – WATER PUMP

80b89817

PRESSURE/VENT CAP

INSPECTION

Visually inspect the gasket on the cap. Replace cap if the gasket is swollen, torn or worn. Inspect the area around the coolant tank filler neck for white deposits that indicate a leaking cap.

The cap must be replaced by a similar threaded-on unit with the correct operating pressures if replacement is necessary.

COOLING SYSTEM CLEANING/REVERSE FLUSHING

CAUTION: The cooling system normally operates at 90-to-117 kPa (13- to-17 psi) pressure. Exceeding this pressure may damage the radiator or hoses.

CLEANING

Drain cooling system and refill with water. Run engine with coolant tank pressure/vent cap installed until upper radiator hose is hot. Stop engine and drain water from system. If water is dirty, fill system with water, run engine and drain system. Repeat until water drains clean.

REVERSE FLUSHING

Reverse flushing of the cooling system is the forcing of water through the cooling system. This is done using air pressure in the opposite direction of normal coolant flow. It is usually only necessary with very dirty systems with evidence of partial plugging.

REVERSE FLUSHING RADIATOR

Disconnect the radiator hoses from the radiator fittings. Attach a section of radiator hose to the radiator bottom outlet fitting and insert the flushing gun. Connect a water supply hose and air supply hose to the flushing gun.

CAUTION: The cooling system normally operates at 90-to-117 kPa (13- to-17 psi) pressure. Exceeding this pressure may damage the radiator or hoses.

Allow the coolant tank and radiator to fill with water. When radiator is filled, apply air in short blasts allowing radiator to refill between blasts. Continue this reverse flushing until clean water flows out through rear of radiator cooling tube passages. For more information, refer to operating instructions supplied with flushing equipment. Have radiator cleaned more extensively by a radiator repair shop.

REVERSE FLUSHING ENGINE

Drain the cooling system. Remove the thermostat housing and thermostat. Install the thermostat housing. Disconnect the radiator upper hose from the radiator and attach the flushing gun to the hose. Disconnect the radiator lower hose from the water pump. Attach a lead away hose to the water pump inlet fitting.

CAUTION: Be sure that the heater water control valve is closed (heat off). This is done to prevent coolant flow with scale and other deposits from entering the heater core.

Connect the water supply hose and air supply hose to the flushing gun. Allow the engine to fill with water. When the engine is filled, apply air in short blasts, allowing the system to fill between air blasts. Continue until clean water flows through the lead away hose. For more information, refer to operating instructions supplied with flushing equipment.

CLEANING AND INSPECTION (Continued)

Remove the lead away hose, flushing gun, water supply hose and air supply hose. Remove the thermostat housing and install thermostat. Install the thermostat housing with a new replacement rubber seal. Refer to Thermostat Installation. Connect the radiator hoses. Refill the cooling system with the correct antifreeze/water mixture.

CHEMICAL CLEANING

In some instances, use a radiator cleaner (Mopar Radiator Kleen or equivalent) before flushing. This will soften scale and other deposits and aid the flushing operation.

CAUTION: Be sure instructions on the container are followed.

SPECIFICATIONS

COOLING SYSTEM CAPACITY

2.5L Diesel Engine: 9.8 Liters (10.4 qts.)

THERMOSTAT

Starts to open at 80°C (176°F).

TORQUE SPECIFICATIONS

| DESCRIPTION | TORQUE |
|--|---------|
| Automatic Belt Tensioner-to-Mounting Bracket Bolt (1) | 75 N·m |
| Automatic Belt Tensioner to Block Bolts (2) | 120 N·m |
| Coolant Tank Cap | 5 N·m |
| Fan Shroud-to-Radiator Mounting Bolts | 3 N·m |
| Fan Blade-to-Thermal Viscous Fan Drive Bolts | 23 N·m |
| Hose Clamps | 4 N·m |
| Radiator-to-A/C Condenser Isolator Nuts | 6 N·m |
| Thermal Viscous Fan Drive-to-Fan Hub Bolts | 56 N·m |
| Thermostat Housing Bolts | 11 N·m |
| Water Pump Mounting Bolts | 24 N·m |
| Water Pump Pulley Bolts | 24 N·m |

BATTERY

TABLE OF CONTENTS

| | page | | page |
|----------------------------------|------|---------------------------------|------|
| DESCRIPTION AND OPERATION | | REMOVAL AND INSTALLATION | |
| BATTERY..... | 1 | BATTERY CABLES | 18 |
| BATTERY CABLES | 3 | BATTERY HOLD DOWNS | 20 |
| BATTERY HOLD DOWNS | 4 | BATTERY..... | 21 |
| BATTERY THERMOGUARD..... | 5 | BATTERY THERMOGUARD..... | 22 |
| BATTERY TRAY..... | 5 | BATTERY TRAY..... | 22 |
| DIAGNOSIS AND TESTING | | CLEANING AND INSPECTION | |
| BATTERY..... | 5 | BATTERY..... | 23 |
| BATTERY CABLES | 14 | SPECIFICATIONS | |
| SERVICE PROCEDURES | | BATTERY..... | 24 |
| BATTERY CHARGING | 16 | | |

DESCRIPTION AND OPERATION

BATTERY

DESCRIPTION

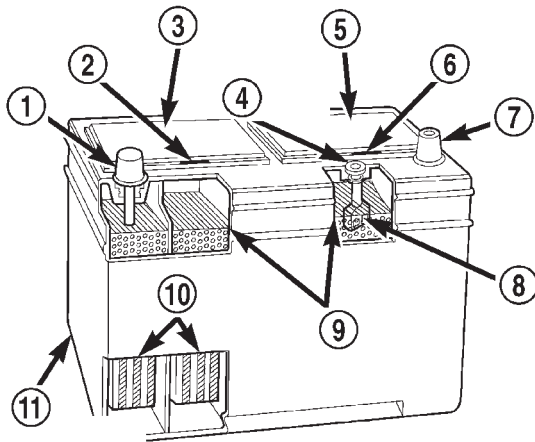

80accfel

Fig. 1 Low-Maintenance Battery - Typical

- 1 - POSITIVE POST
- 2 - VENT
- 3 - CELL CAP
- 4 - TEST INDICATOR
- 5 - CELL CAP
- 6 - VENT
- 7 - NEGATIVE POST
- 8 - GREEN BALL
- 9 - ELECTROLYTE LEVEL
- 10 - PLATE GROUPS
- 11 - LOW-MAINTENANCE BATTERY

A large capacity, low-maintenance storage battery (Fig. 1) is standard factory-installed equipment on this model. Male post type terminals made of a soft lead material protrude from the top of the molded plastic battery case to provide the means for connecting the battery to the vehicle electrical system. The battery positive terminal post is visibly larger in diameter than the negative terminal post, for easy identification. The letters **POS** and **NEG** are also molded into the top of the battery case adjacent to their respective positive and negative terminal posts for additional identification confirmation. Refer to **Battery Cables** in the index of this service manual for the location of more information on the battery cables that connect the battery to the vehicle electrical system.

This battery is designed to provide a safe, efficient and reliable means of storing electrical energy in a chemical form. This means of energy storage allows the battery to produce the electrical energy required to operate the engine starting system, as well as to operate many of the other vehicle accessory systems for limited durations while the engine and/or the charging system are not operating. The battery is made up of six individual cells that are connected in series. Each cell contains positively charged plate groups that are connected with lead straps to the positive terminal post, and negatively charged plate groups that are connected with lead straps to the negative terminal post. Each plate consists of a stiff mesh framework or grid coated with lead dioxide (positive plate) or sponge lead (negative plate). Insulators or plate separators made of a non-conductive material are inserted between the positive and negative plates to prevent them from contacting or short-

DESCRIPTION AND OPERATION (Continued)

ing against one another. These dissimilar metal plates are submerged in a sulfuric acid and water solution called an electrolyte.

The factory-installed battery has a built-in test indicator (hydrometer). The color visible in the sight glass of the indicator will reveal the battery condition. For more information on the use of the built-in test indicator, refer to **Battery** in the index of this service manual for the location of the proper battery diagnosis and testing procedures. **The factory-installed low-maintenance battery has removable battery cell caps.** Water can be added to this battery. The battery is not sealed and has vent holes in the cell caps. The chemical composition of the metal coated plates within the low-maintenance battery reduces battery gassing and water loss, at normal charge and discharge rates. Therefore, the battery should not require additional water in normal service. If the electrolyte level in this battery does become low, water must be added. However, rapid loss of electrolyte can be caused by an overcharging condition. Be certain to diagnose the charging system after replenishing the water in the battery for a low electrolyte condition and before returning the vehicle to service. Refer to **Charging System** in the index of this service manual for the location of the proper charging system diagnosis and testing procedures.

For battery maintenance schedules and jump starting procedures, see the owner's manual in the vehicle glove box. Optionally, refer to **Maintenance Schedules** and **Jump Starting, Towing and Hoisting** in the index of this service manual for the location of the recommended battery maintenance schedules and the proper battery jump starting procedures. While battery charging can be considered a maintenance procedure, the battery charging procedures and information are located in the service procedures section of this service manual. This was done because the battery must be fully-charged before any battery diagnosis or testing procedures can be performed. Refer to **Battery Charging** in the index of this service manual for the location of the proper battery charging procedures.

NOTE: This group covers both Left-Hand Drive (LHD) and Right-Hand Drive (RHD) versions of this model. Whenever required and feasible, the RHD versions of affected vehicle components have been constructed as mirror-image of the LHD versions. While most of the illustrations used in this group represent only the LHD version, the diagnostic and service procedures outlined can generally be applied to either version. Exceptions to this rule have been clearly identified as LHD or RHD, if a special illustration or procedure is required.

BATTERY SIZE AND RATINGS

The battery Group Size number, the Cold Cranking Amperage (CCA) rating, and the Reserve Capacity (RC) rating or Ampere-Hours (AH) rating can be found on the original equipment battery label. Be certain that a replacement battery has the correct Group Size number, as well as CCA, and RC or AH ratings that equal or exceed the original equipment specification for the vehicle being serviced. Refer to **Battery** in the index of this service manual for the location of the proper factory-installed battery specifications. Battery sizes and ratings are discussed in more detail below.

- Group Size

The outside dimensions and terminal placement of the battery conform to standards established by the Battery Council International (BCI). Each battery is assigned a BCI Group Size number to help identify a correctly-sized replacement.

- Cold Cranking Amperage

The Cold Cranking Amperage (CCA) rating specifies how much current (in amperes) the battery can deliver for thirty seconds at -18°C (0°F). Terminal voltage must not fall below 7.2 volts during or after the thirty second discharge period. The CCA required is generally higher as engine displacement increases, depending also upon the starter current draw requirements.

- Reserve Capacity

The Reserve Capacity (RC) rating specifies the time (in minutes) it takes for battery terminal voltage to fall below 10.5 volts, at a discharge rate of 25 amperes. RC is determined with the battery fully-charged at 26.7°C (80°F). This rating estimates how long the battery might last after a charging system failure, under minimum electrical load.

- Ampere-Hours

The Ampere-Hours (AH) rating specifies the current (in amperes) that a battery can deliver steadily for twenty hours, with the voltage in the battery not falling below 10.5 volts. This rating is also sometimes identified as the twenty-hour discharge rating.

OPERATION

When an electrical load is applied to the terminals of the battery, an electrochemical reaction occurs. This reaction causes the battery to discharge electrical current from its terminals. As the battery discharges, a gradual chemical change takes place within each cell. The sulfuric acid in the electrolyte combines with the plate materials, causing both plates to slowly change to lead sulfate. At the same time, oxygen from the positive plate material combines with hydrogen from the sulfuric acid, causing the electrolyte to become mainly water. The chemical changes within the battery are caused by the move-

DESCRIPTION AND OPERATION (Continued)

ment of excess or free electrons between the positive and negative plate groups. This movement of electrons produces a flow of electrical current through the load device attached to the battery terminals.

As the plate materials become more similar chemically, and the electrolyte becomes less acid, the voltage potential of each cell is reduced. However, by charging the battery with a voltage higher than that of the battery itself, the battery discharging process is reversed. Charging the battery gradually changes the sulfated lead plates back into sponge lead and lead dioxide, and the water back into sulfuric acid. This action restores the difference in the electron charges deposited on the plates, and the voltage potential of the battery cells. For a battery to remain useful, it must be able to produce high-amperage current over an extended period. A battery must also be able to accept a charge, so that its voltage potential may be restored.

The battery is vented to release excess hydrogen gas that is created when the battery is being charged or discharged. However, even with these vents, hydrogen gas can collect in or around the battery. If hydrogen gas is exposed to flame or sparks, it may ignite. If the electrolyte level is low, the battery may arc internally and explode. If the battery is equipped with removable cell caps, add distilled water whenever the electrolyte level is below the top of the plates. If the battery cell caps cannot be removed, the battery must be replaced if the electrolyte level becomes low.

In addition to producing and storing electrical energy, the battery serves as a capacitor and voltage stabilizer for the electrical system of the vehicle. It absorbs most abnormal or transient voltages caused by the switching of any of the electrical components in the vehicle.

BATTERY CABLES

DESCRIPTION

The battery cables (Fig. 2) are large gauge, stranded copper wires sheathed within a heavy plastic or synthetic rubber insulating jacket. The wire used in the battery cables combines excellent flexibility and reliability with high electrical current carrying capacity. Refer to **Wiring Diagrams** in the index of this service manual for the location of the proper battery cable wire gauge information.

A clamping type female battery terminal made of soft lead is die cast onto one end of the battery cable wire. A square headed pinch-bolt and hex nut are installed at the open end of the female battery terminal clamp. Large eyelet type terminals are crimped onto the opposite end of the battery cable wire and then solder-dipped. The battery positive cable wires

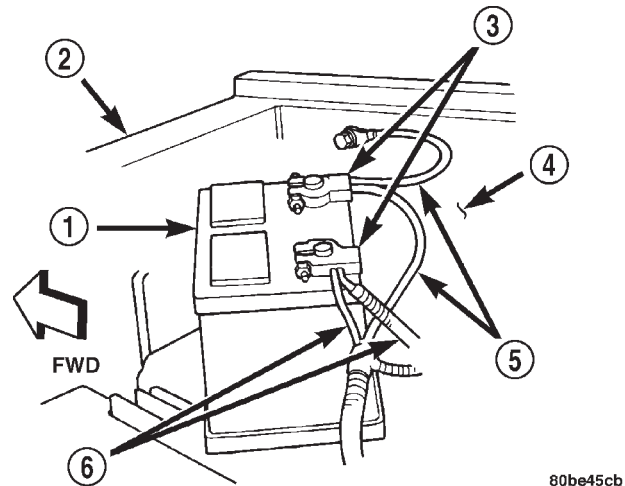

Fig. 2 Battery Cables

- 1 - BATTERY
- 2 - RADIATOR CROSSMEMBER
- 3 - TERMINAL CLAMPS
- 4 - FENDER INNER SHIELD
- 5 - NEGATIVE CABLE
- 6 - POSITIVE CABLE

have a red insulating jacket to provide visual identification and features a larger female battery terminal clamp to allow connection to the larger battery positive terminal post. The battery negative cable wires have a black insulating jacket and a smaller female battery terminal clamp.

The battery cables cannot be repaired and, if damaged or faulty they must be replaced. Both the battery positive and negative cables are available for service replacement only as a unit with the battery wire harness, which may include portions of the wiring circuits for the generator and other components on some models. Refer to **Wiring Diagrams** in the index of this service manual for the location of more information on the various wiring circuits included in the battery wire harness for the vehicle being serviced.

OPERATION

The battery cables connect the battery terminal posts to the vehicle electrical system. These cables also provide a return path for electrical current generated by the charging system for restoring the voltage potential of the battery. The female battery terminal clamps on the ends of the battery cable wires provide a strong and reliable connection of the battery cable to the battery terminal posts. The terminal pinch bolts allow the female terminal clamps to be tightened around the male terminal posts on the top of the battery. The eyelet terminals secured to the ends of the battery cable wires opposite the female battery terminal clamps provide secure and

DESCRIPTION AND OPERATION (Continued)

reliable connection of the battery to the vehicle electrical system.

The battery positive cable terminal clamp is die cast onto the ends of two wires. One wire has an eyelet terminal that connects the battery positive cable to the B(+) terminal stud of the Power Distribution Center (PDC), and the other wire has an eyelet terminal that connects the battery positive cable to the B(+) terminal stud of the engine starter motor solenoid. The battery negative cable terminal clamp is also die cast onto the ends of two wires. One wire has an eyelet terminal that connects the battery negative cable to the vehicle powertrain through a stud on the right side of the engine block. The other wire has an eyelet terminal that connects the battery negative cable to the vehicle body through a ground screw on the right front fender inner shield, near the battery.

BATTERY HOLD DOWNS

DESCRIPTION

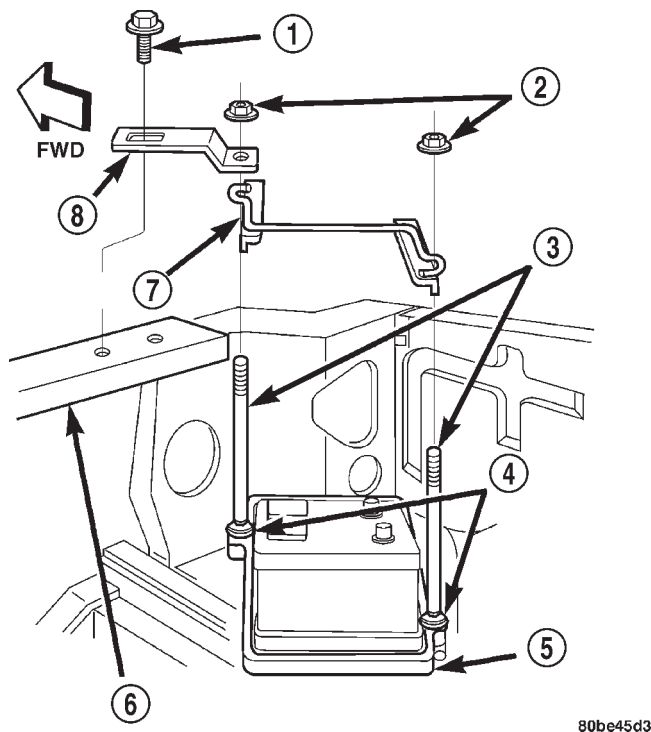

80be45d3

Fig. 3 Battery Hold Downs

- 1 - SCREW AND WASHER (1)
- 2 - NUT AND WASHER (2)
- 3 - T-BOLT (2)
- 4 - RETAINER (2)
- 5 - BATTERY TRAY
- 6 - UPPER RADIATOR CROSS MEMBER
- 7 - BRACKET
- 8 - STRAP

The battery hold down hardware (Fig. 3) includes two T-bolts with plastic push-on retainers, a hold down bracket, a stamped steel battery support strap, two hex nuts with coned washers and a single hex screw with a coned washer. The battery hold down bracket consists of a formed steel rod with a stamped steel angle bracket welded to each end. The hold down bracket assembly is then plastic-coated for corrosion protection.

When installing a battery into the battery tray, be certain that the hold down hardware is properly installed and that the fasteners are tightened to the proper specifications. Improper hold down fastener tightness, whether too loose or too tight, can result in damage to the battery, the vehicle or both. Refer to **Battery Hold Downs** in the index of this service manual for the location of the proper battery hold down installation procedures, including the proper hold down fastener tightness specifications.

OPERATION

The battery hold down hardware secures the battery to the battery tray in the engine compartment. The hold down support strap provides an additional anchor point for the upper end of the battery and hold down hardware at the upper radiator crossmember. This hardware is designed to prevent battery movement during vehicle operation. Unrestrained battery movement during vehicle operation can result in damage to the vehicle, the battery or both.

The hold down T-bolts are installed onto the battery tray before the tray is installed in the engine compartment. The T-bolts are inserted through a hole in a molded formation integral to each side of the battery tray from underneath, with the threaded ends of the bolts extending upward. A plastic push-on retainer is installed over each T-bolt to secure the T-bolts to the battery tray for ease of assembly during the vehicle manufacturing process. However, these plastic push-on retainers are not available or required for service replacement.

The battery hold down bracket is installed across the top of the battery case and over the two upright threaded ends of the T-bolts. The round hole in the support strap is then installed over the threaded end of the forward T-bolt and the slotted hole of the strap is secured by a screw with washer to the upper radiator cross member. A hex nut with coned washer is then installed and tightened onto each of the T-bolts to securely hold down the battery in the battery tray.

DESCRIPTION AND OPERATION (Continued)

BATTERY THERMOGUARD

DESCRIPTION

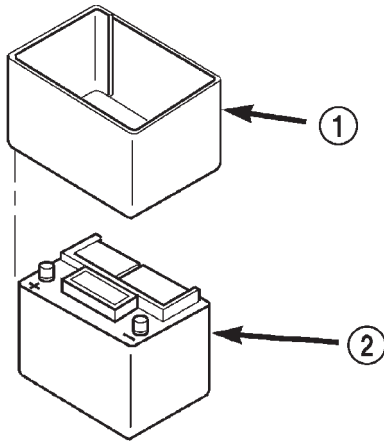

80be45d4

Fig. 4 Battery Thermoguard

- 1 - THERMOGUARD
- 2 - BATTERY

A flexible plastic bubble-wrap style thermoguard (Fig. 4) slides over the battery case to enclose the sides of the battery. The thermoguard consists of a heavy black plastic outer skin and two lighter plies of plastic that have been formed into a sheet with hundreds of small air pockets entrapped between them. The resulting material is very similar to the bubble-wrap used to protect items in many parcel packaging and shipping applications.

OPERATION

The thermoguard protects the battery from engine compartment temperature extremes. The air trapped between the plastic plies of the thermoguard create a dead air space, which helps to insulate the sides of the battery case from the surrounding engine compartment air temperature.

BATTERY TRAY

DESCRIPTION

The battery is mounted in a molded plastic tray (Fig. 5) located in the right front corner of the engine compartment. Two T-bolts that are part of the battery hold down hardware are assembled to the battery tray before the tray is installed in the vehicle. The battery tray is secured by three hex nuts with coned washers to three weld studs located on the front extension of the right front wheelhouse inner panel, forward of the right front wheel.

A hole in the bottom of the battery tray is fitted with a battery temperature sensor. Refer to **Battery Temperature Sensor** in the index of this service

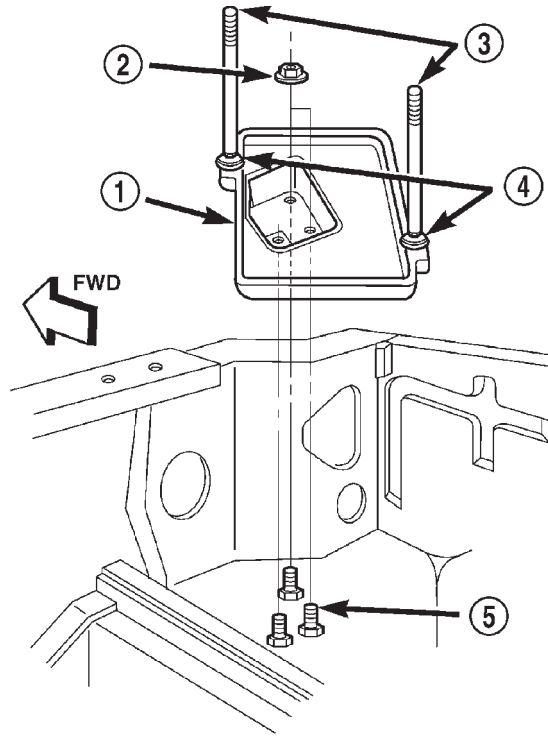

80be45d5

Fig. 5 Battery Tray

- 1 - TRAY
- 2 - NUT AND WASHER (3)
- 3 - T-BOLT (2)
- 4 - RETAINER (2)
- 5 - WELD STUD (3)

manual for the location of more information on the battery temperature sensor. Refer to **Battery Hold Downs** in the index of this service manual for the location of more information on the battery hold down hardware.

OPERATION

The battery tray provides a mounting location and support for the vehicle battery. The battery tray also provides anchor points for the battery hold down hardware. The battery tray and the battery hold down hardware combine to secure and stabilize the battery in the engine compartment, which prevents battery movement during vehicle operation. Unrestrained battery movement during vehicle operation can result in damage to the vehicle, the battery or both.

DIAGNOSIS AND TESTING

BATTERY

DIAGNOSIS

The battery, starting system and charging system in the vehicle operate with one another, and must be

DIAGNOSIS AND TESTING (Continued)

tested as a complete system. In order for the engine to start and the battery to charge properly, all of the components that are used in these systems must perform within specifications. It is important that the battery, starting system and charging system be thoroughly tested and inspected any time a battery needs to be charged or replaced. The cause of abnormal discharge, overcharging or early battery failure must be diagnosed and corrected before a battery is replaced and before a vehicle is returned to service. The service information for these systems has been separated within this service manual to make it easier to locate the specific information you are seeking. However, when attempting to diagnose any of these systems, it is important that you keep their interdependency in mind.

The diagnostic procedures used for the battery, starting system and charging system include the most basic conventional diagnostic methods, to the more sophisticated On-Board Diagnostics (OBD) built into the Powertrain Control Module (PCM). Use of an induction-type milliampere ammeter, a volt/ohmmeter, a battery charger, a carbon pile rheostat (load tester) and a 12-volt test lamp may be required. All OBD-sensed systems are monitored by the PCM. Each monitored circuit is assigned a Diagnostic Trouble Code (DTC). The PCM will store a DTC in electronic memory for any failure it detects. Refer to **Charging System, On-Board Diagnostic Test** in the index of this service manual for the location of the proper on-board diagnostic test procedures.

The battery must be completely charged and the top, posts and terminal clamps should be properly cleaned and inspected before diagnostic procedures are performed. Refer to **Battery** in the index of this service manual for the location of the proper battery cleaning and inspection procedures. Refer to **Battery Charging** in the index of this service manual for the location of the proper battery charging procedures.

WARNING:

- IF THE BATTERY SHOWS SIGNS OF FREEZING, LEAKING, LOOSE POSTS, OR LOW ELECTROLYTE LEVEL, DO NOT TEST, ASSIST-BOOST, OR CHARGE. THE BATTERY MAY ARC INTERNALLY AND EXPLODE. PERSONAL INJURY AND/OR VEHICLE DAMAGE MAY RESULT.

- EXPLOSIVE HYDROGEN GAS FORMS IN AND AROUND THE BATTERY. DO NOT SMOKE, USE FLAME, OR CREATE SPARKS NEAR THE BATTERY. PERSONAL INJURY AND/OR VEHICLE DAMAGE MAY RESULT.

- THE BATTERY CONTAINS SULFURIC ACID, WHICH IS POISONOUS AND CAUSTIC. AVOID CONTACT WITH THE SKIN, EYES, OR CLOTHING. IN THE EVENT OF CONTACT, FLUSH WITH WATER

AND CALL A PHYSICIAN IMMEDIATELY. KEEP OUT OF THE REACH OF CHILDREN.

- IF THE BATTERY IS EQUIPPED WITH REMOVABLE CELL CAPS, BE CERTAIN THAT EACH OF THE CELL CAPS IS IN PLACE AND TIGHT BEFORE THE BATTERY IS RETURNED TO SERVICE. PERSONAL INJURY AND/OR VEHICLE DAMAGE MAY RESULT FROM LOOSE OR MISSING CELL CAPS.

The condition of a battery is determined by two criteria:

1. State-Of-Charge

This can be determined by checking the specific gravity of the battery electrolyte (built-in test indicator or hydrometer test), or by checking the battery voltage (open-circuit voltage test).

2. Cranking Capacity

This can be determined by performing a battery load test, which measures the ability of the battery to supply high-amperage current.

First, determine the battery state-of-charge. This can be done in one of three ways. If the battery has a built-in test indicator, view the test indicator to determine the state-of-charge. If the battery has no test indicator but does have removable cell caps, perform the hydrometer test to determine the state-of-charge. If the battery cell caps are not removable, or a hydrometer is not available, perform the open-circuit voltage test to determine the state-of-charge.

The battery must be charged before proceeding with a load test if:

- The battery built-in test indicator has a black or dark color visible.
- The temperature corrected specific gravity of the battery electrolyte is less than 1.235.
- The battery open-circuit voltage is less than 12.4 volts.

A battery that will not accept a charge is faulty, and must be replaced. Further testing is not required. A fully-charged battery must be load tested to determine its cranking capacity. A battery that is fully-charged, but does not pass the load test, is faulty and must be replaced.

NOTE: Completely discharged batteries may take several hours to accept a charge. Refer to **Battery Charging** in the index of this service manual for the location of the proper battery charging procedures.

A battery is fully-charged when:

- All battery cells are gassing freely during charging.
- A green color is visible in the sight glass of the battery built-in test indicator.
- Three corrected specific gravity tests, taken at one-hour intervals, indicate no increase in the specific gravity of the battery electrolyte.
- Open-circuit voltage of the battery is 12.4 volts or greater.

DIAGNOSIS AND TESTING (Continued)

| Battery Diagnosis | | |
|--|---|---|
| Condition | Possible Causes | Correction |
| <p>The battery seems weak or dead when attempting to start the engine.</p> | <ol style="list-style-type: none"> 1. The battery has an incorrect size or rating for this vehicle. 2. The battery is physically damaged. 3. The battery terminal connections are loose or corroded. 4. The battery is discharged. 5. The electrical system ignition-off draw is excessive. 6. The battery is faulty. 7. The starting system is faulty. 8. The charging system is faulty. | <ol style="list-style-type: none"> 1. Refer to Battery in the index of this service manual for the location of the proper battery specifications. Replace an incorrect battery, as required. 2. Inspect the battery for loose terminal posts or a cracked and leaking case. Replace the damaged battery, as required. 3. Refer to Battery Cables in the index of this service manual for the location of the proper battery cable diagnosis and testing procedures. Clean and tighten the battery terminal connections, as required. 4. Determine the battery state-of-charge. Refer to Built-In Test Indicator, Hydrometer Test, or Open-Circuit Voltage Test in this section for the proper test procedures. Charge the faulty battery, as required. 5. Refer to Ignition-Off Draw Test in this section for the proper test procedures. Repair the faulty electrical system, as required. 6. Determine the battery cranking capacity. Refer to Load Test in this section for the proper test procedures. Replace the faulty battery, as required. 7. Determine if the starting system is performing to specifications. Refer to Starting System in the index of this service manual for the location of the proper starting system diagnosis and testing procedures. Repair the faulty starting system, as required. 8. Determine if the charging system is performing to specifications. Refer to Charging System in the index of this service manual for the location of the proper charging system diagnosis and testing procedures. Repair the faulty charging system, as required. |

DIAGNOSIS AND TESTING (Continued)

| Battery Diagnosis | | |
|---|---|---|
| Condition | Possible Causes | Correction |
| The battery state-of-charge cannot be maintained. | <ol style="list-style-type: none"> 1. The battery has an incorrect size or rating for this vehicle. 2. The battery terminal connections are loose or corroded. 3. The generator drive belt is slipping. 4. The electrical system ignition-off draw is excessive. 5. The battery is faulty. 6. The starting system is faulty. 7. The charging system is faulty. 8. Electrical loads exceed the output of the charging system. 9. Slow driving or prolonged idling with high-amperage draw systems in use. | <ol style="list-style-type: none"> 1. Refer to Battery in the index of this service manual for the location of the proper battery specifications. Replace an incorrect battery, as required. 2. Refer to Battery Cables in the index of this service manual for the location of the proper battery cable diagnosis and testing procedures. Clean and tighten the battery terminal connections, as required. 3. Refer to Accessory Drive Belt Diagnosis in the index of this service manual for the location of the proper accessory drive belt diagnosis and testing procedures. Replace or adjust the faulty generator drive belt, as required. 4. Refer to Ignition-Off Draw Test in this section for the proper test procedures. Repair the faulty electrical system, as required. 5. Determine the battery cranking capacity. Refer to Load Test in this section for the proper test procedures. Replace the faulty battery, as required. 6. Determine if the starting system is performing to specifications. Refer to Starting System in the index of this service manual for the location of the proper starting system diagnosis and testing procedures. Repair the faulty starting system, as required. 7. Determine if the charging system is performing to specifications. Refer to Charging System in the index of this service manual for the location of the proper charging system diagnosis and testing procedures. Repair the faulty charging system, as required. 8. Inspect the vehicle for aftermarket electrical equipment which might cause excessive electrical loads. 9. Advise the vehicle operator, as required. |
| The battery will not accept a charge. | <ol style="list-style-type: none"> 1. The battery is faulty. | <ol style="list-style-type: none"> 1. Refer to Battery Charging in the index of this service manual for the location of the proper battery charging procedures. Charge or replace the faulty battery, as required. |

ABNORMAL BATTERY DISCHARGING

Any of the following conditions can result in abnormal battery discharging:

1. Corroded or loose battery posts and terminal clamps.

2. A loose or worn generator drive belt.

3. Electrical loads that exceed the output of the charging system. This can be due to equipment installed after manufacture, or repeated short trip use.

4. Slow driving speeds (heavy traffic conditions) or prolonged idling, with high-amperage draw systems in use.

5. A faulty circuit or component causing excessive ignition-off draw.

6. A faulty or incorrect charging system component. Refer to **Charging System** in the index of this service manual for the location of the proper charging system diagnosis and testing procedures.

DIAGNOSIS AND TESTING (Continued)

7. A faulty or incorrect starting system component. Refer to **Starting System** in the index of this service manual for the location of the proper starting system diagnosis and testing procedures.

8. A faulty or incorrect battery.

TESTING

BUILT-IN TEST INDICATOR

A test indicator (hydrometer) built into the top of the battery case provides visual information for battery testing (Fig. 6). Like a hydrometer, the built-in test indicator measures the specific gravity of the battery electrolyte. The test indicator reveals the battery state-of-charge; however, it will not reveal the cranking capacity of the battery. A load test must be performed to determine the battery cranking capacity. Refer to **Load Test** in this section for the proper battery load testing procedures.

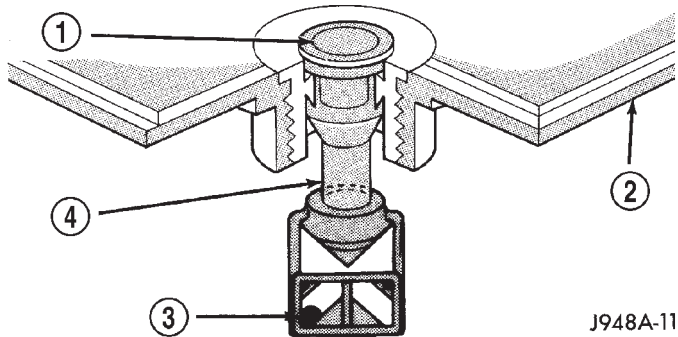

Fig. 6 Built-In Test Indicator

- 1 - SIGHT GLASS
- 2 - BATTERY TOP
- 3 - GREEN BALL
- 4 - PLASTIC ROD

WARNING:

- IF THE BATTERY SHOWS SIGNS OF FREEZING, LEAKING, LOOSE POSTS, OR LOW ELECTROLYTE LEVEL, DO NOT TEST, ASSIST-BOOST, OR CHARGE. THE BATTERY MAY ARC INTERNALLY AND EXPLODE. PERSONAL INJURY AND/OR VEHICLE DAMAGE MAY RESULT.

- EXPLOSIVE HYDROGEN GAS FORMS IN AND AROUND THE BATTERY. DO NOT SMOKE, USE FLAME, OR CREATE SPARKS NEAR THE BATTERY. PERSONAL INJURY AND/OR VEHICLE DAMAGE MAY RESULT.

- THE BATTERY CONTAINS SULFURIC ACID, WHICH IS POISONOUS AND CAUSTIC. AVOID CONTACT WITH THE SKIN, EYES, OR CLOTHING. IN THE EVENT OF CONTACT, FLUSH WITH WATER AND CALL A PHYSICIAN IMMEDIATELY. KEEP OUT OF THE REACH OF CHILDREN.

- IF THE BATTERY IS EQUIPPED WITH REMOVABLE CELL CAPS, BE CERTAIN THAT EACH OF THE CELL CAPS IS IN PLACE AND TIGHT BEFORE THE BATTERY IS RETURNED TO SERVICE. PERSONAL INJURY AND/OR VEHICLE DAMAGE MAY RESULT FROM LOOSE OR MISSING CELL CAPS.

Before testing, visually inspect the battery for any damage (a cracked case or cover, loose posts, etc.) that would cause the battery to be faulty. In order to obtain correct indications from the built-in test indicator, it is important that the battery be level and have a clean sight glass. Additional light may be required to view the indicator. **Do not use open flame as a source of additional light.**

To read the built-in test indicator, look into the sight glass and note the color of the indicator (Fig. 7). The battery condition that each color indicates is described in the following list:

- Green

Indicates 75% to 100% battery state-of-charge. The battery is adequately charged for further testing or return to service. If the starter will not crank for a minimum of fifteen seconds with a fully-charged battery, the battery must be load tested. Refer to **Load Test** in this section for the proper battery load testing procedures.

- Black or Dark

Indicates 0% to 75% battery state-of-charge. The battery is inadequately charged and must be charged until a green indication is visible in the sight glass (12.4 volts or more), before the battery is tested further or returned to service. Refer to **Battery Charging** in the index of this service manual for the location of the proper battery charging procedures. Also refer to **Abnormal Battery Discharging** in this section for the possible causes of the discharged battery condition.

- Clear or Bright

Indicates a low battery electrolyte level. The electrolyte level in the battery is below the test indicator. A maintenance-free battery with non-removable cell caps must be replaced if the electrolyte level is low. Water must be added to a low-maintenance battery with removable cell caps before it is charged. Refer to **Battery Charging** in the index of this service manual for the location of the proper battery charging procedures. A low electrolyte level may be caused by an overcharging condition. Refer to **Charging System** in the index of this service manual for the location of the proper charging system diagnosis and testing procedures.

DIAGNOSIS AND TESTING (Continued)

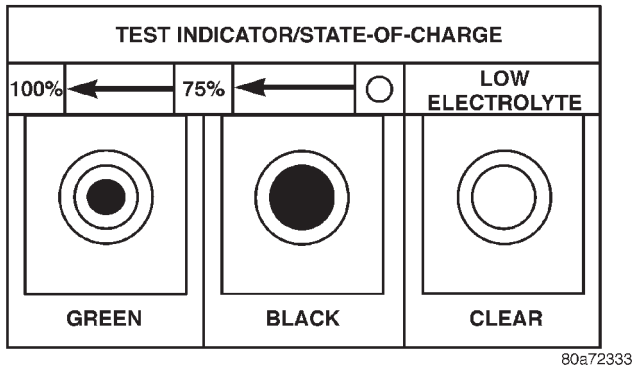

Fig. 7 Built-In Test Indicator Sight Glass

HYDROMETER TEST

The hydrometer test reveals the battery state-of-charge by measuring the specific gravity of the electrolyte. **This test cannot be performed on maintenance-free batteries with non-removable cell caps.** If the battery has non-removable cell caps, refer to **Built-In Test Indicator** or **Open-Circuit Voltage Test** in this section for the proper procedures for performing these alternate tests of the battery state-of-charge.

Specific gravity is a comparison of the density of the battery electrolyte to the density of pure water. Pure water has a specific gravity of 1.000, and sulfuric acid has a specific gravity of 1.835. Sulfuric acid makes up approximately 35% of the battery electrolyte by weight, or 24% by volume. In a fully-charged battery the electrolyte will have a temperature-corrected specific gravity of 1.260 to 1.290. However, a specific gravity of 1.235 or above is satisfactory for battery load testing and/or return to service.

WARNING:

- IF THE BATTERY SHOWS SIGNS OF FREEZING, LEAKING, LOOSE POSTS, OR LOW ELECTROLYTE LEVEL, DO NOT TEST, ASSIST-BOOST, OR CHARGE. THE BATTERY MAY ARC INTERNALLY AND EXPLODE. PERSONAL INJURY AND/OR VEHICLE DAMAGE MAY RESULT.

- EXPLOSIVE HYDROGEN GAS FORMS IN AND AROUND THE BATTERY. DO NOT SMOKE, USE FLAME, OR CREATE SPARKS NEAR THE BATTERY. PERSONAL INJURY AND/OR VEHICLE DAMAGE MAY RESULT.

- THE BATTERY CONTAINS SULFURIC ACID, WHICH IS POISONOUS AND CAUSTIC. AVOID CONTACT WITH THE SKIN, EYES, OR CLOTHING. IN THE EVENT OF CONTACT, FLUSH WITH WATER AND CALL A PHYSICIAN IMMEDIATELY. KEEP OUT OF THE REACH OF CHILDREN.

- IF THE BATTERY IS EQUIPPED WITH REMOVABLE CELL CAPS, BE CERTAIN THAT EACH OF THE CELL CAPS IS IN PLACE AND TIGHT BEFORE

THE BATTERY IS RETURNED TO SERVICE. PERSONAL INJURY AND/OR VEHICLE DAMAGE MAY RESULT FROM LOOSE OR MISSING CELL CAPS.

Before testing, visually inspect the battery for any damage (a cracked case or cover, loose posts, etc.) that would cause the battery to be faulty. Then remove the battery cell caps and check the electrolyte level. Add distilled water if the electrolyte level is below the top of the battery plates.

See the instructions provided by the manufacturer of the hydrometer for recommendations on the correct use of the hydrometer that you are using. Remove only enough electrolyte from the battery cell so that the float is off the bottom of the hydrometer barrel with pressure on the bulb released. To read the hydrometer correctly, hold it with the top surface of the electrolyte at eye level (Fig. 8).

CAUTION: Exercise care when inserting the tip of the hydrometer into a battery cell to avoid damaging the plate separators. Damaged plate separators can cause early battery failure.

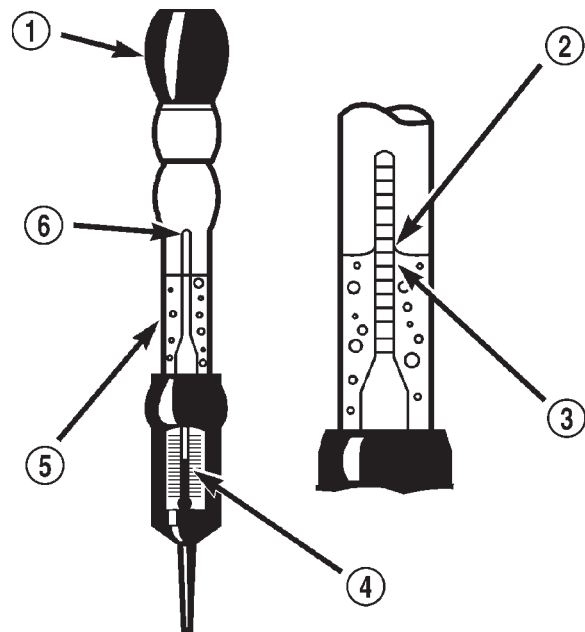

80a483b9

Fig. 8 Hydrometer - Typical

- 1 - BULB
- 2 - SURFACE COHESION
- 3 - SPECIFIC GRAVITY READING
- 4 - TEMPERATURE READING
- 5 - HYDROMETER BARREL
- 6 - FLOAT

Hydrometer floats are generally calibrated to indicate the specific gravity correctly only at 26.7° C (80° F). When testing the specific gravity at any other temperature, a correction factor is required. The cor-

DIAGNOSIS AND TESTING (Continued)

rection factor is approximately a specific gravity value of 0.004, which may also be identified as four points of specific gravity. For each 5.5° C above 26.7° C (10° F above 80° F), add four points. For each 5.5° C below 26.7° C (10° F below 80° F), subtract four points. Always correct the specific gravity for temperature variation.

EXAMPLE: A battery is tested at -12.2° C (10° F) and has a specific gravity of 1.240. Determine the actual specific gravity as follows:

(1) Determine the number of degrees above or below 26.7° C (80° F): **26.6° C - -12.2° C = 38.8° C (80° F - 10° F = 70° F)**

(2) Divide the result from Step 1 by 5.5° C (10° F): **38.8° C ÷ 5.5° C = 7 (70° F ÷ 10° F = 7)**

(3) Multiply the result from Step 2 by the temperature correction factor (0.004): **7 X 0.004 = 0.028**

(4) The temperature at testing was below 26.7° C (80° F); therefore, the temperature correction factor is subtracted: **1.240 - 0.028 = 1.212**

(5) The corrected specific gravity of the battery cell in this example is 1.212.

Test the specific gravity of the electrolyte in each battery cell. If the specific gravity of all cells is above 1.235, but the variation between cells is more than fifty points (0.050), the battery should be replaced. If the specific gravity of one or more cells is less than 1.235, charge the battery at a rate of approximately five amperes. Continue charging the battery until three consecutive specific gravity tests, taken at one-hour intervals, are constant. If the cell specific gravity variation is more than fifty points (0.050) at the end of the charge period, replace the battery.

When the specific gravity of all cells is above 1.235, and the cell variation is less than fifty points (0.050), the battery may be load tested to determine its cranking capacity. Refer to **Load Test** in this section for the proper battery load testing procedures.

OPEN-CIRCUIT VOLTAGE TEST

A battery open-circuit voltage (no load) test will show the state-of-charge of a battery. This test can be used in place of the hydrometer test when a hydrometer is not available, or for maintenance-free batteries with non-removable cell caps.

WARNING:

- IF THE BATTERY SHOWS SIGNS OF FREEZING, LEAKING, LOOSE POSTS, OR LOW ELECTROLYTE LEVEL, DO NOT TEST, ASSIST-BOOST, OR CHARGE. THE BATTERY MAY ARC INTERNALLY AND EXPLODE. PERSONAL INJURY AND/OR VEHICLE DAMAGE MAY RESULT.

- EXPLOSIVE HYDROGEN GAS FORMS IN AND AROUND THE BATTERY. DO NOT SMOKE, USE FLAME, OR CREATE SPARKS NEAR THE BATTERY.

PERSONAL INJURY AND/OR VEHICLE DAMAGE MAY RESULT.

- THE BATTERY CONTAINS SULFURIC ACID, WHICH IS POISONOUS AND CAUSTIC. AVOID CONTACT WITH THE SKIN, EYES, OR CLOTHING. IN THE EVENT OF CONTACT, FLUSH WITH WATER AND CALL A PHYSICIAN IMMEDIATELY. KEEP OUT OF THE REACH OF CHILDREN.

- IF THE BATTERY IS EQUIPPED WITH REMOVABLE CELL CAPS, BE CERTAIN THAT EACH OF THE CELL CAPS IS IN PLACE AND TIGHT BEFORE THE BATTERY IS RETURNED TO SERVICE. PERSONAL INJURY AND/OR VEHICLE DAMAGE MAY RESULT FROM LOOSE OR MISSING CELL CAPS.

Before proceeding with this test, completely charge the battery. Refer to **Battery Charging** in the index of this service manual for the location of the proper battery charging procedures.

(1) Before measuring the open-circuit voltage, the surface charge must be removed from the battery. Turn on the headlamps for fifteen seconds, then allow up to five minutes for the battery voltage to stabilize.

(2) Disconnect and isolate both battery cables, negative cable first.

(3) Using a voltmeter connected to the battery posts (see the instructions provided by the manufacturer of the voltmeter), measure the open-circuit voltage (Fig. 9).

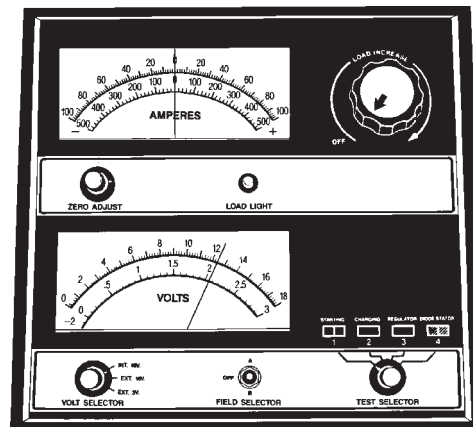

Fig. 9 Testing Open-Circuit Voltage - Typical

See the Open-Circuit Voltage chart. This voltage reading will indicate the battery state-of-charge, but will not reveal its cranking capacity. If a battery has an open-circuit voltage reading of 12.4 volts or greater, it may be load tested to reveal its cranking capacity. Refer to **Load Test** in this section for the proper battery load testing procedures.

DIAGNOSIS AND TESTING (Continued)

| Open Circuit Voltage | |
|----------------------|-------------------|
| Open Circuit Volts | Charge Percentage |
| 11.7 volts or less | 0% |
| 12.0 volts | 25% |
| 12.2 volts | 50% |
| 12.4 volts | 75% |
| 12.6 volts or more | 100% |

LOAD TEST

A battery load test will verify the battery cranking capacity. The test is based on the Cold Cranking Amperage (CCA) rating of the battery. See the label affixed to the battery case, or refer to **Battery** in the index of this service manual for the location of the proper factory-installed battery specifications to determine the battery CCA rating.

WARNING:

- IF THE BATTERY SHOWS SIGNS OF FREEZING, LEAKING, LOOSE POSTS, OR LOW ELECTROLYTE LEVEL, DO NOT TEST, ASSIST-BOOST, OR CHARGE. THE BATTERY MAY ARC INTERNALLY AND EXPLODE. PERSONAL INJURY AND/OR VEHICLE DAMAGE MAY RESULT.

- EXPLOSIVE HYDROGEN GAS FORMS IN AND AROUND THE BATTERY. DO NOT SMOKE, USE FLAME, OR CREATE SPARKS NEAR THE BATTERY. PERSONAL INJURY AND/OR VEHICLE DAMAGE MAY RESULT.

- THE BATTERY CONTAINS SULFURIC ACID, WHICH IS POISONOUS AND CAUSTIC. AVOID CONTACT WITH THE SKIN, EYES, OR CLOTHING. IN THE EVENT OF CONTACT, FLUSH WITH WATER AND CALL A PHYSICIAN IMMEDIATELY. KEEP OUT OF THE REACH OF CHILDREN.

- IF THE BATTERY IS EQUIPPED WITH REMOVABLE CELL CAPS, BE CERTAIN THAT EACH OF THE CELL CAPS IS IN PLACE AND TIGHT BEFORE THE BATTERY IS RETURNED TO SERVICE. PERSONAL INJURY AND/OR VEHICLE DAMAGE MAY RESULT FROM LOOSE OR MISSING CELL CAPS.

Before proceeding with this test, completely charge the battery. Refer to **Battery Charging** in the index of this service manual for the location of the proper battery charging procedures.

(1) Disconnect and isolate both battery cables, negative cable first. The battery top and posts should be clean.

(2) Connect a suitable volt-ammeter-load tester (Fig. 10) to the battery posts (Fig. 11). See the instructions provided by the manufacturer of the tester you are using. Check the open-circuit voltage (no load) of the battery. Refer to **Open-Circuit Volt-**

age Test in this section for the proper battery open-circuit voltage test procedures. The battery open-circuit voltage must be 12.4 volts or greater.

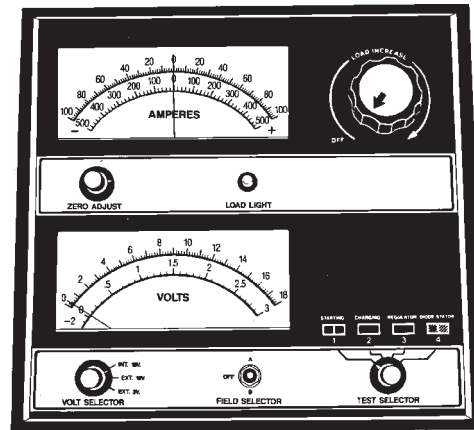

898A-8

Fig. 10 Volt-Ammeter-Load Tester - Typical

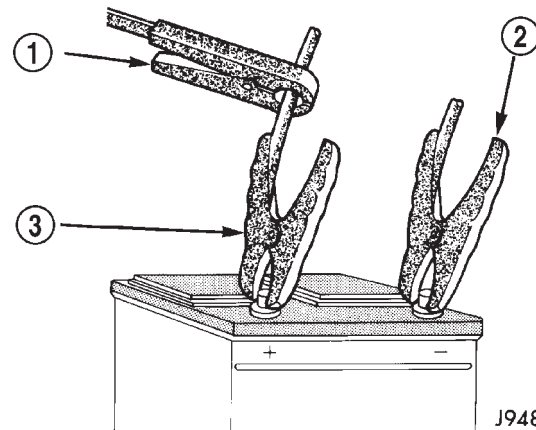

J948A-13

Fig. 11 Volt-Ammeter-Load Tester Connections - Typical

- 1 - INDUCTION AMMETER CLAMP
- 2 - NEGATIVE CLAMP
- 3 - POSITIVE CLAMP

(3) Rotate the load control knob (carbon pile rheostat) to apply a 300 ampere load to the battery for fifteen seconds, then return the control knob to the Off position (Fig. 12). This will remove the surface charge from the battery.

(4) Allow the battery to stabilize to open-circuit voltage. It may take up to five minutes for the battery voltage to stabilize.

(5) Rotate the load control knob to maintain a load equal to 50% of the CCA rating of the battery (Fig. 13). After fifteen seconds, record the loaded voltage reading, then return the load control knob to the Off position.

(6) The voltage drop will vary with the battery temperature at the time of the load test. The battery temperature can be estimated by using the ambient temperature during the past several hours. If the

DIAGNOSIS AND TESTING (Continued)

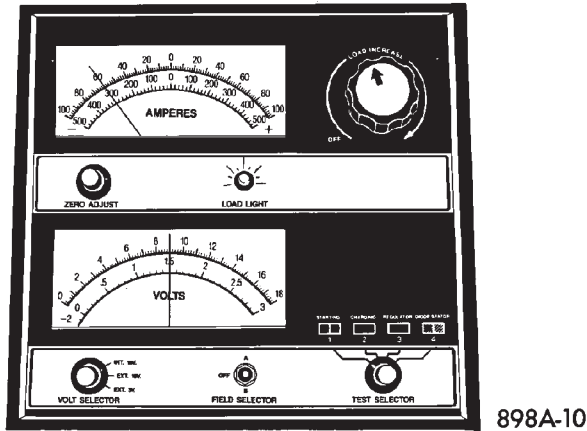

Fig. 12 Remove Surface Charge from Battery - Typical

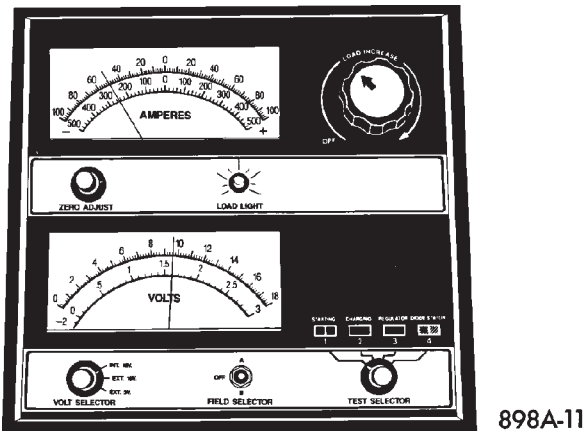

Fig. 13 Load 50% CCA Rating - Note Voltage - Typical

battery has been charged, boosted, or loaded a few minutes prior to the test, the battery will be somewhat warmer. See the Load Test Temperature chart for the proper loaded voltage reading.

(7) If the voltmeter reading falls below 9.6 volts, at a minimum battery temperature of 21° C (70° F), the battery is faulty and must be replaced.

IGNITION-OFF DRAW TEST

The term Ignition-Off Draw (IOD) identifies a normal condition where power is being drained from the battery with the ignition switch in the Off position. A normal vehicle electrical system will draw from five to twenty-five milliamperes (0.005 to 0.025 ampere) with the ignition switch in the Off position, and all

| Minimum Voltage | Load Test Temperature | |
|-----------------|-----------------------|---------------|
| | °F | °C |
| 9.6 volts | 70° and above | 21° and above |
| 9.5 volts | 60° | 16° |
| 9.4 volts | 50° | 10° |
| 9.3 volts | 40° | 4° |
| 9.1 volts | 30° | -1° |
| 8.9 volts | 20° | -7° |
| 8.7 volts | 10° | -12° |
| 8.5 volts | 0° | -18° |

non-ignition controlled circuits in proper working order. The twenty-five milliamperes are needed to enable the memory functions for the Powertrain Control Module (PCM), digital clock, electronically tuned radio, and other modules which may vary with the vehicle equipment.

A vehicle that has not been operated for approximately twenty days, may discharge the battery to an inadequate level. When a vehicle will not be used for twenty days or more (stored), remove the IOD fuse from the Power Distribution Center (PDC). This will reduce battery discharging.

Excessive IOD can be caused by:

- Electrical items left on.
- Faulty or improperly adjusted switches.
- Faulty or shorted electronic modules and components.
- An internally shorted generator.
- Intermittent shorts in the wiring.

If the IOD is over twenty-five milliamperes, the problem must be found and corrected before replacing a battery. In most cases, the battery can be charged and returned to service after the excessive IOD condition has been corrected.

(1) Verify that all electrical accessories are off. Turn off all lamps, remove the ignition key, and close all doors. If the vehicle is equipped with an illuminated entry system or an electronically tuned radio, allow the electronic timer function of these systems to automatically shut off (time out). This may take up to three minutes. See the Electronic Module Ignition-Off Draw table for more information.

DIAGNOSIS AND TESTING (Continued)

| Electronic Module Ignition-Off Draw (IOD) | | | |
|---|---|----------------------|--------------------|
| Module | Time Out? (If Yes, Interval and Wake-Up Input) | IOD | IOD After Time Out |
| Radio | No | 1 to 3 milliamperes | N/A |
| Audio Power Amplifier | No | up to 1 milliamperes | N/A |
| Central Timer Module (CTM) | No | 4.75 milliamperes | N/A |
| Powertrain Control Module (PCM) | No | 0.95 milliamperes | N/A |
| ElectroMechanical Instrument Cluster (EMIC) | No | 0.44 milliamperes | N/A |
| Combination Flasher | No | 0.08 milliamperes | N/A |

(2) Determine that the under-hood lamp is operating properly, then disconnect the lamp wire harness connector or remove the lamp bulb.

(3) Disconnect the battery negative cable.

(4) Set an electronic digital multi-meter to its highest amperage scale. Connect the multi-meter between the disconnected battery negative cable terminal clamp and the battery negative terminal post. Make sure that the doors remain closed so that the illuminated entry system is not activated. The multi-meter amperage reading may remain high for up to three minutes, or may not give any reading at all while set in the highest amperage scale, depending upon the electrical equipment in the vehicle. The multi-meter leads must be securely clamped to the battery negative cable terminal clamp and the battery negative terminal post. If continuity between the battery negative terminal post and the negative cable terminal clamp is lost during any part of the IOD test, the electronic timer function will be activated and all of the tests will have to be repeated.

(5) After about three minutes, the high-amperage IOD reading on the multi-meter should become very low or nonexistent, depending upon the electrical equipment in the vehicle. If the amperage reading remains high, remove and replace each fuse or circuit breaker in the Power Distribution Center (PDC) and then in the Junction Block (JB) one at a time (refer to **Power Distribution Center** and **Junction Block** in the index of this service manual for the location of complete PDC and JB fuse and circuit breaker identification contained in the wiring diagrams) until the amperage reading becomes very low, or nonexistent. This will isolate each circuit and identify the circuit that is the source of the high-amperage IOD. If the amperage reading remains high after removing and replacing each fuse and circuit

breaker, disconnect the wire harness from the generator. If the amperage reading now becomes very low or nonexistent, refer to **Charging System** in the index of this service manual for the location of the proper charging system diagnosis and testing procedures. After the high-amperage IOD has been corrected, switch the multi-meter to progressively lower amperage scales and, if necessary, repeat the fuse and circuit breaker remove-and-replace process to identify and correct all sources of excessive IOD. It is now safe to select the lowest milliamperes scale of the multi-meter to check the low-amperage IOD.

CAUTION: Do not open any doors, or turn on any electrical accessories with the lowest milliamperes scale selected, or the multi-meter may be damaged.

(6) Observe the multi-meter reading. The low-amperage IOD should not exceed twenty-five milliamperes (0.025 ampere). If the current draw exceeds twenty-five milliamperes, isolate each circuit using the fuse and circuit breaker remove-and-replace process in Step 5. The multi-meter reading will drop to within the acceptable limit when the source of the excessive current draw is disconnected. Repair this circuit as required; whether a wiring short, incorrect switch adjustment, or a component failure is at fault.

BATTERY CABLES

DIAGNOSIS

A voltage drop test will determine if there is excessive resistance in the battery cable terminal connections or the battery cables. If excessive resistance is found in the battery cable connections, the connection point should be disassembled, cleaned of all corrosion or foreign material, then reassembled. Following reassembly, check the voltage drop for the

DIAGNOSIS AND TESTING (Continued)

battery cable connection and the battery cable again to confirm repair.

When performing the voltage drop test, it is important to remember that the voltage drop is giving an indication of the resistance between the two points at which the voltmeter probes are attached. **EXAMPLE:** When testing the resistance of the battery positive cable, touch the voltmeter leads to the battery positive cable terminal clamp and to the battery positive cable eyelet terminal at the starter solenoid B(+) terminal stud. If you probe the battery positive terminal post and the battery positive cable eyelet terminal at the starter solenoid B(+) terminal stud, you are reading the combined voltage drop in the battery positive cable terminal clamp-to-terminal post connection and the battery positive cable.

TESTING

VOLTAGE DROP TEST

WARNING:

- IF THE BATTERY SHOWS SIGNS OF FREEZING, LEAKING, LOOSE POSTS, OR LOW ELECTROLYTE LEVEL, DO NOT TEST, ASSIST-BOOST, OR CHARGE. THE BATTERY MAY ARC INTERNALLY AND EXPLODE. PERSONAL INJURY AND/OR VEHICLE DAMAGE MAY RESULT.

- EXPLOSIVE HYDROGEN GAS FORMS IN AND AROUND THE BATTERY. DO NOT SMOKE, USE FLAME, OR CREATE SPARKS NEAR THE BATTERY. PERSONAL INJURY AND/OR VEHICLE DAMAGE MAY RESULT.

- THE BATTERY CONTAINS SULFURIC ACID, WHICH IS POISONOUS AND CAUSTIC. AVOID CONTACT WITH THE SKIN, EYES, OR CLOTHING. IN THE EVENT OF CONTACT, FLUSH WITH WATER AND CALL A PHYSICIAN IMMEDIATELY. KEEP OUT OF THE REACH OF CHILDREN.

- IF THE BATTERY IS EQUIPPED WITH REMOVABLE CELL CAPS, BE CERTAIN THAT EACH OF THE CELL CAPS IS IN PLACE AND TIGHT BEFORE THE BATTERY IS RETURNED TO SERVICE. PERSONAL INJURY AND/OR VEHICLE DAMAGE MAY RESULT FROM LOOSE OR MISSING CELL CAPS.

The following operation will require a voltmeter accurate to 1/10 (0.10) volt. Before performing this test, be certain that the following procedures are accomplished:

- The battery is fully-charged and load tested. Refer to **Battery Charging** in the index of this service manual for the location of the proper battery charging procedures. Refer to **Battery** in the index of this service manual for the location of the battery diagnosis and testing procedures, including the proper battery load test procedures.

- Fully engage the parking brake.
- If the vehicle is equipped with an automatic transmission, place the gearshift selector lever in the Park position. If the vehicle is equipped with a manual transmission, place the gearshift selector lever in the Neutral position and block the clutch pedal in the fully depressed position.

- Verify that all lamps and accessories are turned off.

- To prevent the engine from starting, remove the Automatic ShutDown (ASD) relay. The ASD relay is located in the Power Distribution Center (PDC), in the engine compartment. See the fuse and relay layout label affixed to the underside of the PDC cover for ASD relay identification and location.

(1) Connect the positive lead of the voltmeter to the battery negative terminal post. Connect the negative lead of the voltmeter to the battery negative cable terminal clamp (Fig. 14). Rotate and hold the ignition switch in the Start position. Observe the voltmeter. If voltage is detected, correct the poor connection between the battery negative cable terminal clamp and the battery negative terminal post.

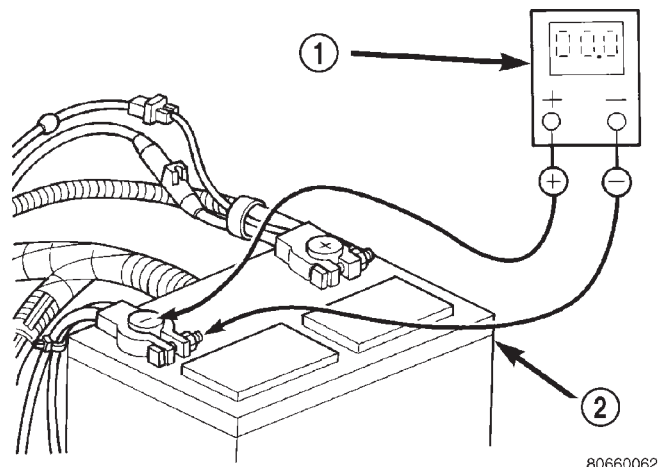

80660062

Fig. 14 Test Battery Negative Connection Resistance - Typical

1 - VOLTMETER
2 - BATTERY

(2) Connect the positive lead of the voltmeter to the battery positive terminal post. Connect the negative lead of the voltmeter to the battery positive cable terminal clamp (Fig. 15). Rotate and hold the ignition switch in the Start position. Observe the voltmeter. If voltage is detected, correct the poor connection between the battery positive cable terminal clamp and the battery positive terminal post.

(3) Connect the voltmeter to measure between the battery positive cable terminal clamp and the starter solenoid B(+) terminal stud (Fig. 16). Rotate and hold the ignition switch in the Start position. Observe the

DIAGNOSIS AND TESTING (Continued)

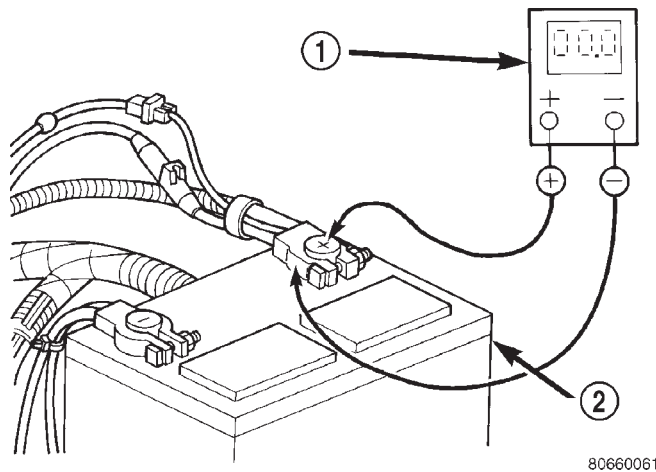

80660061

Fig. 15 Test Battery Positive Connection Resistance - Typical

- 1 - VOLTMETER
2 - BATTERY

voltmeter. If the reading is above 0.2 volt, clean and tighten the battery positive cable eyelet terminal connection at the starter solenoid B(+) terminal stud. Repeat the test. If the reading is still above 0.2 volt, replace the faulty battery positive cable.

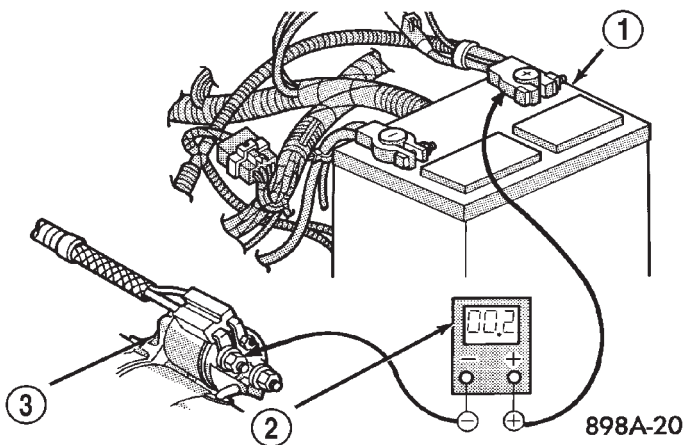

898A-20

Fig. 16 Test Battery Positive Cable Resistance - Typical

- 1 - BATTERY
2 - VOLTMETER
3 - STARTER MOTOR

(4) Connect the voltmeter to measure between the battery negative cable terminal clamp and a good clean ground on the engine block (Fig. 17). Rotate and hold the ignition switch in the Start position. Observe the voltmeter. If the reading is above 0.2 volt, clean and tighten the battery negative cable eyelet terminal connection to the engine block. Repeat the test. If the reading is still above 0.2 volt, replace the faulty battery negative cable.

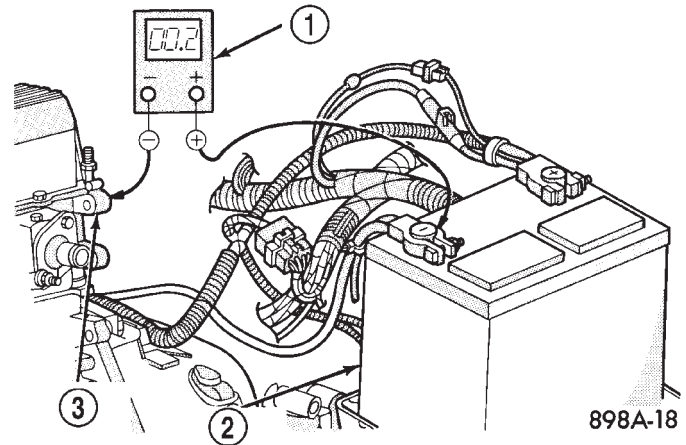

898A-18

Fig. 17 Test Ground Circuit Resistance - Typical

- 1 - VOLTMETER
2 - BATTERY
3 - ENGINE GROUND

SERVICE PROCEDURES

BATTERY CHARGING

Battery charging is the means by which the battery can be restored to its full voltage potential. A battery is fully-charged when:

- All of the battery cells are gassing freely during battery charging.
- A green color is visible in the sight glass of the battery built-in test indicator.
- Three hydrometer tests, taken at one-hour intervals, indicate no increase in the temperature-corrected specific gravity of the battery electrolyte.
- Open-circuit voltage of the battery is 12.4 volts or above.

SERVICE PROCEDURES (Continued)

WARNING:

- IF THE BATTERY SHOWS SIGNS OF FREEZING, LEAKING, LOOSE POSTS, OR LOW ELECTROLYTE LEVEL, DO NOT TEST, ASSIST-BOOST, OR CHARGE. THE BATTERY MAY ARC INTERNALLY AND EXPLODE. PERSONAL INJURY AND/OR VEHICLE DAMAGE MAY RESULT.

- EXPLOSIVE HYDROGEN GAS FORMS IN AND AROUND THE BATTERY. DO NOT SMOKE, USE FLAME, OR CREATE SPARKS NEAR THE BATTERY. PERSONAL INJURY AND/OR VEHICLE DAMAGE MAY RESULT.

- THE BATTERY CONTAINS SULFURIC ACID, WHICH IS POISONOUS AND CAUSTIC. AVOID CONTACT WITH THE SKIN, EYES, OR CLOTHING. IN THE EVENT OF CONTACT, FLUSH WITH WATER AND CALL A PHYSICIAN IMMEDIATELY. KEEP OUT OF THE REACH OF CHILDREN.

- IF THE BATTERY IS EQUIPPED WITH REMOVABLE CELL CAPS, BE CERTAIN THAT EACH OF THE CELL CAPS IS IN PLACE AND TIGHT BEFORE THE BATTERY IS RETURNED TO SERVICE. PERSONAL INJURY AND/OR VEHICLE DAMAGE MAY RESULT FROM LOOSE OR MISSING CELL CAPS.

CAUTION:

- Always disconnect and isolate the battery negative cable before charging a battery. Do not exceed sixteen volts while charging a battery. Damage to the vehicle electrical system components may result.

- Battery electrolyte will bubble inside the battery case during normal battery charging. Electrolyte boiling or being discharged from the battery vents indicates a battery overcharging condition. Immediately reduce the charging rate or turn off the charger to evaluate the battery condition. Damage to the battery may result from overcharging.

- The battery should not be hot to the touch. If the battery feels hot to the touch, turn off the charger and let the battery cool before continuing the charging operation. Damage to the battery may result.

Some battery chargers are equipped with polarity-sensing circuitry. This circuitry protects the battery charger and the battery from being damaged if they are improperly connected. If the battery state-of-charge is too low for the polarity-sensing circuitry to detect, the battery charger will not operate. This makes it appear that the battery will not accept charging current. See the instructions provided by the manufacturer of the battery charger for details on how to bypass the polarity-sensing circuitry.

After the battery has been charged to 12.4 volts or greater, perform a load test to determine the battery

cranking capacity. Refer to **Battery** in the index of this service manual for the location of the battery diagnosis and testing procedures for more information on the proper battery load testing procedures. If the battery will endure a load test, return the battery to service. If the battery will not endure a load test, it is faulty and must be replaced.

Clean and inspect the battery hold downs, tray, terminals, posts, and top before completing battery service. Refer to **Battery** in the index of this service manual for the location of the proper battery cleaning and inspection procedures.

CHARGING A COMPLETELY DISCHARGED BATTERY

The following procedure should be used to recharge a completely discharged battery. Unless this procedure is properly followed, a good battery may be needlessly replaced.

(1) Measure the voltage at the battery posts with a voltmeter, accurate to 1/10 (0.10) volt (Fig. 18). If the reading is below ten volts, the battery charging current will be low. It could take some time before the battery accepts a current greater than a few milliamperes. Such low current may not be detectable on the ammeters built into many battery chargers.

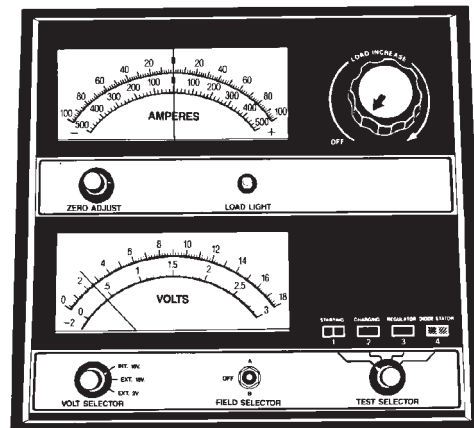

898A-12

Fig. 18 Voltmeter Accurate to 1/10 Volt Connected - Typical

(2) Disconnect and isolate the battery negative cable. Connect the battery charger leads. Some battery chargers are equipped with polarity-sensing circuitry. This circuitry protects the battery charger and the battery from being damaged if they are improperly connected. If the battery state-of-charge is too low for the polarity-sensing circuitry to detect, the battery charger will not operate. This makes it appear that the battery will not accept charging current. See the instructions provided by the manufacturer of the battery charger for details on how to bypass the polarity-sensing circuitry.

SERVICE PROCEDURES (Continued)

(3) Battery chargers vary in the amount of voltage and current they provide. The amount of time required for a battery to accept measurable charging current at various voltages is shown in the Charge Rate chart. If the charging current is still not measurable at the end of the charging time, the battery is faulty and must be replaced. If the charging current is measurable during the charging time, the battery may be good and the charging should be completed in the normal manner.

| Charge Rate | |
|--------------------|----------------|
| Voltage | Hours |
| 16.0 volts maximum | up to 4 hours |
| 14.0 to 15.9 volts | up to 8 hours |
| 13.9 volts or less | up to 16 hours |

CHARGING TIME REQUIRED

The time required to charge a battery will vary, depending upon the following factors:

- Battery Capacity

A completely discharged heavy-duty battery requires twice the charging time of a small capacity battery.

- Temperature

A longer time will be needed to charge a battery at -18° C (0° F) than at 27° C (80° F). When a fast battery charger is connected to a cold battery, the current accepted by the battery will be very low at first. As the battery warms, it will accept a higher charging current rate (amperage).

- Charger Capacity

A battery charger that supplies only five amperes will require a longer charging time. A battery charger that supplies twenty amperes or more will require a shorter charging time.

- State-Of-Charge

A completely discharged battery requires more charging time than a partially discharged battery. Electrolyte is nearly pure water in a completely discharged battery. At first, the charging current (amperage) will be low. As the battery charges, the specific gravity of the electrolyte will gradually rise.

WARNING: NEVER EXCEED TWENTY AMPERES WHEN CHARGING A COLD (-1° C or 30° F) BATTERY. THE BATTERY MAY ARC INTERNALLY AND EXPLODE. PERSONAL INJURY AND/OR VEHICLE DAMAGE MAY RESULT.

| Battery Charging Timetable | | | |
|--|---------------------------------|------------|------------|
| Charging Amperage | 5 Amperes | 10 Amperes | 20 Amperes |
| Open Circuit Voltage | Hours Charging at 21° C (70° F) | | |
| 12.25 to 12.49 | 6 hours | 3 hours | 1.5 hours |
| 12.00 to 12.24 | 10 hours | 5 hours | 2.5 hours |
| 10.00 to 11.99 | 14 hours | 7 hours | 3.5 hours |
| *Below 10.00 | 18 hours | 9 hours | 4.5 hours |
| *Refer to Charging A Completely Discharged Battery | | | |

REMOVAL AND INSTALLATION**BATTERY CABLES**

Both the battery negative cable and the battery positive cable are serviced in the battery wire harness. If either battery cable is damaged or faulty, the battery wire harness unit must be replaced.

REMOVAL

(1) Turn the ignition switch to the Off position. Be certain that all electrical accessories are turned off.

(2) Loosen the battery negative cable terminal clamp pinch-bolt hex nut.

(3) Disconnect the battery negative cable terminal clamp from the battery negative terminal post. If necessary, use a battery terminal puller to remove the terminal clamp from the battery post.

(4) Loosen the battery positive cable terminal clamp pinch-bolt hex nut.

(5) Disconnect the battery positive cable terminal clamp from the battery positive terminal post. If necessary, use a battery terminal puller to remove the terminal clamp from the battery post.

(6) Unlatch and remove the B(+) terminal stud cover from the front of the Power Distribution Center (PDC).

(7) Remove the nut that secures the battery positive cable eyelet terminal and the generator output cable eyelet terminal to the B(+) terminal stud on the PDC.

(8) Remove the battery positive cable eyelet terminal and the generator output cable eyelet terminal from the B(+) terminal stud on the PDC.

(9) Disconnect the battery wire harness connector from the headlamp and dash wire harness connector located below the front of the PDC.

REMOVAL AND INSTALLATION (Continued)

(10) Remove the screw that secures the battery negative cable eyelet terminal to the inner fender shield near the battery.

(11) On LHD models with air conditioning, disconnect the compressor clutch wire harness connector from the battery wire harness connector.

(12) Unlatch and remove the cover from the generator output terminal stud housing on the back of the generator.

(13) Remove the nut that secures the generator output cable eyelet terminal to the generator output terminal stud.

(14) Remove the generator output cable eyelet terminal from the generator output terminal stud.

(15) Disconnect the battery wire harness connector from the generator field terminal connector receptacle on the back of the generator.

(16) Remove the nut that secures the battery negative cable ground eyelet terminal to the stud on the right side of the engine block.

(17) Remove the battery negative cable ground eyelet terminal from the engine block stud.

(18) On models with a 2.5L engine, remove the nut that secures the battery wire harness locator clip to the stud on the right side engine block oil pan rail below and forward of the engine oil filter adapter.

(19) On models with a 4.0L engine, remove the screw that secures the battery wire harness locator clip to the right side of the engine block between and below the right engine mount and the oil filter adapter.

(20) Remove the nut that secures the battery positive cable eyelet terminal to the B(+) terminal stud on the starter solenoid.

(21) Remove the battery positive cable eyelet terminal from the B(+) terminal stud on the starter solenoid.

(22) Disconnect the battery wire harness connector from the connector receptacle on the starter solenoid.

(23) Remove the battery wire harness from the engine compartment.

INSTALLATION

(1) Clean and inspect the battery cable terminal clamps and the battery terminal posts. Refer to **Battery** in the index of this service manual for the location of the proper battery cable terminal clamp and battery terminal post cleaning and inspection procedures.

(2) Position the battery wire harness into the engine compartment.

(3) Reconnect the battery wire harness connector to the connector receptacle on the starter solenoid.

(4) Install the battery positive cable eyelet terminal onto the B(+) terminal stud on the starter solenoid.

(5) Install and tighten the nut that secures the battery positive cable eyelet terminal to the B(+) terminal stud on the starter solenoid. Tighten the nut to 10 N·m (90 in. lbs.).

(6) On models with a 2.5L engine, install and tighten the nut that secures the battery wire harness locator clip to the stud on the right side engine block oil pan rail below and forward of the engine oil filter adapter. Tighten the nut to 8.4 N·m (75 in. lbs.).

(7) On models with a 4.0L engine, install and tighten the screw that secures the battery wire harness locator clip to the right side of the engine block between and below the right engine mount and the oil filter adapter. Tighten the screw to 8.4 N·m (75 in. lbs.).

(8) Install the battery negative cable ground eyelet terminal onto the stud on the right side of the engine block.

(9) Install and tighten the nut that secures the battery negative cable ground eyelet terminal to the stud on the right side of the engine block. Tighten the nut to 15.8 N·m (140 in. lbs.).

(10) Reconnect the battery wire harness connector to the generator field terminal connector receptacle on the back of the generator.

(11) Install the generator output cable eyelet terminal onto the generator output terminal stud.

(12) Install and tighten the nut that secures the generator output cable eyelet terminal to the generator output terminal stud. Tighten the nut to 8.4 N·m (75 in. lbs.).

(13) Position the cover for the generator output terminal stud housing onto the back of the generator and snap it into place.

(14) On LHD models with air conditioning, reconnect the compressor clutch wire harness connector to the battery wire harness connector.

(15) Install and tighten the screw that secures the battery negative cable eyelet terminal to the inner fender shield near the battery. Tighten the screw to 24.8 N·m (220 in. lbs.).

(16) Reconnect the battery wire harness connector to the headlamp and dash wire harness connector located below the front of the PDC.

(17) Install the battery positive cable eyelet terminal and the generator output cable eyelet terminal onto the PDC B(+) terminal stud.

(18) Install and tighten the nut that secures the battery positive cable eyelet terminal and the generator output cable eyelet terminal to the PDC B(+) terminal stud. Tighten the nut to 10.7 N·m (95 in. lbs.).

(19) Engage the tabs on the lower edge of the B(+) terminal stud cover in the slots on the front of the PDC housing, then engage the latch on the top of the cover with the latch tabs on the PDC housing.

REMOVAL AND INSTALLATION (Continued)

(20) Reconnect the battery positive cable terminal clamp to the battery positive terminal post. Tighten the terminal clamp pinch-bolt hex nut to 8.4 N·m (75 in. lbs.).

(21) Reconnect the battery negative cable terminal clamp to the battery negative terminal post. Tighten the terminal clamp pinch-bolt hex nut to 8.4 N·m (75 in. lbs.).

(22) Apply a thin coating of petroleum jelly or chassis grease to the exposed surfaces of the battery cable terminal clamps and the battery terminal posts.

BATTERY HOLD DOWNS

All of the battery hold down hardware except for the T-bolts can be serviced without removal of the battery or the battery tray. The battery tray must be removed from the vehicle to service the T-bolts. If the T-bolts require service replacement, refer to **Battery Tray** in the index of this service manual for the location of the proper battery tray removal and installation procedures.

REMOVAL

(1) Turn the ignition switch to the Off position. Be certain that all electrical accessories are turned off.

(2) Loosen the battery negative cable terminal clamp pinch-bolt hex nut.

(3) Disconnect the battery negative cable terminal clamp from the battery negative terminal post. If necessary, use a battery terminal puller to remove the terminal clamp from the battery post.

(4) Remove the nut with washer from the threaded end of each of the two T-bolts (Fig. 19).

(5) Remove the screw with washer that secures the end of the battery support strap with a slotted hole to the top of the upper radiator crossmember.

(6) Remove the battery support strap from the threaded end of the T-bolt nearest to the front of the vehicle.

(7) Remove the battery hold down bracket from the threaded ends of the two T-bolts and the top of the battery case.

INSTALLATION

(1) Clean and inspect the battery hold down hardware. Refer to **Battery** in the index of this service manual for the location of the proper battery hold down hardware cleaning and inspection procedures.

(2) Position the battery hold down bracket onto the threaded ends of the two T-bolts and across the top of the battery case.

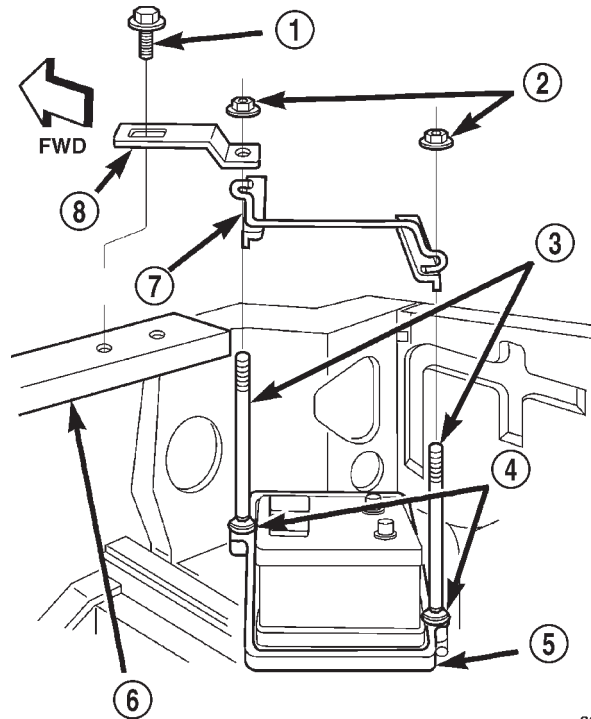

80be45d3

Fig. 19 Battery Hold Downs Remove/Install

- 1 - SCREW AND WASHER (1)
- 2 - NUT AND WASHER (2)
- 3 - T-BOLT (2)
- 4 - RETAINER (2)
- 5 - BATTERY TRAY
- 6 - UPPER RADIATOR CROSS MEMBER
- 7 - BRACKET
- 8 - STRAP

(3) Position the battery support strap with the round hole over the threaded end of the T-bolt nearest to the front of the vehicle and the slotted hole over the mounting hole in the top of the upper radiator crossmember.

(4) Install and tighten the screw with washer that secures the end of the battery support strap with a slotted hole to the top of the upper radiator crossmember. Tighten the screw to 8.7 N·m (77 in. lbs.).

(5) Install and tighten the nut with washer onto the threaded end of each of the two T-bolts. Tighten the nuts to 2.2 N·m (20 in. lbs.).

(6) Reconnect the battery negative cable terminal clamp to the battery negative terminal post. Tighten the terminal clamp pinch-bolt hex nut to 8.4 N·m (75 in. lbs.).

REMOVAL AND INSTALLATION (Continued)

BATTERY

REMOVAL

- (1) Turn the ignition switch to the Off position. Be certain that all electrical accessories are turned off.
- (2) Loosen the battery negative cable terminal clamp pinch-bolt hex nut.
- (3) Disconnect the battery negative cable terminal clamp from the battery negative terminal post. If necessary, use a battery terminal puller to remove the terminal clamp from the battery post (Fig. 20).

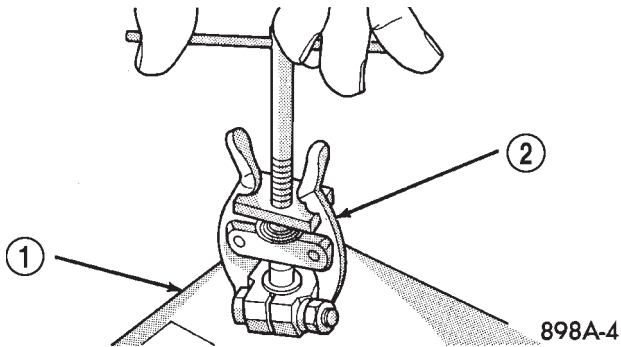

Fig. 20 Remove Battery Cable Terminal Clamp - Typical

- 1 - BATTERY
- 2 - BATTERY TERMINAL PULLER

- (4) Loosen the battery positive cable terminal clamp pinch-bolt hex nut.
- (5) Disconnect the battery positive cable terminal clamp from the battery positive terminal post. If necessary, use a battery terminal puller to remove the terminal clamp from the battery post.
- (6) Remove the battery hold downs from the battery. Refer to **Battery Hold Downs** in the index of this service manual for the location of the proper battery hold down removal procedures.

WARNING: WEAR A SUITABLE PAIR OF RUBBER GLOVES (NOT THE HOUSEHOLD TYPE) WHEN REMOVING A BATTERY BY HAND. SAFETY GLASSES SHOULD ALSO BE WORN. IF THE BATTERY IS CRACKED OR LEAKING, THE ELECTROLYTE CAN BURN THE SKIN AND EYES.

- (7) Remove the battery and the battery thermoguard from the battery tray as a unit.
- (8) Remove the battery thermoguard from the battery case. Refer to **Battery Thermoguard** in the index of this service manual for the location of the proper battery thermoguard removal procedures.

INSTALLATION

- (1) Clean and inspect the battery. Refer to **Battery** in the index of this service manual for the loca-

tion of the proper battery cleaning and inspection procedures.

- (2) Reinstall the battery thermoguard onto the battery case. Refer to **Battery Thermoguard** in the index of this service manual for the location of the proper battery thermoguard installation procedures.

- (3) Position the battery and the battery thermoguard onto the battery tray as a unit. Ensure that the battery positive and negative terminal posts are correctly positioned. The battery cable terminal clamps must reach the correct battery terminal post without stretching the cables (Fig. 21).

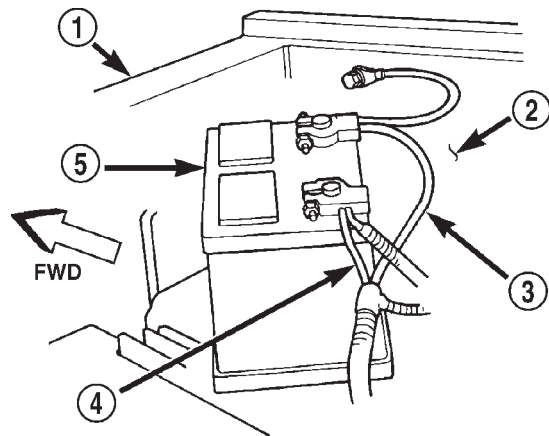

Fig. 21 Battery Cables

- 1 - RADIATOR CROSSMEMBER
- 2 - WHEELHOUSE INNER PANEL
- 3 - NEGATIVE CABLE
- 4 - POSITIVE CABLE
- 5 - BATTERY

8056d9e2

- (4) Reinstall the battery hold downs onto the battery. Refer to **Battery Hold Downs** in the index of this service manual for the location of the proper battery hold down installation procedures.

CAUTION: Be certain that the battery cable terminal clamps are connected to the correct battery terminal posts. Reversed battery polarity may damage electrical components of the vehicle.

- (5) Clean the battery cable terminal clamps and the battery terminal posts. Refer to **Battery** in the index of this service manual for the location of the proper battery cleaning and inspection procedures.

- (6) Reconnect the battery positive cable terminal clamp to the battery positive terminal post. Tighten the terminal clamp pinch-bolt hex nut to 8.4 N·m (75 in. lbs.).

- (7) Reconnect the battery negative cable terminal clamp to the battery negative terminal post. Tighten the terminal clamp pinch-bolt hex nut to 8.4 N·m (75 in. lbs.).

REMOVAL AND INSTALLATION (Continued)

(8) Apply a thin coating of petroleum jelly or chassis grease to the exposed surfaces of the battery cable terminal clamps and the battery terminal posts.

BATTERY THERMOGUARD

REMOVAL

(1) Remove the battery and the battery thermoguard from the battery tray as a unit. Refer to **Battery** in the index of this service manual for the location of the proper battery removal procedures.

(2) Carefully and evenly slide the battery thermoguard up off of the battery case (Fig. 22).

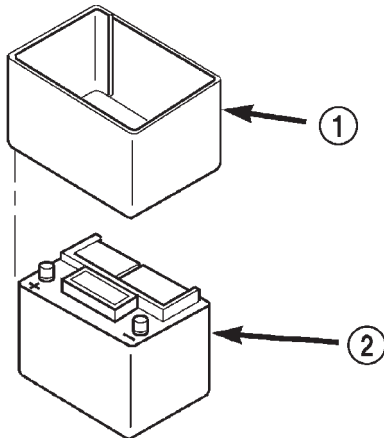

80be45d4

Fig. 22 Battery Thermoguard Remove/Install

- 1 - THERMOGUARD
2 - BATTERY

INSTALLATION

(1) Clean and inspect the battery thermoguard. Refer to **Battery** in the index of this service manual for the location of the proper battery thermoguard cleaning and inspection procedures.

(2) Carefully and evenly slide the battery thermoguard down over the battery case.

(3) Install the battery and the battery thermoguard into the battery tray as a unit. Refer to **Battery** in the index of this service manual for the location of the proper battery installation procedures.

BATTERY TRAY

REMOVAL

(1) Remove the battery from the battery tray. Refer to **Battery** in the index of this service manual for the location of the proper battery removal procedures.

(2) Remove the battery temperature sensor from the battery tray. Refer to **Battery Temperature Sensor** in the index of this service manual for the

location of the proper battery temperature sensor removal procedures.

(3) Remove the three nuts with washers that secure the battery tray to the weld studs on the front extension of the right front wheelhouse inner panel (Fig. 23).

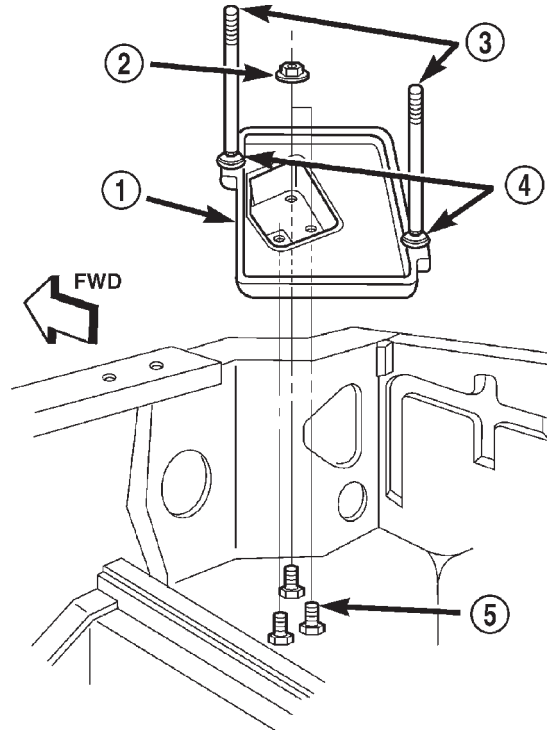

80be45d5

Fig. 23 Battery Tray Remove/Install

- 1 - TRAY
2 - NUT AND WASHER (3)
3 - T-BOLT (2)
4 - RETAINER (2)
5 - WELD STUD (3)

(4) Remove the battery tray from the weld studs on the front extension of the right front wheelhouse inner panel.

(5) From the top of the battery tray, remove the plastic push-on retainers from the T-bolts that secure them to the tray.

(6) From the bottom of the battery tray, remove the two T-bolts from the T-bolt mounts on the tray.

INSTALLATION

(1) Clean and inspect the battery tray. Refer to **Battery** in the index of this service manual for the location of the proper battery tray cleaning and inspection procedures.

(2) From the bottom of the battery tray, position the two T-bolts into the T-bolt mounts on the tray.

(3) From the top of the battery tray, install the plastic push-on retainers onto the T-bolts to secure them to the tray.

REMOVAL AND INSTALLATION (Continued)

(4) Position the battery tray onto the weld studs on the front extension of the right front wheelhouse inner panel.

(5) Install and tighten the three nuts with washers that secure the battery tray to the weld studs on the front extension of the right front wheelhouse inner panel. Tighten the nuts to 5 N·m (45 in. lbs.).

(6) Install the battery temperature sensor onto the battery tray. Refer to **Battery Temperature Sensor** in the index of this service manual for the location of the proper battery temperature sensor installation procedures.

(7) Install the battery onto the battery tray. Refer to **Battery** in the index of this service manual for the location of the proper battery installation procedures.

CLEANING AND INSPECTION

BATTERY

The following information details the recommended cleaning and inspection procedures for the battery and related components. In addition to the maintenance schedules found in this service manual and the owner's manual, it is recommended that these procedures be performed any time the battery or related components must be removed for vehicle service.

CLEANING

(1) Clean the battery cable terminal clamps of all corrosion. Remove any corrosion using a wire brush or a post and terminal cleaning tool, and a sodium bicarbonate (baking soda) and warm water cleaning solution (Fig. 24).

(2) Clean the battery tray and battery hold down hardware of all corrosion. Remove any corrosion using a wire brush and a sodium bicarbonate (baking soda) and warm water cleaning solution. Paint any exposed bare metal.

(3) If the removed battery is to be reinstalled, clean the outside of the battery case and the top cover with a sodium bicarbonate (baking soda) and warm water cleaning solution using a stiff bristle parts cleaning brush to remove any acid film (Fig. 25). Rinse the battery with clean water. Ensure that the cleaning solution does not enter the battery cells through the vent holes. If the battery is being replaced, refer to **Battery** in the index of this service manual for the location of the factory-installed battery specifications. Confirm that the replacement battery is the correct size and has the correct ratings for the vehicle.

(4) Clean the battery thermoguard with a sodium bicarbonate (baking soda) and warm water cleaning solution using a stiff bristle parts cleaning brush to remove any acid film.

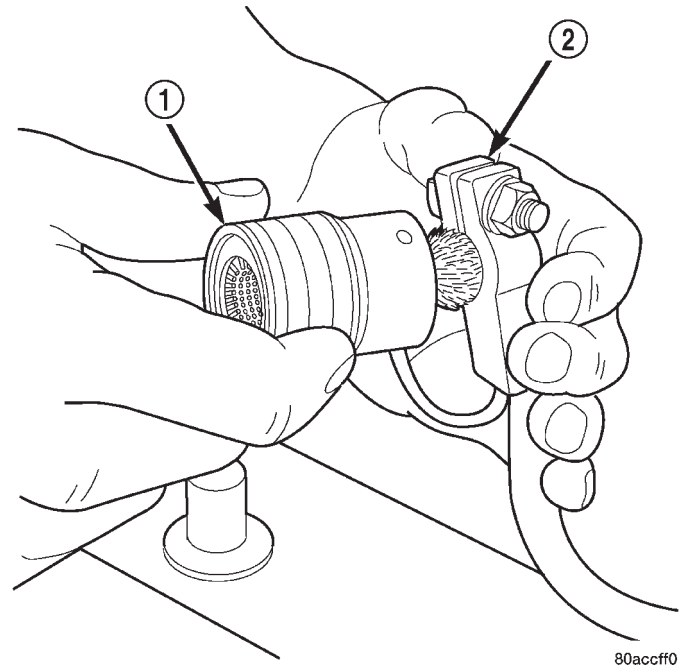

Fig. 24 Clean Battery Cable Terminal Clamp - Typical

- 1 - TERMINAL BRUSH
- 2 - BATTERY CABLE

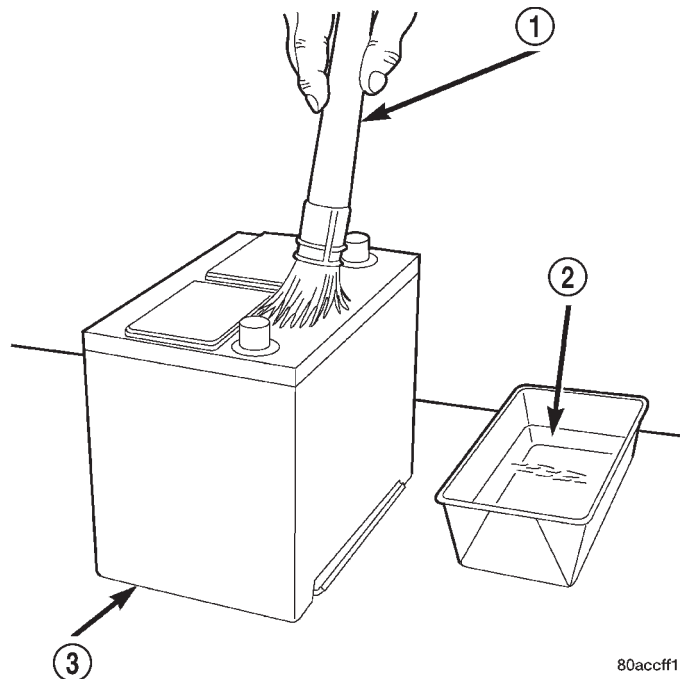

Fig. 25 Clean Battery - Typical

- 1 - CLEANING BRUSH
- 2 - WARM WATER AND BAKING SODA SOLUTION
- 3 - BATTERY

CLEANING AND INSPECTION (Continued)

(5) Clean any corrosion from the battery terminal posts with a wire brush or a post and terminal cleaner, and a sodium bicarbonate (baking soda) and warm water cleaning solution (Fig. 26).

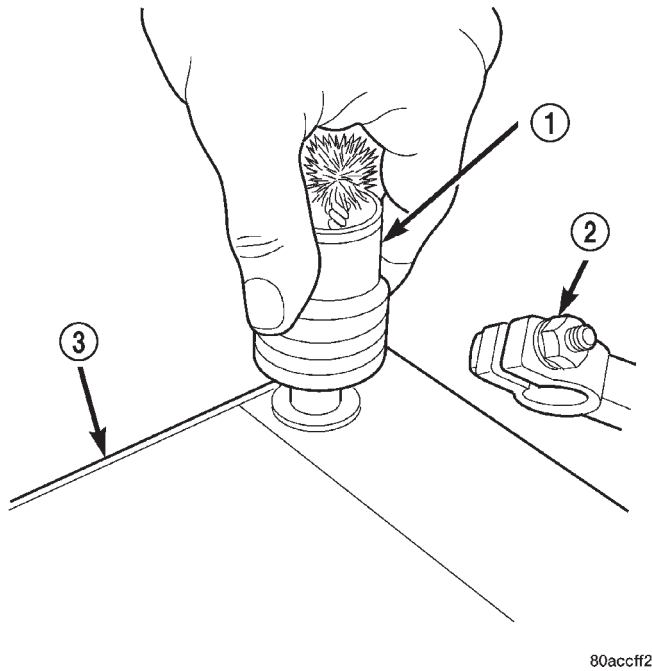

Fig. 26 Clean Battery Terminal Post - Typical

- 1 - TERMINAL BRUSH
- 2 - BATTERY CABLE
- 3 - BATTERY

damaged cases or loose terminal posts must be replaced.

(4) Inspect the battery thermoguard for tears, cracks, deformation or other damage. Replace any battery thermoguard that has been damaged.

(5) Inspect the electrolyte level in the battery. Use a putty knife or another suitable wide flat-bladed tool to pry the cell caps off (Fig. 27). Do not use a screwdriver. Add distilled water to each cell until the liquid reaches the bottom of the vent well. **DO NOT OVERFILL.**

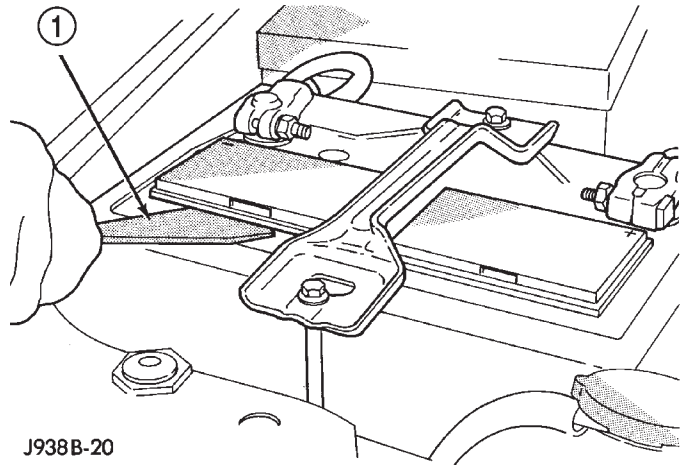

Fig. 27 Removing Battery Cell Caps - Typical

- 1 - PUTTY KNIFE

INSPECTION

(1) Inspect the battery cable terminal clamps for damage. Replace any battery cable that has a damaged or deformed terminal clamp.

(2) Inspect the battery tray and battery hold down hardware for damage. Replace any damaged parts.

(3) Slide the thermoguard off of the battery case. Inspect the battery case for cracks or other damage that could result in electrolyte leaks. Also, check the battery terminal posts for looseness. Batteries with

(6) Inspect the battery built-in test indicator sight glass for an indication of the battery condition. If the battery is discharged, charge as required. Refer to **Battery** in the index of this service manual for the location of the proper battery diagnosis and testing procedures for more information on the use of the battery built-in test indicator. Also refer to **Battery Charging** in the index of this service manual for the location of the proper battery charging procedures.

SPECIFICATIONS

BATTERY

| Battery Classifications and Ratings | | | | | |
|-------------------------------------|-------------------------------|------------------------|------------------|--------------|--------------------|
| Part Number | BCI Group Size Classification | Cold Cranking Amperage | Reserve Capacity | Ampere-Hours | Load Test Amperage |
| 56041105AB | 34 | 500 | 110 Minutes | 60 | 250 |

STARTING SYSTEMS

TABLE OF CONTENTS

| | page | | page |
|---|------|---------------------------------|------|
| DESCRIPTION AND OPERATION | | STARTER RELAY | 10 |
| STARTING SYSTEM | 1 | REMOVAL AND INSTALLATION | |
| STARTER MOTOR | 2 | STARTER MOTOR | 11 |
| STARTER RELAY | 3 | STARTER RELAY | 13 |
| DIAGNOSIS AND TESTING | | CLEANING AND INSPECTION | |
| STARTING SYSTEM | 4 | STARTING SYSTEM | 14 |
| STARTER MOTOR NOISE - 2.5L ENGINE | 8 | SPECIFICATIONS | |
| STARTER MOTOR | 9 | STARTING SYSTEM | 15 |

DESCRIPTION AND OPERATION

STARTING SYSTEM

DESCRIPTION

An electrically operated engine starting system is standard factory-installed equipment on this model. The starting system is designed to provide the vehicle operator with a convenient, efficient and reliable means of cranking and starting the internal combustion engine used to power the vehicle and all of its accessory systems. The starting system includes the following major components:

- Battery
- Battery cables
- Clutch pedal position switch (manual transmission)
- Ignition switch
- Park/neutral position switch (automatic transmission)
- Starter motor (including the integral starter solenoid)
- Starter relay.

The starting system consists of two separate circuits. A high-amperage feed circuit that feeds the starter motor between 150 and 350 amperes of battery current, and a low-amperage control circuit that operates on less than 20 amperes of battery current. The starting system high-amperage feed circuit includes the battery, the battery cables, the contact disc portion of the starter solenoid, and the starter motor. The following starting system feed circuit components are covered in more detail in other areas of this service manual:

- The battery is located in the passenger side front corner of the engine compartment, near the upper radiator crossmember and provides the electrical current needed to operate the starting system.

Refer to **Battery** in the index of this service manual for the location of more information on the battery.

- The battery cables connect the battery to the electrical system of the vehicle and to the starting system. Refer to **Battery Cables** in the index of this service manual for the location of more information on the battery cables.

The starting system low-amperage control circuit includes the ignition switch, the clutch pedal position switch (manual transmission), the park/neutral position switch (automatic transmission), the starter relay, the electromagnetic windings of the starter solenoid, and the wire harnesses that connect these components. The following starting system control circuit components are covered in more detail in other areas of this service manual:

- The ignition switch is mounted on the bottom of the steering column and actuates the starting system when a properly coded ignition key is inserted in the ignition lock cylinder on the right side of the steering column and turned to the spring-loaded momentary Start position. Refer to **Ignition Switch and Key Lock Cylinder** in the index of this service manual for the location of more information on the ignition switch.

- The clutch pedal position switch is integral to the master cylinder of the clutch hydraulic linkage assembly on models equipped with a manual transmission. Refer to **Clutch Hydraulic Linkage** in the index of this service manual for the location of more information on the clutch pedal position switch.

- On models with the 2.5L engine, the park/neutral position switch is threaded into the left side of the automatic transmission case and has a spring-loaded plunger that is actuated by a cam integral to the gearshift mechanism within the transmission. The back up lamp switch is also integral to the park/neutral position switch. On models with the 4.0L

DESCRIPTION AND OPERATION (Continued)

engine, the park/neutral position switch is mounted on the right side of the automatic transmission case. The switch is indexed to and driven by the transmission manual valve shaft. Refer to **Park/Neutral Position Switch** in the index of this service manual for the location of more information on either version of the park/neutral position switch.

Following are general descriptions of the starter relay and the starter motor. See the owner's manual in the vehicle glove box for more information on the features, use and operation of the starting system. Refer to **Starting System** in the index of this service manual for the location of complete wiring diagrams for the starting system.

NOTE: This group covers both Left-Hand Drive (LHD) and Right-Hand Drive (RHD) versions of this model. Whenever required and feasible, the RHD versions of affected vehicle components have been constructed as mirror-image of the LHD versions. While most of the illustrations used in this group represent only the LHD version, the diagnostic and service procedures outlined can generally be applied to either version. Exceptions to this rule have been clearly identified as LHD or RHD, if a special illustration or procedure is required.

OPERATION

If the vehicle is equipped with a manual transmission, the clutch pedal position switch is installed in series between the ignition switch and the coil battery terminal of the starter relay. This normally open switch prevents the starter relay from being energized when the ignition switch is turned to the momentary Start position, unless the clutch pedal is fully depressed. This feature prevents starter motor operation while the clutch disc and the flywheel are engaged. The starter relay coil ground terminal is always grounded on vehicles with a manual transmission.

If the vehicle is equipped with an automatic transmission, battery voltage is supplied through the low-amperage control circuit to the coil battery terminal of the starter relay when the ignition switch is turned to the momentary Start position. The park/neutral position switch is installed in series between the starter relay coil ground terminal and ground. This normally open switch prevents the starter relay from being energized and the starter motor from operating unless the automatic transmission gear selector is in the Neutral or Park positions.

When the starter relay coil windings are energized, the relay directs battery current to the starter solenoid coil windings. When the starter solenoid coil windings are energized, the solenoid directs battery current to the starter motor, which cranks the engine

by engaging the starter pinion gear with the starter ring gear. Once the engine starts, the ignition switch key is released by the vehicle operator. When the ignition switch key is released, the switch automatically returns to the On position, which de-energizes the starting system.

STARTER MOTOR

DESCRIPTION

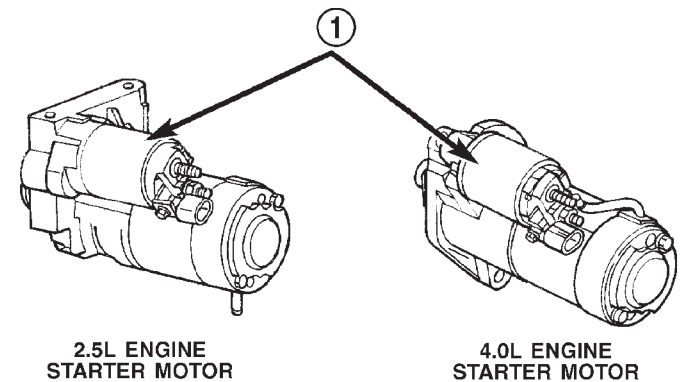

80be46ad

Fig. 1 Starter Motors

1 - STARTER SOLENOID

The starter motors used for both the 2.5L and the 4.0L engines available in this model are not interchangeable (Fig. 1). However, each of these starter motors incorporates several of the same features to create a reliable, efficient, compact, lightweight and powerful unit. Both starters feature high torque direct current electric motors. Inside both starter motors the commutator of the rotating motor armature is contacted by four brushes. The starter motor for the 2.5L engine is driven by four permanent magnet field poles, while the starter motor for the 4.0L engine is driven by four electromagnetic field coils wound around four pole shoes. The 2.5L starter motor is rated at 1.2 kilowatts (about 1.6 horsepower) output at 12 volts, while the 4.0L starter motor is rated at 1.4 kilowatts (about 1.9 horsepower) output at 12 volts.

These starter motors are equipped with a planetary gear reduction (intermediate transmission) system. The planetary gear reduction system consists of a gear that is integral to the output end of the electric motor armature shaft that is in continual engagement with a larger gear that fits on a spline on the input end of the starter pinion gear shaft. This feature makes it possible to reduce the dimensions of the starter. At the same time, it allows higher armature rotational speed and delivers increased torque through the starter pinion gear.

DESCRIPTION AND OPERATION (Continued)

Both starter motors use an overrunning clutch and starter pinion gear unit to engage and drive the starter ring gear, which is integral to the flywheel (manual transmission) or torque converter drive plate (automatic transmission) mounted on the rear crankshaft flange. Shims are available and can be used to adjust the 2.5L starter motor mounting position to correct for improper starter pinion gear to starter ring gear engagement.

The starter motors for both engines are activated by an integral heavy duty starter solenoid switch mounted to the overrunning clutch housing. This electromechanical switch connects and disconnects the feed of battery current to the starter motor through a movable contact on one end of the solenoid core or plunger. At the same time, the solenoid plunger actuates a shift fork that engages and disengages the starter pinion gear with a starter ring gear. The starter solenoid has two electromagnetic windings or coils, a pull-in coil and a hold-in coil. The pull-in coil requires more battery current and produces a stronger electromagnetic field than the hold-in coil.

Both starter motors are serviced only as a unit with their starter solenoids, and cannot be repaired. If either component is faulty or damaged, the entire starter motor and starter solenoid unit must be replaced.

OPERATION

When the starter solenoid pull-in coil windings are energized the solenoid plunger is drawn into the electromagnetic coil. The solenoid plunger pulls the shift lever in the starter motor. This engages the starter overrunning clutch and pinion gear with the starter ring gear on the manual transmission flywheel or on the automatic transmission torque converter drive plate. As the solenoid plunger reaches the end of its travel, it moves the solenoid contact disc to complete the high-amperage starter feed circuit and energizes the solenoid hold-in coil windings. Battery current now flows between the solenoid battery terminal and the starter field terminal, energizing the starter and cranking the engine.

Once the engine starts, the overrunning clutch protects the starter motor from damage by allowing the starter pinion gear to spin faster than the pinion shaft. When the solenoid plunger hold-in coil is de-energized, the solenoid plunger return spring returns the plunger to its relaxed position. This causes the solenoid contact disc to open the starter feed circuit, and the shift lever to disengage the overrunning clutch and pinion gear unit from the starter ring gear.

STARTER RELAY

DESCRIPTION

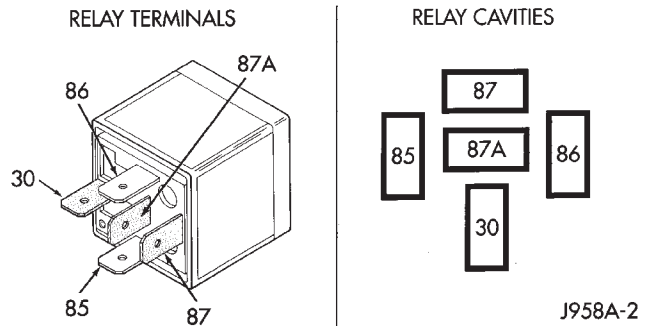

| TERMINAL LEGEND | |
|-----------------|-----------------|
| NUMBER | IDENTIFICATION |
| 30 | COMMON FEED |
| 85 | COIL GROUND |
| 86 | COIL BATTERY |
| 87 | NORMALLY OPEN |
| 87A | NORMALLY CLOSED |

Fig. 2 Starter Relay

The starter relay (Fig. 2) is an electromechanical device that switches battery current to the pull-in coil of the starter solenoid when the ignition switch is turned to the Start position. The starter relay is located in the Power Distribution Center (PDC), in the engine compartment. See the fuse and relay layout label affixed to the inside surface of the PDC cover for starter relay identification and location.

The starter relay is a International Standards Organization (ISO) relay. Relays conforming to the ISO specifications have common physical dimensions, current capacities, terminal patterns, and terminal functions.

The starter relay cannot be repaired or adjusted and, if faulty or damaged, it must be replaced.

OPERATION

The ISO relay consists of an electromagnetic coil, a resistor or diode, and three (two fixed and one movable) electrical contacts. The movable (common feed) relay contact is held against one of the fixed contacts (normally closed) by spring pressure. When the electromagnetic coil is energized, it draws the movable contact away from the normally closed fixed contact, and holds it against the other (normally open) fixed contact.

When the electromagnetic coil is de-energized, spring pressure returns the movable contact to the normally closed position. The resistor or diode is connected in parallel with the electromagnetic coil in the relay, and helps to dissipate voltage spikes that are produced when the coil is de-energized.

DIAGNOSIS AND TESTING

STARTING SYSTEM

DIAGNOSIS

The battery, starting system and charging system in the vehicle operate with one another, and must be tested as a complete system. In order for the engine to start and the battery to charge properly, all of the components that are used in these systems must perform within specifications. The service information for these systems has been separated within this service manual to make it easier to locate the specific information you are seeking. However, when attempting to diagnose any of these systems, it is important that you keep their interdependency in mind.

The diagnostic procedures used for the battery, starting system and charging system include the most basic conventional diagnostic methods, to the more sophisticated On-Board Diagnostics (OBD) built into the Powertrain Control Module (PCM). Use of an induction-type milliampere ammeter, a volt/ohmmeter, a battery charger, a carbon pile rheostat (load tester) and a 12-volt test lamp may be required. All OBD-sensed systems are monitored by the PCM. Each monitored circuit is assigned a Diagnostic Trouble Code (DTC). The PCM will store a DTC in electronic memory for any failure it detects. Refer to **Charging System, On-Board Diagnostic Test** in the index of this service manual for the location of the proper on-board diagnostic test procedures.

| Starting System Diagnosis | | |
|---------------------------|--|--|
| Condition | Possible Cause | Correction |
| Starter fails to operate. | <ol style="list-style-type: none"> 1. Battery discharged or faulty. 2. Starting circuit wiring faulty. 3. Starter relay faulty. 4. Ignition switch faulty. 5. Clutch pedal position switch faulty. 6. Park/Neutral position switch faulty or misadjusted. 7. Starter solenoid faulty. 8. Starter motor faulty. | <ol style="list-style-type: none"> 1. Refer to Battery in the index of this service manual for the location of the proper battery diagnosis and testing procedures. Replace the faulty battery, as required. 2. Refer to Starting System in the index of this service manual for the location of complete starting system wiring diagrams. Test and repair the faulty starter feed and/or control circuits, as required. 3. Refer to Starter Relay in the index of this service manual for the location of the proper starter relay diagnosis and testing procedures. Replace the faulty starter relay, as required. 4. Refer to Ignition Switch and Key Lock Cylinder in the index of this service manual for the location of the proper ignition switch diagnosis and testing procedures. Replace the faulty ignition switch, as required. 5. Refer to Clutch Pedal Position Switch in the index of this service manual for the location of the proper clutch pedal position switch diagnosis and testing procedures. Replace the faulty clutch hydraulic linkage unit, as required. 6. Refer to Park/Neutral Position Switch in the index of this service manual for the location of the proper park/neutral position switch diagnosis and testing procedures. Replace the faulty park/neutral position switch, as required. 7. Refer to Starter Motor in the index of this service manual for the location of the proper starter solenoid diagnosis and testing procedures. Replace the faulty starter motor, as required. 8. Refer to Starter Motor in the index of this service manual for the location of the proper starter motor diagnosis and testing procedures. Replace the faulty starter motor, as required. |

DIAGNOSIS AND TESTING (Continued)

| Starting System Diagnosis | | |
|--|--|--|
| Condition | Possible Cause | Correction |
| Starter engages, fails to turn engine. | <ol style="list-style-type: none"> 1. Battery discharged or faulty. 2. Starting circuit wiring faulty. 3. Starter motor faulty. 4. Engine seized. | <ol style="list-style-type: none"> 1. Refer to Battery in the index of this service manual for the location of the proper battery diagnosis and testing procedures. Replace the faulty battery, as required. 2. Refer to Starting System in the index of this service manual for the location of complete starting system wiring diagrams. Test and repair the faulty starter feed and/or control circuits, as required. 3. Refer to Starter Motor in the index of this service manual for the location of the proper starter motor diagnosis and testing procedures. Replace the faulty starter motor, as required. 4. Refer to Engine Diagnosis in the index of this service manual for the location of the proper engine diagnosis and testing procedures. Repair or replace the faulty engine, as required. |
| Starter engages, spins out before engine starts. | <ol style="list-style-type: none"> 1. Starter ring gear faulty. 2. Starter motor faulty. | <ol style="list-style-type: none"> 1. Refer to Starter Motor in the index of this service manual for the location of the proper starter motor removal and installation procedures. Remove the starter motor to inspect the starter ring gear. Replace the faulty starter ring gear, as required. 2. Refer to Starter Motor in the index of this service manual for the location of the proper starter motor diagnosis and testing procedures. Replace the faulty starter motor, as required. |
| Starter does not disengage. | <ol style="list-style-type: none"> 1. Starter motor improperly installed. 2. Starter relay faulty. 3. Ignition switch faulty. 4. Starter motor faulty. | <ol style="list-style-type: none"> 1. Refer to Starter Motor in the index of this service manual for the location of the proper starter motor installation procedures. Tighten the starter motor mounting hardware to the correct tightness specifications, as required. 2. Refer to Starter Relay in the index of this service manual for the location of the proper starter relay diagnosis and testing procedures. Replace the faulty starter relay, as required. 3. Refer to Ignition Switch and Key Lock Cylinder in the index of this service manual for the location of the proper ignition switch diagnosis and testing procedures. Replace the faulty ignition switch, as required. 4. Refer to Starter Motor in the index of this service manual for the location of the proper starter motor diagnosis and testing procedures. Replace the faulty starter motor, as required. |

TESTING

Before testing the starting system perform a visual inspection of the starting system components and connections. Refer to **Starting System** in the index of this service manual for the location of the proper starting system cleaning and inspection procedures.

COLD CRANKING TEST

Refer to **Starting System** in the index of this service manual for the location of complete starting sys-

tem wiring diagrams. Before performing this test, be certain that the following procedures are accomplished:

- The battery is fully-charged and load tested. Refer to **Battery Charging** in the index of this service manual for the location of the proper battery charging procedures. Refer to **Battery** in the index of this service manual for the location of the battery diagnosis and testing procedures, including the proper battery load test procedures.

DIAGNOSIS AND TESTING (Continued)

- Fully engage the parking brake.
- If the vehicle is equipped with an automatic transmission, place the gearshift selector lever in the Park position. If the vehicle is equipped with a manual transmission, place the gearshift selector lever in the Neutral position and block the clutch pedal in the fully depressed position.
- Verify that all lamps and accessories are turned off.
- To prevent the engine from starting, remove the Automatic ShutDown (ASD) relay. The ASD relay is located in the Power Distribution Center (PDC), in the engine compartment. See the fuse and relay layout label affixed to the underside of the PDC cover for ASD relay identification and location.

(1) Connect a suitable volt-ampere tester to the battery terminals (Fig. 3). See the instructions provided by the manufacturer of the volt-ampere tester being used.

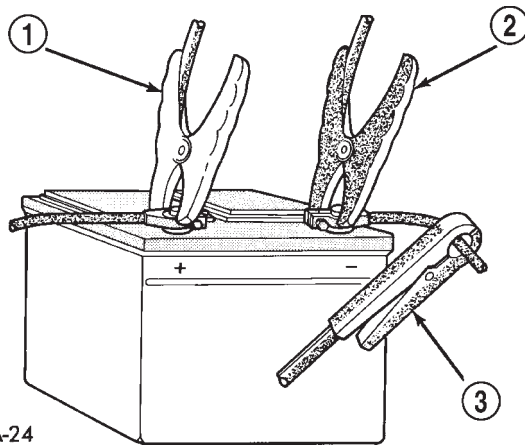

948A-24

Fig. 3 Volts-Amps Tester Connections - Typical

- 1 - POSITIVE CLAMP
 2 - NEGATIVE CLAMP
 3 - INDUCTION AMMETER CLAMP

(2) Rotate and hold the ignition switch in the Start position. Note the cranking voltage and current (amperage) draw readings shown on the volt-ampere tester.

(a) If the voltage reads below 9.6 volts, refer to **Starter Motor** in the index of this service manual for the location of the proper starter motor diagnosis and testing procedures. If the starter motor tests OK, refer to **Engine Diagnosis** in the index of this service manual for the location of the proper engine diagnosis and testing procedures. If the starter motor is not OK, replace the faulty starter motor.

(b) If the voltage reads above 9.6 volts and the current (amperage) draw reads below specifications, refer to the **Feed Circuit Test** in this section.

(c) If the voltage reads 12.5 volts or greater and the starter motor does not turn, refer to the **Control Circuit Test** in this section.

(d) If the voltage reads 12.5 volts or greater and the starter motor turns very slowly, refer to the **Feed Circuit Test** in this section.

NOTE: A cold engine will increase the starter current (amperage) draw reading, and reduce the battery voltage reading.

FEED CIRCUIT TEST

The starter feed circuit test (voltage drop method) will determine if there is excessive resistance in the high-amperage starter feed circuit. Refer to **Starting System** in the index of this service manual for the location of complete starting system wiring diagrams.

When performing the voltage drop test, it is important to remember that the voltage drop is giving an indication of the resistance between the two points at which the voltmeter probes are attached. **EXAMPLE:** When testing the resistance of the battery positive cable, touch the voltmeter leads to the battery positive cable terminal clamp and to the battery positive cable eyelet terminal at the starter solenoid B(+) terminal stud. If you probe the battery positive terminal post and the battery positive cable eyelet terminal at the starter solenoid B(+) terminal stud, you are reading the combined voltage drop in the battery positive cable terminal clamp-to-terminal post connection and the battery positive cable.

The following operation will require a voltmeter accurate to 1/10 (0.10) volt. Before performing this test, be certain that the following procedures are accomplished:

- The battery is fully-charged and load tested. Refer to **Battery Charging** in the index of this service manual for the location of the proper battery charging procedures. Refer to **Battery** in the index of this service manual for the location of the battery diagnosis and testing procedures, including the proper battery load test procedures.

- Fully engage the parking brake.
- If the vehicle is equipped with an automatic transmission, place the gearshift selector lever in the Park position. If the vehicle is equipped with a manual transmission, place the gearshift selector lever in the Neutral position and block the clutch pedal in the fully depressed position.

- Verify that all lamps and accessories are turned off.

DIAGNOSIS AND TESTING (Continued)

• To prevent the engine from starting, remove the Automatic ShutDown (ASD) relay. The ASD relay is located in the Power Distribution Center (PDC), in the engine compartment. See the fuse and relay layout label affixed to the underside of the PDC cover for ASD relay identification and location.

(1) Connect the positive lead of the voltmeter to the battery negative terminal post. Connect the negative lead of the voltmeter to the battery negative cable terminal clamp (Fig. 4). Rotate and hold the ignition switch in the Start position. Observe the voltmeter. If voltage is detected, correct the poor contact between the battery negative cable terminal clamp and the battery negative terminal post.

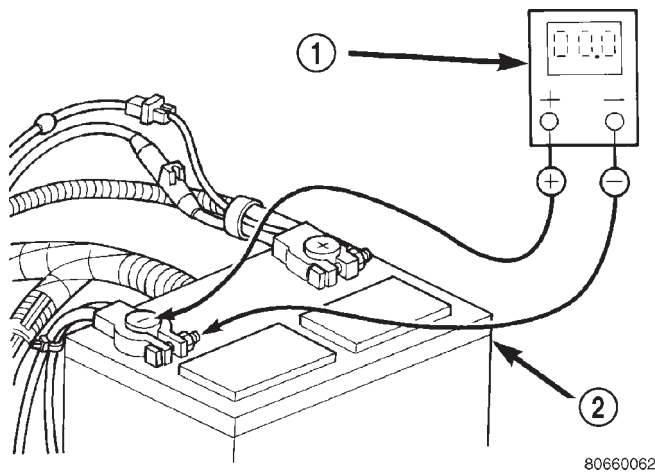

80660062

Fig. 4 Test Battery Negative Connection Resistance - Typical

1 - VOLTMETER
2 - BATTERY

(2) Connect the positive lead of the voltmeter to the battery positive terminal post. Connect the negative lead of the voltmeter to the battery positive cable terminal clamp (Fig. 5). Rotate and hold the ignition switch in the Start position. Observe the voltmeter. If voltage is detected, correct the poor connection between the battery positive cable terminal clamp and the battery positive terminal post.

(3) Connect the voltmeter to measure between the battery positive cable terminal clamp and the starter solenoid B(+) terminal stud (Fig. 6). Rotate and hold the ignition switch in the Start position. Observe the voltmeter. If the reading is above 0.2 volt, clean and tighten the battery positive cable eyelet terminal connection at the starter solenoid B(+) terminal stud. Repeat the test. If the reading is still above 0.2 volt, replace the faulty battery positive cable.

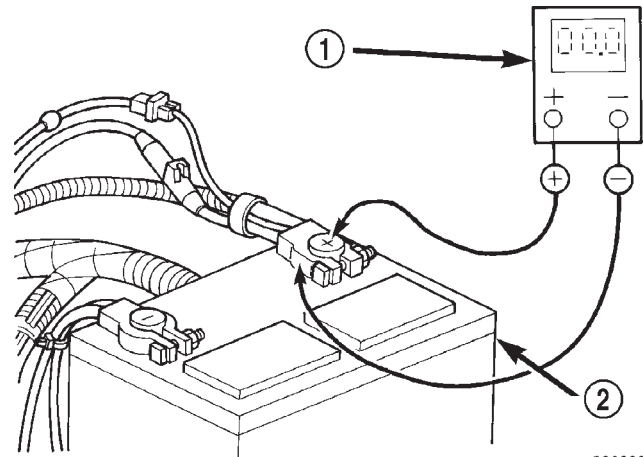

80660061

Fig. 5 Test Battery Positive Connection Resistance - Typical

1 - VOLTMETER
2 - BATTERY

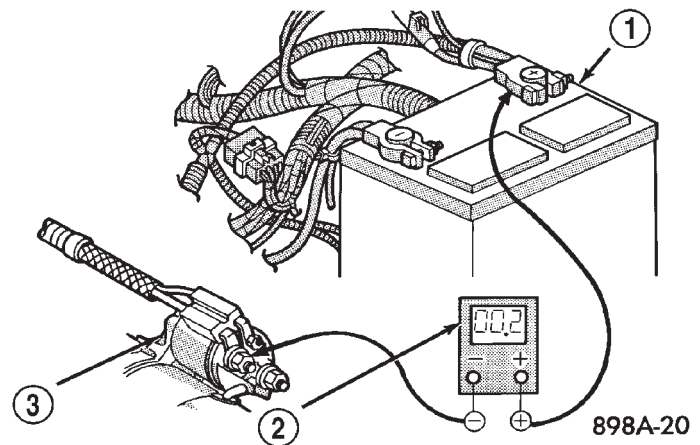

898A-20

Fig. 6 Test Battery Positive Cable Resistance - Typical

1 - BATTERY
2 - VOLTMETER
3 - STARTER MOTOR

(4) Connect the voltmeter to measure between the battery negative cable terminal clamp and a good clean ground on the engine block (Fig. 7). Rotate and hold the ignition switch in the Start position. Observe the voltmeter. If the reading is above 0.2 volt, clean and tighten the battery negative cable eyelet terminal connection to the engine block. Repeat the test. If the reading is still above 0.2 volt, replace the faulty battery negative cable.

DIAGNOSIS AND TESTING (Continued)

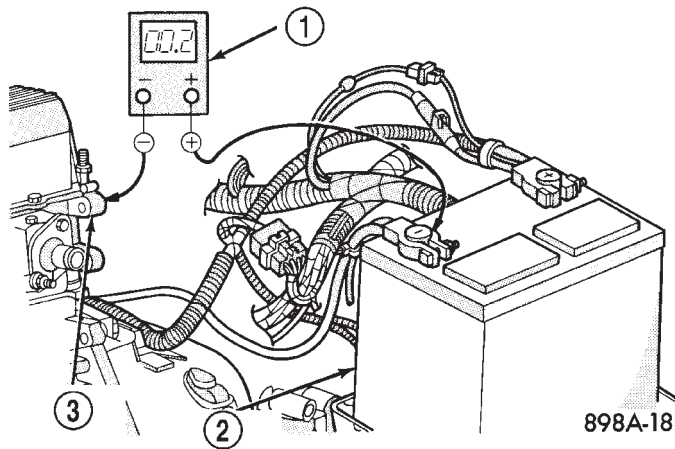

Fig. 7 Test Ground Circuit Resistance - Typical

- 1 - VOLTMETER
- 2 - BATTERY
- 3 - ENGINE GROUND

(5) Connect the positive lead of the voltmeter to the starter housing. Connect the negative lead of the voltmeter to the battery negative terminal post (Fig. 8). Rotate and hold the ignition switch in the Start position. Observe the voltmeter. If the reading is above 0.2 volt, correct the poor starter to engine block ground contact.

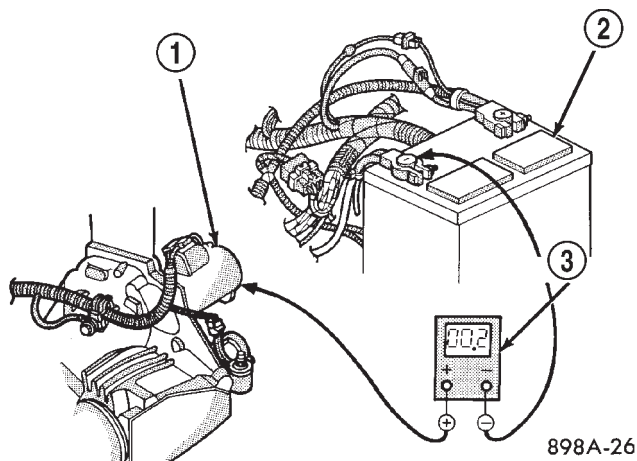

Fig. 8 Test Starter Ground - Typical

- 1 - STARTER MOTOR
- 2 - BATTERY
- 3 - VOLTMETER

If the resistance tests detect no feed circuit problems, refer to **Starter Motor** in the index of this service manual for the location of the proper starter motor diagnosis and testing procedures.

CONTROL CIRCUIT TEST

The starter control circuit components should be tested in the order in which they are listed, as follows:

- Starter Relay Refer to **Starter Relay** in the index of this service manual for the location of the proper starter relay diagnosis and testing procedures.
- Starter Solenoid Refer to **Starter Motor** in the index of this service manual for the location of the proper starter solenoid diagnosis and testing procedures.

- Ignition Switch Refer to **Ignition Switch and Key Lock Cylinder** in the index of this service manual for the location of the proper ignition switch diagnosis and testing procedures.

- Clutch Pedal Position Switch If the vehicle is equipped with a manual transmission, refer to **Clutch Pedal Position Switch** in the index of this service manual for the location of the proper clutch pedal position switch diagnosis and testing procedures.

- Park/Neutral Position Switch If the vehicle is equipped with an automatic transmission, refer to **Park/Neutral Position Switch** in the index of this service manual for the location of the proper park/neutral position switch diagnosis and testing procedures.

STARTER MOTOR NOISE - 2.5L ENGINE

See the Starter Motor Noise Diagnosis chart (Fig. 9). If the complaint is similar to Conditions 1 and 2 in the chart, correction can be made by placing shims between the starter motor and the engine block using the following procedures:

DIAGNOSIS AND TESTING (Continued)

| CONDITION | POSSIBLE CAUSE | CORRECTION |
|--|--|---|
| 1. VERY HIGH FREQUENCY WHINE BEFORE ENGINE STARTS; ENGINE STARTS OK. | 1. Excessive distance between pinion gear and flywheel/drive plate gear. | 1. Move starter motor toward flywheel/drive plate by removing shim(s), if possible. |
| 2. VERY HIGH FREQUENCY WHINE AFTER ENGINE STARTS WITH IGNITION KEY RELEASED. ENGINE STARTS OK. | 2. Insufficient distance between starter motor pinion gear and flywheel/drive plate runout can cause noise to be intermittent. | 2. Shim starter motor away from flywheel/drive plate. Inspect flywheel/drive plate for damage; bent, unusual wear, and excessive runout. Replace flywheel/drive plate as necessary. |
| 3. A LOUD "WHOOOP" AFTER ENGINE STARTS WHILE STARTER MOTOR IS ENGAGED. | 3. Most probable cause is defective overrunning clutch. | 3. Replace starter motor. |
| 4. A "RUMBLE," "GROWL," OR "KNOCK" AS STARTER MOTOR COASTS TO STOP AFTER ENGINE STARTS. | 4. Most probable cause is bent or unbalanced starter motor armature. | 4. Replace starter motor. |

NOTE: A high frequency whine during cranking is normal for this starter motor.

FIG. 9 STARTER MOTOR NOISE DIAGNOSIS

(1) If the complaint is similar to Condition 1, the starter motor must be moved toward the starter ring gear by removing shims from both starter mounting pads on the engine block (Fig. 10). Refer to **Starter Motor** in the index of this service manual for the location of the proper starter motor removal and installation procedures.

NOTE: The shim thickness is 0.381 mm (0.015 in.). These shims may be stacked if additional thickness is required.

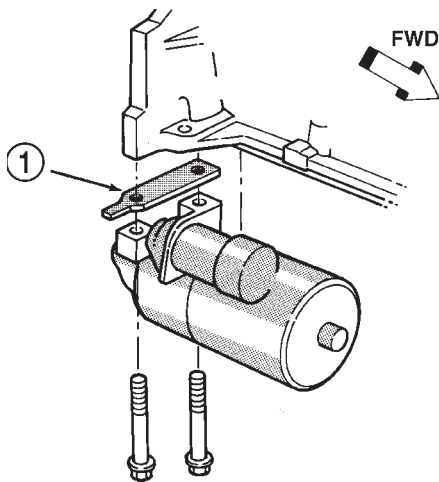

J908C-1

Fig. 10 Starter Motor Shim

1 - STARTER MOTOR SHIM

(2) If the complaint is similar to Condition 2, the starter motor must be moved away from the starter ring gear. This is done by installing shim(s) across both starter mounting pads on the engine block. More than one shim may be required. Refer to **Starter Motor** in the index of this service manual for the location of the proper removal and installation procedures.

NOTE: This is a condition that will generally cause broken starter (flywheel/torque converter drive plate) ring gear teeth or broken starter motor housings.

STARTER MOTOR

Correct starter motor operation can be confirmed by performing the following free running bench test. This test can only be performed with the starter motor removed from the vehicle. Refer to **Starting System** in the index of this service manual for the location of the proper starter motor specifications.

CAUTION: The 2.5L engine uses a permanent magnet starter. Permanent magnet starters are highly sensitive to hammering, shocks, external pressure and reverse polarity. This starter motor must never be clamped in a vise by the starter field frame. The starter should only be clamped by the mounting flange. Do not reverse the battery cable connections to this starter motor when testing. The permanent magnets may be damaged and the starter rendered unserviceable if it is subjected to any of these conditions.

DIAGNOSIS AND TESTING (Continued)

STARTER MOTOR

(1) Remove the starter motor from the vehicle. Refer to **Starter Motor** in the index of this service manual for the location of the proper starter motor removal and installation procedures.

(2) Mount the starter motor securely in a soft-jawed bench vise. The vise jaws should be clamped on the mounting flange of the starter motor. Never clamp on the starter motor by the field frame.

(3) Connect a suitable volt-ampere tester and a 12-volt battery to the starter motor in series, and set the ammeter to the 100 ampere scale. See the instructions provided by the manufacturer of the volt-ampere tester being used.

(4) Install a jumper wire from the solenoid terminal to the solenoid B(+) terminal stud. The starter motor should operate. If the starter motor fails to operate, replace the faulty starter motor.

(5) Adjust the carbon pile load of the tester to obtain the free running test voltage. Refer to **Starting System** in the index of this service manual for the location of the proper starter motor free running test voltage specifications.

(6) Note the reading on the ammeter and compare this reading to the free running test maximum amperage draw. Refer to **Starting System** in the index of this service manual for the location of the proper starter motor free running test maximum amperage draw specifications.

(7) If the ammeter reading exceeds the maximum amperage draw specification, replace the faulty starter motor.

STARTER SOLENOID

This test can only be performed with the starter motor removed from the vehicle.

(1) Remove the starter motor from the vehicle. Refer to **Starter Motor** in the index of this service manual for the location of the proper starter motor removal and installation procedures.

(2) Disconnect the wire from the solenoid field coil terminal.

(3) Check for continuity between the solenoid terminal and the solenoid field coil terminal with a continuity tester (Fig. 11). There should be continuity. If OK, go to Step 4. If not OK, replace the faulty starter motor.

(4) Check for continuity between the solenoid terminal and the solenoid case (Fig. 12). There should be continuity. If not OK, replace the faulty starter motor.

STARTER RELAY

The starter relay (Fig. 13) is located in the Power Distribution Center (PDC), in the engine compartment. Refer to the fuse and relay layout label affixed

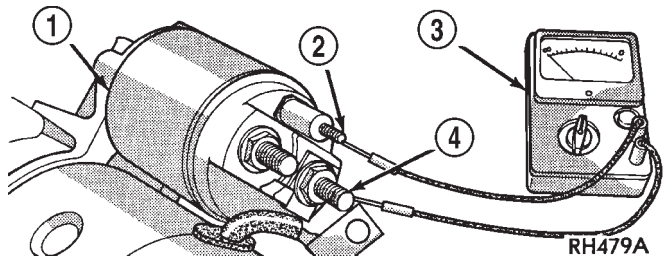

Fig. 11 Continuity Test Between Solenoid Terminal and Field Coil Terminal - Typical

- 1 - SOLENOID
- 2 - SOLENOID TERMINAL
- 3 - OHMMETER
- 4 - FIELD COIL TERMINAL

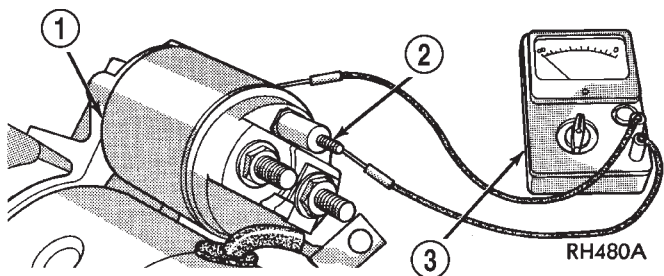

Fig. 12 Continuity Test Between Solenoid Terminal and Solenoid Case - Typical

- 1 - SOLENOID
- 2 - SOLENOID TERMINAL
- 3 - OHMMETER

to the underside of the PDC cover for starter relay identification and location. Refer to **Starting System** in the index of this service manual for the location of complete starting system wiring diagrams.

RELAY TEST

(1) Remove the starter relay from the PDC. Refer to **Starter Relay** in the index of this service manual for the location of the proper starter relay removal and installation procedures.

(2) A relay in the de-energized position should have continuity between terminals 87A and 30, and no continuity between terminals 87 and 30. If OK, go to Step 3. If not OK, replace the faulty relay.

(3) Resistance between terminals 85 and 86 (electromagnet) should be 75 ± 5 ohms. If OK, go to Step 4. If not OK, replace the faulty relay.

(4) Connect a battery to terminals 85 and 86. There should now be continuity between terminals 30 and 87, and no continuity between terminals 87A and 30. If OK, perform the Relay Circuit Test that follows. If not OK, replace the faulty relay.

DIAGNOSIS AND TESTING (Continued)

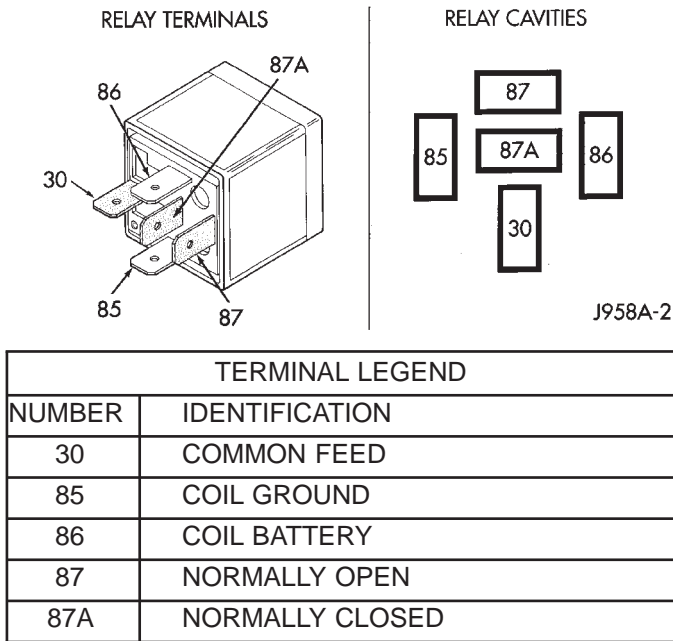

Fig. 13 Starter Relay

RELAY CIRCUIT TEST

(1) The relay common feed terminal cavity (30) is connected to battery voltage and should be hot at all times. If OK, go to Step 2. If not OK, repair the open circuit to the fused B(+) fuse in the PDC as required.

(2) The relay normally closed terminal (87A) is connected to terminal 30 in the de-energized position, but is not used for this application. Go to Step 3.

(3) The relay normally open terminal (87) is connected to the common feed terminal (30) in the energized position. This terminal supplies battery voltage to the starter solenoid field coil. There should be continuity between the cavity for relay terminal 87 and the starter solenoid terminal at all times. If OK, go to Step 4. If not OK, repair the open engine starter motor relay output circuit to the starter solenoid as required.

(4) The coil battery terminal (86) is connected to the electromagnet in the relay. It is energized when the ignition switch is held in the Start position. On vehicles with a manual transmission, the clutch pedal must be blocked in the fully depressed position for this test. Check for battery voltage at the cavity for relay terminal 86 with the ignition switch in the Start position, and no voltage when the ignition switch is released to the On position. If OK, go to Step 5. If not OK with a manual transmission, disconnect the clutch pedal position switch wire harness connector and install a jumper wire between the two cavities in the body half of the connector and check for battery voltage again at the cavity for relay terminal 86. If now OK, replace the faulty clutch pedal position switch. If still not OK with a manual trans-

mission or if not OK with an automatic transmission, check for an open or shorted fused ignition switch output (start) circuit to the ignition switch and repair, as required. If the fused ignition switch output (start) circuit is OK, refer to **Ignition Switch and Key Lock Cylinder** in the index of this service manual for the location of the proper ignition switch diagnosis and testing procedures.

(5) The coil ground terminal (85) is connected to the electromagnet in the relay. On vehicles with a manual transmission, it is grounded at all times. On vehicles with an automatic transmission, it is grounded through the park/neutral position switch only when the gearshift selector lever is in the Park or Neutral positions. Check for continuity to ground at the cavity for relay terminal 85. If not OK with a manual transmission, repair the open park/neutral position switch sense circuit to ground as required. If not OK with an automatic transmission, check for an open or shorted park/neutral position switch sense circuit to the park/neutral position switch and repair, as required. If the park/neutral position switch sense circuit checks OK, refer to **Park/Neutral Position Switch** in the index of this service manual for the location of the proper park/neutral position switch diagnosis and testing procedures.

REMOVAL AND INSTALLATION

STARTER MOTOR

REMOVAL

2.5L ENGINE

(1) Disconnect and isolate the battery negative cable.

(2) Raise and support the vehicle.

(3) While supporting the starter motor with one hand, use the other hand to remove the two screws that secure the starter motor to the engine block (Fig. 14).

(4) Lower the starter motor from the engine block far enough to access and remove the nut that secures the battery positive cable eyelet terminal to the starter solenoid B(+) terminal stud (Fig. 15). Always support the starter motor during this process. Do not let the starter motor hang from the wire harness.

(5) Remove the battery positive cable eyelet terminal from the starter solenoid B(+) terminal stud. Always support the starter motor during this process. Do not let the starter motor hang from the wire harness.

REMOVAL AND INSTALLATION (Continued)

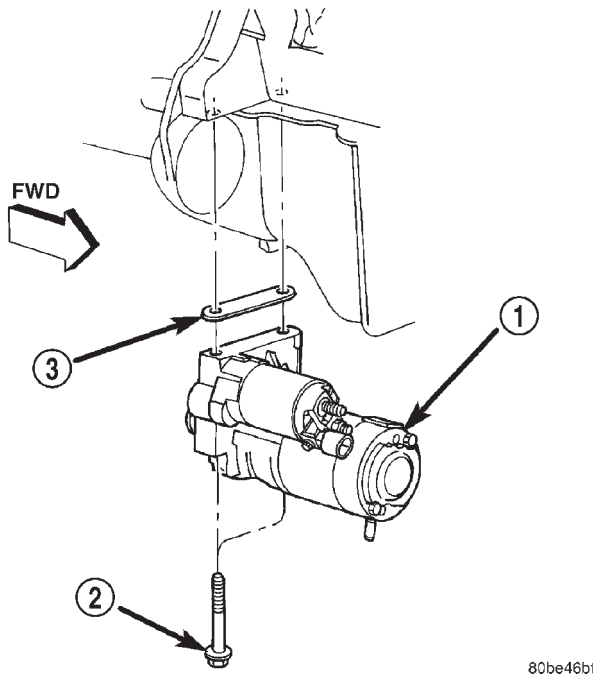

80be46bi

Fig. 14 Starter Motor Remove/Install - 2.5L Engine

- 1 - STARTER MOTOR
- 2 - SCREW (2)
- 3 - SHIM

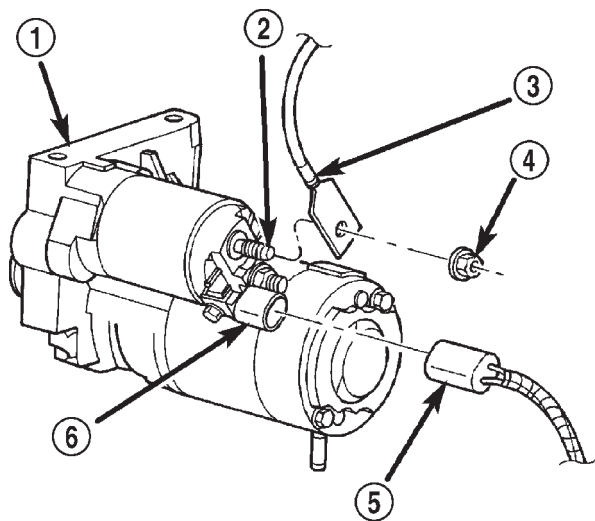

80be46cb

Fig. 15 Starter Connections Remove/Install - Typical

- 1 - STARTER MOTOR
- 2 - SOLENOID B(+) TERMINAL STUD
- 3 - BATTERY POSITIVE CABLE EYELET TERMINAL
- 4 - NUT
- 5 - SOLENOID TERMINAL WIRE HARNESS CONNECTOR
- 6 - SOLENOID TERMINAL CONNECTOR RECEPTACLE

(6) Disconnect the solenoid terminal wire harness connector from the connector receptacle on the starter solenoid. Always support the starter motor

during this process. Do not let the starter motor hang from the wire harness.

(7) Remove the starter motor and any starter motor shims (if used) from the engine block.

4.0L ENGINE

(1) Disconnect and isolate the battery negative cable.

(2) Raise and support the vehicle.

(3) Remove the lower screw (forward facing) that secures the starter motor to the manual transmission clutch housing or the automatic transmission torque converter housing (Fig. 16).

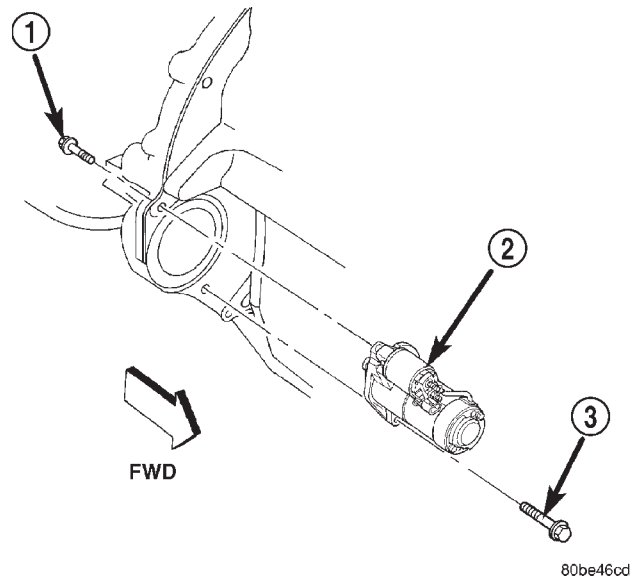

80be46cd

Fig. 16 Starter Motor Remove/Install - 4.0L Engine

- 1 - SCREW
- 2 - STARTER MOTOR
- 3 - SCREW

(4) While supporting the starter motor with one hand, use the other hand to remove the upper screw (rearward facing) that secures the starter motor to the manual transmission clutch housing or the automatic transmission torque converter housing.

(5) Lower the starter motor from the front of the manual transmission clutch housing or automatic transmission torque converter housing far enough to access and remove the nut that secures the battery positive cable eyelet terminal to the starter solenoid B(+) terminal stud (Fig. 15). Always support the starter motor during this process. Do not let the starter motor hang from the wire harness.

(6) Remove the battery positive cable eyelet terminal from the solenoid B(+) terminal stud. Always support the starter motor during this process. Do not let the starter motor hang from the wire harness.

(7) Disconnect the solenoid terminal wire harness connector from the connector receptacle on the

REMOVAL AND INSTALLATION (Continued)

starter solenoid. Always support the starter motor during this process. Do not let the starter motor hang from the wire harness.

(8) Remove the starter motor from the manual transmission clutch housing or automatic transmission torque converter housing.

INSTALLATION

2.5L ENGINE

(1) Position the starter motor to the engine block.

(2) Reconnect the solenoid terminal wire harness connector to the connector receptacle on the starter solenoid. Always support the starter motor during this process. Do not let the starter motor hang from the wire harness.

(3) Install the battery positive cable eyelet terminal onto the starter solenoid B(+) terminal stud. Always support the starter motor during this process. Do not let the starter motor hang from the wire harness.

(4) Install and tighten the nut that secures the battery positive cable eyelet terminal to the starter solenoid B(+) terminal stud. Tighten the nut to 11.3 N·m (100 in. lbs.). Always support the starter motor during this process. Do not let the starter motor hang from the wire harness.

(5) Position the starter motor and any starter motor shims that were removed during the starter motor removal procedure to the engine block. Loosely install the two starter motor mounting screws to secure the starter motor and shims to the engine block.

NOTE: Shim thickness available is 0.381 mm (0.015 in.). Refer to Starter Motor Noise - 2.5L Engine in the index of this service manual for the location of the proper starter motor noise diagnosis and testing procedures.

(6) Tighten the two screws that secure the starter motor and shims to the engine block. Tighten the screws to 44.7 N·m (33 ft. lbs.).

(7) Lower the vehicle.

(8) Reconnect the battery negative cable.

4.0L ENGINE

(1) Position the starter motor to the manual transmission clutch housing or automatic transmission torque converter housing.

(2) Reconnect the solenoid terminal wire harness connector to the connector receptacle on the starter solenoid. Always support the starter motor during this process. Do not let the starter motor hang from the wire harness.

(3) Install the battery positive cable eyelet terminal onto the starter solenoid B(+) terminal stud.

Always support the starter motor during this process. Do not let the starter motor hang from the wire harness.

(4) Install and tighten the nut that secures the battery positive cable eyelet terminal to the starter solenoid B(+) terminal stud. Tighten the nut to 11.3 N·m (100 in. lbs.). Always support the starter motor during this process. Do not let the starter motor hang from the wire harness.

(5) Position the starter motor to the manual transmission clutch housing or automatic transmission torque converter housing. Loosely install the two starter motor mounting screws to secure the starter motor to the manual transmission clutch housing or automatic transmission torque converter housing.

(6) Tighten the lower (forward facing) screw that secures the starter motor to the manual transmission clutch housing or automatic transmission torque converter housing. Tighten the screw to 40.7 N·m (30 ft. lbs.).

(7) Tighten the upper (rearward facing) screw that secures the starter motor to the manual transmission clutch housing or automatic transmission torque converter housing. Tighten the screw to 47.5 N·m (35 ft. lbs.).

(8) Lower the vehicle.

(9) Reconnect the battery negative cable.

STARTER RELAY

REMOVAL

(1) Disconnect and isolate the battery negative cable.

(2) Remove the cover from the Power Distribution Center (PDC) (Fig. 17).

(3) See the fuse and relay layout label affixed to the underside of the PDC cover for starter relay identification and location.

(4) Remove the starter relay from the PDC.

INSTALLATION

(1) See the fuse and relay layout label affixed to the underside of the PDC cover for the proper starter relay location.

(2) Position the starter relay in the proper receptacle in the PDC.

(3) Align the starter relay terminals with the terminal cavities in the PDC receptacle.

(4) Push down firmly on the starter relay until the terminals are fully seated in the terminal cavities in the PDC receptacle.

(5) Install the cover onto the PDC.

(6) Reconnect the battery negative cable.

REMOVAL AND INSTALLATION (Continued)

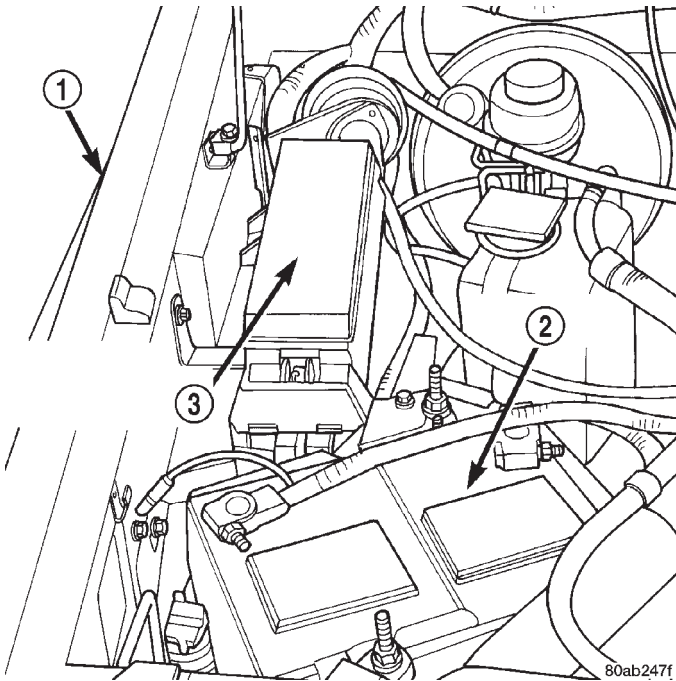

Fig. 17 Power Distribution Center

- 1 - RIGHT FENDER
- 2 - BATTERY
- 3 - POWER DISTRIBUTION CENTER

CLEANING AND INSPECTION

STARTING SYSTEM

The following components of the starting system should be carefully inspected whenever any starting system problem is encountered.

WARNING: ON VEHICLES EQUIPPED WITH AIRBAGS, DISABLE THE AIRBAG SYSTEM BEFORE ATTEMPTING ANY STEERING WHEEL, STEERING COLUMN, OR INSTRUMENT PANEL COMPONENT DIAGNOSIS OR SERVICE. DISCONNECT AND ISOLATE THE BATTERY NEGATIVE (GROUND) CABLE, THEN WAIT TWO MINUTES FOR THE AIRBAG SYSTEM CAPACITOR TO DISCHARGE BEFORE PERFORMING FURTHER DIAGNOSIS OR SERVICE. THIS IS THE ONLY SURE WAY TO DISABLE THE AIRBAG SYSTEM. FAILURE TO TAKE THE PROPER PRECAUTIONS COULD RESULT IN ACCIDENTAL AIRBAG DEPLOYMENT AND POSSIBLE PERSONAL INJURY.

- **Battery** Visually inspect the battery for indications of physical damage and loose or corroded cable connections. Determine the state-of-charge and cranking capacity of the battery. Charge or replace the battery, if required. Refer to **Battery** in the index of this service manual for the location of the proper battery cleaning and inspection procedures.

- **Ignition Switch** Visually inspect the ignition switch for indications of physical damage and loose or corroded wire harness connections. Clean corroded connections as required. Refer to **Wiring Diagrams** in the index of this service manual for the location of the proper wiring repair or connector and terminal service procedures. Refer to **Ignition Switch and Key Lock Cylinder** in the index of this service manual for the location of the proper ignition switch service procedures.

- **Clutch Pedal Position Switch** If the vehicle is equipped with a manual transmission, visually inspect the clutch pedal position switch for indications of physical damage and loose or corroded wire harness connections. Clean corroded connections as required. Refer to **Wiring Diagrams** in the index of this service manual for the location of the proper wiring repair or connector and terminal service procedures. Refer to **Clutch Hydraulic Linkage** in the index of this service manual for the location of the proper clutch pedal position switch service procedures.

- **Park/Neutral Position Switch** If the vehicle is equipped with an automatic transmission, visually inspect the park/neutral position switch for indications of physical damage and loose or corroded wire harness connections. Clean corroded connections as required. Refer to **Wiring Diagrams** in the index of this service manual for the location of the proper wiring repair or connector and terminal service procedures. Refer to **Park/Neutral Position Switch** in the index of this service manual for the location of the proper park/neutral position switch service procedures.

- **Starter Relay** Visually inspect the starter relay for indications of physical damage and loose or corroded wire harness connections. Clean corroded connections as required. Refer to **Wiring Diagrams** in the index of this service manual for the location of the proper wiring repair or connector and terminal service procedures. Refer to **Starter Relay** in the index of this service manual for the location of the proper starter relay service procedures.

- **Starter Motor** Visually inspect the starter motor for indications of physical damage and loose or corroded wire harness connections. Clean corroded connections as required. Refer to **Wiring Diagrams** in the index of this service manual for the location of the proper wiring repair or connector and terminal service procedures. If the problem being diagnosed involves improper starter engagement, disengagement or noise complaints the starter motor should be removed. With the starter motor removed, inspect the starter pinion and ring gears for damaged or missing teeth. Replace faulty components as required. Refer to **Starter Motor** in the index of this

CLEANING AND INSPECTION (Continued)

service manual for the location of the proper starter motor removal and installation procedures.

- **Starter Solenoid** Visually inspect the starter solenoid for indications of physical damage and loose or corroded wire harness connections. Clean corroded connections as required. Refer to **Wiring Diagrams** in the index of this service manual for the location of the proper wiring repair or connector and terminal service procedures. Refer to **Starter Motor** in the index of this service manual for the location of the proper starter solenoid service procedures.

- **Wiring** Visually inspect the starting system wire harnesses for indications of physical damage. Repair or replace any faulty wiring, as required. Refer to **Starting System** in the index of this service manual for the location of complete starting system wiring diagrams. Refer to **Wiring Diagrams** in the index of this service manual for the location of the proper wiring repair or connector and terminal service procedures.

SPECIFICATIONS

STARTING SYSTEM

| Starter Motor and Solenoid | |
|--|--|
| Manufacturer | Mitsubishi |
| Engine Application | 2.5L, 4.0L |
| Power Rating | 2.5L - 1.2 Kilowatt (1.6 Horsepower) 4.0L - 1.4 Kilowatt (1.9 Horsepower) |
| Voltage | 12 Volts |
| Number of Fields | 4 |
| Number of Poles | 4 |
| Number of Brushes | 4 |
| Drive Type | Planetary Gear Reduction |
| Free Running Test Voltage | 11.2 Volts |
| Free Running Test Maximum Amperage Draw | 90 Amperes |
| Free Running Test Minimum Speed | 2.5L - 2600 rpm 4.0L - 2500 rpm |
| Solenoid Closing Maximum Voltage Required | 7.8 Volts |
| *Cranking Amperage Draw Test | 2.5L - 130 Amperes 4.0L - 160 Amperes |
| *Test at operating temperature. Cold engine, tight (new) engine, or heavy oil will increase starter amperage draw. | |

STARTING SYSTEMS

TABLE OF CONTENTS

| | page | | page |
|---------------------------------|------|-----------------------------|------|
| REMOVAL AND INSTALLATION | | SPECIFICATIONS | |
| STARTER — LHD (DIESEL) | 1 | STARTING SYSTEM | 3 |
| STARTER — RHD (DIESEL) | 2 | TORQUE SPECIFICATIONS | 4 |
| STARTER RELAY | 3 | | |

REMOVAL AND INSTALLATION

STARTER — LHD (DIESEL)

Removal

- (1) Disconnect the negative battery cable.
- (2) Remove the innercooler inlet hose from turbocharger and position it out of the way (Fig. 1).

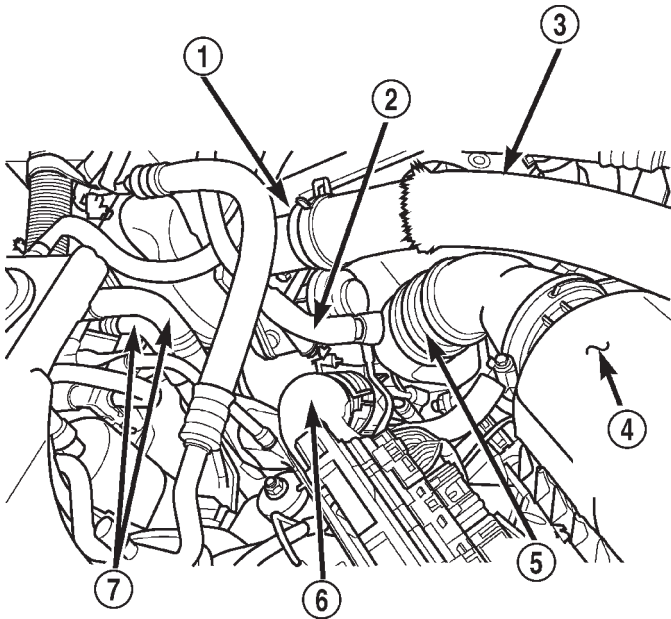

80b8992c

Fig. 1 LHD Engine Compartment — Diesel

- 1 - INTAKE MANIFOLD ELBOW
- 2 - BREATHER HOSE
- 3 - INNERCOOLER OUTLET HOSE
- 4 - AIR FILTER COVER
- 5 - AIR FILTER OUTLET (FRESH AIR) HOSE
- 6 - INNERCOOLER INLET HOSE
- 7 - HEATER CORE COOLANT SUPPLY HOSES

(3) Remove the (2) right engine mount upper sill plate nuts.

(4) Raise the vehicle on a hoist.

- (5) Remove the turbocharger oil return hose from engine block and plug (Fig. 2).

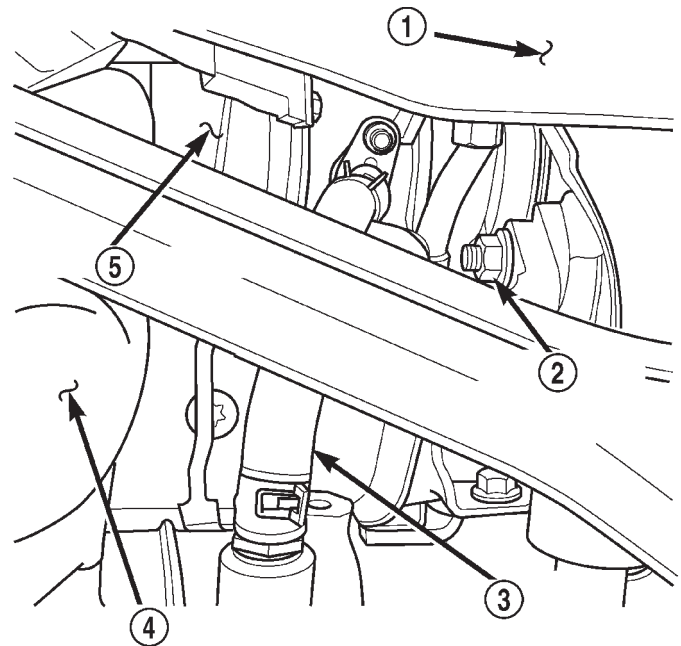

80b8992e

Fig. 2 Turbocharger Oil Return Hose — Position & Orientation

- 1 - VEHICLE UNDERBODY
- 2 - RIGHT ENGINE MOUNT THROUGH BOLT NUT
- 3 - TURBOCHARGER OIL RETURN HOSE
- 4 - EXHAUST MANIFOLD DOWNPIPE
- 5 - TURBOCHARGER

(6) Remove the right engine mount through bolt nut only (Fig. 2). Do not remove the bolt at this time.

(7) Position a jack stand and raise the weight off the right engine mount.

(8) Remove the (2) right engine mount lower sill plate bolts.

(9) Remove the (4) right engine mount bracket to engine block retaining bolts.

(10) Remove the engine mount throughbolt.

(11) Remove the engine mount and the engine mount bracket from the vehicle.

REMOVAL AND INSTALLATION (Continued)

- (12) Remove the starter motor support bracket.
- (13) Disconnect the starter motor electrical connectors.

CAUTION: Heatshields are very sharp. Wear gloves to prevent injury.

- (14) Remove the starter heatshield.
- (15) Remove the (3) starter motor retaining bolts.
- (16) Remove the starter motor from the vehicle.

Installation

- (1) Position the starter motor and install retaining bolts. Torque bolts to 27 N·m (20 ft. lbs.).
- (2) Connect the starter motor electrical. Torque (B+) nut to 27 N·m (20 ft. lbs.).

CAUTION: Heatshields are very sharp. Wear gloves to prevent injury.

- (3) Install the starter heatshield.
- (4) Install the starter motor support bracket. Torque nuts to 10 N·m (90 in. lbs.).
- (5) Install the engine mount and engine mount bracket in the vehicle, making sure sill plate studs are through engine mount.
- (6) Install the engine mount throughbolt and nut leaving them loose at this time.
- (7) Install the (4) engine mount bracket to engine block bolts. Torque bolts to 61 N·m (45 ft. lbs.).
- (8) Tighten, but do not torque (2) right engine mount lower bolts.
- (9) Remove the jack stand.
- (10) Torque the (2) lower engine mount bolts to 54 N·m (40 ft. lbs.).
- (11) Torque throughbolt nut to 65 N·m (48 ft. lbs.).
- (12) Install the oil return line on the engine block nipple.
- (13) Lower the vehicle from the hoist.
- (14) Install the (2) engine mount upper sill plate nuts. Torque nuts to 41 N·m (30 ft. lbs.).
- (15) Install the innercooler inlet hose on turbocharger.
- (16) Connect the negative battery cable.

STARTER — RHD (DIESEL)

REMOVAL

- (1) Disconnect the negative battery cable.
- (2) Make sure steering wheel is in the unlocked position.
- (3) Raise the vehicle on a hoist.
- (4) Rotate the front wheels to access and remove the steering shaft pinch bolt, slide shaft straight off gearbox input shaft and position steering shaft aside.
- (5) Remove the turbocharger oil return line from engine block and plug (Fig. 3).

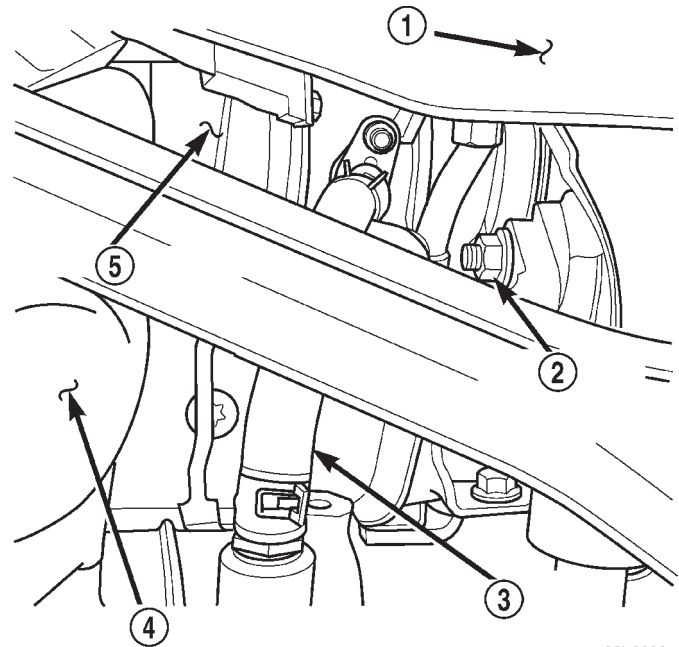

80b8992e

Fig. 3 Turbocharger Oil Return Line

- 1 - VEHICLE UNDERBODY
- 2 - RIGHT ENGINE MOUNT THROUGHBOLT NUT
- 3 - TURBOCHARGER OIL RETURN HOSE
- 4 - EXHAUST MANIFOLD DOWNPIPE
- 5 - TURBOCHARGER

- (6) Remove the right engine mount through bolt nut only (Fig. 3). Do not remove the bolt at this time.
- (7) Remove the engine mount upper sill plate nuts.
- (8) Position a jack stand and raise weight off right engine mount.
- (9) Remove the track bar support bracket retaining bolts and remove bracket.
- (10) Remove the remaining lower engine mount bolt from the sill plate.
- (11) Remove the (4) engine mount bracket bolts.
- (12) Remove the engine mount throughbolt.
- (13) Remove the engine mount and engine mount bracket from the vehicle.
- (14) Remove the starter motor support bracket.

CAUTION: Heatshield is very sharp. Wear gloves to prevent injury.

- (15) Remove the starter heat shield.
- (16) Disconnect the starter motor electrical connectors.
- (17) Remove the (3) stater motor retaining bolts.
- (18) Remove the starter motor from the vehicle.

Installation

- (1) Position the starter motor. Torque retaining bolts to 27 N·m (20 ft. lbs.).

REMOVAL AND INSTALLATION (Continued)

(2) Reconnect the starter motor electrical. Torque (B+) nut to 27 N·m (20 ft. lbs.).

CAUTION: Heatshield is very sharp. Wear gloves to prevent injury.

- (3) Install the starter heat shield.
- (4) Install the starter motor support bracket. Torque bolt to 47 N·m (35 ft. lbs.). Torque nuts to 10 N·m (90 in. lbs.).
- (5) Install the engine mount and engine mount bracket in the vehicle.
- (6) Install the engine mount throughbolt and nut leaving them loose at this time.
- (7) Install, but do not torque the engine mount and track bar support bracket bolts
- (8) Install the (4) engine mount bracket to engine block bolts. Torque bolts to 61 N·m (45 ft. lbs.).
- (9) Remove the jack stand.
- (10) Install and torque the upper engine mount sill plate nuts to 41 N·m (30 ft. lbs.).
- (11) Torque the lower engine mount retaining bolts to 54 N·m (40 ft. lbs.).
- (12) Torque the larger track bar support bracket bolts to 125 N·m (92 ft. lbs.).

(13) Torque the engine mount throughbolt nut to 65 N·m (48 ft. lbs.).

(14) Install the oil return line on the engine block nipple.

(15) Install steering shaft pinch bolt. Torque to 49 N·m (36 ft. lbs.).

(16) Lower the vehicle from the hoist.

(17) Connect the negative battery cable.

STARTER RELAY

- (1) Disconnect and isolate the battery negative cable.
- (2) Remove the cover from the Power Distribution Center (PDC).
- (3) Refer to the label on the PDC for starter relay identification and location.
- (4) Unplug the starter relay from the PDC.
- (5) Install the starter relay by aligning the relay terminals with the cavities in the PDC and pushing the relay firmly into place.
- (6) Install the PDC cover.
- (7) Connect the battery negative cable.
- (8) Test the relay operation.

SPECIFICATIONS

STARTING SYSTEM

| Starter and Solenoid | |
|--|--------------------------|
| Engine Application | 2.5L Diesel |
| Power Rating | 2.2 Kilowatt |
| Voltage | 12 Volts |
| Number of Fields | 4 |
| Number of Poles | 4 |
| Number of Brushes | 4 |
| Drive Type | Planetary Gear Reduction |
| Free Running Test Voltage | 11.5 Volts |
| Free Running Test Maximum Amperage Draw | 160 Amperes |
| Free Running Test Minimum Speed | 5500 rpm |
| Solenoid Closing Maximum Voltage | 7.8 Volts |
| *Cranking Amperage Draw test | 350 Amperes |
| *Test at operating temperature. Cold engine, tight (new) engine, or heavy oil will increase starter amperage draw. | |

TORQUE SPECIFICATIONS

| DESCRIPTION | TORQUE |
|--|--------------------------|
| Engine Mount Throughbolt | 65 N·m (48 ft. lbs.) |
| Engine Mount Upper Sill Plate Nuts | 41 N·m (30 ft. lbs.) |
| Engine Mount to Engine Mounting Bolts . . | 61 N·m (45 ft. lbs.) |
| Lower Engine Mount Bolts | 54 N·m (40 ft. lbs.) |
| Stator Motor (B+) Terminal | 27 N·m (20 ft. lbs.) |
| Starter Motor Retaining Bolts . . | 27 N·m (20 ft. lbs.) |
| Starter Motor Support Bracket Nuts | 10 N·m (90 in. lbs.) |
| Steering Shaft Pinch Bolt | 49 N·m (36 ft. lbs.) |
| Track Bar Support Bracket Bolts | 125 N·m (92 ft. lbs.) |

CHARGING SYSTEM

TABLE OF CONTENTS

| | page | | page |
|-----------------------------------|------|---------------------------------|------|
| DESCRIPTION AND OPERATION | | REMOVAL AND INSTALLATION | |
| CHARGING SYSTEM..... | 1 | GENERATOR..... | 3 |
| GENERATOR..... | 1 | BATTERY TEMPERATURE SENSOR..... | 5 |
| BATTERY TEMPERATURE SENSOR..... | 2 | SPECIFICATIONS | |
| ELECTRONIC VOLTAGE REGULATOR..... | 2 | GENERATOR RATINGS..... | 5 |
| DIAGNOSIS AND TESTING | | TORQUE CHART..... | 5 |
| CHARGING SYSTEM..... | 2 | | |
| ON-BOARD DIAGNOSTIC TEST FOR | | | |
| CHARGING SYSTEM..... | 3 | | |

DESCRIPTION AND OPERATION

CHARGING SYSTEM

DESCRIPTION

The charging system consists of:

- Generator
- Electronic Voltage Regulator (EVR) circuitry within the Powertrain Control Module (PCM)
- Ignition switch (refer to Group 8D, Ignition System for information)
- Battery (refer to Group 8A, Battery for information)
- Battery temperature sensor
- Generator Lamp (if equipped)
- Check Gauges Lamp (if equipped)
- Voltmeter (refer to Group 8E, Instrument Panel and Gauges for information)
- Wiring harness and connections (refer to Group 8W, Wiring for information)

OPERATION

The charging system is turned on and off with the ignition switch. The system is on when the engine is running and the ASD relay is energized. When the ASD relay is on, voltage is supplied to the ASD relay sense circuit at the PCM. This voltage is connected through the PCM and supplied to one of the generator field terminals (Gen. Source +) at the back of the generator.

The amount of DC current produced by the generator is controlled by the EVR (field control) circuitry contained within the PCM. This circuitry is connected in series with the second rotor field terminal and ground.

A battery temperature sensor, located in the battery tray housing, is used to sense battery tempera-

ture. This temperature data, along with data from monitored line voltage, is used by the PCM to vary the battery charging rate. This is done by cycling the ground path to control the strength of the rotor magnetic field. The PCM then compensates and regulates generator current output accordingly.

All vehicles are equipped with On-Board Diagnostics (OBD). All OBD-sensed systems, including EVR (field control) circuitry, are monitored by the PCM. Each monitored circuit is assigned a Diagnostic Trouble Code (DTC). The PCM will store a DTC in electronic memory for certain failures it detects. Refer to On-Board Diagnostics in Group 25, Emission Control System for more DTC information.

The Check Gauges Lamp (if equipped) monitors: **charging system voltage**, engine coolant temperature and engine oil pressure. If an extreme condition is indicated, the lamp will be illuminated. This is done as reminder to check the three gauges. The signal to activate the lamp is sent via the CCD bus circuits. The lamp is located on the instrument panel. Refer to Group 8E, Instrument Panel and Gauges for additional information.

GENERATOR

DESCRIPTION

The generator is belt-driven by the engine using a serpentine type drive belt. It is serviced only as a complete assembly. If the generator fails for any reason, the entire assembly must be replaced.

OPERATION

As the energized rotor begins to rotate within the generator, the spinning magnetic field induces a current into the windings of the stator coil. Once the

DESCRIPTION AND OPERATION (Continued)

generator begins producing sufficient current, it also provides the current needed to energize the rotor.

The Y type stator winding connections deliver the induced AC current to 3 positive and 3 negative diodes for rectification. From the diodes, rectified DC current is delivered to the vehicle electrical system through the generator battery terminal.

Although the generators appear the same externally, different generators with different output ratings are used on this vehicle. Be certain that the replacement generator has the same output rating and part number as the original unit. Refer to Generator Ratings in the Specifications section at the back of this group for amperage ratings and part numbers.

Noise emitting from the generator may be caused by: worn, loose or defective bearings; a loose or defective drive pulley; incorrect, worn, damaged or misadjusted fan drive belt; loose mounting bolts; a misaligned drive pulley or a defective stator or diode.

BATTERY TEMPERATURE SENSOR

DESCRIPTION

The Battery Temperature Sensor (BTS) is attached to the battery tray located under the battery.

OPERATION

The BTS is used to determine the battery temperature and control battery charging rate. This temperature data, along with data from monitored line voltage, is used by the PCM to vary the battery charging rate. System voltage will be higher at colder temperatures and is gradually reduced at warmer temperatures.

The PCM sends 5 volts to the sensor and is grounded through the sensor return line. As temperature increases, resistance in the sensor decreases and the detection voltage at the PCM increases.

The BTS is also used for OBD II diagnostics. Certain faults and OBD II monitors are either enabled or disabled, depending upon BTS input (for example, disable purge and enable Leak Detection Pump (LDP) and O₂ sensor heater tests). Most OBD II monitors are disabled below 20°F.

ELECTRONIC VOLTAGE REGULATOR

DESCRIPTION

The Electronic Voltage Regulator (EVR) is not a separate component. It is actually a voltage regulating circuit located within the Powertrain Control Module (PCM). The EVR is not serviced separately. If replacement is necessary, the PCM must be replaced.

OPERATION

The amount of DC current produced by the generator is controlled by EVR circuitry contained within the PCM. This circuitry is connected in series with the generators second rotor field terminal and its ground.

Voltage is regulated by cycling the ground path to control the strength of the rotor magnetic field. The EVR circuitry monitors system line voltage (B+) and battery temperature (refer to Battery Temperature Sensor for more information). It then determines a target charging voltage. If sensed battery voltage is 0.5 volts or lower than the target voltage, the PCM grounds the field winding until sensed battery voltage is 0.5 volts above target voltage. A circuit in the PCM cycles the ground side of the generator field up to 100 times per second (100Hz), but has the capability to ground the field control wire 100% of the time (full field) to achieve the target voltage. If the charging rate cannot be monitored (limp-in), a duty cycle of 25% is used by the PCM in order to have some generator output. Also refer to Charging System Operation for additional information.

DIAGNOSIS AND TESTING

CHARGING SYSTEM

The following procedures may be used to diagnose the charging system if:

- the generator lamp (if equipped) is illuminated with the engine running
- the voltmeter (if equipped) does not register properly
- an undercharged or overcharged battery condition occurs.

Remember that an undercharged battery is often caused by:

- accessories being left on with the engine not running
- a faulty or improperly adjusted switch that allows a lamp to stay on. See Ignition-Off Draw Test in Group 8A, Battery for more information.

INSPECTION

To perform a complete test of the charging system, refer to the appropriate Powertrain Diagnostic Procedures service manual and the DRB scan tool. Perform the following inspections before attaching the scan tool.

(1) Inspect the battery condition. Refer to Group 8A, Battery for procedures.

(2) Inspect condition of battery cable terminals, battery posts, connections at engine block, starter solenoid and relay. They should be clean and tight. Repair as required.

DIAGNOSIS AND TESTING (Continued)

(3) Inspect all fuses in both the fuseblock and Power Distribution Center (PDC) for tightness in receptacles. They should be properly installed and tight. Repair or replace as required.

(4) Inspect generator mounting bolts for tightness. Replace or tighten bolts if required. Refer to the Generator Removal/Installation section of this group for torque specifications.

(5) Inspect generator drive belt condition and tension. Tighten or replace belt as required. Refer to Belt Tension Specifications in Group 7, Cooling System.

(6) Inspect automatic belt tensioner (if equipped). Refer to Group 7, Cooling System for information.

(7) Inspect generator electrical connections at generator field, battery output, and ground terminal (if equipped). Also check generator ground wire connection at engine (if equipped). They should all be clean and tight. Repair as required.

ON-BOARD DIAGNOSTIC TEST FOR CHARGING SYSTEM

The Powertrain Control Module (PCM) monitors critical input and output circuits of the charging system, making sure they are operational. A Diagnostic Trouble Code (DTC) is assigned to each input and output circuit monitored by the On-Board Diagnostic (OBD) system. Some circuits are checked continuously and some are checked only under certain conditions.

For DTC information, refer to Diagnostic Trouble Codes in Group 25, Emission Control System. This will include a complete list of DTC's including DTC's for the charging system.

REMOVAL AND INSTALLATION

GENERATOR

REMOVAL

WARNING: DISCONNECT NEGATIVE CABLE FROM BATTERY BEFORE REMOVING BATTERY OUTPUT WIRE (B+ WIRE) FROM GENERATOR. FAILURE TO DO SO CAN RESULT IN INJURY OR DAMAGE TO ELECTRICAL SYSTEM.

- (1) Disconnect negative battery cable at battery.
- (2) Remove generator drive belt. Refer to Group 7, Cooling System for procedures.
- (3) Left Hand Drive (LHD) Vehicles Only: Remove generator pivot and mounting bolts/nut (Fig. 1) or (Fig. 2). Position generator for access to wire connectors.
- (4) Right Hand Drive (RHD) Vehicles Only: Remove upper nut (generator adjustment nut) and both belt adjustment bolts (Fig. 3). Remove generator lower nut/bolt. Position generator for access to wire connectors.
- (5) If equipped, unsnap plastic cover from B+ terminal.
- (6) Remove B+ terminal mounting nut at rear of generator (Fig. 4). Disconnect terminal from generator.
- (7) Disconnect field wire connector at rear of generator by pushing on connector tab.
- (8) Remove generator from vehicle.

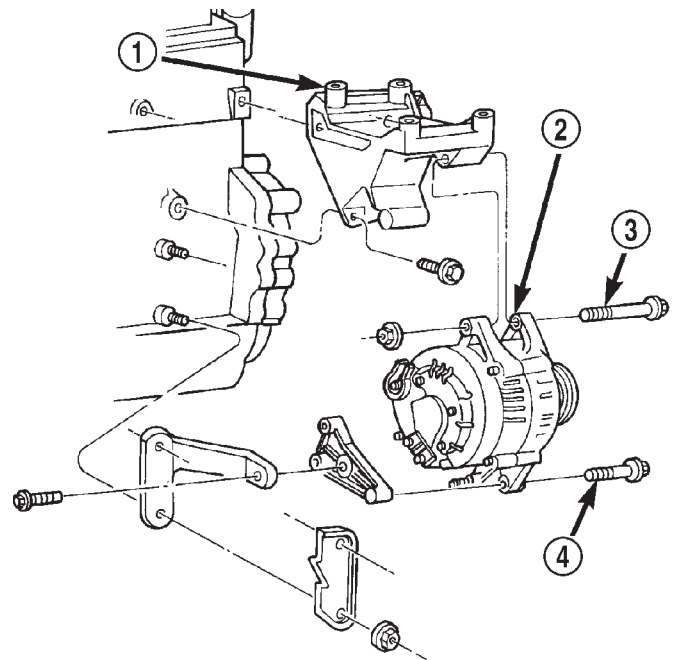

80add395

Fig. 1 Remove/Install Generator—2.5L Engine

- 1 - UPPER MOUNTING BRACKET
- 2 - GENERATOR
- 3 - UPPER BOLT
- 4 - LOWER BOLT

REMOVAL AND INSTALLATION (Continued)

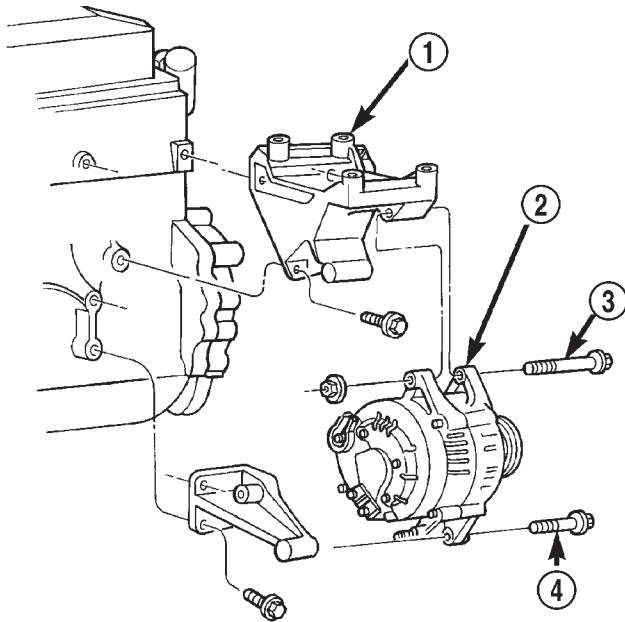

80add396

Fig. 2 Remove/Install Generator—4.0L Engine—LHD

- 1 - UPPER MOUNTING BRACKET
- 2 - GENERATOR
- 3 - UPPER BOLT
- 4 - LOWER BOLT

INSTALLATION

(1) Position generator to engine and snap field wire connector into rear of generator.

(2) Install B+ terminal to generator mounting stud. Tighten mounting nut to 8.5 N·m (75 in. lbs.) torque.

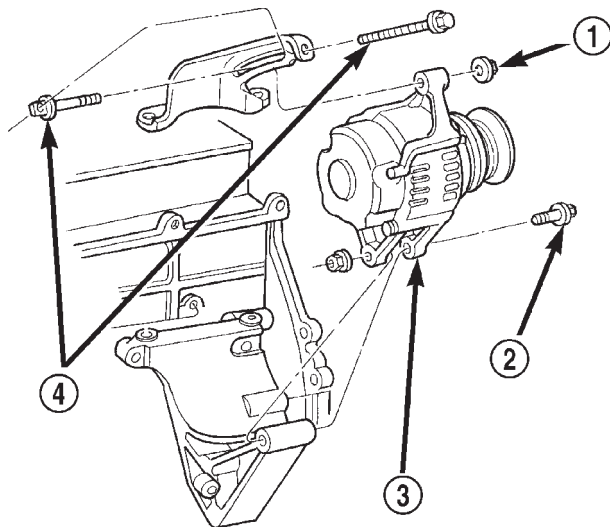

80a92a69

Fig. 3 Remove/Install Generator—4.0L Engine—RHD

- 1 - UPPER NUT
- 2 - LOWER BOLT
- 3 - GENERATOR
- 4 - BELT ADJUSTMENT BOLTS

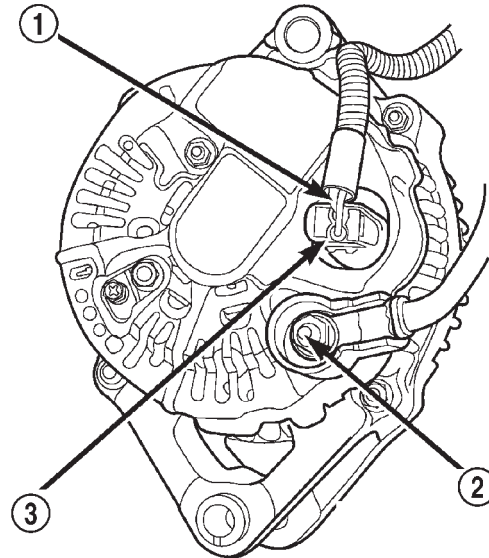

80b6f031

Fig. 4 Generator Connectors—Typical Denso

- 1 - FIELD WIRES
- 2 - B+ (OUTPUT TERMINAL)
- 3 - FIELD WIRE CONNECTOR

(3) If equipped, snap plastic cover to B+ terminal.
 (4) LHD Vehicles: Install generator fasteners and tighten as follows:

- Generator upper mounting bolt-55 N·m (41 ft. lbs.) torque.
- Generator lower pivot bolt/nut-55 N·m (41 ft. lbs.) torque.

CAUTION: Never force a belt over a pulley rim using a screwdriver. The synthetic fiber of the belt can be damaged.

CAUTION: When installing a serpentine accessory drive belt, the belt **MUST** be routed correctly. The water pump will be rotating in the wrong direction if the belt is installed incorrectly, causing the engine to overheat. Refer to belt routing label in engine compartment, or refer to Belt Schematics in Group 7, Cooling System.

(5) LHD Vehicles: Install generator drive belt. Refer to Group 7, Cooling System for procedures.

(6) RHD Vehicles: Install upper nut (generator adjustment nut) and both belt adjustment bolts. Install generator lower nut/bolt.

(7) RHD Vehicles: On vehicles equipped with RHD, the generator is used to adjust the serpentine belt. Refer to Group 7, Cooling System for belt routing, belt adjustment and bolt tightening procedures.

(8) Install negative battery cable to battery.

REMOVAL AND INSTALLATION (Continued)

BATTERY TEMPERATURE SENSOR

The battery temperature sensor is located under vehicle battery (Fig. 5) and is attached to a mounting hole on battery tray.

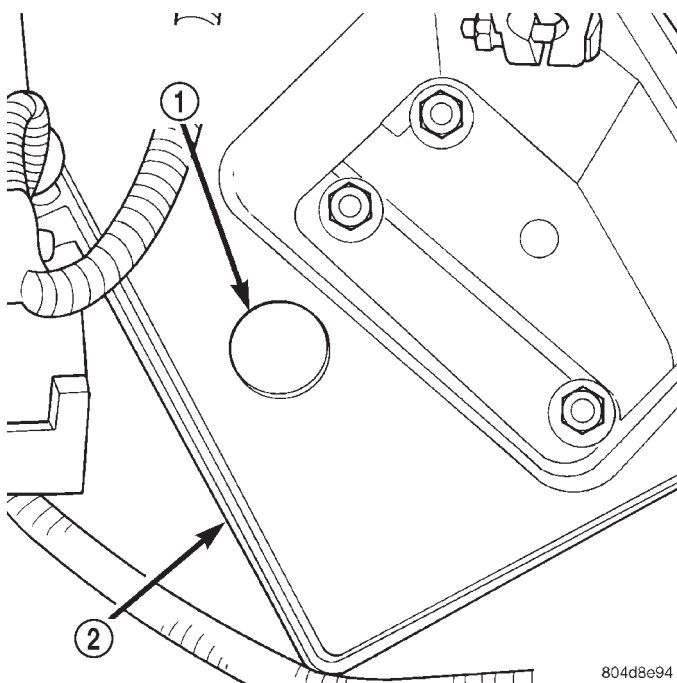

Fig. 5 Battery Temperature Sensor

- 1 - BATTERY TEMPERATURE SENSOR
- 2 - BATTERY TRAY

REMOVAL

- (1) Remove battery. Refer to Group 8A, Battery for procedures.
- (2) Disconnect sensor pigtail harness from engine wire harness.
- (3) Pry sensor straight up from battery tray mounting hole.

INSTALLATION

- (1) Feed pigtail harness through hole in top of battery tray and press sensor into top of battery tray.
- (2) Connect pigtail harness.
- (3) Install battery. Refer to Group 8A, Battery for procedures.

SPECIFICATIONS

GENERATOR RATINGS

| TYPE | PART NUMBER | RATED SAE AMPS | ENGINES | MINIMUM TEST AMPS |
|-------|-------------|----------------|-----------|-------------------|
| DENSO | 56041685AA | 117 | 4.0L | 88 |
| DENSO | 56041565AA | 81 | 4.0L | 57 |
| DENSO | 56005684AB | 81 | 2.5L | 57 |
| DENSO | 56005685AC | 117 | 2.5L | 88 |
| DENSO | 56041822AA | 124 | 2.5L/4.0L | 90 |

TORQUE CHART

Right Hand Drive= RHD, Left Hand Drive= LHD.

| Description | Torque |
|---|-----------------------|
| Generator Mounting Bolt—LHD—2.5L/4.0L Engine | 55 N·m (41 ft. lbs.) |
| Generator Pivot Bolt/Nut—LHD—2.5L/4.0L Engine | 55 N·m (41 ft. lbs.) |
| Battery Terminal Nut—LHD or RHD | 8.5 N·m (75 in. lbs.) |

| Description | Torque |
|----------------------------------|-----------------------|
| Ground Terminal Nut—LHD or RHD | 8.5 N·m (75 in. lbs.) |
| Harness Hold-down Nut—LHD or RHD | 8.5 N·m (75 in. lbs.) |
| Field Terminal Nuts—LHD or RHD | 2.8 N·m (25 in. lbs.) |

CHARGING SYSTEM

TABLE OF CONTENTS

| | | | |
|--------------------------|------|----------------------|------|
| | page | | page |
| REMOVAL AND INSTALLATION | | SPECIFICATIONS | |
| GENERATOR..... | 1 | SPECIFICATIONS | 2 |

REMOVAL AND INSTALLATION

GENERATOR

WARNING: DISCONNECT NEGATIVE CABLE FROM BATTERY BEFORE REMOVING BATTERY OUTPUT WIRE FROM GENERATOR. FAILURE TO DO SO CAN RESULT IN INJURY.

CAUTION: Never force a belt over a pulley rim using a screwdriver. The synthetic fiber of the belt can be damaged.

CAUTION: When installing a serpentine accessory drive belt, the belt **MUST** be routed correctly. The water pump will be rotating in the wrong direction if the belt is installed incorrectly, causing the engine to overheat. Refer to belt routing label in engine compartment, or refer to Belt Schematics in Group 7, Cooling System.

- (1) Disconnect negative battery cable.
- (2) Remove generator drive belt. Refer to Group 7, Cooling System for procedure.
- (3) Remove the nut securing battery output cable to B+ terminal at rear of generator (Fig. 1).
- (4) Unplug field terminal connector at rear of generator (Fig. 1).
- (5) Remove upper generator mounting bolt (Fig. 2).
- (6) Remove lower generator mounting bolt (Fig. 2) and remove generator from vehicle.
- (7) Reverse the removal procedures for installation. Tighten hardware in order as follows:

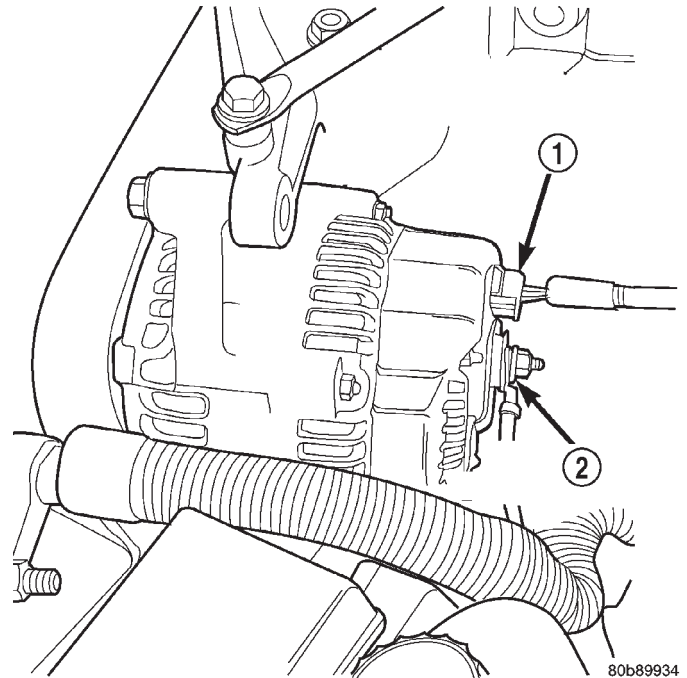

Fig. 1 Generator Electrical

- 1 - GENERATOR FIELD WIRE CONNECTOR
- 2 - GENERATOR B+ CONNECTION

- Upper Generator Mounting Bolt—27.5 N·m (20 ft. lbs.)
- Lower Generator Mounting Bolt—47 N·m (35 ft. lbs.)
- Battery Terminal (generator B+ terminal) Nut—8.5 N·m (75 in. lbs.)

REMOVAL AND INSTALLATION (Continued)

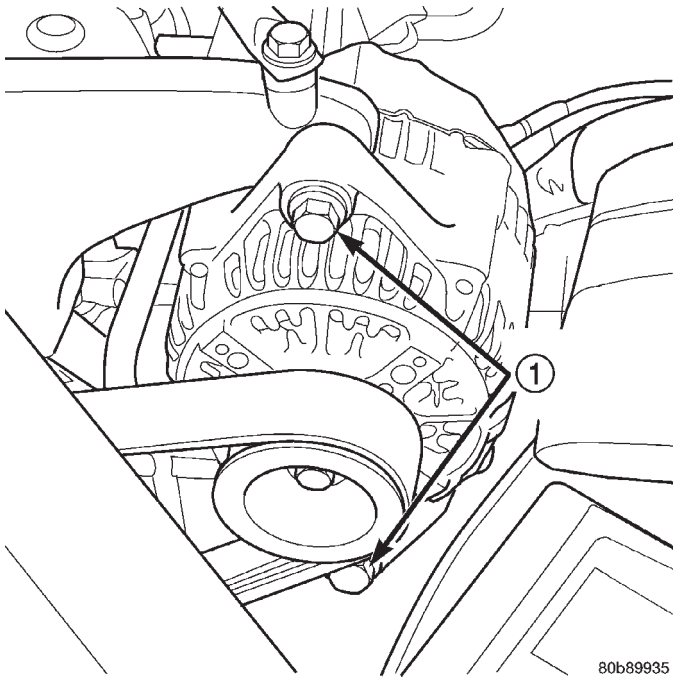

Fig. 2 Generator Mounting Bolts

1 - GENERATOR MOUNTING BOLTS

SPECIFICATIONS

SPECIFICATIONS

Battery Terminal

Nut 8.5 N·m

Lower Generator Mounting

Bolt 47 N·m

Upper Generator Mounting

Bolt 27.5 N·m

Vacuum Pump Oil Feed Hose

Banjo Bolt 15 N·m

IGNITION SYSTEM

TABLE OF CONTENTS

| | page | | page |
|--|------|---|------|
| DESCRIPTION AND OPERATION | | | |
| IGNITION SYSTEM | 1 | SPARK PLUGS | 10 |
| DISTRIBUTOR-2.5L ENGINE | 2 | IGNITION COIL—2.5L ENGINE | 12 |
| SPARK PLUGS | 2 | IGNITION COIL—4.0L ENGINE | 12 |
| SPARK PLUG CABLES-2.5L ENGINE | 2 | CRANKSHAFT POSITION (CKP) SENSOR | 13 |
| IGNITION COIL-2.5L ENGINE | 3 | CAMSHAFT POSITION SENSOR—2.5L ENGINE | 14 |
| IGNITION COIL—4.0L ENGINE | 3 | CAMSHAFT POSITION SENSOR—4.0L ENGINE | 15 |
| CRANKSHAFT POSITION SENSOR | 4 | DISTRIBUTOR—2.5L ENGINE | 17 |
| CAMSHAFT POSITION SENSOR-2.5L ENGINE | 4 | IGNITION SWITCH AND KEY CYLINDER | 20 |
| CAMSHAFT POSITION SENSOR—4.0L ENGINE | 5 | SHIFTER/IGNITION INTERLOCK | 22 |
| IGNITION SWITCH AND KEY LOCK CYLINDER | 5 | SPECIFICATIONS | |
| DIAGNOSIS AND TESTING | | | |
| DISTRIBUTOR CAP-2.5L ENGINE | 6 | IGNITION TIMING | 23 |
| DISTRIBUTOR ROTOR-2.5L ENGINE | 6 | ENGINE FIRING ORDER—2.5L 4-CYLINDER ENGINE | 23 |
| SPARK PLUG CABLES | 7 | ENGINE FIRING ORDER—4.0L 6-CYLINDER ENGINE | 23 |
| SPARK PLUG CONDITIONS | 8 | SPARK PLUGS | 23 |
| IGNITION SWITCH AND KEY LOCK CYLINDER | 9 | SPARK PLUG CABLE RESISTANCE | 23 |
| REMOVAL AND INSTALLATION | | | |
| SPARK PLUG CABLES | 10 | IGNITION COIL RESISTANCE—2.5L ENGINE | 23 |
| | | IGNITION COIL RESISTANCE—4.0L ENGINE | 23 |
| | | TORQUE CHART | 24 |

DESCRIPTION AND OPERATION

IGNITION SYSTEM

DESCRIPTION

Two different ignition systems are used. One type is used for the 2.5L 4-cylinder engine. The other is used for the 4.0L 6-cylinder engine.

OPERATION

2.5L 4-Cylinder Engine:

The ignition system is controlled by the Powertrain Control Module (PCM).

The ignition system consists of:

- Spark Plugs
- Ignition Coil
- Secondary Ignition Cables
- Distributor (contains rotor and camshaft position sensor)

- Powertrain Control Module (PCM)
- Crankshaft Position, Camshaft Position, Throttle Position and MAP Sensors

4.0L 6-Cylinder Engine:

The 4.0L 6-cylinder engine uses a one-piece coil rail containing three independent coils. Although cylinder firing order is the same as 4.0L engines of previous years, spark plug firing is not. The 3 coils dual-fire the spark plugs on cylinders 1-6, 2-5 and/or 3-4. When one cylinder is being fired (on compression stroke), the spark to the opposite cylinder is being wasted (on exhaust stroke). The one-piece coil bolts directly to the cylinder head. Rubber boots seal the secondary terminal ends of the coils to the top of all 6 spark plugs. One electrical connector (located at the rear end of the coil rail) is used for all three coils.

Because of coil design, spark plug cables (secondary cables) are not used on either engine. A **distributor is not used** with the 4.0L engine.

The ignition system is controlled by the Powertrain Control Module (PCM).

The ignition system consists of:

- Spark Plugs
- Ignition Coil(s)
- Powertrain Control Module (PCM)

DESCRIPTION AND OPERATION (Continued)

- Crankshaft Position Sensor
- Camshaft Position Sensor
- The MAP, TPS, IAC and ECT also have an effect on the control of the ignition system.

DISTRIBUTOR-2.5L ENGINE

DESCRIPTION

The 2.5L engine is equipped with a camshaft driven mechanical distributor (Fig. 1) containing a shaft driven distributor rotor. The distributor is also equipped with an internal camshaft position (fuel sync) sensor (Fig. 1).

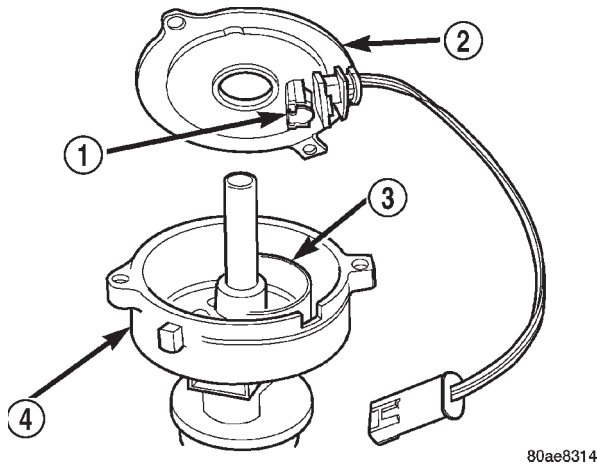

Fig. 1 Distributor and Camshaft Position Sensor-2.5L Engine

- 1 - SYNC SIGNAL GENERATOR
- 2 - CAMSHAFT POSITION SENSOR
- 3 - PULSE RING
- 4 - DISTRIBUTOR ASSEMBLY

OPERATION

The distributor does not have built in centrifugal or vacuum assisted advance. Base ignition timing and all timing advance is controlled by the Powertrain Control Module (PCM). Because ignition timing is controlled by the PCM, **base ignition timing is not adjustable.**

The distributor is locked in place by a fork with a slot located on the distributor housing base. The distributor holddown clamp bolt passes through this slot when installed. Because the distributor position is locked when installed, its rotational position can not be changed. **Do not attempt to modify the distributor housing to get distributor rotation. Distributor position will have no effect on ignition timing. The position of the distributor will determine fuel synchronization only.**

All distributors contain an internal oil seal that prevents oil from entering the distributor housing. The seal is not serviceable.

SPARK PLUGS

DESCRIPTION

Resistor type spark plugs are used.

Spark plug resistance values range from 6,000 to 20,000 ohms (when checked with at least a 1000 volt spark plug tester). **Do not use an ohmmeter to check the resistance values of the spark plugs. Inaccurate readings will result.**

OPERATION

To prevent possible pre-ignition and/or mechanical engine damage, the correct type/heat range/number spark plug must be used.

Always use the recommended torque when tightening spark plugs. Incorrect torque can distort the spark plug and change plug gap. It can also pull the plug threads and do possible damage to both the spark plug and the cylinder head.

Remove the spark plugs and examine them for burned electrodes and fouled, cracked or broken porcelain insulators. Keep plugs arranged in the order in which they were removed from the engine. A single plug displaying an abnormal condition indicates that a problem exists in the corresponding cylinder. Replace spark plugs at the intervals recommended in Group O, Lubrication and Maintenance

Spark plugs that have low mileage may be cleaned and reused if not otherwise defective, carbon or oil fouled. Also refer to Spark Plug Conditions.

CAUTION: Never use a motorized wire wheel brush to clean the spark plugs. Metallic deposits will remain on the spark plug insulator and will cause plug misfire.

SPARK PLUG CABLES-2.5L ENGINE

DESCRIPTION

Spark plug cables are used only on the 2.5L engine. They are sometimes referred to as secondary ignition wires.

OPERATION

The spark plug cables transfer electrical current from the ignition coil(s) and/or distributor, to individual spark plugs at each cylinder. The resistive spark plug cables are of nonmetallic construction. The cables provide suppression of radio frequency emissions from the ignition system.

DESCRIPTION AND OPERATION (Continued)

IGNITION COIL-2.5L ENGINE

DESCRIPTION

A single ignition coil is used with the 2.5L 4-cylinder engine. The coil is not oil filled. The coil windings are embedded in an epoxy compound. This provides heat and vibration resistance that allows the coil to be mounted on the engine.

OPERATION

The Powertrain Control Module (PCM) opens and closes the ignition coil ground circuit for ignition coil operation.

Battery voltage is supplied to the ignition coil positive terminal from the ASD relay. If the PCM does not see a signal from the crankshaft and camshaft sensors (indicating the ignition key is ON but the engine is not running), it will shut down the ASD circuit.

Base ignition timing is not adjustable. By controlling the coil ground circuit, the PCM is able to set the base timing and adjust the ignition timing advance. This is done to meet changing engine operating conditions.

IGNITION COIL—4.0L ENGINE

DESCRIPTION

A one-piece coil rail assembly containing three individual coils is used on the 4.0L 6-cylinder engine (Fig. 2). The coil rail must be replaced as one assembly. The bottom of the coil is equipped with 6 individual rubber boots (Fig. 2) to seal the 6 spark plugs to the coil. Inside each rubber boot is a spring. The spring is used for a mechanical contact between the coil and the top of the spark plug. These rubber boots and springs are a permanent part of the coil and are not serviced separately.

(1) The coil is bolted directly to the cylinder head (Fig. 3). One electrical connector (located at rear of coil) is used for all three coils.

OPERATION

Although cylinder firing order is the same as 4.0L Jeep engines of previous years, spark plug firing is not. The 3 coils dual-fire the spark plugs on cylinders 1-6, 2-5 and/or 3-4. When one cylinder is being fired (on compression stroke), the spark to the opposite cylinder is being wasted (on exhaust stroke).

Battery voltage is supplied to the three ignition coils from the ASD relay. The Powertrain Control Module (PCM) opens and closes the ignition coil ground circuit for ignition coil operation.

Base ignition timing is not adjustable. By controlling the coil ground circuit, the PCM is able to set the base timing and adjust the ignition timing

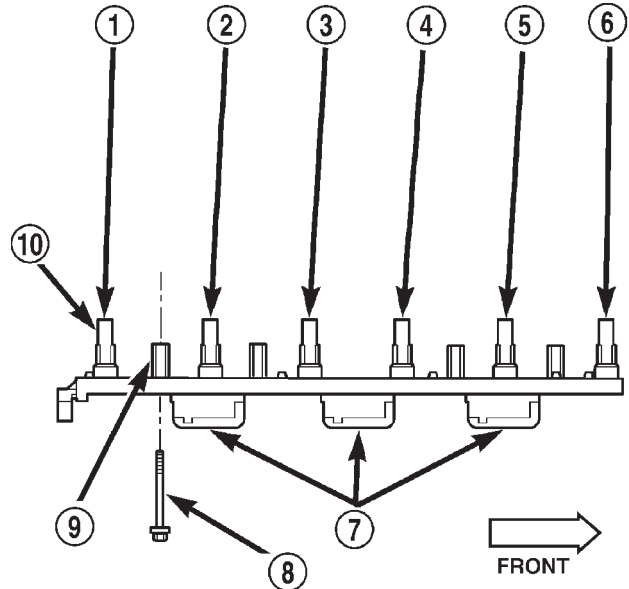

80be45c1

Fig. 2 Ignition Coil Assembly—4.0L 6-Cylinder Engine

- 1 - CYL. #6
- 2 - CYL. #5
- 3 - CYL. #4
- 4 - CYL. #3
- 5 - CYL. #2
- 6 - CYL. #1
- 7 - COILS (3)
- 8 - MOUNTING BOLTS (4)
- 9 - BOLT BASES (4)
- 10 - RUBBER BOOTS (6)

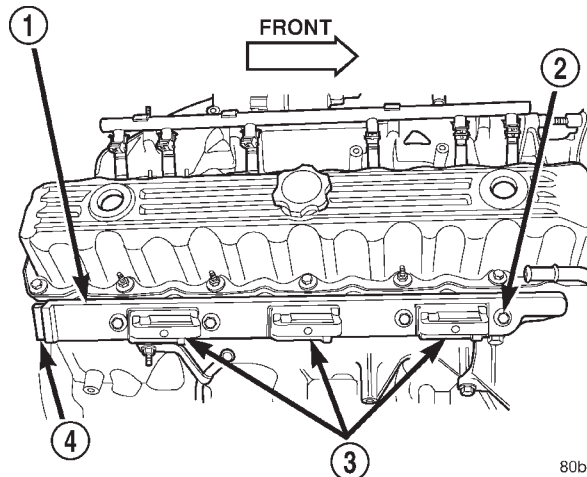

80be45c0

Fig. 3 Coil Location—4.0L Engine

- 1 - COIL RAIL
- 2 - COIL MOUNTING BOLTS (4)
- 3 - COIL
- 4 - COIL ELECTRICAL CONNECTION

DESCRIPTION AND OPERATION (Continued)

advance. This is done to meet changing engine operating conditions.

The ignition coil is not oil filled. The windings are embedded in an epoxy compound. This provides heat and vibration resistance that allows the ignition coil to be mounted on the engine.

Because of coil design, spark plug cables (secondary cables) are not used. The cables are integral within the coil rail.

CRANKSHAFT POSITION SENSOR

DESCRIPTION

The Crankshaft Position (CKP) sensor is located near the outer edge of the flywheel (starter ringear).

OPERATION

Engine speed and crankshaft position are provided through the CKP sensor. The sensor generates pulses that are the input sent to the Powertrain Control Module (PCM). The PCM interprets the sensor input to determine the crankshaft position. The PCM then uses this position, along with other inputs, to determine injector sequence and ignition timing.

The sensor is a hall effect device combined with an internal magnet. It is also sensitive to steel within a certain distance from it.

The flywheel/drive plate has groups of four notches at its outer edge. On 2.5L 4-cylinder engines there are two sets of notches (Fig. 4). On 4.0L 6-cylinder engines there are three sets of notches (Fig. 5).

The notches cause a pulse to be generated when they pass under the sensor. The pulses are the input to the PCM. For each engine revolution there are two groups of four pulses generated on 2.5L 4-cylinder engines. There are 3 groups of four pulses generated on 4.0L 6-cylinder engines.

The trailing edge of the fourth notch, which causes the pulse, is four degrees before top dead center (TDC) of the corresponding piston.

The engine will not operate if the PCM does not receive a CKP sensor input.

CAMSHAFT POSITION SENSOR-2.5L ENGINE

DESCRIPTION

On the 2.5L 4-cylinder engine the Camshaft Position (CMP) sensor is located in the distributor.

OPERATION

The sensor contains a hall effect device called a sync signal generator to generate a fuel sync signal. This sync signal generator detects a rotating pulse ring (shutter) on the distributor shaft. The pulse ring rotates 180 degrees through the sync signal generator. Its signal is used in conjunction with the Crank-

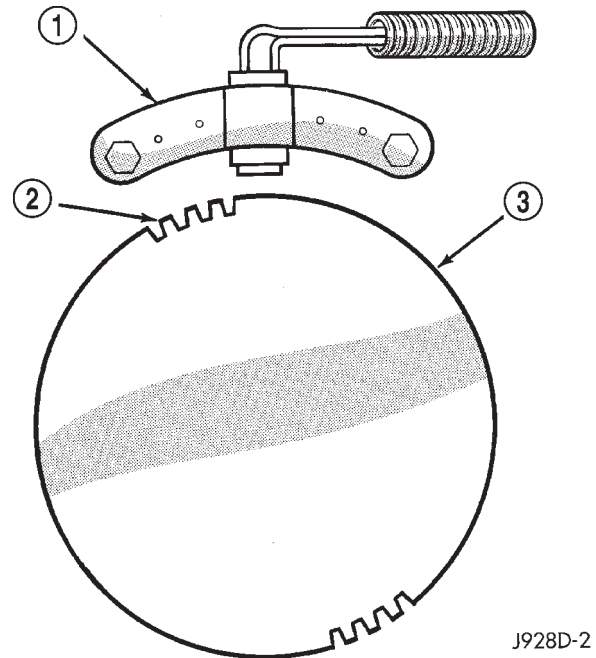

J928D-2

Fig. 4 Sensor Operation—2.5L 4-Cyl. Engine

- 1 - CRANKSHAFT POSITION SENSOR
- 2 - NOTCHES
- 3 - FLYWHEEL

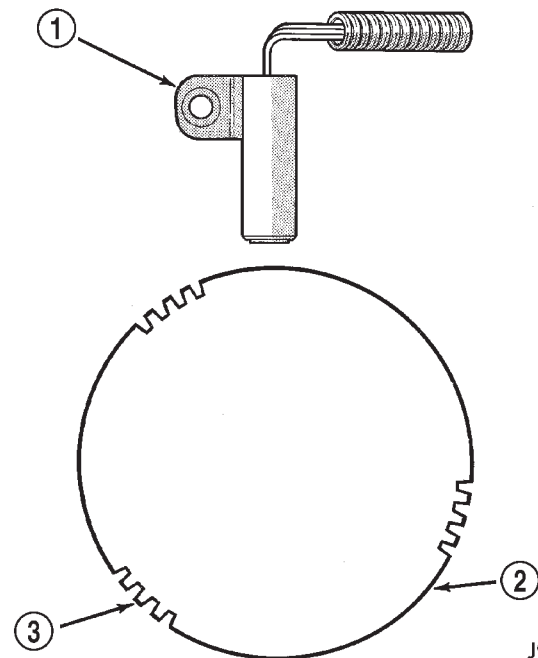

J958D-3

Fig. 5 Sensor Operation—4.0L 6-Cyl. Engine

- 1 - CRANKSHAFT POSITION SENSOR
- 2 - FLYWHEEL
- 3 - FLYWHEEL NOTCHES

shaft Position (CKP) sensor to differentiate between fuel injection and spark events. It is also used to synchronize the fuel injectors with their respective cylinders.

DESCRIPTION AND OPERATION (Continued)

When the leading edge of the pulse ring (shutter) enters the sync signal generator, the following occurs: The interruption of magnetic field causes the voltage to switch high resulting in a sync signal of approximately 5 volts.

When the trailing edge of the pulse ring (shutter) leaves the sync signal generator, the following occurs: The change of the magnetic field causes the sync signal voltage to switch low to 0 volts.

CAMSHAFT POSITION SENSOR—4.0L ENGINE

DESCRIPTION

The Camshaft Position Sensor (CMP) on the 4.0L 6-cylinder engine is bolted to the top of the oil pump drive shaft assembly (Fig. 6). The sensor and drive shaft assembly is located on the right side of the engine near the oil filter (Fig. 7).

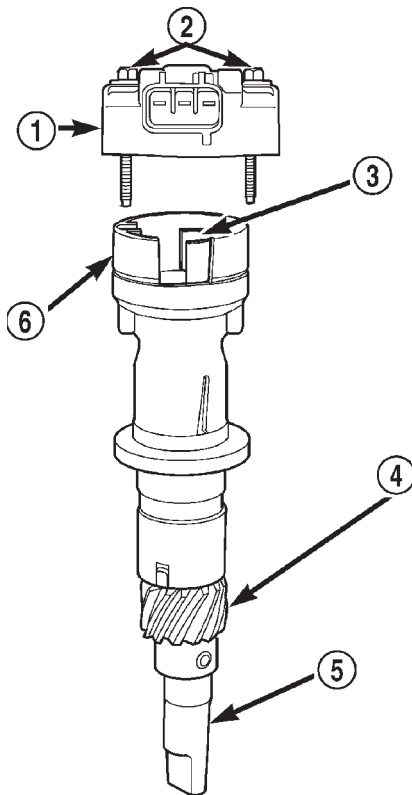

80b76ff3

Fig. 6 CMP and Oil Pump Drive Shaft—4.0L Engine

- 1 - CAMSHAFT POSITION SENSOR
- 2 - MOUNTING BOLTS (2)
- 3 - PULSE RING
- 4 - DRIVE GEAR (TO CAMSHAFT)
- 5 - OIL PUMP DRIVESHAFT
- 6 - SENSOR BASE (OIL PUMP DRIVESHAFT ASSEMBLY)

OPERATION

The CMP sensor contains a hall effect device called a sync signal generator to generate a fuel sync signal. This sync signal generator detects a rotating

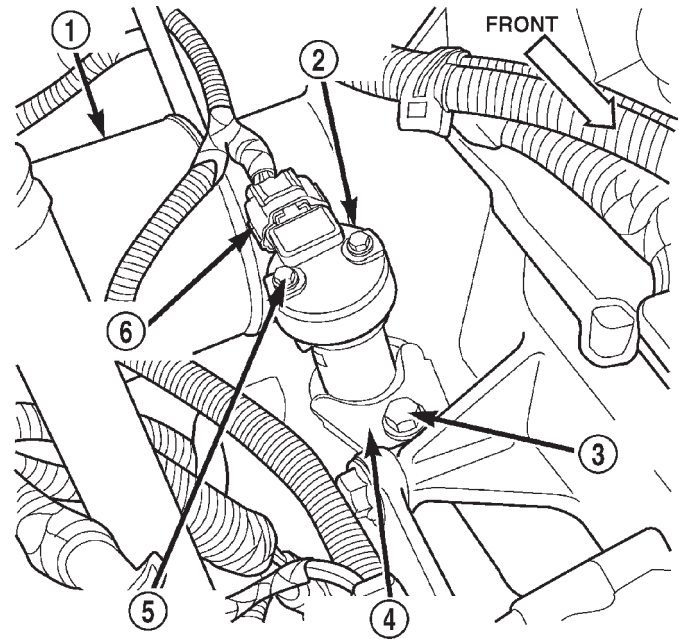

80b76ff4

Fig. 7 CMP Location—4.0L Engine

- 1 - OIL FILTER
- 2 - CAMSHAFT POSITION SENSOR
- 3 - CLAMP BOLT
- 4 - HOLD-DOWN CLAMP
- 5 - MOUNTING BOLTS (2)
- 6 - ELEC. CONNECTOR

pulse ring (shutter) on the oil pump drive shaft (Fig. 6). The pulse ring rotates 180 degrees through the sync signal generator. Its signal is used in conjunction with the crankshaft position sensor to differentiate between fuel injection and spark events. It is also used to synchronize the fuel injectors with their respective cylinders.

When the leading edge of the pulse ring (shutter) enters the sync signal generator, the following occurs: The interruption of magnetic field causes the voltage to switch high resulting in a sync signal of approximately 5 volts.

When the trailing edge of the pulse ring (shutter) leaves the sync signal generator, the following occurs: The change of the magnetic field causes the sync signal voltage to switch low to 0 volts.

IGNITION SWITCH AND KEY LOCK CYLINDER

DESCRIPTION

The electrical ignition switch is located on the steering column. It is used as the main on/off switching device for most electrical components. The mechanical key lock cylinder is used to engage/disengage the electrical ignition switch.

DESCRIPTION AND OPERATION (Continued)

OPERATION

Vehicles equipped with an automatic transmission and a floor mounted shifter: a cable is used to connect the interlock device in the steering column assembly, to the transmission floor shift lever. This interlock device is used to lock the transmission shifter in the PARK position when the key lock cylinder is rotated to the LOCKED or ACCESSORY position. The interlock device within the steering column is not serviceable. If repair is necessary, the steering column assembly must be replaced. Refer to Group 19, Steering for procedures.

If the ignition key is difficult to rotate to or from the LOCK or ACCESSORY position, it may not be the fault of the key cylinder or the steering column components. The brake transmission shift interlock cable may be out of adjustment. Refer to Brake Transmission Shift Interlock Cable Adjustment in Group 21, Transmissions for adjustment procedures.

Vehicles equipped with an automatic transmission and a steering column mounted shifter: an interlock device is located within the steering column. This interlock device is used to lock the transmission shifter in the PARK position when the key lock cylinder is in the LOCKED or ACCESSORY position. If it is difficult to rotate the key to or from the LOCK or ACCESSORY position, the interlock device within the steering column may be defective. This device is not serviceable. If repair is necessary, the steering column assembly must be replaced. Refer to Group 19, Steering for procedures.

Vehicles equipped with a manual transmission and a floor mounted shifter: on certain models, a lever is located on the steering column behind the ignition key lock cylinder. The lever must be manually operated to allow rotation of the ignition key lock cylinder to the LOCK or ACCESSORY position. If it is difficult to rotate the key to the LOCK or ACCESSORY position, the lever mechanism may be defective. This mechanism is not serviceable. If repair is necessary, the steering column assembly must be replaced. Refer to Group 19, Steering for procedures.

On other models, the ignition key cylinder must be depressed to allow it to be rotated into the LOCK or ACCESSORY position. If it is difficult to rotate the key to the LOCK or ACCESSORY position, the lock mechanism within the steering column may be defective. This mechanism is not serviceable. If repair is necessary, the steering column assembly must be replaced. Refer to Group 19, Steering for procedures.

DIAGNOSIS AND TESTING

DISTRIBUTOR CAP-2.5L ENGINE

Remove the distributor cap and wipe it clean with a dry lint free cloth. Visually inspect the cap for cracks, carbon paths, broken towers or damaged rotor button (Fig. 8) or (Fig. 9). Also check for white deposits on the inside (caused by condensation entering the cap through cracks). Replace any cap that displays charred or eroded terminals. The machined surface of a terminal end (faces toward rotor) will indicate some evidence of erosion from normal operation. Examine the terminal ends for evidence of mechanical interference with the rotor tip.

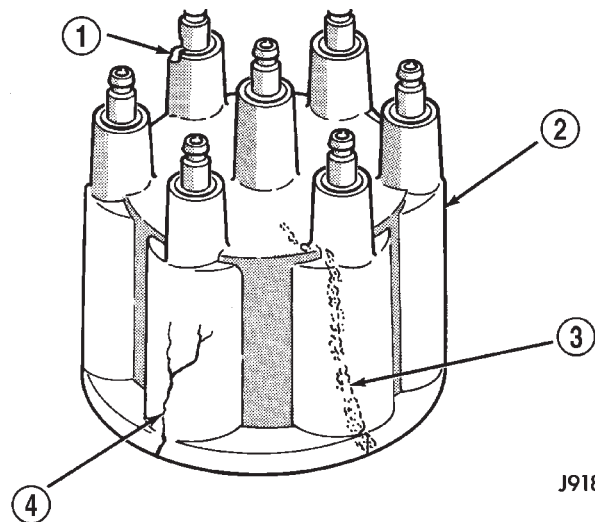

J918D-9

Fig. 8 Cap Inspection—External—Typical

- 1 - BROKEN TOWER
- 2 - DISTRIBUTOR CAP
- 3 - CARBON PATH
- 4 - CRACK

DISTRIBUTOR ROTOR-2.5L ENGINE

Visually inspect the rotor (Fig. 10) for cracks, evidence of corrosion or the effects of arcing on the metal tip. Also check for evidence of mechanical interference with the cap. Some charring is normal on the end of the metal tip. The silicone-dielectric-varnish-compound applied to the rotor tip for radio interference noise suppression, will appear charred. This is normal. **Do not remove the charred compound.** Test the spring for insufficient tension. Replace a rotor that displays any of these adverse conditions.

DIAGNOSIS AND TESTING (Continued)

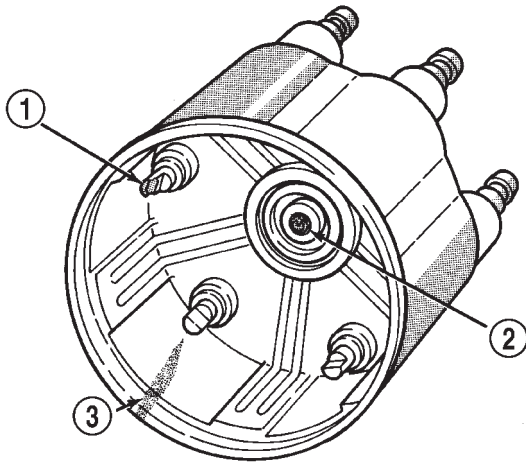

J918D-10

Fig. 9 Cap Inspection—Internal—Typical

- 1 - CHARRED OR ERODED TERMINALS
- 2 - WORN OR DAMAGED ROTOR BUTTON
- 3 - CARBON PATH

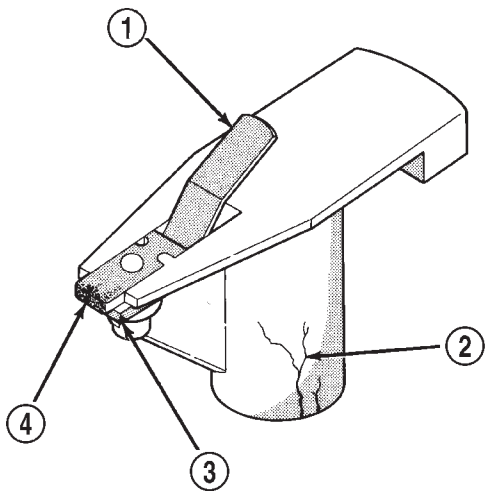

J908D-48

Fig. 10 Rotor Inspection—Typical

- 1 - INSUFFICIENT SPRING TENSION
- 2 - CRACKS
- 3 - EVIDENCE OF PHYSICAL CONTACT WITH CAP
- 4 - ROTOR TIP CORRODED

SPARK PLUG CABLES

TESTING

Check the spark plug cable connections for good contact at the coil(s), distributor cap towers, and spark plugs. Terminals should be fully seated. The insulators should be in good condition and should fit tightly on the coil, distributor and spark plugs. Spark plug cables with insulators that are cracked or torn must be replaced.

Clean high voltage ignition cables with a cloth moistened with a non-flammable solvent. Wipe the cables dry. Check for brittle or cracked insulation.

When testing secondary cables for damage with an oscilloscope, follow the instructions of the equipment manufacturer.

If an oscilloscope is not available, spark plug cables may be tested as follows:

CAUTION: Do not leave any one spark plug cable disconnected for longer than necessary during testing. This may cause possible heat damage to the catalytic converter. Total test time must not exceed ten minutes.

With the engine running, remove spark plug cable from spark plug (one at a time) and hold next to a good engine ground. If the cable and spark plug are in good condition, the engine rpm should drop and the engine will run poorly. If engine rpm does not drop, the cable and/or spark plug may not be operating properly and should be replaced. Also check engine cylinder compression.

With the engine not running, connect one end of a test probe to a good ground. Start the engine and run the other end of the test probe along the entire length of all spark plug cables. If cables are cracked or punctured, there will be a noticeable spark jump from the damaged area to the test probe. The cable running from the ignition coil to the distributor cap can be checked in the same manner. Cracked, damaged or faulty cables should be replaced with resistance type cable. This can be identified by the words **ELECTRONIC SUPPRESSION** printed on the cable jacket.

Use an ohmmeter to test for open circuits, excessive resistance or loose terminals. Remove the distributor cap from the distributor. **Do not remove cables from cap.** Remove cable from spark plug. Connect ohmmeter to spark plug terminal end of cable and to corresponding electrode in distributor cap. Resistance should be 250 to 1000 Ohms per inch of cable. If not, remove cable from distributor cap tower and connect ohmmeter to the terminal ends of cable. If resistance is not within specifications as found in the **SPARK PLUG CABLE RESISTANCE** chart, replace the cable. Test all spark plug cables in this manner.

SPARK PLUG CABLE RESISTANCE

| MINIMUM | MAXIMUM |
|--------------------|----------------------|
| 250 Ohms Per Inch | 1000 Ohms Per Inch |
| 3000 Ohms Per Foot | 12,000 Ohms Per Foot |

To test ignition coil-to-distributor cap cable, do not remove the cable from the cap. Connect ohmmeter to rotor button (center contact) of distributor cap and

DIAGNOSIS AND TESTING (Continued)

terminal at ignition coil end of cable. If resistance is not within specifications as found in the Spark Plug Cable Resistance chart, remove the cable from the distributor cap. Connect the ohmmeter to the terminal ends of the cable. If resistance is not within specifications as found in the Spark Plug Cable Resistance chart, replace the cable. Inspect the ignition coil tower for cracks, burns or corrosion.

SPARK PLUG CONDITIONS

NORMAL OPERATING

The few deposits present on the spark plug will probably be light tan or slightly gray in color. This is evident with most grades of commercial gasoline (Fig. 11). There will not be evidence of electrode burning. Gap growth will not average more than approximately 0.025 mm (.001 in) per 3200 km (2000 miles) of operation. Spark plugs that have normal wear can usually be cleaned, have the electrodes filed, have the gap set and then be installed.

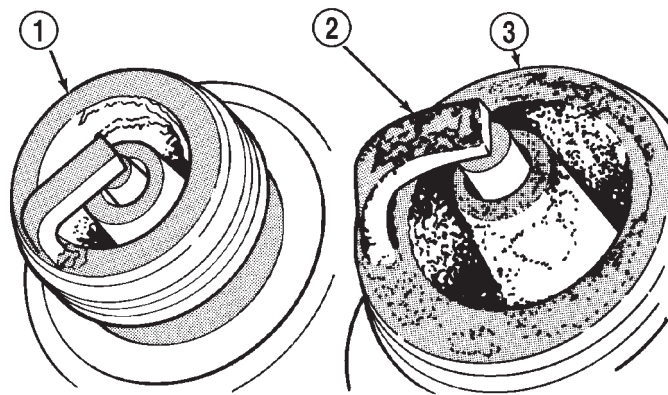

J908D-15

Fig. 11 Normal Operation and Cold (Carbon) Fouling

- 1 - NORMAL
- 2 - DRY BLACK DEPOSITS
- 3 - COLD (CARBON) FOULING

Some fuel refiners in several areas of the United States have introduced a manganese additive (MMT) for unleaded fuel. During combustion, fuel with MMT causes the entire tip of the spark plug to be coated with a rust colored deposit. This rust color can be misdiagnosed as being caused by coolant in the combustion chamber. Spark plug performance may be affected by MMT deposits.

COLD FOULING/CARBON FOULING

Cold fouling is sometimes referred to as carbon fouling. The deposits that cause cold fouling are basically carbon (Fig. 11). A dry, black deposit on one or

two plugs in a set may be caused by sticking valves or defective spark plug cables. Cold (carbon) fouling of the entire set of spark plugs may be caused by a clogged air cleaner element or repeated short operating times (short trips).

WET FOULING OR GAS FOULING

A spark plug coated with excessive wet fuel or oil is wet fouled. In older engines, worn piston rings, leaking valve guide seals or excessive cylinder wear can cause wet fouling. In new or recently overhauled engines, wet fouling may occur before break-in (normal oil control) is achieved. This condition can usually be resolved by cleaning and reinstalling the fouled plugs.

OIL OR ASH ENCRUSTED

If one or more spark plugs are oil or oil ash encrusted (Fig. 12), evaluate engine condition for the cause of oil entry into that particular combustion chamber.

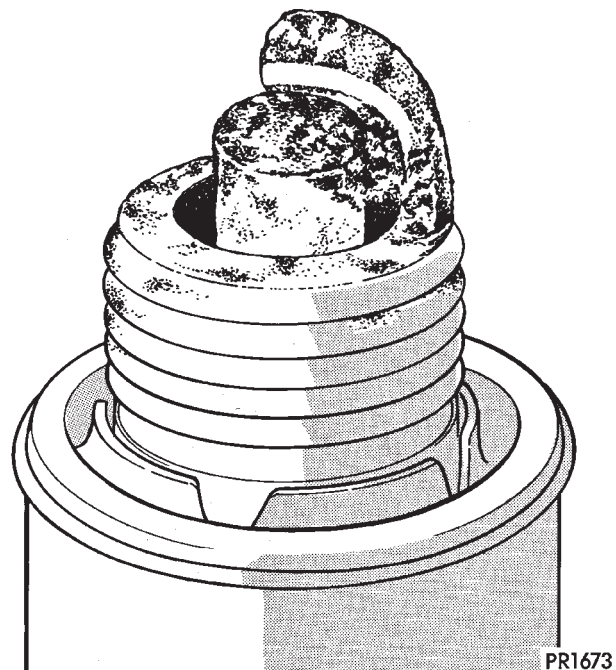

PR1673

Fig. 12 Oil or Ash Encrusted

ELECTRODE GAP BRIDGING

Electrode gap bridging may be traced to loose deposits in the combustion chamber. These deposits accumulate on the spark plugs during continuous stop-and-go driving. When the engine is suddenly subjected to a high torque load, deposits partially liquefy and bridge the gap between electrodes (Fig. 13). This short circuits the electrodes. Spark plugs with electrode gap bridging can be cleaned using standard procedures.

DIAGNOSIS AND TESTING (Continued)

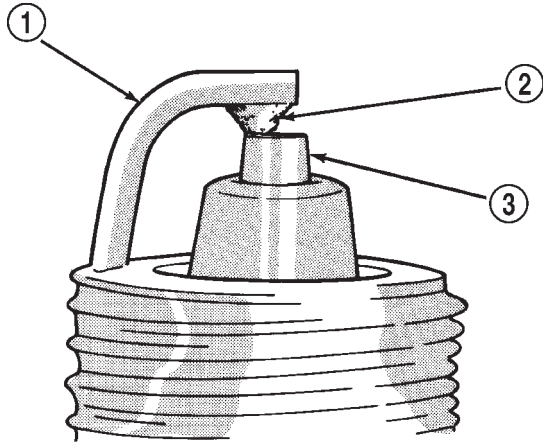

J908D-11

Fig. 13 Electrode Gap Bridging

- 1 - GROUND ELECTRODE
- 2 - DEPOSITS
- 3 - CENTER ELECTRODE

SCAVENGER DEPOSITS

Fuel scavenger deposits may be either white or yellow (Fig. 14). They may appear to be harmful, but this is a normal condition caused by chemical additives in certain fuels. These additives are designed to change the chemical nature of deposits and decrease spark plug misfire tendencies. Notice that accumulation on the ground electrode and shell area may be heavy, but the deposits are easily removed. Spark plugs with scavenger deposits can be considered normal in condition and can be cleaned using standard procedures.

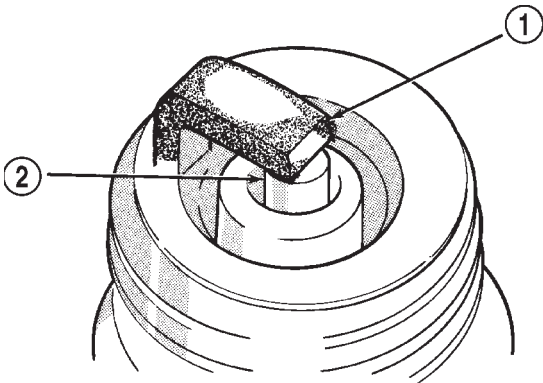

J908D-12

Fig. 14 Scavenger Deposits

- 1 - GROUND ELECTRODE COVERED WITH WHITE OR YELLOW DEPOSITS
- 2 - CENTER ELECTRODE

CHIPPED ELECTRODE INSULATOR

A chipped electrode insulator usually results from bending the center electrode while adjusting the spark plug electrode gap. Under certain conditions,

severe detonation can also separate the insulator from the center electrode (Fig. 15). Spark plugs with this condition must be replaced.

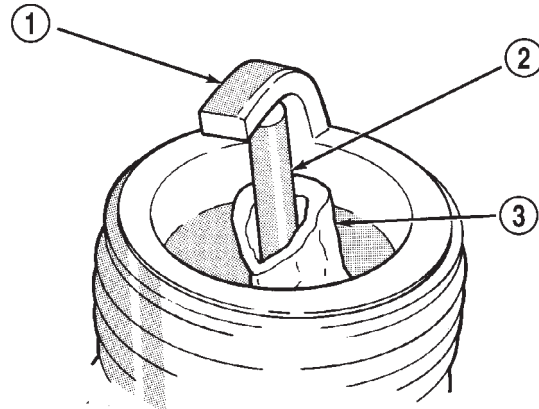

J908D-13

Fig. 15 Chipped Electrode Insulator

- 1 - GROUND ELECTRODE
- 2 - CENTER ELECTRODE
- 3 - CHIPPED INSULATOR

PREIGNITION DAMAGE

Preignition damage is usually caused by excessive combustion chamber temperature. The center electrode dissolves first and the ground electrode dissolves somewhat latter (Fig. 16). Insulators appear relatively deposit free. Determine if the spark plug has the correct heat range rating for the engine. Determine if ignition timing is over advanced or if other operating conditions are causing engine overheating. (The heat range rating refers to the operating temperature of a particular type spark plug. Spark plugs are designed to operate within specific temperature ranges. This depends upon the thickness and length of the center electrodes porcelain insulator.)

SPARK PLUG OVERHEATING

Overheating is indicated by a white or gray center electrode insulator that also appears blistered (Fig. 17). The increase in electrode gap will be considerably in excess of 0.001 inch per 2000 miles of operation. This suggests that a plug with a cooler heat range rating should be used. Over advanced ignition timing, detonation and cooling system malfunctions can also cause spark plug overheating.

IGNITION SWITCH AND KEY LOCK CYLINDER

ELECTRICAL DIAGNOSIS

For ignition switch electrical schematics, refer to Ignition Switch in Group 8W, Wiring Diagrams.

DIAGNOSIS AND TESTING (Continued)

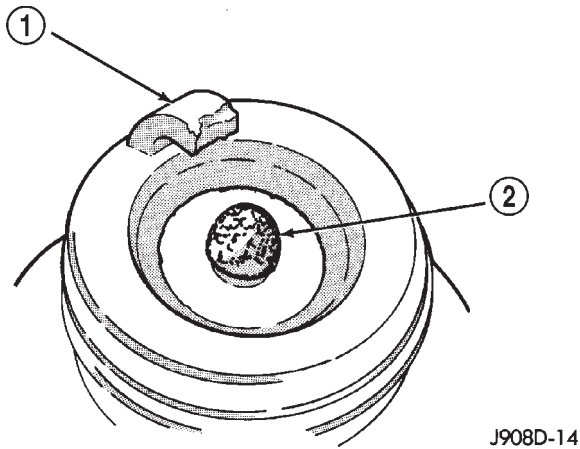

Fig. 16 Preignition Damage

- 1 - GROUND ELECTRODE STARTING TO DISSOLVE
2 - CENTER ELECTRODE DISSOLVED

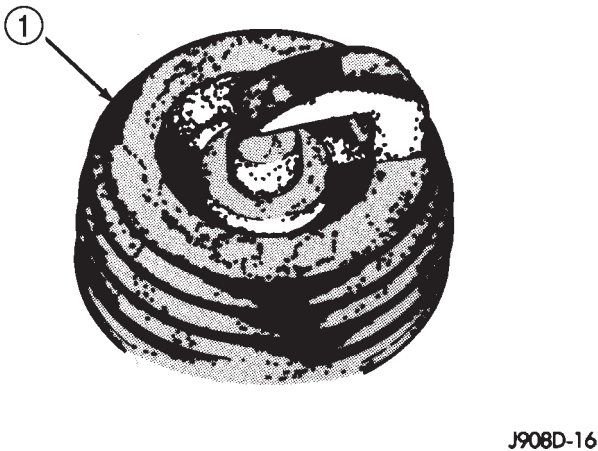

Fig. 17 Spark Plug Overheating

- 1 - BLISTERED WHITE OR GRAY COLORED INSULATOR

MECHANICAL DIAGNOSIS (KEY DIFFICULT TO ROTATE)

Vehicles equipped with an automatic transmission and a floor mounted shifter: a cable is used to connect the interlock device in the steering column assembly, to the transmission floor shift lever. This interlock device is used to lock the transmission shifter in the PARK position when the key lock cylinder is rotated to the LOCKED or ACCESSORY position. The interlock device within the steering column is not serviceable. If repair is necessary, the steering column assembly must be replaced. Refer to Group 19, Steering for procedures.

If the ignition key is difficult to rotate to or from the LOCK or ACCESSORY position, it may not be the fault of the key cylinder or the steering column components. The brake transmission shift interlock cable may be out of adjustment. Refer to Brake

Transmission Shift Interlock Cable Adjustment in Group 21, Transmissions for adjustment procedures.

Vehicles equipped with an automatic transmission and a steering column mounted shifter: an interlock device is located within the steering column. This interlock device is used to lock the transmission shifter in the PARK position when the key lock cylinder is in the LOCKED or ACCESSORY position. If it is difficult to rotate the key to or from the LOCK or ACCESSORY position, the interlock device within the steering column may be defective. This device is not serviceable. If repair is necessary, the steering column assembly must be replaced. Refer to Group 19, Steering for procedures.

Vehicles equipped with a manual transmission and a floor mounted shifter: on certain models, a lever is located on the steering column behind the ignition key lock cylinder. The lever must be manually operated to allow rotation of the ignition key lock cylinder to the LOCK or ACCESSORY position. If it is difficult to rotate the key to the LOCK or ACCESSORY position, the lever mechanism may be defective. This mechanism is not serviceable. If repair is necessary, the steering column assembly must be replaced. Refer to Group 19, Steering for procedures.

On other models, the ignition key cylinder must be depressed to allow it to be rotated into the LOCK or ACCESSORY position. If it is difficult to rotate the key to the LOCK or ACCESSORY position, the lock mechanism within the steering column may be defective. This mechanism is not serviceable. If repair is necessary, the steering column assembly must be replaced. Refer to Group 19, Steering for procedures.

REMOVAL AND INSTALLATION

SPARK PLUG CABLES

REMOVAL

CAUTION: When disconnecting a high voltage cable from a spark plug or from the distributor cap, twist the rubber boot slightly (1/2 turn) to break it loose (Fig. 18). Grasp the boot (not the cable) and pull it off with a steady, even force.

INSTALLATION

Push the cable firmly onto the sparkplug.

SPARK PLUGS

PLUG REMOVAL

On the 4.0L 6-cylinder engine the spark plugs are located below the coil rail assembly. To gain access to

REMOVAL AND INSTALLATION (Continued)

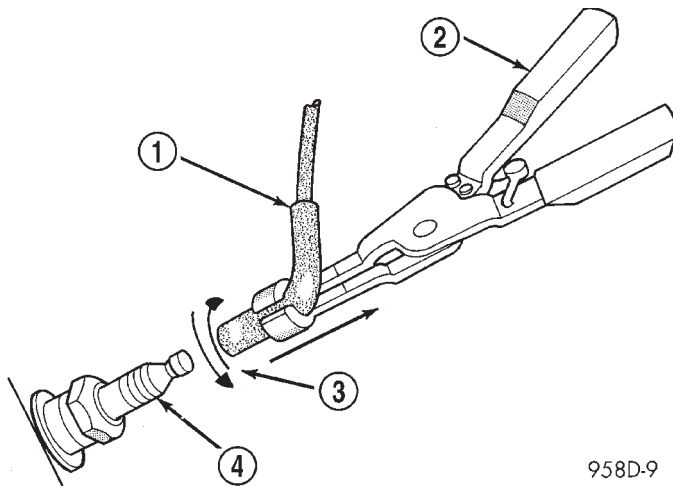
**Fig. 18 Cable Removal**

- 1 - SPARK PLUG CABLE AND BOOT
- 2 - SPARK PLUG BOOT PULLER
- 3 - TWIST AND PULL
- 4 - SPARK PLUG

any/all spark plug(s), refer to Ignition Coil-4.0L Engine Removal/Installation.

(1) 2.5L 4-Cylinder Engine: Always remove spark plug or ignition coil cables by grasping at the cable boot (Fig. 18). Turn the cable boot 1/2 turn and pull straight back in a steady motion. Never pull directly on the cable. Internal damage to cable will result.

(2) Prior to removing the spark plug, spray compressed air around the spark plug hole and the area around the spark plug. This will help prevent foreign material from entering the combustion chamber.

(3) Remove the spark plug using a quality socket with a rubber or foam insert.

(4) Inspect the spark plug condition. Refer to Spark Plugs Conditions.

PLUG CLEANING

The plugs may be cleaned using commercially available spark plug cleaning equipment. After cleaning, file the center electrode flat with a small point file or jewelers file before adjusting gap.

CAUTION: Never use a motorized wire wheel brush to clean the spark plugs. Metallic deposits will remain on the spark plug insulator and will cause plug misfire.

PLUG GAP ADJUSTMENT

Check the spark plug gap with a gap gauge tool. If the gap is not correct, adjust it by bending the ground electrode (Fig. 19). **Never attempt to adjust the gap by bending the center electrode.**

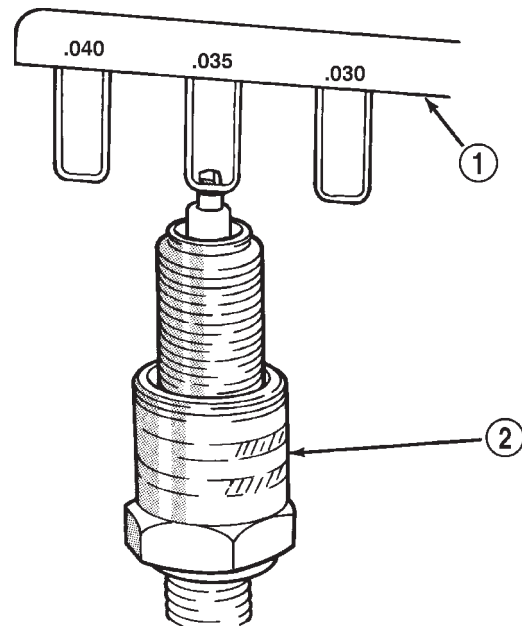
**Fig. 19 Setting Spark Plug Gap—Typical**

- 1 - GAUGE
- 2 - SPARK PLUG

SPARK PLUG GAP

- 2.5L 4-Cylinder Engine Spark Plug Gap:.89 mm (.035 in).
- 4.0L 6-Cylinder Engine Spark Plug Gap:.89 mm (.035 in).

PLUG INSTALLATION

Always tighten spark plugs to the specified torque. Over tightening can cause distortion. This may result in a change in the spark plug gap, or a cracked porcelain insulator.

When replacing the spark plug and ignition coil cables, route the cables correctly and secure them in the appropriate retainers. Failure to route the cables properly can cause the radio to reproduce ignition noise. It could cause cross ignition of the spark plugs, or short circuit the cables to ground.

(1) Start the spark plug into the cylinder head by hand to avoid cross threading.

(2) Tighten the spark plugs to 35-41 N·m (26-30 ft. lbs.) torque.

(3) 2.5L 4-Cylinder Engine: Install spark plug cables over spark plugs.

(4) 4.0L 6-Cylinder Engine: Install coil rail. Refer to Ignition Coil-4.0L Engine Removal/Installation.

REMOVAL AND INSTALLATION (Continued)

IGNITION COIL—2.5L ENGINE

REMOVAL

The ignition coil is an epoxy filled type. If the coil is replaced, it must be replaced with the same type.

On the 2.5L 4-cylinder engine, the ignition coil is mounted to a bracket on side of engine (to rear of distributor) (Fig. 20).

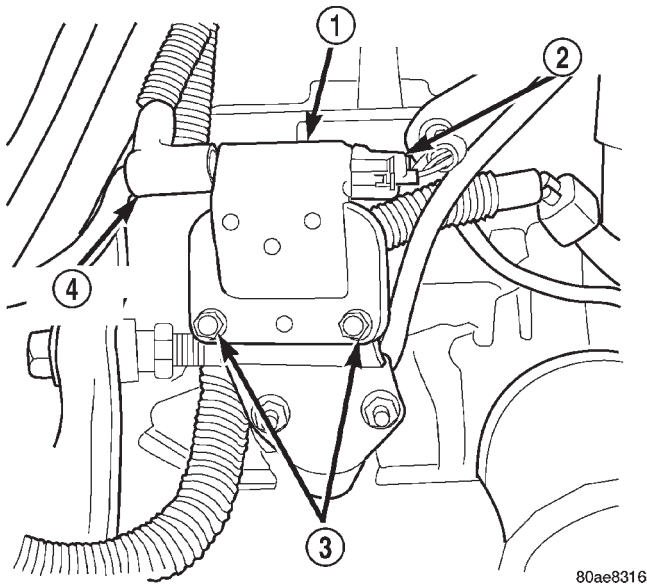

Fig. 20 Ignition Coil—2.5L Engine

- 1 - IGNITION COIL
- 2 - ELECTRICAL CONNECTOR
- 3 - MOUNTING BOLTS (2)
- 4 - SECONDARY CABLE

(1) Disconnect ignition coil secondary cable from ignition coil.

(2) Disconnect engine harness connector from ignition coil.

(3) Remove ignition coil mounting bolts (nuts are used on back side of bracket on some coils).

(4) Remove coil from vehicle.

INSTALLATION

(1) Install ignition coil to bracket on cylinder block with mounting bolts (and nuts if equipped). If equipped with nuts and bolts, tighten to 11 N·m (100 in. lbs.) torque. If equipped with bolts only, tighten to 5 N·m (50 in. lbs.) torque.

(2) Connect engine harness connector to coil.

(3) Connect ignition coil cable to ignition coil.

IGNITION COIL—4.0L ENGINE

REMOVAL

A one-piece coil rail assembly containing three individual coils is used on the 4.0L engine (Fig. 21). The coil rail must be replaced as one assembly. The bottom of the coil is equipped with 6 individual rub-

ber boots (Fig. 21) to seal the 6 spark plugs to the coil. Inside each rubber boot is a spring. The spring is used for an electrical contact between the coil and the top of the spark plug. These rubber boots and springs are a permanent part of the coil and are not serviced separately.

(1) Disconnect negative battery cable at battery.

(2) The coil is bolted directly to the cylinder head. Remove 4 coil mounting bolts (Fig. 22).

(3) Carefully pry up coil assembly from spark plugs. Do this by prying alternately at each end of coil until rubber boots have disengaged from all spark plugs. If boots will not release from spark plugs, use a commercially available spark plug boot removal tool. Twist and loosen a few boots from a few spark plugs to help remove coil.

(4) After coil has cleared spark plugs, position coil for access to primary electrical connector. Disconnect connector from coil by pushing slide tab outwards to right side of vehicle (Fig. 23). After slide tab has been positioned outwards, push in on secondary release lock (Fig. 23) on side of connector and pull connector from coil.

(5) Remove coil from vehicle.

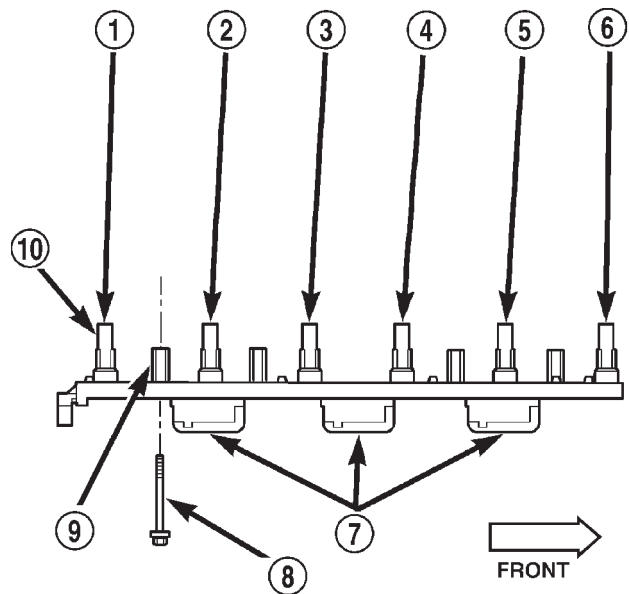
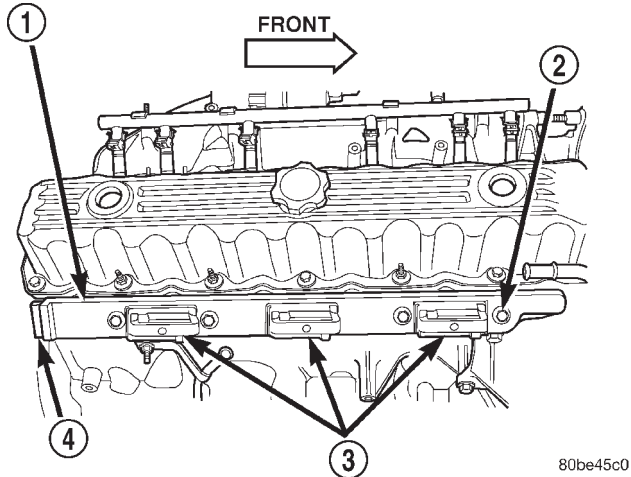

Fig. 21 Ignition Coil Assembly—4.0L 6-Cylinder Engine

- 1 - CYL. #6
- 2 - CYL. #5
- 3 - CYL. #4
- 4 - CYL. #3
- 5 - CYL. #2
- 6 - CYL. #1
- 7 - COILS (3)
- 8 - MOUNTING BOLTS (4)
- 9 - BOLT BASES (4)
- 10 - RUBBER BOOTS (6)

REMOVAL AND INSTALLATION (Continued)



80be45c0

Fig. 22 Ignition Coil Rail Location—4.0L 6-Cylinder Engine

- 1 - COIL RAIL
- 2 - COIL MOUNTING BOLTS (4)
- 3 - COIL
- 4 - COIL ELECTRICAL CONNECTION

INSTALLATION

- (1) Position ignition coil rubber boots to all spark plugs. Push down on coil assembly until bolt bases have contacted cylinder head
- (2) Install 4 coil mounting bolts. Loosely tighten 4 bolts just enough to allow bolt bases to contact cylinder head. Do a final tightening of each bolt in steps down to 29 N·m (250 in. lbs.) torque. Do not apply full torque to any bolt first.
- (3) Connect engine harness connector to coil by snapping into position. Move slide tab towards engine (Fig. 23) for a positive lock.
- (4) Connect negative battery cable to battery.

CRANKSHAFT POSITION (CKP) SENSOR

REMOVAL

The crankshaft position (CKP) sensor is mounted to the transmission bellhousing at the left/rear side of the engine block.

The sensor may be mounted to the transmission with one of the following three different configurations:

- with one bolt (Fig. 24). If sensor is equipped with one mounting bolt, **it is adjustable..**
- with two nuts (Fig. 25).
- with two bolts (Fig. 26).

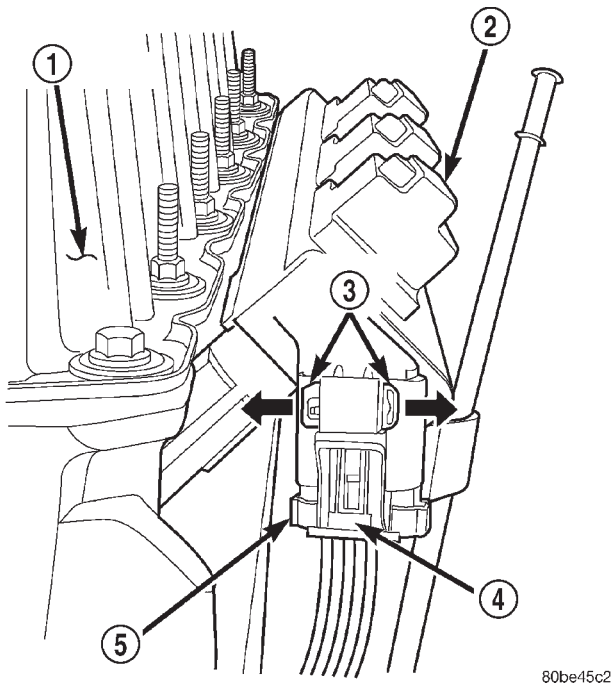

80be45c2

Fig. 23 Ignition Coil Electrical Connector—4.0L 6-Cylinder Engine

- 1 - REAR OF VALVE COVER
- 2 - COIL RAIL
- 3 - SLIDE TAB
- 4 - RELEASE LOCK
- 5 - COIL CONNECTOR

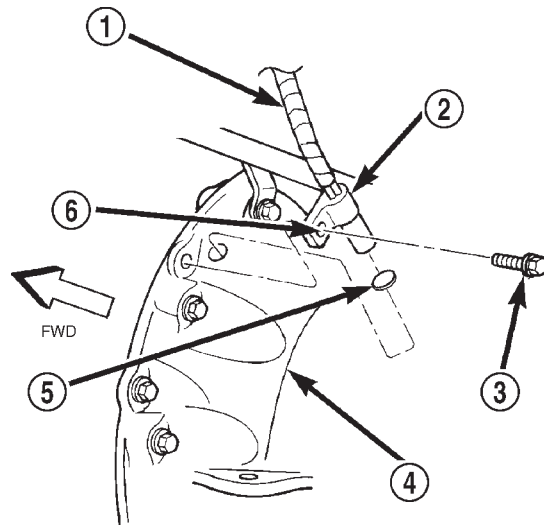

80be45c4

Fig. 24 Crankshaft Position Sensor—One-Bolt Mounting

- 1 - SENSOR PIGTAIL
- 2 - CRANKSHAFT POSITION SENSOR
- 3 - MOUNTING BOLT
- 4 - TRANSMISSION HOUSING
- 5 - PAPER SPACER
- 6 - SLOTTED HOLE

REMOVAL AND INSTALLATION (Continued)

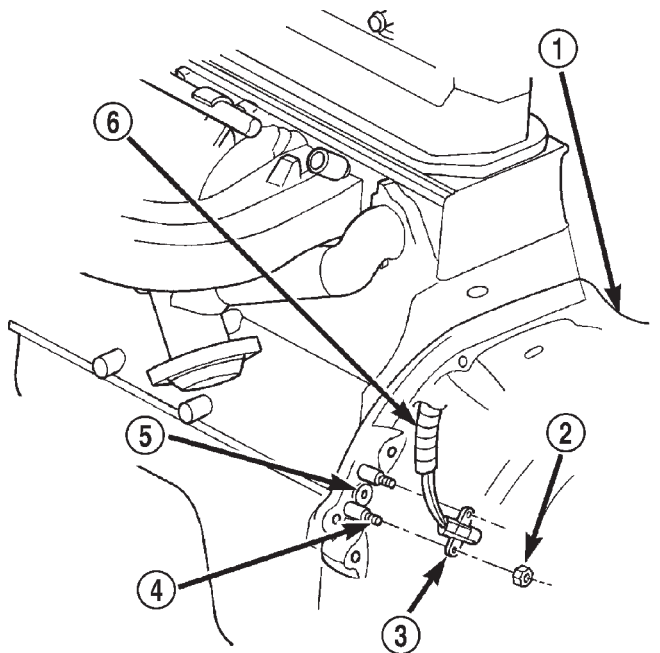

80be45c5

Fig. 25 Crankshaft Position Sensor—Two-Nut Mounting

- 1 - TRANSMISSION BELLHOUSING
- 2 - MOUNTING NUTS (2)
- 3 - CRANKSHAFT POSITION SENSOR
- 4 - MOUNTING STUDS (2)
- 5 - RUBBER GROMMET
- 6 - SENSOR PIGTAIL

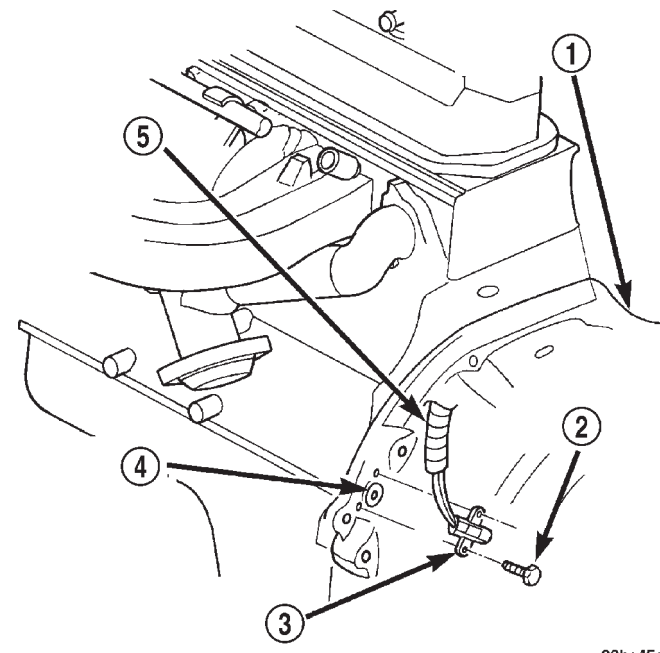

80be45c6

Fig. 26 Crankshaft Position Sensor—Two-Bolt Mounting

- 1 - TRANSMISSION BELLHOUSING
- 2 - MOUNTING BOLTS (2)
- 3 - CRANKSHAFT POSITION SENSOR
- 4 - RUBBER GROMMET
- 5 - SENSOR PIGTAIL

(1) Near left-rear side of engine, disconnect sensor pigtail harness (electrical connector) from main electrical harness connector. These connectors are attached to a bracket which is attached to the left-front side of the transmission.

(2) Depending upon application, remove either sensor mounting bolt(s) or nuts.

(3) Remove sensor from engine.

INSTALLATION

Sensor With 2-Bolt Mounting:

(1) Install sensor flush against opening in transmission housing.

(2) Install and tighten two sensor mounting bolts to 19 N·m (14 ft. lbs.) torque. The two sensor mounting bolts are specially machined to correctly space unit to flywheel. Do not attempt to install any other bolts.

Sensor With 2-Nut Mounting:

(3) Install and tighten two sensor mounting nuts to 19 N·m (14 ft. lbs.) torque.

Sensor With One-Bolt Mounting:

New replacement sensors will be equipped with a paper spacer glued to bottom of sensor. If installing (returning) a **used** sensor to vehicle, a new paper spacer must be installed to bottom of sensor. This

spacer will be ground off the first time engine is started. If spacer is not used, sensor will be broken the first time engine is started.

(4) New Sensors: Be sure paper spacer is installed to bottom of sensor. If not, obtain spacer PN05252229.

(5) Used Sensors: Clean bottom of sensor and install spacer PN05252229.

(6) Install sensor into transmission bellhousing hole.

(7) Push sensor against flywheel/drive plate. With sensor pushed against flywheel/drive plate, tighten mounting bolt to 7 N·m (60 in. lbs.) torque.

(8) Connect sensor pigtail harness electrical connector to main wiring harness connector.

CAMSHAFT POSITION SENSOR—2.5L ENGINE

On 2.5L engines, the camshaft position sensor is located in the distributor (Fig. 27).

REMOVAL

Distributor removal is not necessary to remove camshaft position sensor.

(1) Disconnect negative battery cable at battery.

(2) Remove distributor cap from distributor (two screws).

(3) Disconnect camshaft position sensor wiring harness from main engine wiring harness.

REMOVAL AND INSTALLATION (Continued)

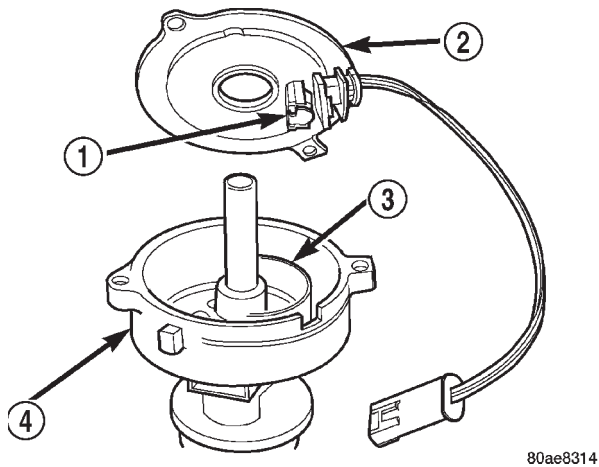

80ae8314

Fig. 27 Camshaft Position Sensor—2.5L Engine

- 1 - SYNC SIGNAL GENERATOR
- 2 - CAMSHAFT POSITION SENSOR
- 3 - PULSE RING
- 4 - DISTRIBUTOR ASSEMBLY

(4) Remove distributor rotor from distributor shaft.
 (5) Lift camshaft position sensor assembly from distributor housing (Fig. 27).

INSTALLATION

- (1) Install camshaft position sensor to distributor. Align sensor into notch on distributor housing.
- (2) Connect wiring harness.
- (3) Install rotor.
- (4) Install distributor cap. Tighten mounting screws.

CAMSHAFT POSITION SENSOR—4.0L ENGINE

The Camshaft Position Sensor (CMP) on the 4.0L 6-cylinder engine is bolted to the top of the oil pump drive shaft assembly (Fig. 28). The sensor and drive shaft assembly is located on the right side of the engine near the oil filter (Fig. 29).

The rotational position of oil pump drive determines fuel synchronization only. It does not determine ignition timing.

NOTE: Do not attempt to rotate the oil pump drive to modify ignition timing.

Two different procedures are needed for removal and installation. The first procedure will detail removal and installation of the sensor only. The second procedure will detail removal and installation of the sensor and oil pump drive shaft assembly. The second procedure is to be used if the engine has been disassembled.

An internal oil seal is used in the drive shaft housing that prevents engine oil at the bottom of the sensor. The seal is not serviceable.

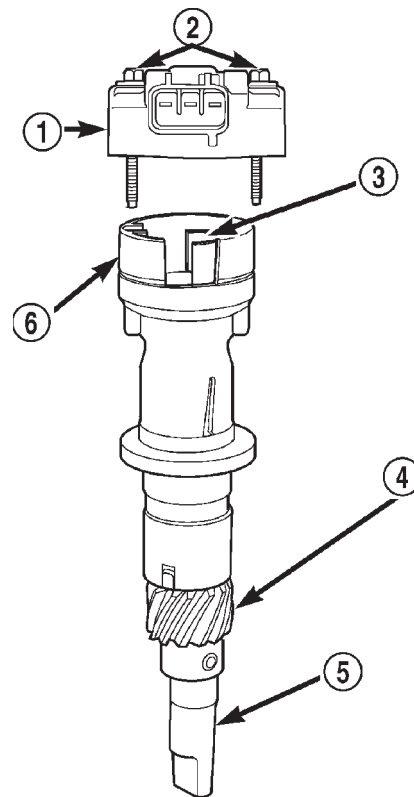

80b76ff3

Fig. 28 CMP and Oil Pump Drive Shaft—4.0L Engine

- 1 - CAMSHAFT POSITION SENSOR
- 2 - MOUNTING BOLTS (2)
- 3 - PULSE RING
- 4 - DRIVE GEAR (TO CAMSHAFT)
- 5 - OIL PUMP DRIVESHAFT
- 6 - SENSOR BASE (OIL PUMP DRIVESHAFT ASSEMBLY)

REMOVAL—SENSOR ONLY

- (1) Disconnect electrical connector at CMP sensor (Fig. 29).
- (2) Remove 2 sensor mounting bolts (Fig. 28) or (Fig. 29).
- (3) Remove sensor from oil pump drive.

INSTALLATION—SENSOR ONLY

- (1) Install sensor to oil pump drive.
- (2) Install 2 sensor mounting bolts and tighten to 2 N·m (15 in. lbs.) torque.
- (3) Connect electrical connector to CMP sensor.

REMOVAL—OIL PUMP DRIVE AND SENSOR

If the CMP and oil pump drive are to be removed and installed, do not allow engine crankshaft or camshaft to rotate. CMP sensor relationship will be lost.

- (1) Disconnect electrical connector at CMP sensor (Fig. 29).
- (2) Remove 2 sensor mounting bolts (Fig. 28) or (Fig. 29).
- (3) Remove sensor from oil pump drive.

REMOVAL AND INSTALLATION (Continued)

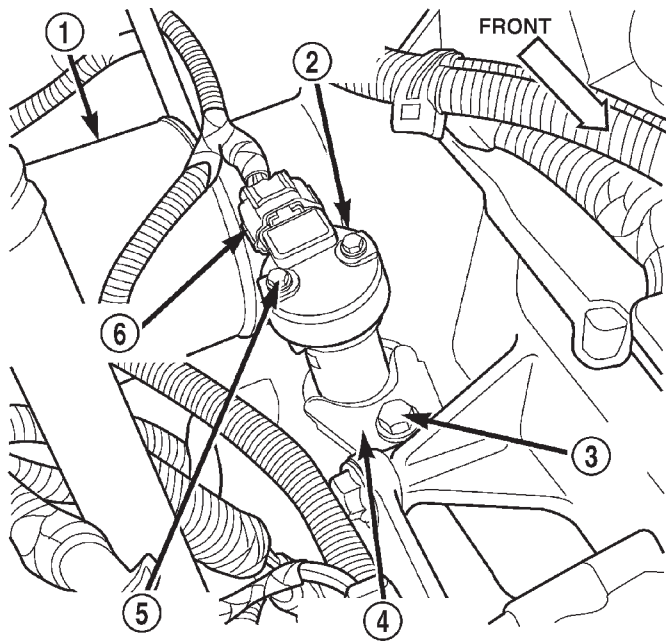

80b76ff4

Fig. 29 CMP Location—4.0L Engine

- 1 - OIL FILTER
- 2 - CAMSHAFT POSITION SENSOR
- 3 - CLAMP BOLT
- 4 - HOLD-DOWN CLAMP
- 5 - MOUNTING BOLTS (2)
- 6 - ELEC. CONNECTOR

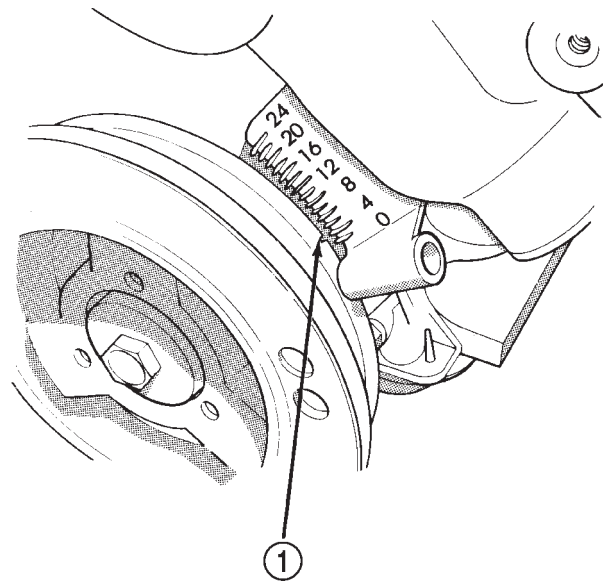

J898D-14

Fig. 31 Align Timing Marks—4.0L Engine

- 1 - CRANKSHAFT VIBRATION DAMPER TIMING MARK

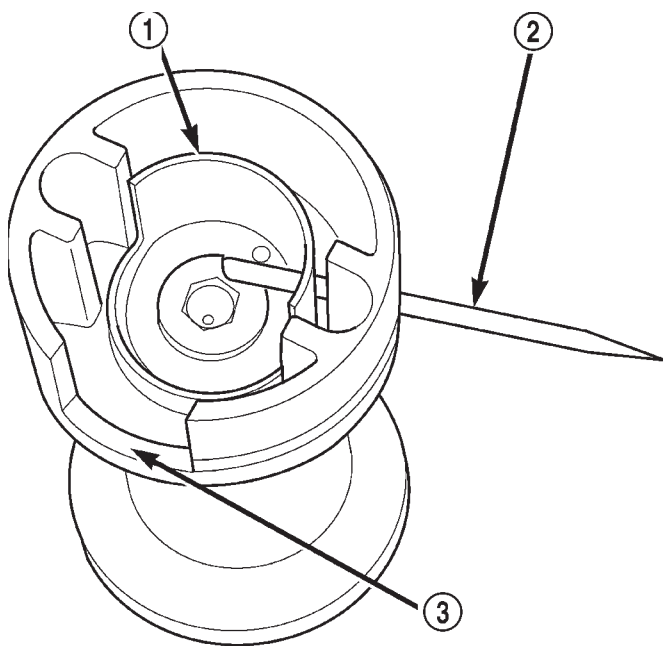

80b76ff5

Fig. 30 CMP Pulse Ring Alignment—4.0L Engine

- 1 - PULSE RING (SHUTTER)
- 2 - TOOTHPICK
- 3 - SENSOR BASE (OIL PUMP DRIVESHAFT ASSEMBLY)

(4) Before proceeding to next step, mark and note rotational position of oil pump drive in relationship to engine block. After installation, the CMP sensor should face rear of engine 0°.

(5) Remove hold-down bolt and clamp (Fig. 29).

(6) While pulling assembly from engine, note direction and position of pulse ring (Fig. 28). After removal, look down into top of oil pump and note direction and position of slot at top of oil pump gear.

(7) Remove and discard old oil pump drive-to-engine block gasket.

INSTALLATION—OIL PUMP DRIVE AND SENSOR

(1) Clean oil pump drive mounting hole area of engine block.

(2) Install new oil pump drive-to-engine block gasket.

(3) Temporarily install a toothpick or similar tool through access hole at side of oil pump drive housing. Align toothpick into mating hole on pulse ring (Fig. 30).

(4) Install oil pump drive into engine while aligning into slot on oil pump. Rotate oil pump drive back to its original position and install hold-down clamp and bolt. Finger tighten bolt. Do not do a final tightening of bolt at this time.

(5) If engine crankshaft or camshaft has been rotated, such as during engine tear-down, CMP sensor relationship must be reestablished.

(a) Remove ignition coil rail assembly. Refer to Ignition Coil Removal/Installation.

REMOVAL AND INSTALLATION (Continued)

(b) Remove cylinder number 1 spark plug.

(c) Hold a finger over the open spark plug hole. Rotate engine at vibration dampener bolt until compression (pressure) is felt.

(d) Slowly continue to rotate engine. Do this until timing index mark on vibration damper pulley aligns with top dead center (TDC) mark (0 degree) on timing degree scale (Fig. 31). Always rotate engine in direction of normal rotation. Do not rotate engine backward to align timing marks.

(e) Install oil pump drive into engine while aligning into slot on oil pump. If pump drive will not drop down flush to engine block, the oil pump slot is not aligned. Remove oil pump drive and align slot in oil pump to shaft at bottom of drive. Install into engine. Rotate oil pump drive back to its original position and install hold-down clamp and bolt. Finger tighten bolt. Do not do a final tightening of bolt at this time.

(f) Remove toothpick from housing.

(6) Install sensor to oil pump drive. After installation, the CMP sensor should face rear of engine 0°.

(7) Install 2 sensor mounting bolts and tighten to 2 N·m (15 in. lbs.) torque.

(8) Connect electrical connector to CMP sensor.

(9) If removed, install spark plug and ignition coil rail.

To verify correct rotational position of oil pump drive, the DRB scan tool must be used.

WARNING: WHEN PERFORMING THE FOLLOWING TEST, THE ENGINE WILL BE RUNNING. BE CAREFUL NOT TO STAND IN LINE WITH THE FAN BLADES OR FAN BELT. DO NOT WEAR LOOSE CLOTHING.

(10) Connect DRB scan tool to data link connector. The data link connector is located in passenger compartment, below and to left of steering column.

(11) Gain access to SET SYNC screen on DRB.

(12) Follow directions on DRB screen and start engine. Bring to operating temperature (engine must be in "closed loop" mode).

(13) With engine running at **idle speed**, the words **IN RANGE** should appear on screen along with 0°. This indicates correct position of oil pump drive.

(14) If a plus (+) or a minus (-) is displayed next to degree number, and/or the degree displayed is not zero, loosen but do not remove hold-down clamp bolt. Rotate oil pump drive until **IN RANGE** appears on screen. Continue to rotate oil pump drive until achieving as close to 0° as possible.

The degree scale on SET SYNC screen of DRB is referring to fuel synchronization only. **It is not referring to ignition timing.** Because of this, do not attempt to adjust ignition timing using this method. Rotating oil pump drive will have no effect

on ignition timing. All ignition timing values are controlled by powertrain control module (PCM).

(15) Tighten hold-down clamp bolt to 23 N·m (17 ft. lbs.) torque.

DISTRIBUTOR—2.5L ENGINE

The distributor contains an internal oil seal that prevents oil from entering the distributor housing. The seal is not serviceable.

Factory replacement distributors are equipped with a plastic alignment pin already installed. The pin is located in an access hole on the bottom of the distributor housing (Fig. 32). It is used to temporarily lock the rotor to the cylinder number 1 position during installation. The pin must be removed after installing the distributor.

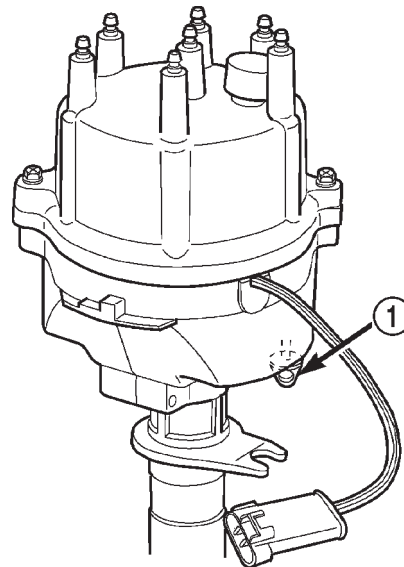

80ae8317

Fig. 32 Plastic Alignment Pin—2.5L Engine

1 - PLASTIC ALIGNMENT PIN

The camshaft position sensor is located in the distributor (Fig. 33). For removal/installation procedures, refer to Camshaft Position Sensor. Distributor removal is not necessary for sensor removal.

Refer to (Fig. 33) for an exploded view of the distributor.

A fork with a slot is supplied on the bottom of the distributor housing where the housing base seats against the engine block (Fig. 33). The centerline of the slot aligns with the distributor holddown bolt hole in the engine block. Because of the fork, the distributor cannot be rotated. Distributor rotation is not necessary as all ignition timing requirements are handled by the Powertrain Control Module (PCM).

The position of the distributor determines fuel synchronization only. It does not determine ignition timing.

REMOVAL AND INSTALLATION (Continued)

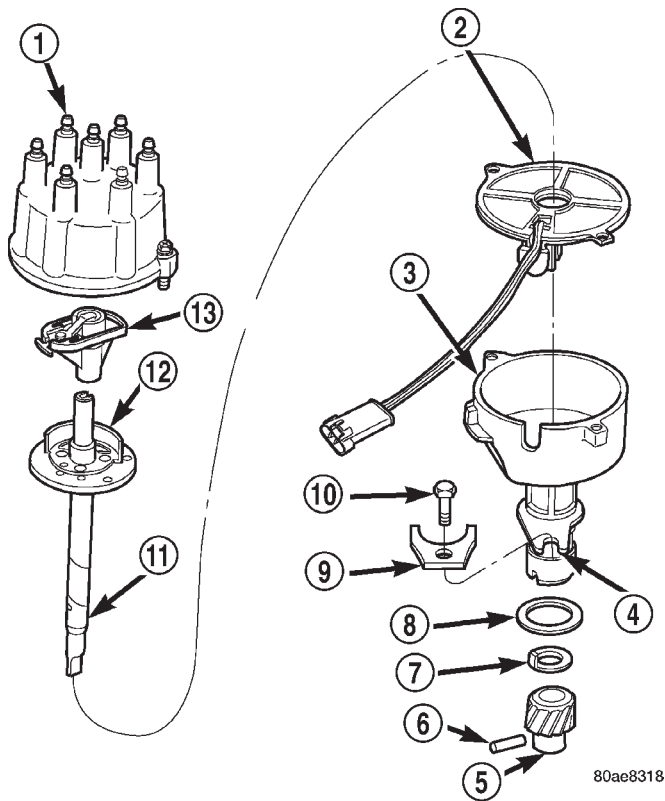
**Fig. 33 Distributor—2.5L Engine—Typical**

- 1 - CAP
- 2 - CAMSHAFT POSITION SENSOR
- 3 - HOUSING
- 4 - FORK WITH SLOT
- 5 - DRIVE GEAR
- 6 - ROLL PIN
- 7 - WASHER
- 8 - GASKET
- 9 - HOLDDOWN CLAMP
- 10 - HOLDDOWN BOLT
- 11 - SHAFT
- 12 - PULSE RING
- 13 - ROTOR

NOTE: Do not attempt to modify this fork to attain ignition timing.

REMOVAL

- (1) Disconnect negative battery cable at battery.
- (2) Disconnect coil secondary cable at coil.
- (3) Remove distributor cap from distributor (2 screws). Do not remove cables from cap. Do not remove rotor.
- (4) Disconnect distributor wiring harness from main engine harness.
- (5) Remove cylinder number 1 spark plug.
- (6) Hold a finger over open spark plug hole. Rotate engine at vibration dampener bolt until compression (pressure) is felt.

(7) Slowly continue to rotate engine. Do this until timing index mark on vibration damper pulley aligns with Top Dead Center (TDC) mark (0 degree) on timing degree scale (Fig. 34). Always rotate engine in direction of normal rotation. Do not rotate engine backward to align timing marks.

(8) On models equipped with A/C, remove electrical cooling fan and shroud assembly from radiator. Refer to Group 7, Cooling System for procedures.

(9) This will provide room to turn engine crankshaft with a socket and ratchet using vibration damper bolt.

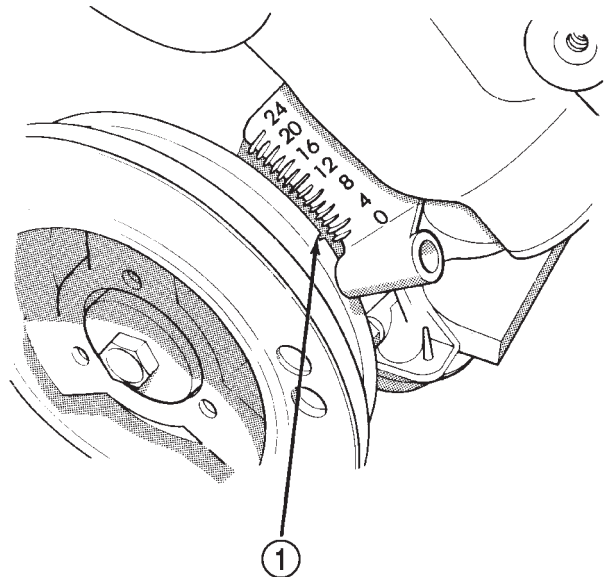
**Fig. 34 Align Timing Marks—2.5L Engine**

- 1 - CRANKSHAFT VIBRATION DAMPER TIMING MARK

(10) Remove distributor holddown bolt and clamp.
 (11) Remove distributor from engine by slowly lifting straight up.

(12) Note that rotor will rotate slightly in a counterclockwise direction while lifting up distributor. The oil pump gear will also rotate slightly in a counterclockwise direction while lifting up distributor. This is due to the helical cut gears on distributor and camshaft.

(13) Note removed position of rotor during distributor removal. During installation, this will be referred to as the Pre-position.

(14) Observe slot in oil pump gear through hole on side of engine. It should be slightly before (counterclockwise of) 10 o'clock position (Fig. 35).

(15) Remove and discard the old distributor-to-engine block gasket.

J898D-14

REMOVAL AND INSTALLATION (Continued)

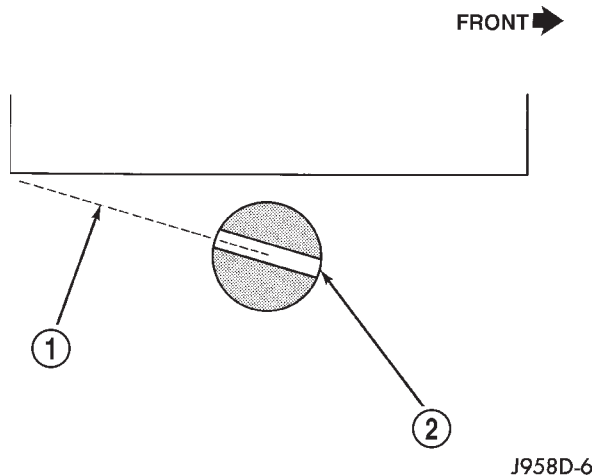
**Fig. 35 Slot At 10 O'clock Position—2.5L Engine**

- 1 - 10 O'CLOCK POSITION
2 - OIL PUMP SLOT

INSTALLATION

(1) If engine crankshaft has been rotated after distributor removal, cylinder number 1 must be returned to its proper firing stroke. Refer to previous REMOVAL Step 5 and Step 6. These steps must be done before installing distributor.

(2) Check position of slot on oil pump gear. On the 2.5L engine, it should be just slightly before (counterclockwise of) 10 o'clock position (Fig. 35). If not, place a flat blade screwdriver into oil pump gear and rotate it into proper position.

(3) Factory replacement distributors are equipped with a plastic alignment pin already installed (Fig. 32). This pin is used to temporarily hold rotor to cylinder number 1 firing position during distributor installation. If pin is in place, proceed to Step 8. If not, proceed to next step.

(4) If original distributor is to be reinstalled, such as during engine overhaul, the plastic pin will not be available. A 3/16 inch drift pin punch tool may be substituted for plastic pin.

(5) Remove camshaft position sensor from distributor housing. Lift straight up.

(6) Four different alignment holes are provided on plastic ring (Fig. 36). **Note that 2.5L and 4.0L engines have different alignment holes (Fig. 36).**

(7) Rotate distributor shaft and install pin punch tool through proper alignment hole in plastic ring (Fig. 36) and into mating access hole in distributor housing. This will prevent distributor shaft and rotor from rotating.

(8) Clean distributor mounting hole area of engine block.

(9) Install new distributor-to-engine block gasket (Fig. 33).

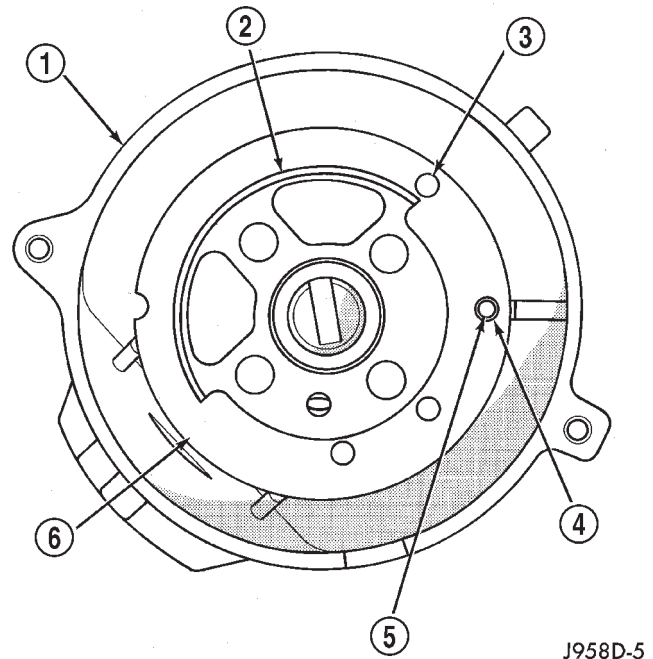
**Fig. 36 Pin Alignment Holes—2.5L Engine**

- 1 - DISTRIBUTOR HOUSING (TOP VIEW)
2 - PULSE RING
3 - 4.0L 6-CYLINDER ENGINE ALIGN. HOLE
4 - 2.5L 4-CYLINDER ENGINE ALIGN. HOLE
5 - MATING ACCESS HOLE IN DISTRIBUTOR HOUSING
6 - PLASTIC RING

(10) Install rotor to distributor shaft.

(11) Pre-position distributor into engine while holding centerline of base slot in 1 o'clock position (Fig. 37). Continue to engage distributor into engine. The rotor and distributor will rotate clockwise during installation. This is due to the helical cut gears on distributor and camshaft. When distributor is fully seated to engine block, the centerline of base slot should be aligned to clamp bolt mounting hole on engine (Fig. 38). The rotor should also be pointed slightly past (clockwise of) 3 o'clock position.

It may be necessary to rotate rotor and distributor shaft (very slightly) to engage distributor shaft with slot in oil pump gear. The same may have to be done to engage distributor gear with camshaft gear.

REMOVAL AND INSTALLATION (Continued)

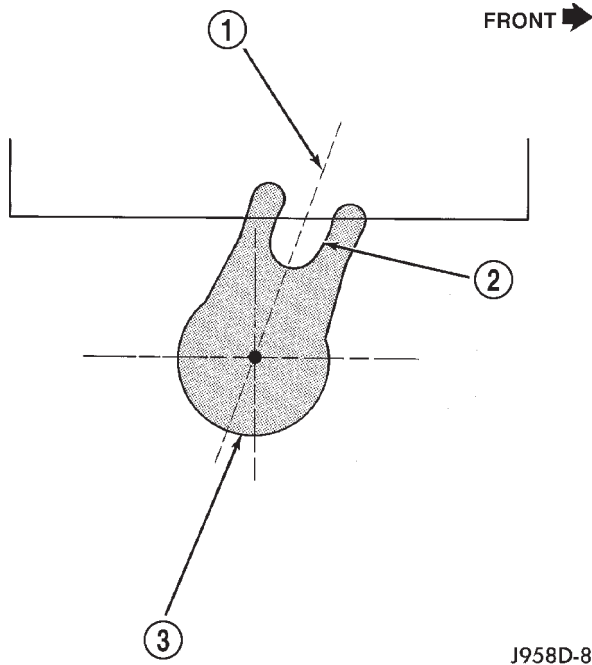

J958D-8

Fig. 37 Distributor Pre-position—2.5L Engine

- 1 - 1 O'CLOCK POSITION
- 2 - BASE SLOT
- 3 - DISTRIBUTOR BASE

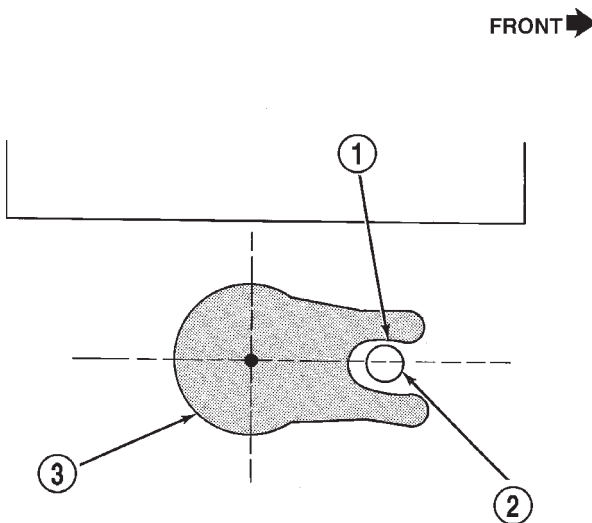

J958D-9

Fig. 38 Distributor Engaged Position—2.5L Engine

- 1 - DISTRIBUTOR BASE SLOT
- 2 - CLAMP BOLT MOUNTING HOLE (ON ENGINE)
- 3 - DISTRIBUTOR BASE

The distributor is correctly installed when:

- rotor is pointed at 3 o'clock position.
- plastic alignment pin (or pin punch tool) is still installed to distributor.
- number 1 cylinder piston is set at top dead center (TDC) (compression stroke).
- centerline of slot at base of distributor is aligned to centerline of distributor holddown bolt hole on engine. In this position, the holddown bolt should easily pass through slot and into engine.

No adjustments are necessary. Proceed to next step.

(12) Install distributor holddown clamp and bolt. Tighten bolt to 23 N·m (17 ft. lbs.) torque.

(13) Remove pin punch tool from distributor. Or, if plastic alignment pin was used, remove it straight down from bottom of distributor. Discard plastic pin.

(14) If removed, install camshaft position sensor to distributor. Align wiring harness grommet to notch in distributor housing.

(15) Install rotor.

CAUTION: If the distributor cap is incorrectly positioned on distributor housing, cap or rotor may be damaged when engine is started.

(16) Install distributor cap. Tighten distributor cap holddown screws to 3 N·m (26 in. lbs.) torque.

(17) If removed, install spark plug cables to distributor cap. For proper firing order, refer to Engine Firing Order.

(18) Connect distributor wiring harness to main engine harness.

(19) Connect battery cable to battery.

IGNITION SWITCH AND KEY CYLINDER

The ignition key must be in the key cylinder for cylinder removal. The key cylinder must be removed first before removing ignition switch.

KEY CYLINDER REMOVAL

- (1) Disconnect negative battery cable at battery.
- (2) If equipped with an automatic transmission, place shifter in PARK position.
- (3) Rotate key to ON position.
- (4) A release tang is located on bottom of key cylinder (Fig. 39).
- (5) Position a small screwdriver or pin punch into tang access hole on bottom of steering column lower cover (Fig. 40).
- (6) Push the pin punch up while pulling key cylinder from steering column.

REMOVAL AND INSTALLATION (Continued)

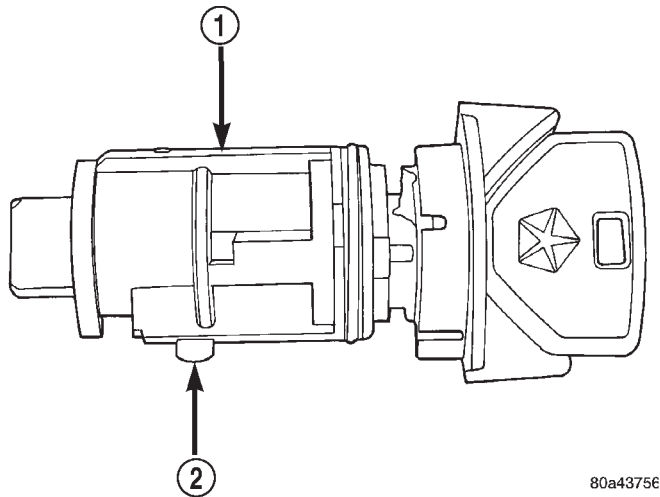

80a43756

Fig. 39 Key Cylinder Release Tang

- 1 - KEY CYLINDER
- 2 - RELEASE TANG

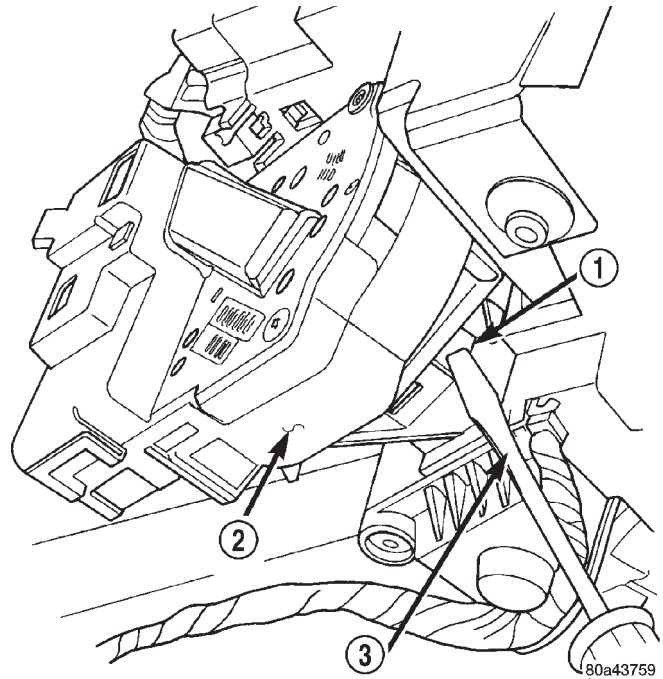

80a43759

Fig. 41 Ignition Switch Lock Tab

- 1 - LOCK TAB
- 2 - IGNITION SWITCH
- 3 - SCREWDRIVER

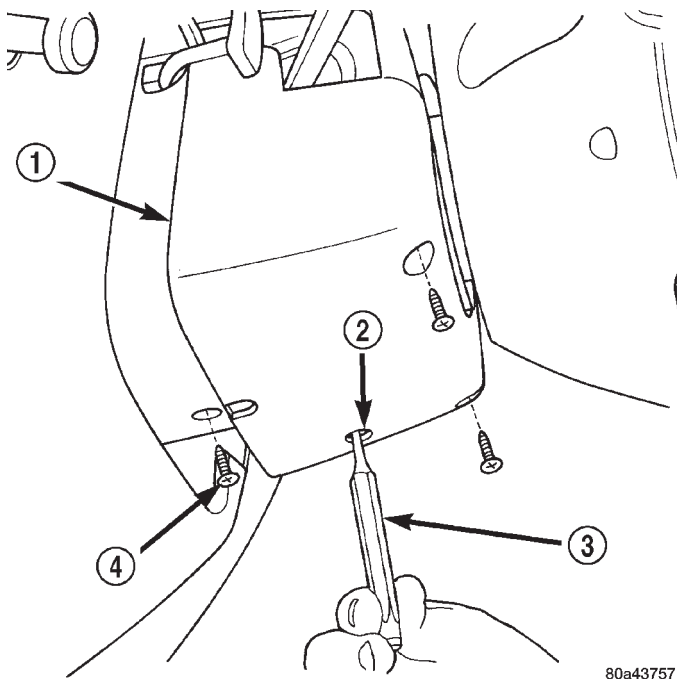

80a43757

Fig. 40 Key Cylinder and Cover Removal

- 1 - LOWER COVER
- 2 - ACCESS HOLE
- 3 - PIN PUNCH
- 4 - COVER SCREWS (3)

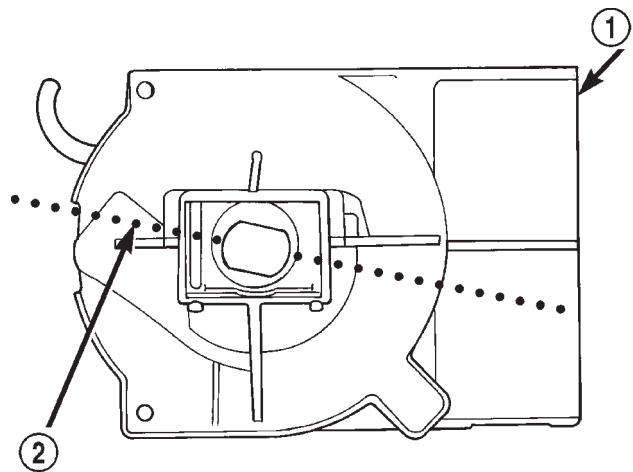

80a43850

Fig. 42 Switch In ON Position

- 1 - IGNITION SWITCH
- 2 - ROTATE TO ON POSITION

IGNITION SWITCH REMOVAL

- (1) Remove key cylinder. Refer to previous steps.
- (2) Remove lower steering column cover screws and remove cover (Fig. 40).
- (3) Remove ignition switch mounting screw (Fig. 43). Use tamper proof torx bit (Snap-On® SDMTR10 or equivalent) to remove the screw.

- (4) Using a small screwdriver, push on locking tab (Fig. 41) and remove switch from steering column.
- (5) Disconnect two electrical connectors at rear of ignition switch (Fig. 43).

REMOVAL AND INSTALLATION (Continued)

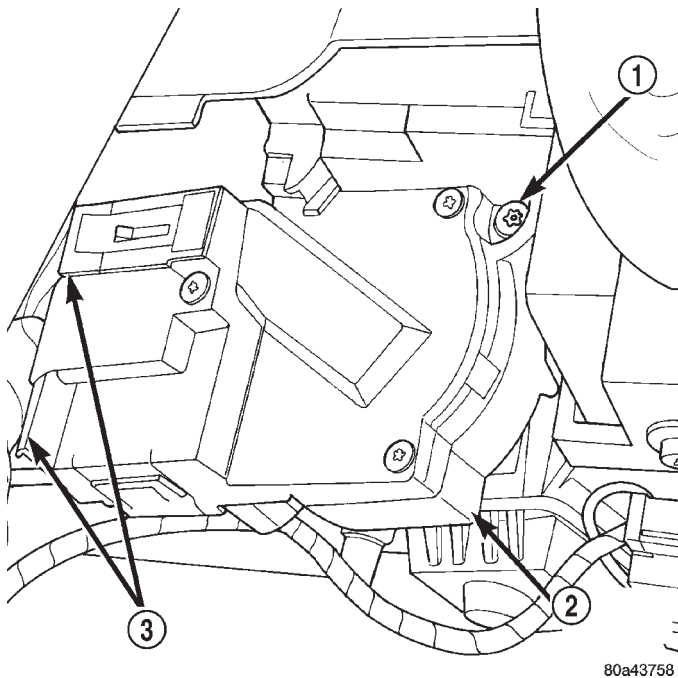

80a43758

Fig. 43 Ignition Switch Removal/Installation

- 1 - TAMPER PROOF SCREW
- 2 - IGNITION SWITCH
- 3 - ELECTRICAL CONNECTORS

IGNITION SWITCH INSTALLATION

- (1) Before installing ignition switch, rotate the slot in the switch to the ON position (Fig. 42).
- (2) Connect two electrical connectors to rear of ignition switch. Make sure that locking tabs are fully seated into wiring connectors.
- (3) Position switch to column and install tamper proof screw. Tighten screw to 3 N·m (26 in. lbs.).
- (4) Install steering column lower cover.

KEY CYLINDER INSTALLATION

- (1) If equipped with an automatic transmission, place shifter in PARK position.
- (2) Position key cylinder into steering column as it would normally be in the ON position.
- (3) Press key cylinder into column until it snaps into position.
- (4) Check mechanical operation of switch. **Automatic Transmission:** Be sure transmission lever is locked in PARK position after key removal. If key is difficult to rotate or is difficult to remove, the shift lever-to-steering column cable may be out of adjustment or defective. Refer to Group 21, Transmission for procedures. **Manual Transmission:** Be sure key cannot be removed until release lever is operated. If key can be removed, release lever mechanism may be defective. Release lever mechanism is not serviced separately. If repair is necessary, the steering column must be replaced. Refer to Group 19, Steering for procedures.
- (5) Connect negative cable to battery.
- (6) Check electrical operation of switch.

SHIFTER/IGNITION INTERLOCK**REMOVAL/INSTALLATION**

On models equipped with an automatic transmission, a cable connects the ignition switch with the floor shift lever. The shifter will be locked in the PARK position when the ignition key is in the LOCK or ACCESSORY positions. The cable can be adjusted or replaced. Refer to Group 21, Transmissions for procedures. The ignition interlock device within the steering column is not serviceable. If service is necessary, the steering column must be replaced. Refer to Group 19, Steering for procedures.

SPECIFICATIONS

IGNITION TIMING

Ignition timing is not adjustable on any engine.

ENGINE FIRING ORDER—2.5L 4-CYLINDER ENGINE

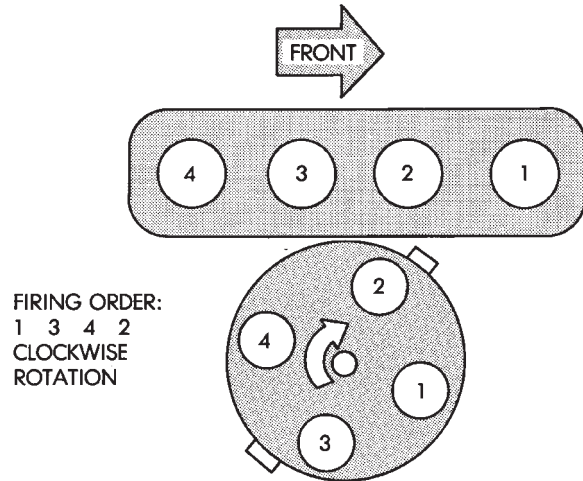

ENGINE FIRING ORDER—4.0L 6-CYLINDER ENGINE

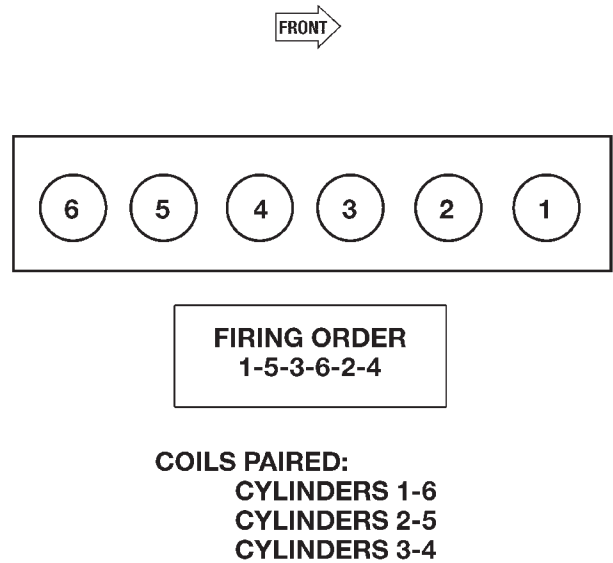

SPARK PLUGS

| ENGINE | PLUG TYPE | ELECTRODE GAP |
|--------|-----------|---------------------|
| 2.5L | RC12ECC | 0.89 mm (0.035 in.) |
| 4.0L | RC12ECC | 0.89 mm (0.035 in.) |

SPARK PLUG CABLE RESISTANCE

| MINIMUM | MAXIMUM |
|--------------------|----------------------|
| 250 Ohms Per Inch | 1000 Ohms Per Inch |
| 3000 Ohms Per Foot | 12,000 Ohms Per Foot |

IGNITION COIL RESISTANCE—2.5L ENGINE

| COIL MANUFACTURER | PRIMARY RESISTANCE @ 21-27°C (70-80°F) | SECONDARY RESISTANCE @ 21-27°C (70-80°F) |
|-------------------|--|--|
| Diamond | 0.97 - 1.18 Ohms | 11,300 - 15,300 Ohms |
| Toyodenso | 0.95 - 1.20 Ohms | 11,300 - 13,300 Ohms |

IGNITION COIL RESISTANCE—4.0L ENGINE

| PRIMARY RESISTANCE @ 21-27°C (70-80°F) |
|--|
| 0.71 - 0.88 Ohms |

SPECIFICATIONS (Continued)

TORQUE CHART

| DESCRIPTION | TORQUE |
|---|--------------------------|
| Camshaft Position Sensor-to-base bolts—4.0L | 28 N·m (15 in. lbs.) |
| Crankshaft Position Sensor Bolts (sensor mounted with 2 bolts) | 19 N·m (14 ft. lbs.) |
| Crankshaft Position Sensor Nuts (sensor mounted with 2 nuts) | 19 N·m (14 ft. lbs.) |
| Crankshaft Position Sensor Bolt (sensor mounted with 1 bolt) | 7 N·m (60 in. lbs.) |
| Distributor Hold Down Bolt—2.5L | 23 N·m (17 ft. lbs.) |
| Distributor Cap Screws—2.5L | 3 N·m (26 in. lbs.) |
| Ignition Coil Mounting (if tapped bolts are used)—2.5L | 5 N·m (50 in. lbs.) |
| Ignition Coil Mounting (if nuts/bolts are used)—2.5L | 11 N·m (100 in. lbs.) |
| Ignition Coil Rail Mounting Bolts—4.0L | 29 N·m (250 in. lbs.) |
| Oil Pump Drive Hold-down Bolt—4.0L | 23 N·m (17 ft. lbs.) |
| Spark Plugs (all engines) | 41 N·m (30 ft. lbs.) |

INSTRUMENT PANEL SYSTEMS

TABLE OF CONTENTS

| | page | | page |
|--------------------------------------|------|--|------|
| DESCRIPTION AND OPERATION | | INSTRUMENT PANEL ACCESSORY SWITCH | |
| INSTRUMENT PANEL SYSTEM | 1 | BEZEL | 15 |
| INSTRUMENT PANEL | 1 | CIGAR LIGHTER RELAY | 16 |
| INSTRUMENT CLUSTER | 2 | CLUSTER BEZEL | 16 |
| INSTRUMENT PANEL CIGAR LIGHTER | 3 | HEADLAMP SWITCH | 17 |
| CIGAR LIGHTER RELAY | 4 | INSTRUMENT CLUSTER | 18 |
| INSTRUMENT PANEL POWER OUTLET | 4 | INSTRUMENT CLUSTER COMPONENTS | 19 |
| DIAGNOSIS AND TESTING | | INSTRUMENT PANEL TOP COVER | 21 |
| INSTRUMENT CLUSTER | 5 | GLOVE BOX | 22 |
| INSTRUMENT PANEL CIGAR LIGHTER | 11 | GLOVE BOX COMPONENTS | 23 |
| CIGAR LIGHTER RELAY | 12 | GLOVE BOX LATCH STRIKER | 24 |
| INSTRUMENT PANEL POWER OUTLET | 12 | INSTRUMENT PANEL END CAP | 25 |
| REMOVAL AND INSTALLATION | | INSTRUMENT PANEL CENTER SUPPORT | |
| STEERING COLUMN OPENING COVER | 13 | BRACKET | 26 |
| KNEE BLOCKER | 14 | INSTRUMENT PANEL ASSEMBLY | 26 |
| INSTRUMENT PANEL CENTER BEZEL | 14 | | |

DESCRIPTION AND OPERATION

INSTRUMENT PANEL SYSTEM

DESCRIPTION

The instrument panel serves as the command center of the vehicle, which necessarily makes it a very complex unit. The instrument panel is designed to house the controls and monitors for standard and optional powertrains, climate control systems, audio systems, lighting systems, safety systems and many other comfort or convenience items. The instrument panel is also designed so that all of the various controls can be safely reached and the monitors can be easily viewed by the vehicle operator when driving, while still allowing relative ease of access to each of these items for service. See the owner's manual in the vehicle glove box for more information on the features, use and operation of all of the instrument panel components and systems.

This group is responsible for covering service information for the vehicle instrument panel systems. However, complete service information coverage for all of the systems and components housed in the instrument panel in a single section of the service manual would not be practical. Therefore, the service information for any component will be found in the group designated to cover the vehicle system that the component belongs to, even though the component is

mounted on or in the instrument panel. If you cannot locate a listing for the component or system you are servicing in the table of contents for this group, or if you are uncertain as to which vehicle system a component belongs to, it is suggested that you refer to the alphabetical **Component and System Index** found at the back of this service manual.

NOTE: This group covers both Left-Hand Drive (LHD) and Right-Hand Drive (RHD) versions of this model. Whenever required and feasible, the RHD versions of affected vehicle components have been constructed as mirror-image of the LHD versions. While most of the illustrations used in this group represent only the LHD version, the diagnostic and service procedures outlined can generally be applied to either version. Exceptions to this rule have been clearly identified as LHD or RHD, if a special illustration or procedure is required.

INSTRUMENT PANEL

DESCRIPTION

This instrument panel uses a full-width structural plastic foundation as its primary support. When the two primary molded plastic components of this structure are vibration welded together they provide superior instrument panel stiffness and integrity to help

DESCRIPTION AND OPERATION (Continued)

reduce buzzes, squeaks, and rattles even on the bumpiest roads.

This type of construction also provides improved energy absorption which, in conjunction with the dual airbag modules and seat belts, helps to improve occupant protection. This foundation structure also serves as the air duct for the heating and air conditioning system panel outlets, which greatly reduces the number of components used over conventional instrument panel construction.

Modular instrument panel construction allows all of the gauges and controls to be serviced from the front of the panel. In addition, most of the instrument panel electrical components can be accessed without complete instrument panel removal. If necessary, the instrument panel can be removed from the vehicle as an assembly.

Removal of the steering column opening cover and knee blocker provides access to the steering column mounts, the steering column wiring, the headlamp switch, the electronic combination flasher, and much of the instrument panel wiring. Removal of the glove box provides access to the heating and air conditioning electrical and vacuum harnesses, the blower motor relay, the radio antenna coaxial cable, the lower passenger side airbag mounts, and additional instrument panel wiring.

Removal of the instrument panel center bezel allows access to the radio, the heating and air conditioning controls, the accessory switches, the cigar lighter, and the accessory power outlet. Removal of the instrument cluster bezel allows access to the instrument cluster. Removal of the cluster assembly allows access to the cluster illumination and indicator lamp bulbs, and more of the instrument panel wiring.

Removal of the instrument panel top cover allows access to the upper passenger side airbag mounts. Instrument panel removal is required for service of most internal components of the heating and air conditioning system housing.

INSTRUMENT CLUSTER

DESCRIPTION

Two basic instrument clusters are offered on this model: low-line, or high-line. Both clusters are electromechanical units that utilize integrated circuitry and information carried on the Chrysler Collision Detection (CCD) data bus network for control of all gauges and many of the indicator lamps. These clusters also incorporate a digital Vacuum Fluorescent Display (VFD) for the odometer/trip odometer display functions. Some variations of each cluster exist due to optional equipment and regulatory requirements.

The low-line cluster includes the following analog gauges:

- Fuel gauge
- Speedometer.

This cluster also includes provisions for the following indicator lamps:

- Airbag indicator lamp
- Anti-lock brake system lamp
- Brake warning lamp
- Coolant temperature warning lamp
- Cruise-on indicator lamp
- Four-wheel drive (Part Time and/or Full Time)

indicator lamps

- Headlamp high beam indicator lamp
- Low oil pressure warning lamp
- Low washer fluid warning lamp
- Malfunction Indicator Lamp (MIL)
- Seat belt reminder lamp
- Sentry Key Immobilizer System (SKIS) indicator lamp

lamp

- Turn signal indicator lamps
- Upshift indicator lamp (manual transmission)
- Voltage warning lamp.

The high-line cluster replaces some of the indicator lamps found in the low-line cluster with analog gauges. The high-line cluster includes the following analog gauges:

- Coolant temperature gauge
- Fuel gauge
- Oil pressure gauge
- Speedometer
- Tachometer
- Voltmeter.

The high-line cluster also adds a check gauges lamp and a low fuel warning lamp to the remaining indicator lamps found in the low-line cluster.

Both instrument clusters feature circuitry that has a self-diagnostic actuator test capability, which will test each of the CCD bus message-controlled functions of the cluster by lighting the appropriate indicator lamps and positioning the gauge needles at several predetermined locations on the gauge faces in a prescribed sequence. For more information on this function, refer to **Instrument Cluster** in the Diagnosis and Testing section of this group.

The instrument cluster circuitry also integrates a chime tone generator and a timer circuit. These items replace the chime or buzzer module, and the separate timer circuit for the rear window defogger system. Refer to **Chime Warning System** in the Description and Operation section of Group 8U - Chime/Buzzer Warning Systems for more information on the chime functions of the instrument cluster. Refer to **Rear Window Defogger System** in the Description and Operation section of Group 8N -

DESCRIPTION AND OPERATION (Continued)

Electrically Heated Systems for more information on the timer function of the instrument cluster.

The instrument clusters for this model are serviced only as complete units. If a cluster gauge or the cluster circuit board are faulty, the entire cluster must be replaced. The cluster lens, the cluster hood and mask, the rear cluster housing cover, the odometer reset knob boot and the incandescent lamp bulbs and holders are available for service replacement.

OPERATION**GAUGE**

With the ignition switch in the On or Start positions, voltage is supplied to all gauges through the instrument cluster electronic circuit board. With the ignition switch in the Off position, voltage is not supplied to the gauges. The gauges do not accurately indicate any vehicle condition unless the ignition switch is in the On or Start positions.

All of the instrument cluster gauges, except the odometer, are air core magnetic units. Two fixed electromagnetic coils are located within the gauge. These coils are wrapped at right angles to each other around a movable permanent magnet. The movable magnet is suspended within the coils on one end of a shaft. The gauge needle is attached to the other end of the shaft.

One of the coils has a fixed current flowing through it to maintain a constant magnetic field strength. Current flow through the second coil changes, which causes changes in its magnetic field strength. The current flowing through the second coil is changed by the instrument cluster electronic circuitry in response to messages received on the Chrysler Collision Detection (CCD) data bus network.

The gauge needle moves as the movable permanent magnet aligns itself to the changing magnetic fields created around it by the electromagnets. The instrument cluster circuitry is programmed to move all of the gauge needles back to the low end of their respective scales after the ignition switch is turned to the Off position.

INDICATOR LAMP

Indicator lamps are located in the instrument cluster and are served by the cluster circuit board and connectors. Many of the indicator lamps in the instrument cluster are controlled by the instrument cluster circuitry in response to messages received over the Chrysler Collision Detection (CCD) data bus network.

The anti-lock brake system lamp, brake warning lamp, four-wheel drive indicator lamps, headlamp high beam indicator lamp, low washer fluid warning lamp and turn signal indicator lamps are hard wired.

The seat belt reminder lamp is controlled by the instrument cluster programming. The Malfunction Indicator Lamp (MIL) is normally controlled by CCD data bus messages from the Powertrain Control Module (PCM); however, if the instrument cluster detects a loss of CCD data bus communication, the cluster will automatically turn the MIL on and display the message "NO BUS" in the odometer VFD until CCD data bus communication is restored. The instrument cluster circuitry uses CCD data bus messages from the Powertrain Control Module (PCM), Airbag Control Module (ACM), and the Sentry Key Immobilizer Module (SKIM) to control all of the remaining indicator lamps.

Each of the indicator lamps in the instrument cluster uses incandescent bulbs and holders, which are available for service replacement.

CLUSTER ILLUMINATION LAMP

The cluster illumination lamps are hard wired in the instrument cluster. When the park or head lamps are turned on, the cluster illumination lamps light. Illumination brightness is adjusted by rotating the headlamp switch knob (clockwise to dim, counterclockwise to brighten). The instrument cluster illumination lamps receive battery feed from the panel dimmer rheostat in the headlamp switch through a fuse in the fuseblock module.

The instrument cluster electronic circuitry also monitors the cluster illumination lamp dimming level whenever the park or head lamps are turned on. The instrument cluster electronic circuitry responds by adjusting the dimming level of the odometer Vacuum Fluorescent Display (VFD), and sending dimming level messages over the Chrysler Collision Detection (CCD) data bus network. When the park lamps or headlamps are turned off, the VFD is illuminated at full brightness for improved daylight visibility.

Each of the cluster illumination lamps is located on the instrument cluster circuit board. Each cluster illumination lamp has a replaceable bulb and bulb holder.

INSTRUMENT PANEL CIGAR LIGHTER**DESCRIPTION**

A cigar lighter is standard equipment on this model. The cigar lighter is installed in the instrument panel accessory switch bezel, which is located near the bottom of the instrument panel center bezel area, below the heater and air conditioner controls. The cigar lighter base is secured by a snap fit within the accessory switch bezel.

The cigar lighter receptacle is serviced only as a part of the accessory switch bezel unit. If the cigar lighter base is faulty or damaged, the accessory

DESCRIPTION AND OPERATION (Continued)

switch bezel unit must be replaced. The cigar lighter knob and heating element unit is available for service. This component cannot be repaired and, if faulty or damaged, it must be replaced.

OPERATION

The cigar lighter consists of two major components: a knob and heating element unit, and the cigar lighter base or receptacle shell. The receptacle shell is connected to ground, and an insulated contact in the bottom of the shell is connected to battery current. The cigar lighter receives battery voltage from a fuse in the junction block through the cigar lighter relay only when the ignition switch is in the Accessory or On positions. Refer to **Cigar Lighter Relay** in the Description and Operation section of this group for more information on this component.

The cigar lighter knob and heating element are encased within a spring-loaded housing, which also features a sliding protective heat shield. When the knob and heating element are inserted in the receptacle shell, the heating element resistor coil is grounded through its housing to the receptacle shell. If the cigar lighter knob is pushed inward, the heat shield slides up toward the knob exposing the heating element, and the heating element extends from the housing toward the insulated contact in the bottom of the receptacle shell.

Two small spring-clip retainers are located on either side of the insulated contact inside the bottom of the receptacle shell. These clips engage and hold the heating element against the insulated contact long enough for the resistor coil to heat up. When the heating element is engaged with the contact, battery current can flow through the resistor coil to ground, causing the resistor coil to heat.

When the resistor coil becomes sufficiently heated, excess heat radiates from the heating element causing the spring-clips to expand. Once the spring-clips expand far enough to release the heating element, the spring-loaded housing forces the knob and heating element to pop back outward to their relaxed position. When the cigar lighter knob and element are pulled out of the receptacle shell, the protective heat shield slides downward on the housing so that the heating element is recessed and shielded around its circumference for safety.

CIGAR LIGHTER RELAY**DESCRIPTION**

The cigar lighter relay is an electromechanical device that switches fused battery current to the cigar lighter when the ignition switch is turned to the Accessory or On positions. The cigar lighter relay is located in the junction block, on the right cowl side

panel below the instrument panel in the passenger compartment.

The cigar lighter relay is a International Standards Organization (ISO) relay. Relays conforming to the ISO specifications have common physical dimensions, current capacities, terminal patterns, and terminal functions.

The cigar lighter relay cannot be repaired or adjusted and, if faulty or damaged, it must be replaced.

OPERATION

The ISO relay consists of an electromagnetic coil, a resistor or diode, and three (two fixed and one movable) electrical contacts. The movable (common feed) relay contact is held against one of the fixed contacts (normally closed) by spring pressure. When the electromagnetic coil is energized, it draws the movable contact away from the normally closed fixed contact, and holds it against the other (normally open) fixed contact.

When the electromagnetic coil is de-energized, spring pressure returns the movable contact to the normally closed position. The resistor or diode is connected in parallel with the electromagnetic coil in the relay, and helps to dissipate voltage spikes that are produced when the coil is de-energized.

INSTRUMENT PANEL POWER OUTLET**DESCRIPTION**

An accessory power outlet is standard equipment on this model. The power outlet is installed in the instrument panel accessory switch bezel, which is located near the bottom of the instrument panel center bezel area, below the heater and air conditioner controls. The power outlet base is secured by a snap fit within the accessory switch bezel. A plastic protective cap snaps into the power outlet base when the power outlet is not being used, and hangs from the power outlet base mount by an integral bail strap while the power outlet is in use.

The power outlet receptacle unit and the accessory power outlet protective cap are serviced only as a part of the accessory switch bezel unit. If the power outlet base is faulty or damaged, the entire accessory switch bezel unit must be replaced.

OPERATION

The power outlet base or receptacle shell is connected to ground, and an insulated contact in the bottom of the shell is connected to battery current. The power outlet receives battery voltage from a fuse in the junction block at all times.

While the power outlet is very similar to a cigar lighter base unit, it does not include the two small

DESCRIPTION AND OPERATION (Continued)

spring-clip retainers inside the bottom of the receptacle shell that are used to secure the cigar lighter heating element to the insulated contact.

DIAGNOSIS AND TESTING

INSTRUMENT CLUSTER

If all of the gauges and/or indicator lamps are inoperative, perform the Preliminary Diagnosis. If an individual gauge or Chrysler Collision Detection (CCD) data bus message-controlled indicator lamp is inoperative, go directly to the Actuator Test. If an individual hard wired indicator lamp is inoperative, refer to **Instrument Cluster - Hard Wired Lamp Diagnosis** in the Diagnosis and Testing section of this group for the procedures to diagnosis that lamp. For complete circuit diagrams, refer to **Instrument Cluster** in the Contents of Group 8W - Wiring Diagrams.

WARNING: ON VEHICLES EQUIPPED WITH AIRBAGS, REFER TO GROUP 8M - PASSIVE RESTRAINT SYSTEMS BEFORE ATTEMPTING ANY STEERING WHEEL, STEERING COLUMN, OR INSTRUMENT PANEL COMPONENT DIAGNOSIS OR SERVICE. FAILURE TO TAKE THE PROPER PRECAUTIONS COULD RESULT IN ACCIDENTAL AIRBAG DEPLOYMENT AND POSSIBLE PERSONAL INJURY.

PRELIMINARY DIAGNOSIS

(1) If the indicator lamps operate, but none of the gauges operate, go to Step 2. If all of the gauges and the data bus message-controlled indicator lamps are inoperative, go to Step 5.

(2) Check the fused B(+) fuse in the Power Distribution Center (PDC). If OK, go to Step 3. If not OK, repair the shorted circuit or component as required and replace the faulty fuse.

(3) Check for battery voltage at the fused B(+) fuse in the PDC. If OK, go to Step 4. If not OK, repair the open fused B(+) circuit to the battery as required.

(4) Disconnect and isolate the battery negative cable. Remove the instrument cluster. Connect the battery negative cable. Check for battery voltage at the fused B(+) circuit cavity of the instrument cluster wire harness connector A. If OK, refer to **Instrument Cluster - Actuator Test** in the Diagnosis and Testing section of this group. If not OK, repair the open fused B(+) circuit to the fuse in the PDC as required.

(5) Check the fused ignition switch output (run/start) fuse in the junction block. If OK, go to Step 6. If not OK, repair the shorted circuit or component as required and replace the faulty fuse.

(6) Turn the ignition switch to the On position and check for battery voltage at the fused ignition switch output (run/start) fuse in the junction block. If OK, go to Step 7. If not OK, repair the open fused ignition switch output (run/start) circuit to the ignition switch as required.

(7) Turn the ignition switch to the Off position. Disconnect and isolate the battery negative cable. Install the instrument cluster. Connect the battery negative cable. Turn the ignition switch to the On position. Set the park brake. The red brake warning lamp should light. If OK, go to Step 8. If not OK, go to Step 9.

(8) Turn the ignition switch to the Off position. Turn on the park lamps and adjust the panel lamps dimmer rheostat in the headlamp switch to the full bright position. The cluster illumination lamps should light. If OK, refer to **Instrument Cluster - Actuator Test** in the Diagnosis and Testing section of this group. If not OK, go to Step 10.

(9) Turn the ignition switch to the Off position. Disconnect and isolate the battery negative cable. Remove the instrument cluster. Connect the battery negative cable. Turn the ignition switch to the On position. Check for battery voltage at the fused ignition switch output (run/start) circuit cavity of the instrument cluster wire harness connector A. If OK, refer to **Instrument Cluster - Actuator Test** in the Diagnosis and Testing section of this group. If not OK, repair the open fused ignition switch output (run/start) circuit to the fuse in the junction block as required.

(10) Disconnect and isolate the battery negative cable. Remove the instrument cluster. Check for continuity between the ground circuit cavity of the instrument cluster wire harness connector A and a good ground. There should be continuity. If OK, refer to **Instrument Cluster - Actuator Test** in the Diagnosis and Testing section of this group. If not OK, repair the open ground circuit to ground as required.

ACTUATOR TEST

The instrument cluster actuator test will put the instrument cluster into its self-diagnostic mode. In this mode the instrument cluster can perform a self-diagnostic test that will confirm that the instrument cluster circuitry, the gauges, and the CCD data bus message controlled indicator lamps are capable of operating as designed. During the actuator test the instrument cluster circuitry will position each of the gauge needles at various specified calibration points, and turn all of the CCD data bus message-controlled lamps on and off at specified time intervals (Fig. 1) or (Fig. 2).

DIAGNOSIS AND TESTING (Continued)

Successful completion of the actuator test will confirm that the instrument cluster is operational. However, there may still be a problem with the CCD data bus, the Powertrain Control Module (PCM), the Airbag Control Module (ACM), the Sentry Key Immobilizer Module (SKIM) or the inputs to one of these electronic control modules. Use a DRB scan tool and the proper Diagnostic Procedures manual for testing of these components.

If an individual gauge does not respond properly, or does not respond at all during the actuator test, the instrument cluster should be removed. However, check that the gauge mounting screws on the instrument cluster electronic circuit board for proper tightness before considering instrument cluster replacement. If the gauge mounting screws check OK, replace the faulty cluster.

If an individual indicator lamp does not illuminate during the actuator test, the instrument cluster should be removed. However, check that the incandescent lamp bulb is not faulty and that the bulb holder is properly installed on the instrument cluster electronic circuit board before considering instrument cluster replacement. If the bulb and bulb holder check OK, replace the faulty instrument cluster.

(1) Begin the test with the ignition switch in the Off position.

(2) Depress the trip odometer reset button.

(3) While holding the trip odometer reset button depressed, turn the ignition switch to the On position, but do not start the engine.

(4) Release the trip odometer reset button.

(5) Compare the operation of the suspect gauge(s) and/or indicator lamp(s) with the Instrument Cluster Actuator Test chart (Fig. 1) or (Fig. 2).

(6) The instrument cluster will automatically exit the self-diagnostic mode and return to normal operation at the completion of the test, if the ignition switch is turned to the Off position during the test, or if a vehicle speed message indicating that the vehicle is moving is received from the PCM on the CCD data bus during the test.

(7) Go back to Step 1 to repeat the test, if required.

HARD WIRED LAMP DIAGNOSIS

Each of the lamps found in this section depends upon a hard wired circuit input to the instrument cluster for proper operation. The following procedures will help to diagnose conditions that may cause an inoperative hard wired lamp circuit condition.

WARNING: ON VEHICLES EQUIPPED WITH AIRBAGS, REFER TO GROUP 8M - PASSIVE RESTRAINT SYSTEMS BEFORE ATTEMPTING ANY STEERING WHEEL, STEERING COLUMN, OR INSTRUMENT PANEL COMPONENT DIAGNOSIS OR

SERVICE. FAILURE TO TAKE THE PROPER PRECAUTIONS COULD RESULT IN ACCIDENTAL AIRBAG DEPLOYMENT AND POSSIBLE PERSONAL INJURY.

ANTI-LOCK BRAKE SYSTEM LAMP

The diagnosis found here addresses an inoperative Anti-lock Brake System (ABS) lamp condition. If the ABS lamp stays on with the ignition switch in the On position, or comes on and stays on while driving, refer to **Antilock Brakes** in the Diagnosis and Testing section of Group 5 - Brakes for diagnosis. If no ABS problem is found, the following procedure will help locate a short or open in the ABS lamp circuit. For complete circuit descriptions, refer to **Instrument Cluster** in the Contents of Group 8W - Wiring Diagrams.

(1) Check the fused ignition switch output (run/start) fuse in the junction block. If OK, go to Step 2. If not OK, repair the shorted circuit or component as required and replace the faulty fuse.

(2) Turn the ignition switch to the On position. Check for battery voltage at the fused ignition switch output (run/start) fuse in the junction block. If OK, go to Step 3. If not OK, repair the open fused ignition switch output (run/start) circuit to the ignition switch as required.

(3) Turn the ignition switch to the Off position. Disconnect and isolate the battery negative cable. Remove the instrument cluster. Connect the battery negative cable. Turn the ignition switch to the On position and within five seconds check for continuity between the ABS warning indicator driver circuit cavity of the instrument cluster wire harness connector A and a good ground. There should be continuity for five seconds after ignition On, and then an open circuit. If OK, replace the faulty bulb. If not OK, go to Step 4.

(4) Turn the ignition switch to the Off position. Disconnect and isolate the battery negative cable. Disconnect the Controller Anti-lock Brake (CAB) wire harness connector. Check for continuity between the ABS warning indicator driver circuit cavity of the instrument cluster wire harness connector A and a good ground. There should be no continuity. If OK, go to Step 5. If not OK, repair the shorted ABS warning indicator driver circuit as required.

(5) Check for continuity between the ABS warning indicator driver circuit cavities of the instrument cluster wire harness connector A and the CAB wire harness connector. There should be continuity. If OK, refer to **Antilock Brakes** in the Diagnosis and Testing section of Group 5 - Brakes for diagnosis of the CAB. If not OK, repair the open ABS warning indicator driver circuit as required.

DIAGNOSIS AND TESTING (Continued)

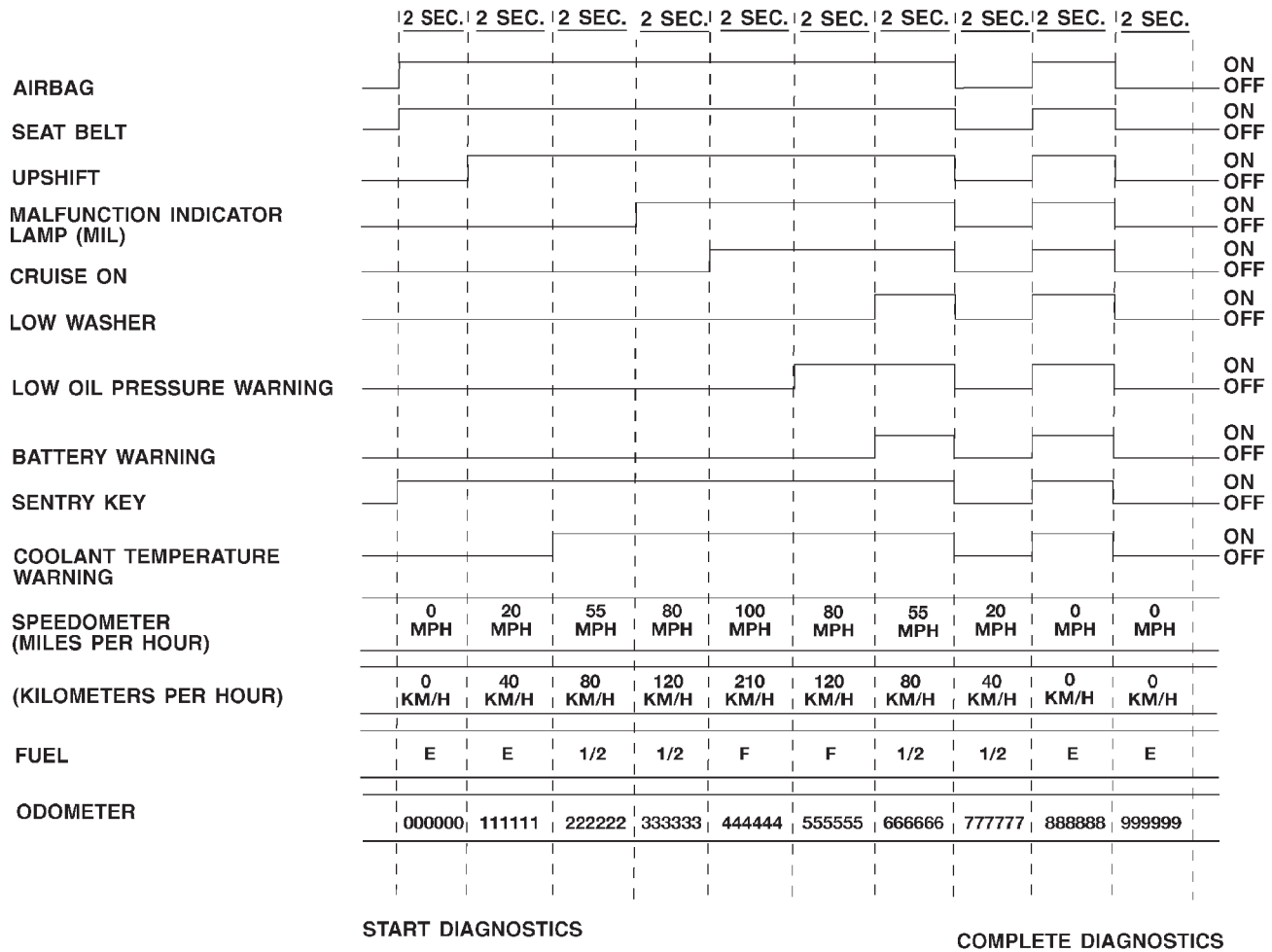

80bdb91

Fig. 1 Low-Line Instrument Cluster Actuator Test

DIAGNOSIS AND TESTING (Continued)

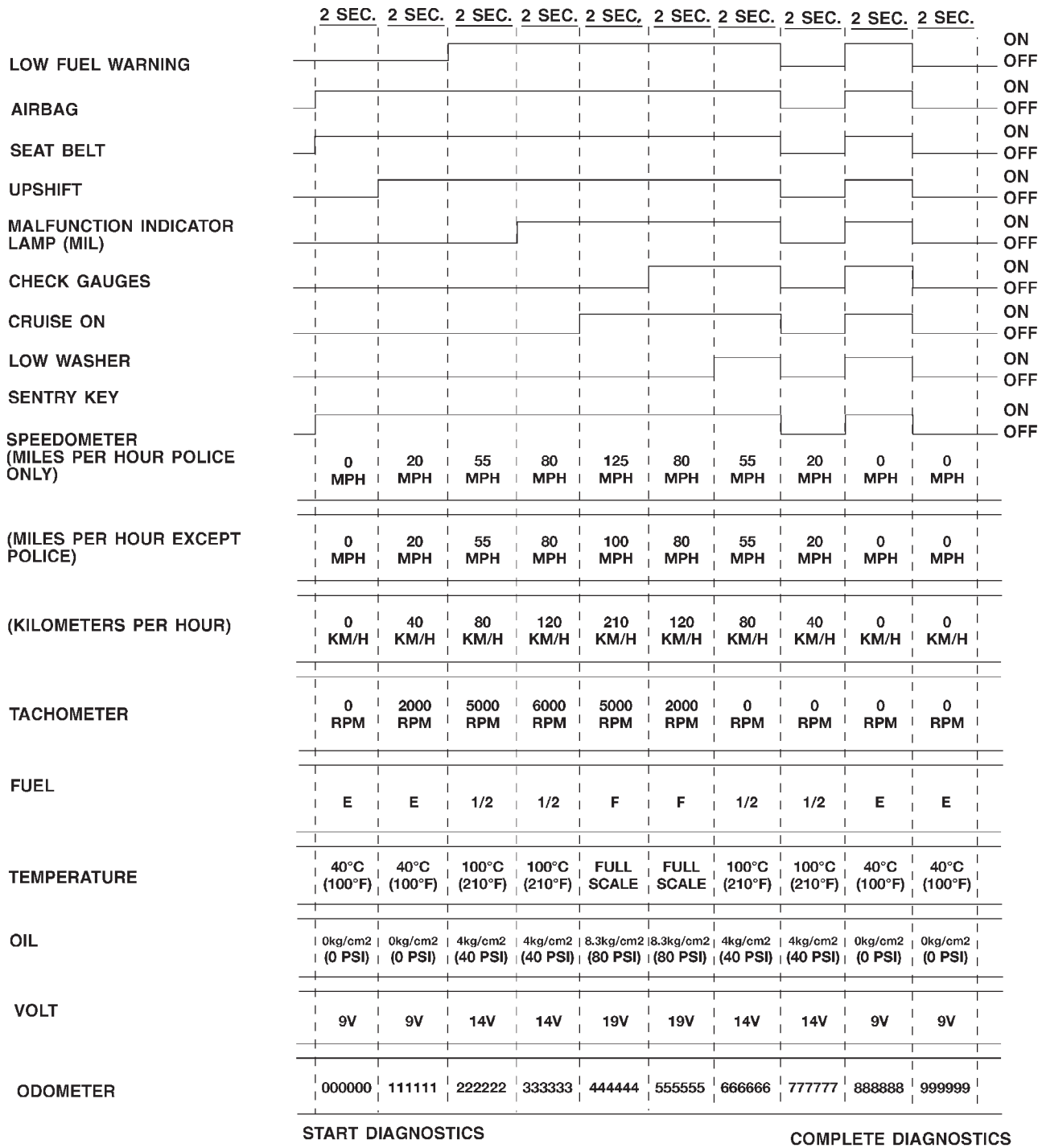

80bdb92

Fig. 2 High-Line Instrument Cluster Actuator Test

DIAGNOSIS AND TESTING (Continued)

BRAKE WARNING LAMP

The diagnosis found here addresses an inoperative brake warning lamp condition. If the brake warning lamp stays on with the ignition switch in the On position and the park brake released, or comes on while driving, refer **Base Brake System** for vehicles not equipped with the four wheel anti-lock brake system, or refer to **Antilock Brakes** for vehicles equipped with the four wheel anti-lock brake system in the Diagnosis and Testing section of Group 5 - Brakes for further diagnosis. If no brake system problem is found, the following procedure will help locate a short or open circuit, or a faulty switch. For complete circuit diagrams, refer to **Instrument Cluster** in the Contents of Group 8W - Wiring Diagrams.

(1) Check the fused ignition switch output (run/start) fuse in the junction block. If OK, go to Step 2. If not OK, repair the shorted circuit or component as required and replace the faulty fuse.

(2) Turn the ignition switch to the On position. Check for battery voltage at the fused ignition switch output (run/start) fuse in the junction block. If OK, go to Step 3. If not OK, repair the open fused ignition switch output (run/start) circuit to the ignition switch as required.

(3) Turn the ignition switch to the Off position. Disconnect and isolate the battery negative cable. Disconnect the wire harness connector at the park brake switch. With the park brake released, check for continuity between the park brake switch terminal and a good ground. There should be no continuity. If OK, go to Step 4. If not OK, adjust or replace the faulty park brake switch.

(4) Disconnect the wire harness connector at the brake warning switch. Check for continuity between the two terminals of the brake warning switch. There should be continuity. If OK, go to Step 5. If not OK, replace the faulty brake warning switch.

(5) Check for continuity between each of the two brake warning switch terminals and a good ground. In each case, there should be no continuity. If OK, go to Step 6. If not OK, replace the faulty brake warning switch.

(6) With both the park brake switch and the brake warning switch wire harness connectors still disconnected, check for continuity between the red brake warning indicator driver circuit cavity of the park brake switch wire harness connector and a good ground. There should be no continuity. If OK, go to Step 7. If not OK, repair the shorted red brake warning indicator driver circuit as required.

(7) With the ignition switch held in the Start position, check for continuity between the red brake warning indicator driver circuit cavity of the park brake switch wire harness connector and a good

ground. There should be continuity. If OK, go to Step 8. If not OK, repair the open red brake warning indicator driver circuit to the ignition switch as required.

(8) Turn the ignition switch to the Off position. Remove the instrument cluster. Check for continuity between the red brake warning indicator driver circuit cavity of the instrument cluster wire harness connector A and a good ground. There should be no continuity. If OK, go to Step 9. If not OK, repair the shorted red brake warning indicator driver circuit as required.

(9) Check for continuity between the red brake warning indicator driver circuit cavities of the instrument cluster wire harness connector A and the brake warning switch wire harness connector. There should be continuity. If OK, replace the faulty bulb. If not OK, repair the open red brake warning indicator driver circuit as required.

FOUR-WHEEL DRIVE INDICATOR LAMP - FULL TIME

The diagnosis found here addresses an inoperative four-wheel drive indicator lamp condition. If the problem being diagnosed is related to lamp accuracy, be certain to confirm that the problem is with the lamp or switch and not with a damaged or inoperative transfer case or transfer case linkage. Refer to **NV242 Diagnosis** in the Diagnosis and Testing section of Group 21 - Transmission for more information. If no transfer case problem is found, the following procedure will help locate a short or open in the indicator lamp circuit. For complete circuit diagrams, refer to **Instrument Cluster** in the Contents of Group 8W - Wiring Diagrams.

(1) Check the fused ignition switch output (run/start) fuse in the junction block. If OK, go to Step 2. If not OK, repair the shorted circuit or component as required and replace the faulty fuse.

(2) Turn the ignition switch to the On position. Check for battery voltage at the fused ignition switch output (run/start) fuse in the junction block. If OK, go to Step 3. If not OK, repair the open fused ignition switch output (run/start) circuit to the ignition switch as required.

(3) Turn the ignition switch to the Off position. Disconnect and isolate the battery negative cable. Disconnect the transfer case switch wire harness connector. Check for continuity between the ground circuit cavity of the transfer case switch wire harness connector and a good ground. There should be continuity. If OK, go to Step 4. If not OK, repair the open ground circuit to ground as required.

(4) Connect the battery negative cable. Turn the ignition switch to the On position. Install a jumper wire between the full time four wheel drive indicator lamp driver circuit cavity of the transfer case switch wire harness connector and a good ground. The full

DIAGNOSIS AND TESTING (Continued)

time four-wheel drive indicator lamp should light. If OK, replace the faulty transfer case switch. If not OK, go to Step 5.

(5) Turn the ignition switch to the Off position. Disconnect and isolate the battery negative cable. Remove the instrument cluster. With the transfer case switch wire harness connector still disconnected, check for continuity between the full time four wheel drive indicator lamp driver circuit cavity of the instrument cluster wire harness connector B and a good ground. There should be no continuity. If OK, go to Step 6. If not OK, repair the shorted full time four wheel drive indicator lamp driver circuit as required.

(6) Check for continuity between the full time four wheel drive indicator lamp driver circuit cavities of the instrument cluster wire harness connector B and the transfer case switch wire harness connector. There should be continuity. If OK, replace the faulty bulb. If not OK, repair the open full time four wheel drive indicator lamp driver circuit as required.

FOUR-WHEEL DRIVE INDICATOR LAMP - PART TIME

The diagnosis found here addresses an inoperative four-wheel drive indicator lamp condition. If the problem being diagnosed is related to lamp accuracy, be certain to confirm that the problem is with the lamp or switch and not with a damaged or inoperative transfer case or transfer case linkage. Refer to **NV231 Diagnosis** or **NV242 Diagnosis** in the Diagnosis and Testing section of Group 21 - Transmission for more information. If no transfer case problem is found, the following procedure will help locate a short or open in the indicator lamp circuit. For complete circuit diagrams, refer to **Instrument Cluster** in the Contents of Group 8W - Wiring Diagrams.

(1) Check the fused ignition switch output (run/start) fuse in the junction block. If OK, go to Step 2. If not OK, repair the shorted circuit or component as required and replace the faulty fuse.

(2) Turn the ignition switch to the On position. Check for battery voltage at the fused ignition switch output (run/start) fuse in the junction block. If OK, go to Step 3. If not OK, repair the open fused ignition switch output (run/start) circuit to the ignition switch as required.

(3) Turn the ignition switch to the Off position. Disconnect and isolate the battery negative cable. Disconnect the transfer case switch wire harness connector. Check for continuity between the ground circuit cavity of the transfer case switch wire harness connector and a good ground. There should be continuity. If OK, go to Step 4. If not OK, repair the open ground circuit to ground as required.

(4) Connect the battery negative cable. Turn the ignition switch to the On position. Install a jumper wire between the part time four wheel drive indicator

lamp driver circuit cavity of the transfer case switch wire harness connector and a good ground. The part time four-wheel drive indicator lamp should light. If OK, replace the faulty transfer case switch. If not OK, go to Step 5.

(5) Turn the ignition switch to the Off position. Disconnect and isolate the battery negative cable. Remove the instrument cluster. With the transfer case switch wire harness connector still disconnected, check for continuity between the part time four wheel drive indicator lamp driver circuit cavity of the instrument cluster wire harness connector B and a good ground. There should be no continuity. If OK, go to Step 6. If not OK, repair the shorted part time four wheel drive indicator lamp driver circuit as required.

(6) Check for continuity between the part time four wheel drive indicator lamp driver circuit cavities of the instrument cluster wire harness connector B and the transfer case switch wire harness connector. There should be continuity. If OK, replace the faulty bulb. If not OK, repair the open part time four wheel drive indicator lamp driver circuit as required.

HEADLAMP HIGH BEAM INDICATOR LAMP

The diagnosis found here addresses an inoperative headlamp high beam indicator lamp condition. If the problem being diagnosed is related to inoperative headlamp high beams, refer to **Headlamp Diagnosis** in the Diagnosis and Testing section of Group 8L - Lamps for diagnosis of the headlamp system. If no headlamp system problems are found, the following procedure will help locate an open in the high beam indicator lamp circuit. For complete circuit diagrams, refer to **Instrument Cluster** in the Contents of Group 8W - Wiring Diagrams.

(1) Disconnect and isolate the battery negative cable. Remove the instrument cluster.

(2) Connect the battery negative cable. Turn the headlamps on and select the high beams with the multi-function switch stalk. Check for battery voltage at the high beam indicator driver circuit cavity of the instrument cluster wire harness connector A. If OK, replace the faulty bulb. If not OK, repair the open high beam indicator driver circuit to the headlamp dimmer (multi-function) switch as required.

LOW WASHER FLUID WARNING LAMP

The diagnosis found here addresses an inoperative low washer fluid warning lamp condition. If the problem being diagnosed is related to lamp accuracy, be certain to confirm that the problem is with the lamp or washer fluid level sensor and not with a damaged or empty washer fluid reservoir. Inspect the reservoir for proper fluid level and signs of damage or distortion that could affect sensor performance before you

DIAGNOSIS AND TESTING (Continued)

proceed with lamp diagnosis. Refer to **Washer System** in the Diagnosis and Testing section of Group 8K - Wiper and Washer Systems for more information. For complete circuit diagrams, refer to **Instrument Cluster** in the Contents of Group 8W - Wiring Diagrams.

(1) Check the fused ignition switch output (run/start) fuse in the junction block. If OK, go to Step 2. If not OK, repair the shorted circuit or component as required and replace the faulty fuse.

(2) Turn the ignition switch to the On position. Check for battery voltage at the fused ignition switch output (run/start) fuse in the junction block. If OK, go to Step 3. If not OK, repair the open fused ignition switch output (run/start) circuit to the ignition switch as required.

(3) Turn the ignition switch to the Off position. Disconnect the wire harness connector from the washer fluid level sensor. Install a jumper wire between the two cavities of the washer fluid level sensor wire harness connector. Turn the ignition switch to the On position. About thirty seconds after the ignition switch is turned to the On position, the low washer fluid warning lamp should light. Remove the jumper wire and the lamp should go off. If OK, replace the faulty washer fluid level sensor. If not OK, go to Step 4.

(4) Turn the ignition switch to the Off position. Check for continuity between the ground circuit cavity of the washer fluid level sensor wire harness connector and a good ground. There should be continuity. If OK, go to Step 5. If not OK, repair the open ground circuit to ground as required.

(5) Disconnect and isolate the battery negative cable. Remove the instrument cluster. The washer fluid level sensor wire harness connector is still disconnected. Check for continuity between the low washer fluid level sense circuit cavity of the instrument cluster wire harness connector B and a good ground. There should be no continuity. If OK, go to Step 6. If not OK, repair the shorted low washer fluid level sense circuit as required.

(6) Check for continuity between the low washer fluid level sense circuit cavities of the instrument cluster wire harness connector B and the washer fluid level sensor wire harness connector. There should be continuity. If OK, replace the faulty bulb. If not OK, repair the open low washer fluid level sense circuit as required.

TURN SIGNAL INDICATOR LAMP

The diagnosis found here addresses an inoperative turn signal indicator lamp condition. For any other turn signal problem, refer to **Turn Signal and Hazard Warning Systems** in the Diagnosis and Testing section of Group 8J - Turn Signal and Hazard Warn-

ing Systems for further diagnosis. If no turn signal or hazard warning system problem is found, the following procedure will help locate a short or open in the indicator lamp circuit. For complete circuit diagrams, refer to **Instrument Cluster** in the Contents of Group 8W - Wiring Diagrams.

(1) Disconnect and isolate the battery negative cable. Remove the instrument cluster.

(2) Connect the battery negative cable. Activate the hazard warning system by moving the hazard warning switch button to the On position. Check for battery voltage at the inoperative (right or left) turn signal circuit cavity of the instrument cluster wire harness connector (connector A - left, or connector B - right). There should be a switching (on and off) battery voltage signal. If OK, replace the faulty (right or left) indicator lamp bulb. If not OK, repair the open (right or left) turn signal circuit to the turn signal/hazard warning (multi-function) switch as required.

INSTRUMENT PANEL CIGAR LIGHTER

For complete circuit diagrams, refer to **Horn/Cigar Lighter** in the Contents of Group 8W - Wiring Diagrams.

WARNING: ON VEHICLES EQUIPPED WITH AIRBAGS, REFER TO GROUP 8M - PASSIVE RESTRAINT SYSTEMS BEFORE ATTEMPTING ANY STEERING WHEEL, STEERING COLUMN, OR INSTRUMENT PANEL COMPONENT DIAGNOSIS OR SERVICE. FAILURE TO TAKE THE PROPER PRECAUTIONS COULD RESULT IN ACCIDENTAL AIRBAG DEPLOYMENT AND POSSIBLE PERSONAL INJURY.

(1) Remove the cigar lighter knob and element from the cigar lighter receptacle shell. Check for continuity between the inside circumference of the cigar lighter receptacle shell and a good ground. There should be continuity. If OK, go to Step 2. If not OK, go to Step 3.

(2) Turn the ignition switch to the On position. Check for battery voltage at the insulated contact located at the back of the cigar lighter receptacle shell. If OK, replace the faulty cigar lighter knob and element. If not OK, go to Step 3.

(3) Turn the ignition switch to the Off position. Disconnect and isolate the battery negative cable. Remove the instrument panel accessory switch bezel. Check for continuity between the ground circuit cavity of the cigar lighter wire harness connector and a good ground. There should be continuity. If OK, go to Step 4. If not OK, repair the open ground circuit to ground as required.

(4) Connect the battery negative cable. Turn the ignition switch to the Accessory or On positions. Check for battery voltage at the cigar lighter relay

DIAGNOSIS AND TESTING (Continued)

output circuit cavity of the cigar lighter wire harness connector. If OK, replace the faulty cigar lighter receptacle (instrument panel accessory switch bezel unit). If not OK, refer to **Cigar Lighter Relay** in the Diagnosis and Testing section of this group for further diagnosis.

CIGAR LIGHTER RELAY

The cigar lighter relay (Fig. 3) is located in the junction block, on the right cowl side inner panel below the instrument panel in the passenger compartment. For complete circuit diagrams, refer to **Horn/Cigar Lighter** in the Contents of Group 8W - Wiring Diagrams.

WARNING: ON VEHICLES EQUIPPED WITH AIR-BAGS, REFER TO GROUP 8M - PASSIVE RESTRAINT SYSTEMS BEFORE ATTEMPTING ANY STEERING WHEEL, STEERING COLUMN, OR INSTRUMENT PANEL COMPONENT DIAGNOSIS OR SERVICE. FAILURE TO TAKE THE PROPER PRECAUTIONS COULD RESULT IN ACCIDENTAL AIR-BAG DEPLOYMENT AND POSSIBLE PERSONAL INJURY.

(1) Remove the cigar lighter relay from the junction block. Refer to **Cigar Lighter Relay** in the Removal and Installation section of this group for the procedures.

(2) A relay in the de-energized position should have continuity between terminals 87A and 30, and no continuity between terminals 87 and 30. If OK, go to Step 3. If not OK, replace the faulty relay.

(3) Resistance between terminals 85 and 86 (electromagnet) should be 75 ± 5 ohms. If OK, go to Step 4. If not OK, replace the faulty relay.

(4) Connect a battery to terminals 85 and 86. There should now be continuity between terminals 30 and 87, and no continuity between terminals 87A and 30. If OK, perform the Relay Circuit Test that follows. If not OK, replace the faulty relay.

RELAY CIRCUIT TEST

(1) The relay common feed terminal cavity (30) of the junction block is connected to battery voltage and should be hot at all times. Check for battery voltage at the fused B(+) circuit cavity of the accessory relay wire harness connector. If OK, go to Step 2. If not OK, repair the fused B(+) circuit to the fuse in the junction block as required.

(2) The relay normally closed terminal (87A) is connected to terminal 30 in the de-energized position, but is not used for this application. Go to Step 3.

(3) The relay normally open terminal (87) is connected to the common feed terminal (30) in the energized position. This terminal supplies battery voltage to the cigar lighter when the relay is energized by

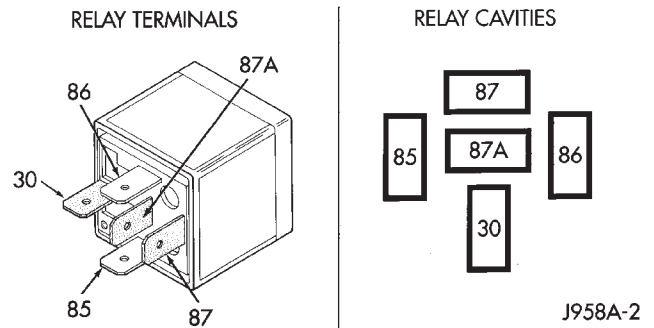

| TERMINAL LEGEND | |
|-----------------|-----------------|
| NUMBER | IDENTIFICATION |
| 30 | COMMON FEED |
| 85 | COIL GROUND |
| 86 | COIL BATTERY |
| 87 | NORMALLY OPEN |
| 87A | NORMALLY CLOSED |

Fig. 3 Cigar Lighter Relay

the ignition switch. There should be continuity between the junction block cavity for relay terminal 87 and the cigar lighter relay output circuit cavity of the cigar lighter wire harness connector at all times. If OK, go to Step 4. If not OK, repair the open cigar lighter relay output circuit to the cigar lighter wire harness connector as required.

(4) The coil battery terminal (86) is connected to the electromagnet in the relay. It receives battery feed to energize the cigar lighter relay when the ignition switch is in the Accessory or On positions. Turn the ignition switch to the On position. Check for battery voltage at the fused ignition switch output (acc/run) circuit cavity for relay terminal 86 in the junction block. If OK, go to Step 5. If not OK, repair the open fused ignition switch output (acc/run) circuit to the ignition switch as required.

(5) The coil ground terminal (85) is connected to the electromagnet in the relay. The junction block cavity for this terminal should have continuity to ground at all times. If not OK, repair the open ground circuit to ground as required.

INSTRUMENT PANEL POWER OUTLET

For complete circuit diagrams, refer to **Horn/Cigar Lighter** in the Contents of Group 8W - Wiring Diagrams.

DIAGNOSIS AND TESTING (Continued)

WARNING: ON VEHICLES EQUIPPED WITH AIR-BAGS, REFER TO GROUP 8M - PASSIVE RESTRAINT SYSTEMS BEFORE ATTEMPTING ANY STEERING WHEEL, STEERING COLUMN, OR INSTRUMENT PANEL COMPONENT DIAGNOSIS OR SERVICE. FAILURE TO TAKE THE PROPER PRECAUTIONS COULD RESULT IN ACCIDENTAL AIR-BAG DEPLOYMENT AND POSSIBLE PERSONAL INJURY.

(1) Check the fused B(+) fuse in the junction block. If OK, go to Step 2. If not OK, repair the shorted circuit or component as required and replace the faulty fuse.

(2) Check for battery voltage at the fused B(+) fuse in the junction block. If OK, go to Step 3. If not OK, repair the open fused B(+) circuit to the Power Distribution Center (PDC) as required.

(3) Remove the plastic protective cap from the power outlet receptacle. Check for continuity between the inside circumference of the power outlet receptacle and a good ground. There should be continuity. If OK, go to Step 4. If not OK, go to Step 5.

(4) Check for battery voltage at the insulated contact located at the back of the power outlet receptacle. If not OK, go to Step 5.

(5) Disconnect and isolate the battery negative cable. Remove the instrument panel accessory switch bezel. Check for continuity between the ground circuit cavity of the power outlet wire harness connector and a good ground. There should be continuity. If OK, go to Step 6. If not OK, repair the open ground circuit to ground as required.

(6) Connect the battery negative cable. Check for battery voltage at the fused B(+) circuit cavity of the power outlet wire harness connector. If OK, replace the faulty power outlet receptacle (instrument panel accessory switch bezel unit). If not OK, repair the open fused B(+) circuit to the junction block fuse as required.

REMOVAL AND INSTALLATION

STEERING COLUMN OPENING COVER

WARNING: ON VEHICLES EQUIPPED WITH AIR-BAGS, REFER TO GROUP 8M - PASSIVE RESTRAINT SYSTEMS BEFORE ATTEMPTING ANY STEERING WHEEL, STEERING COLUMN, OR INSTRUMENT PANEL COMPONENT DIAGNOSIS OR SERVICE. FAILURE TO TAKE THE PROPER PRECAUTIONS COULD RESULT IN ACCIDENTAL AIR-BAG DEPLOYMENT AND POSSIBLE PERSONAL INJURY.

REMOVAL

(1) Disconnect and isolate the battery negative cable.

(2) If the vehicle is so equipped, move the tilt steering column to the fully raised position.

(3) Remove the three screws that secure the lower edge of the steering column opening cover to the lower instrument panel reinforcement (Fig. 4).

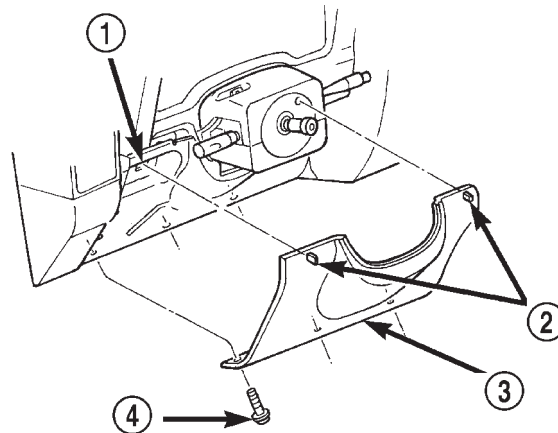

80abac3c

Fig. 4 Steering Column Opening Cover Remove/Install

- 1 - INSTRUMENT PANEL
- 2 - SNAP CLIPS
- 3 - STEERING COLUMN OPENING COVER
- 4 - SCREW

(4) Using a trim stick or another suitable wide flat-bladed tool, gently pry the upper edge of the steering column opening cover just below the cluster bezel on each side of the steering column away from the instrument panel far enough to disengage the two snap clip retainers from the receptacles in the instrument panel.

(5) Remove the steering column opening cover from the instrument panel.

INSTALLATION

(1) Position the steering column opening cover to the instrument panel.

(2) Align the snap clip retainers on the steering column opening cover with the receptacles in the instrument panel.

(3) Press firmly on the steering column opening cover over the snap clip locations until each of the snap clips is fully engaged in its receptacle.

(4) Install and tighten the three screws that secure the lower edge of the steering column opening cover to the lower instrument panel reinforcement. Tighten the screws to 2.2 N·m (20 in. lbs.).

(5) Reconnect the battery negative cable.

REMOVAL AND INSTALLATION (Continued)

KNEE BLOCKER

WARNING: ON VEHICLES EQUIPPED WITH AIR-BAGS, REFER TO GROUP 8M - PASSIVE RESTRAINT SYSTEMS BEFORE ATTEMPTING ANY STEERING WHEEL, STEERING COLUMN, OR INSTRUMENT PANEL COMPONENT DIAGNOSIS OR SERVICE. FAILURE TO TAKE THE PROPER PRECAUTIONS COULD RESULT IN ACCIDENTAL AIR-BAG DEPLOYMENT AND POSSIBLE PERSONAL INJURY.

REMOVAL

(1) Disconnect and isolate the battery negative cable.

(2) Remove the steering column opening cover from the instrument panel. Refer to **Steering Column Opening Cover** in the Removal and Installation section of this group for the procedures.

(3) Remove the two screws that secure the knee blocker to the instrument panel (Fig. 5).

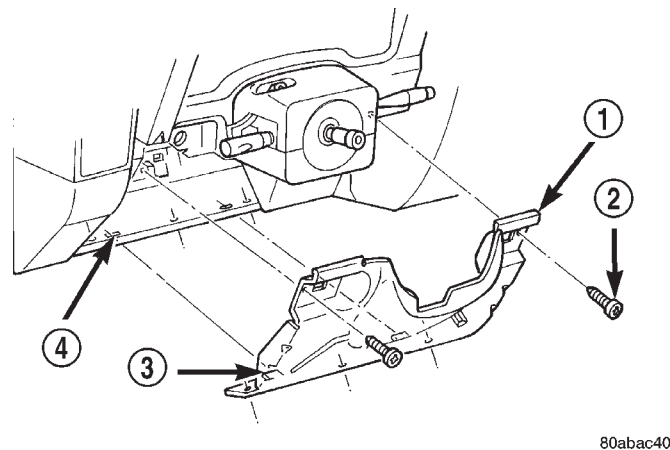

80abac40

Fig. 5 Knee Blocker Remove/Install

- 1 - KNEE BLOCKER
- 2 - SCREW
- 3 - TAB
- 4 - SLOT

(4) Pull the upper edge of the knee blocker away from the instrument panel far enough to disengage the two lower mounting tabs from the mounting slots in the lower instrument panel reinforcement.

(5) Remove the knee blocker from the instrument panel.

INSTALLATION

(1) Position the knee blocker to the instrument panel.

(2) Install and tighten the four screws that secure the knee blocker to the instrument panel. Tighten the screws to 2.2 N·m (20 in. lbs.). Be certain that

the mounting screws are located in the screw hole on each side of the steering column that is closest to the driver side front door of the vehicle (Fig. 6).

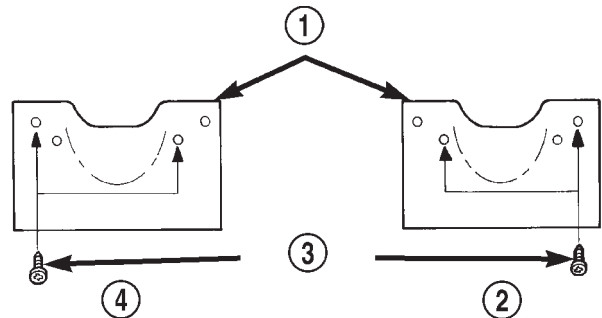

80abac42

Fig. 6 Knee Blocker Mounting Screw Location

- 1 - KNEE BLOCKER
- 2 - RIGHT-HAND DRIVE
- 3 - SCREWS
- 4 - LEFT-HAND DRIVE

(3) Install the steering column opening cover onto the instrument panel. Refer to **Steering Column Opening Cover** in the Removal and Installation section of this group for the procedures.

(4) Reconnect the battery negative cable.

INSTRUMENT PANEL CENTER BEZEL

WARNING: ON VEHICLES EQUIPPED WITH AIR-BAGS, REFER TO GROUP 8M - PASSIVE RESTRAINT SYSTEMS BEFORE ATTEMPTING ANY STEERING WHEEL, STEERING COLUMN, OR INSTRUMENT PANEL COMPONENT DIAGNOSIS OR SERVICE. FAILURE TO TAKE THE PROPER PRECAUTIONS COULD RESULT IN ACCIDENTAL AIR-BAG DEPLOYMENT AND POSSIBLE PERSONAL INJURY.

REMOVAL

(1) Disconnect and isolate the battery negative cable.

(2) Using a trim stick or another suitable wide flat-bladed tool, gently pry the instrument panel center bezel away from the instrument panel far enough to disengage the six snap clip retainers that secure it from the receptacles in the instrument panel (Fig. 7).

(3) Remove the center bezel from the instrument panel.

INSTALLATION

(1) Position the center bezel to the instrument panel.

(2) Align the snap clips on the center bezel with the receptacles in the instrument panel.

REMOVAL AND INSTALLATION (Continued)

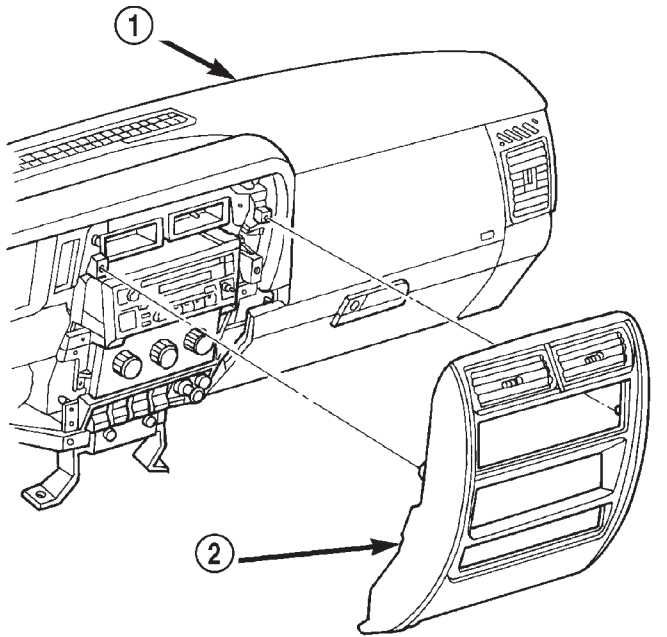

80ab87bc

Fig. 7 Instrument Panel Center Bezel Remove/Install

- 1 - INSTRUMENT PANEL
2 - CENTER BEZEL

(3) Press firmly on the center bezel over each of the snap clip locations until each of the six snap clips is fully engaged in its receptacle on the instrument panel.

(4) Reconnect the battery negative cable.

INSTRUMENT PANEL ACCESSORY SWITCH BEZEL

WARNING: ON VEHICLES EQUIPPED WITH AIR-BAGS, REFER TO GROUP 8M - PASSIVE RESTRAINT SYSTEMS BEFORE ATTEMPTING ANY STEERING WHEEL, STEERING COLUMN, OR INSTRUMENT PANEL COMPONENT DIAGNOSIS OR SERVICE. FAILURE TO TAKE THE PROPER PRECAUTIONS COULD RESULT IN ACCIDENTAL AIR-BAG DEPLOYMENT AND POSSIBLE PERSONAL INJURY.

REMOVAL

(1) Disconnect and isolate the battery negative cable.

(2) Remove the center bezel from the instrument panel. Refer to **Instrument Panel Center Bezel** in the Removal and Installation section of this group for the procedures.

(3) Remove the three screws that secure the accessory switch bezel to the instrument panel (Fig. 8).

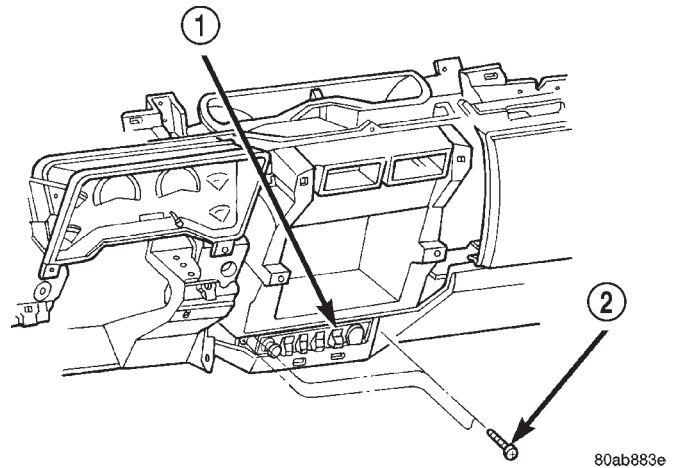

80ab883e

Fig. 8 Instrument Panel Accessory Switch Bezel Remove/Install

- 1 - ACCESSORY SWITCH BEZEL
2 - SCREW

(4) Pull the accessory switch bezel away from the instrument panel far enough to access the instrument panel wire harness connectors.

(5) Disconnect the instrument panel wire harness connectors from the connector receptacles, the accessory switches, the cigar lighter and the accessory power outlet on the back of the accessory switch bezel.

(6) Remove the accessory switch bezel from the instrument panel.

INSTALLATION

(1) Position the accessory switch bezel to the instrument panel.

(2) Reconnect the instrument panel wire harness connectors to the connector receptacles, the accessory switches, the cigar lighter and the accessory power outlet on the back of the accessory switch bezel.

(3) Position the accessory switch bezel onto the instrument panel.

(4) Install and tighten the three screws that secure the accessory switch bezel to the instrument panel. Tighten the screws to 2.2 N·m (20 in. lbs.).

(5) Install the center bezel onto the instrument panel. Refer to **Instrument Panel Center Bezel** in the Removal and Installation section of this group for the procedures.

(6) Reconnect the battery negative cable.

REMOVAL AND INSTALLATION (Continued)

CIGAR LIGHTER RELAY

WARNING: ON VEHICLES EQUIPPED WITH AIRBAGS, REFER TO GROUP 8M - PASSIVE RESTRAINT SYSTEMS BEFORE ATTEMPTING ANY STEERING WHEEL, STEERING COLUMN, OR INSTRUMENT PANEL COMPONENT DIAGNOSIS OR SERVICE. FAILURE TO TAKE THE PROPER PRECAUTIONS COULD RESULT IN ACCIDENTAL AIRBAG DEPLOYMENT AND POSSIBLE PERSONAL INJURY.

REMOVAL

- (1) Disconnect and isolate the battery negative cable.
- (2) Remove the fuse access panel by unsnapping it from the right cowl side trim panel.
- (3) Remove the stamped nut that secures the right cowl side trim to the junction block stud (Fig. 9).

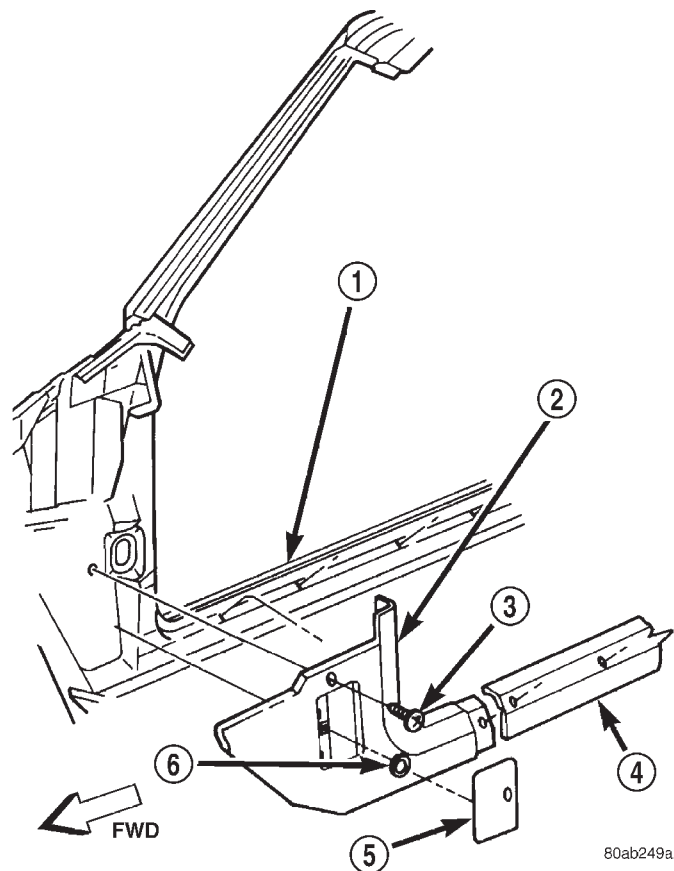

Fig. 9 Right Cowl Side Trim Remove/Install

- 1 - RIGHT FRONT DOOR SILL
- 2 - COWL SIDE TRIM PANEL
- 3 - SCREW
- 4 - SILL TRIM
- 5 - FUSE ACCESS PANEL
- 6 - PUSH-NUT

(4) Remove the screw located above the fuse access opening that secures the right cowl side trim to the right cowl side inner panel.

(5) Remove the screw that secures the right door sill trim and the right cowl side trim to the right door opening sill.

(6) Remove the right cowl side trim panel from the vehicle.

(7) Refer to **Junction Block** in the Contents of Group 8W - Wiring Diagrams for cigar lighter relay identification and location.

(8) Remove the cigar lighter relay from the receptacle in the junction block.

INSTALLATION

(1) Refer to **Junction Block** in the Contents of Group 8W - Wiring Diagrams for the proper cigar lighter relay location.

(2) Position the cigar lighter relay to the receptacle in the junction block.

(3) Align the terminals of the cigar lighter relay with the cavities in the junction block receptacle.

(4) Push on the cigar lighter relay case firmly and evenly until all of the relay terminals are fully seated within the cavities of the junction block receptacle.

(5) Position the right cowl side trim to the right door sill trim.

(6) Install and tighten the screw that secures the right cowl side trim to the right door sill trim. Tighten the screw to 2.2 N·m (20 in. lbs.).

(7) Position the right cowl side trim to the right cowl side inner panel.

(8) Install and tighten the screw that secures the right cowl side trim to the right cowl side inner panel. Tighten the screw to 2.2 N·m (20 in. lbs.).

(9) Install the stamped nut that secures the right cowl side trim to the junction block stud.

(10) Install the fuse access panel by snapping it onto the right cowl side trim panel.

(11) Reconnect the battery negative cable.

CLUSTER BEZEL

WARNING: ON VEHICLES EQUIPPED WITH AIRBAGS, REFER TO GROUP 8M - PASSIVE RESTRAINT SYSTEMS BEFORE ATTEMPTING ANY STEERING WHEEL, STEERING COLUMN, OR INSTRUMENT PANEL COMPONENT DIAGNOSIS OR SERVICE. FAILURE TO TAKE THE PROPER PRECAUTIONS COULD RESULT IN ACCIDENTAL AIRBAG DEPLOYMENT AND POSSIBLE PERSONAL INJURY.

REMOVAL

(1) Disconnect and isolate the battery negative cable.

REMOVAL AND INSTALLATION (Continued)

(2) Remove the knee blocker from the instrument panel. Refer to **Knee Blocker** in the Removal and Installation section of this group for the procedures.

(3) Remove the center bezel from the instrument panel. Refer to **Instrument Panel Center Bezel** in the Removal and Installation section of this group for the procedures.

(4) Remove the four screws exposed by the center bezel removal that secure the cluster bezel to the instrument panel.

(5) Remove the headlamp switch knob and shaft from the headlamp switch. Refer to **Headlamp Switch** in the Removal and Installation section of this group for the procedures.

(6) Disengage the two ends of the steering column sight shield from each other at the connector located below the lower steering column shroud (Fig. 10).

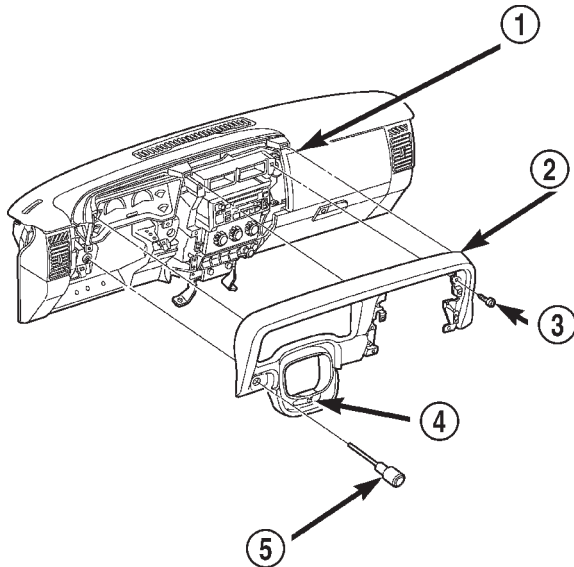

80abac43

Fig. 10 Cluster Bezel Remove/Install

- 1 - INSTRUMENT PANEL
- 2 - CLUSTER BEZEL
- 3 - SCREW
- 4 - STEERING COLUMN SIGHT SHIELD CONNECTOR
- 5 - HEADLAMP SWITCH KNOB AND SHAFT

(7) If the vehicle is so equipped, set the tilt steering column in its lowest position.

(8) Using a trim stick or another suitable wide flat-bladed tool, gently pry around the perimeter of the cluster bezel to disengage the five snap clips from their receptacles in the instrument panel.

(9) Remove the cluster bezel from the instrument panel.

INSTALLATION

(1) Position the cluster bezel to the instrument panel.

(2) Align the snap clips on the cluster bezel with the receptacles in the instrument panel.

(3) Press firmly on the cluster bezel over each of the snap clip locations until each of the snap clips is fully engaged in its receptacle.

(4) Engage the two ends of the steering column sight shield with each other at the connector located below the lower steering column shroud.

(5) Install the headlamp switch knob and shaft onto the headlamp switch. Refer to **Headlamp Switch** in the Removal and Installation section of this group for the procedures.

(6) Install and tighten the four screws that secure the cluster bezel to the instrument panel beneath the instrument panel center bezel. Tighten the screws to 2.2 N·m (20 in. lbs.).

(7) Install the center bezel onto the instrument panel. Refer to **Instrument Panel Center Bezel** in the Removal and Installation section of this group for the procedures.

(8) Install the knee blocker onto the instrument panel. Refer to **Knee Blocker** in the Removal and Installation section of this group for the procedures. Be certain that the two ends of the steering column sight shield connector are engaged with each other before installing the knee blocker.

(9) Reconnect the battery negative cable.

HEADLAMP SWITCH

WARNING: ON VEHICLES EQUIPPED WITH AIRBAGS, REFER TO GROUP 8M - PASSIVE RESTRAINT SYSTEMS BEFORE ATTEMPTING ANY STEERING WHEEL, STEERING COLUMN, OR INSTRUMENT PANEL COMPONENT DIAGNOSIS OR SERVICE. FAILURE TO TAKE THE PROPER PRECAUTIONS COULD RESULT IN ACCIDENTAL AIRBAG DEPLOYMENT AND POSSIBLE PERSONAL INJURY.

WARNING: IF THE HEADLAMP SWITCH WAS ON, WAIT FIVE MINUTES TO ALLOW THE CERAMIC DIMMER RESISTOR TO COOL. IF THE CERAMIC DIMMER RESISTOR IS NOT ALLOWED TO COOL, IT CAN BURN YOUR FINGERS.

REMOVAL

(1) Disconnect and isolate the battery negative cable.

(2) Remove the knee blocker from the instrument panel. Refer to **Knee Blocker** in the Removal and Installation section of this group for the procedures.

(3) Pull the headlamp switch control knob out to the On position stop.

REMOVAL AND INSTALLATION (Continued)

(4) Reach up under the instrument panel through the outboard side of the steering column opening to access and depress the headlamp switch control knob and shaft release button on the inboard side of the switch body.

(5) While holding the release button depressed, pull the headlamp switch control knob and shaft out of the headlamp switch.

(6) Remove the spanner nut that secures the headlamp switch to the instrument panel (Fig. 11).

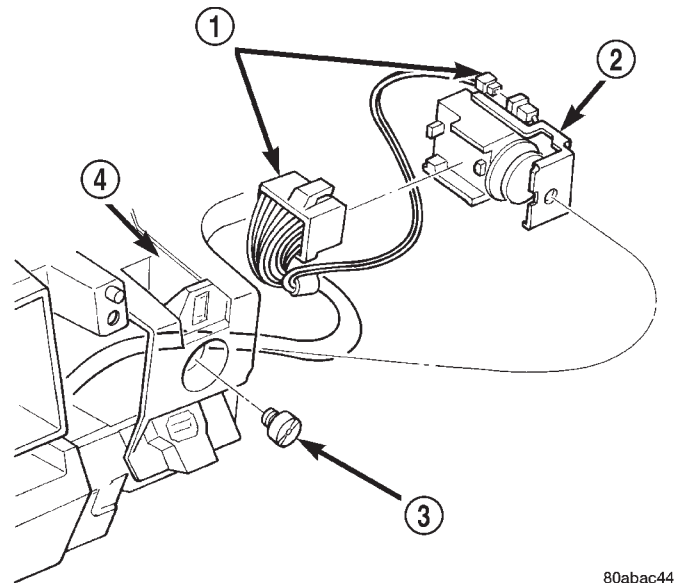

80abac44

Fig. 11 Headlamp Switch Remove/Install

- 1 - WIRE HARNESS CONNECTORS
- 2 - HEADLAMP SWITCH
- 3 - NUT
- 4 - INSTRUMENT PANEL

(7) Pull the headlamp switch into the steering column opening area of the instrument panel far enough to access the instrument panel wire harness connectors.

(8) Disconnect the two instrument panel wire harness connectors from the headlamp switch.

(9) Remove the headlamp switch from the instrument panel.

INSTALLATION

(1) Position the headlamp switch to the instrument panel steering column opening.

(2) Reconnect the two instrument panel wire harness connectors to the headlamp switch.

(3) Position the headlamp switch behind its mounting hole on the instrument panel.

(4) Install and tighten the spanner nut that secures the headlamp switch to the instrument panel. Tighten the nut to 2.7 N-m (24 in. lbs.).

(5) Insert the shaft of the headlamp switch control knob and shaft unit through the opening in the spanner nut and into the headlamp switch.

(6) Push the headlamp switch control knob and shaft unit all the way into the headlamp switch body.

(7) Install the knee blocker onto the instrument panel. Refer to **Knee Blocker** in the Removal and Installation section of this group for the procedures.

(8) Reconnect the battery negative cable.

INSTRUMENT CLUSTER

WARNING: ON VEHICLES EQUIPPED WITH AIRBAGS, REFER TO GROUP 8M - PASSIVE RESTRAINT SYSTEMS BEFORE ATTEMPTING ANY STEERING WHEEL, STEERING COLUMN, OR INSTRUMENT PANEL COMPONENT DIAGNOSIS OR SERVICE. FAILURE TO TAKE THE PROPER PRECAUTIONS COULD RESULT IN ACCIDENTAL AIRBAG DEPLOYMENT AND POSSIBLE PERSONAL INJURY.

REMOVAL

(1) Disconnect and isolate the battery negative cable.

(2) Remove the cluster bezel from the instrument panel. Refer to **Cluster Bezel** in the Removal and Installation section of this group for the procedures.

(3) Remove the four screws that secure the instrument cluster to the instrument panel (Fig. 12).

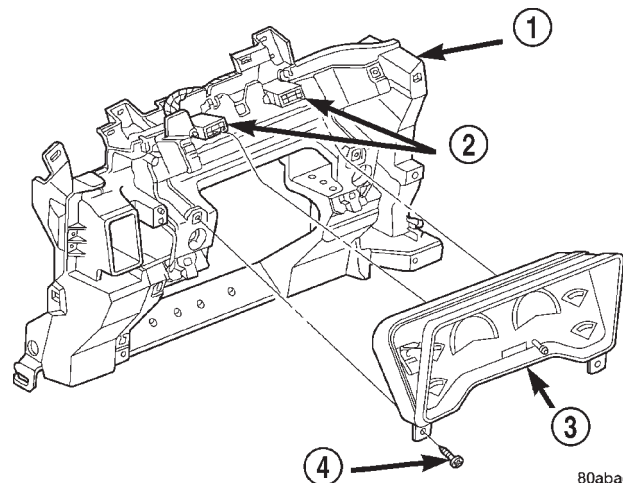

80abac45

Fig. 12 Instrument Cluster Remove/Install

- 1 - INSTRUMENT PANEL
- 2 - SELF-DOCKING WIRE HARNESS CONNECTORS
- 3 - INSTRUMENT CLUSTER
- 4 - SCREW

(4) Pull the instrument cluster rearward far enough to disengage the two self-docking instrument panel wire harness connectors from the connector

REMOVAL AND INSTALLATION (Continued)

receptacles on the back of the cluster housing. **Do not pull on the instrument cluster by the lens or mask sections, or the cluster components may become separated.**

(5) Remove the instrument cluster from the instrument panel.

INSTALLATION

(1) Position the instrument cluster to the instrument panel.

(2) Align the instrument cluster with the cluster opening in the instrument panel and push the cluster firmly and evenly into place. The instrument panel has two self-docking wire harness connectors that will be automatically aligned with, and connected to the cluster connector receptacles when the cluster is installed in the instrument panel.

(3) Install and tighten the four screws that secure the instrument cluster to the instrument panel. Tighten the screws to 2.2 N·m (20 in. lbs.).

(4) Install the cluster bezel onto the instrument panel. Refer to **Cluster Bezel** in the Removal and Installation section of this group for the procedures.

(5) Reconnect the battery negative cable.

INSTRUMENT CLUSTER COMPONENTS

Some of the components for the instrument cluster used in this vehicle are serviced individually. The serviced components include: the incandescent instrument cluster indicator lamp and illumination lamp bulbs (including the integral bulb holders), the odometer reset knob boot, the cluster lens, the cluster hood and mask unit, and the instrument cluster housing rear cover. Following are the service procedures for the instrument cluster components.

WARNING: ON VEHICLES EQUIPPED WITH AIR-BAGS, REFER TO GROUP 8M - PASSIVE RESTRAINT SYSTEMS BEFORE ATTEMPTING ANY STEERING WHEEL, STEERING COLUMN, OR INSTRUMENT PANEL COMPONENT DIAGNOSIS OR SERVICE. FAILURE TO TAKE THE PROPER PRECAUTIONS COULD RESULT IN ACCIDENTAL AIR-BAG DEPLOYMENT AND POSSIBLE PERSONAL INJURY.

REMOVAL

CLUSTER BULB

This procedure applies to each of the incandescent cluster illumination lamp or indicator lamp bulb and bulb holder units. However, the illumination lamps and the indicator lamps use different bulb and bulb holder unit sizes. They must never be interchanged. Be certain that any bulb and bulb holder unit removed from the cluster electronic circuit board is

reinstalled in the correct position. Always use the correct bulb size and type for replacement. An incorrect bulb size or type may overheat and cause damage to the instrument cluster, the electronic circuit board and/or the gauges.

(1) Disconnect and isolate the battery negative cable.

(2) Remove the instrument cluster from the instrument panel. Refer to **Instrument Cluster** in the Removal and Installation section of this group for the procedures.

(3) Turn the bulb holder counterclockwise about sixty degrees on the cluster electronic circuit board.

(4) Pull the bulb and bulb holder unit straight back to remove it from the bulb mounting hole in the cluster electronic circuit board (Fig. 13).

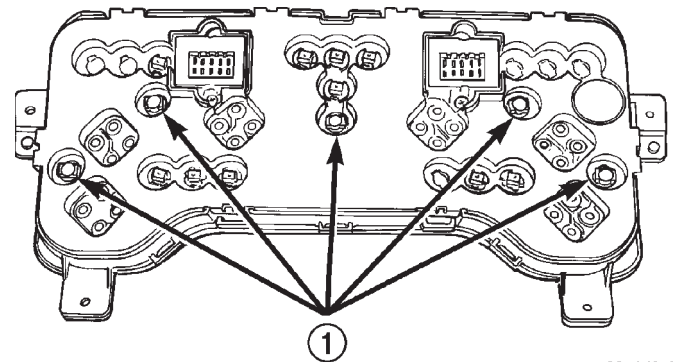

80a4d2ef

Fig. 13 Cluster Bulb Locations

1 - CLUSTER ILLUMINATION BULBS

CLUSTER LENS

(1) Disconnect and isolate the battery negative cable.

(2) Remove the instrument cluster from the instrument panel. Refer to **Instrument Cluster** in the Removal and Installation section of this group for the procedures.

(3) Work around the perimeter of the cluster housing to disengage each of the latches that secure the cluster lens to the cluster housing (Fig. 14).

(4) Gently pull the cluster lens away from the cluster housing.

ODOMETER RESET KNOB BOOT

(1) Disconnect and isolate the battery negative cable.

(2) Remove the instrument cluster from the instrument panel. Refer to **Instrument Cluster** in the Removal and Installation section of this group for the procedures.

(3) Remove the cluster lens from the cluster housing. Refer to **Instrument Cluster Components - Cluster Lens** in the Removal and Installation section of this group for the procedures.

REMOVAL AND INSTALLATION (Continued)

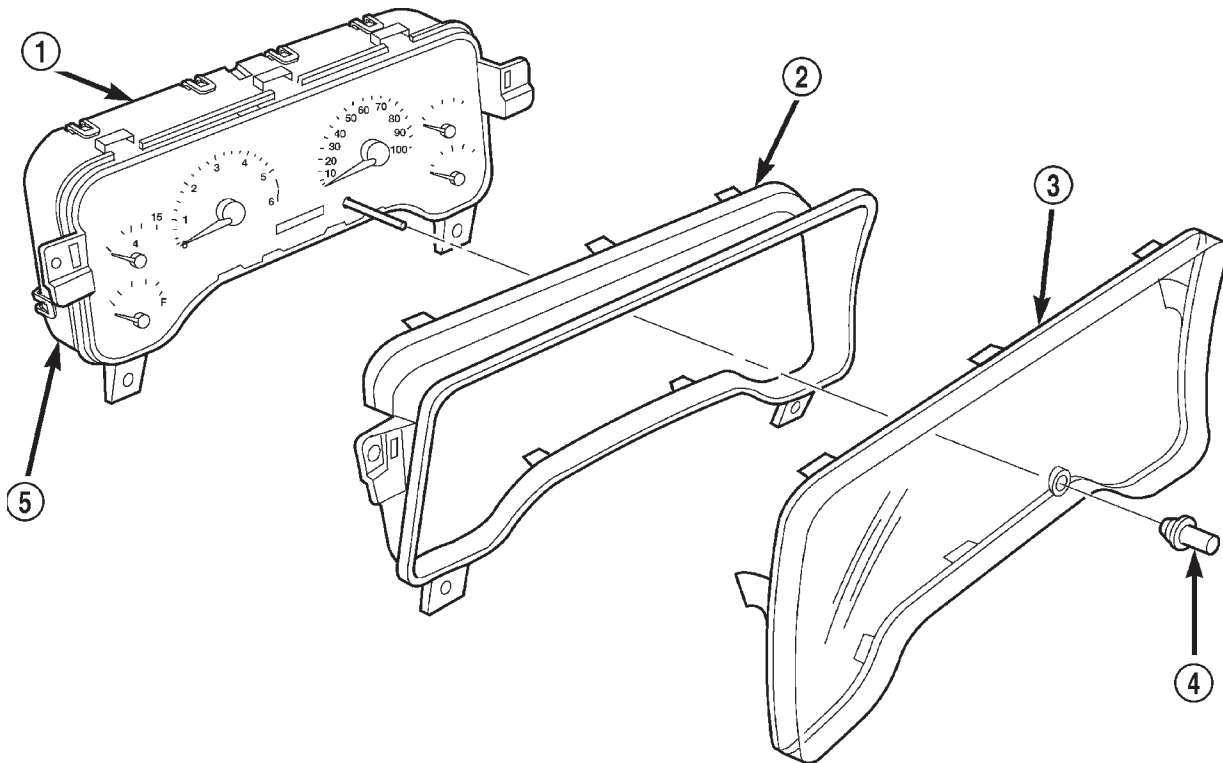

80a9f12c

Fig. 14 Instrument Cluster Components

- 1 - CLUSTER REAR COVER
 2 - CLUSTER HOOD AND MASK
 3 - CLUSTER LENS

- 4 - ODOMETER RESET KNOB BOOT
 5 - INSTRUMENT CLUSTER HOUSING

(4) Remove the odometer reset knob boot by pulling it out of the cluster lens.

CLUSTER HOOD AND MASK

(1) Disconnect and isolate the battery negative cable.

(2) Remove the instrument cluster from the instrument panel. Refer to **Instrument Cluster** in the Removal and Installation section of this group for the procedures.

(3) Remove the cluster lens from the cluster housing. Refer to **Instrument Cluster Components - Cluster Lens** in the Removal and Installation section of this group for the procedures.

(4) Work around the perimeter of the cluster housing to disengage each of the latches that secure the cluster hood and mask unit to the cluster housing (Fig. 14).

(5) Gently pull the cluster hood and mask unit away from the cluster housing.

CLUSTER HOUSING REAR COVER

(1) Disconnect and isolate the battery negative cable.

(2) Remove the instrument cluster from the instrument panel. Refer to **Instrument Cluster** in the

Removal and Installation section of this group for the procedures.

(3) Work around the perimeter of the cluster housing to disengage each of the latches that secure the rear cover to the cluster housing (Fig. 14).

(4) Gently pull the rear cover away from the back of the cluster housing.

INSTALLATION

CLUSTER BULB

This procedure applies to each of the incandescent cluster illumination lamp or indicator lamp bulb and bulb holder units. However, the illumination lamps and the indicator lamps use different bulb and bulb holder unit sizes. They must never be interchanged. Be certain that any bulb and bulb holder unit removed from the cluster electronic circuit board is reinstalled in the correct position.

CAUTION: Always use the correct bulb size and type for replacement. An incorrect bulb size or type may overheat and cause damage to the instrument cluster, the electronic circuit board and/or the gauges.

REMOVAL AND INSTALLATION (Continued)

(1) Insert the bulb and bulb holder unit straight into the correct bulb mounting hole in the cluster electronic circuit board.

(2) With the bulb holder fully seated against the cluster electronic circuit board, turn the bulb holder clockwise about sixty degrees to lock it into place.

(3) Install the instrument cluster onto the instrument panel. Refer to **Instrument Cluster** in the Removal and Installation section of this group for the procedures.

(4) Reconnect the battery negative cable.

CLUSTER LENS

(1) Align the cluster lens with the cluster hood and mask unit.

(2) Press firmly and evenly on the cluster lens to install it onto the cluster housing.

(3) Work around the perimeter of the cluster housing to be certain that each of the latches that secure the cluster lens to the cluster housing is fully engaged.

(4) Install the instrument cluster onto the instrument panel. Refer to **Instrument Cluster** in the Removal and Installation section of this group for the procedures.

(5) Reconnect the battery negative cable.

ODOMETER RESET KNOB BOOT

(1) Position the odometer reset knob to the mounting hole from the back of the cluster lens.

(2) Pull the odometer reset knob into the mounting hole from the face of the cluster lens.

(3) Install the cluster lens onto the cluster housing. Refer to **Instrument Cluster Components - Cluster Lens** in the Removal and Installation section of this group for the procedures.

(4) Install the instrument cluster onto the instrument panel. Refer to **Instrument Cluster** in the Removal and Installation section of this group for the procedures.

(5) Reconnect the battery negative cable.

CLUSTER HOOD AND MASK

(1) Align the hood and mask unit with the cluster housing.

(2) Press firmly and evenly on the hood and mask unit to install it onto the cluster housing.

(3) Work around the perimeter of the cluster housing to be certain that each of the latches that secure the hood and mask unit to the cluster housing is fully engaged.

(4) Install the cluster lens onto the cluster housing. Refer to **Instrument Cluster Components - Cluster Lens** in the Removal and Installation section of this group for the procedures.

(5) Install the instrument cluster onto the instrument panel. Refer to **Instrument Cluster** in the

Removal and Installation section of this group for the procedures.

(6) Reconnect the battery negative cable.

CLUSTER HOUSING REAR COVER

(1) Position the rear cover to the back of the cluster housing.

(2) Press firmly and evenly on the rear cover until each of the latches that secure the rear cover to the cluster housing is fully engaged.

(3) Install the instrument cluster onto the instrument panel. Refer to **Instrument Cluster** in the Removal and Installation section of this group for the procedures.

(4) Reconnect the battery negative cable.

INSTRUMENT PANEL TOP COVER

WARNING: ON VEHICLES EQUIPPED WITH AIR-BAGS, REFER TO GROUP 8M - PASSIVE RESTRAINT SYSTEMS BEFORE ATTEMPTING ANY STEERING WHEEL, STEERING COLUMN, OR INSTRUMENT PANEL COMPONENT DIAGNOSIS OR SERVICE. FAILURE TO TAKE THE PROPER PRECAUTIONS COULD RESULT IN ACCIDENTAL AIR-BAG DEPLOYMENT AND POSSIBLE PERSONAL INJURY.

REMOVAL

(1) Disconnect and isolate the battery negative cable.

(2) Remove the cluster bezel from the instrument panel. Refer to **Cluster Bezel** in the Removal and Installation section of this group for the procedures.

(3) Using a trim stick or another suitable wide flat-bladed tool, gently pry the rear edge (farthest from the windshield) of the instrument panel top cover up and away from the instrument panel far enough to disengage the seven snap clip retainers from their receptacles in the instrument panel (Fig. 15).

(4) Pull the top cover sharply rearwards (away from the windshield) to disengage the four snap clip retainers that secure the forward edge of the top cover from their receptacles in the instrument panel near the base of the windshield.

(5) Remove the top cover from the instrument panel.

INSTALLATION

(1) Position the top cover onto the instrument panel.

(2) Align the four snap clips on the forward edge (nearest the windshield) of the top cover with the snap clip receptacles in the instrument panel.

REMOVAL AND INSTALLATION (Continued)

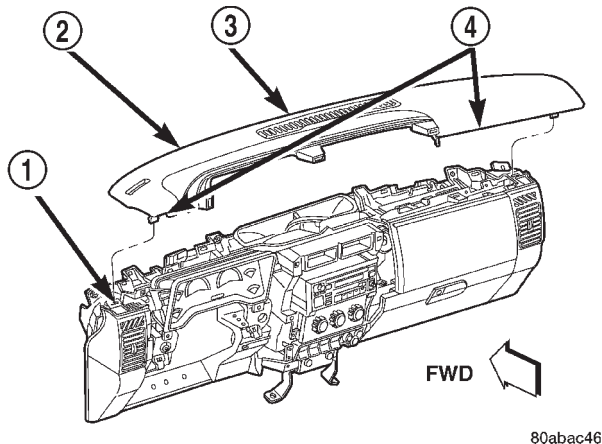

Fig. 15 Instrument Panel Top Cover Remove/Install

- 1 - INSTRUMENT PANEL
- 2 - TOP COVER
- 3 - FRONT EDGE
- 4 - REAR EDGE

(3) Press firmly downward on the top cover over each of the four forward snap clip locations until each of the snap clips is fully seated in their receptacles in the instrument panel.

(4) Align the seven snap clips on the rear edge (farthest from the windshield) of the top cover with the snap clip receptacles in the instrument panel.

(5) Press firmly downward on the top cover over each of the seven rearward snap clip locations until each of the snap clips is fully seated in their receptacles in the instrument panel.

(6) Install the cluster bezel onto the instrument panel. Refer to **Cluster Bezel** in the Removal and Installation section of this group for the procedures.

(7) Reconnect the battery negative cable.

GLOVE BOX

WARNING: ON VEHICLES EQUIPPED WITH AIRBAGS, REFER TO GROUP 8M - PASSIVE RESTRAINT SYSTEMS BEFORE ATTEMPTING ANY STEERING WHEEL, STEERING COLUMN, OR INSTRUMENT PANEL COMPONENT DIAGNOSIS OR SERVICE. FAILURE TO TAKE THE PROPER PRECAUTIONS COULD RESULT IN ACCIDENTAL AIRBAG DEPLOYMENT AND POSSIBLE PERSONAL INJURY.

ROLL DOWN

(1) Disconnect and isolate the battery negative cable.

(2) Open the glove box.

(3) Locate the two rubber stop bumpers on the upper edge of the instrument panel glove box opening (Fig. 16).

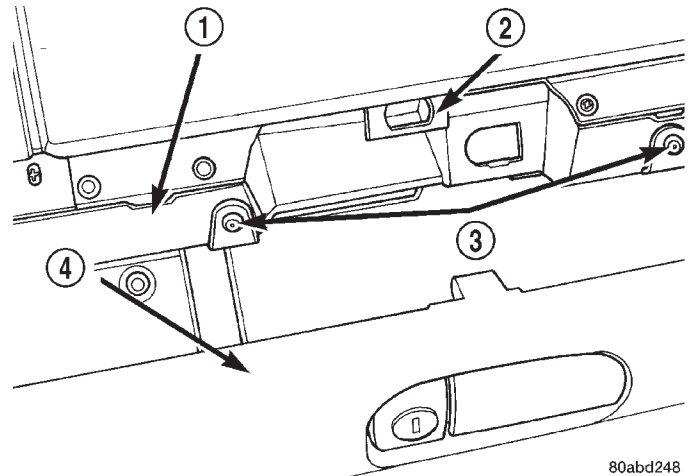

Fig. 16 Glove Box Stop Bumpers Remove/Install

- 1 - GLOVE BOX OPENING UPPER REINFORCEMENT
- 2 - GLOVE BOX LATCH STRIKER
- 3 - STOP BUMPERS
- 4 - GLOVE BOX DOOR

(4) Remove the two glove box stop bumpers by sliding them downward and out of the slots in the instrument panel upper glove box opening reinforcement.

(5) Roll the glove box downward so that the stops molded into the glove box bin pass through the stop bumper slots in the instrument panel upper glove box opening reinforcement.

(6) Reverse the roll down procedure to roll the glove box back up into the instrument panel.

REMOVAL

(1) Disconnect and isolate the battery negative cable.

(2) Remove the three screws that secure the glove box hinge to the instrument panel lower glove box opening reinforcement (Fig. 17).

(3) Release the glove box latch.

(4) Remove the glove box from the instrument panel.

INSTALLATION

(1) Position the glove box to the instrument panel with the bin inserted in the glove box opening far enough so that the stops on each side of the glove box bin are located behind the rubber stop bumpers located on the instrument panel upper glove box opening reinforcement.

(2) Align the screw holes in the glove box hinge with the mounting holes in the instrument panel lower glove box opening reinforcement.

(3) Install and tighten the three screws that secure the glove box hinge to the instrument panel lower glove box opening reinforcement. Tighten the screws to 2.2 N·m (20 in. lbs.).

REMOVAL AND INSTALLATION (Continued)

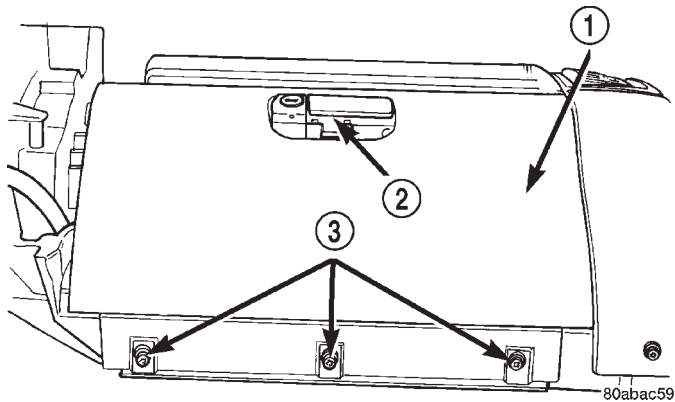
**Fig. 17 Glove Box Remove/Install**

- 1 - GLOVE BOX
- 2 - LATCH
- 3 - SCREWS

(4) Reconnect the battery negative cable.

GLOVE BOX COMPONENTS

The glove box hinge, bin, inner door and latch are serviced only as a complete unit. The glove box outer door and lock cylinder are serviced separately.

WARNING: ON VEHICLES EQUIPPED WITH AIR-BAGS, REFER TO GROUP 8M - PASSIVE RESTRAINT SYSTEMS BEFORE ATTEMPTING ANY STEERING WHEEL, STEERING COLUMN, OR INSTRUMENT PANEL COMPONENT DIAGNOSIS OR SERVICE. FAILURE TO TAKE THE PROPER PRECAUTIONS COULD RESULT IN ACCIDENTAL AIR-BAG DEPLOYMENT AND POSSIBLE PERSONAL INJURY.

REMOVAL**GLOVE BOX HINGE, BIN, INNER DOOR AND LATCH**

- (1) Disconnect and isolate the battery negative cable.
- (2) Remove the glove box from the instrument panel. Refer to **Glove Box - Removal** in the Removal and Installation section of this group for the procedures.
- (3) Remove the seven screws that secure the inner glove box door to the outer glove box door (Fig. 18).
- (4) Remove the inner glove box door unit from the outer glove box door.

GLOVE BOX OUTER DOOR

- (1) Disconnect and isolate the battery negative cable.
- (2) Remove the glove box from the instrument panel. Refer to **Glove Box - Removal** in the

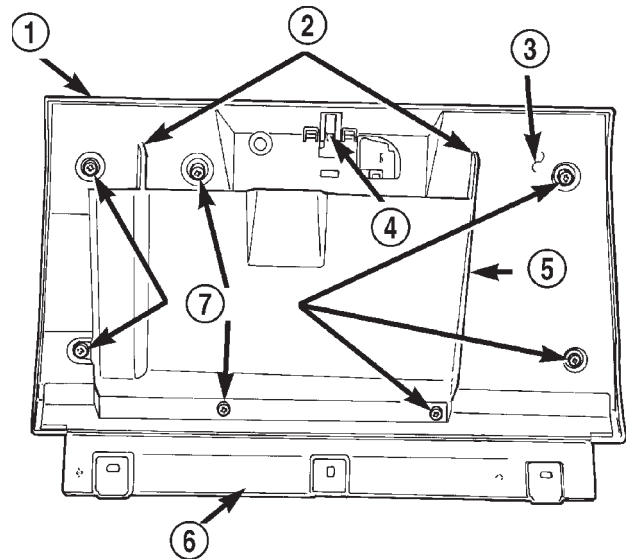
**Fig. 18 Glove Box Components Remove/Install**

- 1 - OUTER DOOR
- 2 - STOPS
- 3 - INNER DOOR
- 4 - LATCH
- 5 - BIN
- 6 - HINGE
- 7 - SCREWS

Removal and Installation section of this group for the procedures.

- (3) Remove the seven screws that secure the inner glove box door to the outer glove box door (Fig. 18).
- (4) Remove the outer glove box door from the inner glove box door unit.

GLOVE BOX LOCK CYLINDER

- (1) Insert the key into the glove box lock cylinder and turn the lock cylinder to the unlocked position.
- (2) Open the glove box.
- (3) With the key still in the lock cylinder, insert a small pin punch or a stiff wire into the lock cylinder release hole (Fig. 19) and depress the lock cylinder retaining tumbler.
- (4) While holding the retaining tumbler depressed, rotate the key in the lock cylinder clockwise and press outward on the back of the lock cylinder from the inside of the glove box door until the lock cylinder comes out of the glove box latch lock cylinder bore.

INSTALLATION**GLOVE BOX HINGE, BIN, INNER DOOR AND LATCH**

- (1) Position the inner glove box door unit onto the outer glove box door.

REMOVAL AND INSTALLATION (Continued)

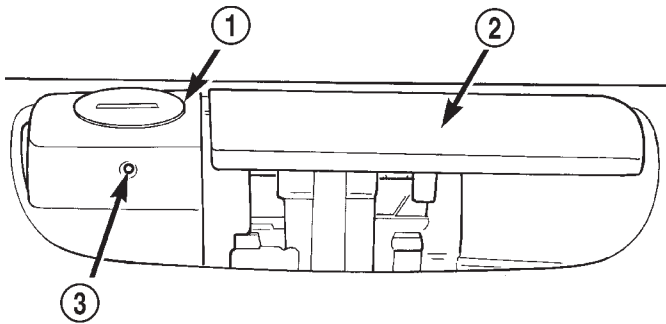

80abac66

Fig. 19 Glove Box Lock Cylinder Remove/Install

- 1 - LOCK CYLINDER
- 2 - LATCH HANDLE
- 3 - RELEASE HOLE

(2) Install and tighten the seven screws that secure the inner glove box door to the outer glove box door. Tighten the screws to 2.2 N·m (20 in. lbs.).

(3) Install the glove box onto the instrument panel. Refer to **Glove Box - Installation** in the Removal and Installation section of this group for the procedures.

(4) Reconnect the battery negative cable.

GLOVE BOX OUTER DOOR

(1) Position the outer glove box door onto the inner glove box door unit.

(2) Install and tighten the seven screws that secure the inner glove box door to the outer glove box door. Tighten the screws to 2.2 N·m (20 in. lbs.).

(3) Install the glove box onto the instrument panel. Refer to **Glove Box - Installation** in the Removal and Installation section of this group for the procedures.

(4) Reconnect the battery negative cable.

GLOVE BOX LOCK CYLINDER

(1) To install the lock cylinder, insert the key into the cylinder and align the lock cylinder tumblers with the ramp in the glove box latch lock cylinder bore. The ramp is located at about the 7 o'clock position.

(2) Push the glove box lock cylinder firmly into the lock cylinder bore while rotating the key and cylinder counterclockwise to the 6 o'clock position, where the lock cylinder retaining tumbler will snap back into place.

GLOVE BOX LATCH STRIKER

WARNING: ON VEHICLES EQUIPPED WITH AIRBAGS, REFER TO GROUP 8M - PASSIVE RESTRAINT SYSTEMS BEFORE ATTEMPTING ANY STEERING WHEEL, STEERING COLUMN, OR

INSTRUMENT PANEL COMPONENT DIAGNOSIS OR SERVICE. FAILURE TO TAKE THE PROPER PRECAUTIONS COULD RESULT IN ACCIDENTAL AIRBAG DEPLOYMENT AND POSSIBLE PERSONAL INJURY.

REMOVAL

(1) Disconnect and isolate the battery negative cable.

(2) Open the glove box.

(3) Remove the passenger side airbag module from the instrument panel. Refer to **Passenger Side Airbag Module** in the Removal and Installation section of Group 8M - Passive Restraint Systems for the procedures.

(4) Remove the two screws that secure the latch striker to the instrument panel glove box opening upper reinforcement (Fig. 20).

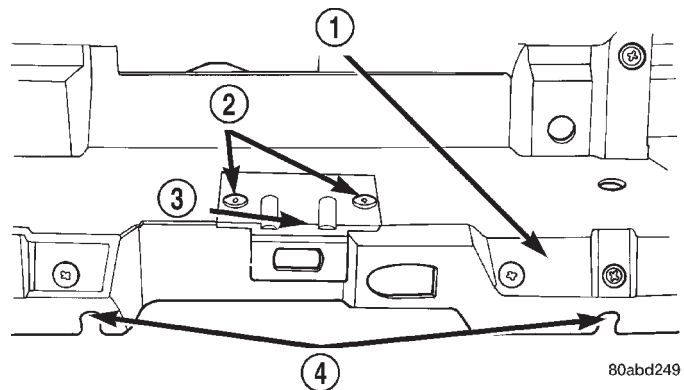

80abd249

Fig. 20 Glove Box Latch Striker Remove/Install

- 1 - GLOVE BOX OPENING UPPER REINFORCEMENT
- 2 - SCREWS
- 3 - LATCH STRIKER
- 4 - STOP BUMPER SLOTS

(5) Remove the latch striker from the instrument panel glove box opening upper reinforcement.

INSTALLATION

(1) Position the latch striker onto the instrument panel glove box opening upper reinforcement.

(2) Install and tighten the two screws that secure the latch striker to the instrument panel glove box opening upper reinforcement. Tighten the screws to 2.2 N·m (20 in. lbs.).

(3) Install the passenger side airbag module onto the instrument panel. Refer to **Passenger Side Airbag Module** in the Removal and Installation section of Group 8M - Passive Restraint Systems for the procedures.

(4) Close the glove box.

(5) Reconnect the battery negative cable.

REMOVAL AND INSTALLATION (Continued)

INSTRUMENT PANEL END CAP

WARNING: ON VEHICLES EQUIPPED WITH AIRBAGS, REFER TO GROUP 8M - PASSIVE RESTRAINT SYSTEMS BEFORE ATTEMPTING ANY STEERING WHEEL, STEERING COLUMN, OR INSTRUMENT PANEL COMPONENT DIAGNOSIS OR SERVICE. FAILURE TO TAKE THE PROPER PRECAUTIONS COULD RESULT IN ACCIDENTAL AIRBAG DEPLOYMENT AND POSSIBLE PERSONAL INJURY.

REMOVAL

DRIVER SIDE

- (1) Disconnect and isolate the battery negative cable.
- (2) Remove the knee blocker from the instrument panel. Refer to **Knee Blocker** in the Removal and Installation section of this group for the procedures.
- (3) Remove the top cover from the instrument panel. Refer to **Instrument Panel Top Cover** in the Removal and Installation section of this group for the procedures.
- (4) Remove the five screws that secure the end cap to the instrument panel (Fig. 21).

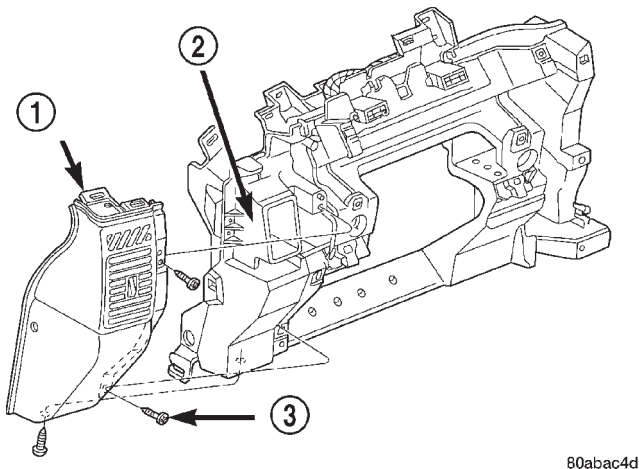

80abac4d

Fig. 21 Instrument Panel End Cap Remove/Install

- 1 - END CAP
2 - INSTRUMENT PANEL
3 - SCREW

- (5) Remove the end cap from the instrument panel.

PASSENGER SIDE

- (1) Disconnect and isolate the battery negative cable.
- (2) Roll down the glove box from the instrument panel. Refer to **Glove Box - Roll Down** in the

Removal and Installation section of this group for the procedures.

- (3) Remove the top cover from the instrument panel. Refer to **Instrument Panel Top Cover** in the Removal and Installation section of this group for the procedures.

- (4) Remove the passenger side airbag module from the instrument panel. Refer to **Passenger Side Airbag Module** in the Removal and Installation section of Group 8M - Passive Restraint Systems for the procedures.

- (5) Remove the six screws that secure the end cap to the instrument panel (Fig. 21).

- (6) Remove the end cap from the instrument panel.

INSTALLATION

DRIVER SIDE

- (1) Position the end cap to the instrument panel.
- (2) Install and tighten the five screws that secure the end cap to the instrument panel. Tighten the screws to 2.2 N-m (20 in. lbs.).
- (3) Install the top cover onto the instrument panel. Refer to **Instrument Panel Top Cover** in the Removal and Installation section of this group for the procedures.
- (4) Install the knee blocker onto the instrument panel. Refer to **Knee Blocker** in the Removal and Installation section of this group for the procedures.
- (5) Reconnect the battery negative cable.

PASSENGER SIDE

- (1) Position the end cap to the instrument panel.
- (2) Install and tighten the six screws that secure the end cap to the instrument panel. Tighten the screws to 2.2 N-m (20 in. lbs.).
- (3) Install the passenger side airbag module onto the instrument panel. Refer to **Passenger Side Airbag Module** in the Removal and Installation section of Group 8M - Passive Restraint Systems for the procedures.

- (4) Install the top cover onto the instrument panel. Refer to **Instrument Panel Top Cover** in the Removal and Installation section of this group for the procedures.

- (5) Roll up the glove box into the instrument panel. Refer to **Glove Box - Roll Down** in the Removal and Installation section of this group for the procedures.

- (6) Reconnect the battery negative cable.

REMOVAL AND INSTALLATION (Continued)

INSTRUMENT PANEL CENTER SUPPORT BRACKET

WARNING: ON VEHICLES EQUIPPED WITH AIR-BAGS, REFER TO GROUP 8M - PASSIVE RESTRAINT SYSTEMS BEFORE ATTEMPTING ANY STEERING WHEEL, STEERING COLUMN, OR INSTRUMENT PANEL COMPONENT DIAGNOSIS OR SERVICE. FAILURE TO TAKE THE PROPER PRECAUTIONS COULD RESULT IN ACCIDENTAL AIR-BAG DEPLOYMENT AND POSSIBLE PERSONAL INJURY.

REMOVAL

- (1) Disconnect and isolate the battery negative cable.
- (2) Remove the center bezel from the instrument panel. Refer to **Instrument Panel Center Bezel** in the Removal and Installation section of this group for the procedures.
- (3) Remove the floor console from the floor panel transmission tunnel. Refer to **Floor Console** in the Removal and Installation section of Group 23 - Body for the procedures.
- (4) Pull the floor carpet back from the front of the floor panel transmission tunnel far enough to access the instrument panel center support bracket mounting nuts.
- (5) Remove the two nuts that secure the center support bracket to the studs on the instrument panel (Fig. 22).

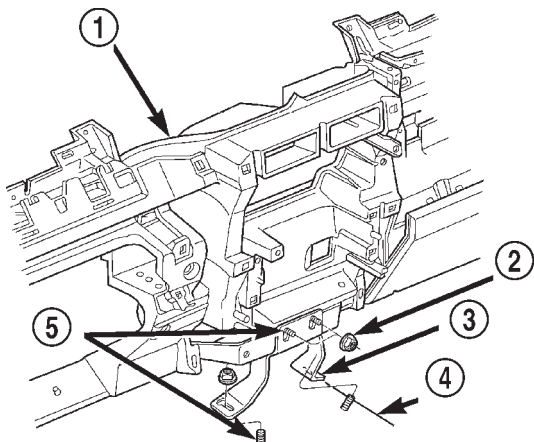

80abac67

Fig. 22 Instrument Panel Center Support Bracket Remove/Install

- 1 - INSTRUMENT PANEL
- 2 - NUT
- 3 - BRACKET
- 4 - FLOOR PAN TRANSMISSION TUNNEL
- 5 - STUDS

(6) Remove the two nuts that secure the instrument panel center support bracket to the studs on the floor panel transmission tunnel.

(7) Remove the center support bracket from the instrument panel.

INSTALLATION

(1) Position the center support bracket to the instrument panel.

(2) Install and tighten the two nuts that secure the instrument panel center support bracket to the studs on the floor panel transmission tunnel. Tighten the nuts to 28 N·m (250 in. lbs.).

(3) Install and tighten the two nuts that secure the center support bracket to the studs on the instrument panel. Tighten the nuts to 28 N·m (250 in. lbs.).

(4) Position the floor carpet back onto the front of the floor panel transmission tunnel.

(5) Install the floor console onto the floor panel transmission tunnel. Refer to **Floor Console** in the Removal and Installation section of Group 23 - Body for the procedures.

(6) Install the center bezel onto the instrument panel. Refer to **Instrument Panel Center Bezel** in the Removal and Installation section of this group for the procedures.

(7) Reconnect the battery negative cable.

INSTRUMENT PANEL ASSEMBLY

WARNING: ON VEHICLES EQUIPPED WITH AIR-BAGS, REFER TO GROUP 8M - PASSIVE RESTRAINT SYSTEMS BEFORE ATTEMPTING ANY STEERING WHEEL, STEERING COLUMN, OR INSTRUMENT PANEL COMPONENT DIAGNOSIS OR SERVICE. FAILURE TO TAKE THE PROPER PRECAUTIONS COULD RESULT IN ACCIDENTAL AIR-BAG DEPLOYMENT AND POSSIBLE PERSONAL INJURY.

REMOVAL

NOTE: Before starting this procedure, be certain to turn the steering wheel until the front wheels are in the straight-ahead position.

(1) Disconnect and isolate the battery negative cable.

(2) Remove the trim from the left and right cowl side inner panels. Refer to **Lower A-Pillar Cowl Trim** in the Removal and Installation section of Group 23 - Body for the procedures.

(3) Remove the knee blocker from the instrument panel. Refer to **Knee Blocker** in the Removal and Installation section of this group for the procedures.

REMOVAL AND INSTALLATION (Continued)

(4) Remove the top cover from the instrument panel. Refer to **Instrument Panel Top Cover** in the Removal and Installation section of this group for the procedures.

(5) Remove the center support bracket from the instrument panel. Refer to **Instrument Panel Center Support Bracket** in the Removal and Installation section of this group for the procedures.

(6) Remove the steering column from the vehicle. Refer to **Steering Column** in the Removal and Installation section of Group 19 - Steering for the procedures.

(7) Remove the screws from the centers of the instrument panel-to-body and the instrument panel-to-headlamp and dash wire harness connectors near the left cowl side inner panel and disconnect both connectors.

(8) Remove the screw from the center of the instrument panel-to-floor wire harness connector near the floor panel transmission tunnel under the instrument panel and disconnect the connector.

(9) Disconnect the two wire harness connectors located near the instrument panel-to-floor wire har-

ness connector at the floor panel transmission tunnel under the instrument panel.

(10) Roll down the glove box from the instrument panel. Refer to **Glove Box - Roll Down** in the Removal and Installation section of this group for the procedures.

(11) Reach through the inboard side of the instrument panel glove box opening to disconnect the two halves of the heater-A/C system vacuum harness connector.

(12) Reach under the right end of the instrument panel to access and disconnect the two halves of the radio antenna coaxial cable connector. On Left-Hand Drive models only, also disengage the retainer on the radio half of the coaxial cable from the heater-A/C housing kick cover.

(13) Loosen the right and left instrument panel cowl side roll down screws about 6 mm (0.25 inch) (Fig. 23).

(14) Remove the four screws and two nuts that secure the top of the instrument panel to the top of the dash panel near the base of the windshield.

(15) With the aid of an assistant, lift the top of the instrument panel assembly off of the two dash panel

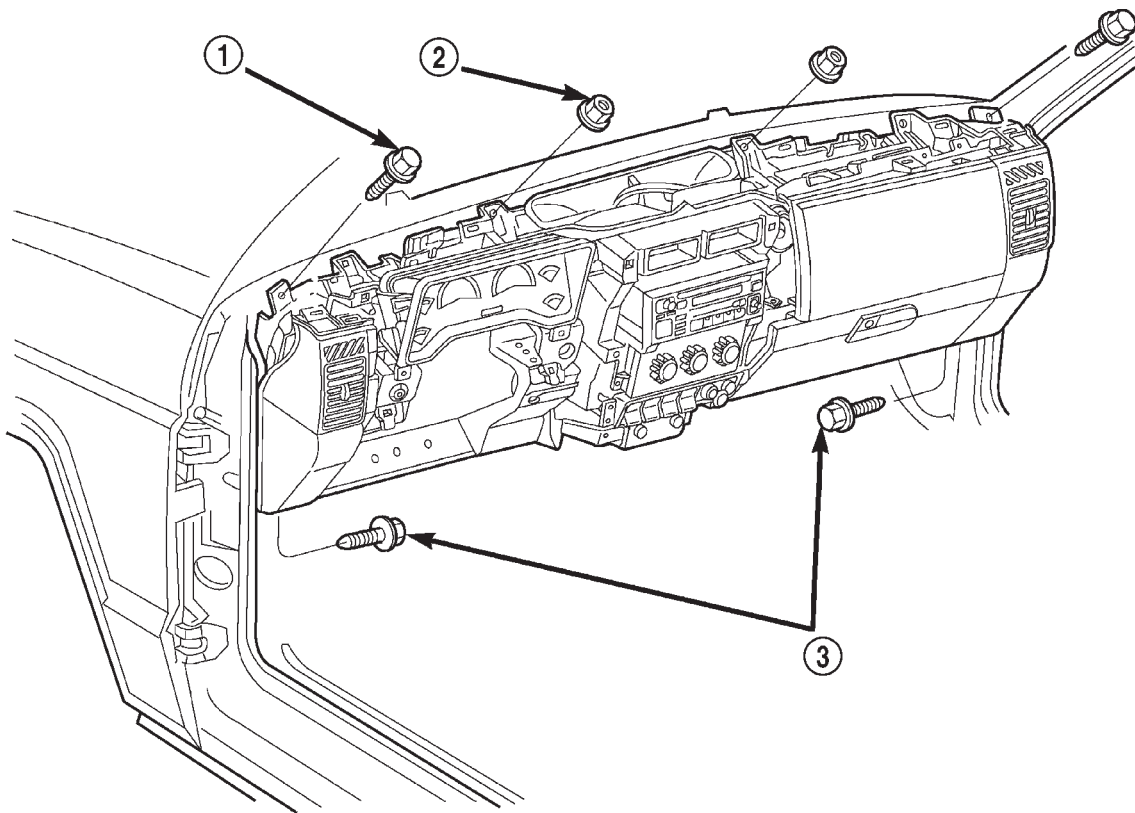

80a9f12b

Fig. 23 Instrument Panel Assembly Remove/Install

1 - SCREW
2 - NUT

3 - INSTRUMENT PANEL COWL SIDE ROLL DOWN SCREWS

REMOVAL AND INSTALLATION (Continued)

studs. Then pull the lower instrument panel rearward to clear the cowl side roll down screws.

(16) Remove the instrument panel assembly from the vehicle.

INSTALLATION

(1) With the aid of an assistant, position the instrument panel assembly onto the cowl side roll down screws and the dash panel studs in the vehicle.

(2) Install and tighten the four screws and two nuts that secure the top of the instrument panel to the top of the dash panel near the base of the windshield. Tighten the screws and nuts to 7 N·m (60 in. lbs.).

(3) Tighten the right and left instrument panel cowl side roll down screws. Tighten the screws to 28 N·m (250 in. lbs.).

(4) Reach under the right end of the instrument panel to access and reconnect the two halves of the radio antenna coaxial cable connector. On Left-Hand Drive models only, also engage the retainer on the radio half of the coaxial cable onto the heater-A/C housing kick cover.

(5) Reach through the inboard side of the instrument panel glove box opening to reconnect the two halves of the heater-A/C system vacuum harness connector.

(6) Roll up the glove box into the instrument panel. Refer to **Glove Box - Roll Down** in the Removal and Installation section of this group for the procedures.

(7) Reconnect the two wire harness connectors located near the instrument panel-to-floor wire har-

ness connector at the floor panel transmission tunnel under the instrument panel.

(8) Reconnect the instrument panel-to-floor wire harness connector near the floor panel transmission tunnel under the instrument panel and tighten the connector screw. Tighten the screw to 4 N·m (35 in. lbs.).

(9) Reconnect the instrument panel-to-body and the instrument panel-to-headlamp and dash wire harness connectors near the left cowl side inner panel and tighten the connector screws. Tighten the screws to 4 N·m (35 in. lbs.).

(10) Install the steering column into the vehicle. Refer to **Steering Column** in the Removal and Installation section of Group 19 - Steering for the procedures.

(11) Install the center support bracket onto the instrument panel. Refer to **Instrument Panel Center Support Bracket** in the Removal and Installation section of this group for the procedures.

(12) Install the top cover onto the instrument panel. Refer to **Instrument Panel Top Cover** in the Removal and Installation section of this group for the procedures.

(13) Install the knee blocker onto the instrument panel. Refer to **Knee Blocker** in the Removal and Installation section of this group for the procedures.

(14) Install the trim onto the left and right cowl side inner panels. Refer to **Lower A-Pillar Cowl Trim** in the Removal and Installation section of Group 23 - Body for the procedures.

(15) Reconnect the battery negative cable.

INSTRUMENT PANEL SYSTEMS

TABLE OF CONTENTS

| | page | page |
|---------------------------------|------|-----------------------------|
| REMOVAL AND INSTALLATION | | |
| HEADLAMP LEVELING SWITCH..... 1 | | REAR FOG LAMP SWITCH..... 1 |

REMOVAL AND INSTALLATION

HEADLAMP LEVELING SWITCH

REMOVAL

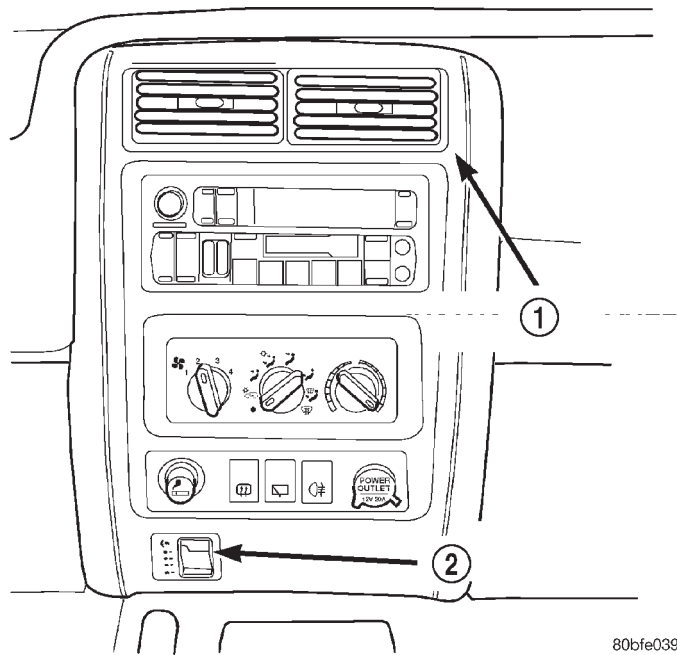

Fig. 1 Headlamp Leveling Switch Position & Orientation

- 1 - INSTRUMENT PANEL CENTER BEZEL
- 2 - HEADLAMP LEVELING SWITCH

- (1) Disconnect and isolate the negative battery cable.
- (2) Using a trim stick or another suitable wide flat-bladed tool, gently pry the instrument panel center bezel away from the instrument panel to release the four snap clip retainers (Fig. 1).
- (3) Pull the center bezel away from the instrument panel far enough to disconnect the wiring harness from the headlamp leveling switch.
- (4) Depress the switch retaining tabs to remove the switch from the center bezel.

INSTALLATION

- (1) Install the instrument panel center bezel on the I. P. Be certain headlamp leveling switch electrical harness is inserted through the hole in center bezel.
- (2) Connect the headlamp leveling switch electrical.
- (3) Verify switch / system operation.
- (4) Install the headlamp leveling switch in the instrument panel center bezel by gently pushing straight in.
- (5) Connect the negative battery cable.

REAR FOG LAMP SWITCH

WARNING: ON VEHICLES EQUIPPED WITH AIRBAGS, REFER TO GROUP 8M - PASSIVE RESTRAINT SYSTEMS BEFORE ATTEMPTING ANY STEERING WHEEL, STEERING COLUMN, OR INSTRUMENT PANEL COMPONENT DIAGNOSIS OR SERVICE. FAILURE TO TAKE THE PROPER PRECAUTIONS COULD RESULT IN ACCIDENTAL AIRBAG DEPLOYMENT AND POSSIBLE PERSONAL INJURY.

- (1) Disconnect and isolate the battery negative cable.
- (2) Using a trim stick or another suitable wide flat-bladed tool, gently pry the instrument panel center bezel away from the instrument panel to release the six snap clip retainers.
- (3) Remove the center bezel from the vehicle.
- (4) Remove the three screws that secure the accessory switch bezel to the instrument panel
- (5) Pull the accessory switch bezel out from the instrument panel far enough to unplug the wire harness connectors (Fig. 2).
- (6) Remove the accessory switch bezel from the instrument panel.
- (7) Carefully pry the snap retainers at the top and bottom of the rear fog lamp switch receptacle on the back of the accessory switch bezel with a small thin-bladed screwdriver and pull the switch out of the receptacle.

REMOVAL AND INSTALLATION (Continued)

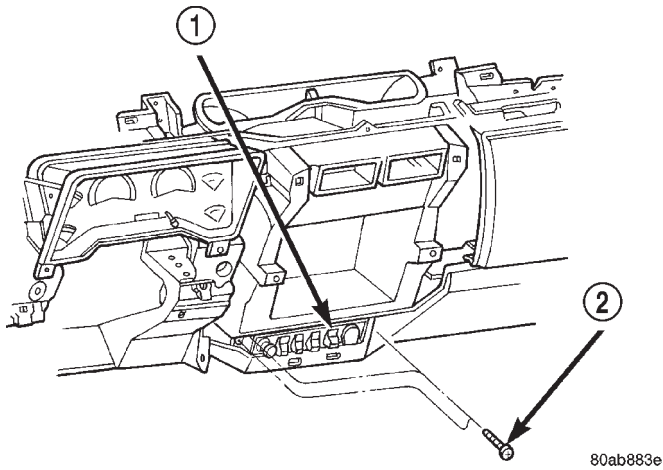

receptacle on the back of the accessory switch bezel are fully engaged. Tighten the mounting screws to 2.2 N-m (20 in. lbs.).

Fig. 2 Accessory Switch Bezel Remove/Install

- 1 - ACCESSORY SWITCH BEZEL
- 2 - SCREW

(8) Reverse the removal procedures to install. Be certain that both of the switch snap retainers in the

AUDIO SYSTEMS

TABLE OF CONTENTS

| | page | | page |
|----------------------------------|------|---|------|
| GENERAL INFORMATION | | SPEAKER | 4 |
| INTRODUCTION | 1 | ANTENNA | 5 |
| AUDIO SYSTEM | 1 | RADIO FREQUENCY INTERFERENCE | 6 |
| DESCRIPTION AND OPERATION | | REMOVAL AND INSTALLATION | |
| RADIO | 1 | RADIO | 7 |
| IGNITION-OFF DRAW FUSE | 1 | AMPLIFIER | 7 |
| SPEAKER | 2 | SPEAKER | 8 |
| ANTENNA | 2 | ANTENNA | 10 |
| RADIO NOISE SUPPRESSION | 2 | RADIO NOISE SUPPRESSION COMPONENTS .. | 11 |
| DIAGNOSIS AND TESTING | | SPECIAL TOOLS | |
| AUDIO SYSTEM | 2 | AUDIO SYSTEMS | 12 |
| RADIO | 4 | | |

GENERAL INFORMATION

INTRODUCTION

An audio system is standard factory-installed equipment on this model, unless the vehicle is ordered with an available radio delete option. Refer to 8W-47 Audio System in Group 8W - Wiring Diagrams for complete circuit descriptions and diagrams.

NOTE: This group covers both Left-Hand Drive (LHD) and Right-Hand Drive (RHD) versions of this model. Whenever required and feasible, the RHD versions of affected vehicle components have been constructed as mirror-image of the LHD versions. While most of the illustrations used in this group represent only the LHD version, the diagnostic and service procedures outlined can generally be applied to either version. Exceptions to this rule have been clearly identified as LHD or RHD, if a special illustration or procedure is required.

AUDIO SYSTEM

Several combinations of radio receivers and speaker systems are offered on this model. The standard equipment audio system includes an AM/FM (RAL sales code) receiver, and speakers in two locations.

Following are general descriptions of the major components in the standard and optional factory-installed audio systems. Refer to the owner's manual in the vehicle glove box for more information on the features, use and operation of each of the available audio systems.

DESCRIPTION AND OPERATION

RADIO

Available factory-installed radio receivers for this model include an AM/FM (RAL sales code), an AM/FM/cassette (RAS sales code), and an AM/FM/CD/cassette/3-band graphic equalizer (RAZ sales code). All factory-installed radio receivers are stereo Electronically Tuned Radios (ETR), and include an electronic digital clock function.

The radio can only be serviced by an authorized radio repair station. Refer to the latest Warranty Policies and Procedures manual for a current listing of authorized radio repair stations.

For more information on radio features, setting procedures, and control functions refer to the owner's manual in the vehicle glove box.

IGNITION-OFF DRAW FUSE

All vehicles are equipped with an Ignition-Off Draw (IOD) fuse that is removed when the vehicle is shipped from the factory. This fuse feeds various accessories that require battery current when the ignition switch is in the Off position, including the clock and radio station preset memory functions. The fuse is removed to prevent battery discharge during vehicle storage.

When removing or installing the IOD fuse, it is important that the ignition switch be in the Off position. Failure to place the ignition switch in the Off position can cause the radio display to become scrambled when the IOD fuse is removed and replaced. Removing and replacing the IOD fuse again, with the

DESCRIPTION AND OPERATION (Continued)

ignition switch in the Off position, will correct the scrambled display condition.

The IOD fuse should be checked if the radio is inoperative. The IOD fuse is located in the Power Distribution Center (PDC). Refer to the PDC label for IOD fuse identification and location.

SPEAKER

The standard equipment speaker system includes two 13.3 centimeter (5.25 inch) diameter full-range speakers. Each speaker is mounted to the lower front corner of the front door inner panel behind the door trim panel.

The four speaker option adds two 13.3 centimeter (5.25 inch) diameter full-range speakers to the standard speaker system, for a total of four speakers. Each of the additional speakers is mounted behind a grille installed on the outboard ends of a speaker support structure, which is integral to the headliner and located just forward of the upper liftgate opening reinforcement near the rear of the vehicle cargo area.

The premium speaker option upgrades all of the speakers to Infinity models, and includes a 100 watt Infinity amplifier. Each front door has two separate Infinity speakers: a woofer mounted low in the door, and a tweeter mounted behind the door flag trim panel. Infinity coaxial speakers are mounted in the headliner speaker support structure. The Infinity amplifier is mounted to the floor panel under the left rear seat cushion.

ANTENNA

All models use a fixed-length stainless steel rod-type antenna mast, installed at the right front fender of the vehicle. The antenna mast is connected to the center wire of the coaxial antenna cable, and is not grounded to any part of the vehicle.

To eliminate static, the antenna base must have a good ground. The coaxial antenna cable shield (the outer wire mesh of the cable) is grounded to the antenna base and the radio chassis.

The antenna coaxial cable has an additional disconnect, located near the right cowl side inner panel behind the instrument panel. This additional discon-

nect allows the instrument panel assembly to be removed and installed without removing the radio.

The factory-installed Electronically Tuned Radios (ETRs) automatically compensate for radio antenna trim. Therefore, no antenna trimmer adjustment is required or possible when replacing the receiver or the antenna.

RADIO NOISE SUPPRESSION

DESCRIPTION

Radio Frequency Interference (RFI) and Electro-Magnetic Interference (EMI) noise suppression is accomplished primarily through circuitry internal to the radio receivers. These internal suppression devices are only serviced as part of the radio receiver.

External suppression devices that are used on this vehicle to control RFI or EMI noise include the following:

- Radio antenna base ground
- Radio receiver chassis ground wire or strap
- Engine-to-body ground strap
- Resistor-type spark plugs
- Radio suppression-type secondary ignition wiring.

For more information on the spark plugs and secondary ignition components, refer to **Ignition System** in the Description and Operation section of Group 8D - Ignition System.

DIAGNOSIS AND TESTING

AUDIO SYSTEM

WARNING: ON VEHICLES EQUIPPED WITH AIR-BAGS, REFER TO GROUP 8M - PASSIVE RESTRAINT SYSTEMS BEFORE ATTEMPTING ANY STEERING WHEEL, STEERING COLUMN, OR INSTRUMENT PANEL COMPONENT DIAGNOSIS OR SERVICE. FAILURE TO TAKE THE PROPER PRECAUTIONS COULD RESULT IN ACCIDENTAL AIR-BAG DEPLOYMENT AND POSSIBLE PERSONAL INJURY.

DIAGNOSIS AND TESTING (Continued)

| Audio System Diagnosis | | |
|-------------------------------|--|---|
| CONDITION | POSSIBLE CAUSE | CORRECTION |
| NO AUDIO. | <ol style="list-style-type: none"> 1. Fuse faulty. 2. Radio connector faulty. 3. Wiring faulty. 4. Ground faulty. 5. Radio faulty. 6. Speakers faulty. 7. Amplifier faulty (if equipped). | <ol style="list-style-type: none"> 1. Check radio fuses in junction block. Replace fuses, if required. 2. Check for loose or corroded radio connector. Repair, if required. 3. Check for battery voltage at radio connector. Repair wiring, if required. 4. Check for continuity between radio chassis and a known good ground. There should be continuity. Repair ground, if required. 5. See Radio in the Diagnosis and Testing section of this group. 6. See Speaker in the Diagnosis and Testing section of this group. 7. See Speaker in the Diagnosis and Testing section of this group. |
| NO DISPLAY. | <ol style="list-style-type: none"> 1. Fuse faulty. 2. Radio connector faulty. 3. Wiring faulty. 4. Ground faulty. 5. Radio faulty. | <ol style="list-style-type: none"> 1. Check radio fuses in junction block. Replace fuses, if required. 2. Check for loose or corroded radio connector. Repair, if required. 3. Check for battery voltage at radio connector. Repair wiring, if required. 4. Check for continuity between radio chassis and a known good ground. There should be continuity. Repair ground, if required. 5. See Radio in the Diagnosis and Testing section of this group. |
| CLOCK WILL NOT KEEP SET TIME. | <ol style="list-style-type: none"> 1. Fuse faulty. 2. Radio connector faulty. 3. Wiring faulty. 4. Ground faulty. 5. Radio faulty. | <ol style="list-style-type: none"> 1. Check ignition-off draw fuse. Replace fuse, if required. 2. Check for loose or corroded radio connector. Repair, if required. 3. Check for battery voltage at radio connector. Repair wiring, if required. 4. Check for continuity between radio chassis and a known good ground. There should be continuity. Repair ground, if required. 5. See Radio in the Diagnosis and Testing section of this group. |
| POOR RADIO RECEPTION. | <ol style="list-style-type: none"> 1. Antenna faulty. 2. Ground faulty. 3. Radio faulty. | <ol style="list-style-type: none"> 1. See Antenna in the Diagnosis and Testing section of this group. 2. Check for continuity between radio chassis and a known good ground. There should be continuity. Repair ground, if required. 3. See Radio in the Diagnosis and Testing section of this group. |
| NO/POOR TAPE OPERATION. | <ol style="list-style-type: none"> 1. Faulty tape. 2. Foreign objects behind tape door. 3. Dirty cassette tape head. 4. Faulty tape deck. | <ol style="list-style-type: none"> 1. Insert known good tape and test operation. 2. Remove foreign objects and test operation. 3. Clean head with Mopar Cassette Head Cleaner. 4. Exchange or replace radio, if required. |
| NO COMPACT DISC OPERATION | <ol style="list-style-type: none"> 1. Faulty CD. 2. Foreign material on CD. 3. Condensation on CD or optics. 4. Faulty CD player. | <ol style="list-style-type: none"> 1. Insert known good CD and test operation. 2. Clean CD and test operation. 3. Allow temperature of vehicle interior to stabilize and test operation. 4. Exchange or replace radio, if required. |

DIAGNOSIS AND TESTING (Continued)

RADIO

For circuit descriptions and diagrams, refer to 8W-47 - Audio System in Group 8W - Wiring Diagrams.

WARNING: ON VEHICLES EQUIPPED WITH AIR-BAGS, REFER TO GROUP 8M - PASSIVE RESTRAINT SYSTEMS BEFORE ATTEMPTING ANY STEERING WHEEL, STEERING COLUMN, OR INSTRUMENT PANEL COMPONENT DIAGNOSIS OR SERVICE. FAILURE TO TAKE THE PROPER PRECAUTIONS COULD RESULT IN ACCIDENTAL AIR-BAG DEPLOYMENT AND POSSIBLE PERSONAL INJURY.

CAUTION: The speaker output of the radio is a "floating ground" system. Do not allow any speaker lead to short to ground, as damage to the radio may result.

(1) Check the fuse(s) in the junction block and the Power Distribution Center (PDC). If OK, go to Step 2. If not OK, repair the shorted circuit or component as required and replace the faulty fuse(s).

(2) Check for battery voltage at the fuse in the PDC. If OK, go to Step 3. If not OK, repair the open circuit to the battery as required.

(3) Turn the ignition switch to the On position. Check for battery voltage at the fuse in the junction block. If OK, go to Step 4. If not OK, repair the open circuit to the ignition switch as required.

(4) Turn the ignition switch to the Off position. Disconnect and isolate the battery negative cable. Remove the radio, but do not unplug the radio wire harness connectors. Check for continuity between the radio chassis and a good ground. There should be continuity. If OK, go to Step 5. If not OK, repair the open radio chassis ground circuit as required.

(5) Connect the battery negative cable. Turn the ignition switch to the On position. Check for battery voltage at the fused ignition switch output (accessory/run) circuit cavity of the left (gray) radio wire harness connector. If OK, go to Step 6. If not OK, repair the open circuit as required.

(6) Turn the ignition switch to the Off position. Check for battery voltage at the fused B(+) circuit cavity of the left (gray) radio wire harness connector. If OK, replace the faulty radio. If not OK, repair the open circuit to the Ignition-Off Draw (IOD) fuse as required.

SPEAKER

For circuit descriptions and diagrams, refer to 8W-47 - Audio System in Group 8W - Wiring Diagrams.

WARNING: ON VEHICLES EQUIPPED WITH AIR-BAGS, REFER TO GROUP 8M - PASSIVE RESTRAINT SYSTEMS BEFORE ATTEMPTING ANY STEERING WHEEL, STEERING COLUMN, OR INSTRUMENT PANEL COMPONENT DIAGNOSIS OR SERVICE. FAILURE TO TAKE THE PROPER PRECAUTIONS COULD RESULT IN ACCIDENTAL AIR-BAG DEPLOYMENT AND POSSIBLE PERSONAL INJURY.

CAUTION: The speaker output of the radio is a "floating ground" system. Do not allow any speaker lead to short to ground, as damage to the radio may result.

(1) Turn the ignition switch to the On position. Turn the radio on. Adjust the balance and fader controls to check the performance of each individual speaker. Note the speaker locations that are not performing correctly. Go to Step 2.

(2) Turn the radio off. Turn the ignition switch to the Off position. Disconnect and isolate the battery negative cable. Remove the radio from the instrument panel. If the vehicle is equipped with the Infinity speaker package, also unplug the wire harness connectors at the amplifier. Check both the speaker feed (+) circuit and return (-) circuit cavities for the inoperative speaker location(s) at the radio wire harness connectors for continuity to ground. In each case, there should be no continuity. If OK, go to Step 3. If not OK, repair the shorted speaker circuit(s) as required.

(3) If the vehicle is equipped with the Infinity speaker package, go to Step 6. If the vehicle is equipped with the standard speaker system, check the resistance between the speaker feed (+) circuit and return (-) circuit cavities of the radio wire harness connectors for the inoperative speaker location(s). The meter should read between 2 and 12 ohms (speaker resistance). If OK, go to Step 4. If not OK, go to Step 5.

(4) Install a known good radio. Connect the battery negative cable. Turn the ignition switch to the On position. Turn on the radio and test the speaker operation. If OK, replace the faulty radio. If not OK, turn the radio off, turn the ignition switch to the Off position, disconnect and isolate the battery negative cable, remove the test radio, and go to Step 5.

(5) Unplug the speaker wire harness connector at the inoperative speaker. Check for continuity between the speaker feed (+) circuit cavities of the radio wire harness connector and the speaker wire harness connector. Repeat the check between the speaker return (-) circuit cavities of the radio wire harness connector and the speaker wire harness connector. In each case, there should be continuity. If

DIAGNOSIS AND TESTING (Continued)

OK, replace the faulty speaker. If not OK, repair the open circuit(s) as required.

(6) For each inoperative speaker location, check for continuity between the speaker feed (+) circuit cavities of the radio wire harness connectors and the amplifier wire harness connectors. Repeat the check for each inoperative speaker location between the speaker return (-) circuit cavities of the radio wire harness connectors and the amplifier wire harness connectors. In each case, there should be continuity. If OK, go to Step 7. If not OK, repair the open circuit as required.

(7) Check for continuity between the two ground circuit cavities of the amplifier wire harness connector and a good ground. There should be continuity. If OK, go to Step 8. If not OK, repair the open circuit(s) as required.

(8) Check the amplifier fuse in the junction block. If OK, go to Step 9. If not OK, repair the shorted circuit or component as required and replace the faulty fuse.

(9) Install the radio. Connect the battery negative cable. Check for battery voltage at the amplifier fuse in the junction block. If OK, go to Step 10. If not OK, repair the open circuit to the PDC as required.

(10) Check for battery voltage at the two fused B(+) circuit cavities of the amplifier wire harness connector. If OK, go to Step 11. If not OK, repair the open circuit to the fuse in the junction block as required.

(11) Turn the ignition switch to the On position. Turn the radio on. Check for battery voltage at the radio 12 volt output circuit cavity of the amplifier wire harness connector. If OK, go to Step 12. If not OK, repair the open circuit to the radio as required.

(12) Turn the radio off. Turn the ignition switch to the Off position. Disconnect and isolate the battery negative cable. For each inoperative speaker location, check both the amplified feed (+) circuit and the amplified return (-) circuit cavities of the amplifier wire harness connectors for continuity to ground. In each case there should be no continuity. If OK, go to Step 13. If not OK, repair the short circuit as required.

(13) For each inoperative speaker location, check the resistance between the amplified feed (+) circuit and the amplified return (-) circuit cavities of the amplifier wire harness connectors. The meter should read between 2 and 12 ohms (speaker resistance). If OK, replace the faulty amplifier. If not OK, go to Step 14.

(14) Unplug the speaker wire harness connector at the inoperative speaker. Check for continuity between the amplified feed (+) circuit cavities of the speaker wire harness connector and the amplifier wire harness connector. Repeat the check between

the amplified return (-) circuit cavities of the speaker wire harness connector and the amplifier wire harness connector. In each case there should be continuity. If OK, replace the faulty speaker. If not OK, repair the open circuit as required.

ANTENNA

WARNING: ON VEHICLES EQUIPPED WITH AIR-BAGS, REFER TO GROUP 8M - PASSIVE RESTRAINT SYSTEMS BEFORE ATTEMPTING ANY STEERING WHEEL, STEERING COLUMN, OR INSTRUMENT PANEL COMPONENT DIAGNOSIS OR SERVICE. FAILURE TO TAKE THE PROPER PRECAUTIONS COULD RESULT IN ACCIDENTAL AIR-BAG DEPLOYMENT AND POSSIBLE PERSONAL INJURY.

The following four tests are used to diagnose the antenna with an ohmmeter:

- **Test 1** - Mast to ground test
- **Test 2** - Tip-of-mast to tip-of-conductor test
- **Test 3** - Body ground to battery ground test
- **Test 4** - Body ground to coaxial shield test.

The ohmmeter test lead connections for each test are shown in Antenna Tests (Fig. 1).

NOTE: This model has a two-piece antenna coaxial cable. Tests 2 and 4 must be conducted in two steps to isolate a coaxial cable problem; from the coaxial cable connection under the right end of the instrument panel near the right cowl side inner panel to the antenna base, and then from the coaxial cable connection to the radio chassis connection.

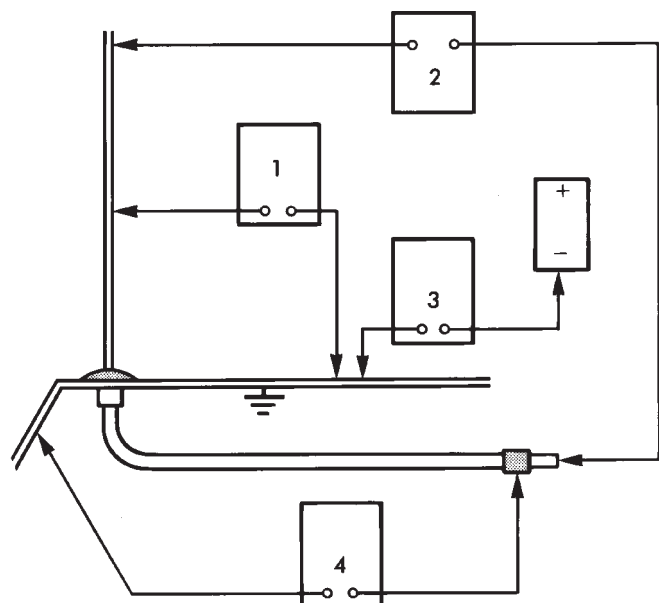

J898F-7

Fig. 1 Antenna Tests

DIAGNOSIS AND TESTING (Continued)

TEST 1

Test 1 determines if the antenna mast is insulated from the base. Proceed as follows:

- (1) Unplug the antenna coaxial cable connector from the radio chassis and isolate.
- (2) Connect one ohmmeter test lead to the tip of the antenna mast. Connect the other test lead to the antenna base. Check for continuity.
- (3) There should be no continuity. If continuity is found, replace the faulty or damaged antenna base and cable assembly.

TEST 2

Test 2 checks the antenna for an open circuit as follows:

- (1) Unplug the antenna coaxial cable connector from the radio chassis.
- (2) Connect one ohmmeter test lead to the tip of the antenna mast. Connect the other test lead to the center pin of the antenna coaxial cable connector.
- (3) Continuity should exist (the ohmmeter should only register a fraction of an ohm). High or infinite resistance indicates damage to the base and cable assembly. Replace the faulty base and cable, if required.

TEST 3

Test 3 checks the condition of the vehicle body ground connection. This test should be performed with the battery positive cable removed from the battery. Disconnect both battery cables, the negative cable first. Reconnect the battery negative cable and perform the test as follows:

- (1) Connect one ohmmeter test lead to the vehicle fender. Connect the other test lead to the battery negative post.
- (2) The resistance should be less than one ohm.
- (3) If the resistance is more than one ohm, check the braided ground strap connected to the engine and the vehicle body for being loose, corroded, or damaged. Repair the ground strap connection, if required.

TEST 4

Test 4 checks the condition of the ground between the antenna base and the vehicle body as follows:

- (1) Connect one ohmmeter test lead to the vehicle fender. Connect the other test lead to the outer crimp on the antenna coaxial cable connector.
- (2) The resistance should be less than one ohm.
- (3) If the resistance is more than one ohm, clean and/or tighten the antenna base to fender mounting hardware.

RADIO FREQUENCY INTERFERENCE

WARNING: ON VEHICLES EQUIPPED WITH AIR-BAGS, REFER TO GROUP 8M - PASSIVE RESTRAINT SYSTEMS BEFORE ATTEMPTING ANY STEERING WHEEL, STEERING COLUMN, OR INSTRUMENT PANEL COMPONENT DIAGNOSIS OR SERVICE. FAILURE TO TAKE THE PROPER PRECAUTIONS COULD RESULT IN ACCIDENTAL AIR-BAG DEPLOYMENT AND POSSIBLE PERSONAL INJURY.

For complete circuit diagrams, see Group 8W - Wiring Diagrams. Inspect the ground paths and connections at the following locations:

- Blower motor
- Electric fuel pump
- Engine-to-body ground strap
- Generator
- Ignition module
- Radio antenna base ground
- Radio receiver chassis ground wire or strap
- Wiper motor.

If the source of RFI or EMI noise is identified as a component on the vehicle (i.e., generator, blower motor, etc.), the ground path for that component should be checked. If excessive resistance is found in any ground circuit, clean, tighten, or repair the ground circuits or connections to ground as required before considering any component replacement.

For service and inspection of secondary ignition components, refer to the Diagnosis and Testing section of Group 8D - Ignition Systems. Inspect the following secondary ignition system components:

- Distributor cap and rotor
- Ignition coil
- Spark plugs
- Spark plug wire routing and condition.

Reroute the spark plug wires or replace the faulty components as required.

If the source of the RFI or EMI noise is identified as two-way mobile radio or telephone equipment, check the equipment installation for the following:

- Power connections should be made directly to the battery, and fused as closely to the battery as possible.
- The antenna should be mounted on the roof or toward the rear of the vehicle. Remember that magnetic antenna mounts on the roof panel can adversely affect the operation of an overhead console compass, if the vehicle is so equipped.
- The antenna cable should be fully shielded coaxial cable, should be as short as is practical, and should be routed away from the factory-installed vehicle wire harnesses whenever possible.

DIAGNOSIS AND TESTING (Continued)

- The antenna and cable must be carefully matched to ensure a low Standing Wave Ratio (SWR).

Fleet vehicles are available with an extra-cost RFI-suppressed Powertrain Control Module (PCM). This unit reduces interference generated by the PCM on some radio frequencies used in two-way radio communications. However, this unit will not resolve complaints of RFI in the commercial AM or FM radio frequency ranges.

REMOVAL AND INSTALLATION

RADIO

WARNING: ON VEHICLES EQUIPPED WITH AIRBAGS, REFER TO GROUP 8M - PASSIVE RESTRAINT SYSTEMS BEFORE ATTEMPTING ANY STEERING WHEEL, STEERING COLUMN, OR INSTRUMENT PANEL COMPONENT DIAGNOSIS OR SERVICE. FAILURE TO TAKE THE PROPER PRECAUTIONS COULD RESULT IN ACCIDENTAL AIRBAG DEPLOYMENT AND POSSIBLE PERSONAL INJURY.

(1) Disconnect and isolate the battery negative cable.

(2) Using a trim stick or another suitable wide flat-bladed tool, gently pry the instrument panel center bezel away from the instrument panel to release the six snap clip retainers (Fig. 2).

(3) Remove the center bezel from the instrument panel.

(4) Remove the two screws that secure the radio to the instrument panel (Fig. 3).

(5) Pull the radio out from the instrument panel far enough to access the wire harness connectors and the antenna coaxial cable connector (Fig. 4).

(6) Unplug the wire harness connectors and the antenna coaxial cable connector from the rear of the radio.

(7) Remove the radio from the instrument panel.

(8) Reverse the removal procedures to install. Tighten the radio mounting screws to 3.9 N·m (35 in. lbs.).

AMPLIFIER

(1) Disconnect and isolate the battery negative cable.

(2) Disengage the rear seat cushion latch by pulling upward on the release strap. Tilt the seat cushion forward.

(3) Lift the carpeting in the left under-seat area as required to access the amplifier.

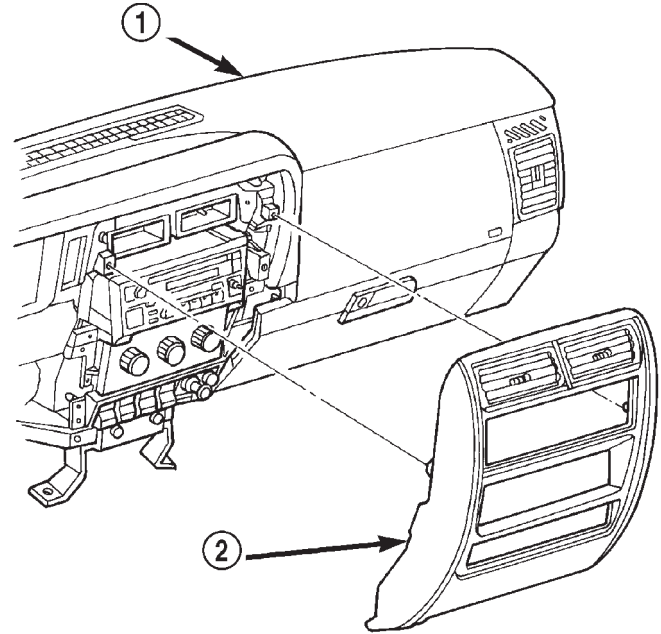

80ab87bc

Fig. 2 Center Bezel Remove/Install

- 1 - INSTRUMENT PANEL
2 - CENTER BEZEL

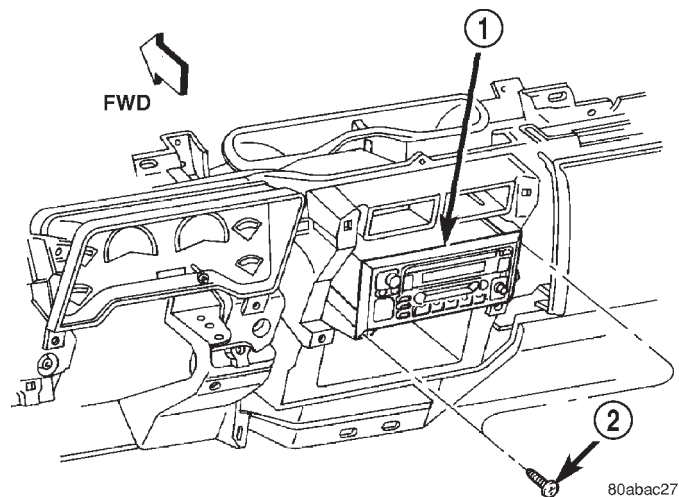

80abac27

Fig. 3 Radio Remove/Install

- 1 - RADIO
2 - SCREW

(4) Unplug the two wire harness connectors from the amplifier (Fig. 5).

(5) Remove the three screws that secure the amplifier to the floor panel.

(6) Remove the amplifier from the floor panel.

(7) Reverse the removal procedures to install. Tighten the amplifier mounting screws to 2.8 N·m (25 in. lbs.).

REMOVAL AND INSTALLATION (Continued)

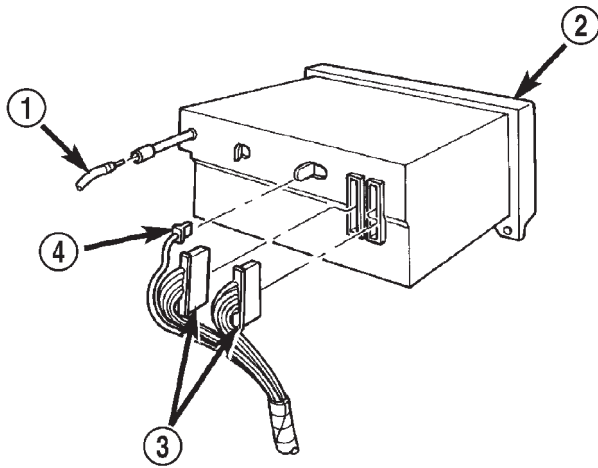

80abac28

Fig. 4 Radio Connections - Typical

- 1 - ANTENNA CABLE
- 2 - RADIO
- 3 - INSTRUMENT PANEL WIRING
- 4 - GROUND WIRE

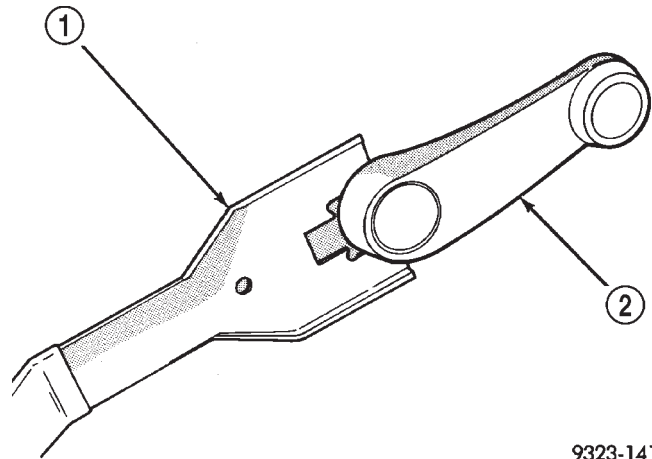

9323-141

Fig. 6 Window Regulator Crank Handle Remove - Typical

- 1 - DOOR HANDLE REMOVAL TOOL
- 2 - WINDOW CRANK

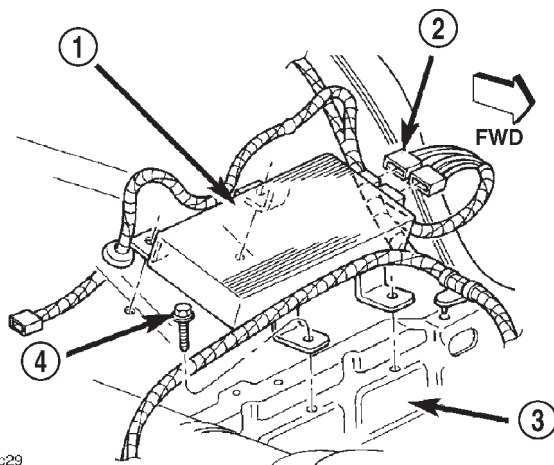

80abac29

Fig. 5 Amplifier Remove/Install

- 1 - AMPLIFIER
- 2 - WIRE HARNESS CONNECTORS
- 3 - REAR FLOOR PAN
- 4 - SCREW

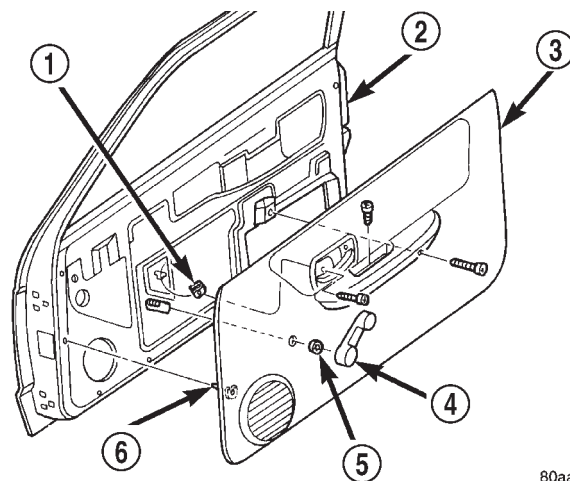

80aafb5c

Fig. 7 Front Door Trim Panel Remove/Install - Manual Window

- 1 - U-NUT
- 2 - DOOR
- 3 - TRIM PANEL
- 4 - WINDOW CRANK
- 5 - SPACER
- 6 - PUSH-IN FASTENER

SPEAKER**FRONT DOOR****LOWER**

(1) Disconnect and isolate the battery negative cable.

(2) If the vehicle is so equipped, remove the manual window regulator crank handle with a removal tool (Fig. 6).

(3) Remove the screws that secure the front door trim panel to the inner door panel (Fig. 7) or (Fig. 8).

(4) Using a trim stick or another suitable wide flat-bladed tool, gently pry the front door trim panel away from the door around the perimeter to release the trim panel retainers.

NOTE: To aid in the removal of the trim panel, start at the bottom of the panel.

(5) Lift the front door trim panel upwards and away from the inner door panel far enough to disen-

REMOVAL AND INSTALLATION (Continued)

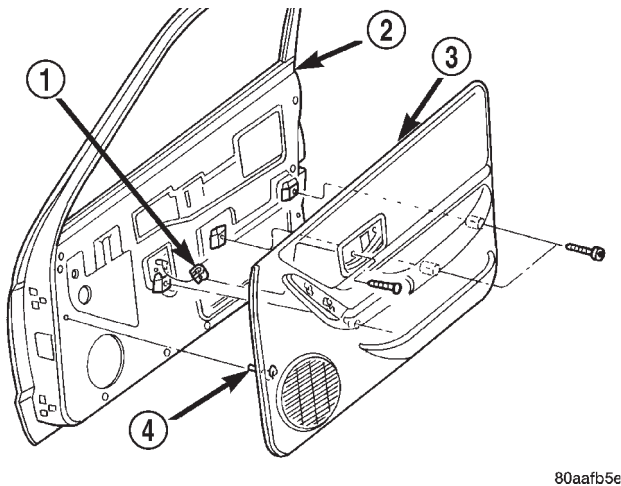

80aafb5e

Fig. 8 Front Door Trim Panel Remove/Install - Power Window

- 1 - U-NUT
- 2 - DOOR
- 3 - TRIM PANEL
- 4 - PUSH-IN FASTENER

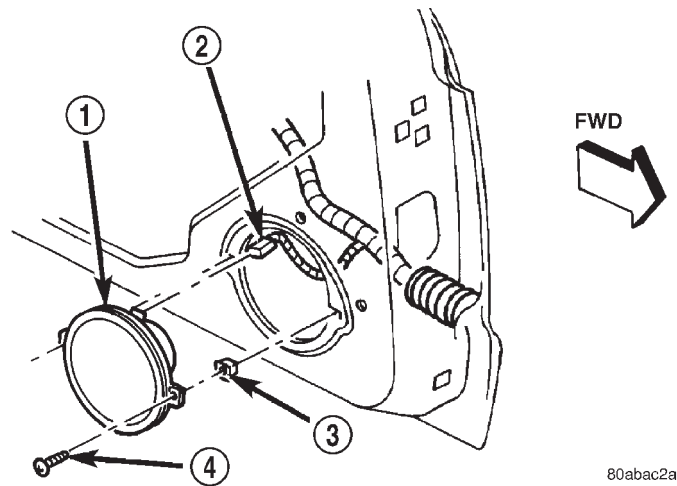

80abac2a

Fig. 9 Front Door Lower Speaker Remove/Install

- 1 - SPEAKER
- 2 - WIRE HARNESS CONNECTORS
- 3 - NUT
- 4 - SCREW

gage the top of the panel from the inner belt weatherstrip.

(6) Pull the front door trim panel away from the inner door panel far enough to access the inside door latch release and lock linkage rods near the back of the inside door remote controls.

(7) Unsnap the plastic retainer clips from the inside door remote control ends of the latch release and lock linkage rods, and remove the rod ends from the inside door remote controls.

(8) If the vehicle is so equipped, unplug the wire harness connectors from the door power switch module and, on the driver side only, the power mirror switch.

(9) Set the front door trim panel aside.

(10) Remove the two screws that secure the speaker to the lower front corner of the inner door panel (Fig. 9).

(11) Pull the speaker away from the inner door panel far enough to access and unplug the speaker wire harness connector.

(12) Remove the speaker from the door.

(13) Reverse the removal procedures to install. Tighten the speaker mounting screws to 1.1 N·m (10 in. lbs.). Tighten the trim panel mounting screws to 2.2 N·m (20 in. lbs.).

UPPER

(1) Remove the front door trim panel from the front door. See Speaker, Front Door, Lower in this group for the procedures.

(2) Remove the one screw that secures the front door flag trim to the inner door panel (Fig. 10).

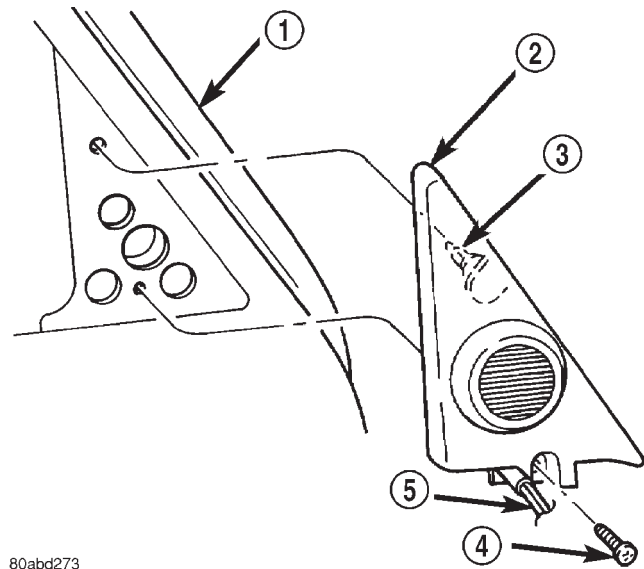

80abd273

Fig. 10 Front Door Flag Trim Panel Remove/Install

- 1 - FRONT DOOR
- 2 - DOOR FLAG TRIM PANEL
- 3 - RETAINER
- 4 - SCREW
- 5 - UPPER SPEAKER WIRE HARNESS

(3) Using a trim stick or another suitable wide flat-bladed tool, gently pry the door flag trim away from the inner door to release the trim panel retainer.

(4) Pull the front door flag trim away from the inner door panel far enough to access and unplug the upper speaker wire harness connector.

(5) Unsnap the speaker from the retainers molded into the back side of the front door flag trim panel.

REMOVAL AND INSTALLATION (Continued)

(6) Reverse the removal procedures to install. Tighten the mounting screw to 2.2 N·m (20 in. lbs.).

REAR HEADLINER

The rear headliner speakers can be serviced without removing the headliner using the procedures that follow. The headliner speaker support structure is integral to the headliner assembly. Refer to Group 23 - Body for the headliner service procedures.

(1) Disconnect and isolate the battery negative cable.

(2) Using a trim stick or another suitable wide flat-bladed tool, gently pry around the perimeter edge of the rear headliner speaker grille to release the five snap retainers that secure the grille to the headliner speaker support structure (Fig. 11).

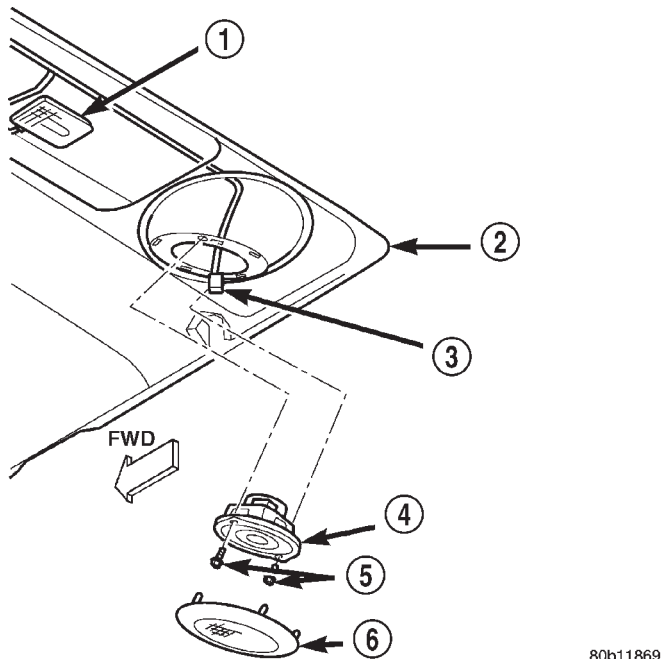

80b11869

Fig. 11 Rear Headliner Speaker Remove/Install

- 1 - CARGO LAMP
- 2 - HEADLINER
- 3 - WIRE HARNESS CONNECTOR
- 4 - SPEAKER
- 5 - SCREWS
- 6 - SPEAKER GRILLE

(3) Remove the speaker grille from the headliner.
 (4) Remove the two screws that secure the speaker to the headliner speaker support structure.

(5) Lower the speaker from the headliner far enough to access and unplug the speaker wire harness connector.

(6) Remove the speaker from the headliner.

(7) Reverse the removal procedures to install. Tighten the mounting screws to 2.2 N·m (20 in. lbs.).

ANTENNA

WARNING: ON VEHICLES EQUIPPED WITH AIR-BAGS, REFER TO GROUP 8M - PASSIVE RESTRAINT SYSTEMS BEFORE ATTEMPTING ANY STEERING WHEEL, STEERING COLUMN, OR INSTRUMENT PANEL COMPONENT DIAGNOSIS OR SERVICE. FAILURE TO TAKE THE PROPER PRECAUTIONS COULD RESULT IN ACCIDENTAL AIR-BAG DEPLOYMENT AND POSSIBLE PERSONAL INJURY.

(1) Disconnect and isolate the battery negative cable.

(2) Remove the right front fender inner splash shield. Refer to Group 23 - Body for the procedures.

(3) Reach under the right end of the instrument panel to unplug the antenna coaxial cable connector (Fig. 12). Unplug the connector by pulling it apart while twisting the metal connector halves. Do not pull on the cable.

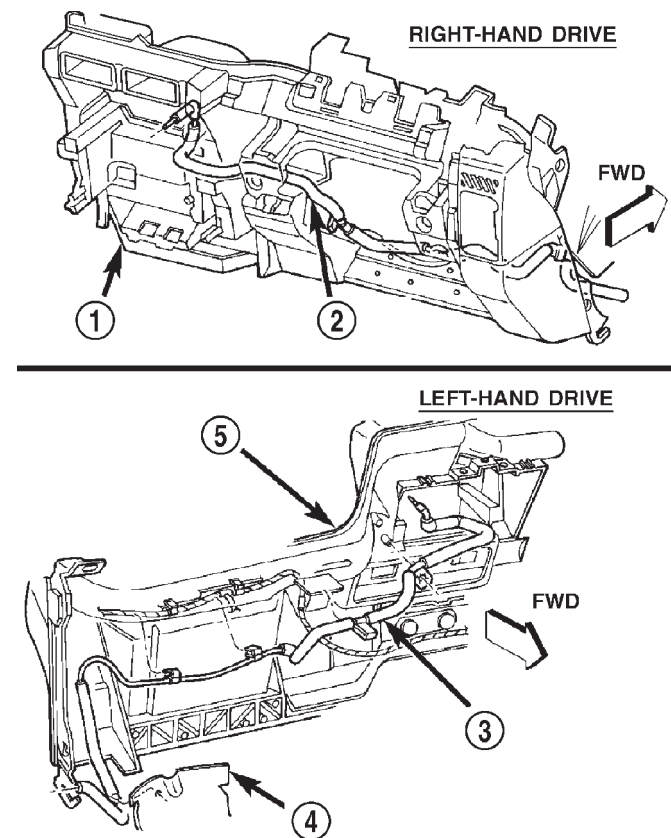

80ac2c51

Fig. 12 Antenna Cable Routing

- 1 - INSTRUMENT PANEL
- 2 - ANTENNA COAXIAL CABLE
- 3 - ANTENNA COAXIAL CABLE
- 4 - HEATER-A/C HOUSING KICK COVER
- 5 - INSTRUMENT PANEL

REMOVAL AND INSTALLATION (Continued)

(4) Unscrew the antenna mast from the antenna body (Fig. 13).

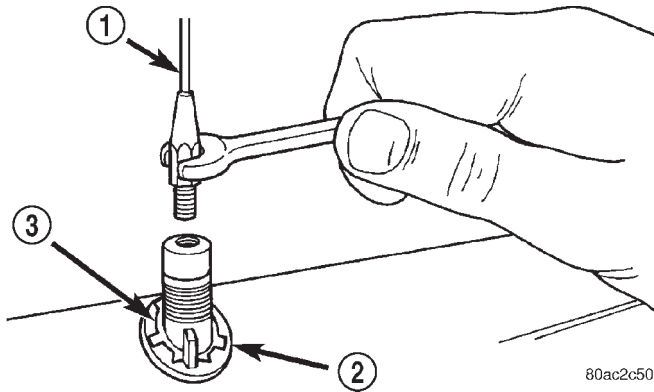

Fig. 13 Antenna Mast Remove/Install - Typical

- 1 - ANTENNA MAST
- 2 - ADAPTER
- 3 - CAP NUT

(5) Remove the antenna cap nut and adapter using an antenna nut wrench (Special Tool C-4816) (Fig. 14).

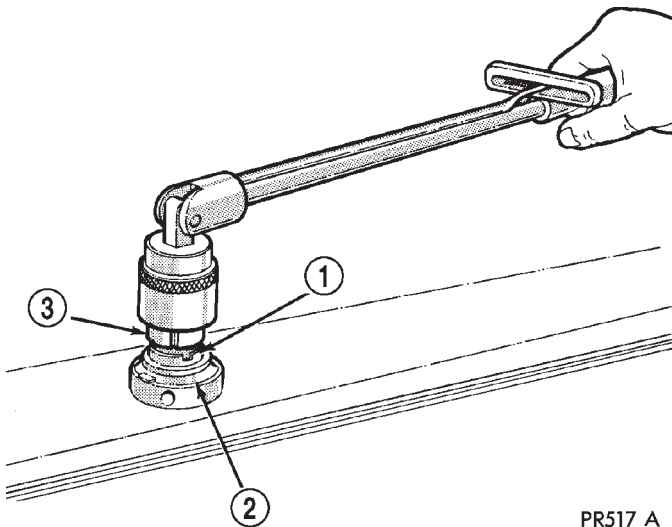

Fig. 14 Antenna Cap Nut and Adapter Remove/Install - Typical

- 1 - CAP NUT
- 2 - ANTENNA ADAPTER
- 3 - TOOL

(6) Lower the antenna body and cable through the top of the fender far enough to access the antenna body by reaching up into the rear of the right front fender wheel housing (Fig. 15).

(7) Disengage the coaxial cable grommet from the hole in the right cowl side outer panel.

(8) Pull the coaxial cable out through the right cowl side outer panel.

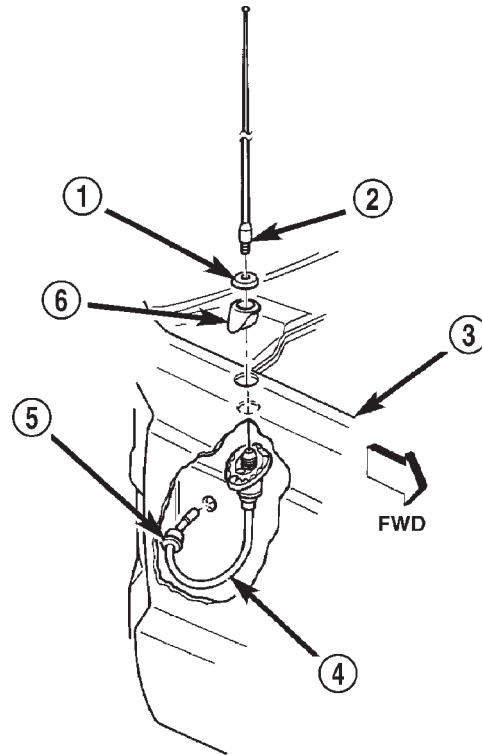

Fig. 15 Antenna Mounting

- 1 - NUT
- 2 - MAST
- 3 - RIGHT FRONT FENDER
- 4 - ANTENNA BODY AND CABLE
- 5 - GROMMET
- 6 - ADAPTER

(9) Remove the antenna body and cable from the vehicle.

(10) Reverse the removal procedures to install. Tighten the antenna cap nut to 6.2 N·m (55 in. lbs.). Tighten the antenna mast to 3.3 N·m (30 in. lbs.).

RADIO NOISE SUPPRESSION COMPONENTS

WARNING: ON VEHICLES EQUIPPED WITH AIRBAGS, REFER TO GROUP 8M - PASSIVE RESTRAINT SYSTEMS BEFORE ATTEMPTING ANY STEERING WHEEL, STEERING COLUMN, OR INSTRUMENT PANEL COMPONENT DIAGNOSIS OR SERVICE. FAILURE TO TAKE THE PROPER PRECAUTIONS COULD RESULT IN ACCIDENTAL AIRBAG DEPLOYMENT AND POSSIBLE PERSONAL INJURY.

REMOVAL

ENGINE-TO-BODY GROUND STRAP

(1) Remove the screw that secures the engine-to-body ground strap eyelet to the dash panel (Fig. 16).

REMOVAL AND INSTALLATION (Continued)

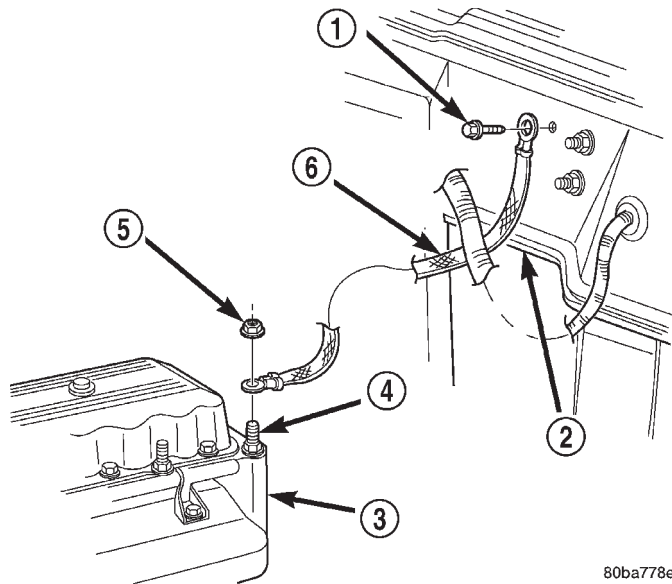

80ba778e

Fig. 16 Engine-To-Body Ground Strap Remove/Install

- 1 - SCREW
- 2 - DASH PANEL
- 3 - ENGINE CYLINDER HEAD
- 4 - STUD
- 5 - NUT
- 6 - GROUND STRAP

(2) Remove the nut that secures the engine-to-body ground strap eyelet to the stud on the left upper rear corner of the engine cylinder head.

(3) Remove the engine-to-body ground strap eyelet from the stud on the left upper rear corner of the engine cylinder head.

(4) Remove the engine-to-body ground strap from the engine compartment.

INSTALLATION**ENGINE-TO-BODY GROUND STRAP**

(1) Position the engine-to-body ground strap in the engine compartment.

(2) Position the engine-to-body ground strap eyelet over the stud on the left upper rear corner of the engine cylinder head.

(3) Install and tighten the nut that secures the engine-to-body ground strap eyelet to the stud on the left upper rear corner of the engine cylinder head. Tighten the nut to 27 N·m (20 ft. lbs.).

(4) Install and tighten the screw that secures the engine-to-body ground strap eyelet to the dash panel. Tighten the screw to 27 N·m (20 ft. lbs.).

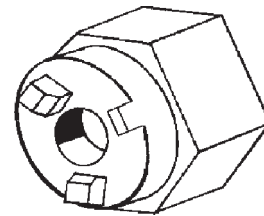
SPECIAL TOOLS**AUDIO SYSTEMS**

Antenna Nut Wrench C-4816

HORN SYSTEMS

TABLE OF CONTENTS

| | page | | page |
|----------------------------------|------|---------------------------------|------|
| DESCRIPTION AND OPERATION | | HORN SWITCH | 4 |
| HORN SYSTEM..... | 1 | HORN | 4 |
| HORN | 1 | REMOVAL AND INSTALLATION | |
| HORN RELAY | 2 | HORN RELAY | 4 |
| HORN SWITCH..... | 2 | HORN | 5 |
| DIAGNOSIS AND TESTING | | | |
| HORN RELAY | 3 | | |

DESCRIPTION AND OPERATION

HORN SYSTEM

DESCRIPTION

A dual-note electric horn system is standard factory-installed equipment on this model. The standard equipment horn system features one low-note horn unit and one high-note horn unit. The horn system uses a non-switched source of battery current so that the system will remain functional, regardless of the ignition switch position. The horn system includes the following components:

- Clockspring
- Horns
- Horn relay
- Horn switch
- Remote Keyless Entry (RKE) receiver (only with the RKE system)

Refer to **Clockspring** in the Description and Operation section of Group 8M - Passive Restraint Systems for more information on this component. Refer to **Remote Keyless Entry System** in the Description and Operation section of Group 8P - Power Lock Systems for more information on this component. Refer to **Horn/Cigar Lighter** in the Contents of Group 8W - Wiring Diagrams for complete circuit diagrams. Following are general descriptions of the remaining major components in the horn system.

OPERATION

The horn system is activated by a horn switch concealed beneath the driver side airbag module trim cover in the center of the steering wheel. Depressing the center of the driver side airbag module trim cover closes the horn switch. Closing the horn switch activates the horn relay. The activated horn relay then switches the battery current needed to energize the horns.

Refer to the owner's manual in the vehicle glove box for more information on the features, use and operation of the horn system.

REMOTE KEYLESS ENTRY RECEIVER

The Remote Keyless Entry (RKE) receiver can also operate the horn system. An RKE receiver is used on this vehicle when it is equipped with the optional RKE system. The RKE receiver controls and integrates the additional electronic functions and features included on models with this option. A customer programmable feature of the RKE system enables the RKE receiver to momentarily energize the horn relay through a hard wired circuit as an audible verification that the receiver has received a valid lock request from the RKE transmitter.

Refer to **Remote Keyless Entry System** in the Description and Operation section of Group 8P - Power Lock Systems for more information on this feature.

HORN

DESCRIPTION

The dual electromagnetic diaphragm-type horns are standard equipment on this model. The low-note horn is secured with a bracket to the left radiator closure panel brace, behind the front bumper. The high-note horn is secured with a bracket to the right radiator closure panel brace, behind the front bumper. Both horns are grounded through their mounting brackets and receives battery feed through its wire harness connector and circuit from the closed contacts of the horn relay.

The horns cannot be repaired or adjusted and, if faulty or damaged, they must be individually replaced.

DESCRIPTION AND OPERATION (Continued)

OPERATION

Within the two halves of the molded plastic horn housing are a flexible diaphragm, a plunger, an electromagnetic coil and a set of contact points. The diaphragm is secured in suspension around its perimeter by the mating surfaces of the horn housing. The plunger is secured to the center of the diaphragm and extends into the center of the electromagnet. The contact points control the current flow through the electromagnet.

When the horn is energized, electrical current flows through the closed contact points to the electromagnet. The resulting electromagnetic field draws the plunger and diaphragm toward it until that movement mechanically opens the contact points. When the contact points open, the electromagnetic field collapses allowing the plunger and diaphragm to return to their relaxed positions and closing the contact points again. This cycle continues repeating at a very rapid rate producing the vibration and movement of air that creates the sound that is directed through the horn outlet.

HORN RELAY

DESCRIPTION

The horn relay is an electromechanical device that switches battery current to the horn when the horn switch grounds the relay coil. The horn relay is located in the junction block on the right cowl side inner panel below the instrument panel in the passenger compartment. If a problem is encountered with a continuously sounding horn, it can usually be quickly resolved by removing the horn relay from the junction block until further diagnosis is completed. Refer to **Junction Block** in the Contents of Group 8W - Wiring Diagrams for horn relay identification and location.

The horn relay is an International Standards Organization (ISO) relay. Relays conforming to the ISO specifications have common physical dimensions, current capacities, terminal patterns, and terminal functions.

The horn relay cannot be repaired or adjusted and, if faulty or damaged, it must be replaced.

OPERATION

The ISO relay consists of an electromagnetic coil, a resistor or diode, and three (two fixed and one movable) electrical contacts. The movable (common feed) relay contact is held against one of the fixed contacts (normally closed) by spring pressure. When the electromagnetic coil is energized, it draws the movable contact away from the normally closed fixed contact, and holds it against the other (normally open) fixed contact.

When the electromagnetic coil is de-energized, spring pressure returns the movable contact to the normally closed position. The resistor or diode is connected in parallel with the electromagnetic coil in the relay, and helps to dissipate voltage spikes that are produced when the coil is de-energized.

HORN SWITCH

DESCRIPTION

A center-blow, normally open, resistive membrane-type horn switch is secured with heat stakes to the back side of the driver side airbag module trim cover in the center of the steering wheel (Fig. 1). The switch consists of two plastic membranes, one that is flat and one that is slightly convex. These two membranes are secured to each other around the perimeter. Inside the switch, the centers of the facing surfaces of these membranes each has a grid made with an electrically conductive material applied to it. One of the grids is connected to a circuit that provides it with continuity to ground at all times. The grid of the other membrane is connected to the horn relay control circuit.

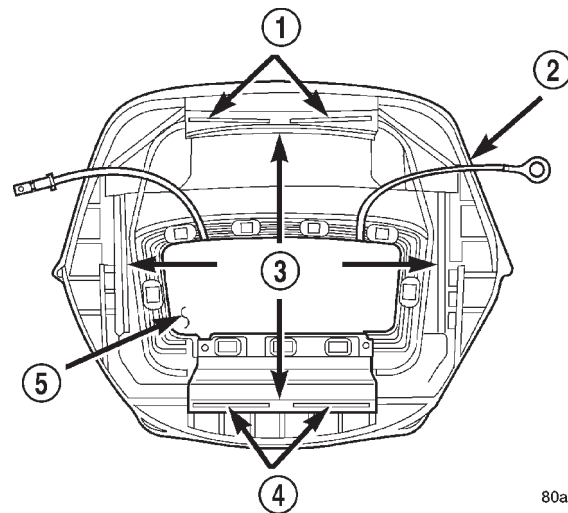

80ab88a6

Fig. 1 Driver Side Airbag Module Trim Cover and Horn Switch

- 1 - RETAINER SLOTS
- 2 - TRIM COVER
- 3 - LOCKING BLOCKS
- 4 - RETAINER SLOTS
- 5 - HORN SWITCH

The steering wheel and steering column must be properly grounded in order for the horn switch to function properly. The horn switch is only serviced as a part of the driver side airbag module trim cover. If the horn switch is damaged or faulty, or if the driver side airbag is deployed, the driver side airbag module

DESCRIPTION AND OPERATION (Continued)

trim cover and horn switch must be replaced as a unit.

OPERATION

When the center area of the driver side airbag trim cover is depressed, the electrically conductive grids on the facing surfaces of the horn switch membranes contact each other, closing the switch circuit. The completed horn switch circuit provides a ground for the control coil side of the horn relay, which activates the relay. When the horn switch is released, the resistive tension of the convex membrane separates the two electrically conductive grids and opens the switch circuit.

DIAGNOSIS AND TESTING

HORN RELAY

The horn relay (Fig. 2) is located in the junction block on the right cowl side inner panel below the instrument panel in the passenger compartment. If a problem is encountered with a continuously sounding horn, it can usually be quickly resolved by removing the horn relay from the junction block until further diagnosis is completed. Refer to **Junction Block** in the Contents of Group 8W - Wiring Diagrams for horn relay identification and location. For complete circuit diagrams, refer to **Horn/Cigar Lighter** in the Contents of Group 8W - Wiring Diagrams.

WARNING: ON VEHICLES EQUIPPED WITH AIRBAGS, REFER TO GROUP 8M - PASSIVE RESTRAINT SYSTEMS BEFORE ATTEMPTING ANY STEERING WHEEL, STEERING COLUMN, OR INSTRUMENT PANEL COMPONENT DIAGNOSIS OR SERVICE. FAILURE TO TAKE THE PROPER PRECAUTIONS COULD RESULT IN ACCIDENTAL AIRBAG DEPLOYMENT AND POSSIBLE PERSONAL INJURY.

- (1) Remove the horn relay from the junction block. Refer to **Horn Relay** in the Removal and Installation section of this group for the procedures.
- (2) A relay in the de-energized position should have continuity between terminals 87A and 30, and no continuity between terminals 87 and 30. If OK, go to Step 3. If not OK, replace the faulty relay.
- (3) Resistance between terminals 85 and 86 (electromagnet) should be 75 ± 5 ohms. If OK, go to Step 4. If not OK, replace the faulty relay.
- (4) Connect a battery to terminals 85 and 86. There should now be continuity between terminals 30 and 87, and no continuity between terminals 87A and 30. If OK, perform the Relay Circuit Test that follows. If not OK, replace the faulty relay.

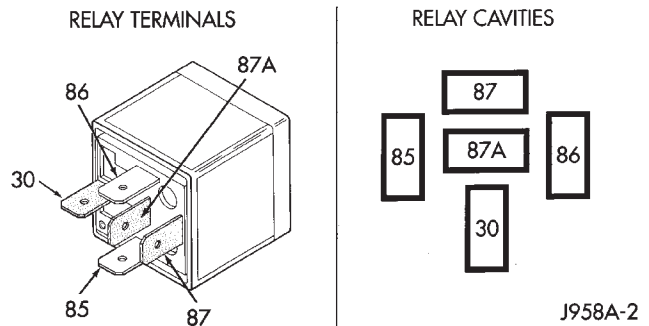

| TERMINAL LEGEND | |
|-----------------|-----------------|
| NUMBER | IDENTIFICATION |
| 30 | COMMON FEED |
| 85 | COIL GROUND |
| 86 | COIL BATTERY |
| 87 | NORMALLY OPEN |
| 87A | NORMALLY CLOSED |

Fig. 2 Horn Relay

RELAY CIRCUIT TEST

- (1) The relay common feed terminal cavity (30) is connected to battery voltage and should be hot at all times. If OK, go to Step 2. If not OK, repair the open circuit to the fuse in the junction block as required.
- (2) The relay normally closed terminal (87A) is connected to terminal 30 in the de-energized position, but is not used for this application. Go to Step 3.
- (3) The relay normally open terminal (87) is connected to the common feed terminal (30) in the energized position. This terminal supplies battery voltage to the horn(s). There should be continuity between the cavity for relay terminal 87 and the horn relay output circuit cavity of each horn wire harness connector at all times. If OK, go to Step 4. If not OK, repair the open circuit to the horn(s) as required.
- (4) The coil battery terminal (86) is connected to the electromagnet in the relay. It is connected to battery voltage and should be hot at all times. Check for battery voltage at the cavity for relay terminal 86. If OK, go to Step 5. If not OK, repair the open circuit to the fuse in the junction block as required.
- (5) The coil ground terminal (85) is connected to the electromagnet in the relay. It is grounded through the horn switch when the horn switch is depressed. On vehicles equipped with the Remote Keyless Entry (RKE) system, the horn relay coil ground terminal can also be grounded by the RKE receiver in response to certain inputs related to the RKE system. Check for continuity to ground at the cavity for relay terminal 85. There should be continuity with the horn switch depressed, and no continuity with the horn switch released. If not OK, refer to **Horn Switch** in the Diagnosis and Testing section of this group.

DIAGNOSIS AND TESTING (Continued)

HORN SWITCH

For complete circuit diagrams, refer to **Horn/Cigar Lighter** in the Contents of Group 8W - Wiring Diagrams.

WARNING: ON VEHICLES EQUIPPED WITH AIRBAGS, REFER TO GROUP 8M - PASSIVE RESTRAINT SYSTEMS BEFORE ATTEMPTING ANY STEERING WHEEL, STEERING COLUMN, OR INSTRUMENT PANEL COMPONENT DIAGNOSIS OR SERVICE. FAILURE TO TAKE THE PROPER PRECAUTIONS COULD RESULT IN ACCIDENTAL AIRBAG DEPLOYMENT AND POSSIBLE PERSONAL INJURY.

(1) Disconnect and isolate the battery negative cable. Remove the knee blocker from the instrument panel.

(2) Check for continuity between the metal steering column jacket and a good ground. There should be continuity. If OK, go to Step 3. If not OK, refer to **Steering Column** in the Removal and Installation section of Group 19 - Steering for proper installation of the steering column.

(3) Remove the driver side airbag module from the steering wheel. Disconnect the horn switch wire harness connectors from the driver side airbag module.

(4) Remove the horn relay from the junction block. Check for continuity between the steering column half of the horn switch feed wire harness connector and a good ground. There should be no continuity. If OK, go to Step 5. If not OK, repair the shorted horn relay control circuit to the horn relay in the junction block as required.

(5) Check for continuity between the steering column half of the horn switch feed wire harness connector and the horn relay control circuit cavity for the horn relay in the junction block. There should be continuity. If OK, go to Step 6. If not OK, repair the open horn relay control circuit to the horn relay in the junction block as required.

(6) Check for continuity between the horn switch feed wire and the horn switch ground wire on the driver side airbag module. There should be no continuity. If OK, go to Step 7. If not OK, replace the faulty horn switch.

(7) Depress the center of the driver side airbag module trim cover and check for continuity between the horn switch feed wire and the horn switch ground wire on the driver side airbag module. There should now be continuity. If not OK, replace the faulty horn switch.

HORN

For complete circuit diagrams, refer to **Horn/Cigar Lighter** in the Contents of Group 8W - Wiring Diagrams.

(1) Measure the resistance between the horn(s) mounting bracket(s) and a good ground. There should be no measurable resistance. If OK, go to Step 2. If not OK, clean and tighten the horn mounting hardware as required.

(2) Disconnect the wire harness connector(s) from the horn connector receptacle(s). Check for battery voltage at the horn relay output circuit cavity of the horn(s) wire harness connector(s). There should be zero volts. If OK, go to Step 3. If not OK, repair the shorted horn relay output circuit or replace the faulty horn relay as required.

(3) Depress the horn switch. There should now be battery voltage at the horn relay output circuit cavity of the horn(s) wire harness connector(s). If OK, replace the faulty horn(s). If not OK, repair the open horn relay output circuit to the horn relay as required.

REMOVAL AND INSTALLATION

HORN RELAY

REMOVAL

(1) Disconnect and isolate the battery negative cable.

(2) Remove the fuse access panel by unsnapping it from the right cowl side inner trim panel (Fig. 3).

(3) Remove the push nut that secures the right cowl side inner trim panel to the junction block stud.

(4) Remove the screw located above the fuse access opening that secures the trim panel to the right cowl side inner panel.

(5) Remove the screw that secures the right cowl side inner trim panel and right front door sill trim to the door opening sill.

(6) Remove the trim from the right cowl side inner panel.

(7) Refer to **Junction Block** in the Contents of Group 8W - Wiring Diagrams for horn relay identification and location.

(8) Remove the horn relay from the junction block.

INSTALLATION

(1) Refer to **Junction Block** in the Contents of Group 8W - Wiring Diagrams for proper horn relay location.

(2) Position the horn relay in the proper receptacle in the junction block.

(3) Align the horn relay terminals with the terminal cavities in the junction block receptacle.

REMOVAL AND INSTALLATION (Continued)

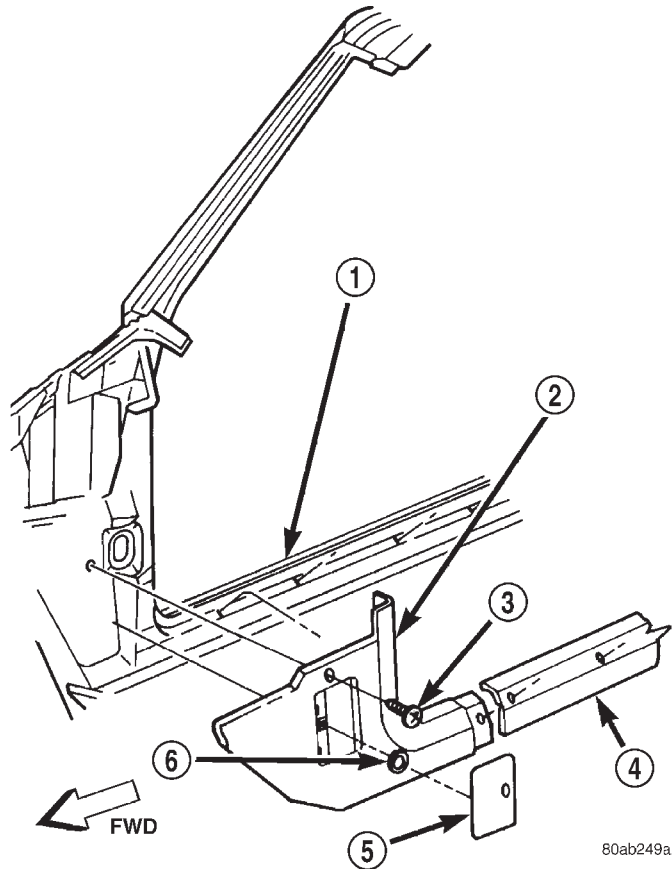

Fig. 3 Right Cowl Side Inner Trim Remove/Install

- 1 - RIGHT FRONT DOOR SILL
- 2 - COWL SIDE TRIM PANEL
- 3 - SCREW
- 4 - SILL TRIM
- 5 - FUSE ACCESS PANEL
- 6 - PUSH-NUT

(4) Push down firmly on the horn relay until the terminals are fully seated in the terminal cavities in the junction block receptacle.

(5) Position the trim onto the right cowl side inner panel.

(6) Install and tighten the screw that secures the right cowl side inner trim panel and right front door sill trim to the door opening sill. Tighten the screw to 2.2 N·m (20 in. lbs.).

(7) Install and tighten the screw located above the fuse access opening that secures the trim panel to the right cowl side inner panel. Tighten the screw to 2.2 N·m (20 in. lbs.).

(8) Install the push nut that secures the right cowl side inner trim panel onto the junction block stud.

(9) Install the fuse access panel by snapping it onto the right cowl side inner trim panel.

(10) Reconnect the battery negative cable.

HORN

REMOVAL

(1) Disconnect and isolate the battery negative cable.

(2) Raise and support the vehicle.

(3) Remove the front underbody splash shield.

NOTE: Remove the horn and its mounting bracket from the vehicle as a unit. Do not remove the horn from its mounting bracket.

(4) Remove the screw that secures the horn and mounting bracket unit to the radiator closure panel brace (Fig. 4).

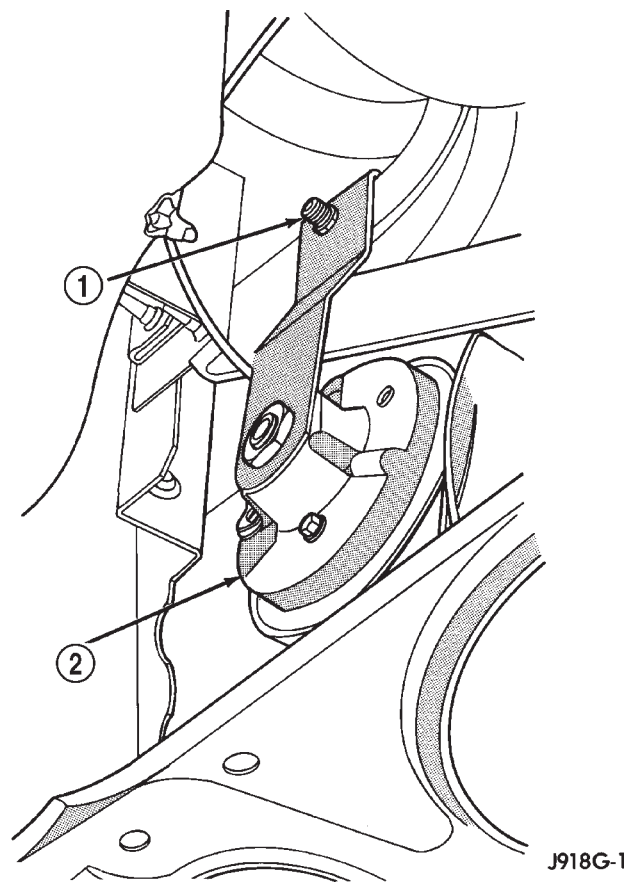

Fig. 4 Horns Remove/Install

- 1 - MOUNTING BOLT
- 2 - HORN

(5) Lower the horn and mounting bracket unit far enough to access and disconnect the wire harness connector from the horn connector receptacle.

(6) Remove the horn and mounting bracket unit from behind the front bumper.

REMOVAL AND INSTALLATION (Continued)

INSTALLATION

(1) Position the horn and mounting bracket unit behind the front bumper.

(2) Reconnect the wire harness connector to the horn connector receptacle.

(3) Position the horn and mounting bracket unit to the radiator closure panel brace.

(4) Install and tighten the screw that secures the horn and mounting bracket unit to the radiator clo-

sure panel brace. Tighten the screw to 28.5 N·m (21 ft. lbs.).

(5) Install the front underbody splash shield.

(6) Lower the vehicle.

(7) Reconnect the battery negative cable.

SPEED CONTROL SYSTEM

TABLE OF CONTENTS

| | page | | page |
|--|------|---------------------------------|------|
| DESCRIPTION AND OPERATION | | DIAGNOSIS AND TESTING | |
| SPEED CONTROL SYSTEM | 1 | ROAD TEST | 4 |
| SPEED CONTROL SERVO..... | 2 | VACUUM SUPPLY TEST..... | 4 |
| SPEED CONTROL SOLENOID CIRCUITS | 2 | REMOVAL AND INSTALLATION | |
| SPEED CONTROL SWITCHES | 2 | SPEED CONTROL SERVO..... | 5 |
| BRAKE LAMP SWITCH..... | 3 | SPEED CONTROL SWITCH..... | 5 |
| SERVO CABLE | 3 | SERVO CABLE | 6 |
| VACUUM RESERVOIR | 3 | VACUUM RESERVOIR | 6 |
| VEHICLE SPEED SENSOR (SPEED CONTROL OPERATION) | 4 | SPECIFICATIONS | |
| | | TORQUE CHART..... | 7 |

DESCRIPTION AND OPERATION

SPEED CONTROL SYSTEM

DESCRIPTION

The speed control system is electronically controlled and vacuum operated. Electronic control of the speed control system is integrated into the Powertrain Control Module (PCM). The controls consist of two steering wheel mounted switches. The switches are labeled: ON/OFF, RES/ACCEL, SET, COAST, and CANCEL.

The system is designed to operate at speeds above 30 mph (50 km/h).

WARNING: THE USE OF SPEED CONTROL IS NOT RECOMMENDED WHEN DRIVING CONDITIONS DO NOT PERMIT MAINTAINING A CONSTANT SPEED, SUCH AS IN HEAVY TRAFFIC OR ON ROADS THAT ARE WINDING, ICY, SNOW COVERED, OR SLIPPERY.

OPERATION

When speed control is selected by depressing the ON switch, the PCM allows a set speed to be stored in PCM RAM for speed control. To store a set speed, depress the SET switch while the vehicle is moving at a speed between 35 and 85 mph. In order for the speed control to engage, the brakes cannot be applied, nor can the gear selector be indicating the transmission is in Park or Neutral.

The speed control can be disengaged manually by:

- Stepping on the brake pedal
- Depressing the OFF switch
- Depressing the CANCEL switch.

- Depressing the clutch pedal (if equipped).

NOTE: Depressing the OFF switch or turning off the ignition switch will erase the set speed stored in the PCM.

For added safety, the speed control system is programmed to disengage for any of the following conditions:

- An indication of Park or Neutral
- A rapid increase rpm (indicates that the clutch has been disengaged)
- Excessive engine rpm (indicates that the transmission may be in a low gear)
 - The speed signal increases at a rate of 10 mph per second (indicates that the coefficient of friction between the road surface and tires is extremely low)
 - The speed signal decreases at a rate of 10 mph per second (indicates that the vehicle may have decelerated at an extremely high rate)

Once the speed control has been disengaged, depressing the RES/ACCEL switch (when speed is greater than 30 mph) restores the vehicle to the target speed that was stored in the PCM.

While the speed control is engaged, the driver can increase the vehicle speed by depressing the RES/ACCEL switch. The new target speed is stored in the PCM when the RES/ACCEL is released. The PCM also has a "tap-up" feature in which vehicle speed increases at a rate of approximately 2 mph for each momentary switch activation of the RES/ACCEL switch.

DESCRIPTION AND OPERATION (Continued)

A “tap down” feature is used to decelerate without disengaging the speed control system. To decelerate from an existing recorded target speed, momentarily depress the COAST switch. For each switch activation, speed will be lowered approximately 1 mph.

SPEED CONTROL SERVO

DESCRIPTION

The servo unit consists of a solenoid valve body, and a vacuum chamber. The solenoid valve body contains three solenoids:

- Vacuum
- Vent
- Dump

The vacuum chamber contains a diaphragm with a cable attached to control the throttle linkage.

OPERATION

The Powertrain Control Module (PCM) controls the solenoid valve body. The solenoid valve body controls the application and release of vacuum to the diaphragm of the vacuum servo. The servo unit cannot be repaired and is serviced only as a complete assembly.

Power is supplied to the servo's by the PCM through the brake switch. The PCM controls the ground path for the vacuum and vent solenoids.

The dump solenoid is energized anytime it receives power. If power to the dump solenoid is interrupted, the solenoid dumps vacuum in the servo. This provides a safety backup to the vent and vacuum solenoids.

The vacuum and vent solenoids must be grounded at the PCM to operate. When the PCM grounds the vacuum servo solenoid, the solenoid allows vacuum to enter the servo and pull open the throttle plate using the cable. When the PCM breaks the ground, the solenoid closes and no more vacuum is allowed to enter the servo. The PCM also operates the vent solenoid via ground. The vent solenoid opens and closes a passage to bleed or hold vacuum in the servo as required.

The PCM duty cycles the vacuum and vent solenoids to maintain the set speed, or to accelerate and decelerate the vehicle. To increase throttle opening, the PCM grounds the vacuum and vent solenoids. To decrease throttle opening, the PCM removes the grounds from the vacuum and vent solenoids. When the brake is released, if vehicle speed exceeds 30 mph to resume, 35 mph to set, and the RES/ACCEL switch has been depressed, ground for the vent and vacuum circuits is restored.

SPEED CONTROL SOLENOID CIRCUITS

OPERATION

When all of the speed control parameters are met, and the SET button is pressed, the PCM actuates the vent solenoid and “duty-cycles” the vacuum solenoid to open the throttle and bring the vehicle up to target speed. When the vehicle is at target speed, it will actuate the vent solenoid with the vacuum solenoid de-activated to maintain the vehicle at target speed. When the vehicle is above target speed, the PCM will “duty-cycle” the vent solenoid with the vacuum solenoid still de-activated to close the throttle to return to target speed.

SPEED CONTROL SWITCHES

DESCRIPTION

There are two separate switch pods that operate the speed control system. The steering-wheel-mounted switches use multiplexed circuits to provide inputs to the PCM for ON, OFF, RESUME, ACCELERATE, SET, DECEL and CANCEL modes. Refer to the owner's manual for more information on speed control switch functions and setting procedures.

The individual switches cannot be repaired. If one switch fails, the entire switch module must be replaced.

OPERATION

When speed control is selected by depressing the ON, OFF switch, the PCM allows a set speed to be stored in its RAM for speed control. To store a set speed, depress the SET switch while the vehicle is moving at a speed between approximately 35 and 85 mph. In order for the speed control to engage, the brakes cannot be applied, nor can the gear selector be indicating the transmission is in Park or Neutral.

The speed control can be disengaged manually by:

- Stepping on the brake pedal
- Depressing the OFF switch
- Depressing the CANCEL switch.

The speed control can be disengaged also by any of the following conditions:

- An indication of Park or Neutral
- The VSS signal increases at a rate of 10 mph per second (indicates that the co-efficient of friction between the road surface and tires is extremely low)
- Depressing the clutch pedal.
- Excessive engine rpm (indicates that the transmission may be in a low gear)
- The VSS signal decreases at a rate of 10 mph per second (indicates that the vehicle may have decelerated at an extremely high rate)
- If the actual speed is not within 20 mph of the set speed

DESCRIPTION AND OPERATION (Continued)

The previous disengagement conditions are programmed for added safety.

Once the speed control has been disengaged, depressing the ACCEL switch restores the vehicle to the target speed that was stored in the PCM's RAM.

NOTE: Depressing the OFF switch will erase the set speed stored in the PCM's RAM.

If, while the speed control is engaged, the driver wishes to increase vehicle speed, the PCM is programmed for an acceleration feature. With the ACCEL switch held closed, the vehicle accelerates slowly to the desired speed. The new target speed is stored in the PCM's RAM when the ACCEL switch is released. The PCM also has a "tap-up" feature in which vehicle speed increases at a rate of approximately 2 mph for each momentary switch activation of the ACCEL switch.

The PCM also provides a means to decelerate without disengaging speed control. To decelerate from an existing recorded target speed, depress and hold the COAST switch until the desired speed is reached. Then release the switch. The ON, OFF switch operates two components: the PCM's ON, OFF input, and the battery voltage to the brake switch, which powers the speed control servo.

Multiplexing

The PCM sends out 5 volts through a fixed resistor and monitors the voltage change between the fixed resistor and the switches. If none of the switches are depressed, the PCM will measure 5 volts at the sensor point (open circuit). If a switch with no resistor is closed, the PCM will measure 0 volts (grounded circuit). Now, if a resistor is added to a switch, then the PCM will measure some voltage proportional to the size of the resistor. By adding a different resistor to each switch, the PCM will see a different voltage depending on which switch is pushed.

Another resistor has been added to the 'at rest circuit' causing the PCM to never see 5 volts. This was done for diagnostic purposes. If the switch circuit should open (bad connection), then the PCM will see the 5 volts and know the circuit is bad. The PCM will then set an open circuit fault.

BRAKE LAMP SWITCH

DESCRIPTION

The switch is mounted on the brake pedal mounting bracket under the instrument panel.

OPERATION

Vehicles equipped with the speed control option use a dual function brake lamp switch. The PCM monitors the state of the dual function brake lamp switch.

Refer to the Brake section for more information on brake lamp switch service and adjustment procedures.

The brake switch is equipped with three sets of contacts, one normally open and the other two normally closed (brakes disengaged). The PCM sends a 12 volt signal to one of the normally closed contacts in the brake switch, which is returned to the PCM as a brake switch state signal. With the contacts closed, the 12 volt signal is pulled to ground causing the signal to go low. The low voltage signal, monitored by the PCM, indicates that the brakes are not applied. When the brakes are applied, the contacts open, causing the PCM's output brake signal to go high, disengaging the speed control, cutting off PCM power to the speed control solenoids.

The second set of normally closed contacts supplies 12 volts from the PCM any time speed control is turned on. Through the brake switch, current is routed to the speed control servo solenoids. The speed control solenoids (vacuum, vent and dump) are provided this current any time the speed control is ON and the brakes are disengaged.

When the driver applies the brakes, the contacts open and current is interrupted to the solenoids. The normally open contacts are fed battery voltage. When the brakes are applied, battery voltage is supplied to the brake lamps.

SERVO CABLE

DESCRIPTION

The speed control servo cable is connected between the speed control vacuum servo diaphragm and the throttle body control linkage.

OPERATION

This cable causes the throttle control linkage to open or close the throttle valve in response to movement of the vacuum servo diaphragm.

VACUUM RESERVOIR

DESCRIPTION

The vacuum reservoir is a plastic storage tank connected to an engine vacuum source by vacuum lines.

OPERATION

The vacuum reservoir is used to supply the vacuum needed to maintain proper speed control operation when engine vacuum drops, such as in climbing a grade while driving. A one-way check valve is used in the vacuum line between the reservoir and the vacuum source. This check valve is used to trap engine vacuum in the reservoir. On certain vehicle applications, this reservoir is shared with the heat-

DESCRIPTION AND OPERATION (Continued)

ing/air-conditioning system. The vacuum reservoir cannot be repaired and must be replaced if faulty.

VEHICLE SPEED SENSOR (SPEED CONTROL OPERATION)

DESCRIPTION

The Vehicle Speed Sensor (VSS) is mounted to an adapter near the transmission output shaft. The sensor is driven through the adapter by a speedometer pinion gear.

OPERATION

The VSS is a pulse generator. The VSS pulse signal to the speedometer/odometer is monitored by the PCM speed control circuitry to determine vehicle speed and to maintain speed control set speed.

DIAGNOSIS AND TESTING

ROAD TEST

Perform a vehicle road test to verify reports of speed control system malfunction. The road test should include attention to the speedometer. Speedometer operation should be smooth and without flutter at all speeds.

Flutter in the speedometer indicates a problem which might cause surging in the speed control system. The cause of any speedometer problems should be corrected before proceeding. Refer to Group 8E, Instrument Panel and Gauges for speedometer diagnosis.

If a road test verifies a system problem and the speedometer operates properly, check for:

- A Diagnostic Trouble Code (DTC). If a DTC exists, conduct tests per the Powertrain Diagnostic Procedures service manual.
- A misadjusted brake (stop) lamp switch. This could also cause an intermittent problem.
- Loose, damaged or corroded electrical connections at the servo. Corrosion should be removed from electrical terminals and a light coating of Mopar MultiPurpose Grease, or equivalent, applied.
 - Leaking vacuum reservoir.
 - Loose or leaking vacuum hoses or connections.
 - Defective one-way vacuum check valve.
 - Secure attachment of both ends of the speed control servo cable.

- Smooth operation of throttle linkage and throttle body air valve.
- Failed speed control servo. Do the servo vacuum test.

CAUTION: When test probing for voltage or continuity at electrical connectors, care must be taken not to damage connector, terminals or seals. If these components are damaged, intermittent or complete system failure may occur.

VACUUM SUPPLY TEST

(1) Disconnect vacuum hose at speed control servo and install a vacuum gauge into the disconnected hose.

(2) Start engine and observe gauge at idle. Vacuum gauge should read at least ten inches of mercury.

(3) If vacuum is less than ten inches of mercury, determine source of leak. Check vacuum line to engine for leaks. Also check actual engine intake manifold vacuum. If manifold vacuum does not meet this requirement, check for poor engine performance and repair as necessary.

(4) If vacuum line to engine is not leaking, check for leak at vacuum reservoir. To locate and gain access to reservoir, refer to Vacuum Reservoir Removal/Installation in this group. Disconnect vacuum line at reservoir and connect a hand-operated vacuum pump to reservoir fitting. Apply vacuum. Reservoir vacuum should not bleed off. If vacuum is being lost, replace reservoir.

(5) Verify operation of one-way check valve and check it for leaks.

(a) Locate one-way check valve. The valve is located in vacuum line between vacuum reservoir and engine vacuum source. Disconnect vacuum hoses (lines) at each end of valve.

(b) Connect a hand-operated vacuum pump to reservoir end of check valve. Apply vacuum. Vacuum should not bleed off. If vacuum is being lost, replace one-way check valve.

(c) Connect a hand-operated vacuum pump to vacuum source end of check valve. Apply vacuum. Vacuum should flow through valve. If vacuum is not flowing, replace one-way check valve. Seal the fitting at opposite end of valve with a finger and apply vacuum. If vacuum will not hold, diaphragm within check valve has ruptured. Replace valve.

REMOVAL AND INSTALLATION

SPEED CONTROL SERVO

REMOVAL

- (1) Disconnect negative battery cable at battery.
- (2) Disconnect vacuum line at servo (Fig. 1).
- (3) Disconnect electrical connector at servo.
- (4) Disconnect servo cable at throttle body. Refer to Servo Cable Removal/Installation.

(5) Remove 2 mounting nuts holding servo cable sleeve to bracket (Fig. 2).

(6) Pull speed control cable sleeve and servo away from servo mounting bracket to expose cable retaining clip (Fig. 2) and remove clip. Note: The servo mounting bracket displayed in (Fig. 2) is a typical bracket and may/may not be applicable to this model vehicle.

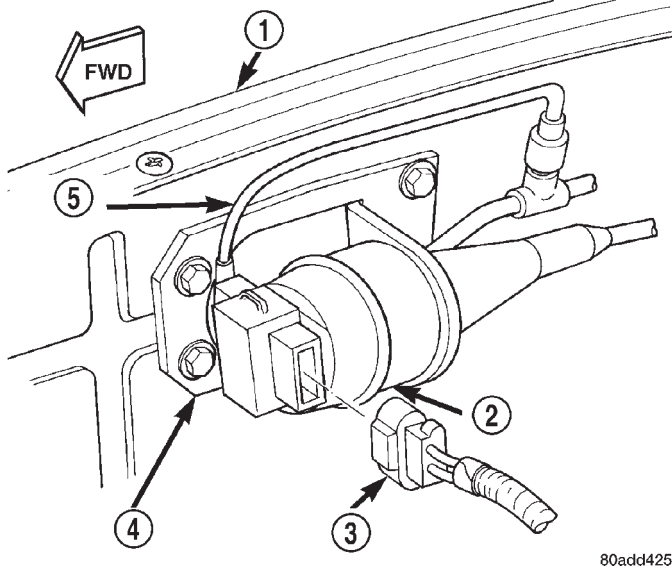

Fig. 1 Speed Control Servo Location

- 1 - R. F. FENDER
- 2 - SPEED CONTROL SERVO
- 3 - ELECTRICAL CONNECTOR
- 4 - MOUNTING BRACKET
- 5 - VACUUM LINE

(7) Remove servo from mounting bracket. While removing, note orientation of servo to bracket.

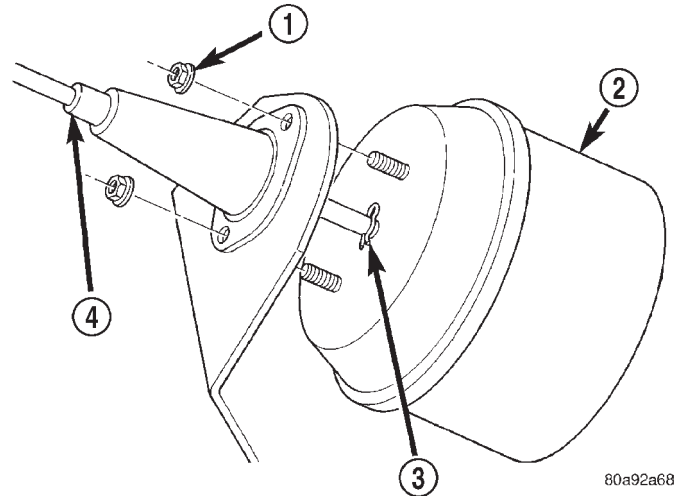

Fig. 2 Servo Cable Clip Remove/Install—Typical

- 1 - SERVO MOUNTING NUTS (2)
- 2 - SERVO
- 3 - CABLE RETAINING CLIP
- 4 - SERVO CABLE AND SLEEVE

INSTALLATION

- (1) Position servo to mounting bracket.
- (2) Align hole in cable connector with hole in servo pin. Install cable-to-servo retaining clip.
- (3) Insert servo mounting studs through holes in servo mounting bracket.
- (4) Install servo mounting nuts and tighten to 8.5 N-m (75 in. lbs.).
- (5) Connect vacuum line at servo.
- (6) Connect electrical connector at servo.
- (7) Connect servo cable to throttle body. Refer to Servo Cable Removal/Installation.
- (8) Connect negative battery cable to battery.
- (9) Before starting engine, operate accelerator pedal to check for any binding.

SPEED CONTROL SWITCH

WARNING: BEFORE ATTEMPTING TO DIAGNOSE, REMOVE OR INSTALL ANY AIRBAG SYSTEM OR RELATED STEERING WHEEL AND STEERING COLUMN COMPONENTS YOU MUST FIRST DISCONNECT AND ISOLATE THE BATTERY NEGATIVE (GROUND) CABLE. WAIT 2 MINUTES FOR SYSTEM CAPACITOR TO DISCHARGE BEFORE FURTHER SYSTEM SERVICE. FAILURE TO DO SO COULD RESULT IN ACCIDENTAL DEPLOYMENT AND POSSIBLE PERSONAL INJURY.

REMOVAL AND INSTALLATION (Continued)

REMOVAL

- (1) Disconnect and isolate negative battery cable from battery.
- (2) Remove airbag module. Refer to Group 8M, Passive Restraint Systems.
- (3) From underside of steering wheel, remove speed control switch mounting screw (Fig. 3).

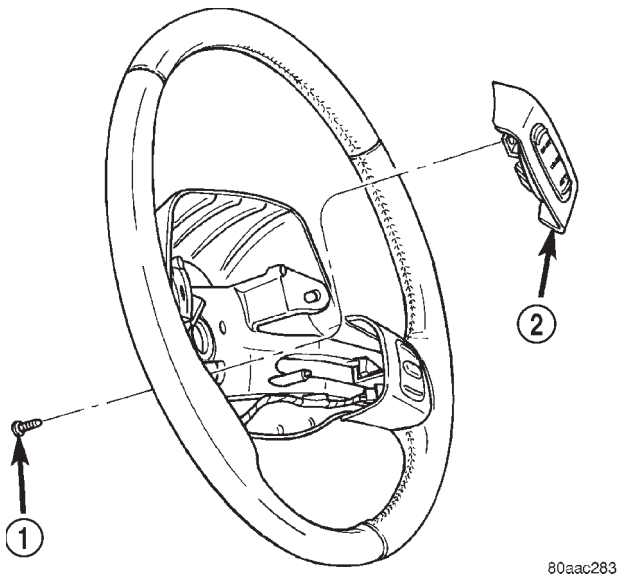

80aac283

Fig. 3 Speed Control Switch Remove/Install

- 1 - MOUNTING SCREW
2 - SPEED CONTROL SWITCH

- (4) Remove switch from steering wheel and unplug electrical connector.

INSTALLATION

- (1) Plug electrical connector into switch.
- (2) Position switch to steering wheel.
- (3) Install switch mounting screw and tighten to 1.5 N·m (14 in. lbs.) torque.
- (4) Install airbag module. Refer to Group 8M, Passive Restraint Systems.
- (5) Connect negative battery cable to battery.

SERVO CABLE

REMOVAL

- (1) Disconnect negative battery cable at battery.
- (2) Using finger pressure only, remove cable connector by pushing connector off the throttle body bellcrank pin (Fig. 4). **DO NOT try to pull cable connector off perpendicular to the bellcrank pin. Connector will be broken.**
- (3) Two release tabs are located on sides of speed control cable at cable bracket (Fig. 4). Squeeze tabs together and push cable out of bracket.
- (4) Unclip cable from cable guide at valve cover.

- (5) Disconnect servo cable at servo. Refer to Speed Control Servo Removal/Installation.

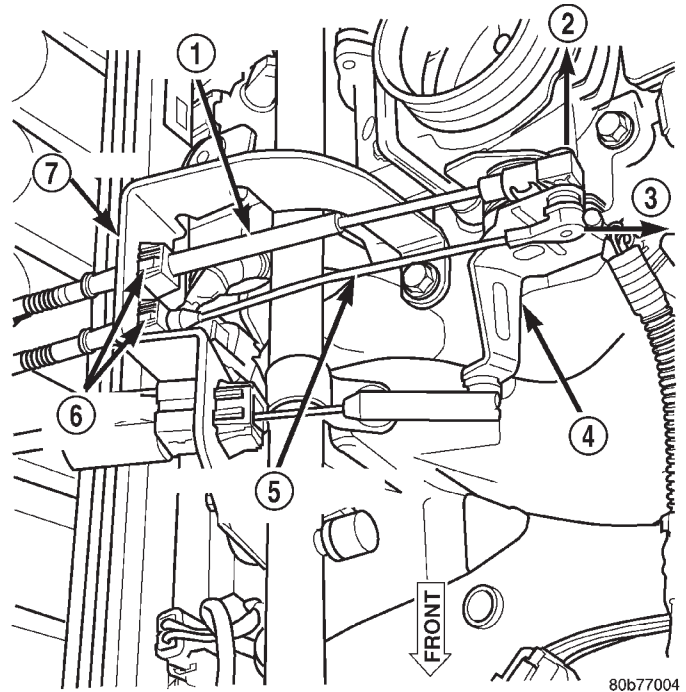

80b77004

Fig. 4 Speed Control Servo Cable at Throttle Body

- 1 - ACCELERATOR CABLE
2 - OFF
3 - OFF
4 - THROTTLE BODY BELLCRANK
5 - SPEED CONTROL CABLE
6 - RELEASE TABS
7 - BRACKET

INSTALLATION

- (1) Attach end of cable to speed control servo. Refer to Speed Control Servo Removal/Installation.
- (2) Install cable into cable bracket (snaps in).
- (3) Install cable connector at throttle body bellcrank pin (snaps on).
- (4) Clip cable to cable guide at valve cover.
- (5) Connect negative battery cable to battery.
- (6) Before starting engine, operate accelerator pedal to check for any binding.

VACUUM RESERVOIR

REMOVAL

- The vacuum reservoir is located behind right front bumper end cap on vehicles equipped with LHD (Left Hand Drive) (Fig. 5). It is located behind left front bumper end cap on vehicles equipped with RHD (Right Hand Drive).
- (1) Remove front bumper end cap. Refer to Front Bumper End Cap Removal/Installation.
 - (2) Remove vacuum line at reservoir (Fig. 6).

REMOVAL AND INSTALLATION (Continued)

- (3) Remove 2 reservoir mounting screws.
- (4) Remove reservoir from bumper bar.

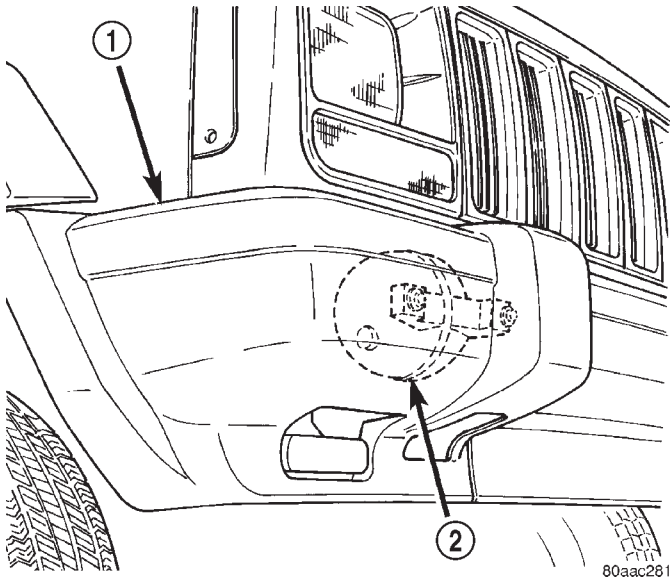

Fig. 5 Vacuum Reservoir Location

- 1 - BUMPER END CAP
- 2 - VACUUM RESERVOIR

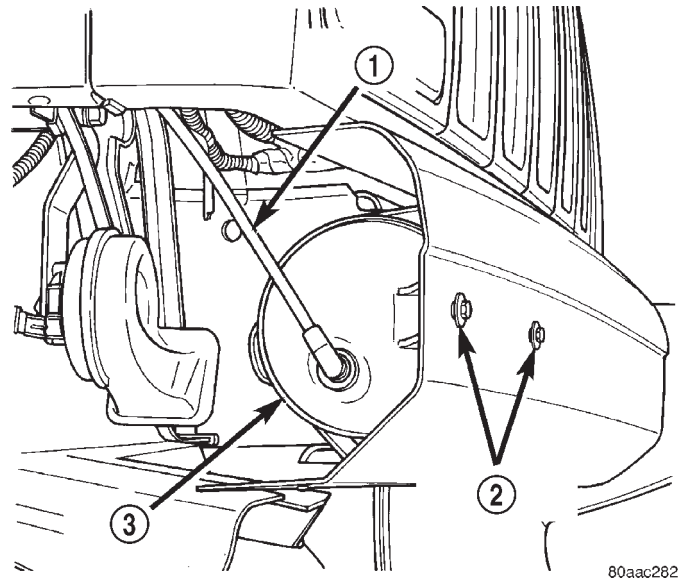

Fig. 6 Vacuum Reservoir Removal/Installation

- 1 - VACUUM LINE
- 2 - RESERVOIR SCREWS
- 3 - VACUUM RESERVOIR

INSTALLATION

- (1) Position reservoir to bumper bar and install mounting screws. Tighten screws to 8 N·m (72 in. lbs.) torque.
- (2) Install vacuum line to reservoir
- (3) Install front bumper end cap. Refer to Front Bumper End Cap Removal/Installation.

SPECIFICATIONS

TORQUE CHART

| Description | Torque |
|--|--------------------------|
| Servo Mounting Bracket-to-Servo Nuts . . . | 8.5 N·m (75 in. lbs.) |
| Servo Mounting Bracket-to-Body Bolts | 2 N·m (20 in. lbs.) |
| Speed Control Switch Mounting Screws . . . | 1.5 N·m (14 in. lbs.) |
| Vacuum Reservoir Mounting Bolts | 8 N·m (72 in. lbs.) |

VEHICLE SPEED CONTROL SYSTEM

TABLE OF CONTENTS

page

DESCRIPTION AND OPERATION

DIESEL ENGINE SPEED CONTROL SYSTEM 1

DESCRIPTION AND OPERATION

DIESEL ENGINE SPEED CONTROL SYSTEM

Unique features for the 2.5L diesel engine will be covered in this section.

- Models equipped with the 2.5L diesel engine do not use a vacuum reservoir to retain engine vacuum for speed control operation. There are no vacuum-operated speed control servos used in vehicles with the 2.5L diesel engine.
- The range of the speed control system operation is restricted to speeds between 56 km/h (35 MPH) to 145 km/h (90 MPH).
- Inputs to the MSA that allow speed control operation are from the vehicle speed sensor and the Speed Control Switch.
- Two separate speed control switch modules are mounted on the steering wheel to the left and right side of the driver's airbag module. Switch features are:
 - Within the two switch modules, five **momentary** contact switches, supporting seven different

speed control functions are used. The outputs from these switches are filtered into one input. The MSA determines which output has been applied through **resistive multiplexing**. The input circuit voltage is measured by the MSA to determine which switch function has been selected.

- A speed control indicator lamp, located on the instrument panel cluster is energized by the MSA via the CCD Bus. This occurs when speed control system power has been turned ON, and the engine is running.
- The two switch modules are labeled: ON/OFF, SET, RESUME/ACCEL, CANCEL and COAST. Refer to the owner's manual for more information on speed control switch functions and setting procedures. The individual switches cannot be repaired. If one individual switch fails, the switch module must be replaced.

TURN SIGNAL AND HAZARD WARNING SYSTEMS

TABLE OF CONTENTS

| | page | | page |
|--------------------------------------|------|---------------------------------|------|
| DESCRIPTION AND OPERATION | | TURN SIGNAL SWITCH AND HAZARD | |
| TURN SIGNAL SYSTEM | 1 | WARNING SWITCH | 5 |
| HAZARD WARNING SYSTEM | 1 | REMOVAL AND INSTALLATION | |
| TURN SIGNAL SWITCH AND HAZARD | | COMBINATION FLASHER | 5 |
| WARNING SWITCH | 2 | TURN SIGNAL SWITCH AND HAZARD | |
| TURN SIGNAL CANCELLING CAM | 3 | WARNING SWITCH | 6 |
| COMBINATION FLASHER | 3 | | |
| DIAGNOSIS AND TESTING | | | |
| TURN SIGNAL AND HAZARD WARNING | | | |
| SYSTEMS | 4 | | |

DESCRIPTION AND OPERATION

TURN SIGNAL SYSTEM

DESCRIPTION

A turn signal system is standard factory-installed safety equipment on this model. The turn signal system uses ignition switched battery current, and will operate only when the ignition switch is in the On or Accessory positions. The turn signal system includes the following components:

- Combination flasher
- Front side marker lamps
- Turn signal cancelling cam
- Turn signal indicator lamps
- Turn signal lamps
- Turn signal switch.

Refer to **Lamp** in the proper section of Group 8L - Lamps for more information on the exterior turn signal lamps. Refer to **Instrument Cluster** in the proper section of Group 8E - Instrument Panel Systems for more information on the turn signal indicator lamps. Following are general descriptions of the major components in the turn signal system. For complete circuit diagrams, refer to **Turn Signals** in the Contents of Group 8W - Wiring Diagrams.

OPERATION

With the ignition switch in the On or Accessory position, and the turn signal (multi-function) switch control stalk moved up (right turn) or down (left turn), the turn signal system is activated. When the turn signal system is activated, the circuitry of the turn signal switch and the combination flasher will cause the selected (right or left) turn signal indicator lamp, front park/turn signal lamp, front side marker

lamp and rear tail/stop/turn signal lamp to flash on and off. If the exterior lamps are turned off, the front park/turn signal lamp and the front side marker lamp will flash in unison. If the exterior lamps are turned on, the front park/turn signal lamp and the front side marker lamp will flash alternately.

See the owner's manual in the vehicle glove box for more information on the features, use and operation of the turn signal system.

HAZARD WARNING SYSTEM

DESCRIPTION

A hazard warning system is standard factory-installed safety equipment on this model. Unlike the turn signal system, the hazard warning system uses a non-switched source of battery current so that the system will operate regardless of the ignition switch position. The hazard warning system includes the following components:

- Combination flasher
- Front side marker lamps
- Hazard warning switch
- Turn signal indicator lamps
- Turn signal lamps.

Refer to **Lamp** in the proper section of Group 8L - Lamps for more information on the exterior turn signal lamps. Refer to **Instrument Cluster** in the proper section of Group 8E - Instrument Panel Systems for more information on the turn signal indicator lamps. Following are general descriptions of the major components in the hazard warning system. For complete circuit diagrams, refer to **Turn Signals** in the Contents of Group 8W - Wiring Diagrams.

DESCRIPTION AND OPERATION (Continued)

OPERATION

With the hazard warning switch in the On position, the hazard warning system is activated. When the hazard warning system is activated, the circuitry of the hazard warning switch and the combination flasher will cause both the right side and the left side turn signal indicator lamps, front park/turn signal lamps, front side marker lamps and rear tail/stop/turn signal lamps to flash on and off. If the exterior lamps are turned off, the front park/turn signal lamps and the front side marker lamps will flash in unison. If the exterior lamps are turned on, the front park/turn signal lamps and the front side marker lamps will flash alternately.

See the owner's manual in the vehicle glove box for more information on the features, use and operation of the hazard warning system.

TURN SIGNAL SWITCH AND HAZARD WARNING SWITCH

DESCRIPTION

The turn signal and hazard warning switches are integral to the multi-function switch unit, which is secured to the left side of the steering column (Fig. 1). The only visible parts of the multi-function switch are the control stalk that extends from the left side of the steering column, and the hazard warning switch button that protrudes from the top of the steering column. The multi-function switch control stalk has international control symbols on it, which identify its functions. The hazard warning switch button is identified with a double triangle, which is the international control symbol for hazard warning. The remainder of the multi-function switch is concealed beneath the steering column shrouds.

The multi-function switch also contains circuitry for the following functions:

- Headlamp beam selection
- Headlamp optical horn

The information contained in this group addresses only the multi-function switch turn signal and hazard warning functions. For information relative to the other systems that are controlled by and circuits that are integral to the multi-function switch, see the group in this service manual that covers that system. However, the turn signal and hazard warning switches cannot be repaired. If these switches or any other circuit or component of the multi-function switch unit is faulty or damaged, the entire multi-function switch unit must be replaced.

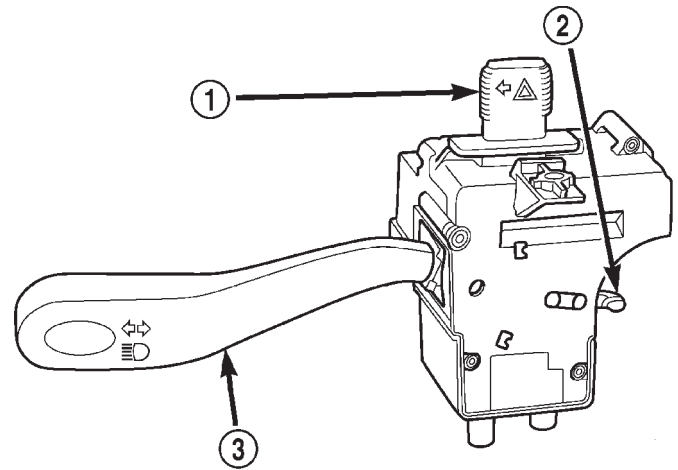

80ad8458

Fig. 1 Multi-Function Switch

- 1 - HAZARD WARNING BUTTON
- 2 - CANCEL ACTUATOR
- 3 - CONTROL STALK

OPERATION

TURN SIGNAL SWITCH

The multi-function switch control stalk that extends from the left side of the steering column just below the steering wheel is moved up or down to activate the turn signal switch. When the control stalk is moved in the upward direction, the right turn signal switch circuitry is activated; and, when the control stalk is moved in the downward direction, the left turn signal switch circuitry is activated. The turn signal switch has a detent position in each direction that provides turn signals with automatic cancellation, and an intermediate momentary position in each direction that provides turn signals only until the multi-function switch control stalk is released.

When the turn signal switch is in a detent position, it is turned off by one of two turn signal cancelling cam lobes that are integral to the rotor of the clockspring mechanism. Turning the steering wheel causes the turn signal cancelling cam lobes to contact a cancel actuator in the multi-function switch, and the turn signal switch automatically returns to the off position.

HAZARD WARNING SWITCH

The hazard warning switch is controlled by the hazard warning switch button. Slide the switch button to the left to turn the switch on and activate the hazard warning system, and slide the button to the right again to turn the switch and the hazard warning system off.

DESCRIPTION AND OPERATION (Continued)

TURN SIGNAL CANCELLING CAM**DESCRIPTION**

The turn signal cancelling cam is concealed within the steering column below the steering wheel. The turn signal cancelling cam consists of two lobes that are integral to the lower surface of the clockspring rotor. The clockspring mechanism provides turn signal cancellation as well as a constant electrical connection between the horn switch, driver side airbag module and speed control switches on the steering wheel and the instrument panel wire harness on the steering column. The housing of the clockspring is secured to the steering column and remains stationary. The rotor of the clockspring, including the turn signal cancelling cam lobes rotate with the steering wheel.

The turn signal cancelling cam is integral to the clockspring and cannot be repaired. If faulty or damaged, the entire clockspring assembly must be replaced. Refer to **Clockspring** in the Removal and Installation section of Group 8M - Passive Restraint Systems for the clockspring service procedures.

OPERATION

The turn signal cancelling cam has two lobes molded into the lower surface of the clockspring rotor. When the turn signals are activated by moving the multi-function switch control stalk to a detent position, a turn signal cancel actuator is extended from the inside surface of the multi-function switch housing toward the clockspring rotor. When the steering wheel is rotated during the turn, one of the two turn signal cancelling cam lobes will contact the turn signal cancel actuator, releasing the multi-function switch control stalk from its detent and cancelling the turn signal event.

COMBINATION FLASHER**DESCRIPTION**

The combination flasher is a smart relay that functions as both the turn signal system and the hazard warning system flasher. The combination flasher contains active electronic Integrated Circuitry (IC) elements. This flasher is designed to handle the current flow requirements of the factory-installed lighting. If supplemental lighting is added to the turn signal lamp circuits, such as when towing a trailer with lights, the combination flasher will automatically try to compensate to keep the flash rate the same.

While the combination flasher has a International Standards Organization (ISO)-type relay terminal configuration or footprint, the internal circuitry is much different. The combination flasher does not use standard ISO-relay inputs or provide ISO-relay type

outputs or functions. The combination flasher should never be substituted for an ISO-relay or replaced with an ISO-relay, or else component and vehicle damage may occur.

Because of the active electronic elements within the combination flasher, it cannot be tested with conventional automotive electrical test equipment. If the combination flasher is believed to be faulty, test the turn signal system and hazard warning system circuits as described in this group. Then replace the combination flasher with a known good unit to confirm system operation.

The combination flasher has five blade-type terminals intended for the following inputs and outputs: fused B(+), fused ignition switch output, ground, turn signal circuit, and hazard warning circuit. Constant battery voltage and ground are supplied to the flasher so that it can perform the hazard warning function, and ignition switched battery voltage is supplied for the turn signal function. Refer to **Turn Signals** in the Contents of Group 8W - Wiring Diagrams for complete circuit diagrams.

The combination flasher is located in a wire harness connector which is secured to the diagnostics splice block bracket outboard of the steering column opening underneath the instrument panel. The combination flasher cannot be repaired or adjusted and, if faulty or damaged, it must be replaced.

OPERATION

The IC within the combination flasher (Fig. 2) contains the logic that controls the flasher operation and the flash rate. Pin 6 of the IC receives a sense voltage from the hazard warning circuit of the multi-function switch. When the hazard warning switch is turned on, the "hazard on sense" voltage will become low due to the circuit being grounded through the turn signal bulbs. This low voltage sense signals the IC to energize the flash control Positive-Negative-Positive (PNP) transistor at a pre-calibrated flash rate or frequency. Each time the PNP transistor energizes the hazard warning circuit, the pin 6 "hazard on sense" voltage will become high and the IC signals the PNP transistor to de-energize the circuit. This cycling will continue until the hazard warning switch is turned off.

Likewise, pin 8 of the IC receives a sense voltage from the turn signal circuits of the multi-function switch. When the left or right turn signal switch is turned on, the "turn signal on sense" voltage will become low due to the circuit being grounded through the turn signal bulbs. This low voltage sense signals the IC to energize the flash control PNP transistor at a pre-calibrated flash rate or frequency. Each time the PNP transistor energizes the turn signal circuit, the pin 8 "turn signal on sense" voltage

DESCRIPTION AND OPERATION (Continued)

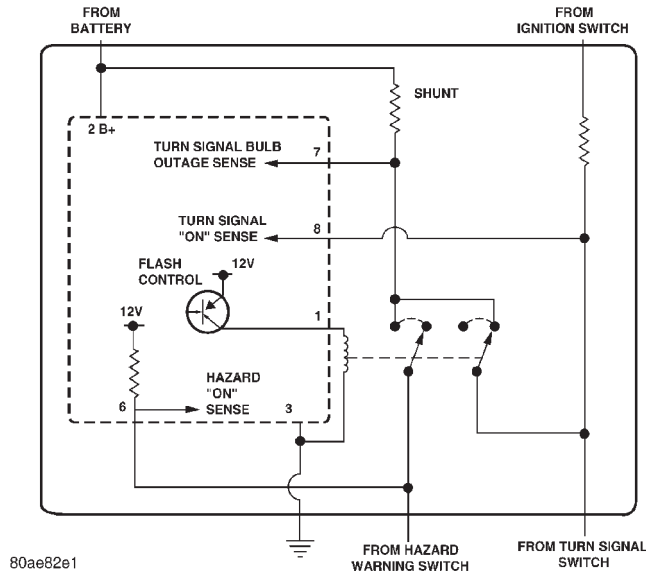

Fig. 2 Combination Flasher - Typical

will become high and the IC signals the PNP transistor to de-energize the circuit. This cycling will continue until the right or left turn signal switch is turned off.

A special design feature of the combination flasher allows it to “sense” that a turn signal circuit or bulb is not operating, and provide the driver an indication of the condition by flashing the remaining bulbs in the affected circuit at a higher rate (120 flashes-per-minute or higher). Conventional flashers either continue flashing at their typical rate (heavy-duty type), or discontinue flashing the affected circuit entirely (standard-duty type). During turn signal operation, the combination flasher IC compares normal battery voltage input on pin 2 with the shunt resistor voltage input on pin 7. If the IC “senses” that the voltage difference between pin 2 and pin 7 is different than the pre-calibrated value of the IC, it will increase the rate at which it signals the PNP transistor to energize the pin 1 output. Thus, the inoperative half (left or right side) of the turn signal circuit will flash faster.

DIAGNOSIS AND TESTING

TURN SIGNAL AND HAZARD WARNING SYSTEMS

When diagnosing the turn signal or hazard warning circuits, remember that high generator output can burn out bulbs rapidly and repeatedly. If this is a problem on the vehicle being diagnosed, refer to **Charging System** in the Diagnosis and Testing section of Group 8C - Charging System for further diagnosis of a possible generator overcharging condition.

If the problem being diagnosed is related to a failure of the turn signals to automatically cancel following completion of a turn, inspect the multi-function switch for a faulty or damaged cancel actuator and inspect the turn signal cancelling cam lobes on the clockspring mechanism for damage or improper installation. For complete circuit diagrams, refer to **Turn Signals** in the Contents of Group 8W - Wiring Diagrams.

WARNING: ON VEHICLES EQUIPPED WITH AIR-BAGS, REFER TO GROUP 8M - PASSIVE RESTRAINT SYSTEMS BEFORE ATTEMPTING ANY STEERING WHEEL, STEERING COLUMN, OR INSTRUMENT PANEL COMPONENT DIAGNOSIS OR SERVICE. FAILURE TO TAKE THE PROPER PRECAUTIONS COULD RESULT IN ACCIDENTAL AIR-BAG DEPLOYMENT AND POSSIBLE PERSONAL INJURY.

(1) Turn the ignition switch to the On position. Actuate the turn signal switch or the hazard warning switch. Observe the turn signal indicator lamp(s) in the instrument cluster. If the flash rate is very high, check for a turn signal bulb that is not lit or is very dimly lit. Repair the circuits to that lamp or replace the faulty bulb, as required. If the turn signal indicator(s) fail to light, go to Step 2.

(2) Turn the ignition switch to the Off position. Check the turn signal fuse in the junction block and/or the hazard warning fuse in the Power Distribution Center (PDC). If OK, go to Step 3. If not OK, repair the shorted circuit or component as required and replace the faulty fuse(s).

(3) Check for battery voltage at the hazard warning fuse in the PDC. If OK, go to Step 4. If not OK, repair the open fused B(+) circuit to the battery as required.

(4) Turn the ignition switch to the On position. Check for battery voltage at the turn signal fuse in the fuseblock module. If OK, go to Step 5. If not OK, repair the open fused ignition switch output (accessory/run) circuit to the ignition switch as required.

(5) Turn the ignition switch to the Off position. Disconnect and isolate the battery negative cable. Remove the combination flasher from its wire harness connector and replace it with a known good unit. Connect the battery negative cable. Test the operation of the turn signal and hazard warning systems. If OK, discard the faulty combination flasher. If not OK, remove the test flasher and go to Step 6.

(6) Turn the ignition switch to the On position. Check for battery voltage at the fused ignition switch output (accessory/run) circuit cavity in the combination flasher wire harness connector. If OK, go to Step 7. If not OK, go to Step 9.

DIAGNOSIS AND TESTING (Continued)

(7) Turn the ignition switch to the Off position. Place the hazard warning switch in the On position. Check for battery voltage again at the fused B+ circuit cavity in the combination flasher wire harness connector. If OK, go to Step 8. If not OK, go to Step 9.

(8) Disconnect and isolate the battery negative cable. Check for continuity between the ground circuit cavity of the combination flasher wire harness connector and a good ground. There should be continuity. If OK, go to Step 9. If not OK, repair the open ground circuit to ground as required.

(9) Disconnect the instrument panel wire harness connector from the multi-function switch connector receptacle. Check for continuity between the turn signal output circuit cavities in the combination flasher wire harness connector and in the instrument panel wire harness connector for the multi-function switch. There should be continuity. If OK, go to Step 10. If not OK, repair the open turn signal output circuit as required.

(10) Check for continuity between the hazard warning output circuit cavities in the combination flasher wire harness connector and in the instrument panel wire harness connector for the multi-function switch. There should be continuity. If OK, refer to **Turn Signal Switch and Hazard Warning Switch** in the Diagnosis and Testing section of this group. If not OK, repair the open hazard warning output circuit as required.

TURN SIGNAL SWITCH AND HAZARD WARNING SWITCH

The turn signal switch and the hazard warning switch are integral to the multi-function switch. Refer to **Turn Signal and Hazard Warning Systems** in the Diagnosis and Testing section of this group before testing the multi-function switch. For complete circuit diagrams, refer to **Turn Signals** in the Contents of Group 8W - Wiring Diagrams.

WARNING: ON VEHICLES EQUIPPED WITH AIRBAGS, REFER TO GROUP 8M - PASSIVE RESTRAINT SYSTEMS BEFORE ATTEMPTING ANY STEERING WHEEL, STEERING COLUMN, OR INSTRUMENT PANEL COMPONENT DIAGNOSIS OR SERVICE. FAILURE TO TAKE THE PROPER PRECAUTIONS COULD RESULT IN ACCIDENTAL AIRBAG DEPLOYMENT AND POSSIBLE PERSONAL INJURY.

(1) Disconnect and isolate the battery negative cable. Disconnect the instrument panel wire harness connector from the multi-function switch connector receptacle.

(2) Using an ohmmeter, perform the switch continuity checks at the connector receptacle terminals as

shown in the Multi-Function Switch Continuity chart (Fig. 3).

| SWITCH POSITION | | CONTINUITY BETWEEN |
|-----------------|----------------|---|
| TURN SIGNAL | HAZARD WARNING | |
| NEUTRAL | OFF | F and H F and K A and E |
| LEFT | OFF | F and H C and K C and I A and E |
| RIGHT | OFF | F and K C and H C and J A and E |
| NEUTRAL | ON | B and E C and H C and K C and I C and J |

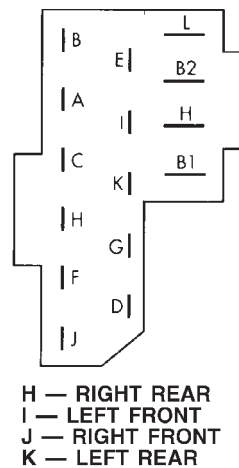

948J-12

Fig. 3 Multi-Function Switch Continuity

(3) If the turn signal switch or hazard warning switch fails any of the continuity checks, replace the faulty multi-function switch assembly as required. If the switch circuits are OK, repair the lighting circuits as required.

REMOVAL AND INSTALLATION

COMBINATION FLASHER

WARNING: ON VEHICLES EQUIPPED WITH AIRBAGS, REFER TO GROUP 8M - PASSIVE RESTRAINT SYSTEMS BEFORE ATTEMPTING ANY STEERING WHEEL, STEERING COLUMN, OR INSTRUMENT PANEL COMPONENT DIAGNOSIS OR SERVICE. FAILURE TO TAKE THE PROPER PRECAUTIONS COULD RESULT IN ACCIDENTAL AIRBAG DEPLOYMENT AND POSSIBLE PERSONAL INJURY.

REMOVAL

(1) Disconnect and isolate the battery negative cable.

(2) Remove the knee blocker from the instrument panel. Refer to **Knee Blocker** in the Removal and Installation section of Group 8E - Instrument Panel Systems for the procedures.

(3) Reach through the outboard side of the steering column opening to access and disengage the combination flasher wire harness connector retainer from

REMOVAL AND INSTALLATION (Continued)

the instrument panel diagnostics mounting bracket (Fig. 4).

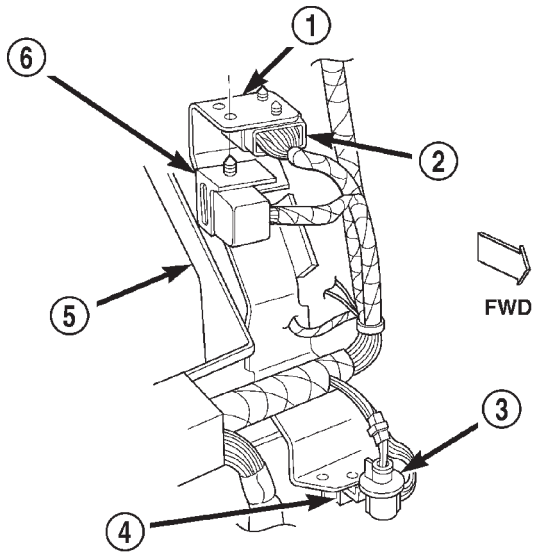

80b099c9

Fig. 4 Combination Flasher Remove/Install

- 1 - DIAGNOSTICS MOUNTING BRACKET
- 2 - DIAGNOSTICS SPLICE BLOCK
- 3 - INSTRUMENT PANEL COURTESY LAMP
- 4 - DATA LINK CONNECTOR
- 5 - OUTBOARD STEERING COLUMN OPENING
- 6 - COMBINATION FLASHER AND CONNECTOR

(4) Pull the combination flasher into the instrument panel steering column opening far enough to access the wire harness connector.

(5) Remove the combination flasher from the wire harness connector.

(6) Remove the combination flasher from under the instrument panel.

INSTALLATION

(1) Position the combination flasher under the instrument panel.

(2) Align the combination flasher terminals with the terminal cavities in the wire harness connector.

(3) Push in firmly on the combination flasher until the terminals are fully seated in the terminal cavities in the wire harness connector.

(4) Install the combination flasher wire harness connector retainer into the mounting hole of the instrument panel diagnostics mounting bracket.

(5) Install the knee blocker onto the instrument panel. Refer to **Knee Blocker** in the Removal and Installation section of Group 8E - Instrument Panel Systems for the procedures.

(6) Reconnect the battery negative cable.

TURN SIGNAL SWITCH AND HAZARD WARNING SWITCH

WARNING: ON VEHICLES EQUIPPED WITH AIRBAGS, REFER TO GROUP 8M - PASSIVE RESTRAINT SYSTEMS BEFORE ATTEMPTING ANY STEERING WHEEL, STEERING COLUMN, OR INSTRUMENT PANEL COMPONENT DIAGNOSIS OR SERVICE. FAILURE TO TAKE THE PROPER PRECAUTIONS COULD RESULT IN ACCIDENTAL AIRBAG DEPLOYMENT AND POSSIBLE PERSONAL INJURY.

REMOVAL

(1) Disconnect and isolate the battery negative cable.

(2) Remove the knee blocker from the instrument panel. Refer to **Knee Blocker** in the Removal and Installation section of Group 8E - Instrument Panel Systems for the procedures.

(3) Remove the three screws that secure the lower steering column shroud to the upper shroud (Fig. 5).

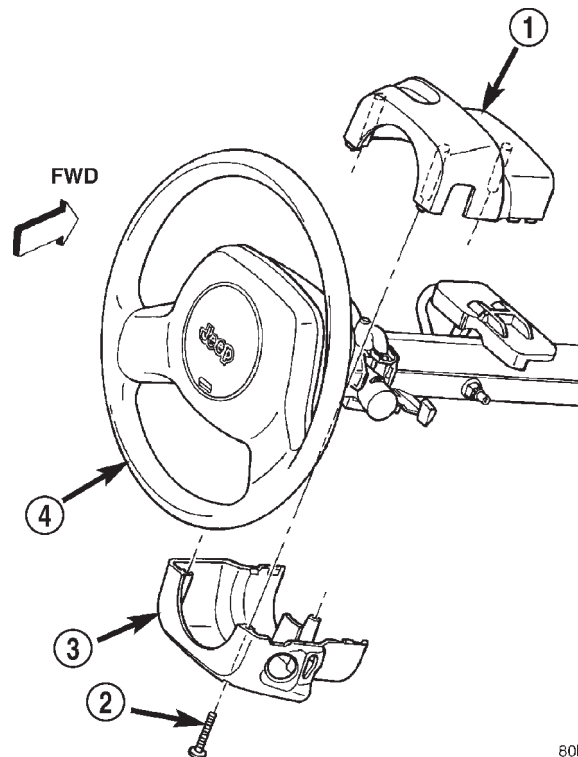

80b76efa

Fig. 5 Steering Column Shrouds Remove/Install

- 1 - UPPER SHROUD
- 2 - SCREW (3)
- 3 - LOWER SHROUD
- 4 - STEERING WHEEL

(4) If the vehicle is equipped with a standard non-tilt steering column, loosen the two upper steering column mounting nuts. If the vehicle is equipped

REMOVAL AND INSTALLATION (Continued)

with the optional tilt steering column, move the tilt steering column to the fully lowered position.

(5) Remove both the upper and lower shrouds from the steering column.

(6) Remove the two screws that secure the multi-function switch water shield and bracket to the top of the steering column (Fig. 6).

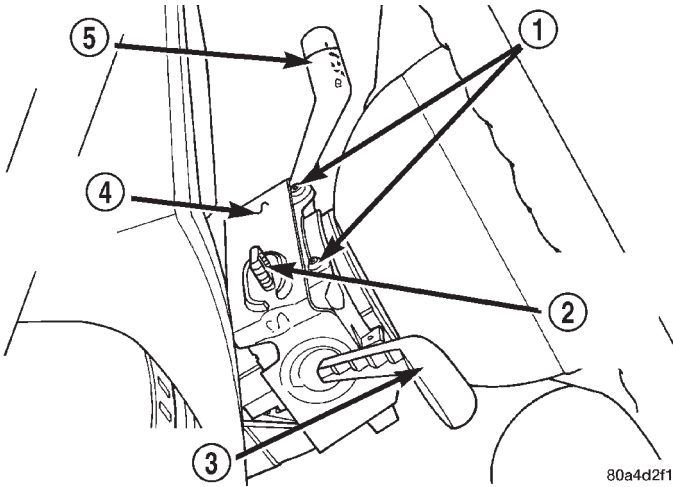

80a4d2f1

Fig. 6 Water Shield Upper Screws Remove/Install

- 1 - MOUNTING SCREWS
- 2 - HAZARD WARNING SWITCH KNOB
- 3 - MULTI-FUNCTION SWITCH LEVER
- 4 - WATER SHIELD AND BRACKET
- 5 - WIPER SWITCH LEVER

(7) Remove the one screw located below the multi-function switch control stalk that secures the multi-function switch water shield and bracket to the steering column (Fig. 7).

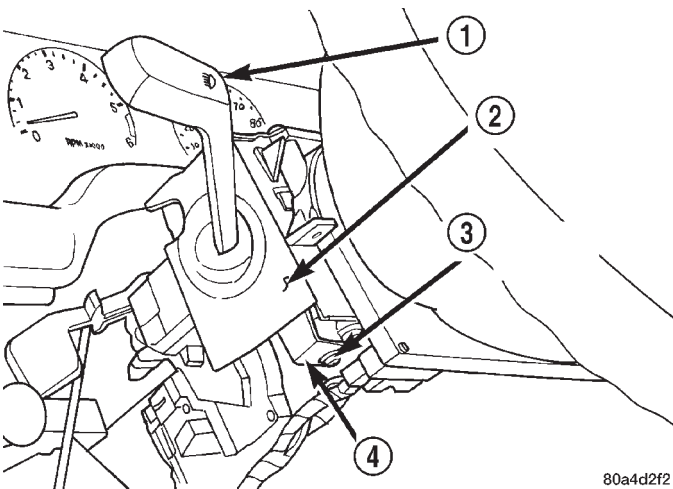

80a4d2f2

Fig. 7 Water Shield Lower Screw Remove/Install

- 1 - MULTI-FUNCTION SWITCH LEVER
- 2 - WATER SHIELD AND BRACKET
- 3 - LOWER MOUNTING SCREW
- 4 - LOWER MOUNTING TAB

(8) Gently pull the lower mounting tab of the multi-function switch water shield bracket away from the steering column far enough to clear the screw boss below the multi-function switch control stalk.

(9) Lift the water shield and bracket with the multi-function switch off of the left side of the steering column far enough to access the two multi-function switch wire harness connectors. If the vehicle is equipped with the optional tilt steering column, lifting gently upward on the tilt release lever will provide additional clearance to ease multi-function switch removal.

(10) Disconnect the two instrument panel wire harness connectors from the multi-function switch connector receptacles.

(11) Remove the multi-function switch and water shield from the steering column as a unit.

(12) Gently and carefully remove the water shield from the switch by pulling it over the hazard warning switch button and the multi-function switch control stalk.

INSTALLATION

(1) Gently and carefully install the water shield onto the switch by pulling it over the hazard warning switch button and the multi-function switch control stalk.

(2) Position the multi-function switch and water shield near its mounts on the steering column as a unit.

(3) Reconnect the two instrument panel wire harness connectors to the multi-function switch connector receptacles.

(4) Position the multi-function switch onto its mounts on the left side of the steering column. If the vehicle is equipped with the optional tilt steering column, lifting gently upward on the tilt release lever will provide additional clearance to ease multi-function switch installation.

(5) Position the lower mounting tab of the multi-function switch water shield bracket to the steering column screw boss below the multi-function switch control stalk.

(6) Install and tighten the one screw located below the multi-function switch control stalk that secures the multi-function switch water shield and bracket to the steering column. Tighten the screw to 1.1 N·m (10 in. lbs.).

(7) Install and tighten the two screws that secure the multi-function switch water shield and bracket to the top of the steering column. Tighten the screws to 2.2 N·m (20 in. lbs.).

(8) Position both the upper and lower shrouds onto the steering column.

REMOVAL AND INSTALLATION (Continued)

(9) Install and tighten the three screws that secure the lower steering column shroud to the upper shroud. Tighten the screws to 2 N·m (18 in. lbs.).

(10) If the vehicle is so equipped, tighten the two nuts that secure the non-tilt steering column upper mounting bracket to the dash panel steering column support bracket studs. Tighten the nuts to 22 N·m (200 in. lbs.).

(11) Install the knee blocker onto the instrument panel. Refer to **Knee Blocker** in the Removal and Installation section of Group 8E - Instrument Panel Systems for the procedures.

(12) Reconnect the battery negative cable.

WIPER AND WASHER SYSTEMS

TABLE OF CONTENTS

| | page | | page |
|--|------|---|------|
| GENERAL INFORMATION | | WASHER NOZZLE AND PLUMBING | 4 |
| INTRODUCTION | 1 | DIAGNOSIS AND TESTING | |
| WINDSHIELD WIPER SYSTEM | 1 | WIPER SYSTEM | 4 |
| WINDSHIELD WASHER SYSTEM | 1 | WASHER SYSTEM | 6 |
| REAR WIPER AND WASHER SYSTEM | 2 | WIPER SWITCH AND WASHER SWITCH | 7 |
| DESCRIPTION AND OPERATION | | REMOVAL AND INSTALLATION | |
| WIPER ARM AND BLADE | 2 | WIPER BLADE | 8 |
| WIPER LINKAGE AND PIVOT | 2 | WIPER ARM | 8 |
| WIPER MOTOR | 2 | WIPER LINKAGE AND PIVOT | 9 |
| WIPER SWITCH AND WASHER SWITCH | 3 | WIPER MOTOR | 9 |
| WASHER RESERVOIR | 3 | WIPER SWITCH AND WASHER SWITCH | 11 |
| WASHER PUMP | 4 | WASHER SYSTEM | 13 |
| WASHER FLUID LEVEL SENSOR | 4 | | |

GENERAL INFORMATION

INTRODUCTION

Windshield wiper and washer systems are standard factory-installed equipment on this model. A rear wiper and washer system is optional factory-installed equipment. Following is general information about the available wiper and washer systems for this vehicle. Refer to 8W-53 - Wipers in Group 8W - Wiring Diagrams for complete circuit descriptions and diagrams.

NOTE: This group covers both Left-Hand Drive (LHD) and Right-Hand Drive (RHD) versions of this model. Whenever required and feasible, the RHD versions of affected vehicle components have been constructed as mirror-image of the LHD versions. While most of the illustrations used in this group represent only the LHD version, the diagnostic and service procedures outlined can generally be applied to either version. Exceptions to this rule have been clearly identified as LHD or RHD, if a special illustration or procedure is required.

WINDSHIELD WIPER SYSTEM

An intermittent windshield wiper system is standard equipment on this model. The intermittent wiper system lets the driver select from either of two wiper speeds, low or high, or the intermittent wiper delay mode.

The intermittent wipe mode delay times are driver adjustable from about one second to about fifteen seconds. The intermittent wipe mode is provided by delay logic and relay control circuitry contained within the intermittent wiper/washer switch. The intermittent wipe relay is also contained within the switch.

The windshield wipers will operate only when the ignition switch is in the Accessory or On positions. A circuit breaker located in the junction block protects the circuitry of the windshield wiper system. Refer to the owner's manual in the vehicle glove box for more information on the features, use and operation of the windshield wiper system.

WINDSHIELD WASHER SYSTEM

An electrically operated windshield washer system is standard equipment. The washer reservoir is located between the inner and outer front fenders, above and forward of the left front wheel housing. The reservoir filler neck is located in the engine compartment on the left inner fender shield.

The washer reservoir holds the washer fluid, which is pressurized by a pump when the windshield washer switch lever is actuated. The windshield washer pump feeds the pressurized washer fluid through the washer system plumbing to the windshield washer nozzles.

A low washer fluid warning lamp is standard equipment on all models equipped with the optional rear wiper and washer system. The low washer fluid warning lamp in the instrument cluster will warn

GENERAL INFORMATION (Continued)

the driver when the washer fluid level needs to be checked. Refer to Group 8E - Instrument Panel Systems for more information on this feature.

The washers will operate only when the ignition switch is in the Accessory or On positions. If the wipers are not already turned on when the washers are activated, the wipers will be automatically cycled for one or two wipes, then be turned off. A fuse located in the junction block protects the circuitry of the washer system. Refer to the owner's manual in the vehicle glove box for more information on the features, use and operation of the windshield washer system.

REAR WIPER AND WASHER SYSTEM

A rear wiper and washer system is an available option on this model. The rear wiper system is a fixed-cycle wiper system. A single switch in the instrument panel accessory switch bezel controls both the rear wiper and washer functions. The rear washer system shares the reservoir of the windshield washer system, but has its own dedicated washer pump and plumbing.

The rear wiper and washer systems will operate only when the ignition switch is in the Accessory or On positions. A fuse in the junction block protects the circuitry of both the rear wiper and washer systems.

Refer to the owner's manual in the vehicle glove box for more information on the features, use and operation of the rear wiper and washer system.

DESCRIPTION AND OPERATION

WIPER ARM AND BLADE

All Cherokee models have two 45.72-centimeter (18-inch) windshield wiper blades with non-replaceable rubber elements (squeegees). The optional rear wiper uses a single 33.0-centimeter (13-inch) wiper blade with a non-replaceable rubber element (squeegee).

Caution should be exercised to protect the rubber squeegees from any petroleum-based cleaners or contaminants, which will rapidly deteriorate the rubber. If the squeegees are damaged, worn, or contaminated, the entire wiper blade assembly must be replaced.

Wiper squeegees exposed to the elements for a long time tend to lose their wiping effectiveness. Periodic cleaning of the squeegees is suggested to remove deposits of salt and road film. The wiper blades, arms, and windshield or rear glass should be cleaned with a sponge or cloth and windshield washer fluid, a mild detergent, or a non-abrasive cleaner. If the squeegees continue to streak or smear, the wiper blades should be replaced.

The blades are mounted to spring-loaded wiper arms. The spring tension of the wiper arms controls the pressure applied to the blades on the glass. The windshield wiper arms are secured by an integral latch to the two wiper pivots on the cowl plenum cover/grille panel at the base of the windshield. The rear wiper arm is secured by a nut directly to the rear wiper motor output shaft on the liftgate below the liftgate glass.

The wiper arms and blades cannot be adjusted or repaired. If faulty or damaged, they must be replaced.

WIPER LINKAGE AND PIVOT

The wiper linkage and pivot module is secured with screws to the cowl top panel beneath the cowl plenum cover/grille panel. The wiper motor is secured with screws to the center of the linkage and pivot module bracket. The wiper pivots are secured to the ends of the module bracket.

The two wiper pivot crank arms and the wiper motor crank arm each have ball studs on their ends. The left pivot ball stud is the longer of the three. A connecting link with a plastic socket-type bushing in the right end, and a plastic sleeve-type bushing in the left end, is fit over the pivot ball studs to join the two pivots.

The wiper drive link has a plastic socket-type bushing on each end. One end of the drive link is snap-fit over the exposed end of the longer left pivot ball stud, while the other end is snap-fit over the ball stud on the wiper motor crank arm.

The wiper linkage, pivots, bushings, motor, crank arm, and mounting bracket are only serviced as a complete unit. If any part of this assembly is faulty or damaged, the entire unit must be replaced.

WIPER MOTOR

FRONT

The two-speed permanent magnet wiper motor has an integral transmission and park switch. The motor also contains an internal automatic resetting circuit breaker to protect the motor from overloads.

The motor is secured to the wiper linkage and pivot module bracket with three screws and is protected by a rubber boot. The wiper motor output shaft passes through a hole in the module bracket, where a nut secures the wiper motor crank arm to the motor output shaft. A reinforcement and stud plate with a rubber-isolated mounting bracket extends from the cowl plenum side of the dash panel to the motor mounting bracket to provide additional support.

Wiper speed is controlled by current flow to the proper set of brushes. The wiper motor completes its

DESCRIPTION AND OPERATION (Continued)

wipe cycle when the windshield wiper switch stalk is moved to the Off position, and parks the blades in the lowest portion of the wipe pattern.

The windshield wiper motor cannot be repaired. If faulty or damaged, the entire wiper linkage and pivot module unit must be replaced. The reinforcement bracket and stud plate are available for service.

REAR

The rear wiper motor is secured to a bracket that is fastened to the liftgate inner panel, below the liftgate glass and behind the liftgate trim panel. The motor output shaft passes through the liftgate outer panel where a rubber gasket and plastic bezel unit, and a nut seal and secure the unit to the liftgate outer panel. The rear wiper arm is secured directly to the motor output shaft with a nut.

The rear wiper motor unit provides three operating modes:

- Constant wipe that operates when the rear wiper switch is turned to the On position.
- Constant wipe that operates when the rear washer switch is depressed.
- A park mode that operates the wiper motor until the blade reaches its park position when either the rear wiper switch or the ignition switch is placed in the Off position.

The rear wiper motor cannot be repaired. If faulty or damaged, the entire rear wiper motor assembly must be replaced.

WIPER SWITCH AND WASHER SWITCH**FRONT**

The windshield wiper and washer switches are mounted on the right side of the steering column (Fig. 1). The switch stalk is moved up or down to select the wiper switch mode, and pulled towards the steering wheel to activate the washer system. An intermittent wipe system control knob on the end of the switch stalk is rotated to select the desired delay interval. The windshield wiper and washer switch contains circuitry for the following functions:

- Windshield wipers
- Intermittent wiper delay relay control and logic
- Intermittent wipe relay
- Windshield washers.

The windshield wiper and washer switch cannot be repaired. If any function of the switch is faulty, or if the switch is damaged, the entire switch unit must be replaced.

REAR

The single two-function rear wiper and washer switch is installed in the instrument panel accessory switch bezel, which is located near the bottom of the

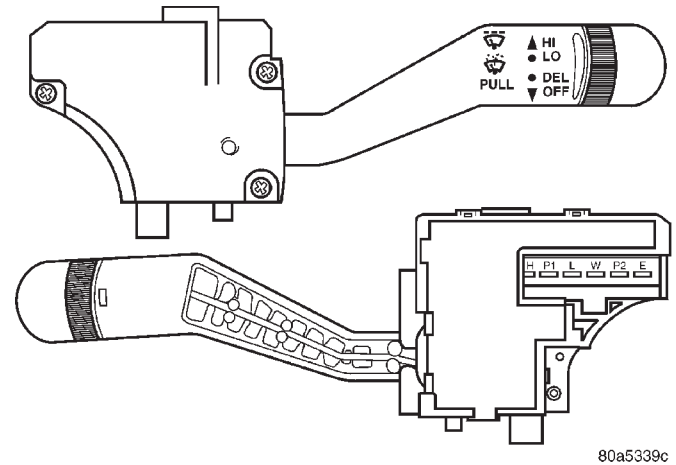

Fig. 1 Windshield Wiper Switch and Washer Switch

instrument panel center bezel area, below the heater and air conditioner controls. The rear wiper and washer switch controls the rear wiper and washer functions.

The toggle-type switch features a detent in the On position, and a momentary Wash position. The rear wiper and washer switch also has an integral illumination lamp with a serviceable bulb. The switch knob is pushed down to its detent to activate the rear wiper system, and down again to the momentary position to activate the rear washer system. Both the rear wiper and rear washer motors will operate continuously for as long as the switch is held in the momentary Wash position.

The rear wiper and washer switch cannot be repaired and, if faulty or damaged, the entire switch unit must be replaced.

WASHER RESERVOIR

A single washer fluid reservoir is used for both the standard front and optional rear washer systems. The washer fluid reservoir is secured between the left front inner and outer fender panels, above and in front of the left front wheel house.

Each washer pump and motor unit has a barbed nipple, which is installed through a rubber grommet seal inserted in a hole near the bottom of the reservoir. The washer pumps are retained by an interference fit between the barbed nipple and the grommet seal, which is a light press fit.

The washer reservoir has a separate filler neck and grommet seal. The filler neck snaps into the reservoir from the engine compartment side of the left inner fender shield. A snap-fit filler cap with an integral bail strap is fit to the reservoir filler neck. On models so equipped, the reservoir also has a hole provided for a washer fluid level sensor.

The washer reservoir, filler neck, grommet seal, and filler cap are each available for service.

DESCRIPTION AND OPERATION (Continued)

WASHER PUMP

The washer pumps and motors are mounted near the bottom of the washer reservoir. A barbed nipple on the pump housing passes through a rubber grommet seal installed in a hole near the bottom of the reservoir. The washer pump is retained by an interference fit between the barbed pump nipple and the grommet seal, which is a light press fit.

A permanently lubricated and sealed motor is coupled to a rotor-type pump. Washer fluid is gravity-fed from the reservoir to the pump. When the motor is energized, the pump pressurizes the washer fluid and forces it through the plumbing to the nozzles.

On vehicles with the optional rear wiper/washer system, the front washer pump and motor is always mounted in the lower hole of the reservoir. The washer pump and motor unit cannot be repaired. If faulty, the entire washer pump and motor unit must be replaced.

WASHER FLUID LEVEL SENSOR

The washer fluid level sensor is mounted near the front of the washer reservoir, above the two washer pumps. A barbed nipple on the sensor is press-fit into a rubber grommet seal installed in a hole in the front of the reservoir.

When the fluid level in the reservoir falls below the pivoting float on the sensor, the float changes position and closes the internal switch contacts of the sensor. Refer to Group 8E - Instrument Panel Systems for diagnosis of the low washer fluid warning lamp and circuit, including the sensor.

The washer fluid level sensor cannot be repaired. If faulty or damaged, the sensor unit must be replaced.

WASHER NOZZLE AND PLUMBING**FRONT**

Pressurized washer fluid is fed through a single hose, attached to a barbed nipple on the front washer pump. The hose is routed to a tee fitting located in the cowl plenum area, beneath the cowl plenum cover/grille panel. Hoses from the tee fitting are routed to the two nozzles, which are riveted into openings in the cowl plenum cover/grille panel below the windshield.

The two fluidic washer nozzles are not adjustable. The nozzles and hose fittings cannot be repaired and, if faulty or damaged, they must be replaced.

REAR

Pressurized washer fluid is fed through a single hose, attached to a barbed nipple on the rear washer pump. The hose is routed from the front of the vehicle to the liftgate with the body wire harness.

Located at the highest point of the supply hose routing, beneath the liftgate opening upper header garnish moulding, the hose connects to a check valve. The check valve prevents washer fluid drain-back or siphoning from occurring. From the check valve, another single hose is routed through a grommet to the liftgate, where it is connected to a nipple that protrudes from the inside of the rear wiper motor output shaft bezel.

The washer fluid passes through the bezel nipple to the outside of the liftgate. There a single hose is connected to a nipple on the outside of the rear wiper motor output shaft bezel. The hose is routed through a plastic trough-like guard snapped to the underside of the rear wiper arm. The hose is then attached to the single rear washer nozzle. The nozzle snaps into place on the rear wiper arm.

The rear washer nozzle cannot be adjusted. The nozzle, bezel, check valve, and hose fittings cannot be repaired and, if faulty or damaged, they must be replaced.

DIAGNOSIS AND TESTING**WIPER SYSTEM****FRONT**

For circuit descriptions and diagrams, refer to 8W-53 - Wipers in Group 8W - Wiring Diagrams.

WARNING: ON VEHICLES EQUIPPED WITH AIR-BAGS, REFER TO GROUP 8M - PASSIVE RESTRAINT SYSTEMS BEFORE ATTEMPTING ANY STEERING WHEEL, STEERING COLUMN, OR INSTRUMENT PANEL COMPONENT DIAGNOSIS OR SERVICE. FAILURE TO TAKE THE PROPER PRECAUTIONS COULD RESULT IN ACCIDENTAL AIR-BAG DEPLOYMENT AND POSSIBLE PERSONAL INJURY.

(1) Check the circuit breaker in the junction block. If OK, go to Step 2. If not OK, replace the faulty circuit breaker.

(2) Disconnect and isolate the battery negative cable. Unplug the windshield wiper switch wire harness connector. Connect the battery negative cable. Turn the ignition switch to the On position. Check for battery voltage at the fused ignition switch output (run/acc) circuit cavity of the wiper switch wire harness connector. If OK, go to Step 3. If not OK, repair the open circuit to the junction block as required.

(3) If the problem being diagnosed involves only the pulse wipe, wipe-after-wash, or intermittent wipe modes, go to Step 4. If not, go to Step 5.

DIAGNOSIS AND TESTING (Continued)

(4) Turn the ignition switch to the Off position. Disconnect and isolate the battery negative cable. Check for continuity between the ground circuit cavity of the wiper switch wire harness connector and a good ground. There should be continuity. If OK, replace the faulty switch. If not OK, repair the open circuit to ground as required.

(5) Turn the ignition switch to the Off position. Disconnect and isolate the battery negative cable. Remove the windshield wiper and washer switch and check the switch continuity. See Wiper Switch and Washer Switch in the Diagnosis and Testing section of this group for the procedures. If OK, go to Step 6. If not OK, replace the faulty switch.

(6) Unplug the windshield wiper motor wire harness connector. Check for continuity between the ground circuit cavity in the body half of the wiper motor wire harness connector and a good ground. There should be continuity. If OK, go to Step 7. If not OK, repair the open circuit to ground as required.

(7) Connect the battery negative cable. Turn the ignition switch to the On position. Check for battery voltage at the fused ignition switch output (run/acc) circuit cavity in the body half of the wiper motor wire harness connector. If OK, go to Step 8. If not OK, repair the open circuit to the junction block as required.

(8) Turn the ignition switch to the Off position. Disconnect and isolate the battery negative cable. With the windshield wiper and washer switch wire harness connector still unplugged, check the cavities for each of the following circuits in the body half of the wiper motor wire harness connector for continuity to ground. In each case, there should be no continuity. If OK, go to Step 9. If not OK, repair the short circuit as required.

- Wiper park switch sense
- Wiper switch low speed output
- Wiper switch high speed output.

(9) Check for continuity between the cavities in the body half of the wiper motor wire harness connector and the cavities in the windshield wiper and washer switch wire harness connector for each of the following circuits. In each case, there should be continuity. If OK, replace the faulty wiper motor. If not OK, repair the open circuit as required.

- Wiper park switch sense
- Wiper switch low speed output
- Wiper switch high speed output.

REAR

For circuit descriptions and diagrams, refer to 8W-53 - Wipers in Group 8W - Wiring Diagrams.

WARNING: ON VEHICLES EQUIPPED WITH AIR-BAGS, REFER TO GROUP 8M - PASSIVE RESTRAINT SYSTEMS BEFORE ATTEMPTING ANY

STEERING WHEEL, STEERING COLUMN, OR INSTRUMENT PANEL COMPONENT DIAGNOSIS OR SERVICE. FAILURE TO TAKE THE PROPER PRECAUTIONS COULD RESULT IN ACCIDENTAL AIR-BAG DEPLOYMENT AND POSSIBLE PERSONAL INJURY.

(1) Check the fuse in the junction block. If OK, go to Step 2. If not OK, repair the shorted circuit or component as required and replace the faulty fuse.

(2) Disconnect and isolate the battery negative cable. Remove the accessory switch bezel and unplug the wire harness connector from the rear wiper and washer switch. Connect the battery negative cable. Turn the ignition switch to the On position. Check for battery voltage at the fused ignition switch output circuit cavity of the rear wiper and washer switch wire harness connector. If OK, go to Step 3. If not OK, repair the open circuit to the junction block as required.

(3) Turn the ignition switch to the Off position. Disconnect and isolate the battery negative cable. Check for continuity between the ground circuit cavity of the rear wiper and washer switch wire harness connector and a good ground. There should be continuity. If OK, go to Step 4. If not OK, repair the open circuit to ground as required.

(4) Test the rear wiper and washer switch continuity. See Wiper Switch and Washer Switch in the Diagnosis and Testing section of this group for the procedures. If OK, go to Step 5. If not OK, replace the faulty switch.

(5) Remove the liftgate trim panel and unplug the rear wiper motor wire harness connector. Connect the battery negative cable. Turn the ignition switch to the On position. Check for battery voltage at the fused ignition switch output (run) circuit cavity of the rear wiper motor wire harness connector. If OK, go to Step 6. If not OK, repair the open circuit to the junction block as required.

(6) Turn the ignition switch to the Off position. Disconnect and isolate the battery negative cable. Check for continuity between the ground circuit cavity of the rear wiper motor wire harness connector and a good ground. There should be continuity. If OK, go to Step 7. If not OK, repair the open circuit to ground as required.

(7) Check for continuity between the rear wiper motor control circuit cavity of the rear wiper motor wire harness connector and a good ground. There should be no continuity. If OK, go to Step 8. If not OK, repair the short circuit as required.

(8) Check for continuity between the rear wiper motor control circuit cavities of the rear wiper motor wire harness connector and the rear wiper and washer switch wire harness connector. There should

DIAGNOSIS AND TESTING (Continued)

be continuity. If OK, replace the faulty rear wiper motor. If not OK, repair the open circuit as required.

WASHER SYSTEM**FRONT**

The diagnosis found here addresses an inoperative front washer pump. If the washer pump operates, but no washer fluid is emitted from the washer nozzles, be certain to check the fluid level in the reservoir. Check for ice or other foreign material in the reservoir, and for pinched, disconnected, broken, or incorrectly routed washer system plumbing. For circuit descriptions and diagrams, refer to 8W-53 - Wipers in Group 8W - Wiring Diagrams.

WARNING: ON VEHICLES EQUIPPED WITH AIR-BAGS, REFER TO GROUP 8M - PASSIVE RESTRAINT SYSTEMS BEFORE ATTEMPTING ANY STEERING WHEEL, STEERING COLUMN, OR INSTRUMENT PANEL COMPONENT DIAGNOSIS OR SERVICE. FAILURE TO TAKE THE PROPER PRECAUTIONS COULD RESULT IN ACCIDENTAL AIR-BAG DEPLOYMENT AND POSSIBLE PERSONAL INJURY.

(1) Turn the ignition switch to the On position. Turn the wiper switch to the Low or High speed position. Check whether the wipers operate. If OK, go to Step 2. If not OK, see the Wiper System diagnosis in this group.

(2) Turn the ignition switch to the Off position. Disconnect and isolate the battery negative cable. Unplug the front washer pump wire harness connector. Check for continuity between the ground circuit cavity of the front washer pump wire harness connector and a good ground. There should be continuity. If OK, go to Step 3. If not OK, repair the open circuit to ground as required.

(3) Connect the battery negative cable. Turn the ignition switch to the On position. Check for battery voltage at the front washer switch output circuit cavity of the front washer pump wire harness connector while actuating the washer switch. If OK, replace the faulty washer pump. If not OK, go to Step 4.

(4) Turn the ignition switch to the Off position. Disconnect and isolate the battery negative cable. Unplug the windshield wiper/washer switch wire harness connector. Check for continuity between the front washer switch output circuit cavity of the front washer pump wire harness connector and a good ground. There should be no continuity. If OK, go to Step 5. If not OK, repair the short circuit as required.

(5) Check for continuity between the front washer switch output circuit cavities of the front washer pump wire harness connector and the wiper/washer switch wire harness connector. There should be con-

tinuity. If OK, replace the faulty switch. If not OK, repair the open circuit as required.

REAR

The diagnosis found here addresses an inoperative rear washer pump. If the washer pump operates, but no washer fluid is emitted from the washer nozzle, be certain to check the fluid level in the reservoir. Check for ice or other foreign material in the reservoir, and for pinched, disconnected, broken, or incorrectly routed washer system plumbing. For circuit descriptions and diagrams, refer to 8W-53 - Wipers in Group 8W - Wiring Diagrams.

WARNING: ON VEHICLES EQUIPPED WITH AIR-BAGS, REFER TO GROUP 8M - PASSIVE RESTRAINT SYSTEMS BEFORE ATTEMPTING ANY STEERING WHEEL, STEERING COLUMN, OR INSTRUMENT PANEL COMPONENT DIAGNOSIS OR SERVICE. FAILURE TO TAKE THE PROPER PRECAUTIONS COULD RESULT IN ACCIDENTAL AIR-BAG DEPLOYMENT AND POSSIBLE PERSONAL INJURY.

(1) Turn the ignition switch to the On position. Place the rear wiper/washer switch in the Wipe position. Check whether the rear wiper is operating. If OK, go to Step 2. If not OK, see the Wiper System diagnosis in this group.

(2) Turn the ignition switch to the Off position. Disconnect and isolate the battery negative cable. Unplug the rear washer pump wire harness connector. Check for continuity between the ground circuit cavity of the rear washer pump wire harness connector and a good ground. There should be continuity. If OK, go to Step 3. If not OK, repair the open circuit to ground as required.

(3) Connect the battery negative cable. Turn the ignition switch to the On position. Check for battery voltage at the rear washer motor control circuit cavity of the rear washer pump wire harness connector while the rear washer switch is actuated. If OK, replace the faulty pump. If not OK, go to Step 4.

(4) Turn the ignition switch to the Off position. Disconnect and isolate the battery negative cable. Unplug the rear wiper/washer switch wire harness connector. Check for continuity between the rear washer motor control circuit cavity of the rear washer pump wire harness connector and a good ground. There should be no continuity. If OK, go to Step 5. If not OK, repair the short circuit as required.

(5) Check for continuity between the rear washer motor control circuit cavities of the rear washer pump wire harness connector and the rear wiper/washer switch wire harness connector. There should

DIAGNOSIS AND TESTING (Continued)

be continuity. If OK, replace the faulty switch. If not OK, repair the open circuit as required.

WIPER SWITCH AND WASHER SWITCH

FRONT

Perform the diagnosis for the front wiper system and/or washer system as described in this group before testing the front wiper and washer switch. For circuit descriptions and diagrams, see 8W-53 - Wipers in Group 8W - Wiring Diagrams.

WARNING: ON VEHICLES EQUIPPED WITH AIR-BAGS, REFER TO GROUP 8M - PASSIVE RESTRAINT SYSTEMS BEFORE ATTEMPTING ANY STEERING WHEEL, STEERING COLUMN, OR INSTRUMENT PANEL COMPONENT DIAGNOSIS OR SERVICE. FAILURE TO TAKE THE PROPER PRECAUTIONS COULD RESULT IN ACCIDENTAL AIR-BAG DEPLOYMENT AND POSSIBLE PERSONAL INJURY.

- (1) Disconnect and isolate the battery negative cable.
- (2) Remove the front wiper and washer switch from the steering column and unplug the wire harness connector from the switch.
- (3) Using an ohmmeter, perform the switch continuity checks at the switch terminals as shown in the Windshield Wiper Switch and Washer Switch Continuity chart (Fig. 2).

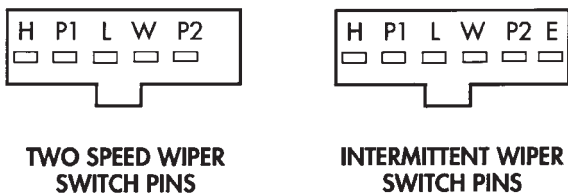

| SWITCH POSITION | CONTINUITY BETWEEN |
|-----------------|--------------------|
| OFF | PIN P2 AND PIN L |
| LOW | PIN P1 AND PIN L |
| HIGH | PIN P1 AND PIN H |
| WASH | PIN P1 AND PIN W |
| INTERMITTENT | CANNOT BE CHECKED |

948K-38

Fig. 2 Windshield Wiper Switch and Washer Switch Continuity

- (4) If the switch fails any of the continuity checks, replace the faulty switch. If the switch is OK, repair

the wiper system and/or washer system wire harness circuits as required.

REAR

Perform the diagnosis for the rear wiper system and/or washer system as described in this group before testing the rear wiper and washer switch. For circuit descriptions and diagrams, see 8W-53 - Wipers in Group 8W - Wiring Diagrams.

WARNING: ON VEHICLES EQUIPPED WITH AIR-BAGS, REFER TO GROUP 8M - PASSIVE RESTRAINT SYSTEMS BEFORE ATTEMPTING ANY STEERING WHEEL, STEERING COLUMN, OR INSTRUMENT PANEL COMPONENT DIAGNOSIS OR SERVICE. FAILURE TO TAKE THE PROPER PRECAUTIONS COULD RESULT IN ACCIDENTAL AIR-BAG DEPLOYMENT AND POSSIBLE PERSONAL INJURY.

- (1) Remove the accessory switch bezel from the instrument panel and unplug the rear wiper and washer switch wire harness connector.
- (2) Using an ohmmeter, check the rear wiper and washer switch continuity at the switch terminals as shown in the Rear Wiper Switch and Washer Switch Continuity chart (Fig. 3).

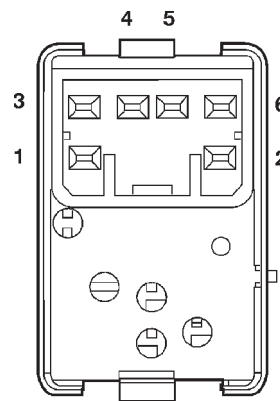

| SWITCH POSITION | CONTINUITY BETWEEN |
|-------------------|--------------------|
| OFF | 1 AND 4 |
| WIPE | 4 AND 5 |
| WASH | 2 AND 5, 4 AND 5 |
| ILLUMINATION LAMP | 1 AND 3 |

80a5035e

Fig. 3 Rear Wiper Switch and Washer Switch Continuity

- (3) If the switch fails any of the continuity checks, replace the faulty switch. If the switch is OK, repair the rear wiper system and/or washer system wire harness circuits as required.

REMOVAL AND INSTALLATION

WIPER BLADE

FRONT

NOTE: The notched retainer end of the wiper element should always be oriented towards the end of the wiper blade that is nearest to the wiper pivot.

(1) Lift the wiper arm to raise the wiper blade and element off of the windshield glass.

(2) To remove the wiper blade from the wiper arm, push the release tab under the arm tip and slide the blade away from the tip towards the pivot end of the arm (Fig. 4).

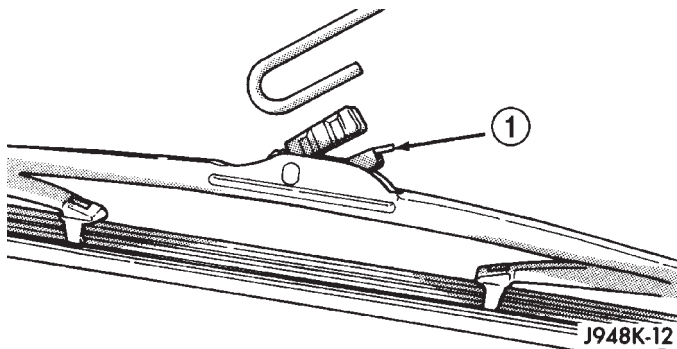

Fig. 4 Wiper Blade Remove/Install - Typical

1 - RELEASE TAB

(3) To install the wiper blade on the wiper arm, slide the blade retainer into the U-shaped formation on the tip of the wiper arm until the release tab snaps into its locked position. Be certain that the notched retainer for the wiper element is oriented towards the end of the wiper blade that is nearest to the wiper pivot.

REAR

NOTE: The notched retainer end of the wiper element should always be oriented towards the end of the wiper blade that is nearest to the wiper pivot.

(1) Lift the rear wiper arm to raise the wiper blade and element off of the rear liftglass.

(2) To remove the wiper blade from the wiper arm, push the release tab under the arm tip and slide the blade away from the tip towards the rear wiper motor output shaft end of the arm (Fig. 4).

(3) To install the wiper blade on the wiper arm, slide the blade retainer into the U-shaped formation on the tip of the wiper arm until the release tab snaps into its locked position. Be certain that the notched retainer for the wiper element is oriented towards the end of the wiper blade that is nearest to the rear wiper motor output shaft.

WIPER ARM

CAUTION: The use of a screwdriver or other prying tool to remove a wiper arm may distort it. This distortion could allow the arm to come off of the pivot shaft, regardless of how carefully it is installed.

FRONT

(1) Lift the wiper arm to permit the latch to be pulled out to its holding position, then release the arm (Fig. 5). The arm will remain off the windshield with the latch in this position.

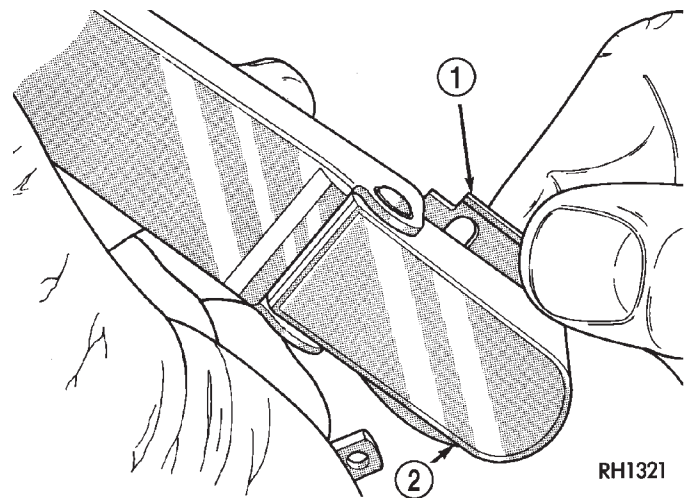

Fig. 5 Wiper Arm Remove/Install

1 - LOCKING LATCH

2 - ARM

(2) Remove the arm from the pivot using a rocking motion.

(3) Install the arm and blade with the wiper motor in the Park position. See the Front Wiper Arm Installation illustration (Fig. 6).

(4) Mount the arms on the pivot shafts so that the distance from the lower edge of the wiper arm tip to the upper edge of the lower windshield moulding is:

- 23 to 52 mm (0.90 to 2.04 inch) on the driver side

REMOVAL AND INSTALLATION (Continued)

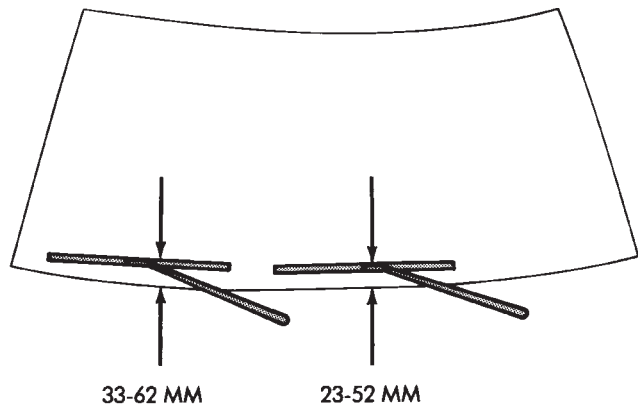

J898K-29

Fig. 6 Front Wiper Arm Installation

- 33 to 62 mm (1.29 to 2.44 inch) on the passenger side.

(5) Lift the wiper arm away from the windshield slightly to relieve the spring tension on the latch. Push the latch into the locked position and slowly release the arm until the wiper blade rests on the windshield.

(6) Operate the wipers with the windshield glass wet, then turn the wiper switch to the Off position. Check for the correct wiper arm positioning and readjust if required.

REAR

(1) Disconnect the washer nozzle hose and clip from the external nipple of the rear wiper motor output shaft bezel.

(2) Lift the wiper arm pivot cover and remove the retaining nut (Fig. 7).

(3) Remove the wiper arm from the motor output shaft using a rocking motion.

(4) Install the rear wiper arm with the wiper motor in the Park position. Place the rear wiper blade on the glass so that it is parallel to the liftgate glass opening, and install the wiper arm retaining nut.

(5) Operate the rear wiper with the liftgate glass wet, then turn the rear wiper switch to the Off position so that the blade moves to the Park position.

(6) The measurement from the tip of the blade should now be from 27 to 35 mm (1.06 to 1.38 inch) above the upper edge of the lower liftgate glass seal (Fig. 8). Check for the correct wiper arm positioning and readjust if required.

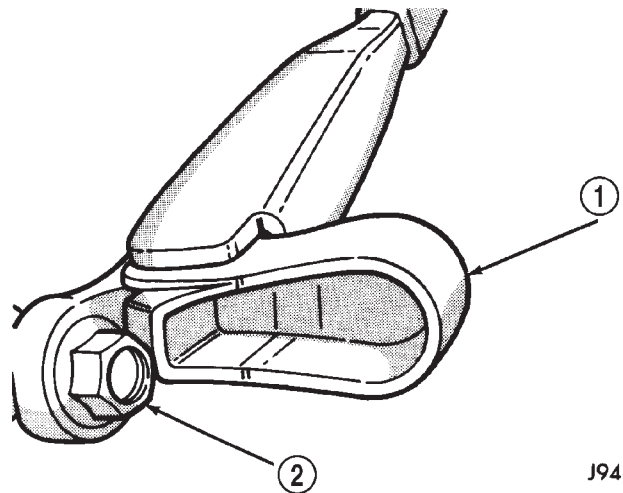

J948K-14

Fig. 7 Rear Wiper Arm Remove/Install

- 1 - PIVOT COVER
- 2 - WIPER ARM RETAINING NUT

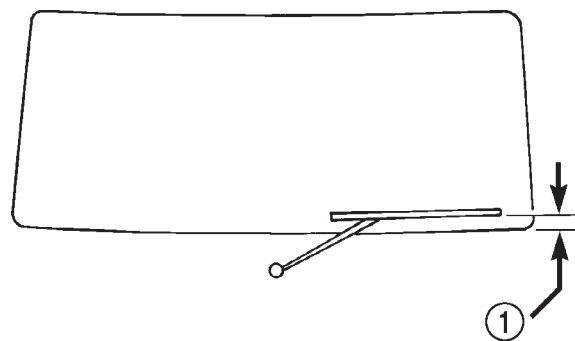

80ab5cc2

Fig. 8 Rear Wiper Arm Installation

- 1 - IN PARKED POSITION —27 TO 35 mm (1.06 TO 1.38 INCH) ABOVE UPPER EDGE OF LOWER GLASS SEAL AT TIP OF WIPER BLADE

(7) Tighten the wiper arm retaining nut to 18 N·m (160 in. lbs.) and close the pivot cover.

WIPER LINKAGE AND PIVOT

The wiper linkage and pivots can only be removed from or installed in the vehicle as a unit with the wiper motor. See Wiper Motor in this group for the service procedures.

WIPER MOTOR

FRONT

(1) Disconnect and isolate the battery negative cable.

REMOVAL AND INSTALLATION (Continued)

(2) Remove the wiper arms from the wiper pivots. See Wiper Arm in this group for the procedures.

(3) Remove the eight screws that secure the cowl plenum cover/grille panel and screen to the cowl top panel (Fig. 9).

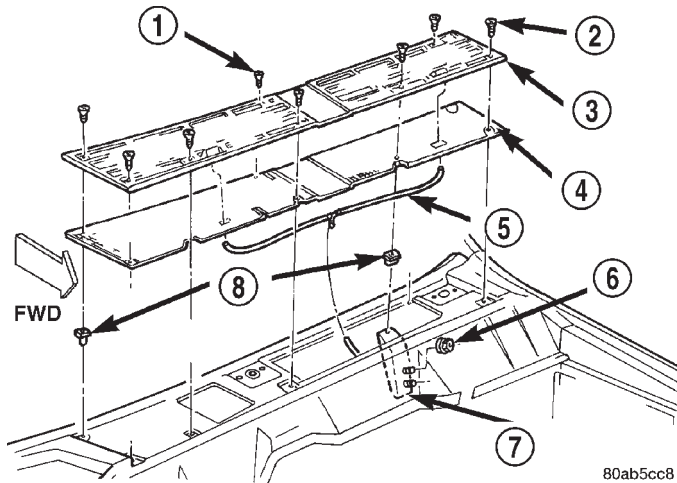

Fig. 9 Cowl Plenum Cover/Grille Panel Remove/Install

- 1 - SCREW
- 2 - SCREW
- 3 - GRILLE PANEL
- 4 - SCREEN
- 5 - WASHER HOSE
- 6 - NUT
- 7 - BRACKET
- 8 - NUT

(4) Carefully lift the cowl plenum cover/grille panel and screen from the vehicle far enough to access the windshield washer plumbing. Use care so as not to damage the paint around the pivot openings of the panel.

(5) Disconnect the windshield washer supply hose and the passenger side washer nozzle hose from the washer nozzle supply hose tee fitting.

(6) Remove the cowl plenum cover/grille panel and screen from the vehicle.

(7) Reach into the cowl plenum and unplug the wiper motor wire harness connector.

(8) Open and support the hood

(9) Remove the two nuts that secure the studs of the wiper module mounting bracket and reinforcement to the dash panel (Fig. 10).

(10) Remove the four screws near the wiper pivots that secure the wiper module to the cowl plenum panel.

(11) Remove the wiper module from the cowl plenum as a unit.

(12) Reverse the removal procedures to install. Tighten the mounting hardware as follows:

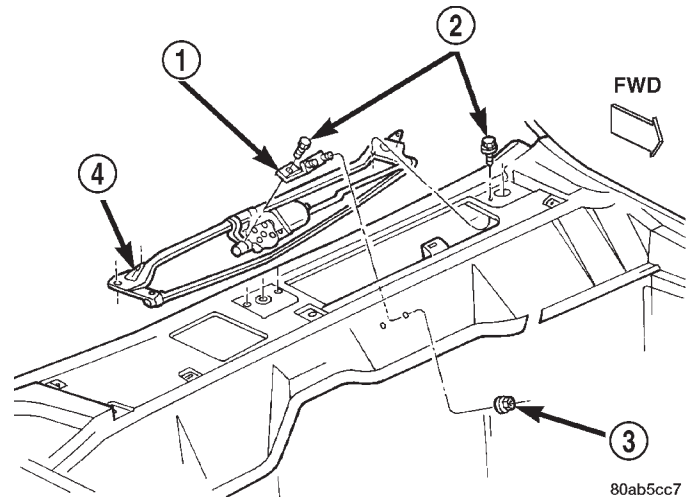

Fig. 10 Wiper Linkage Module Remove/Install

- 1 - BRACKET AND GROMMET
- 2 - SCREW
- 3 - NUT
- 4 - LINKAGE AND PIVOT MODULE

- Wiper module mounting screws - 6 N·m (50 in. lbs.)

- Wiper module mounting bracket and reinforcement nuts - 6 N·m (50 in. lbs.).

REAR

(1) Disconnect and isolate the battery negative cable.

(2) From the outside of the liftgate glass, remove the rear wiper arm from the rear wiper motor output shaft. See Wiper Arm in this group for the procedures.

(3) From the outside of the liftgate, remove the rear wiper motor output shaft nut (Fig. 11).

(4) Pull the rear wiper motor output shaft bezel and rubber gasket away from the liftgate far enough to access the washer supply hose.

(5) Disconnect the washer supply hose from the internal nipple on the bezel.

(6) Remove the bezel and rubber gasket from the motor output shaft.

(7) Remove the liftgate trim panel from the liftgate. Refer to Group 23 - Body for the procedures.

(8) Unplug the rear wiper motor wire harness connector.

(9) Remove the two screws that secure the rear wiper motor mounting bracket to the liftgate inner panel.

(10) Remove the rear wiper motor and mounting bracket from the liftgate as a unit.

(11) Reverse the removal procedures to install. Tighten the mounting hardware as follows:

- Rear wiper motor mounting bracket screws - 5 N·m (45 in. lbs.)

REMOVAL AND INSTALLATION (Continued)

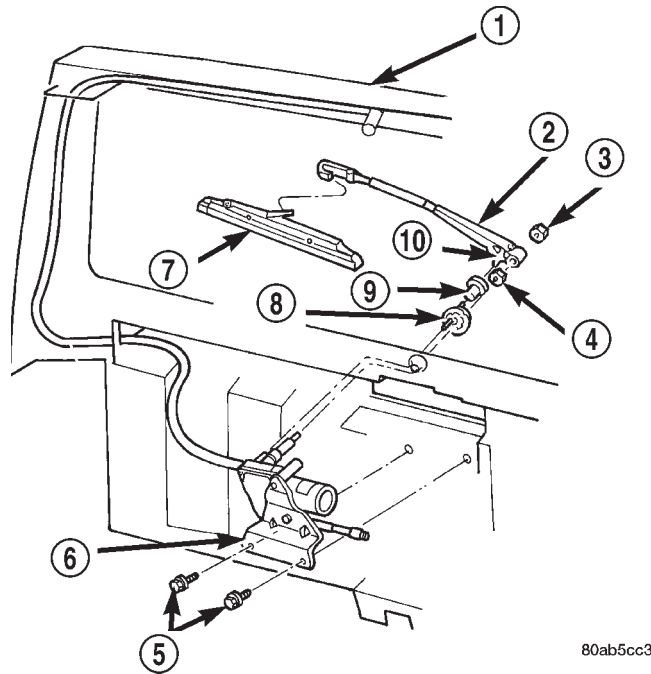

Fig. 11 Rear Wiper Motor Remove/Install

- 1 - LIFTGATE
- 2 - ARM
- 3 - NUT
- 4 - NUT
- 5 - SCREW
- 6 - MOTOR AND BRACKET
- 7 - BLADE
- 8 - BEZEL
- 9 - CLIP
- 10 - HOSE

- Rear wiper motor output shaft retaining nut - 3 N·m (27 in. lbs.).

WIPER SWITCH AND WASHER SWITCH

FRONT

WARNING: ON VEHICLES EQUIPPED WITH AIR-BAGS, REFER TO GROUP 8M - PASSIVE RESTRAINT SYSTEMS BEFORE ATTEMPTING ANY STEERING WHEEL, STEERING COLUMN, OR INSTRUMENT PANEL COMPONENT DIAGNOSIS OR SERVICE. FAILURE TO TAKE THE PROPER PRECAUTIONS COULD RESULT IN ACCIDENTAL AIR-BAG DEPLOYMENT AND POSSIBLE PERSONAL INJURY.

- (1) Disconnect and isolate the battery negative cable.
- (2) Remove the knee blocker from the instrument panel. See Knee Blocker in Group 8E - Instrument Panel Systems for the procedures.

(3) Remove the three screws that secure the lower steering column shroud to the upper shroud (Fig. 12).

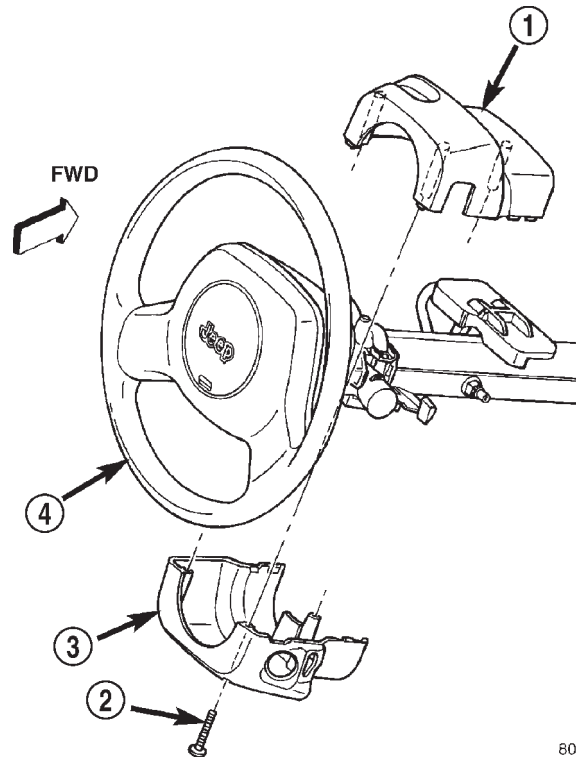

Fig. 12 Steering Column Shrouds Remove/Install

- 1 - UPPER SHROUD
- 2 - SCREW (3)
- 3 - LOWER SHROUD
- 4 - STEERING WHEEL

(4) If the vehicle is equipped with a standard non-tilt steering column, loosen the two upper steering column mounting nuts. If the vehicle is equipped with the optional tilt steering column, move the tilt steering column to the fully lowered position.

(5) Remove both the upper and lower shrouds from the steering column.

(6) Remove the two screws that secure the switch water shield and bracket to the top of the steering column (Fig. 13).

(7) Remove the one screw located below the multi-function switch lever that secures the switch water shield and bracket to the steering column (Fig. 14).

(8) Gently pull the lower mounting tab of the switch water shield bracket away from the steering column far enough to clear the screw boss below the multi-function switch lever.

(9) Lift the water shield and bracket with the multi-function switch off of the left side of the steering column as a unit and move it out of the way. If the vehicle is equipped with the optional tilt steering column, lifting gently upward on the tilt release lever

REMOVAL AND INSTALLATION (Continued)

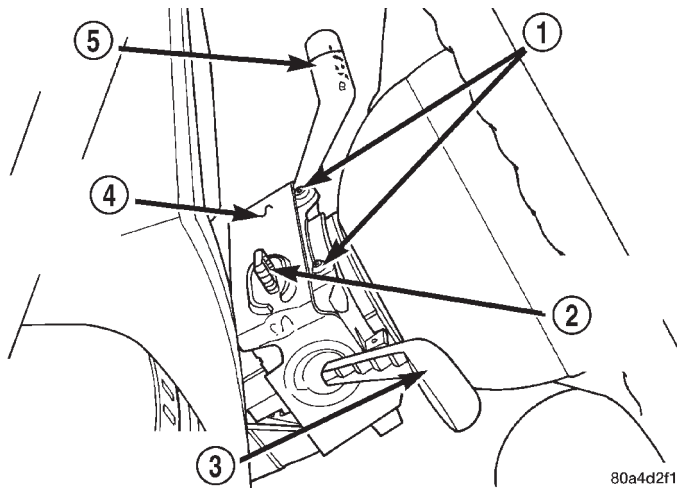

Fig. 13 Water Shield Upper Screws Remove/Install

- 1 - MOUNTING SCREWS
- 2 - HAZARD WARNING SWITCH KNOB
- 3 - MULTI-FUNCTION SWITCH LEVER
- 4 - WATER SHIELD AND BRACKET
- 5 - WIPER SWITCH LEVER

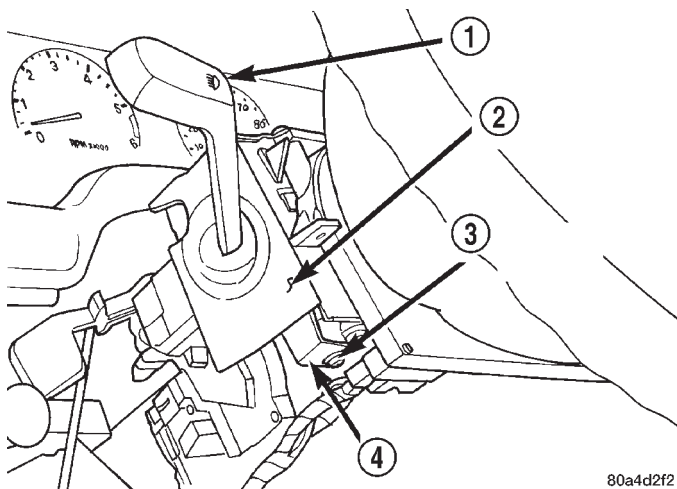

Fig. 14 Water Shield Lower Screw Remove/Install

- 1 - MULTI-FUNCTION SWITCH LEVER
- 2 - WATER SHIELD AND BRACKET
- 3 - LOWER MOUNTING SCREW
- 4 - LOWER MOUNTING TAB

will provide additional clearance to ease multi-function switch removal.

(10) Gently pull the windshield wiper and washer switch up and away from the right side of the steering column far enough to access the wire harness connector.

(11) Unplug the wire harness connector from the windshield wiper and washer switch.

(12) Remove the windshield wiper and washer switch from the steering column.

(13) Reverse the removal procedures to install. Tighten the upper switch mounting screws to 2.2 N-m (20 in. lbs.). Tighten the lower switch water shield and bracket screw to 1.1 N-m (10 in. lbs.). Tighten the non-tilt steering column mounting nuts to 22 N-m (200 in. lbs.) and the steering column shroud mounting screws to 2 N-m (18 in. lbs.).

REAR

WARNING: ON VEHICLES EQUIPPED WITH AIR-BAGS, REFER TO GROUP 8M - PASSIVE RESTRAINT SYSTEMS BEFORE ATTEMPTING ANY STEERING WHEEL, STEERING COLUMN, OR INSTRUMENT PANEL COMPONENT DIAGNOSIS OR SERVICE. FAILURE TO TAKE THE PROPER PRECAUTIONS COULD RESULT IN ACCIDENTAL AIR-BAG DEPLOYMENT AND POSSIBLE PERSONAL INJURY.

(1) Disconnect and isolate the battery negative cable.

(2) Remove the center bezel from the instrument panel. See Instrument Panel Center Bezel in Group 8E - Instrument Panel Systems for the procedures.

(3) Remove the three screws that secure the accessory switch bezel to the instrument panel (Fig. 15).

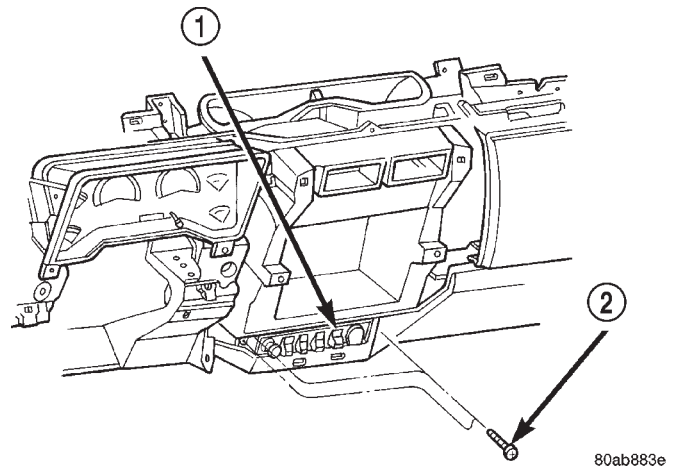

Fig. 15 Accessory Switch Bezel Remove/Install

- 1 - ACCESSORY SWITCH BEZEL
- 2 - SCREW

(4) Pull the accessory switch bezel out from the instrument panel far enough to access the wire harness connectors.

(5) Unplug the wire harness connectors from the rear of the accessory switches, the cigar lighter and the power outlet.

(6) Remove the accessory switch bezel from the instrument panel.

(7) With a small thin-bladed screwdriver, gently pry the snap clips at the top and bottom of the rear

REMOVAL AND INSTALLATION (Continued)

wiper and washer switch receptacle on the back of the accessory switch bezel and pull the switch out of the bezel.

(8) Reverse the removal procedures to install. Be certain that both of the switch snap clip retainers in the receptacle on the back of the accessory switch bezel are fully engaged. Tighten the mounting screws to 2.2 N·m (20 in. lbs.).

WASHER SYSTEM

WASHER RESERVOIR

(1) Disconnect and isolate the battery negative cable.

(2) The washer reservoir filler neck is held in the reservoir by an interference fit. Remove the filler neck from the reservoir using a combination of pulling, rocking and twisting actions (Fig. 16).

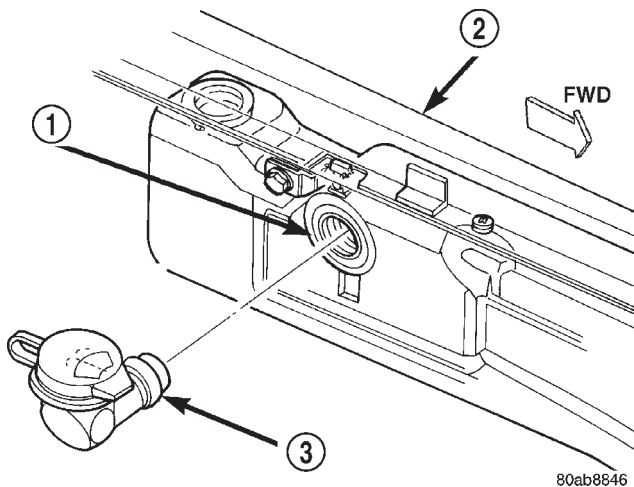

Fig. 16 Washer Reservoir Filler Neck Remove/Install

- 1 - RESERVOIR
- 2 - LEFT FENDER
- 3 - FILLER NECK AND CAP

(3) Remove the engine air filter housing. Refer to Group 14 - Fuel System for the procedures.

(4) Remove the two screws that secure the washer reservoir to the inner fender shield (Fig. 17).

(5) Raise and support the vehicle.

(6) Remove the left front inner wheelhouse splash shield. Refer to Group 23 - Body for the procedures.

(7) Remove the washer supply hose(s) from the washer pump(s) and drain the washer fluid from the reservoir into a clean container for reuse.

(8) Unplug the wire harness connectors from the washer pump(s) and the washer fluid level sensor.

(9) Slide the reservoir slightly towards the rear of the vehicle to release the two hooks from the inner fender ledge slots.

(10) Lower the front of the washer reservoir and slide the unit forward to remove it from the vehicle.

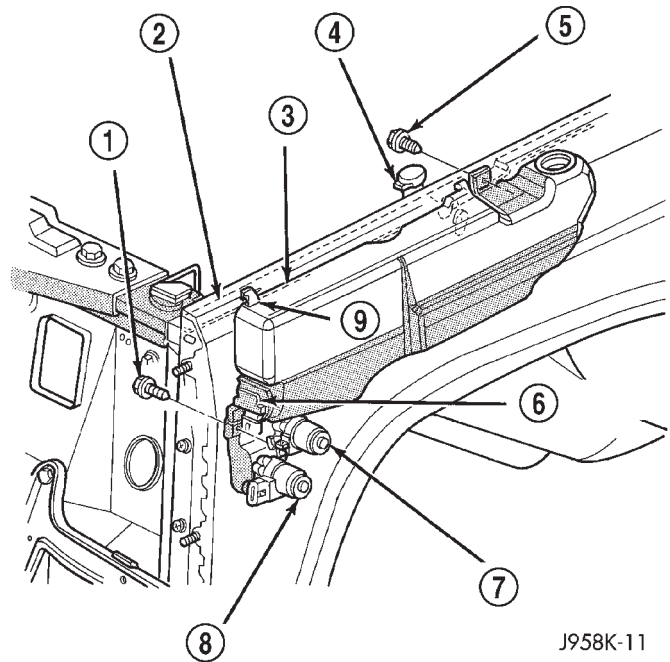

Fig. 17 Washer Reservoir Remove/Install

- 1 - SCREW
- 2 - FENDER
- 3 - WASHER RESERVOIR
- 4 - FILLER NECK
- 5 - SCREW
- 6 - FLUID LEVEL SENSOR
- 7 - REAR WASHER PUMP
- 8 - FRONT WASHER PUMP
- 9 - HOOK

(11) Reverse the removal procedures to install. Tighten the reservoir mounting screws to 3 N·m (26 in. lbs.).

WASHER PUMP

(1) Disconnect and isolate the battery negative cable.

(2) Raise and support the vehicle.

(3) Remove the left front inner wheelhouse splash shield. Refer to Group 23 - Body for the procedures.

(4) Remove the washer supply hose(s) from the barbed outlet nipple of the washer pump(s) and drain the washer fluid from the reservoir into a clean container for reuse.

(5) Unplug the wire harness connectors from the washer pump(s).

(6) Using a trim stick or another suitable wide flat-bladed tool, gently pry the barbed inlet nipple of the washer pump out of the rubber grommet seal in the reservoir. Care must be taken not to damage the reservoir.

(7) Remove the rubber grommet seal from the reservoir and discard.

REMOVAL AND INSTALLATION (Continued)

(8) Reverse the removal procedures to install. Always use a new rubber grommet seal on the reservoir.

WASHER FLUID LEVEL SENSOR

(1) Remove the washer reservoir from the vehicle. See Washer Reservoir in this group for the procedures.

NOTE: The pivoting float of the washer fluid sensor must be in a horizontal position within the reservoir in order to be removed. With the reservoir empty and in an upright position, the pivoting float will orient itself to the horizontal position when the sensor connector is pointed straight downwards.

(2) Using a trim stick or another suitable wide flat-bladed tool, gently pry the washer fluid level sensor out of the rubber grommet seal. Care must be taken not to damage the reservoir.

(3) Remove the rubber grommet seal from the reservoir and discard.

(4) Reverse the removal procedures to install. Always use a new rubber grommet seal on the reservoir.

WASHER NOZZLE

FRONT

(1) Remove the wiper arms from the wiper pivots. See Wiper Arm in this group for the procedures.

(2) Remove the eight screws that secure the cowl plenum cover/grille panel and screen to the cowl top panel (Fig. 18).

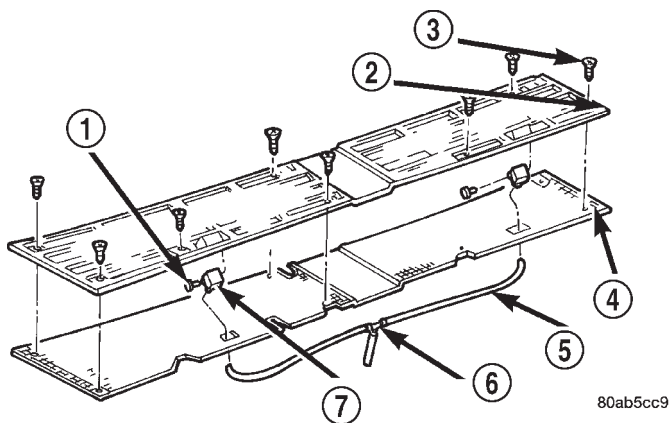

Fig. 18 Front Washer Nozzles Remove/Install

- 1 - RIVET
- 2 - GRILLE PANEL
- 3 - SCREW
- 4 - SCREEN
- 5 - WASHER HOSE
- 6 - TEE
- 7 - NOZZLE

(3) Carefully lift the cowl plenum cover/grille panel and screen from the vehicle far enough to access the windshield washer plumbing. Use care so as not to damage the paint around the pivot openings of the panel.

(4) Disconnect the windshield washer supply hose and the passenger side washer nozzle hose from the washer nozzle supply hose tee fitting.

(5) Remove the cowl plenum cover/grille panel and screen from the vehicle.

(6) From the underside of the cowl plenum cover/grille panel, disconnect the washer hose from the nozzle fitting.

(7) From the underside of the cowl plenum cover/grille panel, remove the rivet that secures the nozzle to the opening in the cowl plenum cover/grille panel.

(8) Remove the washer nozzle from the cowl plenum cover/grille panel.

(9) Reverse the removal procedures to install.

REAR

(1) Unsnap the rear washer nozzle from the rear wiper arm (Fig. 19).

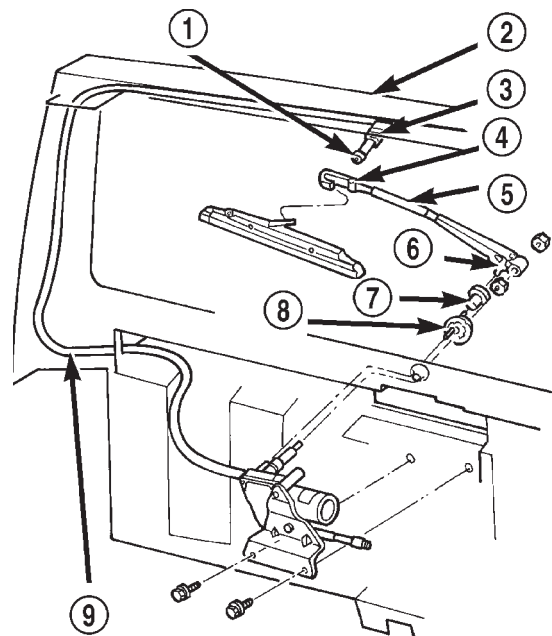

80ab8848

Fig. 19 Rear Washer Nozzle Remove/Install

- 1 - TO CHECK VALVE AND BODY SUPPLY HOSE
- 2 - LIFTGATE
- 3 - GROMMET
- 4 - NOZZLE
- 5 - GUARD
- 6 - HOSE
- 7 - CLIP
- 8 - BEZEL
- 9 - LIFTGATE SUPPLY HOSE

REMOVAL AND INSTALLATION (Continued)

- (2) Disconnect the washer supply hose from the barbed rear washer nozzle nipple.
- (3) Reverse the removal procedures to install.

CHECK VALVE

- (1) Remove the four screws that secure the liftgate opening upper garnish moulding to the upper liftgate opening reinforcement.
- (2) Using a trim stick or another suitable wide-bladed flat tool, gently pry the liftgate opening upper garnish moulding away from the upper liftgate opening reinforcement to release the snap clip retainers.
- (3) Remove the garnish moulding from the upper liftgate opening.
- (4) Disconnect the liftgate half of the washer supply hose from the barbed nipple of the rear washer system check valve.
- (5) Disconnect the body half of the washer supply hose from the other barbed nipple of the rear washer system check valve.
- (6) Remove the check valve from the vehicle.

- (7) When reinstalling the check valve, be certain the valve is properly oriented within the system flow (Fig. 20).

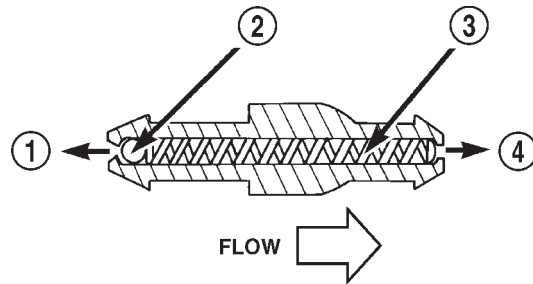

80abfece

Fig. 20 Rear Washer System Check Valve

- 1 - TO RESERVOIR
- 2 - CHECKBALL
- 3 - SPRING
- 4 - TO NOZZLE

- (8) Reverse the remaining removal procedures to complete the installation.

LAMPS

TABLE OF CONTENTS

| | page | | page |
|--------------------------|------|------------------------|------|
| LAMP SYSTEMS | 1 | LAMP SERVICE | 14 |
| LAMP DIAGNOSIS | 3 | LAMP SYSTEMS | 19 |
| HEADLAMP ALIGNMENT | 6 | BULB APPLICATION | 20 |
| LAMP BULB SERVICE | 10 | | |

LAMP SYSTEMS

TABLE OF CONTENTS

| | page | | page |
|----------------------------------|------|---------------------------------|----------|
| DESCRIPTION AND OPERATION | | SAFETY PRECAUTIONS | 2 |
| LAMP SYSTEMS | 1 | | |

DESCRIPTION AND OPERATION

LAMP SYSTEMS

Each vehicle is equipped with various lamp assemblies. A good ground is necessary for proper lighting operation. Grounding is provided through a separate ground wire.

When changing lamp bulbs check the socket for corrosion. If corrosion is present, clean it with a wire brush and coat the inside of the socket lightly with Mopar® Multi-Purpose Grease or equivalent.

HEADLAMPS

DESCRIPTION

Headlamps on the Cherokee are sealed beam units. Each module contains a low beam filament and a high beam filament.

OPERATION

The headlamps are controlled by the headlamp switch and the high beams by the multifunction switch. Each headlamp unit can be serviced individually.

HEADLAMP SWITCH

DESCRIPTION

The headlamp switch is located on the instrument panel. The headlamp switch controls the parking lamps, the headlamps, the interior lamps, and

instrument cluster illumination. The headlamp switch also contains a rheostat for controlling the illumination level of the instrument cluster lamps.

OPERATION

The headlamp switch has an off position, a parking lamp position, and a headlamp on position. High beams are controlled by the multifunction switch on the steering column. The headlamp switch cannot be repaired. It must be replaced. Refer to Group 8E for removal and installation procedures, and Group 8W for wiring.

SENTINEL HEADLAMP DELAY MODULE

DESCRIPTION

The Headlamp Module delays the de-activation of the headlamps for 45 ± 15 seconds after the ignition switch is turned OFF.

OPERATION

The driver engages the module by turning the ignition switch OFF, then turning the headlamps OFF. The module is mounted to a bracket attached to the inside of the instrument panel.

TAIL/TURN SIGNAL/STOP/BACK-UP LAMP

DESCRIPTION

The rear tail lamp modules contains three bulbs, a lens, and a housing. One bulb is a two filament bulb

DESCRIPTION AND OPERATION (Continued)

used for tail light and stop lamp functions. One single filament bulb is for turn signal functions. The other bulb is a single filament bulb used for back-up light illumination.

OPERATION

Each tail lamp module can be serviced separately. Each bulb can also be serviced separately. The headlamp switch controls tail lamp operation. The multifunction switch on the steering column controls turn signal operation, and the back-up light switch controls the back-up light operation. The brake lamp switch controls the stop lamp function.

FRONT TURN SIGNAL/PARKING LAMP

DESCRIPTION

The front turn signal and parking lamp module contains a housing, a lens, and two bulbs.

OPERATION

The parking lamp function is controlled by the headlamp switch. The turn signal function is controlled by the multifunction switch on the steering column. Each bulb can be serviced separately.

CHMSL (CENTER HIGH MOUNTED STOP LAMP)

DESCRIPTION

The center high mounted stop lamp (CHMSL) is mounted on the liftgate. The module consists of a housing, a lens, and a single filament bulb.

OPERATION

The CHMSL is controlled by the brake lamp switch.

DAYTIME RUNNING LAMPS

DESCRIPTION

The Daytime Running Lights (Headlamps) System is installed on vehicles manufactured for sale in Can-

ada only. A separate module, mounted on the cowl, controls the DRL.

OPERATION

The headlamps are illuminated when the ignition switch is turned to the ON position. The DRL module receives a vehicle-moving signal from the vehicle speed sensor. This provides a constant **headlamps-on** condition as long as the vehicle is moving. The lamps are illuminated at less than 50 percent of normal intensity.

SAFETY PRECAUTIONS

WARNING: EYE PROTECTION SHOULD BE USED WHEN SERVICING GLASS COMPONENTS. PERSONAL INJURY CAN RESULT.

CAUTION: Do not touch the glass of halogen bulbs with fingers or other possibly oily surface, reduced bulb life will result.

Do not use bulbs with higher candle power than indicated in the Bulb Application table at the end of this group. Damage to lamp and/or Daytime Running Lamp Module can result.

Do not use fuses, circuit breakers or relays having greater amperage value than indicated on the fuse panel or in the Owners Manual.

When it is necessary to remove components to service another, it should not be necessary to apply excessive force or bend a component to remove it. Before damaging a trim component, verify hidden fasteners or captured edges are not holding the component in place.

LAMP DIAGNOSIS

TABLE OF CONTENTS

| | page | page |
|------------------------------|------|--------------------------|
| DIAGNOSIS AND TESTING | | |
| DIAGNOSTIC PROCEDURES | 3 | |
| | | SYSTEM DIAGNOSIS 3 |

DIAGNOSIS AND TESTING

DIAGNOSTIC PROCEDURES

When a vehicle experiences problems with the headlamp system, verify the condition of the battery connections, fuses, charging system, headlamp bulbs, wire connectors, relay, high beam switch, dimmer switch, and headlamp switch. Refer to Group 8W, Wiring Diagrams for component locations and circuit information.

SYSTEM DIAGNOSIS

HEADLAMP

Always begin any diagnosis by testing all of the fuses and circuit breakers in the system. Refer to Group 8W, Wiring Diagrams.

Conventional and halogen headlamps are interchangeable. It is recommended that they not be intermixed on a given vehicle.

| CONDITION | POSSIBLE CAUSES | CORRECTION |
|---|---|--|
| HEADLAMPS ARE DIM WITH ENGINE IDLING OR IGNITION TURNED OFF | <ol style="list-style-type: none"> 1. Loose or corroded battery cables. 2. Loose or worn generator drive belt. 3. Charging system output too low. 4. Battery has insufficient charge. 5. Battery is sulfated or shorted. 6. Poor lighting circuit Z1-ground. 7. Both headlamp bulbs defective. | <ol style="list-style-type: none"> 1. Clean and secure battery cable clamps and posts. 2. Adjust or replace generator drive belt. 3. Test and repair charging system, refer to Group 8A, 4. Test battery state-of-charge, refer to Group 8A. 5. Load test battery, refer to Group 8A. 6. Test for voltage drop across Z1-ground locations, refer to Group 8W. 7. Replace both headlamp bulbs. |
| HEADLAMP BULBS BURN OUT FREQUENTLY | <ol style="list-style-type: none"> 1. Charging system output too high. 2. Loose or corroded terminals or splices in circuit. | <ol style="list-style-type: none"> 1. Test and repair charging system, refer to Group 8A. 2. Inspect and repair all connectors and splices, refer to Group 8W. |
| HEADLAMPS ARE DIM WITH ENGINE RUNNING ABOVE IDLE* | <ol style="list-style-type: none"> 1. Charging system output too low. 2. Poor lighting circuit Z1-ground. 3. High resistance in headlamp circuit. 4. Both headlamp bulbs defective. | <ol style="list-style-type: none"> 1. Test and repair charging system, refer to Group 8A. 2. Test for voltage drop across Z1-ground locations, refer to Group 8W. 3. Test amperage draw of headlamp circuit. 4. Replace both headlamp bulbs. |

DIAGNOSIS AND TESTING (Continued)

| CONDITION | POSSIBLE CAUSES | CORRECTION |
|--------------------------------------|---|--|
| HEADLAMPS FLASH RANDOMLY | <ol style="list-style-type: none"> Poor lighting circuit Z1-ground. High resistance in headlamp circuit. Faulty headlamp switch. Loose or corroded terminals or splices in circuit. | <ol style="list-style-type: none"> Test for voltage drop across Z1-ground locations, refer to Group 8W. Test amperage draw of headlamp circuit. Should not exceed 30 amps. Replace headlamp switch. Refer to Group 8E. Inspect and repair all connectors and splices, refer to Group 8W. |
| HEADLAMPS DO NOT ILLUMINATE | <ol style="list-style-type: none"> No voltage to headlamps. No Z1-ground at headlamps. Faulty headlamp switch. Faulty headlamp dimmer (multi-function) switch. Broken connector terminal or wire splice in headlamp circuit. | <ol style="list-style-type: none"> Repair open headlamp circuit, refer to Group 8W. Repair circuit ground, refer to Group 8W. Replace headlamp switch. Refer to Group 8E. Replace multi-function switch. Repair connector terminal or wire splice. |
| *Canada vehicles must have lamps ON. | | |

FOG LAMP

| CONDITION | POSSIBLE CAUSES | CORRECTION |
|--|--|--|
| FOG LAMPS ARE DIM WITH ENGINE IDLING OR IGNITION TURNED OFF. | <ol style="list-style-type: none"> Loose or corroded battery cables. Loose or worn generator drive belt. Charging system output too low. Battery has insufficient charge. Battery is sulfated or shorted. Poor lighting circuit Z1-ground. | <ol style="list-style-type: none"> Clean and secure battery cable clamps and posts. Adjust or replace generator drive belt. Test and repair charging system. Refer to Group 8A, Test battery state-of -charge. Refer to Group 8A. Load test battery. Refer to Group 8A. Test for voltage drop across Z1-ground locations. Refer to Group 8W. |
| FOG LAMP BULBS BURN OUT FREQUENTLY | <ol style="list-style-type: none"> Charging system output too high. Loose or corroded terminals or splices in circuit. | <ol style="list-style-type: none"> Test and repair charging system. Refer to Group 8A. Inspect and repair all connectors and splices. Refer to Group 8W. |
| FOG LAMPS ARE DIM WITH ENGINE RUNNING ABOVE IDLE | <ol style="list-style-type: none"> Charging system output too low. Poor lighting circuit Z1-ground. High resistance in fog lamp circuit. | <ol style="list-style-type: none"> Test and repair charging system. Refer to Group 8A. Test for voltage drop across Z1-ground locations. Refer to Group 8W. Test amperage draw of fog lamp circuit. |

DIAGNOSIS AND TESTING (Continued)

| CONDITION | POSSIBLE CAUSES | CORRECTION |
|-----------------------------|--|--|
| FOG LAMPS FLASH RANDOMLY | 1. Poor lighting circuit Z1-ground. 2. High resistance in fog lamp circuit. 3. Faulty fog lamp switch. 4. Loose or corroded terminals or splices in circuit. | 1. Test for voltage drop across Z1-ground locations. Refer to Group 8W. 2. Test amperage draw of fog lamp circuit. 3. Replace fog lamp switch. 4. Inspect and repair all connectors and splices. Refer to Group 8W. |
| FOG LAMPS DO NOT ILLUMINATE | 1. Blown fuse for fog lamp. 2. No Z1-ground at fog lamps. 3. Faulty fog lamp switch. 4. Broken connector terminal or wire splice in fog lamp circuit. 5. Defective or burned out bulb. | 1. Replace fuse. Refer to Group 8W. 2. Repair circuit ground. Refer to Group 8W. 3. Replace fog lamp switch. 4. Repair connector terminal or wire splice. 5. Replace bulb. |

HEADLAMP DELAY MODULE

DELAY FUNCTION INOPERATIVE

- (1) Ensure headlamps operate before proceeding.
- (2) Remove, inspect and test the HDLP delay 10 amp fuse in junction box. Replace if defective.
- (3) With the key off and the connector disconnected, measure the resistance from the delay module connector, terminal 4 to vehicle body ground. The ohmmeter should indicate zero ohms. If not, repair the open circuit in the wire harness to vehicle body ground.
- (4) With the key on measure the voltage between the delay module connector, terminal 8 and vehicle

body ground. The voltmeter should indicate battery voltage. If not, repair the open circuit in the wire harness from ignition switch to HDLP delay module.

(5) Turn headlamps on and measure voltage at delay module connector, terminal 6. The voltmeter should indicate battery voltage. If not repair open circuit between L2 and HDLP delay module.

(6) Measure the voltage between the delay module connector, terminal 2 and vehicle body ground. The voltmeter should indicate battery voltage. If not, repair the open circuit in the wire harness to the HDLP fuse in the PDC.

(7) If steps 1 through 6 prove out good, replace headlamp delay module.

HEADLAMP ALIGNMENT

TABLE OF CONTENTS

| | page | | page |
|---|------|---------------------------|------|
| SERVICE PROCEDURES | | HEADLAMP ADJUSTMENT | 6 |
| HEADLAMP ALIGNMENT | 6 | FOG LAMP ADJUSTMENT | 8 |
| LAMP ALIGNMENT SCREEN PREPARATION | 6 | SPECIAL TOOLS | |
| VEHICLE PREPARATION FOR HEADLAMP ALIGNMENT | 6 | HEADLAMP ALIGNMENT | 9 |

SERVICE PROCEDURES

HEADLAMP ALIGNMENT

Headlamps can be aligned using the screen method provided in this section. Alignment Tool C-4466-A or equivalent can also be used. Refer to instructions provided with the tool for proper procedures.

LAMP ALIGNMENT SCREEN PREPARATION

(1) Position vehicle on a level surface perpendicular to a flat wall 7.62 meters (25 ft) away from front of headlamp lens (Fig. 1).

(2) If necessary, tape a line on the floor 7.62 meters (25 ft) away from and parallel to the wall.

(3) Measure from the floor up 1.27 meters (5 ft) and tape a line on the wall at the centerline of the vehicle. Sight along the centerline of the vehicle (from rear of vehicle forward) to verify accuracy of the line placement.

(4) Rock vehicle side-to-side three times to allow suspension to stabilize.

(5) Jounce front suspension three times by pushing downward on front bumper and releasing.

(6) Measure the distance from the center of headlamp lens to the floor. Transfer measurement to the alignment screen (with tape). Use this line for up/down adjustment reference.

(7) Measure distance from the centerline of the vehicle to the center of each headlamp being aligned. Transfer measurements to screen (with tape) to each side of vehicle centerline. Use these lines for left/right adjustment reference.

VEHICLE PREPARATION FOR HEADLAMP ALIGNMENT

(1) Verify headlamp dimmer switch and high beam indicator operation.

(2) Correct defective components that could hinder proper headlamp alignment.

(3) Verify proper tire inflation.

(4) Clean headlamp lenses.

(5) Verify that luggage area is not heavily loaded.

(6) Fuel tank should be FULL. Add 2.94 kg (6.5 lbs.) of weight over the fuel tank for each estimated gallon of missing fuel.

HEADLAMP ADJUSTMENT

Headlamps can be aligned using the screen method. The Headlamp Alignment Tool C-4466-A or equivalent can also be used. Refer to instructions provided with the tool for proper procedures.

A properly aimed low beam will project the top edge of the beam intensity pattern on the screen from 25 mm (1 in.) above to 75 mm (3 in.) below headlamp centerline. The side-to-side left edge of the beam intensity pattern should be from 50 mm (2 in.) left to 50 mm (2 in.) right of headlamp centerline (Fig. 2).

(1) Remove screws and both headlamp bezels.

(2) Clean front of the headlamps.

(3) Place headlamps on LOW beam.

(4) Cover front of the headlamp that is not being adjusted.

(5) Turn vertical adjustment screw (Fig. 3) until the headlamp beam pattern on screen/wall is similar to the pattern depicted in the alignment screen figure.

NOTE: When using a headlamp aiming screen, adjust the headlamps so that:

- The left edge of the beam intensity pattern is positioned within 50 mm (2 in.) left to 50 mm (2 in.) right of the vertical centerline (Fig. 2).

- The top edge of the beam intensity pattern is positioned within 25 mm (1 in.) above or 75 mm (3 in.) below the headlamp horizontal centerline (Fig. 2).

(6) Cover front of the headlamp and adjust the other headlamp beam as instructed below.

(7) Rotate the adjustment screws until the beam intensity pattern on the aiming screen/wall is aligned within the headlamp the alignment screen target (Fig. 2).

SERVICE PROCEDURES (Continued)

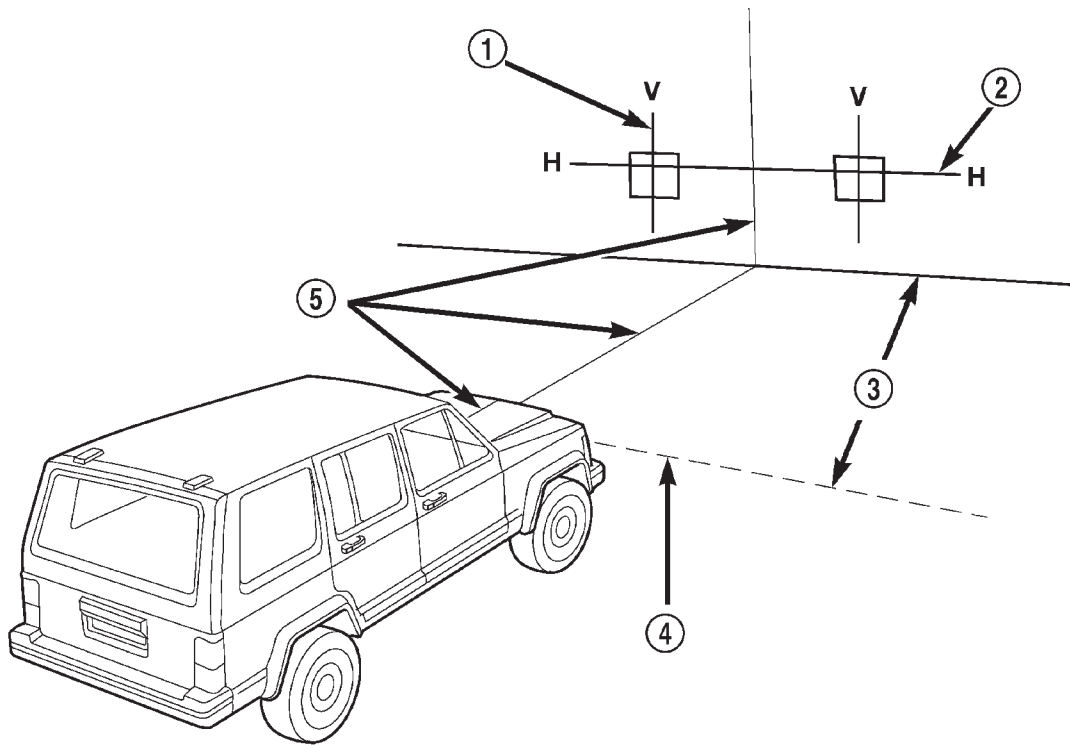

80a624c0

Fig. 1 Headlamp Alignment Screen—Typical

- | | |
|--|------------------------|
| 1 - CENTER OF VEHICLE TO CENTER OF HEADLAMP LENS | 4 - FRONT OF HEADLAMP |
| 2 - FLOOR TO CENTER OF HEADLAMP LENS | 5 - VEHICLE CENTERLINE |
| 3 - 7.62 METERS (25 FEET) | |

(8) Cover front of headlamp that has been adjusted and adjust the other headlamp beam as instructed above.

(9) Install headlamp bezels. Tighten the screws securely.

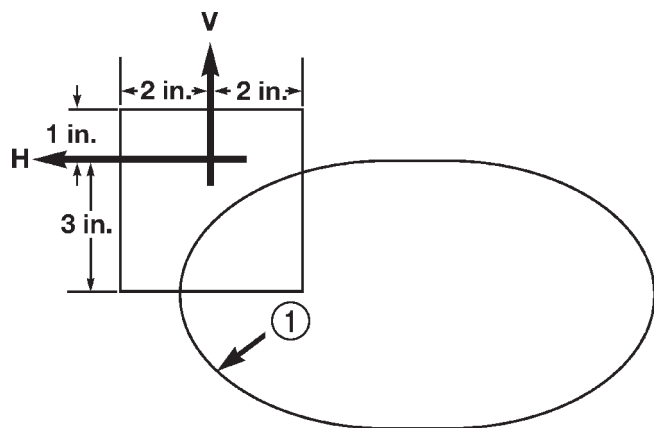

80b6b3aa

Fig. 2 Headlamp Alignment Screen Target

- 1 - LOW BEAM INTENSITY PATTERN (ISO-CANDELA CURVE)

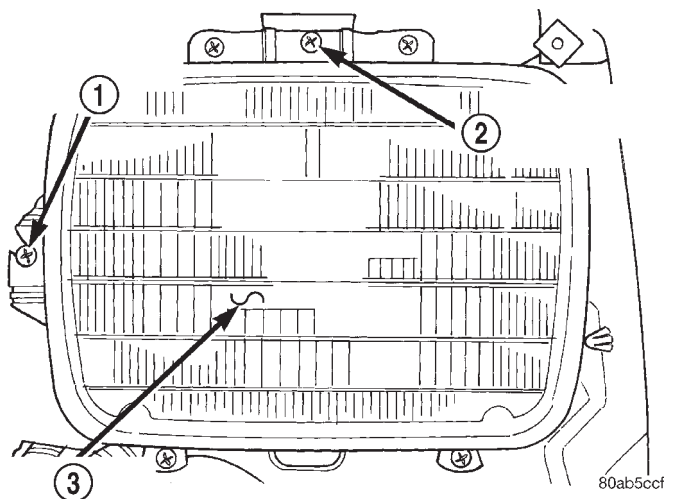

80ab5ccf

Fig. 3 Headlamp Beam Adjustment Screws

- | |
|---------------------------------|
| 1 - LEFT/RIGHT ADJUSTMENT SCREW |
| 2 - UP/DOWN ADJUSTMENT SCREW |
| 3 - HEADLAMP |

SERVICE PROCEDURES (Continued)

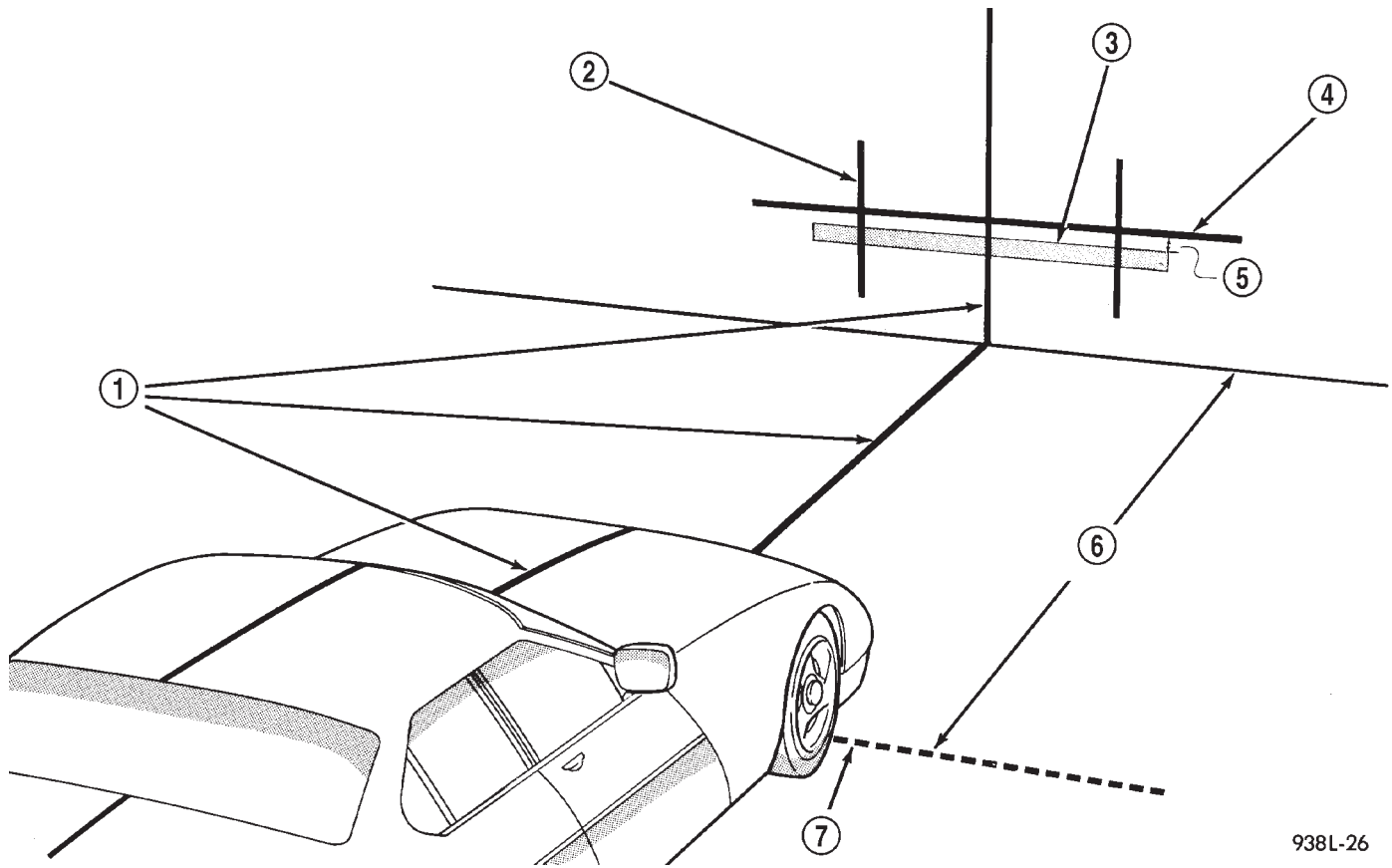

938L-26

Fig. 4 Fog Lamp Alignment —Typical

- | | |
|--|---------------------------|
| 1 - VEHICLE CENTERLINE | 5 - 100 mm (4 in.) |
| 2 - CENTER OF VEHICLE TO CENTER OF FOG LAMP LENS | 6 - 7.62 METERS (25 FEET) |
| 3 - HIGH-INTENSITY AREA | 7 - FRONT OF FOG LAMP |
| 4 - FLOOR TO CENTER OF FOG LAMP LENS | |

FOG LAMP ADJUSTMENT

Prepare an alignment screen. A properly aligned fog lamp will project a pattern on the alignment screen 100 mm (4 in.) below the fog lamp centerline and straight ahead (Fig. 4).

Rotate the adjustment screw to adjust beam height (Fig. 5).

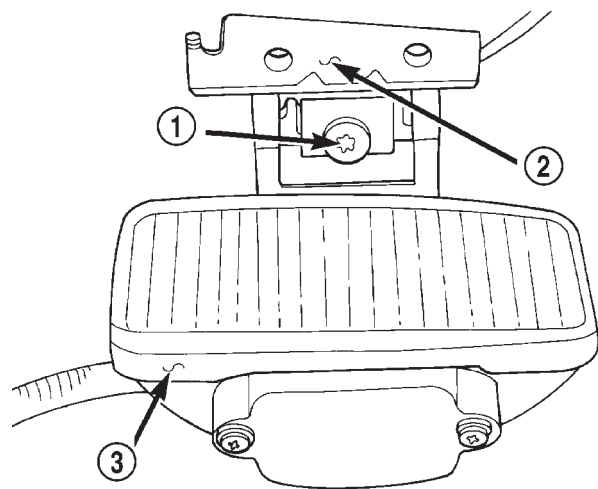

80ab8849

Fig. 5 Fog Lamp Adjustment

- | |
|----------------------|
| 1 - ADJUSTMENT SCREW |
| 2 - MOUNTING BRACKET |
| 3 - FOG LAMP |

SPECIAL TOOLS

HEADLAMP ALIGNMENT

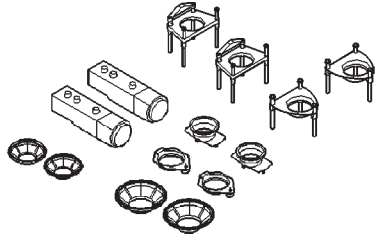

Headlamp Aiming Kit C-4466-A

LAMP BULB SERVICE

TABLE OF CONTENTS

| | page | | page |
|--|------|--|------|
| REMOVAL AND INSTALLATION | | | |
| HEADLAMP BULB | 10 | LICENSE PLATE LAMP BULB | 12 |
| FOG LAMP BULB..... | 10 | CENTER HIGH MOUNTED STOP LAMP (CHMSL) BULB..... | 12 |
| FRONT PARK/TURN SIGNAL LAMP BULB | 11 | UNDERHOOD LAMP BULB | 12 |
| SIDE MARKER LAMP BULB..... | 11 | CARGO LAMP BULB | 13 |
| BACK-UP/BRAKE/REAR TURN SIGNAL/TAIL LAMP BULB | 11 | MAP READING LAMP BULB..... | 13 |
| | | VISOR VANITY LAMP BULB..... | 13 |

REMOVAL AND INSTALLATION

HEADLAMP BULB

REMOVAL

- (1) Remove the screws attaching the bezel to the grille opening panel (Fig. 1).
- (2) Remove screws attaching the retaining ring to the headlamp canister.
- (3) Disconnect the headlamp bulb wire harness connector.
- (4) Separate the sealed beam from the vehicle.

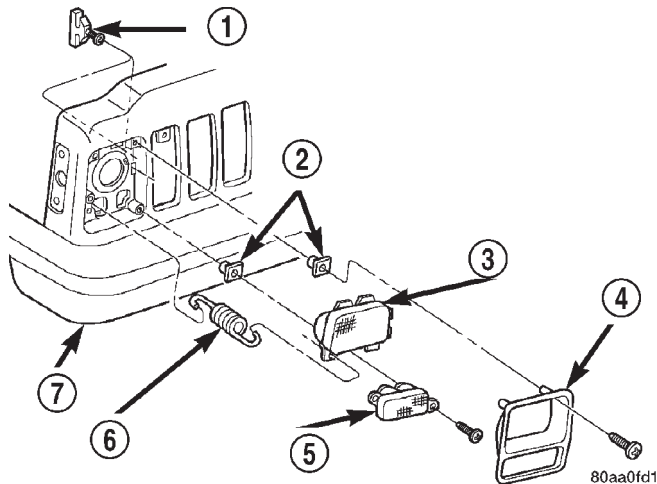

Fig. 1 Headlamp Bezel

- 1 - HEADLAMP ADJUSTMENT
- 2 - NUT
- 3 - HEADLAMP
- 4 - BEZEL
- 5 - PARK/TURN LAMP
- 6 - SPRING
- 7 - BUMPER

- (3) Position retaining ring on sealed beam and install screws.
- (4) Install headlamp bezel.

FOG LAMP BULB

REMOVAL

- (1) Remove the screws attaching the access cover to the bottom of the fog lamp (Fig. 2).
- (2) Remove spring clip securing bulb to fog lamp.
- (3) Disconnect bulb wire connector.
- (4) Remove bulb element from fog lamp.

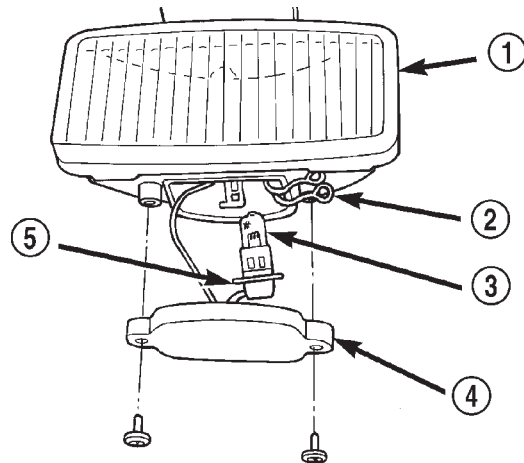

Fig. 2 Fog Lamp Components

- 1 - FOG LAMP
- 2 - CLIP
- 3 - BULB
- 4 - ACCESS COVER
- 5 - BULB SOCKET

INSTALLATION

- (1) Connect wire harness connector.
- (2) Position bulb in canister.

INSTALLATION

- CAUTION: Do not touch the bulb glass with fingers or other oily surfaces. Reduced bulb life will result.**
- (1) Position bulb element in fog lamp.

REMOVAL AND INSTALLATION (Continued)

- (2) Connect bulb wire connector.
- (3) Install spring clip securing bulb to fog lamp.
- (4) Install screws attaching the access cover to the bottom of the fog lamp.

FRONT PARK/TURN SIGNAL LAMP BULB

REMOVAL

- (1) Remove headlamp bezel.
- (2) Remove screws attaching park/turn signal lamp housing to grille opening panel.
- (3) Rotate bulb socket one-third turn counter-clockwise and remove it from lamp housing (Fig. 3).
- (4) Pull bulb from socket.

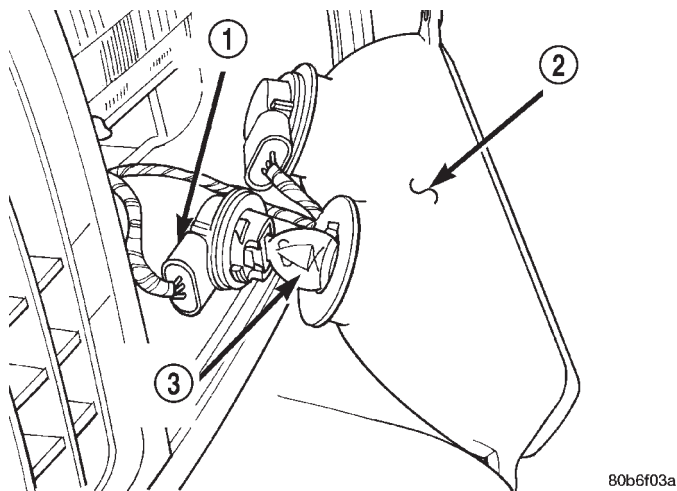

Fig. 3 Park/Turn Signal Lamp Bulb

- 1 - BULB SOCKET
- 2 - PARK LAMP HOUSING
- 3 - PARK LAMP BULB

INSTALLATION

- (1) Install bulb in socket.
- (2) Install socket in lamp housing.
- (3) Install park/turn signal lamp housing.
- (4) Install headlamp bezel.

SIDE MARKER LAMP BULB

REMOVAL

- (1) Remove screws attaching side marker lamp housing.
- (2) Rotate bulb socket counter-clockwise and pull from back side of lamp housing (Fig. 4).
- (3) Pull bulb from socket.

INSTALLATION

- (1) Install bulb in socket.
- (2) Install bulb and socket in back of side marker lamp housing.
- (3) Install side marker lamp housing.

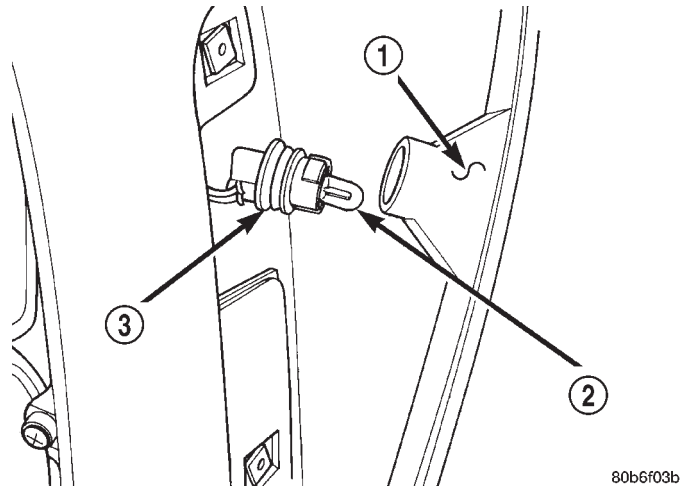

Fig. 4 Side Marker Lamp

- 1 - SIDE MARKER LAMP HOUSING
- 2 - SIDE MARKER LAMP BULB
- 3 - BULB SOCKET

BACK-UP/BRAKE/REAR TURN SIGNAL/TAIL LAMP BULB

REMOVAL

- (1) Remove tail lamp housing.
- (2) Rotate bulb socket one-third turn counter-clockwise and remove bulb socket from lamp housing (Fig. 5).
- (3) Pull bulb from socket.

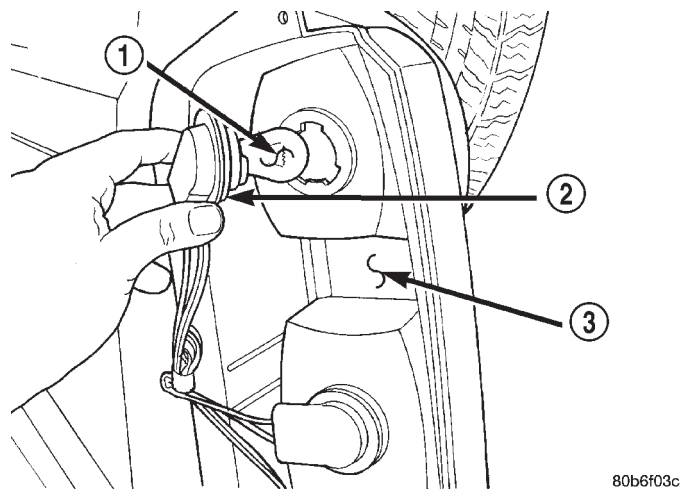

Fig. 5 Bulb Socket Removal

- 1 - TAIL LAMP BULB
- 2 - BULB SOCKET
- 3 - TAIL LAMP HOUSING

INSTALLATION

- (1) Install bulb in socket.
- (2) Install bulb and socket in lamp housing.
- (3) Install lamp housing.

REMOVAL AND INSTALLATION (Continued)

LICENSE PLATE LAMP BULB

REMOVAL

- (1) Remove screws attaching license plate lamp housing to liftgate.
- (2) Rotate bulb socket counter-clockwise and remove bulb socket from lamp housing.
- (3) Pull bulb from socket.

INSTALLATION

- (1) Install bulb in lamp socket.
- (2) Install bulb socket in lamp housing.
- (3) Install screws attaching license plate lamp housing to liftgate.

CENTER HIGH MOUNTED STOP LAMP (CHMSL) BULB

REMOVAL

- (1) Remove the screws attaching the lamp housing to the liftgate.
- (2) Rotate bulb socket 1/4 turn counter-clockwise and pull from housing (Fig. 6).
- (3) Pull bulb from socket.

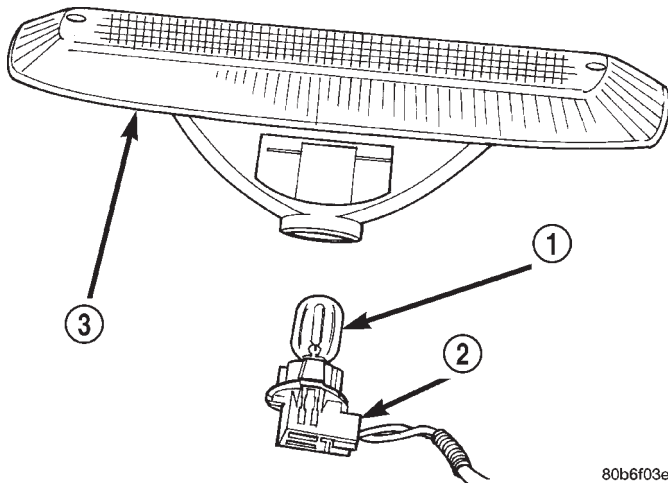

Fig. 6 CHMSL Bulb

- 1 - CHMSL BULB
- 2 - BULB SOCKET
- 3 - CHMSL LAMP HOUSING

INSTALLATION

- (1) Push bulb into socket.
- (2) Position socket in lamp and rotate 1/4 turn clockwise.
- (3) Install screws attaching lamp housing to the liftgate.

UNDERHOOD LAMP BULB

REMOVAL

- (1) Insert a small flat blade in the access slot between the lamp base and lamp lens.
- (2) Pry the lamp lens upward and remove the lamp lens (Fig. 7).
- (3) Depress the bulb terminal inward (Fig. 8) to release the bulb.

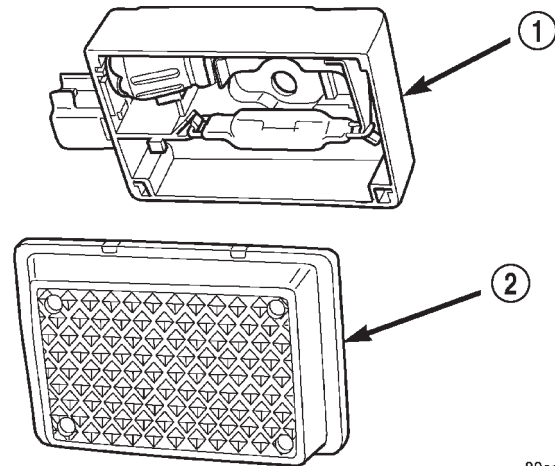

Fig. 7 Underhood Lamp Lens

- 1 - LAMP
- 2 - LAMP LENS

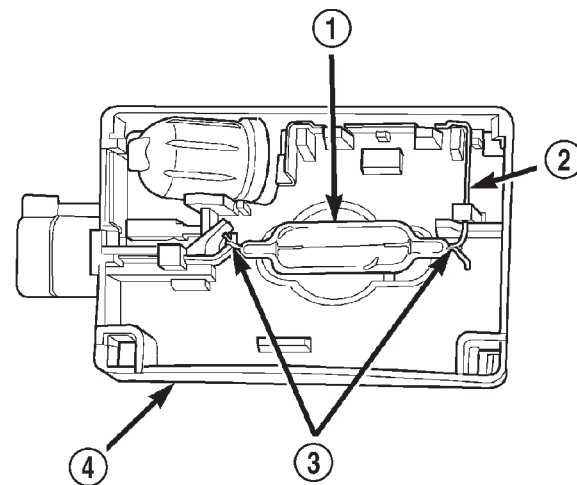

Fig. 8 Underhood Lamp Bulb

- 1 - BULB
- 2 - DEPRESS TERMINAL INWARD
- 3 - BULB WIRE LOOP
- 4 - LAMP BASE

INSTALLATION

- (1) Engage the replacement bulb wire loop to the terminal closest to the lamp base wire connector.

REMOVAL AND INSTALLATION (Continued)

- (2) Depress the opposite terminal inward and engage the remaining bulb wire loop.
- (3) Position the lamp lens on the lamp base and press into place.

CARGO LAMP BULB

REMOVAL

- (1) Insert a small flat blade into the access slots (Fig. 9).
- (2) Carefully pry the lens from the lamp.
- (3) Grasp bulb and pull from lamp.

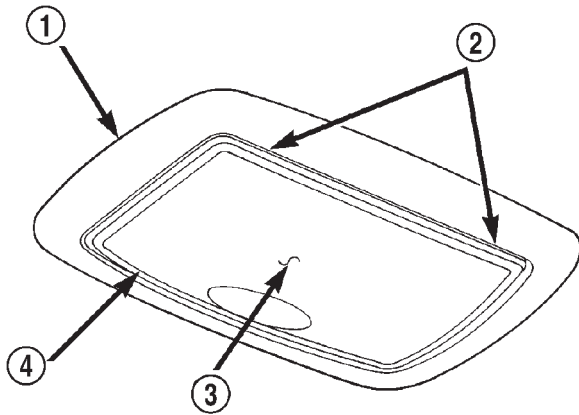

Fig. 9 Cargo Lamp Lens

- 1 - HOUSING
- 2 - SCREWDRIVER SLOTS
- 3 - CARGO LAMP
- 4 - LENS

INSTALLATION

- (1) Position bulb in lamp and snap into place.
- (2) Position the lens at the lamp housing and force it upward into the housing until the mounting tabs are seated on the lamp mounting pins.

MAP READING LAMP BULB

REMOVAL

- (1) Insert a flat blade screwdriver in slot at front of lens (Fig. 10).
- (2) Rotate the screwdriver until lens snaps out of the housing.
- (3) Remove lens from housing.
- (4) Remove bulb from terminals.

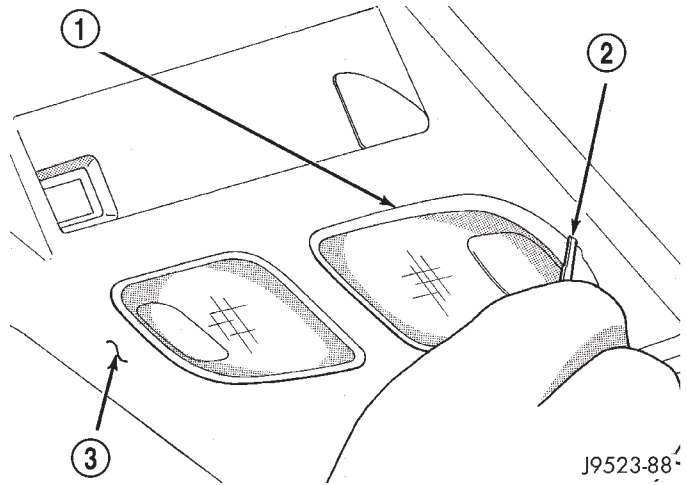

Fig. 10 Reading Lamp Bulb

- 1 - LENS
- 2 - FLAT BLADE
- 3 - CONSOLE

INSTALLATION

- (1) Insert bulb into reading lamp terminals.
- (2) Replace lens by holding lens level and pushing rearward into housing.
- (3) Push lens up to snap into housing.

VISOR VANITY LAMP BULB

REMOVAL

- (1) Using a small flat blade, carefully pry each corner of lens outward from lamp.
- (2) Separate lens from lamp.
- (3) Grasp bulb and pull outward.

INSTALLATION

- (1) Position bulb in socket and push into place.
- (2) Position lens on lamp and snap into place.

LAMP SERVICE

TABLE OF CONTENTS

| | page | | page |
|--|------|---|------|
| REMOVAL AND INSTALLATION | | | |
| HEADLAMP | 14 | CENTER HIGH MOUNTED STOP LAMP (CHMSL) | 16 |
| FOG LAMP | 15 | LICENSE PLATE LAMP | 16 |
| FRONT PARK/TURN SIGNAL LAMP | 15 | UNDERHOOD LAMP | 16 |
| SIDE MARKER LAMP | 15 | CARGO LAMP | 17 |
| BACK-UP/BRAKE/REAR TURN SIGNAL/TAIL LAMP | 16 | MAP/READING LAMP | 17 |
| | | VISOR VANITY LAMP | 18 |

REMOVAL AND INSTALLATION

HEADLAMP

REMOVAL

- (1) Remove the screws attaching the bezel to the grille opening panel
- (2) Remove the screws attaching the retaining ring to the headlamp bucket.
- (3) Disconnect the headlamp bulb wire harness connector (Fig. 1).
- (4) Separate the bulb from the vehicle.
- (5) Remove the spring attaching the headlamp bucket to the grille opening panel (Fig. 2).
- (6) Slide the headlamp bucket downward to disengage it from the headlamp adjusting screws.

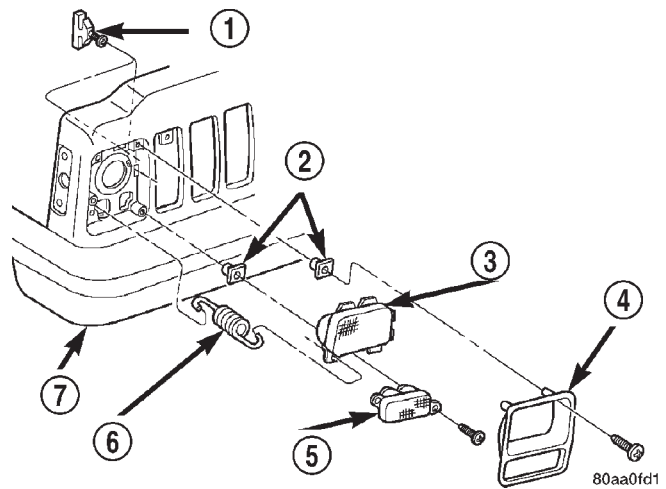

Fig. 2 Headlamp

- 1 - HEADLAMP ADJUSTMENT
- 2 - NUT
- 3 - HEADLAMP
- 4 - BEZEL
- 5 - PARK/TURN LAMP
- 6 - SPRING
- 7 - BUMPER

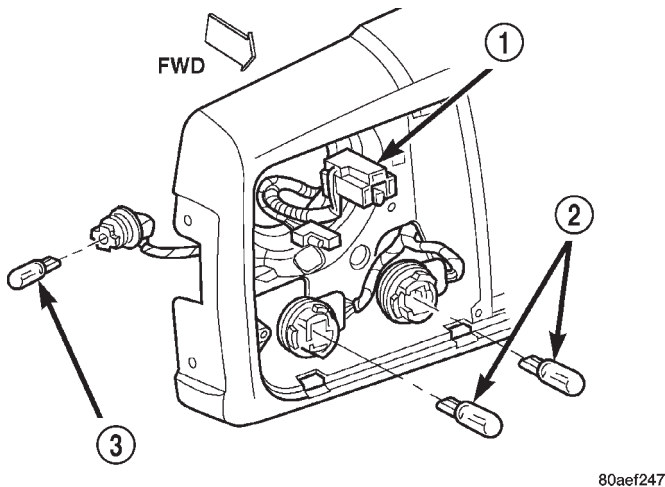

Fig. 1 Headlamp Connector

- 1 - HEADLAMP CONNECTOR
- 2 - PARK/TURN LAMP BULB
- 3 - SIDE MARKER LAMP BULB

INSTALLATION

- (1) Position the headlamp bucket in the grille opening panel and slide the headlamp bucket upward to engage it with the headlamp adjusting screws.
- (2) Install the spring attaching the headlamp bucket to the grille opening panel.
- (3) Connect the wire harness connector.
- (4) Position the bulb in the bucket.
- (5) Position retaining ring on the headlamp bulb and install screws.
- (6) Install the headlamp bezel.

REMOVAL AND INSTALLATION (Continued)

FOG LAMP

REMOVAL

- (1) Disconnect the fog lamp wire harness connector.
- (2) Remove the screws attaching the fog lamp to the support (Fig. 3).
- (3) Separate the fog lamp from the vehicle.

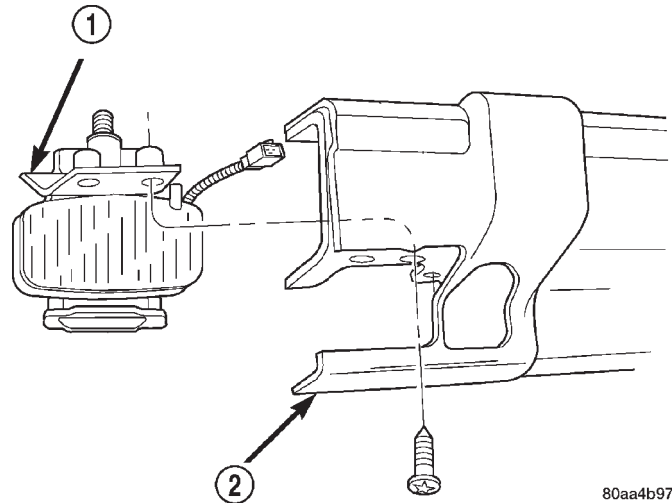

Fig. 3 Fog Lamp

- 1 - FOG LAMP
2 - BUMPER

INSTALLATION

- (1) Position the fog lamp in the support bracket and install the screws.
- (2) Connect the fog lamp wire harness connector.

FRONT PARK/TURN SIGNAL LAMP

REMOVAL

- (1) Remove the headlamp bezel.
- (2) Remove the screws attaching the park/turn signal lamp housing to the grille opening panel (Fig. 4).
- (3) Remove the bulb sockets and separate from the vehicle.

INSTALLATION

- (1) Install bulbs and sockets in the lamp housing.
- (2) Position the park/turn signal lamp housing on the grille opening panel and install the screws.
- (3) Install the headlamp bezel.

SIDE MARKER LAMP

REMOVAL

- (1) Remove screws attaching side marker lamp lens to grille opening panel (Fig. 5).

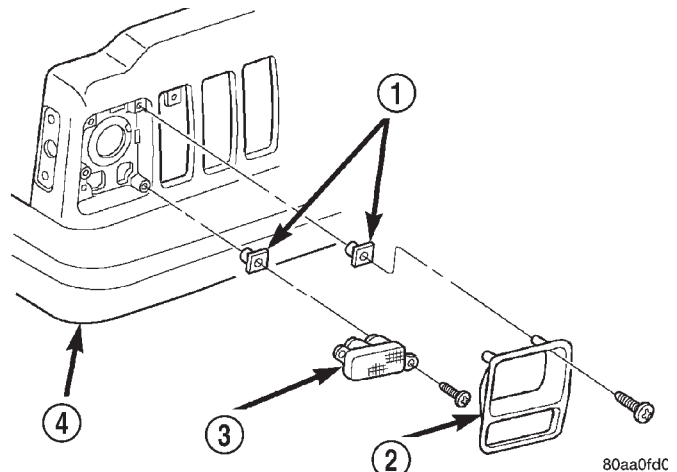

Fig. 4 Park/Turn Signal Lamp

- 1 - NUT
2 - BEZEL
3 - PARK/TURN LAMP
4 - BUMPER

- (2) Remove bulb and socket from back side of lamp.

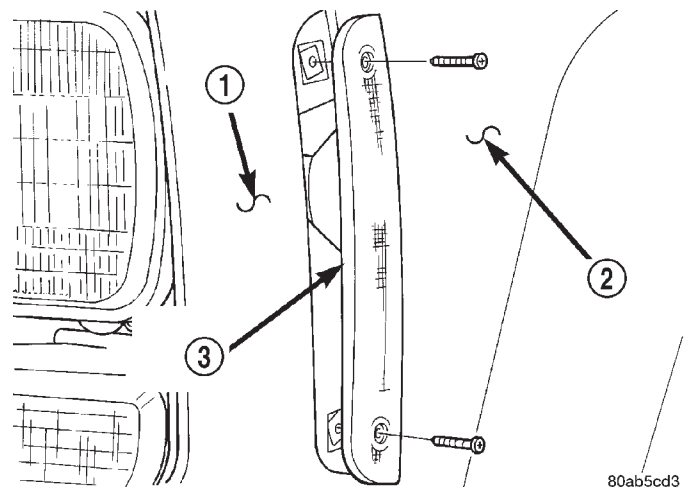

Fig. 5 Side Marker Lamp

- 1 - GRILLE OPENING PANEL
2 - FENDER
3 - SIDE MARKER LAMP

INSTALLATION

- (1) Install bulb and socket in back of side marker lamp.
- (2) Install side marker lamp in grille opening panel.

REMOVAL AND INSTALLATION (Continued)

BACK-UP/BRAKE/REAR TURN SIGNAL/TAIL LAMP**REMOVAL**

- (1) Open the liftgate.
- (2) Remove the bolts attaching the tail lamp housing to the quarter panel (Fig. 6).
- (3) Grasp the lamp and pull to disengage it from the grommet at the base of the lamp.
- (4) Rotate the bulb sockets one-third turn and remove the bulb sockets from the lamp housing.

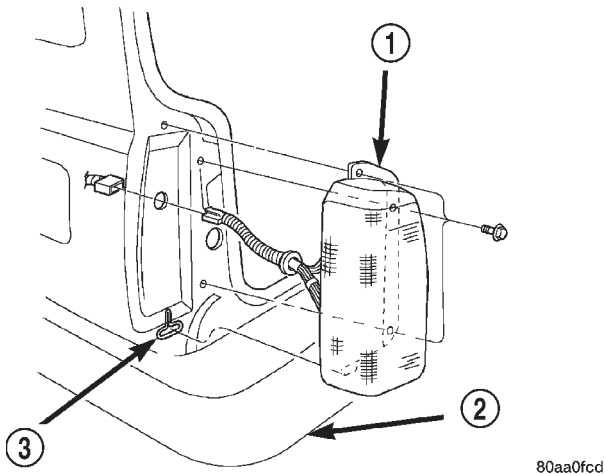
**Fig. 6 Tail Lamp**

- 1 - TAIL LAMP
2 - REAR BUMPER
3 - GROMMET

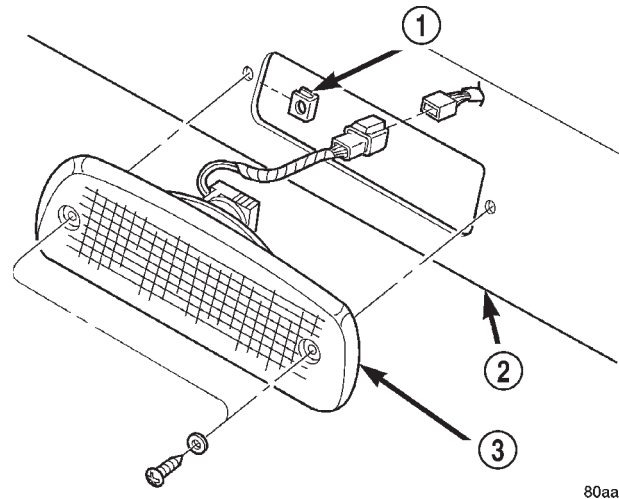

80aa0fcb

Fig. 7 Center High Mounted Stop lamp

- 1 - U-NUT
2 - LIFTGATE
3 - CHMSL

- (3) Install the screws attaching the CHMSL to the liftgate.

LICENSE PLATE LAMP**REMOVAL**

- (1) Remove screws attaching the license plate lamp to the liftgate.
- (2) Remove the bulb from the lamp socket.

INSTALLATION

- (1) Install bulb in the lamp socket.
- (2) Position the license plate lamp on the liftgate and install screws.

UNDERHOOD LAMP

The underhood lamp is installed on the hood inner panel. The lamp illuminates when the hood is opened. A switch that is integral with the lamp base controls the operation. The switch provides automatic ON/OFF functions each time the hood is opened and closed.

REMOVAL

- (1) Disconnect the wire harness connector from the lamp.
- (2) Remove lamp lens.
- (3) Remove bulb.
- (4) Remove screw attaching underhood lamp to the inner hood panel.
- (5) Separate underhood lamp from vehicle.

INSTALLATION

- (1) Install the bulb and sockets in the lamp housing.
- (2) Position the lamp housing in the quarter panel and push to engage the grommet.
- (3) Install the lamp housing screws. Tighten the screws securely.
- (4) Install the bolts attaching the tail lamp housing to the quarter panel.
- (5) Close the liftgate.

CENTER HIGH MOUNTED STOP LAMP (CHMSL)**REMOVAL**

- (1) Remove the screws attaching the CHMSL to the liftgate (Fig. 7).
- (2) Disconnect the wire harness connector.
- (3) Separate the CHMSL from the vehicle.

INSTALLATION

- (1) Connect the wire harness connector.
- (2) Position the CHMSL on the liftgate.

REMOVAL AND INSTALLATION (Continued)

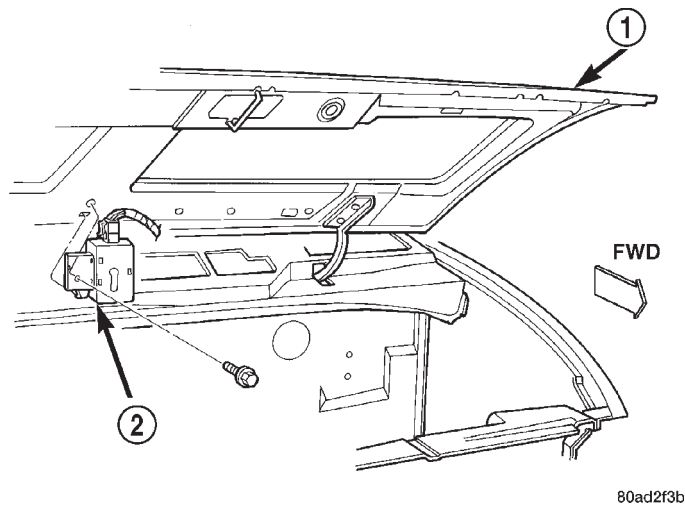

Fig. 8 Underhood Lamp

- 1 - HOOD
- 2 - UNDERHOOD LAMP/SWITCH

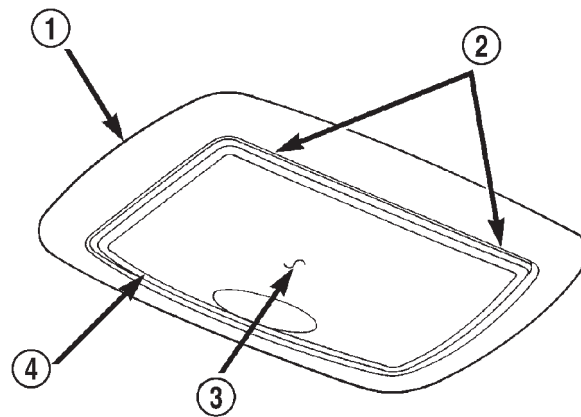

Fig. 9 Cargo Lamp

- 1 - HOUSING
- 2 - SCREWDRIVER SLOTS
- 3 - CARGO LAMP
- 4 - LENS

INSTALLATION

(1) Position underhood lamp on hood inner panel. Ensure anti-rotation tab is positioned in slot on hood inner panel.

(2) Install the attaching screw through the lamp and into the hood panel (Fig. 8). Tighten the screw securely.

(3) Fold lamp housing over and firmly press onto base to snap into place.

(4) Connect the wire harness connector to the lamp.

CARGO LAMP

REMOVAL

(1) Insert a small flat blade into the access slots (Fig. 9).

(2) Carefully pry the lens from the lamp.

(3) Disengage the lens mounting tabs from the lamp mounting pins (Fig. 10).

(4) Remove the fasteners attaching the lamp to the roof.

(5) Remove the lamp housing from the headliner cavity.

(6) Disconnect the wire harness connector.

INSTALLATION

(1) Position the dome lamp housing at the headliner cavity.

(2) Connect the wire harness connector.

(3) Install the fasteners attaching the lamp to the roof.

(4) Position the lens at the lamp housing and force it upward into the housing until the mounting tabs are seated on the lamp mounting pins.

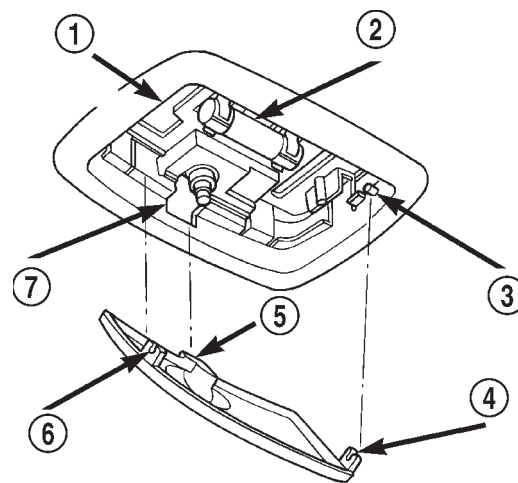

Fig. 10 Cargo Lamp Lens

- 1 - MOUNTING PIN ON UNDERSIDE
- 2 - BULB
- 3 - MOUNTING PIN
- 4 - MOUNTING TAB
- 5 - TAB "A"
- 6 - MOUNTING TAB
- 7 - SLOT "B"

MAP/READING LAMP

The map/reading lamp can be serviced by removing the overhead console. Refer to Group 8C, Overhead Console for removal/installation procedures.

REMOVAL AND INSTALLATION (Continued)

VISOR VANITY LAMP**REMOVAL**

- (1) Fold down sunvisor.
- (2) Starting at the base of the lamp assembly and working right-to-left, use a small flat blade, carefully pry lamp from visor.
- (3) Disconnect visor lamp wire connector and remove from vehicle.

INSTALLATION

- (1) Position visor lamp at visor and connect visor lamp wire connector.
- (2) Position visor lamp in visor and press into place.

LAMP SYSTEMS

TABLE OF CONTENTS

| | page | page |
|--|------|--|
| REMOVAL AND INSTALLATION | | |
| SENTINEL HEADLAMP DELAY MODULE | 19 | |
| | | DAYTIME RUNNING LAMP MODULE 19 |

REMOVAL AND INSTALLATION

SENTINEL HEADLAMP DELAY MODULE

REMOVAL

- (1) Remove the knee blocker.
- (2) Remove the screw that attaches the module to the inside of the instrument panel (Fig. 1).
- (3) Disconnect the wire harness connector and remove the module from the instrument panel.

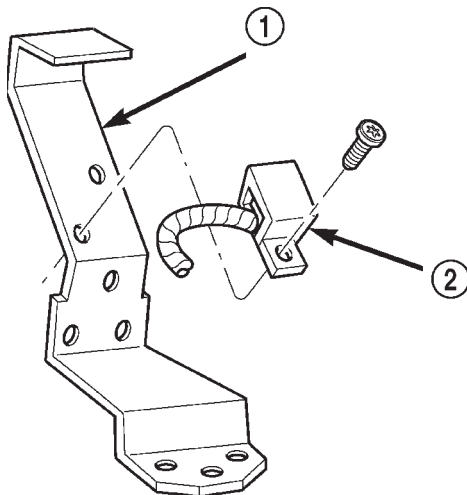

80add41f

Fig. 1 Headlamp Delay Module

- 1 - BRACKET
2 - HEADLAMP DELAY MODULE

INSTALLATION

- (1) Position the module inside the I/P and connect the wire harness connector to the module.
- (2) Install the screw that attaches the module to the inside of the instrument panel.
- (3) Install the knee blocker.

DAYTIME RUNNING LAMP MODULE

REMOVAL

The Daytime Running Lights (DRL) module is located on the right fender inner panel adjacent to the dash panel (Fig. 2).

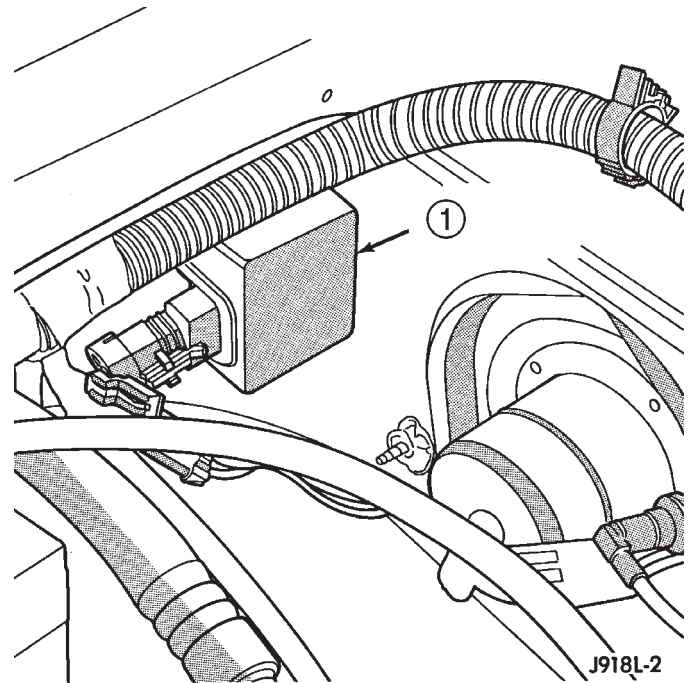

Fig. 2 Daytime Running Lamp Module

- 1 - DAYTIME RUNNING LIGHT MODULE

- (1) Disconnect the wire harness connector from the module.
- (2) Remove the screws that attach the module to the fender inner panel.
- (3) Remove the module from the fender inner panel.

INSTALLATION

- (1) Position the module on the right fender inner panel.
- (2) Install the attaching screws. Tighten the screws securely.
- (3) Connect the wire harness connector to the module.

BULB APPLICATION

TABLE OF CONTENTS

| | | | |
|--------------------------|------|--------------------------|------|
| | page | | page |
| SPECIFICATIONS | | INTERIOR LAMPS | 20 |
| EXTERIOR LAMPS | 20 | | |

SPECIFICATIONS

EXTERIOR LAMPS

CAUTION: Do not use bulbs that have a higher candle power than the bulb listed in the Bulb Application Table. Damage to lamp can result. Do not touch halogen bulbs with fingers or other oily surfaces. Bulb life will be reduced.

The following Bulb Application Table lists the lamp title on the left side of the column and trade number or part number on the right.

| LAMP | BULB |
|--|-------------|
| Back-up | 3157 |
| Center High Mounted Stoplamp | 921 |
| Fog lamp | H3 |
| Front Side Marker | 168 |
| Headlamp/Sealed Beam | 6054BLL |
| License Plate | 168 |
| Park/Turn Signal | 3157 |
| Tail/Brake | 3157 |
| Rear Turn Signal | 3157 |

INTERIOR LAMPS

CAUTION: Do not use bulbs that have a higher candle power than the bulb listed in the Bulb Application Table. Damage to lamp can result.

Service procedures for most of the lamps in the instrument panel, Instrument cluster and switches are located in Group 8E, Instrument Panel and Gauges. Some components have lamps that can only be serviced by an Authorized Service Center (ASC) after the component is removed from the vehicle.

The following Bulb Application Tables lists the lamp title on the left side of the column and trade number or part number on the right.

| LAMP | BULB |
|-------------------------------|-------------|
| Cargo | 561 |
| Dome | 561 |
| Dome/Reading | 906 |
| Overhead Console | 912 |
| Under Hood | 105 |
| Vanity Mirror | 74 |
| Underpanel Courtesy | 168 |

INDICATOR LAMPS

| LAMP | BULB |
|------------------------------------|-------------|
| A/C Control | 74 |
| Airbag | 74 |
| Anti-lock Brake | 74 |
| Brake Warning | 74 |
| Check Engine | 74 |
| Check Gauges | 74 |
| Cigar Lighter | 53 |
| Coolant Temp High | 194 |
| Cruise | 74 |
| Fasten Seat Belts | 74 |
| Four Wheel Drive | 74 |
| Generator | 194 |
| Heater Control | 74 |
| High Beam | 74 |
| Illumination | 103 |
| Low Fuel | 74 |
| Low Oil Pressure | 194 |
| Low Washer Fluid | 74 |
| Radio | ASC |
| Security | 74 |
| Transfer Case | 658 |
| Transmission Floor Shift | 658 |
| Turn Signal | 74 |
| Upshift | 74 |

LAMPS

TABLE OF CONTENTS

| | page | page |
|--------------------------------------|------|------------------------|
| LAMP DIAGNOSIS | 1 | LAMP SERVICE..... 8 |
| HEADLAMP AND FOG LAMP ALIGNMENT..... | 3 | BULB APPLICATION |
| LAMP BULB SERVICE | 6 | 11 |

LAMP DIAGNOSIS

TABLE OF CONTENTS

| | page | page |
|----------------------------------|------|------------------------------------|
| DESCRIPTION AND OPERATION | | DIAGNOSIS AND TESTING |
| HEADLAMP LEVELING MOTOR..... | 1 | 2 |
| DIAGNOSIS AND TESTING | | |
| DIAGNOSTIC PROCEDURES | 1 | |

DESCRIPTION AND OPERATION

HEADLAMP LEVELING MOTOR

DESCRIPTION

Vehicles equipped with a remote headlamp leveling system use two leveling motors attached to each headlamp mounting bracket. They are located just behind the headlamp assemblies and must be accessed from underneath the vehicle.

OPERATION

This system allows the driver to adjust the vertical headlamp aim from the interior of the vehicle to compensate for passenger or cargo load. A headlamp leveling switch is located in the instrument panel and controls the headlamp leveling motor function.

DIAGNOSIS AND TESTING

DIAGNOSTIC PROCEDURES

When a vehicle experiences problems with the headlamp system, verify the condition of the battery connections, fuses, charging system, headlamp bulbs, wire connectors, relay, high beam switch, dimmer switch, and headlamp switch. Refer to Group 8W, Wiring Diagrams for component locations and circuit information.

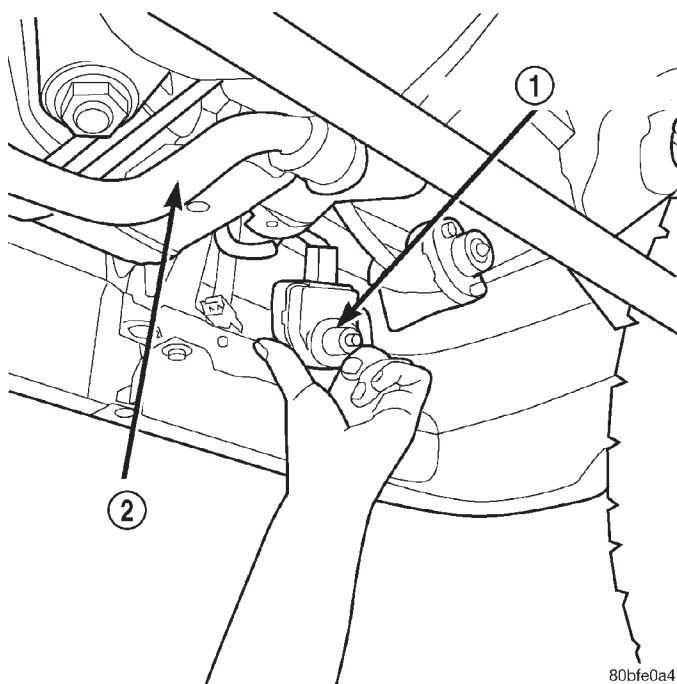

Fig. 1 Headlamp Leveling Motor Position & Orientation

- 1 - HEADLAMP LEVELING MOTOR
- 2 - FRONT STABILIZER BAR

DIAGNOSIS AND TESTING (Continued)

DIAGNOSIS AND TESTING

HEADLAMP LEVELING MOTOR DIAGNOSIS

| CONDITION | POSSIBLE CAUSES | CORRECTION |
|----------------------------|--|--|
| ONE MOTOR DOES NOT OPERATE | <ol style="list-style-type: none">1. Poor connection at motor.2. No voltage at motor.3. Defective motor. | <ol style="list-style-type: none">1. Secure connector on motor.2. Repair circuit. Refer to Group 8W, Wiring.3. Replace motor. |
| BOTH MOTORS DO NOT OPERATE | <ol style="list-style-type: none">1. No voltage at headlamp leveling switch.2. No voltage at both motors.3. Poor connection at motors.4. Both motors defective. | <ol style="list-style-type: none">1. Repair circuit or replace fuse. Refer to Group 8W, Wiring.2. Repair circuit or replace fuse. Refer to Group 8W, Wiring.3. Secure connectors on motors.4. Replace motors. |

HEADLAMP AND FOG LAMP ALIGNMENT

TABLE OF CONTENTS

| | page | | page |
|---|------|--|------|
| SERVICE PROCEDURES | | ADJUSTMENTS | |
| HEADLAMP ALIGNMENT PREPARATION. | 3 | HEADLAMP/FOG LAMP ADJUSTMENT USING ALIGNMENT SCREEN | 3 |

SERVICE PROCEDURES

HEADLAMP ALIGNMENT PREPARATION

- (1) Verify headlamp are on low beam setting.
- (2) Verify that the headlamp leveling switch is in the "0" position.
- (3) Inspect and correct damaged or defective components that could interfere with proper headlamp alignment.
- (4) Verify proper tire inflation.
- (5) Clean headlamp lenses.
- (6) Verify that luggage area is loaded as the vehicle is routinely used.
- (7) Fuel tank should be FULL. Add 2.94 kg (6.5 lbs.) of weight over the fuel tank for each estimated gallon of missing fuel.

ADJUSTMENTS

HEADLAMP/FOG LAMP ADJUSTMENT USING ALIGNMENT SCREEN

ALIGNMENT SCREEN PREPARATION

- (1) Position vehicle on a level surface perpendicular to a flat wall 10 meters (32.8 ft.) away from front of headlamp lens (Fig. 1).
- (2) Place 75 kg in the driver's seat to simulate the ride height of the vehicle when driven.
- (3) If necessary, tape a line on the floor 10 meters (32.8 ft) away from and parallel to the wall.
- (4) From the floor up 1.27 meters (5 ft), tape a line on the wall at the centerline of the vehicle. Sight along the centerline of the vehicle (from rear of vehicle forward) to verify accuracy of the line placement.

- (5) Rock vehicle side-to-side three times and allow suspension to stabilize.
- (6) Jounce front suspension three times by pushing downward on front bumper and releasing.
- (7) Measure the distance from the center of headlamp lens to the floor. Transfer measurement to the alignment screen (with tape). Use this line for up/down adjustment reference.
- (8) Place a tape line 130 mm below and parallel to the center of headlamp line.
- (9) Measure distance from the centerline of the vehicle to the center of each headlamp being aligned. Transfer measurements to screen (with tape) to each side of vehicle centerline. Use these lines for left/right adjustment reference.

HEADLAMP ADJUSTMENT

A properly aimed low beam headlamp will project a high intensity light pattern on the screen with the horizontal cut-off line aligned with the tape line 130 mm (5.12 in.) below the headlamp centerline (Fig. 1). The intersection of the horizontal and 15 degree cut-off lines in the projected pattern should align to the intersection of the headlamp centerline vertical tape line and the tape line 130 mm (5.12 in.) below the headlamp horizontal centerline. The high beams on a vehicle with aero headlamps cannot be aligned. The high beam pattern should be correct when the low beams are aligned properly.

To adjust headlamp alignment, rotate alignment screws (Fig. 2) to achieve the specified low beam hot spot pattern.

ADJUSTMENTS (Continued)

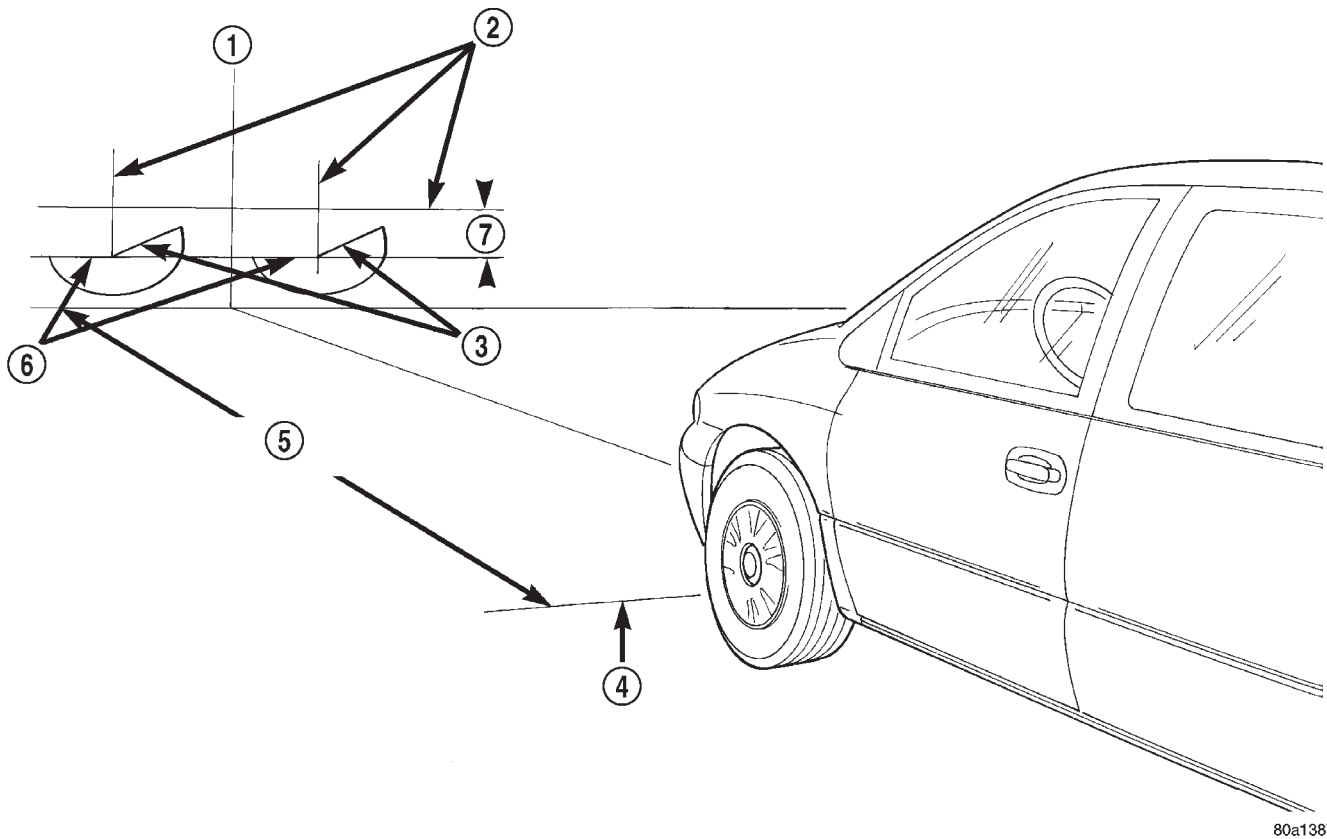

80a1387e

Fig. 1 Headlamp Alignment Screen—Typical

- | | |
|-------------------------|-----------------------------|
| 1 - CENTER OF VEHICLE | 5 - 10 METERS (32.8 ft.) |
| 2 - CENTER OF HEADLAMPS | 6 - HORIZONTAL CUT-OFF LINE |
| 3 - 15° CUT-OFF LINE | 7 - 130mm |
| 4 - FRONT OF HEADLAMP | |

FOG LAMP ALIGNMENT

Prepare an alignment screen. Refer to the Alignment Screen Preparation paragraph in this section. A properly aligned fog lamp will project a pattern on the alignment screen 200 mm (8 in.) below the fog lamp centerline and straight ahead (Fig. 3). To improve visual interpretation of the fog lamp pattern on the alignment screen, disable the headlamps by disengaging the wire connectors from the headlamp bulbs.

To adjust fog lamp alignment, rotate alignment screws (Fig. 4) to achieve the specified pattern.

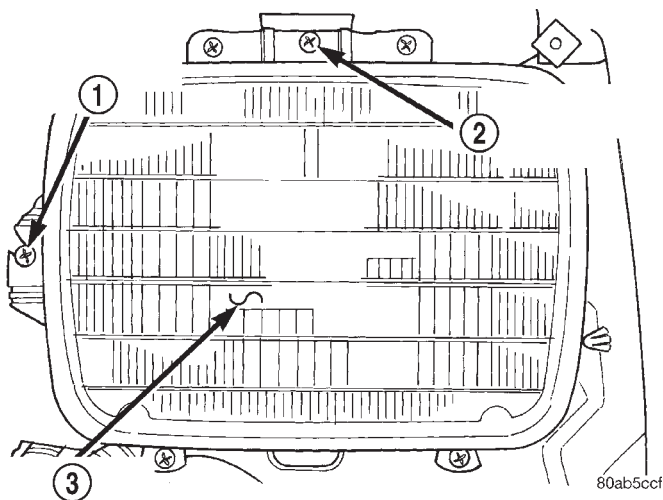

80ab5ccf

Fig. 2 Headlamp Beam Adjustment Screws

- | |
|---------------------------------|
| 1 - LEFT/RIGHT ADJUSTMENT SCREW |
| 2 - UP/DOWN ADJUSTMENT SCREW |
| 3 - HEADLAMP |

ADJUSTMENTS (Continued)

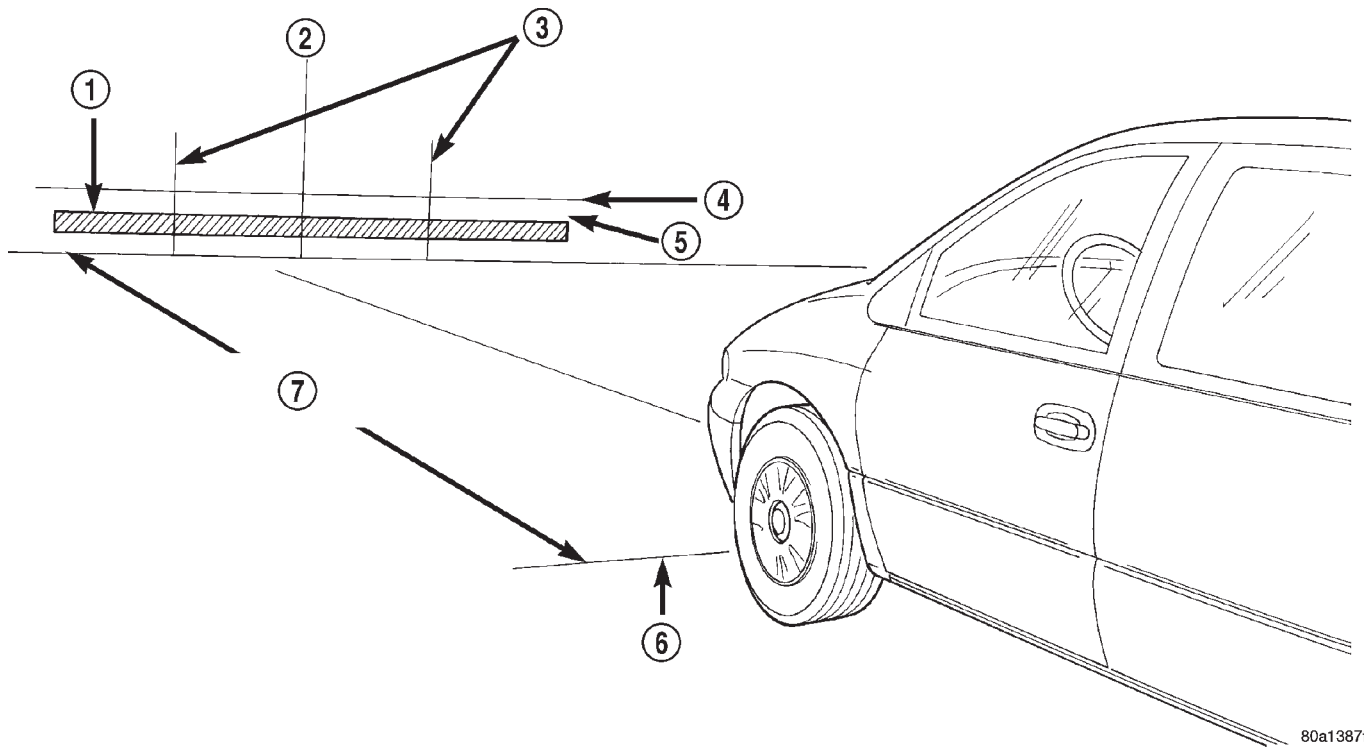

80a1387f

Fig. 3 Fog Lamp Alignment-Typical

- | | |
|-----------------------------------|--------------------------|
| 1 - HIGH INTENSITY AREA | 5 - 200mm (8 in.) |
| 2 - CENTER OF VEHICLE | 6 - FRONT OF FOG LAMP |
| 3 - VERTICAL CENTER OF FOG LAMP | 7 - 10 METERS (32.8 ft.) |
| 4 - HORIZONTAL CENTER OF FOG LAMP | |

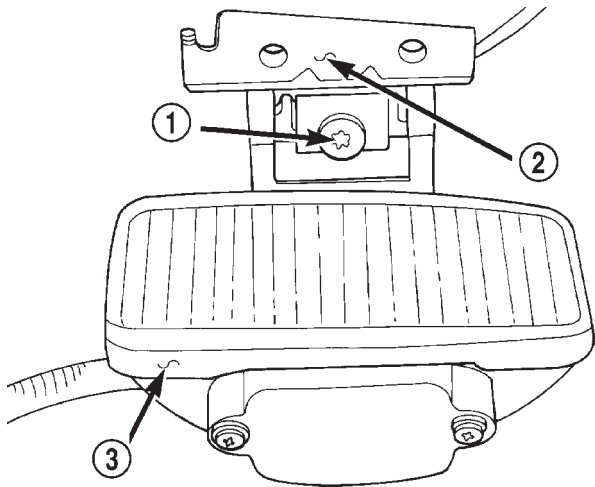

80ab8849

Fig. 4 Fog Lamp Beam Adjustment Screws

- 1 - ADJUSTMENT SCREW
- 2 - MOUNTING BRACKET
- 3 - FOG LAMP

LAMP BULB SERVICE

TABLE OF CONTENTS

| | page | | page |
|---------------------------------|------|-------------------------------|------|
| REMOVAL AND INSTALLATION | | REAR FOG LAMP BULB | 7 |
| FRONT POSITION LAMP BULB | 6 | LICENSE PLATE LAMP BULB | 7 |
| SIDE REPEATER LAMP BULB | 6 | | |

REMOVAL AND INSTALLATION

FRONT POSITION LAMP BULB

REMOVAL

(1) Remove the 2 screws holding the headlamp bezel in place and remove bezel (Fig. 1).

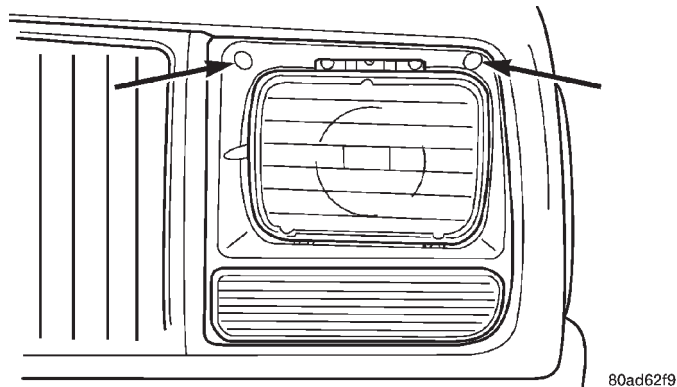

Fig. 1 Headlight Bezel Retaining Screws

(2) Remove the 4 screws holding the headlamp (Fig. 2).

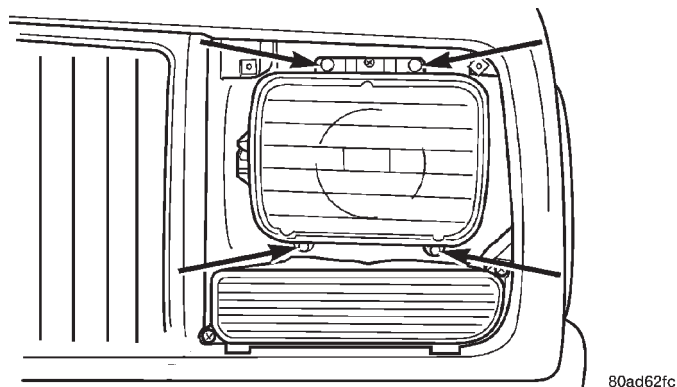

Fig. 2 Headlamp Retaining Screws

(3) Pull the front position lamp straight from headlamp (Fig. 3).

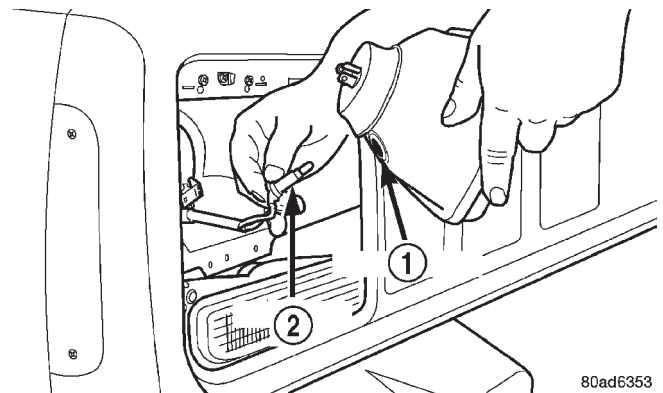

Fig. 3 Front Position Lamp Grommet & Socket Location

- 1 - GROMMET
- 2 - SOCKET

(4) Remove the front position lamp bulb from socket.

INSTALLATION

- (1) Install the front position lamp bulb in lamp socket.
- (2) Verify lamp operation.
- (3) Install front position lamp in headlamp.
- (4) Connect headlamp electrical connector.
- (5) Position the headlamp, headlamp retaining ring and install the retaining screws.
- (6) Position the headlamp bezel and install retaining screws.

SIDE REPEATER LAMP BULB

REMOVAL

- (1) Grip the side repeater lamp assembly and pull straight from the fender.
- (2) Rotate and pull the socket from the housing (Fig. 4).
- (3) Pull the bulb straight from the socket.

REMOVAL AND INSTALLATION (Continued)

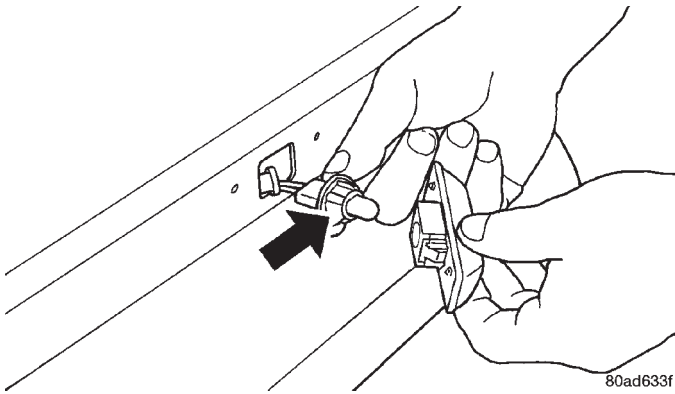
**Fig. 4 Side Repeater Lamp****INSTALLATION**

- (1) Align the side repeater lamp bulb to the socket (Fig. 4).
- (2) Push the bulb into the socket.
- (3) Verify lamp operation.
- (4) Push and rotate the socket into the housing.
- (5) Press the lamp assembly into the fender mounting hole.

REAR FOG LAMP BULB**REMOVAL**

- (1) There are 3 mounting bolts attaching the tail-light assembly. When removing, unfasten the 3 bolts located on the top and side. Lift up and out to remove the assembly.
- (2) Turn the socket assembly 1/3 turn and pull the socket from the housing (Fig. 5).
- (3) Pull the rear fog lamp straight from its socket.

INSTALLATION

- (1) Install rear fog lamp bulb in its socket.
- (2) Verify lamp operation.

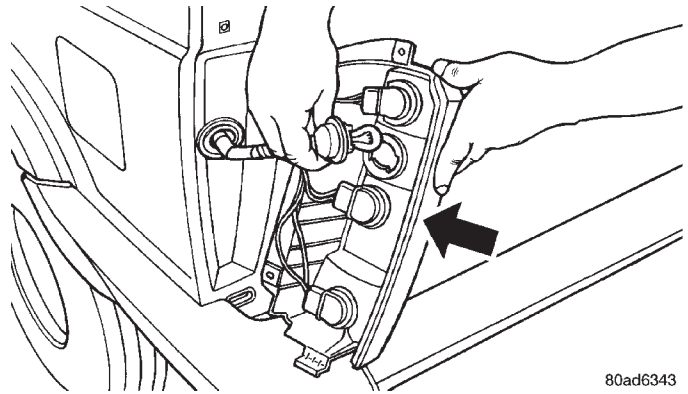
**Fig. 5 Rear Lamp Replacement**

- (3) Install the remaining three lamp sockets in the taillamp assembly.
- (4) Position the taillamp assembly and install the retaining screws.

LICENSE PLATE LAMP BULB**REMOVAL**

- (1) Remove the appropriate license plate lamp retaining screws.
- (2) Pull lamp housing from rear liftgate. Lamp must be positioned properly to allow removal without removing license plate.
- (3) Rotate the lamp socket counter clockwise and pull straight from lamp housing.
- (4) Pull the lamp bulb straight from its socket.

INSTALLATION

- (1) Install bulb in lamp socket.
- (2) Verify lamp operation.
- (3) Install lamp socket in lamp housing.
- (4) Install license plate lamp assembly in liftgate and install retaining screws.

LAMP SERVICE

TABLE OF CONTENTS

| | page | page |
|--|------|------|
| REMOVAL AND INSTALLATION | | |
| HEADLAMP | 8 | |
| HEADLAMP LEVELING MOTOR..... | 8 | |
| SIDE REPEATER LAMP..... | 9 | |
| FRONT FOG LAMP | | 9 |
| REAR TURN SIGNAL, BACKUP, TAILLAMP AND FOG LAMP | | 9 |
| LICENSE PLATE LAMP | | 9 |

REMOVAL AND INSTALLATION

HEADLAMP

REMOVAL

(1) Remove the 2 screws holding the headlamp bezel in place and remove bezel (Fig. 1).

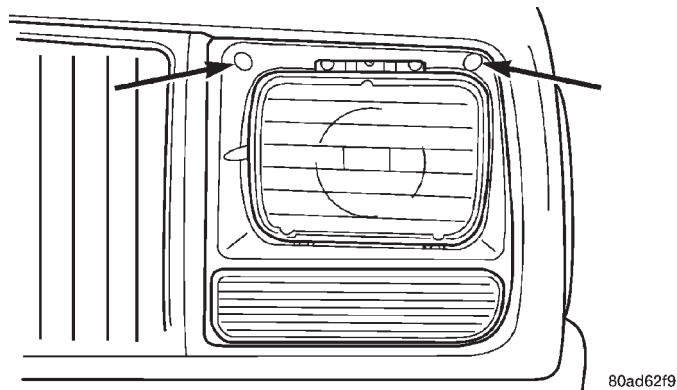

80ad62f9

Fig. 1 Headlight Bezel Retaining Screws

- (2) Remove the 4 screws holding the headlamp (Fig. 2).
- (3) Pull the front position lamp straight from headlamp.
- (4) Disconnect the headlamp electrical connector by pulling straight off.
- (5) Remove the headlamp from the vehicle.

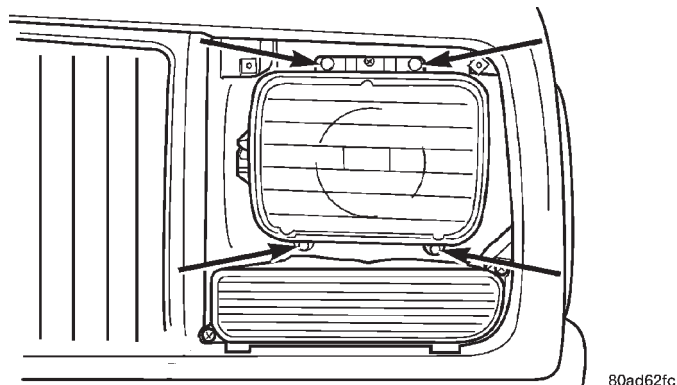

80ad62fc

Fig. 2 Headlamp Retaining Screws

INSTALLATION

- (1) Install front position lamp in headlamp.
- (2) Connect headlamp electrical connector.
- (3) Position the headlamp, headlamp retaining ring and install the retaining screws.
- (4) Position the headlamp bezel and install retaining screws.

HEADLAMP LEVELING MOTOR

REMOVAL

- (1) Open the hood and disconnect the negative battery cable.
- (2) Raise the vehicle on a hoist or position a creeper under the front of the vehicle.
- (3) Remove the appropriate side front splash shield. Located just in front of the front wheel.

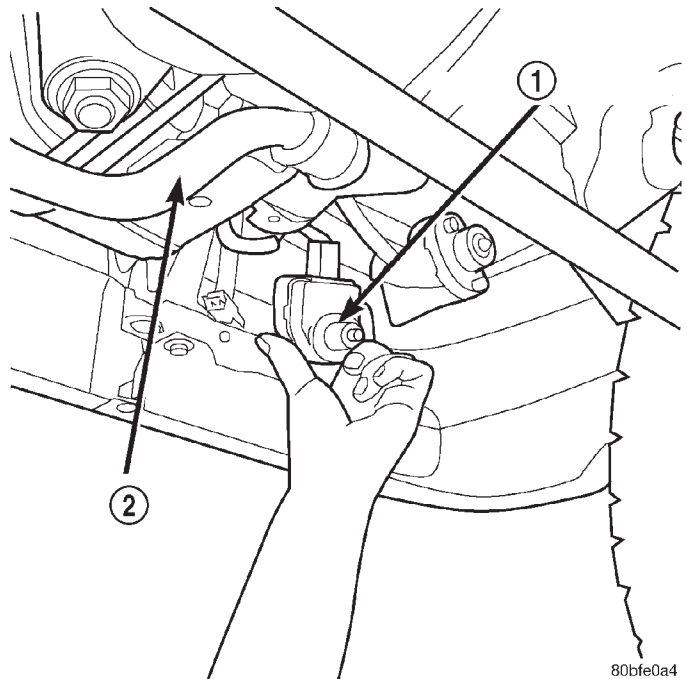

80bfe0a4

Fig. 3 Headlamp Leveling Motor

- 1 - HEADLAMP LEVELING MOTOR
- 2 - FRONT STABILIZER BAR

REMOVAL AND INSTALLATION (Continued)

(4) Disconnect the headlamp leveling motor electrical connector.

(5) Rotate the leveling motor 90 degrees until motor is loose in mounting bracket.

(6) Tilt motor upwards to disconnect motor push rod from the headlamp leveling linkage.

(7) Remove the headlamp leveling motor from the vehicle (Fig. 3).

INSTALLATION

(1) Install leveling motor push rod through hole in mounting bracket and connect push rod on leveling linkage. The proper angle must be achieved to connect the push rod onto the leveling linkage.

(2) Once the push rod is connected, rotate motor until tabs line up with tabs in mounting bracket. Once the tabs are lined up push and rotate the motor 90 degrees to lock in place.

(3) Connect the headlamp leveling motor electrical connector.

(4) Position the front splash shield.

(5) Lower the vehicle and connect the negative battery cable.

SIDE REPEATER LAMP**REMOVAL**

(1) Grip the side repeater lamp assembly and pull straight from the fender.

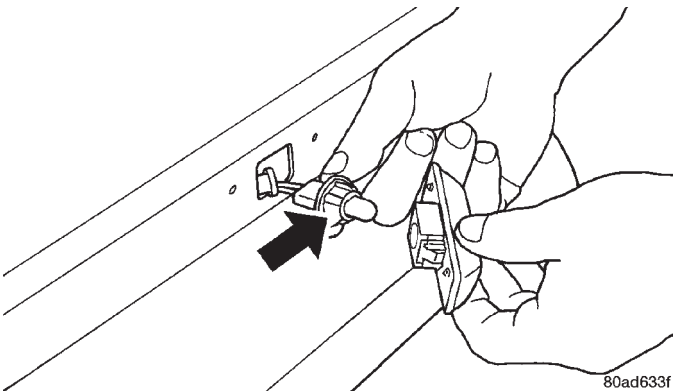

Fig. 4 Side Repeater Lamp

(2) Rotate and pull the socket from the housing (Fig. 4).

INSTALLATION

(1) Push and rotate the socket into the housing.

(2) Verify lamp operation.

(3) Press the lamp assembly into the fender mounting hole.

FRONT FOG LAMP**REMOVAL**

1. Remove the 2 screws from the bottom cover of the lamp body.

2. Disconnect the 2 wires from the lamp element.

3. Remove the lamp element from the housing.

INSTALLATION

1. Install the new lamp element in the housing and reinstall the lower housing.

REAR TURN SIGNAL, BACKUP, TAILLAMP AND FOG LAMP**REMOVAL**

(1) There are 3 mounting bolts attaching the tail-light assembly. When removing, unfasten the 3 bolts located on the top and side. Lift up and out to remove the assembly.

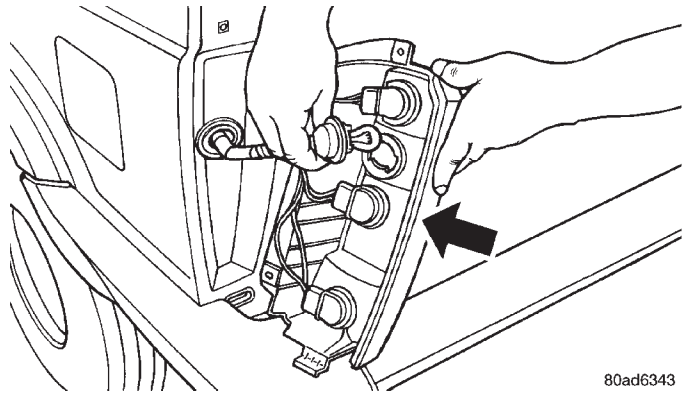

80ad6343

Fig. 5 Rear Lamp Replacement

(2) Turn the socket assembly 1/3 turn and pull the socket from the housing (Fig. 5).

INSTALLATION

(1) Install the four lamp sockets in the taillamp assembly.

(2) Verify lamp operation.

(3) Position the taillamp assembly and install the retaining screws.

LICENSE PLATE LAMP**REMOVAL**

(1) Remove the appropriate license plate lamp retaining screws.

(2) Pull lamp housing from rear liftgate. Lamp must be positioned properly to allow removal without removing license plate.

(3) Rotate the lamp socket counter clockwise and pull straight from lamp housing.

REMOVAL AND INSTALLATION (Continued)

INSTALLATION

- (1) Install lamp socket in lamp housing.
- (2) Verify lamp operation.
- (3) Install license plate lamp assembly in liftgate and install retaining screws.

BULB APPLICATION

TABLE OF CONTENTS

page

SPECIFICATIONS

REPLACEMENT BULBS 11

SPECIFICATIONS

REPLACEMENT BULBS

| Exterior Lamps | Bulb Type |
|--------------------------------------|------------------|
| Headlamp | H4 |
| Front Position | T4W |
| Front Turn Signal | P27/7W |
| Side Turn Signal | W3W |
| License Lamp | W5W |
| Rear Position and Stop | P27/7W |
| Rear Turn Signal | P27/7W |
| Reversing | P27/7W |
| Rear Fog | P27/7W |
| Underhood Lamp | W5W |
| Underhood Retractable Lamp | 105 |
| Front Fog | H3 |
| CHMSL | W16W |

Interior Lamps

Bulb Type

| | |
|---|------|
| Ashtray Lamp | 1891 |
| Cigarette Lighter Lamp | 53 |
| Auto. Trans. Floor Shift Lamp | 658 |
| Cargo Lamp | 561 |
| Climate Control Lamp (2) | 74 |
| Dome Lamp | 561 |
| Dome/Reading Lamp (1) 561 and (2) 906 | |
| Glove Box Lamp | 194 |
| Lighted Vanity Mirror (2) | 74 |
| Map Reading Light in Overhead Console (4) | 912 |
| Rocker Switch | 37 |
| Transfer Case Lamp | 658 |
| Underpanel Courtesy lamps (2) | 168 |

NOTE: Numbers refer to commercial bulb types that can be purchased from your local Jeep dealer.

PASSIVE RESTRAINT SYSTEMS

TABLE OF CONTENTS

| | page | | page |
|----------------------------------|------|---|------|
| DESCRIPTION AND OPERATION | | DRIVER SIDE AIRBAG MODULE TRIM COVER | |
| AIRBAG SYSTEM | 1 | PASSENGER SIDE AIRBAG MODULE | 9 |
| DRIVER SIDE AIRBAG MODULE | 2 | PASSENGER SIDE AIRBAG DOOR | 11 |
| PASSENGER SIDE AIRBAG MODULE | 3 | AIRBAG CONTROL MODULE | 12 |
| AIRBAG CONTROL MODULE | 3 | CLOCKSPRING | 13 |
| CLOCKSPRING | 4 | ADJUSTMENTS | |
| DIAGNOSIS AND TESTING | | CLOCKSPRING CENTERING | 15 |
| AIRBAG SYSTEM | 4 | SPECIAL TOOLS | |
| SERVICE PROCEDURES | | PASSIVE RESTRAINT SYSTEMS | 16 |
| AIRBAG SYSTEM | 5 | | |
| REMOVAL AND INSTALLATION | | | |
| DRIVER SIDE AIRBAG MODULE | 6 | | |

DESCRIPTION AND OPERATION

AIRBAG SYSTEM

DESCRIPTION

A dual front airbag system is standard factory-installed safety equipment on this model. The primary passenger restraints in this vehicle are the standard equipment factory-installed seat belts, which require active use by the vehicle occupants. The airbag system is a supplemental passive restraint that was designed and is intended to enhance the protection for the front seat occupants of the vehicle **only** when used in conjunction with the seat belts. See the owner's manual in the vehicle glove box for more information on the features, use and operation of all of the factory-installed passenger restraints, including the airbag system.

NOTE: This group covers both Left-Hand Drive (LHD) and Right-Hand Drive (RHD) versions of this model. Whenever required and feasible, the RHD versions of affected vehicle components have been constructed as mirror-image of the LHD versions. While most of the illustrations used in this group represent only the LHD version, the diagnostic and service procedures outlined can generally be applied to either version. Exceptions to this rule have been clearly identified as LHD or RHD, if a special illustration or procedure is required.

The dual front airbag system consists of the following components:

- Airbag Control Module (ACM)

- Airbag indicator lamp
- Clockspring
- Driver and passenger side airbag modules (including the airbag inflators)
- Driver and passenger side knee blockers
- Wire harness and connections.

This group provides complete service information for the ACM, both airbag modules, and the clockspring. Complete service information for the other airbag system components can be located as follows:

- Refer to **Instrument Cluster** in the proper section of Group 8E - Instrument Panel Systems for complete service information for the airbag indicator lamp.
- Refer to **Knee Blocker** in the Removal and Installation section of Group 8E - Instrument Panel Systems for complete service information on the driver side knee blocker.
- Refer to **Glove Box** in the Removal and Installation section of Group 8E - Instrument Panel Systems for complete service information on the passenger side knee blocker.
- Refer to **Airbag System** in the Contents of Group 8W - Wiring Diagrams for complete service information and circuit diagrams for the airbag system wiring components.

See the proper Diagnostic Procedures manual to test or diagnose a problem with any component of the airbag system.

OPERATION

The airbag system electrical circuits are continuously monitored and controlled by a microprocessor and software contained within the Airbag Control

DESCRIPTION AND OPERATION (Continued)

Module (ACM). The ACM also contains an impact sensor and a safing sensor, which are monitored by the ACM to determine when an impact occurs that is severe enough to require airbag system protection. When a frontal impact is severe enough, the ACM signals the inflator units of both airbag modules to deploy the airbags.

An airbag indicator lamp in the instrument cluster lights for about seven seconds as a bulb test, each time the ignition switch is turned to the On or Start positions. Following the bulb test, the airbag indicator lamp is turned on or off by the ACM to indicate the status of the airbag system. If the airbag indicator lamp comes on at any time other than during the bulb test, it indicates that there is a problem in the airbag system circuits. Such a problem may cause the airbags not to deploy when required, or to deploy when not required.

The driver side airbag module includes an inflatable airbag and an inflator unit behind a trim cover in the hub area of the steering wheel. The passenger side airbag module includes a second inflatable airbag and an inflator unit behind an airbag door in the instrument panel above the glove box.

During a frontal vehicle impact, the knee blockers work in concert with properly adjusted seat belts to restrain the driver and front seat passenger in the proper position for an airbag deployment. The knee blockers also work to absorb and distribute the crash energy from the driver and front seat passenger to the structure of the instrument panel. The driver side knee blocker is a stamped metal reinforcement located behind the instrument panel steering column opening cover. The passenger side knee blocker is integral to the glove box door.

Following are general descriptions of the major components in the airbag system.

WARNING:

- **THE AIRBAG SYSTEM IS A SENSITIVE, COMPLEX ELECTROMECHANICAL UNIT. BEFORE ATTEMPTING TO DIAGNOSE OR SERVICE ANY AIRBAG SYSTEM OR RELATED STEERING WHEEL, STEERING COLUMN, OR INSTRUMENT PANEL COMPONENTS YOU MUST FIRST DISCONNECT AND ISOLATE THE BATTERY NEGATIVE (GROUND) CABLE. THEN WAIT TWO MINUTES FOR THE SYSTEM CAPACITOR TO DISCHARGE BEFORE FURTHER SYSTEM SERVICE. THIS IS THE ONLY SURE WAY TO DISABLE THE AIRBAG SYSTEM. FAILURE TO DO THIS COULD RESULT IN ACCIDENTAL AIRBAG DEPLOYMENT AND POSSIBLE PERSONAL INJURY.**

- **THE DRIVER SIDE AIRBAG MODULE INFLATOR ASSEMBLY CONTAINS SODIUM AZIDE AND POTASSIUM NITRATE. THESE MATERIALS ARE POISONOUS AND EXTREMELY FLAMMABLE. CONTACT**

WITH ACID, WATER, OR HEAVY METALS MAY PRODUCE HARMFUL AND IRRITATING GASES (SODIUM HYDROXIDE IS FORMED IN THE PRESENCE OF MOISTURE) OR COMBUSTIBLE COMPOUNDS. THE PASSENGER AIRBAG MODULE CONTAINS ARGON GAS PRESSURIZED TO OVER 2500 PSI. DO NOT ATTEMPT TO DISMANTLE AN AIRBAG MODULE OR TAMPER WITH ITS INFLATOR. DO NOT PUNCTURE, INCINERATE, OR BRING INTO CONTACT WITH ELECTRICITY. DO NOT STORE AT TEMPERATURES EXCEEDING 93° C (200° F).

- **REPLACE AIRBAG SYSTEM COMPONENTS ONLY WITH PARTS SPECIFIED IN THE CHRYSLER MOPAR PARTS CATALOG. SUBSTITUTE PARTS MAY APPEAR INTERCHANGEABLE, BUT INTERNAL DIFFERENCES MAY RESULT IN INFERIOR OCCUPANT PROTECTION.**

- **THE FASTENERS, SCREWS, AND BOLTS ORIGINALLY USED FOR THE AIRBAG SYSTEM COMPONENTS HAVE SPECIAL COATINGS AND ARE SPECIFICALLY DESIGNED FOR THE AIRBAG SYSTEM. THEY MUST NEVER BE REPLACED WITH ANY SUBSTITUTES. ANY TIME A NEW FASTENER IS NEEDED, REPLACE IT WITH THE CORRECT FASTENERS PROVIDED IN THE SERVICE PACKAGE OR SPECIFIED IN THE CHRYSLER MOPAR PARTS CATALOG.**

- **WHEN A STEERING COLUMN HAS AN AIRBAG MODULE ATTACHED, NEVER PLACE THE COLUMN ON THE FLOOR OR ANY OTHER SURFACE WITH THE STEERING WHEEL OR AIRBAG MODULE FACE DOWN.**

DRIVER SIDE AIRBAG MODULE**DESCRIPTION**

The driver side airbag module protective trim cover is the most visible part of the driver side airbag system. The driver side airbag module is mounted directly to the steering wheel. Located under the airbag module trim cover are the horn switch, the folded airbag cushion, and the airbag cushion supporting components. The resistive membrane-type horn switch is secured with heat stakes to the inside surface of the airbag module trim cover, between the trim cover and the folded airbag cushion.

The driver side airbag module cannot be repaired, and must be replaced if deployed or in any way damaged. The driver side airbag module trim cover and the horn switch are available as a unit for service replacement.

OPERATION

The driver side airbag module includes a stamped metal housing to which the cushion and an inflator

DESCRIPTION AND OPERATION (Continued)

unit are attached and sealed. The conventional pyrotechnic-type inflator assembly is mounted to studs on the back of the airbag module housing. The inflator seals the hole in the airbag cushion so it can discharge the gas it produces directly into the cushion when supplied with the proper electrical signal. Following an airbag deployment, the airbag cushion quickly deflates by venting this gas towards the instrument panel through the porous fabric material used on the steering wheel side of the airbag cushion.

The protective trim cover is fitted to the front of the airbag module and forms a decorative cover in the center of the steering wheel. The inside of the trim cover has locking blocks molded into it that engage a lip on the airbag module metal housing. Two stamped metal retainers then fit over the inflator mounting studs on the back of the airbag module housing and are engaged in slots on the inside of the cover, securely locking the trim cover into place. The trim cover will split at predetermined breakout lines, then fold back out of the way along with the horn switch upon airbag deployment.

PASSENGER SIDE AIRBAG MODULE

DESCRIPTION

The passenger side airbag door on the instrument panel above the glove box is the most visible part of the passenger side airbag system. Located under the airbag door are the passenger side airbag cushion and the airbag cushion supporting components.

The passenger side airbag module includes an extruded aluminum housing within which the cushion and inflator are mounted and sealed. Two stamped metal brackets, one on each end of the housing, enclose the cushion and inflator and also serve as the mounting brackets for the module. The two mounting brackets at the top front of the airbag module are secured with screws to the top of the instrument panel structural support beneath the instrument panel top cover. The two mounting brackets at the bottom front of the airbag module are secured with screws to the instrument panel structural support over the glove box.

Following a passenger side airbag deployment, the passenger side airbag module and the passenger side airbag door must be replaced. The passenger side airbag module cannot be repaired, and must be replaced if deployed or in any way damaged. The passenger side airbag door is available as a separate service item.

OPERATION

The hybrid-type inflator assembly includes a small canister of highly compressed argon gas. The inflator seals the hole in the airbag cushion so it can dis-

charge the gas it produces directly into the cushion when supplied with the proper electrical signal. Following an airbag deployment, the airbag cushion quickly deflates by venting this gas through the porous fabric material used on each end panel of the airbag cushion.

The molded plastic passenger side airbag door is secured to extruded tabs at the top and bottom rear of the airbag module housing by keyed openings in the upper and lower mounting flange returns of the airbag door. The upper and lower airbag door mounting flanges are then secured to the instrument panel structural support and the upper glove box opening reinforcement with screws. The airbag door has predetermined breakout lines concealed beneath its decorative cover. Upon airbag deployment, the airbag door will split at the breakout lines and the door will fold back over the top of the instrument panel, out of the way.

AIRBAG CONTROL MODULE

DESCRIPTION

The Airbag Control Module (ACM) is secured with nuts to weld-studs on the ACM mounting bracket. The ACM mounting bracket is secured with screws to the floor panel transmission tunnel underneath the center floor console and behind the park brake mechanism in the passenger compartment of the vehicle. The ACM contains an electronic microprocessor, an electronic impact sensor, an electromechanical safing sensor, and an energy storage capacitor.

The ACM cannot be repaired or adjusted and, if damaged or faulty, it must be replaced.

OPERATION

The microprocessor in the ACM contains the airbag system logic. The airbag system logic includes On-Board Diagnostics (OBD), and the ability to communicate with the instrument cluster circuitry over the Chrysler Collision Detection (CCD) data bus to control the airbag indicator lamp. The microprocessor continuously monitors all of the airbag system electrical circuits to determine the system readiness. If the ACM detects a monitored system fault, it sends messages to the instrument cluster over the CCD data bus to turn on the airbag indicator lamp. Refer to **Instrument Cluster** in the proper section of Group 8E - Instrument Panel Systems for more information on the airbag indicator lamp.

One electronic impact sensor is used in this airbag system. The impact sensor is an accelerometer that senses the rate of vehicle deceleration, which provides verification of the direction and severity of an impact. The impact sensor is calibrated for the specific vehicle, and is only serviced as a unit with the

DESCRIPTION AND OPERATION (Continued)

ACM. A pre-programmed decision algorithm in the ACM microprocessor determines when the deceleration rate as signaled by the impact sensor indicates an impact that is severe enough to require airbag system protection. When the programmed conditions are met, the ACM sends an electrical signal to deploy the airbags.

In addition to the electronic impact sensor, there is an electromechanical sensor within the ACM called a safing sensor. The safing sensor is a normally open series switch located in the airbag deployment circuit of the ACM. This sensor detects impact energy of a lesser magnitude than the electronic impact sensor, and must be closed in order for the airbags to deploy.

The ACM also contains an energy-storage capacitor. This capacitor stores enough electrical energy to deploy the airbags for up to one second following a battery disconnect or failure during an impact. The purpose of the capacitor is to provide airbag system protection in a severe secondary impact, if the initial impact has damaged or disconnected the battery, but was not severe enough to deploy the airbags.

CLOCKSPRING

DESCRIPTION

The clockspring assembly is secured with two integral plastic latches onto the steering column lock housing near the top of the steering column behind the steering wheel. The clockspring is used to maintain a continuous electrical circuit between the fixed clockspring wire harness on the steering column and several electrical components that rotate with the steering wheel. The rotating components include the driver side airbag module, the horn switch and, if the vehicle is so equipped, the vehicle speed control switches.

The clockspring cannot be repaired. If the clockspring is faulty, damaged, or if the driver side airbag has been deployed, the clockspring must be replaced.

OPERATION

The clockspring assembly consists of a plastic case which contains a flat, ribbon-like, electrically conductive tape that winds and unwinds like a clockspring with the steering wheel rotation. The electrically conductive tape consists of several fine gauge copper wire leads sandwiched between two narrow strips of plastic film.

Like the clockspring in a timepiece, the clockspring tape has travel limits and can be damaged by being wound too tightly. To prevent this from occurring, the clockspring is centered when it is installed on the steering column. Centering the clockspring indexes the clockspring tape to other steering components so that it can operate within its designed travel limits.

However, if the clockspring is removed for service or if the steering column is disconnected from the steering gear allowing the clockspring tape to change position relative to the other steering components, it must be re-centered following completion of the service or it may be damaged. Refer to **Clockspring Centering** in the Adjustments section of this group for the proper centering procedures.

Service replacement clocksprings are shipped pre-centered and with a locking pin installed. This locking pin should not be removed until the clockspring has been installed on the steering column. If the locking pin is removed before the clockspring is installed on a steering column, the clockspring centering procedure must be performed.

DIAGNOSIS AND TESTING

AIRBAG SYSTEM

A DRB scan tool is required for diagnosis of the airbag system. See the proper Diagnostic Procedures manual for more information.

(1) Connect the DRB scan tool to the 16-way data link wire harness connector. The connector is located on the driver side lower edge of the instrument panel, outboard of the steering column (Fig. 1).

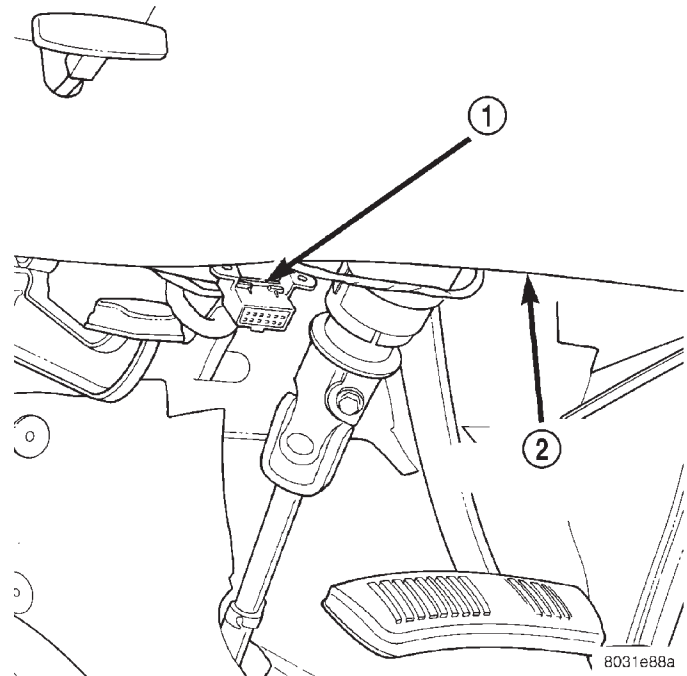

Fig. 1 16-Way Data Link Connector - Typical

- 1 - 16-WAY DATA LINK CONNECTOR
- 2 - BOTTOM OF INSTRUMENT PANEL

(2) Turn the ignition switch to the On position. Exit the vehicle with the DRB. Be certain that the

DIAGNOSIS AND TESTING (Continued)

DRB contains the latest version of the proper DRB software.

(3) Using the DRB, read and record the active Diagnostic Trouble Code (DTC) data.

(4) Read and record any stored DTC data.

(5) See the proper Diagnostic Procedures manual if any DTC is found in Step 3 or Step 4.

(6) After completing the necessary repairs, try to erase the stored DTC data. If any problems remain, the stored DTC data will not erase. See the proper Diagnostic Procedures manual for the procedures to diagnose any stored DTC that will not erase.

(7) With the ignition switch still in the On position, check to be certain that nobody is in the vehicle.

(8) From outside of the vehicle (away from the airbags in case of an accidental deployment) turn the ignition switch to the Off position for about ten seconds, and then back to the On position. Observe the airbag indicator lamp in the instrument cluster. It should light for six to eight seconds, and then go out. This indicates that the airbag system is functioning normally.

NOTE: If the airbag indicator lamp fails to light, or lights and stays on, there is an airbag system malfunction. See the proper Diagnostic Procedures manual to diagnose the problem.

SERVICE PROCEDURES

AIRBAG SYSTEM

NON-DEPLOYED

At no time should any source of electricity be permitted near the inflator on the back of an airbag module. When carrying a non-deployed airbag module, the trim cover or airbag side of the module should be pointed away from the body to minimize injury in the event of an accidental deployment. If the module is placed on a bench or any other surface, the trim cover or airbag side of the module should be face up to minimize movement in the event of an accidental deployment.

In addition, the airbag system should be disarmed whenever any steering wheel, steering column, or instrument panel components require diagnosis or service. Failure to observe this warning could result in accidental airbag deployment and possible personal injury. Refer to **Group 8E - Instrument Panel Systems** for additional service procedures on the instrument panel components. Refer to **Group 19 - Steering** for additional service procedures on the steering wheel and steering column components.

DISPOSAL OF NON-DEPLOYED AIRBAG MODULES

All damaged or faulty and non-deployed driver side or passenger side airbag modules which are replaced on vehicles are to be returned. If an airbag module assembly is faulty or damaged and non-deployed, refer to the parts return list in the current Chrysler Corporation Warranty Policies and Procedures manual for the proper handling and disposal procedures.

DEPLOYED

Any vehicle which is to be returned to use after an airbag deployment, must have both airbag modules, the passenger side airbag module door and the clock-spring replaced. These components will be damaged or weakened as a result of an airbag deployment, which may or may not be obvious during a visual inspection, and are not intended for reuse.

Other vehicle components should be closely inspected, but are to be replaced only as required by the extent of the visible damage incurred.

STORAGE

An airbag module must be stored in its original, special container until used for service. Also, it must be stored in a clean, dry environment; away from sources of extreme heat, sparks, and high electrical energy. Always place or store an airbag module on a surface with its trim cover or airbag side facing up, to minimize movement in case of an accidental deployment.

CLEANUP PROCEDURE

Following an airbag system deployment, the vehicle interior will contain a powdery residue. This residue consists primarily of harmless particulate by-products of the small pyrotechnic charge used to initiate the airbag deployment propellant. However, this residue will also contain traces of sodium hydroxide powder, a chemical by-product of the propellant material that is used to generate the nitrogen gas that inflates the airbag. Since sodium hydroxide powder can irritate the skin, eyes, nose, or throat, be sure to wear safety glasses, rubber gloves, and a long-sleeved shirt during cleanup (Fig. 2).

WARNING: IF YOU EXPERIENCE SKIN IRRITATION DURING CLEANUP, RUN COOL WATER OVER THE AFFECTED AREA. ALSO, IF YOU EXPERIENCE IRRITATION OF THE NOSE OR THROAT, EXIT THE VEHICLE FOR FRESH AIR UNTIL THE IRRITATION CEASES. IF IRRITATION CONTINUES, SEE A PHYSICIAN.

Begin the cleanup by removing the airbag modules from the vehicle. Refer to **Driver Side Airbag Module** and **Passenger Side Airbag Module** in the

SERVICE PROCEDURES (Continued)

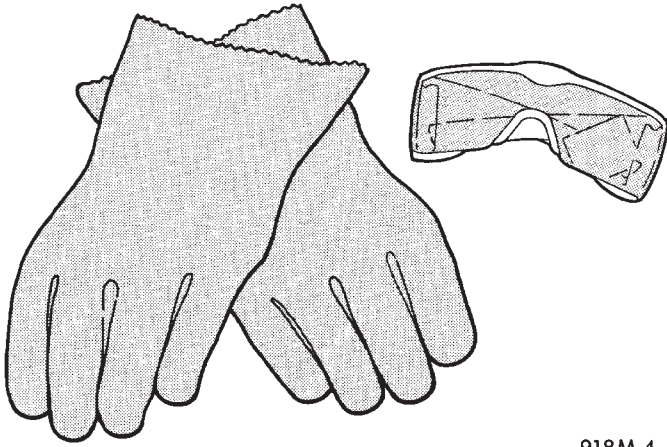

918M-4

Fig. 2 Wear Safety Glasses and Rubber Gloves - Typical

Removal and Installation section of this group for the procedures.

Use a vacuum cleaner to remove any residual powder from the vehicle interior. Clean from outside the vehicle and work your way inside, so that you avoid kneeling or sitting on a non-cleaned area.

Be sure to vacuum the heater and air conditioning outlets as well (Fig. 3). Run the heater and air conditioner blower on the lowest speed setting and vacuum any powder expelled from the outlets. You may need to vacuum the interior of the vehicle a second time to recover all of the powder.

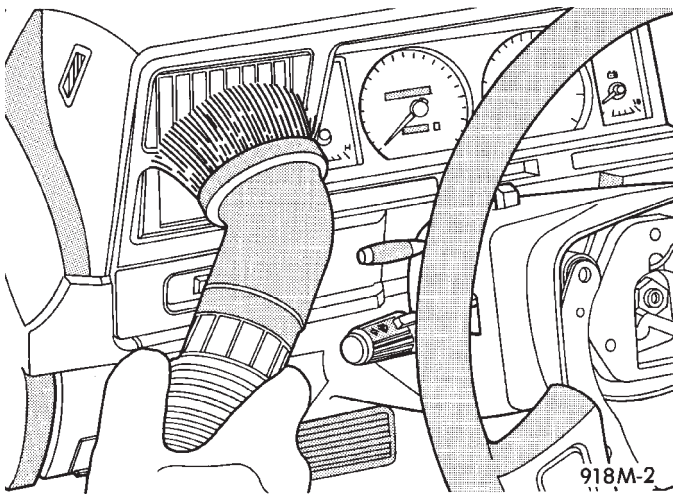

918M-2

Fig. 3 Vacuum Heater and A/C Outlets - Typical

Place the deployed airbag modules in your vehicular scrap pile.

REMOVAL AND INSTALLATION

DRIVER SIDE AIRBAG MODULE

The following procedure is for replacement of a faulty or damaged driver side airbag module. If the

driver side airbag has been deployed, the clockspring must also be replaced. Refer to **Clockspring** in the Removal and Installation section of this group for the additional service procedures for the clockspring.

WARNING:

- **THE AIRBAG SYSTEM IS A SENSITIVE, COMPLEX ELECTROMECHANICAL UNIT. BEFORE ATTEMPTING TO DIAGNOSE OR SERVICE ANY AIRBAG SYSTEM OR RELATED STEERING WHEEL, STEERING COLUMN, OR INSTRUMENT PANEL COMPONENTS YOU MUST FIRST DISCONNECT AND ISOLATE THE BATTERY NEGATIVE (GROUND) CABLE. THEN WAIT TWO MINUTES FOR THE SYSTEM CAPACITOR TO DISCHARGE BEFORE FURTHER SYSTEM SERVICE. THIS IS THE ONLY SURE WAY TO DISABLE THE AIRBAG SYSTEM. FAILURE TO DO THIS COULD RESULT IN ACCIDENTAL AIRBAG DEPLOYMENT AND POSSIBLE PERSONAL INJURY.**

- **WHEN REMOVING A DEPLOYED AIRBAG MODULE, RUBBER GLOVES, EYE PROTECTION, AND A LONG-SLEEVED SHIRT SHOULD BE WORN. THERE MAY BE DEPOSITS ON THE AIRBAG MODULE AND OTHER INTERIOR SURFACES. IN LARGE DOSES, THESE DEPOSITS MAY CAUSE IRRITATION TO THE SKIN AND EYES.**

REMOVAL

(1) Disconnect and isolate the battery negative cable. If either of the airbags has not been deployed, wait two minutes for the system capacitor to discharge before further service.

(2) From the underside of the steering wheel, remove the two screws that secure the driver side airbag module to the steering wheel (Fig. 4).

(3) Pull the airbag module away from the steering wheel far enough to access the two wire harness connectors on the back of the airbag module.

(4) Disconnect the clockspring horn switch wire harness connector from the horn switch feed wire connector, which is located on the back of the airbag module.

(5) The clockspring airbag wire harness connector is a tight snap-fit into the airbag module connector receptacle, which is located on the airbag inflator on the back of the airbag module. Firmly grasp and pull or gently pry on the clockspring airbag wire harness connector to disconnect it from the airbag module. **Do not pull on the clockspring wire harness to disengage the connector from the airbag module connector receptacle.**

(6) Remove the driver side airbag module from the steering wheel.

(7) If the driver side airbag has been deployed, the clockspring must be replaced. Refer to **Clockspring**

REMOVAL AND INSTALLATION (Continued)

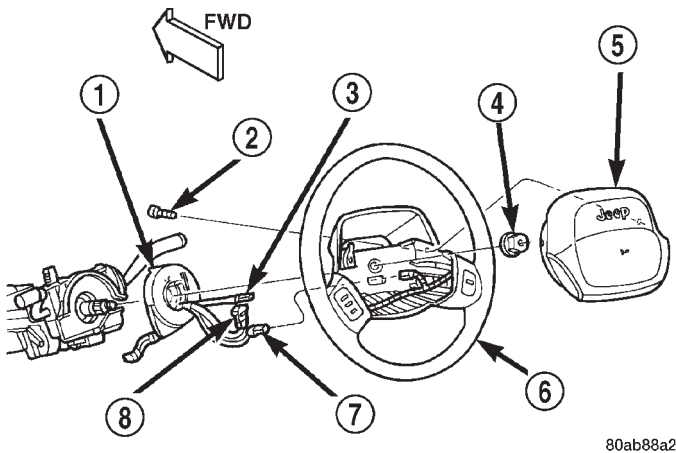

Fig. 4 Driver Side Airbag Module Remove/Install

- 1 - CLOCKSPrING
- 2 - SCREW
- 3 - HORN SWITCH WIRE
- 4 - NUT
- 5 - DRIVER AIRBAG MODULE
- 6 - STEERING WHEEL
- 7 - SPEED CONTROL WIRE
- 8 - AIRBAG WIRE

in the Removal and Installation section of this group for the clockspring service procedures.

INSTALLATION

WARNING:

- USE EXTREME CARE TO PREVENT ANY FOREIGN MATERIAL FROM ENTERING THE DRIVER SIDE AIRBAG MODULE, OR BECOMING ENTRAPPED BETWEEN THE AIRBAG CUSHION AND THE DRIVER SIDE AIRBAG TRIM COVER. FAILURE TO OBSERVE THIS WARNING COULD RESULT IN OCCUPANT INJURIES UPON AIRBAG DEPLOYMENT.

- THE DRIVER SIDE AIRBAG MODULE TRIM COVER MUST NEVER BE PAINTED. REPLACEMENT TRIM COVERS ARE SERVICED IN THE ORIGINAL COLORS. PAINT MAY CHANGE THE WAY IN WHICH THE MATERIAL OF THE TRIM COVER RESPONDS TO AN AIRBAG DEPLOYMENT. FAILURE TO OBSERVE THIS WARNING COULD RESULT IN OCCUPANT INJURIES UPON AIRBAG DEPLOYMENT.

(1) When installing the driver side airbag module, reconnect the clockspring airbag wire harness connector to the airbag module connector receptacle by pressing straight in on the connector. You can be certain that the connector is fully engaged by listening carefully for a distinct audible click as the connector snaps into place.

(2) Reconnect the clockspring horn switch wire harness connector to the horn switch feed wire connector, which is located on the back of the airbag module.

(3) Carefully position the driver side airbag module in the steering wheel. Be certain that the clockspring wire harnesses in the steering wheel hub area are not pinched between the airbag module and the steering wheel.

(4) From the underside of the steering wheel, install and tighten the two driver side airbag module mounting screws. Tighten the screws to 10.2 N·m (90 in. lbs.).

(5) Do not reconnect the battery negative cable at this time. Refer to **Airbag System** in the Diagnosis and Testing section of this group for the proper procedures.

DRIVER SIDE AIRBAG MODULE TRIM COVER

The horn switch is integral to the driver side airbag module trim cover. If either component is faulty or damaged, the entire driver side airbag module trim cover and horn switch unit must be replaced.

WARNING:

- THE AIRBAG SYSTEM IS A SENSITIVE, COMPLEX ELECTROMECHANICAL UNIT. BEFORE ATTEMPTING TO DIAGNOSE OR SERVICE ANY AIRBAG SYSTEM OR RELATED STEERING WHEEL, STEERING COLUMN, OR INSTRUMENT PANEL COMPONENTS YOU MUST FIRST DISCONNECT AND ISOLATE THE BATTERY NEGATIVE (GROUND) CABLE. THEN WAIT TWO MINUTES FOR THE SYSTEM CAPACITOR TO DISCHARGE BEFORE FURTHER SYSTEM SERVICE. THIS IS THE ONLY SURE WAY TO DISABLE THE AIRBAG SYSTEM. FAILURE TO DO THIS COULD RESULT IN ACCIDENTAL AIRBAG DEPLOYMENT AND POSSIBLE PERSONAL INJURY.

- THE HORN SWITCH IS INTEGRAL TO THE AIRBAG MODULE TRIM COVER. SERVICE OF THIS COMPONENT SHOULD BE PERFORMED ONLY BY CHRYSLER-TRAINED AND AUTHORIZED DEALER SERVICE TECHNICIANS. FAILURE TO TAKE THE PROPER PRECAUTIONS OR TO FOLLOW THE PROPER PROCEDURES COULD RESULT IN ACCIDENTAL, INCOMPLETE, OR IMPROPER AIRBAG DEPLOYMENT AND POSSIBLE OCCUPANT INJURIES.

REMOVAL

(1) Disconnect and isolate the battery negative cable. If either of the airbags has not been deployed, wait two minutes for the system capacitor to discharge before further service.

REMOVAL AND INSTALLATION (Continued)

(2) Remove the driver side airbag module from the steering wheel. Refer to **Driver Side Airbag Module** in the Removal and Installation section of this group for the procedures.

(3) Remove the plastic horn switch feed wire retainer from the stud on the back of the driver side airbag housing (Fig. 5).

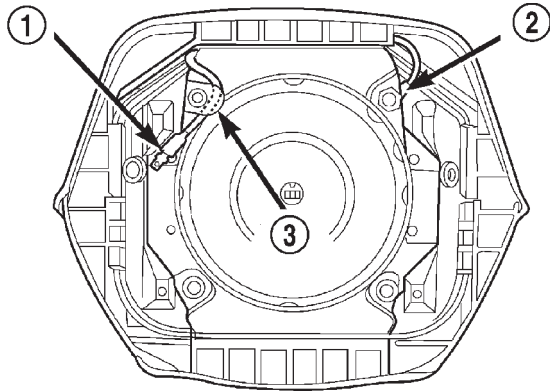

80ab88a3

Fig. 5 Horn Switch Feed Wire Remove/Install

- 1 - HORN SWITCH FEED WIRE
- 2 - HORN SWITCH GROUND WIRE
- 3 - WIRE RETAINER

(4) Remove the four nuts that secure the upper and lower trim cover retainers to the studs on the back of the driver side airbag housing (Fig. 6).

(5) Remove the upper and lower trim cover retainers from the airbag housing studs.

(6) Remove the horn switch ground wire eyelet from the upper airbag housing stud.

(7) Disengage the four trim cover locking blocks from the lip around the outside edge of the driver side airbag housing and remove the housing from the cover (Fig. 7).

INSTALLATION

WARNING:

- USE EXTREME CARE TO PREVENT ANY FOREIGN MATERIAL FROM ENTERING THE DRIVER SIDE AIRBAG MODULE, OR BECOMING ENTRAPPED BETWEEN THE AIRBAG CUSHION AND THE DRIVER SIDE AIRBAG TRIM COVER. FAILURE TO OBSERVE THIS WARNING COULD RESULT IN OCCUPANT INJURIES UPON AIRBAG DEPLOYMENT.

- THE DRIVER SIDE AIRBAG MODULE TRIM COVER MUST NEVER BE PAINTED. REPLACEMENT TRIM COVERS ARE SERVICED IN THE ORIGINAL COLORS. PAINT MAY CHANGE THE WAY IN WHICH THE MATERIAL OF THE TRIM COVER RESPONDS TO AN AIRBAG DEPLOYMENT. FAILURE TO

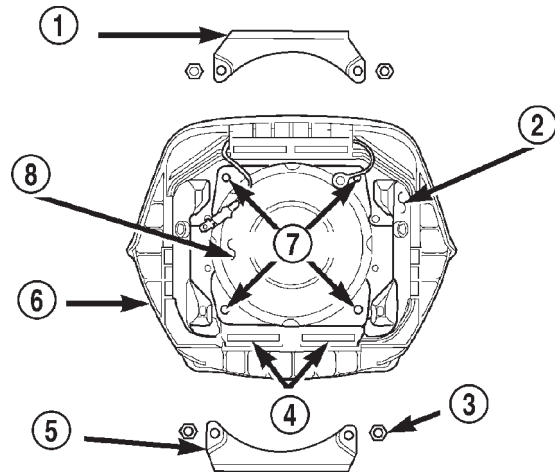

80ab88a4

Fig. 6 Driver Side Airbag Trim Cover Retainers Remove/Install

- 1 - UPPER RETAINER
- 2 - AIRBAG HOUSING
- 3 - NUT (4)
- 4 - RETAINER SLOTS
- 5 - LOWER RETAINER
- 6 - TRIM COVER
- 7 - STUDS
- 8 - INFLATOR

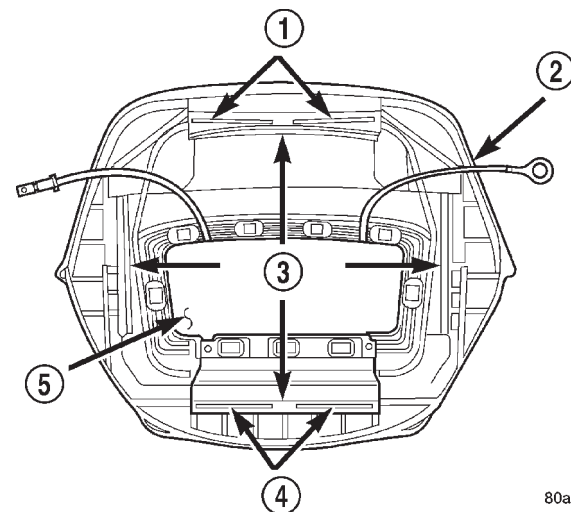

80ab88a6

Fig. 7 Driver Side Airbag Trim Cover Remove/Install

- 1 - RETAINER SLOTS
- 2 - TRIM COVER
- 3 - LOCKING BLOCKS
- 4 - RETAINER SLOTS
- 5 - HORN SWITCH

OBSERVE THIS WARNING COULD RESULT IN OCCUPANT INJURIES UPON AIRBAG DEPLOYMENT.

(1) Carefully position the driver side airbag module in the trim cover. Be certain that the horn switch

REMOVAL AND INSTALLATION (Continued)

feed and ground wires are not pinched between the airbag housing and the trim cover locking blocks.

(2) Engage the upper and lower trim cover locking blocks with the lip of the driver side airbag housing, then engage the locking blocks on each side of the trim cover with the lip of the housing. Be certain that each of the locking blocks is fully engaged on the lip of the airbag housing (Fig. 8).

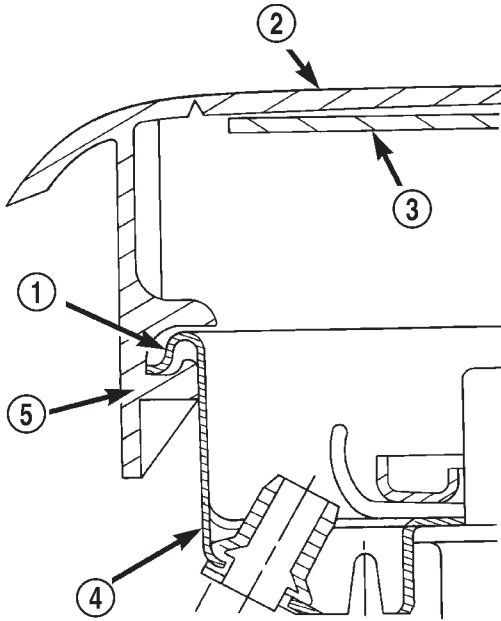

80a0f19f

Fig. 8 Driver Side Airbag Trim Cover Locking Blocks Engaged

- 1 - LIP
- 2 - TRIM COVER
- 3 - HORN SWITCH
- 4 - AIRBAG HOUSING
- 5 - LOCKING BLOCK

(3) Install the horn switch ground wire eyelet over the upper airbag housing stud.

(4) Install the upper and lower airbag trim cover retainers over the airbag housing studs. Be certain that the tabs on each retainer are engaged in the retainer slots of the upper and lower trim cover locking blocks (Fig. 7).

(5) Install and tighten the trim cover retainer mounting nuts on the airbag housing studs. Tighten the nuts to 10 N·m (90 in. lbs.).

(6) Install the driver side airbag module onto the steering wheel. Refer to **Driver Side Airbag Module** in the Removal and Installation section of this group for the procedures.

PASSENGER SIDE AIRBAG MODULE

The following procedure is for replacement of a faulty or damaged passenger side airbag module. If

the passenger side airbag module has been deployed, the passenger side airbag door must also be replaced. Refer to **Passenger Side Airbag Door** in the Removal and Installation section of this group for the additional service procedures for the passenger side airbag door.

WARNING:

- **THE AIRBAG SYSTEM IS A SENSITIVE, COMPLEX ELECTROMECHANICAL UNIT. BEFORE ATTEMPTING TO DIAGNOSE OR SERVICE ANY AIRBAG SYSTEM OR RELATED STEERING WHEEL, STEERING COLUMN, OR INSTRUMENT PANEL COMPONENTS YOU MUST FIRST DISCONNECT AND ISOLATE THE BATTERY NEGATIVE (GROUND) CABLE. THEN WAIT TWO MINUTES FOR THE SYSTEM CAPACITOR TO DISCHARGE BEFORE FURTHER SYSTEM SERVICE. THIS IS THE ONLY SURE WAY TO DISABLE THE AIRBAG SYSTEM. FAILURE TO DO THIS COULD RESULT IN ACCIDENTAL AIRBAG DEPLOYMENT AND POSSIBLE PERSONAL INJURY.**

- **WHEN REMOVING A DEPLOYED AIRBAG MODULE, RUBBER GLOVES, EYE PROTECTION, AND A LONG-SLEEVED SHIRT SHOULD BE WORN. THERE MAY BE DEPOSITS ON THE AIRBAG MODULE AND OTHER INTERIOR SURFACES. IN LARGE DOSES, THESE DEPOSITS MAY CAUSE IRRITATION TO THE SKIN AND EYES.**

REMOVAL

(1) Disconnect and isolate the battery negative cable. If either of the airbags has not been deployed, wait two minutes for the system capacitor to discharge before further service.

(2) Remove the top cover from the instrument panel. Refer to **Instrument Panel Top Cover** in the Removal and Installation section of Group 8E - Instrument Panel Systems for the procedures.

(3) Disconnect the passenger side airbag module wire harness connector from the instrument panel wire harness. This connector is located on the top of the instrument panel structural support between the airbag module and the windshield (Fig. 9).

(4) Disengage the passenger side airbag module wire harness connector retainer from the mounting hole on the top of the instrument panel structural support.

(5) Remove the four screws that secure the upper flange of the passenger side airbag door to the instrument panel structural support (Fig. 10).

(6) Remove the two screws that secure the passenger side airbag module upper mounting brackets to the top of the instrument panel structural support.

(7) Roll down the glove box from the instrument panel. Refer to **Glove Box - Roll Down** in the

REMOVAL AND INSTALLATION (Continued)

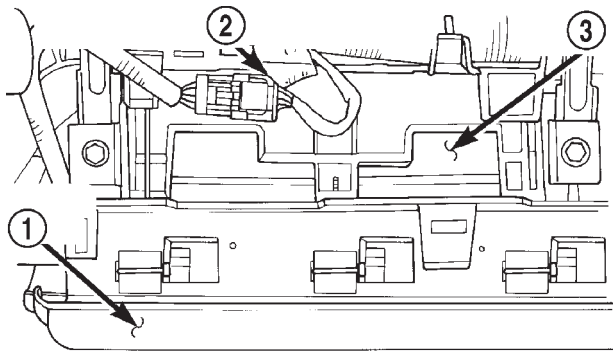

80abac53

Fig. 9 Passenger Side Airbag Module Connector

- 1 - AIRBAG DOOR
- 2 - PASSENGER SIDE AIRBAG WIRE HARNESS CONNECTOR
- 3 - AIRBAG HOUSING

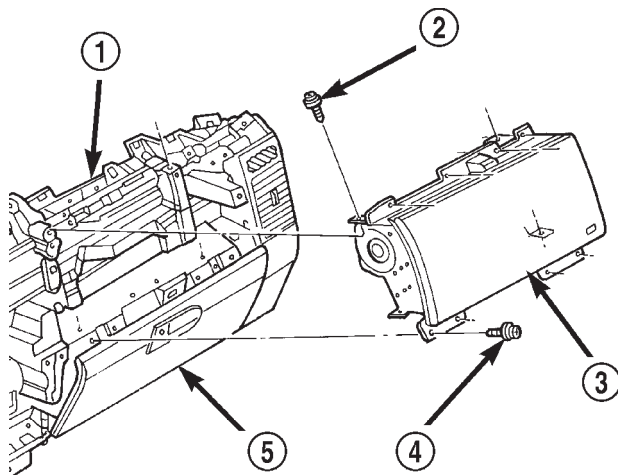

80ab88a1

Fig. 10 Passenger Side Airbag Module Remove/Install

- 1 - INSTRUMENT PANEL
- 2 - SCREW
- 3 - PASSENGER AIRBAG MODULE
- 4 - SCREW
- 5 - GLOVE BOX DOOR

Removal and Installation section of Group 8E - Instrument Panel Systems for the procedures.

(8) Remove the four screws that secure the lower flange of the passenger side airbag door to the instrument panel upper glove box opening reinforcement.

(9) Reach through and above the instrument panel glove box opening to access and remove the two screws that secure the passenger side airbag module lower mounting brackets to the instrument panel structural support.

(10) Remove the passenger side airbag module and airbag door from the instrument panel as a unit.

(11) Remove the passenger side airbag door from the airbag module. Refer to **Passenger Side Airbag Door** in the Removal and Installation section of this group for the procedures.

INSTALLATION

WARNING: USE EXTREME CARE TO PREVENT ANY FOREIGN MATERIAL FROM ENTERING THE PASSENGER SIDE AIRBAG MODULE, OR BECOMING ENTRAPPED BETWEEN THE AIRBAG CUSHION AND THE PASSENGER SIDE AIRBAG DOOR. FAILURE TO OBSERVE THIS WARNING COULD RESULT IN OCCUPANT INJURIES UPON AIRBAG DEPLOYMENT.

(1) Install the passenger side airbag door onto the airbag module. Refer to **Passenger Side Airbag Door** in the Removal and Installation section of this group for the procedures.

(2) Carefully position the passenger side airbag module and airbag door in the instrument panel as a unit.

(3) Reach through and above the instrument panel glove box opening to install and tighten the two screws that secure the passenger side airbag module lower mounting brackets to the instrument panel structural support. Tighten the screws to 11.8 N-m (105 in. lbs.).

(4) Install and tighten the four screws that secure the lower flange of the passenger side airbag door to the instrument panel upper glove box opening reinforcement. Tighten the screws to 2.2 N-m (20 in. lbs.).

(5) Install the glove box into the instrument panel. Refer to **Glove Box - Roll Down** in the Removal and Installation section of Group 8E - Instrument Panel Systems for the procedures.

(6) Install and tighten the two screws that secure the passenger side airbag module upper mounting brackets to the top of the instrument panel structural support. Tighten the screws to 11.8 N-m (105 in. lbs.).

(7) Install and tighten the four screws that secure the upper flange of the passenger side airbag door to the instrument panel structural support. Tighten the screws to 2.2 N-m (20 in. lbs.).

(8) Engage the passenger side airbag module wire harness connector retainer in the mounting hole on the top of the instrument panel structural support.

(9) Reconnect the passenger side airbag module wire harness connector to the instrument panel wire harness. Be certain that the connector is fully engaged and latched.

(10) Install the top cover onto the instrument panel. Refer to **Instrument Panel Top Cover** in the

REMOVAL AND INSTALLATION (Continued)

Removal and Installation section of Group 8E - Instrument Panel Systems for the procedures.

(11) Do not reconnect the battery negative cable at this time. Refer to **Airbag System** in the Diagnosis and Testing section of this group for the proper procedures.

PASSENGER SIDE AIRBAG DOOR

WARNING:

- THE AIRBAG SYSTEM IS A SENSITIVE, COMPLEX ELECTROMECHANICAL UNIT. BEFORE ATTEMPTING TO DIAGNOSE OR SERVICE ANY AIRBAG SYSTEM OR RELATED STEERING WHEEL, STEERING COLUMN, OR INSTRUMENT PANEL COMPONENTS YOU MUST FIRST DISCONNECT AND ISOLATE THE BATTERY NEGATIVE (GROUND) CABLE. THEN WAIT TWO MINUTES FOR THE SYSTEM CAPACITOR TO DISCHARGE BEFORE FURTHER SYSTEM SERVICE. THIS IS THE ONLY SURE WAY TO DISABLE THE AIRBAG SYSTEM. FAILURE TO DO THIS COULD RESULT IN ACCIDENTAL AIRBAG DEPLOYMENT AND POSSIBLE PERSONAL INJURY.

- WHEN REMOVING A DEPLOYED AIRBAG MODULE, RUBBER GLOVES, EYE PROTECTION, AND A LONG-SLEEVED SHIRT SHOULD BE WORN. THERE MAY BE DEPOSITS ON THE AIRBAG MODULE AND OTHER INTERIOR SURFACES. IN LARGE DOSES, THESE DEPOSITS MAY CAUSE IRRITATION TO THE SKIN AND EYES.

REMOVAL

(1) Disconnect and isolate the battery negative cable. If either of the airbags has not been deployed, wait two minutes for the system capacitor to discharge before further service.

(2) Remove the passenger side airbag module from the instrument panel. Refer to **Passenger Side Airbag Module** in the Removal and Installation section of this group for the procedures.

(3) Place the passenger side airbag module on a suitable work surface. Slide the passenger side airbag door sideways on the airbag module until the keyed holes in the returns of the upper and lower airbag door mounting flanges clear the three tabs on the top and the bottom of the airbag module housing (Fig. 11).

(4) Disengage the keyed holes in the returns of the upper and lower airbag door mounting flange returns from the three tabs on the top and the bottom of the passenger side airbag module housing.

(5) Remove the passenger side airbag door from the airbag module.

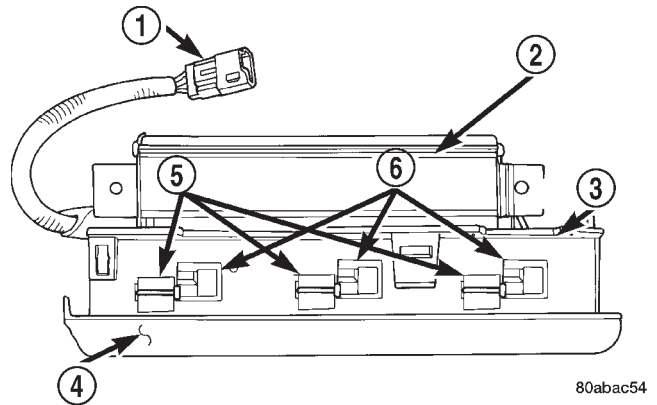

80abac54

Fig. 11 Passenger Side Airbag Door Remove/Install

- 1 - CONNECTOR
- 2 - AIRBAG MODULE HOUSING
- 3 - AIRBAG DOOR FLANGE
- 4 - AIRBAG DOOR
- 5 - TABS
- 6 - KEYED SLOTS

INSTALLATION

WARNING:

- USE EXTREME CARE TO PREVENT ANY FOREIGN MATERIAL FROM ENTERING THE PASSENGER SIDE AIRBAG MODULE, OR BECOMING ENTRAPPED BETWEEN THE AIRBAG CUSHION AND THE PASSENGER SIDE AIRBAG DOOR. FAILURE TO OBSERVE THIS WARNING COULD RESULT IN OCCUPANT INJURIES UPON AIRBAG DEPLOYMENT.

- THE PASSENGER SIDE AIRBAG DOOR MUST NEVER BE PAINTED. REPLACEMENT AIRBAG DOORS ARE SERVICED IN THE ORIGINAL COLORS. PAINT MAY CHANGE THE WAY IN WHICH THE MATERIAL OF THE AIRBAG DOOR RESPONDS TO AN AIRBAG DEPLOYMENT. FAILURE TO OBSERVE THIS WARNING COULD RESULT IN OCCUPANT INJURIES UPON AIRBAG DEPLOYMENT.

(1) Position the passenger side airbag door over the airbag module.

(2) Engage the keyed holes in the returns of the upper and lower airbag door mounting flanges with the three tabs on the top and the bottom of the passenger side airbag module housing.

(3) Slide the passenger side airbag door sideways until the keyed holes in the returns of the upper and lower airbag door mounting flanges are locked onto the three tabs on the top and the bottom of the airbag module housing.

(4) Install the passenger side airbag module onto the instrument panel. Refer to **Passenger Side Airbag Module** in the Removal and Installation section of this group for the procedures.

REMOVAL AND INSTALLATION (Continued)

AIRBAG CONTROL MODULE

WARNING:

• THE AIRBAG CONTROL MODULE CONTAINS THE IMPACT SENSOR, WHICH ENABLES THE SYSTEM TO DEPLOY THE AIRBAG. BEFORE ATTEMPTING TO DIAGNOSE OR SERVICE ANY AIRBAG SYSTEM OR RELATED STEERING WHEEL, STEERING COLUMN, OR INSTRUMENT PANEL COMPONENTS YOU MUST FIRST DISCONNECT AND ISOLATE THE BATTERY NEGATIVE (GROUND) CABLE. THEN WAIT TWO MINUTES FOR THE SYSTEM CAPACITOR TO DISCHARGE BEFORE FURTHER SYSTEM SERVICE. THIS IS THE ONLY SURE WAY TO DISABLE THE AIRBAG SYSTEM. FAILURE TO DO THIS COULD RESULT IN ACCIDENTAL AIRBAG DEPLOYMENT AND POSSIBLE PERSONAL INJURY.

• NEVER STRIKE OR KICK THE AIRBAG CONTROL MODULE, AS IT CAN DAMAGE THE IMPACT SENSOR OR AFFECT ITS CALIBRATION. IF AN AIRBAG CONTROL MODULE IS ACCIDENTALLY DROPPED DURING SERVICE, THE MODULE MUST BE SCRAPPED AND REPLACED WITH A NEW UNIT. ALWAYS REINSTALL THE AIRBAG CONTROL MODULE PROTECTIVE COVER. FAILURE TO OBSERVE THIS WARNING COULD RESULT IN ACCIDENTAL, INCOMPLETE, OR IMPROPER AIRBAG DEPLOYMENT AND POSSIBLE OCCUPANT INJURIES.

REMOVAL

(1) Disconnect and isolate the battery negative cable. If either of the airbags has not been deployed, wait two minutes for the system capacitor to discharge before further service.

(2) Remove the center floor console from the floor panel transmission tunnel. Refer to **Full Floor Console** in the index of this service manual for the location of the proper center floor console removal procedures.

(3) Remove the console rear duct from the floor panel transmission tunnel. Refer to **Ducts And Outlets** in the index of this service manual for the location of the proper console rear duct removal procedures.

(4) Remove the three screws that secure the center floor console rear mounting bracket to the floor panel transmission tunnel.

(5) Remove the center floor console rear mounting bracket from the floor panel transmission tunnel.

(6) Disconnect the instrument panel wire harness connector from the Airbag Control Module (ACM) (Fig. 12). To disconnect the instrument panel wire harness connector from the ACM:

(a) Squeeze the two connector latch tabs between the thumb and forefinger.

(b) Pull the connector straight away from the ACM connector receptacle.

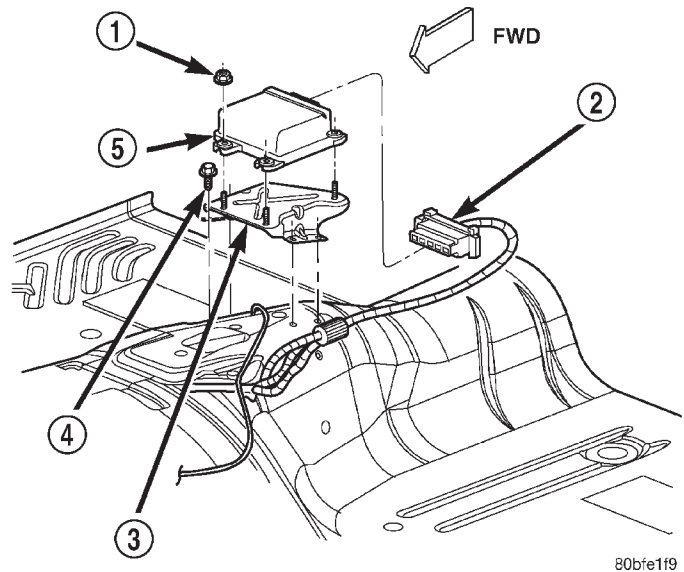

Fig. 12 Airbag Control Module Remove/Install

- 1 - NUT AND WASHER (3)
- 2 - INSTRUMENT PANEL WIRE HARNESS CONNECTOR
- 3 - ACM MOUNTING BRACKET
- 4 - SCREW (4)
- 5 - AIRBAG CONTROL MODULE

(7) Remove the three nuts that secure the ACM to the weld studs on the ACM mounting bracket on the floor panel transmission tunnel.

(8) Remove the ACM from the ACM mounting bracket on the floor panel transmission tunnel.

INSTALLATION

(1) Carefully position the ACM onto the ACM mounting bracket on the floor panel transmission tunnel. When the ACM is correctly positioned the arrow on the ACM label will be pointed forward in the vehicle.

(2) Install and tighten the three nuts that secure the ACM to the weld studs on the ACM mounting bracket on the floor panel transmission tunnel. Tighten the nuts to 7.3 N·m (65 in. lbs.).

(3) Reconnect the instrument panel wire harness connector to the ACM connector receptacle. Be certain that the connector latches are fully engaged.

(4) Position the center floor console rear mounting bracket onto the floor panel transmission tunnel over the ACM.

(5) Install and tighten the three screws that secure the center floor console rear mounting bracket to the floor panel transmission tunnel. Tighten the screws to 1.1 N·m (10 in. lbs.).

REMOVAL AND INSTALLATION (Continued)

(6) Install the console rear duct onto the floor panel transmission tunnel. Refer to **Ducts And Outlets** in the index of this service manual for the location of the proper console rear duct installation procedures.

(7) Install the center floor console onto the floor panel transmission tunnel. Refer to **Full Floor Console** in the index of this service manual for the location of the proper center floor console installation procedures.

(8) Do not reconnect the battery negative cable at this time. Refer to **Airbag System** in the Diagnosis and Testing section of this group for the proper procedures.

CLOCKSPRING

The clockspring cannot be repaired. It must be replaced if faulty or damaged, or if the driver side airbag has been deployed.

WARNING: THE AIRBAG SYSTEM IS A SENSITIVE, COMPLEX ELECTROMECHANICAL UNIT. BEFORE ATTEMPTING TO DIAGNOSE OR SERVICE ANY AIRBAG SYSTEM OR RELATED STEERING WHEEL, STEERING COLUMN, OR INSTRUMENT PANEL COMPONENTS YOU MUST FIRST DISCONNECT AND ISOLATE THE BATTERY NEGATIVE (GROUND) CABLE. THEN WAIT TWO MINUTES FOR THE SYSTEM CAPACITOR TO DISCHARGE BEFORE FURTHER SYSTEM SERVICE. THIS IS THE ONLY SURE WAY TO DISABLE THE AIRBAG SYSTEM. FAILURE TO DO THIS COULD RESULT IN ACCIDENTAL AIRBAG DEPLOYMENT AND POSSIBLE PERSONAL INJURY.

REMOVAL

NOTE: Before starting this procedure, be certain to turn the steering wheel until the front wheels are in the straight-ahead position.

(1) Place the front wheels in the straight-ahead position.

(2) Remove the driver side airbag module from the steering wheel. Refer to **Driver Side Airbag Module** in the Removal and Installation section of this group for the procedures.

(3) If the vehicle is so equipped, disconnect the upper clockspring wire harness connector from the steering wheel wire harness for the vehicle speed control switches located within the hub cavity of the steering wheel.

(4) Remove the nut that secures the steering wheel armature to the steering column upper shaft, which is located within the hub cavity of the steering wheel.

(5) Pull the steering wheel off of the steering column upper shaft spline using a steering wheel puller (Special Tool C-3428-B).

(6) Remove the steering column opening cover from the instrument panel. Refer to **Steering Column Opening Cover** in the Removal and Installation section of Group 8E - Instrument Panel Systems for the procedures.

(7) If the vehicle is so equipped, move the tilt steering column to the fully raised position.

(8) Remove the three screws that secure the lower steering column shroud to the upper shroud (Fig. 13).

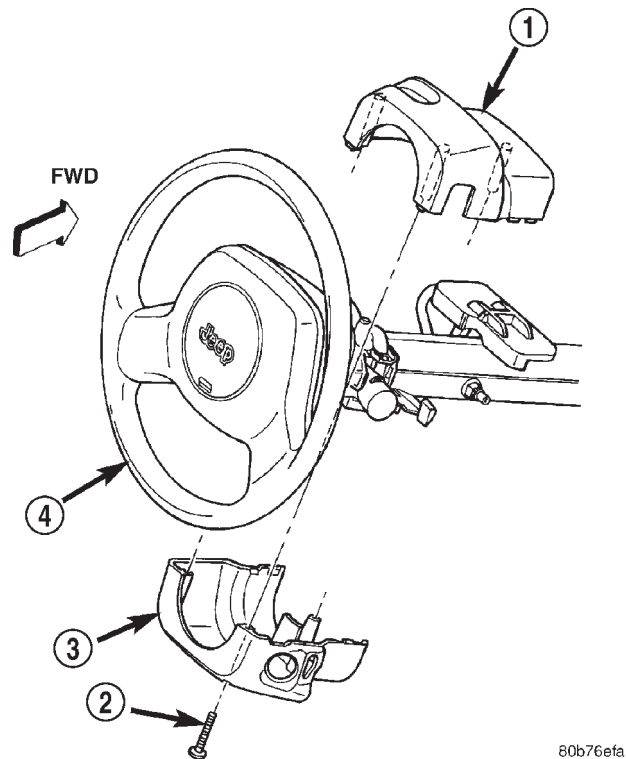

80b76efa

Fig. 13 Steering Column Shrouds Remove/Install

- 1 - UPPER SHROUD
- 2 - SCREW (3)
- 3 - LOWER SHROUD
- 4 - STEERING WHEEL

(9) If the vehicle is equipped with a standard non-tilt steering column, loosen the two upper steering column mounting nuts. If the vehicle is equipped with the optional tilt steering column, move the tilt steering column to the fully lowered position.

(10) Remove both the upper and lower shrouds from the steering column.

(11) Disconnect the two instrument panel wire harness connectors from the lower clockspring connector receptacles (Fig. 14).

(12) The multi-function switch water shield bracket on the top of the steering column has a small access window which allows access to the upper

REMOVAL AND INSTALLATION (Continued)

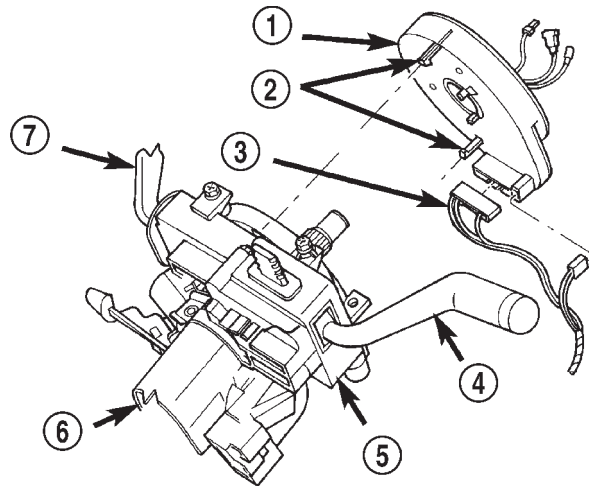

30b76efb

Fig. 14 Clockspring Remove/Install

- 1 - CLOCKSPRING
- 2 - LATCHES
- 3 - WIRE HARNESS
- 4 - TURN SIGNAL SWITCH LEVER
- 5 - WATER SHIELD BRACKET
- 6 - STEERING COLUMN
- 7 - WIPER SWITCH LEVER

clockspring latch with a small screwdriver (Fig. 15). Gently pry both plastic latches of the clockspring assembly to release them from the steering column upper housing.

NOTE: If the clockspring plastic latches are broken, be certain to remove the broken pieces from the steering column upper housing.

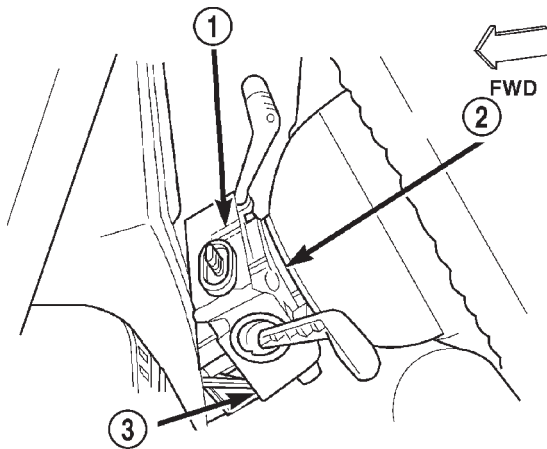

80b6b37a

Fig. 15 Upper Clockspring Latch Access Window

- 1 - UPPER CLOCKSPRING LATCH ACCESS WINDOW
- 2 - CLOCKSPRING
- 3 - WATER SHIELD AND BRACKET

(13) Remove the clockspring from the steering column. The clockspring cannot be repaired. It must be

replaced if faulty or damaged, or if the driver side airbag has been deployed.

(14) If the removed clockspring is to be reused, lock the clockspring rotor to the clockspring case to maintain clockspring centering until it is reinstalled on the steering column. This can be done by inserting a stiff wire through the small index hole located at about the 11 o'clock position in the centered clockspring rotor and case. Refer to **Clockspring Centering** in the Adjustments section of this group for an illustration of the clockspring index hole. Bend the wire over after it has been inserted through the index hole to prevent it from falling out.

INSTALLATION

If the clockspring is not properly centered in relation to the steering wheel, steering shaft and steering gear, it may be damaged. Refer to **Clockspring Centering** in the Adjustments section of this group before installing or reinstalling a clockspring.

Service replacement clocksprings are shipped pre-centered and with a locking pin installed. This locking pin should not be removed until the clockspring has been installed on the steering column. If the locking pin is removed before the clockspring is installed on a steering column, the clockspring centering procedure must be performed.

NOTE: Before starting this procedure, be certain that the front wheels are still in the straight-ahead position.

(1) If the removed clockspring is being reused, remove the wire from the index hole that is locking the clockspring rotor to the clockspring case to maintain clockspring centering.

(2) Be certain that the turn signal switch stalk is in the neutral position, then carefully slide the centered clockspring down over the steering column upper shaft until the clockspring latches engage the steering column upper housing.

(3) If a new clockspring has been installed, remove the locking pin that is securing the clockspring rotor to the clockspring case and maintaining clockspring centering.

(4) Reconnect the two instrument panel wire harness connectors to the lower clockspring connector receptacles. Be certain that the connector latches are fully engaged.

(5) Position the steering column shrouds on the steering column.

(6) Install and tighten the three screws that secure the lower steering column shroud to the upper shroud. Tighten the screws to 2 N·m (18 in. lbs.).

(7) Install the steering column opening cover onto the instrument panel. Refer to **Steering Column Opening Cover** in the Removal and Installation sec-

REMOVAL AND INSTALLATION (Continued)

tion of Group 8E - Instrument Panel Systems for the procedures.

(8) Install the steering wheel onto the steering column upper shaft. Be certain to index the flats on the hub of the steering wheel with the formations on the inside of the clockspring rotor. Pull the upper clockspring wire harnesses through the lower hole in the steering wheel armature.

(9) Install and tighten the steering wheel mounting nut. Tighten the nut to 61 N·m (45 ft. lbs.). Be certain not to pinch the wire harnesses between the steering wheel and the nut.

(10) If the vehicle is so equipped, reconnect the upper clockspring wire harness connector to the steering wheel wire harness for the vehicle speed control switches.

(11) Install the driver side airbag module onto the steering wheel. Refer to **Driver Side Airbag Module** in the Removal and Installation section of this group for the procedures.

ADJUSTMENTS

CLOCKSPRING CENTERING

The clockspring is designed to wind and unwind when the steering wheel is rotated, but is only designed to rotate the same number of turns (about five complete rotations) as the steering wheel can be turned from stop to stop. Centering the clockspring indexes the clockspring tape to other steering components so that it can operate within its designed travel limits. The rotor of a centered clockspring can be rotated two and one-half turns in either direction from the centered position, without damaging the clockspring tape.

However, if the clockspring is removed for service or if the steering column is disconnected from the steering gear, the clockspring tape can change position relative to the other steering components. The clockspring must then be re-centered following completion of the service or the clockspring tape may be damaged.

Service replacement clocksprings are shipped pre-centered and with a locking pin installed. This locking pin should not be removed until the clockspring has been installed on the steering column. If the locking pin is removed before the clockspring is installed on a steering column, the clockspring centering procedure must be performed.

WARNING: THE AIRBAG SYSTEM IS A SENSITIVE, COMPLEX ELECTROMECHANICAL UNIT. BEFORE ATTEMPTING TO DIAGNOSE OR SERVICE ANY AIRBAG SYSTEM OR RELATED STEERING WHEEL, STEERING COLUMN, OR INSTRUMENT PANEL COMPONENTS YOU MUST FIRST DISCONNECT

AND ISOLATE THE BATTERY NEGATIVE (GROUND) CABLE. THEN WAIT TWO MINUTES FOR THE SYSTEM CAPACITOR TO DISCHARGE BEFORE FURTHER SYSTEM SERVICE. THIS IS THE ONLY SURE WAY TO DISABLE THE AIRBAG SYSTEM. FAILURE TO DO THIS COULD RESULT IN ACCIDENTAL AIRBAG DEPLOYMENT AND POSSIBLE PERSONAL INJURY.

NOTE: Before starting this procedure, be certain to turn the steering wheel until the front wheels are in the straight-ahead position.

(1) Place the front wheels in the straight-ahead position.

(2) Remove the clockspring from the steering column. Refer to **Clockspring** in the Removal and Installation section of this group for the procedures.

(3) Hold the clockspring case in one hand so that it is oriented as it would be when it is installed on the steering column (Fig. 16).

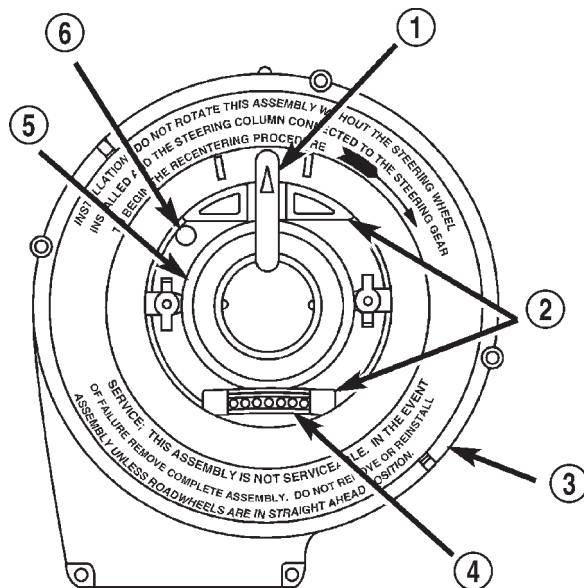

80b76eff

Fig. 16 Clockspring

- 1 - LOCKING PIN
- 2 - ROTOR FLATS
- 3 - CASE
- 4 - UPPER CLOCKSPRING WIRE HARNESSSES (WIRES NOT SHOWN)
- 5 - ROTOR
- 6 - INDEX HOLE

(4) Use your other hand to rotate the clockspring rotor clockwise to the end of its travel. **Do not apply excessive torque.**

(5) From the end of the clockwise travel, rotate the rotor about two and one-half turns counterclockwise,

ADJUSTMENTS (Continued)

until the rotor flats are horizontal. If the upper clockspring wire harnesses are not oriented towards the bottom of the clockspring, rotate the rotor another one-half turn in the counterclockwise direction.

(6) The clockspring is now centered. Lock the clockspring rotor to the clockspring case to maintain clockspring centering until it is reinstalled on the steering column. This can be done by inserting a stiff wire through the small index hole located at about the 11 o'clock position in the centered clockspring rotor and case. Bend the wire over after it has been inserted through the index hole to prevent it from falling out.

(7) The front wheels should still be in the straight-ahead position. Install the clockspring onto the steering column. Refer to **Clockspring** in the Removal and Installation section of this group for the procedures.

SPECIAL TOOLS

PASSIVE RESTRAINT SYSTEMS

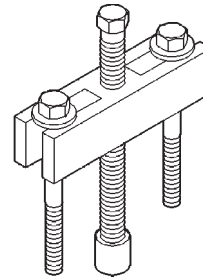

Puller C-3428-B

ELECTRICALLY HEATED SYSTEMS

TABLE OF CONTENTS

| | page | | page |
|---------------------------------------|------|------------------------------|------|
| REAR WINDOW DEFOGGER SYSTEM | 1 | HEATED SEAT SYSTEM | 8 |

REAR WINDOW DEFOGGER SYSTEM

TABLE OF CONTENTS

| | page | | page |
|---------------------------------------|------|--|------|
| GENERAL INFORMATION | | REAR GLASS HEATING GRID | 4 |
| INTRODUCTION | 1 | DEFOGGER SWITCH | 4 |
| REAR WINDOW DEFOGGER SYSTEM | 1 | DEFOGGER RELAY | 4 |
| DESCRIPTION AND OPERATION | | INSTRUMENT CLUSTER | 5 |
| REAR GLASS HEATING GRID | 2 | SERVICE PROCEDURES | |
| OUTSIDE MIRROR HEATING GRID | 2 | REAR GLASS HEATING GRID REPAIR | 6 |
| DEFOGGER SWITCH | 2 | REMOVAL AND INSTALLATION | |
| INSTRUMENT CLUSTER | 2 | DEFOGGER SWITCH | 6 |
| DEFOGGER RELAY | 3 | DEFOGGER RELAY | 7 |
| DIAGNOSIS AND TESTING | | | |
| DEFOGGER SYSTEM | 3 | | |

GENERAL INFORMATION

INTRODUCTION

An electrically heated rear window defogger and electrically heated outside rear view mirrors are available factory-installed options on this model. Refer to 8W-48 - Rear Window Defogger and 8W-62 - Power Mirrors in Group 8W - Wiring Diagrams for complete circuit descriptions and diagrams.

NOTE: This group covers both Left-Hand Drive (LHD) and Right-Hand Drive (RHD) versions of this model. Whenever required and feasible, the RHD versions of affected vehicle components have been constructed as mirror-image of the LHD versions. While most of the illustrations used in this group represent only the LHD version, the diagnostic and service procedures outlined can generally be applied to either version. Exceptions to this rule have been clearly identified as LHD or RHD, if a special illustration or procedure is required.

REAR WINDOW DEFOGGER SYSTEM

The rear window defogger system will only operate when the ignition switch is in the On position. When the defogger switch is in the On position, an electric heater grid on the rear window glass is energized. Vehicles with the heated mirror options also have heater grids located behind the outside rear view mirror glass. Each of these grids produce heat to help clear the rear window glass and outside rear view mirrors of ice, snow, or fog.

The defogger system is controlled by a switch installed in the instrument panel accessory switch bezel, which is located near the bottom of the instrument panel center bezel area, below the heater and air conditioner controls. An amber indicator lamp in the switch button will light to indicate when the defogger system is turned on. The instrument cluster circuitry, which contains the defogger system timer logic, monitors the state of the defogger switch through a hard-wired input. The instrument cluster circuitry controls the defogger system through a hard-wired control output to the defogger relay.

The defogger system will be automatically turned off after a programmed time interval of about ten minutes. After the initial time interval has expired, if

GENERAL INFORMATION (Continued)

the defogger switch is turned on again during the same ignition cycle, the defogger system will automatically turn off after about five minutes.

The defogger system will automatically shut off if the ignition switch is turned to the Off position, or it can be turned off manually by depressing the instrument panel switch. Following are general descriptions of the major components in the defogger system. Refer to the owner's manual in the vehicle glove box for more information on the features, use and operation of the defogger system.

DESCRIPTION AND OPERATION

REAR GLASS HEATING GRID

The heated rear window glass has two electrically conductive vertical bus bars and a series of horizontal grid lines made of a silver-ceramic material, which is baked on and bonded to the inside surface of the glass. The grid lines and bus bars comprise a parallel electrical circuit.

When the rear window defogger switch is placed in the On position, electrical current is directed to the rear window grid lines through the bus bars. The grid lines heat the rear window to clear the surface of fog or snow. Protection for the heated grid circuit is provided by a fuse in the Power Distribution Center (PDC).

The grid lines and bus bars are highly resistant to abrasion. However, it is possible for an open circuit to occur in an individual grid line, resulting in no current flow through the line.

The grid lines can be damaged or scraped off with sharp instruments. Care should be taken when cleaning the glass or removing foreign materials, decals, or stickers from the glass. Normal glass cleaning solvents or hot water used with rags or toweling is recommended.

A repair kit is available to repair the grid lines and bus bars, or to reinstall the heated glass pigtail wires.

OUTSIDE MIRROR HEATING GRID

Vehicles equipped with the optional heated mirror package have an electric heating grid located behind the mirror glass of each outside rear view mirror. The heated mirrors are controlled by the rear window defogger switch. Electrical current is directed to the heating grid inside the mirror only when the rear window defogger switch is in the On position.

If the outside mirror heating grids and the rear window heating grid are all inoperative, diagnosis of the rear window defogger system should be performed as described in this group. If the outside mirror heating grids are inoperative, but the rear

window heating grid is operating as designed, refer to Power Mirror in the Diagnosis and Testing section of Group 8T - Power Mirror Systems for diagnosis of the mirror heating grids.

The heating grid behind each outside mirror glass cannot be repaired and, if faulty or damaged, the entire power mirror unit must be replaced. Refer to Power Mirror in the Removal and Installation section of Group 8T - Power Mirror Systems for the service procedures.

DEFOGGER SWITCH

The rear window defogger switch is installed in the instrument panel accessory switch bezel, which is located near the bottom of the instrument panel center bezel area, below the heater and air conditioner controls. The momentary-type switch provides a hard-wired ground signal to the instrument cluster each time it is depressed. The instrument cluster rear window defogger timer and logic circuitry responds by energizing or de-energizing the rear window defogger relay.

Energizing the rear window defogger relay provides electrical current to the rear window defogger grid and, if the vehicle is so equipped, the outside rear view mirror heating grids. An amber indicator lamp in the defogger switch, which lights to indicate when the defogger system is turned On, is also powered by the defogger relay output.

The defogger switch illumination lamp and indicator lamp bulbs are serviceable. The defogger switch cannot be repaired and, if faulty or damaged, it must be replaced.

INSTRUMENT CLUSTER

The instrument cluster is an electromechanical unit that contains integrated circuitry and internal programming to perform a variety of functions. The instrument cluster circuitry monitors hard-wired switch inputs, as well as message inputs received from other vehicle electronic control modules on the Chrysler Collision Detection (CCD) data bus network.

The instrument cluster uses these many inputs along with its internal programming and integral timer and logic circuitry to perform the functions of the rear window defogger timer on this model. The instrument cluster circuitry also has a self-diagnostic capability. Refer to Instrument Cluster in Group 8E - Instrument Panel Systems for more information on this feature.

However, there are no diagnostics available for the rear window defogger timer and logic circuitry. Therefore, the diagnosis for this system consists of confirming the presence of a rear window defogger switch input signal at the instrument cluster connector, and the resulting rear window defogger relay

DESCRIPTION AND OPERATION (Continued)

control output signal at the defogger relay. For diagnosis of the CCD data bus and the data bus message inputs, a DRB scan tool and the proper Diagnostic Procedures manual are recommended.

Refer to Instrument Cluster in Group 8E - Instrument Panel Systems for the service procedures for the instrument cluster. The rear window defogger timer and logic circuitry cannot be adjusted or repaired and, if faulty or damaged, the instrument cluster assembly must be replaced.

DEFOGGER RELAY

The rear window defogger relay is a International Standards Organization (ISO)-type relay. The rear window defogger relay is a electromechanical device that switches fused battery current to the rear glass and outside mirror heating grids, and the indicator lamp of the defogger switch, when the instrument cluster rear window defogger timer and logic circuitry grounds the relay coil. See Defogger Relay in the Diagnosis and Testing section of this group for more information.

The rear window defogger relay is located in the junction block, on the right cowl side inner panel below the instrument panel in the passenger compartment. The rear window defogger relay cannot be repaired and, if faulty or damaged, it must be replaced.

DIAGNOSIS AND TESTING

DEFOGGER SYSTEM

For circuit descriptions and diagrams, refer to 8W-48 - Rear Window Defogger or 8W-62 Power Mirrors in Group 8W - Wiring Diagrams. The operation of the electrically heated rear window defogger system can be confirmed in one of the following manners:

1. Turn the ignition switch to the On position. While monitoring the instrument panel voltmeter, set the defogger switch in the On position. When the defogger switch is turned On, a distinct voltmeter needle deflection should be noted.

2. Turn the ignition switch to the On position. Set the defogger switch in the On position. The rear window defogger operation can be checked by feeling the rear window or outside rear view mirror glass. A distinct difference in temperature between the grid lines and the adjacent clear glass or the mirror glass can be detected within three to four minutes of operation.

3. Using a 12-volt DC voltmeter, contact the rear glass heating grid terminal A (right side) with the negative lead, and terminal B (left side) with the positive lead (Fig. 1). The voltmeter should read battery voltage.

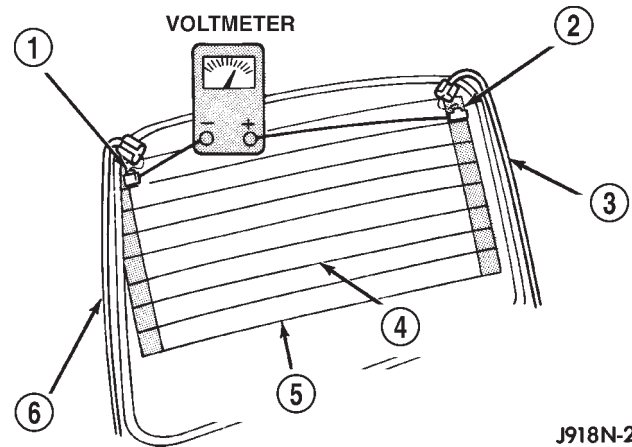

Fig. 1 Rear Window Glass Grid Test

- 1 - TERMINAL "A"
- 2 - TERMINAL "B"
- 3 - FEED WIRE
- 4 - MID-POINT "C" (TYPICAL)
- 5 - HEATED REAR WINDOW DEFOGGER GRID
- 6 - GROUND WIRE

The above checks will confirm system operation. Illumination of the defogger switch indicator lamp means that there is electrical current available at the output of the defogger relay, but does not confirm that the electrical current is reaching the rear glass heating grid lines.

If the defogger system does not operate, the problem should be isolated in the following manner:

(1) Confirm that the ignition switch is in the On position.

(2) Ensure that the rear glass heating grid feed and ground wires are connected to the glass. Confirm that the ground wire has continuity to ground.

(3) Check the fuses in the Power Distribution Center (PDC) and in the junction block. The fuses must be tight in their receptacles and all electrical connections must be secure.

When the above steps have been completed and the rear glass or outside rear view mirror heating grid is still inoperative, one or more of the following is faulty:

- Defogger switch
- Defogger relay
- Instrument cluster circuitry
- Rear window grid lines (all grid lines would have to be broken or one of the feed wires disconnected for the entire system to be inoperative)
- Outside rear view mirror heating grid.

If setting the defogger switch to the On position produces a severe voltmeter deflection, check for a short circuit between the defogger relay output and the rear glass or outside rear view mirror heating grids.

DIAGNOSIS AND TESTING (Continued)

REAR GLASS HEATING GRID

For circuit descriptions and diagrams, refer to 8W-48 - Rear Window Defogger in Group 8W - Wiring Diagrams. To detect breaks in the grid lines, the following procedure is required:

(1) Turn the ignition switch to the On position. Set the defogger switch in the On position. The indicator lamp should light. If OK, go to Step 2. If not OK, see the Defogger Relay diagnosis in this group.

(2) Using a 12-volt DC voltmeter, contact the vertical bus bar on the right side of the vehicle with the negative lead. With the positive lead, contact the vertical bus bar on the left side of the vehicle. The voltmeter should read battery voltage. If OK, go to Step 3. If not OK, repair the open circuit to the defogger relay as required.

(3) With the negative lead of the voltmeter, contact a good body ground point. The voltage reading should not change. If OK, go to Step 4. If not OK, repair the circuit to ground as required.

(4) Connect the negative lead of the voltmeter to the right side bus bar and touch each grid line at midpoint C with the positive lead. A reading of approximately six volts indicates a line is good. A reading of zero volts indicates a break in the grid line between midpoint C and the left side bus bar. A reading of ten to fourteen volts indicates a break between midpoint C and the right side bus bar. Move the positive lead on the grid line towards the break and the voltage reading will change as soon as the break is crossed.

DEFOGGER SWITCH

For circuit descriptions and diagrams, refer to 8W-48 - Rear Window Defogger in Group 8W - Wiring Diagrams.

WARNING: ON VEHICLES EQUIPPED WITH AIRBAGS, REFER TO GROUP 8M - PASSIVE RESTRAINT SYSTEMS BEFORE ATTEMPTING ANY STEERING WHEEL, STEERING COLUMN, OR INSTRUMENT PANEL COMPONENT DIAGNOSIS OR SERVICE. FAILURE TO TAKE THE PROPER PRECAUTIONS COULD RESULT IN ACCIDENTAL AIRBAG DEPLOYMENT AND POSSIBLE PERSONAL INJURY.

(1) Disconnect and isolate the battery negative cable. Remove the accessory switch bezel from the instrument panel and unplug the defogger switch wire harness connector.

(2) Check for continuity between the ground circuit cavity of the defogger switch wire harness connector and a good ground. There should be continuity. If OK, go to Step 3. If not OK, repair the open circuit as required.

(3) Check for continuity between the ground circuit terminal and the rear window defogger switch sense circuit terminal on the back of the defogger switch housing (Fig. 2). There should be momentary continuity as the defogger switch button is depressed, and then no continuity. If OK, see the diagnosis for the Instrument Cluster in this group. If not OK, replace the faulty switch.

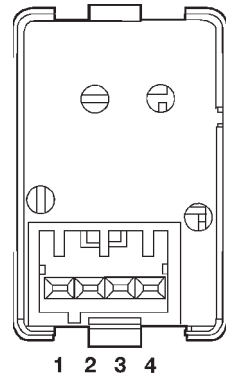

| SWITCH POSITION | CONTINUITY BETWEEN |
|-------------------|--------------------|
| OFF | LAMPS |
| ON | MOMENTARY 1 AND 2 |
| ILLUMINATION LAMP | 1 AND 4 |
| INDICATOR LAMP | 1 AND 3 |

80a5035f

Fig. 2 Defogger Switch Continuity

DEFOGGER RELAY

WARNING: ON VEHICLES EQUIPPED WITH AIRBAGS, REFER TO GROUP 8M - PASSIVE RESTRAINT SYSTEMS BEFORE ATTEMPTING ANY STEERING WHEEL, STEERING COLUMN, OR INSTRUMENT PANEL COMPONENT DIAGNOSIS OR SERVICE. FAILURE TO TAKE THE PROPER PRECAUTIONS COULD RESULT IN ACCIDENTAL AIRBAG DEPLOYMENT AND POSSIBLE PERSONAL INJURY.

RELAY TEST

The defogger relay (Fig. 3) is located in the junction block, on the right cowl side inner panel below the instrument panel in the passenger compartment. Remove the defogger relay from the junction block to perform the following tests:

(1) A relay in the de-energized position should have continuity between terminals 87A and 30, and no continuity between terminals 87 and 30. If OK, go to Step 2. If not OK, replace the faulty relay.

(2) Resistance between terminals 85 and 86 (electromagnet) should be 75 ± 10 ohms. If OK, go to Step 3. If not OK, replace the faulty relay.

DIAGNOSIS AND TESTING (Continued)

(3) Connect a battery to terminals 85 and 86. There should now be continuity between terminals 30 and 87, and no continuity between terminals 87A and 30. If OK, see the Relay Circuit Test in this group. If not OK, replace the faulty relay.

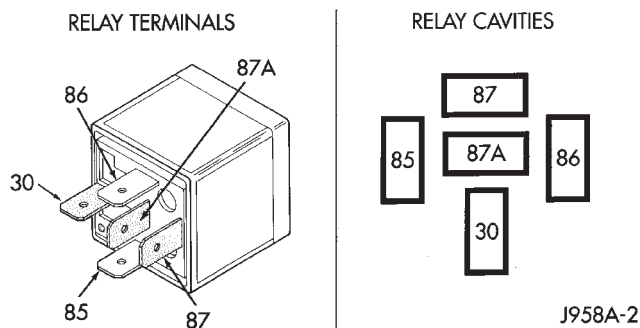

| TERMINAL LEGEND | |
|-----------------|-----------------|
| NUMBER | IDENTIFICATION |
| 30 | COMMON FEED |
| 85 | COIL GROUND |
| 86 | COIL BATTERY |
| 87 | NORMALLY OPEN |
| 87A | NORMALLY CLOSED |

Fig. 3 Defogger Relay

RELAY CIRCUIT TEST

(1) The relay common feed terminal cavity (30) is connected to battery voltage and should be hot at all times. If OK, go to Step 2. If not OK, repair the open circuit to the PDC fuse as required.

(2) The relay normally closed terminal (87A) is connected to terminal 30 in the de-energized position, but is not used for this application. Go to Step 3.

(3) The relay normally open terminal (87) is connected to the common feed terminal (30) in the energized position. This terminal supplies battery voltage to the rear glass and outside rear view mirror heating grids and the defogger switch indicator lamp. There should be continuity between the cavity for relay terminal 87 and the rear window defogger relay output circuit cavities of the rear glass heating grid connector, both outside rear view mirror heating grid connectors, and the defogger switch connector at all times. If OK, go to Step 4. If not OK, repair the open circuit(s) as required.

(4) The coil ground terminal (85) is connected to the electromagnet in the relay. This terminal is provided with ground by the instrument cluster rear window defogger timer and logic circuitry to energize the defogger relay. There should be continuity to ground at the cavity for relay terminal 85 when the defogger switch is turned On. However, with the defogger relay removed, the defogger switch indicator lamp will not light to show that the defogger system

is turned On. Be certain that you depress the defogger switch at least twice to confirm that the system is turned on during this test. If OK, go to Step 5. If not OK, repair the open circuit to the instrument cluster as required.

(5) The coil battery terminal (86) is connected to the electromagnet in the relay. It is connected to fused ignition switch output voltage and should be hot when the ignition switch is in the On position. Check for battery voltage at the cavity for relay terminal 86 with the ignition switch in the On position. If OK, see the diagnosis for Instrument Cluster in this group. If not OK, repair the open circuit to the fuse in the junction block as required.

INSTRUMENT CLUSTER

Before performing this test, complete the Defogger Switch and the Defogger Relay tests as described in this group. For circuit descriptions and diagrams, refer to 8W-48 - Rear Window Defogger in Group 8W - Wiring Diagrams.

WARNING: ON VEHICLES EQUIPPED WITH AIR-BAGS, REFER TO GROUP 8M - PASSIVE RESTRAINT SYSTEMS BEFORE ATTEMPTING ANY STEERING WHEEL, STEERING COLUMN, OR INSTRUMENT PANEL COMPONENT DIAGNOSIS OR SERVICE. FAILURE TO TAKE THE PROPER PRECAUTIONS COULD RESULT IN ACCIDENTAL AIR-BAG DEPLOYMENT AND POSSIBLE PERSONAL INJURY.

(1) Disconnect and isolate the battery negative cable. Remove the defogger relay from the junction block and unplug the defogger switch wire harness connector.

(2) Remove the instrument cluster from the instrument panel. Refer to Instrument Cluster in Group 8E - Instrument Panel Systems for the procedures.

(3) Check for continuity between the rear window defogger switch sense circuit cavity of the right instrument cluster wire harness connector (connector B) and a good ground. There should be no continuity. If OK, go to Step 4. If not OK, repair the short circuit as required.

(4) Check for continuity between the rear window defogger switch sense circuit cavities of the right instrument cluster wire harness connector (connector B) and the defogger switch wire harness connector. There should be continuity. If OK, go to Step 5. If not OK, repair the open circuit as required.

(5) Check for continuity between the rear window defogger relay control circuit cavity of the right instrument cluster wire harness connector (connector B) and a good ground. There should be no continuity. If OK, go to Step 6. If not OK, repair the short circuit as required.

DIAGNOSIS AND TESTING (Continued)

(6) Check for continuity between the rear window defogger relay control circuit cavities of the right instrument cluster wire harness connector (connector B) and the defogger relay receptacle (the cavity for ISO relay terminal 85) in the junction block. There should be continuity. If OK, replace the faulty instrument cluster. If not OK, repair the open circuit as required.

SERVICE PROCEDURES

REAR GLASS HEATING GRID REPAIR

Repair of the rear glass heating grid lines, bus bars, terminals or pigtail wires can be accomplished using a Mopar Rear Window Defogger Repair Kit (Part Number 4267922) or equivalent.

WARNING: MATERIALS CONTAINED IN THE REPAIR KIT MAY CAUSE SKIN OR EYE IRRITATION. THE KIT CONTAINS EPOXY RESIN AND AMINE TYPE HARDENER, WHICH ARE HARMFUL IF SWALLOWED. AVOID CONTACT WITH THE SKIN AND EYES. FOR SKIN CONTACT, WASH THE AFFECTED AREAS WITH SOAP AND WATER. FOR CONTACT WITH THE EYES, FLUSH WITH PLENTY OF WATER. DO NOT TAKE INTERNALLY. IF TAKEN INTERNALLY, INDUCE VOMITING AND CALL A PHYSICIAN IMMEDIATELY. USE WITH ADEQUATE VENTILATION. DO NOT USE NEAR FIRE OR FLAME. CONTAINS FLAMMABLE SOLVENTS. KEEP OUT OF THE REACH OF CHILDREN.

(1) Mask the repair area so that the conductive epoxy can be applied neatly. Extend the epoxy application onto the grid line or the bus bar on each side of the break (Fig. 4).

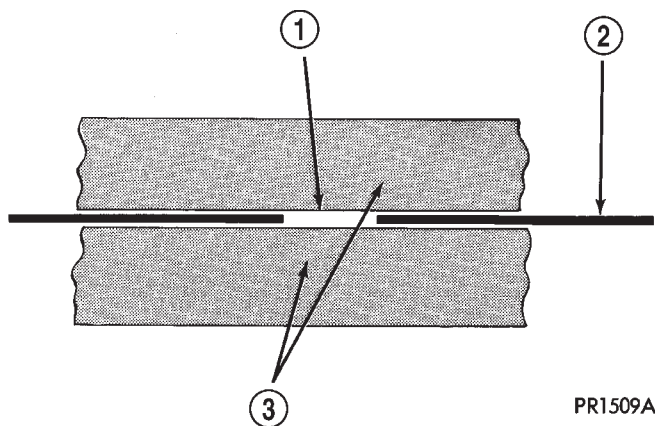

Fig. 4 Grid Line Repair - Typical

- 1 - BREAK
- 2 - GRID LINE
- 3 - MASKING TAPE

(2) Follow the instructions in the repair kit for preparing the damaged area.

(3) Remove the package separator clamp and mix the two conductive epoxy components thoroughly within the packaging. Fold the package in half and cut the center corner to dispense the epoxy.

(4) For grid line repairs, mask the area to be repaired with masking tape or a template.

(5) Apply the epoxy through the slit in the masking tape or template. Overlap both ends of the break by at least 19 millimeters (0.75 inch).

(6) For a terminal or pigtail wire replacement, mask the adjacent areas so the epoxy can be extended onto the adjacent grid line as well as the bus bar. Apply a thin layer of epoxy to the area where the terminal or pigtail wire was fastened and onto the adjacent grid line.

(7) Apply a thin layer of conductive epoxy to the terminal or bare wire end of the pigtail and place it in the proper location on the bus bar. To prevent the terminal or pigtail wire from moving while the epoxy is curing, it must be wedged or clamped.

(8) Carefully remove the masking tape or template.

CAUTION: Do not allow the glass surface to exceed 204° C (400° F) or the glass may fracture.

(9) Allow the epoxy to cure 24 hours at room temperature, or use a heat gun with a 260° to 371° C (500° to 700° F) range for fifteen minutes. Hold the heat gun approximately 25.4 centimeters (10 inches) from the repair.

(10) After the conductive epoxy is properly cured, remove the wedge or clamp from the terminal or pigtail wire. Do not attach the wire harness connectors until the curing process is complete.

(11) Check the operation of the rear window defogger glass heating grid.

REMOVAL AND INSTALLATION

DEFOGGER SWITCH

WARNING: ON VEHICLES EQUIPPED WITH AIRBAGS, REFER TO GROUP 8M - PASSIVE RESTRAINT SYSTEMS BEFORE ATTEMPTING ANY STEERING WHEEL, STEERING COLUMN, OR INSTRUMENT PANEL COMPONENT DIAGNOSIS OR SERVICE. FAILURE TO TAKE THE PROPER PRECAUTIONS COULD RESULT IN ACCIDENTAL AIRBAG DEPLOYMENT AND POSSIBLE PERSONAL INJURY.

(1) Disconnect and isolate the battery negative cable.

REMOVAL AND INSTALLATION (Continued)

(2) Remove the center bezel from the instrument panel. See Instrument Panel Center Bezel in Group 8E - Instrument Panel Systems for the procedures.

(3) Remove the three screws that secure the accessory switch bezel to the instrument panel (Fig. 5).

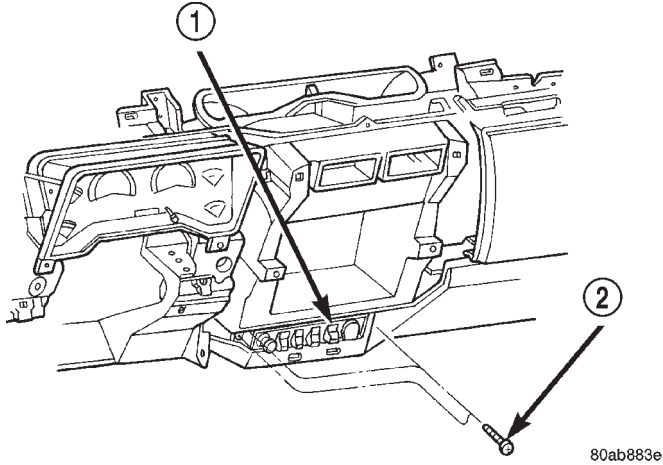

Fig. 5 Accessory Switch Bezel Remove/Install

- 1 - ACCESSORY SWITCH BEZEL
- 2 - SCREW

(4) Pull the accessory switch bezel out from the instrument panel far enough to access the wire harness connectors.

(5) Unplug the wire harness connectors from the rear of the accessory switches and the cigar lighter/power outlet.

(6) Remove the accessory switch bezel from the instrument panel.

(7) With a small thin-bladed screwdriver, gently pry the snap clips at the top and bottom of the rear window defogger switch receptacle on the back of the accessory switch bezel and pull the switch out of the bezel.

(8) Reverse the removal procedures to install. Be certain that both of the switch snap retainers in the receptacle on the back of the accessory switch bezel are fully engaged. Tighten the mounting screws to 2.2 N·m (20 in. lbs.).

DEFOGGER RELAY

WARNING: ON VEHICLES EQUIPPED WITH AIRBAGS, REFER TO GROUP 8M - PASSIVE RESTRAINT SYSTEMS BEFORE ATTEMPTING ANY STEERING WHEEL, STEERING COLUMN, OR INSTRUMENT PANEL COMPONENT DIAGNOSIS OR SERVICE. FAILURE TO TAKE THE PROPER PRECAUTIONS COULD RESULT IN ACCIDENTAL AIRBAG DEPLOYMENT AND POSSIBLE PERSONAL INJURY.

- (1) Disconnect and isolate the battery negative cable.
- (2) Remove the fuse access panel by unsnapping it from the right cowl side trim panel.

(3) Remove the stamped nut that secures the right cowl side trim to the junction block stud (Fig. 6).

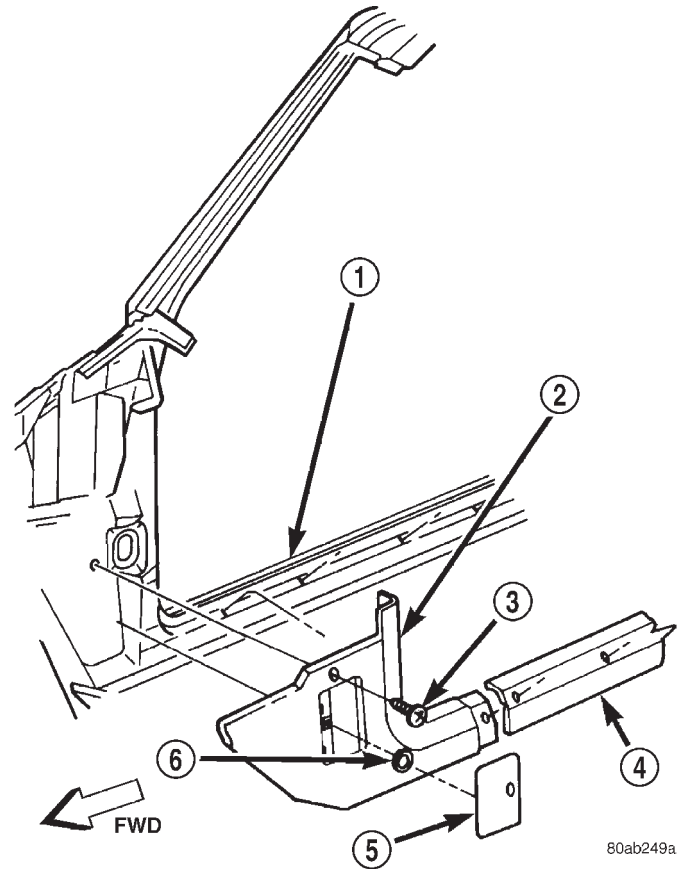

Fig. 6 Right Cowl Side Trim Remove/Install

- 1 - RIGHT FRONT DOOR SILL
- 2 - COWL SIDE TRIM PANEL
- 3 - SCREW
- 4 - SILL TRIM
- 5 - FUSE ACCESS PANEL
- 6 - PUSH-NUT

(4) Remove the screw located above the fuse access opening that secures the right cowl side trim to the right cowl side inner panel.

(5) Remove the screw that secures the right door sill trim and the right cowl side trim to the right door opening sill.

(6) Remove the right cowl side trim panel from the vehicle.

(7) Unplug the rear window defogger relay from the junction block.

(8) Install the defogger relay by aligning the relay terminals with the cavities in the junction block and pushing the relay firmly into place.

(9) Connect the battery negative cable.

(10) Test the relay operation.

(11) Reinstall the right cowl side trim and the fuse access panel. Tighten the mounting screws to 2.2 N·m (20 in. lbs.).

HEATED SEAT SYSTEM

TABLE OF CONTENTS

| | page | | page |
|--------------------------------------|------|-------------------------------------|------|
| GENERAL INFORMATION | | HEATED SEAT SWITCH..... | 10 |
| INTRODUCTION | 8 | HEATED SEAT ELEMENT and SENSOR..... | 11 |
| DESCRIPTION AND OPERATION | | HEATED SEAT RELAY | 11 |
| HEATED SEAT SWITCH..... | 8 | SEAT HEAT INTERFACE MODULE..... | 12 |
| SEAT HEAT INTERFACE MODULE..... | 9 | REMOVAL AND INSTALLATION | |
| HEATED SEAT RELAY..... | 9 | HEATED SEAT SWITCH..... | 12 |
| HEATED SEAT ELEMENT and SENSOR | 9 | SEAT HEAT INTERFACE MODULE..... | 12 |
| DIAGNOSIS AND TESTING | | HEATED SEAT RELAY | 12 |
| HEATED SEAT SYSTEM | 9 | | |

GENERAL INFORMATION

INTRODUCTION

Individually controlled electrically heated front seats are available factory-installed optional equipment on this model. The seat heaters will only operate when the ignition switch is in the ON position, and the surface temperature at the front seat heating element sensors is below the designed temperature set points of the system. The heated seat system will not operate in ambient temperatures greater than about 32° C (90° F).

There are separate momentary, tactile, two-directional rocker switches located in the center console with center NEUTRAL, HI and LO positions for each front seat. Depressing the rocker switch to its momentary HI or LO position signals the Seat Heat Interface Module (SHIM) to power the selected heated seat and maintain the requested temperature setting (HI or LO). Each switch has a HI and LO Light-Emitting Diode (LED) which, via the SHIM, illuminates to give a visual indication that the system is in the HI or LO mode. The LO heat set point is about 32° C (90° F), and the HI heat set point is about 38° C (100° F). The system shall be deactivated whenever the same set position is depressed a second time and shall change states directly when switching from HI to LO or vice versa. The system shall be deactivated whenever the ignition switch is placed in the off position. When the ignition switch is placed back in the run position, the heated seat system shall remain deactivated until a momentary switch is depressed. When a seat heater is turned on, a sensor located near the seat cushion electric heater element provides the SHIM with input indicating the surface temperature of the seat cushion. If the surface temperature input is below the temperature set point of the SHIM for the selected temperature setting, an

N-FET Transistor within the SHIM energizes the heating elements in the seat cushion and back. When the sensor input indicates the correct temperature set point has been achieved, the SHIM de-energizes the N-FET. The SHIM will continue to cycle the N-FET as needed to maintain the temperature set point.

The SHIM will automatically turn off the heating elements if it detects a short or an open in the heating element or a sensor out of range. These conditions will also cause the SHIM to notify the occupant of the failure via flashing the heated seat switch LED's as discussed later.

Switched battery power to the SHIM is supplied by the heated seat relay mounted to the seat cushion frame with the SHIM under the right front seat. The battery feed is protected by a circuit breaker located in the junction block.

Following are general descriptions of the major components in the heated seat system. Refer to 8W-63 - Power Seat With Heated Seats in Group 8W - Wiring Diagrams for complete circuit descriptions and diagrams.

DESCRIPTION AND OPERATION

HEATED SEAT SWITCH

The heated seat switch assembly is located on the center console where the ashtray is normally located (Fig. 1). The two momentary, two-directional rocker switches, one switch for each front seat, provide a resistor-multiplexed signal to the Seat Heat Interface Module (SHIM). Each switch has center NEUTRAL, and momentary LO and HI positions so that both the driver and the front seat passenger can select a preferred seat heating mode.

Each switch has two telltales (LED's) which indicate the mode of the heater of the respective seat.

DESCRIPTION AND OPERATION (Continued)

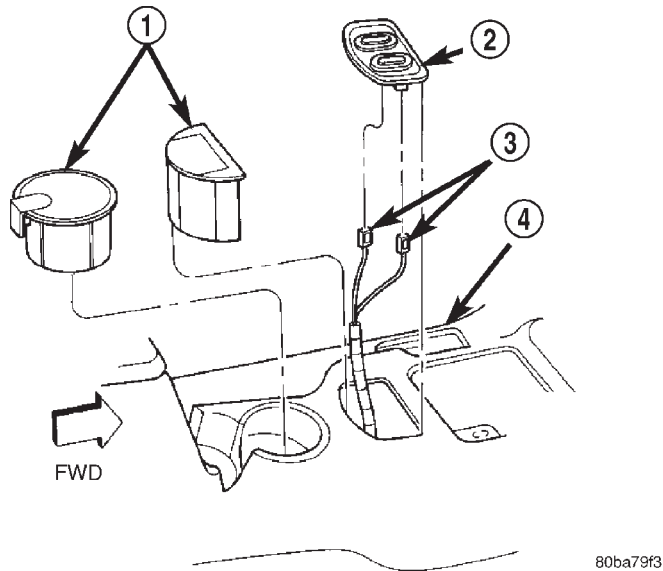

Fig. 1 Heated Seat Switch Location

- 1 - ASH RECEIVER
- 2 - HEATED SEAT SWITCHES & BEZEL
- 3 - WIRE HARNESS CONNECTORS
- 4 - FLOOR CONSOLE

The switches also have LED's which provide back-lighting when the ignition switch is in the ON position. The LED's cannot be repaired. If the LED is faulty, the individual switch must be replaced.

SEAT HEAT INTERFACE MODULE

The Seat Heat Interface Module (SHIM) is an electronic microprocessor controlled device designed to operate the electric seat heater elements. The SHIM is located under the right front seat cushion. Inputs to the module include the console mounted resistor multiplexed switch signals, seat cushion temperature sensors, a relay-switched battery feed, and a ground. The SHIM outputs are the feed for the seat heating elements and sensors, and the switch telltale circuits. The SHIM cannot be repaired and, if faulty or damaged, it must be replaced.

HEATED SEAT RELAY

The heated seat relay is located under the right front seat cushion near the SHIM. Ignition and battery power is fed to the relay, which then provides a switched battery feed to the SHIM. The heated seat relay cannot be repaired and, if faulty or damaged, it must be replaced.

HEATED SEAT ELEMENT and SENSOR

Two heated seat heating elements are used in each front seat, one for the seat cushion and the other for the seat back. The two elements for each seat are connected in series with the SHIM.

The temperature sensor is a Negative Temperature Coefficient (NTC) thermistor. One temperature sensor is used for each seat, and it is integral to the seat cushion heating element.

The heating elements are sewn into the seat cushion cover and seat back cover assemblies, which are serviced individually. The heating elements and temperature sensor cannot be repaired and, if faulty or damaged, the affected seat cover assembly must be replaced. Refer to Group 23 - Body for the seat cushion cover and seat back cover Removal and Installation.

DIAGNOSIS AND TESTING

HEATED SEAT SYSTEM

For circuit descriptions and diagrams, refer to 8W - 63 - Power Seat With Heated Seats in Group 8W - Wiring Diagrams.

WARNING: ON VEHICLES EQUIPPED WITH AIRBAGS, REFER TO GROUP 8M - PASSIVE RESTRAINT SYSTEMS BEFORE ATTEMPTING ANY STEERING WHEEL, STEERING COLUMN, OR INSTRUMENT PANEL COMPONENT DIAGNOSIS OR SERVICE. FAILURE TO TAKE THE PROPER PRECAUTIONS COULD RESULT IN ACCIDENTAL AIRBAG DEPLOYMENT AND POSSIBLE PERSONAL INJURY.

The heated seat system is capable of performing some self-diagnostics. The following table depicts the various failure modes which will be reported to the occupant via flashing the momentary switch telltales. The switch telltales will flash on the driver's switch if the failure exists in the driver's seat portion of the system, similarly with the passenger's switch. The telltale will illuminate for approximately a 1/2second on, 1/2second off pulse for a duration of one minute. This process will repeat every time the system is initiated via the switches until the problem has been corrected.

DIAGNOSIS AND TESTING (Continued)

SEAT HEAT INTERFACE MODULE DIAGNOSTIC ROUTINES

| FAILURE MODE | SWITCH "HI" TELLTALE | SWITCH "LO" TELLTALE |
|-------------------------|----------------------|----------------------|
| Shorted Heating Element | Flashing | Flashing |
| Open Heating Element | Flashing | Off |
| NTC Value Out of Range | Off | Flashing |

Before testing the individual components in the heated seat system, check the following:

- If the heated seat switch backlighting does not illuminate with the ignition switch in the ON position, check the fuse in the junction block. If the fuse is OK, see Heated Seat Switch Backlighting in the Diagnosis and Testing section of this group. If not OK, repair the shorted circuit or component as required and replace the faulty fuse.

- If the heated seat switch telltales do not illuminate with the ignition switch in the ON position, but the heating elements do heat, see Heated Seat Switch Telltales in the Diagnosis and Testing section of this group.

- If the heated seat switch backlighting illuminates with the ignition switch in the ON position, but the heating elements do not heat and the telltales do not illuminate, check the circuit breaker in the junction block. If the circuit breaker is OK, see Heated Seat Switch Multiplexed Resistances in the Diagnosis and Testing section of this group. If not OK, replace the faulty circuit breaker.

- If the heated seat switch backlighting illuminates and the telltales illuminate, but the heating elements do not heat; see Heated Seat Element in the Diagnosis and Testing section of this group.

HEATED SEAT SWITCH

For circuit descriptions and diagrams, refer to 8W - 63 - Power Seat With Heated Seats in Group 8W - Wiring Diagrams.

WARNING: ON VEHICLES EQUIPPED WITH AIRBAGS, REFER TO GROUP 8M - PASSIVE RESTRAINT SYSTEMS BEFORE ATTEMPTING ANY STEERING WHEEL, STEERING COLUMN, OR INSTRUMENT PANEL COMPONENT DIAGNOSIS OR SERVICE. FAILURE TO TAKE THE PROPER PRECAUTIONS COULD RESULT IN ACCIDENTAL AIRBAG DEPLOYMENT AND POSSIBLE PERSONAL INJURY.

BACKLIGHTING

(1) Disconnect and isolate the battery negative cable

(2) Remove the heated seat switch assembly from the center console. Remove the connector from the

suspect switch. Check for continuity between the ground circuit cavity of the 6-way heated seat switch wire harness connector and a good ground. There should be continuity. If OK, go to Step 3. If not OK, repair the open circuit as required.

(3) Connect the battery negative cable. Turn the ignition switch to the ON position. Check for battery voltage at the fused ignition switch output circuit cavity of the 6-way heated seat switch wire harness connector. If OK, turn the ignition switch to the OFF position, disconnect and isolate the battery negative cable, and replace the heated seat switch. If not OK, repair the open circuit as required.

TELLTALES

(1) Replace the heated seat switch with a known good unit and test the operation of the switch telltales. If OK, discard the faulty heated seat switch. If not OK, see Seat Heat Interface Module in the Diagnosis and Testing section of this group.

MULTIPLEXED RESISTANCES

(1) Disconnect and isolate the battery negative cable.

(2) Remove the heated seat switch assembly from the center console. Remove the connector from the suspect switch.

(3) With the suspect heated seat switch in the NEUTRAL position, using an ohmmeter, measure the resistance between the fused ignition switch output circuit terminal and the heated seat switch output circuit terminal in the 6-way connector receptacle on the back of the switch. The resistance reading should be about 2.2 Kohms. If OK, go to Step 4. If not OK, replace the faulty switch.

(4) Hold the suspect heated seat switch in the LO position. Using an ohmmeter, check the resistance between the fused ignition switch output circuit terminal and the heated seat switch output circuit terminal in the 6-way connector receptacle on the back of the switch. The resistance reading should be about 414 Ohms. If OK, go to Step 5. If not OK, replace the faulty switch.

(5) Hold the suspect heated seat switch in the HI position. Using an ohmmeter, check the resistance between the fused ignition switch output circuit terminal and the heated seat switch output circuit terminal in the 6-way connector receptacle on the back

DIAGNOSIS AND TESTING (Continued)

of the switch. The resistance reading should be about 32.5 Ohms. If OK, see Heated Seat Relay in the Diagnosis and Testing section of this group. If not OK, replace the faulty switch.

HEATED SEAT ELEMENT and SENSOR

The wire harness connectors for the seat cushion and seat back heating elements are located under the seat, near the rear edge of the seat cushion frame. For circuit descriptions and diagrams, refer to 8W - 63 - Power Seat With Heated Seats in Group 8W - Wiring Diagrams.

SEAT CUSHION

(1) Disconnect and isolate the battery negative cable. Unplug the 4-way heated seat cushion wire harness connector.

(2) Check for continuity between the two heated seat element circuit cavities of the seat cushion cover half of the heated seat cushion wire harness connector. There should be continuity. If OK, go to Step 3. If not OK, replace the faulty seat cushion cover.

(3) Check for continuity between one of the heated seat element circuit cavities of the seat cushion cover half of the heated seat cushion wire harness connector and the seat cushion frame. There should be no continuity. If OK, see Seat Back in the Diagnosis and Testing section of this group. If not OK, replace the faulty seat cushion cover.

SEAT BACK

(1) Disconnect and isolate the battery negative cable. Unplug the 2-way heated seat back wire harness connector.

(2) Check for continuity between the heated seat element circuit cavity and the ground circuit cavity of the seat back cover half of the heated seat back wire harness connector. There should be continuity. If OK, go to Step 3. If not OK, replace the faulty seat back cover.

(3) Check for continuity between the heated seat element circuit cavity of the seat back cover half of the heated seat back wire harness connector and the seat back frame. There should be no continuity. If OK, see Heated Seat Sensor in the Diagnosis and Testing section of this group. If not OK, replace the faulty seat back cover.

HEATED SEAT SENSOR

The wire harness connector for the seat cushion heating element and sensor are located under the seat, near the rear edge of the seat cushion frame. For circuit descriptions and diagrams, refer to 8W - 63 - Power Seat With Heated Seats in Group 8W - Wiring Diagrams.

(1) Disconnect and isolate the battery negative cable. Unplug the 4-way heated seat cushion wire harness connector.

(2) Using an ohmmeter, check the resistance between the heated seat sensor input circuit cavity and the heated seat sensor feed circuit cavity of the seat cushion cover half of the heated seat cushion wire harness connector. The sensor resistance should be between 1 Kohm and 200 Kohms. If OK, see Heated Seat Relay in the Diagnosis and Testing section of this group. If not OK, replace the faulty seat cushion cover.

HEATED SEAT RELAY

For circuit descriptions and diagrams, refer to 8W - 63 - Power Seat With Heated Seats in Group 8W - Wiring Diagrams.

(1) Disconnect and isolate the battery negative cable. Unplug the 8-way heated seat relay connector.

(2) Check for continuity between the ground circuit cavity of the 8-way heated seat relay wire harness connector and a good ground. There should be continuity. If OK, go to Step 3. If not OK, repair the open circuit as required.

(3) Connect the battery negative cable. Check for battery voltage at the battery feed circuit cavity (pin 8) of the 8-way heated seat relay wire harness connector. If OK, go to Step 4. If not OK, repair the open circuit as required.

(4) Turn the ignition switch to the ON position. Check for battery voltage at the fused ignition switch output circuit cavity of the 8-way heated seat relay wire harness connector. If OK, turn the ignition switch to the OFF position, disconnect and isolate the battery negative cable, and go to Step 5. If not OK, repair the open circuit as required.

(5) Unplug the 14-way seat heat interface module (SHIM) connector. Check for continuity between the two switched battery feed cavities of the 14-way SHIM wire harness connector and the switched battery feed cavity of the 8-way heated seat relay wire harness connector. If OK, reconnect the heated seat relay wire harness connector, and go to Step 6. If not OK, repair the open circuit as required.

(6) Connect the battery negative cable. Turn the ignition switch to the ON position. Check for battery voltage at the switched battery feed cavities of the 14-way SHIM wire harness connector. If OK, turn the ignition switch to the OFF position, disconnect and isolate the battery negative cable, and see Seat Heat Interface Module in the diagnosis and testing section of this group. If not OK, replace the heated seat relay.

DIAGNOSIS AND TESTING (Continued)

SEAT HEAT INTERFACE MODULE

Before testing the seat heat interface module, test the heated seat switch, the heated seat elements, and the heated seat sensor as described in the Diagnosis and Testing section of this group. If testing of the heated seat switch, elements, and sensor reveals no problems, proceed as follows. For circuit descriptions and diagrams, refer to 8W - 63 - Power Seat With Heated Seats in Group 8W - Wiring Diagrams.

(1) Replace the seat heat interface module with a known good unit and test the operation of the heated seats. If OK, discard the faulty seat heat interface module. If not OK, go to Step 2.

(2) Test each of the circuits from the heated seat switch, heated seat relay, heated seat elements, and heated seat sensor to the seat heat interface module. Repair any short or open circuits as required.

REMOVAL AND INSTALLATION**HEATED SEAT SWITCH**

WARNING: ON VEHICLES EQUIPPED WITH AIR-BAGS, REFER TO GROUP 8M - PASSIVE RESTRAINT SYSTEMS BEFORE ATTEMPTING ANY STEERING WHEEL, STEERING COLUMN, OR INSTRUMENT PANEL COMPONENT DIAGNOSIS OR SERVICE. FAILURE TO TAKE THE PROPER PRECAUTIONS COULD RESULT IN ACCIDENTAL AIR-BAG DEPLOYMENT AND POSSIBLE PERSONAL INJURY.

(1) Disconnect and isolate the battery negative cable.

(2) Using a trim stick or another suitable wide flat-bladed tool, gently pry around the perimeter edges of the heated switch assembly bezel to release the assembly from the console. Remove the assembly from the console.

(3) Pull the switch assembly out from the console far enough to access and unplug the wire harness connectors.

(4) Remove the heated seat switch assembly from the console.

(5) Remove the heated seat switch(es) from the heated seat switch assembly.

(6) Reverse the removal procedures to install.

SEAT HEAT INTERFACE MODULE

(1) Move the right power seat adjuster to its full up and full rear stop positions.

(2) Disconnect and isolate the battery negative cable.

(3) Unhook the seat cushion cover retainer from the seat cushion frame and pull back the seat cushion cover.

(4) Pull back the seat cushion to allow access to the Seat Heat Interface Module (SHIM).

(5) Pull the SHIM upward to release the two mounting fasteners from either the module or the mounting bracket. Unplug the wire harness connector from the module (Fig. 2).

WARNING: THERE ARE MANY SHARP METAL EDGES ON THE SEAT CUSHION FRAME AND SEAT ADJUSTER RAILS UNDER THE SEAT. WHEN PERFORMING THIS SERVICE, A LONG-SLEEVED SHIRT AND GLOVES SHOULD BE WORN IN ORDER TO AVOID UNNECESSARY CUTS AND ABRASIONS TO EXPOSED SKIN.

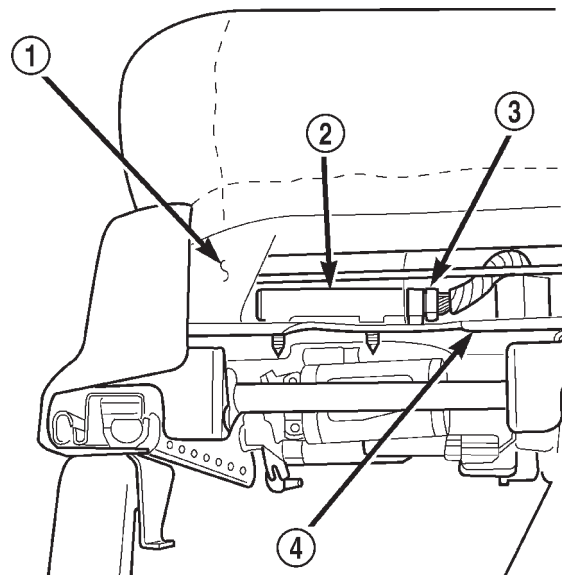

80bcea01

Fig. 2 Seat Heat Interface Module Remove/Install

- 1 - SEAT CUSHION FRAME
- 2 - SEAT HEAT INTERFACE MODULE
- 3 - WIRE HARNESS CONNECTOR
- 4 - POWER SEAT TRACK FRONT BRACKET

(6) Reverse the removal procedures to install. Be certain that the SHIM terminals are aligned with the cavities in the wire harness connector before pushing the module firmly into place.

HEATED SEAT RELAY

(1) Move the right power seat adjuster to its full up and full rear stop positions.

(2) Disconnect and isolate the battery negative cable.

(3) Unhook the seat cushion cover retainer from the seat cushion frame and pull back the seat cushion cover.

(4) Pull back the seat cushion to allow access to the Heated Seat Relay.

REMOVAL AND INSTALLATION (Continued)

(5) Cut the Christmas tree fastener to remove the Heated Seat Relay fastener from the mounting bracket. Unplug the wire harness connector from the relay (Fig. 3).

(6) Reverse the removal procedures to install. A new Christmas tree fastener must be used to mount the relay. Be certain that the relay terminals are aligned with the cavities in the wire harness connector before pushing the relay firmly into place.

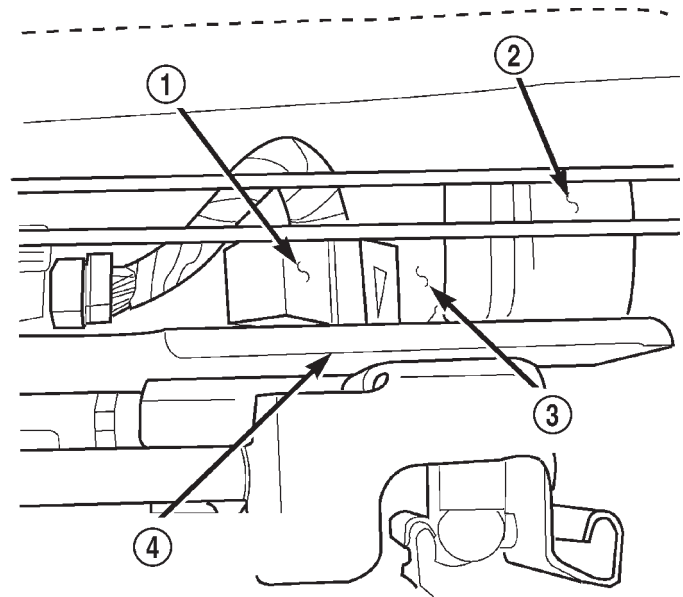

80bcea00

Fig. 3 Heated Seat Relay Remove/Install

- 1 - HEATED SEAT RELAY
- 2 - SEAT CUSHION FRAME
- 3 - WIRE HARNESS CONNECTOR
- 4 - POWER SEAT TRACK FRONT BRACKET

POWER DISTRIBUTION SYSTEMS

TABLE OF CONTENTS

| | page | | page |
|------------------------------------|------|--------------------------------------|------|
| DESCRIPTION AND OPERATION | | IGNITION-OFF DRAW FUSE | 5 |
| POWER DISTRIBUTION SYSTEM. | 1 | JUNCTION BLOCK | 6 |
| POWER DISTRIBUTION CENTER. | 2 | DISASSEMBLY AND ASSEMBLY | |
| IGNITION-OFF DRAW FUSE | 2 | POWER DISTRIBUTION CENTER. | 7 |
| JUNCTION BLOCK | 3 | SPECIAL TOOLS | |
| REMOVAL AND INSTALLATION | | POWER DISTRIBUTION SYSTEMS | 10 |
| POWER DISTRIBUTION CENTER. | 4 | | |

DESCRIPTION AND OPERATION

POWER DISTRIBUTION SYSTEM

DESCRIPTION

This group covers the various standard and optional power distribution components used on this model. The power distribution system for this vehicle consists of the following components:

- Power Distribution Center (PDC)
- Junction Block (JB).

The power distribution system also incorporates various types of circuit control and protection features, including:

- Automatic resetting circuit breakers
- Blade-type fuses
- Maxi fuse-type fusible links
- Relays.

Following are general descriptions of the major components in the power distribution system. See the owner's manual in the vehicle glove box for more information on the features and use of all of the power distribution system components. Refer to the index in this service manual for the location of complete circuit diagrams for the various power distribution system components.

NOTE: This group covers both Left-Hand Drive (LHD) and Right-Hand Drive (RHD) versions of this model. Whenever required and feasible, the RHD versions of affected vehicle components have been constructed as mirror-image of the LHD versions. While most of the illustrations used in this group represent only the LHD version, the diagnostic and service procedures outlined can generally be applied to either version. Exceptions to this rule have been clearly identified as LHD or RHD, if a special illustration or procedure is required.

OPERATION

The power distribution system for this vehicle is designed to provide safe, reliable, and centralized distribution points for the electrical current required to operate all of the many standard and optional factory-installed electrical and electronic powertrain, chassis, safety, security, comfort and convenience systems. At the same time, the power distribution system was designed to provide ready access to these electrical distribution points for the vehicle technician to use when conducting diagnosis and repair of faulty circuits. The power distribution system can also prove useful for the sourcing of additional electrical circuits that may be required to provide the electrical current needed to operate many accessories that the vehicle owner may choose to have installed in the aftermarket.

DESCRIPTION AND OPERATION (Continued)

POWER DISTRIBUTION CENTER

DESCRIPTION

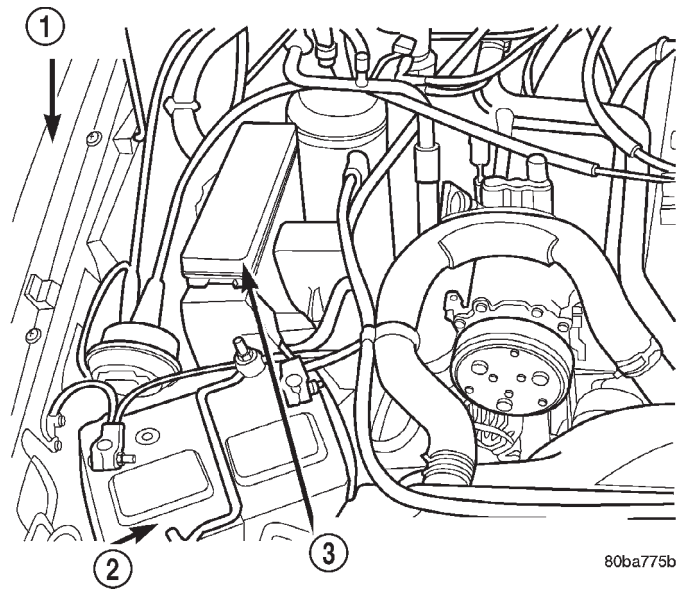

Fig. 1 Power Distribution Center Location

- 1 - LEFT FENDER
- 2 - BATTERY
- 3 - POWER DISTRIBUTION CENTER

All of the electrical current distributed throughout this vehicle is directed through the standard equipment Power Distribution Center (PDC) (Fig. 1). The molded plastic PDC housing is located on the right side of the engine compartment, just behind the battery. The PDC houses up to fourteen blade-type maxi fuses, which replace all in-line fusible links. The PDC also houses up to twelve blade-type mini fuses, and up to eight International Standards Organization (ISO) relays (four standard-type and four micro-type).

The PDC housing is secured to a stamped sheet metal bracket in the engine compartment by mounting slots and tabs that are integral to the PDC housing. The PDC mounting bracket is secured with two screws to the right front inner fender shield above the right front wheel house. The PDC housing has a molded plastic cover that includes two integral hinge tabs on the inboard side, and an integral latch on the outboard side. The PDC cover is easily opened or removed for service access and has a convenient fuse and relay layout map integral to the inside surface of the cover to ensure proper component identification. A separate molded plastic B(+) terminal stud cover is secured by two integral tabs and a latch to one end of the PDC housing.

The PDC cover, the PDC housing lower cover, the PDC B(+) terminal stud cover, the PDC relay wedges and the PDC relay cassettes are available for service

replacement. The PDC main housing unit, the fuse wedges, the fuse cassette and the bus bars cannot be repaired and are only serviced as a unit with the headlamp and dash wire harness. If the PDC main housing unit, fuse wedges, fuse cassette or the bus bars are faulty or damaged, the headlamp and dash wire harness unit must be replaced.

OPERATION

All of the current from the battery and the generator output enters the PDC through two cables and eyelets that are secured with a nut to the PDC B(+) terminal stud located on one end of the PDC housing. The PDC B(+) terminal stud cover is unlatched and removed to access the battery and generator output connection B(+) terminal stud. The PDC cover is unlatched and opened or removed to access the fuses or relays. Internal connection of all of the PDC circuits is accomplished by an intricate combination of hard wiring and bus bars. Refer to **Power Distribution** in the index of this service manual for the location of complete PDC circuit diagrams.

IGNITION-OFF DRAW FUSE

DESCRIPTION

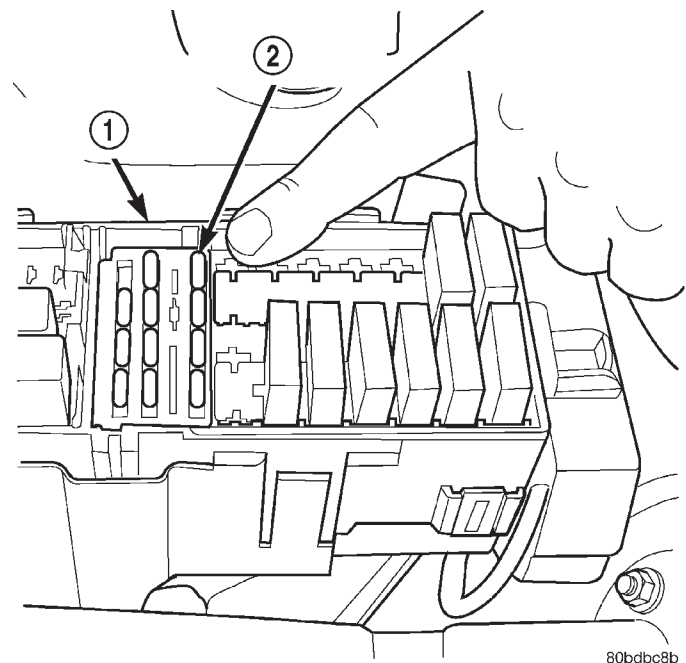

Fig. 2 Ignition-Off Draw Fuse

- 1 - POWER DISTRIBUTION CENTER
- 2 - IGNITION-OFF DRAW FUSE

All vehicles are equipped with an Ignition-Off Draw (IOD) fuse (Fig. 2) that is removed from its cavity in the Power Distribution Center (PDC) when the vehicle is shipped from the factory. Dealer per-

DESCRIPTION AND OPERATION (Continued)

sonnel are to remove the IOD fuse from the storage location and install it into PDC fuse cavity 16 as part of the preparation procedures performed just prior to new vehicle delivery.

The PDC has a molded plastic cover that can be removed to provide service access to all of the fuses and relays in the PDC. An integral latch and hinge tabs are molded into the PDC cover for easy removal. A fuse layout map is integral to the underside of the PDC cover to ensure proper fuse and relay identification. The IOD fuse is a 15 ampere mini blade-type fuse and, when removed, it is stored in a plastic fuse holder formation that is molded into the underside of the PDC cover.

OPERATION

The term ignition-off draw identifies a normal condition where power is being drained from the battery with the ignition switch in the Off position. The IOD fuse feeds the memory and sleep mode functions for many of the electronic modules in the vehicle as well as various other accessories that require battery current when the ignition switch is in the Off position, including the clock. The only reason the IOD fuse is removed is to reduce the normal IOD of the vehicle electrical system during new vehicle transportation and pre-delivery storage to reduce battery depletion, while still allowing vehicle operation so that the vehicle can be loaded, unloaded and moved as needed by both vehicle transportation company and dealer personnel.

The IOD fuse is removed from PDC fuse cavity 16 when the vehicle is shipped from the assembly plant. Dealer personnel must install the IOD fuse when the vehicle is being prepared for delivery in order to restore full electrical system operation. Once the vehicle is prepared for delivery, the IOD function of this fuse becomes transparent and the fuse that has been assigned the IOD designation becomes only another Fused B(+) circuit fuse. The IOD fuse serves no useful purpose to the dealer technician in the service or diagnosis of any vehicle system or condition, other than the same purpose as that of any other standard circuit protection device.

The IOD fuse can be used by the vehicle owner as a convenient means of reducing battery depletion when a vehicle is to be stored for periods not to exceed about thirty days. However, it must be remembered that removing the IOD fuse will not eliminate IOD, but only reduce this normal condition. If a vehicle will be stored for more than about thirty days, the battery negative cable should be disconnected to eliminate normal IOD; and, the battery should be tested and recharged at regular intervals during the vehicle storage period to prevent the battery from becoming discharged or damaged. Refer to

Battery in the index of this service manual for the location of additional service information covering the battery.

JUNCTION BLOCK

DESCRIPTION

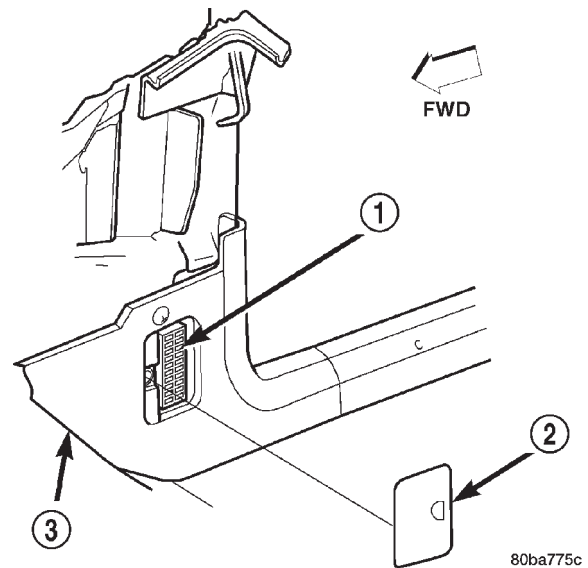

Fig. 3 Junction Block Location

- 1 - JUNCTION BLOCK
- 2 - FUSE ACCESS PANEL
- 3 - RIGHT COWL SIDE INNER TRIM PANEL

An electrical Junction Block (JB) is concealed behind the right cowl side inner trim panel in the passenger compartment of the vehicle (Fig. 3). The JB combines the functions previously provided by a separate fuseblock module and relay center. The JB serves to simplify and centralize numerous electrical components, as well as to distribute electrical current to many of the accessory systems in the vehicle. It also eliminates the need for numerous splice connections and serves in place of a bulkhead connector between many of the engine compartment, instrument panel, and body wire harnesses. The JB houses up to twenty-seven blade-type fuses (three standard-type and twenty-four mini-type), up to three blade-type automatic resetting circuit breakers, and four International Standards Organization (ISO) relays (three standard-type and one micro-type).

The molded plastic JB housing has integral mounting brackets that are secured with three nuts to studs on the right cowl side inner panel below the instrument panel. The right cowl side inner trim panel is secured to a stud on the JB with a push nut. A snap-fit fuse access panel can be removed for service of the JB fuses and also conceals the push nut. A finger recess is molded into the front of the fuse

DESCRIPTION AND OPERATION (Continued)

access panel for easy removal, and a fuse puller and spare fuse holders are located on the back of the fuse access panel.

The JB unit cannot be repaired and is only serviced as an assembly. If any internal circuit or the JB housing is faulty or damaged, the entire JB unit must be replaced.

OPERATION

All of the circuits entering and leaving the JB do so through up to ten wire harness connectors, which are connected to the JB through integral connector receptacles molded into the JB housing. Internal connection of all of the JB circuits is accomplished by an intricate combination of hard wiring and bus bars. Refer to **Junction Block** in the index of this service manual for the location of complete JB circuit diagrams.

REMOVAL AND INSTALLATION

POWER DISTRIBUTION CENTER

The Power Distribution Center (PDC) main housing unit, the PDC fuse wedges, the PDC fuse cassette and the PDC bus bars cannot be repaired and are only serviced as a unit with the headlamp and dash wire harness. If the PDC main housing unit, the fuse wedge, the fuse cassette or the bus bars are faulty or damaged, the entire PDC and headlamp and dash wire harness unit must be replaced.

REMOVAL

(1) Disconnect and isolate the battery negative cable.

(2) Disconnect each of the headlamp and dash wire harness connectors. Refer to **Connector Locations** in the index of this service manual for the location of more information on the headlamp and dash wire harness connector locations.

(3) Remove all of the fasteners that secure each of the headlamp and dash wire harness ground eyelets to the vehicle body and chassis components. Refer to **Connector Locations** in the index of this service manual for the location of more information on the ground eyelet locations.

(4) Disengage each of the retainers that secure the headlamp and dash wire harness to the vehicle body and chassis components. Refer to **Connector Locations** in the index of this service manual for the location of more information on the headlamp and dash wire harness retainer locations.

(5) Unlatch and remove the B(+) terminal stud cover from the end of the PDC (Fig. 4).

(6) Remove the nut that secures the eyelets of the battery wire harness PDC take outs to the PDC B(+) terminal stud.

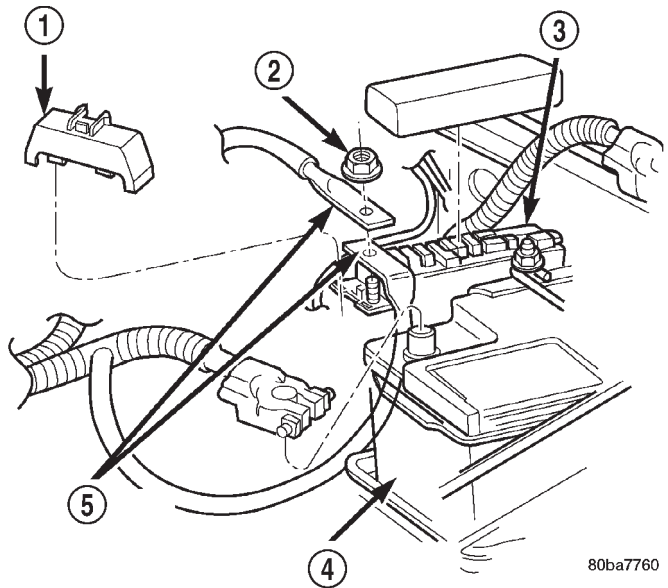

Fig. 4 Power Distribution Center Connections

- 1 - COVER
- 2 - NUT
- 3 - POWER DISTRIBUTION CENTER
- 4 - BATTERY
- 5 - BATTERY WIRE HARNESS PDC TAKE-OUTS

(7) Remove the battery wire harness PDC take out eyelets from the B(+) terminal stud.

(8) Disengage the latches on the PDC mounting bracket from the tabs on the PDC housing, and pull the PDC housing upward to disengage the mounting slots from the stanchions of the mounting bracket (Fig. 5).

(9) Remove the PDC and the headlamp and dash wire harness from the engine compartment as a unit.

(10) Remove the two screws that secure the PDC mounting bracket to the right front inner fender (Fig. 6).

(11) Remove the PDC mounting bracket from the right front inner fender.

INSTALLATION

NOTE: If the PDC is being replaced with a new unit, be certain to transfer each of the fuses and relays from the faulty PDC to the proper cavities of the replacement PDC. Refer to **Power Distribution** in the index of this service manual for the location of complete PDC circuit diagrams and cavity assignments.

(1) Position the PDC mounting bracket onto the right front inner fender.

(2) Install and tighten the two screws that secure the PDC mounting bracket to the right front inner fender. Tighten the screws to 8.1 N·m (72 in. lbs.).

REMOVAL AND INSTALLATION (Continued)

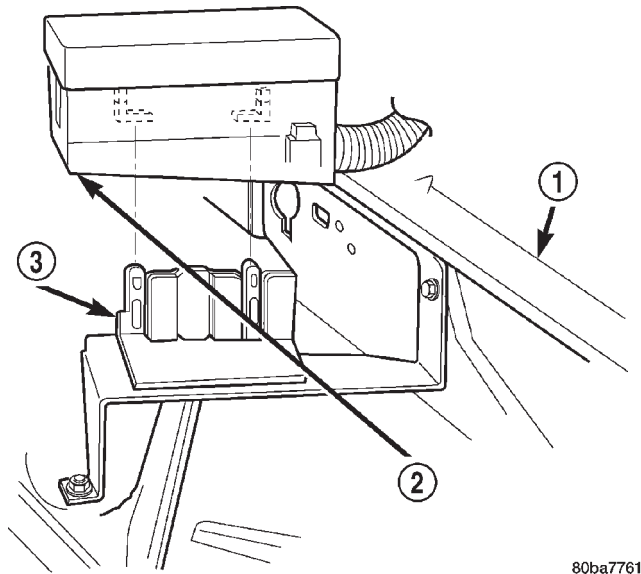

80ba7761

Fig. 5 Power Distribution Center Remove/Install

- 1 - RIGHT FENDER
- 2 - POWER DISTRIBUTION CENTER
- 3 - BRACKET

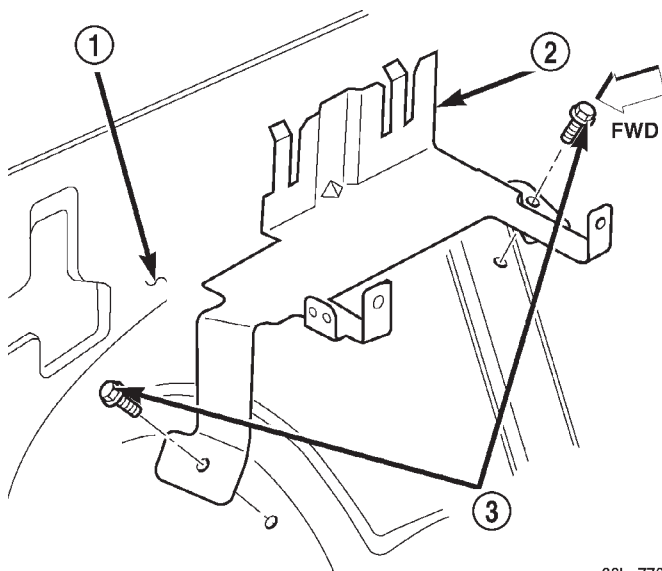

80ba7763

Fig. 6 PDC Mounting Bracket Remove/Install

- 1 - RIGHT FRONT INNER FENDER
- 2 - PDC MOUNTING BRACKET
- 3 - SCREW

(3) Position the PDC and the headlamp and dash wire harness unit in the engine compartment.

(4) Engage the mounting slots on the PDC housing with the stanchions of the PDC mounting bracket and push the unit downward until the mounting bracket latches engage the mounting tabs on the PDC housing.

(5) Install the eyelets of the battery wire harness PDC take outs onto the PDC B(+) terminal stud.

(6) Install and tighten the nut that secures the eyelet of the battery wire harness PDC take outs to the B(+) terminal stud. Tighten the nut to 10.8 N·m (95 in. lbs.).

(7) Engage the tabs on the lower edge of the B(+) terminal stud cover in the slots on the PDC housing, then engage the latch on the top of the cover with the latch receptacle on the PDC housing.

(8) Engage each of the retainers that secure the headlamp and dash wire harness to the vehicle body and chassis components. Refer to **Connector Locations** in the index of this service manual for the location of more information on the headlamp and dash wire harness retainer locations.

(9) Install all of the fasteners that secure each of the headlamp and dash wire harness ground eyelets to the vehicle body and chassis components. Refer to **Connector Locations** in the index of this service manual for the location of more information on the ground eyelet locations.

(10) Reconnect each of the headlamp and dash wire harness connectors. Refer to **Connector Locations** in the index of this service manual for the location of more information on the headlamp and dash wire harness connector locations.

(11) Reconnect the battery negative cable.

IGNITION-OFF DRAW FUSE

The Ignition-Off Draw (IOD) fuse is removed from Power Distribution Center (PDC) fuse cavity 16 (Fig. 7) when the vehicle is shipped from the assembly plant. Dealer personnel must install the IOD fuse when the vehicle is being prepared for delivery in order to restore full electrical system operation.

NOTE: When removing or installing the IOD fuse, it is important that the ignition switch be in the Off position. Failure to place the ignition switch in the Off position can cause the radio display to become scrambled when the IOD fuse is installed. Removing and installing the IOD fuse again with the ignition switch in the Off position will usually correct the scrambled radio display condition.

REMOVAL

(1) Turn the ignition switch to the Off position.
 (2) Unlatch and remove the cover from the PDC.
 (3) Remove the IOD fuse from fuse cavity 16 of the PDC.

(4) Store the removed IOD fuse by inserting the terminal blades of the fuse into the plastic fuse holder formation that is molded into the underside of the PDC cover.

(5) Install and latch the cover onto the PDC.

REMOVAL AND INSTALLATION (Continued)

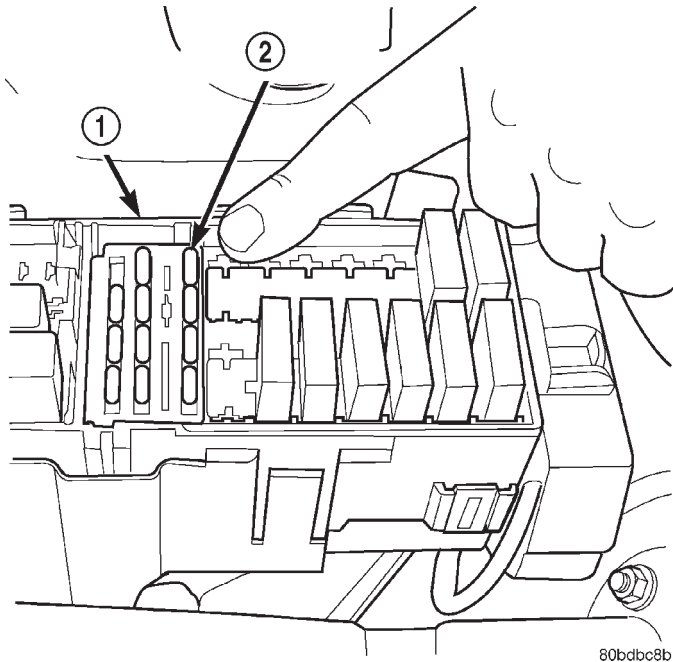

Fig. 7 Ignition-Off Draw Fuse

- 1 - POWER DISTRIBUTION CENTER
2 - IGNITION-OFF DRAW FUSE

INSTALLATION

- (1) Turn the ignition switch to the Off position.
- (2) Unlatch and remove the cover from the PDC.
- (3) Remove the stored IOD fuse from the plastic fuse holder formation that is molded into the underside of the PDC cover.
- (4) Align the terminal blades of the IOD fuse with the terminal receptacles in fuse cavity 16 of the PDC.
- (5) Use a thumb to press the IOD fuse firmly down into PDC fuse cavity 16.
- (6) Install and latch the cover onto the PDC.

JUNCTION BLOCK

WARNING: ON VEHICLES EQUIPPED WITH AIRBAGS, DISABLE THE AIRBAG SYSTEM BEFORE ATTEMPTING ANY STEERING WHEEL, STEERING COLUMN, OR INSTRUMENT PANEL COMPONENT DIAGNOSIS OR SERVICE. DISCONNECT AND ISOLATE THE BATTERY NEGATIVE (GROUND) CABLE, THEN WAIT TWO MINUTES FOR THE AIRBAG SYSTEM CAPACITOR TO DISCHARGE BEFORE PERFORMING FURTHER DIAGNOSIS OR SERVICE. THIS IS THE ONLY SURE WAY TO DISABLE THE AIRBAG SYSTEM. FAILURE TO TAKE THE PROPER PRECAUTIONS COULD RESULT IN ACCIDENTAL AIRBAG DEPLOYMENT AND POSSIBLE PERSONAL INJURY.

REMOVAL

- (1) Disconnect and isolate the battery negative cable.
- (2) Remove the fuse access panel by unsnapping it from the right cowl side inner trim panel (Fig. 8).

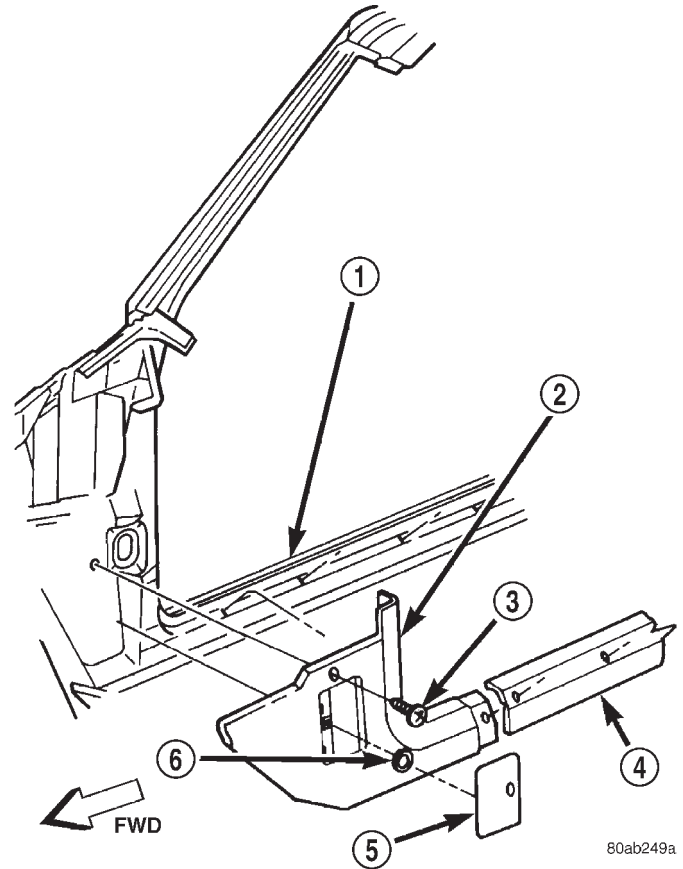

Fig. 8 Right Cowl Side Inner Trim Remove/Install

- 1 - RIGHT FRONT DOOR SILL
2 - COWL SIDE TRIM PANEL
3 - SCREW
4 - SILL TRIM
5 - FUSE ACCESS PANEL
6 - PUSH-NUT

(3) Remove the push nut that secures the right cowl side inner trim panel to the mounting stud on the Junction Block (JB).

(4) Remove the screw located above the fuse access opening that secures the trim panel to the right cowl side inner panel.

(5) Remove the screw that secures the right cowl side inner trim panel and right front door sill trim to the door opening sill.

(6) Remove the trim from the right cowl side inner panel.

(7) Remove the screw that secures the lower instrument panel wire harness connector to the JB.

(8) Disconnect all of the wire harness connectors from the connector receptacles on the JB.

REMOVAL AND INSTALLATION (Continued)

(9) Remove the three nuts that secure the JB to the mounting studs on the right cowl side inner panel (Fig. 9).

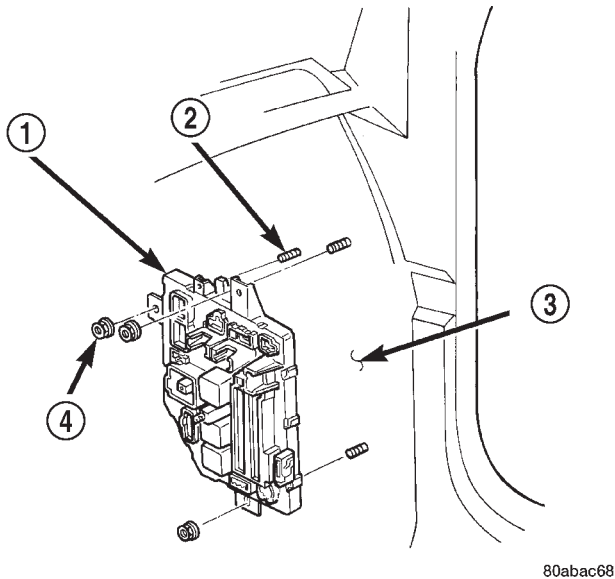

Fig. 9 Junction Block Remove/Install

- 1 - JUNCTION BLOCK
- 2 - STUD
- 3 - RIGHT COWL SIDE INNER PANEL
- 4 - NUT

(10) Remove the JB from the mounting studs on the right cowl side inner panel.

INSTALLATION

NOTE: If the Junction Block (JB) is being replaced with a new unit, be certain to transfer each of the fuses, circuit breakers and relays from the faulty JB to the proper cavities of the replacement JB. Refer to Junction Block in the index of this service manual for the location of complete circuit diagrams and cavity assignments for the JB.

(1) Position the JB onto the mounting studs located on the right cowl side inner panel.

(2) Install and tighten the three nuts that secure the JB to the mounting studs on the right cowl side inner panel. Tighten the nuts to 2.7 N·m (24 in. lbs.).

(3) Reconnect all of the wire harness connectors to the proper connector receptacles on the JB.

(4) Install and tighten the screw that secures the lower instrument panel wire harness connector to the JB connector receptacle. Tighten the screw to 3.5 N·m (31 in. lbs.).

(5) Position the trim onto the right cowl side inner panel.

(6) Install and tighten the screw that secures the right cowl side inner trim panel and right front door

sill trim to the door opening sill. Tighten the screw to 2.2 N·m (20 in. lbs.).

(7) Install and tighten the screw located above the fuse access opening that secures the trim panel to the right cowl side inner panel. Tighten the screw to 2.2 N·m (20 in. lbs.).

(8) Install the push nut that secures the right cowl side inner trim panel to the mounting stud on the JB.

(9) Install the fuse access panel by snapping it onto the right cowl side inner trim panel.

(10) Reconnect the battery negative cable.

DISASSEMBLY AND ASSEMBLY

POWER DISTRIBUTION CENTER

The Power Distribution Center (PDC) cover, the PDC housing lower cover, the PDC relay wedges, the PDC relay cassettes and the PDC B(+) terminal stud cover are available for service replacement (Fig. 10). The PDC cover and B(+) terminal stud cover can be simply unlatched and removed from the PDC housing without the PDC being removed or disassembled. Service of the remaining PDC components requires that the PDC be removed from its mounting and disassembled. Refer to **Wiring Repair** in the index of this service manual for the location of the wiring repair procedures.

DISASSEMBLY

PDC HOUSING LOWER COVER

(1) Disconnect and isolate the battery negative cable.

(2) Unlatch and remove the cover from the PDC.

(3) Unlatch and remove the B(+) terminal stud cover from the PDC.

(4) Remove the nut that secures the two battery wire harness PDC take out eyelets to the B(+) terminal stud of the PDC.

(5) Remove the battery wire harness PDC take out eyelets from the PDC B(+) terminal stud.

(6) Disengage the latches on the PDC mounting bracket from the tabs on the PDC housing, and pull the PDC housing upward to disengage the mounting slots from the stanchions of the mounting bracket.

(7) Using a trim stick or another suitable wide flat-bladed tool, gently pry the latches on each side and one end of the PDC housing that secure the housing lower cover to the PDC and remove the housing lower cover (Fig. 11).

PDC RELAY WEDGE

(1) Remove the PDC housing lower cover.

(2) Remove each of the relays from the PDC relay wedge to be removed.

DISASSEMBLY AND ASSEMBLY (Continued)

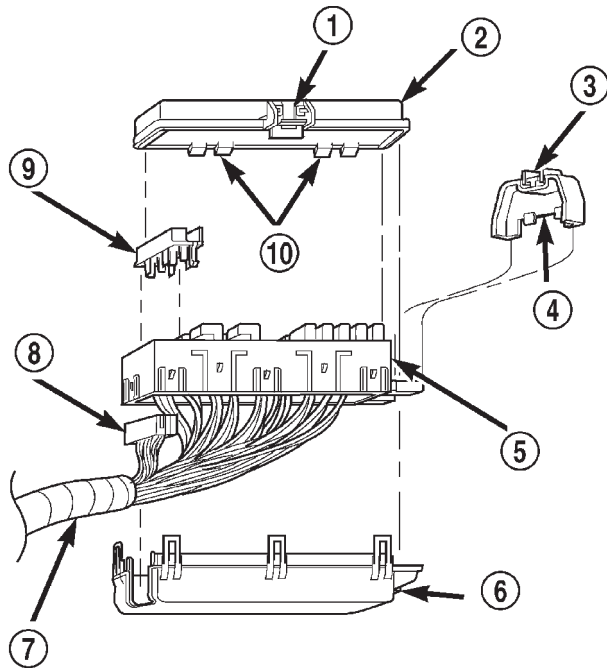

80be454E

Fig. 10 Power Distribution Center Components

- 1 - LATCH
- 2 - COVER
- 3 - LATCH
- 4 - B(+) TERMINAL STUD COVER
- 5 - PDC HOUSING
- 6 - HOUSING LOWER COVER (TYPICAL)
- 7 - WIRE HARNESS
- 8 - RELAY CASSETTE (TYPICAL)
- 9 - RELAY WEDGE (TYPICAL)
- 10 - HINGE TABS

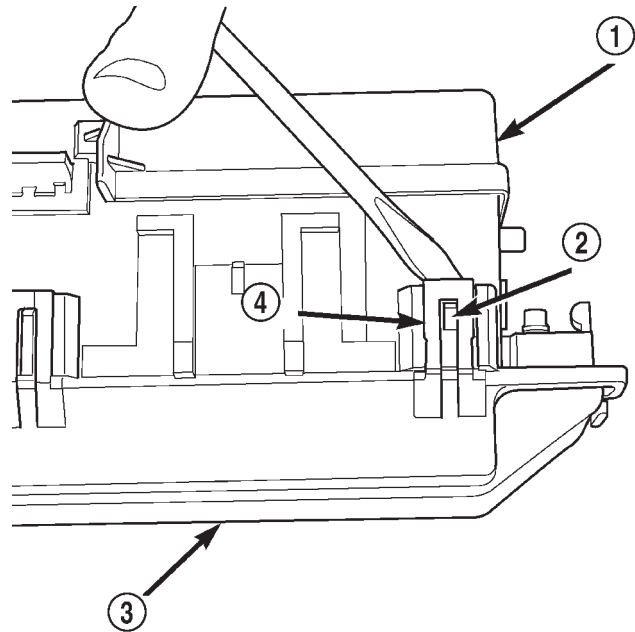

80be4560

Fig. 11 PDC Housing Lower Cover Remove/Install

- 1 - PDC HOUSING
- 2 - TAB
- 3 - PDC HOUSING LOWER COVER
- 4 - LATCH

(3) From the bottom of the PDC housing, use a small screwdriver or a terminal pick tool (Special Tool Kit 6680) to release the two latches (yellow) that secure the relay wedge to the PDC relay cassette.

(4) From the top of the PDC housing, remove the relay wedge from the PDC relay cassette (Fig. 12).

PDC RELAY CASSETTE

(1) Remove the relay wedge from the PDC relay cassette to be removed.

NOTE: It may be necessary to remove relay cassettes that are not being serviced from the PDC housing in order to obtain sufficient clearance to service the faulty relay cassette. The same service procedure is repeated as necessary to remove each of the interfering relay wedges and relay cassettes from the PDC housing.

(2) From the top of the PDC housing, use a small screwdriver or a terminal pick tool (Special Tool Kit 6680) to release the two latches that secure the relay cassette in the PDC (Fig. 13).

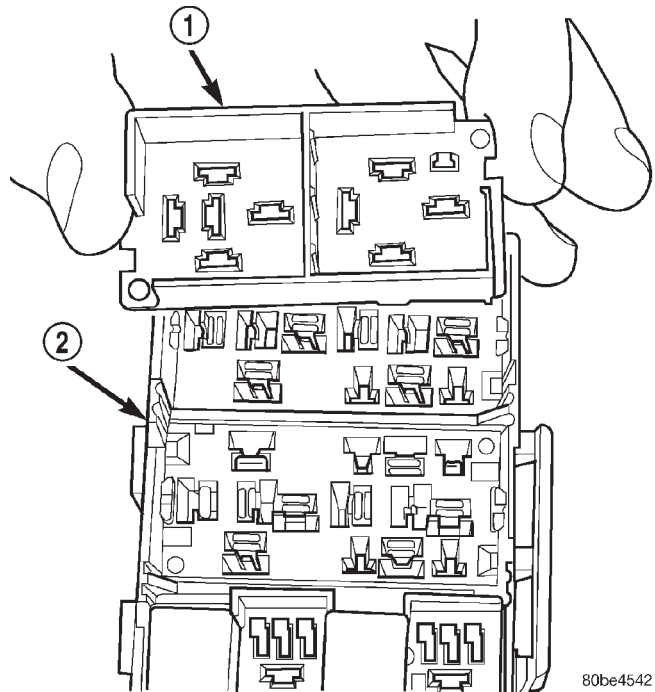

80be4542

Fig. 12 PDC Relay Wedge Remove/Install

- 1 - RELAY WEDGE (TYPICAL)
- 2 - PDC HOUSING

(3) Gently and evenly press the relay cassette down through the PDC housing.

DISASSEMBLY AND ASSEMBLY (Continued)

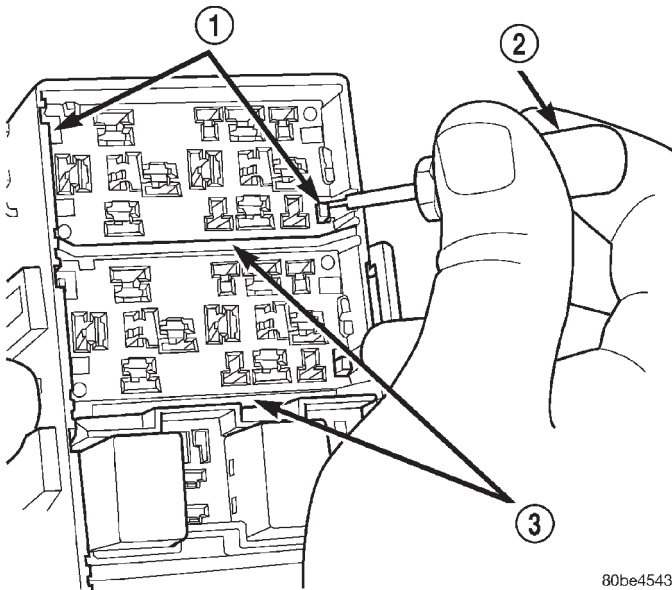

Fig. 13 PDC Relay Cassette Latches

- 1 - LATCHES
 2 - FROM SPECIAL TOOL KIT 6680
 3 - PDC RELAY CASSETTES (TYPICAL)

80be4543

(4) From the bottom of the PDC housing, remove the relay cassette from the PDC (Fig. 14).

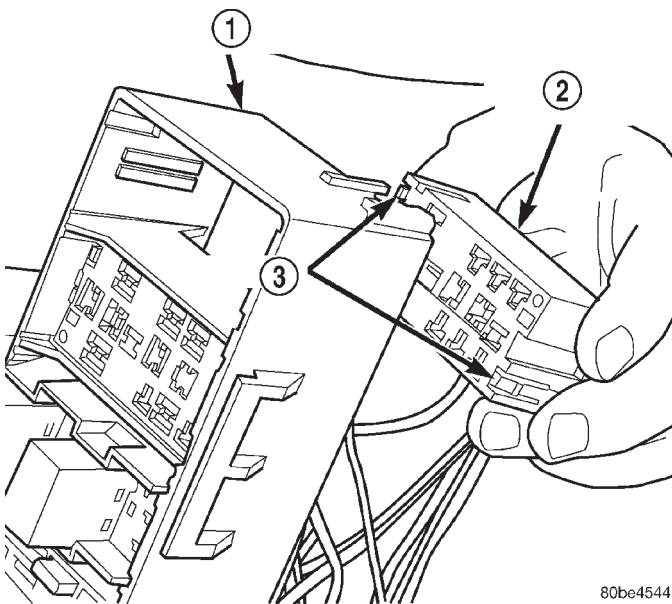

Fig. 14 PDC Relay Cassette Remove/Install

- 1 - PDC HOUSING
 2 - PDC RELAY CASSETTE (TYPICAL)
 3 - LATCHES

80be4544

CAUTION: Do not remove the wiring and terminals from the terminal cavities of the faulty PDC relay cassette at this time. Refer to the Assembly procedure that follows for the proper procedures for transferring the wiring and terminals to the replacement PDC relay cassette.

ASSEMBLY

PDC RELAY CASSETTE

(1) Move the faulty PDC relay cassette with its wiring away from the bottom of the PDC housing far enough to allow the replacement relay cassette to be installed into the PDC.

(2) Using the faulty relay cassette as a guide, be certain that the replacement relay cassette is correctly oriented before installing it into the PDC housing.

(3) From the bottom of the PDC housing, align and insert the replacement relay cassette into the PDC. Press the relay cassette up into the PDC until both of the latches are fully engaged.

CAUTION: Proper care must be taken to be certain that the wiring and terminals from the faulty PDC relay cassette are installed in the correct terminal cavities of the replacement relay cassette. To prevent mistakes it is recommended that the wiring and terminals be removed from the faulty relay cassette one cavity at a time, repaired or spliced as necessary, then installed securely into the correct cavity of the replacement relay cassette. If you are not absolutely certain into which cavity a terminal should be installed, refer to Power Distribution in the index of this service manual for the location of complete circuit diagrams covering the PDC.

(4) While pulling gently on the wire from the bottom of the faulty PDC relay cassette, use a terminal pick tool (Special Tool Kit 6680) from the top of the relay cassette to release the latch that secures the terminal in the relay cassette terminal cavity (Fig. 15).

(5) From the bottom of the faulty PDC relay cassette, remove the wire and terminal from the relay cassette terminal cavity.

(6) Make all necessary repairs and splices to the wire for the removed terminal. Refer to **Wiring Repair** in the index of this service manual for the location of the wiring repair procedures.

(7) From the bottom of the PDC housing, align and insert the removed wire and terminal into the correct terminal cavity of the replacement relay cassette. Push the wire and terminal up into the relay cassette terminal cavity until it is fully engaged by the latch.

(8) Repeat Step 4, Step 5, Step 6 and Step 7 one wire and terminal at a time until each of the wires and terminals have been transferred from the faulty PDC relay cassette into the replacement relay cassette.

(9) Install the PDC relay wedge into the replacement PDC relay cassette.

DISASSEMBLY AND ASSEMBLY (Continued)

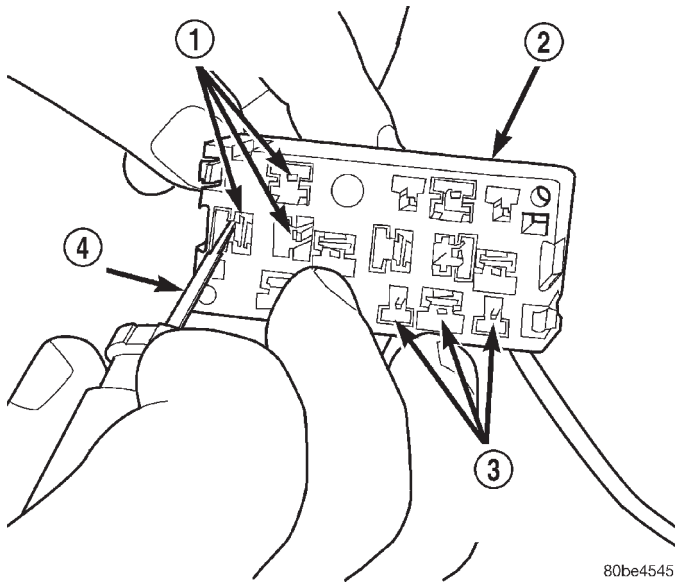

Fig. 15 PDC Relay Cassette Terminal Remove/Install

- 1 - TERMINAL CAVITIES (TYPICAL)
- 2 - PDC RELAY CASSETTE (TYPICAL)
- 3 - TERMINAL LATCHES (TYPICAL)
- 4 - FROM SPECIAL TOOL KIT 6680

PDC RELAY WEDGE

(1) From the top of the PDC housing, align and insert the PDC relay wedge latch arms into the correct cavities in the relay cassette.

(2) Gently and evenly press the PDC relay wedge down into the relay cassette until both of the latches are fully engaged.

(3) Install each of the removed relays into the proper cavities of the PDC relay wedge.

(4) Install the PDC housing lower cover.

PDC HOUSING LOWER COVER

(1) Align the PDC housing lower cover to the bottom of the PDC.

(2) Press the PDC housing lower cover gently and evenly onto the PDC until each of the latches that secure the cover to the PDC is fully engaged.

(3) Engage the mounting slots on the PDC housing with the stanchions of the PDC mounting bracket and push the unit downward until the mounting bracket latches fully engage the mounting tabs on the PDC housing.

(4) Install the battery wire harness PDC take out eyelets over the PDC B(+) terminal stud.

(5) Install and tighten the nut that secures the eyelets of the battery wire harness PDC take outs to the B(+) terminal stud. Tighten the nut to 10.8 N·m (95 in. lbs.).

(6) Install the B(+) terminal stud cover onto the PDC.

(7) Install the cover onto the PDC.

(8) Reconnect the battery negative cable.

SPECIAL TOOLS

POWER DISTRIBUTION SYSTEMS

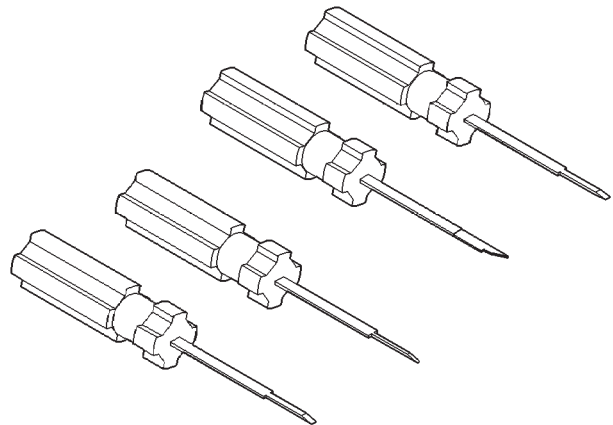

Terminal Pick Kit 6680

POWER LOCK SYSTEMS

TABLE OF CONTENTS

| | page | | page |
|--|------|---|------|
| GENERAL INFORMATION | | POWER LOCK MOTOR | 4 |
| INTRODUCTION | 1 | REMOTE KEYLESS ENTRY TRANSMITTER | 5 |
| POWER LOCK SYSTEM | 1 | REMOTE KEYLESS ENTRY RECEIVER | 5 |
| REMOTE KEYLESS ENTRY SYSTEM | 1 | SERVICE PROCEDURES | |
| DESCRIPTION AND OPERATION | | REMOTE KEYLESS ENTRY TRANSMITTER | |
| POWER LOCK SWITCH | 2 | BATTERY REPLACEMENT | 6 |
| DOOR MODULE | 2 | REMOTE KEYLESS ENTRY TRANSMITTER | |
| POWER LOCK MOTOR..... | 2 | PROGRAMMING | 6 |
| REMOTE KEYLESS ENTRY TRANSMITTER | 2 | REMOTE KEYLESS ENTRY RECEIVER | |
| REMOTE KEYLESS ENTRY RECEIVER..... | 2 | PROGRAMMING | 6 |
| DIAGNOSIS AND TESTING | | REMOVAL AND INSTALLATION | |
| POWER LOCK SYSTEM AND REMOTE | | DOOR MODULE | 7 |
| KEYLESS ENTRY SYSTEM | 3 | POWER LOCK MOTOR..... | 7 |
| DOOR MODULE | 3 | REMOTE KEYLESS ENTRY RECEIVER..... | 8 |

GENERAL INFORMATION

INTRODUCTION

Power locks are optional factory-installed equipment on this model. The power window system and the power mirror system are included on vehicles equipped with the power lock option. The Remote Keyless Entry (RKE) system is an additional option available on vehicles equipped with the power lock option. Refer to 8W-61 - Power Door Locks in Group 8W - Wiring Diagrams for complete circuit descriptions and diagrams.

NOTE: This group covers both Left-Hand Drive (LHD) and Right-Hand Drive (RHD) versions of this model. Whenever required and feasible, the RHD versions of affected vehicle components have been constructed as mirror-image of the LHD versions. While most of the illustrations used in this group represent only the LHD version, the diagnostic and service procedures outlined can generally be applied to either version. Exceptions to this rule have been clearly identified as LHD or RHD, if a special illustration or procedure is required.

POWER LOCK SYSTEM

The power lock system allows all of the doors and the liftgate to be locked or unlocked electrically by operating the switch on either front door trim panel. This system operates with battery power supplied

through a fuse in the junction block, independent of the ignition switch.

The power lock system includes a lock inhibit feature, which prevents the doors from being locked by the power lock system if the driver door is open with the key in the ignition switch or with the headlamp switch in the On position. However, the lock inhibit feature will not prevent manual locking of the vehicle using the manual lock buttons or the key cylinders.

The power lock system includes the front door power lock switches integral to the driver and passenger door modules, and the power lock motors mounted in each door and the liftgate. The power lock control circuitry and the power lock and unlock relays are integral to the Passenger Door Module (PDM).

Following are general descriptions of the major components in the power lock system. Refer to the owner's manual in the vehicle glove box for more information on the features, use and operation of the power lock system.

REMOTE KEYLESS ENTRY SYSTEM

The Remote Keyless Entry (RKE) system is a radio frequency system that allows the use of a remote battery-powered radio transmitter to control the power lock system. On vehicles with the RKE option, the power locks can be operated by depressing the Lock or Unlock buttons of the RKE transmitter. The RKE system includes an illuminated entry feature, which turns on the courtesy lamps for a timed interval

GENERAL INFORMATION (Continued)

(about thirty seconds), when the power locks are unlocked using the RKE transmitter.

The RKE system for this vehicle also features a customer programmable horn chirp feature. This feature allows the customer the option of enabling or disabling the horn chirp request that the RKE receiver issues as an audible indication that a valid Lock signal has been received from the RKE transmitter. See Remote Keyless Entry Receiver Programming in this group for more information on this feature.

The RKE system can retain the vehicle access codes of up to four transmitters. The transmitter codes are retained in memory, even if the battery is disconnected. If a transmitter is faulty or lost, new transmitter vehicle access codes can be programmed into the system using a DRB scan tool and the proper Diagnostic Procedures manual.

The RKE system consists of the remote key fob transmitter and a radio receiver with program logic. The RKE receiver is installed in an RKE housing on the headliner of the vehicle, or in the housing of the optional overhead console, depending upon how the vehicle is equipped.

Following are general descriptions of the major components in the RKE system. Refer to the owner's manual in the vehicle glove box for more information on the features, use and operation of the RKE system.

DESCRIPTION AND OPERATION

POWER LOCK SWITCH

The power locks are controlled by a two-way switch that is integral to the Driver Door Module (DDM) and the Passenger Door Module (PDM) mounted in the trim panel of its respective front door. Each switch is illuminated by a light-emitting diode when the ignition switch is turned to the On position. The power lock switches provide a hard-wired lock or unlock signal to the power lock system control circuitry, which is located in the PDM.

The power lock switches and their lamps cannot be repaired. If the switches are damaged or faulty, the entire PDM or DDM unit must be replaced.

DOOR MODULE

A Driver Door Module (DDM) and a Passenger Door Module (PDM) are used on all models equipped with power locks and power windows. Each door module houses both the front door power lock and power window switches. In addition to the switches for its own door, the DDM houses individual switches for each passenger door power window, a power window lockout switch and the power mirror switch. The

PDM contains the control circuitry and the power lock and unlock relays for the entire power lock system.

In its role as the power lock control module, the PDM receives inputs from the battery, the ignition switch, the DDM, the driver door ajar switch, the key-in ignition switch, and the headlamp switch. It also receives a hard-wired input from the remote Keyless Entry (RKE) receiver, if the vehicle is so equipped. In response to these inputs, the PDM sends the proper outputs to control the power lock motors through its integral power lock and unlock relays.

The DDM and the PDM are mounted to their respective front door trim panels. The DDM and PDM are serviced individually and cannot be repaired. If the DDM or PDM, or any of the switches and circuitry that they contain are faulty or damaged, the complete DDM or PDM unit must be replaced.

POWER LOCK MOTOR

In the power lock and Remote Keyless Entry (RKE) systems, the locks are actuated by a reversible electric motor mounted within each door and the lift-gate. The power lock motor direction is controlled by the battery and ground feeds from the power lock and unlock relays integral to the Passenger Door Module (PDM).

The power lock motors cannot be repaired and, if faulty or damaged, the entire motor must be replaced.

REMOTE KEYLESS ENTRY TRANSMITTER

The Remote Keyless Entry (RKE) system transmitter is equipped with two buttons, labeled Lock and Unlock. It is also equipped with a key ring and is designed to serve as a key fob. The operating range of the transmitter radio signal is up to 7 meters (23 feet) from the RKE receiver.

Each transmitter has a different vehicle access code, which must be programmed into the memory of the RKE receiver in the vehicle in order to operate the RKE system. See Remote Keyless Entry Transmitter Programming in this group for more information.

The transmitter operates on two Panasonic CR2016 (or equivalent) batteries. Typical battery life is from one to two years. The transmitter cannot be repaired and, if faulty or damaged, it must be replaced.

REMOTE KEYLESS ENTRY RECEIVER

On models with the Remote Keyless Entry (RKE) option, an RKE receiver is mounted in an RKE housing, or in the overhead console housing on the vehicle

DESCRIPTION AND OPERATION (Continued)

headliner. The RKE receiver is a radio frequency unit that also contains the RKE system program logic. The RKE receiver also performs as a smart relay for the illuminated entry feature.

The RKE receiver has a memory function to retain the vehicle access codes of at least one, but no more than four RKE transmitters. The receiver is designed to retain the transmitter codes in memory, even if the battery is disconnected.

The RKE receiver receives inputs from the battery, the driver door ajar switch, and the Chrysler Collision Detection (CCD) data bus. It also receives the radio signal input from the RKE transmitter. In response to those inputs, it is programmed to control outputs to the power lock motors, the courtesy lamp circuits, and the vehicle horn.

The RKE system for this vehicle also features a customer programmable horn chirp feature. This feature allows the customer the option of enabling or disabling the horn chirp request that the RKE receiver issues as an audible indication that a valid Lock signal has been received from the RKE transmitter. See Remote Keyless Entry Receiver Programming in this group for more information on this feature.

The RKE receiver cannot be repaired and, if faulty or damaged, it must be replaced.

DIAGNOSIS AND TESTING

POWER LOCK SYSTEM AND REMOTE KEYLESS ENTRY SYSTEM

On models without the Remote Keyless Entry (RKE) option, proceed directly to the Door Module diagnosis. As a preliminary diagnosis for models with the RKE system, note the power lock system and illuminated entry system operation while you actuate both the Lock and Unlock functions with the power lock switches and the RKE transmitter. Then, proceed as follows:

- If the entire power lock system fails to function with either the power lock switches or the RKE transmitter, unplug the wire harness connector from the RKE receiver and test the power lock system operation again using the power lock switches. If the power lock system now operates, see the Remote Keyless Entry Receiver diagnosis in this group. If the power lock system still fails to operate, see the Door Module diagnosis in this group.

- If the power lock system functions with both power lock switches, but not with the RKE transmitter, see the Remote Keyless Entry Transmitter diagnosis in this group.

- If one power lock motor fails to operate with both of the power lock switches and/or the RKE

transmitter, see the Power Lock Motor diagnosis in this group.

- If the RKE and power lock systems are functioning, but the illuminated entry system fails to operate, see the Remote Keyless Entry Receiver diagnosis in this group.

DOOR MODULE

If the power lock system is inoperative with either front door power lock switch, test the Passenger Door Module (PDM). If the power lock system is inoperative with only the driver side front door power lock switch, test the Driver Door Module (DDM). For circuit descriptions and diagrams, refer to 8W-61 - Power Door Locks in Group 8W - Wiring Diagrams.

DRIVER DOOR MODULE

The only function of the Driver Door Module (DDM) in the power lock system is to provide a Lock or Unlock signal to the power lock system control circuitry contained within the Passenger Door Module (PDM). The DDM signals the PDM by providing a hard-wired ground path through the DDM ground circuit and the driver side power lock switch contacts to the lock request or unlock request terminals of the PDM. The DDM power lock switch function can be tested as follows:

- (1) Disconnect and isolate the battery negative cable. Remove the driver side front door trim panel and unplug the 12-way DDM wire harness connector (C-2) from the DDM. Check for continuity between the ground circuit cavity of the 12-way DDM wire harness connector and a good ground. There should be continuity. If OK, go to Step 2. If not OK, repair the open circuit to ground as required.

- (2) If the problem being diagnosed is inoperative power lock switch illumination, proceed as follows. If the problem is not power lock switch illumination, go to Step 4. Connect the battery negative cable. Turn the ignition switch to the Accessory or On positions. Check for battery voltage at both sides of the power window circuit breaker in the junction block. If OK, go to Step 3. If not OK, replace the faulty circuit breaker.

- (3) With the ignition switch still in the On or Accessory position, check for battery voltage at the fused ignition switch output circuit cavity of the 12-way DDM wire harness connector. If OK, replace the faulty DDM. If not OK, repair the open circuit to the junction block as required.

- (4) Test the power lock switch continuity through the DDM 12-way wire harness connector receptacle. See the DDM Power Lock Switch Continuity chart (Fig. 1) to determine if the continuity is correct in both the Lock and Unlock switch positions. If OK, repair the lock request circuit and/or the unlock

DIAGNOSIS AND TESTING (Continued)

request circuit between the DDM and the PDM as required. If not OK, replace the faulty DDM.

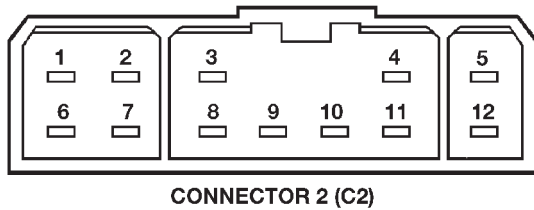

CONNECTOR 2 (C2)

| SWITCH POSITION | CONTINUITY BETWEEN |
|-----------------|--------------------|
| LOCK | 7 & 8 |
| UNLOCK | 11 & 8 |

80abd2c7

Fig. 1 DDM Power Lock Switch Continuity**PASSENGER DOOR MODULE**

The Passenger Door Module (PDM) contains the passenger side front door power lock switch and the power lock system control circuitry. In its role as a power lock switch, it provides the power lock system control circuitry with a ground path through the PDM ground circuit and the driver side power lock switch contacts to indicate a lock request or unlock request.

In its role as the power lock control module, the PDM receives inputs from the battery, the ignition switch, the DDM, the driver door ajar switch, the key-in ignition switch, and the headlamp switch. It also receives a hard-wired input from the RKE receiver, if the vehicle is so equipped. In response to these inputs, the PDM sends the proper outputs to control the power lock motors through its integral power lock and unlock relays. The PDM power lock system functions can be tested as outlined below. If the power lock system operates, but the RKE system lock and/or unlock functions are inoperative, see the diagnosis for the Remote Keyless Entry Transmitter in this group.

(1) Check the fuse in the junction block. If OK, go to Step 2. If not OK, repair the shorted circuit or component as required and replace the faulty fuse.

(2) Disconnect and isolate the battery negative cable. Remove the passenger side front door trim panel and unplug the 8-way PDM wire harness connector (C-1) from the PDM. Check for continuity between the ground circuit cavity of the 8-way PDM wire harness connector and a good ground. There should be continuity. If OK, go to Step 3. If not OK, repair the open circuit to ground as required.

(3) If the problem being diagnosed is inoperative power lock switch illumination, proceed as follows. If the problem is not power lock switch illumination, go

to Step 5. Connect the battery negative cable. Turn the ignition switch to the Accessory or On positions. Check for battery voltage at both sides of the power window circuit breaker in the junction block. If OK, go to Step 4. If not OK, replace the faulty circuit breaker.

(4) With the ignition switch still in the Accessory or On positions, check for battery voltage at the fused ignition switch output circuit cavity of the 8-way PDM wire harness connector. If OK, replace the faulty PDM. If not OK, repair the open circuit to the junction block as required.

(5) If the problem being diagnosed is an inoperative door lock inhibit feature or a power lock system that responds to an Unlock command, but not a Lock command, proceed as follows. Otherwise, go to Step 7. With the driver side front door closed, check for continuity between the door ajar/key-in circuit cavity of the 8-way PDM wire harness connector and a good ground. There should be no continuity. If OK, go to Step 6. If not OK, repair the shorted door ajar and/or key-in ignition circuits as required. Refer to Group 8U - Chime/Buzzer Warning Systems for more information.

(6) Open the driver side front door with the key in the ignition switch or with the headlamp switch in the On position. Check for continuity between the door ajar/key-in circuit cavity of the 8-way PDM wire harness connector and a good ground. There should be continuity. If OK, go to Step 8. If not OK, repair the open door ajar and/or key-in ignition circuits as required. Refer to Group 8U - Chime/Buzzer Warning Systems for more information.

(7) Connect the battery negative cable. Check for battery voltage at the fused B(+) circuit cavity of the 8-way PDM wire harness connector. If OK, go to Step 8. If not OK, repair the open circuit to the fuse in the junction block as required.

(8) Test the PDM power lock switch continuity through the two PDM wire harness connector receptacles. See the PDM Power Lock Switch Continuity chart (Fig. 2) to determine if the continuity is correct in both the Lock and Unlock switch positions. If OK, see the diagnosis for Power Lock Motors in this group. If not OK, replace the faulty PDM.

POWER LOCK MOTOR

Before you proceed with this diagnosis, confirm proper power door lock switch operation. See Door Module in this group for the diagnostic procedures. Remember, the Passenger Door Module (PDM) circuitry controls the output to each of the power lock motors. For circuit descriptions and diagrams, refer to 8W-61 - Power Door Locks in Group 8W - Wiring Diagrams.

DIAGNOSIS AND TESTING (Continued)

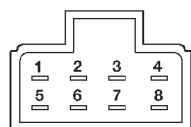

CONNECTOR 1 (C-1)

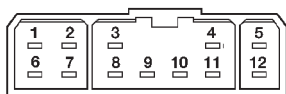

CONNECTOR 2 (C-2)

| LEFT-HAND DRIVE (LHD) | |
|-----------------------|---------------------|
| SWITCH POSITION | CONTINUITY BETWEEN |
| LOCK | C1 PIN 3 & C1 PIN 6 |
| | C1 PIN 3 & C2 PIN 1 |
| | C1 PIN 3 & C2 PIN 5 |
| UNLOCK | C1 PIN 6 & C1 PIN 7 |
| | C1 PIN 7 & C2 PIN 1 |
| | C1 PIN 7 & C2 PIN 5 |

| RIGHT-HAND DRIVE (RHD) | |
|------------------------|---------------------|
| SWITCH POSITION | CONTINUITY BETWEEN |
| LOCK | C1 PIN 7 & C1 PIN 6 |
| | C1 PIN 7 & C2 PIN 1 |
| | C1 PIN 7 & C2 PIN 5 |
| UNLOCK | C1 PIN 6 & C1 PIN 3 |
| | C1 PIN 3 & C2 PIN 1 |
| | C1 PIN 3 & C2 PIN 5 |

80abd2c8

Fig. 2 PDM Power Lock Switch Continuity

(1) Check each power lock motor for correct operation while moving the power lock switch to both the Lock and Unlock positions. If all of the power lock motors are inoperative, go to Step 2. If one power lock motor is inoperative, go to Step 3.

(2) If all of the power lock motors are inoperative, the problem may be caused by one shorted motor. Unplugging a shorted power lock motor from the power lock circuit will allow the good power lock motor to operate. Unplug each power lock motor wire harness connector, one at a time, and recheck both the lock and unlock functions by operating the power lock switch. If all of the power lock motors are still inoperative after the above test, check for a short or open circuit between the power lock motors and the PDM. If unplugging one power lock motor causes the other motors to become functional, go to Step 3 to test the unplugged motor.

(3) Once it is determined which power lock motor is inoperative, that motor can be tested as follows. Unplug the wire harness connector at the inoperative power lock motor. Apply 12 volts to the motor terminals to check its operation in one direction. Reverse the polarity to check the operation in the other direction. If OK, repair the short or open circuits between the power lock motor and the PDM as required. If not OK, replace the faulty power lock motor.

REMOTE KEYLESS ENTRY TRANSMITTER

(1) Replace the Remote Keyless Entry (RKE) transmitter batteries. See Remote Keyless Entry Transmitter Battery Replacement in this group for the procedures. Test each of the transmitter functions. If OK, discard the faulty batteries. If not OK, go to Step 2.

(2) Perform the Remote Keyless Entry Transmitter Programming procedure with the suspect transmitter and another known good transmitter. Use a DRB scan tool, as described in the proper Diagnostic Procedures manual.

(3) Test the RKE system operation with both transmitters. If both transmitters fail to operate the power lock system, see the diagnosis for the Remote Keyless Entry Receiver in this group. If the known good transmitter operates the power locks and the suspect transmitter does not, replace the faulty transmitter.

NOTE: Be certain to perform the Remote Keyless Entry Transmitter Programming procedure again following this test. This procedure will erase the access code of the test transmitter from the RKE receiver.

REMOTE KEYLESS ENTRY RECEIVER

If the problem being diagnosed is an inoperative Remote Keyless Entry (RKE) horn chirp feature, be certain that the horn chirp feature has not been disabled. See Remote Keyless Entry Receiver Programming in this group for the procedures. Also be certain that the vehicle horn system is operational. Refer to Group 8G - Horn Systems for more information.

If the problem being diagnosed is an inoperative RKE illuminated entry system, be certain that the interior courtesy lamp system is operational. Refer to Group 8L - Lamps for more information.

Before you proceed with diagnosis of the RKE receiver, see the diagnosis for Remote Keyless Entry Transmitter in this group. For circuit descriptions and diagrams, refer to 8W-61 - Power Door Locks in Group 8W - Wiring Diagrams.

(1) Check the fuses in the Power Distribution Center (PDC) and the junction block. If OK, go to Step 2.

DIAGNOSIS AND TESTING (Continued)

If not OK, repair the shorted circuit or component as required and replace the faulty fuse.

(2) Disconnect and isolate the battery negative cable. Remove the Remote Keyless Entry (RKE) receiver from the headliner. Unplug the wire harness connector from the RKE receiver.

(3) Check the wire harness connector and the receptacle in the RKE receiver for loose, corroded, or damaged terminals and pins. If OK, go to Step 4. If not OK, repair as required.

(4) Check for continuity between each of the two ground circuit cavities of the RKE receiver wire harness connector and a good ground. In each case, there should be continuity. If OK, go to Step 5. If not OK, repair the circuit to ground as required.

(5) Connect the battery negative cable. Check for battery voltage at each of the two fused B(+) circuit cavities of the RKE receiver wire harness connector. If OK, go to Step 6. If not OK, repair the open circuit to the PDC or the junction block as required.

(6) If the problem being diagnosed involves only the RKE horn chirp feature, go to Step 10. If the problem being diagnosed involves only the RKE illuminated entry feature, go to Step 9. If the problem being diagnosed involves only the RKE power lock feature, go to Step 7.

(7) Disconnect and isolate the battery negative cable. Unplug the 8-way Passenger Door Module (PDM) wire harness connector. Check for continuity between the lock request circuit cavity of the RKE receiver wire harness connector and a good ground. Repeat the test between the unlock request circuit cavity of the RKE receiver wire harness connector and a good ground. In each case, there should be no continuity. If OK, go to Step 8. If not OK, repair the shorted circuit as required.

(8) Check for continuity between the lock request circuit cavities of the RKE receiver wire harness connector and the 8-way PDM wire harness connector. Repeat the test between the unlock request circuit cavities of the RKE receiver wire harness connector and the 8-way PDM wire harness connector. In each case, there should be continuity. If OK, replace the faulty RKE receiver. If not OK, repair the open circuit as required.

(9) Check for continuity between the door ajar circuit cavity of the RKE receiver wire harness connector and a good ground with the driver door closed. There should be no continuity until the driver door is opened. If OK, replace the faulty RKE receiver. If not OK, repair the circuit or replace the faulty driver door ajar switch as required.

(10) Unplug the horn relay from the junction block. Check for continuity between the horn relay output circuit cavity of the RKE receiver wire harness connector and a good ground. There should be

no continuity. If OK, go to Step 11. If not OK, repair the short circuit to the horn relay as required.

(11) Check for continuity between the horn relay output circuit cavity of the RKE receiver wire harness connector and the junction block cavity for the horn relay coil ground terminal (85). There should be continuity. If OK, replace the faulty RKE receiver. If not OK, repair the open circuit to the junction block as required.

SERVICE PROCEDURES

REMOTE KEYLESS ENTRY TRANSMITTER BATTERY REPLACEMENT

The Remote Keyless Entry (RKE) transmitter case snaps open and shut for battery access. To replace the RKE transmitter batteries:

(1) Using a trim stick or another suitable wide flat-bladed tool, gently pry at the center seam of the transmitter case halves near the key ring until the two halves unsnap.

(2) Lift the back half of the transmitter case off of the transmitter.

(3) Remove the two batteries from the transmitter.

(4) Replace the two batteries with new Panasonic CR2016, or their equivalent. Be certain that the batteries are installed with their polarity correctly oriented.

(5) Align the two transmitter case halves with each other, and squeeze them firmly together until they snap back into place.

REMOTE KEYLESS ENTRY TRANSMITTER PROGRAMMING

To program the Remote Keyless Entry (RKE) transmitter access codes into the RKE receiver requires the use of a DRB scan tool. Refer to the proper Diagnostic Procedures manual for more information.

REMOTE KEYLESS ENTRY RECEIVER PROGRAMMING

The optional Remote Keyless Entry (RKE) system for this vehicle has a customer programmable horn chirp feature. The horn chirp is requested by the RKE receiver through a hard-wired circuit to the horn relay, whenever a valid Lock message is received from a programmed RKE radio transmitter.

The purpose of the horn chirp is to provide the vehicle operator with an audible verification that the Lock request has been received by the RKE receiver. However, for any number of reasons, some customers may prefer that this feature be disabled. This RKE system allows them that option.

SERVICE PROCEDURES (Continued)

To program the Remote Keyless Entry (RKE) receiver so that the horn chirp feature is disabled, proceed as follows:

- (1) While within the reception range of the RKE receiver, press and hold the Lock button of a programmed RKE transmitter depressed for five to ten seconds.
 - (2) While holding the RKE transmitter Lock button depressed, press and release the RKE transmitter Unlock button.
 - (3) The RKE horn chirp feature is now disabled.
- Repeating the preceding steps will again enable the RKE horn chirp feature.

REMOVAL AND INSTALLATION

DOOR MODULE

- (1) Disconnect and isolate the battery negative cable.
- (2) Remove the screws that secure the front door trim panel to the inner door panel (Fig. 3).

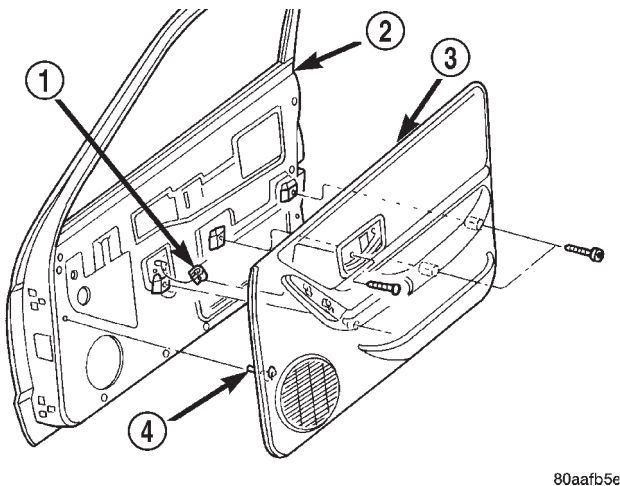

Fig. 3 Front Door Trim Panel Remove/Install

- 1 - U-NUT
- 2 - DOOR
- 3 - TRIM PANEL
- 4 - PUSH-IN FASTENER

(3) Using a trim stick or another suitable wide flat-bladed tool, gently pry the front door trim panel away from the door around the perimeter to release the trim panel retainers.

NOTE: To aid in the removal of the trim panel, start at the bottom of the panel.

(4) Lift the front door trim panel upwards and away from the inner door panel far enough to disengage the top of the panel from the inner belt weatherstrip.

- (5) Pull the front door trim panel away from the inner door panel far enough to access the inside door latch release and lock linkage rods near the back of the inside door remote controls.
- (6) Unsnap the plastic retainer clips from the inside door remote control ends of the latch release and lock linkage rods, and remove the rod ends from the inside door remote controls.
- (7) Unplug the wire harness connectors from the door module.
- (8) Remove the trim panel from the front door.
- (9) Remove the three screws that secure the door module to the front door trim panel (Fig. 4).

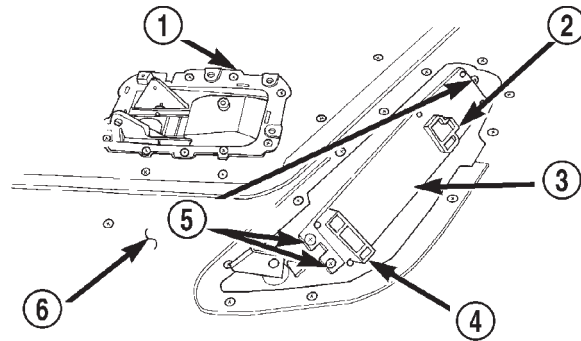

Fig. 4 Door Module Remove/Install

- 1 - INSIDE DOOR LATCH AND LOCK REMOTE CONTROLS
- 2 - CONNECTOR 1 RECEPTACLE
- 3 - DOOR MODULE
- 4 - CONNECTOR 2 RECEPTACLE
- 5 - SCREWS
- 6 - DOOR TRIM PANEL

(10) Remove the door module from the front door trim panel.

(11) Reverse the removal procedures to install. Tighten the mounting screws to 2.2 N·m (20 in. lbs.).

POWER LOCK MOTOR

FRONT DOOR

The front door power lock motor is integral to the front door latch unit. If the front door power lock motor is faulty or damaged, the entire latch unit must be replaced. Refer to Group 23 - Body for the front door latch service procedures.

REAR DOOR

The rear door power lock motor is integral to the rear door latch unit. If the rear door power lock motor is faulty or damaged, the entire latch unit must be replaced. Refer to Group 23 - Body for the rear door latch service procedures.

REMOVAL AND INSTALLATION (Continued)

LIFTGATE

- (1) Disconnect and isolate the battery negative cable.
- (2) Open the liftgate.
- (3) Remove the liftgate trim panel from the liftgate. Refer to Group 23 - Body for the procedures.
- (4) Reach through the liftgate inner panel access hole and disconnect the link from the clip on the power lock motor (Fig. 5).

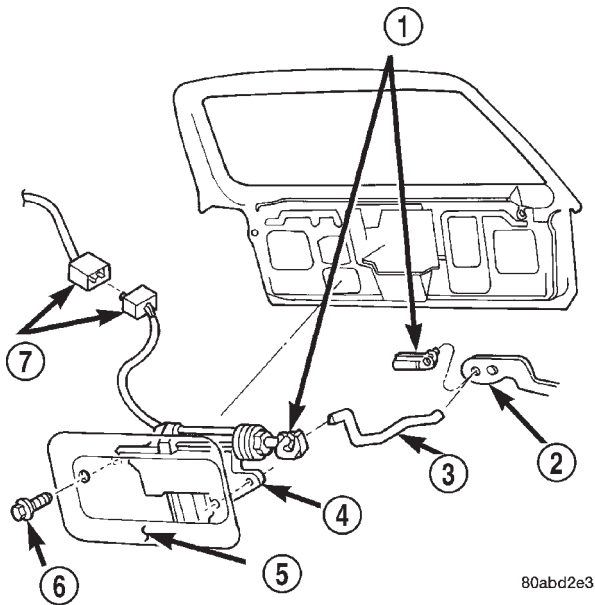

80abd2e3

Fig. 5 Liftgate Power Lock Motor Remove/Install

- 1 - CLIPS
- 2 - LOCK LEVER
- 3 - LINK
- 4 - MOTOR
- 5 - LIFTGATE INNER PANEL
- 6 - SCREW
- 7 - CONNECTORS

- (5) Remove the two screws that secure the power lock motor to the liftgate inner panel.

- (6) Pull the power lock motor out through the liftgate inner panel access hole far enough to access the wire harness connector.

- (7) Unplug the wire harness connector from the power lock motor.

- (8) Remove the power lock motor from the liftgate.

- (9) Reverse the removal procedures to install. Tighten the power lock motor mounting screws to 3 N·m (28 in. lbs.).

REMOTE KEYLESS ENTRY RECEIVER

CAUTION: A discharge of static electricity may damage this unit. At no time should any source of static electricity be permitted near this unit. Technicians handling or servicing the unit should wear

cotton clothing, not synthetic fabric clothing; and, should ground themselves before and during all handling and service procedures. Electrically conductive wrist or heel straps are recommended, or static dissipating shoes are also acceptable. Work and storage areas should be free of static generative materials such as: dry air, glass, nylon, wool, fur, silk, rayon, acrylic, polystyrene foam, polyester, saran, polyethylene, polypropylene, PVC, and teflon.

MINI-DOME MOUNTED TYPE

- (1) Disconnect and isolate the battery negative cable.

- (2) Remove the two screws that secure the Remote Keyless Entry (RKE) mini-dome housing to the roof panel reinforcement (Fig. 6).

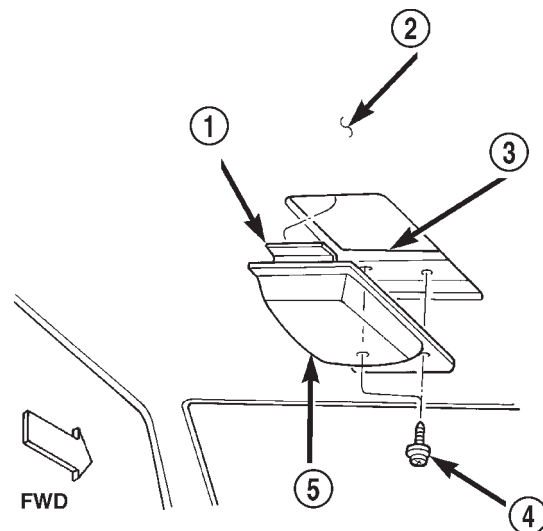

80abd2e6

Fig. 6 Mini-Dome Housing Remove/Install

- 1 - MOUNTING TAB
- 2 - HEADLINER
- 3 - REINFORCEMENT
- 4 - SCREW
- 5 - MINI-DOME HOUSING

- (3) Lower the front of the mini-dome housing and slide the unit forward to disengage the rear mounting tab from the headliner.

- (4) Lower the mini-dome housing far enough to access the RKE receiver wire harness connector.

- (5) Unplug the wire harness connector from the RKE receiver.

- (6) Remove the RKE mini-dome unit from the headliner.

- (7) Reverse the removal procedures to install. Tighten the mounting screws to 2.8 N·m (24 in. lbs.).

REMOVAL AND INSTALLATION (Continued)

OVERHEAD CONSOLE MOUNTED TYPE

(1) Disconnect and isolate the battery negative cable.

(2) Remove the overhead console from the headliner. Refer to Overhead Console in Group 8V - Overhead Console Systems for the procedures.

(3) Remove the six screws that secure the rear overhead console housing to the overhead console bezel (Fig. 7).

(4) Gently flex the sides of the overhead console bezel far enough to clear the tabs on the rear console housing and remove the housing from the bezel.

(5) Remove the two screws that secure the RKE receiver circuit board to the rear overhead console housing.

(6) Remove the RKE circuit board from the rear overhead console housing.

(7) Reverse the removal procedures to install. Tighten the mounting screws to 2.2 N·m (20 in. lbs.).

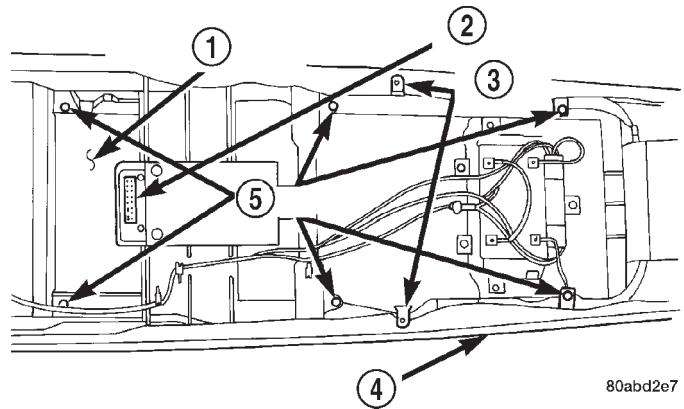

80abd2e7

Fig. 7 RKE Receiver Remove/Install

- 1 - REAR OVERHEAD CONSOLE HOUSING
- 2 - RKE RECEIVER
- 3 - TABS
- 4 - OVERHEAD CONSOLE BEZEL
- 5 - SCREWS

VEHICLE THEFT/SECURITY SYSTEMS

TABLE OF CONTENTS

| | page | | page |
|--|------|---|------|
| GENERAL INFORMATION | | DIAGNOSIS AND TESTING | |
| INTRODUCTION | 1 | SENTRY KEY IMMOBILIZER SYSTEM | 3 |
| SENTRY KEY IMMOBILIZER SYSTEM | 1 | SERVICE PROCEDURES | |
| DESCRIPTION AND OPERATION | | SENTRY KEY IMMOBILIZER SYSTEM | |
| SENTRY KEY IMMOBILIZER MODULE | 1 | TRANSPONDER PROGRAMMING | 4 |
| SENTRY KEY IMMOBILIZER TRANSPONDER | 2 | REMOVAL AND INSTALLATION | |
| SENTRY KEY IMMOBILIZER SYSTEM | | SENTRY KEY IMMOBILIZER MODULE | 4 |
| INDICATOR LAMP | 3 | | |

GENERAL INFORMATION

INTRODUCTION

The Sentry Key Immobilizer System (SKIS) is available factory-installed optional equipment for this model. Following are some general descriptions of the features and components of the SKIS. Refer to the vehicle owner's manual for more information on the use and operation of the SKIS. Refer to 8W-30 - Fuel/Ignition System in Group 8W - Wiring Diagrams for complete circuit descriptions and diagrams.

SENTRY KEY IMMOBILIZER SYSTEM

The Sentry Key Immobilizer System (SKIS) is designed to provide passive protection against unauthorized vehicle use by preventing the engine from operating while the system is armed. The primary components of this system are the Sentry Key Immobilizer Module (SKIM), the Sentry Key transponder, the SKIS indicator lamp, and the Powertrain Control Module (PCM).

The SKIM is installed on the steering column near the ignition lock cylinder. The transponder is located under the molded rubber cap on the head of the ignition key. The SKIS indicator lamp is located in the instrument cluster.

The SKIS includes two valid Sentry Key transponders from the factory. If the customer wishes, additional non-coded blank Sentry Keys are available. These blank keys can be cut to match a valid ignition key, but the engine will not start unless the key transponder is also programmed to the vehicle using the Customer Learn programming procedure or a DRBIII® scan tool. The SKIS will recognize no more than eight valid Sentry Key transponders at any one time.

The SKIS performs a self-test each time the ignition switch is turned to the On position, and will store Diagnostic Trouble Codes (DTCs) if a system

malfunction is detected. The SKIS can be diagnosed, and any stored DTC can be retrieved using a DRBIII® scan tool as described in the proper Diagnostic Procedures manual.

DESCRIPTION AND OPERATION

SENTRY KEY IMMOBILIZER MODULE

The Sentry Key Immobilizer Module (SKIM) contains a Radio Frequency (RF) transceiver and a central processing unit, which includes the Sentry Key Immobilizer System (SKIS) program logic. The SKIS programming enables the SKIM to program and retain in memory the codes of at least one, but no more than eight electronically coded Sentry Key transponders. The SKIS programming also enables the SKIM to communicate over the Chrysler Collision Detection (CCD) data bus network with the Powertrain Control Module (PCM), the instrument cluster and/or the DRBIII® scan tool.

The SKIM transmits and receives RF signals through a tuned antenna enclosed within a molded plastic ring formation that is integral to the SKIM housing. When the SKIM is properly installed on the steering column, the antenna ring is oriented around the circumference of the ignition lock cylinder housing. This antenna ring must be located within eight millimeters (0.31 inches) of the Sentry Key in order to ensure proper RF communication between the SKIM and the Sentry Key transponder.

For added system security, each SKIM is programmed with a unique "Secret Key" code and a security code (PIN). The SKIM keeps the "Secret Key" code in memory. This "Secret Key" code must be transferred to the PCM memory during the initialization/programming of the SKIS when the vehicle is manufactured, and each time the PCM is replaced during vehicle service by the dealer technician. The

DESCRIPTION AND OPERATION (Continued)

SKIM also transfers the “Secret Key” code to the memory of each of the Sentry Key transponders during new key programming. The security code is used by the assembly plant to access the SKIS for initialization, or by the dealer technician to access the system for service. The SKIM also stores in its memory the Vehicle Identification Number (VIN), which it learns through a CCD data bus message from the PCM during initialization.

The SKIM and the PCM both use software that includes a rolling code algorithm strategy, which helps to reduce the possibility of unauthorized SKIS disarming. The rolling code algorithm ensures security by preventing an override of the SKIS through the unauthorized substitution of the SKIM or the PCM. However, the use of this strategy also means that replacement of either the SKIM or the PCM units will require a system initialization procedure to restore system operation.

When the ignition switch is turned to the On or Start positions, the SKIM transmits an RF signal to excite the Sentry Key transponder. The SKIM then listens for a return RF signal from the transponder of the Sentry Key that is inserted in the ignition lock cylinder. If the SKIM receives an RF signal with valid “Secret Key” and transponder identification codes, the SKIM sends a “valid key” message to the PCM over the CCD data bus. If the SKIM receives an invalid RF signal or no response, it sends “invalid key” messages to the PCM. The PCM will enable or disable engine operation based upon the status of the SKIM messages.

The SKIM also sends messages to the instrument cluster over the CCD data bus network to control the SKIS indicator lamp. The SKIM sends messages to the instrument cluster to turn the lamp on for about three seconds when the ignition switch is turned to the On position as a bulb test. After completion of the bulb test, the SKIM sends bus messages to keep the lamp off for a duration of about one second. Then the SKIM sends messages to turn the lamp on or off based upon the results of the SKIS self-tests. If the SKIS indicator lamp comes on and stays on after the bulb test, it indicates that the SKIM has detected a system malfunction and/or that the SKIS has become inoperative.

If the SKIM detects an invalid key when the ignition switch is turned to the On position, it sends messages to the instrument cluster to flash the SKIS indicator lamp. The SKIM can also send messages to the instrument cluster to flash the lamp and to generate a single audible chime tone. These functions serve as an indication to the customer that the SKIS has been placed in its “Customer Learn” programming mode. See Sentry Key Immobilizer System Transponder Programming in this group for more information on the “Customer Learn” programming mode.

For diagnosis or initialization of the SKIM and the PCM, a DRBIII® scan tool and the proper Diagnostic Procedures manual are required. The SKIM cannot be repaired and, if faulty or damaged, the unit must be replaced.

SENTRY KEY IMMOBILIZER TRANSPONDER

The Sentry Key Immobilizer System (SKIS) uses a transponder that is integral to each of the two ignition keys that are supplied with the vehicle when it is shipped from the factory. The transponder chip is insulated within a nylon mount inserted in the head of the key, and invisible beneath a molded rubber cap (Fig. 1).

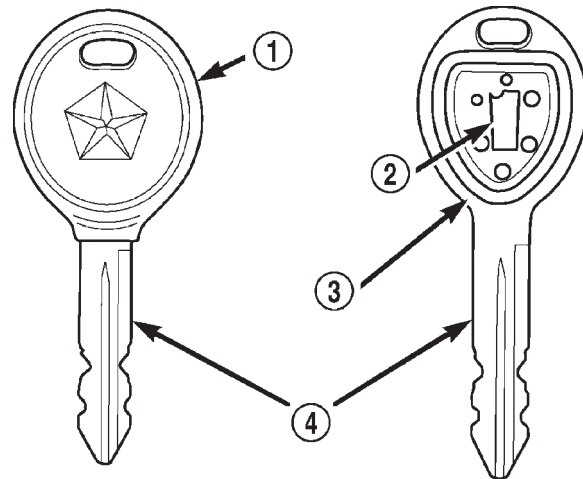

80b5cb75

Fig. 1 Sentry Key Immobilizer Transponder

- 1 - MOLDED CAP
- 2 - TRANSPONDER
- 3 - MOLDED CAP REMOVED
- 4 - SENTRY KEY

Each Sentry Key transponder has a unique transponder identification code programmed into it by the manufacturer. The Sentry Key Immobilizer Module (SKIM) has a unique “Secret Key” code programmed into it by the manufacturer. Each time a new Sentry Key transponder is programmed, the SKIM learns the transponder identification code from the transponder, and the transponder learns the “Secret Key” code from the SKIM. Each of these codes is stored within the transponder and in the nonvolatile memory of the SKIM. Therefore, blank keys for the SKIS must be programmed and their transponder identification codes must be learned by and stored in the SKIM memory, in addition to being cut to match the mechanical coding of the ignition lock cylinder. See Sentry Key Immobilizer System Transponder Programming in this group for more information.

DESCRIPTION AND OPERATION (Continued)

The Sentry Key transponder is within the range of the SKIM transceiver antenna ring when it is inserted in the ignition lock cylinder. When the ignition switch is turned to the Start or On positions, the SKIM transceiver issues a Radio Frequency (RF) signal that excites the transponder chip. The transponder chip responds by issuing an RF signal containing its transponder identification code and the "Secret Key" code. The SKIM transceiver compares the transponder codes with the codes stored in its memory to determine whether a valid key is in the ignition lock cylinder.

The Sentry Key transponder cannot be repaired and, if faulty or damaged, it must be replaced.

SENTRY KEY IMMOBILIZER SYSTEM INDICATOR LAMP

The Sentry Key Immobilizer System (SKIS) indicator lamp gives an indication when the SKIS is faulty or when the vehicle has been immobilized due to the use of an invalid ignition key. The lamp is controlled by the instrument cluster circuitry based upon messages received from the Sentry Key Immobilizer Module (SKIM) on the Chrysler Collision Detection (CCD) data bus.

The SKIM sends messages to the instrument cluster to turn the lamp on for about three seconds when the ignition switch is turned to the On position as a bulb test. After completion of the bulb test, the SKIM sends bus messages to keep the lamp off for a duration of about one second. Then the SKIM sends messages to the instrument cluster circuitry to turn the lamp on or off based upon the results of the SKIS self-tests. If the SKIS indicator lamp comes on and stays on after the bulb test, it indicates that the SKIM has detected a system malfunction and/or that the SKIS has become inoperative.

If the SKIM detects an invalid key when the ignition switch is turned to the On position, it sends messages to the instrument cluster to flash the SKIS indicator lamp. The SKIM can also send messages to the instrument cluster to flash the lamp and to generate a single audible chime tone. These functions serve as an indication to the customer that the SKIS has been placed in its "Customer Learn" programming mode. See Sentry Key Immobilizer System Transponder Programming in this group for more information on the "Customer Learn" programming mode.

The SKIS indicator lamp uses a replaceable incandescent bulb and bulb holder on the instrument cluster electronic circuit board. Refer to Group 8E - Instrument Panel Systems for diagnosis and service of a faulty SKIS indicator lamp. If the SKIS indicator lamp comes on and stays on after the bulb test function, diagnosis of the SKIS should be performed with a DRB scan tool and the proper Diagnostic Procedures manual.

DIAGNOSIS AND TESTING

SENTRY KEY IMMOBILIZER SYSTEM

WARNING: ON VEHICLES EQUIPPED WITH AIRBAGS, REFER TO GROUP 8M - PASSIVE RESTRAINT SYSTEMS BEFORE ATTEMPTING ANY STEERING WHEEL, STEERING COLUMN, OR INSTRUMENT PANEL COMPONENT DIAGNOSIS OR SERVICE. FAILURE TO TAKE THE PROPER PRECAUTIONS COULD RESULT IN ACCIDENTAL AIRBAG DEPLOYMENT AND POSSIBLE PERSONAL INJURY.

NOTE: The following tests may not prove conclusive in the diagnosis of this system. The most reliable, efficient, and accurate means to diagnose the Sentry Key Immobilizer System involves the use of a DRB scan tool. Refer to the proper Diagnostic Procedures manual for the procedures.

The Sentry Key Immobilizer System (SKIS) and the Chrysler Collision Detection (CCD) data bus network should be diagnosed using a DRB scan tool. The DRB will allow confirmation that the CCD data bus is functional, that the Sentry Key Immobilizer Module (SKIM) is placing the proper messages on the CCD data bus, and that the Powertrain Control Module (PCM) and the instrument cluster are receiving the CCD data bus messages. Refer to the proper Diagnostic Procedures manual for the procedures. Refer to 8W-39 - Vehicle Theft Security System in Group 8W - Wiring Diagrams for complete circuit descriptions and diagrams.

(1) Check the fuses in the fuseblock module. If OK, go to Step 2. If not OK, repair the shorted circuit or component as required and replace the faulty fuse.

(2) Disconnect and isolate the battery negative cable. Unplug the wire harness connector at the SKIM. Check for continuity between the ground circuit cavity of the SKIM wire harness connector and a good ground. There should be continuity. If OK, go to Step 3. If not OK, repair the open circuit to ground as required.

(3) Connect the battery negative cable. Check for battery voltage at the fused B(+) circuit cavity of the SKIM wire harness connector. If OK, go to Step 4. If not OK, repair the open circuit to the fuse in the fuseblock module as required.

(4) Turn the ignition switch to the On position. Check for battery voltage at the fused ignition switch output (run/start) circuit cavity of the SKIM wire harness connector. If OK, use a DRB scan tool and the proper Diagnostic Procedures manual to complete the diagnosis of the SKIS. If not OK, repair the open circuit to the fuse in the fuseblock module as required.

SERVICE PROCEDURES

SENTRY KEY IMMOBILIZER SYSTEM TRANSPONDER PROGRAMMING

Two programmed Sentry Key transponders are included with the Sentry Key Immobilizer System (SKIS) when it is shipped from the factory. The Sentry Key Immobilizer Module (SKIM) can be programmed to recognize up to six additional transponders, for a total of eight Sentry Keys. The following "Customer Learn" programming procedure for the programming of additional transponders requires access to at least two of the valid Sentry Keys. If two valid Sentry Keys are not available, Sentry Key programming will require the use of a DRB scan tool and the proper Diagnostic Procedures manual.

CUSTOMER LEARN

(1) Obtain the additional Sentry Key transponder blank(s) that are to be programmed for the vehicle. Cut the additional Sentry Key transponder blanks to match the ignition lock cylinder mechanical key codes.

(2) Insert one of the two valid Sentry Key transponders into the ignition switch and turn the ignition switch to the On position.

(3) After the ignition switch has been in the On position for about three seconds, but no more than fifteen seconds later, cycle the ignition switch back to the Off position. Replace the first valid Sentry Key in the ignition lock cylinder with the second valid Sentry Key and turn the ignition switch back to the On position.

(4) About ten seconds after the completion of Step 3, the SKIS indicator lamp will start to flash and a single audible chime tone will sound to indicate that the system has entered the "Customer Learn" programming mode.

(5) Within about fifty seconds of entering the "Customer Learn" programming mode, turn the ignition switch to the Off position, replace the valid Sentry Key with a blank Sentry Key transponder, and turn the ignition switch back to the On position.

(6) About ten seconds after the completion of Step 5, a single audible chime tone will sound and the SKIS indicator lamp will stop flashing and stay on solid for about three seconds to indicate that the blank Sentry Key transponder has been successfully programmed. The SKIS will immediately return to normal system operation following exit from the "Customer Learn" programming mode.

(7) Go back to Step 2 and repeat this process for each additional Sentry Key transponder blank to be programmed.

If any of the above steps is not completed in the proper sequence, or within the allotted time, the SKIS will automatically exit the "Customer Learn" programming mode. The SKIS will also automatically exit the

"Customer Learn" programming mode if it sees a non-blank Sentry Key transponder when it should see a blank, if it has already programmed eight valid Sentry Keys, or if the ignition switch is turned to the Off position for more than about fifty seconds.

REMOVAL AND INSTALLATION

SENTRY KEY IMMOBILIZER MODULE

WARNING: ON VEHICLES EQUIPPED WITH AIRBAGS, REFER TO GROUP 8M - PASSIVE RESTRAINT SYSTEMS BEFORE ATTEMPTING ANY STEERING WHEEL, STEERING COLUMN, OR INSTRUMENT PANEL COMPONENT DIAGNOSIS OR SERVICE. FAILURE TO TAKE THE PROPER PRECAUTIONS COULD RESULT IN ACCIDENTAL AIRBAG DEPLOYMENT AND POSSIBLE PERSONAL INJURY.

(1) Disconnect and isolate the battery negative cable.

(2) Remove the knee blocker from the instrument panel. See Knee Blocker in Group 8E - Instrument Panel Systems for the procedures.

(3) Remove the three screws that secure the lower steering column shroud to the upper shroud (Fig. 2).

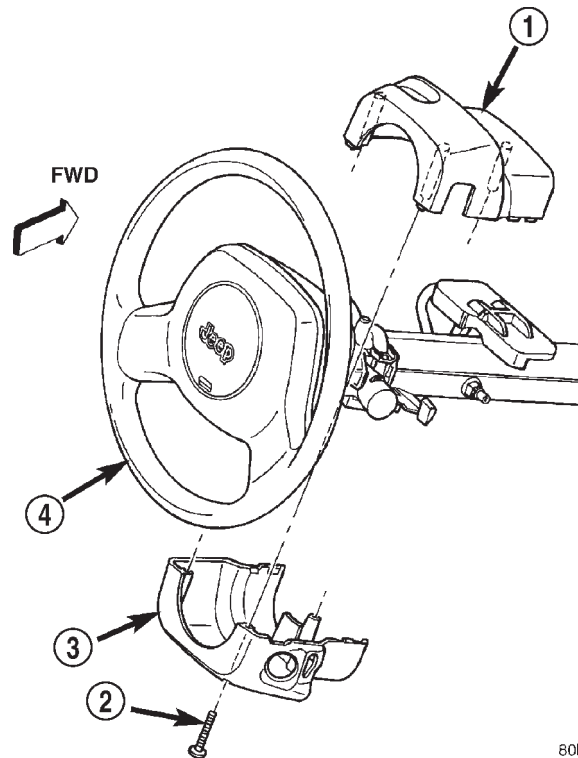

80b76efa

Fig. 2 Steering Column Shrouds Remove/Install

- 1 - UPPER SHROUD
- 2 - SCREW (3)
- 3 - LOWER SHROUD
- 4 - STEERING WHEEL

REMOVAL AND INSTALLATION (Continued)

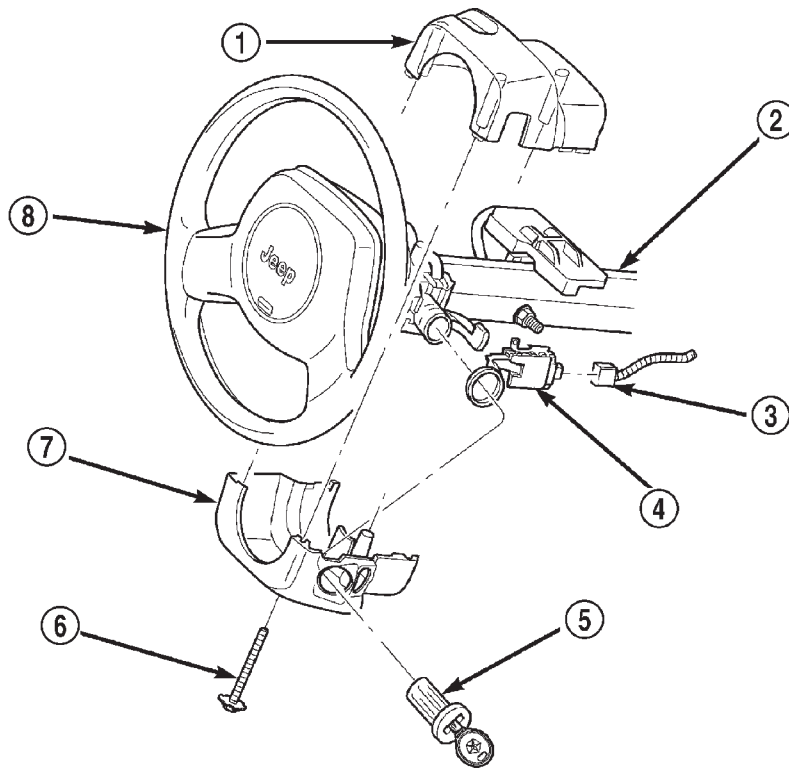

80b46c13

Fig. 3 Sentry Key Immobilizer Module Remove/Install

- | | |
|-----------------------------------|----------------------------|
| 1 - UPPER SHROUD | 5 - IGNITION LOCK CYLINDER |
| 2 - STEERING COLUMN | 6 - SCREW |
| 3 - WIRE HARNESS CONNECTOR | 7 - LOWER SHROUD |
| 4 - SENTRY KEY IMMOBILIZER MODULE | 8 - STEERING WHEEL |

(4) If the vehicle is equipped with a standard non-tilt steering column, loosen the two upper steering column mounting nuts. If the vehicle is equipped with the optional tilt steering column, move the tilt steering column to the fully lowered position.

(5) Remove both the upper and lower shrouds from the steering column.

(6) Disengage the steering column wire harness retainer from the tab on the top of the Sentry Key Immobilizer Module (SKIM) mounting bracket (Fig. 3).

(7) Unplug the wire harness connector from the SKIM receptacle.

(8) The SKIM mounting bracket features a clip formation that secures the SKIM to the inboard lower flange of the steering column jacket. Pull downward on the connector end of the SKIM mounting bracket to release this clip from the steering column jacket.

(9) Rotate the SKIM and its mounting bracket downwards and then to the side away from the steering column to slide the SKIM antenna ring from around the ignition switch lock cylinder housing.

(10) Remove the SKIM from the vehicle.

(11) Reverse the removal procedures to install. Tighten the non-tilt steering column mounting nuts to 22 N·m (200 in. lbs.) and the steering column shroud mounting screws to 2 N·m (18 in. lbs.).

NOTE: If the SKIM is replaced with a new unit, a DRBIII® scan tool and the proper Diagnostic Procedures manual **MUST** be used to initialize the new SKIM and to program at least two Sentry Key transponders.

VEHICLE THEFT/SECURITY SYSTEMS

TABLE OF CONTENTS

| | page | | page |
|--|------|---|------|
| DESCRIPTION AND OPERATION | | SERVICE PROCEDURES | |
| SENTRY KEY IMMOBILIZER SYSTEM | 1 | SENTRY KEY IMMOBILIZER SYSTEM | |
| SENTRY KEY IMMOBILIZER MODULE | 1 | TRANSPONDER PROGRAMMING | 3 |
| SENTRY KEY IMMOBILIZER TRANSPONDER | 2 | REMOVAL AND INSTALLATION | |
| SENTRY KEY IMMOBILIZER SYSTEM | | SENTRY KEY IMMOBILIZER MODULE | 4 |
| INDICATOR LAMP | 2 | | |
| DIAGNOSIS AND TESTING | | | |
| SENTRY KEY IMMOBILIZER SYSTEM | 3 | | |

DESCRIPTION AND OPERATION

SENTRY KEY IMMOBILIZER SYSTEM

The Sentry Key Immobilizer System (SKIS) is designed to provide passive protection against unauthorized vehicle use by preventing the engine from operating. The primary components of this system are the Sentry Key Immobilizer Module (SKIM), the Sentry Key transponder, the SKIS indicator lamp, and the Powertrain Control Module (PCM).

The SKIM is installed on the steering column near the ignition lock cylinder. The transponder is located under the molded rubber cap on the head of the ignition key. The SKIS indicator lamp is located in the instrument cluster.

The SKIS includes two valid Sentry Key transponders from the factory. If the customer wishes, additional non-coded blank Sentry Keys are available. These blank keys can be cut to match a valid ignition key, but the engine will not start unless the key transponder is also programmed to the vehicle. The SKIS will recognize no more than eight valid Sentry Key transponders at any one time.

The SKIS performs a self-test each time the ignition switch is turned to the On position, and will store Diagnostic Trouble Codes (DTCs) if a system malfunction is detected. The SKIS can be diagnosed, and any stored DTC can be retrieved using a DRB scan tool as described in the proper Diagnostic Procedures manual.

SENTRY KEY IMMOBILIZER MODULE

The Sentry Key Immobilizer Module (SKIM) contains a Radio Frequency (RF) transceiver and a central processing unit, which includes the Sentry Key Immobilizer System (SKIS) program logic. The SKIS programming enables the SKIM to program and retain in memory the codes of at least two, but no

more than eight electronically coded Sentry Key transponders. The SKIS programming also enables the SKIM to communicate over the Chrysler Collision Detection (CCD) data bus network with the Powertrain Control Module (PCM), the instrument cluster and/or the DRB scan tool.

The SKIM transmits and receives RF signals through a tuned antenna enclosed within a molded plastic ring formation that is integral to the SKIM housing. When the SKIM is properly installed on the steering column, the antenna ring is oriented around the circumference of the ignition lock cylinder housing. This antenna ring must be located within eight millimeters (0.31 inches) of the Sentry Key in order to ensure proper RF communication between the SKIM and the Sentry Key transponder.

For added system security, each SKIM is programmed with a unique "Secret Key" code and a security code. The SKIM keeps the "Secret Key" code in memory and sends the code over the CCD data bus to the PCM, which also keeps this code in its memory. The SKIM also sends the "Secret Key" code to each of the programmed Sentry Key transponders. The security code is used by the assembly plant to access the SKIS for initialization, or by the dealer technician to access the system for service. The SKIM also stores in its memory the Vehicle Identification Number (VIN), which it learns through a CCD data bus message from the PCM during initialization.

The SKIM and the PCM both use software that includes a rolling code algorithm strategy, which helps to reduce the possibility of unauthorized SKIS disarming. The rolling code algorithm ensures security by preventing an override of the SKIS through the unauthorized substitution of the SKIM or the PCM. However, the use of this strategy also means that replacement of either the SKIM or the PCM

DESCRIPTION AND OPERATION (Continued)

units will require a system initialization procedure to restore system operation.

When the ignition switch is turned to the On or Start positions, the SKIM transmits an RF signal to excite the Sentry Key transponder. The SKIM then listens for a return RF signal from the transponder of the Sentry Key that is inserted in the ignition lock cylinder. If the SKIM receives an RF signal with valid "Secret Key" and transponder identification codes, the SKIM sends a "valid key" message to the PCM over the CCD data bus. If the SKIM receives an invalid RF signal or no response, it sends "invalid key" messages to the PCM. The PCM will enable or disable engine operation based upon the status of the SKIM messages.

The SKIM also sends messages to the instrument cluster over the CCD data bus network to control the SKIS indicator lamp. The SKIM sends messages to the instrument cluster to turn the lamp on for about three seconds when the ignition switch is turned to the On position as a bulb test. After completion of the bulb test, the SKIM sends bus messages to keep the lamp off for a duration of about one second. Then the SKIM sends messages to turn the lamp on or off based upon the results of the SKIS self-tests. If the SKIS indicator lamp comes on and stays on after the bulb test, it indicates that the SKIM has detected a system malfunction and/or that the SKIS has become inoperative.

If the SKIM detects an invalid key or transponder fault when the ignition switch is turned to the On position, it sends messages to the instrument cluster to flash the SKIS indicator lamp.

For diagnosis or initialization of the SKIM and the PCM, a DRB scan tool and the proper Diagnostic Procedures manual are required. The SKIM cannot be repaired and, if faulty or damaged, the unit must be replaced.

SENTRY KEY IMMOBILIZER TRANSPONDER

The Sentry Key Immobilizer System (SKIS) uses a transponder that is integral to each of the two ignition keys that are supplied with the vehicle when it is shipped from the factory. The transponder chip is insulated within a nylon mount inserted in the head of the key, and invisible beneath a molded rubber cap (Fig. 1).

Each Sentry Key transponder has a unique transponder identification code programmed into it by the manufacturer. The Sentry Key Immobilizer Module (SKIM) has a unique "Secret Key" code programmed into it by the manufacturer. When a Sentry Key transponder is programmed into the memory of the SKIM, the SKIM learns the transponder identification code from the transponder, and the transponder learns the "Secret Key" code from the SKIM. Each of

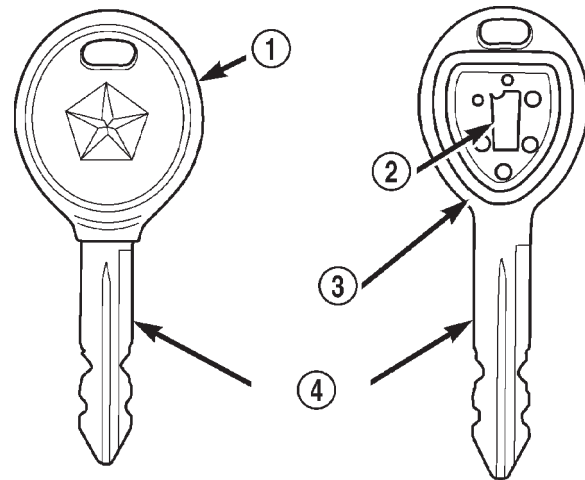

80b898ff

Fig. 1 Sentry Key Immobilizer Transponder

- 1 - MOLDED CAP
- 2 - TRANSPONDER
- 3 - MOLDED CAP REMOVED
- 4 - SENTRY KEY

these codes is stored within the transponder and in the nonvolatile memory of the SKIM. Therefore, blank keys for the SKIS must be programmed by and into the SKIM, in addition to being cut to match the mechanical coding of the ignition lock cylinder. See Sentry Key Immobilizer System Transponder Programming in this group for more information.

The Sentry Key transponder is within the range of the SKIM transceiver antenna ring when it is inserted in the ignition lock cylinder. When the ignition switch is turned to the Start or On positions, the SKIM transceiver issues a Radio Frequency (RF) signal that excites the transponder chip. The transponder chip responds by issuing an RF signal containing its transponder identification code and the "Secret Key" code. The SKIM transceiver compares the transponder codes with the codes stored in its memory to determine whether a valid key is in the ignition lock cylinder.

The Sentry Key transponder cannot be repaired and, if faulty or damaged, it must be replaced.

SENTRY KEY IMMOBILIZER SYSTEM INDICATOR LAMP

The Sentry Key Immobilizer System (SKIS) indicator lamp gives an indication when the SKIS is faulty or when the vehicle has been immobilized due to the use of an invalid ignition key. The lamp is controlled by the instrument cluster circuitry based upon messages received from the Sentry Key Immobilizer Module (SKIM) on the Chrysler Collision Detection (CCD) data bus.

DESCRIPTION AND OPERATION (Continued)

The SKIM sends messages to the instrument cluster to turn the lamp on for about three seconds when the ignition switch is turned to the On position as a bulb test. After completion of the bulb test, the SKIM sends bus messages to keep the lamp off for a duration of about one second. Then the SKIM sends messages to the instrument cluster circuitry to turn the lamp on or off based upon the results of the SKIS self-tests. If the SKIS indicator lamp comes on and stays on after the bulb test, it indicates that the SKIM has detected a system malfunction and/or that the SKIS has become inoperative. If the SKIM detects an invalid key or transponder fault when the ignition switch is turned to the On position, it sends messages to the instrument cluster to flash the SKIS indicator lamp.

The SKIS indicator lamp uses a replaceable incandescent bulb and bulb holder on the instrument cluster electronic circuit board. Refer to Group 8E - Instrument Panel Systems for diagnosis and service of a faulty SKIS indicator lamp. If the SKIS indicator lamp comes on and stays on after the bulb test function, diagnosis of the SKIS should be performed with a DRB scan tool and the proper Diagnostic Procedures manual.

DIAGNOSIS AND TESTING

SENTRY KEY IMMOBILIZER SYSTEM

WARNING: ON VEHICLES EQUIPPED WITH AIRBAGS, REFER TO GROUP 8M - PASSIVE RESTRAINT SYSTEMS BEFORE ATTEMPTING ANY STEERING WHEEL, STEERING COLUMN, OR INSTRUMENT PANEL COMPONENT DIAGNOSIS OR SERVICE. FAILURE TO TAKE THE PROPER PRECAUTIONS COULD RESULT IN ACCIDENTAL AIRBAG DEPLOYMENT AND POSSIBLE PERSONAL INJURY.

NOTE: The following tests may not prove conclusive in the diagnosis of this system. The most reliable, efficient, and accurate means to diagnose the Sentry Key Immobilizer System involves the use of a DRB scan tool. Refer to the proper Diagnostic Procedures manual for the procedures.

The Sentry Key Immobilizer System (SKIS) and the Chrysler Collision Detection (CCD) data bus net-

work should be diagnosed using a DRB scan tool. The DRB will allow confirmation that the CCD data bus is functional, that the Sentry Key Immobilizer Module (SKIM) is placing the proper messages on the CCD data bus, and that the Powertrain Control Module (PCM) and the instrument cluster are receiving the CCD data bus messages. Refer to the proper Diagnostic Procedures manual for the procedures. Refer to 8W-30 - Fuel/Ignition System in Group 8W - Wiring Diagrams for complete circuit descriptions and diagrams.

(1) Check the fuses in the fuseblock module. If OK, go to Step 2. If not OK, repair the shorted circuit or component as required and replace the faulty fuse.

(2) Disconnect and isolate the battery negative cable. Unplug the wire harness connector at the SKIM. Check for continuity between the ground circuit cavity of the SKIM wire harness connector and a good ground. There should be continuity. If OK, go to Step 3. If not OK, repair the open circuit to ground as required.

(3) Connect the battery negative cable. Check for battery voltage at the fused B(+) circuit cavity of the SKIM wire harness connector. If OK, go to Step 4. If not OK, repair the open circuit to the fuse in the fuseblock module as required.

(4) Turn the ignition switch to the On position. Check for battery voltage at the fused ignition switch output (run/start) circuit cavity of the SKIM wire harness connector. If OK, use a DRB scan tool and the proper Diagnostic Procedures manual to complete the diagnosis of the SKIS. If not OK, repair the open circuit to the fuse in the fuseblock module as required.

SERVICE PROCEDURES

SENTRY KEY IMMOBILIZER SYSTEM
TRANSPONDER PROGRAMMING

Two programmed Sentry Key transponders are included with the Sentry Key Immobilizer System (SKIS) when it is shipped from the factory. The Sentry Key Immobilizer Module (SKIM) can be programmed to recognize up to six additional transponders, for a total of eight Sentry Keys. Sentry Key programming will require the use of a DRB scan tool and the proper Diagnostic Procedures manual.

REMOVAL AND INSTALLATION

SENTRY KEY IMMOBILIZER MODULE

WARNING: ON VEHICLES EQUIPPED WITH AIRBAGS, REFER TO GROUP 8M - PASSIVE RESTRAINT SYSTEMS BEFORE ATTEMPTING ANY STEERING WHEEL, STEERING COLUMN, OR INSTRUMENT PANEL COMPONENT DIAGNOSIS OR SERVICE. FAILURE TO TAKE THE PROPER PRECAUTIONS COULD RESULT IN ACCIDENTAL AIRBAG DEPLOYMENT AND POSSIBLE PERSONAL INJURY.

- (1) Disconnect the negative battery cable.
- (2) Remove the knee blocker from the instrument panel. See Knee Blocker in Group 8E - Instrument Panel Systems for the procedures.
- (3) Insert the key in the ignition lock cylinder and turn the ignition switch to the On position.
- (4) Insert a small screwdriver or pin punch through the access hole in the lower steering column shroud and depress the ignition lock cylinder retaining tumbler (Fig. 2).

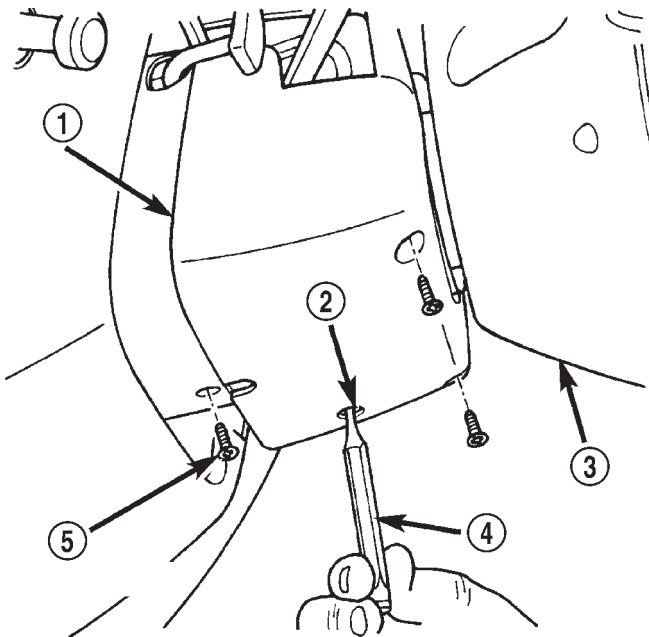

80a463e5

Fig. 2 Steering Column Shrouds Remove/Install

- 1 - LOWER SHROUD
- 2 - ACCESS HOLE
- 3 - STEERING WHEEL
- 4 - PIN PUNCH
- 5 - SCREWS (3)

(5) While holding the retaining tumbler depressed, pull the ignition lock cylinder and key out of the ignition lock housing.

(6) Remove the three screws that secure the lower steering column shroud to the upper shroud.

(7) If the vehicle is so equipped, move the tilt steering column to the fully lowered position.

(8) If the vehicle is so equipped, loosen the two nuts that secure the non-tilt steering column upper mounting bracket to the dash panel steering column support bracket studs. Lower the column far enough to remove the upper steering column shroud.

(9) Remove both the upper and lower shrouds from the steering column.

(10) Disengage the steering column wire harness retainer from the tab on the top of the Sentry Key Immobilizer Module (SKIM) mounting bracket (Fig. 3).

(11) Unplug the wire harness connector from the SKIM receptacle.

(12) The SKIM mounting bracket features a clip formation that secures the SKIM to the inboard lower flange of the steering column jacket. Pull downward on the connector end of the SKIM mounting bracket to release this clip from the steering column jacket.

(13) Rotate the SKIM and its mounting bracket downwards and then to the side away from the steering column to slide the SKIM antenna ring from around the ignition switch lock cylinder housing.

REMOVAL AND INSTALLATION (Continued)

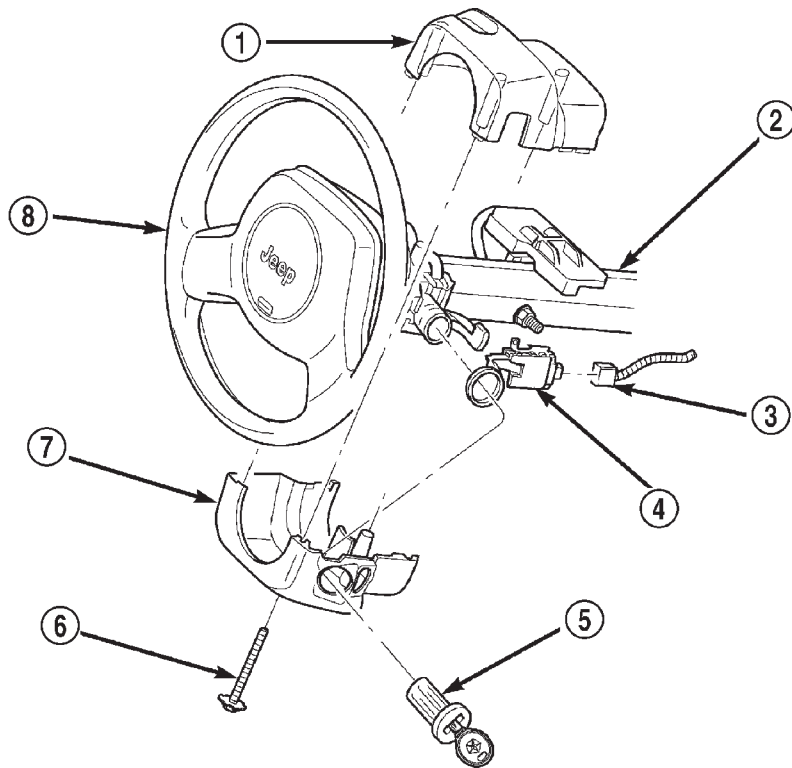

80b46c13

Fig. 3 Sentry Key Immobilizer Module Remove/Install

- | | |
|-----------------------------------|----------------------------|
| 1 - UPPER SHROUD | 5 - IGNITION LOCK CYLINDER |
| 2 - STEERING COLUMN | 6 - SCREW |
| 3 - WIRE HARNESS CONNECTOR | 7 - LOWER SHROUD |
| 4 - SENTRY KEY IMMOBILIZER MODULE | 8 - STEERING WHEEL |

(14) Remove the SKIM from the vehicle.

(15) Reverse the removal procedures to install. Tighten the non-tilt steering column mounting nuts to 22 N·m (200 in. lbs.) and the steering column shroud mounting screws to 2 N·m (18 in. lbs.).

(16) If the SKIM is replaced with a new unit, a DRB scan tool and the proper Diagnostic Procedures manual MUST be used to initialize the new SKIM and to program at least two Sentry Key transponders.

POWER SEAT SYSTEMS

TABLE OF CONTENTS

| | page | | page |
|--|------|--|------|
| GENERAL INFORMATION | | DIAGNOSIS AND TESTING | |
| INTRODUCTION | 1 | POWER SEAT SYSTEM | 2 |
| POWER SEAT SYSTEM | 1 | CIRCUIT BREAKER | 2 |
| DESCRIPTION AND OPERATION | | POWER SEAT ADJUSTER AND MOTORS | 2 |
| POWER SEAT SWITCH | 1 | POWER SEAT SWITCH | 2 |
| POWER SEAT ADJUSTER AND MOTORS | 1 | REMOVAL AND INSTALLATION | |
| CIRCUIT BREAKER | 2 | POWER SEAT SWITCH | 3 |
| | | POWER SEAT ADJUSTER AND MOTORS | 3 |

GENERAL INFORMATION

INTRODUCTION

Six-way power seats are an available factory-installed option for Left-Hand Drive (LHD) versions of this model. Refer to 8W-63 - Power Seat in Group 8W - Wiring Diagrams for complete circuit descriptions and diagrams.

NOTE: This group covers both Left-Hand Drive (LHD) and Right-Hand Drive (RHD) versions of this model. Whenever required and feasible, the RHD versions of affected vehicle components have been constructed as mirror-image of the LHD versions. While most of the illustrations used in this group represent only the LHD version, the diagnostic and service procedures outlined can generally be applied to either version. Exceptions to this rule have been clearly identified as LHD or RHD, if a special illustration or procedure is required.

POWER SEAT SYSTEM

The power seat system option allows the front seating positions to be electrically adjusted for optimum control and comfort using the power seat switches located on the outboard seat cushion side shield. The power seat system allows the seating position to be adjusted forward, rearward, front up, front down, rear up, or rear down. The power seat system receives battery current through a fuse in the Power Distribution Center and a circuit breaker in the junction block, regardless of the ignition switch position.

The power seat system includes the power seat adjuster and motors unit, the power seat switch, and the circuit breaker. Following are general descriptions of the major components in the power seat sys-

tem. Refer to the owner's manual in the vehicle glove box for more information on the features, use and operation of the power seat system.

DESCRIPTION AND OPERATION

POWER SEAT SWITCH

The power seat can be adjusted in six different ways using the power seat switch. The switch is located on the lower outboard side of the seat cushion on the seat cushion side shield. Refer to the owner's manual for more information on the power seat switch functions and the seat adjusting procedures.

The individual switches in the power seat switch unit cannot be repaired. If one switch is damaged or faulty, the entire power seat switch unit must be replaced.

POWER SEAT ADJUSTER AND MOTORS

There are three reversible motors that operate the power seat adjuster. The motors are connected to worm-drive gearboxes that move the seat adjuster through a combination of screw-type drive units.

The front and rear of a seat are operated by different motors. They can be raised or lowered independently of each other. When the center seat switch is pushed to the Up or Down position, both the front and rear motors operate in unison, moving the entire seat up or down. The forward-rearward motor is operated by pushing the center seat switch to the Forward or Rearward position.

When a switch is actuated, a battery feed and a ground path are applied through the switch contacts to the motor(s). The motor(s) and drives operate to move the seat in the selected direction until the switch is released, or until the travel limit of the power seat adjuster is reached. When the switch is

DESCRIPTION AND OPERATION (Continued)

moved in the opposite direction, the battery feed and ground path to the motor(s) are reversed through the switch contacts. This causes the motor to run in the opposite direction.

Each motor contains a self-resetting circuit breaker to protect it from overload. Consecutive or frequent resetting of the circuit breakers must not be allowed to continue, or the motors may be damaged. Make the necessary repairs.

The power seat adjuster and motors cannot be repaired, and are serviced only as a complete unit. If any component in this unit is faulty or damaged, the entire power seat adjuster and motors assembly must be replaced.

CIRCUIT BREAKER

An automatic resetting circuit breaker in the junction block is used to protect the power seat system circuit. The circuit breaker can protect the system from a short circuit, or from an overload condition caused by an obstructed or stuck seat adjuster.

The circuit breaker cannot be repaired and, if faulty or damaged, it must be replaced.

DIAGNOSIS AND TESTING

POWER SEAT SYSTEM

Before any testing of the power seat system is attempted, the battery should be fully-charged and all wire harness connections and pins cleaned and tightened to ensure proper continuity and grounds. For circuit descriptions and diagrams, refer to 8W-63 - Power Seat in Group 8W - Wiring Diagrams.

With the dome lamp on, apply the power seat switch in the direction of the failure. If the dome lamp dims, the seat may be jamming. Check under and behind the seat for binding or obstructions. If the dome lamp does not dim, proceed with testing of the individual components and circuits.

CIRCUIT BREAKER

For circuit descriptions and diagrams, refer to 8W-63 - Power Seat in Group 8W - Wiring Diagrams.

(1) Locate the correct circuit breaker in the junction block. Pull out the circuit breaker slightly, but be certain that the circuit breaker terminals still contact the terminals in the junction block cavities.

(2) Connect the negative lead of a 12-volt DC voltmeter to a good ground.

(3) With the voltmeter positive lead, check both terminals of the circuit breaker for battery voltage.

If only one terminal has battery voltage, the circuit breaker is faulty and must be replaced. If neither terminal has battery voltage, repair the open circuit

from the Power Distribution Center (PDC) as required.

POWER SEAT ADJUSTER AND MOTORS

For circuit descriptions and diagrams, refer to 8W-63 - Power Seat in Group 8W - Wiring Diagrams.

Operate the power seat switch to move all three seat motors in each direction. The seat should move in each of the selected directions. If the power seat adjuster fails to operate in only one direction, move the adjuster a short distance in the opposite direction and test again to be certain that the adjuster is not at its travel limit. If the power seat adjuster still fails to operate in only one direction, see Power Seat Switch in the Diagnosis and Testing section of this group. If the power seat adjuster fails to operate in more than one direction, proceed as follows:

(1) Test the circuit breaker in the junction block as described in this group. If OK, go to Step 2. If not OK, replace the faulty circuit breaker.

(2) Remove the power seat switch from the seat. Check for battery voltage at the fused B(+) circuit cavity of the power seat switch wire harness connector. If OK, go to Step 3. If not OK, repair the open circuit to the junction block as required.

(3) Check for continuity between the ground circuit cavity of the power seat switch wire harness connector and a good ground. There should be continuity. If OK, go to Step 4. If not OK, repair the open circuit to ground as required.

(4) Test the power seat switch as described in this group. If the switch tests OK, check the wire harness for the inoperative power seat motor(s) between the power seat switch and the motor for shorts or opens. If the circuits check OK, replace the faulty power seat adjuster and motors assembly. If the circuits are not OK, repair the wire harness as required.

POWER SEAT SWITCH

For circuit descriptions and diagrams, refer to 8W-63 - Power Seat in Group 8W - Wiring Diagrams.

(1) Disconnect and isolate the battery negative cable.

(2) Remove the power seat switch from the power seat.

(3) Use an ohmmeter to test the continuity of the power seat switches in each position. See the Power Seat Switch Continuity chart (Fig. 1). If OK, see the diagnosis for the Power Seat Adjuster and Motors in this group. If not OK, replace the faulty power seat switch module.

DIAGNOSIS AND TESTING (Continued)

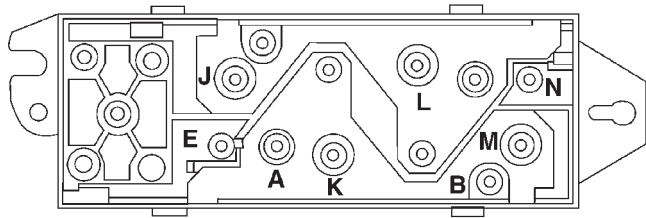

| POWER SEAT SWITCH | |
|---------------------|------------------------------|
| LEFT SEAT SWITCH | |
| SWITCH POSITION | CONTINUITY BETWEEN |
| Off | B-E, B-J, B-K, B-L, B-M, B-N |
| Vertical Up | A-J, A-M, B-E, B-N |
| Vertical Down | A-E, A-N, B-J, B-M |
| Horizontal Forward | A-L, B-K |
| Horizontal Rearward | A-K, B-L |
| Front Tilt Up | A-M, B-N |
| Front Tilt Down | A-N, B-M |
| Rear Tilt Up | A-J, B-E |
| Rear Tilt Down | A-E, B-J |

| RIGHT SEAT SWITCH | |
|---------------------|------------------------------|
| SWITCH POSITION | CONTINUITY BETWEEN |
| Off | A-E, A-J, A-K, A-L, A-M, A-N |
| Vertical Up | A-J, A-N, B-E, B-M |
| Vertical Down | A-E, A-M, B-J, B-N |
| Horizontal Forward | A-L, B-K |
| Horizontal Rearward | A-K, B-L |
| Front Tilt Up | A-N, B-M |
| Front Tilt Down | A-M, B-N |
| Rear Tilt Up | A-J, B-E |
| Rear Tilt Down | A-E, B-J |

80ba7a5a

Fig. 1 Power Seat Switch Continuity

REMOVAL AND INSTALLATION

POWER SEAT SWITCH

- (1) Disconnect and isolate the battery negative cable.
- (2) Remove the three screws that secure the seat cushion side shield to the outboard seat cushion frame.
- (3) Pull the seat cushion side shield away from the seat cushion frame far enough to access the power seat switch wire harness connector.
- (4) Unplug the wire harness connector from the power seat switch.
- (5) Remove the seat cushion side shield from the seat.
- (6) Remove the two screws that secure the power seat switch to the inside of the seat cushion side shield (Fig. 2).

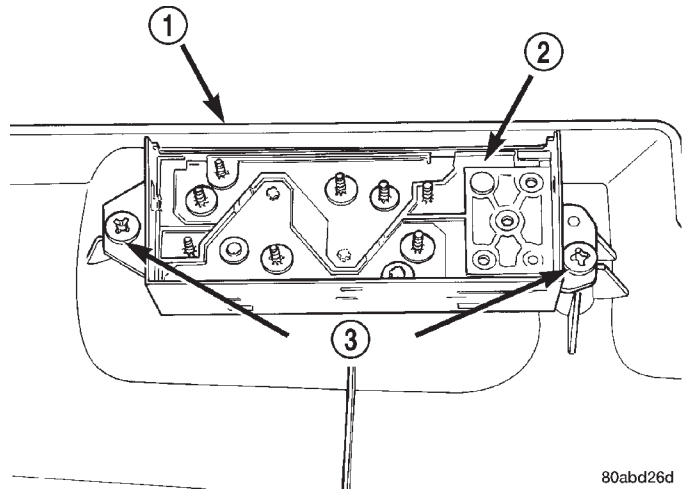

80abd26d

Fig. 2 Power Seat Switch Remove/Install

- 1 - SEAT SIDE SHIELD
- 2 - POWER SEAT SWITCH
- 3 - SCREWS

- (7) Remove the power seat switch from the seat cushion side shield.
- (8) Reverse the removal procedures to install. Tighten the mounting screws to 2.2 N-m (20 in. lbs.).

POWER SEAT ADJUSTER AND MOTORS

- (1) Move the seat to its fully raised and fully forward position, if possible.
- (2) Disconnect and isolate the battery negative cable.
- (3) For the driver side power seat only, unplug the seat belt switch wire harness connector from the driver side seat belt buckle half on the inboard side of the seat (Fig. 3).
- (4) Unplug the power seat wire harness connector from the body wire harness connector.

REMOVAL AND INSTALLATION (Continued)

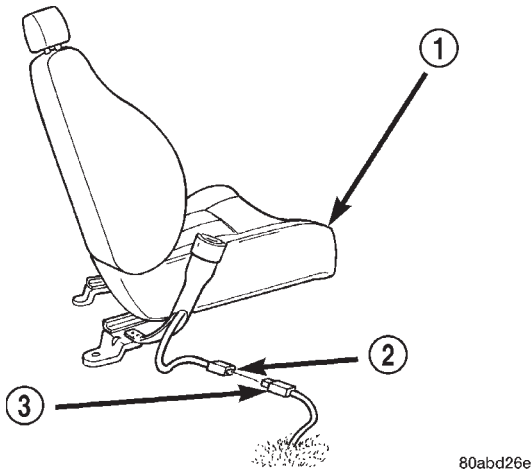

Fig. 3 Driver Seat Belt Switch Connector

- 1 - DRIVER SIDE FRONT SEAT
 2 - SEAT BELT SWITCH CONNECTOR
 3 - BODY WIRE HARNESS CONNECTOR

(5) Remove the two screws that secure the front of the seat adjuster frame to the floor panel seat mounting reinforcement (Fig. 4).

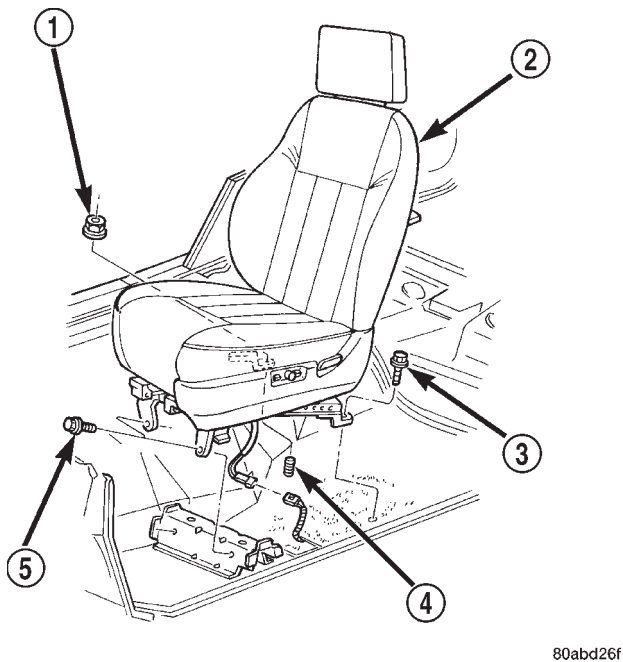

Fig. 4 Power Seat Remove/Install

- 1 - NUT
 2 - DRIVER SIDE FRONT SEAT
 3 - SCREW
 4 - STUD
 5 - SCREW

(6) Remove the screw that secures the outboard rear of the seat adjuster frame to the floor panel.

(7) Remove the nut that secures the inboard rear of the seat adjuster frame to the stud on the floor panel.

(8) Remove the seat and the power seat adjuster and motors assembly from the vehicle as a unit.

(9) Remove the four nuts that secure the power seat adjuster and motors assembly to the seat cushion frame (Fig. 5).

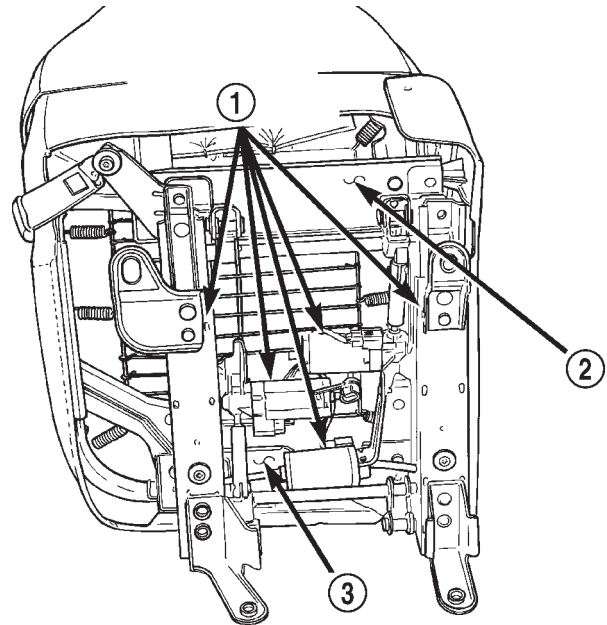

Fig. 5 Power Seat Adjuster and Motors Remove/Install

- 1 - POWER SEAT ADJUSTER AND MOTORS
 2 - SEAT CUSHION FRAME
 3 - SEAT CUSHION FRAME

(10) Remove the power seat switch from the outboard side of the seat. Refer to **Power Seat Switch** in the index of this service manual for the location of the proper power seat switch removal and installation procedures.

(11) Disengage the power seat switch wire harness and connector from the seat cushion frame.

(12) Remove the power seat adjuster and motors assembly from the seat cushion frame.

(13) Reverse the removal procedures to install. Tighten the seat mounting hardware as follows:

- Seat adjuster to seat cushion frame nuts - 25 N·m (18 ft. lbs.)
- Seat adjuster to floor panel screws - 27 N·m (20 ft. lbs.)
- Seat adjuster to floor panel nut - 40 N·m (30 ft. lbs.).

POWER WINDOW SYSTEMS

TABLE OF CONTENTS

| | page | | page |
|----------------------------------|------|---------------------------------|------|
| GENERAL INFORMATION | | CIRCUIT BREAKER..... | 3 |
| INTRODUCTION | 1 | DOOR MODULE | 3 |
| POWER WINDOW SYSTEM | 1 | POWER WINDOW SWITCH | 4 |
| DESCRIPTION AND OPERATION | | POWER WINDOW MOTOR..... | 4 |
| POWER WINDOW SWITCH | 1 | REMOVAL AND INSTALLATION | |
| DOOR MODULE | 2 | DOOR MODULE | 4 |
| POWER WINDOW MOTOR..... | 2 | POWER WINDOW SWITCH | 5 |
| CIRCUIT BREAKER..... | 2 | POWER WINDOW MOTOR..... | 6 |
| DIAGNOSIS AND TESTING | | | |
| POWER WINDOW SYSTEM | 2 | | |

GENERAL INFORMATION

INTRODUCTION

Power windows are available as factory-installed optional equipment on this model. The power lock system and power mirror system are included on vehicles equipped with the power window option. Refer to 8W-60 - Power Windows in Group 8W - Wiring Diagrams for complete circuit descriptions and diagrams.

NOTE: This group covers both Left-Hand Drive (LHD) and Right-Hand Drive (RHD) versions of this model. Whenever required and feasible, the RHD versions of affected vehicle components have been constructed as mirror-image of the LHD versions. While most of the illustrations used in this group represent only the LHD version, the diagnostic and service procedures outlined can generally be applied to either version. Exceptions to this rule have been clearly identified as LHD or RHD, if a special illustration or procedure is required.

POWER WINDOW SYSTEM

The power window system allows all of the door windows to be raised and lowered electrically by actuating a switch on the trim panel of each respective door. Additionally, a set of master switches on the driver side front door trim panel allows the driver to raise or lower each of the passenger door windows. A power window lockout switch on the driver side front door trim panel can prevent the passenger door windows from being operated, except from the master switches. The power window system receives battery current through a circuit breaker in

the junction block, only when the ignition switch is in the On or Accessory positions.

The power window system includes the power window switches on each door trim panel, the circuit breaker in the junction block, and the power window motors inside each door. This group covers diagnosis and service of only the electrical components in the power window system. For service of mechanical components, such as the regulator, lift plate, window tracks, or glass refer to Group 23 - Body.

Following are general descriptions of the major components in the power window system. Refer to the owner's manual in the vehicle glove box for more information on the features, use and operation of the power window system.

DESCRIPTION AND OPERATION

POWER WINDOW SWITCH

The individual power windows are controlled by a two-way momentary switch mounted on the trim panel of the passenger side front door trim panel and, on four-door models, on each of the rear door trim panels. Two-way momentary master switches on the driver side front door trim panel control all of the power windows in the vehicle. The driver side front door trim panel also has a two-position power window lockout switch.

The front door power window switches and the power window lockout switch are integral to the Driver Door Module (DDM) or Passenger Door Module (PDM), respectively. The rear door power window switches are stand-alone units.

Each power window switch controls its power window motor by switching battery current and ground

DESCRIPTION AND OPERATION (Continued)

between the terminals of the power window motor. The passenger side front door and, on four-door models, both rear door power window switches receive their battery feed through the power window lockout switch or through the master switches in the DDM. Also, each of the individual power window switches receives its ground through the DDM. When the lockout switch is placed in the Lock position, the individual power window switches become inoperative because they have no battery current available to them. However, the master switches are unaffected by the lockout switch position.

Each power window switch, except the lockout switch, is illuminated by a Light-Emitting Diode (LED) when the ignition switch is turned to the On position. However, when the power window lockout switch is placed in the Lock position, the LED for the locked-out passenger side front and, on four-door models, the rear passenger door power window switches is turned off.

The front door power window switches and their lamps cannot be repaired and, if faulty or damaged, the entire door module must be replaced. The rear door power window switches and their lamps cannot be repaired but, if faulty or damaged, only the affected switch unit must be replaced.

DOOR MODULE

A Driver Door Module (DDM) and a Passenger Door Module (PDM) are used on all models equipped with power locks and power windows. Each door module houses both the front door power lock and power window switches. In addition to the switches for its own door, the DDM houses individual switches for each passenger door power window, a power window lockout switch, the power mirror switch, and circuitry to support the one-touch down feature of the driver side front door power window. The PDM also houses the control circuitry and the power lock and unlock relays for the power lock system.

The DDM and the PDM are mounted to their respective front door trim panels. The DDM and PDM are serviced individually and cannot be repaired. If the DDM or PDM, or any of the switches and circuitry that they contain are faulty or damaged, the complete DDM or PDM unit must be replaced.

POWER WINDOW MOTOR

A permanent magnet reversible motor moves the window regulator through an integral gearbox mechanism. A positive and negative battery connection to the two motor terminals will cause the motor to rotate in one direction. Reversing the current through these same two connections will cause the motor to rotate in the opposite direction.

In addition, each power window motor is equipped with an integral self-resetting circuit breaker to protect the motor from overloads. The power window motor and gearbox assembly cannot be repaired and, if faulty or damaged, the entire power window regulator assembly must be replaced.

CIRCUIT BREAKER

An automatic resetting circuit breaker in the junction block is used to protect the power window system circuit. The circuit breaker can protect the system from a short circuit, or from an overload condition caused by an obstructed or stuck window glass or regulator.

The circuit breaker cannot be repaired and, if faulty, it must be replaced.

DIAGNOSIS AND TESTING

POWER WINDOW SYSTEM

For circuit descriptions and diagrams, refer to 8W-60 - Power Windows in Group 8W - Wiring Diagrams.

ALL WINDOWS INOPERATIVE

(1) Check the circuit breaker in the junction block, as described in this group. If OK, go to Step 2. If not OK, replace the faulty circuit breaker.

(2) Disconnect and isolate the battery negative cable. Remove the driver side front door trim panel and unplug the Driver Door Module (DDM) wire harness connectors from the DDM. Check for continuity between the ground circuit cavity of the 8-way DDM wire harness connector and a good ground. If OK, go to Step 3. If not OK, repair the circuit to ground as required.

(3) Connect the battery negative cable. Turn the ignition switch to the On position. Check for battery voltage at the master switch power feed (run/acc) circuit cavity of the 12-way DDM wire harness connector. If OK, see the diagnosis for the Door Module in this group. If not OK, repair the open circuit to the circuit breaker in the junction block as required.

ONE WINDOW INOPERATIVE

The window glass must be free to slide up and down for the power window motor to function properly. If the glass is not free to move up and down, the motor will overload and trip the integral circuit breaker. To determine if the glass is free, disconnect the regulator plate from the glass. Then slide the window up and down by hand.

There is an alternate method to check if the glass is free. Position the glass between the up and down stops. Then, shake the glass in the door. Check that

DIAGNOSIS AND TESTING (Continued)

the glass can be moved slightly from side to side, front to rear, and up and down. Then check that the glass is not bound tight in the tracks. If the glass is free, proceed with the diagnosis that follows. If the glass is not free, refer to Group 23 - Body for the door window glass and hardware service and adjustment procedures.

(1) Check the power window switch continuity as described in the diagnosis for the Door Module (front doors) or Power Window Switch (rear doors) in this group. If OK and the driver side front window is inoperative, see the Power Window Motor diagnosis in this group. If OK and the inoperative window is other than the driver side front, go to Step 2. If not OK, replace the faulty door module or switch.

(2) Refer to the circuit diagrams in 8W-60 - Power Windows in Group 8W - Wiring Diagrams. Check the continuity in each circuit between the inoperative Passenger Door Module (PDM) or power window switch wire harness connector cavities and the corresponding Driver Door Module (DDM) wire harness connector cavities. If OK, see the diagnosis for the Power Window Motor in this group. If not OK, repair the open circuit(s) as required.

NOTE: All individual power window switches receive their battery and ground feeds through the Driver Door Module (DDM) and wire harness connectors.

CIRCUIT BREAKER

For circuit descriptions and diagrams, refer to 8W-60 - Power Windows in Group 8W - Wiring Diagrams.

(1) Locate the circuit breaker in the junction block. Pull out the circuit breaker slightly, but be certain that the circuit breaker terminals still contact the terminals in the junction block cavities.

(2) Connect the negative lead of a 12-volt DC voltmeter to a good ground.

(3) With the voltmeter positive lead, check both terminals of the circuit breaker for battery voltage.

If only one terminal has battery voltage, the circuit breaker is faulty and must be replaced. If neither terminal has battery voltage, repair the open circuit from the Power Distribution Center (PDC) as required. If the circuit breaker checks OK, but no power windows operate, see Power Window System in the Diagnosis and Testing section of this group.

DOOR MODULE

The Driver Door Module (DDM) contains the master switches and the lockout switch in the power window system. The DDM also contains an integrated circuit to support the one-touch down feature of the driver side front door power window. Remember that

the passenger side front door power window switch and, on four-door models, the rear door power window switches get their battery current through the power window lockout switch in the Driver Door Module (DDM). In addition, each individual power window switch gets its ground through the master switch in the DDM.

The one-touch down feature circuitry within the DDM will not operate the power window motor if the door glass, window regulator, or gearbox mechanism are stuck, obstructed, or binding. If the driver side front door power window operates as designed, but the one-touch down feature is inoperative, replace the faulty DDM.

If the problem being diagnosed is an inoperative power window switch illumination lamp, but the power window switch operates as designed, replace the faulty door module. For circuit descriptions and diagrams, refer to 8W-60 - Power Windows in Group 8W - Wiring Diagrams.

(1) Disconnect and isolate the battery negative cable. Remove the front door trim panel and unplug the door module wire harness connectors from the door module.

(2) Check the door module power window switch and/or power window lockout switch continuity in each position, as shown in the proper chart (Fig. 1) or (Fig. 2). If OK, see the Power Window Motor diagnosis in this group. If not OK, replace the faulty door module.

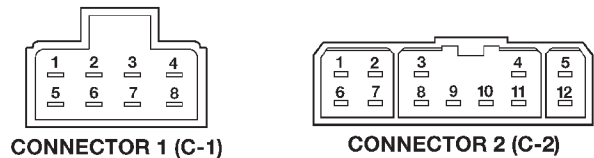

**POWER WINDOWS
CONNECTOR 2 (C2)**

| SWITCH POSITION | CONTINUITY BETWEEN |
|------------------|-----------------------------------|
| OFF (NORMAL) | 1&8,2&8,3&8,4&8,5&8,6&8,10&8,12&8 |
| RIGHT REAR DOWN | 1&9,2&8 |
| RIGHT REAR UP | 2&9,1&8 |
| RIGHT FRONT UP | 3&9,6&8 |
| LEFT REAR UP | 4&9,10&8 |
| LEFT FRONT UP | 5&9,12&8 |
| RIGHT FRONT DOWN | 6&9,3&8 |
| LEFT REAR DOWN | 10&9,4&8 |
| LEFT FRONT DOWN | 12&9,5&8 |

**WINDOW LOCKOUT
CONNECTOR 1 (C1), CONNECTOR 2 (C2)**

| SWITCH POSITION | CONTINUITY BETWEEN |
|-------------------|---|
| LOCKOUT OFF (UP) | C1 PIN 8 & C2 PIN 9 |
| LOCKOUT ON (DOWN) | NO CONTINUITY BETWEEN C1 PIN 8 & C2 PIN 9 |

80ba7a4f

Fig. 1 DDM Power Window Switch Continuity

DIAGNOSIS AND TESTING (Continued)

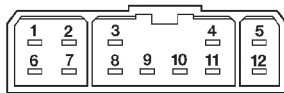

CONNECTOR 2 (C-2)

| POWER WINDOWS | |
|---------------|---|
| OFF (NORMAL) | C2 PIN 2 & C2 PIN 3 C2 PIN 4 & C2 PIN 9 |
| UP | C2 PIN 2 & C2 PIN 3 C2 PIN 9 & C2 PIN 10 |
| DOWN | C2 PIN 2 & C2 PIN 10 C2 PIN 4 & C2 PIN 9 |

80abd2ec

Fig. 2 PDM Power Window Switch Continuity

POWER WINDOW SWITCH

The diagnosis found here applies only to the rear door power window switches. For diagnosis of the front door power window switches, see Door Module in this group. If the problem being diagnosed is an inoperative power window switch illumination lamp, but the power window switch operates as designed, replace the faulty switch. For circuit descriptions and diagrams, refer to 8W-60 - Power Windows in Group 8W - Wiring Diagrams.

- (1) Disconnect and isolate the battery negative cable.
- (2) Remove the power window switch from the rear door trim panel.
- (3) Check the power window switch continuity in each position as shown in the Rear Door Power Window Switch Continuity chart (Fig. 3). If OK, see the Power Window Motor diagnosis in this group. If not OK, replace the faulty switch.

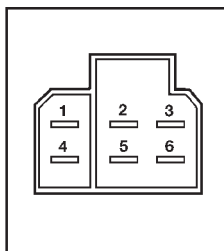

| SWITCH POSITION | CONTINUITY BETWEEN |
|-----------------|--------------------|
| OFF (NORMAL) | 1&4 2&5 |
| UP | 1&6 2&5 |
| DOWN | 1&4 5&6 |

80abd2ed

Fig. 3 Rear Door Power Window Switch Continuity

POWER WINDOW MOTOR

For circuit descriptions and diagrams, refer to 8W-60 - Power Windows in Group 8W - Wiring Diagrams. Before you proceed with this diagnosis, confirm proper switch operation. See the Door Module and/or Power Window Switch diagnosis in this group.

- (1) Disconnect and isolate the battery negative cable. Remove the trim panel from the door with the inoperative power window.
- (2) Unplug the power window motor wire harness connector. Apply 12 volts across the motor terminals to check its operation in one direction. Reverse the connections across the motor terminals to check the operation in the other direction. Remember, if the window is in the full up or full down position, the motor will not operate in that direction by design. If OK, repair the circuits from the power window motor to the door module or the power window switch as required. If not OK, replace the faulty motor.
- (3) If the motor operates in both directions, check the operation of the window glass and lift mechanism through its complete up and down travel. There should be no binding or sticking of the window glass or lift mechanism through the entire travel range. If not OK, refer to Group 23 - Body to check the window glass, tracks, and regulator for sticking, binding, or improper adjustment.

REMOVAL AND INSTALLATION

DOOR MODULE

- (1) Disconnect and isolate the battery negative cable.
- (2) Remove the screws that secure the front door trim panel to the inner door panel (Fig. 4).
- (3) Using a trim stick or another suitable wide flat-bladed tool, gently pry the front door trim panel away from the door around the perimeter to release the trim panel retainers.

NOTE: To aid in the removal of the trim panel, start at the bottom of the panel.

- (4) Lift the front door trim panel upwards and away from the inner door panel far enough to disengage the top of the panel from the inner belt weatherstrip.
- (5) Pull the front door trim panel away from the inner door panel far enough to access the inside door latch release and lock linkage rods near the back of the inside door remote controls.
- (6) Unsnap the plastic retainer clips from the inside door remote control ends of the latch release and lock linkage rods, and remove the rod ends from the inside door remote controls.

REMOVAL AND INSTALLATION (Continued)

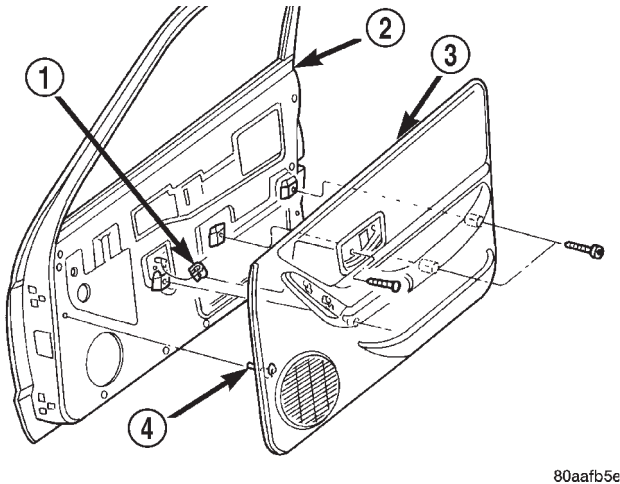

80aafb5e

Fig. 4 Front Door Trim Panel Remove/Install

- 1 - U-NUT
- 2 - DOOR
- 3 - TRIM PANEL
- 4 - PUSH-IN FASTENER

(7) Unplug the wire harness connectors from the door module.

(8) Remove the trim panel from the front door.

(9) Remove the three screws that secure the door module to the front door trim panel (Fig. 5).

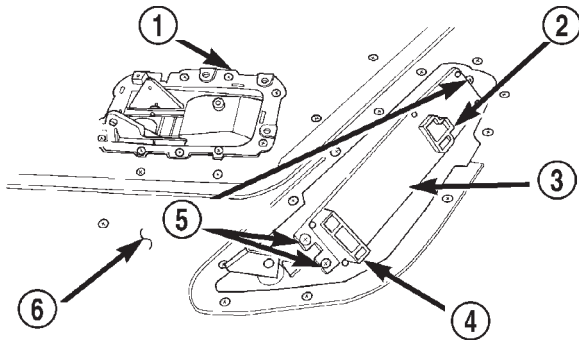

80abd2da

Fig. 5 Door Module Remove/Install

- 1 - INSIDE DOOR LATCH AND LOCK REMOTE CONTROLS
- 2 - CONNECTOR 1 RECEPTACLE
- 3 - DOOR MODULE
- 4 - CONNECTOR 2 RECEPTACLE
- 5 - SCREWS
- 6 - DOOR TRIM PANEL

(10) Remove the door module from the front door trim panel.

(11) Reverse the removal procedures to install. Tighten the mounting screws to 2.2 N-m (20 in. lbs.).

POWER WINDOW SWITCH

(1) Disconnect and isolate the battery negative cable.

(2) Remove the screws that secure the door trim panel to the inner door panel (Fig. 6).

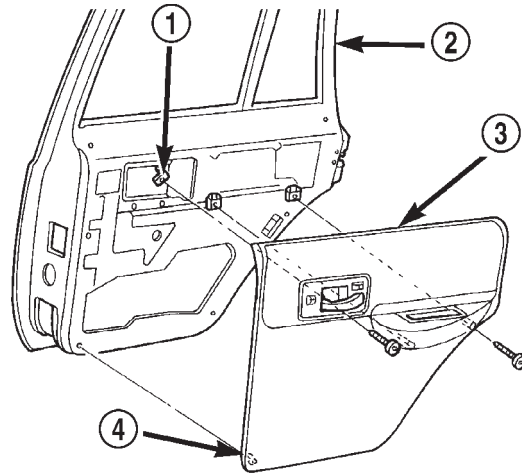

80aafb5a

Fig. 6 Rear Door Trim Panel Remove/Install

- 1 - U-NUT
- 2 - REAR DOOR
- 3 - TRIM PANEL
- 4 - PUSH-IN FASTENER

(3) Using a trim stick or another suitable wide flat-bladed tool, gently pry the rear door trim panel away from the door around the perimeter to release the trim panel retainers.

NOTE: To aid in the removal of the trim panel, start at the bottom of the panel.

(4) Lift the rear door trim panel upwards and away from the inner door panel far enough to disengage the top of the panel from the inner belt weatherstrip.

(5) Pull the rear door trim panel away from the inner door panel far enough to access the inside door latch release and lock linkage rods near the back of the inside door remote controls.

(6) Unsnap the plastic retainer clips from the inside door remote control ends of the latch release and lock linkage rods, and remove the rod ends from the inside door remote controls.

(7) Unplug the wire harness connector from the rear door power window switch.

(8) Remove the trim panel from the rear door.

(9) With a small thin-bladed screwdriver, gently pry the snap clips at the sides of the power window switch receptacle on the back of the rear door trim panel and pull the switch out of the receptacle (Fig. 7).

(10) Reverse the removal procedures to install. Be certain that both of the switch snap retainers in the receptacle on the back of the trim panel are fully engaged.

REMOVAL AND INSTALLATION (Continued)

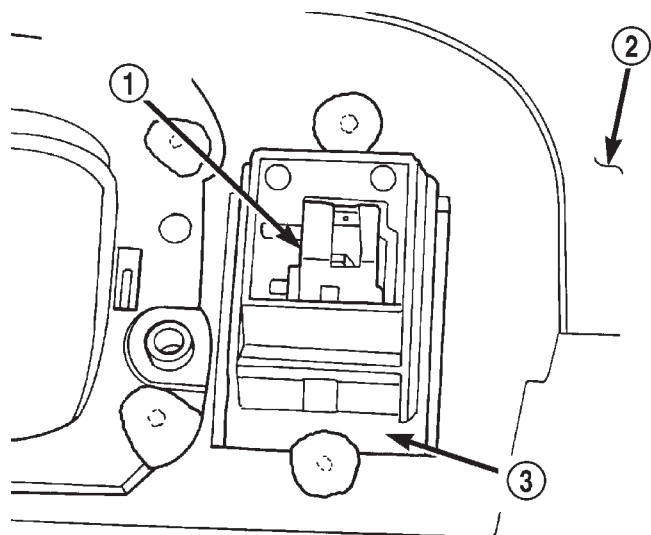

80abd2f0

**Fig. 7 Rear Door Power Window Switch Remove/
Install**

- 1 - REAR DOOR POWER WINDOW SWITCH
- 2 - TRIM PANEL
- 3 - SWITCH RECEPTACLE

ulator unit. If the front door power window motor or mechanism is faulty or damaged, the entire power window regulator unit must be replaced. Refer to Group 23 - Body for the front door window regulator service procedures.

REAR DOOR

The rear door power window motor and mechanism is integral to the rear door power window regulator unit. If the rear door power window motor or mechanism is faulty or damaged, the entire power window regulator unit must be replaced. Refer to Group 23 - Body for the rear door window regulator service procedures.

POWER WINDOW MOTOR

FRONT DOOR

The front door power window motor and mechanism is integral to the front door power window reg-

POWER MIRROR SYSTEMS

TABLE OF CONTENTS

| | page | | page |
|----------------------------------|------|---------------------------------|------|
| GENERAL INFORMATION | | DIAGNOSIS AND TESTING | |
| INTRODUCTION | 1 | POWER MIRROR SYSTEM. | 2 |
| POWER MIRROR SYSTEM. | 1 | REMOVAL AND INSTALLATION | |
| DESCRIPTION AND OPERATION | | POWER MIRROR SWITCH. | 3 |
| POWER MIRROR | 1 | DOOR MODULE | 3 |
| POWER MIRROR SWITCH. | 1 | POWER MIRROR | 4 |
| DOOR MODULE | 2 | | |

GENERAL INFORMATION

INTRODUCTION

Power operated or power operated and heated outside rear view mirrors are available factory-installed options on this model. Refer to 8W-62 - Power Mirrors in Group 8W - Wiring Diagrams for complete circuit descriptions and diagrams.

NOTE: This group covers both Left-Hand Drive (LHD) and Right-Hand Drive (RHD) versions of this model. Whenever required and feasible, the RHD versions of affected vehicle components have been constructed as mirror-image of the LHD versions. While most of the illustrations used in this group represent only the LHD version, the diagnostic and service procedures outlined can generally be applied to either version. Exceptions to this rule have been clearly identified as LHD or RHD, if a special illustration or procedure is required.

POWER MIRROR SYSTEM

The power operated or power operated and heated outside rear view mirrors allow the driver to adjust both outside mirrors electrically from the driver seat position by operating a switch on the driver side front door trim panel. The power mirrors receive battery current through a fuse in the junction block, and will only operate when the ignition switch is in the On or Accessory positions.

The heated mirror option includes an electric heating grid behind the mirror glass in each outside mirror, which can clear the mirror glass of ice, snow, or fog. The heating grid receives fused battery current through the rear window defogger relay only when the rear window defogger system is turned on. Refer to Group 8N - Electrically Heated Systems for more information on the rear window defogger system.

Following are general descriptions of the major components in the power mirror system. Refer to the owner's manual in the vehicle glove box for more information on the features, use and operation of the power mirror system.

DESCRIPTION AND OPERATION

POWER MIRROR

Each power mirror head contains two electric motors, two drive mechanisms, and the mirror glass. One motor and drive controls mirror up-and-down movement, and the other controls right-and-left movement.

The power mirrors in vehicles equipped with the available heated mirror option also include an electric heating grid located behind the mirror glass. This heating grid is energized by the rear window defogger relay whenever the rear window defogger system is turned on. Refer to Group 8N - Electrically Heated Systems for more information on the operation of the rear window defogger system.

The power mirror assembly cannot be repaired. Only the mirror glass is serviced separately. If any other component of the power mirror unit is faulty or damaged, the entire assembly must be replaced.

POWER MIRROR SWITCH

Both the right and left power outside mirrors are controlled by a single multi-function switch unit located on the driver side front door trim panel. Two versions of this switch are offered. Models without power windows or power locks have a stand-alone switch mounted in the driver side front door trim panel. Models equipped with power windows and power locks have a power mirror switch that is integral to the Driver Door Module (DDM).

Both versions of the switch are operated in the same manner. A three position rocker-type mirror

DESCRIPTION AND OPERATION (Continued)

selector switch is moved right (right mirror control), left (left mirror control), or center to turn the power mirrors off. Then one of four directional control buttons is depressed to control movement of the selected mirror up, down, right, or left. The directional control buttons of the DDM-mounted switch are illuminated when the ignition switch is in the On or Accessory positions. The stand-alone switch is not illuminated.

The stand-alone power mirror switch cannot be repaired and, if faulty or damaged, it must be replaced as a complete unit. If the DDM power mirror switch is faulty or damaged, the entire DDM unit must be replaced.

DOOR MODULE

A Driver Door Module (DDM) and a Passenger Door Module (PDM) are used on all models equipped with power locks and power windows. Each door module houses both the front door power lock and power window switches. In addition to the switches for its own door, the DDM houses individual switches for each passenger door power window, a power window lockout switch, the power mirror switch, and circuitry to support the one-touch down feature of the driver side front door power window. The PDM also houses the control circuitry and the power lock and unlock relays for the power lock system.

The DDM and the PDM are mounted to their respective front door trim panels. The DDM and PDM are serviced individually and cannot be repaired. If the DDM or PDM, or any of the switches and circuitry that they contain are faulty or damaged, the complete DDM or PDM unit must be replaced.

DIAGNOSIS AND TESTING

POWER MIRROR SYSTEM

For circuit descriptions and diagrams, refer to 8W-62 - Power Mirrors in Group 8W - Wiring Diagrams.

(1) Check the fuse in the junction block. If OK, go to Step 2. If not OK, repair the shorted circuit or component as required and replace the faulty fuse.

(2) Turn the ignition switch to the On position. Check for battery voltage at the fuse in the junction block. If OK, go to Step 3. If not OK, repair the open circuit to the ignition switch as required.

(3) If the problem being diagnosed is inoperative illumination of the power mirror switch directional buttons for the Driver Door Module (DDM)-type switch, proceed as follows. If not, go to Step 5. Check the power window circuit breaker in the junction block. If OK, go to Step 4. If not OK, replace the faulty circuit breaker.

(4) Turn the ignition switch to the Off position. Disconnect and isolate the battery negative cable. Remove the driver side front door trim panel and unplug the DDM wire harness connectors. Connect the battery negative cable. Turn the ignition switch to the On position. Check for battery voltage at the fused ignition switch output circuit cavity of the 12-way DDM wire harness connector. If OK, replace the faulty DDM. If not OK, repair the open circuit to the power window circuit breaker in the junction block as required.

(5) If the problem being diagnosed is an inoperative power mirror electric heating grid, proceed as follows. If not, go to Step 8. Disconnect and isolate the battery negative cable. Remove the front door trim panel on the side of the vehicle with the inoperative mirror heating grid. Unplug the wire harness connector at the mirror. Check for continuity between the ground circuit cavity in the body half of the power mirror wire harness connector and a good ground. If OK, go to Step 6. If not OK, repair the open circuit to ground as required.

(6) Connect the battery negative cable. Turn the ignition switch to the On position. Turn on the rear window defogger system. Check for battery voltage at the rear window defogger relay output circuit cavity in the body half of the power mirror wire harness connector. If OK, go to Step 7. If not OK, repair the open circuit to the rear window defogger relay as required.

(7) Check for continuity between the ground circuit and the rear window defogger relay output circuit cavities in the mirror half of the power mirror wire harness connector. There should be continuity. If not OK, replace the faulty power mirror. If OK, check the resistance through the electric heating grid circuit. Correct resistance through the electric heating grid should be from 10 to 16 ohms when measured at an ambient temperature of 21° C (70° F). If not OK, replace the faulty power mirror.

(8) Disconnect and isolate the battery negative cable. Remove the stand-alone power mirror switch from the driver side front door trim panel or, with a DDM-mounted switch, remove the driver side front door trim panel. Unplug the wire harness connector from the stand-alone switch or the 8-way wire harness connector from the DDM. Connect the battery negative cable. Turn the ignition switch to the On position. Check for battery voltage at the fused ignition switch output circuit cavity of the stand-alone switch wire harness connector or the 8-way DDM wire harness connector. If OK, go to Step 9. If not OK, repair the open circuit to the junction block as required.

(9) Turn the ignition switch to the Off position. Disconnect and isolate the battery negative cable.

DIAGNOSIS AND TESTING (Continued)

Check for continuity between the ground circuit cavity of the stand-alone switch wire harness connector or the 8-way DDM wire harness connector and a good ground. There should be continuity. If OK, go to Step 10. If not OK, repair the circuit to ground as required.

(10) Check the stand-alone power mirror switch or DDM-mounted power mirror switch continuity as shown in (Fig. 1) or (Fig. 2). If OK, go to Step 11. If not OK, replace the faulty stand-alone power mirror switch or the faulty DDM.

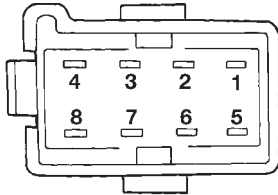

| SELECT RIGHT MIRROR | |
|---------------------|----------------------------|
| SWITCH POSITION | CONTINUITY BETWEEN |
| OFF | 1 & 3, 1 & 4, 1 & 5, 1 & 6 |
| UP | 2 & 4, 1 & 3, 1 & 5, 1 & 6 |
| DOWN | 2 & 5, 1 & 3, 1 & 4, 1 & 6 |
| RIGHT | 2 & 6, 1 & 3, 1 & 4, 1 & 5 |
| LEFT | 2 & 3, 1 & 4, 1 & 5, 1 & 6 |

| SELECT LEFT MIRROR | |
|--------------------|----------------------------|
| SWITCH POSITION | CONTINUITY BETWEEN |
| OFF | 1 & 5, 1 & 6, 1 & 7, 1 & 8 |
| UP | 2 & 8, 1 & 5, 1 & 6, 1 & 7 |
| DOWN | 2 & 5, 1 & 6, 1 & 7, 1 & 8 |
| RIGHT | 2 & 6, 1 & 5, 1 & 7, 1 & 8 |
| LEFT | 2 & 7, 1 & 5, 1 & 6, 1 & 8 |

80abfecb

Fig. 1 Stand-Alone Power Mirror Switch Continuity

(11) Connect the battery negative cable. Use two jumper wires, one connected to a 12-volt battery feed, and the other connected to a good body ground. See the Power Mirror Test chart for the correct jumper wire connections at the mirror half of the power mirror wire harness connector (Fig. 3). If the mirror reactions are OK, repair the wire harness between the mirror and the stand-alone power mirror switch or the DDM as required. If the mirror reactions are not OK, replace the faulty power outside mirror assembly.

REMOVAL AND INSTALLATION

POWER MIRROR SWITCH

This procedure covers removal of the stand-alone type power mirror switch. Vehicles with power windows and power locks have a power mirror switch

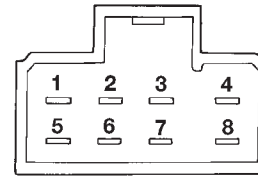

CONNECTOR 1 (C-1)

| SELECT RIGHT MIRROR | |
|---------------------|--------------------|
| SWITCH POSITION | CONTINUITY BETWEEN |
| UP | 7 & 3, 2 & 5 |
| DOWN | 2 & 3, 7 & 5 |
| RIGHT | 4 & 3, 2 & 5 |
| LEFT | 2 & 3, 6 & 5 |

| SELECT LEFT MIRROR | |
|--------------------|--------------------|
| SWITCH POSITION | CONTINUITY BETWEEN |
| UP | 1 & 3, 2 & 5 |
| DOWN | 2 & 3, 1 & 5 |
| RIGHT | 6 & 3, 2 & 5 |
| LEFT | 2 & 3, 6 & 5 |

80abfecb

Fig. 2 Driver Door Module Power Mirror Switch Continuity

which is integral to the Driver Door Module (DDM). See Door Module in this group for the DDM-type power mirror switch service procedures.

- (1) Disconnect and isolate the battery negative cable.
- (2) Using a trim stick or another suitable wide flat-bladed tool, gently pry around the perimeter edge of the switch to release the snap clips that secure the switch to the trim panel (Fig. 4).
- (3) Pull the power mirror switch away from the trim panel far enough to access the wire harness connector.
- (4) Unplug the power mirror switch from the wire harness connector.
- (5) Reverse the removal procedures to install.

DOOR MODULE

- (1) Disconnect and isolate the battery negative cable.
- (2) Remove the screws that secure the front door trim panel to the inner door panel (Fig. 5).
- (3) Using a trim stick or another suitable wide flat-bladed tool, gently pry the front door trim panel away from the door around the perimeter to release the trim panel retainers.

NOTE: To aid in the removal of the trim panel, start at the bottom of the panel.

REMOVAL AND INSTALLATION (Continued)

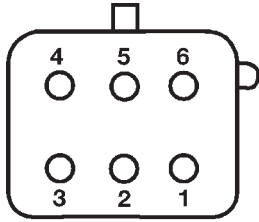

| POWER MIRROR TEST | | |
|-------------------|--------|-----------------|
| 12 VOLTS | GROUND | MIRROR REACTION |
| PIN 1 | PIN 4 | UP |
| PIN 4 | PIN 1 | DOWN |
| PIN 2 | PIN 3 | LEFT |
| PIN 3 | PIN 2 | RIGHT |
| PIN 5 | PIN 6 | HEATER |

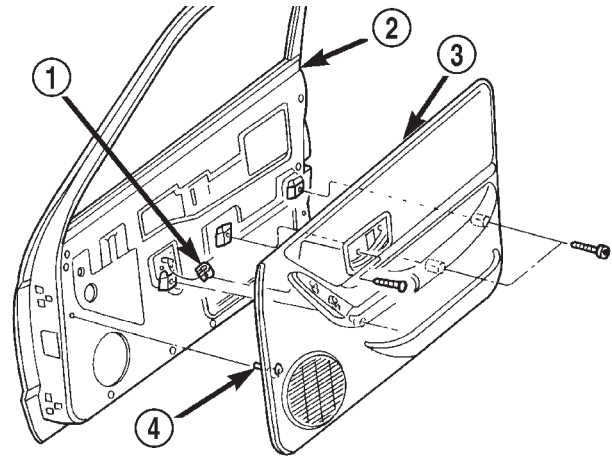

80aafb5e

Fig. 5 Front Door Trim Panel Remove/Install

- 1 - U-NUT
- 2 - DOOR
- 3 - TRIM PANEL
- 4 - PUSH-IN FASTENER

Fig. 3 Power Mirror Test

80ac2c55

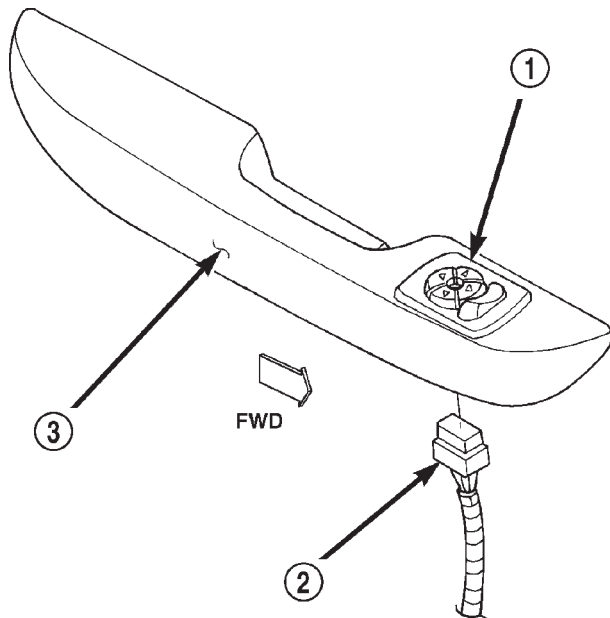

80abfecd

Fig. 4 Stand-Alone Power Mirror Switch Remove/Install

- 1 - STAND-ALONE POWER MIRROR SWITCH
- 2 - CONNECTOR
- 3 - DOOR TRIM PANEL

(4) Lift the front door trim panel upwards and away from the inner door panel far enough to disen-

gage the top of the panel from the inner belt weatherstrip.

(5) Pull the front door trim panel away from the inner door panel far enough to access the inside door latch release and lock linkage rods near the back of the inside door remote controls.

(6) Unsnap the plastic retainer clips from the inside door remote control ends of the latch release and lock linkage rods, and remove the rod ends from the inside door remote controls.

(7) Unplug the wire harness connectors from the door module.

(8) Remove the trim panel from the front door.

(9) Remove the three screws that secure the door module to the front door trim panel (Fig. 6).

(10) Remove the door module from the front door trim panel.

(11) Reverse the removal procedures to install. Tighten the mounting screws to 2.2 N·m (20 in. lbs.).

POWER MIRROR

(1) Disconnect and isolate the battery negative cable.

(2) If the vehicle is so equipped, remove the manual window regulator crank handle with a removal tool (Fig. 7).

(3) Remove the screws that secure the front door trim panel to the inner door panel (Fig. 8) or (Fig. 9).

(4) Using a trim stick or another suitable wide flat-bladed tool, gently pry the front door trim panel away from the door around the perimeter to release the trim panel retainers.

REMOVAL AND INSTALLATION (Continued)

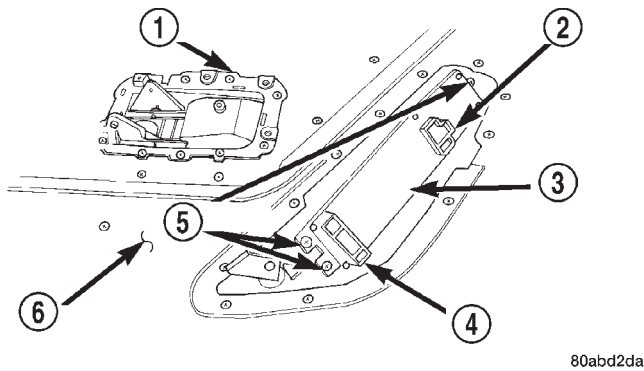

Fig. 6 Door Module Remove/Install

- 1 - INSIDE DOOR LATCH AND LOCK REMOTE CONTROLS
- 2 - CONNECTOR 1 RECEPTACLE
- 3 - DOOR MODULE
- 4 - CONNECTOR 2 RECEPTACLE
- 5 - SCREWS
- 6 - DOOR TRIM PANEL

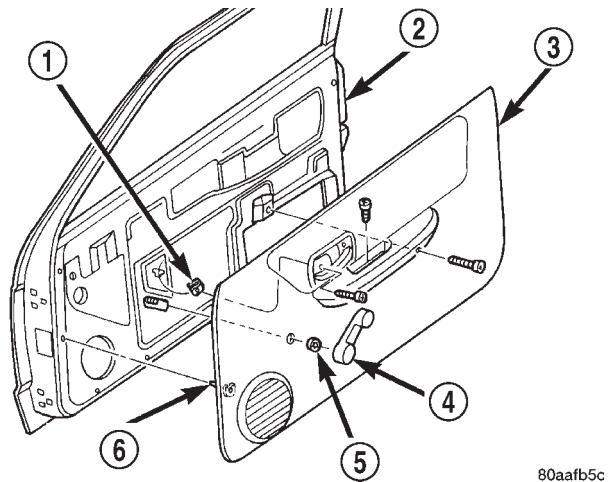

Fig. 8 Front Door Trim Panel Remove/Install - Manual Window

- 1 - U-NUT
- 2 - DOOR
- 3 - TRIM PANEL
- 4 - WINDOW CRANK
- 5 - SPACER
- 6 - PUSH-IN FASTENER

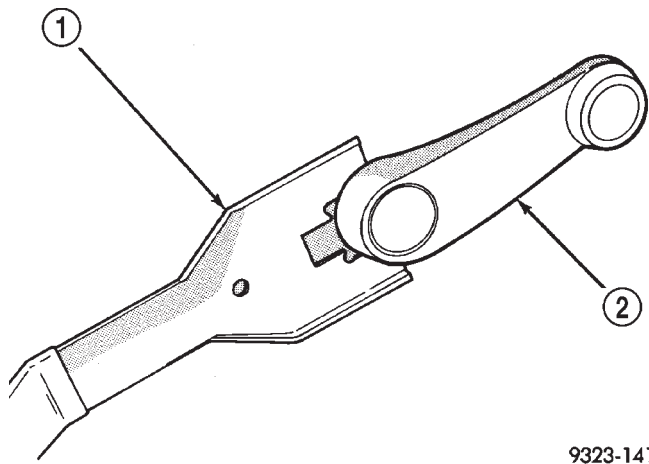

Fig. 7 Window Regulator Crank Handle Remove - Typical

- 1 - DOOR HANDLE REMOVAL TOOL
- 2 - WINDOW CRANK

NOTE: To aid in the removal of the trim panel, start at the bottom of the panel.

(5) Lift the front door trim panel upwards and away from the inner door panel far enough to disengage the top of the panel from the inner belt weatherstrip.

(6) Pull the front door trim panel away from the inner door far enough to access the inside door latch release and lock linkage rods near the back of the inside door remote controls.

(7) Unsnap the plastic retainer clips from the inside door remote control ends of the latch release and lock linkage rods, and remove the rod ends from the inside door remote controls.

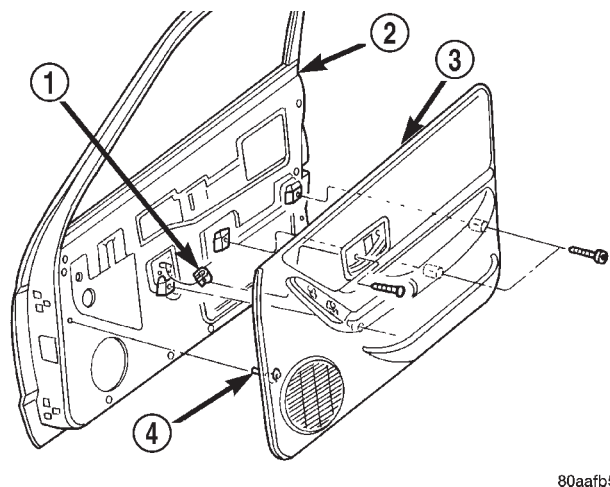

Fig. 9 Front Door Trim Panel Remove/Install - Power Window

- 1 - U-NUT
- 2 - DOOR
- 3 - TRIM PANEL
- 4 - PUSH-IN FASTENER

(8) Unplug the wire harness connectors from the door power switch module or, on the driver side only, the stand-alone power mirror switch.

(9) Set the front door trim panel aside.

(10) Remove the one screw that secures the front door flag trim to the inner door panel (Fig. 10).

(11) Using a trim stick or another suitable wide flat-bladed tool, gently pry the door flag trim away

REMOVAL AND INSTALLATION (Continued)

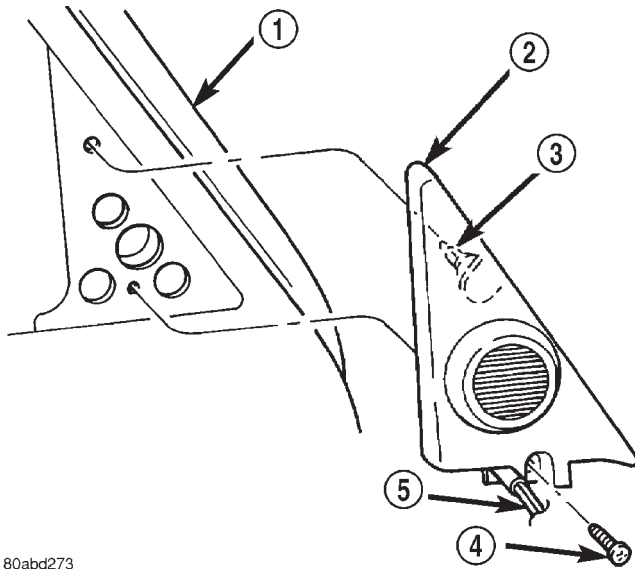

80abd273

Fig. 10 Front Door Flag Trim Panel Remove/Install

- 1 - FRONT DOOR
- 2 - DOOR FLAG TRIM PANEL
- 3 - RETAINER
- 4 - SCREW
- 5 - UPPER SPEAKER WIRE HARNESS

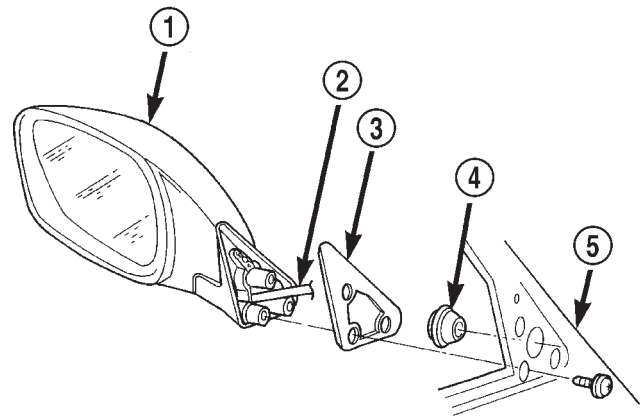

80aafb5f

Fig. 11 Power Mirror Remove/Install

- 1 - SIDE VIEW MIRROR
- 2 - WIRE HARNESS
- 3 - SEAL
- 4 - GROMMET
- 5 - DOOR

from the inner door to release the trim panel retainer.

(12) Unplug the power mirror wire harness connector.

(13) Remove the three screws that secure the power mirror to the inner door panel (Fig. 11).

(14) Unseat the power mirror wire harness grommet by pushing it out through the hole in the door flag from the inside.

(15) Pull the mirror and seal from the outside of the door while feeding the wire harness, grommet, and connector out through the hole from the inside of the door.

(16) Reverse the removal procedures to install. Tighten the mirror mounting screws to 4.3 N·m (38 in. lbs.). Tighten the door trim mounting screws to 2.2 N·m (20 in. lbs.).

CHIME/BUZZER WARNING SYSTEMS

TABLE OF CONTENTS

| | page | | page |
|-----------------------------------|------|---|------|
| GENERAL INFORMATION | | DIAGNOSIS AND TESTING | |
| INTRODUCTION | 1 | DRIVER DOOR JAMB SWITCH | 2 |
| CHIME WARNING SYSTEM | 1 | DRIVER SEAT BELT SWITCH | 2 |
| DESCRIPTION AND OPERATION | | KEY-IN IGNITION SWITCH | 3 |
| INSTRUMENT CLUSTER | 1 | HEADLAMP SWITCH | 3 |
| DRIVER DOOR JAMB SWITCH | 2 | INSTRUMENT CLUSTER | 3 |
| DRIVER SEAT BELT SWITCH | 2 | REMOVAL AND INSTALLATION | |
| KEY-IN IGNITION SWITCH | 2 | CHIME WARNING SYSTEM SWITCHES | 4 |
| HEADLAMP SWITCH | 2 | | |

GENERAL INFORMATION

INTRODUCTION

This group covers the chime warning system, which is standard factory-installed equipment on this model. Refer to 8W-40 Instrument Cluster or 8W-44 - Interior Lighting in Group 8W - Wiring Diagrams for complete circuit descriptions and diagrams.

NOTE: This group covers both Left-Hand Drive (LHD) and Right-Hand Drive (RHD) versions of this model. Whenever required and feasible, the RHD versions of affected vehicle components have been constructed as mirror-image of the LHD versions. While most of the illustrations used in this group represent only the LHD version, the diagnostic and service procedures outlined can generally be applied to either version. Exceptions to this rule have been clearly identified as LHD or RHD, if a special illustration or procedure is required.

CHIME WARNING SYSTEM

The chime warning system provides an audible warning to the driver under the following conditions:

- Driver side seat belt is not fastened (chimes will sound after the ignition switch is turned to the On position for the duration of the seat belt reminder lamp illumination or until the driver side seat belt is buckled, whichever occurs first)
 - Engine coolant temperature is high
 - Head or park lamps are turned on with the ignition switch Off and the driver side front door open
 - Key is in the ignition switch with the ignition switch Off and the driver side front door open
 - Low fuel warning lamp illumination - less than about one-eighth tank of fuel remaining

- Overhead console trip computer is reset
- The optional Sentry Key Immobilizer System (SKIS) is in the “customer programming” mode.

Following are general descriptions of the major components in the chime warning system. Refer to the owner’s manual in the vehicle glove box for more information on the features, use and operation of the chime warning system.

DESCRIPTION AND OPERATION

INSTRUMENT CLUSTER

The instrument cluster is an electromechanical unit that contains integrated circuitry and internal programming to perform a variety of functions. The instrument cluster circuitry monitors hard-wired switch inputs, as well as message inputs received from other vehicle electronic modules on the Chrysler Collision Detection (CCD) data bus network.

The instrument cluster uses these many inputs along with its internal programming and an integral chime tone generator to perform the functions of the chime warning module on this model. The instrument cluster circuitry also has a self-diagnostic capability. Refer to Group 8E - Instrument Panel Systems for more information on this feature.

Hard-wired chime warning system inputs to the instrument cluster include the following:

- Driver door jamb switch
- Driver seat belt switch
- Headlamp switch
- Key-in ignition switch.

The only instrument cluster diagnosis found in this group consists of confirming the viability of the hard-wired chime request inputs to the instrument cluster circuitry. For diagnosis of the CCD data bus and the

DESCRIPTION AND OPERATION (Continued)

data bus message inputs, a DRB scan tool and the proper Diagnostic Procedures manual are recommended.

Refer to Group 8E - Instrument Panel Systems for the instrument cluster service procedures. The instrument cluster chime warning circuitry and chime tone generator cannot be repaired and, if faulty or damaged, the instrument cluster assembly must be replaced.

DRIVER DOOR JAMB SWITCH

The driver door jamb switch is mounted to the driver side front door hinge pillar. The switch closes a path to ground for the instrument cluster chime warning circuitry through the key-in ignition switch and/or the headlamp switch when the driver door is opened, and opens the ground path when the driver door is closed.

The driver door jamb switch cannot be repaired and, if faulty or damaged, it must be replaced. Refer to Group 8L - Lamps for the service procedures.

DRIVER SEAT BELT SWITCH

The driver seat belt switch is integral to the driver seat belt buckle-half assembly. The switch is normally closed, providing a ground path to the instrument panel chime warning circuitry. When the tip-half of the seat belt is inserted into the seat belt buckle, the switch opens the ground path.

The driver seat belt switch cannot be repaired and, if faulty or damaged, the entire driver seat belt buckle-half unit must be replaced. Refer to Group 23 - Body for the service procedures.

KEY-IN IGNITION SWITCH

The key-in ignition switch is integral to the ignition switch, which is mounted on the left side of the steering column, opposite the ignition lock cylinder. It closes a path to ground for the instrument cluster chime warning circuitry when the ignition key is inserted in the ignition lock cylinder and the driver door jamb switch is closed (driver door is open). The key-in ignition switch opens the ground path when the key is removed from the ignition lock cylinder.

The key-in ignition switch cannot be repaired and, if faulty or damaged, the entire ignition switch must be replaced. Refer to Group 8D - Ignition Systems for the service procedures.

HEADLAMP SWITCH

The headlamp switch is located in the instrument panel, outboard of the steering column. It closes a path to ground for the instrument cluster chime warning circuitry when the park or head lamps are on and the driver door jamb switch is closed (driver

door is open). The headlamp switch opens the ground path when the headlamp switch is turned off.

The headlamp switch cannot be repaired and, if faulty or damaged, it must be replaced. Refer to Group 8E - Instrument Panel Systems for the service procedures.

DIAGNOSIS AND TESTING

DRIVER DOOR JAMB SWITCH

For circuit descriptions and diagrams, refer to 8W-40 - Instrument Cluster or 8W-44 - Interior Lighting in Group 8W - Wiring Diagrams.

WARNING: ON VEHICLES EQUIPPED WITH AIR-BAGS, REFER TO GROUP 8M - PASSIVE RESTRAINT SYSTEMS BEFORE ATTEMPTING ANY STEERING WHEEL, STEERING COLUMN, OR INSTRUMENT PANEL COMPONENT DIAGNOSIS OR SERVICE. FAILURE TO TAKE THE PROPER PRECAUTIONS COULD RESULT IN ACCIDENTAL AIR-BAG DEPLOYMENT AND POSSIBLE PERSONAL INJURY.

(1) Rotate the headlamp switch knob counterclockwise to ensure that the dome lamps are not switched off. Open the driver door and note whether the interior lamps light. They should light. If OK, see the diagnosis for the Key-In Ignition Switch or the Headlamp Switch in this group. If not OK, go to Step 2.

(2) Disconnect and isolate the battery negative cable. Unplug the driver door jamb switch from its wire harness connector. Check for continuity between the ground circuit cavity of the driver door jamb switch wire harness connector and a good ground. There should be continuity. If OK, go to Step 3. If not OK, repair the circuit to ground as required.

(3) Check for continuity between the door jamb switch ground circuit terminal and the left front door jamb switch sense terminal of the door jamb switch. There should be continuity with the switch plunger released, and no continuity with the switch plunger depressed. If not OK, replace the faulty switch.

DRIVER SEAT BELT SWITCH

For circuit descriptions and diagrams, refer to 8W-40 - Instrument Cluster or 8W-44 - Interior Lighting in Group 8W - Wiring Diagrams.

DIAGNOSIS AND TESTING (Continued)

WARNING: ON VEHICLES EQUIPPED WITH AIR-BAGS, REFER TO GROUP 8M - PASSIVE RESTRAINT SYSTEMS BEFORE ATTEMPTING ANY STEERING WHEEL, STEERING COLUMN, OR INSTRUMENT PANEL COMPONENT DIAGNOSIS OR SERVICE. FAILURE TO TAKE THE PROPER PRECAUTIONS COULD RESULT IN ACCIDENTAL AIR-BAG DEPLOYMENT AND POSSIBLE PERSONAL INJURY.

(1) Disconnect and isolate the battery negative cable. Unplug the driver seat belt switch wire harness connector on the floor under the driver seat near the seat belt buckle-half anchor. Check for continuity between the seat belt switch sense circuit and the ground circuit cavities of the seat belt half of the driver seat belt switch wire harness connector. There should be continuity with the seat belt unbuckled, and no continuity with the seat belt buckled. If OK, go to Step 2. If not OK, replace the faulty seat belt buckle-half assembly.

(2) Check for continuity between the ground circuit cavity in the body half of the driver seat belt switch wire harness connector and a good ground. There should be continuity. If OK, see the Instrument Cluster diagnosis in this group. If not OK, repair the circuit to ground as required.

KEY-IN IGNITION SWITCH

For circuit descriptions and diagrams, refer to 8W-40 - Instrument Cluster or 8W-44 - Interior Lighting in Group 8W - Wiring Diagrams.

WARNING: ON VEHICLES EQUIPPED WITH AIR-BAGS, REFER TO GROUP 8M - PASSIVE RESTRAINT SYSTEMS BEFORE ATTEMPTING ANY STEERING WHEEL, STEERING COLUMN, OR INSTRUMENT PANEL COMPONENT DIAGNOSIS OR SERVICE. FAILURE TO TAKE THE PROPER PRECAUTIONS COULD RESULT IN ACCIDENTAL AIR-BAG DEPLOYMENT AND POSSIBLE PERSONAL INJURY.

(1) Disconnect and isolate the battery negative cable. Remove the steering column shrouds. Refer to Group 8D - Ignition Systems for the procedures. Unplug the key-in ignition switch wire harness connector from the ignition switch.

(2) Check for continuity between the key-in switch sense circuit and the left front door jamb switch sense circuit terminals of the key-in ignition switch. There should be continuity with the key in the ignition lock cylinder, and no continuity with the key removed from the ignition lock cylinder. If OK, go to Step 3. If not OK, replace the faulty ignition switch assembly.

(3) Check for continuity between the left front door jamb switch sense circuit cavity of the key-in ignition switch wire harness connector and a good ground. There should be continuity with the driver door open, and no continuity with the driver door closed. If OK, see the diagnosis for Instrument Cluster in this group. If not OK, repair the circuit to the driver door jamb switch as required.

HEADLAMP SWITCH

For circuit descriptions and diagrams, refer to 8W-40 - Instrument Cluster or 8W-44 - Interior Lighting in Group 8W - Wiring Diagrams.

WARNING: ON VEHICLES EQUIPPED WITH AIR-BAGS, REFER TO GROUP 8M - PASSIVE RESTRAINT SYSTEMS BEFORE ATTEMPTING ANY STEERING WHEEL, STEERING COLUMN, OR INSTRUMENT PANEL COMPONENT DIAGNOSIS OR SERVICE. FAILURE TO TAKE THE PROPER PRECAUTIONS COULD RESULT IN ACCIDENTAL AIR-BAG DEPLOYMENT AND POSSIBLE PERSONAL INJURY.

(1) Disconnect and isolate the battery negative cable. Remove the headlamp switch from the instrument panel. Refer to Group 8E - Instrument Panel Systems for the procedures. Unplug the headlamp switch wire harness connectors. Check for continuity between the left front door jamb switch sense circuit cavity of the headlamp switch wire harness connector and a good ground. There should be continuity with the driver door closed, and no continuity with the driver door open. If OK, go to Step 2. If not OK, repair the circuit to the driver door jamb switch as required.

(2) Check for continuity between the key-in switch sense circuit terminal and the left front door jamb switch sense terminal of the headlamp switch. There should be no continuity with the switch in the Off position, and continuity with the switch in the park or head lamps On position. If OK, see the diagnosis for the Instrument Cluster in this group. If not OK, replace the faulty headlamp switch.

INSTRUMENT CLUSTER

Before performing this test, complete the testing of the hard-wired chime warning system switches as described in this group. For circuit descriptions and diagrams, refer to 8W-40 - Instrument Cluster or 8W-44 - Interior Lighting in Group 8W - Wiring Diagrams.

DIAGNOSIS AND TESTING (Continued)

WARNING: ON VEHICLES EQUIPPED WITH AIR-BAGS, REFER TO GROUP 8M - PASSIVE RESTRAINT SYSTEMS BEFORE ATTEMPTING ANY STEERING WHEEL, STEERING COLUMN, OR INSTRUMENT PANEL COMPONENT DIAGNOSIS OR SERVICE. FAILURE TO TAKE THE PROPER PRECAUTIONS COULD RESULT IN ACCIDENTAL AIR-BAG DEPLOYMENT AND POSSIBLE PERSONAL INJURY.

(1) Disconnect and isolate the battery negative cable. Remove the instrument cluster from the instrument panel. Refer to Group 8E - Instrument Panel Systems for the procedures.

(2) Unplug the headlamp switch and the key-in ignition switch wire harness connectors. Check for continuity between the key-in switch sense circuit cavity of the right instrument cluster wire harness connector (connector B) and a good ground. There should be no continuity. If OK, go to Step 3. If not OK, repair the short circuit as required.

(3) Check for continuity between the key-in switch sense circuit cavities of the right instrument cluster wire harness connector (connector B) and the headlamp switch wire harness connector. There should be continuity. If OK, go to Step 4. If not OK, repair the open circuit as required.

(4) Unplug the driver seat belt switch wire harness connector. Check for continuity between the seat

belt switch sense circuit cavity of the right instrument cluster wire harness connector (connector B) and a good ground. There should be no continuity. If OK, go to Step 5. If not OK, repair the short circuit as required.

(5) Check for continuity between the seat belt switch sense circuit cavities of the right instrument cluster wire harness connector (connector B) and the driver seat belt switch wire harness connector. There should be continuity. If OK, test the instrument cluster as described in Group 8E - Instrument Panel Systems. If not OK, repair the open circuit as required.

REMOVAL AND INSTALLATION

CHIME WARNING SYSTEM SWITCHES

Service procedures for the various hard-wired switches used in the chime warning system can be found in the proper group as follows:

- Driver door jamb switch - refer to Group 8L - Lamps
- Driver seat belt switch - refer to Group 23 - Body
- Headlamp switch - refer to Group 8E - Instrument Panel Systems
- Key-in ignition switch - refer to Group 8D - Ignition Systems.

OVERHEAD CONSOLE SYSTEMS

TABLE OF CONTENTS

| | page | | page |
|--|------|--|------|
| GENERAL INFORMATION | | | |
| INTRODUCTION | 1 | COMPASS CALIBRATION | 5 |
| OVERHEAD CONSOLE | 1 | COMPASS DEMAGNETIZING | 6 |
| DESCRIPTION AND OPERATION | | REMOVAL AND INSTALLATION | |
| TRIP COMPUTER | 1 | OVERHEAD CONSOLE | 6 |
| COMPASS | 2 | TRIP COMPUTER, COMPASS, AND | |
| THERMOMETER | 2 | THERMOMETER DISPLAY MODULE | 7 |
| READING AND COURTESY LAMP | 2 | PUSH BUTTON MODULE | 7 |
| GARAGE DOOR OPENER STORAGE BIN | 3 | READING AND COURTESY LAMP BULB | 8 |
| SUNGLASSES STORAGE BIN | 3 | GARAGE DOOR OPENER STORAGE BIN | |
| DIAGNOSIS AND TESTING | | DOOR | 8 |
| TRIP COMPUTER, COMPASS, AND | | SUNGLASSES STORAGE BIN | 8 |
| THERMOMETER DISPLAY MODULE | 3 | AMBIENT TEMPERATURE SENSOR | 8 |
| THERMOMETER | 4 | SPECIAL TOOLS | |
| SERVICE PROCEDURES | | COMPASS | 9 |
| COMPASS VARIATION ADJUSTMENT | 4 | | |

GENERAL INFORMATION

INTRODUCTION

An overhead console featuring a mini trip computer, an electronic compass, and an outside ambient temperature thermometer is an available factory-installed option on this model. Refer to 8W-49 - Overhead Console in Group 8W - Wiring Diagrams for complete circuit descriptions and diagrams.

NOTE: This group covers both Left-Hand Drive (LHD) and Right-Hand Drive (RHD) versions of this model. Whenever required and feasible, the RHD versions of affected vehicle components have been constructed as mirror-image of the LHD versions. While most of the illustrations used in this group represent only the LHD version, the diagnostic and service procedures outlined can generally be applied to either version. Exceptions to this rule have been clearly identified as LHD or RHD, if a special illustration or procedure is required.

OVERHEAD CONSOLE

The overhead console for this model includes a mini trip computer, an electronic compass, and an outside ambient temperature thermometer. The overhead console also houses two front-mounted and two rear-mounted reading and courtesy lamps, a garage

door opener storage bin, and a sunglasses storage bin.

On models equipped with the Remote Keyless Entry (RKE) option, the RKE receiver is also located within the overhead console housing. Refer to Group 8P - Power Lock Systems for more information on this feature.

Following are general descriptions of the major components used in the overhead console. Refer to the owner's manual in the vehicle glove box for more information on the features, use and operation of the various overhead console components.

DESCRIPTION AND OPERATION

TRIP COMPUTER

A mini trip computer is available on this model to provide several electronic functions and features. The trip computer contains a central processing unit and interfaces with other modules in the vehicle on the Chrysler Collision Detection (CCD) data bus network.

The CCD data bus network allows the sharing of sensor information. This helps to reduce wire harness complexity, reduce internal controller hardware, and reduce component sensor current loads. At the same time, this system provides increased reliability, enhanced diagnostics, and allows the addition of many new feature capabilities.

DESCRIPTION AND OPERATION (Continued)

Some of the functions and features that the trip computer supports and/or controls, include the following display options:

- Compass and temperature
- Trip odometer (ODO)
- Average fuel economy (AVG ECO)
- Instant fuel economy (ECO)
- Distance to empty (DTE)
- Elapsed time (ET)
- Blank display.

Momentarily depressing and releasing the Step button when the ignition switch is in the On position will cause the overhead console display to step sequentially through the listed display options. Momentarily depressing and releasing the U. S./Metric button toggles the display between U. S. and Metric measurements.

The push button (Step and U. S./Metric) switch module in the overhead console is hard wired to the trip computer. The compass flux-gate unit is integral to the trip computer, compass, and thermometer display module unit. Data input for all other trip computer functions is received through CCD data bus messages. The trip computer uses its internal programming and all of these inputs to calculate and display the requested data. If the data displayed is incorrect, see Trip Computer, Compass, and Thermometer Display Module - Self-Diagnostic Test in the Diagnosis and Testing section of this group. If these tests prove inconclusive, the use of a DRB scan tool and the proper Diagnostic Procedures manual are recommended for further testing of the trip computer and the CCD data bus.

The trip computer, compass, and thermometer display module cannot be repaired, and is only available for service as a unit. If faulty or damaged, the complete module must be replaced. The push button (Step and U. S./Metric) switch module is serviced separately.

COMPASS

The compass will display the direction in which the vehicle is pointed using the eight major compass headings (Examples: north is N, northeast is NE). It does not display the headings in actual degrees.

The self-calibrating compass unit requires no adjusting in normal use. The only calibration that may prove necessary is to drive the vehicle in three complete circles, on level ground, in not less than 48 seconds. This will reorient the compass unit to its vehicle.

The compass unit also will compensate for magnetism the body of the vehicle may acquire during normal use. However, avoid placing anything magnetic directly on the roof of the vehicle. Magnetic mounts for an antenna, a repair order hat, or a funeral pro-

cession flag can exceed the compensating ability of the compass unit if placed on the roof panel. Magnetic bit drivers used on the fasteners that hold the assembly to the roof header can also affect compass operation. If the vehicle roof should become magnetized, demagnetizing and calibration may be required to restore proper compass operation. See Compass Calibration or Compass Demagnetizing in the Service Procedures section of this group for these procedures.

The compass, trip computer, and thermometer display module cannot be repaired, and is only available for service as a unit. If faulty or damaged, the complete module must be replaced. The push button (Step and U. S./Metric) switch module is serviced separately.

THERMOMETER

The thermometer displays the outside ambient temperature. The temperature display can be changed from Fahrenheit to Celsius using the U. S./Metric button, located just rearward of the display module. The displayed temperature is not an instant reading of conditions, but an average temperature. It may take the thermometer display several minutes to respond to a major temperature change, such as driving out of a heated garage into winter temperatures.

When the ignition switch is turned to the Off position, the last displayed temperature reading stays in the thermometer unit memory. When the ignition switch is turned to the On position again, the thermometer will display the memory temperature if the engine coolant temperature is above about 52° C (125° F). If the engine coolant temperature is below about 52° C (125° F), the thermometer will display the actual temperature sensed by the ambient temperature sensor. The thermometer temperature display update interval varies with the vehicle speed.

The thermometer function is supported by an ambient temperature sensor. The sensor is mounted outside the passenger compartment near the front and center of the vehicle and is hard-wired to the module. The ambient temperature sensor is available as a separate service item.

The thermometer, compass, and trip computer display module cannot be repaired, and are only available for service as a unit. If faulty or damaged, the complete module must be replaced. The push button (Step and U. S./Metric) switch module and ambient temperature sensor are serviced separately.

READING AND COURTESY LAMP

All reading and courtesy lamps located in the overhead console are activated by the door ajar switches. When the doors are closed, the lamps can be individually activated by depressing the corresponding lens.

DESCRIPTION AND OPERATION (Continued)

When a door is open, depressing the lamp lens switches will not turn the lamps off. Refer to Group 8L - Lamps, for diagnosis of the reading and courtesy lamps.

The reading and courtesy lamp lens, and bulbs are available for service replacement. The reading and courtesy lamp holders and switches are only available as part of the overhead console wire harness. If any reading lamp switch is faulty or damaged, the wire harness and all four switches must be replaced.

GARAGE DOOR OPENER STORAGE BIN

A compartment in the overhead console is designed to hold most garage door opener remote control transmitters. The transmitter is mounted within the compartment with an adhesive-backed hook and loop fastener patch.

With the transmitter mounted in the storage bin, adapter pegs located on the front of the storage bin door are selected and mounted on a post near the center of the storage bin door. The peg(s) selected and/or the post must be long enough to depress the button of the transmitter, when the garage door opener storage bin door is depressed. The pegs may be stacked, if necessary. Refer to the owner's manual in the vehicle glove box for more information.

A transmitter mounting kit including the adhesive-backed hook and loop fastener material and a selection of pegs is available for service. The garage door opener storage bin door assembly is also available for service replacement.

SUNGLASSES STORAGE BIN

A sunglasses storage bin is included in the overhead console. The interior of the bin is lined with a foam rubber padding material to protect the sunglasses from being scratched. This bin features a push/push-type latching mechanism, and a viscous dampening system for a fluid opening action.

The sunglasses storage bin door, latch, viscous damper, hinge spring and housing are available for service only as a complete module. If any part of this unit is faulty or damaged, the entire module must be replaced.

DIAGNOSIS AND TESTING

TRIP COMPUTER, COMPASS, AND THERMOMETER DISPLAY MODULE

If the problem with the trip computer, compass, and thermometer display module is an inaccurate or scrambled display, use the Self-Diagnostic Test procedures. If the problem is incorrect display lighting levels, use a DRB scan tool and the proper Diagnostic Procedures manual to test for the correct dimming

message inputs being received from the instrument cluster over the Chrysler Collision Detection (CCD) data bus. If the problem is a no-display condition, use the following procedures. For circuit descriptions and diagrams, refer to 8W-49 - Overhead Console in Group 8W - Wiring Diagrams.

(1) Check the fuses in the junction block and the Power Distribution Center (PDC). If OK, go to Step 2. If not OK, repair the shorted circuit or component as required and replace the faulty fuse(s).

(2) Turn the ignition switch to the On position. Check for battery voltage at the fused ignition switch output fuse in the junction block. If OK, go to Step 3. If not OK, repair the open circuit to the ignition switch as required.

(3) Turn the ignition switch to the Off position. Disconnect and isolate the battery negative cable. Remove the overhead console from the headliner. Check for continuity between the ground circuit cavities of the overhead console wire harness connector and a good ground. There should be continuity. If OK, go to Step 4. If not OK, repair the open circuit to ground as required.

(4) Connect the battery negative cable. Check for battery voltage at the fused B(+) circuit cavity of the overhead console wire harness connector. If OK, go to Step 5. If not OK, repair the open circuit to the junction block as required.

(5) Turn the ignition switch to the On position. Check for battery voltage at the fused ignition switch output circuit cavity of the overhead console wire harness connector. If OK, proceed to the Self-Diagnostic Test in this group for further diagnosis of the module and the CCD data bus. If not OK, repair the open circuit to the junction block as required.

SELF-DIAGNOSTIC TEST

A self-diagnostic test is used to determine that the trip computer, compass, thermometer, and all of the display module segments are operating properly electrically. Initiate the self-diagnostic test as follows:

(1) With the ignition switch in the Off position, simultaneously press and hold the Step button and the U. S./Metric button.

(2) Turn the ignition switch to the On position.

(3) Continue to hold both buttons until the display module performs a display segment test. In this test, all of the vacuum fluorescent display segments are lighted. This test will:

- a. Verify that all display segments are functional
- b. Check the internal circuitry of the module
- c. Check that all of the CCD data bus messages needed are being received.

(4) Respond to the respective test results as follows. If all tests are passed, the module will automatically return to normal operation.

DIAGNOSIS AND TESTING (Continued)

a. In the display segment test, if any segment should fail to light the unit is faulty and must be replaced.

b. If the internal circuitry test is failed, the module will display "FAIL". If "FAIL" is displayed, the unit is faulty and must be replaced.

c. If the CCD data bus message test is failed, the module will display "CCD". If "CCD" is displayed, the use of a DRB scan tool and the proper Diagnostic Procedures manual are required for further diagnosis.

(5) Momentarily depress and release either button one time to exit the self-diagnostic test mode and return the trip computer, compass, and thermometer display module to normal operation.

NOTE: If the compass functions, but accuracy is suspect, it may be necessary to perform a variation adjustment. This procedure allows the compass unit to accommodate variations in the earth's magnetic field strength, based on geographic location. See the Compass Variation Adjustment procedures, in this group.

NOTE: If the compass reading has blanked out, and only "CAL" appears in the display module, demagnetizing may be necessary to remove excessive residual magnetic fields from the vehicle. See the Compass Demagnetizing procedure, in this group.

THERMOMETER

The thermometer function is supported by a ambient temperature sensor, a wiring circuit, and a portion of the overhead console trip computer, compass, and thermometer display module display. The sensor is mounted outside the passenger compartment near the front and center of the vehicle.

If any portion of the ambient temperature sensor circuit fails, the thermometer display will self-diagnose the circuit. An "SC" (short circuit) will appear in the display in place of the temperature, when the sensor is exposed to temperatures above 55° C (131° F), or if the sensor circuit is shorted. An "OC" (open circuit) will appear in the display in place of the temperature, when the sensor is exposed to temperatures below -40° C (-40° F), or if the sensor circuit is open.

The ambient temperature sensor circuit can also be diagnosed using the following Sensor Test, and Sensor Circuit Test. If the temperature sensor and circuit are confirmed to be OK, but the temperature display is inoperative or incorrect, see the Trip Computer, Compass, and Thermometer Display Module diagnosis in this group. For circuit descriptions and diagrams, refer to 8W-49 - Overhead Console in Group 8W - Wiring Diagrams.

SENSOR TEST

(1) Turn the ignition switch to the Off position. Disconnect and isolate the battery negative cable. Unplug the temperature sensor wire harness connector.

(2) Measure the resistance of the temperature sensor. At -40° C (-40° F), the sensor resistance is 336 kilohms. At 55° C (131° F), the sensor resistance is 2.986 kilohms. The sensor resistance should read between these two values. If OK, go to the Sensor Circuit Test. If not OK, replace the faulty sensor.

SENSOR CIRCUIT TEST

(1) Turn the ignition switch to the Off position. Disconnect and isolate the battery negative cable. Unplug the ambient temperature sensor wire harness connector and the overhead console wire harness connector.

(2) Connect a jumper wire between the two terminals in the body half of the sensor wire harness connector.

(3) Check for continuity between the sensor return circuit and the ambient temperature sensor signal circuit cavities of the overhead console wire harness connector. There should be continuity. If OK, go to Step 4. If not OK, repair the open circuit as required.

(4) Remove the jumper wire from the ambient temperature sensor wire harness connector. Check for continuity between the sensor return circuit cavity of the overhead console wire harness connector and a good ground. There should be no continuity. If OK, go to Step 5. If not OK, repair the short circuit as required.

(5) Check for continuity between the ambient temperature sensor signal circuit cavity of the overhead console wire harness connector and a good ground. There should be no continuity. If OK, see the Trip Computer, Compass, and Thermometer Display Module diagnosis in this group. If not OK, repair the short circuit as required.

SERVICE PROCEDURES

COMPASS VARIATION ADJUSTMENT

Variance is the difference between magnetic north and geographic north. In some geographic locations, the difference between magnetic and geographic north is great enough to cause the compass to give false readings. If this problem occurs, the compass variance must be set.

To set the compass variance:

(1) Using the Variance Settings map, find your geographic location and note the zone number (Fig. 1).

SERVICE PROCEDURES (Continued)

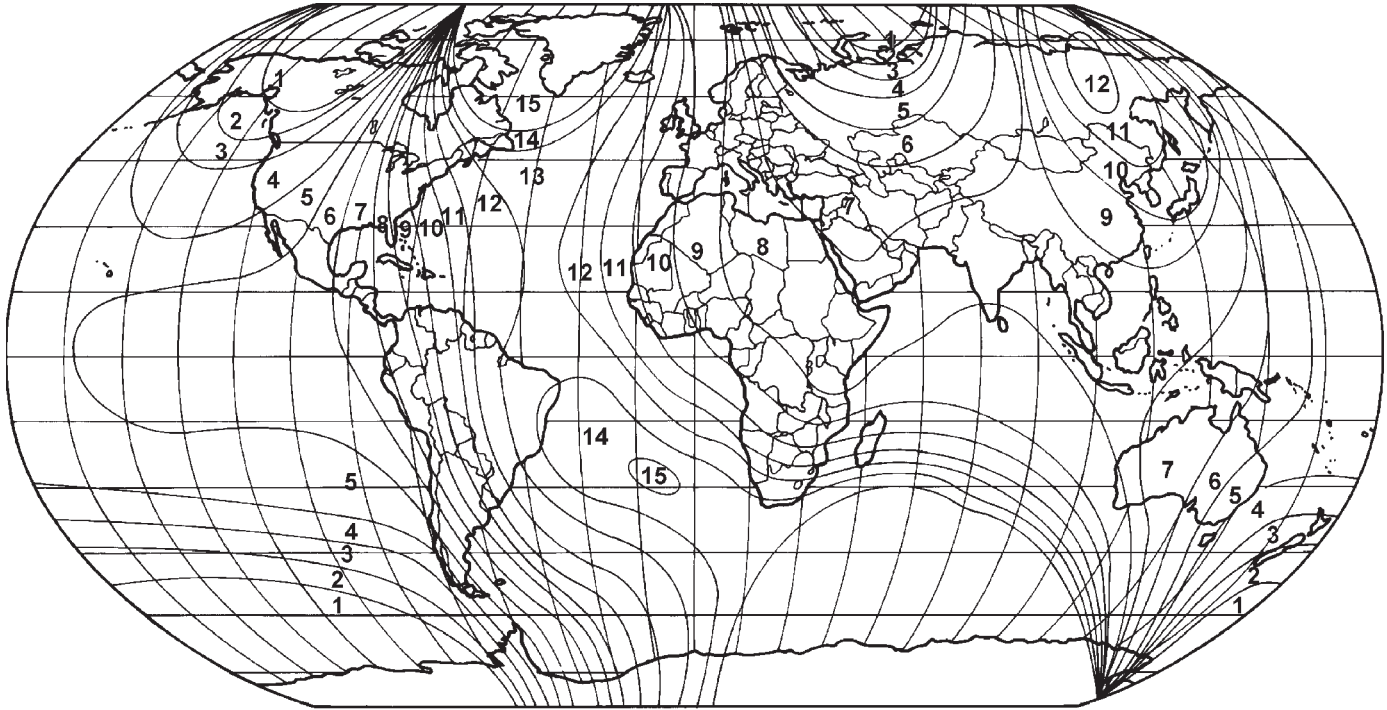

80a13863

Fig. 1 Variance Settings

(2) Turn the ignition switch to the On position. If the compass/temperature data is not currently being displayed, momentarily depress and release the Step button to step through the display options until you have reached the compass/temperature display.

(3) Depress both the U. S./Metric, and the Step buttons. Hold the buttons down until "VAR" appears in the display. This takes about five seconds.

(4) Release both of the buttons. The current variance zone number setting will appear in the display.

(5) Press and release the U. S./Metric button to step through the zone numbers, until the zone number for your geographic location appears in the display.

(6) Press the Step button to enter this zone number into the compass unit memory.

(7) Confirm that the correct directions are now indicated by the compass.

COMPASS CALIBRATION

CAUTION: Do not place any external magnets, such as magnetic roof mount antennas, in the vicinity of the compass. Do not use magnetic tools when servicing the overhead console.

The electronic compass unit features a self-calibrating design, which simplifies the calibration procedure. This feature automatically updates the compass calibration while the vehicle is being driven.

This allows the compass unit to compensate for small changes in the residual magnetism that the vehicle may acquire during normal use. Do not attempt to calibrate the compass near large metal objects such as other vehicles, large buildings, or bridges.

NOTE: Whenever the compass is calibrated manually, the variation number must also be reset. See **Compass Variation Adjustment** in the **Service Procedures** section of this group.

Calibrate the compass manually as follows:

(1) Start the engine. If the compass/temperature data is not currently being displayed, momentarily depress and release the Step button to step through the display options until you have reached the compass/temperature display.

(2) Depress both the U. S./Metric and the Step buttons. Hold the buttons down until "CAL" appears in the display. This takes about ten seconds, and appears about five seconds after "VAR" is displayed.

(3) Release both of the buttons.

(4) Drive the vehicle on a level surface, away from large metal objects, through three or more complete circles in not less than 48 seconds. The "CAL" message will disappear from the display to indicate that the compass is now calibrated.

SERVICE PROCEDURES (Continued)

NOTE: If the "CAL" message remains in the display, either there is excessive magnetism near the compass, or the unit is faulty. Repeat the demagnetizing and calibration procedures at least one more time.

NOTE: If the wrong direction is still indicated in the compass display, the area selected for calibration may be too close to a strong magnetic field. Repeat the calibration procedure in another location.

COMPASS DEMAGNETIZING

A degaussing tool (Special Tool 6029) is used to demagnetize, or degauss, the overhead console forward mounting screw(s) and the roof panel. Equivalent units must be rated as continuous duty for 110/115 volts and 60 Hz. They must also have a field strength of over 350 gauss at 7 millimeters (0.25 inch) beyond the tip of the probe.

To demagnetize the roof panel and the overhead console forward mounting screw(s), proceed as follows:

(1) Be certain that the ignition switch is in the Off position, before you begin the demagnetizing procedure.

(2) Plug in the degaussing tool, while keeping the tool at least 61 centimeters (2 feet) away from the compass unit.

(3) Slowly approach the head of the overhead console forward mounting screw with the degaussing tool plugged in.

(4) Contact the head of each screw with the plastic coated tip of the degaussing tool for about two seconds.

(5) With the degaussing tool still energized, slowly back it away from the screw. When the tip of the tool is at least 61 centimeters (2 feet) from the screw head, unplug the tool.

(6) Place a piece of paper approximately 22 by 28 centimeters (8.5 by 11 inches), oriented on the vehicle lengthwise from front to rear, on the center line of the roof at the windshield header (Fig. 2). The purpose of the paper is to protect the roof panel from scratches, and to define the area to be demagnetized.

(7) Plug in the degaussing tool, while keeping the tool at least 61 centimeters (2 feet) away from the compass unit.

(8) Slowly approach the center line of the roof panel at the windshield header, with the degaussing tool plugged in.

(9) Contact the roof panel with the plastic coated tip of the degaussing tool. Be sure that the template is in place to avoid scratching the roof panel. Using a slow, back-and-forth sweeping motion, and allowing 13 millimeters (0.50 inch) between passes, move the

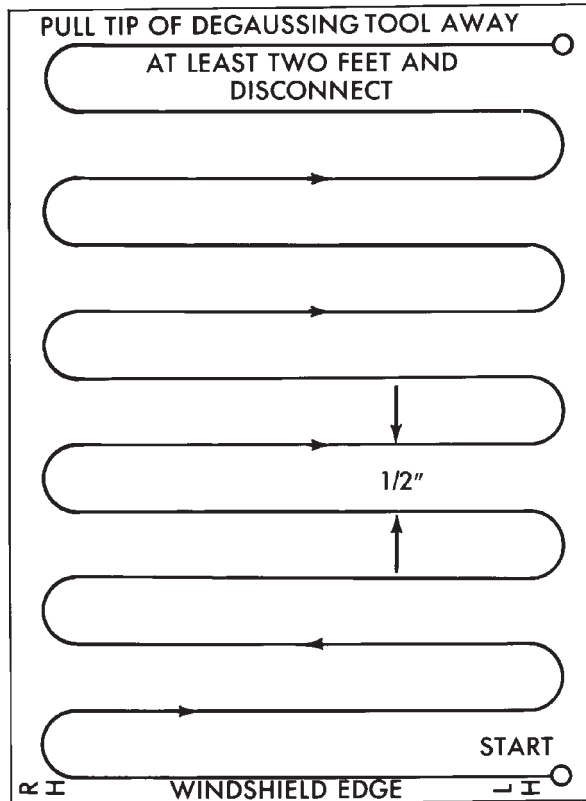

J908E-27

Fig. 2 Roof Demagnetizing Pattern

tool at least 11 centimeters (4 inches) to each side of the roof center line, and 28 centimeters (11 inches) back from the windshield header.

(10) With the degaussing tool still energized, slowly back it away from the roof panel. When the tip of the tool is at least 61 centimeters (2 feet) from the roof panel, unplug the tool.

(11) Calibrate the compass and adjust the compass variance as described in the Service Procedures section of this group.

REMOVAL AND INSTALLATION

OVERHEAD CONSOLE

(1) Disconnect and isolate the battery negative cable.

(2) Remove the two screws located forward of the display module that secure the overhead console to the upper windshield opening reinforcement (Fig. 3).

(3) To release the overhead console from the rear mounting bracket, use your fingertips to gently pull the sides of the overhead console housing outward near the rear mounting bracket.

(4) Move the overhead console forward to disengage the rear mounting tab from the headliner.

REMOVAL AND INSTALLATION (Continued)

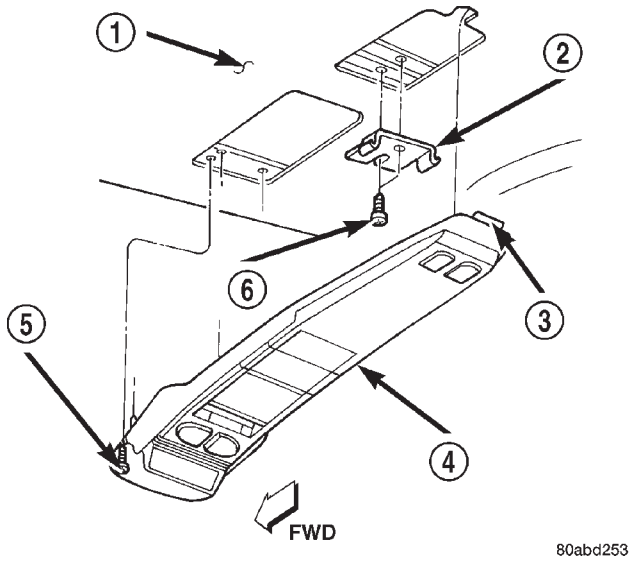

Fig. 3 Overhead Console Remove/Install

- 1 - HEADLINER
- 2 - REAR BRACKET
- 3 - REAR MOUNTING TAB
- 4 - OVERHEAD CONSOLE
- 5 - SCREW
- 6 - SCREW

(5) Lower the overhead console far enough to access the two wire harness connectors.

(6) Unplug one wire harness connector near the push button module towards the front of the overhead console.

(7) Unplug one wire harness connector from the Remote Keyless Entry (RKE) receiver near the center of the overhead console, if the vehicle is so equipped.

(8) Remove the overhead console from the headliner.

(9) Reverse the removal procedures to install. Tighten the overhead console mounting screws to 2.7 N·m (24 in. lbs.).

TRIP COMPUTER, COMPASS, AND THERMOMETER DISPLAY MODULE

(1) Remove the overhead console from the vehicle. See Overhead Console in this group for the procedures.

(2) Remove the two screws that secure the forward end of the trip computer, compass, and thermometer display module to the overhead console housing (Fig. 4).

(3) Gently flex the sides of the overhead console housing as required to release the trip computer, compass, and thermometer display module mounting pins.

(4) Pull the trip computer, compass, and thermometer display module away from the overhead console

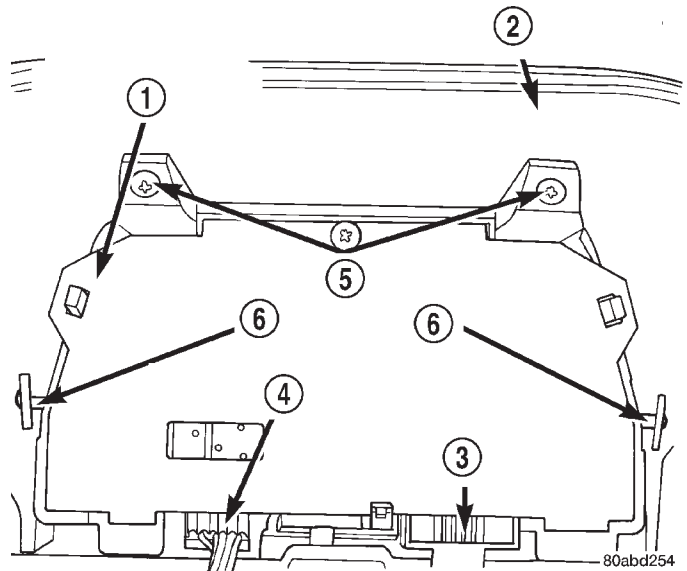

Fig. 4 Trip Computer, Compass, and Thermometer Display Module Remove/Install

- 1 - TRIP COMPUTER, COMPASS AND THERMOMETER DISPLAY MODULE
- 2 - OVERHEAD CONSOLE HOUSING
- 3 - PUSH BUTTON MODULE CONNECTOR
- 4 - OVERHEAD CONSOLE WIRE HARNESS CONNECTOR
- 5 - MOUNTING SCREWS
- 6 - MOUNTING PINS

housing far enough to access the two wire harness connectors.

(5) Unplug the overhead console and push button module wire harness connectors from the trip computer, compass, and thermometer display module.

(6) Remove the trip computer, compass, and thermometer display module from the overhead console housing.

(7) Reverse the removal procedures to install. Tighten the mounting screws to 2.2 N·m (20 in. lbs.).

PUSH BUTTON MODULE

(1) Remove the overhead console from the vehicle. See Overhead Console in this group for the procedures.

(2) Unplug the push button module wire harness connector from the trip computer, compass, and thermometer display module.

(3) Remove the four screws that secure the push button module to the overhead console housing (Fig. 5).

(4) Remove the push button module from the overhead console.

(5) Reverse the removal procedures to install. Tighten the mounting screws to 2.2 N·m (20 in. lbs.).

REMOVAL AND INSTALLATION (Continued)

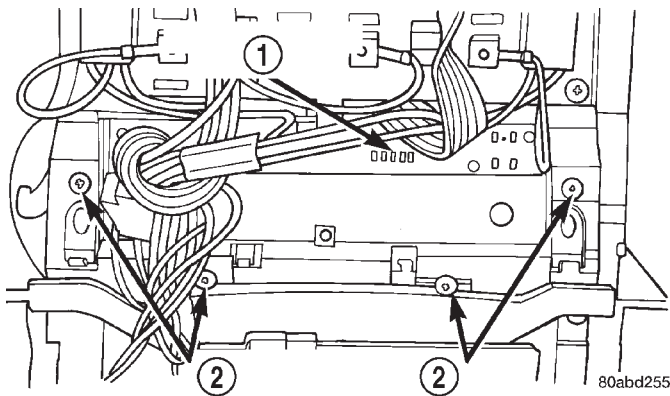
**Fig. 5 Push Button Module Remove/Install**

- 1 - PUSH BUTTON MODULE
2 - MOUNTING SCREWS

READING AND COURTESY LAMP BULB

- (1) Disconnect and isolate the battery negative cable.
- (2) Insert a long, narrow, flat-bladed tool in the notch on the edge of the reading and courtesy lamp lens.
- (3) Gently pry the lens downward from the overhead console housing and pivot the lens down. It may be necessary to move the tool along the edge of the lens to free the lens from the console housing.
- (4) Unsnap the bulb from the bulb holders by pulling the bulb gently downwards.
- (5) Install a new bulb by aligning its base with the bulb holders and pushing the bulb firmly into place.
- (6) Pivot the lens back up into position and press upward firmly until it snaps into place.
- (7) Connect the battery negative cable.
- (8) Test the lamp by depressing the lens to check for proper lamp switching and lighting.

GARAGE DOOR OPENER STORAGE BIN DOOR

- (1) Open the garage door opener storage bin door.
- (2) Using a trim stick or another suitable wide flat-bladed tool, gently pry between the door pivot pin and the pivot hole on one side of the overhead console housing until the pivot pin clears the pivot hole.
- (3) Use a gentle twisting action to remove the garage door opener storage bin door from the overhead console housing.
- (4) To install, insert the pivot pin on one side of the door into the pivot hole in the overhead console housing. Gently depress the pivot pin on the other side of the door until it clears the side of the garage door opener storage bin opening of the overhead console housing, and push the door into the opening. Guide the door into the opening so that the second pivot pin snaps into its pivot hole.

SUNGLASSES STORAGE BIN

The sunglasses storage bin door and bin, housing, damper, spring and latch are serviced only as a unit. Remove the sunglasses storage bin module from the overhead console as follows:

- (1) Remove the overhead console from the vehicle. See Overhead Console in this group for the procedures.
- (2) Disengage the overhead console courtesy lamp wire harness from the retainers molded into the sunglasses storage bin housing.
- (3) Remove the six screws that secure the sunglasses storage bin module to the overhead console housing (Fig. 6).

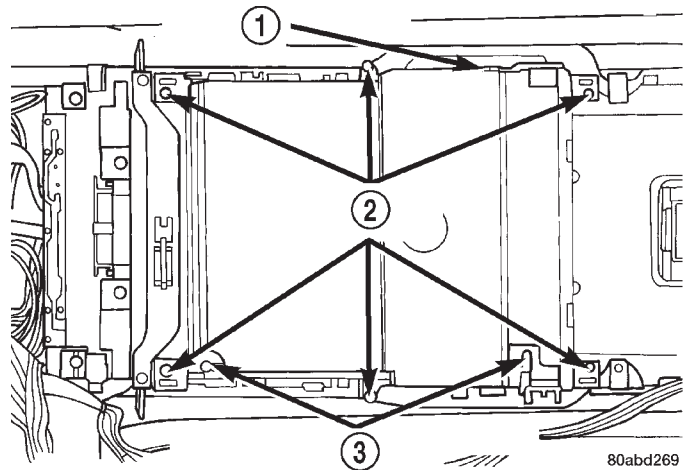
**Fig. 6 Sunglasses Storage Bin Module Remove/Install**

- 1 - SUNGLASSES STORAGE BIN MODULE
2 - MOUNTING SCREWS
3 - WIRE HARNESS RETAINERS

- (4) Remove the sunglasses storage bin module from the overhead console.
- (5) Reverse the removal procedures to install. Tighten the mounting screws to 2.2 N·m (20 in. lbs.).

AMBIENT TEMPERATURE SENSOR

- (1) Disconnect and isolate the battery negative cable.
- (2) Locate the ambient temperature sensor, below the grille and behind the front bumper on the radiator support crossmember (Fig. 7).
- (3) Unplug the ambient temperature sensor wire harness connector.
- (4) Remove the screw that secures the ambient temperature sensor to the radiator support crossmember.
- (5) Remove the ambient temperature sensor from the vehicle.

REMOVAL AND INSTALLATION (Continued)

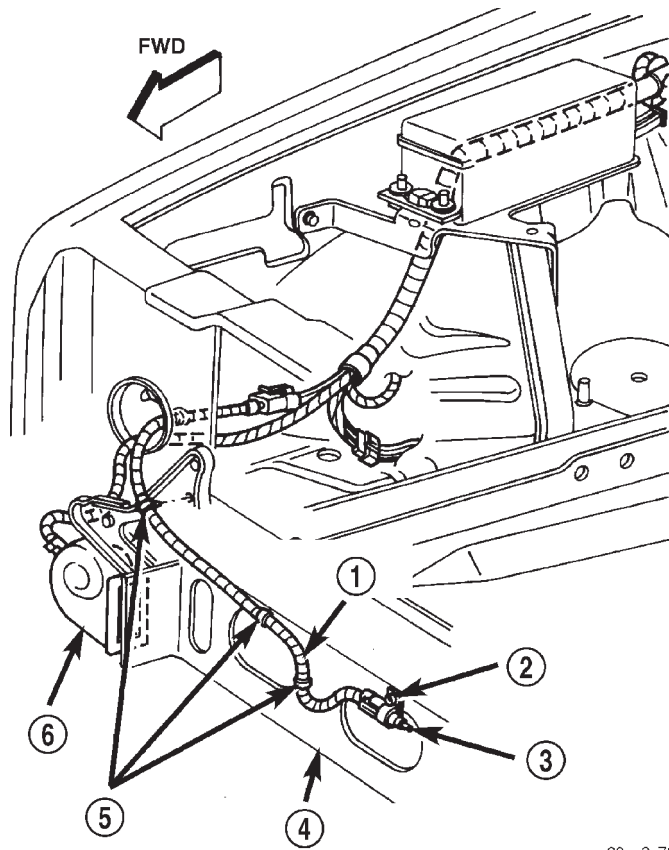

80ac2c73

Fig. 7 Ambient Temperature Sensor Remove/Install

- 1 - WIRE HARNESS
- 2 - SCREW
- 3 - SENSOR
- 4 - RADIATOR SUPPORT CROSSMEMBER
- 5 - CLIPS
- 6 - HORN

(6) Reverse the removal procedures to install. Tighten the ambient temperature sensor mounting screw to 3.4 N·m (30 in. lbs.).

SPECIAL TOOLS

COMPASS

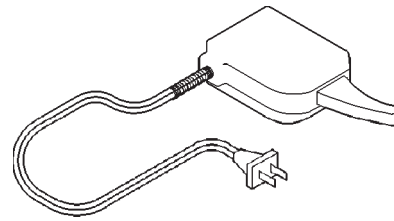

Degaussing Tool 6029

WIRING DIAGRAMS

CONTENTS

| | page | | page |
|------------------------------------|---------|-------------------------------------|---------|
| AIR CONDITIONING-HEATER | 8W-42-1 | POWER DISTRIBUTION | 8W-10-1 |
| AIRBAG SYSTEM | 8W-43-1 | POWER DOOR LOCKS | 8W-61-1 |
| ANTI-LOCK BRAKES | 8W-35-1 | POWER MIRRORS | 8W-62-1 |
| AUDIO SYSTEM | 8W-47-1 | POWER SEAT | 8W-63-1 |
| CHARGING SYSTEM | 8W-20-1 | POWER WINDOWS | 8W-60-1 |
| COMPONENT INDEX | 8W-02-1 | REAR LIGHTING | 8W-51-1 |
| CONNECTOR LOCATIONS | 8W-90-1 | REAR WINDOW DEFOGGER | 8W-48-1 |
| CONNECTOR PIN-OUTS | 8W-80-1 | SPLICE INFORMATION | 8W-70-1 |
| FRONT LIGHTING | 8W-50-1 | SPLICE LOCATIONS | 8W-95-1 |
| FUEL/IGNITION SYSTEM | 8W-30-1 | STARTING SYSTEM | 8W-21-1 |
| GENERAL INFORMATION | 8W-01-1 | TRAILER TOW | 8W-54-1 |
| GROUND DISTRIBUTION | 8W-15-1 | TRANSMISSION CONTROL SYSTEM | 8W-31-1 |
| HORN/CIGAR LIGHTER/POWER OUTLET .. | 8W-41-1 | TURN SIGNALS | 8W-52-1 |
| INSTRUMENT CLUSTER | 8W-40-1 | VEHICLE SPEED CONTROL | 8W-33-1 |
| INTERIOR LIGHTING | 8W-44-1 | VEHICLE THEFT SECURITY SYSTEM | 8W-39-1 |
| JUNCTION BLOCK | 8W-12-1 | WIPERS | 8W-53-1 |
| OVERHEAD CONSOLE | 8W-49-1 | | |

8W-01 GENERAL INFORMATION

INDEX

| | page | page |
|---|------|--|
| DESCRIPTION AND OPERATION | | |
| CIRCUIT FUNCTIONS | 4 | |
| CIRCUIT INFORMATION | 4 | |
| CONNECTOR INFORMATION | 7 | |
| ELECTROSTATIC DISCHARGE (ESD) | | |
| SENSITIVE DEVICES | 8 | |
| INTRODUCTION | 1 | |
| NOTES, CAUTIONS, and WARNINGS | 7 | |
| SECTION IDENTIFICATION | 5 | |
| SPLICE LOCATIONS | 7 | |
| SYMBOLS | 5 | |
| TAKE OUTS | 8 | |
| TERMINOLOGY | 7 | |
| DIAGNOSIS AND TESTING | | |
| INTERMITTENT AND POOR CONNECTIONS | 9 | |
| TROUBLESHOOTING TESTS | 9 | |
| TROUBLESHOOTING TOOLS | 8 | |
| | | |
| | | TROUBLESHOOTING WIRING PROBLEMS 10 |
| | | |
| | | SERVICE PROCEDURES |
| | | CONNECTOR AND TERMINAL |
| | | REPLACEMENT 13 |
| | | CONNECTOR REPLACEMENT 12 |
| | | DIODE REPLACEMENT 14 |
| | | TERMINAL REPLACEMENT 14 |
| | | TERMINAL/CONNECTOR REPAIR- AUGAT |
| | | CONNECTORS 12 |
| | | TERMINAL/CONNECTOR REPAIR-MOLEX |
| | | CONNECTORS 11 |
| | | TERMINAL/CONNECTOR REPAIR—THOMAS |
| | | AND BETTS CONNECTORS 11 |
| | | WIRING REPAIR 10 |
| | | SPECIAL TOOLS |
| | | WIRING/TERMINAL 15 |

DESCRIPTION AND OPERATION

INTRODUCTION

Chrysler wiring diagrams are designed to provide information regarding the vehicles wiring content. In order to effectively use Chrysler wiring diagrams to diagnose and repair a Chrysler vehicle, it is important to understand all of their features and characteristics.

Diagrams are arranged such that the power (B+) side of the circuit is placed near the top of the page, and the ground (B-) side of the circuit is placed near the bottom of the page.

All switches, components, and modules are shown in the at rest position with the doors closed and the key removed from the ignition.

Components are shown two ways. A solid line around a component indicates that the component is complete. A dashed line around a component indicates that the component being shown is not complete. Incomplete components have a reference number to indicate the page where the component is shown complete.

It is important to realize that no attempt is made on the diagrams to represent components and wiring as they appear on the vehicle. For example, a short piece of wire is treated the same as a long one. In addition, switches and other components are shown as simply as possible, with regard to function only.

DESCRIPTION AND OPERATION (Continued)

DIAGRAMS ARE ARRANGED WITH THE POWER B+ SIDE OF THE CIRCUIT NEAR THE TOP OF THE PAGE, AND THE GROUND SIDE OF THE CIRCUIT NEAR THE BOTTOM OF THE PAGE.

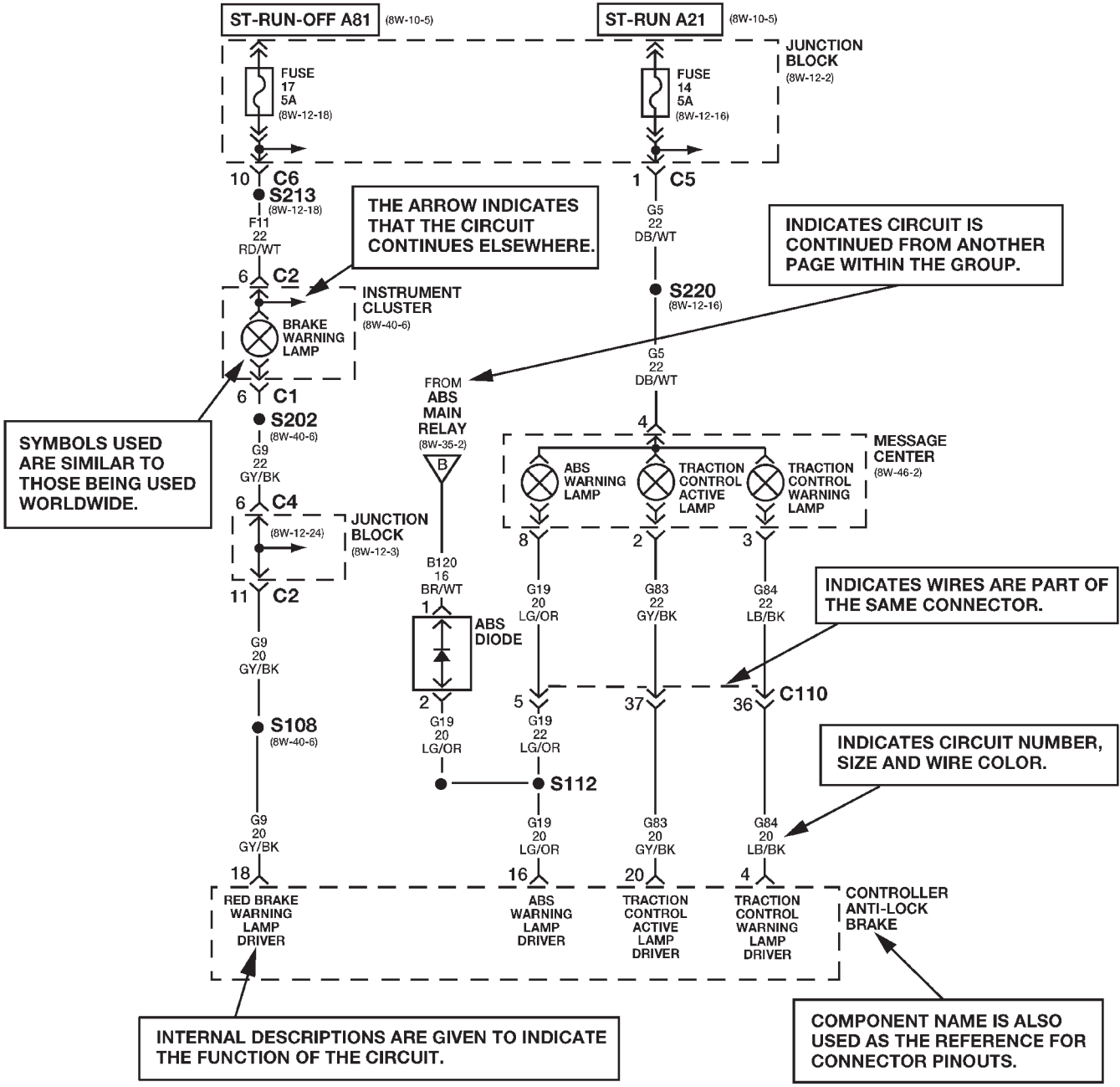

80b3b272

The System shown here is an EXAMPLE ONLY. It does not represent the actual circuit shown in the WIRING DIAGRAM SECTION.

DESCRIPTION AND OPERATION (Continued)

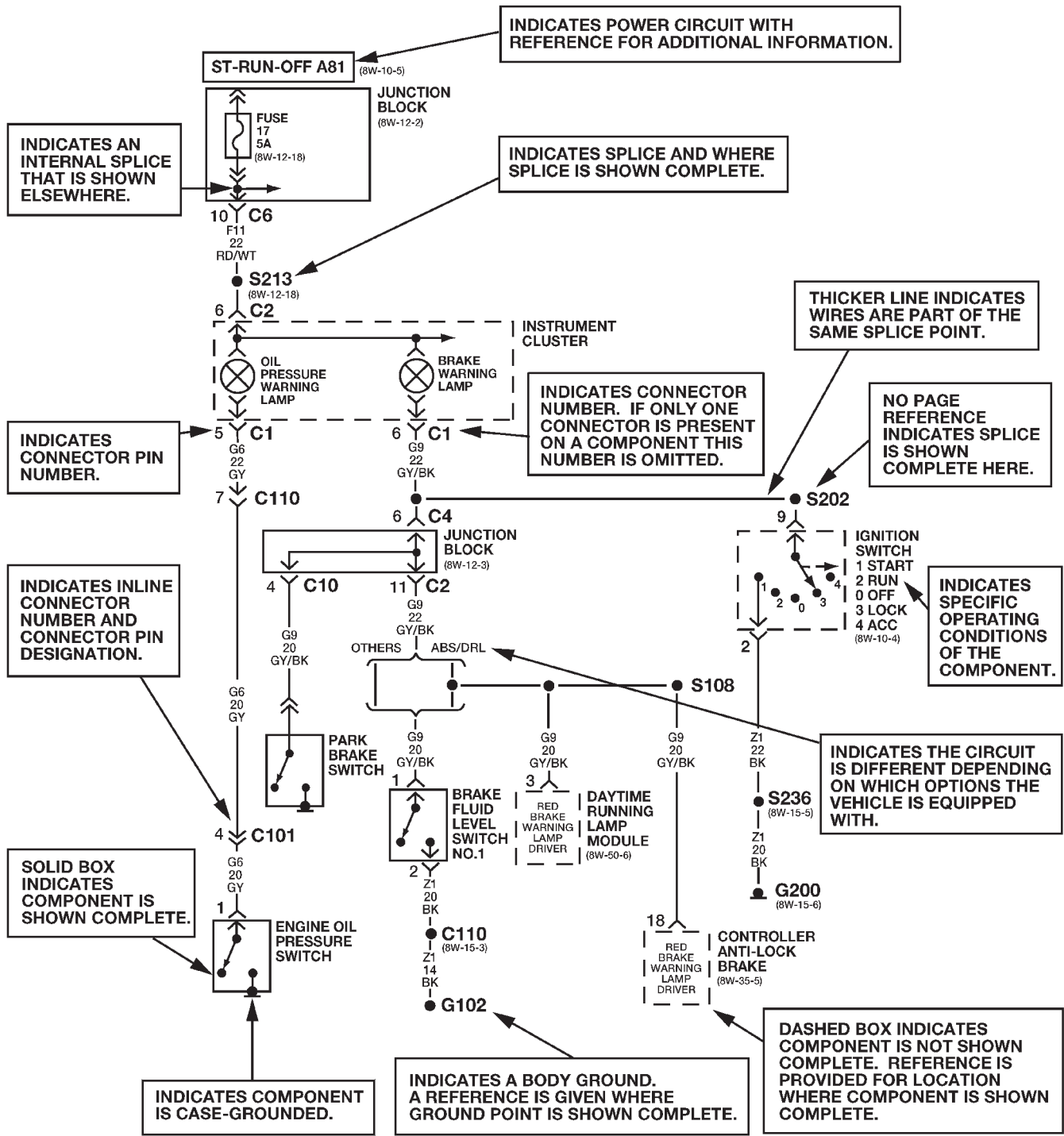

80b3b273

The System shown here is an EXAMPLE ONLY. It does not represent the actual circuit shown in the WIRING DIAGRAM SECTION.

DESCRIPTION AND OPERATION (Continued)

CIRCUIT INFORMATION

Each wire shown in the diagrams contains a code which identifies the main circuit, part of the main circuit, gage of wire, and color (Fig. 1).

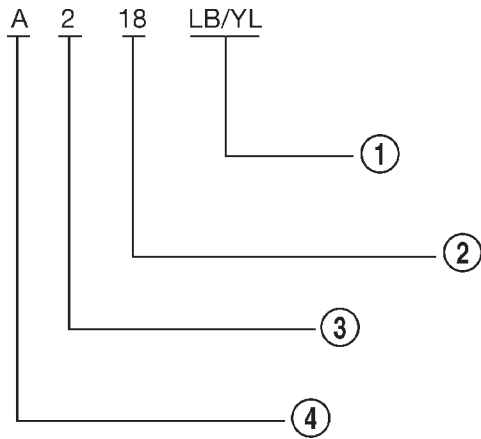

80aff571

Fig. 1 Wire Code Identification

- 1 - COLOR OF WIRE (LIGHT BLUE WITH YELLOW TRACER)
- 2 - GAUGE OF WIRE (18 GAUGE)
- 3 - PART OF MAIN CIRCUIT (VARIES DEPENDING ON EQUIPMENT)
- 4 - MAIN CIRCUIT IDENTIFICATION

WIRE COLOR CODE CHART

| COLOR CODE | COLOR | STANDARD TRACER COLOR |
|------------|-------------|-----------------------|
| BL | BLUE | WT |
| BK | BLACK | WT |
| BR | BROWN | WT |
| DB | DARK BLUE | WT |
| DG | DARK GREEN | WT |
| GY | GRAY | BK |
| LB | LIGHT BLUE | BK |
| LG | LIGHT GREEN | BK |
| OR | ORANGE | BK |
| PK | PINK | BK or WT |
| RD | RED | WT |
| TN | TAN | WT |
| VT | VIOLET | WT |
| WT | WHITE | BK |
| YL | YELLOW | BK |
| * | WITH TRACER | |

CIRCUIT FUNCTIONS

All circuits in the diagrams use an alpha/numeric code to identify the wire and its function. To identify which circuit code applies to a system, refer to the Circuit Identification Code Chart. This chart shows the main circuits only and does not show the secondary codes that may apply to some models.

CIRCUIT IDENTIFICATION CODE CHART

| CIRCUIT | FUNCTION |
|---------|--|
| A | BATTERY FEED |
| B | BRAKE CONTROLS |
| C | CLIMATE CONTROLS |
| D | DIAGNOSTIC CIRCUITS |
| E | DIMMING ILLUMINATION CIRCUITS |
| F | FUSED CIRCUITS |
| G | MONITORING CIRCUITS (GAUGES) |
| H | OPEN |
| I | NOT USED |
| J | OPEN |
| K | POWERTRAIN CONTROL MODULE |
| L | EXTERIOR LIGHTING |
| M | INTERIOR LIGHTING |
| N | NOT USED |
| O | NOT USED |
| P | POWER OPTION (BATTERY FEED) |
| Q | POWER OPTIONS (IGNITION FEED) |
| R | PASSIVE RESTRAINT |
| S | SUSPENSION/STEERING |
| T | TRANSMISSION/TRANSAXLE/ TRANSFER CASE |
| U | OPEN |
| V | SPEED CONTROL, WIPER/WASHER |
| W | OPEN |
| X | AUDIO SYSTEMS |
| Y | OPEN |
| Z | GROUNDS |

DESCRIPTION AND OPERATION (Continued)

SECTION IDENTIFICATION

































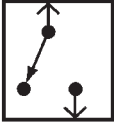
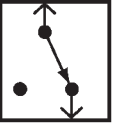



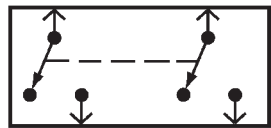
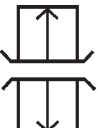



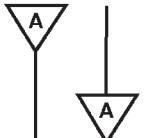



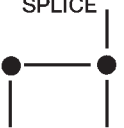
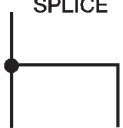

The wiring diagrams are grouped into individual sections. If a component is most likely found in a particular group, it will be shown complete (all wires, connectors, and pins) within that group. For example, the Auto Shutdown Relay is most likely to be found in Group 30, so it is shown there complete. It can, however, be shown partially in another group if it contains some associated wiring.

SYMBOLS

International symbols are used throughout the wiring diagrams. These symbols are consistent with those being used around the world

| GROUP | TOPIC |
|---------------------|---|
| 8W-01 thru 8W-09 | General Information and Diagram Overview |
| 8W-10 thru 8W-19 | Main Sources of Power and Vehicle Grounding |
| 8W-20 thru 8W-29 | Starting and Charging |
| 8W-30 thru 8W-39 | Powertrain/Drivetrain Systems |
| 8W-40 thru 8W-49 | Body Electrical items and A/C |
| 8W-50 thru 8W-59 | Exterior Lighting, Wipers, and Trailer Tow |
| 8W-60 thru 8W-69 | Power Accessories |
| 8W-70 | Splice Information |
| 8W-80 | Connector Pin Outs |
| 8W-90 | Connector Locations (including grounds) |
| 8W-95 | Splice Locations |

DESCRIPTION AND OPERATION (Continued)

| | |
|--|--|
|  BATTERY  GENERATOR STATOR COILS |  2 C123 IN-LINE CONNECTORS  2 C123 |
|  FUSIBLE LINK  FUSE  CIRCUIT BREAKER | MULTIPLE CONNECTOR  8  5  2 C123 MALE CONNECTOR  4 C1 FEMALE CONNECTOR  6 C3 |
|  BATT A0 HOT BAR  CHOICE BRACKET (8W-30-10) PAGE REFERENCE |  SINGLE FILAMENT LAMP  DUAL FILAMENT LAMP  ANTENNA |
|  CLOCKSPRING  GROUND G101  SCREW TERMINAL | NPN TRANSISTOR  PNP TRANSISTOR  TONE GENERATOR  |
|  OPEN SWITCH  CLOSED SWITCH |  LED  PHOTODIODE  DIODE  ZENER DIODE |
|  GANGED SWITCH  SLIDING DOOR CONTACT |  OXYGEN SENSOR  GAUGE  PIEZOELECTRIC CELL |
|  WIRE ORIGIN & DESTINATION SHOWN WITHIN CELL  WIRE DESTINATION SHOWN IN ANOTHER CELL |  RESISTOR  POTENTIOMETER  VARIABLE RESISTOR  HEATER ELEMENT |
| EXTERNAL SPLICE  S350 INTERNAL SPLICE  INCOMPLETE SPLICE (INTERNAL)  | NON-POLARIZED CAPACITOR  POLARIZED CAPACITOR  VARIABLE CAPACITOR  |
|  ONE SPEED MOTOR  TWO SPEED MOTOR  REVERSIBLE MOTOR |  COIL  SOLENOID  SOLENOID VALVE |

Wiring Diagram Symbols

DESCRIPTION AND OPERATION (Continued)

TERMINOLOGY

This a list of terms with there definitions used in the wiring diagrams.

| | |
|---------------------------|--|
| Built-Up-Export | Vehicles Built For Sale In Markets Other Than North America |
| Except-Built-Up-Export . | Vehicles Built For Sale In North America |
| LHD | Left Hand Drive Vehicles |
| RHD | Right Hand Drive Vehicles |
| EATX . . . | Electronic Automatic Transmission-Front Wheel Drive |
| ATX . . | Automatic Transmission-Front Wheel Drive |
| MTX | Manual Transmission-Front Wheel Drive |
| A/T | Automatic Transmission-Rear Wheel Drive |
| M/T | Manual Transmission-Rear Wheel Drive |
| SOHC | Single Over Head Cam Engine |
| DOHC | Dual Over Head Cam Engine |

CONNECTOR INFORMATION

CAUTION: Not all connectors are serviced. Some connectors are serviced only with a harness. A typical example might be the Supplemental Restraint System connectors. Always check parts availability before attempting a repair.

IDENTIFICATION

In-line connectors are identified by a number, as follows:

- In-line connectors located on the **engine compartment harness** are **C100** series numbers.
- Connectors located on the **instrument panel harness** are **C200** series numbers.
- Connectors located on the **body harness** are **C300** series numbers.
- **Jumper harness connectors** are **C400** series numbers.
- **Grounds and ground connectors** are identified with a "G" and follow the same series numbering as the in-line connector.

Component connectors are identified by the component name instead of a number. Multiple connectors on a component use a C1, C2, etc. identifier.

LOCATIONS

Section 8W-90 contains connector/ground location illustrations. The illustrations contain the connector name (or number)/ground number and component identification. Connector/ground location charts in Section 8W-90 reference the illustration number for components and connectors.

Section 8W-80 shows each connector and the circuits involved with that connector. The connectors

are identified using the name/number on the Diagram pages.

SPLICE LOCATIONS

Splice Location charts in Section 8W-70 show the entire splice, and provide references to other sections the splice serves.

Section 8W-95 contains illustrations that show the general location of the splices in each harness. The illustrations show the splice by number, and provide a written location.

NOTES, CAUTIONS, and WARNINGS

Throughout this group additional important information is presented in three ways; Notes, Cautions, and Warnings.

NOTES are used to help describe how switches or components operate to complete a particular circuit. They are also used to indicate different conditions that may appear on the vehicle. For example, an up-to and after condition.

CAUTIONS are used to indicate information that could prevent making an error that may damage the vehicle.

WARNINGS provide information to prevent personal injury and vehicle damage. Below is a list of general warnings that should be followed any time a vehicle is being serviced.

WARNING: ALWAYS WEAR SAFETY GLASSES FOR EYE PROTECTION.

WARNING: USE SAFETY STANDS ANYTIME A PROCEDURE REQUIRES BEING UNDER A VEHICLE.

WARNING: BE SURE THAT THE IGNITION SWITCH ALWAYS IS IN THE OFF POSITION, UNLESS THE PROCEDURE REQUIRES IT TO BE ON.

WARNING: SET THE PARKING BRAKE WHEN WORKING ON ANY VEHICLE. AN AUTOMATIC TRANSMISSION SHOULD BE IN PARK. A MANUAL TRANSMISSION SHOULD BE IN NEUTRAL.

WARNING: OPERATE THE ENGINE ONLY IN A WELL-VENTILATED AREA.

WARNING: KEEP AWAY FROM MOVING PARTS WHEN THE ENGINE IS RUNNING, ESPECIALLY THE FAN AND BELTS.

DESCRIPTION AND OPERATION (Continued)

WARNING: TO PREVENT SERIOUS BURNS, AVOID CONTACT WITH HOT PARTS SUCH AS THE RADIATOR, EXHAUST MANIFOLD(S), TAIL PIPE, CATALYTIC CONVERTER, AND MUFFLER.

WARNING: DO NOT ALLOW FLAME OR SPARKS NEAR THE BATTERY. GASES ARE ALWAYS PRESENT IN AND AROUND THE BATTERY.

WARNING: ALWAYS REMOVE RINGS, WATCHES, LOOSE HANGING JEWELRY, AND LOOSE CLOTHING.

TAKE OUTS

The abbreviation T/O is used in the component location section to indicate a point in which the wiring harness branches out to a component.

ELECTROSTATIC DISCHARGE (ESD) SENSITIVE DEVICES

All ESD sensitive components are solid state and a symbol (Fig. 2) is used to indicate this. When handling any component with this symbol comply with the following procedures to reduce the possibility of electrostatic charge build up on the body and inadvertent discharge into the component. If it is not known whether the part is ESD sensitive, assume that it is.

(1) Always touch a known good ground before handling the part. This should be repeated while handling the part and more frequently after sliding across a seat, sitting down from a standing position, or walking a distance.

(2) Avoid touching electrical terminals of the part, unless instructed to do so by a written procedure.

(3) When using a voltmeter, be sure to connect the ground lead first.

(4) Do not remove the part from its protective packing until it is time to install the part.

(5) Before removing the part from its package, ground the package to a known good ground on the vehicle.



948W-193

Fig. 2 Electrostatic Discharge Symbol

DIAGNOSIS AND TESTING

TROUBLESHOOTING TOOLS

When diagnosing a problem in an electrical circuit there are several common tools necessary. These tools are listed and explained below.

- Jumper Wire - This is a test wire used to connect two points of a circuit. It can be used to bypass an open in a circuit.

WARNING: NEVER USE A JUMPER WIRE ACROSS A LOAD, SUCH AS A MOTOR, CONNECTED BETWEEN A BATTERY FEED AND GROUND.

- Voltmeter - Used to check for voltage on a circuit. Always connect the black lead to a known good ground and the red lead to the positive side of the circuit.

CAUTION: Most of the electrical components used in today's vehicle are solid state. When checking voltages in these circuits use a meter with a 10-megohm or greater impedance rating.

- Ohmmeter - Used to check the resistance between two points of a circuit. Low or no resistance in a circuit means good continuity.

CAUTION: - Most of the electrical components used in today's vehicle are Solid State. When checking resistance in these circuits use a meter with a 10-megohm or greater impedance rating. In addition, make sure the power is disconnected from the circuit. Circuits that are powered up by the vehicle electrical system can cause damage to the equipment and provide false readings.

- Probing Tools - These tools are used for probing terminals in connectors (Fig. 3). Select the proper size tool from Special Tool Package 6807, and insert it into the terminal being tested. Use the other end of the tool to insert the meter probe.

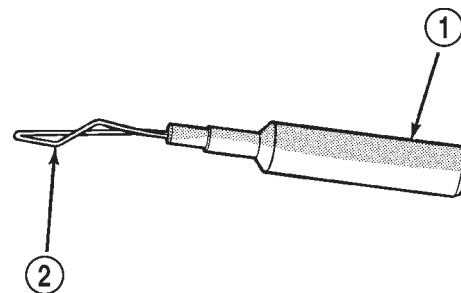

948W-233

Fig. 3 Probing Tool

1 - SPECIAL TOOL 6801

2 - PROBING END

DIAGNOSIS AND TESTING (Continued)

INTERMITTENT AND POOR CONNECTIONS

Most intermittent electrical problems are caused by faulty electrical connections or wiring. It is also possible for a sticking component or relay to cause a problem. Before condemning a component or wiring assembly check the following items.

- Connectors are fully seated
- Spread terminals, or terminal push out
- Terminals in the wiring assembly are fully seated into the connector/component and locked in position
 - Dirt or corrosion on the terminals. Any amount of corrosion or dirt could cause an intermittent problem
 - Damaged connector/component casing exposing the item to dirt and moisture
 - Wire insulation that has rubbed through causing a short to ground
 - Some or all of the wiring strands broken inside of the insulation covering.
 - Wiring broken inside of the insulation

TROUBLESHOOTING TESTS

Before beginning any tests on a vehicles electrical system use the Wiring Diagrams and study the circuit. Also refer to the Troubleshooting Wiring Problems in this section.

TESTING FOR VOLTAGE POTENTIAL

(1) Connect the ground lead of a voltmeter to a known good ground (Fig. 4).

(2) Connect the other lead of the voltmeter to the selected test point. The vehicle ignition may need to be turned ON to check voltage. Refer to the appropriate test procedure.

TESTING FOR CONTINUITY

(1) Remove the fuse for the circuit being checked or, disconnect the battery.

(2) Connect one lead of the ohmmeter to one side of the circuit being tested (Fig. 5).

(3) Connect the other lead to the other end of the circuit being tested. Low or no resistance means good continuity.

TESTING FOR A SHORT TO GROUND

(1) Remove the fuse and disconnect all items involved with the fuse.

(2) Connect a test light or a voltmeter across the terminals of the fuse.

(3) Starting at the fuse block, wiggle the wiring harness about six to eight inches apart and watch the voltmeter/test lamp.

(4) If the voltmeter registers voltage or the test lamp glows, there is a short to ground in that general area of the wiring harness.

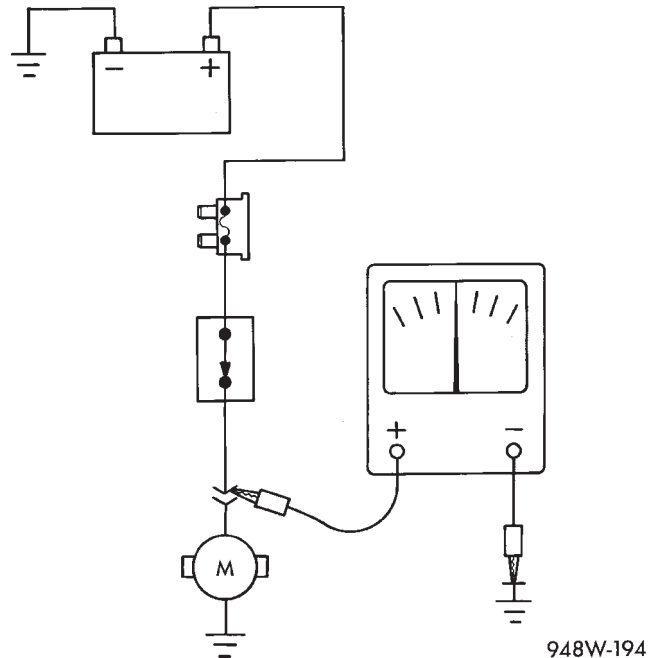

Fig. 4 Testing for Voltage Potential

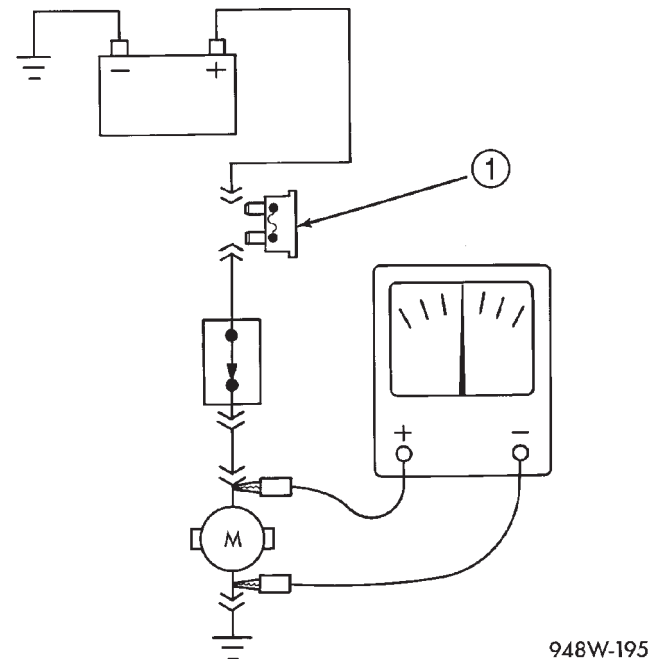

Fig. 5 Testing for Continuity

1 - FUSE REMOVED FROM CIRCUIT

TESTING FOR A SHORT TO GROUND ON FUSES POWERING SEVERAL LOADS

(1) Refer to the wiring diagrams and disconnect or isolate all items on the suspected fused circuits.

(2) Replace the blown fuse.

(3) Supply power to the fuse by turning ON the ignition switch or re-connecting the battery.

DIAGNOSIS AND TESTING (Continued)

(4) Start connecting the items in the fuse circuit one at a time. When the fuse blows the circuit with the short to ground has been isolated.

TESTING FOR A VOLTAGE DROP

- (1) Connect the positive lead of the voltmeter to the side of the circuit closest to the battery (Fig. 6).
- (2) Connect the other lead of the voltmeter to the other side of the switch or component.
- (3) Operate the item.
- (4) The voltmeter will show the difference in voltage between the two points.

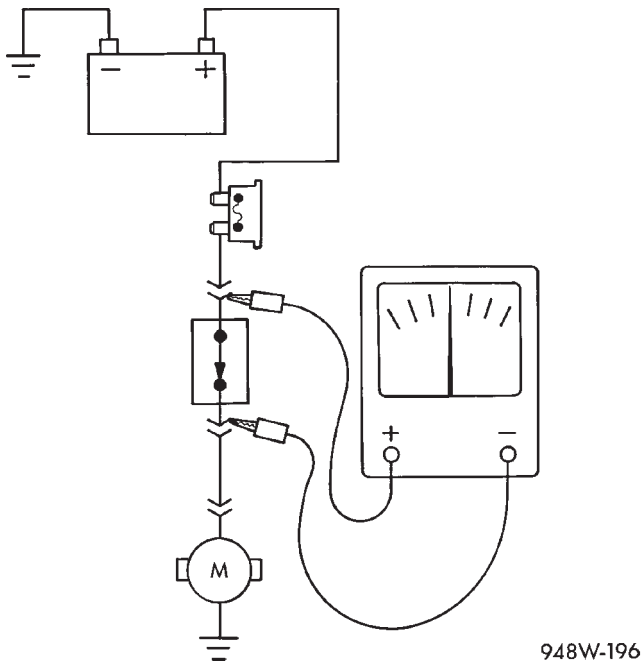

948W-196

Fig. 6 Testing for Voltage Drop

TROUBLESHOOTING WIRING PROBLEMS

When troubleshooting wiring problems there are six steps which can aid in the procedure. The steps are listed and explained below. Always check for non-factory items added to the vehicle before doing any diagnosis. If the vehicle is equipped with these items, disconnect them to verify these add-on items are not the cause of the problem.

- (1) Verify the problem.
- (2) Verify any related symptoms. Do this by performing operational checks on components that are in the same circuit. Refer to the wiring diagrams.
- (3) Analyze the symptoms. Use the wiring diagrams to determine what the circuit is doing, where the problem most likely is occurring and where the diagnosis will continue.
- (4) Isolate the problem area.
- (5) Repair the problem.
- (6) Verify proper operation. For this step check for proper operation of all items on the repaired circuit. Refer to the wiring diagrams.

SERVICE PROCEDURES

WIRING REPAIR

When replacing or repairing a wire, it is important that the correct gage be used as shown in the wiring diagrams. The wires must also be held securely in place to prevent damage to the insulation.

- (1) Disconnect battery negative cable
- (2) Remove 1 inch of insulation from each end of the wire.
- (3) Place a piece of heat shrink tubing over one side of the wire. Make sure the tubing will be long enough to cover and seal the entire repair area.
- (4) Spread the strands of the wire apart on each part of the exposed wire (example 1). (Fig. 7)
- (5) Push the two ends of wire together until the strands of wire are close to the insulation (example 2) (Fig. 7)
- (6) Twist the wires together (example 3) (Fig. 7)
- (7) Solder the connection together using rosin core type solder only. **Do not use acid core solder.**
- (8) Center the heat shrink tubing over the joint, and heat using a heat gun. Heat the joint until the tubing is tightly sealed and sealant comes out of both ends of the tubing.
- (9) Secure the wire to the existing ones to prevent chafing or damage to the insulation
- (10) Connect battery and test all affected systems.

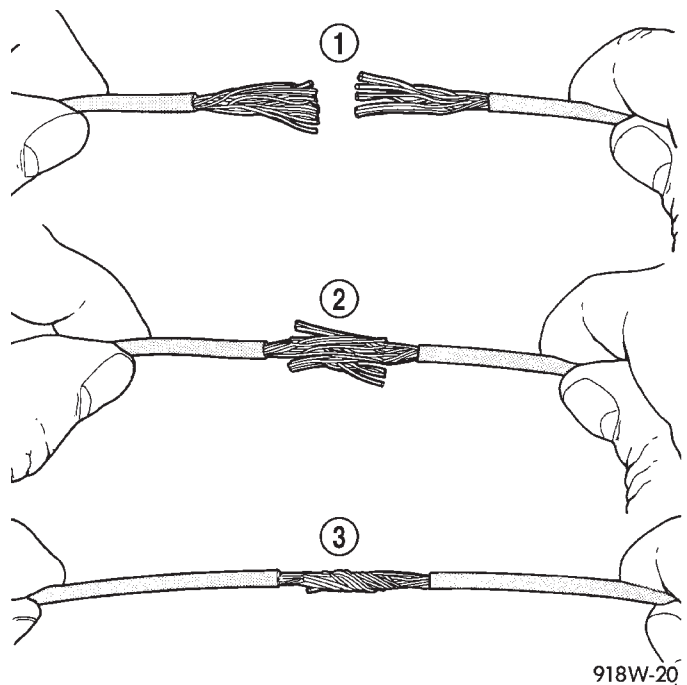

918W-20

Fig. 7 Wire Repair

- 1 - EXAMPLE 1
- 2 - EXAMPLE 2
- 3 - EXAMPLE 3

SERVICE PROCEDURES (Continued)

TERMINAL/CONNECTOR REPAIR-MOLEX CONNECTORS

- (1) Disconnect battery.
- (2) Disconnect the connector from its mating half/component.
- (3) Insert the terminal releasing special tool 6742 into the terminal end of the connector (Fig. 8).

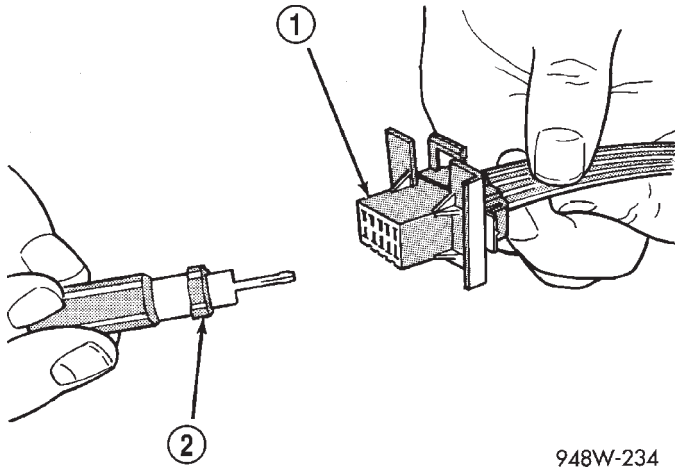

948W-234

Fig. 8 Molex Connector Repair

- 1 - CONNECTOR
- 2 - SPECIAL TOOL 6742

- (4) Using special tool 6742 release the locking fingers on the terminal (Fig. 9).
- (5) Pull on the wire to remove it from the connector.
- (6) Repair or replace the connector or terminal, as necessary.

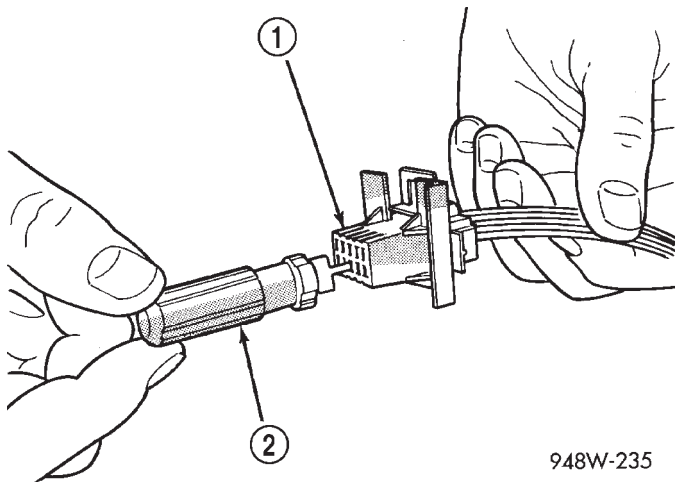

948W-235

Fig. 9 Using Special Tool 6742

- 1 - CONNECTOR
- 2 - SPECIAL TOOL 6742

TERMINAL/CONNECTOR REPAIR—THOMAS AND BETTS CONNECTORS

- (1) Disconnect battery.
- (2) Disconnect the connector from its mating half/component.
- (3) Push in the two lock tabs on the side of the connector (Fig. 10).

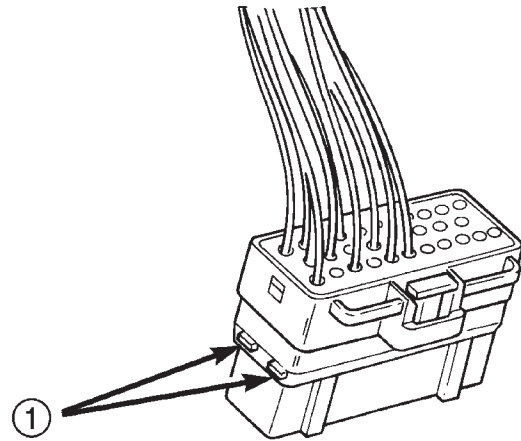

803f588a

Fig. 10 Thomas and Betts Connector Lock Release Tabs

- 1 - LOCK TABS

- (4) Insert the probe end of special tool 6934 into the back of the connector cavity (Fig. 11).
- (5) Grasp the wire and tool 6934 and slowly remove the wire and terminal from the connector.

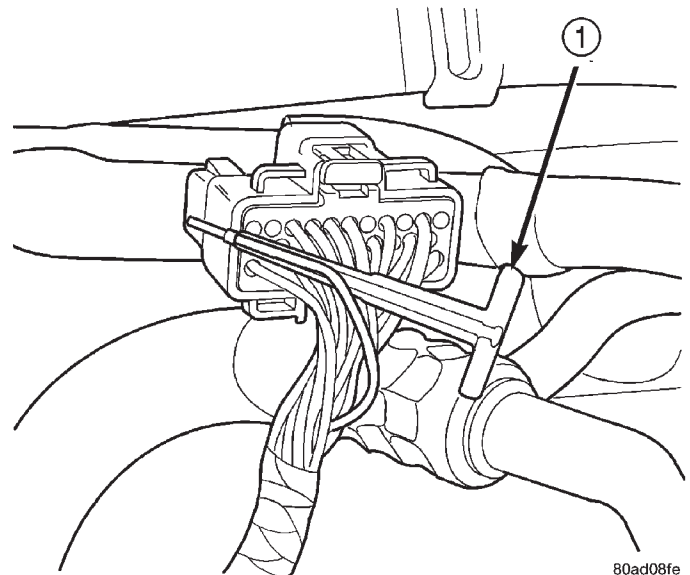

80ad08fe

Fig. 11 Removing Wire Terminal

- 1 - SPECIAL TOOL 6934

SERVICE PROCEDURES (Continued)

- (6) Repair or replace the terminal.
- (7) Install the wire and terminal in the connector.
- Fully seat the terminal in the connector.
- (8) Push in the single lock tab on the side of the connector (Fig. 12).

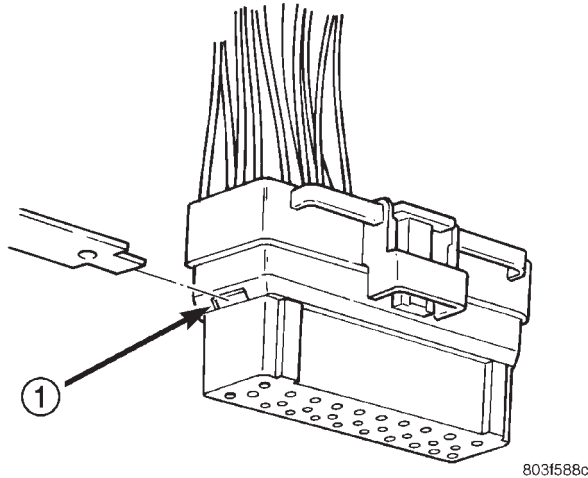
**Fig. 12 Single Lock Tab**

1 - SINGLE LOCK TAB

TERMINAL/CONNECTOR REPAIR- AUGAT CONNECTORS

- (1) Disconnect battery.
- (2) Disconnect the connector from its mating half/component.
- (3) Push down on the yellow connector locking tab to release the terminals (Fig. 13).

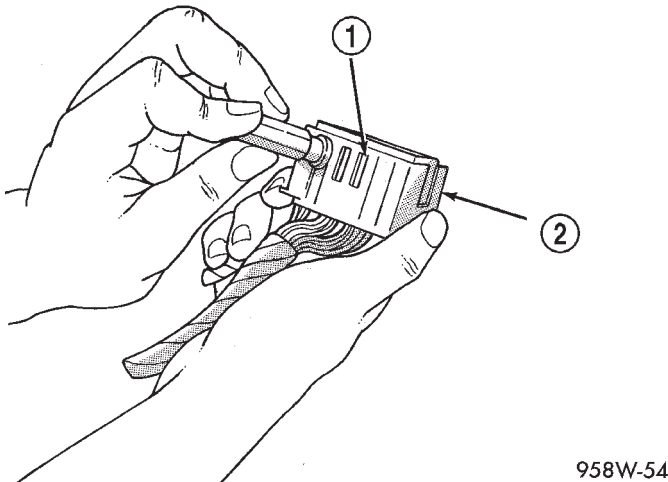
**Fig. 13 Augat Connector Repair**1 - LOCKING TAB
2 - CONNECTOR

- (4) Using special tool 6932, push the terminal to remove it from the connector (Fig. 14).

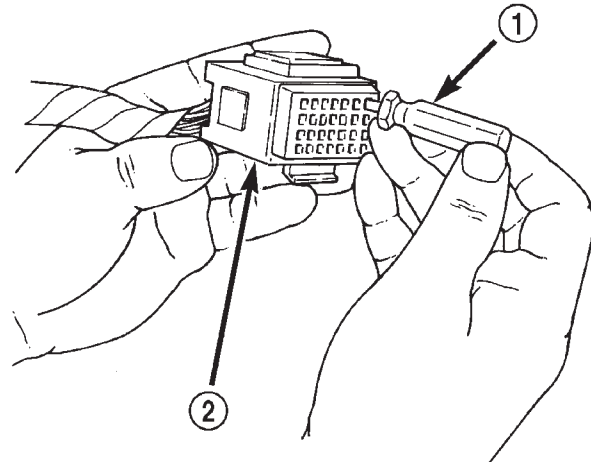
**Fig. 14 Using Special Tool 6932**1 - SPECIAL TOOL 6932
2 - CONNECTOR

- (5) Repair or replace the connector or terminal as necessary.

- (6) When re-assembling the connector, the locking wedge must be placed in the locked position to prevent terminal push out.

CONNECTOR REPLACEMENT

- (1) Disconnect battery.
- (2) Disconnect the connector that is to be repaired from its mating half/component
- (3) Remove the connector locking wedge, if required (Fig. 15)

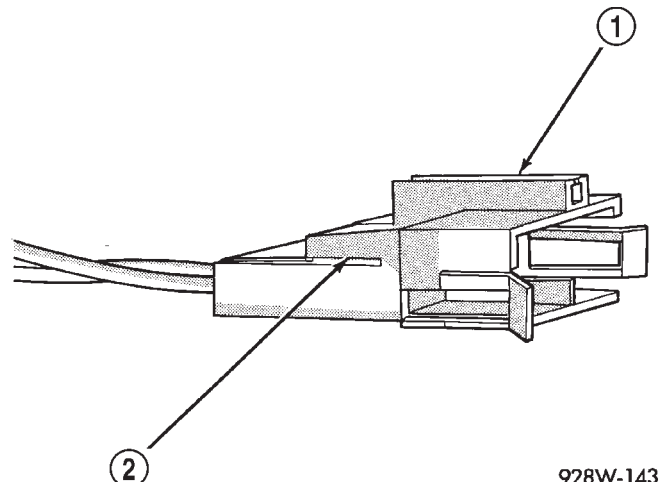
**Fig. 15 Connector Locking Wedge**1 - CONNECTOR
2 - CONNECTOR LOCKING WEDGE TAB

- (4) Position the connector locking finger away from the terminal using the proper pick from special tool

SERVICE PROCEDURES (Continued)

kit 6680. Pull on the wire to remove the terminal from the connector (Fig. 16) (Fig. 17).

- (5) Reset the terminal locking tang, if it has one.
- (6) Insert the removed wire in the same cavity on the repair connector.
- (7) Repeat steps four through six for each wire in the connector, being sure that all wires are inserted into the proper cavities. For additional connector pin-out identification, refer to the wiring diagrams.
- (8) Insert the connector locking wedge into the repaired connector, if required.
- (9) Connect connector to its mating half/component.
- (10) Connect battery and test all affected systems.

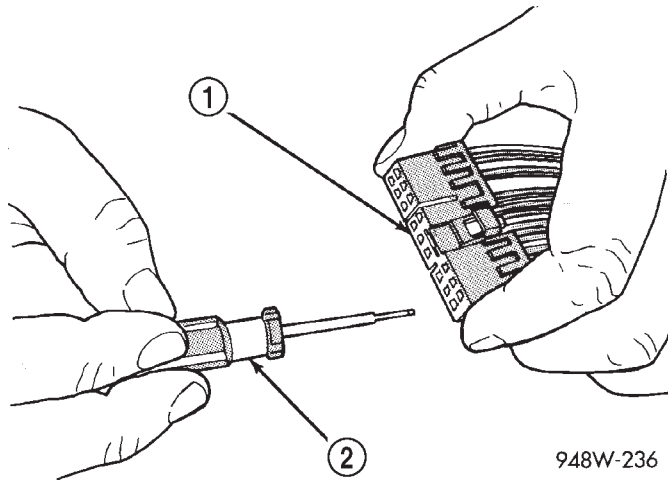

Fig. 16 Terminal Removal

- 1 - CONNECTOR
- 2 - FROM SPECIAL TOOL KIT 6680

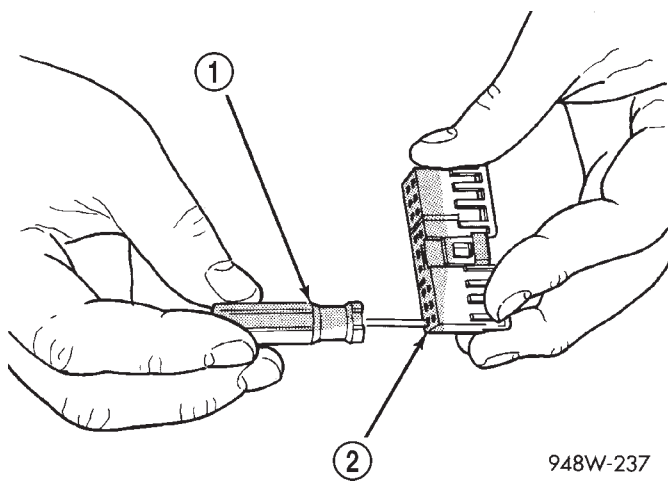

Fig. 17 Terminal Removal Using Special Tool

- 1 - FROM SPECIAL TOOL KIT 6680
- 2 - CONNECTOR

CONNECTOR AND TERMINAL REPLACEMENT

- (1) Disconnect battery.
- (2) Disconnect the connector (that is to be repaired) from its mating half/component.
- (3) Cut off the existing wire connector directly behind the insulator. Remove six inches of tape from the harness.
- (4) Stagger cut all wires on the harness side at 1/2 inch intervals (Fig. 18).
- (5) Remove 1 inch of insulation from each wire on the harness side.
- (6) Stagger cut the matching wires on the repair connector assembly in the opposite order as was done on the harness side of the repair. Allow extra length for soldered connections. Check that the overall length is the same as the original (Fig. 18).

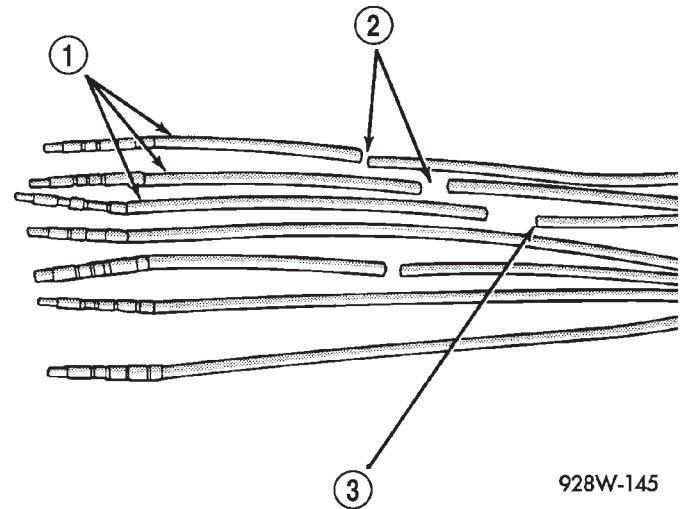

Fig. 18 Stagger Cutting Wires

- 1 - REPAIR SIDE WIRES
- 2 - STAGER CUTS
- 3 - HARNESS WIRES

- (7) Remove 1 inch of insulation from each wire.
- (8) Place a piece of heat shrink tubing over one side of the wire. Be sure the tubing will be long enough to cover and seal the entire repair area.
- (9) Spread the strands of the wire apart on each part of the exposed wires.
- (10) Push the two ends of wire together until the strands of wire are close to the insulation.
- (11) Twist the wires together.
- (12) Solder the connection together using rosin core type solder only. **Do not use acid core solder.**
- (13) Center the heat shrink tubing over the joint and heat using a heat gun. Heat the joint until the tubing is tightly sealed and sealant comes out of both ends of the tubing
- (14) Repeat steps 8 through 13 for each wire.
- (15) Re-tape the wire harness starting 1-1/2 inches behind the connector and 2 inches past the repair.

SERVICE PROCEDURES (Continued)

(16) Re-connect the repaired connector.

(17) Connect the battery, and test all affected systems.

TERMINAL REPLACEMENT

(1) Disconnect battery.

(2) Disconnect the connector being repaired from its mating half. Remove connector locking wedge, if required (Fig. 19).

(3) Remove connector locking wedge, if required (Fig. 19).

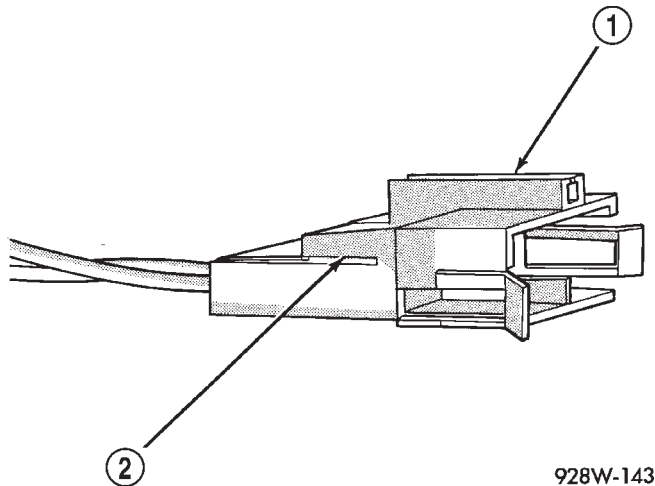

928W-143

Fig. 19 Connector Locking Wedge Tab (Typical)

- 1 - CONNECTOR
2 - CONNECTOR LOCKING WEDGE TAB

(4) Position the connector locking finger away from the terminal using the proper pick from special tool kit 6680. Pull on the wire to remove the terminal from the connector (Fig. 20) (Fig. 21).

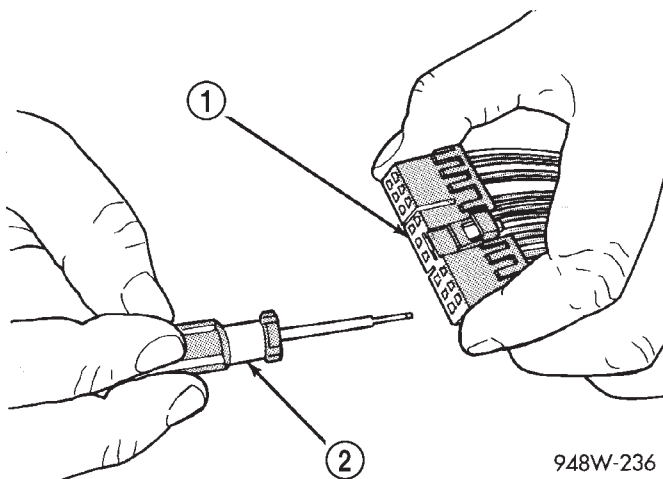

948W-236

Fig. 20 Terminal Removal

- 1 - CONNECTOR
2 - FROM SPECIAL TOOL KIT 6680

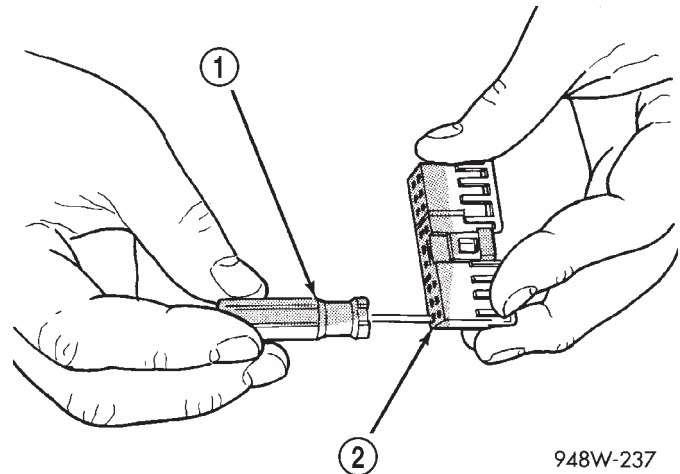

948W-237

Fig. 21 Terminal Removal Using Special Tool

- 1 - FROM SPECIAL TOOL KIT 6680
2 - CONNECTOR

(5) Cut the wire 6 inches from the back of the connector.

(6) Remove 1 inch of insulation from the wire on the harness side.

(7) Select a wire from the terminal repair assembly that best matches the color wire being repaired.

(8) Cut the repair wire to the proper length and remove 1 inch of insulation.

(9) Place a piece of heat shrink tubing over one side of the wire. Make sure the tubing will be long enough to cover and seal the entire repair area.

(10) Spread the strands of the wire apart on each part of the exposed wires.

(11) Push the two ends of wire together until the strands of wire are close to the insulation.

(12) Twist the wires together.

(13) Solder the connection together using rosin core type solder only. **Do not use acid core solder.**

(14) Center the heat shrink tubing over the joint and heat using a heat gun. Heat the joint until the tubing is tightly sealed and sealant comes out of both ends of the tubing.

(15) Insert the repaired wire into the connector.

(16) Install the connector locking wedge, if required, and reconnect the connector to its mating half/component.

(17) Re-tape the wire harness starting 1-1/2 inches behind the connector and 2 inches past the repair.

(18) Connect battery, and test all affected systems.

DIODE REPLACEMENT

(1) Disconnect the battery.

(2) Locate the diode in the harness, and remove the protective covering.

(3) Remove the diode from the harness, pay attention to the current flow direction (Fig. 22).

SERVICE PROCEDURES (Continued)

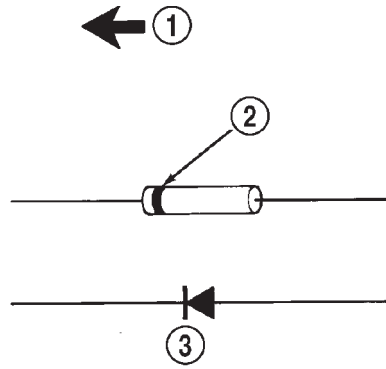

948W-197

Fig. 22 Diode Identification

- 1 - CURRENT FLOW
- 2 - BAND AROUND DIODE INDICATES CURRENT FLOW
- 3 - DIODE AS SHOWN IN THE DIAGRAMS

(4) Remove the insulation from the wires in the harness. Only remove enough insulation to solder in the new diode.

(5) Install the new diode in the harness, making sure current flow is correct. If necessary refer to the appropriate wiring diagram for current flow.

(6) Solder the connection together using rosin core type solder only. **Do not use acid core solder.**

(7) Tape the diode to the harness using electrical tape making, sure the diode is completely sealed from the elements.

(8) Re-connect the battery, and test affected systems.

SPECIAL TOOLS

WIRING/TERMINAL

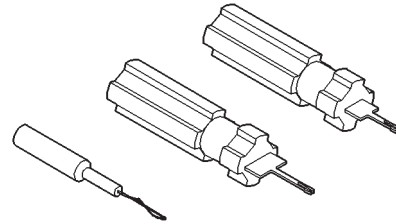

Probing Tool Package 6807

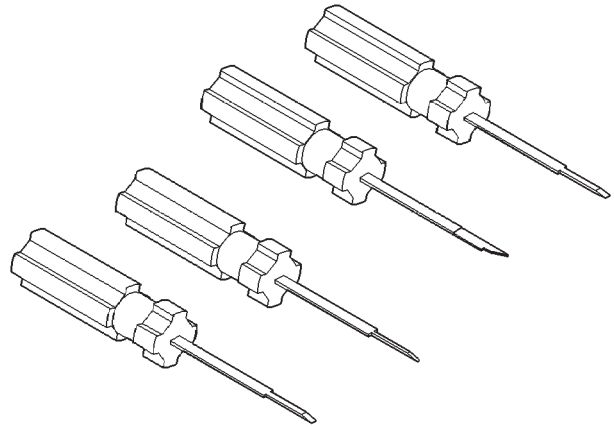

Terminal Pick 6680

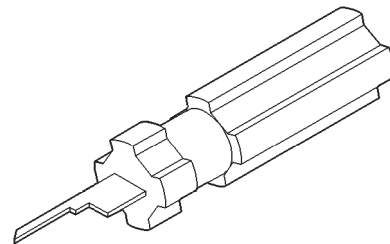

Terminal Removing Tool 6932

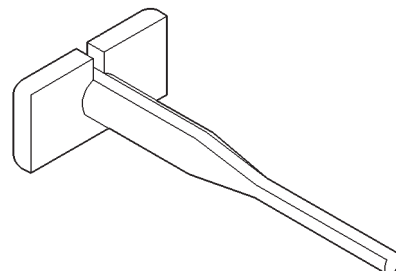

Terminal Removing Tool 6934

8W-02 COMPONENT INDEX

| Component | Page | Component | Page |
|--|-------------------|---|-------------|
| 1-2 And 3-4 Solenoid | 8W-31 | Engine Starter Motor Relay | 8W-21 |
| 2-3 Solenoid | 8W-31 | Engine Starter Motor | 8W-21 |
| A/C Compressor Clutch Relay | 8W-42 | Evap Leak Detection Pump | 8W-30 |
| A/C Compressor Clutch | 8W-42 | Extended Idle Switch | 8W-30 |
| A/C- Heater Control | 8W-42 | Fog Lamp Relays | 8W-50 |
| A/C Pressure Switches | 8W-42 | Fog Lamps | 8W-50, 51 |
| Accelerator Pedal Position Sensor | 8W-30 | Forward/Rearward Motor | 8W-63 |
| Airbag Control Module | 8W-43 | Front Fog Lamp Switch | 8W-44, 50 |
| Airbags | 8W-43 | Front Motor | 8W-63 |
| Ambient Temperature Sensor | 8W-49 | Front Wiper Motor | 8W-53 |
| Antenna | 8W-47 | Fuel Gauge | 8W-40 |
| Automatic Shut Down Relay | 8W-30 | Fuel Injection Pump | 8W-30 |
| Back-Up Lamp Switch | 8W-51 | Fuel Injectors | 8W-30 |
| Back-Up Lamps | 8W-51 | Fuel Level Sensor | 8W-30 |
| Battery Temperature Sensor | 8W-30 | Fuel Pump Module | 8W-30 |
| Battery | 8W-20 | Fuel Pump Relay | 8W-30 |
| Blend Door Actuator | 8W-42 | Fuses (JB) | 8W-12 |
| Blower Motor Relay | 8W-42 | Fuses (PDC) | 8W-10 |
| Blower Motor Resistor Block | 8W-42 | Fusible Link A11 | 8W-10 |
| Blower Motor | 8W-42 | Fusible Link | 8W-20 |
| Brake Lamp Switch | 8W-33 | G Switch | 8W-35 |
| Brake Warning Pressure Switch | 8W-40 | Generator | 8W-20 |
| Camshaft Position Sensor | 8W-30 | Glow Plug Assembly | 8W-30 |
| Cargo Lamp/Switch | 8W-44 | Glow Plug Relay | 8W-30 |
| Center High Mounted Stop Lamp | 8W-51 | Glow Plugs | 8W-30 |
| Cigar Lighter Relay | 8W-41 | Grounds | 8W-15 |
| Cigar Lighter | 8W-41 | Headlamp Beam Select Switch | 8W-50 |
| Circuit Breakers (JB) | 8W-12 | Headlamp Delay Module | 8W-50 |
| City Lamps | 8W-50 | Headlamp Leveling Motors | 8W-50 |
| Clockspring | 8W-30, 33, 41, 43 | Headlamp Leveling Switch | 8W-50 |
| Cluster Illumination Lamps | 8W-40 | Headlamp Switch | 8W-50 |
| Clutch Interlock Switch Jumper | 8W-12, 21 | Headlamps | 8W-50, 50 |
| Clutch Interlock Switch | 8W-12, 21 | Heated Seat Backs | 8W-63 |
| Combination Flasher | 8W-52 | Heated Seat Cushions | 8W-63 |
| Compass | 8W-49 | Heated Seat Relay | 8W-63 |
| Controller Anti-Lock Brake Relay | 8W-35 | Heated Seat Switches | 8W-63 |
| Controller Anti-Lock Brake | 8W-35 | Heater Control | 8W-42 |
| Courtesy Lamps | 8W-44 | Horn Relay | 8W-41 |
| Crankshaft Position Sensor | 8W-30 | Horn Switch | 8W-41 |
| Data Link Connector | 8W-30 | Horns | 8W-41 |
| Daytime Running Lamp Module | 8W-50 | Idle Air Control Motor | 8W-30 |
| Diode Module | 8W-51 | Ignition Coil | 8W-30 |
| Dome Lamp | 8W-44 | Ignition Switch | 8W-10 |
| Dome Lamps Switch | 8W-44 | Indicators | 8W-40 |
| Door Jamb Switches | 8W-39, 44 | Input Speed Sensor | 8W-31 |
| Door Lock Motors | 8W-61 | Instrument Cluster | 8W-40 |
| Duty Cycle Evap/Purge Solenoid | 8W-30 | Intake Air Temperature Sensor | 8W-30 |
| Engine Control Module | 8W-30 | Junction Block | 8W-12 |
| Engine Coolant Temperature Gauge | 8W-40 | License Lamps | 8W-51 |
| Engine Coolant Temperature Sensors | 8W-30 | Liftgate Lock Motor | 8W-61 |
| Engine Oil Pressure Sensor | 8W-30 | Liftgate Switch | 8W-44 |
| Engine Speed Sensor | 8W-30 | Lock-Up Solenoid | 8W-31 |

| Component | Page | Component | Page |
|---|---------------|--|---------------|
| Low Coolant Switch | 8W-30 | Rear Wiper Motor | 8W-53 |
| Manifold Absolute Pressure Sensor | 8W-30 | Rear Wiper/Washer Switch | 8W-53 |
| Message Center | 8W-30 | Repeater Lamps | 8W-50, 52 |
| Needle Movement Sensor | 8W-30 | Seat Belt Switch | 8W-40 |
| Odometer | 8W-40 | Seat Heat Interface Module | 8W-63 |
| Oil Pressure Gauge | 8W-40 | Sentry Key Immobilizer Module | 8W-39 |
| Output Speed Sensor | 8W-31 | Shift Lock Solenoid | 8W-31 |
| Overhead Module | 8W-49 | Side Marker Lamps | 8W-50, 52 |
| Oxygen Sensor Downstream Relay | 8W-30 | Speakers | 8W-47 |
| Oxygen Sensor Upstream Relay | 8W-30 | Speed Control Switches | 8W-33 |
| Oxygen Sensors | 8W-30 | Speedometer | 8W-40 |
| Park Brake Switch | 8W-40 | Splice Information | 8W-70 |
| Park/Neutral Position Switch | 8W-31 | Tachometer | 8W-40 |
| Park/Turn Signal Lamps | 8W-50, 52 | Tail/Stop Lamps | 8W-51 |
| Power Amplifier | 8W-47 | Throttle Position Sensor | 8W-30 |
| Power Antenna Relay | 8W-47 | Torque Converter Clutch Solenoid | 8W-31 |
| Power Antenna | 8W-47 | Trailer Tow Connector | 8W-54 |
| Power Distribution Center | 8W-10 | Trailer Tow Electric Brake Provision | 8W-54 |
| Power Lock/Window Switches | 8W-60, 61, 62 | Trailer Tow Relays | 8W-54 |
| Power Mirror Switch | 8W-62 | Transfer Case Switch Illumination | 8W-44 |
| Power Mirrors | 8W-48, 62 | Transfer Case Switch | 8W-40 |
| Power Outlet | 8W-41 | Transmission Control Module | 8W-31 |
| Power Seat Motors | 8W-63 | Transmission Range Sensor | 8W-31 |
| Power Seat Switches | 8W-63 | Transmission Solenoid | 8W-31 |
| Power Steering Pressure Switch | 8W-30 | Trip Reset Switch | 8W-40 |
| Power Window Motors | 8W-60 | Turbo Boost Pressure Sensor | 8W-30 |
| Powertrain Control Module | 8W-20, 30 | Turn Signal Lamps | 8W-50, 52, 52 |
| PRNDL Illumination | 8W-44 | Turn Signal/Hazard Switch | 8W-52 |
| Radiator Fan Motor | 8W-42 | Underhood Lamp/Switch | 8W-44 |
| Radiator Fan Relay | 8W-42 | Vehicle Speed Control Servo | 8W-33 |
| Radio | 8W-47 | Vehicle Speed Sensor | 8W-30 |
| Rail Coil | 8W-30 | Visor/Vanity Lamps | 8W-44 |
| Rear Fog Lamp Indicator | 8W-51 | Volt Meter | 8W-40 |
| Rear Fog Lamp Relay | 8W-51 | Washer Fluid Level Switch | 8W-40 |
| Rear Fog Lamp Switch | 8W-51 | Water In Fuel Sensor | 8W-30 |
| Rear Motor | 8W-63 | Wheel Speed Sensors | 8W-35 |
| Rear Washer Pump | 8W-53 | Windshield Washer Pump | 8W-53 |
| Rear Window Defogger Relay | 8W-48 | Wipe/Wash Switch | 8W-53 |
| Rear Window Defogger Switch | 8W-48 | Wiper Motor Relay | 8W-53 |
| Rear Window Defogger | 8W-48 | | |

8W-10 POWER DISTRIBUTION

| Component | Page | Component | Page |
|-------------------------------|----------------------|------------------------------------|--|
| A/C Compressor Clutch | 8W-10-22, 32 | Fuse 17 (JB) | 8W-10-15, 16 |
| A/C Compressor Clutch Relay | 8W-10-19, 22, 32 | Fuse 17 (PDC) | 8W-10-12, 27 |
| Automatic Shut Down Relay | 8W-10-19, 23, 34 | Fuse 18 (JB) | 8W-10-15, 16 |
| Battery | 8W-10-11, 13 | Fuse 18 (PDC) | 8W-10-23 |
| Blower Motor | 8W-10-21 | Fuse 19 (JB) | 8W-10-18 |
| Blower Motor Relay | 8W-10-11, 21, 26 | Fuse 19 (PDC) | 8W-10-12, 14, 28, 29, 32 |
| Brake Lamp Switch | 8W-10-32, 33 | Fuse 20 (JB) | 8W-10-20, 26 |
| Brake Warning Pressure Switch | 8W-10-15, 16 | Fuse 20 (PDC) | 8W-10-12, 14, 31, 32 |
| Cargo Lamp/Switch | 8W-10-27, 30 | Fuse 21 (JB) | 8W-10-20, 26 |
| Center High Mounted Stop Lamp | 8W-10-32, 33 | Fuse 21 (PDC) | 8W-10-19, 23, 34 |
| Cigar Lighter | 8W-10-20, 26 | Fuse 22 (JB) | 8W-10-18 |
| Cigar Lighter Relay | 8W-10-15, 16, 20, 26 | Fuse 22 (PDC) | 8W-10-12, 14, 31, 34 |
| Circuit Breaker 28 (JB) | 8W-10-15, 16 | Fuse 23 (PDC) | 8W-10-12, 14, 33, 35 |
| Circuit Breaker 29 (JB) | 8W-10-20, 26 | Fuse 24 (JB) | 8W-10-18 |
| Circuit Breaker 30 (JB) | 8W-10-15, 16 | Fuse 24 (PDC) | 8W-10-19 |
| Combination Flasher | 8W-10-31, 35 | Fuse 25 (JB) | 8W-10-18 |
| Compass | 8W-10-28, 29, 30 | Fuse 25 (PDC) | 8W-10-12, 14, 32, 33, 35 |
| Controller Anti-Lock Brake | 8W-10-25, 26, 32, 33 | Fuse 26 (JB) | 8W-10-18 |
| Data Link Connector | 8W-10-28, 29 | Fuse 26 (PDC) | 8W-10-12, 14, 29, 33 |
| Daytime Running Lamp Module | 8W-10-22 | Fuse 27 (JB) | 8W-10-17 |
| Dome Lamp | 8W-10-28, 29, 30 | Fuse 27 (PDC) | 8W-10-22, 32 |
| Dome Lamps Switch | 8W-10-28, 29, 30 | Fusible Link A11 | 8W-10-11, 13 |
| Driver Door Jamb Switch | 8W-10-17 | G108 | 8W-10-15, 16 |
| Electronic Vacuum Modulator | 8W-10-34 | Generator | 8W-10-11, 13 |
| Engine Control Module | 8W-10-19, 32 | Glow Plug Assembly | 8W-10-19 |
| Engine Starter Motor | 8W-10-11, 13, 24, 25 | Glow Plug Relay | 8W-10-19, 34 |
| Engine Starter Motor Relay | 8W-10-24, 25 | Headlamp Delay Module | 8W-10-22, 24 |
| Fog Lamp Relay | 8W-10-32, 35 | Headlamp Switch | 8W-10-17, 22, 24, 28, 29 |
| Fog Lamp Relay No. 2 | 8W-10-33 | High Note Horn | 8W-10-20, 26 |
| Fuel Heater | 8W-10-24 | Horn Relay | 8W-10-20, 26 |
| Fuel Heater Relay | 8W-10-24 | Ignition Coil | 8W-10-23 |
| Fuel Injection Pump | 8W-10-19, 34 | Ignition Switch | 8W-10-15, 16, 17, 18 |
| Fuel Injector No. 1 | 8W-10-23 | Instrument Cluster | 8W-10-17, 27, 30 |
| Fuel Injector No. 2 | 8W-10-23 | Junction Block | 8W-10-15, 16, 17, 18, 20, 24, 25, 26, 27, 30 |
| Fuel Injector No. 3 | 8W-10-23 | Left Courtesy Lamp | 8W-10-27, 30 |
| Fuel Injector No. 4 | 8W-10-23 | Left Fog Lamp | 8W-10-32, 33, 35 |
| Fuel Injector No. 5 | 8W-10-23 | Left Tail/Stop Lamp | 8W-10-32, 33 |
| Fuel Injector No. 6 | 8W-10-23 | Left Visor/Vanity Lamp | 8W-10-28, 29, 30 |
| Fuel Pump Module | 8W-10-31 | Low Note Horn | 8W-10-20, 26 |
| Fuel Pump Relay | 8W-10-31 | Overhead Module | 8W-10-28, 29, 30 |
| Fuse 1 (JB) | 8W-10-20, 26 | Oxygen Sensor 1/1 Upstream | 8W-10-23 |
| Fuse 2 (JB) | 8W-10-20, 26 | Oxygen Sensor 1/2 Downstream | 8W-10-23 |
| Fuse 2 (PDC) | 8W-10-11, 13, 15, 19 | Oxygen Sensor Downstream Relay | 8W-10-27 |
| Fuse 3 (PDC) | 8W-10-11, 13, 15, 19 | Oxygen Sensor Upstream Relay | 8W-10-27 |
| Fuse 4 (PDC) | 8W-10-11, 13, 19, 20 | Park Brake Switch | 8W-10-15, 16 |
| Fuse 5 (PDC) | 8W-10-11, 13, 16, 21 | Passenger Power Lock/Window Switch | 8W-10-17 |
| Fuse 6 (PDC) | 8W-10-11, 13, 21, 24 | Power Amplifier | 8W-10-33, 34 |
| Fuse 7 (PDC) | 8W-10-11, 13, 22, 24 | Power Antenna Relay | 8W-10-29 |
| Fuse 8 (JB) | 8W-10-17 | Power Distribution Center | 8W-10-2, 7, 11, 12, 13, 14, 15, 16, 19, 20, 21, 22, 23, 24, 25, 26, 27, 28, 29, 30, 31, 32, 33, 34, 35 |
| Fuse 8 (PDC) | 8W-10-11, 13, 23, 24 | Powertrain Control Module | 8W-10-19, 23, 31 |
| Fuse 9 (JB) | 8W-10-17 | Radiator Fan Motor | 8W-10-21, 26 |
| Fuse 9 (PDC) | 8W-10-11, 13, 22, 26 | Radiator Fan Relay | 8W-10-19, 21, 26 |
| Fuse 10 (JB) | 8W-10-17 | Radio | 8W-10-27, 30 |
| Fuse 10 (PDC) | 8W-10-11, 13, 16, 25 | Rail Coil | 8W-10-23 |
| Fuse 11 (JB) | 8W-10-17 | Rear Window Defogger | 8W-10-24, 25 |
| Fuse 11 (PDC) | 8W-10-11, 13, 25, 26 | Rear Window Defogger Relay | 8W-10-18, 24, 25 |
| Fuse 12 (JB) | 8W-10-18 | Right Courtesy Lamp | 8W-10-27, 30 |
| Fuse 12 (PDC) | 8W-10-12, 13, 25, 26 | Right Fog Lamp | 8W-10-32, 33, 35 |
| Fuse 13 (JB) | 8W-10-24, 25 | Right Tail/Stop Lamp | 8W-10-32, 33 |
| Fuse 13 (PDC) | 8W-10-12, 14, 25, 26 | Right Visor/Vanity Lamp | 8W-10-28, 29, 30 |
| Fuse 14 (JB) | 8W-10-24, 25 | Sentry Key Immobilizer Module | 8W-10-22, 32 |
| Fuse 14 (PDC) | 8W-10-14, 26 | Transmission Control Module | 8W-10-27 |
| Fuse 15 (JB) | 8W-10-20, 26 | Underhood Lamp/Mercury Switch | 8W-10-27, 30 |
| Fuse 15 (PDC) | 8W-10-14, 24 | | |
| Fuse 16 (PDC) | 8W-10-12, 14, 27, 30 | | |

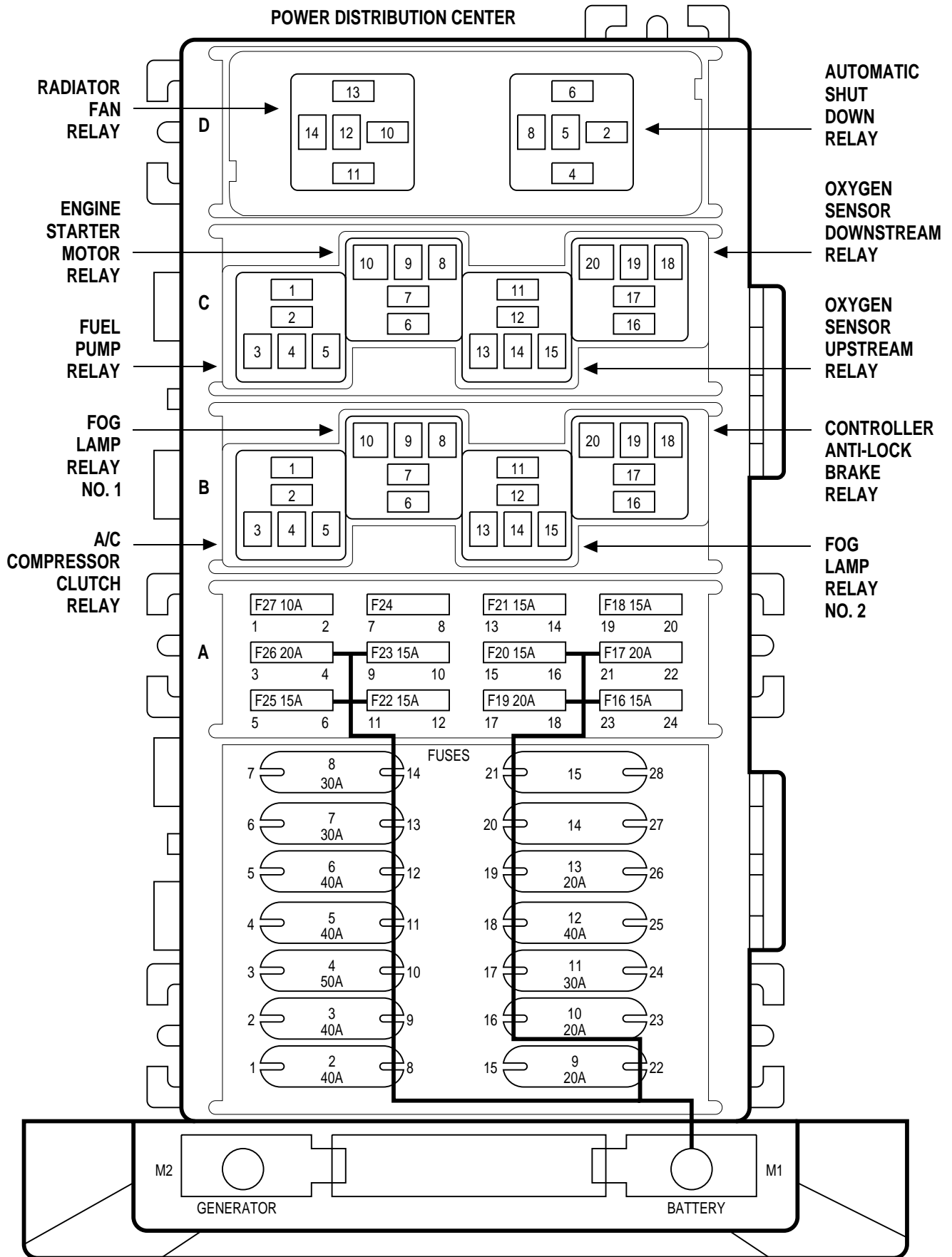

FUSES

| FUSE NO. | AMPS | FUSED CIRCUIT | FEED CIRCUIT |
|----------|------|---------------|--------------|
| 1 | - | - | - |
| 2 | 40A | A1 12RD | A0 6RD |
| 3 | 40A | A2 12PK/BK | A0 6RD |
| 4 | 50A | A7 10RD/BK | A0 6RD |
| 5 | 40A | F141 12LG/RD | A0 6RD |
| 6 | 40A | A111 12RD/LG | A0 6RD |
| 7 | 30A | A3 14RD/WT | A0 6RD |
| | | A3 14RD/WT ▲ | |
| 8 | 30A | A16 14RD/LG | A0 6RD |
| 9 | 20A | A17 16RD/BK | A0 6RD |
| | | A17 16RD/BK | |
| 10 | 20A | A41 16YL | A0 6RD |
| 11 | 30A | A4 12BK/PK | A0 6RD |
| 12 ● | 40A | A10 12RD/DG | A0 6RD |
| 13 ● | 20A | A20 12RD/DB | A0 6RD |
| 14 | - | - | A0 6RD |
| 15 | - | - | A0 6RD |
| 16 | 15A | M1 20PK | A0 6RD |
| 17 ■ | 20A | F99 18RD | A0 6RD |
| 18 | 15A | A142 18DG/OR | A999 16RD |
| 19 | 20A | F34 18TN/BK | A0 6RD |
| 20 | 15A | L9 20BK/PK | A0 6RD |
| 21 | 15A | F142 18DG/WT | A999 16RD |
| 22 | 15A | A61 14DG/BK | A0 6RD |
| 23 | 15A | F32 20PK/DB | A0 6RD |
| 24 | - | - | - |
| 25 | 15A | F61 20WT/OR | A0 6RD |
| 26 | 20A | F75 16VT | A0 6RD |
| 27 | 10A | F1 20DB/GY | A17 16RD/BK |

- ABS
- ▲ DRL
- 4.0L

GAS

A/C
COMPRESSOR
CLUTCH
RELAY

| CAVITY | CIRCUIT | FUNCTION |
|--------|-------------|---------------------------------------|
| B1 | A17 16RD/BK | FUSED B(+) |
| B2 | C3 16DB/BK | A/C COMPRESSOR CLUTCH RELAY OUTPUT |
| B3 | C13 18DB/OR | A/C COMPRESSOR CLUTCH RELAY CONTROL |
| B4 | - | - |
| B5 | F20 18WT | FUSED IGNITION SWITCH OUTPUT (ST-RUN) |

AUTOMATIC
SHUT
DOWN
RELAY

| CAVITY | CIRCUIT | FUNCTION |
|--------|-------------|---------------------------------------|
| D2 | A16 14RD/LG | FUSED B(+) |
| D4 | F12 18DB/WT | FUSED IGNITION SWITCH OUTPUT (ST-RUN) |
| D5 | - | - |
| D6 | K51 18DB/YL | AUTOMATIC SHUT DOWN RELAY CONTROL |
| D8 | A999 16RD | AUTOMATIC SHUT DOWN RELAY OUTPUT |
| | A999 16RD | |

CONTROLLER
ANTI-LOCK
BRAKE
RELAY

| CAVITY | CIRCUIT | FUNCTION |
|--------|-------------|------------------------------------|
| B16 | G19 20LG/OR | ABS WARNING INDICATOR DRIVER |
| B17 | - | - |
| B18 | G83 18GY/BK | ABS RELAY CONTROL |
| B19 | Z1 20BK | GROUND |
| B19 | Z1 20BK ■ | GROUND |
| B20 | F15 20DB/WT | FUSED IGNITION SWITCH OUTPUT (RUN) |

ENGINE
STARTER
MOTOR
RELAY

| CAVITY | CIRCUIT | FUNCTION |
|--------|-----------------|---------------------------------------|
| C6 | A41 16YL | FUSED B(+) |
| C7 | T40 16BR | ENGINE STARTER MOTOR RELAY OUTPUT |
| C8 | F45 20YL/RD ● | FUSED B(+) ENGINE STARTER MOTOR RELAY |
| C8 | T141 20YL ▲ | IGNITION SWITCH OUTPUT (START) |
| C9 | - | - |
| C10 | Z1 20BK ■■ | GROUND |
| C10 | Z1 20BK ▲▲ | GROUND |
| C10 | T41 20BK/WT ●● | PARK/NEUTRAL POSITION SWITCH SENSE |
| C10 | T41 20BK/WT ■■■ | PARK/NEUTRAL POSITION SWITCH SENSE |

- 4.0L ABS EXCEPT DRL
- 4.0L M/T
- 4.0L A/T

- ▲ 2.5L, 4.0L M/T, RHD 4.0L A/T
- ▲▲ LHD 4.0L M/T EXCEPT ABS EXCEPT DRL

- LHD 4.0 A/T
- EXCEPT 4.0L M/T

**FOG
LAMP
RELAY
NO. 1**

| CAVITY | CIRCUIT | FUNCTION |
|--------|----------------|------------------------------|
| B6 | L77 20BR/YL | FUSED HEADLAMP SWITCH OUTPUT |
| | L77 20BR/YL | FUSED HEADLAMP SWITCH OUTPUT |
| B7 | - | - |
| B8 | Z1 20BK | GROUND |
| | Z1 20BK | GROUND |
| B9 | L139 20VT | FOG LAMP RELAY OUTPUT NO. 1 |
| B10 | L33 20RD/WT ▲ | FUSED B(+) |
| B10 | G34 16RD/GY ▲▲ | HIGH BEAM INDICATOR DRIVER |
| | G34 16RD/GY ▲▲ | HIGH BEAM INDICATOR DRIVER |

**FOG
LAMP
RELAY
NO. 2**

| CAVITY | CIRCUIT | FUNCTION |
|--------|-------------|------------------------|
| B11 | F61 20WT/OR | FUSED B(+) |
| B12 | L39 20LB | FOG LAMP RELAY OUTPUT |
| B13 | Z1 20BK | GROUND |
| B14 | - | - |
| B15 | L92 20PK | FOG LAMP SWITCH OUTPUT |

**FUEL
PUMP
RELAY**

| CAVITY | CIRCUIT | FUNCTION |
|--------|--------------|---------------------------------------|
| C1 | A61 14DG/BK | FUSED B(+) |
| | A61 16DG/BK | FUSED B(+) |
| C2 | A141 14DG/WT | FUEL PUMP RELAY OUTPUT |
| C3 | K31 18BR | FUEL PUMP RELAY CONTROL |
| C4 | - | - |
| C5 | F12 18DB/WT | FUSED IGNITION SWITCH OUTPUT (ST-RUN) |

▲ EXCEPT DRL
 ▲▲ DRL

**OXYGEN
SENSOR
DOWNSTREAM
RELAY
(GAS)**

| CAVITY | CIRCUIT | FUNCTION |
|--------|--------------|--|
| C16 | F99 18RD | FUSED B(+) |
| | F99 18RD | FUSED B(+) |
| C17 | A242 18VT/OR | OXYGEN SENSOR 1/2 DOWNSTREAM |
| C18 | F20 18WT | • FUSED IGNITION SWITCH OUTPUT (ST-RUN) |
| | F20 18WT | • FUSED IGNITION SWITCH OUTPUT (ST-RUN) |
| C18 | F26 18PK/OR | •• FUSED IGNITION SWITCH OUTPUT (ST-RUN) |
| | F26 18PK/OR | •• FUSED IGNITION SWITCH OUTPUT (ST-RUN) |
| C19 | - | - |
| C20 | K74 18BR/VT | OXYGEN SENSOR DOWNSTREAM RELAY CONTROL |

**OXYGEN
SENSOR
UPSTREAM
RELAY
(GAS)**

| CAVITY | CIRCUIT | FUNCTION |
|--------|-------------|--|
| C11 | F99 18RD | FUSED B(+) |
| C12 | A42 18DG | OXYGEN SENSOR 1/1 UPSTREAM |
| C13 | F20 18WT | • FUSED IGNITION SWITCH OUTPUT (ST-RUN) |
| | F20 18WT | • FUSED IGNITION SWITCH OUTPUT (ST-RUN) |
| C13 | F26 18PK/OR | •• FUSED IGNITION SWITCH OUTPUT (ST-RUN) |
| C14 | - | - |
| C15 | K73 18BR/OR | KNOCK SENSOR SIGNAL (-) |

**RADIATOR
FAN
RELAY**

| CAVITY | CIRCUIT | FUNCTION |
|--------|--------------|---------------------------------------|
| D10 | F141 12LG/RD | FUSED B(+) |
| D11 | F20 18WT | FUSED IGNITION SWITCH OUTPUT (ST-RUN) |
| | F20 18WT | FUSED IGNITION SWITCH OUTPUT (ST-RUN) |
| D12 | - | - |
| D13 | C27 18DB/PK | RADIATOR FAN RELAY CONTROL |
| D14 | C25 12LB | RADIATOR FAN RELAY OUTPUT |

- 2.5L, 4.0L A/T FOG EXCEPT DRL
- 4.0L (A/T DRL), (A/T EXCEPT FOG), (M/T)

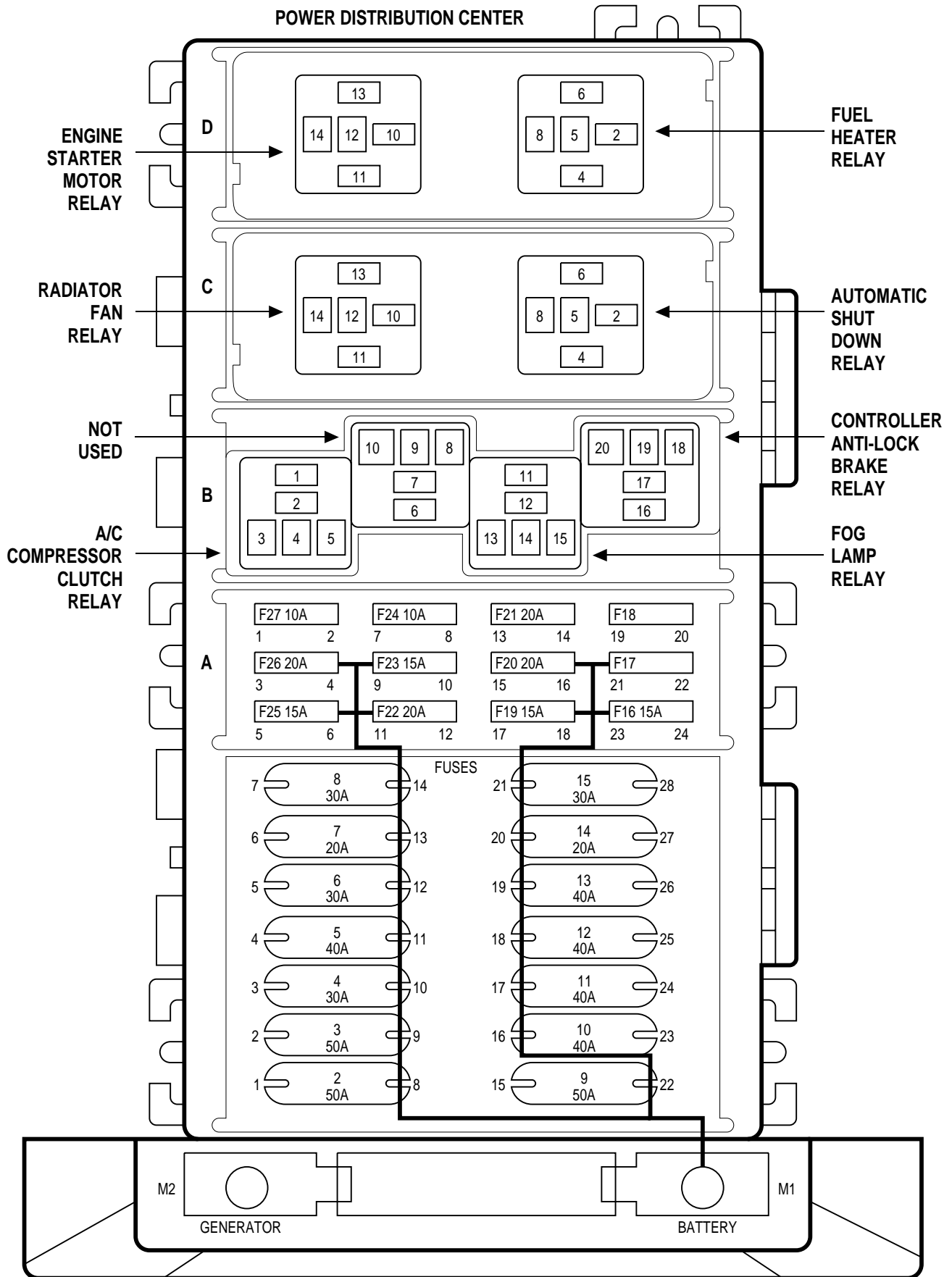

FUSES

| FUSE NO. | AMPS | FUSED CIRCUIT | FEED CIRCUIT |
|----------|-------|---------------|--------------|
| 1 | - | - | - |
| 2 | 50A | A54 12RD/GY | A0 6RD |
| 3 | 50A | A54 12RD/GY | A0 6RD |
| 4 | 30A | A16 12RD/LG | A0 6RD |
| 5 | 40A | A1 12RD | A0 6RD |
| 6 | 30A | A61 14LG/RD | A0 6RD |
| 7 | 20A | A41 16YL | A0 6RD |
| 8 | 30A | A3 14RD/WT | A0 6RD |
| 9 | 50A | A7 10RD/BK | A0 6RD |
| 10 | 40A | A2 12PK/BK | A0 6RD |
| 11 | 40A | A111 12RD/LG | A0 6RD |
| 12 | • 40A | A10 12RD/DG | A0 6RD |
| 13 | 40A | F141 12LG/RD | A0 6RD |
| 14 | • 20A | A20 12RD/DB | A0 6RD |
| 15 | 30A | A4 12BK/PK | A0 6RD |
| 16 | 15A | M1 20PK | A0 6RD |
| | | M1 20PK | |
| 17 | - | - | A0 6RD |
| 18 | - | - | - |
| 19 | 15A | F32 20PK/DB | A0 6RD |
| 20 | 20A | A17 18RD/BK | A0 6RD |
| | | A17 16RD/BK | |
| 21 | 20A | F142 16DG/OR | A142 16DG/OR |
| 22 | 20A | F75 16VT | A0 6RD |
| 23 | 15A | L9 20BK/PK | A0 6RD |
| 24 | 10A | F16 16RD/LG | A16 12RD/LG |
| 25 | 15A | F61 20WT/OR | A0 6RD |
| 26 | 20A | F34 18TN/BK | A0 6RD |
| 27 | 10A | F1 20DB/GY | A17 18RD/BK |

• ABS

**A/C
 COMPRESSOR
 CLUTCH
 RELAY**

| CAVITY | CIRCUIT | FUNCTION |
|--------|--------------|-------------------------------------|
| B1 | A17 16RD/BK | FUSED B(+) |
| B2 | C3 16DB/BK | A/C COMPRESSOR CLUTCH RELAY OUTPUT |
| B3 | C13 20DB/OR | A/C COMPRESSOR CLUTCH RELAY CONTROL |
| B4 | - | - |
| B5 | A142 18DG/OR | AUTOMATIC SHUT DOWN RELAY OUTPUT |

**AUTOMATIC
 SHUT
 DOWN
 RELAY**

| CAVITY | CIRCUIT | FUNCTION |
|--------|--------------|-----------------------------------|
| C2 | A16 12RD/LG | FUSED B(+) |
| C4 | A16 12RD/LG | FUSED B(+) |
| C5 | - | - |
| C6 | K51 20DB/YL | AUTOMATIC SHUT DOWN RELAY CONTROL |
| C8 | A142 16DG/OR | AUTOMATIC SHUT DOWN RELAY OUTPUT |
| | A142 18DG/OR | AUTOMATIC SHUT DOWN RELAY OUTPUT |

**CONTROLLER
 ANTI-LOCK
 BRAKE
 RELAY**

| CAVITY | CIRCUIT | FUNCTION |
|--------|-------------|------------------------------------|
| B16 | G19 20LG/OR | ABS WARNING INDICATOR DRIVER |
| B17 | - | - |
| B18 | F15 20DB/WT | FUSED IGNITION SWITCH OUTPUT (RUN) |
| | F15 18DB/WT | FUSED IGNITION SWITCH OUTPUT (RUN) |
| B19 | Z1 20BK | GROUND |
| B20 | G83 18GY/BK | ABS RELAY CONTROL |

ENGINE
STARTER
MOTOR
RELAY

| CAVITY | CIRCUIT | FUNCTION |
|--------|------------|-----------------------------------|
| D10 | A41 16YL | FUSED B(+) |
| D11 | T141 20YL | IGNITION SWITCH OUTPUT (START) |
| D12 | - | - |
| D13 | Z1 20BK | GROUND |
| | Z1 20BK/YL | GROUND |
| D14 | T40 16BR | ENGINE STARTER MOTOR RELAY OUTPUT |

FOG
LAMP
RELAY

| CAVITY | CIRCUIT | FUNCTION |
|--------|-------------|----------------------------|
| B11 | F61 20WT/OR | FUSED B(+) |
| B12 | L39 20LB | FOG LAMP RELAY OUTPUT |
| B13 | Z1 20BK | GROUND |
| | Z1 20BK/YL | GROUND |
| B14 | - | - |
| B15 | L92 20PK | FUSED FOG LAMP SWITCH FEED |

FUEL
HEATER
RELAY

| CAVITY | CIRCUIT | FUNCTION |
|--------|-------------|---------------------------------------|
| D2 | A61 14LG/RD | FUSED B(+) |
| D4 | F12 18DB/WT | FUSED IGNITION SWITCH OUTPUT (ST-RUN) |
| D5 | - | - |
| D6 | Z1 18BK | GROUND |
| D8 | A93 14RD/BK | FUEL HEATER RELAY OUTPUT |

RADIATOR
FAN
RELAY

| CAVITY | CIRCUIT | FUNCTION |
|--------|--------------|----------------------------------|
| C10 | F141 12LG/RD | FUSED B(+) |
| C11 | A142 18DG/OR | AUTOMATIC SHUT DOWN RELAY OUTPUT |
| | A142 18DG/OR | AUTOMATIC SHUT DOWN RELAY OUTPUT |
| C12 | - | - |
| C13 | C27 20DB/PK | RADIATOR FAN RELAY CONTROL |
| C14 | C25 12LB | RADIATOR FAN RELAY OUTPUT |

GAS

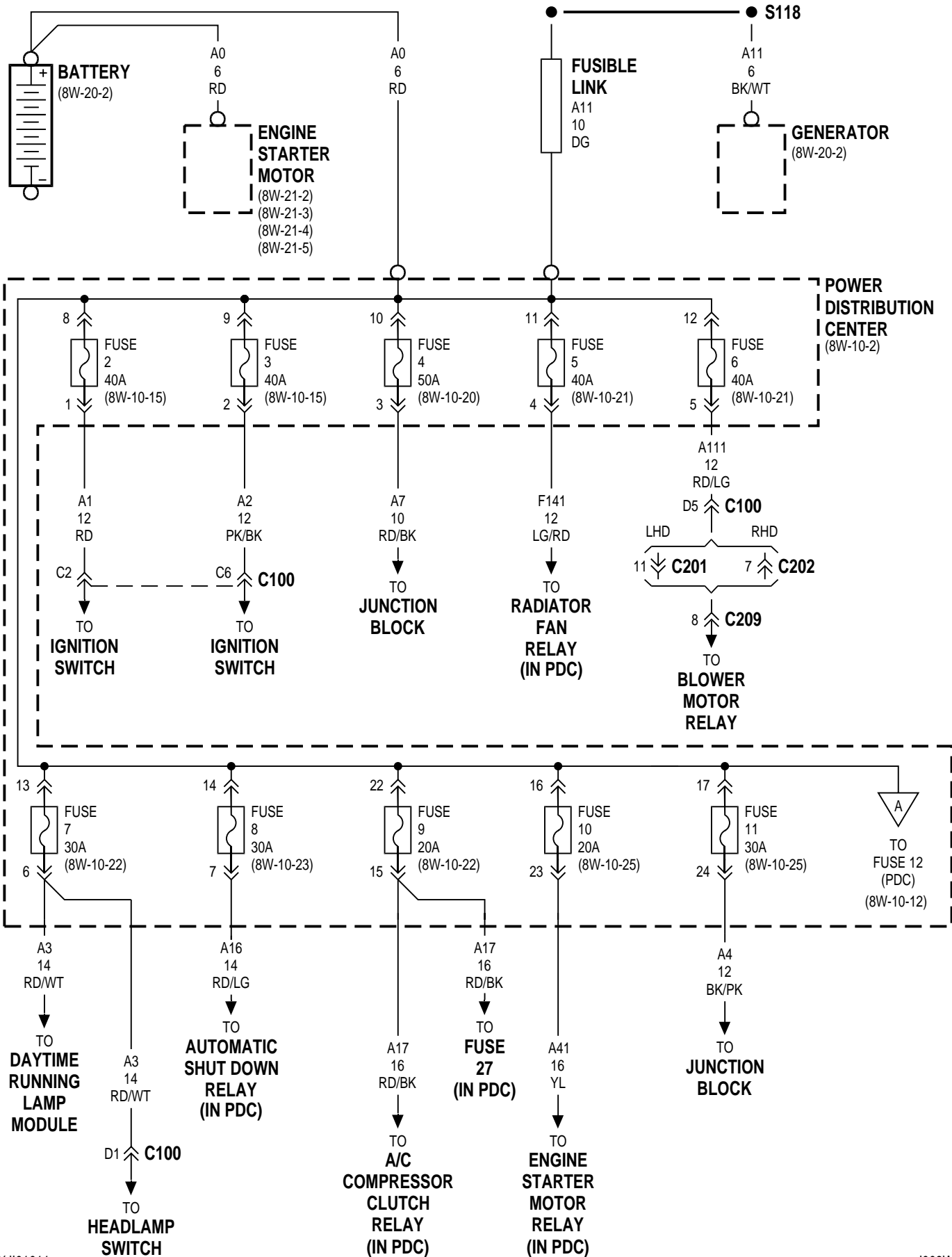

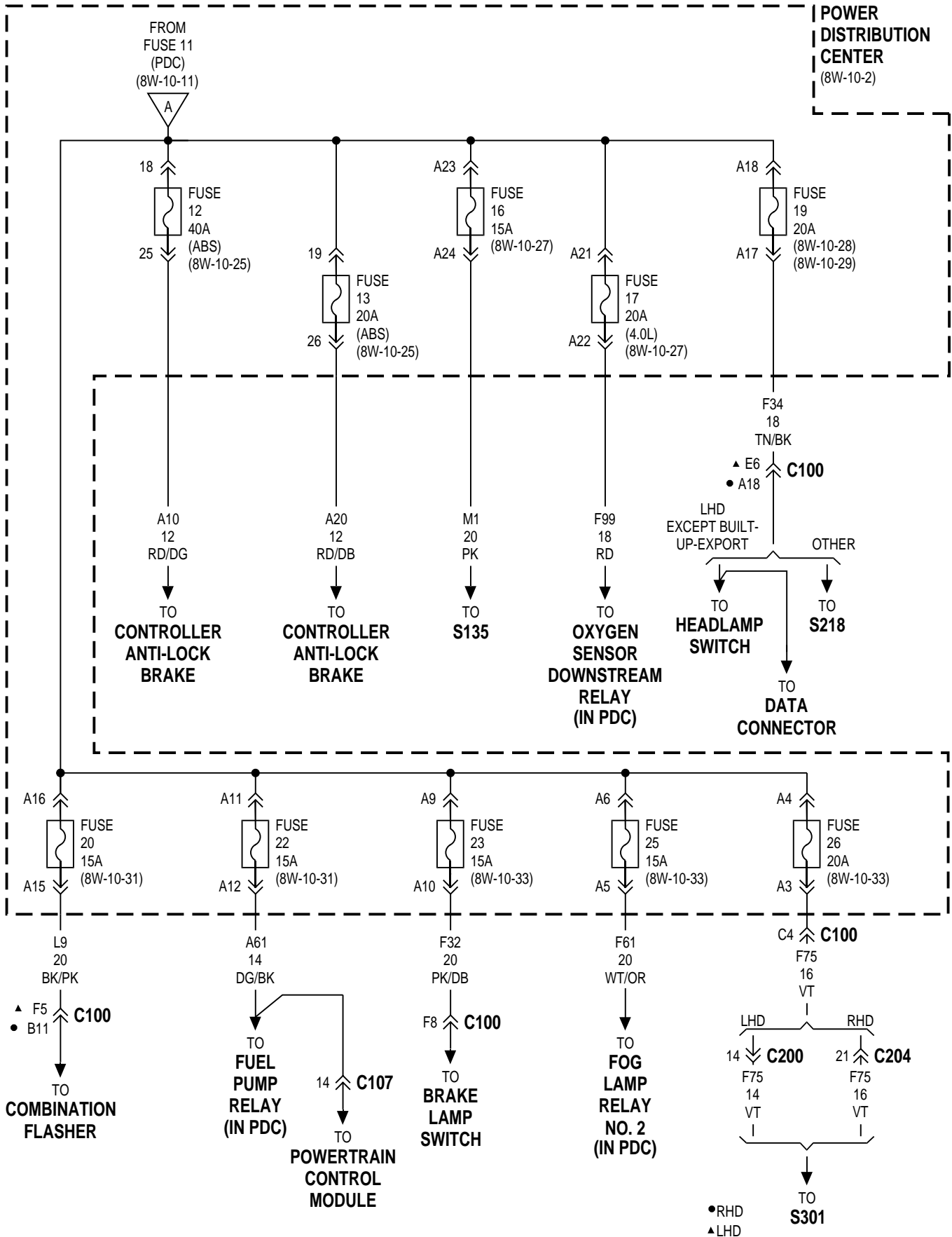

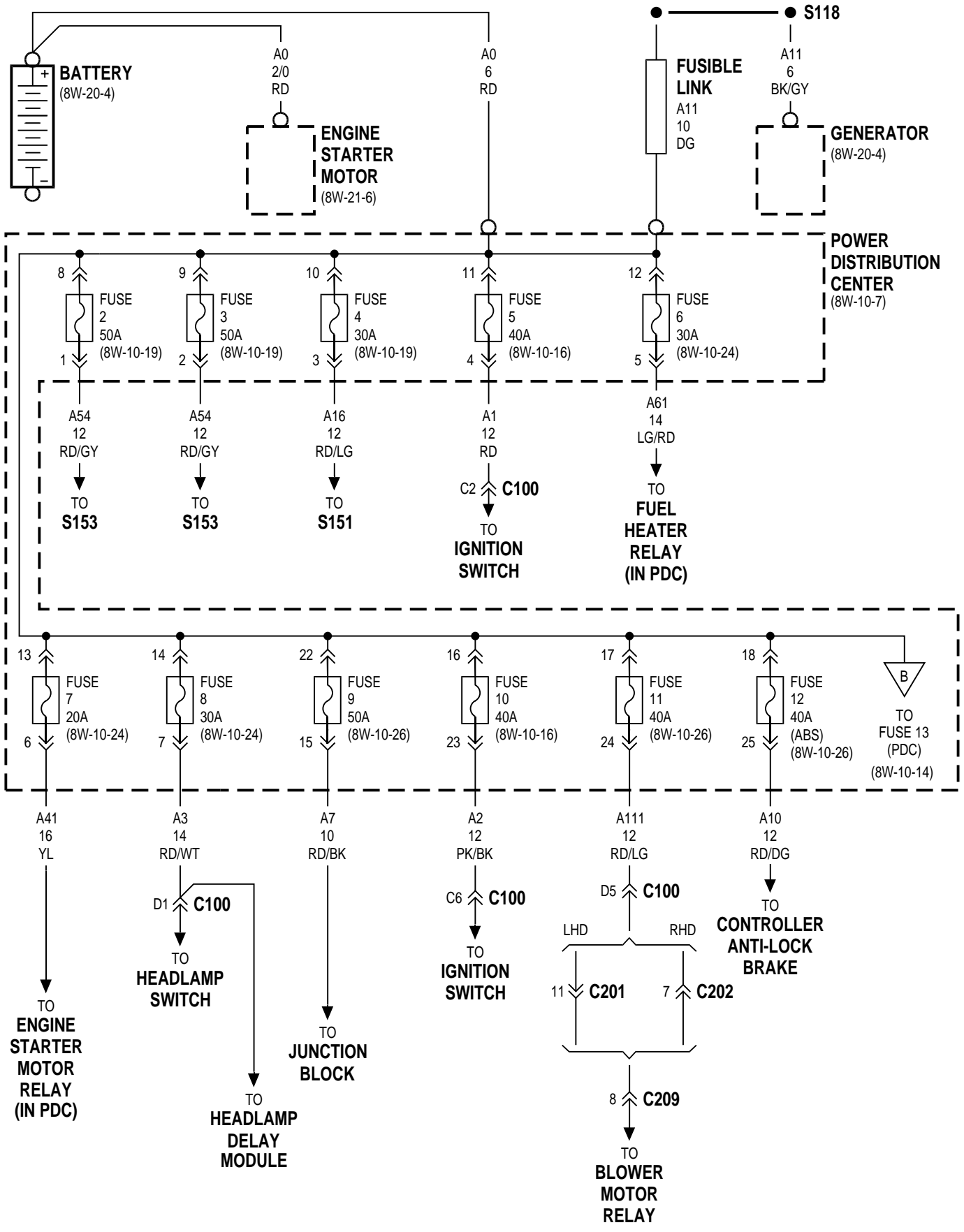

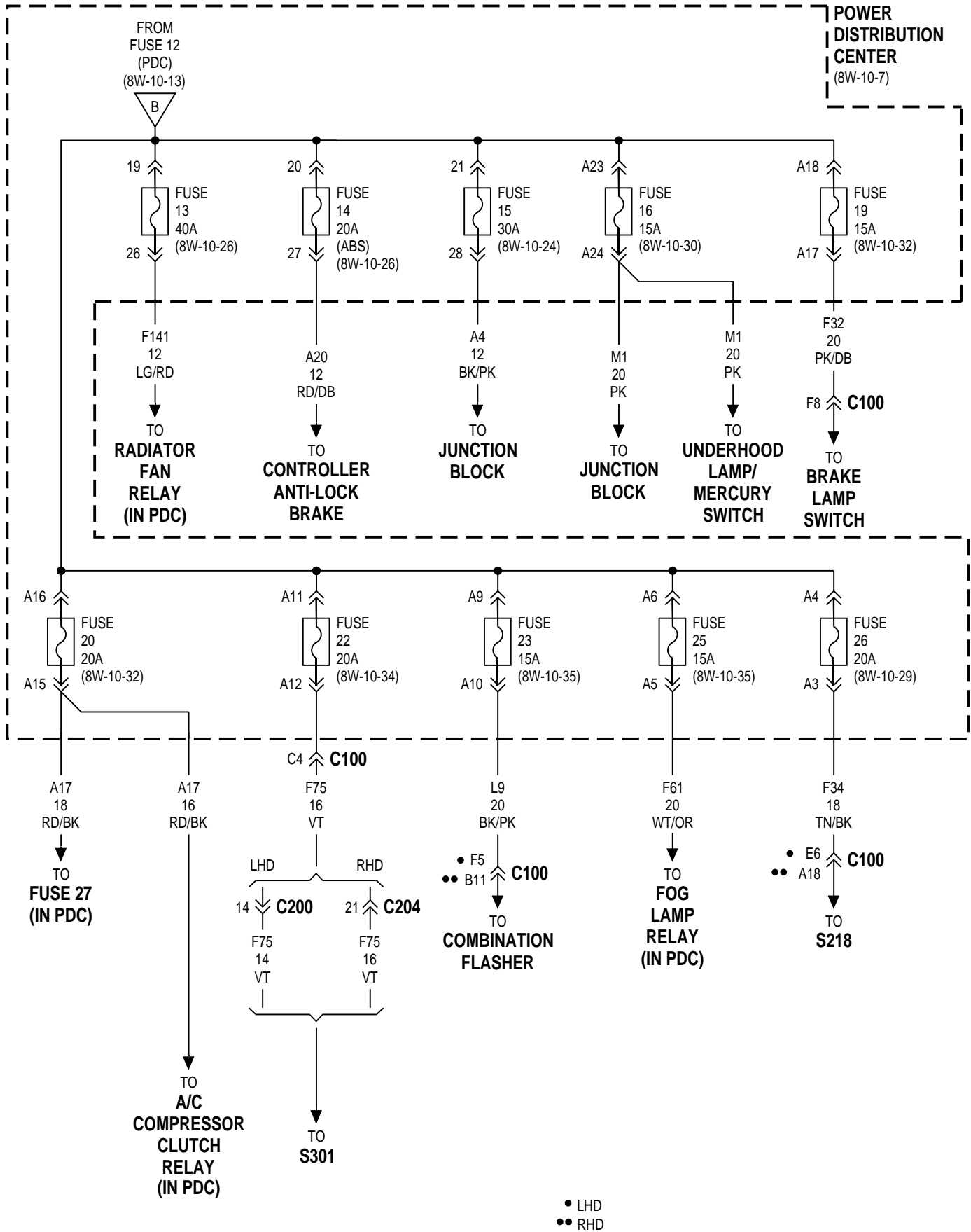

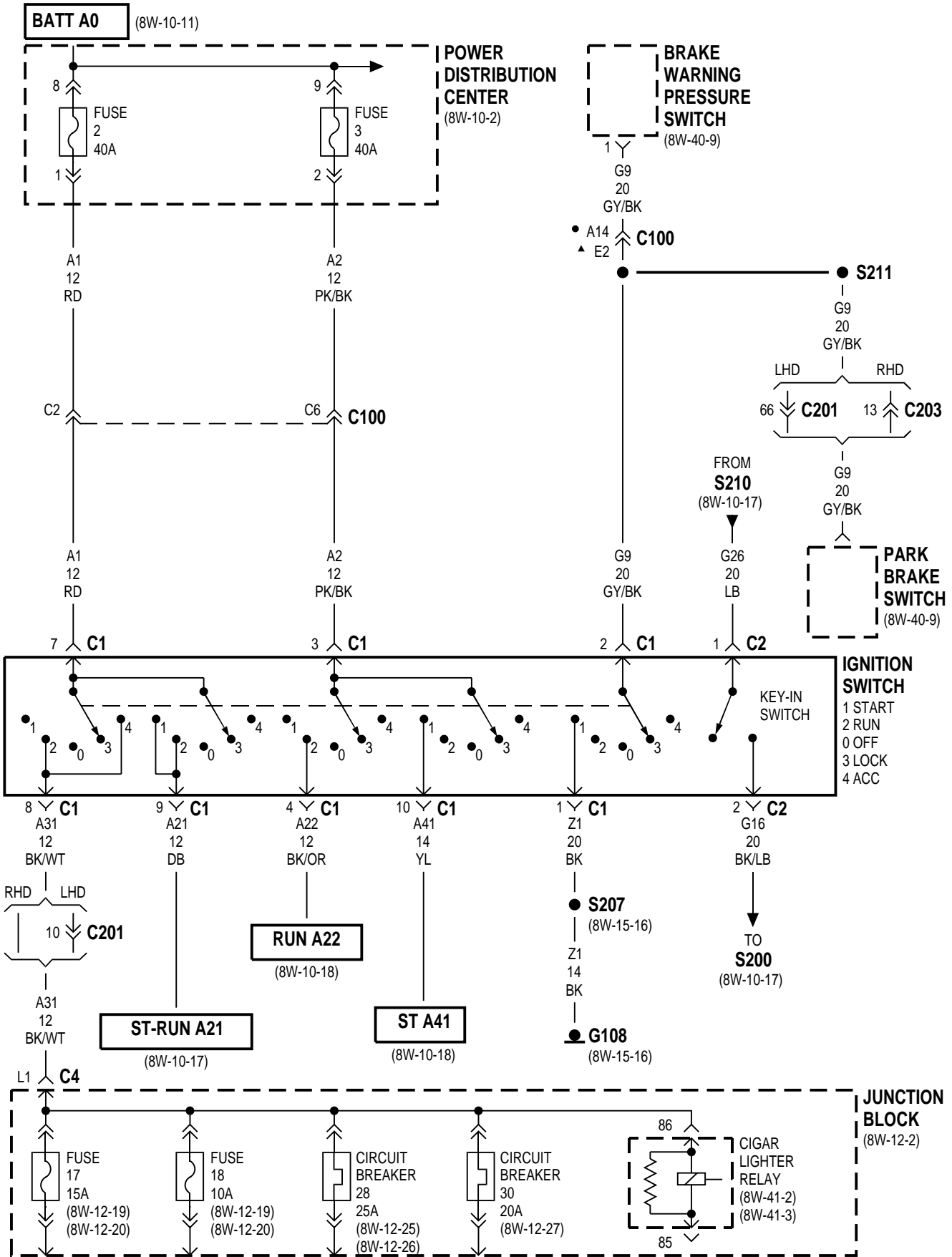

● RHD
▲ LHD

DIESEL

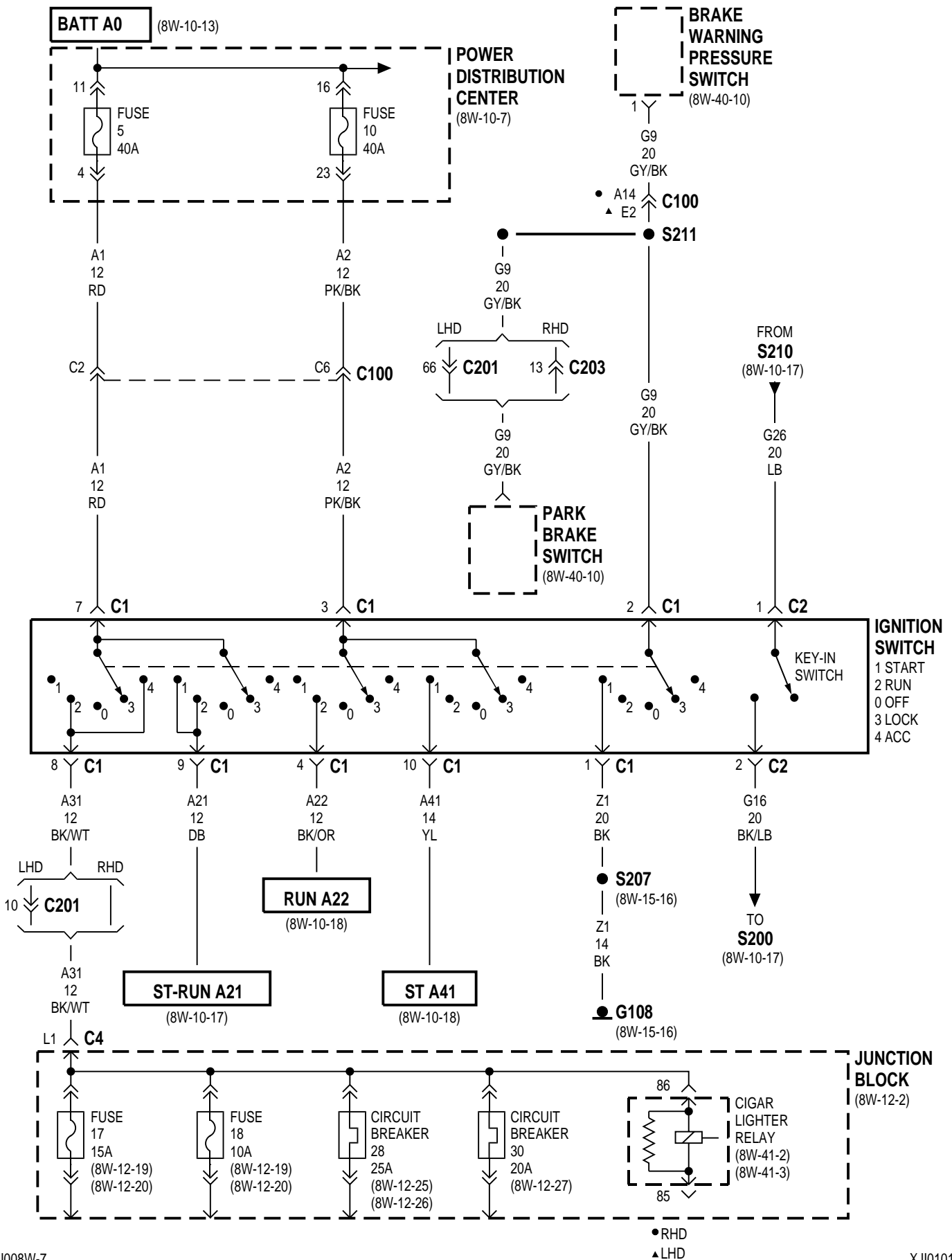

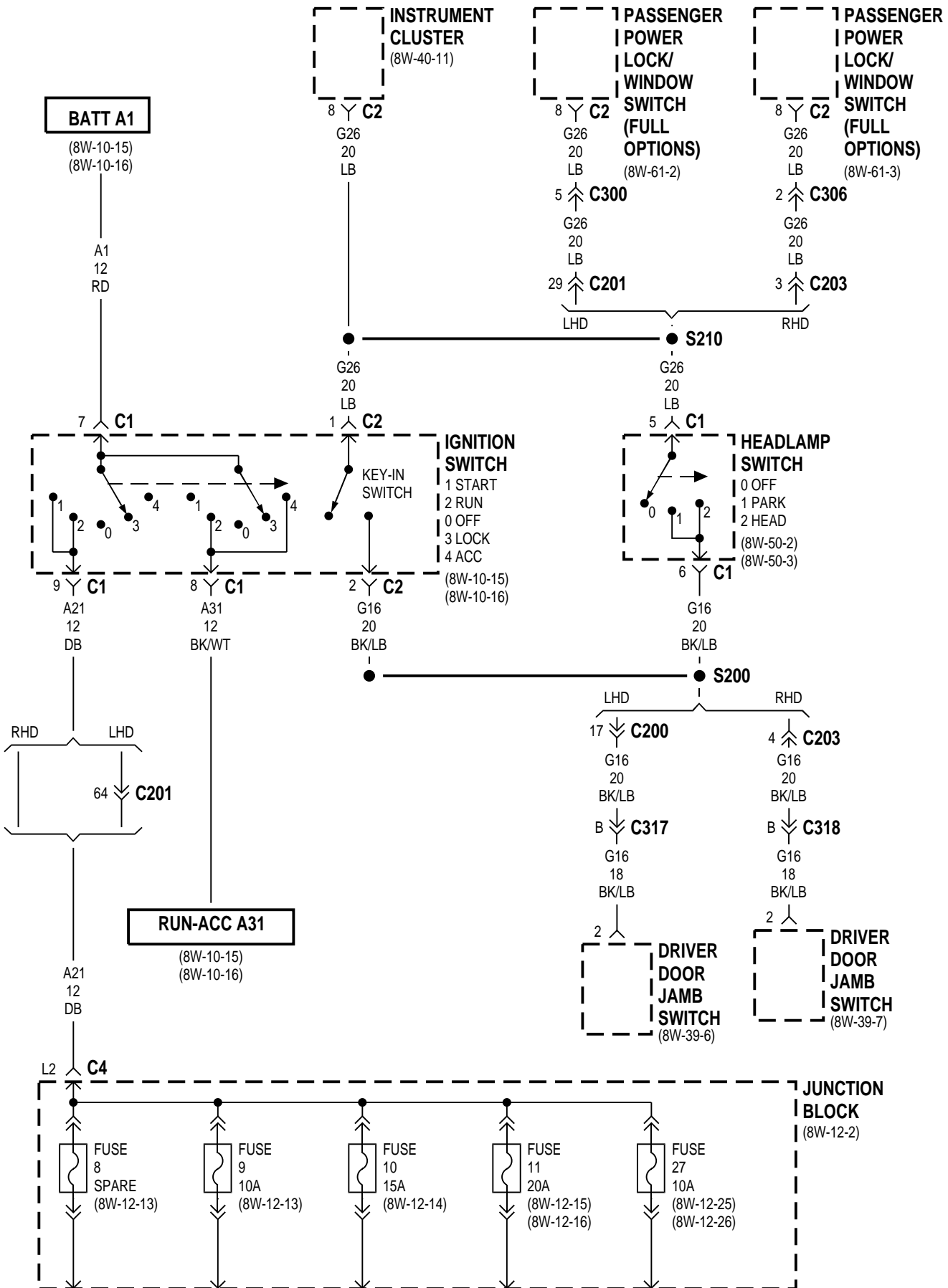

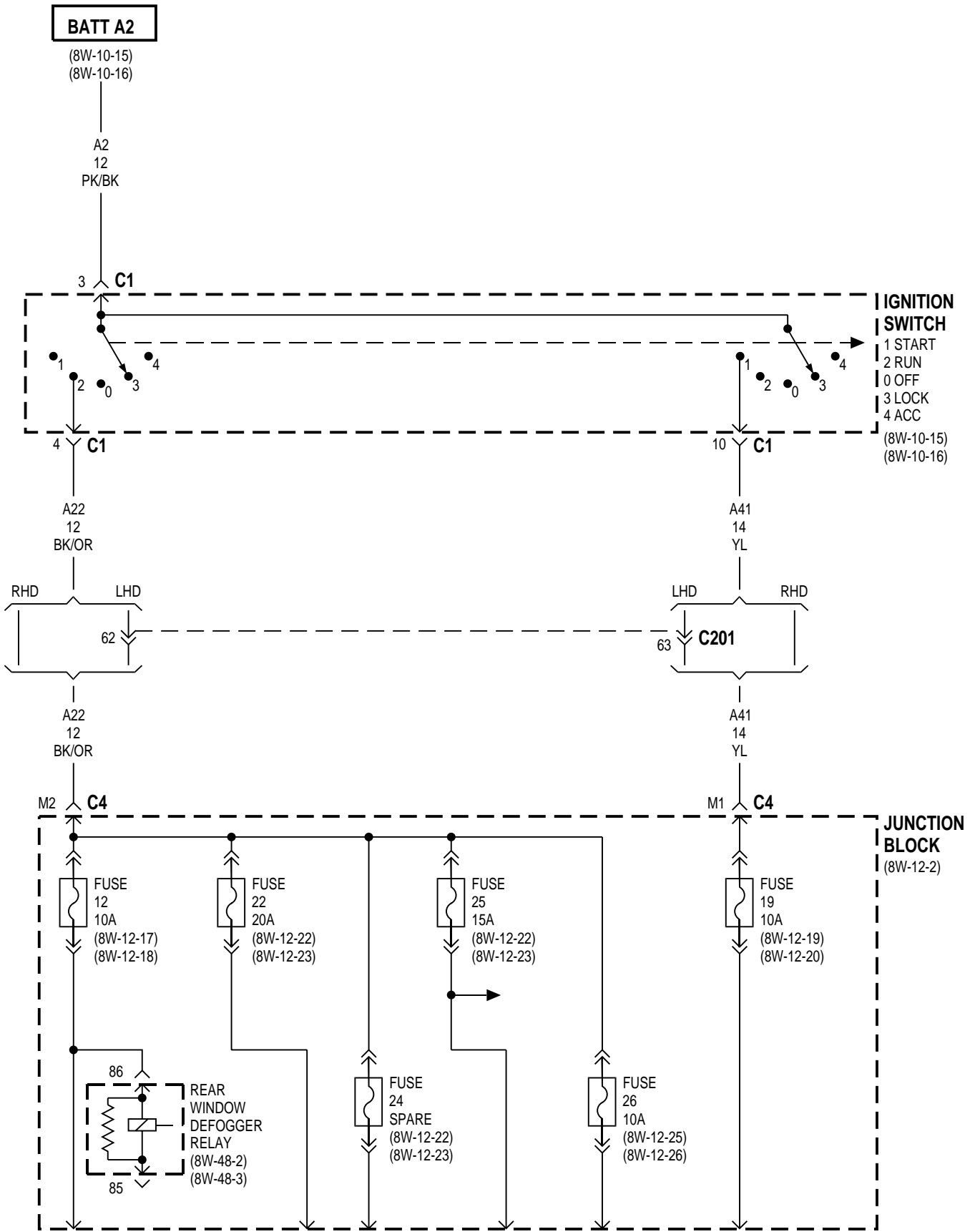

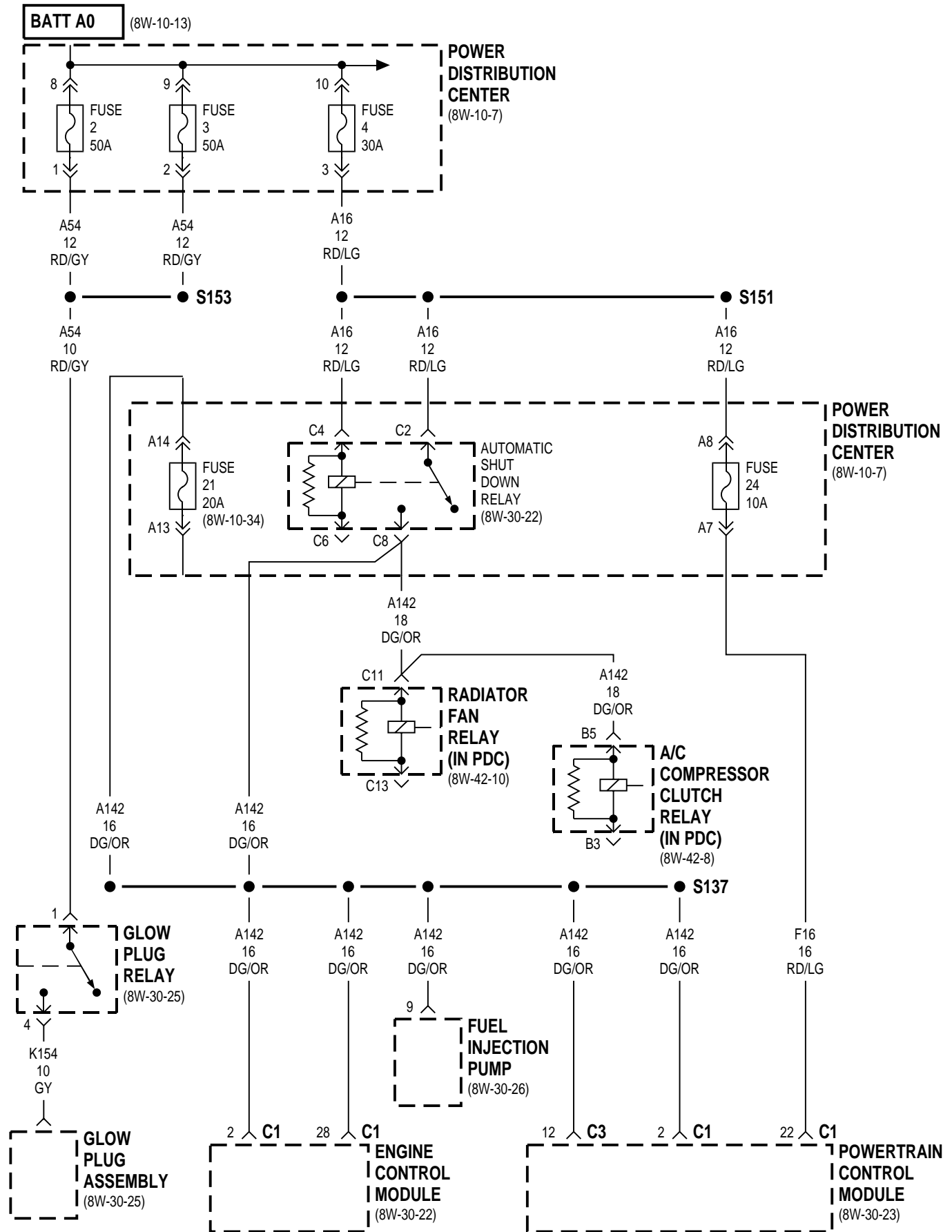

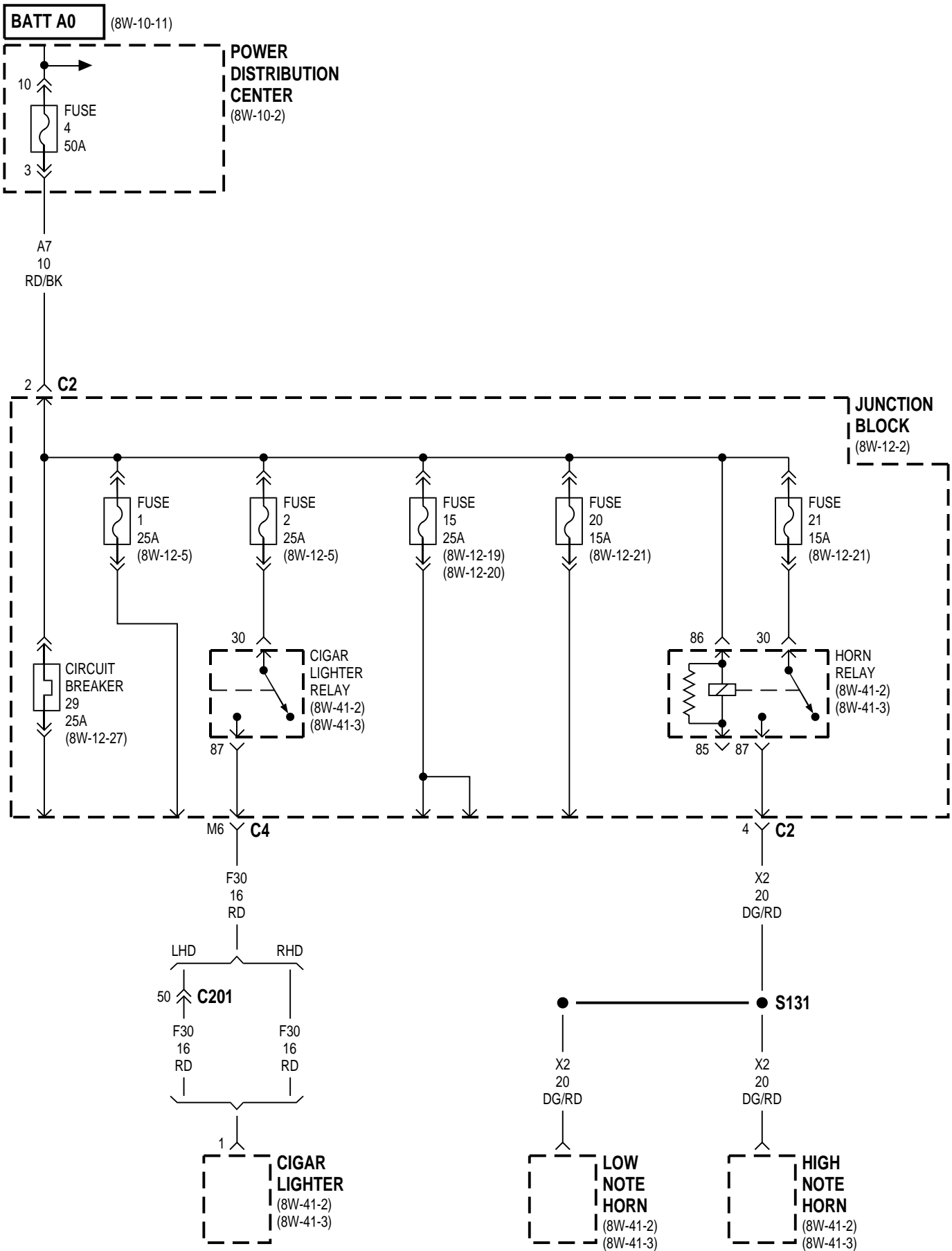

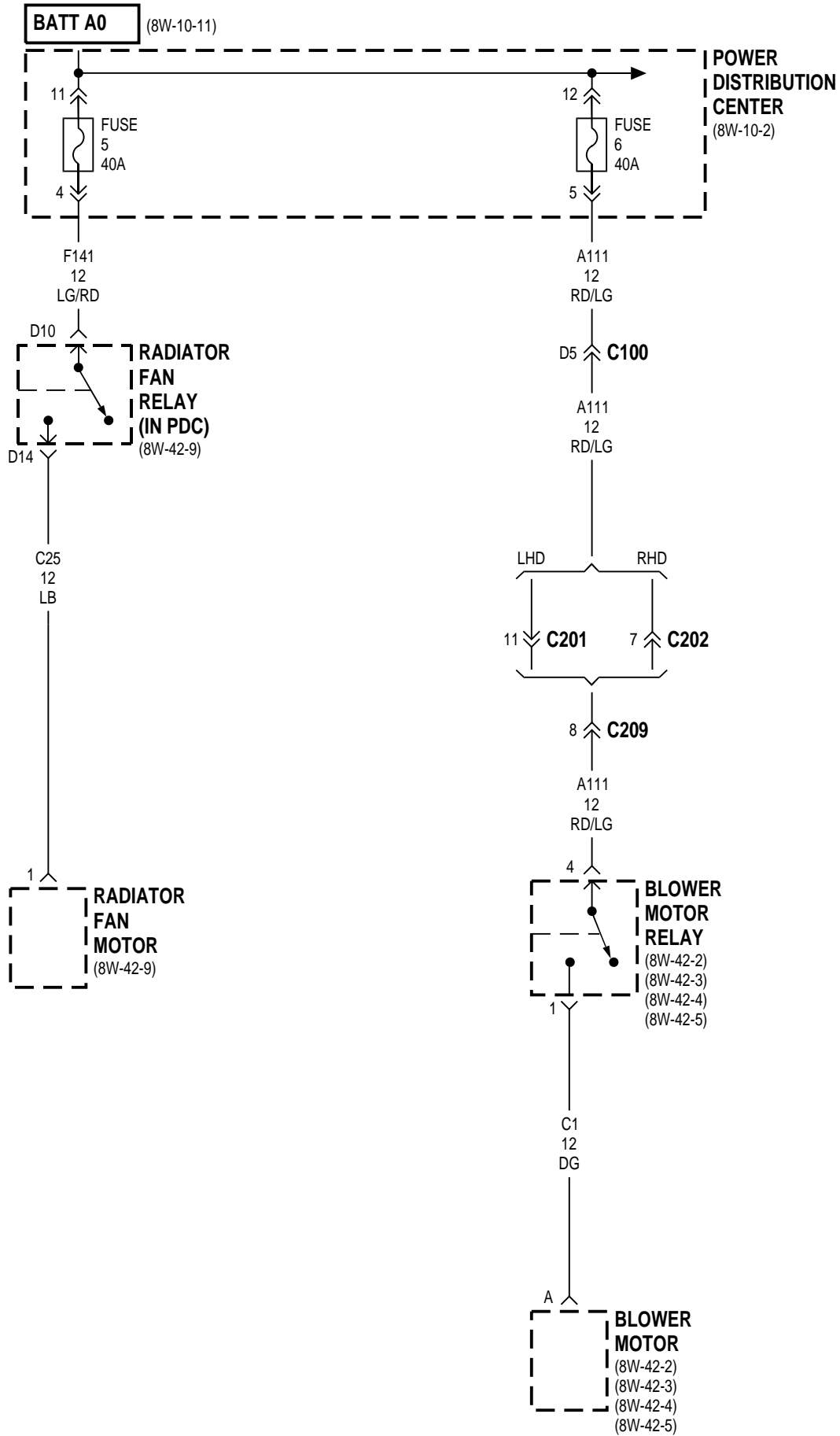

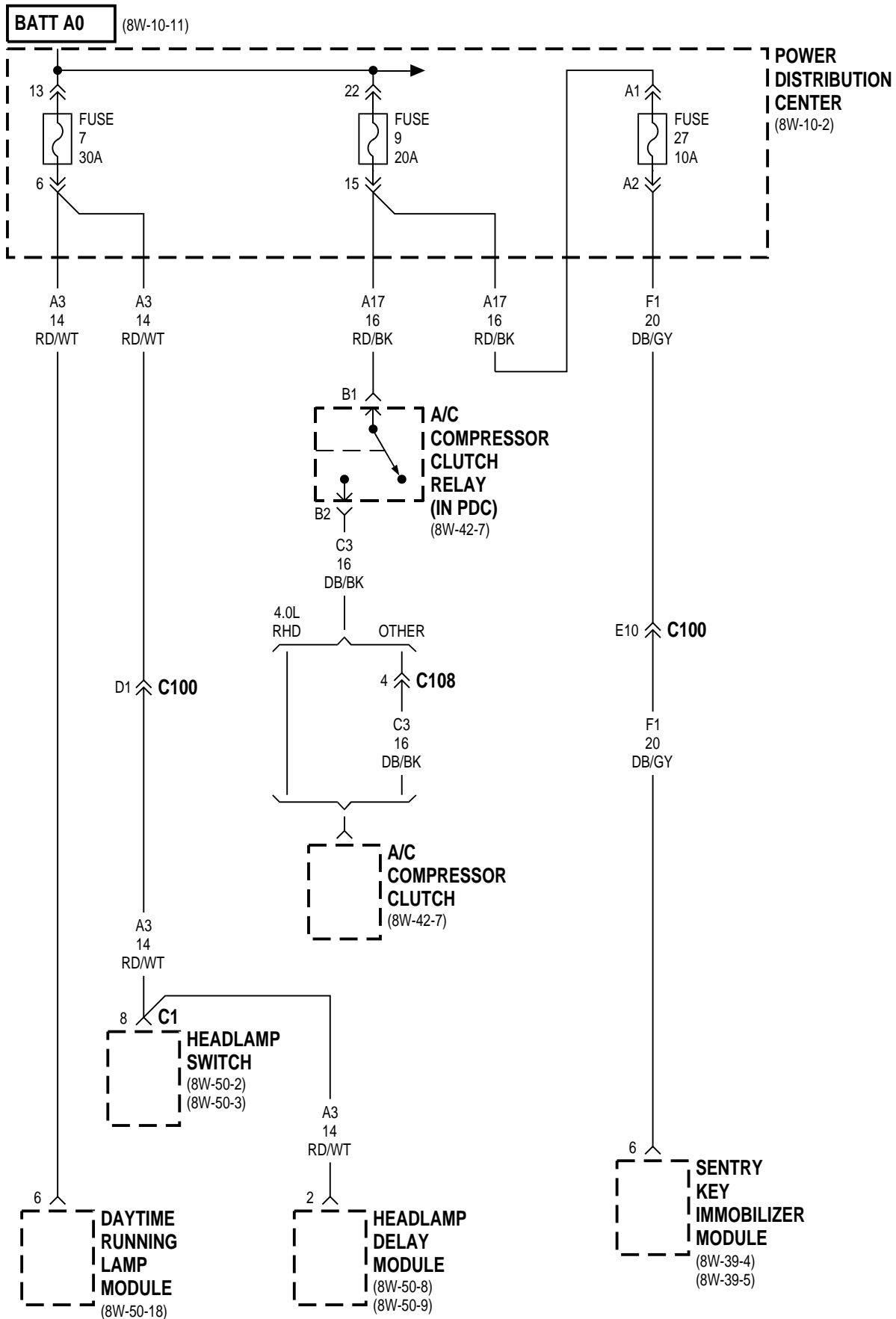

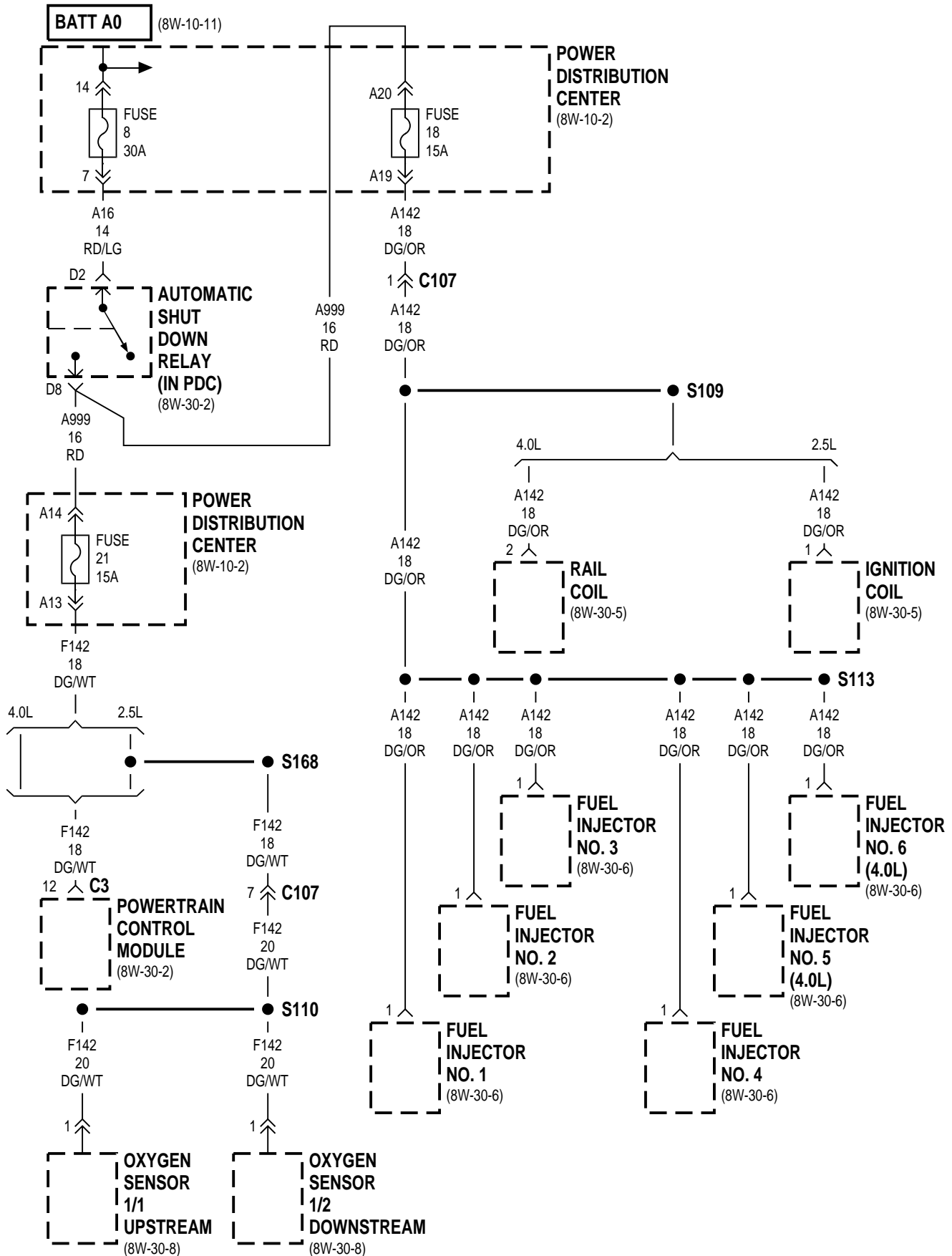

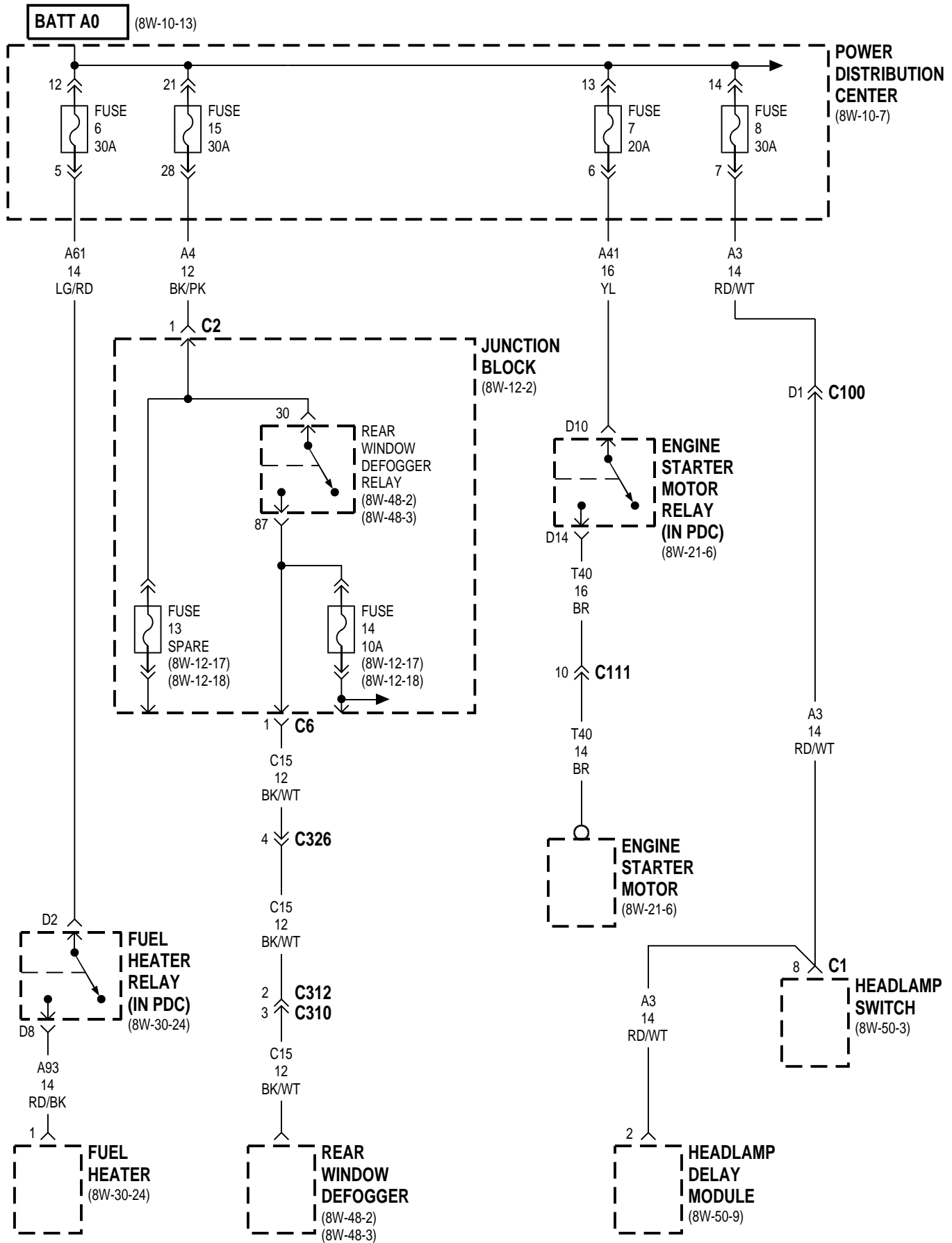

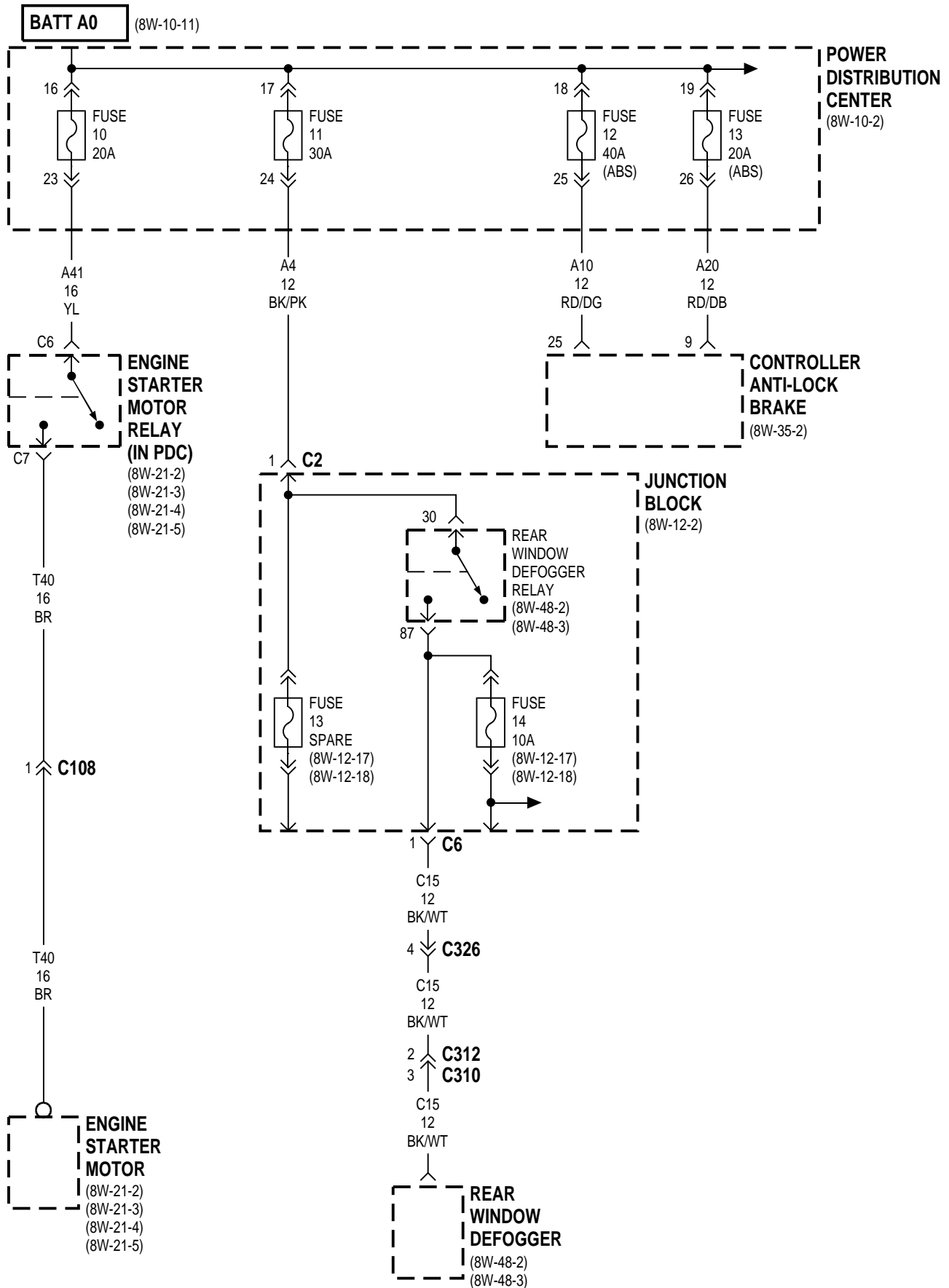

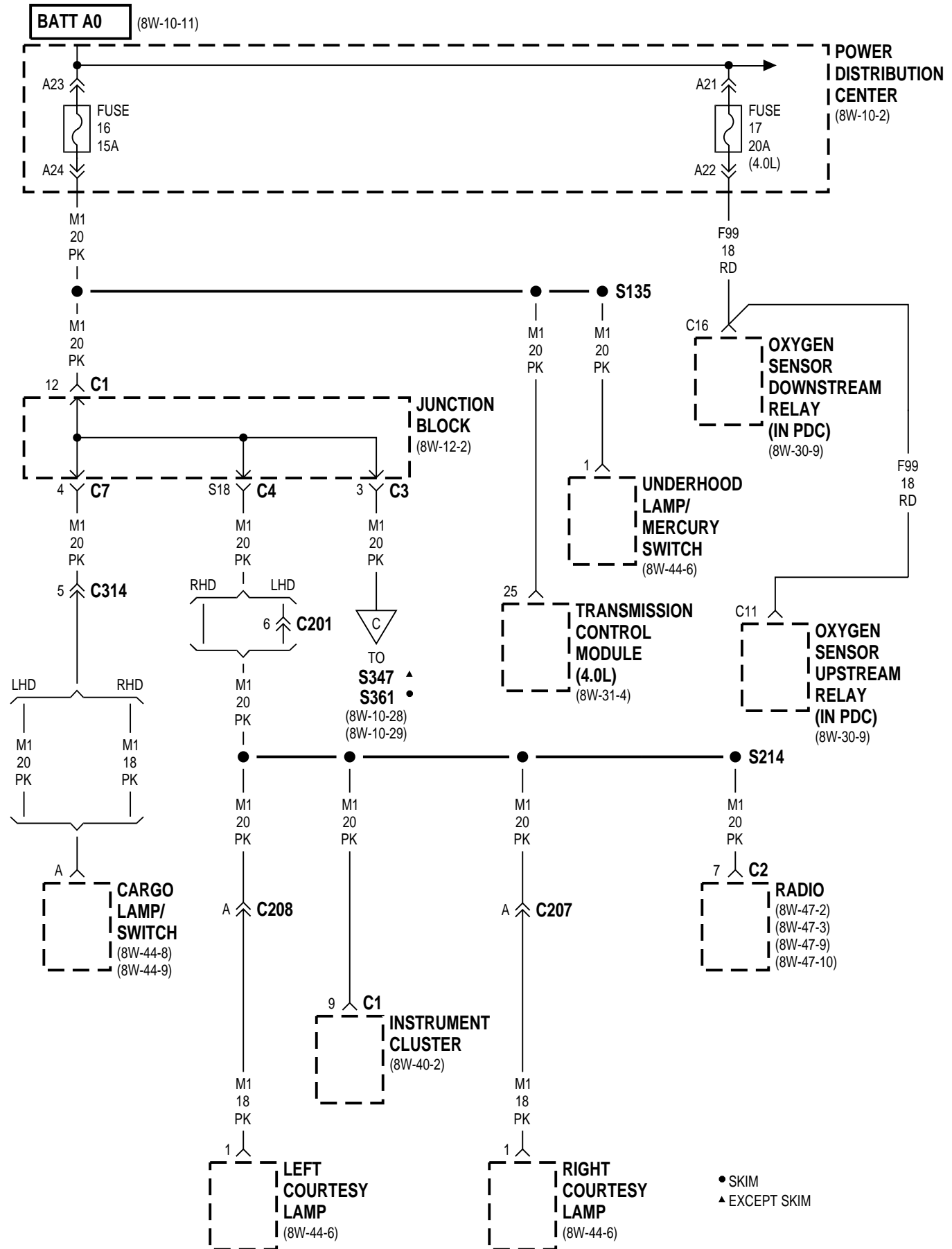

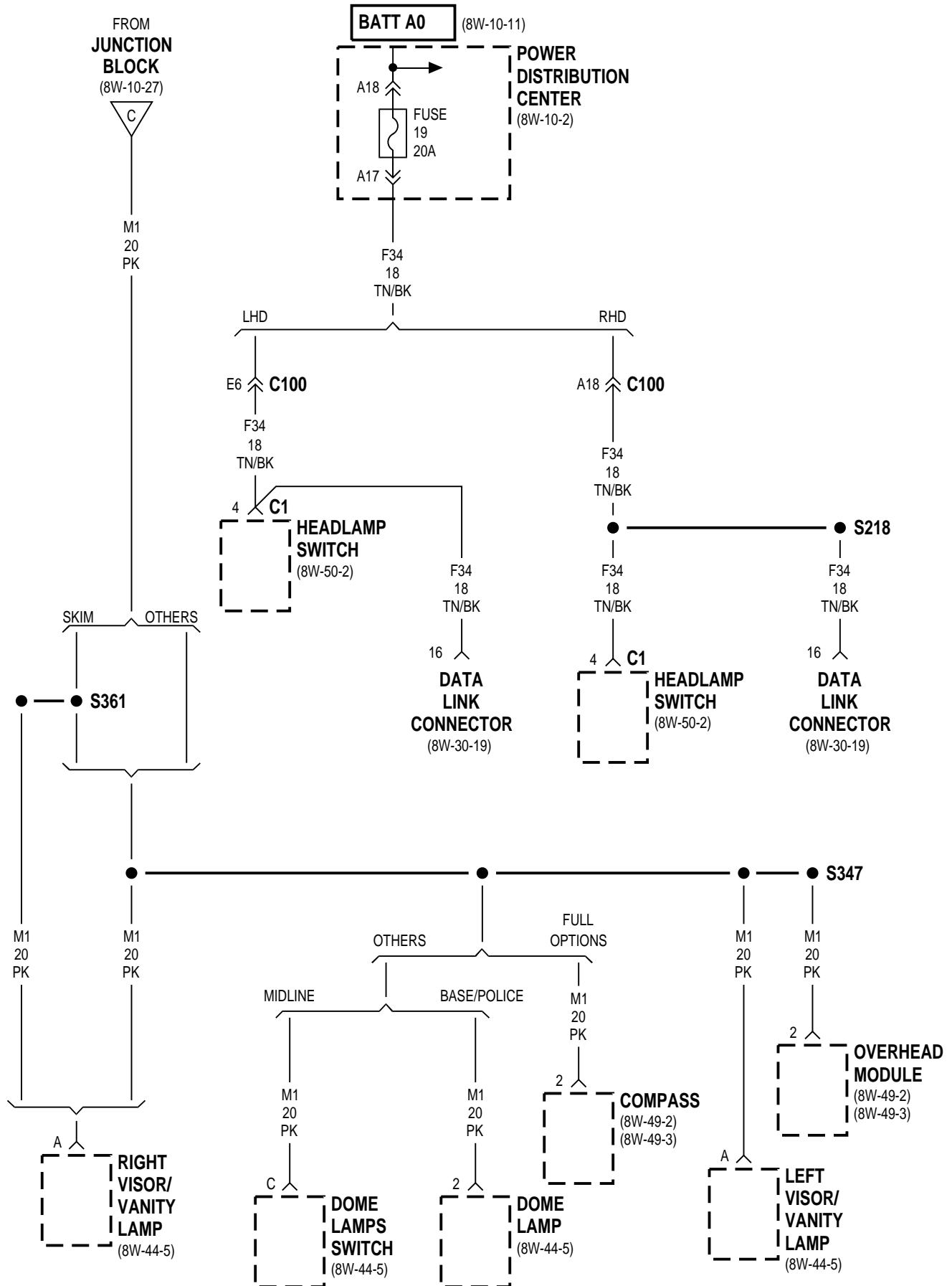

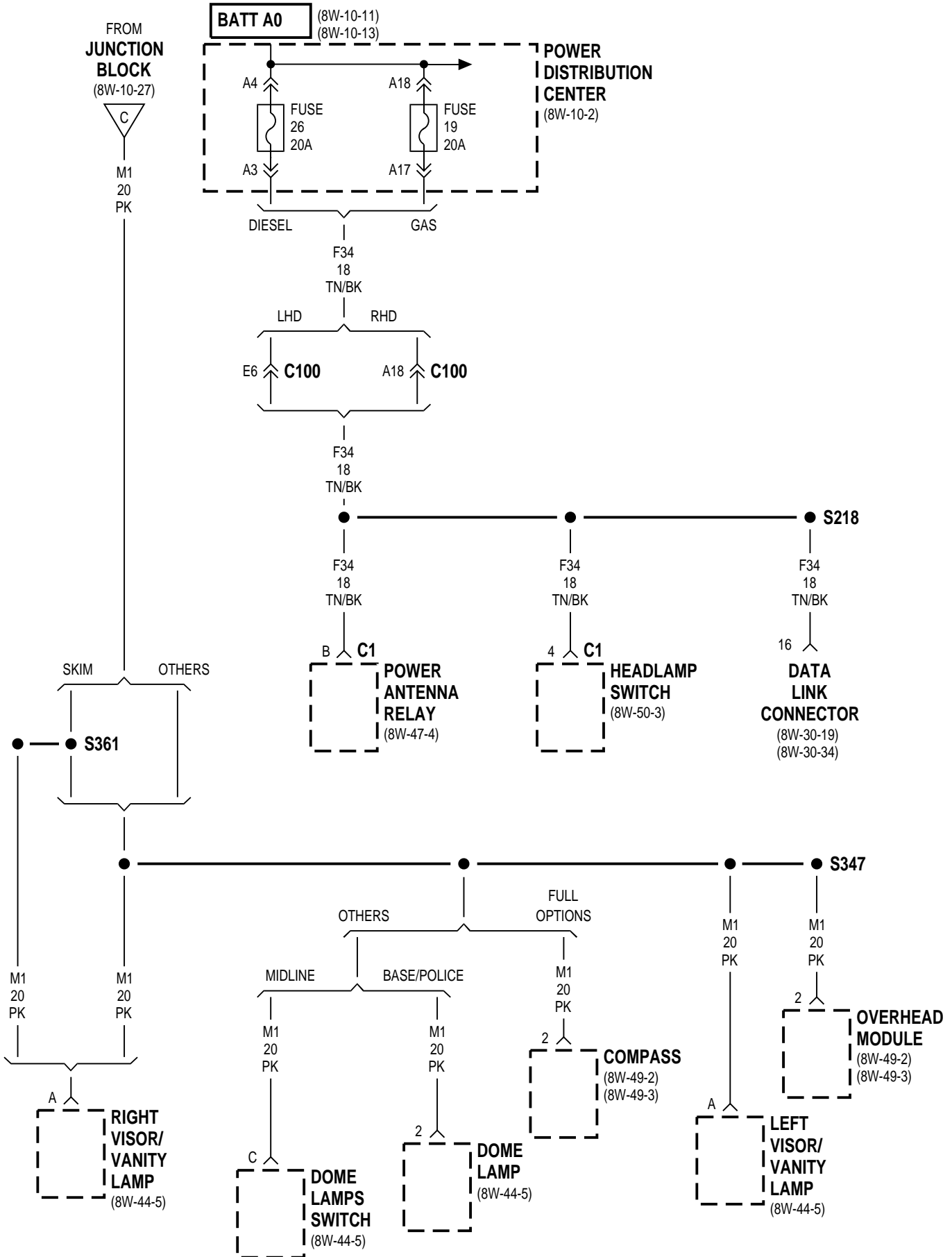

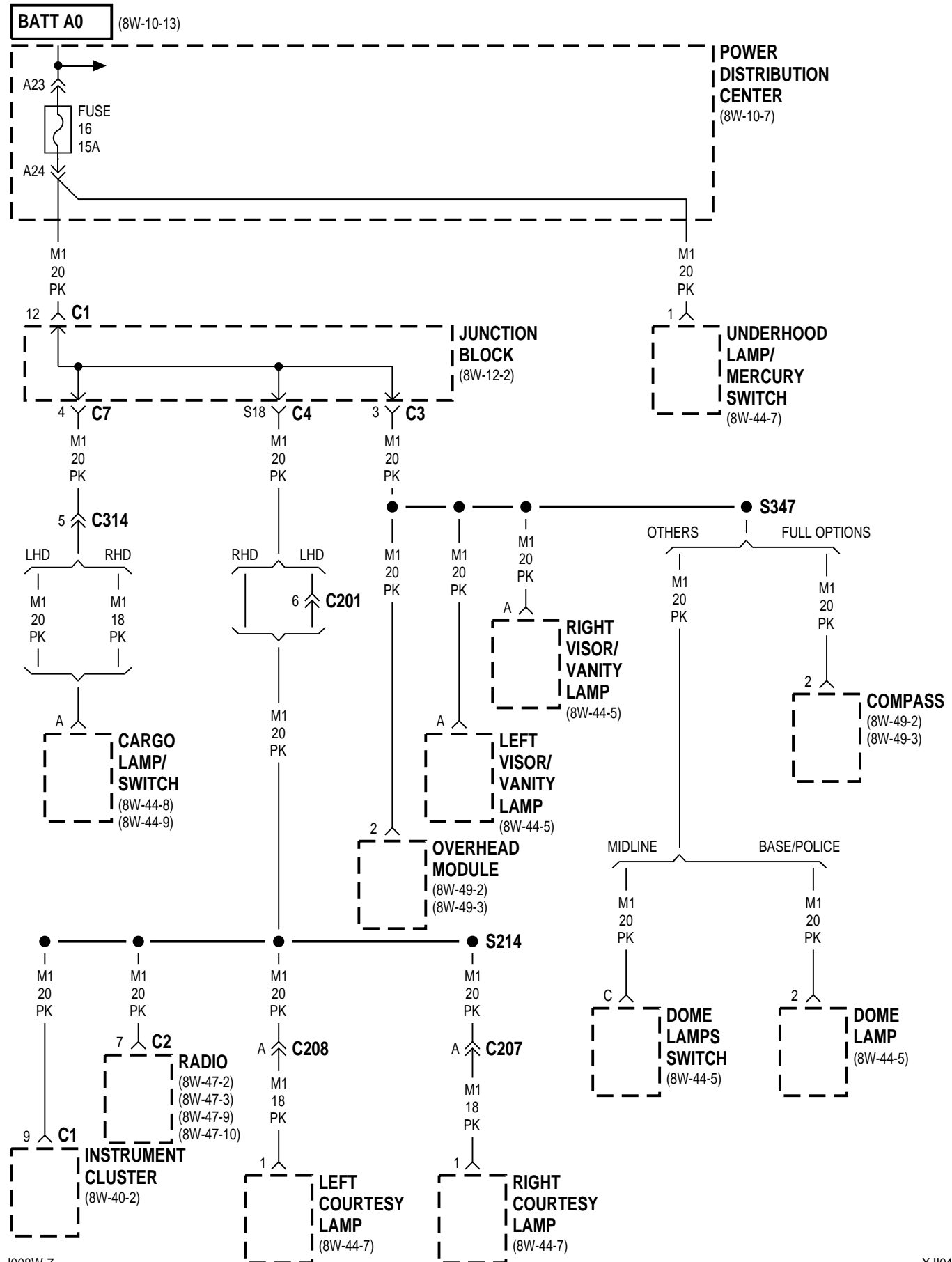

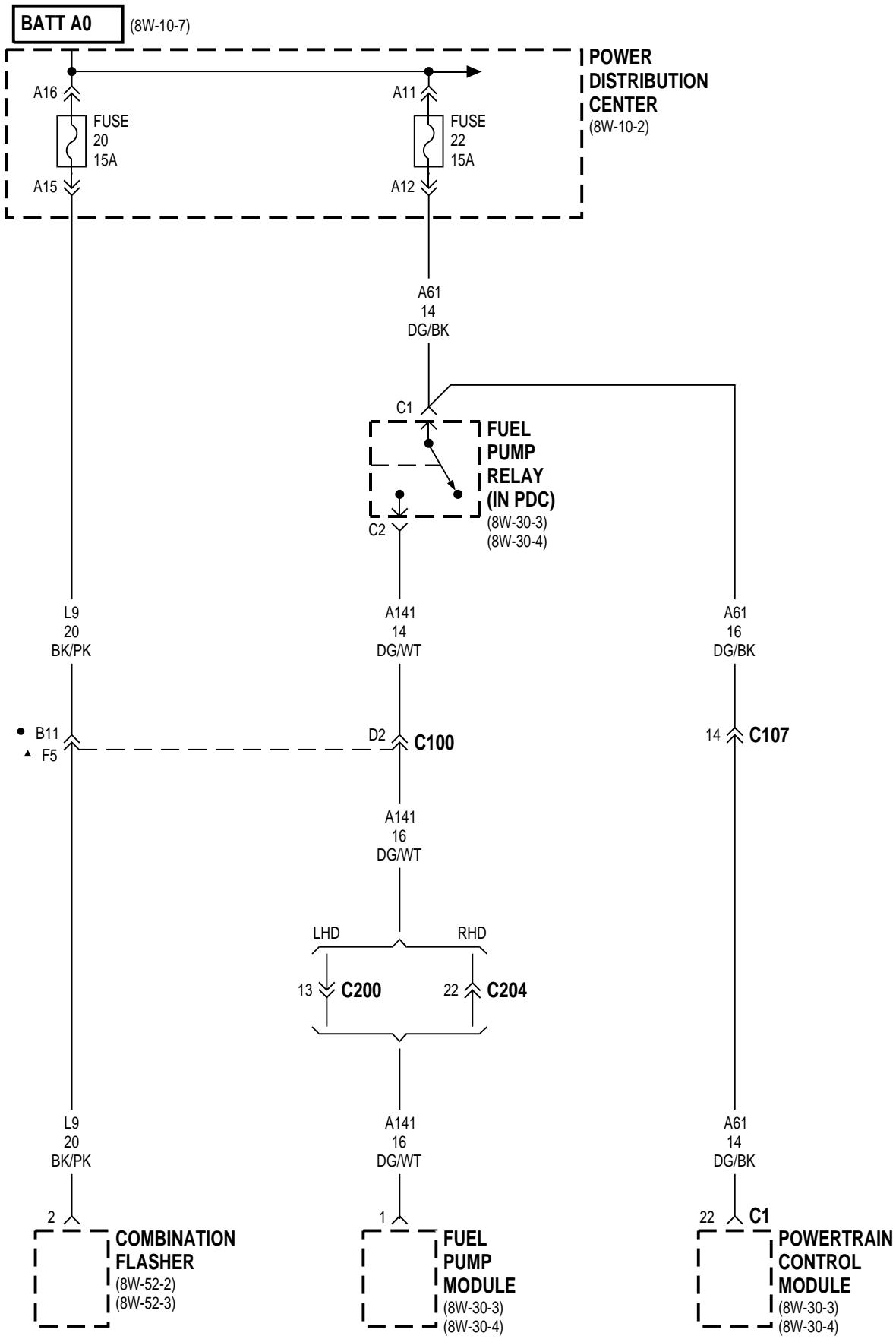

▲ LHD
 ● RHD

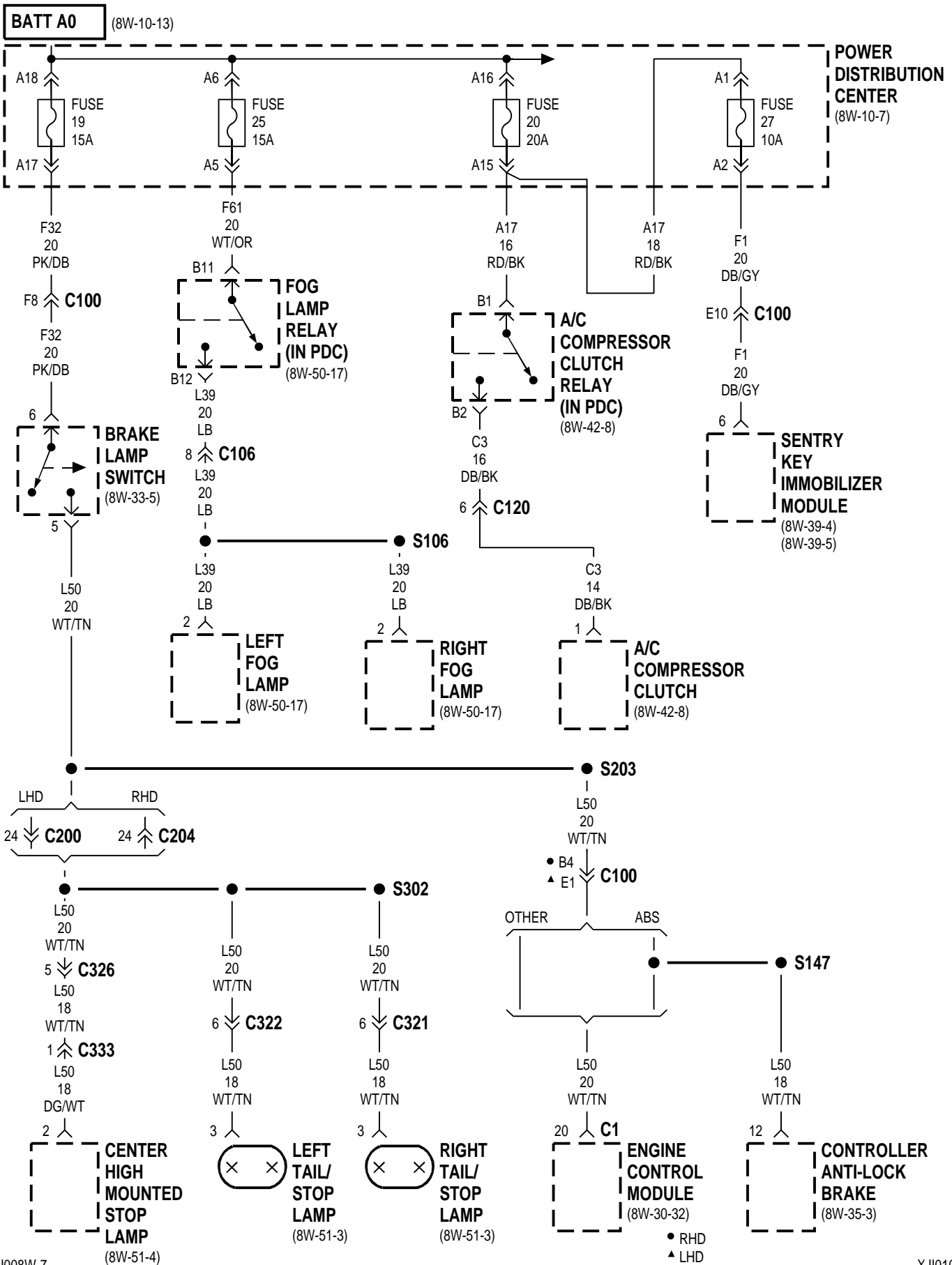

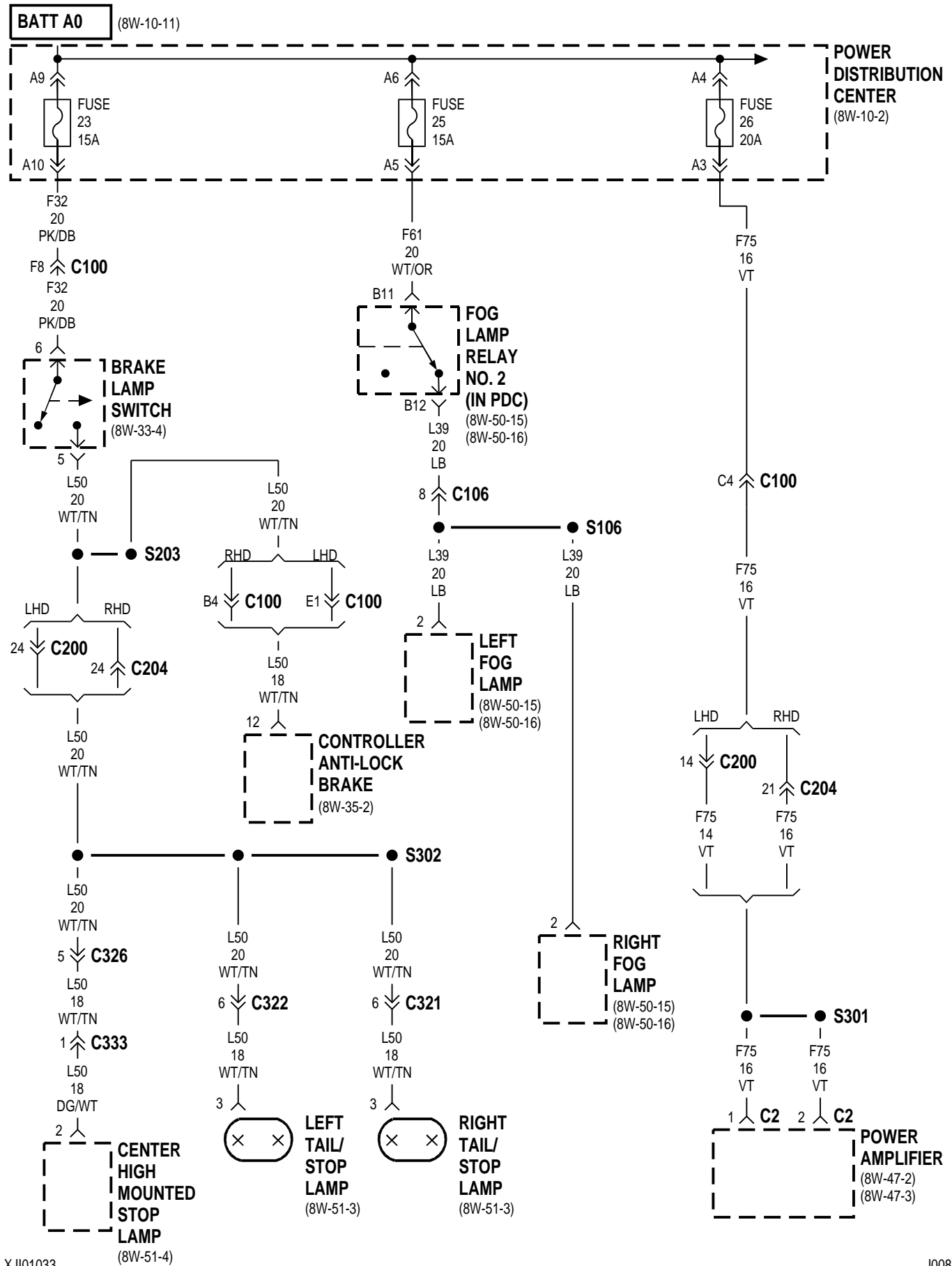

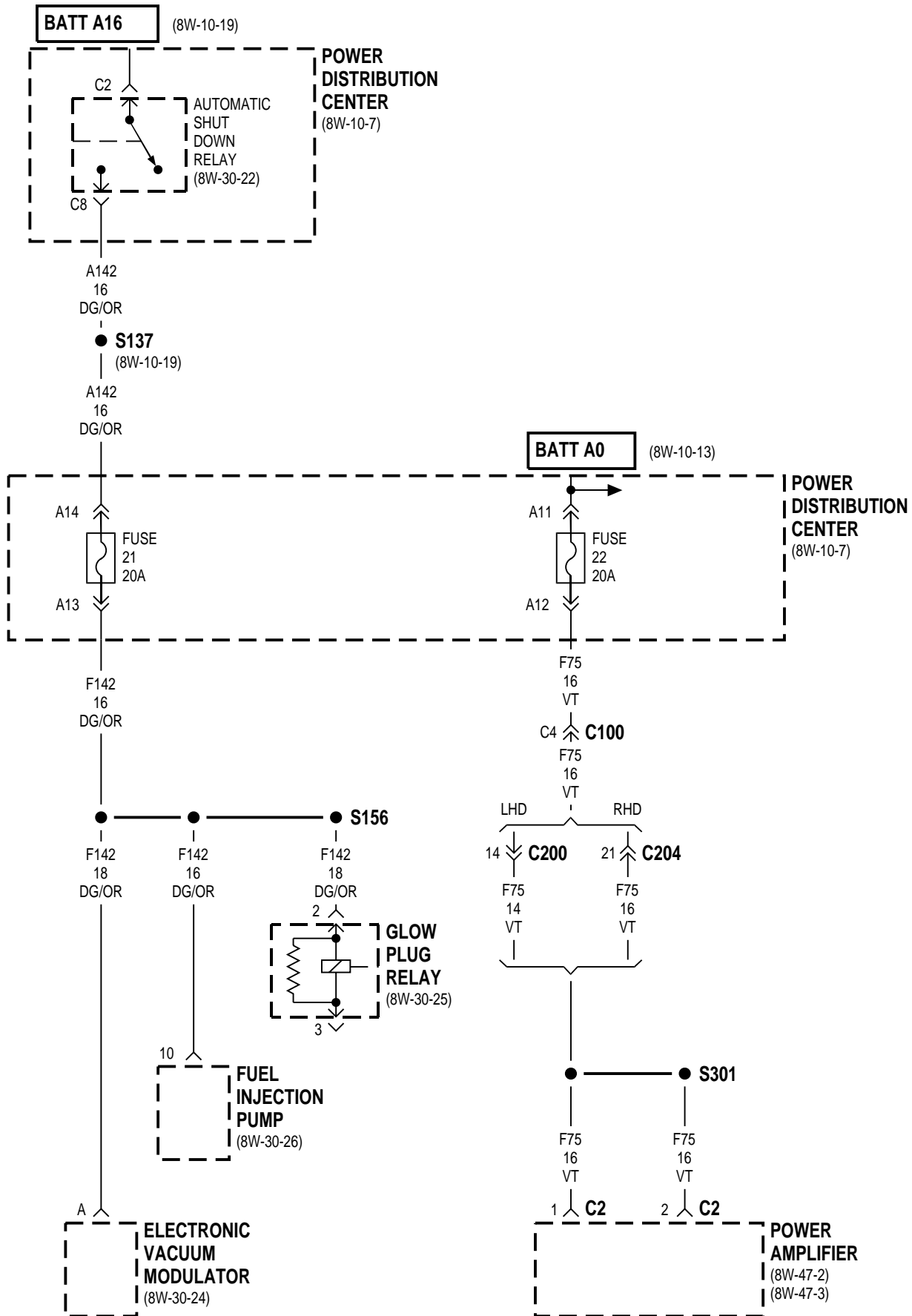

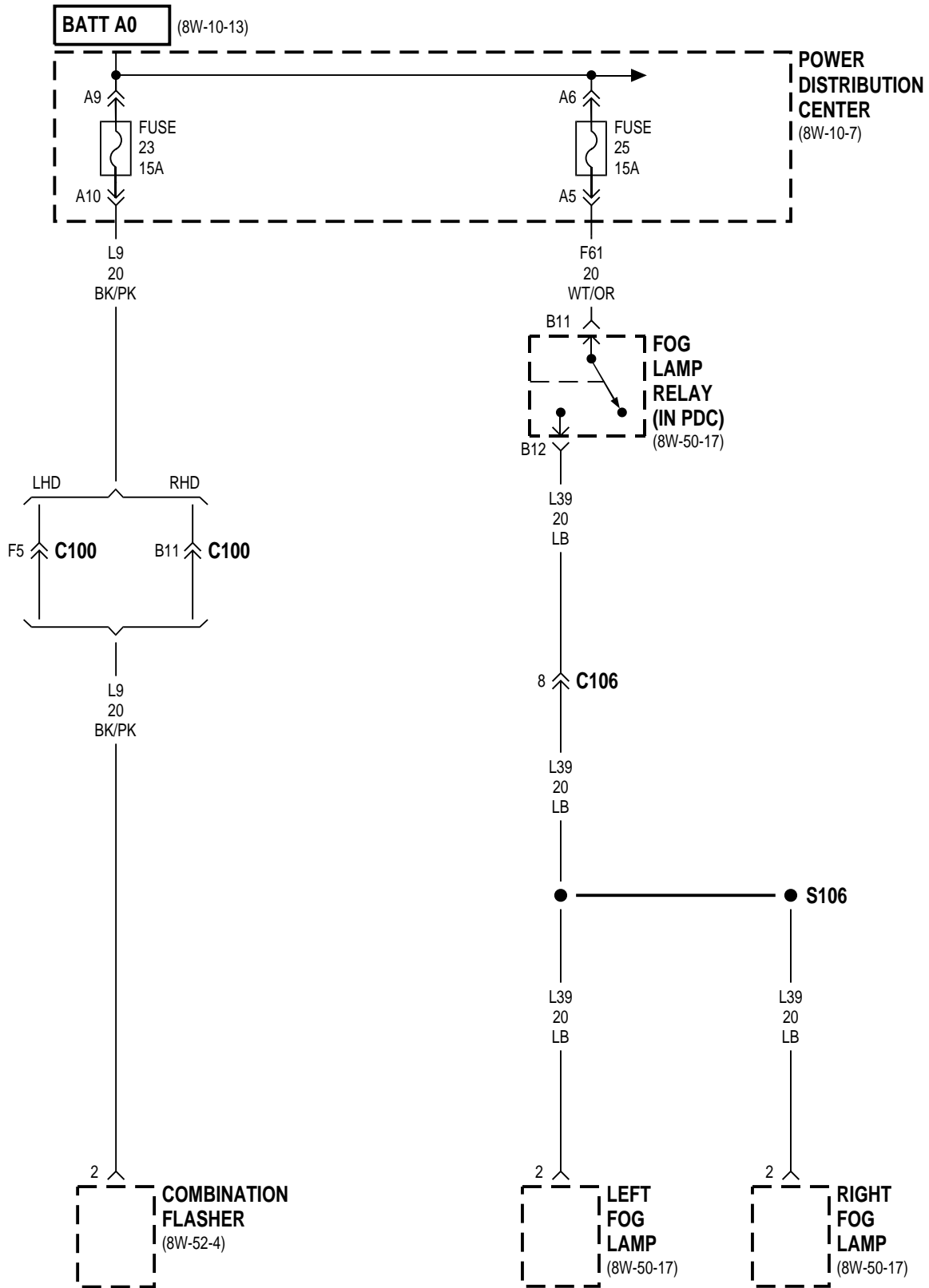

8W-12 JUNCTION BLOCK

| Component | Page |
|----------------------------------|----------------------------------|
| A/C Compressor Clutch Relay | 8W-12-14 |
| A/C- Heater Control | 8W-12-8, 9, 22, 23 |
| Airbag Control Module | 8W-12-25, 26 |
| Automatic Shut Down Relay | 8W-12-15, 16 |
| Back-Up Lamp Switch | 8W-12-14 |
| Blend Door Actuator | 8W-12-22, 23 |
| Blower Motor Relay | 8W-12-22, 23 |
| Cargo Lamp/Switch | 8W-12-28, 29, 30 |
| Cigar Lighter | 8W-12-5 |
| Cigar Lighter Relay | 8W-12-5, 37 |
| Circuit Breaker 28 (JB) | 8W-12-25, 26 |
| Circuit Breaker 29 (JB) | 8W-12-27 |
| Circuit Breaker 30 (JB) | 8W-12-27 |
| Clockspring | 8W-12-21 |
| Clutch Interlock Switch | 8W-12-19, 20 |
| Clutch Interlock Switch Jumper | 8W-12-19, 20 |
| Combination Flasher | 8W-12-17, 18 |
| Compass | 8W-12-13, 30, 37 |
| Controller Anti-Lock Brake | 8W-12-22, 23 |
| Controller Anti-Lock Brake Relay | 8W-12-22, 23 |
| Daytime Running Lamp Module | 8W-12-7, 14 |
| Diode Module | 8W-12-11, 12 |
| Dome Lamp | 8W-12-30 |
| Dome Lamps Switch | 8W-12-30, 37 |
| Driver Door Jamb Switch | 8W-12-30 |
| Driver Door Lock Motor | 8W-12-31, 32 |
| Driver Power Lock/Window Switch | 8W-12-19, 20, 25, 26, 34, 36 |
| Driver Power Mirror | 8W-12-17, 18, 33, 34, 35, 36, 37 |
| Duty Cycle Evap/Purge Solenoid | 8W-12-14 |
| Engine Control Module | 8W-12-15 |
| Engine Starter Motor Relay | 8W-12-19, 20 |
| Extended Idle Switch | 8W-12-8, 22 |
| Fog Lamp Relay | 8W-12-12 |
| Fog Lamp Relay No. 1 | 8W-12-6, 10, 11 |
| Fog Lamp Relay No. 2 | 8W-12-10, 11 |
| Front Fog Lamp Switch | 8W-12-8, 9, 10, 11, 12 |
| Front Wiper Motor | 8W-12-27 |
| Fuel Heater Relay | 8W-12-15 |
| Fuel Pump Relay | 8W-12-15, 16 |
| Fuse 1 (JB) | 8W-12-5 |
| Fuse 2 (JB) | 8W-12-5 |
| Fuse 3 (JB) | 8W-12-6 |
| Fuse 4 (JB) | 8W-12-7 |
| Fuse 5 (JB) | 8W-12-7 |
| Fuse 6 (JB) | 8W-12-8 |
| Fuse 6 (JB) | 8W-12-9 |
| Fuse 7 (JB) | 8W-12-10, 11, 12 |
| Fuse 8 (JB) | 8W-12-13 |
| Fuse 9 (JB) | 8W-12-13 |
| Fuse 10 (JB) | 8W-12-14 |
| Fuse 11 (JB) | 8W-12-15, 16 |
| Fuse 12 (JB) | 8W-12-17, 18 |
| Fuse 13 (JB) | 8W-12-17, 18 |
| Fuse 14 (JB) | 8W-12-17, 18 |
| Fuse 15 (JB) | 8W-12-19, 20 |
| Fuse 16 (JB) | 8W-12-6, 28, 29 |
| Fuse 17 (JB) | 8W-12-19, 20 |
| Fuse 18 (JB) | 8W-12-19, 20 |
| Fuse 19 (JB) | 8W-12-19, 20 |
| Fuse 20 (JB) | 8W-12-21 |
| Fuse 21 (JB) | 8W-12-21 |
| Fuse 22 (JB) | 8W-12-22, 23 |
| Fuse 23 (JB) | 8W-12-24 |
| Fuse 24 (JB) | 8W-12-22, 23 |
| Fuse 25 (JB) | 8W-12-22, 23 |
| Fuse 26 (JB) | 8W-12-25, 26 |
| Fuse 27 (JB) | 8W-12-25, 26 |
| G107 | 8W-12-35, 37 |
| Headlamp Beam Select Switch | 8W-12-6, 7 |
| Headlamp Delay Module | 8W-12-13 |
| Headlamp Leveling Switch | 8W-12-7 |
| Headlamp Switch | 8W-12-8, 9, 10, 11, 24, 30 |
| Heated Seat Relay | 8W-12-27 |
| Heater Control | 8W-12-8, 9 |

| Component | Page |
|---|--|
| High Note Horn | 8W-12-21 |
| Horn Relay | 8W-12-21 |
| Horn Switch | 8W-12-21 |
| Instrument Cluster | 8W-12-8, 9, 13, 17, 18, 28, 29 |
| Junction Block | 8W-12-2, 5, 6, 7, 8, 9, 10, 11, 13, 14, 15, 16, 17, 18, 19, 20, 21, 22, 23, 24, 25, 26, 27, 28, 29, 30, 31, 32, 33, 34, 35, 36, 37 |
| Left City Lamp | 8W-12-11, 12 |
| Left Courtesy Lamp | 8W-12-28, 29, 30 |
| Left Front Park/Turn Signal Lamp No. 1 | 8W-12-10 |
| Left Front Park/Turn Signal Lamp No. 2 | 8W-12-10 |
| Left Headlamp | 8W-12-6, 7 |
| Left Headlamp Leveling Motor | 8W-12-7 |
| Left Heated Seat Switch | 8W-12-19, 20 |
| Left License Lamp | 8W-12-11 |
| Left Power Seat Switch | 8W-12-27 |
| Left Rear Door Jamb Switch | 8W-12-30 |
| Left Rear Door Lock Motor | 8W-12-31, 32 |
| Left Side Marker Lamp | 8W-12-10 |
| Left Tail/Stop Lamp | 8W-12-10, 11 |
| Left Visor/Vanity Lamp | 8W-12-37 |
| License Lamp | 8W-12-10 |
| Liftgate Lock Motor | 8W-12-31, 32 |
| Low Note Horn | 8W-12-21 |
| Message Center | 8W-12-13 |
| Overhead Module | 8W-12-21, 30, 37 |
| Oxygen Sensor Downstream Relay | 8W-12-14 |
| Oxygen Sensor Upstream Relay | 8W-12-14 |
| Passenger Door Jamb Switch | 8W-12-30 |
| Passenger Door Lock Motor | 8W-12-31, 32 |
| Passenger Power Lock/Window Switch | 8W-12-19, 20, 25, 26, 31, 32, 37 |
| Passenger Power Mirror | 8W-12-17, 18, 33, 34, 35, 36, 37 |
| Power Distribution Center | 8W-12-28, 29 |
| Power Mirror Switch | 8W-12-19, 20, 33, 35, 37 |
| Power Outlet | 8W-12-5 |
| Powertrain Control Module | 8W-12-15, 16 |
| PRNDL Illumination | 8W-12-8, 9 |
| Radiator Fan Relay | 8W-12-14 |
| Radio | 8W-12-8, 9, 10, 11, 19, 20, 28, 29 |
| Rear Fog Lamp Relay | 8W-12-19, 20 |
| Rear Fog Lamp Switch | 8W-12-8, 9 |
| Rear Window Defogger | 8W-12-17, 18 |
| Rear Window Defogger Relay | 8W-12-17, 18 |
| Rear Window Defogger Switch | 8W-12-8, 9, 17, 18 |
| Rear Wiper Motor | 8W-12-22, 23 |
| Rear Wiper/Washer Switch | 8W-12-8, 9, 22, 23 |
| Right City Lamp | 8W-12-24 |
| Right Courtesy Lamp | 8W-12-28, 29, 30 |
| Right Front Park/Turn Signal Lamp No. 1 | 8W-12-24 |
| Right Front Park/Turn Signal Lamp No. 2 | 8W-12-24 |
| Right Headlamp | 8W-12-6, 7 |
| Right Headlamp Leveling Motor | 8W-12-7 |
| Right Heated Seat Switch | 8W-12-19, 20 |
| Right License Lamp | 8W-12-11 |
| Right Power Seat Switch | 8W-12-27 |
| Right Rear Door Jamb Switch | 8W-12-30 |
| Right Rear Door Lock Motor | 8W-12-31, 32 |
| Right Side Marker Lamp | 8W-12-24 |
| Right Tail/Stop Lamp | 8W-12-24 |
| Right Visor/Vanity Lamp | 8W-12-37 |
| Sentry Key Immobilizer Module | 8W-12-13 |
| Shift Lock Solenoid | 8W-12-22, 23 |
| Trailer Tow Connector | 8W-12-10, 11, 21 |
| Trailer Tow Left Turn Relay | 8W-12-21 |
| Trailer Tow Right Turn Relay | 8W-12-21 |
| Transfer Case Switch Illumination | 8W-12-8, 9 |
| Transmission Control Module | 8W-12-16, 28 |
| Transmission Range Sensor | 8W-12-14 |
| Underhood Lamp/Mercury Switch | 8W-12-28, 29 |
| Wipe/Wash Switch | 8W-12-27 |

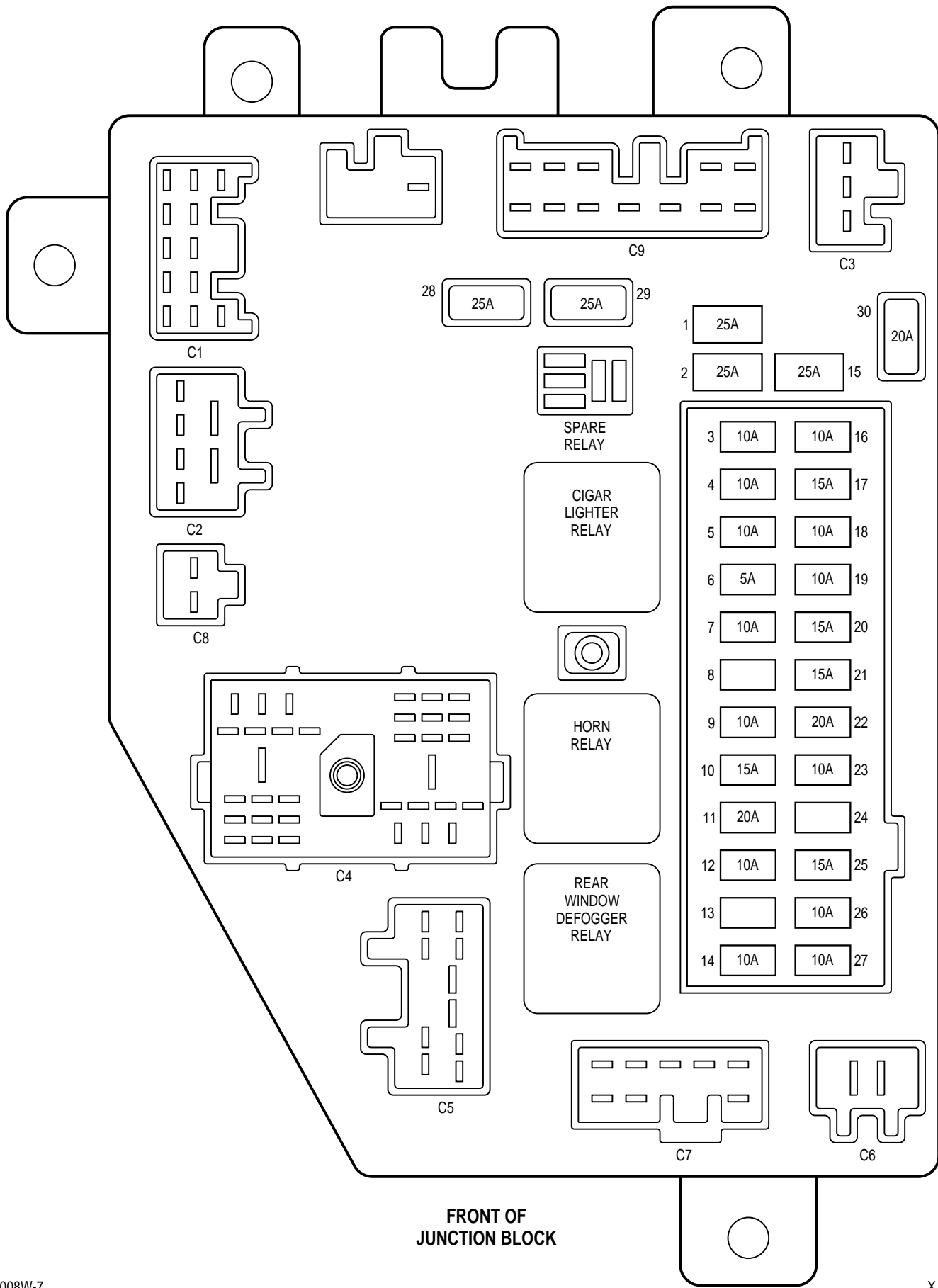

FUSES

| FUSE NO. | AMPS | FUSED CIRCUIT | FEED CIRCUIT |
|----------|------|---------------|--------------|
| 1 | 25A | F38 16RD/LB | A7 10RD/BK |
| 2 | 25A | INTERNAL | A7 10RD/BK |
| 3 | 10A | L33 20RD | L3 16RD/OR |
| 4 | 10A | L43 20VT | L4 16VT/WT |
| 5 | 10A | L44 20VT/RD | L4 16VT/WT |
| 6 | 5A | E2 20OR | E1 20TN |
| 7 | 10A | INTERNAL | L7 18BK/YL |
| 8 | - | - | A21 12DB |
| 9 | 10A | F87 20WT/BK | A21 12DB |
| 10 | 15A | F20 18WT | A21 12DB |
| 11 | 20A | F12 18DB/WT | A21 12DB |
| 12 | 10A | INTERNAL | A22 12BK/OR |
| 13 | - | - | A4 12BK/PK |
| 14 | 10A | INTERNAL | INTERNAL |
| 15 | 25A | F35 16RD | A7 10RD/BK |
| 16 | 10A | L34 20RD/OR | L3 16RD/OR |
| 17 | 15A | X12 16RD/WT | A31 12BK/WT |
| 18 | 10A | F83 18YL/DG | A31 12BK/WT |
| 19 | 10A | F45 20YL/RD | A41 14YL |
| 20 | 15A | A6 20RD/OR | A7 10RD/BK |
| 21 | 15A | INTERNAL | A7 10RD/BK |
| 22 | 20A | V23 18BR/PK | A22 12BK/OR |
| 23 | 10A | INTERNAL | L7 18BK/YL |
| 24 | - | - | A22 12BK/OR |
| 25 | 15A | F15 20DB/WT | A22 12BK/OR |
| 26 | 10A | F14 18LG/YL | A22 12BK/OR |
| 27 | 10A | F23 18DB/YL | A21 12DB |

CIRCUIT BREAKERS

| CB NO. | AMPS | FUSED CIRCUIT | FEED CIRCUIT |
|--------|------|---------------|--------------|
| 28 | 25A | INTERNAL | A31 12BK/WT |
| 29 | 25A | F37 14RD/LB | A7 10RD/BK |
| 30 | 20A | V6 16DB | A31 12BK/WT |

CIGAR
LIGHTER
RELAY

| CAVITY | CIRCUIT | FUNCTION |
|--------|-------------|--|
| 30 | INTERNAL | FUSED B(+) |
| 85 | INTERNAL | GROUND |
| 86 | A31 12BK/WT | FUSED IGNITION SWITCH OUTPUT (RUN-ACC) |
| 87 | F30 16RD | CIGAR LIGHTER RELAY OUTPUT |
| 87A | - | - |

HORN
RELAY

| CAVITY | CIRCUIT | FUNCTION |
|--------|------------|--------------------|
| 30 | INTERNAL | FUSED B(+) |
| 85 | X3 20BK/RD | HORN RELAY CONTROL |
| 86 | INTERNAL | FUSED B(+) |
| 87 | X2 20DG/RD | HORN RELAY OUTPUT |
| 87A | - | - |

REAR
WINDOW
DEFOGGER
RELAY

| CAVITY | CIRCUIT | FUNCTION |
|--------|-------------|------------------------------------|
| 30 | A4 12BK/PK | FUSED B(+) |
| 85 | C81 20LB/WT | REAR WINDOW DEFOGGER RELAY CONTROL |
| 86 | INTERNAL | FUSED IGNITION SWITCH OUTPUT (RUN) |
| 87 | INTERNAL | REAR WINDOW DEFOGGER RELAY OUTPUT |
| 87A | - | - |

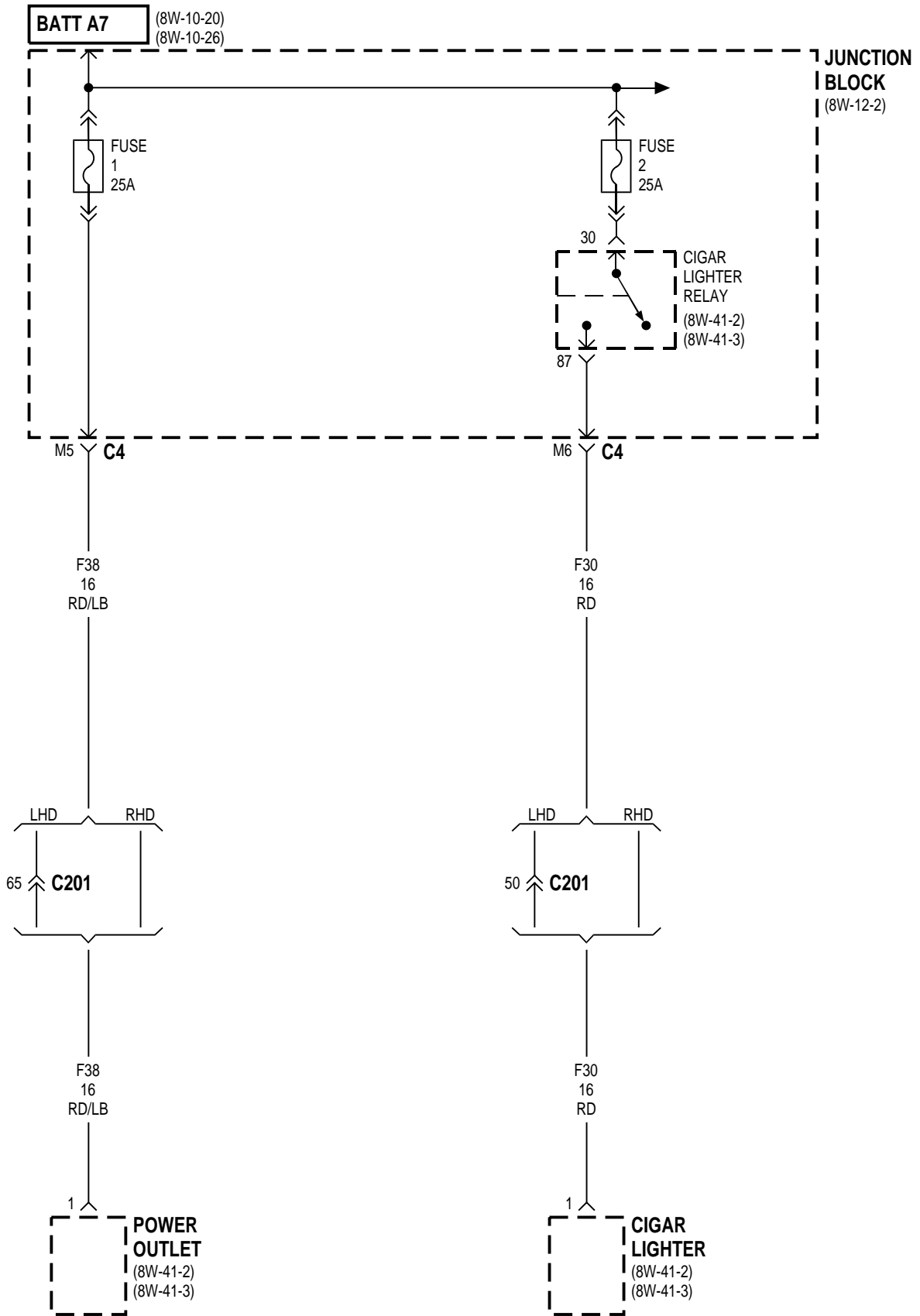

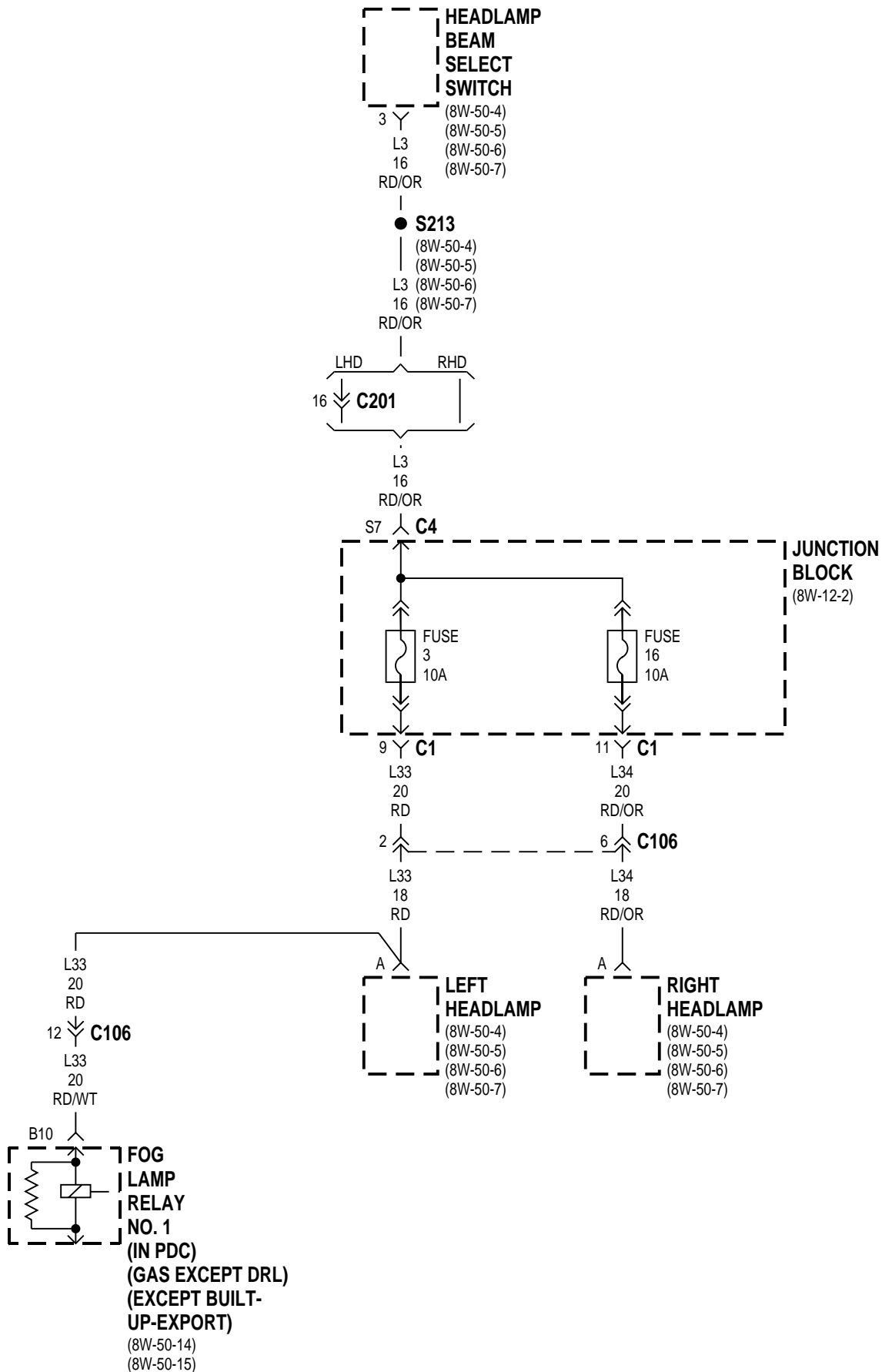

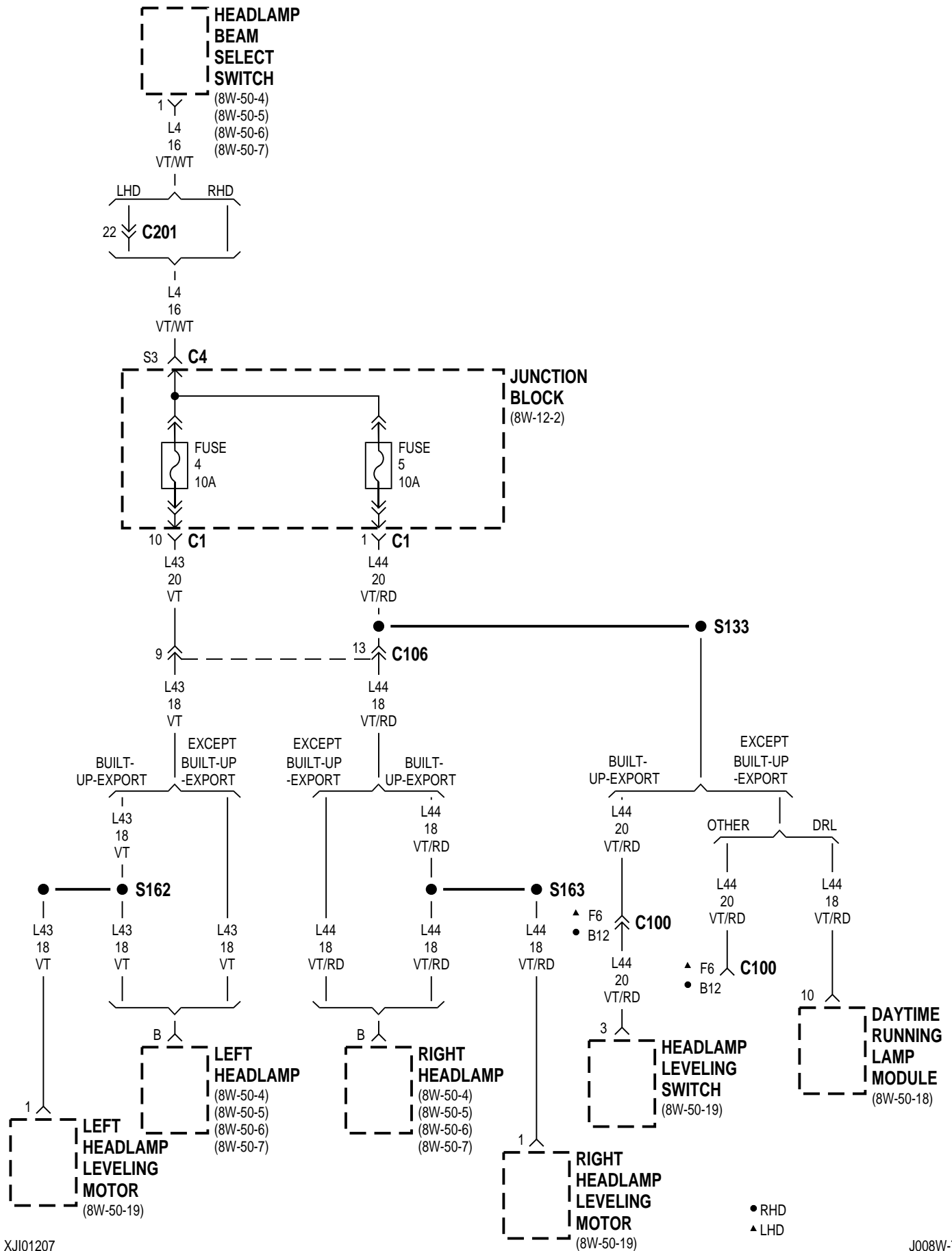

LHD

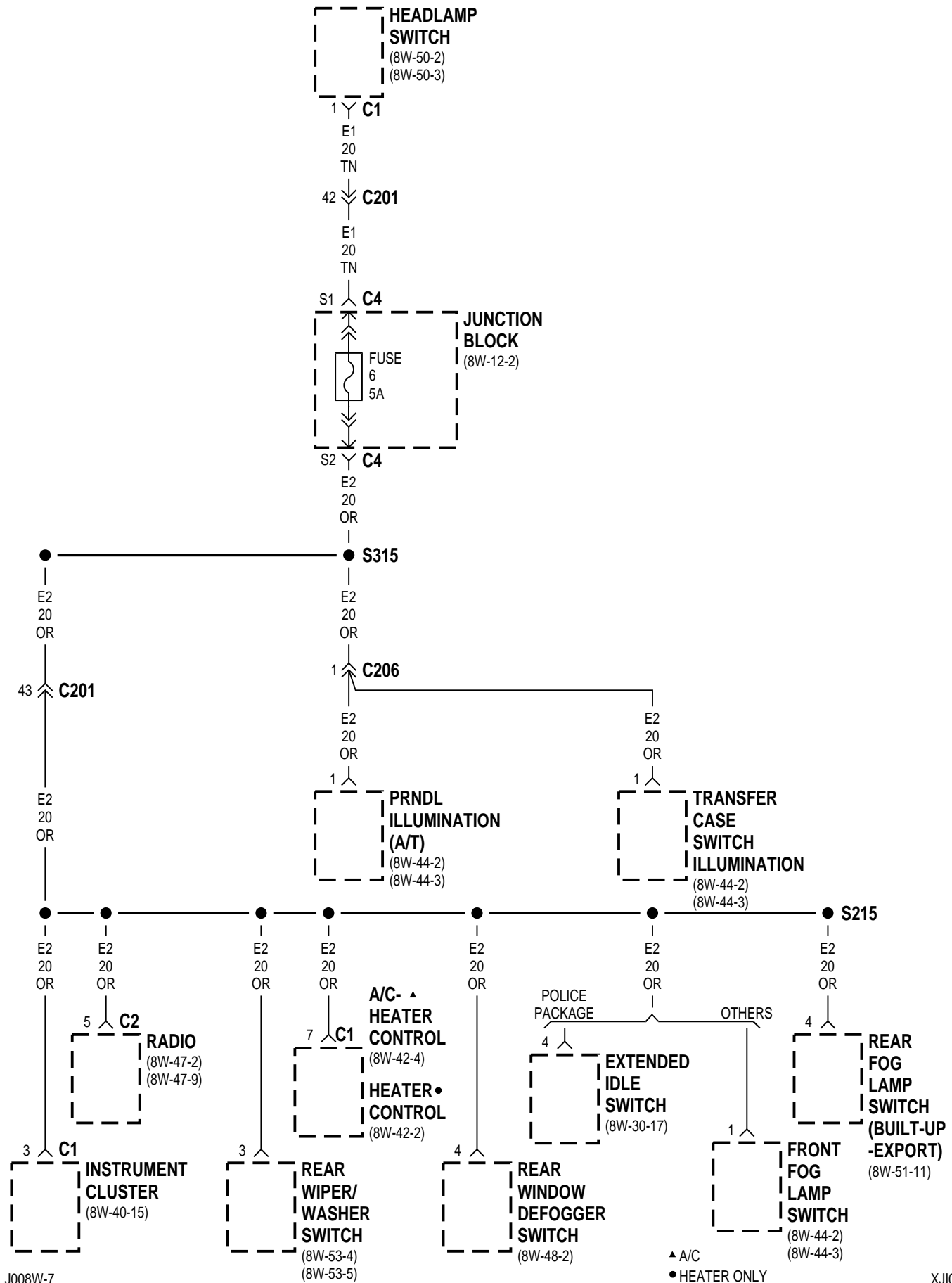

XJ ————— **8W-12 JUNCTION BLOCK** ————— **8W - 12 - 9**
RHD

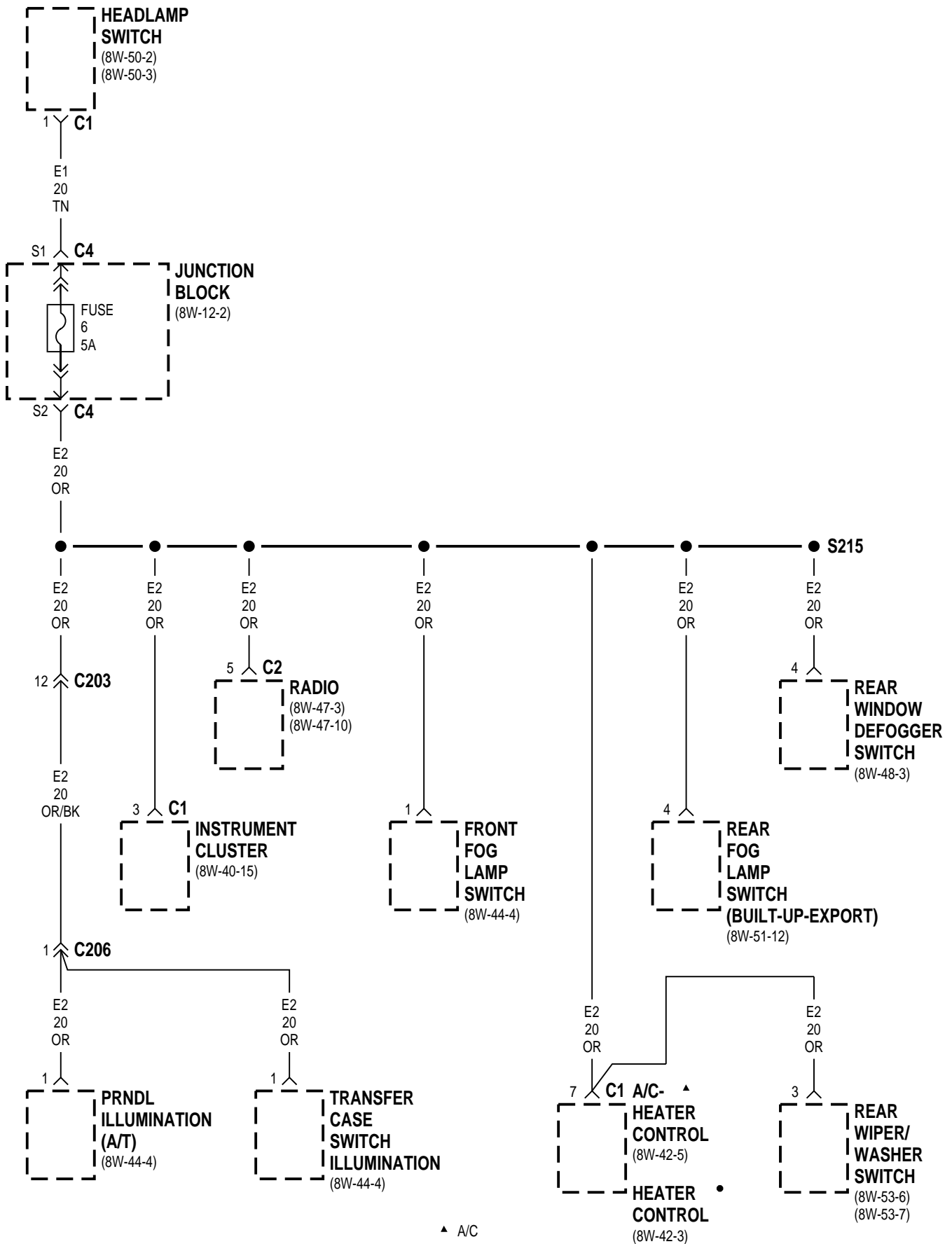

8W-12 JUNCTION BLOCK EXCEPT BUILT-UP-EXPORT

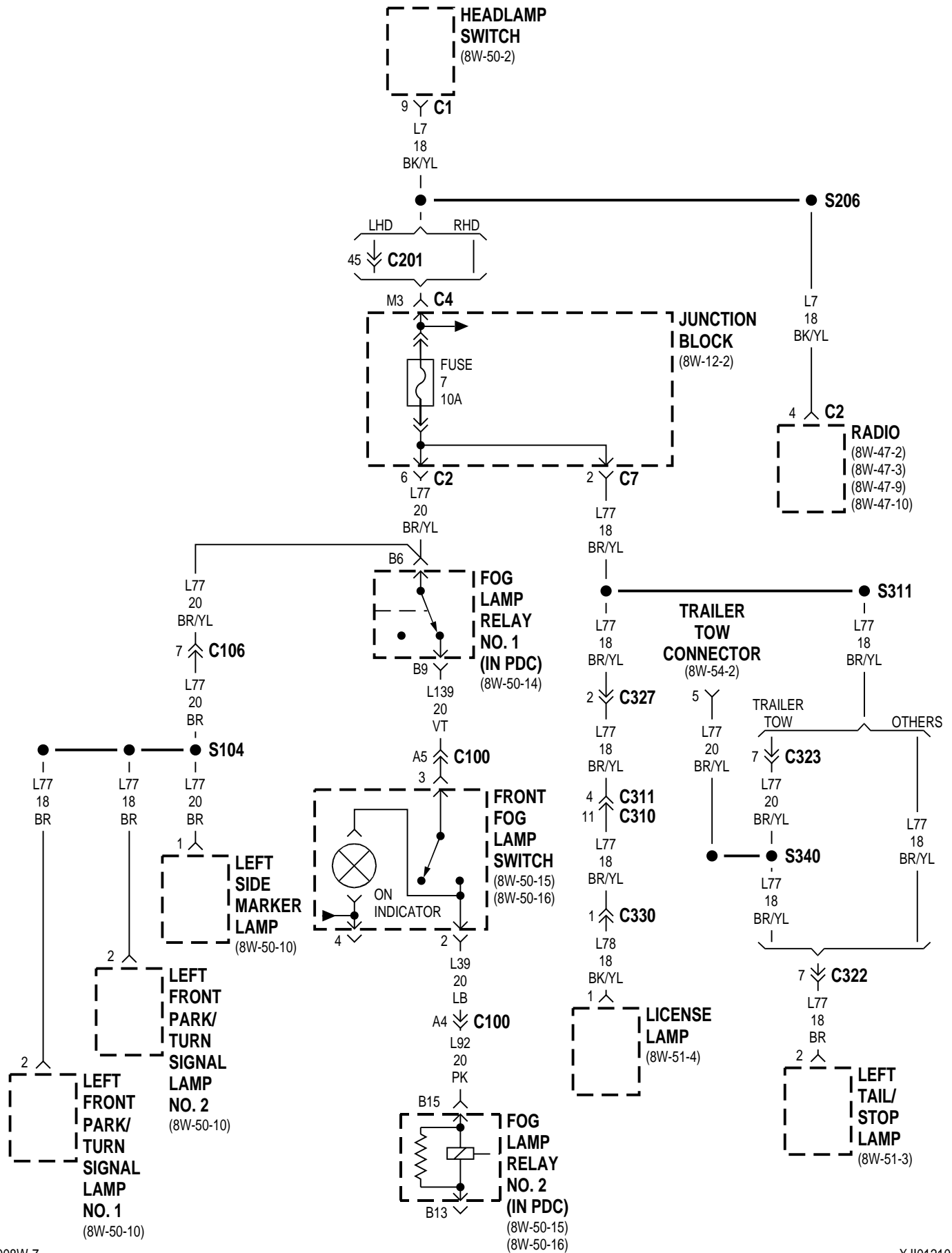

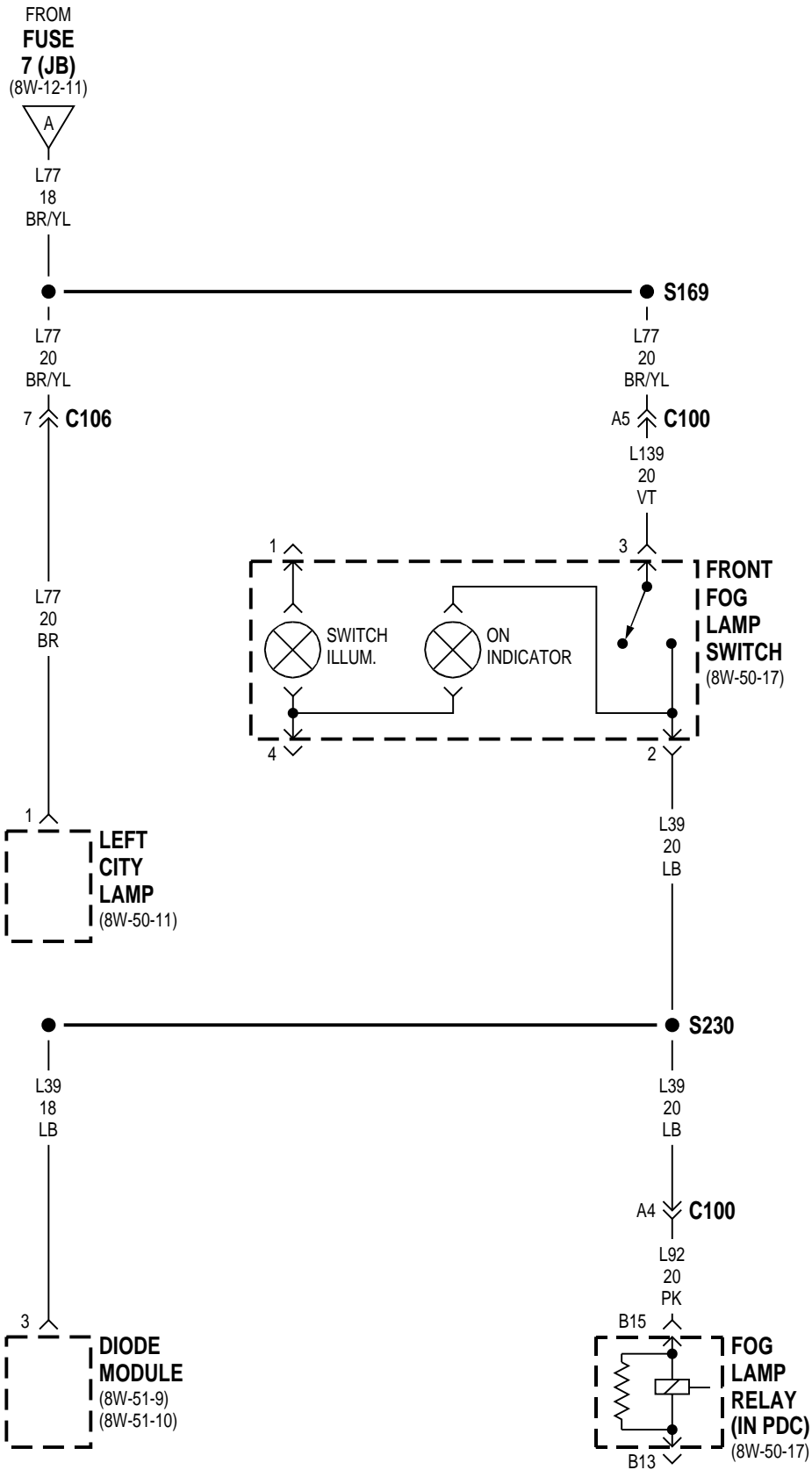

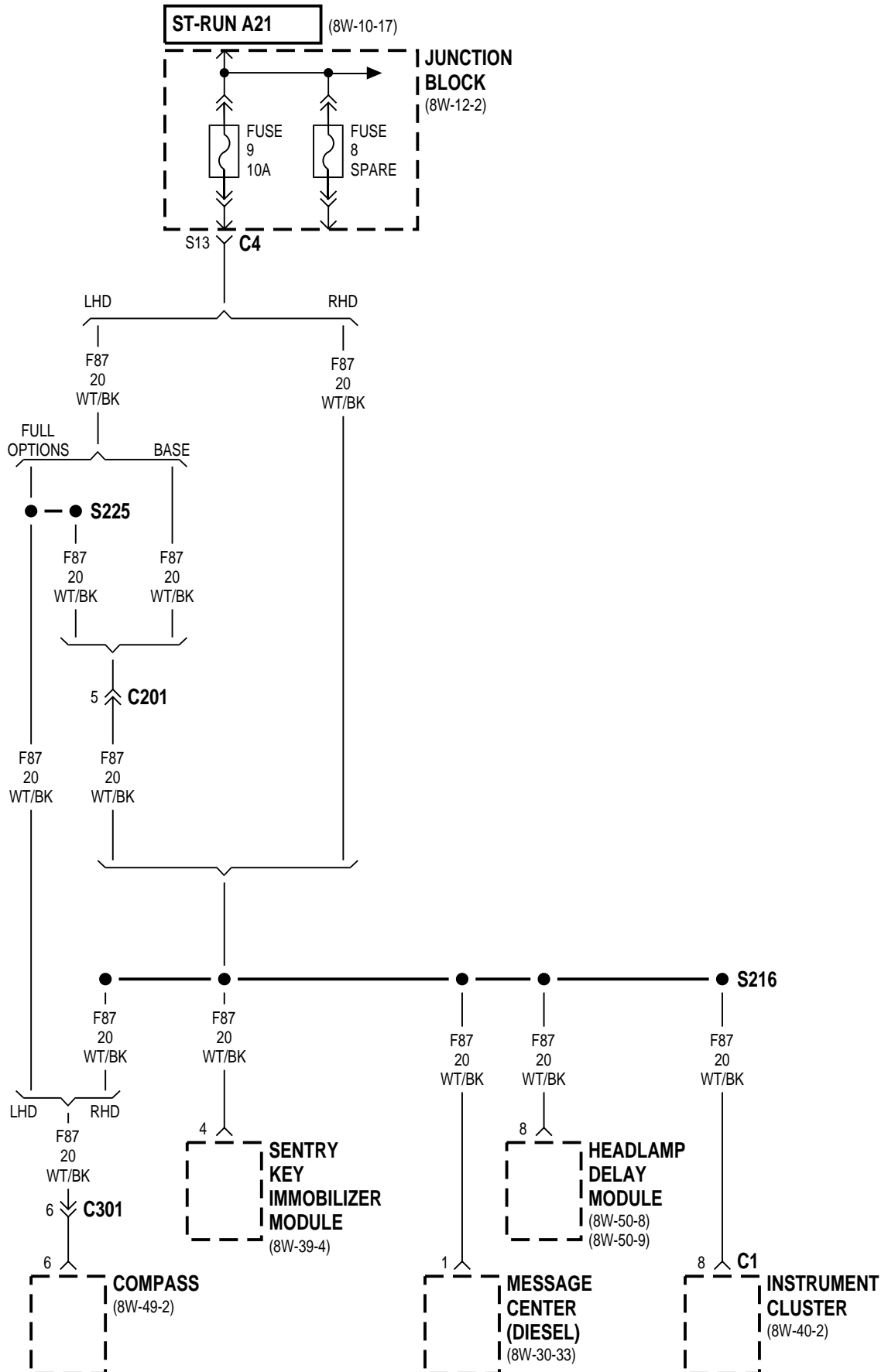

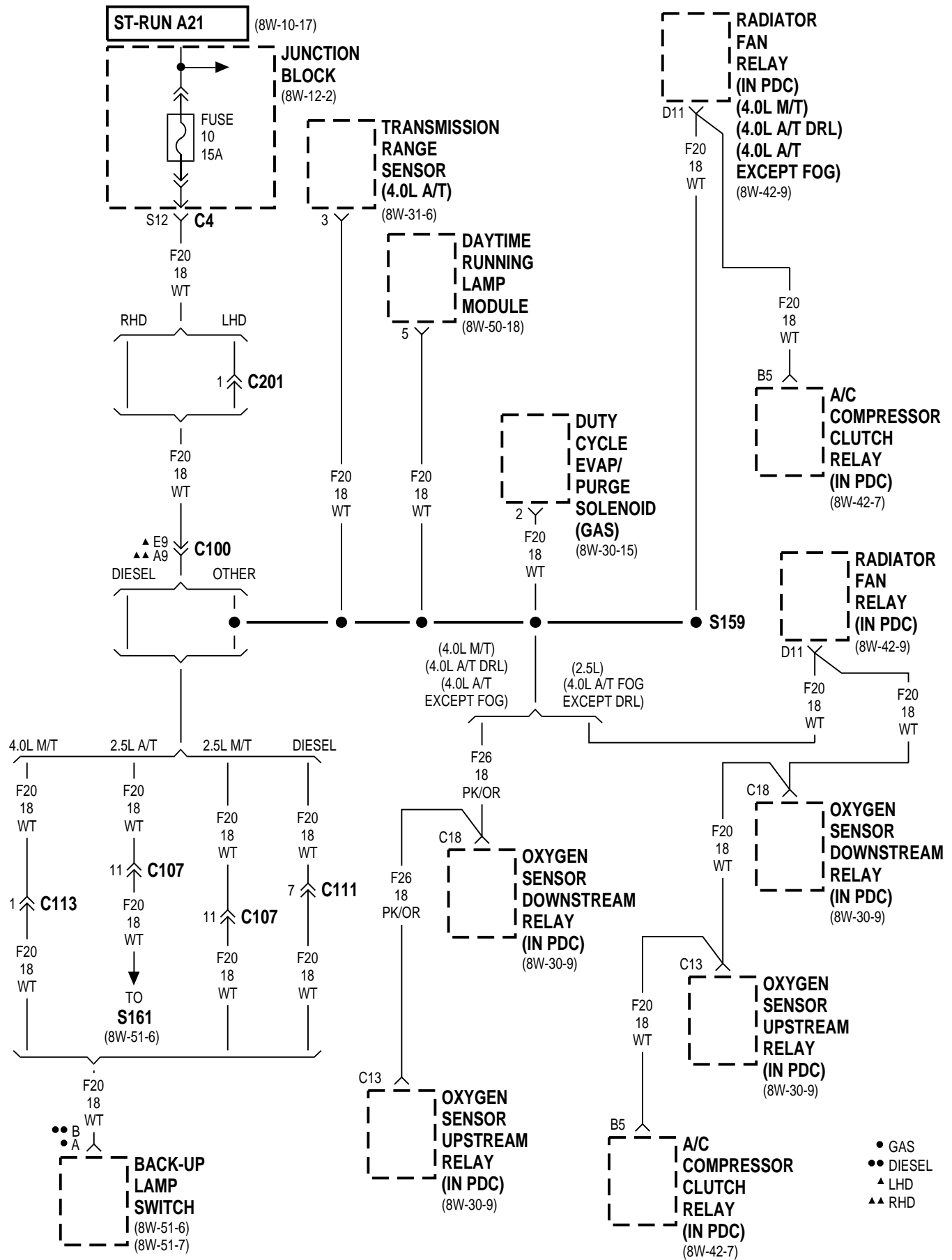

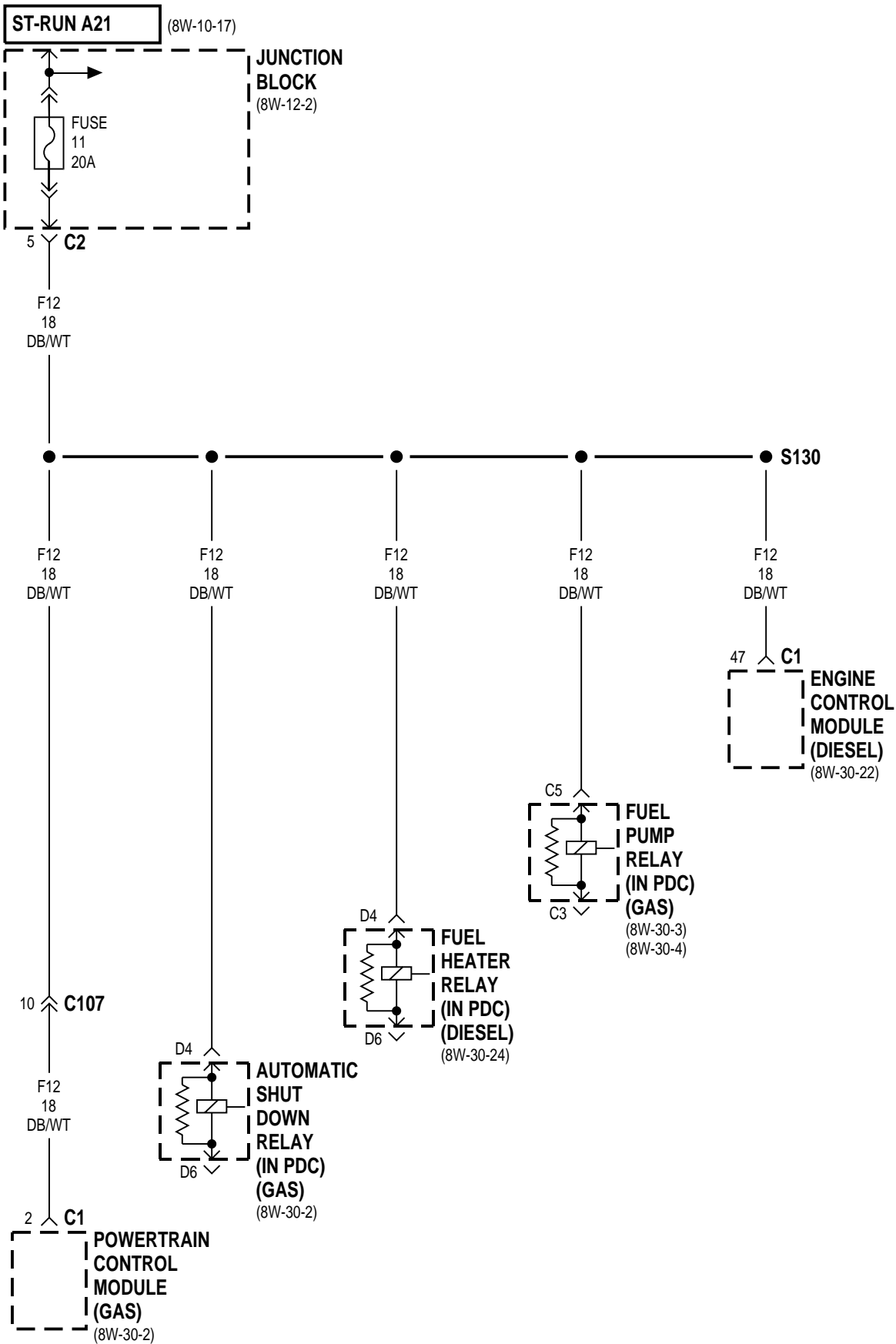

4.0L

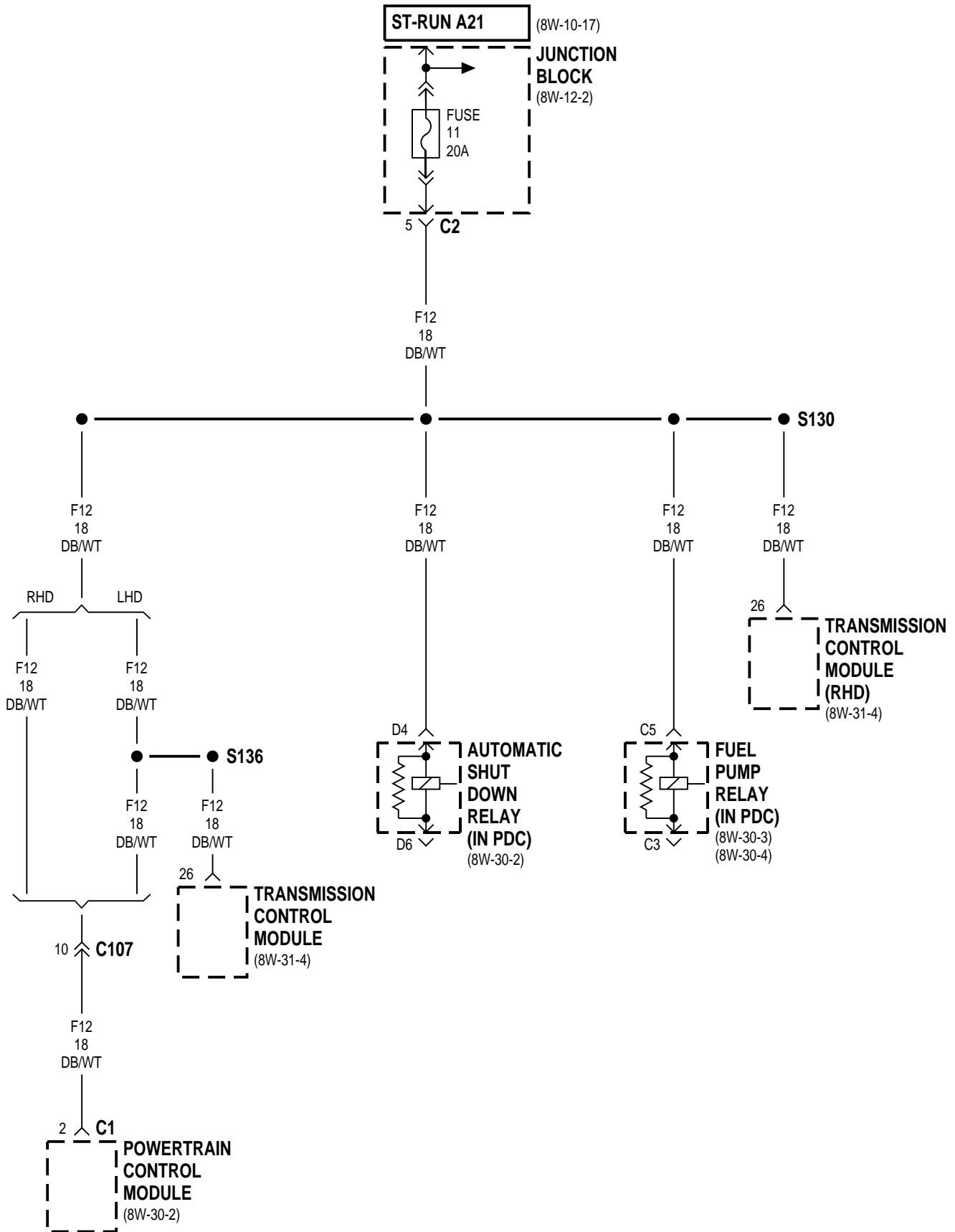

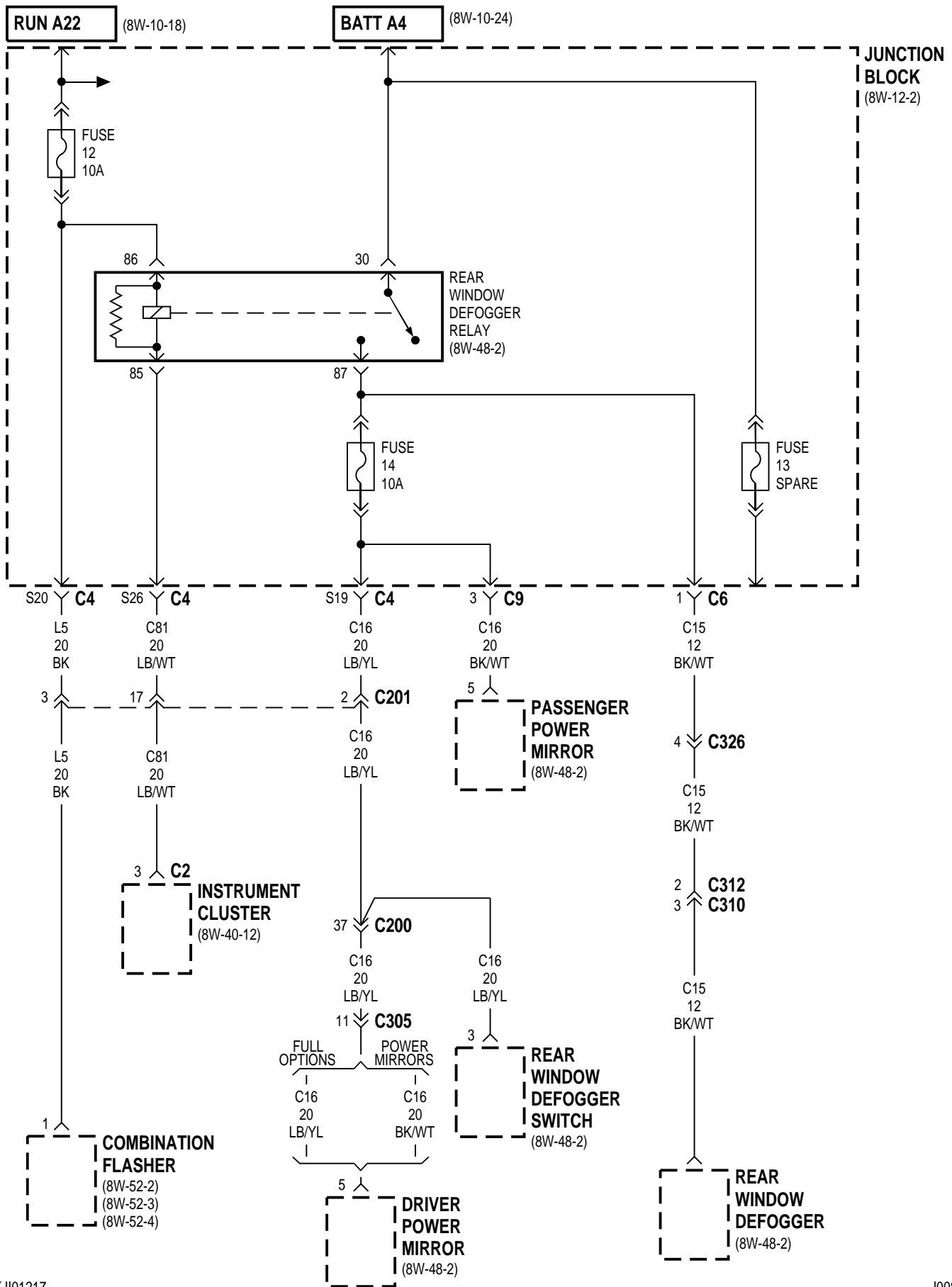

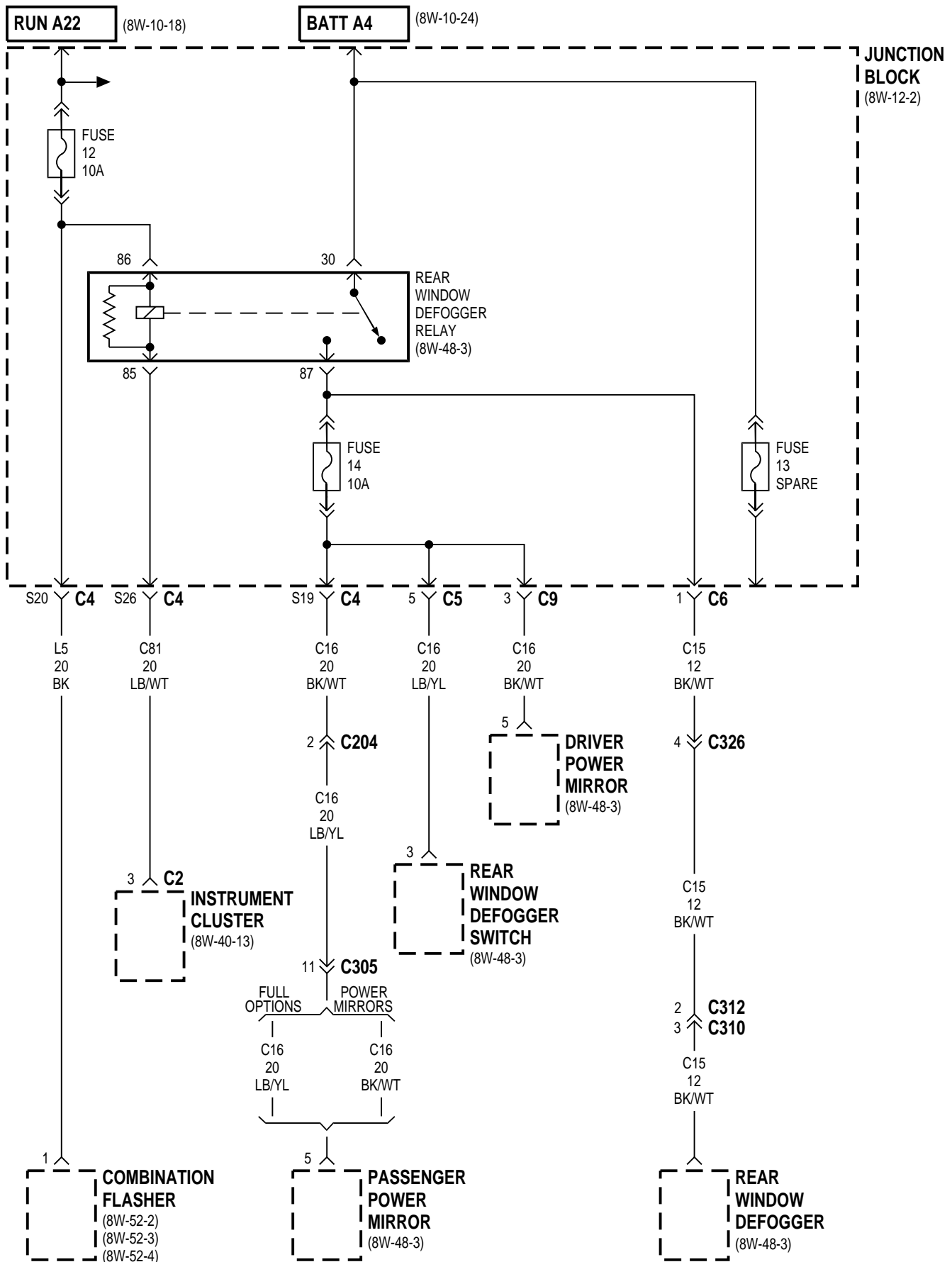

RHD

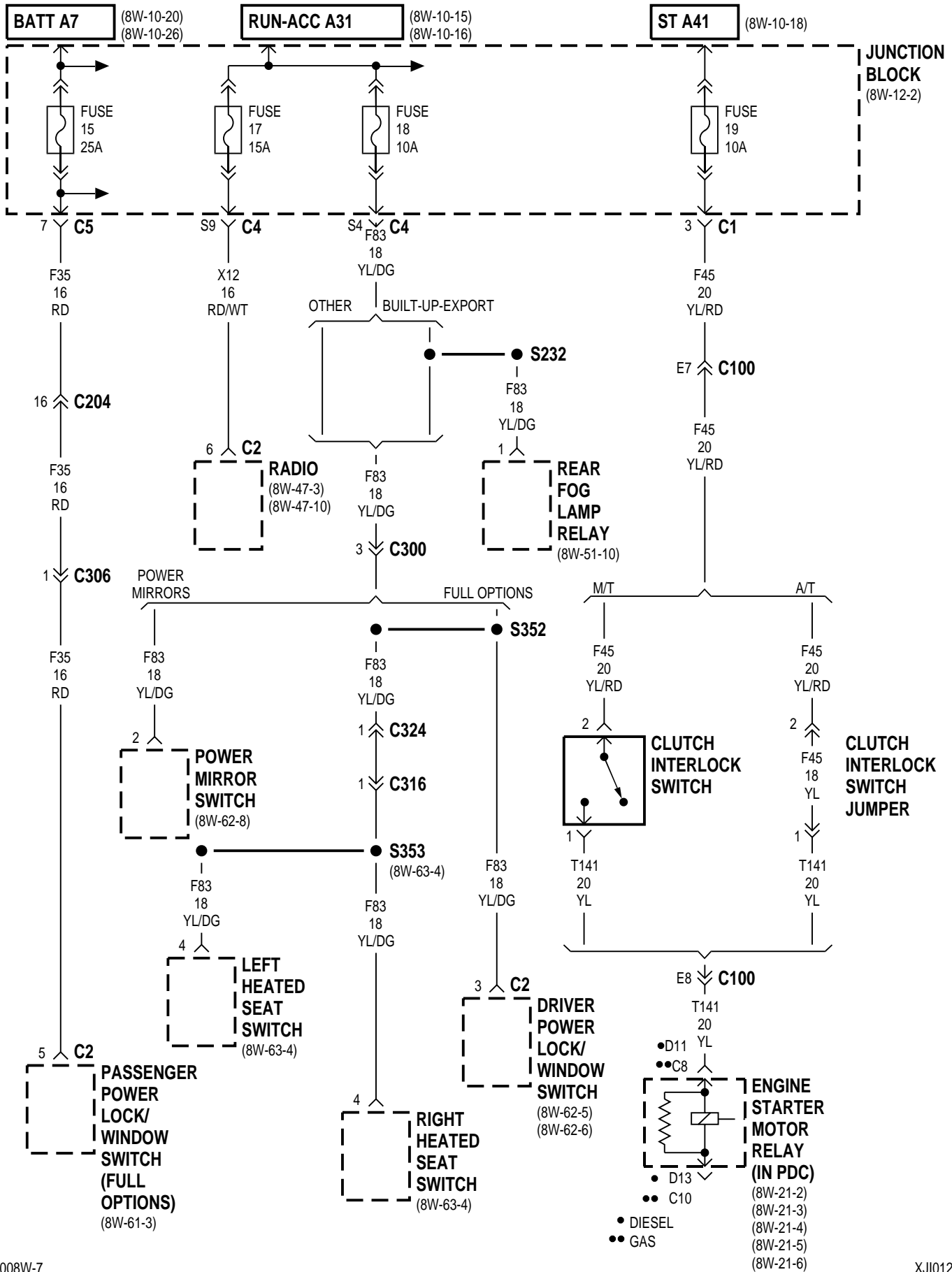

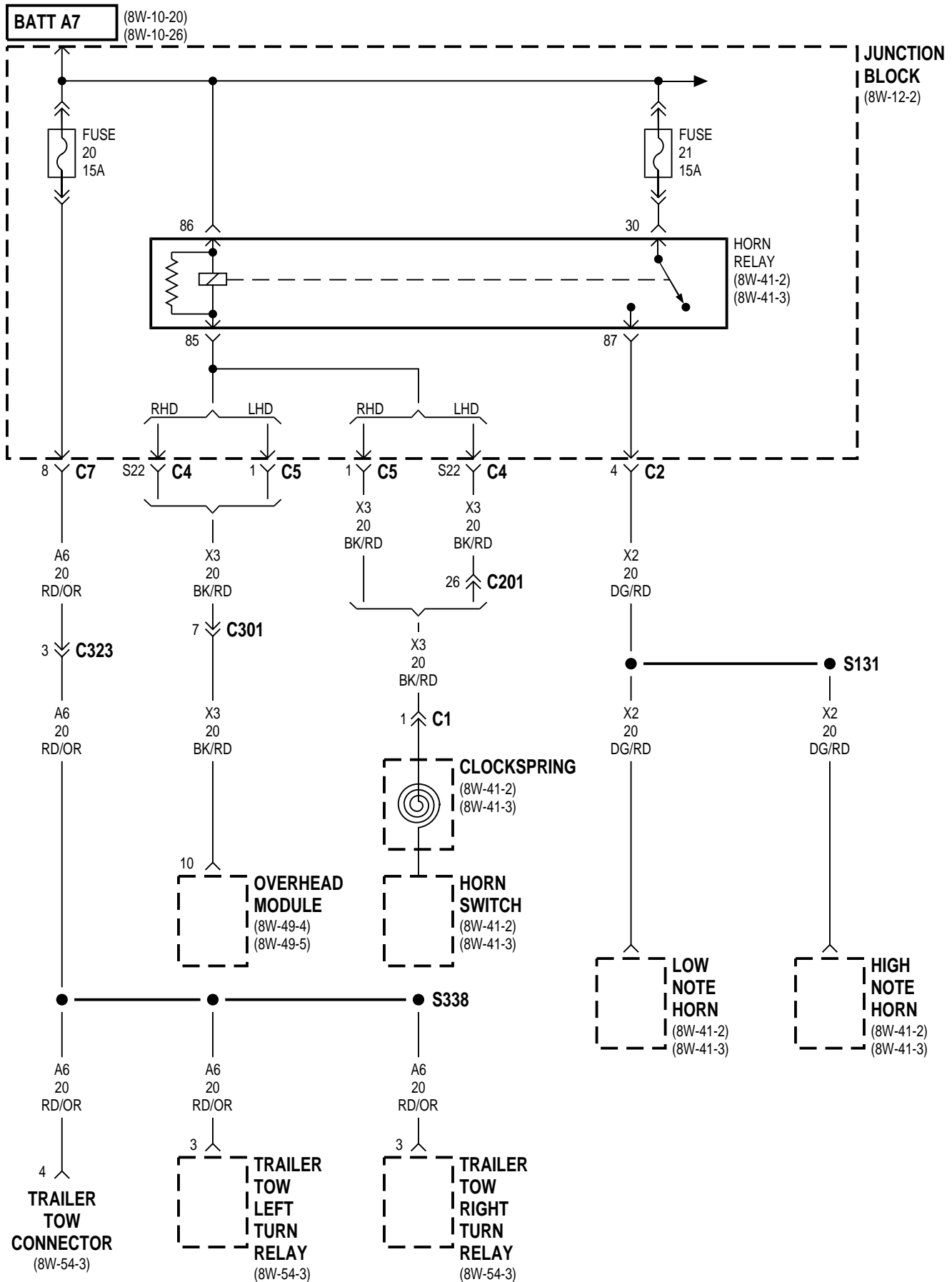

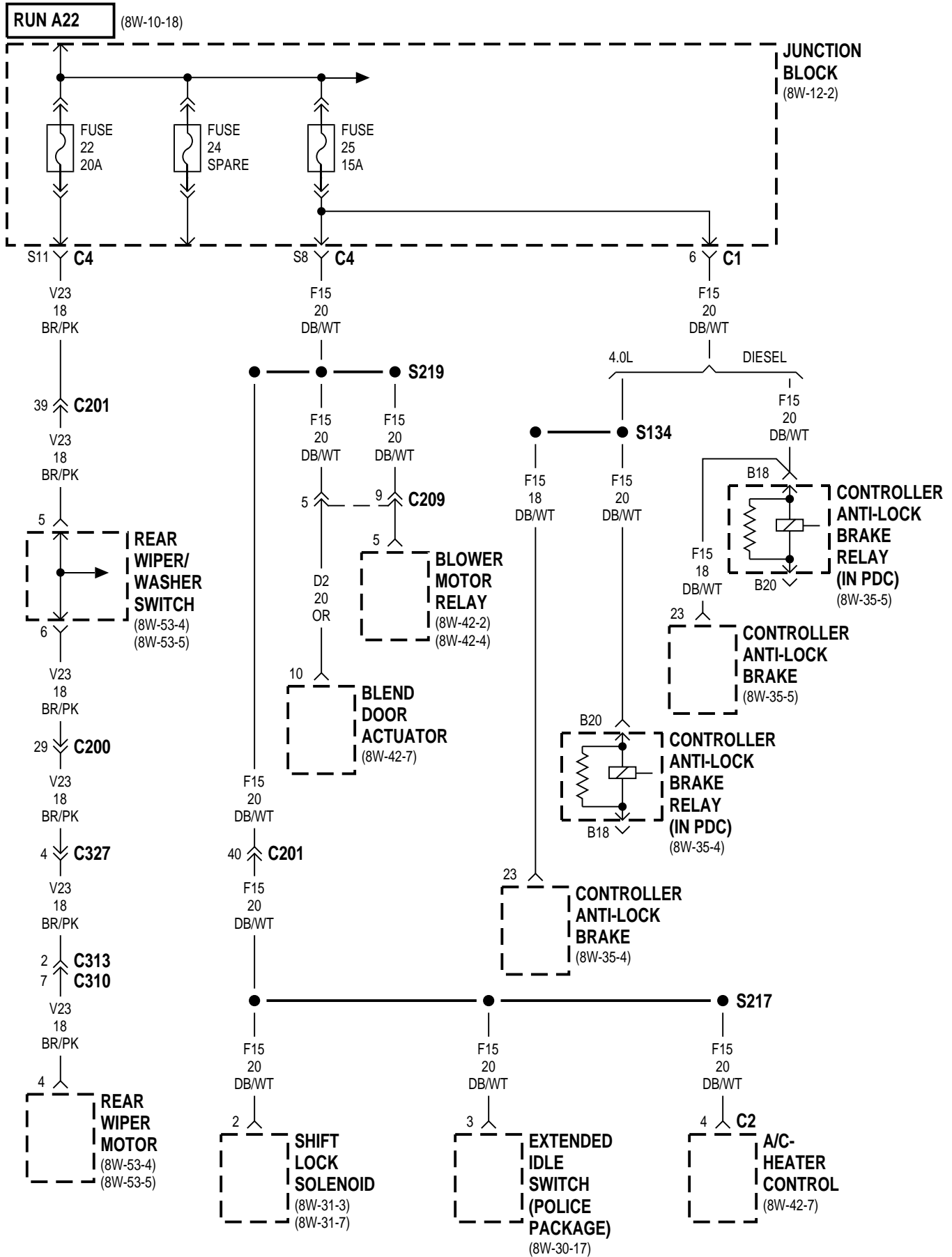

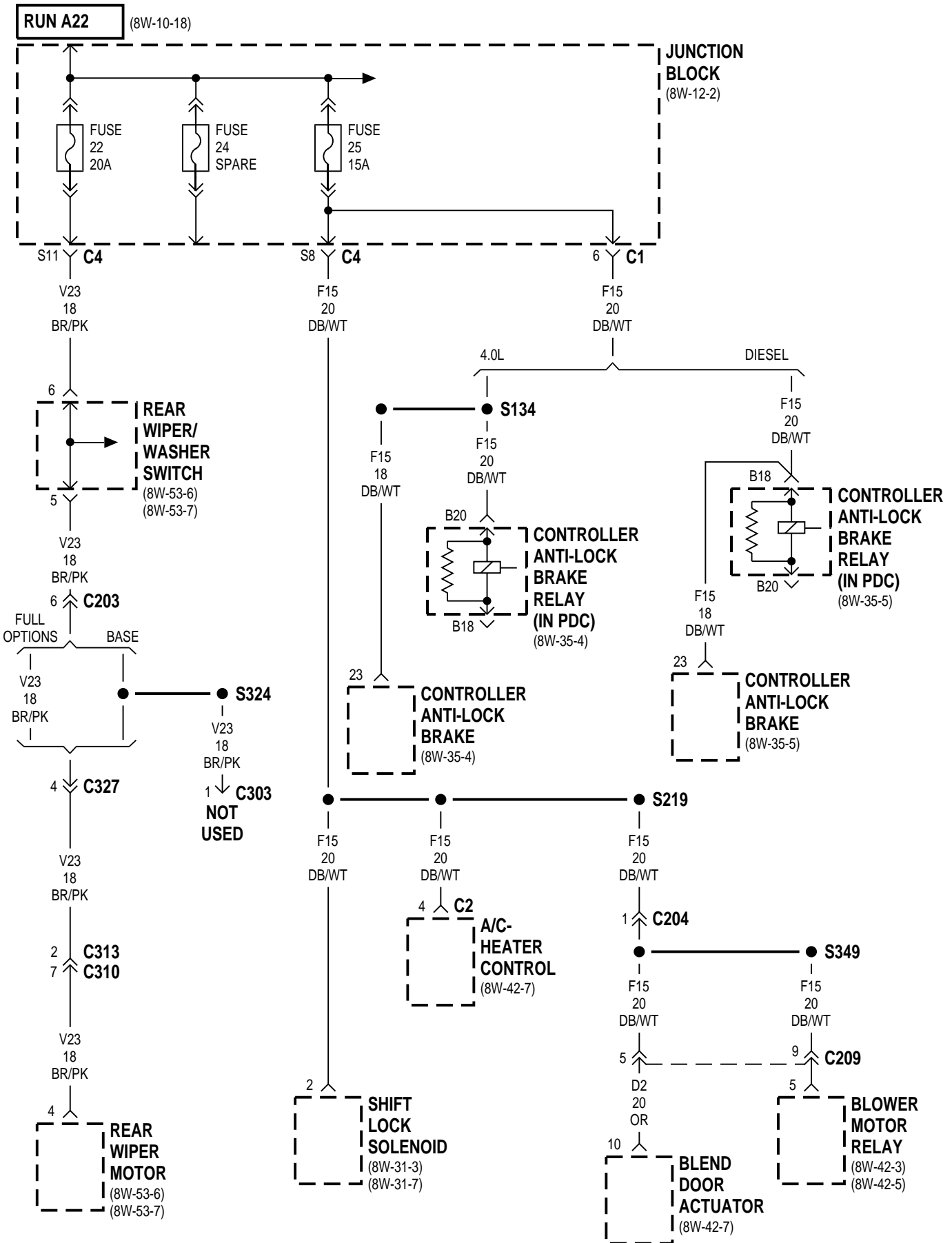

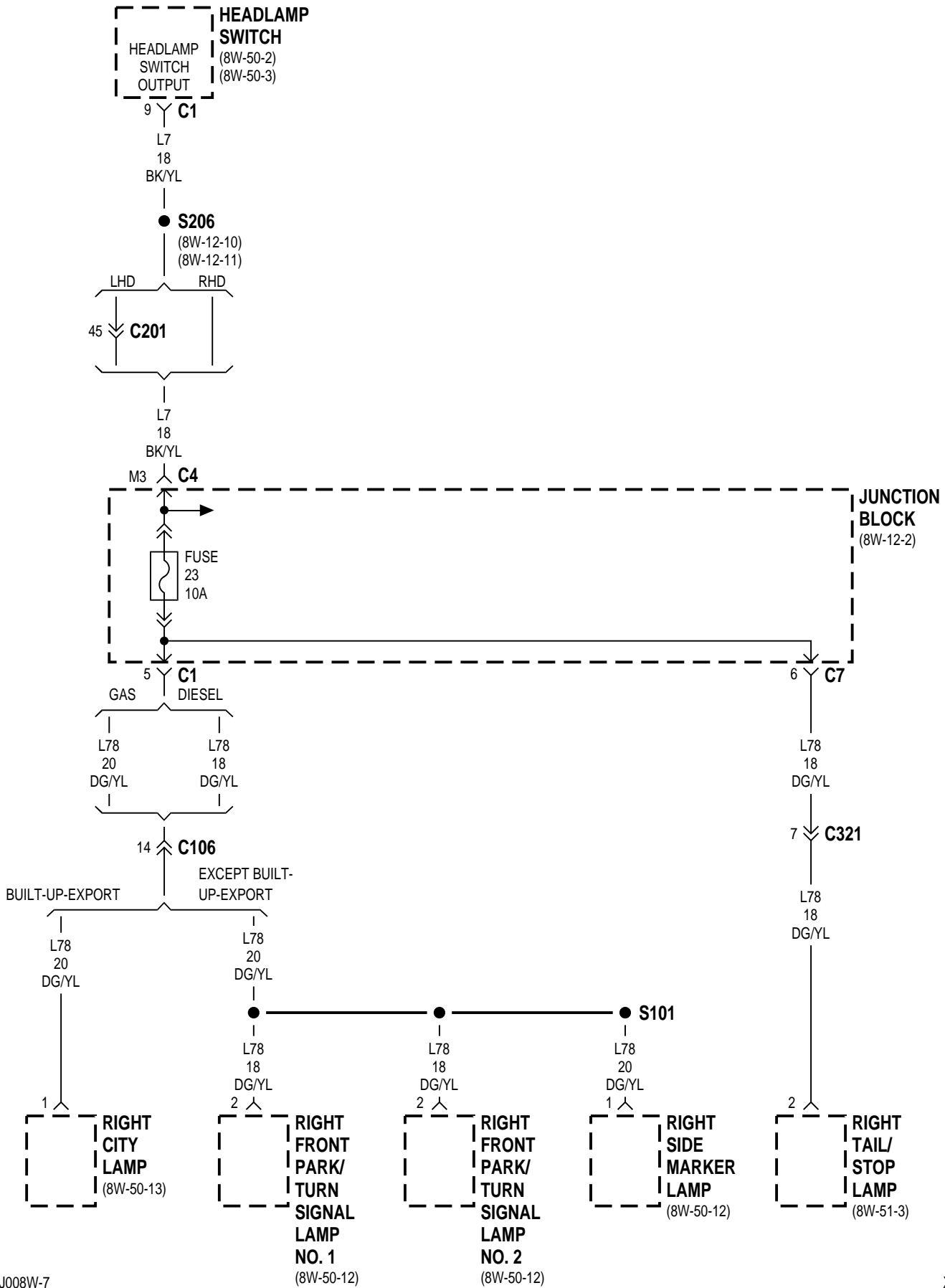

XJ ————— **8W-12 JUNCTION BLOCK** ————— **8W - 12 - 25**
LHD

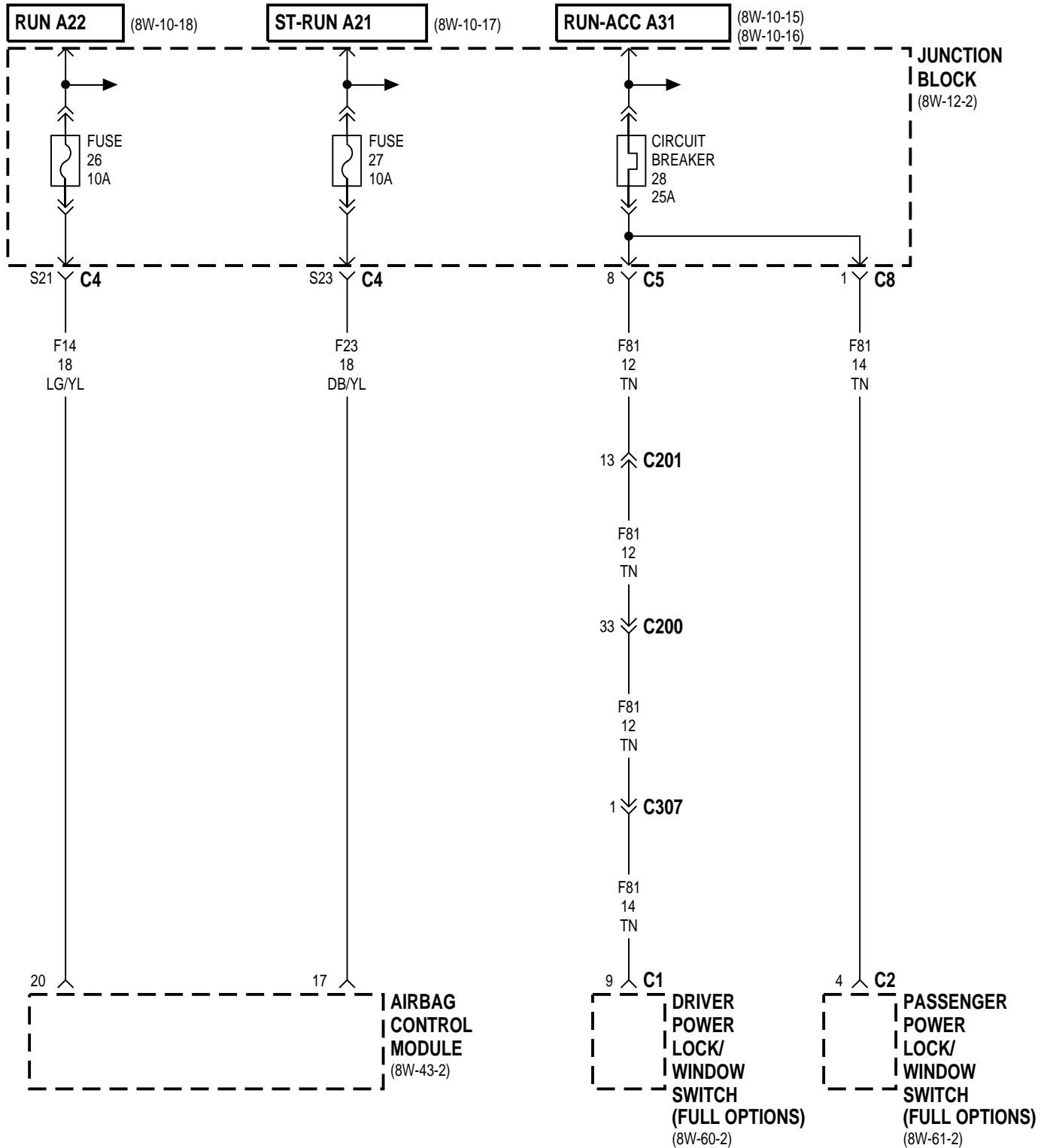

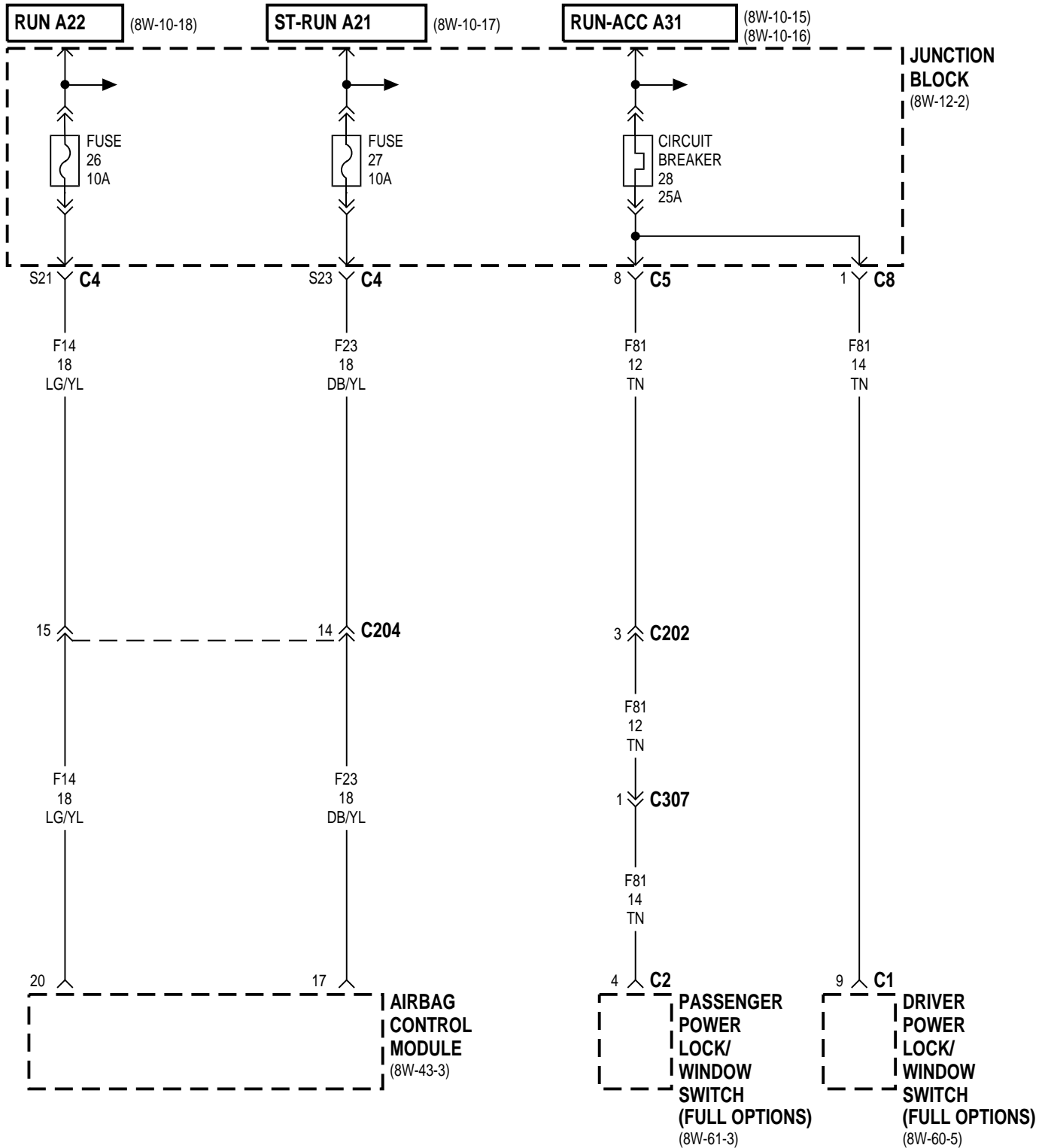

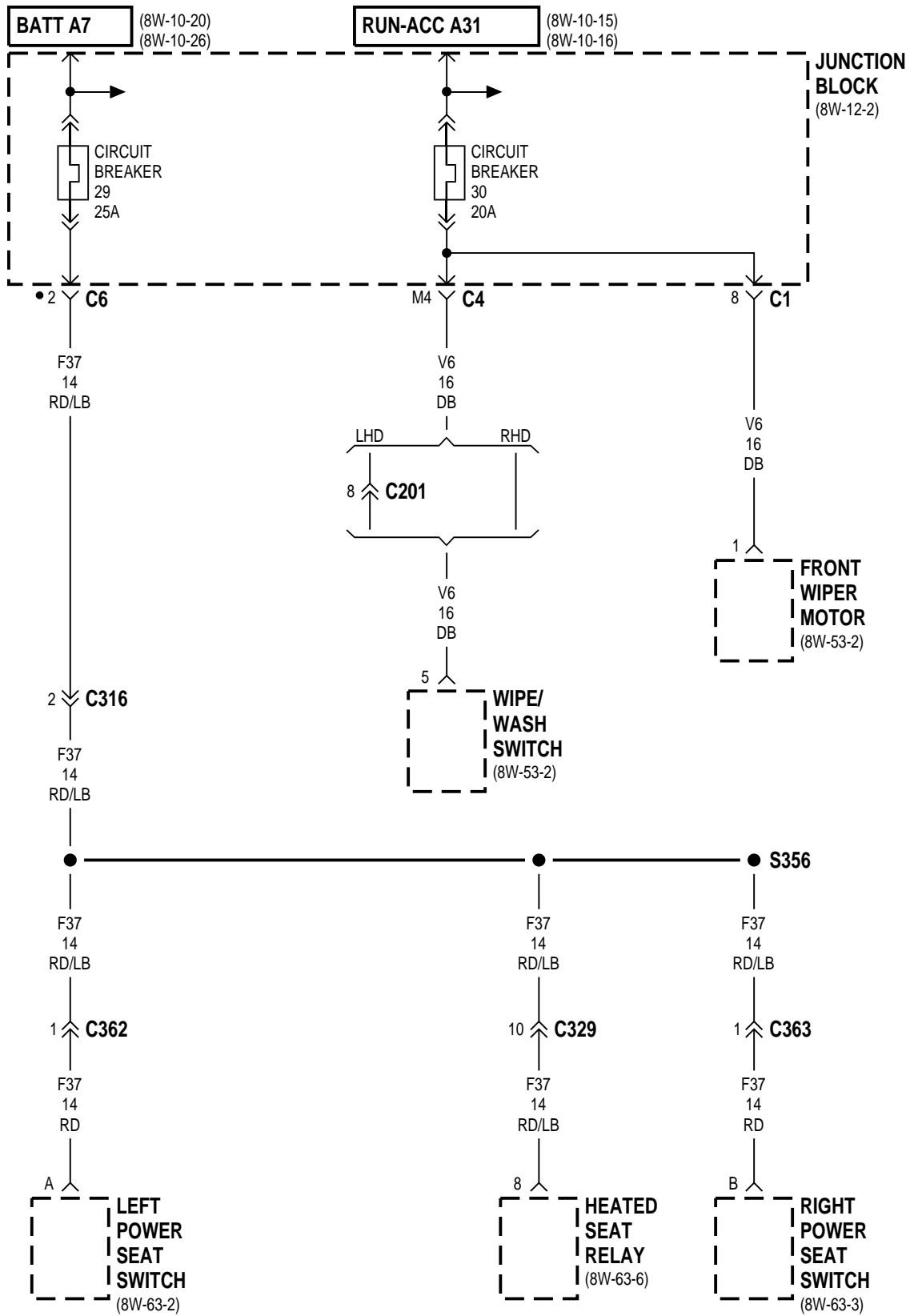

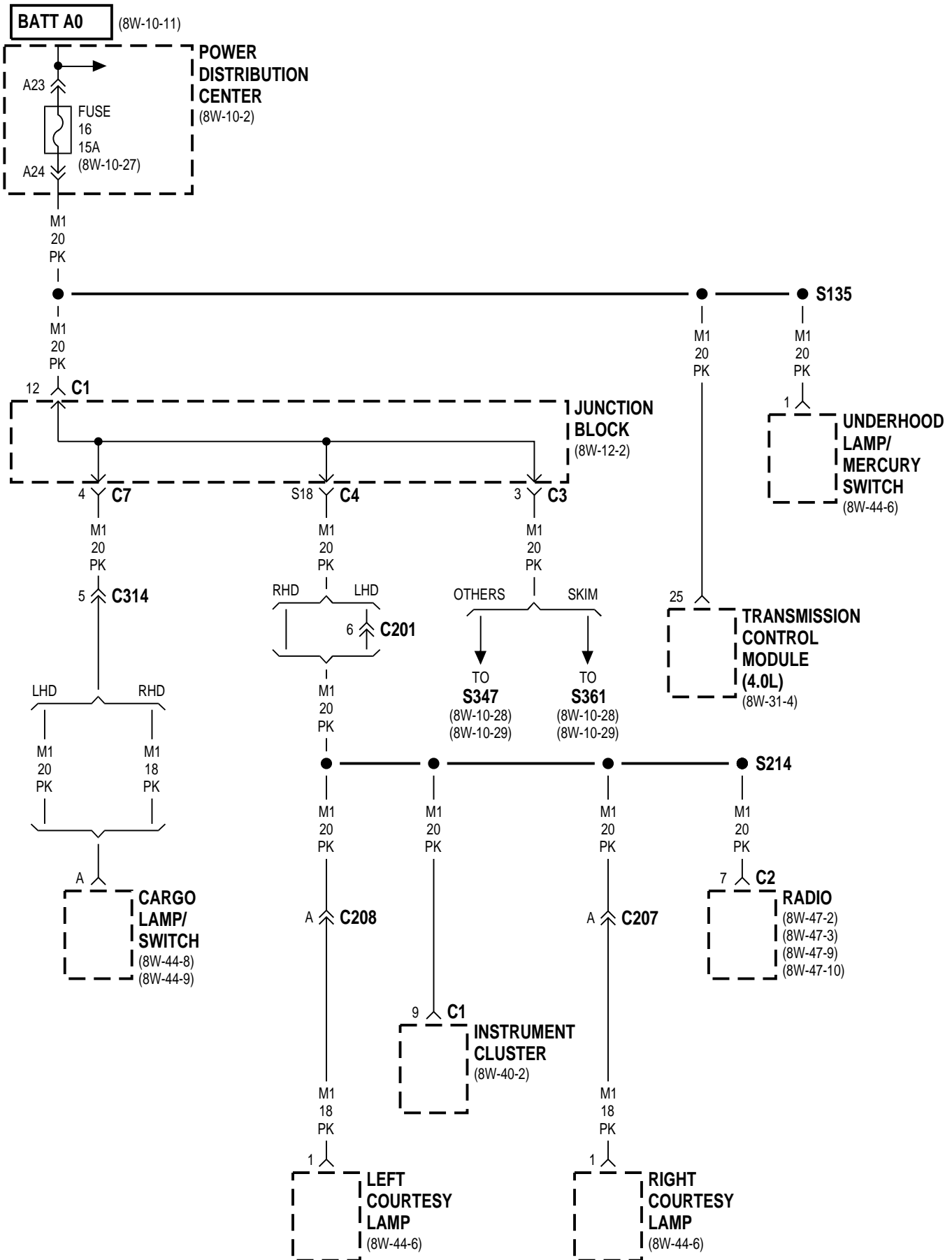

XJ **8W-12 JUNCTION BLOCK** **8W - 12 - 29**
DIESEL

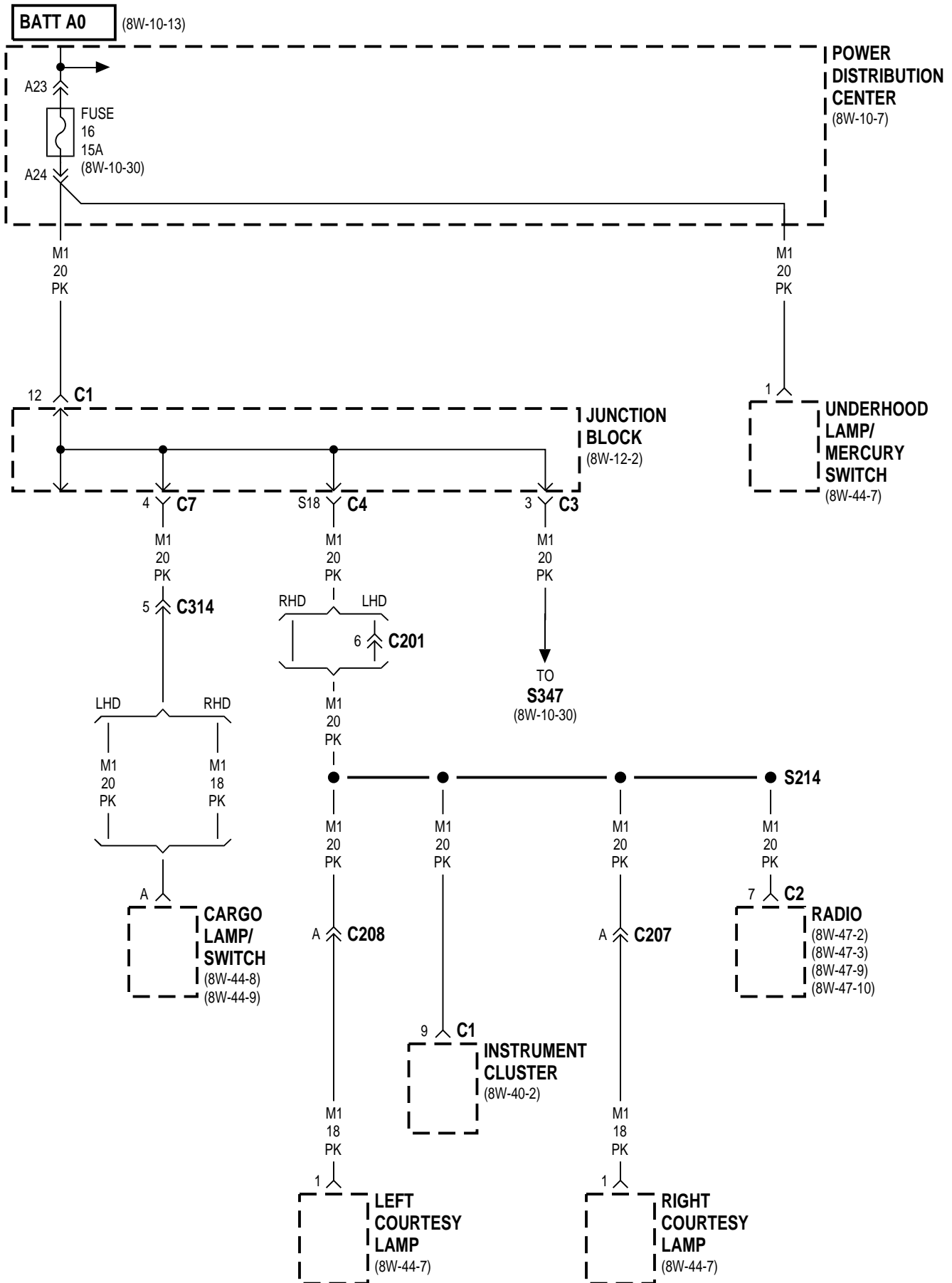

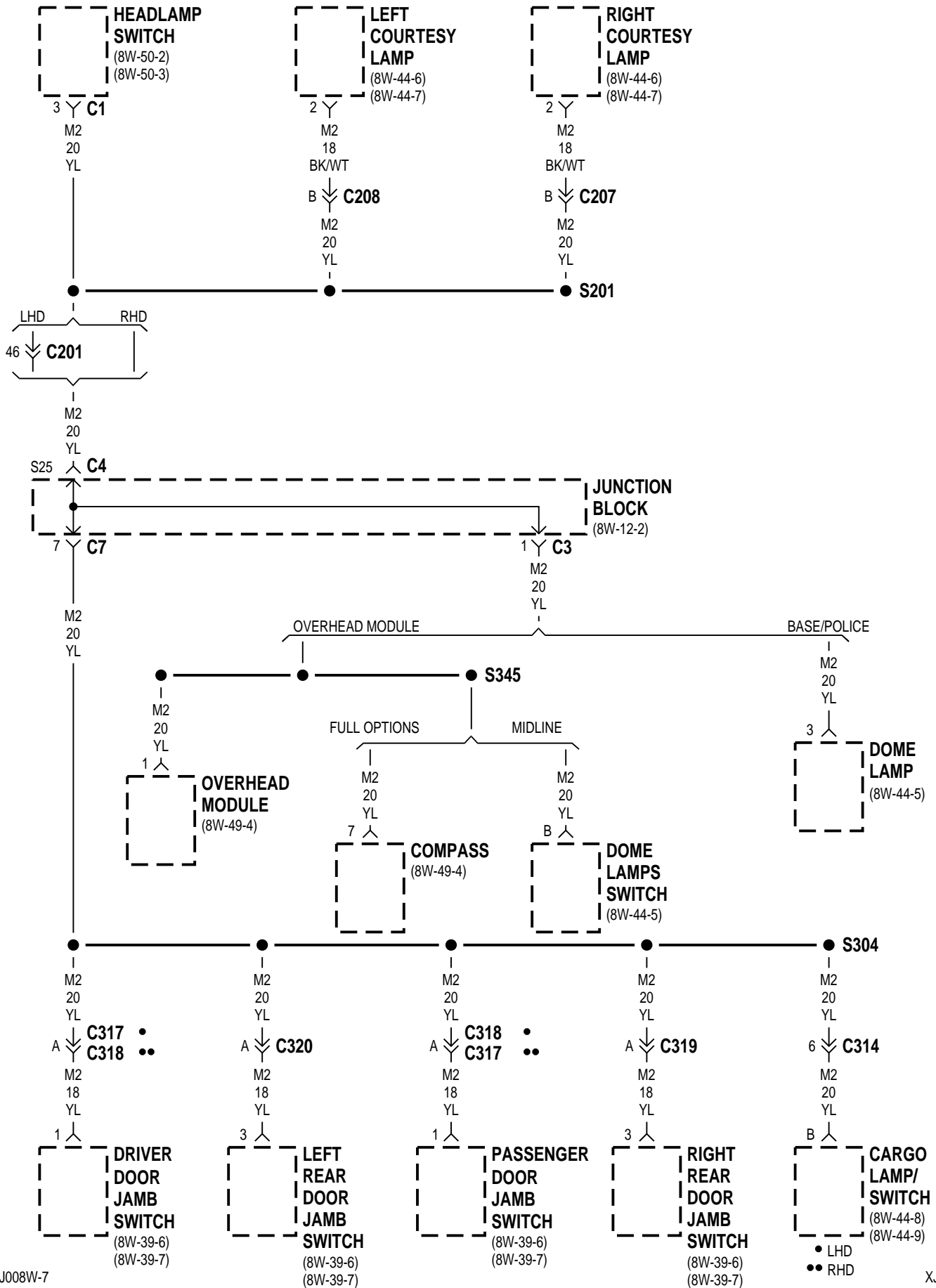

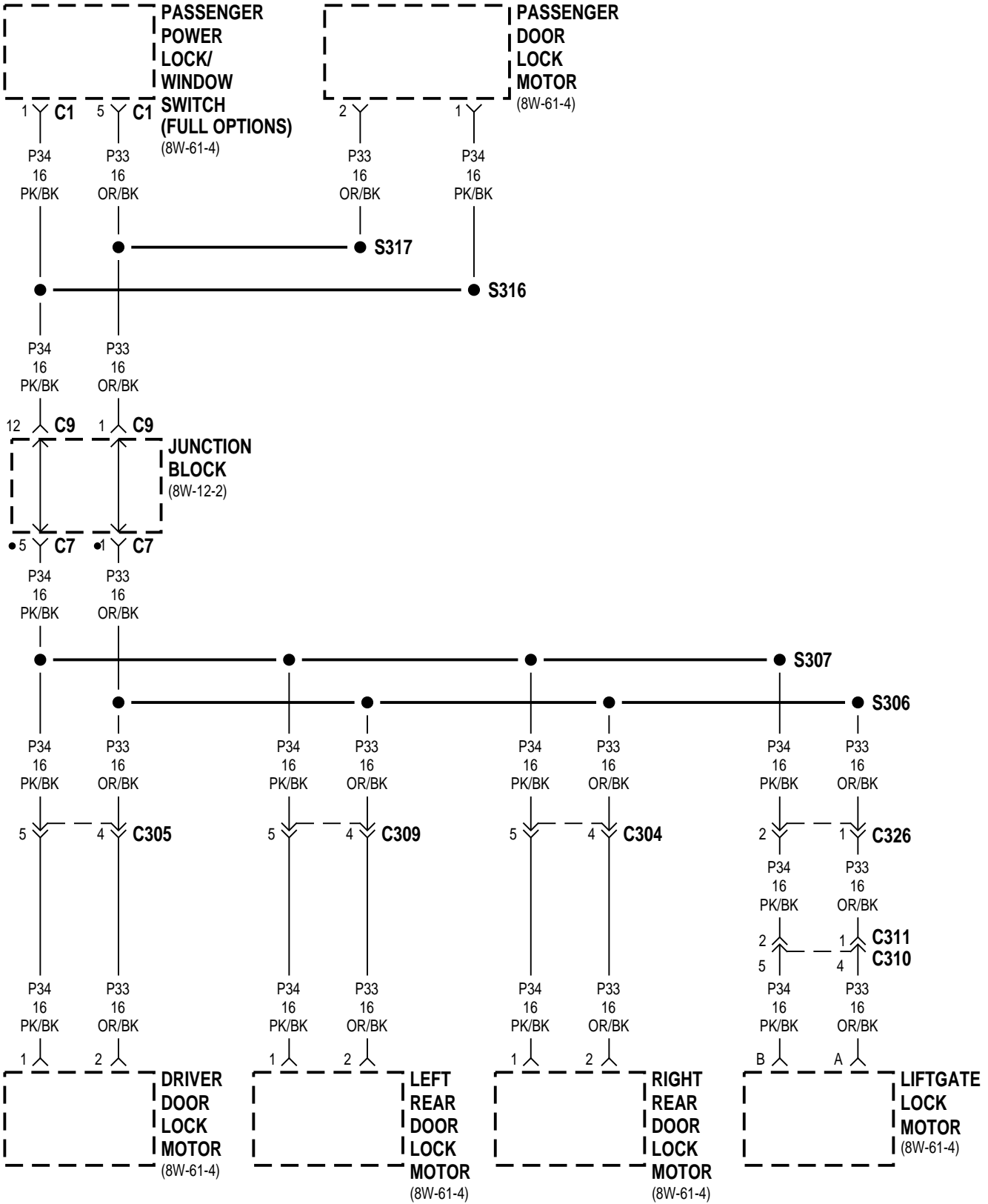

● FULL OPTIONS

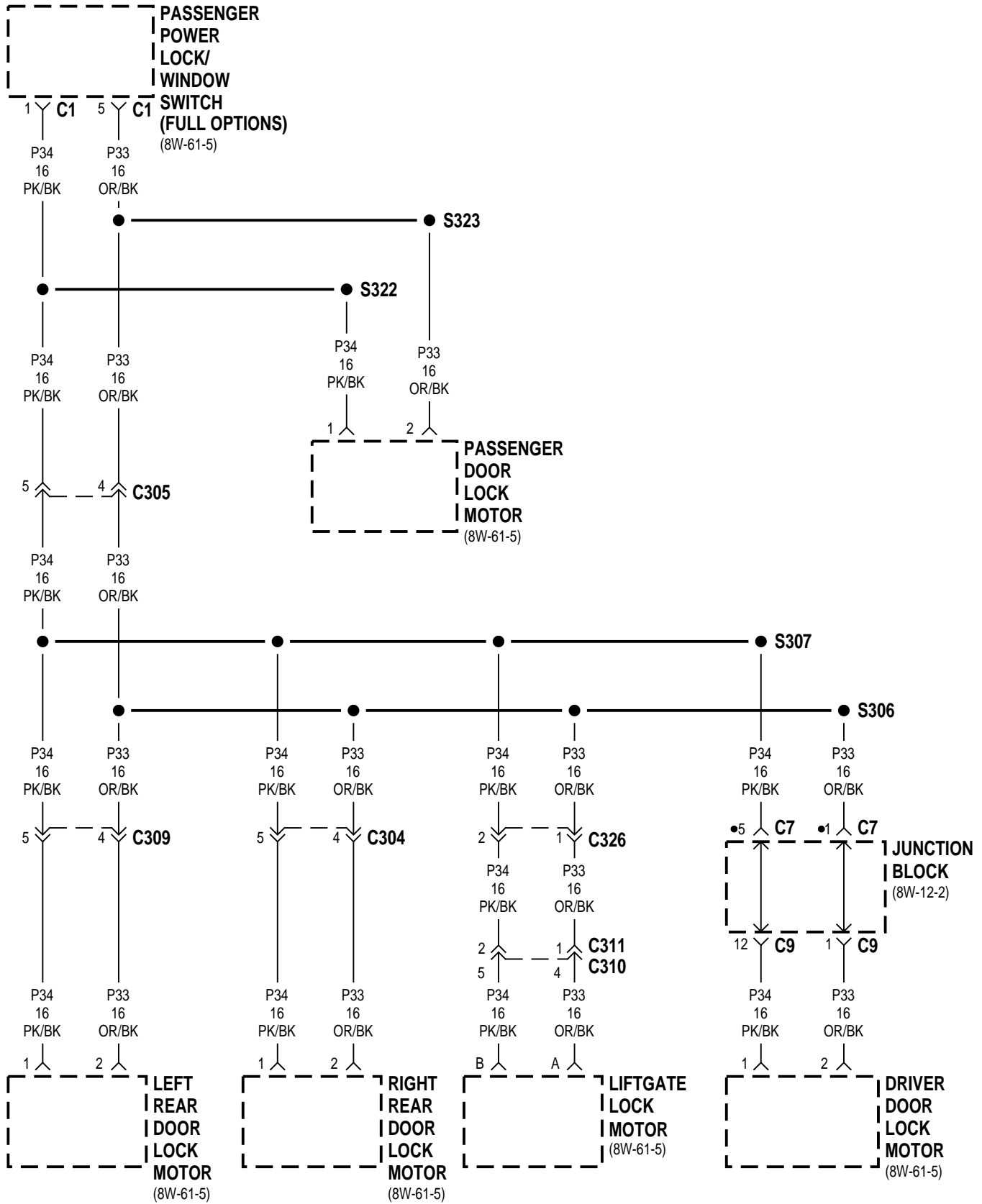

• FULL OPTIONS

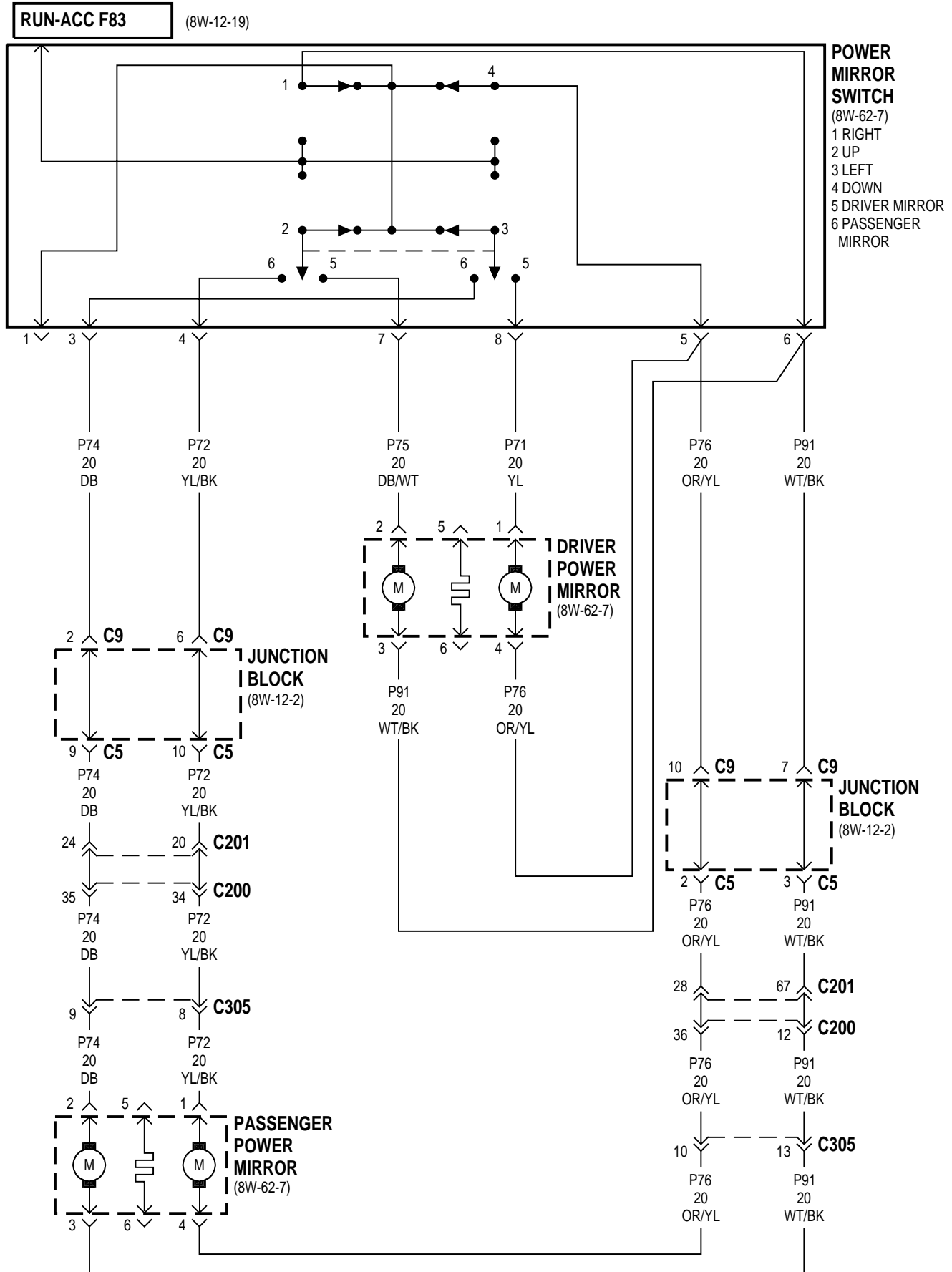

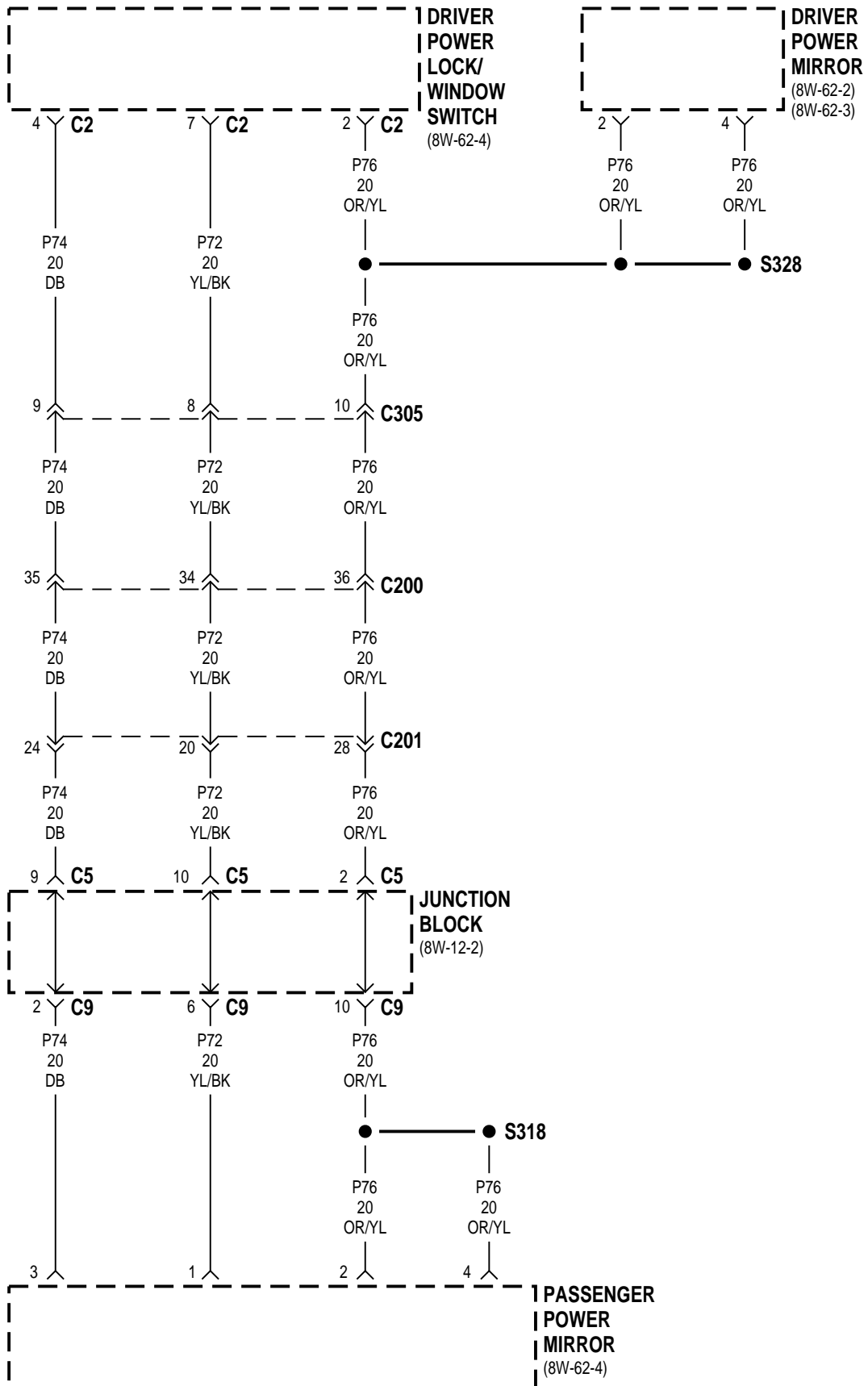

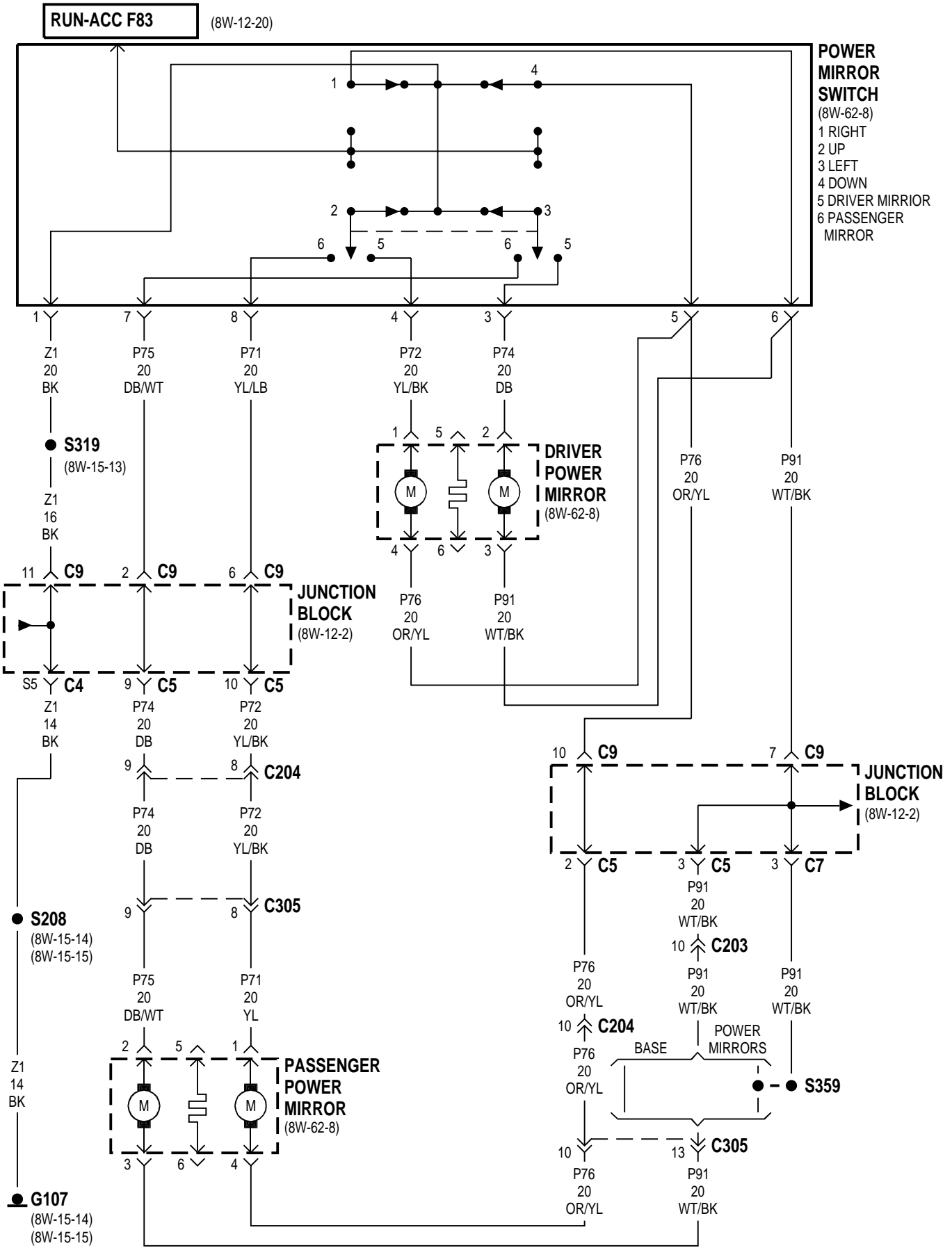

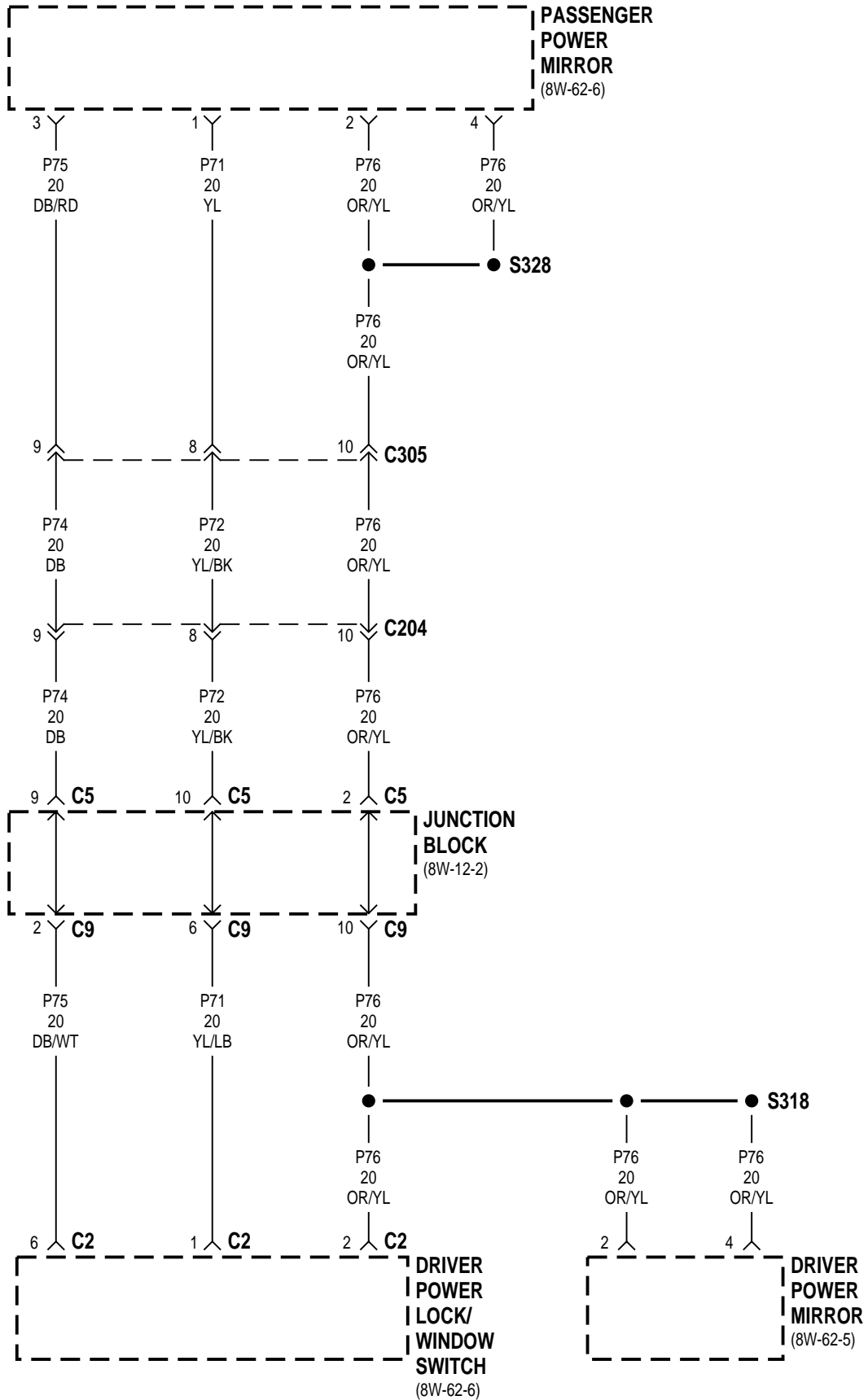

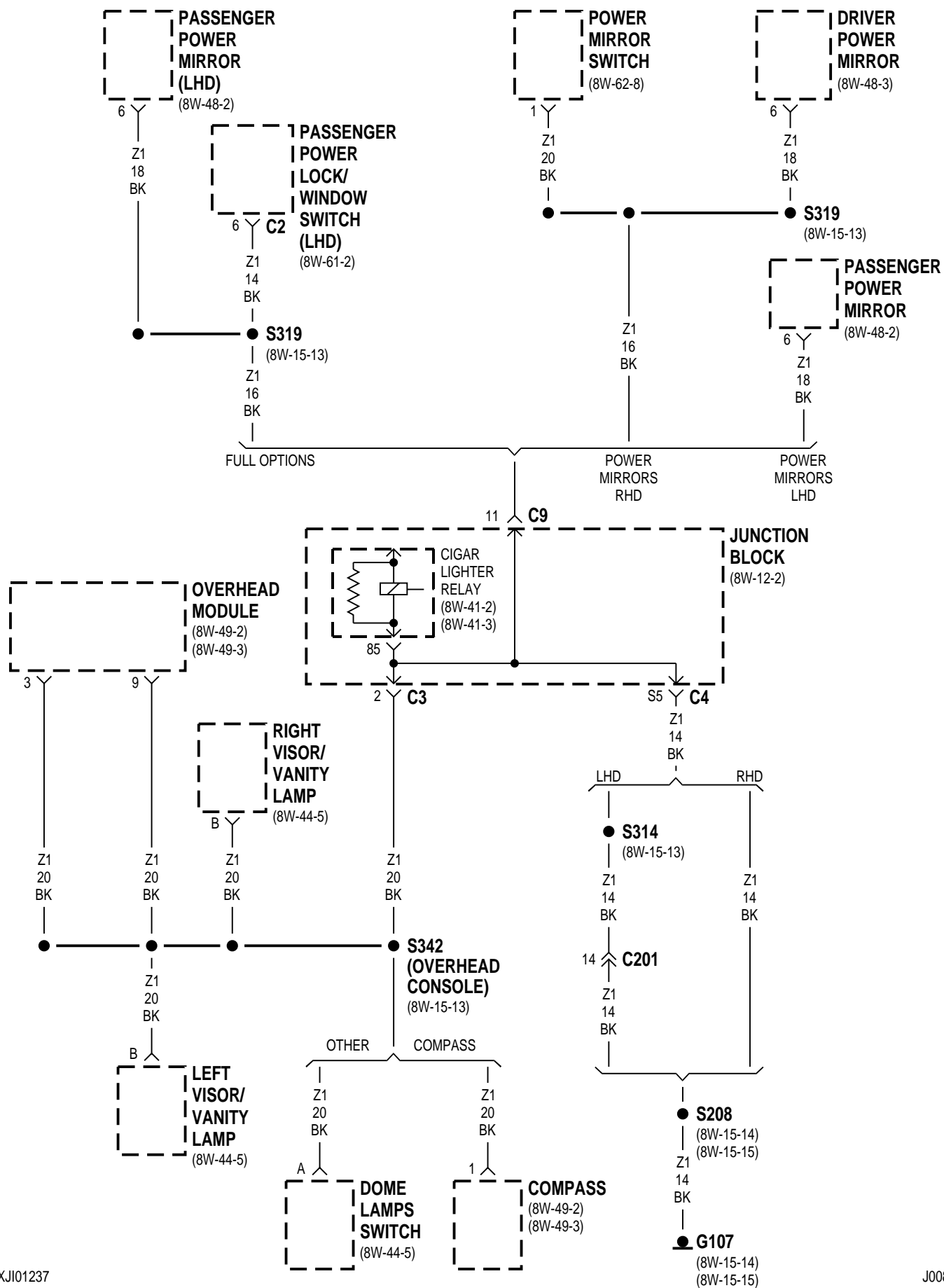

8W-15 GROUND DISTRIBUTION

| Component | Page | Component | Page |
|--|--------------------------|---|-------------------------|
| A/C Compressor Clutch | 8W-15-11 | Left License Lamp | 8W-15-21 |
| A/C High Pressure Switch | 8W-15-11 | Left Power Seat Switch | 8W-15-22 |
| A/C Low Pressure Switch | 8W-15-11 | Left Rear Door Jamb Switch | 8W-15-17, 18 |
| A/C- Heater Control | 8W-15-14, 15, 16 | Left Rear Fog Lamp | 8W-15-17, 18 |
| Airbag Control Module | 8W-15-17, 18 | Left Repeater Lamp | 8W-15-10, 12 |
| Battery | 8W-15-2, 3 | Left Tail/Stop Lamp | 8W-15-17, 18 |
| Blend Door Actuator | 8W-15-14, 15 | Left Turn Signal Lamp | 8W-15-17, 18 |
| Blower Motor Relay | 8W-15-16 | Left Visor/Vanity Lamp | 8W-15-13 |
| Brake Lamp Switch | 8W-15-16 | License Lamp | 8W-15-21 |
| Center High Mounted Stop Lamp | 8W-15-21 | Liftgate Switch | 8W-15-21 |
| Cigar Lighter | 8W-15-14, 15 | Overhead Module | 8W-15-13 |
| Cigar Lighter Relay | 8W-15-13 | Oxygen Sensor 1/1 Upstream | 8W-15-2 |
| Combination Flasher | 8W-15-14, 15 | Oxygen Sensor 1/2 Downstream | 8W-15-2 |
| Compass | 8W-15-13, 16 | Oxygen Sensor 2/1 Upstream | 8W-15-2 |
| Controller Anti-Lock Brake | 8W-15-2, 3 | Oxygen Sensor 2/2 Downstream | 8W-15-2 |
| Controller Anti-Lock Brake Relay | 8W-15-5, 6, 8, 9, 11 | Passenger Door Jamb Switch | 8W-15-18, 19 |
| Data Link Connector | 8W-15-2, 3 | Passenger Power Lock/Window Switch | 8W-15-13, 18 |
| Daytime Running Lamp Module | 8W-15-7 | Passenger Power Mirror | 8W-15-13, 18 |
| Dome Lamps Switch | 8W-15-13 | Power Amplifier | 8W-15-17, 18 |
| Driver Door Jamb Switch | 8W-15-17, 20 | Power Antenna Relay | 8W-15-15 |
| Driver Power Lock/Window Switch | 8W-15-17, 20 | Power Mirror Switch | 8W-15-13, 17 |
| Driver Power Mirror | 8W-15-13, 17, 20 | Power Outlet | 8W-15-14, 15 |
| Electronic Vacuum Modulator | 8W-15-11 | Power Steering Pressure Switch | 8W-15-2 |
| Engine Control Module | 8W-15-3 | Powertrain Control Module | 8W-15-2, 3, 5, 9 |
| Engine Starter Motor Relay | 8W-15-2, 5, 9, 11 | PRNDL Illumination | 8W-15-13, 18 |
| Extended Idle Switch | 8W-15-14 | Radiator Fan Motor | 8W-15-7, 10, 12 |
| Fog Lamp Relay | 8W-15-11 | Radio | 8W-15-16 |
| Fog Lamp Relay No. 1 | 8W-15-4, 5, 6, 8, 9, 10 | Rear Fog Lamp Relay | 8W-15-15 |
| Fog Lamp Relay No. 2 | 8W-15-4, 5, 6, 8, 9 | Rear Fog Lamp Switch | 8W-15-15 |
| Front Fog Lamp Switch | 8W-15-14, 15 | Rear Washer Pump | 8W-15-4, 5, 6, 8, 9, 11 |
| Front Wiper Motor | 8W-15-5, 6, 7, 8, 10, 11 | Rear Window Defogger | 8W-15-21 |
| Fuel Heater | 8W-15-12 | Rear Window Defogger Switch | 8W-15-14, 15 |
| Fuel Heater Relay | 8W-15-11 | Rear Wiper Motor | 8W-15-21 |
| Fuel Pump Module | 8W-15-17, 18 | Rear Wiper/Washer Switch | 8W-15-14, 15 |
| G100 | 8W-15-2 | Right Back-Up Lamp | 8W-15-19, 20 |
| G101 | 8W-15-2 | Right City Lamp | 8W-15-10, 12 |
| G102 | 8W-15-2, 3 | Right Fog Lamp | 8W-15-7, 10, 12 |
| G104 | 8W-15-3 | Right Front Park/Turn Signal Lamp No. 1 | 8W-15-7 |
| G105 | 8W-15-3 | Right Front Park/Turn Signal Lamp No. 2 | 8W-15-7 |
| G106 | 8W-15-7, 10, 12 | Right Front Turn Signal Lamp No. 1 | 8W-15-10, 12 |
| G107 | 8W-15-14, 15 | Right Front Turn Signal Lamp No. 2 | 8W-15-10, 12 |
| G108 | 8W-15-16 | Right Headlamp | 8W-15-7, 10, 12 |
| G200 | 8W-15-17 | Right Headlamp Leveling Motor | 8W-15-10, 12 |
| G300 | 8W-15-18 | Right Heated Seat Back | 8W-15-22 |
| G301 | 8W-15-17, 18 | Right Heated Seat Switch | 8W-15-22 |
| G302 | 8W-15-17, 18 | Right License Lamp | 8W-15-21 |
| G303 | 8W-15-19, 20 | Right Power Seat Switch | 8W-15-22 |
| G304 | 8W-15-21 | Right Rear Door Jamb Switch | 8W-15-19, 20 |
| G306 | 8W-15-22 | Right Rear Fog Lamp | 8W-15-19, 20 |
| Headlamp Delay Module | 8W-15-16 | Right Repeater Lamp | 8W-15-10, 12 |
| Headlamp Leveling Switch | 8W-15-15 | Right Tail/Stop Lamp | 8W-15-19, 20 |
| Headlamp Switch | 8W-15-16 | Right Turn Signal Lamp | 8W-15-19, 20 |
| Heated Seat Relay | 8W-15-22 | Right Visor/Vanity Lamp | 8W-15-13 |
| Heater Control | 8W-15-16 | Seat Belt Switch | 8W-15-13, 18 |
| Ignition Switch | 8W-15-16 | Seat Heat Interface Module | 8W-15-22 |
| Instrument Cluster | 8W-15-16 | Sentry Key Immobilizer Module | 8W-15-16 |
| Junction Block | 8W-15-13, 14, 15 | Trailer Tow Connector | 8W-15-17, 18 |
| Left Back-Up Lamp | 8W-15-17, 18 | Transfer Case Switch | 8W-15-2, 11 |
| Left City Lamp | 8W-15-10, 12 | Transfer Case Switch Illumination | 8W-15-13, 18 |
| Left Fog Lamp | 8W-15-7, 10, 12 | Transmission Control Module | 8W-15-2 |
| Left Front Park/Turn Signal Lamp No. 1 | 8W-15-7 | Transmission Range Sensor | 8W-15-5, 6, 8 |
| Left Front Park/Turn Signal Lamp No. 2 | 8W-15-7 | Underhood Lamp/Mercury Switch | 8W-15-4, 5, 6, 8, 9, 11 |
| Left Front Turn Signal Lamp No. 1 | 8W-15-10, 12 | Vehicle Speed Control Servo | 8W-15-4, 5, 6, 8, 9 |
| Left Front Turn Signal Lamp No. 2 | 8W-15-10, 12 | Washer Fluid Level Switch | 8W-15-11 |
| Left Headlamp | 8W-15-7, 10, 12 | Washer Fluid Level Switch | 8W-15-4, 5, 6, 8, 9 |
| Left Headlamp Leveling Motor | 8W-15-10, 12 | Windshield Washer Pump | 8W-15-4, 5, 6, 8, 9, 11 |
| Left Heated Seat Back | 8W-15-22 | Wipe/Wash Switch | 8W-15-16 |
| Left Heated Seat Switch | 8W-15-22 | | |

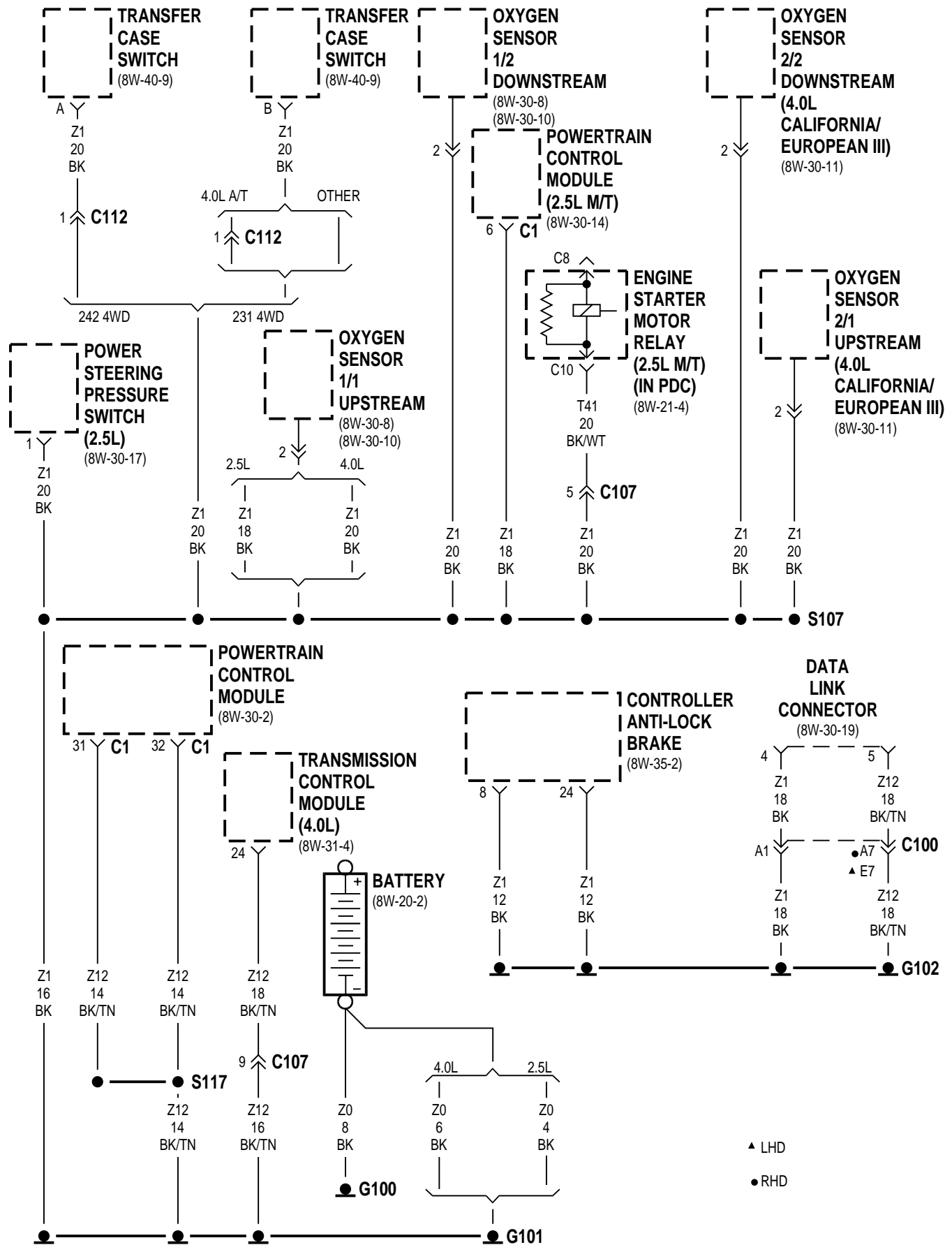

XJ ————— **8W-15 GROUND DISTRIBUTION** ————— **8W - 15 - 3**
DIESEL

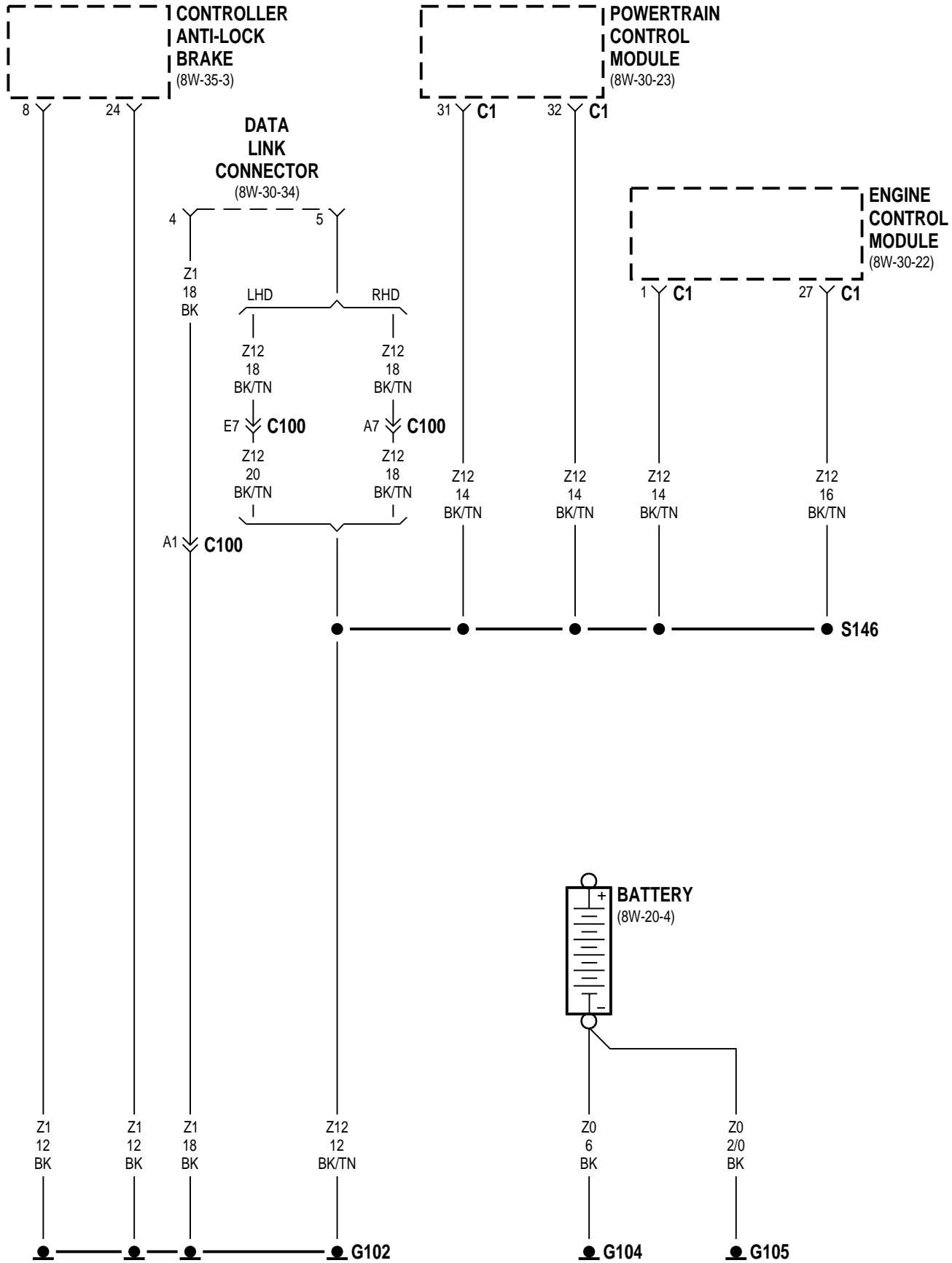

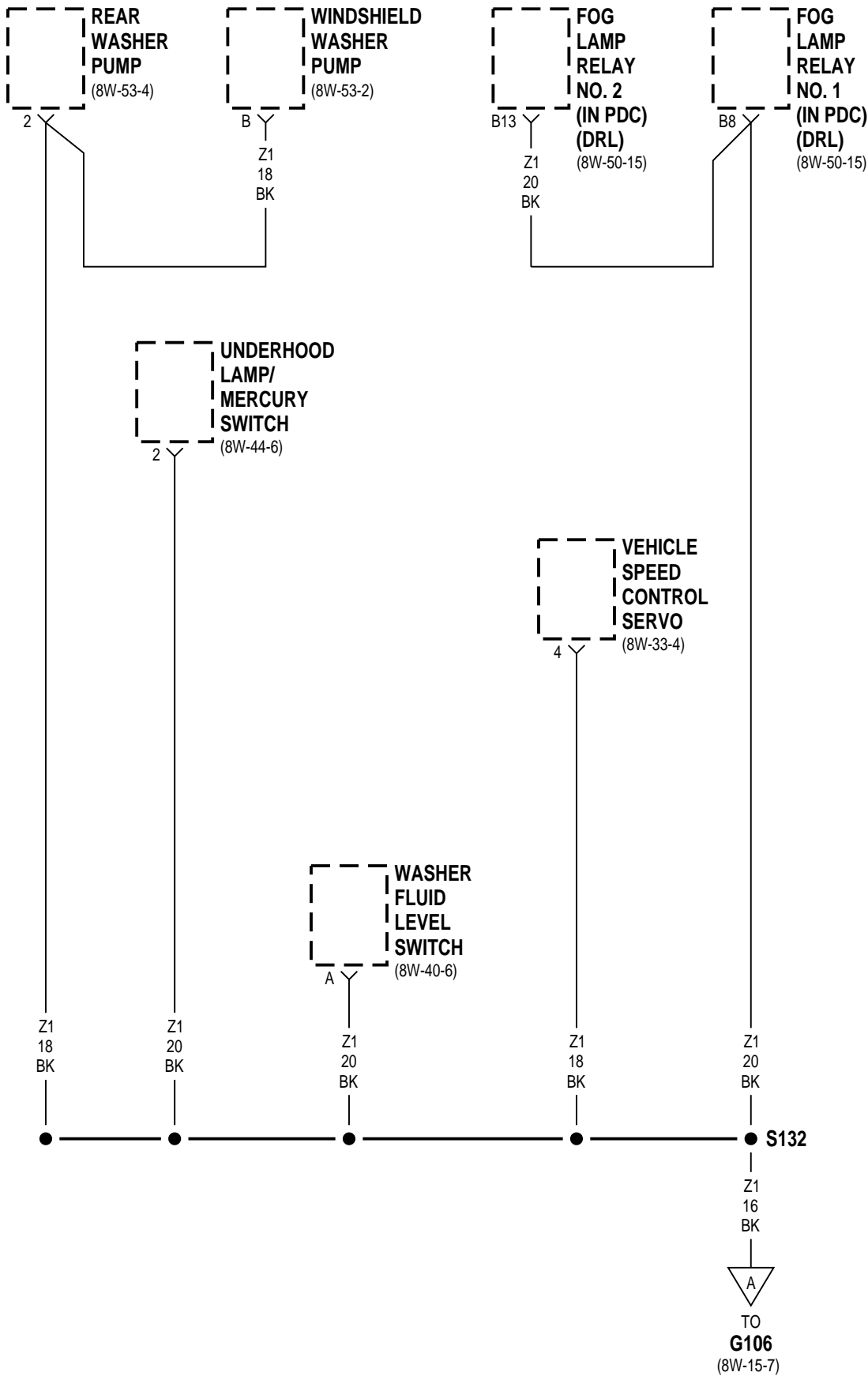

XJ **8W-15 GROUND DISTRIBUTION** **8W - 15 - 5**
LHD 4.0L EXCEPT BUILT-UP-EXPORT

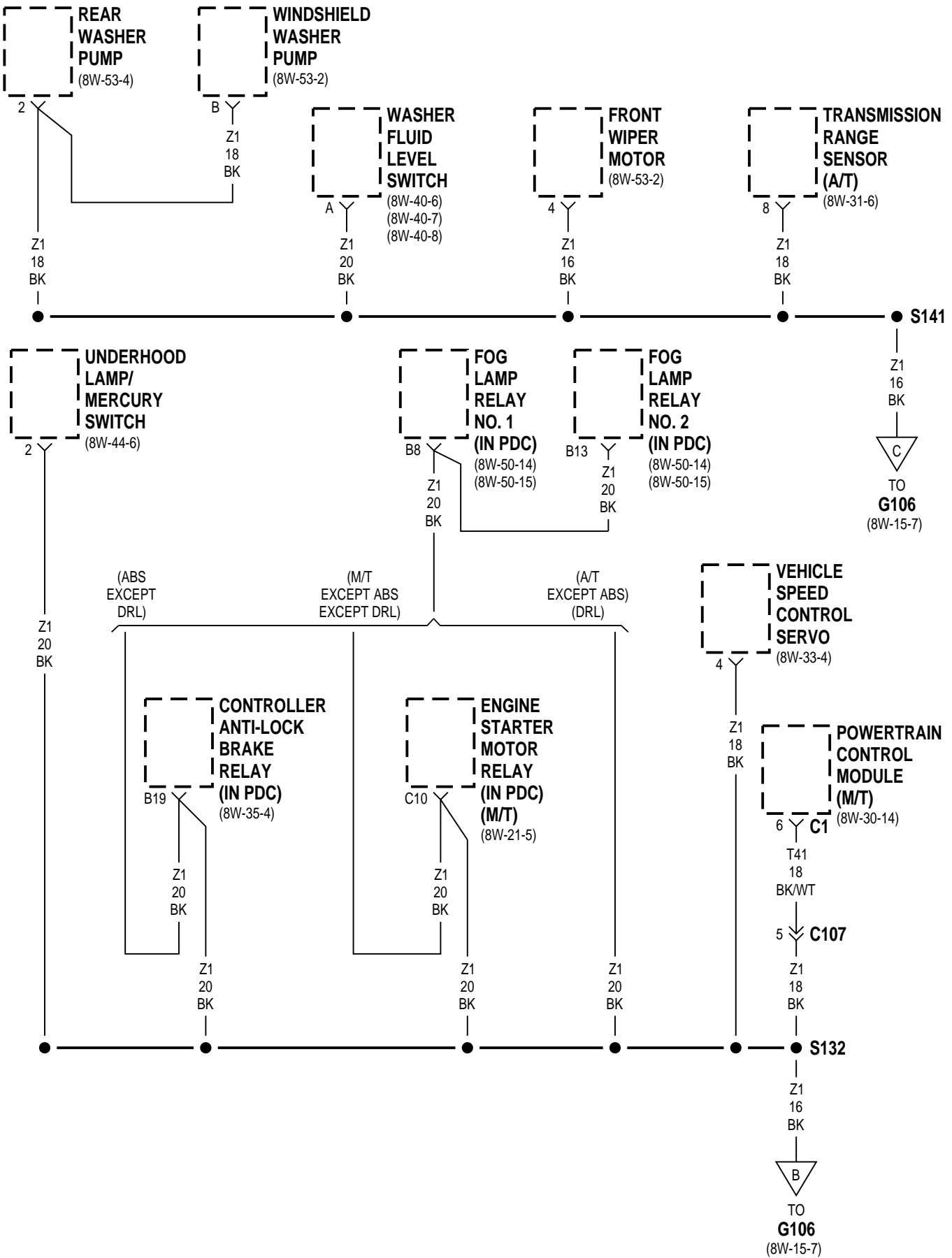

RHD GAS

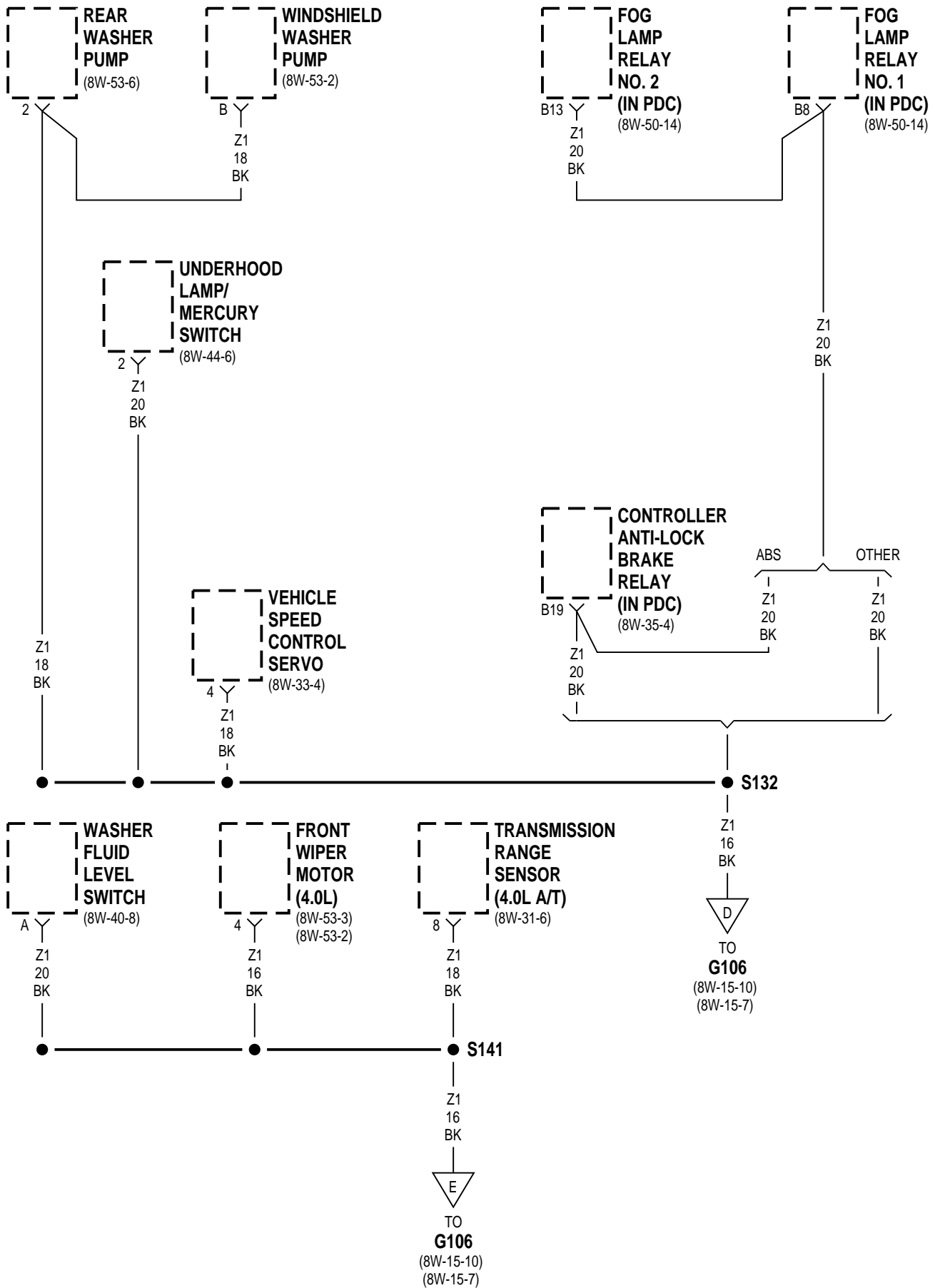

XJ ————— **8W-15 GROUND DISTRIBUTION** ————— **8W - 15 - 7**
EXCEPT BUILT-UP-EXPORT

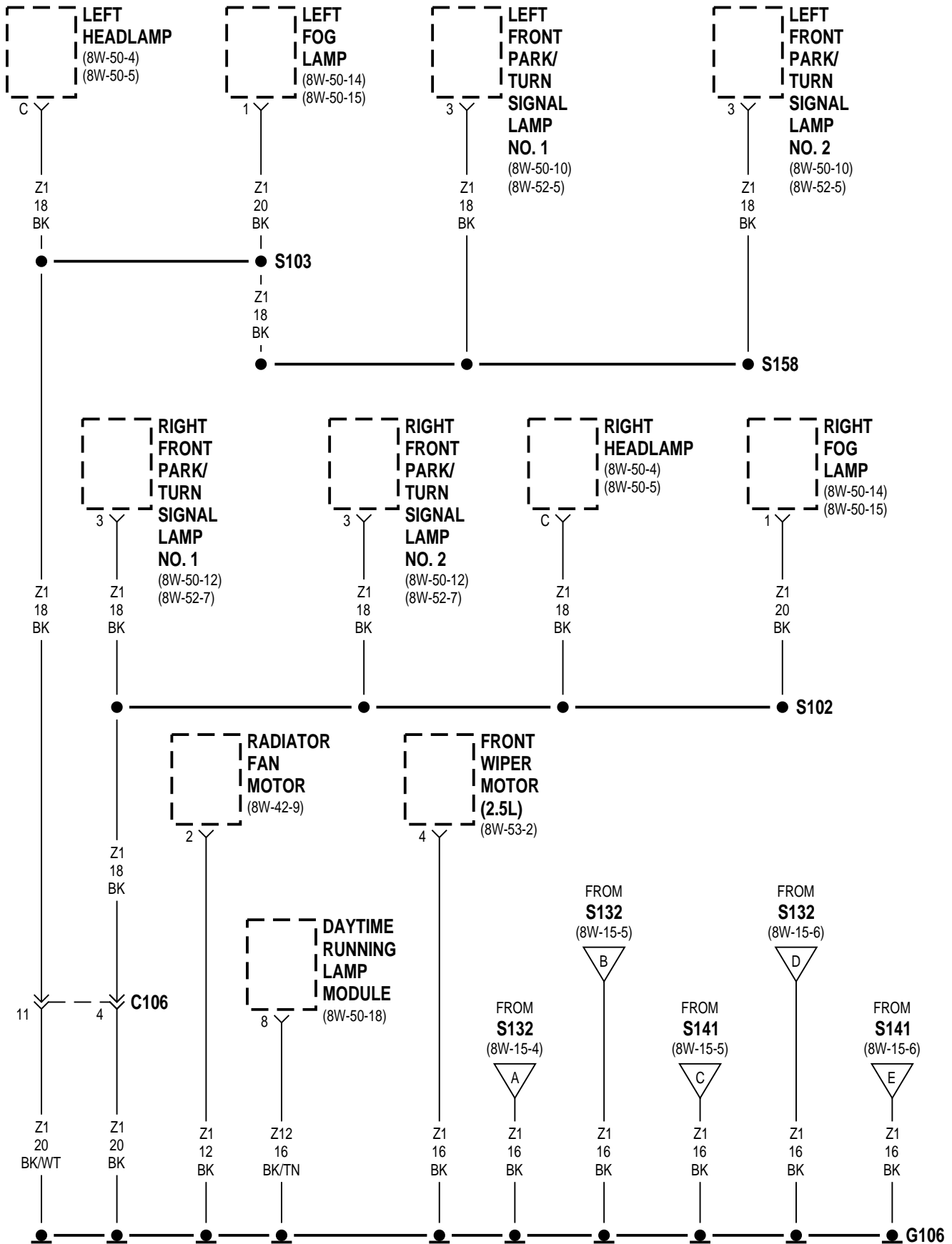

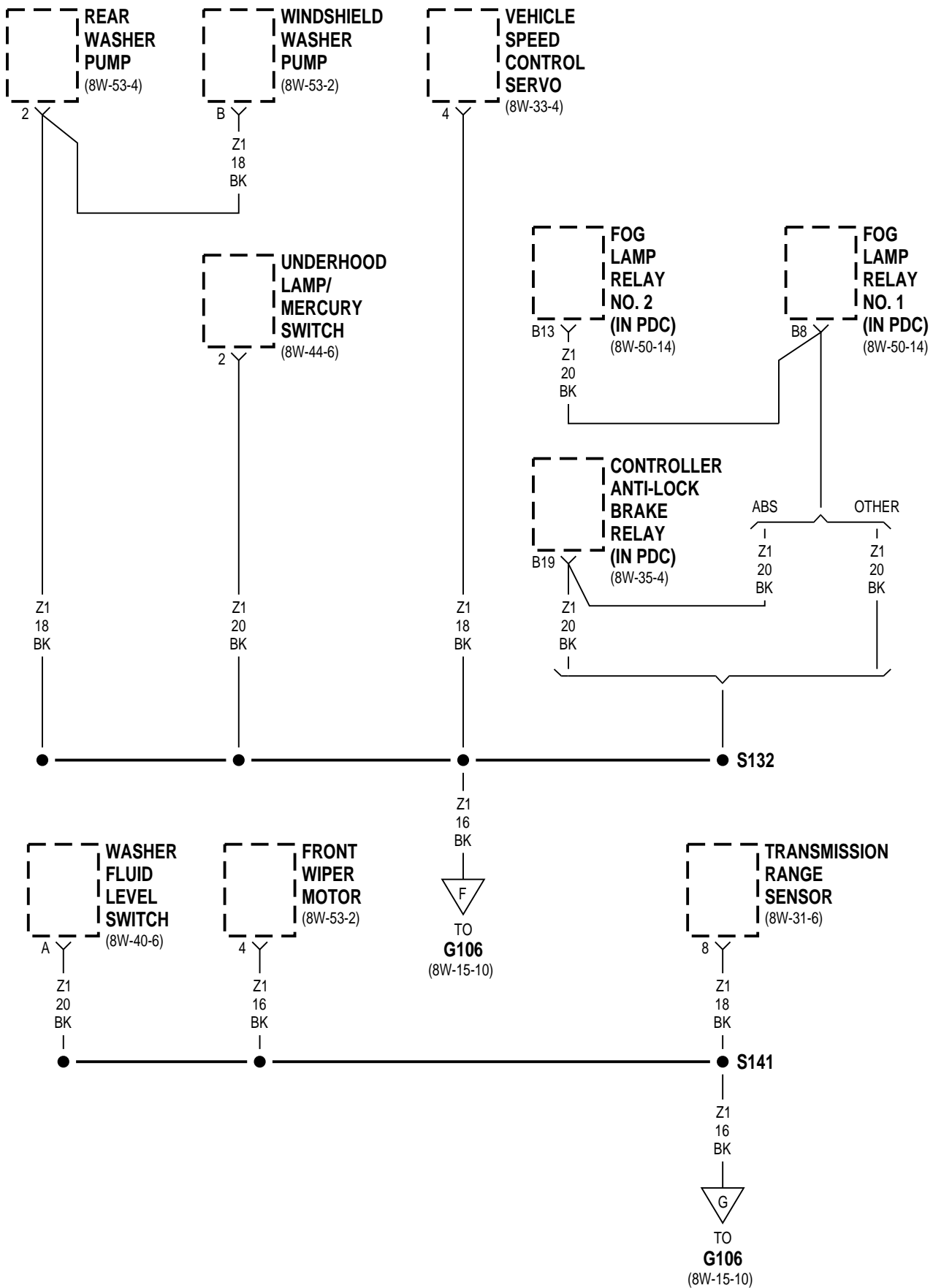

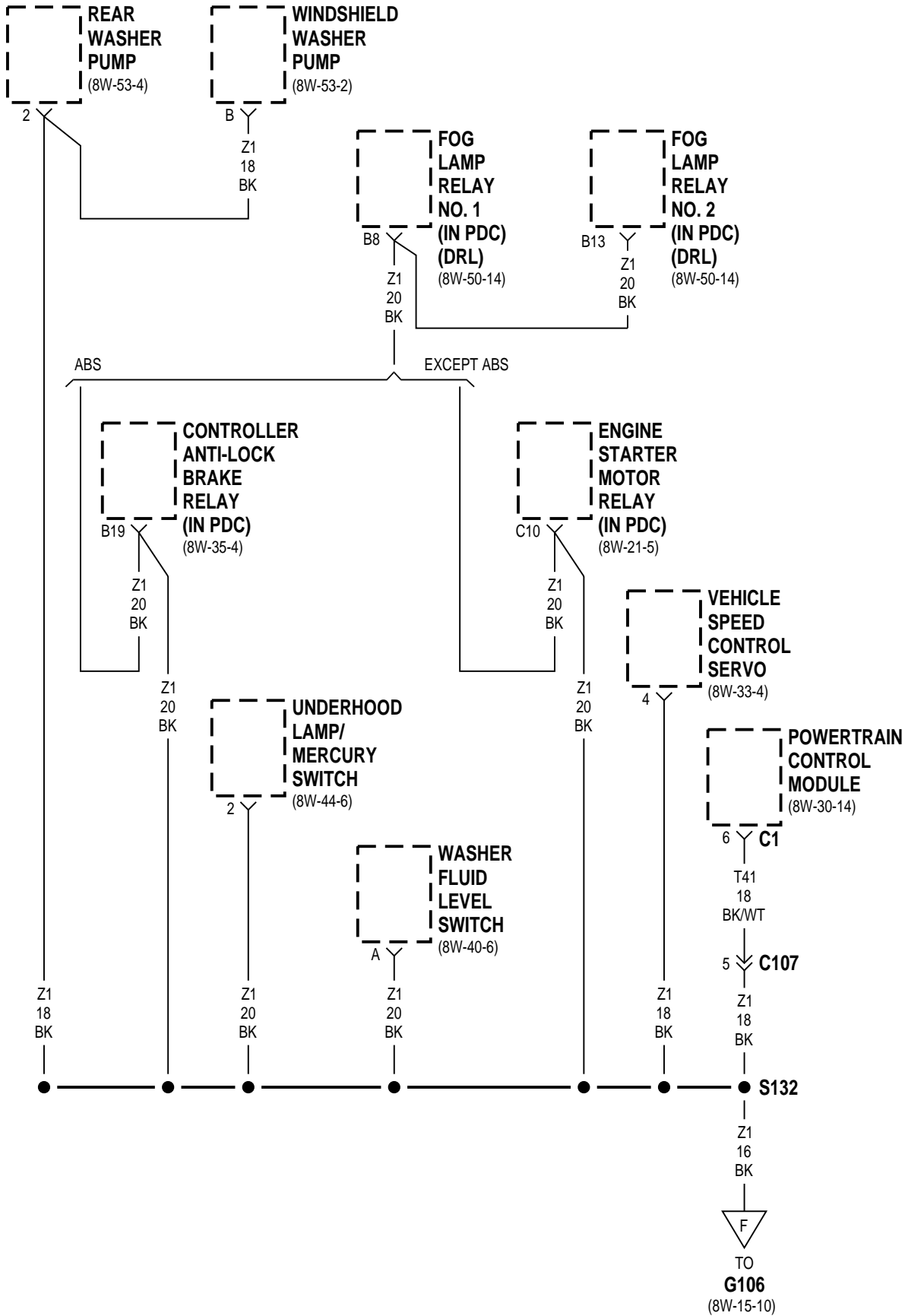

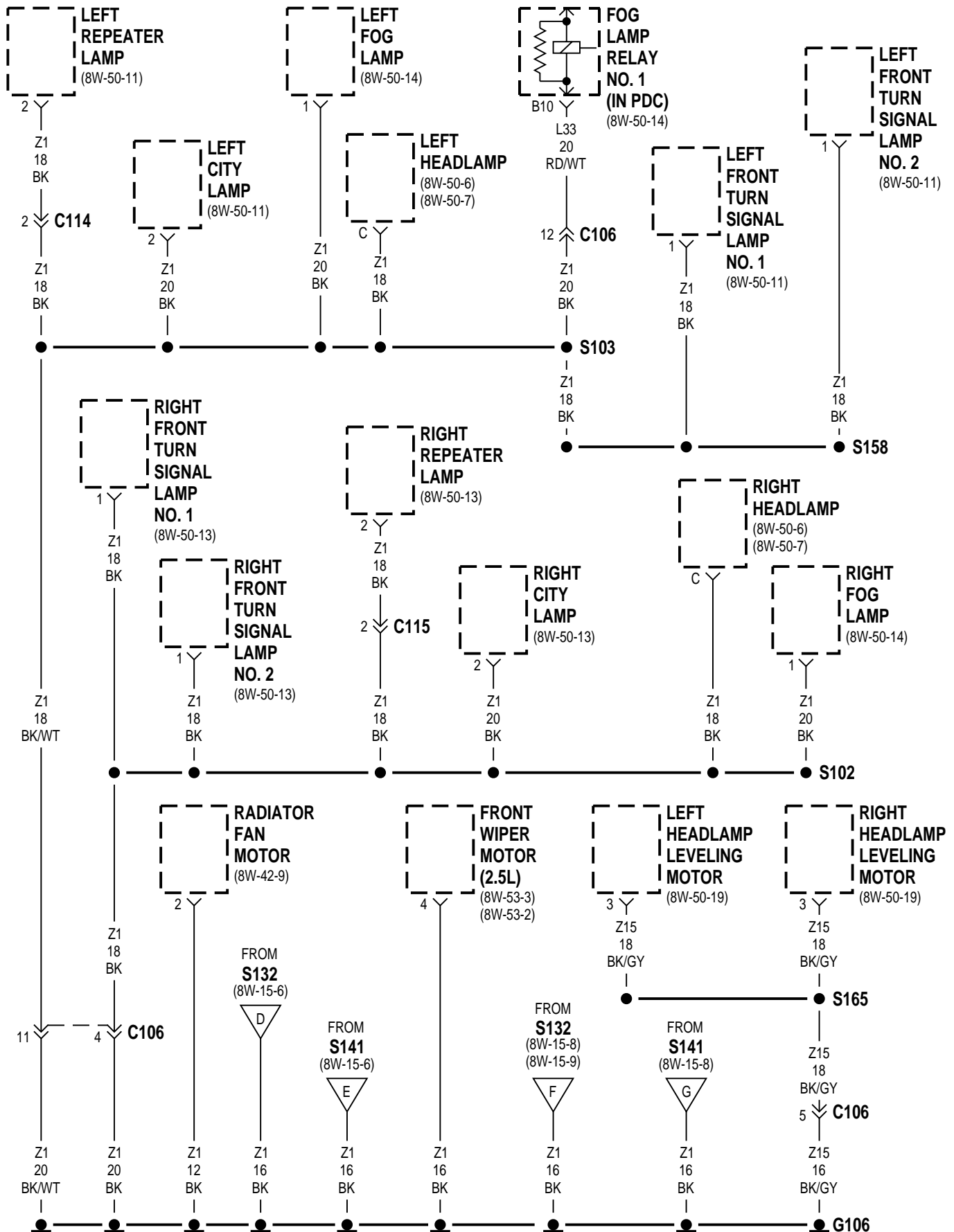

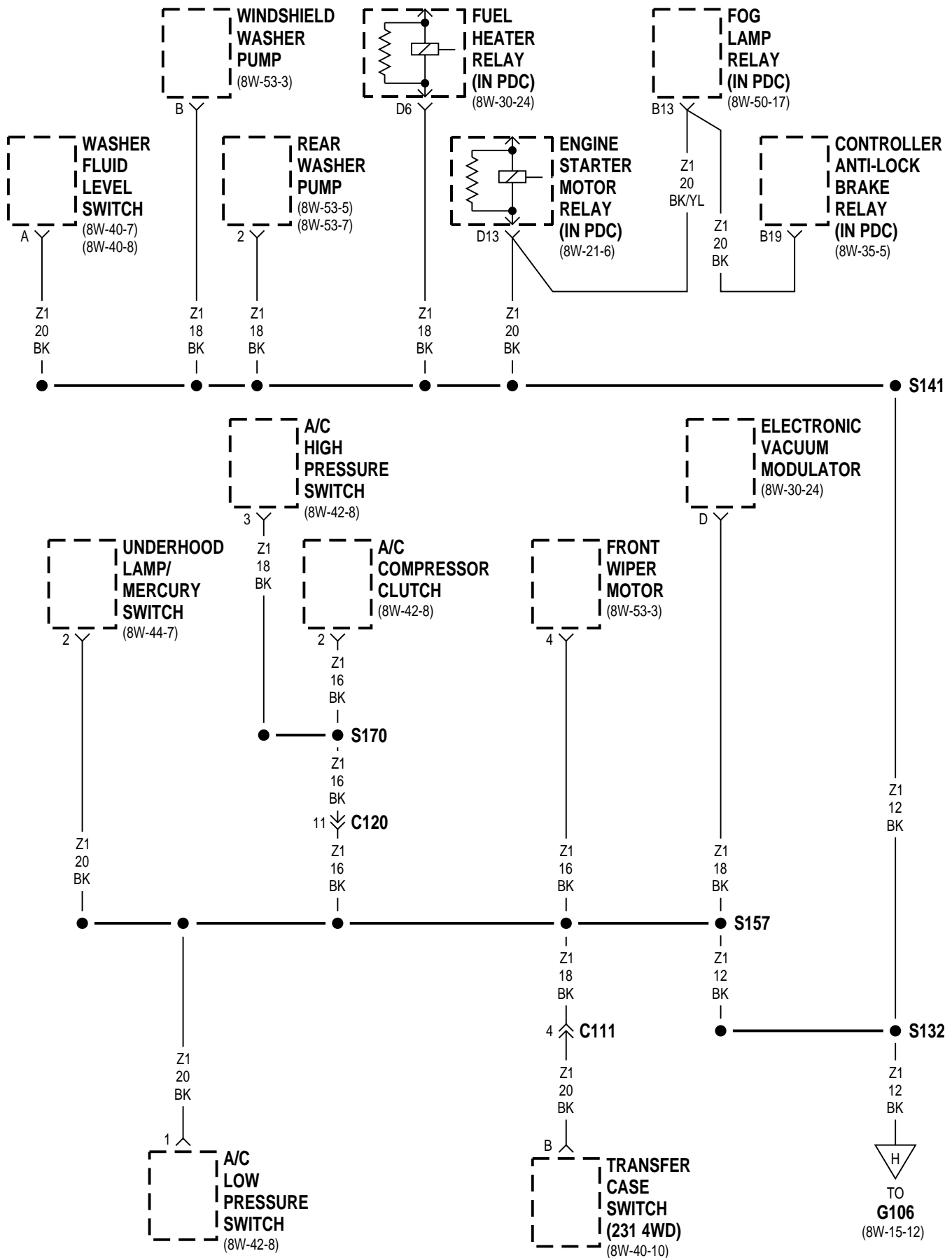

DIESEL

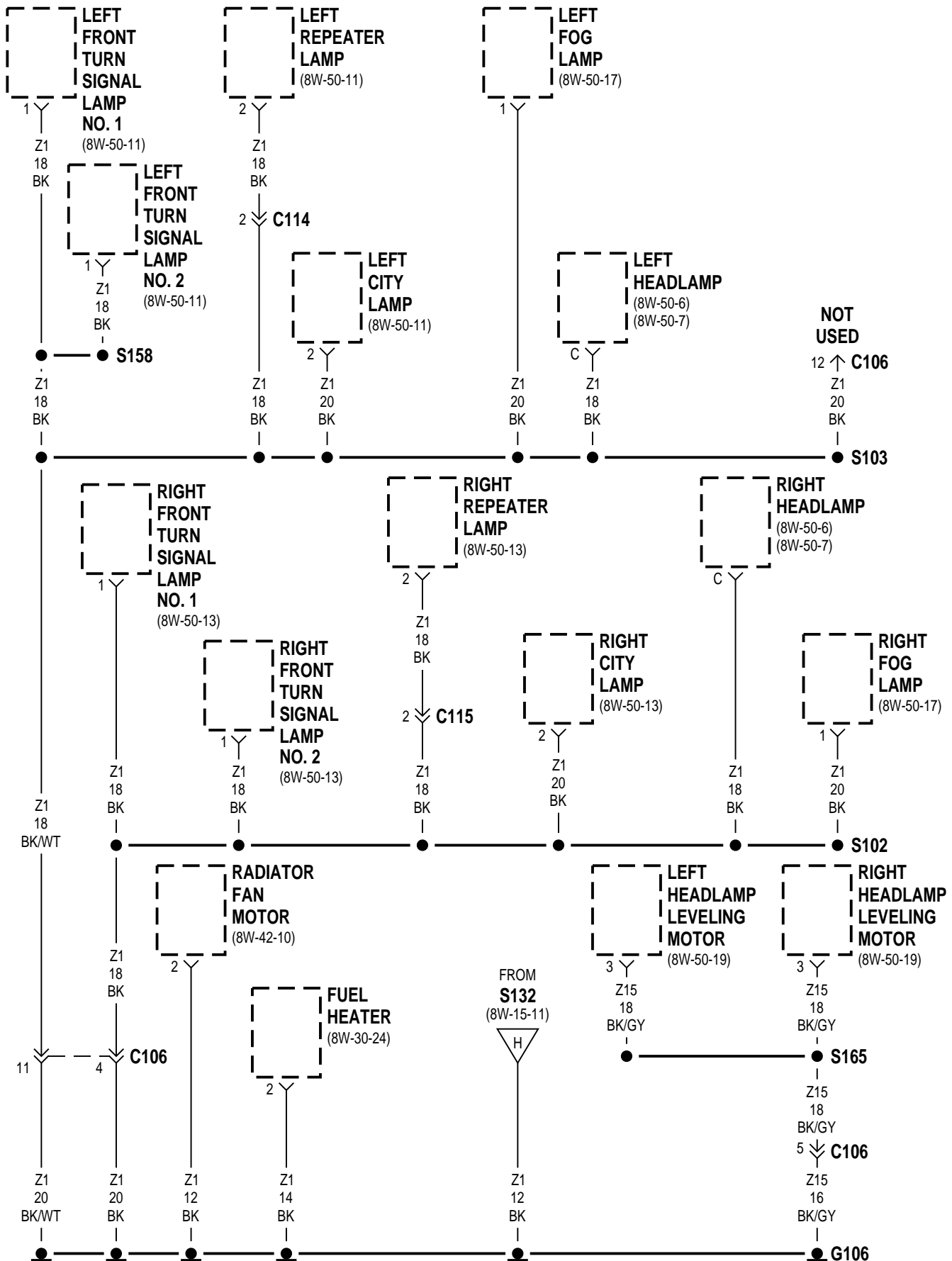

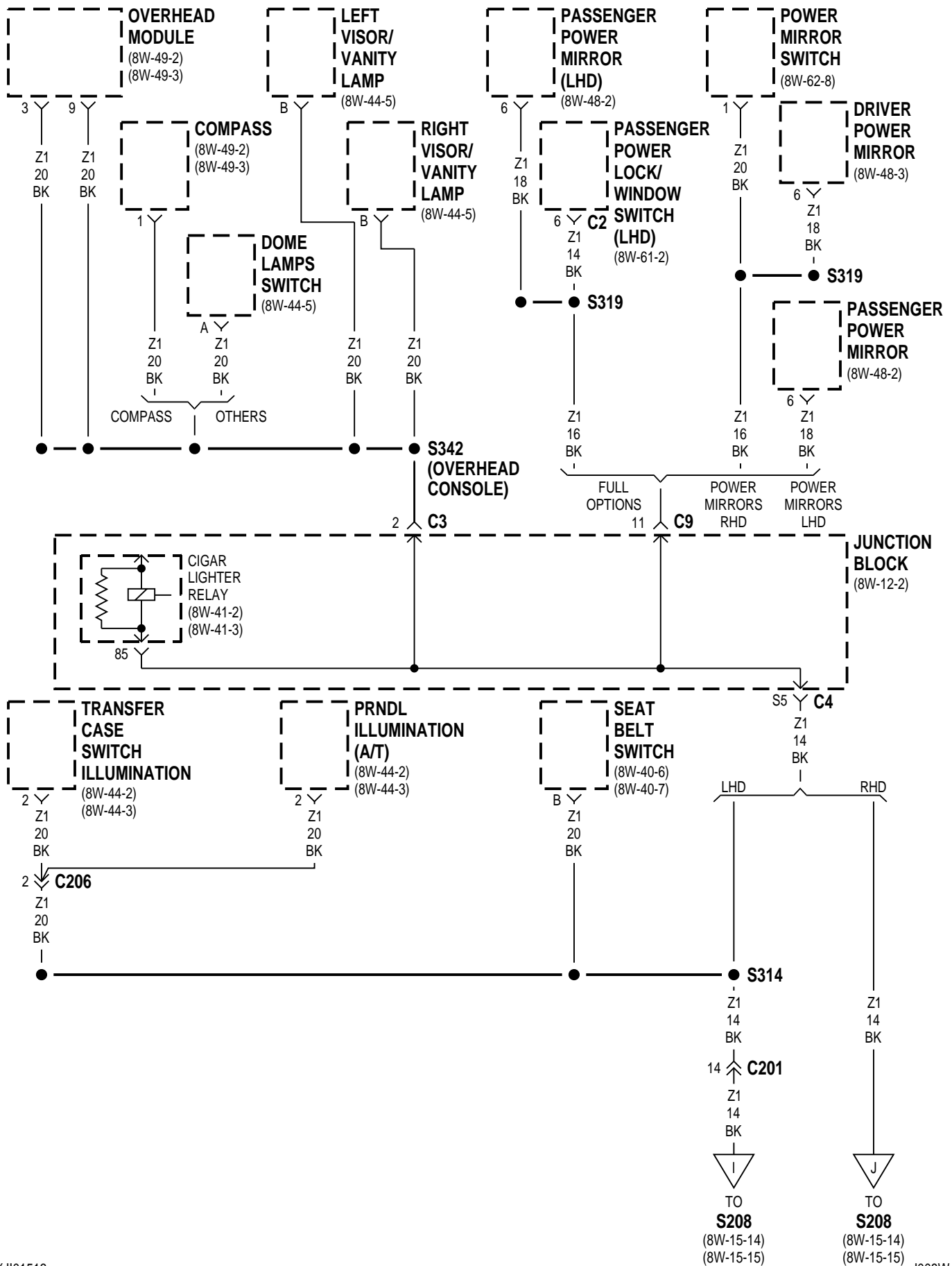

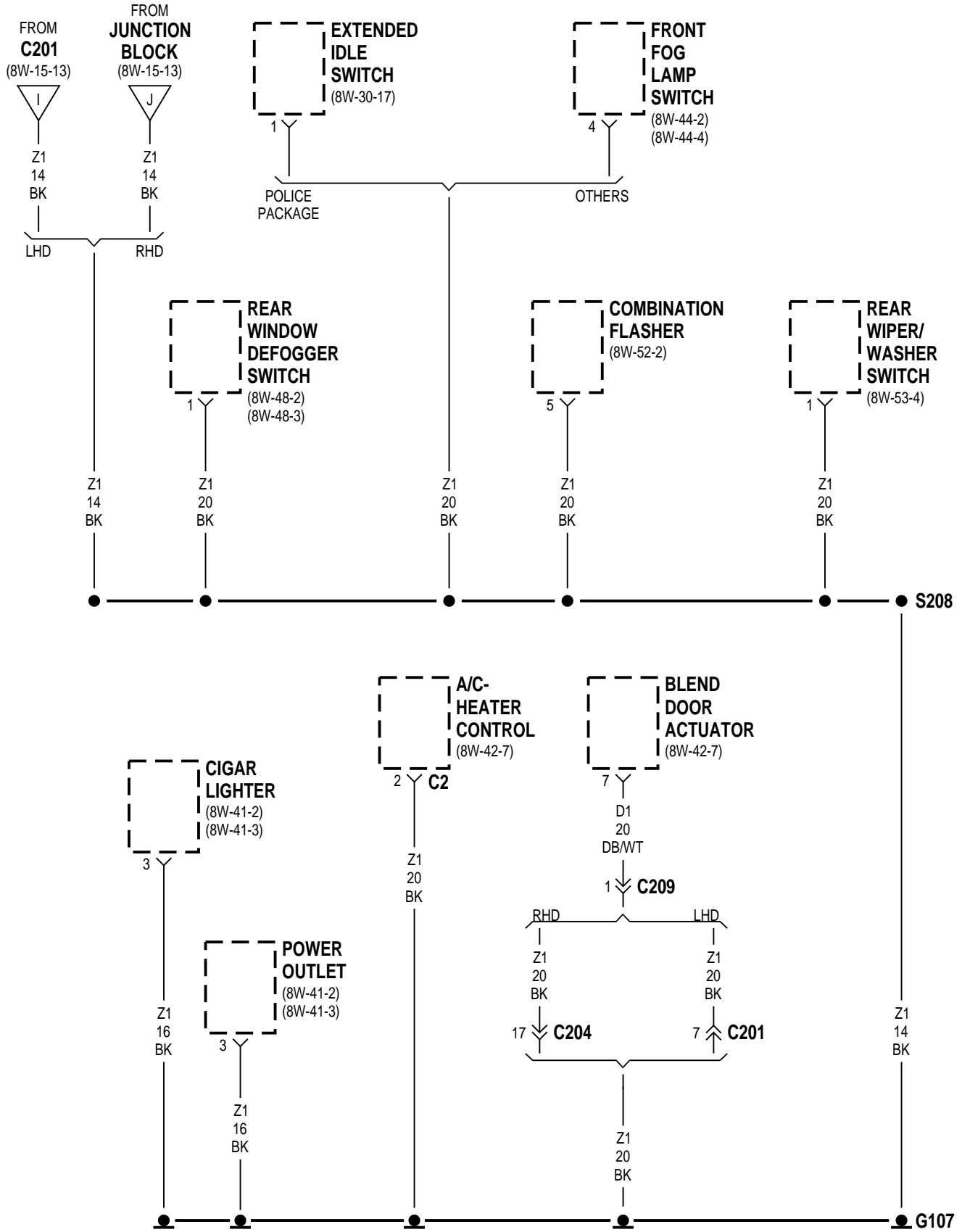

XJ **8W-15 GROUND DISTRIBUTION** **8W - 15 - 15**
BUILT-UP-EXPORT

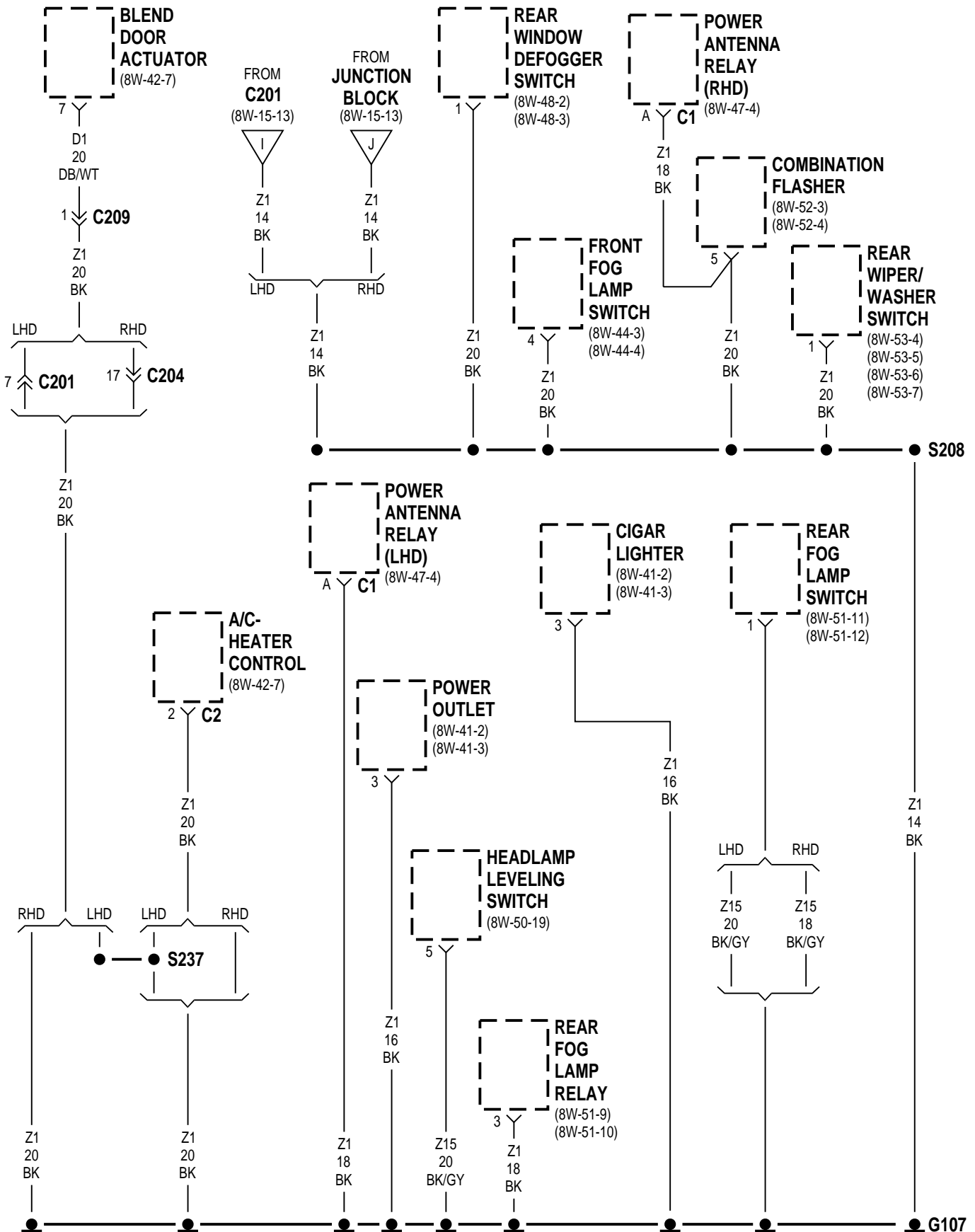

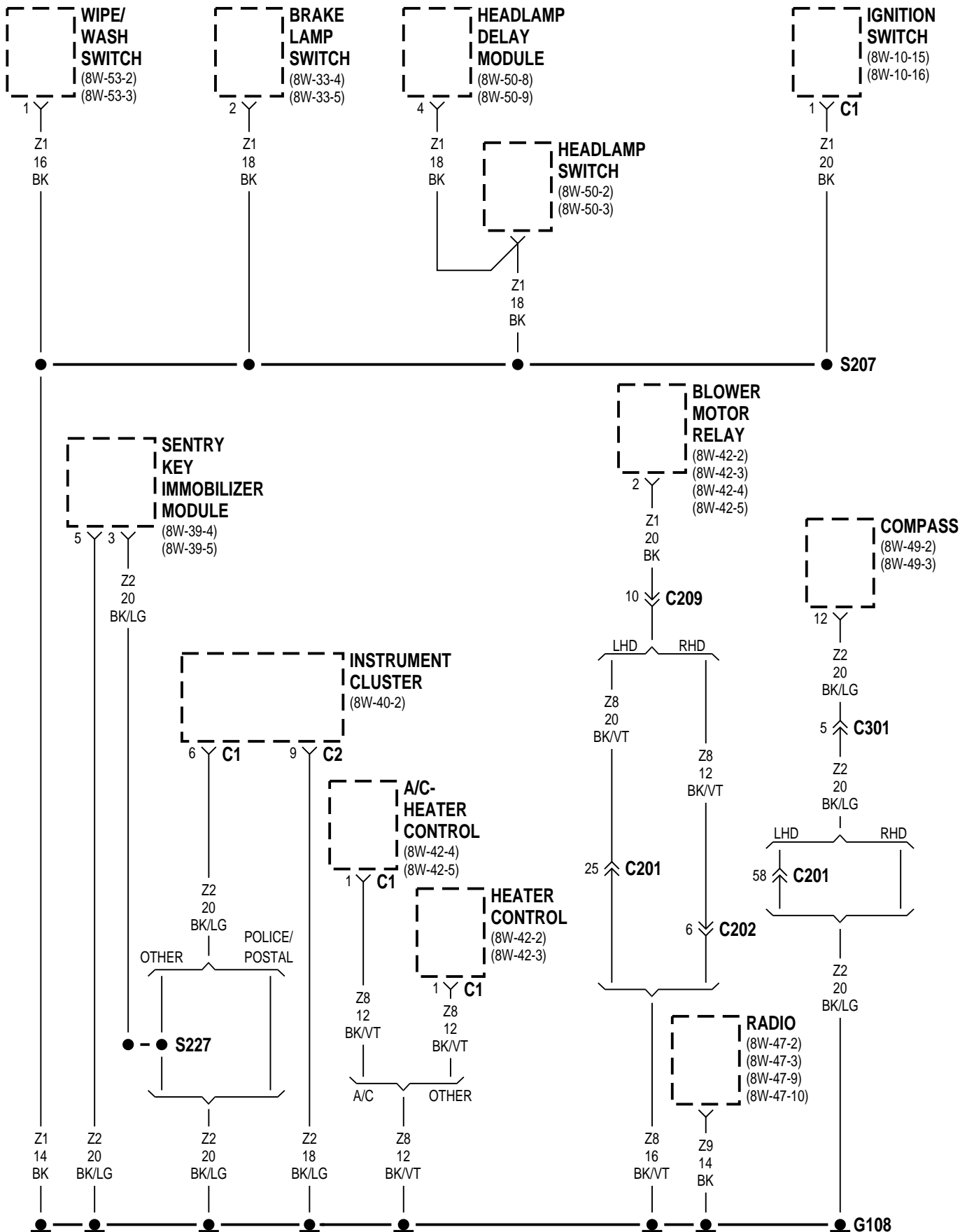

LHD

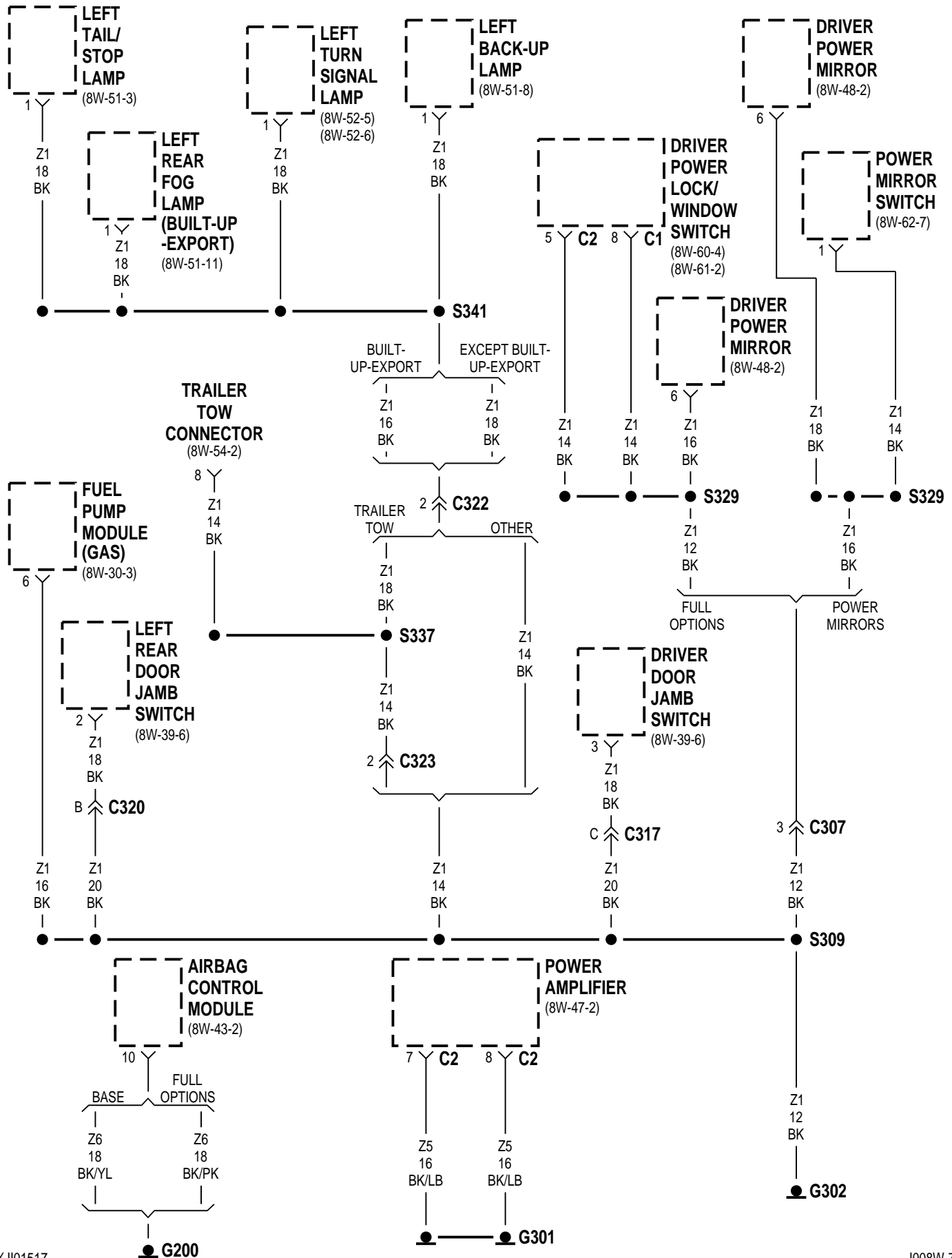

RHD

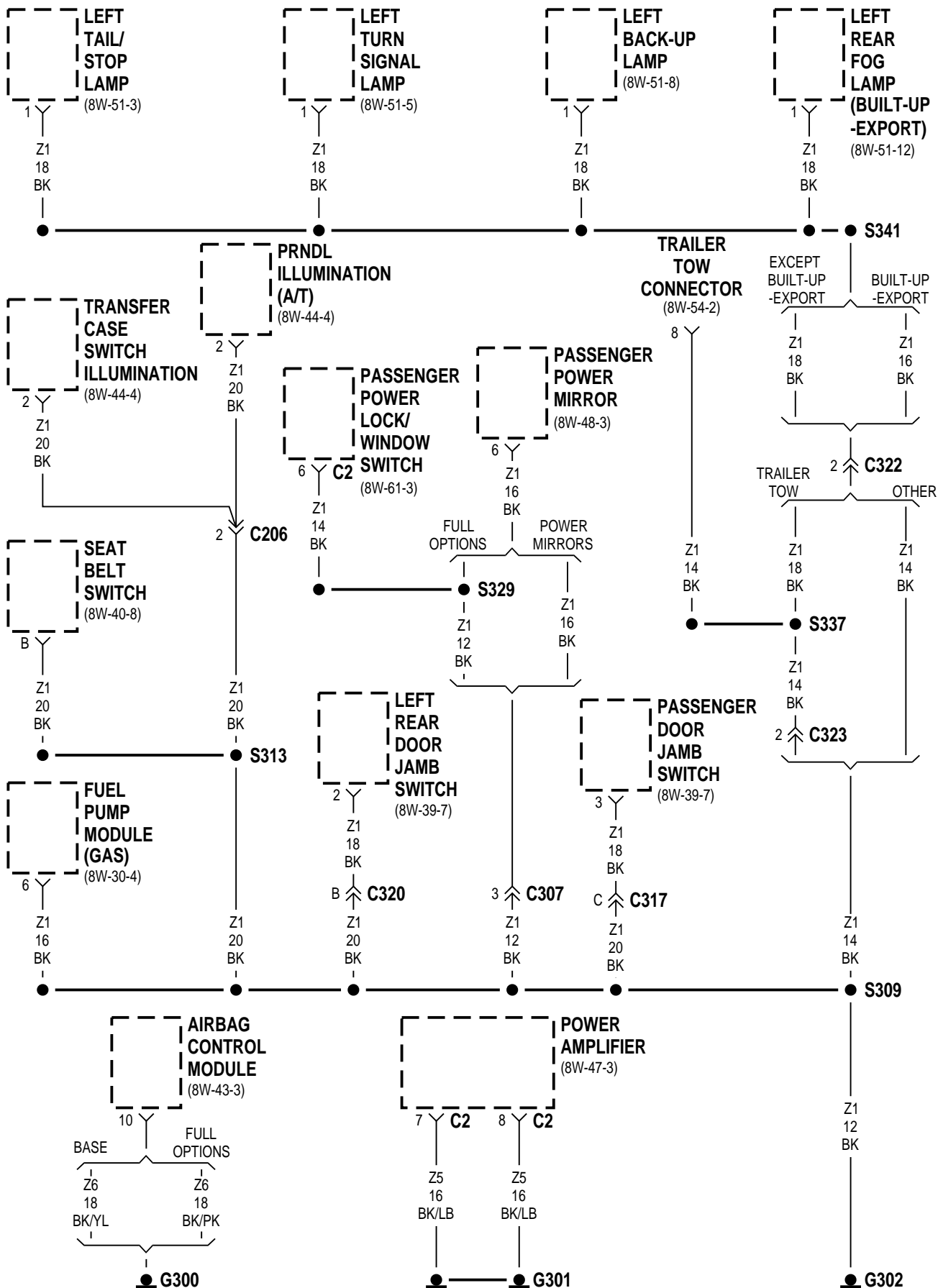

XJ ————— **8W-15 GROUND DISTRIBUTION** ————— **8W - 15 - 19**
LHD

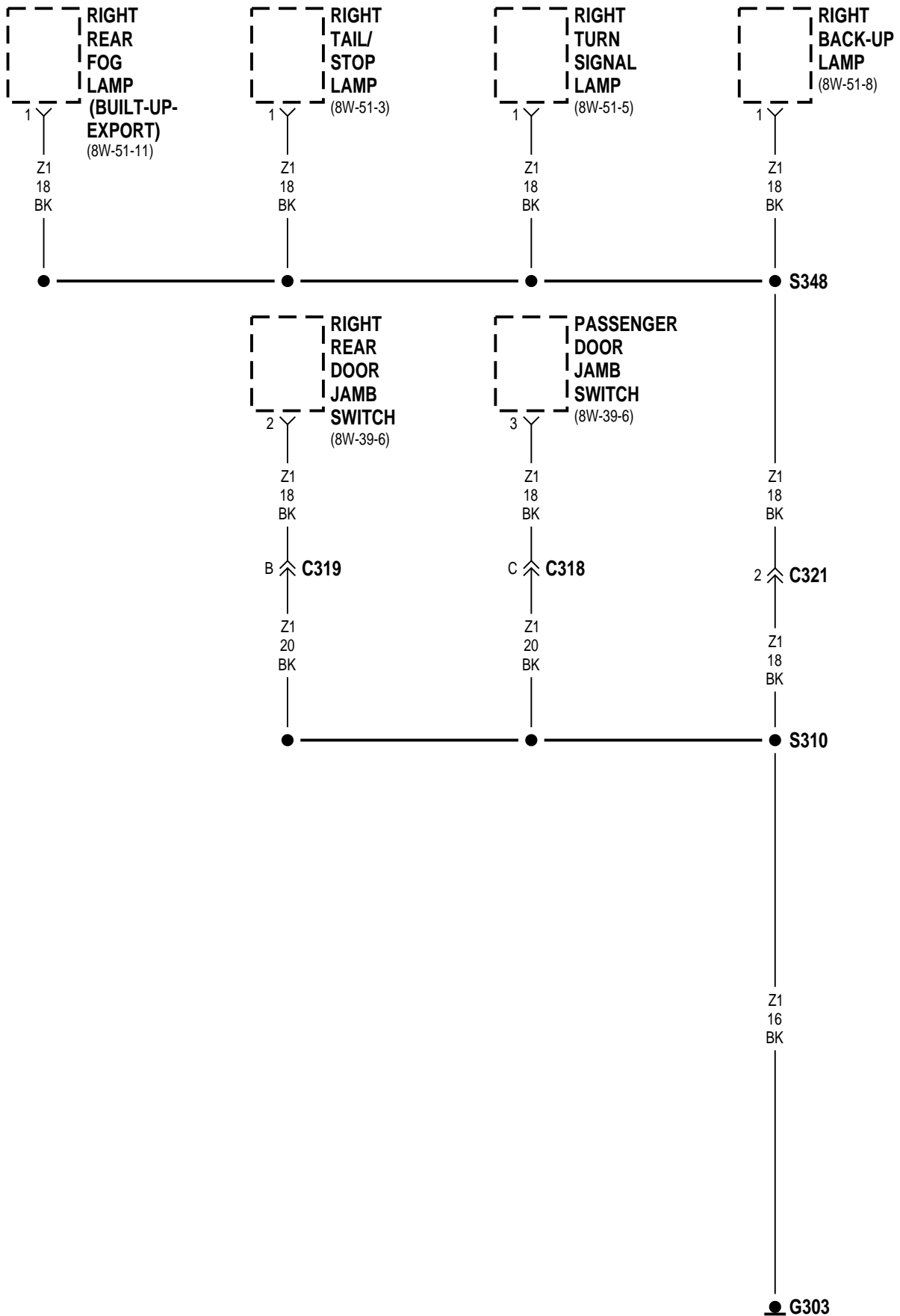

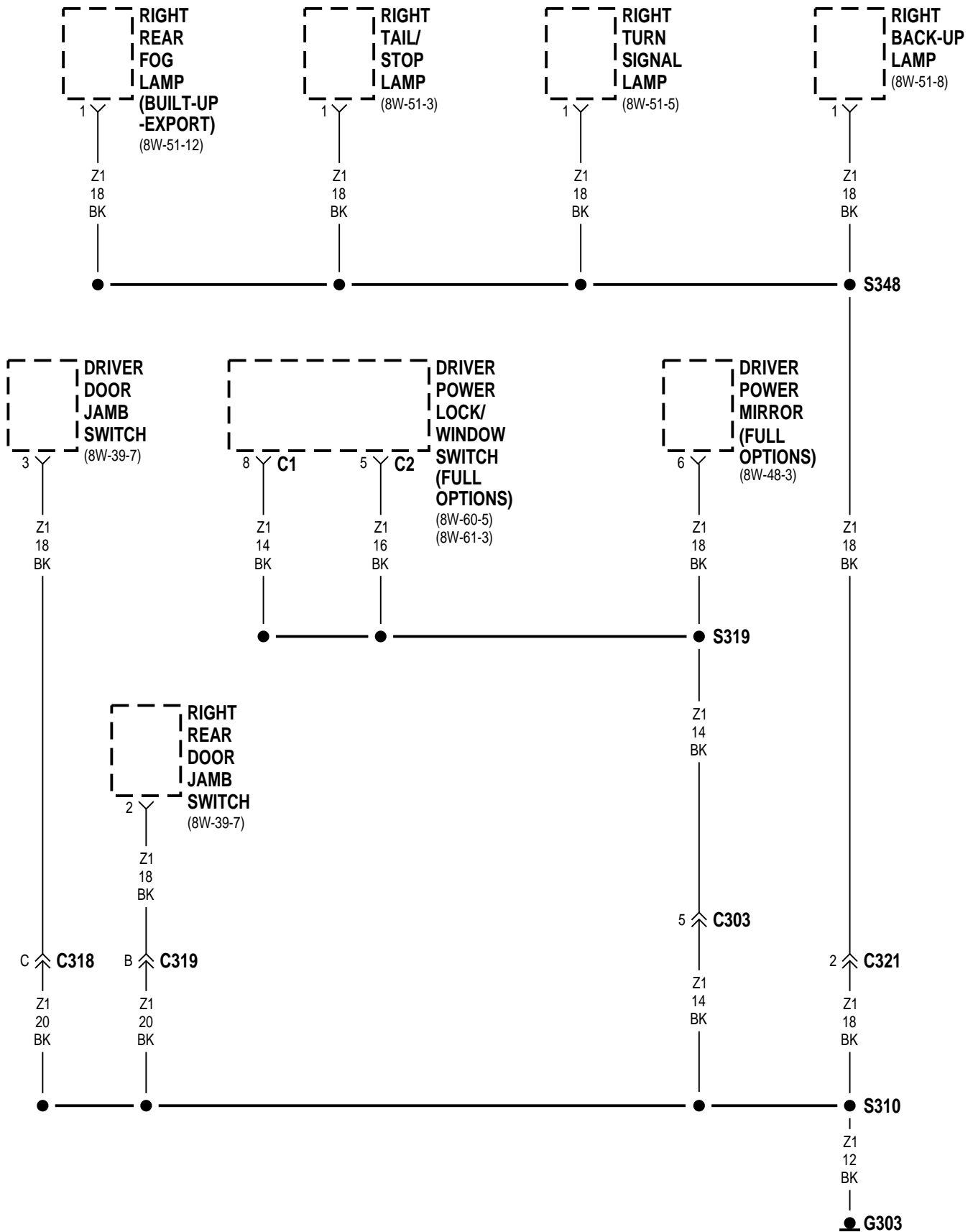

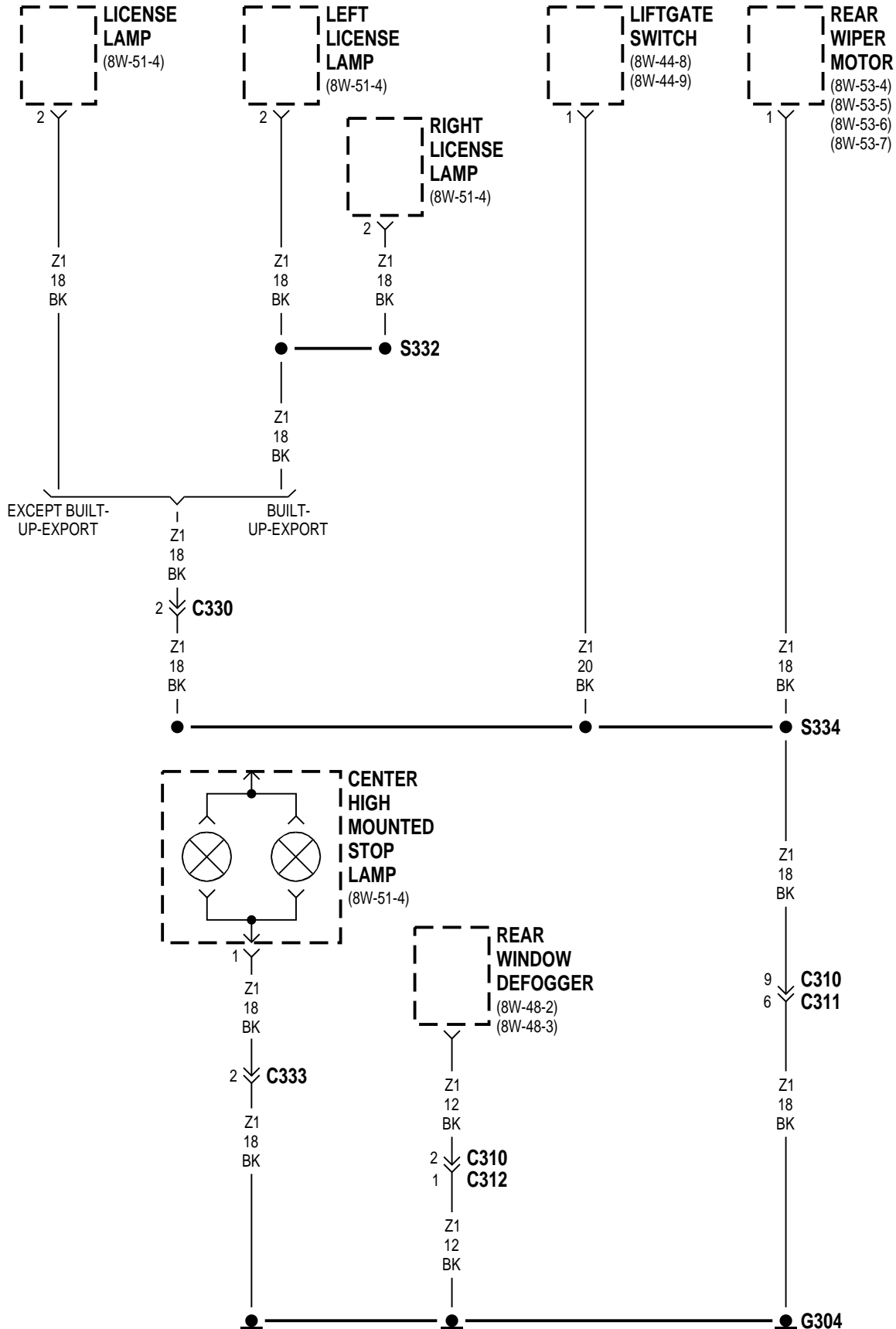

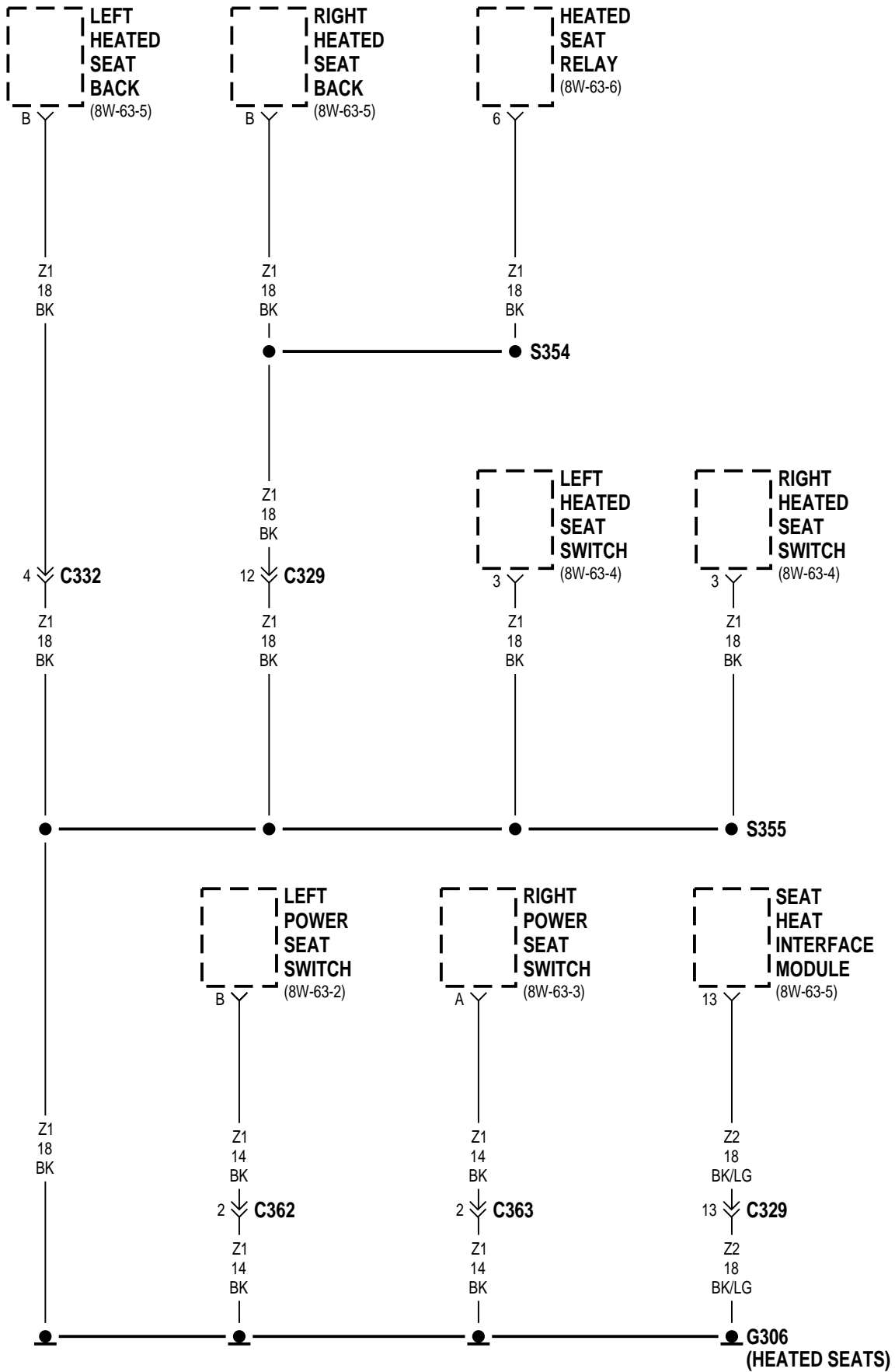

8W-20 CHARGING SYSTEM

| Component | Page | Component | Page |
|--------------------------------------|-------------|-------------------------------------|------------------|
| Automatic Shut Down Relay | 8W-20-2, 4 | Fuse 22 (PDC) | 8W-20-3 |
| Battery | 8W-20-2, 4 | Fuse 24 (PDC) | 8W-20-5 |
| Battery Temperature Sensor | 8W-20-3, 5 | Fusible Link | 8W-20-2, 4 |
| Engine Control Module | 8W-20-4 | G100 | 8W-20-2 |
| Engine Starter Motor | 8W-20-2, 4 | G101 | 8W-20-2 |
| Fuel Pump Relay | 8W-20-3 | G104 | 8W-20-4 |
| Fuse 4 (PDC) | 8W-20-4 | G105 | 8W-20-4 |
| Fuse 8 (PDC) | 8W-20-2 | Generator | 8W-20-2, 4 |
| Fuse 18 (PDC) | 8W-20-2 | Power Distribution Center | 8W-20-2, 3, 4, 5 |
| Fuse 21 (PDC) | 8W-20-2 | Powertrain Control Module | 8W-20-2, 3, 4, 5 |

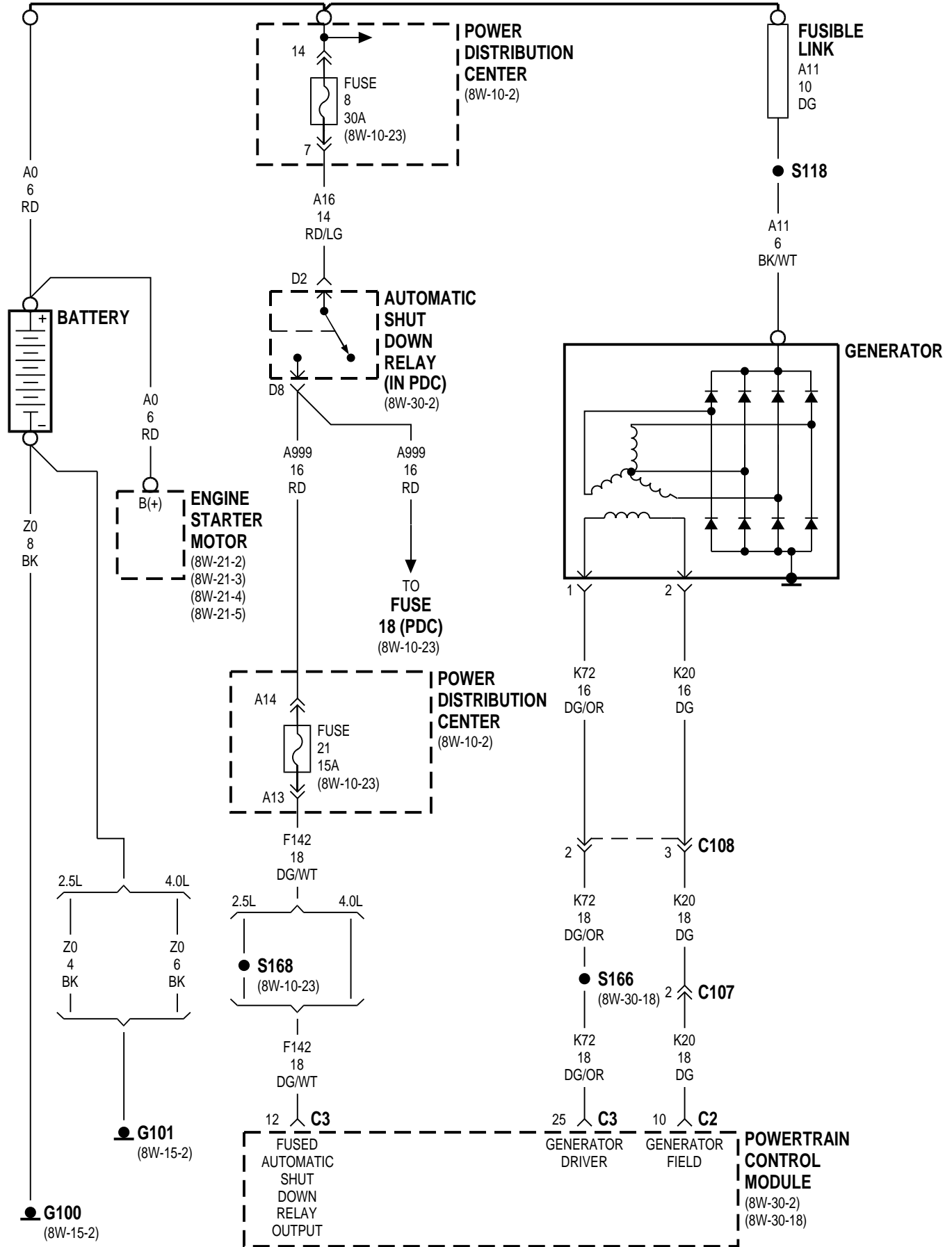

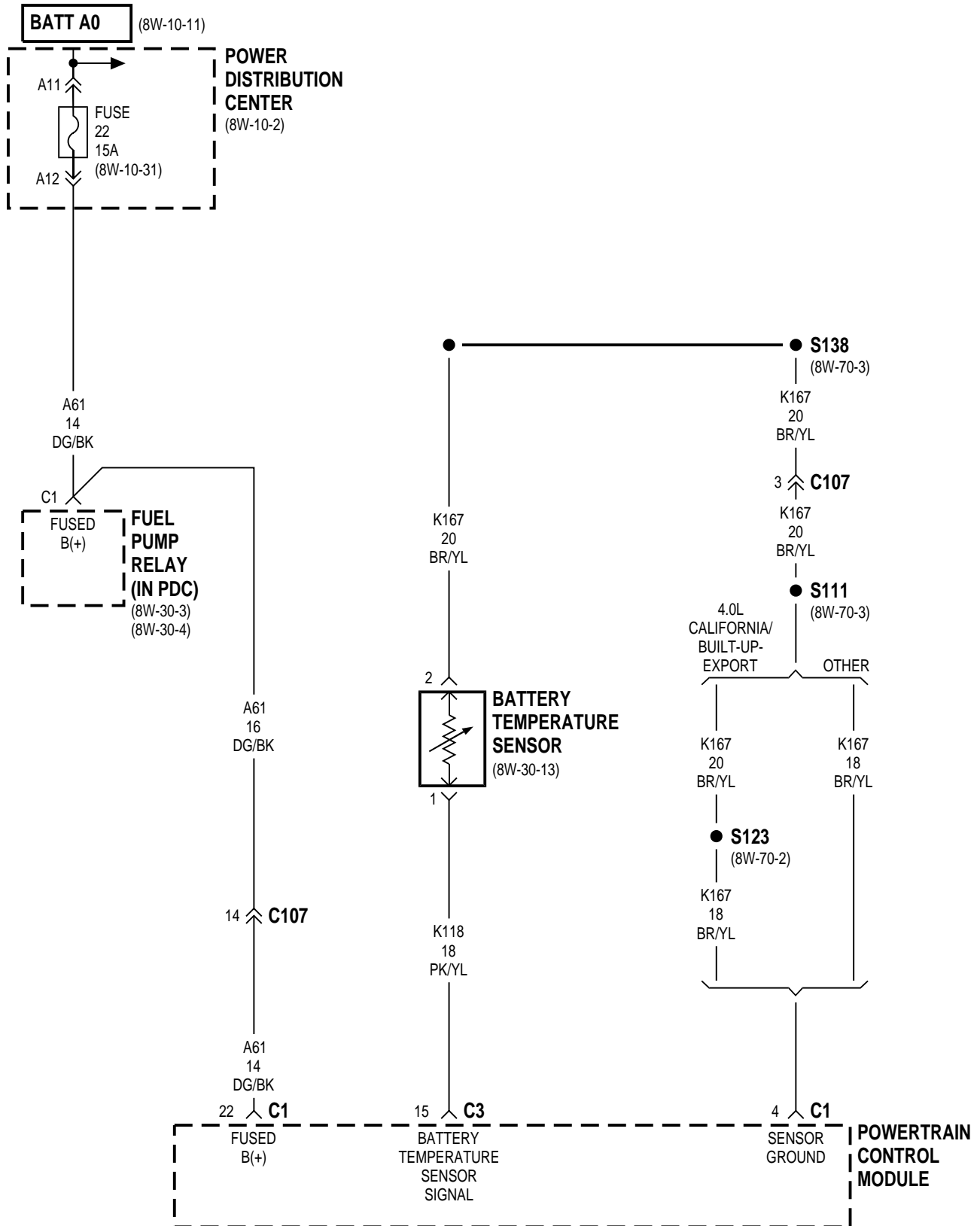

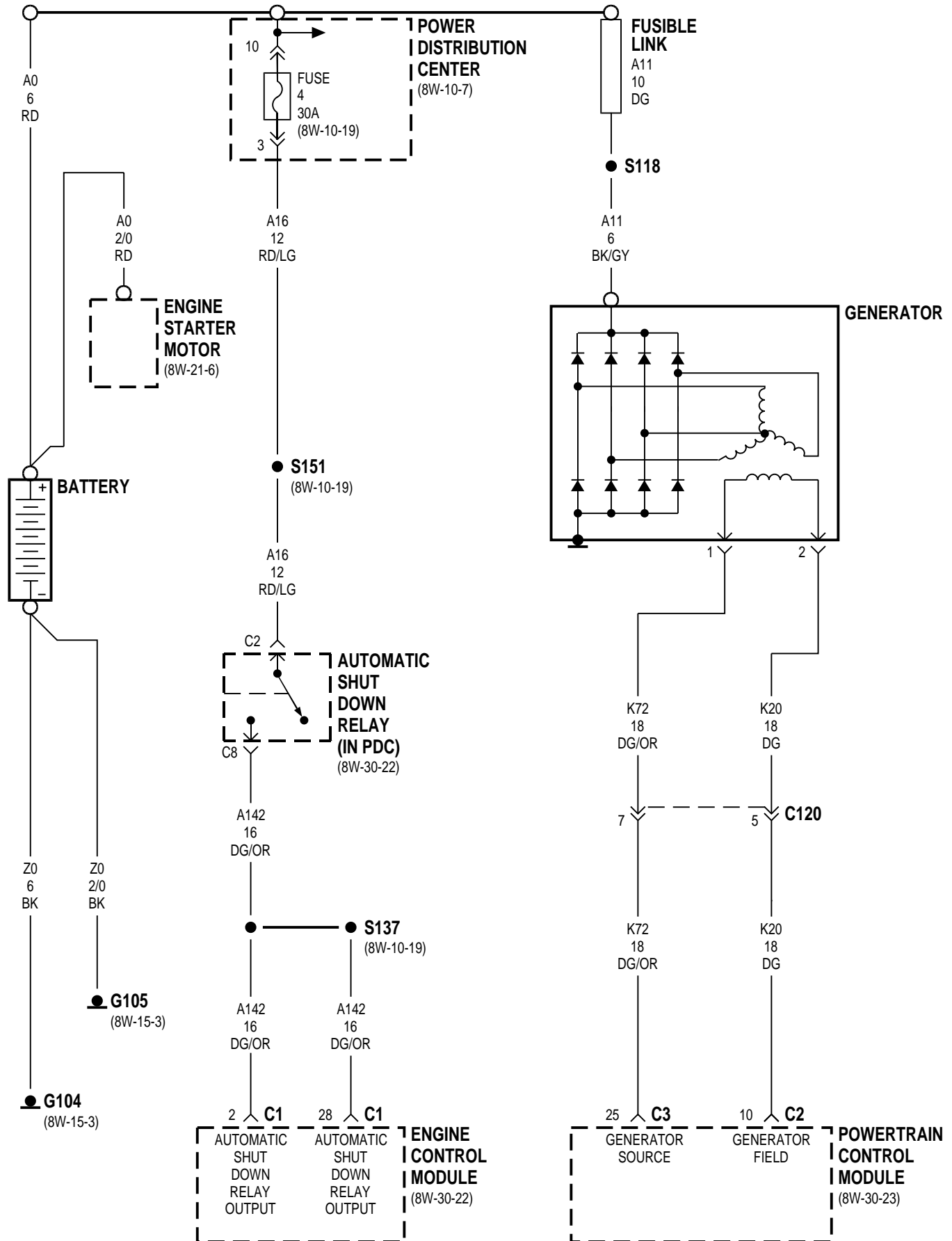

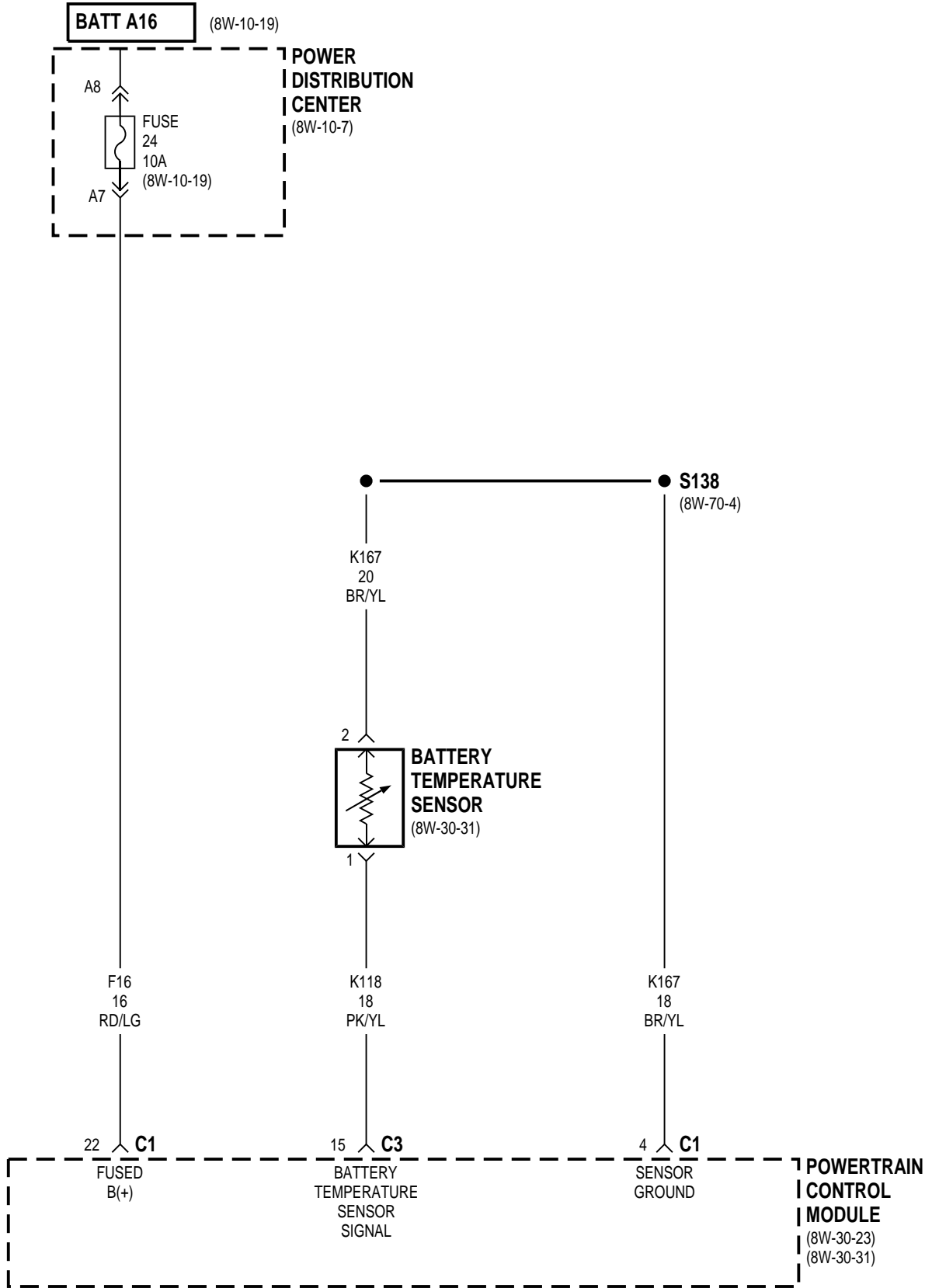

8W-21 STARTING SYSTEM

| Component | Page | Component | Page |
|--|---------------------|--|---------------------|
| Battery | 8W-21-2, 3, 4, 5, 6 | Fuse 19 (JB) | 8W-21-2, 3, 4, 5, 6 |
| Clutch Interlock Switch | 8W-21-4, 5, 6 | G101 | 8W-21-4 |
| Clutch Interlock Switch Jumper | 8W-21-2, 3 | G106 | 8W-21-3, 5, 6 |
| Engine Starter Motor | 8W-21-2, 3, 4, 5, 6 | Junction Block | 8W-21-2, 3, 4, 5, 6 |
| Engine Starter Motor Relay | 8W-21-2, 3, 4, 5, 6 | Park/Neutral Position Switch | 8W-21-2 |
| Fog Lamp Relay | 8W-21-6 | Power Distribution Center | 8W-21-2, 3, 4, 5, 6 |
| Fog Lamp Relay No. 1 | 8W-21-5 | Powertrain Control Module | 8W-21-2, 3 |
| Fuse 7 (PDC) | 8W-21-6 | Transmission Range Sensor | 8W-21-3 |
| Fuse 10 (PDC) | 8W-21-2, 3, 4, 5 | | |

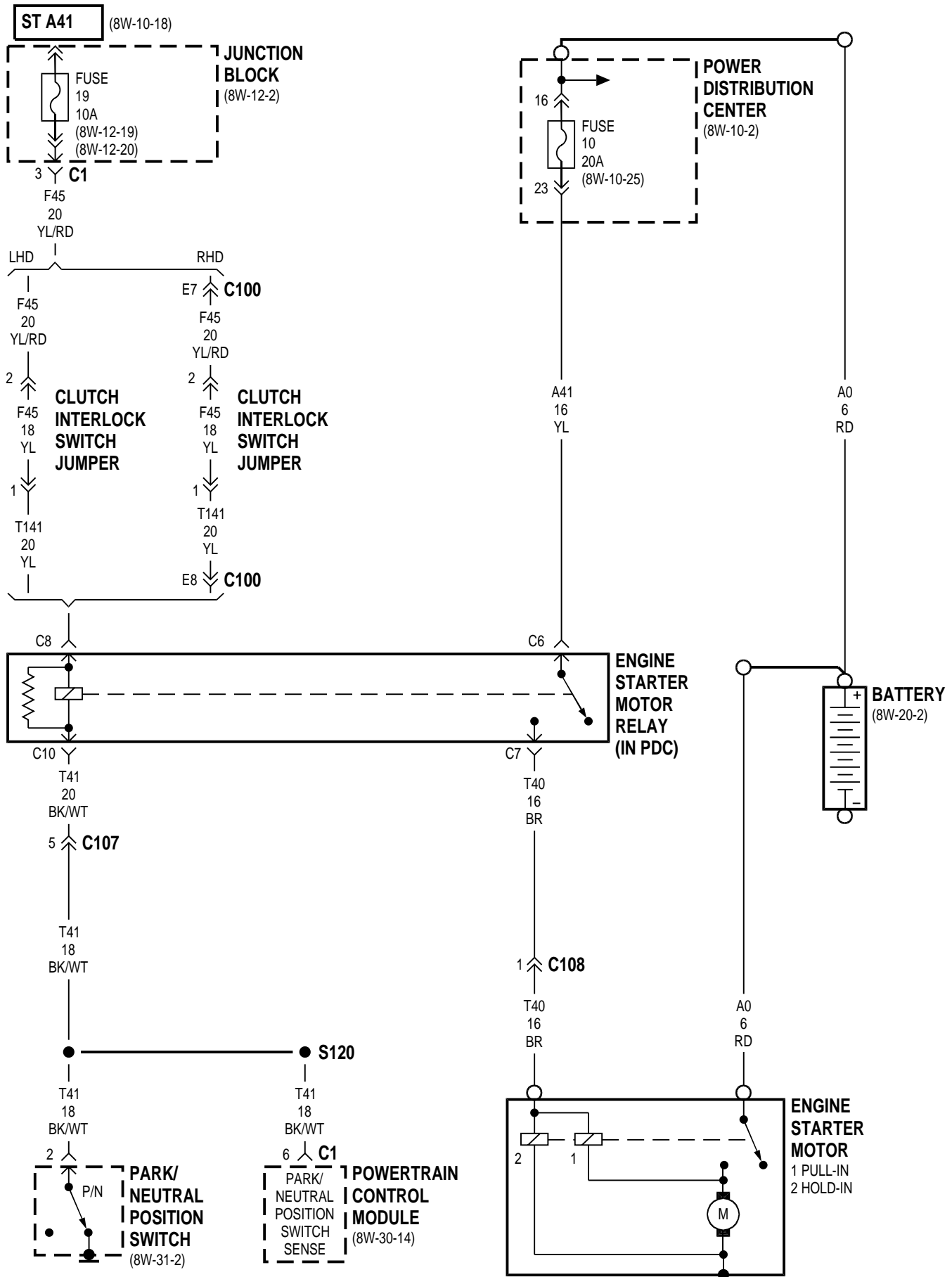

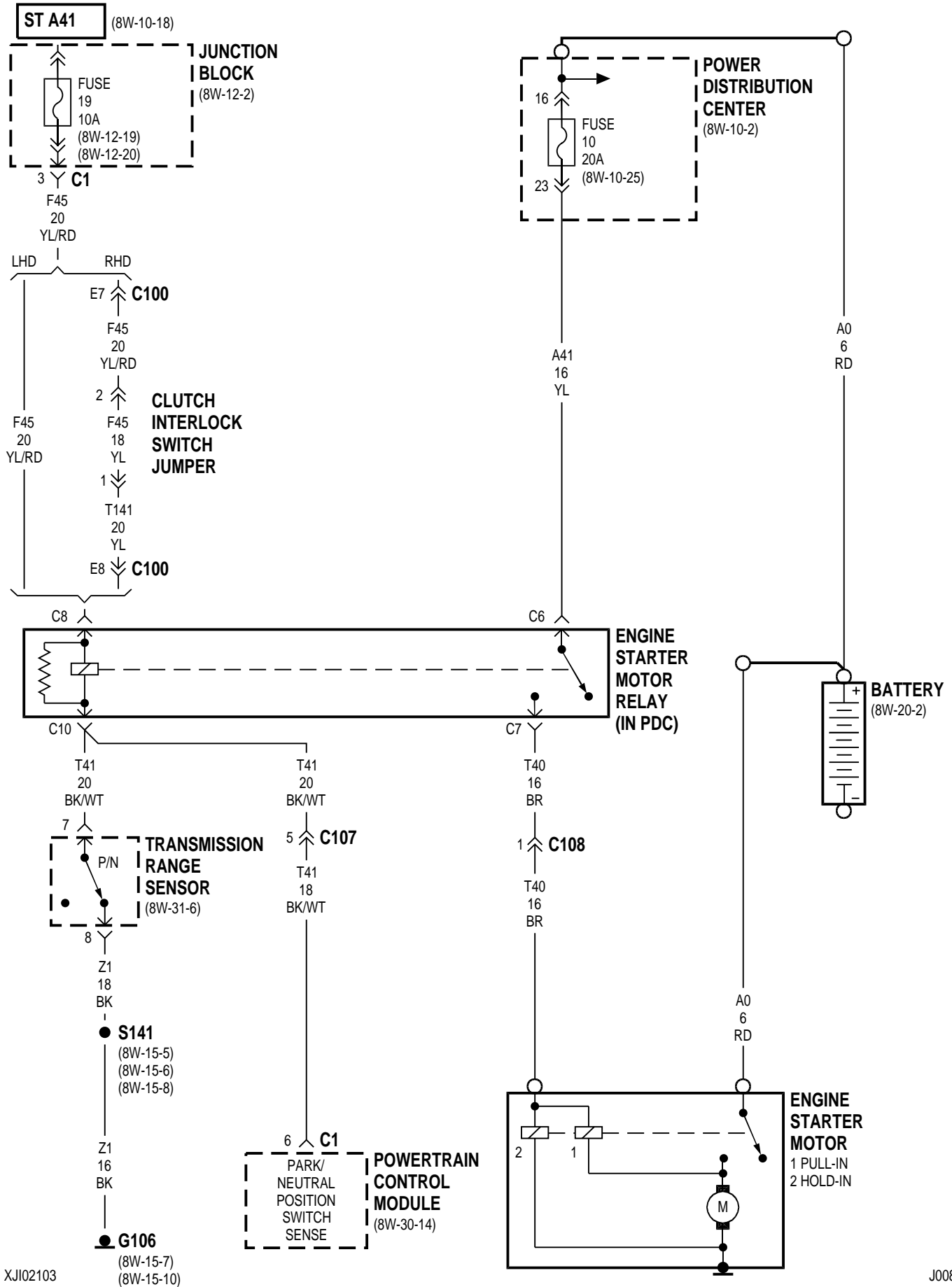

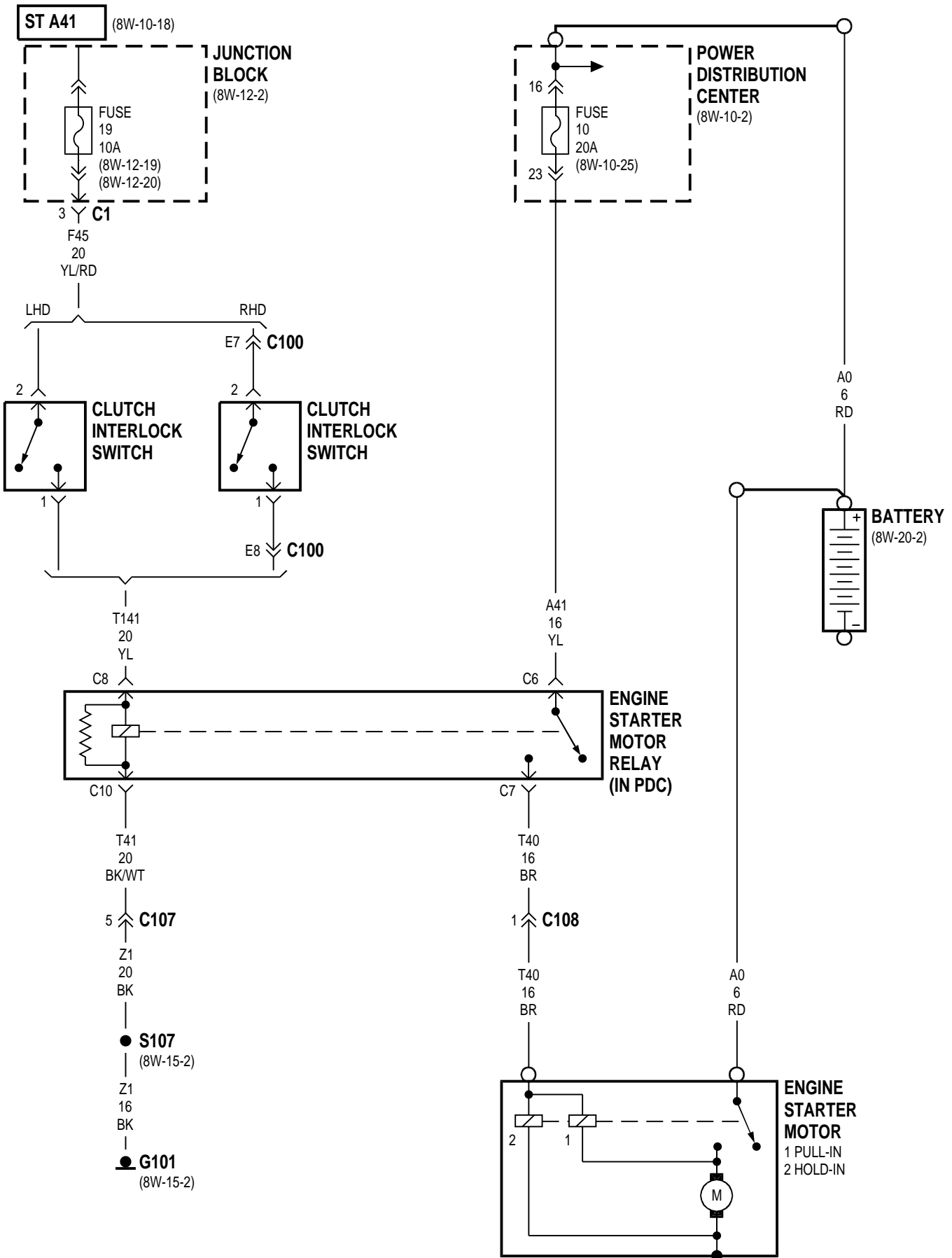

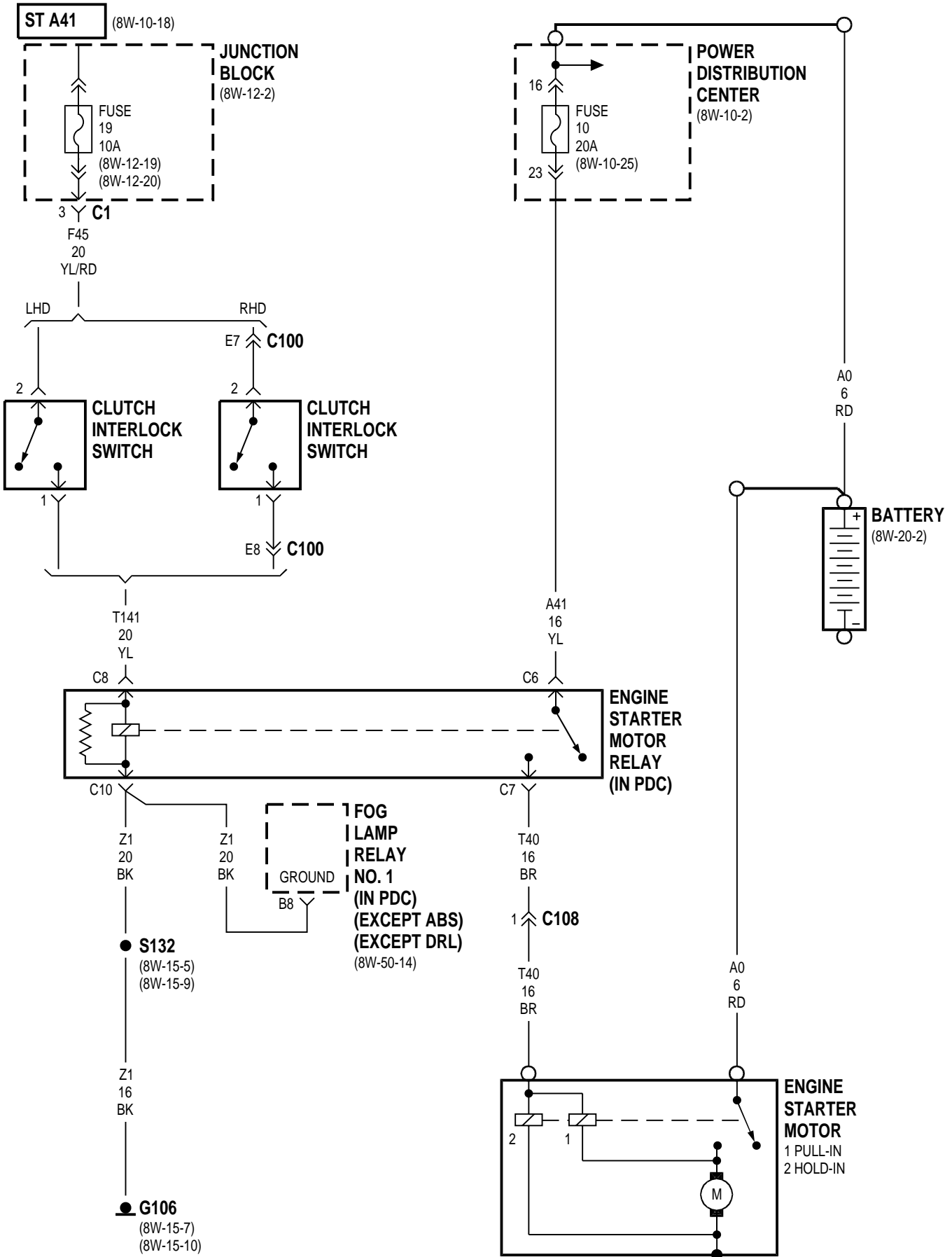

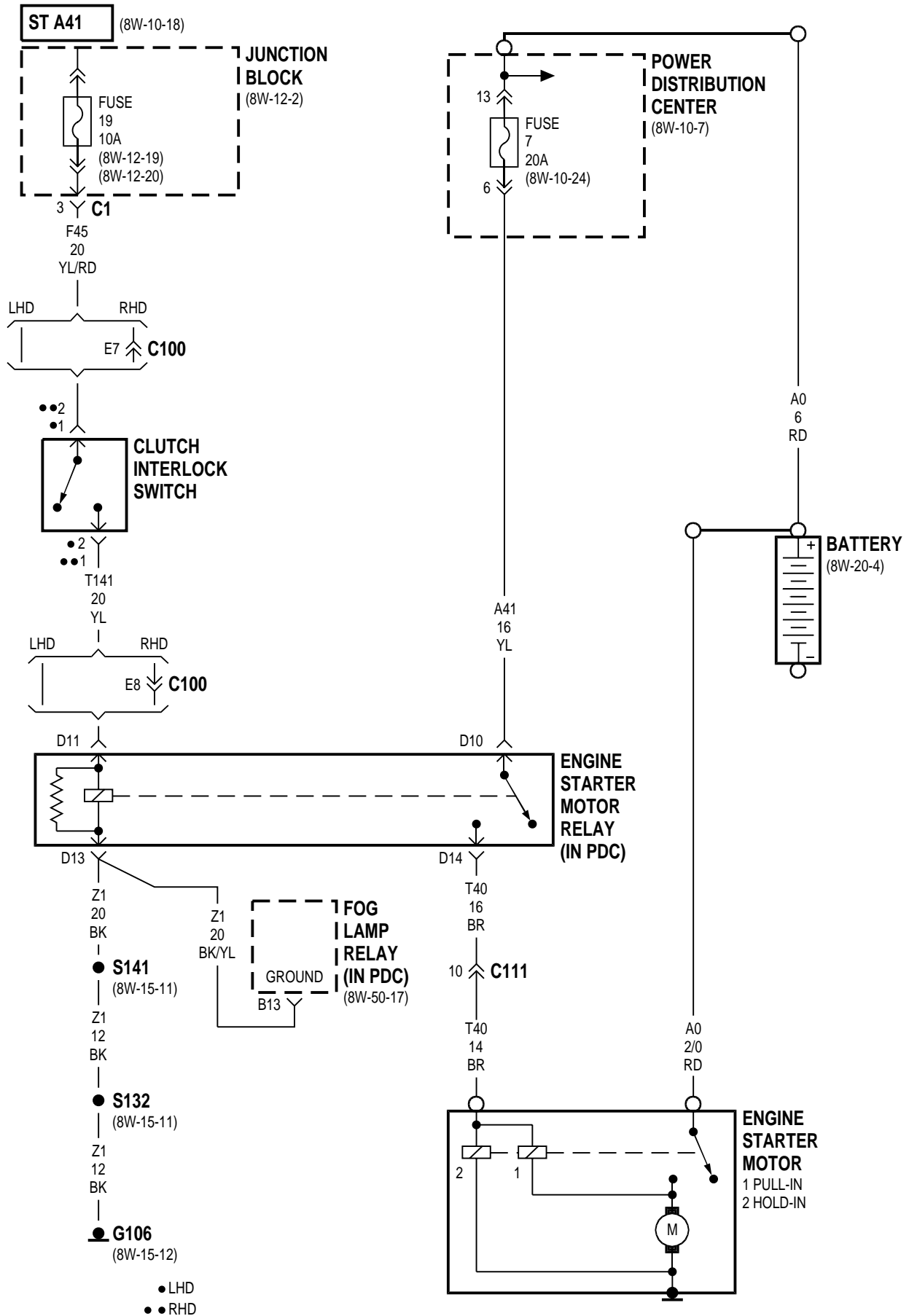

8W-30 FUEL/IGNITION SYSTEM

| Component | Page | Component | Page |
|---|--|---|--|
| A/C Compressor Clutch Relay | 8W-30-9, 18, 22, 27 | G102 | 8W-30-19, 22, 23, 34 |
| A/C High Pressure Switch | 8W-30-18, 30 | G106 | 8W-30-14 |
| A/C Low Pressure Switch | 8W-30-18 | G107 | 8W-30-17 |
| A/C- Heater Control | 8W-30-18, 30 | G108 | 8W-30-16, 32 |
| Accelerator Pedal Position Sensor | 8W-30-28 | G123 | 8W-30-31 |
| Airbag Control Module | 8W-30-20, 21 | G154 | 8W-30-33 |
| Automatic Shut Down | | G302 | 8W-30-3, 4 |
| Relay | 8W-30-2, 5, 6, 8, 22, 23, 25, 26, 27, 33 | Generator | 8W-30-18, 23 |
| Battery Temperature Sensor | 8W-30-13, 31 | Glow Plug Assembly | 8W-30-25 |
| Brake Lamp Switch | 8W-30-14, 16, 32 | Glow Plug No. 1 | 8W-30-25 |
| Camshaft Position Sensor | 8W-30-5 | Glow Plug No. 2 | 8W-30-25 |
| Clockspring | 8W-30-13, 32 | Glow Plug No. 3 | 8W-30-25 |
| Compass | 8W-30-20, 21 | Glow Plug No. 4 | 8W-30-25 |
| Controller Anti-Lock Brake | 8W-30-19, 34 | Glow Plug Relay | 8W-30-25 |
| Crankshaft Position Sensor | 8W-30-5 | Headlamp Switch | 8W-30-17, 19, 34 |
| Data Link Connector | 8W-30-19, 20, 21, 34 | Idle Air Control Motor | 8W-30-16 |
| Daytime Running Lamp Module | 8W-30-12 | Ignition Coil | 8W-30-5 |
| Duty Cycle Evap/Purge Solenoid | 8W-30-15 | Instrument Cluster | 8W-30-20, 21 |
| Engine Control | | Intake Air Temperature Sensor | 8W-30-7 |
| Module | 8W-30-22, 25, 26, 27, 28, 29, 30, 32, 33, 34 | Junction Block | 8W-30-2, 3, 4, 9, 17, 22, 33 |
| Engine Coolant Temperature Sensor | 8W-30-7 | Left Speed Control Switch | 8W-30-13, 32 |
| Engine Coolant Temperature Sensor No. 1 | 8W-30-29 | Low Coolant Level Warning Indicator | 8W-30-33 |
| Engine Coolant Temperature Sensor No. 2 | 8W-30-29 | Low Coolant Switch | 8W-30-31 |
| Engine Oil Pressure Sensor | 8W-30-12, 29 | Manifold Absolute Pressure Sensor | 8W-30-12 |
| Engine Speed Sensor | 8W-30-30 | Message Center | 8W-30-33 |
| Engine Starter Motor Relay | 8W-30-14 | Needle Movement Sensor | 8W-30-28 |
| Evap Leak Detection Pump | 8W-30-18 | Overhead Module | 8W-30-20, 21 |
| Extended Idle Switch | 8W-30-17 | Oxygen Sensor 1/1 Upstream | 8W-30-8, 10, 11 |
| Fuel Injection Pump | 8W-30-26, 27 | Oxygen Sensor 1/2 Downstream | 8W-30-8, 10, 11 |
| Fuel Injector No. 1 | 8W-30-6 | Oxygen Sensor 2/1 Upstream | 8W-30-11 |
| Fuel Injector No. 2 | 8W-30-6 | Oxygen Sensor 2/2 Downstream | 8W-30-11 |
| Fuel Injector No. 3 | 8W-30-6 | Oxygen Sensor Downstream Relay | 8W-30-9, 10, 11 |
| Fuel Injector No. 4 | 8W-30-6 | Oxygen Sensor Upstream Relay | 8W-30-9, 10, 11 |
| Fuel Injector No. 5 | 8W-30-6 | Park/Neutral Position Switch | 8W-30-14 |
| Fuel Injector No. 6 | 8W-30-6 | Power Distribution Center | 8W-30-2, 3, 4, 5, 6, 8, 9, 14, 18, 19, 22, 23, 25, 26, 27, 32, 33, 34, |
| Fuel Level Sensor | 8W-30-31 | Power Steering Pressure Switch | 8W-30-17 |
| Fuel Pump Module | 8W-30-3, 4 | Powertrain Control Module | 8W-30-2, 3, 4, 5, 6, 7, 8, 9, 10, 11, 12, 13, 14, 15, 16, 17, 18, 19, 20, 21, 23, 29, 30, 31, 33, 34 |
| Fuel Pump Relay | 8W-30-2, 3, 4 | Radiator Fan Relay | 8W-30-9, 18, 22, 27, 33 |
| Fuse 2 (PDC) | 8W-30-25 | Rail Coil | 8W-30-5 |
| Fuse 3 (PDC) | 8W-30-25 | Right Speed Control Switch | 8W-30-13, 32 |
| Fuse 4 (PDC) | 8W-30-22 | Sentry Key Immobilizer Module | 8W-30-20, 21 |
| Fuse 6 (JB) | 8W-30-17 | Throttle Position Sensor | 8W-30-7 |
| Fuse 8 (PDC) | 8W-30-2 | Torque Converter Clutch Solenoid | 8W-30-15 |
| Fuse 9 (JB) | 8W-30-33 | Transmission Control Module | 8W-30-7, 19, 20, 21 |
| Fuse 10 (JB) | 8W-30-9, 15 | Transmission Range Sensor | 8W-30-14 |
| Fuse 11 (JB) | 8W-30-2, 3, 4, 15, 22 | Turbo Boost Pressure Sensor | 8W-30-27 |
| Fuse 17 (PDC) | 8W-30-9 | Vehicle Speed Control Servo | 8W-30-14 |
| Fuse 18 (PDC) | 8W-30-2, 5, 6 | Vehicle Speed Sensor | 8W-30-12, 29 |
| Fuse 19 (PDC) | 8W-30-19, 32 | Wait To Start Warning Indicator | 8W-30-33 |
| Fuse 21 (PDC) | 8W-30-2, 5, 6, 8, 25, 26 | Water In Fuel Sensor | 8W-30-31 |
| Fuse 22 (PDC) | 8W-30-2, 3, 4 | Water In Fuel Warning Indicator | 8W-30-33 |
| Fuse 24 (PDC) | 8W-30-23 | | |
| Fuse 25 (JB) | 8W-30-17 | | |
| Fuse 26 (PDC) | 8W-30-34 | | |
| G101 | 8W-30-2, 8, 10, 11, 14, 17 | | |

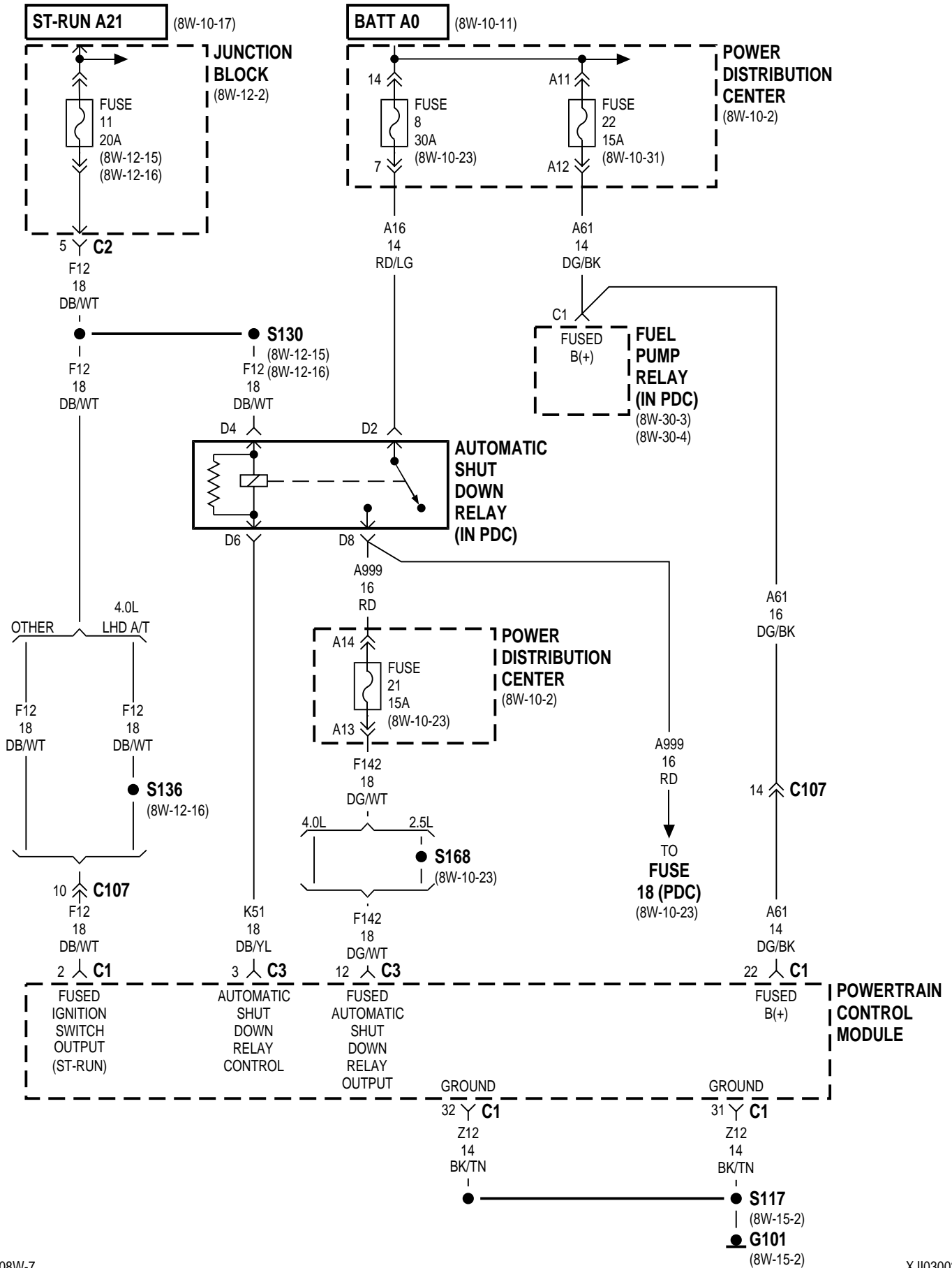

LHD GAS

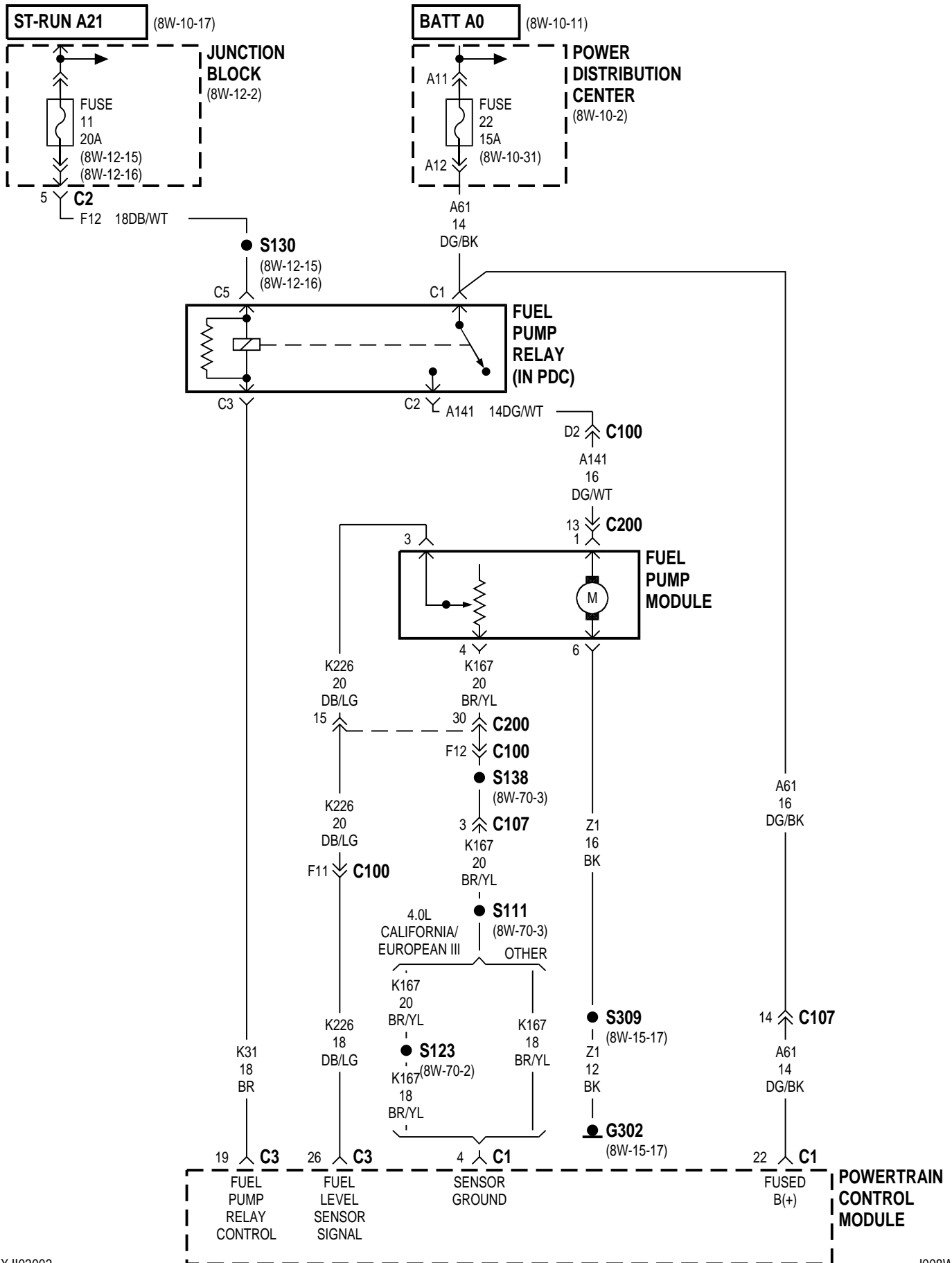

RHD GAS

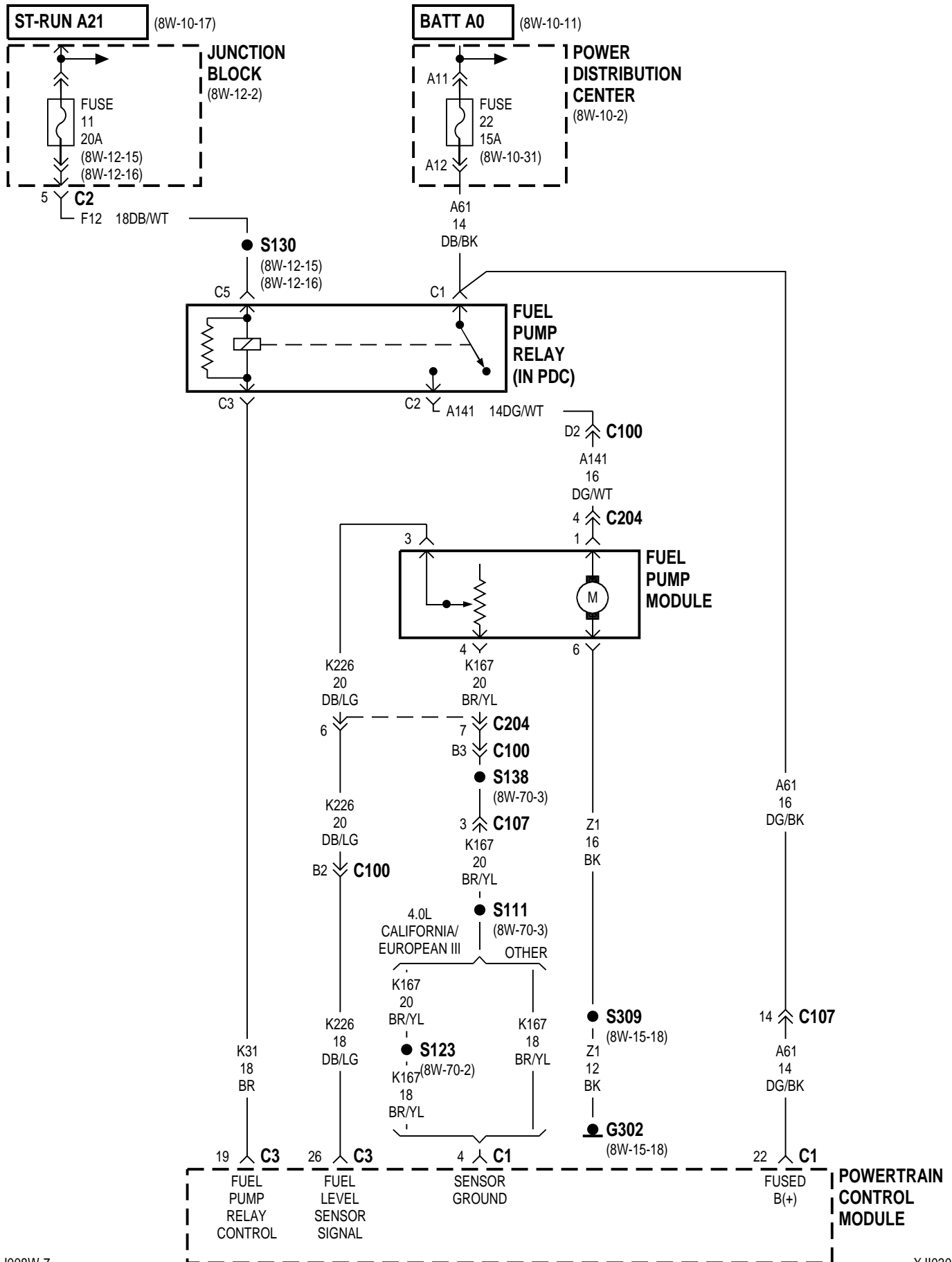

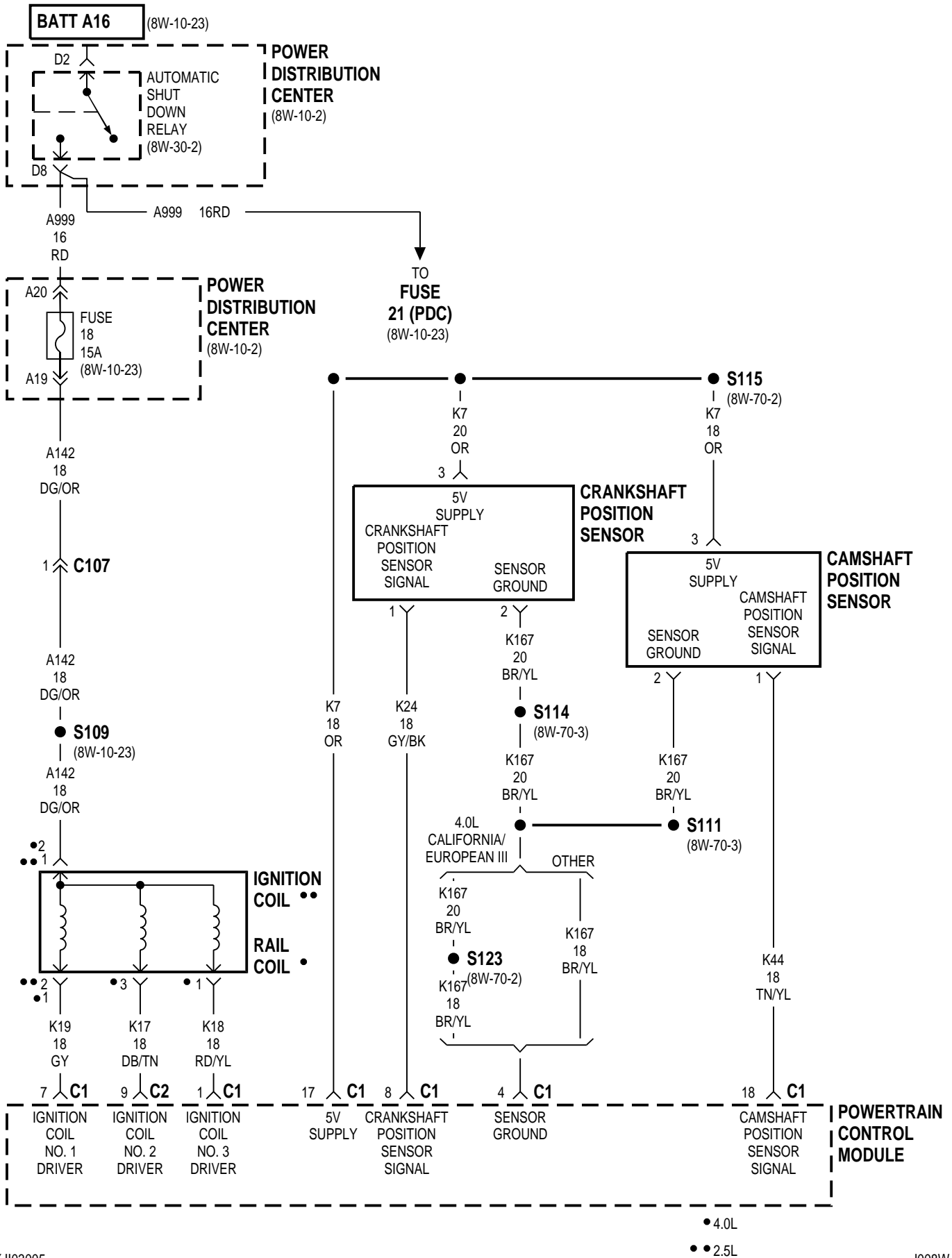

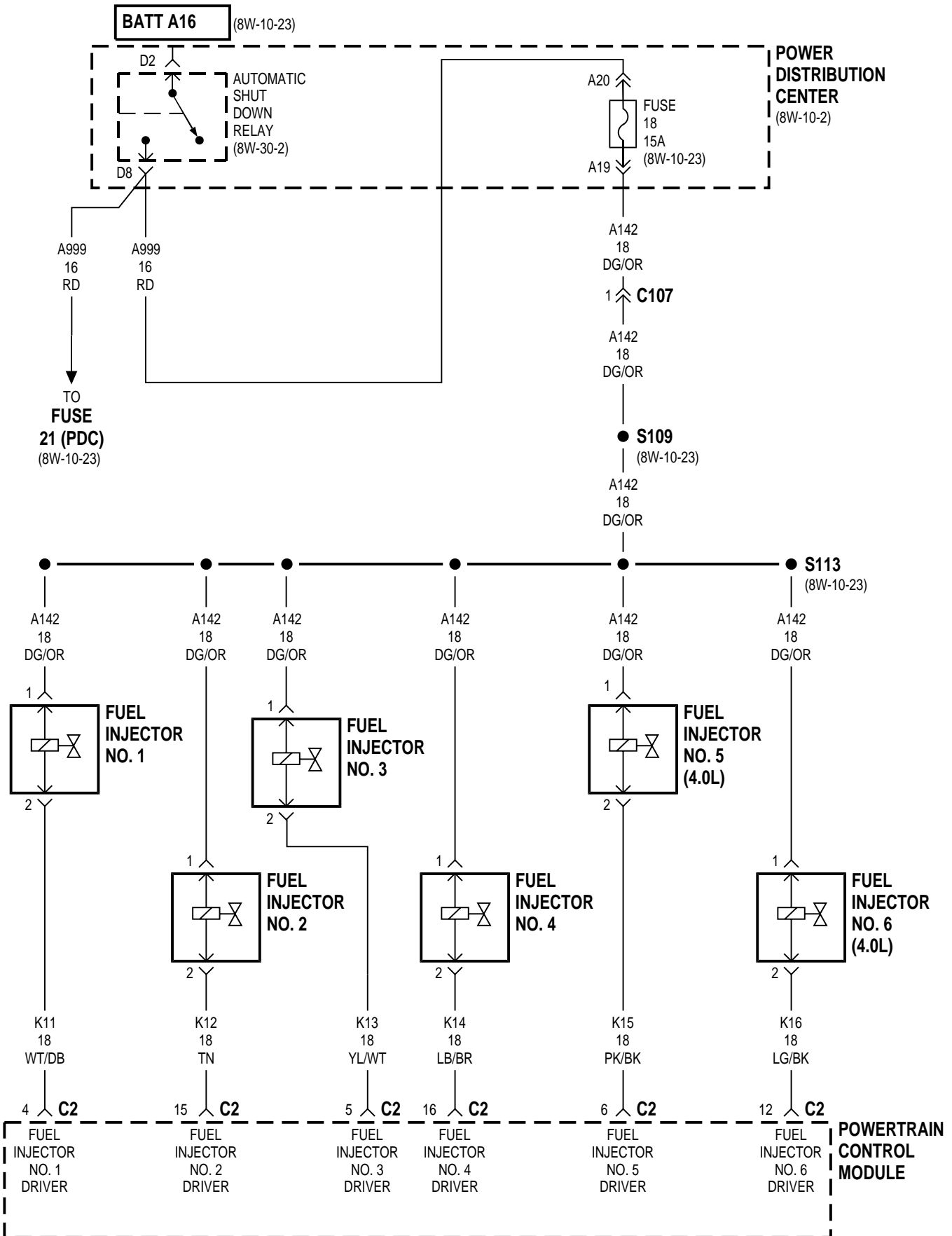

XJ ————— **8W-30 FUEL/IGNITION SYSTEM** ————— **8W - 30 - 7**
GAS

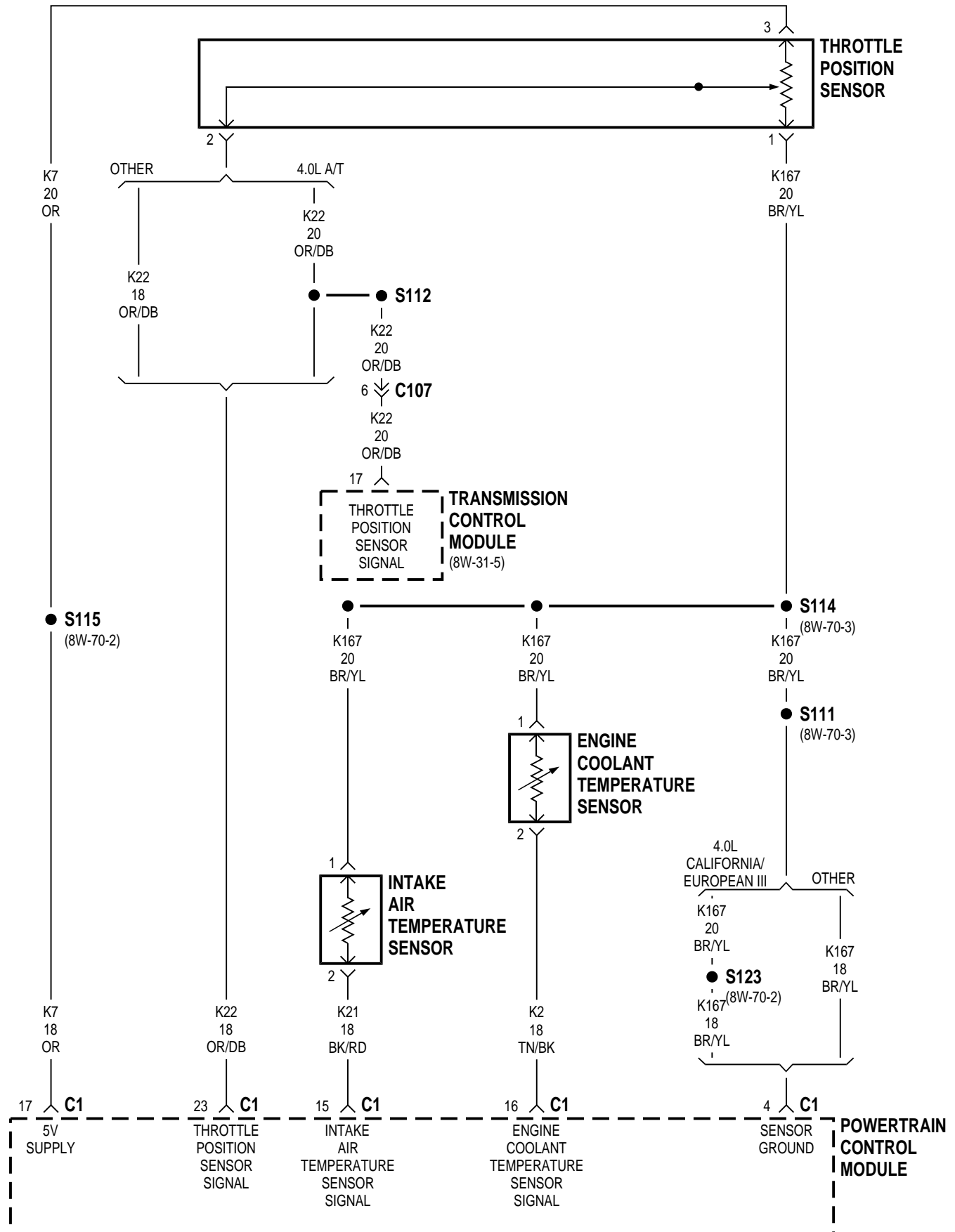

2.5L

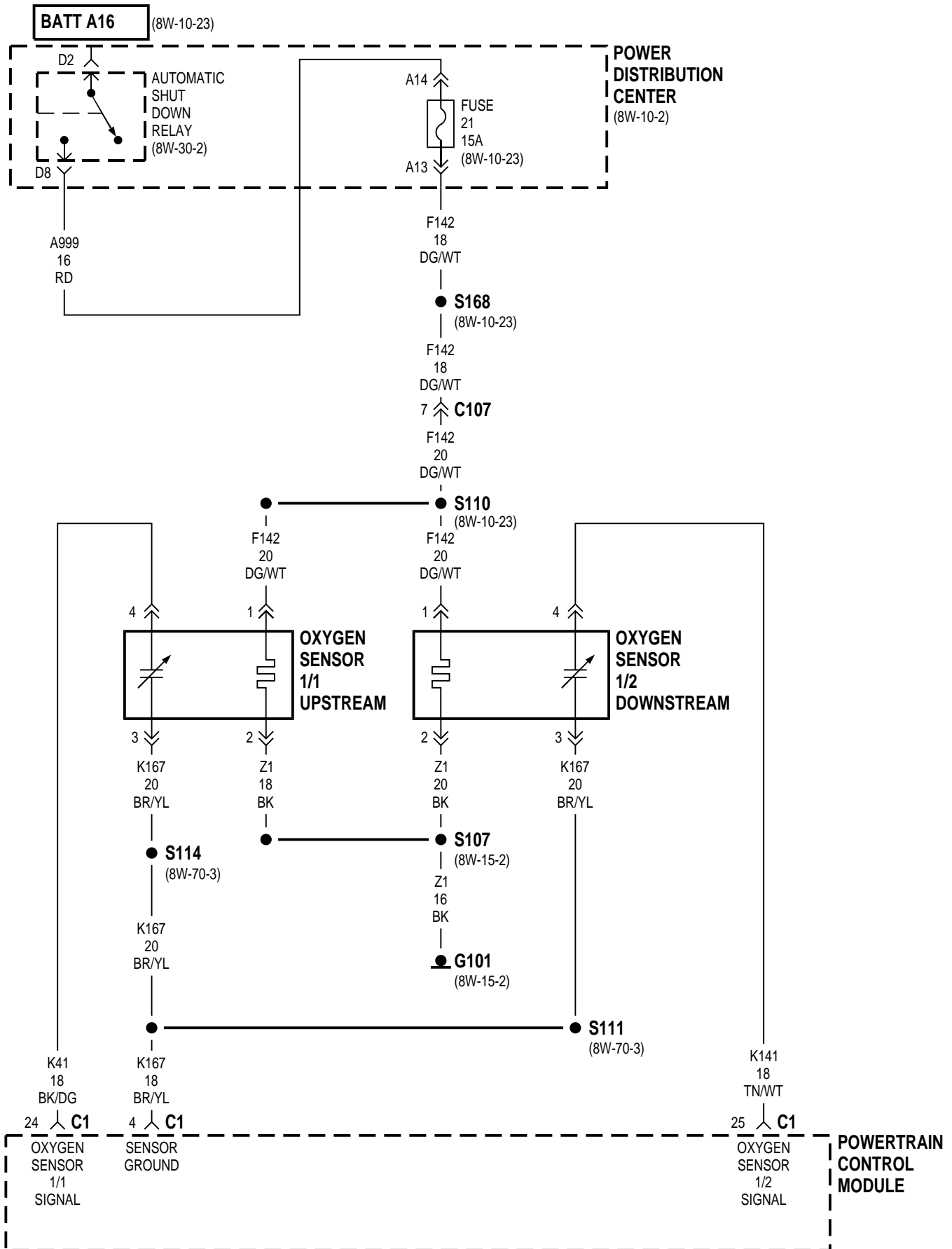

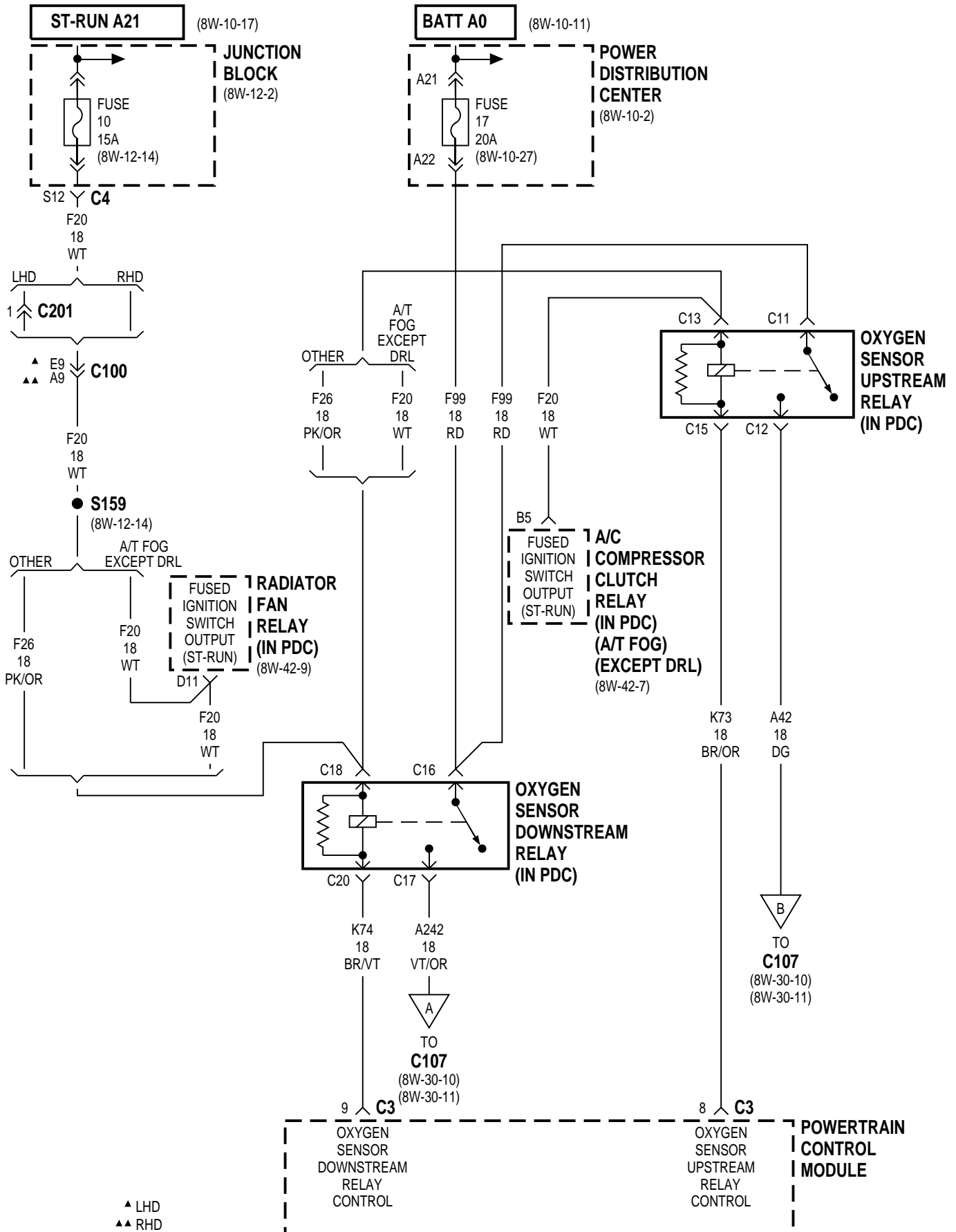

4.0L

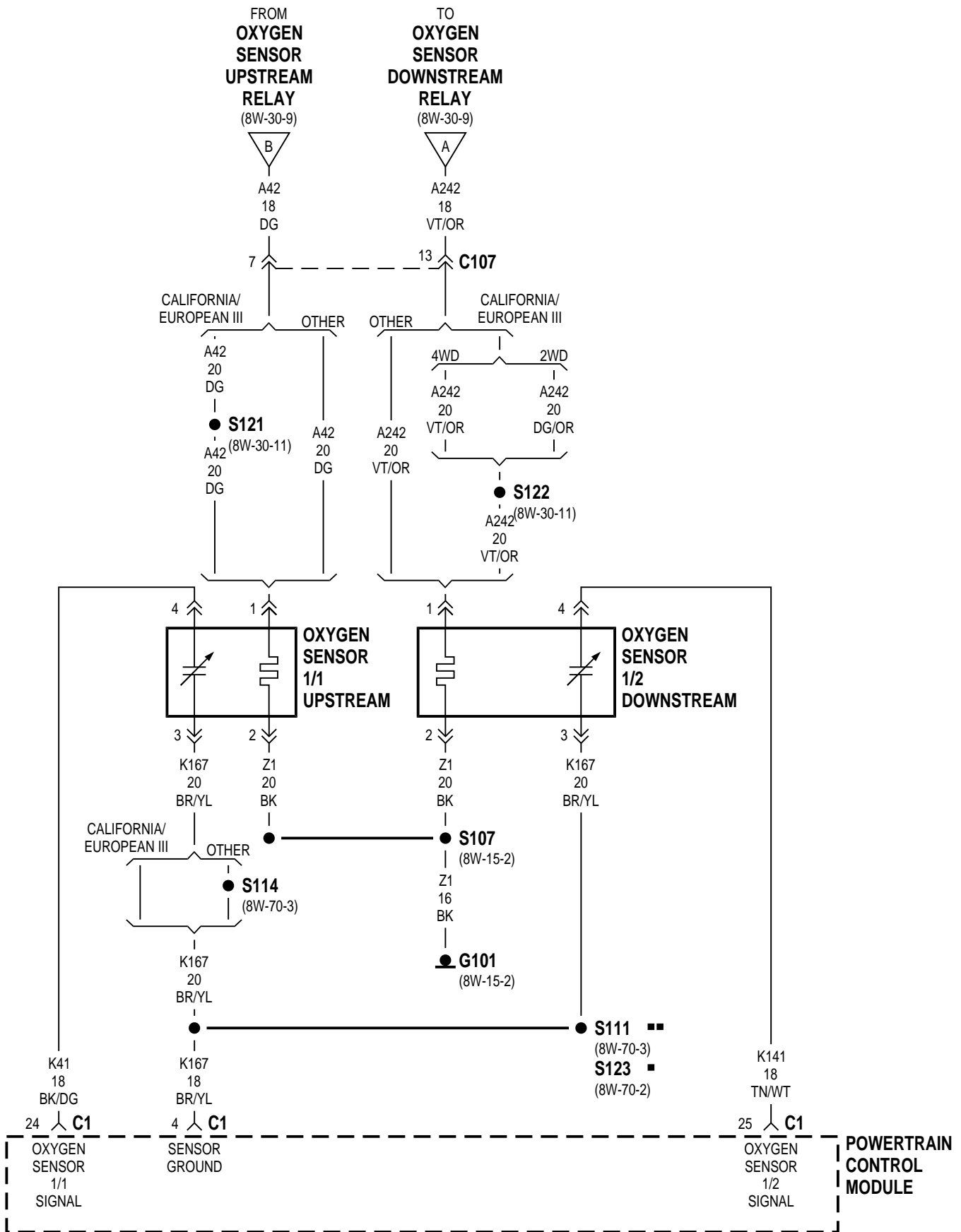

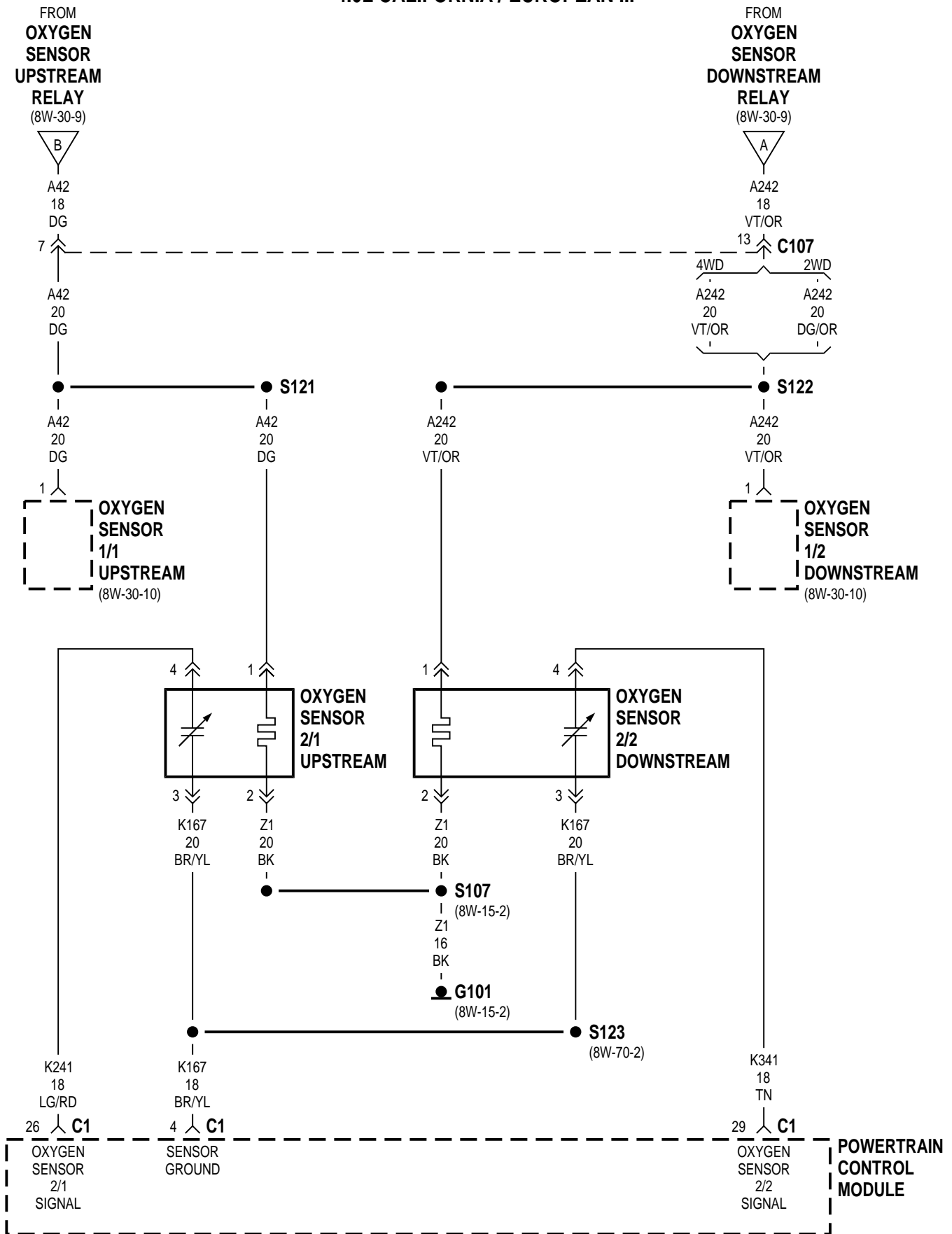

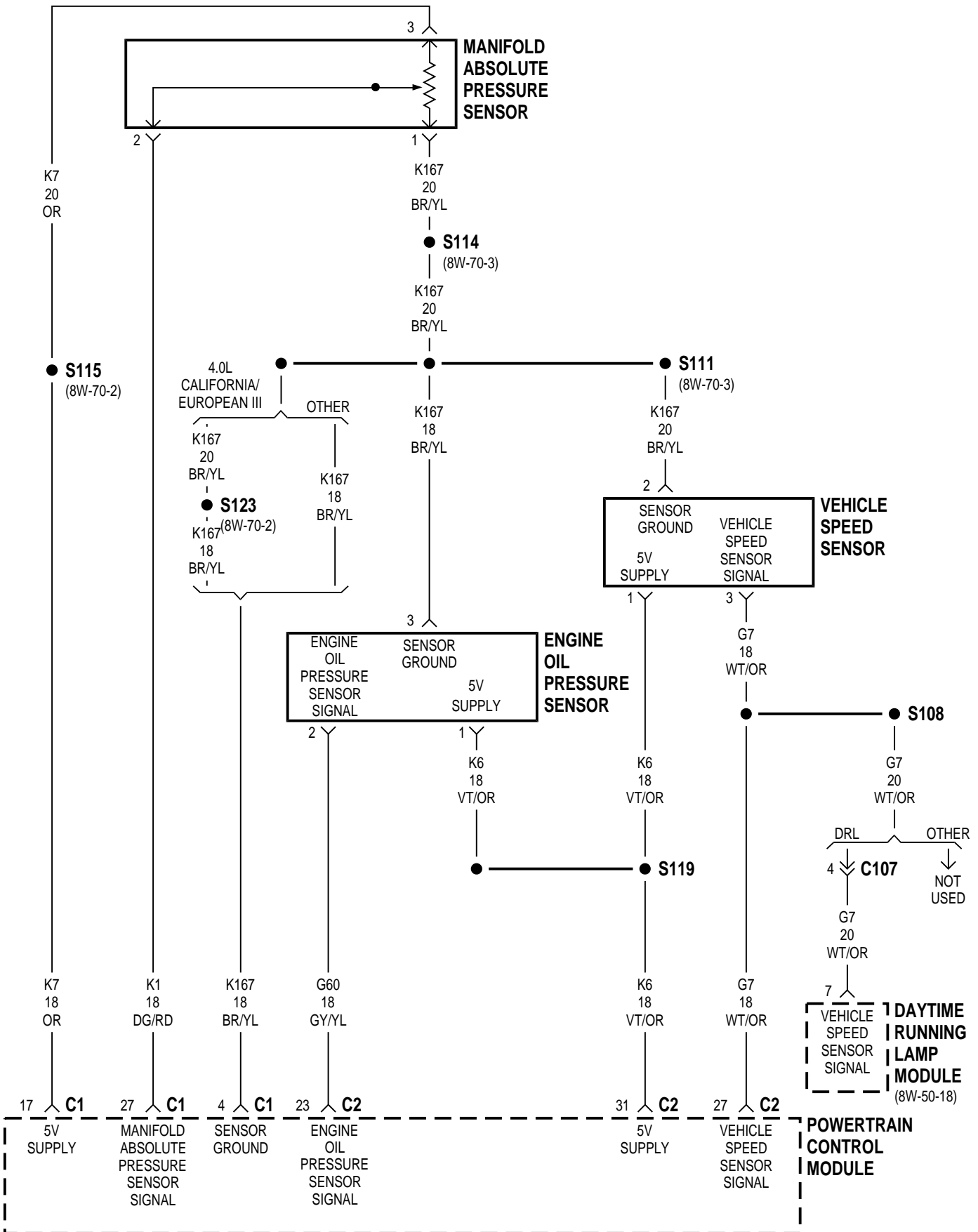

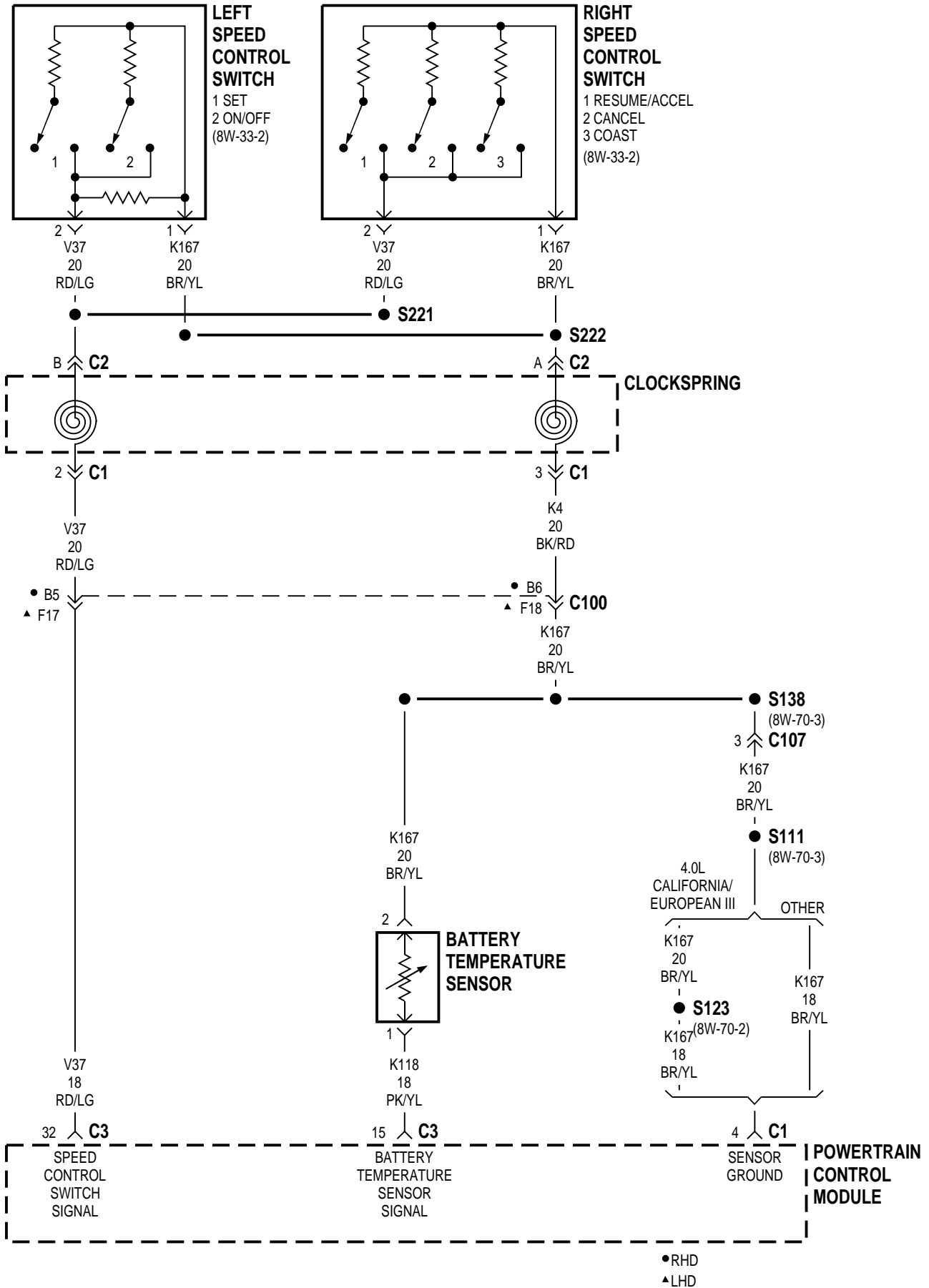

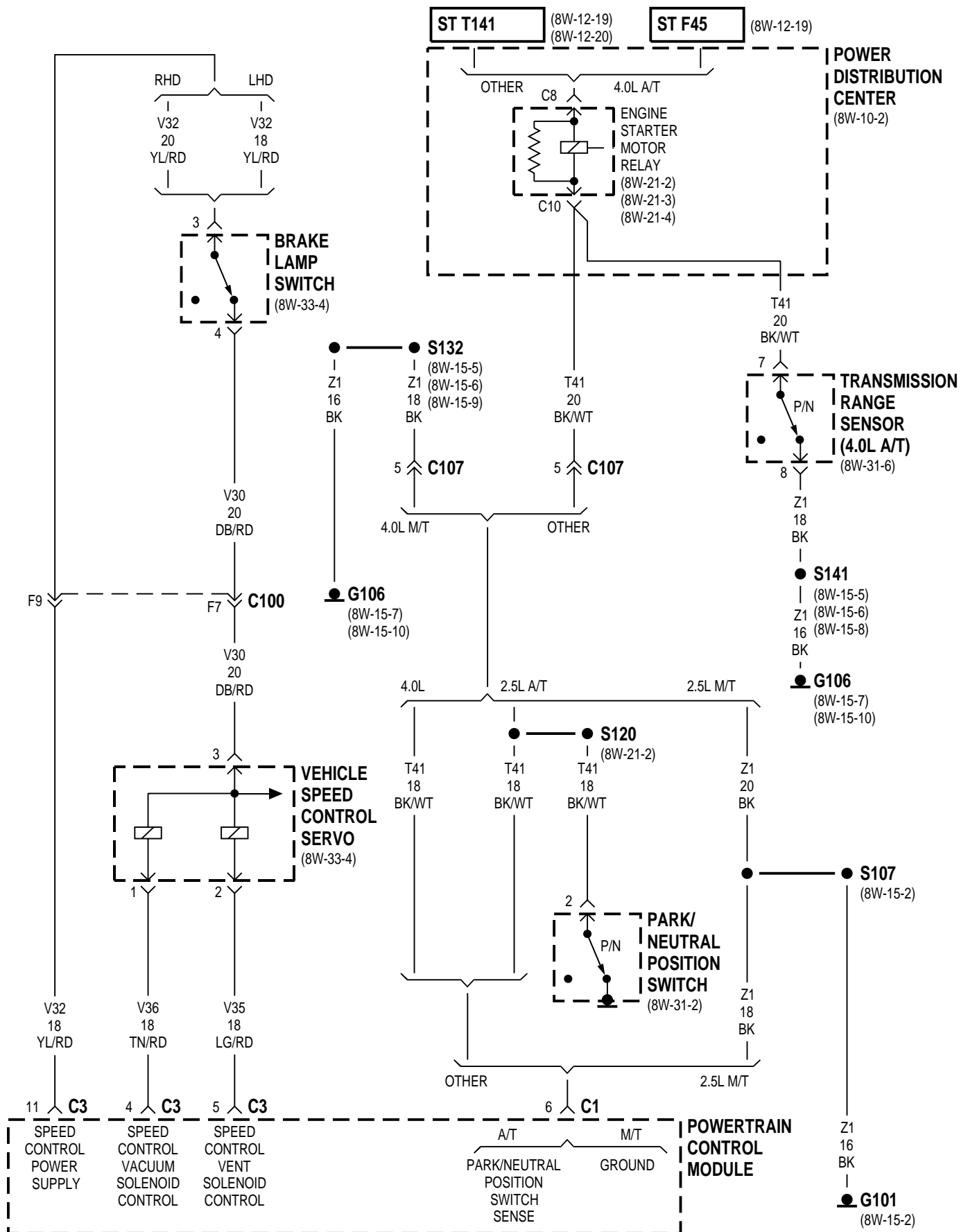

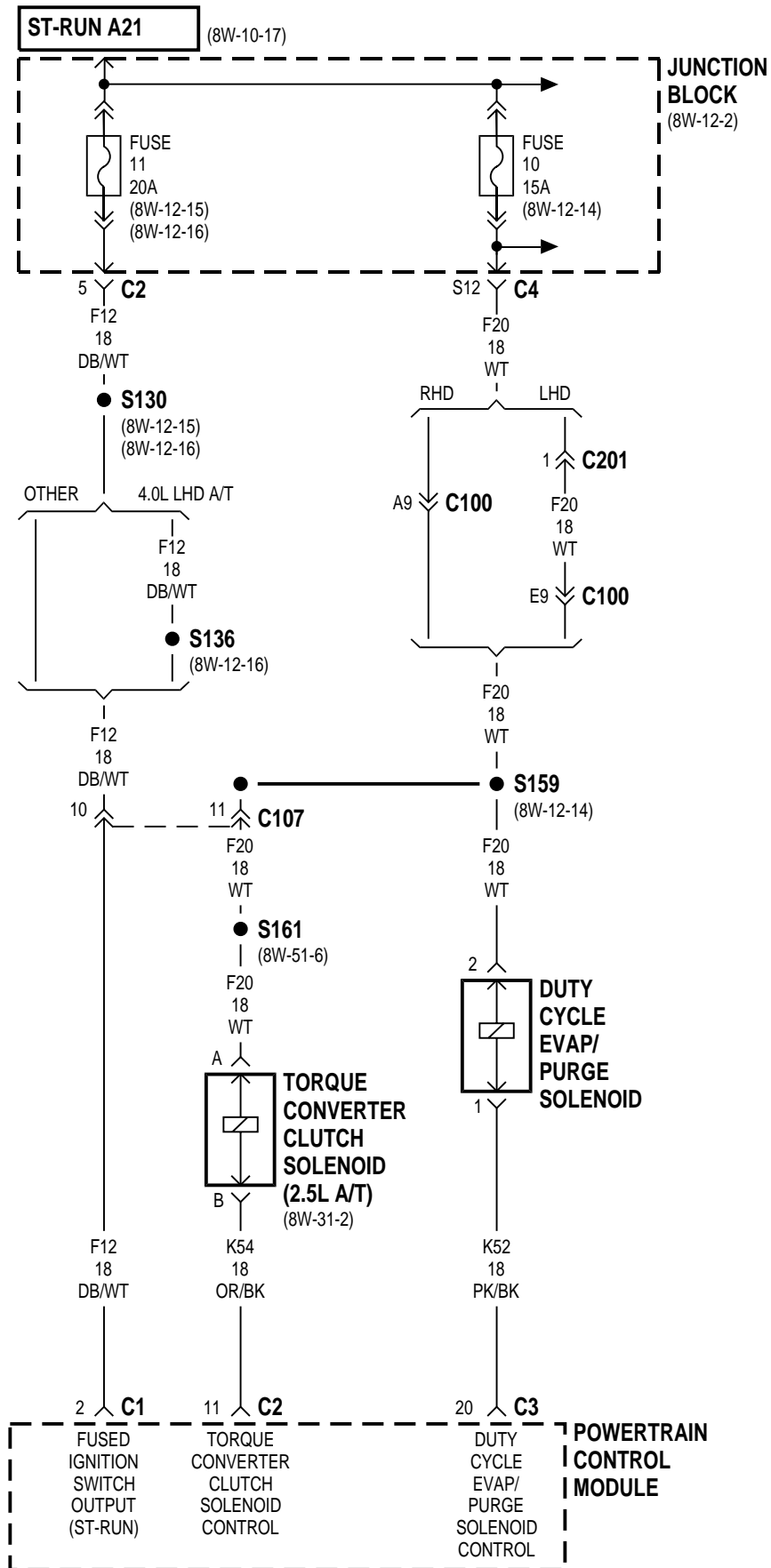

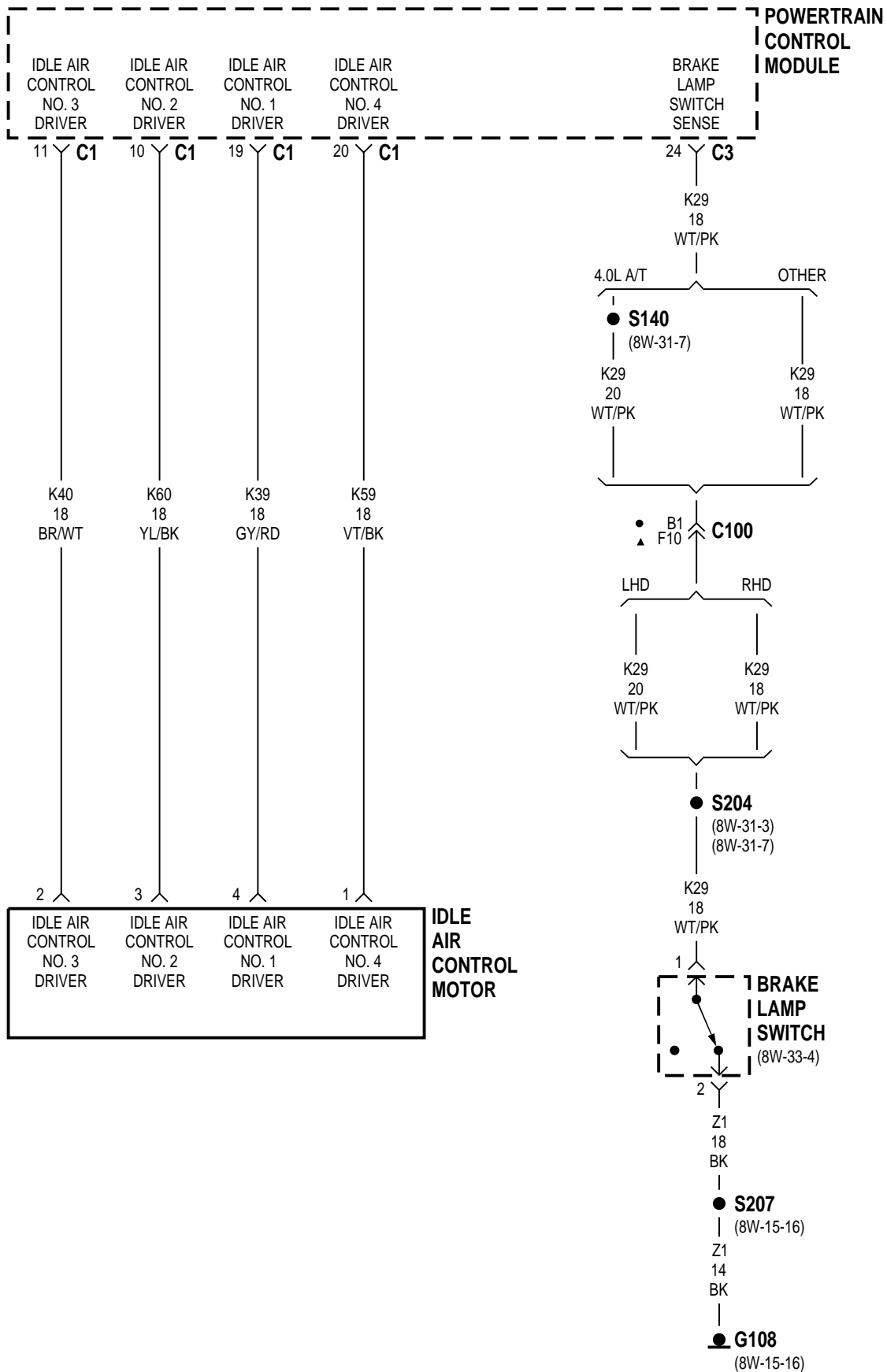

● RHD
▲ LHD

XJ **8W-30 FUEL/IGNITION SYSTEM** **8W - 30 - 17**
EXCEPT BUILT-UP-EXPORT

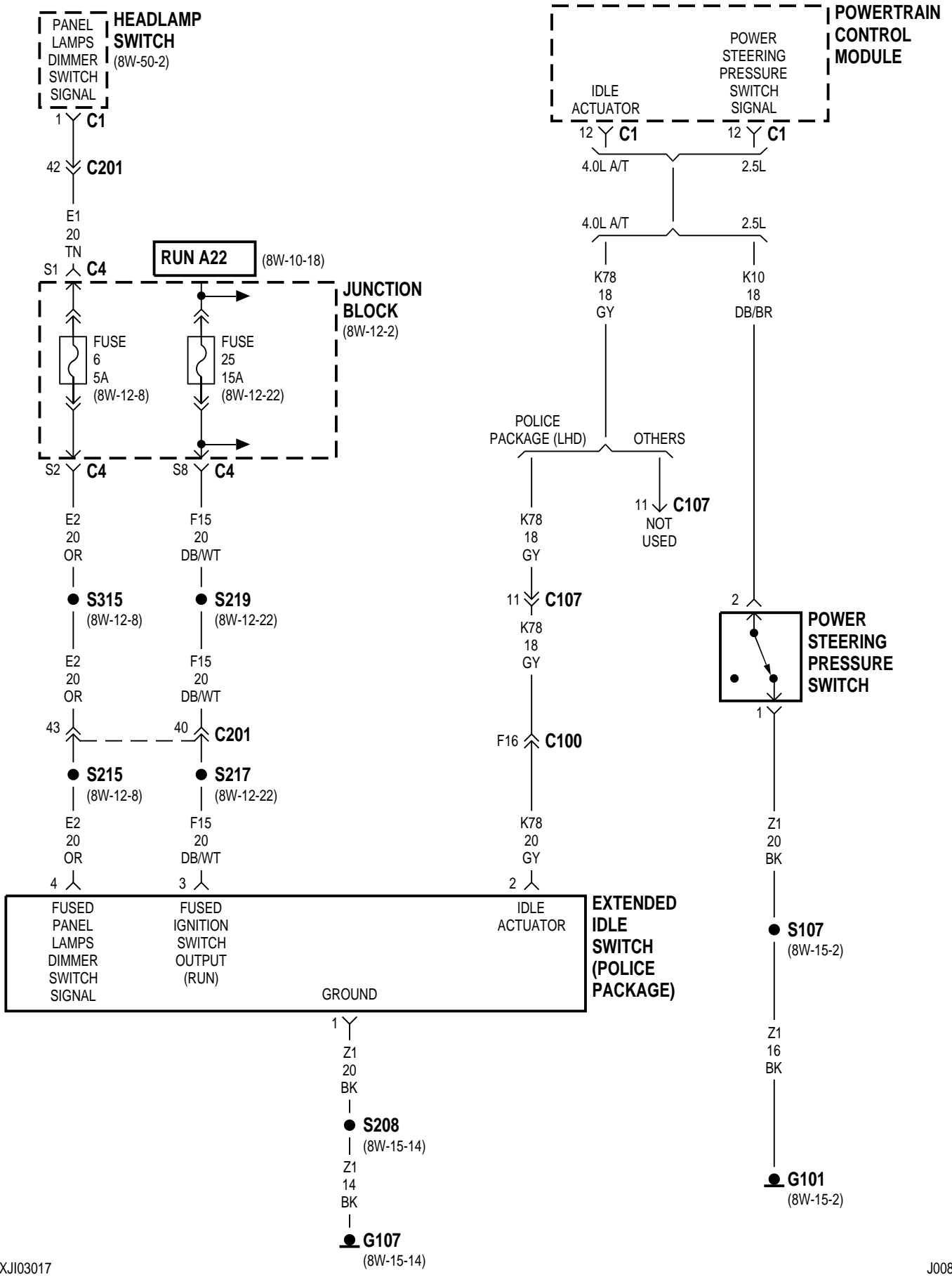

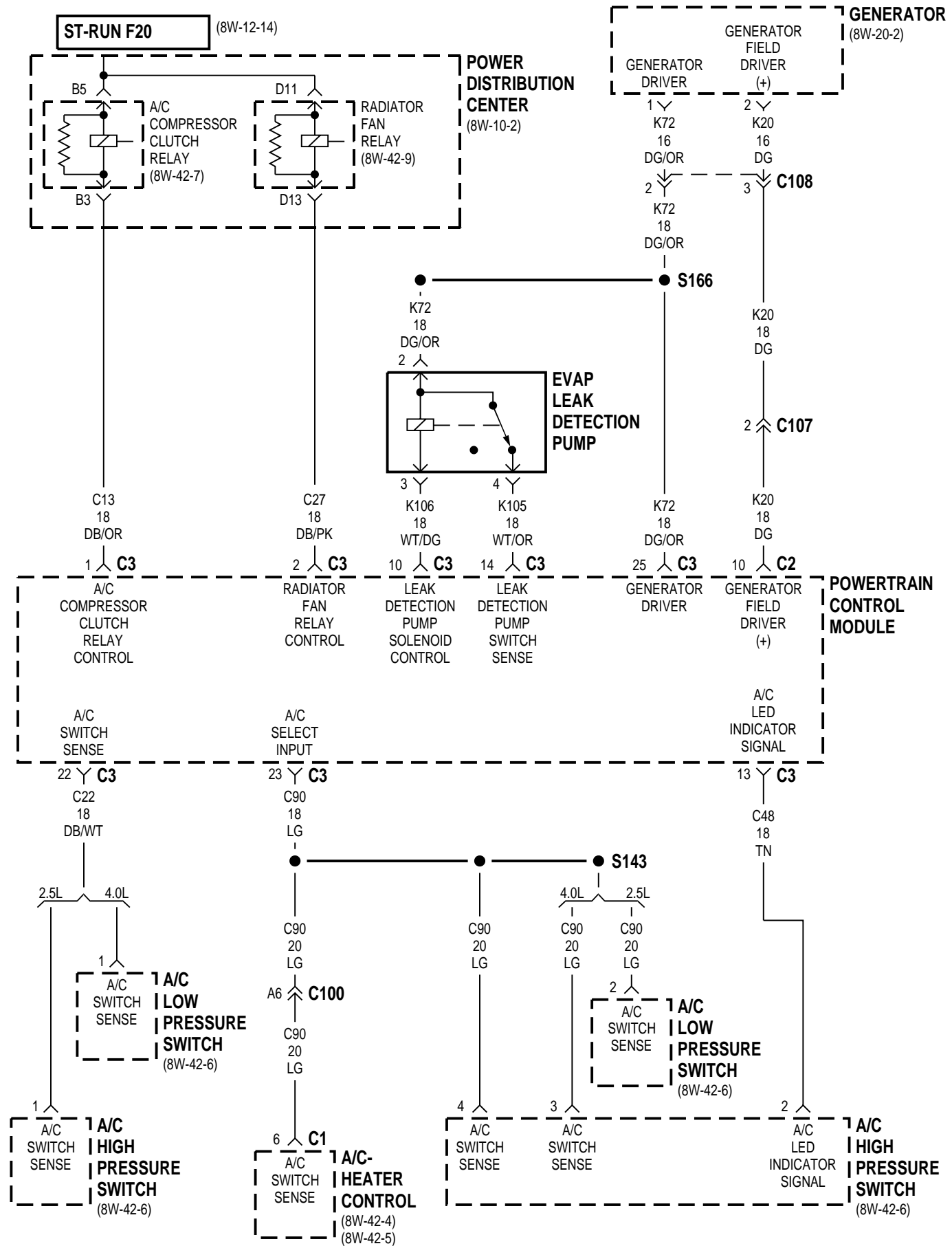

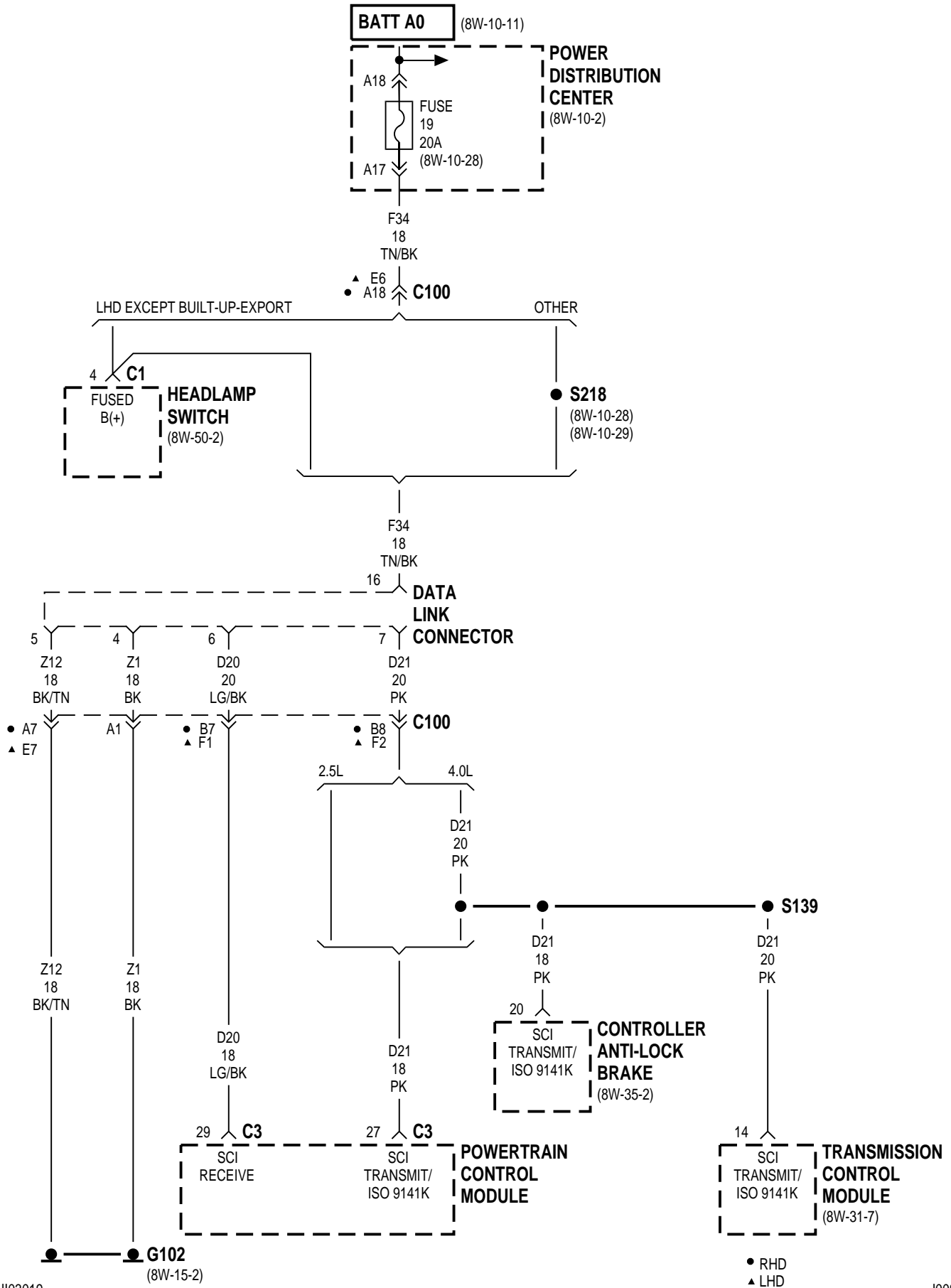

LHD

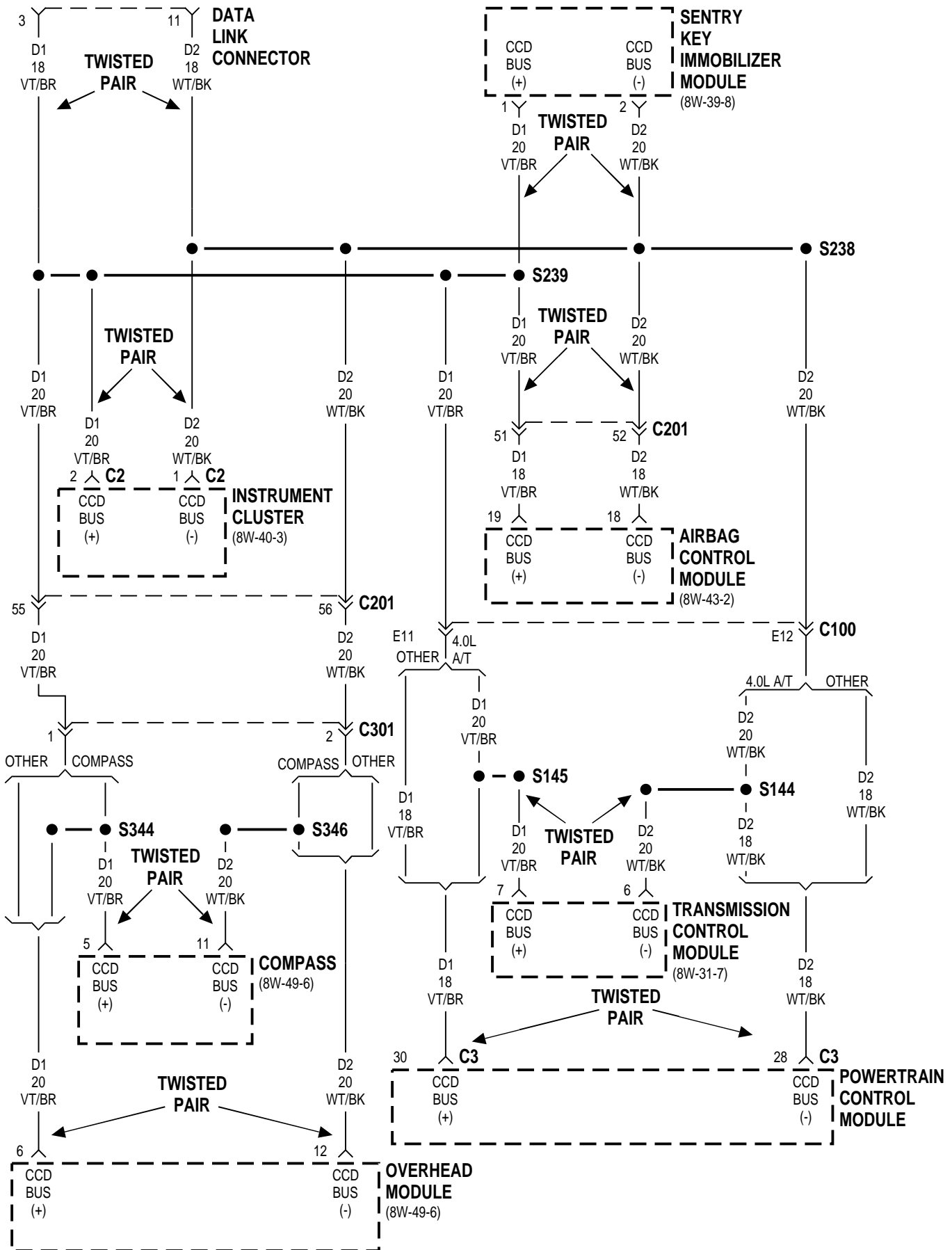

RHD

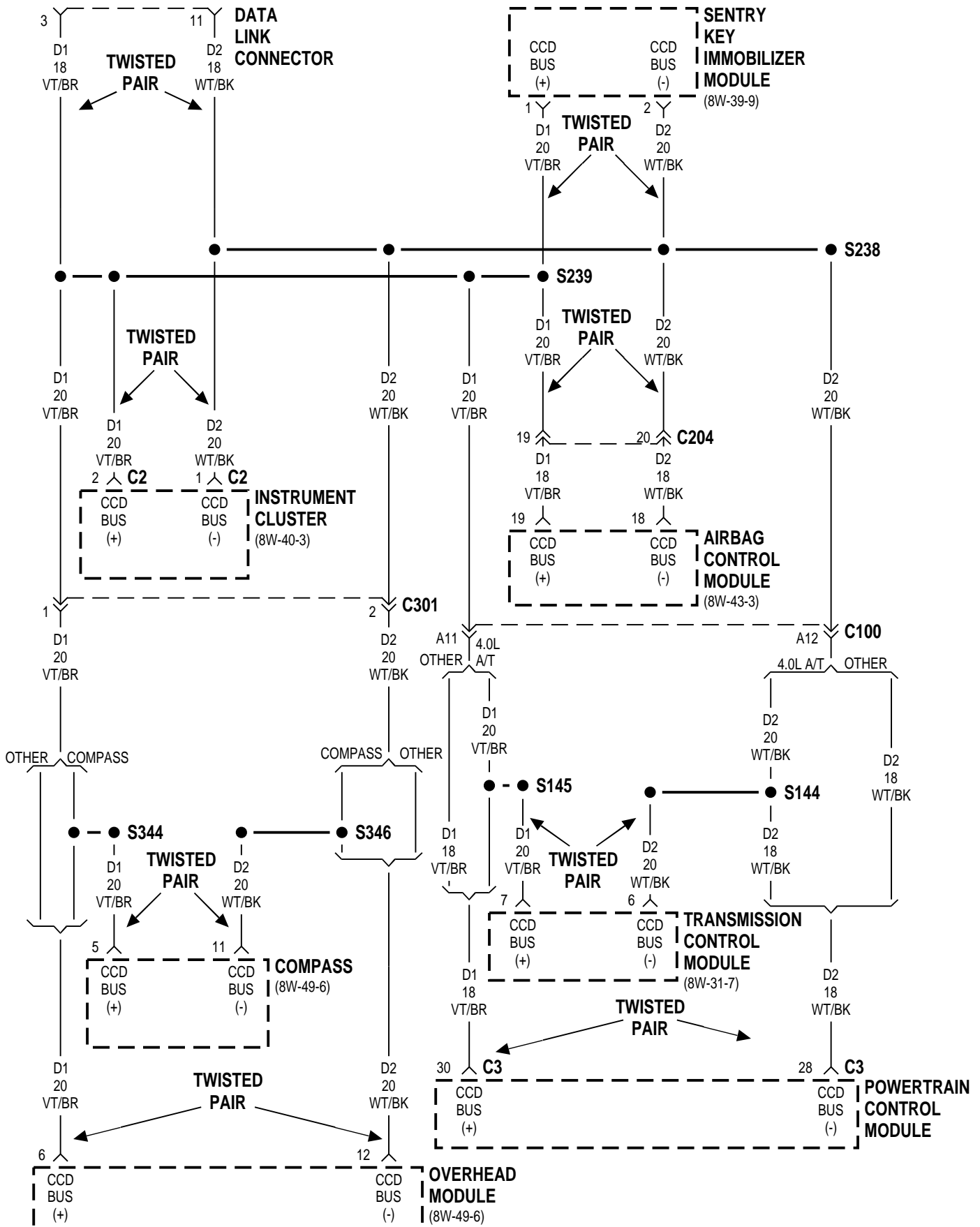

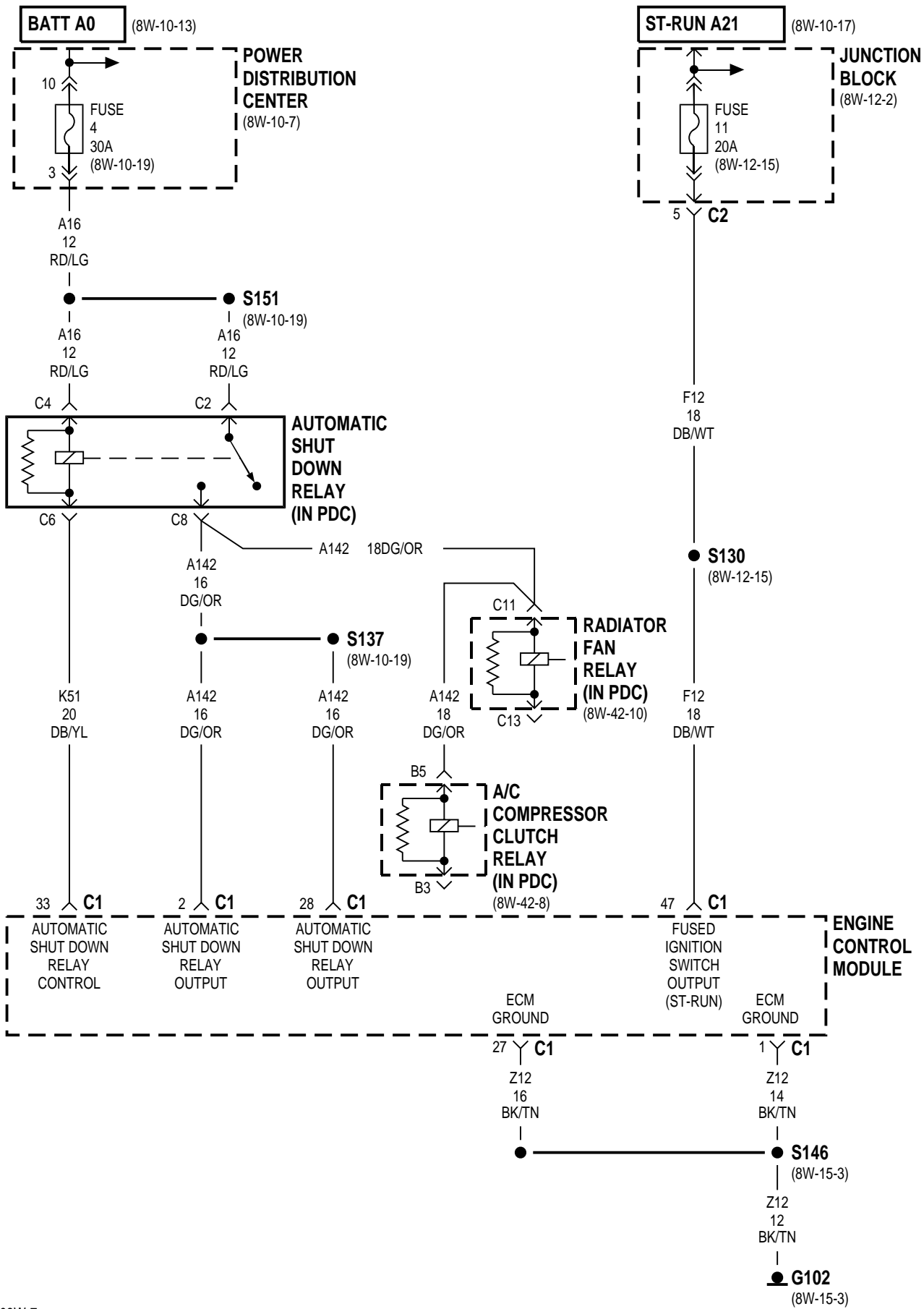

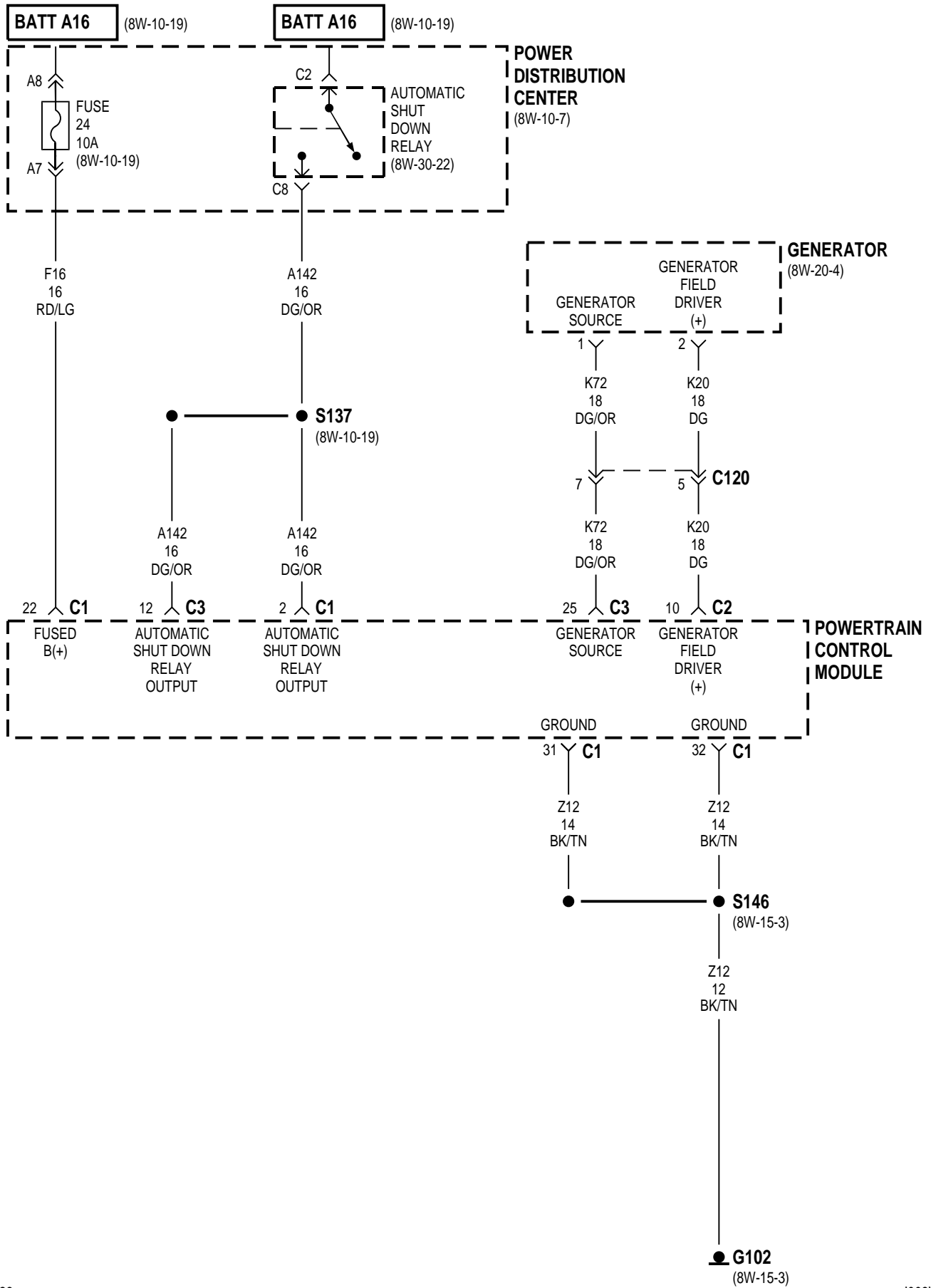

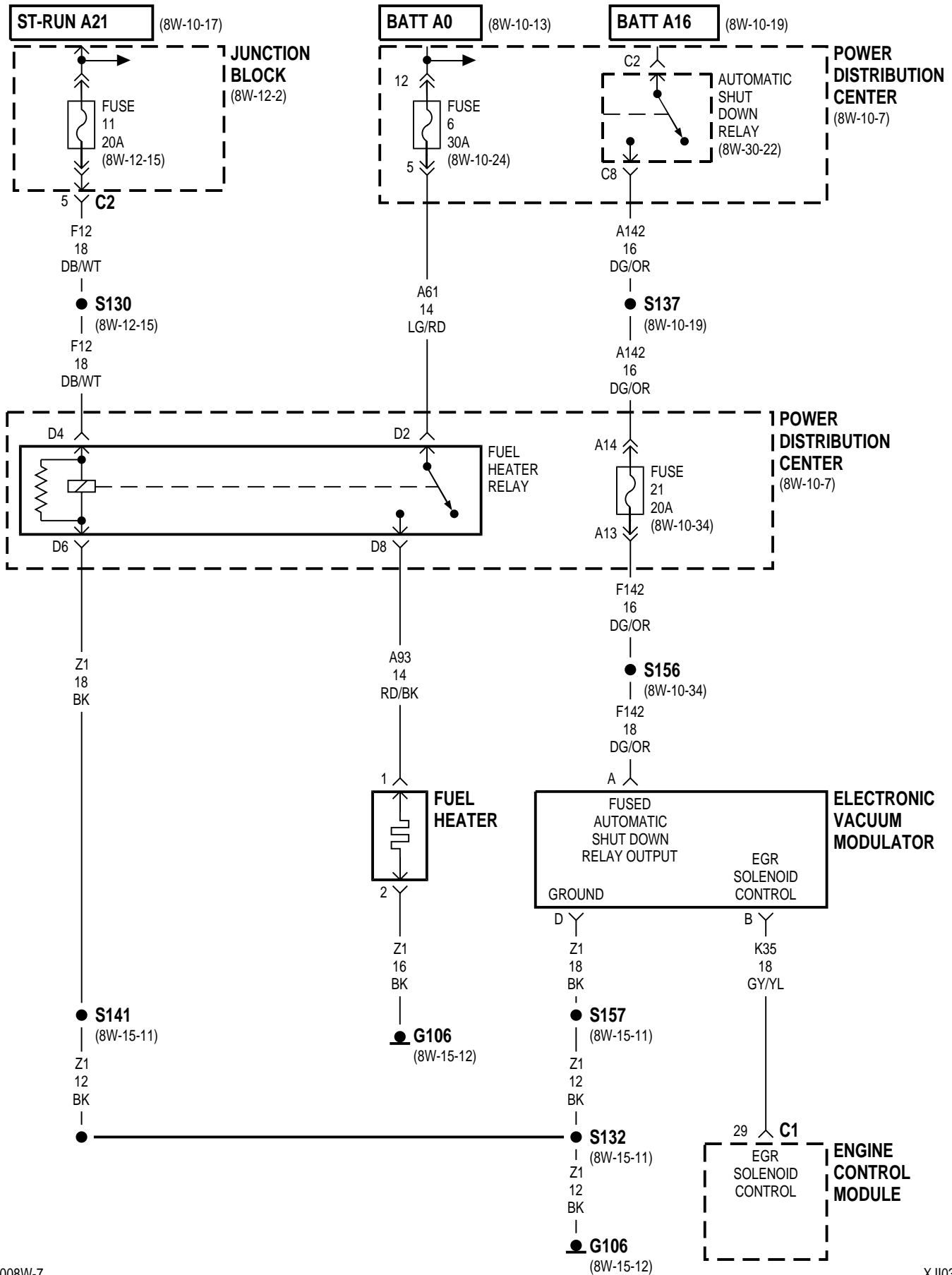

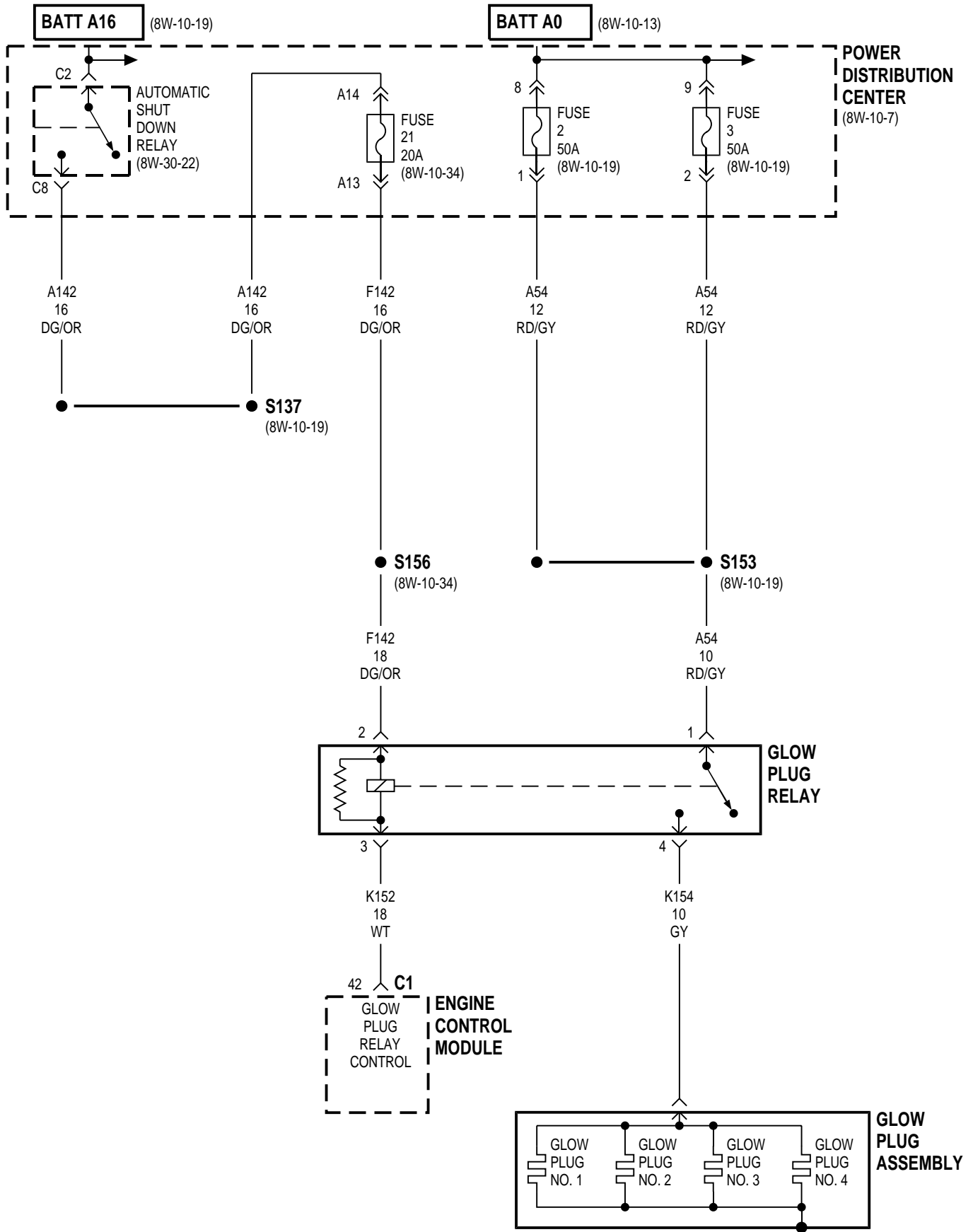

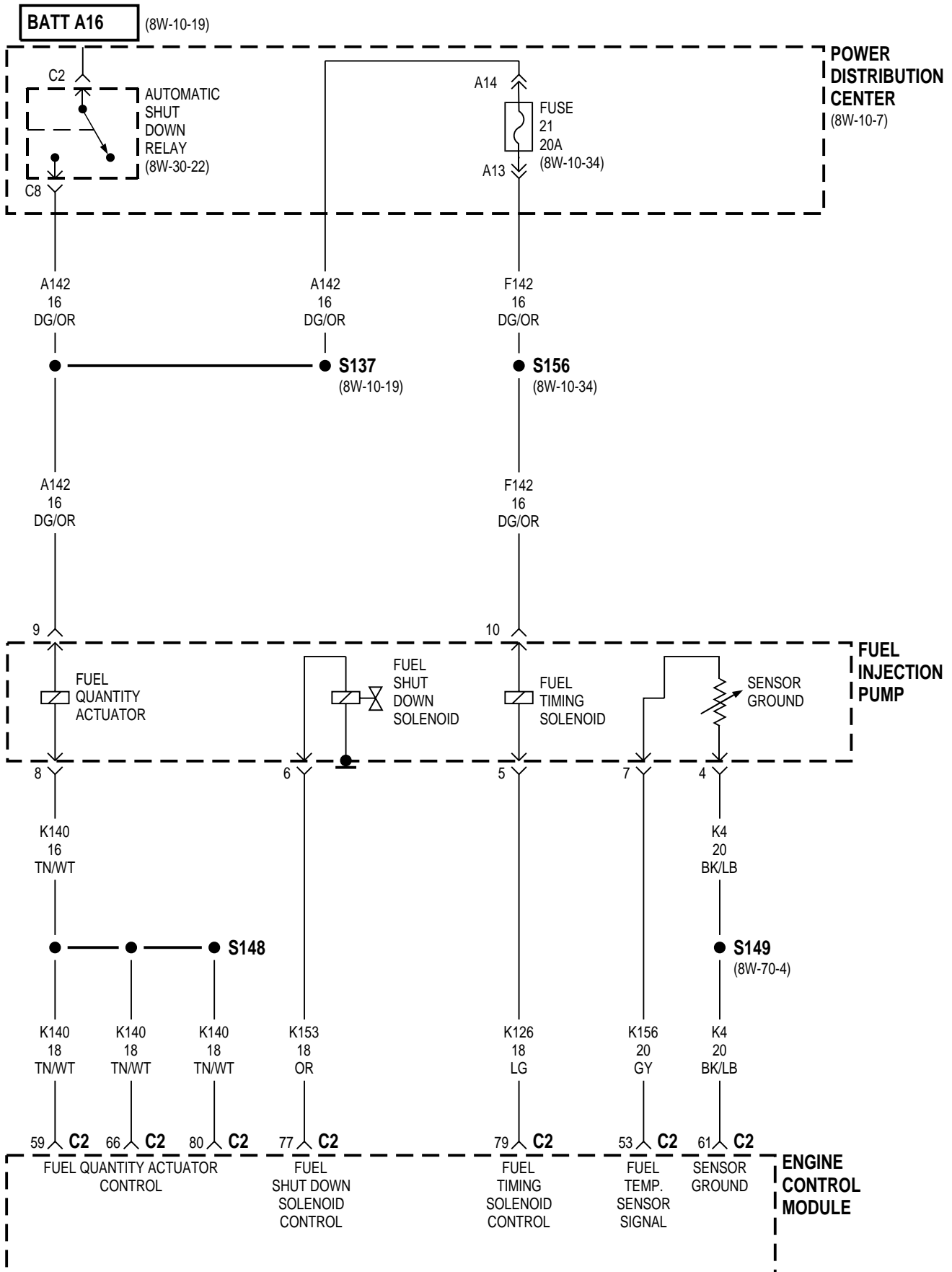

DIESEL

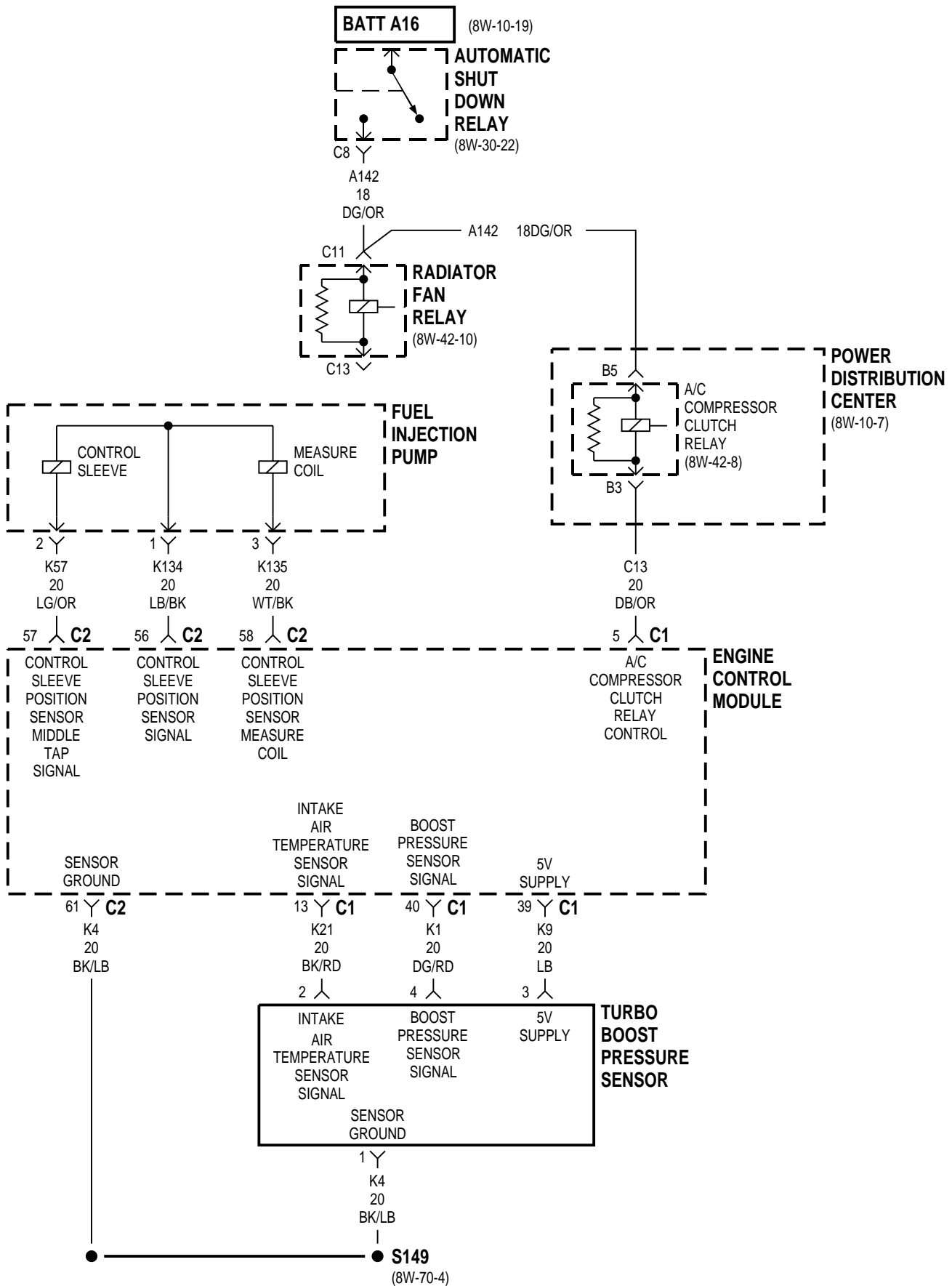

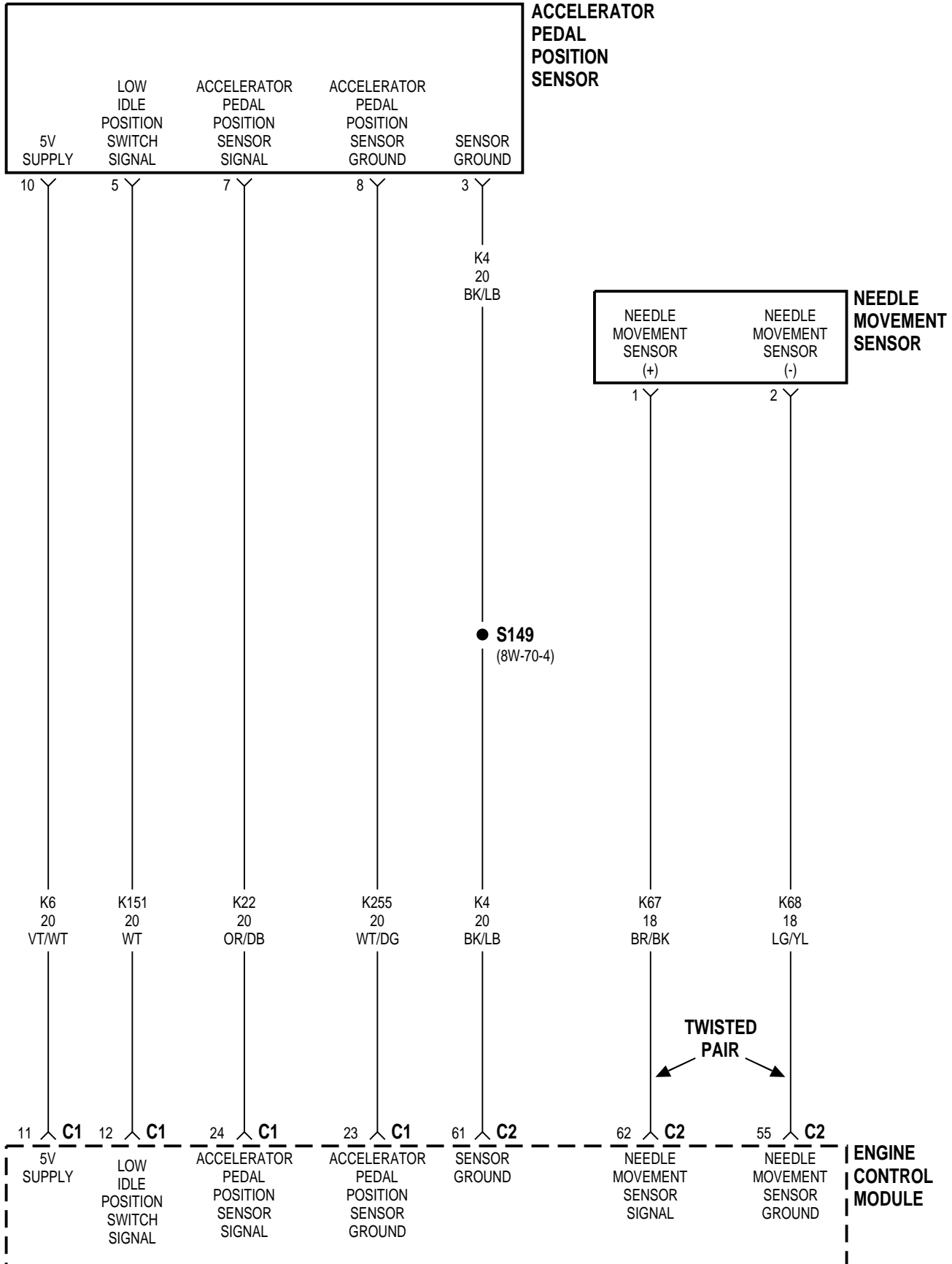

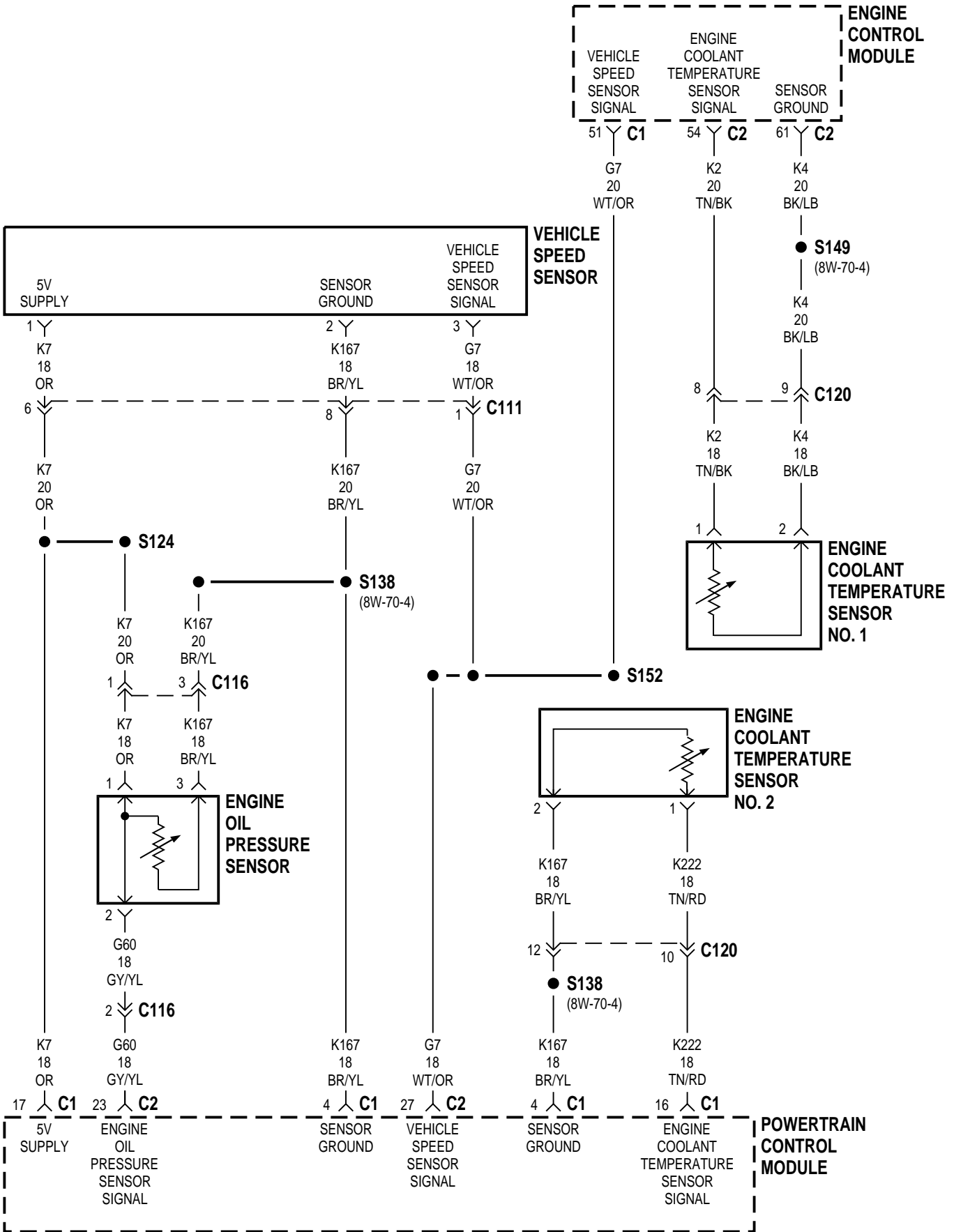

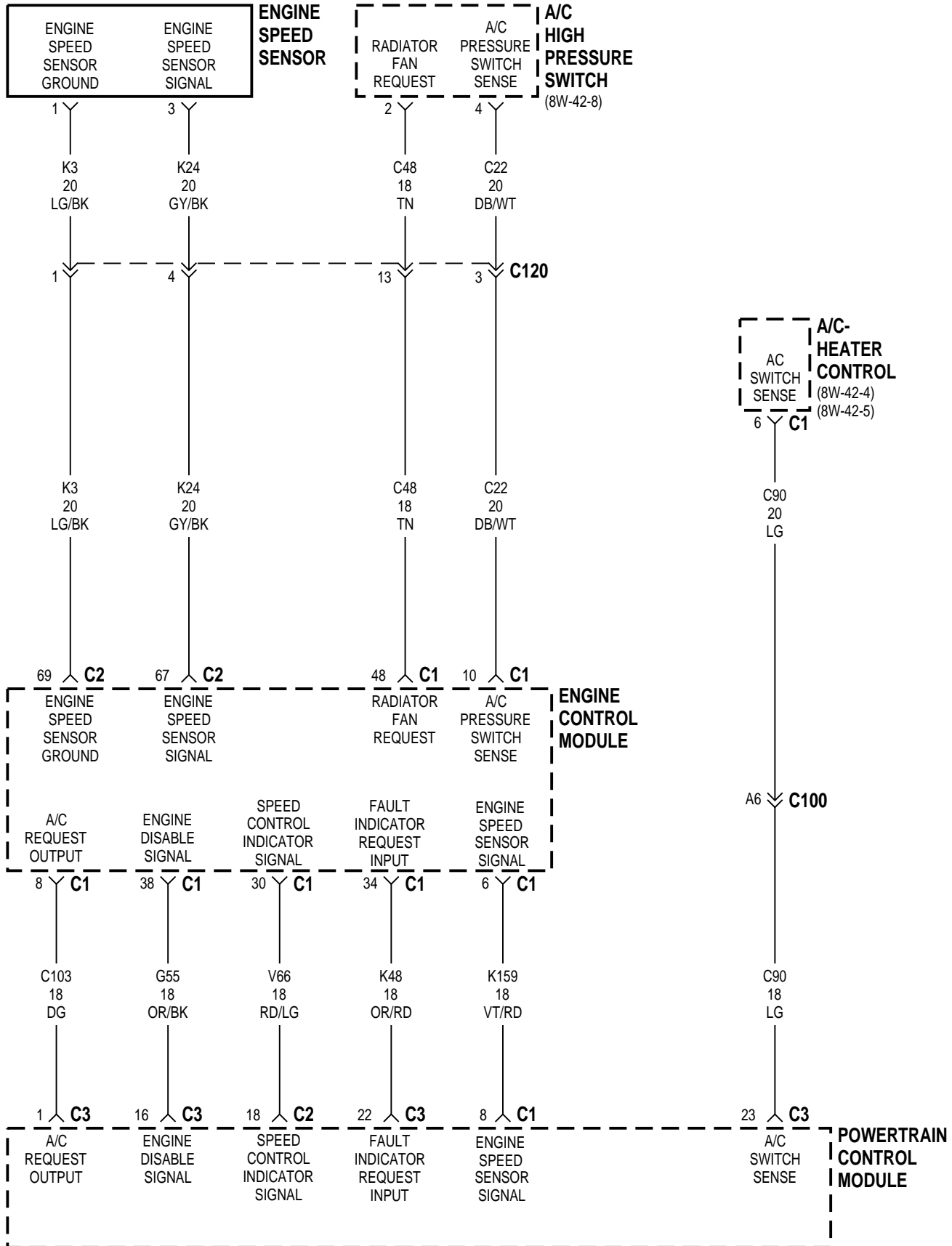

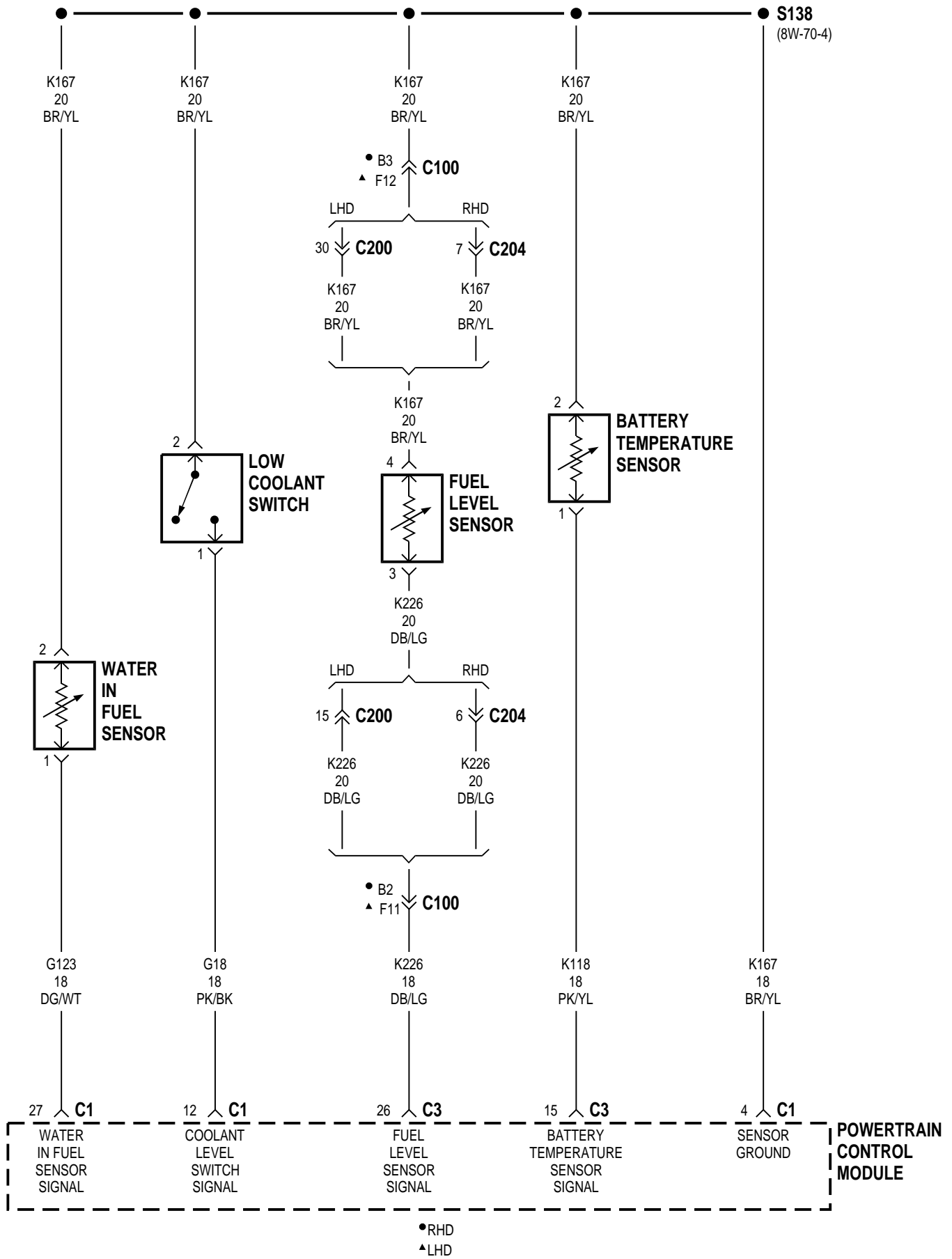

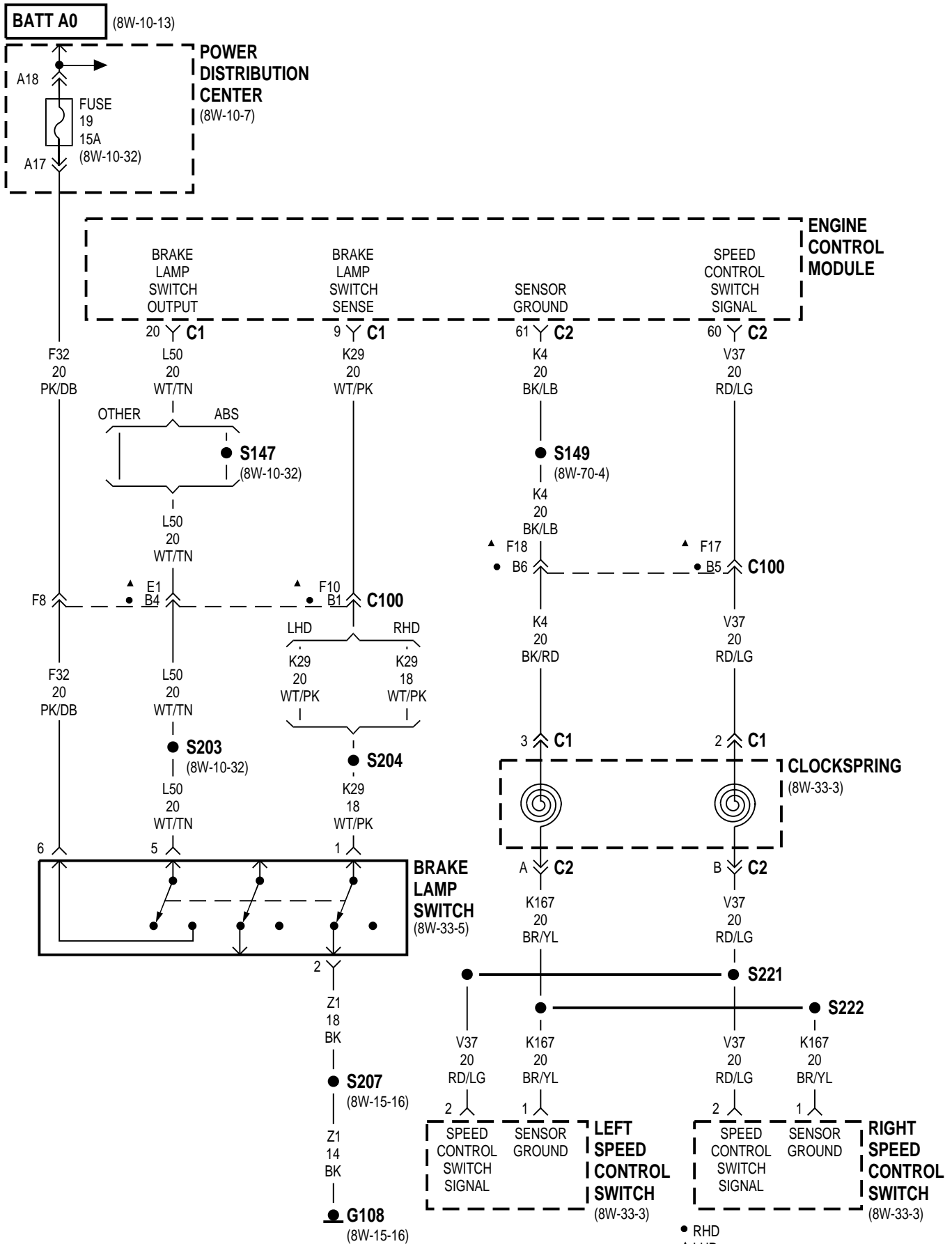

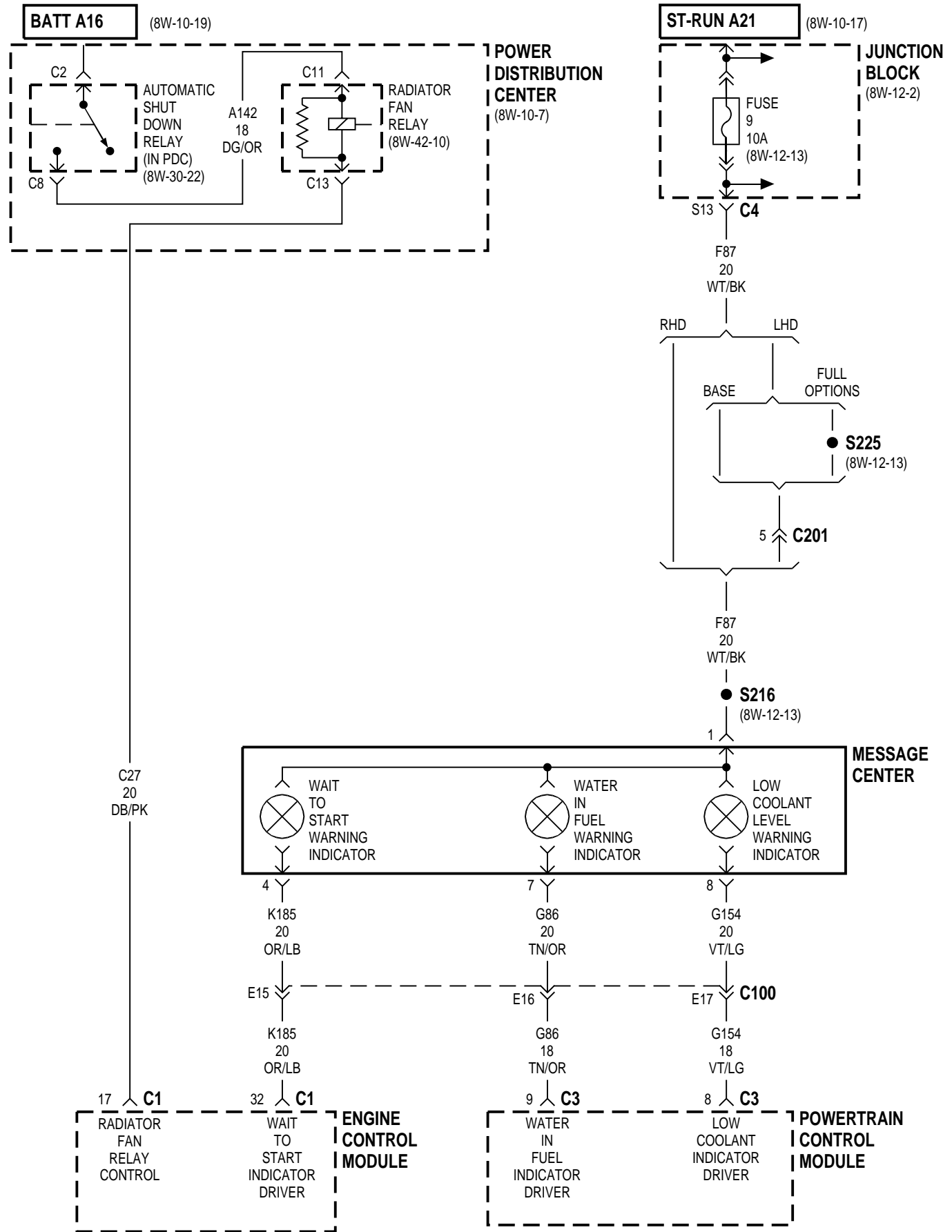

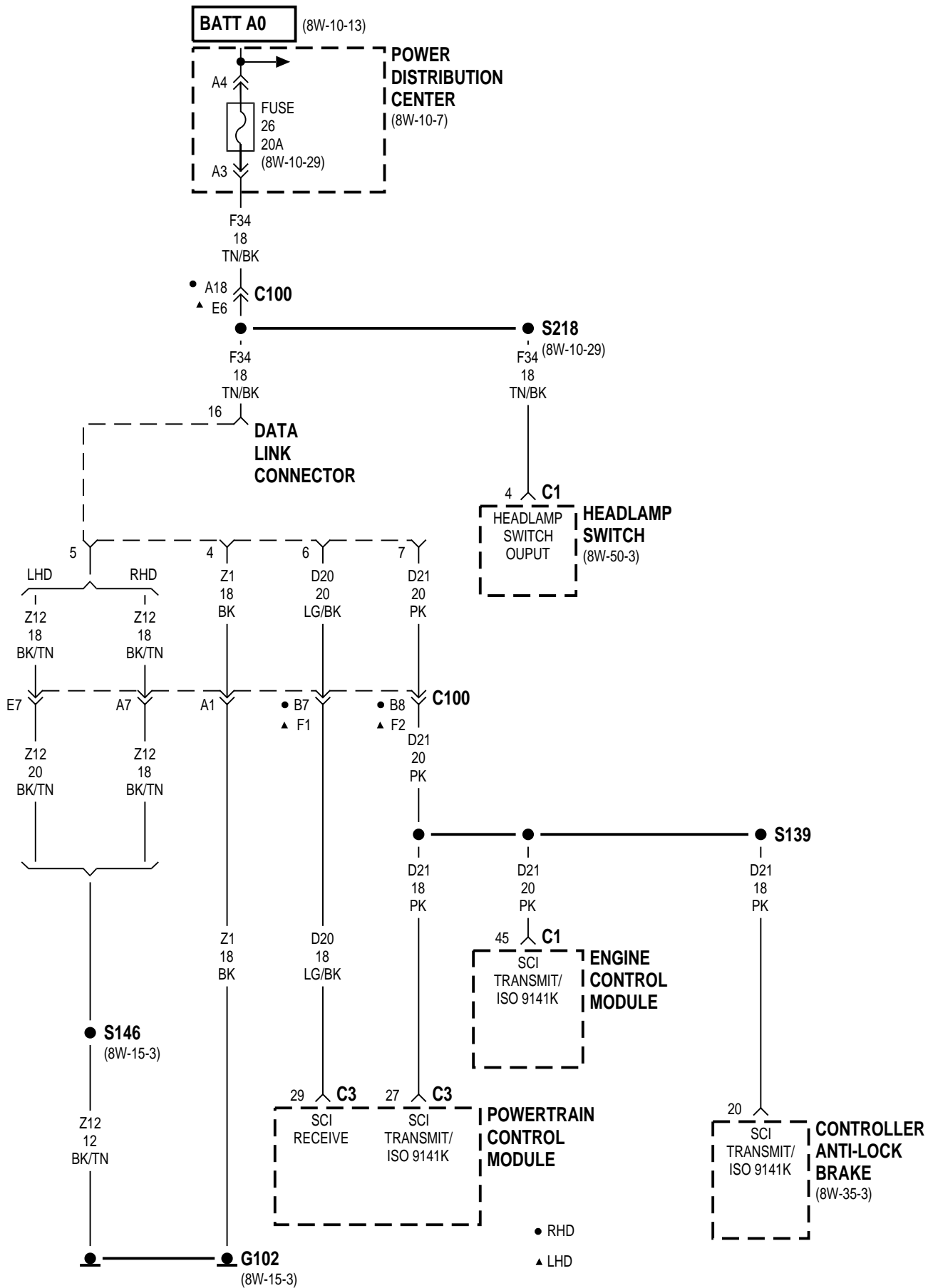

8W-31 TRANSMISSION CONTROL SYSTEM

| Component | Page | Component | Page |
|----------------------------------|---------------------|--|------------------|
| Brake Lamp Switch | 8W-31-3, 7 | Lock-Up Solenoid | 8W-31-4 |
| Data Link Connector | 8W-31-7 | Output Speed Sensor | 8W-31-5 |
| Engine Starter Motor Relay | 8W-31-2, 6 | Park/Neutral Position Switch | 8W-31-2 |
| Fuse 10 (JB) | 8W-31-2, 6 | Power Distribution Center | 8W-31-2, 4 |
| Fuse 11 (JB) | 8W-31-2, 4 | Powertrain Control Module | 8W-31-2, 3, 5, 7 |
| Fuse 16 (PDC) | 8W-31-4 | Shift Lock Solenoid | 8W-31-3, 7 |
| Fuse 25 (JB) | 8W-31-3, 7 | Throttle Position Sensor | 8W-31-5 |
| G101 | 8W-31-4 | Torque Converter Clutch Solenoid | 8W-31-2 |
| G106 | 8W-31-6 | Transmission Control Module | 8W-31-4, 5, 6, 7 |
| G108 | 8W-31-3, 7 | Transmission Range Sensor | 8W-31-6 |
| Input Speed Sensor | 8W-31-5 | Transmission Solenoid | 8W-31-4, 5 |
| Junction Block | 8W-31-2, 3, 4, 6, 7 | | |

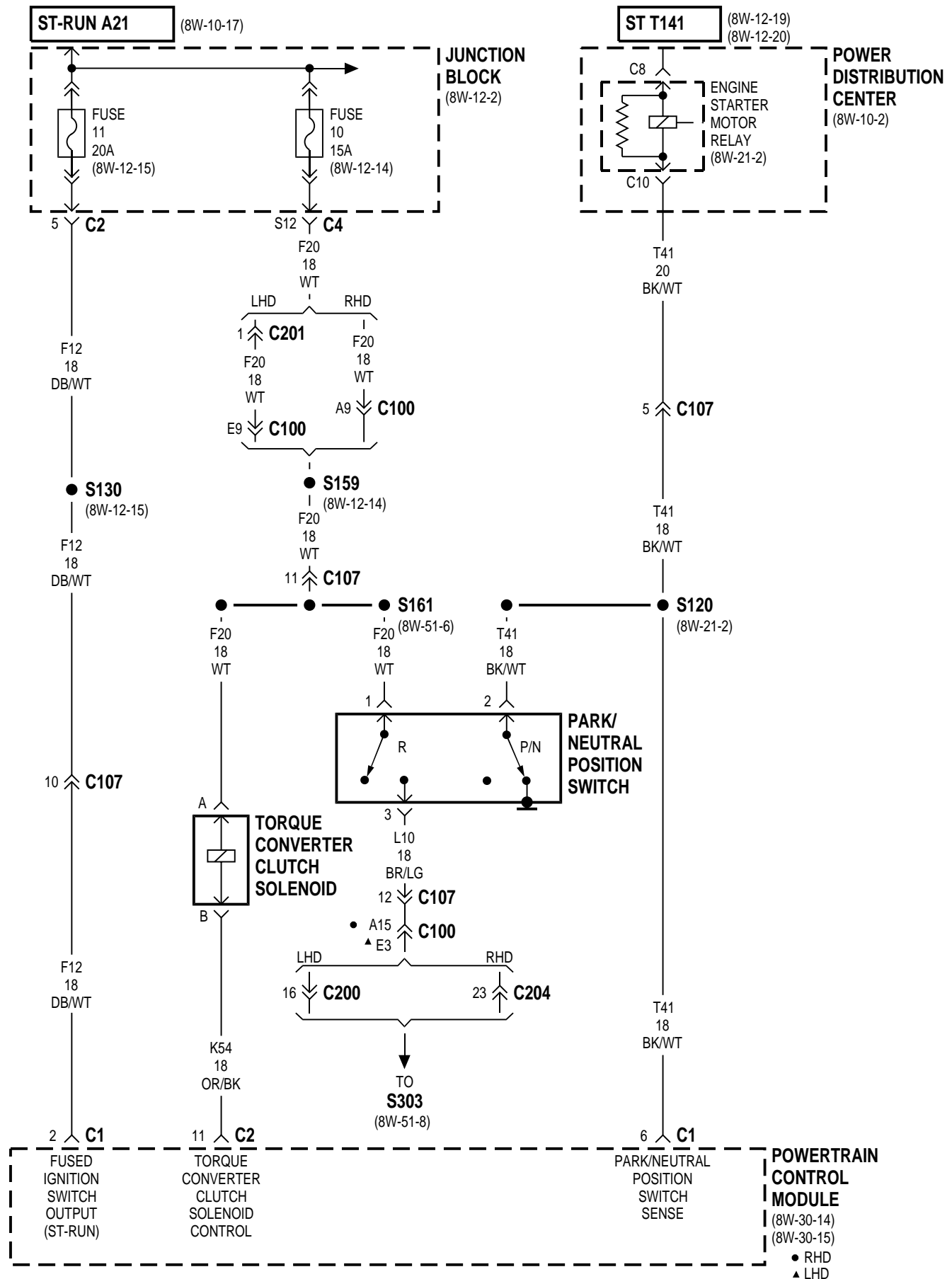

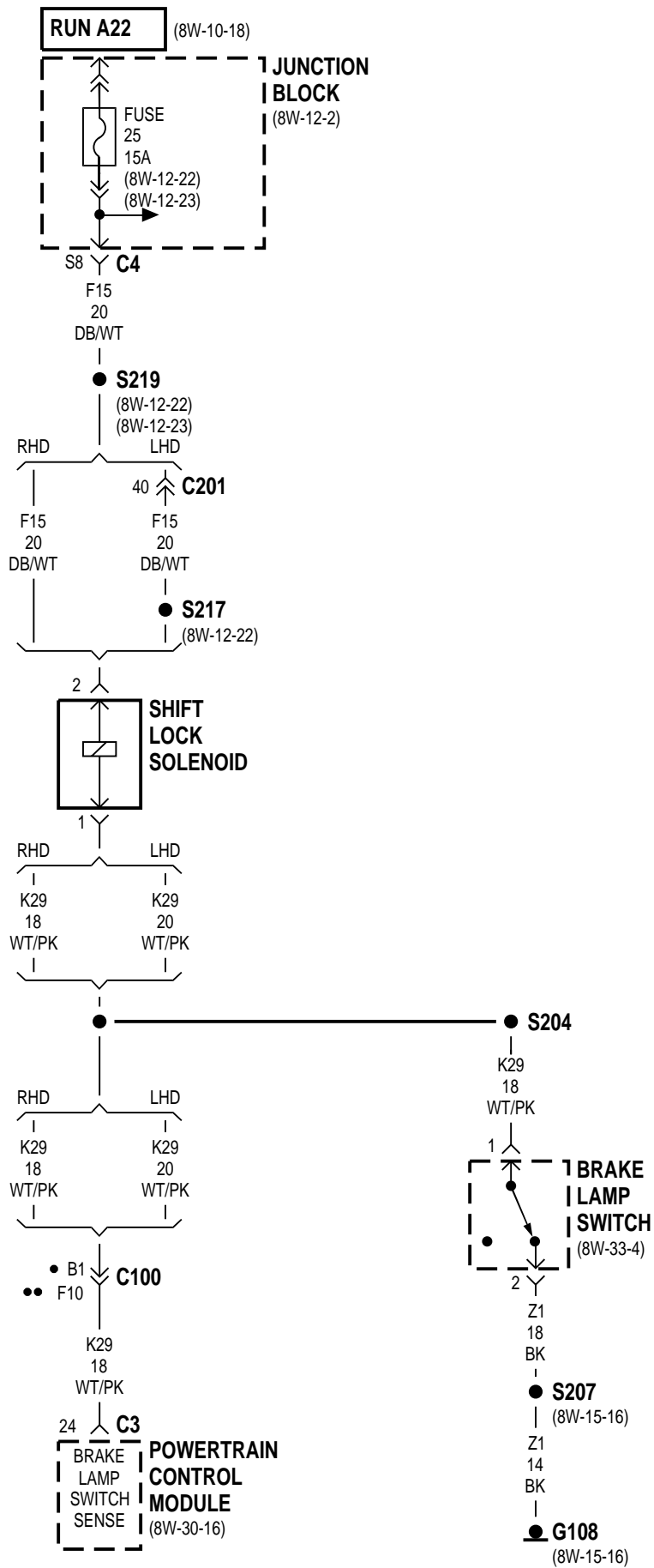

4.0L

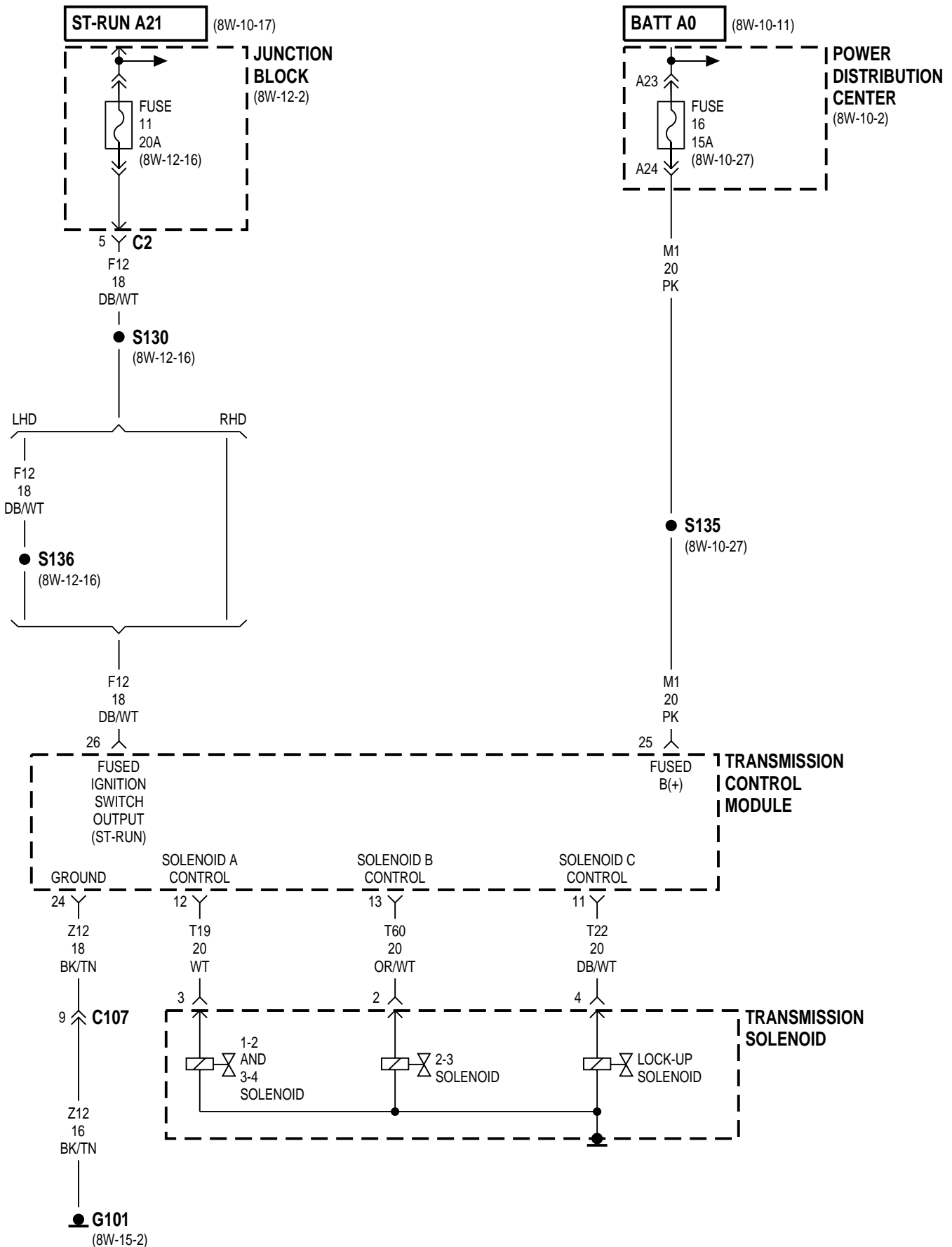

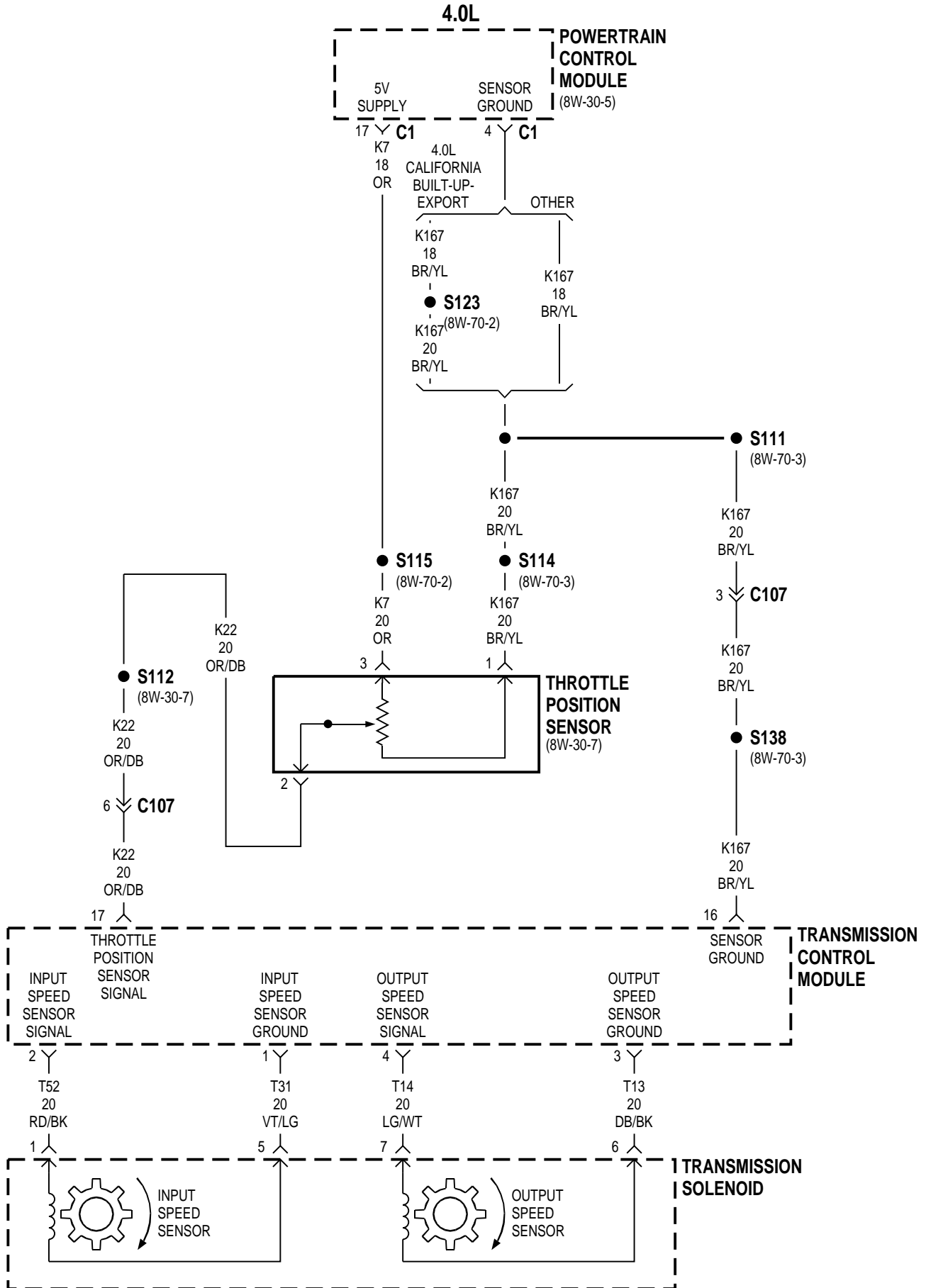

4.0L

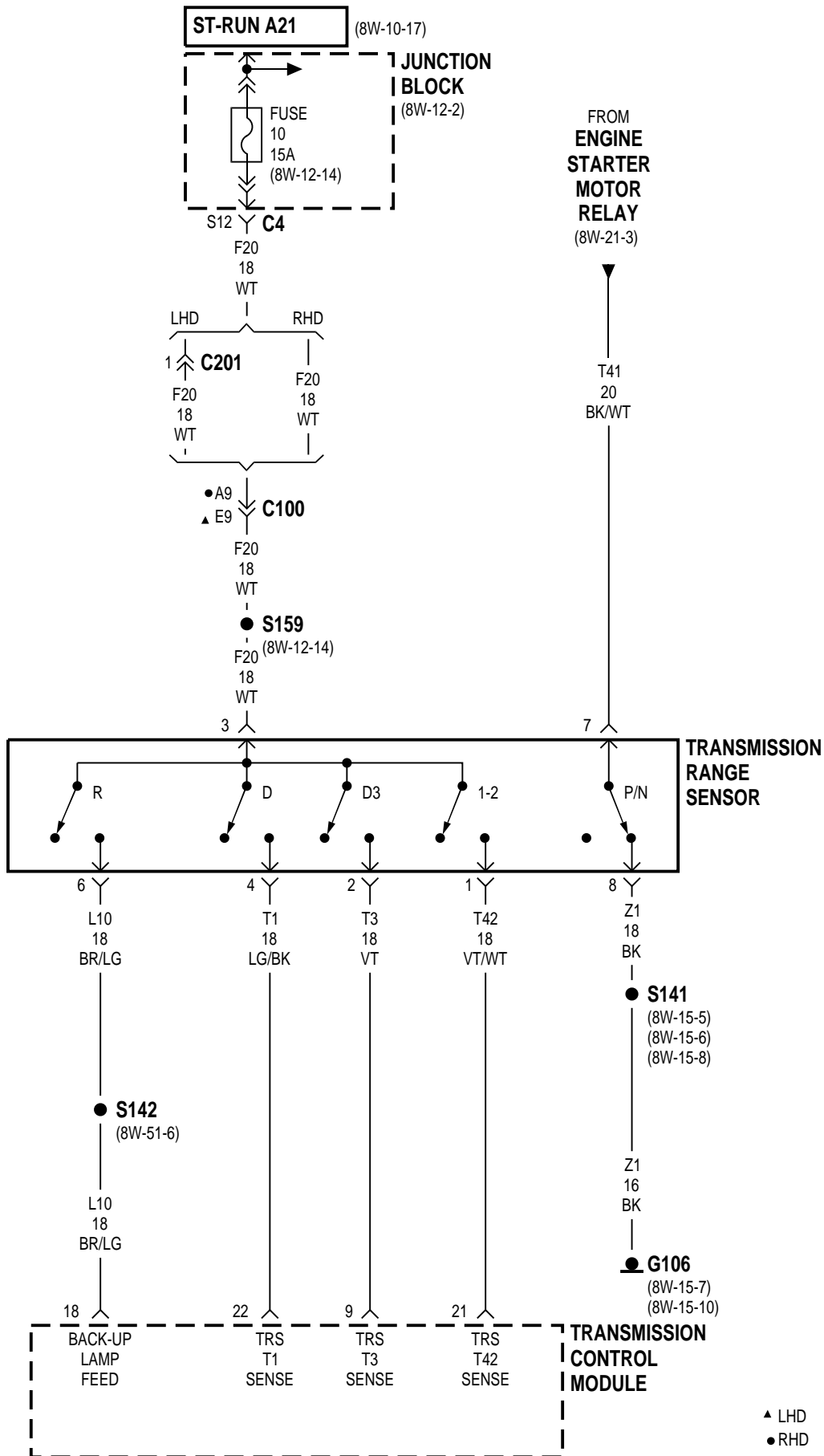

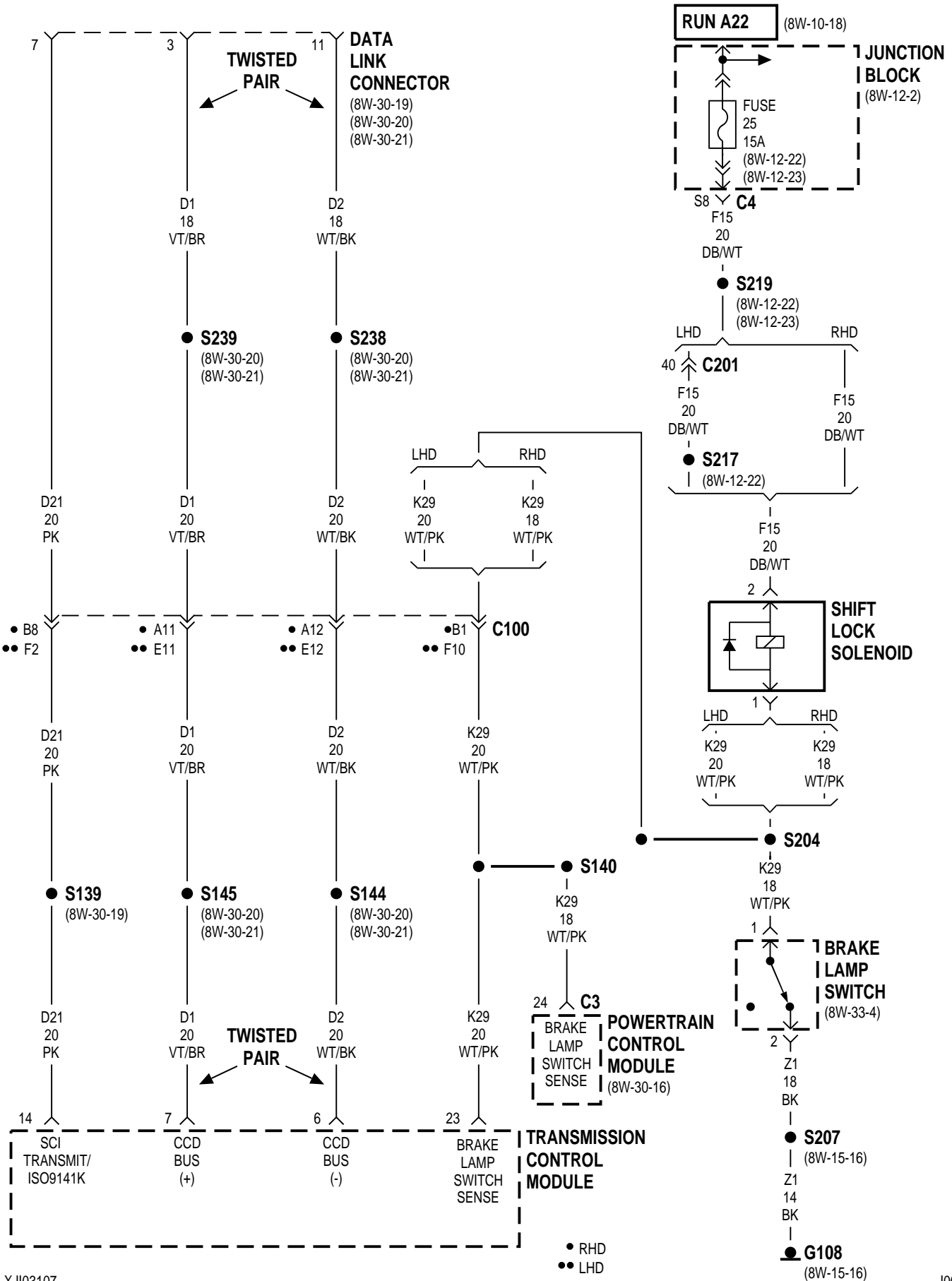

8W-33 VEHICLE SPEED CONTROL

| Component | Page | Component | Page |
|---|-------------|---------------------------------------|---------------|
| Accelerator Pedal Position Sensor | 8W-33-5 | G106 | 8W-33-4 |
| Brake Lamp Switch | 8W-33-4, 5 | G108 | 8W-33-4, 5 |
| Clockspring | 8W-33-2, 3 | Left Speed Control Switch | 8W-33-2, 3 |
| Engine Control Module | 8W-33-3, 5 | Power Distribution Center | 8W-33-4, 5 |
| Fuel Injection Pump | 8W-33-5 | Powertrain Control Module | 8W-33-2, 4, 5 |
| Fuse 19 (PDC) | 8W-33-5 | Right Speed Control Switch | 8W-33-2, 3 |
| Fuse 23 (PDC) | 8W-33-4 | Vehicle Speed Control Servo | 8W-33-4 |

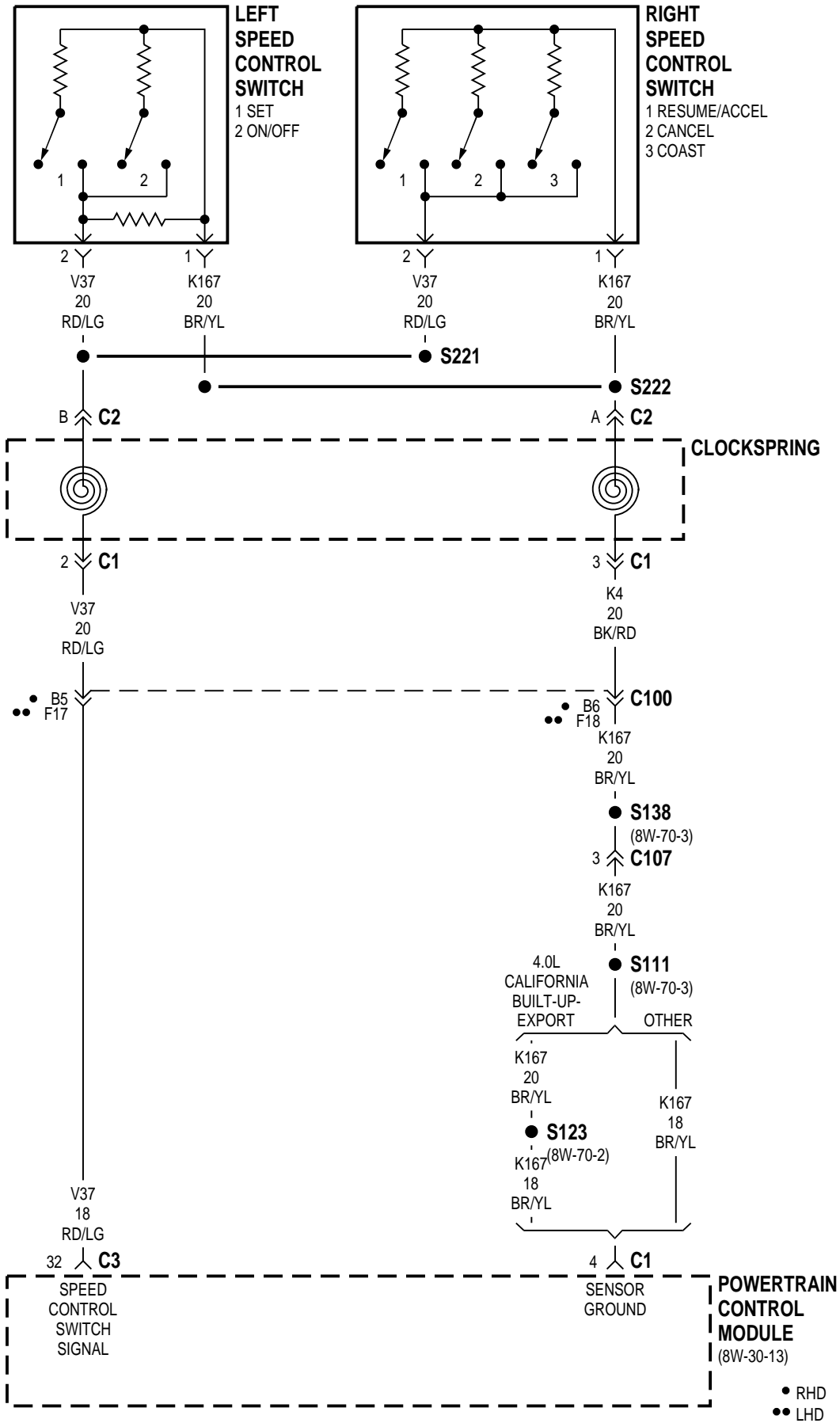

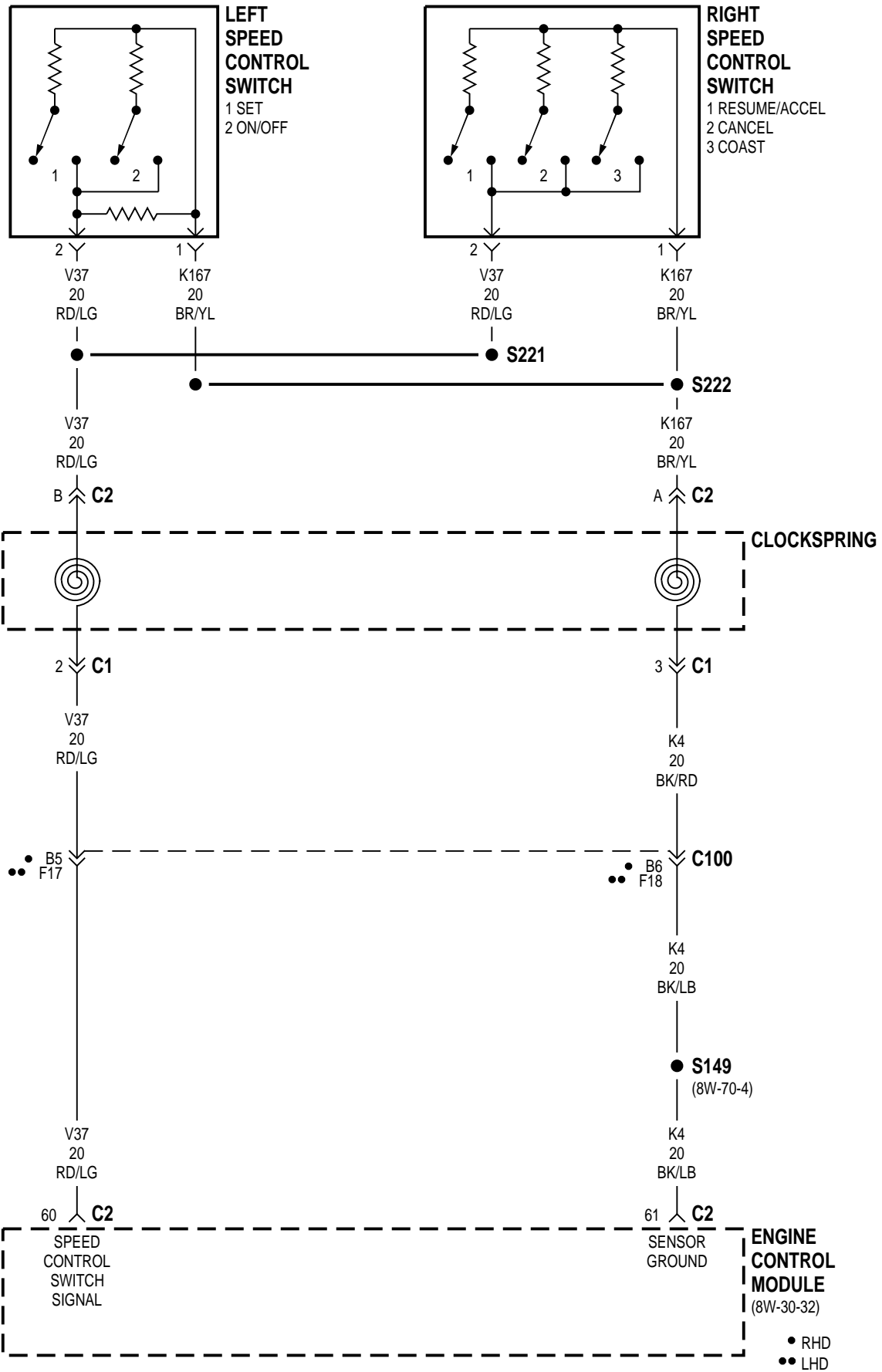

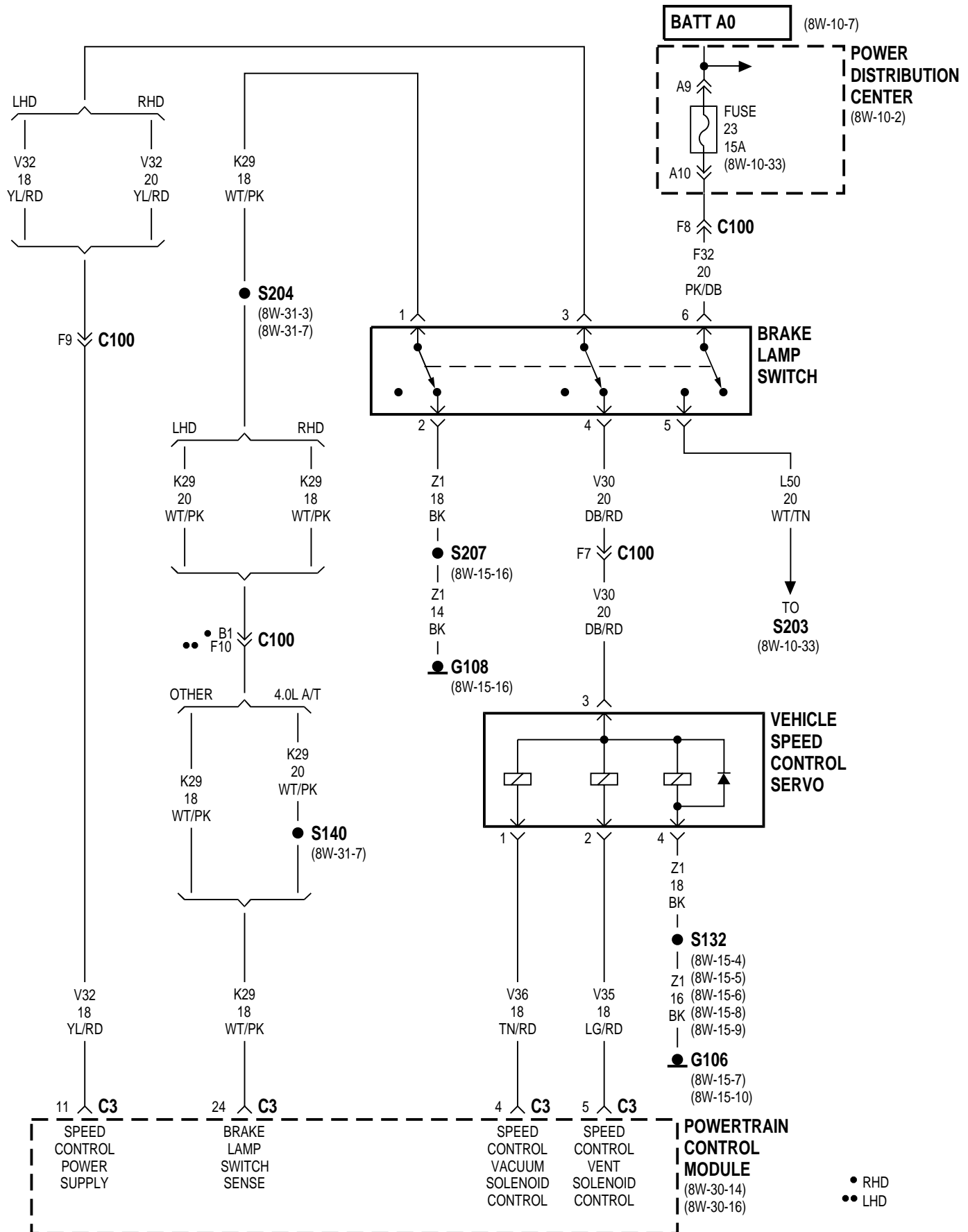

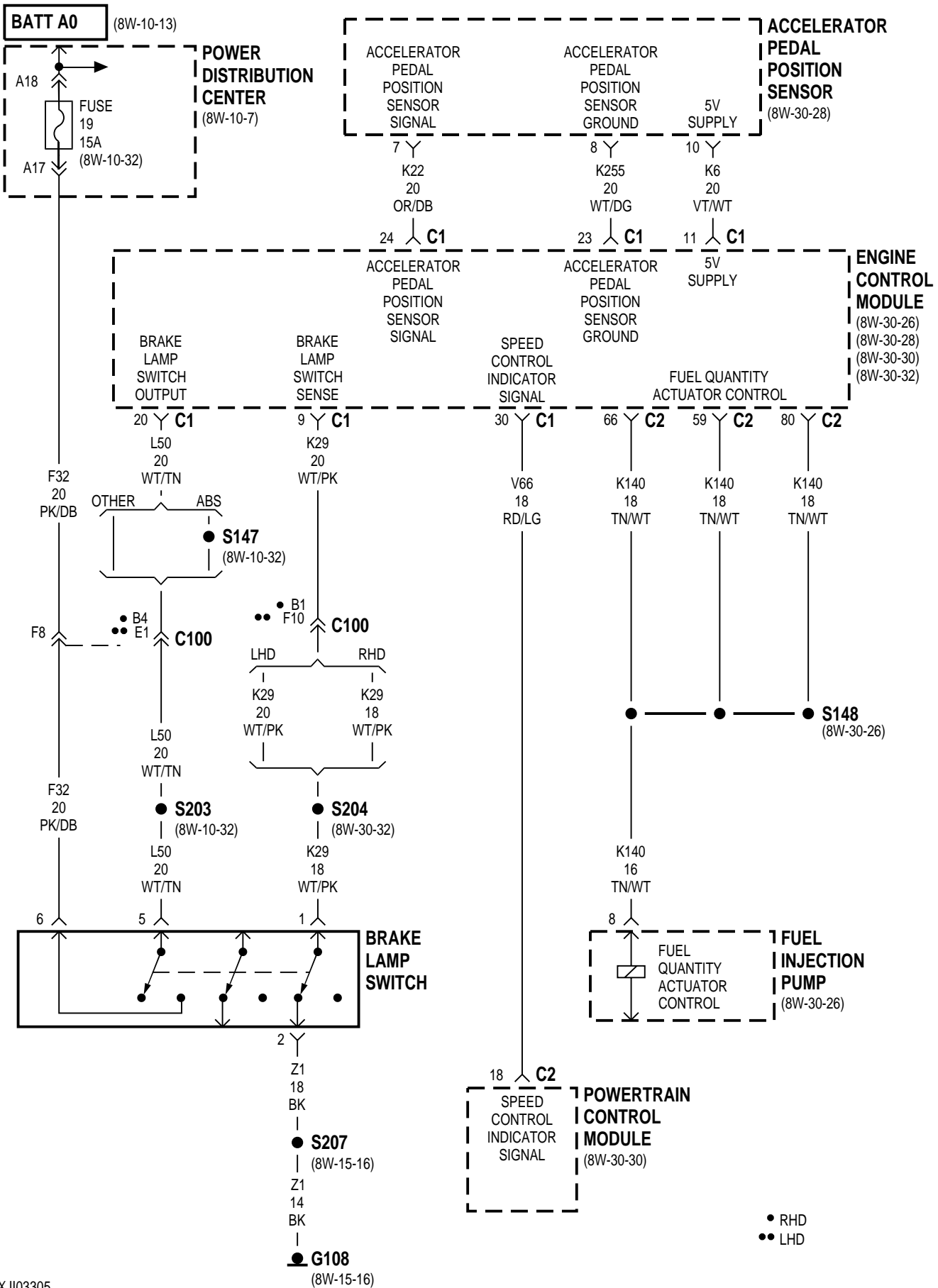

8W-35 ANTI-LOCK BRAKES

| Component | Page | Component | Page |
|--|---------------------|--|-------------|
| ABS Indicator | 8W-35-4, 5 | Fuse 23 (PDC) | 8W-35-2 |
| Brake Lamp Switch | 8W-35-2, 3 | Fuse 25 (JB) | 8W-35-4, 5 |
| Controller Anti-Lock Brake | 8W-35-2, 3, 4, 5, 6 | G Switch | 8W-35-2, 3 |
| Controller Anti-Lock Brake Relay | 8W-35-4, 5 | G102 | 8W-35-2, 3 |
| Data Link Connector | 8W-35-2, 3 | G106 | 8W-35-4, 5 |
| Engine Starter Motor Relay | 8W-35-5 | Instrument Cluster | 8W-35-4, 5 |
| Fog Lamp Relay | 8W-35-5 | Junction Block | 8W-35-4, 5 |
| Fog Lamp Relay No. 1 | 8W-35-4 | Left Front Wheel Speed Sensor | 8W-35-6 |
| Fuse 9 (JB) | 8W-35-4, 5 | Left Rear Wheel Speed Sensor | 8W-35-6 |
| Fuse 12 (PDC) | 8W-35-2, 3 | Power Distribution Center | 8W-35-2, 3 |
| Fuse 13 (PDC) | 8W-35-2 | Right Front Wheel Speed Sensor | 8W-35-6 |
| Fuse 14 (PDC) | 8W-35-3 | Right Rear Wheel Speed Sensor | 8W-35-6 |
| Fuse 19 (PDC) | 8W-35-3 | | |

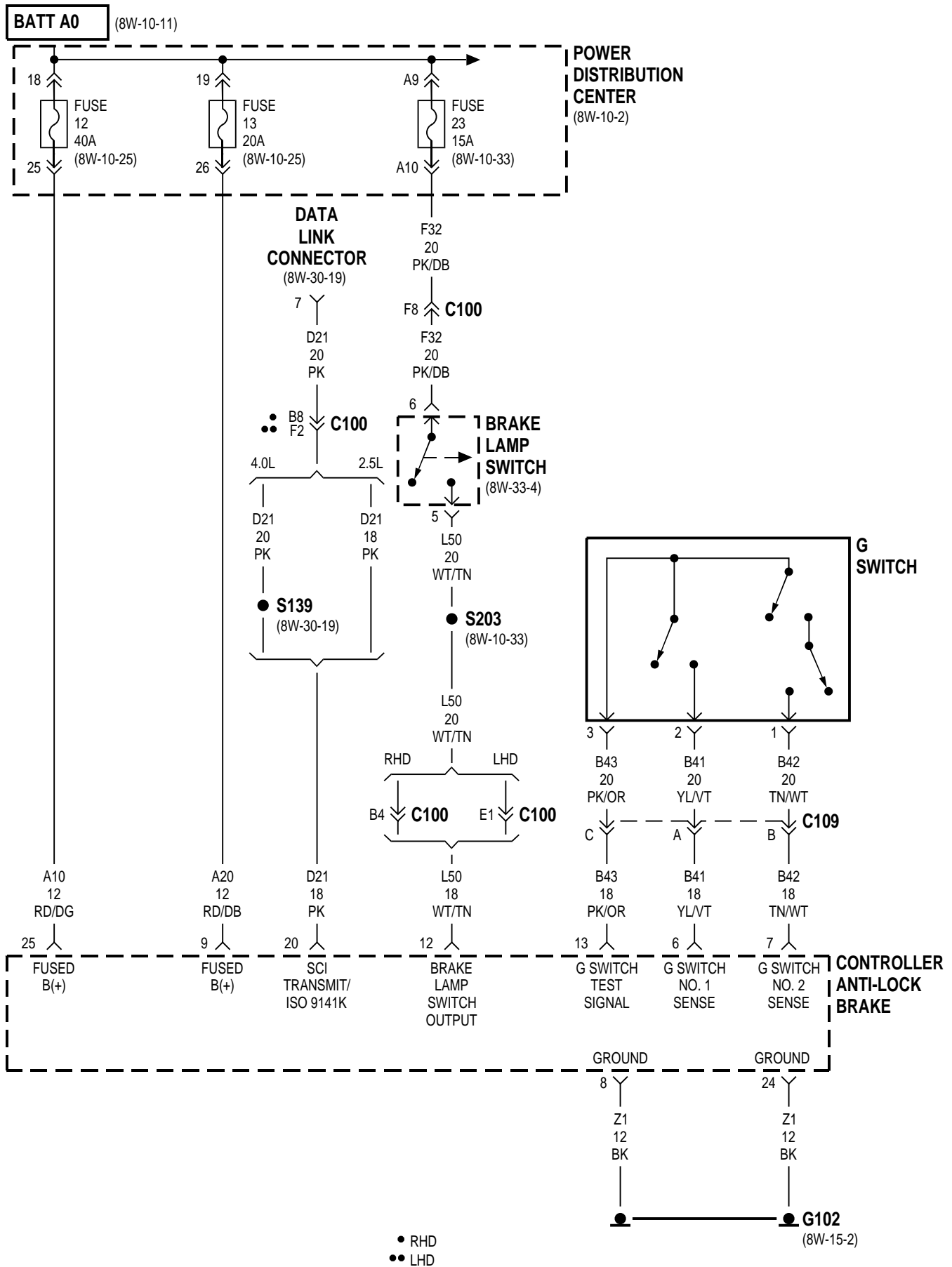

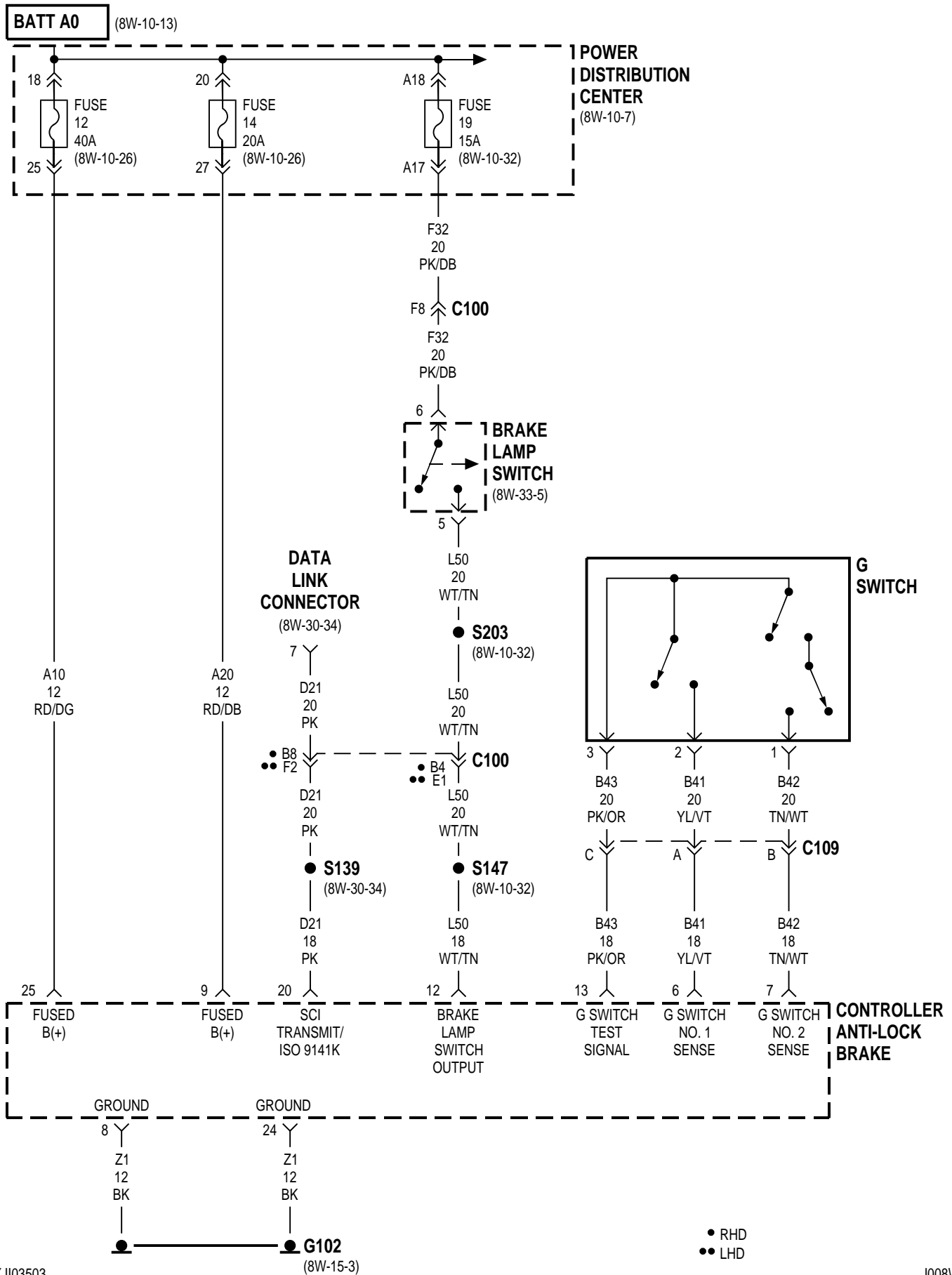

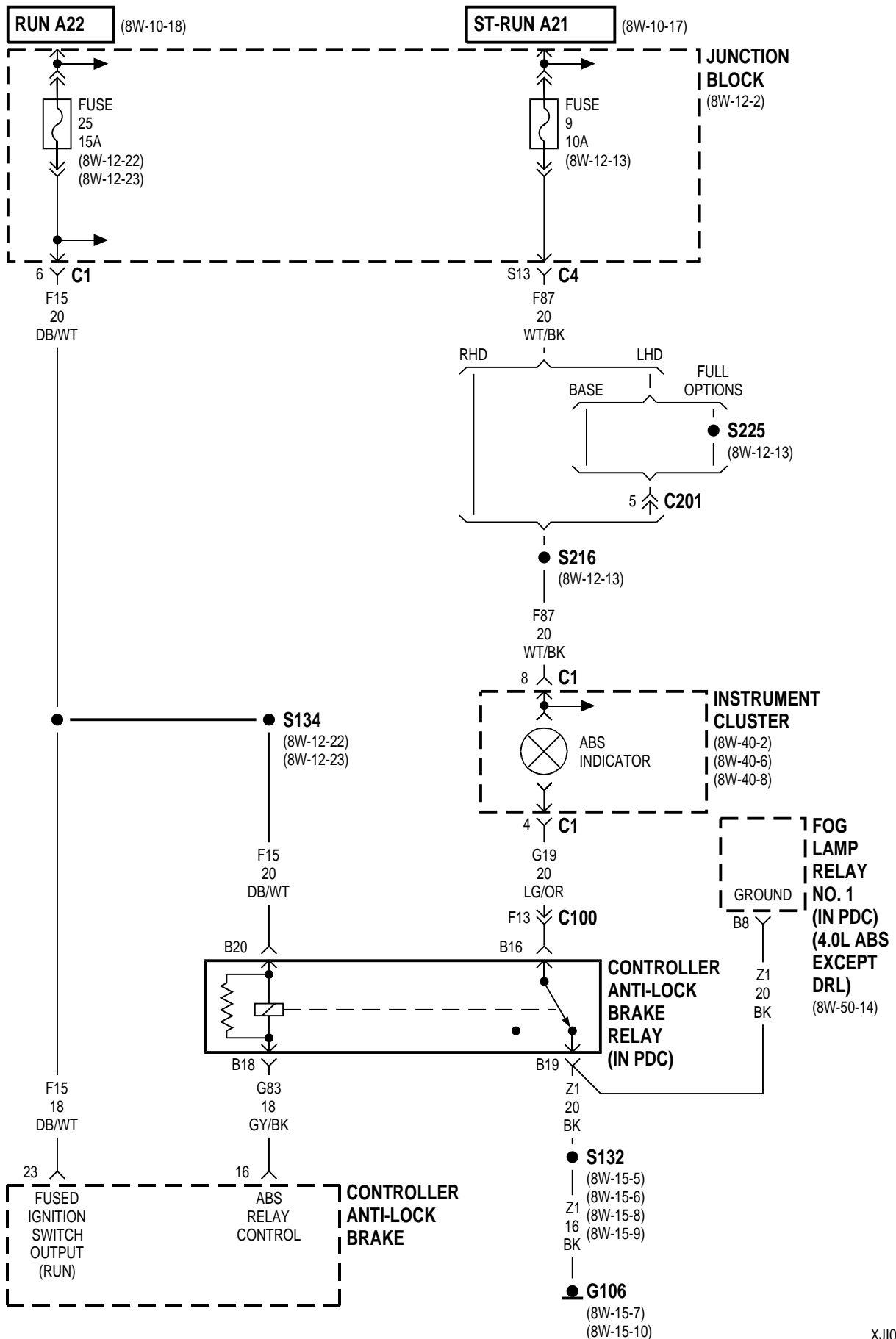

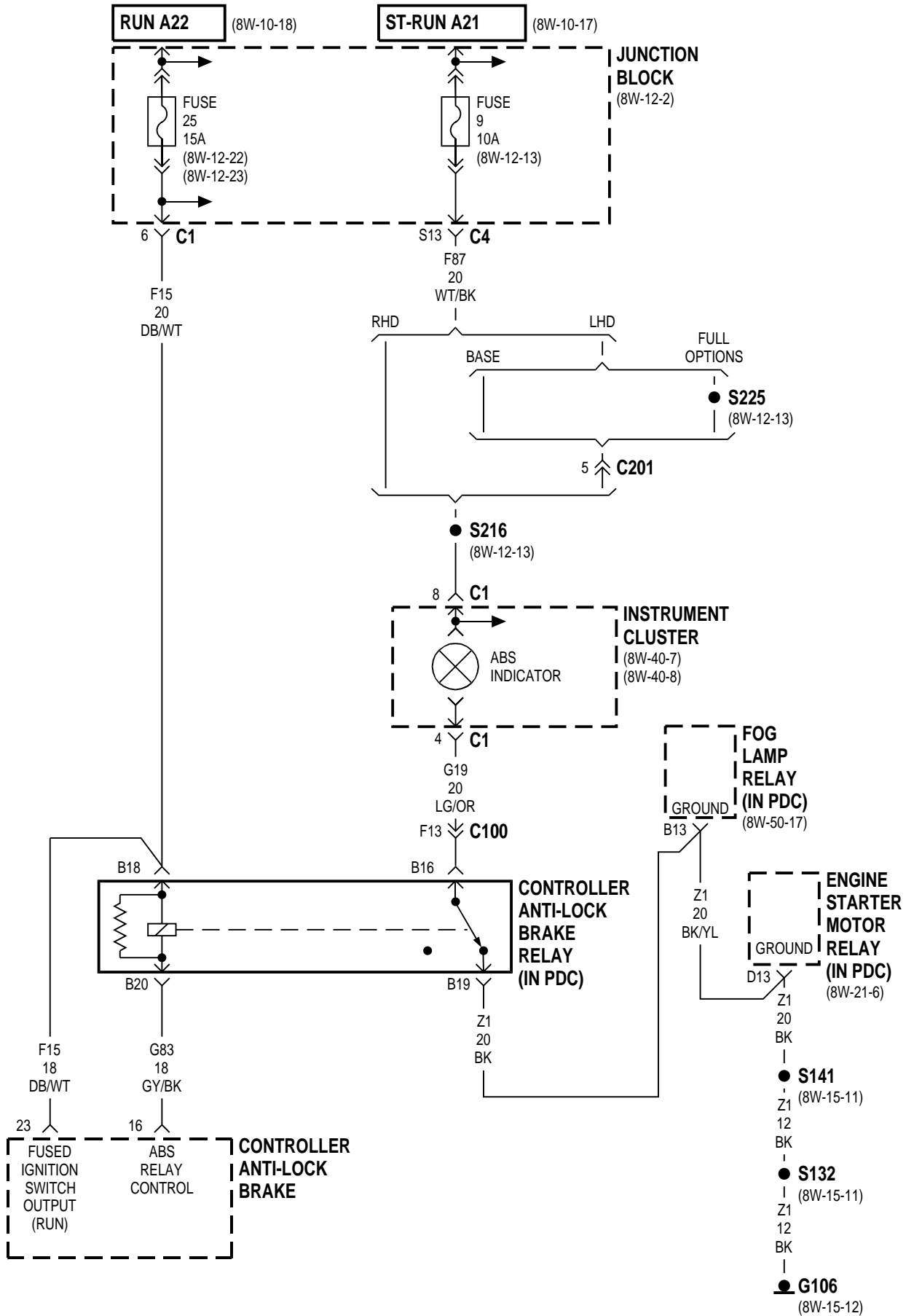

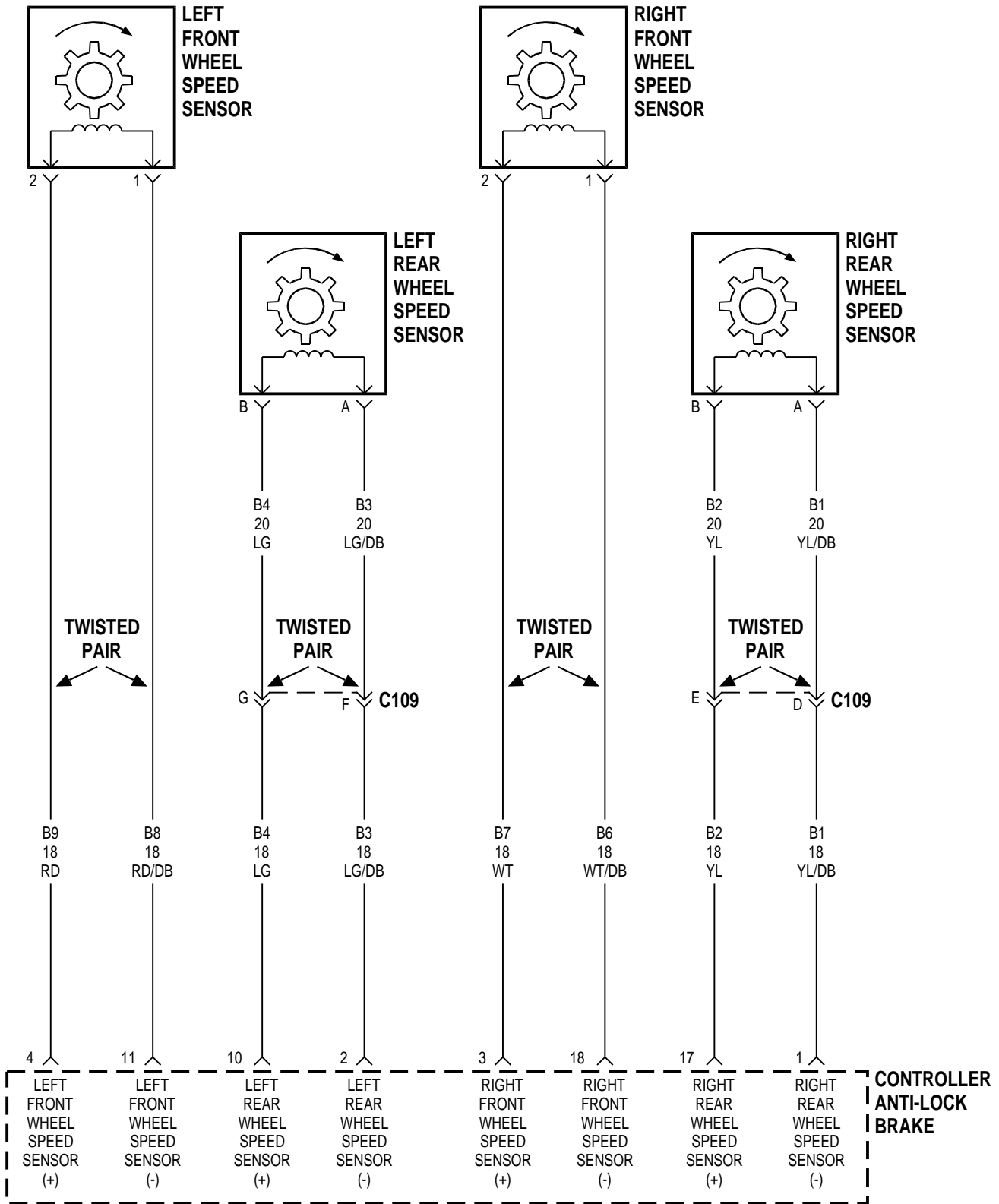

8W-39 VEHICLE THEFT SECURITY SYSTEM

| Component | Page | Component | Page |
|-----------------------------------|-------------|--|------------------------------|
| Cargo Lamp/Switch | 8W-39-6, 7 | Horn Relay | 8W-39-8, 9 |
| Data Link Connector | 8W-39-8, 9 | Ignition Switch | 8W-39-6, 7 |
| Driver Door Jamb Switch | 8W-39-6, 7 | Instrument Cluster | 8W-39-8, 9 |
| Engine Control Module | 8W-39-8, 9 | Junction Block | 8W-39-2, 3, 4, 5, 6, 7, 8, 9 |
| Fuse 16 (PDC) | 8W-39-2, 3 | Left Rear Door Jamb Switch | 8W-39-6, 7 |
| Fuse 27 (PDC) | 8W-39-4, 5 | Liftgate Switch | 8W-39-6, 7 |
| Fuse 9 (JB) | 8W-39-4, 5 | Overhead Module | 8W-39-2, 3, 6, 7, 8, 9 |
| G107 | 8W-39-2, 3 | Passenger Door Jamb Switch | 8W-39-6, 7 |
| G108 | 8W-39-4, 5 | Passenger Power Lock/Window Switch . . | 8W-39-2, 3 |
| G302 | 8W-39-6, 7 | Power Distribution Center | 8W-39-2, 3, 4, 5, 8, 9 |
| G303 | 8W-39-6, 7 | Right Rear Door Jamb Switch | 8W-39-6, 7 |
| G304 | 8W-39-6, 7 | Sentry Key Immobilizer Module | 8W-39-4, 5, 8, 9 |
| Headlamp Switch | 8W-39-6, 7 | Underhood Lamp/Switch | 8W-39-2, 3 |

LHD

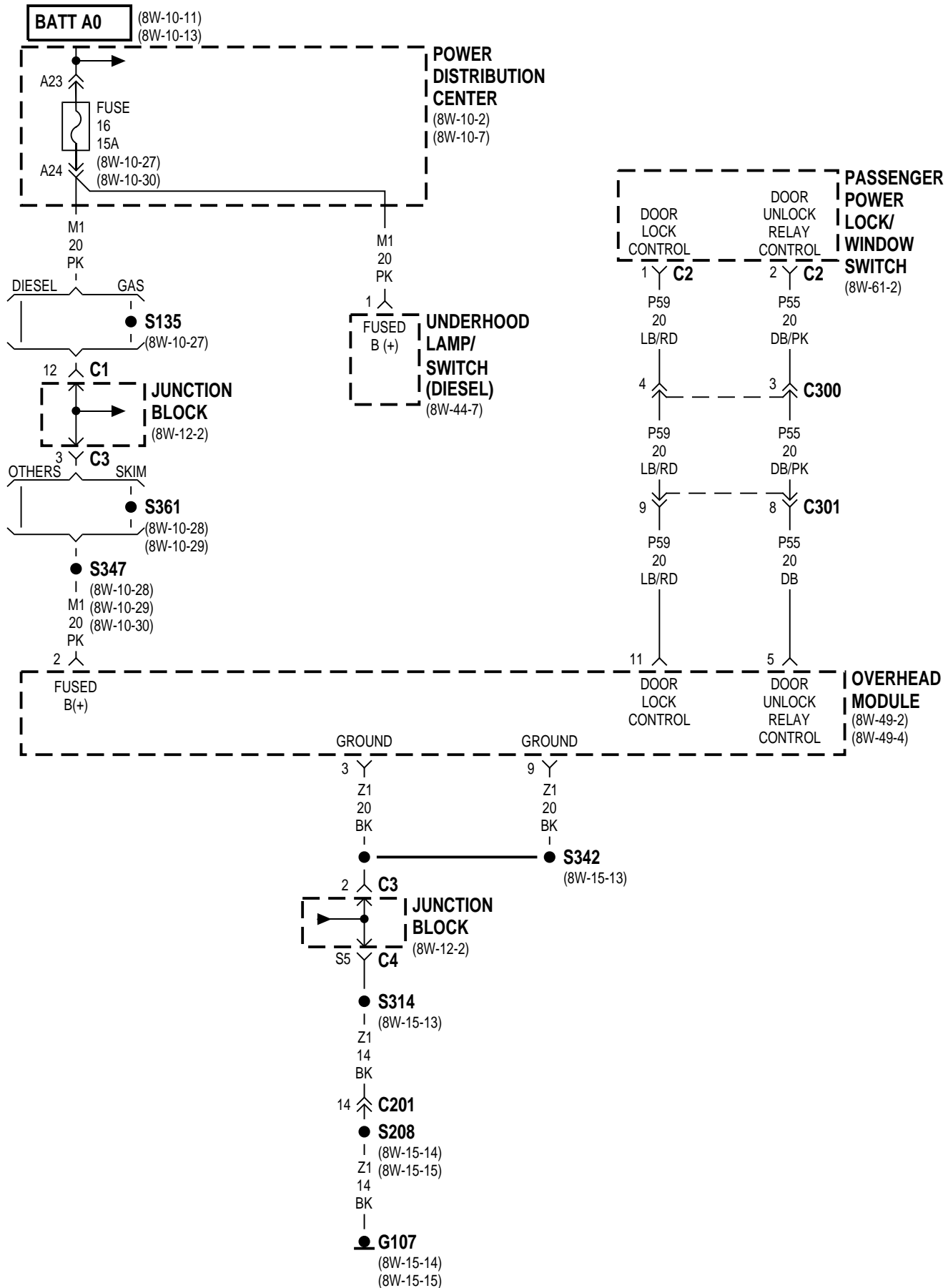

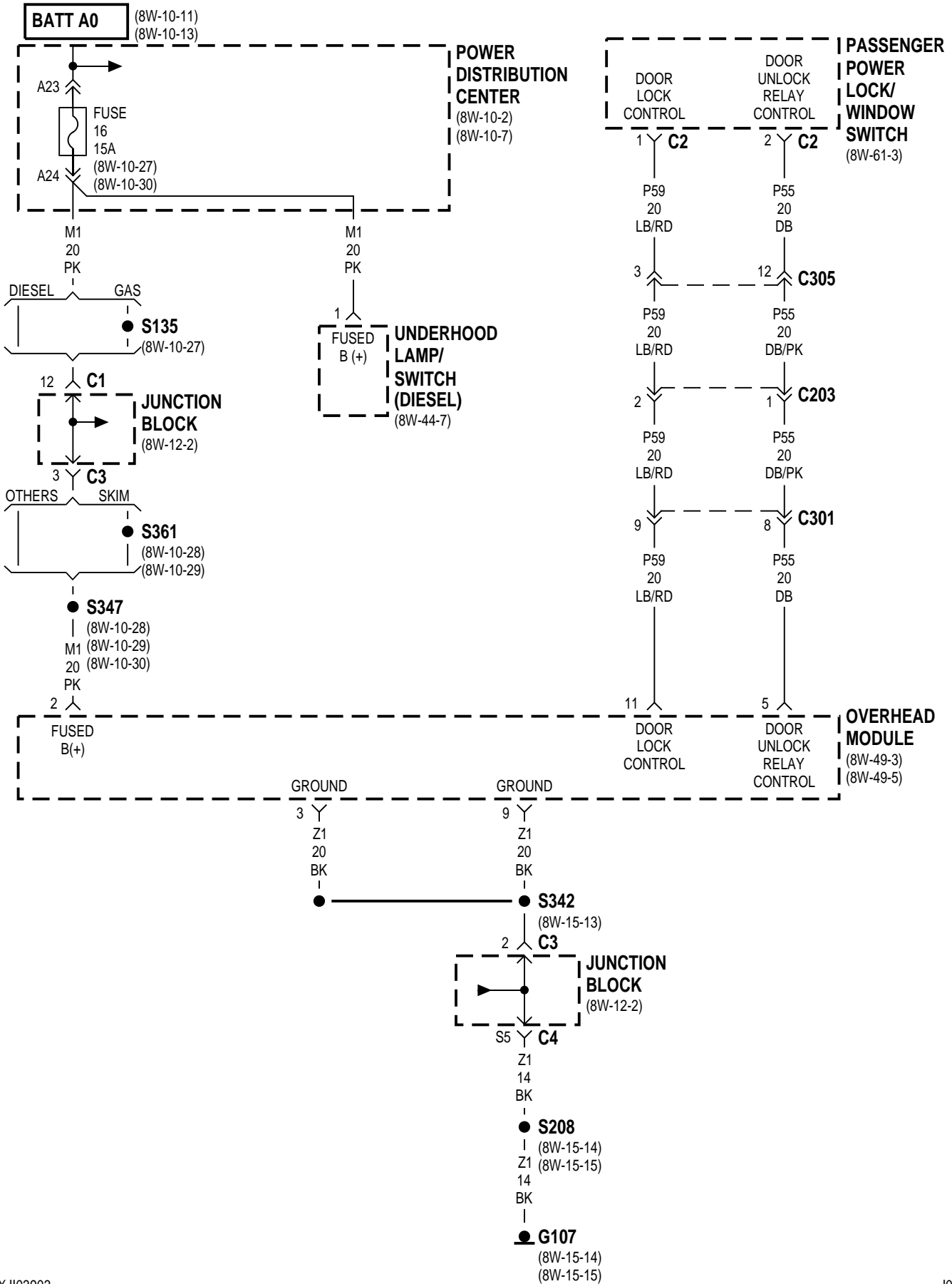

LHD

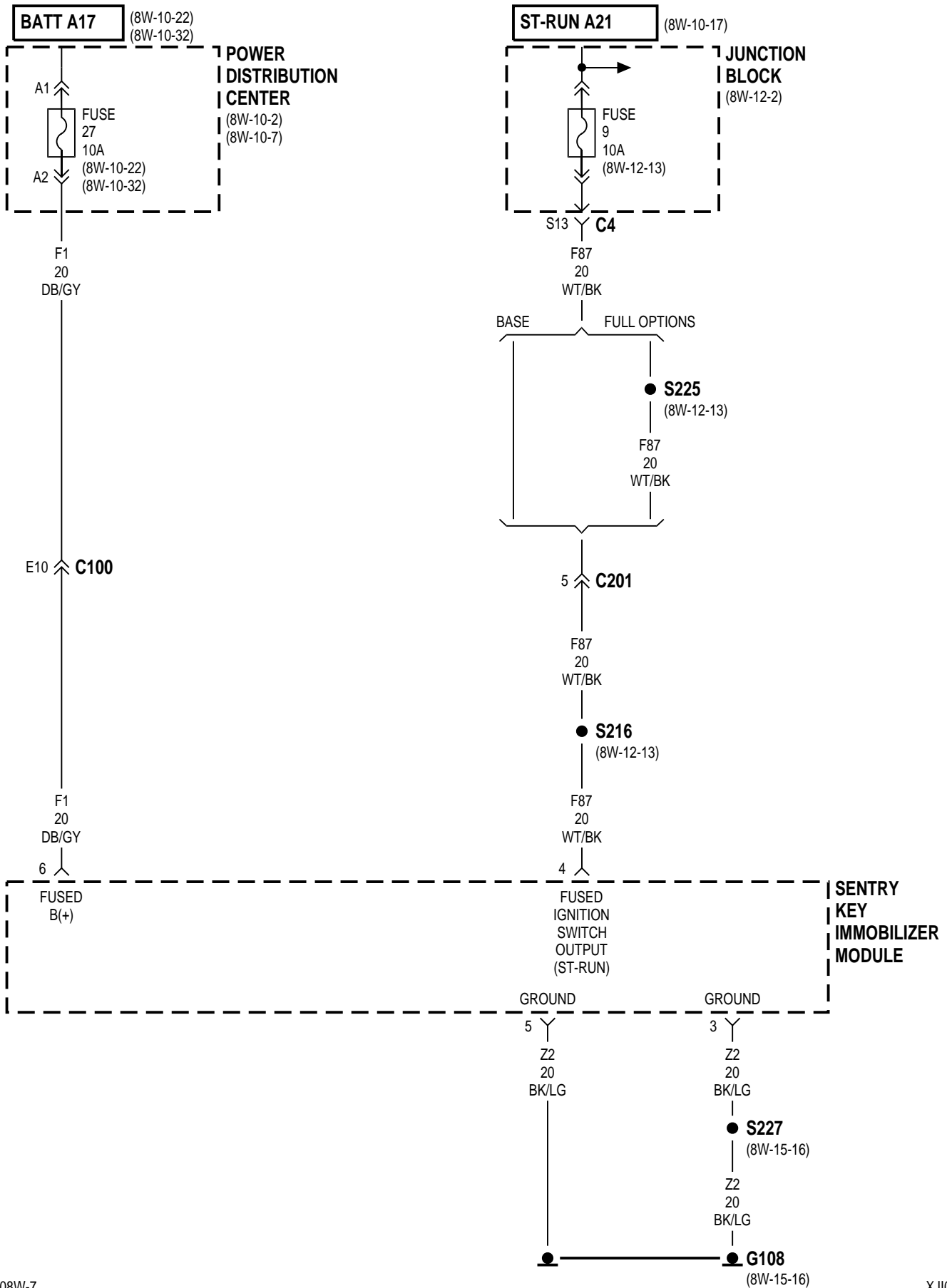

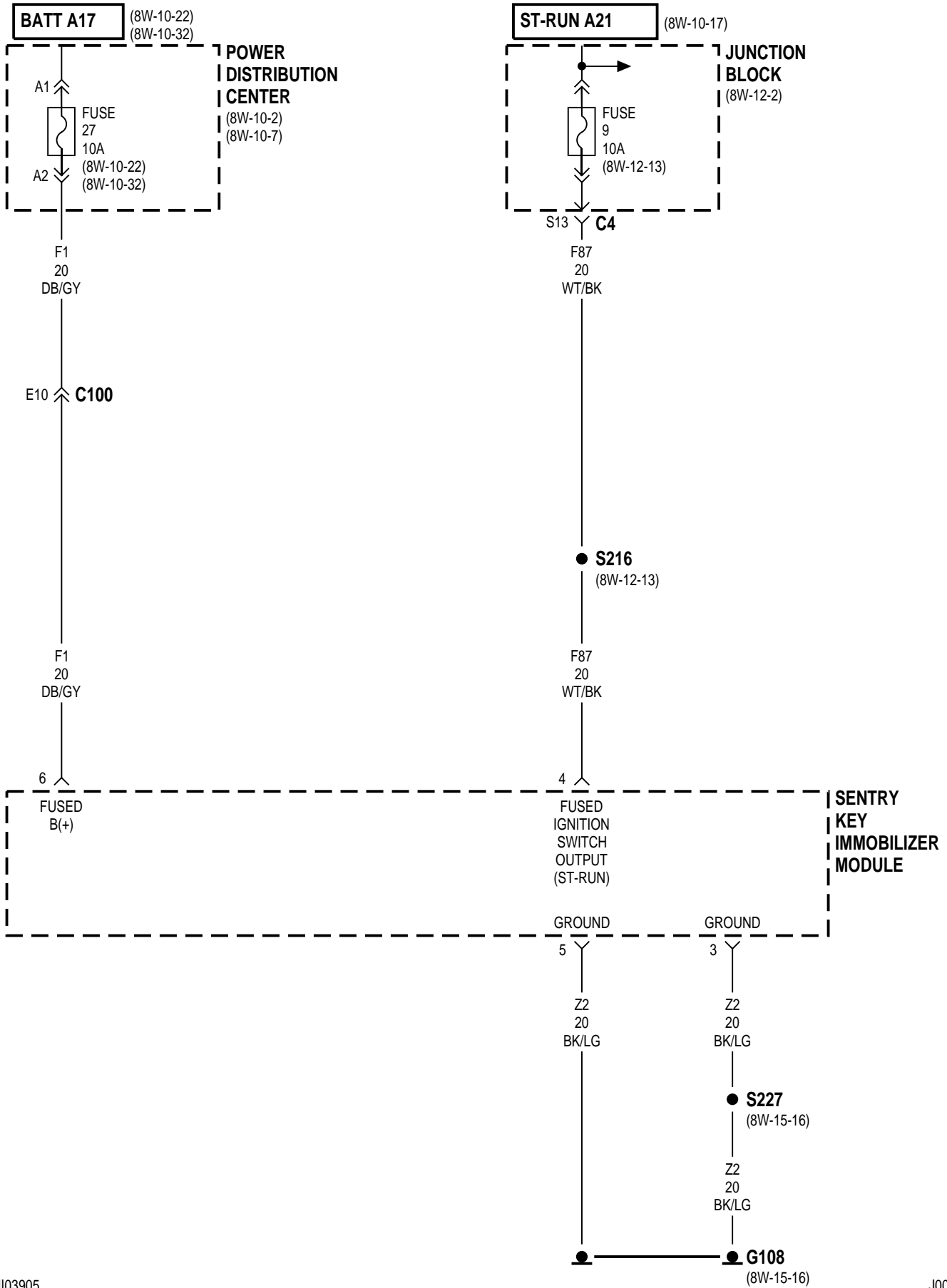

LHD

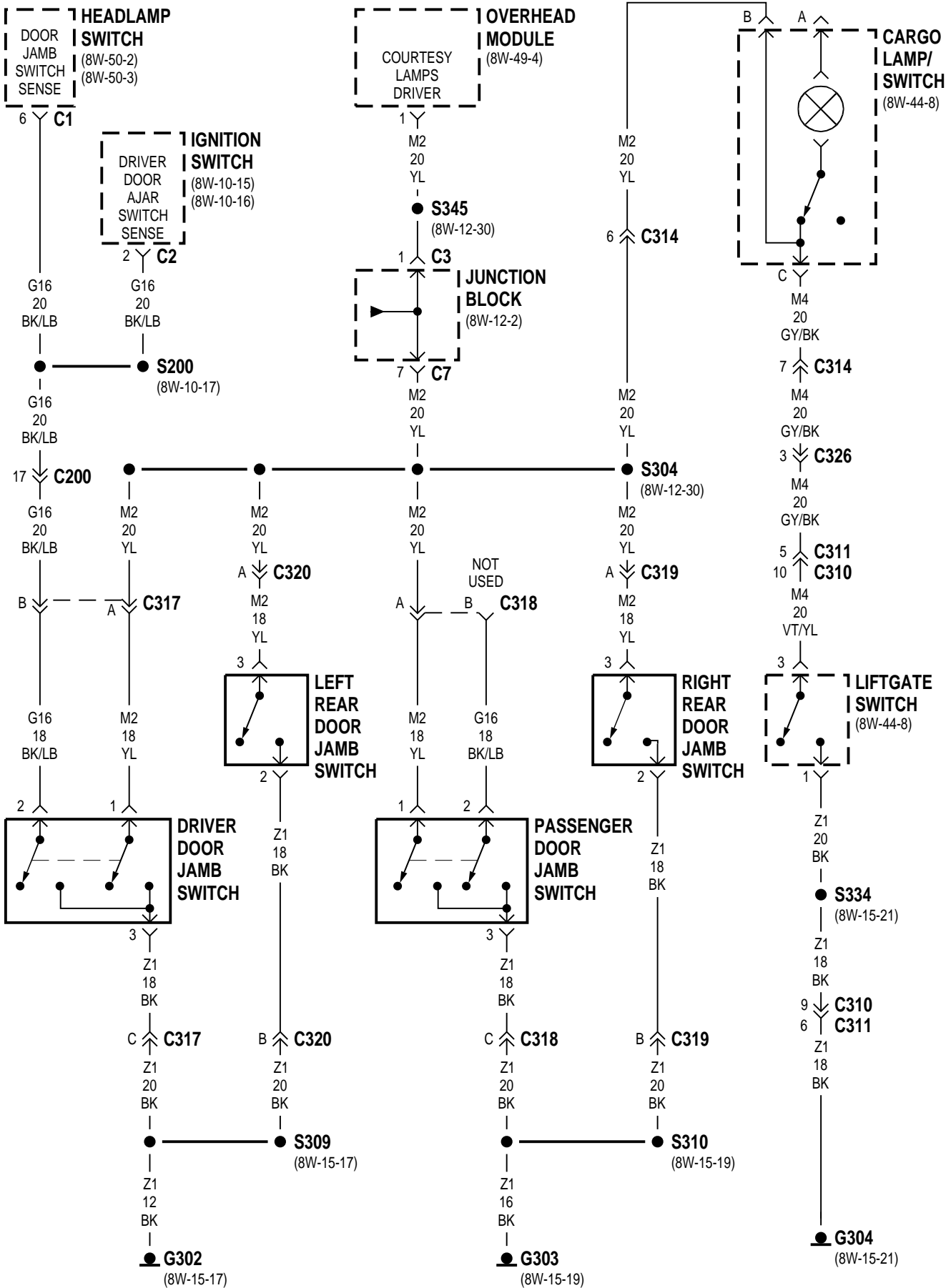

RHD

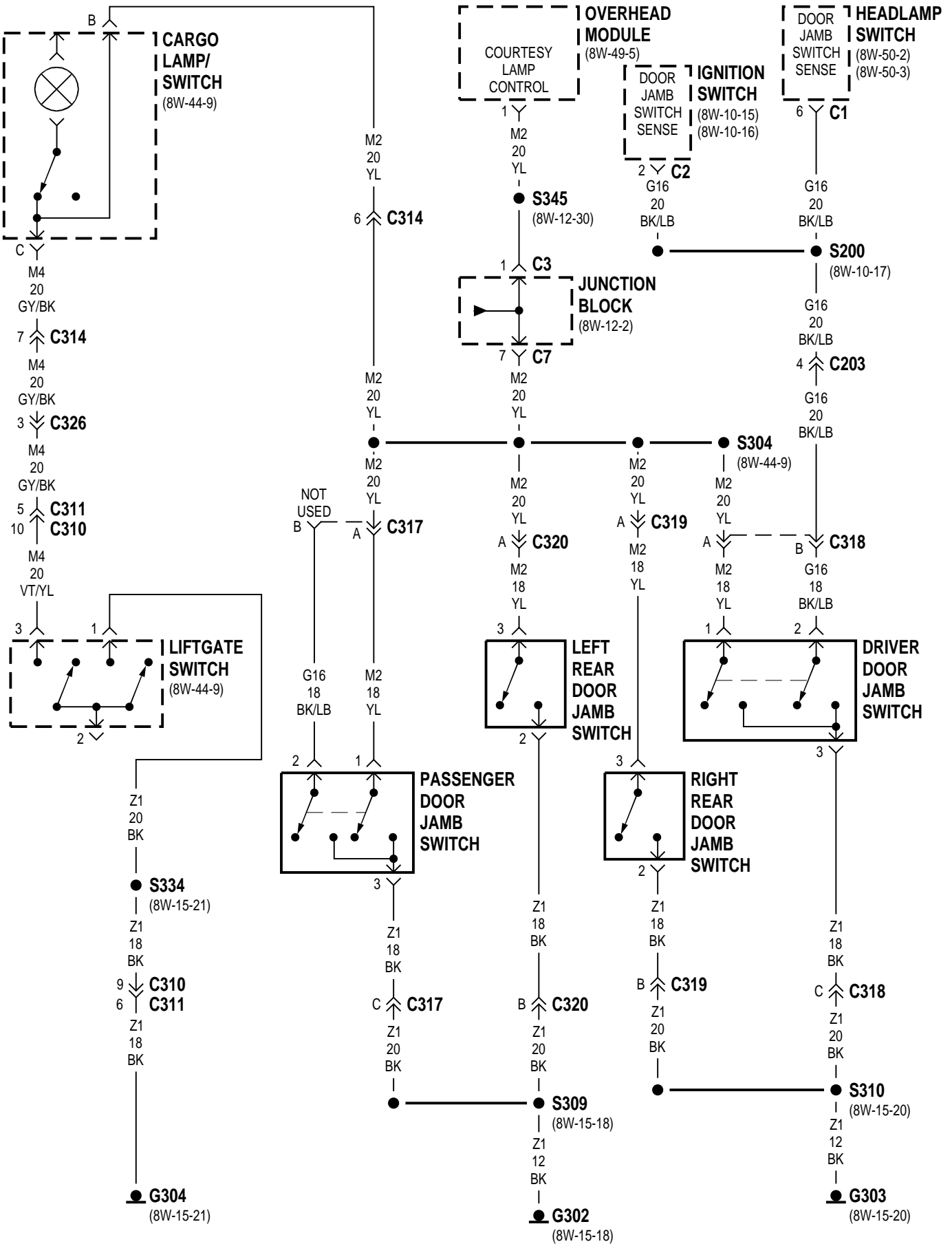

LHD

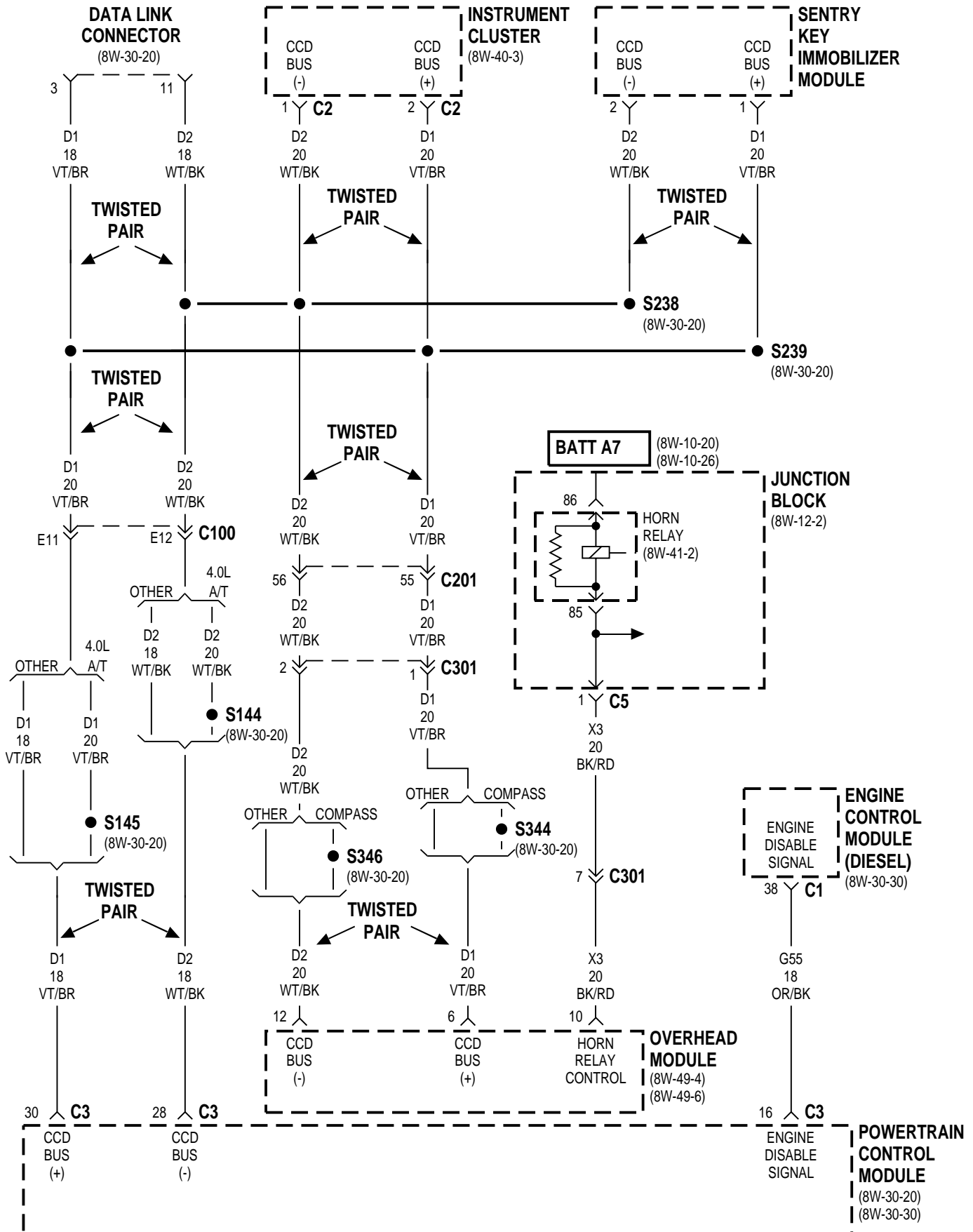

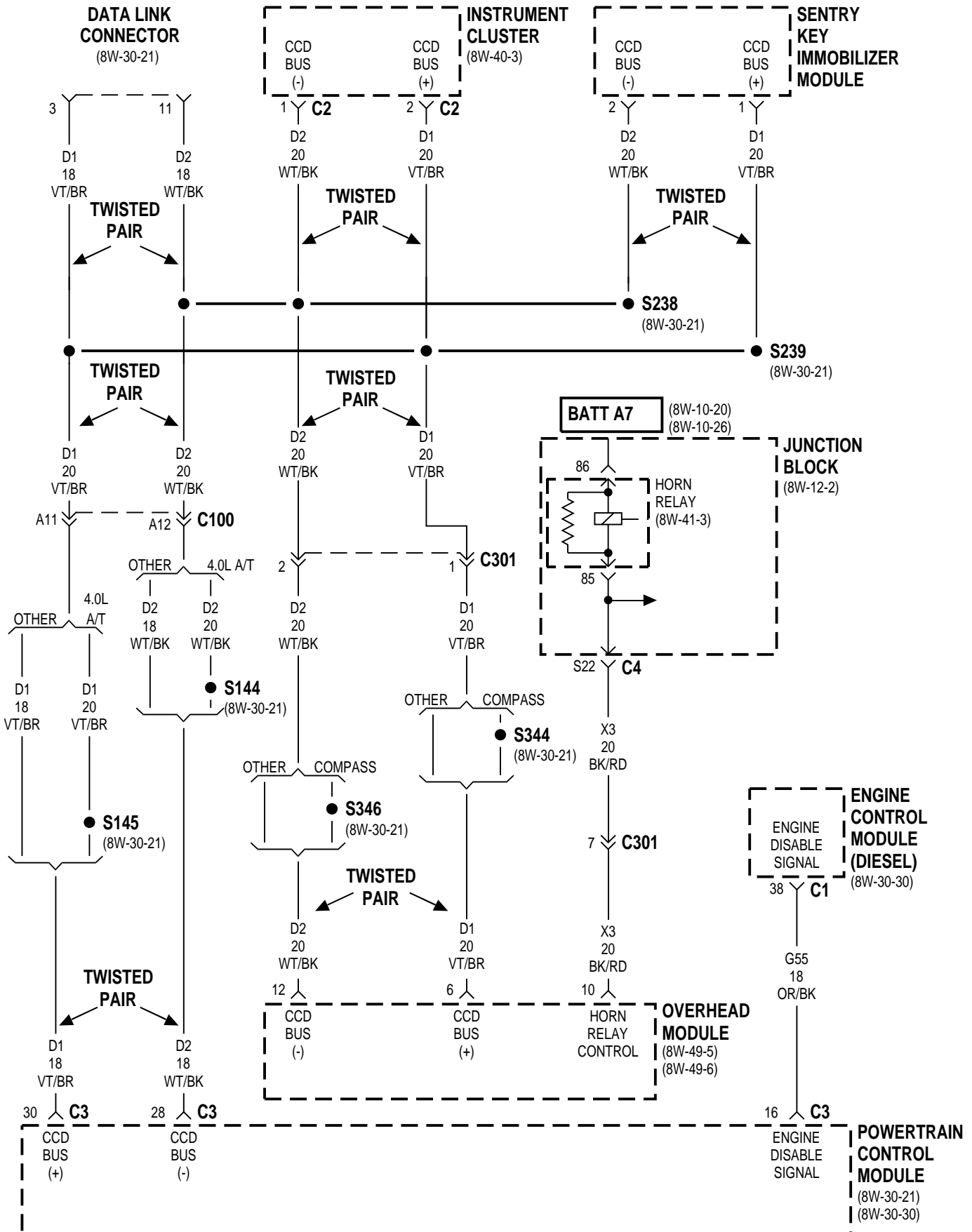

8W-40 INSTRUMENT CLUSTER

| Component | Page | Component | Page |
|---|--------------------|---|---|
| ABS Indicator | 8W-40-6, 7, 8 | Ignition Switch | 8W-40-9, 10, 11 |
| Airbag Control Module | 8W-40-6, 7, 8 | Instrument Cluster | 8W-40-2, 3, 4, 5, 6, 7, 8, 9, 10, 11, 12, 13, 14, 15, 16 |
| Airbag Warning Indicator | 8W-40-6, 7, 8 | Junction Block | 8W-40-2, 12, 13, 15, 17 |
| Brake Warning Indicator | 8W-40-9 | Left Turn Signal Indicator | 8W-40-14 |
| Brake Warning Pressure Switch | 8W-40-9, 10 | Liftgate Ajar Indicator | 8W-40-15 |
| Check Engine Warning Indicator | 8W-40-4, 5 | Liftgate Switch | 8W-40-15 |
| Check Gauges Warning Indicator | 8W-40-3 | Low Coolant Switch | 8W-40-17 |
| Cluster Illumination Lamps | 8W-40-15 | Low Fuel Warning Indicator | 8W-40-3 |
| Controller Anti-Lock Brake Relay | 8W-40-6, 7, 8 | Low Washer Fluid Indicator | 8W-40-6, 7, 8 |
| Cruise Engaged Indicator | 8W-40-16 | Message Center | 8W-40-17 |
| Daytime Running Lamp Module | 8W-40-14 | Odometer | 8W-40-15 |
| Driver Door Jamb Switch | 8W-40-11 | Oil Pressure Gauge | 8W-40-4, 5 |
| Engine Control Module | 8W-40-16, 17 | Overhead Module | 8W-40-12, 13 |
| Engine Coolant Temperature Gauge | 8W-40-4, 5 | Park Brake Switch | 8W-40-9, 10 |
| Engine Coolant Temperature Sensor | 8W-40-4 | Part Time 4WD Indicator | 8W-40-9, 10 |
| Engine Coolant Temperature Sensor No. 2 | 8W-40-5 | Power Distribution Center | 8W-40-2 |
| Engine Oil Pressure Sensor | 8W-40-4, 5 | Powertrain Control Module | 8W-40-3, 4, 5, 16, 17 |
| Engine Starter Motor Relay | 8W-40-7, 8 | Rear Window Defogger Relay | 8W-40-12, 13 |
| Fog Lamp Relay | 8W-40-7, 8 | Rear Window Defogger Switch | 8W-40-12, 13 |
| Fog Lamp Relay No. 1 | 8W-40-14 | Red Brake Warning Indicator | 8W-40-10 |
| Fuel Gauge | 8W-40-3 | Right Turn Signal Indicator | 8W-40-14 |
| Fuel Level Sensor | 8W-40-3 | Seat Belt Switch | 8W-40-6, 7, 8 |
| Fuel Pump Module | 8W-40-3 | Seat Belt Warning Indicator | 8W-40-6, 7, 8 |
| Full Time 4wd Indicator | 8W-40-9 | Sentry Key Immobilizer Module | 8W-40-12, 13 |
| Fuse 6 (JB) | 8W-40-15 | Speedometer | 8W-40-3 |
| Fuse 9 (JB) | 8W-40-2, 17 | Tachometer | 8W-40-3 |
| Fuse 12 (JB) | 8W-40-12, 13 | Transfer Case Switch | 8W-40-9, 10 |
| Fuse 16 (PDC) | 8W-40-2 | Transmission Control Module | 8W-40-3 |
| G101 | 8W-40-9 | Trip Reset Switch | 8W-40-15 |
| G106 | 8W-40-6, 7, 8, 10 | Turn Signal/Hazard Switch | 8W-40-14 |
| G107 | 8W-40-6, 7, 12, 13 | Underhood Lamp/Switch | 8W-40-2 |
| G108 | 8W-40-2, 9, 10, 14 | Upshift Indicator | 8W-40-3 |
| G123 | 8W-40-17 | Vehicle Speed Sensor | 8W-40-3 |
| G154 | 8W-40-17 | Volt Meter | 8W-40-3 |
| G302 | 8W-40-8, 11 | VTSS Indicator | 8W-40-12, 13 |
| G303 | 8W-40-11 | Washer Fluid Level Switch | 8W-40-6, 7, 8 |
| Headlamp Beam Select Switch | 8W-40-14 | Water In Fuel Sensor | 8W-40-17 |
| Headlamp Switch | 8W-40-11, 15 | | |
| High Beam Indicator | 8W-40-14 | | |

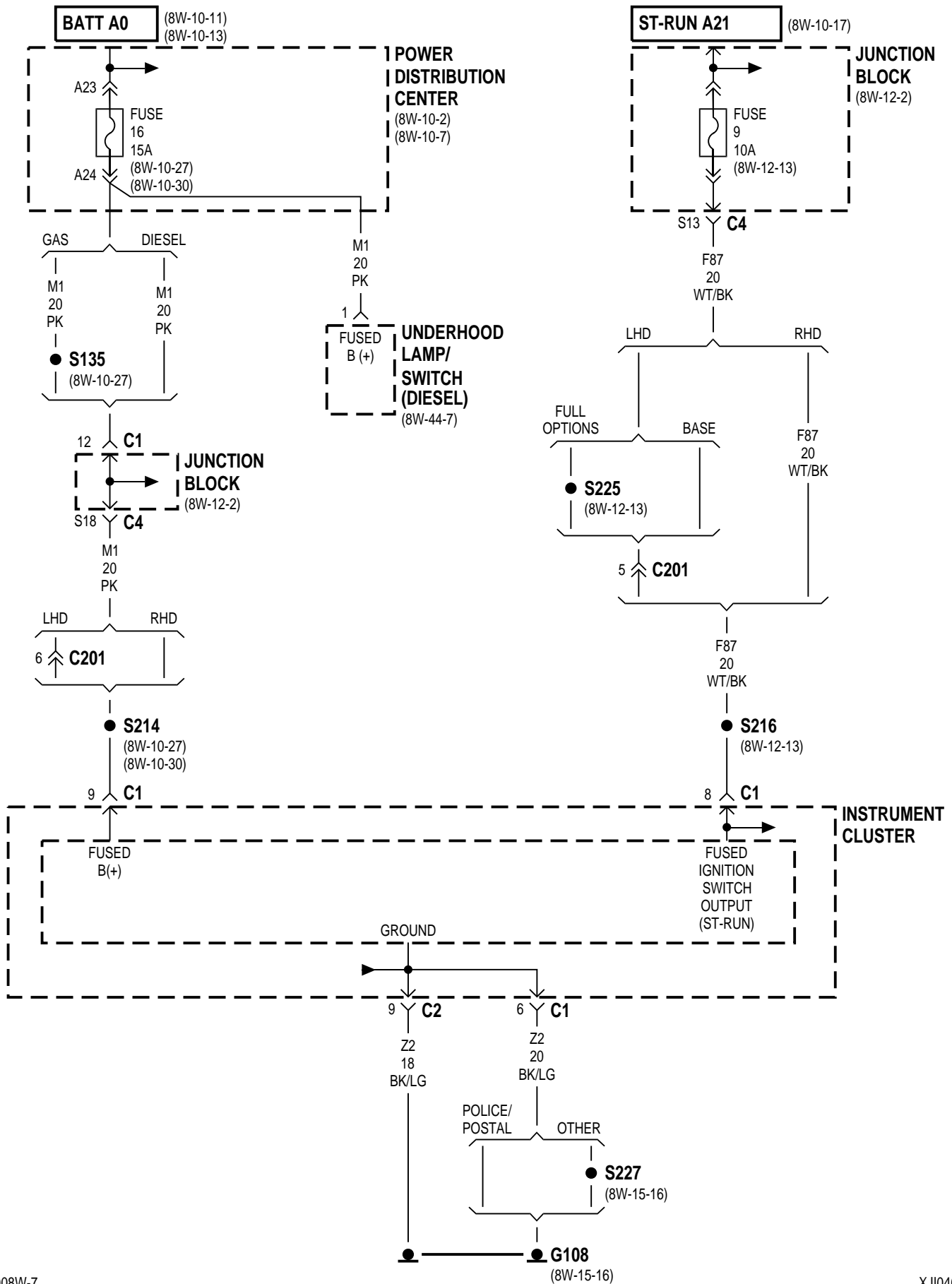

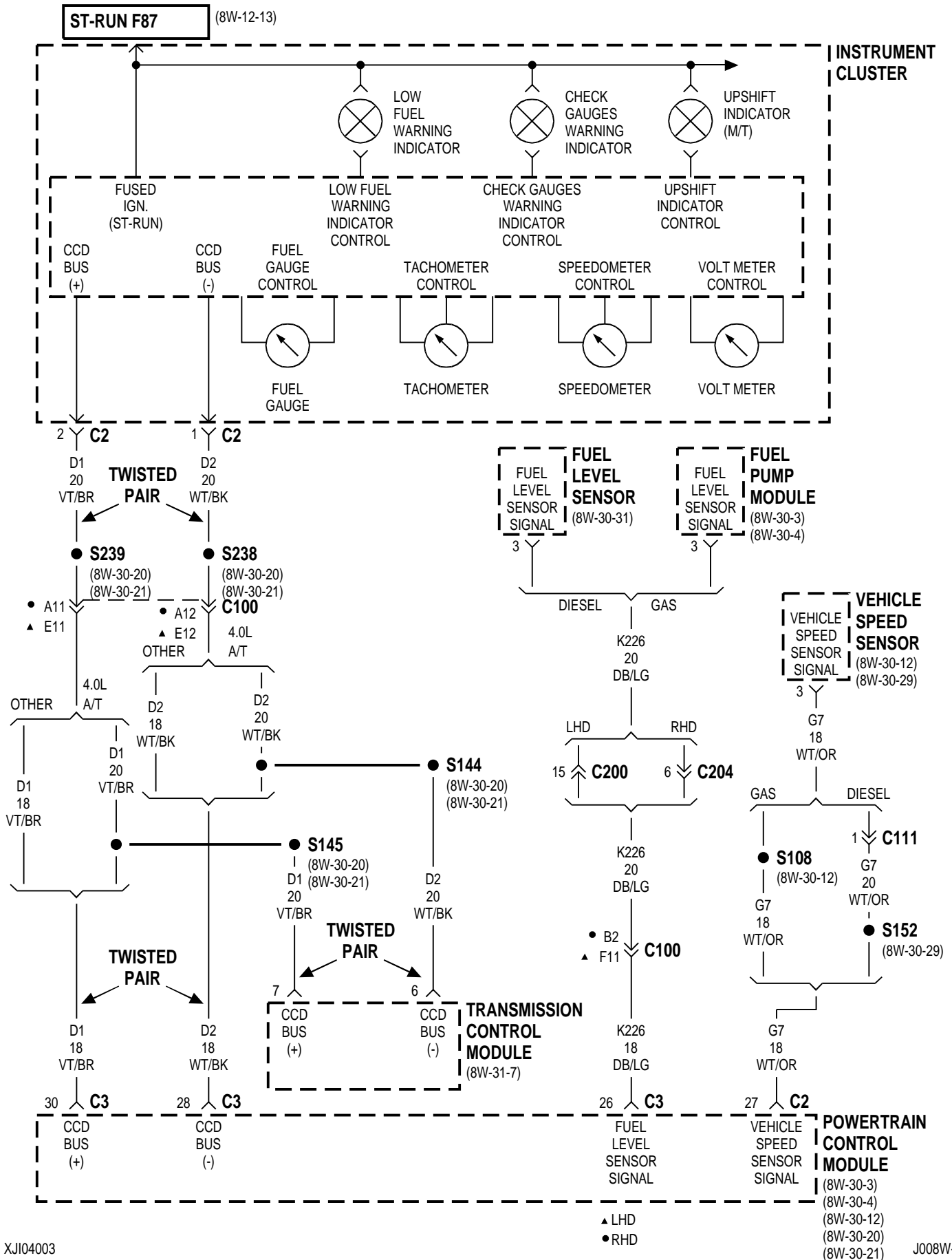

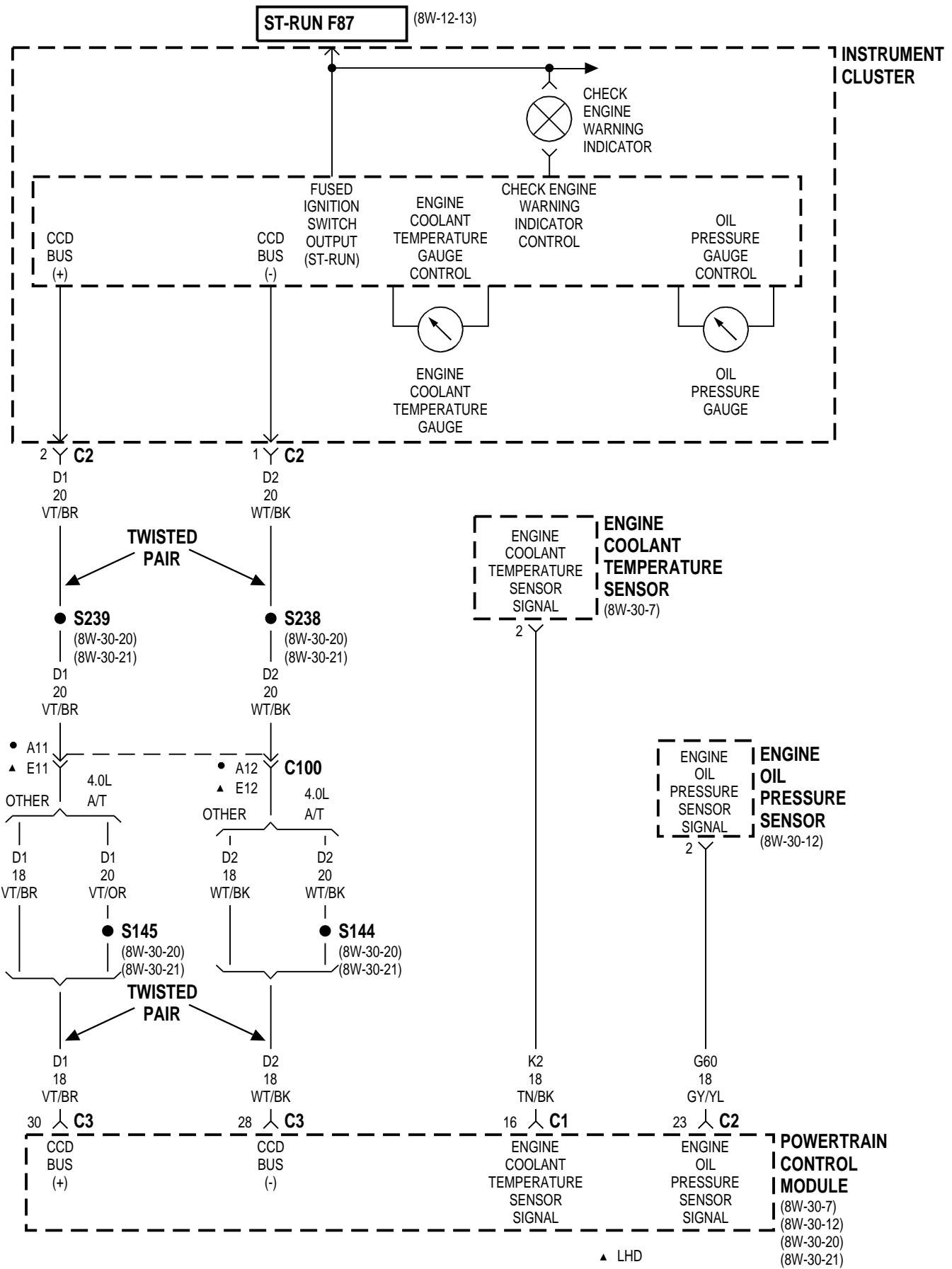

XJ **8W-40 INSTRUMENT CLUSTER** **8W - 40 - 5**
DIESEL

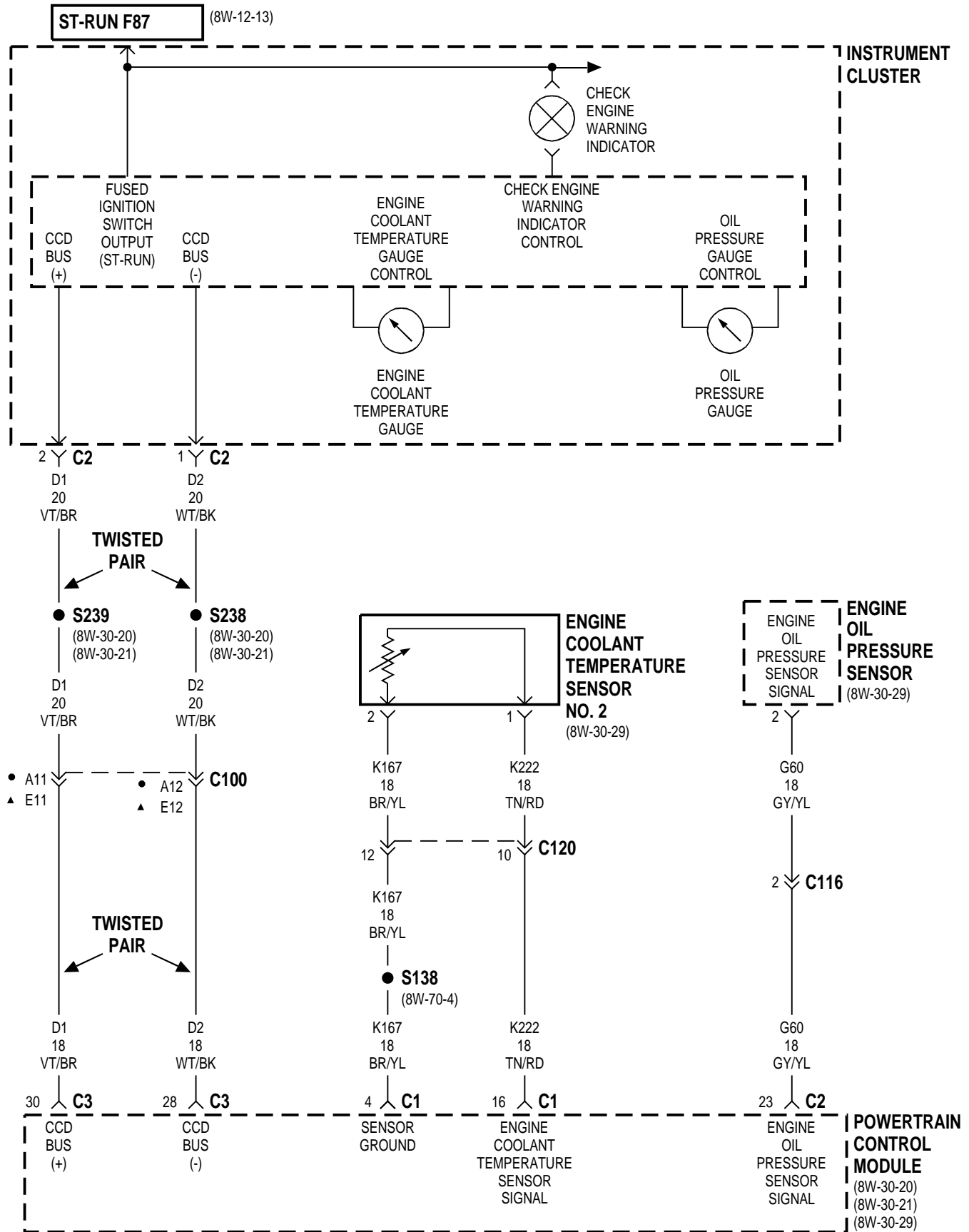

▲ LHD
 ● RHD

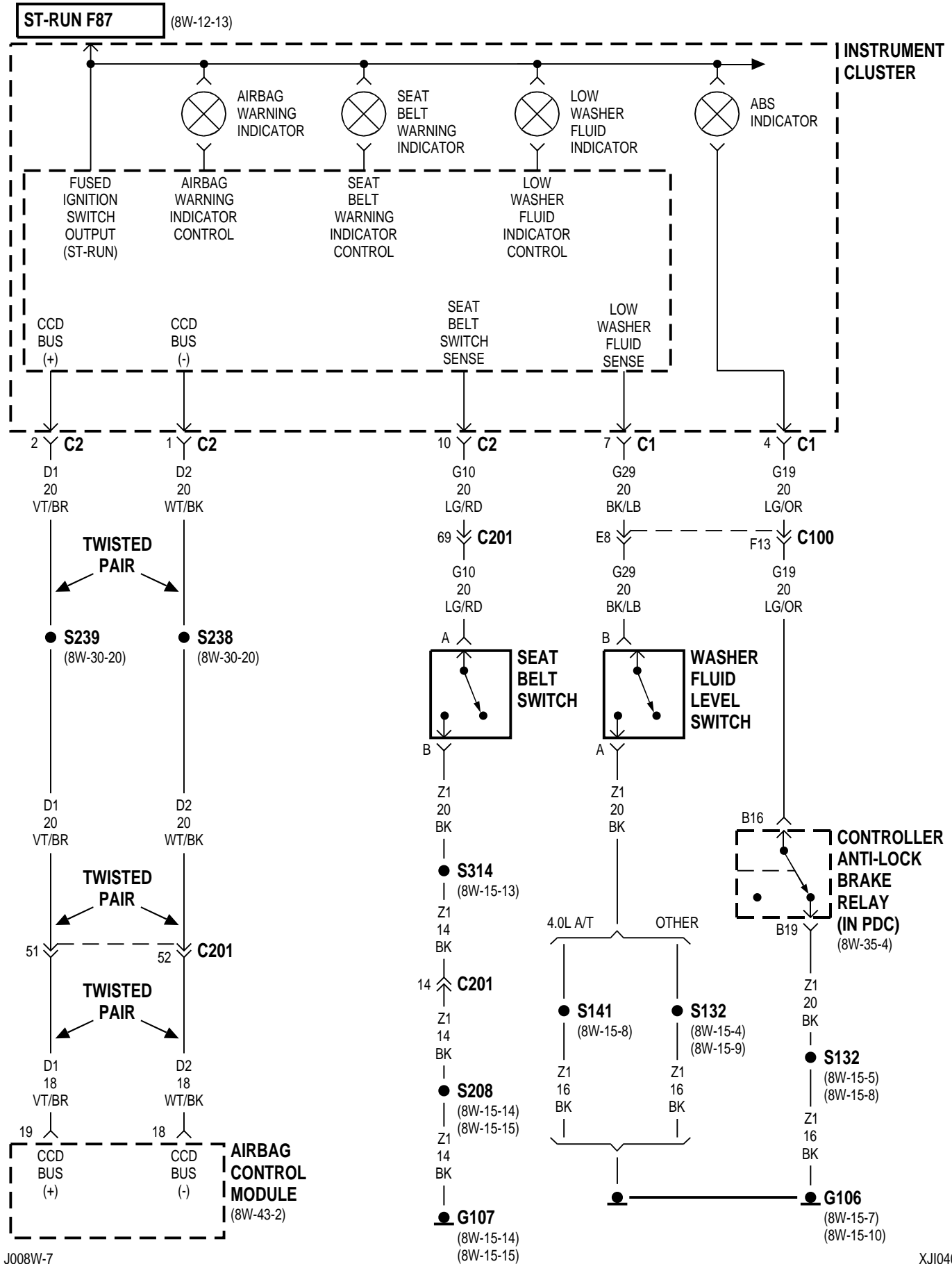

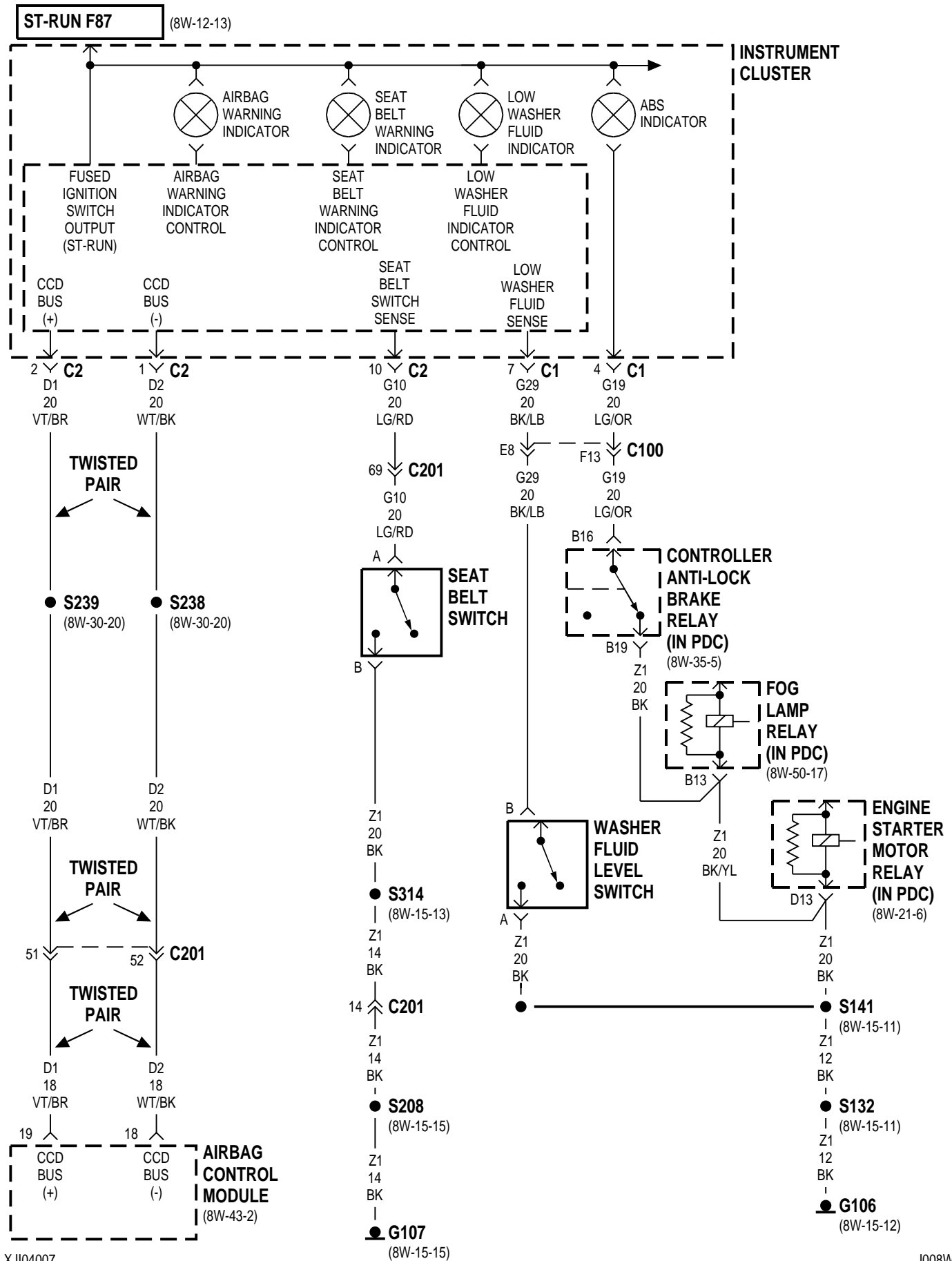

RHD

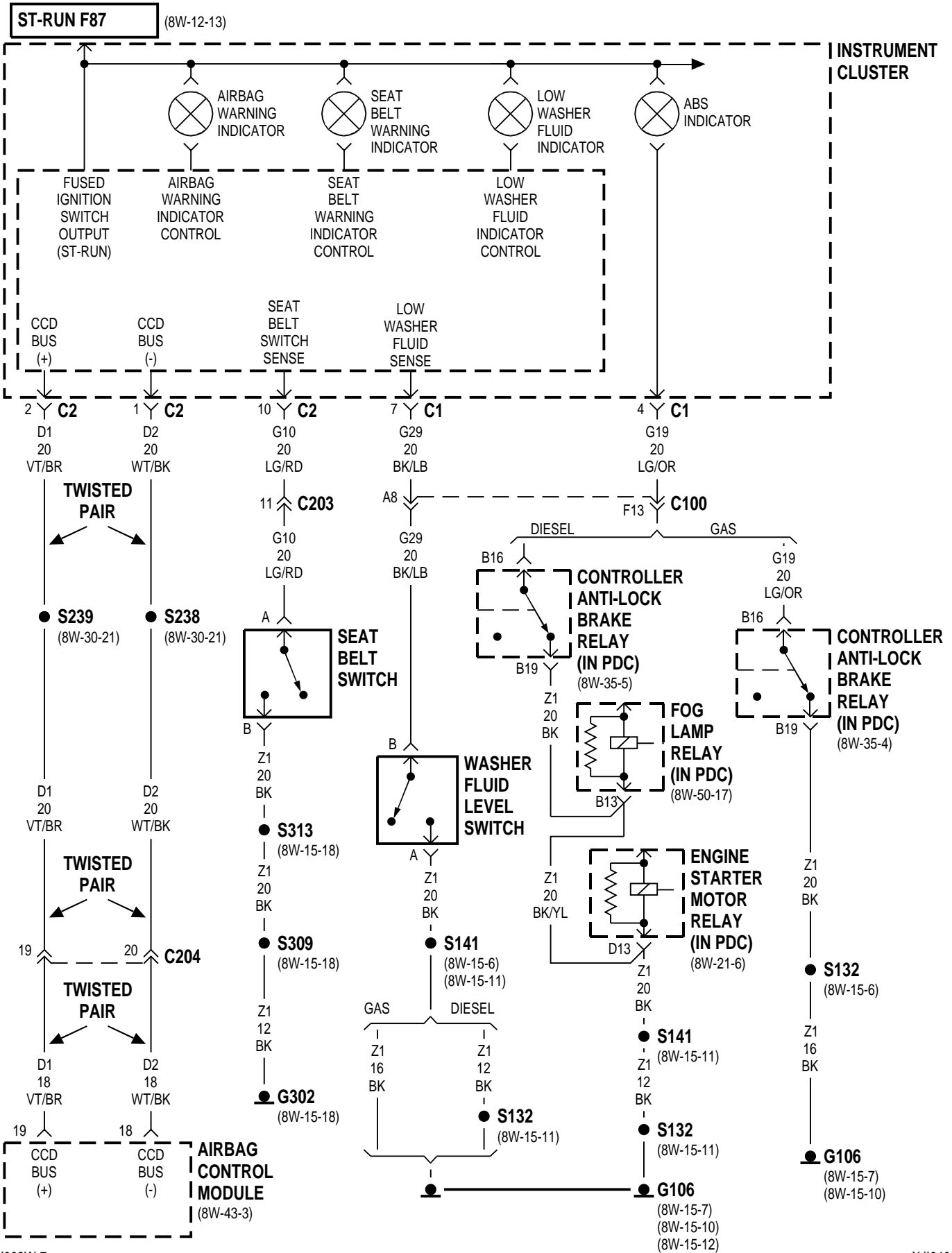

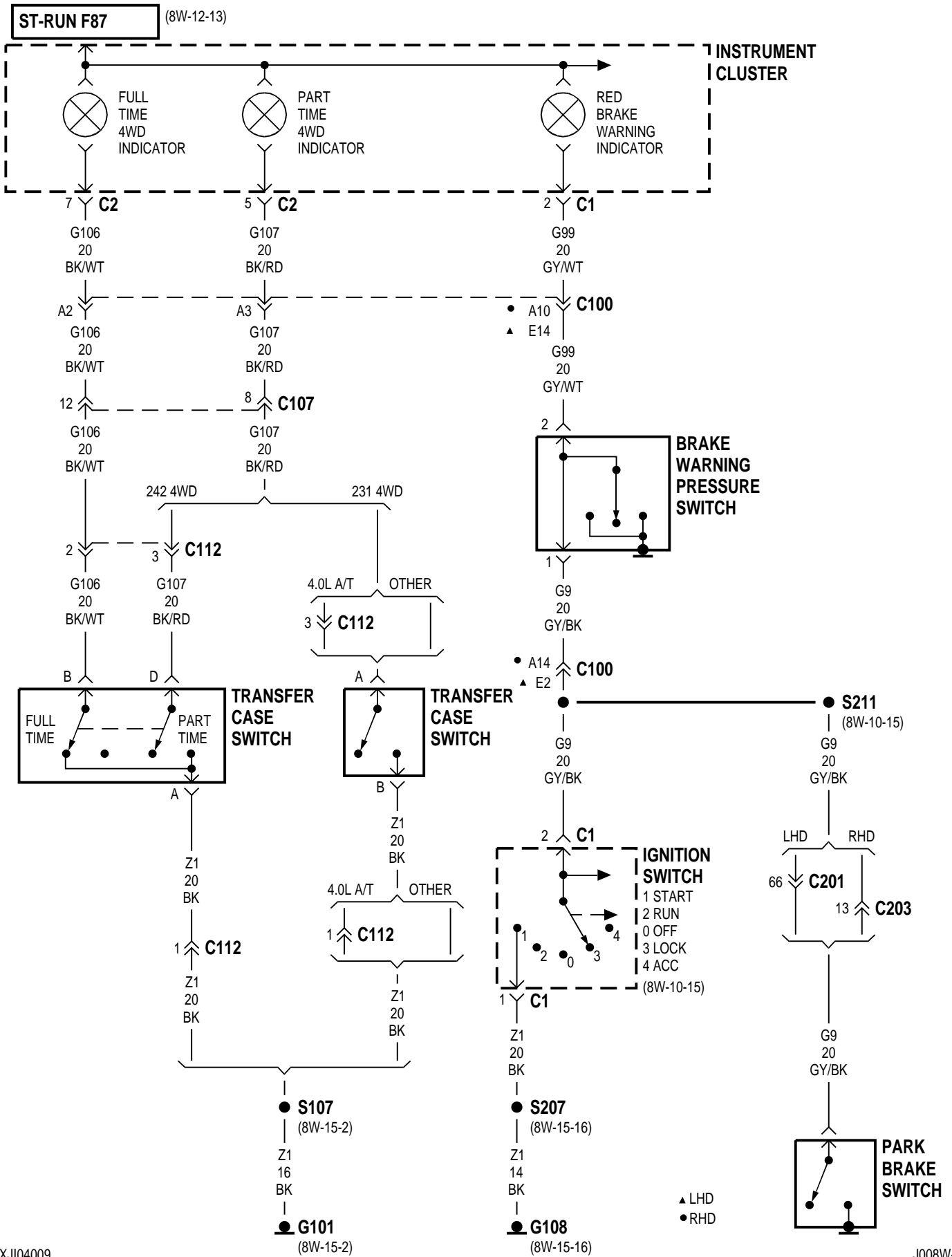

ST-RUN F87 (8W-12-13)

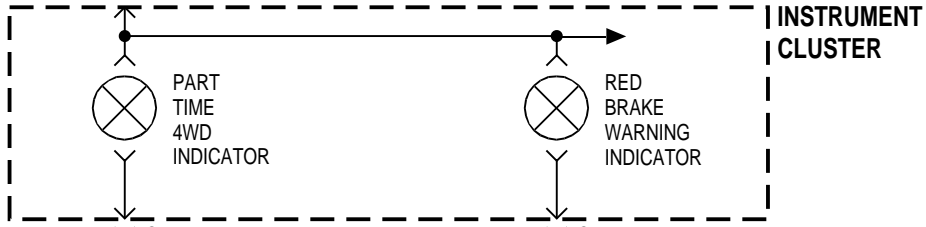

G107
20
BK/RD

G99
20
GY/WT

A3

A10
E14

G107
20
BK/RD

G99
20
GY/WT

3 C111

2

G107
20
BK/RD

G99
20
GY/WT

A

1

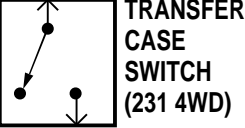

G9
20
GY/BK

A14
E2

G9
20
GY/BK

S211
(8W-10-16)

Z1
20
BK

G9
20
GY/BK

4 C111

2 C1

Z1
18
BK

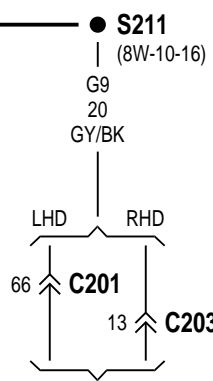
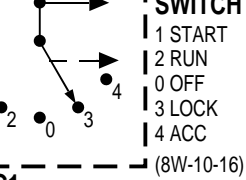

S157
(8W-15-11)

1 C1

Z1
12
BK

Z1
20
BK

S132
(8W-15-11)

S207
(8W-15-16)

Z1
12
BK

Z1
14
BK

G106
(8W-15-12)

G108 (8W-15-16) ▲ LHD
● RHD

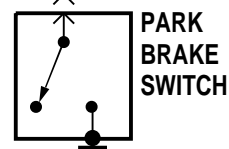

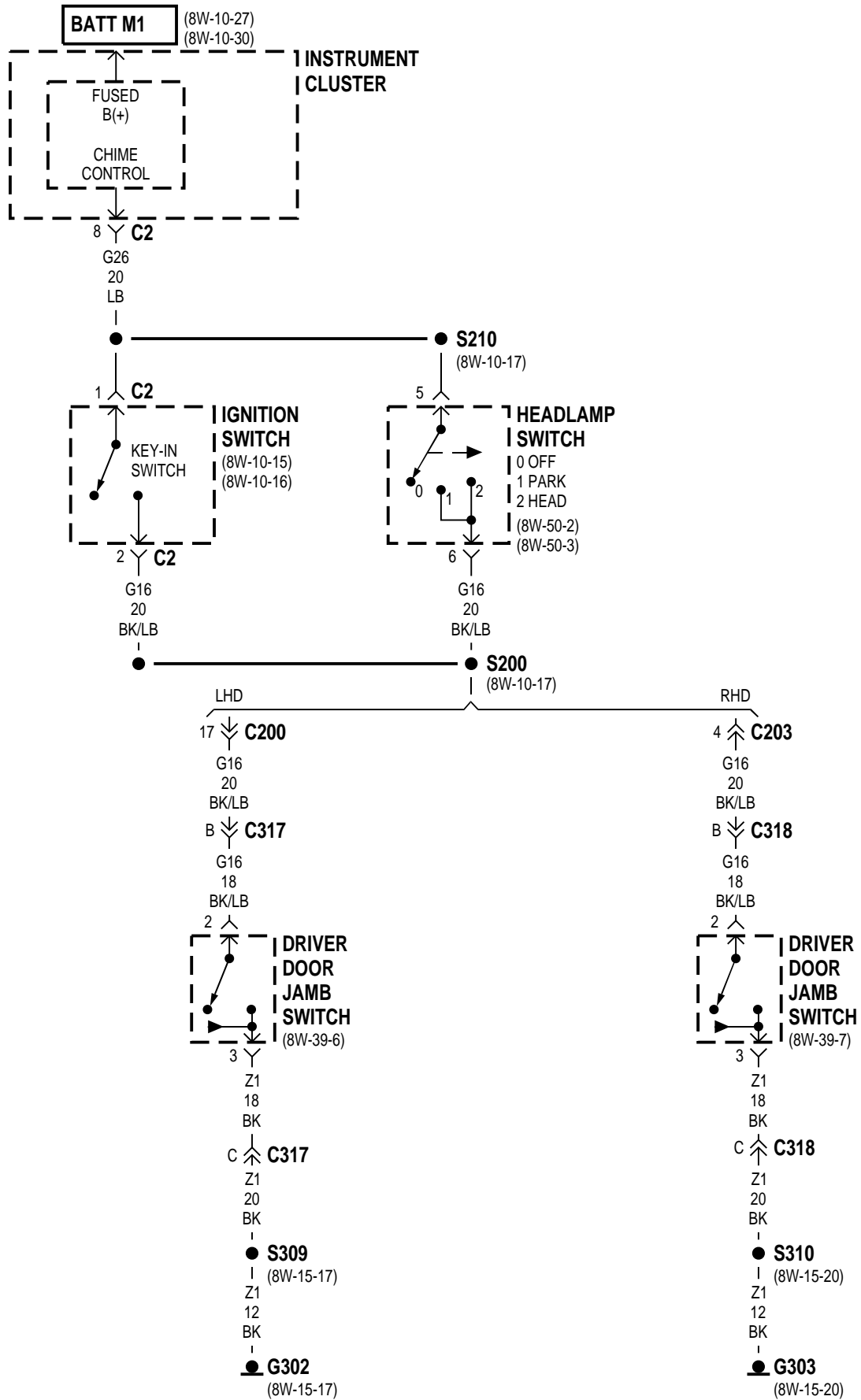

LHD

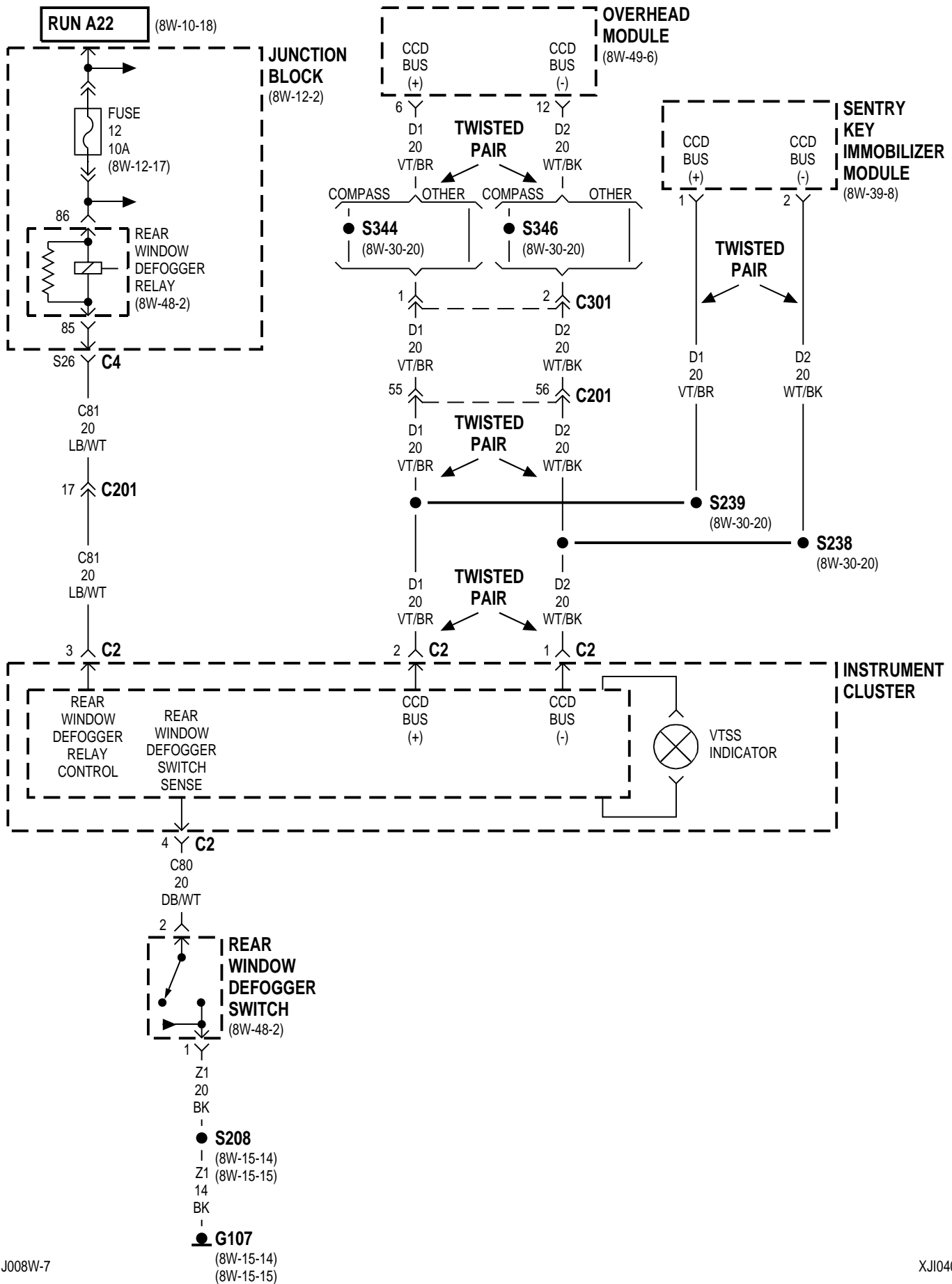

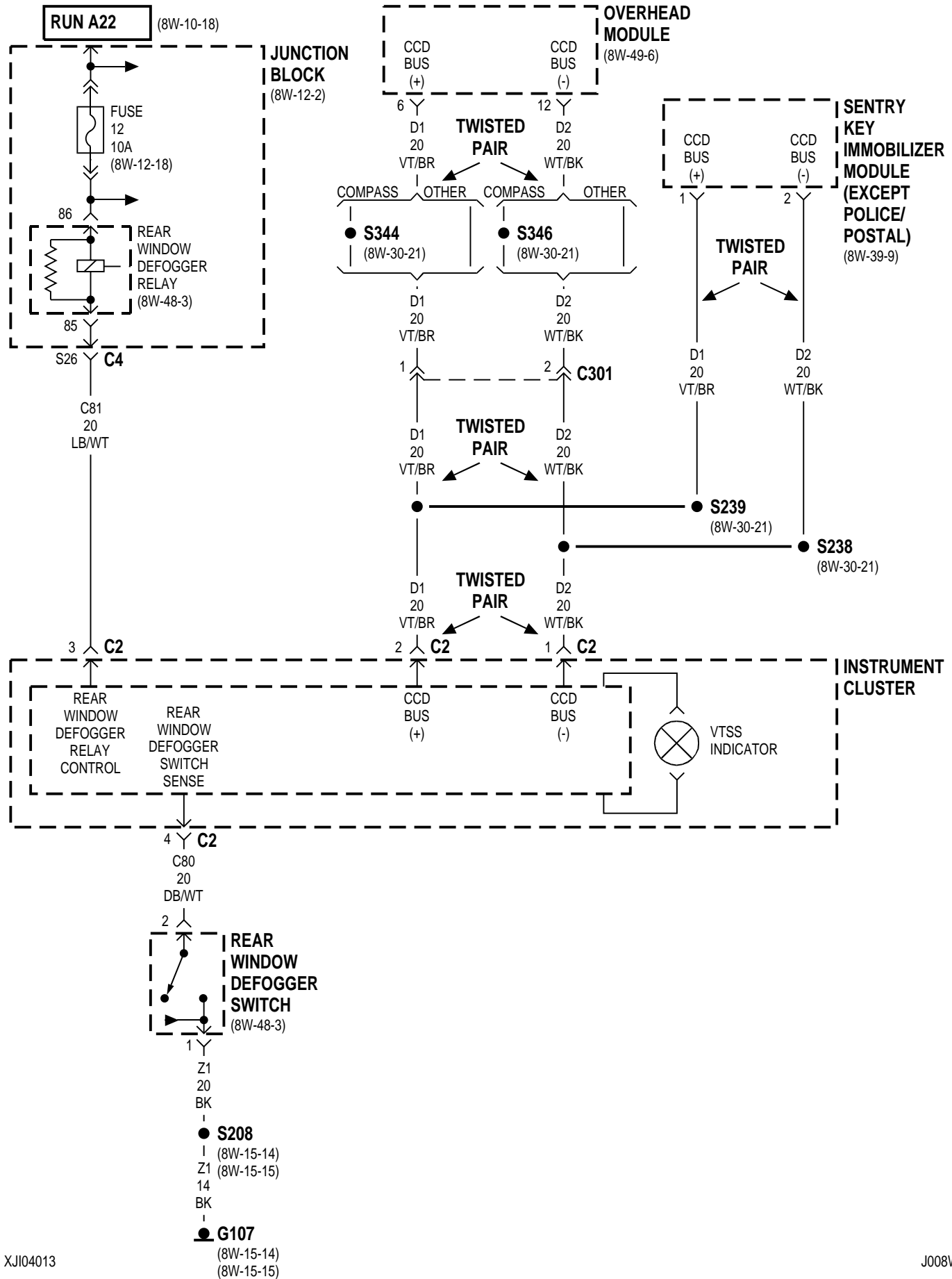

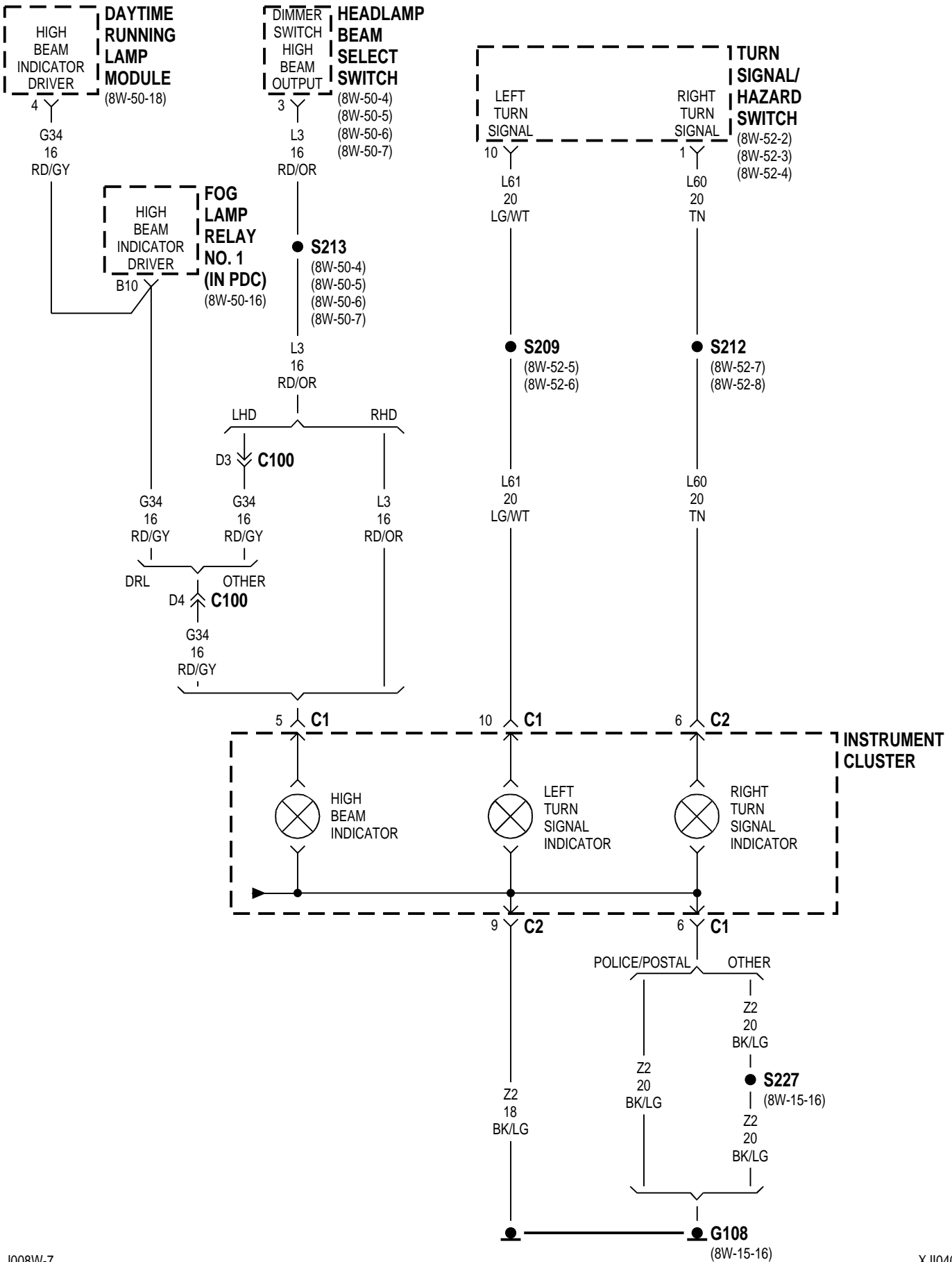

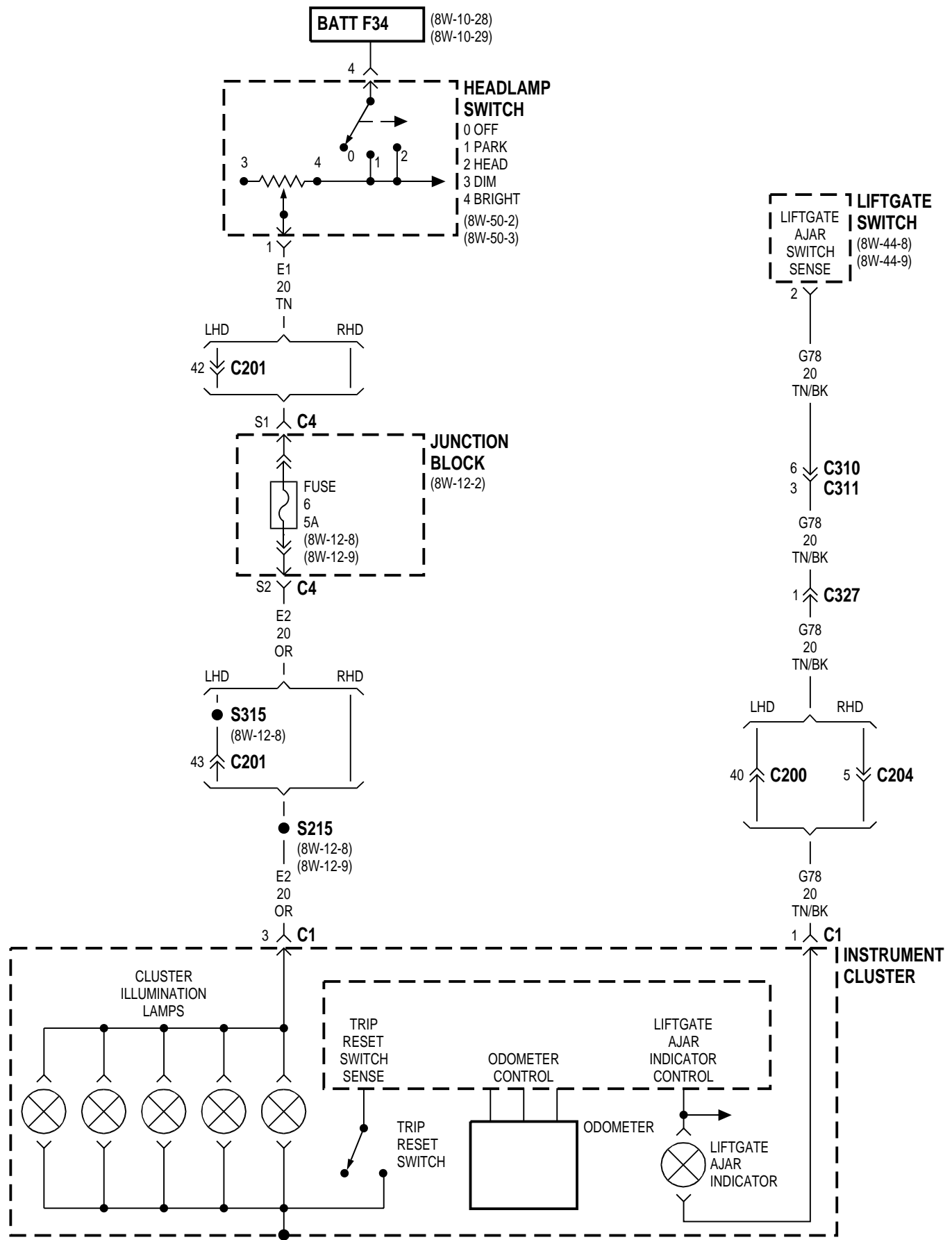

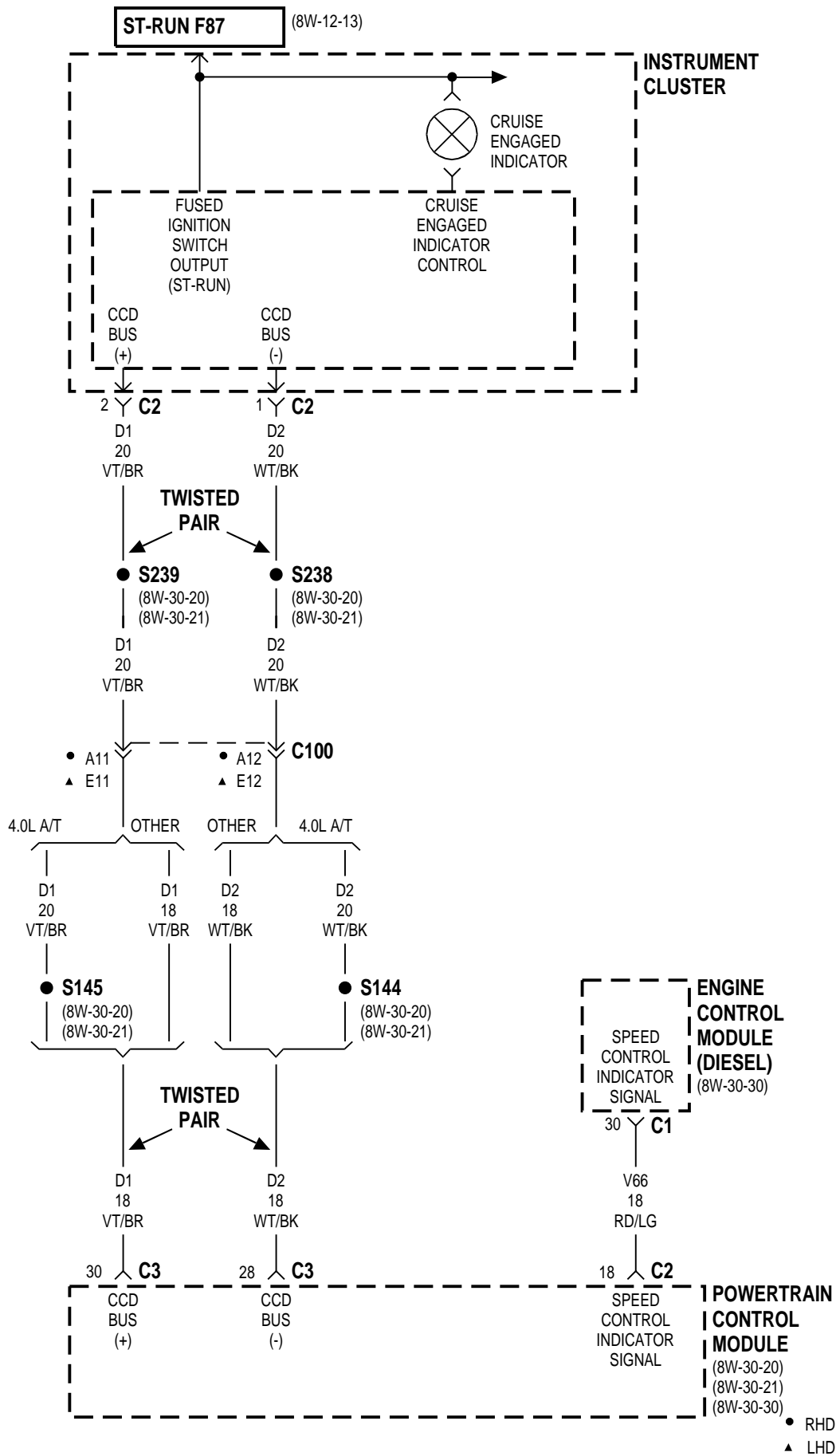

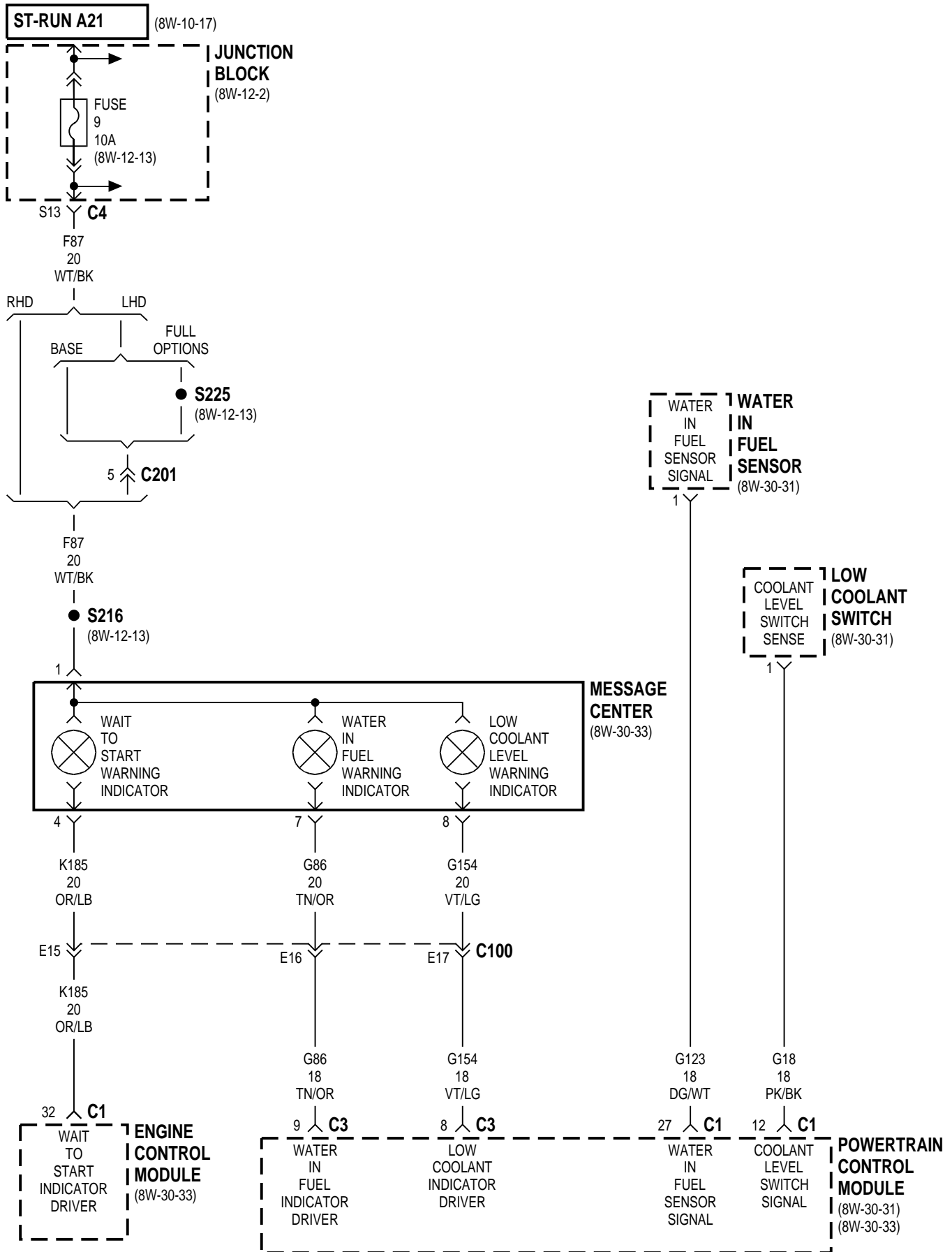

8W-41 HORN/CIGAR LIGHTER/POWER OUTLET

| Component | Page | Component | Page |
|---------------------------|-------------|-----------------------|-------------|
| Cigar Lighter | 8W-41-2, 3 | High Note Horn | 8W-41-2, 3 |
| Cigar Lighter Relay | 8W-41-2, 3 | Horn Relay | 8W-41-2, 3 |
| Clockspring | 8W-41-2, 3 | Horn Switch | 8W-41-2, 3 |
| Fuse 1 (JB) | 8W-41-2, 3 | Junction Block | 8W-41-2, 3 |
| Fuse 2 (JB) | 8W-41-2, 3 | Low Note Horn | 8W-41-2, 3 |
| Fuse 21 (JB) | 8W-41-2, 3 | Overhead Module | 8W-41-2, 3 |
| G107 | 8W-41-2, 3 | Power Outlet | 8W-41-2, 3 |

LHD

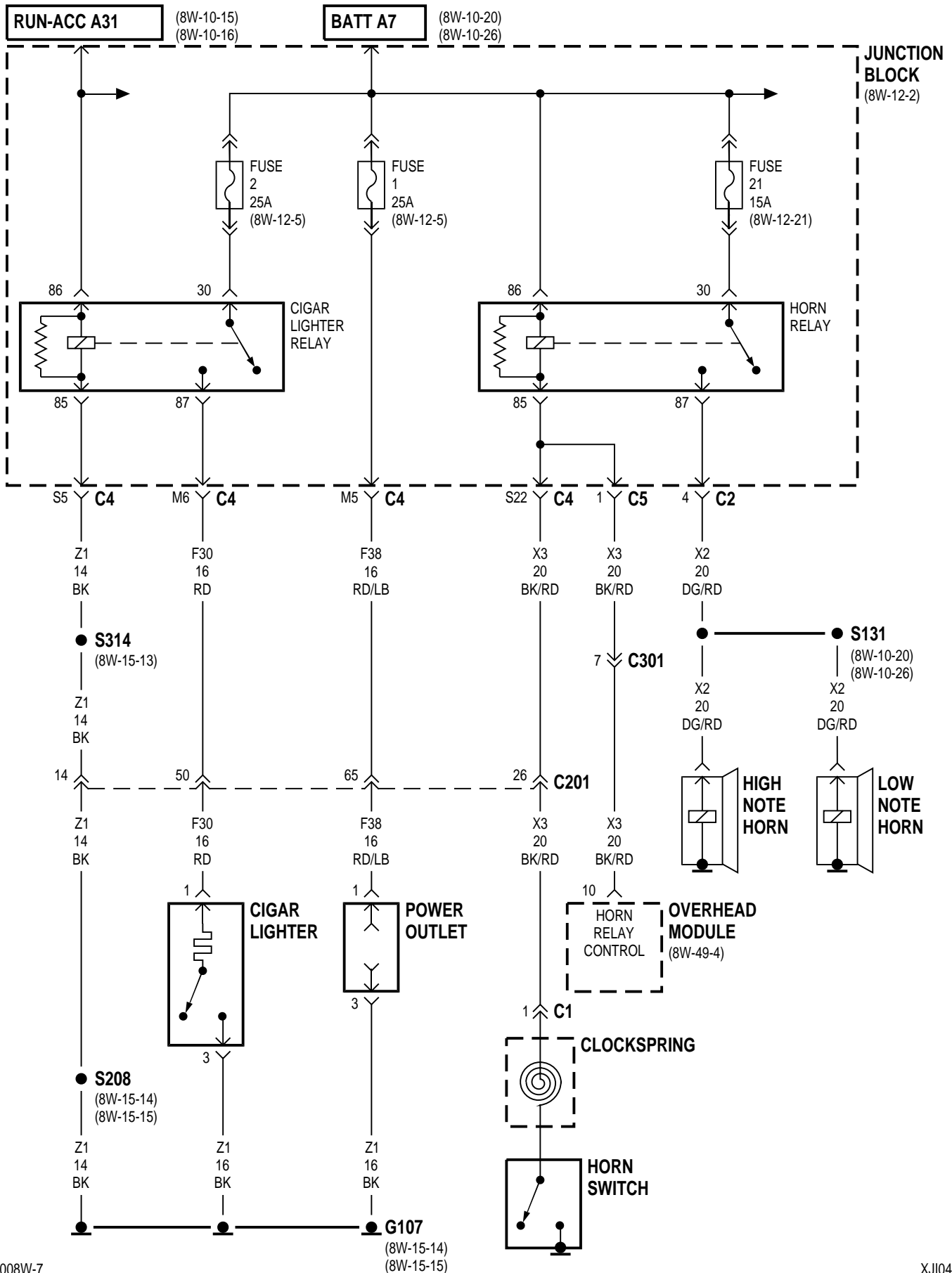

XJ ————— **8W-41 HORN/CIGAR LIGHTER/POWER OUTLET** ————— **8W - 41 - 3**
RHD

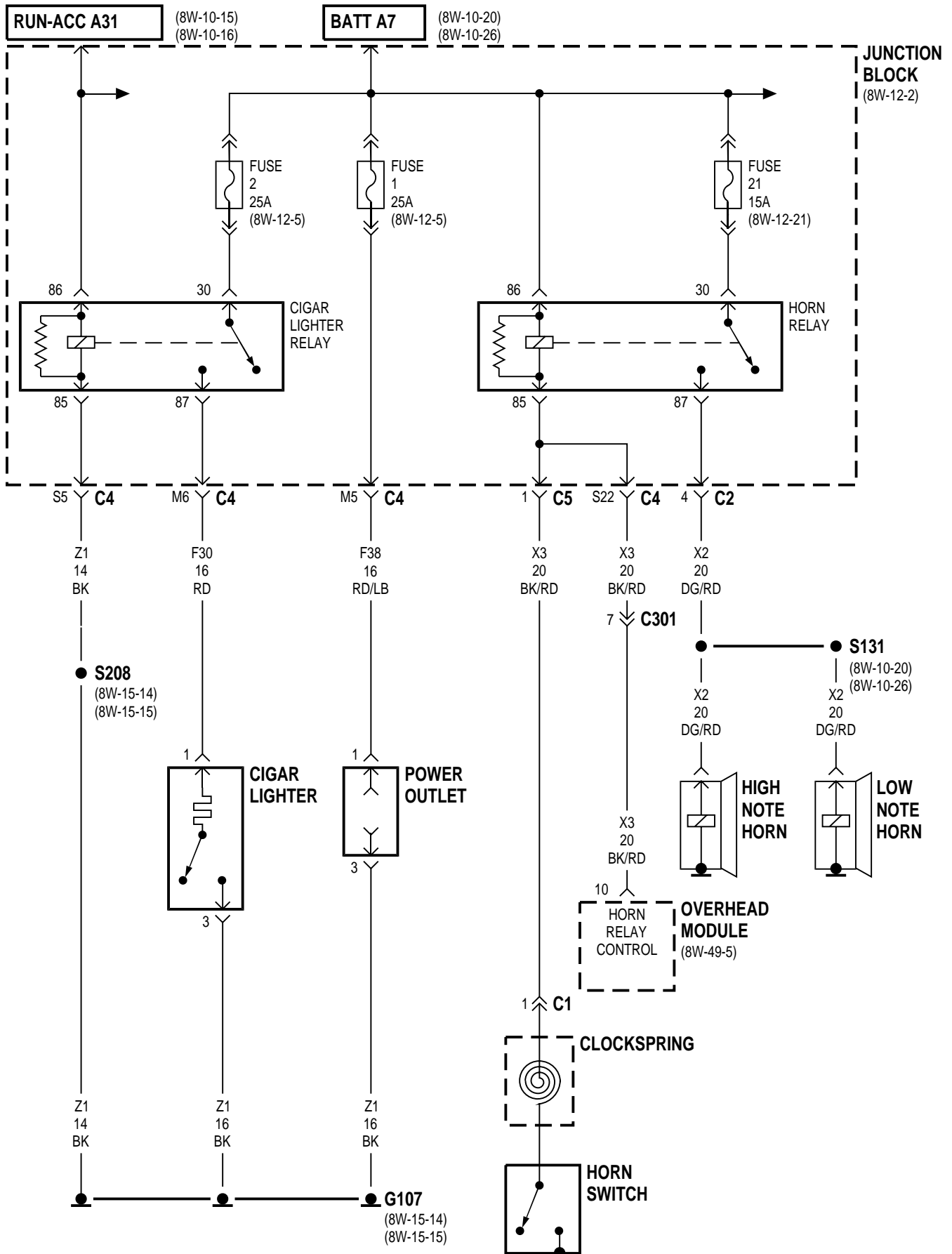

8W-42 AIR CONDITIONING-HEATER

| Component | Page | Component | Page |
|---------------------------------------|------------------|-------------------------------------|-------------------------------|
| A/C Compressor Clutch | 8W-42-7, 8 | Fuse 11 (PDC) | 8W-42-2, 3, 4, 5 |
| A/C Compressor Clutch Relay | 8W-42-7, 8, 10 | Fuse 25 (JB) | 8W-42-2, 3, 4, 5, 7 |
| A/C High Pressure Switch | 8W-42-6, 8 | G106 | 8W-42-8, 9, 10 |
| A/C Low Pressure Switch | 8W-42-6, 8 | G107 | 8W-42-7 |
| A/C- Heater Control | 8W-42-4, 5, 6, 7 | G108 | 8W-42-2, 3, 4, 5 |
| Automatic Shut Down Relay | 8W-42-8, 10 | Heater Control | 8W-42-2, 3 |
| Blend Door Actuator | 8W-42-7 | Junction Block | 8W-42-2, 3, 4, 5, 7 |
| Blower Motor | 8W-42-2, 3, 4, 5 | Power Distribution | |
| Blower Motor Relay | 8W-42-2, 3, 4, 5 | Center | 8W-42-2, 3, 4, 5, 7, 8, 9, 10 |
| Blower Motor Resistor Block | 8W-42-2, 3, 4, 5 | Powertrain Control Module | 8W-42-6, 7, 9 |
| Engine Control Module | 8W-42-8, 10 | Radiator Fan Relay | 8W-42-8, 9, 10 |
| Fuse 6 (PDC) | 8W-42-2, 3, 4, 5 | | |

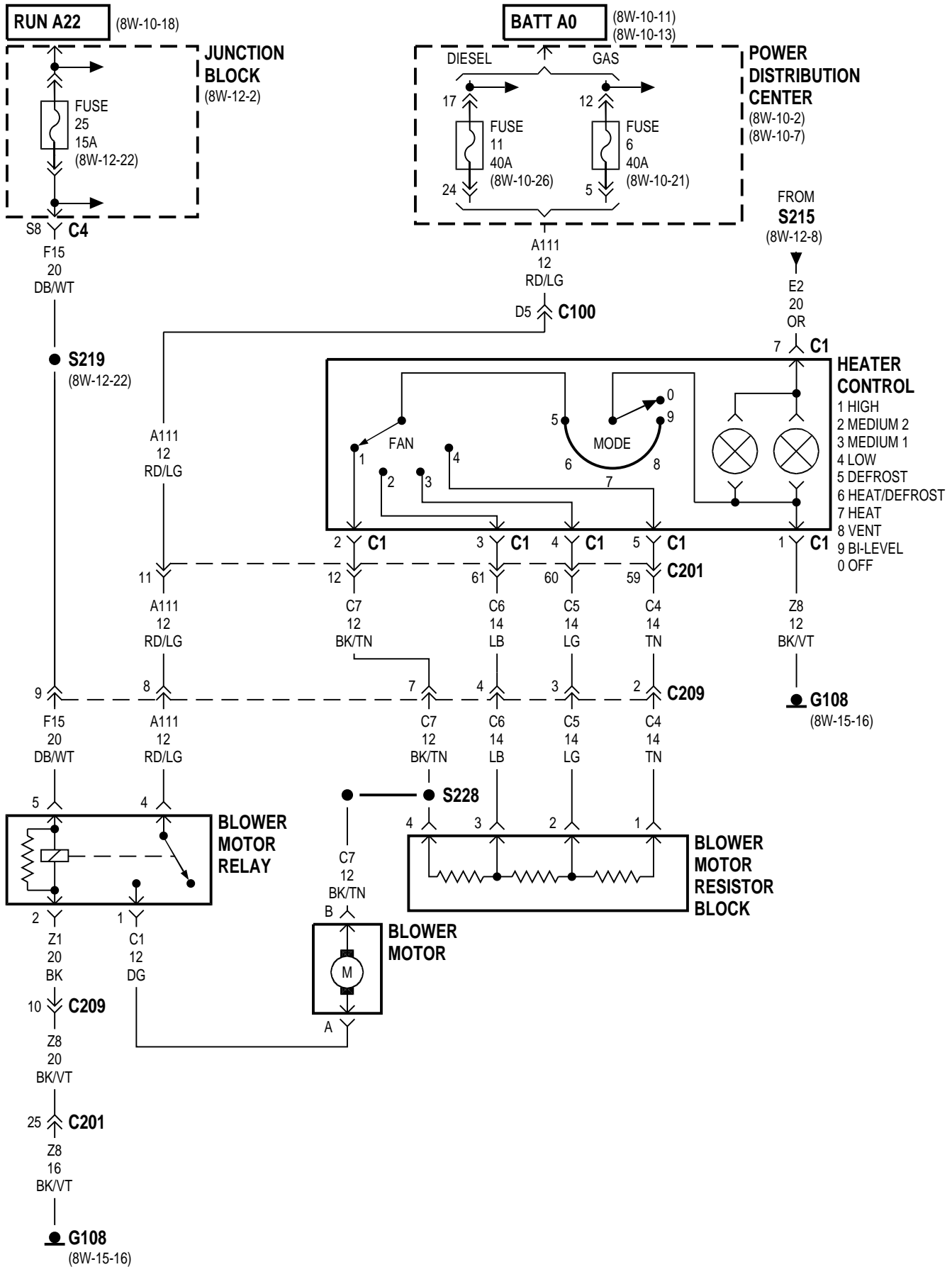

RHD HEATER ONLY

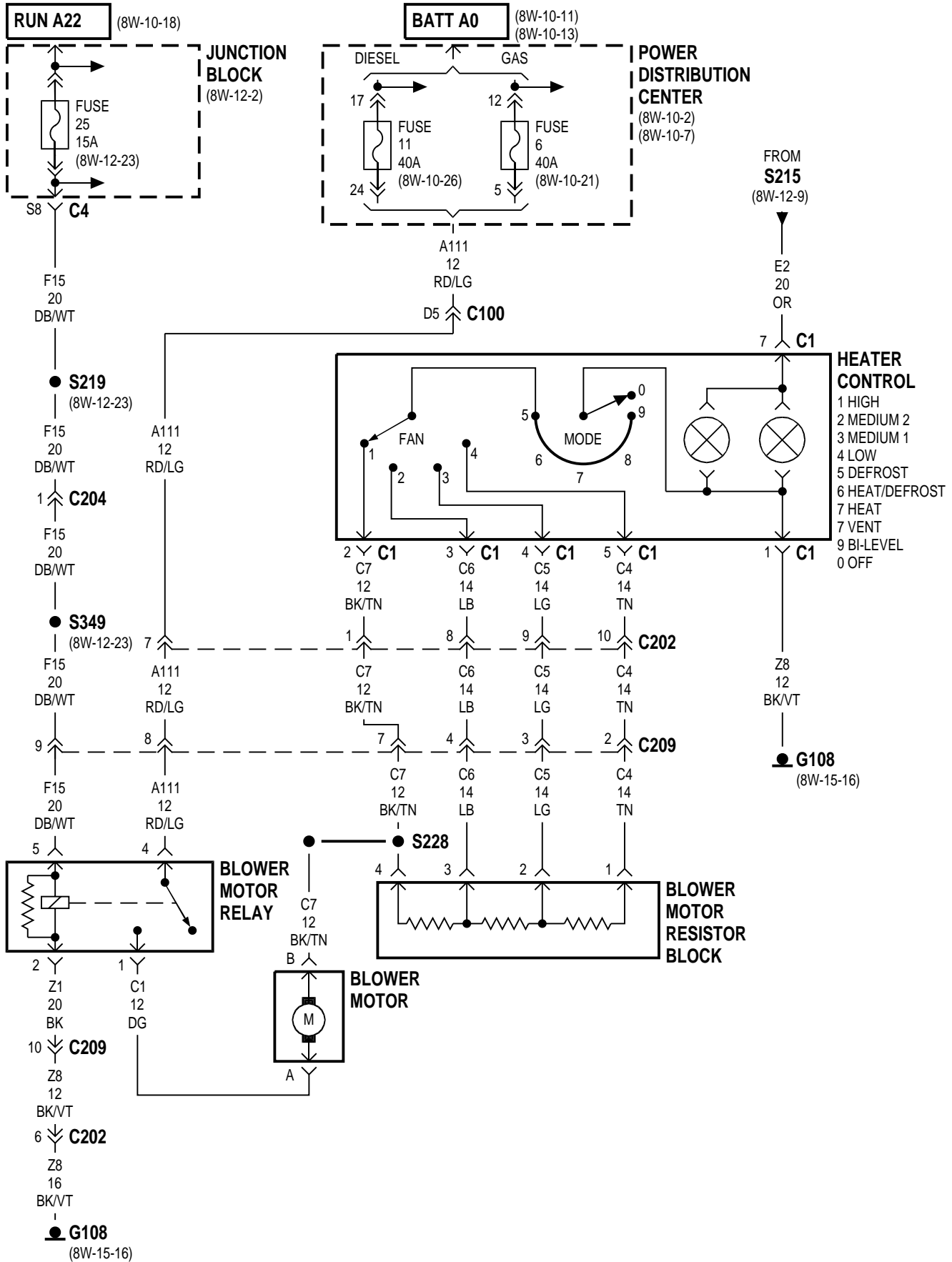

LHD

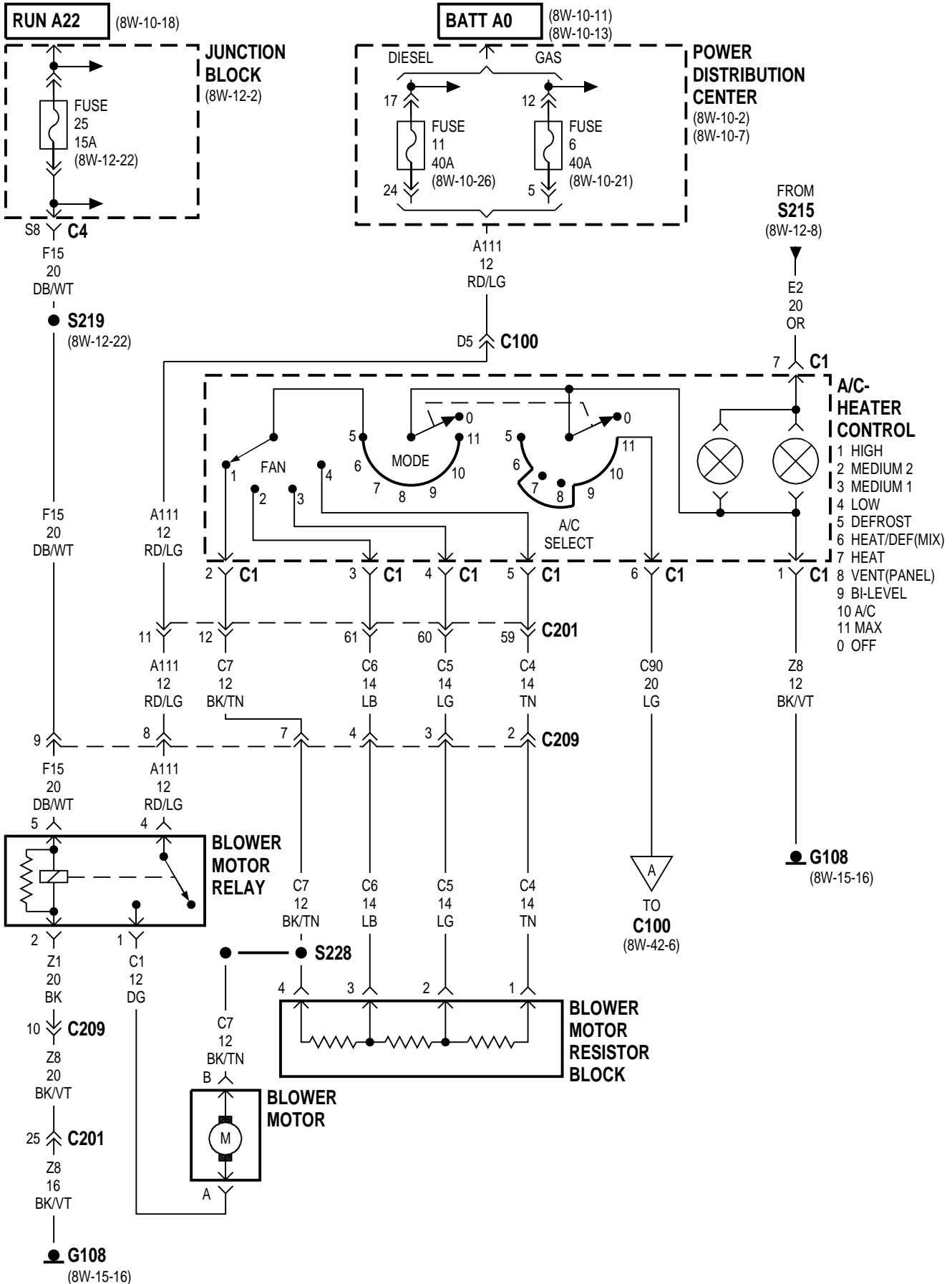

RHD

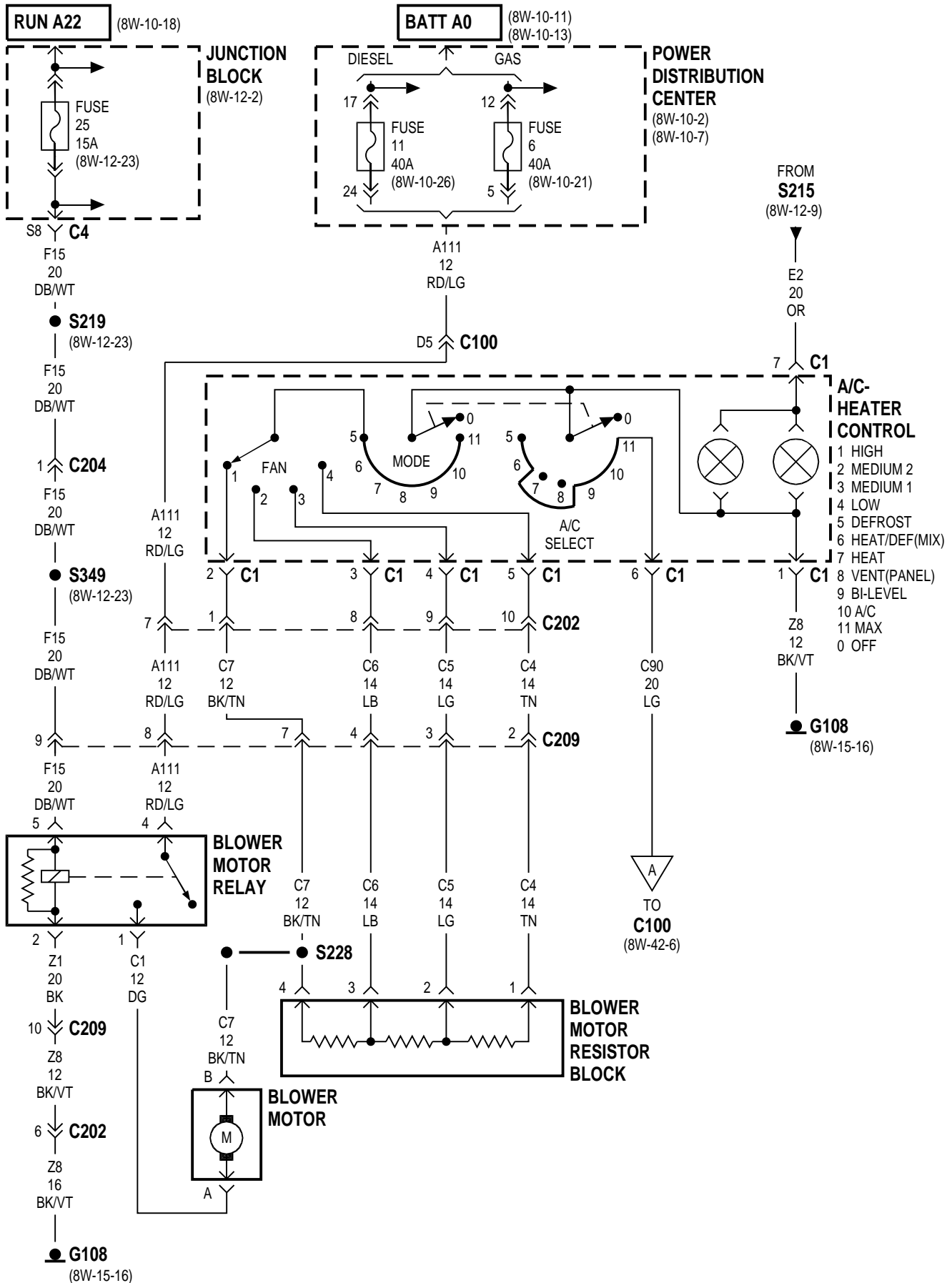

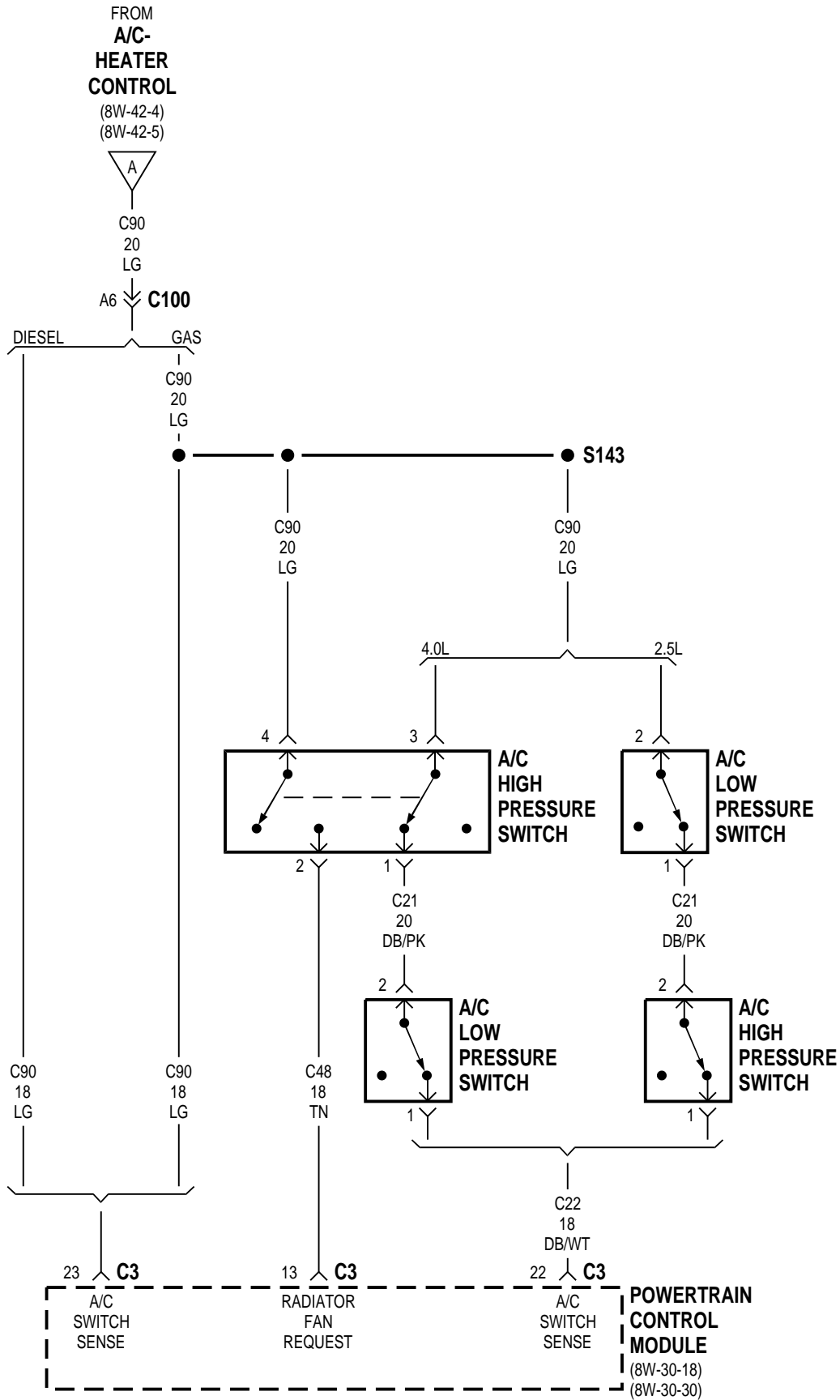

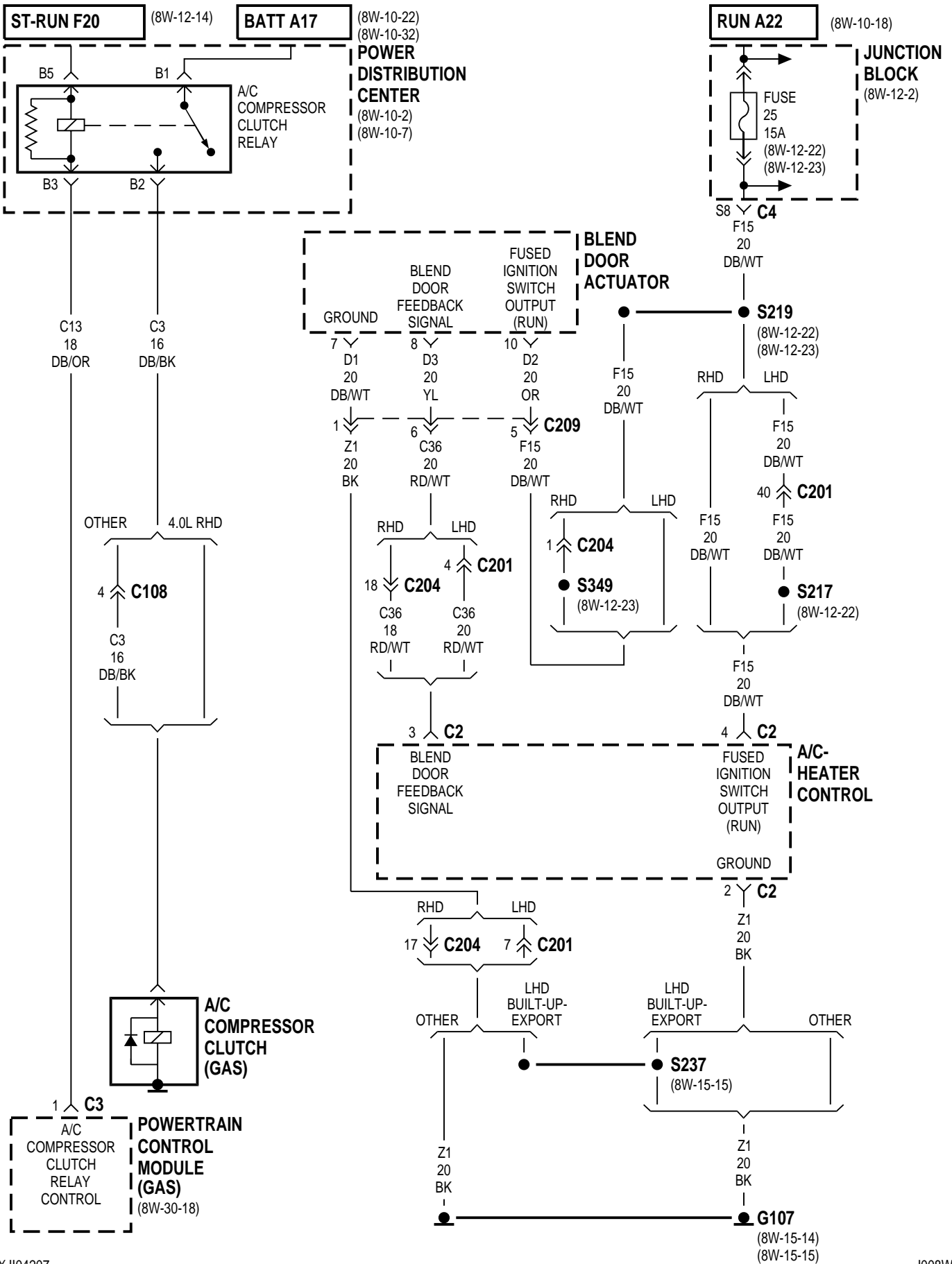

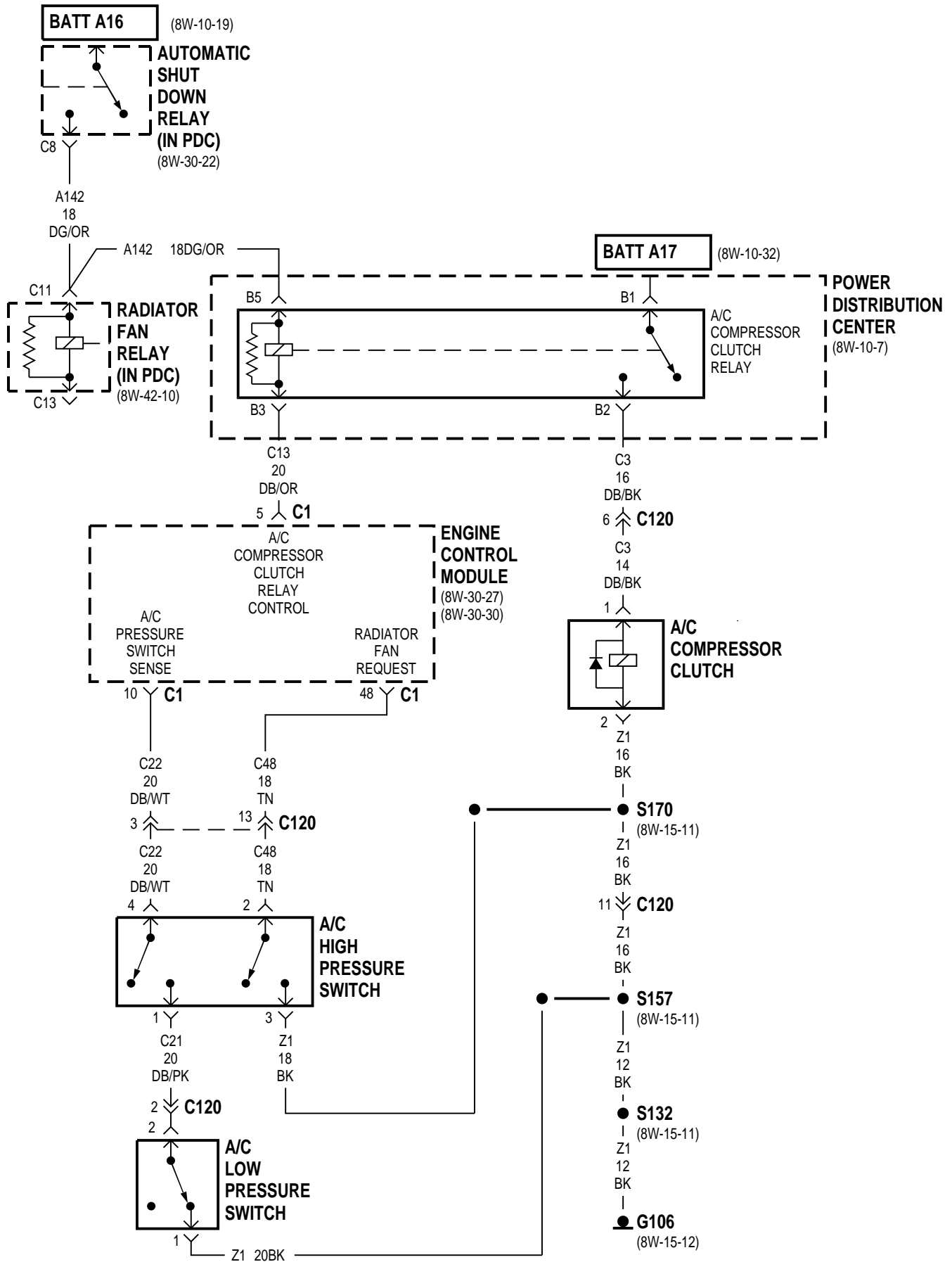

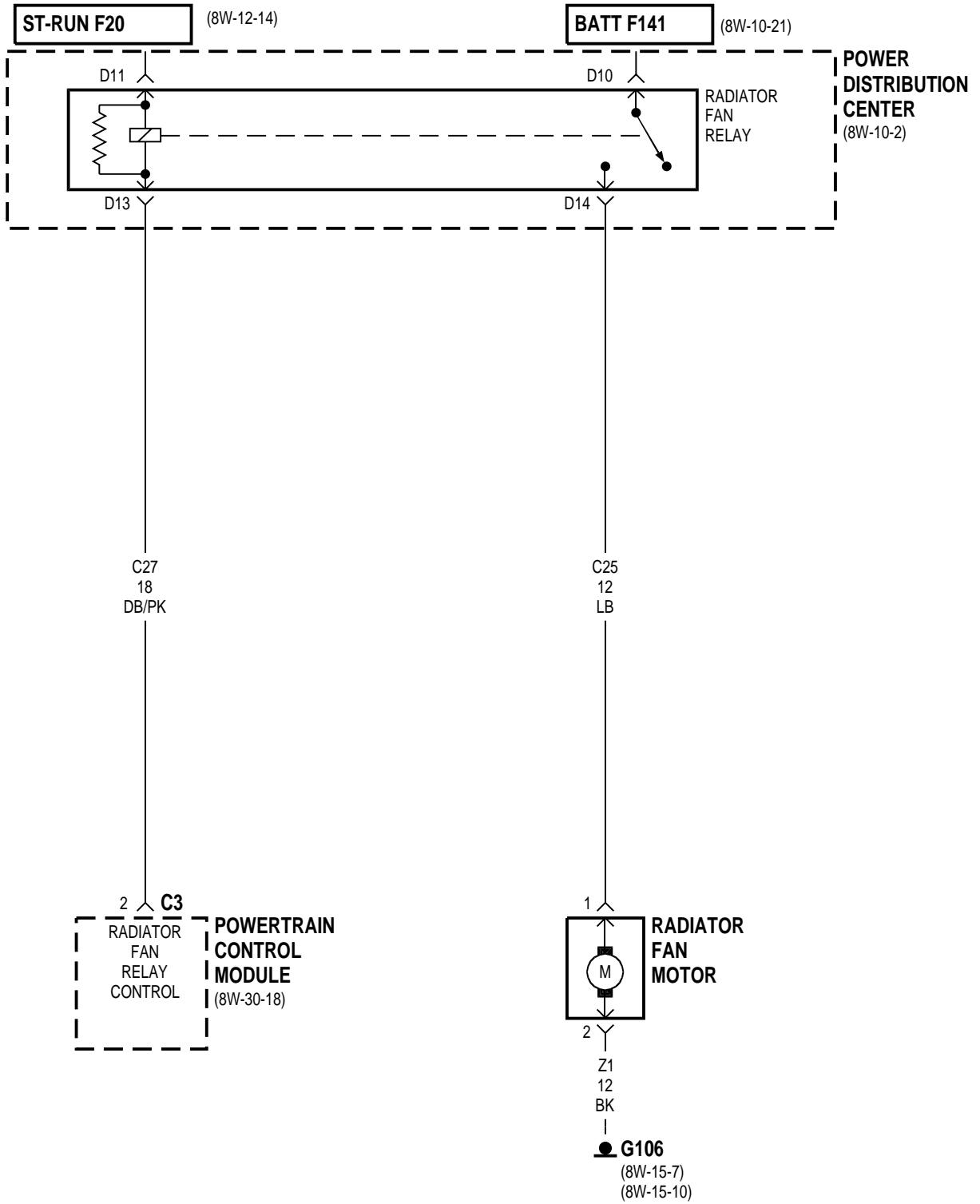

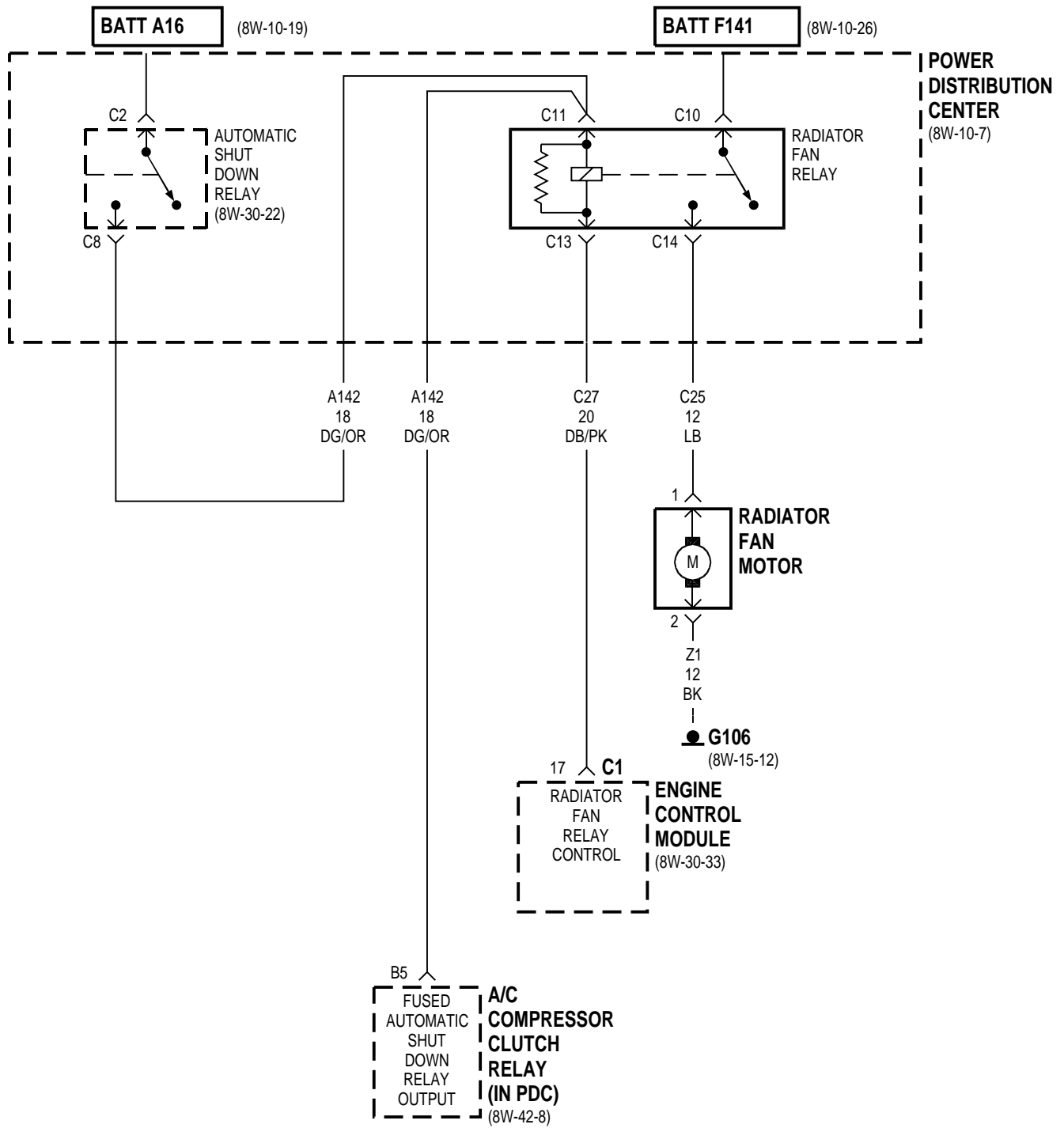

8W-43 AIRBAG SYSTEM

| Component | Page | Component | Page |
|-----------------------------|---------------|------------------------|-------------|
| Airbag Control Module | 8W-43-2, 3, 4 | Fuse 27 (JB) | 8W-43-2, 3 |
| Clockspring | 8W-43-4 | G200 | 8W-43-2 |
| Data Link Connector | 8W-43-2, 3 | G300 | 8W-43-3 |
| Driver Airbag | 8W-43-4 | Junction Block | 8W-43-2, 3 |
| Fuse 26 (JB) | 8W-43-2, 3 | Passenger Airbag | 8W-43-4 |

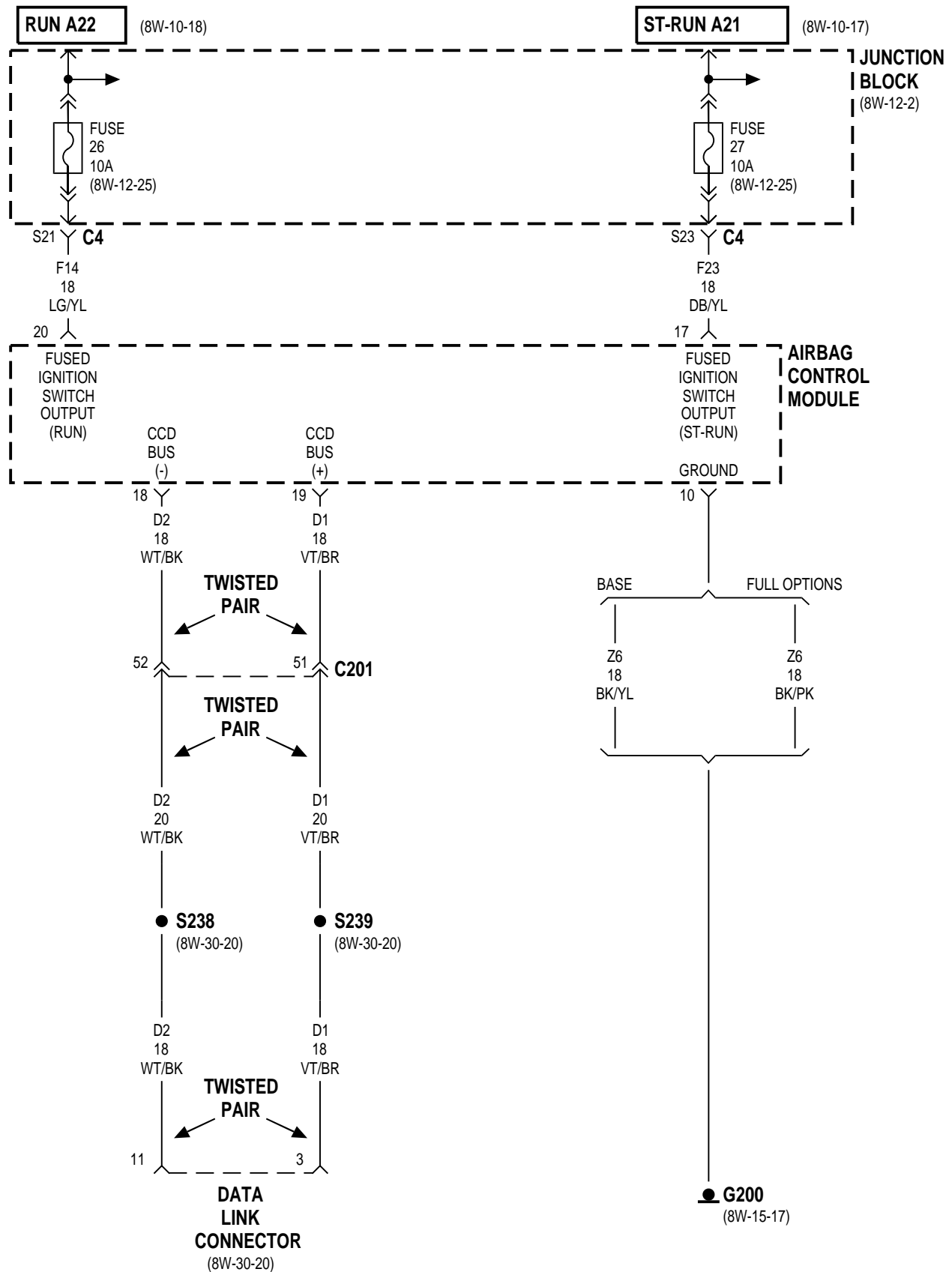

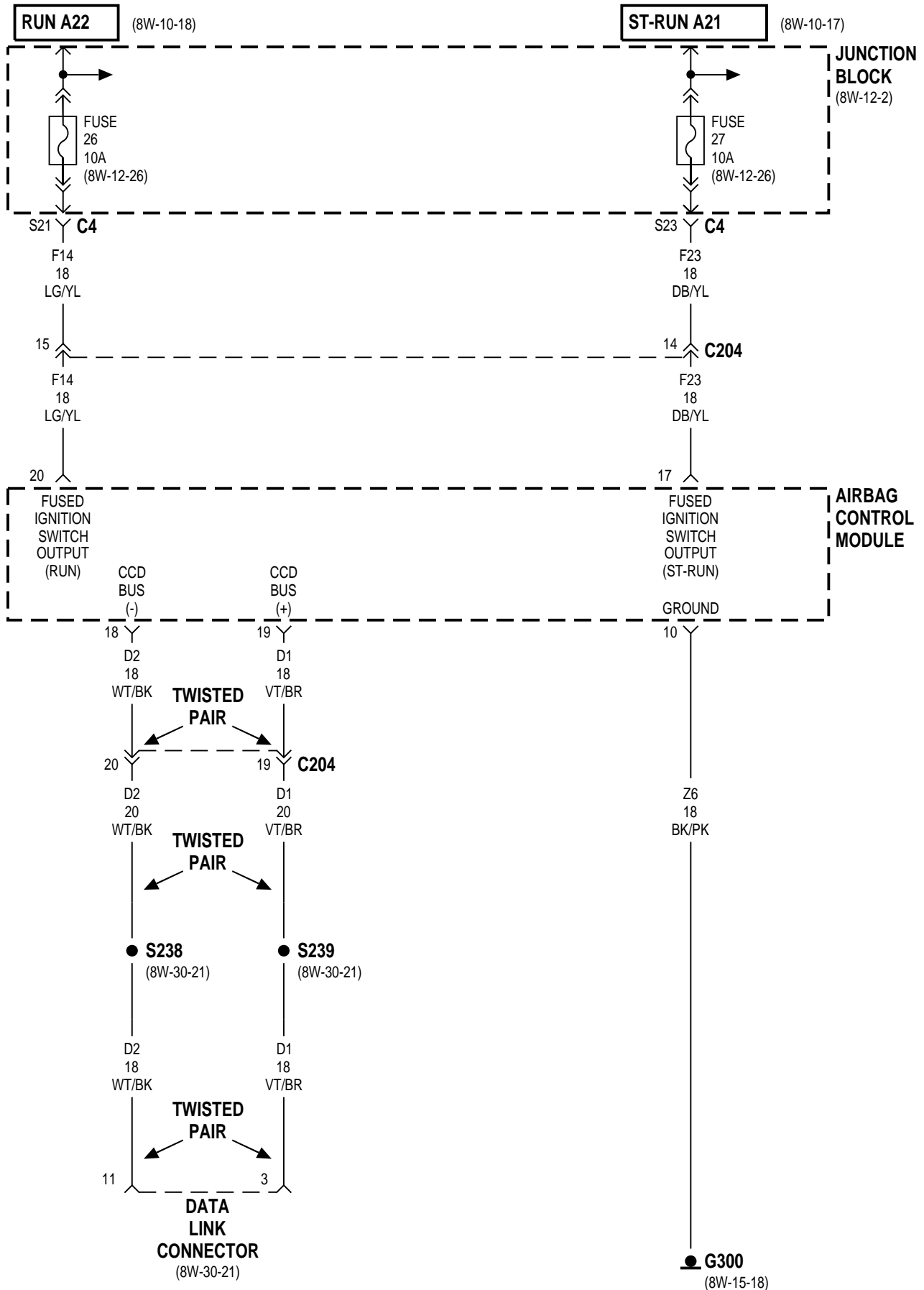

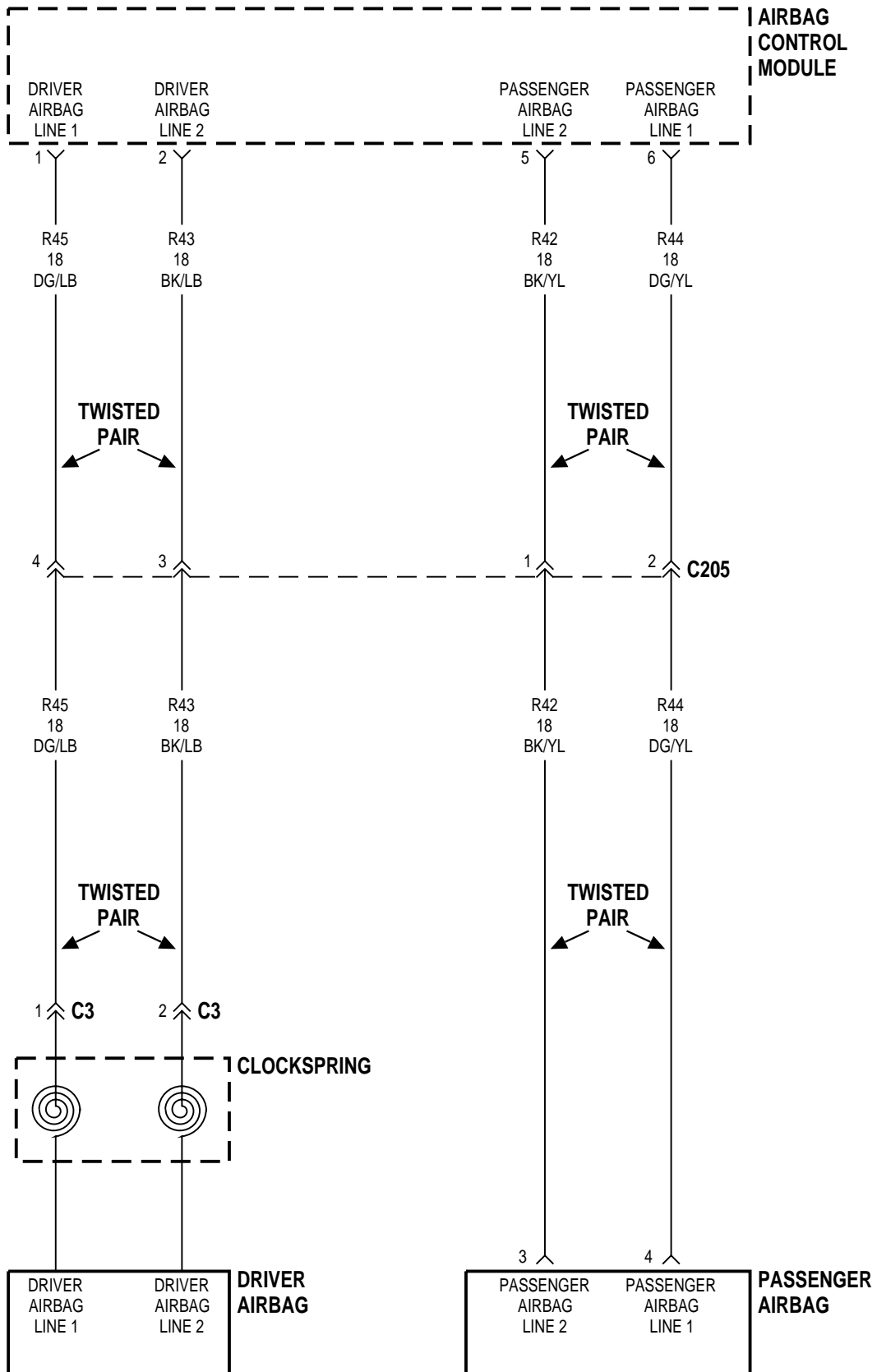

8W-44 INTERIOR LIGHTING

| Component | Page | Component | Page |
|-----------------------------------|---------------------|---|------------------------|
| A/C- Heater Control | 8W-44-2, 3, 4 | Instrument Cluster | 8W-44-2, 3, 4, 8, 9 |
| Cargo Lamp/Switch | 8W-44-8, 9 | Junction Block | 8W-44-2, 3, 4, 5, 6, 7 |
| Compass | 8W-44-5 | Left Courtesy Lamp | 8W-44-6, 7 |
| Dome Lamp | 8W-44-5 | Left Rear Door Jamb Switch | 8W-44-8, 9 |
| Dome Lamps Switch | 8W-44-5 | Left Visor/Vanity Lamp | 8W-44-5 |
| Driver Door Jamb Switch | 8W-44-8, 9 | Liftgate Switch | 8W-44-8, 9 |
| Extended Idle Switch | 8W-44-2 | Passenger Door Jamb Switch | 8W-44-8, 9 |
| Front Fog Lamp Switch | 8W-44-2, 3, 4 | Power Distribution Center | 8W-44-6, 7 |
| Fuse 6 (JB) | 8W-44-2, 3, 4 | PRNDL Illumination | 8W-44-2, 3, 4 |
| Fuse 16 (PDC) | 8W-44-6, 7 | Radio | 8W-44-2, 3, 4 |
| G106 | 8W-44-6, 7 | Rear Fog Lamp Switch | 8W-44-3, 4 |
| G107 | 8W-44-2, 3, 4, 5 | Rear Window Defogger Switch | 8W-44-2, 3, 4 |
| G108 | 8W-44-2, 3, 4, 6, 7 | Rear Wiper/Washer Switch | 8W-44-2, 3, 4 |
| G302 | 8W-44-4, 8, 9 | Right Courtesy Lamp | 8W-44-6, 7 |
| G303 | 8W-44-8, 9 | Right Rear Door Jamb Switch | 8W-44-8, 9 |
| G304 | 8W-44-8, 9 | Right Visor/Vanity Lamp | 8W-44-5 |
| Headlamp Delay Module | 8W-44-6, 7 | Transfer Case Switch Illumination | 8W-44-2, 3, 4 |
| Headlamp Switch | 8W-44-2, 3, 4, 6, 7 | Underhood Lamp/Switch | 8W-44-6, 7 |

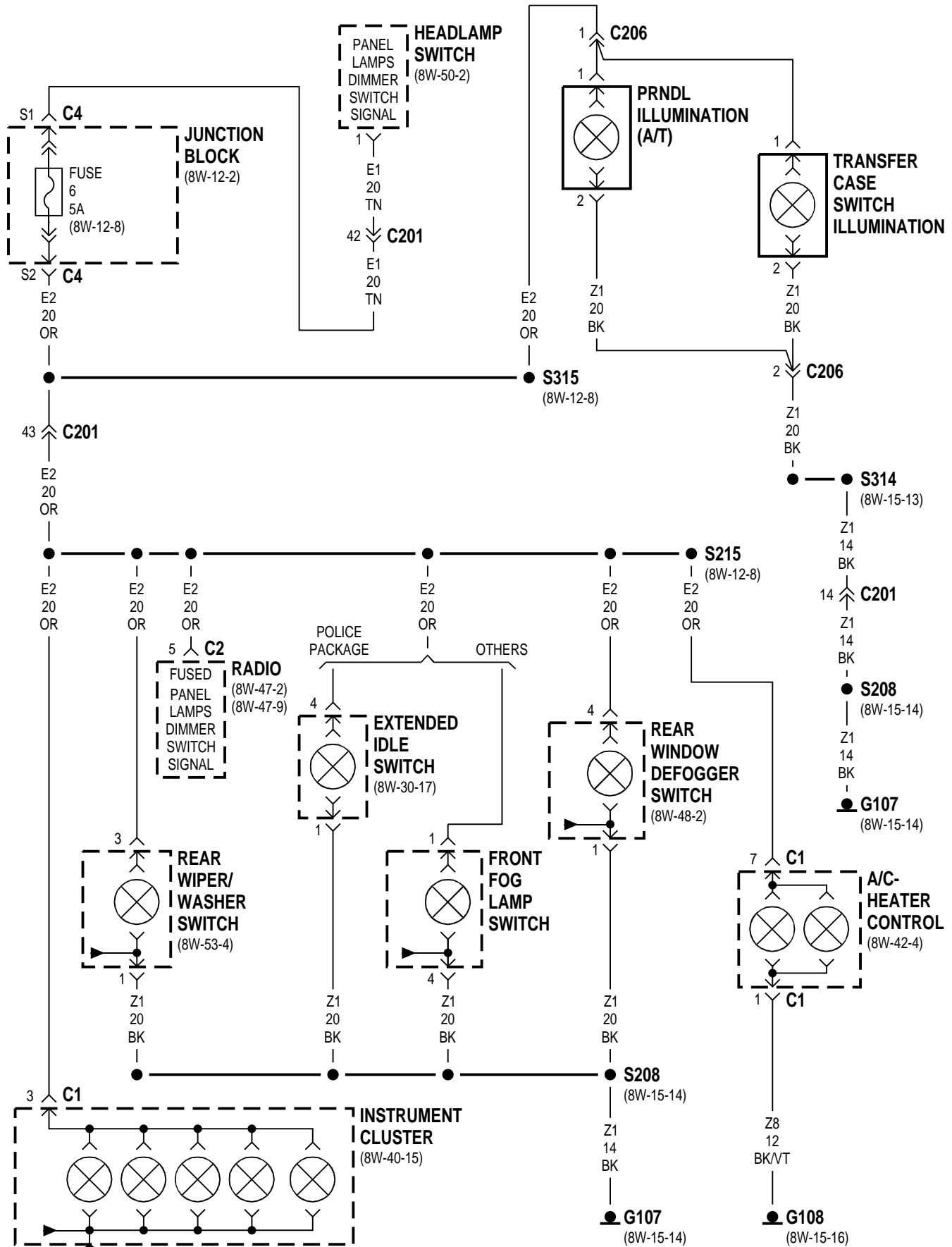

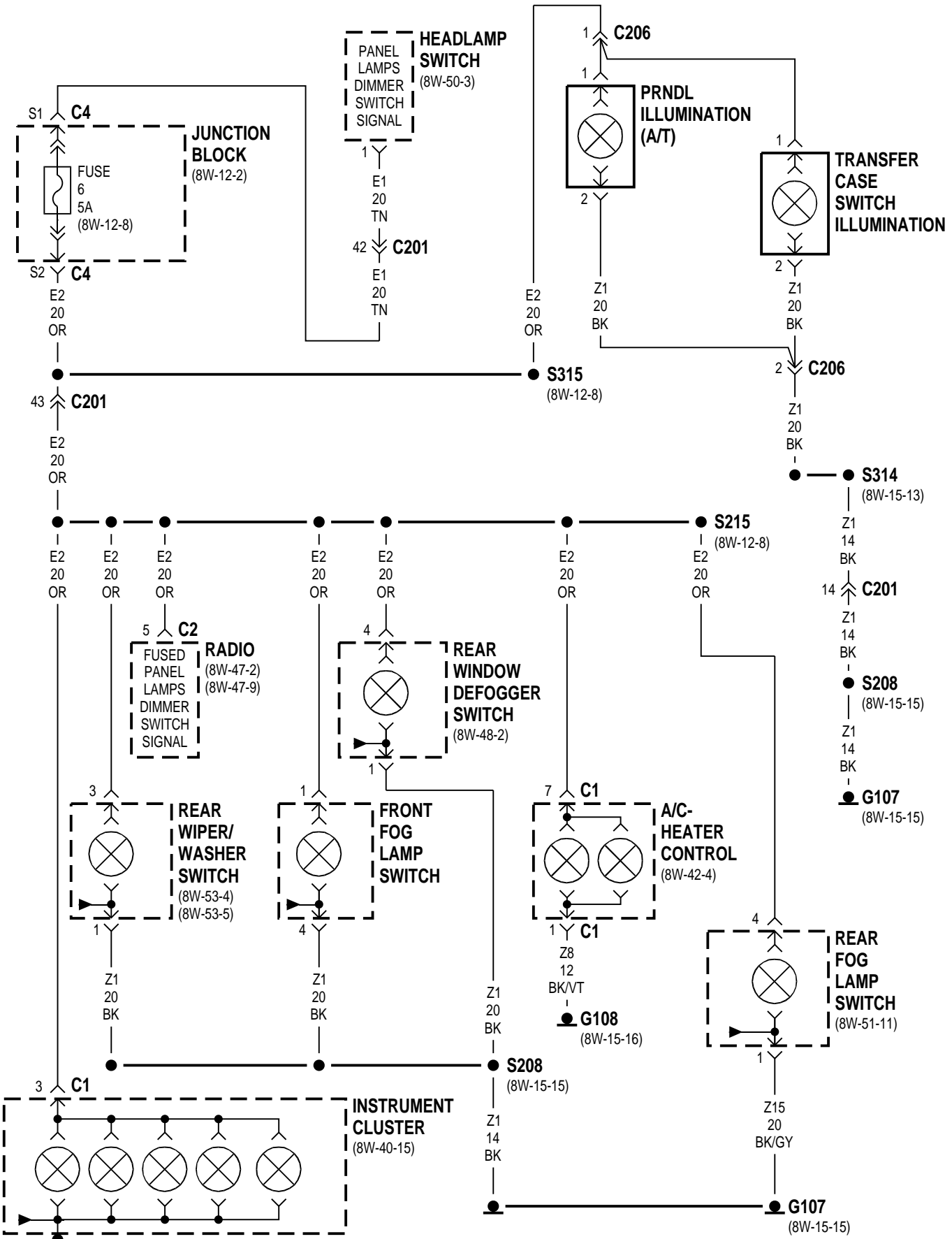

RHD

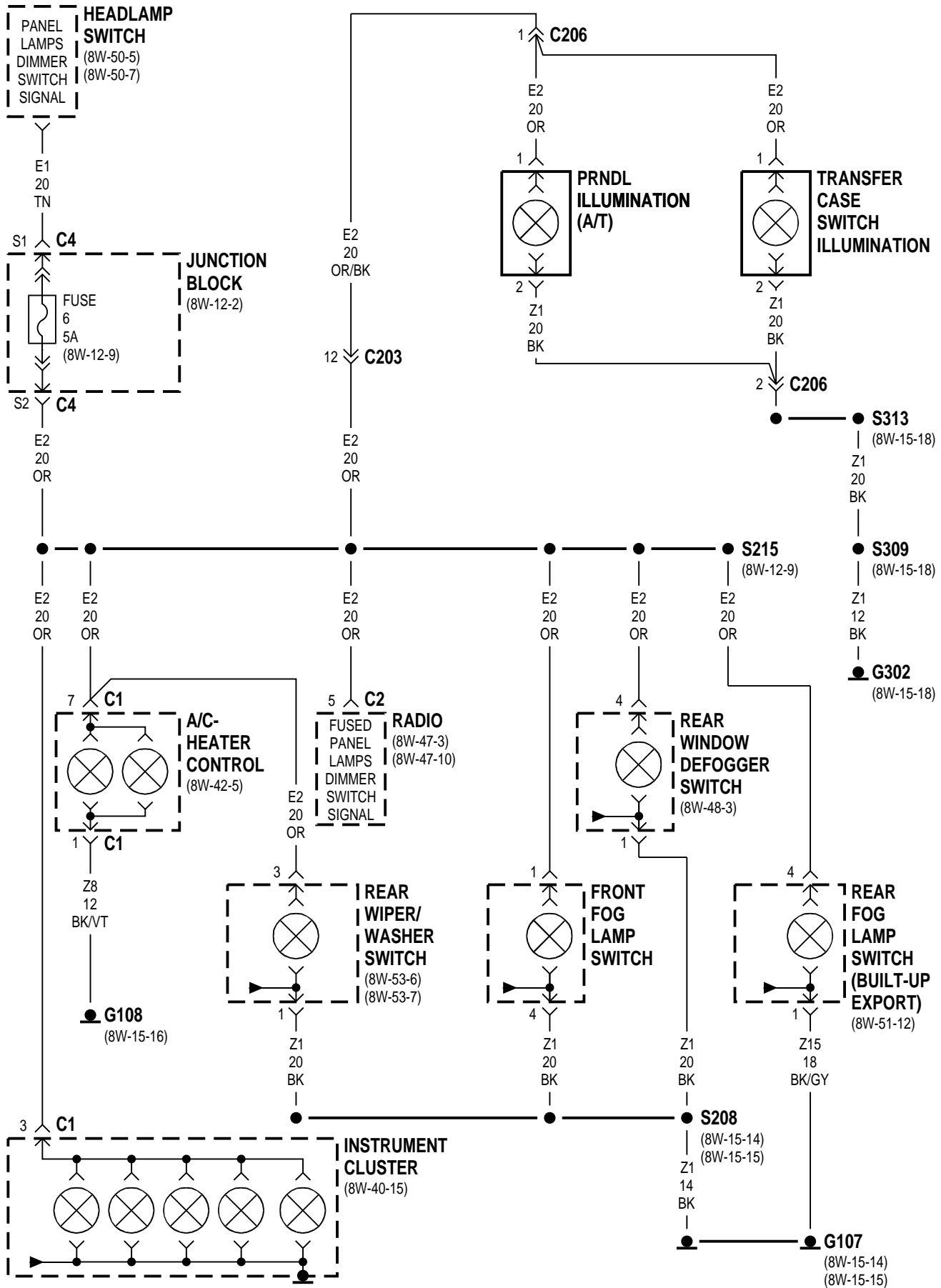

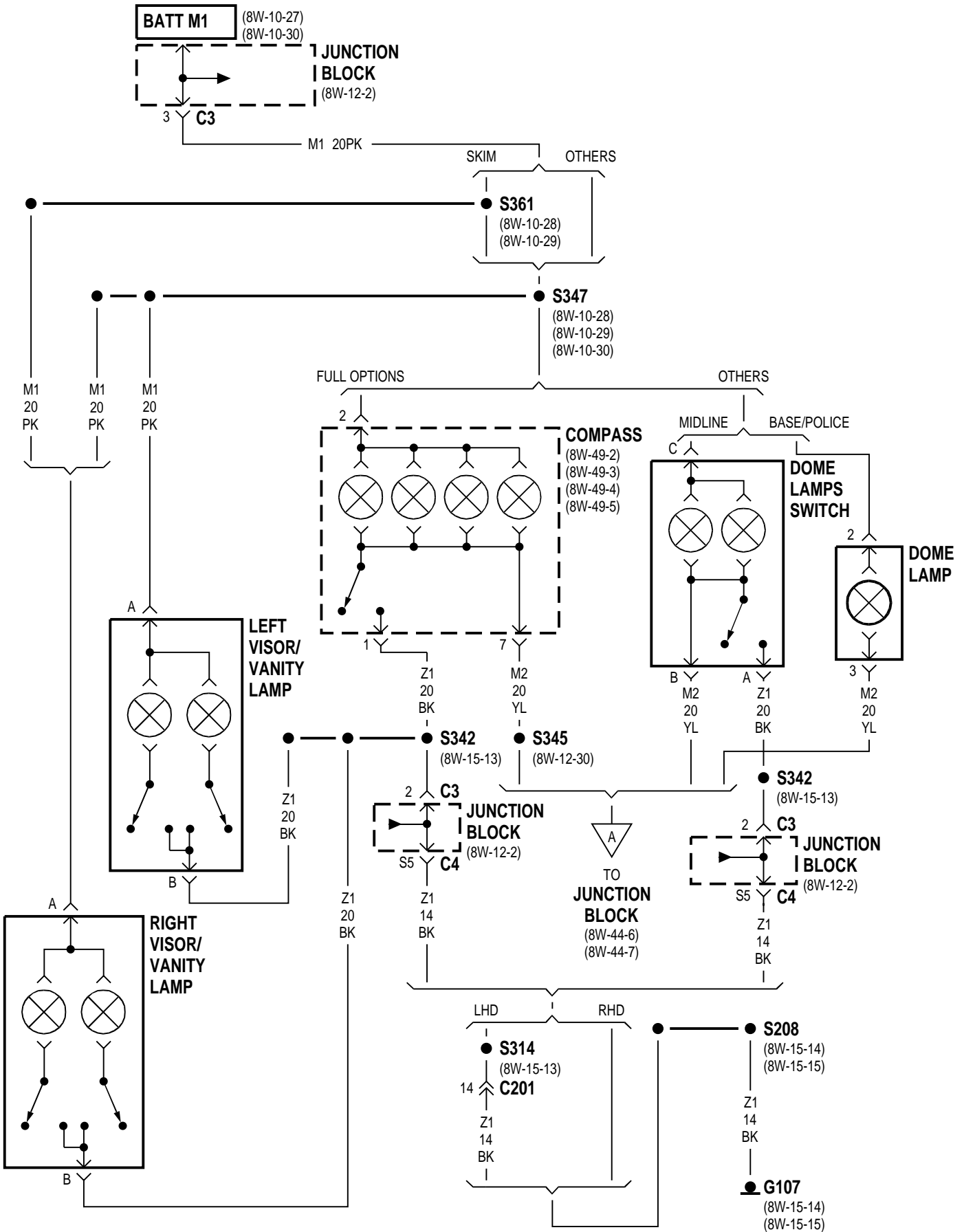

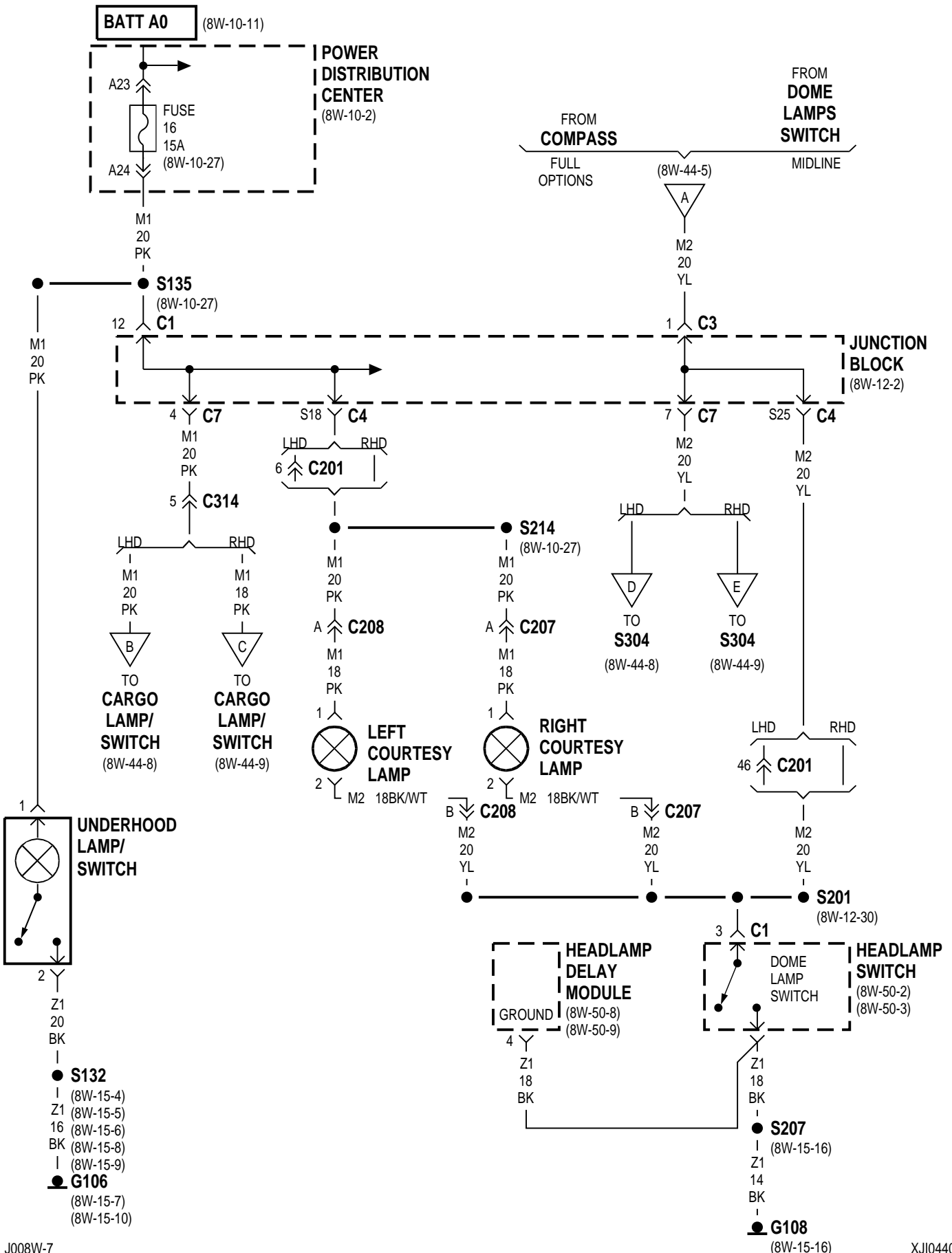

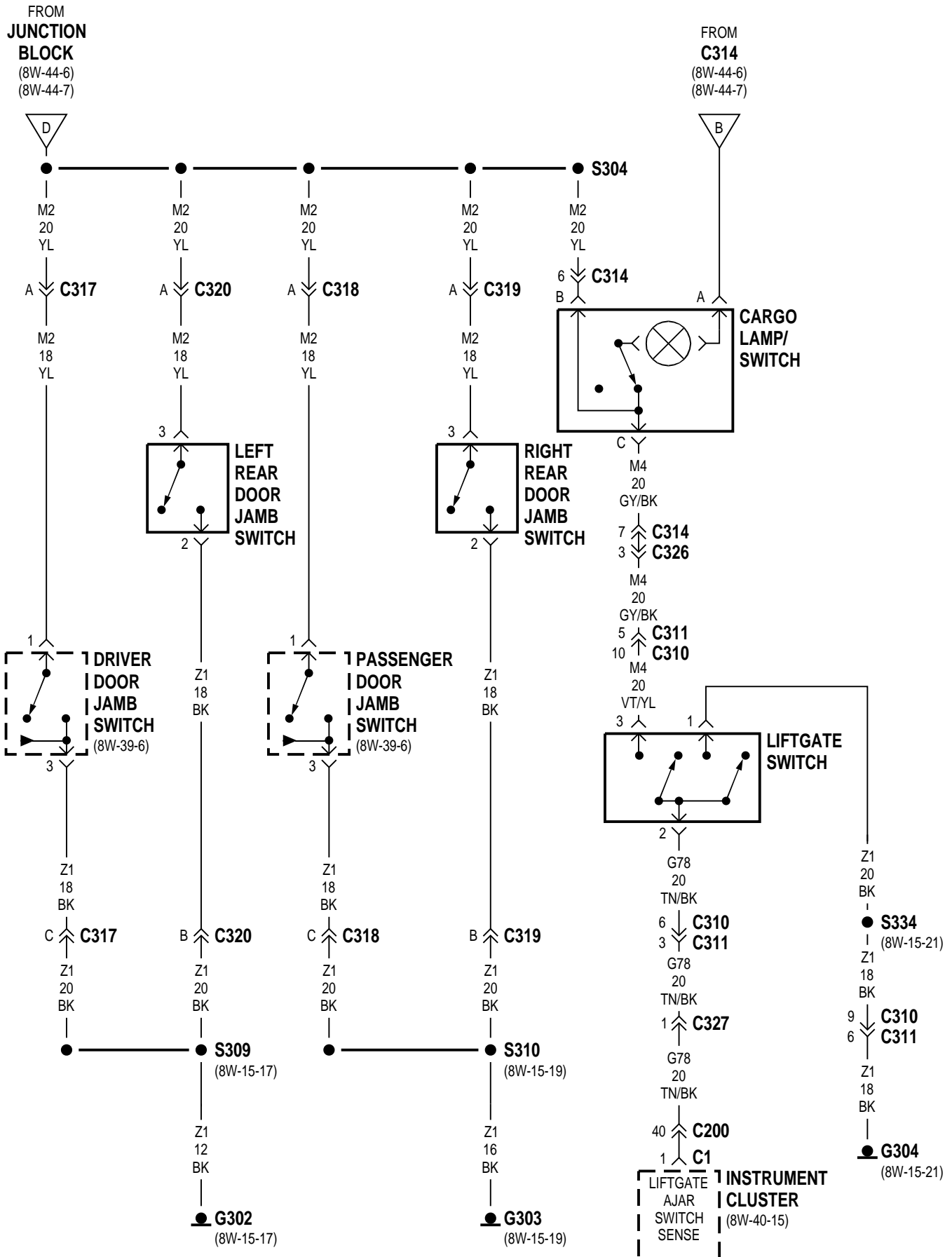

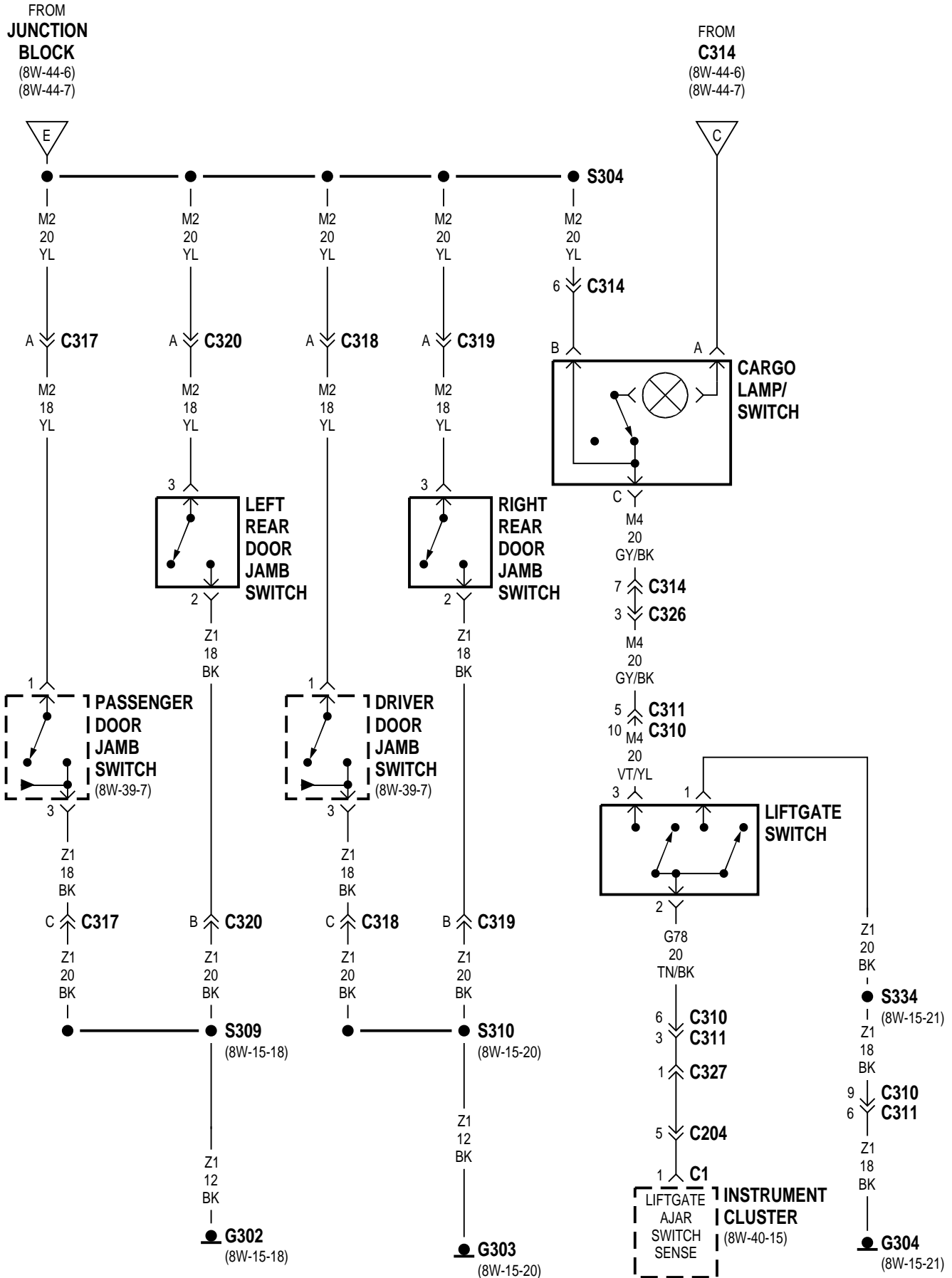

8W-47 AUDIO SYSTEM

| Component | Page | Component | Page |
|-------------------------------|-------------------|-------------------------------------|--------------------------------------|
| Antenna | 8W-47-2, 3, 9, 10 | Left Front Door Speaker | 8W-47-5, 6, 9, 10 |
| Combination Flasher | 8W-47-4 | Left Front Door Tweeter | 8W-47-5, 6 |
| Fuse 6 (JB) | 8W-47-2, 3, 9, 10 | Left Soundbar Speaker | 8W-47-5, 6, 11 |
| Fuse 16 (PDC) | 8W-47-2, 3 | Power Amplifier | 8W-47-2, 3, 4, 5, 6, 7, 8 |
| Fuse 17 (JB) | 8W-47-2, 3, 9, 10 | Power Antenna | 8W-47-4 |
| Fuse 19 (PDC) | 8W-47-4 | Power Antenna Relay | 8W-47-4 |
| Fuse 22 (PDC) | 8W-47-2, 3 | Power Distribution Center | 8W-47-2, 3, 4 |
| Fuse 26 (PDC) | 8W-47-2, 3, 4 | Radio | 8W-47-2, 3, 4, 5, 6, 7, 8, 9, 10, 11 |
| G107 | 8W-47-4 | Right Front Door Speaker | 8W-47-7, 8, 9, 10 |
| G108 | 8W-47-2, 3, 9, 10 | Right Front Door Tweeter | 8W-47-7, 8 |
| G301 | 8W-47-2, 3 | Right Soundbar Speaker | 8W-47-7, 8, 11 |
| Headlamp Switch | 8W-47-2, 3, 9, 10 | Underhood Lamp/Switch | 8W-47-2, 3 |
| Junction Block | 8W-47-2, 3, 9, 10 | | |

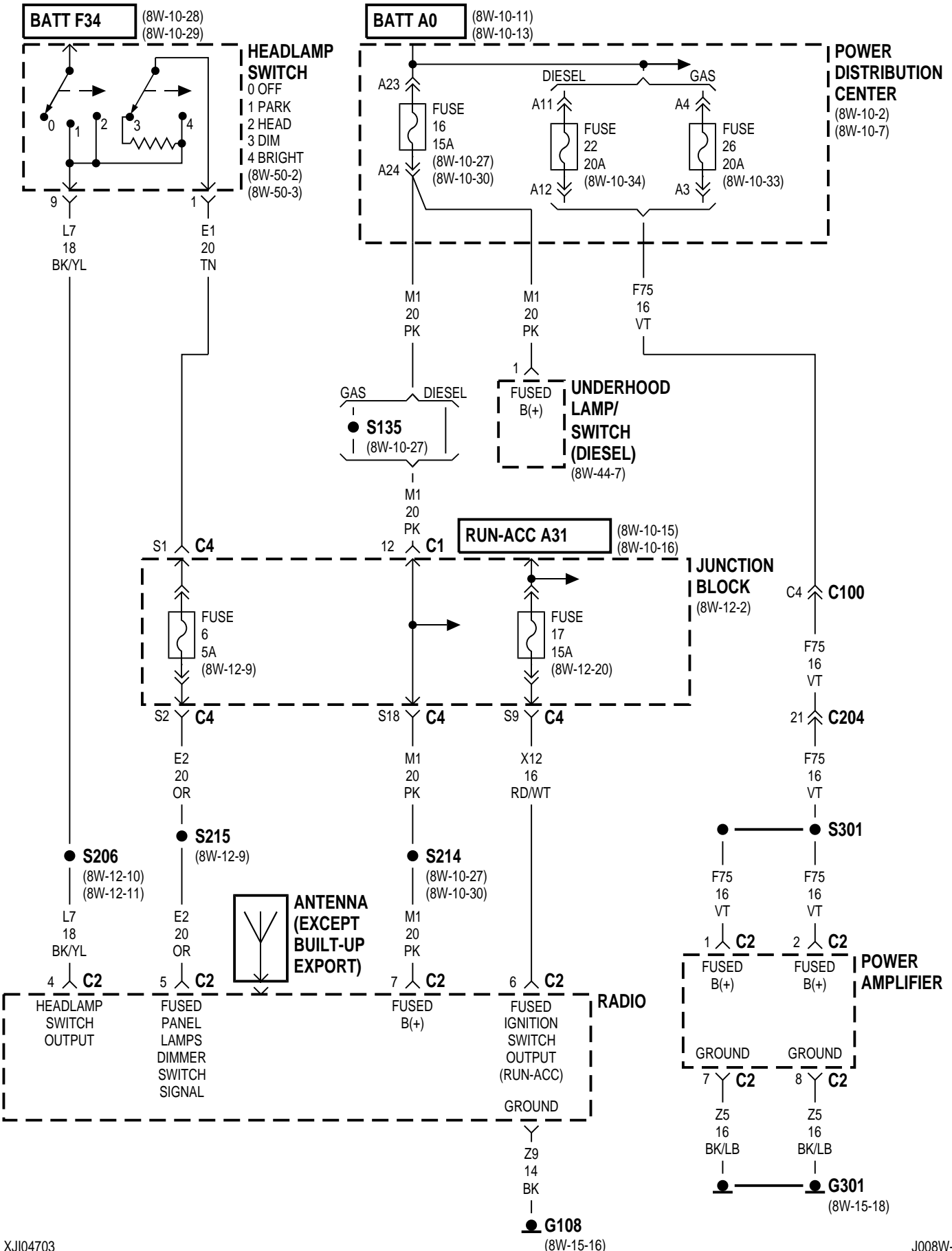

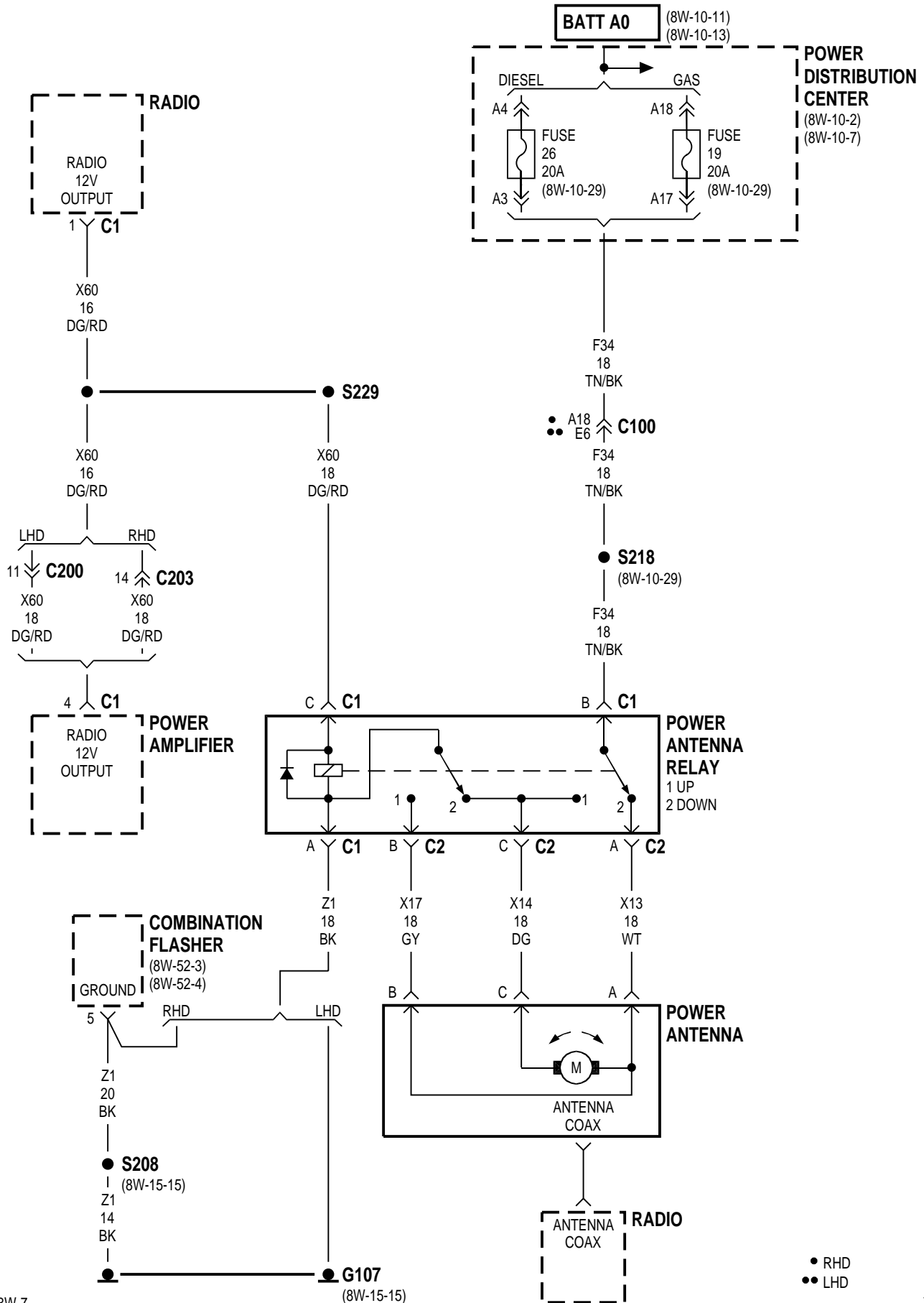

XJ **8W-47 AUDIO SYSTEM** **8W - 47 - 5**
LHD 6 SPEAKER SYSTEM

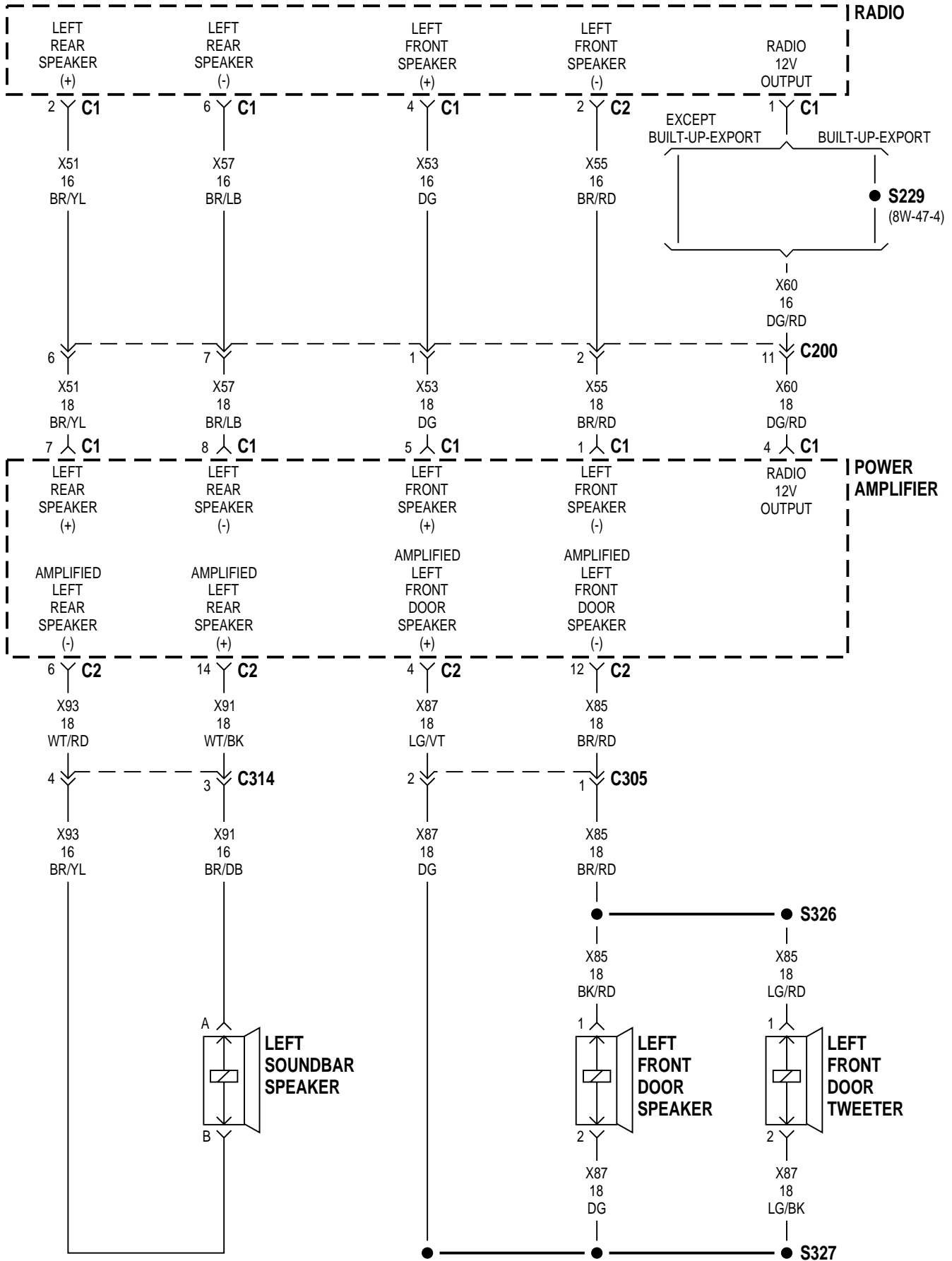

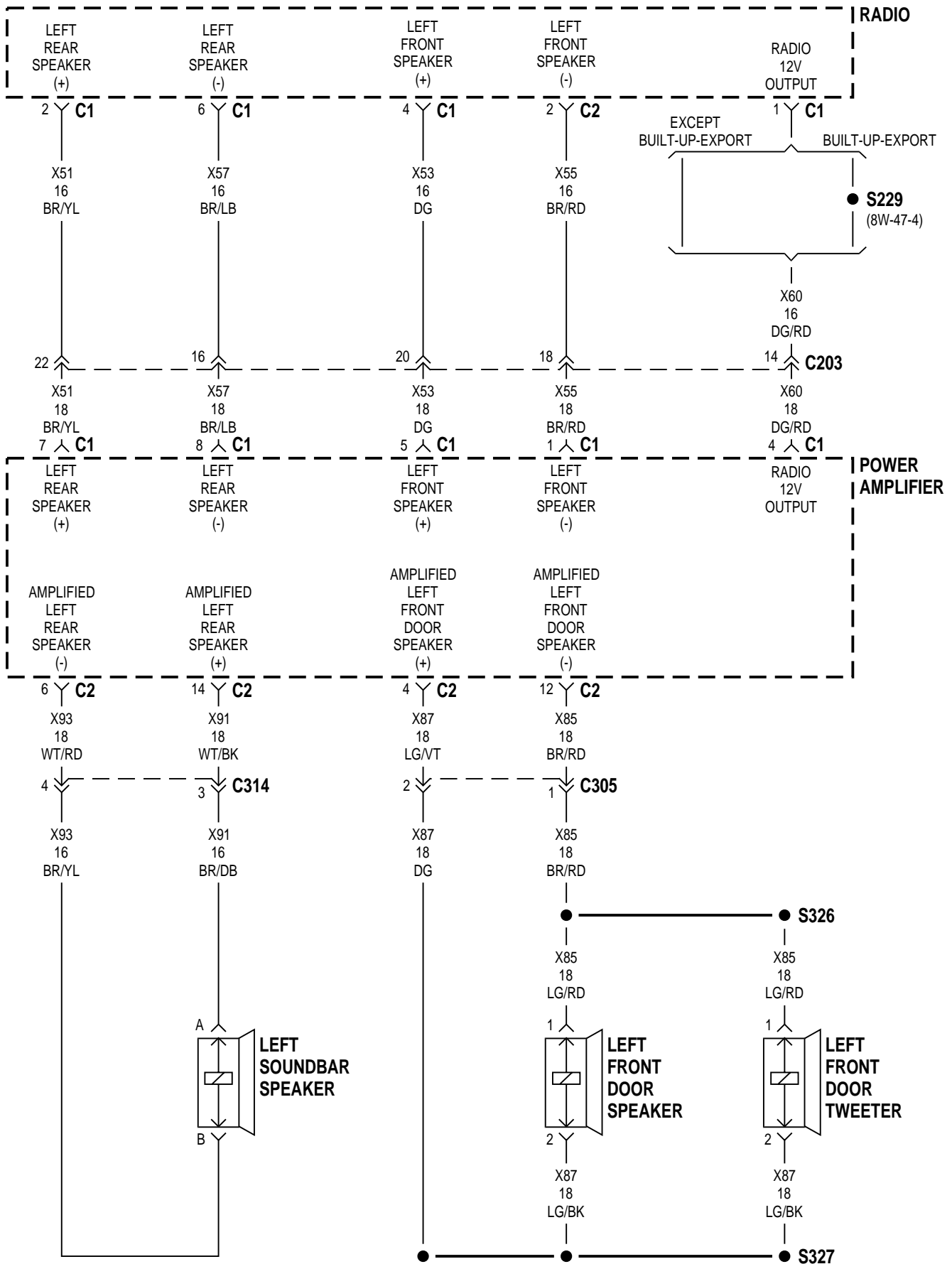

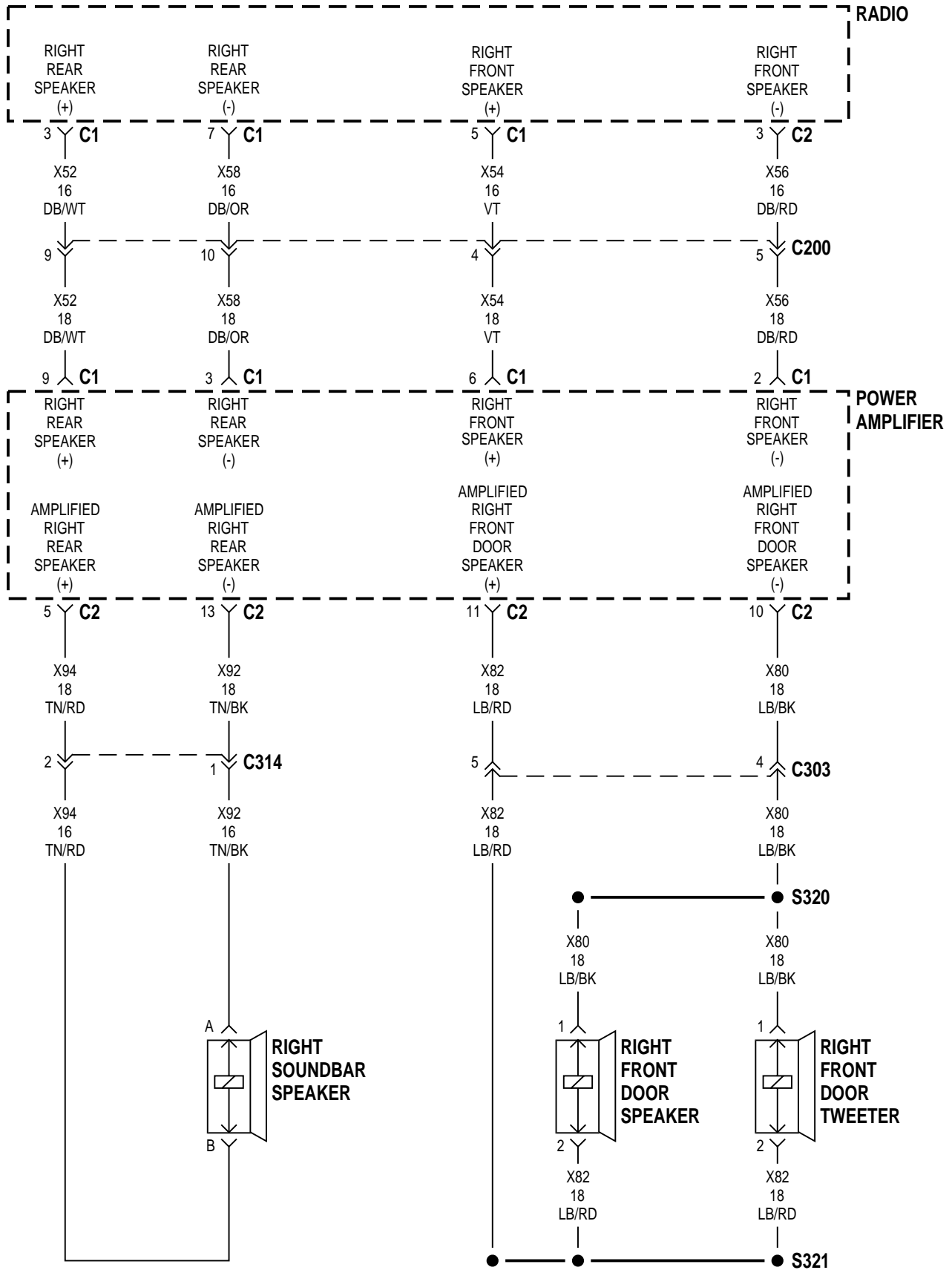

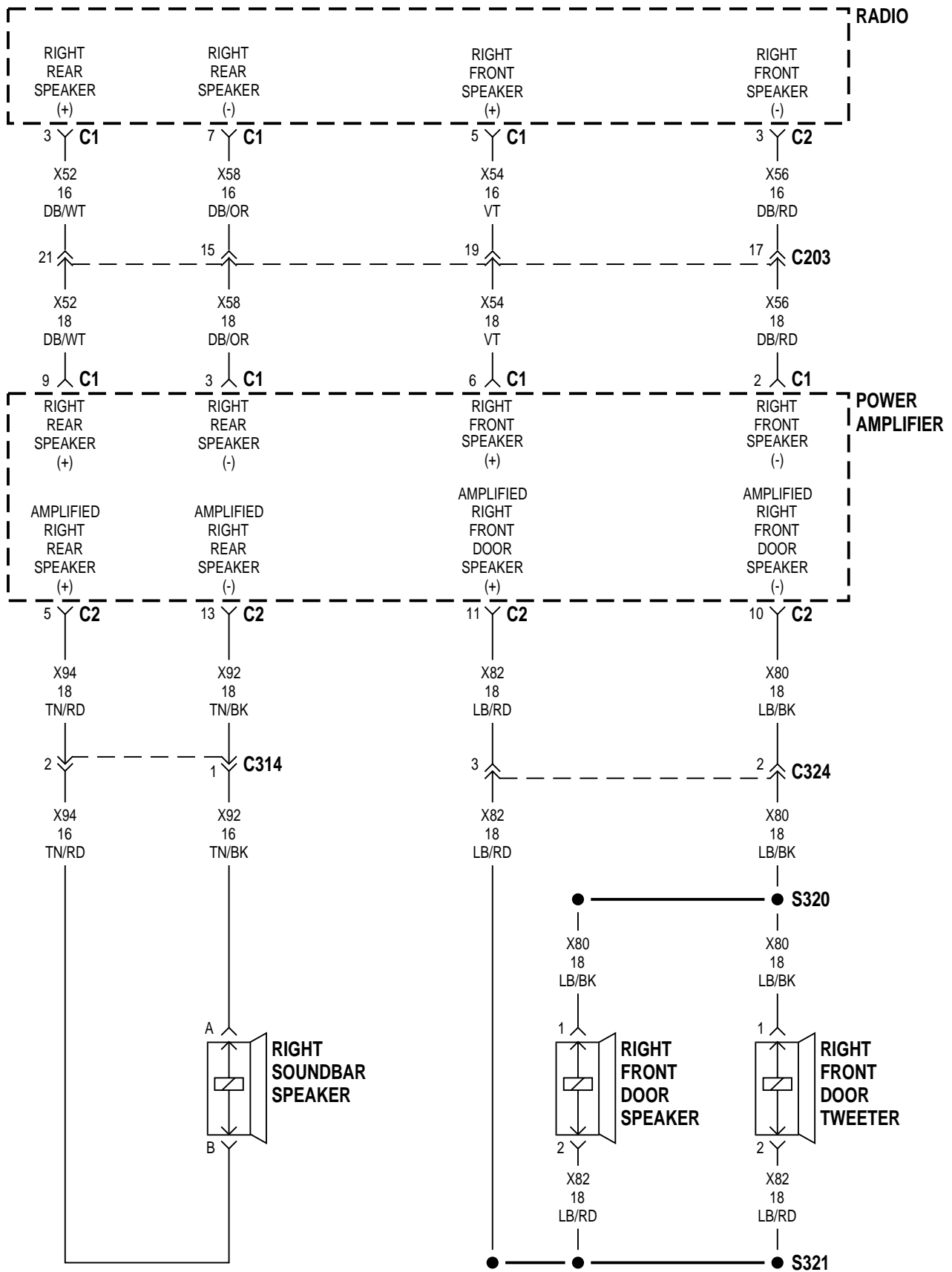

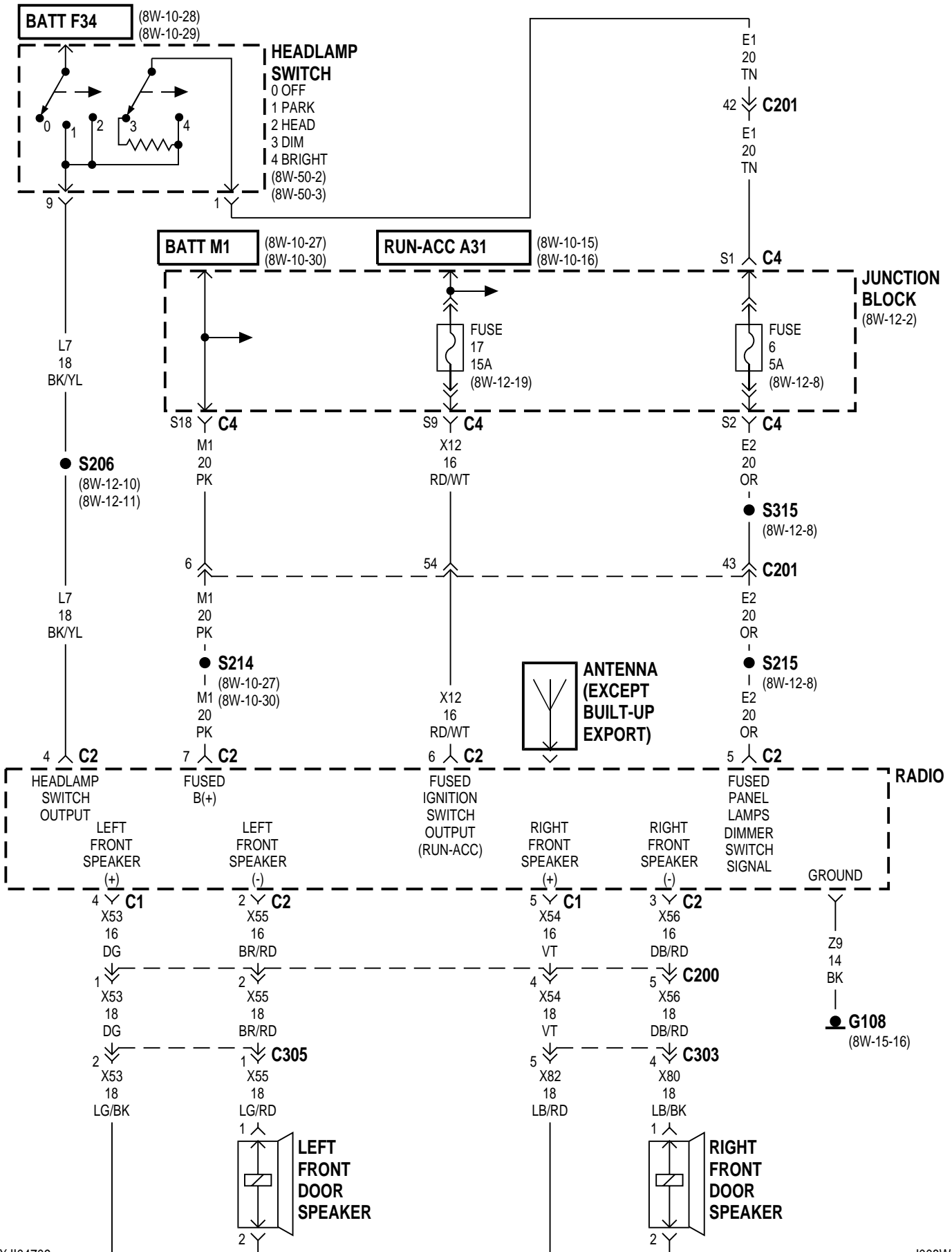

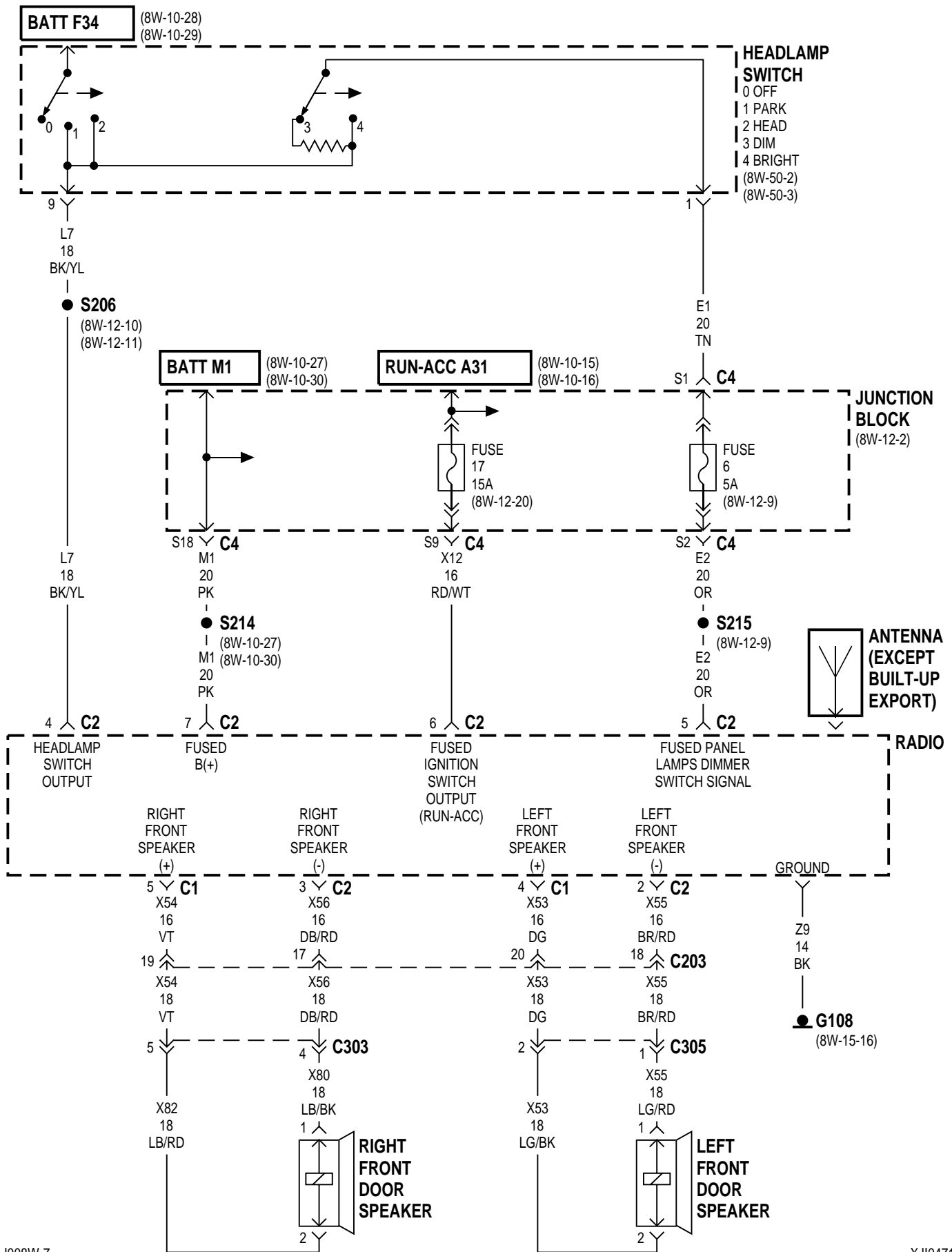

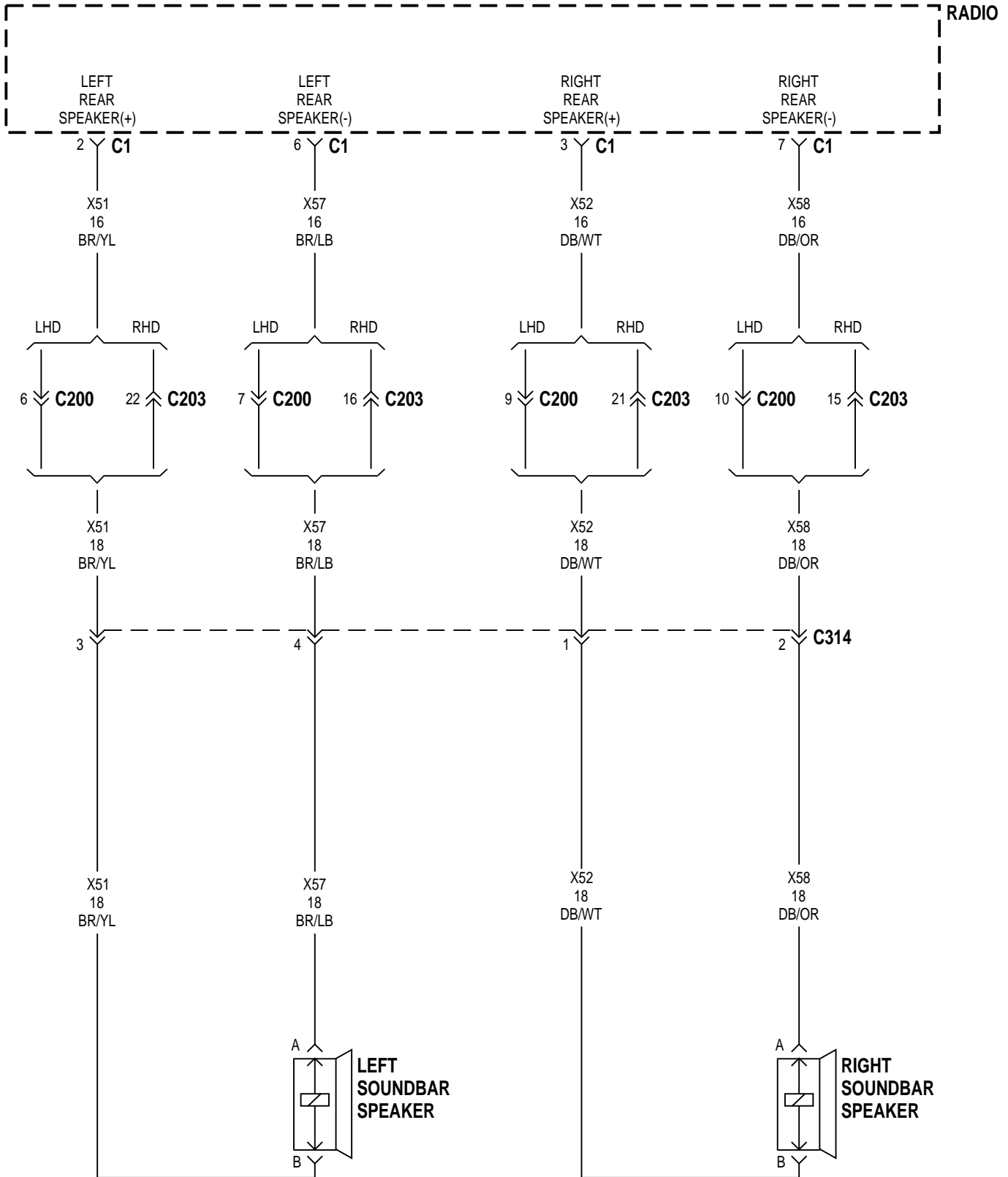

8W-48 REAR WINDOW DEFOGGER

| Component | Page | Component | Page |
|---------------------------|-------------|-----------------------------------|-------------|
| Driver Power Mirror | 8W-48-2, 3 | Instrument Cluster | 8W-48-2, 3 |
| Fuse 12 (JB) | 8W-48-2, 3 | Junction Block | 8W-48-2, 3 |
| Fuse 14 (JB) | 8W-48-2, 3 | Passenger Power Mirror | 8W-48-2, 3 |
| G107 | 8W-48-2, 3 | Rear Window Defogger | 8W-48-2, 3 |
| G302 | 8W-48-2, 3 | Rear Window Defogger Relay | 8W-48-2, 3 |
| G303 | 8W-48-3 | Rear Window Defogger Switch | 8W-48-2, 3 |
| G304 | 8W-48-2, 3 | | |

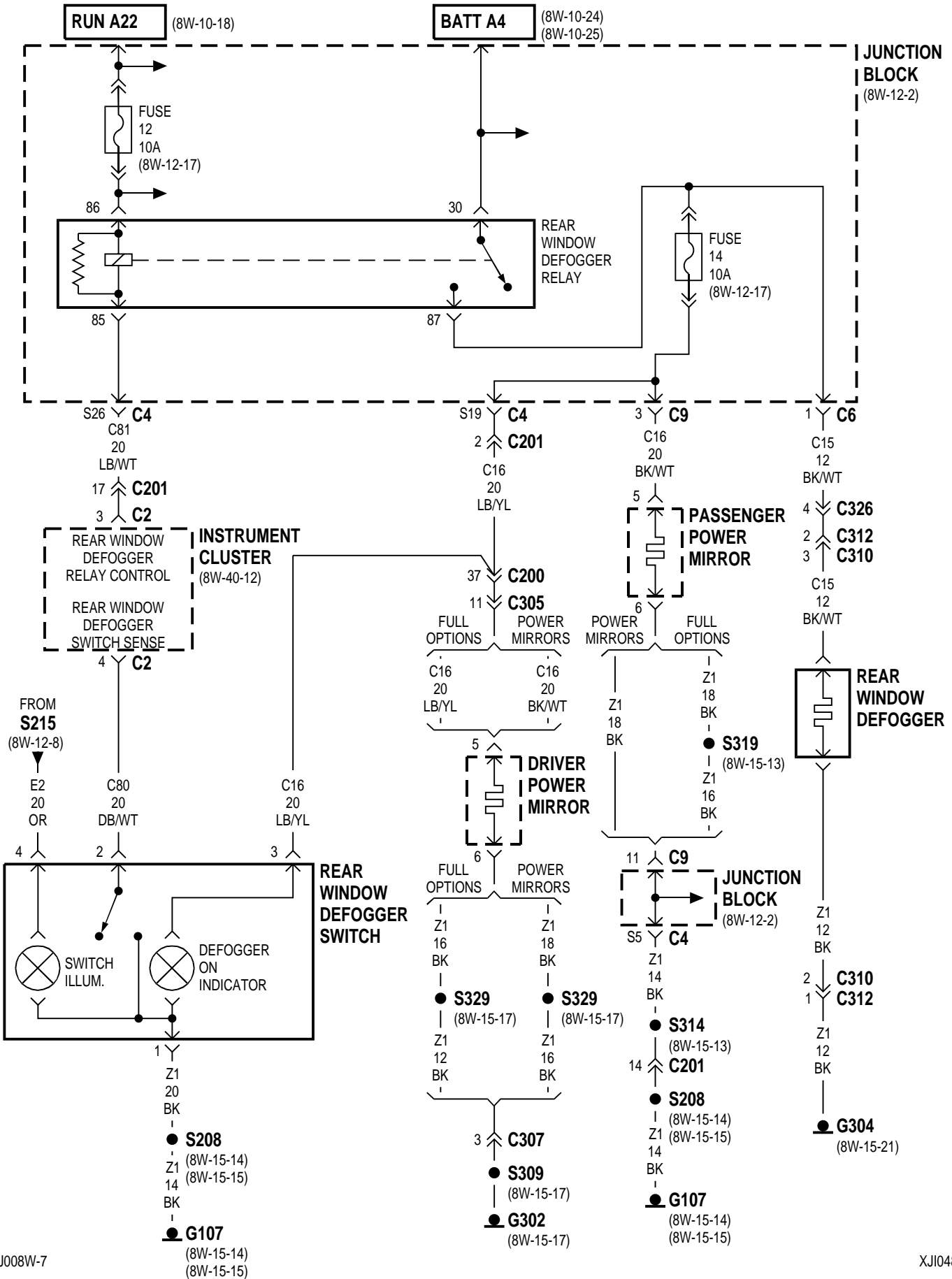

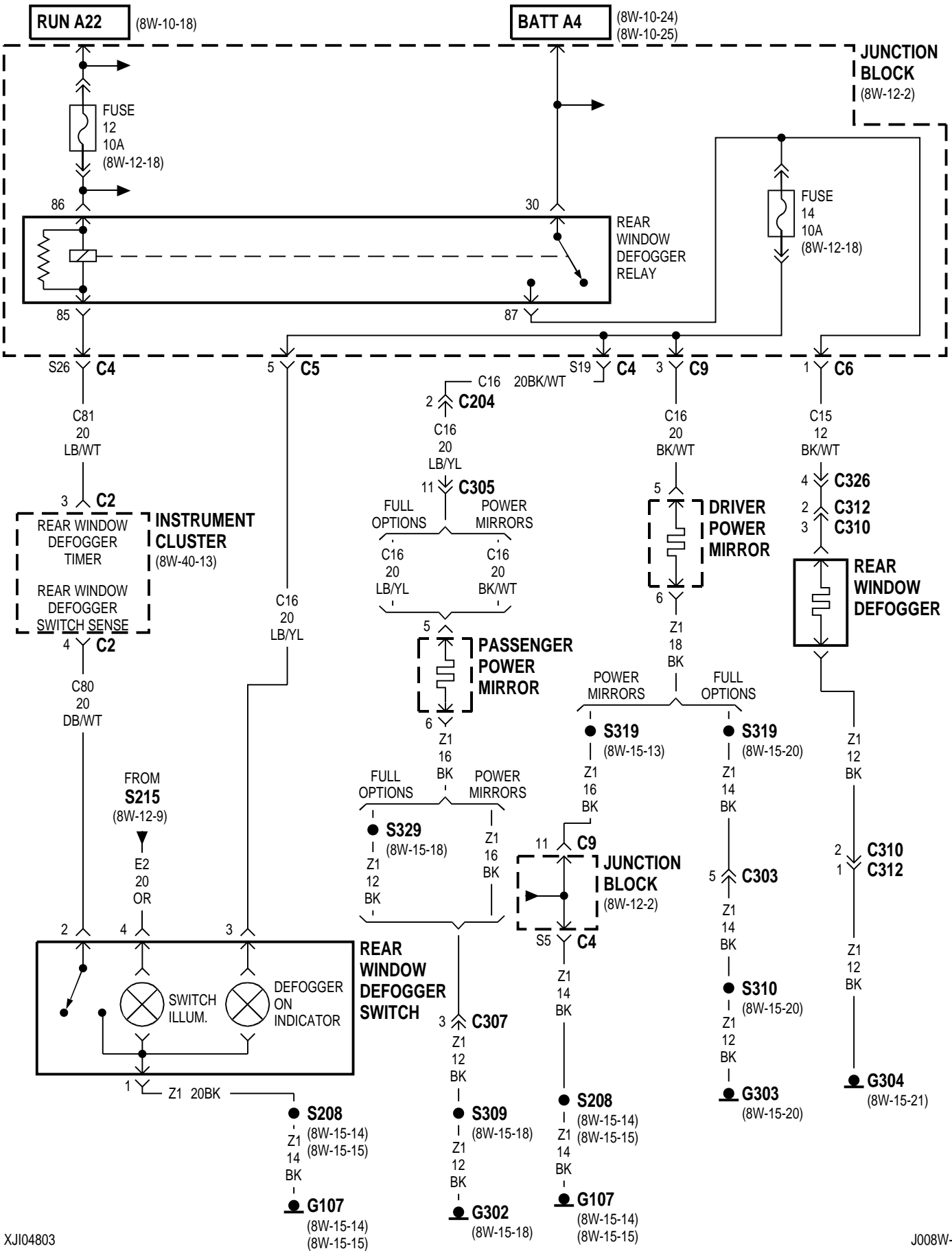

8W-49 OVERHEAD CONSOLE

| Component | Page | Component | Page |
|--------------------------------------|---------------------|--|---------------------|
| Ambient Temperature Sensor | 8W-49-4, 5 | G108 | 8W-49-2, 3 |
| Compass | 8W-49-2, 3, 4, 5, 6 | Horn Relay | 8W-49-4, 5 |
| Data Link Connector | 8W-49-6 | Junction Block | 8W-49-2, 3, 4, 5 |
| Driver Door Jamb Switch | 8W-49-4, 5 | Overhead Module | 8W-49-2, 3, 4, 5, 6 |
| Fuse 9 (JB) | 8W-49-2, 3 | Passenger Power Lock/Window Switch . . | 8W-49-4, 5 |
| Fuse 16 (PDC) | 8W-49-2, 3 | Power Distribution Center | 8W-49-2, 3 |
| G107 | 8W-49-2, 3 | Underhood Lamp/Switch | 8W-49-2, 3 |

LHD

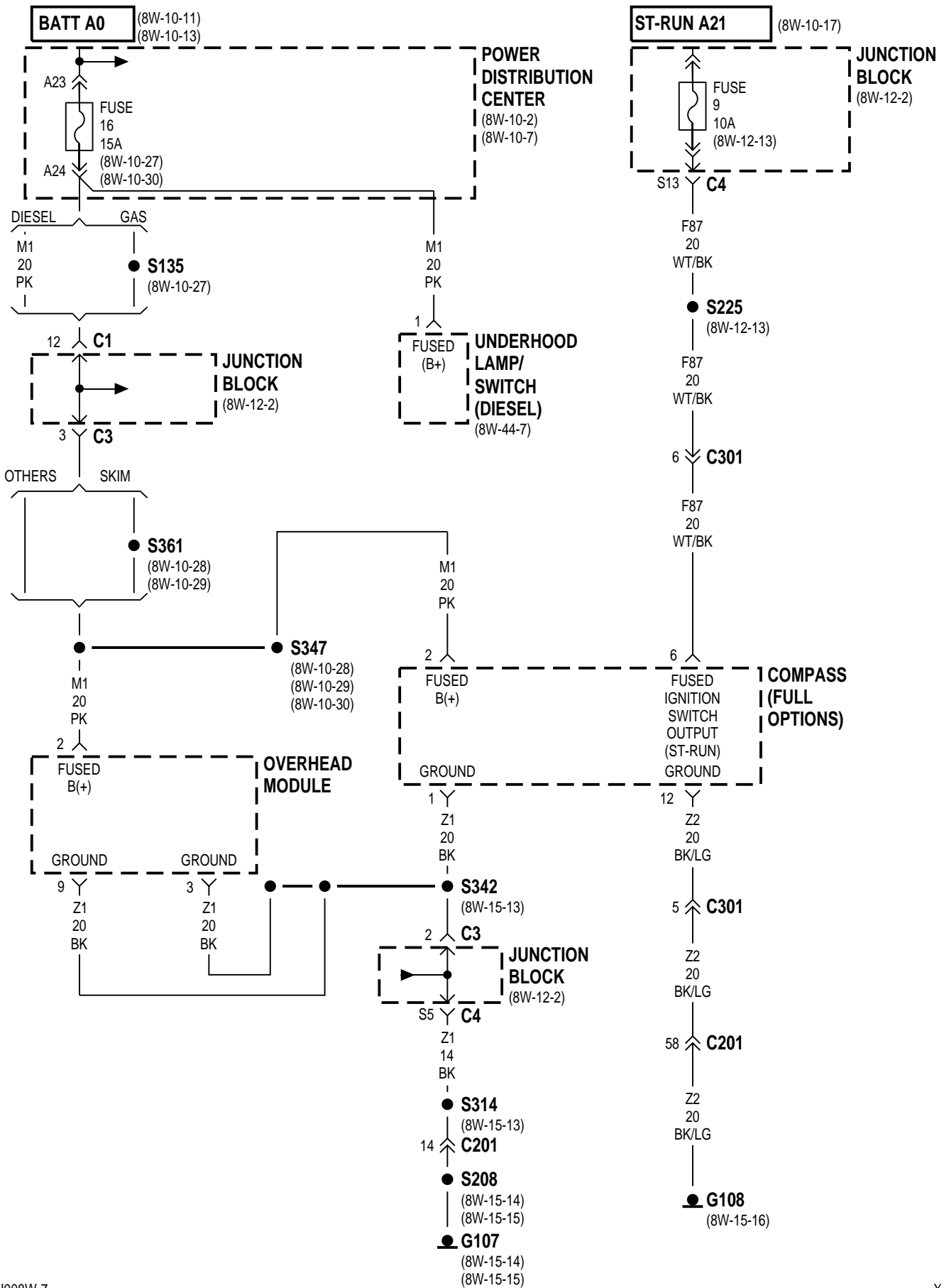

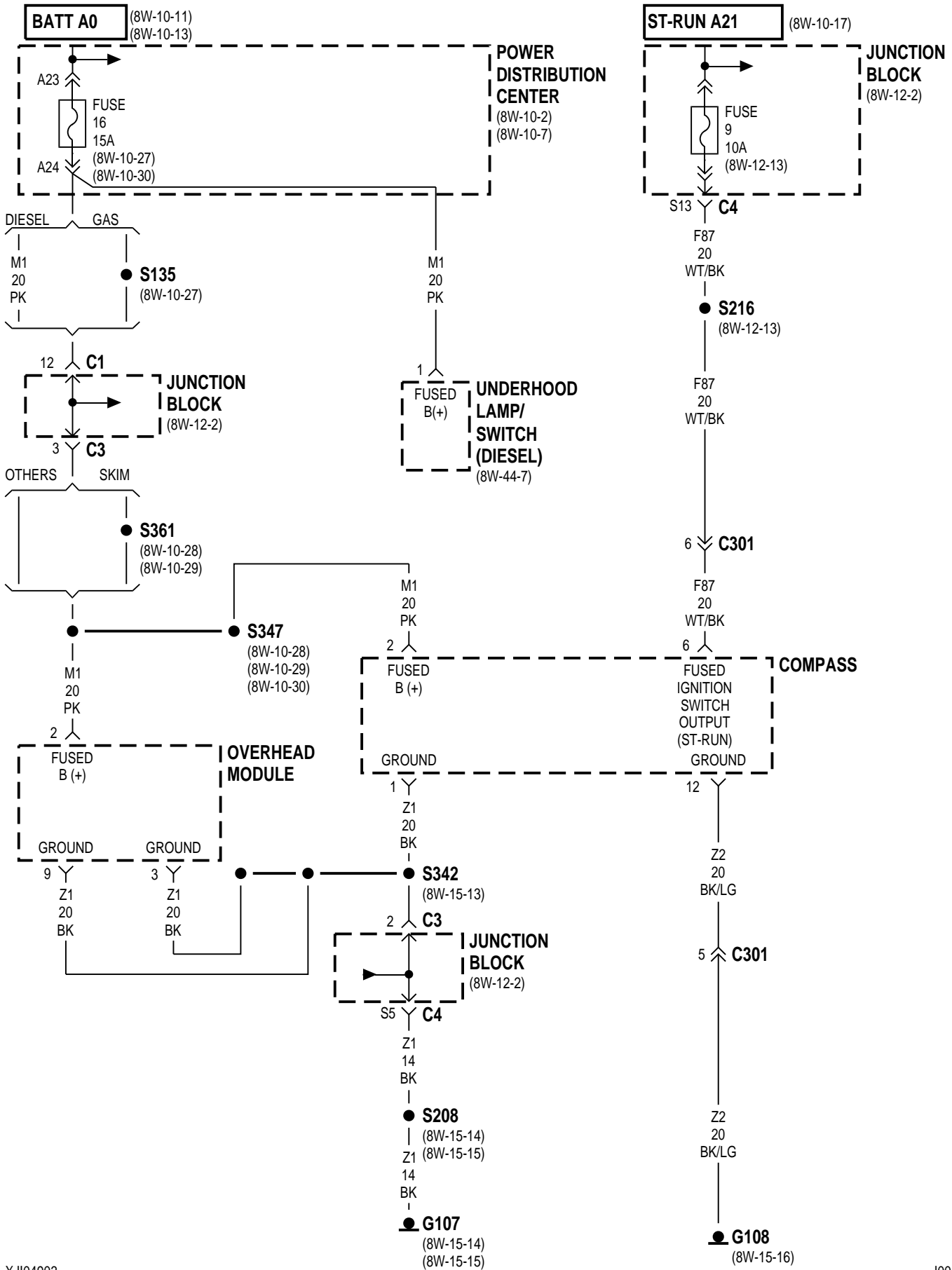

LHD

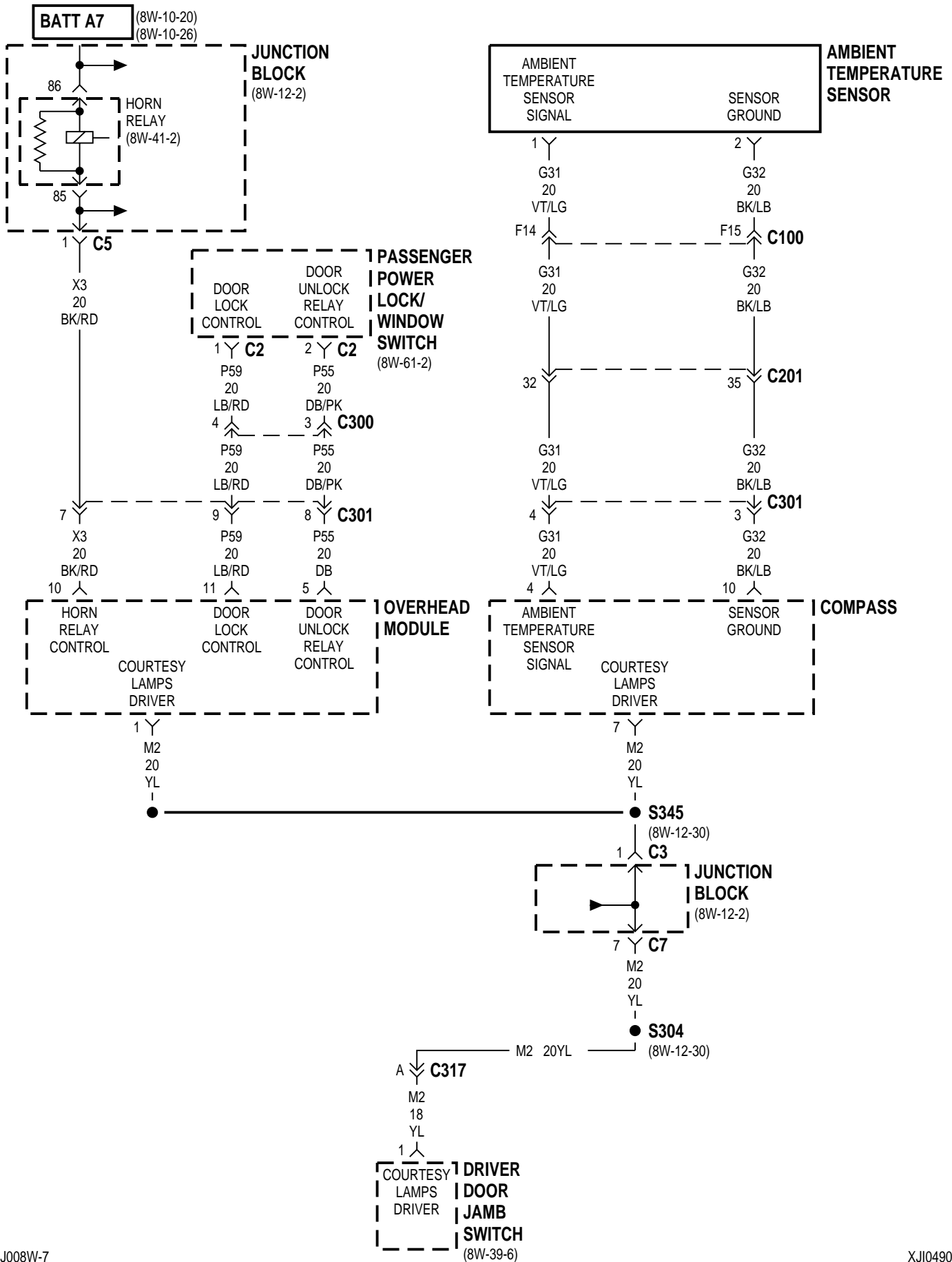

RHD

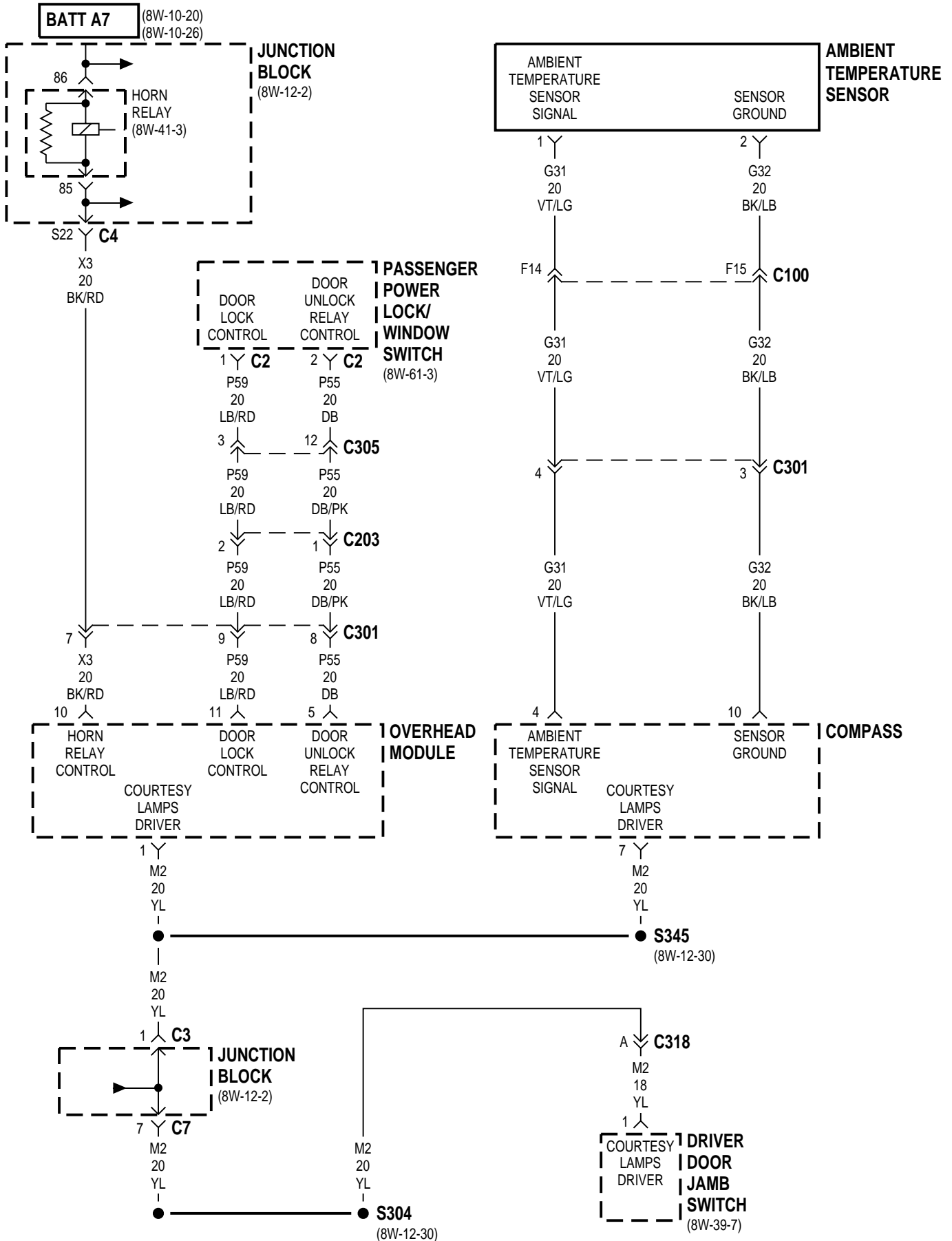

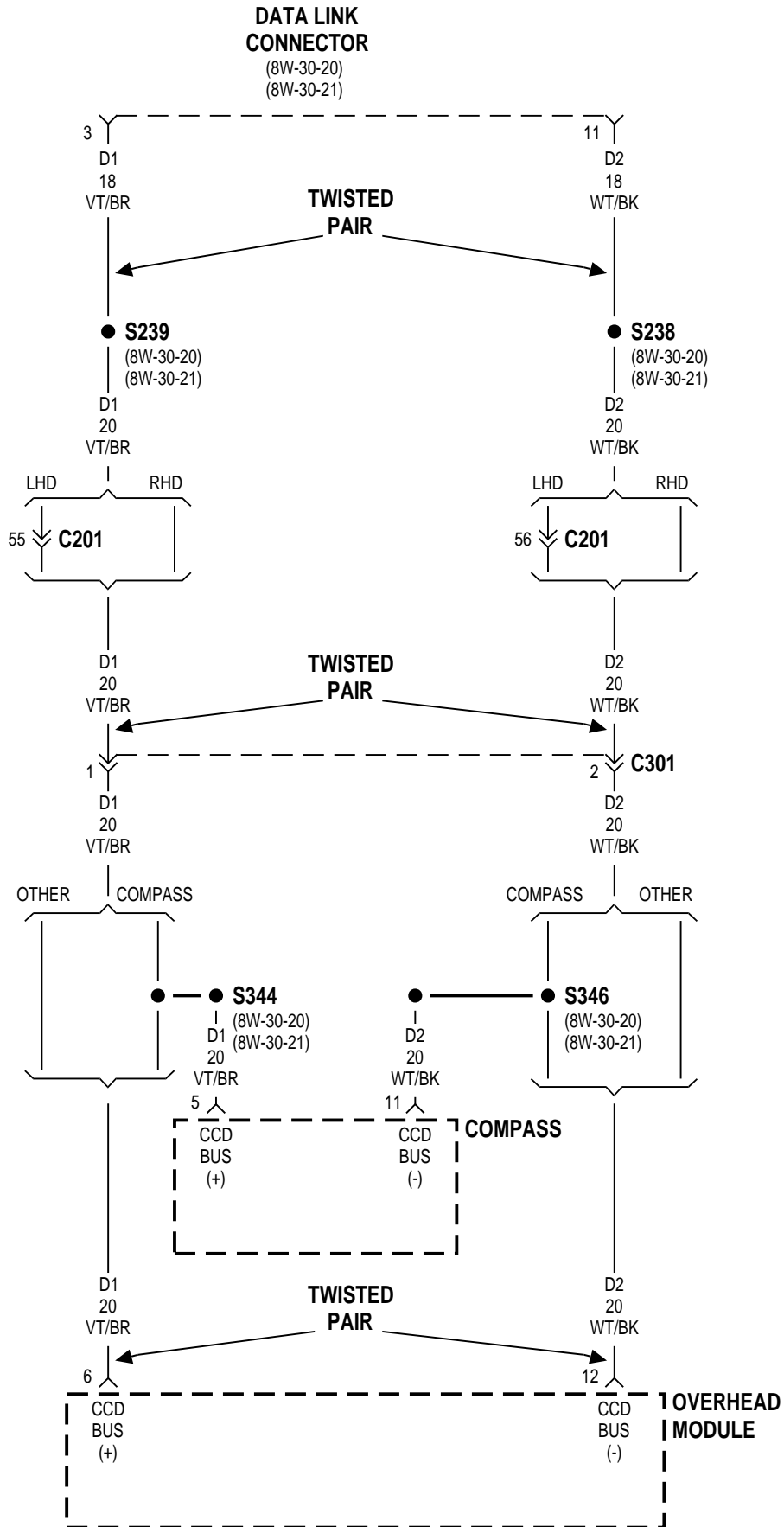

8W-50 FRONT LIGHTING

| Component | Page | Component | Page |
|--|---|---|---|
| Controller Anti-Lock Brake Relay | 8W-50-14, 17 | Instrument Cluster | 8W-50-4, 5, 6, 7, 16, 18 |
| Daytime Running Lamp | | Junction Block | 8W-50-4, 5, 6, 7, 8, 9, 10, 11, 12, 13, 14, 16, 17, 18, 19 |
| Module | 8W-50-2, 4, 8, 16, 18 | Left City Lamp | 8W-50-11, 14, 17 |
| Diode Module | 8W-50-3, 15, 17 | Left Fog Lamp | 8W-50-15, 16, 17 |
| Engine Starter Motor Relay | 8W-50-14, 17 | Left Front Park/Turn Signal Lamp No. 1 . | 8W-50-10 |
| Fog Lamp Relay | 8W-50-17 | Left Front Park/Turn Signal Lamp No. 2 . | 8W-50-10 |
| Fog Lamp Relay No. 1 | 8W-50-10, 11, 14, 16, 18 | Left Front Turn Signal Lamp No. 1 | 8W-50-11 |
| Fog Lamp Relay No. 2 | 8W-50-15, 16 | Left Front Turn Signal Lamp No. 2 | 8W-50-11 |
| Front Fog Lamp Switch | 8W-50-15, 16, 17 | Left Headlamp | 8W-50-4, 5, 6, 7, 19 |
| Fuse 3 (JB) | 8W-50-4, 5, 6, 7, 18 | Left Headlamp Leveling Motor | 8W-50-19 |
| Fuse 4 (JB) | 8W-50-4, 5, 6, 7, 19 | Left Repeater Lamp | 8W-50-11 |
| Fuse 5 (JB) | 8W-50-4, 5, 6, 7, 19 | Left Side Marker Lamp | 8W-50-10 |
| Fuse 6 (JB) | 8W-50-2, 3 | Power Distribution | |
| Fuse 7 (JB) | 8W-50-10, 11, 14, 16, 17 | Center | 8W-50-2, 3, 8, 9, 14, 15, 16, 17, 18 |
| Fuse 7 (PDC) | 8W-50-2, 3, 8, 9, 18 | Right City Lamp | 8W-50-13 |
| Fuse 8 (PDC) | 8W-50-3, 9 | Right Fog Lamp | 8W-50-15, 16, 17 |
| Fuse 9 (JB) | 8W-50-8, 9 | Right Front Park/Turn Signal | |
| Fuse 10 (JB) | 8W-50-18 | Lamp No. 1 | 8W-50-12 |
| Fuse 16 (JB) | 8W-50-4, 5, 6, 7, 18 | Right Front Park/Turn Signal | |
| Fuse 19 (PDC) | 8W-50-2, 3 | Lamp No. 2 | 8W-50-12 |
| Fuse 23 (JB) | 8W-50-12, 13 | Right Front Turn Signal Lamp No. 1 | 8W-50-13 |
| Fuse 26 (PDC) | 8W-50-3 | Right Front Turn Signal Lamp No. 2 | 8W-50-13 |
| G106 | 8W-50-4, 5, 6, 7, 10, 11, 12, 13, 14, 15, 16, 17, 18, 19 | Right Headlamp | 8W-50-4, 5, 6, 7, 18, 19 |
| G107 | 8W-50-15, 16, 17, 19 | Right Headlamp Leveling Motor | 8W-50-19 |
| G108 | 8W-50-2, 3, 8, 9 | Right Repeater Lamp | 8W-50-13 |
| Headlamp Beam Select | | Right Side Marker Lamp | 8W-50-12 |
| Switch | 8W-50-4, 5, 6, 7, 8, 9, 19 | Turn Signal/Hazard Switch | 8W-50-10, 11, 12, 13 |
| Headlamp Delay Module | 8W-50-2, 3, 8, 9 | Vehicle Speed Sensor | 8W-50-18 |
| Headlamp Leveling Switch | 8W-50-6, 7, 19 | | |
| Headlamp Switch | 8W-50-2, 3, 8, 9, 10, 11, 12, 13, 14, 16, 17 | | |

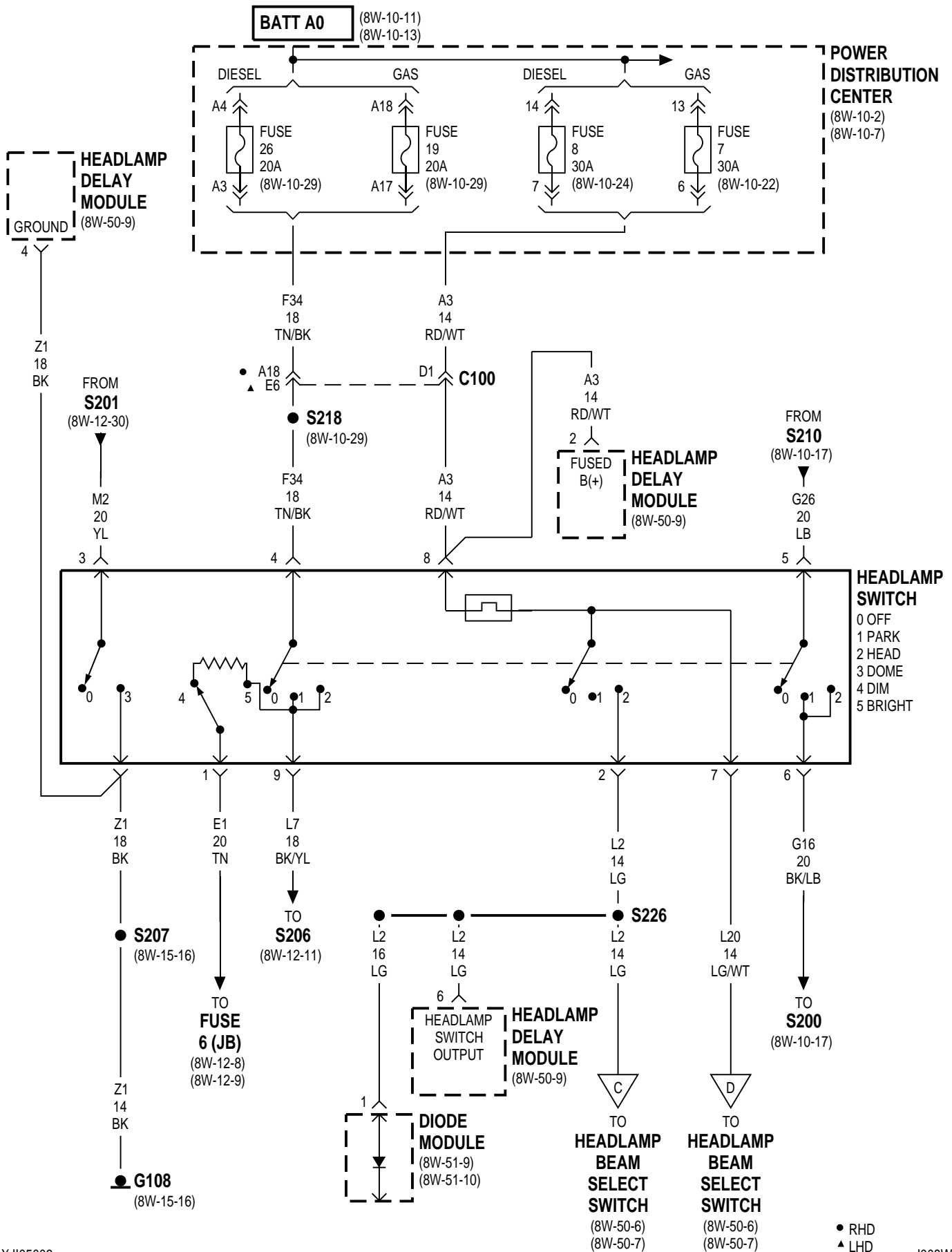

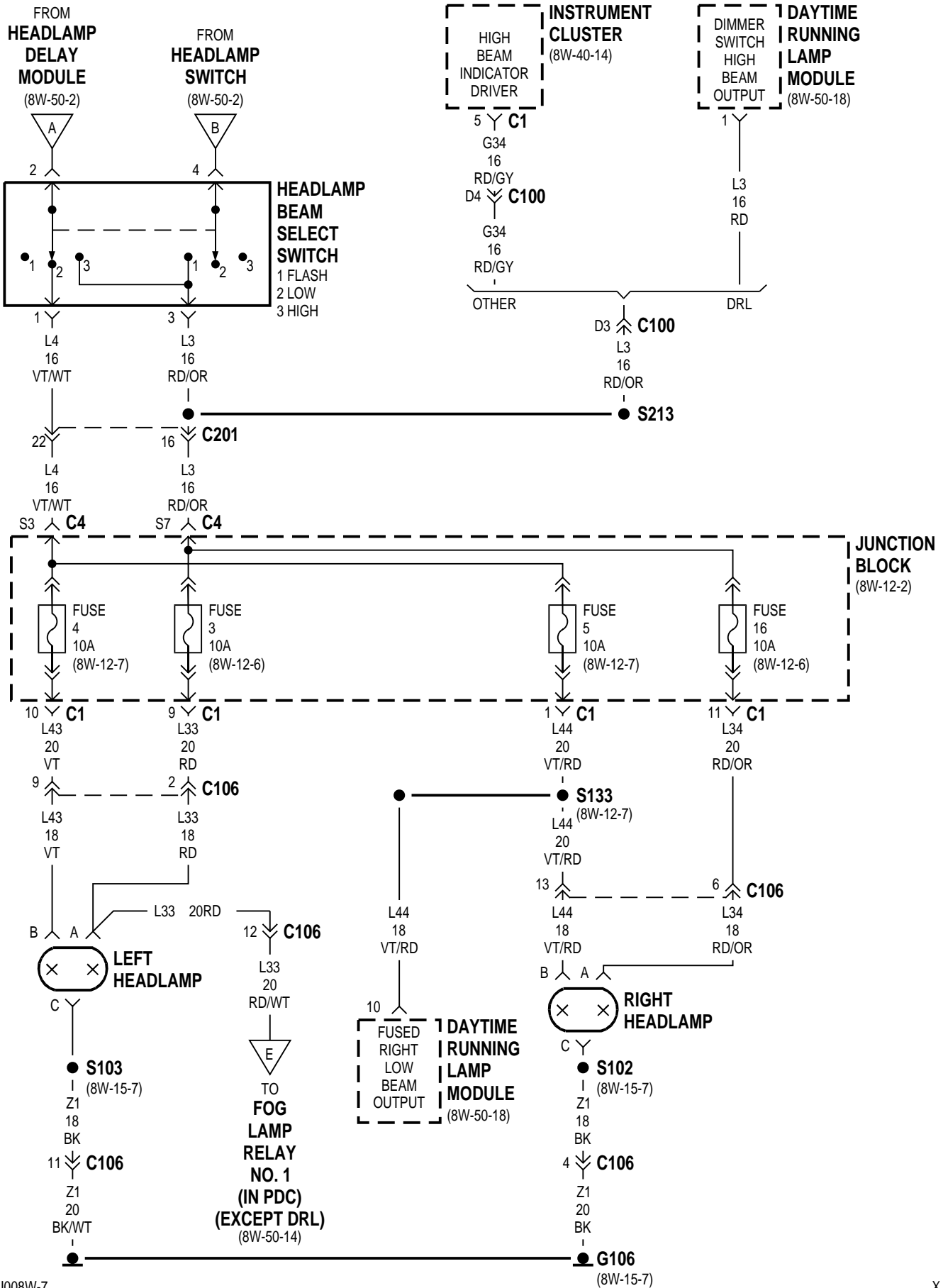

XJ **8W-50 FRONT LIGHTING** **8W - 50 - 5**
RHD EXCEPT BUILT-UP-EXPORT

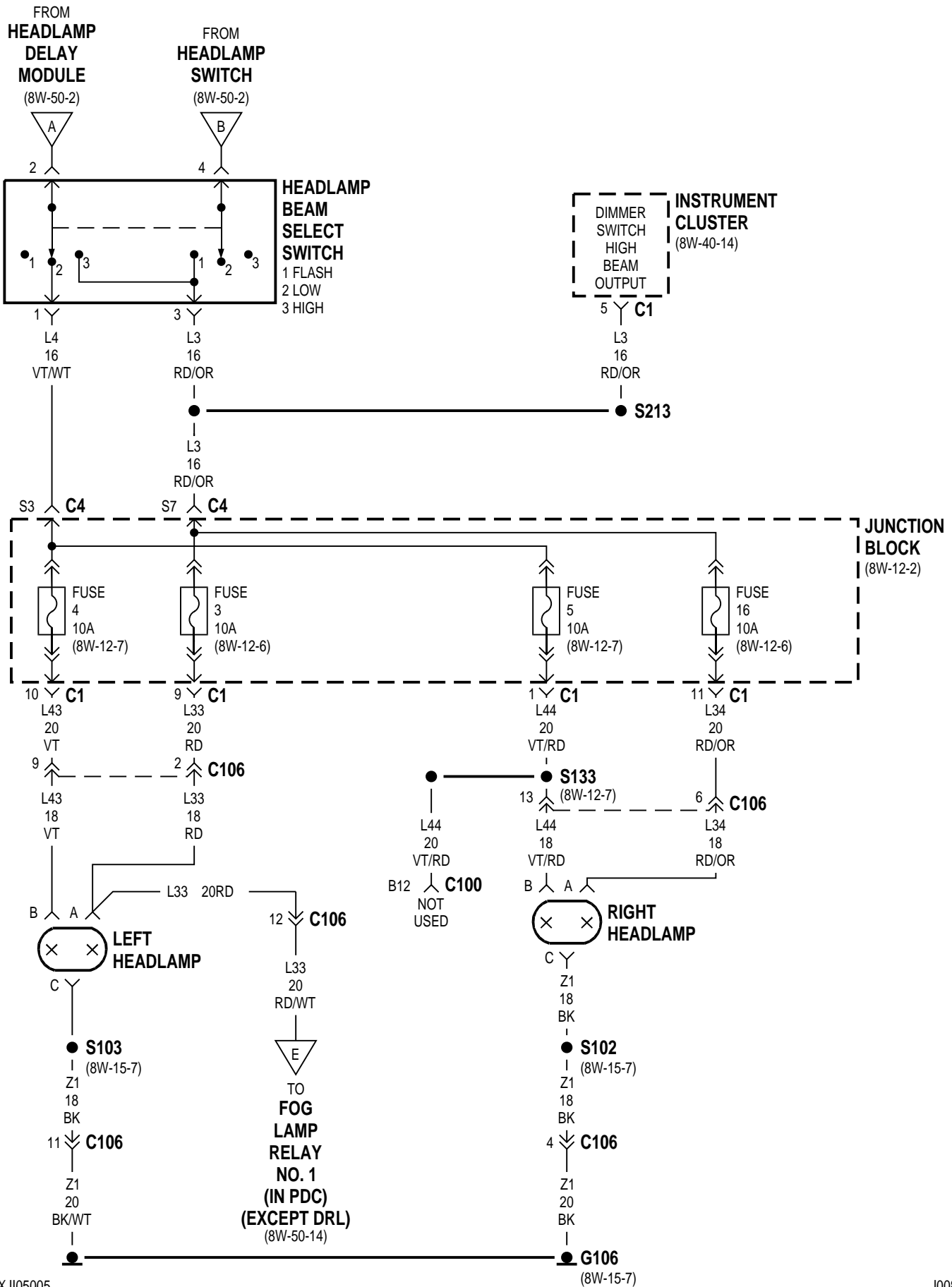

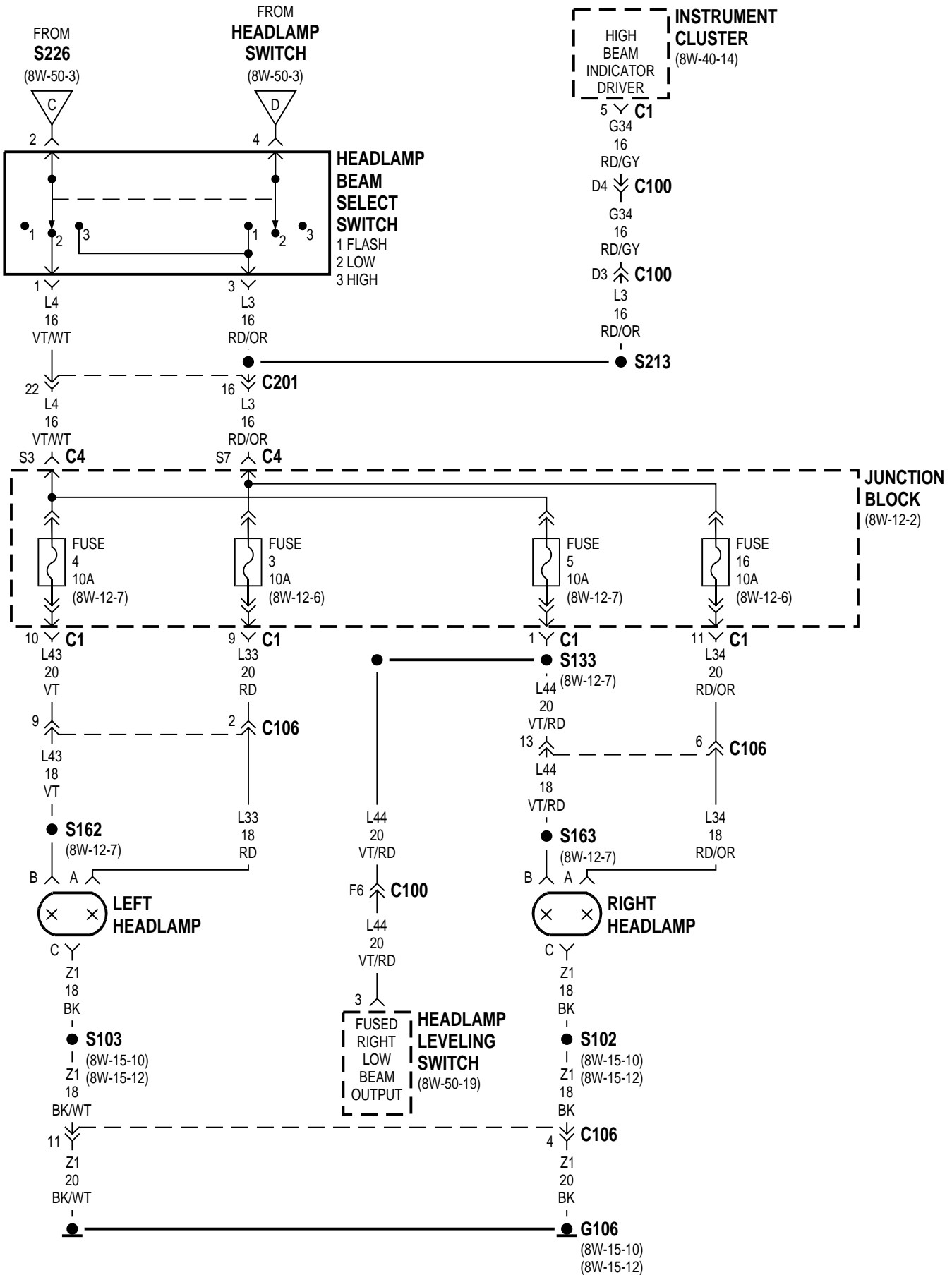

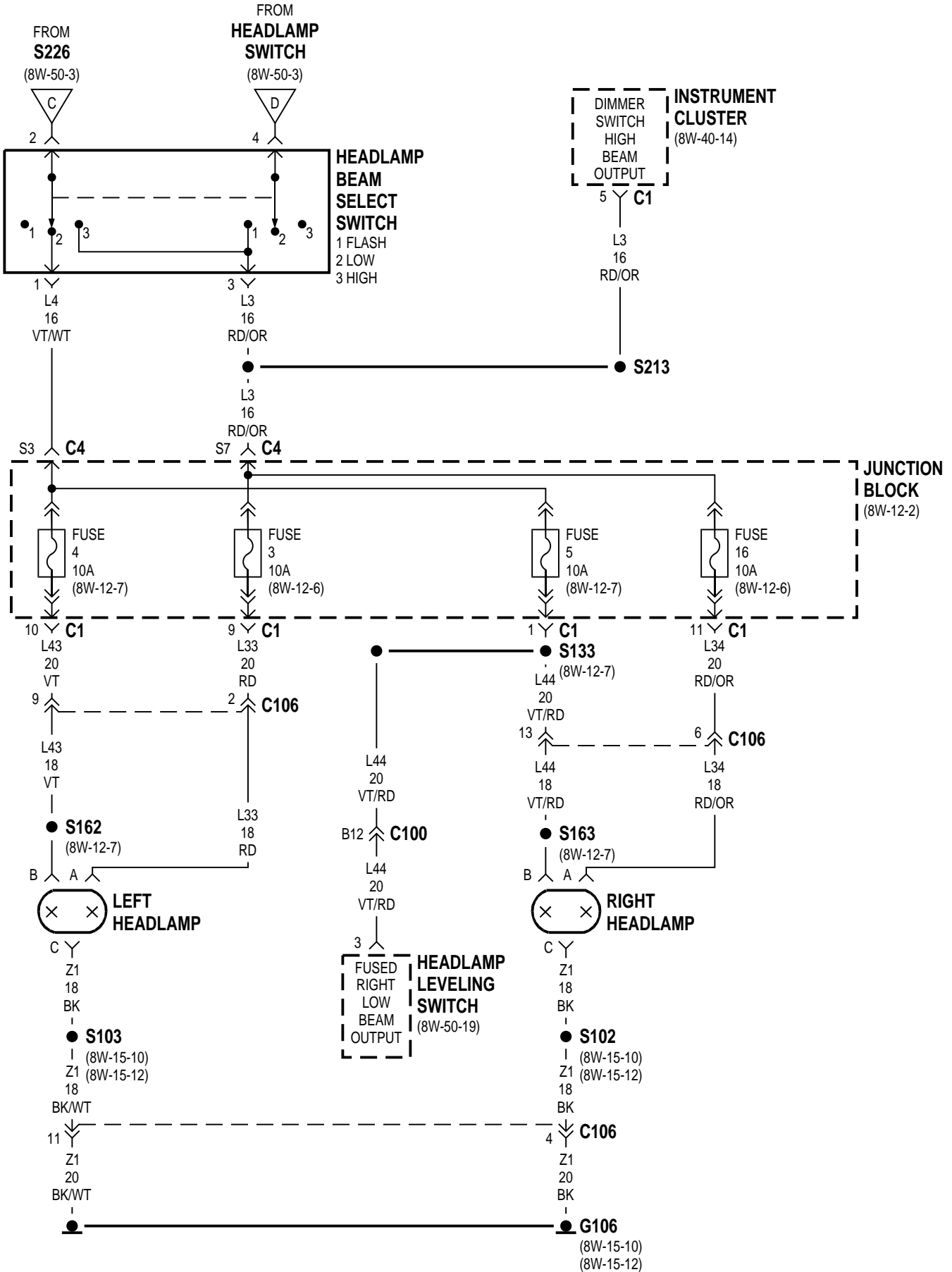

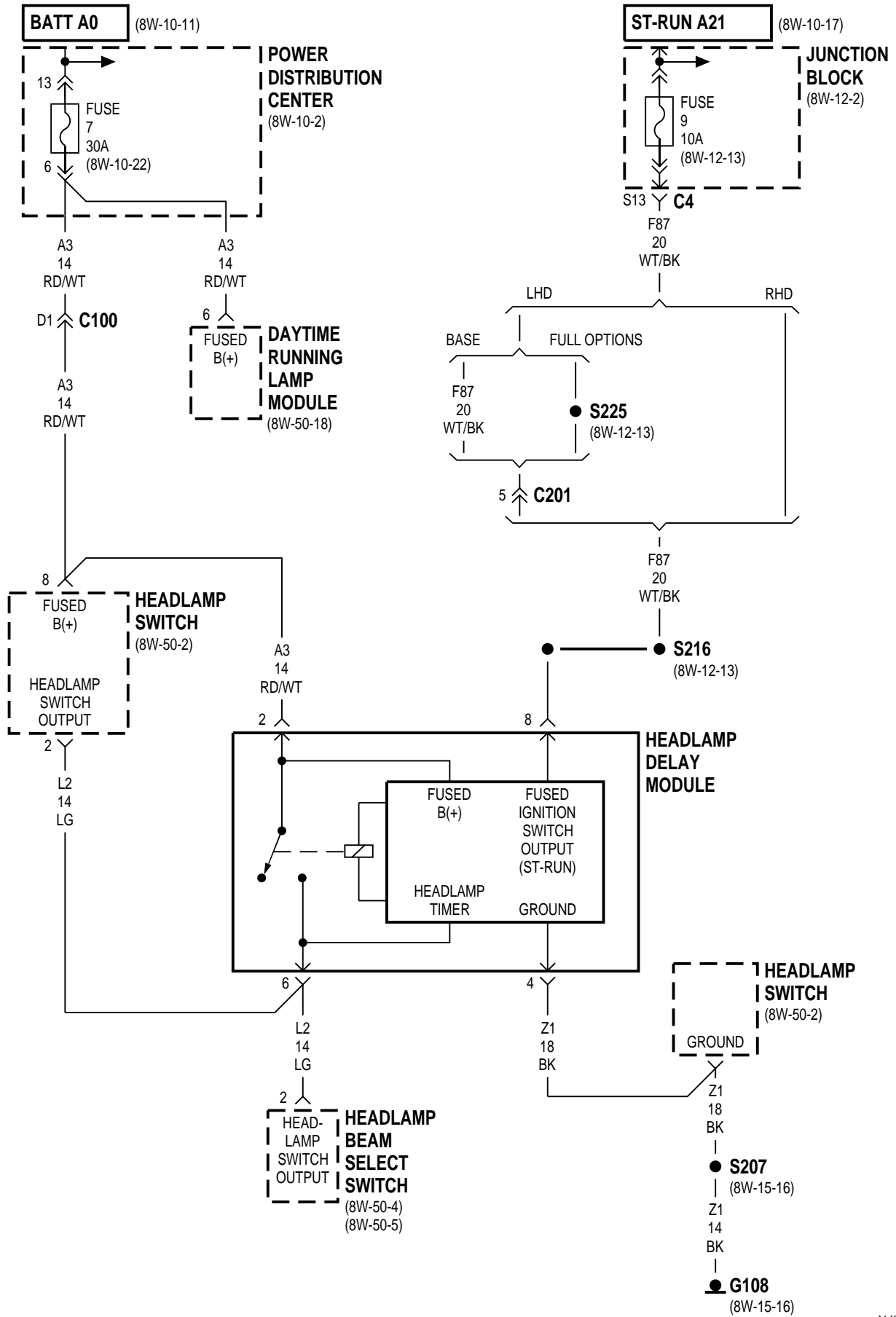

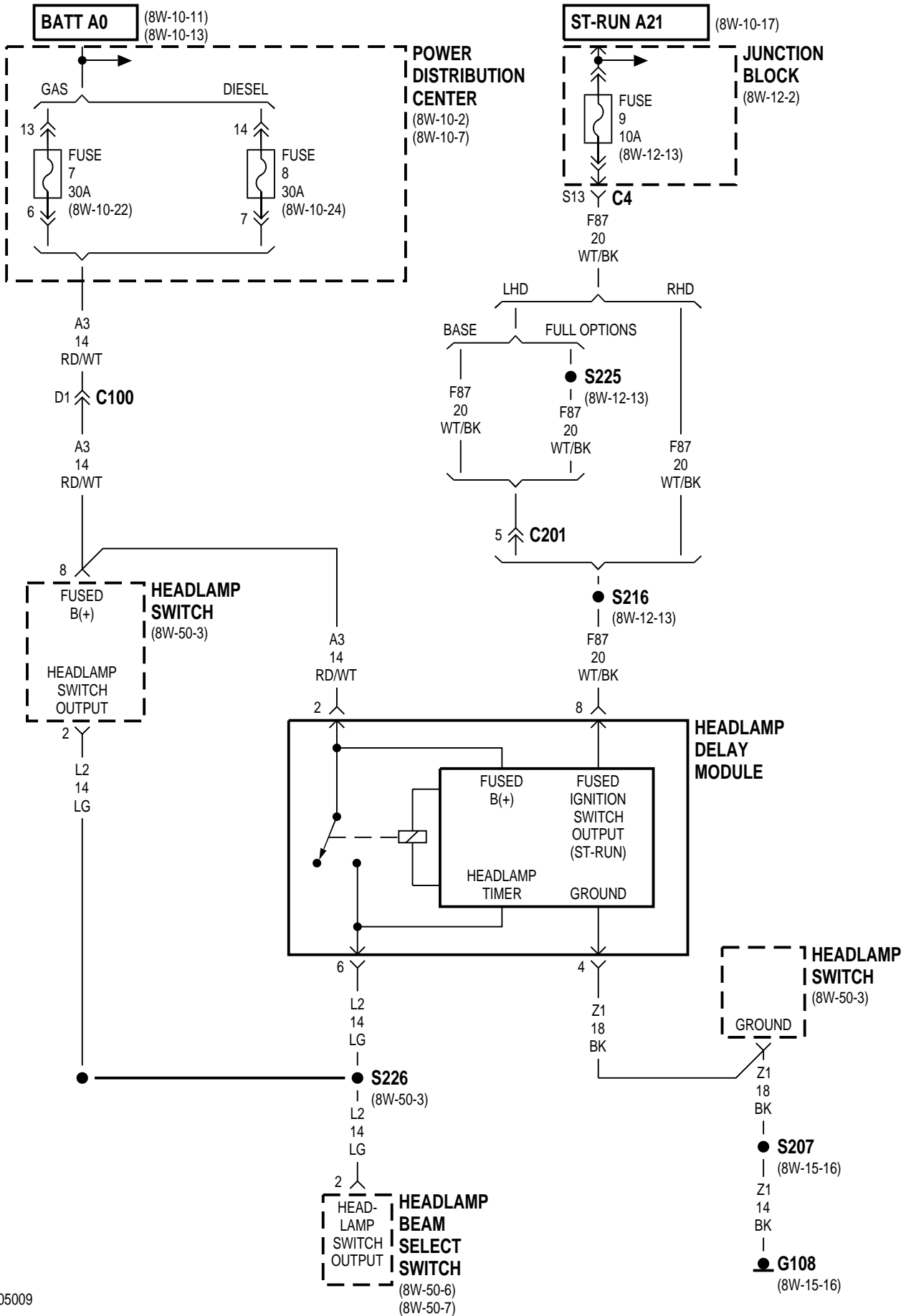

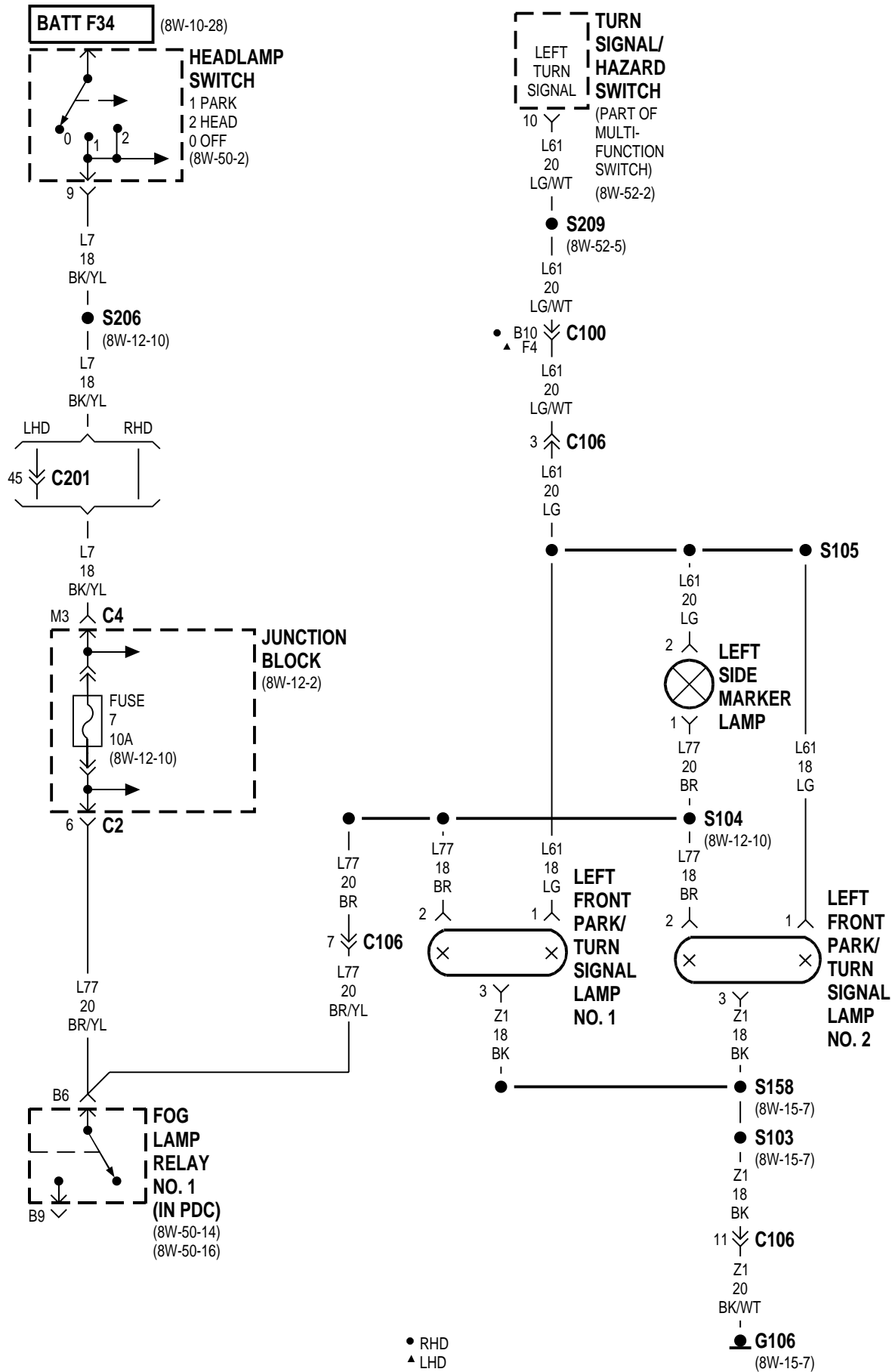

● RHD
▲ LHD

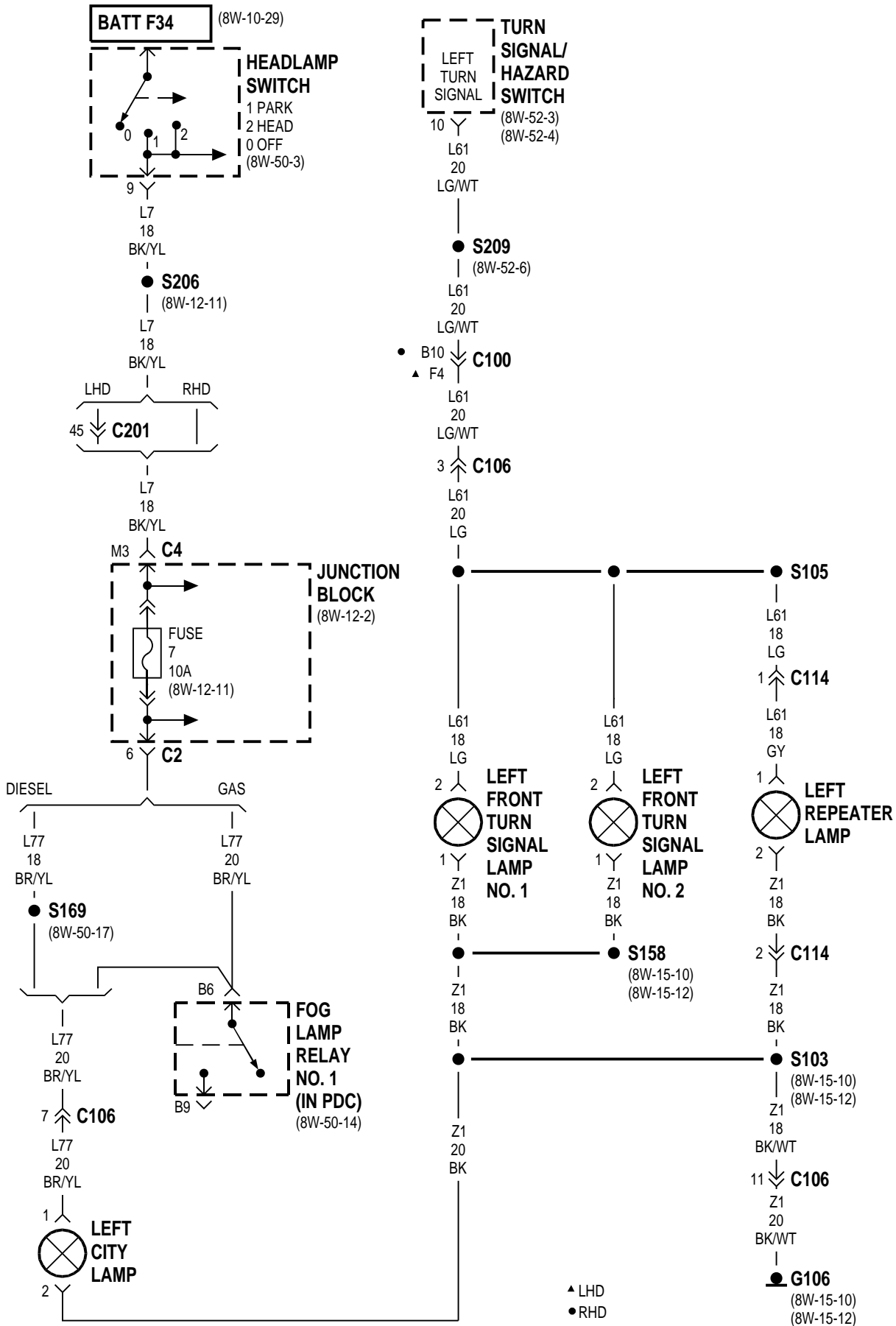

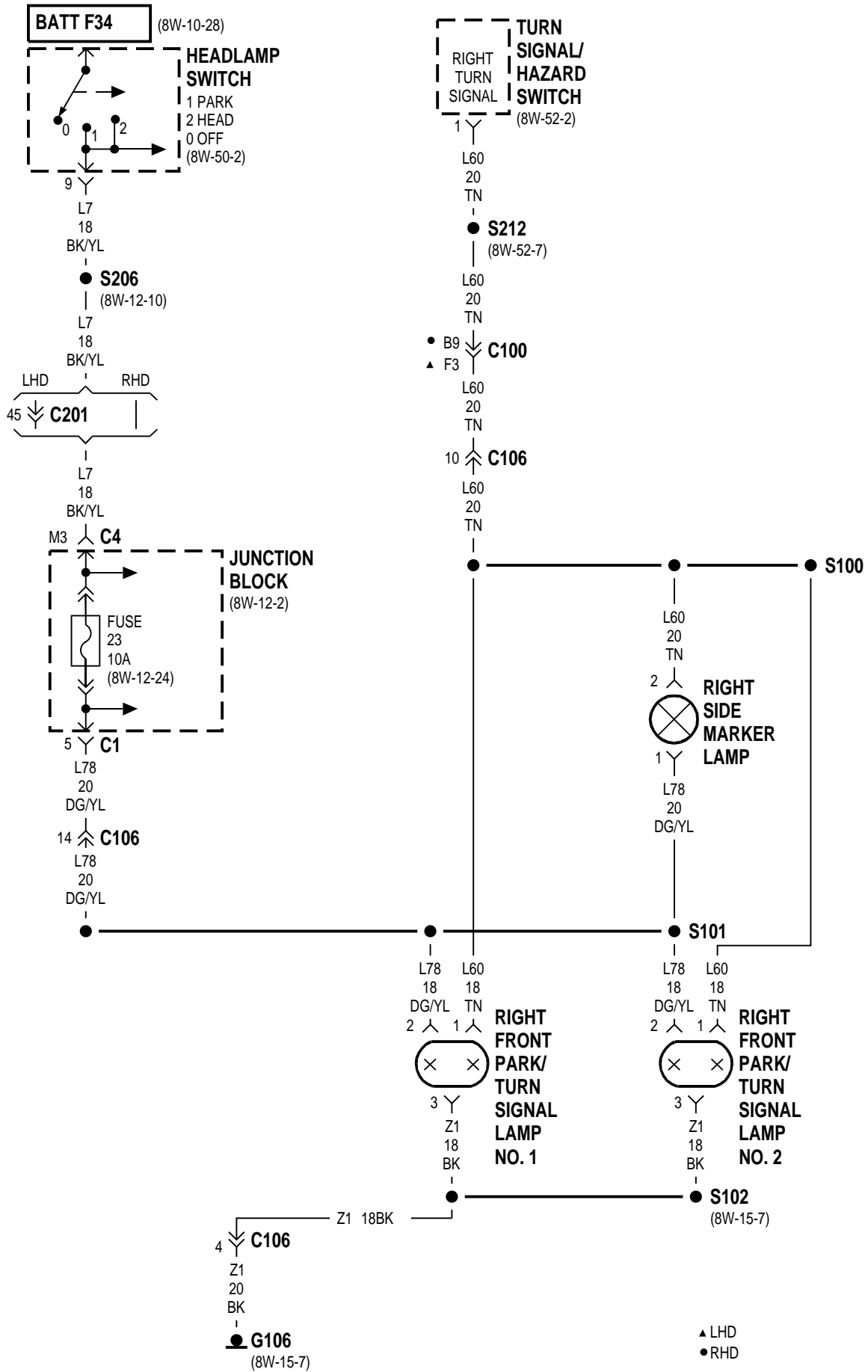

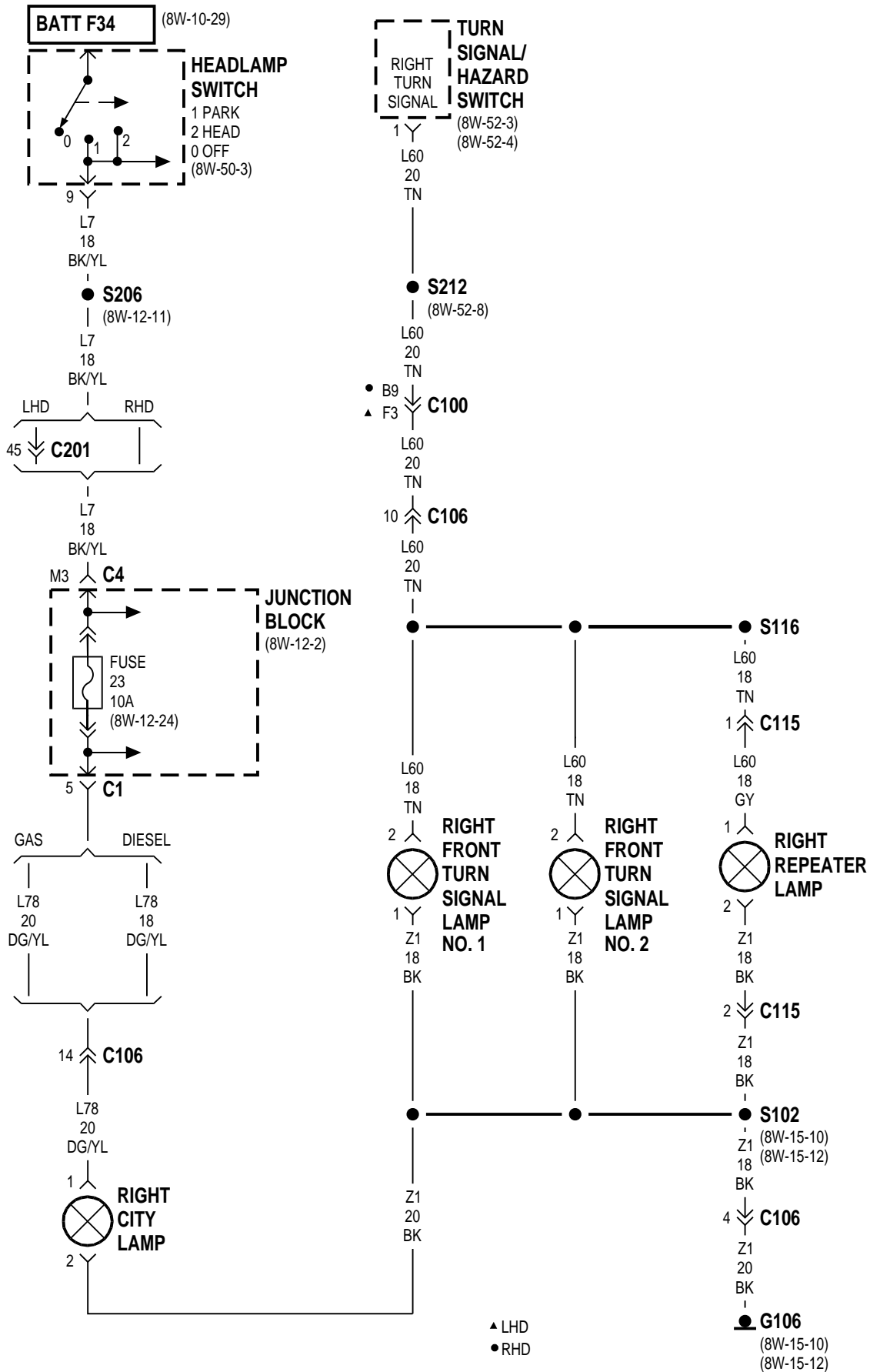

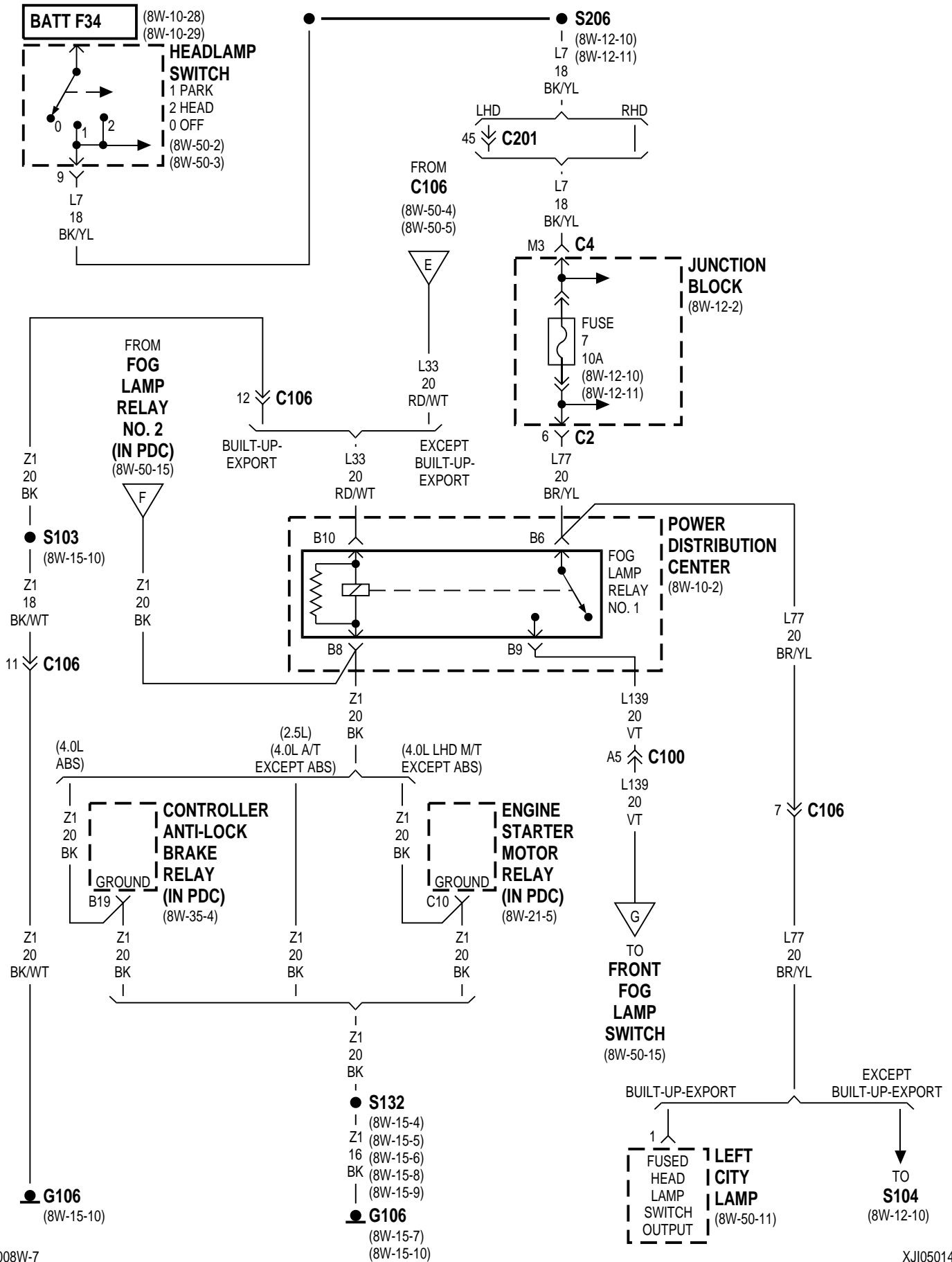

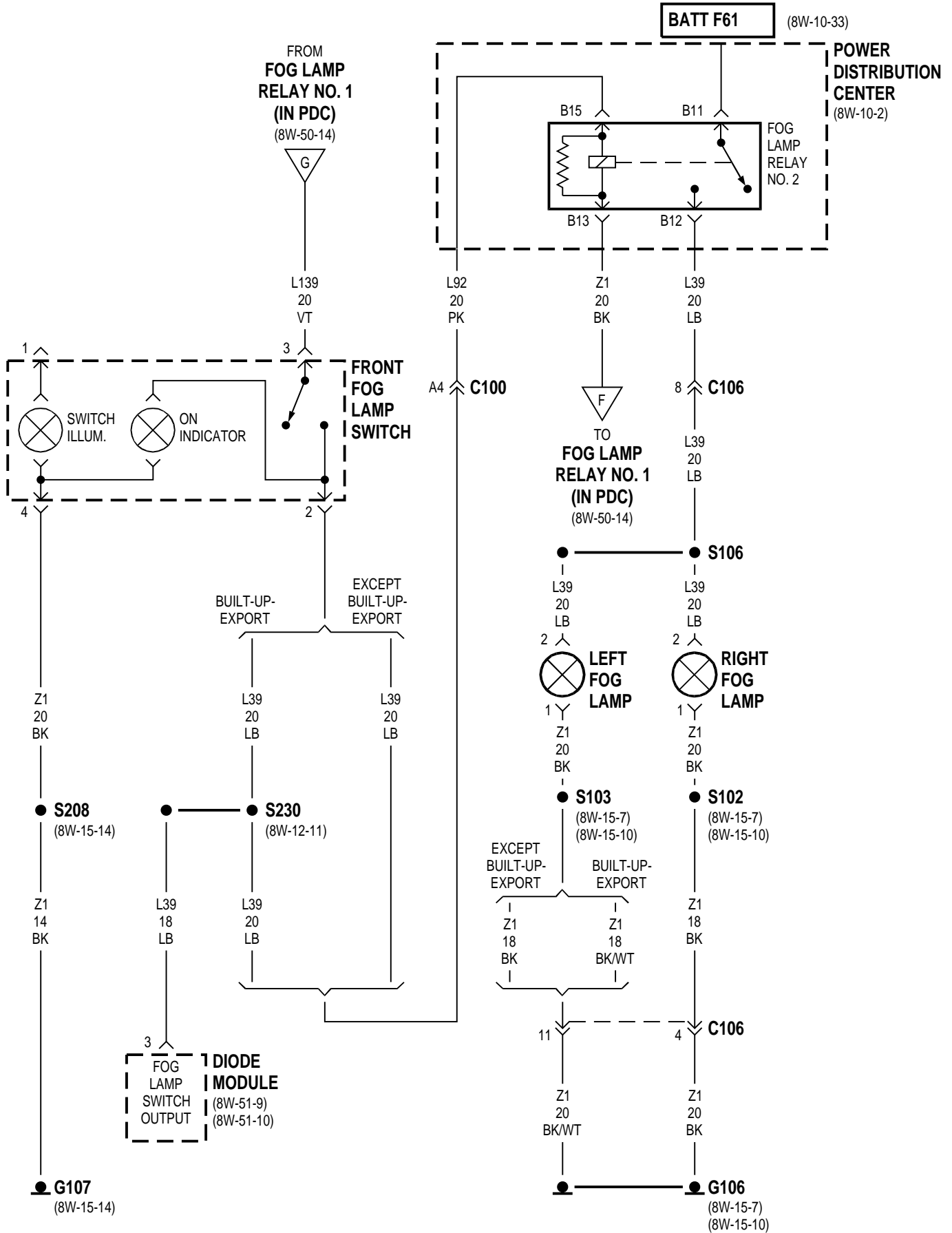

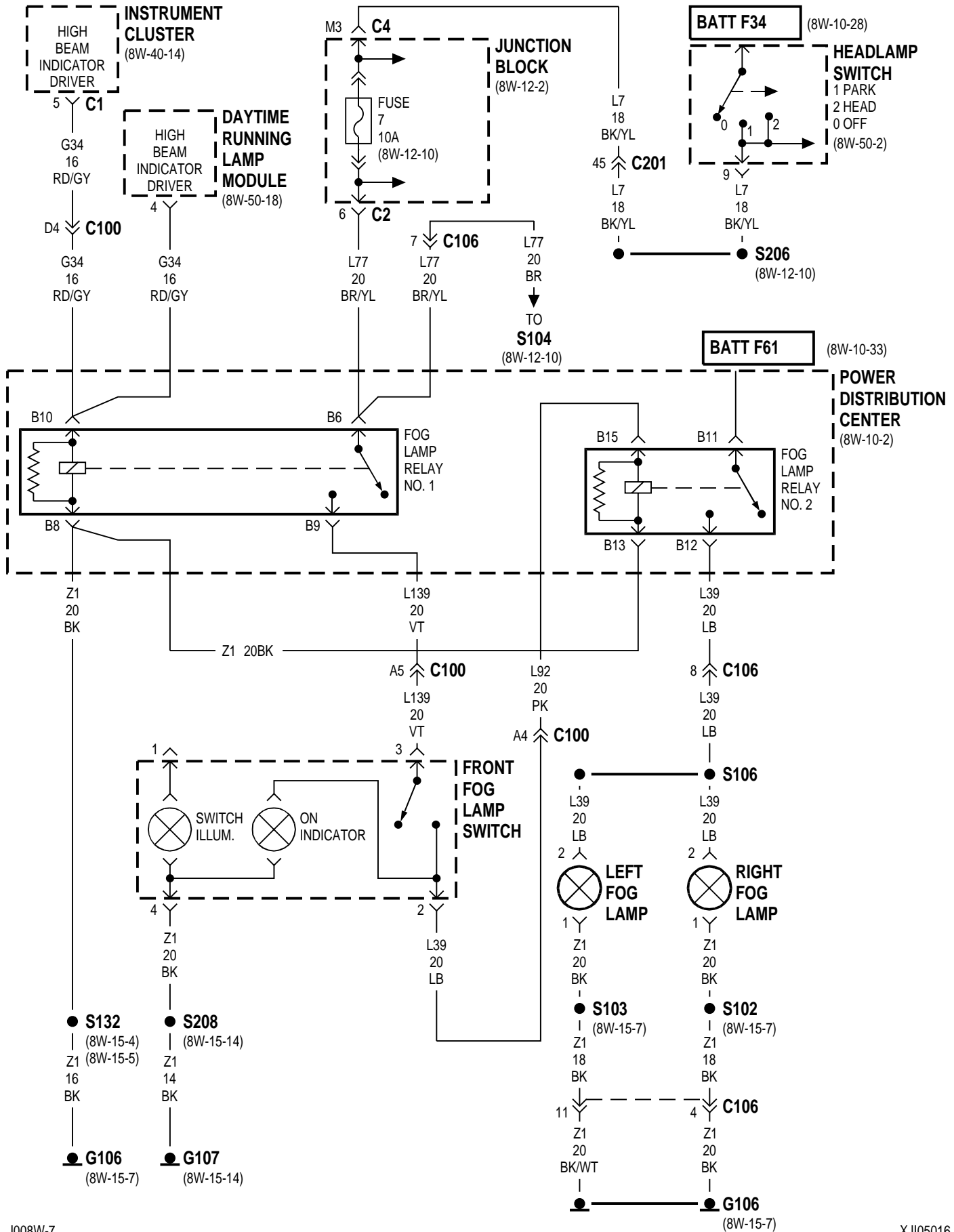

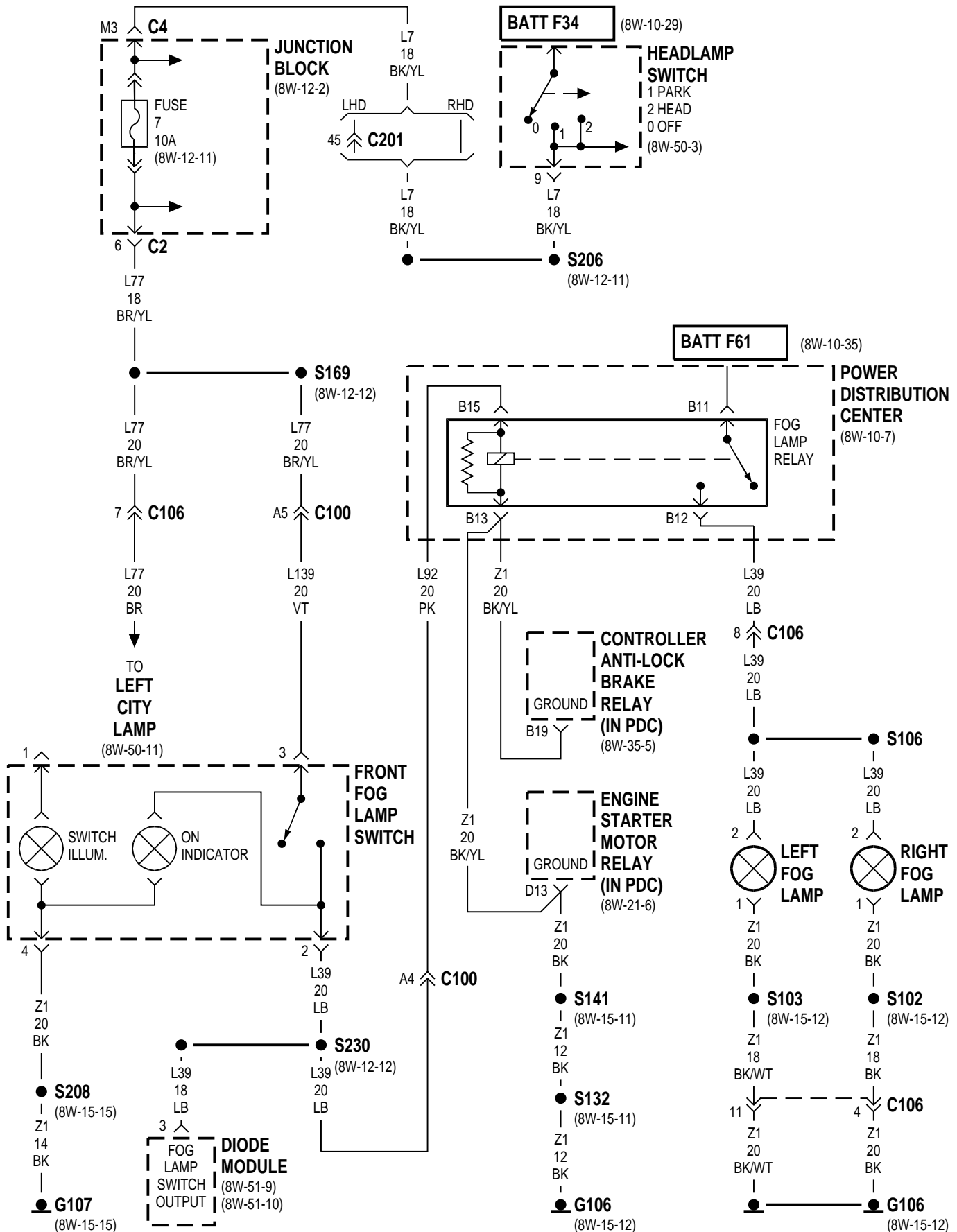

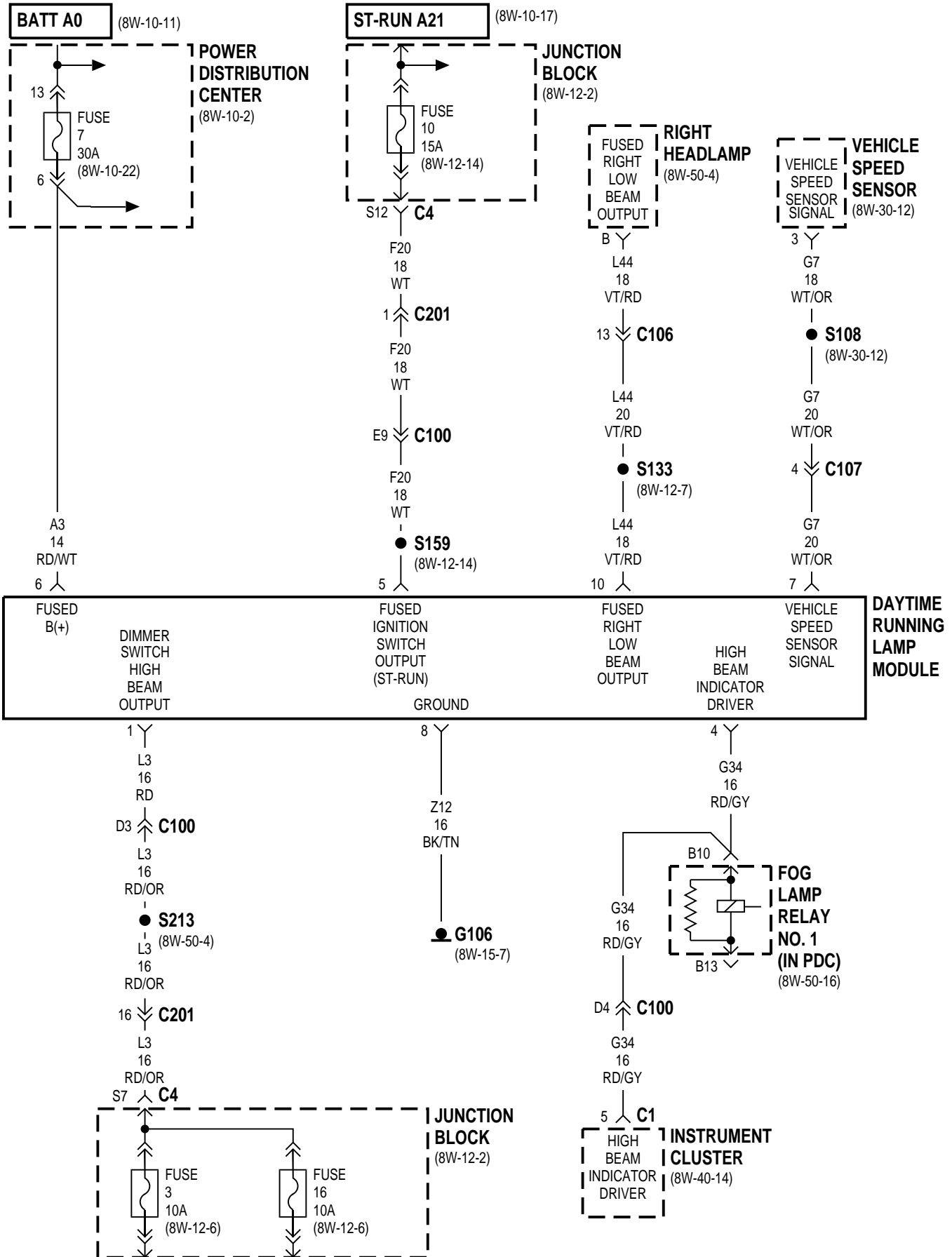

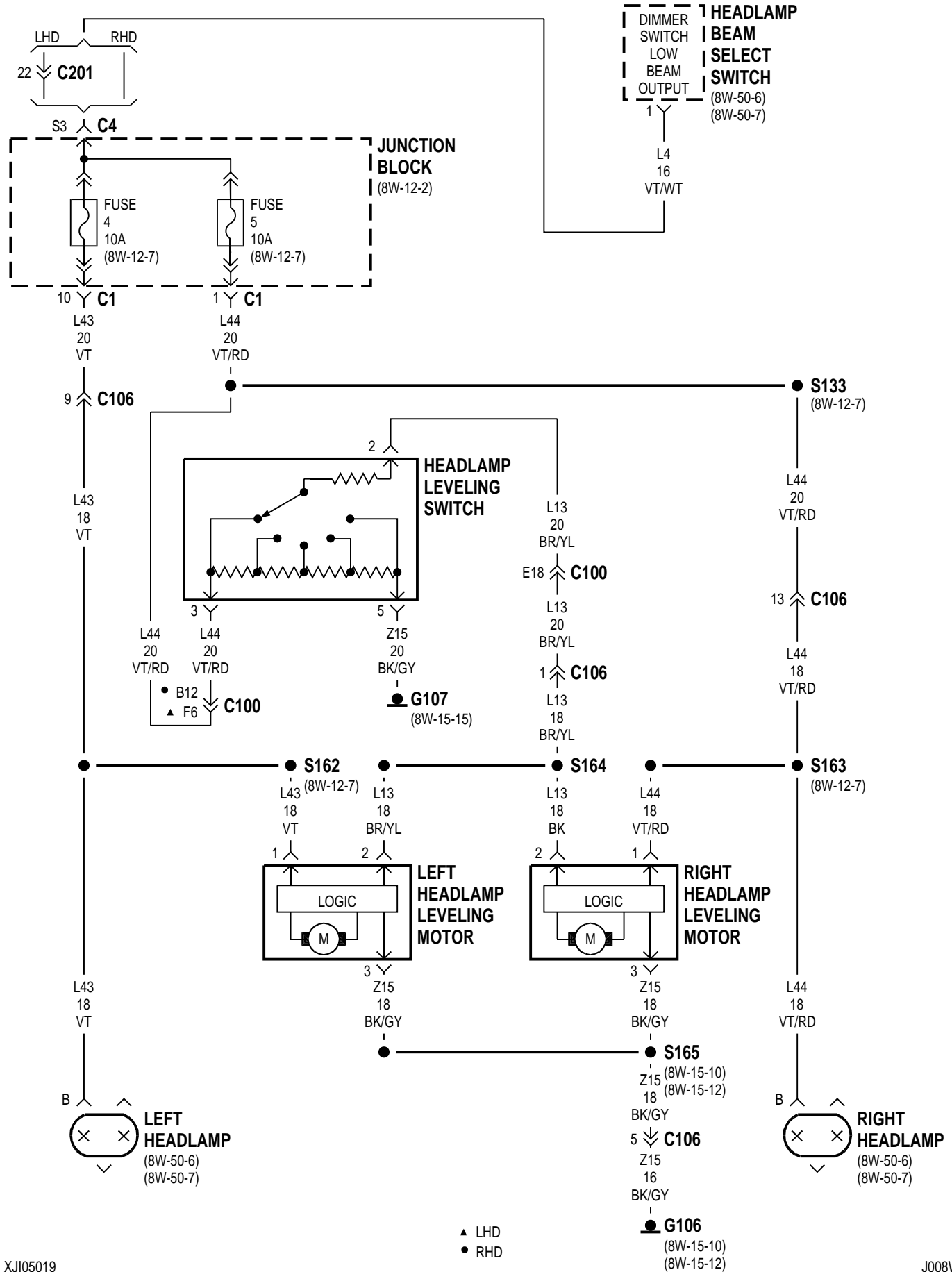

8W-51 REAR LIGHTING

| Component | Page | Component | Page |
|---|-----------------------|--|---------------|
| Back-Up Lamp Switch | 8W-51-6, 7 | Left Rear Fog Lamp | 8W-51-11, 12 |
| Brake Lamp Switch | 8W-51-2 | Left Tail/Stop Lamp | 8W-51-3 |
| Center High Mounted Stop Lamp | 8W-51-4 | Left Turn Signal Lamp | 8W-51-5 |
| Diode Module | 8W-51-9, 10 | License Lamp | 8W-51-4 |
| Driver Power Lock/Window Switch | 8W-51-9, 10 | Park/Neutral Position Switch | 8W-51-6 |
| Fog Lamp Relay | 8W-51-9, 10 | Power Distribution Center | 8W-51-2 |
| Fog Lamp Relay No. 2 | 8W-51-9, 10 | Powertrain Control Module | 8W-51-6 |
| Front Fog Lamp Switch | 8W-51-9, 10 | Rear Fog Lamp Indicator | 8W-51-11, 12 |
| Fuse 7 (JB) | 8W-51-2 | Rear Fog Lamp Relay | 8W-51-9, 10 |
| Fuse 10 (JB) | 8W-51-6, 7 | Rear Fog Lamp Switch | 8W-51-11, 12 |
| Fuse 18 (JB) | 8W-51-9, 10 | Right Back-Up Lamp | 8W-51-8 |
| Fuse 19 (PDC) | 8W-51-2 | Right License Lamp | 8W-51-4 |
| Fuse 23 (JB) | 8W-51-2 | Right Rear Fog Lamp | 8W-51-11, 12 |
| Fuse 23 (PDC) | 8W-51-2 | Right Tail/Stop Lamp | 8W-51-3 |
| G107 | 8W-51-9, 10, 11, 12 | Right Turn Signal Lamp | 8W-51-5 |
| G302 | 8W-51-3, 5, 8, 11, 12 | Switch Illumination | 8W-51-11, 12 |
| G303 | 8W-51-3, 5, 8, 11, 12 | Torque Converter Clutch Solenoid | 8W-51-6 |
| G304 | 8W-51-4 | Trailer Tow Connector | 8W-51-3, 5, 8 |
| Headlamp Switch | 8W-51-2, 9, 10 | Transmission Control Module | 8W-51-6 |
| Junction Block | 8W-51-2, 6, 7, 9, 10 | Transmission Range Sensor | 8W-51-6 |
| Left Back-Up Lamp | 8W-51-8 | Turn Signal/Hazard Switch | 8W-51-5 |
| Left License Lamp | 8W-51-4 | | |

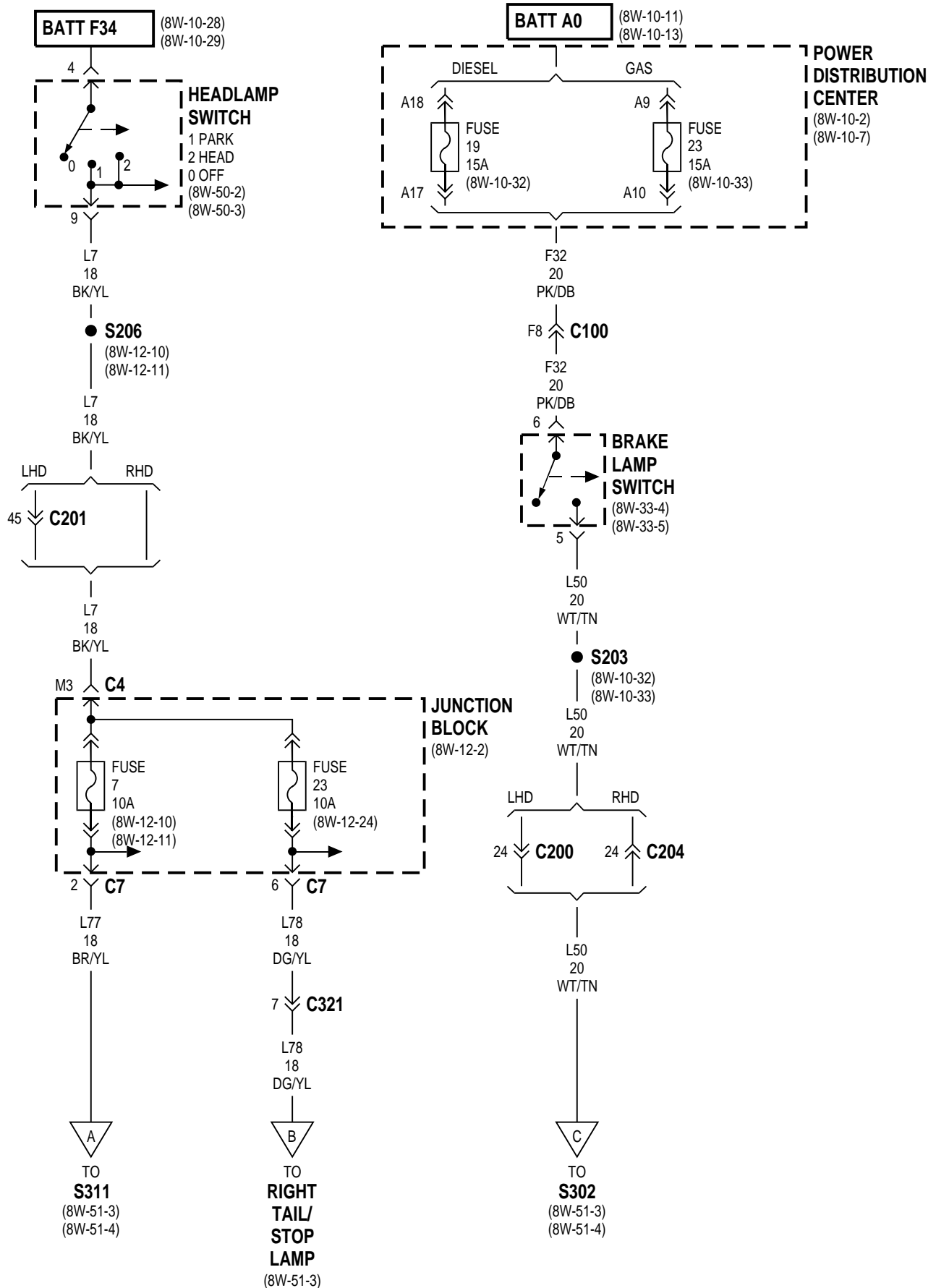

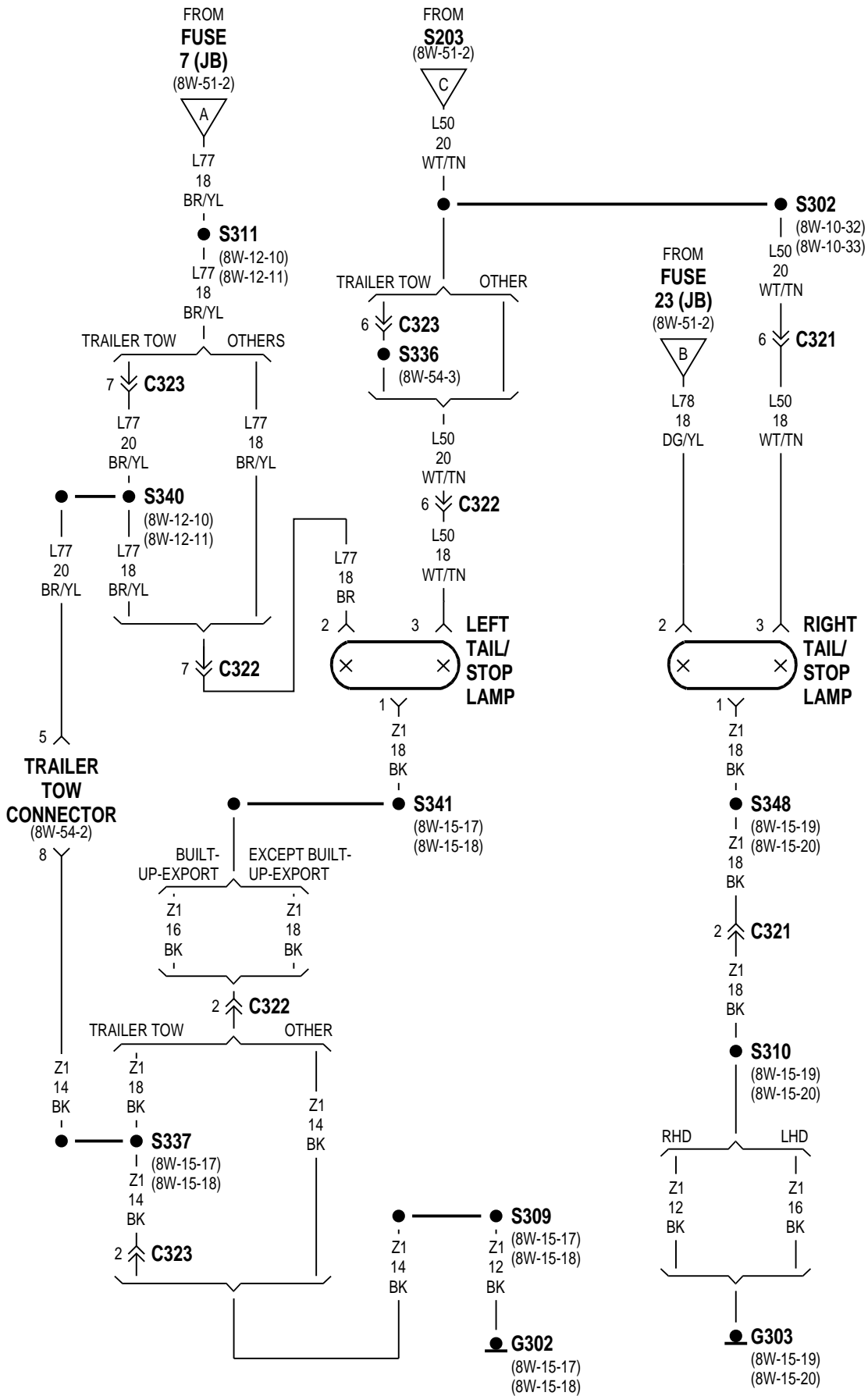

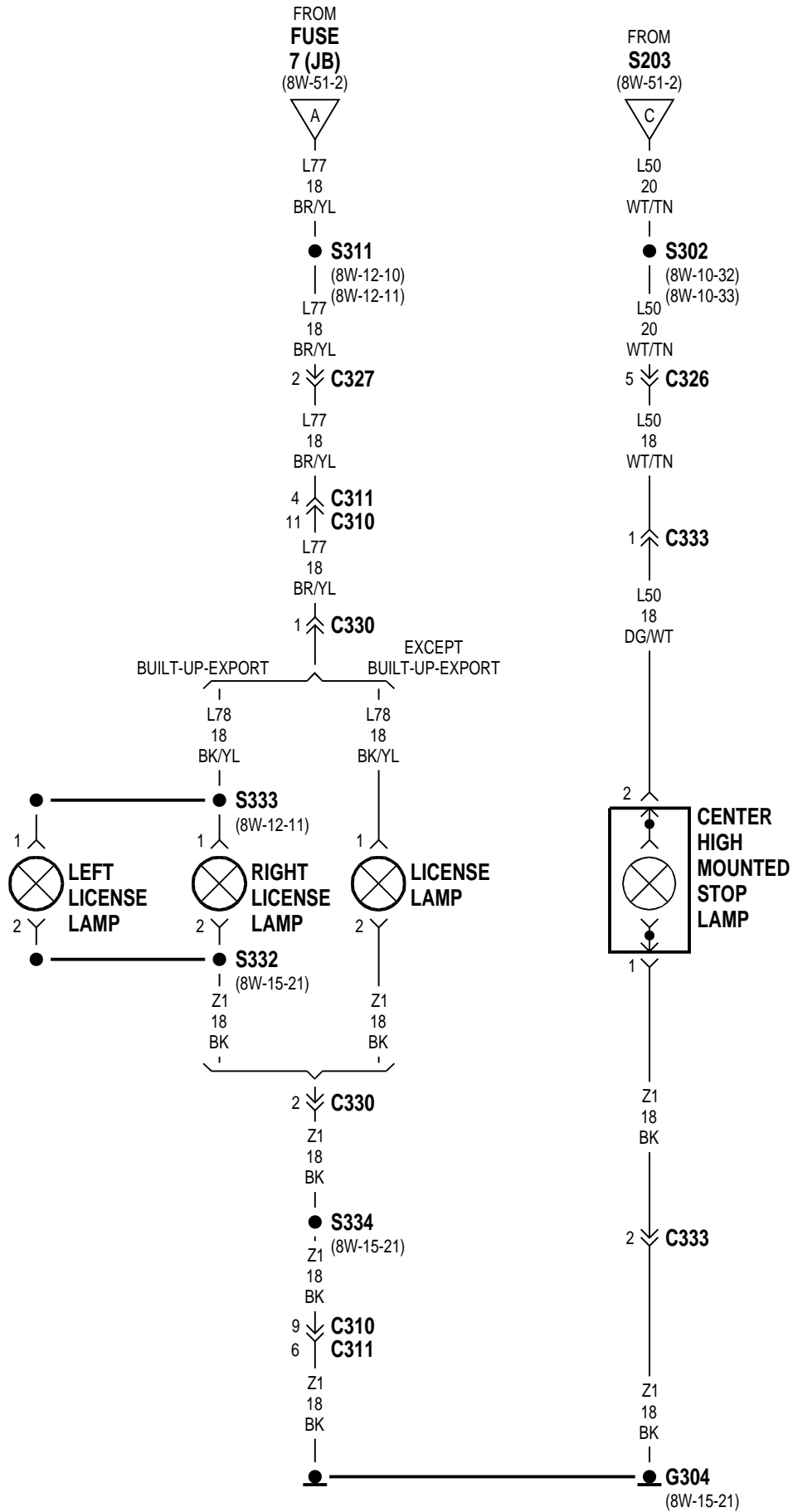

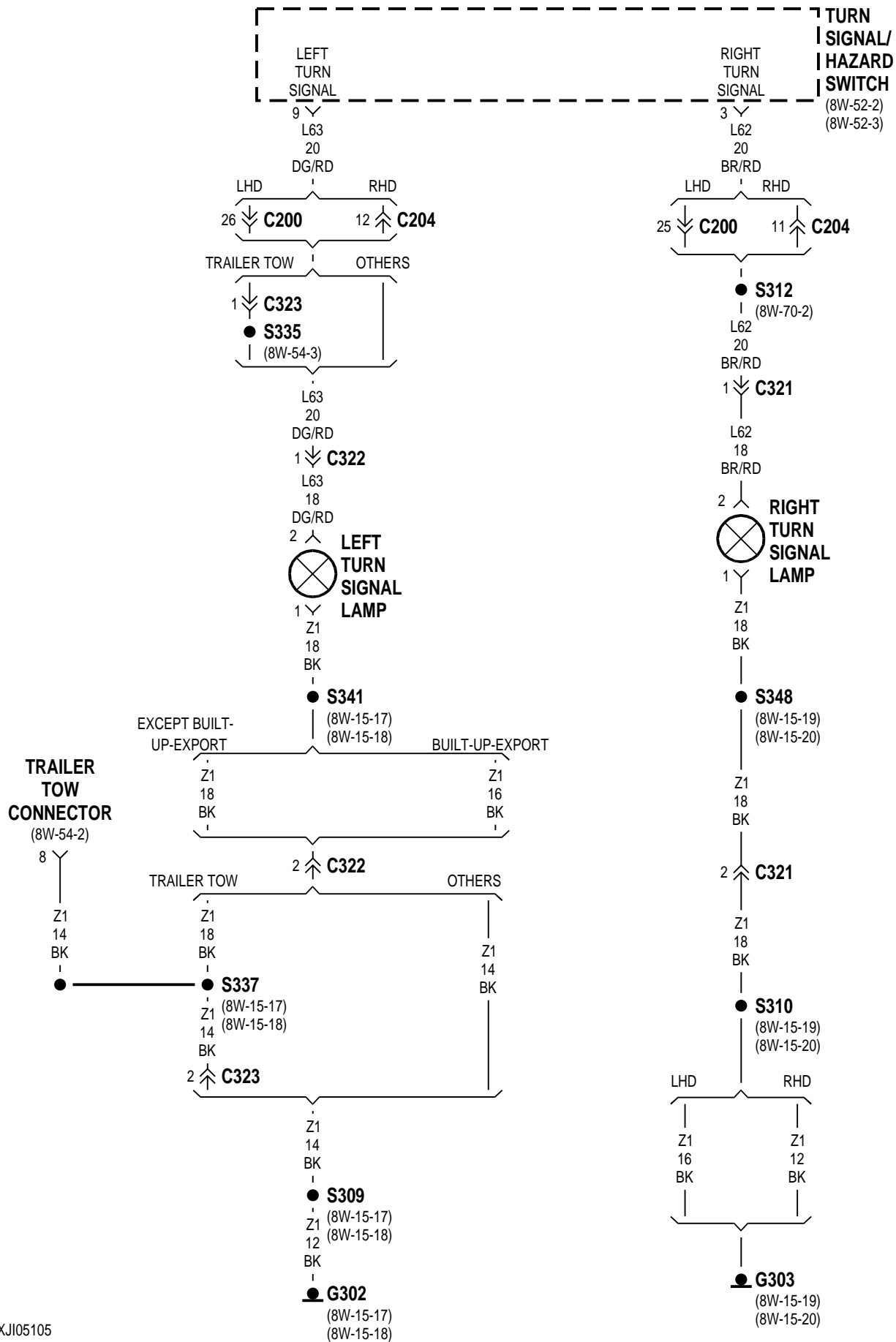

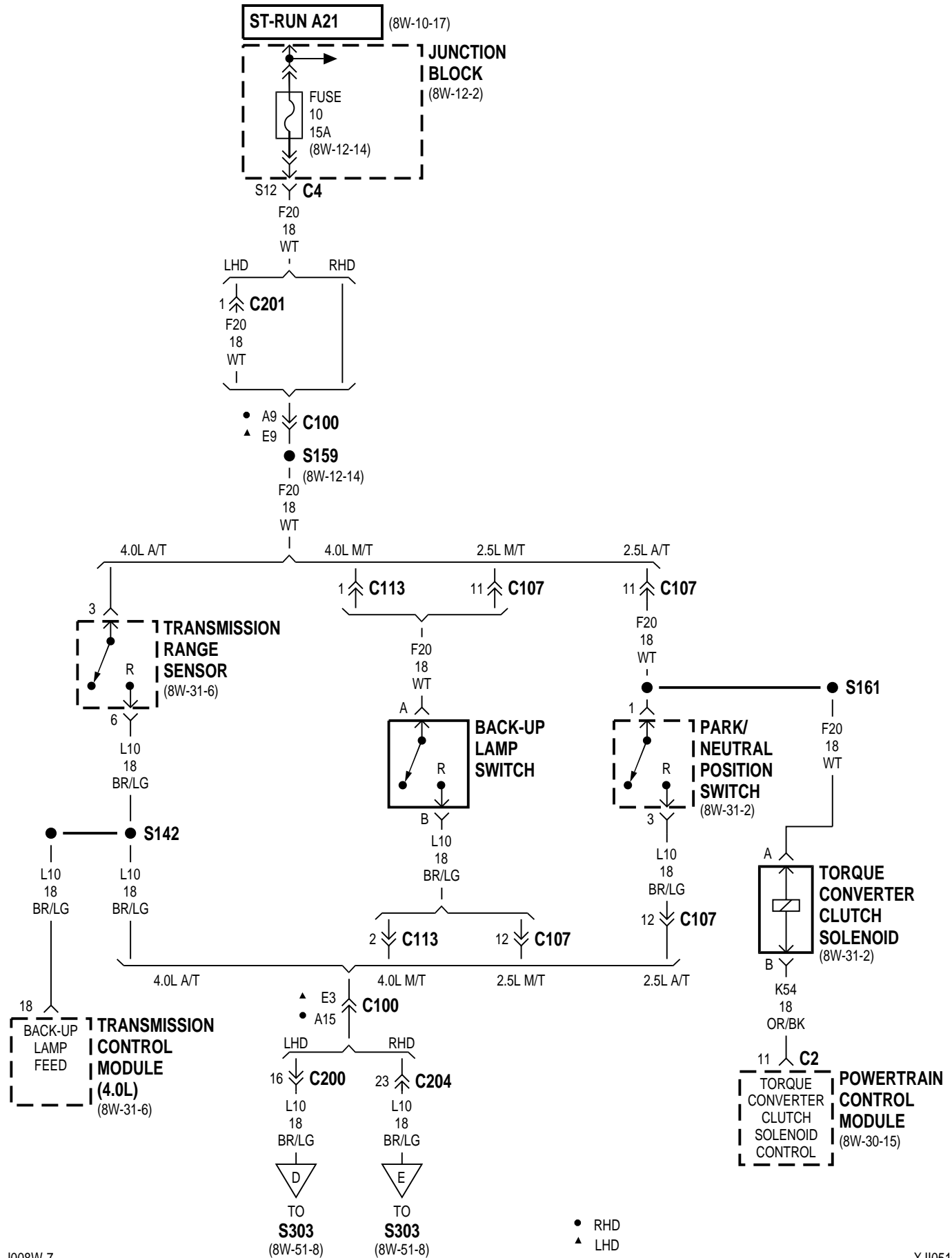

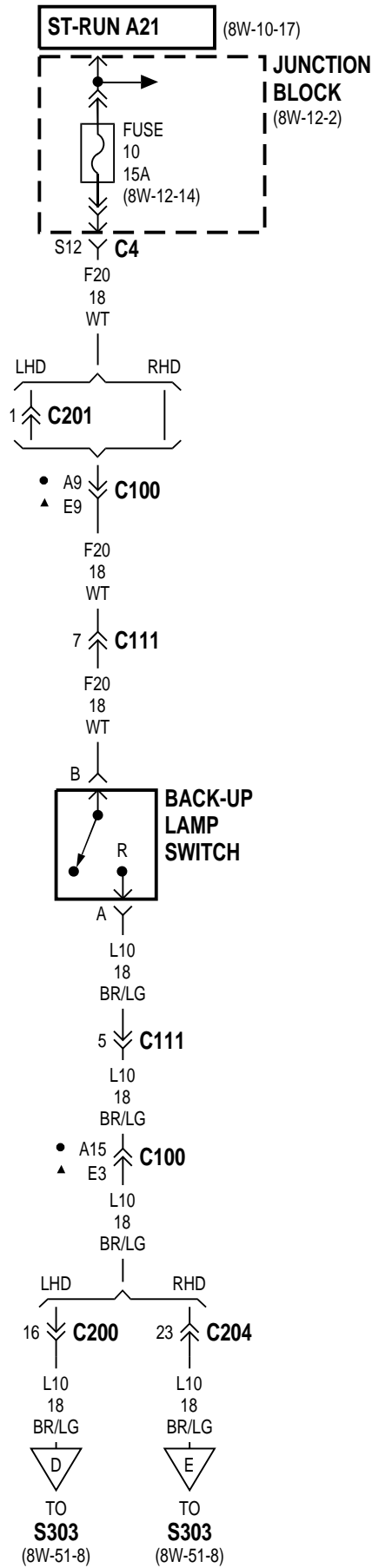

● RHD
 ▲ LHD

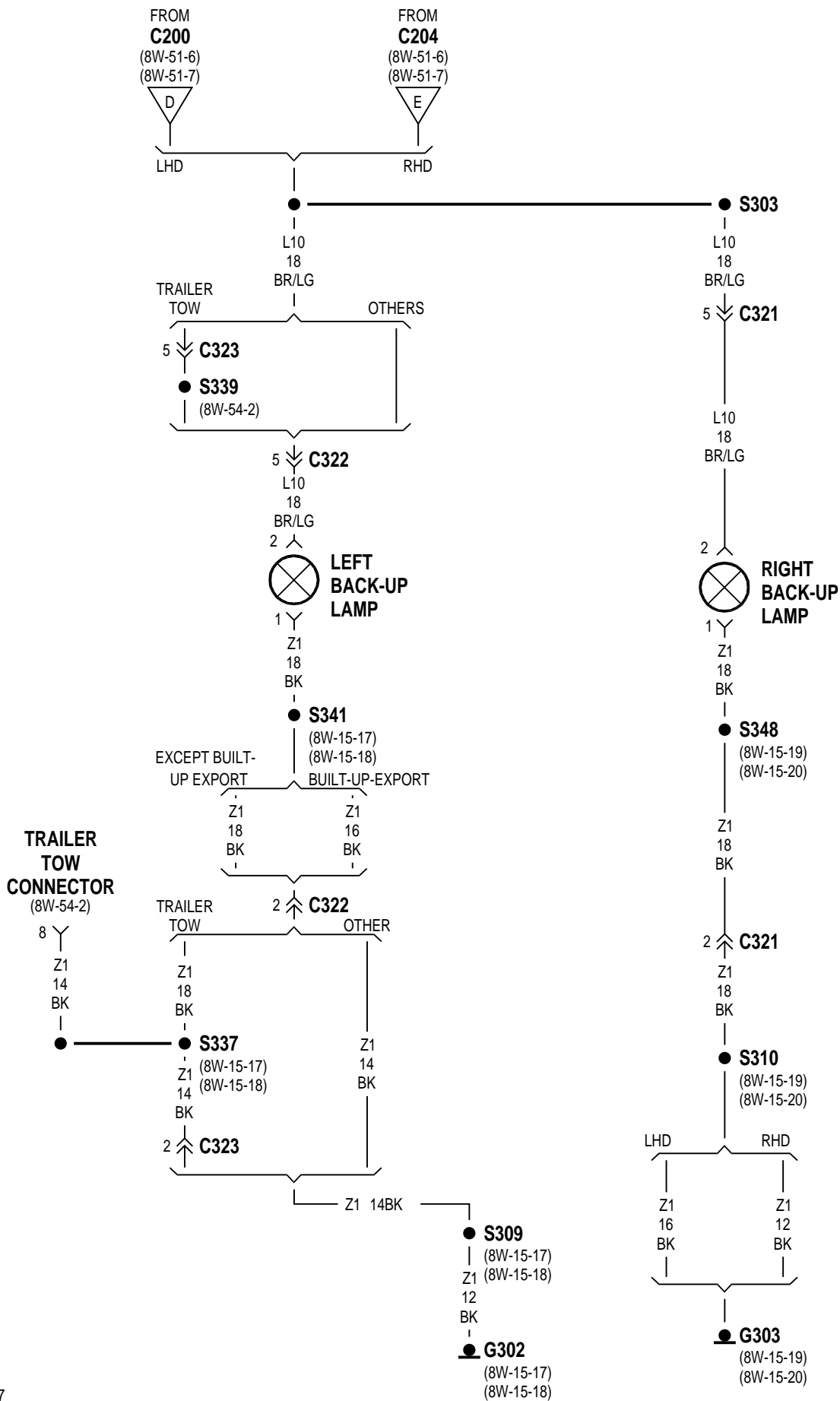

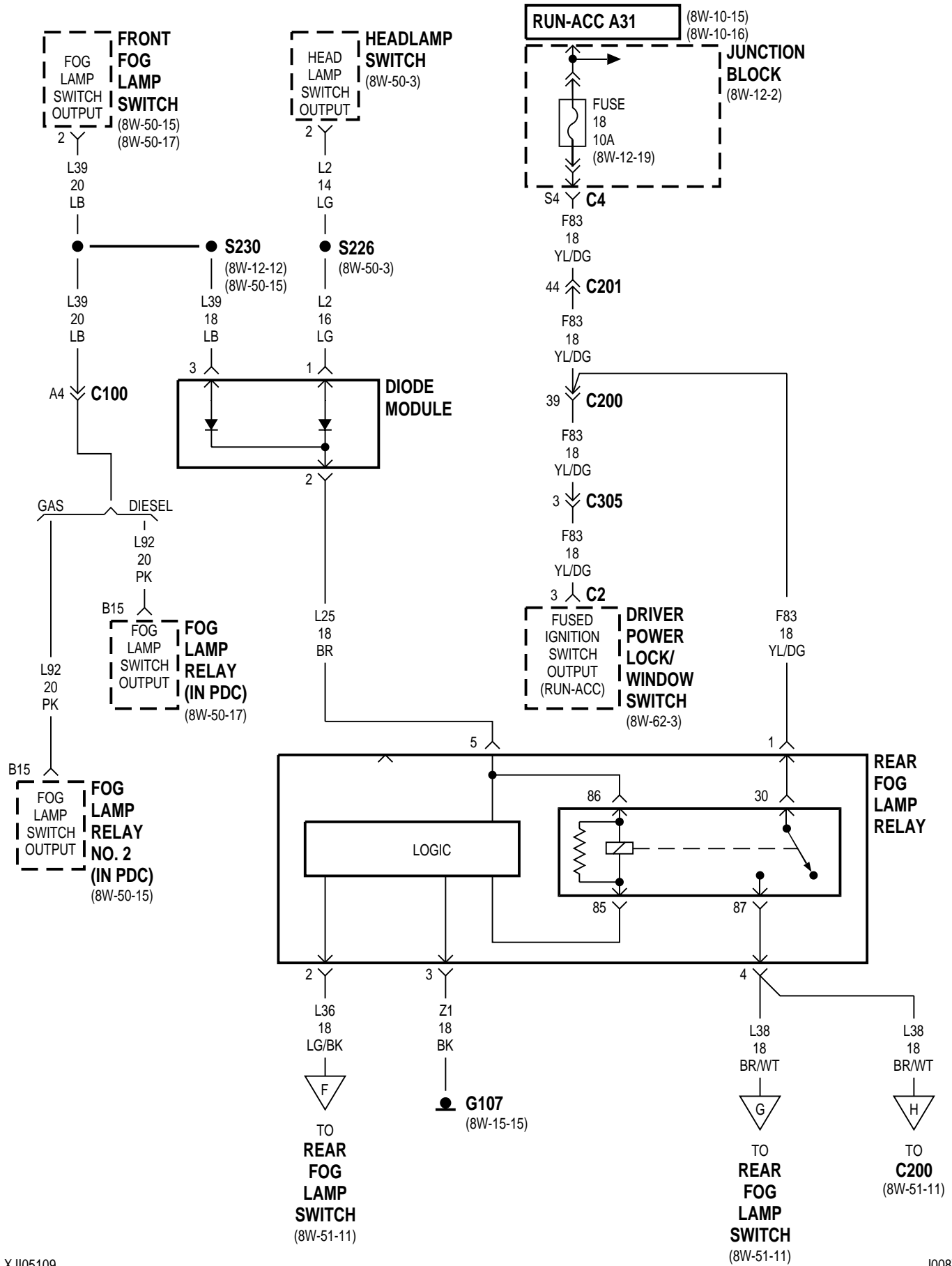

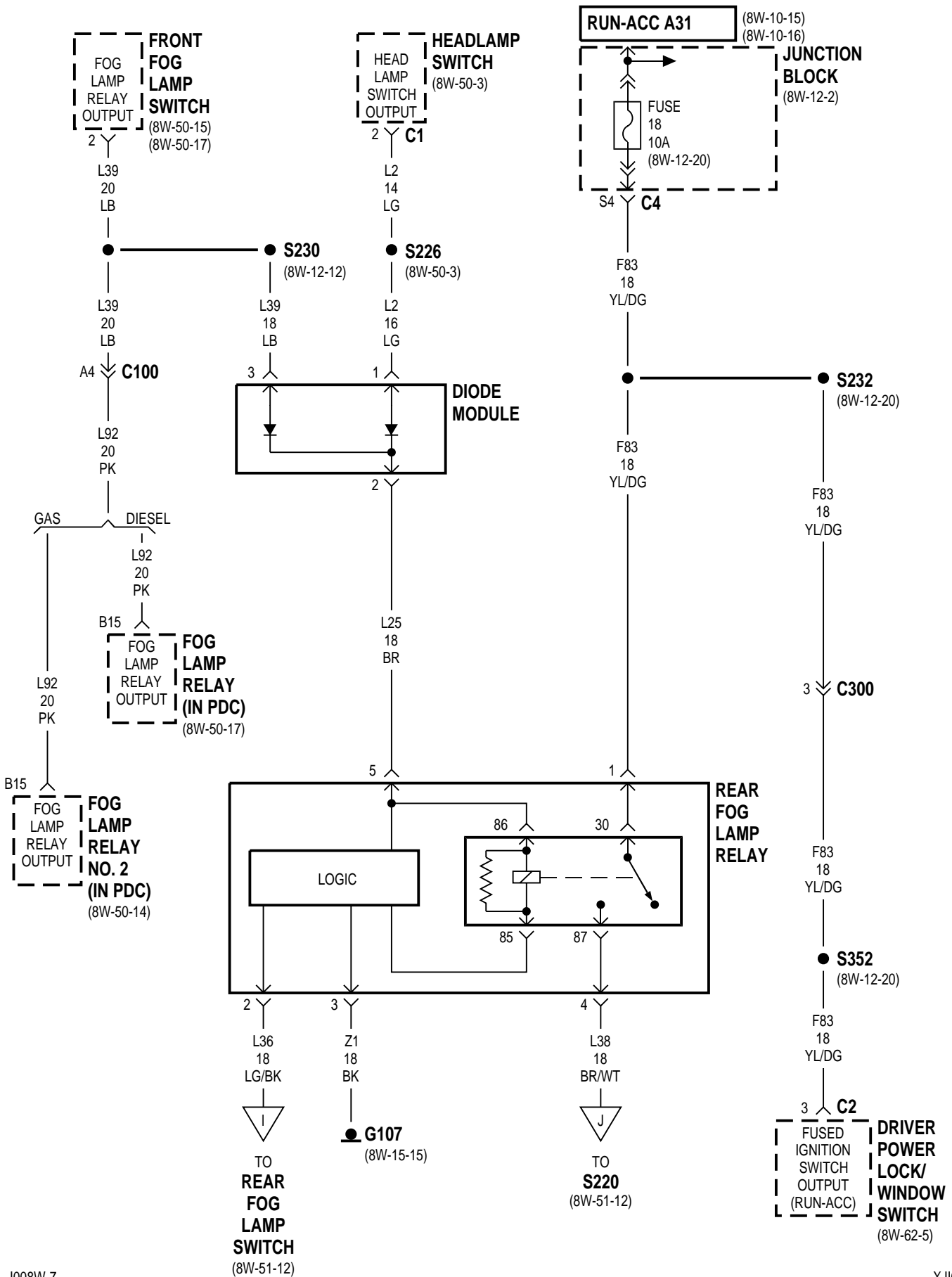

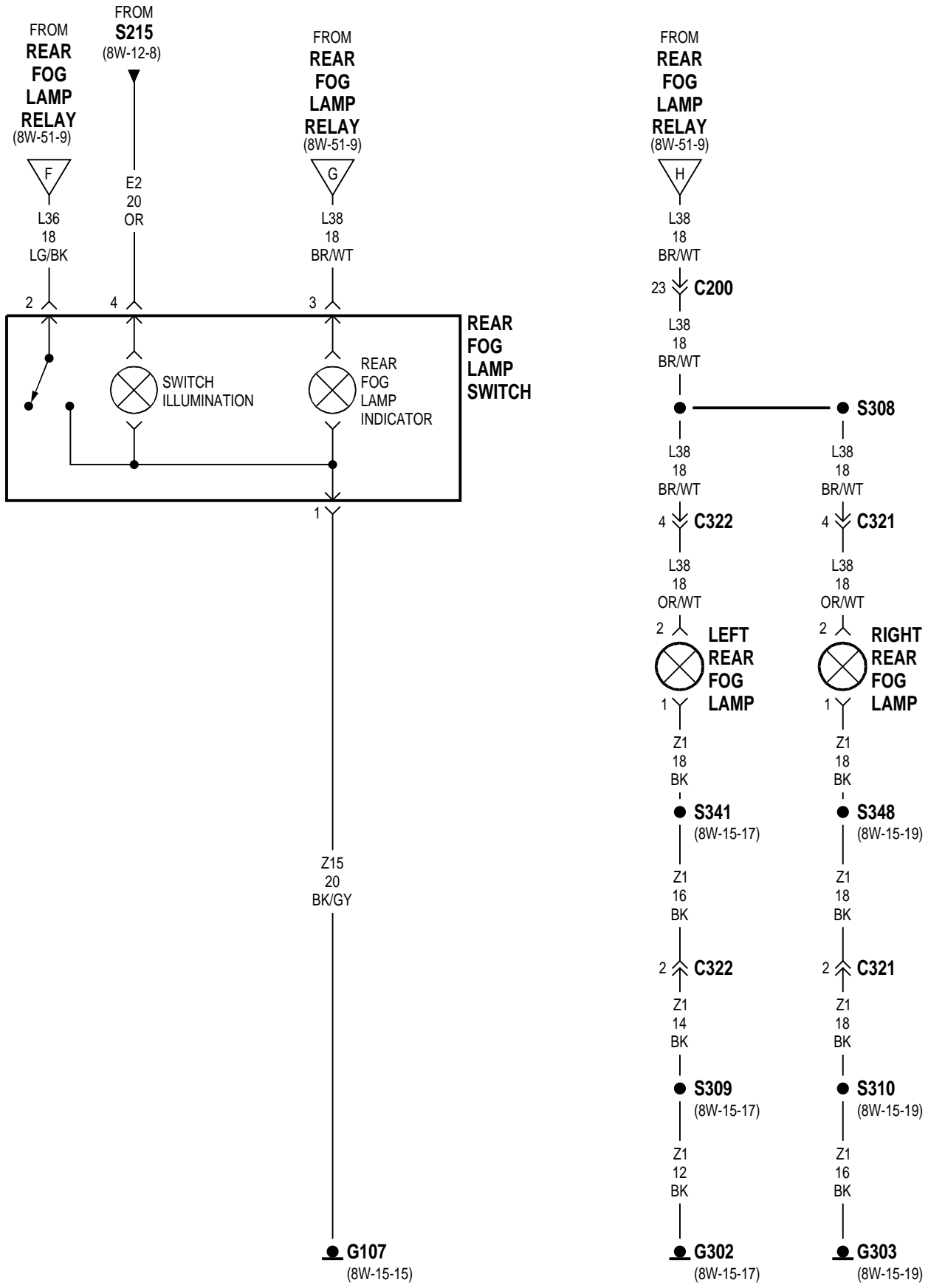

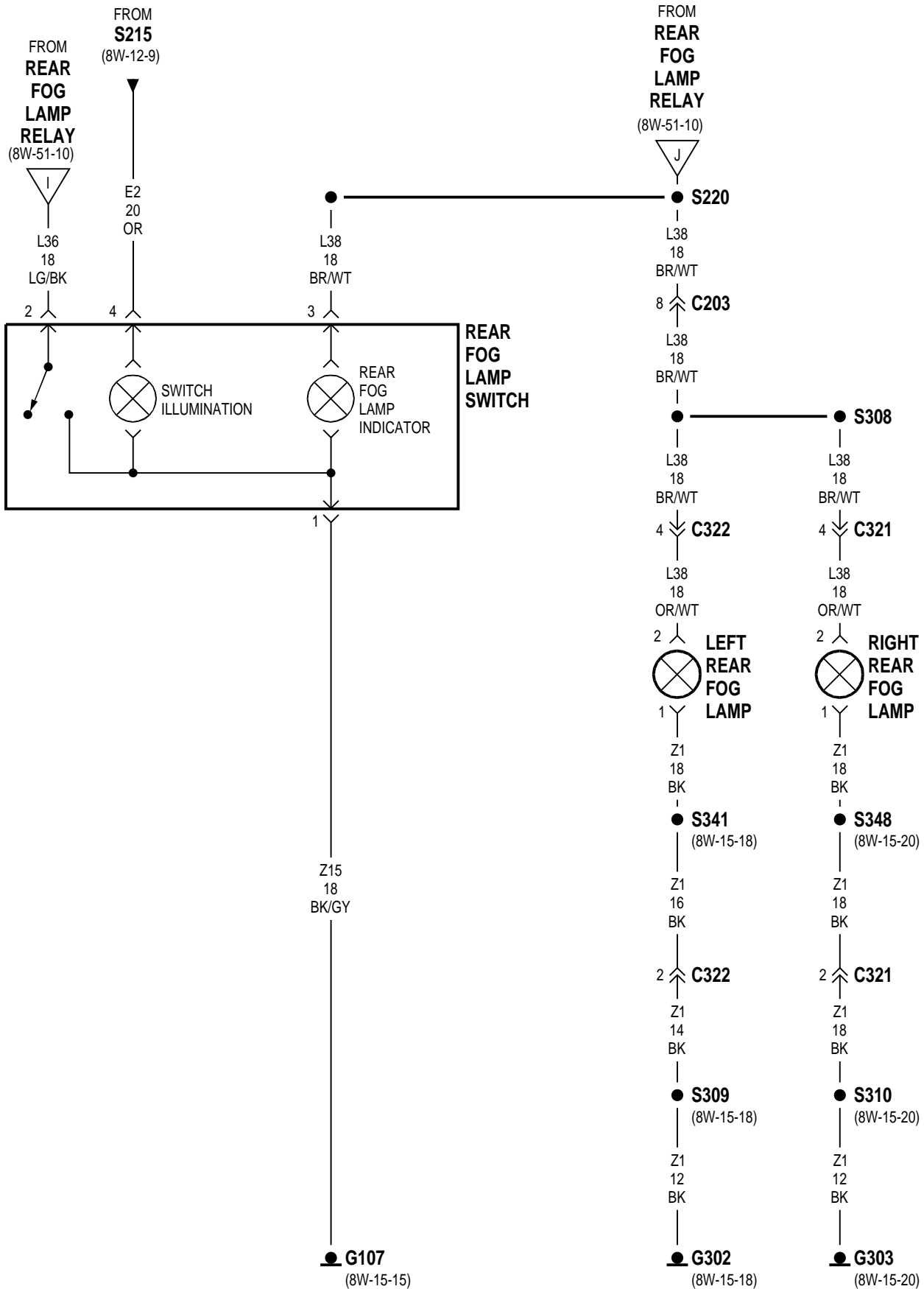

8W-52 TURN SIGNALS

| Component | Page | Component | Page |
|--|------------------|---|---------------|
| Combination Flasher | 8W-52-2, 3, 4 | Left Repeater Lamp | 8W-52-6 |
| Fuse 12 (JB) | 8W-52-2, 3, 4 | Left Side Marker Lamp | 8W-52-5 |
| Fuse 20 (PDC) | 8W-52-2, 3 | Left Turn Signal Lamp | 8W-52-5, 6 |
| Fuse 23 (PDC) | 8W-52-4 | Power Antenna Relay | 8W-52-3, 4 |
| G106 | 8W-52-5, 6, 7, 8 | Power Distribution Center | 8W-52-2, 3, 4 |
| G107 | 8W-52-2, 3, 4 | Right Front Park/Turn Signal Lamp No. 1 . | 8W-52-7 |
| G302 | 8W-52-5, 6 | Right Front Park/Turn Signal Lamp No. 2 . | 8W-52-7 |
| G303 | 8W-52-7, 8 | Right Front Turn Signal Lamp No. 1 | 8W-52-8 |
| Instrument Cluster | 8W-52-5, 6, 7, 8 | Right Front Turn Signal Lamp No. 2 | 8W-52-8 |
| Junction Block | 8W-52-2, 3, 4 | Right Repeater Lamp | 8W-52-8 |
| Left Front Park/Turn Signal Lamp No. 1 . . | 8W-52-5 | Right Side Marker Lamp | 8W-52-7 |
| Left Front Park/Turn Signal Lamp No. 2 . . | 8W-52-5 | Right Turn Signal Lamp | 8W-52-7, 8 |
| Left Front Turn Signal Lamp No. 1 | 8W-52-6 | Turn Signal/Hazard Switch | 8W-52-2, 3, 4 |
| Left Front Turn Signal Lamp No. 2 | 8W-52-6 | | |

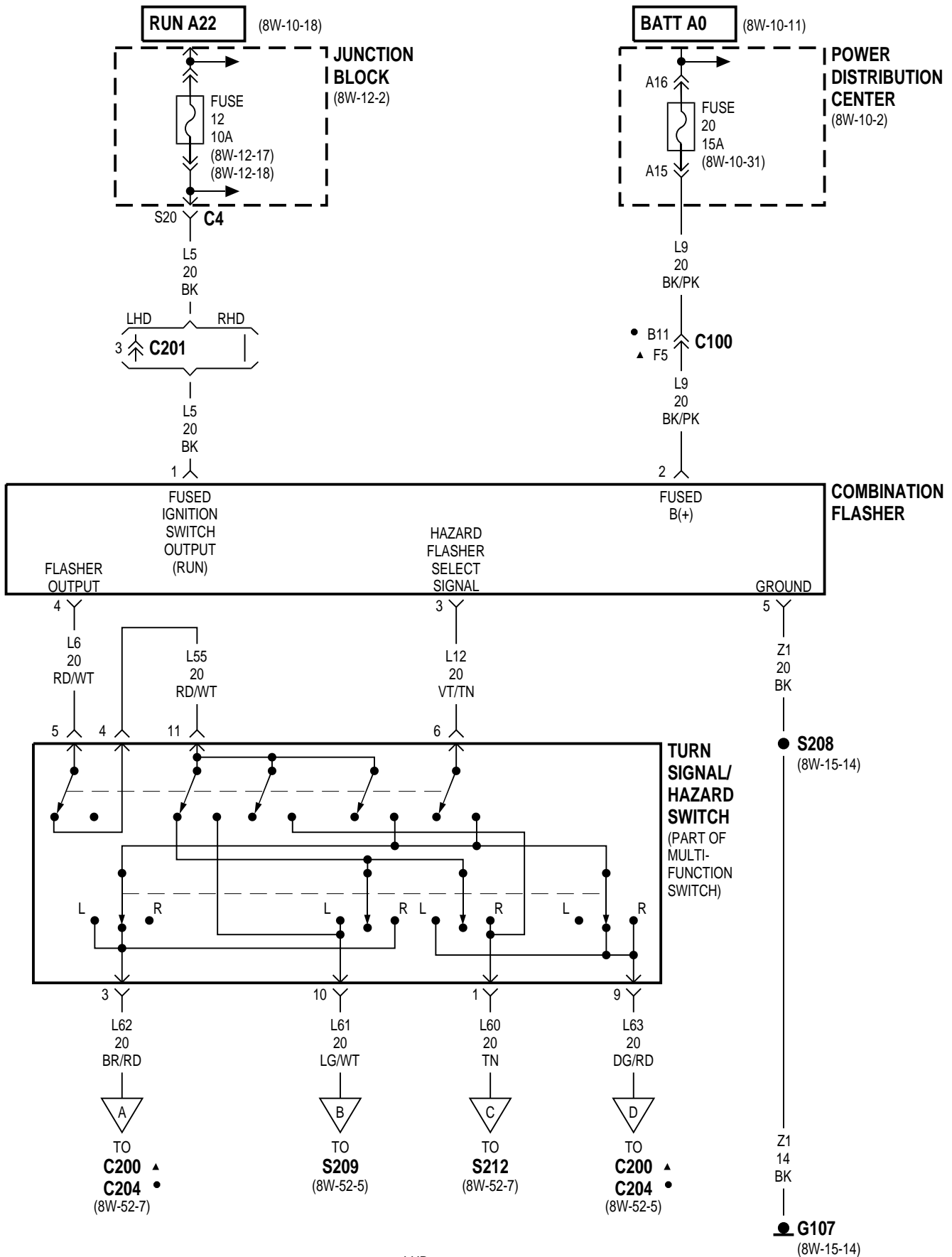

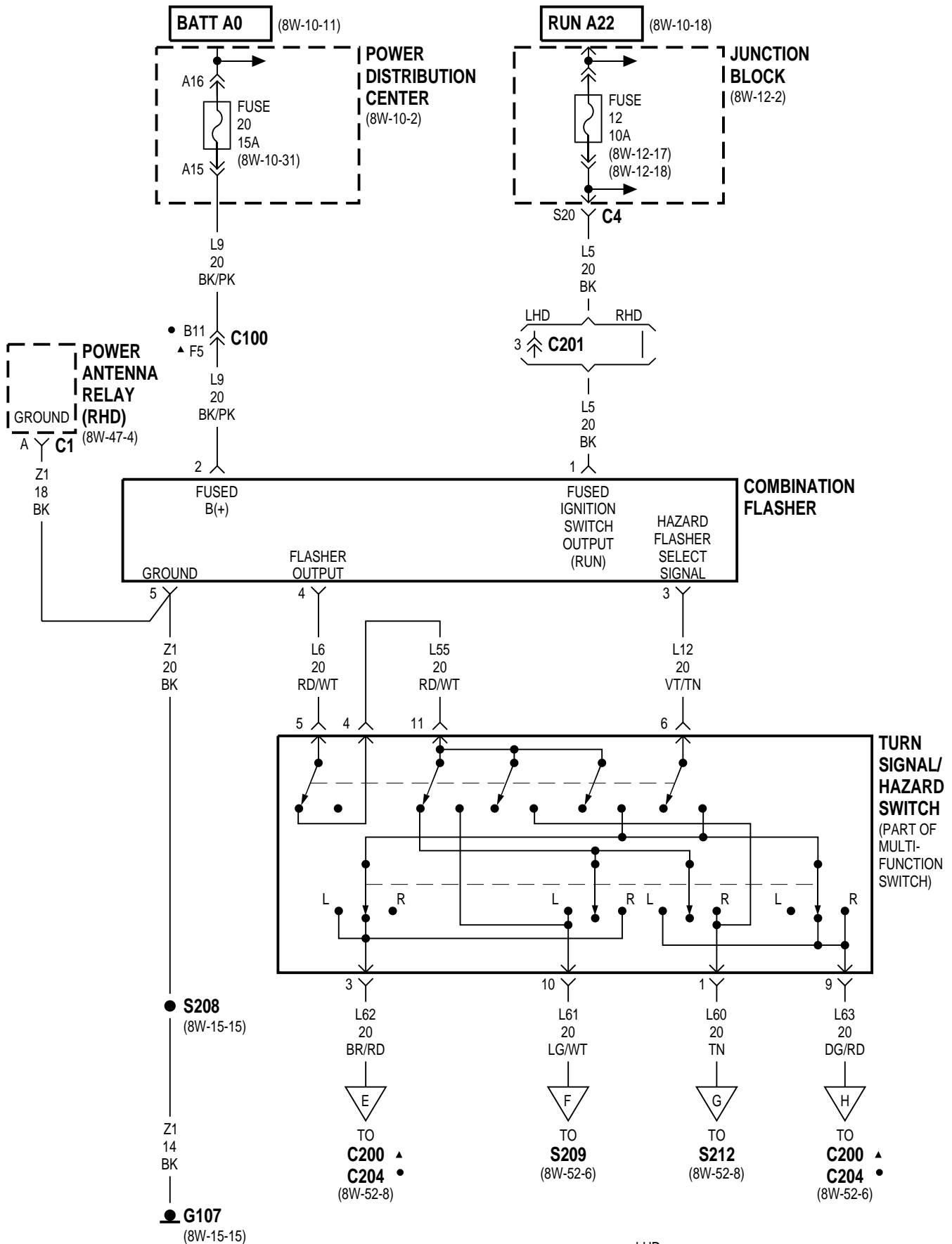

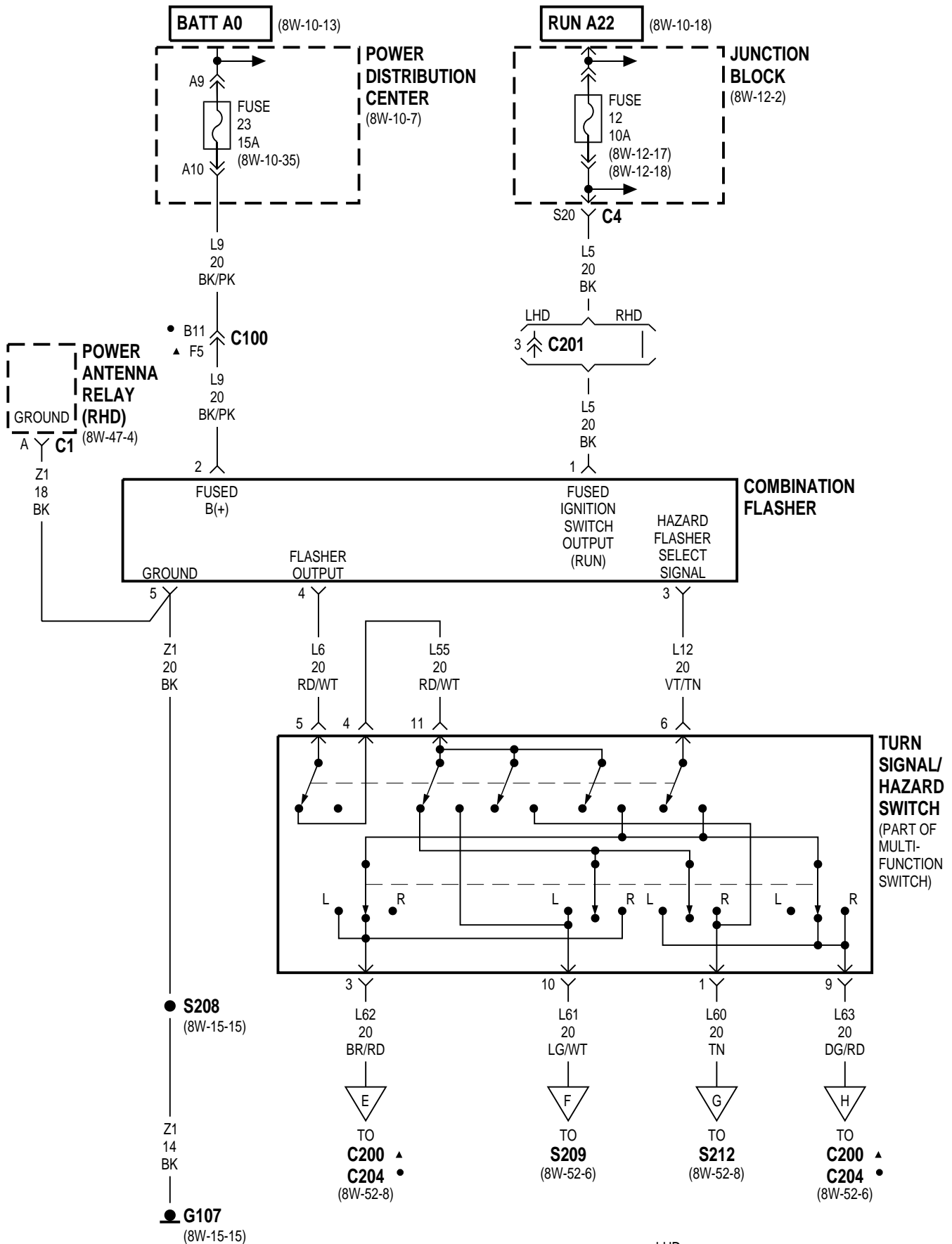

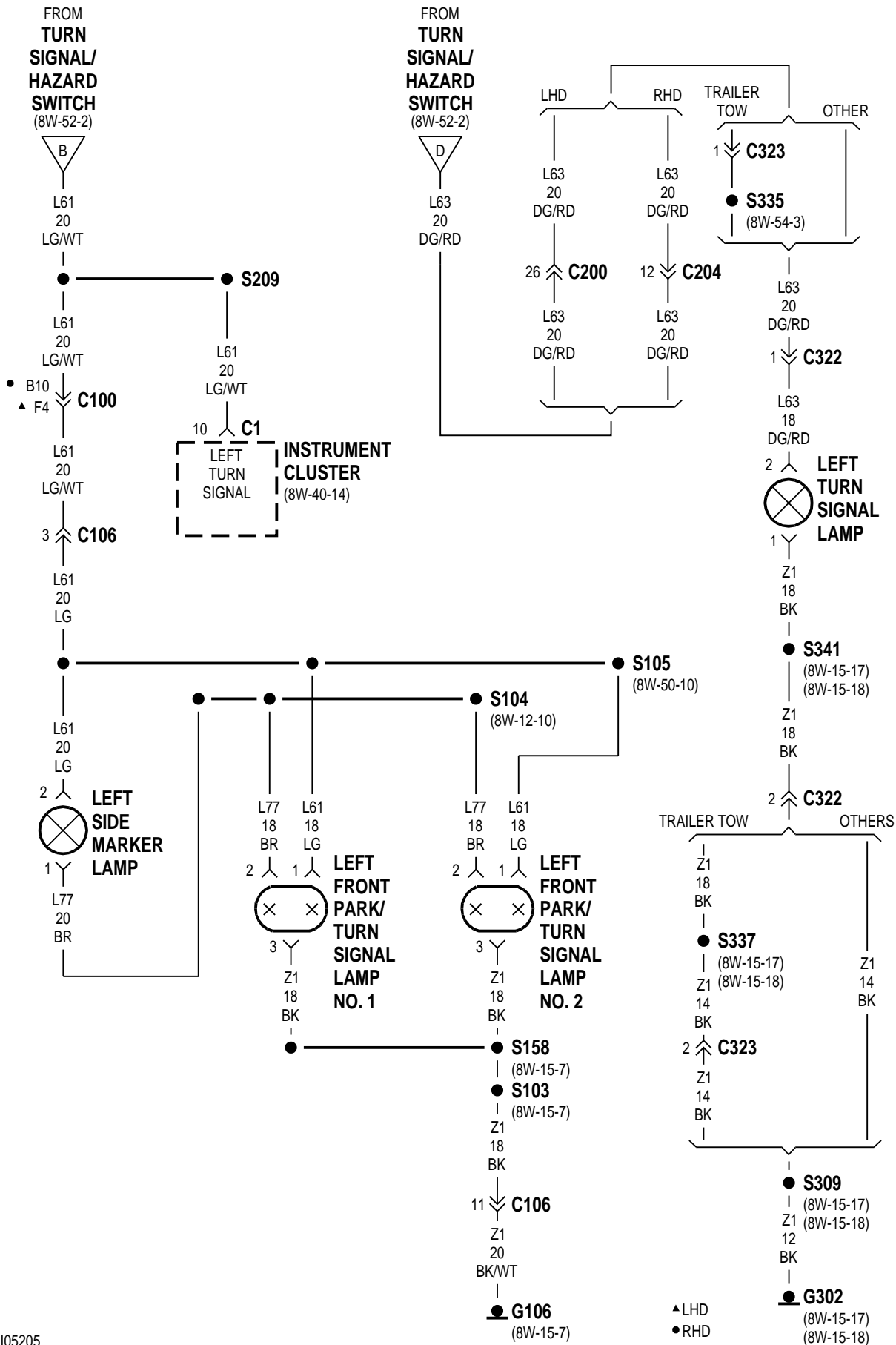

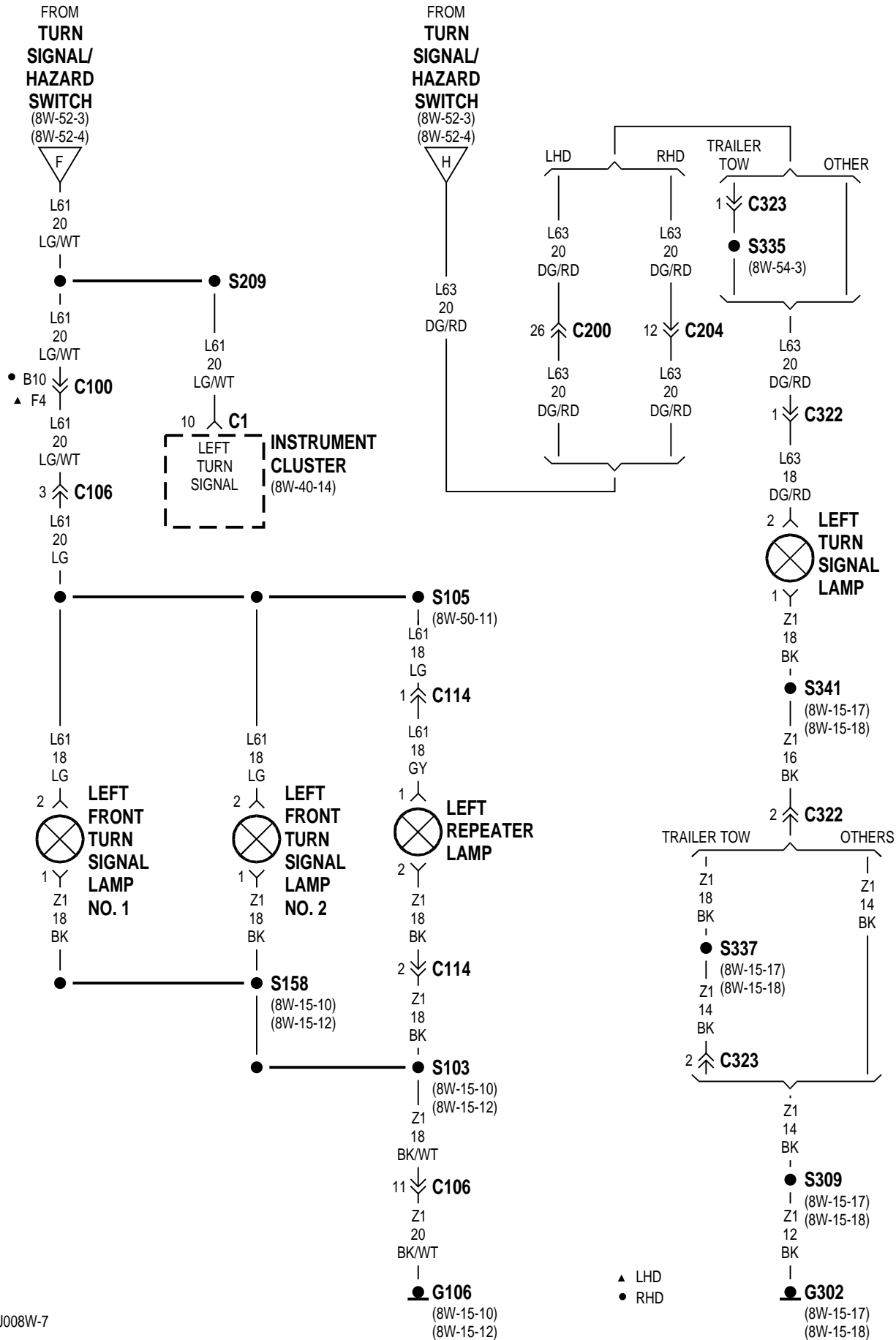

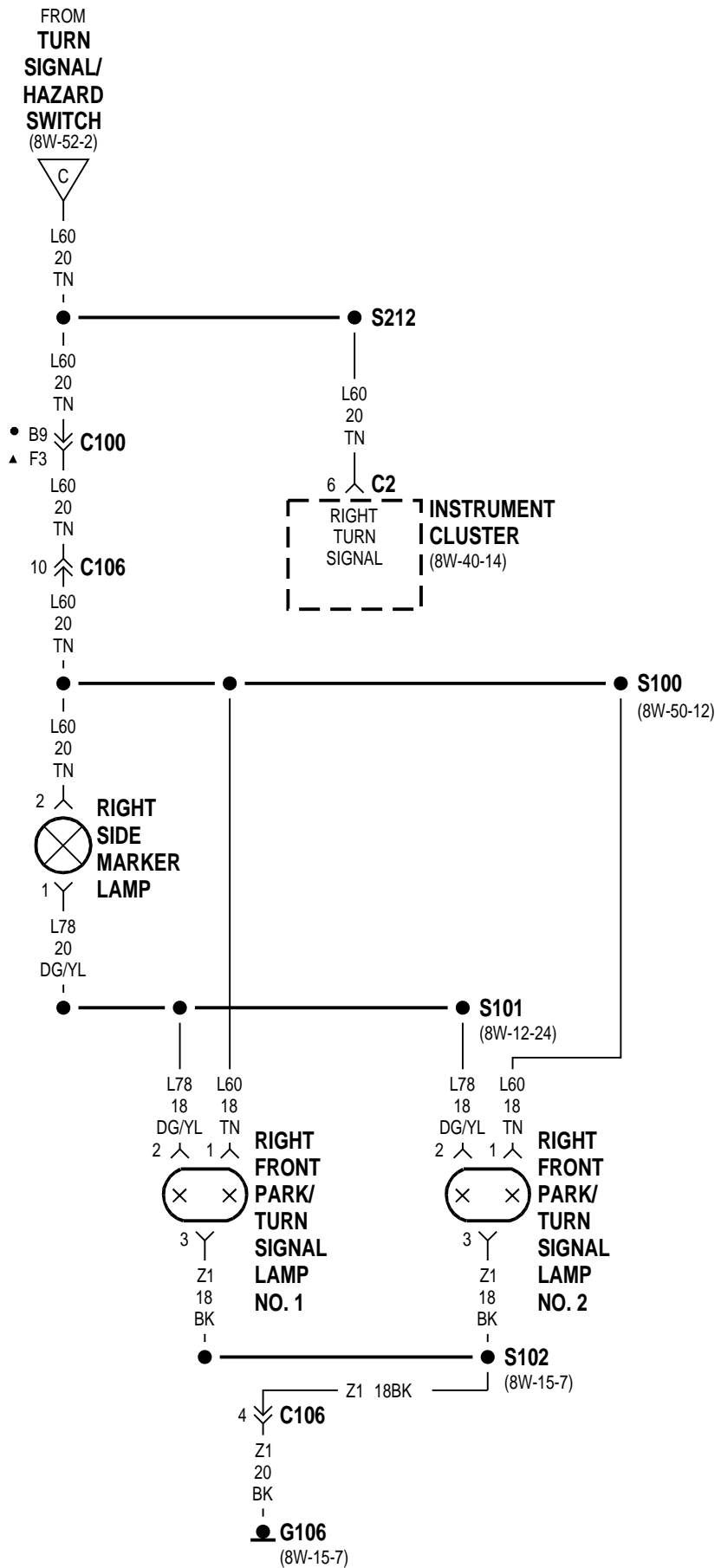
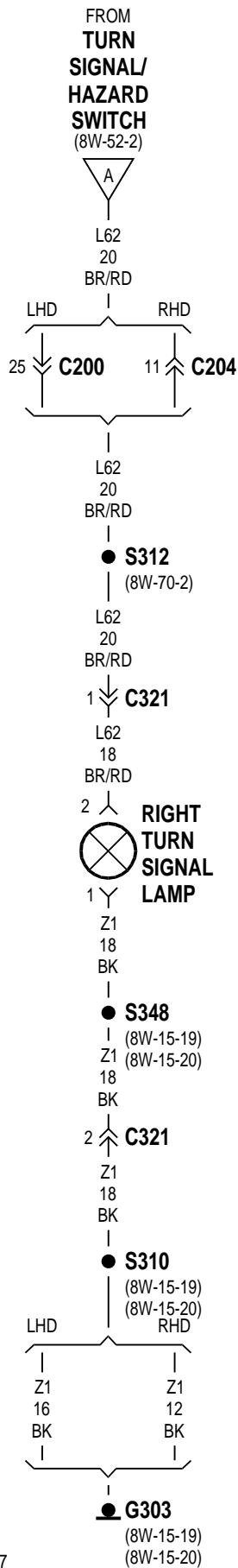

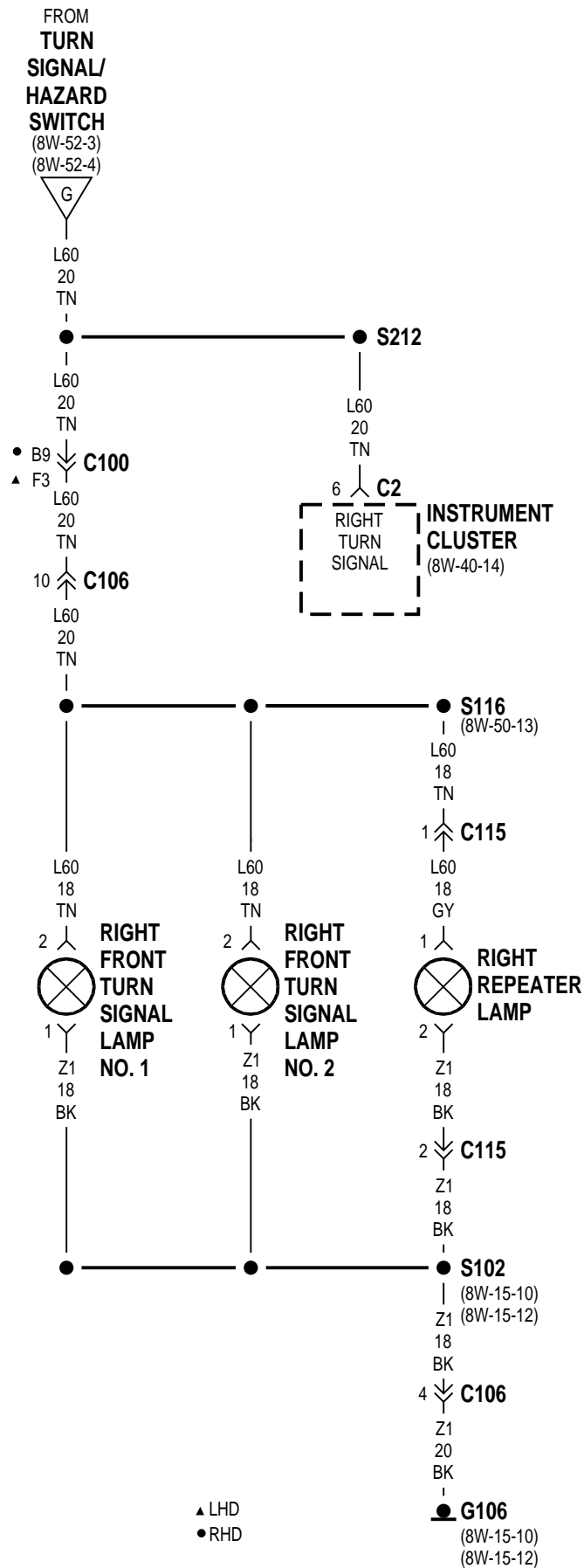
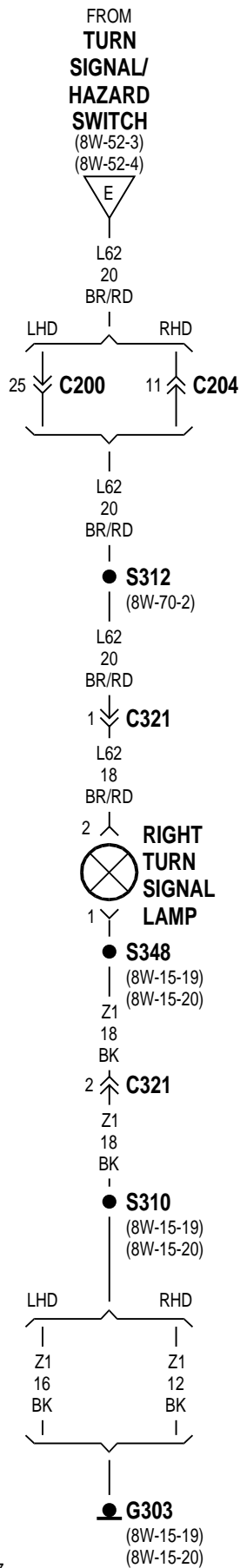

8W-53 WIPERS

| Component | Page | Component | Page |
|-------------------------------|------------------------|--------------------------------|------------------------|
| A/C- Heater Control | 8W-53-6, 7 | Headlamp Switch | 8W-53-4, 5, 6, 7 |
| Circuit Breaker 30 (JB) | 8W-53-2, 3 | Junction Block | 8W-53-2, 3, 4, 5, 6, 7 |
| Front Wiper Motor | 8W-53-2, 3 | Rear Washer Pump | 8W-53-2, 4, 5, 6, 7 |
| Fuse 6 (JB) | 8W-53-4, 5, 6, 7 | Rear Wiper Motor | 8W-53-4, 5, 6, 7 |
| Fuse 22 (JB) | 8W-53-4, 5, 6, 7 | Rear Wiper/Washer Switch | 8W-53-4, 5, 6, 7 |
| G106 | 8W-53-2, 3, 4, 5, 6, 7 | Windshield Washer Pump | 8W-53-2, 3, 4, 6 |
| G107 | 8W-53-4, 5, 6, 7 | Wipe/Wash Switch | 8W-53-2, 3 |
| G108 | 8W-53-2, 3 | Wiper Motor Relay | 8W-53-2, 3 |
| G304 | 8W-53-4, 5, 6, 7 | | |

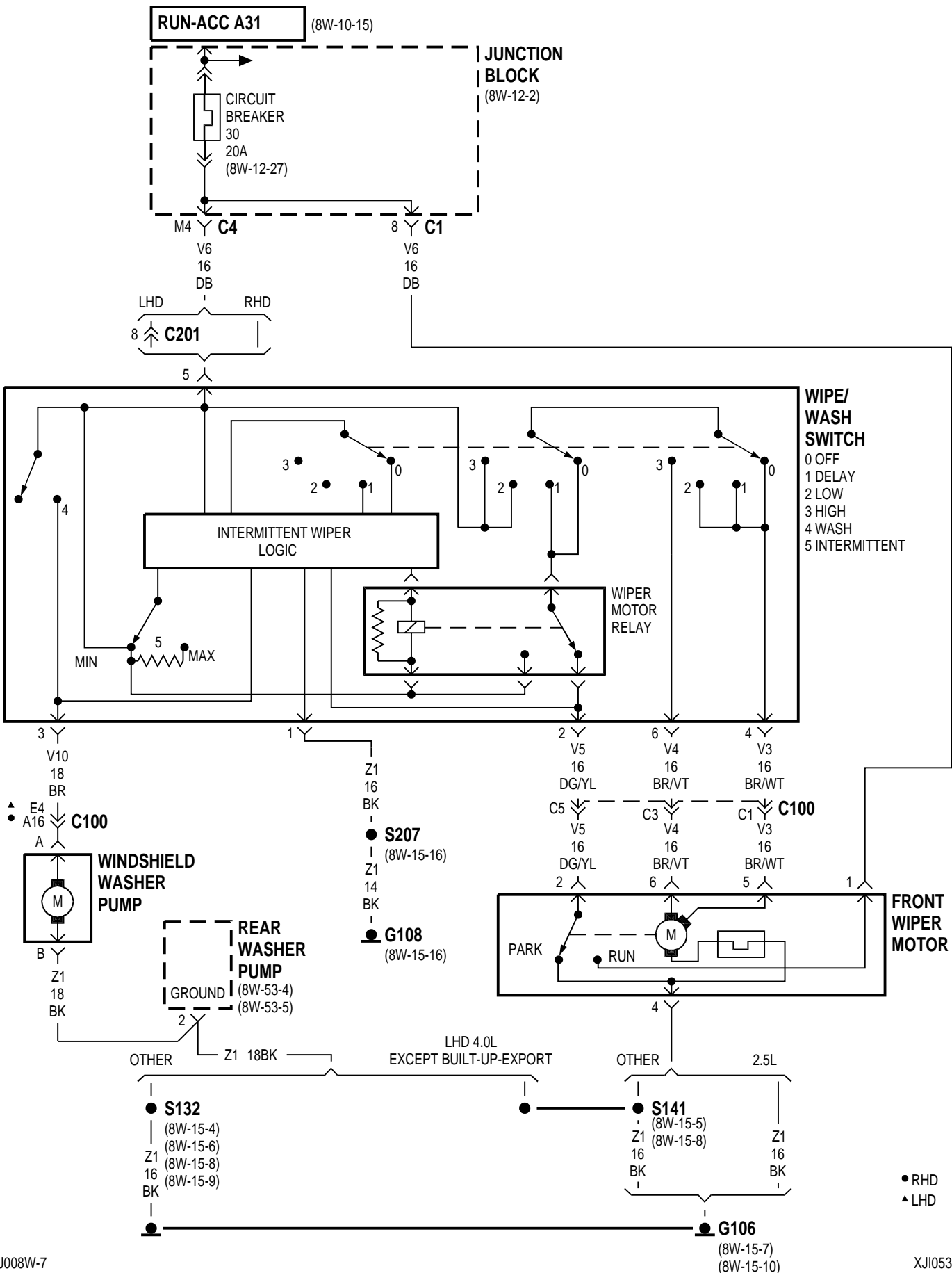

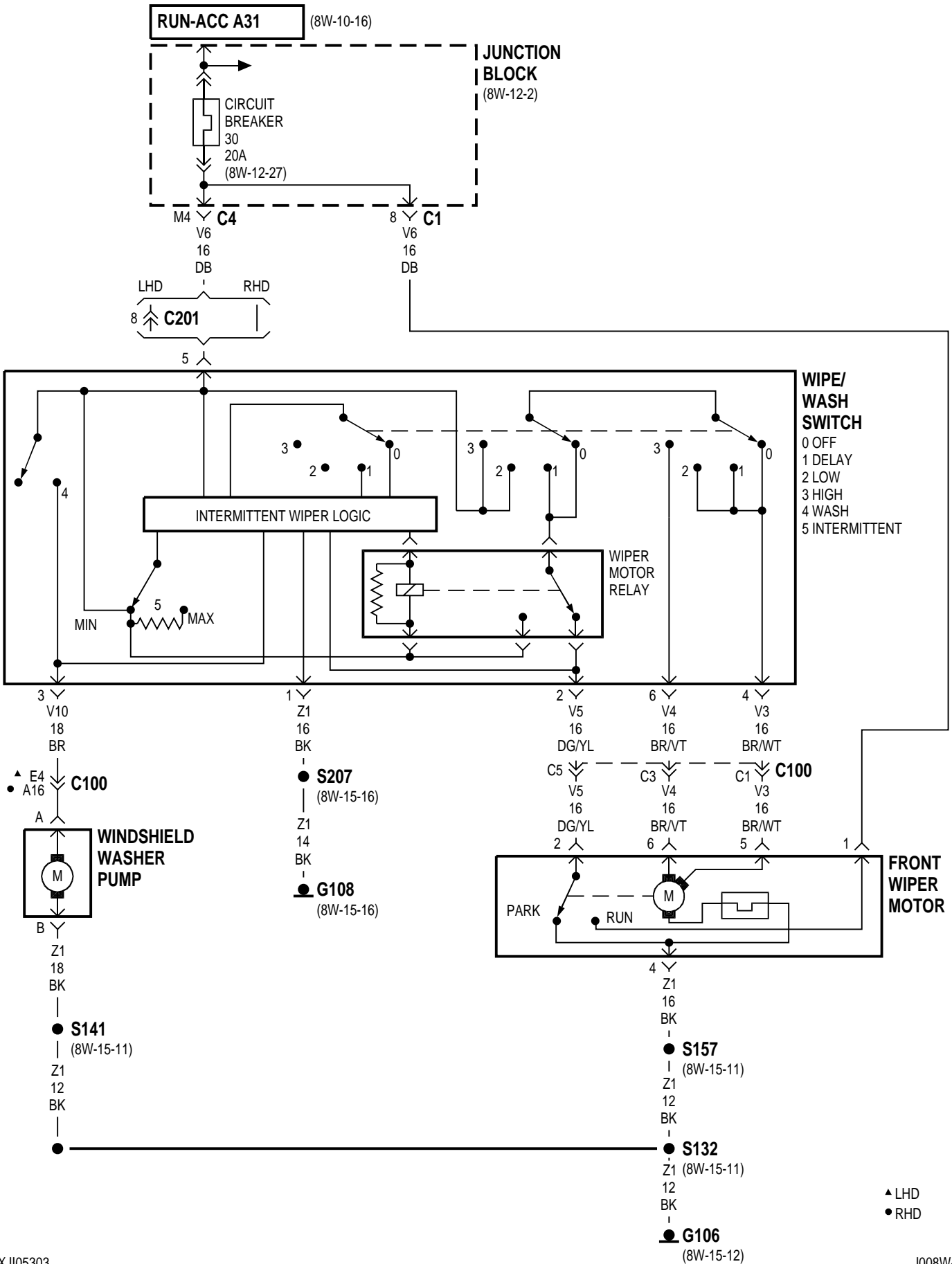

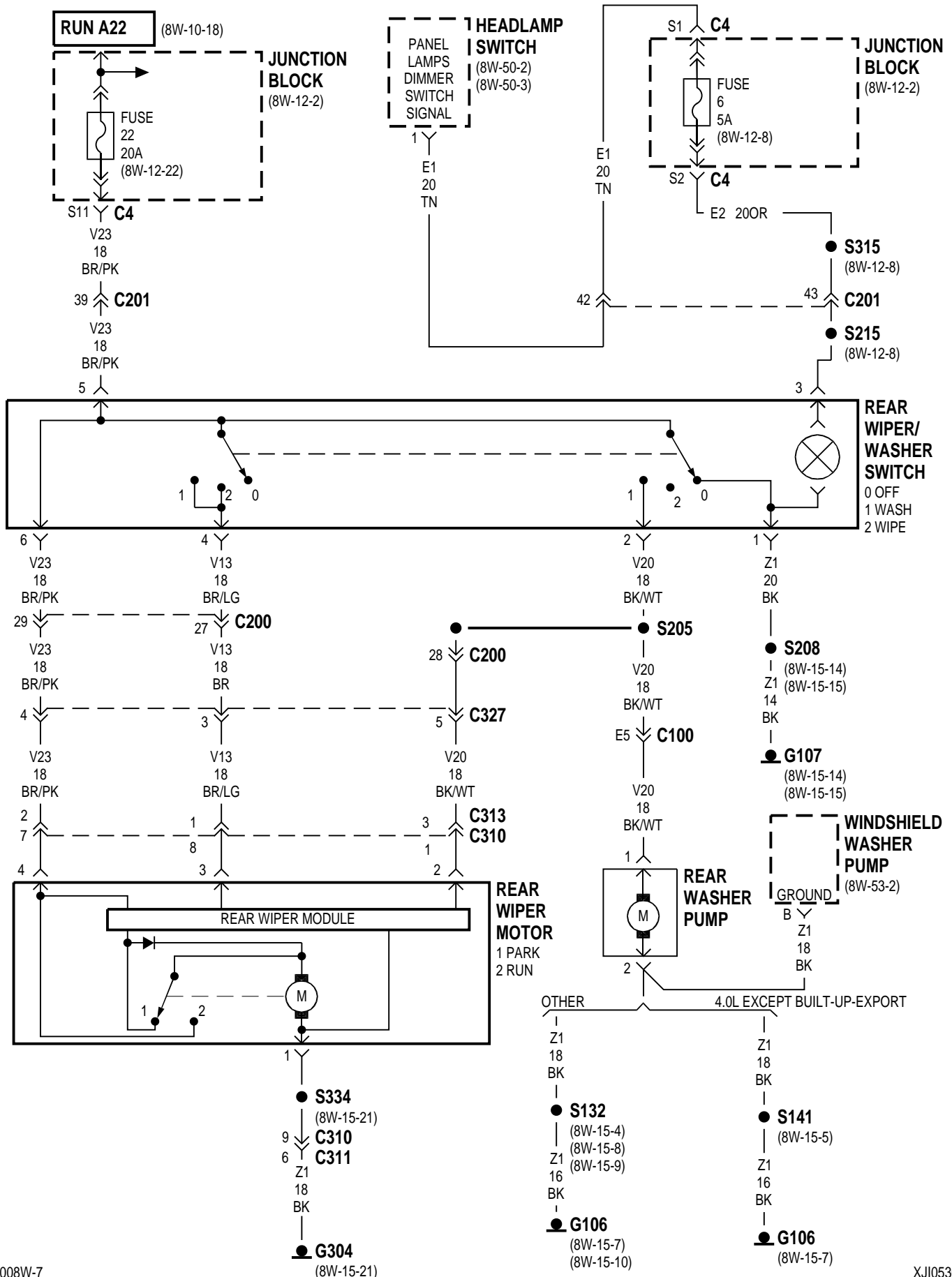

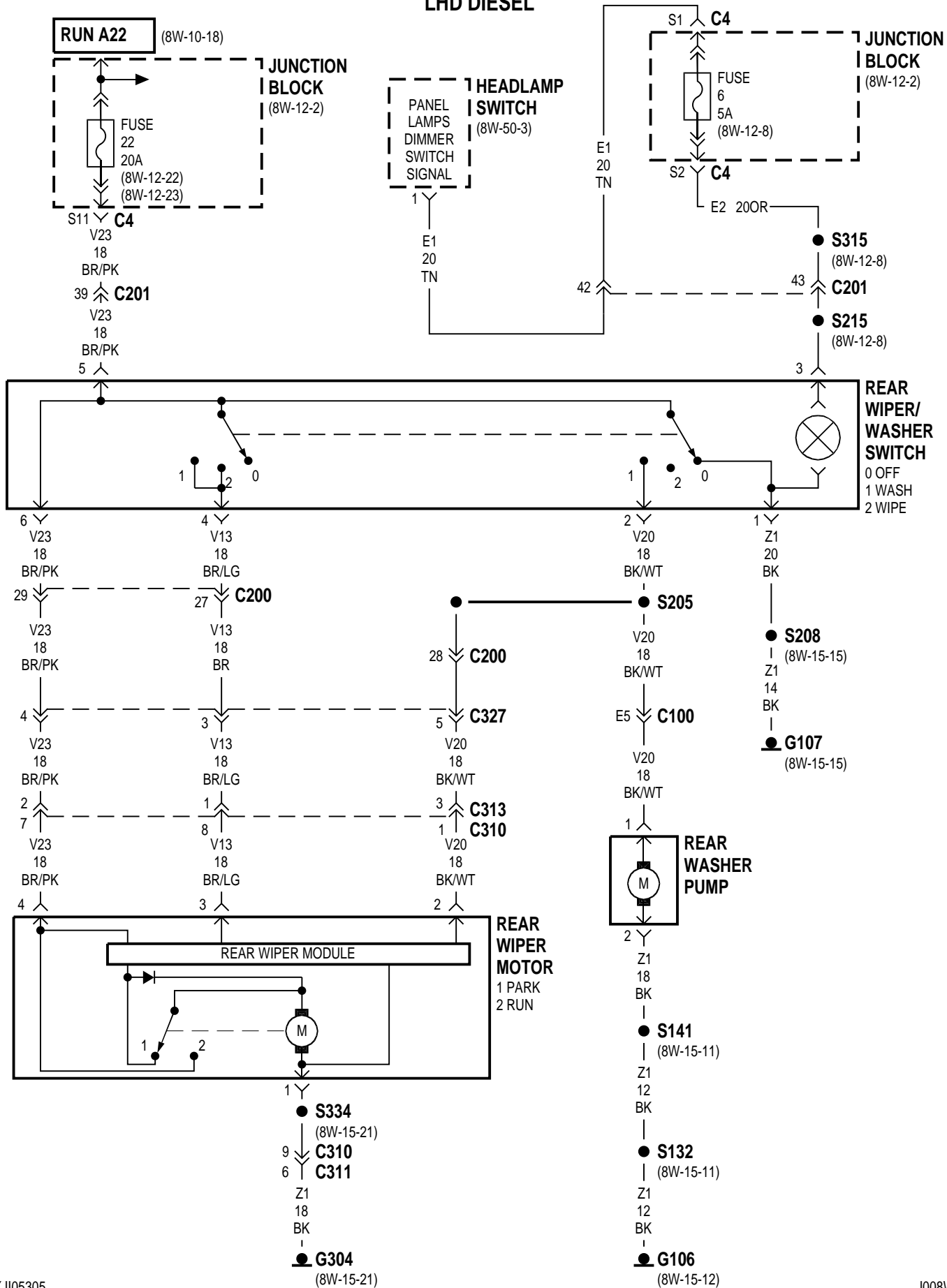

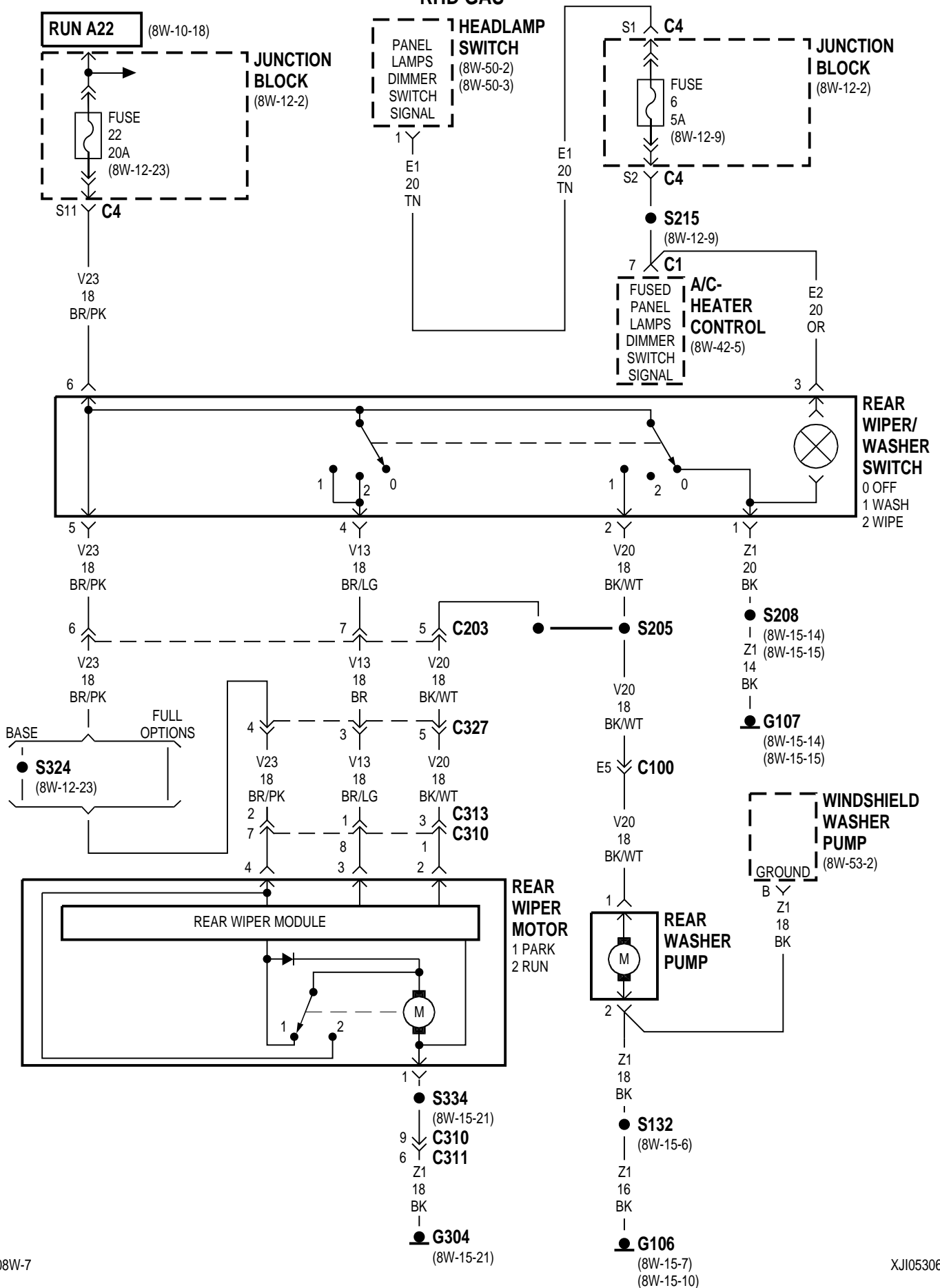

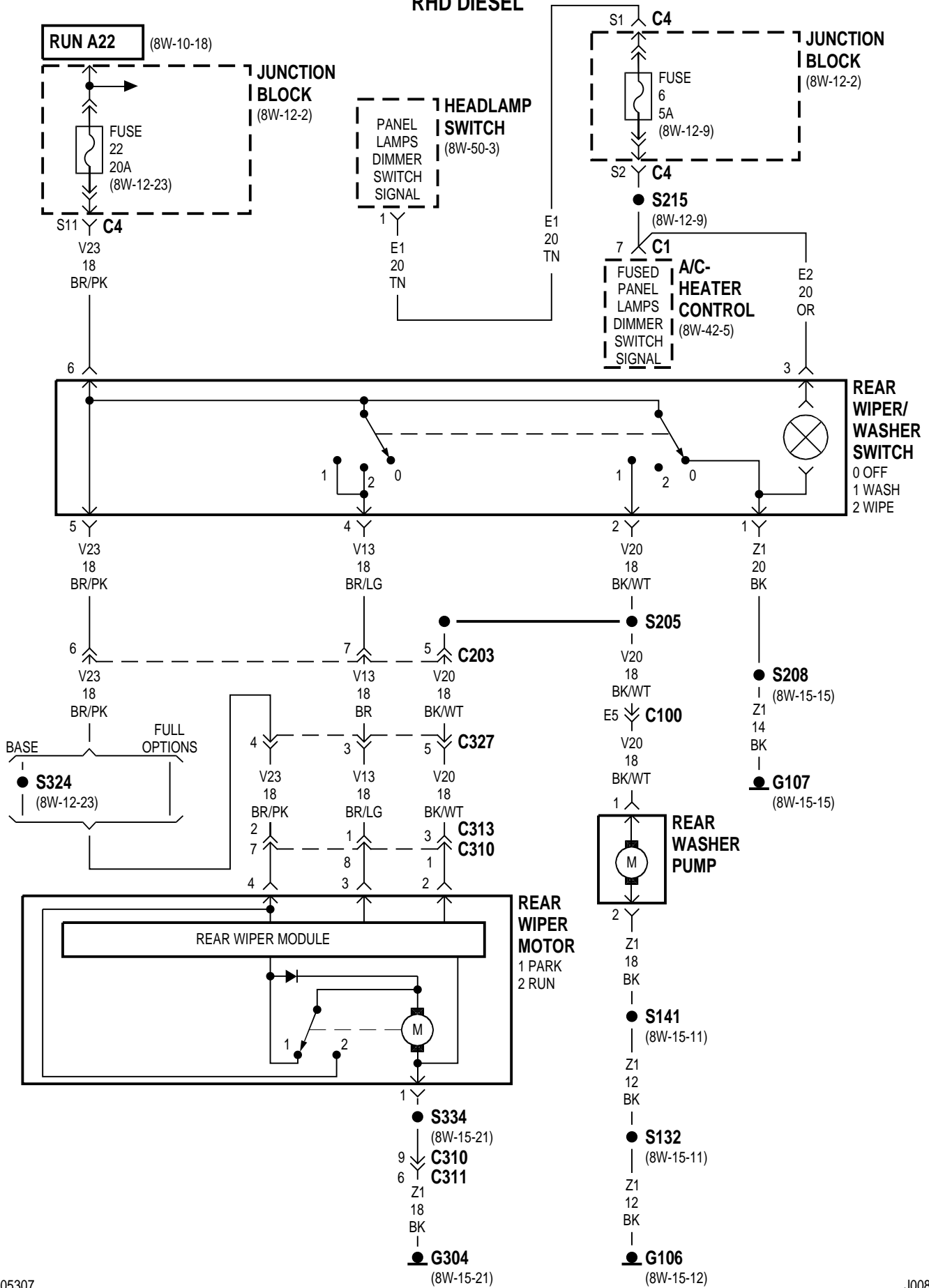

8W-54 TRAILER TOW

| Component | Page | Component | Page |
|-------------------------|-------------|--|-------------|
| Brake Lamp Switch | 8W-54-3 | Left Tail/Stop Lamp | 8W-54-3 |
| Fuse 7 (JB) | 8W-54-2 | Left Turn Signal Lamp | 8W-54-3 |
| Fuse 20 (JB) | 8W-54-3 | Trailer Tow Connector | 8W-54-2, 3 |
| G302 | 8W-54-2 | Trailer Tow Electric Brake Provision | 8W-54-2 |
| Headlamp Switch | 8W-54-2 | Trailer Tow Left Turn Relay | 8W-54-3 |
| Junction Block | 8W-54-2, 3 | Trailer Tow Right Turn Relay | 8W-54-3 |
| Left Back-Up Lamp | 8W-54-2 | Turn Signal/Hazard Switch..... | 8W-54-3 |

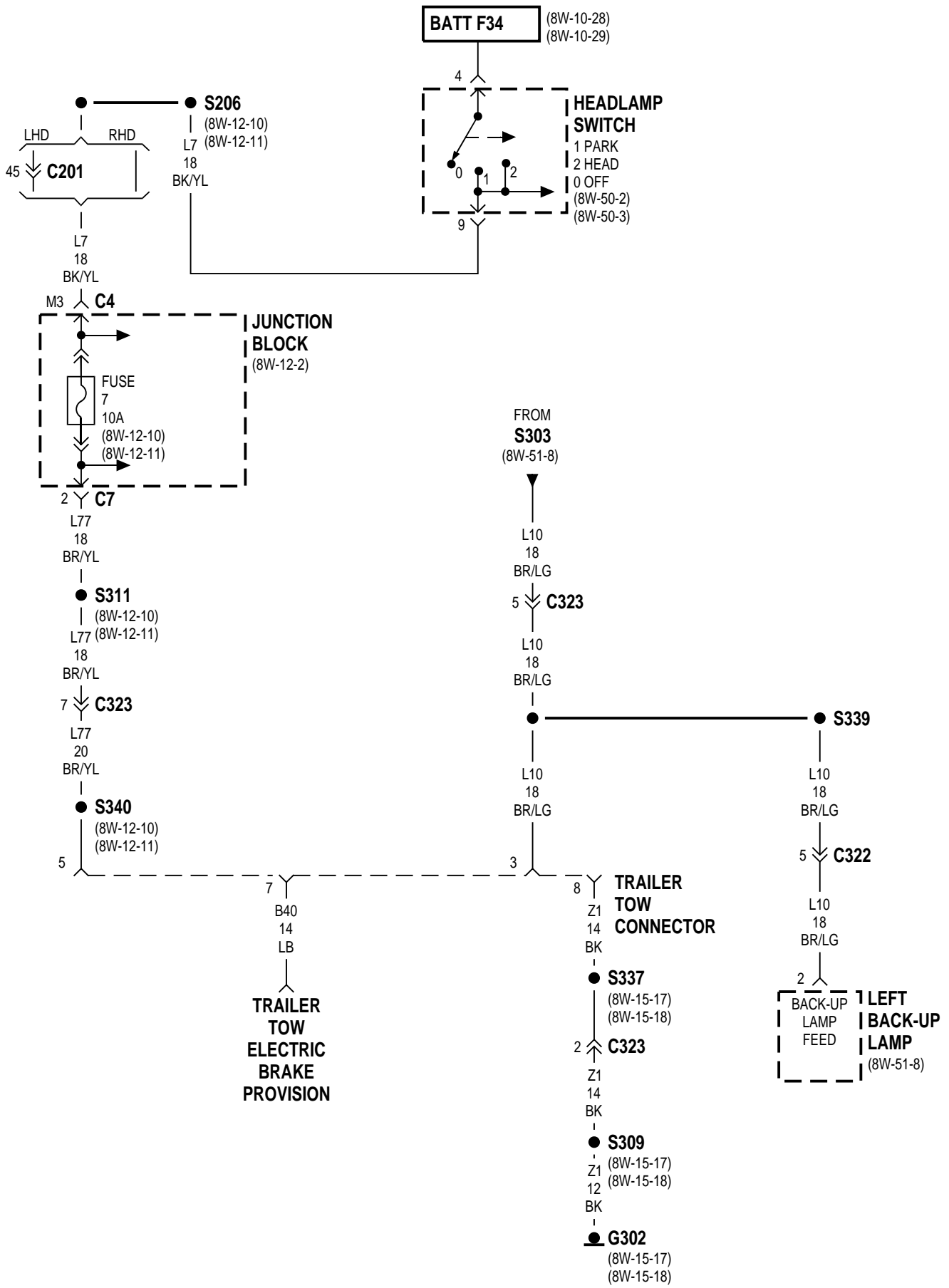

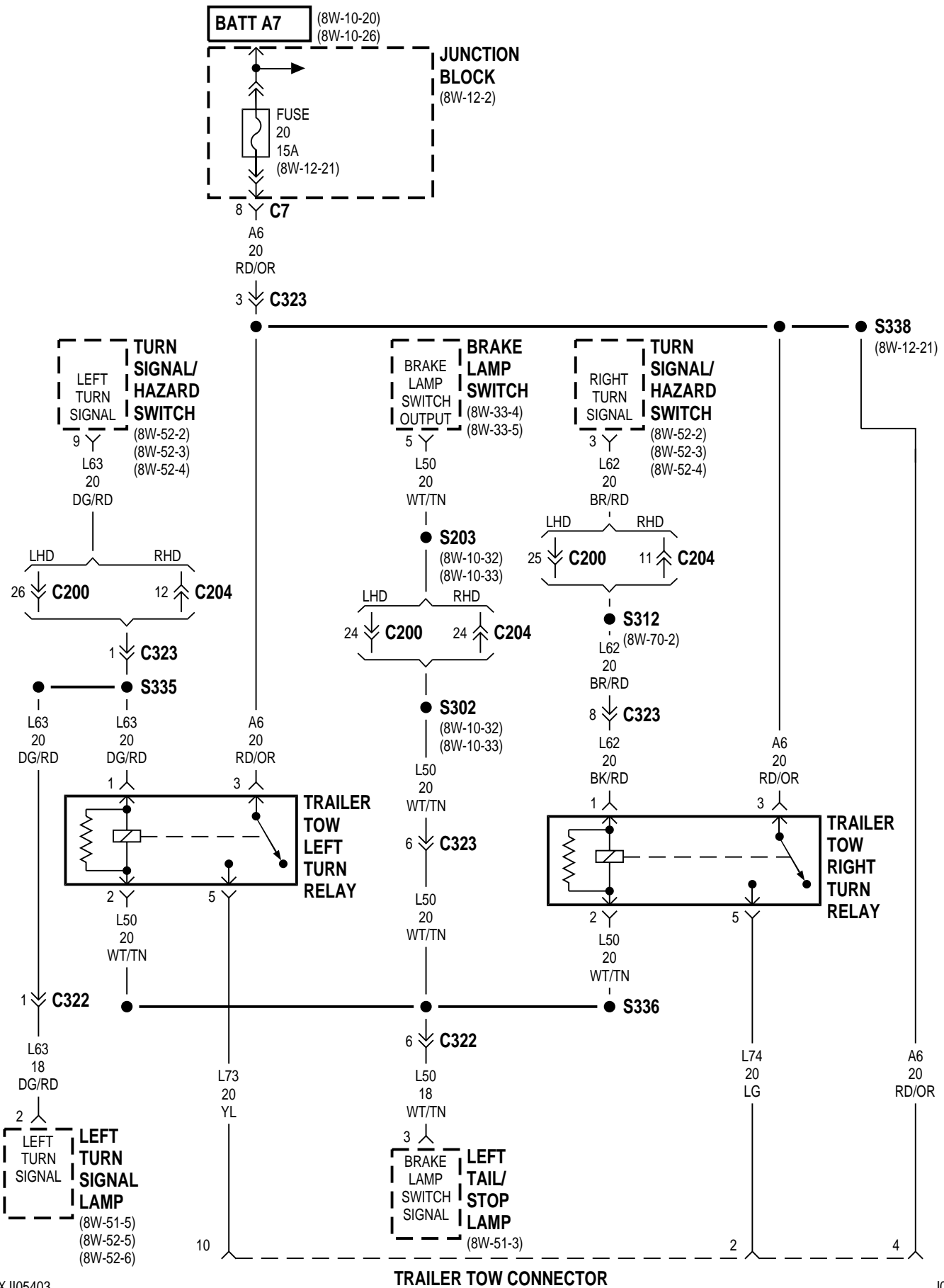

8W-60 POWER WINDOWS

| Component | Page | Component | Page |
|---|------------------|--|------------------|
| Circuit Breaker 28 (JB) | 8W-60-2, 3 | Left Rear Window Motor | 8W-60-4, 5 |
| Driver Power Lock/Window Switch | 8W-60-2, 3, 4, 5 | Left Rear Window Switch | 8W-60-2, 3, 4, 5 |
| Driver Power Window Motor | 8W-60-2, 3 | Passenger Power Lock/Window Switch | 8W-60-2, 3 |
| G302 | 8W-60-2, 4 | Passenger Power Window Motor | 8W-60-2, 3 |
| G303 | 8W-60-3, 5 | Right Rear Window Motor | 8W-60-4, 5 |
| Junction Block | 8W-60-2, 3 | Right Rear Window Switch | 8W-60-2, 3, 4, 5 |

LHD

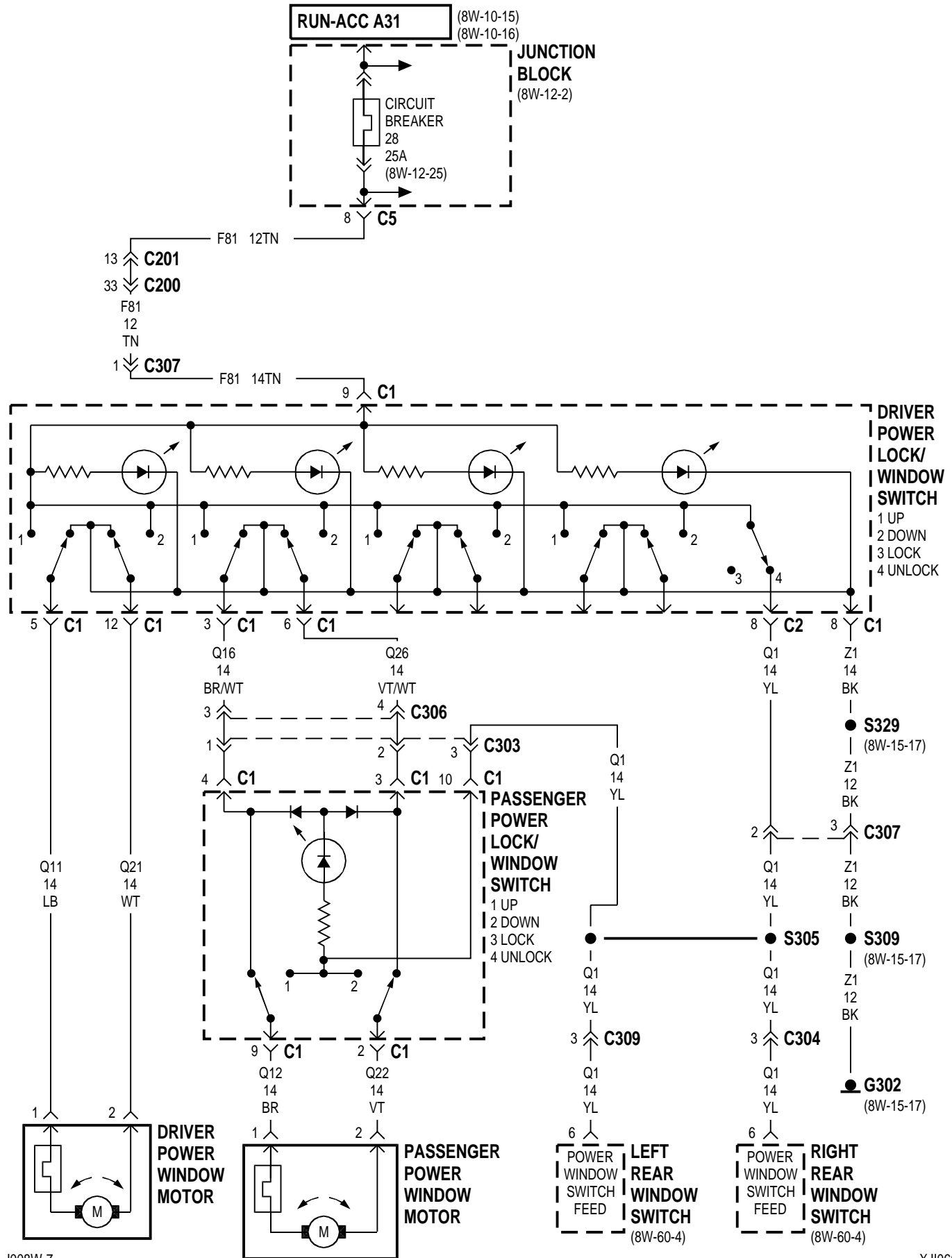

RHD

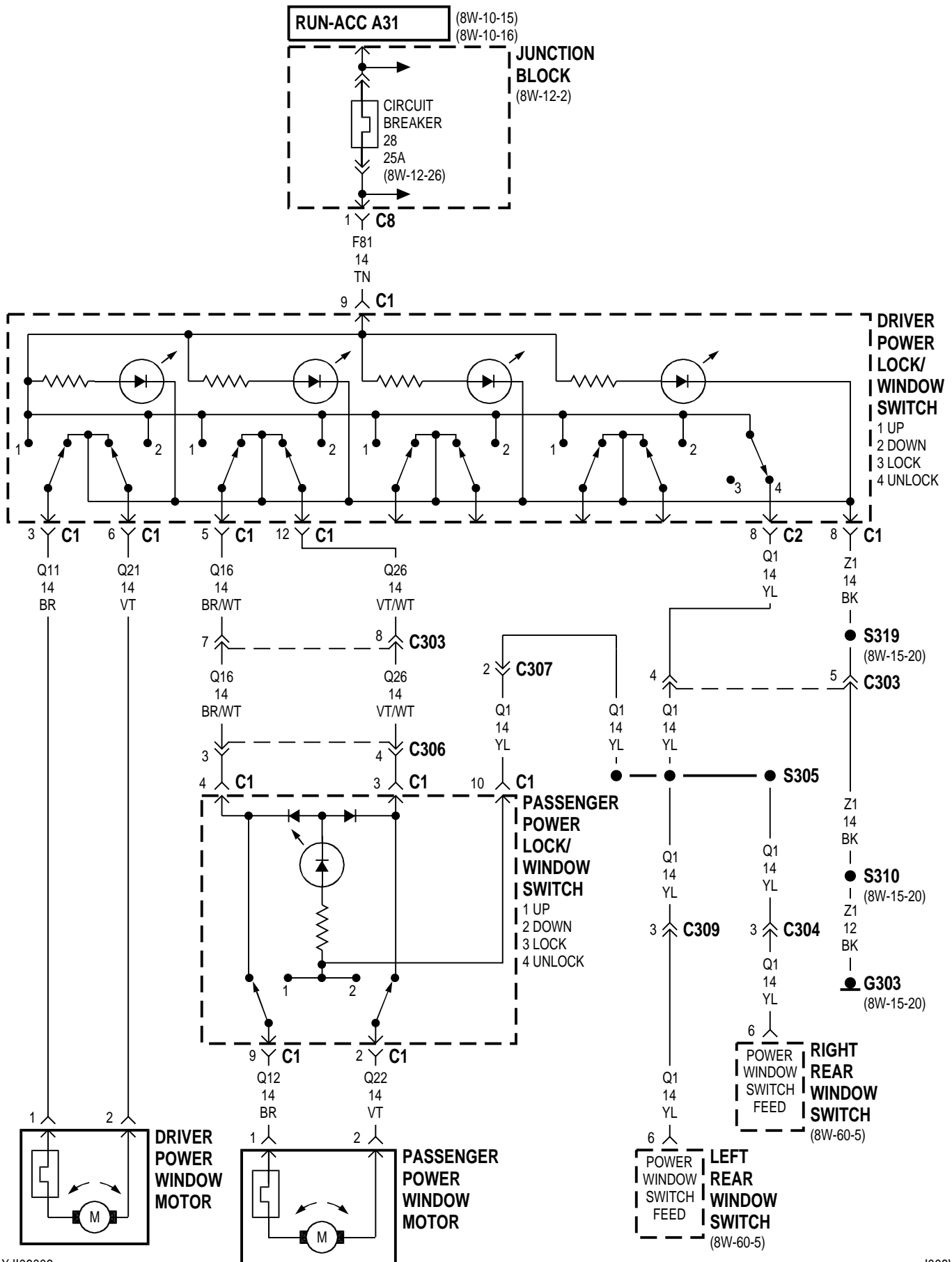

LHD

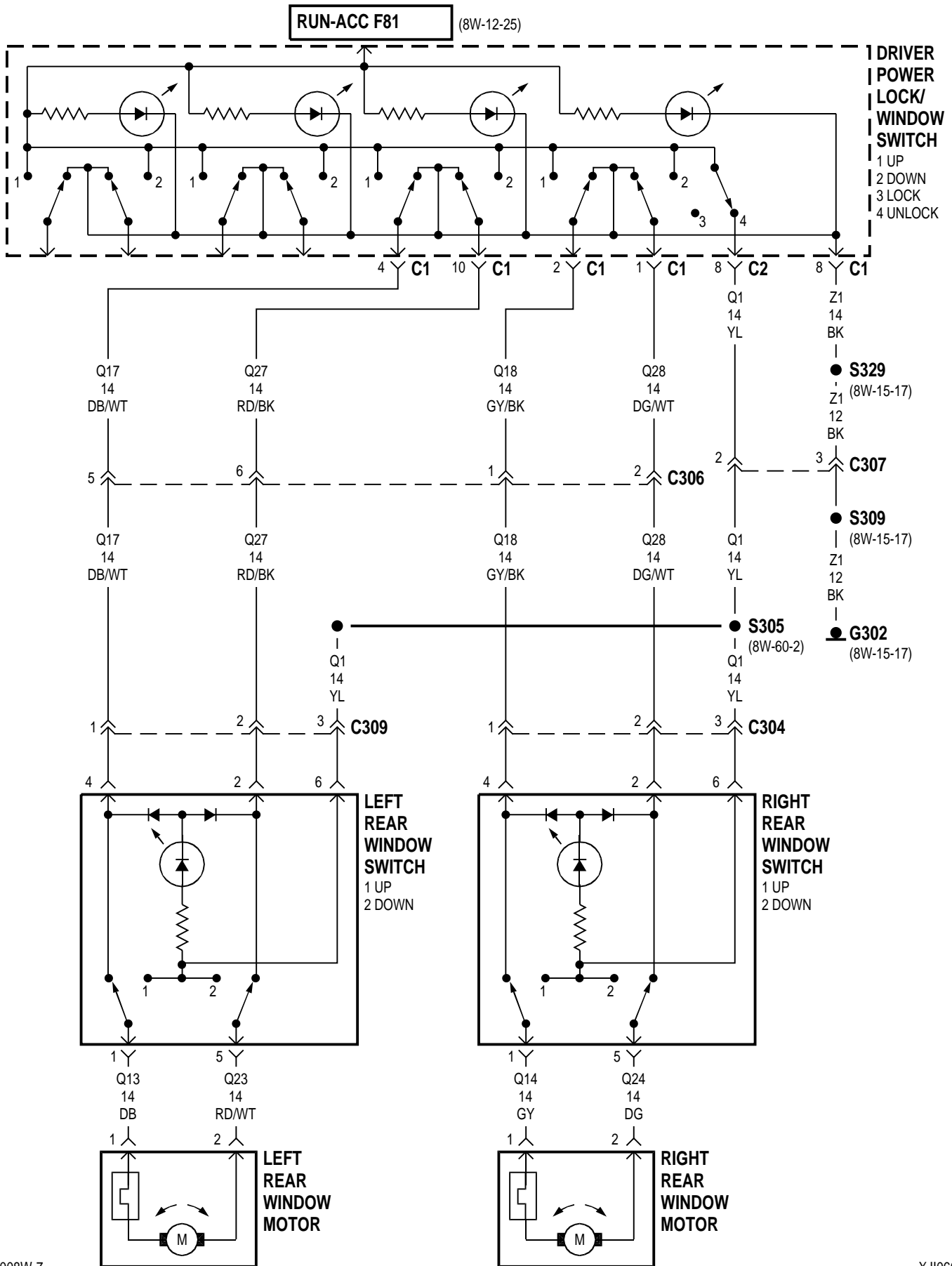

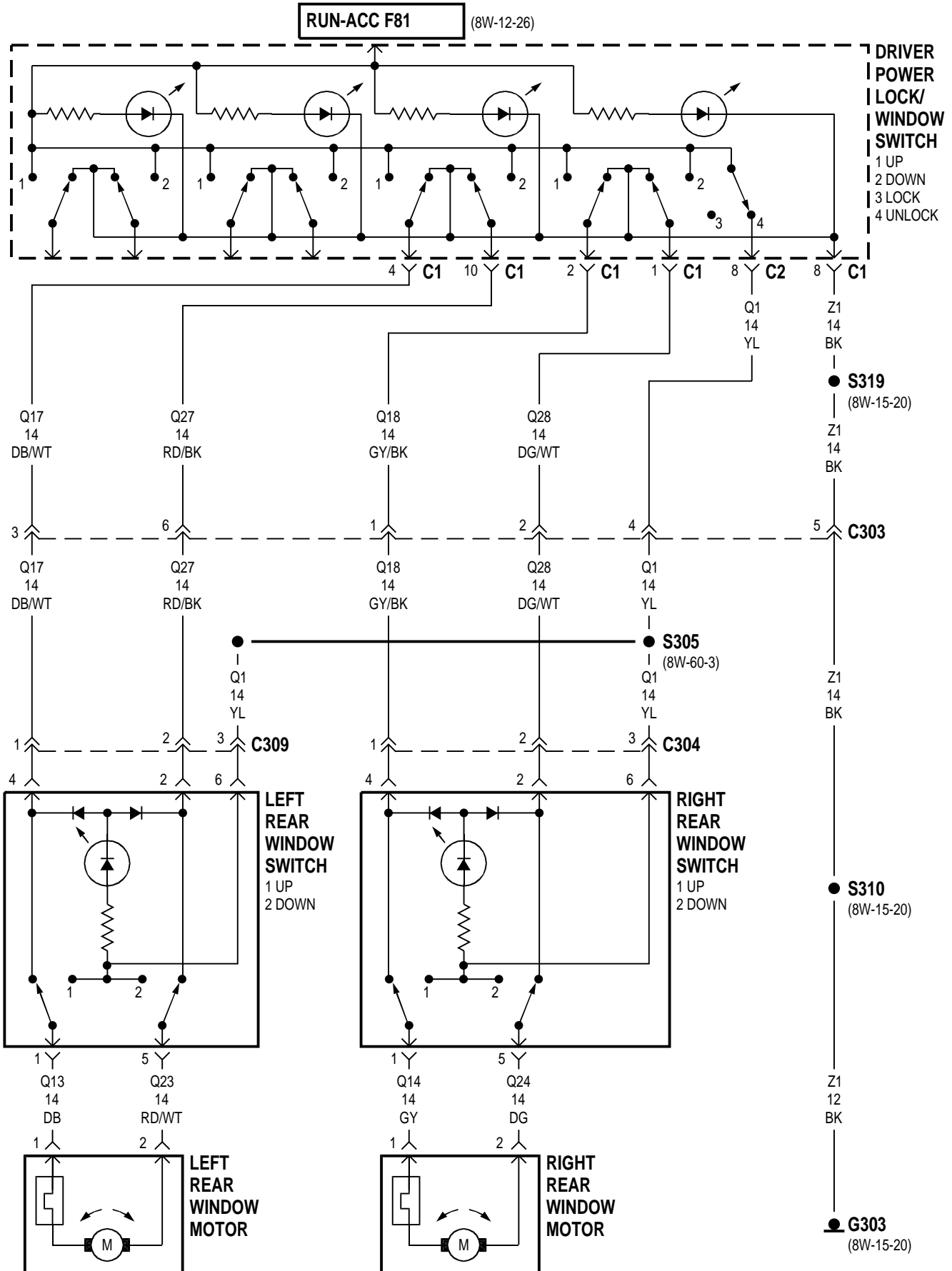

8W-61 POWER DOOR LOCKS

| Component | Page | Component | Page |
|---------------------------------------|-------------|----------------------------------|------------------|
| Circuit Breaker 28 (JB) | 8W-61-2, 3 | Junction Block | 8W-61-2, 3, 4, 5 |
| Driver Door Lock Motor | 8W-61-4, 5 | Left Rear Door Lock Motor | 8W-61-4, 5 |
| Driver Power Lock/Window Switch | 8W-61-2, 3 | Liftgate Lock Motor | 8W-61-4, 5 |
| Fuse 15 (JB) | 8W-61-2, 3 | Overhead Module | 8W-61-2, 3 |
| G107 | 8W-61-2 | Passenger Door Lock Motor | 8W-61-4, 5 |
| G302 | 8W-61-2, 3 | Passenger Power Lock/Window | |
| G303 | 8W-61-3 | Switch | 8W-61-2, 3, 4, 5 |
| Ignition Switch | 8W-61-2, 3 | Right Rear Door Lock Motor | 8W-61-4, 5 |

LHD

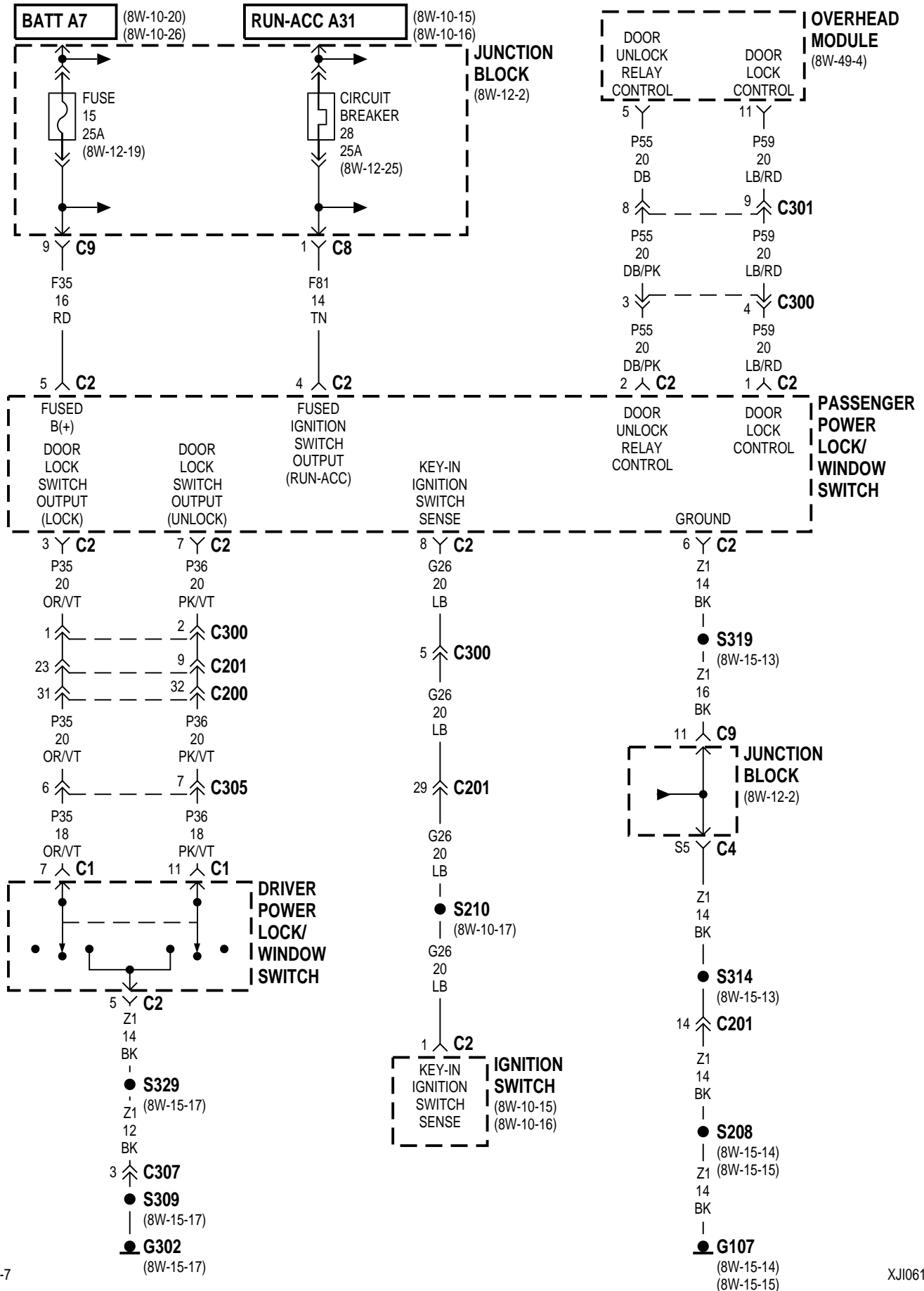

RHD

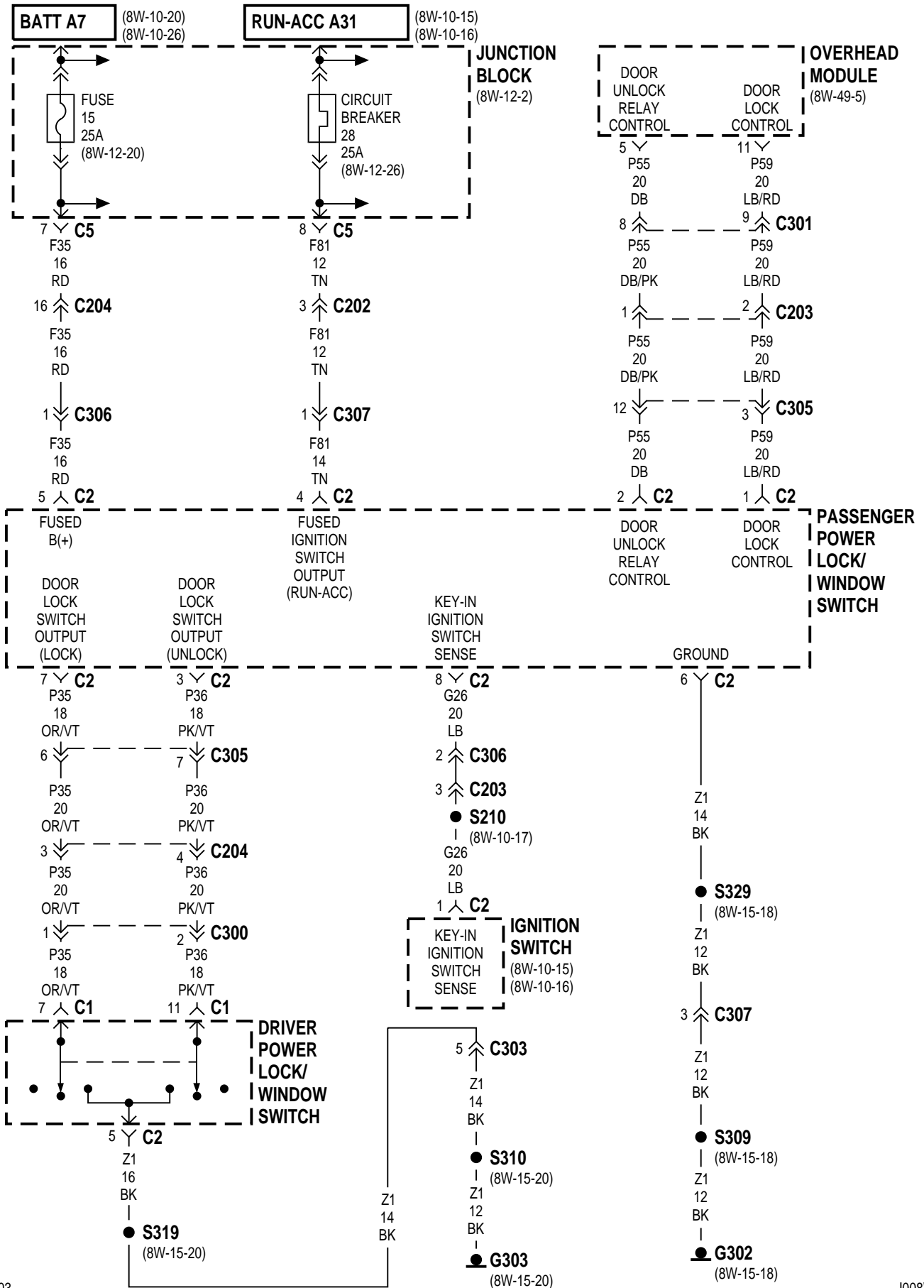

LHD

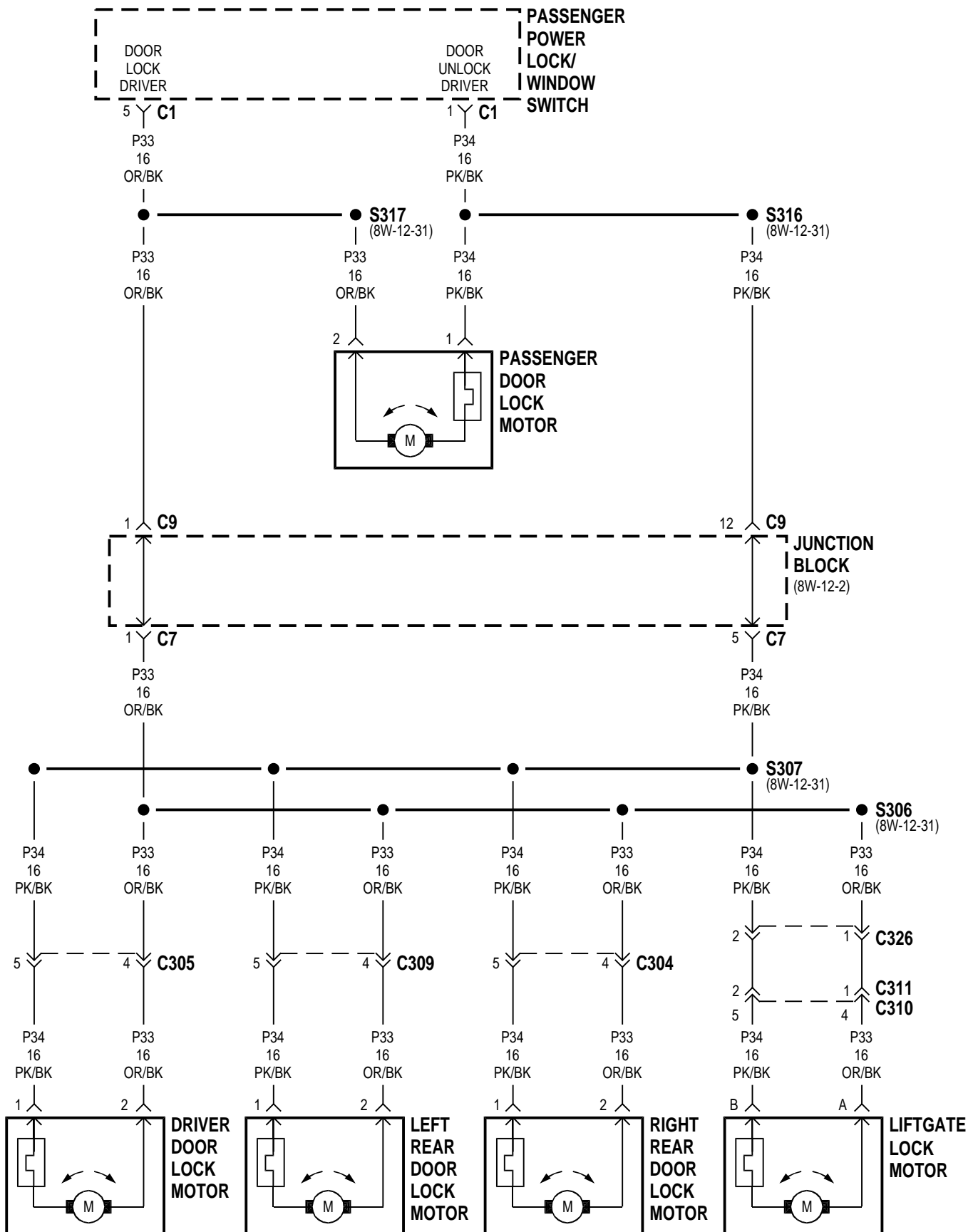

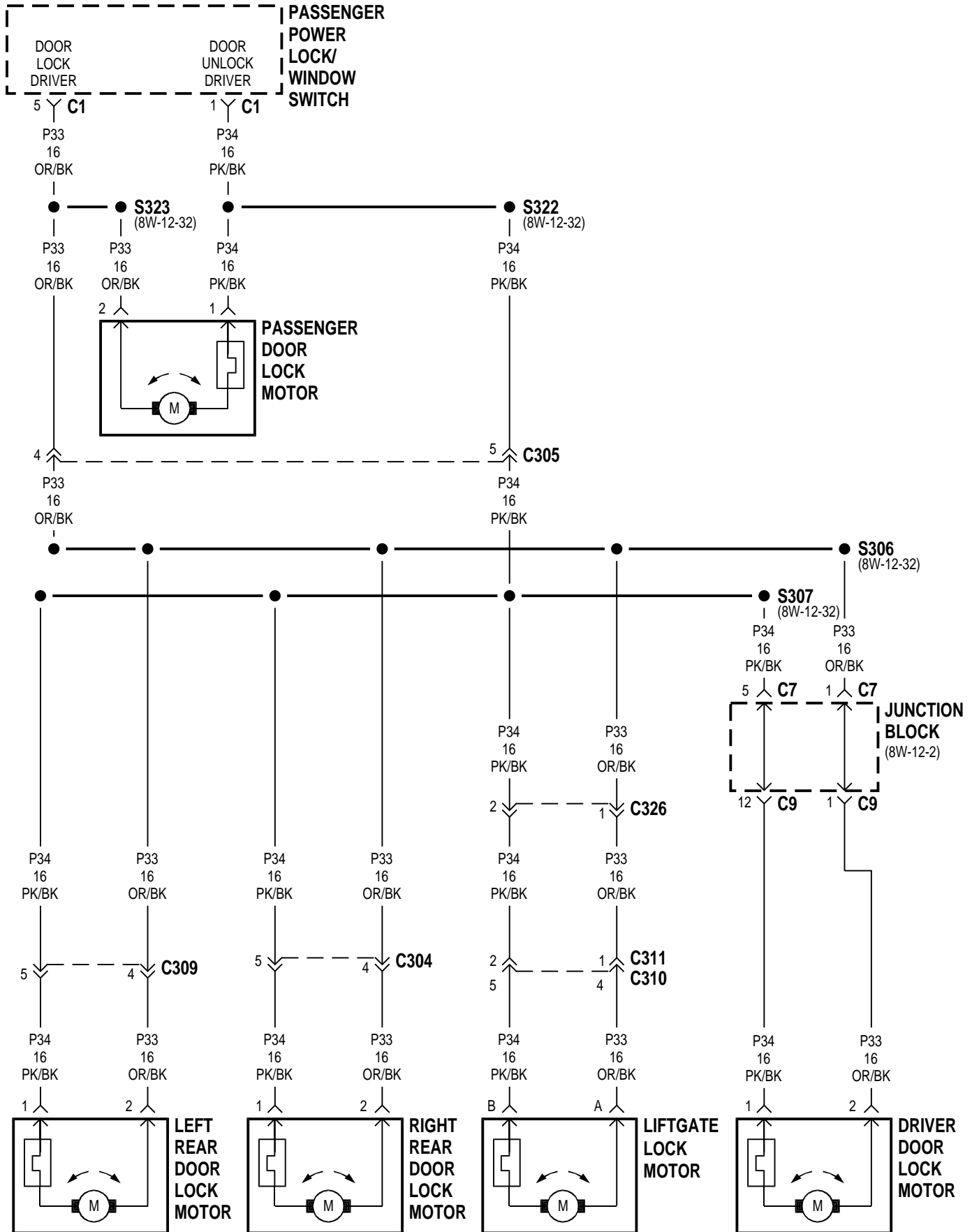

8W-62 POWER MIRRORS

| Component | Page | Component | Page |
|---------------------------|---------------------------|------------------------------|---------------------------|
| Driver Power Lock/Window | | G303 | 8W-62-5, 6 |
| Switch | 8W-62-2, 3, 4, 5, 6 | Junction Block | 8W-62-2, 3, 4, 5, 6, 7, 8 |
| Driver Power Mirror | 8W-62-2, 3, 4, 5, 6, 7, 8 | Passenger Power Mirror | 8W-62-4, 6, 7, 8 |
| Fuse 18 (JB) | 8W-62-2, 3, 5 | Power Mirror Switch | 8W-62-7, 8 |
| G107 | 8W-62-8 | Rear Fog Lamp Relay | 8W-62-3 |
| G302 | 8W-62-2, 3, 4, 7 | | |

LHD EXCEPT BUILT-UP-EXPORT FULL OPTIONS

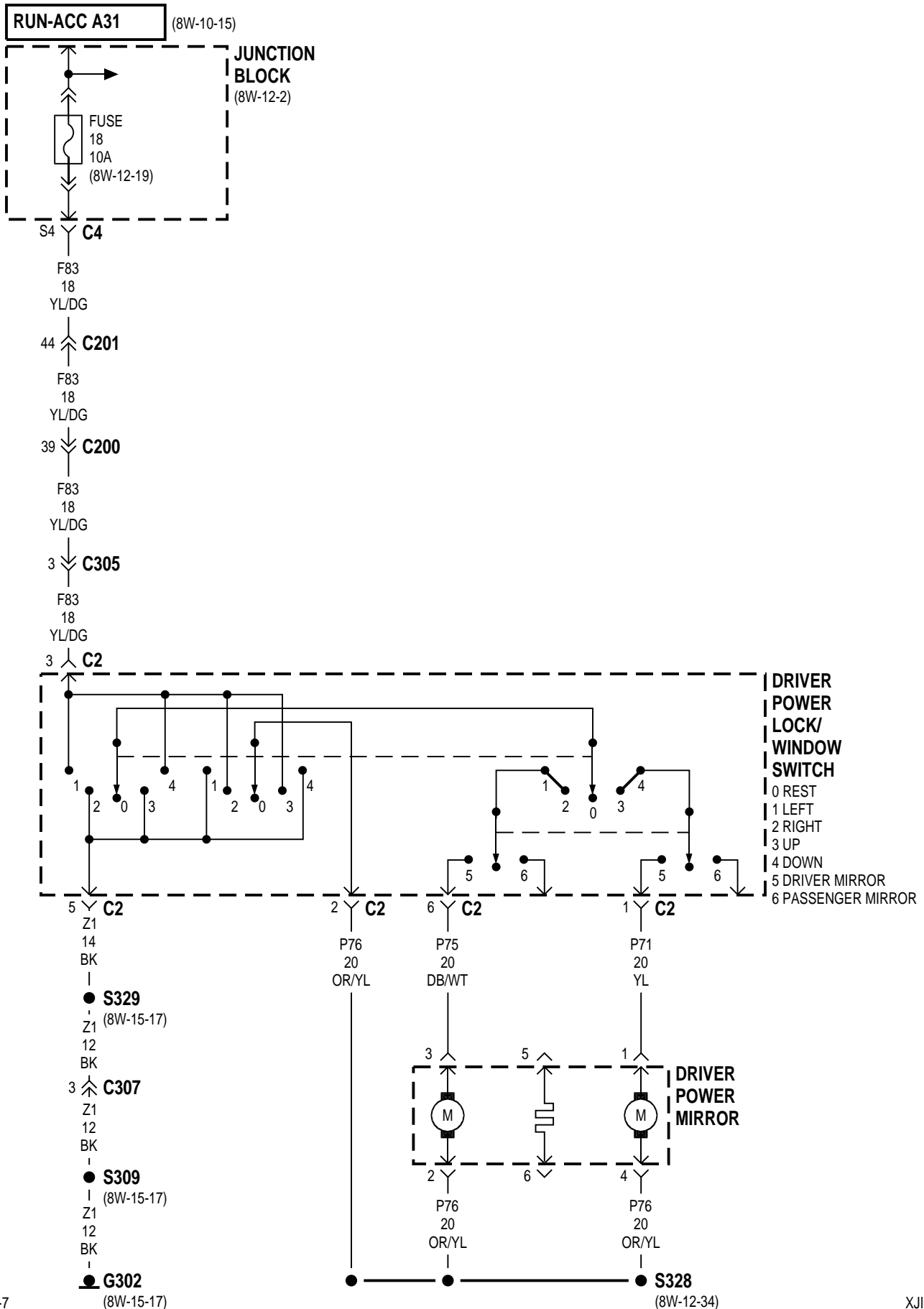

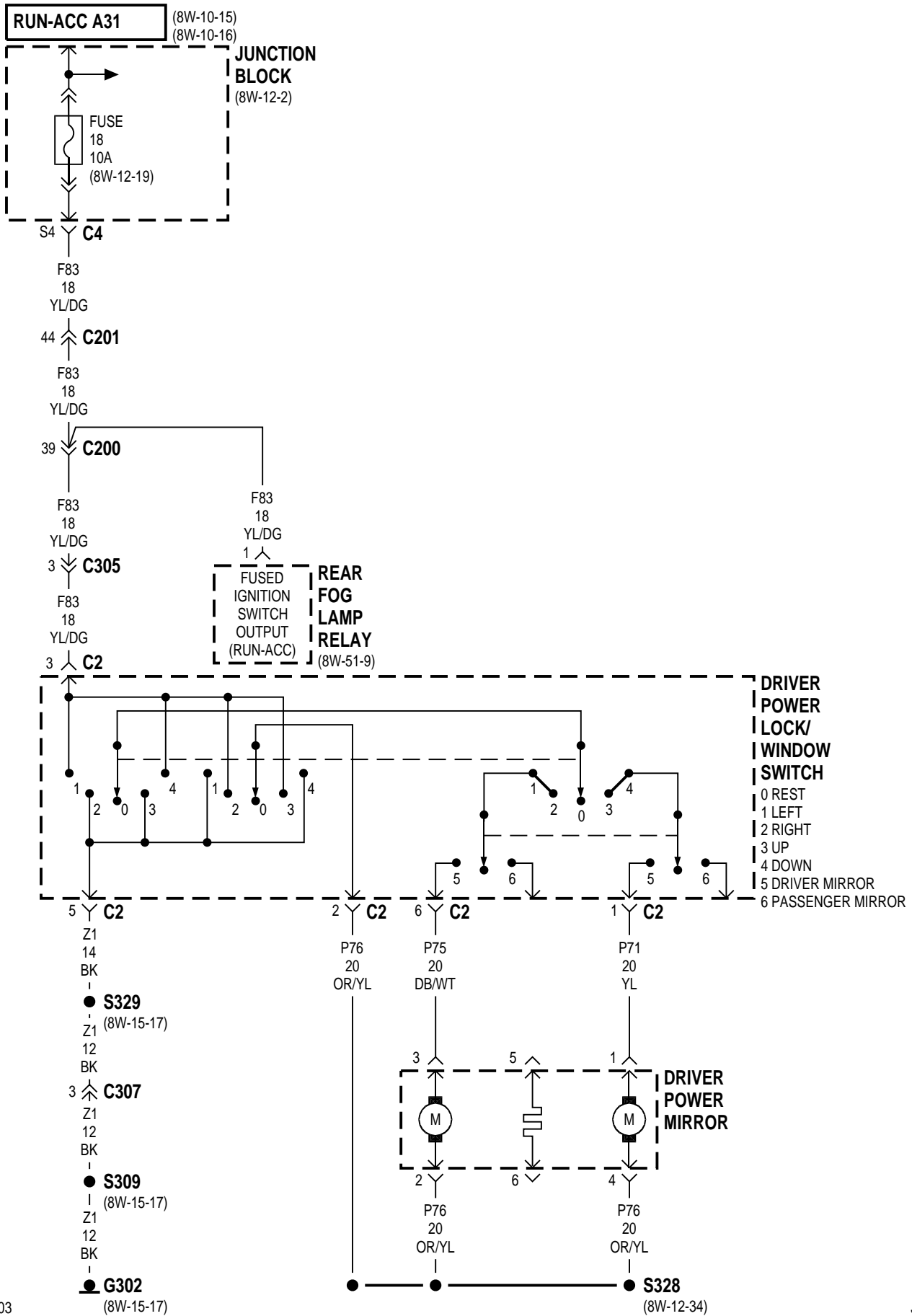

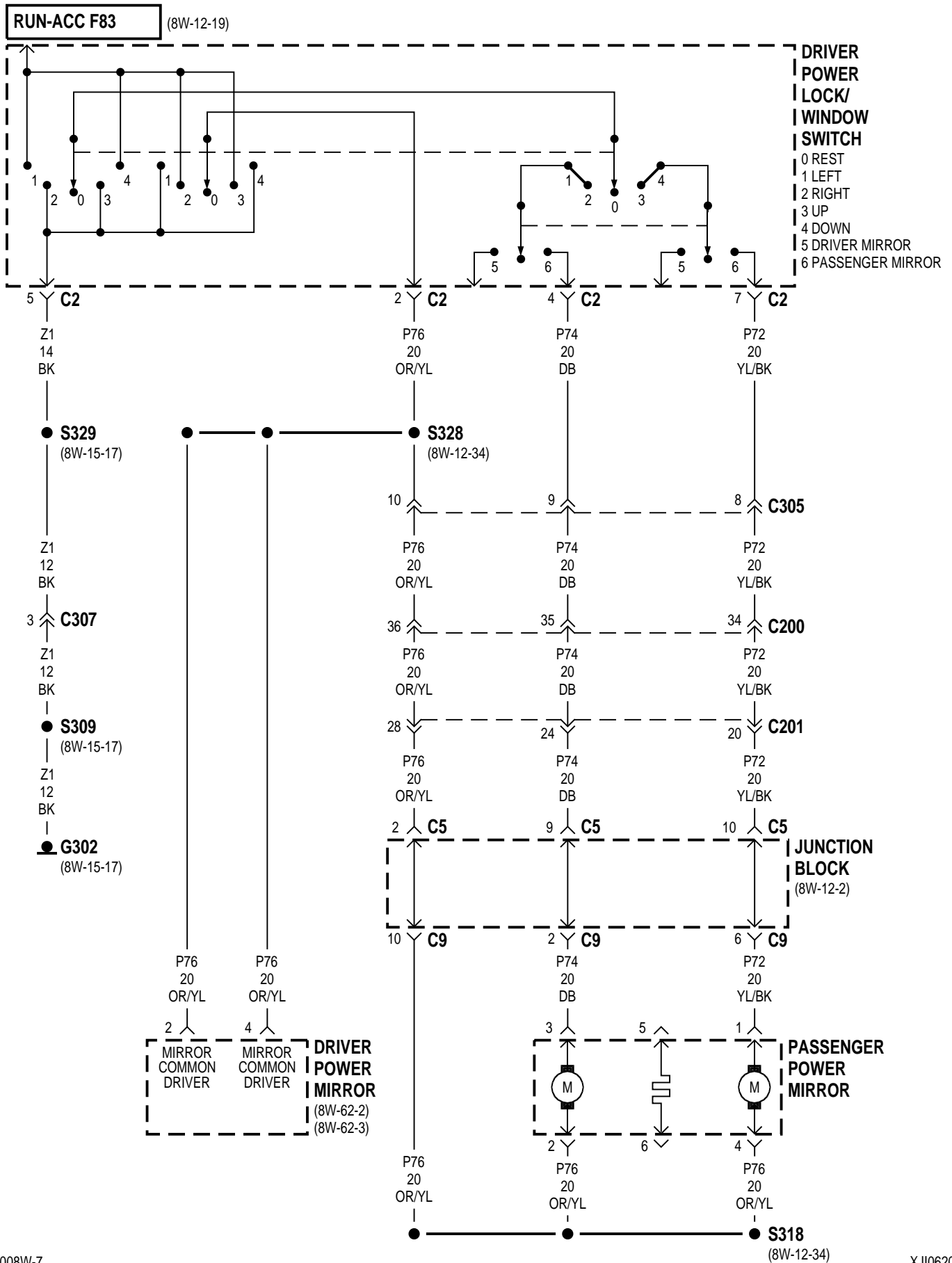

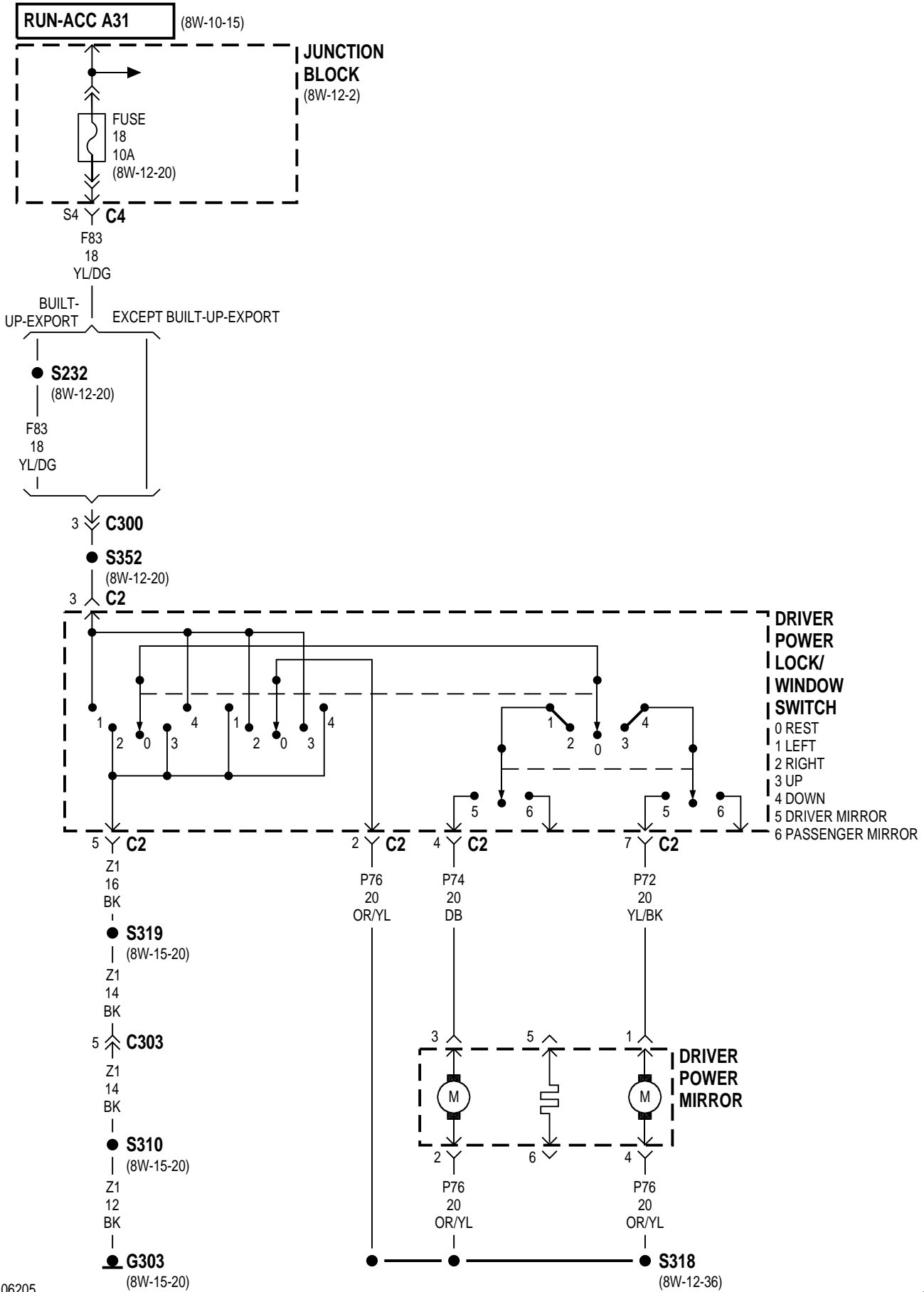

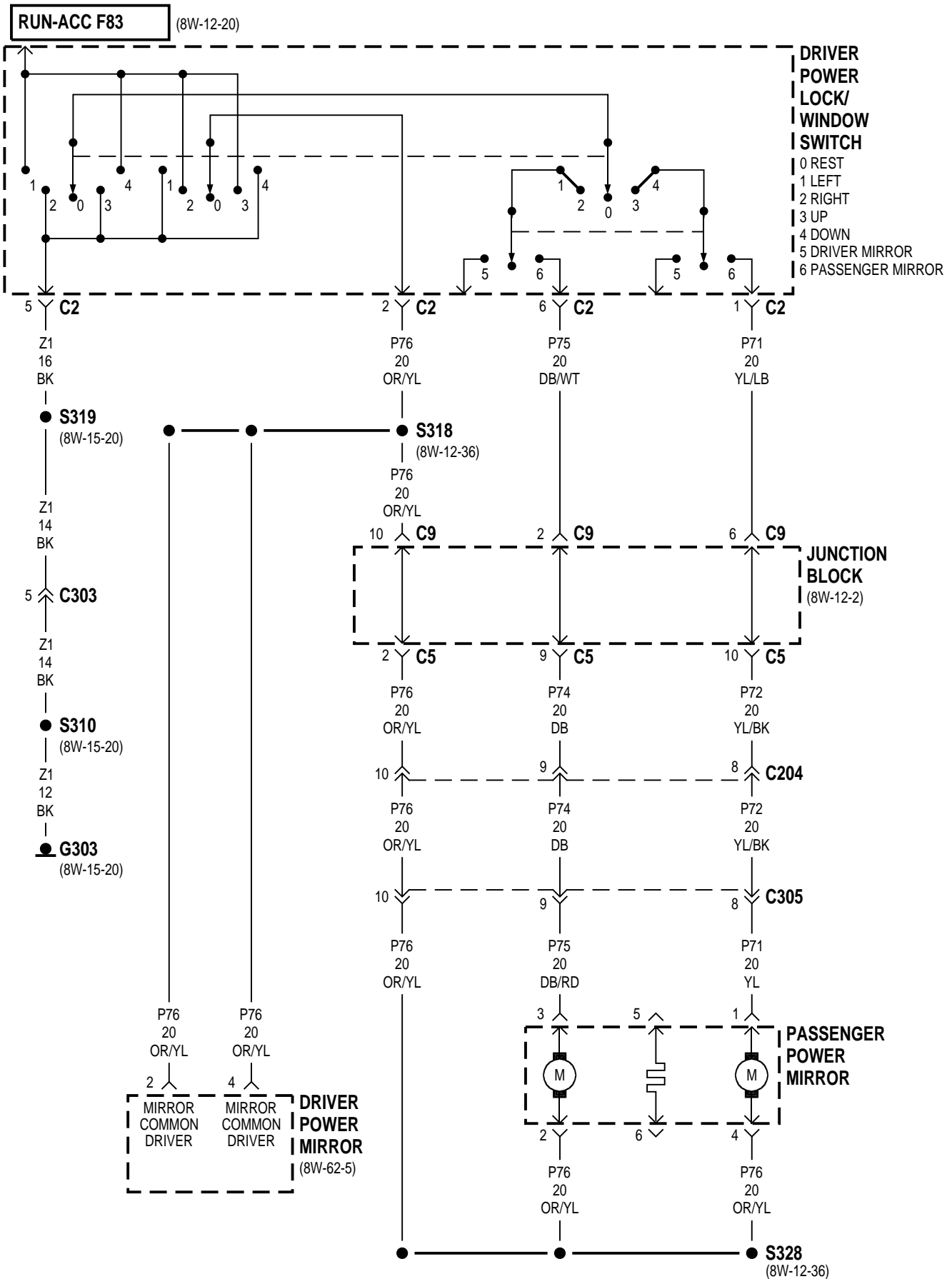

XJ **8W-62 POWER MIRRORS** **8W - 62 - 7**
LHD EXCEPT FULL OPTIONS

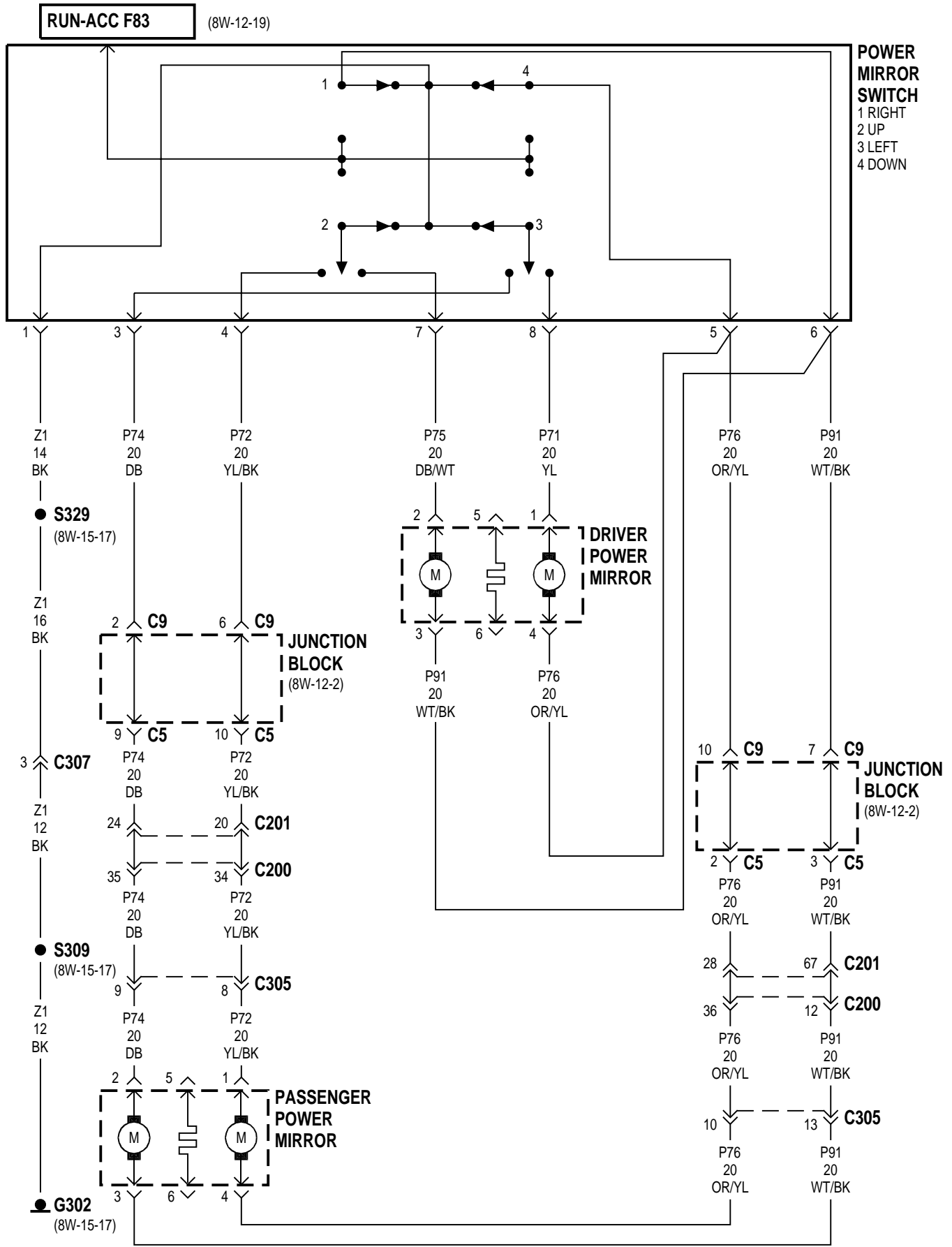

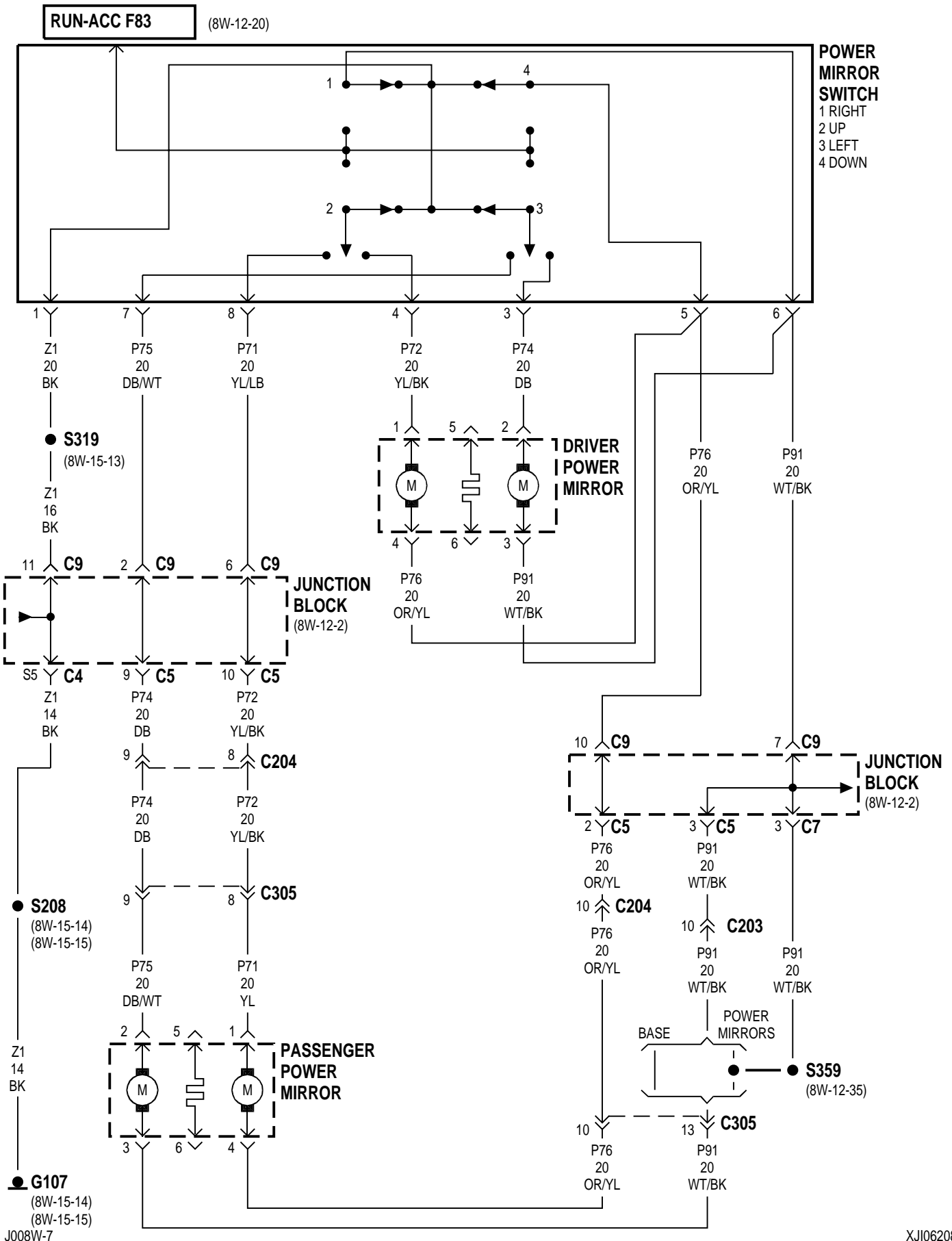

8W-63 POWER SEAT

| Component | Page | Component | Page |
|--------------------------------|---------------------|----------------------------------|---------------|
| Circuit Breaker 29 (JB) | 8W-63-2, 3, 6 | Left Power Seat Motors | 8W-63-2 |
| Forward/Rearward Motor | 8W-63-2, 3 | Left Power Seat Switch | 8W-63-2, 3, 6 |
| Front Motor | 8W-63-2, 3 | Rear Motor | 8W-63-2, 3 |
| Fuse 18 (JB) | 8W-63-4, 6 | Right Heated Seat Back | 8W-63-5 |
| G306 | 8W-63-2, 3, 4, 5, 6 | Right Heated Seat Cushion | 8W-63-5 |
| Heated Seat Relay | 8W-63-4, 6 | Right Heated Seat Switch | 8W-63-4 |
| Junction Block | 8W-63-2, 3, 4, 6 | Right Power Seat Motors | 8W-63-3 |
| Left Heated Seat Back | 8W-63-5 | Right Power Seat Switch | 8W-63-3, 6 |
| Left Heated Seat Cushion | 8W-63-5 | Seat Heat Interface Module | 8W-63-4, 5, 6 |
| Left Heated Seat Switch | 8W-63-4 | | |

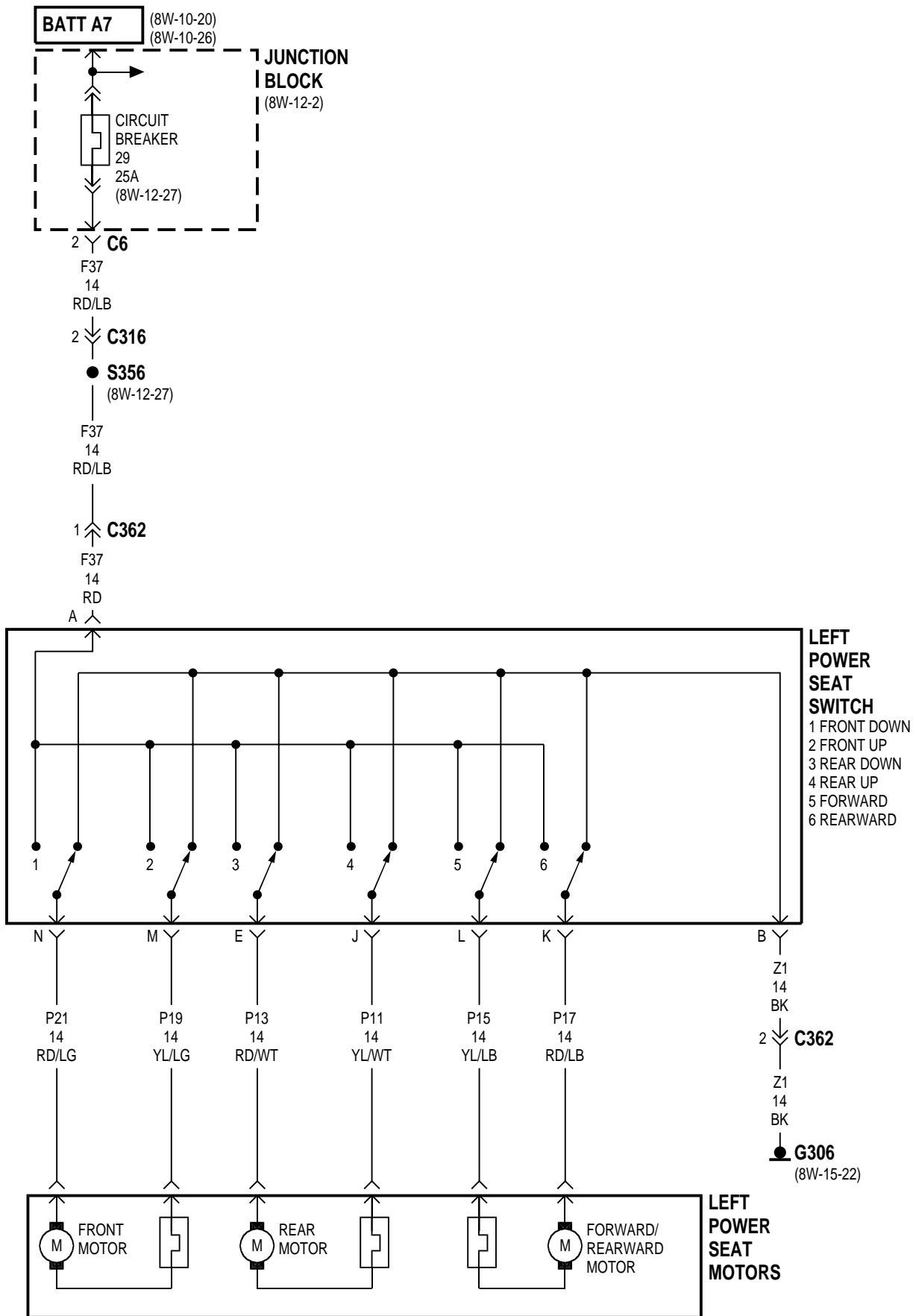

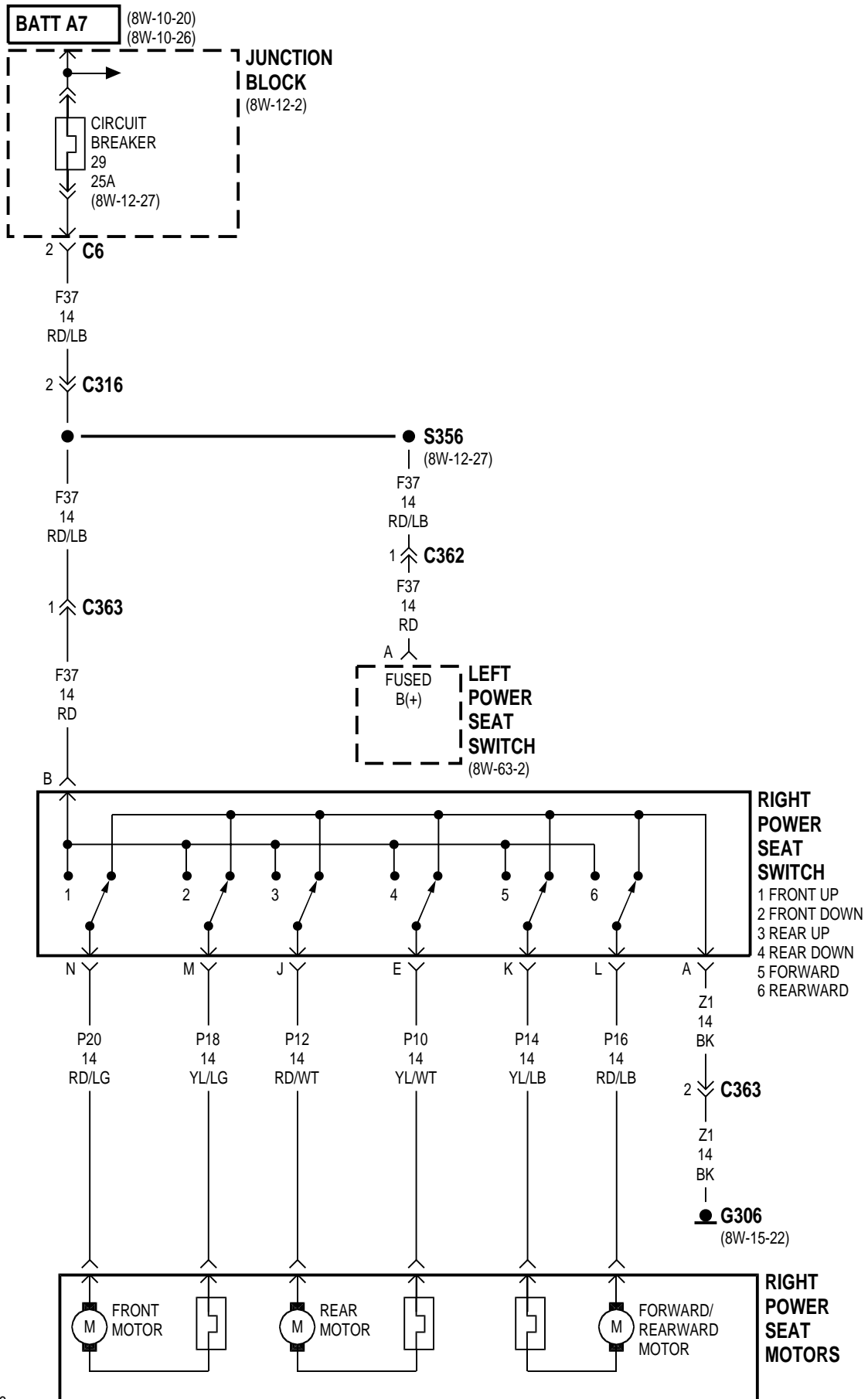

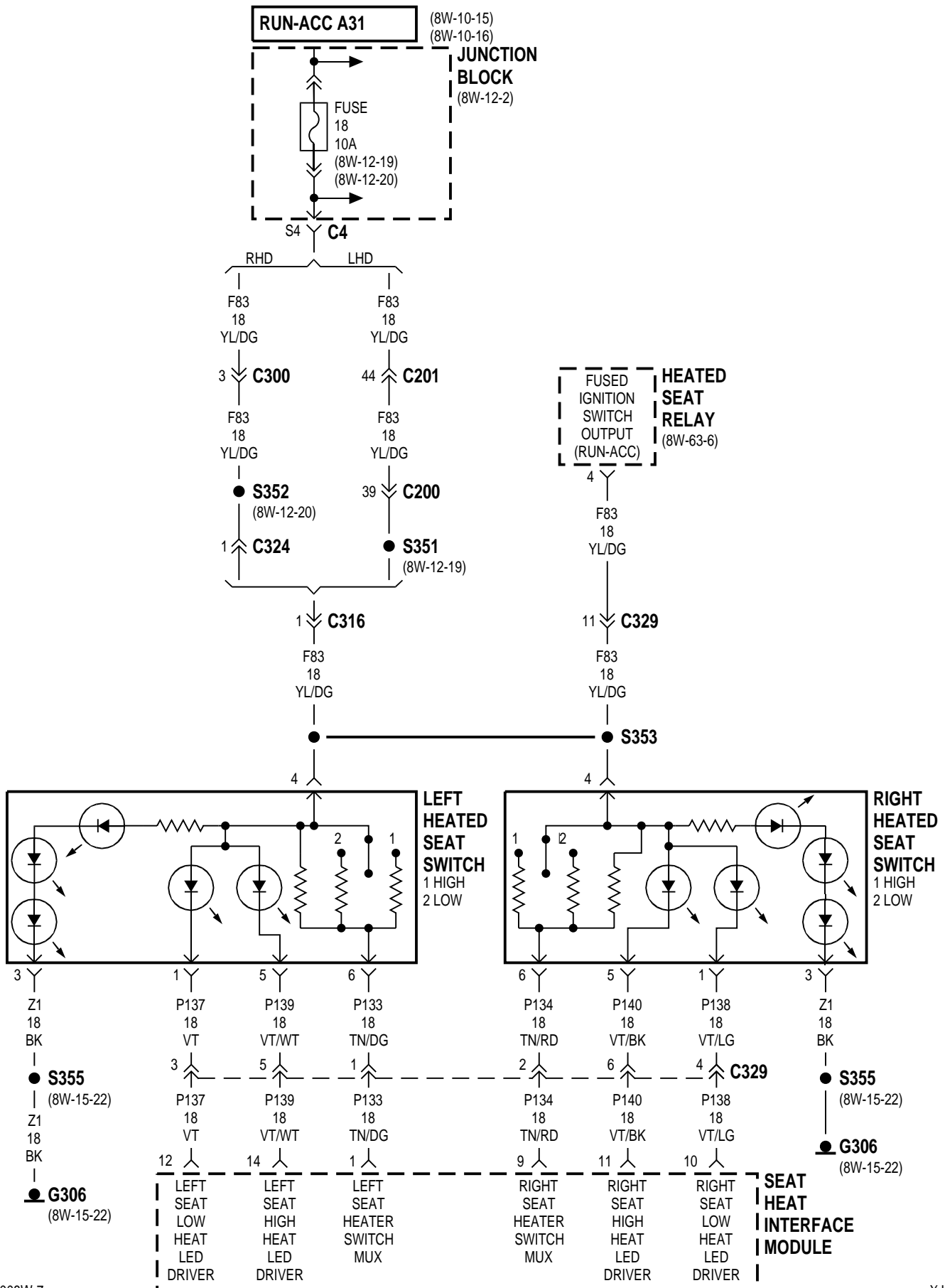

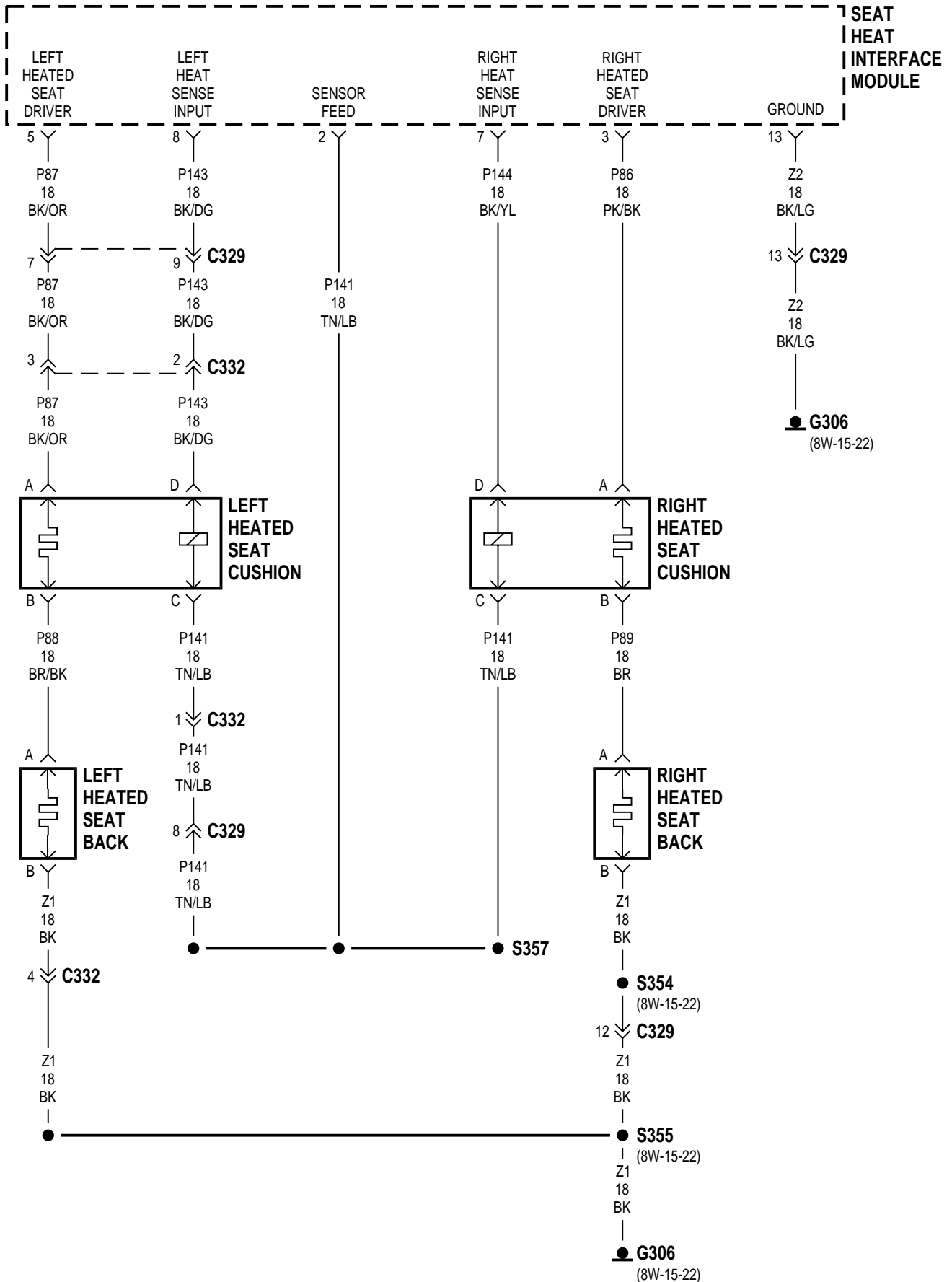

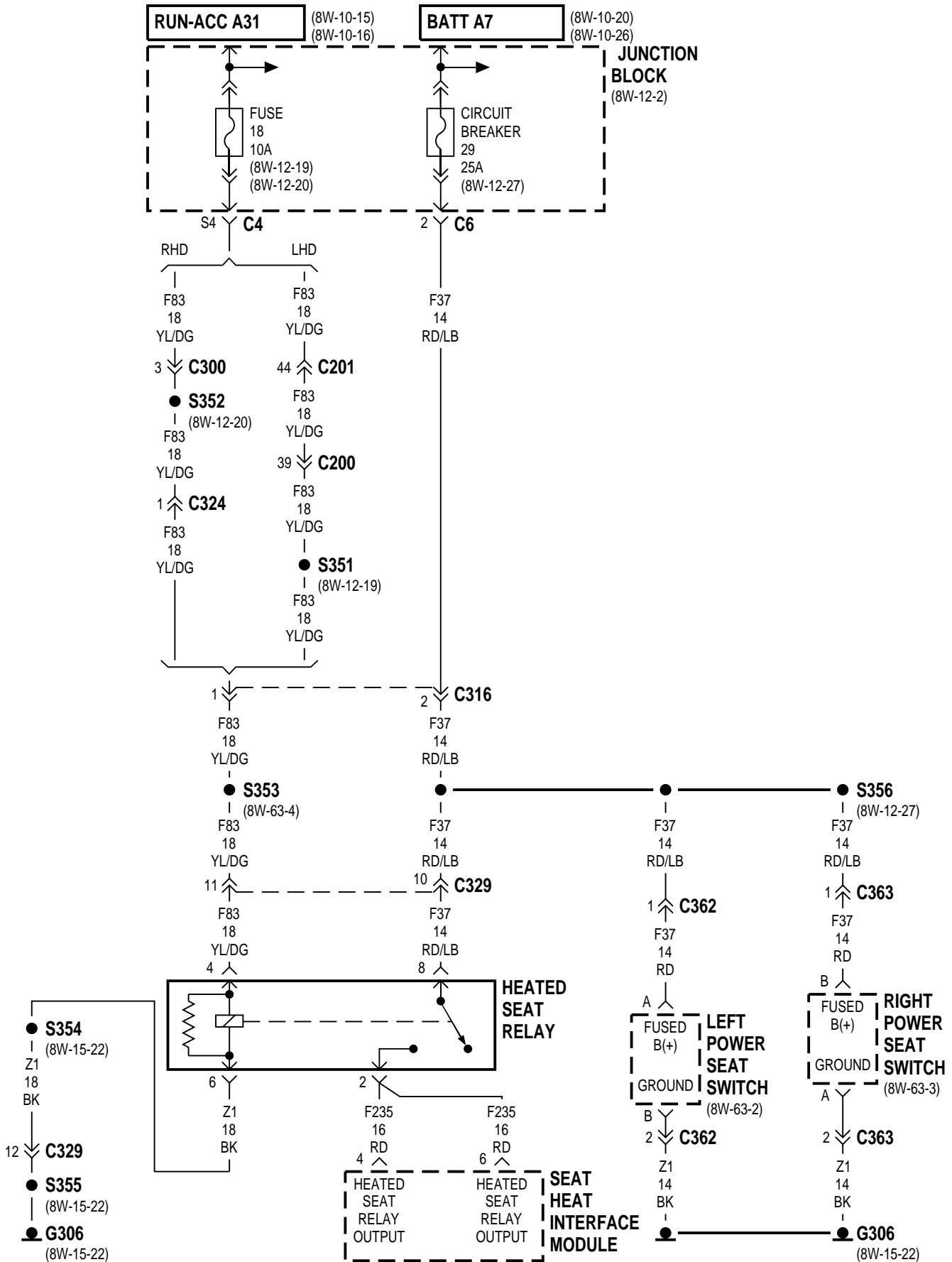

8W-70 SPLICE INFORMATION

| Component | Page | Component | Page |
|------------------|-----------------------------|------------------|--------------------|
| S100 | 8W-50-12 | S214 | 8W-12-28, 29 |
| S101 | 8W-12-24 | S215 | 8W-12-8, 9 |
| S102 | 8W-15-7, -10, 12 | S216 | 8W-12-13 |
| S103 | 8W-15-7, -10, 12 | S217 | 8W-12-22 |
| S104 | 8W-12-10 | S218 | 8W-10-28, 29 |
| S105 | 8W-50-10, 11 | S219 | 8W-12-22, 23 |
| S106 | 8W-10-32, -33, 35 | S220 | 8W-51-12 |
| S107 | 8W-15-2 | S221 | 8W-30-13, 32 |
| S108 | 8W-30-12 | S222 | 8W-30-13, 32 |
| S109 | 8W-10-23 | S225 | 8W-12-13 |
| S110 | 8W-10-23 | S226 | 8W-50-3 |
| S111 | 8W-70-3 | S227 | 8W-15-16 |
| S112 | 8W-30-7 | S228 | 8W-42-2, -3, -4, 5 |
| S113 | 8W-10-23 | S229 | 8W-47-4 |
| S114 | 8W-70-3 | S230 | 8W-12-11, 12 |
| S115 | 8W-70-2 | S232 | 8W-12-20 |
| S116 | 8W-50-13 | S237 | 8W-15-15 |
| S117 | 8W-15-2 | S238 | 8W-30-20, 21 |
| S118 | 8W-10-11, 13 | S239 | 8W-30-20, 21 |
| S119 | 8W-30-12 | S301 | 8W-10-33, 34 |
| S120 | 8W-21-2 | S302 | 8W-10-32, 33 |
| S121 | 8W-30-11 | S303 | 8W-51-8 |
| S122 | 8W-30-11 | S304 | 8W-12-30 |
| S123 | 8W-70-2 | S305 | 8W-60-2, 3 |
| S124 | 8W-30-29 | S306 | 8W-12-31, 32 |
| S130 | 8W-12-15, 16 | S307 | 8W-12-31, 32 |
| S131 | 8W-10-20, 26 | S308 | 8W-51-11, 12 |
| S132 | 8W-15-4, -5, -6, -8, -9, 11 | S309 | 8W-15-17, 18 |
| S133 | 8W-12-7 | S310 | 8W-15-19, 20 |
| S134 | 8W-12-22, 23 | S311 | 8W-12-10, 11 |
| S135 | 8W-10-27 | S312 | 8W-70-2 |
| S136 | 8W-12-16 | S313 | 8W-15-18 |
| S137 | 8W-10-19 | S314 | 8W-15-13 |
| S138 | 8W-70-3, 4 | S315 | 8W-12-8 |
| S139 | 8W-30-19, 34 | S316 | 8W-12-31 |
| S140 | 8W-31-7 | S317 | 8W-12-31 |
| S141 | 8W-15-5, -6, -8, 11 | S318 | 8W-12-34, 36 |
| S142 | 8W-51-6 | S319 | 8W-15-13, 20 |
| S143 | 8W-30-18 | S320 | 8W-47-7, 8 |
| S144 | 8W-30-20, 21 | S321 | 8W-47-7, 8 |
| S145 | 8W-30-20, 21 | S322 | 8W-12-32 |
| S146 | 8W-15-3 | S323 | 8W-12-32 |
| S147 | 8W-10-32 | S324 | 8W-12-23 |
| S148 | 8W-30-26 | S326 | 8W-47-5, 6 |
| S149 | 8W-70-4 | S327 | 8W-47-5, 6 |
| S151 | 8W-10-19 | S328 | 8W-12-34, 36 |
| S152 | 8W-30-29 | S329 | 8W-15-17, 18 |
| S153 | 8W-10-19 | S332 | 8W-15-21 |
| S156 | 8W-10-34 | S333 | 8W-12-11 |
| S157 | 8W-15-11 | S334 | 8W-15-21 |
| S158 | 8W-15-7, -10, 12 | S335 | 8W-54-3 |
| S159 | 8W-12-14 | S336 | 8W-54-3 |
| S161 | 8W-51-6 | S337 | 8W-15-17, 18 |
| S162 | 8W-12-7 | S338 | 8W-12-21 |
| S163 | 8W-12-7 | S339 | 8W-54-2 |
| S164 | 8W-50-19 | S340 | 8W-12-10, 11 |
| S165 | 8W-15-10, 12 | S341 | 8W-15-17, 18 |
| S166 | 8W-30-18 | S342 | 8W-15-13 |
| S168 | 8W-10-23 | S344 | 8W-30-20, 21 |
| S169 | 8W-12-12 | S345 | 8W-12-30 |
| S170 | 8W-15-11 | S346 | 8W-30-20, 21 |
| S200 | 8W-10-17 | S347 | 8W-10-28, -29, 30 |
| S201 | 8W-12-30 | S348 | 8W-15-19, 20 |
| S203 | 8W-10-32, 33 | S349 | 8W-12-23 |
| S204 | 8W-30-32 | S351 | 8W-12-19 |
| S205 | 8W-53-4, -5, -6, 7 | S352 | 8W-12-20 |
| S206 | 8W-12-10, 11 | S353 | 8W-63-4 |
| S207 | 8W-15-16 | S354 | 8W-15-22 |
| S208 | 8W-15-14, 15 | S355 | 8W-15-22 |
| S209 | 8W-52-5, 6 | S356 | 8W-12-27 |
| S210 | 8W-10-17 | S357 | 8W-63-5 |
| S211 | 8W-10-15, 16 | S359 | 8W-12-35 |
| S212 | 8W-52-7, 8 | S361 | 8W-10-28, 29 |
| S213 | 8W-50-4, -5, -6, 7 | | |
| S214 | 8W-10-27, 30 | | |

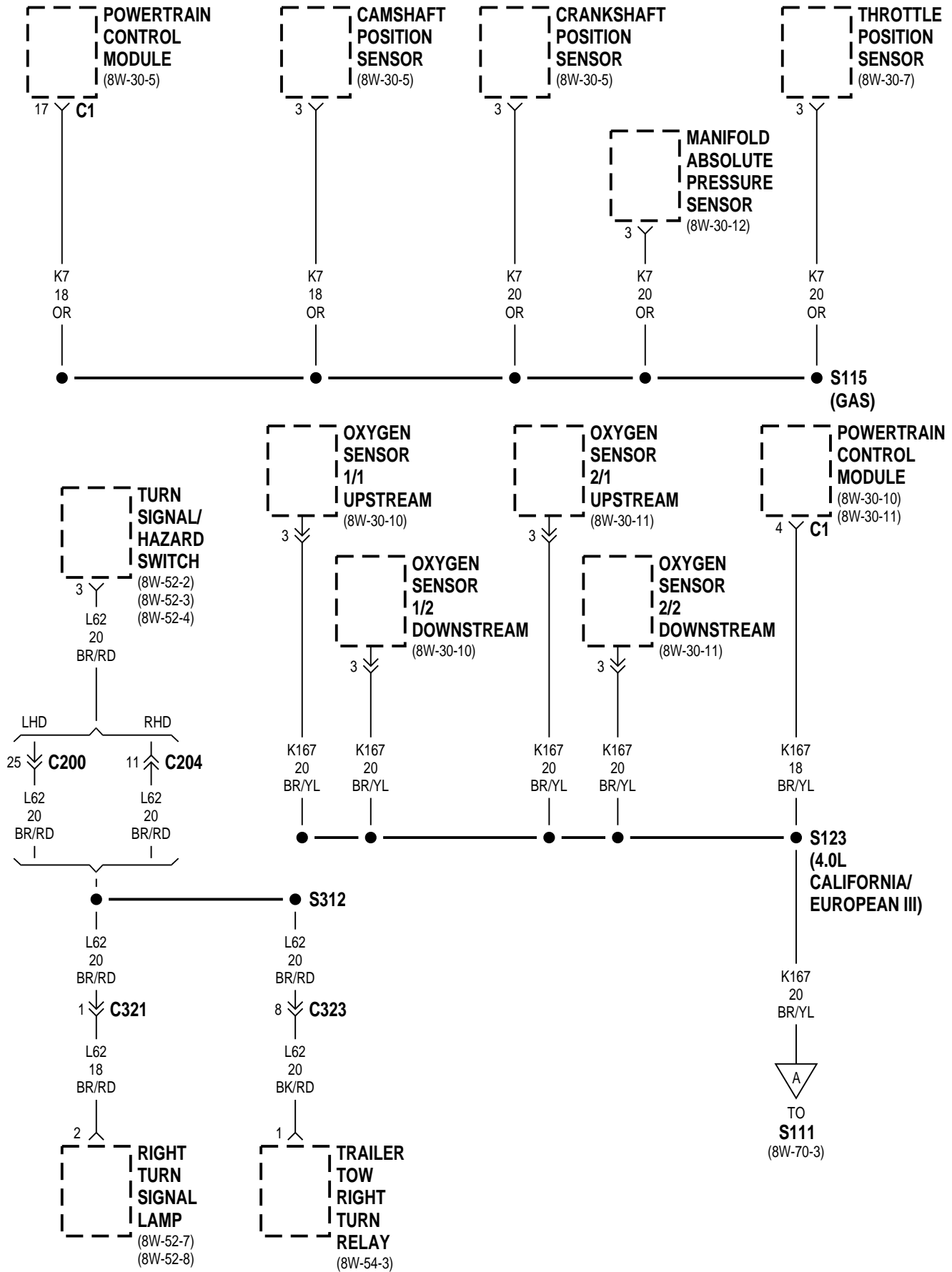

GAS

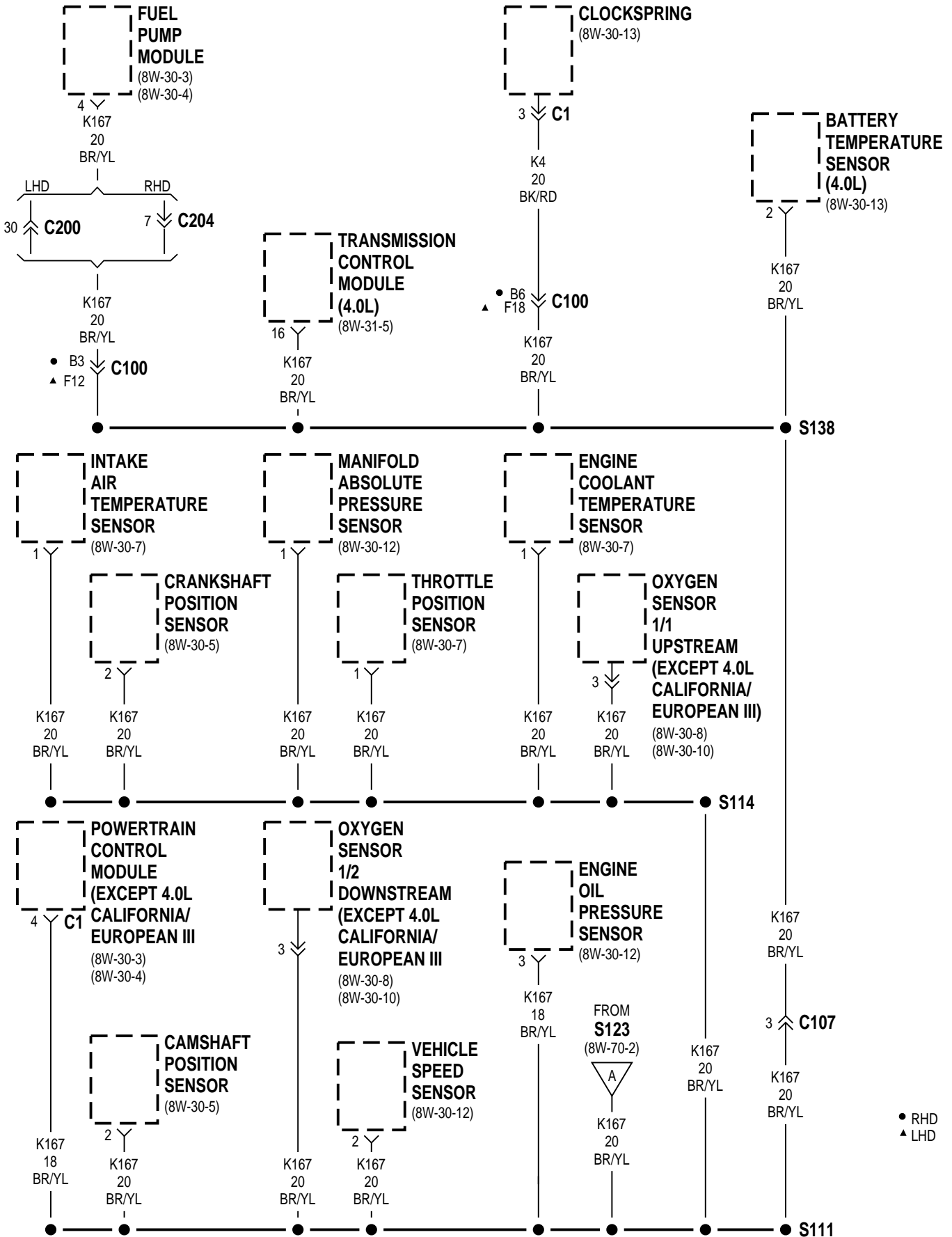

DIESEL

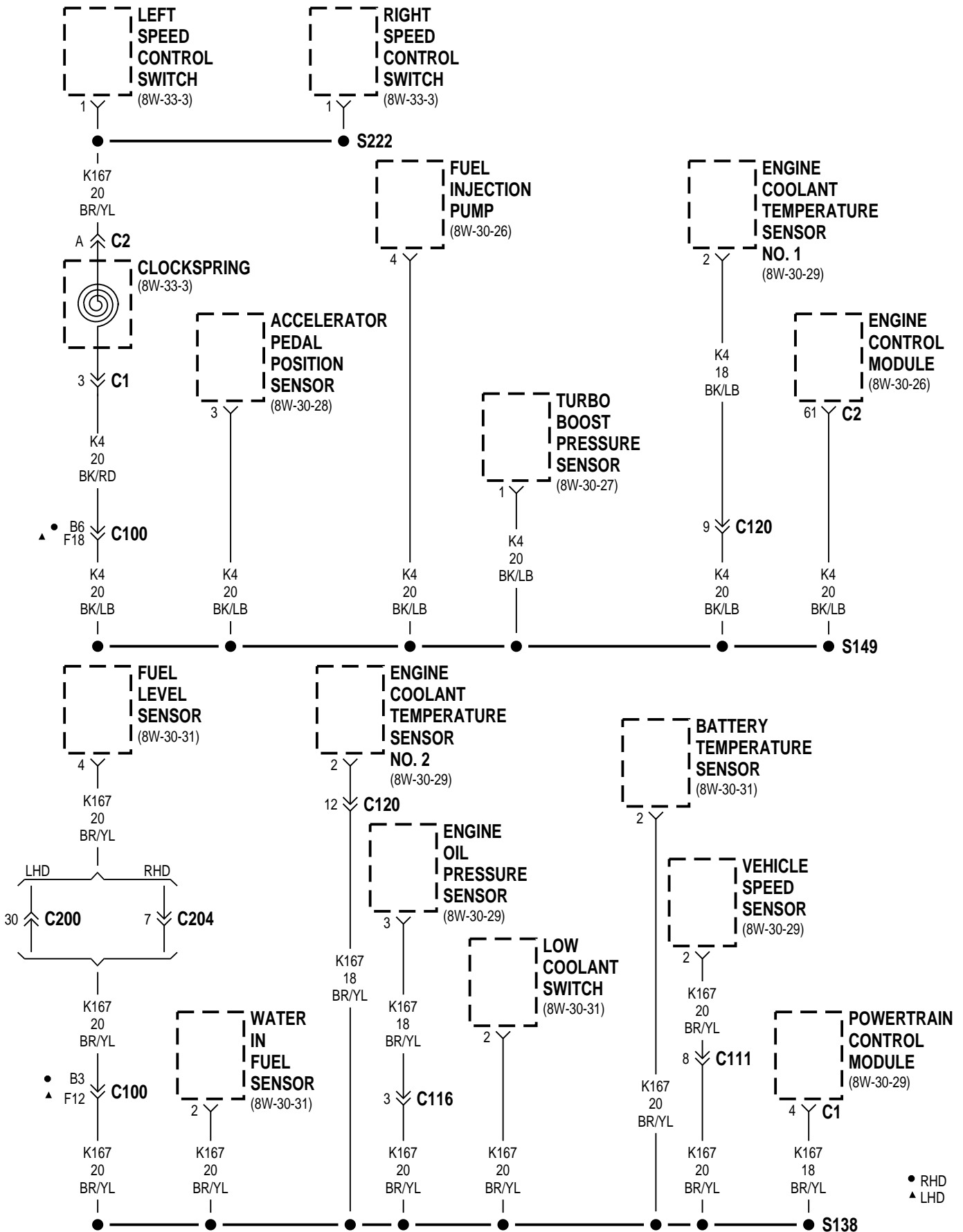

8W-80 CONNECTOR PIN-OUTS

| Component | Page | Component | Page |
|-----------------------------------|--------------------|-----------------------------------|--------------|
| A/C Compressor Clutch | 8W-80-4 | C320 | 8W-80-28 |
| A/C Heater Control | 8W-80-4 | C321 | 8W-80-28 |
| A/C High Pressure Switch | 8W-80-4 | C322 | 8W-80-28, 29 |
| A/C Low Pressure Switch | 8W-80-5 | C323 | 8W-80-29 |
| Accelerator Pedal Position Sensor | 8W-80-5 | C324 | 8W-80-29 |
| Airbag Control Module | 8W-80-5 | C326 | 8W-80-30 |
| Ambient Temperature Sensor | 8W-80-6 | C327 | 8W-80-30 |
| Back-Up Lamp Switch | 8W-80-6 | C329 | 8W-80-31 |
| Battery Temperature Sensor | 8W-80-6 | C330 | 8W-80-31 |
| Blend Door Actuator | 8W-80-6 | C332 | 8W-80-31 |
| Blower Motor | 8W-80-7 | C333 | 8W-80-32 |
| Blower Motor Relay | 8W-80-7 | C362 | 8W-80-32 |
| Blower Motor Resistor Block | 8W-80-7 | C363 | 8W-80-32 |
| Brake Lamp Switch | 8W-80-7 | Camshaft Position Sensor | 8W-80-32 |
| Brake Warning Pressure Switch | 8W-80-7 | Cargo Lamp/Switch | 8W-80-32 |
| C100 | 8W-80-8, 9, 10, 11 | Center High Mounted Stop Lamp | 8W-80-33 |
| C106 | 8W-80-12 | Cigar Lighter | 8W-80-33 |
| C107 | 8W-80-13, 14 | Clockspring-C1 | 8W-80-33 |
| C108 | 8W-80-15 | Clockspring-C2 | 8W-80-33 |
| C109 | 8W-80-15 | Clockspring-C3 | 8W-80-33 |
| C111 | 8W-80-15 | Clutch Interlock Switch | 8W-80-34 |
| C113 | 8W-80-15 | Clutch Interlock Switch Jumper | 8W-80-34 |
| C114 | 8W-80-16 | Combination Flasher | 8W-80-34 |
| C115 | 8W-80-16 | Compass | 8W-80-35 |
| C116 | 8W-80-16 | Controller Anti-Lock Brake | 8W-80-35 |
| C120 | 8W-80-16 | Crankshaft Position Sensor | 8W-80-36 |
| C200 | 8W-80-17 | Data Link Connector | 8W-80-36 |
| C201 | 8W-80-18, 19 | Daytime Running Lamp Module | 8W-80-37 |
| C202 | 8W-80-20 | Diode Module | 8W-80-37 |
| C203 | 8W-80-20 | Dome Lamp | 8W-80-37 |
| C204 | 8W-80-21 | Dome Lamps Switch | 8W-80-37 |
| C205 | 8W-80-21 | Driver Door Jamb Switch | 8W-80-38 |
| C206 | 8W-80-21, 22 | Driver Door Lock Motor | 8W-80-38 |
| C207 | 8W-80-22 | Driver Power Lock/Window Switch | 8W-80-38, 39 |
| C208 | 8W-80-22 | Driver Power Mirror | 8W-80-39 |
| C300 | 8W-80-22, 23 | Driver Power Window Motor | 8W-80-40 |
| C301 | 8W-80-23 | Duty Cycle Evap/Purge Solenoid | 8W-80-40 |
| C303 | 8W-80-23 | Electronic Vacuum Modulator | 8W-80-40 |
| C304 | 8W-80-24 | Engine Control Module | 8W-80-41, 42 |
| C305 | 8W-80-24, 25 | Engine Coolant Temperature Sensor | 8W-80-43 |
| C306 | 8W-80-25 | Engine Oil Pressure Sensor | 8W-80-43 |
| C307 | 8W-80-26 | Engine Speed Sensor | 8W-80-43 |
| C309 | 8W-80-26 | Evap Leak Detection Pump | 8W-80-44 |
| C310 | 8W-80-26 | Extended Idle Switch | 8W-80-44 |
| C311 | 8W-80-26 | Front Fog Lamp Switch | 8W-80-44 |
| C312 | 8W-80-26 | Front Wiper Motor | 8W-80-44 |
| C313 | 8W-80-26 | Fuel Heater | 8W-80-45 |
| C314 | 8W-80-27 | Fuel Injector No. 1 | 8W-80-45, 46 |
| C316 | 8W-80-27 | Fuel Injector No. 2 | 8W-80-45, 46 |
| C317 | 8W-80-27 | Fuel Injector No. 3 | 8W-80-45, 46 |
| C318 | 8W-80-28 | Fuel Injector No. 4 | 8W-80-45, 46 |
| C319 | 8W-80-28 | Fuel Injector No. 5 | 8W-80-46 |

| Component | Page | Component | Page |
|--|----------------------|---------------------------------------|------------------------------|
| Fuel Injector No. 6 | 8W-80-46 | Liftgate Switch | 8W-80-64 |
| Fuel Level Sensor | 8W-80-47 | Low Coolant Switch | 8W-80-64 |
| Fuel Pump Module | 8W-80-47 | Manifold Absolute Pressure Sensor | 8W-80-65 |
| G Switch | 8W-80-47 | Needle Movement Sensor | 8W-80-65 |
| Generator | 8W-80-47 | Overhead Module | 8W-80-65 |
| Glow Plug Relay | 8W-80-48 | Oxygen Sensor 1/1 Upstream | 8W-80-65 |
| Headlamp Beam Select Switch | 8W-80-48 | Oxygen Sensor 1/2 Downstream | 8W-80-66 |
| Headlamp Delay Module | 8W-80-48 | Oxygen Sensor 2/1 Upstream | 8W-80-66 |
| Headlamp Leveling Switch | 8W-80-49 | Oxygen Sensor 2/2 Downstream | 8W-80-66 |
| Headlamp Switch | 8W-80-49 | Park/Neutral Position Switch | 8W-80-66 |
| Heated Seat Relay | 8W-80-50 | Passenger Airbag | 8W-80-66 |
| Heater Control | 8W-80-4 | Passenger Door Jamb Switch | 8W-80-66 |
| Idle Air Control Motor | 8W-80-50 | Passenger Door Lock Motor | 8W-80-67 |
| Ignition Coil | 8W-80-51 | Passenger Power Lock/Window Switch | 8W-80-67 |
| Ignition Switch | 8W-80-51 | Passenger Power Mirror | 8W-80-68 |
| Instrument Cluster | 8W-80-52 | Passenger Power Window Motor | 8W-80-68 |
| Intake Air Temperature Sensor | 8W-80-53 | Power Amplifier | 8W-80-69 |
| Junction Block | 8W-80-53, 54, 55, 56 | Power Antenna | 8W-80-69 |
| Left Back-Up Lamp | 8W-80-56 | Power Antenna Relay | 8W-80-69, 70 |
| Left City Lamp | 8W-80-57 | Power Mirror Switch | 8W-80-70 |
| Left Courtesy Lamp | 8W-80-57 | Power Outlet | 8W-80-70 |
| Left Fog Lamp | 8W-80-57 | Power Steering Pressure Switch | 8W-80-70 |
| Left Front Door Speaker | 8W-80-57 | Powertrain Control | |
| Left Front Door Tweeter | 8W-80-57 | Module | 8W-80-71, 72, 73, 74, 75, 76 |
| Left Front Park/Turn Signal Lamp No. 1 | 8W-80-58 | PRNDL Illumination | 8W-80-77 |
| Left Front Park/Turn Signal Lamp No. 2 | 8W-80-58 | Radiator Fan Motor | 8W-80-77 |
| Left Front Turn Signal Lamp No. 1 | 8W-80-58 | Radio | 8W-80-77 |
| Left Front Turn Signal Lamp No. 2 | 8W-80-58 | Rail Coil | 8W-80-77 |
| Left Front Wheel Speed Sensor | 8W-80-59 | Rear Fog Lamp Relay | 8W-80-78 |
| Left Headlamp | 8W-80-59 | Rear Fog Lamp Switch | 8W-80-78 |
| Left Headlamp Leveling Motor | 8W-80-59 | Rear Washer Pump | 8W-80-78 |
| Left Heated Seat Back | 8W-80-59 | Rear Window Defogger Switch | 8W-80-78 |
| Left Heated Seat Cushion | 8W-80-59 | Rear Wiper Motor | 8W-80-78 |
| Left Heated Seat Switch | 8W-80-60 | Rear Wiper/Washer Switch | 8W-80-79 |
| Left License Lamp | 8W-80-60 | Right Back-Up Lamp | 8W-80-79 |
| Left Power Seat Front Vertical Motor | 8W-80-60 | Right City Lamp | 8W-80-79 |
| Left Power Seat Horizontal Motor | 8W-80-60 | Right Courtesy Lamp | 8W-80-79 |
| Left Power Seat Rear Vertical Motor | 8W-80-60 | Right Fog Lamp | 8W-80-79 |
| Left Power Seat Switch | 8W-80-61 | Right Front Door Speaker | 8W-80-80 |
| Left Rear Door Jamb Switch | 8W-80-61 | Right Front Door Tweeter | 8W-80-80 |
| Left Rear Door Lock Motor | 8W-80-61 | Right Front Park/Turn Signal | |
| Left Rear Fog Lamp | 8W-80-61 | Lamp No. 1 | 8W-80-80 |
| Left Rear Wheel Speed Sensor | 8W-80-62 | Right Front Park/Turn Signal | |
| Left Rear Window Motor | 8W-80-62 | Lamp No. 2 | 8W-80-80 |
| Left Rear Window Switch | 8W-80-62 | Right Front Turn Signal Lamp No. 1 | 8W-80-80 |
| Left Repeater Lamp | 8W-80-62 | Right Front Turn Signal Lamp No. 2 | 8W-80-81 |
| Left Side Marker Lamp | 8W-80-63 | Right Front Wheel Speed Sensor | 8W-80-81 |
| Left Soundbar Speaker | 8W-80-63 | Right Headlamp | 8W-80-81 |
| Left Speed Control Switch | 8W-80-63 | Right Headlamp Leveling Motor | 8W-80-81 |
| Left Tail/Stop Lamp | 8W-80-63 | Right Heated Seat Back | 8W-80-81 |
| Left Turn Signal Lamp | 8W-80-64 | Right Heated Seat Cushion | 8W-80-81 |
| Left Visor/Vanity Lamp | 8W-80-64 | Right Heated Seat Switch | 8W-80-82 |
| License Lamp | 8W-80-64 | Right License Lamp | 8W-80-82 |
| Liftgate Lock Motor | 8W-80-64 | Right Power Seat Front Vertical Motor | 8W-80-82 |

| Component | Page | Component | Page |
|--|-------------|---|--------------|
| Right Power Seat Rear Vertical Motor . . . | 8W-80-82 | Throttle Position Sensor | 8W-80-87 |
| Right Power Seat Switch | 8W-80-83 | Torque Converter Clutch Solenoid | 8W-80-87 |
| Right Rear Door Jamb Switch | 8W-80-83 | Trailer Tow Connector | 8W-80-87 |
| Right Rear Door Lock Motor | 8W-80-83 | Trailer Tow Left Turn Relay | 8W-80-87 |
| Right Rear Fog Lamp | 8W-80-83 | Trailer Tow Right Turn Relay | 8W-80-87 |
| Right Rear Wheel Speed Sensor | 8W-80-84 | Transfer Case Switch | 8W-80-88 |
| Right Rear Window Motor | 8W-80-84 | Transfer Case Switch Illumination | 8W-80-88 |
| Right Rear Window Switch | 8W-80-84 | Transmission Solenoid | 8W-80-88 |
| Right Repeater Lamp | 8W-80-84 | Transmission Control Module | 8W-80-89 |
| Right Side Marker Lamp | 8W-80-84 | Transmission Range Sensor | 8W-80-89 |
| Right Soundbar Speaker | 8W-80-84 | Turbo Boost Pressure Sensor | 8W-80-89 |
| Right Speed Control Switch | 8W-80-85 | Turn Signal/Hazard Switch | 8W-80-90 |
| Right Tail/Stop Lamp | 8W-80-85 | Underhood Lamp/Switch | 8W-80-90 |
| Right Turn Signal Lamp | 8W-80-85 | Vehicle Speed Control Servo | 8W-80-90 |
| Right Visor/Vanity Lamp | 8W-80-85 | Vehicle Speed Sensor | 8W-80-90, 91 |
| Seat Belt Switch | 8W-80-85 | Washer Fluid Level Switch | 8W-80-91 |
| Seat Heat Interface Module | 8W-80-86 | Water In Fuel Sensor | 8W-80-91 |
| Sentry Key Immobilizer Module | 8W-80-86 | Windshield Washer Pump | 8W-80-91 |
| Shift Lock Solenoid | 8W-80-86 | Wipe/Wash Switch | 8W-80-91 |

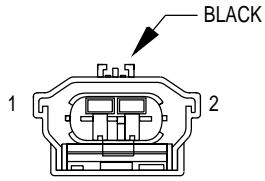

A/C COMPRESSOR CLUTCH (DIESEL)

| CAV | CIRCUIT | FUNCTION |
|-----|------------|------------------------------------|
| 1 | C3 14DB/BK | A/C COMPRESSOR CLUTCH RELAY OUTPUT |
| 2 | Z1 16BK | GROUND |

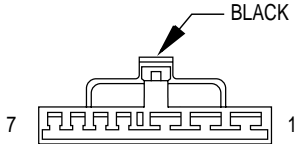

A/C-HEATER CONTROL-C1 OR HEATER CONTROL-C1

| CAV | CIRCUIT | FUNCTION |
|-----|------------|--|
| 1 | Z8 12BK/VT | GROUND |
| 2 | C7 12BK/TN | BLOWER MOTOR HIGH DRIVER |
| 3 | C6 14LB | BLOWER MOTOR M2 DRIVER |
| 4 | C5 14LG | BLOWER MOTOR M1 DRIVER |
| 5 | C4 14TN | BLOWER MOTOR LOW DRIVER |
| 6 | C90 20LG ▲ | A/C SWITCH SENSE |
| 7 | E2 20OR ▲▲ | FUSED PANEL LAMPS DIMMER SWITCH SIGNAL |
| | E2 20OR | FUSED PANEL LAMPS DIMMER SWITCH SIGNAL |

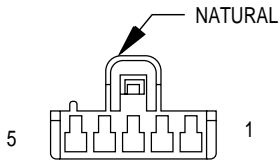

A/C-HEATER CONTROL-C2

| CAV | CIRCUIT | FUNCTION |
|-----|-----------------|------------------------------------|
| 1 | - | - |
| 2 | Z1 20BK | GROUND |
| 3 | C36 20RD/WT ▲▲▲ | BLEND DOOR FEEDBACK SIGNAL |
| 3 | C36 18RD/WT ▲▲ | BLEND DOOR FEEDBACK SIGNAL |
| 4 | F15 20DB/WT | FUSED IGNITION SWITCH OUTPUT (RUN) |
| 5 | - | - |

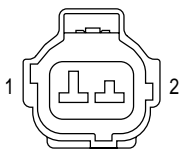

A/C HIGH PRESSURE SWITCH (2.5L GAS)

| CAV | CIRCUIT | FUNCTION |
|-----|-------------|------------------|
| 1 | C22 18DB/WT | A/C SWITCH SENSE |
| 2 | C21 20DB/PK | A/C SWITCH SENSE |

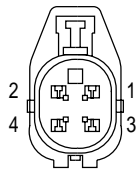

A/C HIGH PRESSURE SWITCH (4.0L GAS, DIESEL)

| CAV | CIRCUIT | FUNCTION |
|-----|----------------|---------------------------|
| 1 | C21 20DB/PK | A/C SWITCH SENSE |
| 2 | C48 18TN | RADIATOR FAN REQUEST |
| 3 | C90 20LG ● | A/C SWITCH SENSE |
| 3 | Z1 18BK ●● | GROUND |
| 4 | C90 20LG ● | A/C SWITCH SENSE |
| 4 | C22 20DB/WT ●● | A/C PRESSURE SWITCH SENSE |

- ▲ A/C ONLY
- ▲▲ RHD
- ▲▲▲ LHD
- GAS
- DIESEL

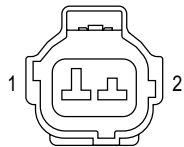

A/C LOW PRESSURE SWITCH (DIESEL)

| CAV | CIRCUIT | FUNCTION |
|-----|-------------|------------------|
| 1 | Z1 20BK | GROUND |
| 2 | C21 20DB/PK | A/C SWITCH SENSE |

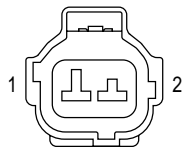

A/C LOW PRESSURE SWITCH (GAS)

| CAV | CIRCUIT | FUNCTION |
|-----|----------------|------------------------|
| 1 | C21 20DB/PK ◇ | A/C SWITCH SENSE |
| 1 | C22 18DB/WT ◇◇ | PRESSURE SWITCH OUTPUT |
| 2 | C90 20LG ◇ | A/C SWITCH SENSE |
| 2 | C21 20DB/PK ◇◇ | A/C SWITCH SENSE |

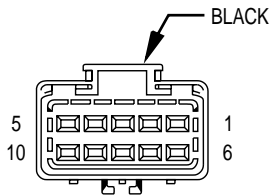

ACCELERATOR PEDAL POSITION SENSOR (DIESEL)

| CAV | CIRCUIT | FUNCTION |
|-----|--------------|--|
| 1 | - | - |
| 2 | - | - |
| 3 | K4 20BK/LB | SENSOR GROUND |
| 4 | - | - |
| 5 | K151 20WT | LOW IDLE POSITION SWITCH SIGNAL |
| 6 | - | - |
| 7 | K22 20OR/DB | ACCELERATOR PEDAL POSITION SENSOR SIGNAL |
| 8 | K255 20WT/DG | ACCELERATOR PEDAL POSITION SENSOR GROUND |
| 9 | - | - |
| 10 | K6 20VT/WT | 5V SUPPLY |

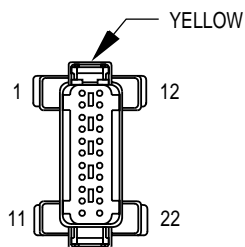

AIRBAG CONTROL MODULE

| CAV | CIRCUIT | FUNCTION |
|-----|---------------|---------------------------------------|
| 1 | R45 18DG/LB | DRIVER AIRBAG LINE 1 |
| 2 | R43 18BK/LB | DRIVER AIRBAG LINE 2 |
| 3 | - | - |
| 4 | - | - |
| 5 | R42 18BK/YL | PASSENGER AIRBAG LINE 2 |
| 6 | R44 18DG/YL | PASSENGER AIRBAG LINE 1 |
| 7 | - | - |
| 8 | - | - |
| 9 | - | - |
| 10 | Z6 18BK/PK ● | GROUND |
| 10 | Z6 18BK/YL ●● | GROUND |
| 11 | - | - |
| 12 | - | - |
| 13 | - | - |
| 14 | - | - |
| 15 | - | - |
| 16 | - | - |
| 17 | F23 18DB/YL | FUSED IGNITION SWITCH OUTPUT (ST-RUN) |
| 18 | D2 18WT/BK | CCD BUS(-) |
| 19 | D1 18VT/BR | CCD BUS(+) |
| 20 | F14 18LG/YL | FUSED IGNITION SWITCH OUTPUT (RUN) |

◇ 2.5L
◇◇ 4.0L

● FULL OPTIONS
●● BASE

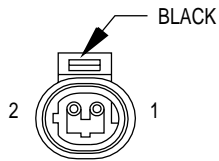

**AMBIENT
TEMPERATURE
SENSOR**

| CAV | CIRCUIT | FUNCTION |
|-----|-------------|-----------------------------------|
| 1 | G31 20VT/LG | AMBIENT TEMPERATURE SENSOR SIGNAL |
| 2 | G32 20BK/LB | SENSOR GROUND |

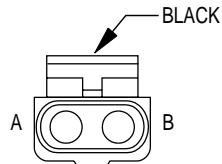

**BACK-UP LAMP
SWITCH**

| CAV | CIRCUIT | FUNCTION |
|-----|----------------|---------------------------------------|
| A | L10 18BR/LG ●● | BACK UP LAMP FEED |
| A | F20 18WT ● | FUSED IGNITION SWITCH OUTPUT (ST-RUN) |
| B | L10 18BR/LG ● | BACK UP LAMP FEED |
| B | F20 18WT ●● | FUSED IGNITION SWITCH OUTPUT (ST-RUN) |

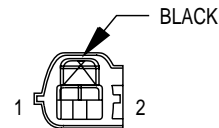

**BATTERY
TEMPERATURE
SENSOR
(GAS)**

| CAV | CIRCUIT | FUNCTION |
|-----|--------------|-----------------------------------|
| 1 | K118 18PK/YL | BATTERY TEMPERATURE SENSOR SIGNAL |
| 2 | K167 20BR/YL | SENSOR GROUND |

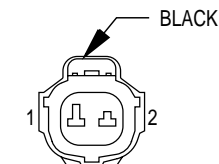

**BATTERY
TEMPERATURE
SENSOR
(DIESEL)**

| CAV | CIRCUIT | FUNCTION |
|-----|--------------|-----------------------------------|
| 1 | K118 18PK/YL | BATTERY TEMPERATURE SENSOR SIGNAL |
| 2 | K167 20BR/YL | SENSOR GROUND |

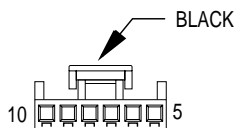

**BLEND
DOOR
ACTUATOR**

| CAV | CIRCUIT | FUNCTION |
|-----|------------|------------------------------------|
| 5 | - | - |
| 6 | - | - |
| 7 | D1 20DB/WT | GROUND |
| 8 | D3 20YL | BLEND DOOR FEEDBACK SIGNAL |
| 9 | - | - |
| 10 | D2 20OR | FUSED IGNITION SWITCH OUTPUT (RUN) |

● GAS
●● DIESEL

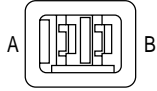

BLOWER MOTOR

| CAV | CIRCUIT | FUNCTION |
|-----|------------|---------------------------|
| A | C1 12DG | BLOWER MOTOR RELAY OUTPUT |
| B | C7 12BK/TN | BLOWER MOTOR HIGH DRIVER |

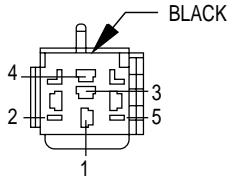

BLOWER MOTOR RELAY

| CAV | CIRCUIT | FUNCTION |
|-----|--------------|------------------------------------|
| 1 | C1 12DG | BLOWER MOTOR RELAY OUTPUT |
| 2 | Z1 20BK | GROUND |
| 3 | - | - |
| 4 | A111 12RD/LG | FUSED B(+) |
| 5 | F15 20DB/WT | FUSED IGNITION SWITCH OUTPUT (RUN) |

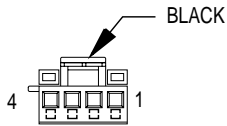

BLOWER MOTOR RESISTOR BLOCK

| CAV | CIRCUIT | FUNCTION |
|-----|------------|--------------------------|
| 1 | C4 14TN | BLOWER MOTOR LOW DRIVER |
| 2 | C5 14LG | BLOWER MOTOR M1 DRIVER |
| 3 | C6 14LB | BLOWER MOTOR M2 DRIVER |
| 4 | C7 12BK/TN | BLOWER MOTOR HIGH DRIVER |

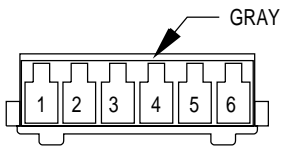

BRAKE LAMP SWITCH

| CAV | CIRCUIT | FUNCTION |
|-----|---------------|-----------------------------------|
| 1 | K29 18WT/PK | BRAKE LAMP SWITCH SENSE |
| 2 | Z1 18BK | GROUND |
| 3 | V32 20YL/RD ▲ | SPEED CONTROL POWER SUPPLY |
| 3 | V32 18YL/RD ● | SPEED CONTROL POWER SUPPLY |
| 4 | V30 20DB/RD | SPEED CONTROL BRAKE SWITCH OUTPUT |
| 5 | L50 20WT/TN | BRAKE LAMP SWITCH OUTPUT |
| 6 | F32 20PK/DB | FUSED B(+) |

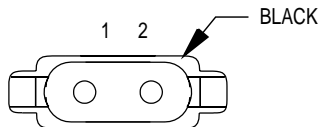

BRAKE WARNING PRESSURE SWITCH

| CAV | CIRCUIT | FUNCTION |
|-----|-------------|------------------------------------|
| 1 | G9 20GY/BK | RED BRAKE WARNING INDICATOR DRIVER |
| 2 | G99 20GY/WT | RED BRAKE WARNING INDICATOR DRIVER |

● LHD
▲ RHD

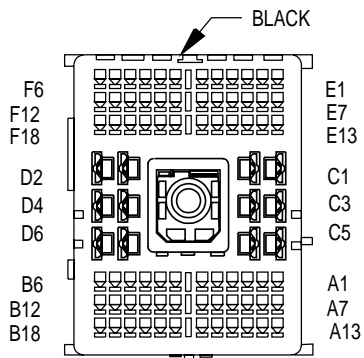

**C100
(LHD)**

| CAV | CIRCUIT |
|-----|-----------------|
| A1 | Z1 18BK |
| A2 | G106 20BK/WT ● |
| A3 | G107 20BK/RD |
| A4 | L92 20PK ▲▲ |
| A5 | L139 20VT ▲▲ |
| A5 | L77 20BR/YL ■■ |
| A6 | C90 20LG ■■■ |
| A6 | C90 18LG ■■ |
| A7 | - |
| A8 | - |
| A9 | - |
| A10 | - |
| A11 | - |
| A12 | - |
| A13 | - |
| A14 | - |
| A15 | - |
| A16 | - |
| A17 | - |
| A18 | - |
| B1 | - |
| B2 | - |
| B3 | - |
| B4 | - |
| B5 | - |
| B6 | - |
| B7 | - |
| B8 | - |
| B9 | - |
| B10 | - |
| B11 | - |
| B12 | - |
| B13 | - |
| B14 | - |
| B15 | - |
| B16 | - |
| B17 | - |
| B18 | - |
| C1 | V3 16BR/WT |
| C2 | A1 12RD |
| C3 | V4 16BR/VT |
| C4 | F75 16VT ▲ |
| C5 | V5 16DG/YL |
| C6 | A2 12PK/BK |
| D1 | A3 14RD/WT |
| D2 | A141 14DG/WT ●● |
| D3 | G34 16RD/GY ▲▲▲ |
| D4 | G34 16RD/GY |
| D5 | A111 12RD/LG |
| D6 | - |

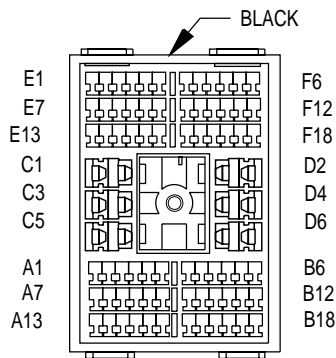

**C100
(LHD)**

| CAV | CIRCUIT |
|-----|-----------------|
| A1 | Z1 18BK |
| A2 | G106 20BK/WT ● |
| A3 | G107 20BK/RD |
| A4 | L39 20LB ▲▲ |
| A5 | L139 20VT ▲▲ |
| A6 | C90 20LG |
| A7 | - |
| A8 | - |
| A9 | - |
| A10 | - |
| A11 | - |
| A12 | - |
| A13 | - |
| A14 | - |
| A15 | - |
| A16 | - |
| A17 | - |
| A18 | - |
| B1 | - |
| B2 | - |
| B3 | - |
| B4 | - |
| B5 | - |
| B6 | - |
| B7 | - |
| B8 | - |
| B9 | - |
| B10 | - |
| B11 | - |
| B12 | - |
| B13 | - |
| B14 | - |
| B15 | - |
| B16 | - |
| B17 | - |
| B18 | - |
| C1 | V3 16BR/WT |
| C2 | A1 12RD |
| C3 | V4 16BR/VT |
| C4 | F75 16VT ▲ |
| C5 | V5 16DG/YL |
| C6 | A2 12PK/BK |
| D1 | A3 14RD/WT |
| D2 | A141 16DG/WT ●● |
| D3 | L3 16RD/OR |
| D4 | G34 16RD/GY |
| D5 | A111 12RD/LG |
| D6 | - |

(CONTINUED ON NEXT PAGE)

- 4.0L A/T
- GAS
- ▲ POWER AMPLIFIER
- ▲▲ FOG LAMPS
- DRL
- DIESEL
- GAS
- ▲▲▲ EXCEPT DRL

(CONTINUED)

| CAV | CIRCUIT |
|-----|------------------|
| E1 | L50 18WT/TN ▲▲▲ |
| E1 | L50 20WT/TN ●●● |
| E2 | G9 20GY/BK |
| E3 | L10 18BR/LG |
| E4 | V10 18BR |
| E5 | V20 18BK/WT |
| E6 | F34 18TN/BK |
| E7 | Z12 20BK/TN ●●● |
| E7 | Z12 18BK/TN |
| E8 | G29 20BK/LB |
| E9 | F20 18WT |
| E10 | F1 20DB/GY ■■■ |
| E11 | D1 20VT/BR ●● |
| E11 | D1 18VT/BR ◇◇ |
| E12 | D2 20WT/BK ●● |
| E12 | D2 18WT/BK ◇◇ |
| E13 | F26 18PK/OR |
| E14 | G99 20GY/WT |
| E15 | K185 20OR/LB |
| E16 | G86 18TN/OR |
| E17 | G154 18VT/LG |
| E18 | L13 20BR/YL ■■ |
| F1 | D20 18LG/BK |
| F2 | D21 20PK ◇◇◇ |
| F2 | D21 18PK ■ |
| F3 | L60 20TN |
| F4 | L61 20LG/WT |
| F5 | L9 20BK/PK |
| F6 | L44 20VT/RD |
| F7 | V30 20DB/RD |
| F8 | F32 20PK/DB |
| F9 | V32 18YL/RD |
| F10 | K29 18WT/PK ▲ |
| F10 | K29 20WT/PK ◇ |
| F11 | K226 18DB/LG |
| F12 | K167 20BR/YL |
| F13 | G19 20LG/OR ● |
| F14 | G31 20VT/LG |
| F15 | G32 20BK/LB |
| F16 | K78 18GY |
| F17 | V37 20RD/LG ●●● |
| F17 | V37 18RD/LG ▲▲▲ |
| F18 | K4 20BK/LB ●●● |
| F18 | K167 20BR/YL ▲▲▲ |

| CAV | CIRCUIT |
|-----|----------------|
| E1 | L50 20WT/TN |
| E2 | G9 20GY/BK |
| E3 | L10 18BR/LG |
| E4 | V10 18BR |
| E5 | V20 18BK/WT |
| E6 | F34 18TN/BK |
| E7 | Z12 18BK/TN |
| E8 | G29 20BK/LB |
| E9 | F20 18WT |
| E10 | F1 20DB/GY ■■■ |
| E11 | D1 20VT/BR |
| E12 | D2 20WT/BK |
| E13 | - |
| E14 | G99 20GY/WT |
| E15 | K185 20OR/LB |
| E16 | G86 20TN/OR |
| E17 | G154 20VT/LG |
| E18 | L13 20BR/YL ■■ |
| F1 | D20 20LG/BK |
| F2 | D21 20PK |
| F3 | L60 20TN |
| F4 | L61 20LG/WT |
| F5 | L9 20BK/PK |
| F6 | L44 20VT/RD ■■ |
| F7 | V30 20DB/RD |
| F8 | F32 20PK/DB |
| F9 | V32 18YL/RD |
| F10 | K29 20WT/PK |
| F11 | K226 20DB/LG |
| F12 | K167 20BR/YL |
| F13 | G19 20LG/OR ● |
| F14 | G31 20VT/LG |
| F15 | G32 20BK/LB |
| F16 | K78 20GY |
| F17 | V37 20RD/LG |
| F18 | K4 20BK/RD |

- 2.5L GAS
- HEADLAMP LEVELING
- SENTRY KEY IMMOBILIZER MODULE
- ◇◇ 4.0L A/T / DIESEL
- ◇◇◇ EXCEPT 4.0L A/T
- ◇◇◇ EXCEPT 2.5L GAS

- ABS
- 4.0L A/T
- DIESEL
- ▲ EXCEPT 4.0L A/T / EXCEPT DIESEL
- ▲▲ SPEED CONTROL (GAS)
- ▲▲▲ GAS

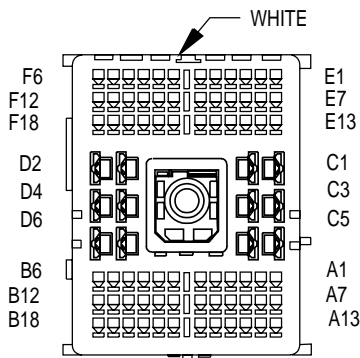

**C100
(RHD)**

| CAV | CIRCUIT |
|-----|------------------|
| A1 | Z1 18BK |
| A2 | G106 20BK/WT ●● |
| A3 | G107 20BK/RD |
| A4 | L92 20PK ●●● |
| A5 | L77 20BR/YL ●●●■ |
| A5 | L139 20VT ●●●■ |
| A6 | C90 20LG ■ |
| A6 | C90 18LG ■■ |
| A7 | Z12 18BK/TN |
| A8 | G29 20BK/LB |
| A9 | F20 18WT |
| A10 | G99 20GY/WT |
| A11 | D1 18VT/BR ▼▼ |
| A11 | D1 20VT/BR ●● |
| A12 | D2 18WT/BK ▼▼ |
| A12 | D2 20WT/BK ●● |
| A13 | - |
| A14 | G9 20GY/BK |
| A15 | L10 18BR/LG |
| A16 | V10 18BR |
| A17 | V20 18BK/WT |
| A18 | F34 18TN/BK |
| B1 | K29 18WT/PK ■ |
| B1 | K29 20WT/PK ■■ |
| B2 | K226 18DB/LG |
| B3 | K167 20BR/YL |
| B4 | L50 18WT/TN ■ |
| B4 | L50 20WT/TN ■■ |
| B5 | V37 18RD/LG ■ |
| B5 | V37 20RD/LG ■■ |
| B6 | K167 20BR/YL ■ |
| B6 | K4 20BK/LB ■■ |
| B7 | D20 18LG/BK |
| B8 | D21 18PK ▲▲ |
| B8 | D21 20PK |
| B9 | L60 20TN |
| B10 | L61 20LG/WT |
| B11 | L9 20BK/PK |
| B12 | L44 20VT/RD |
| B13 | - |
| B14 | - |
| B15 | - |
| B16 | - |
| B17 | - |
| B18 | - |
| C1 | V3 16BR/WT |
| C2 | A1 12RD |
| C3 | V4 16BR/VT |
| C4 | F75 16VT ▲▲▲ |
| C5 | V5 16DG/YL |
| C6 | A2 12PK/BK |
| D1 | A3 14RD/WT |
| D2 | A141 14DG/WT |
| D3 | - |
| D4 | - |
| D5 | A111 12RD/LG |
| D6 | - |

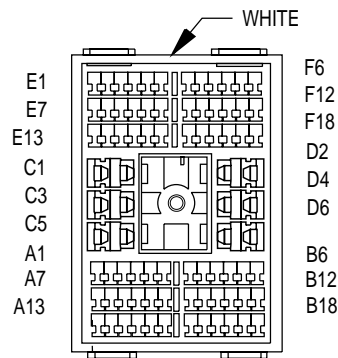

**C100
(RHD)**

| CAV | CIRCUIT |
|-----|-----------------|
| A1 | Z1 18BK |
| A2 | G106 20BK/WT ●● |
| A3 | G107 20BK/RD |
| A4 | L39 20LB ●●● |
| A5 | L139 20VT ●●● |
| A6 | C90 20LG |
| A7 | Z12 18BK/TN |
| A8 | G29 20BK/LB |
| A9 | F20 18WT |
| A10 | G99 20GY/WT |
| A11 | D1 20VT/BR |
| A12 | D2 20WT/BK |
| A13 | - |
| A14 | G9 20GY/BK |
| A15 | L10 18BR/LG |
| A16 | V10 18BR |
| A17 | V20 18BK/WT |
| A18 | F34 18TN/BK |
| B1 | K29 18WT/PK |
| B2 | K226 20DB/LG |
| B3 | K167 20BR/YL |
| B4 | L50 20WT/TN |
| B5 | V37 20RD/LG |
| B6 | K4 20BK/RD |
| B7 | D20 20LG/BK |
| B8 | D21 20PK |
| B9 | L60 20TN |
| B10 | L61 20LG/WT |
| B11 | L9 20BK/PK |
| B12 | L44 20VT/RD ▼ |
| B13 | - |
| B14 | - |
| B15 | - |
| B16 | - |
| B17 | - |
| B18 | - |
| C1 | V3 16BR/WT |
| C2 | A1 12RD |
| C3 | V4 16BR/VT |
| C4 | F75 16VT ▲▲▲ |
| C5 | V5 16DG/YL |
| C6 | A2 12PK/BK |
| D1 | A3 14RD/WT |
| D2 | A141 16DG/WT |
| D3 | - |
| D4 | - |
| D5 | A111 12RD/LG |
| D6 | - |

(CONTINUED ON NEXT PAGE)

- GAS
- DIESEL
- ▲ ABS
- ▲▲ 2.5L
- ▲▲▲ POWER AMP
- DRL
- 4.0L A/T
- FOG LAMPS
- ▼ HEADLAMP LEVELING
- ▼▼ EXCEPT 4.0L A/T

(CONTINUED)

| CAV | CIRCUIT |
|-----|----------------|
| E1 | - |
| E2 | - |
| E3 | - |
| E4 | - |
| E5 | - |
| E6 | - |
| E7 | F45 20YL/RD |
| E8 | T141 20YL |
| E9 | - |
| E10 | F1 20DB/GY ●● |
| E11 | - |
| E12 | - |
| E13 | - |
| E14 | - |
| E15 | K185 20OR/LB ■ |
| E16 | G86 18TN/OR ■ |
| E17 | G154 18VT/LG ■ |
| E18 | L13 20BR/YL ▲ |
| F1 | D20 18LG/BK |
| F2 | - |
| F3 | - |
| F4 | - |
| F5 | - |
| F6 | - |
| F7 | V30 20DB/RD |
| F8 | F32 20PK/DB |
| F9 | V32 18YL/RD |
| F10 | - |
| F11 | - |
| F12 | - |
| F13 | G19 20LG/OR ● |
| F14 | G31 20VT/LG |
| F15 | G32 20BK/LB |
| F16 | - |
| F17 | - |
| F18 | - |

| CAV | CIRCUIT |
|-----|----------------|
| E1 | - |
| E2 | - |
| E3 | - |
| E4 | - |
| E5 | - |
| E6 | - |
| E7 | F45 20YL/RD |
| E8 | T141 20YL |
| E9 | - |
| E10 | F1 20DB/GY ●● |
| E11 | - |
| E12 | - |
| E13 | - |
| E14 | - |
| E15 | K185 20OR/LB ■ |
| E16 | G86 20TN/OR ■ |
| E17 | G154 20VT/LG ■ |
| E18 | L13 20BR/YL ▲ |
| F1 | - |
| F2 | - |
| F3 | - |
| F4 | - |
| F5 | - |
| F6 | - |
| F7 | V30 20DB/RD |
| F8 | F32 20PK/DB |
| F9 | V32 20YL/RD |
| F10 | - |
| F11 | - |
| F12 | - |
| F13 | G19 20LG/OR |
| F14 | G31 20VT/LG |
| F15 | G32 20BK/LB |
| F16 | - |
| F17 | - |
| F18 | - |

- ABS
- SENTRY KEY IMMOBILIZER MODULE
- MESSAGE CENTER
- ▲ HEADLAMP LEVELING

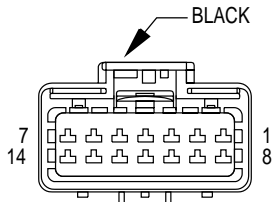

**C106
(DIESEL)**

| CAV | CIRCUIT |
|-----|----------------|
| 1 | L13 20BR/YL ** |
| 2 | L33 20RD |
| 3 | L61 20LG/WT |
| 4 | Z1 20BK |
| 5 | Z15 16BK/GY ** |
| 6 | L34 20RD/OR |
| 7 | L77 20BR/YL |
| 8 | L39 20LB ▽▽▽ |
| 9 | L43 20VT |
| 10 | L60 20TN |
| 11 | Z1 20BK/WT |
| 12 | - |
| 13 | L44 20VT/RD |
| 14 | L78 18DG/YL |

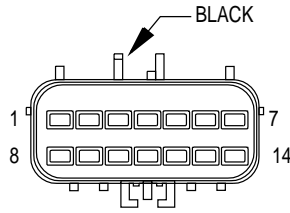

**C106
(DIESEL)**

| CAV | CIRCUIT |
|-----|----------------|
| 1 | L13 18BR/YL ** |
| 2 | L33 18RD |
| 3 | L61 20LG |
| 4 | Z1 18BK |
| 5 | Z15 18BK/GY ** |
| 6 | L34 18RD/OR |
| 7 | L77 20BR |
| 8 | L39 20LB ▽▽▽ |
| 9 | L43 18VT |
| 10 | L60 20TN |
| 11 | Z1 18BK/WT |
| 12 | Z1 20BK ▽ |
| 13 | L44 18VT/RD |
| 14 | L78 20DG/YL |

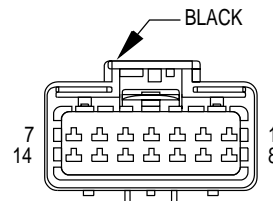

**C106
(GAS)**

| CAV | CIRCUIT |
|-----|----------------|
| 1 | L13 20BR/YL ** |
| 2 | L33 20RD |
| 3 | L61 20LG/WT |
| 4 | Z1 20BK |
| 5 | Z15 16BK/GY ** |
| 6 | L34 20RD/OR |
| 7 | L77 20BR/YL |
| 8 | L39 20LB ▽ |
| 9 | L43 20VT |
| 10 | L60 20TN |
| 11 | Z1 20BK/WT |
| 12 | L33 20RD/WT |
| 13 | L44 20VT/RD |
| 14 | L78 20DG/YL |

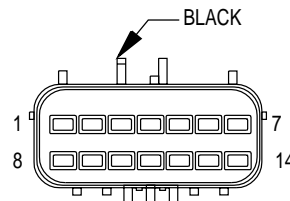

**C106
(GAS)**

| CAV | CIRCUIT |
|-----|----------------|
| 1 | L13 18BR/YL ** |
| 2 | L33 18RD |
| 3 | L61 20LG |
| 4 | Z1 18BK |
| 5 | Z15 18BK/GY ** |
| 6 | L34 18RD/OR |
| 7 | L77 20BR |
| 8 | L39 20LB ▽ |
| 9 | L43 18VT |
| 10 | L60 20TN |
| 11 | Z1 18BK ▲ |
| 11 | Z1 18BK/WT ▲▲ |
| 12 | L33 20RD ▽▽ |
| 12 | Z1 20BK ▲▲ |
| 13 | L44 18VT/RD |
| 14 | L78 20DG/YL |

- ▽ FOG LAMPS
- ▽▽ FOG LAMPS EXCEPT BUILT-UP-EXPORT
- ▽▽▽ FOG LAMPS BUILT-UP-EXPORT
- ▲ EXCEPT BUILT-UP-EXPORT
- ▲▲ BUILT-UP-EXPORT
- RHD
- * EXCEPT ABS
- ** HEADLAMP LEVELING

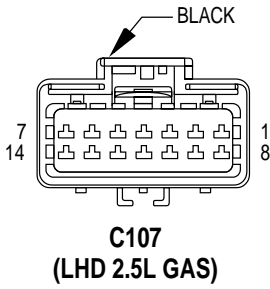

| CAV | CIRCUIT |
|-----|---------------|
| 1 | A142 18DG/OR |
| 2 | K20 18DG |
| 3 | K167 20BR/YL |
| 4 | G7 20WT/OR ■■ |
| 5 | T41 20BK/WT |
| 6 | - |
| 7 | F142 18DG/WT |
| 8 | G107 20BK/RD |
| 9 | - |
| 10 | F12 18DB/WT |
| 11 | F20 18WT |
| 12 | - |
| 13 | - |
| 14 | A61 16DG/BK |

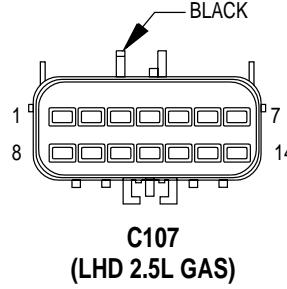

| CAV | CIRCUIT |
|-----|---------------|
| 1 | A142 18DG/OR |
| 2 | K20 18DG |
| 3 | K167 20BR/YL |
| 4 | G7 20WT/OR ■■ |
| 5 | Z1 20 BK ●● |
| 5 | T41 18BK/WT ● |
| 6 | - |
| 7 | F142 20DG/WT |
| 8 | G107 20BK/RD |
| 9 | - |
| 10 | F12 18DB/WT |
| 11 | F20 18WT |
| 12 | L10 18BR/LG |
| 13 | - |
| 14 | A61 14DG/BK |

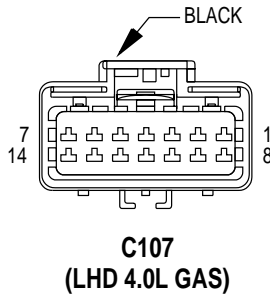

| CAV | CIRCUIT |
|-----|-----------------|
| 1 | A142 18DG/OR |
| 2 | K20 18DG |
| 3 | K167 20BR/YL |
| 4 | G7 20WT/OR ■■ |
| 5 | T41 20BK/WT ● |
| 5 | Z1 18BK ●● |
| 6 | K22 20OR/DB ▲ |
| 7 | A42 18DG |
| 8 | G107 20BK/RD ◀▶ |
| 9 | Z12 18BK/TN ▲ |
| 10 | F12 18DB/WT |
| 11 | K78 18GY ▼▼▼ |
| 12 | G106 20BK/WT ◀▶ |
| 13 | A242 18VT/OR |
| 14 | A61 16DG/BK |

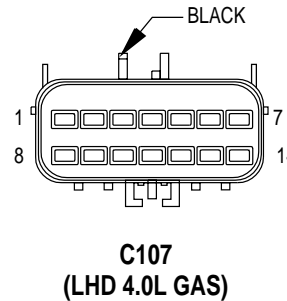

| CAV | CIRCUIT |
|-----|-----------------|
| 1 | A142 18DG/OR |
| 2 | K20 18DG |
| 3 | K167 20BR/YL |
| 4 | G7 20WT/OR ■■ |
| 5 | T41 18BK/WT |
| 6 | K22 20OR/DB ▲ |
| 7 | A42 20DG |
| 8 | G107 20BK/RD ◀▶ |
| 9 | Z12 16BK/TN ▲ |
| 10 | F12 18DB/WT |
| 11 | K78 18GY ▲ |
| 12 | G106 20BK/WT ▲▲ |
| 13 | A242 20VT/OR ▼▼ |
| 13 | A242 20DG/OR ▼ |
| 14 | A61 14DG/BK |

- ▲ 4.0L A/T
- ◀▶ 4WD
- A/T
- M/T
- ▲▲ 4WD A/T
- EXCEPT 4.0L M/T 2WD
- DRL
- ▼ 2WD CALIFORNIA, BUILT-UP-EXPORT
- ▼▼ 4WD CALIFORNIA, BUILT-UP-EXPORT
- ▼▼▼ EXTENDED IDLE

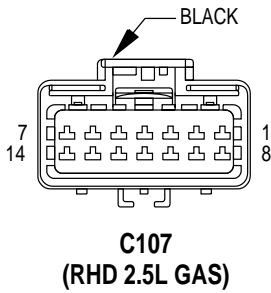

| CAV | CIRCUIT |
|-----|--------------|
| 1 | A142 18DG/OR |
| 2 | K20 18DG |
| 3 | K167 20BR/YL |
| 4 | - |
| 5 | T41 20BK/WT |
| 6 | - |
| 7 | F142 18DG/WT |
| 8 | G107 20BK/RD |
| 9 | - |
| 10 | F12 18DB/WT |
| 11 | F20 18WT |
| 12 | L10 18BR/LG |
| 13 | - |
| 14 | A61 16DG/BK |

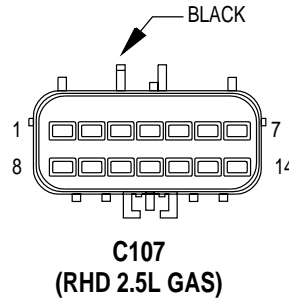

| CAV | CIRCUIT |
|-----|---------------|
| 1 | A142 18DG/OR |
| 2 | K20 18DG |
| 3 | K167 20BR/YL |
| 4 | G7 20WT/OR ■■ |
| 5 | Z1 20 BK ●● |
| 5 | T41 18BK/WT ● |
| 6 | - |
| 7 | F142 20DG/WT |
| 8 | G107 20BK/RD |
| 9 | - |
| 10 | F12 18DB/WT |
| 11 | F20 18WT |
| 12 | L10 18BR/LG |
| 13 | - |
| 14 | A61 14DG/BK |

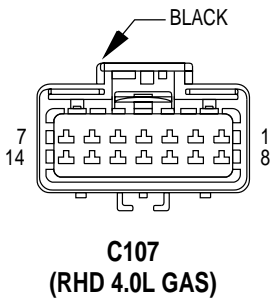

| CAV | CIRCUIT |
|-----|-----------------|
| 1 | A142 18DG/OR |
| 2 | K20 18DG |
| 3 | K167 20BR/YL |
| 4 | G7 20WT/OR |
| 5 | T41 20BK/WT ● |
| 5 | Z1 18BK ●● |
| 6 | K22 20OR/DB ■ |
| 7 | A42 18DG |
| 8 | G107 20BK/RD ◀▶ |
| 9 | Z12 18BK/TN ■ |
| 10 | F12 18DB/WT |
| 11 | - |
| 12 | G106 20BK/WT |
| 13 | A242 18VT/OR |
| 14 | A61 16DG/BK |

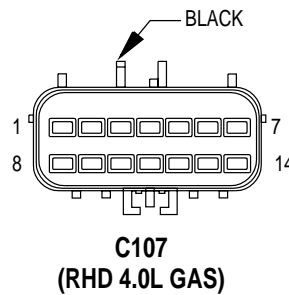

| CAV | CIRCUIT |
|-----|-----------------|
| 1 | A142 18DG/OR |
| 2 | K20 18DG |
| 3 | K167 20BR/YL |
| 4 | G7 20WT/OR ■■ |
| 5 | T41 18BK/WT |
| 6 | K22 20OR/DB ▲ |
| 7 | A42 20DG |
| 8 | G107 20BK/RD ◀▶ |
| 9 | Z12 16BK/TN ▲ |
| 10 | F12 18DB/WT |
| 11 | - |
| 12 | G106 20BK/WT ▲▲ |
| 13 | A242 20VT/OR ▼▼ |
| 13 | A242 20DG/OR ▼ |
| 14 | A61 14DG/BK |

- ▲ 4.0L A/T
- ◀▶ 4WD
- A/T
- M/T
- ▲▲ 4WD A/T
- 4.0L GAS (EXCEPT M/T 2WD)
- DRL
- ▼ 2WD CALIFORNIA/BUILT-UP-EXPORT
- ▼▼ 4WD CALIFORNIA/BUILT-UP-EXPORT

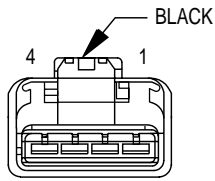

**C108
(GAS)**

| CAV | CIRCUIT |
|-----|-------------|
| 1 | T40 16BR |
| 2 | K72 18DG/OR |
| 3 | K20 18DG |
| 4 | C3 16DB/BK |

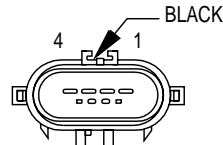

**C108
(GAS)**

| CAV | CIRCUIT |
|-----|-------------|
| 1 | T40 16BR |
| 2 | K72 16DG/OR |
| 3 | K20 16DG |
| 4 | C3 16DB/BK |

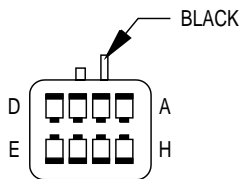

C109

| CAV | CIRCUIT |
|-----|-------------|
| A | B41 18YL/VT |
| B | B42 18TN/WT |
| C | B43 18PK/OR |
| D | B1 18YL/DB |
| E | B2 18YL |
| F | B3 18LG/DB |
| G | B4 18LG |

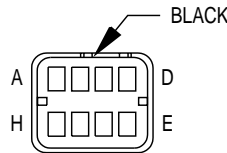

C109

| CAV | CIRCUIT |
|-----|-------------|
| A | B41 20YL/VT |
| B | B42 20TN/WT |
| C | B43 20PK/OR |
| D | B1 20YL/DB |
| E | B2 20YL |
| F | B3 20LG/DB |
| G | B4 20LG |

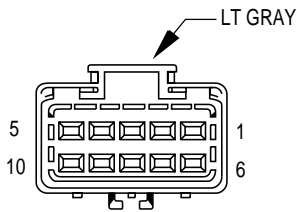

**C111
(DIESEL)**

| CAV | CIRCUIT |
|-----|--------------|
| 1 | G7 20WT/OR |
| 2 | - |
| 3 | G107 20BK/RD |
| 4 | Z1 18BK |
| 5 | L10 18BR/LG |
| 6 | K7 20OR |
| 7 | F20 18WT |
| 8 | K167 20BR/YL |
| 9 | - |
| 10 | T40 16BR |

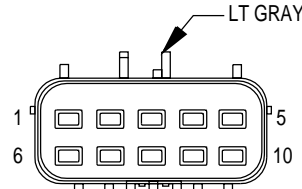

**C111
(DIESEL)**

| CAV | CIRCUIT |
|-----|--------------|
| 1 | G7 18WT/OR |
| 2 | - |
| 3 | G107 20BK/RD |
| 4 | Z1 20BK |
| 5 | L10 18BR/LG |
| 6 | K7 18OR |
| 7 | F20 18WT |
| 8 | K167 18BR/YL |
| 9 | - |
| 10 | T40 14BR |

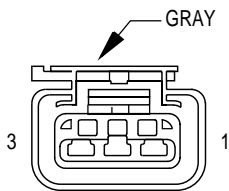

**C112
(4.0L A/T 4WD)**

| CAV | CIRCUIT |
|-----|--------------|
| 1 | Z1 20BK |
| 2 | G106 20BK/WT |
| 3 | G107 20BK/RD |

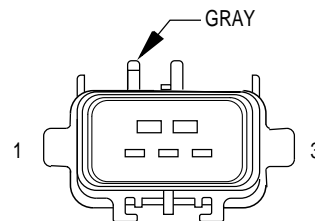

**C112
(4.0L A/T 4WD)**

| CAV | CIRCUIT |
|-----|--------------|
| 1 | Z1 20BK |
| 2 | G106 20BK/WT |
| 3 | G107 20BK/RD |

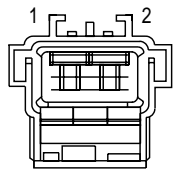

**C113
(GAS M/T)**

| CAV | CIRCUIT |
|-----|-------------|
| 1 | F20 18WT |
| 2 | L10 18BR/LG |

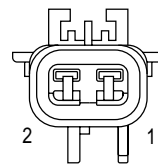

**C113
(GAS M/T)**

| CAV | CIRCUIT |
|-----|-------------|
| 1 | F20 18WT |
| 2 | L10 18BR/LG |

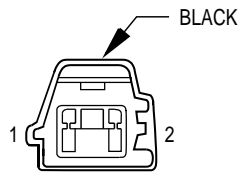

**C114
(BUILT-UP-EXPORT)**

| CAV | CIRCUIT |
|-----|----------|
| 1 | L61 18LG |
| 2 | Z1 18BK |

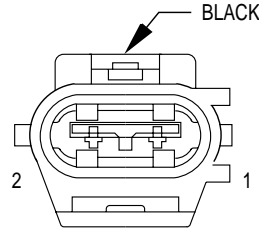

**C114
(BUILT-UP-EXPORT)**

| CAV | CIRCUIT |
|-----|----------|
| 1 | L61 18GY |
| 2 | Z1 18BK |

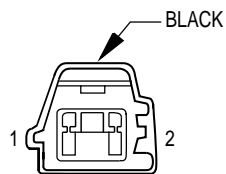

**C115
(BUILT-UP-EXPORT)**

| CAV | CIRCUIT |
|-----|----------|
| 1 | L60 18TN |
| 2 | Z1 18BK |

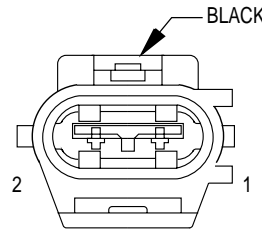

**C115
(BUILT-UP-EXPORT)**

| CAV | CIRCUIT |
|-----|----------|
| 1 | L60 18GY |
| 2 | Z1 18BK |

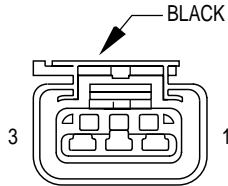

**C116
(DIESEL)**

| CAV | CIRCUIT |
|-----|--------------|
| 1 | K7 20OR |
| 2 | G60 18GY/YL |
| 3 | K167 20BR/YL |

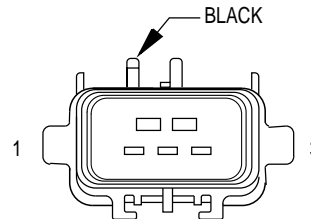

**C116
(DIESEL)**

| CAV | CIRCUIT |
|-----|--------------|
| 1 | K7 18OR |
| 2 | G60 18GY/YL |
| 3 | K167 18BR/YL |

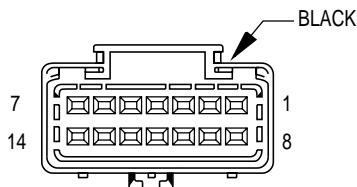

**C120
(DIESEL)**

| CAV | CIRCUIT |
|-----|--------------|
| 1 | K3 20LG/BK |
| 2 | C21 20DB/PK |
| 3 | C22 20DB/WT |
| 4 | K24 20GY/BK |
| 5 | K20 18DG |
| 6 | C3 16DB/BK |
| 7 | K72 18DG/OR |
| 8 | K2 20TN/BK |
| 9 | K4 20BK/LB |
| 10 | K222 18TN/RD |
| 11 | Z1 16BK |
| 12 | K167 18BR/YL |
| 13 | C48 18TN |
| 14 | - |

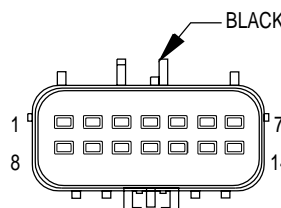

**C120
(DIESEL)**

| CAV | CIRCUIT |
|-----|--------------|
| 1 | K3 20LG/BK |
| 2 | C21 20DB/PK |
| 3 | C22 20DB/WT |
| 4 | K24 20GY/BK |
| 5 | K20 18DG |
| 6 | C3 14DB/BK |
| 7 | K72 18DG/OR |
| 8 | K2 18TN/BK |
| 9 | K4 18BK/LB |
| 10 | K222 18TN/RD |
| 11 | Z1 16BK |
| 12 | K167 18BR/YL |
| 13 | C48 18TN |
| 14 | - |

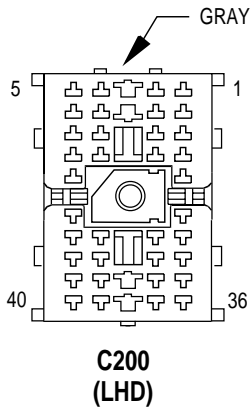

| CAV | CIRCUIT |
|-----|----------------|
| 1 | X53 18DG |
| 2 | X55 18BR/RD |
| 3 | - |
| 4 | X54 18VT |
| 5 | X56 18DB/RD |
| 6 | X51 18BR/YL |
| 7 | X57 18BR/LB |
| 8 | - |
| 9 | X52 18DB/WT |
| 10 | X58 18DB/OR |
| 11 | X60 18DG/RD ● |
| 12 | P91 20WT/BK |
| 13 | A141 16DG/WT |
| 14 | F75 14VT ● |
| 15 | K226 20DB/LG |
| 16 | L10 18BR/LG |
| 17 | G16 20BK/LB |
| 18 | - |
| 19 | - |
| 20 | - |
| 21 | - |
| 22 | - |
| 23 | L38 18BR/WT |
| 24 | L50 20WT/TN |
| 25 | L62 20BR/RD |
| 26 | L63 20DG/RD |
| 27 | V13 18BR |
| 28 | V20 18BK/WT |
| 29 | V23 18BR/PK |
| 30 | K167 20BR/YL |
| 31 | P35 20OR/VT ●● |
| 32 | P36 20PK/VT ●● |
| 33 | F81 12TN ●● |
| 34 | P72 20YL/BK |
| 35 | P74 20DB |
| 36 | P76 20OR/YL |
| 37 | C16 20LB/YL |
| 38 | - |
| 39 | F83 18YL/DG |
| 40 | G78 20TN/BK |

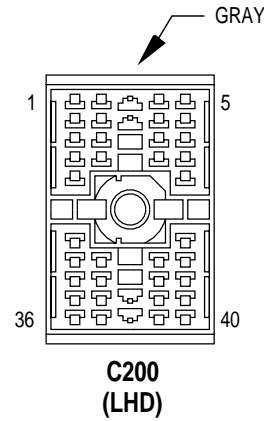

| CAV | CIRCUIT |
|-----|----------------|
| 1 | X53 16DG |
| 2 | X55 16BR/RD |
| 3 | - |
| 4 | X54 16VT |
| 5 | X56 16DB/RD |
| 6 | X51 16BR/YL |
| 7 | X57 16BR/LB |
| 8 | - |
| 9 | X52 16DB/WT |
| 10 | X58 16DB/OR |
| 11 | X60 16DG/RD ● |
| 12 | P91 20WT/BK |
| 13 | A141 16DG/WT |
| 14 | F75 16VT ● |
| 15 | K226 20DB/LG |
| 16 | L10 18BR/LG |
| 17 | G16 20BK/LB |
| 18 | - |
| 19 | - |
| 20 | - |
| 21 | - |
| 22 | - |
| 23 | L38 18BR/WT ▲ |
| 24 | L50 20WT/TN |
| 25 | L62 20BR/RD |
| 26 | L63 20DG/RD |
| 27 | V13 18BR/LG |
| 28 | V20 18BK/WT |
| 29 | V23 18BR/PK |
| 30 | K167 20BR/YL |
| 31 | P35 20OR/VT ●● |
| 32 | P36 20PK/VT ●● |
| 33 | F81 12TN ●● |
| 34 | P72 20YL/BK |
| 35 | P74 20DB |
| 36 | P76 20OR/YL |
| 37 | C16 20LB/YL |
| 38 | - |
| 39 | F83 18YL/DG |
| 40 | G78 20TN/BK |

- FULL OPTIONS (WITH POWER AMPLIFIER)
- FULL OPTIONS
- ▲ BUILT-UP-EXPORT

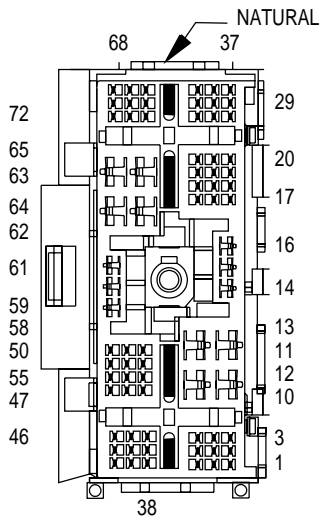

**C201
(LHD)**

| CAV | CIRCUIT |
|-----|--------------|
| 1 | F20 18WT |
| 2 | C16 20LB/YL |
| 3 | L5 20BK |
| 4 | C36 20RD/WT |
| 5 | F87 20WT/BK |
| 6 | M1 20PK |
| 7 | Z1 20BK |
| 8 | V6 16DB |
| 9 | P36 20PK/VT |
| 10 | A31 12BK/WT |
| 11 | A111 12RD/LG |
| 12 | C7 12BK/TN |
| 13 | F81 12TN |
| 14 | Z1 14BK |
| 15 | - |
| 16 | L3 16RD/OR |
| 17 | C81 20LB/WT |
| 18 | - |
| 19 | - |
| 20 | P72 20YL/BK |
| 21 | - |
| 22 | L4 16VT/WT |
| 23 | P35 20OR/VT |
| 24 | P74 20DB |
| 25 | Z8 20BK/VT |
| 26 | X3 20BK/RD |
| 27 | - |
| 28 | P76 20OR/YL |
| 29 | G26 20LB |
| 30 | - |
| 31 | - |
| 32 | G31 20VT/LG |
| 33 | - |
| 34 | - |
| 35 | G32 20BK/LB |
| 36 | - |
| 37 | - |
| 38 | - |
| 39 | V23 18BR/PK |
| 40 | F15 20DB/WT |
| 41 | - |
| 42 | E1 20TN |
| 43 | E2 20OR |

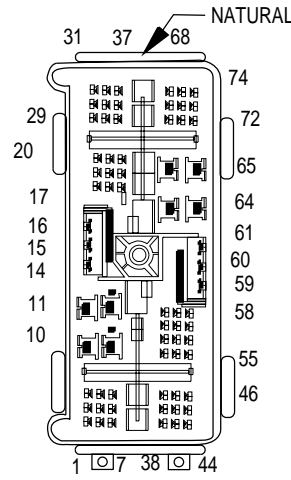

**C201
(LHD)**

| CAV | CIRCUIT |
|-----|--------------|
| 1 | F20 18WT |
| 2 | C16 20LB/YL |
| 3 | L5 20BK |
| 4 | C36 20RD/WT |
| 5 | F87 20WT/BK |
| 6 | M1 20PK |
| 7 | Z1 20BK |
| 8 | V6 16DB |
| 9 | P36 20PK/VT |
| 10 | A31 12BK/WT |
| 11 | A111 12RD/LG |
| 12 | C7 12BK/TN |
| 13 | F81 12TN |
| 14 | Z1 14BK |
| 15 | - |
| 16 | L3 16RD/OR |
| 17 | C81 20LB/WT |
| 18 | - |
| 19 | - |
| 20 | P72 20YL/BK |
| 21 | - |
| 22 | L4 16VT/WT |
| 23 | P35 20OR/VT |
| 24 | P74 20DB |
| 25 | Z8 16BK/VT |
| 26 | X3 20BK/RD |
| 27 | - |
| 28 | P76 20OR/YL |
| 29 | G26 20LB |
| 30 | - |
| 31 | - |
| 32 | G31 20VT/LG |
| 33 | - |
| 34 | - |
| 35 | G32 20BK/LB |
| 36 | - |
| 37 | - |
| 38 | - |
| 39 | V23 18BR/PK |
| 40 | F15 20DB/WT |
| 41 | - |
| 42 | E1 20TN |
| 43 | E2 20OR |

(CONTINUED)

(CONTINUED)

| CAV | CIRCUIT |
|-----|-------------|
| 44 | F83 18YL/DG |
| 45 | L7 18BK/YL |
| 46 | M2 20YL |
| 47 | - |
| 48 | - |
| 49 | - |
| 50 | F30 16RD |
| 51 | D1 18VT/BR |
| 52 | D2 18WT/BK |
| 53 | - |
| 54 | X12 16RD/WT |
| 55 | D1 20VT/BR |
| 56 | D2 20WT/BK |
| 57 | - |
| 58 | Z2 20BK/LG |
| 59 | C4 14TN |
| 60 | C5 14LG |
| 61 | C6 14LB |
| 62 | A22 12BK/OR |
| 63 | A41 14YL |
| 64 | A21 12DB |
| 65 | F38 16RD/LB |
| 66 | G9 20GY/BK |
| 67 | P91 20WT/BK |
| 68 | - |
| 69 | G10 20LG/RD |
| 70 | - |
| 71 | - |
| 72 | - |
| 73 | - |
| 74 | - |

| CAV | CIRCUIT |
|-----|-------------|
| 44 | F83 18YL/DG |
| 45 | L7 18BK/YL |
| 46 | M2 20YL |
| 47 | - |
| 48 | - |
| 49 | - |
| 50 | F30 16RD |
| 51 | D1 20VT/BR |
| 52 | D2 20WT/BK |
| 53 | - |
| 54 | X12 16RD/WT |
| 55 | D1 20VT/BR |
| 56 | D2 20WT/BK |
| 57 | - |
| 58 | Z2 20BK/LG |
| 59 | C4 14TN |
| 60 | C5 14LG |
| 61 | C6 14LB |
| 62 | A22 12BK/OR |
| 63 | A41 14YL |
| 64 | A21 12DB |
| 65 | F38 16RD/LB |
| 66 | G9 20GY/BK |
| 67 | P91 20WT/BK |
| 68 | - |
| 69 | G10 20LG/RD |
| 70 | - |
| 71 | - |
| 72 | - |
| 73 | - |
| 74 | - |

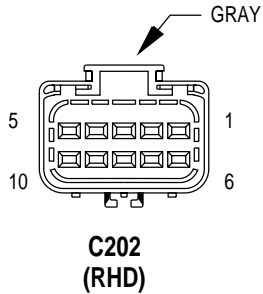

| CAV | CIRCUIT |
|-----|--------------|
| 1 | C7 12BK/TN |
| 2 | - |
| 3 | F81 12TN ● |
| 4 | - |
| 5 | - |
| 6 | Z8 16BK/VT |
| 7 | A111 12RD/LG |
| 8 | C6 14LB |
| 9 | C5 14LG |
| 10 | C4 14TN |

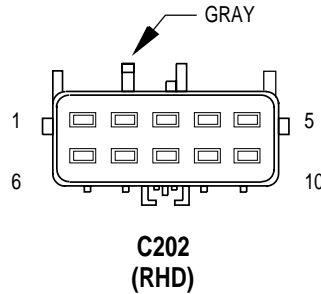

| CAV | CIRCUIT |
|-----|--------------|
| 1 | C7 12BK/TN |
| 2 | - |
| 3 | F81 12TN ● |
| 4 | - |
| 5 | - |
| 6 | Z8 12BK/VT |
| 7 | A111 12RD/LG |
| 8 | C6 14LB |
| 9 | C5 14LG |
| 10 | C4 14TN |

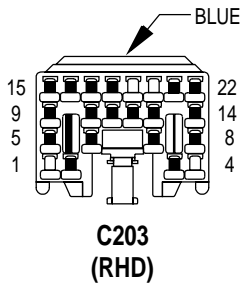

| CAV | CIRCUIT |
|-----|---------------|
| 1 | P55 20DB/PK ● |
| 2 | P59 20LB/RD ● |
| 3 | G26 20LB ● |
| 4 | G16 20BK/LB |
| 5 | V20 18BK/WT |
| 6 | V23 18BR/PK |
| 7 | V13 18BR/LG |
| 8 | L38 18BR/WT ■ |
| 9 | - |
| 10 | P91 20WT/BK |
| 11 | G10 20LG/RD |
| 12 | E2 20OR |
| 13 | G9 20GY/BK |
| 14 | X60 16DG/RD |
| 15 | X58 16DB/OR |
| 16 | X57 16BR/LB |
| 17 | X56 16DB/RD |
| 18 | X55 16BR/RD |
| 19 | X54 16VT |
| 20 | X53 16DG |
| 21 | X52 16DB/WT |
| 22 | X51 16BR/YL |

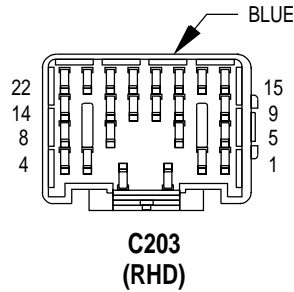

| CAV | CIRCUIT |
|-----|-----------------|
| 1 | P55 20DB/PK ● |
| 2 | P59 20LB/RD ● |
| 3 | G26 20LB ● |
| 4 | G16 20BK/LB |
| 5 | V20 18BK/WT |
| 6 | V23 18BR/PK |
| 7 | V13 18BR |
| 8 | L38 18BR/WT |
| 9 | - |
| 10 | P91 20WT/BK |
| 11 | G10 20LG/RD |
| 12 | E2 20OR/BK |
| 13 | G9 20GY/BK |
| 14 | X60 18DG/RD ■ ■ |
| 15 | X58 18DB/OR |
| 16 | X57 18BR/LB |
| 17 | X56 18DB/RD |
| 18 | X55 18BR/RD |
| 19 | X54 18VT |
| 20 | X53 18DG |
| 21 | X52 18DB/WT |
| 22 | X51 18BR/YL |

- ■ FULL OPTIONS W/ POWER AMPLIFIER
- BUILT UP EXPORT
- BASE AND FULL OPTIONS W/O POWER AMPLIFIER
- FULL OPTIONS

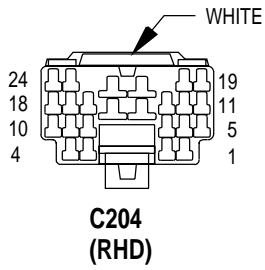

| CAV | CIRCUIT |
|-----|--------------|
| 1 | F15 20DB/WT |
| 2 | C16 20BK/WT |
| 3 | P35 20OR/VT |
| 4 | P36 20PK/VT |
| 5 | G78 20TN/BK |
| 6 | K226 20DB/LG |
| 7 | K167 20BR/YL |
| 8 | P72 20YL/BK |
| 9 | P74 20DB |
| 10 | P76 20OR/YL |
| 11 | L62 20BR/RD |
| 12 | L63 20DG/RD |
| 13 | - |
| 14 | F23 18DB/YL |
| 15 | F14 18LG/YL |
| 16 | F35 16RD |
| 17 | Z1 20BK |
| 18 | C36 18RD/WT |
| 19 | D1 20VT/BR |
| 20 | D2 20WT/BK |
| 21 | F75 16VT ● |
| 22 | A141 16DG/WT |
| 23 | L10 18BR/LG |
| 24 | L50 20WT/TN |

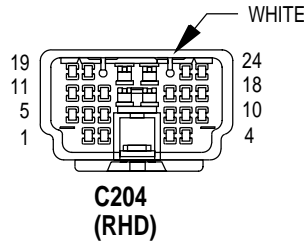

| CAV | CIRCUIT |
|-----|---------------|
| 1 | F15 20DB/WT |
| 2 | C16 20LB/YL |
| 3 | P35 20OR/VT ● |
| 4 | P36 20PK/VT ● |
| 5 | G78 20TN/BK |
| 6 | K226 20DB/LG |
| 7 | K167 20BR/YL |
| 8 | P72 20YL/BK |
| 9 | P74 20DB |
| 10 | P76 20OR/YL |
| 11 | L62 20BR/RD |
| 12 | L63 20DG/RD |
| 13 | - |
| 14 | F23 18DB/YL |
| 15 | F14 18LG/YL |
| 16 | F35 16RD ● |
| 17 | Z1 20BK |
| 18 | C36 20RD/WT |
| 19 | D1 18VT/BR |
| 20 | D2 18WT/BK |
| 21 | F75 16VT ■■ |
| 22 | A141 16DG/WT |
| 23 | L10 18BR/LG |
| 24 | L50 20WT/TN |

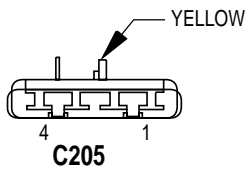

| CAV | CIRCUIT |
|-----|-------------|
| 1 | R42 18BK/YL |
| 2 | R44 18DG/YL |
| 3 | R43 18BK/LB |
| 4 | R45 18DG/LB |

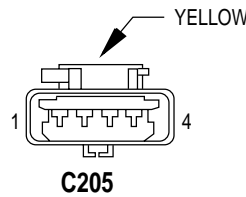

| CAV | CIRCUIT |
|-----|-------------|
| 1 | R42 18BK/YL |
| 2 | R44 18DG/YL |
| 3 | R43 18BK/LB |
| 4 | R45 18DG/LB |

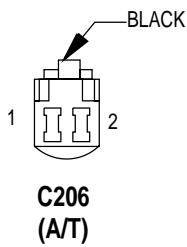

| CAV | CIRCUIT |
|-----|--------------|
| 1 | E2 20OR ■ |
| 1 | E2 20OR/BK ▲ |
| 2 | Z1 20BK |

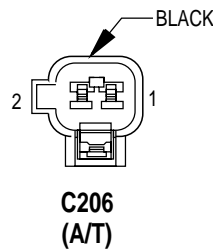

| CAV | CIRCUIT |
|-----|---------|
| 1 | E2 20OR |
| | E2 20OR |
| 2 | Z1 20BK |
| | Z1 20BK |

- FULL OPTIONS
- ▲ RHD
- LHD
- FULL OPTIONS W/POWER AMP

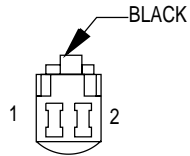

C206 (M/T)

| CAV | CIRCUIT |
|-----|--------------|
| 1 | E2 20OR ▲ |
| 1 | E2 20OR/BK ● |
| 2 | Z1 20BK |

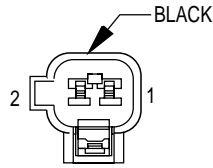

C206 (M/T)

| CAV | CIRCUIT |
|-----|---------|
| 1 | E2 20OR |
| 2 | Z1 20BK |

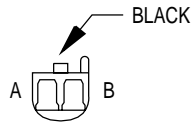

C207

| CAV | CIRCUIT |
|-----|---------|
| A | M1 20PK |
| B | M2 20YL |

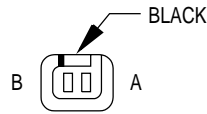

C207

| CAV | CIRCUIT |
|-----|------------|
| A | M1 18PK |
| B | M2 18BK/WT |

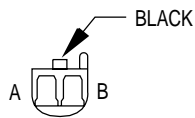

C208

| CAV | CIRCUIT |
|-----|---------|
| A | M1 20PK |
| B | M2 20YL |

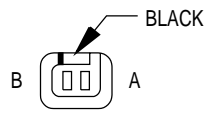

C208

| CAV | CIRCUIT |
|-----|------------|
| A | M1 18PK |
| B | M2 18BK/WT |

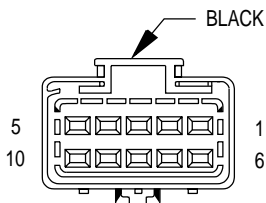

C209

| CAV | CIRCUIT |
|-----|--------------|
| 1 | Z1 20BK |
| 2 | C4 14TN |
| 3 | C5 14LG |
| 4 | C6 14LB |
| 5 | F15 20DB/WT |
| 6 | C36 20RD/WT |
| 7 | C7 12BK/TN |
| 8 | A111 12RD/LG |
| 9 | F15 20DB/WT |
| 10 | Z8 12BK/VT ● |
| 10 | Z8 20BK/VT ▲ |

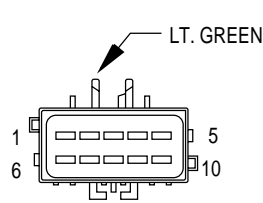

C209

| CAV | CIRCUIT |
|-----|--------------|
| 1 | D1 20DB/WT |
| 2 | C4 14TN |
| 3 | C5 14LG |
| 4 | C6 14LB |
| 5 | D2 20OR |
| 6 | D3 20YL |
| 7 | C7 12BK/TN |
| 8 | A111 12RD/LG |
| 9 | F15 20DB/WT |
| 10 | Z1 20BK |

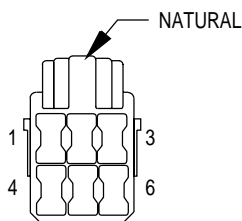

C300 (LHD)

| CAV | CIRCUIT |
|-----|-------------|
| 1 | P35 20OR/VT |
| 2 | P36 20PK/VT |
| 3 | P55 20DB/PK |
| 4 | P59 20LB/RD |
| 5 | G26 20LB |
| 6 | - |

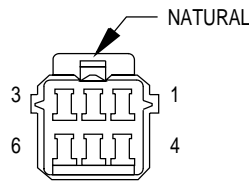

C300 (LHD)

| CAV | CIRCUIT |
|-----|-------------|
| 1 | P35 20OR/VT |
| 2 | P36 20PK/VT |
| 3 | P55 20DB/PK |
| 4 | P59 20LB/RD |
| 5 | G26 20LB |
| 6 | - |

● RHD
▲ LHD

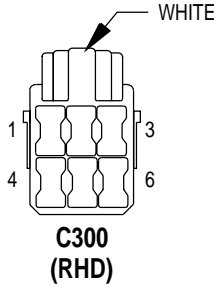

| CAV | CIRCUIT |
|-----|---------------|
| 1 | P35 18OR/VT |
| 2 | P36 18PK/VT |
| 3 | F83 18YL/DG ● |
| 4 | - |
| 5 | - |
| 6 | - |

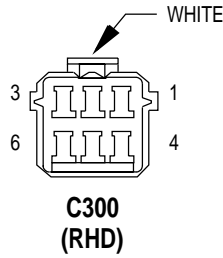

| CAV | CIRCUIT |
|-----|---------------|
| 1 | P35 20OR/VT |
| 2 | P36 20PK/VT |
| 3 | F83 18YL/DG ● |
| 4 | - |
| 5 | - |
| 6 | - |

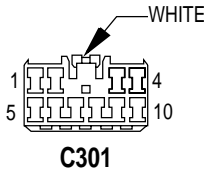

| CAV | CIRCUIT |
|-----|----------------|
| 1 | D1 20VT/BR |
| 2 | D2 20WT/BK |
| 3 | G32 20BK/LB ■■ |
| 4 | G31 20VT/LG ■■ |
| 5 | Z2 20BK/LG ■■ |
| 6 | F87 20WT/BK ■■ |
| 7 | X3 20BK/RD |
| 8 | P55 20DB |
| 9 | P59 20LB/RD |
| 10 | - |

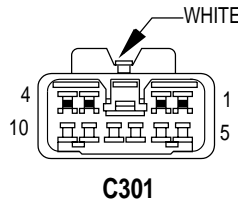

| CAV | CIRCUIT |
|-----|----------------|
| 1 | D1 20VT/BR |
| 2 | D2 20WT/BK |
| 3 | G32 20BK/LB ■■ |
| 4 | G31 20VT/LG ■■ |
| 5 | Z2 20BK/LG ■■ |
| 6 | F87 20WT/BK ■■ |
| 7 | X3 20BK/RD |
| 8 | P55 20DB/PK |
| 9 | P59 20LB/RD |
| 10 | - |

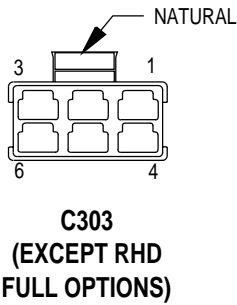

| CAV | CIRCUIT |
|-----|---------------|
| 1 | Q16 14BR/WT ■ |
| 2 | Q26 14VT/WT ■ |
| 3 | Q1 14YL ■ |
| 4 | X80 18LB/BK |
| 5 | X82 18LB/RD |
| 6 | - |

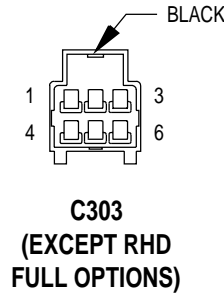

| CAV | CIRCUIT |
|-----|----------------|
| 1 | Q16 14BR/WT ■ |
| 1 | V23 18BR/PK ●● |
| 2 | Q26 14VT/WT ■ |
| 3 | Q1 14YL ■ |
| 4 | X80 18LB/BK ▲▲ |
| 4 | X56 18DB/RD ▲ |
| 5 | X82 18LB/RD ▲▲ |
| 5 | X54 18VT ▲ |
| 6 | - |

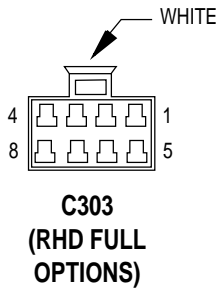

| CAV | CIRCUIT |
|-----|---------------|
| 1 | Q18 14GY/BK ■ |
| 2 | Q28 14DG/WT |
| 3 | Q17 14DB/WT ■ |
| 4 | Q1 14YL ■ |
| 5 | Z1 14BK ■ |
| 6 | Q27 14RD/BK ■ |
| 7 | Q16 14BR/WT ■ |
| 8 | Q26 14VT/WT ■ |

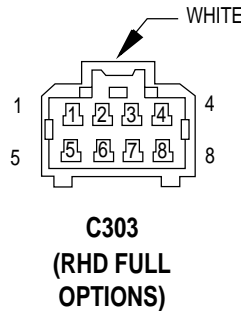

| CAV | CIRCUIT |
|-----|----------------|
| 1 | Q18 14GY/BK ■ |
| 1 | V23 18BR/PK ●● |
| 2 | Q28 14DG/WT ■ |
| 3 | Q17 14DB/WT ■ |
| 4 | Q1 14YL ■ |
| 4 | X56 18DB/RD ●● |
| 5 | Z1 14BK ■ |
| 5 | X54 18VT ●● |
| 6 | Q27 14RD/BK ■ |
| 7 | Q16 14BR/WT ■ |
| 8 | Q26 14VT/WT ■ |

- FULL OPTIONS
- OVERHEAD CONSOLE
- FULL OPTIONS AND POWER MIRRORS
- BASE

- ▲ 4 SPEAKER SYSTEM
- ▲▲ 6 SPEAKER SYSTEM

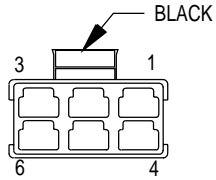

**C304
(LHD)**

| CAV | CIRCUIT |
|-----|-------------|
| 1 | Q18 14GY/BK |
| 2 | Q28 14DG/WT |
| 3 | Q1 14YL |
| 4 | P33 16OR/BK |
| 5 | P34 16PK/BK |
| 6 | - |

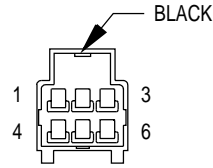

**C304
(LHD)**

| CAV | CIRCUIT |
|-----|-------------|
| 1 | Q18 14GY/BK |
| 2 | Q28 14DG/WT |
| 3 | Q1 14YL |
| 4 | P33 16OR/BK |
| 5 | P34 16PK/BK |
| 6 | - |

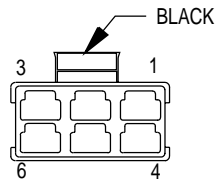

**C304
(RHD)**

| CAV | CIRCUIT |
|-----|-------------|
| 1 | Q18 14GY/BK |
| 2 | Q28 14DG/WT |
| 3 | Q1 14YL |
| 4 | P33 16OR/BK |
| 5 | P34 16PK/BK |
| 6 | - |

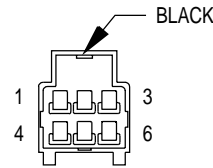

**C304
(RHD)**

| CAV | CIRCUIT |
|-----|-------------|
| 1 | Q18 14GY/BK |
| 2 | Q28 14DG/WT |
| 3 | Q1 14YL |
| 4 | P33 16OR/BK |
| 5 | P34 16PK/BK |
| 6 | - |

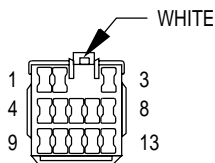

**C305
(LHD)**

| CAV | CIRCUIT |
|-----|----------------|
| 1 | X85 18BR/RD ■■ |
| 1 | X55 18LG/RD ■ |
| 2 | X87 18DG ■■ |
| 2 | X53 18LG/BK ■ |
| 3 | F83 18YL/DG ● |
| 4 | P33 16OR/BK ▲ |
| 5 | P34 16PK/BK ▲ |
| 6 | P35 20OR/VT ▲ |
| 7 | P36 20PK/VT ▲ |
| 8 | P72 20YL/BK |
| 9 | P74 20DB |
| 10 | P76 20OR/YL |
| 11 | C16 20LB/YL ●● |
| 11 | C16 20BK/WT ▲▲ |
| 12 | - |
| 13 | P91 20WT/BK ● |

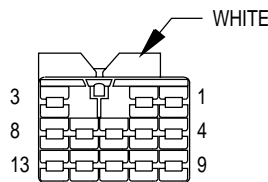

**C305
(LHD)**

| CAV | CIRCUIT |
|-----|----------------|
| 1 | X85 18BR/RD ■■ |
| 1 | X55 18BR/RD ■ |
| 2 | X87 18LG/VT ■■ |
| 2 | X53 18DG ■ |
| 3 | F83 18YL/DG ● |
| 4 | P33 16OR/BK |
| 5 | P34 16PK/BK |
| 6 | P35 18OR/VT |
| 7 | P36 18PK/VT |
| 8 | P72 20YL/BK |
| 9 | P74 20DB |
| 10 | P76 20OR/YL |
| 11 | C16 20LB/YL |
| 12 | - |
| 13 | P91 20WT/BK ● |

- ▲▲ POWER MIRRORS
- FULL OPTIONS
- FULL OPTIONS AND POWER MIRRORS
- ▲ POWER LOCK/WINDOWS
- 4 SPEAKERS
- 6 SPEAKERS

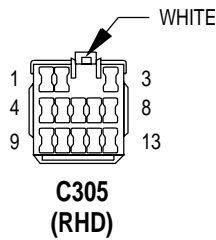

| CAV | CIRCUIT | |
|-----|-------------|-----|
| 1 | X85 18BR/RD | ■ ■ |
| 1 | X55 18LG/RD | ■ |
| 2 | X87 18DG | ■ ■ |
| 2 | X53 18LG/BK | ■ |
| 3 | P59 20LB/RD | |
| 4 | P33 16OR/BK | ▲ |
| 5 | P34 16PK/BK | ▲ |
| 6 | P35 20OR/VT | ▲ |
| 7 | P36 20PK/VT | ▲ |
| 8 | P71 20YL | |
| 9 | P75 20DB/RD | ● ● |
| 9 | P75 20DB/WT | ● |
| 10 | P76 20OR/YL | |
| 11 | C16 20LB/YL | ● ● |
| 11 | C16 20BK/WT | ▲ ▲ |
| 12 | P55 20DB | |
| 13 | P91 20WT/BK | |

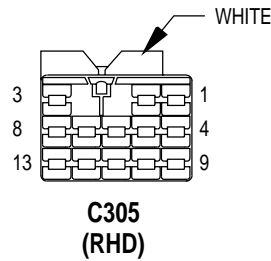

| CAV | CIRCUIT | |
|-----|-------------|-----|
| 1 | X85 18BR/RD | ■ ■ |
| 1 | X55 18BR/RD | ■ |
| 2 | X87 18LG/VT | ■ ■ |
| 2 | X53 18DG | ■ |
| 3 | P59 20LB/RD | |
| 4 | P33 16OR/BK | |
| 5 | P34 16PK/BK | |
| 6 | P35 18OR/VT | |
| 7 | P36 18PK/VT | |
| 8 | P72 20YL/BK | |
| 9 | P74 20DB | |
| 10 | P76 20OR/YL | |
| 11 | C16 20LB/YL | |
| 12 | P55 20DB/PK | |
| 13 | P91 20WT/BK | |

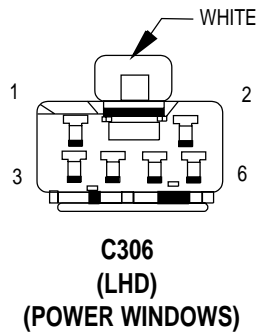

| CAV | CIRCUIT |
|-----|-------------|
| 1 | Q18 14GY/BK |
| 2 | Q28 14DG/WT |
| 3 | Q16 14BR/WT |
| 4 | Q26 14VT/WT |
| 5 | Q17 14DB/WT |
| 6 | Q27 14RD/BK |

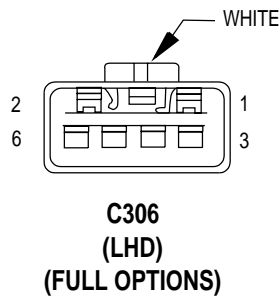

| CAV | CIRCUIT |
|-----|-------------|
| 1 | Q18 14GY/BK |
| 2 | Q28 14DG/WT |
| 3 | Q16 14BR/WT |
| 4 | Q26 14VT/WT |
| 5 | Q17 14DB/WT |
| 6 | Q27 14RD/BK |

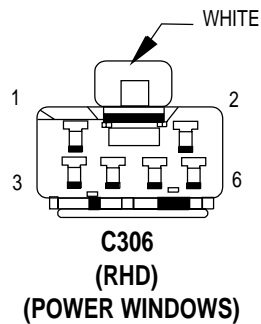

| CAV | CIRCUIT |
|-----|-------------|
| 1 | F35 16RD |
| 2 | G26 20LB |
| 3 | Q16 14BR/WT |
| 4 | Q26 14VT/WT |
| 5 | - |
| 6 | - |

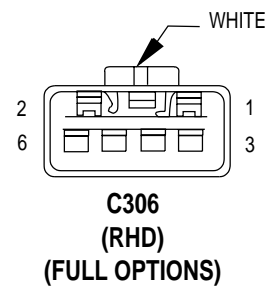

| CAV | CIRCUIT |
|-----|-------------|
| 1 | F35 16RD |
| 2 | G26 20LB |
| 3 | Q16 14BR/WT |
| 4 | Q26 14VT/WT |
| 5 | - |
| 6 | - |

- ▲ ▲ POWER MIRRORS
- ● FULL OPTIONS
- POWER MIRRORS W/O FULL OPTIONS
- ▲ POWER LOCK/WINDOW SWITCHES
- 4 SPEAKERS
- ■ 6 SPEAKERS

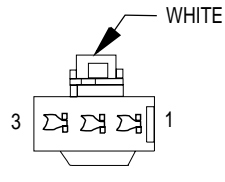

C307

| CAV | CIRCUIT | |
|-----|----------|---|
| 1 | F81 14TN | ● |
| 2 | Q1 14YL | |
| 3 | Z1 12BK | ● |
| 3 | Z1 16BK | ▲ |

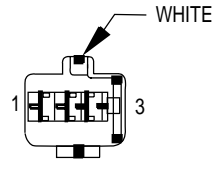

C307

| CAV | CIRCUIT | |
|-----|----------|---|
| 1 | F81 12TN | ● |
| 2 | Q1 14YL | ● |
| 3 | Z1 12BK | |

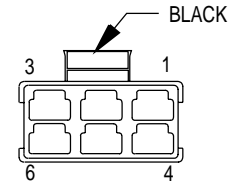

**C309
(FULL OPTIONS)**

| CAV | CIRCUIT | |
|-----|-------------|--|
| 1 | Q17 14DB/WT | |
| 2 | Q27 14RD/BK | |
| 3 | Q1 14YL | |
| 4 | P33 16OR/BK | |
| 5 | P34 16PK/BK | |
| 6 | - | |

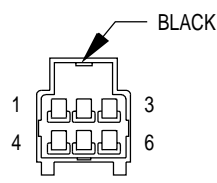

**C309
(FULL OPTIONS)**

| CAV | CIRCUIT | |
|-----|-------------|--|
| 1 | Q17 14DB/WT | |
| 2 | Q27 14RD/BK | |
| 3 | Q1 14YL | |
| 4 | P33 16OR/BK | |
| 5 | P34 16PK/BK | |
| 6 | - | |

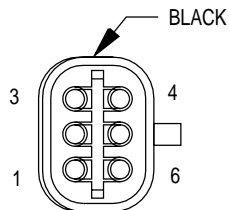

C311

| CAV | CIRCUIT | |
|-----|-------------|--|
| 1 | P33 16OR/BK | |
| 2 | P34 16PK/BK | |
| 3 | G78 20TN/BK | |
| 4 | L77 18BR/YL | |
| 5 | M4 20GY/BK | |
| 6 | Z1 18BK | |

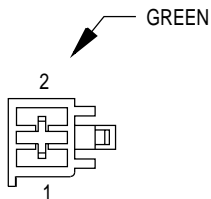

C312

| CAV | CIRCUIT | |
|-----|-------------|--|
| 1 | Z1 12BK | |
| 2 | C15 12BK/WT | |

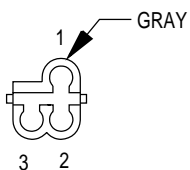

C313

| CAV | CIRCUIT | |
|-----|-------------|--|
| 1 | V13 18BR/LG | |
| 2 | V23 18BR/PK | |
| 3 | V20 18BK/WT | |

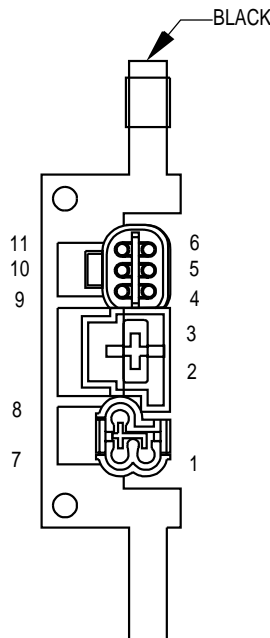

C310

| CAV | CIRCUIT | |
|-----|-------------|--|
| 1 | V20 18BK/WT | |
| 2 | Z1 12BK | |
| 3 | C15 12BK/WT | |
| 4 | P33 16OR/BK | |
| 5 | P34 16PK/BK | |
| 6 | G78 20TN/BK | |
| 7 | V23 18BR/PK | |
| 8 | V13 18BR/LG | |
| 9 | Z1 18BK | |
| 10 | M4 20VT/YL | |
| 11 | L77 18BR/YL | |

▲ POWER MIRRORS
● FULL OPTIONS

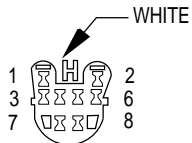

C314

| CAV | CIRCUIT |
|-----|----------------|
| 1 | X92 16TN/BK ▲ |
| 1 | X52 18DB/WT ▲▲ |
| 2 | X94 16TN/RD ▲ |
| 2 | X58 18DB/OR ▲▲ |
| 3 | X91 16BR/DB ▲ |
| 3 | X51 18BR/YL ▲▲ |
| 4 | X93 16BR/YL ▲ |
| 4 | X57 18BR/LB ▲▲ |
| 5 | M1 20PK |
| 6 | M2 20YL |
| 7 | M4 20GY/BK |
| 8 | - |

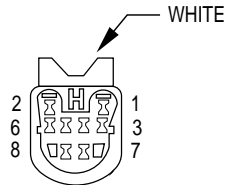

C314

| CAV | CIRCUIT |
|-----|----------------|
| 1 | X92 18TN/BK ▲ |
| 1 | X52 18DB/WT ▲▲ |
| 2 | X94 18TN/RD ▲ |
| 2 | X58 18DB/OR ▲▲ |
| 3 | X91 18WT/BK ▲ |
| 3 | X51 18BR/YL ▲▲ |
| 4 | X93 18WT/RD ▲ |
| 4 | X57 18BR/LB ▲▲ |
| 5 | M1 18PK ● |
| 5 | M1 20PK ●● |
| 6 | M2 20YL |
| 7 | M4 20GY/BK |
| 8 | - |

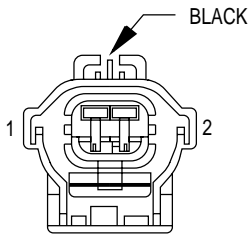

C316

| CAV | CIRCUIT |
|-----|---------------|
| 1 | F83 18YL/DG ■ |
| 2 | F37 14RD/LB |

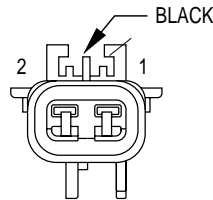

C316

| CAV | CIRCUIT |
|-----|-------------|
| 1 | F83 18YL/DG |
| 2 | F37 14RD/LB |

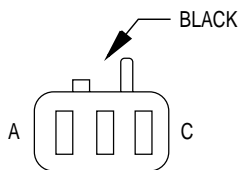

C317

| CAV | CIRCUIT |
|-----|-------------|
| A | M2 18YL |
| B | G16 18BK/LB |
| C | Z1 18BK |

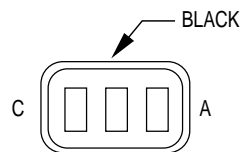

C317

| CAV | CIRCUIT |
|-----|----------------|
| A | M2 20YL |
| B | G16 20BK/LB ●● |
| C | Z1 20BK |

- HEATED SEATS
- ▲ 6 SPEAKER
- ▲▲ 4 SPEAKER
- LHD
- RHD

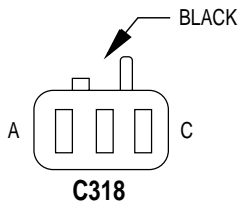

| CAV | CIRCUIT |
|-----|-------------|
| A | M2 18YL |
| B | G16 18BK/LB |
| C | Z1 18BK |

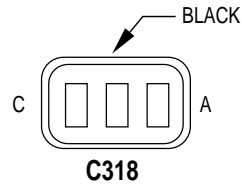

| CAV | CIRCUIT |
|-----|---------------|
| A | M2 20YL |
| B | G16 20BK/LB ■ |
| C | Z1 20BK |

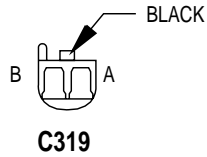

| CAV | CIRCUIT |
|-----|---------|
| A | M2 18YL |
| B | Z1 18BK |

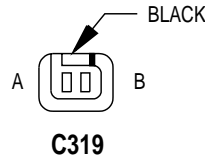

| CAV | CIRCUIT |
|-----|---------|
| A | M2 20YL |
| B | Z1 20BK |

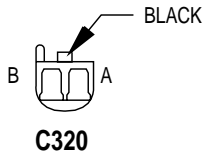

| CAV | CIRCUIT |
|-----|---------|
| A | M2 18YL |
| B | Z1 18BK |

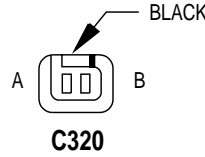

| CAV | CIRCUIT |
|-----|---------|
| A | M2 20YL |
| B | Z1 20BK |

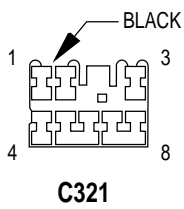

| CAV | CIRCUIT |
|-----|----------------|
| 1 | L62 18BR/RD |
| 2 | Z1 18BK |
| 3 | - |
| 4 | L38 18OR/WT ▲▲ |
| 5 | L10 18BR/LG |
| 6 | L50 18WT/TN |
| 7 | L78 18DG/YL |
| 8 | - |

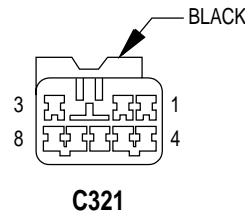

| CAV | CIRCUIT |
|-----|-------------|
| 1 | L62 20BR/RD |
| 2 | Z1 18BK |
| 3 | - |
| 4 | L38 18BR/WT |
| 5 | L10 18BR/LG |
| 6 | L50 20WT/TN |
| 7 | L78 18DG/YL |
| 8 | - |

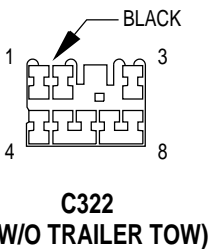

| CAV | CIRCUIT |
|-----|----------------|
| 1 | L63 18DG/RD |
| 2 | Z1 16BK ▲▲ |
| 2 | Z1 18BK ● |
| 3 | - |
| 4 | L38 18OR/WT ▲▲ |
| 5 | L10 18BR/LG |
| 6 | L50 18WT/TN |
| 7 | L77 18BR |
| 8 | - |

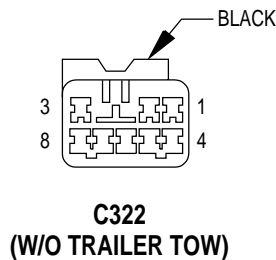

| CAV | CIRCUIT |
|-----|-------------|
| 1 | L63 20DG/RD |
| 2 | Z1 14BK |
| 3 | A6 20RD/OR |
| 4 | L38 18BR/WT |
| 5 | L10 18BR/LG |
| 6 | L50 20WT/TN |
| 7 | L77 18BR/YL |
| 8 | L62 20BR/RD |

▲▲ BUILT-UP-EXPORT
 ● EXCEPT BUILT-UP-EXPORT
 ■ RHD

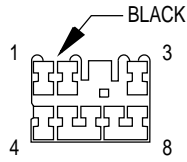

**C322
(TRAILER TOW)**

| CAV | CIRCUIT |
|-----|---------------|
| 1 | L63 18DG/RD |
| 2 | Z1 16BK ▲ |
| 2 | Z1 18BK ● |
| 3 | - |
| 4 | L38 18OR/WT ▲ |
| 5 | L10 18BR/LG |
| 6 | L50 18WT/TN |
| 7 | L77 18BR |
| 8 | - |

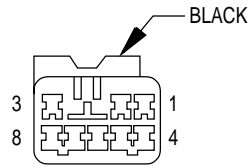

**C322
(TRAILER TOW)**

| CAV | CIRCUIT |
|-----|-------------|
| 1 | L63 20DG/RD |
| 2 | Z1 18BK |
| 3 | - |
| 4 | L38 18BR/WT |
| 5 | L10 18BR/LG |
| 6 | L50 20WT/TN |
| 7 | L77 18BR/YL |
| 8 | - |

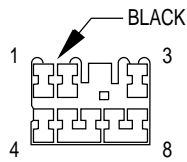

**C323
(TRAILER TOW)**

| CAV | CIRCUIT |
|-----|-------------|
| 1 | L63 20DG/RD |
| 2 | Z1 14BK |
| 3 | A6 20RD/OR |
| 4 | L38 20OR/WT |
| 5 | L10 18BR/LG |
| 6 | L50 20WT/TN |
| 7 | L77 20BR/YL |
| 8 | L62 20BK/RD |

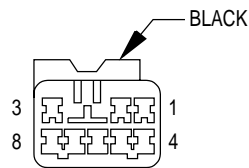

**C323
(TRAILER TOW)**

| CAV | CIRCUIT |
|-----|-------------|
| 1 | L63 20DG/RD |
| 2 | Z1 14BK |
| 3 | A6 20RD/OR |
| 4 | L38 18BR/WT |
| 5 | L10 18BR/LG |
| 6 | L50 20WT/TN |
| 7 | L77 18BR/YL |
| 8 | L62 20BR/RD |

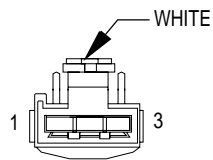

**C324
(RHD)
(FULL OPTIONS)**

| CAV | CIRCUIT |
|-----|-------------|
| 1 | F83 18YL/DG |
| 2 | X80 18LB/BK |
| 3 | X82 18LB/RD |

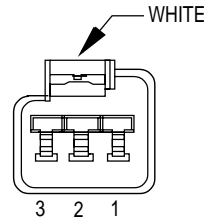

**C324
(RHD)
(FULL OPTIONS)**

| CAV | CIRCUIT |
|-----|---------------|
| 1 | F83 18YL/DG |
| 2 | X80 18LB/BK ■ |
| 3 | X82 18LB/RD ■ |

- W/ POWER AMPLIFIER
- ▲ BUILT-UP-EXPORT
- EXCEPT BUILT-UP-EXPORT

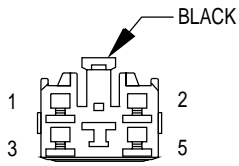

C326

| CAV | CIRCUIT |
|-----|-------------|
| 1 | P33 16OR/BK |
| 2 | P34 16PK/BK |
| 3 | M4 20GY/BK |
| 4 | C15 12BK/WT |
| 5 | L50 18WT/TN |

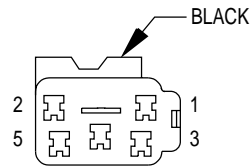

C326

| CAV | CIRCUIT |
|-----|---------------|
| 1 | P33 16OR/BK ● |
| 2 | P34 16PK/BK ● |
| 3 | M4 20GY/BK |
| 4 | C15 12BK/WT |
| 5 | L50 20WT/TN |

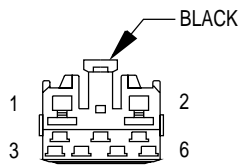

C327

| CAV | CIRCUIT |
|-----|-------------|
| 1 | G78 20TN/BK |
| 2 | L77 18BR/YL |
| 3 | V13 18BR/LG |
| 4 | V23 18BR/PK |
| 5 | V20 18BK/WT |
| 6 | - |

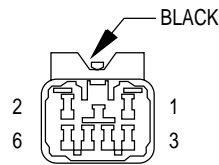

C327

| CAV | CIRCUIT |
|-----|-------------|
| 1 | G78 20TN/BK |
| 2 | L77 18BR/YL |
| 3 | V13 18BR |
| 4 | V23 18BR/PK |
| 5 | V20 18BK/WT |
| 6 | - |

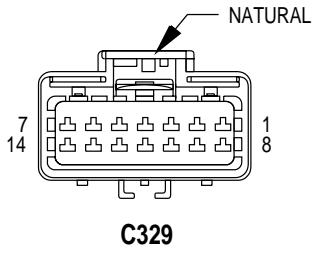

| CAV | CIRCUIT |
|-----|--------------|
| 1 | P133 18TN/DG |
| 2 | P134 18TN/RD |
| 3 | P137 18VT |
| 4 | P138 18VT/LG |
| 5 | P139 18VT/WT |
| 6 | P140 18VT/BK |
| 7 | P87 18BK/OR |
| 8 | P141 18TN/LB |
| 9 | P143 18BK/DG |
| 10 | F37 14RD/LB |
| 11 | F83 18YL/DG |
| 12 | Z1 18BK |
| 13 | Z2 18BK/LG |
| 14 | - |

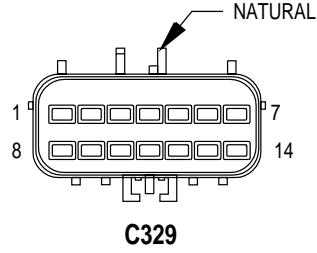

| CAV | CIRCUIT |
|-----|--------------|
| 1 | P133 18TN/DG |
| 2 | P134 18TN/RD |
| 3 | P137 18VT |
| 4 | P138 18VT/LG |
| 5 | P139 18VT/WT |
| 6 | P140 18VT/BK |
| 7 | P87 18BK/OR |
| 8 | P141 18TN/LB |
| 9 | P143 18BK/DG |
| 10 | F37 14RD/LB |
| 11 | F83 18YL/DG |
| 12 | Z1 18BK |
| 13 | Z2 18BK/LG |
| 14 | - |

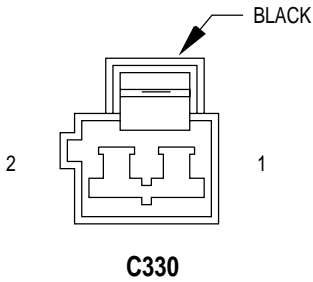

| CAV | CIRCUIT |
|-----|-------------|
| 1 | L77 18BR/YL |
| 2 | Z1 18BK |

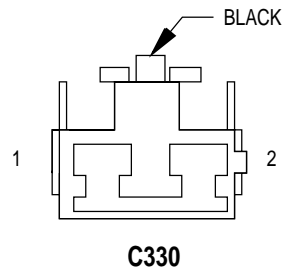

| CAV | CIRCUIT |
|-----|-------------|
| 1 | L78 18BK/YL |
| 2 | Z1 18BK |

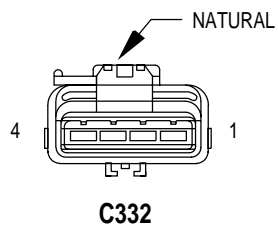

| CAV | CIRCUIT |
|-----|--------------|
| 1 | P141 18TN/LB |
| 2 | P143 18BK/DG |
| 3 | P87 18BK/OR |
| 4 | Z1 18BK |

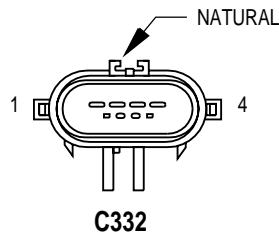

| CAV | CIRCUIT |
|-----|--------------|
| 1 | P141 18TN/LB |
| 2 | P143 18BK/DG |
| 3 | P87 18BK/OR |
| 4 | Z1 18BK |

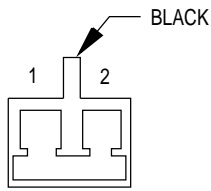

C333

| CAV | CIRCUIT |
|-----|-------------|
| 1 | L50 18WT/TN |
| 2 | Z1 18BK |

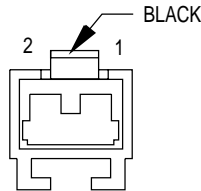

C333

| CAV | CIRCUIT |
|-----|-------------|
| 1 | L50 18DG/WT |
| 2 | Z1 18BK |

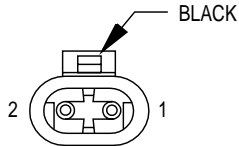

C362

| CAV | CIRCUIT |
|-----|-------------|
| 1 | F37 14RD/LB |
| 2 | Z1 14BK |

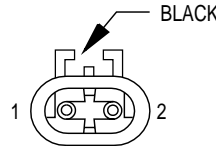

C362

| CAV | CIRCUIT |
|-----|----------|
| 1 | F37 14RD |
| 2 | Z1 14BK |

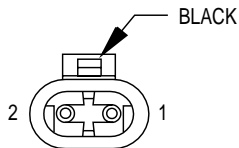

C363

| CAV | CIRCUIT |
|-----|-------------|
| 1 | F37 14RD/LB |
| 2 | Z1 14BK |

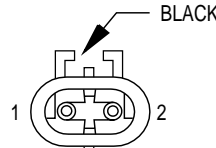

C363

| CAV | CIRCUIT |
|-----|----------|
| 1 | F37 14RD |
| 2 | Z1 14BK |

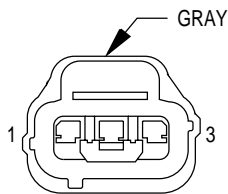

**CAMSHAFT
POSITION
SENSOR
(GAS)**

| CAV | CIRCUIT | FUNCTION |
|-----|--------------|---------------------------------|
| 1 | K44 18TN/YL | CAMSHAFT POSITION SENSOR SIGNAL |
| 2 | K167 20BR/YL | SENSOR GROUND |
| 3 | K7 18OR | 5V SUPPLY |

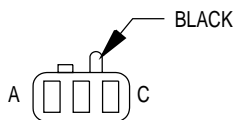

**CARGO
LAMP/SWITCH**

| CAV | CIRCUIT | FUNCTION |
|-----|------------|-------------------------------|
| A | M1 18PK ● | FUSED B(+) |
| A | M1 20PK ●● | FUSED B(+) |
| B | M2 20YL | COURTESY LAMPS DRIVER |
| C | M4 20GY/BK | LIFTGATE COURTESY LAMP DRIVER |

- RHD
- LHD

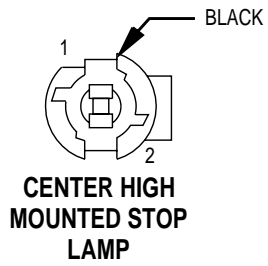

| CAV | CIRCUIT | FUNCTION |
|-----|-------------|--------------------------|
| 1 | Z1 18BK | GROUND |
| 2 | L50 18DG/WT | BRAKE LAMP SWITCH OUTPUT |

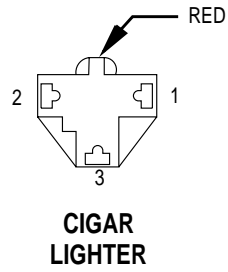

| CAV | CIRCUIT | FUNCTION |
|-----|----------|----------------------------|
| 1 | F30 16RD | CIGAR LIGHTER RELAY OUTPUT |
| 2 | - | - |
| 3 | Z1 16BK | GROUND |

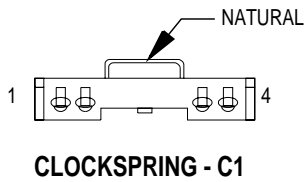

| CAV | CIRCUIT | FUNCTION |
|-----|-------------|-----------------------------|
| 1 | X3 20BK/RD | HORN RELAY CONTROL |
| 2 | V37 20RD/LG | SPEED CONTROL SWITCH SIGNAL |
| 3 | K4 20BK/RD | SENSOR GROUND |
| 4 | - | - |

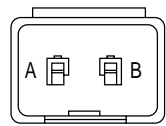

| CAV | CIRCUIT | FUNCTION |
|-----|--------------|-----------------------------|
| A | K167 20BR/YL | SENSOR GROUND |
| B | V37 20RD/LG | SPEED CONTROL SWITCH SIGNAL |

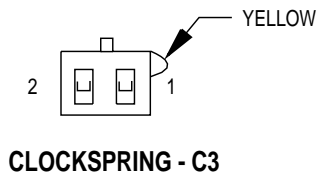

| CAV | CIRCUIT | FUNCTION |
|-----|-------------|----------------------|
| 1 | R45 18DG/LB | DRIVER AIRBAG LINE 1 |
| 2 | R43 18BK/LB | DRIVER AIRBAG LINE 2 |

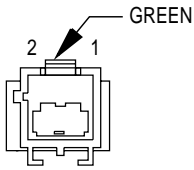

CLUTCH INTERLOCK SWITCH

| CAV | CIRCUIT | | FUNCTION |
|-----|-------------|----|---------------------------------------|
| 1 | F45 20YL/RD | ▲ | FUSED B(+) ENGINE STARTER MOTOR RELAY |
| 1 | T141 20YL | ▲▲ | IGNITION SWITCH OUTPUT (START) |
| 2 | T141 20YL | ▲ | IGNITION SWITCH OUTPUT (START) |
| 2 | F45 20YL/RD | ▲▲ | FUSED B(+) ENGINE STARTER MOTOR RELAY |

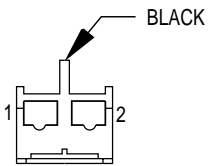

CLUTCH INTERLOCK SWITCH JUMPER

| CAV | CIRCUIT | | FUNCTION |
|-----|----------|--|---------------------------------------|
| 1 | F45 18YL | | FUSED B(+) ENGINE STARTER MOTOR RELAY |
| 2 | F45 18YL | | FUSED B(+) ENGINE STARTER MOTOR RELAY |

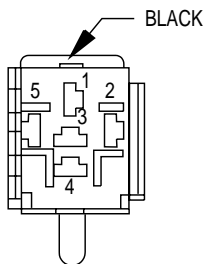

COMBINATION FLASHER

| CAV | CIRCUIT | | FUNCTION |
|-----|-------------|---|------------------------------------|
| 1 | L5 20BK | | FUSED IGNITION SWITCH OUTPUT (RUN) |
| 2 | L9 20BK/PK | | FUSED B (+) |
| 3 | L12 20VT/TN | | HAZARD FLASHER SELECT SIGNAL |
| 4 | L6 20RD/WT | | FLASHER OUTPUT |
| 5 | Z1 18BK | ● | GROUND |
| | Z1 20BK | | GROUND |

- RHD BUILT-UP-EXPORT
- ▲ LHD DIESEL
- ▲▲ EXCEPT LHD DIESEL

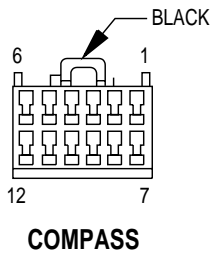

| CAV | CIRCUIT | FUNCTION |
|-----|-------------|---------------------------------------|
| 1 | Z1 20BK | GROUND |
| 2 | M1 20PK | FUSED B(+) |
| 3 | - | - |
| 4 | G31 20VT/LG | AMBIENT TEMPERATURE SENSOR SIGNAL |
| 5 | D1 20VT/BR | CCD BUS (+) |
| 6 | F87 20WT/BK | FUSED IGNITION SWITCH OUTPUT (ST-RUN) |
| 7 | M2 20YL | COURTESY LAMPS DRIVER |
| 8 | - | - |
| 9 | - | - |
| 10 | G32 20BK/LB | SENSOR GROUND |
| 11 | D2 20WT/BK | CCD BUS (-) |
| 12 | Z2 20BK/LG | GROUND |

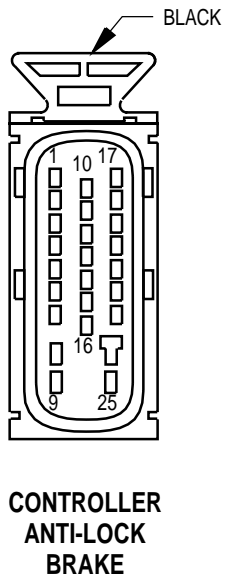

| CAV | CIRCUIT | FUNCTION |
|-----|-------------|------------------------------------|
| 1 | B1 18YL/DB | RIGHT REAR WHEEL SPEED SENSOR (-) |
| 2 | B3 18LG/DB | LEFT REAR WHEEL SPEED SENSOR (-) |
| 3 | B7 18WT | RIGHT FRONT WHEEL SPEED SENSOR (+) |
| 4 | B9 18RD | LEFT FRONT WHEEL SPEED SENSOR (+) |
| 5 | - | - |
| 6 | B41 18YL/VT | G SWITCH NO. 1 SENSE |
| 7 | B42 18TN/WT | G SWITCH NO. 2 SENSE |
| 8 | Z1 12BK | GROUND |
| 9 | A20 12RD/DB | FUSED B(+) |
| 10 | B4 18LG | LEFT REAR WHEEL SPEED SENSOR (+) |
| 11 | B8 18RD/DB | LEFT FRONT WHEEL SPEED SENSOR (-) |
| 12 | L50 18WT/TN | BRAKE LAMP SWITCH OUTPUT |
| 13 | B43 18PK/OR | G SWITCH TEST SIGNAL |
| 14 | - | - |
| 15 | - | - |
| 16 | G83 18GY/BK | ABS RELAY CONTROL |
| 17 | B2 18YL | RIGHT REAR WHEEL SPEED SENSOR (+) |
| 18 | B6 18WT/DB | RIGHT REAR WHEEL SPEED SENSOR (-) |
| 19 | - | - |
| 20 | D21 18PK | SCI TRANSMIT/ ISO 9141K |
| 21 | - | - |
| 22 | - | - |
| 23 | F15 18DB/WT | FUSED IGNITION SWITCH OUTPUT (RUN) |
| 24 | Z1 12BK | GROUND |
| 25 | A10 12RD/DG | FUSED B(+) |

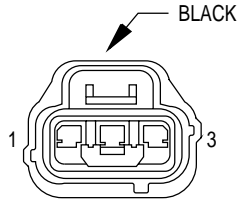

**CRANKSHAFT
POSITION
SENSOR
(GAS)**

| CAV | CIRCUIT | FUNCTION |
|-----|--------------|-----------------------------------|
| 1 | K24 18GY/BK | CRANKSHAFT POSITION SENSOR SIGNAL |
| 2 | K167 20BR/YL | SENSOR GROUND |
| 3 | K7 20OR | 5V SUPPLY |

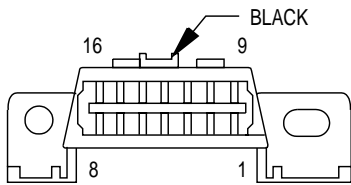

**DATA LINK
CONNECTOR**

| CAV | CIRCUIT | FUNCTION |
|-----|-------------|-------------------------|
| 1 | - | - |
| 2 | - | - |
| 3 | D1 18VT/BR | CCD BUS (+) |
| 4 | Z1 18BK | GROUND |
| 5 | Z12 18BK/TN | GROUND |
| 6 | D20 20LG/BK | SCI RECEIVE |
| 7 | D21 20PK | SCI TRANSMIT/ ISO 9141K |
| 8 | - | - |
| 9 | - | - |
| 10 | - | - |
| 11 | D2 18WT/BK | CCD BUS (-) |
| 12 | - | - |
| 13 | - | - |
| 14 | - | - |
| 15 | - | - |
| 16 | F34 18TN/BK | FUSED B(+) |

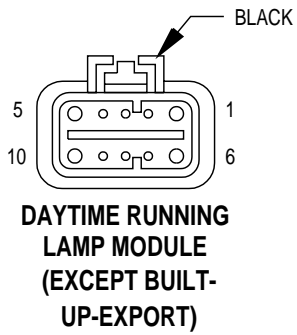

| CAV | CIRCUIT | FUNCTION |
|-----|-------------|---------------------------------------|
| 1 | L3 16RD | DIMMER SWITCH HIGH BEAM OUTPUT |
| 2 | - | - |
| 3 | - | - |
| 4 | G34 16RD/GY | HIGH BEAM INDICATOR DRIVER |
| 5 | F20 18WT | FUSED IGNITION SWITCH OUTPUT (ST-RUN) |
| 6 | A3 14RD/WT | FUSED B(+) |
| 7 | G7 20WT/OR | VEHICLE SPEED SENSOR SIGNAL |
| 8 | Z12 16BK/TN | GROUND |
| 9 | - | - |
| 10 | L44 18VT/RD | FUSED RIGHT LOW BEAM OUTPUT |

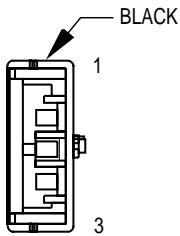

| CAV | CIRCUIT | FUNCTION |
|-----|----------|------------------------|
| 1 | L2 16LG | HEADLAMP RELAY OUTPUT |
| 2 | L25 18BR | REAR FOG LAMP FEED |
| 3 | L39 18LB | FOG LAMP SWITCH OUTPUT |

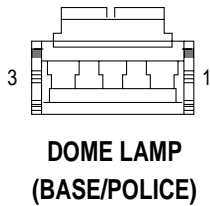

| CAV | CIRCUIT | FUNCTION |
|-----|---------|-----------------------|
| 1 | - | - |
| 2 | M1 20PK | FUSED B(+) |
| 3 | M2 20YL | COURTESY LAMPS DRIVER |

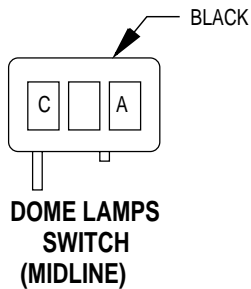

| CAV | CIRCUIT | FUNCTION |
|-----|---------|-----------------------|
| A | Z1 20BK | GROUND |
| B | M2 20YL | COURTESY LAMPS DRIVER |
| C | M1 20PK | FUSED B(+) |

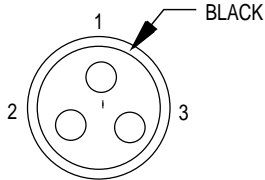

**DRIVER DOOR
JAMB SWITCH**

| CAV | CIRCUIT | FUNCTION |
|-----|-------------|-------------------------------|
| 1 | M2 18YL | COURTESY LAMPS DRIVER |
| 2 | G16 18BK/LB | DRIVER DOOR AJAR SWITCH SENSE |
| 3 | Z1 18BK | GROUND |

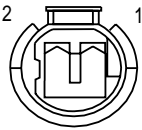

**DRIVER DOOR
LOCK MOTOR**

| CAV | CIRCUIT | FUNCTION |
|-----|-------------|--------------------|
| 1 | P34 16PK/BK | DOOR UNLOCK DRIVER |
| 2 | P33 16OR/BK | DOOR LOCK DRIVER |

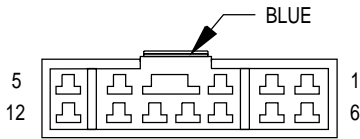

**DRIVER POWER
LOCK/WINDOW
SWITCH-C1
(LHD)
(FULL OPTIONS)**

| CAV | CIRCUIT | FUNCTION |
|-----|-------------|--|
| 1 | Q28 14DG/WT | MASTER WINDOW SWITCH RIGHT REAR DOWN |
| 2 | Q18 14GY/BK | RIGHT REAR WINDOW DRIVER UP |
| 3 | Q16 14BR/WT | MASTER WINDOW SWITCH PASSENGER UP |
| 4 | Q17 14DB/WT | LEFT REAR WINDOW DRIVER UP |
| 5 | Q11 14LB | DRIVER WINDOW DRIVER UP |
| 6 | Q26 14VT/WT | MASTER WINDOW SWITCH PASSENGER DOWN |
| 7 | P35 18OR/VT | DOOR LOCK SWITCH OUTPUT (LOCK) |
| 8 | Z1 14BK | GROUND |
| 9 | F81 14TN | FUSED IGNITION SWITCH OUTPUT (RUN-ACC) |
| 10 | Q27 14RD/BK | LEFT REAR WINDOW DRIVER DOWN |
| 11 | P36 18PK/VT | DOOR LOCK SWITCH OUPUT (UNLOCK) |
| 12 | Q21 14WT | DRIVER WINDOW DRIVER DOWN |

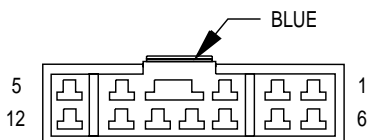

**DRIVER POWER
LOCK/WINDOW
SWITCH-C1
(RHD)
(FULL OPTIONS)**

| CAV | CIRCUIT | FUNCTION |
|-----|-------------|--|
| 1 | Q28 14DG/WT | MASTER WINDOW SWITCH RIGHT REAR DOWN |
| 2 | Q18 14GY/BK | RIGHT REAR WINDOW DRIVER UP |
| 3 | Q11 14BR | DRIVER WINDOW DRIVER UP |
| 4 | Q17 14DB/WT | LEFT REAR WINDOW DRIVER UP |
| 5 | Q16 14BR/WT | MASTER WINDOW SWITCH PASSENGER UP |
| 6 | Q21 14VT | DRIVER WINDOW DRIVER DOWN |
| 7 | P35 18OR/VT | DOOR LOCK SWITCH OUTPUT (LOCK) |
| 8 | Z1 14BK | GROUND |
| 9 | F81 14TN | FUSED IGNITION SWITCH OUTPUT (RUN-ACC) |
| 10 | Q27 14RD/BK | LEFT REAR WINDOW DRIVER DOWN |
| 11 | P36 18PK/VT | DOOR LOCK SWITCH OUTPUT (UNLOCK) |
| 12 | Q26 14VT/WT | MASTER WINDOW SWITCH PASSENGER DOWN |

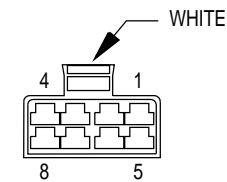

**DRIVER POWER
LOCK/WINDOW
SWITCH-C2
(FULL OPTIONS)**

| CAV | CIRCUIT | FUNCTION |
|-----|----------------|--|
| 1 | P71 20YL ■ | LEFT POWER MIRROR VERTICAL DRIVER |
| 1 | P71 20YL/LB ●● | LEFT POWER MIRROR VERTICAL DRIVER |
| 2 | P76 20OR/YL ▲ | MIRROR COMMON DRIVER |
| 3 | F83 18YL/DG | FUSED IGNITION SWITCH OUTPUT (RUN-ACC) |
| 4 | P74 20DB ● | RIGHT POWER MIRROR HORIZONTAL DRIVER |
| 5 | Z1 14BK ■ | GROUND |
| 5 | Z1 16BK ●● | GROUND |
| 6 | P75 20DB/WT ● | LEFT POWER MIRROR HORIZONTAL DRIVER |
| 7 | P72 20YL/BK ● | RIGHT POWER MIRROR VERTICAL DRIVER |
| 8 | Q1 14YL | POWER WINDOW SWITCH FEED |

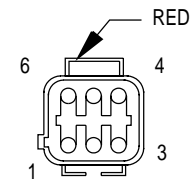

**DRIVER POWER
MIRROR
(LHD)**

| CAV | CIRCUIT | FUNCTION |
|-----|---------------|---|
| 1 | P71 20YL | LEFT POWER MIRROR VERTICAL DRIVER |
| 2 | P75 20DB/WT ● | LEFT POWER MIRROR HORIZONTAL DRIVER |
| 2 | P76 20OR/YL ▲ | MIRROR COMMON DRIVER |
| 3 | P91 20WT/BK ● | MIRROR COMMON DRIVER |
| 3 | P75 20DB/WT ▲ | LEFT POWER MIRROR HORIZONTAL DRIVER |
| 4 | P76 20OR/YL | MIRROR COMMON DRIVER |
| 5 | C16 20BK/WT ● | FUSED REAR WINDOW DEFOGGER RELAY OUTPUT |
| 5 | C16 20LB/YL ▲ | FUSED REAR WINDOW DEFOGGER RELAY OUTPUT |
| 6 | Z1 18BK ● | GROUND |
| 6 | Z1 16BK ▲ | GROUND |

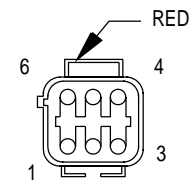

**DRIVER POWER
MIRROR
(RHD)**

| CAV | CIRCUIT | FUNCTION |
|-----|---------------|---|
| 1 | P72 20YL/BK ● | RIGHT POWER MIRROR VERTICAL DRIVER |
| 2 | P74 20DB ● | RIGHT POWER MIRROR HORIZONTAL DRIVER |
| 2 | P76 20OR/YL ▲ | MIRROR COMMON DRIVER |
| 3 | P91 20WT/BK ● | MIRROR COMMON DRIVER |
| 3 | P74 20DB ▲ | RIGHT POWER MIRROR HORIZONTAL DRIVER |
| 4 | P76 20OR/YL | MIRROR COMMON DRIVER |
| 5 | C16 20BK/WT | FUSED REAR WINDOW DEFOGGER RELAY OUTPUT |
| 6 | Z1 18BK | GROUND |

- POWER MIRRORS
- ▲ FULL OPTIONS
- LHD
- RHD

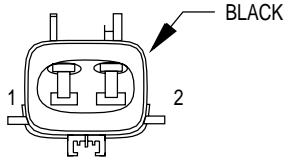

DRIVER POWER WINDOW MOTOR (LHD)

| CAV | CIRCUIT | FUNCTION |
|-----|----------|-------------------------------|
| 1 | Q11 14LB | LEFT FRONT WINDOW DRIVER UP |
| 2 | Q21 14WT | LEFT FRONT WINDOW DRIVER DOWN |

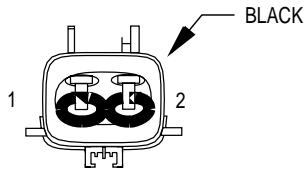

DRIVER POWER WINDOW MOTOR (RHD)

| CAV | CIRCUIT | FUNCTION |
|-----|----------|-------------------------------|
| 1 | Q11 14BR | LEFT WINDOW DRIVER UP |
| 2 | Q21 14VT | LEFT FRONT WINDOW DRIVER DOWN |

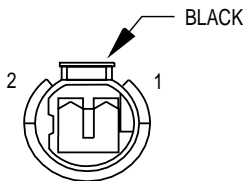

DUTY CYCLE EVAP/PURGE SOLENOID (GAS)

| CAV | CIRCUIT | FUNCTION |
|-----|-------------|--|
| 1 | K52 18PK/BK | DUTY CYCLE EVAP PURGE/SOLENOID CONTROL |
| 2 | F20 18WT | FUSED IGNITION SWITCH OUTPUT (ST-RUN) |

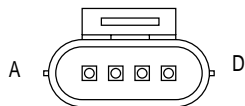

ELECTRONIC VACUUM MODULATOR (DIESEL)

| CAV | CIRCUIT | FUNCTION |
|-----|--------------|--|
| A | F142 18DG/OR | FUSED AUTOMATIC SHUT DOWN RELAY OUTPUT |
| B | K35 18GY/YL | EGR SOLENOID CONTROL |
| C | - | - |
| D | Z1 18BK | GROUND |

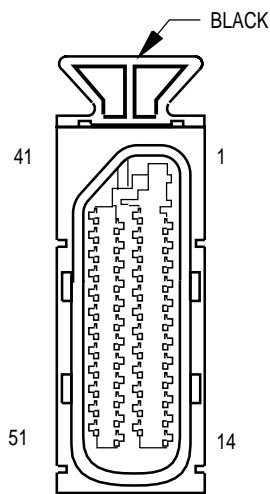

**ENGINE CONTROL
MODULE - C1
(DIESEL)**

| CAV | CIRCUIT | FUNCTION |
|-----|--------------|--|
| 1 | Z12 14BK/TN | GROUND |
| 2 | A142 16DG/OR | AUTOMATIC SHUT DOWN RELAY OUTPUT |
| 3 | - | - |
| 4 | - | - |
| 5 | C13 20DB/OR | A/C COMPRESSOR CLUTCH RELAY CONTROL |
| 6 | K159 18VT/RD | ENGINE SPEED SENSOR SIGNAL |
| 7 | | |
| 8 | C103 18DG | A/C REQUEST INPUT |
| 9 | K29 20WT/PK | BRAKE LAMP SWITCH SENSE |
| 10 | C22 20DB/WT | A/C PRESSURE SWITCH SENSE |
| 11 | K6 20VT/WT | 5V SUPPLY |
| 12 | K151 20WT | LOW IDLE POSITION SWITCH SIGNAL |
| 13 | K21 20BK/RD | INTAKE AIR TEMPERATURE SENSOR SIGNAL |
| 14 | - | - |
| 15 | - | - |
| 16 | - | - |
| 17 | C27 20DB/PK | RADIATOR FAN RELAY CONTROL |
| 18 | G8 18LB/BK | FUEL MONITOR OUTPUT SIGNAL |
| 19 | - | - |
| 20 | L50 20WT/TN | BRAKE LAMP SWITCH OUTPUT |
| 21 | - | - |
| 22 | - | - |
| 23 | K255 20WT/DG | ACCELERATOR PEDAL POSITION SENSOR GROUND |
| 24 | K22 20OR/DB | ACCELERATOR PEDAL POSITION SENSOR SIGNAL |
| 25 | - | - |
| 26 | - | - |
| 27 | Z12 16BK/TN | GROUND |
| 28 | A142 16DG/OR | AUTOMATIC SHUT DOWN RELAY OUTPUT |
| 29 | K35 18GY/YL | EGR SOLENOID CONTROL |
| 30 | V66 18RD/LG | SPEED CONTROL INDICATOR SIGNAL |
| 31 | - | - |
| 32 | K185 20OR/LB | WAIT TO START INDICATOR DRIVER |
| 33 | K51 20DB/YL | AUTOMATIC SHUT DOWN RELAY CONTROL |
| 34 | K48 18OR/RD | FAULT INDICATOR REQUEST INPUT |
| 35 | - | - |
| 36 | - | - |
| 37 | - | - |
| 38 | G55 18OR/BK | ENGINE DISABLE SIGNAL |
| 39 | K9 20LB | 5V SUPPLY |
| 40 | K1 20DG/RD | BOOST PRESSURE SENSOR SIGNAL |
| 41 | - | - |
| 42 | K152 18WT | GLOW PLUG RELAY CONTROL |
| 43 | - | - |
| 44 | - | - |
| 45 | D21 20PK | SCI TRANSMIT/ ISO 9141K |
| 46 | - | - |
| 47 | F12 18DB/WT | FUSED IGNITION SWITCH OUTPUT (ST-RUN) |
| 48 | C48 18TN | RADIATOR FAN REQUEST - |
| 49 | - | - |
| 50 | - | - |
| 51 | G7 20WT/OR | VEHICLE SPEED SENSOR SIGNAL |

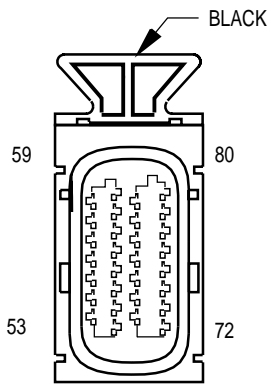

**ENGINE CONTROL
MODULE - C2
(DIESEL)**

| CAV | CIRCUIT | FUNCTION |
|-----|--------------|---|
| 52 | - | - |
| 53 | K156 20GY | FUEL TEMPERATURE SENSOR SIGNAL |
| 54 | K2 20TN/BK | ENGINE COOLANT TEMPERATURE SENSOR SIGNAL |
| 55 | K68 18LG/YL | NEEDLE MOVEMENT SENSOR GROUND |
| 56 | K134 20LB/BK | CONTROL SLEEVE POSITION SENSOR SIGNAL |
| 57 | K57 20LG/OR | CONTROL SLEEVE POSITION SENSOR MIDDLE TAP |
| 58 | K135 20WT/BK | CONTROL SLEEVE POSITION SENSOR MEASURE COIL |
| 59 | K140 18TN/WT | FUEL QUANTITY ACTUATOR CONTROL |
| 60 | V37 20RD/LG | SPEED CONTROL SWITCH SIGNAL |
| 61 | K4 20BK/LB | SENSOR GROUND |
| 62 | K67 18BR/BK | NEEDLE MOVEMENT SENSOR SIGNAL |
| 63 | - | |
| 64 | - | |
| 65 | - | |
| 66 | K140 18TN/WT | FUEL QUANTITY ACTUATOR CONTROL |
| 67 | K24 20GY/BK | ENGINE SPEED SENSOR SIGNAL |
| 68 | - | |
| 69 | K3 20LG/BK | ENGINE SPEED SENSOR GROUND |
| 70 | - | |
| 71 | - | |
| 72 | - | |
| 73 | - | |
| 74 | - | |
| 75 | - | |
| 76 | - | |
| 77 | K153 18OR | FUEL SHUTDOWN SOLENOID CONTROL |
| 78 | - | |
| 79 | K126 18LG | FUEL TIMING SOLENOID CONTROL |
| 80 | K140 18TN/WT | FUEL QUANTITY ACTUATOR CONTROL |

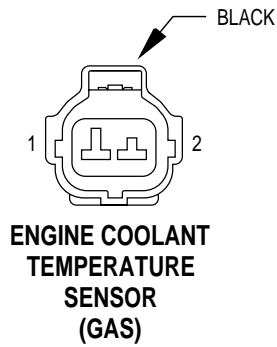

| CAV | CIRCUIT | FUNCTION |
|-----|--------------|--|
| 1 | K167 20BR/YL | SENSOR GROUND |
| 2 | K2 18TN/BK | ENGINE COOLANT TEMPERATURE SENSOR SIGNAL |

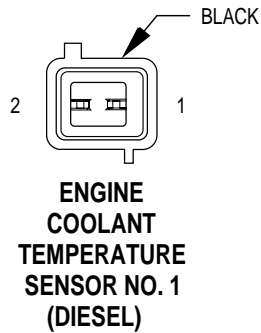

| CAV | CIRCUIT | FUNCTION |
|-----|------------|--|
| 1 | K2 18TN/BK | ENGINE COOLANT TEMPERATURE SENSOR SIGNAL |
| 2 | K4 18BK/LB | SENSOR GROUND |

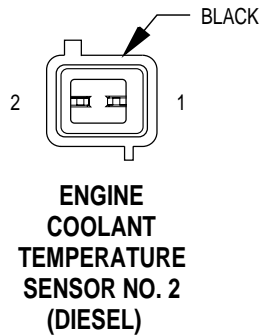

| CAV | CIRCUIT | FUNCTION |
|-----|--------------|--|
| 1 | K222 18TN/RD | ENGINE COOLANT TEMPERATURE SENSOR SIGNAL |
| 2 | K167 18BR/YL | SENSOR GROUND |

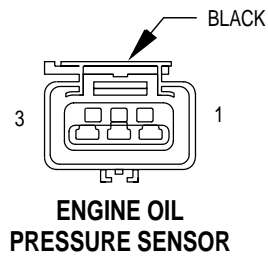

| CAV | CIRCUIT | FUNCTION |
|-----|--------------|-----------------------------------|
| 1 | K6 18VT/OR • | 5V SUPPLY |
| 1 | K7 18OR •• | 5V SUPPLY |
| 2 | G60 18GY/YL | ENGINE OIL PRESSURE SENSOR SIGNAL |
| 3 | K167 18BR/YL | SENSOR GROUND |

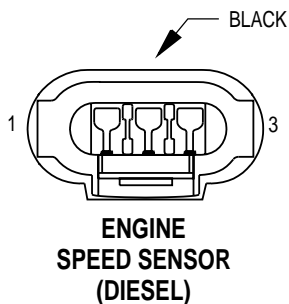

| CAV | CIRCUIT | FUNCTION |
|-----|-------------|----------------------------|
| 1 | K3 20LG/BK | ENGINE SPEED-SENSOR GROUND |
| 2 | - | - |
| 3 | K24 20GY/BK | ENGINE SPEED SENSOR SIGNAL |

• GAS
•• DIESEL

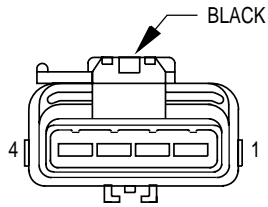

**EVAP LEAK
DETECTION
PUMP**

| CAV | CIRCUIT | FUNCTION |
|-----|--------------|--------------------------------------|
| 1 | - | - |
| 2 | K72 18DG/OR | GENERATOR DRIVER |
| 3 | K106 18WT/DG | LEAK DETECTION PUMP SOLENOID CONTROL |
| 4 | K105 18WT/OR | LEAK DETECTION PUMP SWITCH SENSE |

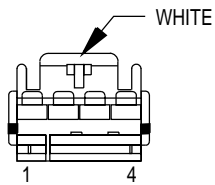

**EXTENDED IDLE
SWITCH
(POLICE PACKAGE)**

| CAV | CIRCUIT | FUNCTION |
|-----|-------------|--|
| 1 | Z1 20BK | GROUND |
| 2 | K78 20GY | IDLE ACTUATOR |
| 3 | F15 20DB/WT | FUSED IGNITION SWITCH OUTPUT (RUN) |
| 4 | E2 20OR | FUSED PANEL LAMPS DIMMER SWITCH SIGNAL |

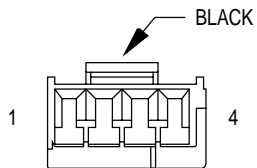

**FRONT FOG
LAMP
SWITCH**

| CAV | CIRCUIT | FUNCTION |
|-----|-----------|--|
| 1 | E2 20OR | FUSED PANEL LAMPS DIMMER SWITCH SIGNAL |
| 2 | L39 20LB | FOG LAMP SWITCH OUTPUT |
| 3 | L139 20VT | FUSED HEADLAMP SWITCH OUTPUT |
| 4 | Z1 20BK | GROUND |

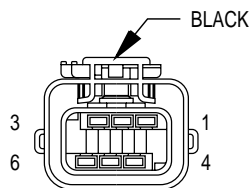

**FRONT WIPER
MOTOR**

| CAV | CIRCUIT | FUNCTION |
|-----|------------|--|
| 1 | V6 16DB | FUSED IGNITION SWITCH OUTPUT (RUN-ACC) |
| 2 | V5 16DG/YL | WIPER PARK SWITCH SENSE |
| 3 | - | - |
| 4 | Z1 16BK | GROUND |
| 5 | V3 16BR/WT | WIPER LOW SPEED OUTPUT |
| 6 | V4 16BR/VT | WIPER HIGH SPEED OUTPUT |

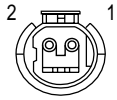

**FUEL HEATER
(DIESEL)**

| CAV | CIRCUIT | FUNCTION |
|-----|-------------|--------------------------|
| 1 | A93 14RD/BK | FUEL HEATER RELAY OUTPUT |
| 2 | Z1 14BK | GROUND |

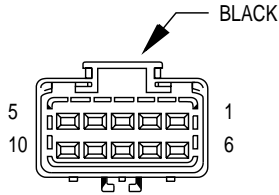

**FUEL INJECTION
PUMP
(DIESEL)**

| CAV | CIRCUIT | FUNCTION |
|-----|--------------|--|
| 1 | K134 20LB/BK | CONTROL SLEEVE POSITION SENSOR SIGNAL |
| 2 | K57 20LG/OR | CONTROL SLEEVE POSITION SENSOR MIDDLE TAP SIGNAL |
| 3 | K135 20WT/BK | CONTROL SLEEVE POSITION SENSOR MEASURE COIL |
| 4 | K4 20BK/LB | SENSOR GROUND |
| 5 | K126 18LG | FUEL TIMING SOLENOID CONTROL |
| 6 | K153 18OR | FUEL SHUT DOWN SOLENOID CONTROL |
| 7 | K156 20GY | FUEL TEMPERATURE SENSOR SIGNAL |
| 8 | K140 16TN/WT | FUEL QUANTITY ACTUATOR CONTROL |
| 9 | A142 16DG/OR | AUTOMATIC SHUT DOWN RELAY OUTPUT |
| 10 | F142 16DG/OR | FUSED AUTOMATIC SHUT DOWN RELAY OUTPUT |

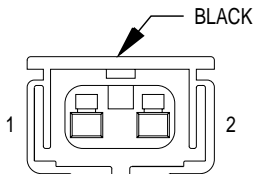

**FUEL INJECTOR
NO. 1
(2.5L GAS)**

| CAV | CIRCUIT | FUNCTION |
|-----|--------------|--|
| 1 | A142 18DG/OR | FUSED AUTOMATIC SHUT DOWN RELAY OUTPUT |
| 2 | K11 18WT/DB | FUEL INJECTOR NO. 1 DRIVER |

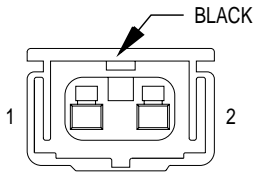

**FUEL INJECTOR
NO. 2
(2.5L GAS)**

| CAV | CIRCUIT | FUNCTION |
|-----|--------------|--|
| 1 | A142 18DG/OR | FUSED AUTOMATIC SHUT DOWN RELAY OUTPUT |
| 2 | K12 18TN | FUEL INJECTOR NO. 2 DRIVER |

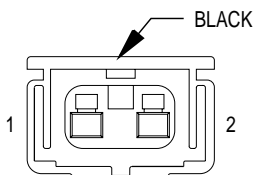

**FUEL INJECTOR
NO. 3
(2.5L GAS)**

| CAV | CIRCUIT | FUNCTION |
|-----|--------------|--|
| 1 | A142 18DG/OR | FUSED AUTOMATIC SHUT DOWN RELAY OUTPUT |
| 2 | K13 18YL/WT | FUEL INJECTOR NO. 3 DRIVER |

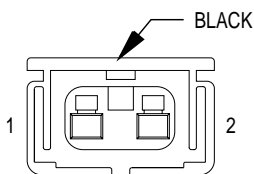

**FUEL INJECTOR
NO. 4
(2.5L GAS)**

| CAV | CIRCUIT | FUNCTION |
|-----|--------------|--|
| 1 | A142 18DG/OR | FUSED AUTOMATIC SHUT DOWN RELAY OUTPUT |
| 2 | K14 18LB/BR | FUEL INJECTOR NO. 4 DRIVER |

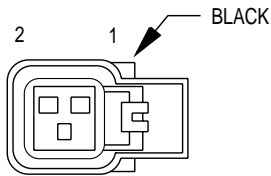

**FUEL INJECTOR NO. 1
(4.0L GAS)**

| CAV | CIRCUIT | FUNCTION |
|-----|--------------|--|
| 1 | A142 18DG/OR | FUSED AUTOMATIC SHUT DOWN RELAY OUTPUT |
| 2 | K11 18WT/DB | FUEL INJECTOR NO. 1 DRIVER |

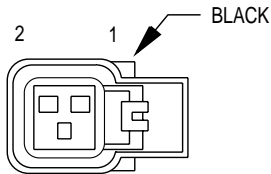

**FUEL INJECTOR NO. 2
(4.0L GAS)**

| CAV | CIRCUIT | FUNCTION |
|-----|--------------|--|
| 1 | A142 18DG/OR | FUSED AUTOMATIC SHUT DOWN RELAY OUTPUT |
| 2 | K12 18TN | FUEL INJECTOR NO. 2 DRIVER |

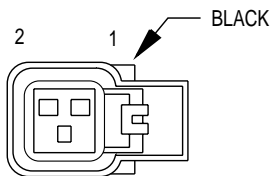

**FUEL INJECTOR NO. 3
(4.0L GAS)**

| CAV | CIRCUIT | FUNCTION |
|-----|--------------|--|
| 1 | A142 18DG/OR | FUSED AUTOMATIC SHUT DOWN RELAY OUTPUT |
| 2 | K13 18YL/WT | FUEL INJECTOR NO. 3 DRIVER |

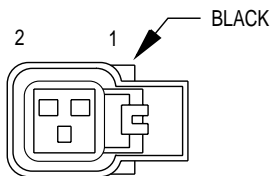

**FUEL INJECTOR NO. 4
(4.0L GAS)**

| CAV | CIRCUIT | FUNCTION |
|-----|--------------|--|
| 1 | A142 18DG/OR | FUSED AUTOMATIC SHUT DOWN RELAY OUTPUT |
| 2 | K14 18LB/BR | FUEL INJECTOR NO. 4 DRIVER |

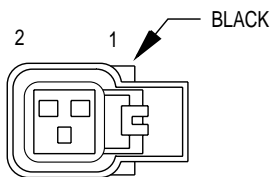

**FUEL INJECTOR NO. 5
(4.0L GAS)**

| CAV | CIRCUIT | FUNCTION |
|-----|--------------|--|
| 1 | A142 18DG/OR | FUSED AUTOMATIC SHUT DOWN RELAY OUTPUT |
| 2 | K15 18PK/BK | FUEL INJECTOR NO. 5 DRIVER |

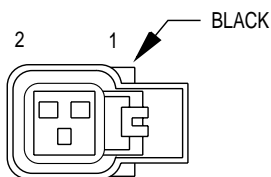

**FUEL INJECTOR NO. 6
(4.0L GAS)**

| CAV | CIRCUIT | FUNCTION |
|-----|--------------|--|
| 1 | A142 18DG/OR | FUSED AUTOMATIC SHUT DOWN RELAY OUTPUT |
| 2 | K16 18LG/BK | FUEL INJECTOR NO. 6 DRIVER |

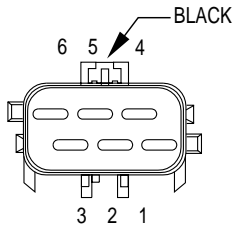

FUEL LEVEL SENSOR (DIESEL)

| CAV | CIRCUIT | FUNCTION |
|-----|--------------|--------------------------|
| 1 | A141 16DG/WT | NOT USED |
| 2 | - | - |
| 3 | K226 20DB/LG | FUEL LEVEL SENSOR SIGNAL |
| 4 | K167 20BR/YL | SENSOR GROUND |
| 5 | - | - |
| 6 | Z1 16BK | NOT USED |

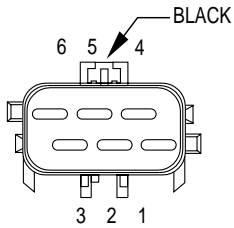

FUEL PUMP MODULE (GAS)

| CAV | CIRCUIT | FUNCTION |
|-----|--------------|--------------------------|
| 1 | A141 16DG/WT | FUEL PUMP RELAY OUTPUT |
| 2 | - | - |
| 3 | K226 20DB/LG | FUEL LEVEL SENSOR SIGNAL |
| 4 | K167 20BR/YL | SENSOR GROUND |
| 5 | - | - |
| 6 | Z1 16BK | GROUND |

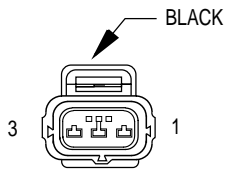

G SWITCH

| CAV | CIRCUIT | FUNCTION |
|-----|-------------|----------------------|
| 1 | B42 20TN/WT | G SWITCH NO. 2 SENSE |
| 2 | B41 20YL/VT | G SWITCH NO.1 SENSE |
| 3 | B43 20PK/OR | G SWITCH TEST SIGNAL |

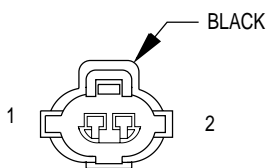

GENERATOR

| CAV | CIRCUIT | FUNCTION |
|-----|----------------|------------------|
| 1 | K72 18DG/OR ■■ | GENERATOR SOURCE |
| 1 | K72 16DG/OR ■ | GENERATOR SOURCE |
| 2 | K20 18DG ■■ | GENERATOR FIELD |
| 2 | K20 16DG ■ | GENERATOR FIELD |

■ GAS
 ■■ DIESEL

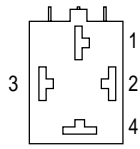

GLOW PLUG RELAY (DIESEL)

| CAV | CIRCUIT | FUNCTION |
|-----|--------------|--|
| 1 | A54 10RD/GY | FUSED B (+) |
| 2 | F142 18DG/OR | FUSED AUTOMATIC SHUT DOWN RELAY OUTPUT |
| 3 | K152 18WT | GLOW PLUG RELAY CONTROL |
| 4 | K154 10GY | GLOW PLUG RELAY OUTPUT |

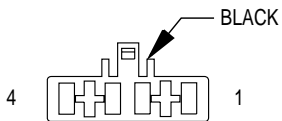

HEADLAMP BEAM SELECT SWITCH

| CAV | CIRCUIT | FUNCTION |
|-----|-------------|--------------------------------|
| 1 | L4 16VT/WT | DIMMER SWITCH LOW BEAM OUTPUT |
| 2 | L2 14LG | HEADLAMP SWITCH OUTPUT |
| 3 | L3 16RD/OR | DIMMER SWITCH HIGH BEAM OUTPUT |
| 4 | L20 14LG/WT | FUSED B (+) |

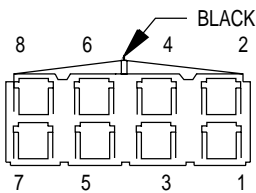

HEADLAMP DELAY MODULE

| CAV | CIRCUIT | FUNCTION |
|-----|-------------|---------------------------------------|
| 1 | - | - |
| 2 | A3 14RD/WT | FUSED B(+) |
| 3 | - | - |
| 4 | Z1 18BK | GROUND |
| 5 | - | - |
| 6 | L2 14LG | HEADLAMP SWITCH OUTPUT |
| | L2 14LG | • HEADLAMP SWITCH OUTPUT |
| 7 | - | - |
| 8 | F87 20WT/BK | FUSED IGNITION SWITCH OUTPUT (ST-RUN) |

• EXCEPT BUILT-UP-EXPORT

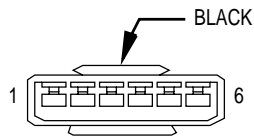

**HEADLAMP
LEVELING SWITCH
(BUILT-UP-EXPORT)**

| CAV | CIRCUIT | FUNCTION |
|-----|-------------|-----------------------------|
| 1 | - | - |
| 2 | L13 20BR/YL | HEADLAMP ADJUST SIGNAL |
| 3 | L44 20VT/RD | FUSED RIGHT LOW BEAM OUTPUT |
| 4 | - | - |
| 5 | Z15 20BK/GY | GROUND |
| 6 | - | - |

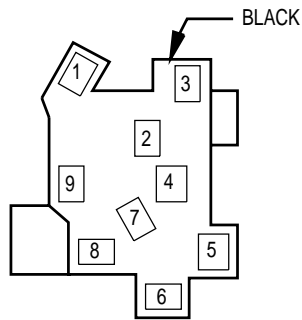

**HEADLAMP
SWITCH**

| CAV | CIRCUIT | FUNCTION |
|-----|---------------|----------------------------------|
| 1 | E1 20TN | PANEL LAMPS DIMMER SWITCH SIGNAL |
| 2 | L2 14LG | HEADLAMP SWITCH OUTPUT |
| 3 | M2 20YL | COURTESY LAMPS DRIVER |
| 4 | F34 18TN/BK | FUSED B(+) |
| | F34 18TN/BK • | FUSED B(+) |
| 5 | G26 20LB | KEY-IN IGNITION SWITCH SENSE |
| 6 | G16 20BK/LB | DRIVER DOOR AJAR SWITCH SENSE |
| 7 | L20 14LG/WT | FUSED B (+) |
| 8 | A3 14RD/WT | FUSED B (+) |
| | A3 14RD/WT | FUSED B (+) |
| 9 | L7 18BK/YL | HEADLAMP SWITCH OUTPUT |

• LHD EXCEPT BUILT-UP-EXPORT

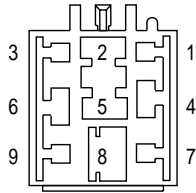

HEATED SEAT RELAY

| CAV | CIRCUIT | FUNCTION |
|-----|-------------|--|
| 1 | - | - |
| 2 | F235 16RD | B(+) TO HEATED SEAT MODULE |
| | F235 16RD | B(+) TO HEATED SEAT MODULE |
| 3 | - | - |
| 4 | F83 18YL/DG | FUSED IGNITION SWITCH OUTPUT (RUN-ACC) |
| 5 | - | - |
| 6 | Z1 18BK | GROUND |
| 7 | - | - |
| 8 | F37 14RD/LB | FUSED B(+) |

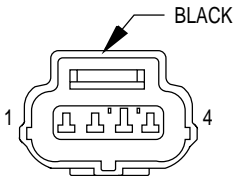

IDLE AIR CONTROL MOTOR

| CAV | CIRCUIT | FUNCTION |
|-----|-------------|-------------------------------|
| 1 | K59 18VT/BK | IDLE AIR CONTROL NO. 4 DRIVER |
| 2 | K40 18BR/WT | IDLE AIR CONTROL NO. 3 DRIVER |
| 3 | K60 18YL/BK | IDLE AIR CONTROL NO. 2 DRIVER |
| 4 | K39 18GY/RD | IDLE AIR CONTROL NO. 1 DRIVER |

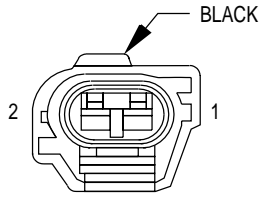

**IGNITION COIL
(2.5L GAS)**

| CAV | CIRCUIT | FUNCTION |
|-----|--------------|--|
| 1 | A142 18DG/OR | FUSED AUTOMATIC SHUT DOWN RELAY OUTPUT |
| 2 | K19 18GY | IGNITION COIL NO. 1 DRIVER |

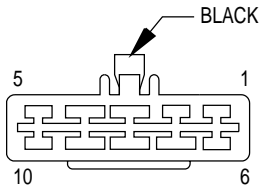

IGNITION SWITCH - C1

| CAV | CIRCUIT | FUNCTION |
|-----|-------------|------------------------------------|
| 1 | Z1 20BK | GROUND |
| 2 | G9 20GY/BK | RED BRAKE WARNING INDICATOR DRIVER |
| 3 | A2 12PK/BK | FUSED B(+) |
| 4 | A22 12BK/OR | IGNITION SWITCH OUTPUT (RUN) |
| 5 | - | - |
| 6 | - | - |
| 7 | A1 12RD | FUSED B(+) |
| 8 | A31 12BK/WT | IGNITION SWITCH OUTPUT (RUN-ACC) |
| 9 | A21 12DB | IGNITION SWITCH OUTPUT (ST-RUN) |
| 10 | A41 14YL | IGNITION SWITCH OUTPUT (START) |

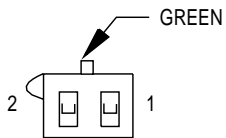

IGNITION SWITCH - C2

| CAV | CIRCUIT | FUNCTION |
|-----|-------------|-------------------------------|
| 1 | G26 20LB | KEY-IN IGNITION SWITCH SENSE |
| 2 | G16 20BK/LB | DRIVER DOOR AJAR SWITCH SENSE |

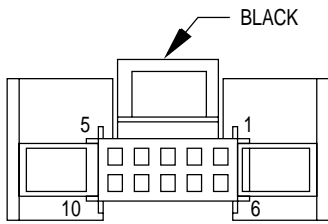

INSTRUMENT CLUSTER - C1 (LHD)

| CAV | CIRCUIT | FUNCTION |
|-----|-------------|--|
| 1 | G78 20TN/BK | LIFTGATE AJAR SWITCH SENSE |
| 2 | G99 20GY/WT | RED BRAKE WARNING INDICATOR DRIVER |
| 3 | E2 20OR | FUSED PANEL LAMPS DIMMER SWITCH SIGNAL |
| 4 | G19 20LG/OR | ABS WARNING INDICATOR DRIVER |
| 5 | G34 16RD/GY | HIGH BEAM INDICATOR DRIVER |
| 6 | Z2 20BK/LG | GROUND |
| 7 | G29 20BK/LB | LOW WASHER FLUID SENSE |
| 8 | F87 20WT/BK | FUSED IGNITION SWITCH OUTPUT (START-RUN) |
| 9 | M1 20PK | FUSED B(+) |
| 10 | L61 20LG/WT | LEFT TURN SIGNAL |

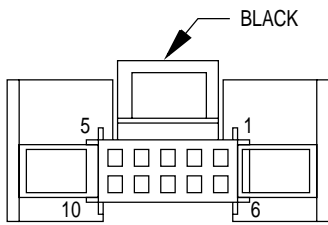

INSTRUMENT CLUSTER - C1 (RHD)

| CAV | CIRCUIT | FUNCTION |
|-----|-------------|--|
| 1 | G78 20TN/BK | LIFTGATE AJAR SWITCH SENSE |
| 2 | G99 20GY/WT | RED BRAKE WARNING INDICATOR DRIVER |
| 3 | E2 20OR | FUSED PANEL LAMPS SWITCH SIGNAL |
| 4 | G19 20LG/OR | ABS WARNING INDICATOR DRIVER |
| 5 | L3 16RD/OR | DIMMER SWITCH HIGH BEAM OUTPUT |
| 6 | Z2 20BK/LG | GROUND |
| 7 | G29 20BK/LB | LOW WASHER FLUID SENSE |
| 8 | F87 20WT/BK | FUSED IGNITION SWITCH OUTPUT (START-RUN) |
| 9 | M1 20PK | FUSED B(+) |
| 10 | L61 20LG/WT | LEFT TURN SIGNAL |

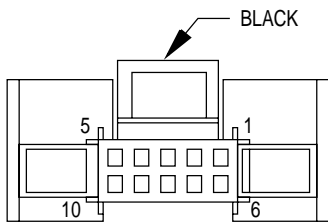

INSTRUMENT CLUSTER - C2

| CAV | CIRCUIT | FUNCTION |
|-----|--------------|------------------------------------|
| 1 | D2 20WT/BK | CCD BUS (-) |
| 2 | D1 20VT/BR | CCD BUS (+) |
| 3 | C81 20LB/WT | REAR WINDOW DEFOGGER RELAY CONTROL |
| 4 | C80 20DB/WT | REAR WINDOW DEFOGGER SWITCH SENSE |
| 5 | G107 20BK/RD | 4WD SWITCH SENSE (PART-TIME) |
| 6 | L60 20TN | RIGHT TURN SIGNAL |
| 7 | G106 20BK/WT | 4WD SWITCH SENSE (FULL-TIME) |
| 8 | G26 20LB | KEY-IN IGNITION SWITCH SENSE |
| 9 | Z2 18BK/LG | GROUND |
| 10 | G10 20LG/RD | SEAT BELT SWITCH SENSE |

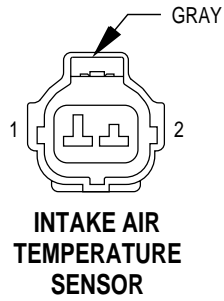

| CAV | CIRCUIT | FUNCTION |
|-----|--------------|--------------------------------------|
| 1 | K167 20BR/YL | SENSOR GROUND |
| 2 | K21 18BK/RD | INTAKE AIR TEMPERATURE SENSOR SIGNAL |

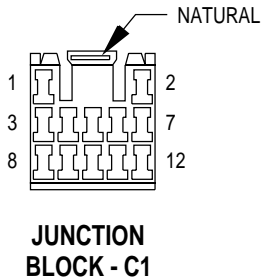

| CAV | CIRCUIT | FUNCTION |
|-----|----------------|--|
| 1 | L44 20VT/RD | FUSED RIGHT LOW BEAM OUTPUT |
| 2 | - | - |
| 3 | F45 20YL/RD | FUSED B(+) ENGINE STARTER MOTOR RELAY |
| 4 | - | - |
| 5 | L78 18DG/YL ● | FUSED HEADLAMP SWITCH OUTPUT |
| 5 | L78 20DG/YL ▲ | FUSED HEADLAMP SWITCH OUTPUT |
| 6 | F15 20DB/WT ●● | FUSED IGNITION SWITCH OUTPUT (RUN) |
| 7 | - | - |
| 8 | V6 16DB | FUSED IGNITION SWITCH OUTPUT (RUN-ACC) |
| 9 | L33 20RD | FUSED LEFT HIGH BEAM OUTPUT |
| 10 | L43 20VT | FUSED LEFT LOW BEAM OUTPUT |
| 11 | L34 20RD/OR | FUSED RIGHT HIGH BEAM OUTPUT |
| 12 | M1 20PK | FUSED B(+) |

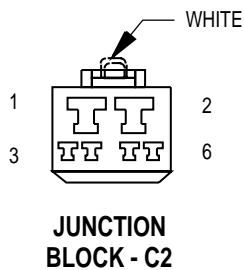

| CAV | CIRCUIT | FUNCTION |
|-----|---------------|---------------------------------------|
| 1 | A4 12BK/PK | FUSED B(+) |
| 2 | A7 10RD/BK | FUSED B(+) |
| 3 | - | - |
| 4 | X2 20DG/RD | HORN RELAY OUTPUT |
| 5 | F12 18DB/WT | FUSED IGNITION SWITCH OUTPUT (ST-RUN) |
| 6 | L77 20BR/YL ▲ | FUSED HEADLAMP SWITCH OUTPUT |
| 6 | L77 18BR/YL ● | FUSED HEADLAMP SWITCH OUTPUT |

- ▲ GAS
- DIESEL
- 4.0L AND DIESEL

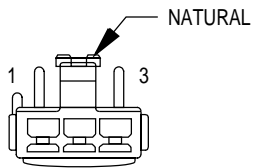

**JUNCTION
BLOCK - C3**

| CAV | CIRCUIT | FUNCTION |
|-----|---------|-----------------------|
| 1 | M2 20YL | COURTESY LAMPS DRIVER |
| 2 | Z1 20BK | GROUND |
| 3 | M1 20PK | FUSED B(+) |

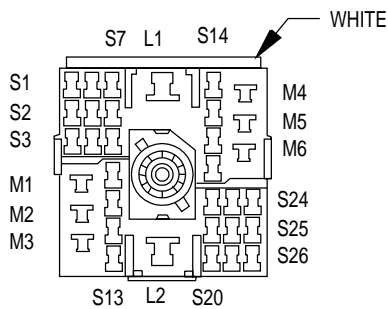

**JUNCTION
BLOCK - C4**

| CAV | CIRCUIT | FUNCTION |
|-----|-----------------|--|
| L1 | A31 12BK/WT | IGNITION SWITCH OUTPUT (RUN-ACC) |
| L2 | A21 12DB | IGNITION SWITCH OUTPUT (ST-RUN) |
| M1 | A41 14YL | IGNITION SWITCH OUTPUT (ST) |
| M2 | A22 12BK/OR | IGNITION SWITCH OUTPUT (RUN) |
| M3 | L7 18BK/YL | HEADLAMP SWITCH OUTPUT |
| M4 | V6 16DB | FUSED IGNITION SWITCH OUTPUT (RUN-ACC) |
| M5 | F38 16RD/LB | FUSED B(+) |
| M6 | F30 16RD | CIGAR LIGHTER RELAY OUTPUT |
| S1 | E1 20TN | PANEL LAMPS DIMMER SWITCH SIGNAL |
| S2 | E2 20OR | FUSED PANEL LAMPS DIMMER SWITCH SIGNAL |
| S3 | L4 16VT/WT | DIMMER SWITCH LOW BEAM OUTPUT |
| S4 | F83 18YL/DG | FUSED IGNITION SWITCH OUTPUT (RUN-ACC) |
| S5 | Z1 14BK | GROUND |
| S6 | - | - |
| S7 | L3 16RD/OR | DIMMER SWITCH HIGH BEAM OUTPUT |
| S8 | F15 20DB/WT | FUSED IGNITION SWITCH OUTPUT (RUN) |
| S9 | X12 16RD/WT | FUSED IGNITION SWITCH OUTPUT (RUN-ACC) |
| S10 | - | - |
| S11 | V23 18BR/PK | FUSED IGNITION SWITCH OUTPUT (RUN) |
| S12 | F20 18WT | FUSED IGNITION SWITCH OUTPUT (ST-RUN) |
| S13 | F87 20WT/BK | FUSED IGNITION SWITCH OUTPUT (ST-RUN) |
| S14 | - | - |
| S15 | - | - |
| S16 | - | - |
| S17 | - | - |
| S18 | M1 20PK | FUSED B(+) |
| S19 | C16 20LB/YL ●● | FUSED REAR WINDOW DEFFOGGER RELAY OUTPUT |
| S19 | C16 20BK/WT ●●● | FUSED REAR WINDOW DEFFOGGER RELAY OUTPUT |
| S20 | L5 20BK | FUSED IGNITION SWITCH OUTPUT (RUN) |
| S21 | F14 18LG/YL | FUSED IGNITION SWITCH OUTPUT (RUN) |
| S22 | X3 20BK/RD | HORN RELAY CONTROL |
| S23 | F23 18DB/YL | FUSED IGNITION SWITCH OUTPUT (ST-RUN) |
| S24 | - | - |
| S25 | M2 20YL | COURTESY LAMPS DRIVER |
| S26 | C81 20LB/WT | REAR WINDOW DEFOGGER RELAY CONTROL |

- OVERHEAD CONSOLE
- LHD
- RHD

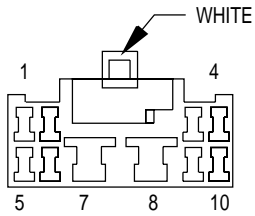

**JUNCTION
BLOCK - C5**

| CAV | CIRCUIT | FUNCTION |
|-----|----------------|---|
| 1 | X3 20BK/RD | HORN RELAY CONTROL |
| 2 | P76 20OR/YL | MIRROR COMMON DRIVER |
| 3 | P91 20WT/BK | MIRROR COMMON DRIVER |
| 4 | - | - |
| 5 | C16 20LB/YL ▲▲ | FUSED REAR WINDOW DEFOGGER RELAY OUTPUT |
| 6 | - | - |
| 7 | F35 16RD ▲▲ | FUSED B(+) |
| 8 | F81 12TN | FUSED IGNITION SWITCH OUTPUT (RUN-ACC) |
| 9 | P74 20DB ▲▲ | LEFT POWER MIRROR HORIZONTAL DRIVER |
| 9 | P74 20DB ■■ | RIGHT POWER MIRROR HORIZONTAL DRIVER |
| 10 | P72 20YL/BK ▲▲ | LEFT POWER MIRROR VERTICAL DRIVER |
| 10 | P72 20YL/BK ■■ | RIGHT POWER MIRROR VERTICAL DRIVER |

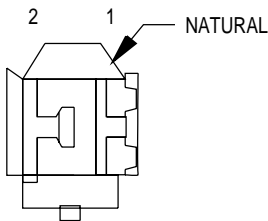

**JUNCTION
BLOCK - C6**

| CAV | CIRCUIT | FUNCTION |
|-----|---------------|-----------------------------------|
| 1 | C15 12BK/WT | REAR WINDOW DEFOGGER RELAY OUTPUT |
| 2 | F37 14RD/LB ■ | FUSED B(+) |

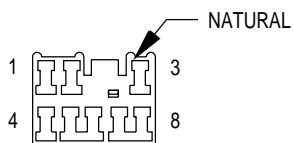

**JUNCTION
BLOCK - C7**

| CAV | CIRCUIT | FUNCTION |
|-----|----------------|------------------------------|
| 1 | P33 16OR/BK ● | DOOR LOCK DRIVER |
| 2 | L77 18BR/YL | FUSED HEADLAMP SWITCH OUTPUT |
| 3 | P91 20WT/BK ●● | MIRROR COMMON DRIVER |
| 4 | M1 20PK | FUSED B(+) |
| 5 | P34 16PK/BK ● | DOOR UNLOCK DRIVER |
| 6 | L78 18DG/YL | FUSED HEADLAMP SWITCH OUTPUT |
| 7 | M2 20YL | COURTESY LAMPS DRIVER |
| 8 | A6 20RD/OR | FUSED B(+) |

- FULL OPTIONS
- RHD EXCEPT FULL OPTIONS
- ▲ BASE
- ▲▲ RHD
- POWER SEATS
- LHD

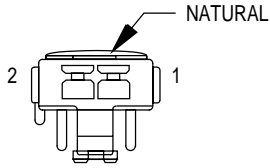

**JUNCTION
BLOCK - C8**

| CAV | CIRCUIT | FUNCTION |
|-----|----------|--|
| 1 | F81 14TN | FUSED IGNITION SWITCH OUTPUT (RUN-ACC) |
| 2 | - | - |

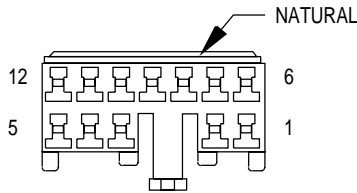

**JUNCTION
BLOCK - C9
(LHD)**

| CAV | CIRCUIT | FUNCTION |
|-----|-------------|---|
| 1 | P33 16OR/BK | DOOR LOCK DRIVER |
| 2 | P74 20DB | ● RIGHT POWER MIRROR HORIZONTAL DRIVER |
| 3 | C16 20BK/WT | FUSED REAR WINDOW DEFOGGER RELAY OUTPUT |
| 4 | - | - |
| 5 | - | - |
| 6 | P72 20YL/BK | ● RIGHT POWER MIRROR VERTICAL DRIVER |
| 7 | P91 20WT/BK | ● COMMON MIRROR DRIVER |
| 8 | - | - |
| 9 | F35 16RD | FUSED B(+) |
| 10 | P76 20OR/YL | ● MIRROR COMMON DRIVER |
| 11 | Z1 18BK | ● GROUND |
| 11 | Z1 16BK | ▲ GROUND |
| 12 | P34 16PK/BK | DOOR UNLOCK DRIVER |

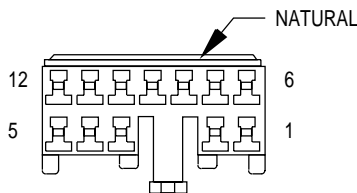

**JUNCTION
BLOCK - C9
(RHD)**

| CAV | CIRCUIT | FUNCTION |
|-----|-------------|---|
| 1 | P33 16OR/BK | DOOR LOCK DRIVER |
| 2 | P75 20DB/WT | LEFT POWER MIRROR HORIZONTAL DRIVER |
| 3 | C16 20BK/WT | FUSED REAR WINDOW DEFOGGER RELAY OUTPUT |
| 4 | - | - |
| 5 | - | - |
| 6 | P71 20YL/LB | LEFT POWER MIRROR VERTICAL DRIVER |
| 7 | P91 20WT/BK | ● MIRROR COMMON DRIVER |
| 8 | - | - |
| 9 | - | - |
| 10 | P76 20OR/YL | MIRROR COMMON DRIVER |
| 11 | Z1 16BK | ● GROUND |
| 12 | P34 16PK/BK | DOOR UNLOCK DRIVER |

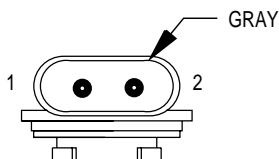

**LEFT BACK-UP
LAMP**

| CAV | CIRCUIT | FUNCTION |
|-----|-------------|-------------------|
| 1 | Z1 18BK | GROUND |
| 2 | L10 18BR/LG | BACK-UP LAMP FEED |

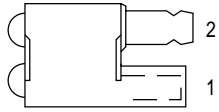

**LEFT CITY LAMP
(BUILT-UP-EXPORT)**

| CAV | CIRCUIT | FUNCTION |
|-----|----------|------------------------------|
| 1 | L77 20BR | FUSED HEADLAMP SWITCH OUTPUT |
| 2 | Z1 20BK | GROUND |

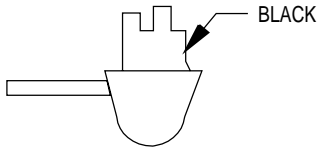

LEFT COURTESY LAMP

| CAV | CIRCUIT | FUNCTION |
|-----|------------|-----------------------|
| 1 | M1 18PK | FUSED B(+) |
| 2 | M2 18BK/WT | COURTESY LAMPS DRIVER |

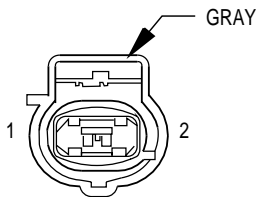

LEFT FOG LAMP

| CAV | CIRCUIT | FUNCTION |
|-----|----------|-----------------------|
| 1 | Z1 20BK | GROUND |
| 2 | L39 20LB | FOG LAMP RELAY OUTPUT |

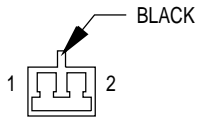

LEFT FRONT DOOR SPEAKER

| CAV | CIRCUIT | FUNCTION |
|-----|----------------|---------------------------------------|
| 1 | X85 18BK/RD ● | AMPLIFIED LEFT FRONT DOOR SPEAKER (-) |
| 1 | X55 18LG/RD ●● | LEFT FRONT SPEAKER (-) |
| 1 | X85 18LG/RD ▲ | AMPLIFIED LEFT FRONT DOOR SPEAKER (-) |
| 2 | X87 18DG ● | AMPLIFIED LEFT FRONT DOOR SPEAKER (+) |
| 2 | X53 18LG/BK ●● | LEFT FRONT SPEAKER (+) |
| 2 | X87 18LG/BK ▲ | AMPLIFIED LEFT FRONT DOOR SPEAKER (+) |

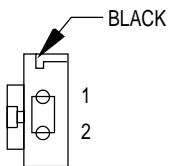

LEFT FRONT DOOR TWEETER

| CAV | CIRCUIT | FUNCTION |
|-----|-------------|---------------------------------------|
| 1 | X85 18LG/RD | AMPLIFIED LEFT FRONT DOOR SPEAKER (-) |
| 2 | X87 18LG/BK | AMPLIFIED LEFT FRONT DOOR SPEAKER (+) |

- 6 SPEAKER LHD
- ▲ 6 SPEAKER RHD
- 4 SPEAKER

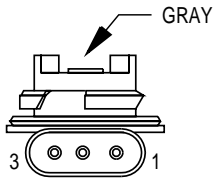

**LEFT FRONT
PARK/TURN
SIGNAL LAMP NO. 1
(EXCEPT BUILT-UP-
EXPORT)**

| CAV | CIRCUIT | FUNCTION |
|-----|----------|------------------------------|
| 1 | L61 18LG | LEFT TURN SIGNAL |
| 2 | L77 18BR | FUSED HEADLAMP SWITCH OUTPUT |
| 3 | Z1 18BK | GROUND |

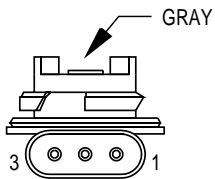

**LEFT FRONT
PARK/TURN
SIGNAL LAMP NO. 2
(EXCEPT BUILT-UP-
EXPORT)**

| CAV | CIRCUIT | FUNCTION |
|-----|----------|------------------------------|
| 1 | L61 18LG | LEFT TURN SIGNAL |
| 2 | L77 18BR | FUSED HEADLAMP SWITCH OUTPUT |
| 3 | Z1 18BK | GROUND |

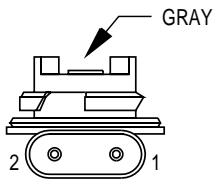

**LEFT FRONT
TURN SIGNAL
LAMP NO. 1
(BUILT-UP-EXPORT)**

| CAV | CIRCUIT | FUNCTION |
|-----|----------|------------------|
| 1 | Z1 18BK | GROUND |
| 2 | L61 18LG | LEFT TURN SIGNAL |

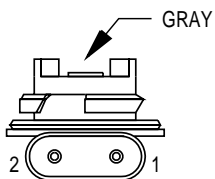

**LEFT FRONT
TURN SIGNAL
LAMP NO. 2
(BUILT-UP-EXPORT)**

| CAV | CIRCUIT | FUNCTION |
|-----|----------|------------------|
| 1 | Z1 18BK | GROUND |
| 2 | L61 18LG | LEFT TURN SIGNAL |

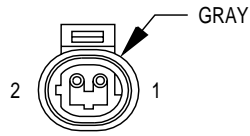

LEFT FRONT WHEEL SPEED SENSOR

| CAV | CIRCUIT | FUNCTION |
|-----|------------|-----------------------------------|
| 1 | B8 18RD/DB | LEFT FRONT WHEEL SPEED SENSOR (-) |
| 2 | B9 18RD | LEFT FRONT WHEEL SPEED SENSOR (+) |

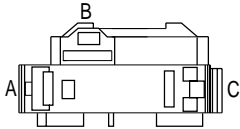

LEFT HEADLAMP

| CAV | CIRCUIT | FUNCTION |
|-----|----------|-------------------------------|
| A | L33 18RD | FUSED LEFT HIGH BEAM OUTPUT |
| | L33 20RD | • FUSED LEFT HIGH BEAM OUTPUT |
| B | L43 18VT | FUSED LEFT LOW BEAM OUTPUT |
| C | Z1 18BK | GROUND |

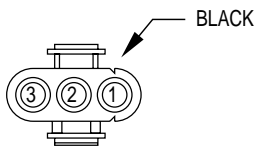

LEFT HEADLAMP LEVELING MOTOR (BUILT-UP-EXPORT)

| CAV | CIRCUIT | FUNCTION |
|-----|-------------|----------------------------|
| 1 | L43 18VT | FUSED LEFT LOW BEAM OUTPUT |
| 2 | L13 18BR/YL | HEADLAMP ADJUST SIGNAL |
| 3 | Z15 18BK/GY | GROUND |

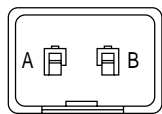

LEFT HEATED SEAT BACK

| CAV | CIRCUIT | FUNCTION |
|-----|-------------|------------------------------|
| A | P88 18BR/BK | LEFT HEATED SEAT BACK DRIVER |
| B | Z1 18BK | GROUND |



LEFT HEATED SEAT CUSHION

| CAV | CIRCUIT | FUNCTION |
|-----|--------------|------------------------------|
| A | P87 18BK/OR | LEFT HEATED SEAT DRIVER |
| B | P88 18BR/BK | LEFT HEATED SEAT BACK DRIVER |
| C | P141 18TN/LB | SENSOR FEED |
| D | P143 18BK/DG | LEFT HEAT SENSE INPUT |

• FOG LAMPS

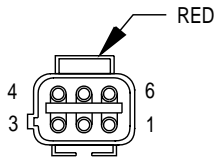

LEFT HEATED SEAT SWITCH

| CAV | CIRCUIT | FUNCTION |
|-----|--------------|--|
| 1 | P137 18VT | LEFT SEAT LOW HEAT LED DRIVER |
| 2 | - | - |
| 3 | Z1 18BK | GROUND |
| 4 | F83 18YL/DG | FUSED IGNITION SWITCH OUTPUT (RUN-ACC) |
| 5 | P139 18VT/WT | LEFT SEAT HIGH HEAT LED DRIVER |
| 6 | P133 18TN/DG | LEFT SEAT HEATER SWITCH MUX |

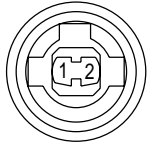

LEFT LICENCE LAMP (BUILT-UP-EXPORT)

| CAV | CIRCUIT | FUNCTION |
|-----|-------------|------------------------------|
| 1 | L78 18BK/YL | FUSED HEADLAMP SWITCH OUTPUT |
| 2 | Z1 18BK | GROUND |

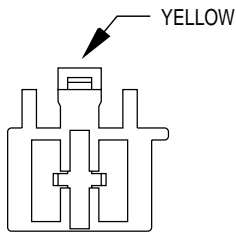

LEFT POWER SEAT FRONT VERTICAL MOTOR

| CAV | CIRCUIT | FUNCTION |
|-----|-------------|----------------------------|
| 1 | P19 14YL/LG | LEFT POWER SEAT FRONT UP |
| 2 | P21 14RD/LG | LEFT POWER SEAT FRONT DOWN |

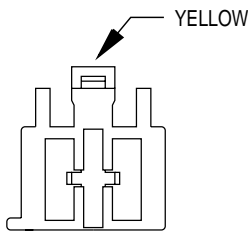

LEFT POWER SEAT HORIZONTAL MOTOR

| CAV | CIRCUIT | FUNCTION |
|-----|-------------|-------------------------------------|
| 1 | P17 14RD/LB | LEFT POWER SEAT HORIZONTAL REARWARD |
| 2 | P15 14YL/LB | LEFT POWER SEAT HORIZONTAL FORWARD |

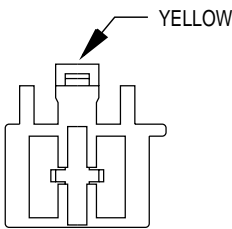

LEFT POWER SEAT REAR VERTICAL MOTOR

| CAV | CIRCUIT | FUNCTION |
|-----|-------------|---------------------------|
| 1 | P13 14RD/WT | LEFT POWER SEAT REAR DOWN |
| 2 | P11 14YL/WT | LEFT POWER SEAT REAR UP |

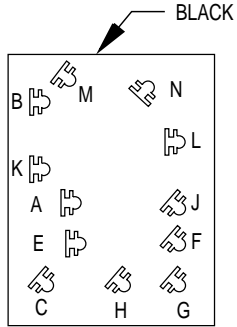

LEFT POWER SEAT SWITCH

| CAV | CIRCUIT | FUNCTION |
|-----|-------------|-------------------------------------|
| A | F37 14RD | FUSED B(+) |
| B | Z1 14BK | GROUND |
| C | - | - |
| E | P13 14RD/WT | LEFT POWER SEAT REAR DOWN |
| F | - | - |
| G | - | - |
| H | - | - |
| J | P11 14YL/WT | LEFT POWER SEAT REAR UP |
| K | P17 14RD/LB | LEFT POWER SEAT HORIZONTAL REARWARD |
| L | P15 14YL/LB | LEFT POWER SEAT HORIZONTAL FORWARD |
| M | P19 14YL/LG | LEFT POWER SEAT FRONT UP |
| N | P21 14RD/LG | LEFT POWER SEAT FRONT DOWN |

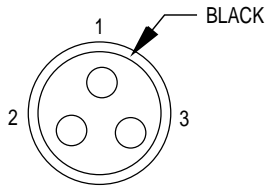

LEFT REAR DOOR JAMB SWITCH

| CAV | CIRCUIT | FUNCTION |
|-----|---------|-----------------------|
| 1 | - | - |
| 2 | Z1 18BK | GROUND |
| 3 | M2 18YL | COURTESY LAMPS DRIVER |

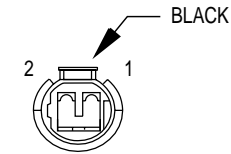

LEFT REAR DOOR LOCK MOTOR

| CAV | CIRCUIT | FUNCTION |
|-----|-------------|--------------------|
| 1 | P34 16PK/BK | DOOR UNLOCK DRIVER |
| 2 | P33 16OR/BK | DOOR LOCK DRIVER |

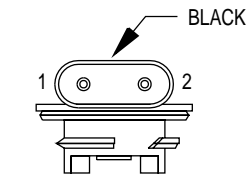

LEFT REAR FOG LAMP (BUILT-UP-EXPORT)

| CAV | CIRCUIT | FUNCTION |
|-----|-------------|--------------------|
| 1 | Z1 18BK | GROUND |
| 2 | L38 18OR/WT | REAR FOG LAMP FEED |

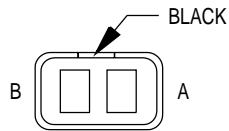

LEFT REAR WHEEL SPEED SENSOR

| CAV | CIRCUIT | FUNCTION |
|-----|------------|----------------------------------|
| A | B3 20LG/DB | LEFT REAR WHEEL SPEED SENSOR (-) |
| B | B4 20LG | LEFT REAR WHEEL SPEED SENSOR (+) |

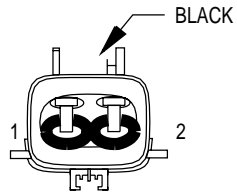

LEFT REAR WINDOW MOTOR

| CAV | CIRCUIT | FUNCTION |
|-----|-------------|--------------------------------|
| 1 | Q13 14DB | POWER WINDOW LEFT REAR B(+) UP |
| 2 | Q23 14RD/WT | LEFT REAR WINDOW DRIVER DOWN |

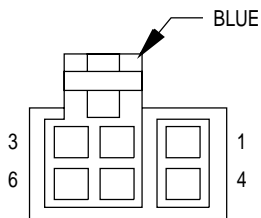

LEFT REAR WINDOW SWITCH

| CAV | CIRCUIT | FUNCTION |
|-----|-------------|--------------------------------|
| 1 | Q13 14DB | POWER WINDOW LEFT REAR B(+) UP |
| 2 | Q27 14RD/BK | LEFT REAR WINDOW DRIVER DOWN |
| 3 | - | |
| 4 | Q17 14DB/WT | LEFT REAR WINDOW DRIVER UP |
| 5 | Q23 14RD/WT | LEFT REAR WINDOW DRIVER DOWN |
| 6 | Q1 14YL | POWER WINDOW SWITCH FEED |

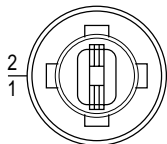

LEFT REPEATER LAMP (BUILT-UP-EXPORT)

| CAV | CIRCUIT | FUNCTION |
|-----|----------|------------------|
| 1 | L61 18GY | LEFT TURN SIGNAL |
| 2 | Z1 18BK | GROUND |

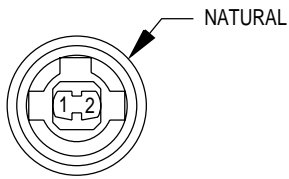

**LEFT SIDE
MARKER LAMP
(EXCEPT BUILT
-UP-EXPORT)**

| CAV | CIRCUIT | FUNCTION |
|-----|----------|-----------------------------------|
| 1 | L77 20BR | FUSED LEFT HEADLAMP SWITCH OUTPUT |
| 2 | L61 20LG | LEFT TURN SIGNAL |

**LEFT
SOUNDBAR
SPEAKER**

| CAV | CIRCUIT | FUNCTION |
|-----|---------------|---------------------------------|
| A | X57 18BR/LB ● | LEFT REAR SPEAKER (-) |
| A | X91 16BR/DB ▲ | AMPLIFIED LEFT REAR SPEAKER (+) |
| B | X51 18BR/YL ● | LEFT REAR SPEAKER (+) |
| B | X93 16BR/YL ▲ | AMPLIFIED LEFT REAR SPEAKER (-) |

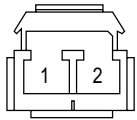

**LEFT SPEED
CONTROL
SWITCH**

| CAV | CIRCUIT | FUNCTION |
|-----|--------------|-----------------------------|
| 1 | K167 20BR/YL | SENSOR GROUND |
| 2 | V37 20RD/LG | SPEED CONTROL SWITCH SIGNAL |

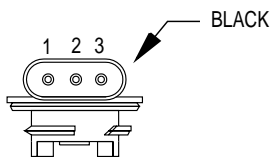

**LEFT TAIL/
STOP LAMP**

| CAV | CIRCUIT | FUNCTION |
|-----|-------------|-----------------------------------|
| 1 | Z1 18BK | GROUND |
| 2 | L77 18BR | FUSED LEFT HEADLAMP SWITCH OUTPUT |
| 3 | L50 18WT/TN | BRAKE LAMP SWITCH OUTPUT |

● 4 SPEAKER SYSTEM
▲ 6 SPEAKER SYSTEM

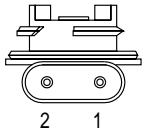

LEFT TURN SIGNAL LAMP

| CAV | CIRCUIT | FUNCTION |
|-----|-------------|------------------|
| 1 | Z1 18BK | GROUND |
| 2 | L63 18DG/RD | LEFT TURN SIGNAL |

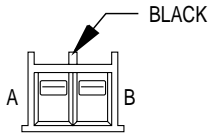

**LEFT VISOR/
VANITY LAMP**

| CAV | CIRCUIT | FUNCTION |
|-----|---------|------------|
| A | M1 20PK | FUSED B(+) |
| B | Z1 20BK | GROUND |

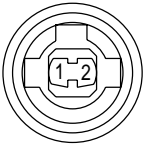

LICENSE LAMP

| CAV | CIRCUIT | FUNCTION |
|-----|-------------|------------------------------|
| 1 | L78 18BK/YL | FUSED HEADLAMP SWITCH OUTPUT |
| 2 | Z1 18BK | GROUND |

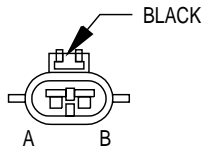

LIFTGATE LOCK MOTOR

| CAV | CIRCUIT | FUNCTION |
|-----|-------------|--------------------|
| A | P33 16OR/BK | DOOR LOCK DRIVER |
| B | P34 16PK/BK | DOOR UNLOCK DRIVER |

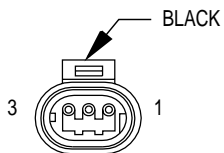

LIFTGATE SWITCH

| CAV | CIRCUIT | FUNCTION |
|-----|-------------|-------------------------------|
| 1 | Z1 20BK | GROUND |
| 2 | G78 20TN/BK | LIFTGATE AJAR SWITCH SENSE |
| 3 | M4 20VT/YL | LIFTGATE COURTESY LAMP DRIVER |

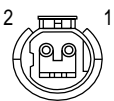

LOW COOLANT SWITCH (DIESEL)

| CAV | CIRCUIT | FUNCTION |
|-----|--------------|-----------------------------|
| 1 | G18 18PK/BK | COOLANT LEVEL SWITCH SIGNAL |
| 2 | K167 20BR/YL | SENSOR GROUND |

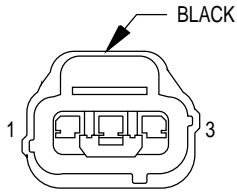

MANIFOLD ABSOLUTE PRESSURE SENSOR

| CAV | CIRCUIT | FUNCTION |
|-----|--------------|--|
| 1 | K167 20BR/YL | SENSOR GROUND |
| 2 | K1 18DG/RD | MANIFOLD ABSOLUTE PRESSURE SENSOR SIGNAL |
| 3 | K7 20OR | 5V SUPPLY |

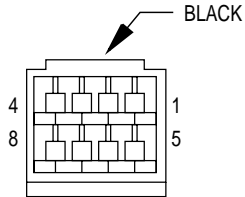

MESSAGE CENTER (DIESEL)

| CAV | CIRCUIT | FUNCTION |
|-----|--------------|---------------------------------------|
| 1 | F87 20WT/BK | FUSED IGNITION SWITCH OUTPUT (ST-RUN) |
| 2 | - | - |
| 3 | - | - |
| 4 | K185 20OR/LB | WAIT TO START INDICATOR DRIVER |
| 5 | - | - |
| 6 | - | - |
| 7 | G86 20TN/OR | WATER IN FUEL INDICATOR DRIVER |
| 8 | G154 20VT/LG | LOW COOLANT INDICATOR DRIVER |

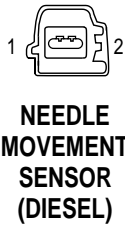

NEEDLE MOVEMENT SENSOR (DIESEL)

| CAV | CIRCUIT | FUNCTION |
|-----|-------------|----------------------------|
| 1 | K67 18BR/BK | NEEDLE MOVEMENT SENSOR (+) |
| 2 | K68 18LG/YL | NEEDLE MOVEMENT SENSOR (-) |

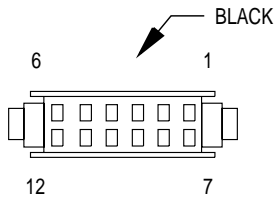

OVERHEAD MODULE

| CAV | CIRCUIT | FUNCTION |
|-----|-------------|---------------------------|
| 1 | M2 20YL | COURTESY LAMPS DRIVER |
| 2 | M1 20PK | FUSED B(+) |
| 3 | Z1 20BK | GROUND |
| 4 | - | - |
| 5 | P55 20DB | DOOR UNLOCK RELAY CONTROL |
| 6 | D1 20VT/BR | CCD BUS(+) |
| 7 | - | - |
| 8 | - | - |
| 9 | Z1 20BK | GROUND |
| 10 | X3 20BK/RD | HORN RELAY CONTROL |
| 11 | P59 20LB/RD | DOOR LOCK CONTROL |
| 12 | D2 20WT/BK | CCD BUS(-) |

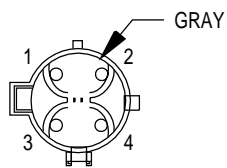

OXYGEN SENSOR 1/1 UPSTREAM

| CAV | CIRCUIT | FUNCTION |
|-----|----------------|---------------------------------------|
| 1 | A42 20DG ■■ | FUSED AUTOMATIC SHUTDOWN RELAY OUTPUT |
| 1 | F142 20DG/WT ■ | FUSED AUTOMATIC SHUTDOWN RELAY OUTPUT |
| 2 | Z1 20BK ■■ | GROUND |
| 2 | Z1 18BK ■ | GROUND |
| 3 | K167 20BR/YL | SENSOR GROUND |
| 4 | K41 18BK/DG | OXYGEN SENSOR 1/1 SIGNAL |

■ 2.5L
 ■■ 4.0L

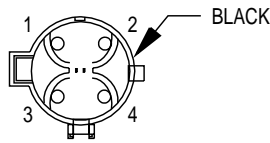

**OXYGEN
SENSOR 1/2
DOWNSTREAM**

| CAV | CIRCUIT | FUNCTION |
|-----|-----------------|--|
| 1 | F142 20DG/WT ■ | FUSED AUTOMATIC SHUT DOWN RELAY OUTPUT |
| 1 | A242 20VT/OR ■■ | OXYGEN SENSOR RELAY OUTPUT |
| 2 | Z1 20BK | GROUND |
| 3 | K167 20BR/YL | SENSOR GROUND |
| 4 | K141 18TN/WT | OXYGEN SENSOR 1/2 SIGNAL |

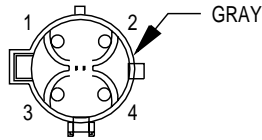

**OXYGEN
SENSOR 2/1
UPSTREAM
(4.0L CALIFORNIA/
EUROPEAN III)**

| CAV | CIRCUIT | FUNCTION |
|-----|--------------|----------------------------|
| 1 | A42 20DG | OXYGEN SENSOR RELAY OUTPUT |
| 2 | Z1 20BK | GROUND |
| 3 | K167 20BR/YL | SENSOR GROUND |
| 4 | K241 18LG/RD | OXYGEN SENSOR 2/1 SIGNAL |

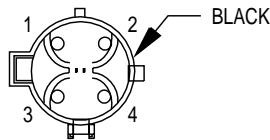

**OXYGEN
SENSOR 2/2
DOWNSTREAM
(4.0L CALIFORNIA/
EUROPEAN III)**

| CAV | CIRCUIT | FUNCTION |
|-----|--------------|----------------------------|
| 1 | A242 20VT/OR | OXYGEN SENSOR RELAY OUTPUT |
| 2 | Z1 20BK | GROUND |
| 3 | K167 20BR/YL | SENSOR GROUND |
| 4 | K341 18TN | OXYGEN SENSOR 2/2 SIGNAL |

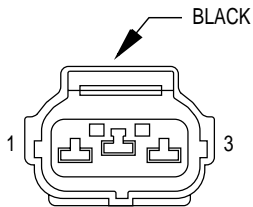

**PARK/NEUTRAL
POSITION SWITCH
(2.5L GAS A/T)**

| CAV | CIRCUIT | FUNCTION |
|-----|-------------|---------------------------------------|
| 1 | F20 18WT | FUSED IGNITION SWITCH OUTPUT (ST-RUN) |
| 2 | T41 18BK/WT | PARK/NETURAL POSITION SWITCH SENSE |
| 3 | L10 18BR/LG | BACK-UP LAMP FEED |

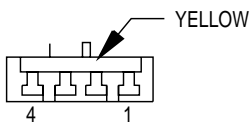

**PASSENGER
AIRBAG**

| CAV | CIRCUIT | FUNCTION |
|-----|-------------|-------------------------|
| 1 | - | - |
| 2 | - | - |
| 3 | R42 18BK/YL | PASSENGER AIRBAG LINE 2 |
| 4 | R44 18DG/YL | PASSENGER AIRBAG LINE 1 |

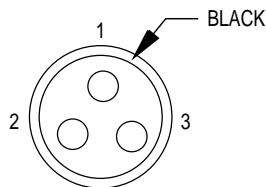

**PASSENGER
DOOR JAMB
SWITCH**

| CAV | CIRCUIT | FUNCTION |
|-----|-------------|-------------------------------|
| 1 | M2 18YL | COURTESY LAMPS DRIVER |
| 2 | G16 18BK/LB | DRIVER DOOR AJAR SWITCH SENSE |
| 3 | Z1 18BK | GROUND |

■ 2.5L
■■ 4.0L

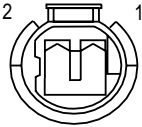

**PASSENGER DOOR
LOCK MOTOR**

| CAV | CIRCUIT | FUNCTION |
|-----|-------------|--------------------|
| 1 | P34 16PK/BK | DOOR UNLOCK DRIVER |
| 2 | P33 16OR/BK | DOOR LOCK DRIVER |

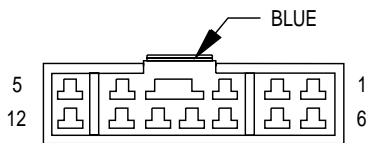

**PASSENGER
POWER
LOCK/WINDOW
SWITCH - C1
(FULL OPTIONS)**

| CAV | CIRCUIT | FUNCTION |
|-----|-------------|---|
| 1 | P34 16PK/BK | DOOR UNLOCK DRIVER |
| 2 | Q22 14VT | PASSENGER FRONT WINDOW DRIVER DOWN |
| 3 | Q26 14VT/WT | MASTER WINDOW SWITCH PASSENGER FRONT DOWN |
| 4 | Q16 14BR/WT | MASTER WINDOW SWITCH PASSENGER FRONT UP |
| 5 | P33 16OR/BK | DOOR LOCK DRIVER |
| 6 | - | - |
| 7 | - | - |
| 8 | - | - |
| 9 | Q12 14BR | PASSENGER FRONT WINDOW DRIVER UP |
| 10 | Q1 14YL | POWER WINDOW SWITCH FEED |
| 11 | - | - |
| 12 | - | - |

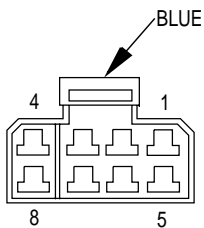

**PASSENGER
POWER LOCK/WINDOW
SWITCH - C2
(FULL OPTIONS)**

| CAV | CIRCUIT | FUNCTION |
|-----|----------------|--|
| 1 | P59 20LB/RD | DOOR LOCK CONTROL |
| 2 | P55 20DB/PK ■ | DOOR UNLOCK RELAY CONTROL |
| 2 | P55 20DB ●● | DOOR UNLOCK RELAY CONTROL |
| 3 | P35 20OR/VT ■ | DOOR LOCK SWITCH OUTPUT (LOCK) |
| 3 | P36 18PK/VT ●● | DOOR LOCK SWITCH OUTPUT (UNLOCK) |
| 4 | F81 14TN | FUSED IGNITION SWITCH OUTPUT (RUN-ACC) |
| 5 | F35 16RD | FUSED B(+) |
| 6 | Z1 14BK | GROUND |
| 7 | P36 20PK/VT ■ | DOOR LOCK SWITCH OUTPUT (UNLOCK) |
| 7 | P35 18OR/VT ●● | DOOR LOCK SWITCH OUTPUT (LOCK) |
| 8 | G26 20LB | KEY-IN IGNITION SWITCH SENSE |

■ LHD
●● RHD

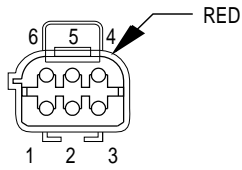

**PASSENGER
POWER MIRROR
(LHD)**

| CAV | CIRCUIT | FUNCTION |
|-----|-------------|---|
| 1 | P72 20YL/BK | RIGHT POWER MIRROR VERTICAL DRIVER |
| 2 | P74 20DB | RIGHT POWER MIRROR HORIZONTAL DRIVER |
| 2 | P76 20OR/YL | ▲ MIRROR COMMON DRIVER |
| 3 | P91 20WT/BK | ● MIRROR COMMON DRIVER |
| 3 | P74 20DB | ▲ RIGHT POWER MIRROR HORIZONTAL DRIVER |
| 4 | P76 20OR/YL | MIRROR COMMON DRIVER |
| 5 | C16 20BK/WT | FUSED REAR WINDOW DEFOGGER RELAY OUTPUT |
| 6 | Z1 18BK | GROUND |

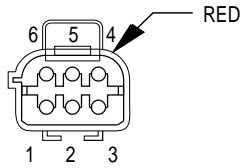

**PASSENGER
POWER MIRROR
(RHD)**

| CAV | CIRCUIT | FUNCTION |
|-----|-------------|---|
| 1 | P71 20YL | LEFT POWER MIRROR VERTICAL DRIVER |
| 2 | P75 20DB/WT | ● LEFT POWER MIRROR HORIZONTAL DRIVER |
| 2 | P76 20OR/YL | ▲ MIRROR COMMON DRIVER |
| 3 | P91 20WT/BK | ● MIRROR COMMON DRIVER |
| 3 | P75 20DB/RD | ▲ LEFT POWER MIRROR HORIZONTAL DRIVER |
| 4 | P76 20OR/YL | MIRROR COMMON DRIVER |
| 5 | C16 20BK/WT | ● FUSED REAR WINDOW DEFOGGER RELAY OUTPUT |
| 5 | C16 20LB/YL | ▲ FUSED REAR WINDOW DEFOGGER RELAY OUTPUT |
| 6 | Z1 16BK | GROUND |

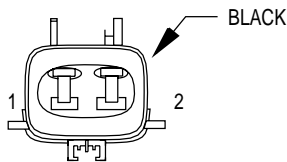

**PASSENGER POWER
WINDOW MOTOR**

| CAV | CIRCUIT | FUNCTION |
|-----|----------|----------------------------------|
| 1 | Q12 14BR | RIGHT FRONT WINDOW DRIVER (UP) |
| 2 | Q22 14VT | RIGHT FRONT WINDOW DRIVER (DOWN) |

● POWER MIRRORS
▲ FULL OPTIONS

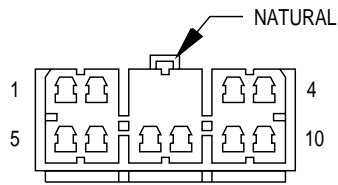

POWER AMPLIFIER - C1

| CAV | CIRCUIT | FUNCTION |
|-----|-------------|-------------------------|
| 1 | X55 18BR/RD | LEFT FRONT SPEAKER (-) |
| 2 | X56 18DB/RD | RIGHT FRONT SPEAKER (-) |
| 3 | X58 18DB/OR | RIGHT REAR SPEAKER (-) |
| 4 | X60 18DG/RD | RADIO 12V OUTPUT |
| 5 | X53 18DG | LEFT FRONT SPEAKER (+) |
| 6 | X54 18VT | RIGHT FRONT SPEAKER (+) |
| 7 | X51 18BR/YL | LEFT REAR SPEAKER (+) |
| 8 | X57 18BR/LB | LEFT REAR SPEAKER (-) |
| 9 | X52 18DB/WT | RIGHT REAR SPEAKER (+) |
| 10 | - | - |

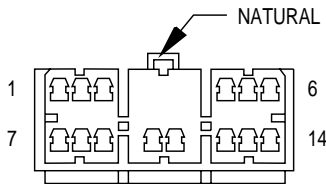

POWER AMPLIFIER - C2

| CAV | CIRCUIT | FUNCTION |
|-----|-------------|--|
| 1 | F75 16VT | FUSED B(+) |
| 2 | F75 16VT | FUSED B(+) |
| 3 | - | - |
| 4 | X87 18LG/VT | AMPLIFIED LEFT FRONT DOOR SPEAKER (+) |
| 5 | X94 18TN/RD | AMPLIFIED RIGHT REAR SPEAKER (+) |
| 6 | X93 18WT/RD | AMPLIFIED LEFT REAR SPEAKER (-) |
| 7 | Z5 16BK/LB | GROUND |
| 8 | Z5 16BK/LB | GROUND |
| 9 | - | - |
| 10 | X80 18LB/BK | AMPLIFIED RIGHT FRONT DOOR SPEAKER (-) |
| 11 | X82 18LB/RD | AMPLIFIED RIGHT FRONT DOOR SPEAKER (+) |
| 12 | X85 18BR/RD | AMPLIFIED LEFT FRONT DOOR SPEAKER (-) |
| 13 | X92 18TN/BK | AMPLIFIED RIGHT REAR SPEAKER (-) |
| 14 | X91 18WT/BK | AMPLIFIED LEFT REAR SPEAKER (+) |

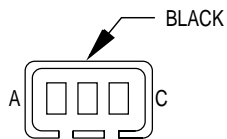

POWER ANTENNA (BUILT-UP-EXPORT)

| CAV | CIRCUIT | FUNCTION |
|-----|----------|-------------------------|
| A | X13 18WT | RADIO CHOKE OUTPUT |
| B | X17 18GY | POWER ANTENNA UP (-) |
| C | X14 18DG | POWER ANTENNA B(+) DOWN |

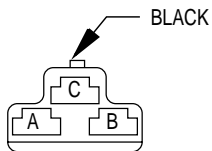

POWER ANTENNA RELAY - C1 (BUILT-UP-EXPORT)

| CAV | CIRCUIT | FUNCTION |
|-----|-------------|------------------|
| A | Z1 18BK | GROUND |
| B | F34 18TN/BK | FUSED B(+) |
| C | X60 18DG/RD | RADIO 12V OUTPUT |

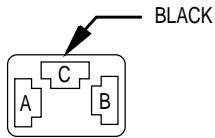

POWER ANTENNA RELAY - C2 (BUILT-UP-EXPORT)

| CAV | CIRCUIT | FUNCTION |
|-----|----------|-------------------------|
| A | X13 18WT | RADIO CHOKE OUTPUT |
| B | X17 18GY | POWER ANTENNA UP (-) |
| C | X14 18DG | POWER ANTENNA B(+) DOWN |

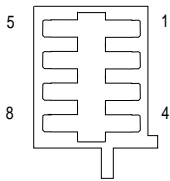

POWER MIRROR SWITCH

| CAV | CIRCUIT | FUNCTION |
|-----|---------------|--|
| 1 | Z1 20BK ● | GROUND |
| 1 | Z1 14BK ▲ | GROUND |
| 2 | F83 18YL/DG | FUSED IGNITION SWITCH OUTPUT (RUN-ACC) |
| 3 | P74 20DB | RIGHT POWER MIRROR HORIZONTAL DRIVER |
| 4 | P72 20YL/BK | RIGHT POWER MIRROR VERTICAL DRIVER |
| 5 | P76 20OR/YL | MIRROR COMMON DRIVER |
| | P76 20OR/YL | MIRROR COMMON DRIVER |
| 6 | P91 20WT/BK | MIRROR COMMON DRIVER |
| | P91 20WT/BK | MIRROR COMMON DRIVER |
| 7 | P75 20 DB/WT | LEFT POWER MIRROR HORIZONTAL DRIVER |
| 8 | P71 20YL/LB ● | LEFT POWER MIRROR VERTICAL DRIVER |
| 8 | P71 20YL ▲ | LEFT POWER MIRROR VERTICAL DRIVER |

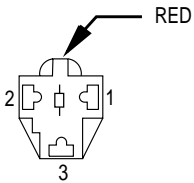

POWER OUTLET

| CAV | CIRCUIT | FUNCTION |
|-----|-------------|------------|
| 1 | F38 16RD/LB | FUSED B(+) |
| 2 | - | - |
| 3 | Z1 16BK | GROUND |

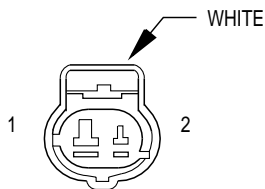

POWER STEERING PRESSURE SWITCH (2.5L GAS)

| CAV | CIRCUIT | FUNCTION |
|-----|-------------|--------------------------------------|
| 1 | Z1 20BK | GROUND |
| 2 | K10 18DB/BR | POWER STEERING PRESSURE SWITCH SENSE |

● RHD
▲ LHD

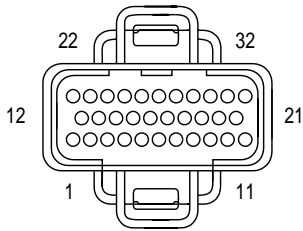

**POWERTRAIN
CONTROL MODULE - C1
(DIESEL)**

| CAV | CIRCUIT | FUNCTION |
|-----|--------------|-----------------------------------|
| 1 | - | - |
| 2 | A142 16DG/DR | AUTOMATIC SHUT DOWN RELAY OUTPUT |
| 3 | - | - |
| 4 | K167 18BR/YL | SENSOR GROUND |
| 5 | - | - |
| 6 | - | - |
| 6 | - | - |
| 6 | - | - |
| 7 | - | - |
| 8 | K159 18VT/RD | ENGINE SPEED SENSOR SIGNAL |
| 9 | - | - |
| 10 | - | - |
| 11 | - | - |
| 12 | G18 18PK/BK | COOLANT LEVEL SWITCH SIGNAL |
| 13 | - | - |
| 14 | - | - |
| 15 | - | - |
| 16 | K222 18TN/RD | ENGINE COOLANT TEMP SENSOR SIGNAL |
| 17 | K7 18OR | 5V SUPPLY |
| 18 | G8 18LB/BK | FUEL MONITOR OUTPUT SIGNAL |
| 19 | - | - |
| 20 | - | - |
| 21 | - | - |
| 22 | F16 16RD/LG | FUSED B(+) |
| 23 | - | - |
| 24 | - | - |
| 25 | - | - |
| 26 | - | - |
| 27 | G123 18DG/WT | WATER IN FUEL SENSOR SIGNAL |
| 28 | - | - |
| 29 | - | - |
| 30 | - | - |
| 31 | Z12 14BK/TN | GROUND |
| 32 | Z12 14BK/TN | GROUND |

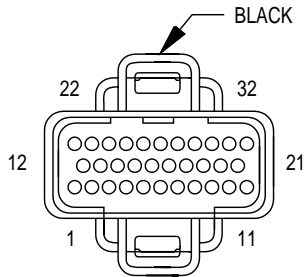

**POWERTRAIN
CONTROL MODULE - C1
(GAS)**

| CAV | CIRCUIT | FUNCTION |
|-----|----------------|--|
| 1 | K18 18RD/YL ▲▲ | IGNITION COIL NO. 3 DRIVER |
| 2 | F12 18DB/WT | FUSED IGNITION SWITCH OUTPUT (ST-RUN) |
| 3 | - | - |
| 4 | K167 18BR/YL | SENSOR GROUND |
| 5 | - | - |
| 6 | T41 18BK/WT ▼▼ | PARK/NEUTRAL POSITION SWITCH SENSE |
| 6 | Z1 18BK ▼ | GROUND |
| 7 | K19 18GY | IGNITION COIL NO. 1 DRIVER |
| 8 | K24 18GY/BK | CRANKSHAFT POSITION SENSOR SIGNAL |
| 9 | - | - |
| 10 | K60 18YL/BK | IDLE AIR CONTROL NO. 2 DRIVER |
| 11 | K40 18BR/WT | IDLE AIR CONTROL NO. 3 DRIVER |
| 12 | K10 18DB/BR ▲ | POWER STEERING PRESSURE SWITCH SENSE |
| 12 | K78 18GY ●● | IDLE ACTUATOR |
| 13 | - | - |
| 14 | - | - |
| 15 | K21 18BK/RD | INTAKE AIR TEMPERATURE SENSOR SIGNAL |
| 16 | K2 18TN/BK | ENGINE COOLANT TEMPERATURE SENSOR SIGNAL |
| 17 | K7 18OR | 5V SUPPLY |
| 18 | K44 18TN/YL | CAMSHAFT POSITION SENSOR SIGNAL |
| 19 | K39 18GY/RD | IDLE AIR CONTROL NO. 1 DRIVER |
| 20 | K59 18VT/BK | IDLE AIR CONTROL NO. 4 DRIVER |
| 21 | - | - |
| 22 | A61 14DG/BK | FUSED B(+) |
| 23 | K22 18OR/DB | THROTTLE POSITION SENSOR SIGNAL |
| 24 | K41 18BK/DG | OXYGEN SENSOR 1/1 SIGNAL |
| 25 | K141 18TN/WT | OXYGEN SENSOR 1/2 SIGNAL |
| 26 | K241 18LG/RD ■ | OXYGEN SENSOR 2/1 SIGNAL |
| 27 | K1 18DG/RD | MANIFOLD ABSOLUTE PRESSURE SENSOR SIGNAL |
| 28 | - | - |
| 29 | K341 18TN ■ | OXYGEN SENSOR 2/2 SIGNAL |
| 30 | - | - |
| 31 | Z12 14BK/TN | GROUND |
| 32 | Z12 14BK/TN | GROUND |

- 4.0L CALIFORNIA/ BUILT-UP-EXPORT
- ▼ 2.5L M/T
- ▼▼ EXCEPT 2.5L M/T
- ▲▲ 4.0L
- ▲ 2.5L
- 2.5L A/T
- 4.0L A/T

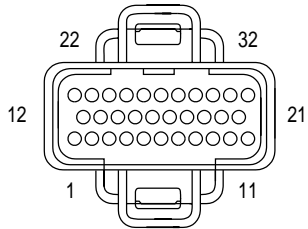

**POWERTRAIN
CONTROL MODULE - C2
(DIESEL)**

| CAV | CIRCUIT | FUNCTION |
|-----|-------------|-----------------------------------|
| 1 | - | - |
| 2 | - | - |
| 3 | - | - |
| 4 | - | - |
| 5 | - | - |
| 6 | - | - |
| 7 | - | - |
| 8 | - | - |
| 9 | - | - |
| 10 | K20 18DG | GENERATOR FIELD |
| 11 | - | - |
| 12 | - | - |
| 13 | - | - |
| 14 | - | - |
| 15 | - | - |
| 16 | - | - |
| 17 | - | - |
| 18 | V66 18RD/LG | SPEED CONTROL INDICATOR SIGNAL |
| 19 | - | - |
| 20 | - | - |
| 21 | - | - |
| 22 | - | - |
| 23 | G60 18GY/YL | ENGINE OIL PRESSURE SENSOR SIGNAL |
| 24 | - | - |
| 25 | - | - |
| 26 | - | - |
| 27 | G7 18WT/OR | VEHICLE SPEED SENSOR SIGNAL |
| 28 | - | - |
| 29 | - | - |
| 30 | - | - |
| 31 | - | - |
| 32 | - | - |

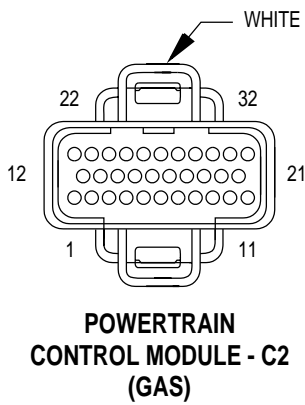

| CAV | CIRCUIT | FUNCTION |
|-----|----------------|--|
| 1 | - | - |
| 2 | - | - |
| 3 | - | - |
| 4 | K11 18WT/DB | FUEL INJECTOR NO. 1 DRIVER |
| 5 | K13 18YL/WT | FUEL INJECTOR NO. 3 DRIVER |
| 6 | K15 18PK/BK • | FUEL INJECTOR NO. 5 DRIVER |
| 7 | - | - |
| 8 | - | - |
| 9 | K17 18DB/TN • | IGNITION COIL NO. 2 DRIVER |
| 10 | K20 18DG | GENERATOR FIELD |
| 11 | K54 18OR/BK •• | TORQUE CONVERTER CLUTCH SOLENOID CONTROL |
| 12 | K16 18LG/BK • | FUEL INJECTOR NO. 6 DRIVER |
| 13 | - | - |
| 14 | - | - |
| 15 | K12 18TN | FUEL INJECTOR NO. 2 DRIVER |
| 16 | K14 18LB/BR | FUEL INJECTOR NO. 4 DRIVER |
| 17 | - | - |
| 18 | - | - |
| 19 | - | - |
| 20 | - | - |
| 21 | - | - |
| 22 | - | - |
| 23 | G60 18GY/YL | ENGINE OIL PRESSURE SENSOR SIGNAL |
| 24 | - | - |
| 25 | - | - |
| 26 | - | - |
| 27 | G7 18WT/OR | VEHICLE SPEED SENSOR SIGNAL |
| 28 | - | - |
| 29 | - | - |
| 30 | - | - |
| 31 | K6 18VT/OR | 5V SUPPLY |
| 32 | - | - |

• 4.0L
•• 2.5L A/T

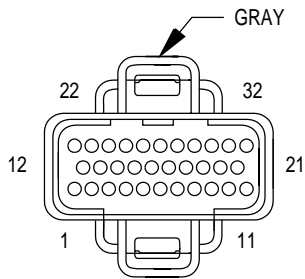

**POWERTRAIN
CONTROL MODULE - C3
(DIESEL)**

| CAV | CIRCUIT | FUNCTION |
|-----|--------------|-----------------------------------|
| 1 | C103 18DG | A/C REQUEST OUTPUT |
| 2 | - | - |
| 3 | - | - |
| 4 | - | - |
| 5 | - | - |
| 6 | - | - |
| 7 | - | - |
| 8 | G154 18VT/LG | LOW COOLANT INDICATOR DRIVER |
| 9 | G86 18TN/OR | WATER IN FUEL INDICATOR DRIVER |
| 10 | - | - |
| 11 | - | - |
| 12 | A142 16DG/OR | AUTOMATIC SHUT DOWN RELAY OUTPUT |
| 13 | - | - |
| 14 | - | - |
| 15 | K118 18PK/YL | BATTERY TEMPERATURE SENSOR SIGNAL |
| 16 | G55 18OR/BK | ENGINE DISABLE SIGNAL |
| 17 | - | - |
| 18 | - | - |
| 19 | - | - |
| 20 | - | - |
| 21 | - | - |
| 22 | K48 18OR/RD | FAULT INDICATOR REQUEST INPUT |
| 23 | C90 18LG | A/C SWITCH SENSE |
| 24 | - | - |
| 25 | K72 18DG/OR | GENERATOR SOURCE |
| 26 | K226 18DB/LG | FUEL LEVEL SENSOR SIGNAL |
| 27 | D21 18PK | SCI TRANSMIT/ ISO 9141K |
| 28 | D2 18WT/BK | CCD BUS(-) |
| 29 | D20 18LG/BK | SCI RECEIVE |
| 30 | D1 18VT/BR | CCD BUS(+) |
| 31 | - | - |
| 32 | - | - |

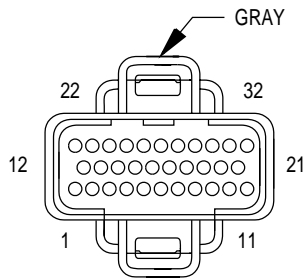

**POWERTRAIN
CONTROL
MODULE - C3
(GAS)**

| CAV | CIRCUIT | FUNCTION |
|-----|----------------|--|
| 1 | C13 18DB/OR | A/C COMPRESSOR CLUTCH RELAY CONTROL |
| 2 | C27 18DB/PK | RADIATOR FAN RELAY CONTROL |
| 3 | K51 18DB/YL | AUTOMATIC SHUT DOWN RELAY CONTROL |
| 4 | V36 18TN/RD | SPEED CONTROL VACUUM SOLENOID CONTROL |
| 5 | V35 18LG/RD | SPEED CONTROL VENT SOLENOID CONTROL |
| 6 | - | - |
| 7 | - | - |
| 8 | K73 18BR/OR ●● | OXYGEN SENSOR UPSTREAM RELAY CONTROL |
| 9 | K74 18BR/VT ●● | OXYGEN SENSOR DOWNSTREAM RELAY CONTROL |
| 10 | K106 18WT/DG ● | LEAK DETECTION PUMP SOLENOID CONTROL |
| 11 | V32 18YL/RD | SPEED CONTROL POWER SUPPLY |
| 12 | F142 18DG/WT | FUSED AUTOMATIC SHUT DOWN RELAY OUTPUT |
| 13 | C48 18TN | RADIATOR FAN REQUEST |
| 14 | K105 18WT/OR ● | LEAK DETECTION PUMP SWITCH SENSE |
| 15 | K118 18PK/YL | BATTERY TEMPERATURE SENSOR SIGNAL |
| 16 | - | - |
| 17 | - | - |
| 18 | - | - |
| 19 | K31 18BR | FUEL PUMP RELAY CONTROL |
| 20 | K52 18PK/BK | DUTY CYCLE EVAP/PURGE SOLENOID CONTROL |
| 21 | - | - |
| 22 | C22 18DB/WT | A/C SWITCH SENSE |
| 23 | C90 18LG | A/C SELECT INPUT |
| 24 | K29 18WT/PK | BRAKE LAMP SWITCH SENSE |
| 25 | K72 18DG/OR | GENERATOR DRIVER |
| 26 | K226 18DB/LG | FUEL LEVEL SENSOR SIGNAL |
| 27 | D21 18PK | SCI TRANSMIT/ ISO 9141K |
| 28 | D2 18WT/BK | CCD BUS (-) |
| 29 | D20 18LG/BK | SCI RECEIVE |
| 30 | D1 18VT/BR | CCD BUS (+) |
| 31 | - | - |
| 32 | V37 18RD/LG | SPEED CONTROL SWITCH SIGNAL |

● LEAK DETECT
●● 4.0L



**PRNDL
ILLUMINATION
(A/T)**

| CAV | CIRCUIT | FUNCTION |
|-----|---------|--|
| 1 | E2 20OR | FUSED PANEL LAMPS DIMMER SWITCH SIGNAL |
| 2 | Z1 20BK | GROUND |

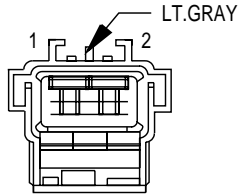

**RADIATOR
FAN MOTOR**

| CAV | CIRCUIT | FUNCTION |
|-----|----------|---------------------------|
| 1 | C25 12LB | RADIATOR FAN RELAY OUTPUT |
| 2 | Z1 12BK | GROUND |

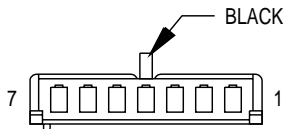

RADIO - C1

| CAV | CIRCUIT | FUNCTION |
|-----|-------------|-------------------------|
| 1 | X60 16DG/RD | RADIO 12V OUTPUT |
| 2 | X51 16BR/YL | LEFT REAR SPEAKER (+) |
| 3 | X52 16DB/WT | RIGHT REAR SPEAKER (+) |
| 4 | X53 16DG | LEFT FRONT SPEAKER (+) |
| 5 | X54 16VT | RIGHT FRONT SPEAKER (+) |
| 6 | X57 16BR/LB | LEFT REAR SPEAKER (-) |
| 7 | X58 16DB/OR | RIGHT REAR SPEAKER (-) |

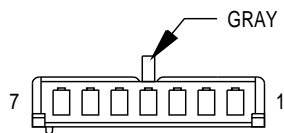

RADIO - C2

| CAV | CIRCUIT | FUNCTION |
|-----|-------------|--|
| 1 | - | - |
| 2 | X55 16BR/RD | LEFT FRONT SPEAKER (-) |
| 3 | X56 16DB/RD | RIGHT FRONT SPEAKER (-) |
| 4 | L7 18BK/YL | HEADLAMP SWITCH OUTPUT |
| 5 | E2 20OR | FUSED PANEL LAMPS DIMMER SWITCH SIGNAL |
| 6 | X12 16RD/WT | FUSED IGNITION SWITCH OUTPUT (RUN-ACC) |
| 7 | M1 20PK | FUSED B(+) |

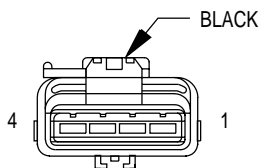

**RAIL COIL
(4.0L GAS)**

| CAV | CIRCUIT | FUNCTION |
|-----|--------------|--|
| 1 | K19 18GY | IGNITION COIL NO. 1 DRIVER |
| 2 | A142 18DG/OR | FUSED AUTOMATIC SHUT DOWN RELAY OUTPUT |
| 3 | K17 18DB/TN | IGNITION COIL NO. 2 DRIVER |
| 4 | K18 18RD/YL | IGNITION COIL NO. 3 DRIVER |

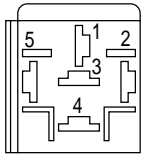

REAR FOG LAMP RELAY (BUILT-UP-EXPORT)

| CAV | CIRCUIT | FUNCTION |
|-----|---------------|--|
| 1 | F83 18YL/DG | FUSED IGNITION SWITCH OUTPUT (RUN-ACC) |
| 2 | L36 18LG/BK | REAR FOG LAMP |
| 3 | Z1 18BK | GROUND |
| 4 | L38 18BR/WT | REAR FOG LAMP FEED |
| | L38 18BR/WT ● | REAR FOG LAMP FEED |
| 5 | L25 18BR | REAR FOG LAMP FEED |

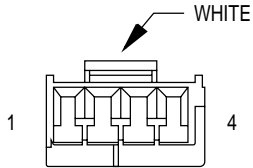

REAR FOG LAMP SWITCH (BUILT-UP-EXPORT)

| CAV | CIRCUIT | FUNCTION |
|-----|---------------|--|
| 1 | Z15 18BK/GY ▲ | GROUND |
| 1 | Z15 20BK/GY ● | GROUND |
| 2 | L36 18LG/BK | REAR FOG LAMP |
| 3 | L38 18BR/WT | REAR FOG LAMP FEED |
| 4 | E2 20OR | FUSED PANEL LAMPS DIMMER SWITCH SIGNAL |

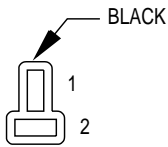

REAR WASHER PUMP

| CAV | CIRCUIT | FUNCTION |
|-----|-------------|---------------------------|
| 1 | V20 18BK/WT | REAR WASHER MOTOR CONTROL |
| 2 | Z1 18BK | GROUND |
| | Z1 18BK ■ | GROUND |

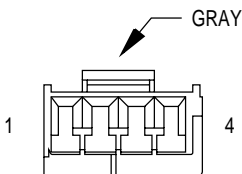

REAR WINDOW DEFOGGER SWITCH

| CAV | CIRCUIT | FUNCTION |
|-----|-------------|---|
| 1 | Z1 20BK | GROUND |
| 2 | C80 20DB/WT | REAR WINDOW DEFOGGER SWITCH SENSE |
| 3 | C16 20LB/YL | FUSED REAR WINDOW DEFOGGER RELAY OUTPUT |
| 4 | E2 20OR | FUSED PANEL LAMPS DIMMER SWITCH SIGNAL |

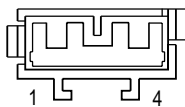

REAR WIPER MOTOR

| CAV | CIRCUIT | FUNCTION |
|-----|-------------|------------------------------------|
| 1 | Z1 18BK | GROUND |
| 2 | V20 18BK/WT | REAR WASHER MOTOR CONTROL |
| 3 | V13 18BR/LG | REAR REAR WIPER MOTOR CONTROL |
| 4 | V23 18BR/PK | FUSED IGNITION SWITCH OUTPUT (RUN) |

- GAS
- LHD
- ▲ RHD

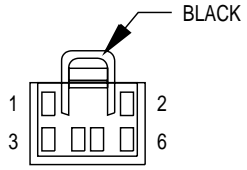

**REAR WIPER/
WASHER SWITCH**

| CAV | CIRCUIT | FUNCTION |
|-----|-------------|--|
| 1 | Z1 20BK | GROUND |
| 2 | V20 18BK/WT | REAR WASHER MOTOR CONTROLLER |
| 3 | E2 20OR | FUSED PANEL LAMPS DIMMER SWITCH SIGNAL |
| 4 | V13 18BR/LG | REAR WIPER MOTOR CONTROL |
| 5 | V23 18BR/PK | FUSED IGNITION SWITCH OUTPUT (RUN) |
| 6 | V23 18BR/PK | FUSED IGNITION SWITCH OUTPUT (RUN) |

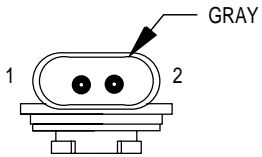

**RIGHT BACK-UP
LAMP**

| CAV | CIRCUIT | FUNCTION |
|-----|-------------|-------------------|
| 1 | Z1 18BK | GROUND |
| 2 | L10 18BR/LG | BACK-UP LAMP FEED |

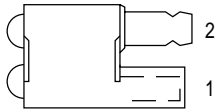

**RIGHT CITY
LAMP
(BUILT-UP-EXPORT)**

| CAV | CIRCUIT | FUNCTION |
|-----|-------------|------------------------------|
| 1 | L78 20DG/YL | FUSED HEADLAMP SWITCH OUTPUT |
| 2 | Z1 20BK | GROUND |

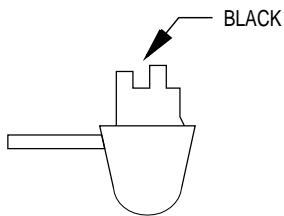

**RIGHT COURTESY
LAMP**

| CAV | CIRCUIT | FUNCTION |
|-----|------------|-----------------------|
| 1 | M1 18PK | FUSED B(+) |
| 2 | M2 18BK/WT | COURTESY LAMPS DRIVER |

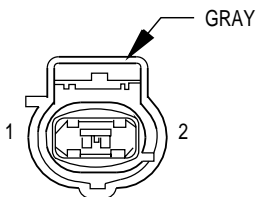

**RIGHT
FOG LAMP**

| CAV | CIRCUIT | FUNCTION |
|-----|----------|-----------------------|
| 1 | Z1 20BK | GROUND |
| 2 | L39 20LB | FOG LAMP RELAY OUTPUT |

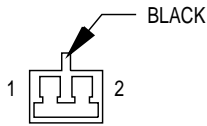

**RIGHT FRONT
DOOR SPEAKER**

| CAV | CIRCUIT | FUNCTION |
|-----|-------------|--|
| 1 | X80 18LB/BK | AMPLIFIED RIGHT FRONT DOOR SPEAKER (-) |
| 2 | X82 18LB/RD | AMPLIFIED RIGHT FRONT DOOR SPEAKER (+) |

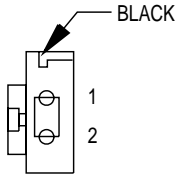

**RIGHT FRONT
DOOR TWEETER**

| CAV | CIRCUIT | FUNCTION |
|-----|-------------|--|
| 1 | X80 18LB/BK | AMPLIFIED RIGHT FRONT DOOR SPEAKER (-) |
| 2 | X82 18LB/RD | AMPLIFIED RIGHT FRONT DOOR SPEAKER (+) |

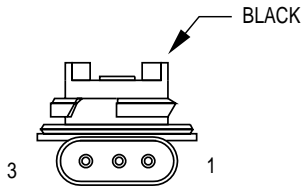

**RIGHT FRONT
PARK/TURN
SIGNAL LAMP NO. 1
(EXCEPT BUILT-UP-EXPORT)**

| CAV | CIRCUIT | FUNCTION |
|-----|-------------|------------------------------|
| 1 | L60 18TN | RIGHT TURN SIGNAL |
| 2 | L78 18DG/YL | FUSED HEADLAMP SWITCH OUTPUT |
| 3 | Z1 18BK | GROUND |

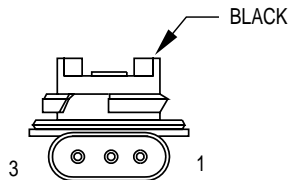

**RIGHT FRONT
PARK/TURN
SIGNAL LAMP NO. 2
(EXCEPT BUILT-UP-EXPORT)**

| CAV | CIRCUIT | FUNCTION |
|-----|-------------|------------------------------|
| 1 | L60 18TN | RIGHT TURN SIGNAL |
| 2 | L78 18DG/YL | FUSED HEADLAMP SWITCH OUTPUT |
| 3 | Z1 18BK | GROUND |

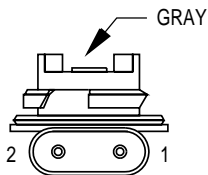

**RIGHT FRONT
TURN SIGNAL
LAMP NO. 1
(BUILT-UP-EXPORT)**

| CAV | CIRCUIT | FUNCTION |
|-----|----------|-------------------|
| 1 | Z1 18BK | GROUND |
| 2 | L60 18TN | RIGHT TURN SIGNAL |

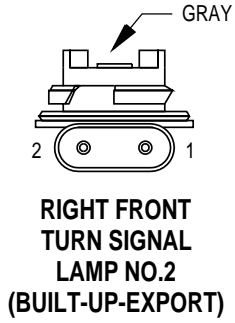

| CAV | CIRCUIT | FUNCTION |
|-----|----------|-------------------|
| 1 | Z1 18BK | GROUND |
| 2 | L60 18TN | RIGHT TURN SIGNAL |

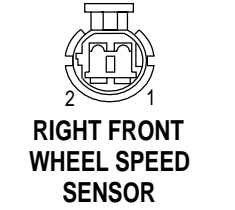

| CAV | CIRCUIT | FUNCTION |
|-----|------------|------------------------------------|
| 1 | B6 18WT/DB | RIGHT FRONT WHEEL SPEED SENSOR (-) |
| 2 | B7 18WT | RIGHT FRONT WHEEL SPEED SENSOR (+) |

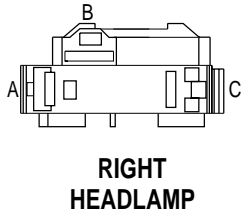

| CAV | CIRCUIT | FUNCTION |
|-----|-------------|------------------------------|
| A | L34 18RD/OR | FUSED RIGHT HIGH BEAM OUTPUT |
| B | L44 18VT/RD | FUSED RIGHT LOW BEAM OUTPUT |
| C | Z1 18BK | GROUND |

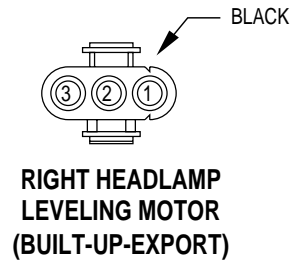

| CAV | CIRCUIT | FUNCTION |
|-----|-------------|-----------------------------|
| 1 | L44 18VT/RD | FUSED RIGHT LOW BEAM OUTPUT |
| 2 | L13 18BK | HEADLAMP ADJUST SIGNAL |
| 3 | Z15 18BK/GY | GROUND |

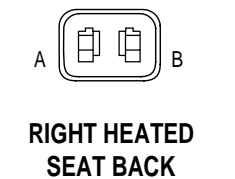

| CAV | CIRCUIT | FUNCTION |
|-----|----------|-------------------------------|
| A | P89 18BR | RIGHT HEATED SEAT BACK DRIVER |
| B | Z1 18BK | GROUND |

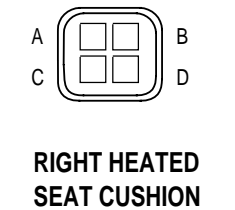

| CAV | CIRCUIT | FUNCTION |
|-----|--------------|-------------------------------|
| A | P86 18PK/BK | RIGHT HEAT SEAT DRIVER |
| B | P89 18BR | RIGHT HEATED SEAT BACK DRIVER |
| C | P141 18TN/LB | SENSOR FEED |
| D | P144 18BK/YL | RIGHT HEAT SENSE INPUT |

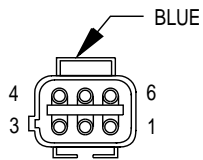

RIGHT HEATED SEAT SWITCH

| CAV | CIRCUIT | FUNCTION |
|-----|--------------|--|
| 1 | P138 18VT/LG | RIGHT SEAT LOW HEAT LED DRIVER |
| 2 | - | - |
| 3 | Z1 18BK | GROUND |
| 4 | F83 18YL/DG | FUSED IGNITION SWITCH OUTPUT (RUN-ACC) |
| 5 | P140 18VT/BK | RIGHT SEAT HIGH HEAT LED DRIVER |
| 6 | P134 18TN/RD | RIGHT SEAT HEATER SWITCH MUX |

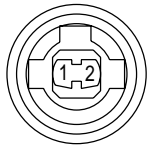

RIGHT LICENCE LAMP (BUILT-UP-EXPORT)

| CAV | CIRCUIT | FUNCTION |
|-----|-------------|------------------------------|
| 1 | L78 18BK/YL | FUSED HEADLAMP SWITCH OUTPUT |
| 2 | Z1 18BK | GROUND |

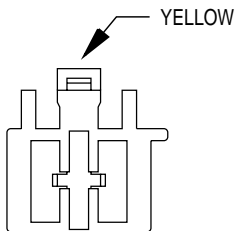

RIGHT POWER SEAT FRONT VERTICAL MOTOR

| CAV | CIRCUIT | FUNCTION |
|-----|-------------|-----------------------------|
| 1 | P18 14YL/LG | RIGHT POWER SEAT FRONT UP |
| 2 | P20 14RD/LG | RIGHT POWER SEAT FRONT DOWN |

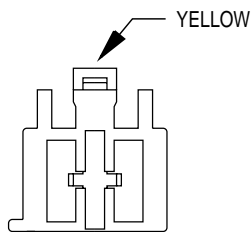

RIGHT POWER SEAT HORIZONTAL MOTOR

| CAV | CIRCUIT | FUNCTION |
|-----|-------------|--------------------------------------|
| 1 | P16 14RD/LB | RIGHT POWER SEAT HORIZONTAL REARWARD |
| 2 | P14 14YL/LB | RIGHT POWER SEAT HORIZONTAL FORWARD |

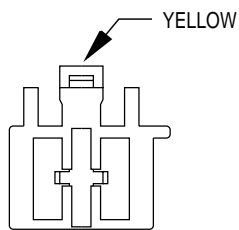

RIGHT POWER SEAT REAR VERTICAL MOTOR

| CAV | CIRCUIT | FUNCTION |
|-----|-------------|----------------------------|
| 1 | P10 14YL/WT | RIGHT POWER SEAT REAR UP |
| 2 | P12 14RD/WT | RIGHT POWER SEAT REAR DOWN |

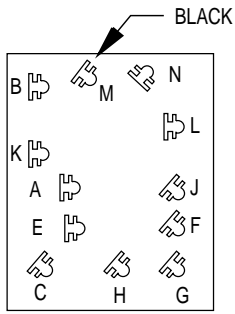

RIGHT POWER SEAT SWITCH

| CAV | CIRCUIT | FUNCTION |
|-----|-------------|--------------------------------------|
| A | Z1 14BK | GROUND |
| B | F37 14RD | FUSED B(+) |
| C | - | - |
| E | P10 14YL/WT | RIGHT POWER SEAT REAR UP |
| F | - | - |
| G | - | - |
| H | - | - |
| J | P12 14RD/WT | RIGHT POWER SEAT REAR DOWN |
| K | P14 14YL/LB | RIGHT POWER SEAT HORIZONTAL FORWARD |
| L | P16 14RD/LB | RIGHT POWER SEAT HORIZONTAL REARWARD |
| M | P18 14YL/LG | RIGHT POWER SEAT FRONT UP |
| N | P20 14RD/LG | RIGHT POWER SEAT FRONT DOWN |

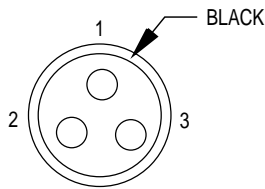

RIGHT REAR DOOR JAMB SWITCH

| CAV | CIRCUIT | FUNCTION |
|-----|---------|-----------------------|
| 1 | - | - |
| 2 | Z1 18BK | GROUND |
| 3 | M2 18YL | COURTESY LAMPS DRIVER |

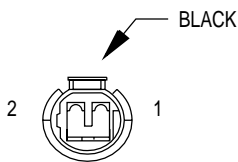

RIGHT REAR DOOR LOCK MOTOR

| CAV | CIRCUIT | FUNCTION |
|-----|-------------|--------------------|
| 1 | P34 16PK/BK | DOOR UNLOCK DRIVER |
| 2 | P33 16OR/BK | DOOR LOCK DRIVER |

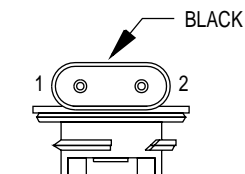

RIGHT REAR FOG LAMP (BUILT-UP-EXPORT)

| CAV | CIRCUIT | FUNCTION |
|-----|-------------|--------------------|
| 1 | Z1 18BK | GROUND |
| 2 | L38 18OR/WT | REAR FOG LAMP FEED |

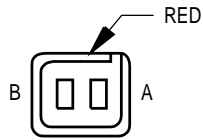

RIGHT REAR WHEEL SPEED SENSOR

| CAV | CIRCUIT | FUNCTION |
|-----|------------|-----------------------------------|
| A | B1 20YL/DB | RIGHT REAR WHEEL SPEED SENSOR (-) |
| B | B2 20YL | RIGHT REAR WHEEL SPEED SENSOR (+) |

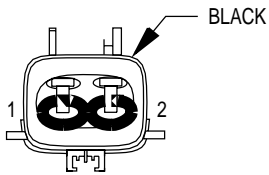

RIGHT REAR WINDOW MOTOR

| CAV | CIRCUIT | FUNCTION |
|-----|----------|---------------------------------|
| 1 | Q14 14GY | POWER WINDOW RIGHT REAR B(+) UP |
| 2 | Q24 14DG | RIGHT REAR WINDOW DRIVER DOWN |

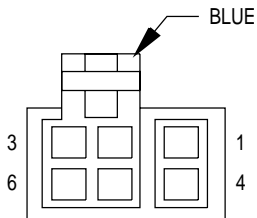

RIGHT REAR WINDOW SWITCH

| CAV | CIRCUIT | FUNCTION |
|-----|-------------|--------------------------------------|
| 1 | Q14 14GY | POWER WINDOW RIGHT REAR B(+) UP |
| 2 | Q28 14DG/WT | MASTER WINDOW SWITCH RIGHT REAR DOWN |
| 3 | - | - |
| 4 | Q18 14GY/BK | RIGHT REAR WINDOW DRIVER (UP) |
| 5 | Q24 14DG | RIGHT REAR WINDOW DRIVER (DOWN) |
| 6 | Q1 14YL | POWER WINDOW SWITCH FEED |

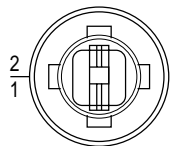

RIGHT REPEATER LAMP (BUILT-UP-EXPORT)

| CAV | CIRCUIT | FUNCTION |
|-----|----------|-------------------|
| 1 | L60 18GY | RIGHT TURN SIGNAL |
| 2 | Z1 18BK | GROUND |

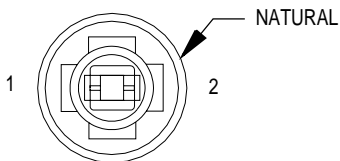

RIGHT SIDE MARKER LAMP (EXCEPT BUILT-UP-EXPORT)

| CAV | CIRCUIT | FUNCTION |
|-----|-------------|------------------------------|
| 1 | L78 20DG/YL | FUSED HEADLAMP SWITCH OUTPUT |
| 2 | L60 20TN | RIGHT TURN SIGNAL |

RIGHT SOUNDBAR SPEAKER

| CAV | CIRCUIT | FUNCTION |
|-----|-------------|------------------------------------|
| A | X58 18DB/OR | ● RIGHT REAR SPEAKER (-) |
| A | X92 16TN/BK | ▲ AMPLIFIED RIGHT REAR SPEAKER (-) |
| B | X52 18DB/WT | ● RIGHT REAR SPEAKER (+) |
| B | X94 16TN/RD | ▲ AMPLIFIED RIGHT REAR SPEAKER (+) |

● 4 SPEAKER SYSTEM
▲ 6 SPEAKER SYSTEM

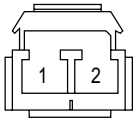

**RIGHT SPEED
CONTROL SWITCH**

| CAV | CIRCUIT | FUNCTION |
|-----|--------------|-----------------------------|
| 1 | K167 20BR/YL | SENSOR GROUND |
| 2 | V37 20RD/LG | SPEED CONTROL SWITCH SIGNAL |

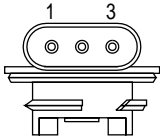

**RIGHT TAIL/
STOP LAMP**

| CAV | CIRCUIT | FUNCTION |
|-----|-------------|------------------------------|
| 1 | Z1 18BK | GROUND |
| 2 | L78 18DG/YL | FUSED HEADLAMP SWITCH OUTPUT |
| 3 | L50 18WT/TN | BRAKE LAMP SWITCH OUTPUT |

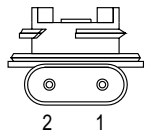

**RIGHT TURN
SIGNAL LAMP**

| CAV | CIRCUIT | FUNCTION |
|-----|-------------|-------------------|
| 1 | Z1 18BK | GROUND |
| 2 | L62 18BR/RD | RIGHT TURN SIGNAL |

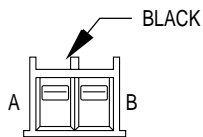

**RIGHT VISOR/
VANITY
LAMP**

| CAV | CIRCUIT | FUNCTION |
|-----|---------|------------|
| A | M1 20PK | FUSED B(+) |
| B | Z1 20BK | GROUND |

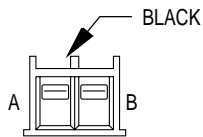

**SEAT BELT
SWITCH**

| CAV | CIRCUIT | FUNCTION |
|-----|-------------|------------------------|
| A | G10 20LG/RD | SEAT BELT SWITCH SENSE |
| B | Z1 20BK | GROUND |

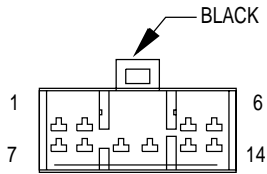

**SEAT
HEAT
INTERFACE
MODULE**

| CAV | CIRCUIT | FUNCTION |
|-----|--------------|---------------------------------|
| 1 | P133 18TN/DG | LEFT SEAT HEATER SWITCH MUX |
| 2 | P141 18TN/LB | SENSOR FEED |
| 3 | P86 18PK/BK | RIGHT HEAT ELEMENT OUTPUT |
| 4 | F235 16RD | HEATED SEAT RELAY OUTPUT |
| 5 | P87 18BK/OR | LEFT HEAT ELEMENT OUTPUT |
| 6 | F235 16RD | HEATED SEAT RELAY OUTPUT |
| 7 | P144 18BK/YL | RIGHT HEAT SENSE INPUT |
| 8 | P143 18BK/DG | LEFT HEAT SENSE INPUT |
| 9 | P134 18TN/RD | RIGHT SEAT HEATER SWITCH MUX |
| 10 | P138 18VT/LG | RIGHT SEAT LOW HEAT LED DRIVER |
| 11 | P140 18VT/BK | RIGHT SEAT HIGH HEAT LED DRIVER |
| 12 | P137 18VT | LEFT SEAT LOW HEAT LED DRIVER |
| 13 | Z2 18BK/LG | GROUND |
| 14 | P139 18VT/WT | LEFT SEAT HIGH HEAT LED DRIVER |

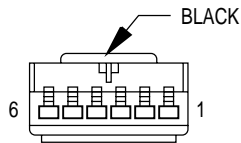

**SENTRY KEY
IMMOBILIZER
MODULE**

| CAV | CIRCUIT | FUNCTION |
|-----|-------------|---------------------------------------|
| 1 | D1 20VT/BR | CCD BUS (+) |
| 2 | D2 20WT/BK | CCD BUS (-) |
| 3 | Z2 20BK/LG | GROUND |
| 4 | F87 20WT/BK | FUSED IGNITION SWITCH OUTPUT (ST-RUN) |
| 5 | Z2 20BK/LG | GROUND |
| 6 | F1 20DB/GY | FUSED B(+) |

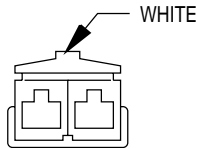

**SHIFT LOCK
SOLENOID**

| CAV | CIRCUIT | FUNCTION |
|-----|-------------|------------------------------------|
| 1 | K29 20WT/PK | • BRAKE SWITCH SENSE |
| 1 | K29 18WT/PK | •• BRAKE SWITCH SENSE |
| 2 | F15 20DB/WT | FUSED IGNITION SWITCH OUTPUT (RUN) |

• LHD
•• RHD

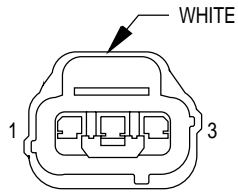

THROTTLE POSITION SENSOR

| CAV | CIRCUIT | FUNCTION |
|-----|----------------|---------------------------------|
| 1 | K167 20BR/YL | SENSOR GROUND |
| 2 | K22 18OR/DB ▲▲ | THROTTLE POSITION SENSOR SIGNAL |
| 2 | K22 20OR/DB ▲ | THROTTLE POSITION SENSOR SIGNAL |
| 3 | K7 20OR | 5V SUPPLY |

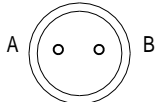

TORQUE CONVERTER CLUTCH SOLENOID (2.5L GAS A/T)

| CAV | CIRCUIT | FUNCTION |
|-----|-------------|--|
| A | F20 18WT | FUSED IGNITION SWITCH OUTPUT (ST-RUN) |
| B | K54 18OR/BK | TORQUE CONVERTER CLUTCH SOLENOID CONTROL |

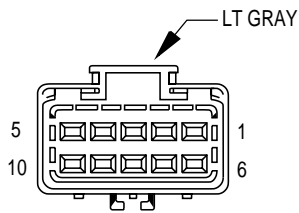

TRAILER TOW CONNECTOR

| CAV | CIRCUIT | FUNCTION |
|-----|-------------|------------------------------|
| 1 | - | - |
| 2 | L74 20LG | BRAKE LAMP SWITCH OUTPUT |
| 3 | L10 18BR/LG | BACK-UP LAMP FEED |
| 4 | A6 20RD/OR | FUSED B(+) |
| 5 | L77 20BR/YL | FUSED HEADLAMP SWITCH OUTPUT |
| 6 | - | - |
| 7 | B40 14LB | TRAILER TOW BRAKE B(+) |
| 8 | Z1 14BK | GROUND |
| 9 | - | - |
| 10 | L73 20YL | BRAKE LAMP SWITCH OUTPUT |

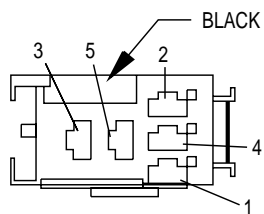

TRAILER TOW LEFT TURN RELAY

| CAV | CIRCUIT | FUNCTION |
|-----|-------------|--------------------------|
| 1 | L63 20DG/RD | LEFT TURN SIGNAL |
| 2 | L50 20WT/TN | BRAKE LAMP SWITCH OUTPUT |
| 3 | A6 20RD/OR | FUSED B(+) |
| 4 | - | - |
| 5 | L73 20YL | BRAKE LAMP SWITCH OUTPUT |

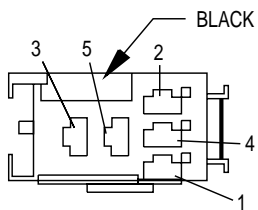

TRAILER TOW RIGHT TURN RELAY

| CAV | CIRCUIT | FUNCTION |
|-----|-------------|--------------------------|
| 1 | L62 20BK/RD | RIGHT TURN SIGNAL |
| 2 | L50 20WT/TN | BRAKE LAMP SWITCH OUTPUT |
| 3 | A6 20RD/OR | FUSED B(+) |
| 4 | - | - |
| 5 | L74 20LG | BRAKE LAMP SWITCH OUTPUT |

▲ 4.0L A/T
▲▲ EXCEPT 4.0L A/T

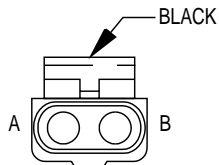

TRANSFER CASE SWITCH (231 4WD)

| CAV | CIRCUIT | FUNCTION |
|-----|--------------|------------------------------|
| A | G107 20BK/RD | 4WD SWITCH SENSE (PART-TIME) |
| B | Z1 20BK | GROUND |

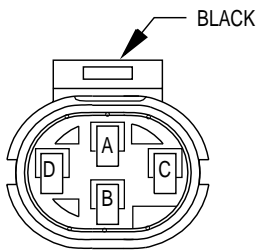

TRANSFER CASE SWITCH (242 4WD)

| CAV | CIRCUIT | FUNCTION |
|-----|--------------|------------------------------|
| A | Z1 20BK | GROUND |
| B | G106 20BK/WT | 4WD SWITCH SENSE (FULL-TIME) |
| C | - | - |
| D | G107 20BK/RD | 4WD SWITCH SENSE (PART-TIME) |

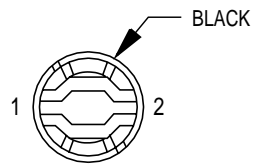

TRANSFER CASE SWITCH ILLUMINATION

| CAV | CIRCUIT | FUNCTION |
|-----|---------|--|
| 1 | E2 20OR | FUSED PANEL LAMPS DIMMER SWITCH SIGNAL |
| 2 | Z1 20BK | GROUND |

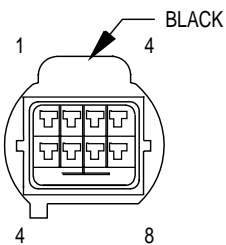

TRANSMISSION SOLENOID (4.0L)

| CAV | CIRCUIT | FUNCTION |
|-----|-------------|----------------------------|
| 1 | T52 20RD/BK | INPUT SPEED SENSOR SIGNAL |
| 2 | T60 20OR/WT | SOLENOID B CONTROL |
| 3 | T19 20WT | SOLENOID A CONTROL |
| 4 | T22 20DB/WT | SOLENOID C CONTROL |
| 5 | T31 20VT/LG | INPUT SPEED SENSOR GROUND |
| 6 | T13 20DB/BK | OUTPUT SPEED SENSOR GROUND |
| 7 | T14 20LG/WT | OUTPUT SPEED SENSOR SIGNAL |
| 8 | - | - |

- DIESEL
- GAS

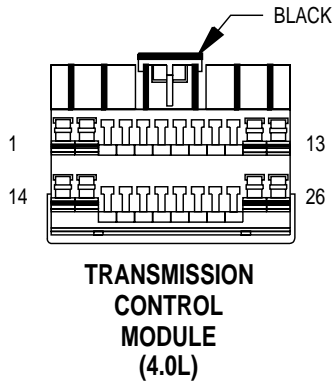

| CAV | CIRCUIT | FUNCTION |
|-----|--------------|---------------------------------------|
| 1 | T31 20VT/LG | INPUT SPEED SENSOR GROUND |
| 2 | T52 20RD/BK | INPUT SPEED SENSOR SIGNAL |
| 3 | T13 20DB/BK | OUTPUT SPEED SENSOR GROUND |
| 4 | T14 20LG/WT | OUTPUT SPEED SENSOR SIGNAL |
| 5 | - | - |
| 6 | D2 20WT/BK | CCD BUS (-) |
| 7 | D1 20VT/BR | CCD BUS (+) |
| 8 | - | - |
| 9 | T3 18VT | TRS T3 SENSE |
| 10 | - | - |
| 11 | T22 20DB/WT | SOLENOID C CONTROL |
| 12 | T19 20WT | SOLENOID A CONTROL |
| 13 | T60 20OR/WT | SOLENOID B CONTROL |
| 14 | D21 20PK | SCI TRANSMIT/ISO 9141K |
| 15 | - | - |
| 16 | K167 20BR/YL | SENSOR GROUND |
| 17 | K22 20OR/DB | THROTTLE POSITION SENSOR SIGNAL |
| 18 | L10 18BR/LG | BACK-UP LAMP FEED |
| 19 | - | - |
| 20 | - | - |
| 21 | T42 18VT/WT | TRS T42 SENSE |
| 22 | T1 18LG/BK | TRS T1 SENSE |
| 23 | K29 20WT/PK | BRAKE LAMP SWITCH SENSE |
| 24 | Z12 18BK/TN | GROUND |
| 25 | M1 20PK | FUSED B(+) |
| 26 | F12 18DB/WT | FUSED IGNITION SWITCH OUTPUT (ST-RUN) |

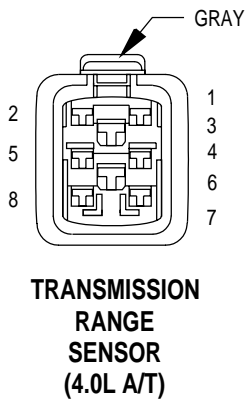

| CAV | CIRCUIT | FUNCTION |
|-----|-------------|---------------------------------------|
| 1 | T42 18VT/WT | TRS T42 SENSE |
| 2 | T3 18VT | TRS T3 SENSE |
| 3 | F20 18WT | FUSED IGNITION SWITCH OUTPUT (ST-RUN) |
| 4 | T1 18LG/BK | TRS T1 SENSE |
| 5 | - | - |
| 6 | L10 18BR/LG | BACK-UP LAMP FEED |
| 7 | T41 20BK/WT | PARK/ NEUTRAL POSITION SWITCH SENSE |
| 8 | Z1 18BK | GROUND |

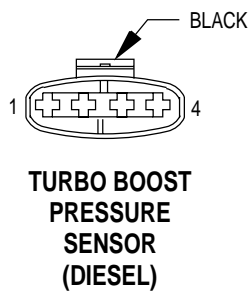

| CAV | CIRCUIT | FUNCTION |
|-----|-------------|--------------------------------------|
| 1 | K4 20BK/LB | SENSOR GROUND |
| 2 | K21 20BK/RD | INTAKE AIR TEMPERATURE SENSOR SIGNAL |
| 3 | K9 20LB | 5V SUPPLY |
| 4 | K1 20DG/RD | BOOST PRESSURE SENSOR SIGNAL |

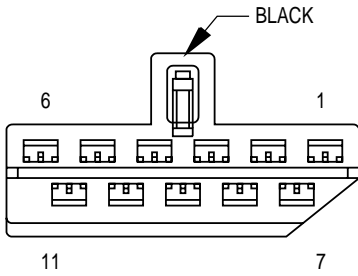

**TURN SIGNAL/
HAZARD SWITCH**

| CAV | CIRCUIT | FUNCTION |
|-----|-------------|------------------------------|
| 1 | L60 20TN | RIGHT TURN SIGNAL |
| 2 | - | - |
| 3 | L62 20BR/RD | RIGHT TURN SIGNAL |
| 4 | L55 20RD/WT | COMBINATION FLASHER INPUT |
| 5 | L6 20RD/WT | FLASHER OUTPUT |
| 6 | L12 20VT/TN | HAZARD FLASHER SELECT SIGNAL |
| 7 | - | - |
| 8 | - | - |
| 9 | L63 20DG/RD | LEFT TURN SIGNAL |
| 10 | L61 20LG/WT | LEFT TURN SIGNAL |
| 11 | L55 20RD/WT | COMBINATION FLASHER INPUT |

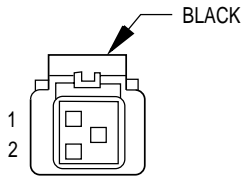

**UNDERHOOD
LAMP/
SWITCH**

| CAV | CIRCUIT | FUNCTION |
|-----|---------|------------|
| 1 | M1 20PK | FUSED B(+) |
| 2 | Z1 20BK | GROUND |

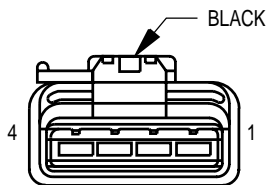

**VEHICLE SPEED
CONTROL SERVO**

| CAV | CIRCUIT | FUNCTION |
|-----|-------------|---------------------------------------|
| 1 | V36 18TN/RD | SPEED CONTROL VACUUM SOLENOID CONTROL |
| 2 | V35 18LG/RD | SPEED CONTROL VENT SOLENOID CONTROL |
| 3 | V30 20DB/RD | SPEED CONTROL BRAKE SWITCH OUTPUT |
| 4 | Z1 18BK | GROUND |

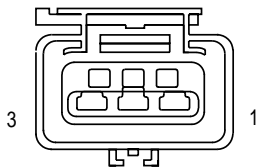

**VEHICLE SPEED
SENSOR
(DIESEL)**

| CAV | CIRCUIT | FUNCTION |
|-----|--------------|-----------------------------|
| 1 | K7 18OR | 5V SUPPLY |
| 2 | K167 20BR/YL | SENSOR GROUND |
| 3 | G7 18WT/OR | VEHICLE SPEED SENSOR SIGNAL |

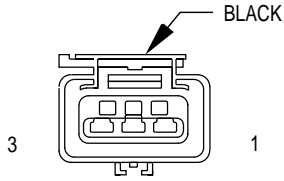

**VEHICLE SPEED
SENSOR
(GAS)**

| CAV | CIRCUIT | FUNCTION |
|-----|--------------|-----------------------------|
| 1 | K6 18VT/OR | 5V SUPPLY |
| 2 | K167 20BR/YL | SENSOR GROUND |
| 3 | G7 18WT/OR | VEHICLE SPEED SENSOR SIGNAL |

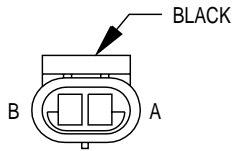

**WASHER
FLUID LEVEL
SWITCH**

| CAV | CIRCUIT | FUNCTION |
|-----|-------------|------------------------|
| A | Z1 20BK | GROUND |
| B | G29 20BK/LB | LOW WASHER FLUID SENSE |

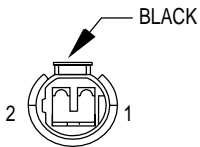

**WATER IN FUEL
SENSOR
(DIESEL)**

| CAV | CIRCUIT | FUNCTION |
|-----|--------------|-----------------------------|
| 1 | G123 18DG/WT | WATER IN FUEL SENSOR SIGNAL |
| 2 | K167 20BR/YL | SENSOR GROUND |

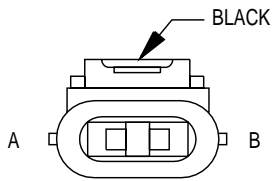

**WINDSHIELD
WASHER PUMP**

| CAV | CIRCUIT | FUNCTION |
|-----|----------|---------------------|
| A | V10 18BR | WASHER PUMP CONTROL |
| B | Z1 18BK | GROUND |

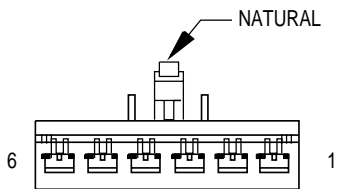

**WIPE/WASH
SWITCH**

| CAV | CIRCUIT | FUNCTION |
|-----|------------|--|
| 1 | Z1 16BK | GROUND |
| 2 | V5 16DG/YL | WIPER PARK SWITCH SENSE |
| 3 | V10 18BR | WASHER PUMP CONTROL |
| 4 | V3 16BR/WT | WIPER LOW SPEED OUTPUT |
| 5 | V6 16DB | FUSED IGNITION SWITCH OUTPUT (RUN-ACC) |
| 6 | V4 16BR/VT | WIPER HIGH SPEED OUTPUT |

8W-90 CONNECTOR LOCATIONS

DESCRIPTION AND OPERATION

INTRODUCTION

This section provides illustrations identifying component and connector locations in the vehicle. A connector index is provided. Use the wiring diagrams in

each section for connector number identification. Refer to the index for the proper figure number.

CONNECTOR/GROUND LOCATIONS

For items that are not shown in this section N/S is placed in the Fig. column.

| Connector Name/Number | Color | Location | Fig. |
|---|-------|--|--------|
| A/C Compressor Clutch (Diesel) | BK | Left Rear of Engine Compartment | 41, 42 |
| A/C-Heater Control or Heater Control - C1 | BK | Center of Instrument Panel | 22, 23 |
| A/C-Heater Control - C2 | NAT | Center of Instrument Panel | 22, 23 |
| A/C High Pressure Switch (2.5L)(LHD) | | Near T/O for C107 | 8 |
| A/C High Pressure Switch (2.5L)(RHD) | | Right Side of Engine Compartment Near Power Distribution Center | 7 |
| A/C High Pressure Switch (4.0L)(LHD) | | Right Side of Engine Compartment Near Power Distribution Center | 12, 14 |
| A/C High Pressure Switch (4.0L)(RHD) | | Left Side of Engine Compartment Near T/O for A/C Compressor Clutch | 15 |
| A/C High Pressure Switch (Diesel) | | Left Side of Engine | 41, 42 |
| A/C Low Pressure Switch (Diesel)(LHD) | | Right Rear of Engine Compartment | 39 |

| Connector Name/Number | Color | Location | Fig. |
|--|-------|---|--------------------------|
| A/C Low Pressure Switch (Diesel)(RHD) | | Left Rear of Engine Compartment | 37 |
| A/C Low Pressure Switch (Gas)(LHD) | | Right Rear of Engine Compartment | 4, 12 |
| A/C Low Pressure Switch (Gas)(RHD) | | Left Rear of Engine Compartment | 3, 11 |
| Accelerator Pedal Position Sensor (Diesel) (LHD) | BK | Near T/O for Engine Control Module - C1, C2 | N/S |
| Accelerator Pedal Position Sensor (Diesel)(RHD) | BK | Right Kick Panel Area | 40 |
| Airbag Control Module | YL | Under Center Console | 27, 32 |
| Ambient Temperature Sensor | BK | Center Grill Opening | 4, 5, 12, 13, 39, 40 |
| Back-Up Lamp Switch (2.5L) | BK | Right Side of Transmission Near Shifter | 19 |
| Back-Up Lamp Switch (4.0L) | BK | Left Side of Transmission | 20 |
| Back-Up Lamp Switch (Diesel) | BK | Left Side of Transmission | 43 |
| Battery Temperature Sensor | BK | At Battery | 6, 7, 12, 13, 14, 15, 38 |
| Blend Door Actuator | BK | T/O at T/O for C209 on HVAC Harness | N/S |
| Blower Motor | | On HVAC Harness | N/S |

DESCRIPTION AND OPERATION (Continued)

| Connector Name/Number | Color | Location | Fig. |
|-------------------------------------|-------|-----------------------------------|----------------------------|
| Blower Motor Relay | BK | Near T/O for C209 | N/S |
| Blower Motor Resistor Block | BK | On HVAC Harness | N/S |
| Brake Lamp Switch | GY | Near Brake Pedal | 21, 24, 25 |
| Brake Warning Pressure Switch (LHD) | BK | Left Side of Engine Compartment | 2, 10, 36 |
| Brake Warning Pressure Switch (RHD) | BK | Right Side of Engine Compartment | 5, 7, 13, 15, 40 |
| C100 (LHD) | BK | Left Lower Instrument Panel | 6, 14, 21, 25 |
| C100 (RHD) | WT | Right Lower Instrument Panel | 24, 40 |
| C106 | BK | Left Front Engine Compartment | 1, 6, 7, 14, 15, 38 |
| C107 (2.5L) | BK | Rear of Engine Compartment | 2, 3, 4, 5, 16 |
| C107 (4.0L) | BK | Rear of Engine Compartment | 12, 13, 17 |
| C108 (Gas) | BK | Right Side of Engine Compartment | 4, 5, 6, 7, 12, 13, 14, 15 |
| C109 | BK | Left Lower Instrument Panel | 14, 15, 26, 27, 38 |
| C111 (Diesel) | LT GY | Left Rear of Engine Compartment | 36, 37, 42 |
| C112 (4.0L A/T 4WD) | GY | Left Side of Transfer Case | 20 |
| C113 (Gas M/T) | | Rear Center of Engine Compartment | 12, 17 |
| C114 (Built-Up-Export) | BK | T/O at Left Headlamp T/O | 1 |
| C115 (Built-Up-Export) | BK | T/O at Right Headlamp T/O | N/S |
| C116 (Diesel) | BK | Right Side of Engine | 39, 40, 41 |
| C120 (Diesel) | BK | Rear of Engine | 36, 37, 41 |

| Connector Name/Number | Color | Location | Fig. |
|-----------------------|------------------------------|----------------------------------|------------|
| C200 (LHD) | GY | Left Lower Instrument Panel | 21, 26 |
| C201 (LHD) | NAT | Lower Center of Instrument Panel | 21 |
| C202 (RHD) | GY | Lower Center of Instrument Panel | 24, 27 |
| C203 (RHD) | BL | Lower Center of Instrument Panel | 24, 27 |
| C204 (RHD) | WT | Lower Center of Instrument Panel | 24, 27 |
| C205 (LHD) | YL | Left Lower Instrument Panel | 21, 22 |
| C205 (RHD) | YL | Right Lower Instrument Panel | 23, 24 |
| C206 | BK | At Center Console | 26, 27, 32 |
| C207 | BK | Right Lower Instrument Panel | 21, 24 |
| C208 | BK | Left Lower Instrument Panel | 21, 24 |
| C209 (LHD) | BK/LT GN | Right Lower Instrument Panel | 32 |
| C209 (RHD) | BK/LT GN | Left Lower Instrument Panel | 27 |
| C300 (LHD) | NAT | At Right Kick Panel | 32 |
| C300 (RHD) | WT | At Right Kick Panel | 24 |
| C301 | WT | At Right Kick Panel | 24, 32 |
| C303 | NAT/ BK (LHD) WT (RHD) | T/O at Junction Block - C7 T/O | N/S |
| C304 | BK | Right Lower B Pillar | 29 |

DESCRIPTION AND OPERATION (Continued)

| Connector Name/Number | Color | Location | Fig. |
|----------------------------|-------|--------------------------------|------------|
| C305 | WT | At Left Kick Panel | 26, 27 |
| C306 | WT | At Left Kick Panel | 26, 27 |
| C307 | WT | At Left Kick Panel | 26, 27 |
| C309 | BK | Left Lower B Pillar | 26, 27 |
| C310 | BK | Top Center of Liftgate | 31 |
| C311 | BK | Top Center of Liftgate | 31 |
| C312 | GN | Top Center of Liftgate | 31 |
| C313 | GY | Top Center of Liftgate | 31 |
| C314 | WT | At Soundbar | N/S |
| C316 | BK | Under Right Front Seat | 26, 27, 29 |
| C317 | BK | Left Lower A Pillar | 26, 27 |
| C318 | BK | Right Lower A Pillar | 29 |
| C319 | BK | Right Lower B Pillar | 29 |
| C320 | BK | Left Lower B Pillar | 26, 27 |
| C321 | BK | At Right Tail Lamp Harness | N/S |
| C322 (Trailer Tow) | BK | At Left Tail Lamp Harness | 33 |
| C322 (Without Trailer Tow) | BK | At Left Tail Lamp Harness | 28 |
| C323 (Trailer Tow) | BK | At Trailer Tow Harness | 28, 33 |
| C324 (RHD) | WT | In T/O for Junction Block - C7 | N/S |
| C326 | BK | At Left Rear Quarter Panel | 28 |
| C327 | BK | At Left Rear Quarter Panel | 28 |
| C329 | NAT | Under Right Front Seat | 26, 27 |
| C330 | BK | Center of Liftgate | 31 |

| Connector Name/Number | Color | Location | Fig. |
|--------------------------------------|-------|---|----------------|
| C332 | NAT | Under Left Front Seat | 26, 27 |
| C333 | BK | At Center High Mounted Stop Lamp Jumper | N/S |
| C362 | BK | Under Left Front Seat | 26, 27 |
| C363 | BK | Under Right Front Seat | 26, 27 |
| Camshaft Position Sensor (GAS) | GY | Right Side of Engine | 16, 17 |
| Cargo Lamp/Switch | BK | At Lamp | N/S |
| Center High Mounted Stop Lamp | BK | At Liftgate | N/S |
| Cigar Lighter | RD | Lower Center of Instrument Panel | 22, 23 |
| Clockspring - C1 | NAT | At Clockspring | 35 |
| Clockspring - C2 | | At Clockspring | N/S |
| Clockspring - C3 | YL | At Clockspring | 35 |
| Clutch Interlock Switch | GN | At Clutch Pedal | 14, 24, 25 |
| Clutch Interlock Switch Jumper (LHD) | BK | Lower Steering Column | N/S |
| Clutch Interlock Switch Jumper (RHD) | BK | Lower Steering Column | 24 |
| Combination Flasher | BK | Lower Left of Instrument Panel | 21 |
| Compass | BK | In Headliner | 34 |
| Controller Anti-Lock Brake | BK | Left Side of Engine Compartment | 10, 11, 36, 37 |
| Crankshaft Position Sensor (Gas) | BK | Left Side of Transmission | 20 |
| Data Link Connector (LHD) | BK | Lower Left of Instrument Panel | 21 |

DESCRIPTION AND OPERATION (Continued)

| Connector Name/Number | Color | Location | Fig. |
|--|-------|---------------------------------------|--------------|
| Data Link Connector (RHD) | BK | Lower Right of Instrument Panel | N/S |
| Daytime Running Lamp Module (Except Built-Up-Export) | BK | Right Rear of Engine Compartment | 6, 8, 14 |
| Diode Module (Built-Up-Export) | BK | T/O at Rear Fog Lamp Relay T/O | N/S |
| Dome Lamp (Base/Police) | | At Lamp | N/S |
| Dome Lamps Switch (Midline) | BK | At Switch | N/S |
| Driver Door Jamb Switch | BK | Left Lower A Pillar | N/S |
| Driver Door Lock Motor | | At Motor | 30 |
| Driver Power Lock/Window Switch-C1 | BL | At Switch | 30 |
| Driver Power Door Lock/Window Switch-C2 | WT | At Switch | 30 |
| Driver Power Mirror | RD | At Mirror | 30 |
| Driver Power Window Motor | BK | At Motor | 30 |
| Duty Cycle EVAP/Purge Solenoid (Gas) (LHD) | BK | Right Rear of Engine Compartment | 2, 4, 10, 12 |
| Duty Cycle EVAP/Purge Solenoid (Gas) (RHD) | BK | Left Rear of Engine Compartment | 3, 11 |
| Electronic Vacuum Modulator (Diesel) | | Right Front of Engine Compartment | 39, 40 |
| Engine Control Module - C1 (Diesel) | BK | Center of Cowl Under Instrument Panel | 38 |
| Engine Control Module - C2 (Diesel) | BK | Center of Cowl Under Instrument Panel | 38 |

| Connector Name/Number | Color | Location | Fig. |
|---|-------|---|------------|
| Engine Coolant Temperature Sensor (GAS) | BK | Front of Engine | 16, 17 |
| Engine Coolant Temperature Sensor NO.1 (Diesel) | BK | Left Rear of Engine | 41 |
| Engine Coolant Temperature Sensor NO.2 (Diesel) | BK | Left Side of Engine | 41, 42 |
| Engine Oil Pressure Sensor | BK | Right Side of Engine | 16, 17, 41 |
| Engine Speed Sensor (Diesel) | BK | Left Side of Engine | 41 |
| EVAP Leak Detection Pump (Except Built-Up-Export) | BK | In T/O for Power Distribution Center | N/S |
| Extended Idle Switch (Police Package) | WT | Instrument Panel Harness Near T/O to Power Outlet | N/S |
| Front Fog Lamp Switch | BK | Lower Center of Instrument Panel | 22, 23 |
| Front Wiper Motor | BK | At Wiper Motor | 8, 9 |
| Fuel Heater (Diesel) | | Left Rear of Engine Compartment | 36, 37 |
| Fuel Injection Pump (Diesel) | BK | Left Side of Engine | 36, 37, 42 |
| Fuel Injector No. 1 | BK | At Injector | 16, 17 |
| Fuel Injector No. 2 | BK | At Injector | 16, 17 |
| Fuel Injector No. 3 | BK | At Injector | 16, 17 |
| Fuel Injector No. 4 | BK | At Injector | 16, 17 |
| Fuel Injector No. 5 (4.0L) | BK | At Injector | 17 |
| Fuel Injector No. 6 (4.0L) | BK | At Injector | 17 |
| Fuel Level Sensor (Diesel) | BK | At Sensor | 28 |

DESCRIPTION AND OPERATION (Continued)

| Connector Name/Number | Color | Location | Fig. |
|------------------------|-------|--|--------------------|
| Fuel Pump Module (GAS) | BK | At Fuel Pump Module | 28 |
| G100 (4.0L) | | Right Front of Engine Compartment | 12, 13 |
| G100 (2.5L) | | Right Front of Engine Compartment at Battery Negative Terminal | N/S |
| G101 | | Right Side of Engine | 16, 17 |
| G102 (Diesel) | | Right Side of Engine | 39, 40 |
| G102 (Gas) | | Rear of Engine Compartment | 2, 3, 4, 5, 12, 13 |
| G104 (Gas) | | T/O at Engine Starter Motor T/O on Battery Harness | N/S |
| G104 (Diesel) | | T/O at Battery Negative Terminal on Battery Harness | N/S |
| G105 (Diesel) | | On Negative Battery Harness | N/S |
| G106 | | Left Side of Engine Compartment | 2, 3, 10, 11 |
| G107 (LHD) | | Right Side of Instrument Panel | 21 |
| G107 (RHD) | | Left Side of Instrument Panel | 24 |
| G108 (LHD) | | Left Side of Instrument Panel | 21 |
| G108 (RHD) | | Right Side of Instrument Panel | 24 |
| G200 | | Under Left Front Seat | 27, 32 |

| Connector Name/Number | Color | Location | Fig. |
|--|-------|----------------------------------|------------|
| G300 | | In T/O for Airbag Control Module | N/S |
| G301 | | Near T/O for Power Amplifier | 28 |
| G302 | | At Left Rear Quarter Panel | 28 |
| G303 | | Under Right Front Seat | 26, 27, 29 |
| G304 | | T/O at T/O's for C326 and C327 | N/S |
| G306 | | Under Right Front Seat | 26, 27 |
| G Switch | BK | Under Rear Seat | 28, 29 |
| Generator (2.5L) | BK | At Generator | N/S |
| Generator (4.0L) | BK | At Generator | 18 |
| Generator (Diesel) | BK | At Generator | 41, 42 |
| Glow Plug Relay (Diesel) | | Left Rear of Engine Compartment | 36, 37 |
| Headlamp Beam Select Switch | BK | On Steering Column | 35 |
| HeadLamp Delay Module (LHD) | BK | Lower Left of Instrument Panel | 21 |
| Headlamp Delay Module (RHD) | BK | Lower Right of Instrument Panel | N/S |
| Headlamp Leveling Switch (Built-Up-Export) | BK | Lower Center of Instrument Panel | 22, 23 |
| Headlamp Switch (LHD) | BK | Left Side of Instrument Panel | 22 |
| Headlamp Switch (RHD) | BK | Right Side of Instrument Panel | 23 |
| Heated Seat Relay | | Under Right Front Seat | N/S |
| Idle Air Control Motor | BK | Left Side of Engine | 16, 17 |

DESCRIPTION AND OPERATION (Continued)

| Connector Name/Number | Color | Location | Fig. |
|----------------------------------|-------|--------------------------------|----------------|
| Ignition Coil (2.5L) | BK | Right Side of Engine | 16 |
| Ignition Switch - C1 | BK | At Steering Column | 21, 24, 35 |
| Ignition Switch - C2 | GN | At Steering Column | 21, 24, 35 |
| Instrument Cluster - C1 | BK | At Instrument Cluster | 21, 22, 23, 24 |
| Instrument Cluster - C2 | BK | At Instrument Cluster | 21, 22, 23, 24 |
| Intake Air Temperature Sensor | GY | Left Side of Engine | 16, 17 |
| Junction Block - C1 | NAT | At Right Kick Panel Area | 25, 29 |
| Junction Block - C2 | WT | At Right Kick Panel Area | 25, 29 |
| Junction Block - C3 | NAT | At Right Kick Panel Area | 29 |
| Junction Block - C4 | WT | At Right Kick Panel Area | 24, 29 |
| Junction Block - C5 | WT | At Right Kick Panel Area | 24, 29 |
| Junction Block - C6 | NAT | At Right Kick Panel Area | 29 |
| Junction Block - C7 | NAT | At Right Kick Panel Area | 29 |
| Junction Block - C8 | NAT | At Right Kick Panel Area | 29 |
| Junction Block - C9 | NAT | At Right Kick Panel Area | 29 |
| Left Back-Up Lamp | GY | At Lamp | N/S |
| Left City Lamp (Built-Up-Export) | | At Lamp | 1 |
| Left Courtesy Lamp | BK | Lower Left of Instrument Panel | 21, 24 |
| Left Fog Lamp | GY | At Lamp | 1 |
| Left Front Door Speaker | BK | At Speaker | 30 |
| Left Front Door Tweeter | BK | Left Front Door | 30 |

| Connector Name/Number | Color | Location | Fig. |
|--|-------|---------------------------------|------------|
| Left Front Park/Turn Signal Lamp NO.1 (Except Built-Up-Export) | GY | At Lamp | 1 |
| Left Front Park/Turn Signal Lamp NO.2 (Except Built-Up-Export) | GY | At Lamp | 1 |
| Left Front Turn Signal Lamp NO.1 (Built-Up-Export) | GY | At Lamp | 1 |
| Left Front Turn Signal Lamp NO.2 (Built-Up-Export) | GY | At Lamp | 1 |
| Left Front Wheel Speed Sensor | GY | Left Side of Engine Compartment | 10, 11, 38 |
| Left Headlamp | | At Headlamp | 1 |
| Left Headlamp Leveling Motor (Built-Up-Export) | BK | At Headlamp | 1 |
| Left Heated Seat Back | | At Left Seat | N/S |
| Left Heated Seat Cushion | | At Left Seat | N/S |
| Left Heated Seat Switch | RD | At Center Console | 26, 27 |
| Left License Lamp (Built-Up-Export) | | At Lamp | N/S |
| Left Power Seat Front Vertical Motor | YL | Under Left Seat | N/S |
| Left Power Seat Horizontal Motor | YL | Under Left Seat | N/S |
| Left Power Seat Rear Vertical Motor | YL | Under Left Seat | N/S |
| Left Power Seat Switch | BK | At Switch | N/S |
| Left Rear Door Jamb Switch | BK | At Left B Pillar | N/S |

DESCRIPTION AND OPERATION (Continued)

| Connector Name/Number | Color | Location | Fig. |
|--|-------|----------------------------------|----------------|
| Left Rear Door Lock Motor | BK | In Left Rear Door | 30 |
| Left Rear Fog Lamp (Built-Up-Export) | BK | At Lamp | N/S |
| Left Rear Wheel Speed Sensor | BK | Under Rear Seat | 28 |
| Left Rear Window Motor | BK | In Left Rear Door | 30 |
| Left Rear Window Switch | BL | In Left Rear Door | 30 |
| Left Repeater Lamp (Built-Up-Export) | | At Lamp | 1 |
| Left Side Marker Lamp (Except Built-Up-Export) | NAT | At Lamp | 1 |
| Left Soundbar Speaker | | At Soundbar | N/S |
| Left Speed Control Switch | | On Steering Wheel | N/S |
| Left Tail/Stop Lamp | BK | At Lamp | N/S |
| Left Turn Signal Lamp | | At Rear Lamp | N/S |
| Left Visor/Vanity Lamp | BK | Left Side of Headliner | 34 |
| License Lamp | | At Lamp | N/S |
| Liftgate Lock Motor | BK | In Liftgate | 31 |
| Liftgate Switch | BK | In Liftgate | 31 |
| Low Coolant Switch (Diesel) | | Right Side of Engine Compartment | 39, 40 |
| Manifold Absolute Pressure Sensor | BK | Left Side of Engine | 16, 17 |
| Message Center (Diesel) | BK | Upper Center of Instrument Panel | 21, 22, 23, 24 |
| Needle Movement sensor (Diesel) | | Rear of Engine Compartment | 36, 37 |

| Connector Name/Number | Color | Location | Fig. |
|--|-------|---------------------------------|----------------|
| Overhead Module | BK | Front Center of Headliner | 34 |
| Oxygen Sensor 1/1 Upstream (2.5L) | GY | Left Side of Engine | 16 |
| Oxygen Sensor 1/1 Upstream (4.0L) | GY | Right Side of Transmission | 20 |
| Oxygen Sensor 1/1 Upstream (California/European III) | GY | Left Side of Engine | 17 |
| Oxygen Sensor 1/2 Downstream (2.5L) | BK | Right Side of Transmission | 19 |
| Oxygen Sensor 1/2 Downstream (4.0L) | BK | Right Side of Transmission | 20 |
| Oxygen Sensor 1/2 Downstream (California/European III) | BK | Left Side of Engine | 17 |
| Oxygen Sensor 2/1 Upstream (California/European III) | GY | Left Side of Engine | 17 |
| Oxygen Sensor 2/2 Downstream (California/European III) | BK | Left Side of Engine | 20 |
| Park/Neutral Position Switch (2.5L Gas A/T) | BK | Left Side of Transmission | 19 |
| Passenger Airbag | YL | At Airbag | 21, 22, 23, 24 |
| Passenger Door Jamb Switch | BK | Kick Panel Area at Door Opening | N/S |
| Passenger Door Lock Motor | | At Motor | 30 |
| Passenger Power Lock/Window Switch - C1 | BL | At Switch | 30 |
| Passenger Power Lock/Window Switch - C2 | BL | At Switch | 30 |

DESCRIPTION AND OPERATION (Continued)

| Connector Name/Number | Color | Location | Fig. |
|--|-------|----------------------------------|--------------------|
| Passenger Power Mirror | RD | At Mirror | 30 |
| Passenger Power Window Motor | BK | At Motor | 30 |
| Power Amplifier - C1 | NAT | Under Left Rear Seat | 28 |
| Power Amplifier - C2 | NAT | Under Left Rear Seat | 28 |
| Power Antenna (Built-Up-Export) | BK | Right Side of Instrument Panel | 21, 24 |
| Power Antenna Relay - C1 (Built-Up-Export) | BK | Right Side of Instrument Panel | 21, 24 |
| Power Antenna Relay - C2 (Built-Up-Export) | BK | Right Side of Instrument Panel | 21, 24 |
| Power Mirror Switch | | At Switch | N/S |
| Power Outlet | RD | Lower Center of Instrument Panel | 22, 23 |
| Power Steering Pressure Switch (2.5L) | WT | Front of Engine | 16 |
| Powertrain Control Module - C1 (Diesel) | | Right Side of Engine Compartment | 39, 40 |
| Powertrain Control Module - C1 (Gas) | BK | Left Side of Engine Compartment | 8, 9, 16, 17 |
| Powertrain Control Module - C2 (Diesel) | | Right Side of Engine Compartment | 39, 40 |
| Powertrain Control Module - C2 (Gas) | WT | Left Side of Engine Compartment | 8, 9, 16, 17 |
| Powertrain Control Module - C3 (Diesel) | GY | Right Side of Engine Compartment | 39, 40 |
| Powertrain Control Module - C3 (Gas) | GY | Left Side of Engine Compartment | 8, 9, 2, 3, 10, 11 |
| PRNDL Illumination (A/T) | | At Center Console | 26, 27 |

| Connector Name/Number | Color | Location | Fig. |
|---|-------|----------------------------------|--|
| Radiator Fan Motor | LT GY | Front of Engine Compartment | 2, 3, 6, 7, 10, 11, 14, 15, 36, 37, 38 |
| Radio - C1 | BK | Center of Instrument Panel | 22, 23 |
| Radio - C2 | GY | Center of Instrument Panel | 22, 23 |
| Rail Coil (4.0L) | BK | Right Side of Engine | 17 |
| Rear Fog Lamp Relay (Built-Up-Export) (LHD) | | Right Side of Instrument Panel | 21 |
| Rear Fog Lamp Relay (Built-Up-Export) (RHD) | | Left Side of Instrument Panel | 24 |
| Rear Fog Lamp Switch (Built-Up-Export) | WT | Center of Instrument Panel | 22, 23 |
| Rear Washer Pump | BK | Left Front of Engine Compartment | 2, 3, 8, 9, 10, 11, 36, 37 |
| Rear Window Defogger Switch | GY | Center of Instrument Panel | 22, 23 |
| Rear Wiper Motor | | In Liftgate | 31 |
| Rear Wiper/Washer Switch | BK | Center of Instrument Panel | 22, 23 |
| Right Back-Up Lamp | GY | At Lamp | N/S |
| Right City Lamp (Built-Up-Export) | | At Lamp | 1 |
| Right Courtesy Lamp | BK | Lower Right of Instrument Panel | 21, 24 |
| Right Fog Lamp | GY | At Lamp | 1 |
| Right Front Door Speaker | BK | At Speaker | 30 |

DESCRIPTION AND OPERATION (Continued)

| Connector Name/Number | Color | Location | Fig. |
|---|-------|----------------------------------|----------------|
| Right Front Door Tweeter | BK | At Right Front Door | 30 |
| Right Front Park/Turn Signal Lamp NO.1 (Except Built-Up-Export) | BK | At Lamp | 1 |
| Right Front Park/Turn Signal lamp NO.2 (Except Built-Up-Export) | BK | At Lamp | 1 |
| Right Front Turn Signal Lamp NO.1 (Built-Up-Export) | GY | At Lamp | 1 |
| Right Front Turn Signal Lamp NO.2 (Built-Up-Export) | GY | At Lamp | 1 |
| Right Front Wheel Speed Sensor | | Right Side of Engine Compartment | 11, 12, 39, 40 |
| Right Headlamp | | At Headlamp | 1 |
| Right Headlamp Leveling Motor (Built-Up-Export) | BK | At Headlamp | 1 |
| Right Heated Seat Back | | At Right Seat | N/S |
| Right Heated Seat Cushion | | At Right Seat | N/S |
| Right Heated Seat Switch | BL | At Center Console | 26, 27 |
| Right License Lamp (Built-Up-Export) | | At Lamp | N/S |
| Right Power Seat Front Vertical Motor | YL | Under Right Seat | N/S |
| Right Power Seat Horizontal Motor | YL | Under Right Seat | N/S |
| Right Power Seat Rear Vertical Motor | YL | Under Right Seat | N/S |
| Right Power Seat Switch | BK | At Switch | N/S |

| Connector Name/Number | Color | Location | Fig. |
|---|-------|--------------------------------------|--------|
| Right Rear Door Jamb Switch | BK | At Right B Pillar | 29 |
| Right Rear Door Lock Motor | BK | In Right Rear Door | 30 |
| Right Rear Fog Lamp (Built-Up-Export) | BK | At Lamp | N/S |
| Right Rear Wheel Speed Sensor | RD | Under Rear Seat | 28 |
| Right Rear Window Motor | BK | In Right Rear Door | 30 |
| Right Rear Window Switch | BL | In Right Rear Door | 30 |
| Right Repeater Lamp (Built-Up-Export) | | At Lamp | N/S |
| Right Side Marker Lamp (Except Built-Up-Export) | NAT | At Lamp | 1 |
| Right Sound Bar Speaker | | At Soundbar | N/S |
| Right Speed Control Switch | | On Steering Wheel | N/S |
| Right Tail/Stop Lamp | | At Lamp | N/S |
| Right Turn Signal Lamp | | At Rear Lamp | N/S |
| Right Visor/Vanity Lamp | BK | Right Side of Headliner | 34 |
| Seat Belt Switch (LHD) | BK | T/O at T/O for Airbag Control Module | 32 |
| Seat Belt Switch (RHD) | BK | T/O at T/O for C206 | N/S |
| Seat Heat Interface Module | BK | Under Right Front Seat | N/S |
| Sentry Key Immobilizer Module | BK | At Steering Column | 21, 24 |
| Shift Lock Solenoid (LHD) | WT | At Steering Column | 21, 35 |
| Shift Lock Solenoid (RHD) | WT | At Steering Column | 35 |

DESCRIPTION AND OPERATION (Continued)

| Connector Name/Number | Color | Location | Fig. |
|---|--------|---|------------|
| Throttle Position Sensor | WT | Left Side of Engine | 16, 17 |
| Torque Converter Clutch Solenoid (2.5L Gas A/T) | | Left Side of Transmission | 19 |
| Trailer Tow Connector | LT GY | At Rear Bumper | 33 |
| Trailer Tow Left Turn Relay | BK | At Left Rear Quarter Panel | 33 |
| Trailer Tow Right Turn Relay | BK | At Left Rear Quarter Panel | 33 |
| Transfer Case Switch (231 4WD) | BK | Left Side of Transmission | 19, 20, 43 |
| Transfer Case Switch (242 4WD) | BK | Left Side of Transmission | 20 |
| Transfer Case Switch Illumination | BK | At Center Console | 26, 27 |
| Transmission Control Assembly or Transmission Solenoid (4.0L) | BK | Rear of Engine Compartment | 12, 13 |
| Transmission Control Module (4.0L) | BK | Under Instrument Panel near Transmission Tunnel | 14, 15, 25 |
| Transmission Range Sensor (4.0L A/T) | BK/ GY | Rear of Engine Compartment | 12, 13 |

| Connector Name/Number | Color | Location | Fig. |
|--------------------------------------|-------|-----------------------------------|----------------------------|
| Turbo Boost Pressure Sensor (Diesel) | BK | Rear of Engine Compartment | 36, 37 |
| Turn Signal/Hazard Switch | BK | At Steering Column | 21, 24, 35 |
| Underhood Lamp/Switch | BK | At Lamp | 2, 5, 10, 11, 36, 37 |
| Vehicle Speed Control Servo (LHD) | BK | Right Front of Engine Compartment | 4, 12, 14 |
| Vehicle Speed Control Servo (RHD) | BK | Right Rear of Engine Compartment | 5, 9, 13, 15 |
| Vehicle Speed Sensor (Diesel) | | Left Side of Transmission | 43 |
| Vehicle Speed Sensor (Gas) | BK | Left Side of Transmission | 19, 20 |
| Washer Fluid Level Switch | BK | Left Front of Engine Compartment | 2, 3, 8, 9, 10, 11, 36, 37 |
| Water In Fuel Sensor (Diesel) | BK | Rear of Engine Compartment | 36, 37 |
| Windshield Washer Pump | BK | Left Front of Engine Compartment | 2, 3, 8, 9, 10, 11, 36, 37 |
| Wipe/Wash Switch | NAT | At Steering Column | 21, 24, 35 |

DESCRIPTION AND OPERATION (Continued)

80be4747

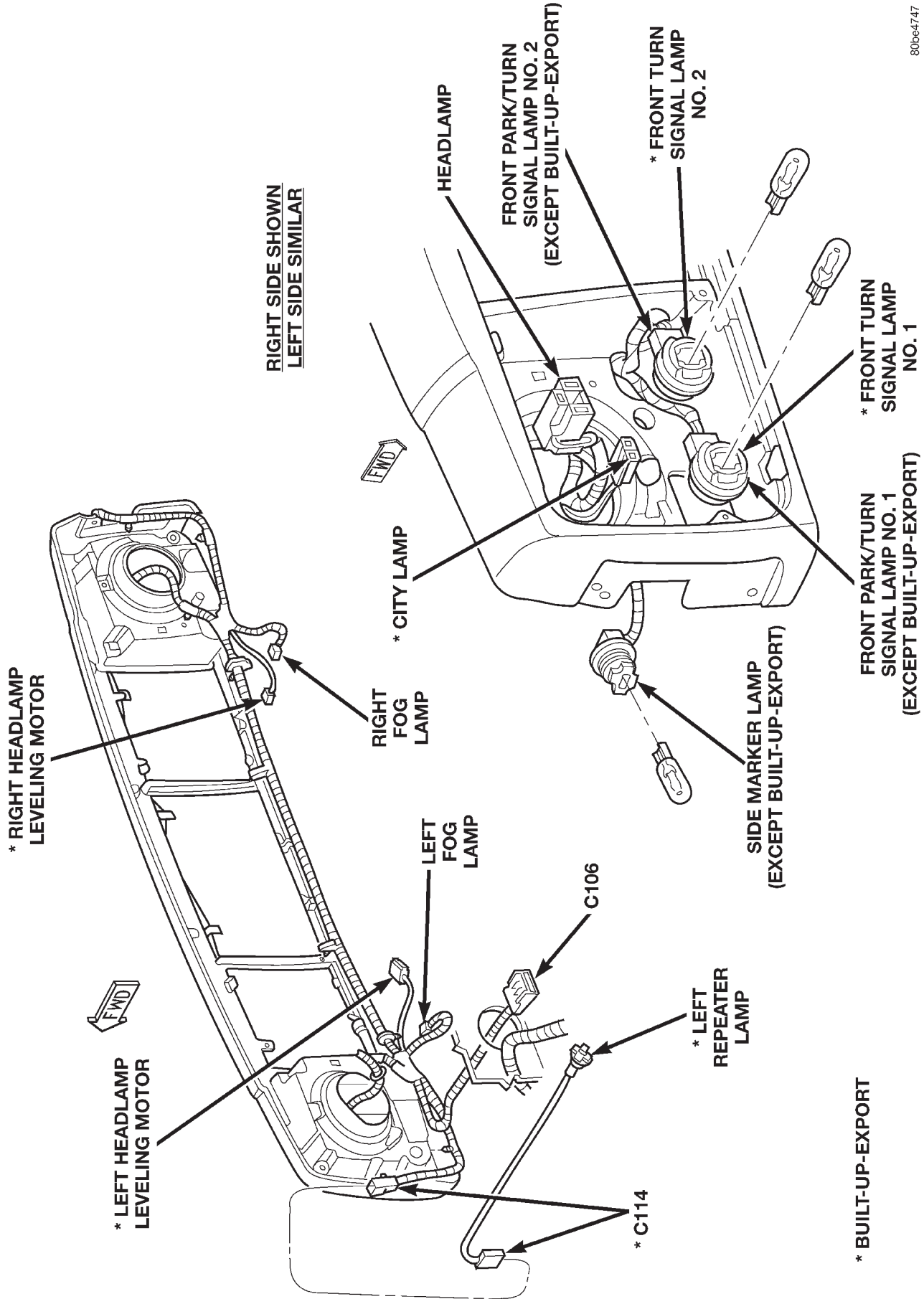
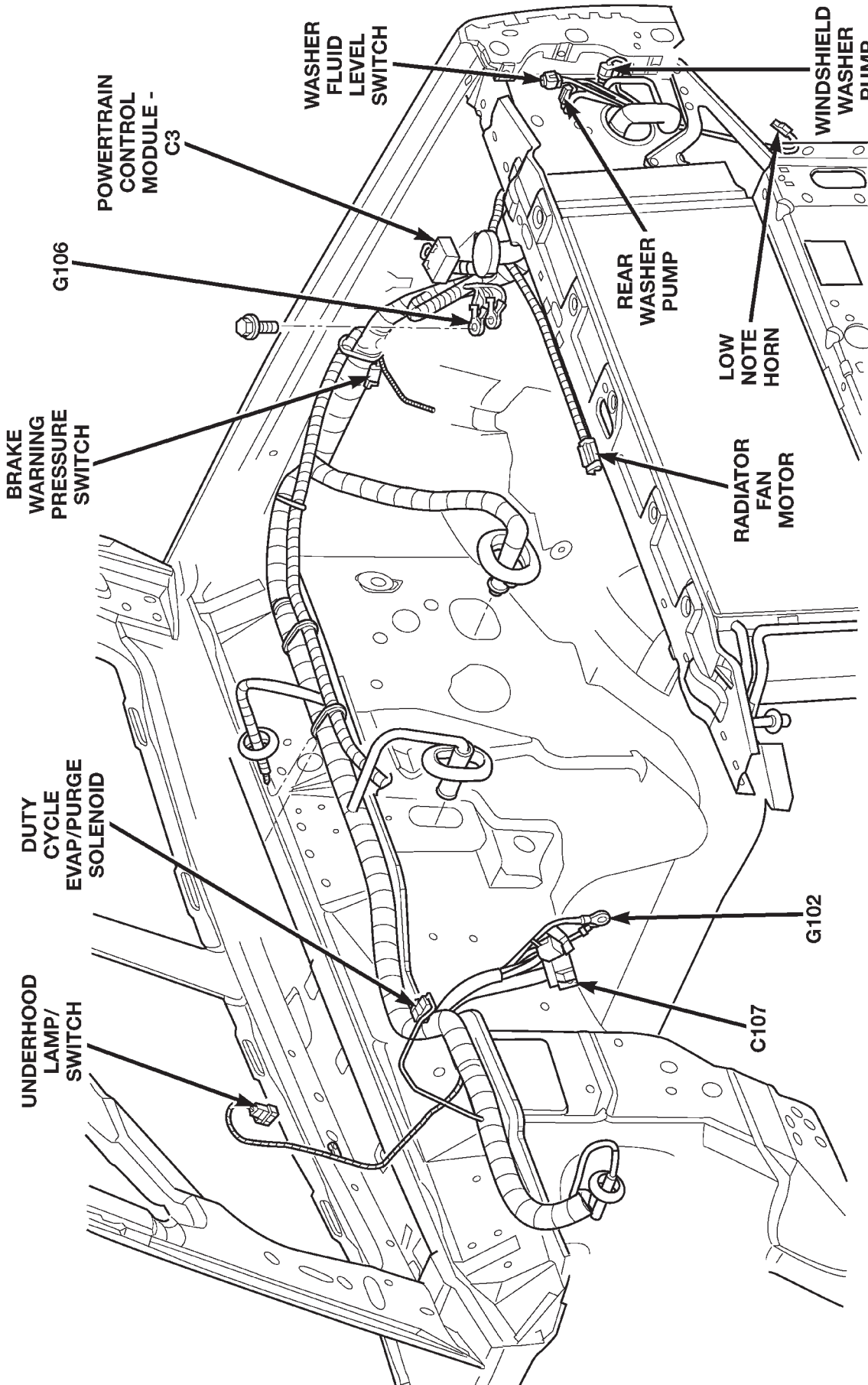

Fig. 1 Front End Lighting

DESCRIPTION AND OPERATION (Continued)



80be4748

Fig. 2 Left Engine Compartment 2.5L Engine LHD

DESCRIPTION AND OPERATION (Continued)

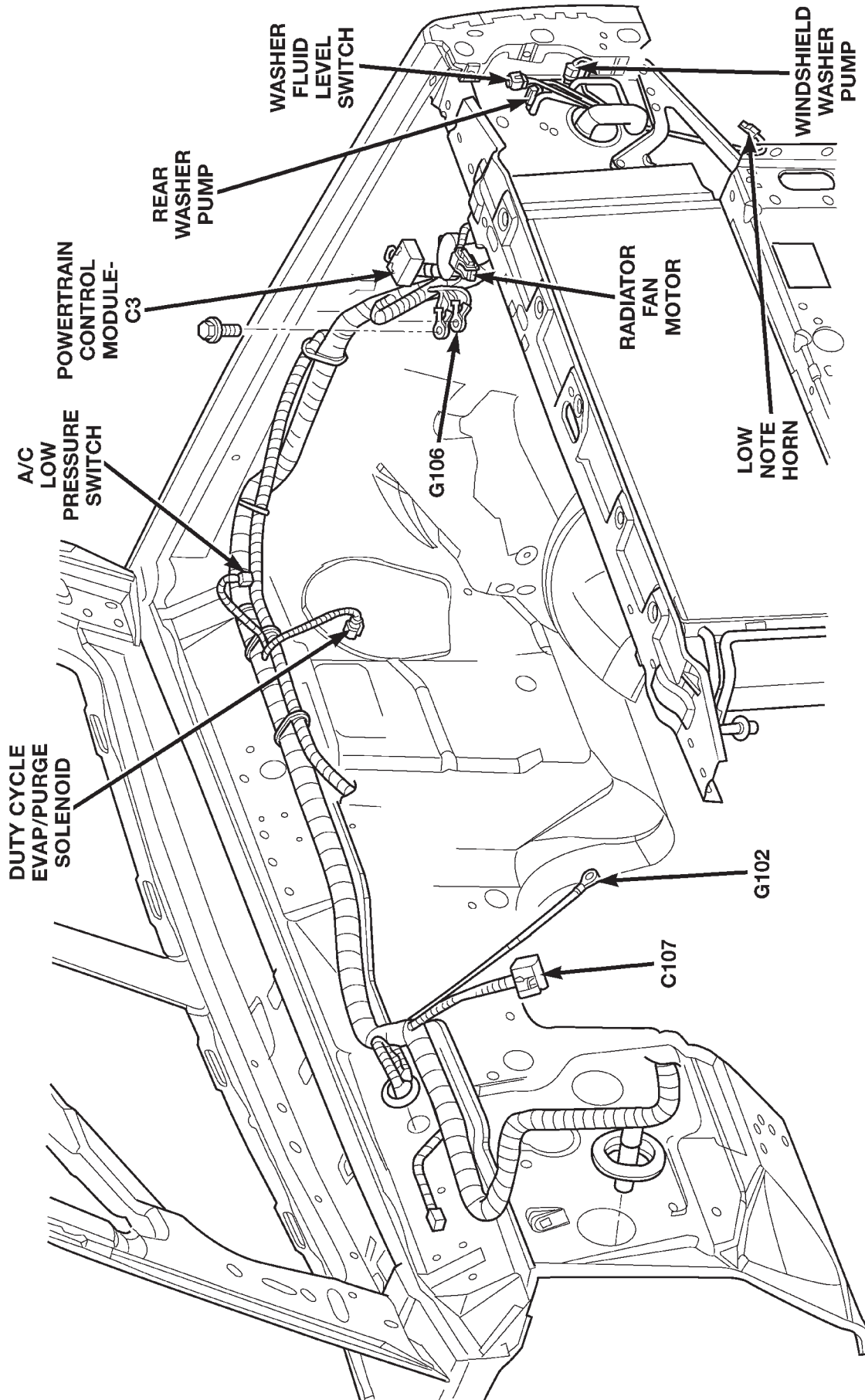

80be4749

Fig. 3 Left Engine Compartment 2.5L Engine RHD

DESCRIPTION AND OPERATION (Continued)

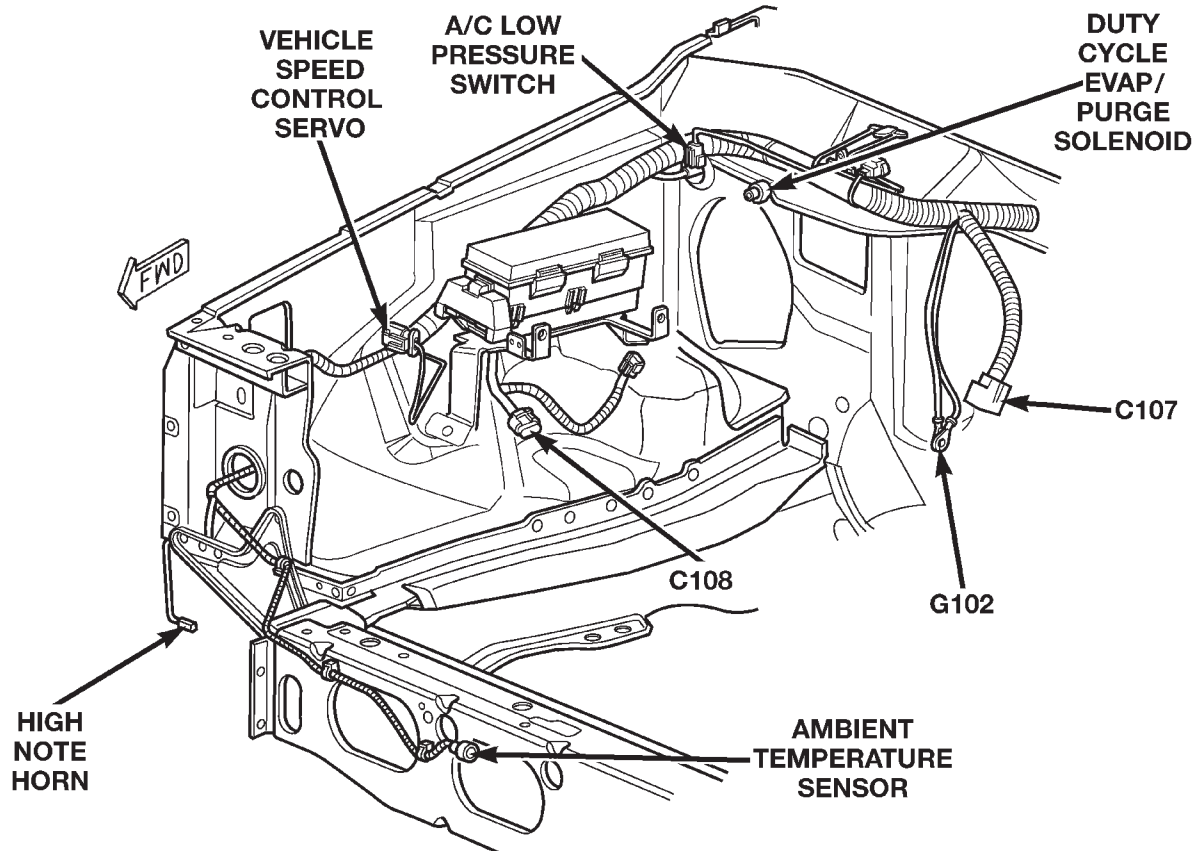

Fig. 4 Right Engine Compartment 2.5L Engine LHD

80be474a

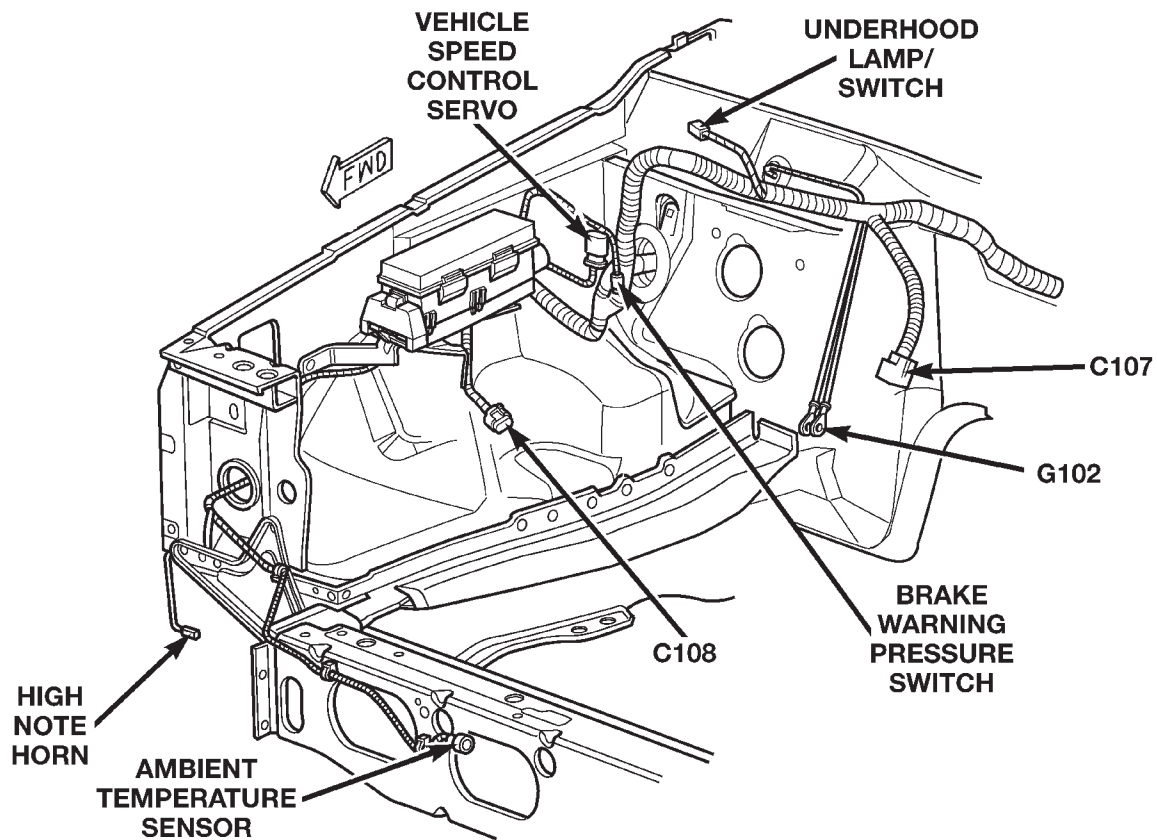

Fig. 5 Right Engine Compartment 2.5L Engine RHD

80be474b

DESCRIPTION AND OPERATION (Continued)

80be474c

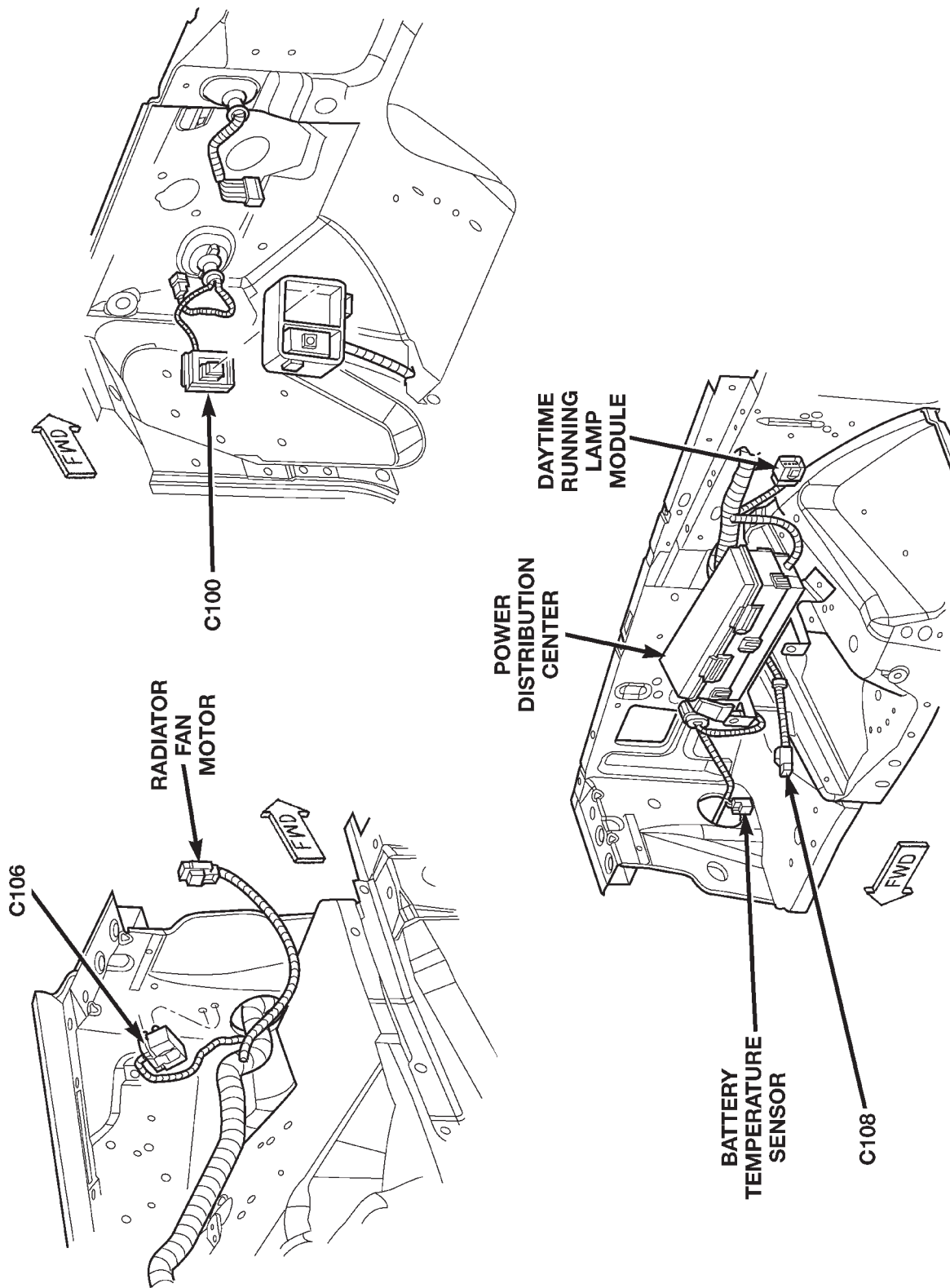

Fig. 6 Engine Compartment Auxiliary Views 2.5L Engine LHD

DESCRIPTION AND OPERATION (Continued)

80be474d

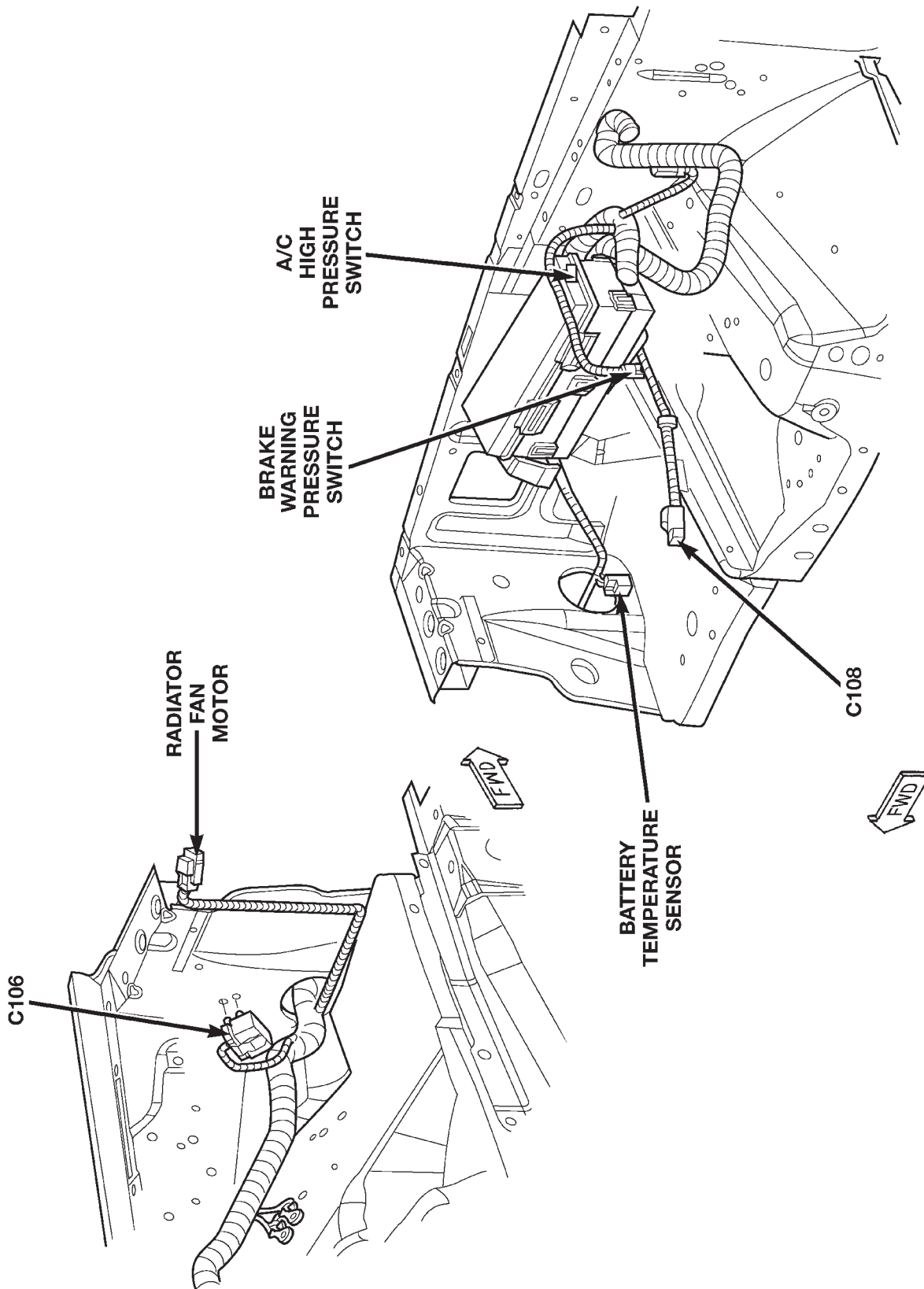
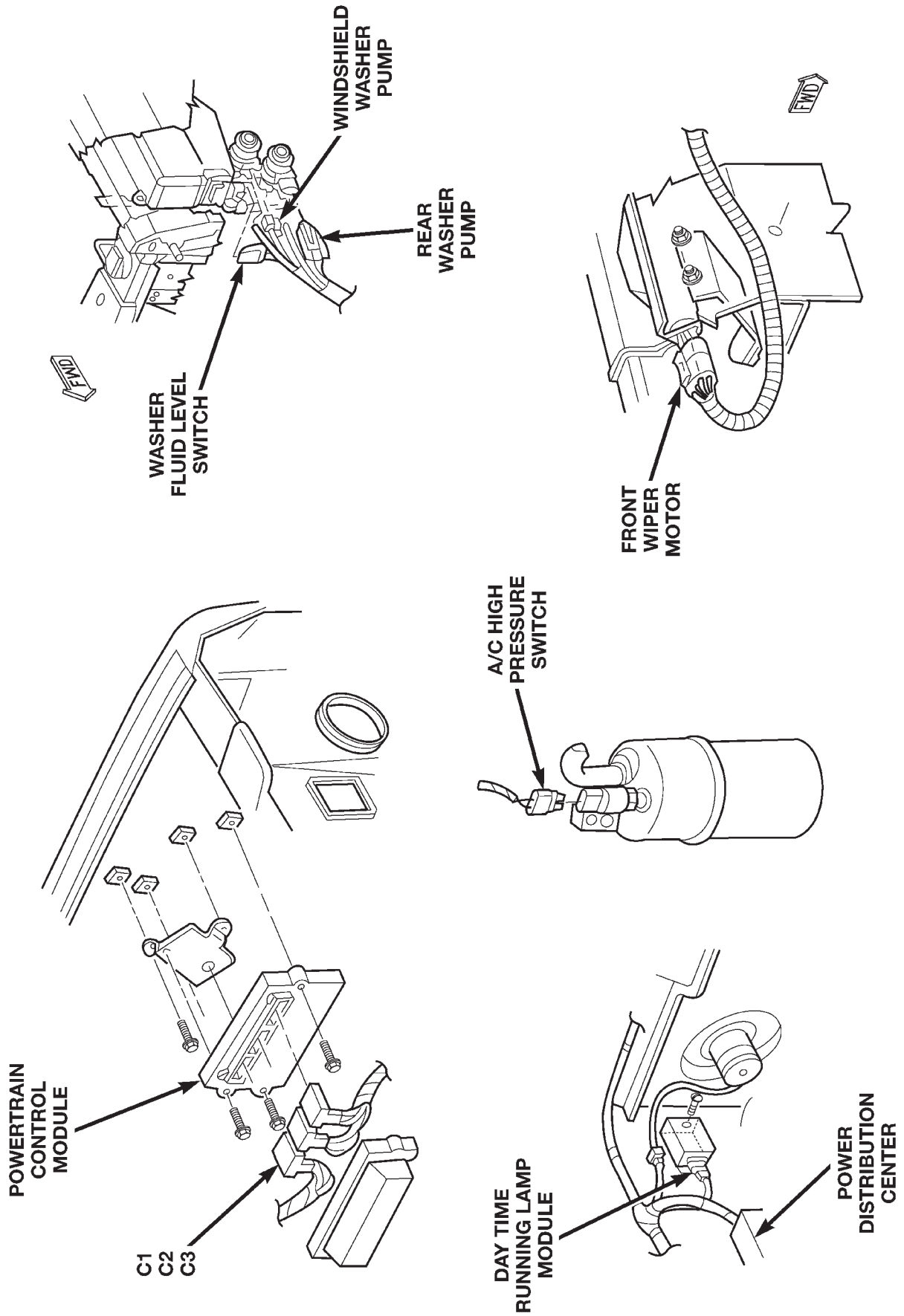

Fig. 7 Engine Compartment Auxiliary Views 2.5L Engine RHD

DESCRIPTION AND OPERATION (Continued)



80be474e

Fig. 8 Engine Compartment Components LHD

DESCRIPTION AND OPERATION (Continued)

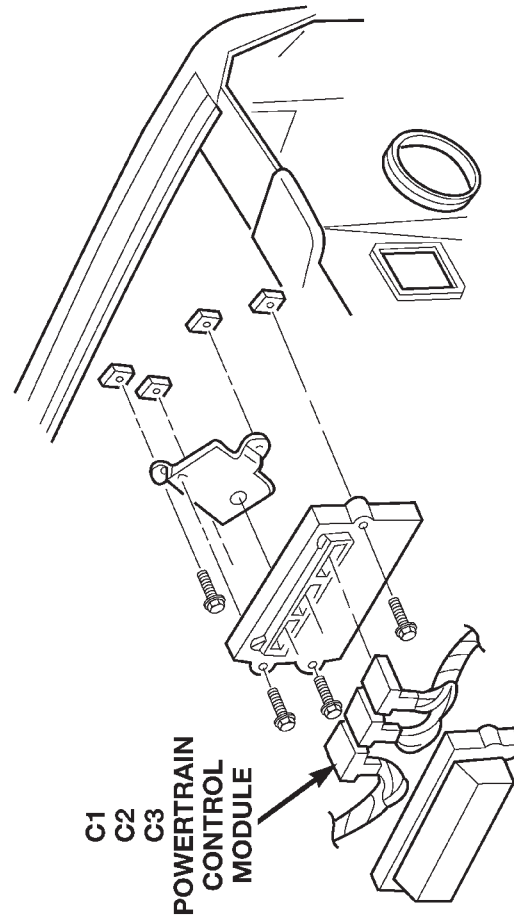
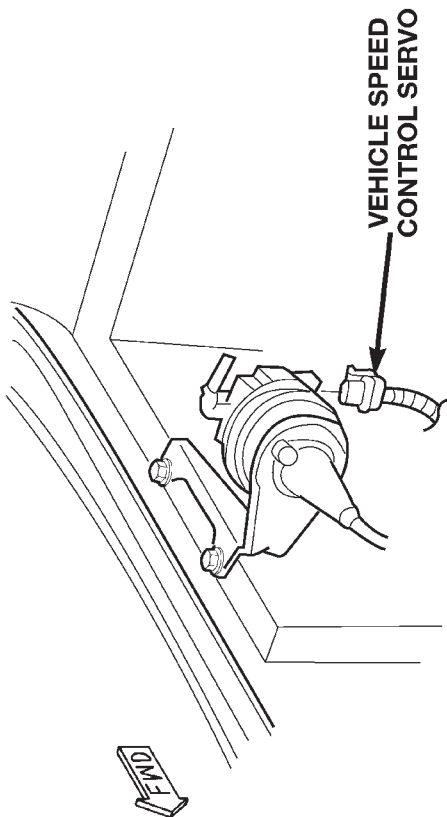
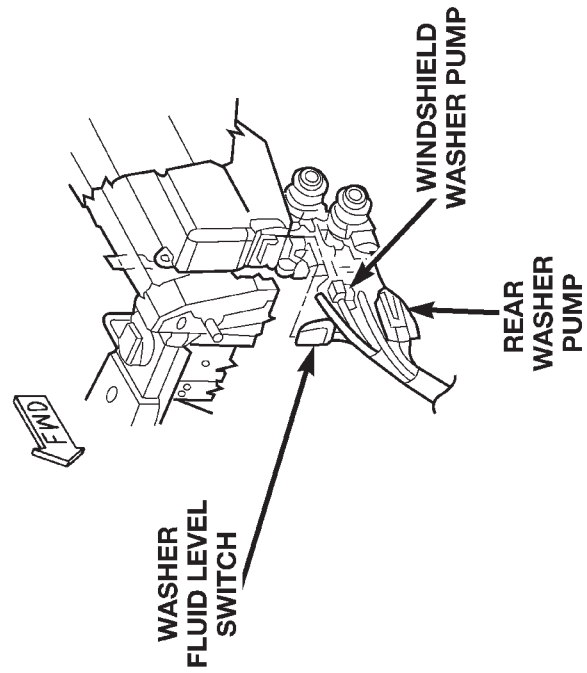
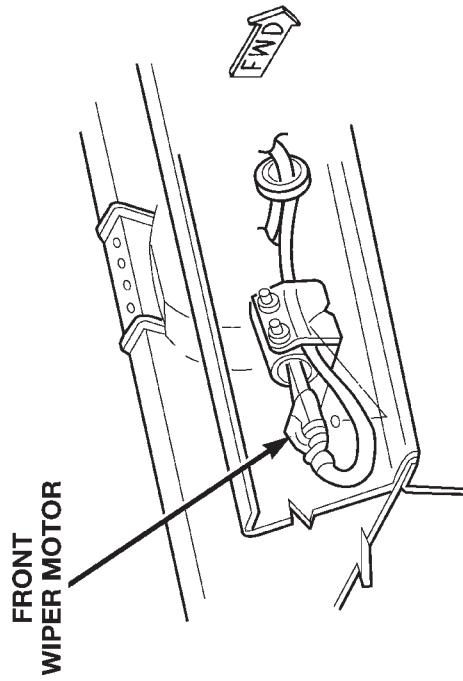

80be474f

Fig. 9 Engine Compartment Components RHD

DESCRIPTION AND OPERATION (Continued)

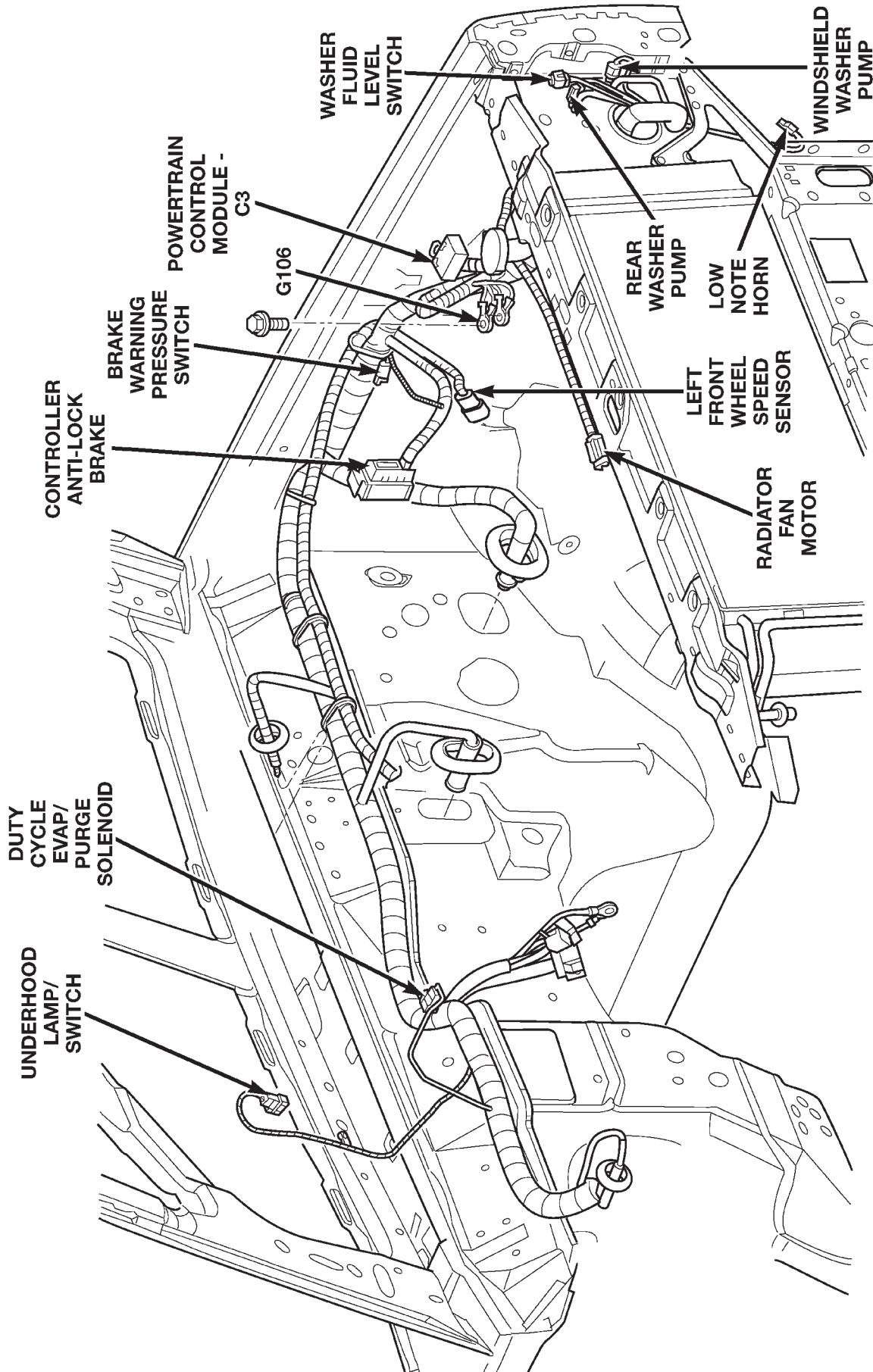

80be4750

Fig. 10 Left Engine Compartment 4.0L Engine LHD

DESCRIPTION AND OPERATION (Continued)

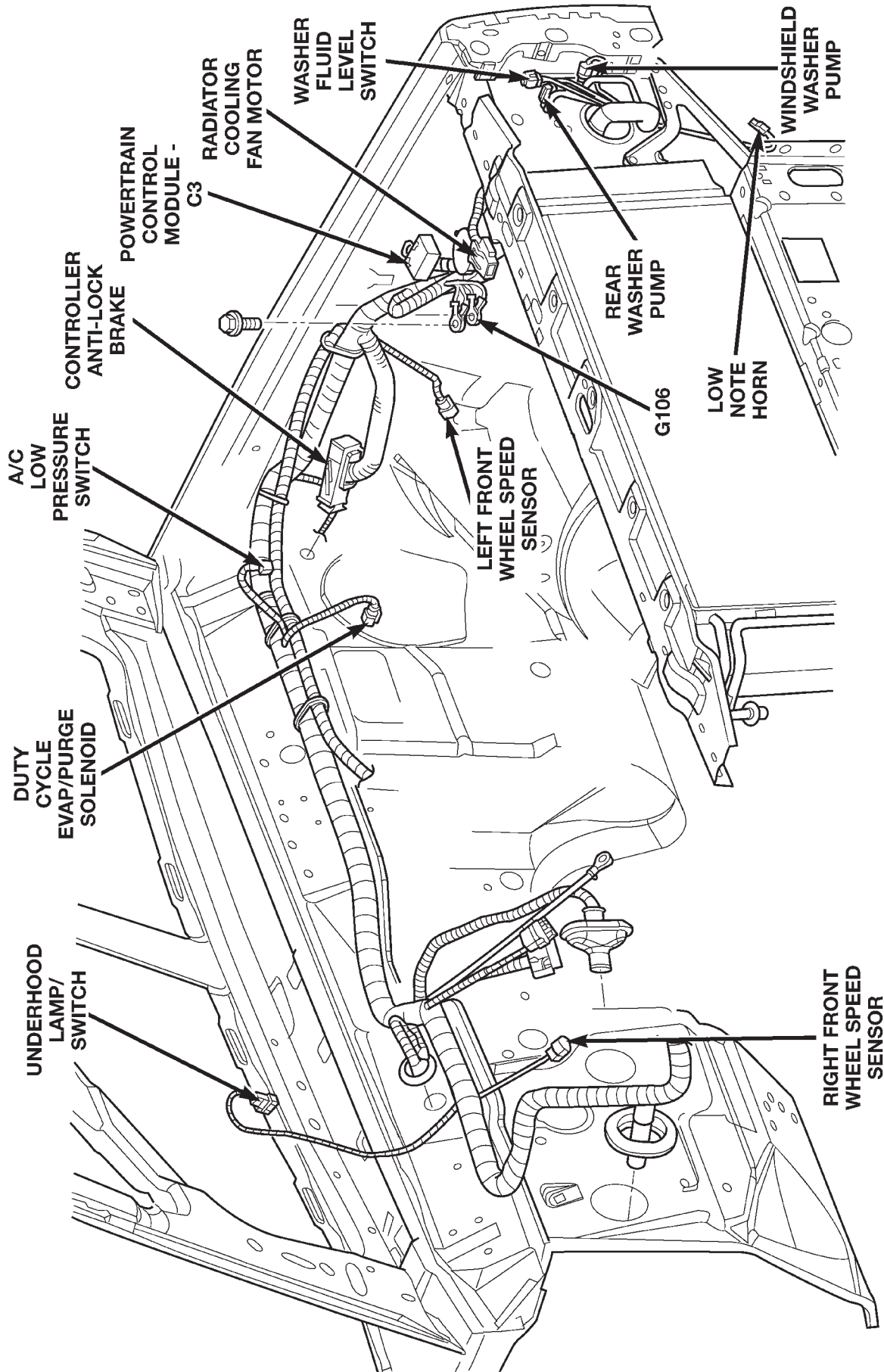

80be4751

Fig. 11 Left Engine Compartment 4.0L Engine RHD

DESCRIPTION AND OPERATION (Continued)

80be4752

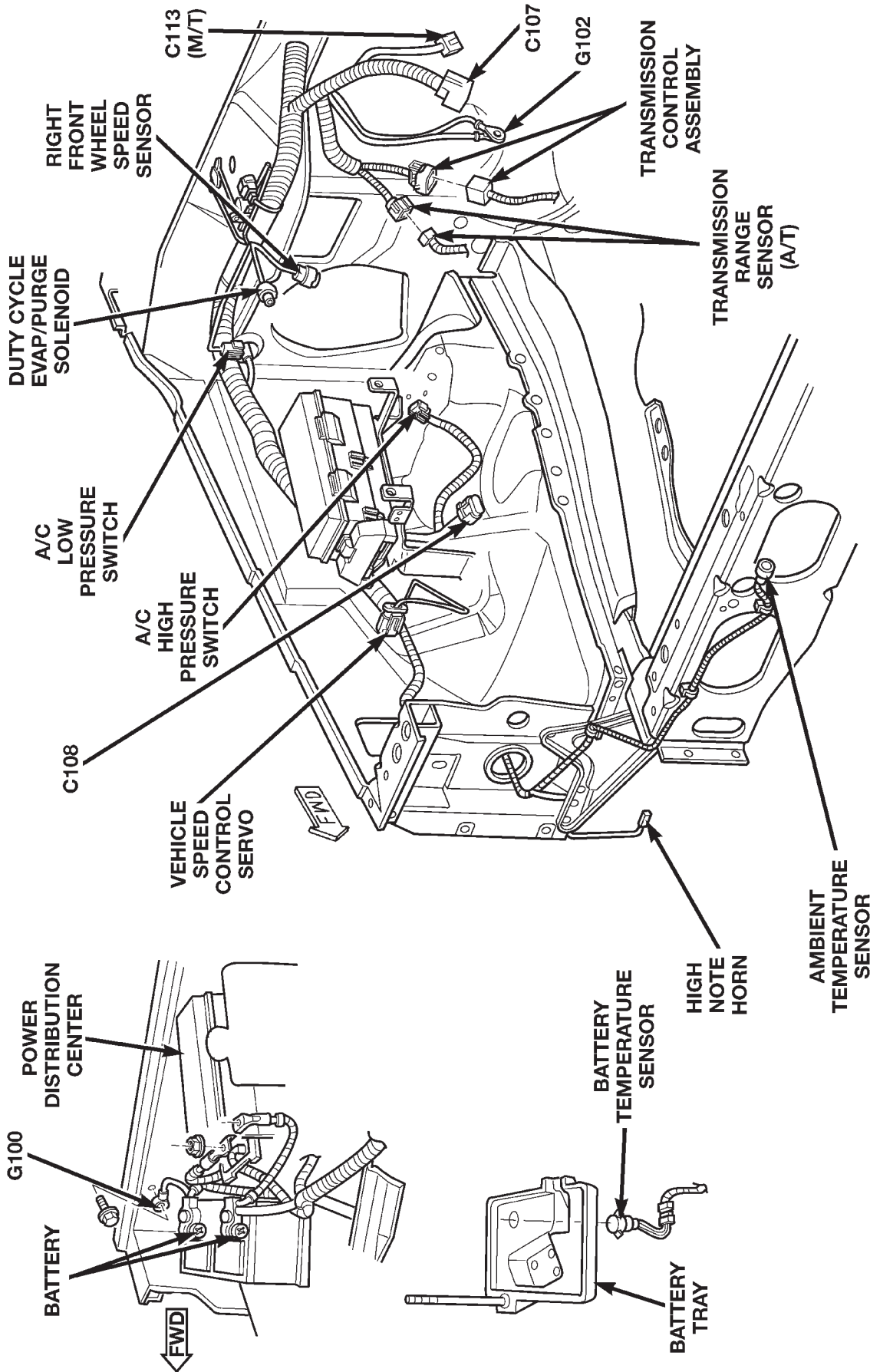

Fig. 12 Right Engine Compartment 4.0L Engine LHD

DESCRIPTION AND OPERATION (Continued)

80be4763

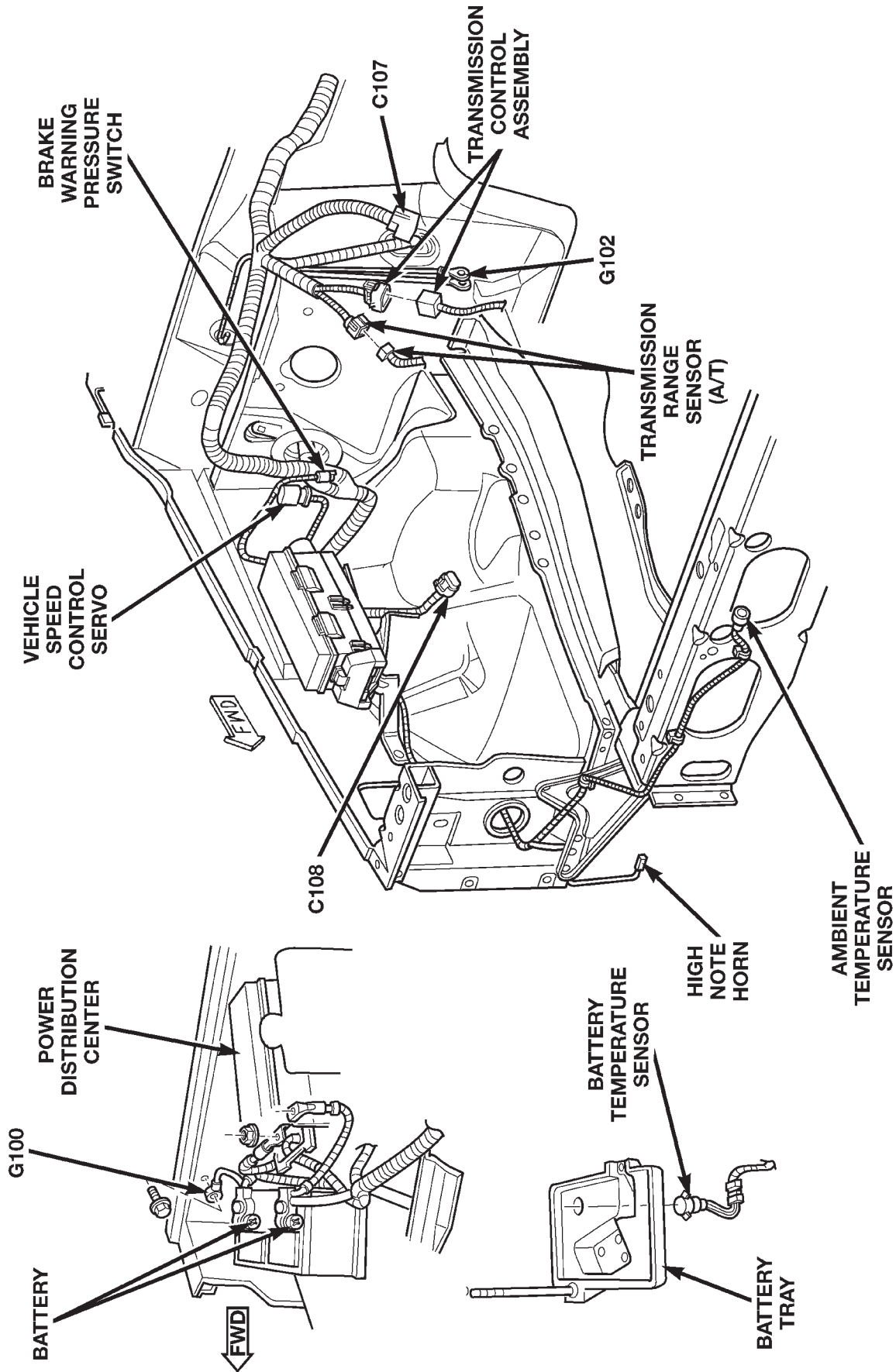

Fig. 13 Right Engine Compartment 4.0L Engine RHD

DESCRIPTION AND OPERATION (Continued)

80be4754

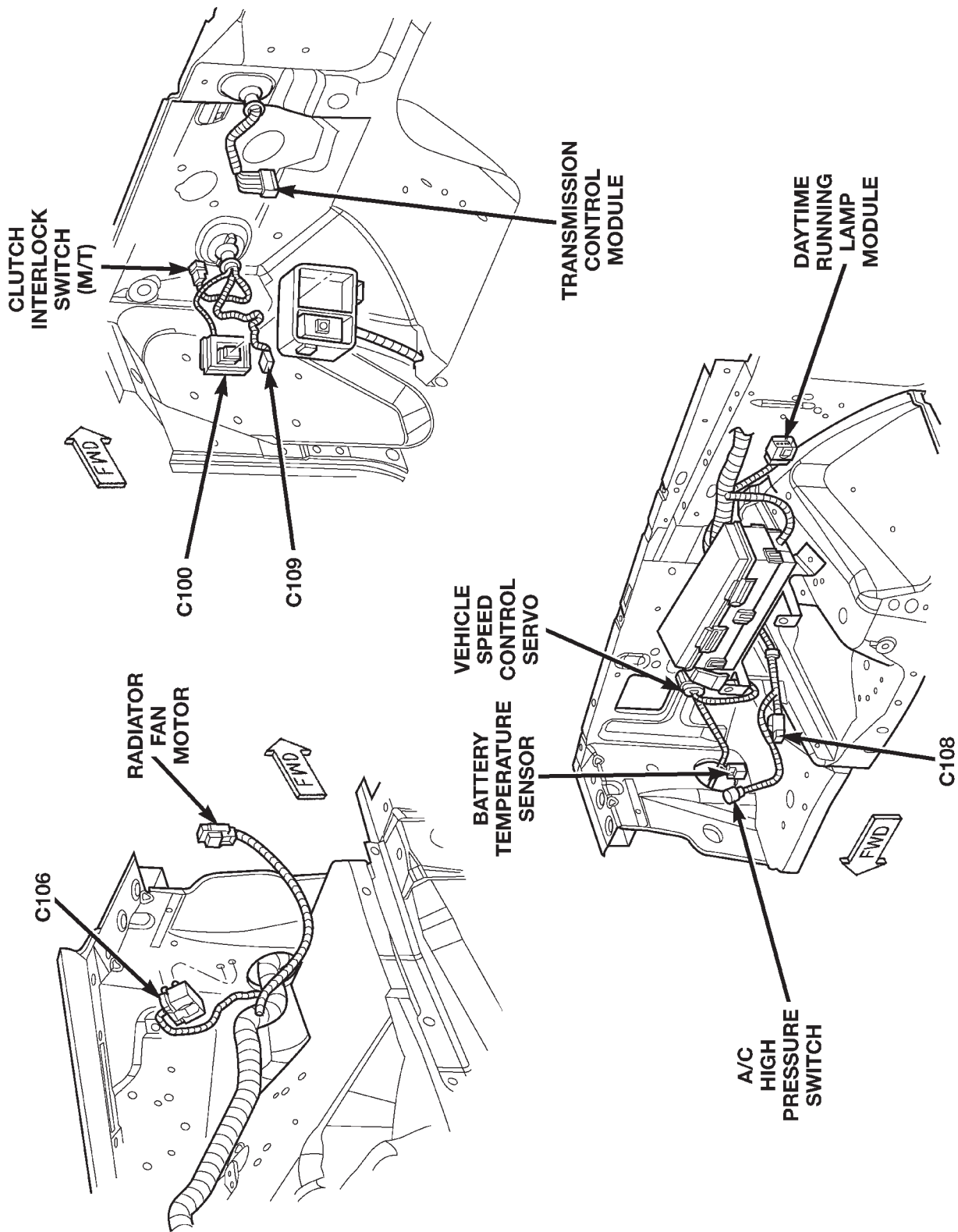

Fig. 14 Engine Compartment Auxiliary Views 4.0L Engine LHD

DESCRIPTION AND OPERATION (Continued)

80be4755

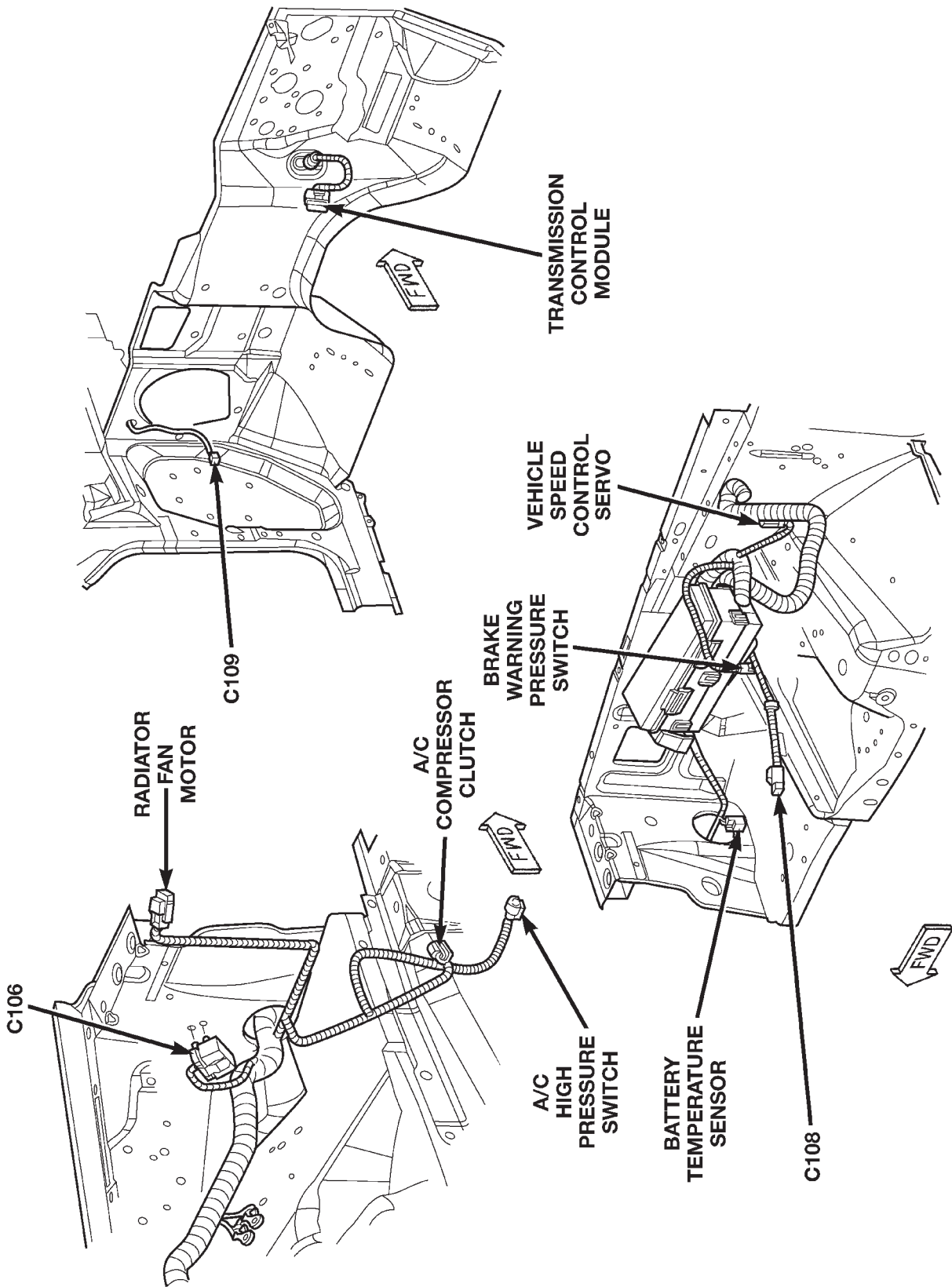
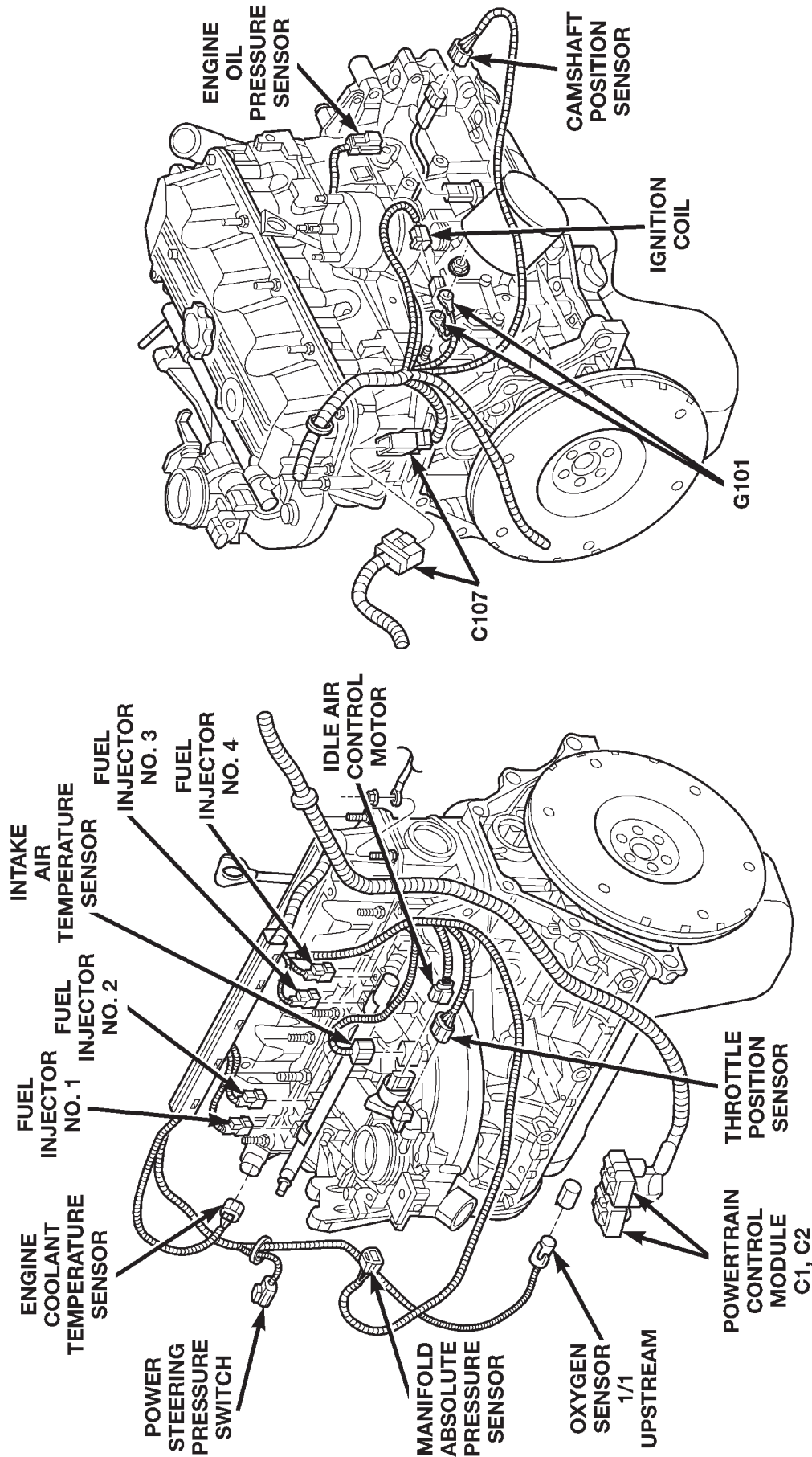

Fig. 15 Engine Compartment Auxiliary Views 4.0L Engine RHD

DESCRIPTION AND OPERATION (Continued)



80be4756

Fig. 16 2.5L Engine

DESCRIPTION AND OPERATION (Continued)

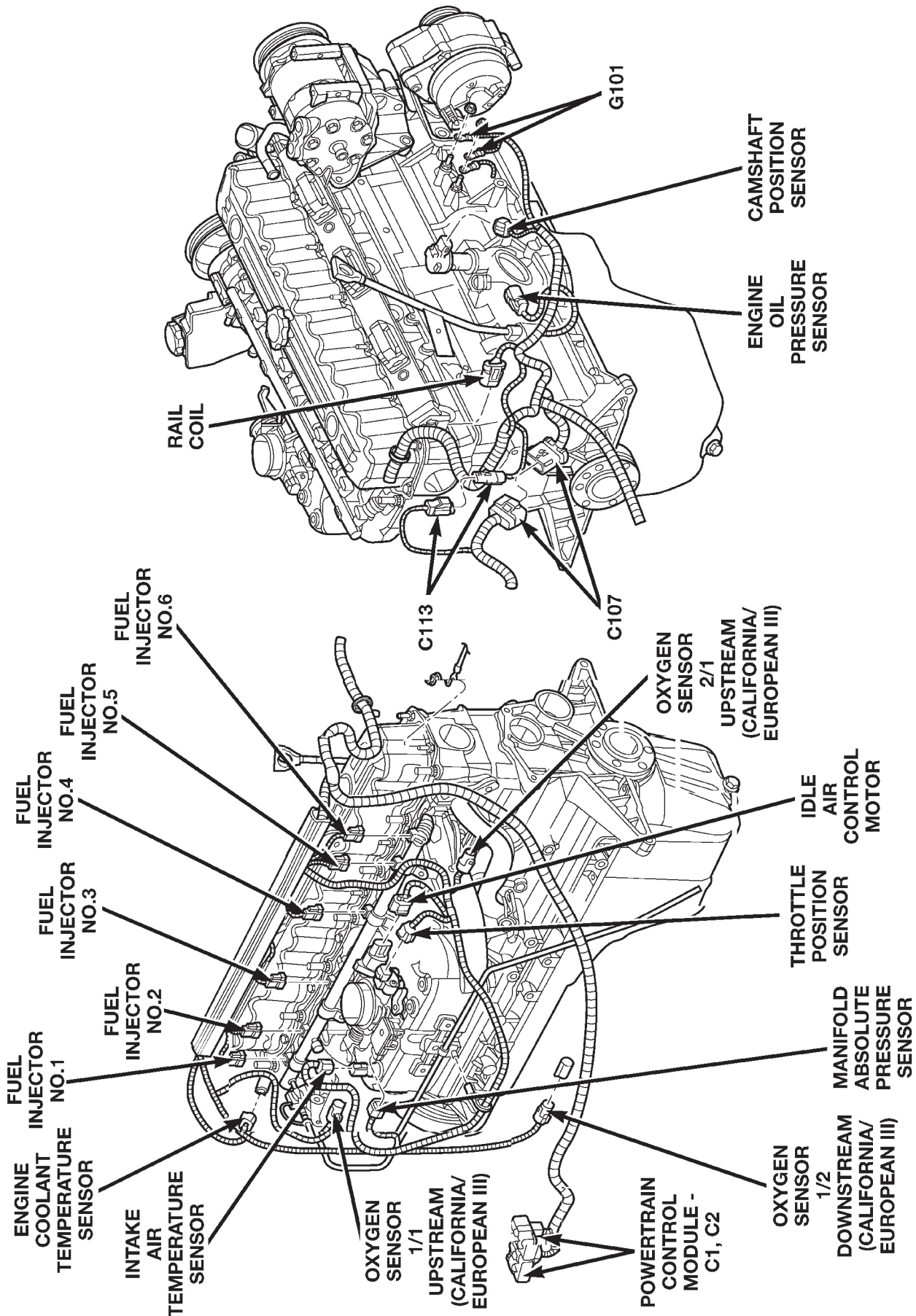

80be4757

Fig. 17 4.0L Engine

DESCRIPTION AND OPERATION (Continued)

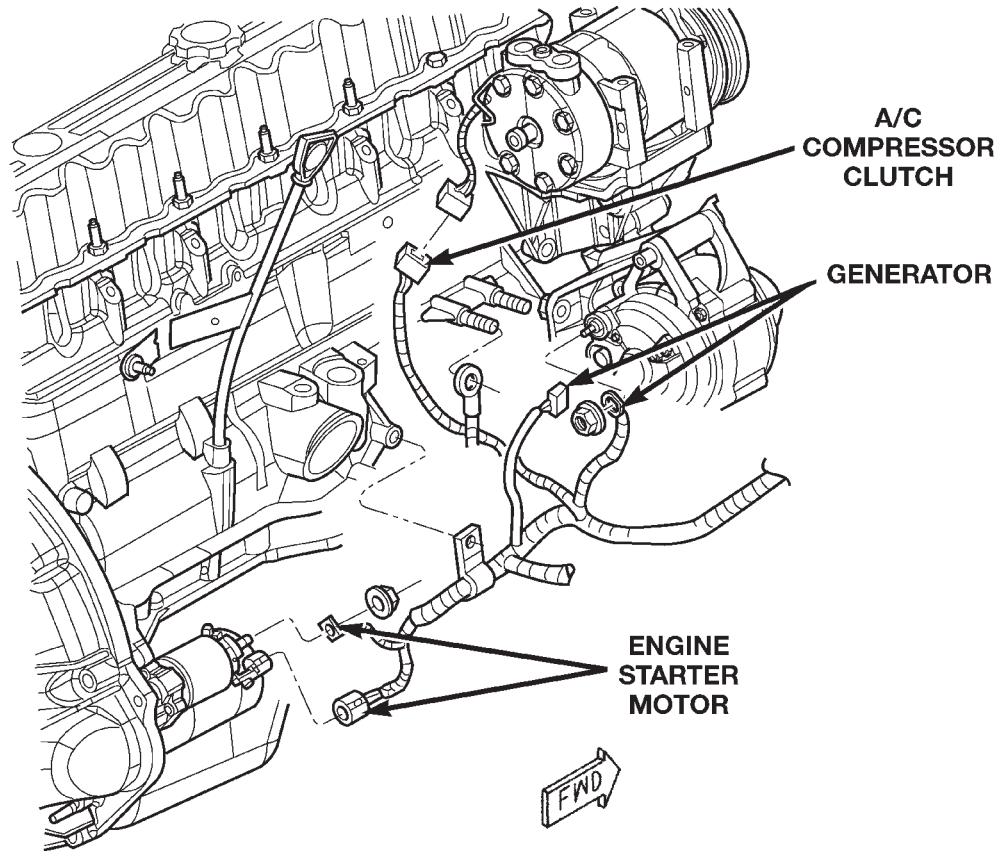

80be4758

Fig. 18 4.0L Engine

DESCRIPTION AND OPERATION (Continued)

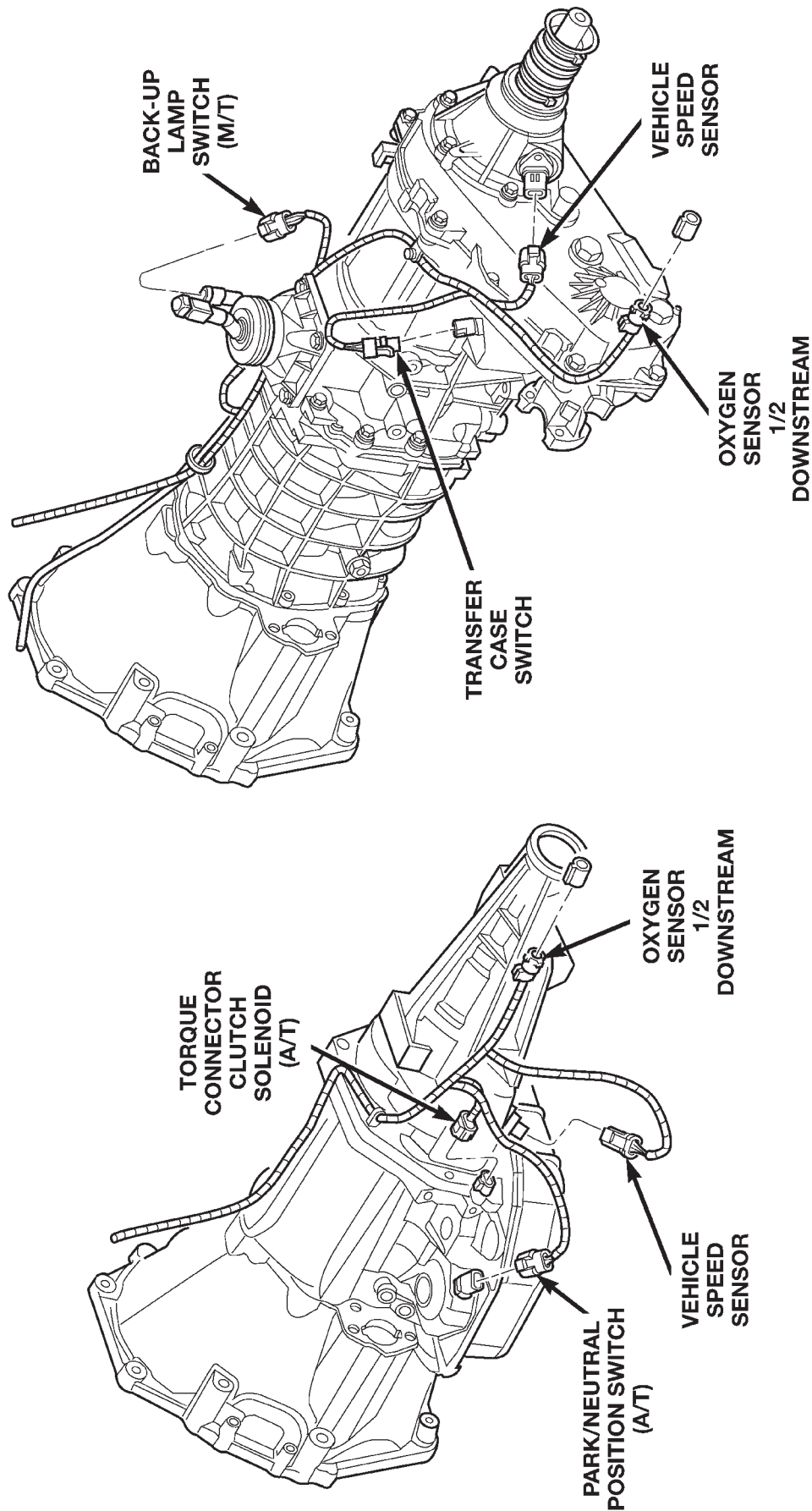

80be4759

Fig. 19 Transmission Connectors 2.5L Engine

DESCRIPTION AND OPERATION (Continued)

80be475a

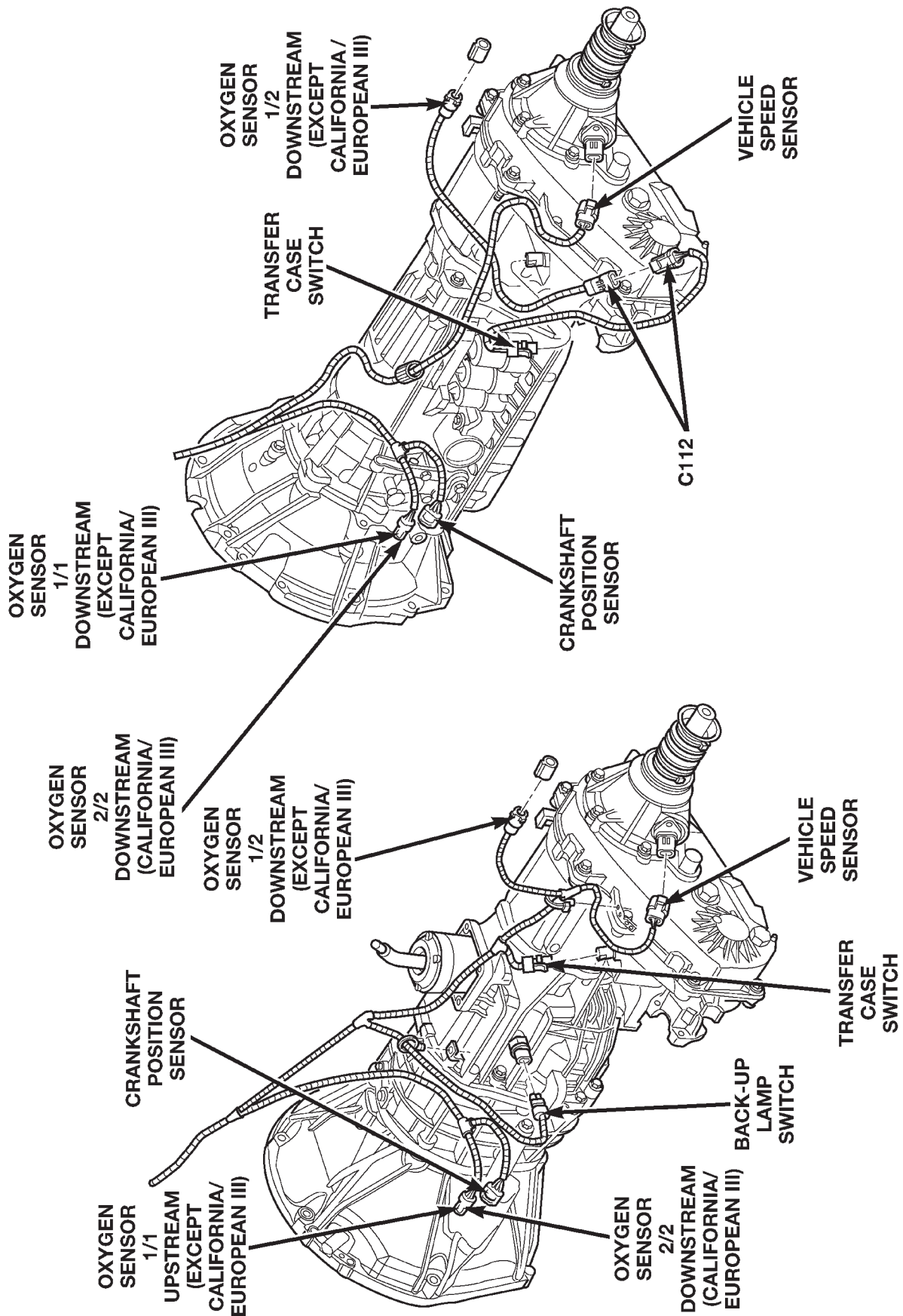
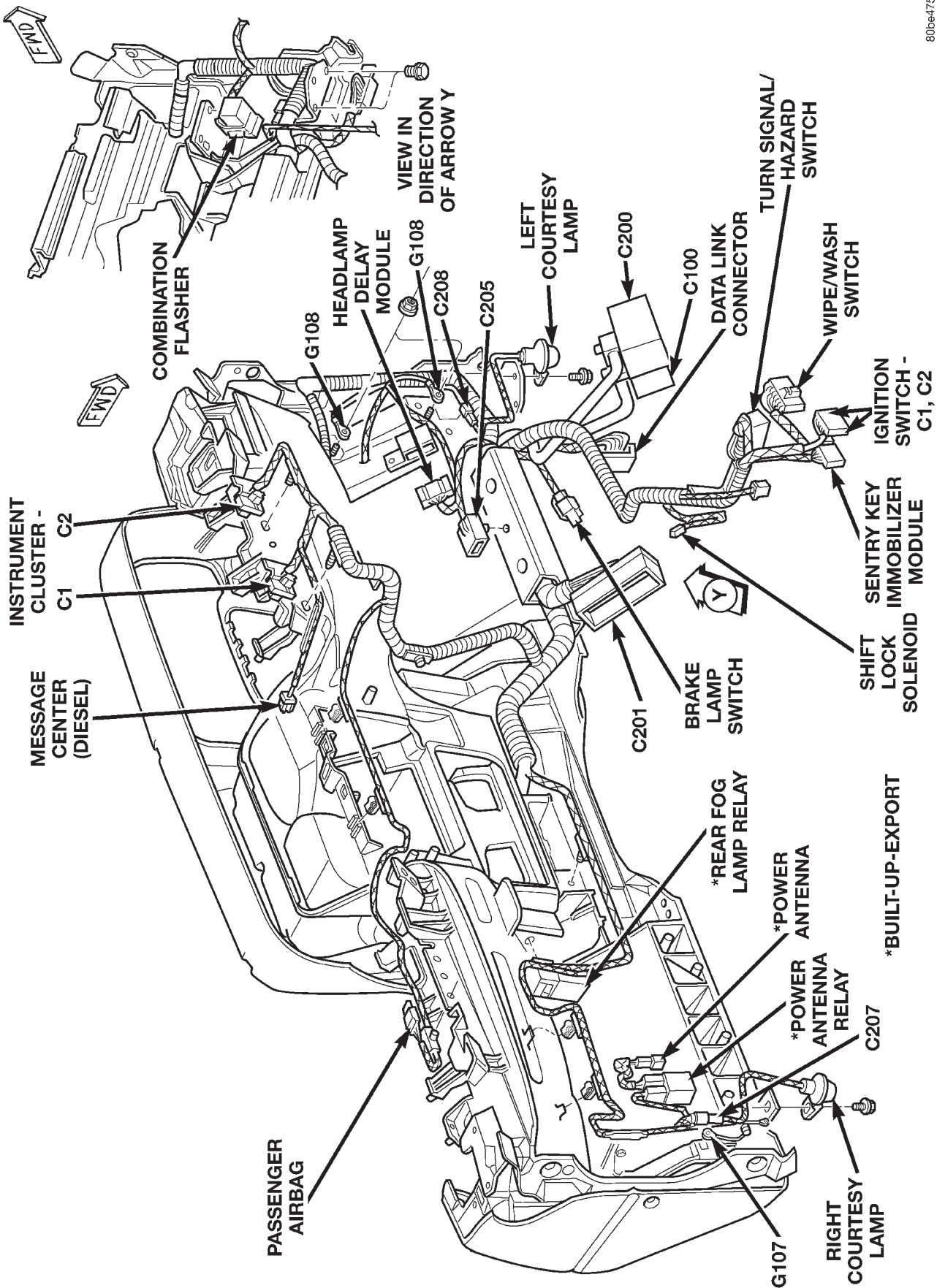

Fig. 20 Transmission Connectors 4.0L Engine

DESCRIPTION AND OPERATION (Continued)



80be475b

Fig. 21 Instrument Panel LHD

DESCRIPTION AND OPERATION (Continued)

80be475c

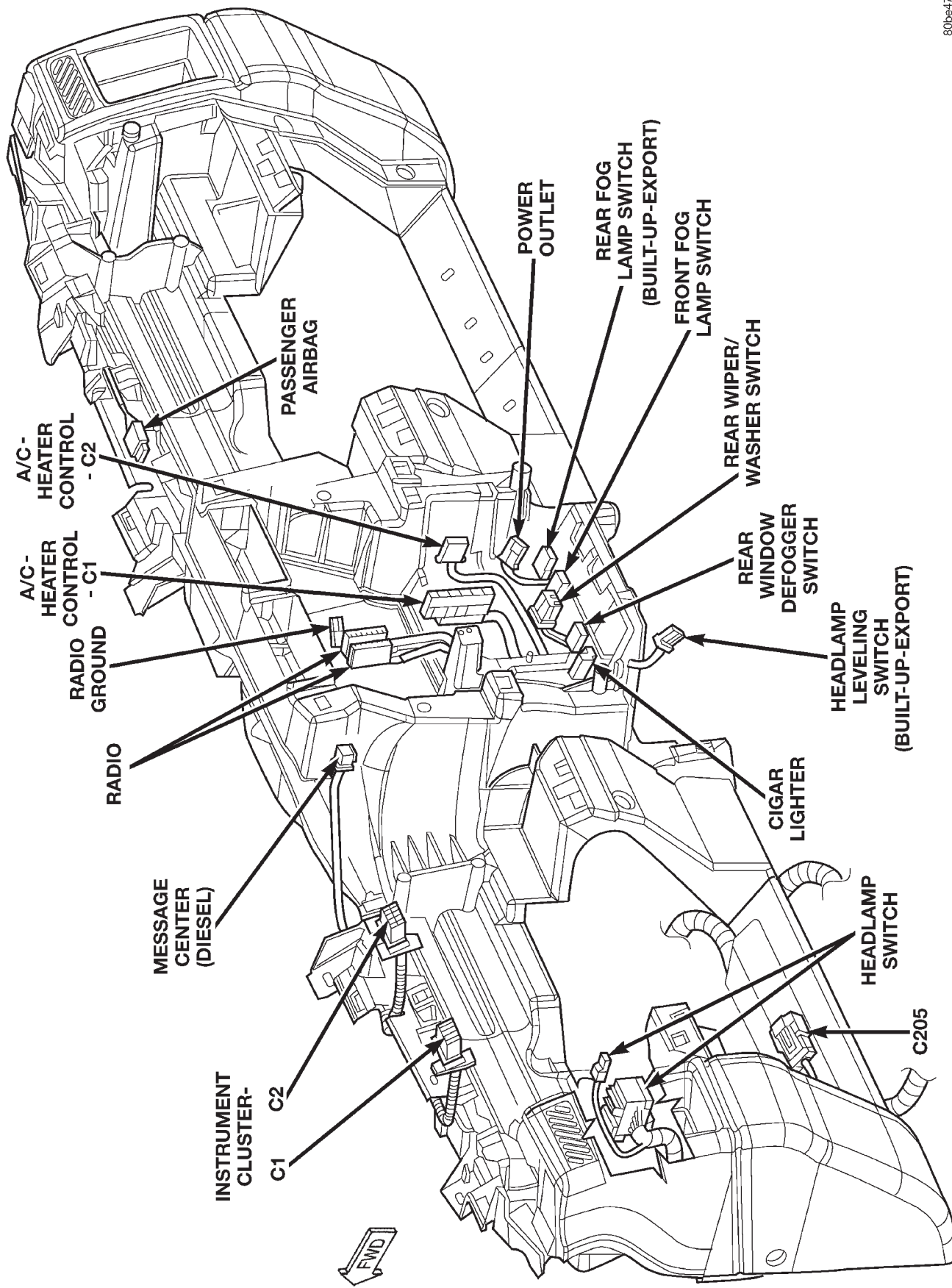
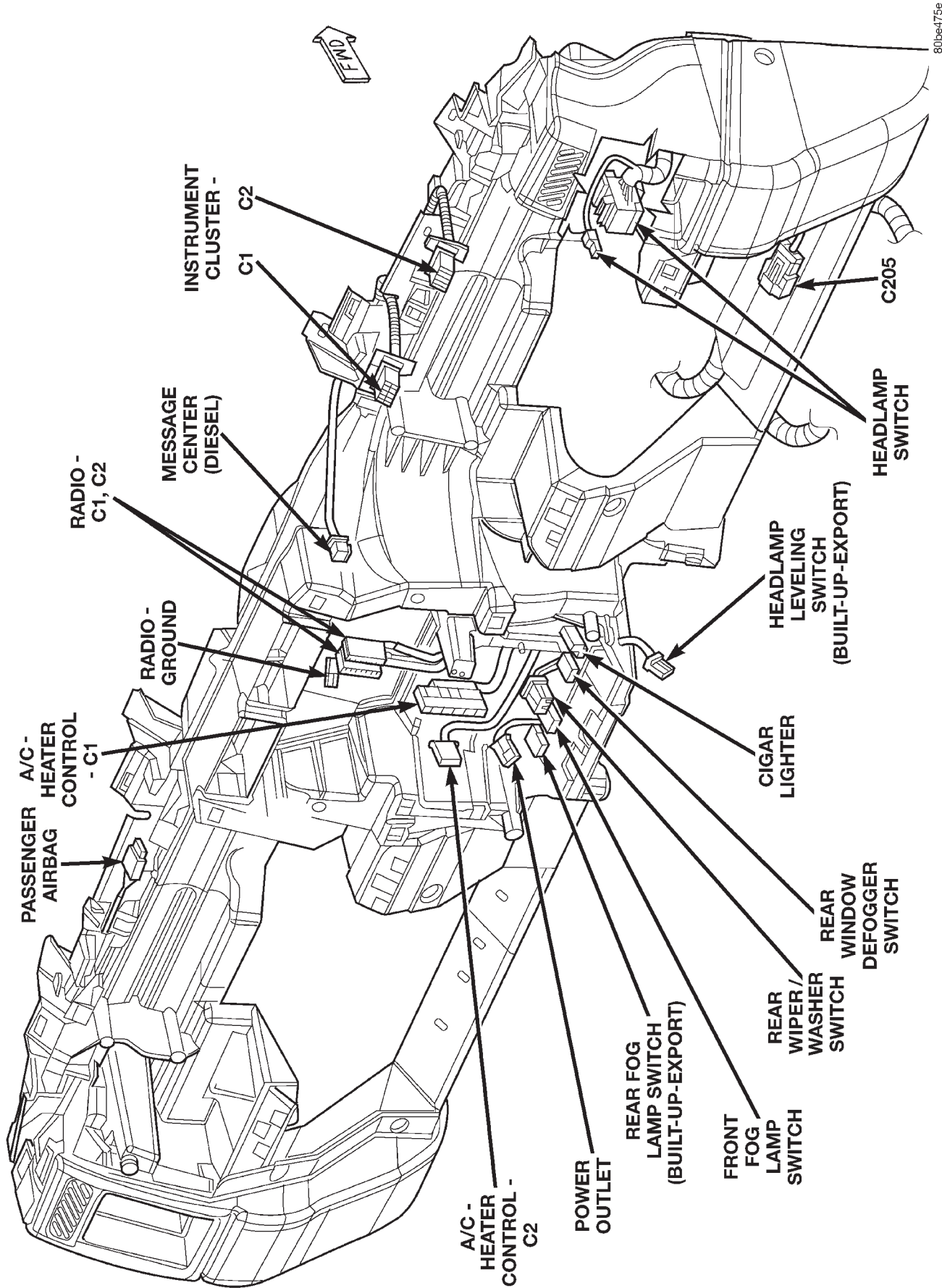

Fig. 22 Instrument Panel LHD

DESCRIPTION AND OPERATION (Continued)



80be475e

Fig. 23 Instrument Panel RHD

DESCRIPTION AND OPERATION (Continued)

80be475f

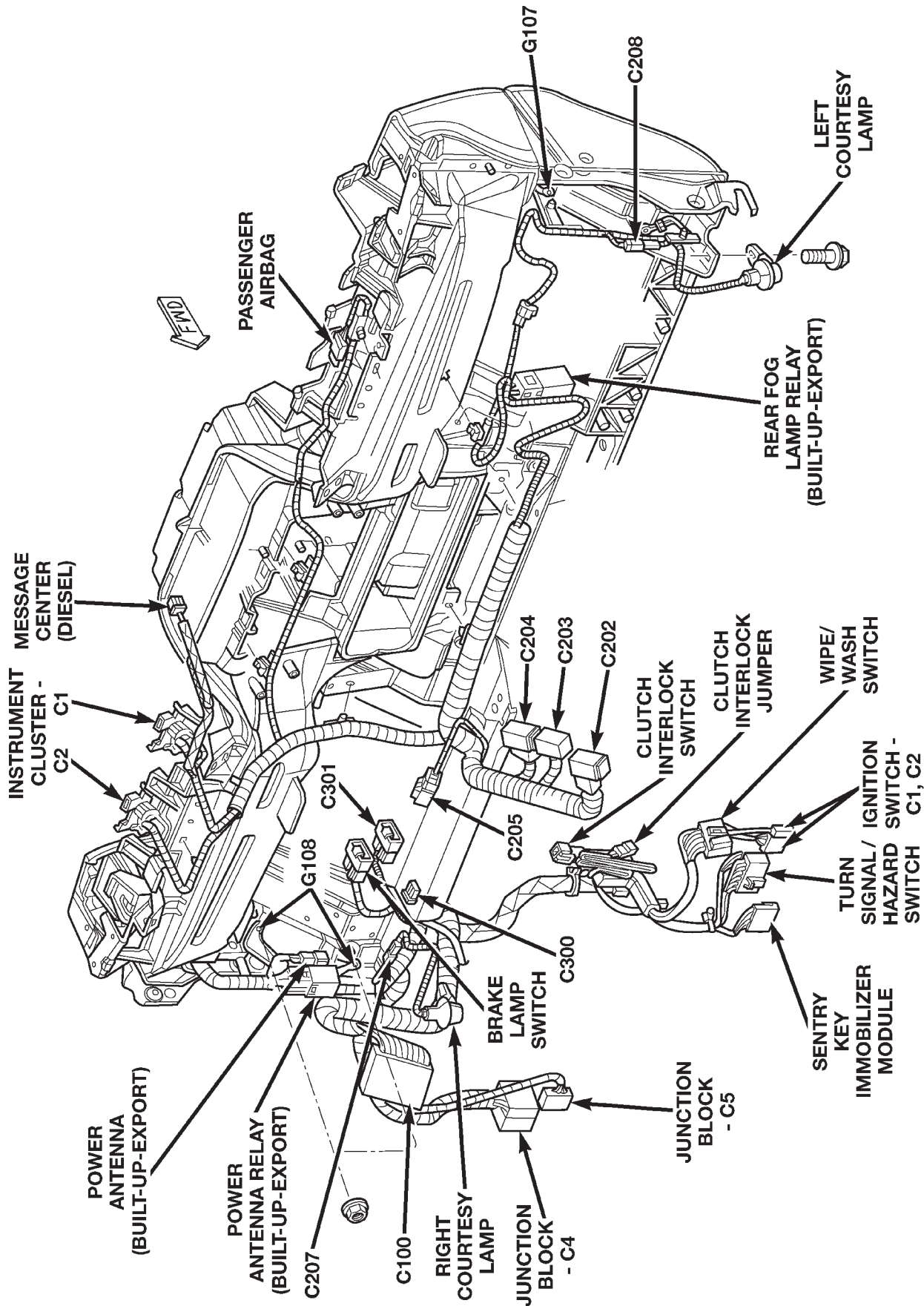
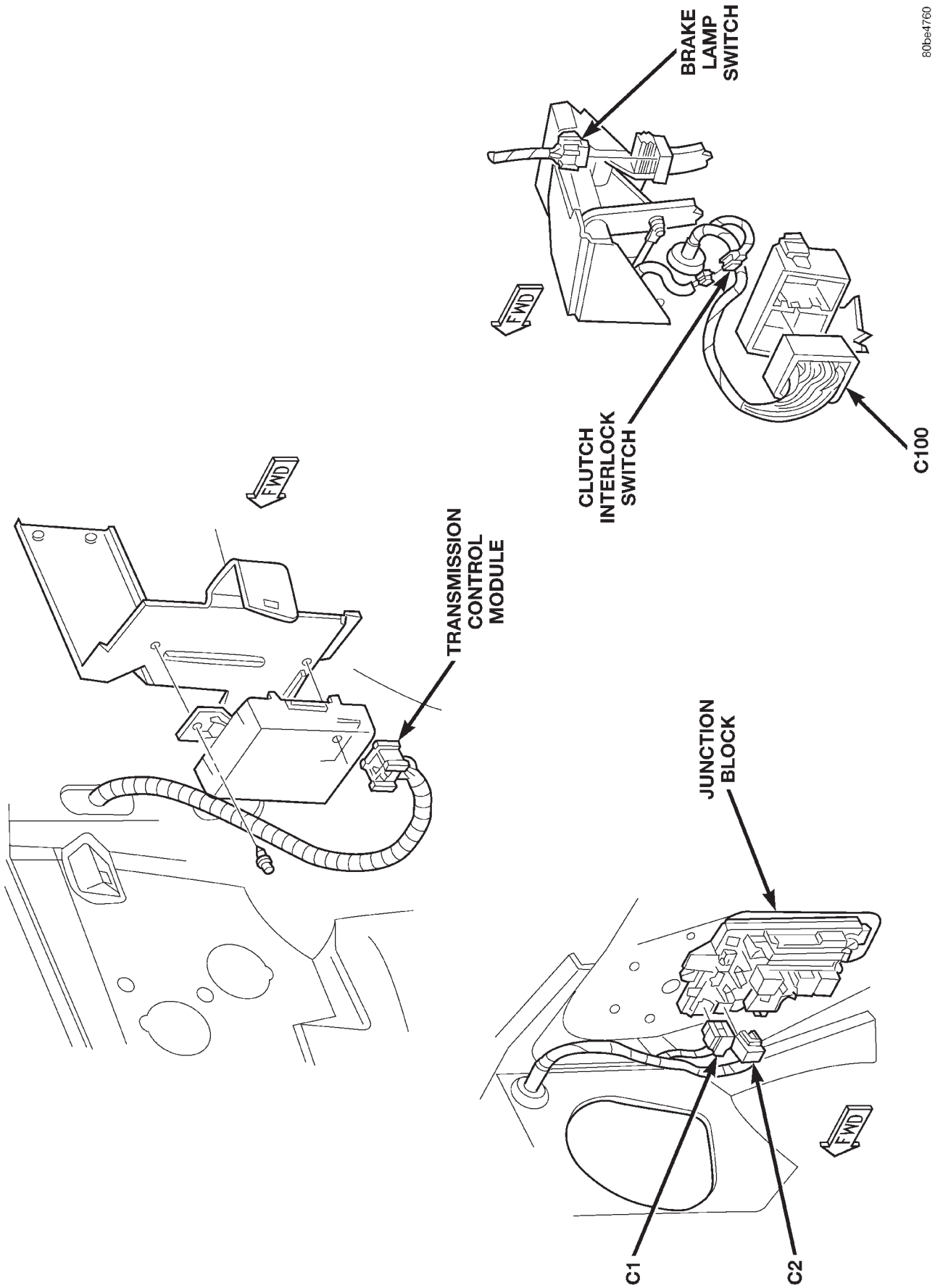

Fig. 24 Instrument Panel RHD

DESCRIPTION AND OPERATION (Continued)



80be4760

Fig. 25 Under Dash Components

DESCRIPTION AND OPERATION (Continued)

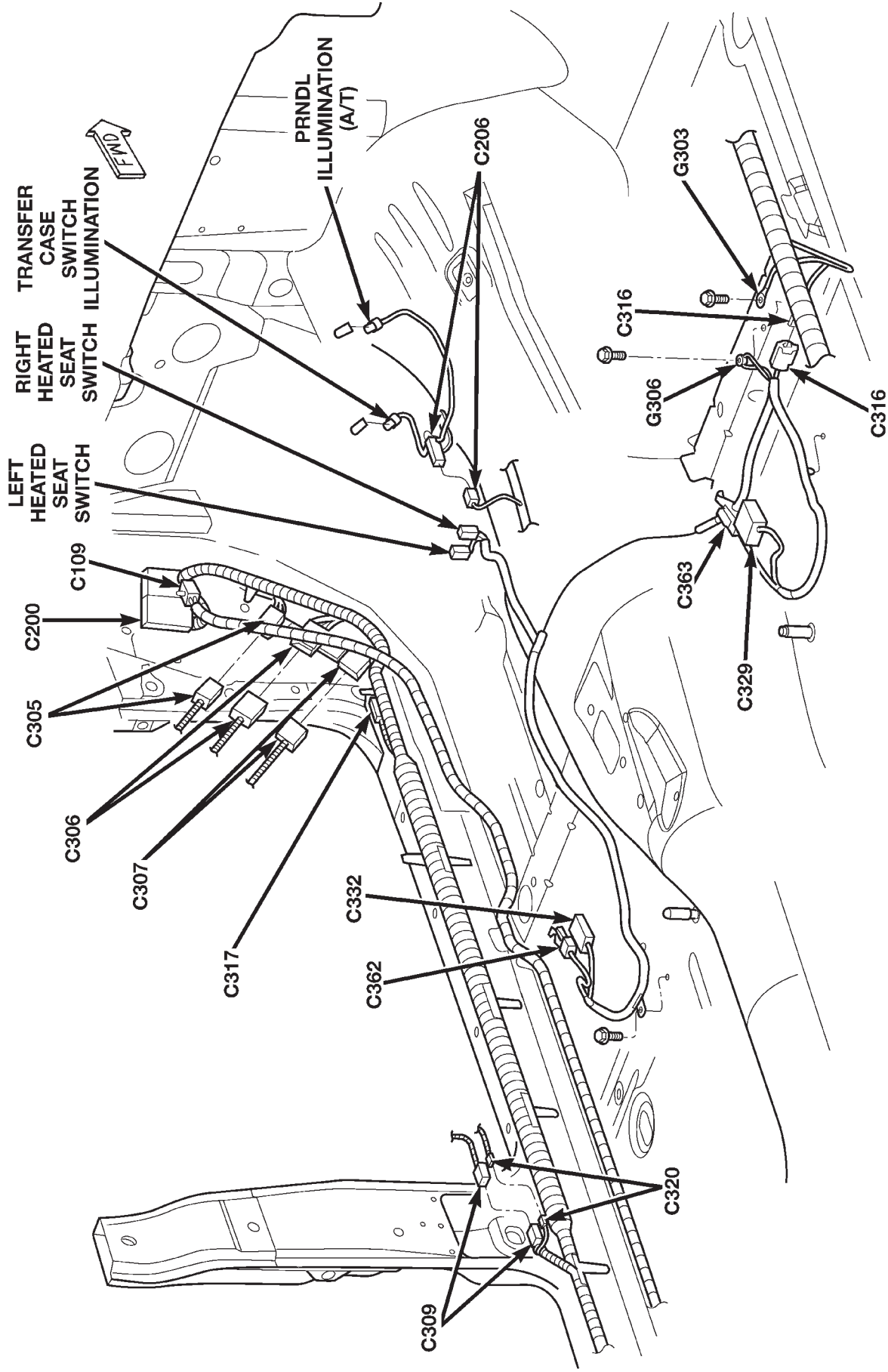

80be4761

Fig. 26 Left Side Body LHD

DESCRIPTION AND OPERATION (Continued)

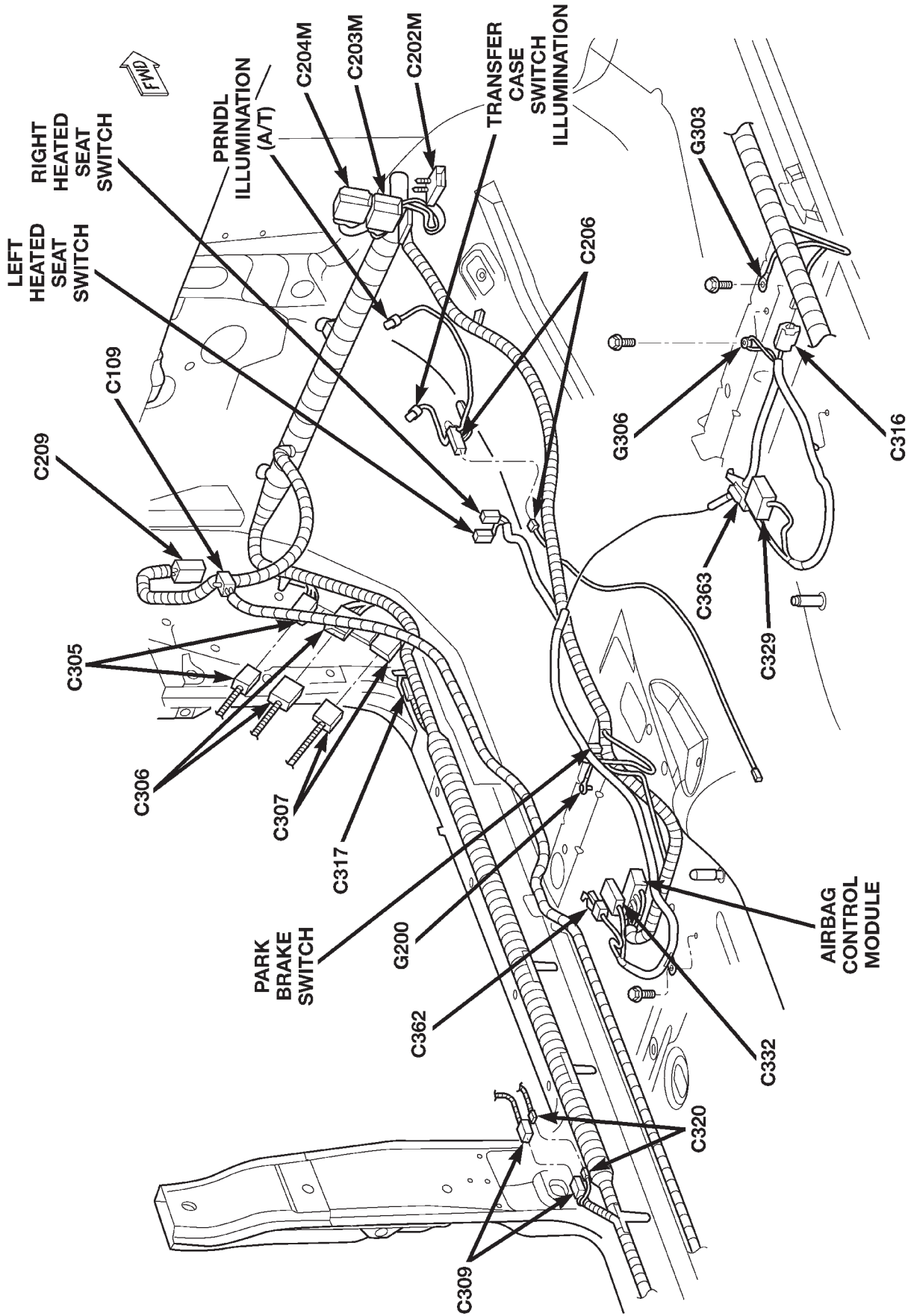

80be4762

Fig. 27 Left Side Body RHD

DESCRIPTION AND OPERATION (Continued)

80be4763

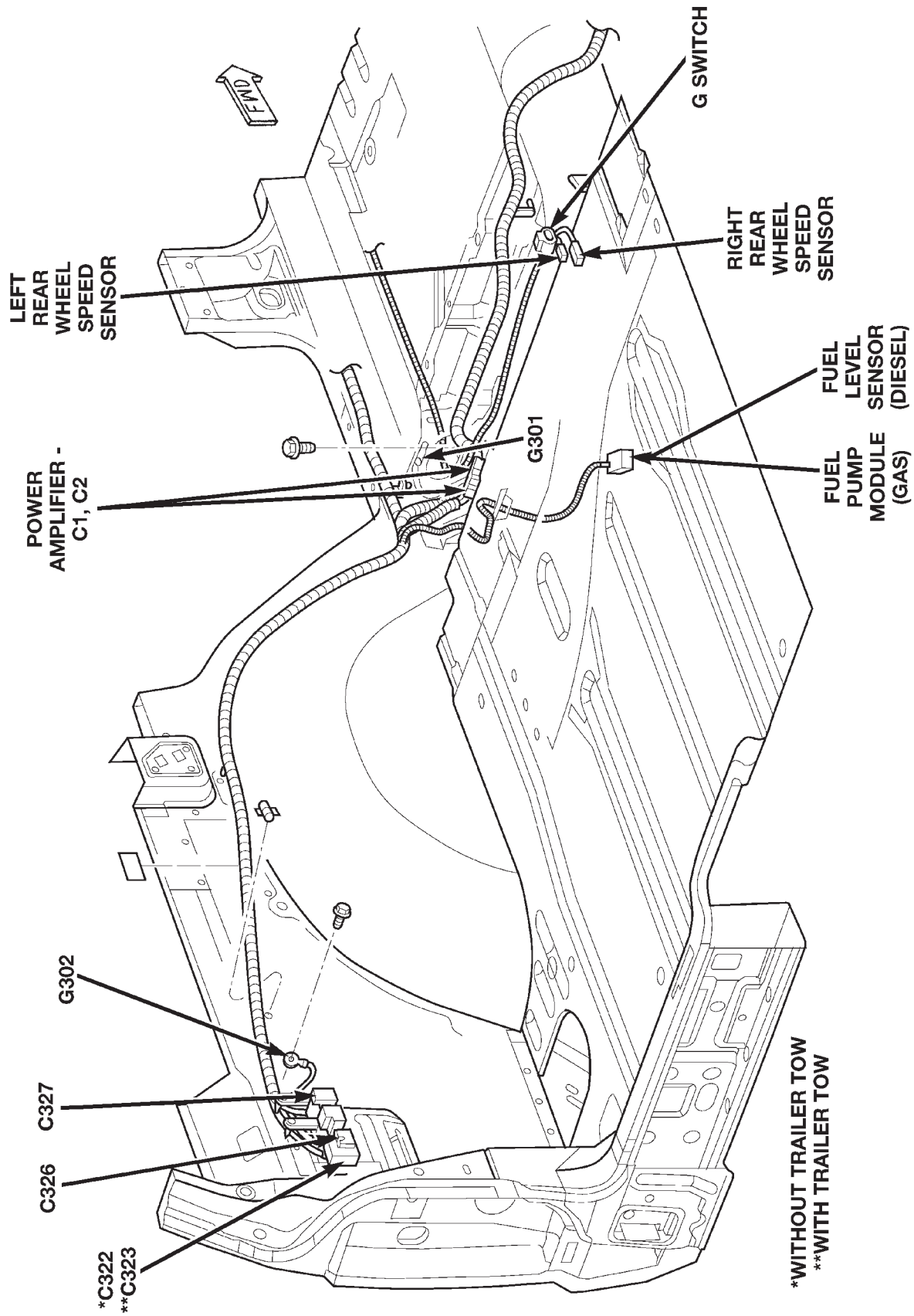

Fig. 28 Left Rear Body

DESCRIPTION AND OPERATION (Continued)

80be4764

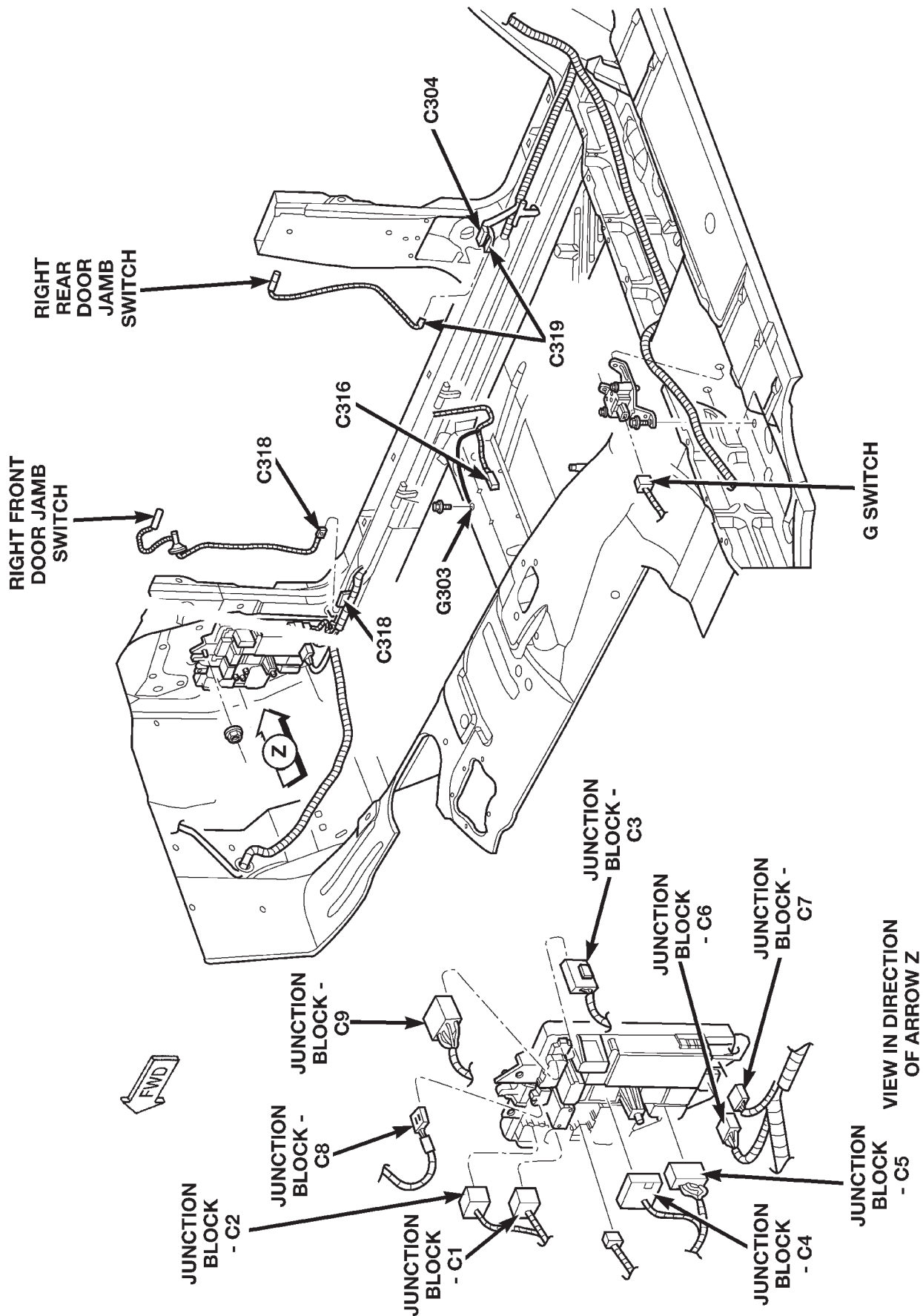

Fig. 29 Right Side Body and Junction Block

DESCRIPTION AND OPERATION (Continued)

80be4765

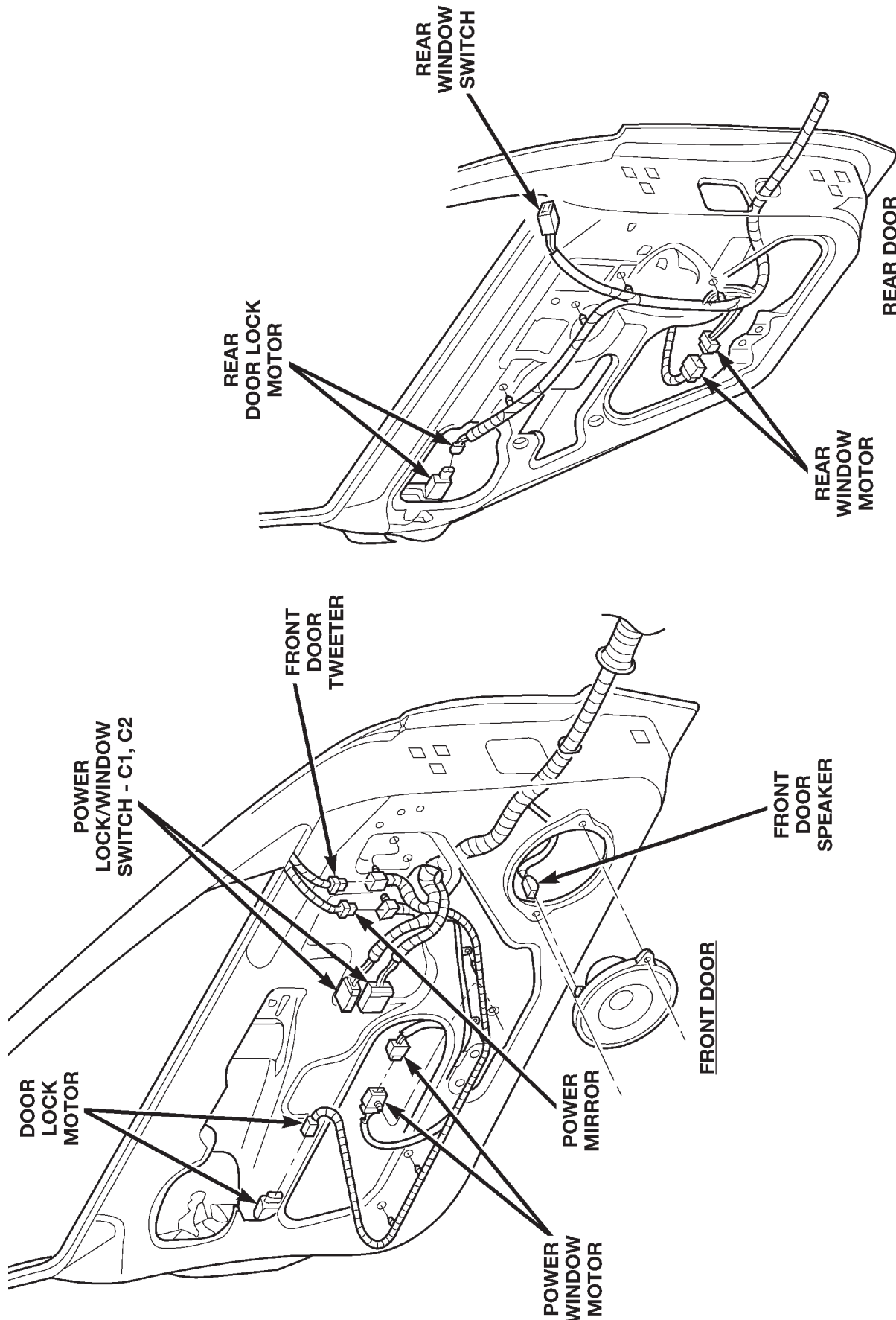
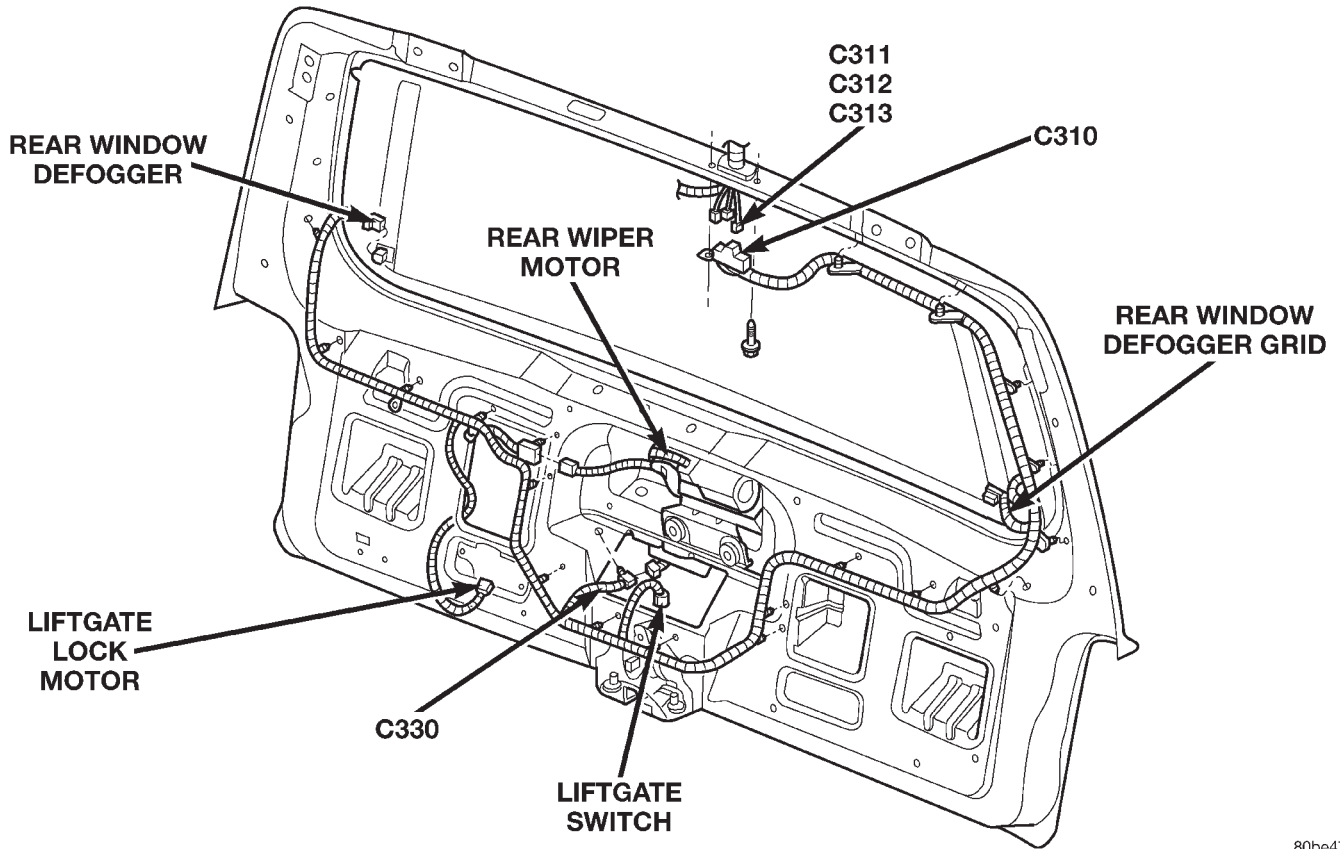

Fig. 30 Front and Rear Doors (Left Side Shown, Right Side Similar)

DESCRIPTION AND OPERATION (Continued)



80be4766

Fig. 31 Liftgate

DESCRIPTION AND OPERATION (Continued)

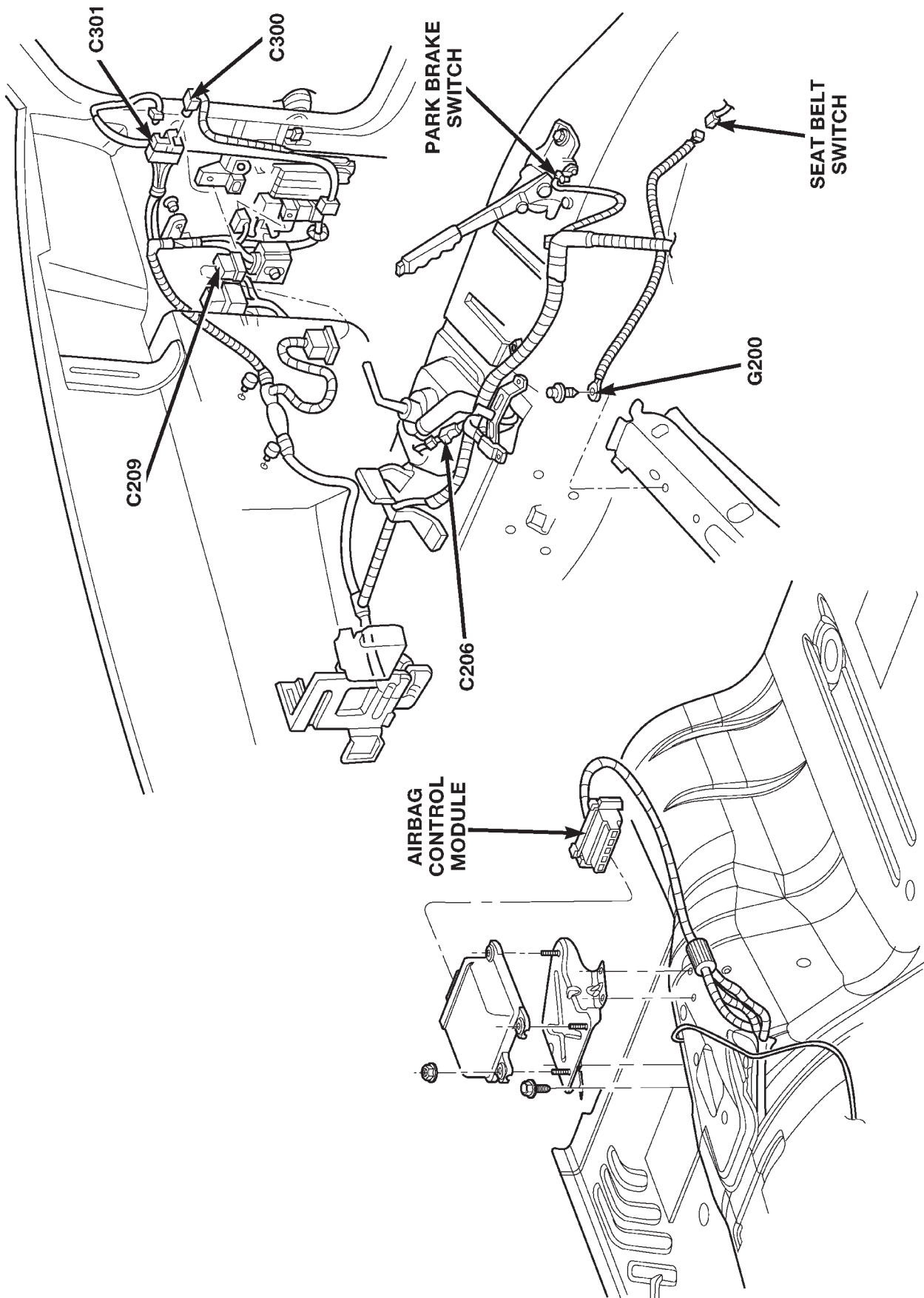

80be4767

Fig. 32 Center Console LHD

DESCRIPTION AND OPERATION (Continued)

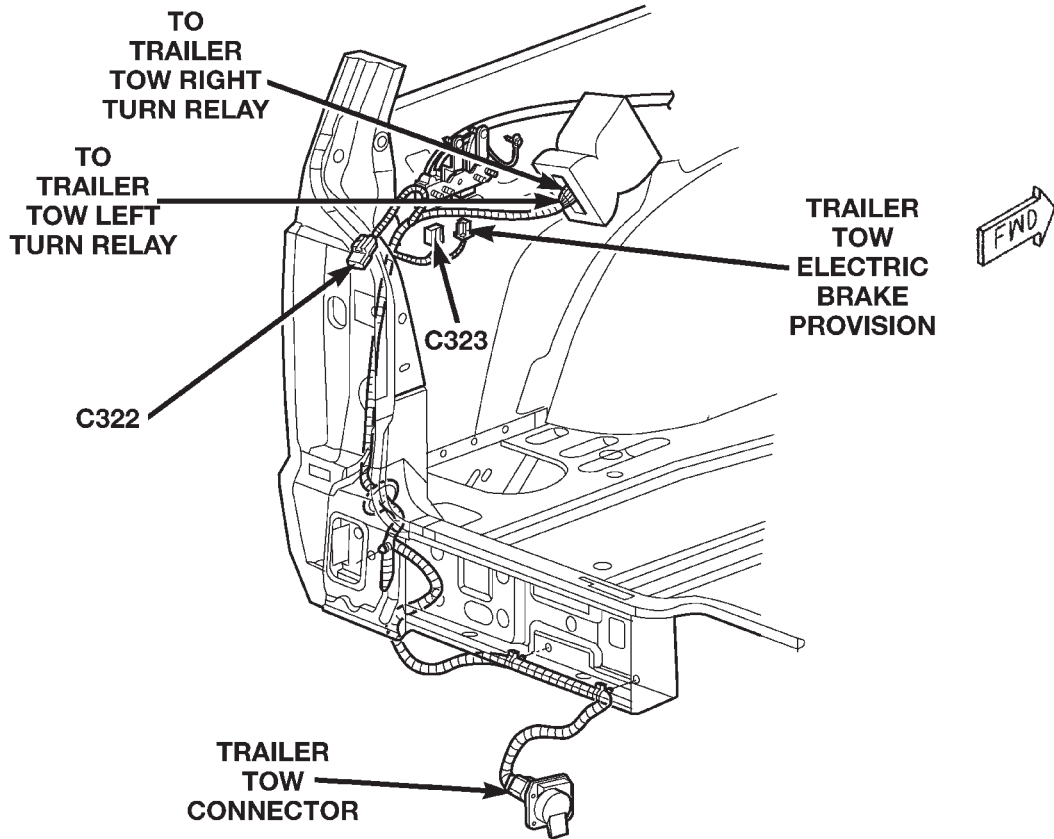

Fig. 33 Trailer Tow

80be4768

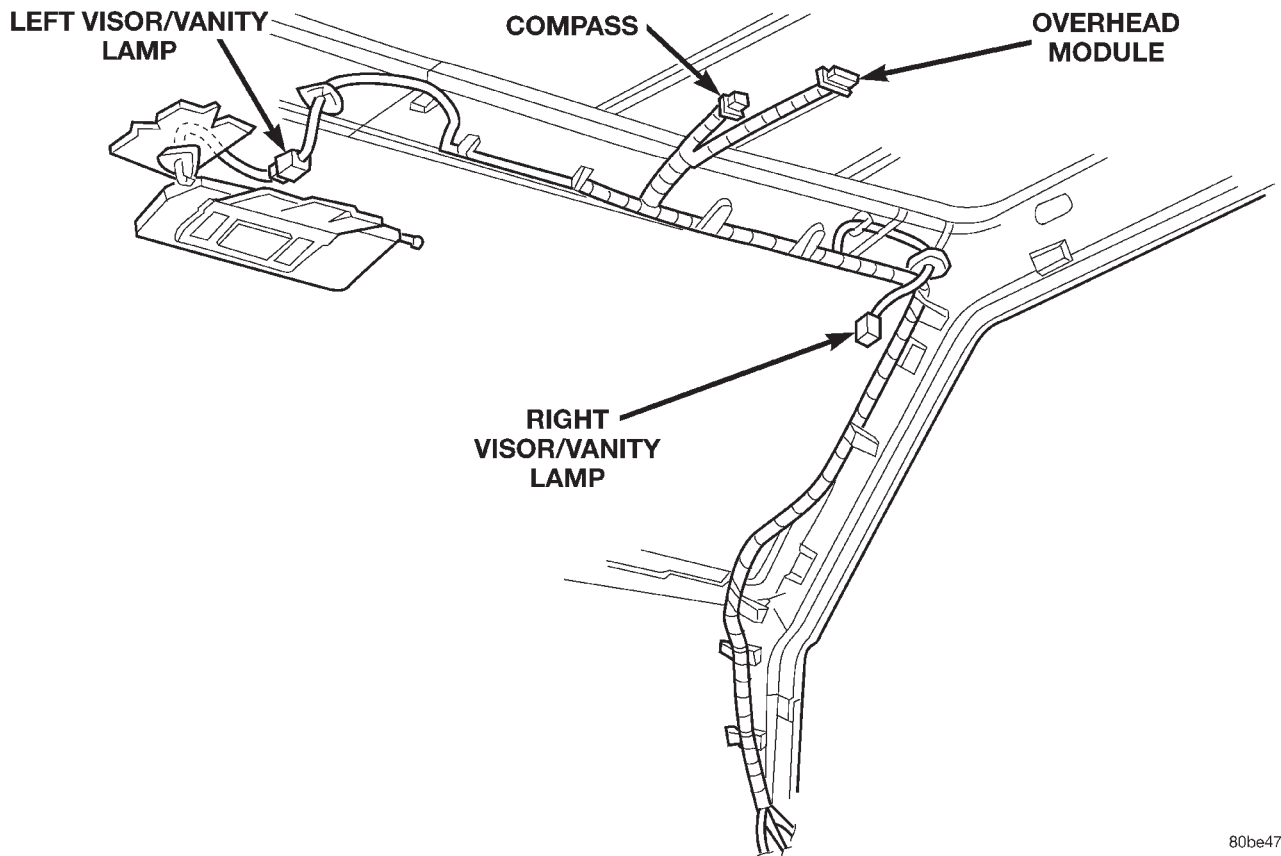
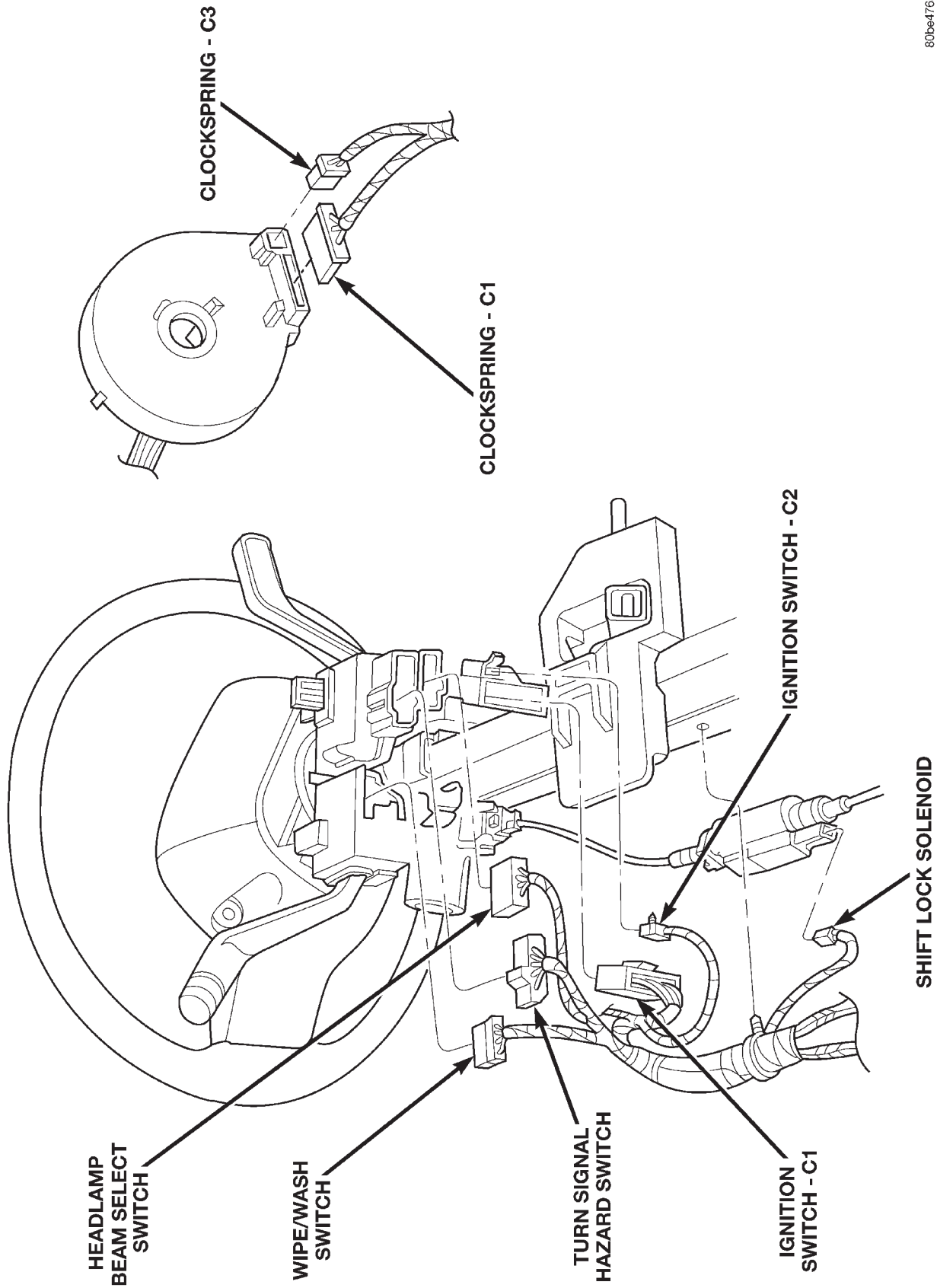

Fig. 34 Headliner

80be4769

DESCRIPTION AND OPERATION (Continued)



80be476a

Fig. 35 Steering Column

DESCRIPTION AND OPERATION (Continued)

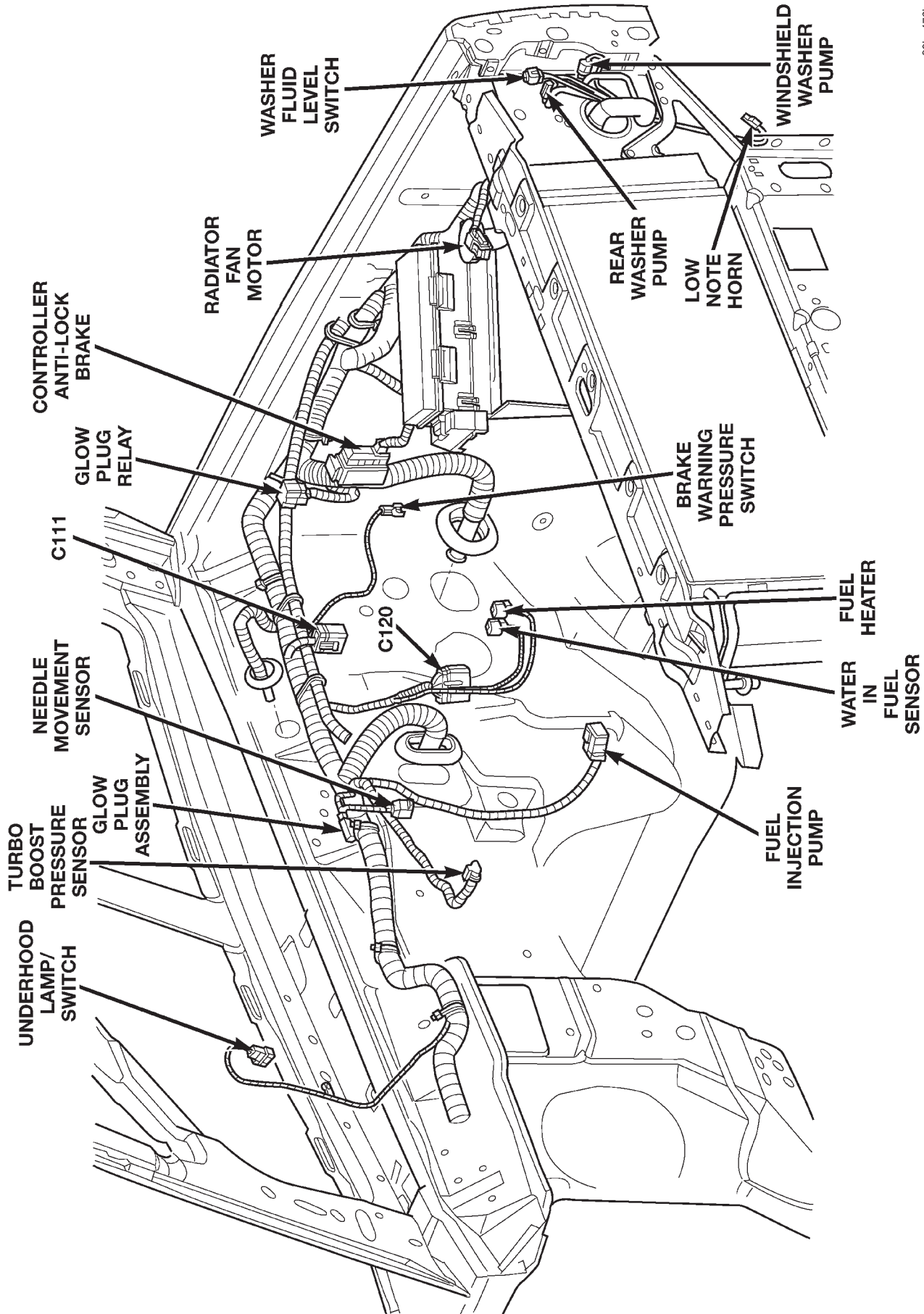

80be476b

Fig. 36 Left Engine Compartment Diesel Engine LHD

DESCRIPTION AND OPERATION (Continued)

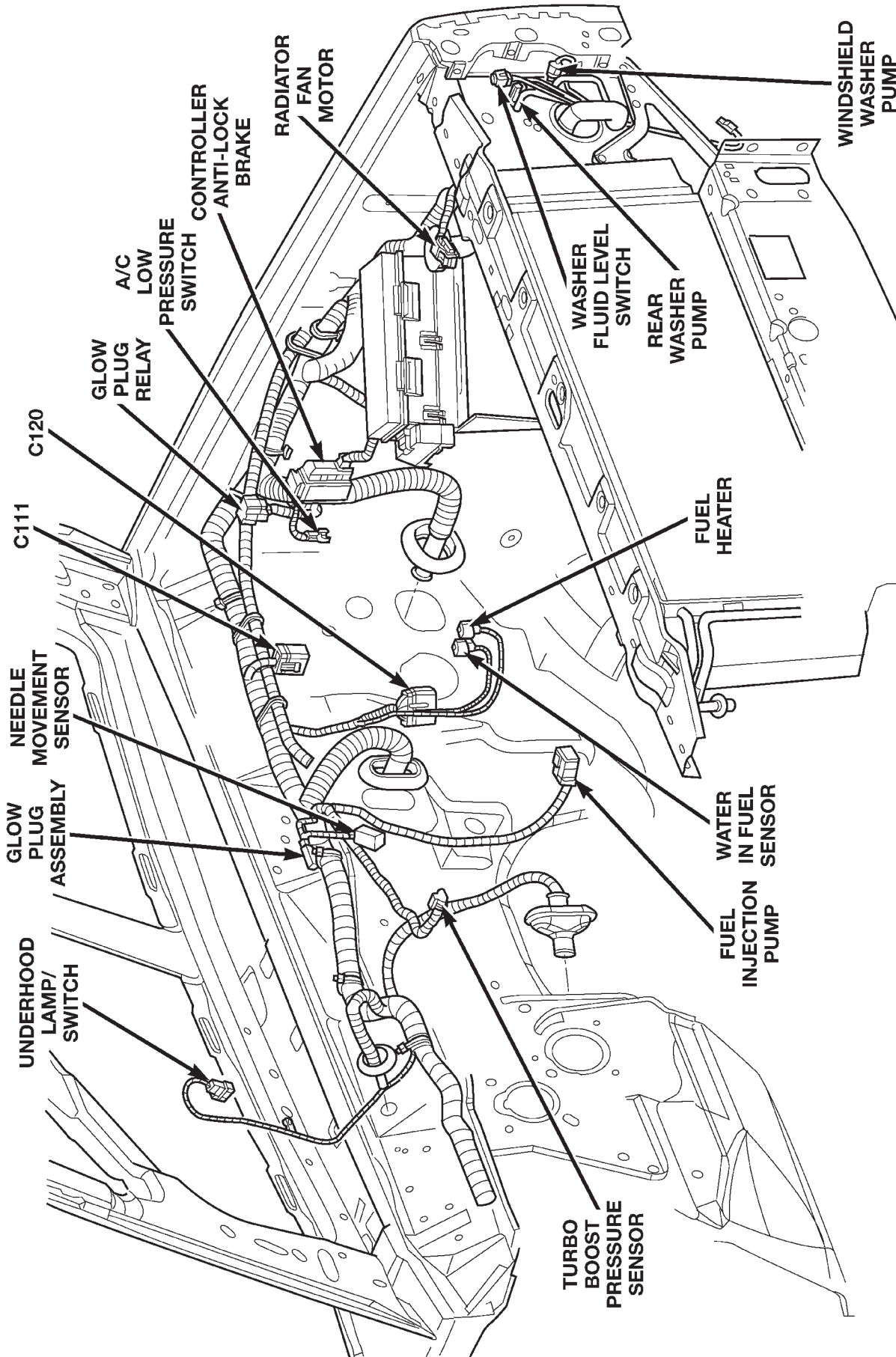

80be476c

Fig. 37 Left Engine Compartment Diesel Engine RHD

DESCRIPTION AND OPERATION (Continued)

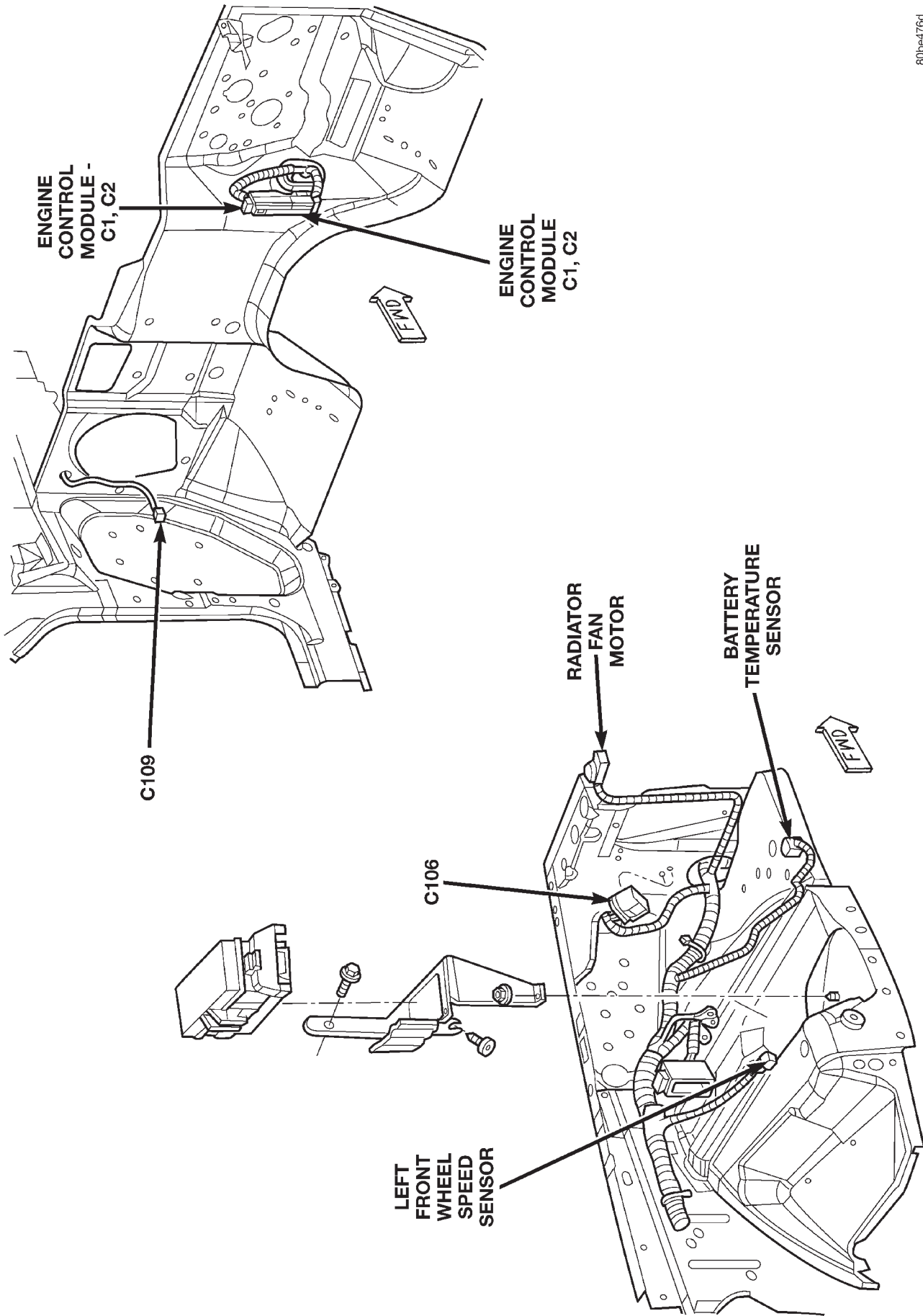

80be476d

Fig. 38 Engine Compartment Auxiliary Views Diesel Engine

DESCRIPTION AND OPERATION (Continued)

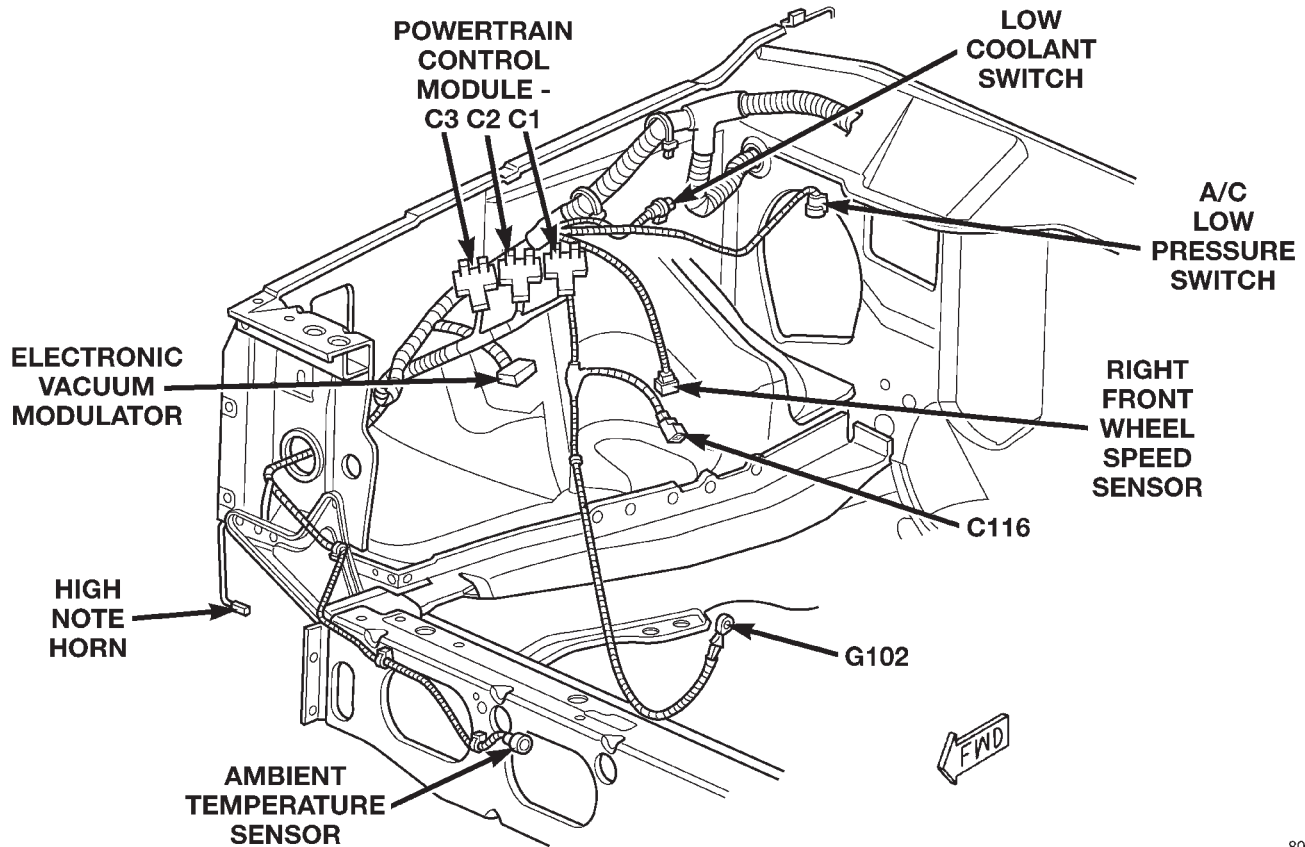

80be476e

Fig. 39 Right Engine Compartment Diesel Engine LHD

DESCRIPTION AND OPERATION (Continued)

80be476f

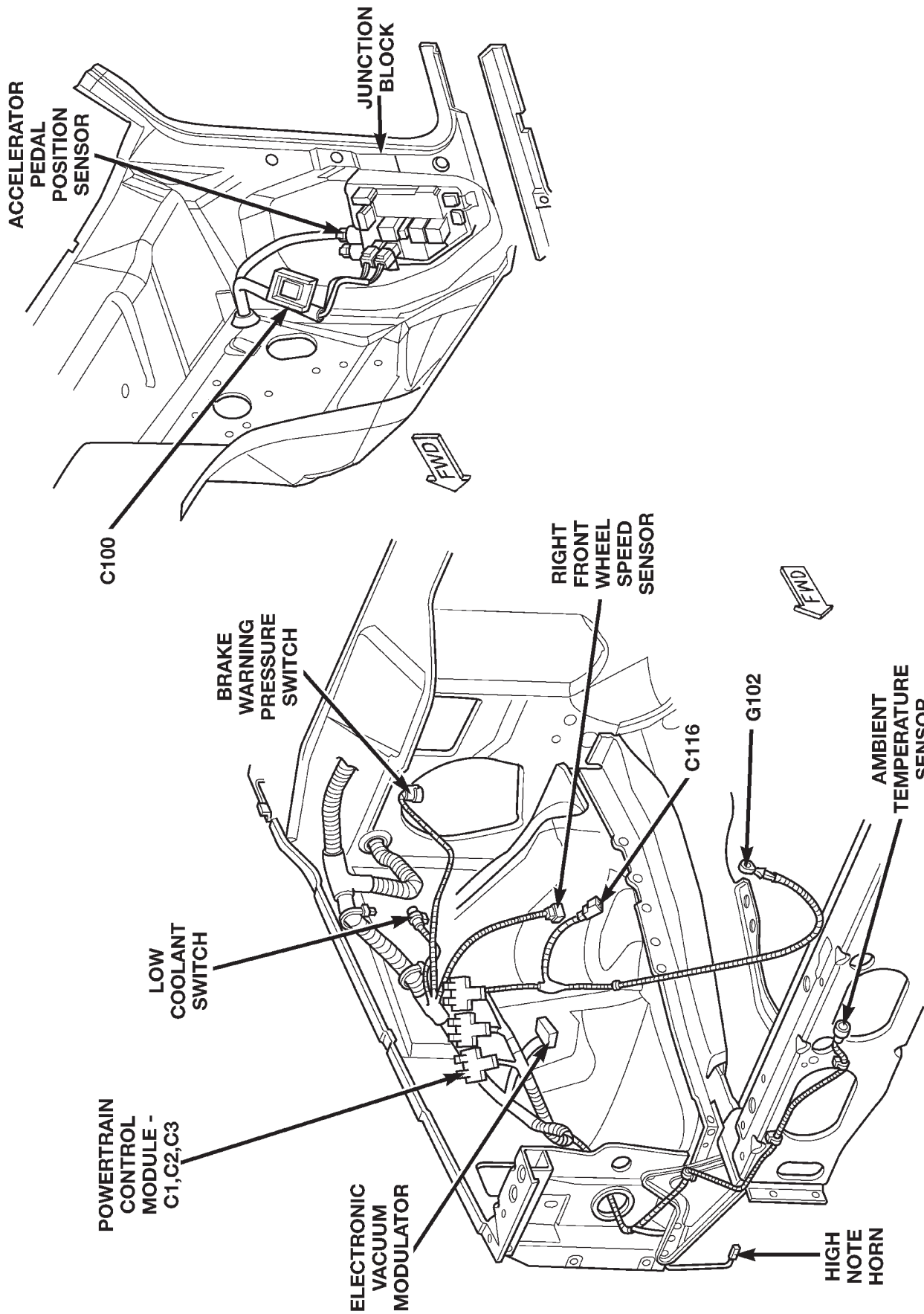
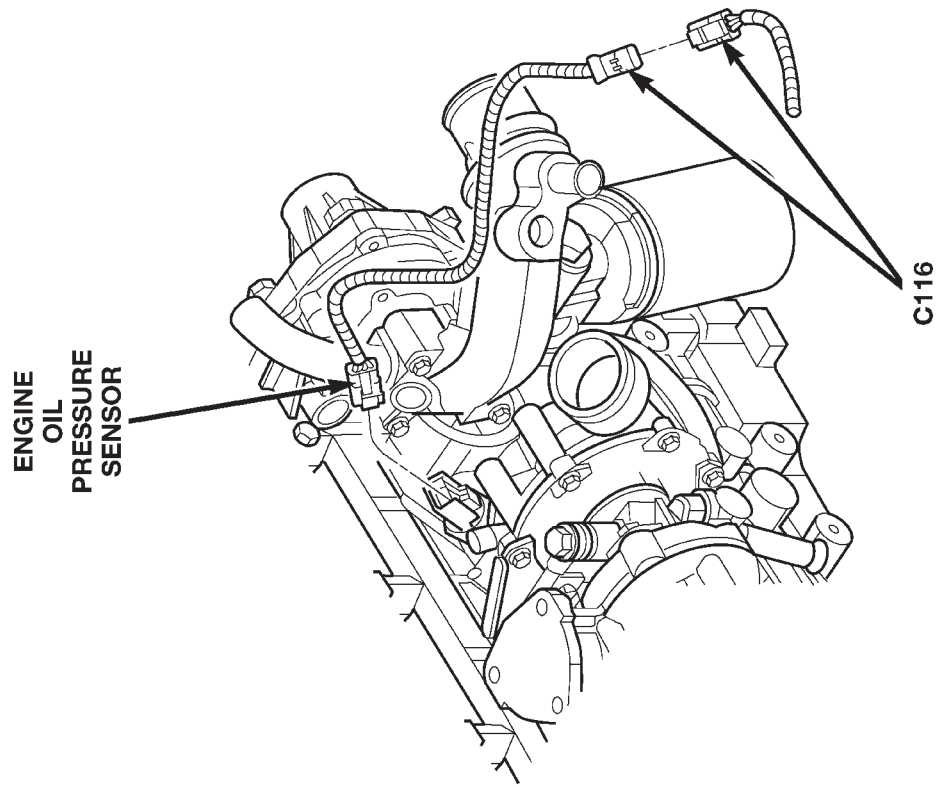

Fig. 40 Right Engine Compartment Diesel Engine RHD

DESCRIPTION AND OPERATION (Continued)



80be4770

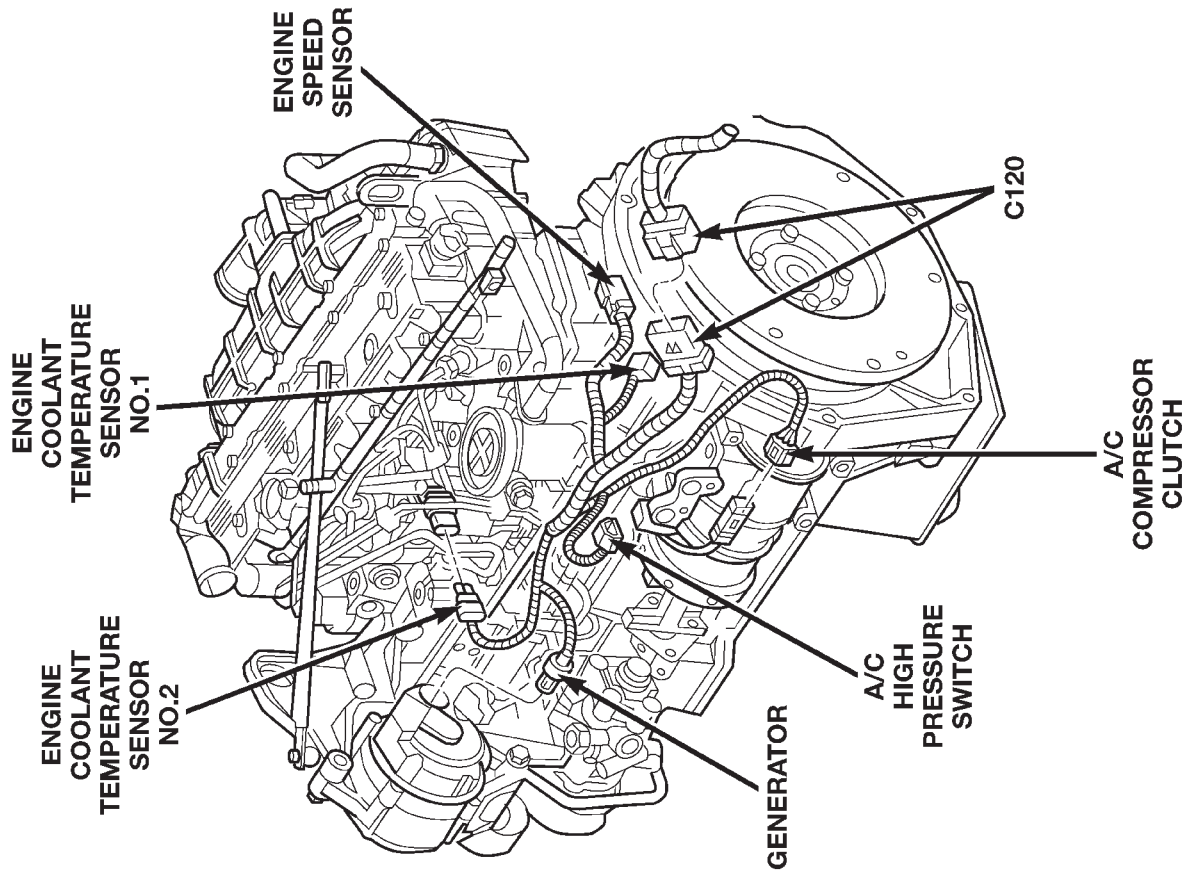

Fig. 41 Diesel Engine

DESCRIPTION AND OPERATION (Continued)

80be4771

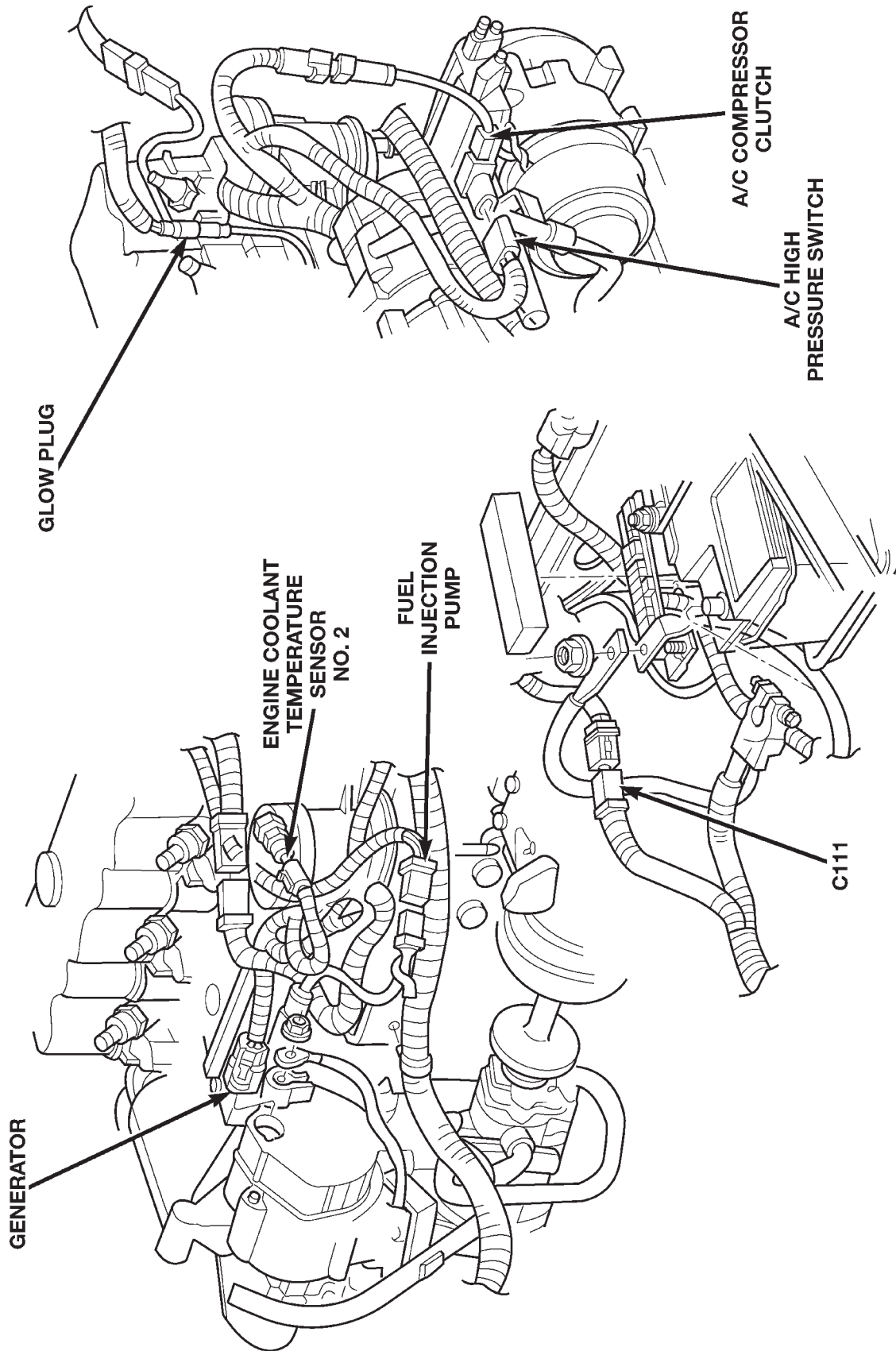
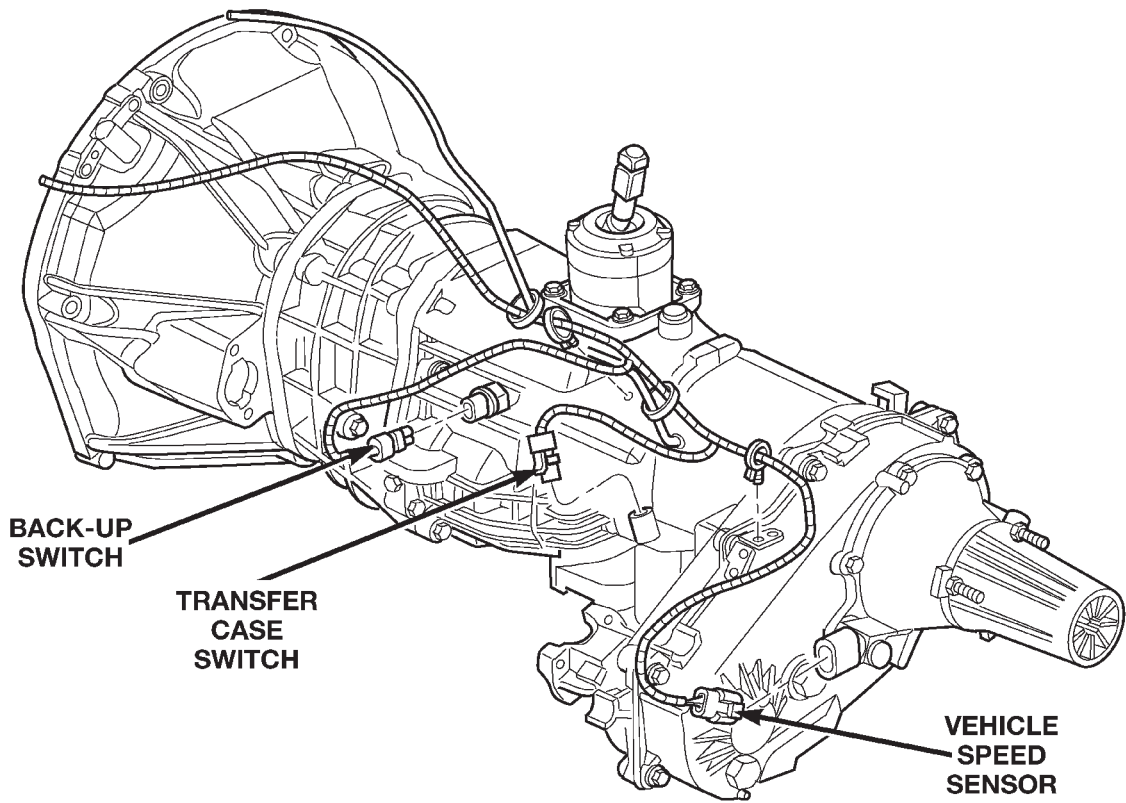

Fig. 42 Engine and Battery Diesel Engine

DESCRIPTION AND OPERATION (Continued)



80be4772

Fig. 43 Transmission Diesel Engine

8W-95 SPLICE LOCATIONS

DESCRIPTION AND OPERATION

INTRODUCTION

This section provides illustrations identifying the general location of the splices in this vehicle. A splice index is provided. Use the wiring diagrams in each

section for splice number identification. Refer to the index for proper splice number.

SPLICE LOCATIONS

For splices that are not shown in the figures in this section a N/S is placed in the Fig. column.

| Splice Number | Location | Fig. |
|--|----------------------------------|------|
| S100 (Except Built-Up-Export) | Near T/O for Right Headlamp | 9 |
| S101 | Near T/O for Right Headlamp | 9 |
| S102 | Near T/O for Right Headlamp | 9 |
| S103 | Near T/O for Left Headlamp | 9 |
| S104 | Near T/O for Left Headlamp | 9 |
| S105 | Near T/O for Left Headlamp | 9 |
| S106 | Near T/O for Left Headlamp | 9 |
| S107 (2.5L) | Near T/O for G101 | 11 |
| S107 (4.0L) | Near T/O for Fuel Injector NO. 6 | 10 |
| S108 (2.5L) | Near Fuel Injector T/O's | 11 |
| S108 (4.0L) | Near T/O for Ignition Coil Pack | 10 |
| S108 (4.0L) (California/ European III) | Near Fuel Injector T/O's | 10 |
| S109 (2.5L) | Near Fuel Injector T/O's | 11 |
| S109 (4.0L) | Near Fuel Injector T/O's | 10 |
| S110 | Near Fuel Injector T/O's | 11 |
| S111 (2.5L) | Near T/O for G101 | 11 |
| S111 (4.0L) | Near Fuel Injector T/O's | 10 |
| S112 | Near Fuel Injector T/O's | 10 |
| S113 (2.5L) | Near T/O for Fuel Injector NO. 3 | 11 |

| Splice Number | Location | Fig. |
|--|---|------------|
| S113 (4.0L) | Between Fuel Injector NO. 2 and Fuel Injector NO. 3 T/O's | 10 |
| S114 (2.5L) | Near T/O for Fuel Injector NO. 2 | 11 |
| S114 (4.0L) | Between Fuel Injector NO. 2 and Fuel Injector NO. 3 T/O's | 10 |
| S115 (2.5L) | Near T/O for Crankshaft Position Sensor | 11 |
| S115 (4.0L) | Near T/O for Idle Air Control Motor | 10 |
| S116 (Built-Up-Export) | Near T/O for Right Headlamp | 9 |
| S118 | In T/O for Generator Terminal | N/S |
| S119 (2.5L) | In T/O for Engine Oil Pressure Sensor | 11 |
| S119 (4.0L) | Near Fuel Injector T/O's | 10 |
| S120 (A/T) (2.5L) | Near Fuel Injector T/O's | 11 |
| S121 | Near Fuel Injector T/O's | 10 |
| S122 | Near T/O for Ignition Coil Pack | 10 |
| S123 (4.0L) (California/ European III) | Near T/O for Powertrain Control Module - C2 | N/S |
| S124 | Near T/O for Electronic Vacuum Modulator | 26, 27 |
| S130 (Diesel) | Near T/O for Power Distribution Center | 24, 25 |
| S130 (Gas) | Near Grommet T/O for Junction Block - C2 | 3, 4, 7, 8 |
| S131 (Diesel) (LHD) | Near T/O for Underhood Lamp | 26 |

DESCRIPTION AND OPERATION (Continued)

| Splice Number | Location | Fig. | Splice Number | Location | Fig. |
|-------------------------------------|---|------------|--------------------------------------|---|--------|
| S131 (Diesel) (RHD) | Near T/O for Low Coolant Sensor | 27 | S135 (LHD) (4.0L) (M/T ABS) | Near T/O for Right Front Wheel Speed Sensor | 3 |
| S131 (Diesel) (RHD) (ABS) | Near Accelerator Pedal Position Sensor | 27 | S135 (RHD) | Near T/O for Underhood Lamp | 4, 8 |
| S131 (Gas) | Near Grommet T/O for Junction Block - C2 | 3, 4, 7, 8 | S135 (RHD) (ABS) | Near Grommet T/O for C100 | 4, 8 |
| S132 (Diesel) | Near T/O for G106 | 24, 25 | S136 | Near T/O for C107 | 3 |
| S132 (LHD) (2.5L) | Near Grommet T/O for Junction Block - C2 | 7 | S137 (LHD) | Between Power Distribution Center T/O and Glow Plug Relay T/O | 24 |
| S132 (LHD) (4.0L) | Near T/O for A/C Low Pressure Switch | 3 | S137 (RHD) | Near T/O for A/C Low Pressure Switch | 25 |
| S132 (LHD) (GAS) (M/T ABS) | Near T/O for Underhood Lamp | 3 | S138 (2.5L) | Near Grommet T/O for Front Wiper Motor | 5, 6 |
| S132 (RHD) | Near Grommet T/O for C100 | 4, 8 | S138 (4.0L) | Near T/O for Transmission Control Module or C107 | 1, 2 |
| S133 (Diesel) (LHD) | Near T/O for C111 | 24 | S138 (Diesel) (LHD) | Near T/O for Underhood Lamp | 24 |
| S133 (Diesel) (RHD) | Near T/O for Underhood Lamp | 27 | S138 (Diesel) (RHD) | Near Grommet T/O for Engine Control Module - C1 and C2 | 25 |
| S133 (DRL) | Near Grommet T/O for Junction Block - C2 or A/C Low Pressure Switch | 3, 7 | S139 (Diesel) (LHD) | Near T/O for C120 | 24 |
| S133 (LHD) (Gas) | Near Grommet T/O for Front Wiper Motor | 1, 5 | S139 (Diesel) (RHD) | Near T/O for C111 | 25 |
| S133 (RHD) (Gas) | Near T/O for A/C Low Pressure Switch | 2, 6 | S139 (LHD) (A/T) | Near T/O for Brake Warning Pressure Switch | 1 |
| S134 (LHD) | Near T/O for Underhood Lamp or C107 | 3 | S139 (LHD)(M/T ABS) | Near Grommet T/O for C100 | 1 |
| S134 (RHD) (ABS) | Near T/O for Transmission Control Module | 2 | S139 (RHD) | Near T/O for A/C Low Pressure Switch | 2 |
| S135 (LHD) (2.5L) | Near T/O for A/C High Pressure Switch | 7 | S140 | Near T/O for Transmission Control Module | 1, 2 |
| S135 (LHD) (4.0L) | Near T/O for C107 | 3 | S141 (Diesel) | Near T/O for G106 | 24, 25 |
| | | | S141 (LHD) | Near Grommet T/O for Front Wiper Motor | 1 |
| | | | S141 (RHD) | Near T/O for C107 | 2, 6 |

DESCRIPTION AND OPERATION (Continued)

| Splice Number | Location | Fig. | Splice Number | Location | Fig. |
|------------------------|---|--------|---------------|---|------------|
| S142 (4.0L LHD) | Near Grommet T/O for Front Wiper Motor | 1 | S156 (RHD) | Near Grommet T/O for Engine Control Module - C1 and C2 | 25 |
| S142 (4.0L RHD) | Near Grommet T/O for Transmission Control Module | 4 | S157 (LHD) | Near T/O for Glow Plug Relay | 24 |
| S143 (LHD) | Near Grommet T/O for C100 | 1, 5 | S157 (RHD) | Near T/O for A/C Low Pressure Switch | 25 |
| S143 (RHD) | Near T/O for C107 | 4, 8 | S158 | Near T/O for Left Headlamp | 9 |
| S144 (LHD) | Near Grommet T/O for C100 | 1 | S159 | Near Grommet T/O for Junction Block - C2 | 3, 4, 7, 8 |
| S144 (RHD) | Near T/O for G106 | 2 | S161 (A/T) | Near T/O for Vehicle Speed Sensor | 11 |
| S144 (RHD) (ABS) | Near T/O for A/C Low Pressure Switch | 2 | S162 | Near T/O for Left Headlamp | 9 |
| S145 (LHD) | Near Grommet T/O for C100 | 1 | S163 | Near T/O for Left Headlamp | 9 |
| S145 (RHD) | Near T/O for G106 | 2 | S164 | Near T/O for Right Headlamp | 9 |
| S145 (RHD) (ABS) | Near T/O for A/C Low Pressure Switch | 2 | S165 | Near T/O for Right Headlamp | 9 |
| S146 | Near T/O for Electronic Vacuum Modulator | 26, 27 | S166 | Near T/O for Power Distribution Center | 3, 7 |
| S147 (ABS) (LHD) | Near T/O for C111 | 24 | S168 | Near T/O for C107 | 5, 6 |
| S147 (ABS) (RHD) | Near T/O for A/C Low Pressure Switch | 25 | S169 (LHD) | Near T/O for C111 | 24 |
| S148 (LHD) | Near Grommet T/O for Engine Control Module - C1 and C2 | 24 | S169 (RHD) | Near T/O for Accelerator Pedal Position Sensor | 27 |
| S148 (RHD) | Near T/O for C120 | 25 | S170 | Near T/O for C120 | N/S |
| S149 (LHD) | Near T/O for C120 | 24 | S200 | In T/O for Headlamp Switch | 12, 13 |
| S149 (RHD) | Near T/O for C111 | 25 | S201 (LHD) | Near T/O for C200 | 12 |
| S151 | Near Power Distribution Center T/O | 24, 25 | S201 (RHD) | Near T/O for Data Link Connector | 13 |
| S152 | Near T/O for C120 | 24, 25 | S203 | In T/O for Brake Lamp Switch | 12, 13 |
| S153 | In T/O to Power Distribution Center | 24, 25 | S204 (LHD) | In T/O for Brake Lamp Switch | 12 |
| S156 (LHD) | Near T/O for Underhood Lamp | 24 | S204 (RHD) | Near T/O for Shift Lock Solenoid | 13 |
| | | | S205 (LHD) | In T/O for C100 | 12 |
| | | | S205 (RHD) | Near T/O for C202, C203 and C204 | 13 |
| | | | S206 | In Lower Instrument Panel Trough | 12, 13 |
| | | | S207 | In Lower Instrument Panel Trough | 12, 13 |
| | | | S208 (LHD) | In Lower Instrument Panel Trough | 12 |

DESCRIPTION AND OPERATION (Continued)

| Splice Number | Location | Fig. | Splice Number | Location | Fig. |
|-------------------------------------|---|--------|--------------------------------------|---|--------|
| S208 (RHD) (Built-Up-Export) | Near T/O for Instrument Cluster - C1 | 13 | S222 | Near T/O for Clockspring - C2 | N/S |
| S208 (RHD) (Except Built-Up-Export) | Near T/O for Cigar Lighter | 13 | S225 | In T/O for C301 | 14 |
| S209 | In Lower Instrument Panel Trough | 12, 13 | S226 | In T/O for Headlamp Switch | 12, 13 |
| S210 | In Lower Instrument Panel Trough | 12, 13 | S227 | In T/O for Headlamp Switch | 12, 13 |
| S211 | In Lower Instrument Panel Trough | 12, 13 | S228 | Near T/O for Blower Motor Resistor Block | N/S |
| S212 (LHD) | Between Trough and T/O to Turn Signal/Hazard Switch | 12 | S229 (LHD) | Near T/O for Diode Module and Rear Fog Lamp Relay | 12 |
| S212 (RHD) | In Lower Instrument Panel Trough | 13 | S229 (RHD) | Near T/O for C202, C203 and C204 | 13 |
| S213 | Near T/O to Turn Signal/Hazard Switch | 12, 13 | S230 | Near T/O for Cigar Lighter | 12, 13 |
| S214 (LHD) | Near T/O for Diode Module, Rear Fog Lamp Relay and G107 | 12 | S232 | Near T/O for Junction Block - C4 and C5 | 13 |
| S214 (RHD) | Near T/O for Instrument Cluster - C1 | 13 | S237 | Near T/O for Diode Module and Rear Fog Lamp Relay | 12 |
| S215 (LHD) | Near T/O for Cigar Lighter | 12 | S238 | In T/O for Combination Flasher | 12, 13 |
| S215 (RHD) | Near T/O for A/C-Heater Control - C2 | 13 | S239 | In T/O for Combination Flasher | 12, 13 |
| S216 (LHD) | Near T/O for Instrument Cluster - C2 | 12 | S301 | In T/O for Power Amplifier | 15 |
| S216 (RHD) | Near T/O for Junction Block -C4 and C5 | 13 | S302 (Diesel) | Near T/O for Fuel Level Sensor | 15 |
| S217 (Police Package) | In Lower Instrument Panel Trough | 12 | S302 (Gas) | Near T/O for Fuel Pump Module | 15 |
| S218 (LHD) | In T/O for Headlamp Switch | 12 | S303 | Near T/O for C326 and C327 | 15 |
| S218 (RHD) | In T/O for C100 | 13 | S304 | Near T/O for G303 | 16 |
| S219 (LHD) | In T/O for C209 | 14 | S305 | Under Right Rear Seat | 16 |
| S219 (RHD) | Near T/O for Junction Block - C4 and C5 | 13 | S306 | Under Right Rear Seat | 16 |
| S220 | Near T/O for Rear Fog Lamp Relay | 13 | S307 (LHD With Power Amplifier, RHD) | Under Right Rear Seat | 16 |
| S221 | Near T/O for Clockspring - C2 | N/S | S307 (LHD Without Power Amplifier) | Under Left Rear Seat | 15 |
| | | | S308 | Near T/O for C326 and C327 | 17 |
| | | | S309 | Near T/O for C326 and C327 | 17 |
| | | | S310 (LHD) | Near T/O for C304 and C319 | 16 |
| | | | S310 (RHD) | Near T/O for C314 and C321 | 16 |
| | | | S311 | Near T/O for C326 and C327 | 17 |
| | | | S312 | Under Left Rear Seat | 15 |

DESCRIPTION AND OPERATION (Continued)

| Splice Number | Location | Fig. |
|---|---|------|
| S312 (LHD with Power Amplifier, RHD) | Near T/O for C304 and C319 | 16 |
| S313 | Near T/O for C206 at Center Console | N/S |
| S314 | Near T/O for C209 | 14 |
| S315 | Near T/O for C205 | 14 |
| S316 | Near T/O for Power Window Motor | 20 |
| S317 | Near T/O for Power Window Motor | 20 |
| S318 | Near T/O for Front Door Speaker | 20 |
| S319 | Near T/O for Front Door Speaker | 20 |
| S320 | Near T/O for Front Door Speaker | 20 |
| S321 | Near T/O for Front Door Speaker | 20 |
| S322 | Near T/O for Power Window Motor | 21 |
| S323 | Near T/O for Power Window Motor | 21 |
| S324 | Near T/O for C320 | 15 |
| S326 | Near T/O for Front Door Speaker | 21 |
| S327 | Near T/O for Front Door Speaker | 21 |
| S328 | Near T/O for Front Door Speaker | 21 |
| S329 | Near T/O for Front Door Speaker | 21 |
| S332 | Near T/O for Left License Lamp | N/S |
| S333 | Near T/O for Right License Lamp | N/S |
| S334 | Near T/O for Liftgate Switch | 22 |
| S335 | Near T/O for Trailer Tow Right Turn Relay | 18 |
| S336 | Near T/O for C322 | 18 |
| S337 | Near T/O for C322 | 18 |
| S338 | Near T/O for C323 | 18 |

| Splice Number | Location | Fig. |
|--|--|------|
| S339 | Near T/O for C323 | 18 |
| S340 | Near Grommet for Trailer Tow Connector | 18 |
| S341 | In Left Tail Lamp Harness near C321 | N/S |
| S342 (With Remote Keyless Entry) | In T/O for Overhead Module | 23 |
| S344 | In T/O for Overhead Module | 23 |
| S345 (With Remote Keyless Entry) | In T/O for Overhead Module | 23 |
| S346 | In T/O for Overhead Module | 23 |
| S347 (With Remote Keyless Entry) | In T/O for Compass | N/S |
| S347 (Without Remote Keyless Entry) | In T/O for Overhead Module | 23 |
| S348 | In Right Tail Lamp Harness near C322 | N/S |
| S349 (RHD) | In T/O for C209 | N/S |
| S351 | Near T/O for C305 and C306 | 15 |
| S352 | In T/O for C300 | N/S |
| S353 | Near T/O for C316 | 19 |
| S354 | In T/O for C329 | N/S |
| S355 | Near T/O for C329 and C363 | 19 |
| S356 | Near T/O for C316 | 19 |
| S357 | Near T/O for Heated Seat Relay | N/S |
| S359 (RHD) | Near T/O for C209 | N/S |
| S361 | Near T/O for Right Visor/Vanity Lamp | 23 |

DESCRIPTION AND OPERATION (Continued)

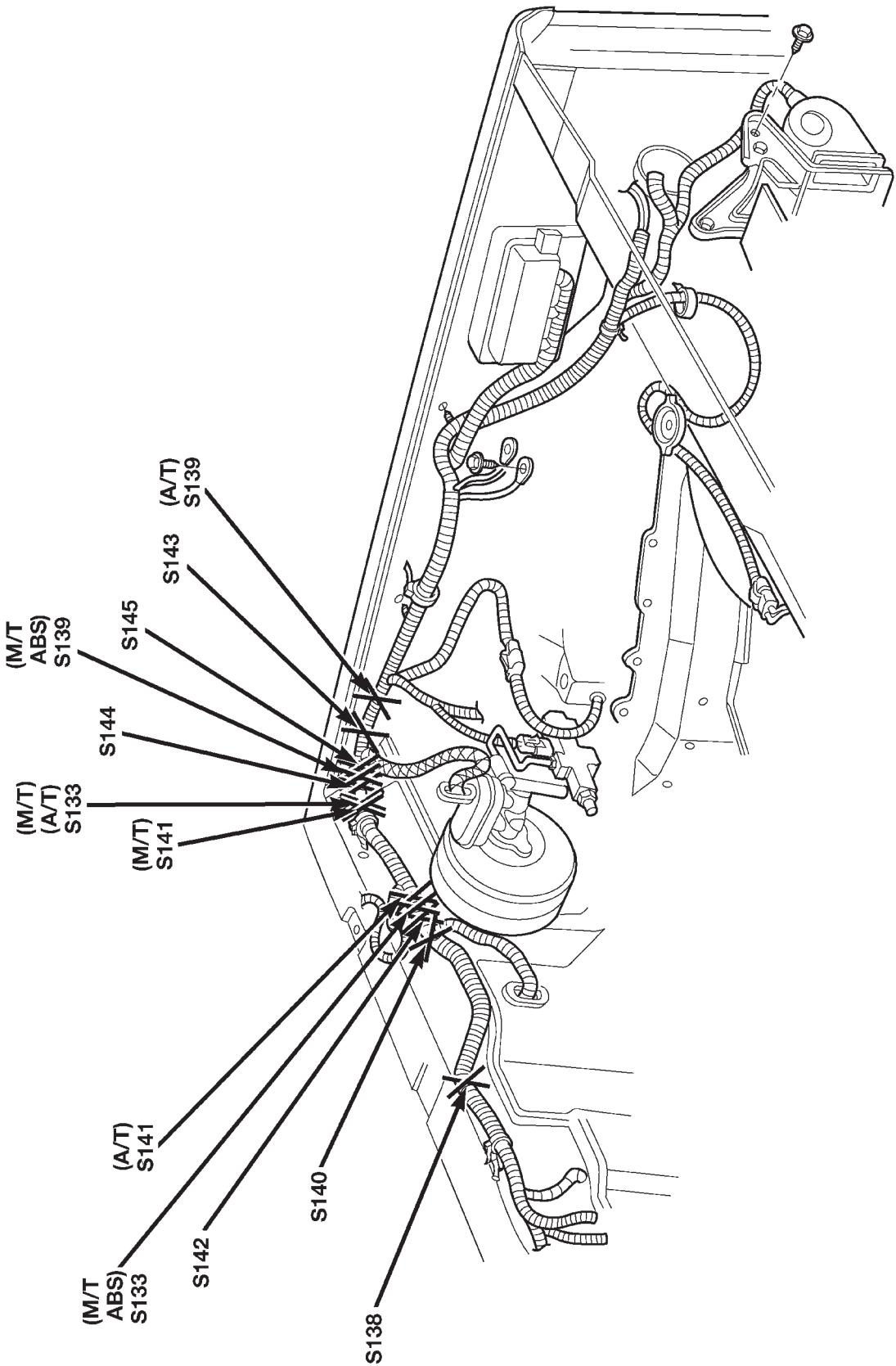

80be477f

Fig. 1 Left Engine Compartment Splices 4.0L Engine LHD

DESCRIPTION AND OPERATION (Continued)

80be4786

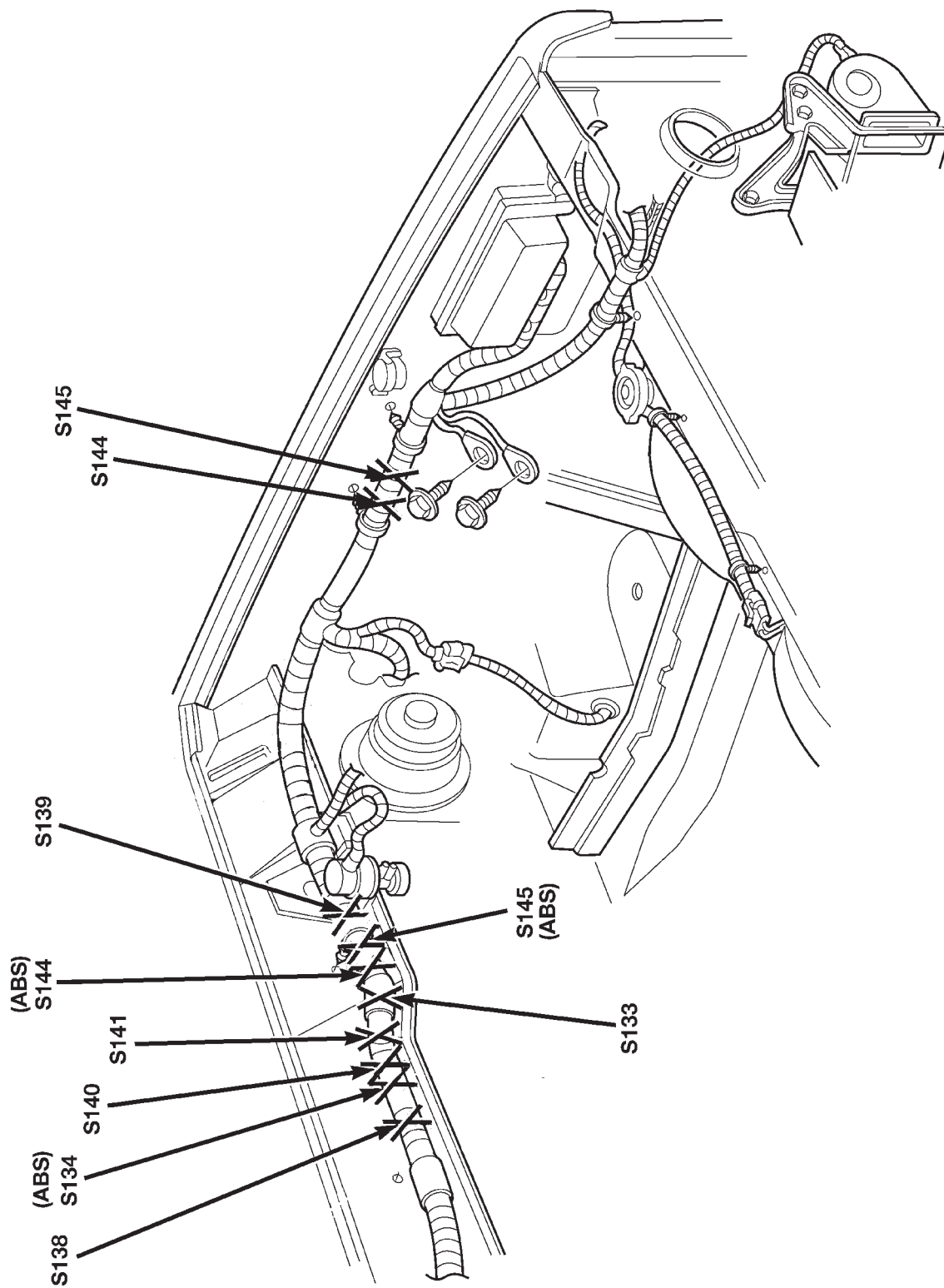

Fig. 2 Left Engine Compartment Splices 4.0L Engine RHD

DESCRIPTION AND OPERATION (Continued)

80be4787

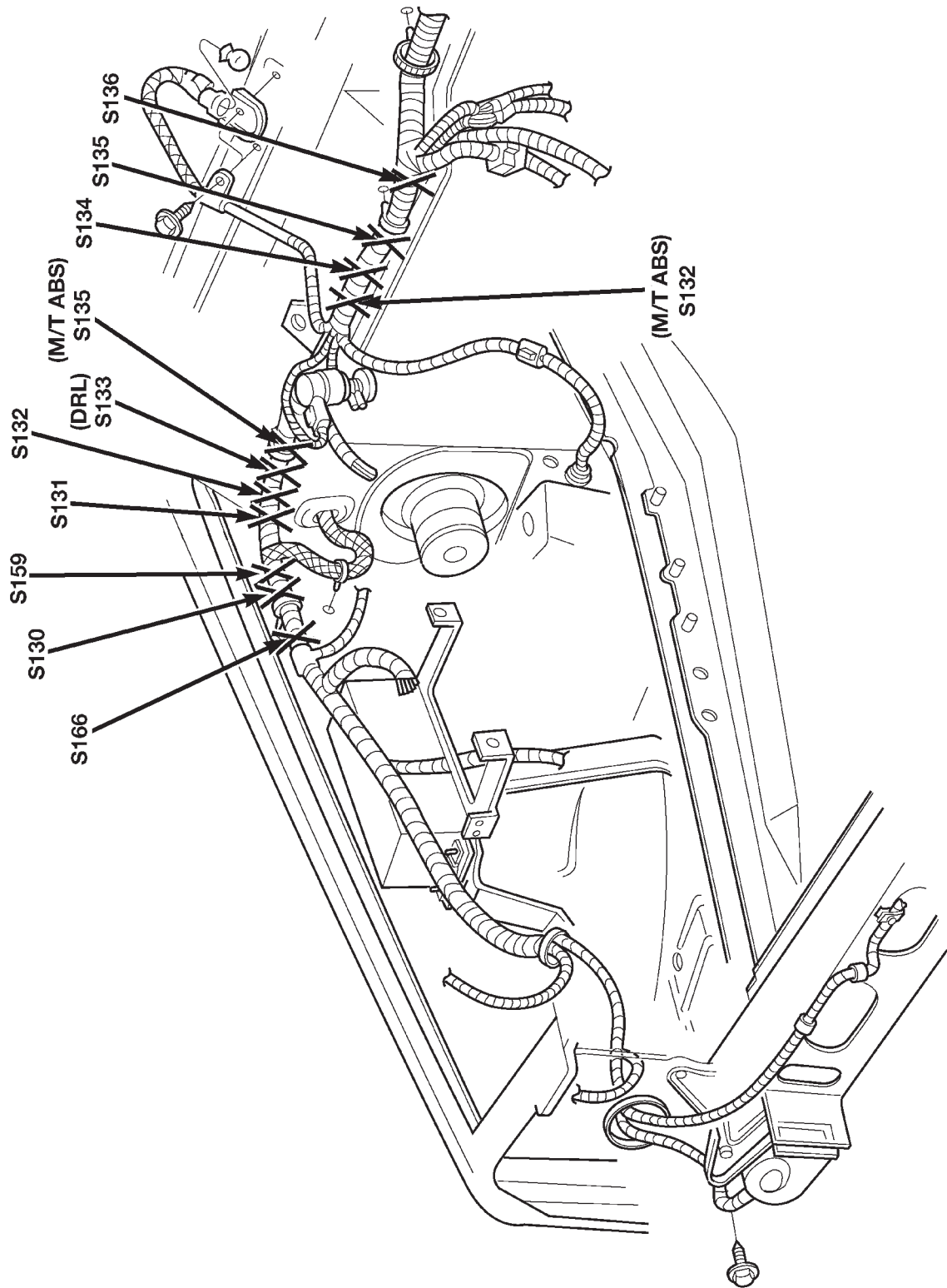

Fig. 3 Right Engine Compartment Splices 4.0L Engine LHD

DESCRIPTION AND OPERATION (Continued)

80bbcc9e

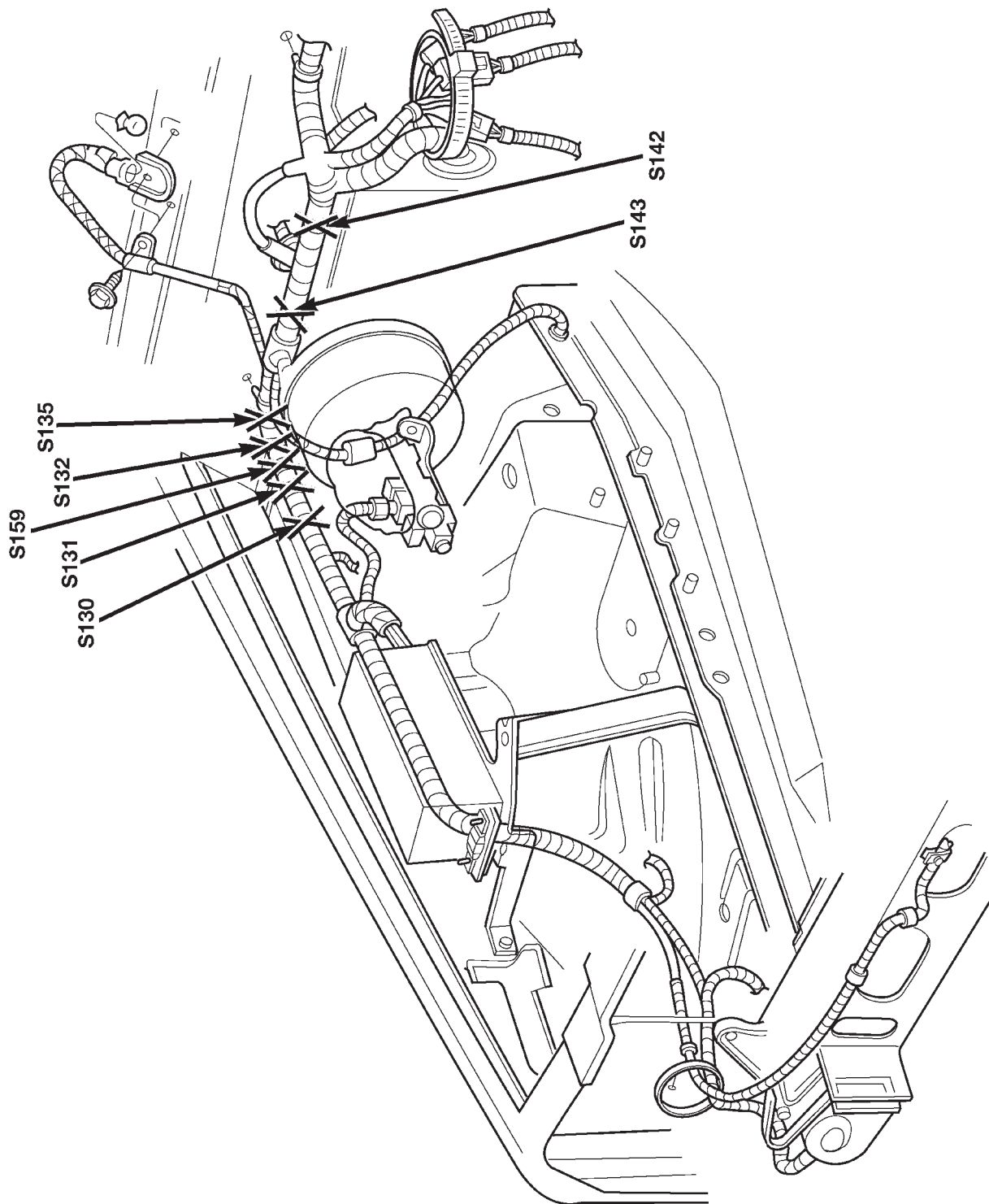

Fig. 4 Right Engine Compartment Splices 4.0L Engine RHD

DESCRIPTION AND OPERATION (Continued)

80be4789

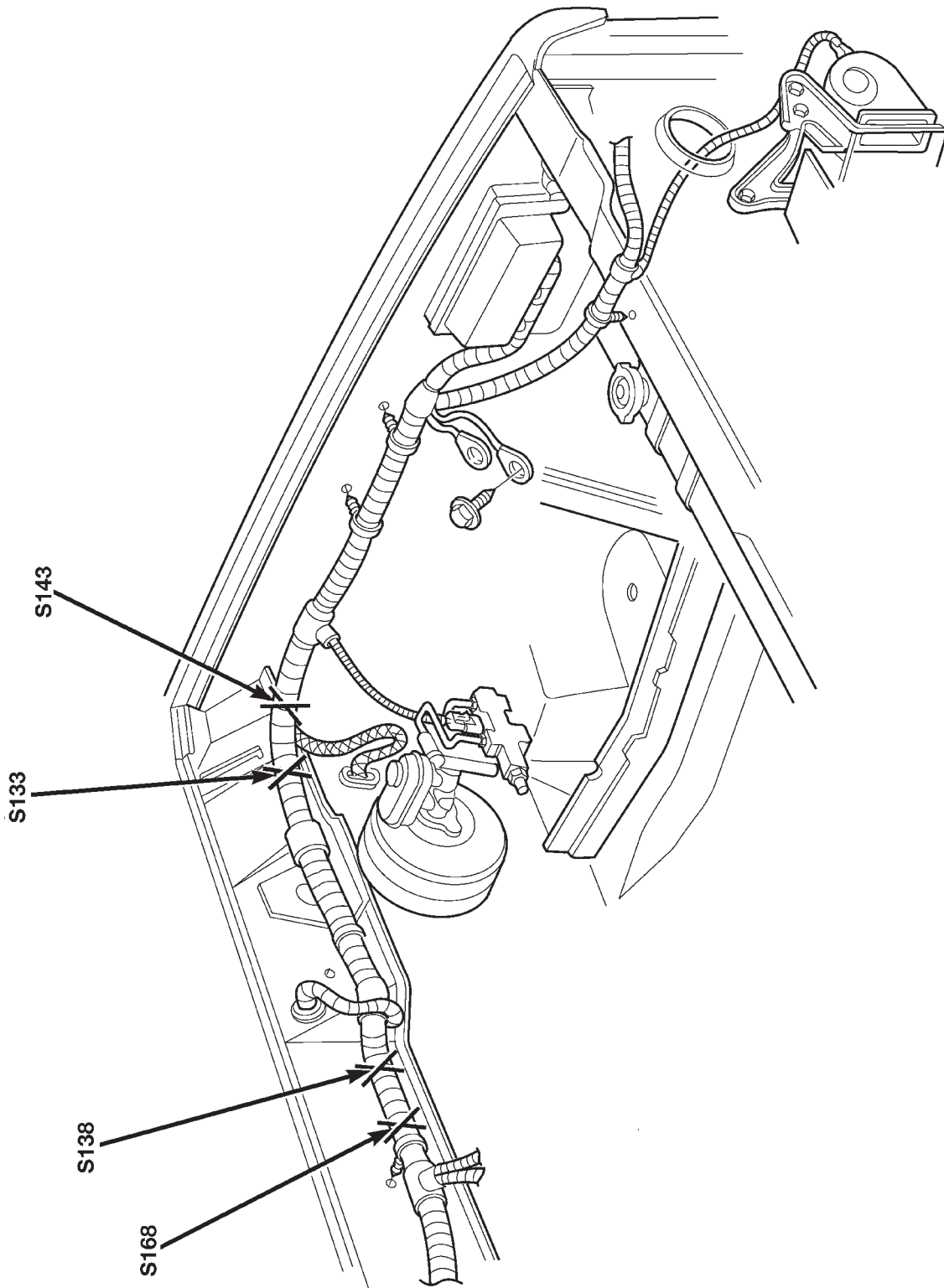

Fig. 5 Left Engine Compartment Splices 2.5L Engine LHD

DESCRIPTION AND OPERATION (Continued)

80be478a

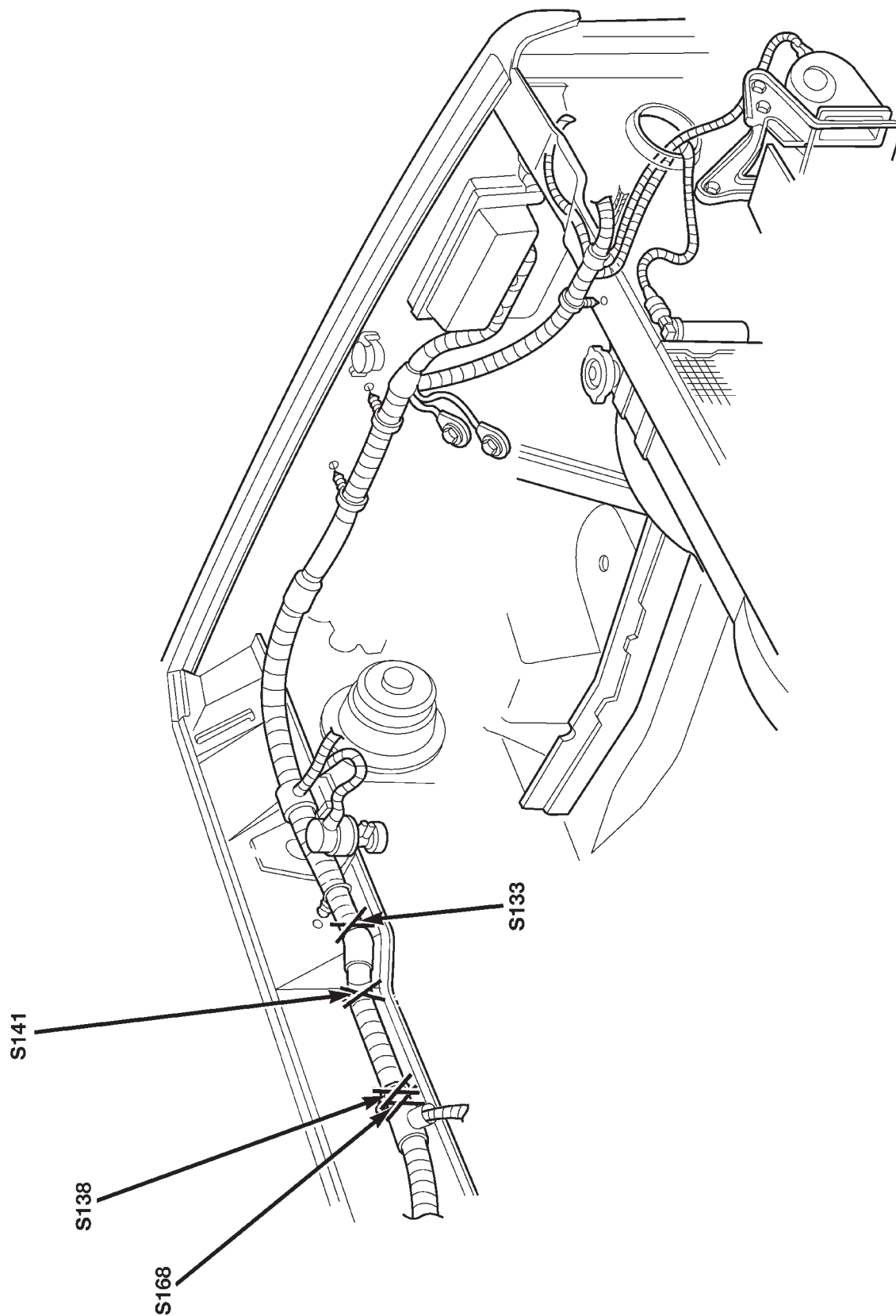

Fig. 6 Left Engine Compartment Splices 2.5L Engine RHD

DESCRIPTION AND OPERATION (Continued)

80be478b

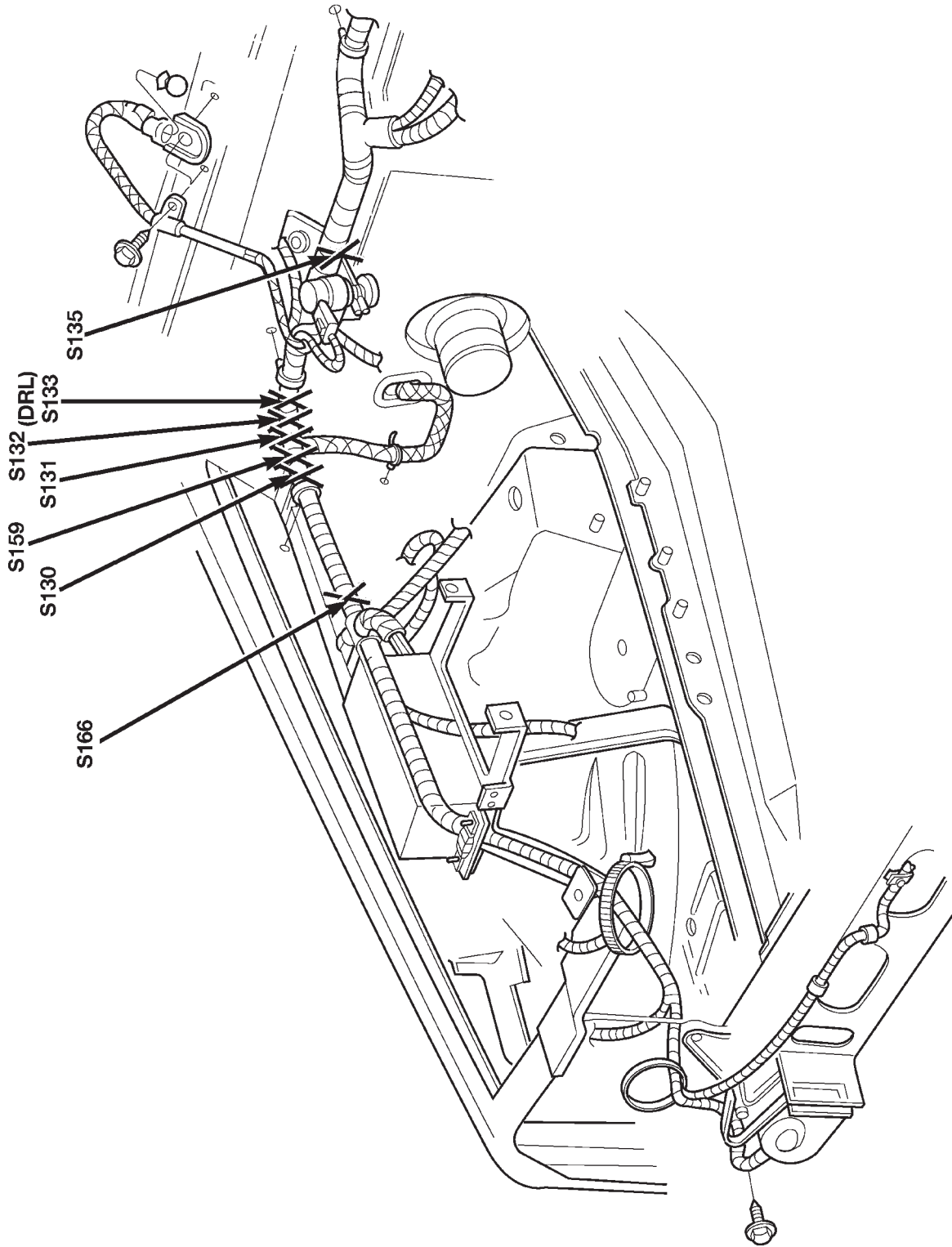

Fig. 7 Right Engine Compartment Splices 2.5L Engine LHD

DESCRIPTION AND OPERATION (Continued)

80be478c

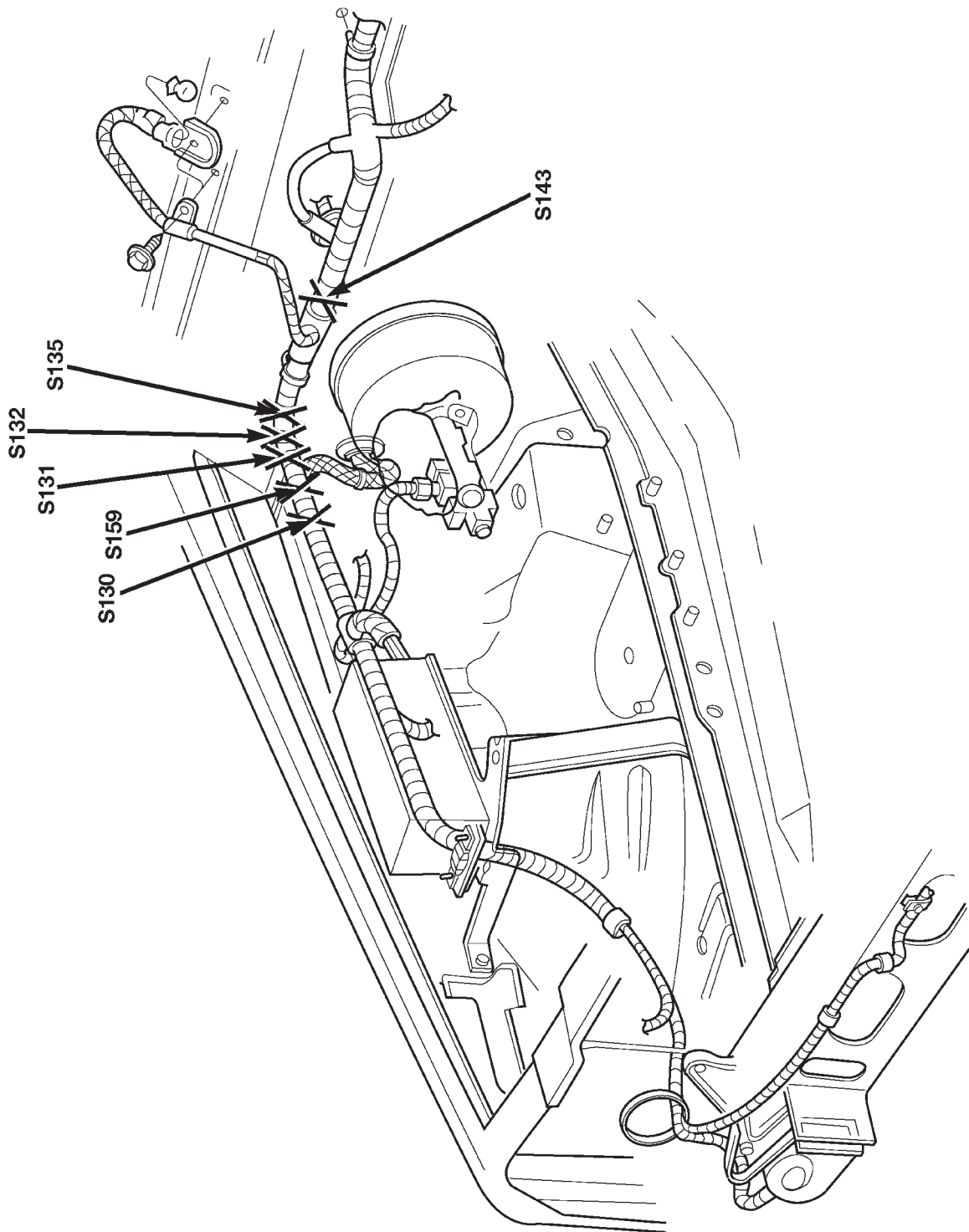

Fig. 8 Right Engine Compartment Splices 2.5L Engine RHD

DESCRIPTION AND OPERATION (Continued)

80be478d

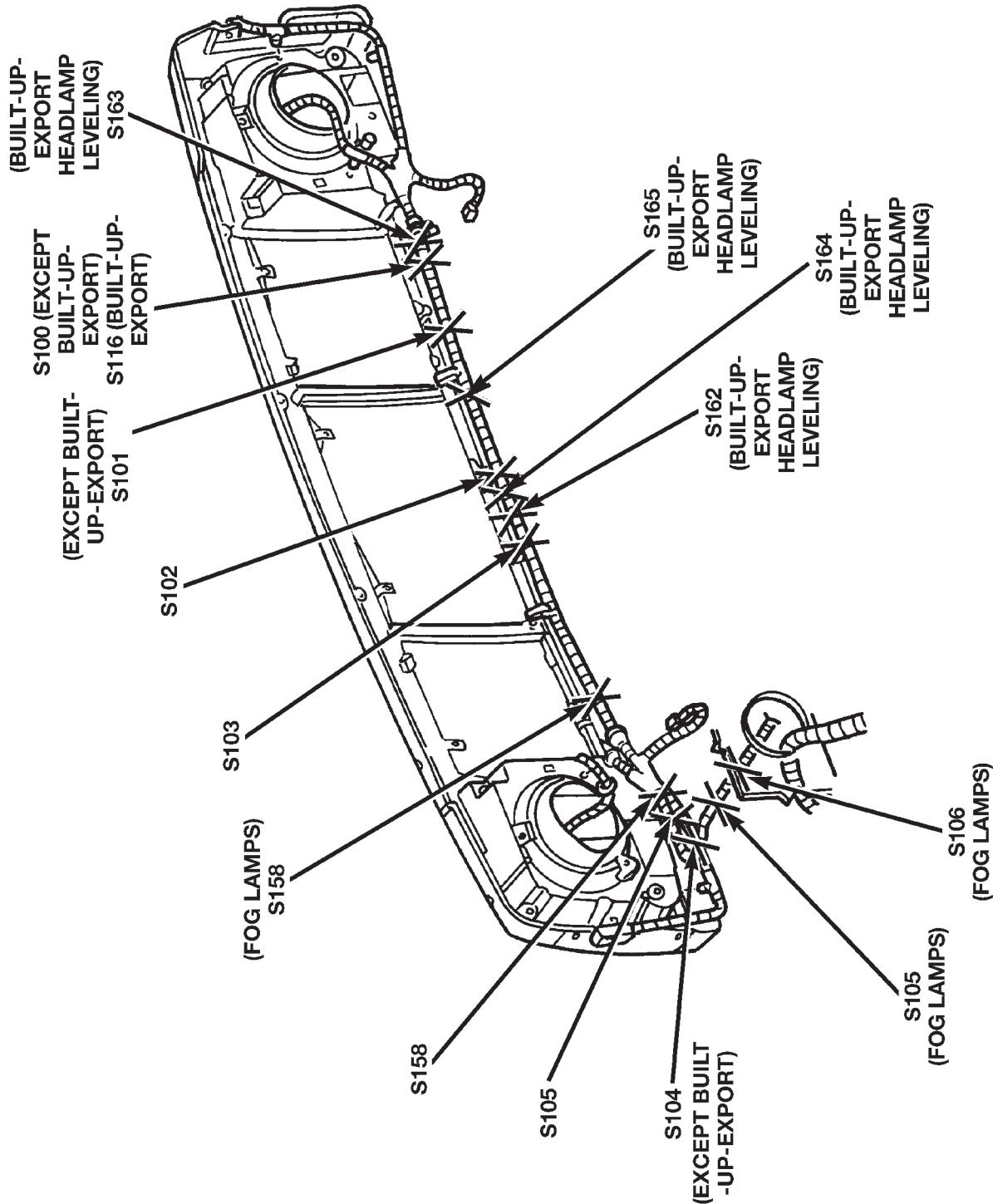
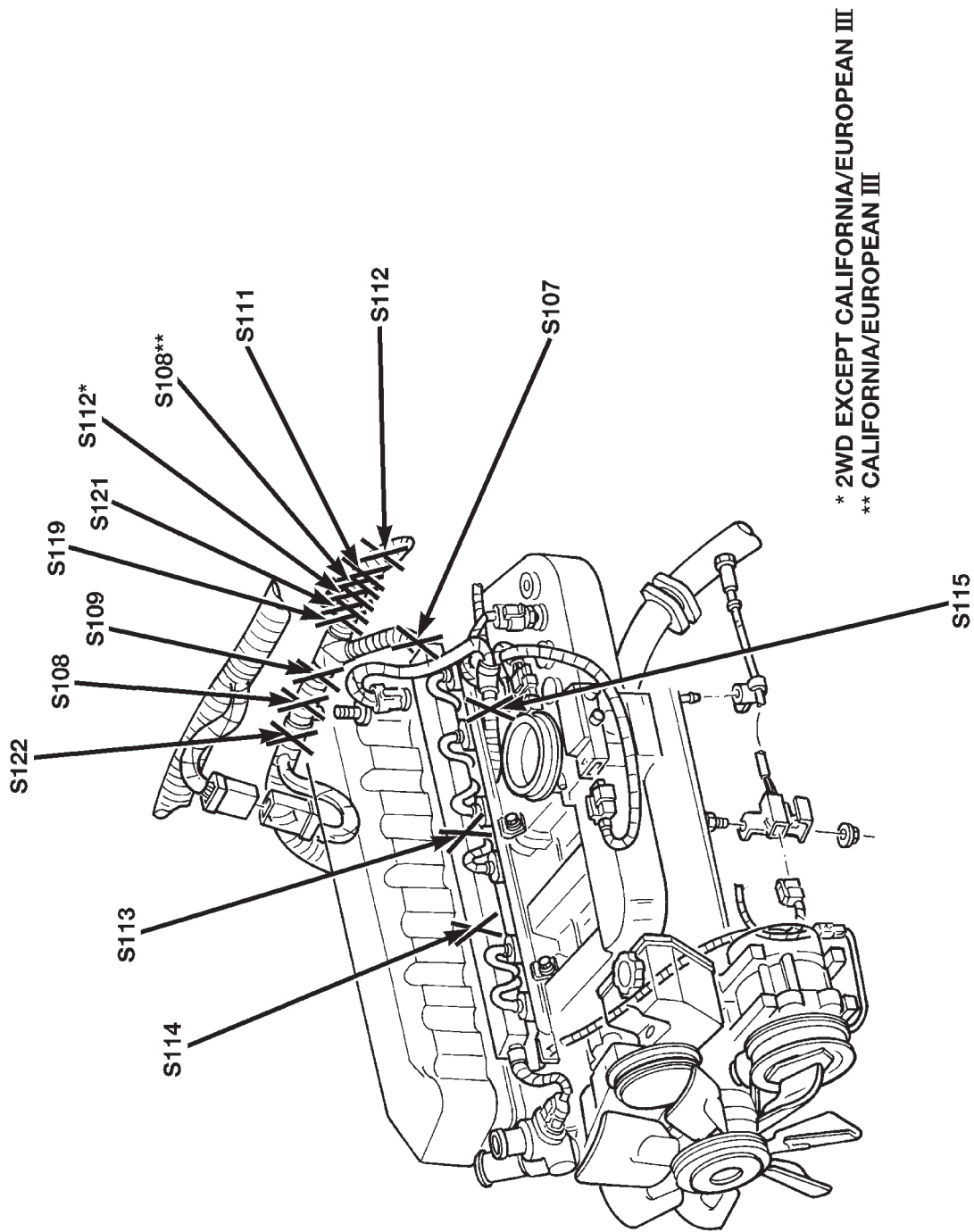

Fig. 9 Front End Lighting Splices

DESCRIPTION AND OPERATION (Continued)



80be478e

Fig. 10 Engine Wiring Splices 4.0L Engine

DESCRIPTION AND OPERATION (Continued)

80be478f

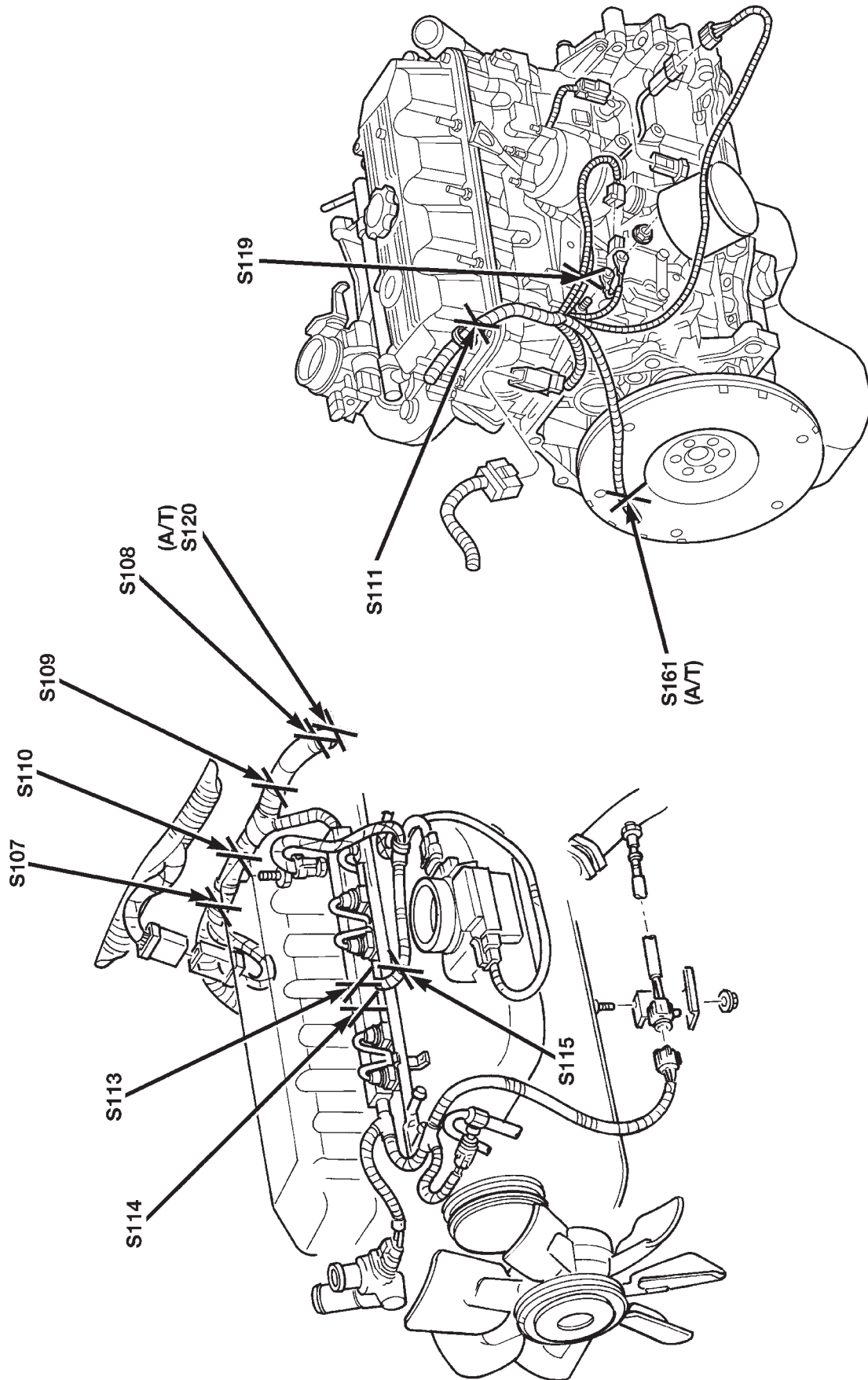
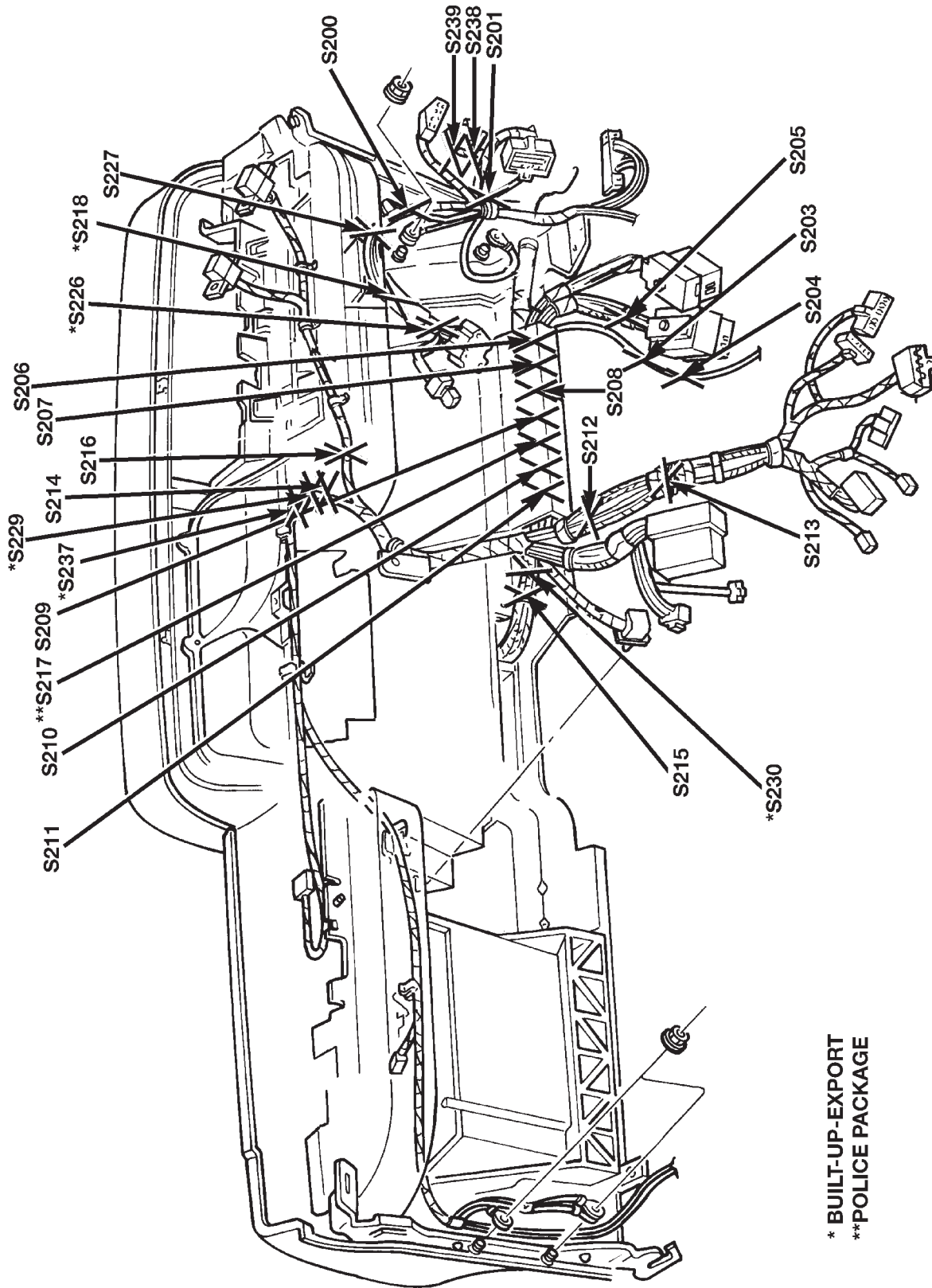

Fig. 11 Engine Wiring Splices 2.5L Engine

DESCRIPTION AND OPERATION (Continued)

80b64792



* BUILT-UP-EXPORT
**POLICE PACKAGE

Fig. 12 Instrument Panel Wiring Splices LHD

DESCRIPTION AND OPERATION (Continued)

80be4793

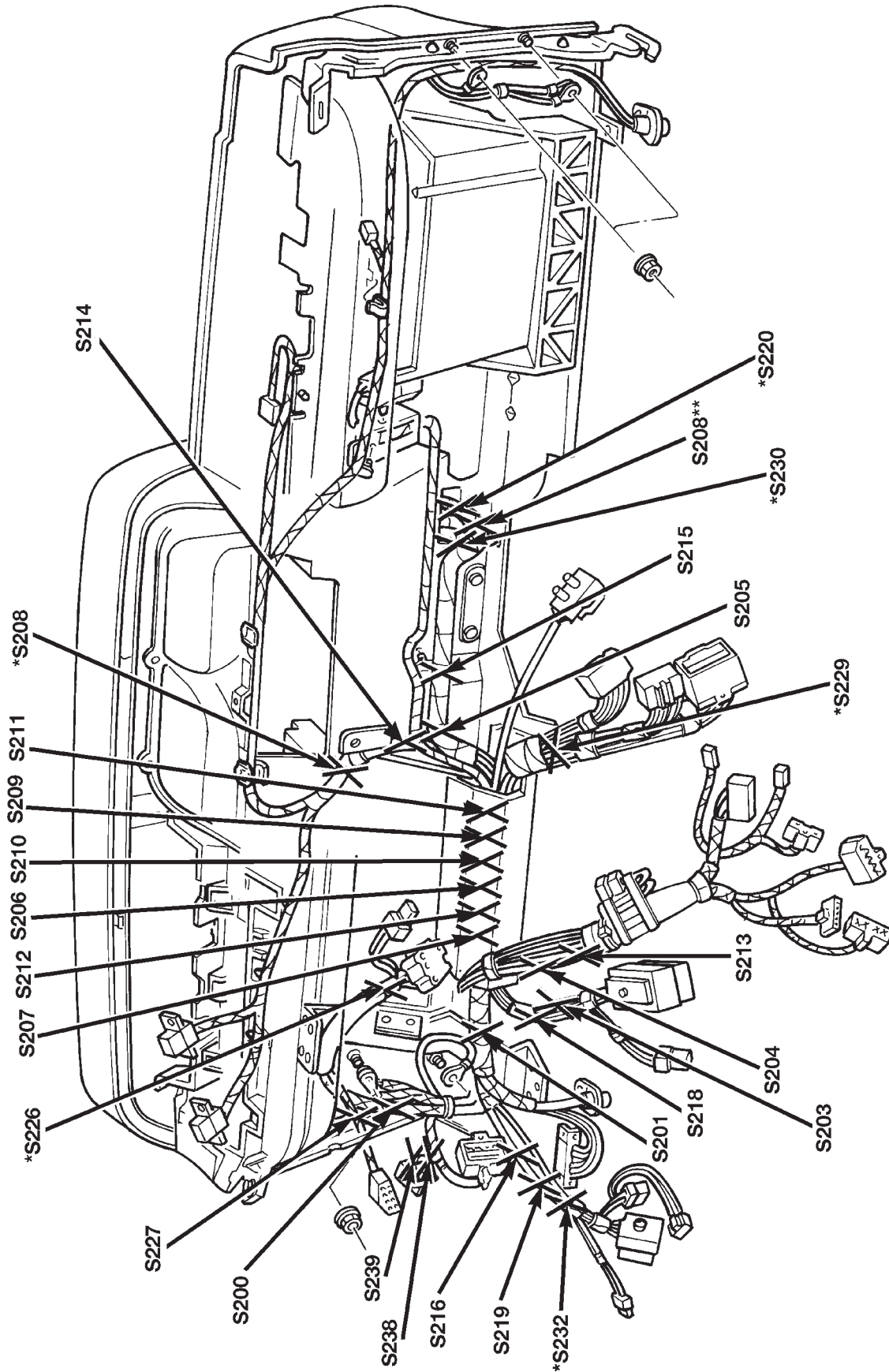

Fig. 13 Instrument Panel Wiring Splices RHD

* BUILT-UP-EXPORT
 ** EXCEPT BUILT-UP-EXPORT

80be4794

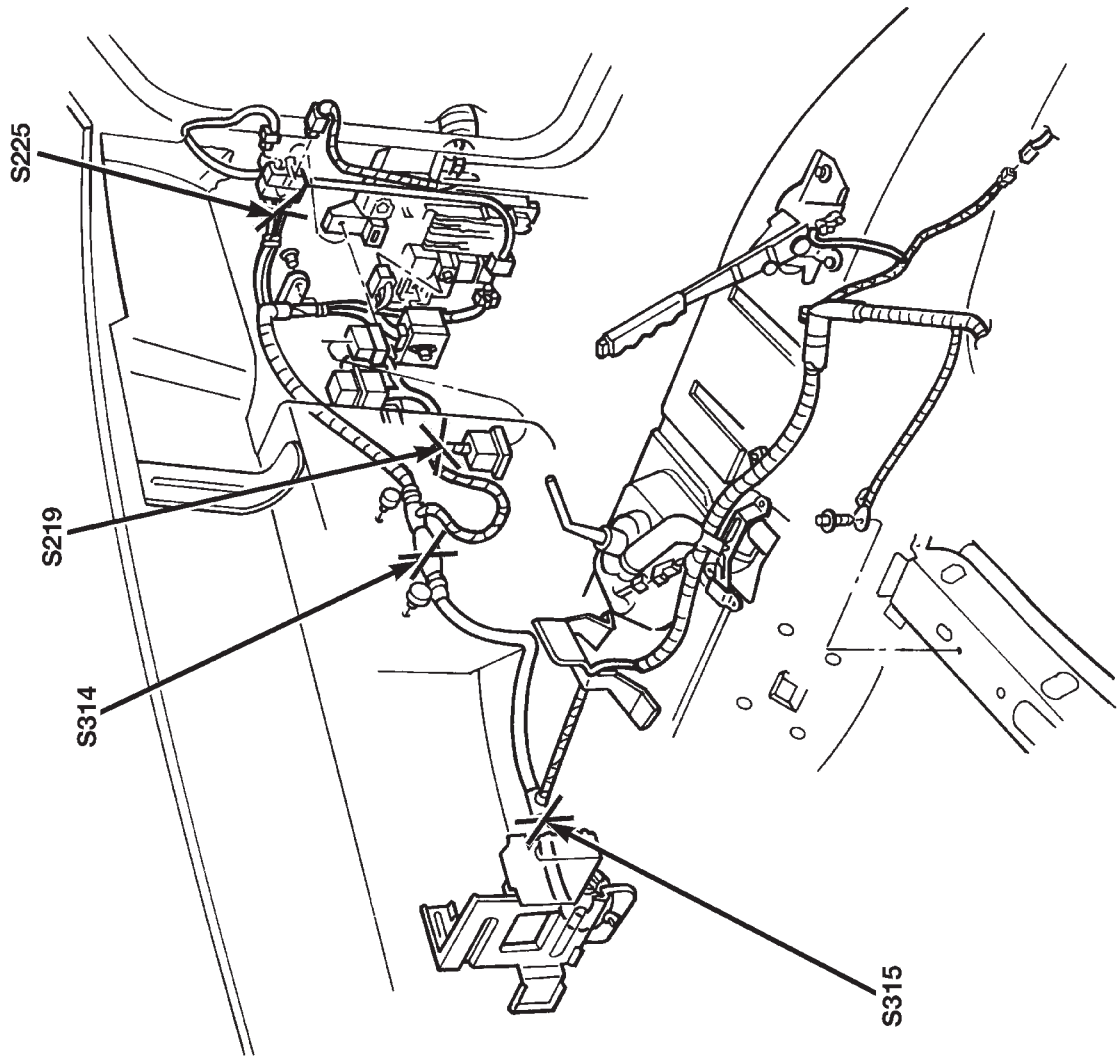
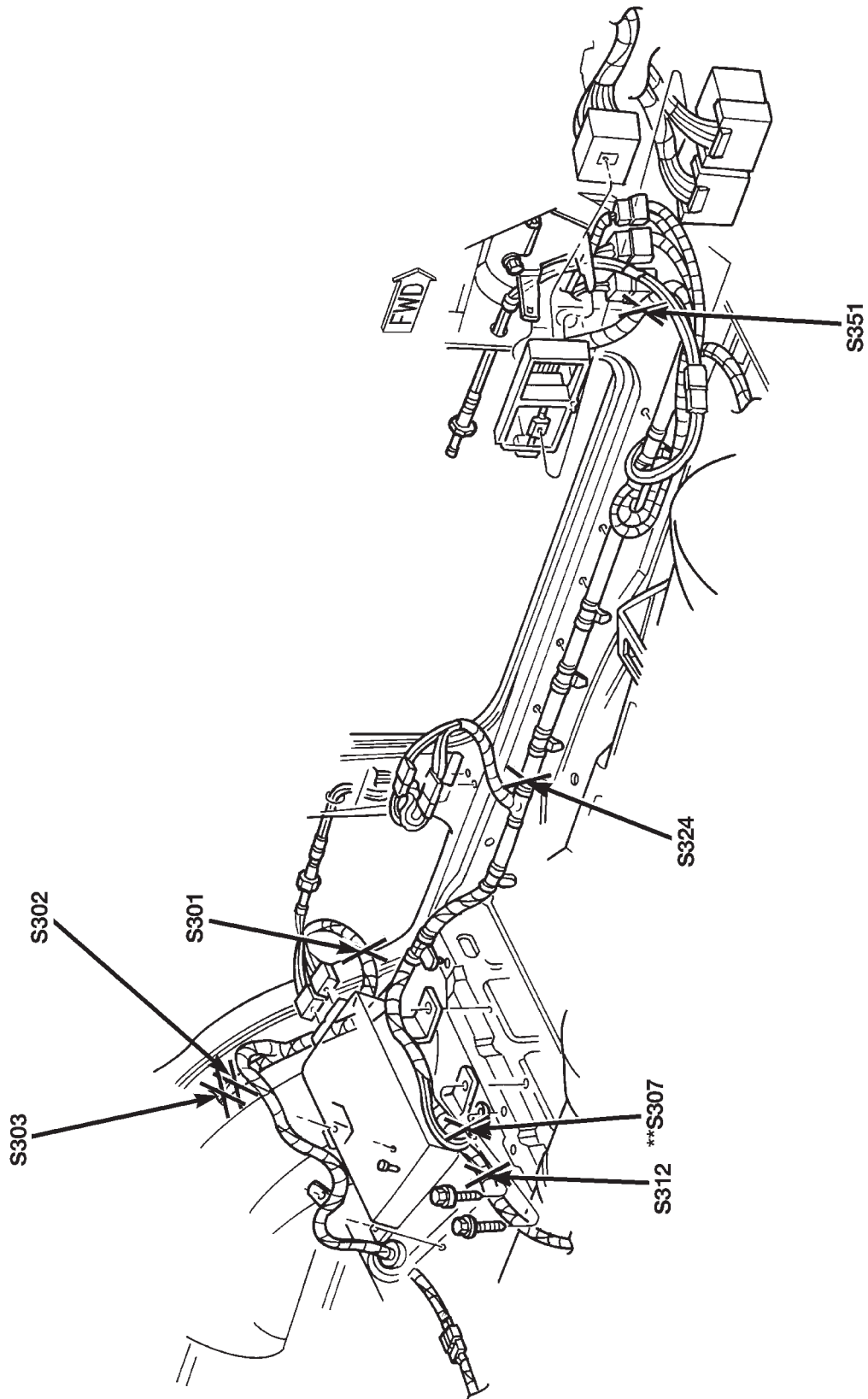

Fig. 14 Instrument Panel to Body Harness Splices

DESCRIPTION AND OPERATION (Continued)

80bed796



** LHD WITHOUT POWER AMPLIFIER

Fig. 15 Left Side Body Harness Splices

DESCRIPTION AND OPERATION (Continued)

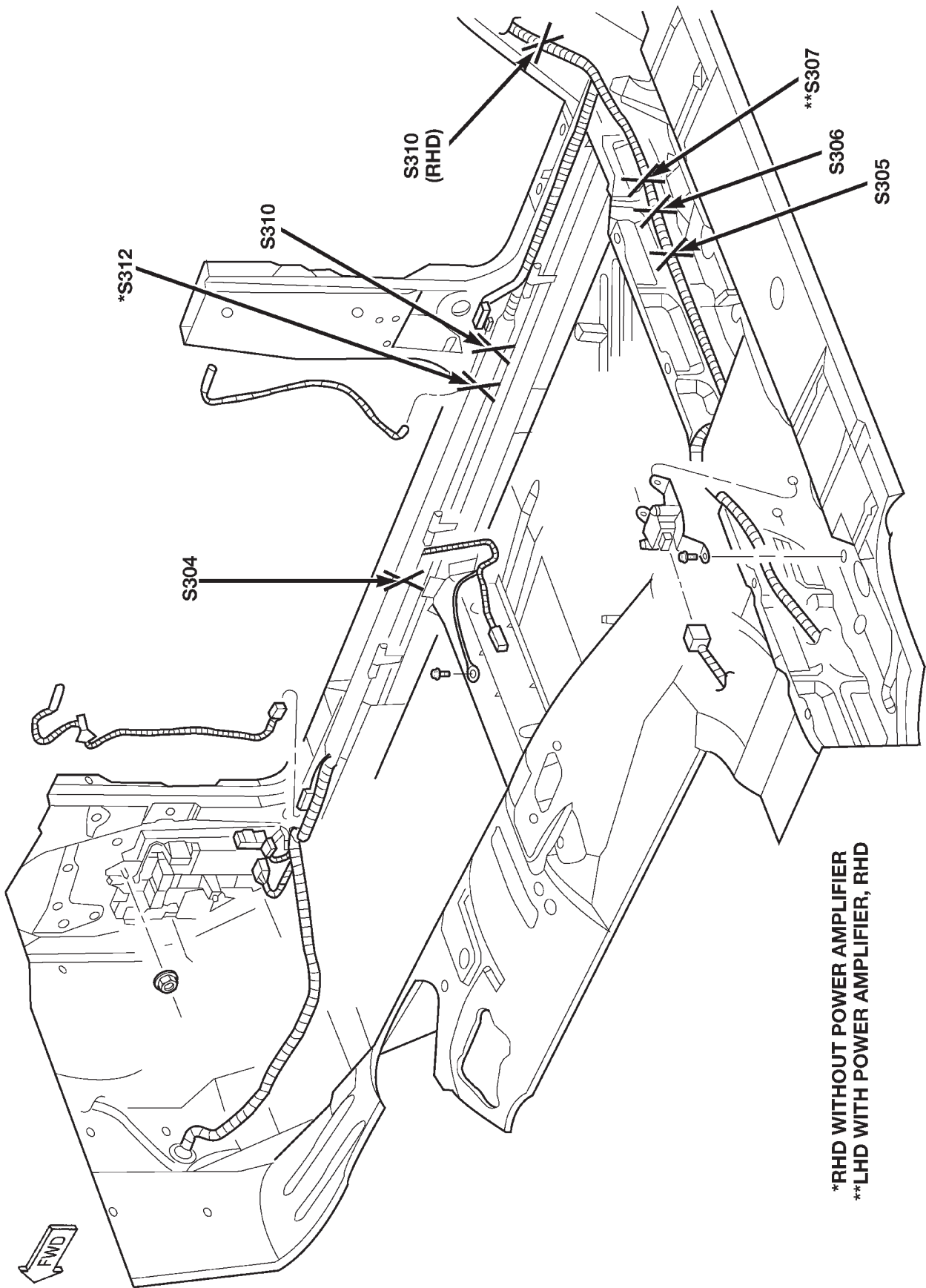

80be4797

Fig. 16 Right Side Body Harness Splices

DESCRIPTION AND OPERATION (Continued)

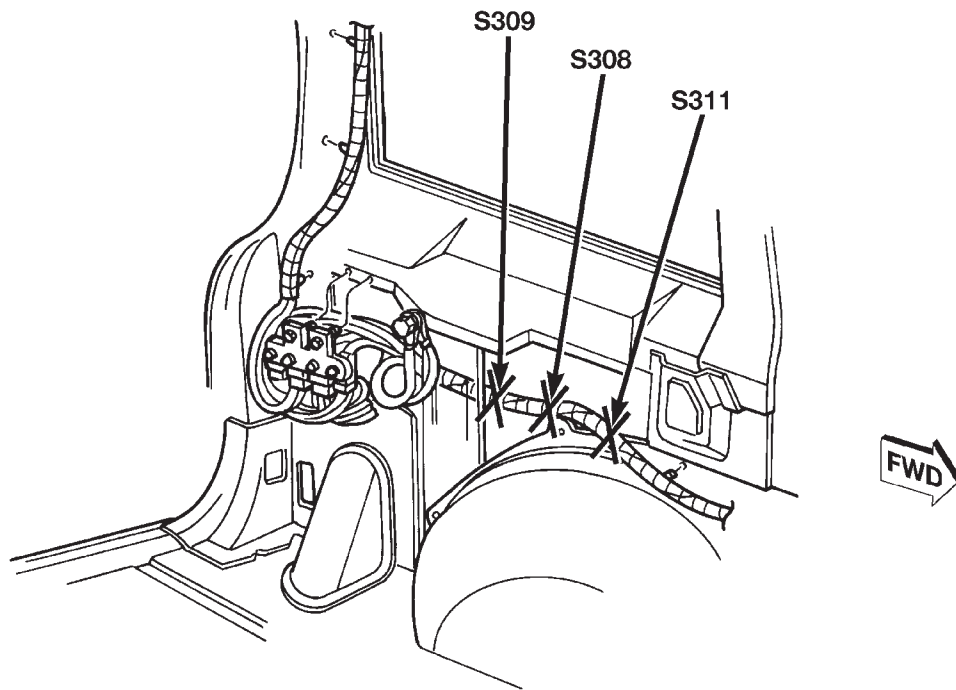

Fig. 17 Left Side Body Harness Splices

80be4798

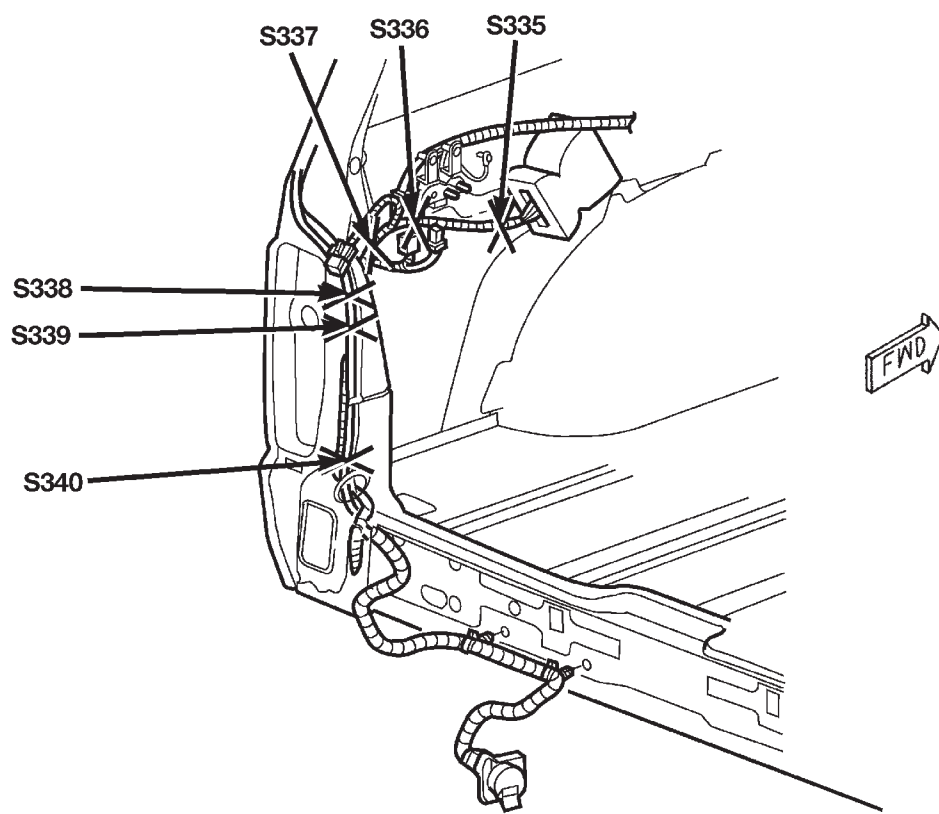

Fig. 18 Trailer Tow Splices

80be4799

DESCRIPTION AND OPERATION (Continued)

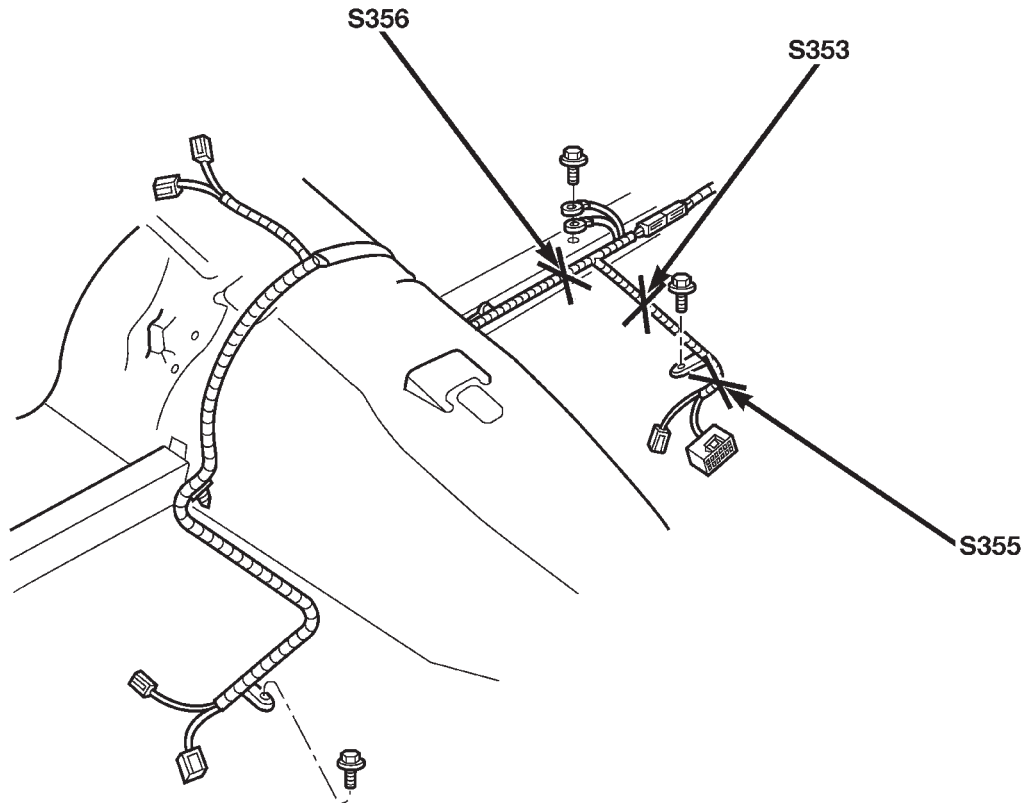

Fig. 19 Power Seat Splices

80be479a

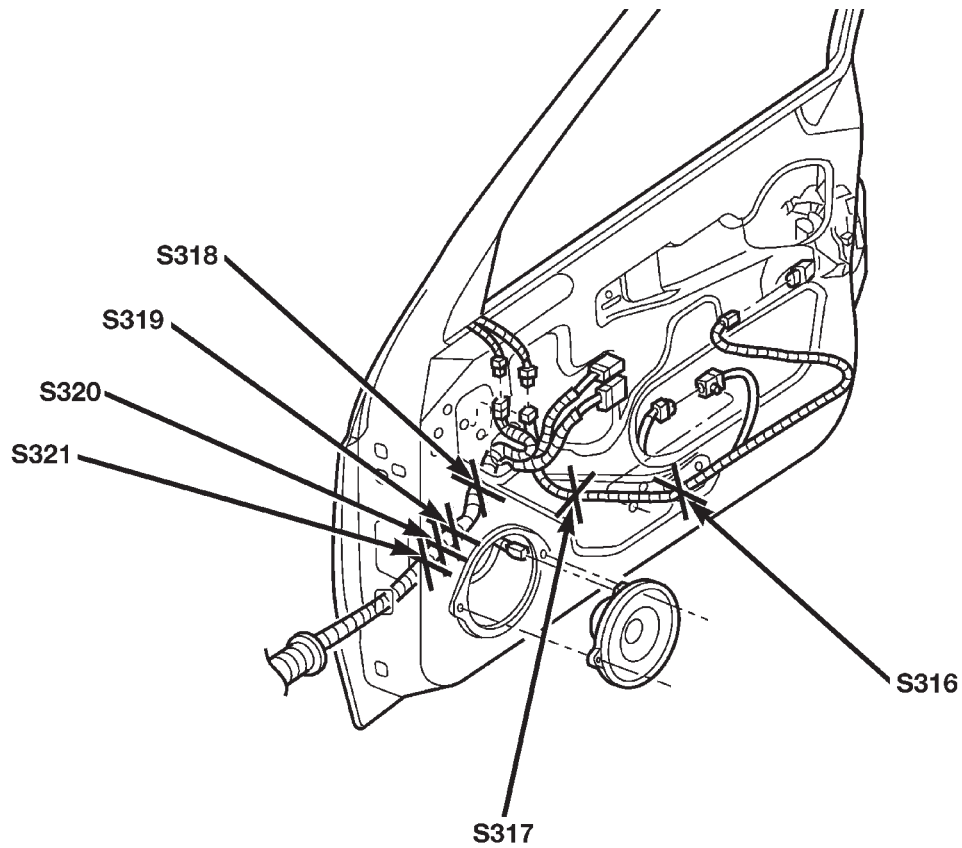

Fig. 20 Right Front Door Splices

80be479b

DESCRIPTION AND OPERATION (Continued)

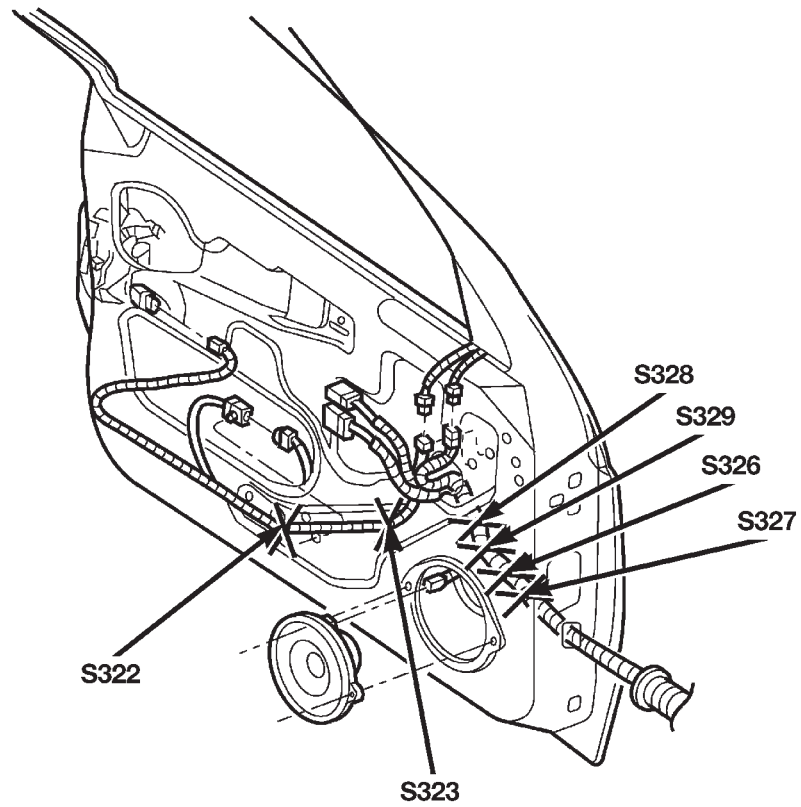

Fig. 21 Left Front Door Splices

80be479c

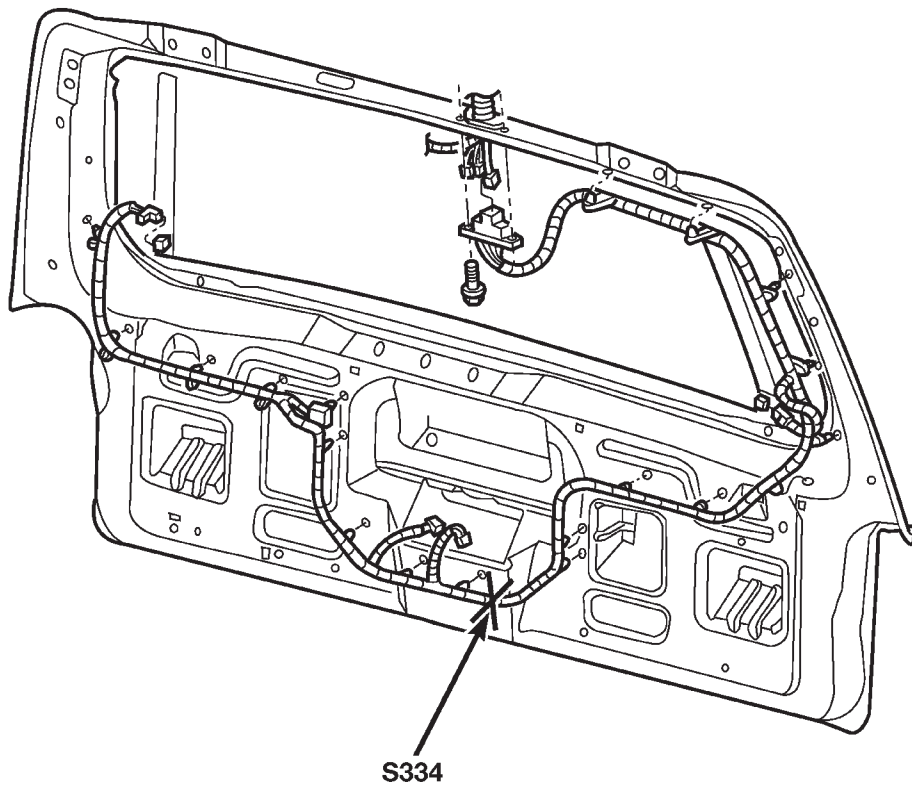
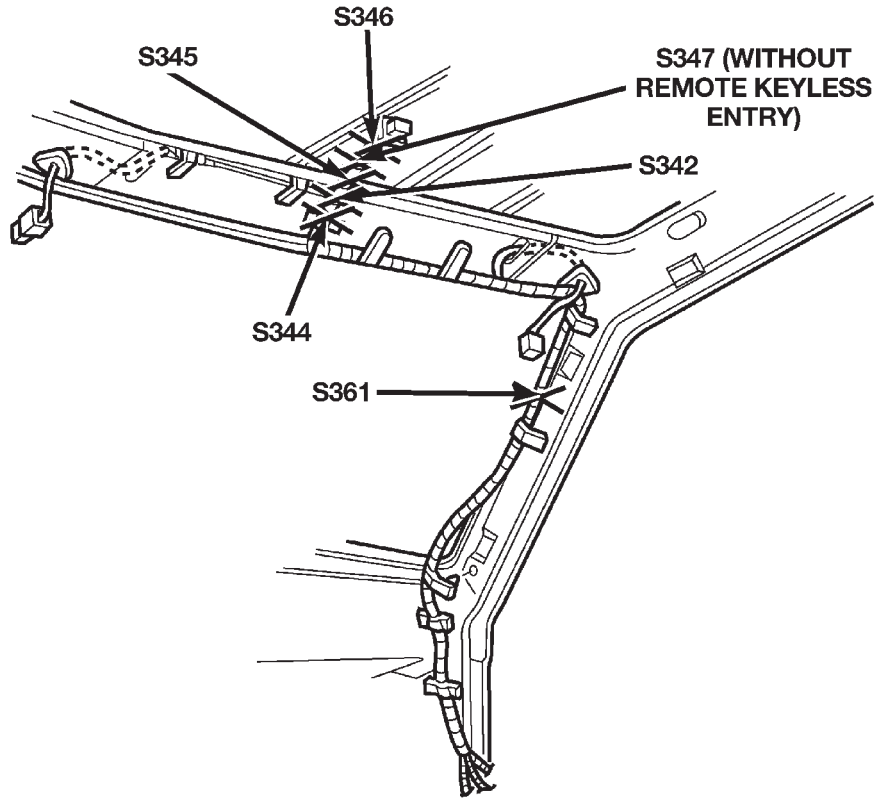

Fig. 22 Liftgate Splices

80be479e

DESCRIPTION AND OPERATION (Continued)



80be479f

Fig. 23 Headliner Splices

DESCRIPTION AND OPERATION (Continued)

80be47a0

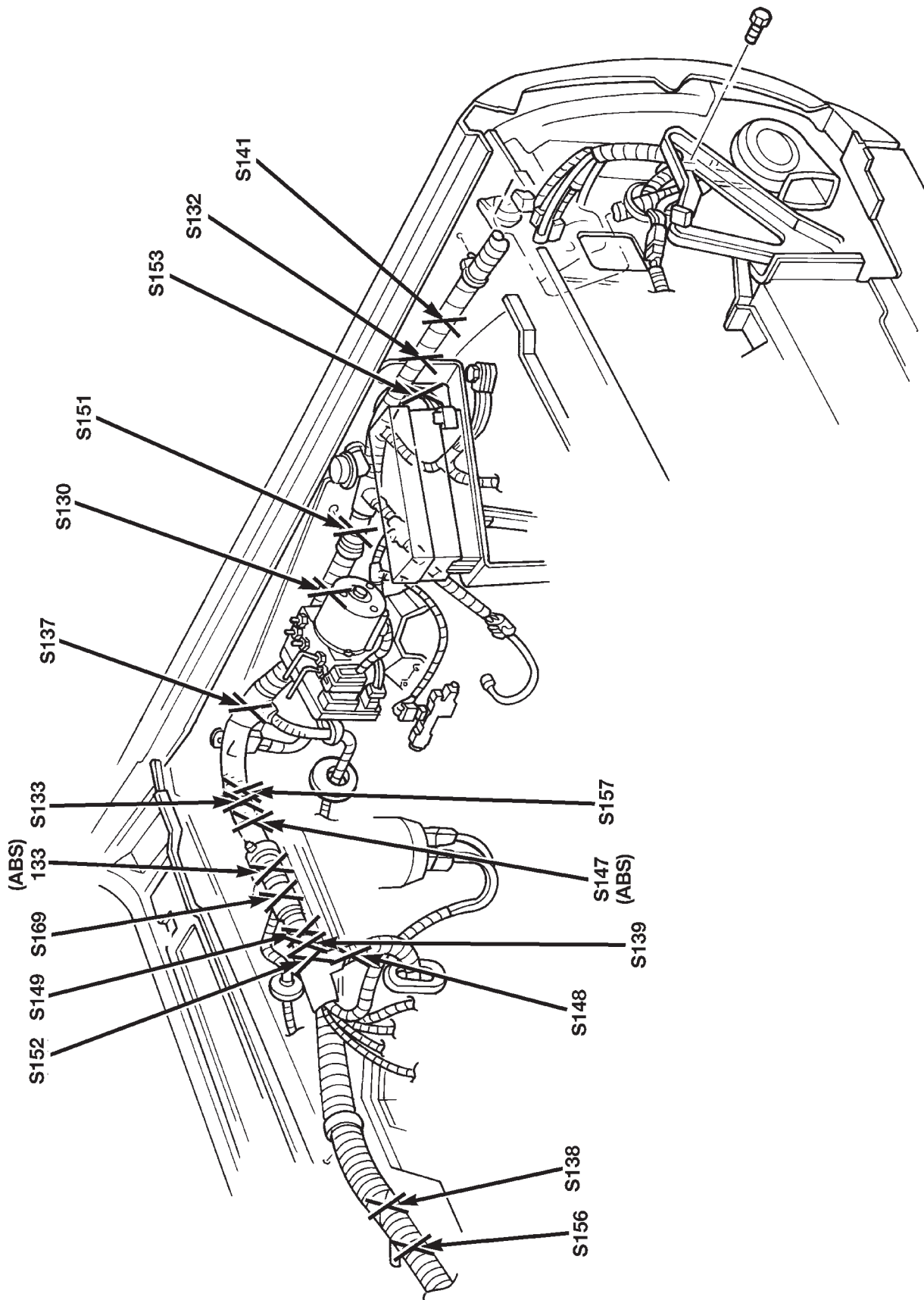

Fig. 24 Left Engine Compartment Splices Diesel LHD

DESCRIPTION AND OPERATION (Continued)

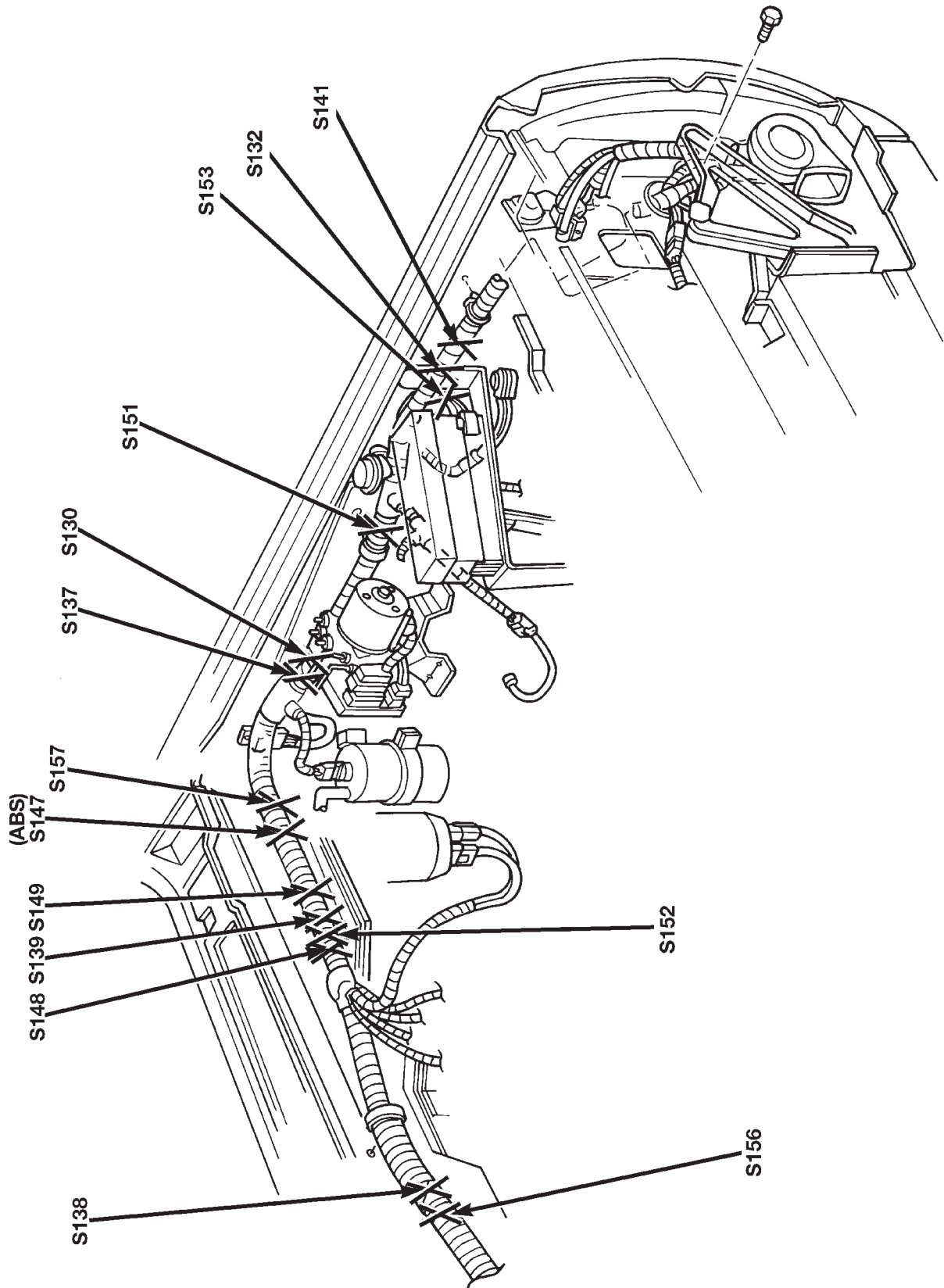

Fig. 25 Left Engine Compartment Splices Diesel RHD

80bed7a1

DESCRIPTION AND OPERATION (Continued)

80be47a2

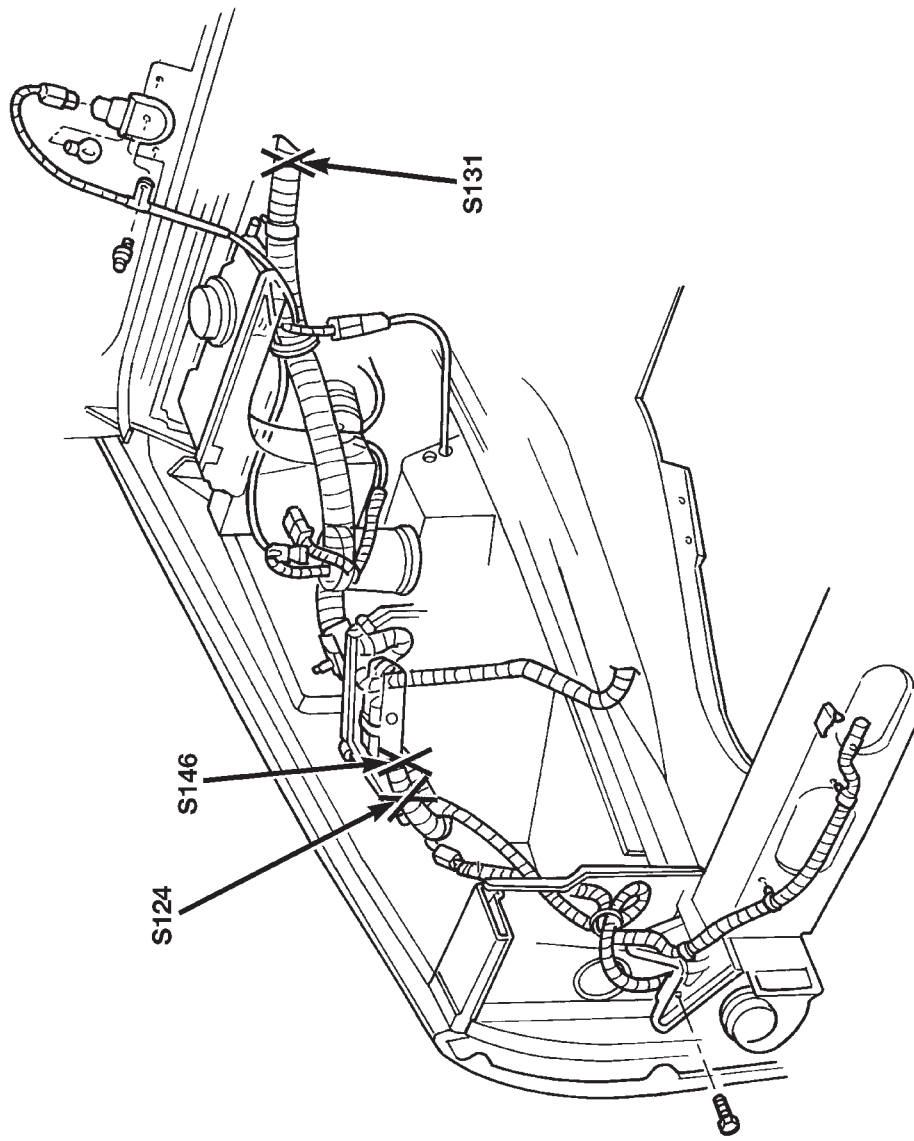
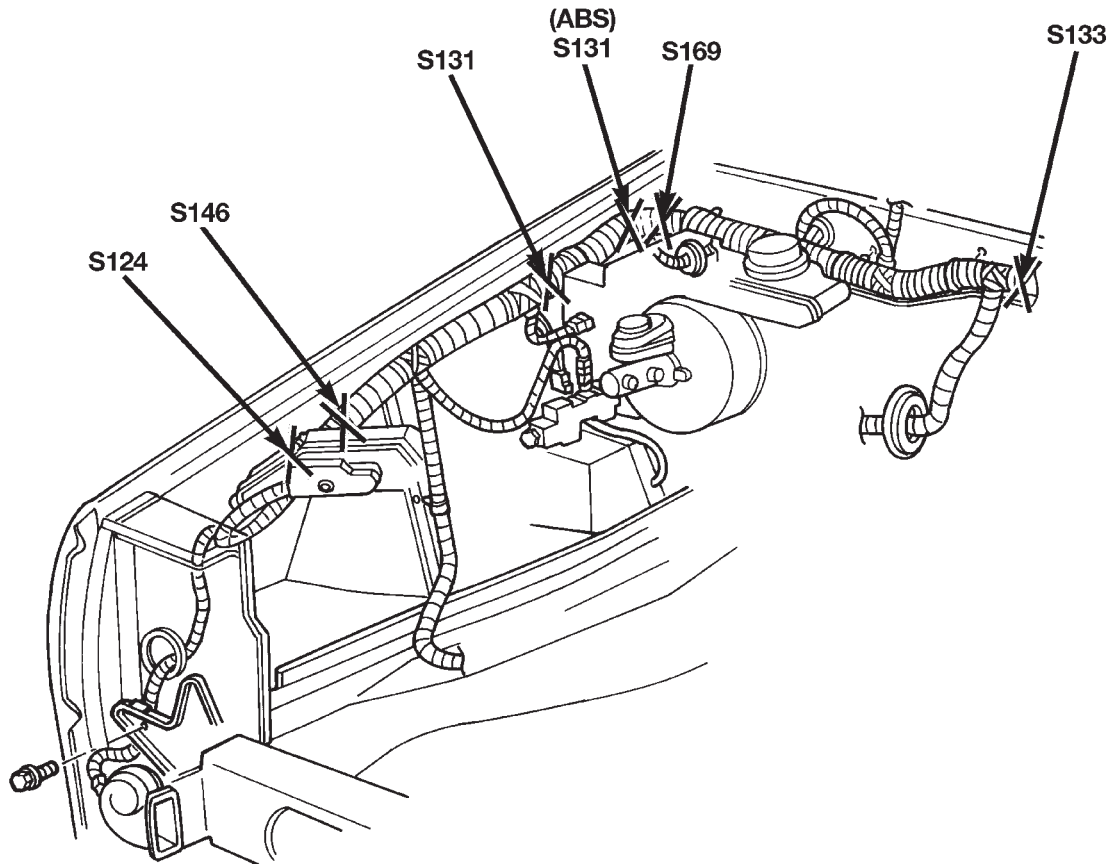

Fig. 26 Right Engine Compartment Splices Diesel LHD

DESCRIPTION AND OPERATION (Continued)



80be47a3

Fig. 27 Right Engine Compartment Splices Diesel RHD

ENGINE

TABLE OF CONTENTS

| | page | | page |
|------------------|------|------------------|------|
| 2.5L ENGINE..... | 1 | 4.0L ENGINE..... | 61 |

2.5L ENGINE

TABLE OF CONTENTS

| | page | | page |
|--|------|---|------|
| DESCRIPTION AND OPERATION | | | |
| ENGINE..... | 2 | REPAIR DAMAGED OR WORN THREADS..... | 27 |
| LUBRICATION SYSTEM..... | 2 | SERVICE ENGINE ASSEMBLY (SHORT BLOCK).... | 27 |
| CYLINDER BLOCK..... | 5 | HYDROSTATIC LOCK..... | 27 |
| CYLINDER HEAD..... | 5 | ENGINE OIL SERVICE..... | 27 |
| CRANKSHAFT..... | 5 | REMOVAL AND INSTALLATION | |
| PISTON AND CONNECTING ROD..... | 6 | ENGINE MOUNTS—FRONT..... | 29 |
| CAMSHAFT..... | 6 | ENGINE MOUNT—REAR..... | 30 |
| ROCKER ARM..... | 6 | ENGINE..... | 31 |
| VALVES..... | 6 | INTAKE MANIFOLD..... | 33 |
| VALVE SPRING..... | 7 | EXHAUST MANIFOLD..... | 35 |
| CYLINDER HEAD COVER..... | 7 | CYLINDER HEAD COVER..... | 35 |
| HYDRAULIC TAPPET..... | 7 | ROCKER ARMS AND PUSH RODS..... | 36 |
| VALVE GUIDE..... | 7 | VALVE SPRING AND SEAL..... | 37 |
| OIL PAN..... | 7 | CYLINDER HEAD..... | 38 |
| VALVE STEM SEAL..... | 8 | CYLINDER HEAD..... | 40 |
| INTAKE MANIFOLD..... | 8 | HYDRAULIC TAPPETS..... | 40 |
| EXHAUST MANIFOLD..... | 8 | VIBRATION DAMPER..... | 41 |
| DIAGNOSIS AND TESTING | | | |
| ENGINE DIAGNOSIS—INTRODUCTION..... | 8 | TIMING CASE COVER OIL SEAL..... | 41 |
| SERVICE DIAGNOSIS—PERFORMANCE..... | 9 | TIMING CASE COVER..... | 42 |
| SERVICE DIAGNOSIS—MECHANICAL..... | 10 | TIMING CHAIN AND SPROCKETS..... | 43 |
| INTAKE MANIFOLD LEAKAGE DIAGNOSIS..... | 13 | CAMSHAFT..... | 44 |
| CYLINDER COMPRESSION PRESSURE TEST .. | 13 | CAMSHAFT PIN REPLACEMENT..... | 45 |
| ENGINE CYLINDER HEAD GASKET FAILURE | | CAMSHAFT BEARINGS..... | 47 |
| DIAGNOSIS..... | 13 | CRANKSHAFT MAIN BEARINGS..... | 47 |
| CYLINDER COMBUSTION PRESSURE | | OIL PAN..... | 49 |
| LEAKAGE TEST..... | 13 | OIL PUMP..... | 50 |
| ENGINE OIL LEAK INSPECTION..... | 14 | PISTON AND CONNECTING ROD..... | 51 |
| ENGINE OIL PRESSURE..... | 15 | REAR MAIN OIL SEAL..... | 52 |
| SERVICE PROCEDURES | | | |
| VALVE TIMING..... | 15 | DISASSEMBLY AND ASSEMBLY | |
| VALVE, GUIDE AND SEAL..... | 15 | CYLINDER BLOCK..... | 53 |
| PISTON—FITTING..... | 17 | CLEANING AND INSPECTION | |
| PISTON RING—FITTING..... | 18 | ROCKER ARMS AND PUSH RODS..... | 53 |
| CONNECTING ROD BEARINGS—FITTING..... | 21 | ENGINE CYLINDER HEAD..... | 54 |
| FITTING CRANKSHAFT MAIN BEARINGS..... | 23 | CYLINDER BLOCK..... | 54 |
| FORM-IN-PLACE GASKETS..... | 25 | SPECIFICATIONS | |
| ENGINE PERFORMANCE..... | 26 | ENGINE SPECIFICATIONS..... | 55 |
| HONING CYLINDER BORES..... | 26 | SPECIFICATIONS—TORQUE..... | 59 |
| | | SPECIAL TOOLS | |
| | | 2.5L ENGINE SPECIAL TOOLS..... | 60 |

DESCRIPTION AND OPERATION

ENGINE

DESCRIPTION

The 2.5 liter (150 CID) four-cylinder engine is an In-line, lightweight, overhead valve engine.

This engine is designed for unleaded fuel. The engine cylinder head has dual quench-type combustion chambers that create turbulence and fast burning of the air/fuel mixture. This results in good fuel economy.

The cylinders are numbered 1 through 4 from front to rear. The firing order is 1-3-4-2 (Fig. 1).

The crankshaft rotation is clockwise, when viewed from the front of the engine. The crankshaft rotates within five main bearings and the camshaft rotates within four bearings.

The engine Build Date Code is located on a machined surface on the right side of the cylinder block between the No.3 and No.4 cylinders (Fig. 2).

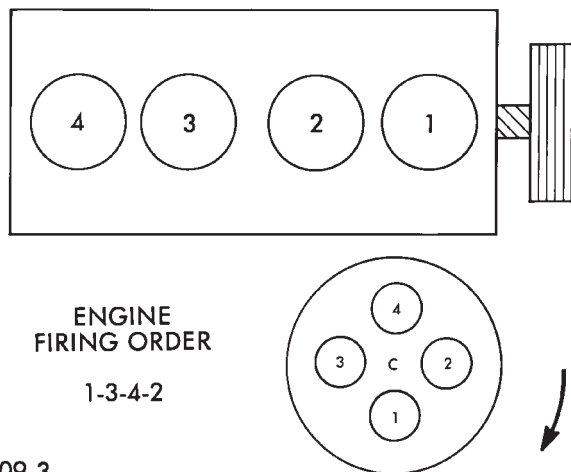

Fig. 1 Engine Firing Order

The digits of the code identify:

- 1st Digit—The year (8 = 1998).
- 2nd & 3rd Digits—The month (01 - 12).
- 4th & 5th Digits—The engine type/fuel system/compression ratio (HX = A 2.5 liter (150 CID) 9.1:1 compression ratio engine with a multi-point fuel injection system).

- 6th & 7th Digits—The day of engine build (01 - 31).

FOR EXAMPLE: Code * 801HX23 * identifies a 2.5 liter (150 CID) engine with a multi-point fuel injection system, 9.1:1 compression ratio and built on January 23, 1998.

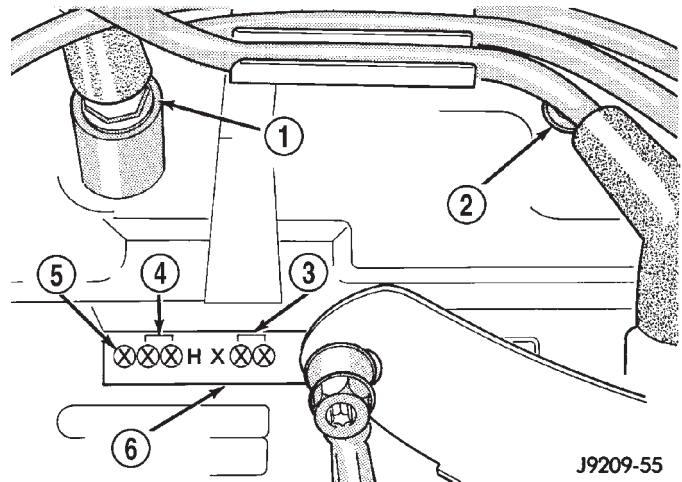

Fig. 2 Build Date Code Location

- 1 - NO. 4 CYLINDER
- 2 - NO. 3 CYLINDER
- 3 - DAY
- 4 - MONTH
- 5 - YEAR
- 6 - MACHINED SURFACE

LUBRICATION SYSTEM

DESCRIPTION

A gear-type positive displacement pump is mounted at the underside of the block opposite the No. 4 main bearing.

OPERATION

The pump draws oil through the screen and inlet tube from the sump at the rear of the oil pan. The oil is driven between the drive and idler gears and pump body, then forced through the outlet to the block. An oil gallery in the block channels the oil to the inlet side of the full flow oil filter. After passing through the filter element, the oil passes from the center outlet of the filter through an oil gallery that channels the oil up to the main gallery which extends the entire length of the block.

Galleries extend downward from the main oil gallery to the upper shell of each main bearing. The crankshaft is drilled internally to pass oil from the main bearing journals (except number 4 main bearing journal) to the connecting rod journals. Each connecting rod bearing cap has a small squirt hole, oil passes through the squirt hole and is thrown off as the rod rotates. This oil throwoff lubricates the camshaft lobes, distributor drive gear, cylinder walls, and piston pins.

The hydraulic valve tappets receive oil directly from the main oil gallery. Oil is provided to the camshaft bearing through galleries. The front camshaft bearing journal passes oil through the camshaft

DESCRIPTION AND OPERATION (Continued)

sprocket to the timing chain. Oil drains back to the oil pan under the number one main bearing cap.

The oil supply for the rocker arms and bridged pivot assemblies is provided by the hydraulic valve tappets which pass oil through hollow push rods to a

hole in the corresponding rocker arm. Oil from the rocker arm lubricates the valve train components, then passes down through the push rod guide holes in the cylinder head past the valve tappet area, and returns to the oil pan.

DESCRIPTION AND OPERATION (Continued)

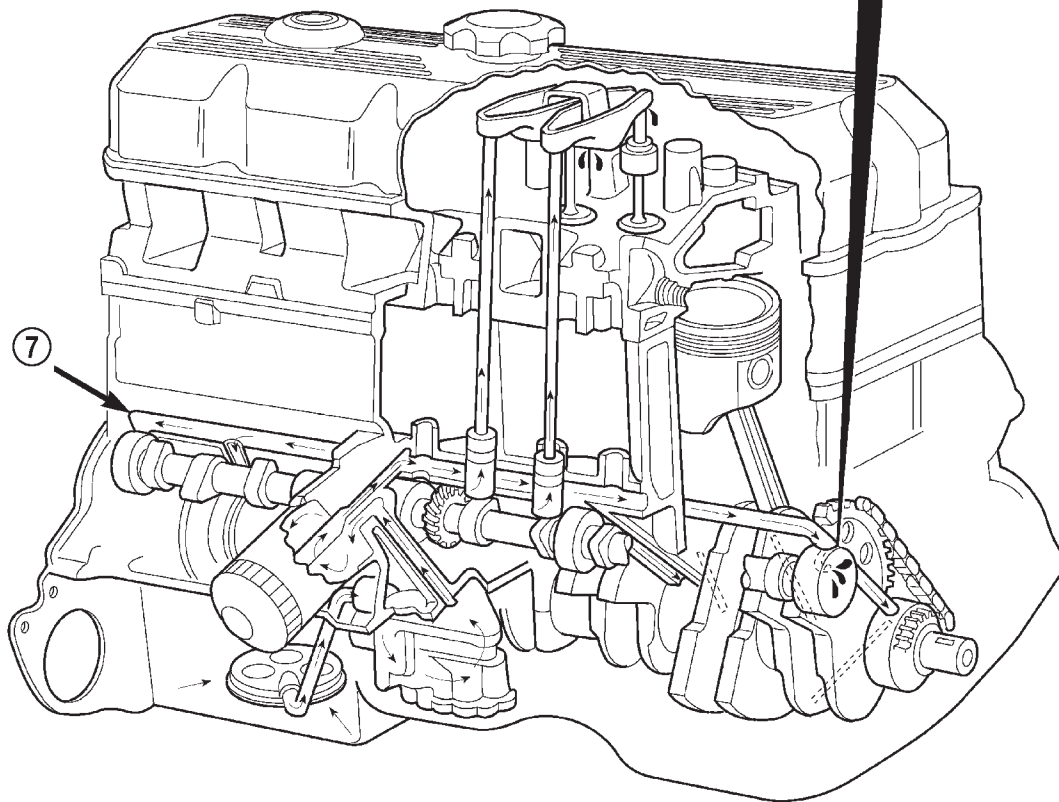
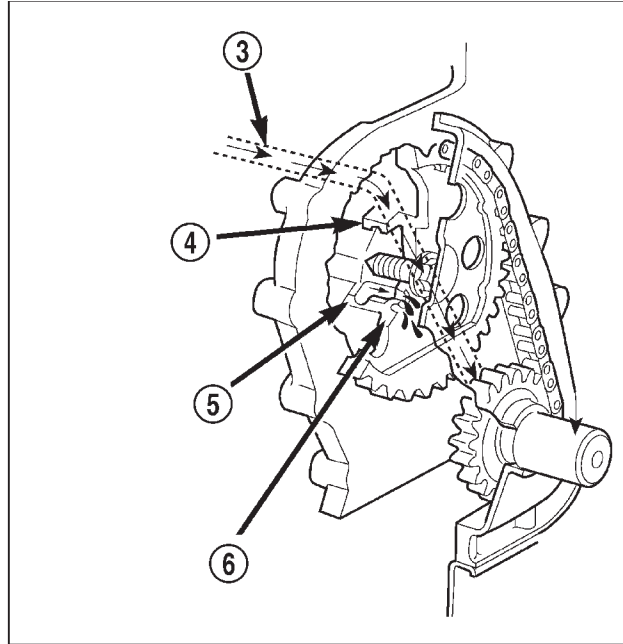
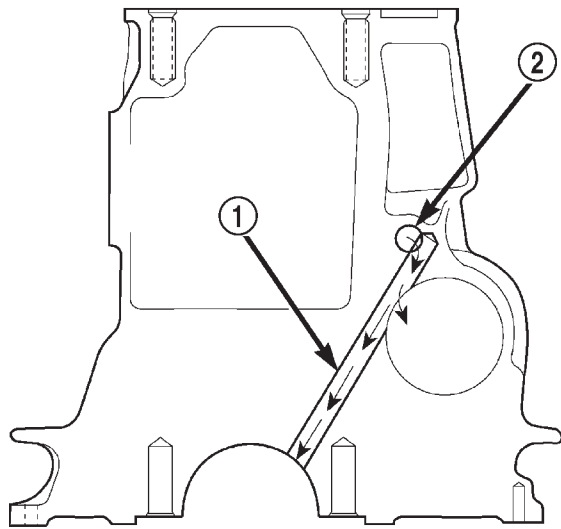

Oil Lubrication System—2.5L Engine

80be47c8

- 1 - CAM/CRANK MAIN GALLERY (7)
- 2 - TAPPET GALLERY
- 3 - TAPPET GALLERY
- 4 - CAMSHAFT BEARING

- 5 - NUMBER 1 CAMSHAFT BEARING JOURNAL
- 6 - CAMSHAFT SPROCKET
- 7 - TAPPET GALLERY

DESCRIPTION AND OPERATION (Continued)

CYLINDER BLOCK

DESCRIPTION

The cylinder block is a cast iron inline four cylinder design. The cylinder block is drilled forming galleries for both oil and coolant.

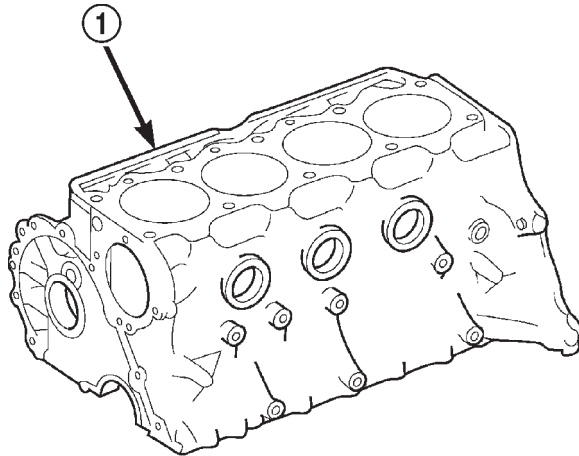

80be4676

Fig. 3 Cylinder Block—2.5L

- 1 - CYLINDER BLOCK

CYLINDER HEAD

DESCRIPTION

The cylinder head is made of cast iron containing eight valves made of chrome plated heat resistant steel, valve stem seals, springs, retainers and keepers. The cylinder head, valve seats and guides can be resurfaced for service purposes.

The cylinder head uses dual quench-type design combustion chambers which cause turbulence in the cylinders allowing faster burning of the air/fuel mixture, resulting in better fuel economy.

The valve guides are integral to the cylinder head. They are not replaceable. However, they are serviceable.

CRANKSHAFT

DESCRIPTION

The crankshaft is constructed of nodular cast iron.

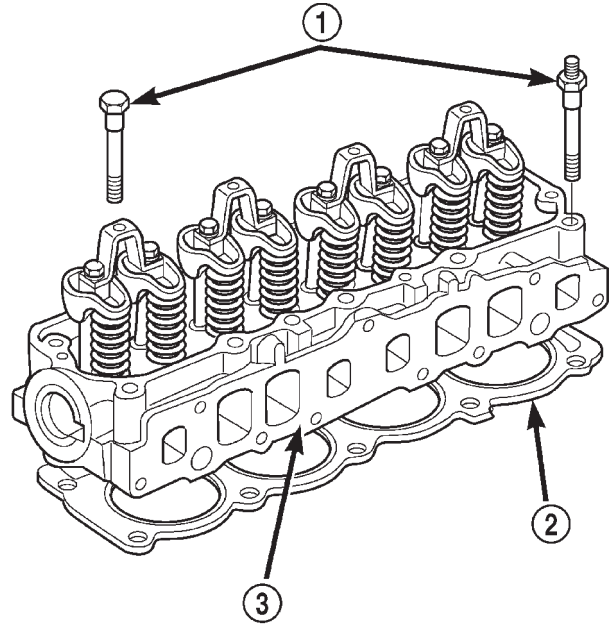

80be4674

Fig. 4 Cylinder Head

- 1 - CYLINDER HEAD BOLTS
- 2 - CYLINDER HEAD GASKET
- 3 - CYLINDER HEAD

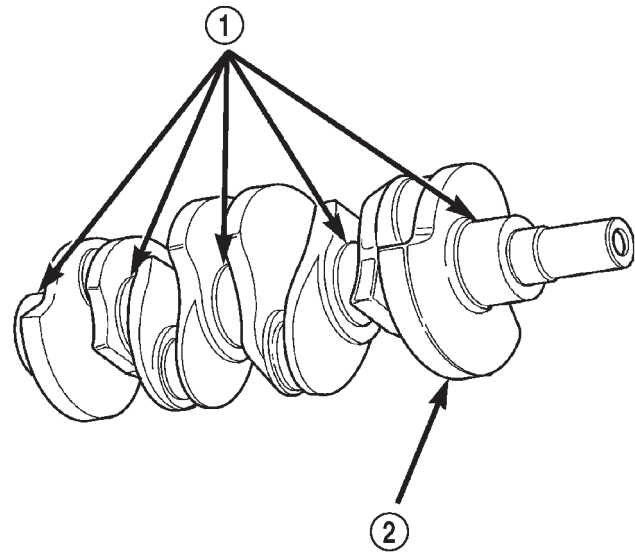

80bcea52

Fig. 5 Crankshaft—Typical

- 1 - MAIN BEARING JOURNALS
- 2 - COUNTER BALANCE WEIGHTS

DESCRIPTION AND OPERATION (Continued)

PISTON AND CONNECTING ROD

DESCRIPTION

The pistons are made of a high strength aluminum alloy, the piston skirts are coated with a solid lubricant (Molykote) to reduce friction and provide scuff resistance. The connecting rods are made of cast iron.

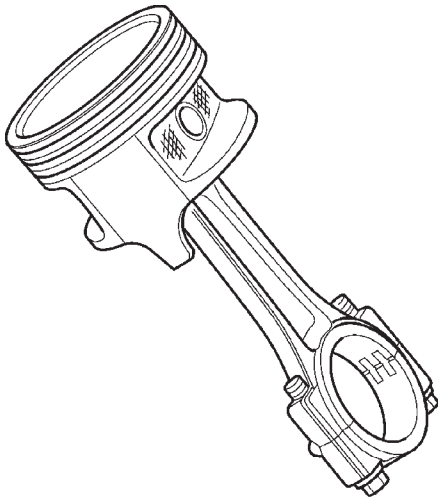

80bcea5c

Fig. 6 Piston and Connecting Rod Assembly

CAMSHAFT

DESCRIPTION

The camshaft is made of cast iron with eight machined lobes and four bearing journals.

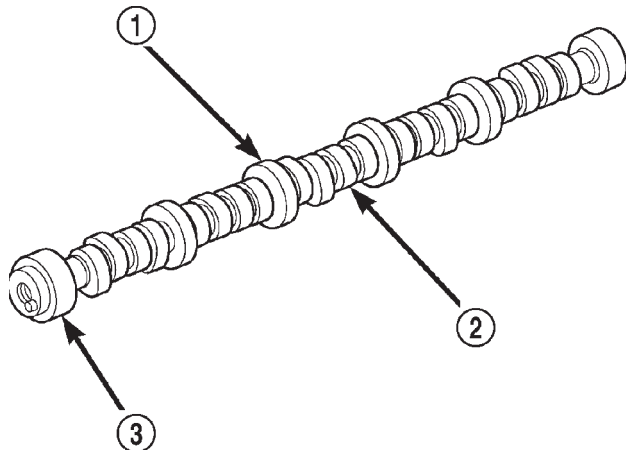

80be4673

Fig. 7 Camshaft—Typical

- 1 - CAMSHAFT
- 2 - LOBES
- 3 - BEARING JOURNAL

OPERATION

When the camshaft rotates, the lobes actuate the tappets and push rods forcing upward on the rocker arms which applies downward force on the valves.

ROCKER ARM

DESCRIPTION

The rocker arms are made of stamped steel and have a operational ratio of 1.6:1.

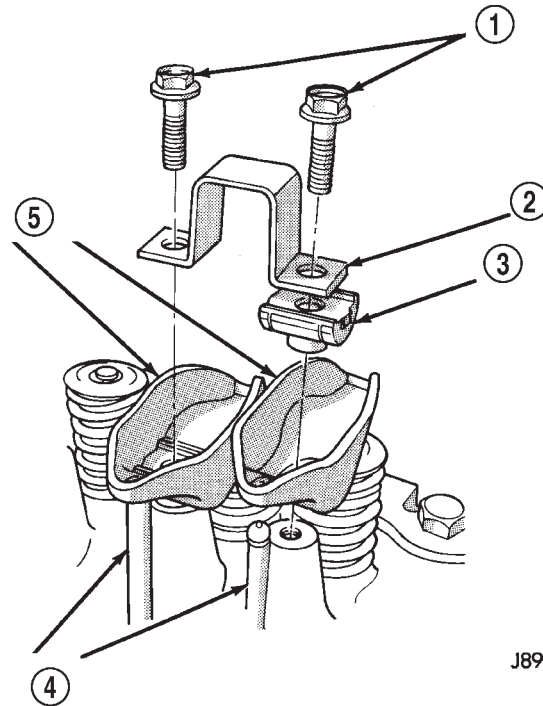

J8909-8

Fig. 8 Rocker Arms—Typical

- 1 - CAPSCREWS
- 2 - BRIDGE
- 3 - PIVOT ASSEMBLY
- 4 - PUSH RODS
- 5 - ROCKER ARMS

OPERATION

When the push rods are forced upward by the camshaft lobes the push rod presses upward on the rocker arms, the rocker arms pivot, forcing downward pressure on the valves forcing the valves to move downward and off from their seats.

VALVES

DESCRIPTION

The valves are made of heat resistant steel and have chrome plated stems to prevent scuffing. All valves use three bead lock keepers to retain the valve spring and promote valve rotation (Fig. 9).

DESCRIPTION AND OPERATION (Continued)

VALVE SPRING

DESCRIPTION

The valve springs are made of high strength chrome silicon steel. The springs are common for both intake and exhaust valves.

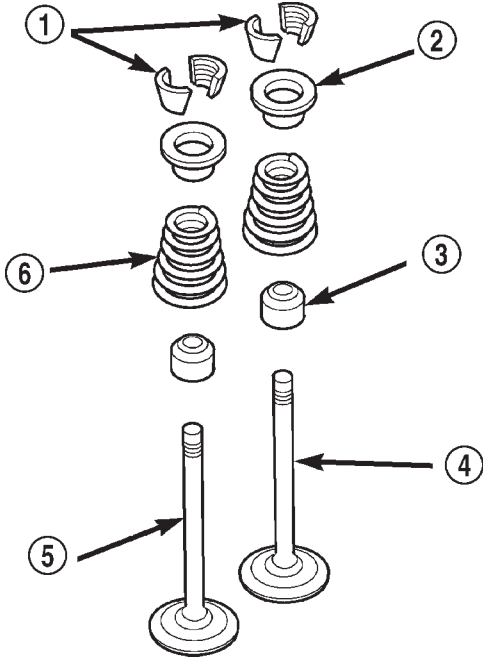

80b7704b

Fig. 9 Valve and Keeper Configuration 2.5L Engine

- 1 - VALVE LOCKS (3-BEAD)
- 2 - RETAINER
- 3 - VALVE STEM OIL SEAL
- 4 - INTAKE VALVE
- 5 - EXHAUST VALVE
- 6 - VALVE SPRING

CYLINDER HEAD COVER

DESCRIPTION

The cylinder head cover is made of die cast aluminum and incorporates the Crankcase Ventilation (CCV) Hoses and the oil fill opening.

HYDRAULIC TAPPET

DESCRIPTION

Valve lash is controlled by hydraulic tappets located inside the cylinder block, in tappet bores above the camshaft.

VALVE GUIDE

DESCRIPTION

The valve guides are integral to the cylinder head. They are not replaceable. However, they are serviceable.

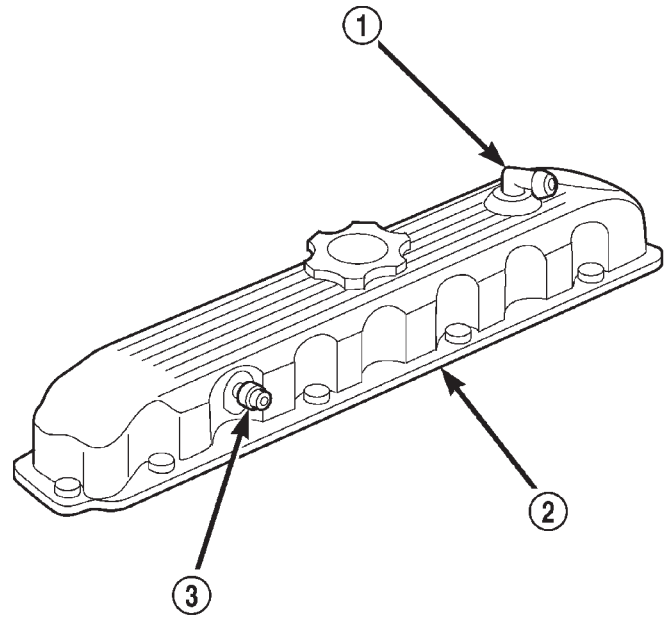

80be4679

Fig. 10 Cylinder Head Cover

- 1 - AIR INLET FITTING
- 2 - CYLINDER HEAD COVER
- 3 - FIXED ORIFICE FITTING

OIL PAN

DESCRIPTION

The oil pan is made of stamped steel. The oil pan gasket is a one piece steel backbone silicone coated gasket.

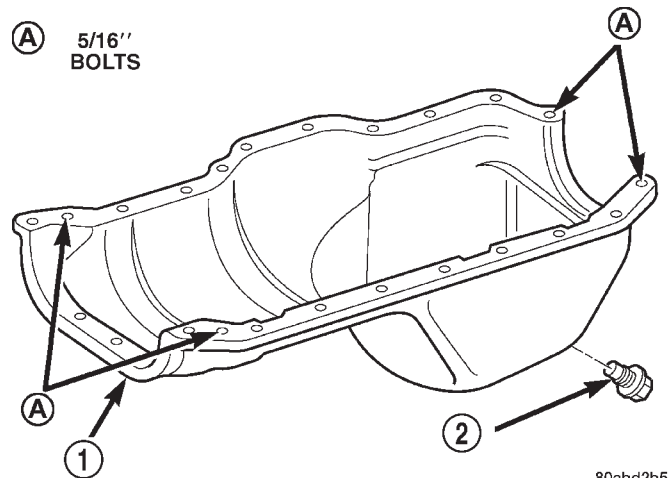

80abd2b5

Fig. 11 Oil Pan

- 1 - OIL PAN
- 2 - OIL PAN DRAIN PLUG

DESCRIPTION AND OPERATION (Continued)

VALVE STEM SEAL

DESCRIPTION

The valve stem seals are made of rubber and incorporate a garter spring to maintain consistent lubrication control (Fig. 9).

INTAKE MANIFOLD

DESCRIPTION

The intake manifold is made of cast aluminum and uses seven bolts to mount to the cylinder head. This mounting style improves sealing and reduces the chance of leaks.

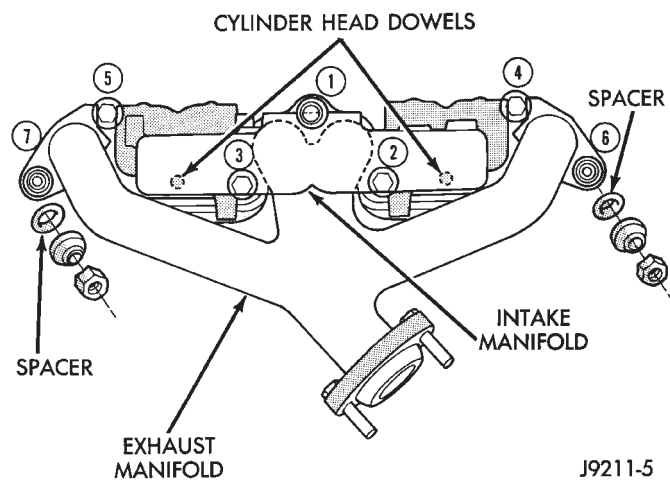

Fig. 12 Intake and Exhaust Manifold

EXHAUST MANIFOLD

DESCRIPTION

The exhaust manifold is log style and is made of high silicon molybdenum cast iron. The exhaust manifold shares a common gasket with the intake manifold. The exhaust manifold also incorporates a ball flange outlet for improved sealing and strain free connections (Fig. 12).

DIAGNOSIS AND TESTING

ENGINE DIAGNOSIS—INTRODUCTION

Engine diagnosis is helpful in determining the causes of malfunctions not detected and remedied by routine maintenance.

These malfunctions may be classified as either performance (e.g., engine idles rough and stalls) or mechanical (e.g., a strange noise).

Refer to the Service Diagnosis—Performance chart and the Service Diagnosis—Mechanical chart for possible causes and corrections of malfunctions. Refer to Group 14, Fuel System for the fuel system diagnosis.

Additional tests and diagnostic procedures may be necessary for specific engine malfunctions that can not be isolated with the Service Diagnosis charts. Information concerning additional tests and diagnosis is provided within the following diagnosis:

- Cylinder Compression Pressure Test.
- Cylinder Combustion Pressure Leakage Test.
- Engine Cylinder Head Gasket Failure Diagnosis.
- Intake Manifold Leakage Diagnosis.

DIAGNOSIS AND TESTING (Continued)

SERVICE DIAGNOSIS—PERFORMANCE

ENGINE PERFORMANCE DIAGNOSIS CHART

| CONDITION | POSSIBLE CAUSES | CORRECTION |
|----------------------------------|--|--|
| ENGINE WILL NOT CRANK | <ol style="list-style-type: none"> 1. Weak or dead battery 2. Corroded or loose battery connections 3. Faulty starter or related circuit(s) 4. Siezed accessory drive component 5. Engine internal mechanical failure or hydro-static lock | <ol style="list-style-type: none"> 1. Charge/Replace Battery. Refer to Group 8A, Battery, for correct procedures. Check charging system. Refer to Group 8C, Charging Systems, for correct procedures. 2. Clean/tighten suspect battery/ starter connections 3. Check starting system. Refer to Group 8B, Starting Systems, for correct diagnostics/procedures 4. Remove accessory drive belt and attempt to start engine. If engine starts, repair/replace siezed component. 5. Refer to Group 9, Engine, for correct diagnostics/procedures |
| ENGINE CRANKS BUT WILL NOT START | <ol style="list-style-type: none"> 1. No spark 2. No fuel 3. Low or no engine compression | <ol style="list-style-type: none"> 1. Check for spark. Refer to Group 8D, Ignition System, for correct procedures. 2. Perform fuel pressure test, and if necessary, inspect fuel injector(s) and driver circuits. Refer to Group 14, Fuel System, for correct procedures. 3. Perform cylinder compression pressure test. Refer to Group 9, Engine, for correct procedures. |
| ENGINE LOSS OF POWER | <ol style="list-style-type: none"> 1. Worn or burned distributor rotor 2. Worn distributor shaft 3. Worn or incorrect gapped spark plugs 4. Dirt or water in fuel system 5. Faulty fuel pump 6. Incorrect valve timing 7. Blown cylinder head gasket 8. Low compression 9. Burned, warped, or pitted valves 10. Plugged or restricted exhaust system 11. Faulty ignition cables | <ol style="list-style-type: none"> 1. Install new distributor rotor 2. Remove and repair distributor (Refer to group 8D, Ignition System) 3. Clean plugs and set gap. (Refer to group 8D, Ignition System) 4. Clean system and replace fuel filter 5. Install new fuel pump 6. Correct valve timing 7. Install new cylinder head gasket 8. Test cylinder compression 9. Install/Reface valves as necessary 10. Install new parts as necessary 11. Replace any cracked or shorted cables |

DIAGNOSIS AND TESTING (Continued)

| CONDITION | POSSIBLE CAUSES | CORRECTION |
|-------------------------------|---|--|
| | 12. Faulty ignition coil | 12. Test and replace, as necessary (Refer to Group 8D, ignition system) |
| ENGINE STALLS OR ROUGH IDLE | 1. Carbon build-up on throttle plate 2. Engine idle speed too low 3. Worn or incorrectly gapped spark plugs 4. Worn or burned distributor rotor 5. Spark plug cables defective or crossed 6. Faulty coil 7. Intake manifold vacuum leak 8. EGR valve leaking or stuck open | 1. Remove throttle body and de-carbon. (Refer to Group 14 for correct procedures) 2. Check Idle Air Control circuit. (Refer to Group 14, Fuel System) 3. Replace or clean and re-gap spark plugs (Refer to group 8D, Ignition System) 4. Install new distributor rotor 5. Check for correct firing order or replace spark plug cables. (Refer to Group 8D, Ignition System for correct procedures.) 6. Test and replace, if necessary (Refer to group 8D, Ignition System) 7. Inspect intake manifold gasket and vacuum hoses. Replace if necessary (Refer to Group 11, Exhaust System & Intake Manifold) 8. Test and replace, if necessary (Refer to group 25, Emission Control Systems) |
| ENGINE MISSES ON ACCELERATION | 1. Worn or incorrectly gapped spark plugs 2. Spark plug cables defective or crossed 3. Dirt in fuel system 4. Burned, warped or pitted valves 5. Faulty coil | 1. Replace spark plugs or clean and set gap. (Refer to group 8D, Ignition System) 2. Check Idle Air Control circuit. (Refer to Group 14, Fuel System) 3. Clean fuel system 4. Install new valves 5. Test and replace as necessary (refer to group 8D, Ignition System) |

SERVICE DIAGNOSIS—MECHANICAL

ENGINE MECHANICAL DIAGNOSIS CHART

| CONDITION | POSSIBLE CAUSES | CORRECTION |
|----------------------|--|---|
| NOISY VALVES/LIFTERS | 1. High or low oil level in crankcase 2. Thin or diluted oil 3. Low oil pressure | 1. Check for correct oil level. Adjust oil level by draining or adding as needed 2. Change oil (Refer to Engine Oil Service in this group) 3. Check engine oil level. If ok, Perform oil pressure test. Refer to this group for engine oil pressure test/specifications |

DIAGNOSIS AND TESTING (Continued)

| CONDITION | POSSIBLE CAUSES | CORRECTION |
|----------------------|---|---|
| | 4. Dirt in tappets/lash adjusters 5. Bent push rod(s) 6. Worn rocker arms 7. Worn tappets/lash adjusters 8. Worn valve guides 9. Excessive runout of valve seats or valve faces | 4. Clean/replace hydraulic tappets/lash adjusters 5. Install new push rods 6. Inspect oil supply to rocker arms and replace worn arms as needed 7. Install new hydraulic tappets/lash adjusters 8. Inspect all valve guides and replace as necessary 9. Grind valves and seats |
| CONNECTING ROD NOISE | 1. Insufficient oil supply 2. Low oil pressure 3. Thin or diluted oil 4. Excessive connecting rod bearing clearance 5. Connecting rod journal out of round 6. Misaligned connecting rods | 1. Check engine oil level. (Refer to group 0, Lubrication and Maintenance) 2. Check engine oil level. If ok, Perform oil pressure test. Refer to this group for engine oil pressure test/specifications 3. Change oil to correct viscosity. Refer to this group for correct procedure/engine oil specifications Measure bearings for correct clearance with plasti-gage. Repair as necessary 5. Replace crankshaft or grind journals 6. Replace bent connecting rods |
| MAIN BEARING NOISE | 1. Insufficient oil supply 2. Low oil pressure 3. Thin or diluted oil 4. Excessive main bearing clearance 5. Excessive end play 6. Crankshaft main journal out of round or worn 7. Loose flywheel or torque converter | 1. Check engine oil level. (Refer to group 0, Lubrication and Maintenance) 2. Check engine oil level. If ok, Perform oil pressure test. Refer to this group for engine oil pressure test/specifications 3. Change oil to correct viscosity. Refer to this group for correct procedure/engine oil specifications 4. Measure bearings for correct clearance. Repair as necessary 5. Check crankshaft thrust bearing for excessive wear on flanges 6. Grind journals or replace crankshaft 7. Inspect crankshaft, flexplate/flywheel and bolts for damage. Tighten to correct torque |

DIAGNOSIS AND TESTING (Continued)

| CONDITION | POSSIBLE CAUSES | CORRECTION |
|---|--|---|
| LOW OIL PRESSURE | <ol style="list-style-type: none"> 1. Low oil level 2. Faulty oil pressure sending unit 3. Clogged oil filter 4. Worn oil pump 5. Thin or diluted oil 6. Excessive bearing clearance 7. Oil pump relief valve stuck 8. Oil pump suction tube loose, broken, bent or clogged 9. Oil pump cover warped or cracked | <ol style="list-style-type: none"> 1. Check oil level and fill if necessary 2. Install new sending unit 3. Install new oil filter 4. Replace worn gears or oil pump assy 5. Change oil to correct viscosity. Refer to this group for correct procedure/engine oil specifications 6. Measure bearings for correct clearance 7. Remove valve to inspect, clean and reinstall 8. Inspect suction tube and clean or replace if necessary 9. Install new oil pump |
| OIL LEAKS | <ol style="list-style-type: none"> 1. Misaligned or deteriorated gaskets 2. Loose fastener, broken or porous metal part 3. Front or rear crankshaft oil seal leaking 4. Leaking oil gallery plug or cup plug | <ol style="list-style-type: none"> 1. Replace gasket 2. Tighten, repair or replace the part 3. Replace seal 4. Remove and reseal threaded plug. Replace cup style plug |
| EXCESSIVE OIL CONSUMPTION OR SPARK PLUGS OIL FOULED | <ol style="list-style-type: none"> 1. PCV System malfunction 2. Defective valve stem seal(s) 3. Worn or broken piston rings 4. Scuffed pistons/cylinder walls 5. Carbon in oil control ring groove 6. Worn valve guides 7. Piston rings fitted too tightly in grooves | <ol style="list-style-type: none"> 1. Refer to group 25, Emission Control System for correct operation 2. Repair or replace seal(s) 3. Hone cylinder bores. Install new rings 4. Hone cylinder bores and replace pistons as required 5. Remove rings and de-carbon piston 6. Inspect/replace valve guides as necessary 7. Remove rings and check ring end gap and side clearance. Replace if necessary |

DIAGNOSIS AND TESTING (Continued)

INTAKE MANIFOLD LEAKAGE DIAGNOSIS

An intake manifold air leak is characterized by lower than normal manifold vacuum. Also, one or more cylinders may not be functioning.

WARNING: USE EXTREME CAUTION WHEN THE ENGINE IS OPERATING. DO NOT STAND IN A DIRECT LINE WITH THE FAN. DO NOT PUT YOUR HANDS NEAR THE PULLEYS, BELTS OR THE FAN. DO NOT WEAR LOOSE CLOTHING.

- (1) Start the engine.
- (2) Spray a small stream of water at the suspected leak area.
- (3) If a change in RPM is observed the area of the suspected leak has been found.
- (4) Repair as required.

CYLINDER COMPRESSION PRESSURE TEST

The results of a cylinder compression pressure test can be utilized to diagnose several engine malfunctions.

Ensure the battery is completely charged and the engine starter motor is in good operating condition. Otherwise the indicated compression pressures may not be valid for diagnosis purposes.

- (1) Clean the spark plug recesses with compressed air.
- (2) Remove the spark plugs.
- (3) Secure the throttle in the wide-open position.
- (4) Disable the fuel system. (Refer to Group 14, Fuel System for the correct procedure)
- (5) Disconnect the ignition coil.
- (6) Insert a compression pressure gauge and rotate the engine with the engine starter motor for three revolutions.
- (7) Record the compression pressure on the 3rd revolution. Continue the test for the remaining cylinders.

Refer to Engine Specifications for the correct engine compression pressures.

ENGINE CYLINDER HEAD GASKET FAILURE DIAGNOSIS

A leaking engine cylinder head gasket usually results in loss of power, loss of coolant and engine misfiring.

An engine cylinder head gasket leak can be located between adjacent cylinders or between a cylinder and the adjacent water jacket.

- An engine cylinder head gasket leaking between adjacent cylinders is indicated by a loss of power and/or engine misfire.
- An engine cylinder head gasket leaking between a cylinder and an adjacent water jacket is indicated by coolant foaming or overheating and loss of coolant.

CYLINDER-TO-CYLINDER LEAKAGE TEST

To determine if an engine cylinder head gasket is leaking between adjacent cylinders; follow the proce-

dures outlined in Cylinder Compression Pressure Test. An engine cylinder head gasket leaking between adjacent cylinders will result in approximately a 50-70% reduction in compression pressure.

CYLINDER-TO-WATER JACKET LEAKAGE TEST

WARNING: USE EXTREME CAUTION WHEN THE ENGINE IS OPERATING. DO NOT STAND IN A DIRECT LINE WITH THE FAN. DO NOT PUT YOUR HANDS NEAR THE PULLEYS, BELTS OR THE FAN. DO NOT WEAR LOOSE CLOTHING.

Remove the radiator cap.

Start the engine and allow it to warm up until the engine thermostat opens.

If a large combustion/compression pressure leak exists, bubbles will be visible in the coolant.

If bubbles are not visible, install a radiator pressure tester and pressurize the coolant system.

If a cylinder is leaking combustion pressure into the water jacket, the tester pointer will pulsate with every combustion stroke of the cylinder.

CYLINDER COMBUSTION PRESSURE LEAKAGE TEST

The combustion pressure leakage test provides an accurate means for determining engine condition.

Combustion pressure leakage testing will detect:

- Exhaust and intake valve leaks (improper seating).
- Leaks between adjacent cylinders or into water jacket.

- Any causes for combustion/compression pressure loss.

(1) Check the coolant level and fill as required. **DO NOT** install the radiator cap.

(2) Start and operate the engine until it attains normal operating temperature, then turn the engine OFF.

(3) Remove the spark plugs.

(4) Remove the oil filler cap.

(5) Remove the air cleaner.

(6) Calibrate the tester according to the manufacturer's instructions. The shop air source for testing should maintain 483 kPa (70 psi) minimum, 1,379 kPa (200 psi) maximum and 552 kPa (80 psi) recommended.

(7) Perform the test procedures on each cylinder according to the tester manufacturer's instructions. While testing, listen for pressurized air escaping through the throttle body, tailpipe and oil filler cap opening. Check for bubbles in the radiator coolant.

All gauge pressure indications should be equal, with no more than 25% leakage.

FOR EXAMPLE: At 552 kPa (80 psi) input pressure, a minimum of 414 kPa (60 psi) should be maintained in the cylinder.

Refer to the Cylinder Combustion Pressure Leakage Test Diagnosis chart.

DIAGNOSIS AND TESTING (Continued)

CYLINDER COMBUSTION PRESSURE LEAKAGE DIAGNOSIS CHART

| CONDITION | POSSIBLE CAUSE | CORRECTION |
|---|---|---|
| AIR ESCAPES THROUGH THROTTLE BODY | Intake valve bent, burnt, or not seated properly | Inspect valve and valve seat. Reface or replace, as necessary |
| AIR ESCAPES THROUGH TAILPIPE | Exhaust valve bent, burnt, or not seated properly | Inspect valve and valve seat. Reface or replace, as necessary |
| AIR ESCAPES THROUGH RADIATOR | Head gasket leaking or cracked cylinder head or block | Remove cylinder head and inspect. Replace defective part |
| MORE THAN 50% LEAKAGE FROM ADJACENT CYLINDERS | Head gasket leaking or crack in cylinder head or block between adjacent cylinders | Remove cylinder head and inspect. Replace gasket, head, or block as necessary |
| MORE THAN 25% LEAKAGE AND AIR ESCAPES THROUGH OIL FILLER CAP OPENING ONLY | Stuck or broken piston rings; cracked piston; worn rings and/or cylinder wall | Inspect for broken rings or piston. Measure ring gap and cylinder diameter, taper and out-of-round. Replace defective part as necessary |

ENGINE OIL LEAK INSPECTION

Begin with a thorough visual inspection of the engine, particularly at the area of the suspected leak. If an oil leak source is not readily identifiable, the following steps should be followed:

(1) Do not clean or degrease the engine at this time because some solvents may cause rubber to swell, temporarily stopping the leak.

(2) Add an oil soluble dye (use as recommended by manufacturer). Start the engine and let idle for approximately 15 minutes. Check the oil dipstick to make sure the dye is thoroughly mixed as indicated with a bright yellow color under a black light.

(3) Using a black light, inspect the entire engine for fluorescent dye, particularly at the suspected area of oil leak. If the oil leak is found and identified, repair per service manual instructions.

(4) If dye is not observed, drive the vehicle at various speeds for approximately 24km (15 miles), and repeat inspection.

(4) **If the oil leak source is not positively identified at this time**, proceed with the air leak detection test method.

Air Leak Detection Test Method

(1) Disconnect the breather cap to air cleaner hose at the breather cap end. Cap or plug breather cap nipple.

(2) Remove the PCV valve from the cylinder head cover. Cap or plug the PCV valve grommet.

(3) Attach an air hose with pressure gauge and regulator to the dipstick tube.

CAUTION: Do not subject the engine assembly to more than 20.6 kpa (3 PSI) of test pressure.

(4) Gradually apply air pressure from 1 psi to 2.5 psi maximum while applying soapy water at the suspected source. Adjust the regulator to the suitable test pressure that provide the best bubbles which will pinpoint the leak source. If the oil leak is detected and identified, repair per service manual procedures.

(5) If the leakage occurs at the rear oil seal area, refer to the section, Inspection for Rear Seal Area Leak.

(6) If no leaks are detected, turn off the air supply and remove the air hose and all plugs and caps. Install the PCV valve and breather cap hose.

(7) Clean the oil off the suspect oil leak area using a suitable solvent. Drive the vehicle at various speeds approximately 24 km (15 miles). Inspect the engine for signs of an oil leak by using a black light.

INSPECTION FOR REAR SEAL AREA LEAKS

Since it is sometimes difficult to determine the source of an oil leak in the rear seal area of the engine, a more involved inspection is necessary. The following steps should be followed to help pinpoint the source of the leak.

If the leakage occurs at the crankshaft rear oil seal area:

(1) Disconnect the battery.

(2) Raise the vehicle.

(3) Remove torque converter or clutch housing cover and inspect rear of block for evidence of oil.

Use a black light to check for the oil leak:

(a) Circular spray pattern generally indicates seal leakage or crankshaft damage.

(b) Where leakage tends to run straight down, possible causes are a porous block, distributor seal, camshaft bore cup plugs oil galley pipe plugs, oil

DIAGNOSIS AND TESTING (Continued)

filter runoff, and main bearing cap to cylinder block mating surfaces.

(4) If no leaks are detected, pressurize the crankcase as outlined in the, Inspection (Engine oil Leaks in general)

CAUTION: Do not exceed 20.6 kPa (3 psi).

(5) If the leak is not detected, very slowly turn the crankshaft and watch for leakage. If a leak is detected between the crankshaft and seal while slowly turning the crankshaft, it is possible the crankshaft seal surface is damaged. The seal area on the crankshaft could have minor nicks or scratches that can be polished out with emery cloth.

CAUTION: Use extreme caution when crankshaft polishing is necessary to remove minor nicks and scratches. The crankshaft seal flange is especially machined to complement the function of the rear oil seal.

(6) For bubbles that remain steady with shaft rotation, no further inspection can be done until disassembled.

ENGINE OIL PRESSURE

(1) Disconnect connector and remove oil pressure sending unit.

(2) Install Oil Pressure Line and Gauge Tool C-3292 or equivalent. Start engine and record pressure. Refer to Oil Pressure in Engine Specifications for the correct pressures.

SERVICE PROCEDURES

VALVE TIMING

- Disconnect the spark plug wires and remove the spark plugs.
- Remove the engine cylinder head cover.
- Remove the capscrews, bridge and pivot assembly, and rocker arms from above the No.1 cylinder.
- Alternately loosen each capscrew, one turn at a time, to avoid damaging the bridge.
- Rotate the crankshaft until the No.4 piston is at top dead center (TDC) on the compression stroke.
- Rotate the crankshaft counterclockwise (viewed from the front of the engine) 90°.
- Install a dial indicator on the end of the No.1 cylinder intake valve push rod. Use rubber tubing to secure the indicator stem on the push rod.
- Set the dial indicator pointer at zero.
- Set the dial indicator pointer at zero.
- Rotate the crankshaft clockwise (viewed from the front of the engine) until the dial indicator

pointer indicates 0.305 mm (0.012 inch) travel distance (lift).

- The timing notch index on the vibration damper should be aligned with the TDC mark on the timing degree scale.

- If the timing notch is more than 13 mm (1/2 inch) away from the TDC mark in either direction, the valve timing is incorrect.

- If the valve timing is incorrect, the cause may be a broken camshaft pin. It is not necessary to replace the camshaft because of pin failure. A spring pin is available for service replacement.

VALVE, GUIDE AND SEAL

Clean all carbon deposits from the combustion chambers, valve ports, valve stems, valve stem guides and head.

Clean all grime and gasket material from the engine cylinder head machined gasket surface.

Inspect for cracks in the combustion chambers and valve ports.

Inspect for cracks on the exhaust seat.

Inspect for cracks in the gasket surface at each coolant passage.

Inspect valves for burned, cracked or warped heads.

Inspect for scuffed or bent valve stems.

Replace valves displaying any damage.

VALVE REFACING

(1) Use a valve refacing machine to reface the intake and exhaust valves to the specified angle.

(2) After refacing, a margin of at least 0.787 mm (0.031 inch) must remain (Fig. 13). If the margin is less than 0.787 mm (0.031 inch), the valve must be replaced.

VALVE SEAT REFACING

(1) Install a pilot of the correct size in the valve guide bore. Reface the valve seat to the specified angle with a good dressing stone. Remove only enough metal to provide a smooth finish.

(2) Use tapered stones to obtain the specified seat width when required.

(3) Control valve seat runout to a maximum of 0.0635 mm (0.0025 in.)— (Fig. 14).

VALVE STEM OIL SEAL REPLACEMENT

Valve stem oil seals are installed on each valve stem to prevent rocker arm lubricating oil from entering the combustion chamber through the valve guide bores. One seal is marked INT (intake valve) and the other is marked EXH (exhaust valve).

Replace the oil seals whenever valve service is performed or if the seals have deteriorated.

SERVICE PROCEDURES (Continued)

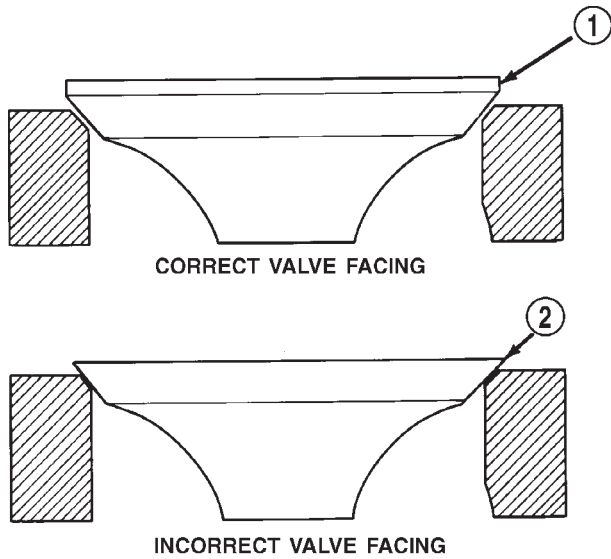

J8909-89

Fig. 13 Valve Facing Margin

- 1 - 0.787 MM (1/32 INCH) VALVE MARGIN
- 2 - NO MARGIN

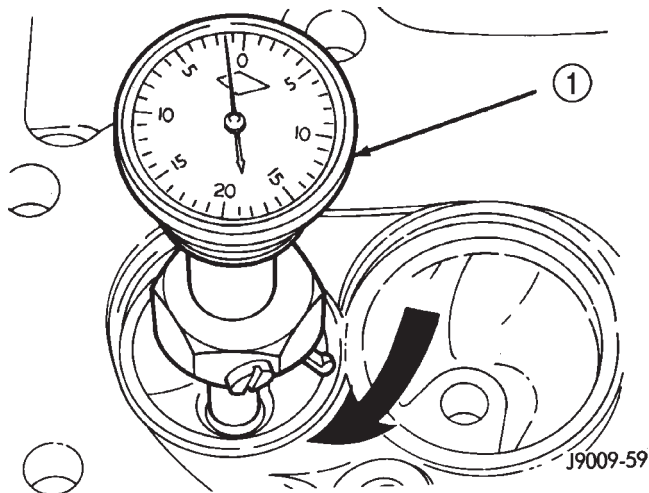

J9009-59

Fig. 14 Measurement of Valve Seat Runout

- 1 - DIAL INDICATOR

VALVE GUIDES

The valve guides are an integral part of the engine cylinder head and are not replaceable.

When the valve stem guide clearance is excessive, the valve guide bores must be reamed oversize. Service valves with oversize stems are available in 0.076 mm (0.003 inch) and 0.381 mm (0.015 inch) increments.

Corresponding oversize valve stem seals are also available and must be used with valves having 0.381 mm (0.015 inch) oversize stems, 0.076mm (.003in.) oversize stems do not require oversize seals.

NOTE: If the valve guides are reamed oversize, the valve seats must be ground to ensure that the valve seat is concentric to the valve guide.

VALVE STEM-TO-GUIDE CLEARANCE MEASUREMENT

Valve stem-to-guide clearance may be measured by either of the following two methods.

PREFERRED METHOD:

- (1) Remove the valve from the head.
- (2) Clean the valve stem guide bore with solvent and a bristle brush.
- (3) Insert a telescoping gauge into the valve stem guide bore approximately 9.525 mm (.375 inch) from the valve spring side of the head (Fig. 15).

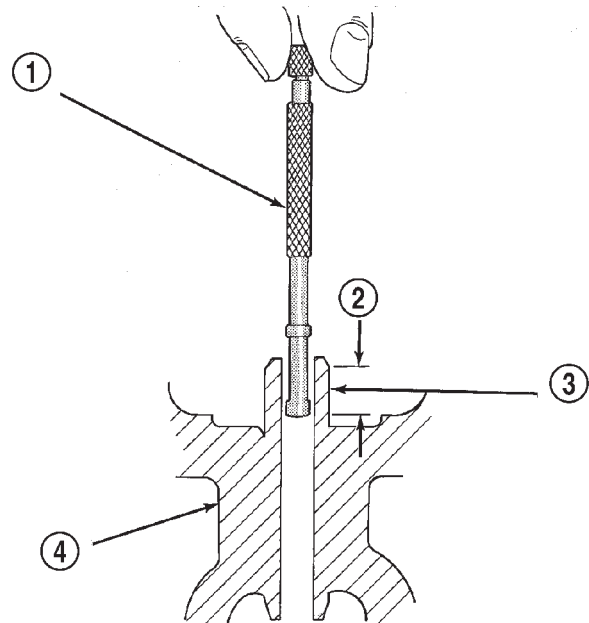

J9509-87

Fig. 15 Measurement of Valve Guide Bore Diameter

- 1 - GAUGE
- 2 - 9.525 MM (3/8 INCH)
- 3 - VALVE STEM GUIDE
- 4 - CYLINDER HEAD

(4) Remove and measure telescoping gauge with a micrometer.

(5) Repeat the measurement with contacts lengthwise to engine cylinder head.

(6) Compare the crosswise to lengthwise measurements to determine out-of-roundness. If the measurements differ by more than 0.0635 mm (0.0025 in.), ream the guide bore to accommodate an oversize valve stem.

(7) Compare the measured valve guide bore diameter with specifications (7.95-7.97 mm or 0.313-0.314

SERVICE PROCEDURES (Continued)

inch). If the measurement differs from specification by more than 0.076 mm (0.003 inch), ream the guide bore to accommodate an oversize valve stem.

ALTERNATIVE METHOD:

(1) Use a dial indicator to measure the lateral movement of the valve stem (stem-to-guide clearance). This must be done with the valve installed in its guide and just off the valve seat (Fig. 16).

(2) Correct clearance is 0.025-0.0762 mm (0.001-0.003 inch). If indicated movement exceeds the specification ream the valve guide to accommodate an oversize valve stem.

NOTE: Valve seats must be ground after reaming the valve guides to ensure that the valve seat is concentric to the valve guide.

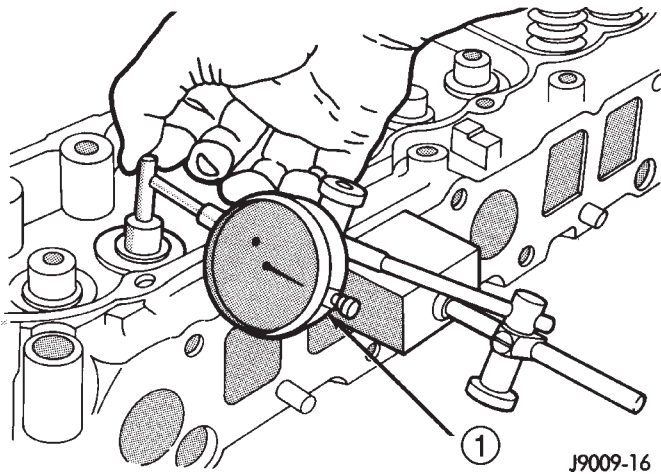

Fig. 16 Measurement of Lateral Movement Of Valve Stem

1 - DIAL INDICATOR

VALVE SPRING TENSION TEST

Use a Universal Valve Spring Tester and a torque wrench to test each valve spring for the specified tension value (Fig. 17).

Replace valve springs that are not within specifications.

PISTON—FITTING

BORE GAUGE METHOD

(1) To correctly select the proper size piston, a cylinder bore gauge, capable of reading in 0.003 mm (.0001 in.) INCREMENTS is required. If a bore gauge is not available, do not use an inside micrometer.

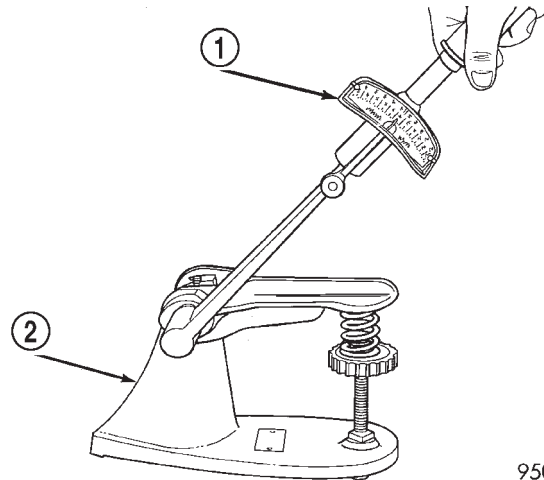

9509-79

Fig. 17 Valve Spring Tester

1 - TORQUE WRENCH
2 - VALVE SPRING TESTER

(2) Measure the inside diameter of the cylinder bore at a point 49.5 mm (1-15/16 inches) below top of bore. Start perpendicular (across or at 90 degrees) to the axis of the crankshaft at point A and then take an additional bore reading 90 degrees to that at point B (Fig. 19).

(3) The coated pistons will be serviced with the piston pin and connecting rod pre-assembled. **The coated piston connecting rod assembly can be used to service previous built engines and MUST be replaced as complete sets.** Tin coated pistons should not be used as replacements for coated pistons.

(4) The coating material is applied to the piston after the final piston machining process. Measuring the outside diameter of a coated piston will not provide accurate results (Fig. 18). Therefore measuring the inside diameter of the cylinder bore with a dial Bore Gauge is **MANDATORY**. To correctly select the proper size piston, a cylinder bore gauge capable of reading in 0.003 mm (.0001 in.) increments is required.

(5) Piston installation into the cylinder bore requires slightly more pressure than that required for non-coated pistons. The bonded coating on the piston will give the appearance of a line-to-line fit with the cylinder bore.

SERVICE PROCEDURES (Continued)

DO NOT MEASURE MOLY COATED PISTON

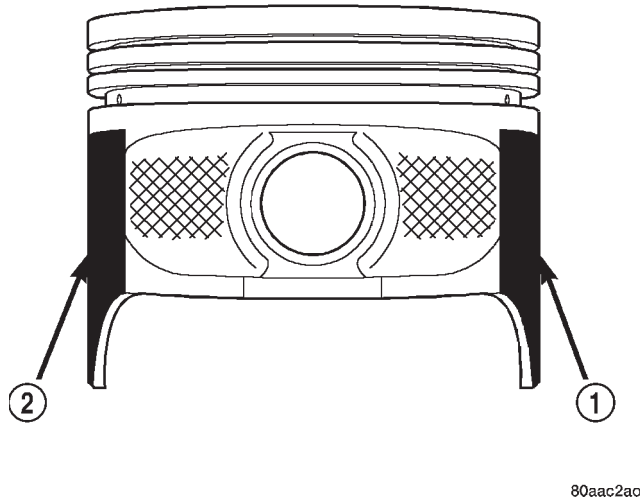

Fig. 18 Moly Coated Piston

- 1 - MOLY COATED
- 2 - MOLY COATED

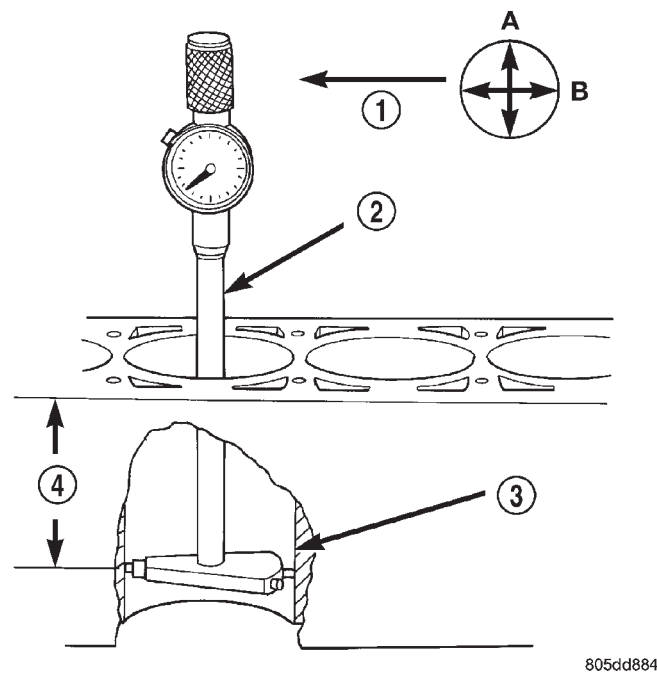

Fig. 19 Bore Gauge

- 1 - FRONT
- 2 - BORE GAUGE
- 3 - CYLINDER BORE
- 4 - 49.5 MM (1-15/16 in)

PISTON SIZE CHART

| CYLINDER BORE SIZE | PISTON LETTER SIZE |
|---|--------------------|
| 98.438 - 98.448 mm (3.8755 - 3.8759 in.) | A |
| 98.448 - 98.458 mm (3.8759 - 3.8763 in.) | B |
| 98.458 - 98.468 mm (3.8763 - 3.8767 in.) | C |
| 98.468 - 98.478 mm (3.8767 - 3.8771 in.) | D |
| 98.478 - 98.488 mm (3.8771 - 3.8775 in.) | E |
| 98.488 - 98.498 mm (3.8775 - 3.8779 in.) | F |

PISTON RING—FITTING

(1) Carefully clean the carbon from all ring grooves. Oil drain openings in the oil ring groove and pin boss must be clear. DO NOT remove metal from the grooves or lands. This will change ring-to-groove clearances and will damage the ring-to-land seating.

(2) Be sure the piston ring grooves are free of nicks and burrs.

(3) Measure the ring side clearance with a feeler gauge fitted snugly between the ring land and ring (Fig. 20) (Fig. 21). Rotate the ring in the groove. It must move freely around circumference of the groove.

GROOVE HEIGHT

- A 1.530-1.555 mm (0.0602-0.0612 in)
- B 4.035-4.060 mm (0.1589-0.1598 in)

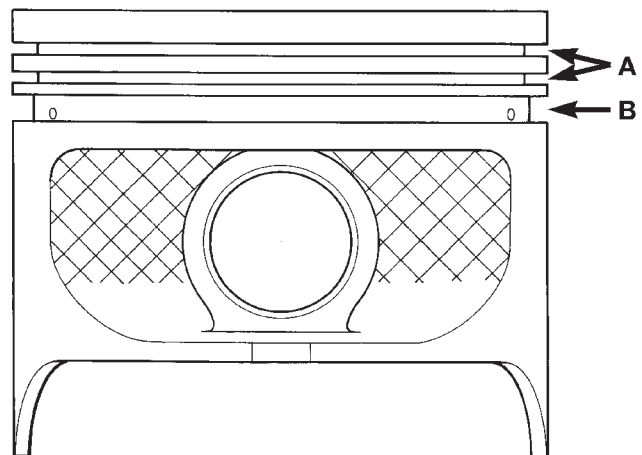

Fig. 20 Piston Dimensions

SERVICE PROCEDURES (Continued)

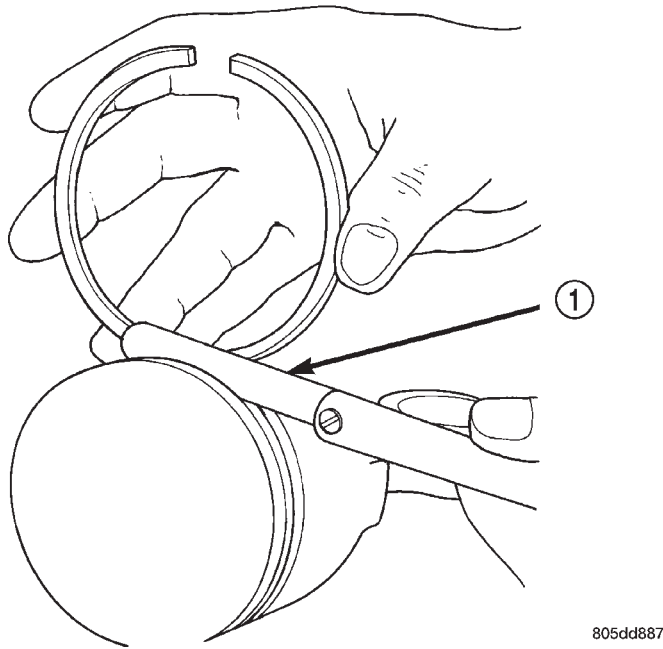

Fig. 21 Ring Side Clearance Measurement

1 - FEELER GAUGE

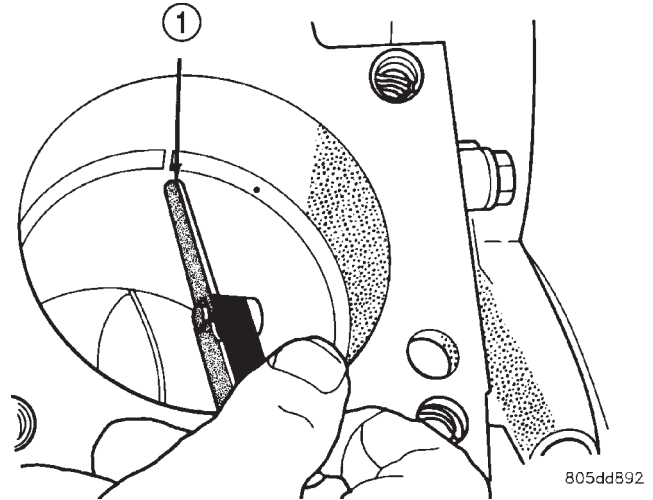

Fig. 22 Gap Measurement

1 - FEELER GAUGE

RING SIDE CLEARANCE CHART

| ITEM | SPECIFICATION |
|-------------------------|---|
| Top Compression Ring | 0.042 - 0.084 mm (0.0017 - 0.0033 in.) |
| Second Compression Ring | 0.042 - 0.084 mm (0.0017 - 0.0033 in.) |
| Oil Control Ring | 0.06 - 0.21 mm (0.0024 - 0.0083 in.) |

RING GAP MEASUREMENT CHART

| ITEM | SPECIFICATION |
|-------------------------|---|
| Top Compression Ring | 0.229 - 0.610 mm (0.0090 - 0.0240 in.) |
| Second Compression Ring | 0.483 - 0.965 mm (0.0190 - 0.080 in.) |
| Oil Control Ring | 0.254 - 1.500 mm (0.010 - 0.060 in.) |

(4) Place ring in the cylinder bore and push down with inverted piston to position near lower end of the ring travel. Measure ring gap with a feeler gauge fitting snugly between ring ends (Fig. 22).

(5) The oil control rings are symmetrical, and can be installed with either side up. It is not necessary to use a tool to install the upper and lower rails. Insert oil rail spacer first, then side rails.

(6) The two compression rings are different and cannot be interchanged. The top compression ring can be identified by the shiny coating on the outer sealing surface and can be installed with either side up. (Fig. 23).

(7) The second compression ring has a slight chamfer on the bottom of the inside edge and a dot on the top for correct installation (Fig. 24).

(8) Using a ring installer, install the second compression ring with the dot facing up (Fig. 24) (Fig. 26).

(9) Using a ring installer, install the top compression ring (either side up).

Ring Gap Orientation

- Position the gaps on the piston as shown (Fig. 27).
- Oil spacer - Gap on center line of piston skirt.
- Oil rails - gap 180° apart on centerline of piston pin bore.
- No. 2 Compression ring - Gap 180° from top oil rail gap.
- No. 1 Compression ring - Gap 180° from No. 2 compression ring gap.

SERVICE PROCEDURES (Continued)

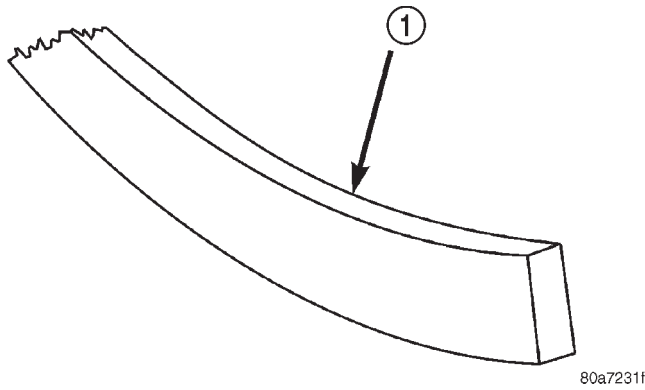

80a7231f

Fig. 23 Top Compression ring identification

- 1 - TOP COMPRESSION RING

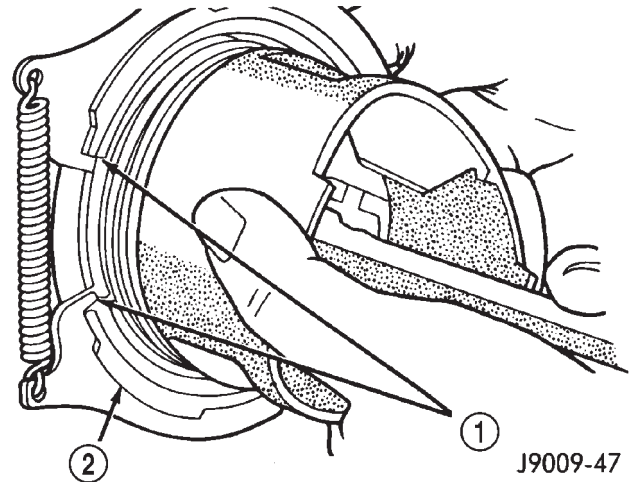

J9009-47

Fig. 26 Compression Ring Installation

- 1 - COMPRESSION RING
2 - RING EXPANDER RECOMMENDED

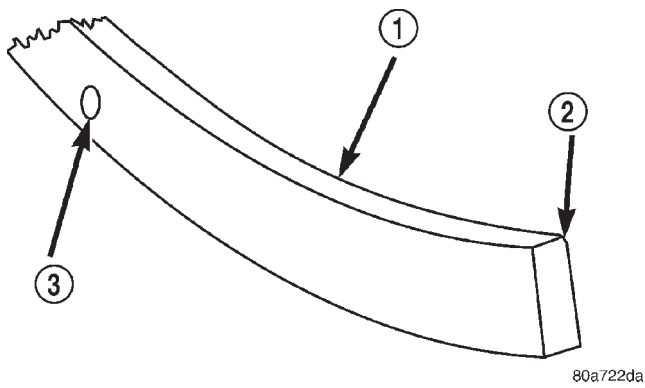

80a722da

Fig. 24 Second Compression Ring Identification

- 1 - SECOND COMPRESSION RING
2 - CHAMFER
3 - ONE DOT

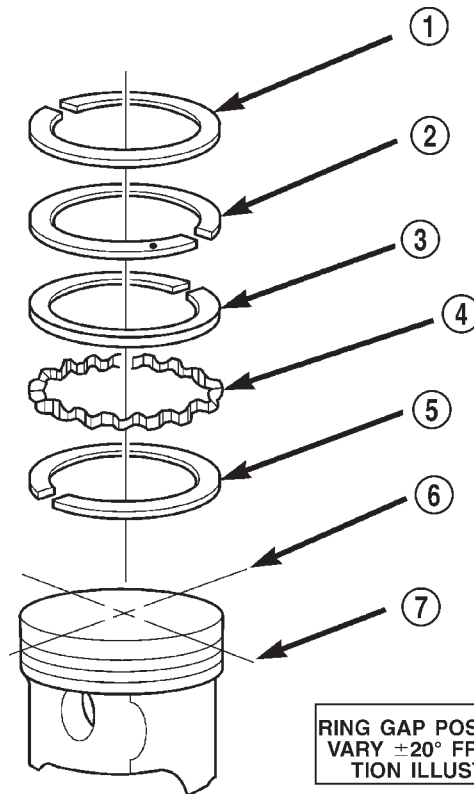

RING GAP POSITION MAY VARY $\pm 20^\circ$ FROM POSITION ILLUSTRATED

80a7233c

Fig. 27 Ring Gap Orientation

- 1 - TOP COMPRESSION RING
2 - BOTTOM COMPRESSION RING
3 - TOP OIL CONTROL RAIL
4 - OIL RAIL SPACER
5 - BOTTOM OIL CONTROL RAIL
6 - IMAGINARY LINE PARALLEL TO PISTON PIN
7 - IMAGINARY LINE THROUGH CENTER OF PISTON SKIRT

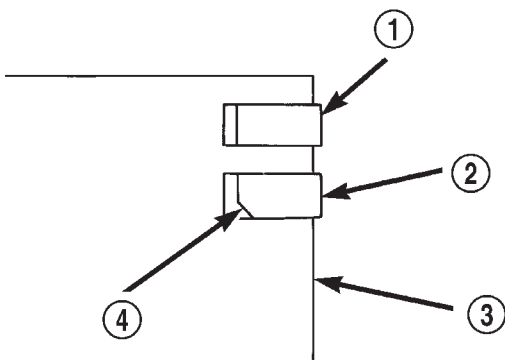

805dd898

Fig. 25 Compression Ring Chamfer Location

- 1 - TOP COMPRESSION RING
2 - SECOND COMPRESSION RING
3 - PISTON
4 - CHAMFER

SERVICE PROCEDURES (Continued)

CONNECTING ROD BEARINGS—FITTING

Inspect the connecting rod bearings for scoring and bent alignment tabs (Fig. 28) (Fig. 29). Check the bearings for normal wear patterns, scoring, grooving, fatigue and pitting (Fig. 30). Replace any bearing that shows abnormal wear.

Inspect the connecting rod journals for signs of scoring, nicks and burrs.

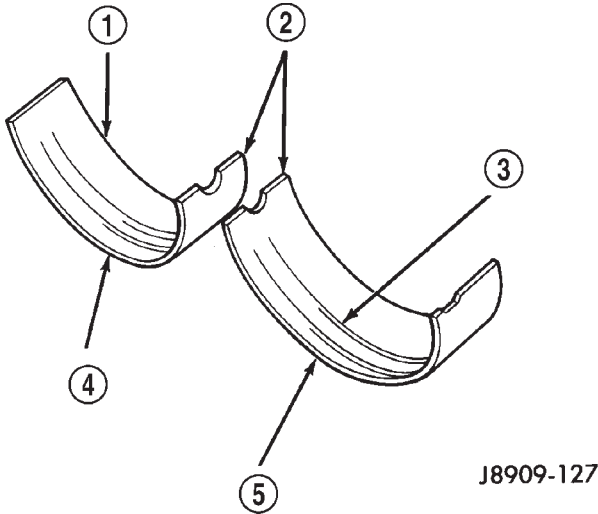

Fig. 28 Connecting Rod Bearing Inspection

- 1 - UPPER BEARING HALF
- 2 - MATING EDGES
- 3 - GROOVES CAUSED BY ROD BOLTS SCRATCHING JOURNAL DURING INSTALLATION
- 4 - WEAR PATTERN — ALWAYS GREATER ON UPPER BEARING
- 5 - LOWER BEARING HALF

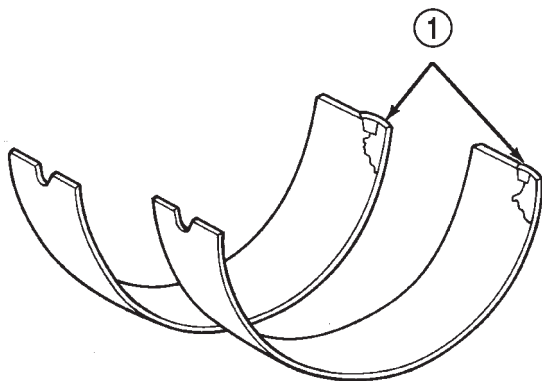

Fig. 29 Locking Tab Inspection

- 1 - ABNORMAL CONTACT AREA CAUSED BY LOCKING TABS NOT FULLY SEATED OR BEING BENT

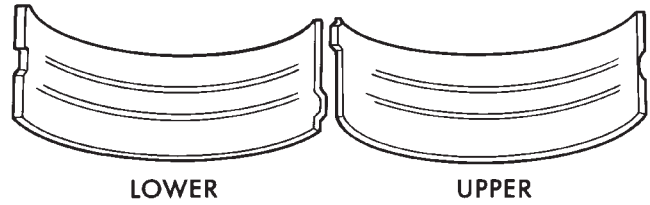

Fig. 30 Scoring Caused by Insufficient Lubrication or by Damaged Crankshaft Pin Journal

necting rod journals. If wear patterns or damage to any of these components indicate the probability of a misaligned connecting rod, inspect it for correct rod alignment. Replace misaligned, bent or twisted connecting rods.

- (1) Wipe the oil from the connecting rod journal.
- (2) Use short rubber hose sections over rod bolts during installation.
- (3) Lubricate the upper bearing insert and install in connecting rod.
- (4) Use piston ring compressor to install the rod and piston assemblies. The oil squirt holes in the rods must face the camshaft. The arrow on the piston crown should point to the front of the engine (Fig. 31). Verify that the oil squirt holes in the rods face the camshaft and that the arrows on the pistons face the front of the engine.

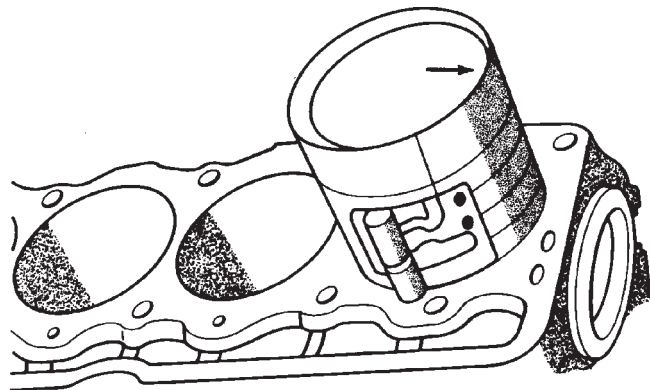

Fig. 31 Rod and Piston Assembly Installation

(5) Install the lower bearing insert in the bearing cap. The lower insert must be dry. Place strip of Plastigage across full width of the lower insert at the center of bearing cap. Plastigage must not crumble in use. If brittle, obtain fresh stock.

(6) Install bearing cap and connecting rod on the journal and tighten nuts to 45 N-m (33 ft. lbs.) torque. DO NOT rotate crankshaft. Plastigage will smear, resulting in inaccurate indication.

(7) Remove the bearing cap and determine amount of bearing-to-journal clearance by measuring the width of compressed Plastigage (Fig. 32). Refer to

Misaligned or bent connecting rods can cause abnormal wear on pistons, piston rings, cylinder walls, connecting rod bearings and crankshaft con-

SERVICE PROCEDURES (Continued)

Engine Specifications for the proper clearance. **Plastigage should indicate the same clearance across the entire width of the insert. If the clearance varies, it may be caused by either a tapered journal, bent connecting rod or foreign material trapped between the insert and cap or rod.**

(8) If the correct clearance is indicated, replacement of the bearing inserts is not necessary. Remove the Plastigage from crankshaft journal and bearing insert. Proceed with installation.

(9) If bearing-to-journal clearance exceeds the specification, install a pair of 0.0254 mm (0.001 inch) undersize bearing inserts. All the odd size inserts must be on the bottom. The sizes of the service replacement bearing inserts are stamped on the backs of the inserts. Measure the clearance as described in the previous steps.

(10) The clearance is measured with a pair of 0.0254 mm (0.001 inch) undersize bearing inserts installed. This will determine if two 0.0254 mm (0.001 inch) undersize inserts or another combination is needed to provide the correct clearance (refer to Connecting Rod Bearing Fitting Chart).

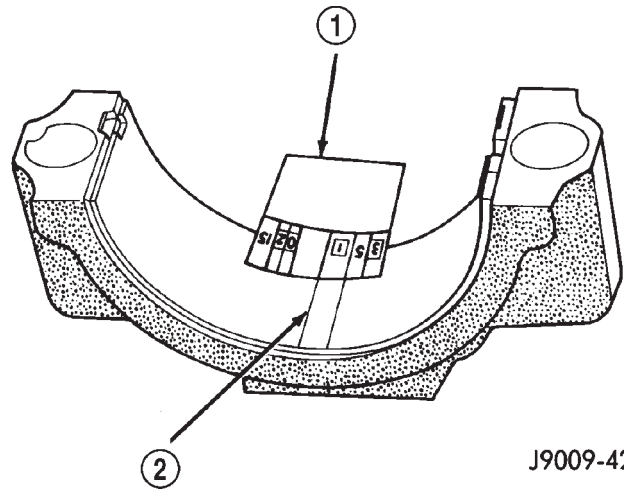

J9009-42

Fig. 32 Measuring Bearing Clearance with Plastigage

- 1 - PLASTIGAGE SCALE
- 2 - COMPRESSED PLASTIGAGE

CONNECTING ROD BEARING FITTING CHART

| CRANKSHAFT JOURNAL | | CORRESPONDING CONNECTING ROD BEARING INSERT | |
|--------------------|--|---|--|
| Color Code | Diameter | Upper Insert Size | Lower Insert Size |
| Yellow | 53.2257-53.2079 mm (2.0955-2.0948 in.) | Yellow - Standard | Yellow - Standard |
| Orange | 53.2079 - 53.1901 mm (2.0948 - 2.0941 in.) 0.0178 mm (0.0007 in.) Undersize | Yellow - Standard | Blue - Undersize 0.025 mm (0.001 in.) |
| Blue | 53.1901 - 53.1724 mm (2.0941 - 2.0934 in.) 0.0356 mm (0.0014 in.) Undersize | Blue - Undersize 0.025 mm (0.001 in.) | Blue - Undersize 0.025 mm (0.001 in.) |
| Red | 52.9717 - 52.9539 mm (2.0855 - 2.0848 in.) 0.254 mm (0.010 in.) Undersize | Red - Undersize 0.254 mm (0.010 in.) | Red - Undersize 0.254 mm (0.010 in.) |

SERVICE PROCEDURES (Continued)

(11) **FOR EXAMPLE:** If the initial clearance was 0.0762 mm (0.003 inch), 0.025 mm (0.001 inch) undersize inserts would reduce the clearance by 0.025 mm (0.001 inch). The clearance would be 0.002 inch and within specification. A 0.051 mm (0.002 inch) undersize insert would reduce the initial clearance an additional 0.013 mm (0.0005 inch). The clearance would then be 0.038 mm (0.0015 inch).

(12) Repeat the Plastigage measurement to verify your bearing selection prior to final assembly.

(13) Once you have selected the proper insert, install the insert and cap. Tighten the connecting rod bolts to 45 N·m (33 ft. lbs.) torque.

Slide snug-fitting feeler gauge between the connecting rod and crankshaft journal flange (Fig. 33). Refer to Engine Specifications for the proper clearance. Replace the connecting rod if the side clearance is not within specification.

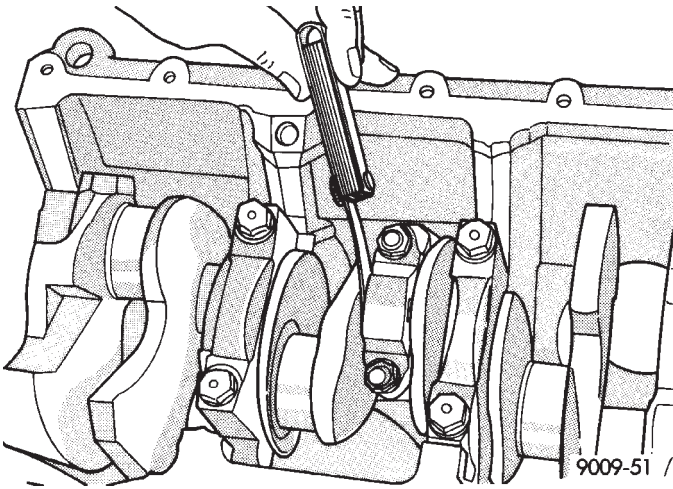

Fig. 33 Checking Connecting Rod Side Clearance—Typical

FITTING CRANKSHAFT MAIN BEARINGS

INSPECTION

Wipe the inserts clean and inspect for abnormal wear patterns and for metal or other foreign material imbedded in the lining. Normal main bearing insert wear patterns are illustrated (Fig. 34). In general the lower bearing half will have a heavier wear pattern.

NOTE: If any of the crankshaft journals are scored, remove the engine for crankshaft repair.

Inspect the back of the inserts for fractures, scrapings or irregular wear patterns.

Inspect the upper insert locking tabs for damage. Replace all damaged or worn bearing inserts.

FITTING BEARINGS (CRANKSHAFT INSTALLED)

The main bearing caps, numbered (front to rear) from 1 through 5 have an arrow to indicate the for-

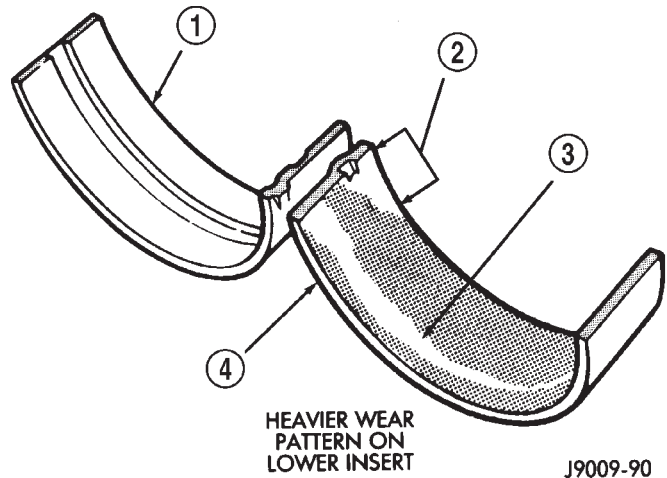

Fig. 34 Main Bearing Wear Patterns

- 1 - UPPER INSERT
- 2 - NO WEAR IN THIS AREA
- 3 - LOW AREA IN BEARING LINING
- 4 - LOWER INSERT

ward position. The upper main bearing inserts are grooved to provide oil channels while the lower inserts are smooth.

Each bearing insert pair is selectively fitted to its respective journal to obtain the specified operating clearance. In production, the select fit is obtained by using various-sized color-coded bearing insert pairs as listed in the Main Bearing Fitting Chart. The bearing color code appears on the edge of the insert. **The size is not stamped on bearing inserts used for engine production.**

The main bearing journal size (diameter) is identified by a color-coded paint mark on the adjacent cheek. The rear main journal, is identified by a color-coded paint mark on the crankshaft rear flange.

When required, upper and lower bearing inserts of different sizes may be used as a pair. A standard size insert is sometimes used in combination with a 0.025 mm (0.001 inch) undersize insert to reduce the clearance by 0.013 mm (0.0005 inch). **Never use a pair of bearing inserts with greater than a 0.025 mm (0.001 inch) difference in size. Refer to the Bearing Insert Pair Chart.**

BEARING INSERT PAIR CHART

| INSERT | CORRECT | INCORRECT |
|--------|--------------------------------------|--------------------------------------|
| UPPER | STANDARD | STANDARD |
| LOWER | 0.025 mm (0.001 in.) UNDERSIZE | 0.051 mm (0.002 in.) UNDERSIZE |

SERVICE PROCEDURES (Continued)

NOTE: When replacing inserts, the odd size inserts must be either all on the top (in cylinder block) or all on the bottom (in main bearing cap).

Once the bearings have been properly fitted, proceed to Crankshaft Main Bearing—Installation.

BEARING-TO-JOURNAL CLEARANCE (CRANKSHAFT INSTALLED)

When using Plastigage, check only one bearing clearance at a time.

Install the grooved main bearings into the cylinder block and the non-grooved bearings into the bearing caps.

Install the crankshaft into the upper bearings dry.

Place a strip of Plastigage across full width of the crankshaft journal to be checked.

Install the bearing cap and tighten the bolts to 108 N·m (80 ft. lbs.) torque.

NOTE: DO NOT rotate the crankshaft. This will cause the Plastigage to shift, resulting in an inaccurate reading. Plastigage must not be permitted to crumble. If brittle, obtain fresh stock.

Remove the bearing cap. Determine the amount of clearance by measuring the width of the compressed Plastigage with the scale on the Plastigage envelope (Fig. 35). Refer to Engine Specifications for the proper clearance.

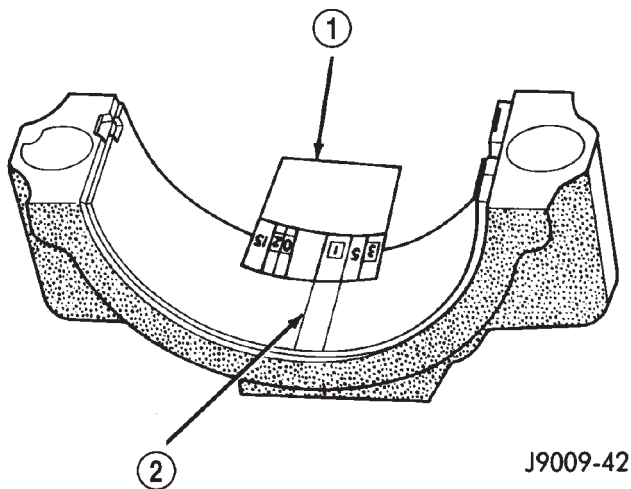

J9009-42

Fig. 35 Measuring Bearing Clearance with Plastigage

- 1 - PLASTIGAGE SCALE
2 - COMPRESSED PLASTIGAGE

Plastigage should indicate the same clearance across the entire width of the insert. If clearance varies, it may indicate a tapered journal or foreign material trapped behind the insert.

If the specified clearance is indicated and there are no abnormal wear patterns, replacement of the bear-

ing inserts is not necessary. Remove the Plastigage from the crankshaft journal and bearing insert. Proceed to Crankshaft Main Bearing—Installation.

If the clearance exceeds specification, install a pair of 0.025 mm (0.001 inch) undersize bearing inserts and measure the clearance as described in the previous steps.

The clearance indicated with the 0.025 mm (0.001 inch) undersize insert pair installed will determine if this insert size or some other combination will provide the specified clearance. **FOR EXAMPLE:** If the clearance was 0.0762 mm (0.003 inch) originally, a pair of 0.0254 mm (0.001 inch) undersize inserts would reduce the clearance by 0.0254 mm (0.001 inch). The clearance would then be 0.0508 mm (0.002 inch) and within the specification. A 0.051 mm (0.002 inch) undersize bearing insert and a 0.0254 mm (0.001 inch) undersize insert would reduce the original clearance an additional 0.0127 mm (0.0005 inch). The clearance would then be 0.0381 mm (0.0015 inch).

CAUTION: Never use a pair of inserts that differ more than one bearing size as a pair.

FOR EXAMPLE: DO NOT use a standard size upper insert and a 0.051 mm (0.002 inch) undersize lower insert.

If the clearance exceeds specification using a pair of 0.051 mm (0.002 inch) undersize bearing inserts, measure crankshaft journal diameter with a micrometer. If the journal diameter is correct, the crankshaft bore in the cylinder block may be misaligned, which requires cylinder block replacement or machining to true bore.

If journals 1 through 5 diameters are less than 63.4517 mm (2.4981 inches), replace crankshaft or grind crankshaft down to accept the appropriate undersize bearing inserts.

Once the proper clearances have been obtained, proceed to Crankshaft Main Bearing—Installation.

MAIN BEARING JOURNAL DIAMETER (CRANKSHAFT REMOVED)

Remove the crankshaft from the cylinder block (refer to Cylinder Block - Disassemble).

Clean the oil off the main bearing journal.

Determine the maximum diameter of the journal with a micrometer. Measure at two locations 90° apart at each end of the journal.

The maximum allowable taper and out of round is 0.013 mm (0.0005 inch). Compare the measured diameter with the journal diameter specification (Main Bearing Fitting Chart). Select inserts required to obtain the specified bearing-to-journal clearance.

Once the proper clearances have been obtained, proceed to Crankshaft Main Bearing—Installation.

SERVICE PROCEDURES (Continued)

MAIN BEARING FITTING CHART

| CRANKSHAFT JOURNALS | | CORRESPONDING CRANKSHAFT BEARING INSERT | |
|---------------------|--|--|---|
| Color Code | Diameter | Upper Insert Size | Lower Insert Size |
| Yellow | 63.5025 - 63.4898 mm (2.5001 - 2.4996 in.) | Yellow - Standard | Yellow - Standard |
| Orange | 63.4898 - 63.4771 mm (2.4996 - 2.4991 in.) 0.0127 mm (0.0005 in.) Undersize | Yellow - Standard | Blue- Undersize 0.025 mm (0.001 in.) |
| Blue | 63.4771 - 63.4644 mm (2.4991 - 2.4986 in.) 0.0254 mm (0.001 in.) Undersize | Blue- Undersize 0.025 mm (0.001 in.) | Blue- Undersize 0.025 mm (0.001 in.) |
| Green | 63.4644 - 63.4517 mm (2.4986 - 2.4981 in.) 0.0381 mm (0.0015 in.) Undersize | Blue - Undersize 0.025 mm (0.001 in.) | Green - Undersize 0.051 mm (0.002 in.) |
| Red | 63.2485 - 63.2358 mm (2.4901 - 2.4896 in.) 0.254 mm (0.010 in.) Undersize | Red - Undersize 0.254 mm (0.010 in.) | Red - Undersize 0.254 mm (0.010 in.) |

FORM-IN-PLACE GASKETS

There are several places where form-in-place gaskets are used on the engine. **DO NOT use form-in-place gasket material unless specified.** Care must be taken when applying form-in-place gaskets. Bead size, continuity and location are of great importance. Too thin a bead can result in leakage while too much can result in spill-over. A continuous bead of the proper width is essential to obtain a leak-free joint.

Two types of form-in-place gasket materials are used in the engine area (Mopar Silicone Rubber Adhesive Sealant and Mopar Gasket Maker). Each have different properties and cannot be used interchangeably.

MOPAR SILICONE RUBBER ADHESIVE SEALANT

Mopar Silicone Rubber Adhesive Sealant, normally black in color, is available in 3 ounce tubes. Moisture in the air causes the sealant material to cure. This material is normally used on flexible metal flanges. It has a shelf life of a year and will not properly cure if over aged. Always inspect the package for the expiration date before use.

MOPAR GASKET MAKER

Mopar Gasket Maker, normally red in color, is available in 6 cc tubes. This anaerobic type gasket material cures in the absence of air when squeezed between smooth machined metallic surfaces. It will not cure if left in the uncovered tube. DO NOT use on flexible metal flanges.

SURFACE PREPARATION

Parts assembled with form-in-place gaskets may be disassembled without unusual effort. In some instances, it may be necessary to lightly tap the part with a mallet or other suitable tool to break the seal between the mating surfaces. A flat gasket scraper may also be lightly tapped into the joint but care must be taken not to damage the mating surfaces.

Scrape or wire brush all gasket surfaces to remove all loose material. Inspect stamped parts to ensure gasket rails are flat. Flatten rails with a hammer on a flat plate, if required. Gasket surfaces must be free of oil and dirt. Make sure the old gasket material is removed from blind attaching holes.

GASKET APPLICATION

Assembling parts using a form-in-place gasket requires care.

SERVICE PROCEDURES (Continued)

Mopar Silicone Rubber Adhesive Sealant should be applied in a continuous bead approximately 3 mm (0.12 inch) in diameter. All mounting holes must be circled. For corner sealing, a 3 or 6 mm (1/8 or 1/4 inch) drop is placed in the center of the gasket contact area. Uncured sealant may be removed with a shop towel. Components should be torqued in place while the sealant is still wet to the touch (within 10 minutes). The use of a locating dowel is recommended during assembly to prevent smearing the material off location.

Mopar Gasket Maker should be applied sparingly to one gasket surface. The sealant diameter should be 1.00 mm (0.04 inch) or less. Be certain the material surrounds each mounting hole. Excess material can easily be wiped off. Components should be torqued in place within 15 minutes. The use of a locating dowel is recommended during assembly to prevent smearing the material off location.

ENGINE PERFORMANCE

It is important that the vehicle is operating to its optimum performance level to maintain fuel economy and the lowest emission levels. If vehicle is not operating to these standards, refer to Engine Diagnosis outlined in this section. The following procedures can assist in achieving the proper engine diagnosis.

- (1) Test cranking amperage draw. Refer to Electrical Group 8B, Cold Cranking Test.
- (2) Check intake manifold bolt torque; Refer to Group 11, Exhaust System and Intake Manifold.
- (3) Perform cylinder compression test. Refer to Cylinder Compression Pressure Test in the Engine Diagnosis area of this section.
- (4) Clean or replace spark plugs as necessary and adjust gap as specified in Electrical Group 8D. Tighten to specifications.
- (5) Test resistance of spark plug cables. Refer to Electrical Group 8D, Spark Plug Cables.
- (6) Inspect the primary wires. Test coil output voltage and primary resistance. Replace parts as necessary. Refer to Electrical Group 8D, for specifications.
- (7) Test fuel pump for pressure. Refer to Group 14, Fuel System Specifications.
- (8) The air filter elements should be replaced as specified in Lubrication and Maintenance, Group 0.
- (9) Inspect crankcase ventilation system as outlined in Group 0, Lubrication and Maintenance. For emission controls see Group 25, Emission Controls for service procedures.
- (10) Road test vehicle as a final test.

HONING CYLINDER BORES

Before honing, stuff plenty of clean shop towels under the bores and over the crankshaft to keep

abrasive materials from entering the crankshaft area.

(1) Used carefully, the Cylinder Bore Sizing Hone C-823 equipped with 220 grit stones, is the best tool for this job. In addition to deglazing, it will reduce taper and out-of-round as well as removing light scuffing, scoring or scratches. Usually a few strokes will clean up a bore and maintain the required limits.

CAUTION: DO NOT use rigid type hones to remove cylinder wall glaze.

(2) Deglazing of the cylinder walls may be done if the cylinder bore is straight and round. Use a cylinder surfacing hone, Honing Tool C-3501, equipped with 280 grit stones (C-3501-3810). 20-60 strokes, depending on the bore condition, will be sufficient to provide a satisfactory surface. Using honing oil C-3501-3880 or a light honing oil available from major oil distributors.

CAUTION: DO NOT use engine or transmission oil, mineral spirits or kerosene.

(3) Honing should be done by moving the hone up and down fast enough to get a crosshatch pattern. The hone marks should INTERSECT at 50° to 60° for proper seating of rings (Fig. 36).

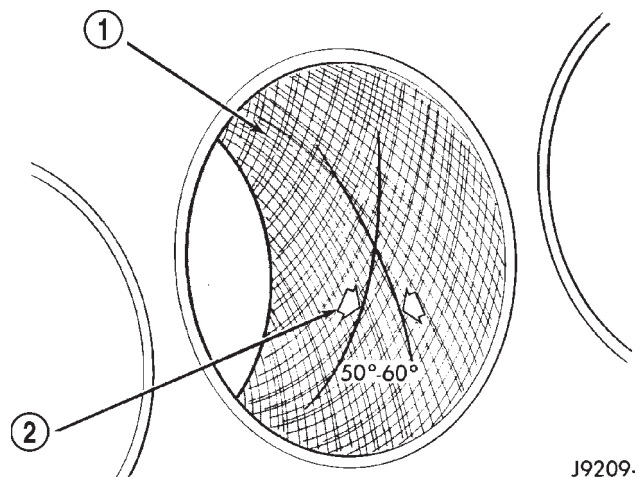

Fig. 36 Cylinder Bore Crosshatch Pattern

- 1 - CROSSHATCH PATTERN
2 - INTERSECT ANGLE

(4) A controlled hone motor speed between 200 and 300 RPM is necessary to obtain the proper crosshatch angle. The number of up and down strokes per minute can be regulated to get the desired 50° to 60° angle. Faster up and down strokes increase the crosshatch angle.

(5) After honing, it is necessary that the block be cleaned to remove all traces of abrasive. Use a brush

SERVICE PROCEDURES (Continued)

to wash parts with a solution of hot water and detergent. Dry parts thoroughly. Use a clean, white, lint-free cloth to check that the bore is clean. Oil the bores after cleaning to prevent rusting.

REPAIR DAMAGED OR WORN THREADS

CAUTION: Be sure that the tapped holes maintain the original center line.

Damaged or worn threads can be repaired. Essentially, this repair consists of:

- Drilling out worn or damaged threads.
- Tapping the hole with a special Heli-Coil Tap, or equivalent.
- Installing an insert into the tapped hole to bring the hole back to its original thread size.

SERVICE ENGINE ASSEMBLY (SHORT BLOCK)

A service replacement engine assembly (short block) may be installed whenever the original cylinder block is defective or damaged beyond repair. It consists of the cylinder block, crankshaft, piston and rod assemblies. If needed, the camshaft must be procured separately and installed before the engine is installed in the vehicle.

A short block is identified with the letter "S" stamped on the same machined surface where the build date code is stamped for complete engine assemblies.

Installation includes the transfer of components from the defective or damaged original engine. Follow the appropriate procedures for cleaning, inspection and torque tightening.

HYDROSTATIC LOCK

When an engine is suspected of hydrostatic lock (regardless of what caused the problem), follow the steps below.

- (1) Perform the Fuel Pressure Release Procedure (refer to Group 14, Fuel System).
- (2) Disconnect the negative cable from the battery.
- (3) Inspect air cleaner, induction system and intake manifold to ensure system is dry and clear of foreign material.
- (4) Place a shop towel around the spark plugs to catch any fluid that may possibly be under pressure in the cylinder head. Remove the plugs from the engine.

CAUTION: DO NOT use the starter motor to rotate the crankshaft. Severe damage could occur.

- (5) With all spark plugs removed, rotate the crankshaft using a breaker bar and socket.
- (6) Identify the fluid in the cylinders (i.e. coolant, fuel, oil, etc.).

(7) Make sure all fluid has been removed from the cylinders.

(8) Repair engine or components as necessary to prevent this problem from occurring again.

(9) Squirt engine oil into the cylinders to lubricate the walls. This will prevent damage on restart.

(10) Install new spark plugs. Tighten the spark plugs to 37 N·m (27 ft. lbs.) torque.

(11) Drain engine oil. Remove and discard the oil filter.

(12) Install the drain plug. Tighten the plug to 34 N·m (25 ft. lbs.) torque.

(13) Install a new oil filter.

(14) Fill engine crankcase with the specified amount and grade of oil (refer to Group 0, Lubrication and Maintenance).

(15) Connect the negative cable to the battery.

(16) Start the engine and check for any leaks.

ENGINE OIL SERVICE

WARNING: NEW OR USED ENGINE OIL CAN BE IRRITATING TO THE SKIN. AVOID PROLONGED OR REPEATED SKIN CONTACT WITH ENGINE OIL. CONTAMINANTS IN USED ENGINE OIL, CAUSED BY INTERNAL COMBUSTION, CAN BE HAZARDOUS TO YOUR HEALTH. THOROUGHLY WASH EXPOSED SKIN WITH SOAP AND WATER. DO NOT WASH SKIN WITH GASOLINE, DIESEL FUEL, THINNER, OR SOLVENTS, HEALTH PROBLEMS CAN RESULT. DO NOT POLLUTE, DISPOSE OF USED ENGINE OIL PROPERLY.

ENGINE OIL SPECIFICATION

CAUTION: Do not use non-detergent or straight mineral oil when adding or changing crankcase lubricant. Engine failure can result.

API SERVICE GRADE CERTIFIED

In gasoline engines, use an engine oil that is API Service Grade Certified (Fig. 37).

Standard engine oil identification notations have been adopted to aid in the proper selection of engine oil. The identifying notations are located on the label of engine oil plastic bottles and the top of engine oil cans (Fig. 37).

SAE VISCOSITY

An SAE viscosity grade is used to specify the viscosity of engine oil. SAE 10W-30 specifies a multiple viscosity engine oil.

When choosing an engine oil, consider the range of temperatures the vehicle will be operated in before the next oil change. Select an engine oil that is best

SERVICE PROCEDURES (Continued)

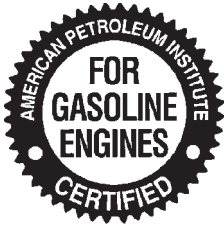

9400-9

Fig. 37 Engine Oil Container Standard Notations

suited to your area's particular ambient temperature range and variation (Fig. 38).

| ENGINE OIL VISCOSITY GRADES | | | | | | | | | |
|--|-------|------|------|--------------------|-----|-----|-----|------|--|
| | | | | 10W-30 (Preferred) | | | | | |
| | 5W-30 | | | | | | | | |
| °F | -20° | 0° | 10° | 20° | 32° | 60° | 80° | 100° | |
| °C | -29° | -18° | -12° | -7° | 0° | 16° | 27° | 38° | |
| Temperature range anticipated before next oil change | | | | | | | | | |

Fig. 38 Temperature/Engine Oil Viscosity**ENERGY CONSERVING OIL**

An Energy Conserving type oil is recommended for gasoline engines. The designation of ENERGY CONSERVING is located on the label of an engine oil container.

CRANKCASE OIL LEVEL INSPECTION

CAUTION: Do not overfill crankcase with engine oil, oil foaming and oil pressure loss can result.

The engine oil level indicator (Dipstick) is located at the right rear of the 2.5L engine. Inspect engine oil level approximately every 800 kilometers (500 miles). Unless the engine has exhibited loss of oil pressure, run the engine for about five minutes before checking oil level. Checking engine oil level on a cold engine is not accurate.

To ensure proper lubrication of an engine, the engine oil must be maintained at an acceptable level. The acceptable levels are indicated between the ADD and SAFE marks on the engine oil dipstick (Fig. 39).

- (1) Position vehicle on level surface.
- (2) With engine OFF, allow approximately ten minutes for oil to settle to bottom of crankcase, remove engine oil dipstick.
- (3) Wipe dipstick clean.
- (4) Install dipstick and verify it is seated in the tube.

(5) Remove dipstick, with handle held above the tip, note oil level reading (Fig. 39).

(6) Add oil only if level is below the ADD mark on dipstick.

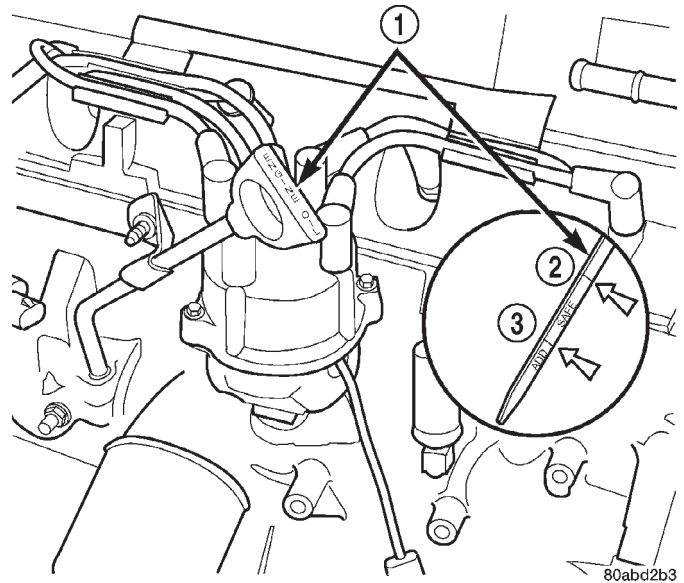
**Fig. 39 Engine Oil Dipstick—2.5L Engine**

- 1 - DIPSTICK
- 2 - SAFE
- 3 - ADD

ENGINE OIL CHANGE

Change engine oil at mileage and time intervals described in Maintenance Schedules.

Run engine until achieving normal operating temperature.

(1) Position the vehicle on a level surface and turn engine off.

(2) Hoist and support vehicle on safety stands.

(3) Remove oil fill cap.

(4) Place a suitable drain pan under crankcase drain.

(5) Remove drain plug from crankcase and allow oil to drain into pan. Inspect drain plug threads for stretching or other damage. Replace drain plug if damaged.

(6) Install drain plug in crankcase.

(7) Lower vehicle and fill crankcase with specified type and amount of engine oil described in this section.

(8) Install oil fill cap.

(9) Start engine and inspect for leaks.

(10) Stop engine and inspect oil level.

SERVICE PROCEDURES (Continued)

ENGINE OIL FILTER CHANGE

FILTER SPECIFICATION

CAUTION: Do not use oil filter with metric threads. The proper oil filter has SAE type 3/4 X 16 threads. An oil filter with metric threads can result in oil leaks and engine failure.

All Jeep engines are equipped with a high quality full-flow, throw-away type oil filter. Chrysler Corporation recommends a Mopar or equivalent oil filter be used.

OIL FILTER REMOVAL

- (1) Position a drain pan under the oil filter.
- (2) Using a suitable oil filter wrench loosen filter.
- (3) Rotate the oil filter counterclockwise to remove it from the cylinder block oil filter boss (Fig. 40).

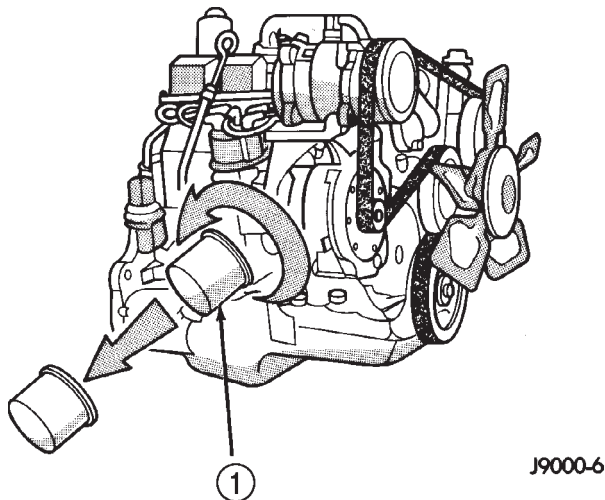

Fig. 40 Oil Filter—2.5L Engine

1 - OIL FILTER

(4) When filter separates from adapter nipple, tip gasket end upward to minimize oil spill. Remove filter from vehicle.

(5) With a wiping cloth, clean the gasket sealing surface (Fig. 41) of oil and grime.

OIL FILTER INSTALLATION

(1) Lightly lubricate oil filter gasket with engine oil or chassis grease.

(2) Thread filter onto adapter nipple. When gasket makes contact with sealing surface, (Fig. 41) hand tighten filter one full turn, do not over tighten.

(3) Add oil, verify crankcase oil level and start engine. Inspect for oil leaks.

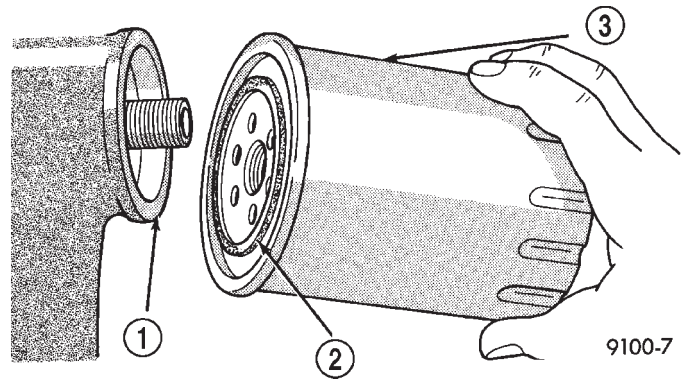

Fig. 41 Oil Filter Sealing Surface—Typical

- 1 - SEALING SURFACE
- 2 - RUBBER GASKET
- 3 - OIL FILTER

USED ENGINE OIL DISPOSAL

Care should be exercised when disposing used engine oil after it has been drained from a vehicle engine. Refer to the WARNING at beginning of this section.

REMOVAL AND INSTALLATION

ENGINE MOUNTS—FRONT

The front mounts support the engine at each side. These supports are made of resilient rubber.

REMOVAL

- (1) Disconnect negative cable from battery.
- (2) Raise the vehicle.
- (3) Support the engine.
- (4) Remove through bolt nut (Fig. 42). DO NOT remove the through bolt.
- (5) Remove the retaining bolts and nuts from the support cushions (Fig. 42).
- (6) Remove the through bolt.
- (7) Remove the support cushions.

INSTALLATION

(1) If the engine support bracket was removed, position the LEFT bracket (Fig. 42) and the RIGHT bracket (Fig. 43) onto the cylinder block. Install the bolts and stud nuts.

(a) RIGHT SIDE (Fig. 43) —Tighten the bolts to 61 N·m (45 ft. lbs.) torque. Tighten the stud nuts to 46 N·m (34 ft. lbs.) torque.

(b) LEFT SIDE (Fig. 42) —Tighten the bolts to 61 N·m (45 ft. lbs.) torque.

(2) If the support cushion brackets were removed, position the brackets onto the lower front sill (Fig. 42) (Fig. 44). Install the bolts and stud nuts. Tighten the bolts to 54 N·m (40 ft. lbs.) torque and the stud nuts to 41 N·m (30 ft. lbs.) torque.

REMOVAL AND INSTALLATION (Continued)

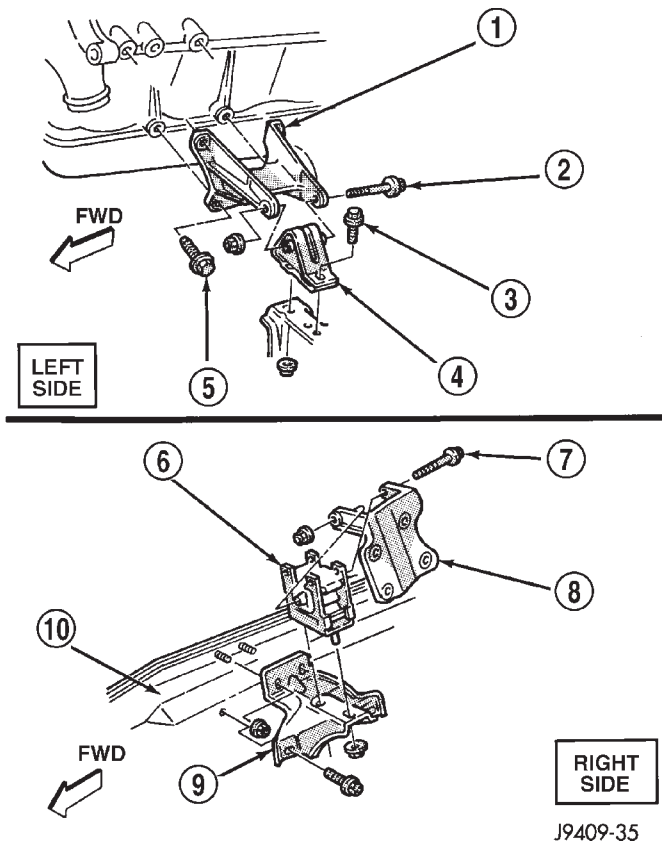
**Fig. 42 Front Mounts**

- 1 - ENGINE SUPPORT BRACKET
- 2 - THROUGH BOLT
- 3 - RETAINING BOLT
- 4 - SUPPORT CUSHION
- 5 - ATTACHING BOLT
- 6 - SUPPORT CUSHION
- 7 - THROUGH BOLT
- 8 - ENGINE SUPPORT BRACKET
- 9 - SUPPORT CUSHION BRACKET
- 10 - SILL

(3) Place the support cushions onto the support cushion brackets (Fig. 42). Tighten the right support cushion nuts to 65 N·m (48 ft. lbs.) torque. Tighten the left support cushion bolt and nut to 41 N·m (30 ft. lbs.) torque.

(4) Install the through bolt and the retaining nut (Fig. 42). Tighten the through bolt nut to 65 N·m (48 ft. lbs.) torque.

(5) Remove the engine support.

(6) Lower the vehicle.

(7) Connect negative cable to battery.

ENGINE MOUNT—REAR

A resilient rubber cushion supports the transmission at the rear between the transmission extension housing and the rear support crossmember or skid plate.

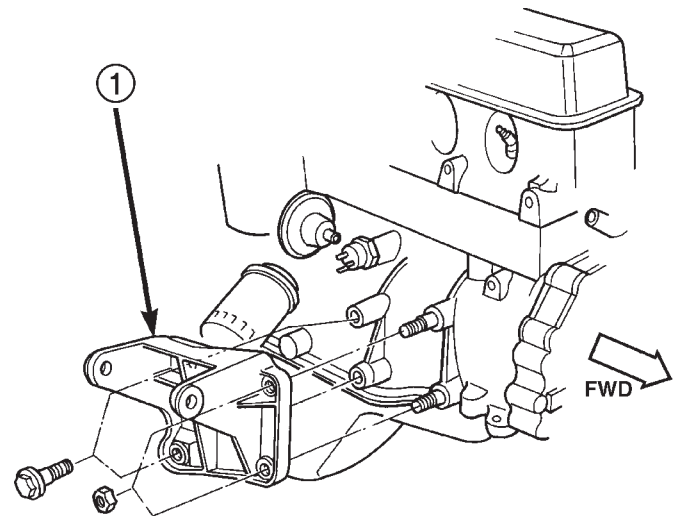

805dd883

Fig. 43 Engine Support Bracket—Right Side

- 1 - ENGINE SUPPORT BRACKET

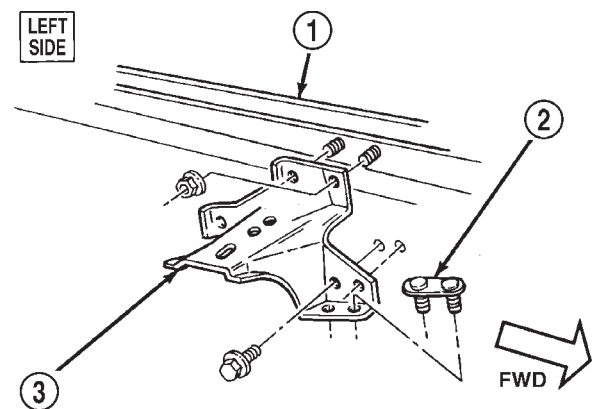

J9409-39

Fig. 44 Support Cushion Bracket—Left Side

- 1 - LOWER FRONT SILL
- 2 - TRACK BAR MOUNTING PLATE
- 3 - SUPPORT CUSHION BRACKET

REMOVAL

- (1) Disconnect negative cable from battery.
- (2) Raise the vehicle and support the transmission.
- (3) Remove the nuts holding the support cushion to the crossmember (Fig. 45) (Fig. 46). Remove the crossmember.

MANUAL TRANSMISSION:

- a. Remove the support cushion nuts and remove the cushion.
- b. If necessary, remove the bolts holding the transmission support bracket to the transmission (Fig. 45). Remove the bracket.

REMOVAL AND INSTALLATION (Continued)

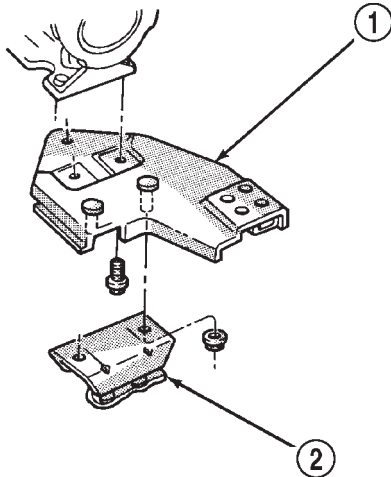

J9409-44

Fig. 45 Rear Mount (Manual Transmission)

- 1 - TRANSMISSION SUPPORT BRACKET
2 - SUPPORT CUSHION

AUTOMATIC TRANSMISSION:

- a. Remove the support cushion bolts and remove the cushion and the transmission support bracket.
- b. If necessary on 2WD vehicles, remove the bolts holding the transmission support adaptor bracket to the transmission (Fig. 46). Remove the adaptor bracket.

INSTALLATION**MANUAL TRANSMISSION:**

- a. If removed, position the transmission support bracket to the transmission and install the bolts. Tighten the bolts to 43 N·m (32 ft. lbs.) torque.
- b. Position the support cushion onto the transmission support bracket. Install and tighten the nuts to 46 N·m (34 ft. lbs.) torque.

AUTOMATIC TRANSMISSION:

- a. If removed, position the transmission support adaptor bracket (2WD vehicles) to the transmission and install the bolts. Tighten the bolts to 75 N·m (55 ft. lbs.) torque.
- b. Position the transmission support bracket and support cushion to the transmission and install the bolts. Tighten the bolts to 75 N·m (55 ft. lbs.) torque.
 - (1) Position the crossmember onto the support cushion studs and install the nuts. Tighten the nuts to 22 N·m (192 in. lbs.) torque.
 - (2) Install the crossmember to sill bolts and tighten to 41 N·m (30 ft. lbs.) torque.
 - (3) Remove the transmission support.
 - (4) Lower the vehicle.
 - (5) Connect negative cable to battery.

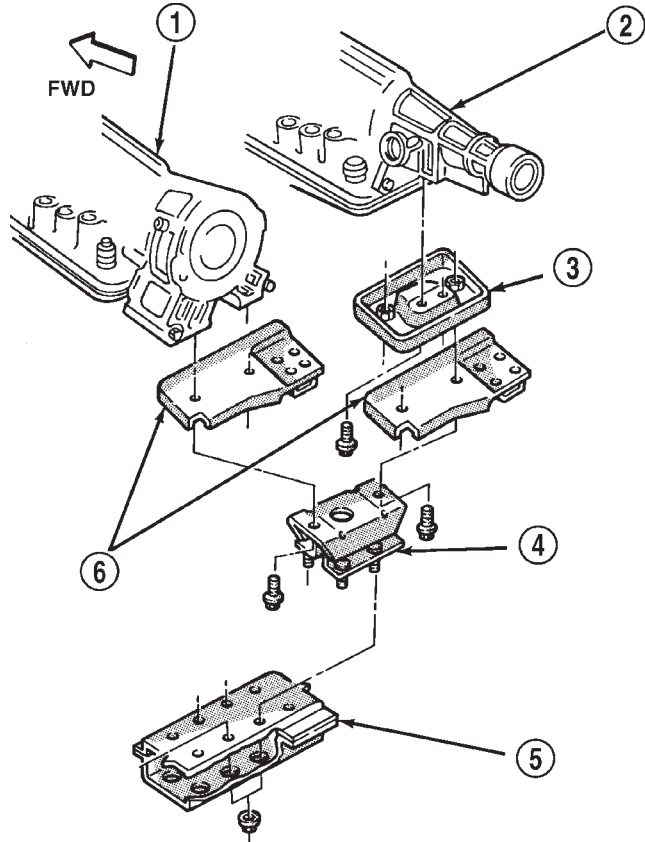

J9409-45

Fig. 46 Rear Mount (Automatic Transmission)

- 1 - 4×4
2 - 2×4
3 - TRANSMISSION SUPPORT ADAPTOR BRACKET
4 - SUPPORT CUSHION
5 - CROSSMEMBER ASSEMBLY
6 - TRANSMISSION SUPPORT BRACKET

ENGINE**REMOVAL**

- (1) Disconnect the battery cables. Remove the battery.
- (2) Mark the hinge locations on the hood panel for alignment reference during installation. Remove the engine compartment lamp. Remove the hood.

WARNING: THE COOLANT IN A RECENTLY OPERATED ENGINE IS HOT AND PRESSURIZED. USE CARE TO PREVENT SCALDING BY HOT COOLANT. CAREFULLY RELEASE THE PRESSURE BEFORE REMOVING THE RADIATOR DRAIN COCK AND CAP.

- (3) Loosen the radiator drain cock and radiator cap to drain the coolant. DO NOT waste usable coolant. If the solution is clean, drain the coolant into a clean container for reuse.
- (4) Remove the air cleaner assembly (Fig. 47).
- (5) Remove the lower radiator hose.

REMOVAL AND INSTALLATION (Continued)

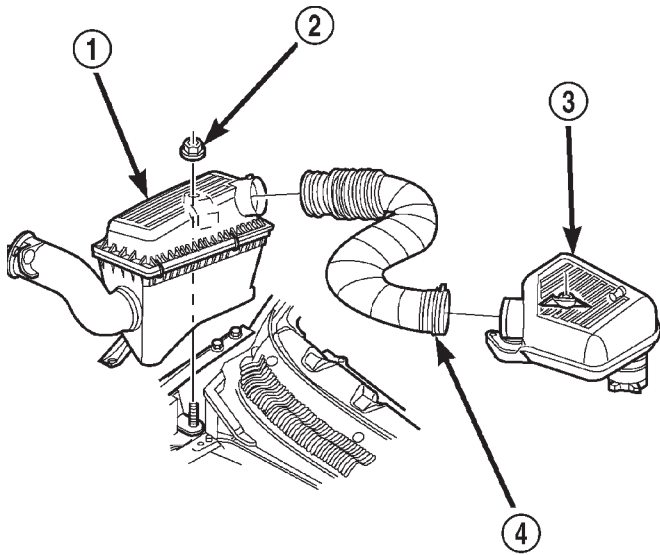

80bcea63

Fig. 47 Air Cleaner and Resonator Removal and Installation

- 1 - AIR CLEANER ASSEMBLY
- 2 - NUT AND WASHER
- 3 - RESONATOR ASSEMBLY
- 4 - AIR INLET HOSE

(6) Remove the upper radiator hose and coolant recovery hose (Fig. 48).

(7) Remove the fan shroud (Fig. 48).

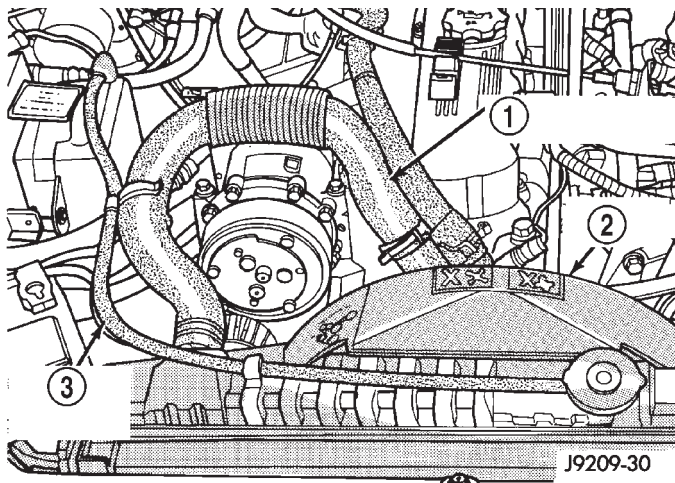

Fig. 48 Upper Radiator Hose, Coolant Recovery Hose & Fan Shroud

- 1 - UPPER RADIATOR HOSE
- 2 - FAN SHROUD
- 3 - COOLANT RECOVERY HOSE

(8) Remove the radiator/condenser (if equipped with air conditioning).

(9) Remove fan assembly and install a 5/16 x 1/2-inch SAE capscrew through fan pulley into water pump flange. This will maintain the pulley and water pump in alignment when crankshaft is rotated.

(10) Disconnect the heater hoses.

(11) Disconnect the throttle cable, speed control cable (if equipped) and transmission cable (if equipped).

(12) Disconnect the body ground at the firewall.

(13) Disconnect the wires from the starter motor solenoid.

(14) Disconnect all fuel injection harness connections.

WARNING: THE FUEL SYSTEM IS UNDER A CONSTANT PRESSURE (EVEN WITH THE ENGINE TURNED OFF). BEFORE DISCONNECTING FUEL LINES, THE FUEL SYSTEM PRESSURE MUST BE RELEASED.

(15) Perform fuel pressure release procedure. (refer to Group 14, Fuel System for the proper procedure).

(16) Remove latch clip and disconnect the quick-connect fuel line at the fuel rail

(17) Recover refrigerant (if equipped with A/C). (Refer to group 24, Heating and Air Conditioning for proper procedures.)

(18) Disconnect suction/discharge hose from A/C compressor and cap off ports to prevent intrusion of foreign material or refrigerant oil loss.

(19) Remove the power brake vacuum check valve from the booster, if equipped.

(20) If equipped with power steering :

(a) Disconnect the power steering hoses from the fittings at the steering gear.

(b) Drain the pump reservoir.

(c) Cap the fittings on the hoses and steering gear to prevent foreign material from entering the system.

(21) Identify, tag and disconnect all necessary wire connectors and vacuum hoses.

(22) Raise the vehicle.

(23) Remove the oil filter.

(24) Remove the starter motor.

(25) Disconnect the exhaust pipe from the exhaust manifold.

(26) Remove the flywheel housing access cover.

(27) Remove the upper flywheel and converter housing bolts and loosen the bottom bolts.

(28) Remove the engine support cushion-to-engine compartment bracket bolts.

(29) Remove the engine shock damper bracket from the sill.

(30) Lower the vehicle.

(31) Attach a lifting device to the engine.

REMOVAL AND INSTALLATION (Continued)

(32) Raise the engine slightly off the front supports.

(33) Place a support stand under the converter or flywheel housing.

(34) Lift the engine out of the engine compartment and install on an engine stand.

(35) Install the oil filter to keep foreign material out of the engine.

INSTALLATION

(1) Remove the oil filter.

(2) Lift the engine off the stand and lower it into the engine compartment. For easier installation, it may be useful to remove the engine support cushions from the engine support brackets as an aide for alignment of the engine-to-transmission.

(3) Insert the transmission shaft into the clutch spline. (M/T models)

(4) Align the flywheel housing with the engine.

(5) Install and tighten the flywheel housing lower bolts.

(6) Install the engine support cushions (if removed).

(7) Lower the engine and engine support cushions onto the engine compartment brackets.

(8) Remove the engine lifting device.

(9) Raise the vehicle.

(10) Install the converter-housing access cover.

(11) Install the exhaust pipe support.

(12) Install the starter motor and connect the cable. Tighten the bolts to 45 N·m (33 ft. lbs.) torque.

(13) Tighten the engine support cushion through-bolt nuts.

(14) Connect the exhaust pipe to the manifold.

(15) Install the oil filter.

(16) Lower the vehicle.

(17) Connect the coolant hoses and tighten the clamps.

(18) If equipped with power steering:

(a) Remove the protective caps

(b) Connect the hoses to the fittings at the steering gear. Tighten the nut to 52 N·m (38 ft. lbs.) torque.

(c) Fill the pump reservoir with fluid.

(19) Remove the pulley-to-water pump flange alignment capscrew and install the fan assembly.

(20) Install the fan shroud and radiator and condenser (if equipped with air conditioning).

(21) Connect the radiator hoses.

(22) Connect the oxygen sensor wire connector.

(23) Connect the throttle cable and install the rod. Connect the transmission and speed control cables (if equipped)

(24) Connect the fuel supply line to the injector rail. push until a "click" is heard. Re-install latch clip.

(25) Connect all the vacuum hoses and wire connectors.

(26) Connect suction/discharge hose to compressor. (if equipped)

(27) Fill the power steering reservoir.

(28) Connect the battery cables.

(29) Install the air cleaner (Fig. 47).

(30) Install the hood.

(31) Add engine oil and coolant.

(32) Start the engine and inspect for leaks.

(33) Stop the engine and check the fluid levels.

Add fluid, as required.

(34) Recharge air conditioning (Refer to group 24, Heating and Air Conditioning for proper procedures).

INTAKE MANIFOLD**REMOVAL**

(1) Disconnect the battery negative cable.

(2) Remove the air inlet hose and resonator from the throttle body and air cleaner (Fig. 49).

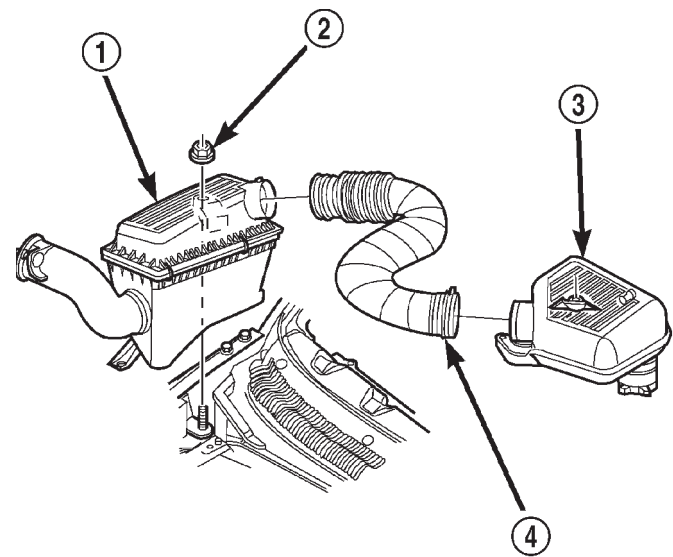

80bcea63

Fig. 49 Air Cleaner, Resonator and air Inlet Hose Removal and Installation

1 - AIR CLEANER ASSEMBLY

2 - NUT AND WASHER

3 - RESONATOR ASSEMBLY

4 - AIR INLET HOSE

(3) Loosen the accessory drive belt tension and remove the belt from the power steering pump (refer to Group 07, Cooling Systems for proper procedures).

(4) Remove the power steering pump and brackets from the water pump and intake manifold. Secure power steering pump and bracket out of the way.

REMOVAL AND INSTALLATION (Continued)

(5) Perform fuel system pressure release procedure (refer to Group 14, Fuel System for correct procedure).

(6) Disconnect fuel supply tube from the fuel rail. Some fuel lines require a special tool for removal/installation (refer to Group 14, Fuel System - Quick Connect Fittings).

(7) Disconnect the accelerator cable, the cruise control cable (if equipped), and the transmission line pressure cable (if equipped) from the throttle body and remove them from the cable bracket.

CAUTION: When disconnecting the cruise control connector at the throttle body, **DO NOT** pry the connector off with pliers or screwdriver. Use finger pressure only. Prying the connector off could break it.

(8) Disconnect the electrical connectors. Pull the harnesses away from the manifold and secure them so they do not interfere with the manifold removal and installation process.

- The throttle position sensor.
- The idle air control motor.
- The coolant temperature sensor at the thermostat.
- The manifold air temperature sensor at the intake manifold.
- The fuel injectors.
- The oxygen sensor.

(9) Disconnect the crankcase ventilation (CCV) vacuum hose and manifold absolute pressure (MAP) sensor vacuum hose connector at the intake manifold.

(10) Disconnect vacuum hose from vacuum port on the intake manifold.

(11) Disconnect CCV hose at the cylinder head cover (Fig. 50).

(12) Remove the molded vacuum harness.

(13) Disconnect the vacuum brake booster hose at the intake manifold.

(14) Remove bolts 2 through 5 securing the intake manifold to the cylinder head (Fig. 51). Slightly loosen bolt No.1 and nuts 6 and 7.

(15) Remove the intake manifold and gaskets. Drain the coolant from the manifold.

INSTALLATION

(1) Clean the intake manifold and cylinder head mating surfaces. **DO NOT allow foreign material to enter either the intake manifold or the ports in the cylinder head.**

(2) Install the new intake manifold gasket over the locating dowels.

(3) Position the manifold in place and finger tighten the mounting bolts.

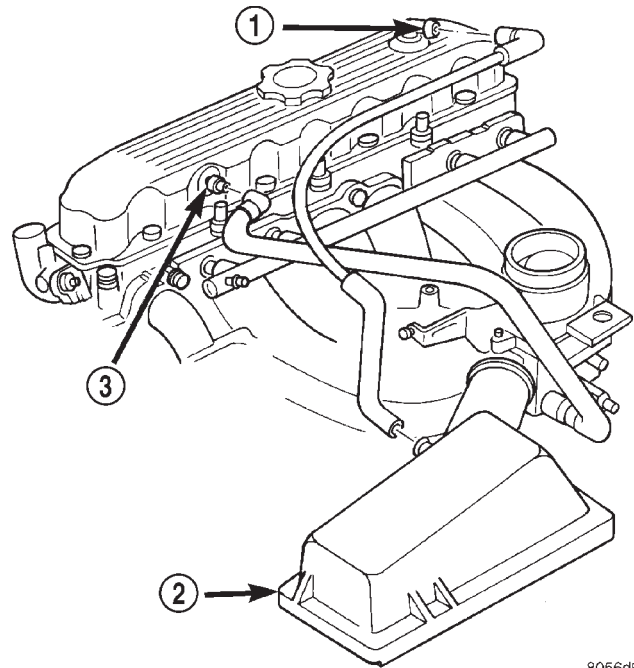

8056d9f4

Fig. 50 Crankcase Ventilation (CCV) Hose—2.5L Engine

- 1 - AIR INLET FITTING
- 2 - AIR FILTER COVER
- 3 - FIXED ORIFICE FITTING

(4) Tighten the fasteners in sequence and to the specified torque (Fig. 51).

- Fastener No.1—Tighten to 41 N·m (30 ft. lbs.) torque.
- Fasteners Nos.2 through 5—Tighten to 31 N·m (23 ft. lbs.) torque.
- Fasteners Nos.6 and 7—Tighten to 23 N·m (17 ft. lbs.) torque.

(5) Connect fuel supply tube to the fuel rail inlet. Push tube until a “click” is heard. **Before connecting the fuel line to the fuel rail replace the O-rings at the quick-connect fuel line coupling.**

(6) Pull out on the fuel supply tube to ensure that it is locked in place.

(7) Connect the molded vacuum hoses to the vacuum port on the intake manifold and the cylinder head cover.

(8) Connect the electrical connectors.

- The throttle position sensor.
- The idle air control motor.
- The coolant temperature sensor at the thermostat housing.
- The fuel injectors.
- The air manifold temperature sensor.
- The oxygen sensor.

(9) Connect the CCV vacuum hose and MAP sensor vacuum hose connectors to the throttle body.

REMOVAL AND INSTALLATION (Continued)

(10) Install the power steering pump and bracket assembly to the water pump and intake manifold. Hand start the three (3) tensioner bracket to p/s pump to intake manifold bolts and the two (2) tensioner bracket to water pump bolts.

(11) Tighten the power steering pump bolts to 28 N·m (21 ft. lbs.) Tighten the tensioner bracket to water pump bolts to 28 N·m (21 ft. lbs.).

(12) Connect the accelerator cable, cruise control cable (if equipped), and the transmission line pressure cable (if equipped) to the hold-down bracket and the throttle lever.

(13) Install and tension the accessory drive belt. Refer to Group 7, Cooling System for the proper procedure.

CAUTION: Ensure that the accessory drive belt is routed correctly. Failure to do so can cause the water pump to turn in the opposite direction resulting in engine overheating. Refer to Group 7, Cooling System for the proper procedure.

(14) Connect the air inlet hose and resonator to the throttle body and the air cleaner.

(15) Connect the battery negative cable.

(16) Start the engine and check for leaks.

EXHAUST MANIFOLD

REMOVAL

(1) Disconnect the battery negative cable.

(2) Raise the vehicle.

(3) Disconnect the exhaust pipe from the engine exhaust manifold.

(4) Lower the vehicle.

(5) Remove intake manifold (refer to procedure in this section)

(6) Remove fasteners 2 through 5 and remove the intake manifold (Fig. 51).

(7) Remove fasteners 1, 6 and 7 and remove the engine exhaust manifold (Fig. 51).

INSTALLATION

(1) Clean the intake and engine exhaust manifolds and cylinder head mating surfaces. **DO NOT allow foreign material to enter either the intake manifold or the ports in the cylinder head.**

(2) Install a new intake manifold gasket over the alignment dowels on the cylinder head.

(3) Install the engine exhaust manifold assembly. **Exhaust manifold must be centrally located over the end studs and spacer (Fig. 51).**

(4) Tighten bolt No.1 to 41 N·m (30 ft. lbs.) torque (Fig. 51).

(5) Install the intake manifold on the cylinder head dowels (Fig. 51).

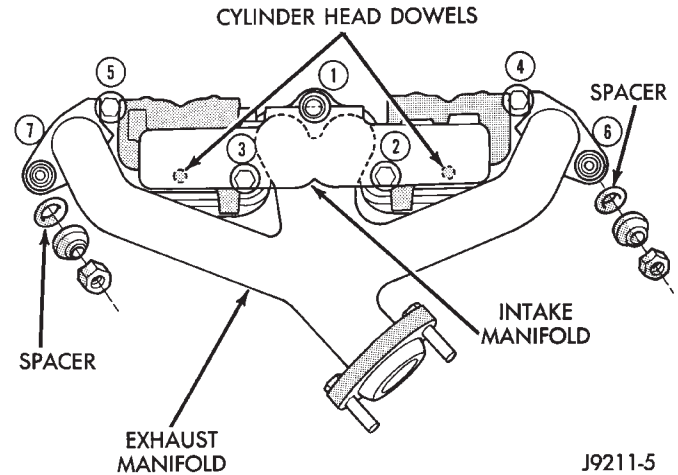

Fig. 51 Intake/Exhaust Manifold Removal/Installation—2.5L Engine

(6) Install bolts 2 through 5 (Fig. 51). Tighten these bolts to 31 N·m (23 ft. lbs.) torque.

(7) Install new engine exhaust manifold spacers over the engine exhaust manifold mounting studs in the cylinder head (Fig. 51).

(8) Tighten nuts 6 and 7 to 23 N·m (17 ft. lbs.) torque (Fig. 51).

(9) Install all components to the intake manifold.

(10) Raise the vehicle.

(11) Connect the exhaust pipe to the engine exhaust manifold. Tighten the bolts to 31 N·m (23 ft. lbs.) torque.

(12) Lower the vehicle.

(13) Connect the battery negative cable.

(14) Start the engine and check for leaks.

CYLINDER HEAD COVER

A cured gasket is part of the engine cylinder head cover.

REMOVAL

(1) Disconnect negative cable from battery.

(2) Disconnect the Crankcase Ventilation (CCV) vacuum hose from engine cylinder head cover (Fig. 52).

(3) Remove the air inlet hose and resonator from the air cleaner and throttle body.

(4) Remove the engine cylinder head cover mounting bolts.

(5) Remove the engine cylinder head cover (Fig. 52).

(6) Remove any original sealer from the cover sealing surface of the engine cylinder head and clean the surface using a fabric cleaner.

(7) Remove all residue from the sealing surface using a clean, dry cloth.

REMOVAL AND INSTALLATION (Continued)

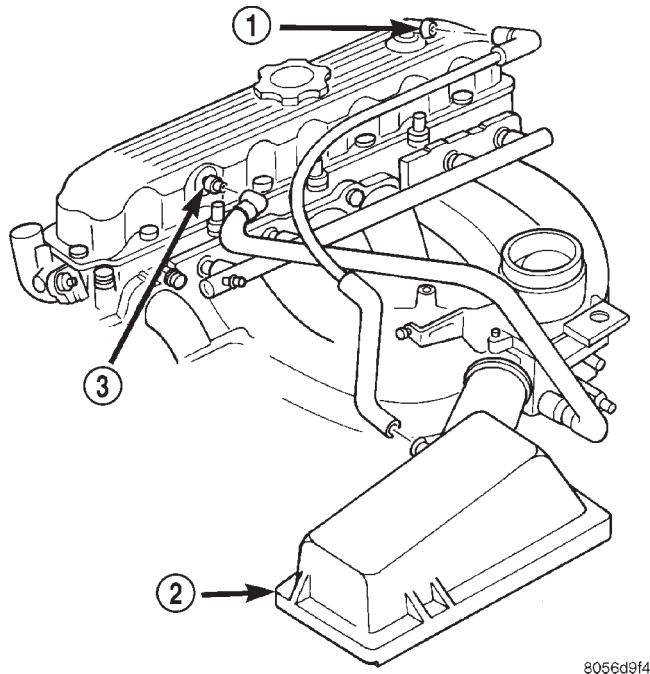

8056d9f4

Fig. 52 Engine Cylinder Head Cover

- 1 - AIR INLET FITTING
- 2 - AIR FILTER COVER
- 3 - FIXED ORIFICE FITTING

INSTALLATION

(1) Inspect the engine cylinder head cover for cracks. Replace the cover, if cracked.

NOTE: The original dark grey gasket material should **NOT** be removed. If sections of the gasket material are missing or are compressed, replace the engine cylinder head cover. However, sections with minor damage such as small cracks, cuts or chips may be repaired with a hand held applicator. The new material must be smoothed over to maintain gasket height. Allow the gasket material to cure prior to engine cylinder head cover installation.

(2) If a replacement cover is installed, transfer the CCV valve grommet the oil filler cap from the original cover to the replacement cover.

(3) Install engine cylinder head cover. Tighten the mounting bolts to 13 N·m (115 in. lbs.) torque.

(4) Connect the CCV hoses (Fig. 52).

(5) Connect negative cable to battery.

(6) Install the air inlet hose and resonator.

ROCKER ARMS AND PUSH RODS

This procedure can be done with the engine in or out of the vehicle.

REMOVAL

(1) Remove the engine cylinder head cover. (Refer to procedure in this section)

(2) Check for rocker arm bridges which are causing misalignment of the rocker arm to valve tip area.

(3) Remove the capscrews at each bridge and pivot assembly (Fig. 53). Alternately loosen the capscrews one turn at a time to avoid damaging the bridges.

(4) Remove the bridges, pivots and corresponding pairs of rocker arms (Fig. 53). Place them on a bench in the same order as removed.

(5) Remove the push rods and place them on a bench in the same order as removed.

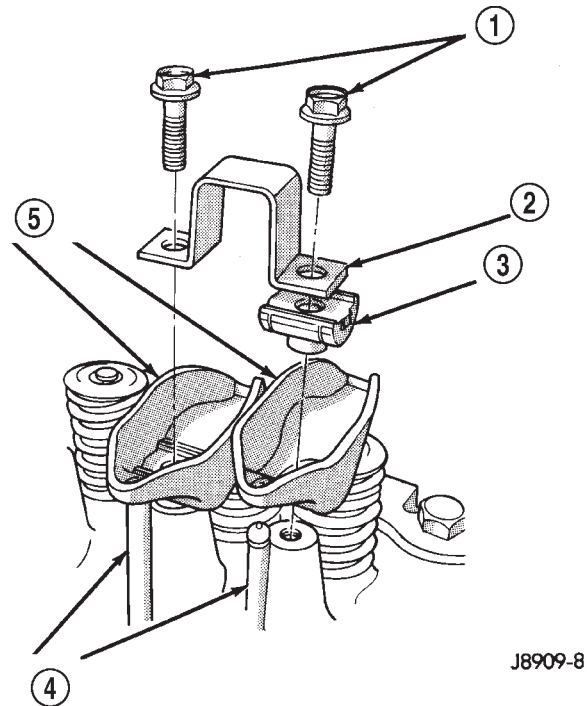

J8909-8

Fig. 53 Rocker Arm Assembly

- 1 - CAPSCREWS
- 2 - BRIDGE
- 3 - PIVOT ASSEMBLY
- 4 - PUSH RODS
- 5 - ROCKER ARMS

(6) Clean all the components with cleaning solvent.

(7) Use compressed air to blow out the oil passages in the rocker arms and push rods.

INSTALLATION

(1) Lubricate the ball ends of the push rods with Mopar Engine Oil Supplement, or equivalent and install push rods in their original locations. Ensure that the bottom end of each push rod is centered in the tappet plunger cap seat.

(2) Using Mopar Engine Oil Supplement, or equivalent, lubricate the area of the rocker arm that the

REMOVAL AND INSTALLATION (Continued)

pivot contacts. Install rocker arms, pivots and bridge above each cylinder in their original position.

(3) Loosely install the capscrews through each bridge.

(4) At each bridge, tighten the capscrews alternately, one turn at a time, to avoid damaging the bridge. Tighten the capscrews to 28 N·m (21 ft. lbs.) torque.

(5) Install the engine cylinder head cover.

VALVE SPRING AND SEAL

This procedure can be done with the engine cylinder head installed on the block.

REMOVAL

Each valve spring is held in place by a retainer and a set of conical valve locks. The locks can be removed only by compressing the valve spring.

(1) Remove the engine cylinder head cover. Refer to procedure in this section.

(2) Remove cap screws, bridge and pivot assemblies and rocker arms for access to each valve spring to be removed.

(3) Remove push rods. **Retain the push rods, bridges, pivots and rocker arms in the same order and position as removed.**

(4) Inspect the springs and retainer for cracks and possible signs of weakening.

(5) Remove the spark plug(s) adjacent to the cylinder(s) below the valve springs to be removed.

(6) Install a 14 mm (1/2 inch) (thread size) air hose adaptor in the spark plug hole.

(7) Connect an air hose to the adapter and apply air pressure slowly. Maintain at least 621 kPa (90 psi) of air pressure in the cylinder to hold the valves against their seats. For vehicles equipped with an air conditioner, use a flexible air adaptor when servicing the No.1 cylinder.

(8) Tap the retainer or tip with a rawhide hammer to loosen the lock from the retainer. Use Valve Spring Compressor Tool MD-998772A to compress the spring and remove the locks (Fig. 54).

(9) Remove valve spring and retainer (Fig. 54).

(10) Remove valve stem oil seals (Fig. 54). Note the valve seals are different for intake and exhaust valves. The top of each seal is marked either INT (intake/black in color) or EXH (exhaust/brown in color). DO NOT mix the seals.

INSTALLATION

Inspect the valve stems, especially the grooves. An Arkansas smooth stone should be used to remove nicks and high spots.

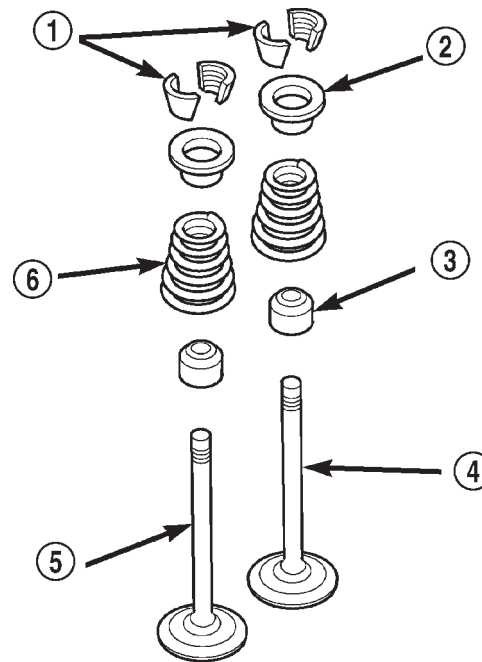

80b7704b

Fig. 54 Valve and Valve Components

- 1 - VALVE LOCKS (3-BEAD)
- 2 - RETAINER
- 3 - VALVE STEM OIL SEAL
- 4 - INTAKE VALVE
- 5 - EXHAUST VALVE
- 6 - VALVE SPRING

CAUTION: Install oil seals carefully to prevent damage from the sharp edges of the valve spring lock groove.

(1) Lightly push the valve seal over the valve stem and valve guide boss. Be sure the seal is completely seated on the valve guide boss.

(2) Install valve spring and retainer.

(3) Compress the valve spring with Valve Spring Compressor Tool MD-998772A and insert the valve locks. Release the spring tension and remove the tool. Tap the spring from side-to-side to ensure that the spring is seated properly on the engine cylinder head.

(4) Release air pressure and disconnect the air hose. Remove the adaptor from the spark plug hole and install the spark plug.

(5) Repeat the procedures for each remaining valve spring to be removed.

(6) Install the push rods. Ensure the bottom end of each rod is centered in the plunger cap seat of the hydraulic valve tappet.

(7) Install the rocker arms, pivots and bridge at their original location.

(8) Tighten the bridge cap screws alternately, one at a time, to avoid damaging the bridge. Tighten the cap screws to 28 N·m (21 ft. lbs.) torque.

REMOVAL AND INSTALLATION (Continued)

(9) Install the engine cylinder head cover.

CYLINDER HEAD

This procedure can be done with the engine in or out of the vehicle.

REMOVAL

(1) Disconnect negative cable from battery.

WARNING: DO NOT REMOVE THE CYLINDER BLOCK DRAIN PLUGS OR LOOSEN THE RADIATOR DRAIN COCK WITH THE SYSTEM HOT AND PRESSURIZED BECAUSE SERIOUS BURNS FROM THE COOLANT CAN OCCUR.

(2) Drain the coolant and disconnect the hoses at the engine thermostat housing. **DO NOT** waste reusable coolant. If the solution is clean and is being drained only to service the engine or cooling system, drain the coolant into a clean container for reuse.

(3) Remove the air cleaner assembly.

(4) Remove the engine cylinder head cover. (Refer to procedure in this section)

(5) Remove the capscrews, bridge and pivot assemblies and rocker arms (Fig. 55).

(6) Remove the push rods (Fig. 55). **Retain the push rods, bridges, pivots and rocker arms in the same order as removed.**

(7) Loosen the accessory drive belt at the power steering pump bracket, if equipped or at the idler pulley bracket (refer to Group 7, Cooling System for the proper procedure).

(8) If equipped with air conditioning, perform the following:

(a) Remove the bolts from the A/C compressor mounting bracket and set the compressor aside.

(b) Remove the air conditioner compressor bracket bolts from the engine cylinder head.

(c) Loosen the through bolt at the bottom of the bracket.

(9) If equipped, disconnect the power steering pump bracket. Set the pump and bracket aside. **DO NOT** disconnect the hoses.

(10) Perform fuel pressure release procedure (Refer to Group 14, fuel systems for proper procedures).

(11) Remove the latch clip and disconnect the fuel supply hose.

(12) Remove the intake and engine exhaust manifolds from the engine cylinder head (refer to Group 11, Exhaust System and Intake Manifold for the proper procedures).

(13) Number and disconnect the ignition wires and remove the spark plugs.

(14) Disconnect the coolant temperature sending unit connector.

(15) Remove the engine cylinder head bolts.

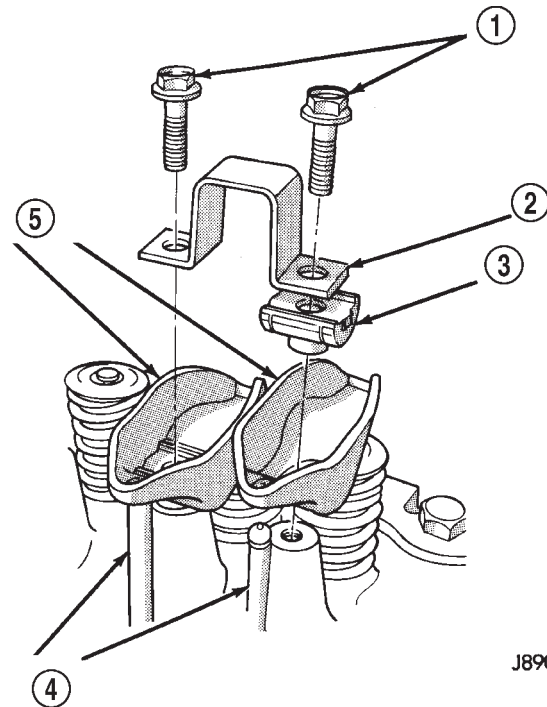

J8909-8

Fig. 55 Rocker Arm Assembly

- 1 - CAPSCREWS
- 2 - BRIDGE
- 3 - PIVOT ASSEMBLY
- 4 - PUSH RODS
- 5 - ROCKER ARMS

(16) Remove the engine cylinder head and gasket (Fig. 56).

(17) If this was the first time the bolts were removed, put a paint dab on the top of the bolt. If the bolts have a paint dab on the top of the bolt or it isn't known if they were used before, discard the bolts.

(18) Stuff clean lint free shop towels into the cylinder bores.

NOTE: If valves, springs, or seals are to be inspected/replaced at this time, refer to Valves and Valve Springs later in this section for proper inspection procedures.

INSTALLATION

The engine cylinder head gasket is a composition gasket. The gasket is to be installed **DRY**. **DO NOT use a gasket sealing compound on the gasket.**

If the engine cylinder head is to be replaced and the original valves used, measure the valve stem diameter. Only standard size valves can be used with a service replacement engine cylinder head unless the replacement head valve stem guide bores are reamed to accommodate oversize valve stems. Remove all carbon buildup and reface the valves.

REMOVAL AND INSTALLATION (Continued)

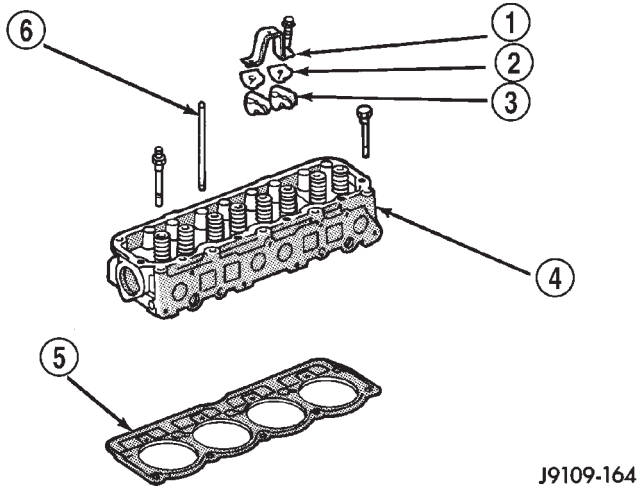
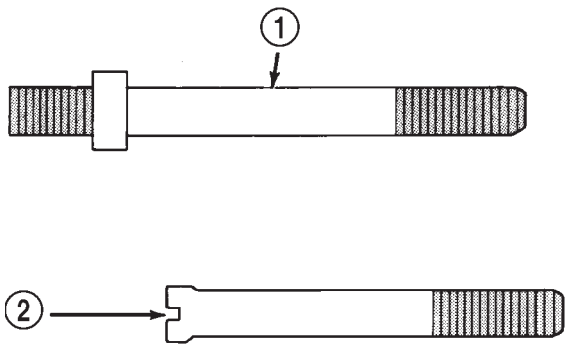

Fig. 56 Engine Cylinder Head Assembly

- 1 - BRIDGE
- 2 - PIVOT ASM.
- 3 - ROCKER ARM
- 4 - CYLINDER HEAD
- 5 - HEAD GASKET
- 6 - PUSH ROD

J9109-164

(1) Fabricate two engine cylinder head alignment dowels from used head bolts (Fig. 57). Use the longest head bolt. Cut the head of the bolt off below the hex head. Then cut a slot in the top of the dowel to allow easier removal with a screwdriver.



J9009-13

Fig. 57 Fabricate Alignment Dowels

- 1 - USED CYLINDER HEAD BOLT
- 2 - SLOT

(2) Install one dowel in bolt hole No.10 and the other dowel in bolt hole No.8 (Fig. 58).
 (3) Remove the shop towels from the cylinder bores. Coat the bores with clean engine oil.
 (4) Place the engine cylinder head gasket (with the numbers facing up) over the dowels.
 (5) Place the engine cylinder head over the dowels.

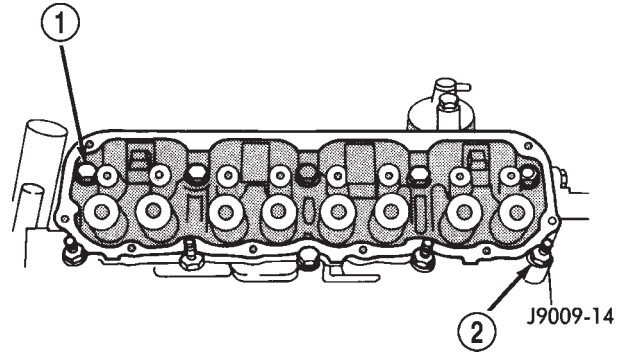

Fig. 58 Alignment Dowel Locations

- 1 - ALIGNMENT DOWEL
- 2 - ALIGNMENT DOWEL

CAUTION: Engine cylinder head bolts should be reused only once. Replace the head bolts if they were used before or if they have a paint dab on the top of the bolt.

- (6) Coat the threads of bolt No.7, only, with Loctite PST sealant or equivalent.
- (7) Install all head bolts, except No.8 and No.10.
- (8) Remove the dowels.
- (9) Install No.8 and No.10 head bolts.

CAUTION: During the final tightening sequence, bolt No.7 will be tightened to a lower torque than the rest of the bolts. DO NOT overtighten bolt No.7.

(10) Tighten the engine cylinder head bolts in sequence according to the following procedure (Fig. 59) :

- (a) Tighten all bolts in sequence (1 through 10) to 30 N·m (22 ft. lbs.) torque.
- (b) Tighten all bolts in sequence (1 through 10) to 61 N·m (45 ft. lbs.) torque.
- (c) Check all bolts to verify they are set to 61 N·m (45 ft. lbs.) torque.
- (d) Tighten bolts (in sequence):
 - Bolts 1 through 6 to 149 N·m (110 ft. lbs.) torque.
 - Bolt 7 to 136 N·m (100 ft. lbs.) torque.
 - Bolts 8 through 10 to 149 N·m (110 ft. lbs.) torque.

(e) Check all bolts in sequence to verify the correct torque.

(f) If not already done, clean and mark each bolt with a dab of paint after tightening. Should you encounter bolts which were painted in an earlier service operation, replace them.

(11) Connect the coolant temperature sending unit connector.

(12) Install the spark plugs and tighten to 37 N·m (27 ft. lbs.) torque. Connect the ignition wires.

REMOVAL AND INSTALLATION (Continued)

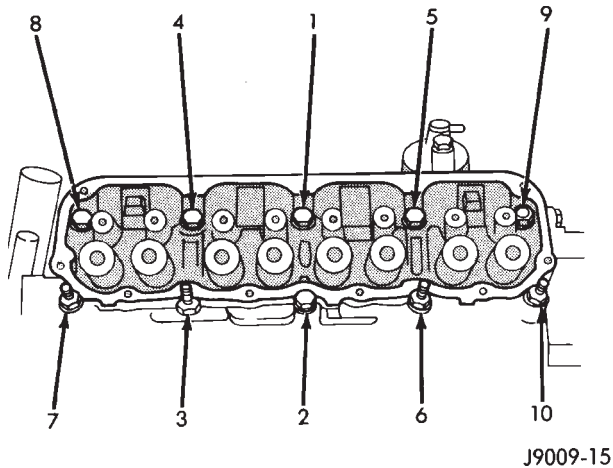

Fig. 59 Engine cylinder head Bolt Tightening Sequence

(13) Install the intake and exhaust manifolds (refer to Group 11, Exhaust System and Intake Manifold for the proper procedures).

(14) Install the fuel supply line. Push until a "click" is heard. Reinstall latch clip.

(15) If equipped, attach the power steering pump and bracket.

(16) Install the push rods, rocker arms, pivots and bridges in the order they were removed.

(17) Install the engine cylinder head cover.

(18) Attach the air conditioning compressor mounting bracket to the engine cylinder head and block. Tighten the bolts to 40 N·m (30 ft. lbs.) torque.

(19) Attach the air conditioning compressor to the bracket. Tighten the bolts to 27 N·m (20 ft. lbs.) torque.

CAUTION: The accessory drive belt must be routed correctly. Incorrect routing can cause the water pump to turn in the opposite direction causing the engine to overheat.

(20) Install the accessory drive belt and correctly tension the belt (refer to Group 7, Cooling System for the proper procedure).

(21) Install the air cleaner assembly.

(22) Connect the hoses to the thermostat housing and fill the cooling system to the specified level (refer to Group 7, Cooling Systems for the proper procedure).

(23) Install the coolant temperature sending unit connector.

(24) Connect negative cable to battery.

(25) Connect the upper radiator hose and heater hose at the thermostat housing.

(26) Fill the cooling system. Check for leaks.

WARNING: USE EXTREME CAUTION WHEN THE ENGINE IS OPERATING. DO NOT STAND IN DIRECT

LINE WITH THE FAN. DO NOT PUT HANDS NEAR THE PULLEYS, BELTS OR FAN. DO NOT WEAR LOOSE CLOTHING.

(27) Operate the engine with the radiator cap off. Inspect for leaks and continue operating the engine until the thermostat opens. Add coolant, if required.

CYLINDER HEAD

DISASSEMBLY

(1) Use Valve Spring Compressor Tool MD-998772A and compress each valve spring.

(2) Remove the valve locks, retainers, springs and valve stem oil seals. Discard the oil seals.

(3) Use an Arkansas smooth stone or a jewelers file to remove any burrs on the top of the valve stem, especially around the groove for the locks.

(4) Remove the valves, and place them in a rack in the same order as removed.

ASSEMBLY

(1) Thoroughly clean the valve stems and the valve guide bores.

(2) Lightly lubricate the stem.

(3) Install the valve in the original valve guide bore.

(4) Install the replacement valve stem oil seals on the valve stems. If the 0.381 mm (0.015 inch) over-size valve stems are used, oversize oil seals are required.

(5) Position the valve spring and retainer on the engine cylinder head and compress the valve spring with Valve Spring Compressor Tool MD-998772A.

(6) Install the valve locks and release the tool.

(7) Tap the valve spring from side to side with a hammer to ensure that the spring is properly seated at the engine cylinder head. Also tap the top of the retainer to seat the valve locks.

HYDRAULIC TAPPETS

REMOVAL

Retain all the components in the same order as removed.

(1) Remove the engine cylinder head cover (refer to procedure earlier in this section)

(2) Remove the bridge and pivot assemblies and rocker arms by removing the capscrews at each bridge. Alternately loosen each capscrew, one turn at a time, to avoid damaging the bridges.

(3) Remove the push rods.

(4) Remove the tappets through the push rod openings in the cylinder head with a Hydraulic Valve Tappet Removal/Installation Tool (Fig. 60).

REMOVAL AND INSTALLATION (Continued)

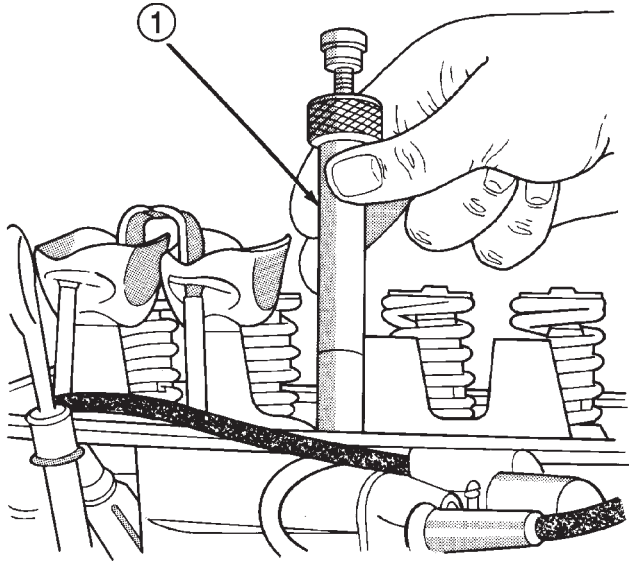

J8909-96

Fig. 60 Hydraulic Valve Tappet Removal/Installation Tool

1 - HYDRAULIC VALVE TAPPET REMOVAL/INSTALLATION TOOL

INSTALLATION

It is not necessary to charge the tappets with engine oil. They will charge themselves within a very short period of engine operation.

(1) Dip each tappet in Mopar Engine Oil Supplement, or equivalent.

(2) Use Hydraulic Valve Tappet Removal/Installation Tool to install each tappet in the same bore from where it was originally removed.

(3) Install the push rods in their original locations.

(4) Install the rocker arms and bridge and pivot assemblies at their original locations. Loosely install the capscrews at each bridge.

(5) Tighten the capscrews alternately, one turn at a time, to avoid damaging the bridges. Tighten the capscrews to 28 N·m (21 ft. lbs.) torque.

(6) Install the engine cylinder head cover.

VIBRATION DAMPER

REMOVAL

(1) Disconnect negative cable from battery.

(2) Remove the serpentine drive belt and fan shroud.

(3) Remove the vibration damper retaining bolt and washer.

(4) Use Vibration Damper Removal Tool 7697 to remove the damper from the crankshaft (Fig. 61).

INSTALLATION

(1) Apply Mopar Silicone Rubber Adhesive Sealant to the keyway in the crankshaft and insert the key.

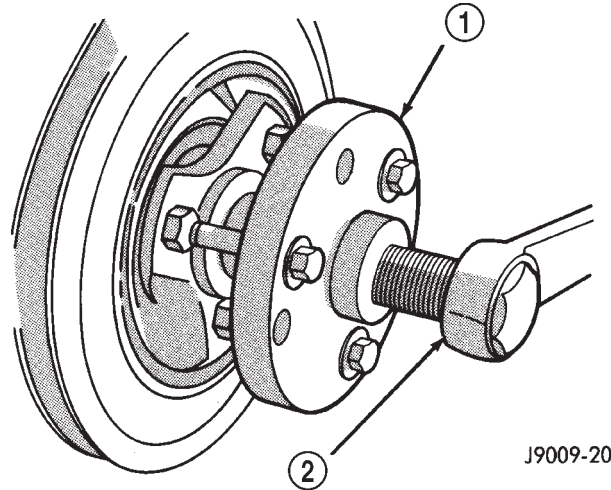

J9009-20

Fig. 61 Vibration Damper Removal Tool 7697

1 - VIBRATION DAMPER REMOVAL TOOL

2 - WRENCH

With the key in position, align the keyway on the vibration damper hub with the crankshaft key and tap the damper onto the crankshaft.

(2) Install the vibration damper retaining bolt and washer.

(3) Tighten the damper retaining bolt to 108 N·m (80 ft. lbs.) torque.

(4) Install the serpentine drive belt and tighten to the specified tension (refer to Group 7, Cooling Systems for the proper specifications and procedures).

(5) Connect negative cable to battery.

TIMING CASE COVER OIL SEAL

REMOVAL

This procedure is done with the timing case cover installed.

(1) Disconnect negative cable from battery.

(2) Remove the serpentine drive belt.

(3) Remove the vibration damper.

(4) Remove the radiator shroud.

(5) Carefully remove the oil seal. Make sure seal bore is clean.

INSTALLATION

(1) Position the replacement oil seal on Timing Case Cover Alignment and Seal Installation Tool 6139 with seal open end facing inward. Apply a light film of Perfect Seal, or equivalent, on the outside diameter of the seal. Lightly coat the crankshaft with engine oil.

(2) Position the tool and seal over the end of the crankshaft and insert a draw screw tool into Seal Installation Tool 6139 (Fig. 62). Tighten the nut against the tool until it contacts the cover.

REMOVAL AND INSTALLATION (Continued)

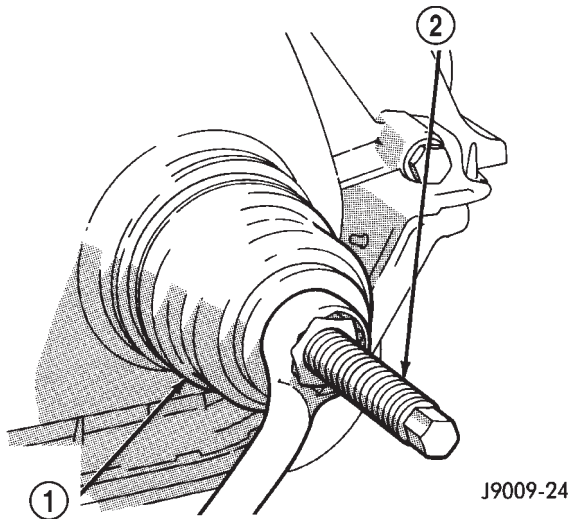
**Fig. 62 Timing Case Cover Oil Seal Installation**

- 1 - SEAL INSTALLATION TOOL
- 2 - DRAW SCREW TOOL

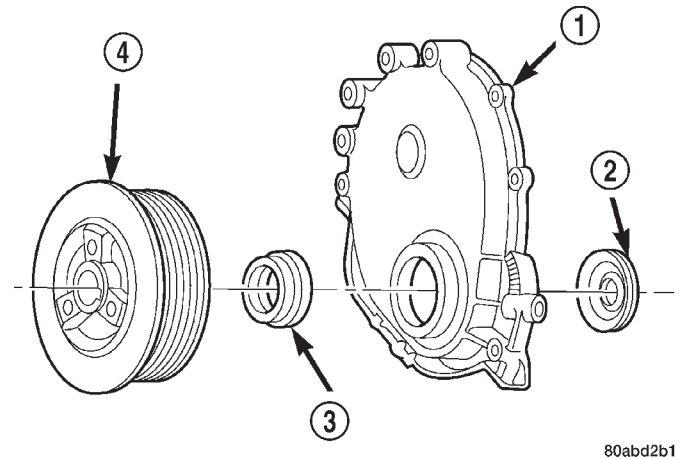
**Fig. 63 Timing Case Cover Components**

- 1 - TIMING CASE COVER
- 2 - OIL SLINGER
- 3 - CRANKSHAFT OIL SEAL
- 4 - VIBRATION DAMPER PULLEY

(3) Remove the tools. Apply a light film of engine oil on the vibration damper hub contact surface of the seal.

(4) Apply Mopar Silicone Rubber Adhesive Sealant to the keyway in the crankshaft and insert the key. With the key inserted in the keyway in the crankshaft, install the vibration damper, washer and bolt. Lubricate and tighten the bolt to 108 N·m (80 ft. lbs.) torque.

(5) Install the serpentine belt and tighten to the specified tension (refer to Group 7, Cooling Systems for the proper specifications and procedures).

(6) Install the radiator shroud.

(7) Connect negative cable to battery.

TIMING CASE COVER**REMOVAL**

(1) Disconnect battery negative cable.

(2) Remove accessory drive belt (Refer to Group 07, Cooling System for proper procedure)

(3) Remove the accessory drive brackets that are attached to the timing case cover.

(4) Remove the fan and hub assembly and remove the fan shroud.

(5) Remove the A/C compressor (if equipped) and generator bracket assembly from the engine cylinder head and move to one side.

(6) Remove the vibration damper (Fig. 63).

(7) Remove the oil pan-to-timing case cover bolts and timing case cover-to-cylinder block bolts.

(8) Remove the timing case cover and gasket from the engine.

(9) Pry the crankshaft oil seal from the front of the timing case cover (Fig. 63).

INSTALLATION

(1) Clean the timing case cover, oil pan and cylinder block gasket surfaces.

(2) Install a new crankshaft oil seal in the timing case cover. The open end of the seal should be toward the inside of the cover. Support the cover at the seal area while installing the seal. Force it into position with Seal Installation Tool 6139.

(3) Position the gasket on the cylinder block.

(4) Position the timing case cover on the oil pan gasket and the cylinder block.

(5) Insert Timing Case Cover Alignment and Seal Installation Tool 6139 in the crankshaft opening in the cover (Fig. 64).

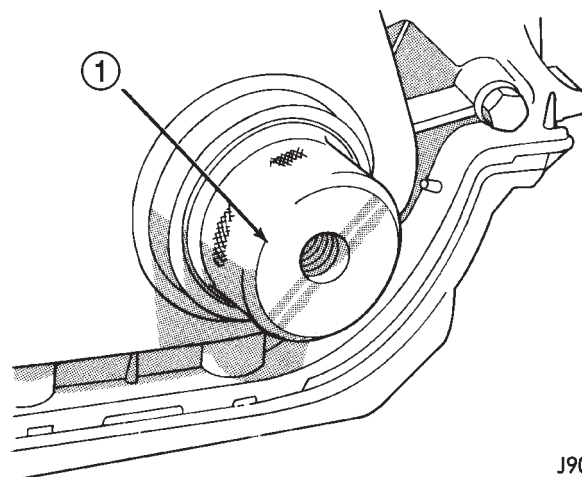
**Fig. 64 Timing Case Cover Alignment and Seal Installation Tool 6139**

- 1 - TIMING CASE COVER ALIGNMENT AND SEAL INSTALLATION TOOL

REMOVAL AND INSTALLATION (Continued)

(6) Install the timing case cover-to-cylinder block and the oil pan-to-timing case cover bolts.

(7) Tighten the 1/4 inch cover-to-block bolts to 7 N·m (60 in. lbs.) torque. Tighten the 5/16 inch front cover-to-block bolts to 22 N·m (192 in. lbs.) torque. Tighten the oil pan-to-cover bolts to 9.5 N·m (84 in. lbs.) torque.

(8) Remove the cover alignment tool.

(9) Apply a light film of engine oil on the vibration damper hub contact surface of the seal.

(10) Apply Mopar Silicone Rubber Adhesive Sealant to the keyway in the crankshaft and insert the key. With the key inserted in the keyway in the crankshaft, install the vibration damper, washer and bolt. Lubricate and tighten the bolt to 108 N·m (80 ft. lbs.) torque.

(11) Install the A/C compressor (if equipped) and generator bracket assembly.

(12) Install the engine fan and hub assembly and shroud.

(13) Install the accessory drive belt and tighten to obtain the specified tension.

(14) Connect negative cable to battery.

TIMING CHAIN AND SPROCKETS

The chain drive system is equipped with a timing chain tensioner which reduces noise and prolongs timing chain life. In addition, it compensates for wear and temperature changes on the valve train for proper engine operation.

REMOVAL

(1) Disconnect negative cable from battery.

(2) Remove the fan and shroud.

(3) Remove the serpentine drive belt.

(4) Remove the crankshaft vibration damper.

(5) Remove the timing case cover.

(6) Rotate crankshaft until the "0" timing mark is closest to and on the center line with camshaft sprocket timing mark (Fig. 65).

(7) Remove the oil slinger from the crankshaft.

(8) Remove the camshaft retaining bolt and remove the sprockets and chain as an assembly (Fig. 66).

(9) To replace the timing chain tensioner, the oil pan must be removed.

INSTALLATION

(1) Turn the tensioner lever to the unlocked (down) position (Fig. 67).

(2) Pull the tensioner block toward the tensioner lever to compress the spring. Hold the block and turn the tensioner lever to the lock position (Fig. 67).

(3) Apply Mopar Silicone Rubber Adhesive Sealant to the keyway in the crankshaft and insert the key. With the key in the crankshaft keyway, install the

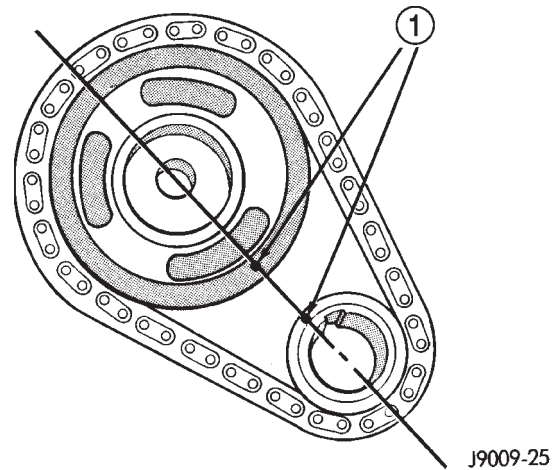

Fig. 65 Crankshaft—Camshaft Alignment

1 - TIMING MARKS

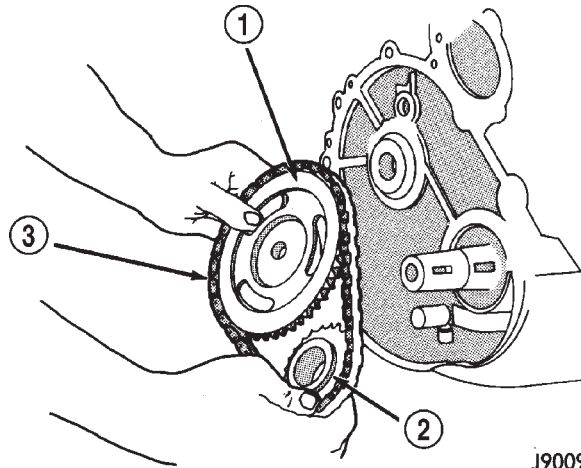

Fig. 66 Camshaft and Crankshaft Sprockets and Chain

1 - CAMSHAFT SPROCKET

2 - CRANKSHAFT SPROCKET

3 - CHAIN

crankshaft, camshaft sprockets and timing chain. Ensure the timing marks on the sprockets are properly aligned (Fig. 65).

(4) Install the camshaft sprocket retaining bolt and washer. Tighten the bolt to 108 N·m (80 ft. lbs.) torque.

(5) To verify correct installation of the timing chain, turn the crankshaft to position the camshaft sprocket timing mark as shown in (Fig. 68). Count the number of chain pins between the timing marks of both sprockets. There must be 20 pins.

(6) Turn the chain tensioner lever to the unlocked (down) position (Fig. 67).

(7) Install the oil slinger.

(8) Replace the oil seal in the timing case cover.

(9) Install the timing case cover and gasket.

REMOVAL AND INSTALLATION (Continued)

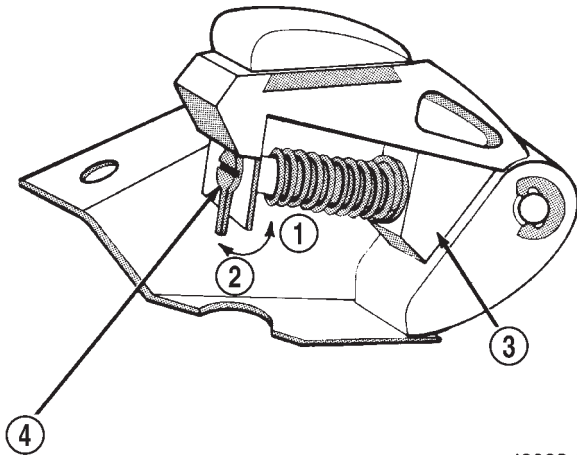

J9009-27

Fig. 67 Loading Timing Chain Tensioner

- 1 - LOCK
- 2 - UNLOCK
- 3 - TENSIONER BLOCK
- 4 - TENSIONER LEVER

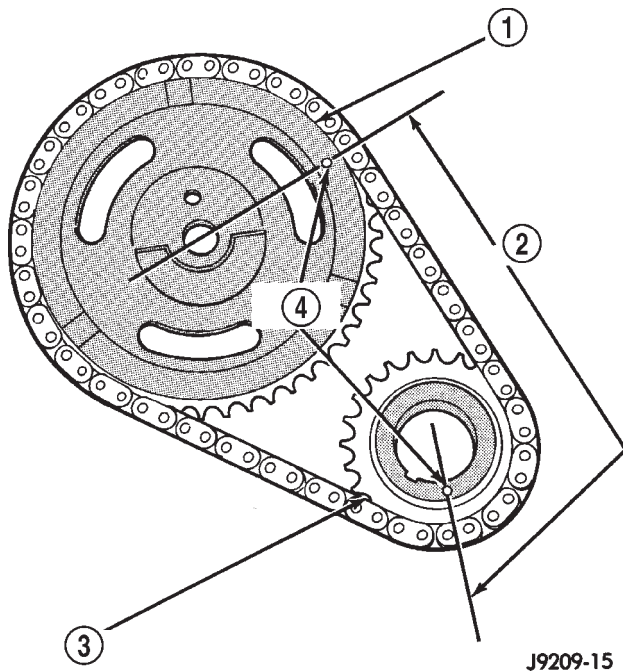

J9209-15

Fig. 68 Verify Sprocket—Chain Installation

- 1 - CAMSHAFT SPROCKET
- 2 - 20 PINS
- 3 - CRANKSHAFT SPROCKET
- 4 - TIMING MARKS

(10) With the key inserted in the keyway in the crankshaft, install the vibration damper, washer and bolt. Lubricate and tighten the bolt to 108 N·m (80 ft. lbs.) torque.

- (11) Install the fan and shroud.
- (12) Connect negative cable to battery.

CAMSHAFT

REMOVAL

WARNING: THE COOLANT IN A RECENTLY OPERATED ENGINE IS HOT AND PRESSURIZED. RELEASE THE PRESSURE BEFORE REMOVING THE DRAIN COCK, CAP AND DRAIN PLUGS.

- (1) Disconnect negative cable from battery.
- (2) Drain the cooling system. DO NOT waste reusable coolant. If the solution is clean, drain it into a clean container for reuse.
- (3) Remove the radiator or radiator and condenser, if equipped with A/C.
- (4) Scribe a mark on the distributor housing in line with the lip of the rotor.
- (5) Scribe a mark on the distributor housing near the clamp and continue the scribe mark on the cylinder block in line with the distributor mark.
- (6) For ease of installation, note the position of the rotor and distributor housing in relation to adjacent engine components.
- (7) Remove the distributor and ignition wires.
- (8) Remove the engine cylinder head cover.
- (9) Remove the rocker arms, bridges and pivots.
- (10) Remove the push rods.
- (11) Remove the hydraulic valve tappets from the engine cylinder head.
- (12) Remove the vibration damper.
- (13) Remove the timing case cover.
- (14) Remove the timing chain and sprockets.
- (15) Remove the camshaft (Fig. 69).

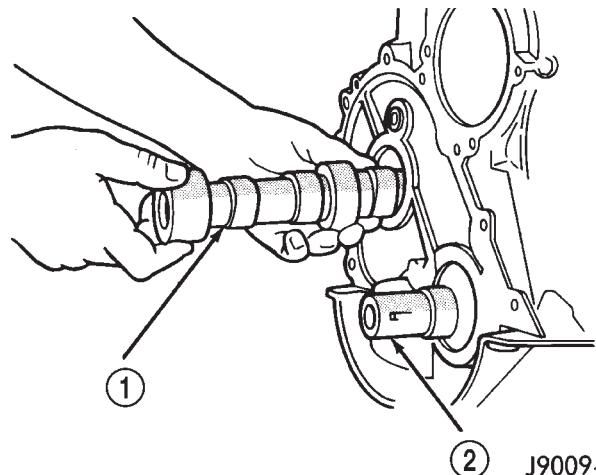

J9009-31

Fig. 69 Camshaft

- 1 - CAMSHAFT
- 2 - CRANKSHAFT

INSTALLATION

- (1) Inspect the cam lobes for wear.

REMOVAL AND INSTALLATION (Continued)

(2) Inspect the bearing journals for uneven wear pattern or finish.

(3) Inspect the bearings for wear.

(4) Inspect the distributor drive gear for wear.

(5) If the camshaft appears to have been rubbing against the timing case cover, examine the oil pressure relief holes in the rear cam journal. The oil pressure relief holes must be free of debris.

(6) Lubricate the camshaft with Mopar Engine Oil Supplement, or equivalent.

(7) Carefully install the camshaft to prevent damage to the camshaft bearings (Fig. 69).

(8) Turn the tensioner lever to the unlocked (down) position (Fig. 70).

(9) Pull the tensioner block toward the tensioner lever to compress the spring. Hold the block and turn the tensioner lever to the lock position (Fig. 70).

(10) Install the timing chain, crankshaft sprocket and camshaft sprocket with the timing marks aligned.

(11) Install the camshaft sprocket retaining bolt and washer. Tighten the bolt to 108 N·m (80 ft. lbs.) torque.

(12) Release the timing chain tensioner by moving the lever to the unlock position (Fig. 70).

(13) Install the timing case cover with a replacement oil seal (Fig. 71). Refer to Timing Case Cover Installation.

(14) Install the vibration damper.

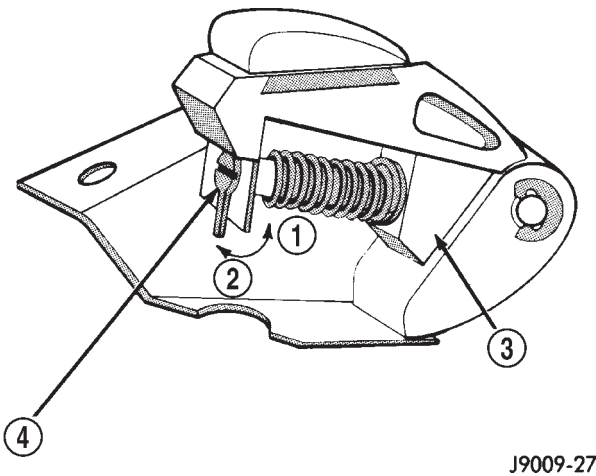

Fig. 70 Loading Timing Chain Tensioner

- 1 - LOCK
- 2 - UNLOCK
- 3 - TENSIONER BLOCK
- 4 - TENSIONER LEVER

(15) Install the hydraulic valve tappets.

(16) Install the push rods.

(17) Install the rocker arms, bridges and pivots.

(18) Install the engine cylinder head cover.

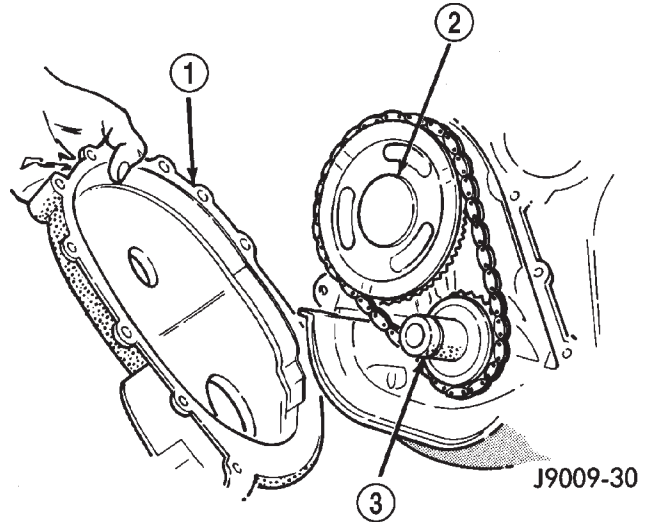

Fig. 71 Timing Case Cover

- 1 - TIMING CASE COVER
- 2 - CAMSHAFT
- 3 - CRANKSHAFT

(19) Position the oil pump gear. Refer to Distributor in the Component Removal/Installation section of Group 8D, Ignition Systems.

(20) Install the distributor and ignition wires. Refer to Distributor in the Component Removal/Installation section of Group 8D, Ignition Systems.

(21) Install the radiator or radiator and condenser, if equipped with A/C.

(22) Fill the cooling system.

(23) Connect negative cable to battery.

CAMSHAFT PIN REPLACEMENT

REMOVAL

WARNING: DO NOT LOOSEN THE RADIATOR DRAIN COCK WITH THE SYSTEM HOT AND PRESSURIZED BECAUSE SERIOUS BURNS FROM COOLANT CAN OCCUR.

- (1) Disconnect negative cable from battery.
- (2) Drain the radiator. DO NOT waste reusable coolant. Drain the coolant into a clean container.
- (3) Remove the fan and shroud.
- (4) Disconnect the radiator overflow tube, radiator hoses, automatic transmission fluid cooler pipes (if equipped).
- (5) Remove the radiator.
- (6) If equipped with air conditioning:

CAUTION: DO NOT loosen or disconnect any air conditioner system fittings. Move the condenser and receiver/drier aside as a complete assembly.

REMOVAL AND INSTALLATION (Continued)

- (a) Remove the A/C compressor serpentine drive belt idler pulley.
- (b) Disconnect and remove the generator.
- (c) Remove the A/C condenser attaching bolts and move the condenser and receiver/drier assembly up and out of the way.
- (7) Remove the serpentine drive belt.
- (8) Remove the crankshaft vibration damper.
- (9) Remove the timing case cover. Clean the gasket material from the cover.
- (10) Rotate crankshaft until the crankshaft sprocket timing mark is closest to and on the center line with the camshaft sprocket timing mark (Fig. 72).

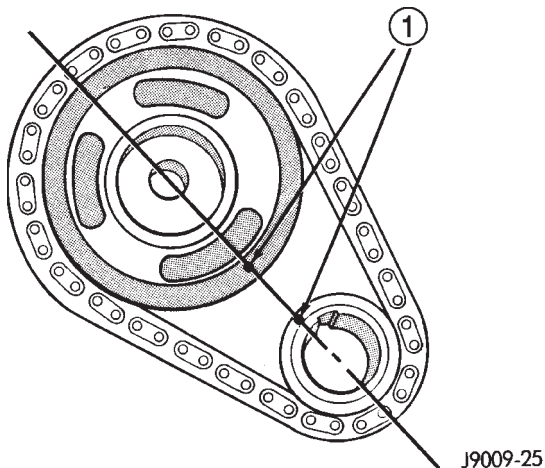
**Fig. 72 Timing Chain Alignment**

1 - TIMING MARKS

- (11) Remove camshaft sprocket retaining bolt.
- (12) Remove the crankshaft oil slinger.
- (13) Remove the sprockets and chain as an assembly (Fig. 73).

CAUTION: The following procedural step must be accomplished to prevent the camshaft from damaging the rear camshaft plug during pin installation.

- (14) Inspect the damaged camshaft pin.
- (15) If the pin is a spring-type pin, remove the broken pin by inserting a self-tapping screw into the pin and carefully pulling the pin from the camshaft.
- (16) If the pin is a dowel-type pin, center-punch it. Ensure the exact center is located when center-punching the pin.

CAUTION: Cover the opened oil pan area to prevent metal chips from entering the pan.

- (17) Drill into the pin center with a 4 mm (5/32 inch) drill bit.
- (18) Insert a self-tapping screw into the drilled pin and carefully pull the pin from the camshaft.

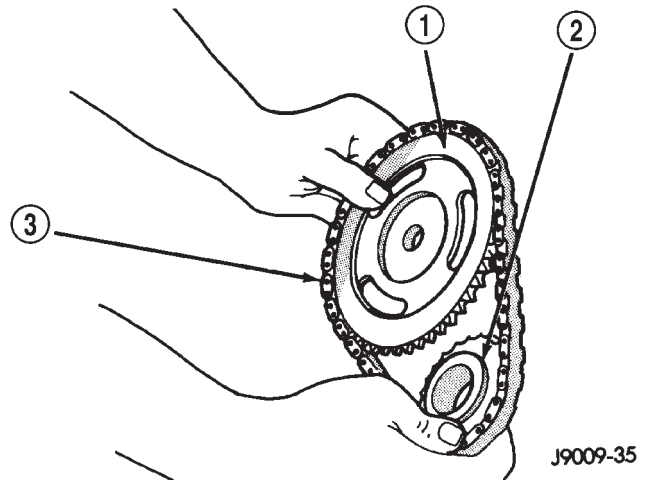
**Fig. 73 Camshaft and Crankshaft Sprocket and Chain**

- 1 - CAMSHAFT SPROCKET
- 2 - CRANKSHAFT SPROCKET
- 3 - CHAIN

INSTALLATION

- (1) Clean the camshaft pin hole.
- (2) Compress the center of the replacement spring pin with vise grips.
- (3) Carefully drive the pin into the camshaft pin hole until it is seated.
- (4) Install the camshaft sprocket, crankshaft sprocket and timing chain with the timing marks aligned (Fig. 72).
- (5) To verify correct installation of the timing chain, turn the crankshaft to position the camshaft sprocket timing mark as shown in (Fig. 74). Count the number of chain pins between the timing marks of both sprockets. There must be 20 pins.
- (6) Install the crankshaft oil slinger.
- (7) Tighten the camshaft sprocket bolt to 108 N·m (80 ft. lbs.) torque.
- (8) Check the valve timing.
- (9) Coat both sides of the replacement timing case cover gasket with gasket sealer. Apply a 3 mm (1/8 inch) bead of Mopar Silicone Rubber Adhesive Sealant, or equivalent to the joint formed at the timing case cover and cylinder block.
- (10) Position the timing case cover on the oil pan gasket and the cylinder block.
- (11) Place Timing Case Cover Alignment and Seal Installation Tool 6139 in the crankshaft opening of the cover (Fig. 75).
- (12) Install the timing case cover-to-cylinder block bolts. Install the oil pan-to-timing case cover bolts.
- (13) Tighten the 1/4 inch cover-to-block bolts to 7 N·m (60 in. lbs.) torque. Tighten the 5/16 inch front cover-to-block bolts to 22 N·m (192 in. lbs.) torque. Tighten the oil pan-to-cover 1/4 inch bolts to 14 N·m

REMOVAL AND INSTALLATION (Continued)

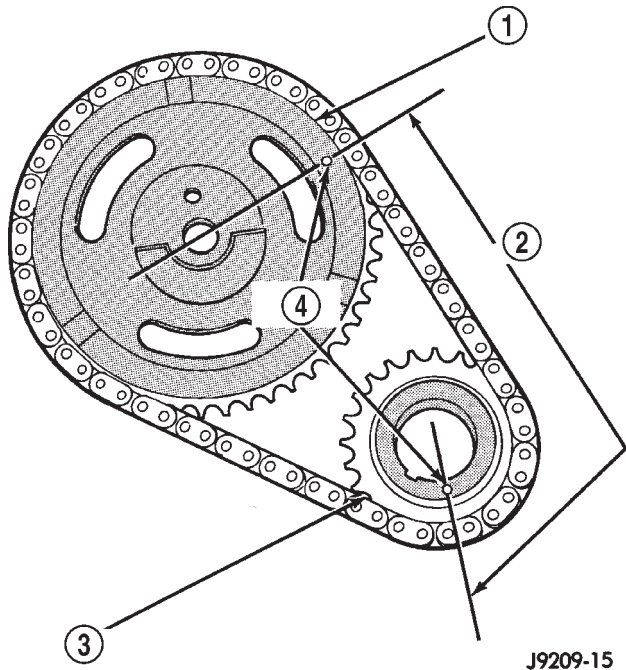

Fig. 74 Verify Crankshaft—Camshaft Installation

- 1 - CAMSHAFT SPROCKET
- 2 - 20 PINS
- 3 - CRANKSHAFT SPROCKET
- 4 - TIMING MARKS

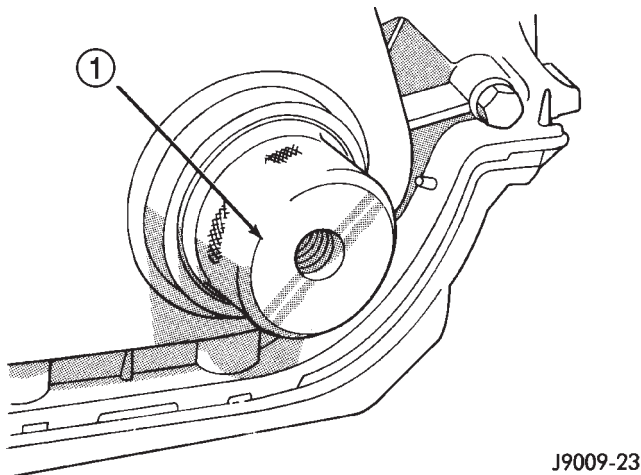

Fig. 75 Timing Case Cover Alignment and Seal Installation Tool 6139

- 1 - TIMING CASE COVER ALIGNMENT AND SEAL INSTALLATION TOOL

(120 in. lbs.) torque. Tighten the oil pan-to-cover 5/16 inch bolts to 18 N·m (156 in. lbs.) torque.

(14) Remove the cover alignment tool and install a replacement oil seal into the cover.

(15) Install the vibration damper on the crankshaft.

(16) Lubricate and tighten the damper bolt to 108 N·m (80 ft. lbs.) torque.

(17) If equipped with air conditioning:

(a) Install the A/C compressor serpentine drive belt idler pulley.

(b) Install the generator.

(c) Install the A/C condenser and receiver/drier assembly.

(18) Install the serpentine drive belt on the pulleys and tighten (refer to Group 7, Cooling System for the specifications and procedures).

(19) Install the radiator. Connect the radiator hoses and automatic transmission fluid cooler pipes, if equipped. Fill the cooling system.

(20) Install the fan and shroud.

(21) Connect negative cable to battery.

CAMSHAFT BEARINGS

The camshaft rotates within four steel-shelled, babbitt-lined bearings that are pressed into the cylinder block and then line reamed. The camshaft bearing bores and bearing diameters are not the same size. They are stepped down in 0.254 mm (0.010 inch) increments from the front bearing (largest) to the rear bearing (smallest). This permits easier removal and installation of the camshaft. The camshaft bearings are pressure lubricated.

NOTE: It is not advisable to attempt to replace camshaft bearings unless special removal and installation tools are available, such as recommended tool 8544 Camshaft Bushing Remover Installer.

Camshaft end play is maintained by the load placed on the camshaft by the oil pump and distributor drive gear. The helical cut of the gear holds the camshaft sprocket thrust face against the cylinder block face.

CRANKSHAFT MAIN BEARINGS

REMOVAL

- (1) Disconnect negative cable from battery.
- (2) Remove the spark plugs.
- (3) Raise the vehicle.
- (4) Remove the oil pan and oil pump.
- (5) Remove only one main bearing cap and lower insert at a time (Fig. 76).

(6) Remove the lower insert from the bearing cap.

(7) Remove the upper insert by LOOSENING (DO NOT REMOVE) all of the other bearing caps. Now insert a small cotter pin tool in the crankshaft journal oil hole. Bend the cotter pin as illustrated to fabricate the tool (Fig. 77). With the cotter pin tool in place, rotate the crankshaft so that the upper bearing insert will rotate in the direction of its locking tab. Because there is no hole in the No.3 main journal, use a tongue depressor or similar soft-faced tool

REMOVAL AND INSTALLATION (Continued)

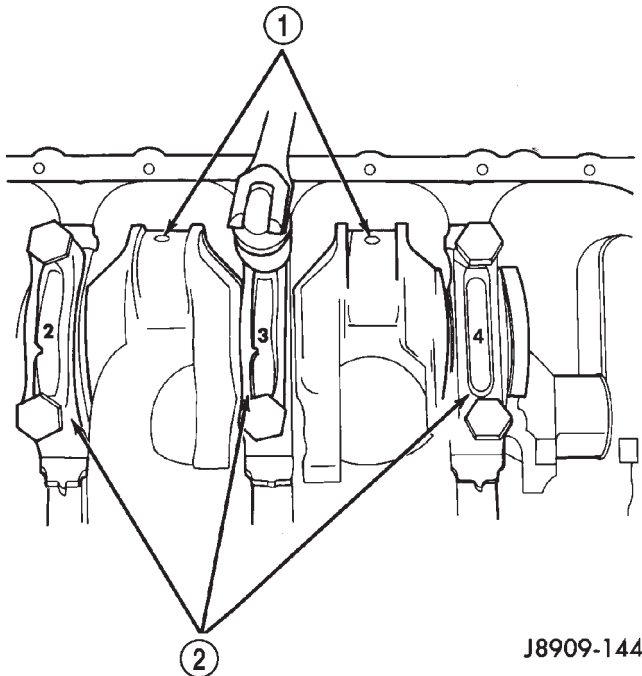

J8909-144

Fig. 76 Removing Main Bearing Caps and Lower Inserts

- 1 - CONNECTING ROD JOURNAL
2 - MAIN BEARING CAPS

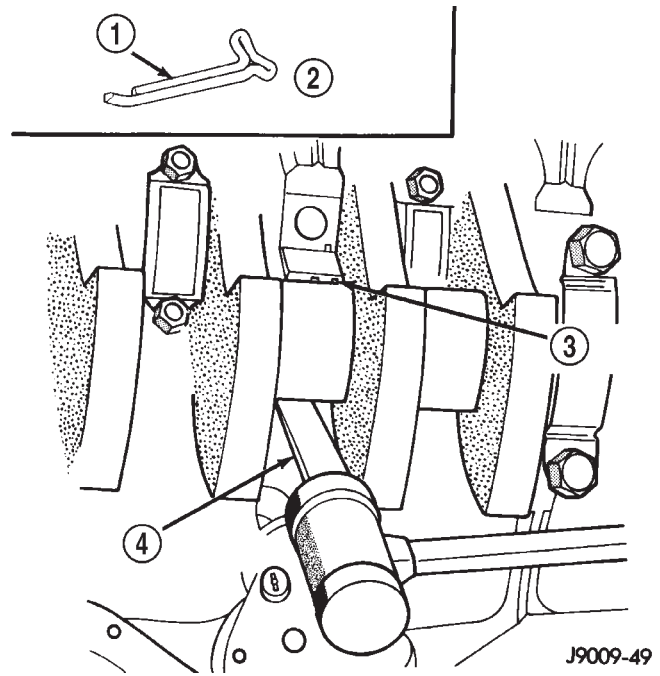

J9009-49

Fig. 77 Removing Upper Inserts

- 1 - COTTER PIN
2 - FABRICATED TOOL
3 - BEARING INSERT
4 - TONGUE DEPRESSOR

to remove the bearing insert (Fig. 77). After moving the insert approximately 25 mm (1 inch), it can be removed by applying pressure under the tab.

(8) Using the same procedure described above, remove the remaining bearing inserts one at a time for inspection.

INSTALLATION

(1) Lubricate the bearing surface of each insert with engine oil.

(2) Loosen all the main bearing caps. Install the main bearing upper inserts.

(3) Install the lower bearing inserts into the main bearing caps.

(4) Install the main bearing cap(s) and lower insert(s).

(5) Clean the rear main bearing cap (No.5) mating surfaces.

(6) Apply Mopar® Gasket Maker, or equivalent on the rear bearing cap (Fig. 78). The bead should be 3 mm (0.125 in) thick. DO NOT apply Mopar® Gasket Maker, or equivalent to the lip of the seal.

(7) Install the rear main bearing cap. DO NOT strike the cap more than twice for proper engagement.

(8) Tighten the bolts of caps 1, 3, 4 and 5 to 54 N·m (40 ft. lbs.) torque. Now tighten these bolts to 95 N·m (70 ft. lbs.) torque. Finally, tighten these bolts to 108 N·m (80 ft. lbs.) torque.

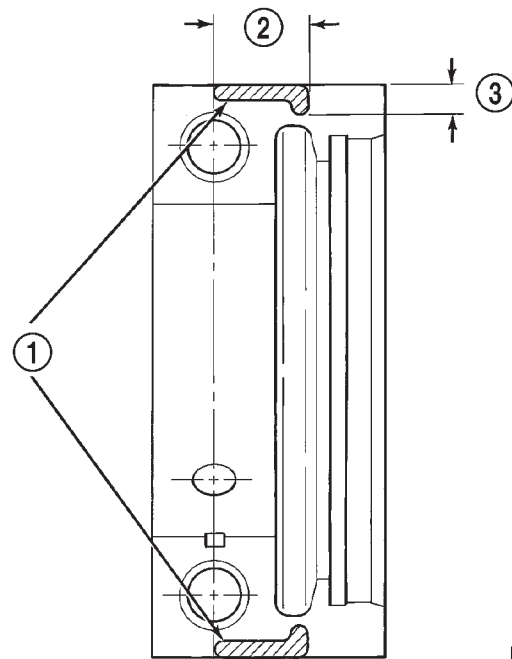

J9509-90

Fig. 78 Location of Mopar® Gasket Maker

- 1 - MOPAR® GASKET MAKER (OR EQUIVALENT)
2 - 19 mm (.75 IN)
3 - 6 mm (0.025 IN)

REMOVAL AND INSTALLATION (Continued)

(9) Push the crankshaft forward and backward. Load the crankshaft front or rear and tighten cap bolt No.2 to 54 N·m (40 ft. lbs.) torque. Then tighten to 95 N·m (70 ft. lbs.) torque and finally tighten to 108 N·m (80 ft. lbs.) torque.

(10) Rotate the crankshaft after tightening each main bearing cap to ensure the crankshaft rotates freely.

(11) Check crankshaft end play. Crankshaft end play is controlled by the thrust bearing which is flange and installed at the No.2 main bearing position.

(a) Attach a magnetic base dial indicator to the cylinder block at either the front or rear of the engine.

(b) Position the dial indicator rod so that it is parallel to the center line of the crankshaft.

(c) Pry the crankshaft forward, position the dial indicator to zero.

(d) Pry the crankshaft forward and backward. Note the dial indicator readings. End play is the difference between the high and low measurements (Fig. 79). Correct end play is 0.038-0.165 mm (0.0015-0.0065 inch). The desired specifications are 0.051-0.064 mm (0.002-0.0025 inch).

(e) If end play is not within specification, inspect crankshaft thrust faces for wear. If no wear is apparent, replace the thrust bearing and measure end play. If end play is still not within specification, replace the crankshaft.

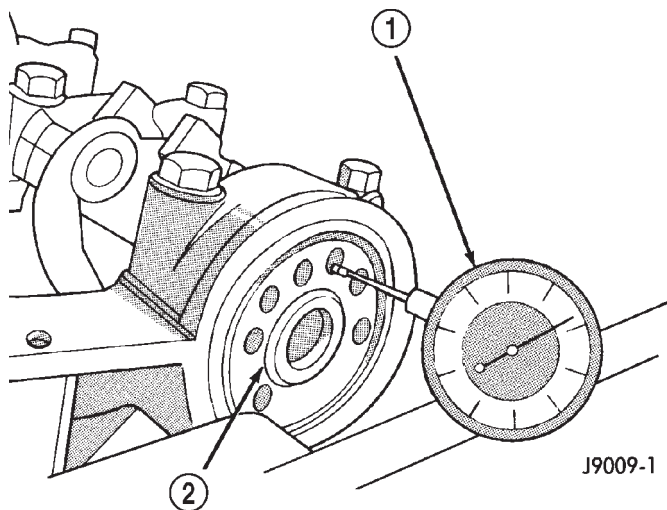

Fig. 79 Crankshaft End Play Measurement

- 1 - DIAL INDICATOR
2 - CRANKSHAFT

(12) If the crankshaft was removed, install the crankshaft into the cylinder block (refer to Cylinder Block - Assemble).

(13) Install the oil pan.

(14) Install the drain plug. Tighten the plug to 34 N·m (25 ft. lbs.) torque.

(15) Install new rear main seal. Refer to Rear Main Seal in this section.

(16) Lower the vehicle.

(17) Install the spark plugs. Tighten the plugs to 37 N·m (27 ft. lbs.) torque.

(18) Fill the oil pan with engine oil to the safe mark on the dipstick level.

(19) Connect negative cable to battery.

OIL PAN

REMOVAL

(1) Disconnect negative cable from battery.

(2) Raise the vehicle.

(3) Remove the oil pan drain plug and drain the engine oil.

(4) Disconnect the exhaust pipe at the engine exhaust manifold.

(5) Disconnect the exhaust hanger at the catalytic converter and lower the pipe.

(6) Remove the engine starter motor.

(7) Remove the flywheel/torque converter housing access cover.

(8) Position a jack stand directly under the engine vibration damper.

(9) Place a piece of wood (2 x 2) between the jack stand and the engine vibration damper.

(10) Remove the engine mount through bolts.

(11) Using the jack stand, raise the engine until adequate clearance is obtained to remove the oil pan.

(12) If equipped, disconnect the transmission cooler lines and oxygen sensor harness from oil pan mounting studs.

(13) Remove the oil pan bolts and studs. Carefully remove the oil pan and gasket.

INSTALLATION

(1) Clean the block and pan gasket surfaces.

(2) Fabricate 4 alignment dowels from 1/4 x 1 1/2 inch bolts. Cut the head off the bolts and cut a slot into the top of the dowel. This will allow easier installation and removal with a screwdriver (Fig. 80).

(3) Install two dowels in the timing case cover. Install the other two dowels in the cylinder block (Fig. 81).

(4) Apply Mopar® Silicone Adhesive Sealant onto the cylinder block in four location as shown (Fig. 82)

(5) Slide the one-piece gasket over the dowels and onto the block and timing case cover.

(6) Position the oil pan over the dowels and onto the gasket.

(7) Install the 1/4 inch oil pan bolts. Tighten these bolts to 9.5 N·m (84 in. lbs.) torque. Install the 5/16

REMOVAL AND INSTALLATION (Continued)

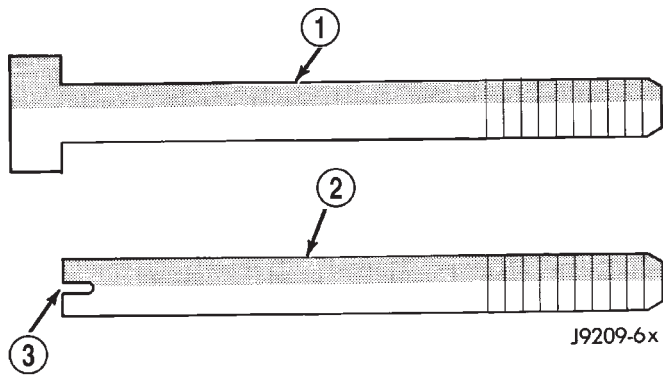
**Fig. 80 Fabrication of Alignment Dowels**

- 1 - 1/4" × 1 1/2" BOLT
- 2 - DOWEL
- 3 - SLOT

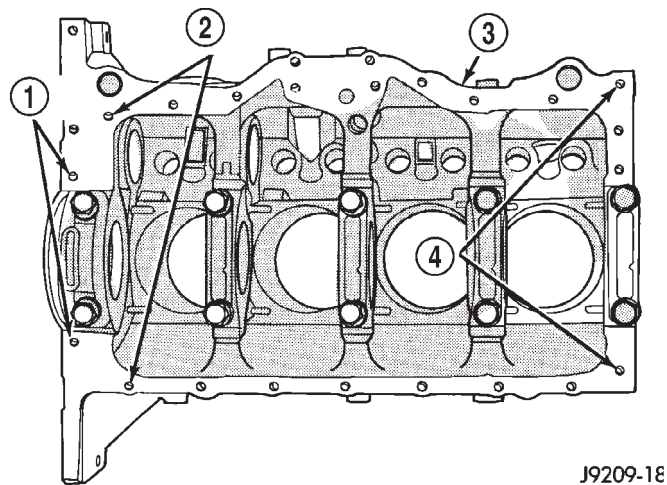
**Fig. 81 Position of Dowels in Cylinder Block**

- 1 - 5/16" HOLES
- 2 - DOWEL HOLES
- 3 - CYLINDER BLOCK
- 4 - 5/16" HOLES

inch oil pan bolts (Fig. 83). Tighten these bolts to 15 N·m (132 in. lbs.) torque.

(8) Remove the dowels. Install the remaining 1/4 inch oil pan bolts. Tighten these bolts to 9.5 N·m (84 in. lbs.) torque.

(9) Lower the engine until it is properly located on the engine mounts.

(10) Install the through bolts and tighten the nuts.

(11) Lower the jack stand and remove the piece of wood.

(12) Install the flywheel and torque converter housing access cover.

(13) Install the engine starter motor.

(14) Connect the exhaust pipe to the hanger and to the engine exhaust manifold.

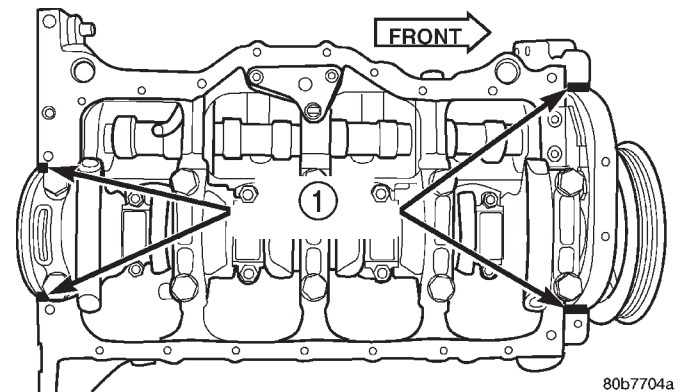
**Fig. 82 Location of Mopar® Silicone Adhesive Sealant on Cylinder Block**

- 1 - SEALER LOCATIONS

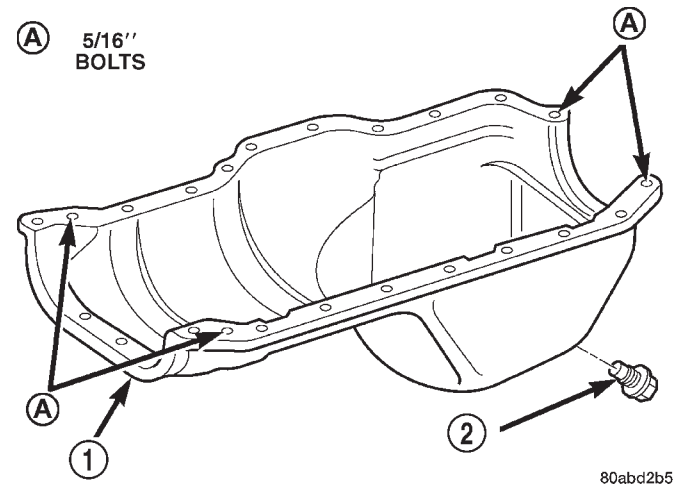
**Fig. 83 Position of 5/16 inch Oil Pan Bolts**

- 1 - OIL PAN
- 2 - OIL PAN DRAIN PLUG

(15) Install the oil pan drain plug (Fig. 83). Tighten the plug to 34 N·m (25 ft. lbs.) torque.

(16) Lower the vehicle.

(17) Connect negative cable to battery.

(18) Fill the oil pan with engine oil to the specified level.

WARNING: USE EXTREME CAUTION WHEN THE ENGINE IS OPERATING. DO NOT STAND IN A DIRECT LINE WITH THE FAN. DO NOT PUT YOUR HANDS NEAR THE PULLEYS, BELTS OR FAN. DO NOT WEAR LOOSE CLOTHING.

(19) Start the engine and inspect for leaks.

OIL PUMP

The positive-displacement gear-type oil pump is driven by the distributor shaft, which is driven by a gear on the camshaft. Oil is siphoned into the pump

REMOVAL AND INSTALLATION (Continued)

through an inlet tube and strainer assembly that is pressed into the pump body.

The pump incorporates a nonadjustable pressure relief valve to limit maximum pressure to 517 kPa (75 psi). In the relief position, the valve permits oil to bypass through a passage in the pump body to the inlet side of the pump.

Oil pump removal or replacement will not affect the distributor timing because the distributor drive gear remains in mesh with the camshaft gear.

REMOVAL

- (1) Drain the engine oil.
- (2) Remove the oil pan.
- (3) Remove the pump-to-cylinder block attaching bolts. Remove the pump assembly with gasket (Fig. 84).

CAUTION: If the oil pump is not to be serviced, **DO NOT** disturb position of oil inlet tube and strainer assembly in pump body. If the tube is moved within the pump body, a replacement tube and strainer assembly must be installed to assure an airtight seal.

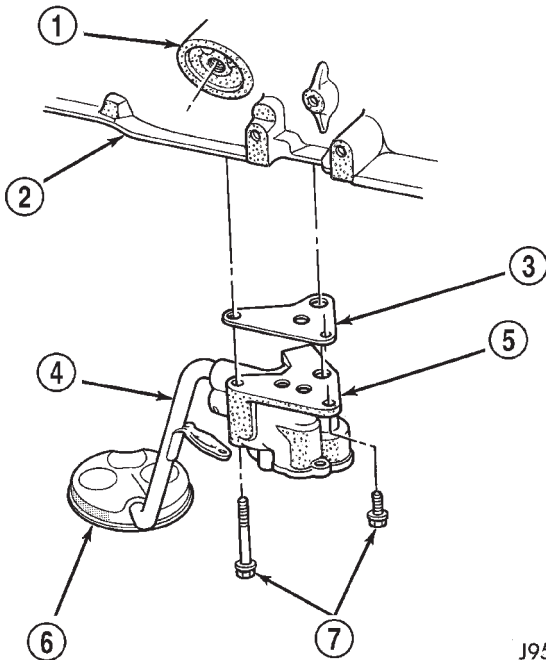

J9509-85

Fig. 84 Oil Pump Assembly

- 1 - OIL FILTER ADAPTOR
- 2 - BLOCK
- 3 - GASKET
- 4 - OIL INLET TUBE
- 5 - OIL PUMP
- 6 - STRAINER ASSEMBLY
- 7 - ATTACHING BOLTS

INSTALLATION

- (1) Install the oil pump on the cylinder block using a replacement gasket. Tighten the bolts to 23 N·m (17 ft. lbs.) torque.
- (2) Install the oil pan and gasket.
- (3) Fill the oil pan with oil to the specified level.

PISTON AND CONNECTING ROD

REMOVAL

- (1) Remove the engine cylinder head cover.
- (2) Remove the rocker arms, bridges and pivots.
- (3) Remove the push rods.
- (4) Remove the engine cylinder head.
- (5) Position the pistons one at a time near the bottom of the stroke. Use a ridge reamer to remove the ridge from the top end of the cylinder walls. Use a protective cloth to collect the cuttings.
- (6) Raise the vehicle.
- (7) Drain the engine oil.
- (8) Remove the oil pan and gasket.
- (9) Remove the connecting rod bearing caps and inserts. Mark the caps and rods with the cylinder bore location. The connecting rods and caps are stamped with a two letter combination (Fig. 85).

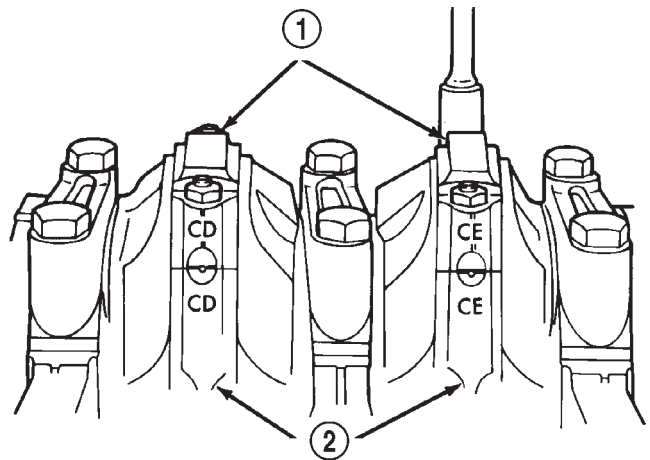

J9409-20

Fig. 85 Stamped Connecting Rods and Caps

- 1 - CONNECTING ROD CAP
- 2 - CONNECTING ROD

- (10) Lower the vehicle until it is about 2 feet from the floor.

CAUTION: Ensure that the connecting rod bolts **DO NOT** scratch the crankshaft journals or cylinder walls. Short pieces of rubber hose, slipped over the rod bolts will provide protection during removal.

- (11) Have an assistant push the piston and connecting rod assemblies up and through the top of the cylinder bores (Fig. 86).

REMOVAL AND INSTALLATION (Continued)

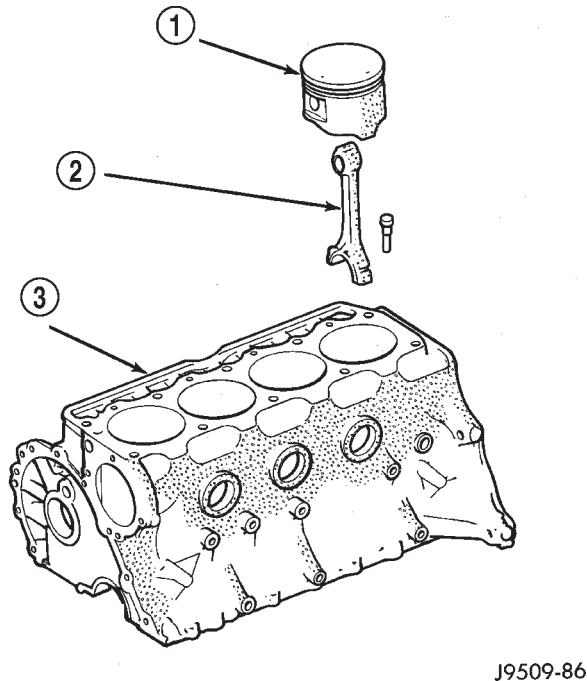

Fig. 86 Removal of Connecting Rod and Piston Assembly

- 1 - PISTON
2 - CONNECTING ROD
3 - CYLINDER BLOCK

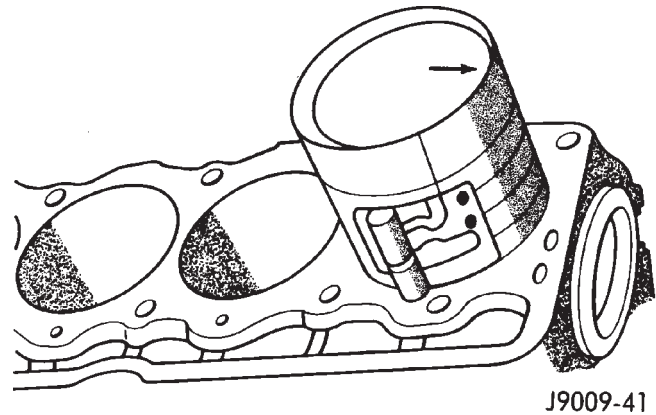

Fig. 87 Rod and Piston Assembly Installation

the bearing insert. The size is not stamped on inserts used for production of engines.

(9) The rod journal is identified during the engine production by a color-coded paint mark on the adjacent cheek or counterweight toward the flange (rear) end of the crankshaft. The color codes used to indicate journal sizes are listed in the Connecting Rod Bearing Fitting Chart.

(10) When required, upper and lower bearing inserts of different sizes may be used as a pair (refer to Connecting Rod Bearing Fitting Chart). A standard size insert is sometimes used in combination with a 0.025 mm (0.001 inch) undersize insert to reduce clearance 0.013 mm (0.0005 inch).

CAUTION: DO NOT intermix bearing caps. Each connecting rod and bearing cap are stamped with the cylinder number. The stamp is located on a machined surface adjacent to the oil squirt hole that faces the camshaft side of the cylinder block.

(11) Install the connecting rod bearing caps and inserts in the same positions as removed.

CAUTION: Verify that the oil squirt holes in the rods face the camshaft and that the arrows on the pistons face the front of the engine.

(13) Install the oil pan and gaskets as outlined in the installation procedure.

(14) Lower the vehicle.

(15) Install the engine cylinder head, push rods, rocker arms, bridges, pivots and engine cylinder head cover.

(16) Fill the crankcase with engine oil.

REAR MAIN OIL SEAL

REMOVAL

(1) Remove the flywheel or converter drive plate. Discard the old bolts.

INSTALLATION

(1) Clean the cylinder bores thoroughly. Apply a light film of clean engine oil to the bores with a clean lint-free cloth.

(2) Install the piston rings on the pistons if removed.

(3) Lubricate the piston and rings with clean engine oil.

CAUTION: Ensure that connecting rod bolts do not scratch the crankshaft journals or cylinder walls. Short pieces of rubber hose slipped over the connecting rod bolts will provide protection during installation.

(5) Use a piston ring compressor to install the connecting rod and piston assemblies through the top of the cylinder bores (Fig. 87).

(6) Ensure the arrow on the piston top points to the front of the engine (Fig. 87).

(7) Raise the vehicle.

(8) Each bearing insert is fitted to its respective journal to obtain the specified clearance between the bearing and the journal. In production, the select fit is obtained by using various-sized, color-coded bearing inserts as listed in the Connecting Rod Bearing Fitting Chart. The color code appears on the edge of

REMOVAL AND INSTALLATION (Continued)

(2) Pry out the seal from around the crankshaft flange, making sure not to scratch or nick the crankshaft. (Fig. 88).

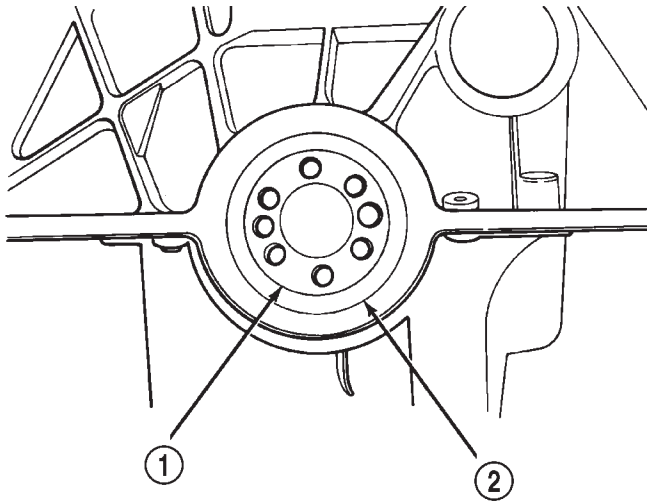

J8909-149

Fig. 88 Replacement of Rear Crankshaft Oil Seal

- 1 - CRANKSHAFT
2 - CRANKSHAFT OIL SEAL

INSTALLATION

(1) Wipe the seal surface area of the crankshaft until it is clean.

(2) Coat the outer lip of the replacement rear main bearing seal with engine oil.

(3) Carefully position the seal into place. Use rear main Seal Installer Tool 6271A to install the seal flush with the cylinder block.

CAUTION: The felt lip must be located inside the flywheel mounting surface. If the lip is not positioned correctly the flywheel could tear the seal.

(4) Install the flywheel or converter drive plate. New bolts **MUST** be used when installing the flywheel or converter plate. Tighten the new bolts to 68 N·m (50 ft. lbs.) torque. Turn the bolts an additional 60°.

DISASSEMBLY AND ASSEMBLY**CYLINDER BLOCK****DISASSEMBLY**

(1) Drain the engine oil. Remove and discard the oil filter.

(2) Remove the water pump from the cylinder block.

(3) Remove the distributor from the cylinder block.

(4) Remove the vibration damper.

(5) Remove the timing case cover and lay the cover upside down.

(6) Position a drift punch into the slot in the back of the cover and tap the old seal out.

(7) Remove the timing chain bumper.

(8) Remove the oil slinger from crankshaft.

(9) Remove the camshaft retaining bolt and remove the sprockets and chain as an assembly.

(10) Remove the camshaft.

(11) Remove the oil pan and gasket.

(12) Remove the timing chain tensioner.

(13) Remove the front and rear oil galley plugs.

(14) Remove the connecting rods and the pistons.

Remove the connecting rod and piston assemblies through the top of the cylinder bores.

(15) Remove the crankshaft.

ASSEMBLY

(1) Install the crankshaft.

(2) Install the connecting rods and the pistons through the top of the cylinder bores.

(3) Install the front and rear oil galley plugs.

(4) Install the timing chain tensioner.

(5) Install the camshaft.

(6) Install the sprockets and chain as an assembly.

(7) Install the oil slinger to the crankshaft.

(8) Install the timing chain bumper.

(9) Install the timing case cover seal.

(10) Install the timing case cover.

(11) Install the oil pan gasket and oil pan.

(12) Install the vibration damper.

(13) Install the water pump. Tighten the mounting bolts to 31 N·m (270 in. lbs.) torque.

(14) Remove the distributor from the cylinder block.

(15) Lubricate the oil filter seal with clean engine oil. Tighten oil filter to 18 N·m (13 ft. lbs.) torque.

(16) Install the engine into the vehicle.

(17) Fill the engine with clean lubrication oil.

(18) Fill the cooling system.

CLEANING AND INSPECTION**ROCKER ARMS AND PUSH RODS****CLEANING**

Clean all the components with cleaning solvent.

Use compressed air to blow out the oil passages in the rocker arms and push rods.

INSPECTION

Inspect the pivot surface area of each rocker arm. Replace any that are scuffed, pitted, cracked or excessively worn.

CLEANING AND INSPECTION (Continued)

Inspect the valve stem tip contact surface of each rocker arm and replace any rocker arm that is deeply pitted.

Inspect each push rod end for excessive wear and replace as required. If any push rod is excessively worn because of lack of oil, replace it and inspect the corresponding hydraulic tappet for excessive wear.

Inspect the push rods for straightness by rolling them on a flat surface or by shining a light between the push rod and the flat surface.

A wear pattern along the length of the push rod is not normal. Inspect the engine cylinder head for obstruction if this condition exists.

ENGINE CYLINDER HEAD

CLEANING

Thoroughly clean the engine cylinder head and cylinder block mating surfaces. Clean the intake and exhaust manifold and engine cylinder head mating surfaces. Remove all gasket material and carbon.

Check to ensure that no coolant or foreign material has fallen into the tappet bore area.

Remove the carbon deposits from the combustion chambers and top of the pistons.

INSPECTION

Use a straightedge and feeler gauge to check the flatness of the engine cylinder head and block mating surfaces.

CYLINDER BLOCK

CLEANING

Thoroughly clean the oil pan and engine block gasket surfaces.

Use compressed air to clean out:

- The galley at the oil filter adaptor hole, the filter bypass hole (Fig. 89).
- The front and rear oil galley holes (Fig. 90) (Fig. 91).
- The feed holes for the crankshaft main bearings.

Once the block has been completely cleaned, apply Mopar® Thread Sealant with Teflon to the threads of the front and rear oil galley plugs. Tighten the plugs to 41 N·m (30 ft. lbs.) torque.

INSPECTION

Inspect the cylinder bores for signs of scarring, pitting or cracks. If the cylinder bores are scorred or pitted the cylinder bores will require boring or honing to clean them up. Refer to Honing Cylinder Bores in this Section. If the cylinder bore(s) are cracked the cylinder block must be replaced.

Inspect the cylinder block to cylinder head mating surface for flatness and/or pitting.

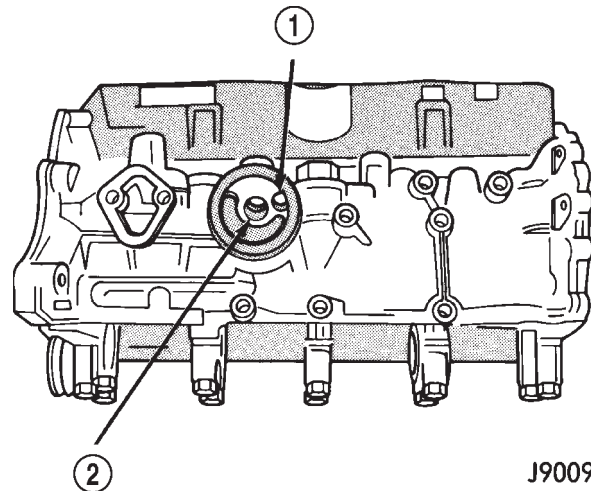

J9009-50

Fig. 89 Oil Filter Adaptor Hole

- 1 - FILTER BYPASS HOLE
2 - OIL FILTER ADAPTOR HOLE

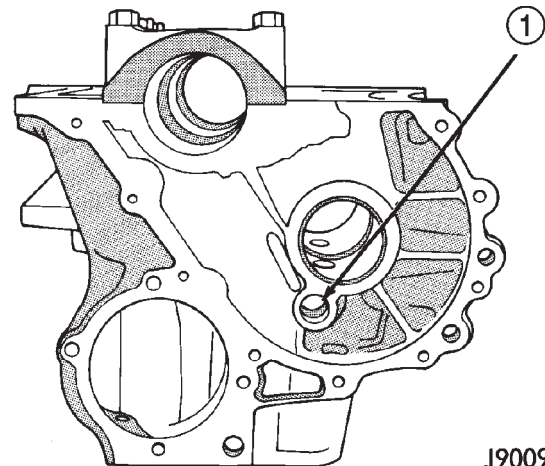

J9009-51

Fig. 90 Front Oil Galley Hole

- 1 - FRONT OIL GALLEY HOLE

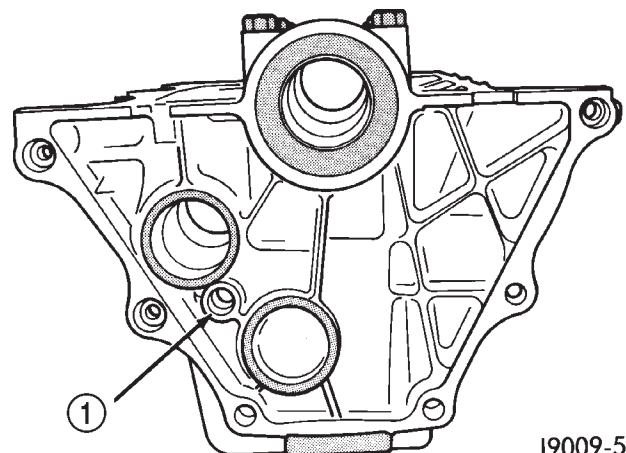

J9009-52

Fig. 91 Rear Oil Galley Hole

- 1 - REAR OIL GALLEY HOLE

SPECIFICATIONS

ENGINE SPECIFICATIONS

ENGINE DESCRIPTION

| DESCRIPTION | SPECIFICATION |
|----------------------------------|---|
| Engine Type | In-line 4 Cylinder |
| Bore and Stroke | 98.4 x 81.0 mm (3.88 x 3.19 in.) |
| Displacement | 2.5L (150 cu. in.) |
| Compression Ratio | 9.1:1 |
| Compression Pressure Range | 827 to 1,034 kPa (120 to 150 psi) |
| Max. Variation Between Cylinders | 206 kPa (30 psi) |
| Firing Order | 1-3-4-2 |
| Lubrication | Pressure Feed-Full Flow Filtration |
| Cooling System | Liquid Cooled-Forced Circulation |
| Cylinder Block | Cast Iron |
| Crankshaft | Cast Nodular Iron |
| Cylinder Head | Cast Iron |
| Camshaft | Cast Iron |
| Pistons | Aluminum Alloy |
| Cylinder Combustion Cavity | Double Quench |
| Connecting Rods | Cast Iron |
| CAMSHAFT | |
| Hydraulic Tappet Clearance | Zero Lash |
| Bearing Clearance | 0.025 - 0.076 mm (0.001 - 0.003 in.) |

| DESCRIPTION | SPECIFICATION |
|--------------------------|---|
| Bearing Journal Diameter | |
| No. 1 | 51.54 - 51.56 mm (2.029 - 2.030 in.) |
| No. 2 | 51.28 - 51.31 mm (2.019 - 2.020 in.) |
| No. 3 | 51.03 - 51.05 mm (2.009 - 2.010 in.) |
| No. 4 | 50.78 - 50.80 mm (1.999 - 2.000 in.) |
| Base Circle Runout (Max) | 0.03 mm (0.001 in.) |
| Camshaft Lobe Lift | |
| Exhaust | 6.579 mm (0.259 in.) |
| Intake | 6.477 mm (0.255 in.) |
| Camshaft Duration | |
| Intake | 253.3° |
| Exhaust | 259° |
| VALVES | |
| Valve Lift | |
| Exhaust | 10.528 mm (0.4145 in.) |
| Intake | 10.350 mm (0.4075 in.) |
| Intake Valve Timing | |
| Opens | 15.4° (BTDC) |
| Closes | 58° (ABDC) |
| Duration | 253.3° |
| Exhaust Valve Timing | |
| Opens | 52.8° (BBDC) |
| Closes | 26.2° (ATDC) |
| Duration | 259° |
| Valve Overlap | 41.6° |
| Valve Length (Overall) | |
| Intake | 124.435 - 125.070 mm (4.899 - 4.924 in.) |
| Exhaust | 125.120 - 125.755 mm (4.927 - 4.952 in.) |
| Valve Stem Diameter | 7.899 - 7.925 mm (0.311 - 0.312 in.) |

SPECIFICATIONS (Continued)

| DESCRIPTION | SPECIFICATION |
|---------------------------------|--|
| Stem to Guide Clearance | 0.025 - 0.076 mm (0.001 - 0.003 in.) |
| ValveFace Angle | |
| Intake | 46.5° |
| Exhaust | 46.5° |
| Valve Head Diameter | |
| Intake | 48.387 - 48.641 mm (1.905 - 1.915 in.) |
| Exhaust | 37.973 - 38.227 mm (1.495 - 1.505 in.) |
| Tip Refinishing (Max Allowable) | 0.25 mm (0.010 in.) |
| VALVE SPRINGS | |
| Free Length (Approx.) | 47.65 mm (1.876 in.) |
| Spring Load | |
| Valve Closed | 316 to 351 N @ 41.656 mm (71 to 79 Lbs. @ 1.64 in.) |
| Valve Open | 898.6 to 969.7 N @ 30.89 mm (202 to 218 Lbs. @ 1.216 in.) |
| Inside Diameter (Top) | 21.0 mm to 21.51 mm (0.827 to 0.847 in.) |
| Installed Height | 41.656 mm (1.640 in.) |
| CRANKSHAFT | |
| End Play | 0.038 to 0.165 mm (0.0015 to 0.0065 in.) |
| Main Bearing Journal Diameter | 63.489 to 63.502 mm (2.4996 to 2.5001 in.) |

| DESCRIPTION | SPECIFICATION |
|------------------------------------|---|
| Main Bearing Journal Width | |
| No. 1 | 27.58 to 27.89 mm (1.086 to 1.098 in.) |
| No. 2 | 32.28 to 32.33 mm (1.271 to 1.273 in.) |
| No. 3-4-5 | 30.02 to 30.18 mm (1.182 to 1.188 in.) |
| Main Bearing Clearance | 0.03 to 0.06 mm (0.001 to 0.0025 in.) |
| Main Bearing Clearance (Preferred) | 0.051 mm (0.002 in.) |
| Connecting Rod Journal Diameter | 53.17 to 53.23 mm (2.0934 to 2.0955 in.) |
| Connecting Rod Journal Width | 27.18 to 27.33 mm (1.070 to 1.076 in.) |
| Out of Round - Max | 0.013 mm (0.0005 in.) |
| Taper - Max | 0.013 mm (0.0005 in.) |
| CYLINDER BLOCK | |
| Deck Height | 236.73 mm (9.320 in.) |
| Deck Clearance | 0.000 mm (0.000 in.) |
| Cylinder Bore Diameter—Standard | 98.45 to 98.48 mm (3.8759 to 3.8775 in.) |
| Cylinder Bore Diameter—Taper (Max) | 0.025 mm (0.001 in.) |
| Out of Round (Max) | 0.025 mm (0.001 in.) |
| Tappet Bore Diameter | 23.000 to 23.025 mm (0.9055 to 0.9065 in.) |
| Flatness | 0.03 mm per 25 mm (0.001 in. per 1 in.) 0.05 mm per 152 mm (0.002 in. per 6 in.) |

SPECIFICATIONS (Continued)

| DESCRIPTION | SPECIFICATION |
|---------------------------------------|--|
| Flatness Max | 0.20 mm for total length (0.008 in. for total length) |
| Main Bearing Bore Diameter | 68.3514 to 68.3768 mm (2.691 to 2.692 in.) |
| CONNECTING RODS | |
| Total Weight (Less Bearing) | 663 to 671 grams (23.39 to 23.67 oz.) |
| Length (Center to Center) | 155.52 to 155.62 mm (6.123 to 6.127 in.) |
| Piston Pin Bore Diameter | 23.59 to 23.62 mm (0.9288 to 0.9298 in.) |
| Bore (Less Bearings) | 56.08 to 56.09 mm (2.2080 to 2.2085 in.) |
| Bearing Clearance | 0.025 to 0.076 mm (0.001 to 0.003 in.) |
| Bearing Clearance (Preferred) | 0.044 to 0.050 mm (0.0015 to 0.0020 in.) |
| Side Clearance | 0.25 to 0.48 mm (0.010 to 0.019 in.) |
| Twist (Max) | 0.002 mm per mm (0.002 in. per in.) |
| Bend (Max) | 0.006 mm per mm (0.006 in. per inch.) |
| CYLINDER HEAD | |
| Combustion Chamber | 49.9 to 52.9 cc (3.04 to 3.23 cu. in.) |
| Valve Guide I. D. (Integral) | 7.95 to 7.97 mm (0.313 to 0.314 in.) |
| Valve Seat Angle Intake Exhaust | 44.5° 44.5° |
| Valve Seat Width | 1.01 to 1.52 mm (0.040 to 0.060 in.) |

| DESCRIPTION | SPECIFICATION |
|---|--|
| Valve Seat Runout | 0.064 mm (0.0025 in.) |
| Flatness | 0.03 mm per 25 mm (0.001 in. per 1 in.) 0.05 mm per 152 mm (0.002 in. per 6 in.) |
| Flatness (Max) | 0.20 mm for total length (0.008 in. for total length) |
| ROCKER ARMS, PUSH RODS & TAPPETS | |
| Rocker Arm Ratio | 1.6:1 |
| Push Rod Length (Blue) | 241.300 to 241.808 mm (9.500 to 9.520 in.) |
| Push Rod Diameter | 7.92 to 8.00 mm (0.312 to 0.315 in.) |
| Hydraulic Tappet Diameter | 22.962 to 22.974 mm (0.904 to 0.9045 in.) |
| Tappet to Bore Clearance | 0.025 to 0.063 mm (0.001 to 0.0025 in.) |
| PISTON | |
| Weight (Less Pin) | 417 to 429 grams (14.7 to 15.1 oz.) |
| Compression Height | 40.61 to 40.72 mm (1.599 to 1.603 in.) |
| Piston to Bore Clearance | 0.018 to 0.038 mm (0.0008 to 0.0015 in.) |
| Piston Ring Groove Height Compression Rings Oil Control Ring | 1.530 to 1.555 mm (0.0602 to 0.0612 in.) 4.035 to 4.060 mm (0.1589 to 0.1598 in.) |
| Piston Ring Groove Diameter Compression Ring #1 Compression Ring #2 | 88.39 to 88.65 mm (3.48 to 3.49 in.) 87.63 to 87.88 mm (89.66 to 89.92 in.) |

SPECIFICATIONS (Continued)

| DESCRIPTION | SPECIFICATION |
|--|---|
| Oil Control Ring | 89.66 to 89.92 mm (3.53 to 3.54 in.) |
| Piston Pin Bore Diameter | 23.650 to 23.658 mm (0.9312 to 0.9315 in.) |
| Piston Pin Diameter | 23.637 to 23.640 mm (0.9306 to 0.9307 in.) |
| Piston to Pin Clearance | 0.0102 to 0.0208 mm (0.0005 to 0.0009 in.) |
| PISTON RINGS | |
| Ring Gap Clearance Top Compression Ring | 0.229 to 0.610 mm (0.0090 to 0.0240 in.) |
| 2nd Compression Ring | 0.483 to 0.965 mm (0.0190 to 0.0380 in.) |
| Oil Control Steel Rails | 0.254 to 1.500 mm (0.010 to 0.060 in.) |
| Ring Side Clearance Compression Rings | 0.042 to 0.084 mm (0.0017 to 0.0033 in.) |
| Oil Control Rings | 0.06 to 0.21 mm (0.0024 to 0.0083 in.) |

| DESCRIPTION | SPECIFICATION |
|--|---|
| OIL PUMP AND OIL PRESSURE | |
| Gear to Body Clearance (Radial) | 0.051 to 0.102 mm (0.002 to 0.004 in.) |
| (Radial Preferred) | 0.051 mm (0.002 in.) |
| Gear End Clearance— Plastigage | 0.051 to 0.152 mm (0.002 to 0.006 in.) |
| Plastigage Preferred | 0.051 mm (0.002 in.) |
| Feeler Gauge | 0.1016 to 0.2032 mm (0.004 to 0.008 in.) |
| Feeler Gauge Preferred | 0.1778 mm (0.007 in.) |
| Min. Pressure (600 rpm) | 89.6 kPa (13 psi) |
| Min. Pressure at Idle (800 rpm) | 172 to 241 kPa (25 to 35 psi) |
| Min. Pressure at 1600 rpm and Higher | 255 to 517 kPa (37 to 75 psi) |
| Oil Pressure Relief | 517 kPa (75 psi) |

SPECIFICATIONS (Continued)

SPECIFICATIONS—TORQUE

TORQUE CHART 2.5L ENGINE

| DESCRIPTION | N-m | Ft. Lbs. | In. Lbs |
|---|-----|----------|---------|
| A/C Compressor Bracket to Engine—Bolts | 47 | 35 | — |
| A/C Compressor Mounting Bolts | 28 | — | 250 |
| Block Heater Nut | 1.8 | — | 16 |
| Camshaft Sprocket Bolt | 108 | 80 | — |
| Clutch Cover to Flywheel Bolts | 31 | 23 | — |
| Connecting Rod Cap Nuts | 45 | 33 | — |
| Cylinder Block Drain Plugs | 41 | 30 | — |
| Cylinder Head Bolts #1–10 & #12–14 | 149 | 110 | — |
| Cylinder Head Bolt #11 | 135 | 100 | — |
| Cylinder Head Cover Bolts | 13 | — | 115 |
| Dipstick Tube Bracket to Cylinder Block—Bolt | 19 | — | 168 |
| Distributor Hold-Down Clamp Bolt | 23 | — | 204 |
| Engine Front Insulator Bracket—Bolts | 81 | 60 | — |
| Insulator Bracket—Nuts | 47 | 35 | — |
| Insulator—Through Bolt | 81 | 60 | — |
| Engine Rear Support Cushion /Crossmember—Nuts | 22 | — | 192 |
| Support Cushion/Bracket Nuts | 46 | 34 | — |
| Transmission Support Bracket—Bolts | 43 | 32 | — |
| Transmission Support Bracket /Cushion—Bolt | 75 | 55 | — |
| Transmission Support Adaptor Bracket—Bolts | 75 | 55 | — |
| Exhaust Manifold/Pipe Nuts | 27 | 20 | — |

| DESCRIPTION | N-m | Ft. Lbs. | In. Lbs |
|--|-----|----------|---------|
| Exhaust Manifold Bolt #1 | 41 | 30 | — |
| Bolts #2-5 | 31 | 23 | — |
| Nuts 6 and 7 | 14 | — | 126 |
| Flywheel/Converter Housing Bolts | 38 | 28 | — |
| Flywheel to Crankshaft Bolts | 143 | 105 | — |
| Front Cover to Block Bolts 1/4-20 | 7 | — | 60 |
| Front Cover to Block 5/16-18 | 22 | — | 192 |
| Generator Mounting—Bolts | 57 | 42 | — |
| Generator Mounting Bracket to Engine—Bolts | 47 | 35 | — |
| Main Bearing Cap Bolts | 108 | 80 | — |
| Oil Filter Adaptor Bolt | 102 | 75 | — |
| Oil Filter Connector | 68 | 50 | — |
| Oil Filter | 18 | 13 | — |
| Oil Galley Plug | 41 | 30 | — |
| Oil Pan 1/4-20 Bolts | 9.5 | — | 84 |
| Oil Pan 5/16-18 Bolts | 15 | — | 132 |
| Oil Pan Drain Plug | 34 | 25 | — |
| Oil Pressure Sending Unit | 15 | — | 130 |
| Oil Pump Short Attaching Bolts | 23 | — | 204 |
| Oil Pump Long Attaching Bolts | 23 | — | 204 |
| Oil Pump Cover Bolts | 8 | — | 70 |
| Rocker Arm—Bolts | 28 | 21 | — |
| Spark Plugs | 37 | 27 | — |
| Starter Motor Mounting Bolts | 45 | 33 | — |
| Thermostat Housing Bolts | 18 | — | 156 |
| Throttle Body Bolts | 10 | — | 90 |
| Vibration Damper Bolt | 108 | 80 | — |
| Water Pump to Block Bolts | 31 | 23 | — |

SPECIAL TOOLS

2.5L ENGINE SPECIAL TOOLS

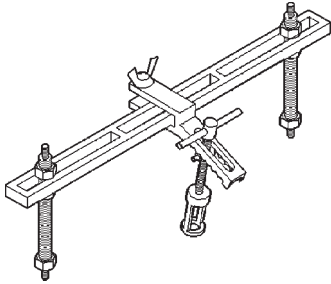

Valve Spring Compressor Tool MD-998772A

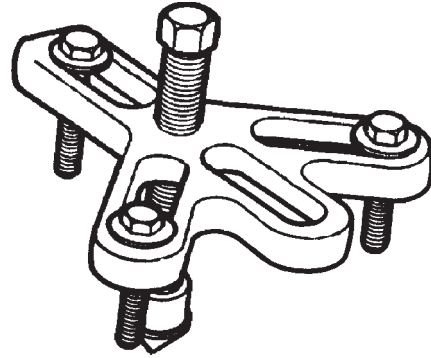

Vibration Damper Removal Tool 7697

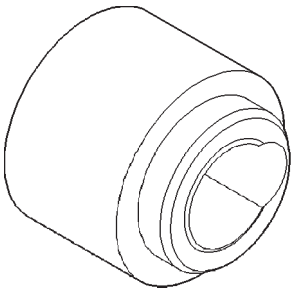

**Timing Case Cover Alignment and Seal installation
Tool 6139**

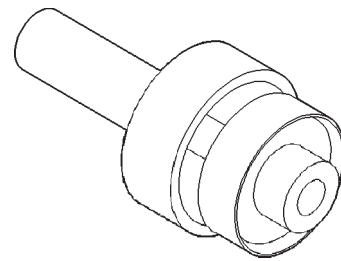

Rear Main Seal Installer Tool 6271A

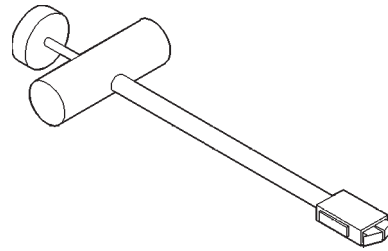

**Hydraulic Valve Tappet Removal/Installation Tool
C-4129-A**

4.0L ENGINE

TABLE OF CONTENTS

| | page | | page |
|---|------|---------------------------------------|------|
| DESCRIPTION AND OPERATION | | | |
| ENGINE | 62 | SERVICE ENGINE ASSEMBLY (SHORT BLOCK) | 88 |
| LUBRICATION SYSTEM | 62 | HYDROSTATIC LOCK | 88 |
| CYLINDER BLOCK | 65 | ENGINE OIL SERVICE | 88 |
| CYLINDER HEAD | 65 | REMOVAL AND INSTALLATION | |
| CRANKSHAFT | 65 | ENGINE MOUNTS—FRONT | 90 |
| PISTON AND CONNECTING ROD | 66 | ENGINE MOUNT—REAR | 91 |
| CAMSHAFT | 66 | ENGINE ASSEMBLY | 92 |
| ROCKER ARM | 66 | INTAKE AND EXHAUST MANIFOLD | 95 |
| VALVES | 67 | EXHAUST MANIFOLD—4.0L ENGINE | 96 |
| VALVE SPRING | 67 | CYLINDER HEAD COVER | 96 |
| CYLINDER HEAD COVER | 67 | ROCKER ARMS AND PUSH RODS | 96 |
| HYDRAULIC TAPPET | 67 | VALVE SPRINGS AND OIL SEALS | 97 |
| VALVE GUIDE | 67 | CYLINDER HEAD | 98 |
| OIL PAN | 67 | VALVES AND VALVE SPRINGS | 100 |
| VALVE STEM SEAL | 67 | HYDRAULIC TAPPETS | 100 |
| INTAKE MANIFOLD | 67 | VIBRATION DAMPER | 101 |
| EXHAUST MANIFOLD | 68 | TIMING CASE COVER | 101 |
| DIAGNOSIS AND TESTING | | | |
| ENGINE DIAGNOSIS—INTRODUCTION | 68 | TIMING CHAIN AND SPROCKETS | 102 |
| SERVICE DIAGNOSIS—PERFORMANCE | 69 | CAMSHAFT | 103 |
| SERVICE DIAGNOSIS—MECHANICAL | 70 | CAMSHAFT BEARINGS | 104 |
| INTAKE MANIFOLD LEAKAGE DIAGNOSIS | 72 | CRANKSHAFT MAIN BEARINGS | 105 |
| CYLINDER COMPRESSION PRESSURE TEST | 73 | OIL PAN | 107 |
| ENGINE CYLINDER HEAD GASKET FAILURE DIAGNOSIS | 73 | PISTONS AND CONNECTING RODS | 108 |
| CYLINDER COMBUSTION PRESSURE LEAKAGE TEST | 73 | CRANKSHAFT OIL SEALS—REAR | 110 |
| ENGINE OIL LEAK INSPECTION | 74 | OIL PUMP | 111 |
| ENGINE OIL PRESSURE | 75 | TIMING CASE COVER OIL SEAL | 112 |
| SERVICE PROCEDURES | | | |
| VALVE TIMING | 75 | DISASSEMBLY AND ASSEMBLY | |
| VALVE SERVICE | 75 | CYLINDER BLOCK | 112 |
| PISTON FITTING | 77 | CLEANING AND INSPECTION | |
| PISTON RING—FITTING | 77 | CYLINDER HEAD | 113 |
| FITTING CONNECTING ROD BEARINGS | 80 | CYLINDER HEAD COVER | 113 |
| FITTING CRANKSHAFT MAIN BEARINGS | 83 | ROCKER ARMS AND PUSH RODS | 113 |
| FORM-IN-PLACE GASKETS | 86 | HYDRAULIC TAPPETS | 113 |
| ENGINE PERFORMANCE | 87 | CYLINDER BLOCK | 114 |
| HONING CYLINDER BORES | 87 | SPECIFICATIONS | |
| REPAIR DAMAGED OR WORN THREADS | 88 | SPECIFICATIONS | 115 |
| | | TORQUE SPECIFICATIONS | 118 |
| | | SPECIAL TOOLS | |
| | | 4.0L ENGINE | 119 |

DESCRIPTION AND OPERATION

ENGINE

DESCRIPTION

The 4.0 Liter (242 CID) six-cylinder engine is an In-line, lightweight, overhead valve engine.

This engine is designed for unleaded fuel. The engine cylinder head has dual quench-type combustion chambers that create turbulence and fast burning of the air/fuel mixture. This results in good fuel economy.

The cylinders are numbered 1 through 6 from front to rear. The firing order is 1-5-3-6-2-4 (Fig. 1).

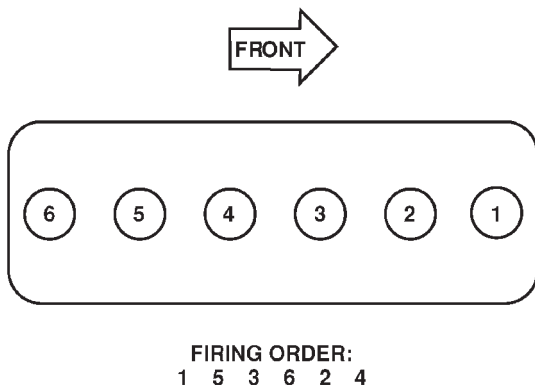

80b770a2

Fig. 1 Engine Firing Order

The crankshaft rotation is clockwise, when viewed from the front of the engine. The crankshaft rotates within seven main bearings. The camshaft rotates within four bearings.

BUILD DATE CODE

The engine Build Date Code is located on a machined surface on the right side of the cylinder block between the No.2 and No.3 cylinders (Fig. 2).

The digits of the code identify:

- 1st Digit—The year (8 = 1998).
- 2nd & 3rd Digits—The month (01 - 12).
- 4th & 5th Digits—The engine type/fuel system/compression ratio (MX = A 4.0 Liter (242 CID) 8.7:1 compression ratio engine with a multi-point fuel injection system).
- 6th & 7th Digits—The day of engine build (01 - 31).

(1) **FOR EXAMPLE:** Code * 801MX12 * identifies a 4.0 Liter (242 CID) engine with a multi-point fuel injection system, 8.7:1 compression ratio and built on January 12, 1998.

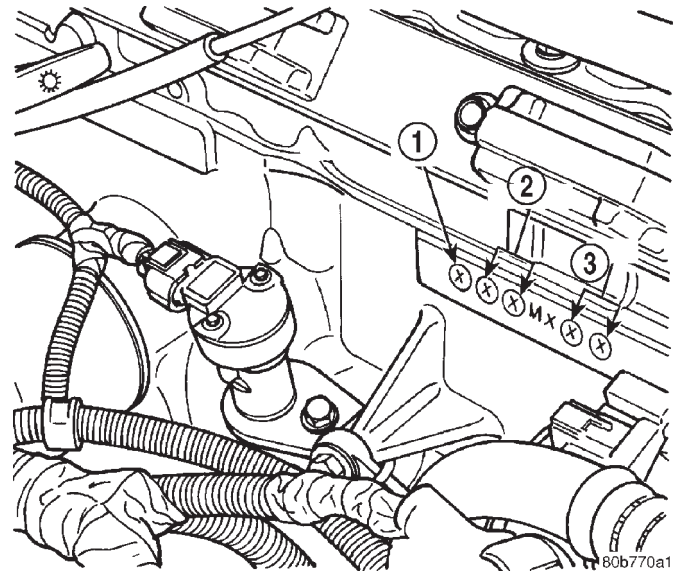

Fig. 2 Build Date Code Location

- 1 - YEAR
- 2 - MONTH
- 3 - DAY

LUBRICATION SYSTEM

DESCRIPTION

A gear-type positive displacement pump is mounted at the underside of the block opposite the No. 4 main bearing.

OPERATION

The pump draws oil through the screen and inlet tube from the sump at the rear of the oil pan. The oil is driven between the drive and idler gears and pump body, then forced through the outlet to the block. An oil gallery in the block channels the oil to the inlet side of the full flow oil filter. After passing through the filter element, the oil passes from the center outlet of the filter through an oil gallery that channels the oil up to the main gallery which extends the entire length of the block.

Galleries extend downward from the main oil gallery to the upper shell of each main bearing. The crankshaft is drilled internally to pass oil from the main bearing journals (except number 4 main bearing journal) to the connecting rod journals. Each connecting rod bearing cap has a small squirt hole, oil passes through the squirt hole and is thrown off as the rod rotates. This oil throwoff lubricates the camshaft lobes, distributor drive gear, cylinder walls, and piston pins.

The hydraulic valve tappets receive oil directly from the main oil gallery. Oil is provided to the camshaft bearing through galleries. The front camshaft bearing journal passes oil through the camshaft

DESCRIPTION AND OPERATION (Continued)

sprocket to the timing chain. Oil drains back to the oil pan under the number one main bearing cap.

The oil supply for the rocker arms and bridged pivot assemblies is provided by the hydraulic valve tappets which pass oil through hollow push rods to a

hole in the corresponding rocker arm. Oil from the rocker arm lubricates the valve train components, then passes down through the push rod guide holes in the cylinder head past the valve tappet area, and returns to the oil pan.

DESCRIPTION AND OPERATION (Continued)

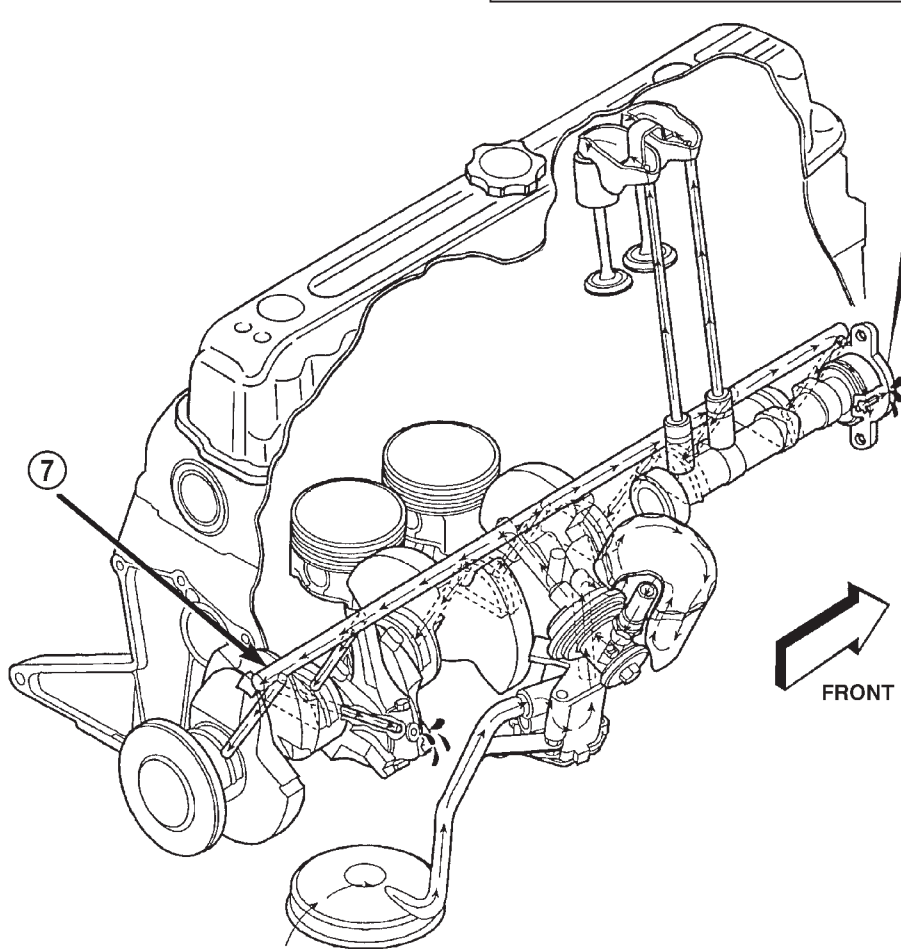
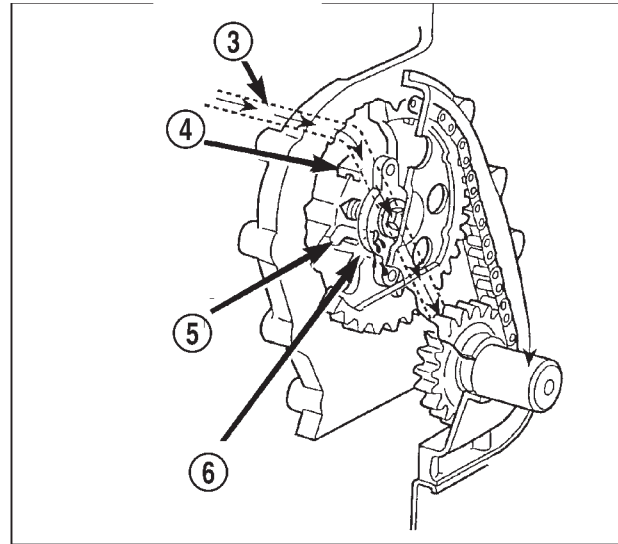
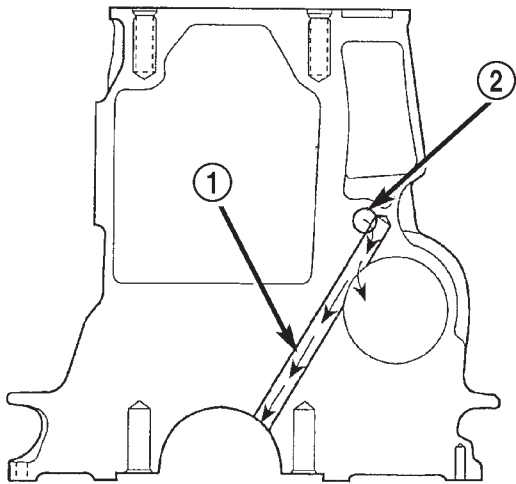

Oil Lubrication System—4.0L Engine

80be47c9

- 1 - CAM/CRANK MAIN GALLERY (7)
- 2 - TAPPET GALLERY
- 3 - TAPPET GALLERY
- 4 - CAMSHAFT BEARING

- 5 - NUMBER 1 CAMSHAFT BEARING JOURNAL
- 6 - CAMSHAFT SPROCKET
- 7 - TAPPET GALLERY

DESCRIPTION AND OPERATION (Continued)

CYLINDER BLOCK

DESCRIPTION

The cylinder block is a cast iron inline six cylinder design. The cylinder block is drilled forming galleries for both oil and coolant (Fig. 3).

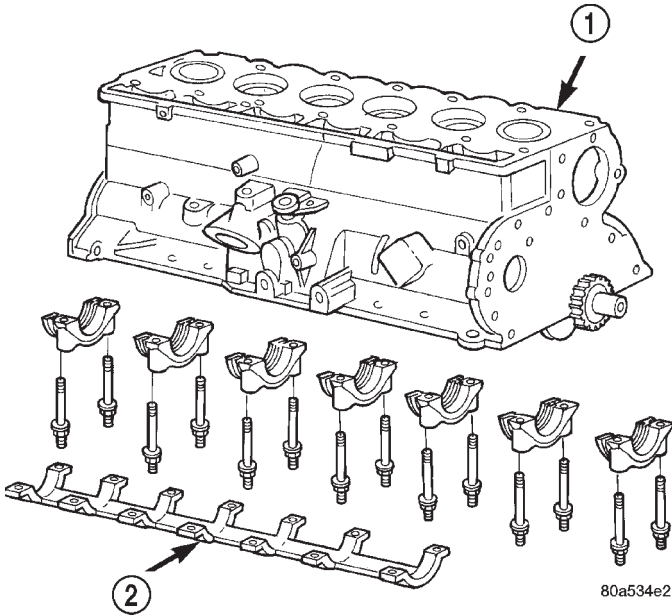

Fig. 3 4.0L Cylinder Block with Main Bearing Caps and Cap Brace

- 1 - BLOCK
- 2 - MAIN BEARING CAP BRACE

CYLINDER HEAD

DESCRIPTION

The cylinder head is made of cast iron containing twelve valves made of chrome plated heat resistant steel, valve stem seals, springs, retainers and keepers. The cylinder head and valve seats can be resurfaced for service purposes.

The valve guides are integral to the cylinder head, They are not replaceable. However, they are serviceable.

The cylinder head uses dual quench-type design combustion chambers which cause turbulence in the cylinders allowing faster burning of the air/fuel mixture, resulting in better fuel economy (Fig. 4).

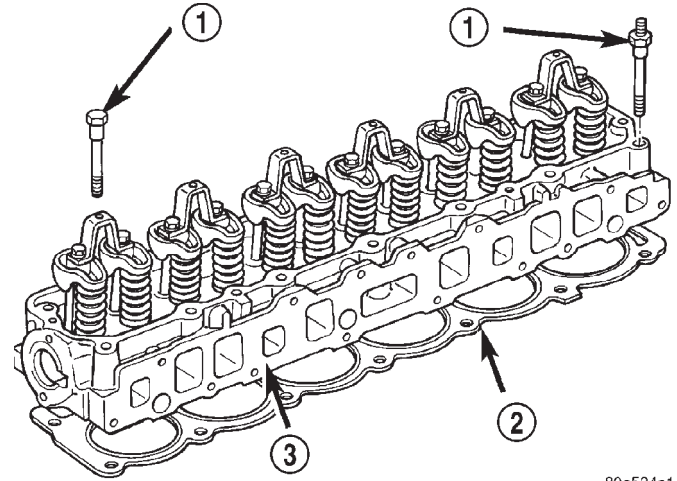

Fig. 4 Cylinder Head 4.0L Engine

- 1 - CYLINDER HEAD BOLTS
- 2 - CYLINDER HEAD GASKET
- 3 - CYLINDER HEAD

CRANKSHAFT

DESCRIPTION

The crankshaft is constructed of nodular cast iron. The crankshaft is a crossshaped four throw design with eight counterweights for balancing purposes. The crankshaft is supported by seven select main bearings with the number three serving as the thrust washer location. The main journals of the crankshaft are cross drilled to improve rod bearing lubrication. The select fit main bearing markings are located on the crankshaft counter weights. The crankshaft rear oil seal is a two piece design. The front oil seal is a one piece design retained in the timing chain cover (Fig. 5).

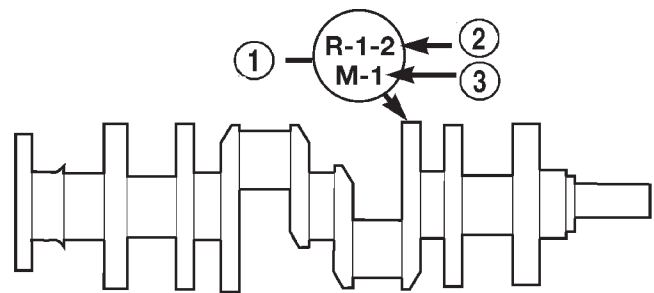

Fig. 5 Crankshaft with Select Fit Marking Location

- 1 - 1/4" LETTERS
- 2 - (ROD)
- 3 - (MAIN)

80ba7a6b

DESCRIPTION AND OPERATION (Continued)

PISTON AND CONNECTING ROD

DESCRIPTION

The pistons are made of a high strength aluminum alloy with an anodized top ring groove and crown. Piston skirts are coated with a solid lubricant (Molykote) to reduce friction and provide scuff resistance. The connecting rods are made of ductile iron. A pressed fit piston pin is used to attach the piston and connecting rod.

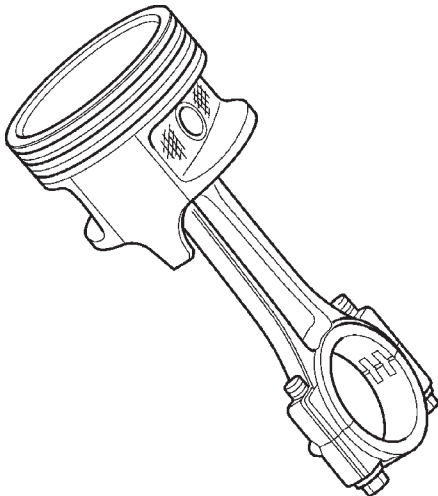

80bcea5c

Fig. 6 Piston and Connecting Rod Assembly

CAMSHAFT

DESCRIPTION

The camshaft is made of gray cast iron with twelve machined lobes and four bearing journals. When the camshaft rotates the lobes actuate the tappets and push rods, forcing upward on the rocker arms which applies downward force on the valves.

ROCKER ARM

DESCRIPTION

The rocker arms are made of stamped steel and have a operational ratio of 1.6:1. When the push rods are forced upward by the camshaft lobes the push rod presses upward on the rocker arms, the rocker arms pivot, forcing downward pressure on the valves forcing the valves to move downward and off from their seats (Fig. 8).

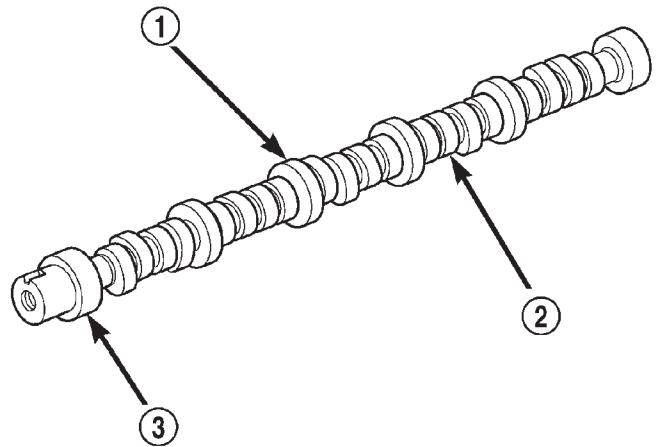

80bfe13b

Fig. 7 Camshaft—Typical

- 1 - CAMSHAFT
- 2 - LOBES
- 3 - BEARING JOURNAL

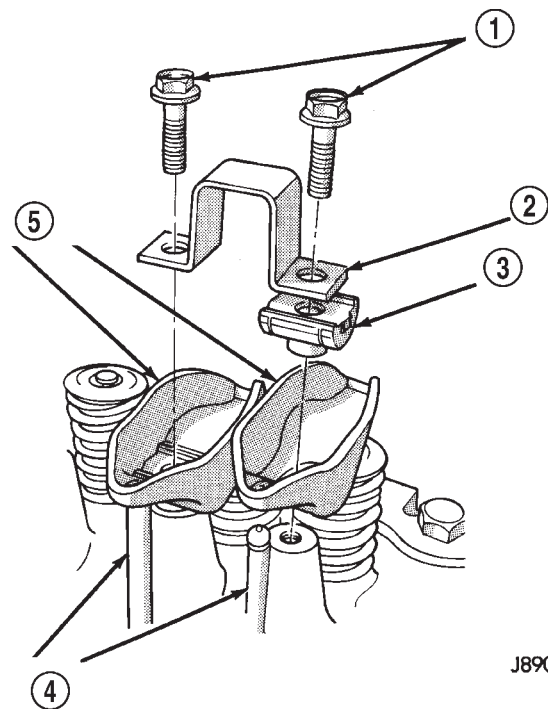

J8909-8

Fig. 8 Rocker Arms 4.0L Engine

- 1 - CAPSCREWS
- 2 - BRIDGE
- 3 - PIVOT ASSEMBLY
- 4 - PUSH RODS
- 5 - ROCKER ARMS

DESCRIPTION AND OPERATION (Continued)

VALVES

DESCRIPTION

The valves are made of heat resistant steel and have chrome plated stems to prevent scuffing. All valves use three bead locks to promote valve rotation (Fig. 9).

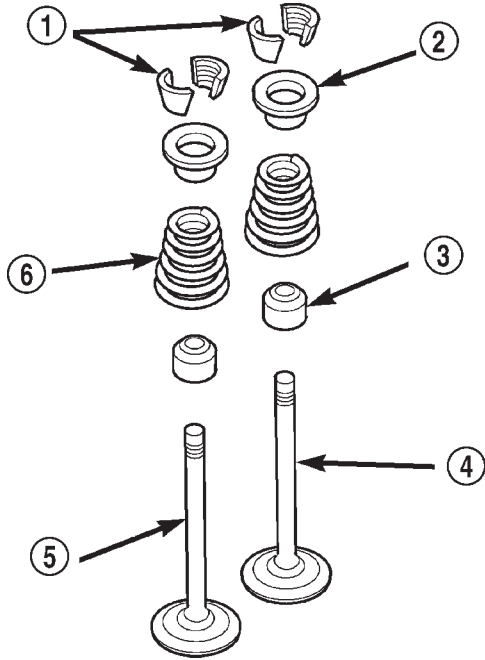

80b7704b

Fig. 9 Valve and Keeper Configuration 4.0L Engine

- 1 - VALVE LOCKS (3-BEAD)
- 2 - RETAINER
- 3 - VALVE STEM OIL SEAL
- 4 - INTAKE VALVE
- 5 - EXHAUST VALVE
- 6 - VALVE SPRING

VALVE SPRING

DESCRIPTION

The valve springs are made of high strength silicon chrome spring steel. The springs are common for both intake and exhaust valves. (Fig. 9).

CYLINDER HEAD COVER

DESCRIPTION

The cylinder head cover (Fig. 10) is made of stamped steel and incorporates the Crankcase Ventilation (CCV) Hoses and the oil fill opening.

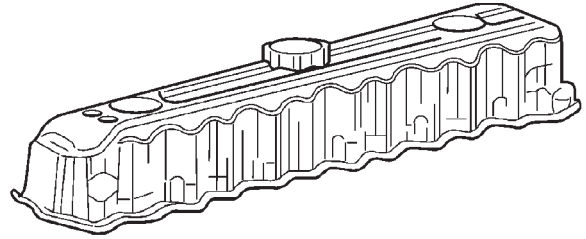

80bcea5b

Fig. 10 Cylinder Head Cover

HYDRAULIC TAPPET

DESCRIPTION

Valve lash is controlled by hydraulic tappets located inside the cylinder block, in tappet bores above the camshaft.

VALVE GUIDE

DESCRIPTION

The valve guides are integral to the cylinder head. They are not replaceable. However, they are serviceable.

OIL PAN

DESCRIPTION

The oil pan is made of stamped steel. The oil pan gasket is a one piece steel backbone silicone coated gasket.

VALVE STEM SEAL

DESCRIPTION

The valve stem seals are made of rubber and incorporate a garter spring to maintain consistent lubrication control (Fig. 9).

INTAKE MANIFOLD

DESCRIPTION

The intake manifold is made of cast aluminum and uses eleven bolts to mount to the cylinder head. This mounting style improves sealing and reduces the chance of leaks.

DESCRIPTION AND OPERATION (Continued)

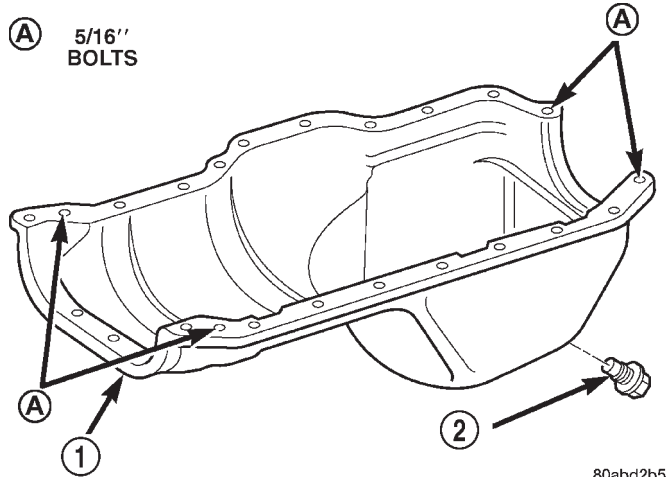

Fig. 11 Oil Pan

- 1 - OIL PAN
- 2 - OIL PAN DRAIN PLUG

exhaust manifolds share a common gasket with the intake manifold. The exhaust manifolds also incorporate ball flange outlets for improved sealing and strain free connections.

DIAGNOSIS AND TESTING

ENGINE DIAGNOSIS—INTRODUCTION

Engine diagnosis is helpful in determining the causes of malfunctions not detected and remedied by routine maintenance.

These malfunctions may be classified as either performance (e.g., engine idles rough and stalls) or mechanical (e.g., a strange noise).

Refer to the Service Diagnosis—Performance chart and the Service Diagnosis—Mechanical chart for possible causes and corrections of malfunctions. Refer to Group 14, Fuel System for the fuel system diagnosis.

Additional tests and diagnostic procedures may be necessary for specific engine malfunctions that can not be isolated with the Service Diagnosis charts. Information concerning additional tests and diagnosis is provided within the following diagnosis:

- Cylinder Compression Pressure Test.
- Cylinder Combustion Pressure Leakage Test.
- Engine Cylinder Head Gasket Failure Diagnosis.
- Intake Manifold Leakage Diagnosis.

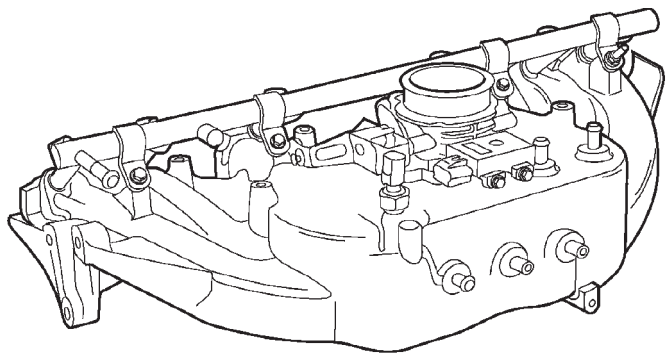

Fig. 12 Intake Manifold 4.0L Engine

EXHAUST MANIFOLD

DESCRIPTION

The two exhaust manifolds are log style and are made of high silicon molybdenum cast iron. The

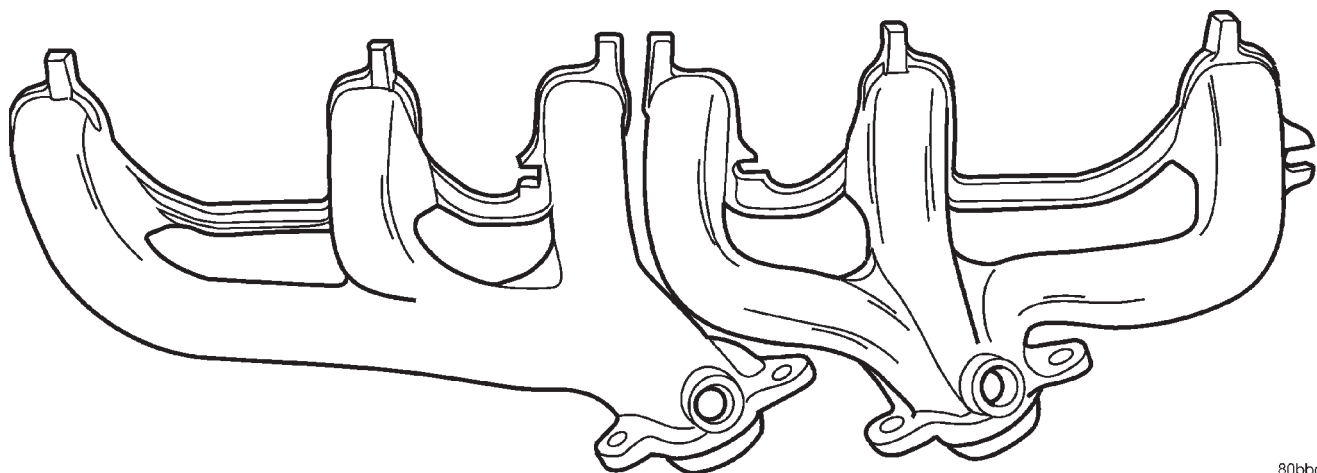

Fig. 13 Exhaust Manifolds 4.0L Engine

DIAGNOSIS AND TESTING (Continued)

SERVICE DIAGNOSIS—PERFORMANCE

ENGINE PERFORMANCE DIAGNOSIS CHART

| CONDITION | POSSIBLE CAUSES | CORRECTION |
|----------------------------------|--|--|
| ENGINE WILL NOT CRANK | <ol style="list-style-type: none"> 1. Weak or dead battery 2. Corroded or loose battery connections 3. Faulty starter or related circuit(s) 4. Siezed accessory drive component 5. Engine internal mechanical failure or hydro-static lock | <ol style="list-style-type: none"> 1. Charge/Replace Battery. Refer to Group 8A, Battery, for correct procedures. Check charging system. Refer to Group 8C, Charging Systems, for correct procedures. 2. Clean/tighten suspect battery/ starter connections 3. Check starting system. Refer to Group 8B, Starting Systems, for correct diagnostics/procedures 4. Remove accessory drive belt and attempt to start engine. If engine starts, repair/replace siezed component. 5. Refer to Group 9, Engine, for correct diagnostics/procedures |
| ENGINE CRANKS BUT WILL NOT START | <ol style="list-style-type: none"> 1. No spark 2. No fuel 3. Low or no engine compression | <ol style="list-style-type: none"> 1. Check for spark. Refer to Group 8D, Ignition System, for correct procedures. 2. Perform fuel pressure test, and if necessary, inspect fuel injector(s) and driver circuits. Refer to Group 14, Fuel System, for correct procedures. 3. Perform cylinder compression pressure test. Refer to Group 9, Engine, for correct procedures. |
| ENGINE LOSS OF POWER | <ol style="list-style-type: none"> 1. Worn or burned distributor rotor 2. Worn distributor shaft 3. Worn or incorrect gapped spark plugs 4. Dirt or water in fuel system 5. Faulty fuel pump 6. Incorrect valve timing 7. Blown cylinder head gasket 8. Low compression 9. Burned, warped, or pitted valves 10. Plugged or restricted exhaust system 11. Faulty ignition cables | <ol style="list-style-type: none"> 1. Install new distributor rotor 2. Remove and repair distributor (Refer to group 8D, Ignition System) 3. Clean plugs and set gap. (Refer to group 8D, Ignition System) 4. Clean system and replace fuel filter 5. Install new fuel pump 6. Correct valve timing 7. Install new cylinder head gasket 8. Test cylinder compression 9. Install/Reface valves as necessary 10. Install new parts as necessary 11. Replace any cracked or shorted cables |

DIAGNOSIS AND TESTING (Continued)

| CONDITION | POSSIBLE CAUSES | CORRECTION |
|-------------------------------|---|--|
| | 12. Faulty ignition coil | 12. Test and replace, as necessary (Refer to Group 8D, ignition system) |
| ENGINE STALLS OR ROUGH IDLE | 1. Carbon build-up on throttle plate 2. Engine idle speed too low 3. Worn or incorrectly gapped spark plugs 4. Worn or burned distributor rotor 5. Spark plug cables defective or crossed 6. Faulty coil 7. Intake manifold vacuum leak 8. EGR valve leaking or stuck open | 1. Remove throttle body and de-carbon. (Refer to Group 14 for correct procedures) 2. Check Idle Air Control circuit. (Refer to Group 14, Fuel System) 3. Replace or clean and re-gap spark plugs (Refer to group 8D, Ignition System) 4. Install new distributor rotor 5. Check for correct firing order or replace spark plug cables. (Refer to Group 8D, Ignition System for correct procedures.) 6. Test and replace, if necessary (Refer to group 8D, Ignition System) 7. Inspect intake manifold gasket and vacuum hoses. Replace if necessary (Refer to Group 11, Exhaust System & Intake Manifold) 8. Test and replace, if necessary (Refer to group 25, Emission Control Systems) |
| ENGINE MISSES ON ACCELERATION | 1. Worn or incorrectly gapped spark plugs 2. Spark plug cables defective or crossed 3. Dirt in fuel system 4. Burned, warped or pitted valves 5. Faulty coil | 1. Replace spark plugs or clean and set gap. (Refer to group 8D, Ignition System) 2. Check Idle Air Control circuit. (Refer to Group 14, Fuel System) 3. Clean fuel system 4. Install new valves 5. Test and replace as necessary (refer to group 8D, Ignition System) |

SERVICE DIAGNOSIS—MECHANICAL

ENGINE MECHANICAL DIAGNOSIS CHART

| CONDITION | POSSIBLE CAUSES | CORRECTION |
|----------------------|--|---|
| NOISY VALVES/LIFTERS | 1. High or low oil level in crankcase 2. Thin or diluted oil 3. Low oil pressure | 1. Check for correct oil level. Adjust oil level by draining or adding as needed 2. Change oil (Refer to Engine Oil Service in this group) 3. Check engine oil level. If ok, Perform oil pressure test. Refer to this group for engine oil pressure test/specifications |

DIAGNOSIS AND TESTING (Continued)

| CONDITION | POSSIBLE CAUSES | CORRECTION |
|----------------------|---|---|
| | 4. Dirt in tappets/lash adjusters 5. Bent push rod(s) 6. Worn rocker arms 7. Worn tappets/lash adjusters 8. Worn valve guides 9. Excessive runout of valve seats or valve faces | 4. Clean/replace hydraulic tappets/lash adjusters 5. Install new push rods 6. Inspect oil supply to rocker arms and replace worn arms as needed 7. Install new hydraulic tappets/lash adjusters 8. Inspect all valve guides and replace as necessary 9. Grind valves and seats |
| CONNECTING ROD NOISE | 1. Insufficient oil supply 2. Low oil pressure 3. Thin or diluted oil 4. Excessive connecting rod bearing clearance 5. Connecting rod journal out of round 6. Misaligned connecting rods | 1. Check engine oil level. (Refer to group 0, Lubrication and Maintenance) 2. Check engine oil level. If ok, Perform oil pressure test. Refer to this group for engine oil pressure test/specifications 3. Change oil to correct viscosity. Refer to this group for correct procedure/engine oil specifications Measure bearings for correct clearance with plasti-gage. Repair as necessary 5. Replace crankshaft or grind journals 6. Replace bent connecting rods |
| MAIN BEARING NOISE | 1. Insufficient oil supply 2. Low oil pressure 3. Thin or diluted oil 4. Excessive main bearing clearance 5. Excessive end play 6. Crankshaft main journal out of round or worn 7. Loose flywheel or torque converter | 1. Check engine oil level. (Refer to group 0, Lubrication and Maintenance) 2. Check engine oil level. If ok, Perform oil pressure test. Refer to this group for engine oil pressure test/specifications 3. Change oil to correct viscosity. Refer to this group for correct procedure/engine oil specifications 4. Measure bearings for correct clearance. Repair as necessary 5. Check crankshaft thrust bearing for excessive wear on flanges 6. Grind journals or replace crankshaft 7. Inspect crankshaft, flexplate/flywheel and bolts for damage. Tighten to correct torque |

DIAGNOSIS AND TESTING (Continued)

| CONDITION | POSSIBLE CAUSES | CORRECTION |
|---|--|---|
| LOW OIL PRESSURE | <ol style="list-style-type: none"> 1. Low oil level 2. Faulty oil pressure sending unit 3. Clogged oil filter 4. Worn oil pump 5. Thin or diluted oil 6. Excessive bearing clearance 7. Oil pump relief valve stuck 8. Oil pump suction tube loose, broken, bent or clogged 9. Oil pump cover warped or cracked | <ol style="list-style-type: none"> 1. Check oil level and fill if necessary 2. Install new sending unit 3. Install new oil filter 4. Replace worn gears or oil pump assy 5. Change oil to correct viscosity. Refer to this group for correct procedure/engine oil specifications 6. Measure bearings for correct clearance 7. Remove valve to inspect, clean and reinstall 8. Inspect suction tube and clean or replace if necessary 9. Install new oil pump |
| OIL LEAKS | <ol style="list-style-type: none"> 1. Misaligned or deteriorated gaskets 2. Loose fastener, broken or porous metal part 3. Front or rear crankshaft oil seal leaking 4. Leaking oil gallery plug or cup plug | <ol style="list-style-type: none"> 1. Replace gasket 2. Tighten, repair or replace the part 3. Replace seal 4. Remove and reseal threaded plug. Replace cup style plug |
| EXCESSIVE OIL CONSUMPTION OR SPARK PLUGS OIL FOULED | <ol style="list-style-type: none"> 1. PCV System malfunction 2. Defective valve stem seal(s) 3. Worn or broken piston rings 4. Scuffed pistons/cylinder walls 5. Carbon in oil control ring groove 6. Worn valve guides 7. Piston rings fitted too tightly in grooves | <ol style="list-style-type: none"> 1. Refer to group 25, Emission Control System for correct operation 2. Repair or replace seal(s) 3. Hone cylinder bores. Install new rings 4. Hone cylinder bores and replace pistons as required 5. Remove rings and de-carbon piston 6. Inspect/replace valve guides as necessary 7. Remove rings and check ring end gap and side clearance. Replace if necessary |

INTAKE MANIFOLD LEAKAGE DIAGNOSIS

An intake manifold air leak is characterized by lower than normal manifold vacuum. Also, one or more cylinders may not be functioning.

WARNING: USE EXTREME CAUTION WHEN THE ENGINE IS OPERATING. DO NOT STAND IN A DIRECT LINE WITH THE FAN. DO NOT PUT YOUR HANDS NEAR THE PULLEYS, BELTS OR THE FAN. DO NOT WEAR LOOSE CLOTHING.

DIAGNOSIS AND TESTING (Continued)

- (1) Start the engine.
- (2) Spray a small stream of water at the suspected leak area.
- (3) If a change in RPM is observed the area of the suspected leak has been found.
- (4) Repair as required.

CYLINDER COMPRESSION PRESSURE TEST

The results of a cylinder compression pressure test can be utilized to diagnose several engine malfunctions.

Ensure the battery is completely charged and the engine starter motor is in good operating condition. Otherwise the indicated compression pressures may not be valid for diagnosis purposes.

- (1) Clean the spark plug recesses with compressed air.
- (2) Remove the spark plugs.
- (3) Secure the throttle in the wide-open position.
- (4) Disable the fuel system. (Refer to Group 14, Fuel System for the correct procedure)
- (5) Disconnect the ignition coil.
- (6) Insert a compression pressure gauge and rotate the engine with the engine starter motor for three revolutions.
- (7) Record the compression pressure on the 3rd revolution. Continue the test for the remaining cylinders.

Refer to Engine Specifications for the correct engine compression pressures.

ENGINE CYLINDER HEAD GASKET FAILURE DIAGNOSIS

A leaking engine cylinder head gasket usually results in loss of power, loss of coolant and engine misfiring.

An engine cylinder head gasket leak can be located between adjacent cylinders or between a cylinder and the adjacent water jacket.

- An engine cylinder head gasket leaking between adjacent cylinders is indicated by a loss of power and/or engine misfire.
- An engine cylinder head gasket leaking between a cylinder and an adjacent water jacket is indicated by coolant foaming or overheating and loss of coolant.

CYLINDER-TO-CYLINDER LEAKAGE TEST

To determine if an engine cylinder head gasket is leaking between adjacent cylinders; follow the procedures outlined in Cylinder Compression Pressure Test. An engine cylinder head gasket leaking between adjacent cylinders will result in approximately a 50-70% reduction in compression pressure.

CYLINDER-TO-WATER JACKET LEAKAGE TEST

WARNING: USE EXTREME CAUTION WHEN THE ENGINE IS OPERATING. DO NOT STAND IN A DIRECT LINE WITH THE FAN. DO NOT PUT YOUR HANDS NEAR THE PULLEYS, BELTS OR THE FAN. DO NOT WEAR LOOSE CLOTHING.

Remove the radiator cap.

Start the engine and allow it to warm up until the engine thermostat opens.

If a large combustion/compression pressure leak exists, bubbles will be visible in the coolant.

If bubbles are not visible, install a radiator pressure tester and pressurize the coolant system.

If a cylinder is leaking combustion pressure into the water jacket, the tester pointer will pulsate with every combustion stroke of the cylinder.

CYLINDER COMBUSTION PRESSURE LEAKAGE TEST

The combustion pressure leakage test provides an accurate means for determining engine condition.

Combustion pressure leakage testing will detect:

- Exhaust and intake valve leaks (improper seating).
- Leaks between adjacent cylinders or into water jacket.
- Any causes for combustion/compression pressure loss.

(1) Check the coolant level and fill as required. DO NOT install the radiator cap.

(2) Start and operate the engine until it attains normal operating temperature, then turn the engine OFF.

(3) Remove the spark plugs.

(4) Remove the oil filler cap.

(5) Remove the air cleaner.

(6) Calibrate the tester according to the manufacturer's instructions. The shop air source for testing should maintain 483 kPa (70 psi) minimum, 1,379 kPa (200 psi) maximum and 552 kPa (80 psi) recommended.

(7) Perform the test procedures on each cylinder according to the tester manufacturer's instructions. While testing, listen for pressurized air escaping through the throttle body, tailpipe and oil filler cap opening. Check for bubbles in the radiator coolant.

All gauge pressure indications should be equal, with no more than 25% leakage.

FOR EXAMPLE: At 552 kPa (80 psi) input pressure, a minimum of 414 kPa (60 psi) should be maintained in the cylinder.

Refer to the Cylinder Combustion Pressure Leakage Test Diagnosis chart.

DIAGNOSIS AND TESTING (Continued)

CYLINDER COMBUSTION PRESSURE LEAKAGE DIAGNOSIS CHART

| CONDITION | POSSIBLE CAUSE | CORRECTION |
|---|---|---|
| AIR ESCAPES THROUGH THROTTLE BODY | Intake valve bent, burnt, or not seated properly | Inspect valve and valve seat. Reface or replace, as necessary |
| AIR ESCAPES THROUGH TAILPIPE | Exhaust valve bent, burnt, or not seated properly | Inspect valve and valve seat. Reface or replace, as necessary |
| AIR ESCAPES THROUGH RADIATOR | Head gasket leaking or cracked cylinder head or block | Remove cylinder head and inspect. Replace defective part |
| MORE THAN 50% LEAKAGE FROM ADJACENT CYLINDERS | Head gasket leaking or crack in cylinder head or block between adjacent cylinders | Remove cylinder head and inspect. Replace gasket, head, or block as necessary |
| MORE THAN 25% LEAKAGE AND AIR ESCAPES THROUGH OIL FILLER CAP OPENING ONLY | Stuck or broken piston rings; cracked piston; worn rings and/or cylinder wall | Inspect for broken rings or piston. Measure ring gap and cylinder diameter, taper and out-of-round. Replace defective part as necessary |

ENGINE OIL LEAK INSPECTION

Begin with a thorough visual inspection of the engine, particularly at the area of the suspected leak. If an oil leak source is not readily identifiable, the following steps should be followed:

(1) Do not clean or degrease the engine at this time because some solvents may cause rubber to swell, temporarily stopping the leak.

(2) Add an oil soluble dye (use as recommended by manufacturer). Start the engine and let idle for approximately 15 minutes. Check the oil dipstick to make sure the dye is thoroughly mixed as indicated with a bright yellow color under a black light.

(3) Using a black light, inspect the entire engine for fluorescent dye, particularly at the suspected area of oil leak. If the oil leak is found and identified, repair per service manual instructions.

(4) If dye is not observed, drive the vehicle at various speeds for approximately 24km (15 miles), and repeat inspection.

(4) **If the oil leak source is not positively identified at this time**, proceed with the air leak detection test method.

Air Leak Detection Test Method

(1) Disconnect the breather cap to air cleaner hose at the breather cap end. Cap or plug breather cap nipple.

(2) Remove the PCV valve from the cylinder head cover. Cap or plug the PCV valve grommet.

(3) Attach an air hose with pressure gauge and regulator to the dipstick tube.

CAUTION: Do not subject the engine assembly to more than 20.6 kpa (3 PSI) of test pressure.

(4) Gradually apply air pressure from 1 psi to 2.5 psi maximum while applying soapy water at the suspected source. Adjust the regulator to the suitable test pressure that provide the best bubbles which will pinpoint the leak source. If the oil leak is detected and identified, repair per service manual procedures.

(5) If the leakage occurs at the rear oil seal area, refer to the section, Inspection for Rear Seal Area Leak.

(6) If no leaks are detected, turn off the air supply and remove the air hose and all plugs and caps. Install the PCV valve and breather cap hose.

(7) Clean the oil off the suspect oil leak area using a suitable solvent. Drive the vehicle at various speeds approximately 24 km (15 miles). Inspect the engine for signs of an oil leak by using a black light.

INSPECTION FOR REAR SEAL AREA LEAKS

Since it is sometimes difficult to determine the source of an oil leak in the rear seal area of the engine, a more involved inspection is necessary. The following steps should be followed to help pinpoint the source of the leak.

If the leakage occurs at the crankshaft rear oil seal area:

(1) Disconnect the battery.

(2) Raise the vehicle.

(3) Remove torque converter or clutch housing cover and inspect rear of block for evidence of oil.

Use a black light to check for the oil leak:

(a) Circular spray pattern generally indicates seal leakage or crankshaft damage.

(b) Where leakage tends to run straight down, possible causes are a porous block, distributor seal, camshaft bore cup plugs oil galley pipe plugs, oil

DIAGNOSIS AND TESTING (Continued)

filter runoff, and main bearing cap to cylinder block mating surfaces.

(4) If no leaks are detected, pressurize the crankcase as outlined in the, Inspection (Engine oil Leaks in general)

CAUTION: Do not exceed 20.6 kPa (3 psi).

(5) If the leak is not detected, very slowly turn the crankshaft and watch for leakage. If a leak is detected between the crankshaft and seal while slowly turning the crankshaft, it is possible the crankshaft seal surface is damaged. The seal area on the crankshaft could have minor nicks or scratches that can be polished out with emery cloth.

CAUTION: Use extreme caution when crankshaft polishing is necessary to remove minor nicks and scratches. The crankshaft seal flange is especially machined to complement the function of the rear oil seal.

(6) For bubbles that remain steady with shaft rotation, no further inspection can be done until disassembled.

ENGINE OIL PRESSURE

(1) Disconnect connector and remove oil pressure sending unit.

(2) Install Oil Pressure Line and Gauge Tool C-3292 or equivalent. Start engine and record pressure. Refer to Oil Pressure in Engine Specifications for the correct pressures.

SERVICE PROCEDURES

VALVE TIMING

Disconnect the spark plug wires and remove the spark plugs.

Remove the engine cylinder head cover.

Remove the capscrews, bridge and pivot assembly, and rocker arms from above the No.1 cylinder.

Alternately loosen each capscrew, one turn at a time, to avoid damaging the bridge.

Rotate the crankshaft until the No.6 piston is at top dead center (TDC) on the compression stroke.

Rotate the crankshaft counterclockwise (viewed from the front of the engine) 90°.

Install a dial indicator on the end of the No.1 cylinder intake valve push rod. Use rubber tubing to secure the indicator stem on the push rod.

Set the dial indicator pointer at zero.

Rotate the crankshaft clockwise (viewed from the front of the engine) until the dial indicator pointer indicates 0.305 mm (0.012 inch) travel distance (lift).

The timing notch index on the vibration damper should be aligned with the TDC mark on the timing degree scale.

If the timing notch is more than 13 mm (1/2 inch) away from the TDC mark in either direction, the valve timing is incorrect.

If the valve timing is incorrect, the cause may be a broken camshaft pin. It is not necessary to replace the camshaft because of pin failure. A spring pin is available for service replacement.

VALVE SERVICE

Clean all carbon deposits from the combustion chambers, valve ports, valve stems, valve stem guides and head.

Clean all grime and gasket material from the engine cylinder head machined gasket surface.

Inspect for cracks in the combustion chambers and valve ports.

Inspect for cracks on the exhaust seat.

Inspect for cracks in the gasket surface at each coolant passage.

Inspect valves for burned, cracked or warped heads.

Inspect for scuffed or bent valve stems.

Replace valves displaying any damage.

VALVE REFACING

(1) Use a valve refacing machine to reface the intake and exhaust valves to the specified angle.

(2) After refacing, a margin of at least 0.787 mm (0.031 inch) must remain (Fig. 14). If the margin is less than 0.787 mm (0.031 inch), the valve must be replaced.

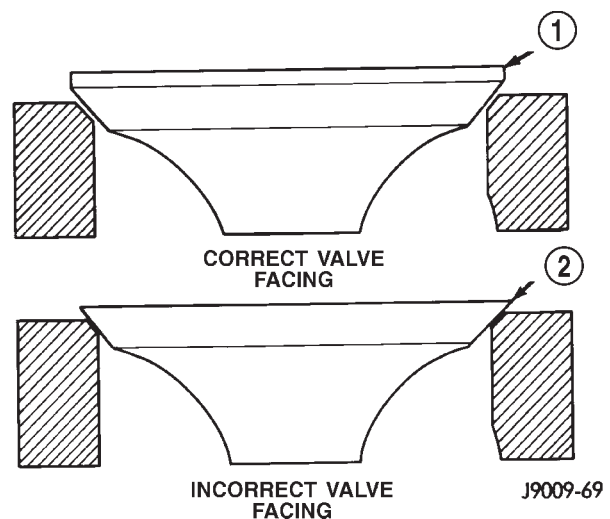

Fig. 14 Valve Facing Margin

- 1 - VALVE MARGIN
2 - NO MARGIN

SERVICE PROCEDURES (Continued)

VALVE SEAT REFACING

(1) Install a pilot of the correct size in the valve guide bore. Reface the valve seat to the specified angle with a good dressing stone. Remove only enough metal to provide a smooth finish.

(2) Use tapered stones to obtain the specified seat width when required.

(3) Control valve seat runout to a maximum of 0.0635 mm (0.0025 in.) (Fig. 15).

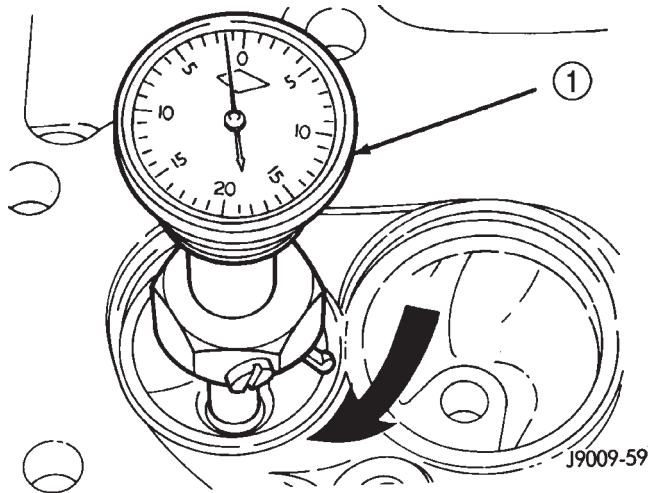

Fig. 15 Measurement of Valve Seat Runout

1 - DIAL INDICATOR

VALVE STEM OIL SEAL REPLACEMENT

Valve stem oil seals are installed on each valve stem to prevent rocker arm lubricating oil from entering the combustion chamber through the valve guide bores. One seal is marked INT (intake valve) and the other is marked EXH (exhaust valve).

Replace the oil seals whenever valve service is performed or if the seals have deteriorated.

VALVE GUIDES

The valve guides are an integral part of the engine cylinder head and are not replaceable.

When the valve stem guide clearance is excessive, the valve guide bores must be reamed oversize. Service valves with oversize stems are available in 0.076 mm (0.003 inch) and 0.381 mm (0.015 inch) increments.

Corresponding oversize valve stem seals are also available and must be used with valves having 0.381 mm (0.015 inch) oversize stems.

NOTE: If the valve guides are reamed oversize, the valve seats must be ground to ensure that the valve seat is concentric to the valve guide.

VALVE STEM-TO-GUIDE CLEARANCE MEASUREMENT

Valve stem-to-guide clearance may be measured by either of the following two methods.

PREFERRED METHOD

(1) Remove the valve from the head.

(2) Clean the valve stem guide bore with solvent and a bristle brush.

(3) Insert a telescoping gauge into the valve stem guide bore approximately 9.525 mm (.375 inch) from the valve spring side of the head (Fig. 16).

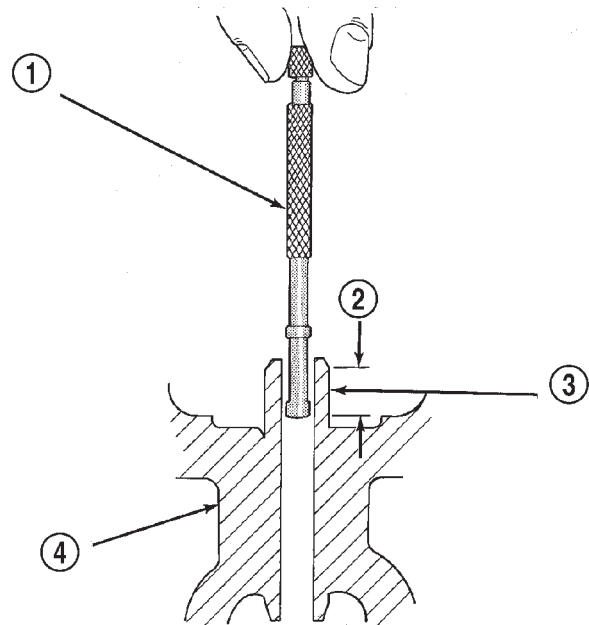

J9509-87

Fig. 16 Measurement of Valve Guide Bore Diameter

- 1 - GAUGE
- 2 - 9.525 MM (3/8 INCH)
- 3 - VALVE STEM GUIDE
- 4 - CYLINDER HEAD

(4) Remove and measure telescoping gauge with a micrometer.

(5) Repeat the measurement with contacts lengthwise to engine cylinder head.

(6) Compare the crosswise to lengthwise measurements to determine out-of-roundness. If the measurements differ by more than 0.0635 mm (0.0025 in.), ream the guide bore to accommodate an oversize valve stem.

(7) Compare the measured valve guide bore diameter with specifications (7.95-7.97 mm or 0.313-0.314 inch). If the measurement differs from specification by more than 0.076 mm (0.003 inch), ream the guide bore to accommodate an oversize valve stem.

SERVICE PROCEDURES (Continued)

ALTERNATIVE METHOD

(1) Use a dial indicator to measure the lateral movement of the valve stem (stem-to-guide clearance). This must be done with the valve installed in its guide and just off the valve seat (Fig. 17).

(2) Correct clearance is 0.025-0.0762 mm (0.001-0.003 inch). If indicated movement exceeds the specification ream the valve guide to accommodate an oversize valve stem.

NOTE: Valve seats must be ground after reaming the valve guides to ensure that the valve seat is concentric to the valve guide.

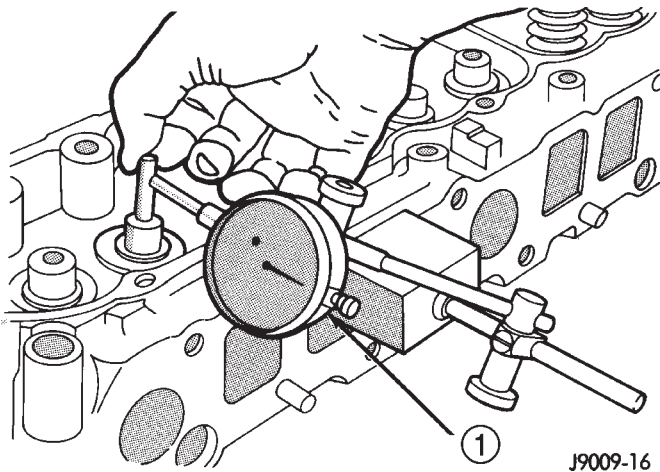

Fig. 17 Measurement of Lateral Movement of Valve Stem

1 - DIAL INDICATOR

VALVE SPRING TENSION TEST

Use a universal Valve Spring Tester and a torque wrench to test each valve spring for the specified tension value (Fig. 18).

Replace valve springs that are not within specifications.

PISTON FITTING

BORE GAGE METHOD

(1) To correctly select the proper size piston, a cylinder bore gauge, capable of reading in 0.003 mm (.0001 in.) INCREMENTS is required. If a bore gauge is not available, do not use an inside micrometer.

(2) Measure the inside diameter of the cylinder bore at a point 49.5 mm (1-15/16 inches) below top of bore. Start perpendicular (across or at 90 degrees) to the axis of the crankshaft at point A and then take an additional bore reading 90 degrees to that at point B (Fig. 20).

(3) The coated pistons will be serviced with the piston pin and connecting rod pre-assembled. **The**

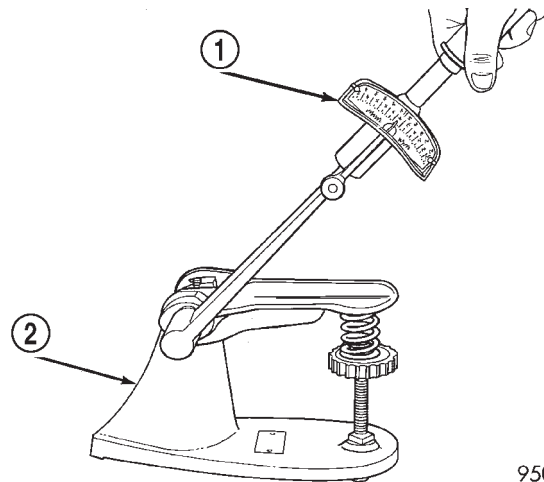

9509-79

Fig. 18 Valve Spring Tester

1 - TORQUE WRENCH
2 - VALVE SPRING TESTER

coated piston connecting rod assembly can be used to service previous built engines and MUST be replaced as complete sets. Tin coated pistons should not be used as replacements for coated pistons.

(4) The coating material is applied to the piston after the final piston machining process. Measuring the outside diameter of a coated piston will not provide accurate results (Fig. 19). Therefore measuring the inside diameter of the cylinder bore with a dial Bore Gauge is **MANDATORY**. To correctly select the proper size piston, a cylinder bore gauge capable of reading in 0.003 mm (.0001 in.) increments is required.

(5) Piston installation into the cylinder bore requires slightly more pressure than that required for non-coated pistons. The bonded coating on the piston will give the appearance of a line-to-line fit with the cylinder bore.

PISTON RING—FITTING

(1) Carefully clean the carbon from all ring grooves. Oil drain openings in the oil ring groove and pin boss must be clear. **DO NOT** remove metal from the grooves or lands. This will change ring-to-groove clearances and will damage the ring-to-land seating.

(2) Be sure the piston ring grooves are free of nicks and burrs.

(3) Measure the ring side clearance with a feeler gauge fitted snugly between the ring land and ring (Fig. 21) (Fig. 22). Rotate the ring in the groove. It must move freely around circumference of the groove.

(4) Place ring in the cylinder bore and push down with inverted piston to position near lower end of the ring travel. Measure ring gap with a feeler gauge fitting snugly between ring ends (Fig. 23).

SERVICE PROCEDURES (Continued)

DO NOT MEASURE MOLY COATED PISTON

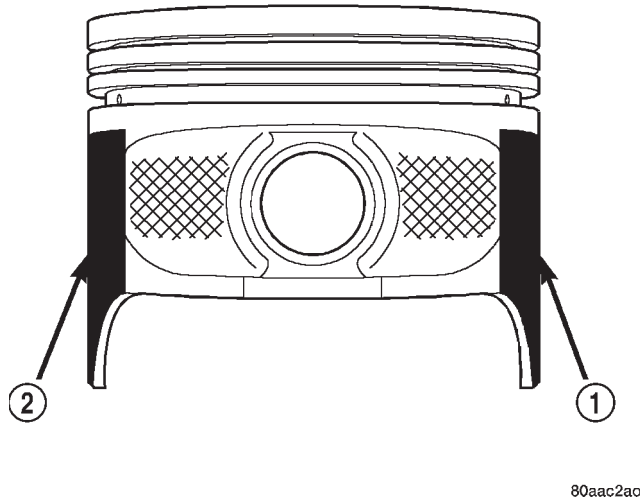

Fig. 19 Moly Coated Piston

- 1 - MOLY COATED
- 2 - MOLY COATED

PISTON SIZE CHART

| CYLINDER BORE SIZE | PISTON LETTER SIZE |
|---|--------------------|
| 98.438 - 98.448 mm (3.8755 - 3.8759 in.) | A |
| 98.448 - 98.458 mm (3.8759 - 3.8763 in.) | B |
| 98.458 - 98.468 mm (3.8763 - 3.8767 in.) | C |
| 98.468 - 98.478 mm (3.8767 - 3.8771 in.) | D |
| 98.478 - 98.488 mm (3.8771 - 3.8775 in.) | E |
| 98.488 - 98.498 mm (3.8775 - 3.8779 in.) | F |

GROOVE HEIGHT

- A 1.530-1.555 mm (0.0602-0.0612 in)
- B 4.035-4.060 mm (0.1589-0.1598 in)

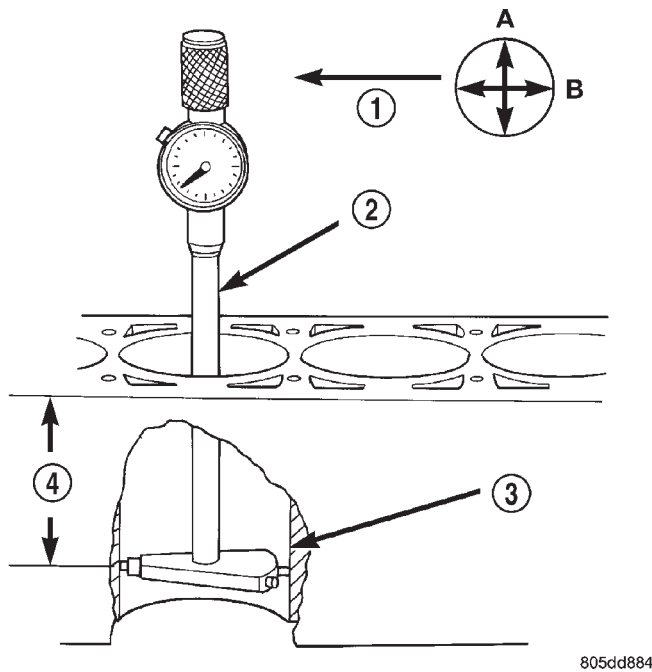

Fig. 20 Bore Gauge

- 1 - FRONT
- 2 - BORE GAUGE
- 3 - CYLINDER BORE
- 4 - 49.5 MM (1-15/16 in)

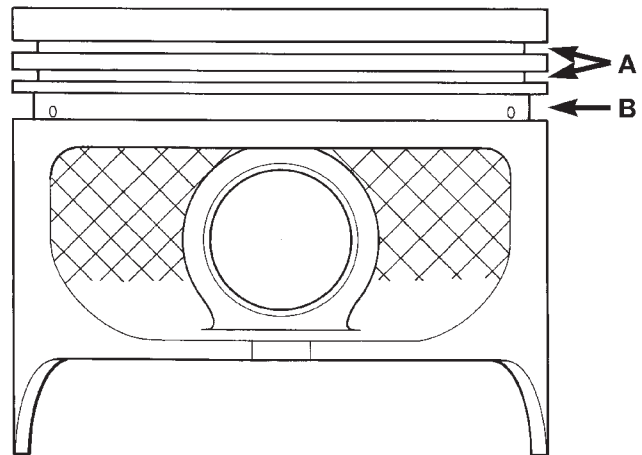

Fig. 21 Piston Dimensions

(5) The oil control rings are symmetrical, and can be installed with either side up. It is not necessary to use a tool to install the upper and lower rails. Insert oil rail spacer first, then side rails.

(6) The two compression rings are different and cannot be interchanged. The top compression ring can be identified by the shiny coating on the outer sealing surface and can be installed with either side up. (Fig. 24).

SERVICE PROCEDURES (Continued)

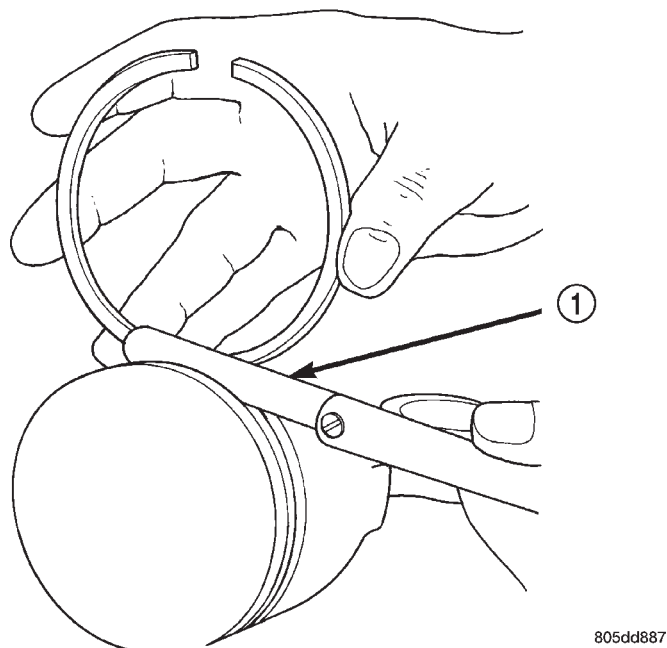

Fig. 22 Ring Side Clearance Measurement

1 - FEELER GAUGE

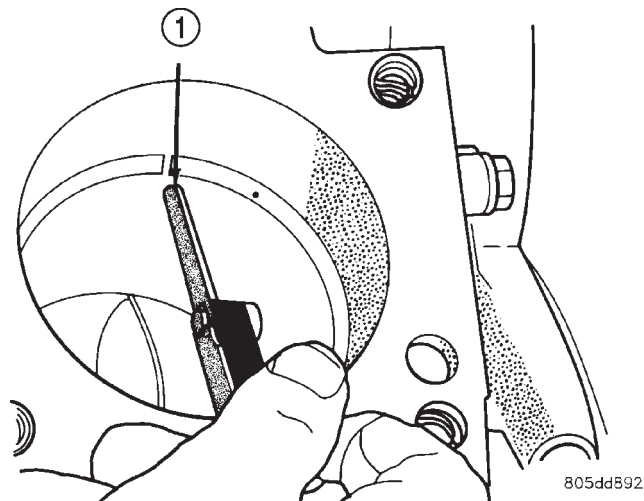

Fig. 23 Gap Measurement

1 - FEELER GAUGE

RING SIDE CLEARANCE CHART

| ITEM | SPECIFICATION |
|-------------------------|---|
| Top Compression Ring | 0.042 - 0.084 mm (0.0017 - 0.0033 in.) |
| Second Compression Ring | 0.042 - 0.084 mm (0.0017 - 0.0033 in.) |
| Oil Control Ring | 0.06 - 0.21 mm (0.0024 - 0.0083 in.) |

RING GAP MEASUREMENT CHART

| ITEM | SPECIFICATION |
|-------------------------|---|
| Top Compression Ring | 0.229 - 0.610 mm (0.0090 - 0.0240 in.) |
| Second Compression Ring | 0.483 - 0.965 mm (0.0190 - 0.080 in.) |
| Oil Control Ring | 0.254 - 1.500 mm (0.010 - 0.060 in.) |

(7) The second compression ring has a slight chamfer on the bottom of the inside edge and a dot on the top for correct installation (Fig. 25).

(8) Using a ring installer, install the second compression ring with the dot facing up (Fig. 25) (Fig. 27).

(9) Using a ring installer, install the top compression ring (either side up).

Ring Gap Orientation

- Position the gaps on the piston as shown (Fig. 28).
- Oil spacer - Gap on center line of piston skirt.
- Oil rails - gap 180° apart on centerline of piston pin bore.

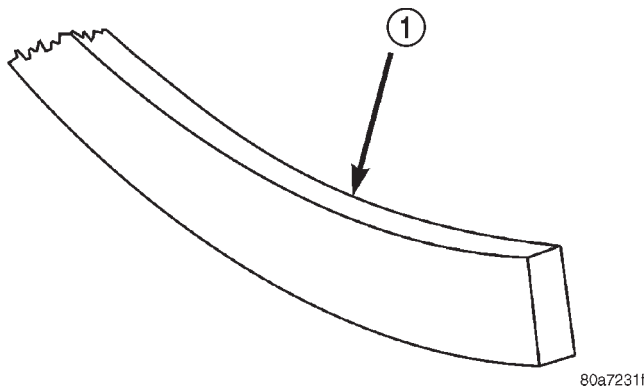
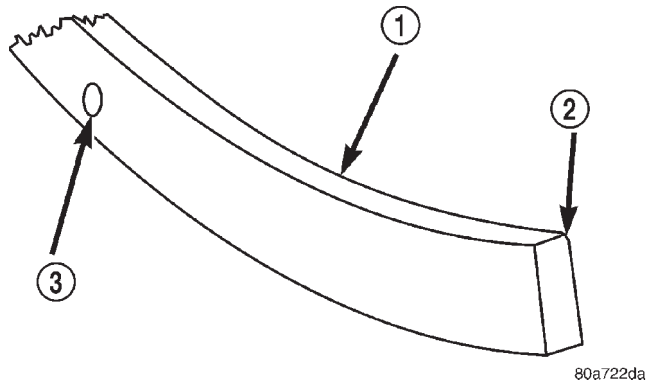

Fig. 24 Top Compression ring identification

1 - TOP COMPRESSION RING

- No. 2 Compression ring - Gap 180° from top oil rail gap.
- No. 1 Compression ring - Gap 180° from No. 2 compression ring gap.

SERVICE PROCEDURES (Continued)



80a722da

Fig. 25 Second Compression Ring Identification

- 1 - SECOND COMPRESSION RING
- 2 - CHAMFER
- 3 - ONE DOT

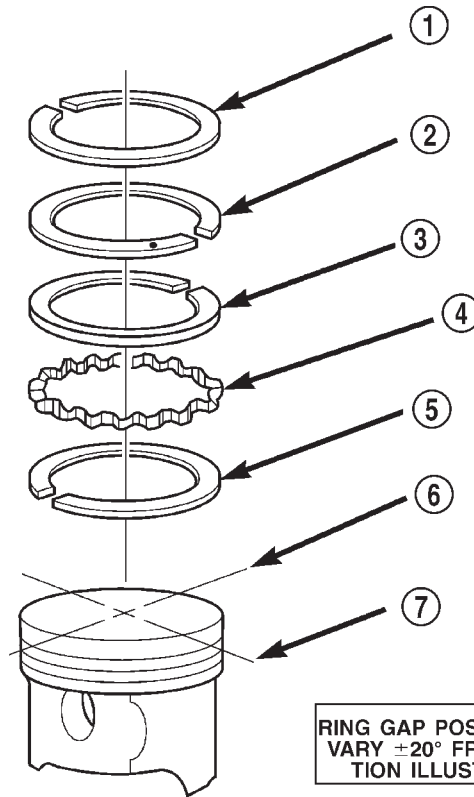

80a7239c

Fig. 28 Ring Gap Orientation

- 1 - TOP COMPRESSION RING
- 2 - BOTTOM COMPRESSION RING
- 3 - TOP OIL CONTROL RAIL
- 4 - OIL RAIL SPACER
- 5 - BOTTOM OIL CONTROL RAIL
- 6 - IMAGINARY LINE PARALLEL TO PISTON PIN
- 7 - IMAGINARY LINE THROUGH CENTER OF PISTON SKIRT

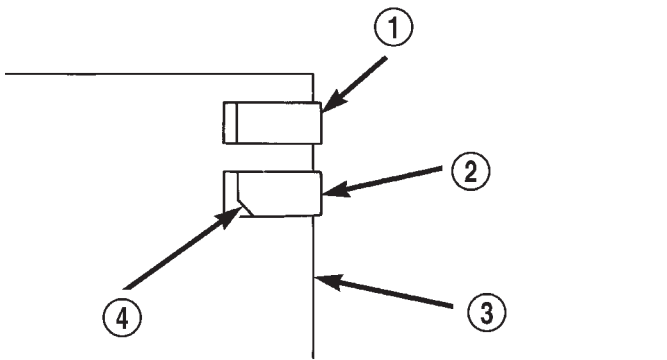

805dd898

Fig. 26 Compression Ring Chamfer Location

- 1 - TOP COMPRESSION RING
- 2 - SECOND COMPRESSION RING
- 3 - PISTON
- 4 - CHAMFER

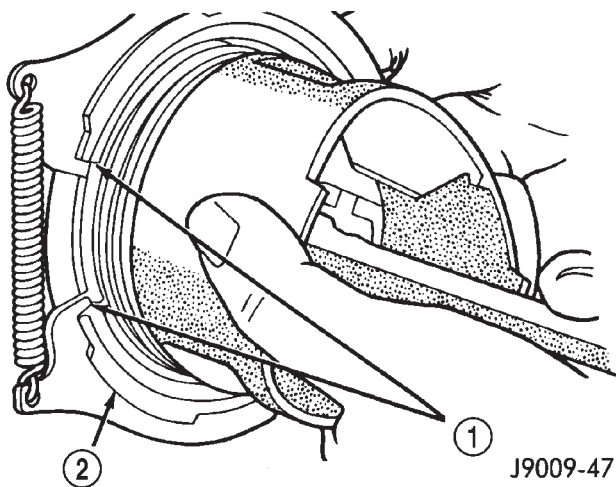

J9009-47

Fig. 27 Compression Ring Installation

- 1 - COMPRESSION RING
- 2 - RING EXPANDER RECOMMENDED

FITTING CONNECTING ROD BEARINGS

INSPECTION

BEARINGS

Inspect the connecting rod bearings for scoring and bent alignment tabs (Fig. 29) (Fig. 30). Check the bearings for normal wear patterns, scoring, grooving, fatigue and pitting (Fig. 31). Replace any bearing that shows abnormal wear.

Inspect the connecting rod journals for signs of scoring, nicks and burrs.

CONNECTING RODS

Misaligned or bent connecting rods can cause abnormal wear on pistons, piston rings, cylinder walls, connecting rod bearings and crankshaft connecting rod journals. If wear patterns or damage to any of these components indicate the probability of a misaligned connecting rod, inspect it for correct rod

SERVICE PROCEDURES (Continued)

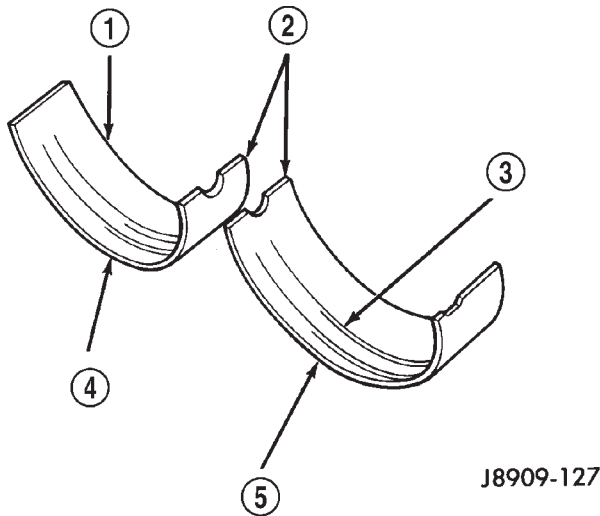

Fig. 29 Connecting Rod Bearing Inspection

- 1 - UPPER BEARING HALF
- 2 - MATING EDGES
- 3 - GROOVES CAUSED BY ROD BOLTS SCRATCHING JOURNAL DURING INSTALLATION
- 4 - WEAR PATTERN — ALWAYS GREATER ON UPPER BEARING
- 5 - LOWER BEARING HALF

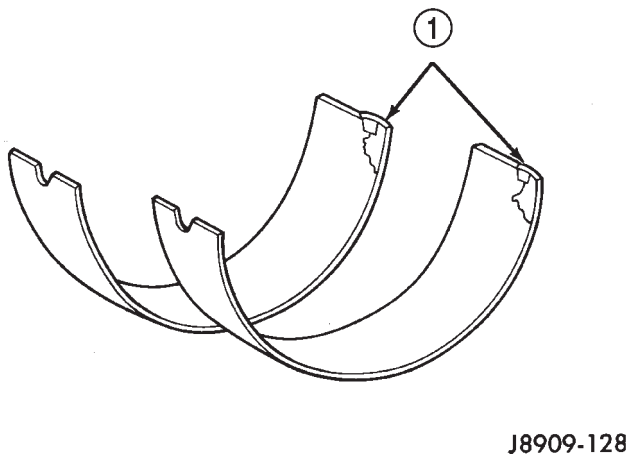

Fig. 30 Locking Tab Inspection

- 1 - ABNORMAL CONTACT AREA CAUSED BY LOCKING TABS NOT FULLY SEATED OR BEING BENT

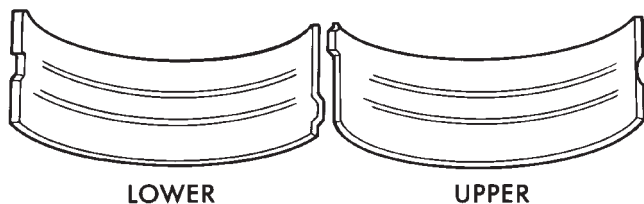

Fig. 31 Scoring Caused by Insufficient Lubrication or by Damaged Crankshaft Pin Journal

alignment. Replace misaligned, bent or twisted connecting rods.

BEARING-TO-JOURNAL CLEARANCE

- (1) Wipe the oil from the connecting rod journal.
- (2) Use short rubber hose sections over rod bolts during installation.
- (3) Lubricate the upper bearing insert and install in connecting rod.
- (4) Use piston ring compressor to install the rod and piston assemblies. The oil squirt holes in the rods must face the camshaft. The arrow on the piston crown should point to the front of the engine (Fig. 32). Verify that the oil squirt holes in the rods face the camshaft and that the arrows on the pistons face the front of the engine.

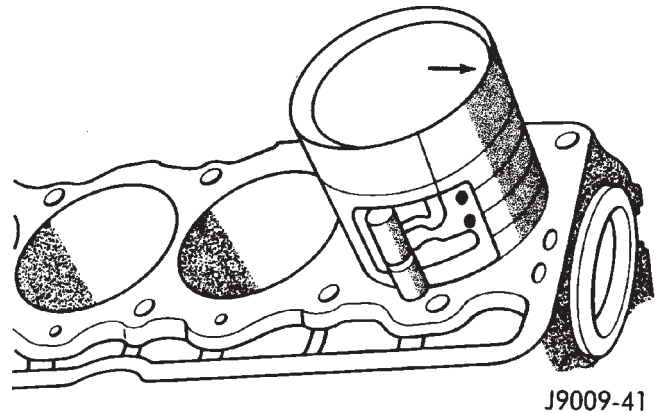
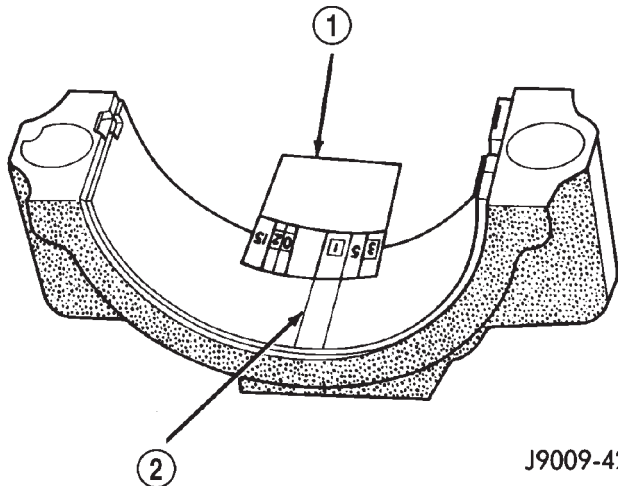

Fig. 32 Rod and Piston Assembly Installation

- (5) Install the lower bearing insert in the bearing cap. The lower insert must be dry. Place strip of Plastigage across full width of the lower insert at the center of bearing cap. Plastigage must not crumble in use. If brittle, obtain fresh stock.
- (6) Install bearing cap and connecting rod on the journal and tighten nuts to 45 N·m (33 ft. lbs.) torque. DO NOT rotate crankshaft. Plastigage will smear, resulting in inaccurate indication.
- (7) Remove the bearing cap and determine amount of bearing-to-journal clearance by measuring the width of compressed Plastigage (Fig. 33). Refer to Engine Specifications for the proper clearance. **Plastigage should indicate the same clearance across the entire width of the insert. If the clearance varies, it may be caused by either a tapered journal, bent connecting rod or foreign material trapped between the insert and cap or rod.**
- (8) If the correct clearance is indicated, replacement of the bearing inserts is not necessary. Remove the Plastigage from crankshaft journal and bearing insert. Proceed with installation.

SERVICE PROCEDURES (Continued)



J9009-42

Fig. 33 Measuring Bearing Clearance with Plastigage

- 1 - PLASTIGAGE SCALE
- 2 - COMPRESSED PLASTIGAGE

(9) If bearing-to-journal clearance exceeds the specification, install a pair of 0.0254 mm (0.001 inch) undersize bearing inserts. All the odd size inserts must be on the bottom. The sizes of the service replacement bearing inserts are stamped on the backs of the inserts. Measure the clearance as described in the previous steps.

(10) The clearance is measured with a pair of 0.0254 mm (0.001 inch) undersize bearing inserts installed. This will determine if two 0.0254 mm (0.001 inch) undersize inserts or another combination is needed to provide the correct clearance (refer to Connecting Rod Bearing Fitting Chart).

CONNECTING ROD BEARING FITTING CHART

| CRANKSHAFT JOURNAL | | CORRESPONDING ROD BEARING INSERT | |
|--------------------|--|--|--|
| Color Code | Diameter | Upper Insert Size | Lower Insert Size |
| Yellow | 53.2257 - 53.2079 mm (2.0955 - 2.0948 in.) | Yellow - Standard | Yellow - Standard |
| Orange | 53.2079 - 53.1901 mm (2.0948 - 2.0941 in.) 0.0178 mm (0.0007 in.) Undersize | Yellow - Standard | Blue - Undersize 0.025 mm (0.001 in.) |
| Blue | 53.1901 - 53.1724 mm (2.0941 - 2.0934 in.) 0.0356 mm (0.0014 in.) Undersize | Blue - Undersize 0.025 mm (0.001 in.) | Blue - Undersize 0.025 mm (0.001 in.) |
| Red | 52.9717 - 52.9539 mm (2.0855 - 2.0848 in.) 0.254 mm (0.010 in.) Undersize | Red - Undersize 0.254 mm (0.010 in.) | Red - Undersize 0.254 mm (0.010 in.) |

(11) **FOR EXAMPLE:** If the initial clearance was 0.0762 mm (0.003 inch), 0.025 mm (0.001 inch) undersize inserts would reduce the clearance by 0.025 mm (0.001 inch). The clearance would be 0.051 mm (0.002 inch) and within specification. A 0.051 mm (0.002 inch) undersize insert would reduce the initial clearance an additional 0.013 mm (0.0005 inch). The clearance would then be 0.038 mm (0.0015 inch).

(12) Repeat the Plastigage measurement to verify your bearing selection prior to final assembly.

(13) Once you have selected the proper insert, install the insert and cap. Tighten the connecting rod bolts to 45 N·m (33 ft. lbs.) torque.

SIDE CLEARANCE MEASUREMENT

Slide snug-fitting feeler gauge between the connecting rod and crankshaft journal flange (Fig. 34). Refer to Engine Specifications for the proper clearance. Replace the connecting rod if the side clearance is not within specification.

SERVICE PROCEDURES (Continued)

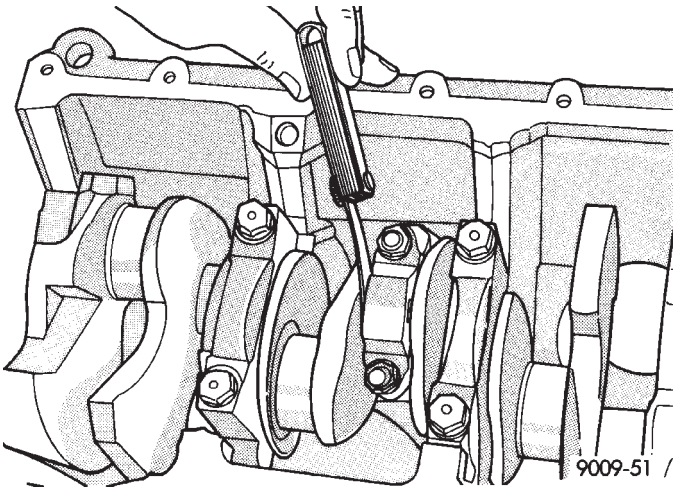

Fig. 34 Checking Connecting Rod Side Clearance—Typical

FITTING CRANKSHAFT MAIN BEARINGS

INSPECTION

Wipe the inserts clean and inspect for abnormal wear patterns and for metal or other foreign material imbedded in the lining. Normal main bearing insert wear patterns are illustrated (Fig. 35). In general the lower bearing half will have a heavier wear pattern.

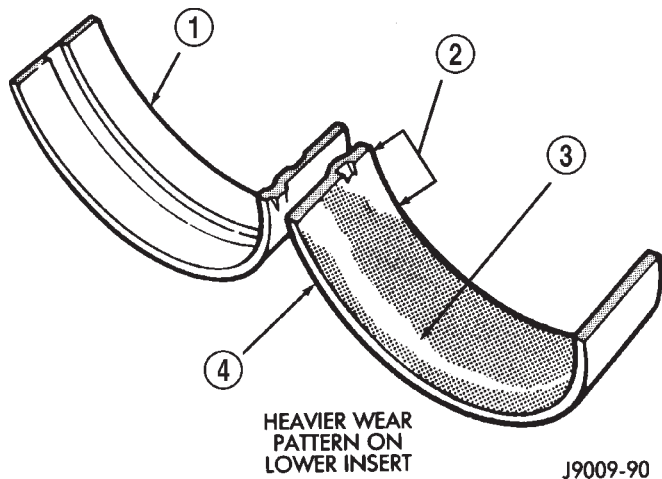

Fig. 35 Main Bearing Wear Patterns

- 1 - UPPER INSERT
- 2 - NO WEAR IN THIS AREA
- 3 - LOW AREA IN BEARING LINING
- 4 - LOWER INSERT

NOTE: If any of the crankshaft journals are scored, remove the engine for crankshaft repair.

Inspect the back of the inserts for fractures, scrapings or irregular wear patterns.

Inspect the upper insert locking tabs for damage.

Replace all damaged or worn bearing inserts.

FITTING BEARINGS (CRANKSHAFT INSTALLED)

The main bearing caps, numbered (front to rear) from 1 through 7 have an arrow to indicate the forward position. The upper main bearing inserts are grooved to provide oil channels while the lower inserts are smooth.

Each bearing insert pair is selectively fitted to its respective journal to obtain the specified operating clearance. In production, the select fit is obtained by using various-sized color-coded bearing insert pairs as listed in the Main Bearing Fitting Chart. The bearing color code appears on the edge of the insert. **The size is not stamped on bearing inserts used for engine production.**

The main bearing journal size (diameter) is identified by a color-coded paint mark (Fig. 36) on the adjacent cheek or counterweight towards the rear of the crankshaft (flange end). The rear main journal, is identified by a color-coded paint mark on the crankshaft rear flange.

When required, upper and lower bearing inserts of different sizes may be used as a pair. A standard size insert is sometimes used in combination with a 0.025 mm (0.001 inch) undersize insert to reduce the clearance by 0.013 mm (0.0005 inch). **Never use a pair of bearing inserts with greater than a 0.025 mm (0.001 inch) difference in size. Refer to the Bearing Insert Pair Chart.**

NOTE: When replacing inserts, the odd size inserts must be either all on the top (in cylinder block) or all on the bottom (in main bearing cap).

Once the bearings have been properly fitted, proceed to Crankshaft Main Bearing—Installation.

BEARING-TO-JOURNAL CLEARANCE (CRANKSHAFT INSTALLED)

When using Plastigage, check only one bearing clearance at a time.

Install the grooved main bearings into the cylinder block and the non-grooved bearings into the bearing caps.

Install the crankshaft into the upper bearings dry.

Place a strip of Plastigage across full width of the crankshaft journal to be checked.

Install the bearing cap and tighten the bolts to 108 N·m (80 ft. lbs.) torque.

NOTE: DO NOT rotate the crankshaft. This will cause the Plastigage to shift, resulting in an inaccurate reading. Plastigage must not be permitted to crumble. If brittle, obtain fresh stock.

Remove the bearing cap. Determine the amount of clearance by measuring the width of the compressed Plastigage with the scale on the Plastigage envelope

SERVICE PROCEDURES (Continued)

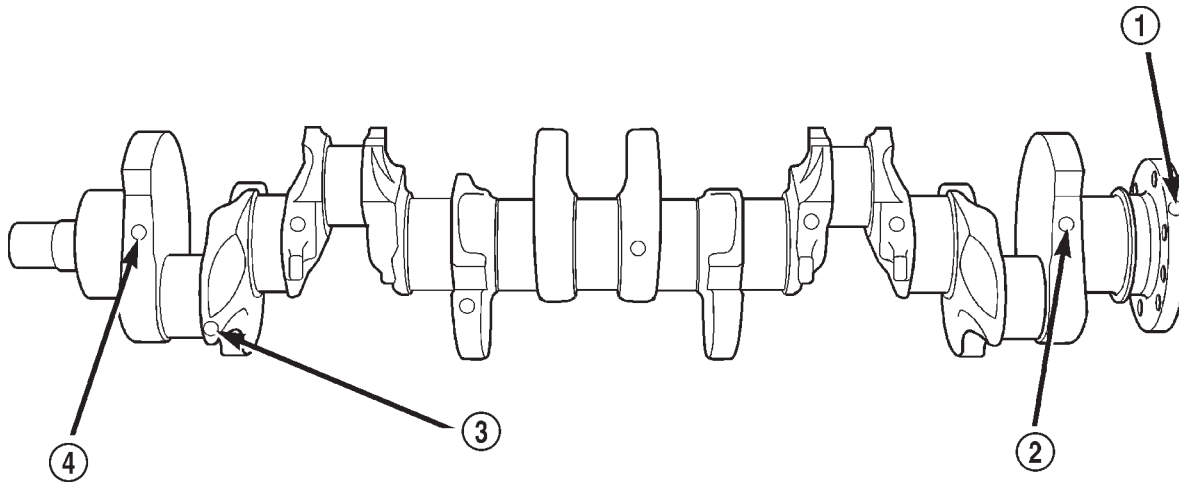

80a9f121

Fig. 36 Crankshaft Journal Size Paint I. D. Location

- 1 - NO. 7 MAIN JOURNAL SIZE PAINT MARK
- 2 - NO. 6 CONNECTING ROD JOURNAL SIZE PAINT MARK
- 3 - NO. 1 CONNECTING ROD JOURNAL SIZE PAINT MARK
- 4 - NO. 1 MAIN JOURNAL SIZE PAINT MARK

BEARING INSERT PAIRS CHART

| INSERT | CORRECT | INCORRECT |
|--------|--------------------------------------|--------------------------------------|
| UPPER | STANDARD | STANDARD |
| LOWER | 0.025 mm (0.001 in.) UNDERSIZE | 0.051 mm (0.002 in.) UNDERSIZE |

(Fig. 37). Refer to Engine Specifications for the proper clearance.

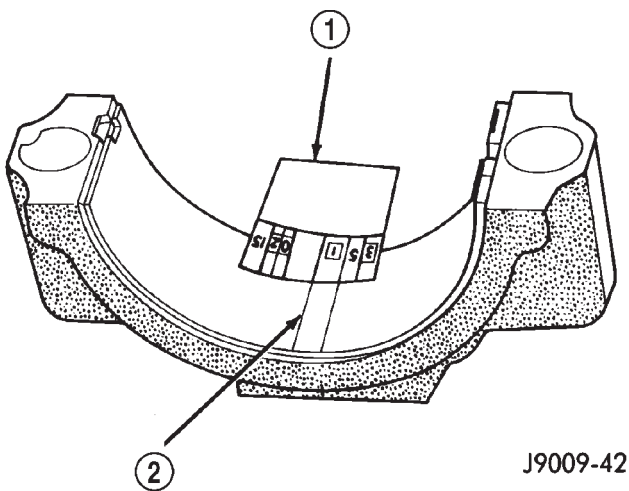

J9009-42

Fig. 37 Measuring Bearing Clearance with Plastigage

- 1 - PLASTIGAGE SCALE
- 2 - COMPRESSED PLASTIGAGE

Plastigage should indicate the same clearance across the entire width of the insert. If clearance varies, it may indicate a tapered journal or foreign material trapped behind the insert.

If the specified clearance is indicated and there are no abnormal wear patterns, replacement of the bearing inserts is not necessary. Remove the Plastigage from the crankshaft journal and bearing insert. Proceed to Crankshaft Main Bearing—Installation.

If the clearance exceeds specification, install a pair of 0.025 mm (0.001 inch) undersize bearing inserts and measure the clearance as described in the previous steps.

The clearance indicate with the 0.025 mm (0.001 inch) undersize insert pair installed will determine if this insert size or some other combination will provide the specified clearance. **FOR EXAMPLE:** If the clearance was 0.0762 mm (0.003 inch) originally, a pair of 0.0254 mm (0.001 inch) undersize inserts would reduce the clearance by 0.0254 mm (0.001 inch). The clearance would then be 0.0508 mm (0.002 inch) and within the specification. A 0.051 mm (0.002 inch) undersize bearing insert and a 0.0254 mm (0.001 inch) undersize insert would reduce the original clearance an additional 0.0127 mm (0.0005 inch). The clearance would then be 0.0381 mm (0.0015 inch).

CAUTION: Never use a pair of inserts that differ more than one bearing size as a pair.

FOR EXAMPLE: DO NOT use a standard size upper insert and a 0.051 mm (0.002 inch) undersize lower insert.

SERVICE PROCEDURES (Continued)

If the clearance exceeds specification using a pair of 0.051 mm (0.002 inch) undersize bearing inserts, measure crankshaft journal diameter with a micrometer. If the journal diameter is correct, the crankshaft bore in the cylinder block may be misaligned, which requires cylinder block replacement or machining to true bore.

Replace the crankshaft or grind to accept the appropriate undersize bearing inserts if:

- Journal diameters 1 through 6 are less than 63.4517 mm (2.4981 inches)
- Journal 7 diameter is less than 63.4365 mm (2.4975 inches).

Once the proper clearances have been obtained, proceed to Crankshaft Main Bearing—Installation.

MAIN BEARING JOURNAL DIAMETER (CRANKSHAFT REMOVED)

Remove the crankshaft from the cylinder block (refer to Cylinder Block - Disassemble).

Clean the oil off the main bearing journal.

Determine the maximum diameter of the journal with a micrometer. Measure at two locations 90° apart at each end of the journal.

The maximum allowable taper and out of round is 0.013 mm (0.0005 inch). Compare the measured diameter with the journal diameter specification (Main Bearing Fitting Chart). Select inserts required to obtain the specified bearing-to-journal clearance.

Install the crankshaft into the cylinder block (refer to Cylinder Block - Assemble and Crankshaft Main Bearings - Installation).

MAIN BEARING FITTING CHART

| Crankshaft Journals #1-6 | | Corresponding Crankshaft Bearing Insert | |
|--------------------------|--|--|---|
| Color Code | Diameter | Upper Insert Size | Lower Insert Size |
| Yellow | 63.5025 -63.4898 mm (2.5001 - 2.4996 in.) | Yellow - Standard | Yellow - Standard |
| Orange | 63.4898 - 63.4771 mm (2.4996 - 2.4991 in.) 0.0127 mm (0.0005 in.) Undersize | Yellow - Standard | Blue - Undersize 0.025 mm (0.001 in.) |
| Blue | 63.4771 - 63.4644 mm (2.4991 - 2.4986 in.) 0.0254 mm (0.001 in.) Undersize | Blue - Undersize 0.025 mm (0.001 in.) | Blue - Undersize 0.025 mm (0.001 in.) |
| Green | 63.4644 - 63.4517 mm (2.4986 - 2.4981 in.) 0.0381 mm (0.0015 in.) Undersize | Blue - Undersize 0.025 mm (0.001 in.) | Green - Undersize 0.051 mm (0.002 in.) |
| Red | 63.2485 - 63.2358 mm (2.4901 - 2.4896 in.) 0.254 mm (0.010 in.) Undersize | Red - Undersize 0.254 mm (0.010 in.) | Red - Undersize 0.254 mm (0.010 in.) |

SERVICE PROCEDURES (Continued)

| Crankshaft Journal #7 Only | | Corresponding Bearing Insert | |
|----------------------------|--|--|---|
| Color Code | Diameter | Upper Insert Size | Lower Insert Size |
| Yellow | 63.4873 - 63.4746 mm (2.4995 - 2.4990 in.) | Yellow - Standard | Yellow - Standard |
| Orange | 63.4746 - 63.4619 mm (2.4996 - 2.4991 in.) 0.0127 mm (0.0005 in.) Undersize | Yellow - Standard | Blue - Undersize 0.025 mm (0.001 in.) |
| Blue | 63.4619 - 63.4492 mm (2.4985 - 2.4980 in.) 0.0254 mm (0.001 in.) Undersize | Blue - Undersize 0.025 mm (0.001 in.) | Blue - Undersize 0.025 mm (0.001 in.) |
| Green | 63.4492 - 63.4365 mm (2.4980 - 2.4975 in.) 0.0381 mm (0.0015 in.) Undersize | Blue - Undersize 0.025 mm (0.001 in.) | Green - Undersize 0.051 mm (0.002 in.) |
| Red | 63.2333 - 63.2206 mm (2.4895 - 2.4890 in.) 0.254 mm (0.010 in.) Undersize | Red - Undersize 0.254 mm (0.010 in.) | Red - Undersize 0.254 mm (0.010 in.) |

FORM-IN-PLACE GASKETS

There are several places where form-in-place gaskets are used on the engine. **DO NOT use form-in-place gasket material unless specified.** Care must be taken when applying form-in-place gaskets. Bead size, continuity and location are of great importance. Too thin a bead can result in leakage while too much can result in spill-over. A continuous bead of the proper width is essential to obtain a leak-free joint.

Two types of form-in-place gasket materials are used in the engine area (Mopar Silicone Rubber Adhesive Sealant and Mopar Gasket Maker). Each have different properties and cannot be used interchangeably.

MOPAR SILICONE RUBBER ADHESIVE SEALANT

Mopar Silicone Rubber Adhesive Sealant, normally black in color, is available in 3 ounce tubes. Moisture in the air causes the sealant material to cure. This material is normally used on flexible metal flanges. It has a shelf life of a year and will not properly cure if over aged. Always inspect the package for the expiration date before use.

MOPAR GASKET MAKER

Mopar Gasket Maker, normally red in color, is available in 6 cc tubes. This anaerobic type gasket

material cures in the absence of air when squeezed between smooth machined metallic surfaces. It will not cure if left in the uncovered tube. **DO NOT** use on flexible metal flanges.

SURFACE PREPARATION

Parts assembled with form-in-place gaskets may be disassembled without unusual effort. In some instances, it may be necessary to lightly tap the part with a mallet or other suitable tool to break the seal between the mating surfaces. A flat gasket scraper may also be lightly tapped into the joint but care must be taken not to damage the mating surfaces.

Scrape or wire brush all gasket surfaces to remove all loose material. Inspect stamped parts to ensure gasket rails are flat. Flatten rails with a hammer on a flat plate, if required. Gasket surfaces must be free of oil and dirt. Make sure the old gasket material is removed from blind attaching holes.

GASKET APPLICATION

Assembling parts using a form-in-place gasket requires care.

Mopar Silicone Rubber Adhesive Sealant should be applied in a continuous bead approximately 3 mm (0.12 inch) in diameter. All mounting holes must be circled. For corner sealing, a 3 or 6 mm (1/8 or 1/4 inch) drop is placed in the center of the gasket con-

SERVICE PROCEDURES (Continued)

tact area. Uncured sealant may be removed with a shop towel. Components should be torqued in place while the sealant is still wet to the touch (within 10 minutes). The use of a locating dowel is recommended during assembly to prevent smearing the material off location.

Mopar Gasket Maker should be applied sparingly to one gasket surface. The sealant diameter should be 1.00 mm (0.04 inch) or less. Be certain the material surrounds each mounting hole. Excess material can easily be wiped off. Components should be torqued in place within 15 minutes. The use of a locating dowel is recommended during assembly to prevent smearing the material off location.

ENGINE PERFORMANCE

It is important that the vehicle is operating to its optimum performance level to maintain fuel economy and the lowest emission levels. If vehicle is not operating to these standards, refer to Engine Diagnosis outlined in this section. The following procedures can assist in achieving the proper engine diagnosis.

- (1) Test cranking amperage draw. Refer to Electrical Group 8B, Cold Cranking Test.
- (2) Check intake manifold bolt torque; Refer to Group 11, Exhaust System and Intake Manifold.
- (3) Perform cylinder compression test. Refer to Cylinder Compression Pressure Test in the Engine Diagnosis area of this section.
- (4) Clean or replace spark plugs as necessary and adjust gap as specified in Electrical Group 8D. Tighten to specifications.
- (5) Test resistance of spark plug cables. Refer to Electrical Group 8D, Spark Plug Cables.
- (6) Inspect the primary wires. Test coil output voltage and primary resistance. Replace parts as necessary. Refer to Electrical Group 8D, for specifications.
- (7) Test fuel pump for pressure. Refer to Group 14, Fuel System Specifications.
- (8) The air filter elements should be replaced as specified in Lubrication and Maintenance, Group 0.
- (9) Inspect crankcase ventilation system as outlined in Group 0, Lubrication and Maintenance. For emission controls see Group 25, Emission Controls for service procedures.
- (10) Road test vehicle as a final test.

HONING CYLINDER BORES

Before honing, stuff plenty of clean shop towels under the bores and over the crankshaft to keep abrasive materials from entering the crankshaft area.

(1) Used carefully, the Cylinder Bore Sizing Hone C-823 equipped with 220 grit stones, is the best tool for this job. In addition to deglazing, it will reduce taper and out-of-round as well as removing light

scuffing, scoring or scratches. Usually a few strokes will clean up a bore and maintain the required limits.

CAUTION: DO NOT use rigid type hones to remove cylinder wall glaze.

(2) Deglazing of the cylinder walls may be done if the cylinder bore is straight and round. Use a cylinder surfacing hone, Honing Tool C-3501, equipped with 280 grit stones (C-3501-3810). 20-60 strokes, depending on the bore condition, will be sufficient to provide a satisfactory surface. Using honing oil C-3501-3880 or a light honing oil available from major oil distributors.

CAUTION: DO NOT use engine or transmission oil, mineral spirits or kerosene.

(3) Honing should be done by moving the hone up and down fast enough to get a crosshatch pattern. The hone marks should INTERSECT at 50° to 60° for proper seating of rings (Fig. 38).

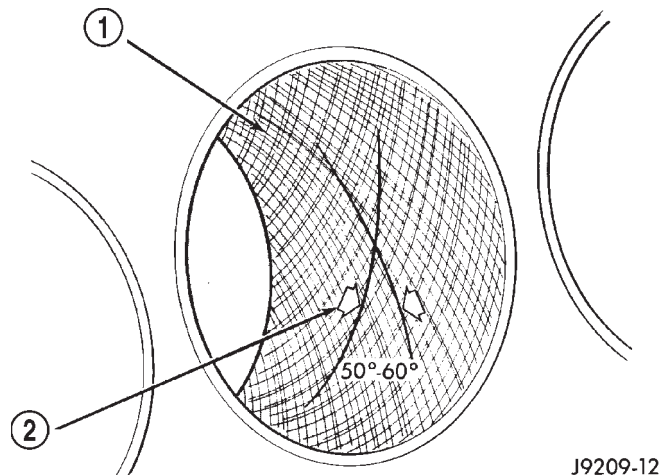

Fig. 38 Cylinder Bore Crosshatch Pattern

- 1 - CROSSHATCH PATTERN
2 - INTERSECT ANGLE

(4) A controlled hone motor speed between 200 and 300 RPM is necessary to obtain the proper crosshatch angle. The number of up and down strokes per minute can be regulated to get the desired 50° to 60° angle. Faster up and down strokes increase the crosshatch angle.

(5) After honing, it is necessary that the block be cleaned to remove all traces of abrasive. Use a brush to wash parts with a solution of hot water and detergent. Dry parts thoroughly. Use a clean, white, lint-free cloth to check that the bore is clean. Oil the bores after cleaning to prevent rusting.

SERVICE PROCEDURES (Continued)

REPAIR DAMAGED OR WORN THREADS

CAUTION: Be sure that the tapped holes maintain the original center line.

Damaged or worn threads can be repaired. Essentially, this repair consists of:

- Drilling out worn or damaged threads.
- Tapping the hole with a special Heli-Coil Tap, or equivalent.
- Installing an insert into the tapped hole to bring the hole back to its original thread size.

SERVICE ENGINE ASSEMBLY (SHORT BLOCK)

A service replacement engine assembly (short block) may be installed whenever the original cylinder block is defective or damaged beyond repair. It consists of the cylinder block, crankshaft, piston and rod assemblies. If needed, the camshaft must be procured separately and installed before the engine is installed in the vehicle.

A short block is identified with the letter "S" stamped on the same machined surface where the build date code is stamped for complete engine assemblies.

Installation includes the transfer of components from the defective or damaged original engine. Follow the appropriate procedures for cleaning, inspection and torque tightening.

HYDROSTATIC LOCK

When an engine is suspected of hydrostatic lock (regardless of what caused the problem), follow the steps below.

- (1) Perform the Fuel Pressure Release Procedure (refer to Group 14, Fuel System).
- (2) Disconnect the negative cable from the battery.
- (3) Inspect air cleaner, induction system and intake manifold to ensure system is dry and clear of foreign material.
- (4) Place a shop towel around the spark plugs to catch any fluid that may possibly be under pressure in the cylinder head. Remove the plugs from the engine.

CAUTION: DO NOT use the starter motor to rotate the crankshaft. Severe damage could occur.

- (5) With all spark plugs removed, rotate the crankshaft using a breaker bar and socket.
- (6) Identify the fluid in the cylinders (i.e. coolant, fuel, oil, etc.).
- (7) Make sure all fluid has been removed from the cylinders.
- (8) Repair engine or components as necessary to prevent this problem from occurring again.

(9) Squirt engine oil into the cylinders to lubricate the walls. This will prevent damage on restart.

(10) Install new spark plugs. Tighten the spark plugs to 37 N·m (27 ft. lbs.) torque.

(11) Drain engine oil. Remove and discard the oil filter.

(12) Install the drain plug. Tighten the plug to 34 N·m (25 ft. lbs.) torque.

(13) Install a new oil filter.

(14) Fill engine crankcase with the specified amount and grade of oil (refer to Group 0, Lubrication and Maintenance).

(15) Connect the negative cable to the battery.

(16) Start the engine and check for any leaks.

ENGINE OIL SERVICE

WARNING: NEW OR USED ENGINE OIL CAN BE IRRITATING TO THE SKIN. AVOID PROLONGED OR REPEATED SKIN CONTACT WITH ENGINE OIL. CONTAMINANTS IN USED ENGINE OIL, CAUSED BY INTERNAL COMBUSTION, CAN BE HAZARDOUS TO YOUR HEALTH. THOROUGHLY WASH EXPOSED SKIN WITH SOAP AND WATER. DO NOT WASH SKIN WITH GASOLINE, DIESEL FUEL, THINNER, OR SOLVENTS, HEALTH PROBLEMS CAN RESULT. DO NOT POLLUTE, DISPOSE OF USED ENGINE OIL PROPERLY.

ENGINE OIL SPECIFICATION

CAUTION: Do not use non-detergent or straight mineral oil when adding or changing crankcase lubricant. Engine failure can result.

API SERVICE GRADE CERTIFIED

Use an engine oil that is API Service Grade Certified. MOPAR provides engine oils that conform to the latest recommended service grades.

Standard engine oil identification notations have been adopted to aid in the proper selection of engine oil. The identifying notations are located on the label of engine oil plastic bottles and the top of engine oil cans (Fig. 39).



SERVICE PROCEDURES (Continued)

SAE VISCOSITY

An SAE viscosity grade is used to specify the viscosity of engine oil. SAE 10W-30 specifies a multiple viscosity engine oil. Engine oils also have multiple viscosities. These are specified with a dual SAE viscosity grade which indicates the cold-to-hot temperature viscosity range. Select an engine oil that is best suited to your particular temperature range and variation (Fig. 40).

| ENGINE OIL VISCOSITY GRADES | | | | | | | | |
|--|-------|--------------------|------|-----|-----|-----|-----|------|
| | | 10W-30 (Preferred) | | | | | | |
| | 5W-30 | | | | | | | |
| °F | -20° | 0° | 10° | 20° | 32° | 60° | 80° | 100° |
| °C | -29° | -18° | -12° | -7° | 0° | 16° | 27° | 38° |
| Temperature range anticipated before next oil change | | | | | | | | |
| 80bce9ea | | | | | | | | |

Fig. 40 Temperature/Engine Oil Viscosity

ENERGY CONSERVING OIL

An Energy Conserving type oil is recommended for gasoline engines. The designation of ENERGY CONSERVING is located on the label of an engine oil container.

CRANKCASE OIL LEVEL INSPECTION

CAUTION: Do not overfill crankcase with engine oil, oil foaming and oil pressure loss can result.

The engine oil level indicator (Dipstick) is located at the right rear of the 4.0L engine. Inspect engine oil level approximately every 800 kilometers (500 miles). Unless the engine has exhibited loss of oil pressure, run the engine for about five minutes before checking oil level. Checking engine oil level on a cold engine is not accurate.

To ensure proper lubrication of an engine, the engine oil must be maintained at an acceptable level. The acceptable levels are indicated between the ADD and SAFE marks on the engine oil dipstick (Fig. 41).

- (1) Position vehicle on level surface.
- (2) With engine OFF, allow approximately ten minutes for oil to settle to bottom of crankcase, remove engine oil dipstick.
- (3) Wipe dipstick clean.
- (4) Install dipstick and verify it is seated in the tube.
- (5) Remove dipstick, with handle held above the tip, take oil level reading (Fig. 41).
- (6) Add oil only if level is below the ADD mark on dipstick.

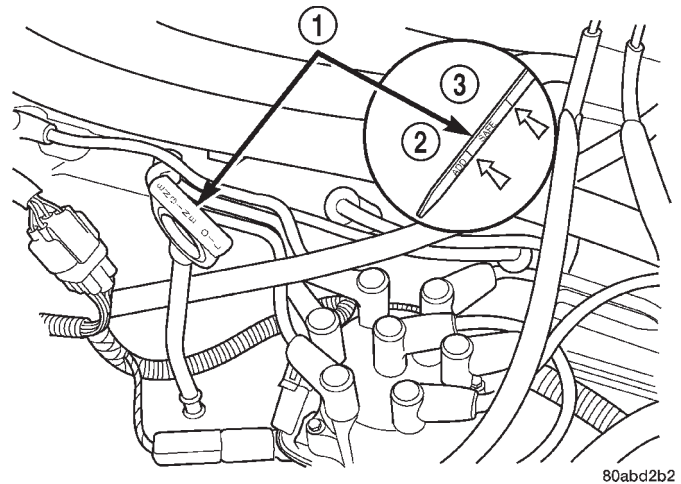

Fig. 41 Engine Oil Dipstick—4.0L Engine

- 1 - DIPSTICK
- 2 - ADD
- 3 - SAFE

ENGINE OIL CHANGE

Change engine oil at mileage and time intervals described in Maintenance Schedules.

Run engine until achieving normal operating temperature.

- (1) Position the vehicle on a level surface and turn engine off.
- (2) Hoist and support vehicle on safety stands.
- (3) Remove oil fill cap.
- (4) Place a suitable drain pan under crankcase drain.
- (5) Remove drain plug from crankcase and allow oil to drain into pan. Inspect drain plug threads for stretching or other damage. Replace drain plug if damaged.
- (6) Install drain plug in crankcase.
- (7) Lower vehicle and fill crankcase with specified type and amount of engine oil described in this section.
- (8) Install oil fill cap.
- (9) Start engine and inspect for leaks.
- (10) Stop engine and inspect oil level.

ENGINE OIL FILTER CHANGE

FILTER SPECIFICATION

CAUTION: Do not use oil filter with metric threads. The proper oil filter has SAE type 3/4 X 16 threads. An oil filter with metric threads can result in oil leaks and engine failure.

All Jeep engines are equipped with a high quality full-flow, throw-away type oil filter. DaimlerChrysler

SERVICE PROCEDURES (Continued)

Corporation recommends a Mopar or equivalent oil filter be used.

OIL FILTER REMOVAL

- (1) Position a drain pan under the oil filter.
- (2) Using a suitable oil filter wrench loosen filter.
- (3) Rotate the oil filter counterclockwise to remove it from the cylinder block oil filter boss or filter adapter housing (Fig. 42).

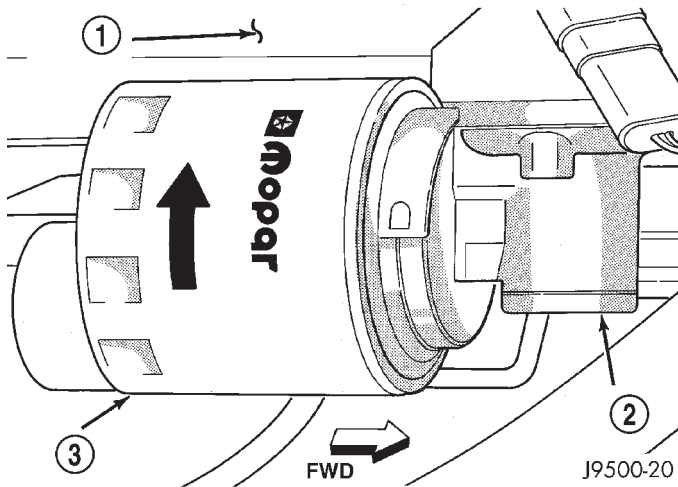

Fig. 42 Oil Filter—4.0L Engine

- 1 - CYLINDER BLOCK
- 2 - ADAPTER
- 3 - OIL FILTER

(4) When filter separates from adapter nipple, tip gasket end upward to minimize oil spill. Remove filter from vehicle.

(5) Make sure old gasket comes off with oil filter. With a wiping cloth, clean the gasket sealing surface (Fig. 43) of oil and grime.

OIL FILTER INSTALLATION

- (1) Lightly lubricate oil filter gasket with engine oil or chassis grease.
- (2) Thread filter onto adapter nipple. When gasket makes contact with sealing surface, (Fig. 43) hand tighten filter one full turn, do not over tighten.
- (3) Add oil, verify crankcase oil level and start engine. Inspect for oil leaks.

USED ENGINE OIL DISPOSAL

Care should be exercised when disposing used engine oil after it has been drained from a vehicle engine. Refer to the WARNING at beginning of this section.

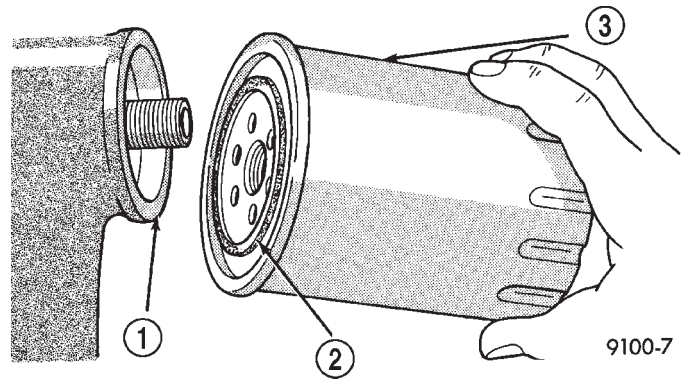

Fig. 43 Oil Filter Sealing Surface—Typical

- 1 - SEALING SURFACE
- 2 - RUBBER GASKET
- 3 - OIL FILTER

REMOVAL AND INSTALLATION

ENGINE MOUNTS—FRONT

The front mounts support the engine at each side. These supports are made of resilient rubber.

REMOVAL

- (1) Disconnect negative cable from battery.
- (2) Raise the vehicle.
- (3) Support the engine.
- (4) Remove the nut from the through bolt (Fig. 44). DO NOT remove the through bolt.
- (5) Remove the retaining bolts and nuts from the support cushions (Fig. 44).
- (6) Remove the through bolt.
- (7) Remove the support cushions.

INSTALLATION

- (1) If the engine support bracket was removed, position the bracket onto the block and install the attaching bolts (Fig. 44). Tighten the engine support bracket bolts to 61 N·m (45 ft. lbs.) torque.
- (2) If the support cushion bracket was removed, position the bracket onto the lower front sill (Fig. 45). Install support cushion bracket bolts and nuts. Tighten the bolts to 54 N·m (40 ft. lbs.) torque. Tighten the nuts to 41 N·m (30 ft. lbs.) torque.
- (3) Place the support cushion into position on the support cushion bracket (Fig. 44). Install and tighten the bolts and nuts to 41 N·m (30 ft. lbs.) torque.
- (4) Install the through bolt and the retaining nut (Fig. 44). Tighten the through bolt nut to 65 N·m (48 ft. lbs.) torque.

REMOVAL AND INSTALLATION (Continued)

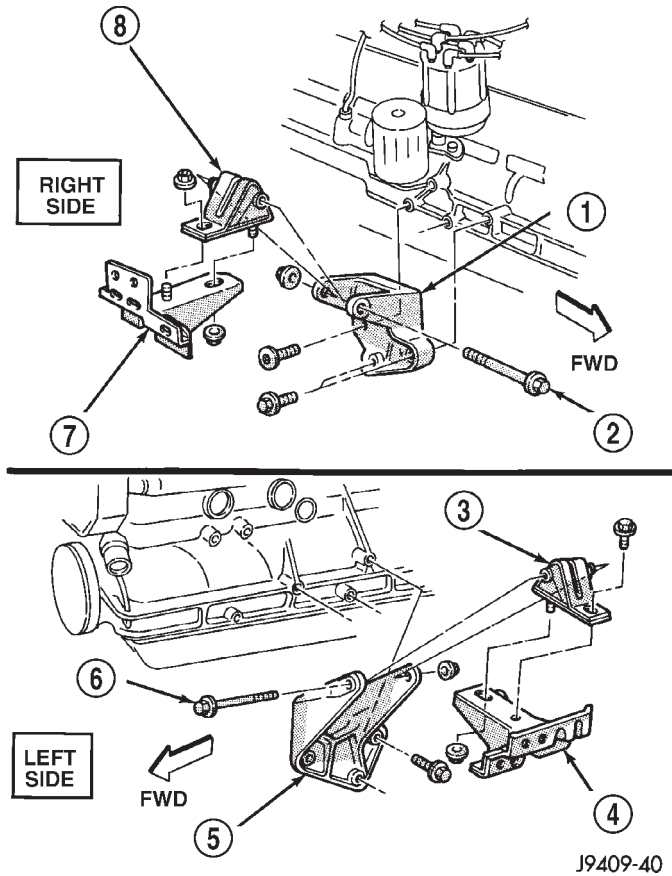

Fig. 44 Front Mounts

- 1 - ENGINE SUPPORT BRACKET
- 2 - THROUGH BOLT
- 3 - SUPPORT CUSHION
- 4 - SUPPORT CUSHION BRACKET
- 5 - ENGINE SUPPORT BRACKET
- 6 - THROUGH BOLT
- 7 - SUPPORT CUSHION BRACKET
- 8 - SUPPORT CUSHION

- (5) Remove the engine support.
- (6) Lower the vehicle.
- (7) Connect negative cable to battery.

ENGINE MOUNT—REAR

A resilient rubber cushion supports the transmission at the rear between the transmission extension housing and the rear support crossmember or skid plate.

REMOVAL

- (1) Disconnect negative cable from battery.
- (2) Raise the vehicle and support the transmission.
- (3) Remove the nuts holding the support cushion to the crossmember (Fig. 46) (Fig. 47). Remove the crossmember.

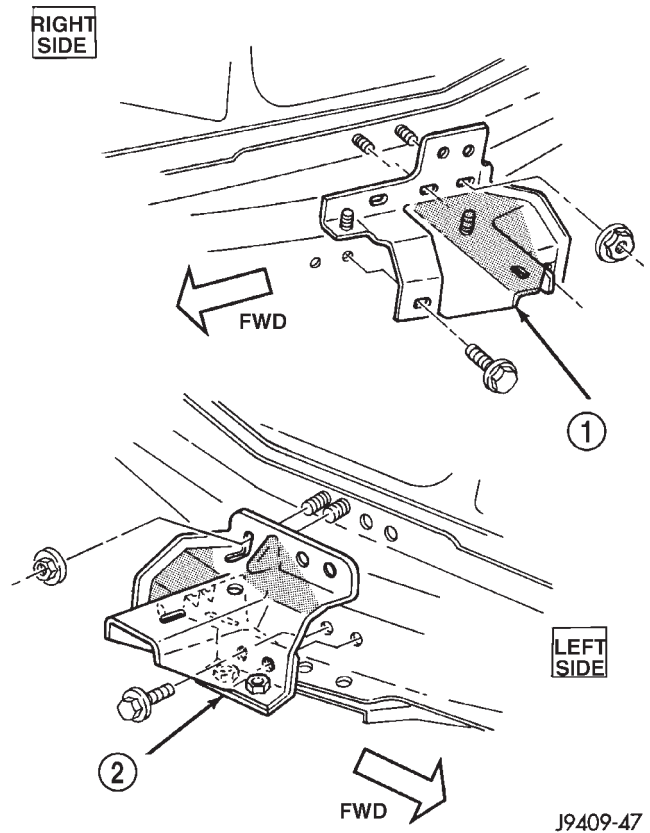

Fig. 45 Support Cushion Bracket

- 1 - SUPPORT CUSHION BRACKET
- 2 - SUPPORT CUSHION BRACKET

MANUAL TRANSMISSION

(Fig. 46)

- a. Remove the support cushion nuts and remove the cushion.
- b. Remove the transmission support bracket bolts and remove the bracket from the transmission.

AUTOMATIC TRANSMISSION

(Fig. 47)

- a. Remove the support cushion bolts and remove the cushion and the support bracket from the transmission (4WD) or from the adaptor bracket (2WD).
- b. On 2WD vehicles, remove the bolts holding the transmission support adaptor bracket to the transmission (Fig. 47). Remove the adaptor bracket.

INSTALLATION

MANUAL TRANSMISSION:

- a. Install the transmission support bracket to the transmission. Install the bolts and tighten to 46 N·m (34 ft. lbs.) torque.

REMOVAL AND INSTALLATION (Continued)

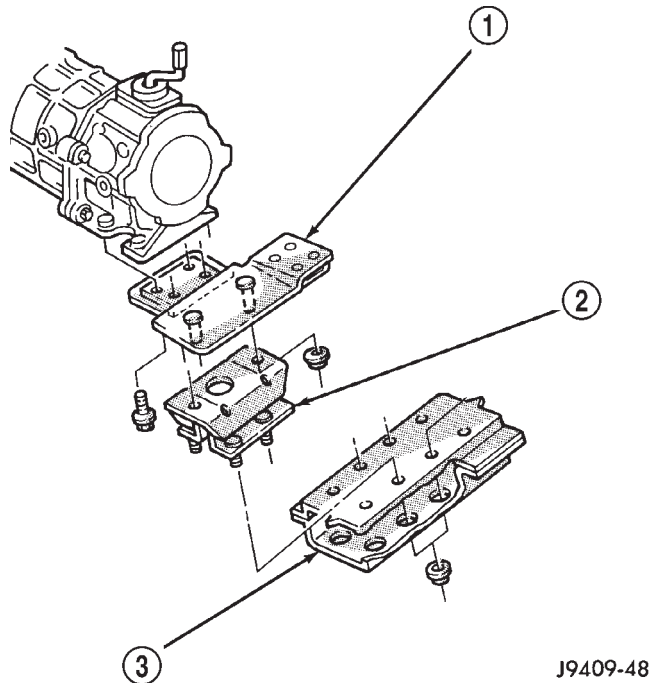

J9409-48

Fig. 46 Rear Mount(Manual Transmission)

- 1 - TRANSMISSION SUPPORT BRACKET
- 2 - SUPPORT CUSHION
- 3 - CROSSMEMBER ASSEMBLY

b. Install the support cushion to the support bracket. Install the nuts and tighten to 75 N·m (55 ft. lbs.) torque.

AUTOMATIC TRANSMISSION:

a. On 2WD vehicles, position the transmission support adaptor bracket to the transmission. Install the bolts and tighten to 75 N·m (55 ft. lbs.) torque.

b. Position the transmission support bracket and support cushion to the adaptor bracket (2WD) or the transmission (4WD). Install the bolts and tighten to 75 N·m (55 ft. lbs.) torque.

(1) Position the crossmember onto the support cushion studs. Install the stud nuts and tighten to 22 N·m (192 in. lbs) torque.

(2) Install crossmember-to-sill bolts and tighten to 41 N·m (30 ft. lbs.) torque.

(3) Remove the transmission support.

(4) Lower the vehicle.

(5) Connect negative cable to battery.

ENGINE ASSEMBLY**REMOVAL**

(1) Disconnect the battery cables. Remove the battery.

(2) Mark the hinge locations on the hood panel for alignment reference during installation. Remove the engine compartment lamp. Remove the hood.

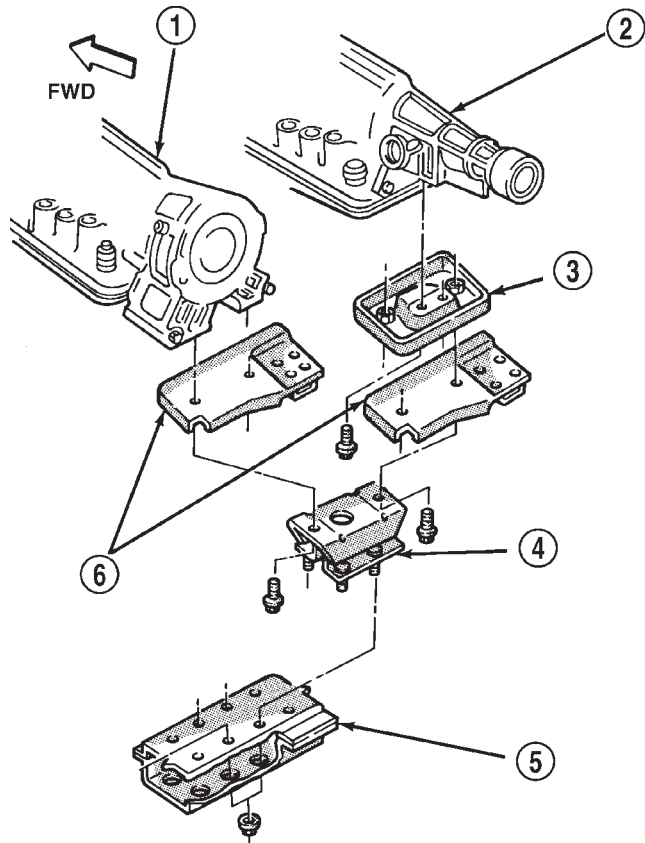

J9409-45

Fig. 47 Rear Mount(Automatic Transmission)

- 1 - 4×4
- 2 - 2×4
- 3 - TRANSMISSION SUPPORT ADAPTOR BRACKET
- 4 - SUPPORT CUSHION
- 5 - CROSSMEMBER ASSEMBLY
- 6 - TRANSMISSION SUPPORT BRACKET

WARNING: THE COOLANT IN A RECENTLY OPERATED ENGINE IS HOT AND PRESSURIZED. USE CARE TO PREVENT SCALDING BY HOT COOLANT. CAREFULLY RELEASE THE PRESSURE BEFORE REMOVING THE RADIATOR DRAIN COCK AND CAP.

(3) Remove the air cleaner assembly.

(4) Loosen the radiator drain cock and radiator cap to drain the coolant. DO NOT waste usable coolant. If the solution is clean, drain the coolant into a clean container for reuse.

(5) Remove the lower radiator hose.

(6) Remove the upper radiator hose and coolant recovery hose (Fig. 48).

(7) Remove upper radiator support retaining bolts and remove radiator support.

(8) Remove the fan shroud (Fig. 48) and electric cooling fan.

(9) Disconnect the transmission fluid cooler tubing (automatic transmission).

REMOVAL AND INSTALLATION (Continued)

(10) Disconnect radiator fan switch wire connector.

(11) **Vehicles with Air Conditioning:**

(a) Discharge A/C system (refer to group 24, Heating and Air Conditioning for proper procedures)

(b) Disconnect the suction/discharge hose and cap off compressor ports to prevent foreign material and refrigerant oil loss.

(12) Remove the radiator or radiator and condenser (if equipped with A/C).

(13) Remove the fan assembly from the idler pulley.

(14) Disconnect the heater hoses at the engine thermostat housing and water pump (Fig. 48) (Fig. 49).

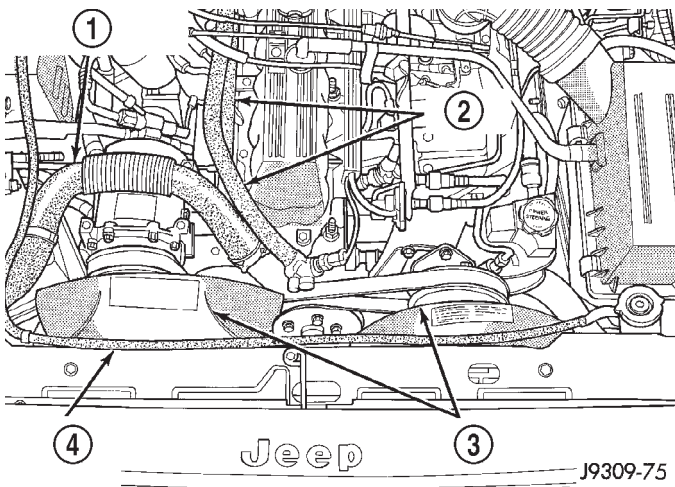

Fig. 48 Upper Radiator Hose, Coolant Recovery Hose, Fan Shroud & Heater hoses

- 1 - UPPER RADIATOR HOSE
- 2 - HEATER HOSES
- 3 - FAN SHROUDS
- 4 - COOLANT RECOVERY HOSE

(15) Disconnect the throttle cable.

(16) Disconnect the speed control cable (if equipped).

(17) Disconnect the line pressure cable (if equipped with automatic transmission).

(18) Disconnect the fuel injector harness at the injectors.

(19) Disconnect the distributor electrical connection and the oil pressure switch connector.

WARNING: THE FUEL SYSTEM IS UNDER A CONSTANT PRESSURE (EVEN WITH THE ENGINE TURNED OFF). BEFORE DISCONNECTING FUEL LINES, THE FUEL SYSTEM PRESSURE MUST BE RELEASED.

(20) Perform the Fuel System Pressure Release procedure (refer to Group 14, Fuel System).

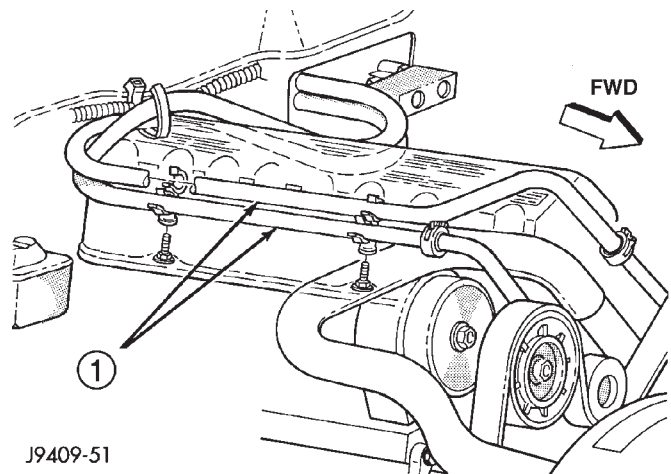

Fig. 49 Heater Hoses (RH Drive Vehicle)

- 1 - HEATER HOSES

(21) Remove the latch clip and disconnect fuel supply line.

(22) Remove the power brake vacuum check valve from the booster, if equipped.

(23) If equipped with power steering :

(a) Disconnect the hoses from the fittings at the steering gear.

(b) Drain the pump reservoir.

(c) Cap the fittings on the hoses and steering gear to prevent foreign objects from entering the system.

(24) Identify, tag and disconnect all necessary wire connectors and vacuum hoses.

(25) Raise and support the vehicle.

(26) Disconnect the wires from the starter motor solenoid.

(27) Remove the starter motor.

(28) Disconnect the exhaust pipe from the manifold.

(29) Disconnect the engine speed sensor wire connection.

(30) Remove the exhaust pipe support.

(31) Remove the flywheel and converter housing access cover.

(32) **Vehicles with Automatic Transmission:**

(a) Mark the converter and drive plate location.

(b) Remove the converter-to-drive plate bolts.

(33) Remove the upper flywheel and converter housing bolts and loosen the bottom bolts.

(34) Remove the engine mount cushion-to-engine compartment bracket bolts.

(35) Lower the vehicle.

(36) Attach a lifting device to the engine.

(37) Raise the engine off the front supports.

(38) Place a support or floor jack under the converter (or flywheel) housing.

REMOVAL AND INSTALLATION (Continued)

(39) Remove the remaining converter (or flywheel) housing bolts.

(40) Lift the engine out of the engine compartment.

INSTALLATION

CAUTION: When installing the engine into a vehicle equipped with an automatic transmission, be careful not to damage the trigger wheel on the flywheel.

(1) Attach a lifting device to the engine and lower the engine into the engine compartment. For easier installation, it may be necessary to remove the engine mount cushions from the engine mount bracket as an aide in alignment of the engine to the transmission.

(2) **Vehicles with Manual Transmission:**

(a) Insert the transmission shaft into the clutch spline.

(b) Align the flywheel housing with the engine.

(c) Install and tighten the flywheel housing lower bolts finger tight.

(3) **Vehicles with Automatic Transmission:**

(a) Align the transmission torque converter housing with the engine.

(b) Loosely install the converter housing lower bolts and install the next higher bolt and nut on each side.

(c) Tighten all 4 bolts finger tight.

(4) Install the engine mount cushions (if removed).

(5) Lower the engine and engine mount cushions onto the engine compartment brackets. Install the bolts and finger tighten the nuts.

(6) Remove the engine lifting device.

(7) Raise and support the vehicle.

(8) Install the remaining flywheel and converter housing bolts. Tighten all bolts to 38 N·m (28 ft. lbs.) torque.

(9) **Vehicles with Automatic Transmission:**

(a) Install the converter-to-drive plate bolts.

(b) Ensure the installation reference marks are aligned.

(10) Install the flywheel and converter housing access cover.

(11) Install the exhaust pipe support and tighten the screw.

(12) Tighten the engine mount-to-bracket bolts.

(13) Connect the engine speed sensor wire connections and tighten the screws.

(14) Connect the exhaust pipe to the manifold.

(15) Install the starter motor and connect the cable.

(16) Connect the wires to the starter motor solenoid.

(17) Lower the vehicle.

(18) Connect all the vacuum hoses and wire connectors identified during engine removal.

(19) **Vehicles with Power Steering:**

(a) Remove the protective caps

(b) Connect the hoses to the fittings at the steering gear. Tighten the nut to 52 N·m (38 ft. lbs.) torque.

(c) Fill the pump reservoir with fluid.

(20) Install the power brake vacuum check valve to the booster, if equipped.

(21) Connect the fuel supply hose the fuel rail. Push until a "click" is heard. Install latch clip

(22) Connect the fuel injector harness to the injectors.

(23) Connect the distributor electrical connector and oil pressure switch connector.

(24) Connect the line pressure cable (if equipped with automatic transmission).

(25) Connect the speed control cable, if equipped.

(26) Connect the throttle cable.

(27) Connect the heater hoses at the engine thermostat housing and water pump.

(28) Install the fan assembly to the idler pulley.

(29) Connect the suction/discharge hose to the compressor.

(30) Connect automatic transmission fluid cooler lines, if equipped.

(31) Install the fan shroud, electric cooling fan and radiator and condenser (if equipped with A/C).

(32) Connect the electric fan connector.

(33) Install upper radiator support.

(34) Connect the upper radiator hose.

(35) Connect the lower radiator hose.

(36) Align the hood to the scribe marks. Install the hood.

(37) Install the air cleaner assembly.

(38) Install the battery and connect the battery cable.

(39) Add the proper amount of engine oil and coolant.

WARNING: USE EXTREME CAUTION WHEN THE ENGINE IS OPERATING. DO NOT STAND IN A DIRECT LINE WITH THE FAN. DO NOT PUT YOUR HANDS NEAR THE PULLEYS, BELTS OR FAN. DO NOT WEAR LOOSE CLOTHING.

(40) Start the engine, inspect for leaks and correct the fluid levels, as necessary.

(41) Charge the air conditioning system (refer to Group 24, Heating and Air Conditioning for proper procedures).

REMOVAL AND INSTALLATION (Continued)

INTAKE AND EXHAUST MANIFOLD

REMOVAL

NOTE: THE ENGINE INTAKE AND EXHAUST MANIFOLD MUST BE REMOVED AND INSTALLED TOGETHER. THE MANIFOLDS USE A COMMON GASKET AT THE CYLINDER HEAD.

- (1) Disconnect the battery negative cable.
- (2) Remove air cleaner inlet hose from the resonator assembly.
- (3) Remove the air cleaner assembly.
- (4) Remove the throttle cable, vehicle speed control cable (if equipped) and the transmission line pressure cable.
- (5) Disconnect the following electrical connections and secure their harness out of the way:
 - Throttle Position Sensor
 - Idle Air Control Motor
 - Coolant Temperature Sensor (at thermostat housing)
 - Intake Air Temperature Sensor
 - Oxygen Sensor
 - Crank Position Sensor
 - Six (6) Fuel Injector Connectors
 - Manifold Absolute Pressure (MAP) Sensor.
- (6) Disconnect HVAC, and Brake Booster vacuum supply hoses at the intake manifold.
- (7) Perform the fuel pressure release procedure. (Refer to Group 14, Fuel Systems for correct procedure)
- (8) Disconnect and remove the fuel system supply line from the fuel rail assembly. (Refer to Group 14, Quick Connect Fittings for correct procedures)
- (9) Remove the accessory drive belt (refer to Group 7, Cooling System). Loosen the tensioner.
- (10) Remove the power steering pump from the intake manifold and set aside.
- (11) Raise the vehicle.
- (12) Disconnect the exhaust pipes from the engine exhaust manifolds.
- (13) Lower the vehicle.
- (14) Remove the intake manifold and engine exhaust manifolds.

INSTALLATION

If the manifold is being replaced, ensure all the fitting, etc. are transferred to the replacement manifold.

- (1) Install a new engine exhaust/intake manifold gasket over the alignment dowels on the cylinder head.
- (2) Position the engine exhaust manifolds to the cylinder head. Install fastener Number 3 and finger tighten at this time (Fig. 50).

(3) Install intake manifold on the cylinder head dowels.

(4) Install washer and fastener Numbers 1, 2, 4, 5, 8, 9, 10 and 11 (Fig. 50).

(5) Install washer and fastener Numbers 6 and 7 (Fig. 50).

(6) Tighten the fasteners in sequence and to the specified torque (Fig. 50).

• Fastener Numbers 1 through 5—Tighten to 33 N-m (24 ft. lbs.) torque.

• Fastener Numbers 6 and 7—Tighten to 31 N-m (23 ft. lbs.) torque.

• Fastener Numbers 8 through 11—Tighten to 33 N-m (24 ft. lbs.) torque.

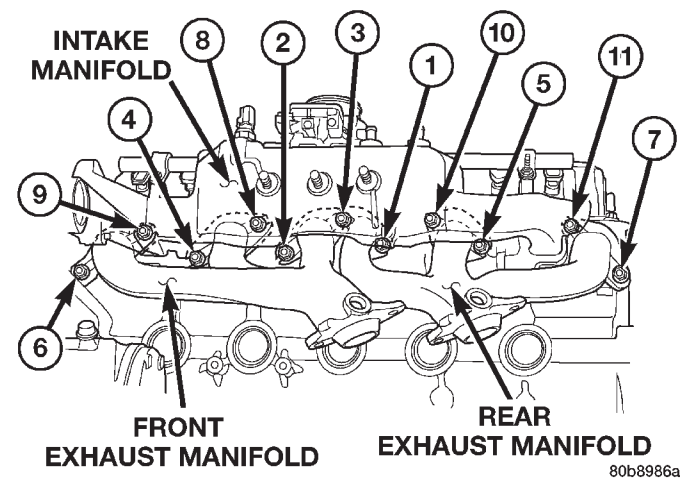

Fig. 50 Intake and Exhaust Manifolds—4.0L

(7) Install the power steering pump to the intake manifold.

(8) Install the accessory drive belt. (Refer to Group 7, Cooling System for the correct procedures)

(9) Install the fuel system supply line to the fuel rail assembly. **Before connecting the fuel supply line to the fuel rail inspect the O-rings and replace if necessary. Refer to Group 14, Fuel System for the correct procedure.**

(10) Connect all electrical connections on the intake manifold.

(11) Connect the vacuum hoses previously removed.

(12) Install throttle cable, vehicle speed control cable (if equipped).

(13) Install the transmission line pressure cable (if equipped). Refer to Group 21, Transmission for the adjustment procedures.

(14) Install air cleaner assembly.

(15) Connect air inlet hose to the resonator assembly.

(16) Raise the vehicle.

(17) Connect the exhaust pipes to the engine exhaust manifolds. Tighten the bolts to 31 N-m (23 ft. lbs.)

REMOVAL AND INSTALLATION (Continued)

- (18) Lower the vehicle.
- (19) Connect the battery negative cable.
- (20) Start the engine and check for leaks.

EXHAUST MANIFOLD—4.0L ENGINE

The intake and engine exhaust manifolds on the 4.0L engine must be removed and installed together. The manifolds use a common gasket at the cylinder head.

Refer to Intake Manifold—4.0L Engine in this section for the proper removal and installation procedures.

CYLINDER HEAD COVER

The cylinder head cover is isolated from the cylinder head via grommets and a reusable molded rubber gasket. The grommet and limiter are retained in the cylinder head cover.

There are two cylinder head bolts that have a pin to locate the cylinder head cover gasket, they are located at position 8 and 9 (Fig. 52)

REMOVAL

- (1) Disconnect negative cable from battery.
- (2) Disconnect the Crankcase Ventilation (CCV) vacuum hose from engine cylinder head cover.
- (3) Disconnect the fresh air inlet hose from the engine cylinder head cover.
- (4) Disconnect the accelerator, transmission, and speed (if equipped) control cables from the throttle body (Fig. 51).
- (5) Remove the three bolts that fasten the control cable bracket to the intake manifold.
- (6) Remove control cables from cylinder head cover clip.
- (7) Position control cables and bracket away from cylinder head cover secure with tie straps.
- (8) Remove the engine cylinder head cover mounting bolts.
- (9) Remove the engine cylinder head cover and gasket.

INSTALLATION

- (1) If a replacement cover is installed, transfer the CCV valve grommet and oil filler cap from the original cover to the replacement cover.
- (2) Install cylinder head cover and gasket. Tighten the mounting bolts to 10 N·m (85 in. lbs.) torque.
- (3) Connect the CCV hoses.
- (4) Install control cables and bracket on intake manifold and tighten bolts to 8.7 N·m (77 in. lbs.) torque.
- (5) Connect control cables to throttle body linkage.
- (6) Snap control cables into cylinder head cover clip.
- (7) Connect negative cable to battery.

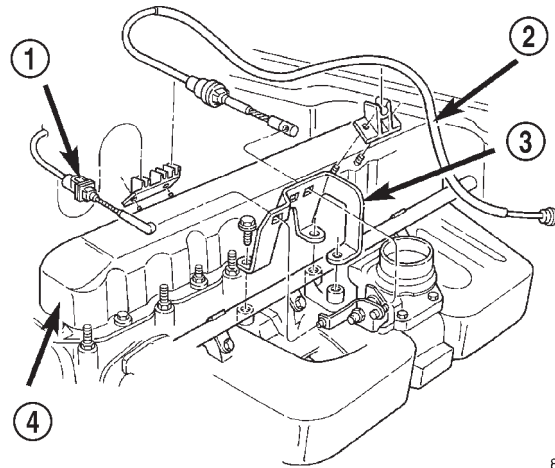

80a7e396

Fig. 51 Engine Cylinder Head Cover

- 1 - TRANS CONTROL CABLE
- 2 - ACCELERATOR CABLE
- 3 - CONTROL CABLE BRACKET
- 4 - CYLINDER HEAD COVER

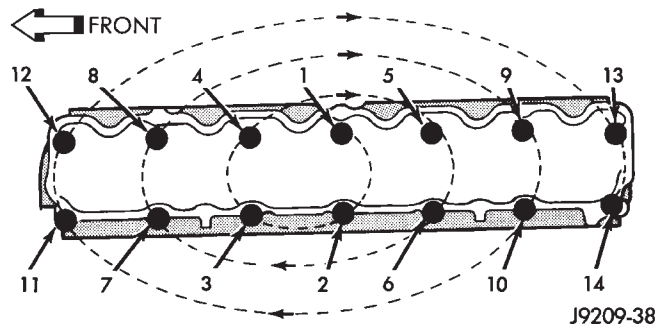

J9209-38

Fig. 52 Cylinder Head Cover Gasket Locator Pins at #8 & #9

ROCKER ARMS AND PUSH RODS

This procedure can be done with the engine in or out of the vehicle.

REMOVAL

- (1) Remove the engine cylinder head cover.
- (2) Check for rocker arm bridges which are causing misalignment of the rocker arm to valve tip area.
- (3) Remove the capscrews at each bridge and pivot assembly (Fig. 53). Alternately loosen the capscrews one turn at a time to avoid damaging the bridges.
- (4) Remove the bridges, pivots and corresponding pairs of rocker arms (Fig. 53). Place them on a bench in the same order as removed.
- (5) Remove the push rods and place them on a bench in the same order as removed.

INSTALLATION

- (1) Lubricate the ball ends of the push rods with Mopar Engine Oil Supplement, or equivalent and install push rods in their original locations. Ensure

REMOVAL AND INSTALLATION (Continued)

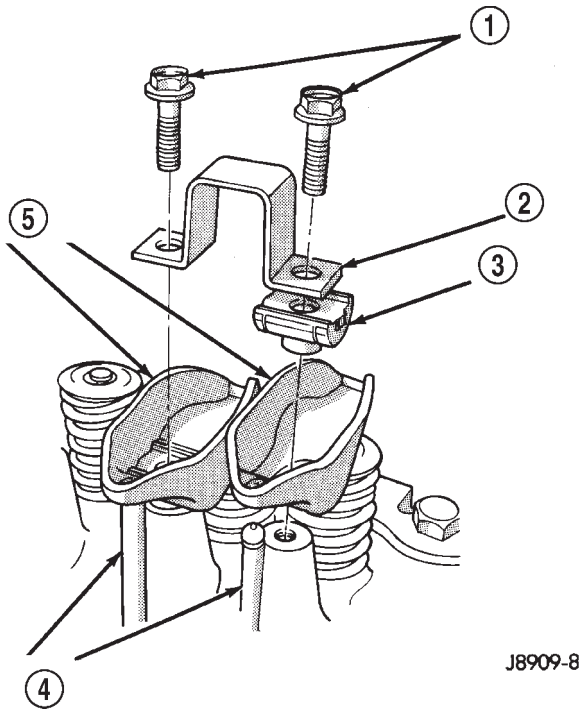

J8909-8

Fig. 53 Rocker Arm Assembly

- 1 - CAPSCREWS
- 2 - BRIDGE
- 3 - PIVOT ASSEMBLY
- 4 - PUSH RODS
- 5 - ROCKER ARMS

that the bottom end of each push rod is centered in the tappet plunger cap seat.

(2) Using Mopar Engine Oil Supplement, or equivalent, lubricate the area of the rocker arm that the pivot contacts. Install rocker arms, pivots and bridge above each cylinder in their originally position.

(3) Loosely install the capscrews through each bridge.

(4) At each bridge, tighten the capscrews alternately, one turn at a time, to avoid damaging the bridge. Tighten the capscrews to 28 N·m (21 ft. lbs.) torque.

(5) Install the engine cylinder head cover.

VALVE SPRINGS AND OIL SEALS

This procedure can be done with the engine cylinder head installed on the block.

REMOVAL

Inspect the valve stems, especially the grooves. An Arkansas smooth stone should be used to remove nicks and high spots.

Each valve spring is held in place by a retainer and a set of conical valve locks. The locks can be removed only by compressing the valve spring.

(1) Remove the engine cylinder head cover.

(2) Remove cap screws, bridge and pivot assemblies and rocker arms for access to each valve spring to be removed.

(3) Remove push rods. **Retain the push rods, bridges, pivots and rocker arms in the same order and position as removed.**

(4) Inspect the springs and retainer for cracks and possible signs of weakening.

(5) Remove the spark plug(s) adjacent to the cylinder(s) below the valve springs to be removed.

(6) Connect an air hose to the adapter and apply air pressure slowly. Maintain at least 621 kPa (90 psi) of air pressure in the cylinder to hold the valves against their seats. For vehicles equipped with an air conditioner, use a flexible air adaptor when servicing the No.1 cylinder.

(7) Tap the retainer or tip with a rawhide hammer to loosen the lock from the retainer. Use Valve Spring Compressor Tool MD-998772A to compress the spring and remove the locks (Fig. 54).

(8) Remove valve spring and retainer (Fig. 54).

(9) Remove valve stem oil seals (Fig. 54). Note the valve seals are different for intake and exhaust valves. The top of each seal is marked either INT (intake/black in color) or EXH (exhaust/brown in color). DO NOT mix the seals.

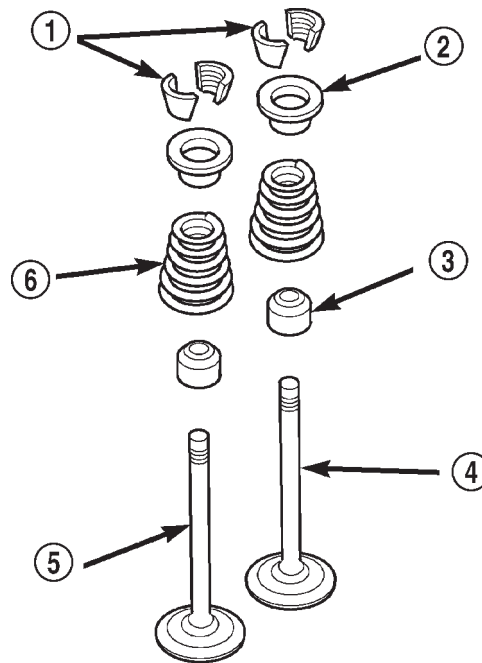

80b7704b

Fig. 54 Valve and Valve Components

- 1 - VALVE LOCKS (3-BEAD)
- 2 - RETAINER
- 3 - VALVE STEM OIL SEAL
- 4 - INTAKE VALVE
- 5 - EXHAUST VALVE
- 6 - VALVE SPRING

REMOVAL AND INSTALLATION (Continued)

INSTALLATION

CAUTION: Install oil seals carefully to prevent damage from the sharp edges of the valve spring lock groove.

(1) Lightly push the valve seal over the valve stem and valve guide boss. Be sure the seal is completely seated on the valve guide boss.

(2) Install valve spring and retainer.

(3) Compress the valve spring with Valve Spring Compressor Tool MD-998772A and insert the valve locks. Release the spring tension and remove the tool. Tap the spring from side-to-side to ensure that the spring is seated properly on the engine cylinder head.

(4) Release air pressure and disconnect the air hose. Remove the adaptor from the spark plug hole and install the spark plug.

(5) Repeat the procedures for each remaining valve spring to be removed.

(6) Install the push rods. Ensure the bottom end of each rod is centered in the plunger cap seat of the hydraulic valve tappet.

(7) Install the rocker arms, pivots and bridge at their original location.

(8) Tighten the bridge cap screws alternately, one at a time, to avoid damaging the bridge. Tighten the cap screws to 28 N·m (21 ft. lbs.) torque.

(9) Install the engine cylinder head cover.

CYLINDER HEAD

This procedure can be done with the engine in or out of the vehicle.

REMOVAL

(1) Disconnect the battery negative cable.

WARNING: DO NOT REMOVE THE CYLINDER BLOCK DRAIN PLUGS OR LOOSEN THE RADIATOR DRAIN COCK WITH THE SYSTEM HOT AND PRESSURIZED BECAUSE SERIOUS BURNS FROM THE COOLANT CAN OCCUR.

(2) Drain the coolant and disconnect the hoses at the engine thermostat housing and the water pump inlet. DO NOT waste reusable coolant. If the solution is clean and is being drained only to service the engine or cooling system, drain the coolant into a clean container for reuse.

(3) Remove the air cleaner assembly.

(4) Remove the engine cylinder head cover.

(5) Remove the capscrews, bridge and pivot assemblies and rocker arms.

(6) Remove the push rods. **Retain the push rods, bridges, pivots and rocker arms in the same order as removed.**

(7) Loosen the accessory drive belt at the power steering pump. (Refer to Group 7, Cooling System for the correct procedure). Slip the belt off of the power steering pulley.

(8) Remove the A/C compressor mounting bolts and secure the compressor to the side.

(9) Remove the power steering pump and bracket from the intake manifold and water pump. Set the pump and bracket aside. DO NOT disconnect the hoses.

(10) Perform the Fuel System Pressure Release procedure. (Refer to Group 14, Fuel System)

(11) Disconnect the fuel supply line at the fuel rail. (Refer to Group 14, Quick-Connect Fittings for the correct procedures)

(12) Remove the intake and engine exhaust manifolds from the engine cylinder head. (Refer to Group 11, Exhaust System and Intake Manifold for the proper procedures)

(13) Disconnect the coil rail electrical connectors and remove the coil rail.

(14) Remove spark plugs.

(15) Disconnect the temperature sending unit wire connector.

(16) Remove the engine cylinder head bolts. Bolt No.14 cannot be removed until the head is moved forward (Fig. 55). Pull bolt No.14 out as far as it will go and then suspend the bolt in this position (tape around the bolt).

(17) Remove the engine cylinder head and gasket (Fig. 55).

(18) If this was the first time the bolts were removed, put a paint dab on the top of the bolt. If the bolts have a paint dab on the top of the bolt or it isn't known if they were used before, discard the bolts.

(19) Stuff clean lint free shop towels into the cylinder bores.

NOTE: If the valves, springs, or seals are to be inspected/replaced at this time, refer to Valves and Valve Springs in this section for proper inspection procedures.

INSTALLATION

The engine cylinder head gasket is a composition gasket. The gasket is to be installed DRY. **DO NOT use a gasket sealing compound on the gasket.**

If the engine cylinder head is to be replaced and the original valves used, measure the valve stem diameter. Only standard size valves can be used with a service replacement engine cylinder head unless the replacement head valve stem guide bores are reamed to accommodate oversize valve stems. Remove all carbon buildup and reface the valves.

REMOVAL AND INSTALLATION (Continued)

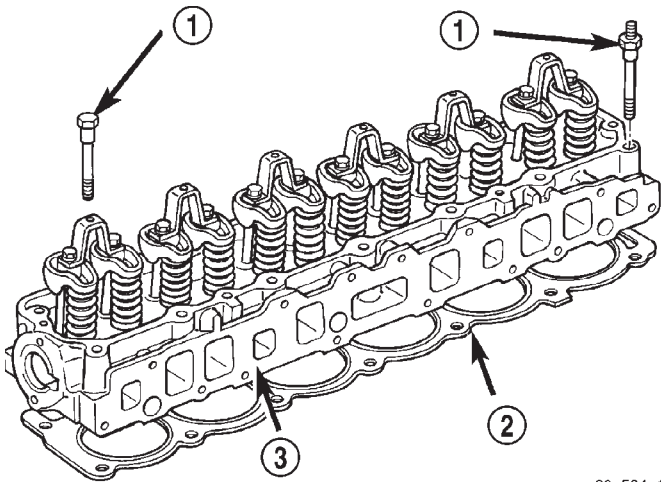

80a534a1

Fig. 55 Engine Cylinder Head Assembly

- 1 - CYLINDER HEAD BOLTS
- 2 - CYLINDER HEAD GASKET
- 3 - CYLINDER HEAD

(1) Remove the shop towels from the cylinder bores. Coat the bores with clean engine oil.

(2) Position the engine cylinder head gasket (with the numbers facing up) using the alignment dowels in the cylinder block, to position the gasket.

CAUTION: Engine cylinder head bolts should be reused only once. Replace the head bolts if they were used before or if they have a paint dab on the top of the bolt.

(3) With bolt No.14 held in place (tape around bolt), install the engine cylinder head over the same dowels used to locate the gasket. Remove the tape from bolt No.14.

(4) Coat the threads of stud bolt No.11 with Loctite 592 sealant, or equivalent.

(5) Tighten the engine cylinder head bolts in sequence according to the following procedure (Fig. 56).

CAUTION: During the final tightening sequence, bolt No.11 will be tightened to a lower torque than the rest of the bolts. **DO NOT** overtighten bolt No.11.

- (a) Tighten all bolts in sequence (1 through 14) to 30 N·m (22 ft. lbs.) torque.
- (b) Tighten all bolts in sequence (1 through 14) to 61 N·m (45 ft. lbs.) torque.
- (c) Check all bolts to verify they are set to 61 N·m (45 ft. lbs.) torque.
- (d) Tighten bolts in sequence:
 - Bolts 1 through 10 to 149 N·m (110 ft. lbs.) torque.
 - Bolt 11 to 135 N·m (100 ft. lbs.) torque.

- Bolts 12 through 14 to 149 N·m (110 ft. lbs.) torque.

CYLINDER HEAD BOLTS

| POSITION | DESCRIPTION |
|--|--------------------------------------|
| 1,4,5,12,13 | 1/2 in.-13 BOLT |
| 8,9 | 1/2 in.-13 BOLT WITH DOWEL POINT |
| 2,3,6,7,10,11,14 | 1/2 in.-13 WITH 7/16 in.-14 STUD END |
| All bolts are 12 point drives for rocker cover clearance | |

(e) Check all bolts in sequence to verify the correct torque.

(f) If not already done, clean and mark each bolt with a dab of paint after tightening. Should you encounter bolts which were painted in an earlier service operation, replace them.

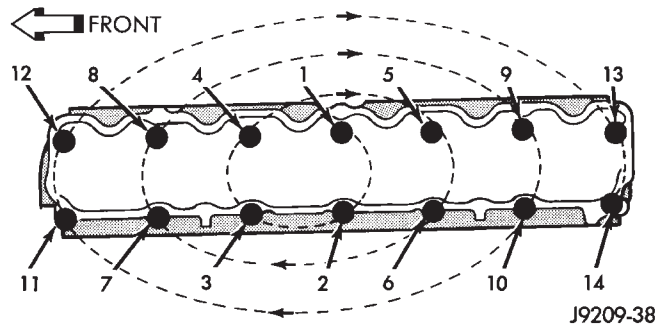

J9209-38

Fig. 56 Engine Cylinder Head Bolt Tightening Sequence

(6) Install the spark plugs and tighten to 37 N·m (27 ft. lbs.) torque.

(7) Connect the temperature sending unit wire connector.

(8) Install the ignition coil rail and coil rail electrical connectors.

(9) Install the intake and engine exhaust manifolds (refer to procedures in this section).

(10) Install the fuel line and the vacuum advance hose.

(11) Attach the power steering pump and bracket.

(12) Install the push rods, rocker arms, pivots and bridges in the order they were removed (refer to Rocker Arms and Push Rods in this section).

(13) Install the engine cylinder head cover.

(14) Attach the air conditioner compressor mounting bracket to the engine cylinder head and block. Tighten the bolts to 40 N·m (30 ft. lbs.) torque.

(15) Attach the air conditioning compressor to the bracket. Tighten the bolts to 27 N·m (20 ft. lbs.) torque.

REMOVAL AND INSTALLATION (Continued)

CAUTION: The serpentine drive belt must be routed correctly. Incorrect routing can cause the water pump to turn in the opposite direction causing the engine to overheat.

(16) Install the serpentine drive belt. (refer to Group 7, Cooling System for the proper procedure).

(17) Install the air cleaner and ducting.

(18) Connect the hoses to the engine thermostat housing and fill the cooling system to the specified level (refer to Group 7, Cooling Systems for the proper procedure).

(19) The automatic transmission throttle linkage and cable must be adjusted after completing the engine cylinder head installation (refer to Group 21, Transmissions for the proper procedures).

(20) Install the temperature sending unit and connect the wire connector.

(21) If equipped with air conditioning, install A/C compressor and charge A/C system (refer to Group 24 Heating and Air Conditioning).

(22) Connect negative cable to battery.

WARNING: USE EXTREME CAUTION WHEN THE ENGINE IS OPERATING. DO NOT STAND IN DIRECT LINE WITH THE FAN. DO NOT PUT HANDS NEAR THE PULLEYS, BELTS OR FAN. DO NOT WEAR LOOSE CLOTHING.

(23) Operate the engine with the radiator cap off. Inspect for leaks and continue operating the engine until the engine thermostat opens. Add coolant, if required.

VALVES AND VALVE SPRINGS

This procedure is done with the engine cylinder head removed from the block.

REMOVAL

(1) Remove the engine cylinder head from the cylinder block.

(2) Use Valve Spring Compressor Tool MD-998772A and compress each valve spring.

(3) Remove the valve locks, retainers, springs and valve stem oil seals. Discard the oil seals.

(4) Use a smooth stone or a jewelers file to remove any burrs on the top of the valve stem, especially around the groove for the locks.

(5) Remove the valves, and place them in a rack in the same order as removed.

INSTALLATION

(1) Thoroughly clean the valve stems and the valve guide bores.

(2) Lightly lubricate the stem.

(3) Install the valve in the original valve guide bore.

(4) Install the replacement valve stem oil seals on the valve stems. If the 0.381 mm (0.015 inch) over-size valve stems are used, oversize oil seals are required.

(5) Position the valve spring and retainer on the engine cylinder head and compress the valve spring with Valve Spring Compressor Tool MD-998772A.

(6) Install the valve locks and release the tool.

(7) Tap the valve spring from side to side with a hammer to ensure that the spring is properly seated at the engine cylinder head. Also tap the top of the retainer to seat the valve locks.

(8) Install the engine cylinder head.

HYDRAULIC TAPPETS

Retain all the components in the same order as removed.

REMOVAL

(1) Remove the engine cylinder head (Refer to cylinder head r&i in this section).

(2) Remove the push rods.

(3) Remove the tappets through the push rod openings in the cylinder block with a Hydraulic Valve Tappet Removal/Installation Tool (Fig. 57).

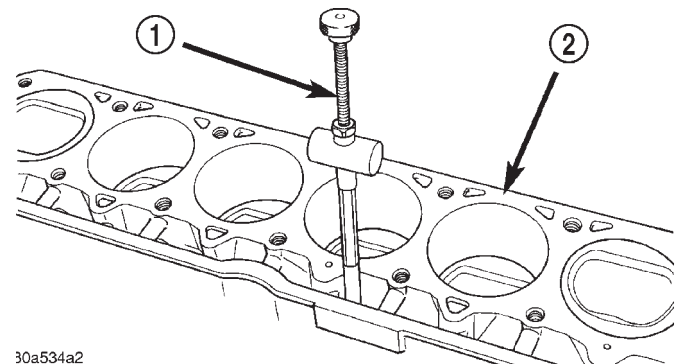

30a534a2

**Fig. 57 Hydraulic Valve Tappet Removal—
Installation Tool**

1 - HYDRAULIC TAPPET REMOVAL TOOL

2 - CYLINDER BLOCK

INSTALLATION

It is not necessary to charge the tappets with engine oil. They will charge themselves within a very short period of engine operation.

(1) Dip each tappet in Mopar Engine Oil Supplement, or equivalent.

(2) Use Hydraulic Valve Tappet Removal/Installation Tool to install each tappet in the same bore from where it was originally removed.

(3) Install the cylinder head assy (Refer to cylinder head r&i in this section).

(4) Install the push rods in their original locations.

REMOVAL AND INSTALLATION (Continued)

(5) Install the rocker arms and bridge and pivot assemblies at their original locations. Loosely install the capscrews at each bridge.

(6) Tighten the capscrews alternately, one turn at a time, to avoid damaging the bridges. Tighten the capscrews to 28 N·m (21 ft. lbs.) torque.

(7) Pour the remaining Mopar Engine Oil Supplement, or equivalent over the entire valve actuating assembly. The Mopar Engine Oil Supplement, or equivalent must remain with the engine oil for at least 1 609 km (1,000 miles). The oil supplement need not be drained until the next scheduled oil change.

(8) Install the engine cylinder head cover.

VIBRATION DAMPER

REMOVAL

- (1) Disconnect negative cable from battery.
- (2) Remove the serpentine drive belt and fan shroud. Refer to Group 7, Cooling Systems for the procedures.
- (3) Remove the vibration damper retaining bolt and washer.
- (4) Use Vibration Damper Removal Tool 7697 to remove the damper from the crankshaft (Fig. 58).

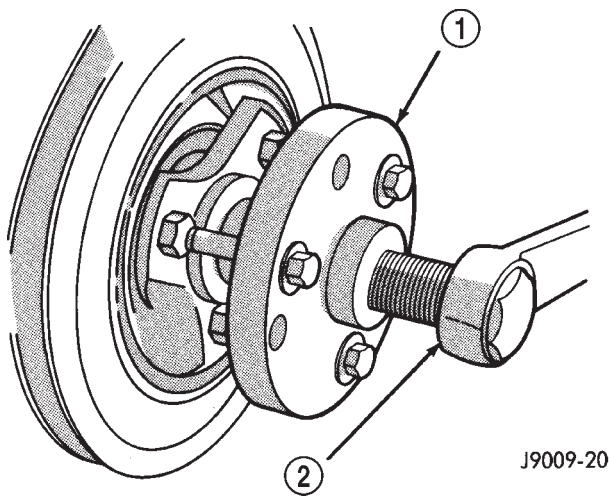

Fig. 58 Vibration Damper Removal Tool 7697

- 1 - VIBRATION DAMPER REMOVAL TOOL
- 2 - WRENCH

INSTALLATION

(1) Apply Mopar Silicone Rubber Adhesive Sealant to the keyway in the crankshaft and insert the key. With the key in position, align the keyway on the vibration damper hub with the crankshaft key and tap the damper onto the crankshaft.

(2) Install the vibration damper retaining bolt and washer.

(3) Tighten the damper retaining bolt to 108 N·m (80 ft. lbs.) torque.

(4) Install the serpentine drive belt. (Refer to Group 7, Cooling Systems for the proper specifications and procedures).

(5) Connect negative cable to battery.

TIMING CASE COVER

REMOVAL

- (1) Disconnect negative cable from battery.
- (2) Remove the vibration damper.
- (3) Remove the fan and hub assembly and remove the fan shroud.
- (4) Remove the accessory drive brackets that are attached to the timing case cover.
- (5) Remove the A/C compressor (if equipped) and generator bracket assembly from the engine cylinder head and move to one side.
- (6) Remove the oil pan-to-timing case cover bolts and timing case cover-to-cylinder block bolts.
- (7) Remove the timing case cover and gasket from the engine.
- (8) Pry the crankshaft oil seal from the front of the timing case cover (Fig. 59).

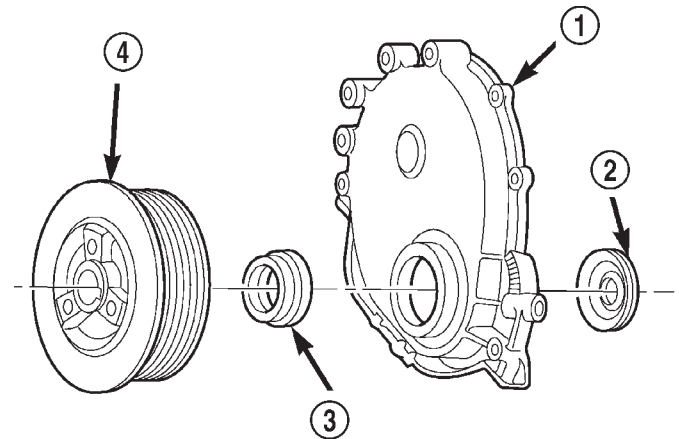

80abd2b1

Fig. 59 Timing Case Cover Components

- 1 - TIMING CASE COVER
- 2 - OIL SLINGER
- 3 - CRANKSHAFT OIL SEAL
- 4 - VIBRATION DAMPER PULLEY

INSTALLATION

Clean the timing case cover, oil pan and cylinder block gasket surfaces.

(1) Install a new crankshaft oil seal in the timing case cover. The open end of the seal should be toward the inside of the cover. Support the cover at the seal area while installing the seal. Force it into position with Seal Installation Tool 6139.

(2) Position the gasket on the cylinder block.

REMOVAL AND INSTALLATION (Continued)

(3) Position the timing case cover on the oil pan gasket and the cylinder block.

(4) Insert Timing Case Cover Alignment and Seal Installation Tool 6139 in the crankshaft opening in the cover (Fig. 60).

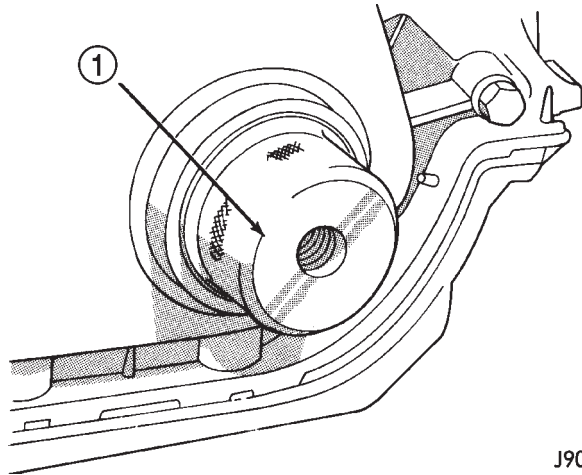

J9009-23

Fig. 60 Timing Case Cover Alignment and Seal Installation Tool 6139

1 - TIMING CASE COVER ALIGNMENT AND SEAL INSTALLATION TOOL

(5) Install the timing case cover-to-cylinder block and the oil pan-to-timing case cover bolts.

(6) Tighten the 1/4 inch cover-to-block bolts to 7 N·m (60 in. lbs.) torque. Tighten the 5/16 inch front cover-to-block bolts to 22 N·m (192 in. lbs.) torque. Tighten the oil pan-to-cover 1/4 inch bolts to 9.5 N·m (84 in. lbs.) torque.

(7) Remove the cover alignment tool.

(8) Apply a light film of engine oil on the vibration damper hub contact surface of the seal.

(9) Apply Mopar Silicone Rubber Adhesive Sealant to the keyway in the crankshaft and insert the key. With the key inserted in the keyway in the crankshaft, install the vibration damper, washer and bolt. Lubricate and tighten the bolt to 108 N·m (80 ft. lbs.) torque.

(10) Install the A/C compressor (if equipped) and generator bracket assembly.

(11) Install the engine fan and hub assembly and shroud.

(12) Install the serpentine drive belt.

(13) Connect negative cable to battery.

TIMING CHAIN AND SPROCKETS

REMOVAL

- (1) Disconnect negative cable from battery.
- (2) Remove the fan and shroud.
- (3) Remove the serpentine drive belt.
- (4) Remove the crankshaft vibration damper.
- (5) Remove the timing case cover.

(6) Rotate crankshaft until the "0" timing mark is closest to and on the center line with camshaft sprocket timing mark (Fig. 61).

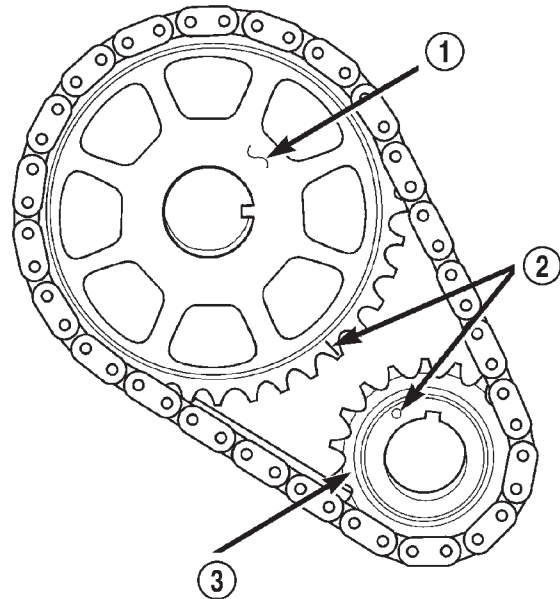

80bfe0fa

Fig. 61 Crankshaft—Camshaft Alignment

1 - CAMSHAFT SPROCKET
2 - TIMING MARKS
3 - CRANKSHAFT SPROCKET

- (7) Remove the oil slinger from the crankshaft.
- (8) Remove the camshaft sprocket bolt and washer (Fig. 62).

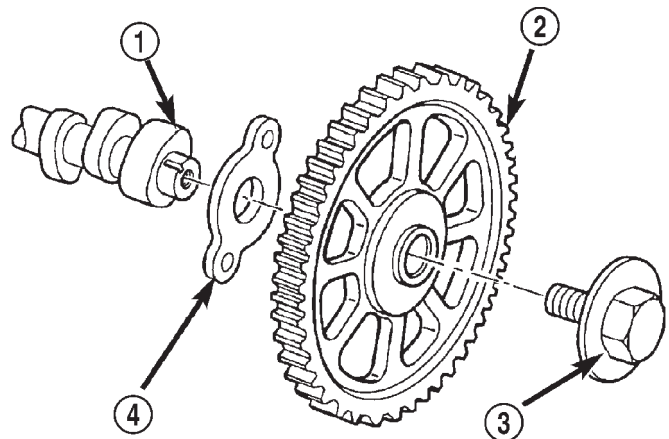

80ble167

Fig. 62 Camshaft Sprocket and Thrust Plate

1 - CAMSHAFT
2 - CAMSHAFT SPROCKET W/INTEGRAL KEY
3 - BOLT & CUP WASHER
4 - THRUST PLATE

- (9) Remove the crankshaft sprocket, camshaft sprocket and timing chain as an assembly.

REMOVAL AND INSTALLATION (Continued)

(10) Installation of the timing chain with the timing marks on the crankshaft and camshaft sprockets properly aligned ensures correct valve timing. A worn or stretched timing chain will adversely affect valve timing. If the timing chain deflects more than 12.7 mm (1/2 inch) replace it.

INSTALLATION

Assemble the timing chain, crankshaft sprocket and camshaft sprocket with the timing marks aligned (Fig. 61).

(1) Apply Mopar Silicone Rubber Adhesive Sealant to the keyway in the crankshaft and insert the key. With the key in the keyway on the crankshaft, install the assembly on the crankshaft and camshaft.

(2) Install the camshaft sprocket bolt and washer (Fig. 62). Tighten the bolt to 68 N·m (50 ft. lbs.) torque.

(3) To verify correct installation of the timing chain, rotate the crankshaft 2 revolutions. The camshaft and crankshaft sprocket timing mark should align (Fig. 61).

(4) Install the crankshaft oil slinger.

(5) Replace the oil seal in the timing case cover.

(6) Install the timing case cover and gasket.

(7) With the key installed in the crankshaft keyway, install the vibration damper, washer and bolt. Lubricate and tighten the bolt to 108 N·m (80 ft. lbs.) torque.

(8) Install the serpentine drive belt. (refer to Group 7, Cooling System for the proper procedure).

(9) Install the fan and hub assembly. Install the shroud.

(10) Connect negative cable to battery.

CAMSHAFT

REMOVAL

WARNING: THE COOLANT IN A RECENTLY OPERATED ENGINE IS HOT AND PRESSURIZED. RELEASE THE PRESSURE BEFORE REMOVING THE DRAIN COCK, CAP AND DRAIN PLUGS.

(1) Disconnect negative cable from battery.

(2) Drain the cooling system. DO NOT waste reusable coolant. If the solution is clean, drain it into a clean container for reuse.

(3) Remove the radiator or radiator and condenser, if equipped with A/C (refer to Group 7, Cooling System for the proper procedure).

(4) Remove the engine cylinder head cover.

(5) Remove the rocker arms, bridges and pivots.

(6) Remove the push rods.

(7) Remove the engine cylinder head and gasket.

(8) Remove the hydraulic valve tappets from the engine cylinder block.

(9) Remove the vibration damper.

(10) Remove the timing case cover.

(11) Rotate the crankshaft until the crankshaft sprocket timing mark is aligned on centerline with the camshaft sprocket timing mark (Fig. 64).

(12) Remove the timing chain and sprockets.

(13) Remove the front bumper and/or grille, as required.

(14) Remove the two thrust plate retaining screws, thrust plate and camshaft (Fig. 63).

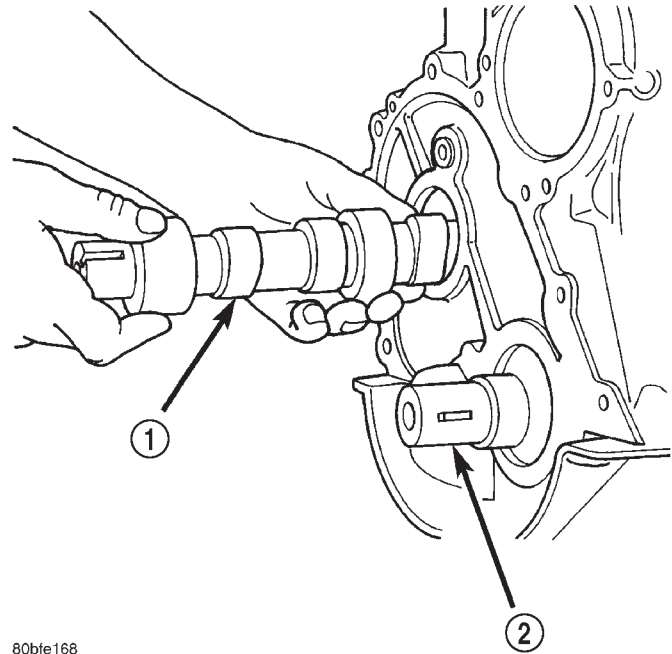

80bfe168

Fig. 63 Camshaft

1 - CAMSHAFT
2 - CRANKSHAFT

INSTALLATION

(1) Inspect the cam lobes for wear.

(2) Inspect the bearing journals for uneven wear pattern or finish.

(3) Inspect the bearings for wear.

(4) Inspect the distributor drive gear for wear.

(5) If the camshaft appears to have been rubbing against the thrust washer, examine the oil pressure relief holes in the rear cam journal. The oil pressure relief holes must be free of debris.

(6) Lubricate the camshaft with Mopar Engine Oil Supplement, or equivalent.

(7) Carefully install the camshaft to prevent damage to the camshaft bearings (Fig. 63).

(8) Position thrust plate and install retaining screws. Tighten screws to 24 N·m (18 ft. lbs.).

(9) Install the timing chain, crankshaft sprocket and camshaft sprocket with the timing marks aligned.

(10) Install the camshaft sprocket bolt/cup washer. Tighten the bolt to 68 N·m (50 ft. lbs.).

REMOVAL AND INSTALLATION (Continued)

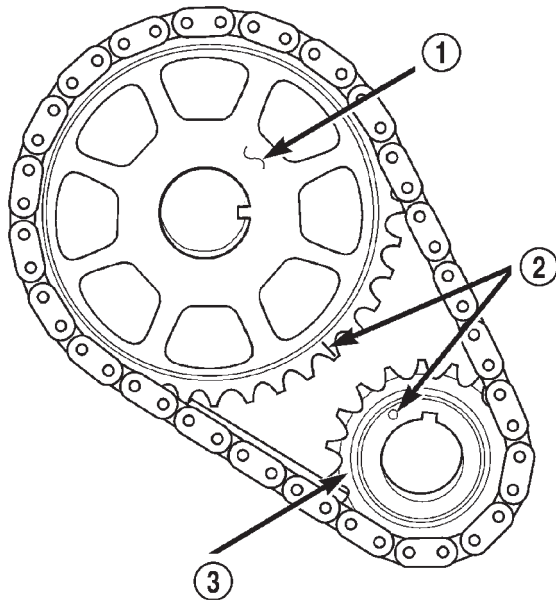

80bfe0fa

Fig. 64 Crankshaft / Camshaft Sprocket Timing Mark Alignment

- 1 - CAMSHAFT SPROCKET
- 2 - TIMING MARKS
- 3 - CRANKSHAFT SPROCKET

(11) Install the timing case cover with a replacement oil seal (Fig. 65). Refer to Timing Case Cover Installation.

(12) Install the vibration damper (Fig. 65).

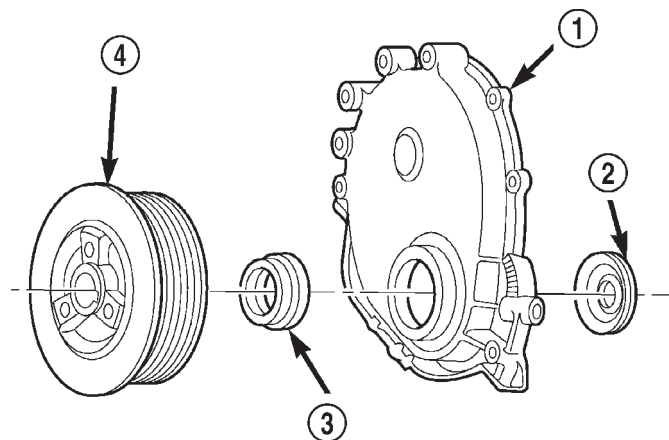

80abd2b1

Fig. 65 Timing Case Cover Components

- 1 - TIMING CASE COVER
- 2 - OIL SLINGER
- 3 - CRANKSHAFT OIL SEAL
- 4 - VIBRATION DAMPER PULLEY

(13) Install the hydraulic valve tappets.

(14) Install the cylinder head gasket with the numbers facing up.

(15) Install the cylinder head and head bolts (Refer to cylinder head R&I in this section for torque values and tightening sequence).

(16) Install the push rods.

(17) Install the rocker arms and pivot and bridge assemblies. Tighten each of the capscrews for each bridge alternately, one turn at a time, to avoid damaging the bridge (Refer to Rocker Arms and Push Rods in this section).

(18) Install the engine cylinder head cover.

(19) Install the serpentine drive belt. (refer to Group 7, Cooling System for the proper procedure).

NOTE: During installation, lubricate the hydraulic valve tappets and all valve components with Mopar Engine Oil Supplement, or equivalent. The Mopar Engine Oil Supplement, or equivalent must remain with the engine oil for at least 1609 km (1,000 miles). The oil supplement need not be drained until the next scheduled oil change.

(20) Install the radiator, connect the hoses and fill the cooling system to the specified level (refer to Group 7, Cooling System for the proper procedure).

(21) Check the ignition timing and adjust as necessary.

(22) Install the grille and bumper, if removed.

(23) Connect negative cable to battery.

CAMSHAFT BEARINGS

REMOVAL

The camshaft rotates within four steel-shelled, babbit-lined bearings that are pressed into the cylinder block and then line reamed. The camshaft bearing bores and bearing diameters are not the same size. They are stepped down in 0.254 mm (0.010 inch) increments from the front bearing (largest) to the rear bearing (smallest). This permits easier removal and installation of the camshaft. The camshaft bearings are pressure lubricated. Camshaft end play is maintained by the thrust plate.

(1) Remove the camshaft. Refer to Camshaft in this section for procedure.

NOTE: It is not advisable to attempt to replace camshaft bearings unless special removal and installation tools are available, such as recommended tool 8544 Camshaft Bushing Remover Installer.

(2) Using Special tool, remove the camshaft bearings.

INSTALLATION

(1) Inspect the camshaft bearing journals for uneven wear pattern or finish.

(2) Inspect the camshaft lobes and distributor gear for wear.

REMOVAL AND INSTALLATION (Continued)

(3) Inspect the camshaft thrust plate for wear. If the plate shows excessive wear inspect the camshaft oil pressure relief holes in the rear cam journal. The relief holes must be clean and free of debris.

CAUTION: Make sure outside diameter of number 1 bearing is clean. Make sure that the bearing is properly installed in the engine block, align the oil hole in the bearing with the oil gallery in the bearing bore. Failure to do so will cause inadequate oil supply for the sprockets and timing chain.

(4) Using special tool, install new camshaft bearings.

(5) Lubricate the camshaft with Mopar® engine oil supplement, or equivalent.

(6) Carefully install the camshaft to prevent damage to the camshaft bearings

(7) Position the thrust plate and install the two retaining screws. Tighten screws to 24 N·m (18 ft. lbs.).

(8) Install the camshaft sprocket, crankshaft sprocket and timing chain with the timing marks aligned. Install the sprocket bolt.

(9) Tighten the camshaft sprocket bolt and washer to 68 N·m (50 ft. lbs.).

(10) To verify correct installation of the timing chain, turn the crankshaft two full revolutions then position the camshaft sprocket timing mark as shown in (Fig. 66).

(11) Install the timing chain cover refer to the procedure in this section.

CRANKSHAFT MAIN BEARINGS

REMOVAL

(1) Disconnect negative cable from battery.
 (2) Remove the spark plugs.
 (3) Raise the vehicle.
 (4) Remove the oil pan and oil pump.
 (5) Remove main bearing cap brace (Fig. 67).
 (6) Remove only one main bearing cap and lower insert at a time (Fig. 68).

(7) Remove the lower insert from the bearing cap.

(8) Remove the upper insert by LOOSENING (DO NOT REMOVE) all of the other bearing caps. Now insert a small cotter pin tool in the crankshaft journal oil hole. Bend the cotter pin as illustrated to fabricate the tool (Fig. 69). With the cotter pin tool in place, rotate the crankshaft so that the upper bearing insert will rotate in the direction of its locking tab. Because there is no hole in the No.3 main journal, use a tongue depressor or similar soft-faced tool to remove the bearing insert (Fig. 69). After moving the insert approximately 25 mm (1 inch), it can be removed by applying pressure under the tab.

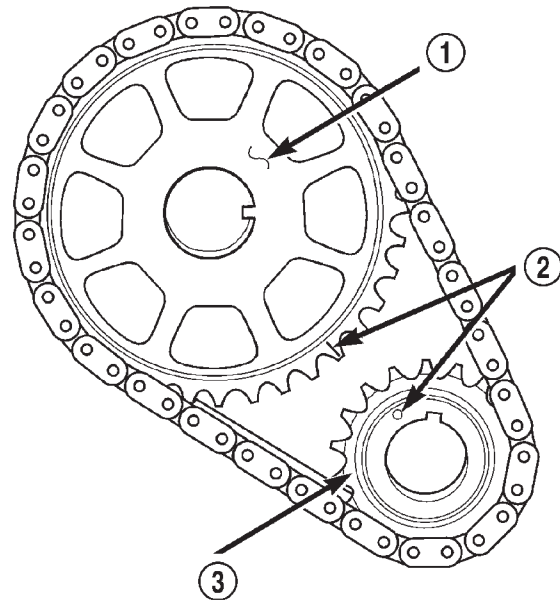

80bfe0fa

Fig. 66 Crankshaft / Camshaft Chain Drive Installation—Typical

- 1 - CAMSHAFT SPROCKET
- 2 - TIMING MARKS
- 3 - CRANKSHAFT SPROCKET

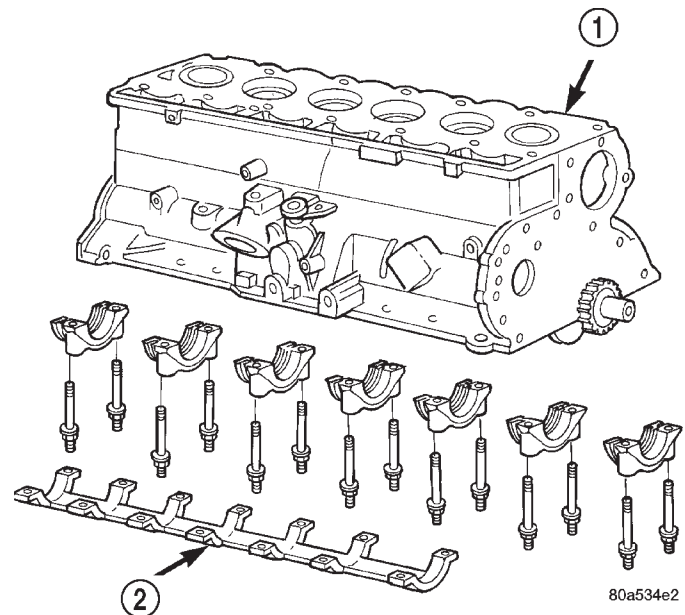

80a534e2

Fig. 67 Main Bearing Caps and Brace.

- 1 - BLOCK
- 2 - MAIN BEARING CAP BRACE

(9) Using the same procedure described above, remove the remaining bearing inserts one at a time for inspection.

REMOVAL AND INSTALLATION (Continued)

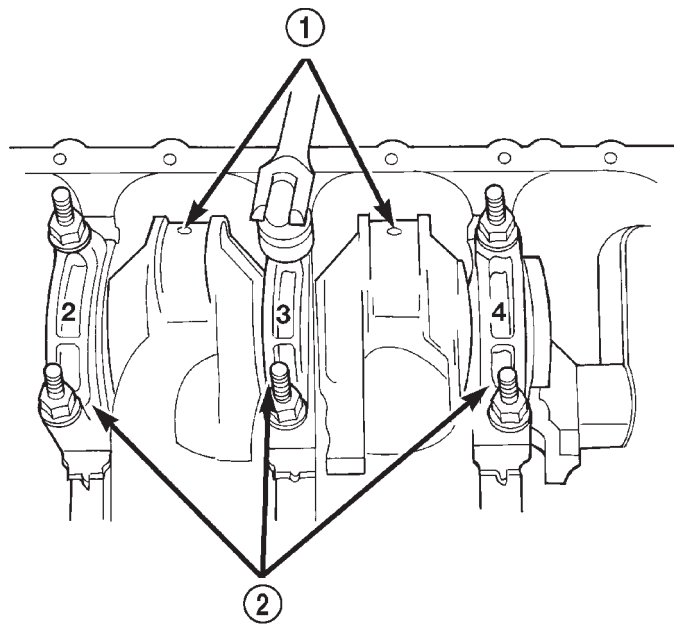

80a534e3

Fig. 68 Removing Main Bearing Caps and Lower Inserts

- 1 - CONNECTING ROD JOURNAL
- 2 - MAIN BEARING CAPS

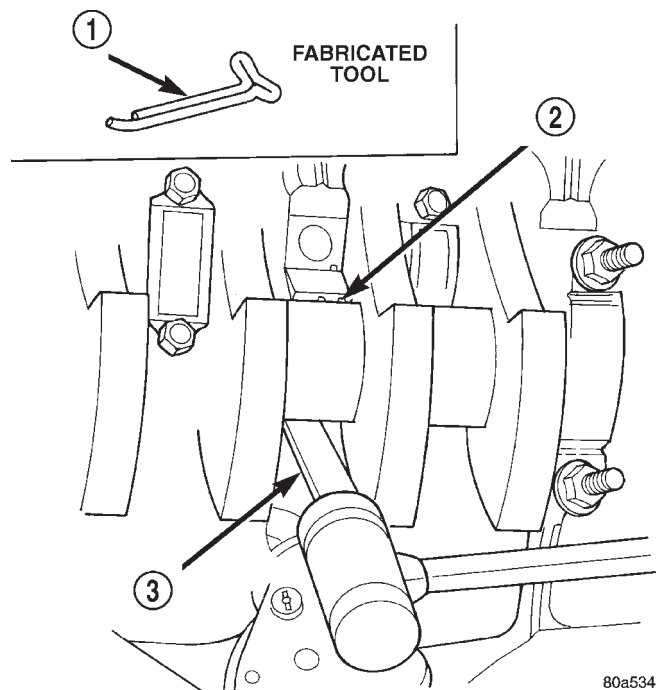

80a534e4

Fig. 69 Removing Upper Inserts

- 1 - COTTER PIN
- 2 - BEARING INSERT
- 3 - TONGUE DEPRESSOR

INSTALLATION

(1) Lubricate the bearing surface of each insert with engine oil.

(2) Loosen all the main bearing caps. Install the main bearing upper inserts.

(3) Install the lower bearing inserts into the main bearing caps.

(4) On the rear main cap, apply Mopar® Gasket Maker sealer on both sides of cylinder block as shown in (Fig. 70). The dab of sealer should be 3 mm (0.125 in.) in diameter.

(5) Apply Mopar® Gasket Maker on the rear bearing cap. The bead should be 2.3 mm (0.09 in.) in diameter. DO NOT apply sealer to the lip of the seal.

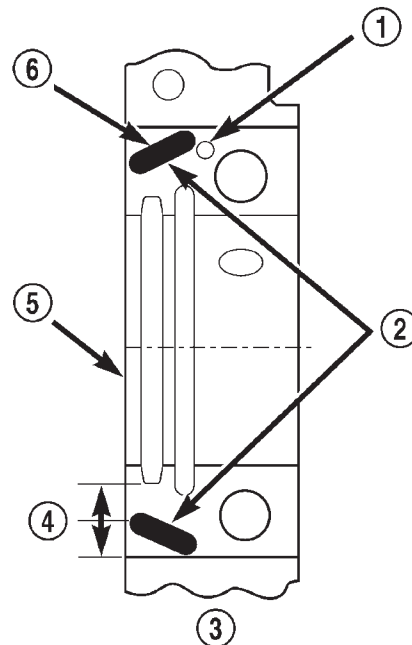

80bfe13c

Fig. 70 Location of Sealer

- 1 - DOWEL
- 2 - SEALER LOCATIONS
- 3 - CYLINDER BLOCK
- 4 - HALFWAY BETWEEN
- 5 - REAR FACE OF CYLINDER BLOCK
- 6 - 3mm (0.125 in.)

(6) Install the main bearing cap(s) and lower insert(s).

(7) Tighten the bolts of caps 1, 2, 4, 5, 6, and 7 to 54 N·m (40 ft. lbs.) torque. Now tighten these bolts to 95 N·m (70 ft. lbs.) torque. Finally, tighten these bolts to 108 N·m (80 ft. lbs.) torque.

(8) Push the crankshaft forward and backward. Load the crankshaft front or rear and tighten cap bolt No.3 to 54 N·m (40 ft. lbs.) torque. Then tighten to 95 N·m (70 ft. lbs.) torque and finally tighten to 108 N·m (80 ft. lbs.) torque.

(9) Rotate the crankshaft after tightening each main bearing cap to ensure the crankshaft rotates freely.

(10) Check crankshaft end play. Crankshaft end play is controlled by the thrust bearing which is flange and installed at the No.2 main bearing position.

REMOVAL AND INSTALLATION (Continued)

(a) Attach a magnetic base dial indicator to the cylinder block at either the front or rear of the engine.

(b) Position the dial indicator rod so that it is parallel to the center line of the crankshaft.

(c) Pry the crankshaft forward, position the dial indicator to zero.

(d) Pry the crankshaft forward and backward. Note the dial indicator readings. End play is the difference between the high and low measurements (Fig. 71). Correct end play is 0.038-0.165 mm (0.0015-0.0065 inch). The desired specifications are 0.051-0.064 mm (0.002-0.0025 inch).

(e) If end play is not within specification, inspect crankshaft thrust faces for wear. If no wear is apparent, replace the thrust bearing and measure end play. If end play is still not within specification, replace the crankshaft.

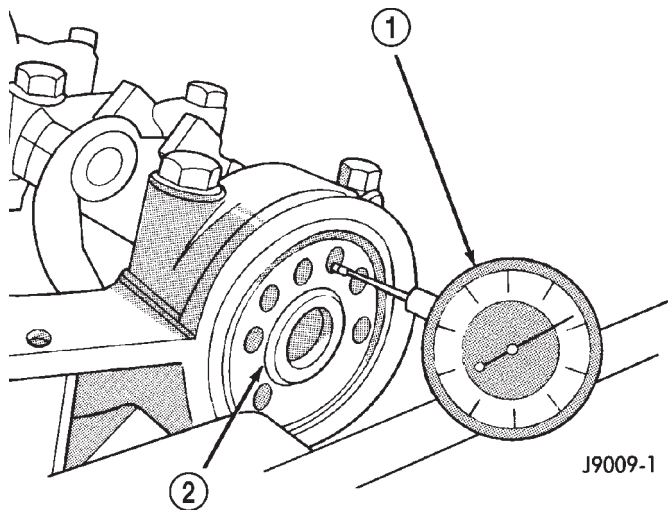

Fig. 71 Crankshaft End Play Measurement

- 1 - DIAL INDICATOR
2 - CRANKSHAFT

(11) If the crankshaft was removed, install the crankshaft into the cylinder block (refer to Cylinder Block - Assemble).

(12) Install main bearing cap brace tighten nuts to 47 N·m (35 ft. lbs.) torque.

(13) Install oil pump assy. and tighten attaching bolts to 23 N·m (17 ft. lbs.)

(14) Install the oil pan.

(15) Install the drain plug. Tighten the plug to 34 N·m (25 ft. lbs.) torque.

(16) Lower the vehicle.

(17) Install the spark plugs. Tighten the plugs to 37 N·m (27 ft. lbs.) torque.

(18) Fill the oil pan with engine oil to the full mark on the dipstick level.

(19) Connect negative cable to battery.

OIL PAN

REMOVAL

- (1) Disconnect negative cable from battery.
- (2) Raise the vehicle.
- (3) Remove the oil pan drain plug and drain the engine oil.
- (4) Disconnect the exhaust pipe at the exhaust manifold.
- (5) Disconnect the exhaust hanger at the catalytic converter and lower the pipe.
- (6) Remove the starter motor.
- (7) Remove the engine flywheel and transmission torque converter housing access cover.
- (8) If equipped with an oil level sensor, disconnect the sensor.
- (9) Position a jack stand directly under the engine vibration damper.
- (10) Place a piece of wood (2 x 2) between the jack stand and the engine vibration damper.
- (11) Remove the engine mount through bolts.
- (12) Using the jack stand, raise the engine until adequate clearance is obtained to remove the oil pan.
- (13) Remove transmission oil cooling lines (if equipped) and oxygen sensor wiring supports that are attached to the oil pan studs.
- (14) Remove the oil pan bolts and studs. Carefully slide the oil pan and gasket to the rear. If equipped with an oil level sensor, take care not to damage the sensor.

INSTALLATION

- (1) Clean the block and pan gasket surfaces.
- (2) Fabricate 4 alignment dowels from 1 1/2 x 1/4 inch bolts. Cut the head off the bolts and cut a slot into the top of the dowel. This will allow easier installation and removal with a screwdriver (Fig. 72).

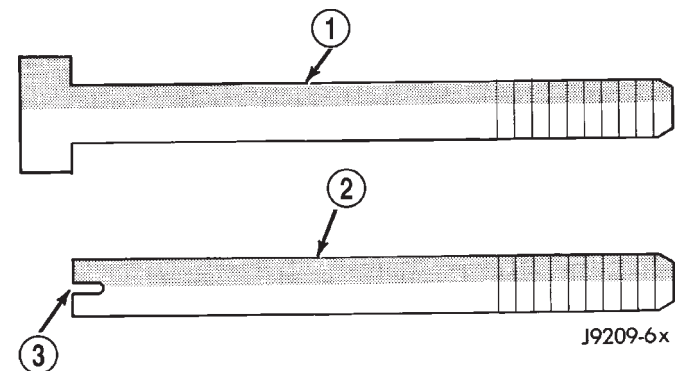
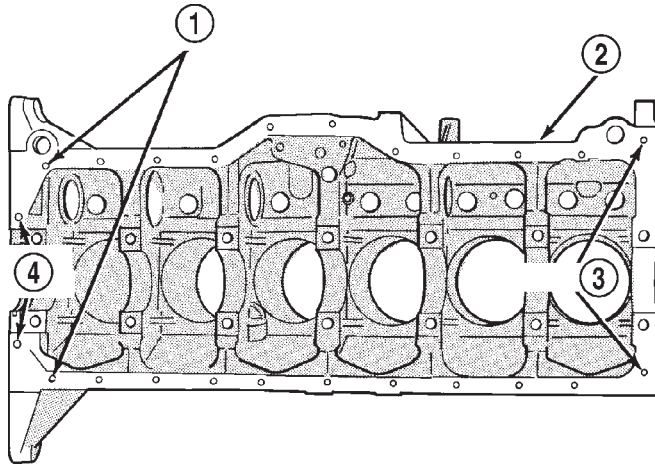

Fig. 72 Fabrication of Alignment Dowels

- 1 - 1/4" x 1 1/2" BOLT
2 - DOWEL
3 - SLOT

REMOVAL AND INSTALLATION (Continued)

(3) Install two dowels in the timing case cover. Install the other two dowels in the cylinder block (Fig. 73).



J9209-17

Fig. 73 Position of Dowels in Cylinder Block

- 1 - DOWEL HOLES
- 2 - CYLINDER BLOCK
- 3 - 5/16" HOLES
- 4 - 5/16" HOLES

(4) Apply Mopar® Silicone Rubber Adhesive Sealant on cylinder block to rear main bearing cap corners and cylinder block to front cover joints (four places) (Fig. 74).

(5) Slide the one-piece gasket over the dowels and onto the block and timing case cover.

(6) Position the oil pan over the dowels and onto the gasket. If equipped with an oil level sensor, take care not to damage the sensor.

(7) Install the 1/4 inch oil pan bolts. Tighten these bolts to 9.5 N·m (84 in. lbs.) torque. Install the 5/16 inch oil pan bolts (Fig. 75). Tighten these bolts to 15 N·m (132 in. lbs.) torque.

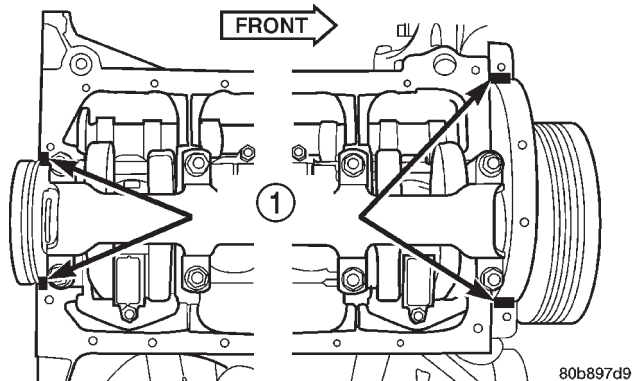

80b897d9

Fig. 74 Oil Pan Sealer Location

- 1 - SEALER LOCATIONS

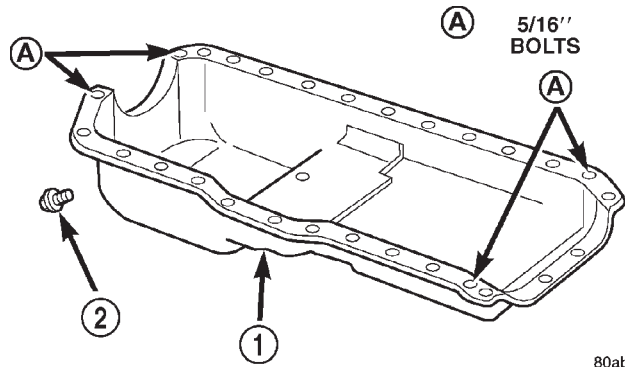

80abd2b4

Fig. 75 Position of 5/16 inch Oil Pan Bolts

- 1 - OIL PAN
- 2 - OIL PAN DRAIN PLUG

(8) Remove the dowels. Install the remaining 1/4 inch oil pan bolts. Tighten these bolts to 9.5 N·m (84 in. lbs.) torque.

(9) Lower the engine until it is properly located on the engine mounts.

(10) Install the through bolts and tighten the nuts.

(11) Lower the jack stand and remove the piece of wood.

(12) Install the engine flywheel and transmission torque converter housing access cover.

(13) Install the engine starter motor.

(14) Connect the exhaust pipe to the hanger and to the engine exhaust manifold.

(15) Install transmission oil cooling lines (if equipped) and oxygen sensor wiring supports that attach to the oil pan studs.

(16) Install the oil pan drain plug (Fig. 75). Tighten the plug to 34 N·m (25 ft. lbs.) torque.

(17) Lower the vehicle.

(18) Connect negative cable to battery.

(19) Fill the oil pan with engine oil to the specified level.

WARNING: USE EXTREME CAUTION WHEN THE ENGINE IS OPERATING. DO NOT STAND IN A DIRECT LINE WITH THE FAN. DO NOT PUT YOUR HANDS NEAR THE PULLEYS, BELTS OR FAN. DO NOT WEAR LOOSE CLOTHING.

(20) Start the engine and inspect for leaks.

PISTONS AND CONNECTING RODS

REMOVAL

- (1) Remove the engine cylinder head cover.
- (2) Remove the rocker arms, bridges and pivots.
- (3) Remove the push rods.
- (4) Remove the engine cylinder head.
- (5) Position the pistons one at a time near the bottom of the stroke. Use a ridge reamer to remove the

REMOVAL AND INSTALLATION (Continued)

ridge from the top end of the cylinder walls. Use a protective cloth to collect the cuttings.

- (6) Raise the vehicle.
- (7) Drain the engine oil.
- (8) Remove the oil pan and gasket.
- (9) Remove main bearing cap brace (Fig. 76).

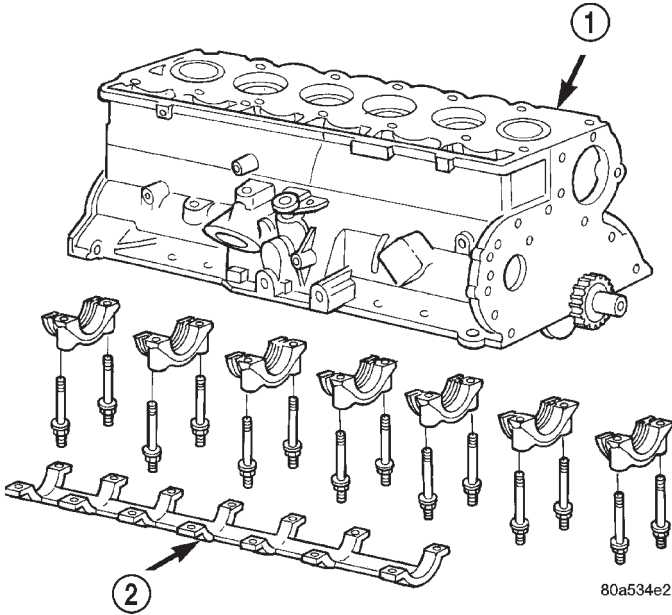

Fig. 76 Main Bearings Caps and Brace

- 1 - BLOCK
- 2 - MAIN BEARING CAP BRACE

(10) Remove the connecting rod bearing caps and inserts. Mark the caps and rods with the cylinder bore location. The connecting rods and caps are stamped with a two letter combination (Fig. 77).

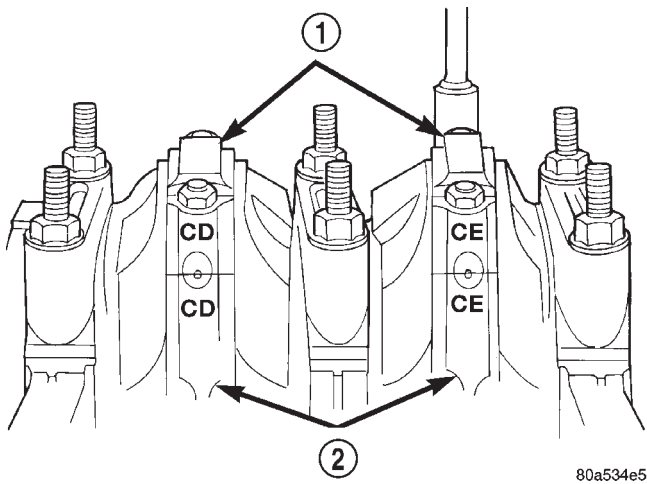

Fig. 77 Stamped Connecting Rods and Caps

- 1 - CONNECTING ROD CAP
- 2 - CONNECTING ROD

(11) Lower the vehicle until it is about 2 feet from the floor.

CAUTION: Ensure that the connecting rod bolts **DO NOT** scratch the crankshaft journals or cylinder walls. Short pieces of rubber hose, slipped over the rod bolts will provide protection during removal.

(12) Have an assistant push the piston and connecting rod assemblies up and through the top of the cylinder bores (Fig. 78).

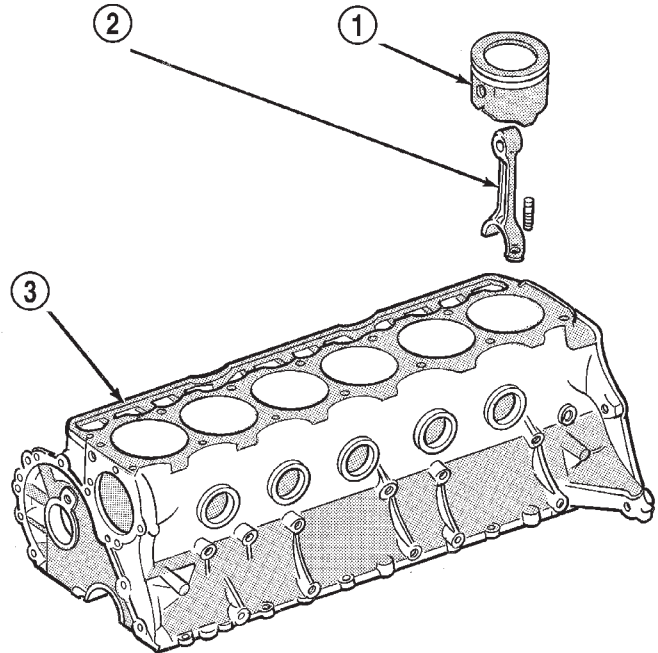

Fig. 78 Removal of Connecting Rod and Piston Assembly

- 1 - PISTON
- 2 - CONNECTING ROD
- 3 - BLOCK

INSTALLATION

(1) Clean the cylinder bores thoroughly. Apply a light film of clean engine oil to the bores with a clean lint-free cloth.

(2) Install the piston rings on the pistons if removed.

(3) Lubricate the piston and rings with clean engine oil.

CAUTION: Ensure that connecting rod bolts **DO NOT** scratch the crankshaft journals or cylinder walls. Short pieces of rubber hose slipped over the connecting rod bolts will provide protection during installation.

REMOVAL AND INSTALLATION (Continued)

(4) Use a piston ring compressor to install the connecting rod and piston assemblies through the top of the cylinder bores (Fig. 79).

(5) Ensure the arrow on the piston top points to the front of the engine (Fig. 79).

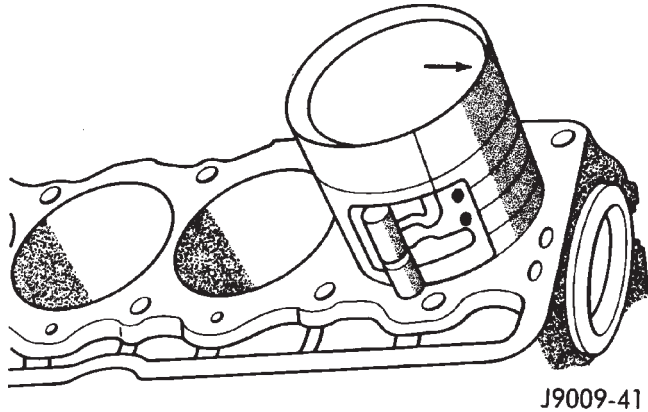

Fig. 79 Rod and Piston Assembly Installation

(6) Raise the vehicle.

(7) Each bearing insert is fitted to its respective journal to obtain the specified clearance between the bearing and the journal. In production, the select fit is obtained by using various-sized, color-coded bearing inserts as listed in the Connecting Rod Bearing Fitting Chart. The color code appears on the edge of the bearing insert. The size is not stamped on inserts used for production of engines.

(8) The rod journal is identified during the engine production by a color-coded paint mark on the adjacent cheek or counterweight toward the flange (rear) end of the crankshaft. The color codes used to indicate journal sizes are listed in the Connecting Rod Bearing Fitting Chart.

(9) When required, upper and lower bearing inserts of different sizes may be used as a pair (refer to Connecting Rod Bearing Fitting Chart). A standard size insert is sometimes used in combination with a 0.025 mm (0.001 inch) undersize insert to reduce clearance 0.013 mm (0.0005 inch).

CAUTION: DO NOT intermix bearing caps. Each connecting rod and bearing cap are stamped with the cylinder number. The stamp is located on a machined surface adjacent to the oil squirt hole that faces the camshaft side of the cylinder block.

(10) Install the connecting rod bearing caps and inserts in the same positions as removed.

CAUTION: Verify that the oil squirt holes in the rods face the camshaft and that the arrows on the pistons face the front of the engine.

(11) Install main bearing cap brace (Fig. 76). Tighten nuts to 47 N·m (35 ft. lbs.).

(12) Install the oil pan and gaskets as outlined in the installation procedure.

(13) Lower the vehicle.

(14) Install the engine cylinder head, push rods, rocker arms, bridges, pivots and engine cylinder head cover.

(15) Fill the crankcase with engine oil.

CRANKSHAFT OIL SEALS—REAR

The crankshaft rear main bearing oil seal consists of two half pieces of viton with a single lip that effectively seals the rear of the crankshaft. Replace the upper and lower seal halves as a unit to ensure leak-free operation.

REMOVAL

(1) Remove transmission inspection cover.

(2) Remove oil pan. Refer to procedure in this section

(3) Remove main bearing cap brace.

(4) Remove rear main bearing cap (No.7).

(5) Push upper seal out of the groove. Ensure that the crankshaft and seal groove are not damaged.

(6) Remove lower half of the seal from the bearing cap.

INSTALLATION

(1) Wipe the seal surface area of the crankshaft until it is clean.

(2) Apply a thin coat of engine oil.

(3) Coat lip of the seal with engine oil.

(4) Carefully position the upper seal into the groove in the cylinder block. The lip of the seal faces toward the front of the engine.

(5) Apply Mopar® Gasket Maker sealer on both sides of cylinder block as shown in (Fig. 80). The dab of sealer should be 3 mm (0.125 in.) in diameter.

(6) Apply Mopar® Gasket Maker on the rear bearing cap (Fig. 80). The bead should be 2.3 mm (0.09 in.) in diameter. DO NOT apply sealer to the lip of the seal.

(7) Position the lower seal into the bearing cap recess and seat it firmly. Be sure the seal is flush with the cylinder block pan rail.

(8) Coat the outer curved surface of the lower seal with soap and the lip of the seal with engine oil.

(9) Install the rear main bearing cap. DO NOT strike the cap more than twice for proper engagement.

(10) Tighten all main bearing bolts to 108 N·m (80 ft. lbs.) torque.

(11) Install the main bearing cap brace. Tighten nuts to 47 N·m (35 ft. lbs.).

(12) Install the oil pan gasket and oil pan. Tighten 1/4 - 20 screws to 14 N·m (120 in. lbs.). Tighten 5/16 - 18 screws to 18 N·m (156 in. lbs.).

REMOVAL AND INSTALLATION (Continued)

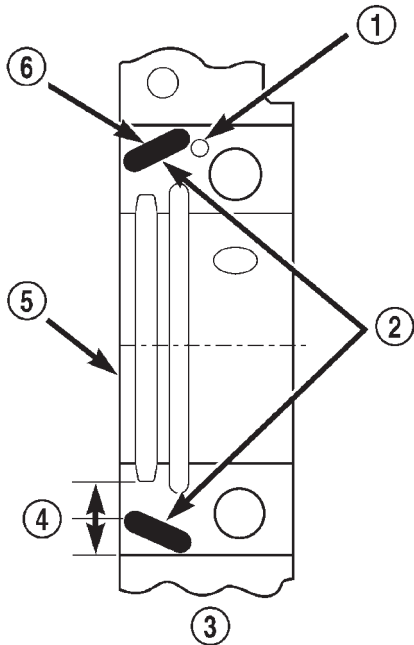

80bfe13c

Fig. 80 Location of Sealer

- 1 - DOWEL
- 2 - SEALER LOCATIONS
- 3 - CYLINDER BLOCK
- 4 - HALFWAY BETWEEN
- 5 - REAR FACE OF CYLINDER BLOCK
- 6 - 3mm (0.125 in.)

(13) Apply Mopar® Silicone Rubber Adhesive Sealant on cylinder block to rear main bearing cap corners and cylinder block to front cover joints (four places) (Fig. 81)

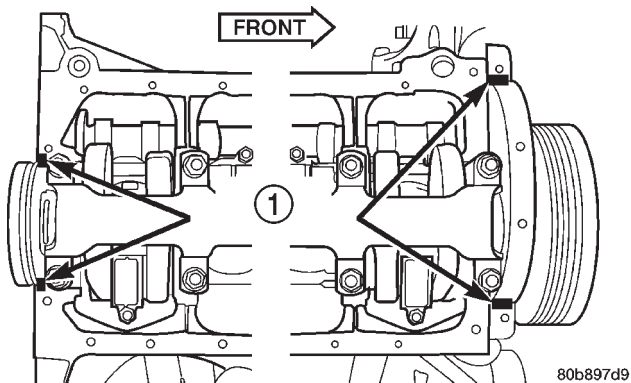

80b897d9

Fig. 81 Oil Pan Sealer Location

- 1 - SEALER LOCATIONS

(14) Install transmission inspection cover.

OIL PUMP

A gear-type oil pump is mounted at the underside of the cylinder block opposite the No.4 main bearing.

The pump incorporates a nonadjustable pressure relief valve to limit maximum pressure to 517 kPa (75 psi). In the relief position, the valve permits oil to bypass through a passage in the pump body to the inlet side of the pump.

Oil pump removal or replacement will not affect the distributor timing because the distributor drive gear remains in mesh with the camshaft gear.

REMOVAL

- (1) Drain the engine oil.
- (2) Remove the oil pan.
- (3) Remove the pump-to-cylinder block attaching bolts. Remove the pump assembly with gasket (Fig. 82).

CAUTION: If the oil pump is not to be serviced, DO NOT disturb position of oil inlet tube and strainer assembly in pump body. If the tube is moved within the pump body, a replacement tube and strainer assembly must be installed to assure an airtight seal.

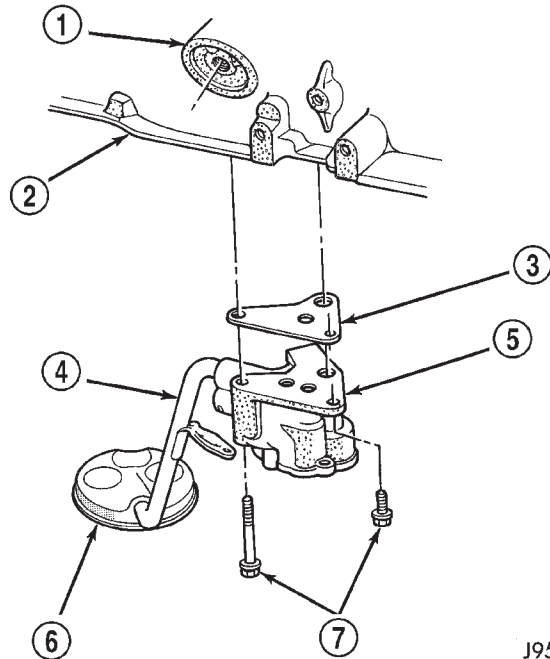

J9509-85

Fig. 82 Oil Pump Assembly

- 1 - OIL FILTER ADAPTOR
- 2 - BLOCK
- 3 - GASKET
- 4 - OIL INLET TUBE
- 5 - OIL PUMP
- 6 - STRAINER ASSEMBLY
- 7 - ATTACHING BOLTS

REMOVAL AND INSTALLATION (Continued)

INSTALLATION

- (1) Install the oil pump on the cylinder block using a replacement gasket. Tighten the bolts to 23 N·m (17 ft. lbs.) torque.
- (2) Install the oil pan.
- (3) Fill the oil pan with oil to the specified level.

TIMING CASE COVER OIL SEAL

This procedure is done with the timing case cover installed.

REMOVAL

- (1) Disconnect negative cable from battery.
- (2) Remove the serpentine drive belt.
- (3) Remove the vibration damper.
- (4) Remove the radiator shroud.
- (5) Carefully remove the oil seal. Make sure seal bore is clean.

INSTALLATION

(1) Position the replacement oil seal on Timing Case Cover Alignment and Seal Installation Tool 6139 with seal open end facing inward. Apply a light film of Perfect Seal, or equivalent, on the outside diameter of the seal. Lightly coat the crankshaft with engine oil.

(2) Position the tool and seal over the end of the crankshaft and insert a draw screw tool into Seal Installation Tool 6139 (Fig. 83). Tighten the nut against the tool until it contacts the cover.

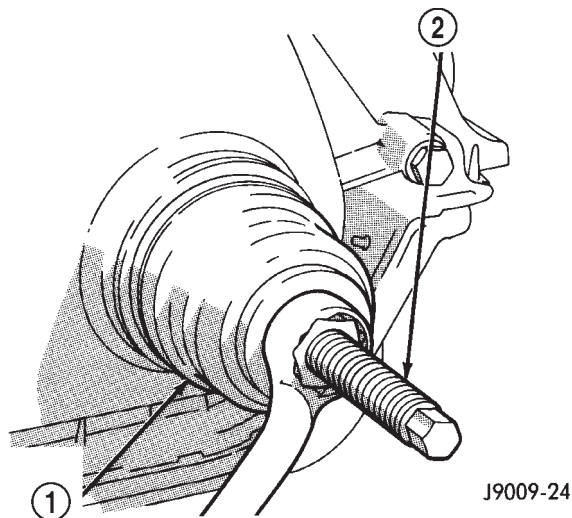

Fig. 83 Timing Case Cover Oil Seal Installation

- 1 - SEAL INSTALLATION TOOL
2 - DRAW SCREW TOOL

(3) Remove the tools. Apply a light film of engine oil on the vibration damper hub contact surface of the seal.

(4) Apply Mopar Silicone Rubber Adhesive Sealant to the keyway in the crankshaft and insert the key. With the key inserted in the keyway in the crankshaft, install the vibration damper, washer and bolt. Lubricate and tighten the bolt to 108 N·m (80 ft. lbs.) torque.

(5) Install the serpentine belt and tighten to the specified tension (refer to Group 7, Cooling Systems for the proper specifications and procedures).

(6) Install the radiator shroud.

(7) Connect negative cable to battery.

DISASSEMBLY AND ASSEMBLY

CYLINDER BLOCK

DISASSEMBLY

Refer to the applicable sections for detailed instructions.

(1) Drain the engine oil. Remove and discard the oil filter.

(2) Remove the water pump from the cylinder block.

(3) Remove the vibration damper.

(4) Remove the timing case cover and lay the cover upside down.

(5) Position a drift punch into the slot in the back of the cover and tap the old seal out.

(6) Remove the oil slinger from crankshaft.

(7) Remove the camshaft retaining bolt and remove the sprockets and chain as an assembly.

(8) Remove the camshaft.

(9) Remove the oil pan and gasket.

(10) Remove the front and rear oil galley plugs.

(11) Remove the oil pump.

(12) Remove the connecting rods and the pistons. Remove the connecting rod and piston assemblies through the top of the cylinder bores.

(13) Remove the crankshaft.

ASSEMBLY

Refer to the applicable sections for detailed instructions.

(1) Install the crankshaft.

(2) Install the connecting rods and the pistons through the top of the cylinder bores.

(3) Install the oil pump.

(4) Install the oil pan and gasket.

(5) Install the camshaft.

(6) Install the sprockets and chain as an assembly.

(7) Install the oil slinger from the crankshaft.

(8) Install the timing case cover seal.

(9) Install the timing case cover.

(10) Install the vibration damper.

(11) Install the water pump. Tighten the mounting bolts to 31 N·m (23 ft. lbs.) torque.

DISASSEMBLY AND ASSEMBLY (Continued)

- (12) Lubricate the oil filter seal with clean engine oil. Tighten oil filter to 18 N·m (156 in. lbs.) torque.
- (13) Install the engine into the vehicle.
- (14) Fill the engine with clean lubrication oil (refer to Group 0, Lubrication and Maintenance).
- (15) Fill the cooling system.

CLEANING AND INSPECTION

CYLINDER HEAD

CLEANING

Thoroughly clean the engine cylinder head and cylinder block mating surfaces. Clean the intake and engine exhaust manifold and engine cylinder head mating surfaces. Remove all gasket material and carbon.

Check to ensure that no coolant or foreign material has fallen into the tappet bore area.

Remove the carbon deposits from the combustion chambers and top of the pistons.

INSPECTION

Use a straightedge and feeler gauge to check the flatness of the engine cylinder head and block mating surfaces.

CYLINDER HEAD COVER

CLEANING

Remove any original sealer from the cover sealing surface of the engine cylinder head and clean the surface using a fabric cleaner.

Remove all residue from the sealing surface using a clean, dry cloth.

INSPECTION

Inspect the engine cylinder head cover for cracks. Replace the cover, if cracked.

The original dark grey gasket material should NOT be removed. If sections of the gasket material are missing or are compressed, replace the engine cylinder head cover. However, sections with minor damage such as small cracks, cuts or chips may be repaired with a hand held applicator. The new material must be smoothed over to maintain gasket height. Allow the gasket material to cure prior to engine cylinder head cover installation.

ROCKER ARMS AND PUSH RODS

CLEANING

Clean all the components with cleaning solvent. Use compressed air to blow out the oil passages in the rocker arms and push rods.

INSPECTION

Inspect the pivot surface area of each rocker arm. Replace any that are scuffed, pitted, cracked or excessively worn.

Inspect the valve stem tip contact surface of each rocker arm and replace any rocker arm that is deeply pitted.

Inspect each push rod end for excessive wear and replace as required. If any push rod is excessively worn because of lack of oil, replace it and inspect the corresponding hydraulic tappet for excessive wear.

Inspect the push rods for straightness by rolling them on a flat surface or by shining a light between the push rod and the flat surface.

A wear pattern along the length of the push rod is not normal. Inspect the engine cylinder head for obstruction if this condition exists.

HYDRAULIC TAPPETS

CLEANING

Clean each tappet assembly in cleaning solvent to remove all varnish, gum and sludge deposits.

INSPECTION

Inspect for indications of scuffing on the side and base of each tappet body.

Inspect each tappet base for concave wear with a straightedge positioned across the base. If the base is concave, the corresponding lobe on the camshaft is also worn. Replace the camshaft and defective tappets.

After cleaning and inspection, test each tappet for specified leak-down rate tolerance to ensure zero-lash operation (Fig. 84).

Swing the weighted arm of the hydraulic valve tappet tester away from the ram of the Leak-Down Tester.

(1) Place a 7.925-7.950 mm (0.312-0.313 inch) diameter ball bearing on the plunger cap of the tappet.

(2) Lift the ram and position the tappet (with the ball bearing) inside the tester cup.

(3) Lower the ram, then adjust the nose of the ram until it contacts the ball bearing. DO NOT tighten the hex nut on the ram.

(4) Fill the tester cup with hydraulic valve tappet test oil until the tappet is completely submerged.

(5) Swing the weighted arm onto the push rod and pump the tappet plunger up and down to remove air. When the air bubbles cease, swing the weighted arm away and allow the plunger to rise to the normal position.

(6) Adjust the nose of the ram to align the pointer with the SET mark on the scale of the tester and tighten the hex nut.

CLEANING AND INSPECTION (Continued)

(7) Slowly swing the weighted arm onto the push rod.

(8) Rotate the cup by turning the handle at the base of the tester clockwise one revolution every 2 seconds.

(9) Observe the leak-down time interval from the instant the pointer aligns with the START mark on the scale until the pointer aligns with the 0.125 mark. A normally functioning tappet will require 20-110 seconds to leak-down. Discard tappets with leak-down time interval not within this specification.

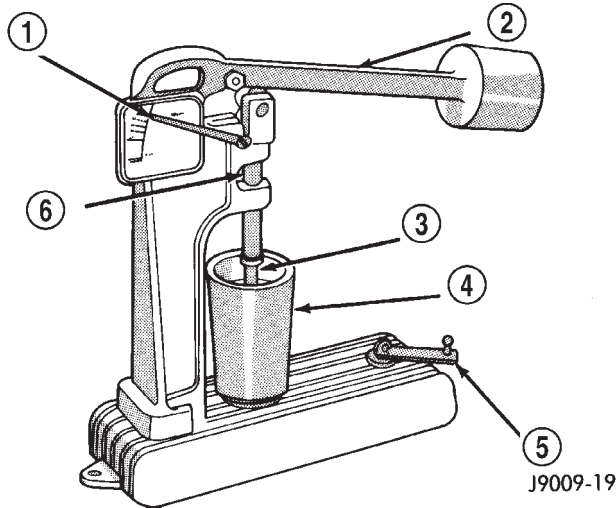

Fig. 84 Leak-Down Tester

- 1 - POINTER
- 2 - WEIGHTED ARM
- 3 - RAM
- 4 - CUP
- 5 - HANDLE
- 6 - PUSH ROD

CYLINDER BLOCK

CLEANING

Thoroughly clean the oil pan and engine block gasket surfaces.

Use compressed air to clean out:

- The galley at the oil filter adaptor hole.
- The front and rear oil galley holes.
- The feed holes for the crankshaft main bearings.

Once the block has been completely cleaned, apply Loctite PST pipe sealant with Teflon 592 to the threads of the front and rear oil galley plugs. Tighten the plugs to 34 N·m (25 ft. lbs.) torque.

INSPECTION

(1) It is mandatory to use a dial bore gauge to measure each cylinder bore diameter (Fig. 85). To correctly select the proper size piston, a cylinder bore gauge, capable of reading in 0.003 mm (.0001 in.) INCREMENTS is required. If a bore gauge is not available, do not use an inside micrometer.

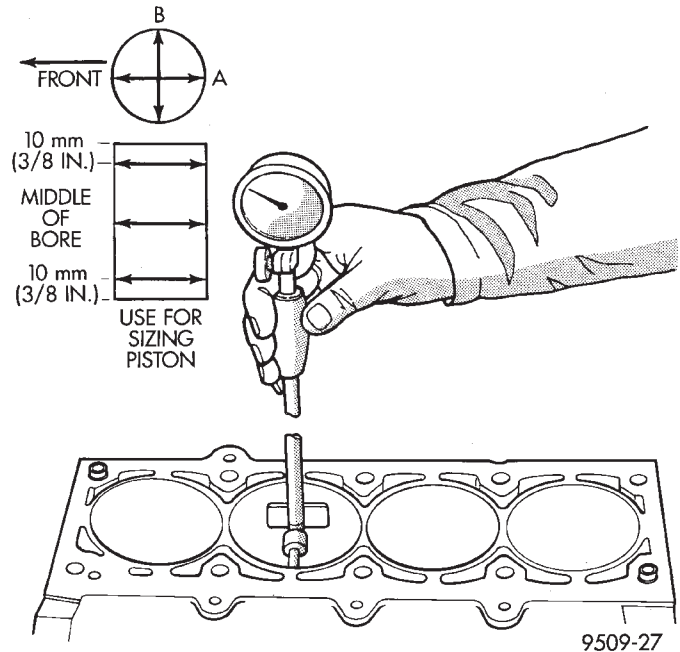

Fig. 85 Cylinder Bore Measurement

(2) Measure the inside diameter of the cylinder bore at three levels below top of bore. Start perpendicular (across or at 90 degrees) to the axis of the crankshaft and then take two additional readings.

(3) Measure the cylinder bore diameter crosswise to the cylinder block near the top of the bore. Repeat the measurement near the middle of the bore, then repeat the measurement near the bottom of the bore.

(4) Determine taper by subtracting the smaller diameter from the larger diameter.

(5) Rotate measuring device 90° and repeat steps above.

(6) Determine out-of-roundness by comparing the difference between each measurement.

(7) If cylinder bore taper does not exceed 0.025 mm (0.001 inch) and out-of-roundness does not exceed 0.025 mm (0.001 inch), the cylinder bore can be honed. If the cylinder bore taper or out-of-round condition exceeds these maximum limits, the cylinder must be bored and then honed to accept an oversize piston. A slight amount of taper always exists in the cylinder bore after the engine has been in use for a period of time.

SPECIFICATIONS

SPECIFICATIONS

4.0L ENGINE

| DESCRIPTION | SPECIFICATION |
|----------------------------|---|
| Engine Type | In-line 6 Cylinder |
| Bore and Stroke | 98.4 x 86.69 mm (3.88 x 3.413 in.) |
| Displacement | 4.0L (242 cu. in.) |
| Compression Ratio | 8.8:1 |
| Firing Order | 1-5-3-6-2-4 |
| Lubrication | Pressure Feed-Full Flow Filtration |
| Cooling System | Liquid Cooled-Forced Circulation |
| Cylinder Block | Cast Iron |
| Crankshaft | Cast Nodular Iron |
| Cylinder Head | Cast Iron |
| Camshaft | Cast Iron |
| Pistons | Aluminum Alloy |
| Combustion Chamber | Dual-Quench |
| Connecting Rods | Cast Malleable Iron |
| CAMSHAFT | |
| Hydraulic Tappet Clearance | Zero Lash |
| Bearing Clearance | 0.025 to 0.076 mm (0.001 to 0.003 in.) |
| Bearing Journal Diameter | |
| No. 1 | 51.54 to 51.56 mm (2.029 to 2.030 in.) |
| No. 2 | 51.28 to 51.31 mm (2.019 to 2.020 in.) |
| No. 3 | 51.03 to 51.05 mm (2.009 to 2.010 in.) |
| No. 4 | 50.78 to 50.80 mm (1.999 to 2.000 in.) |

| DESCRIPTION | SPECIFICATION |
|-------------------------------|---|
| Base Circle Runout (MAX) | 0.03 mm (0.001 in.) |
| Valve Lift | |
| Intake | 10.350 mm (0.4075 in.) |
| Exhaust | 10.528 mm (0.4145 in.) |
| Valve Timing | |
| Intake | |
| Opens | 12.4° BTDC |
| Closes | 60.9° ABDC |
| Exhaust | |
| Opens | 49.8 BBDC |
| Closes | 29.2° ATDC |
| Valve Overlap | 41.6° |
| Intake Duration | 253.3° |
| Exhaust Duration | 259.° |
| CRANKSHAFT | |
| End Play | 0.038 to 0.165 mm (0.0015 to 0.0065 in.) |
| Main Bearing Journal Diameter | |
| No. 1-6 | 63.489 to 63.502 mm (2.4996 to 2.5001 in.) |
| No. 7 | 63.449 to 63.487 mm (2.4980 to 2.4995 in.) |
| Main Bearing Journal Width | |
| No. 1 | 27.58 to 27.89 mm (1.086 to 1.098 in.) |
| No. 3 | 32.28 to 32.33 mm (1.271 to 1.273 in.) |
| No. 2-4-5-6-7 | 30.02 to 30.18 mm (1.182 to 1.188 in.) |
| Main Bearing Clearance | 0.03 to 0.06 mm (0.001 to 0.0025 in.) |
| Preferred | 0.051 mm (0.002 in.) |

SPECIFICATIONS (Continued)

| DESCRIPTION | SPECIFICATION |
|------------------------------------|---|
| Connecting Rod Journal Diameter | 53.17 to 53.23 mm (2.0934 to 2.0955 in.) |
| Connecting Rod Journal Width | 27.18 to 27.33 mm (1.070 to 1.076 in.) |
| Out-of-Round (MAX) | 0.013 mm (0.0005 in.) |
| Taper (MAX) | 0.013 mm (0.0005 in.) |
| CYLINDER BLOCK | |
| Deck Height | 240.03 to 240.18 mm (9.450 to 9.456 in.) |
| Deck Clearance (Below Block) | 0.546 mm (0.0215 in.) |
| Cylinder Bore Diameter Standard | 98.45 to 98.48 mm (3.8759 to 3.8775 in.) |
| Taper | 0.025 mm (0.001 in.) |
| Out-ofRound | 0.025 mm (0.001 in.) |
| Tappet Bore Diameter | 23.000 to 23.025 mm (0.9055 to 0.9065 in.) |
| Flatness | 0.03 mm per 25 mm (0.001 in. per 1 in.) 0.05 mm per 152 mm (0.002 in. per 6 in.) |
| Flatness Max. | 0.20 mm max. for total length (0.008 in. max. for total length) |
| Main Bearing Bore Diameter | 68.3514 to 68.3768 mm (2.691 to 2.692 in.) |
| CONNECTING ROD | |
| Total Weight (Less Bearing) | 663 to 671 grams (23.39 to 23.67 oz.) |
| Length (Center-to-Center) | 155.52 to 155.62 mm (6.123 to 6.127 in.) |
| Piston Pin Bore Diameter | 23.59 to 23.62 mm (0.9288 to 0.9298 in.) |

| DESCRIPTION | SPECIFICATION |
|--------------------------------------|---|
| Bore (Less Bearings) | 56.08 to 56.09 mm (2.2080 to 2.2085 in.) |
| Bearing Clearance | 0.025 to 0.076 mm (0.001 to 0.003 in.) |
| Preferred | 0.044 to 0.050 mm (0.0015 to 0.0020 in.) |
| Side Clearance | 0.25 to 0.48 mm (0.010 to 0.019 in.) |
| Twist (Max.) | 0.002 mm per mm (0.002 in. per inch) |
| Bend (Max.) | 0.002 mm per mm (0.002 in. per inch.) |
| CYLINDER COMPRESSION PRESSURE | |
| Pressure Range | 827 to 1,034 kPa (120 to 150 psi) |
| Max. Variation Between Cylinders | 206 kPa (30 psi) |
| CYLINDER HEAD | |
| Combustion Chamber | 55.22 to 58.22 cc (3.37 to 3.55 cu. in.) |
| Valve Guide I. D. (Integral) | 7.95 to 7.97 mm (0.313 to 0.314 in.) |
| Valve Stem-to-Guide Clearance | 0.025 to 0.076 mm (0.001 to 0.003 in.) |
| Valve Seat Angle | |
| Intake | 44.5° |
| Exhaust | 44.5° |
| Valve Seat Width | 1.02 to 1.52 mm (0.040 to 0.060 in.) |
| Valve Seat Runout | 0.064 mm (0.0025 in.) |
| Flatness | 0.03 mm per 25 mm (0.001 in. per 1 in.) 0.05 mm per 152 mm (0.002 in. per 6 in.) |

SPECIFICATIONS (Continued)

| DESCRIPTION | SPECIFICATION |
|---|--|
| Flatness Max. | 0.20 mm - max. for total length (0.008 in. max. for total length) |
| ROCKER ARMS, PUSH RODS & TAPPETS | |
| Rocker Arm Ratio | 1.6:1 |
| Push Rod Length (Pink) | 244.856 to 245.364 mm (9.640 to 9.660 in.) |
| Push Rod Diameter | 7.92 to 8.00 mm (0.312 to 0.315 in.) |
| Hydraulic Tappet Diameter | 22.962 to 22.974 mm (0.904 to 0.9045 in.) |
| Tappet-to-Bore Clearance | 0.025 to 0.063 mm (0.001 to 0.0025 in.) |
| VALVES | |
| Valve Length (Overall) | |
| Intake | 122.479 to 122.860 mm (4.822 to 4.837 in.) |
| Exhaust | 122.860 to 123.241 mm (4.837 to 4.852 in.) |
| Valve Stem Diameter | 7.899 to 7.925 mm (0.311 to 0.312 in.) |
| Stem-to-Guide Clearance | 0.025 to 0.076 mm (0.001 to 0.003 in.) |
| Valve Head Diameter | |
| Intake | 48.387 to 48.641 mm (1.905 to 1.915 in.) |
| Exhaust | 37.973 to 38.227 mm (1.495 to 1.505 in.) |
| Valve Face Angle | |
| Intake | 46.5° |
| Exhaust | 46.5° |
| Tip Refinishing (Max. Allowable) | 0.25 mm (0.010 in.) |

| DESCRIPTION | SPECIFICATION |
|--|---|
| VALVE SPRINGS | |
| Free Length (Approx.) | 47.65 mm (1.876 in.) |
| Spring Load | |
| Valve Closed | 316 to 351 N @ 41.656 mm (71 to 79 lbf. @ 1.64 in.) |
| Valve Open | 898.6 to 969.7 N @ 30.89 mm (202 to 218 lbf @ 1.216 in.) |
| Inside Diameter | 21.0 mm to 21.51 mm (0.827 to 0.847 in.) |
| Installed Height | 41.656 mm (1.64 in.) |
| PISTONS | |
| Weight (Less Pin) | 417 to 429 grams (14.7 to 15.1 oz.) |
| Piston Pin Bore (Centerline to Piston Top) | 40.61 to 40.72 mm (1.599 to 1.603 in.) |
| Piston-to-Bore Clearance | 0.018 to 0.038 mm (0.0008 to 0.0015 in.) |
| Ring Gap Clearance | |
| Top Compression Ring | 0.229 to 0.610 mm (0.0090 to 0.0240 in.) |
| 2nd Compression Ring | 0.483 to 0.965 mm (0.0190 to 0.0380 in.) |
| Oil Control Steel Rails | 0.254 to 1.500 mm (0.010 to 0.060 in.) |
| Ring Side Clearance | |
| Compression Rings | 0.042 to 0.084 mm (0.0017 to 0.0033 in.) |
| Oil Control Rings | 0.06 to 0.21 mm (0.0024 to 0.0083 in.) |
| Piston Ring Groove Height | |
| Compression Rings | 1.530 to 1.555 mm (0.0602 to 0.0612 in.) |
| Oil Control Ring | 4.035 to 4.060 mm (0.1589 to 0.1598 in.) |

SPECIFICATIONS (Continued)

| DESCRIPTION | SPECIFICATION |
|---|---|
| Piston Ring Groove Diameter | |
| No.1 Compression Ring | 88.39 to 88.65 mm (3.48 to 3.49 in.) |
| No.2 Compression Ring | 87.63 to 87.88 mm (3.45 to 3.46 in.) |
| Oil Control Ring | 89.66 to 89.92 mm (3.53 to 3.54 in.) |
| Piston Pin Bore Diameter | 23.650 to 23.658 mm (0.9312 to 0.9315 in.) |
| Piston Pin Diameter | 23.637 to 23.640 mm (0.9306 to 0.9307 in.) |
| Piston-to-Pin Clearance | 0.0102 to 0.0208 mm (0.0005 to 0.0009 in.) |
| Piston-to-Pin Connecting Rod (Press Fit) | 8.9 kN (2000 lbf.) |
| OIL PUMP | |
| Gear-to-Body Clearance | 0.051 to 0.102 mm |
| (Radial) | (0.002 to 0.004 in.) |
| Gear-to-Body Clearance (Radial) Preferred | 0.051 mm (0.002 in.) |
| Gear End Clearance Plastigage | 0.051 to 0.152 mm (0.002 to 0.006 in.) |
| Gear End Clearance Plastigage (Preferred) | 0.051 mm (0.002 in.) |
| Gear End Clearance Feeler Gauge | 0.1016 to 0.2032 mm (0.004 to 0.008 in.) |
| Gear End Clearance Feeler Gauge (Preferred) | 0.1778 mm (0.007 in.) |
| Oil Pressure | |
| At Idle Speed | 89.6 kPa (13 psi) |
| At 1600 rpm & Higher | 255 to 517 kPa (37 to 75 psi) |
| Oil Pressure Relief | 517 kPa (75 psi) |

TORQUE SPECIFICATIONS

4.0L ENGINE

| DESCRIPTION | N·m | Ft. Lbs. | In. Lbs. |
|---|-----|----------|----------|
| A/C Compressor—Bolts | 28 | — | 250 |
| Block Heater—Nut | 2 | — | 16 |
| Camshaft Sprocket—Bolt | 68 | 50 | — |
| Camshaft Thrust Plate to Cylinder Block—Screws | 24 | 18 | — |
| Clutch Cover to Flywheel—Bolts | 54 | 40 | — |
| Coil Bracket to Block—Bolts | 22 | — | 192 |
| Connecting Rod—Nuts | 45 | 33 | — |
| Cylinder Block—Drain Plugs | 34 | 25 | — |
| Cylinder Head—Bolts | 135 | 100 | — |
| Cylinder Head Cover—Bolts | 10 | — | 85 |
| Distributor Clamp—Bolts | 23 | — | 204 |
| Engine Mounts—Front | | | |
| Support Bracket Bolts | 61 | 45 | — |
| Support Cushion Bolts/Nuts | 41 | 30 | — |
| Support Cushion Bracket Bolts | 54 | 40 | — |
| Support Cushion Bracket Stud Nuts | 41 | 30 | — |
| Support Cushion Thru-Bolt | 65 | 48 | — |
| Engine Mounts—Rear | | | |
| Crossmember to Sill Bolts—(Automatic) | 41 | 30 | — |
| Insulator Stud Assembly—Nut | 41 | 30 | — |
| Support Cushion/Crossmember—Nuts | 22 | — | 192 |
| Support Cushion/Bracket—Nuts (Manual) | 75 | 55 | — |
| Transmission Support Bracket—Bolt (Manual) | 46 | 34 | — |
| Transmission Support Bracket/Cushion—Bolt (4WD Auto) | 75 | 55 | — |
| Transmission Support Adaptor Bracket—Bolts (2WD Auto) | 75 | 55 | — |
| Exhaust Manifold/Pipe—Nuts | 27 | 20 | — |

SPECIFICATIONS (Continued)

| DESCRIPTION | N-m | Ft. Lbs. | In. Lbs. |
|--|-----|-------------|-------------|
| Intake/Exhaust Manifold | | | |
| Fasteners #1-5 | 33 | 24 | — |
| Fasteners #6 and 7 | 14 | — | 126 |
| Fasteners #8-11 | 33 | 24 | — |
| Flywheel to Converter Housing—Bolts | 38 | 28 | — |
| Flywheel to Crankshaft—Bolts | 143 | 105 | — |
| Front Cover to Block—Bolts | | | |
| 1/4-20 | 7 | — | 60 |
| 5/16-18 | 22 | — | 192 |
| Fuel Rail—Bolts/Stud | 12 | — | 108 |
| Generator—Bolts | 57 | 42 | — |
| Generator Bracket to Engine—Bolts | 47 | 35 | — |
| Idler Pulley to Cylinder Head—Bolt | 47 | 35 | — |
| Main Bearing Cap—Bolts | 108 | 80 | — |
| Oil Filter | 18 | — | 156 |
| Oil Filter Connector to | | | |
| Adaptor | 47 | 35 | — |
| Block | 68 | 50 | — |
| Adaptor Bolts | 102 | 50 | — |
| Oil Galley—Plug | 41 | 30 | — |
| Oil Pan—Bolts | | | |
| 1/4-20 | 9.5 | — | 84 |
| 5/16-18 | 15 | — | 132 |
| Oil Pan—Drain Plug | 34 | 25 | — |
| Oil Pump | | | |
| Mounting Bolts | 23 | — | 204 |
| Cover Bolts | 8 | — | 70 |
| Rocker Arm Assembly to Cylinder Head—Capscrews | 30 | 21 | — |
| Spark Plugs | 37 | 27 | — |
| Starter Motor—Mounting Bolts | 45 | 33 | — |
| Thermostat Housing—Bolts | 18 | — | 156 |
| Throttle Body—Bolts | 10 | — | 90 |
| Vibration Damper—Bolt | 108 | 80 | — |
| Water Pump to Block—Bolts | 23 | 17 | — |

SPECIAL TOOLS

4.0L ENGINE

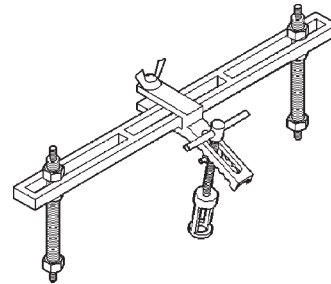

Valve Spring Compressor Tool MD-998772A

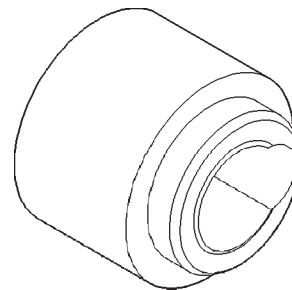

Timing Case Cover Alignment and Seal installation Tool 6139

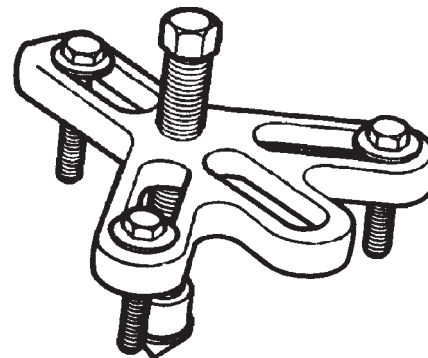

Vibration Damper Removal Tool 7697

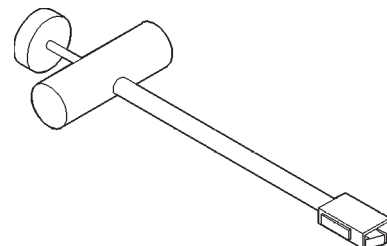

Hydraulic Valve Tappet Removal/Installation Tool C-4129-A

ENGINE

TABLE OF CONTENTS

| | page | | page |
|----------------------------------|------|---|------|
| DESCRIPTION AND OPERATION | | OIL PAN | 33 |
| ENGINE IDENTIFICATION | 1 | OIL PUMP | 33 |
| DIAGNOSIS AND TESTING | | INTERNAL VACUUM PUMP | 33 |
| SERVICE DIAGNOSIS—DIESEL— | | OIL PUMP PRESSURE RELIEF VALVE | 34 |
| PERFORMANCE | 2 | OIL FILTER ADAPTER AND ENGINE OIL | |
| SERVICE DIAGNOSIS—DIESEL— | | COOLER | 35 |
| MECHANICAL | 9 | PISTONS AND CONNECTING ROD | |
| TAPPET NOISE | 11 | ASSEMBLY | 35 |
| SERVICE PROCEDURES | | CYLINDER WALL LINER ASSEMBLY | 38 |
| VALVE SERVICE | 11 | CRANKSHAFT MAIN BEARINGS | 40 |
| REMOVAL AND INSTALLATION | | DISASSEMBLY AND ASSEMBLY | |
| ENGINE MOUNTS — LHD DIESEL | 13 | HYDRAULIC TAPPETS | 43 |
| ENGINE MOUNTS — RHD DIESEL | 15 | CLEANING AND INSPECTION | |
| 2.5L DIESEL ENGINE | 18 | CYLINDER HEAD | 43 |
| CYLINDER HEAD COVER | 22 | ROCKER ARMS AND PUSH RODS | 43 |
| HYDRAULIC TAPPETS | 23 | PISTONS AND CONNECTING ROD | |
| HYDRAULIC TAPPETS | 23 | ASSEMBLY | 44 |
| ROCKER ARMS AND PUSH RODS | 24 | CYLINDER WALL LINER ASSEMBLY | 45 |
| VALVE SPRINGS | 24 | OIL PUMP | 46 |
| ENGINE CYLINDER HEAD | 25 | SPECIFICATIONS | |
| VIBRATION DAMPER | 30 | ENGINE SPECIFICATIONS | 46 |
| TIMING GEAR COVER OIL SEAL | 30 | TORQUE SPECIFICATIONS | 48 |
| TIMING GEAR COVER | 30 | SPECIAL TOOLS | |
| CAMSHAFT | 31 | SPECIAL TOOLS | 49 |
| CAMSHAFT BEARINGS | 32 | | |

DESCRIPTION AND OPERATION

ENGINE IDENTIFICATION

DESCRIPTION

The engine model code and serial number are stamped on the left side of the engine block, just below the oil dipstick tube (Fig. 1). The engine code on the XJ 2.5L is DD85C followed by a 5 digit serial number.

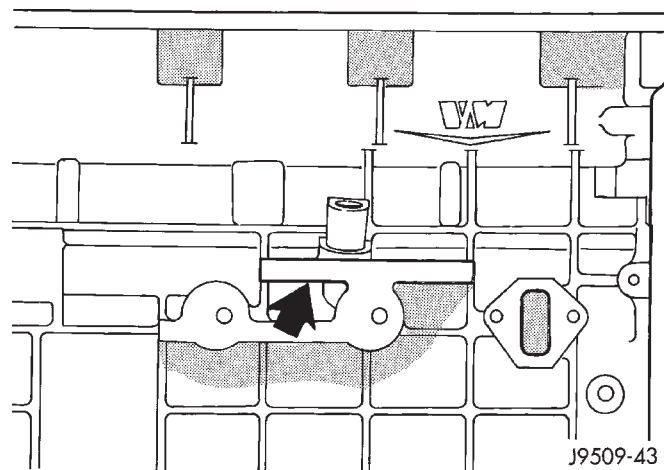

Fig. 1 Engine Code Location

DIAGNOSIS AND TESTING (Continued)

- Displacement 2.5L (2499 cc)
- Bore 92.00
- Stroke 94.00
- Compression Ratio 21:1

- Vacuum at idle 600 mm/Hg (23.6 In/Hg)
- Belt Tension 400/500 N Automatic
Tensioner
- Thermostat Opening . . . 80°C ± 2°C
- Generator Rating Denso 12V—95A
- Cooling System Capacity. 9.5 Liter
- P/S Capacity 0.75 Liter
- Engine Oil Capacity . . . 7.2L w/filter change
- Timing System Pushrod operated overhead
valves, with gear-driven
camshaft in crankcase.

- Air Intake Dry filter.
- Fuel Feed Vane pump incorporated in
injection pump.
- Fuel System Indirect fuel injection
(precumbustion chamber).

- Combustion Cycle 4 stroke
- Cooling System Water cooling.
- Injection Pump Rotary pump and
electronically managed.

- Lubrication Pressure lubrication by
rotary pump, full-flow
filtration.

- Engine Rotation Clockwise viewed from
front cover.

Engine Description

DIAGNOSIS AND TESTING

SERVICE DIAGNOSIS—DIESEL—
PERFORMANCE

| CONDITION | POSSIBLE CAUSES | CORRECTION |
|--|---|--|
| ENGINE WILL NOT CRANK OR CRANKS SLOWLY | <ol style="list-style-type: none"> 1. Starting motor operating, but not cranking the engine. 2. Crankshaft rotation restricted. 3. Starting circuit connections loose or corroded. 4. Neutral safety switch or starter relay inoperative. 5. Battery charge low. | <ol style="list-style-type: none"> 1. Remove the starter motor. Check for broken flywheel teeth or a broken starting motor spring. 2. Rotate the engine to check for rotational resistance. 3. Clean and tighten connections. 4. Check starter relay supply voltage and proper operation of neutral safety switch (if equipped). Replace defective parts. 5. Check battery voltage. Replace battery if a charge cannot be held. |

DIAGNOSIS AND TESTING (Continued)

| CONDITION | POSSIBLE CAUSES | CORRECTION |
|--|---|--|
| | 6. No voltage to starter solenoid. 7. Solenoid or starter motor inoperative. | 6. Check voltage to solenoid. If necessary, replace the solenoid. 7. Replace starter motor. |
| ENGINE CRANKS, BUT WILL NOT START NO SMOKE | 1. No fuel in supply tank. 2. Electrical fuel shutdown solenoid not operating. 3. Exhaust plugged. 4. Fuel filter plugged. 5. Excessive fuel inlet restriction. 6. Injection pump not getting fuel or fuel is aerated. 7. Worn or inoperative injection pump. | 1. Fill fuel supply. 2. Check for loose wires and verify that the fuel shutdown solenoid and fuel shutdown solenoid relay is functioning. 3. Remove the obstruction. 4. Drain fuel/water separator and replace fuel filter. 5. Check fuel inlet restriction. Correct cause. 6. Check fuel flow/bleed fuel system. 7. Visually check delivery with externally connected injector to one of the pump outlets. Repair or replace the pump if fuel is not being delivered. |
| ENGINE HARD TO START, OR WILL NOT START SMOKE FROM EXHAUST | 1. Incorrect starting procedure. 2. Cranking speed too slow. 3. Cylinder heads heater plugs relay defective. 4. One or more cylinder head heater plugs defective. 5. Insufficient intake air. | 1. The fuel shutoff solenoid control must be in the run position. Ensure proper procedure is being used. 2. (A) Verify that the transmission is not engaged. (B) Check the battery, starting motor and look for loose or corroded wiring connections. 3. Verify system is working. Repair/replace inoperative parts. 4. Verify system is working. Repair/replace inoperative parts. 5. Inspect or replace filter and check for obstruction to the air supply tube. |

DIAGNOSIS AND TESTING (Continued)

| CONDITION | POSSIBLE CAUSES | CORRECTION |
|--|--|--|
| ENGINE HARD TO START, OR WILL NOT START SMOKE FROM EXHAUST (CONT.) | <p>6. Air in fuel system or the fuel supply is inadequate.</p> <p>7. Contaminated fuel.</p> <p>8. Fuel screen plugged.</p> <p>9. One or more injectors worn or not operating properly.</p> <p>10. Worn or inoperative injection pump.</p> <p>11. Injection pump out of time.</p> <p>12. Engine compression low.</p> <p>13. Camshaft out of time.</p> | <p>6. Check the flow through the filter and bleed the system. Locate and eliminate the air source.</p> <p>7. Verify by operating the engine with clean fuel from a temporary tank. Check for presence of gasoline. Drain and flush fuel supply tank. Replace fuel/water separator filter.</p> <p>8. Check fuel screen.</p> <p>9. Check/replace improperly operating injectors.</p> <p>10. Visually check fuel delivery with an externally connected injector to one of the pump outlets. Repair or replace the pump if fuel is not being delivered.</p> <p>11. Check/Time the pump (refer to Group 14, Fuel System).</p> <p>12. Check compression to identify the problem.</p> <p>13. Check camshaft timing.</p> |
| ENGINE STARTS, BUT WILL NOT KEEP RUNNING | <p>1. Cylinder heads heater plugs relay defective.</p> <p>2. One or more cylinder head heater plugs defective.</p> <p>3. Intake air or exhaust system restricted.</p> <p>4. Air in the fuel supply system or the fuel supply is inadequate.</p> <p>5. Fuel waxing due to extremely cold weather.</p> <p>6. Contaminated fuel.</p> | <p>1. Verify system is working. Repair/replace inoperative parts.</p> <p>2. Verify system is working. Repair/replace inoperative parts.</p> <p>3. Visually check for exhaust restriction and inspect the air intake.</p> <p>4. Check flow through the filter and bleed the system. Locate and eliminate the air source.</p> <p>5. Verify by inspecting the fuel filter. Clean the system and use climatized fuel. Replace fuel/water separator filter. Check fuel heater for proper operation.</p> <p>6. Verify by operating the engine with clean fuel from a temporary supply tank. Check for presence of gasoline. Replace fuel/water separator filter.</p> |
| SURGING (SPEED CHANGE) | <p>1. If the condition occurs at idle, the idle speed is set too low for the accessories.</p> <p>2. High pressure fuel leak.</p> <p>3. One or more injectors worn or not operating properly.</p> <p>4. Improperly operating injection pump.</p> | <p>1. Adjust the idle speed.</p> <p>2. Inspect/correct leaks in the high pressure lines. Fitting and delivery valve sealing washers.</p> <p>3. Check/replace the inoperative injectors.</p> <p>4. Replace the injector pump.</p> |

DIAGNOSIS AND TESTING (Continued)

| CONDITION | POSSIBLE CAUSES | CORRECTION |
|---|--|--|
| ROUGH IDLE (IRREGULARLY FIRING OR ENGINE SHAKING) | <ol style="list-style-type: none"> 1. If engine is cold, glow plug relay or glow plug(s) defective. 2. Engine mounts damaged or loose. 3. High pressure fuel leaks. 4. Air in the fuel system. 5. Sticking needle valve in an injector. | <ol style="list-style-type: none"> 1. Refer to troubleshooting for cylinder head heater plugs (see Group 14, Fuel system). 2. Repair or replace mounts. 3. Correct leaks in the high pressure lines, fittings or delivery valves. 4. Bleed the fuel system and eliminate the source of the air. 5. Check and replace the injector with the sticking needle valve. |
| ENGINE RUNS ROUGH | <ol style="list-style-type: none"> 1. Fuel injection lines leaking. 2. Air in the fuel or the fuel supply is inadequate. 3. Contaminated fuel. 4. Incorrect valve operation. 5. Injection pump timing incorrect. 6. Improperly operating injectors. 7. Defective injection pump (delivery valve). 8. Camshaft out of time. 9. Damaged camshaft or tappets. 10. Automatic timing advance not operating. | <ol style="list-style-type: none"> 1. Correct leaks in the high pressure lines, fittings, injectors sealing washers or delivery valves. 2. Check the flow through the filter and bleed the system. Locate and eliminate the air source. 3. Verify by operating the engine with clean fuel from a temporary supply tank. Check for presence of gasoline. Replace fuel/water separator filter. 4. Check for a bent push rod and adjust valves. Replace push rod, if necessary. 5. Check/time pump (refer to Group 14, Fuel System). 6. Replace inoperative injectors. 7. Repair or replace injection pump. 8. Check/correct gear train timing alignment. 9. Inspect camshaft valve lift. Replace camshaft and tappets. 10. Check injection pump. Check fuel injector sensor at number 1 cylinder injector. |
| ENGINE RPM WILL NOT REACH RATED SPEED | <ol style="list-style-type: none"> 1. Engine overload. 2. Improperly operating tachometer. 3. Inadequate fuel supply. 4. Air/fuel controls leak. | <ol style="list-style-type: none"> 1. Verify high idle speed without load. Investigate operation to be sure correct gear is being used. 2. Verify engine speed with hand tachometer, correct as required. 3. Check the fuel flow through the system to locate the reason for inadequate fuel supply, correct as required. 4. Check and repair leak. Check AFC tubing for obstruction. |

DIAGNOSIS AND TESTING (Continued)

| CONDITION | POSSIBLE CAUSES | CORRECTION |
|---|--|---|
| ENGINE RPM WILL NOT REACH RATED SPEED (CONT.) | 6. Improperly operating injection pump. | 6. Repair or replace injection pump. |
| LOW POWER | <p>1. Fuel control lever not moving to full throttle.</p> <p>2. High oil level.</p> <p>3. Engine overloaded.</p> <p>4. Slow throttle response caused by leaking or obstructed air control tube or improperly operating control in the pump.</p> <p>5. Inadequate intake air flow.</p> <p>6. Inadequate fuel supply. Air in the fuel.</p> <p>7. Excessive exhaust restriction.</p> <p>8. High fuel temperature.</p> <p>9. Poor quality fuel or fuel contaminated with gasoline.</p> <p>10. Air leak between the turbocharger and the intake manifold.</p> <p>11. Exhaust leak at the manifold or turbocharger.</p> <p>12. Improperly operating turbocharger.</p> <p>13. Wastegate operation.</p> <p>14. Valve not operating.</p> <p>15. Worn or improperly operating injectors.</p> <p>16. Incorrect injection pump timing.</p> <p>17. Improperly operating injection pump.</p> | <p>1. Check/correct for stop-to-stop travel.</p> <p>2. Check/correct oil level.</p> <p>3. Check for added loading from accessories or driven units, brakes dragging and other changes in vehicle loading. Repair/replace as needed.</p> <p>4. Check for leaks and obstructions. Tighten the fittings. Repair or replace the pump if the controls are not functioning.</p> <p>5. Inspect/replace air cleaner element. Look for other restrictions.</p> <p>6. Check the flow through the filter to locate the source of the restriction. Check fuel pressure and inlet restriction.</p> <p>7. Check/correct the restriction in the exhaust system.</p> <p>8. Verify that fuel heater is off when engine is warm. Check for restricted fuel drain tubes. Repair/replace as needed.</p> <p>9. Verify by operating from a temporary tank with good fuel. Check for presence of gasoline. Replace fuel/water separator filter.</p> <p>10. Check/correct leaks in hoses, gaskets, charge air cooler and around mounting capscrews or through holes in the manifold cover.</p> <p>11. Check/correct leaks in the manifold or turbocharger gaskets. If manifold is cracked, replace manifold.</p> <p>12. Inspect/replace turbocharger.</p> <p>13. Check wastegate operation.</p> <p>14. Check for bent push rod, replace if necessary.</p> <p>15. Check/replace injectors.</p> <p>16. Verify injection pump timing (see Group 14, Fuel System).</p> <p>17. Repair or replace injection pump.</p> |

DIAGNOSIS AND TESTING (Continued)

| CONDITION | POSSIBLE CAUSES | CORRECTION |
|---------------------------------|---|---|
| <p>EXCESSIVE EXHAUST SMOKE</p> | <ol style="list-style-type: none"> 1. Engine running too cold (white smoke). 2. Improper starting procedure (white smoke). 3. Fuel supply inadequate. 4. Injection pump timing. 5. Inadequate intake air. 6. Air leak between turbocharger and intake manifold. 7. Exhaust leak at the manifold or turbocharger. 8. Improperly operating turbocharger. 9. Improperly operating injectors. 10. Improperly operating or overfueled injector pump. 11. Piston rings not sealing (blue smoke). | <ol style="list-style-type: none"> 1. Refer to troubleshooting for coolant temperature below normal (refer to Group 7, Cooling System). Inspect cylinder head heater plugs for proper operation. 2. Use proper starting procedures. 3. Check fuel supply pressure and inlet restriction. 4. Check and time pump (refer to Group 14, Fuel System). 5. Inspect/change air filter. Look for other restriction. Check charge air cooler for obstructions. 6. Check/correct leaks in the air crossover tube, hoses, gaskets, mounting capscrews or through holes in the manifold cover. 7. Check/correct leaks in the manifold or turbocharger gaskets. If cracked replace manifold. 8. Inspect/replace turbocharger. 9. Check and replace inoperative injectors. 10. Repair or replace injection pump. 11. Perform blow-by check. Correct as required. |
| <p>ENGINE WILL NOT SHUT-OFF</p> | <ol style="list-style-type: none"> 1. Fuel shutoff solenoid inoperative. 2. Engine running on fumes drawn into the air intake. 3. Fuel injection pump malfunction | <ol style="list-style-type: none"> 1. Check/replace fuel shutoff solenoid. 2. Check the air intake ducts for the source of fumes. WARNING: In case of engine runaway due to flammable fumes from gasoline spills or turbocharger oil leaks being sucked into the engine, shut off engine ignition switch first then use a CO2 fire extinguisher and direct the spray under the front bumper to remove oxygen supply. The engine air intake is on the passenger side behind the bumper. The fire extinguisher must be directed at this location for emergency shutdown conditions. 3. Repair or replace fuel injection pump. |

DIAGNOSIS AND TESTING (Continued)

| CONDITION | POSSIBLE CAUSES | CORRECTION |
|----------------------------------|---|---|
| COOLANT TEMPERATURE ABOVE NORMAL | <ol style="list-style-type: none"> 1. Low coolant level. 2. Incorrect/improperly operating pressure cap. 3. Loose drive belt on water pump/fan. 4. Inadequate air flow to the radiator. 5. Radiator fins plugged. 6. Collapsed radiator hose. 7. Improperly operating temperature sensor/gauge. 8. Improperly operating, incorrect or no thermostat. 9. Air in the cooling system. 10. Inoperative water pump. 11. Incorrect injection pump timing. 12. Overfueled injection pump. 13. Plugged cooling passages in radiator, head, head gasket or block. 14. Engine overloaded. | <ol style="list-style-type: none"> 1. Check coolant level. Add coolant, if necessary. Locate and correct the source of the coolant loss, (refer to Group 7, Cooling). 2. Replace cap with the correct rating for the system. 3. Check/replace belt or belt tensioner. 4. Check/repair radiator core, fan shroud and viscous fan drive as required. 5. Blow debris from fins. 6. Replace the hose. Check coolant tank cap operation, (refer to Group 7, Cooling Tanks). 7. Verify that the gauge and temperature sensor are accurate. Replace gauge/sensor, if bad. 8. check and replace the thermostat. 9. (A) make sure the fill rate is not being exceeded and the correct vented thermostat is installed. (B) Check for loose hose clamps. Tighten if loose. (C) If aeration continued, check for a compression leak through the head gasket. 10. Check and replace the water pump. 11. Verify pump timing marks are aligned. Check/time the injector pump (refer to Group 14, Fuel System). 12. Repair or replace the injection pump. 13. Flush the system and fill with clean coolant. 14. Verify that the engine load rating is not being exceeded. |
| COOLANT TEMPERATURE BELOW NORMAL | <ol style="list-style-type: none"> 1. Too much air flow across the radiator. 2. Incorrect thermostat or contamination in thermostat. 3. Temperature sensor or gauge inoperative. 4. Coolant not flowing by temperature sensor. | <ol style="list-style-type: none"> 1. Check/repair viscous fan drive as required. 2. Check and replace thermostat. 3. Verify that the gauge and sensor are accurate. If not, replace gauge/sensor. 4. Check and clean coolant passages. |

DIAGNOSIS AND TESTING (Continued)

SERVICE DIAGNOSIS—DIESEL—MECHANICAL.

| CONDITION | POSSIBLE CAUSES | CORRECTION |
|--|---|--|
| <p>LUBRICATING OIL PRESSURE LOW</p> | <ol style="list-style-type: none"> 1. Low oil level. 2. Oil viscosity thin, diluted or wrong specification. 3. Improperly operating pressure switch/gauge. 4. Relief valve stuck open. 5. Plugged oil filter. 6. If cooler was replaced, shipping plugs left in cooler. 7. Worn oil pump. 8. Suction tube loose or seal leaking. 9. Loose main bearing cap. 10. Worn bearings or wrong bearings installed. 11. Oil jet under piston bad fit into main carrier. | <ol style="list-style-type: none"> 1. (A) Check and fill with clean engine oil. (B) Check for a severe external oil leak that could reduce the pressure. 2. Verify the correct oil is being used. Check for oil dilution. Refer to Contaminated Lube Oil (Engine Diagnosis Mechanical). 3. Verify the pressure switch is functioning correctly. If not, replace switch/gauge. 4. Check/replace valve. 5. Change oil filter. Oil filter change interval may need to be revised. 6. Check/remove shipping plugs. 7. Check and replace oil pump. 8. Check and replace seal. Check and install new bearing and tighten cap to proper torque. 10. Inspect and replace connecting rod or main bearings. Check and replace piston cooling nozzles. 11. Check oil jet position. |
| <p>LUBRICATING OIL PRESSURE TOO HIGH</p> | <ol style="list-style-type: none"> 1. Pressure switch/gauge not operating properly. 2. Engine running too cold. 3. Oil viscosity too thick. 4. Oil pressure relief valve stuck closed or binding. | <ol style="list-style-type: none"> 1. Verify the pressure switch is functioning correctly. If not, replace switch/gauge. 2. Refer to Coolant Temperature Below Normal (Engine Diagnosis Performance). 3. Make sure the correct oil is being used, (Refer to Group 0, Lubrication and Maintenance). 4. Check and replace valve. |

DIAGNOSIS AND TESTING (Continued)

| CONDITION | POSSIBLE CAUSES | CORRECTION |
|----------------------|---|--|
| LUBRICATING OIL LOSS | <ol style="list-style-type: none"> 1. External leaks. 2. Crankcase being overfilled. 3. Incorrect oil specification or viscosity. 4. Oil cooler leak. 5. High blow-by forcing oil out the breather. 6. Turbocharger leaking oil to the air intake. 7. Piston rings not sealing (oil being consumed by the engine). | <ol style="list-style-type: none"> 1. Visually inspect for oil leaks. Repair as required. 2. Verify that the correct dipstick is being used. 3. (A) Make sure the correct oil is being used. (B) Look for reduced viscosity from dilution with fuel. (C) Review/reduce the oil change intervals. 4. Check and replace the oil cooler. 5. Check the breather tube area for signs of oil loss. Perform the required repairs. 6. Inspect the air ducts for evidence of oil transfer. Repair as required. 7. Perform blow-by check. Repair as required. |
| COMPRESSION KNOCKS | <ol style="list-style-type: none"> 1. Air in the fuel system. 2. Poor quality fuel or water/gasoline contaminated fuel 3. Engine overloaded. 4. Incorrect injection pump timing. 5. Improperly operating injectors. | <ol style="list-style-type: none"> 1. Bleed the fuel system (refer to Group 14, Fuel System). 2. Verify by operating from a temporary tank with good fuel. Clean and flush the fuel supply tanks. Replace fuel/water separator. 3. Verify the engine load rating is not being exceeded. 4. Check and time injection pump (refer to Group 14, Fuel System). 5. Check and replace inoperative injectors. |
| EXCESSIVE VIBRATION | <ol style="list-style-type: none"> 1. Loose or broken engine mounts. 2. Damaged fan or improperly operating accessories. 3. Improperly operating vibration damper. 4. Improperly operating viscous fan drive. 5. Worn or damaged generator bearing. 6. Flywheel housing misaligned. 7. Loose or broken power component. 8. Worn or unbalanced driveline components. | <ol style="list-style-type: none"> 1. Replace engine mounts. 2. Check and replace the vibrating components. 3. Inspect/replace the vibration damper. 4. Inspect/replace the fan drive. 5. Check/replace the generator. 6. Check/correct flywheel alignment. 7. Inspect the crankshaft and rods for damage that causes an unbalance. Repair/replace as required. 8. Check/repair driveline components. |

DIAGNOSIS AND TESTING (Continued)

| CONDITION | POSSIBLE CAUSES | CORRECTION |
|---|---|--|
| EXCESSIVE ENGINE NOISES | 1. Drive belt squeal, insufficient tension or abnormally high loading. | 1. Check the automatic tensioner and inspect the drive belt. Make sure water pump, tensioner pulley, fan hub and generator turn freely. |
| | 2. Intake air or exhaust leaks. | 2. Refer to Excessive Exhaust smoke (Engine Diagnosis Performance). |
| | 3. Turbocharger noise. | 3. Check turbocharger impeller and turbine wheel for housing contact. Repair/replace as required. |
| | 4. Gear train noise. | 4. Visually inspect and measure gear backlash. Replace gears as required. |
| | 5. Power function knock. | 5. Check/replace rod and main bearings. |
| GENERATOR NOT CHARGING OR INSUFFICIENT CHARGING | 1. Loose or corroded battery. 2. Generator belt slipping. 3. Generator pulley loose on shaft. 4. Improperly operating generator. | 1. Clean/tighten battery connection. 2. Check/replace automatic abelt tensioner. Check/replace and adjust belt. 3. Tighten pulley 4. Check/replace generator. |

TAPPET NOISE

(1) To determine source of tappet noise, operate engine at idle with cylinder head covers removed.

(2) Feel each valve spring or rocker arm to detect noisy tappet. The noisy tappet will cause the affected spring and/or rocker arm to vibrate or feel rough in operation.

NOTE: Worn valve guides or cocked springs are sometimes mistaken for noisy tappets. If such is the case, noise may be dampened by applying side thrust on the valve spring. If noise is not appreciably reduced, it can be assumed the noise is in the tappet. Inspect the rocker arm push rod sockets and push rod ends for wear.

(3) Valve tappet noise ranges from light noise to a heavy click. A light noise is usually caused by excessive leak down around the unit plunger or by the plunger partially sticking in the tappet body cylinder. The tappet should be replaced. A heavy click is caused by a tappet check valve not seating or by foreign particles becoming wedged between the plunger and the tappet body. This will cause the plunger to stick in the down position. This heavy click will be accompanied by excessive clearance between the valve stem and rocker arm as valve closes. In either case, tappet assembly should be removed for inspection and cleaning.

The valve train generates a noise very much like a light tappet noise during normal operation. Care

must be taken to ensure that tappets are making the noise. In general, if more than one tappet seems to be noisy, its probably not the tappets.

SERVICE PROCEDURES

VALVE SERVICE

This procedure is done with the engine cylinder head removed from the block.

DISASSEMBLY

(1) Remove the engine cylinder head from the cylinder block. Refer to cylinder head removal and installation in this section.

(2) Use Valve Spring Compressor Tool and compress each valve spring.

(3) Remove the valve locks, retainers, and springs.

(4) Use an Arkansas smooth stone or a jewelers file to remove any burrs on the top of the valve stem, especially around the groove for the locks.

(5) Remove the valves, and place them in a rack in the same order as removed.

VALVE CLEANING

(1) Clean all carbon deposits from the combustion chambers, valve ports, valve stems, valve stem guides and head.

(2) Clean all grime and gasket material from the engine cylinder head machined gasket surface.

SERVICE PROCEDURES (Continued)

INSPECTION

- (1) Inspect for cracks in the combustion chambers and valve ports.
- (2) Inspect for cracks on the exhaust seat.
- (3) Inspect for cracks in the gasket surface at each coolant passage.
- (4) Inspect valves for burned, cracked or warped heads.
- (5) Inspect for scuffed or bent valve stems.
- (6) Replace valves displaying any damage.
- (7) Check valve spring height (Fig. 2).

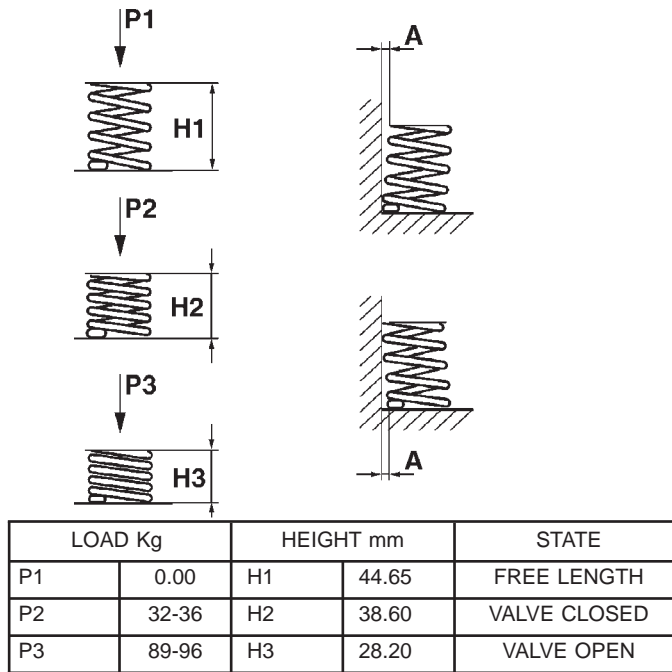

Fig. 2 Valve Spring Chart

VALVE REFACING

- (1) Use a valve refacing machine to reface the intake and exhaust valves to the specified angle.
- (2) After refacing, a margin of at least 4.52-4.49 mm (.178-.177 inch) must remain (Fig. 3). If the margin is less than 4.49 mm (.177 inch), the valve must be replaced.

VALVE SEAT REFACING

- (1) Install a pilot of the correct size in the valve guide bore. Reface the valve seat to the specified angle with a good dressing stone. Remove only enough metal to provide a smooth finish.
- (2) Use tapered stones to obtain the specified seat width when required.

VALVE STAND DOWN

Valve stand down is to maintain the adequate compression ratio.

- (1) Invert cylinder head.
- (2) Fit each valve to its respective valve guide.

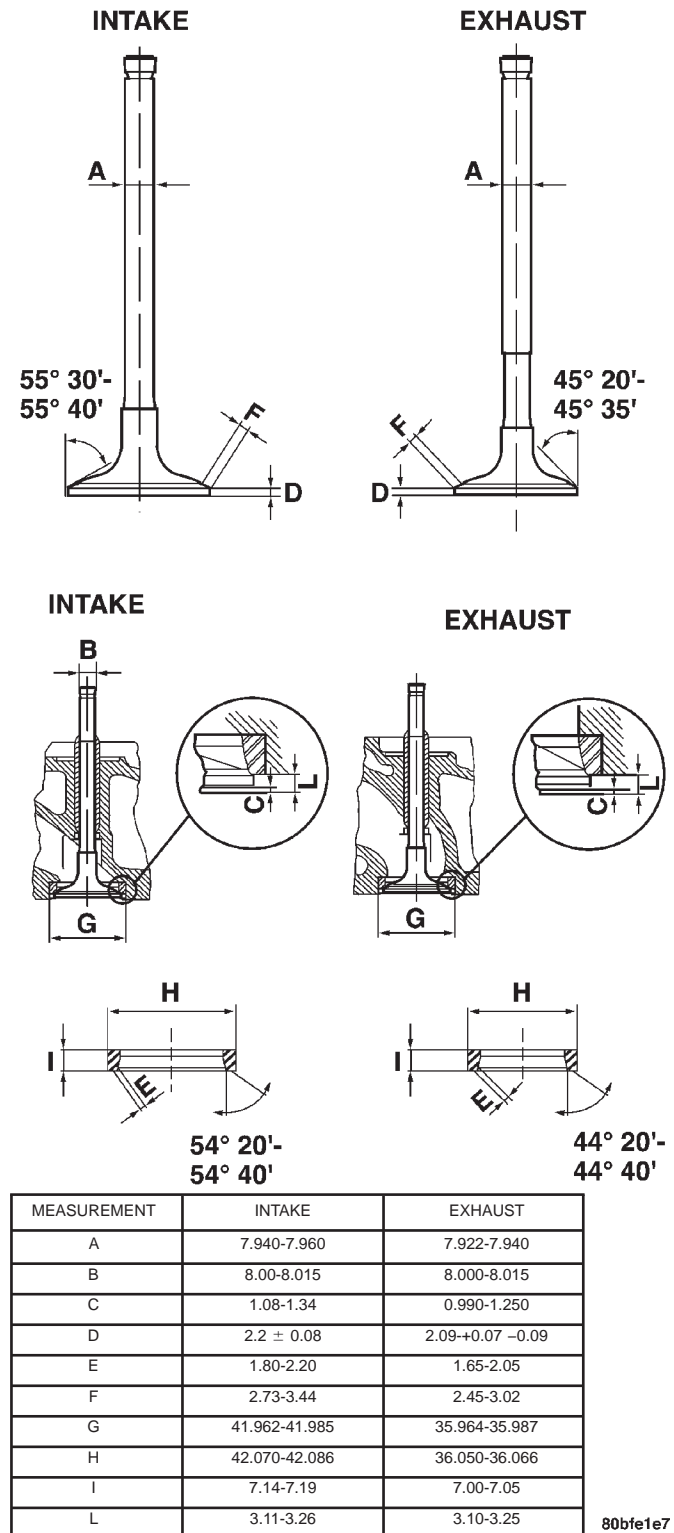
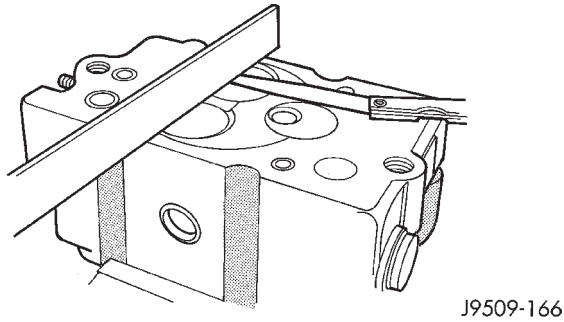

Fig. 3 Valve Specification

- (3) Using a straight edge and feeler gauge (Fig. 4), check valve head stand down: Inlet valve head stand down 1.08 to 1.34 mm (.042 to .052 ins.) and exhaust valve stand down .99 to 1.25 mm (.035 to .049 ins.).
- (4) If valve head stand down is not in accordance with above, discard original valves, check stand down

SERVICE PROCEDURES (Continued)

with new valves and recut valve seat inserts to obtain correct stand down.



J9509-166

Fig. 4 Checking Valve Stand Down

VALVE GUIDES

- (1) Valve Guides height requirement.
- (2) Measurement A (Fig. 5): 13.50 - 14.00 mm.

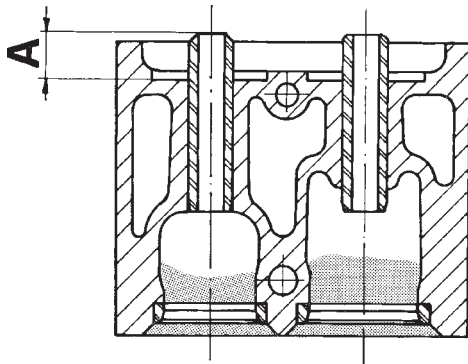

J9509-36

Fig. 5 Valve Guide Height

VALVE STEM-TO-GUIDE CLEARANCE MEASUREMENT

- (1) Measure and record internal diameter of valve guides. Valve guide internal diameter is 8.0 to 8.015 mm (.3149 to .3155 ins.).
- (2) Measure valve stems and record diameters. Intake valve stem diameter 7.94 to 7.96 mm (.3125 to .3133 in). Exhaust valve stem diameter 7.92 to 7.94 mm (.3118 to .31215 in).
- (3) Subtract diameter of valve stem from internal diameter of its respective valve guide to obtain valve stem clearance in valve guide. Clearance of inlet valve stem in valve guide is .040 to .075 mm (.0015 to .0029 in). Clearance of exhaust valve stem in valve guide is .060 to .093 mm (.0023 to .0036 in).
- (4) If valve stem clearance in valve guide exceeds tolerances, new valve guides must be installed.

REMOVAL AND INSTALLATION

ENGINE MOUNTS — LHD DIESEL

The engine mounts support the engine at each side. These supports are made of resilient rubber.

REMOVAL—RIGHT SIDE

- (1) Disconnect the negative battery cable.
- (2) Remove the innercooler inlet hose from the turbocharger and position it out of the way (Fig. 6).

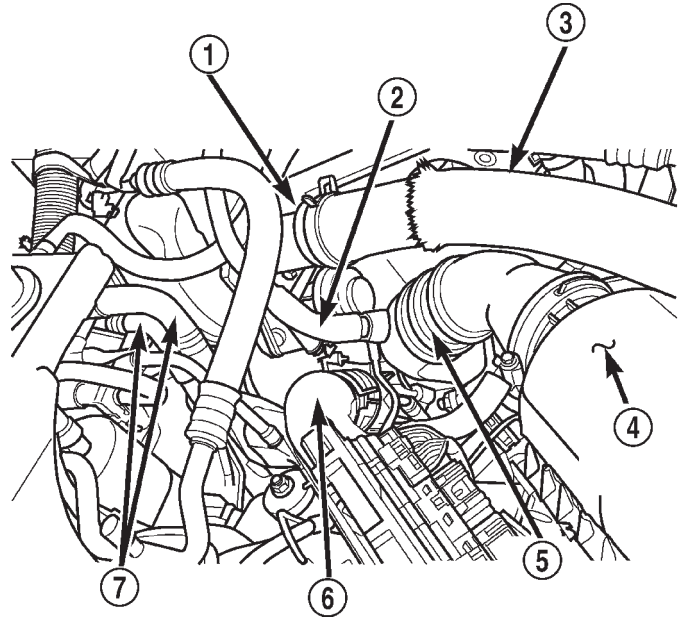

80b8992c

Fig. 6 Engine Compartment View — Diesel

- 1 - INTAKE MANIFOLD ELBOW
 - 2 - BREATHER HOSE
 - 3 - INNERCOOLER OUTLET HOSE
 - 4 - AIR FILTER COVER
 - 5 - AIR FILTER OUTLET (FRESH AIR) HOSE
 - 6 - INNERCOOLER INLET HOSE
 - 7 - HEATER CORE COOLANT SUPPLY HOSES
-
- (3) Remove the right engine mount upper sill plate nuts.
 - (4) Raise the vehicle on a hoist.
 - (5) Remove the oil filter and adaptor from the engine.
 - (6) Remove the engine mount throughbolt nut only. Do not remove the bolt at this time.
 - (7) Position a jack stand and raise the weight off the right engine mount.
 - (8) Remove the (2) engine mount lower sill plate bolts.
 - (9) Remove the (4) engine mount bracket bolts from the engine block.
 - (10) Remove the engine mount through bolt.
 - (11) Remove the right engine mount from the vehicle.

REMOVAL AND INSTALLATION (Continued)

INSTALLATION—RIGHT SIDE

(1) Position the engine mount and bracket and install the engine mount through bolt and nut, leaving them loose at this time.

(2) Install, but do not torque the engine mount lower sill plate bolts.

(3) Install the (4) engine mount bracket to engine block retaining bolts and torque to 61 N·m (45 ft. lbs.).

(4) Torque the engine mount lower sill plate bolts to 41 N·m (30 ft. lbs.).

(5) Remove the jack stand.

(6) Torque the engine mount throughbolt nut to 65 N·m (48 ft. lbs.).

(7) Install the oil filter and adaptor on the engine. Torque the adaptor retaining bolt to 69 N·m (51 ft. lbs.).

(8) Lower the vehicle from the hoist.

(9) Install the engine mount upper sill plate nuts. Torque to 41 N·m (30 ft. lbs.).

(10) Install the innercooler inlet hose on the turbocharger (Fig. 6).

(11) Connect the negative battery cable.

REMOVAL—LEFT SIDE

(1) Disconnect the negative battery cable.

(2) Remove the refrigerant line support bracket from the rear of the rocker cover.

(3) Disconnect the A/C compressor electrical connector.

(4) Remove the (2) engine mount upper sill plate nuts (Fig. 7).

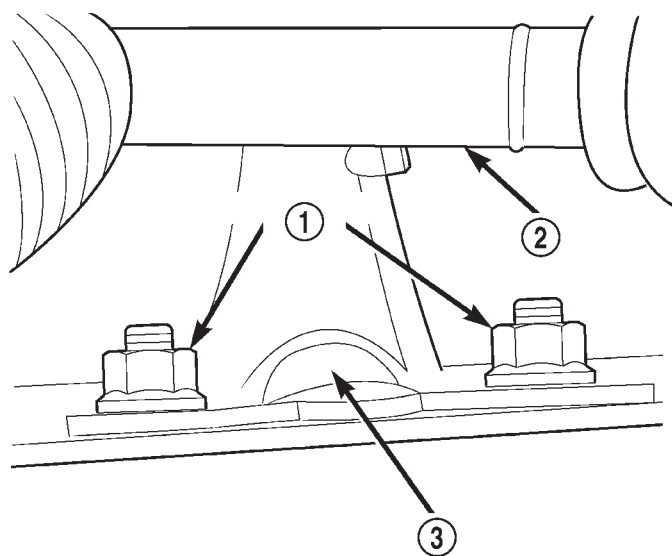

80b9a4c1

Fig. 7 Left Engine Mount Sill Plate Nuts

- 1 - SILL PLATE NUTS
- 2 - STEERING SHAFT
- 3 - ENGINE MOUNT

(5) Make sure the steering shaft is in the unlocked position. Raise the vehicle on a hoist.

(6) Remove the steering shaft pinchbolt. Remove the shaft from the gearbox by sliding it straight off the gearbox input shaft.

CAUTION: Do not rotate the steering shaft while removed from the gearbox input shaft. Damage to the steering column clockspring will occur.

(7) Remove the left engine mount throughbolt nut only (Fig. 8). Do not remove the bolt at this time.

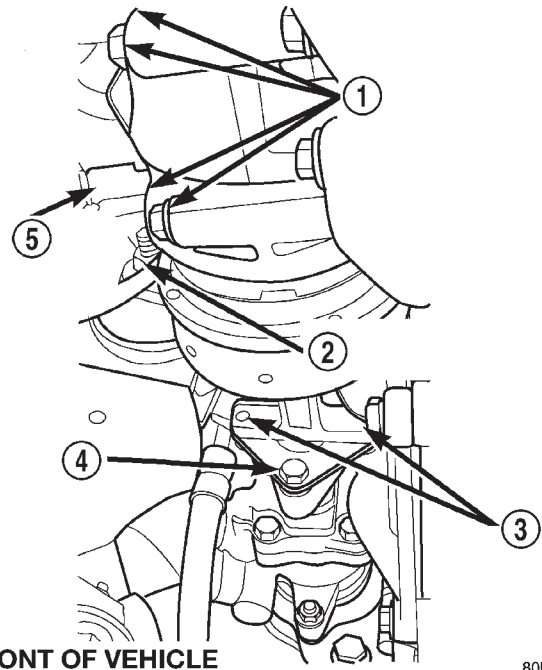

80b9a4c0

Fig. 8 A/C Compressor Position & Orientation

- 1 - A/C COMPRESSOR MOUNTING BOLTS
- 2 - LEFT ENGINE MOUNT THROUGH BOLT NUT
- 3 - H BLOCK BOLTS
- 4 - COUPLER PINCH BOLT
- 5 - COMPRESSOR ELECTRICAL CONNECTOR

(8) Loosen the (4) H-Block retaining bolts, Do not remove the bolts at this time.

NOTE: Mark the position of the H-Block in relation to the power steering pump and the A/C Compressor so it may be installed in its original position.

(9) Remove the (2) H-Block retaining bolts from the power steering pump side of the block (Fig. 8).

(10) Support the A/C Compressor with mechanics wire before proceeding to the next step.

(11) Remove the (4) A/C Compressor retaining bolts (Fig. 8).

(12) Remove the remaining (2) bolts from the H-Block and remove the H-Block from the compressor.

REMOVAL AND INSTALLATION (Continued)

(13) Position a jack stand and raise the weight off the left engine mount.

(14) Remove the (4) engine mount bracket bolts from the engine block.

(15) Remove the (4) trackbar support bracket bolts and remove the bracket (Fig. 9).

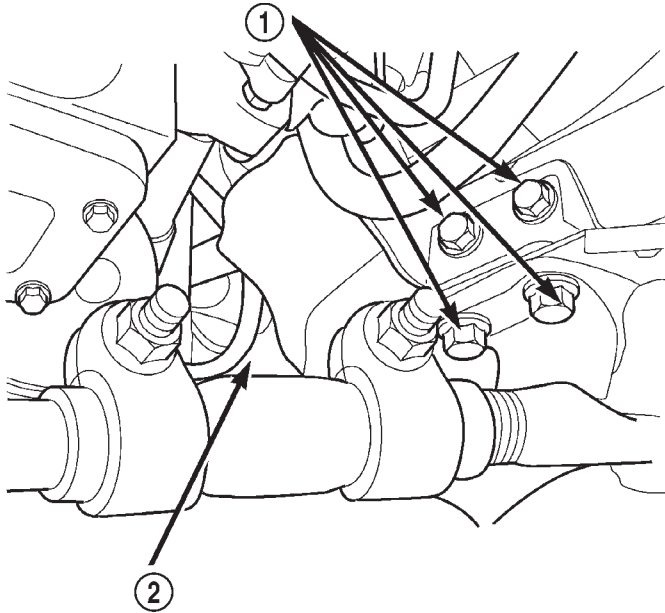

80b9a4be

Fig. 9 Left Engine Mount Retaining Bolts

- 1 - TRACK BAR SUPPORT BRACKET RETAINING BOLTS
2 - ENGINE MOUNT SILL PLATE BOLT

(16) Remove the remaining engine mount lower sill plate bolt (Fig. 9).

(17) Remove the engine mount troughbolt.

(18) Remove the left engine mount from the vehicle.

INSTALLATION—LEFT SIDE

(1) Position the engine mount and bracket and install the engine mount through bolt and nut, leaving them loose at this time.

(2) Install, but do not torque the engine mount lower sill plate bolt and the trackbar support bracket bolts (Fig. 9).

(3) Install the (4) engine mount bracket bolts. Torque to 61 N·m (45 ft. lbs.).

(4) Torque the lower engine mount sill plate bolts to 41 N·m (30 ft. lbs.) (Fig. 9).

(5) Torque the larger trackbar support bracket bolts to 125 N·m (92 ft. lbs.) (Fig. 9).

(6) Remove the jack stand.

(7) Position the H-Block and the A/C Compressor in their original positions and install the retaining bolts (Fig. 10).

(8) Torque the A/C Compressor mounting bolts to 41 N·m (30 ft. lbs.) (Fig. 10).

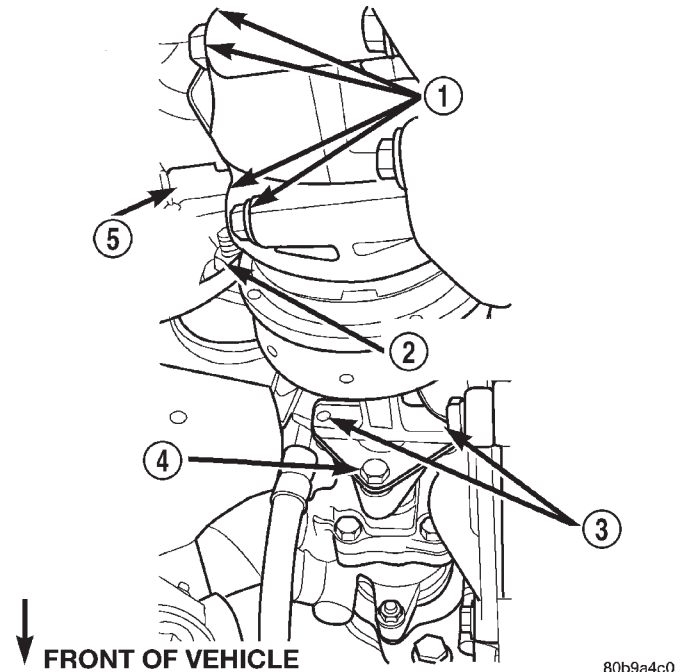

80b9a4c0

Fig. 10 A/C Compressor Position & Orientation

- 1 - A/C COMPRESSOR MOUNTING BOLTS
2 - LEFT ENGINE MOUNT THROUGH BOLT NUT
3 - H BLOCK BOLTS
4 - COUPLER PINCH BOLT
5 - COMPRESSOR ELECTRICAL CONNECTOR

(9) Torque all the H-Block retaining bolts to 18 N·m (159 in. lbs.).

(10) Torque the engine mount throughbolt nut to 65 N·m (48 ft. lbs.) (Fig. 10).

(11) Install the steering shaft. Torque the pinch-bolt to 49 N·m (36 ft. lbs.).

(12) Lower the vehicle from the hoist.

(13) Install the engine mount upper sill plate nuts. Torque to 41 N·m (30 ft. lbs.) (Fig. 11).

(14) Install the refrigerant line support bracket on the rear of the rocker cover.

(15) Connect the A/C compressor electrical connector.

(16) Connect the negative battery cable.

ENGINE MOUNTS — RHD DIESEL

The engine mounts support the engine at each side. These supports are made of resilient rubber.

REMOVAL—RIGHT SIDE

(1) Disconnect the negative battery cable.

(2) Make sure the steering wheel is in the unlocked position. Raise the vehicle on a hoist.

(3) Remove the steering shaft pinchbolt and slide the steering shaft straight off the gearbox input shaft.

REMOVAL AND INSTALLATION (Continued)

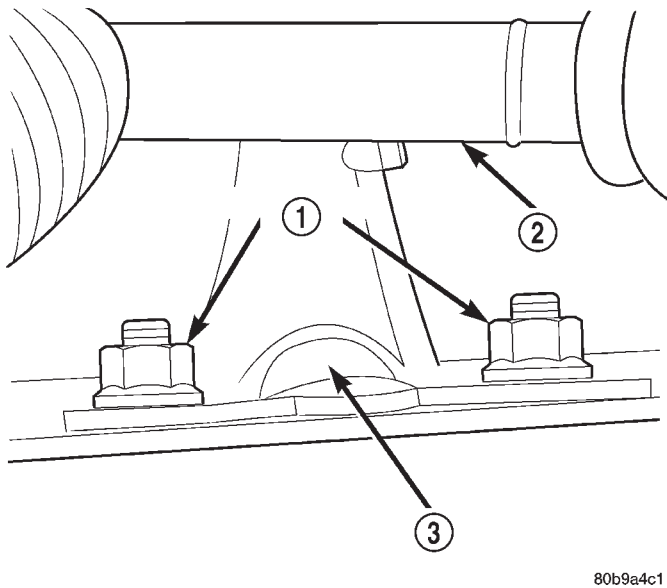

80b9a4c1

Fig. 11 Left Engine Mount Sill Plate Nuts

- 1 - SILL PLATE NUTS
- 2 - STEERING SHAFT
- 3 - ENGINE MOUNT

CAUTION: Do not rotate the steering shaft while removed from the gearbox input shaft. Damage to the steering column clockspring will occur.

(4) Remove the oil filter adaptor retaining bolt and remove oil filter and adaptor from the vehicle.

(5) Remove the engine mount upper sill plate nuts (Fig. 12).

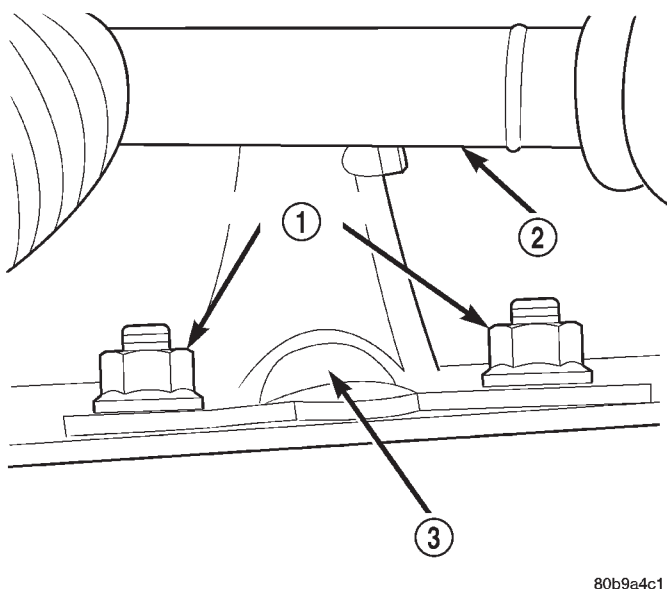

80b9a4c1

Fig. 12 Right Engine Mount Sill Plate Nuts

- 1 - SILL PLATE NUTS
- 2 - STEERING SHAFT
- 3 - ENGINE MOUNT

(6) Remove the engine mount throughbolt nut only. Leave the bolt installed at this time.

(7) Position a jack stand and raise the weight off the right engine mount.

(8) Remove the (4) trackbar support bracket retaining bolts and remove the bracket.

(9) Remove the (4) engine mount bracket bolts from the engine block.

(10) Remove the remaining engine mount lower sill plate bolt.

(11) Remove the engine mount through bolt.

(12) Remove the right engine mount from the vehicle.

INSTALLATION—RIGHT SIDE

(1) Position the engine mount and bracket in position and install the engine mount through bolt and nut, leaving them loose at this time.

(2) Install, but do not torque the engine mount lower sill plate bolts and the trackbar support bracket bolts.

(3) Install the (4) engine mount bracket to engine block retaining bolts. Torque bolts to 61 N·m (45 ft. lbs.).

(4) Torque the engine mount lower sill plate bolts to 41 N·m (30 ft. lbs.).

(5) Torque the larger trackbar support bracket bolts to 125 N·m (92 ft. lbs.).

(6) Install the oil filter and adaptor on the engine. Torque oil filter adaptor retaining bolt to 69 N·m (51 ft. lbs.).

(7) Remove the jack stand.

(8) Install the engine mount upper sill plate nuts. Torque to 41 N·m (30 ft. lbs.).

(9) Torque the engine mount throughbolt nut to 65 N·m (48 ft. lbs.).

(10) Install the steering shaft and torque the pinchbolt to 49 N·m (36 ft. lbs.).

(11) Lower the vehicle from the hoist.

(12) Connect the negative battery cable.

REMOVAL—LEFT SIDE

(1) Disconnect the negative battery cable.

(2) Remove the refrigerant line support bracket bolt from the upper radiator support crossmember..

(3) Remove the A/C filter-drier assembly support bracket nuts from the left fenderwell.

(4) Disconnect A/C compressor electrical connector (Fig. 13).

(5) Raise the vehicle on a hoist.

(6) Remove the engine mount throughbolt nut only (Fig. 13). Leave the bolt installed at this time.

(7) Loosen the (4) H-Block retaining bolts, Do not remove the bolts at this time.

REMOVAL AND INSTALLATION (Continued)

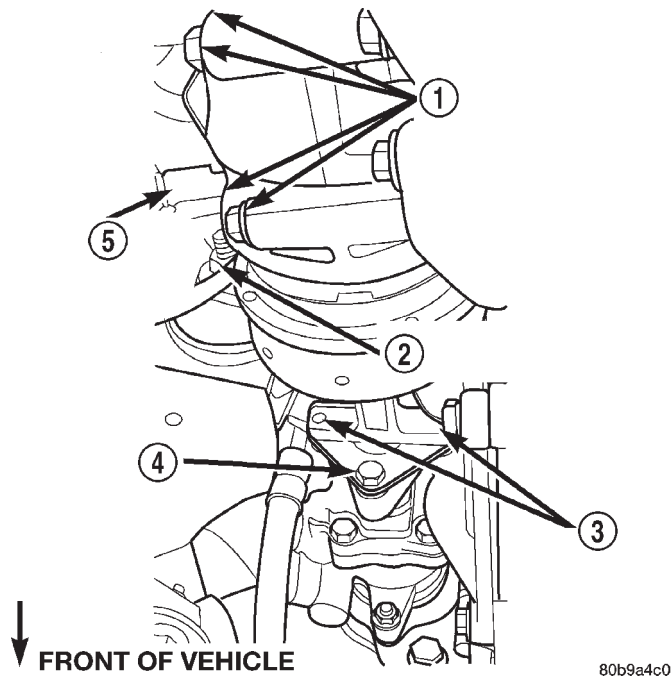
**Fig. 13 A/C Compressor Position & Orientation**

- 1 - A/C COMPRESSOR MOUNTING BOLTS
- 2 - LEFT ENGINE MOUNT THROUGH BOLT NUT
- 3 - H BLOCK BOLTS
- 4 - COUPLER PINCH BOLT
- 5 - COMPRESSOR ELECTRICAL CONNECTOR

NOTE: Mark the position of the H-Block in relation to the power steering pump and A/C Compressor so it may be installed in its original position.

(8) Remove the (2) H-Block retaining bolts from the power steering pump side of the block (Fig. 13).

(9) Support the A/C Compressor with mechanics wire before proceeding to the next step.

(10) Remove the (4) A/C Compressor mounting bolts (Fig. 13).

(11) Remove the remaining (2) bolts from H-Block and remove the H-Block from the compressor.

(12) Position a jack stand and raise the weight off the left engine mount.

(13) Remove the (2) engine mount upper sill plate nuts.

(14) Remove the (4) engine mount bracket bolts from the engine block.

(15) Remove the (2) engine mount lower sill plate bolts.

(16) Remove the engine mount troughbolt.

(17) Remove the left engine mount from the vehicle.

INSTALLATION—LEFT SIDE

(1) Position the engine mount and bracket in position and install the engine mount through bolt and nut, leaving them loose at this time.

(2) Install, but do not torque engine mount lower sill plate bolts.

(3) Install the (4) engine mount bracket to engine block retaining bolts. Torque to 61 N·m (45 ft. lbs.).

(4) Torque the (2) lower engine mount sill plate bolts to 41 N·m (30 ft. lbs.).

(5) Install the (2) engine mount upper sill plate nuts. Torque to 41 N·m (30 ft. lbs.).

(6) Remove the jack stand.

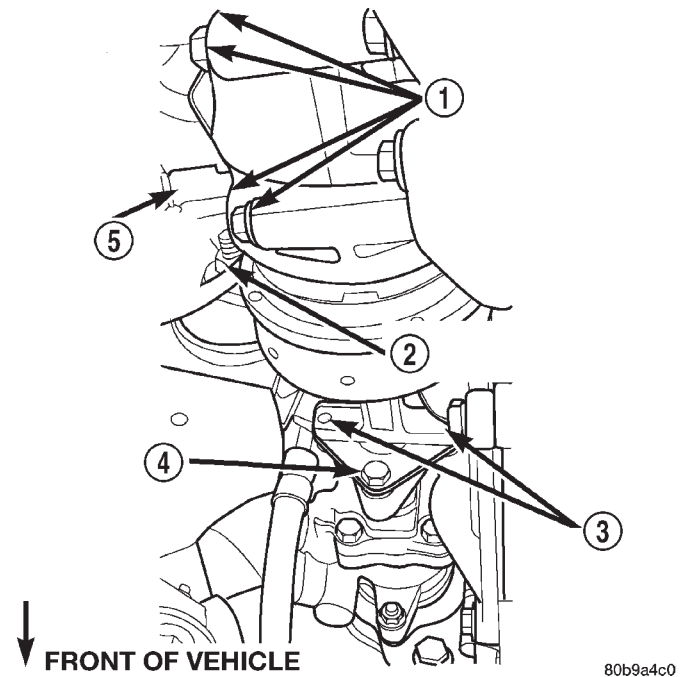
**Fig. 14 A/C Compressor Position & Orientation**

- 1 - A/C COMPRESSOR MOUNTING BOLTS
- 2 - LEFT ENGINE MOUNT THROUGH BOLT NUT
- 3 - H BLOCK BOLTS
- 4 - COUPLER PINCH BOLT
- 5 - COMPRESSOR ELECTRICAL CONNECTOR

(7) Position the H-Block and the A/C Compressor in their original positions and install the retaining bolts (Fig. 14).

(8) Torque the A/C Compressor mounting bolts to 41 N·m (30 ft. lbs.) (Fig. 14).

(9) Torque all the H-Block bolts to 18 N·m (159 in. lbs.) (Fig. 14).

(10) Torque the engine mount throughbolt nut to 65 N·m (48 ft. lbs.) (Fig. 14).

(11) Lower the vehicle from the hoist.

(12) Install the refrigerant line support bracket.

(13) Install the A/C filter-drier support bracket.

(14) Connect the negative battery cable.

REMOVAL AND INSTALLATION (Continued)

2.5L DIESEL ENGINE

REMOVAL

(1) Disconnect both of the battery cables and remove the battery.

(2) Mark the hinge locations on the hood for alignment reference during installation.

CAUTION: Wrap the appropriate size drillbit with masking tape 1/4 inch from tip. This will prevent damaging the hood outer panel when drilling out the rivets retaining the hood latch cable control assembly.

(3) Drill out the rivets retaining the hood latch cable control assembly.

(4) Remove the hood latch assemblies from the hood.

(5) Disconnect and remove the engine compartment lamp.

(6) With assistance from another person, remove the hood

(7) Cover both of the fenders and the grill opening panel to prevent paint damage.

(8) Remove the battery tray.

(9) Disconnect the radiator cooling fan electrical.

(10) Remove the manual cooling fan and let set inside of the fan shroud.

(11) If equipped, recover the refrigerant. Refer to Group 24, Heating and Air Conditioning for the procedure.

(12) Disconnect the suction and discharge lines and remove the lines from the vehicle.

(13) Disconnect the breather hose and remove the air filter outlet hose from the vehicle (Fig. 15).

(14) Disconnect the oil pressure sensor electrical connector (Fig. 15).

(15) Disconnect the EGR vacuum supply hose from the engine (Fig. 15).

(16) Remove the coolant reservoir cap.

(17) Drain the cooling system. Refer to Group 7, Cooling System for the procedure.

(18) Remove the upper and lower radiator hoses from the engine.

(19) Remove the innercooler inlet and outlet hoses from the engine (Fig. 15).

(20) Remove the coolant reservoir supply hose from the engine (Fig. 15).

(21) On L. H. D. vehicles, disconnect the heater core coolant supply and the brake vacuum supply hoses from the engine.

(22) On R. H. D. vehicles, disconnect the heater core coolant supply and the brake vacuum supply hoses from the right side of the engine compartment. Remove the line assembly retaining bolt and bracket

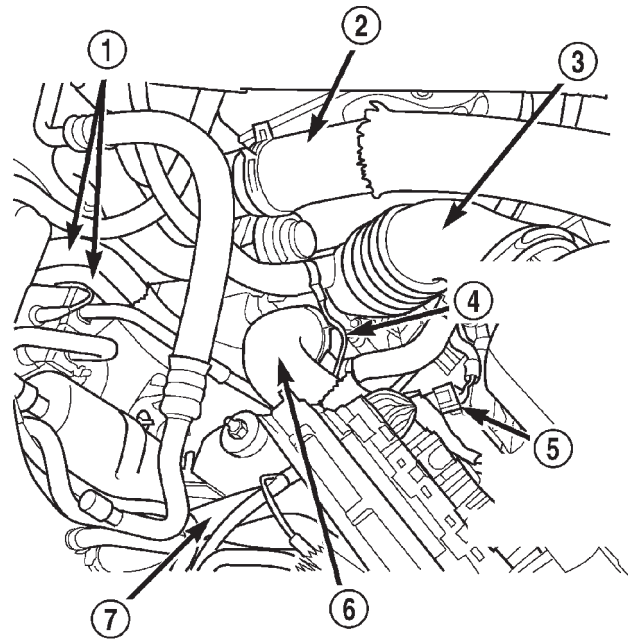

80b9a492

Fig. 15 LHD Engine Compartment — Diesel

- 1 - HEATER CORE COOLANT SUPPLY HOSES
- 2 - INNERCOOLER OUTLET HOSE
- 3 - AIR FLITER OUTLET HOSE
- 4 - EGR VACUUM SUPPLY HOSE
- 5 - OIL PRESSURE SENSOR CONNECTOR
- 6 - INNERCOOLER INLET HOSE
- 7 - COOLANT SUPPLY HOSE

from the rear of the rocker cover and position the assembly out of the way.

(23) Working inside of the vehicle, remove the center console. Refer to Group 23, Body for the procedure.

(24) Remove the shifter boot seal.

(25) Disconnect the shifter from the transmission

(26) Raise the vehicle on a hoist.

(27) Remove the lower fan shroud retaining bolts and remove the lower fan shroud panel.

(28) Remove the engine ground wire (Fig. 16).

(29) Remove the right and left engine mount throughbolt nuts only. Do not remove the bolts at this time (Fig. 16).

(30) Drain the transmission fluid. Refer to Group 21, Transmission and Transfer Case for the procedure.

(31) Mark the position of the front and rear driveshafts in relation to there companion flanges.

(32) Remove the front driveshaft. Refer to Group 3, Differential and Driveline for the procedure.

(33) Remove the rear driveshaft. Refer to Group 3, Differential and Driveline for the procedure.

(34) Disconnect the exhaust system at the (3) bolt flange (Fig. 17).

REMOVAL AND INSTALLATION (Continued)

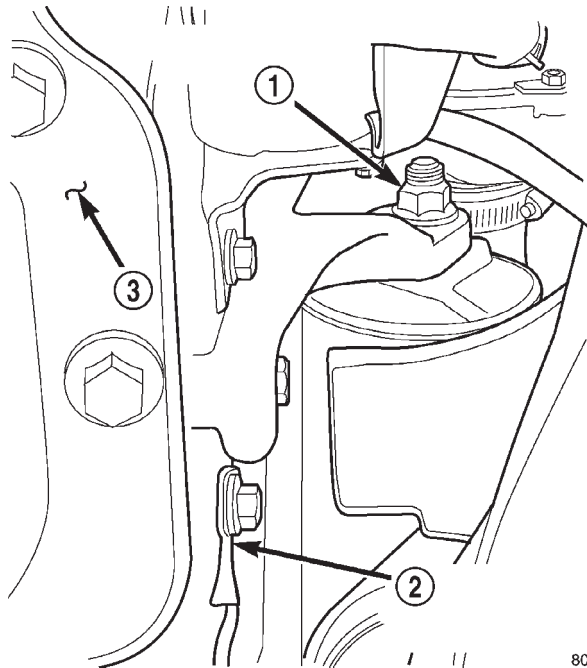

80b9a493

Fig. 16 Engine Ground Wire Location

- 1 - RIGHT ENGINE MOUNT THROUGHBOLT NUT
- 2 - ENGINE GROUND WIRE
- 3 - OIL PAN

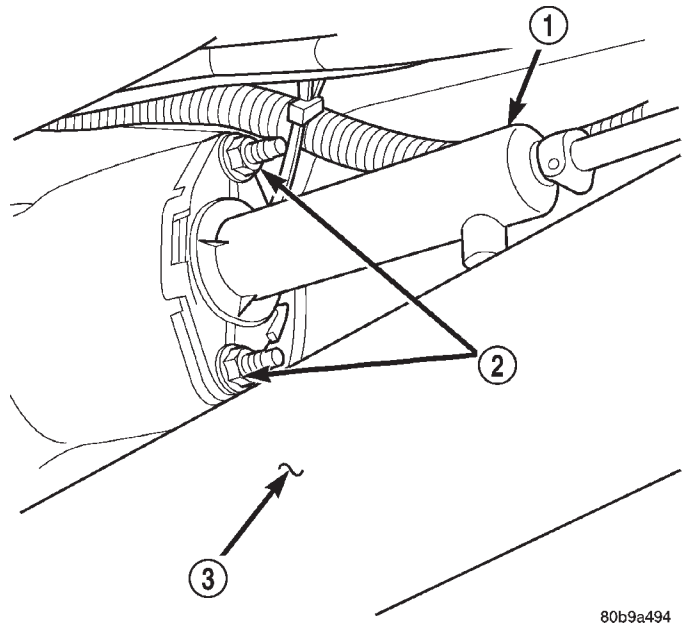

80b9a494

Fig. 18 Clutch Slave Cylinder

- 1 - CLUTCH SLAVE CYLINDER
- 2 - CLUTCH SLAVE CYLINDER RETAINING NUTS
- 3 - FRONT DRIVESHAFT

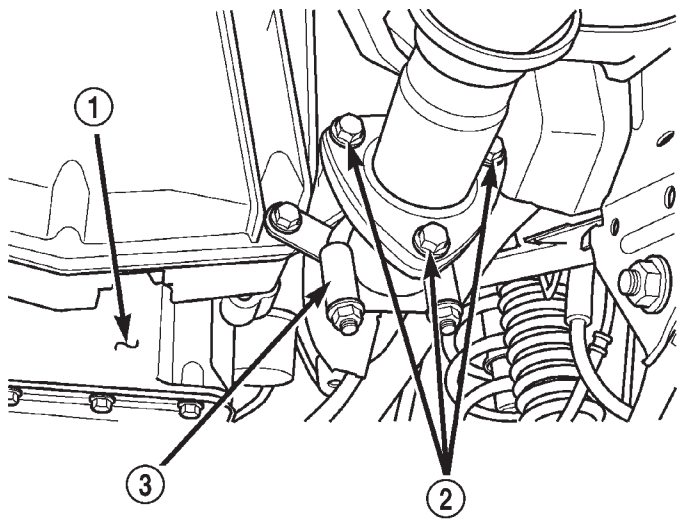

80b8992b

Fig. 17 Exhaust System Inlet Pipe Connection

- 1 - OIL PAN
- 2 - EXHAUST INLET PIPE FLANGE RETAINING BOLTS
- 3 - EXHAUST SYSTEM SUPPORT CLAMP

(35) Remove the exhaust system support clamp (Fig. 17).

(36) Remove the clutch slave cylinder from the clutch housing (Fig. 18).

(37) Remove the (3) nuts retaining the transfer case shift linkage and position the linkage aside (Fig. 19).

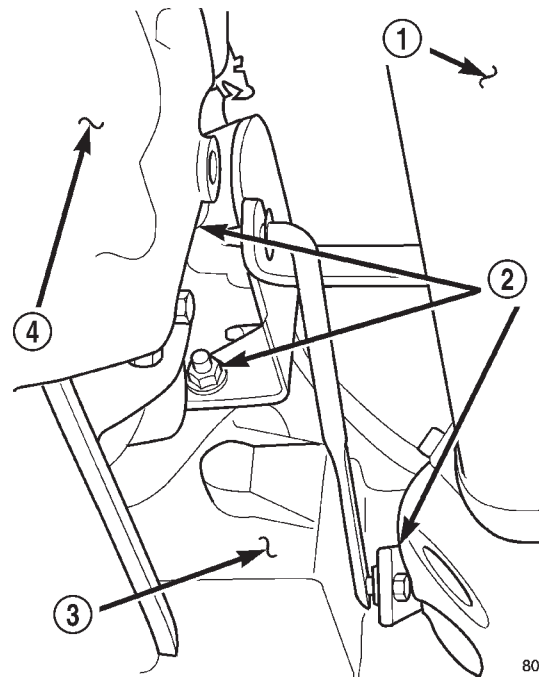

80b9a495

Fig. 19 Transfer Case Shift Linkage — 4x4

- 1 - FRONT DRIVESHAFT
- 2 - SHIFTER LINKAGE RETAINING NUTS
- 3 - TRANSFER CASE
- 4 - TRANSMISSION

REMOVAL AND INSTALLATION (Continued)

(38) Disconnect the electrical connectors and the vent hose and from the transfer case and transmission.

(39) Support the rear of the transmission with a jack.

(40) Remove the transmission support crossmember.

(41) Lower the transmission to gain access to the transmission to engine retaining bolts.

(42) Remove all the bolts securing the transmission to the engine assembly. Remove the transmission and the transfer case assembly from the vehicle.

(43) Lower the vehicle from the hoist.

(44) Remove the fan shroud and both cooling fans as an assembly.

(45) Remove the oil filter and adaptor from the vehicle as an assembly.

(46) Remove the power steering fluid pressure line from the steering gear.

(47) Disconnect the electrical connectors from the bottom of the fuel / water separator.

(48) Drain the fuel / water separator. Refer to Group 9, Fuel System for the procedure.

(49) Remove the fuel lines from the fuel / water separator and cap.

(50) Remove the fuel / water separator and mounting bracket assembly from the bulkhead.

(51) Remove all the remaining wiring from the engine assembly and position it out of the way.

(52) Attach a lifting device to the engine lifting brackets and slightly raise the weight off the engine mounts.

(53) Remove the right and left engine mount throughbolts.

(54) Carefully lift the engine out of the engine compartment.

INSTALLATION

(1) Carefully place the engine assembly into the engine compartment..

(2) Install the engine mount throughbolts and nuts in their original position. Leaving them loose at this time.

(3) Install the fuel / water separator and mounting bracket on the bulkhead.

(4) Install the fuel lines on the fuel / water separator.

(5) Connect the electrical connectors to the bottom of the fuel/water separator.

(6) Install the power steering fluid pressure line on the steering gear.

(7) Install the oil filter and adaptor on the engine. Torque adaptor retaining bolt to 69 N·m (51 ft. lbs.). Fill the oil filter prior to installation.

(8) Install the fan shroud and both cooling fans as an assembly in the vehicle.

(9) Raise the vehicle on a hoist.

(10) Install the transmission and transfer case assembly in the vehicle.

(11) Install the bolts securing the transmission to the engine assembly. Torque to 74.6 N·m (55 ft. lbs.).

(12) Position, connect and secure all electrical connectors and vent hoses on the transfer case and transmission in their original positions.

(13) Install the transmission support crossmember. Torque bolts to 50 N·m (37 ft. lbs.).

(14) Install the (3) nuts retaining the transfer case shift linkage (Fig. 20).

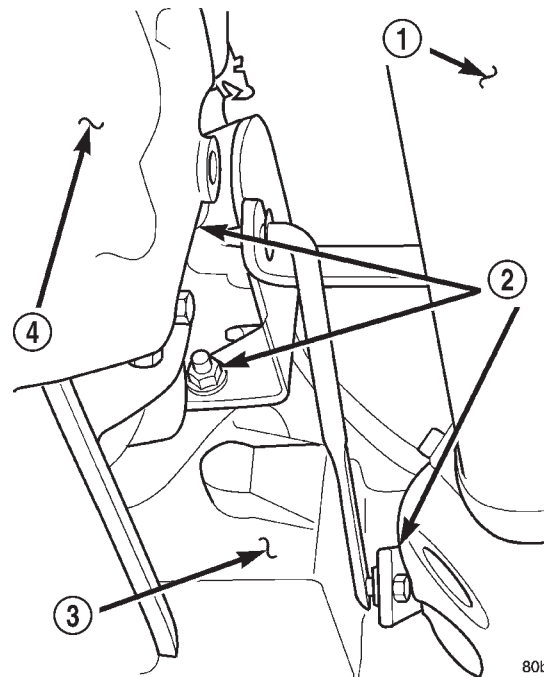

80b9a495

Fig. 20 Transfer Case Shift Linkage — 4x4

- 1 - FRONT DRIVESHAFT
- 2 - SHIFTER LINKAGE RETAINING NUTS
- 3 - TRANSFER CASE
- 4 - TRANSMISSION

(15) Install the clutch slave cylinder on the clutch housing, making sure the cylinder pushrod is properly aligned with the clutch fork (Fig. 21).

(16) Connect the exhaust system at the (3) bolt flange (Fig. 22).

(17) Install the exhaust system support clamp (Fig. 22).

(18) Install the rear driveshaft in its original position.

(19) Install the front driveshaft in its original position.

(20) Install the lower fan shroud panel and retaining bolt.

(21) Install the engine ground wire (Fig. 23).

(22) Lower the vehicle from the hoist.

REMOVAL AND INSTALLATION (Continued)

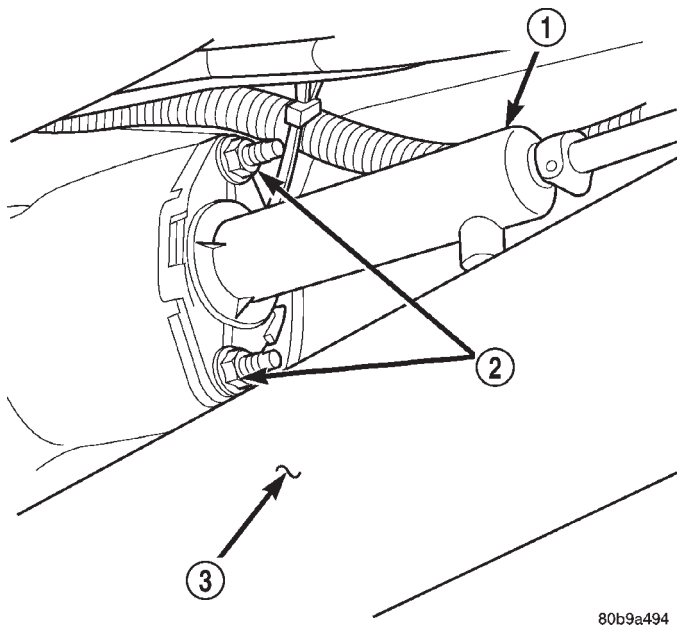

Fig. 21 Clutch Slave Cylinder

- 1 - CLUTCH SLAVE CYLINDER
- 2 - CLUTCH SLAVE CYLINDER RETAINING NUTS
- 3 - FRONT DRIVESHAFT

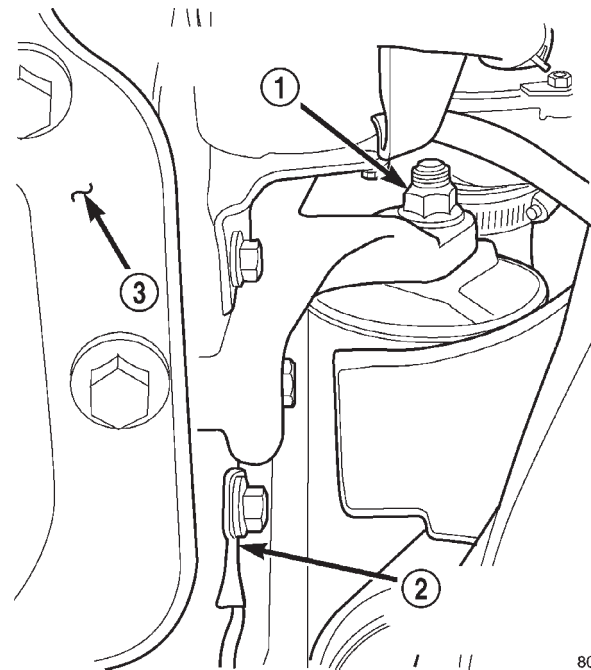

Fig. 23 Engine Ground Wire Location

- 1 - RIGHT ENGINE MOUNT THROUGHBOLT NUT
- 2 - ENGINE GROUND WIRE
- 3 - OIL PAN

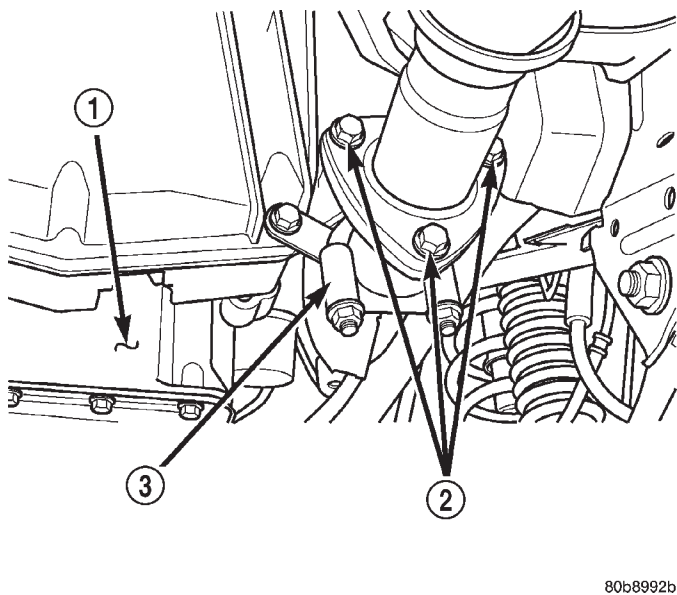

Fig. 22 Exhaust System Inlet Pipe Connection

- 1 - OIL PAN
- 2 - EXHAUST INLET PIPE FLANGE RETAINING BOLTS
- 3 - EXHAUST SYSTEM SUPPORT CLAMP

(23) Working inside the vehicle, install the shifter on the transmission

(24) Install the shifter boot seal.

(25) Install the center console. Refer to Group 23, Body for the procedure.

(26) Position, connect and secure all engine wiring in its original position

(27) On L. H. D. vehicles, connect the heater core coolant supply and brake vacuum supply hoses on the engine.

(28) On R. H. D. vehicles, position the steel line assembly and connect the heater core coolant supply and the brake vacuum supply hoses on the engine.

(29) Install the coolant reservoir supply hose on the engine (Fig. 24).

(30) Install the innercooler inlet and outlet hoses on the engine (Fig. 24).

(31) Install the upper and lower radiator hoses on the engine.

(32) Fill the cooling system. Refer to Group 7, Cooling System, for the procedure.

(33) Connect the oil pressure sensor electrical connector (Fig. 24).

(34) Connect the EGR vacuum supply hose on the engine (Fig. 24).

(35) Install the air filter outlet hose and connect the breather hose on the engine (Fig. 24).

(36) Install the refrigerant suction and discharge lines. Torque the retaining bolts on the A/C compressor to 22 N·m (200 in. lbs.). Make sure the O-Rings are well lubricated and free of tears.

(37) Charge the refrigerant system. Refer to Group 24, Heating and Air Conditioning for the procedure.

(38) Install the manual cooling fan.

REMOVAL AND INSTALLATION (Continued)

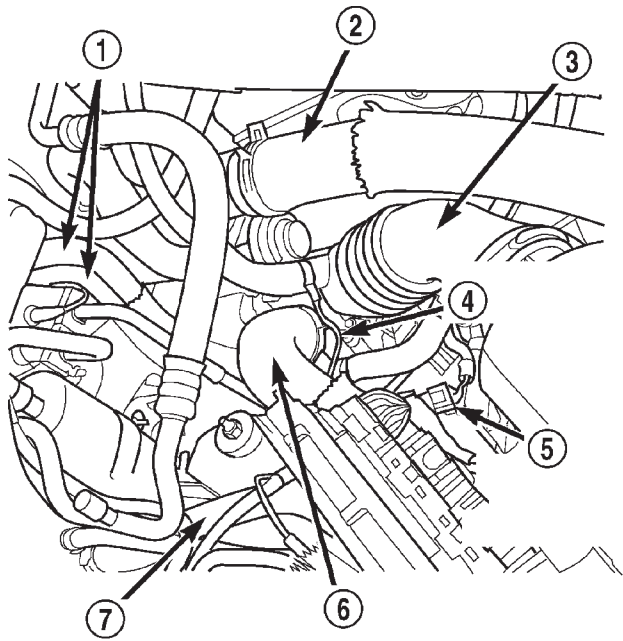

80b9a492

Fig. 24 LHD Engine Compartment — Diesel

- 1 - HEATER CORE COOLANT SUPPLY HOSES
- 2 - INNERCOOLER OUTLET HOSE
- 3 - AIR FILTER OUTLET HOSE
- 4 - EGR VACUUM SUPPLY HOSE
- 5 - OIL PRESSURE SENSOR CONNECTOR
- 6 - INNERCOOLER INLET HOSE
- 7 - COOLANT SUPPLY HOSE

(39) Connect the electric cooling fan electrical connector.

(40) Install the battery tray.

(41) With assistance from another person, install the hood.

NOTE: Use the previously marked hinge locations for alignment reference.

(42) Install the hood retaining bolts.

(43) Install the rivets on the hood latch cable control assembly.

(44) Install the hood latch assemblies on the hood.

(45) Install and connect the engine compartment lamp.

(46) Install the battery and connect both of the battery cables.

(47) Fill the power steering fluid. Refer to Group 19, Steering — Power Steering Pump-Initial operation for the procedure.

(48) Fill the transmission fluid. Refer to Group 21, Transmission and Transfer Case for the procedure.

(49) Check the engine oil level before engine start up.

CYLINDER HEAD COVER**REMOVAL**

- (1) Disconnect the negative battery cable.

WARNING: DO NOT REMOVE THE CYLINDER BLOCK DRAIN PLUGS OR LOOSEN THE RADIATOR DRAIN COCK WITH THE SYSTEM HOT AND PRESSURIZED BECAUSE SERIOUS BURNS FROM THE COOLANT CAN OCCUR.

- (2) On right hand drive vehicles, drain the cooling system. Refer to Group 7, Cooling System for the procedure.

- (3) Recover the air conditioning system, if equipped. Refer to Group 24, Heating and Air Conditioning for the procedure.

- (4) Remove the A/C lines at the compressor and cap all openings. Refer to Group 24, Heating and Air Conditioning for the procedure. Remove the A/C line support bracket attached to cylinder head cover, and move the A/C, vacuum lines away from the cylinder head.

- (5) Remove the generator support brace.

- (6) Remove the Crankcase breather hose from the rear of the valve cover

- (7) Remove the cylinder head cover bolts.

- (8) Remove the cylinder head cover.

INSTALLATION

- (1) Install the cylinder head cover. Torque the bolts to 15 N·m (133 in. lbs.).

- (2) Connect the crankcase breather hose.

- (3) Install the generator support brace. Torque bolt to 27 N·m (20 ft. lbs.) and nut to 11 N·m (8 ft. lbs.).

- (4) Install the A/C lines on the compressor and install the support bracket on the cylinder head cover. Torque bolt to 7 N·m (62 in. lbs.).

- (5) Connect the negative battery cable.

- (6) If equipped with A/C, evacuate and charge the air conditioning system. Refer to Group 24, Heater and Air Conditioning.

- (7) On right hand drive vehicles, fill the cooling system. Check for leaks.

WARNING: USE EXTREME CAUTION WHEN THE ENGINE IS OPERATING. DO NOT STAND IN DIRECT LINE WITH THE FAN. DO NOT PUT HANDS NEAR THE PULLEYS, BELTS OR FAN. DO NOT WEAR LOOSE CLOTHING.

- (8) Operate the engine with the radiator cap off. Inspect for leaks and continue operating the engine until the thermostat opens. Add coolant, if required.

REMOVAL AND INSTALLATION (Continued)

HYDRAULIC TAPPETS

Before disassembling any part of the engine to correct tappet noise, check the oil pressure. If vehicle has no oil pressure gauge, install a reliable gauge at the pressure sending unit. The pressure should be between 4 bars (50 psi) at 3000 RPM.

Check the oil level after the engine reaches normal operating temperature. Allow 5 minutes to stabilize oil level, check dipstick. The oil level in the pan should never be above the FULL mark or below the ADD OIL mark on dipstick. Either of these 2 conditions could be responsible for noisy tappets:

OIL LEVEL HIGH

If oil level is above the FULL mark, it is possible for the connecting rods to dip into the oil. With the engine running, this condition could create foam in the oil pan. Foam in oil pan would be fed to the hydraulic tappets by the oil pump causing them to lose length and allow valves to seat noisily.

OIL LEVEL LOW

Low oil level may allow oil pump to take in air. When air is fed to the tappets, they lose length which allows valves to seat noisily. Any leaks on intake side of oil pump through which air can be drawn will create the same tappet action. Check the lubrication system from the intake strainer to the pump cover, including the relief valve retainer cap. When tappet noise is due to aeration, it may be intermittent or constant, and usually more than 1 tappet will be noisy. When oil level and leaks have been corrected, operate the engine at fast idle. Run engine for a sufficient time to allow all of the air inside the tappets to be bled out.

HYDRAULIC TAPPETS

REMOVAL

- (1) Disconnect the negative battery cable.
- (2) Discharge the air conditioning system, if equipped. Refer to Group 24, Heating and Air Conditioning for procedure.
- (3) If equipped with air conditioning, remove the A/C lines at the compressor and cap.
- (4) Remove the A/C line bracket attached to the cylinder head cover and move the lines away from the cylinder head.
- (5) Remove cylinder head cover. Refer to cylinder head cover removal and installation procedure in this section.
- (6) Remove the rocker assemblies and push rods. Refer to rocker arms and push rod removal and installation procedure in this section. Identify push rods to ensure installation in original location.
- (7) Remove cylinder head, intake manifold, and exhaust manifold. Refer to cylinder head removal and installation in this section.

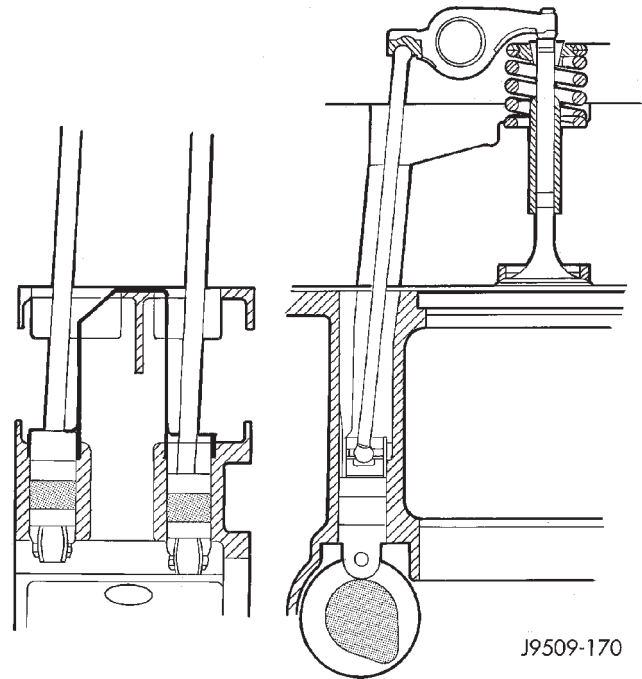

Fig. 25 Tappet And Rocker Arm Assembly

- (8) Remove the tappet retainers (Fig. 26).

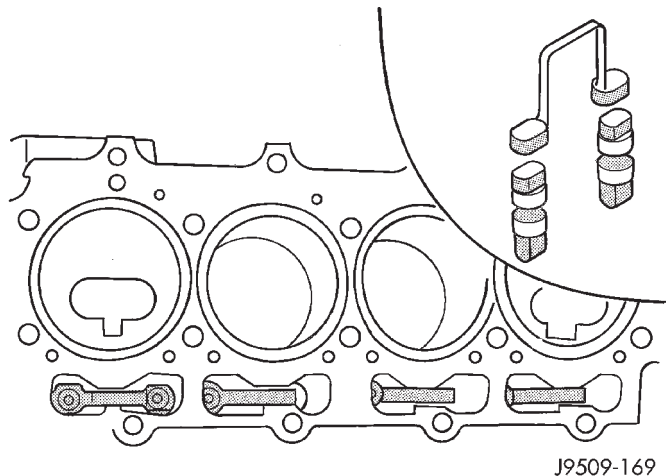

Fig. 26 Tappet And Retainer

- (9) Slide Hydraulic Tappet Remover/Installer Tool through opening in block and seat tool firmly in the head of tappet.

- (10) Pull the tappet out of the bore with a twisting motion. If all tappets are to be removed, identify tappets to ensure installation in original location.

CAUTION: The plunger and tappet bodies are not interchangeable. The plunger and valve must always be fitted to the original body. It is advisable to work on one tappet at a time to avoid mixing of parts. Mixed parts are not compatible. **DO NOT** disassemble a tappet on a dirty work bench.

REMOVAL AND INSTALLATION (Continued)

INSTALLATION

- (1) Lubricate the tappets.
- (2) Install the tappets and retainers in their original positions. Ensure that the oil feed hole in the side of the tappet body faces up (away from the crankshaft).
- (3) Install the cylinder head, intake manifold, and exhaust manifold. Refer to cylinder head removal and installation in this section.
- (4) Install the push rods.
- (5) Install the rocker arms. Refer to rocker arms and push rod removal and installation in this section.
- (6) Install the cylinder head cover. Refer to cylinder head cover removal and installation in this section.
- (7) Connect the negative battery cable.

CAUTION: To prevent damage to valve mechanism, engine must not be run above fast idle until all hydraulic tappets have filled with oil and have become quiet.

- (8) Start and operate engine. Warm up to normal operating temperature.

ROCKER ARMS AND PUSH RODS

REMOVAL

- (1) Disconnect the negative battery cable.
- (2) Discharge the air conditioning system, if equipped. Refer to Group 24, Heating and Air Conditioning for procedure.
- (3) If equipped with air conditioning, remove the service valves and cap the compressor ports. Refer to Group 24, Heating and Air Conditioning.
- (4) Remove the generator bracket.
- (5) Remove the cylinder head cover. Refer to cylinder head cover removal and installation in this section.
- (6) Remove the rocker arm retaining nut (Fig. 27).
- (7) Remove the rocker assembly. Place them on a bench in the same order as removed.
- (8) Remove the push rods and place them on a bench in the same order as removed.

INSTALLATION

WARNING: During the installation of the rocker arm assemblies it is possible to cause valve interference between the piston and valve if the piston is near Top Dead Center (TDC). This is due to the slow bleed down rate of the tappets when adjusting the rocker arm assemblies. Follow the procedure below to ensure that engine damage does not occur.

- Install the rocker arm assemblies in the same order as removed.

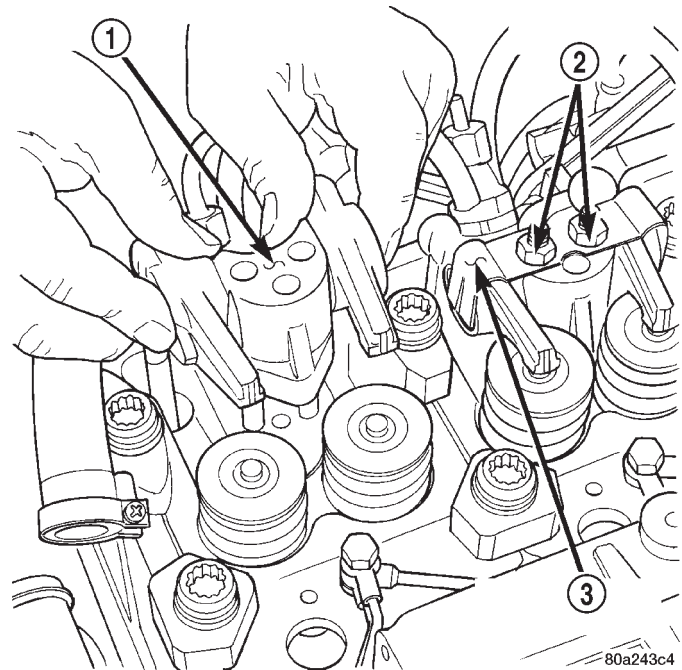

Fig. 27 Rocker Arm Retaining Nut

- 1 - ROCKER ARM ASSEMBLY
- 2 - ROCKER ARM RETAINING NUTS
- 3 - ROCKER ARM SPRING PLATE

- Bring piston # 1 to Top Dead Center.
- Rotate the engine 40° counter clockwise and stop.
- At this point tighten all of the rocker arm nuts. Torque nuts to 27 N·m (20 ft. lbs.).

NOTE: You must allow 30 minutes before starting the engine once the rocker arms are torqued. This will allow the hydraulic tappets to stabilize and prevent the possibility of piston to valve contact.

- (2) Install the cylinder head cover. Refer to cylinder head cover removal and installation in this group.
- (3) Evacuate and charge the air conditioning system. Refer to Group 24, Heater and Air Conditioning.
- (4) Connect the negative battery cable.

VALVE SPRINGS

This procedure can be done with the engine cylinder head installed on the block.

REMOVAL

- (1) Disconnect the negative battery cable. Each valve spring is held in place by a retainer and a set of conical valve locks. The locks can be removed only by compressing the valve spring.
- (2) Remove the cylinder head cover. Refer to cylinder head cover removal and installation in this section.

REMOVAL AND INSTALLATION (Continued)

(3) Remove the rocker arms assemblies and push rods. Refer to rocker arm and push rod removal and installation in this section. Retain the push rods, and rocker arms assemblies in the same order and position as removed.

(4) Inspect the springs and retainer for cracks and possible signs of weakening.

(5) Install an air hose adaptor in the fuel injector hole.

(6) Connect an air hose to the adapter and apply air pressure slowly. Maintain at least 621 kPa (90 psi) of air pressure in the cylinder to hold the valves against their seats.

(7) Tap the retainer or tip with a rawhide hammer to loosen the lock from the retainer. Use Valve Spring Compressor Tool to compress the spring and remove the locks.

(8) Remove the valve spring and retainer.

(9) Inspect the valve stems, especially the grooves. An Arkansas smooth stone should be used to remove nicks and high spots.

INSTALLATION

(1) Install the valve spring and retainer.

(2) Compress the valve spring with Valve Spring Compressor Tool and insert the valve locks. Release the spring tension and remove the tool. Tap the spring from side-to-side to ensure that the spring is seated properly on the engine cylinder head.

(3) Disconnect the air hose. Remove the adaptor from the fuel injector hole and install the fuel injector.

(4) Repeat the procedures for each remaining valve spring to be removed.

(5) Install the push rods. Ensure the bottom end of each rod is centered in the plunger cap seat of the hydraulic valve tappet.

(6) Install the rocker arm assemblies, in their original locations. Torque nuts to 29.4 N·m (264 in. lbs.).

(7) Install the cylinder head cover. Refer to cylinder head cover removal and installation in this section.

(8) Connect the negative battery cable.

ENGINE CYLINDER HEAD

REMOVAL

(1) Disconnect the negative battery cable.

WARNING: DO NOT REMOVE THE CYLINDER BLOCK DRAIN PLUGS OR LOOSEN THE RADIATOR DRAIN COCK WITH THE SYSTEM HOT AND PRESSURIZED BECAUSE SERIOUS BURNS FROM THE COOLANT CAN OCCUR.

(2) Drain the cooling system. Refer to Group 7, Cooling System for procedure.

(3) Discharge the air conditioning system, if equipped. Refer to Group 24, Heating and Air Conditioning for procedure.

(4) If equipped with air conditioning, remove the A/C lines at the compressor and cap. Refer to Group 24, Heating and Air Conditioning. Remove A/C line bracket attached to cylinder head cover, and move A/C lines away from cylinder head.

(5) Remove the air cleaner hose from turbocharger and breather hose.

(6) Remove the air cleaner assembly and breather hose.

(7) Remove the generator support bracket.

(8) Remove the upper radiator hose and coolant recovery hose.

(9) Remove the water manifold and recovery hose.

(10) Disconnect the heater hoses and coolant recover bottle hose.

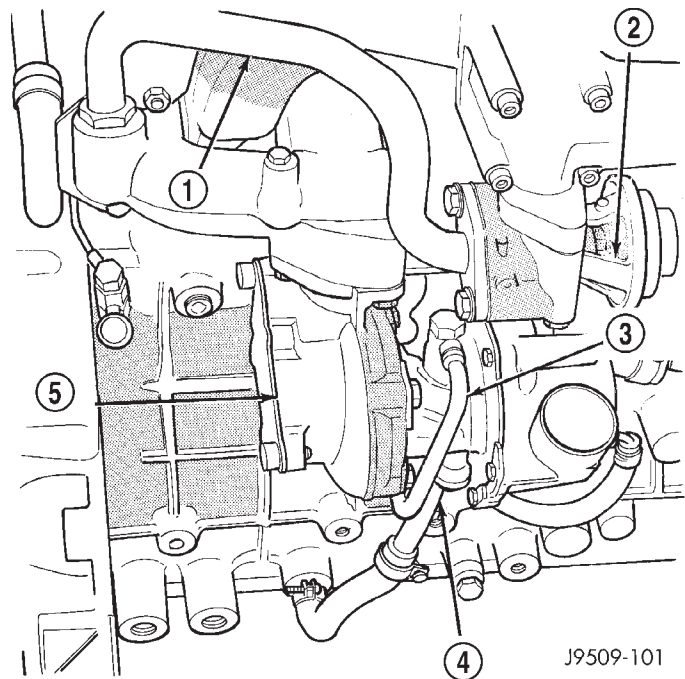

Fig. 28 Turbocharger

- 1 - EGR TUBE
- 2 - EGR VALVE
- 3 - OIL FEED LINE
- 4 - OIL DRAIN
- 5 - TURBO

(11) Disconnect the EGR tube from EGR valve.
 (12) Remove the EGR valve
 (13) Remove the exhaust heat shield from exhaust manifold.

(14) Remove the exhaust heat shield from down pipe.

(15) Remove the exhaust down pipe from turbocharger (Fig. 28).

(16) Disconnect the oil feed line from turbocharger.

REMOVAL AND INSTALLATION (Continued)

(17) Disconnect the oil drain line from turbo-charger.

(18) Remove the Exhaust manifold. Refer to Group 11, Exhaust System and Turbocharger.

(19) Remove the Intake manifold. Refer to intake manifold removal and installation procedure in this section.

(20) Remove the oil feed line retaining bracket at rear of #4 cylinder head.

(21) Remove the oil feed line retaining bracket (Fig. 29).

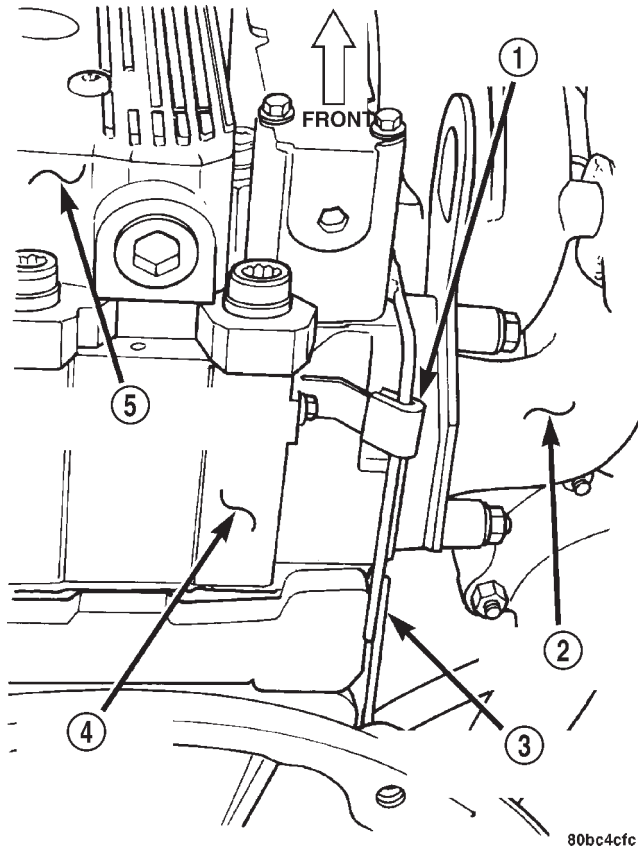

Fig. 29 Oil Feed Line Retainer

- 1 - CYLINDER HEAD OIL SUPPLY LINE RETAINING CLIP
- 2 - EXHAUST MANIFOLD
- 3 - CYLINDER HEAD OIL SUPPLY LINE
- 4 - REAR OF CYLINDER HEADS
- 5 - CYLINDER HEAD COVER

(22) Remove the oil feed line for rocker arm assemblies (Fig. 30).

(23) Remove the Crankcase breather hose from rear of the valve cover

(24) Remove the injector sensor wire and the glow plug hot lead.

(25) Remove the fuel lines and fuel filter. Refer to Group 14, Fuel Systems for procedure.

(26) Remove the injector fuel lines from injectors to pump.

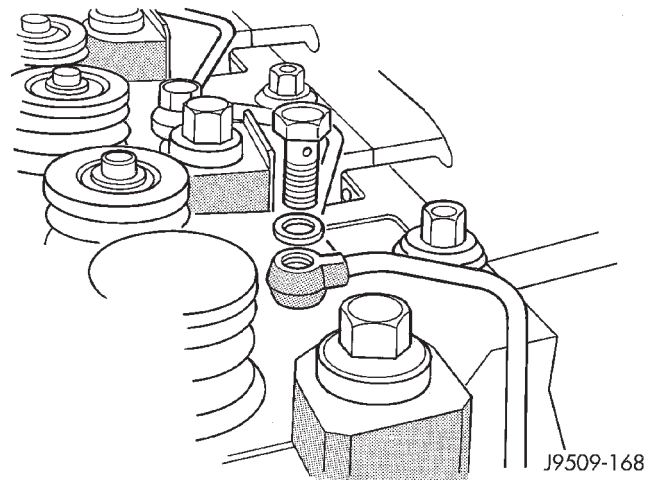

Fig. 30 Rocker Arm Oil Feed Lines

(27) Remove the fuel injectors with tool VM.1012 (Fig. 31). Refer to Group 14, Fuel System for procedure.

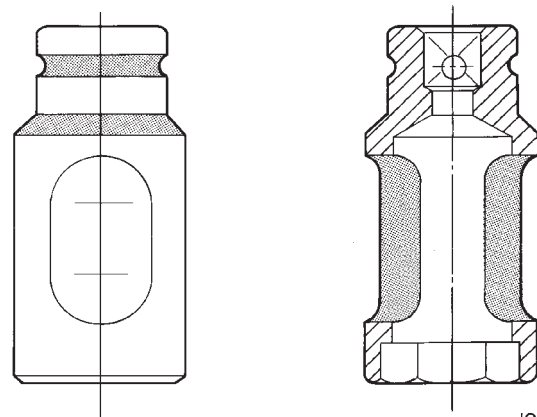

Fig. 31 Fuel Injector Tool VM.1012B

(28) Remove the engine cylinder head cover.

(29) Remove the rocker retaining nuts (Fig. 33).

(30) Remove the rocker arm assemblies. Place them on a bench in the same order as removed.

(31) Remove the push rods and place them on a bench in the same order as removed.

(32) Mark the cylinder head positions.

(33) Remove the engine cylinder head bolts with special tool VM.1018 and VM.1019.

(34) Remove the engine cylinder head and gasket.

(35) Stuff clean lint free shop towels into the cylinder bores.

CYLINDER HEAD GASKETS

A steel cylinder head gasket is used for all four cylinder heads.

Cylinder head gaskets are available in three thicknesses. Identification holes in the right front corner of the gasket indicate the thickness of the gasket (Fig. 34).

REMOVAL AND INSTALLATION (Continued)

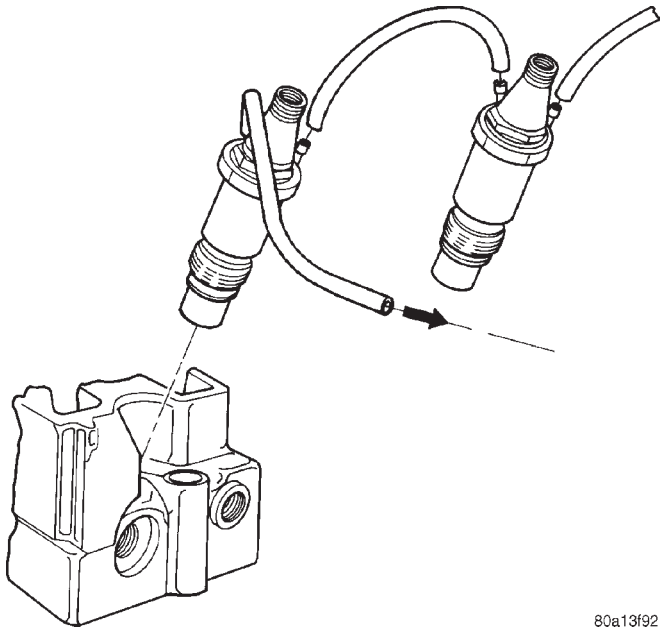

80a13f92

Fig. 32 Fuel Injector

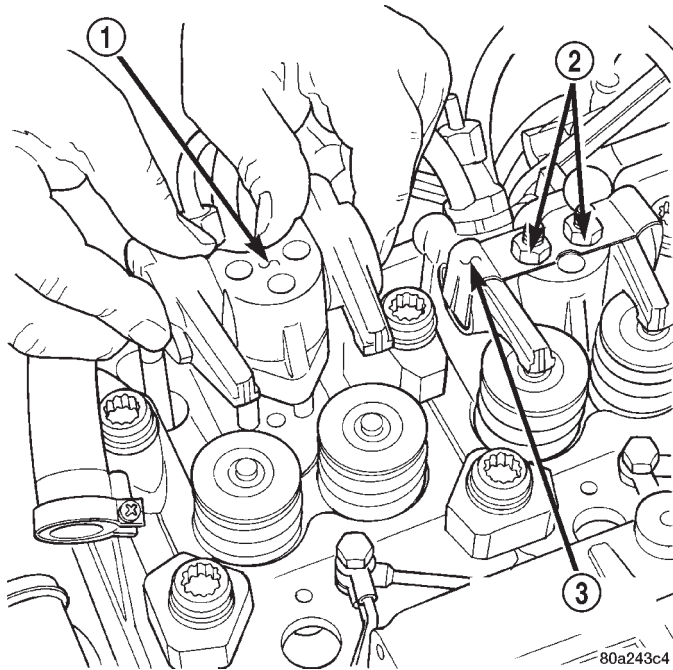

80a243c4

Fig. 33 Rocker Arm Retaining Nuts

- 1 - ROCKER ARM ASSEMBLY
- 2 - ROCKER ARM RETAINING NUTS
- 3 - ROCKER ARM SPRING PLATE

CAUTION: Piston protrusion must be measured, to determine cylinder head gasket thickness, if one or more cylinder wall liners have been replaced.

NOTE: If cylinder wall liners have not been removed; the same thickness head gasket removed, may be used.

HOLES OR NOTCHES CAN BE LOCATED AT THE RIGHT FRONT CORNER OF THE CYLINDER BLOCK

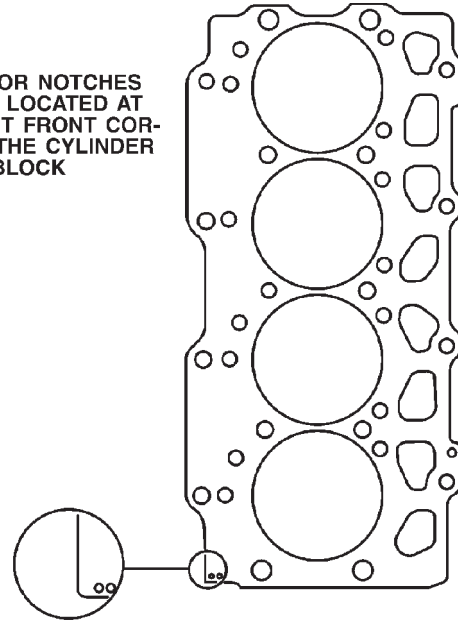

| HOW TO IDENTIFY GASKET THICKNESS | |
|----------------------------------|--------|
| NO HOLES | 1.41mm |
| 2 HOLES | 1.51mm |
| 1 HOLE | 1.61mm |

80bf1e6

Fig. 34 Steel Type Cylinder Head Gasket—identification

MEASURING PISTON PROTRUSION

(1) Use special tool VM.1010 with dial indicator special tool VM.1013 (Fig. 35).

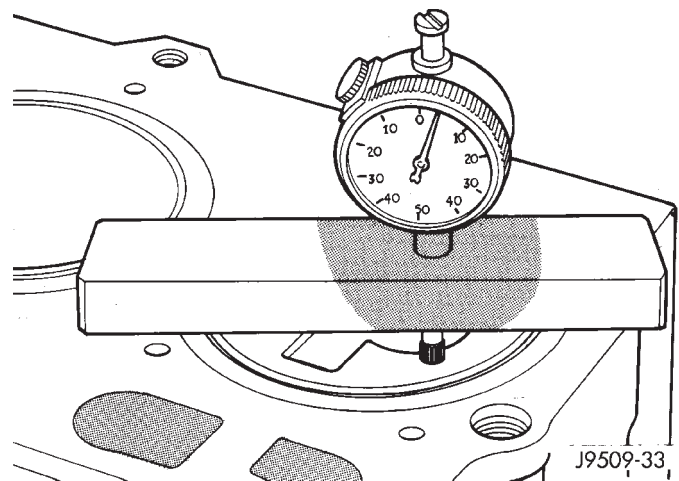

J9509-33

Fig. 35 Measuring Piston Protrusion

(2) Bring the piston of cylinder no. 1 exactly to top dead center.

(3) Zero the dial indicator on the cylinder block mating surface.

(4) Setup the dial indicator on the piston crown (above the center of the piston pin) 5mm (1/8 in.)

REMOVAL AND INSTALLATION (Continued)

from the edge of the piston and note the measurement (Fig. 36).

(5) Repeat the procedure with the rest of the cylinders.

(6) Establish the thickness of the steel gasket for all four cylinder heads on the basis of the greatest piston protrusion (Fig. 34).

| | |
|---|-------------|
| Measured dimension (mm) | 0.53 - 0.62 |
| Cyl. head gasket thickness (mm) | 1.41 |
| Piston clearance (mm) | 0.80 - 0.89 |
| Measured dimension (mm) | 0.63-0.72 |
| Cyl. head gasket thickness (mm) | 1.51 |
| Piston clearance (mm) | 0.80-0.89 |
| Measured dimension (mm) | 0.73-0.82 |
| Cyl. head gasket thickness (mm) | 1.61 |
| Piston clearance (mm) | 0.80-0.89 |

Fig. 36 Piston Protrusion Chart

CAUTION: Gaskets are to be installed DRY. DO NOT use a gasket sealing compound on the gasket.

INSTALLATION

(1) Remove the shop towels from the cylinder bores. Coat the bores with clean engine oil.

(2) Install cylinder head alignment studs VM.1009.

(3) After determining the correct head gasket thickness, clean the block and head mating surfaces,

place the engine cylinder head gasket over the alignment studs.

(4) Place the engine cylinder head over the alignment studs.

CAUTION: New cylinder head bolts should be used.

(5) Tighten the engine cylinder head bolts in sequence according to the following procedure (Fig. 37) :

a. The threads and underside heads of the bolts should be lubricated. Use the cylinder head alignment studs tool number VM-1009. Position the heads on the block and secure with the ten large center bolts (14mm) and spacers (clamps), finger tight only.

b. Ensure that the various clamps are installed correctly and the head gasket remains in it's proper position, completely covered. Then, lubricate and install the eight small bolts (12mm), also finger tight.

(6) Install the intake and exhaust manifolds with a new gasket, partially tightening the nuts to a maximum of 5 N·m (44 in. lbs.). This will align the heads. Refer to Group 11, Exhaust System and Turbo-charger for the proper procedure. Install lift eye and brake vacuum tube at this time.

(7) Then, tighten the 14mm bolts with special tool VM.1019 in the following manner:

(8) **1st Phase: Tightening Head Bolts** (Fig. 37). Central bolts (A-L): Tighten all bolts, starting with bolt H then G-F-E-D-C-B-A-L-I, to 30 N·m. Tighten all bolts an additional 70°, starting with bolt A and continuing in alphabetical order. Finally, tighten all bolts an additional 70°, starting again with bolt A and continuing in alphabetical order.

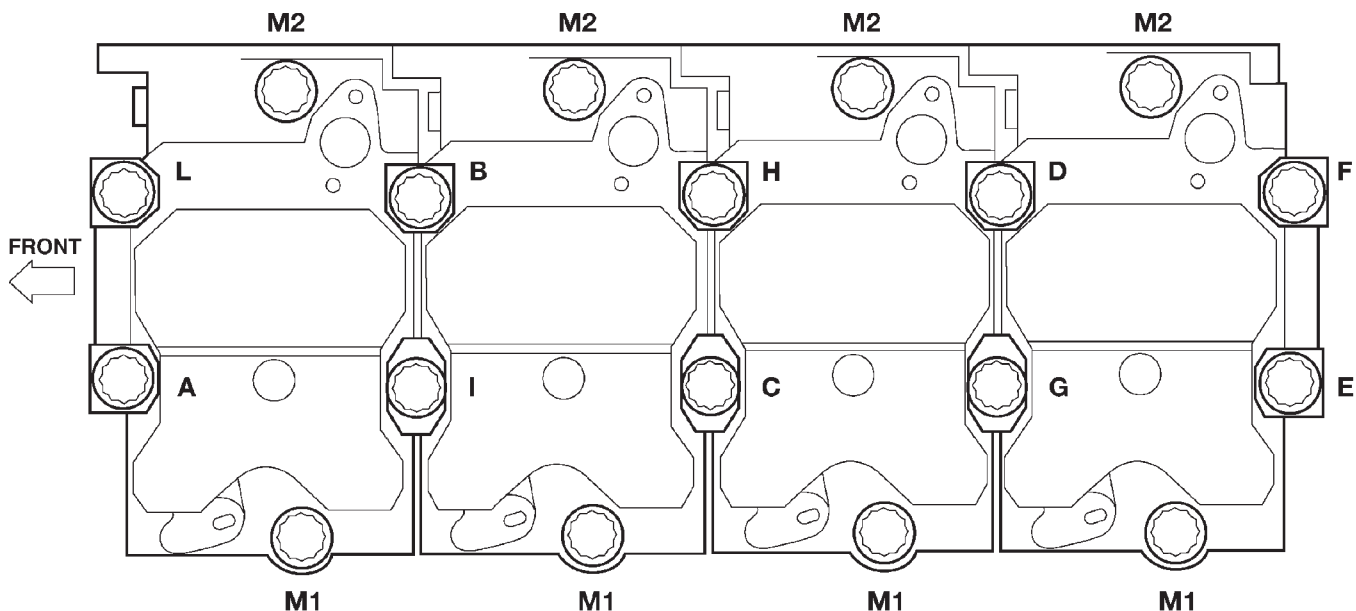

Fig. 37 Engine Cylinder Head Bolt Tightening Sequence

REMOVAL AND INSTALLATION (Continued)

(9) Tighten the 12mm bolts in the following manner:

(10) Side bolts (M1-M2): Tighten M1 bolts to 30 N·m, then rotate them 85° (±5). Tighten M2 bolts to 30 N·m, then rotate them 85° (±5).

NOTE: If vehicle is equipped with A/C do not install A/C lines to compressor and charge A/C till Phase 2 is complete.

(11) **2nd Phase:** After 20 minutes of engine operation at operating temperature, allow engine to cool down completely. Then retorquer the head bolts as follows:

(12) Central bolts A-L: Completely back off bolts one-by-one and then retighten to 30 N·m plus 130° (±5°). Then proceed in the same way, bolt by bolt, following alphabetical order, as indicated.

(13) Side bolts M1-M2: **Without slackening**, torque bolts M1 then bolts M2 to 90 N·m (66 ft. lbs.).

(14) Torque intake nuts to 32 N·m (24 ft. lbs.) and exhaust manifolds nuts to 32 N·m (24 ft. lbs.) after completing the cylinder head torquing procedure.

(15) Install the oil feed lines for the rocker arm assemblies. Torque oil feed lines to 13 N·m (115 in. lbs.).

(16) Install the oil feed line retaining bracket at rear of #4 cylinder head (Fig. 29).

(17) Install the push rods and rocker arm assemblies. Refer to the rocker arm and pushrod removal and installation procedure in this group.

(18) Install the cylinder head cover. Torque bolts to 15 N·m (133 in. lbs.).

(19) Connect the crankcase breather hose.

(20) Connect the injector sensor wire and the glow plug hot lead.

(21) Install the turbocharger oil feed line. Torque banjo bolts to 27 N·m (20 ft. lbs.).

(22) Install the turbocharger oil drain line. Torque bolts to 11 N·m (97 in. lbs.).

(23) Install the water manifold. Torque bolts to 12 N·m (106 in. lbs.).

(24) Install the generator support bracket.

(25) Raise the vehicle on hoist.

(26) Install the exhaust down pipe to turbocharger, tighten bolts to 22 N·m (16 ft. lbs.).

(27) Install the exhaust down pipe heat shield.

(28) Install the exhaust heat shield, Tighten bolts to 11 N·m (8 ft. lbs.).

(29) Install the EGR valve to intake manifold, tighten bolts to 27 N·m (20 ft. lbs.).

(30) Install the EGR tube to EGR valve, tighten bolts to 27 N·m (20 ft. lbs.).

(31) Install the lower charge air cooler hose to turbocharger.

(32) Install the air cleaner assembly and hose.

(33) Install the oil breather hose to air cleaner hose.

(34) Install the upper charge cooler hose to turbocharger.

(35) Connect the recover bottle hose to water manifold.

(36) Install the fuel injectors using special tool VM.1012. Refer to Group 14, Fuel System for procedures.

(37) Install the fuel injector lines from the pump to injectors. Torque nuts to 19 N·m (14 ft. lbs.).

(38) Connect the A/C lines to compressor and install bracket on cylinder head cover, if equipped with air conditioning.

(39) Install the fuel filter, Tighten bolts to 28 N·m (250 in. lbs.).

(40) Connect the fuel supply and return lines

(41) Connect the upper radiator hose.

(42) Connect the negative cable battery.

(43) If equipped with A/C, evacuate and charge the air conditioning system. Refer to Group 24, Heater and Air Conditioning.

(44) Fill the cooling system. Check for leaks.

WARNING: USE EXTREME CAUTION WHEN THE ENGINE IS OPERATING. DO NOT STAND IN DIRECT LINE WITH THE FAN. DO NOT PUT HANDS NEAR THE PULLEYS, BELTS OR FAN. DO NOT WEAR LOOSE CLOTHING.

(45) Operate the engine with the radiator cap off. Inspect for leaks and continue operating the engine until the thermostat opens. Add coolant, if required.

NOTE: After rebuild or cylinder head gasket replacement, the cylinder head must be retorqued within the first 20,000km. If individual fiber type head gaskets were used.

NOTE: The one piece steel type head gasket does not require, the above mentioned, retorquer procedure.

CYLINDER HEAD RE-TORQUE

Within the first 20,000 km (12,000 miles) after rebuild, retorquer the cylinder head bolts as follows: (Fig. 37) Central bolts A-L: Without slackening the bolts, following alphabetical order tighten the bolts through an angle of 15°. Side bolts M1-M2: Without slackening, tighten M1 then M2 bolts through an angle of 15°.

REMOVAL AND INSTALLATION (Continued)

VIBRATION DAMPER

REMOVAL

- (1) Disconnect the negative battery cable.
- (2) Remove the fan and set fan inside fan shroud then remove fan shroud and fan as an assembly.
- (3) Remove the accessory drive belt. Refer to Group 7, Cooling System for procedure.
- (4) Remove the vibration damper nut.
- (5) Install special tool VM.1000-A to remove vibration damper.

INSTALLATION

- (1) Install the vibration damper and align with key way.
- (2) Install the vibration damper nut. Torque nut to 196 N·m (147 ft. lbs.).
- (3) Install the accessory drive belt. Refer to Group 7, Cooling System for procedure.
- (4) Connect the negative battery cable.

TIMING GEAR COVER OIL SEAL

REMOVAL

- (1) Disconnect the negative battery cable.
- (2) Remove the vibration damper. Refer to vibration damper removal and installation in this section.

CAUTION: Use care when removing the old seal. Be sure not to damage the timing gear cover.

- (3) Pry out the old seal.

INSTALLATION

Remove the oil seal ring. The seating diameter must be 68.000 - 68.030 mm.

- (1) Install the new seal using special tool VM.1015A.
- (2) Install the vibration damper. Refer to vibration damper removal and installation in this section.
- (3) Connect the negative battery cable.

TIMING GEAR COVER

REMOVAL

- (1) Disconnect the negative battery cable.
- (2) Remove the fan and set fan inside fan shroud then remove fan shroud and fan as an assembly.
- (3) Remove the accessory drive belt. Refer to Group 7, Cooling System for procedure.
- (4) Remove the vibration damper nut.
- (5) Install special tool VM.1000-A to remove the vibration damper.
- (6) Remove the fan pulley.

NOTE: The idler pulley bolt has left hand thread.

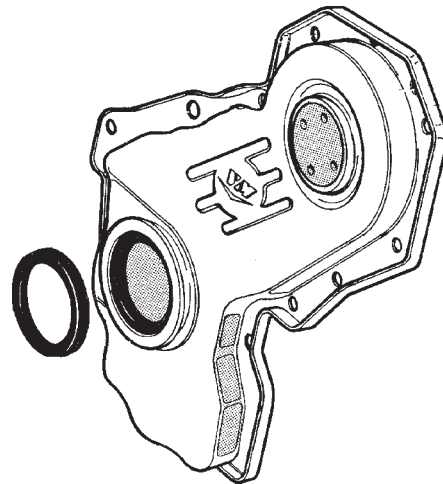

J9509-4

Fig. 38 Timing Gear Cover Oil Seal

- (7) Remove the idler pulley and bracket.
- (8) Remove the automatic belt tensioner.
- (9) Remove the Power steering pump pulley.
- (10) Remove the timing gear retaining bolts and cover.

INSTALLATION

(1) Be sure the mating surfaces of the gear case cover and the cylinder block are clean and free from burrs.

(2) Apply a continuous 3 mm bead of Silicone Sealer (Fig. 39) to timing cover, install within 10 minutes, tighten bolts to 10.3 N·m (91 in. lbs.).

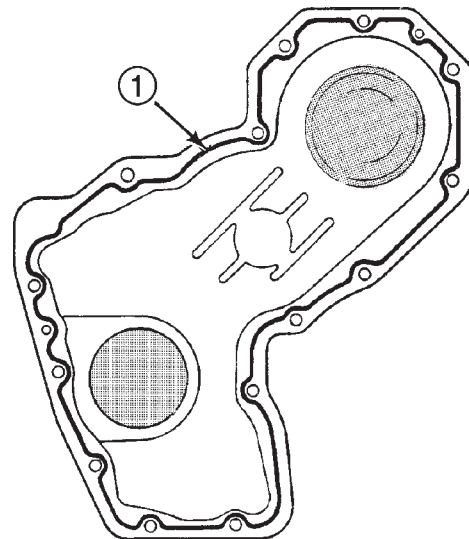

J9509-7

Fig. 39 Front Cover Sealer Location

1 - MOPAR SILICONE RUBBER ADHESIVE SEALANT

- (3) Install Power steering pump pulley. Torque bolts to 166 N·m.

REMOVAL AND INSTALLATION (Continued)

(4) Install the automatic belt tensioner.

NOTE: The idler pulley has left hand thread.

(5) Install the idler pulley. Torque nut to 40 N·m (29 ft. lbs.).

(6) Install the fan pulley. Torque bolts to 56 N·m (41 ft. lbs.).

(7) Install the vibration damper. torque nut to 196 N·m (147 ft. lbs.).

(8) Install the accessory drive belt. Refer to Group 7, Cooling System for procedure).

(9) Install the fan and fan shroud.

(10) Connect the negative battery cable.

CAMSHAFT

REMOVAL

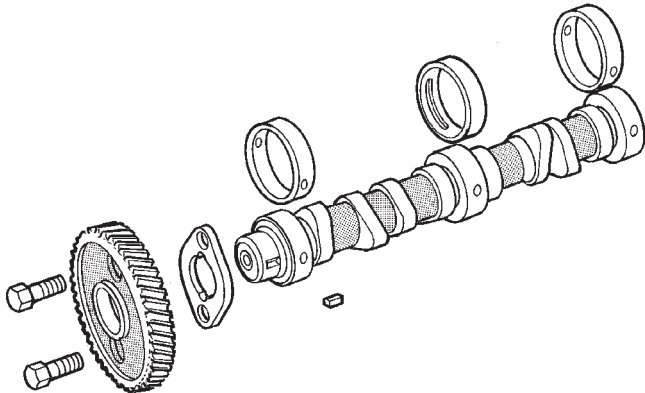

J9509-173

Fig. 40 Camshaft Assembly

- (1) Disconnect the negative battery cable.
- (2) Remove the cylinder head cover. Refer to cylinder head cover removal and installation in this section.
- (3) Remove the cylinder heads. Refer to cylinder head removal and installation in this section.
- (4) Remove the rocker arm assemblies, push rods, and hydraulic tappets. Refer to the respective groups in this section.
- (5) Remove the fan and set fan inside fan shroud then remove fan shroud and fan as an assembly.
- (6) Remove the accessory drive belt. Refer to Group 7, Cooling System for procedure.
- (7) Remove the radiator. Refer to Group 7, Cooling System for procedure.
- (8) Remove the A/C condenser. Refer to Group 24, Heating and Air Conditioning for procedure.
- (9) Remove the vibration damper. Refer to vibration damper removal and installation in this section.
- (10) Remove the power steering pump pulley.

(11) Remove timing gear cover. Refer to timing gear cover removal and installation in this section.

(12) Rotate the engine to align the timing marks as shown (Fig. 41).

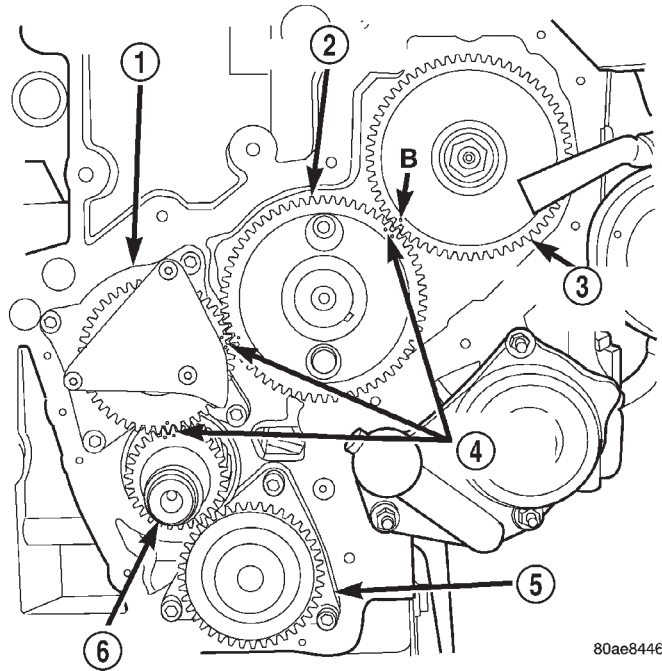

80ae844e

Fig. 41 Timing Marks

- 1 - VACUUM PUMP
- 2 - CAMSHAFT
- 3 - INJECTION PUMP
- 4 - TIMING MARKS
- 5 - OIL PUMP
- 6 - CRANKSHAFT

(13) Unscrew the flange bolts and remove camshaft (Fig. 42).

THRUST PLATE INSPECTION

Check the thickness (Fig. 43) of the plate at points a-b-c-d. If the measurement is not between 3.950 - 4.050 it must be changed.

INSTALLATION

(1) Coat the camshaft journals with clean engine oil and carefully install the camshaft complete with thrust plate and gear. Tighten retaining bolts to 27.5 N·m (20 ft. lbs.) torque. Be sure to align the timing marks as shown (Fig. 44).

(2) Install the hydraulic tappets and retainers. Refer to hydraulic tappet removal and installation in this section.

(3) Install the cylinder heads. Refer to cylinder head removal and installation in this section).

(4) Install the push rods and rocker arm assemblies. Refer to the respective sections.

REMOVAL AND INSTALLATION (Continued)

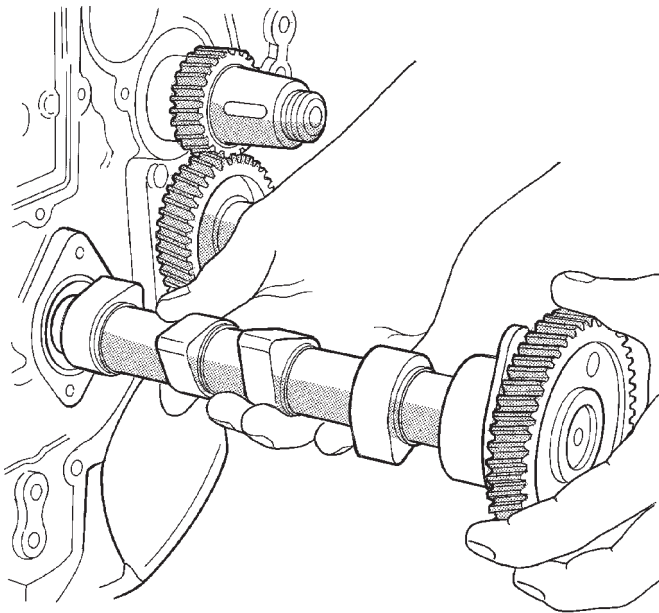

J9509-15

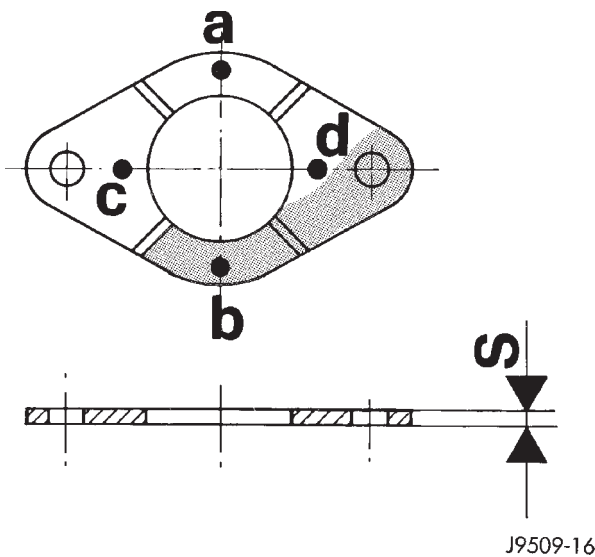
Fig. 42 Camshaft Removal

J9509-16

Fig. 43 Camshaft Thrust Plate

(5) Install the cylinder head cover. Refer to cylinder head cover removal and installation in this section.

(6) Install the timing gear cover. Refer to timing gear cover removal and installation in this section.

(7) Install the vibration damper. Refer to the vibration damper removal and installation in this section.

(8) Install the A/C condenser. Refer to Group 24, Heating and Air Conditioning for procedure.

(9) Install the radiator. Refer to Group 7, Cooling System for procedure.

(10) Install the fan and fan shroud. Torque fan to 56 N·m (41 ft. lbs.).

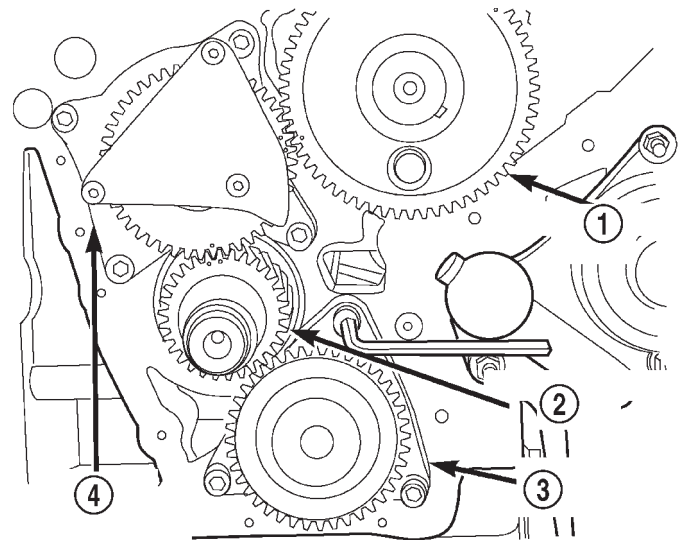

80ae8458

Fig. 44 Timing Marks

- 1 - CAMSHAFT GEAR
- 2 - CRANKSHAFT GEAR
- 3 - OIL PUMP
- 4 - VACUUM PUMP

(11) If equipped, evacuate and charge the air conditioning system. Refer to Group 24, Heater and Air Conditioning for procedure.

(12) Connect the negative battery cable.

(13) Fill the cooling system. Check for leaks.

WARNING: USE EXTREME CAUTION WHEN THE ENGINE IS OPERATING. DO NOT STAND IN DIRECT LINE WITH THE FAN. DO NOT PUT HANDS NEAR THE PULLEYS, BELTS OR FAN. DO NOT WEAR LOOSE CLOTHING.

(14) Operate the engine with the radiator cap off. Inspect for leaks and continue operating the engine until the thermostat opens. Add coolant, if required.

CAMSHAFT BEARINGS

This procedure requires that the engine is removed from the vehicle.

REMOVAL

(1) With the engine completely disassembled, remove camshaft rear plate and o-ring.

(2) Install the proper size adapters and horseshoe washers (part of Crankshaft Bearing Remover/Installer Tool VM-1002) at back of each bearing shell. Drive out the bearing shells.

INSTALLATION

(1) Install the new camshaft bearings with Camshaft Bearing Remover/Installer Tool C3131-A by

REMOVAL AND INSTALLATION (Continued)

sliding the new camshaft bearing shell over proper adapter.

(2) Position the rear bearing in the tool. Install horseshoe lock and by reversing removal procedure, carefully drive bearing shell into place.

(3) Install the remaining bearings in the same manner. **The Bearings must be carefully aligned to bring oil holes into full register with oil passages from the main bearing. If the camshaft bearing shell oil holes are not in exact alignment, remove and install them correctly.**

(4) Install a new rear plate o-ring at the rear of camshaft. **Be sure this seal does not leak.**

OIL PAN

REMOVAL

- (1) Disconnect the negative battery cable.
- (2) Raise the vehicle on hoist.
- (3) Drain the oil.
- (4) Remove the oil pan lower cover (Fig. 45).
- (5) Remove the bolts from oil pan. Remove the 6 bolts that are on the inside of the oil pan.
- (6) Remove the oil pan.

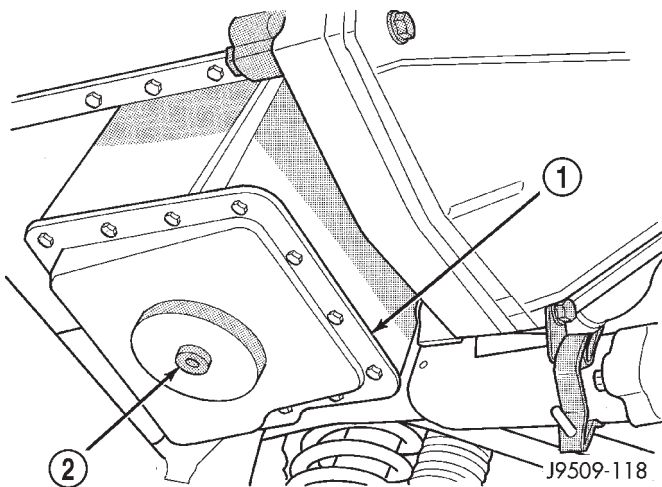

Fig. 45 Oil Pan

- 1 - LOWER OIL PAN COVER
- 2 - OIL DRAIN PLUG

INSTALLATION

(1) Remove all gasket material from cylinder block. Be careful not to gouge or scratch aluminum pan sealing surface.

(2) Apply a continuous 3 mm bead of Silicone Sealer to oil pan, install within 10 minutes. Install the oil pan.

(3) Install the inside oil pan bolts. Torque bolts to 11 N·m (8 ft. lbs.).

(4) Torque the smaller oil pan bolts to 11 N·m (8 ft. lbs.). Torque the larger oil pan bolts to 25 N·m (18 ft. lbs.).

(5) Install the oil drain plug. Torque to 79 N·m (58 ft. lbs.).

(6) Lower the vehicle from hoist.

(7) Fill engine with proper amount of oil.

(8) Connect the negative battery cable.

OIL PUMP

REMOVAL

- (1) Disconnect the negative battery cable.
- (2) Remove the timing gear cover. Refer to timing gear cover removal and installation in this section.
- (3) Remove the oil pump (Fig. 46).

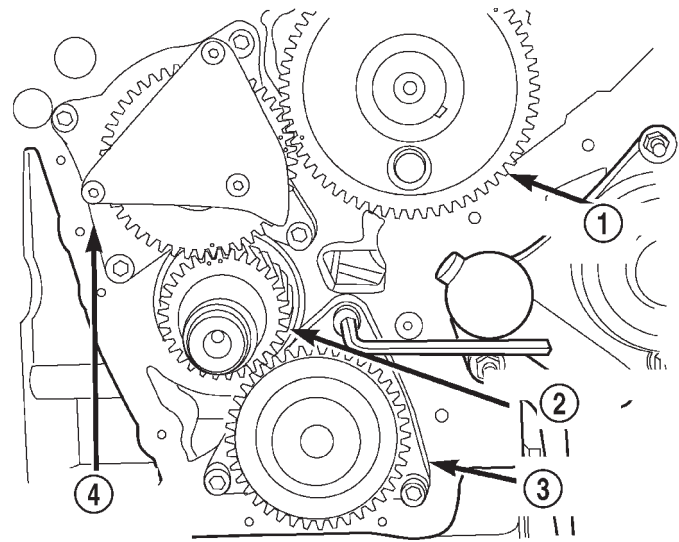

80ae8458

Fig. 46 Oil Pump Removal

- 1 - CAMSHAFT GEAR
- 2 - CRANKSHAFT GEAR
- 3 - OIL PUMP
- 4 - VACUUM PUMP

INSTALLATION

(1) Install new O-ring and lubricate with clean engine oil.

(2) Install the oil pump. Torque screws to 27.5 N·m (20 ft. lbs.). Check for normal backlash between pump and crankshaft gears.

(3) Install the timing gear cover. Refer to timing gear cover removal and installation in this section.

INTERNAL VACUUM PUMP

REMOVAL

- (1) Disconnect the negative battery cable.

REMOVAL AND INSTALLATION (Continued)

(2) Remove the timing gear cover. Refer to timing gear cover removal in this section.

(3) Align all the timing marks before removing the vacuum pump (Fig. 47).

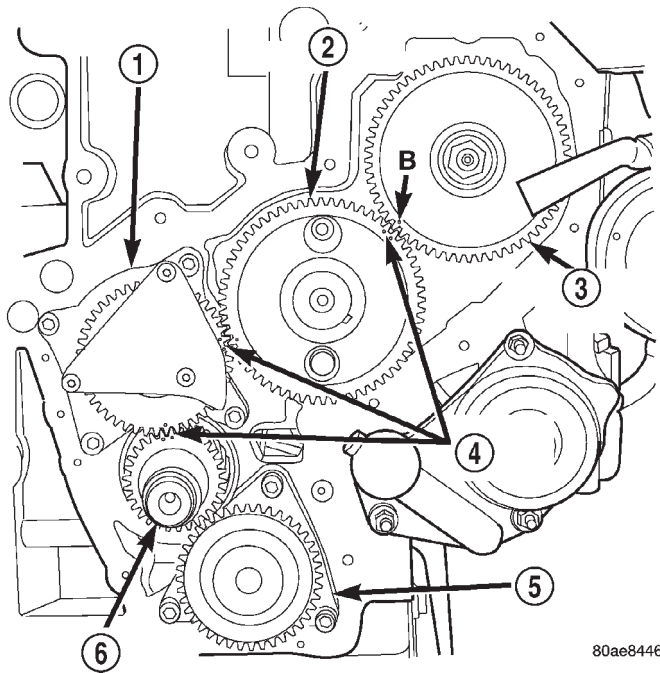

80ae844e

Fig. 47 Timing Marks

- 1 - VACUUM PUMP
- 2 - CAMSHAFT
- 3 - INJECTION PUMP
- 4 - TIMING MARKS
- 5 - OIL PUMP
- 6 - CRANKSHAFT

- (4) Remove the vacuum pump retaining bolts..
- (5) Remove the internal vacuum pump.

INSTALLATION

(1) To install the vacuum pump, align with timing marks on gear set and install (Fig. 47). Torque bolts to 27.5 N·m (20 ft. lbs.).

(2) Install the timing gear cover. Refer to timing gear cover removal in this section.

(3) Connect the negative battery cable.

OIL PUMP PRESSURE RELIEF VALVE

REMOVAL

- (1) Disconnect the negative battery cable
- (2) Remove the oil pan. Refer to oil pan removal and installation procedure in this section.
- (3) Remove the relief valve snap ring.
- (4) Remove the relief valve cap, spring, and plunger (Fig. 51).
- (5) Check the relief valve spring length. Relief valve spring free length is 57.5mm (2.263 in.). If

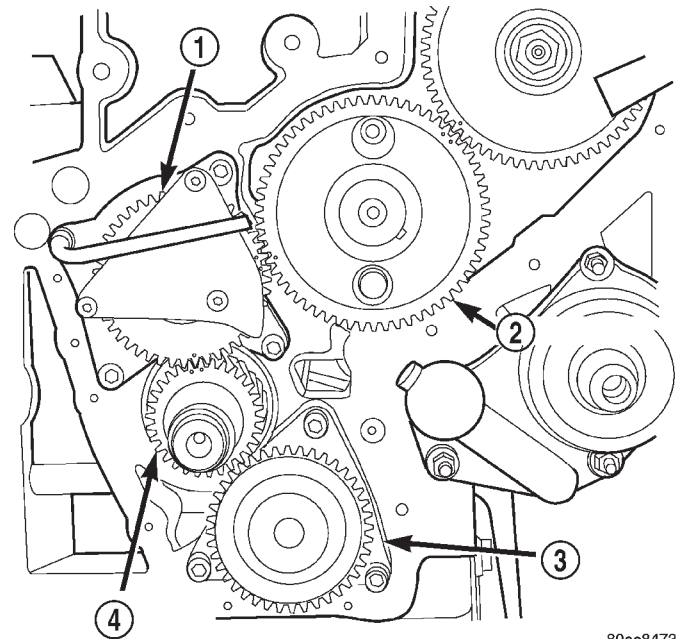

80ae8473

Fig. 48 Vacuum Pump

- 1 - VACUUM PUMP
- 2 - CAMSHAFT
- 3 - OIL PUMP
- 4 - CRANKSHAFT

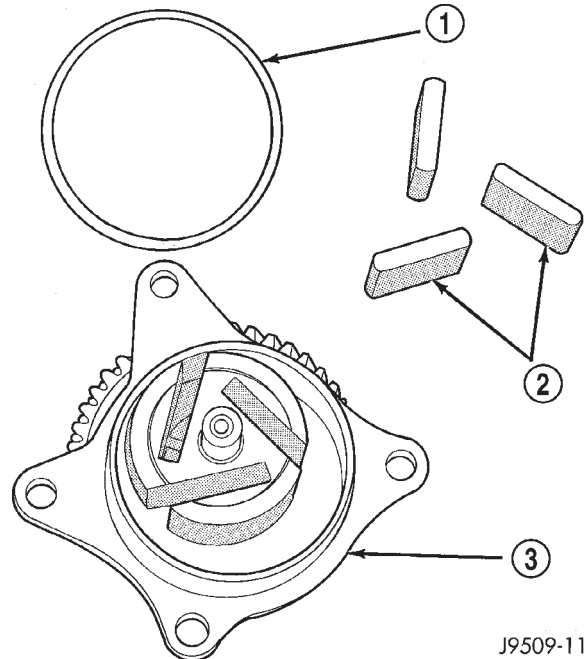

J9509-112

Fig. 49 Vacuum Pump Parts

- 1 - O-RING
- 2 - ROTOR BLADES
- 3 - VACUUM PUMP

spring length is less or spring is distorted it must be replaced.

REMOVAL AND INSTALLATION (Continued)

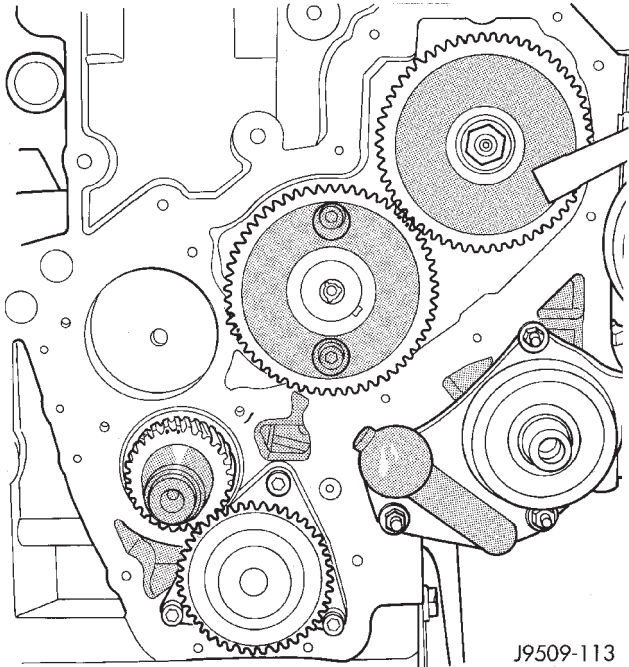

Fig. 50 Vacuum Pump Mounting Hole

(6) Check the plunger for scoring, replace if necessary.

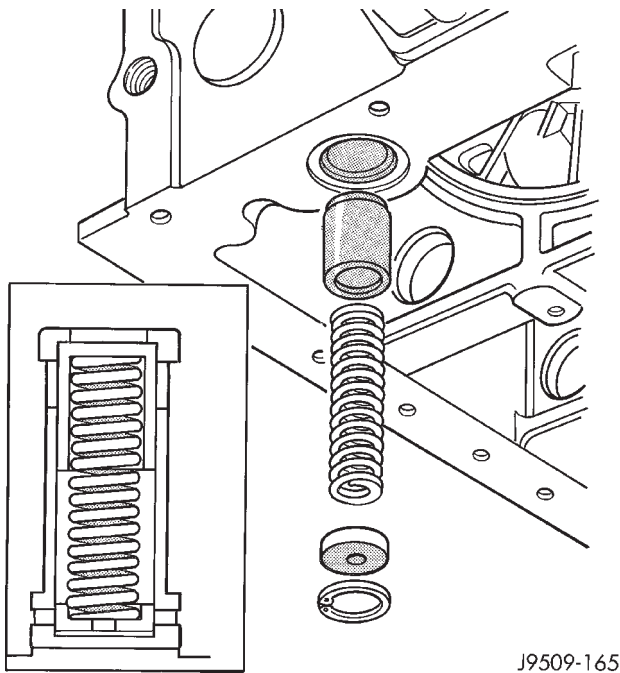

Fig. 51 Oil Pressure Relief Valve

INSTALLATION

- (1) Thoroughly clean all components and relief valve pocket in cylinder block.
- (2) Fit plunger, spring and cap into block.
- (3) Compress spring and install the snap ring. Ensure the snap ring is completely seated in groove.
- (4) Install the oil pan. Refer to oil pan removal and installation procedure in this section.

(5) Connect the negative battery cable.

OIL FILTER ADAPTER AND ENGINE OIL COOLER

REMOVAL

- (1) Disconnect the negative battery cable.
- (2) Remove the oil filter.
- (3) Remove the oil filter adapter/oil cooler retaining bolt (Fig. 52).
- (4) Remove the oil filter adapter.
- (5) Disconnect the engine oil cooler coolant hoses and remove the oil cooler.

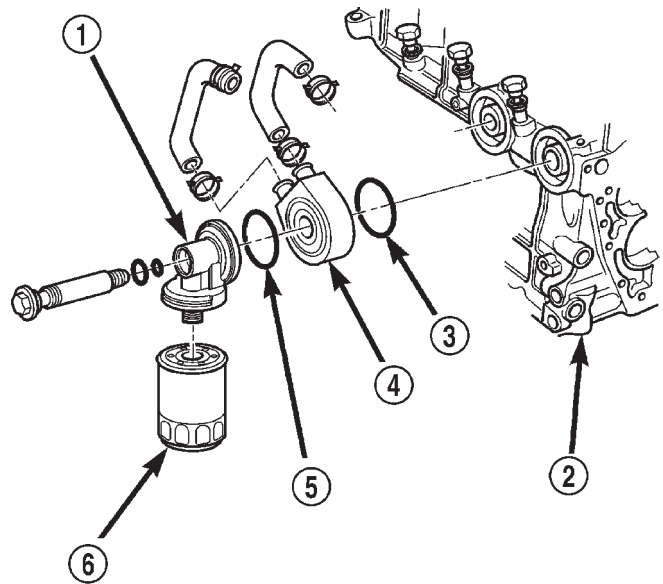

Fig. 52 Oil Filter Adapter and Engine Oil Cooler

- 1 - OIL FILTER ADAPTER
- 2 - ENGINE BLOCK
- 3 - O-RING
- 4 - ENGINE OIL COOLER
- 5 - O-RING
- 6 - OIL FILTER

INSTALLATION

- (1) Connect the engine oil cooler coolant hoses.
- (2) Install a new o-ring on the oil cooler.
- (3) Install the oil filter adapter to the engine oil cooler with a new o-ring using the oil filter adapter/oil cooler retaining bolt (Fig. 52). Torque bolt to 69 N·m (51 ft. lbs.).
- (4) Install the oil filter and add oil.
- (5) Connect the negative battery cable.

PISTONS AND CONNECTING ROD ASSEMBLY

REMOVAL

- (1) Disconnect the battery cable.

REMOVAL AND INSTALLATION (Continued)

(2) Remove cylinder heads, refer to cylinder head removal in this section.

(3) Raise vehicle on host.

(4) Remove oil pan, refer to oil pan removal in this section.

(5) Remove top ridge of cylinder bores with a reliable ridge reamer before removing pistons from cylinder block. **Be sure to keep tops of pistons covered during this operation.** Mark piston with matching cylinder number.

(6) Pistons and connecting rods must be removed from top of cylinder block. Rotate crankshaft so that each connecting rod is centered in cylinder bore.

(7) Remove connecting rod cap. Install connecting rod bolt protectors on connecting rod bolts. Push each piston and rod assembly out of cylinder bore.

NOTE: Be careful not to nick crankshaft journals.

(8) After removal, install bearing cap on the mating rod.

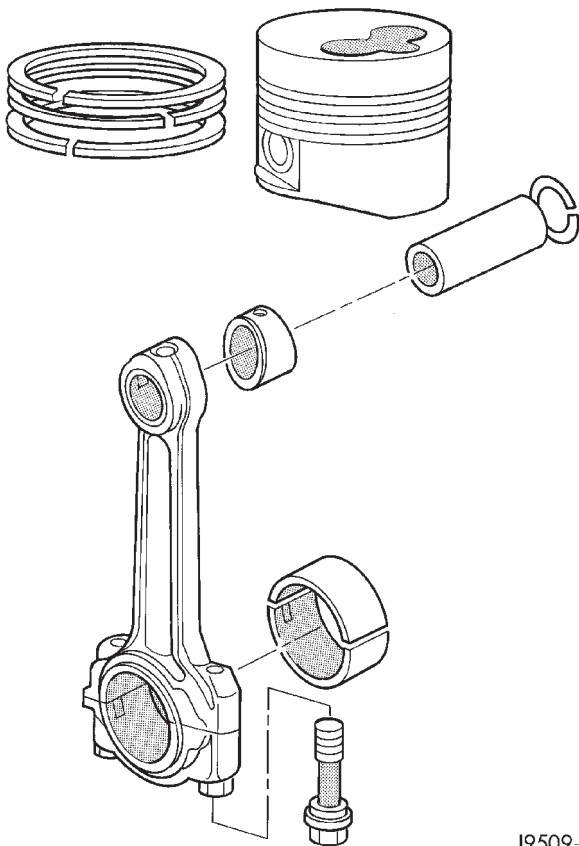

Fig. 53 Piston Assembly

PISTON PIN—REMOVAL

- (1) Secure connecting rod in a soft jawed vice.
- (2) Remove 2 clips securing piston pin.
- (3) Push piston pin out of piston and connecting rod.

PISTON RING—REMOVAL

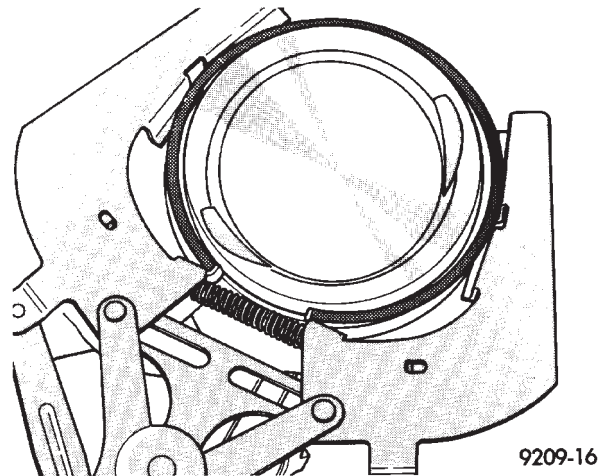

Fig. 54 Piston Rings—Removing and Installing

- (1) ID mark on face of upper and intermediate piston rings must point toward piston crown.
- (2) Using a suitable ring expander, remove upper and intermediate piston rings (Fig. 54).
- (3) Remove the upper oil ring side rail, lower oil ring side rail and then oil ring expander from piston.
- (4) Carefully clean carbon from piston crowns, skirts and ring grooves ensuring the 4 oil holes in the oil control ring groove are clear.

PISTON RING FITTING

(1) Wipe cylinder bore clean. Insert ring and push down with piston to ensure it is square in bore. The ring gap measurement must be made with the ring positioning at least 12 mm (0.50 in.) from bottom of cylinder bore. Check gap with feeler gauge. Top compression ring gap .25 to .50mm (.0098 to .0196 in.). Second compression ring gap .25 to .35mm (.0098 to .0137 in.). Oil control ring gap .25 to .58mm (.0098 to .0228 in.).

(2) If ring gaps exceed dimension given, new rings or cylinder liners must be fitted. Keep piston rings in piston sets.

(3) Check piston ring to groove clearance (Fig. 56). Top compression ring gap .08 to .130mm (.0031 to .0051 in.). Second compression ring gap .070 to .102mm (.0027 to .0040 in.). Oil control ring gap .040 to .072mm (.0015 to .0028 in.).

PISTON RINGS—INSTALLATION

(1) Install rings on the pistons using a suitable ring expander (Fig. 57).

(2) Top compression ring is tapered and chromium plated. The second ring is of the scraper type and must be installed with scraping edge facing bottom of the piston. The third is an oil control ring. Ring gaps must be positioned, before inserting piston into the liners, as follows (Fig. 59).

REMOVAL AND INSTALLATION (Continued)

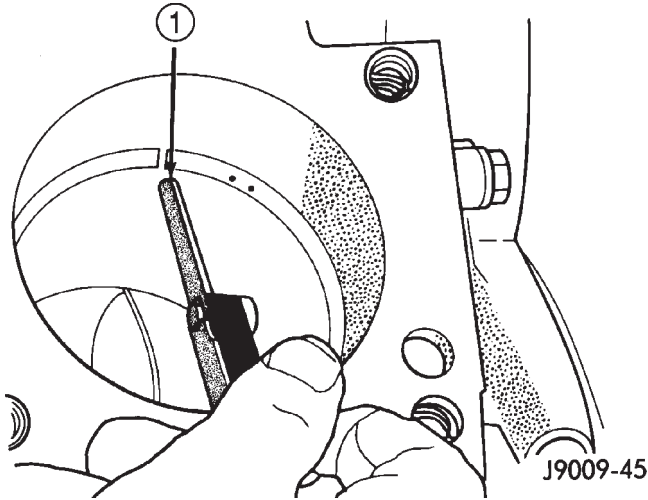

Fig. 55 Ring Gap Measurement

1 - FEELER GAUGE

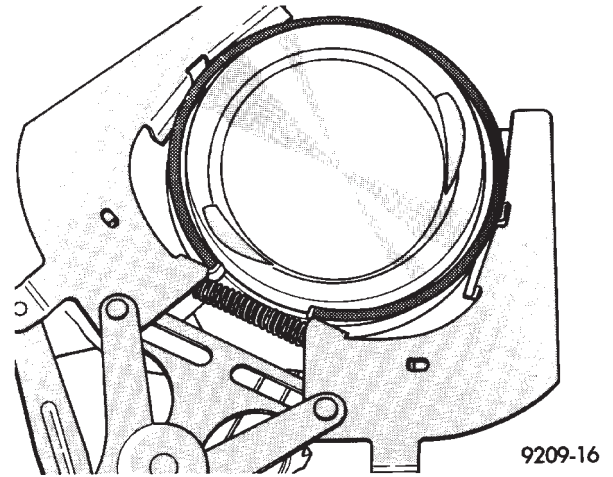

Fig. 57 Piston Rings—Removing and Installing

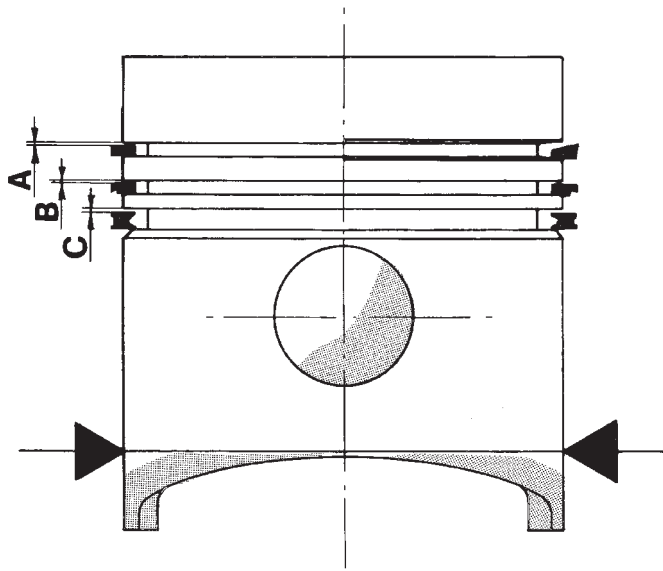

Fig. 56 Piston Ring to Groove Clearance

(3) Top ring gap must be positioned at 30 degrees to the right of the combustion chamber recess (looking at the piston crown from above).

(4) Second piston ring gap should be positioned on the opposite side of the combustion chamber recess.

(5) Oil control ring gap to be located 30 degrees to the left of combustion chamber recess.

(6) When assembling pistons check that components are installed in the same position as before disassembly, determined by the numbers stamped on the crown of individual pistons. Engine cylinders are numbered starting from gear train end of the engine. **Face chamber recess side of piston towards camshaft.** Therefore, the numbers stamped on con

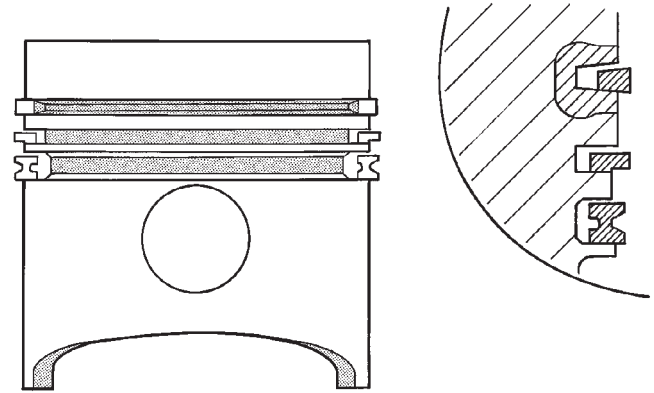

Fig. 58 Piston Ring Identification

rod big end should also face in the same direction. To insert piston into cylinder use a ring compressor as shown in (Fig. 57).

PISTON PIN INSTALLATION

- (1) Secure connecting rod in soft jawed vice.
- (2) Lubricate piston pin and piston with clean oil.
- (3) Position piston on connecting rod.

CAUTION: Ensure combustion recess in piston crown and the bearing cap numbers on the connecting rod are on the same side.

- (4) Install piston pin.
- (5) Install clips in piston to retain piston pin.
- (6) Remove connecting rod from vice.

INSTALLATION

(1) Before installing pistons, and connecting rod assemblies into the bore, be sure that compression ring gaps are staggered so that neither is in line with oil ring rail gap (Fig. 59).

REMOVAL AND INSTALLATION (Continued)

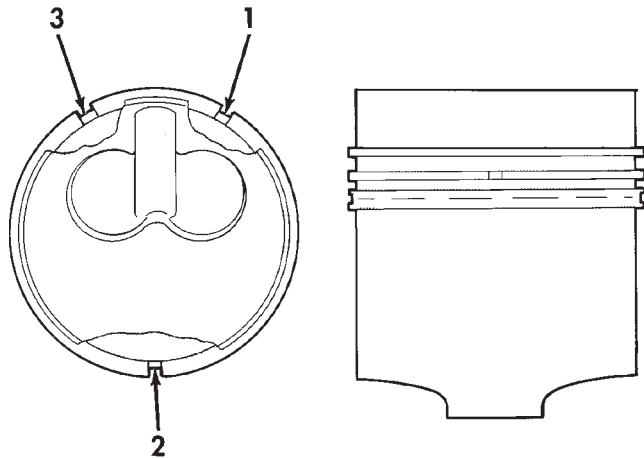

80bce8f2

Fig. 59 Piston Ring Gap Location

(2) Before installing the ring compressor, make sure the oil ring expander ends are butted and the rail gaps located as shown in (Fig. 59).

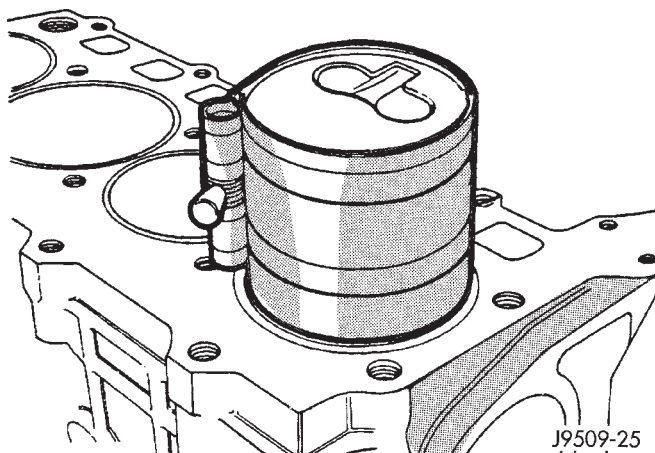

J9509-25

Fig. 60 Installing Piston

(3) Immerse the piston head and rings in clean engine oil, slide the ring compressor, over the piston and tighten with the special wrench (Fig. 60). **Ensure position of rings does not change during this operation.**

(4) Face chamber recess side of piston towards camshaft.

NOTE: Be careful not to nick crankshaft journals.

(5) Rotate crankshaft so that the connecting rod journal is on the center of the cylinder bore. Insert rod and piston into cylinder bore and guide rod over the crankshaft journal.

(6) Tap the piston down in cylinder bore, using a hammer handle. At the same time, guide connecting rod into position on connecting rod journal.

(7) Install rod caps. Install rod bolts and tighten to 29 N·m (21 ft. lb.) plus 60°.

CYLINDER WALL LINER ASSEMBLY

REMOVAL

- (1) Remove cylinder heads.
- (2) Remove Oil pan.
- (3) Remove pistons.
- (4) Use tool VM-1001 to remove liners (Fig. 61).

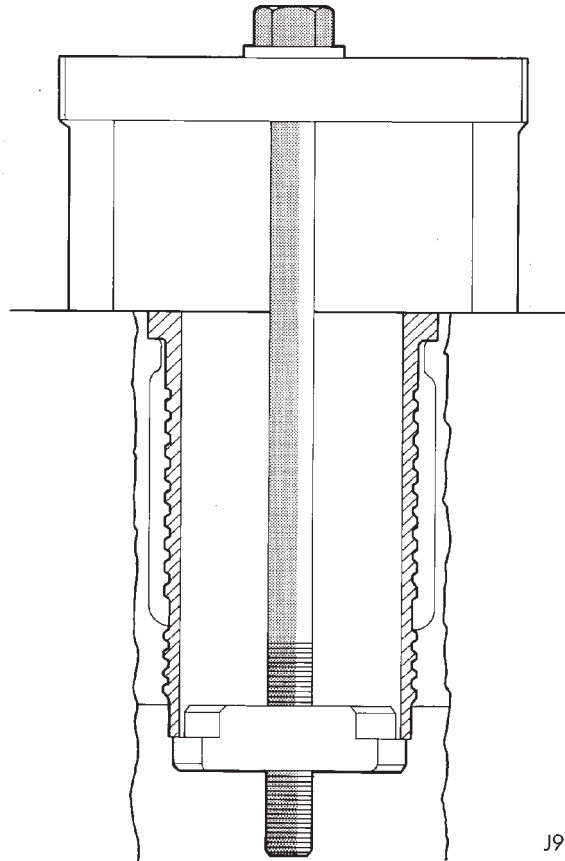

J9509-12

Fig. 61 Liner Removal Tool

(5) Remove shims from cylinder liner or cylinder block recess. Keep shims with each cylinder liner.

INSTALLATION

(1) Carefully clean residual LOCTITE from liner and crankcase, and degrease the crankcase where it comes into contact with the liners. Install the liners in the crankcase as shown (A), rotating them back and forth by 45° in order to guarantee correct positioning (Fig. 63).

(2) Measure the liner recess relative to block deck with a dial indicator mounted on a special tool

REMOVAL AND INSTALLATION (Continued)

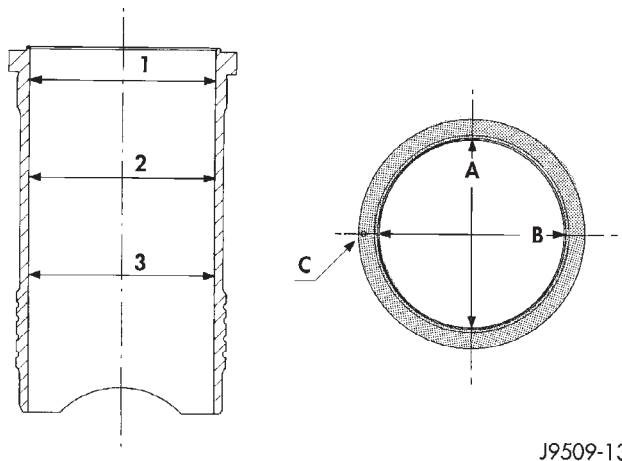

J9509-13

Fig. 62 Liner Inspection

VM-1010 A. All the measurements must be taken on camshaft side. Zero dial gauge on block deck.

(3) Move dial gauge to cylinder liner record reading on dial gauge.

- (4) Remove liner and special tool.
- (5) Then select the correct shim thickness to give proper protrusion (0.01 - 0.06 mm).
- (6) Fit the shim and the O-rings onto the liner.
- (7) Lubricate the lower liner location in the block. Apply LOCTITE AVX to the corner of the liner seat. Apply LOCTITE AVX uniformly to the upper part of the liner at area.
- (8) Fit the liners in the crankcase making sure that the shim is positioned correctly in the seat. Lock the liners in position using special tool (VM-1016) and bolts (Fig. 64). Clean the residual LOCTITE on the upper surface of the block deck.
- (9) Recheck the liner protrusion. It should be 0.01 - 0.06 mm.

NOTE: A period of six hours must elapse between the liners being installed and engine start-up. If engine assembly is not continued after liner installation, the liners need to be clamped for twelve hours minimum.

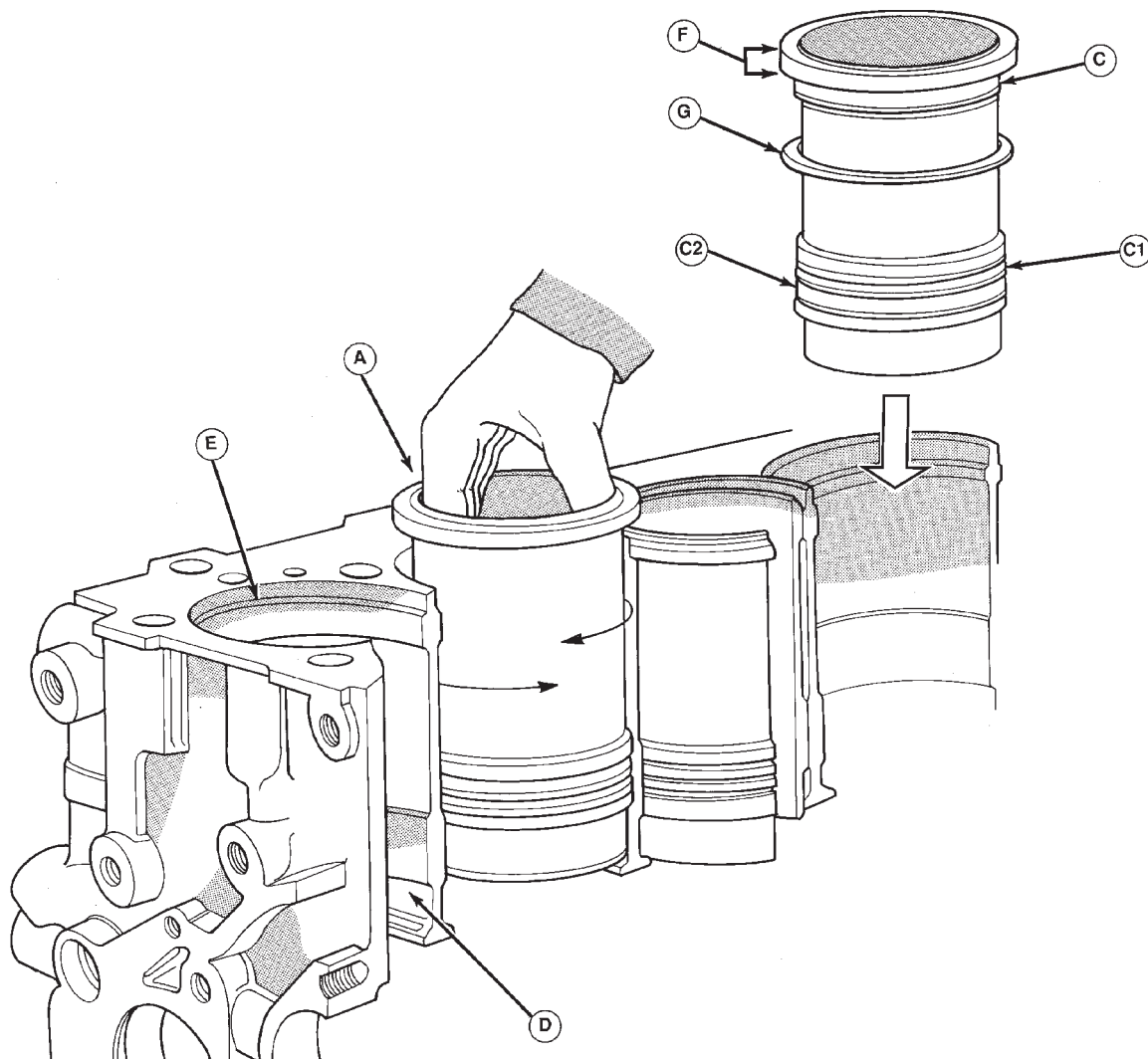
**Fig. 63 Liner Installation**

J9509-120

REMOVAL AND INSTALLATION (Continued)

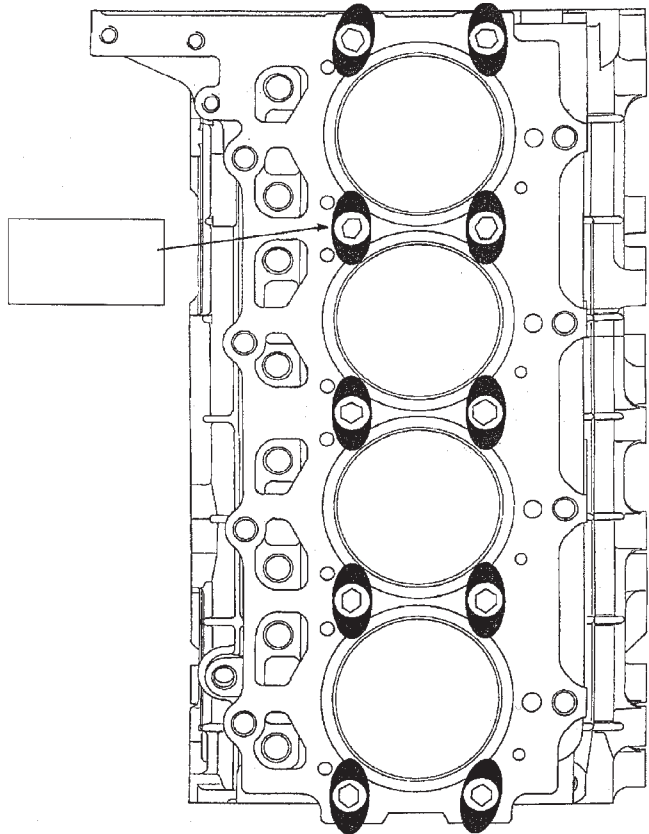

Fig. 64 Liner Clamp Location

CRANKSHAFT MAIN BEARINGS

REMOVAL

- (1) Disconnect the negative battery cable.
- (2) Remove the engine from vehicle. Refer to engine removal and installation in this section.

- (3) Install the engine on an engine stand.
- (4) Remove the accessory drive system.
- (5) Remove the cylinder head cover. Refer to cylinder head cover removal and installation in this section.
- (6) Remove the rocker arm assemblies and push rods. Refer to rocker arm and push rod removal and installation in this section.
- (7) Remove the intake manifold, exhaust manifold and turbocharger. Refer to Group 11, Exhaust System and Turbocharger.
- (8) Remove the water manifold.
- (9) Remove the oil feed lines to rocker arms.
- (10) Remove the cylinder heads. Refer to cylinder head removal and installation in this section.
- (11) Remove the oil pan and oil pick-up.
- (12) Remove the pistons and connecting rods.
- (13) Remove the vibration damper. Refer to vibration damper removal and installation in this section.
- (14) Remove the timing gear cover. Refer to timing gear cover removal and installation in this section.
- (15) Remove the oil pump and vacuum pump from block.
- (16) Install special tool VM.1004 onto crankshaft over gear (Fig. 66).
- (17) Remove the main bearing oil feed and crankshaft carrier locators from block.
- (18) Remove the flywheel and adaptor plate from engine block.
- (19) Remove the thrust bearings from rear main bearing carrier.
- (20) Slide the crankshaft and bearing carriers rearward to rear of block. If you encounter difficulty in removing the complete assembly as previously described, slide the assembly rearward sufficiently to gain access to the main bearing carrier bolts. Mark

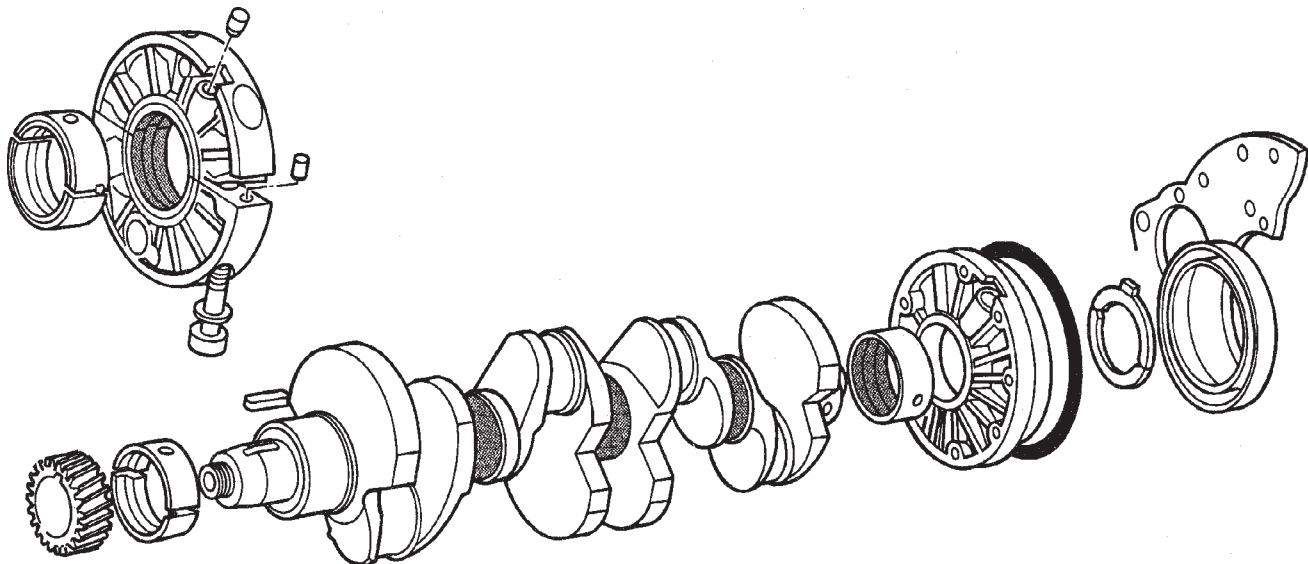

Fig. 65 Crankshaft and Bearing Assembly

REMOVAL AND INSTALLATION (Continued)

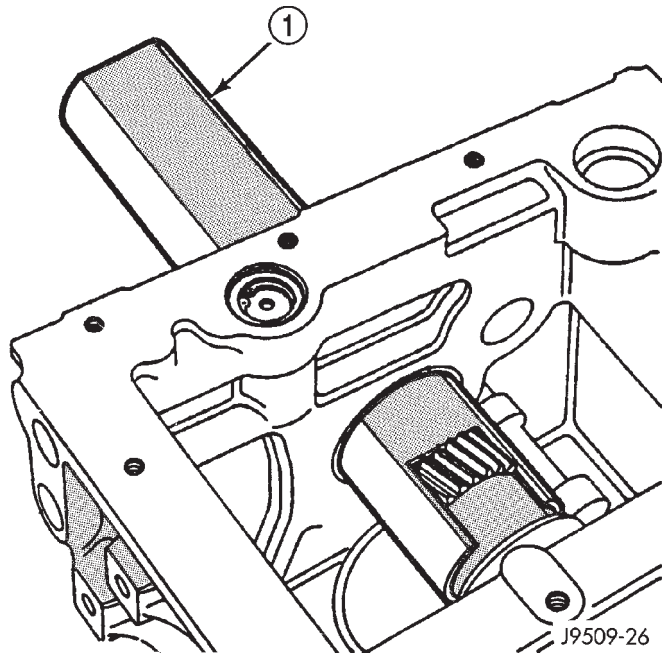

Fig. 66 Crankshaft Special Tool VM.1004

1 - TOOL

the carriers for assembly and remove the bolts, two for each carrier (Fig. 67).

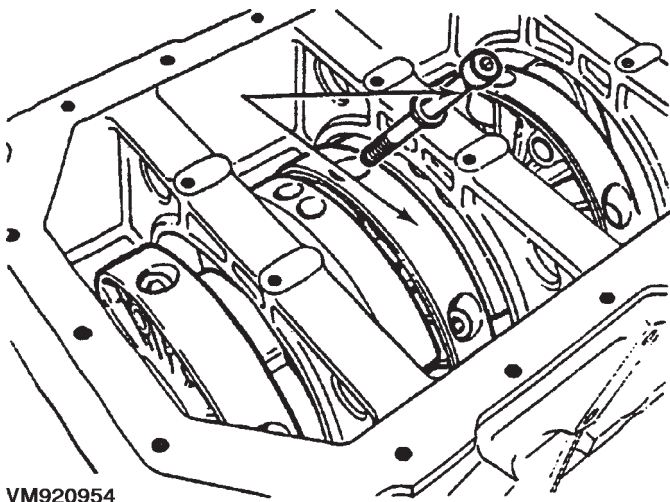

Fig. 67 Crankshaft Support Locator Bolts

(21) Separate the two halves of each carrier, remove from the crankshaft and temporarily re-assemble the carriers (Fig. 68). Withdraw the crankshaft through the rear of the crankcase.

INSTALLATION

- (1) Fit the main bearing supports together. Torque to 44 N·m (32 ft. lbs.)
- (2) Check internal diameter of bearings.
- (3) If internal diameter of original bearing is being checked and figures are not within specifications, new bearings must be used.

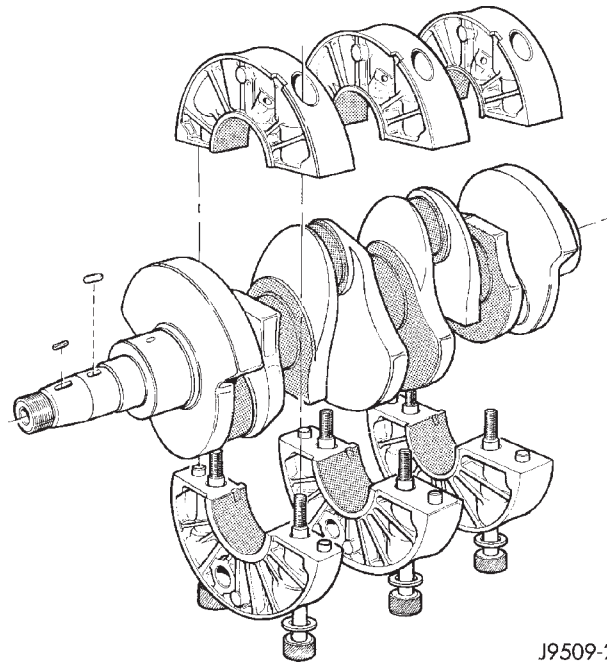

Fig. 68 Crankshaft and Carrier Bearing Assembly

(4) Check the crankshaft main bearing journals to bearing clearances. Clearances of main bearings is .03 to .088mm (.0011 to .0035 in.).

NOTE: Assemble engine according to sequence described, thus saving time and preventing damages to engine components. Clean parts with a suitable solvent and dry them with compressed air before assembly. Use new gaskets where applicable and torque wrenches for correct tightening of components.

(5) Thoroughly clean crankcase and oil passages, and blow dry with compressed air.

(6) Install new main bearing shells in each of the carrier halves. Assemble the carriers to the crankshaft journals, ensuring that the carriers are installed in their original locations and that the **piston jet notch is towards the front of the crankshaft**. Secure each carrier with the two bolts tightening evenly to 44 N·m (32 ft. lbs.). Check that the oil jet is in position (Fig. 68).

(7) Slide special tool VM.1004 over the crankshaft gear and, insert the crankshaft and carrier assembly into the crankcase in the same manner used for removal.

(8) Align the holes in the lower supports, with the center of the crankcase webs (Fig. 69).

(9) Secure each support assembly to the crankcase with the main bearing oil feed and support locators. Torque to 54 N·m (40 ft. lbs.).

(10) Install the rear main bearing support onto crankshaft ensuring arrow on bearing support aligns with vertical web in center of crankcase.

REMOVAL AND INSTALLATION (Continued)

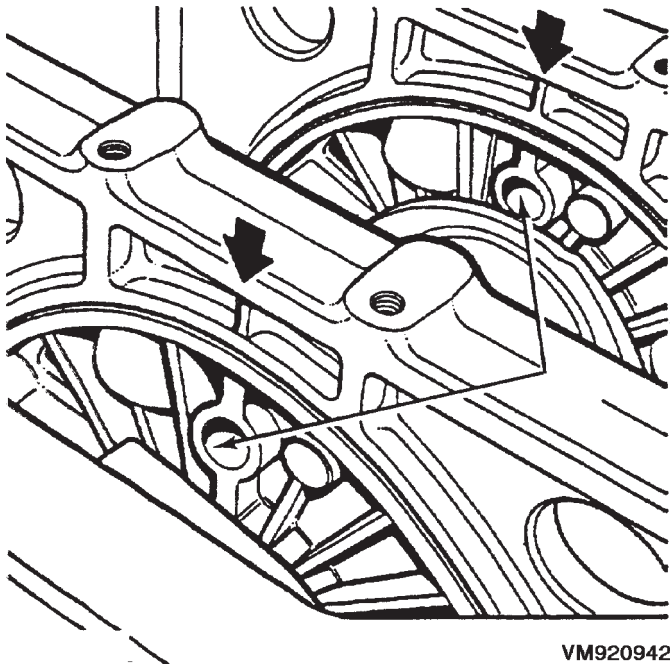

VM920942

Fig. 69 Main Bearing Support Alignment

- (11) Install the rear oil seal.
- (12) Install the new O-rings in adaptor plate.
- (13) Install the adaptor plate to block. Torque nuts to 26.5 N·m (20 ft. lbs.).
- (14) Install the Allen bolts through adaptor plate to rear main bearing support. Torque to 11 N·m (97 in. lbs.).
- (15) Position the flywheel and O-ring on crankshaft and align bolt holes.

NOTE: For purposes of checking crankshaft end play, used flywheel bolts may be used. Final assembly requires new flywheel bolts.

- (16) Install 2 flywheel bolts, 180° apart, and tighten bolts to 20 N·m plus 60° (15 ft. lbs.) plus 60°.
- (17) Attach dial indicator to engine block.
- (18) Move crankshaft toward front of engine and zero indicator.
- (19) Move crankshaft toward the rear of engine and record measurement.
- (20) Subtract specified crankshaft end play from figure obtained. Crankshaft end play.153 to.304mm (.0060 to.0119 in.).
- (21) Select thrust washers which will give correct end play.
- (22) Remove tools and flywheel.
- (23) Lubricate thrust washer halves and fit them into the rear main bearing carrier.
- (24) Ensure that crankshaft end and flywheel mating surfaces are clean and dry. Install "O" ring in flywheel groove.

(25) To verify correct end play, install 2 flywheel bolts 180° apart, and tighten bolts to 20 N·m plus 60° (15 ft. lbs. plus 60°).

(26) Measure crankshaft end play with a dial gauge. Crankshaft end play should not exceed.153 to.304mm (.0060 to.0119 in.) (Fig. 70).

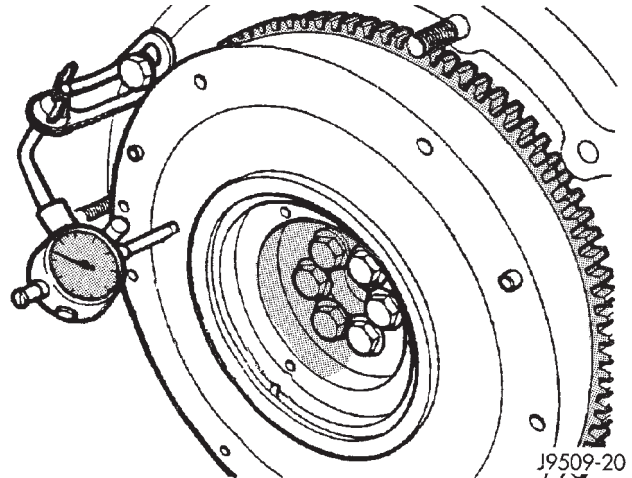

J9509-20

Fig. 70 Measuring Crankshaft End Play

CAUTION: Use NEW flywheel bolts for the following procedure.

- (27) Install a new O-ring on flywheel. Install flywheel on crankshaft. The 6 flywheel bolts must be tightened as follows:
 - a. Lubricate and install the 6 new flywheel bolts.
 - b. Torque the 6 flywheel bolts to 49 N·m (36 ft. lbs.) starting one bolt and following with the opposite one (cross tightening) until completion, in a clockwise direction..
 - c. Loosen one bolt at a time and tighten to 19.6 N·m (14 ft. lbs.) plus 75° using the cross tightening method.
- (28) Install the pistons and connecting rod assemblies. Refer to piston and connecting rods removal and installation in this section.
- (29) Install the oil pick up tube. Torque bolts to 25 N·m (18 ft. lbs.).
- (30) Install the oil pan. Refer to oil pan removal and installation in this section.
- (31) Install the vacuum pump, being careful to align the gear timing marks with those on the crankshaft gear. Torque screws to 20 N·m (15 ft. lbs.).
- (32) Before installing the oil pump check pump bore depth in block (A) and pump body height (B) (Fig. 71). Difference between A and B should be 0.020-0.082 mm (.0007 to 0032 in.).
- (33) Install the oil pump. Torque screws to 27 N·M (20 ft.lbs.). Check for normal backlash between pump and crankshaft gears.
- (34) Install the timing gear cover. Refer to timing gear cover removal and installation in this section.

REMOVAL AND INSTALLATION (Continued)

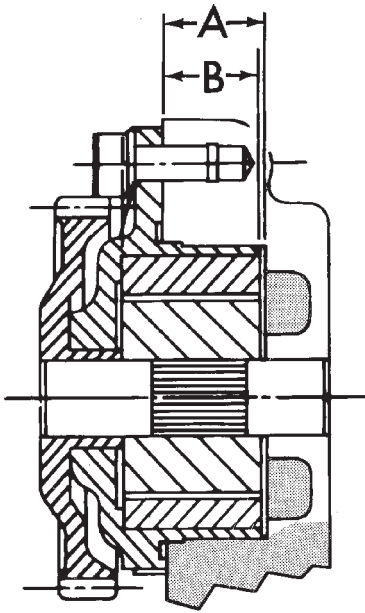

J9509-8

Fig. 71 Oil Pump Bore Depth

- (35) Install the vibration damper. Refer to vibration damper removal and installation in this section.
- (36) Install the cylinder heads. Refer to cylinder head removal and installation in this section.
- (37) Install the rocker arms and push rods. Refer to rocker arm and push rod removal and installation in this section.
- (38) Install the cylinder head cover. Refer to cylinder head cover removal and installation in this section.
- (39) Install the accessory drive system.
- (40) Install the engine in vehicle. Refer to engine removal and installation in this section.
- (41) Fill engine with the correct amount of fluids specified.
- (42) Connect the negative battery cable.

DISASSEMBLY AND ASSEMBLY

HYDRAULIC TAPPETS

DISASSEMBLE

- (1) Pry out plunger retainer spring clip.
- (2) Clean varnish deposits from inside of tappet body above plunger cap.
- (3) Invert tappet body and remove plunger cap, plunger, check valve, check valve spring, check valve retainer and plunger spring. Check valve could be flat or ball.

ASSEMBLE

- (1) Clean all tappet parts in a solvent that will remove all varnish and carbon.
- (2) Replace tappets that are unfit for further service with new assemblies.
- (3) If plunger shows signs of scoring or wear, install a new tappet assembly. If valve is pitted, or valve seat on end of plunger is prevented from seating, install a new tappet assembly.
- (4) Assemble tappets.

CLEANING AND INSPECTION

CYLINDER HEAD

CLEANING

Thoroughly clean the engine cylinder head and cylinder block mating surfaces. Clean the intake and exhaust manifold and engine cylinder head mating surfaces. Remove all gasket material and carbon.

Check to ensure that no coolant or foreign material has fallen into the tappet bore area.

Remove the carbon deposits from the combustion chambers and top of the pistons.

INSPECTION

Use a straightedge and feeler gauge to check the flatness of the engine cylinder head and block mating surfaces (Fig. 72).

Minimum cylinder head thickness 89.95mm (3.541 in.)

CAUTION: If only one cylinder head is found to be distorted and requires machining, it will also be necessary to machine the remaining cylinder heads and end plates by a corresponding amount to maintain correct cylinder alignment.

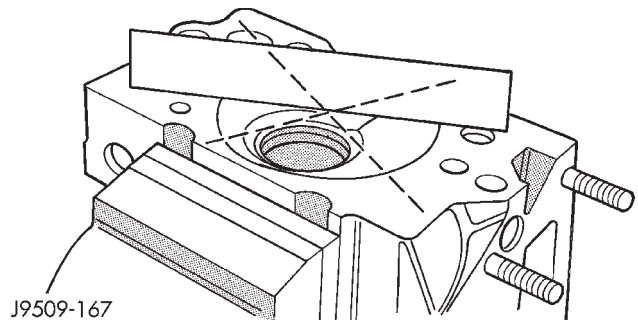

J9509-167

Fig. 72 Checking Cylinder Head Flatness

ROCKER ARMS AND PUSH RODS

CLEANING

Clean all the components (Fig. 73) with cleaning solvent.

CLEANING AND INSPECTION (Continued)

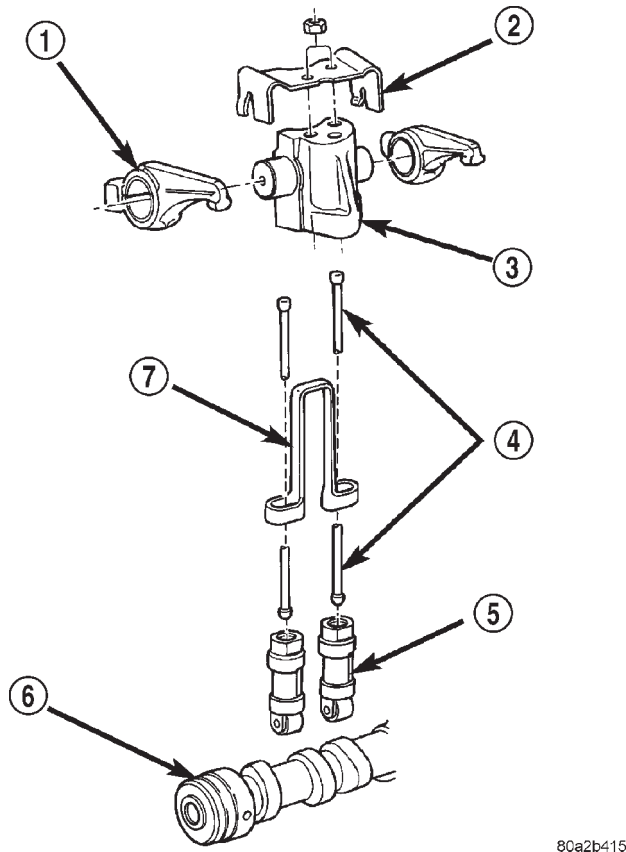

80a2b415

Fig. 73 Rocker Arm Components

- 1 - ROCKER ARM
- 2 - SPRING PLATE
- 3 - ROCKER SUPPORT
- 4 - PUSH ROD
- 5 - HYDRAULIC TAPPET
- 6 - CAMSHAFT
- 7 - ANTIROTATION BRACKET

Use compressed air to blow out the oil passages in the rocker arms and push rods.

INSPECTION

Inspect the pivot surface area of each rocker arm. Replace any that are scuffed, pitted, cracked or excessively worn.

Inspect the valve stem tip contact surface of each rocker arm and replace any rocker arm that is deeply pitted.

Inspect each push rod end for excessive wear and replace as required. If any push rod is excessively worn because of lack of oil, replace it and inspect the corresponding hydraulic tappet for excessive wear.

Inspect the push rods for straightness by rolling them on a flat surface or by shining a light between the push rod and the flat surface.

A wear pattern along the length of the push rod is not normal. Inspect the engine cylinder head for obstruction if this condition exists.

PISTONS AND CONNECTING ROD ASSEMBLY**INSPECTION—PISTONS**

(1) Piston Diameter: Size: 91.93-91.94mm (3.6191-3.6196 in.) Maximum wear limit.05mm (.0019 in.).

(2) Check piston pin bores in piston for roundness. Make 3 checks at 120° intervals. Maximum out of roundness.05mm (.0019in.).

(3) The piston diameter should be measured approximately 15 mm (.590 in.) up from the base.

(4) Skirt wear should not exceed 0.1 mm (.00039 in.).

(5) The clearance between the cylinder liner and piston should not exceed 0.25 mm (.0009 in.).

(6) Make sure the weight of the pistons does not differ by more than 5 g.

INSPECTION—CONNECTING ROD

(1) Assemble bearing shells and bearing caps to their respective connecting rods ensuring that the serrations on the cap and reference marks are aligned.

(2) Tighten bearing cap bolts to 29N·m (21 ft. lbs.) plus 60°.

(3) Check and record internal diameter of crank end of connecting rod.

NOTE: When changing connecting rods, all four must have the same weight and be stamped with the same number. Replacement connecting rods will only be supplied in sets of four.

Connecting rods are supplied in sets of four since they all must be of the same weight category. Max allowable weight difference is 18 gr.

NOTE: On one side of the big end of the con-rod there is a two-digit number which refers to the weight category. On the other side of the big end there is a four digit number on both the rod and the cap. These numbers must both face the camshaft as well as the recess on the piston crown (Fig. 75). Lightly heat the piston in oven. Insert piston pin in position and secure it with provided snap rings.

The Four digit numbers marked on con rod big end and rod cap must be on the same side as the camshaft (Fig. 75). After having coated threads with Molyguard, tighten con rod bolts to 29 N·m (21 ft. lbs.) plus 60°.

INSPECTION—PISTON PIN

(1) Measure the diameter of piston pin in the center and both ends.

(2) Piston pin diameter is 29.990 to 29.996mm (1.1807 to 1.1809 in.).

CLEANING AND INSPECTION (Continued)

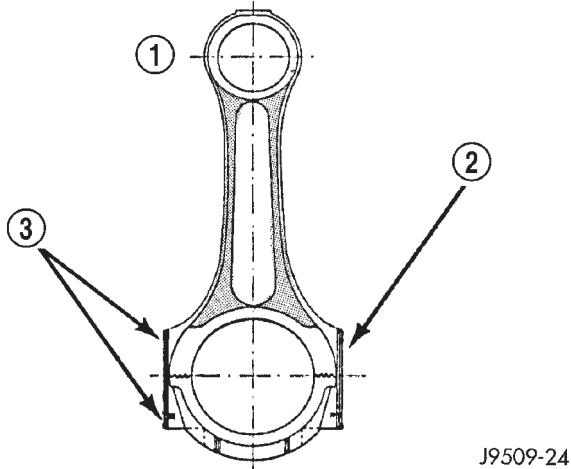

J9509-24

Fig. 74 Connecting Rod Identification

- 1 - CAMSHAFT SIDE
- 2 - 2-DIGIT NUMBER FOR WEIGHT CATEGORY
- 3 - 4-DIGIT REFERENCE NUMBERS FOR CORRECT ASSEMBLING

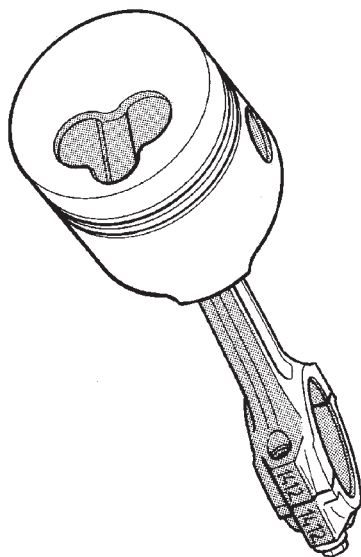

J9509-21

Fig. 75 Piston and Connecting Rod Assembly

INSPECTION—CRANKSHAFT JOURNALS

(1) Using a micrometer, measure and record crankshaft connecting rod journals, take reading of each journal 120° apart. Crankshaft journal diameter is 53.84 to 53.955mm (2.1196 to 2.1242 in.).

(2) Crankshaft journals worn beyond limits or show signs of out of roundness must be reground or replaced. Minimum reground diameter is 53.69mm (2.1137 in.).

BEARING-TO-JOURNAL CLEARANCE

Compare internal diameters of connecting rod with crankshaft journal diameter. Maximum clearance between connecting rod and crankshaft journals.022 to.076mm (.0008 to.0029 in.).

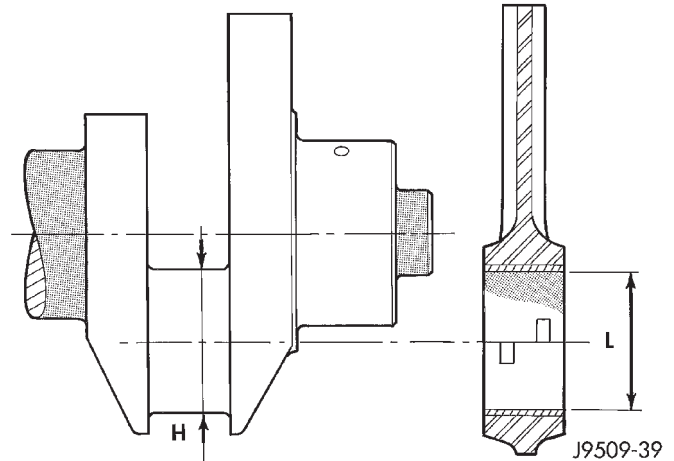

J9509-39

Fig. 76 Bearing Clearance

CYLINDER WALL LINER ASSEMBLY

INSPECTION

The cylinder walls should be checked for out-of-round and taper with dial bore gauge. The cylinder bore out-of-round is 0.100 mm (.0039 inch) maximum and cylinder bore taper is 0.100 mm (0.0039 inch) maximum. If the cylinder walls are badly scuffed or scored, new liners should be installed and honed, and new pistons and rings fitted.

Measure the cylinder bore at three levels in directions A and B (Fig. 77). Top measurement should be 10 mm (3/8 inch) down and bottom measurement should be 10 mm (3/8 inch.) up from bottom of bore.

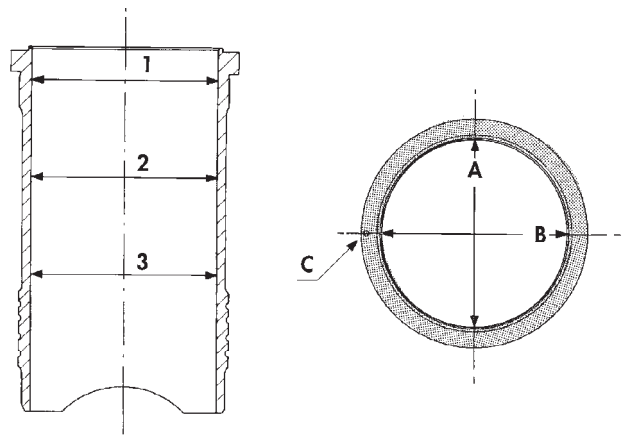

J9509-13

Fig. 77 Liner Inspection

CLEANING AND INSPECTION (Continued)

OIL PUMP

CLEANING

Wash all parts in a suitable solvent and inspect carefully for damage or wear.

INSPECTION

(1) Before installing oil pump check pump bore depth in block (A) and pump body height (B) (Fig. 78). Difference between A and B should be 0.020-0.082 mm.

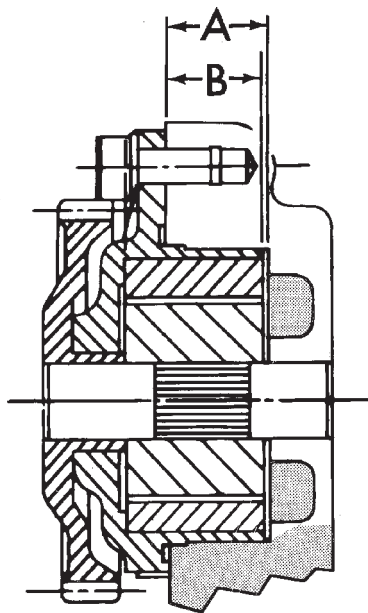

J9509-8

Fig. 78 Oil Pump Bore Depth

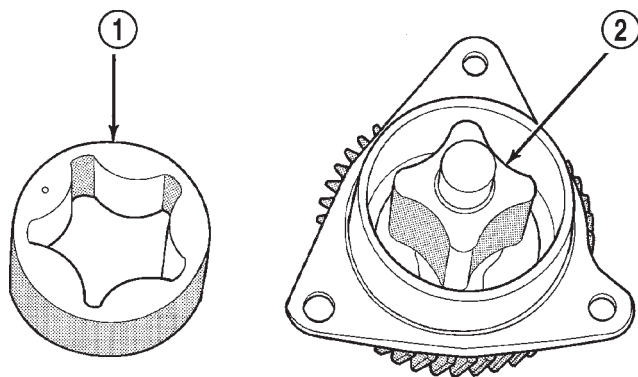

J9509-109

Fig. 79 Oil Pump Inner and Outer Rotors

- 1 - OUTER ROTOR
- 2 - INNER ROTOR

(2) Check clearance between rotors (Fig. 80).

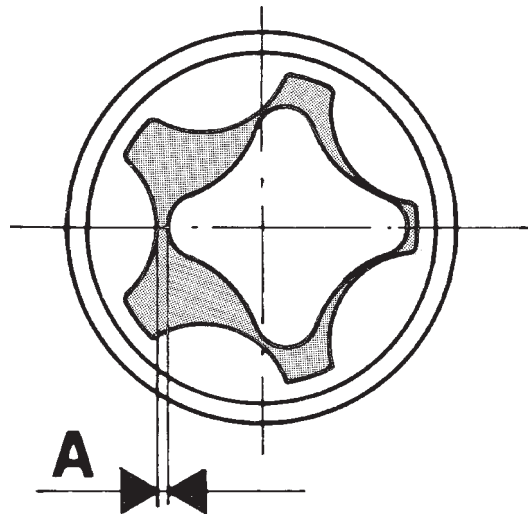

J9509-10

Fig. 80 Checking Rotor Clearance

SPECIFICATIONS

ENGINE SPECIFICATIONS

| DESCRIPTION | SPECIFICATIONS |
|--|------------------|
| Type | 425 CX2 |
| Number of cylinders | 4 |
| Bore | 92 mm |
| Stroke | 94 mm |
| Capacity | 2499.5cc |
| Injection order | 1-3-4-2 |
| Compression ratio | 21 : 1 (+/- 0.5) |
| Gasket | Asbestos free |
| Crankshaft | |
| Front journal diameter | |
| Nominal | 62.985-63.005 mm |
| -0.25 | 62.735-62.755 mm |
| -0.125 | 62.860-62.880 mm |
| Front bearing diameter | |
| Nominal | 63.043-63.088 mm |
| -0.25 | 62.793-62.838 mm |
| -0.125 | 62.919-62.964 mm |
| Clearance between journal and bearing: | 0.038-0.103 mm |
| Center journal diameter | |
| Nominal | 63.005-63.020 mm |
| -0.25 | 62.755-62.770 mm |
| -0.125 | 62.880-62.895 mm |

SPECIFICATIONS (Continued)

| DESCRIPTION | SPECIFICATIONS |
|---|-----------------------------|
| Center bearing diameter | |
| Nominal | 63.050-63.093 mm |
| -0.25 | 62.800-62.843 mm |
| -0.125 | 62.925-62.968 mm |
| Clearance between journal and bearing: 0.030-0.088 mm | |
| Rear journal diameter | |
| Nominal | 79.980-80.000 mm |
| -0.25 | 79.730-79.750 mm |
| -0.125 | 79.855-79.875 mm |
| Rear bearing diameter | |
| Nominal | 80.045-80.070 mm |
| -0.25 | 79.795-79.820 mm |
| -0.125 | 79.920-79.945 mm |
| Clearance between journal and bearing: 0.045-0.090 mm | |
| Wear limit: 0.200 mm. | |
| Connecting rod journal | |
| Nominal | 53.940-53.955 mm |
| -0.25 | 53.690-53.705 mm |
| -0.125 | 53.815-53.830 mm |
| Connecting rod bearing | |
| Nominal | 53.977-54.016 mm |
| -0.25 | 53.727-53.766 mm |
| -0.125 | 53.852-53.891 mm |
| Clearance between journal and bearing: 0.022-0.076 mm | |
| Wear limit: 0.200 mm | |
| Crankshaft end play | |
| End play | 0.080-0.280 mm |
| Adjustment | Thrust washers |
| Thrust washers available: | 2.31-2.36 mm |
| | 2.41-2.46 mm |
| | 2.51-2.56 mm |
| Main bearing carriers | |
| Internal diameter | |
| Front | 67.025-67.050 mm |
| Center | 66.670-66.687 mm |
| Rear | 85.985-86.005 mm |
| Liners | |
| Internal diameter | 91.997-92.015 mm |
| Protrusion | 0.01-0.06 mm |
| Adjustment | Shims |
| Available shims: | 0.15 mm |
| | 0.17 mm |
| | 0.20 mm |
| | 0.23 mm |
| | 0.25 mm |
| Cylinder head | |
| Minimum thickness | 89.95-90.05 mm |
| Gaskets thickness | 1.41 mm +/- 0.08, 0 notches |
| | 1.61 mm +/- 0.08, 1 notch |
| | 1.51 mm +/- 0.08, 2 notches |

| DESCRIPTION | SPECIFICATIONS |
|--|-----------------------------------|
| End plates: | |
| Height | 89.92-90.00 mm |
| Connecting rods | |
| Weight (without the crank bearing): 966 grams | |
| Small end bearing | |
| Internal diameter | |
| Minimum | 30.035 mm |
| Maximum | 30.050 mm |
| Crankshaft bearings | |
| Standard Internal diameter . . . | 53.977-54.016 mm |
| Pistons | |
| Skirt diameter | 91.918-91.932 mm |
| (measured at approximately 10 mm above the bottom of the skirt). | |
| Piston clearance: | 0.065-0.083 mm |
| Top of piston to cylinder head | 0.80-0.89 mm |
| Piston protrusion | 0.53 - 0.62 Fit gasket |
| | Number (1.41), 0 notches or holes |
| | 0.73 - 0.82 Fit gasket |
| | Number (1.61), 1 notch or hole |
| | 0.63 - 0.72 Fit gasket |
| | Number (1.51), 2 notches or holes |
| Piston pins | |
| Type | Fully floating |
| Pin diameter | 29.992-29.996 mm |
| Clearance | 0.004-0.012 mm |
| Piston rings | |
| Clearance in groove: | |
| Top | 0.080-0.130 mm |
| Second | 0.070-0.110 mm |
| Oil control | 0.040-0.080 mm |
| Fitted gap: | |
| Top | 0.30 - 0.45 mm |
| Second | 0.30 - 0.45 mm |
| Oil control | 0.25 - 0.50 mm |
| Camshaft | |
| Journal diameter, front | 53.495-53.51 mm |
| Bearing clearance | 0.030-0.095 mm |
| Center | 53.45-53.47 mm |
| Bearing clearance | 0.07-0.14 mm |
| Rear | 53.48-53.50 mm |
| Bearing clearance | 0.04-0.11 mm |
| Tappets | |
| Outside diameter | 22.195-22.212 mm |
| Rocker gear | |
| Shaft diameter | 21.979-22.00 mm |
| Bush internal diameter | 22.020-22.041 mm |
| Assembly clearance | 0.020-0.062 mm |
| Valves | |
| Intake valve: | |
| Opens | 26° B. T. D. C. |
| Closes | 58° A. B. D. C. |

SPECIFICATIONS (Continued)

| DESCRIPTION | SPECIFICATIONS | DESCRIPTION | TORQUE |
|---|-------------------------------------|-----------------------------------|------------------|
| Exhaust valve: | | Generator | |
| Opens | 66° B. B. D. C. | Mounting bolt | 47 N·m |
| Closes | 36° A. T. D. C. | Camshaft thrust plate | |
| Face angle: | | Bolts | 24 N·m |
| Intake | 55° 30' - 55° 40' | Connecting rod | |
| Exhaust | 45° 25' - 45° 35' | Mounting bolt | 29.5 N·m +60° |
| Head diameter: | | Crankshaft bearing | |
| Intake | 40.05-40.25 mm | Carrier screw | 42 N·m |
| Exhaust | 33.8-34.0 mm | Crankshaft pulley | |
| Head stand down: | | Locknut | 160 N·m |
| Intake | 1.08-1.34 mm | Crossmember | |
| Exhaust | 0.99-1.25 mm | Bolts | 42 N·m |
| Stem diameter: | | Diesel delivery | |
| Intake | 7.940-7.960 mm | Union nut | 18.5 N·m |
| Exhaust | 7.922-7.940 mm | EGR valve | |
| Clearance in guide: | | To intake manifold | 26 N·m |
| Intake | 0.040-0.075 mm | EGR tube | |
| Exhaust | 0.060-0.093 mm | To EGR valve | 27 N·m |
| Valve guide | | Engine mount—Front | |
| Inside diameter | 8.0-8.015 mm | Engine support bracket | 61 N·m |
| Fitted height | 13.5-14 mm | Support Cushion | 47 N·m |
| Valve springs | | Support cushion bracket bolts | 54 N·m |
| Free length | 44.65 mm | Support cushion bracket stud nuts | 41 N·m |
| Fitted length | 38.6 mm | Support Cushion through bolt | 65 N·m |
| Load at fitted length | 34 +/- 6% Kg | Engine mount—Rear | |
| Load at top of lift | 92.5 +/- 4% Kg | Transmission support bracket | 46 N·m |
| Number of coils | 5.33 Valve timing | Support Cushion nuts | 75 N·m |
| Lubrication | | Support Cushion through bolt | 65 N·m |
| System pressure at 4000 rev/min | 3.5 to 5.0 bar (oil at 90-100°C) | Exhaust down pipe | |
| Pressure relief valve opens | 6.84 bar | To turbocharger | 22 N·m |
| Pressure relief valve spring - free length | 57.5 mm | Exhaust heat shield | |
| Oil pump: | | Screws | 11 N·m |
| Outer rotor end float | 0.030-0.107 mm | Exhaust manifold collar | |
| Inner rotor end float | 0.030-0.107 mm | Mounting nut | 24.5 to 29.5 N·m |
| Outer rotor to body diam. clearance | 0.130-0.230 mm | Exhaust manifold | |
| Rotor body to drive gear clearance (pump not fitted) | 0.30-0.50 mm | Mounting nut | 32.5 N·m |
| TORQUE SPECIFICATIONS | | Fan drive | |
| DESCRIPTION | | TORQUE | |
| Adaptor Plate to Block | | To fan hub | |
| Nuts (6) | 27 N·m (20 ft. lbs.) | Flywheel | |
| Automatic Belt Tensioner to Block | | Lock bolt | 20 N·m +60° |
| Bolts (2) | 121 N·m | Front timing cover | |
| Automatic Belt Tensioner to Mounting Bracket | | 6 mm bolts | 10 N·m |
| Bolt (1) | 75 N·m | 8 mm bolts | 26 N·m |
| Generator belt | | Fuel filter | |
| Tensioner | 79 N·m | Nuts | 28 N·m |
| Generator bracket | | Glow plug | |
| Mounting bolts (6 mm) | 10 N·m | Torque | 13.0 N·m |
| Mounting bolts (8 mm) | 24.4 N·m | Idler pulley bracket | |
| | | Bolts | 40 N·m |
| | | Idler pulley | |
| | | Bolt (left hand thread) | 47 N·m |
| | | Injection pump fuel lines | |
| | | Nut | 23 N·m |

SPECIFICATIONS (Continued)

| DESCRIPTION | TORQUE |
|--|-------------|
| Injection pump gear | |
| Lock nut | 86 N·m |
| Injection pump | |
| Mounting nut | 27.5 N·m |
| Injector | |
| Torque | 68.5 N·m |
| Intake manifold | |
| Mounting nut | 32.5 N·m |
| Main bearing oil delivery | |
| Union | 54 N·m |
| Water hose to cylinder head | |
| Nut | 8 to 10 N·m |
| Oil cooler adaptor | |
| Bolt | 60 N·m |
| Oil feed line | |
| For rocker arms | 12 N·m |
| To block | 27 N·m |
| To vacuum pump | 15 N·m |
| Oil filter | |
| Torque | 18 N·m |
| Oil filter adaptor | |
| Torque | 46.6 N·m |
| Oil filter base | |
| Torque | 46.6 N·m |
| Oil pan | |
| Mounting bolts | 13 N·m |
| Oil pickup tube | |
| Torque | 25 N·m |
| Oil pump | |
| Mounting screw | 27 N·m |
| Oil sump drain plug | |
| Torque | 54 N·m |
| Power steering pressure hose | |
| Nut | 28 N·m |
| Power steering pulley | |
| Nut | 130 N·m |
| Rear crankshaft bearing carrier Allen Bolts | |
| Torque | 11 N·m |
| Rocker cover | |
| Bolts | 19 N·m |
| Rocker mounting | |
| Lock Nut | 35 N·m |
| Steering pump | |
| Bolts | 28 N·m |
| Turbocharger | |
| Mounting nuts | 32.5 N·m |
| Turbocharger | |
| Oil delivery fitting | 27.5 N·m |
| Turbocharger oil drain | |
| Plug | 10.8 N·m |
| Vacuum pump | |
| Torque | 27 N·m |
| Water manifold | |

| DESCRIPTION | TORQUE |
|--------------------------|--------|
| Bolts | 12 N·m |
| Water pump pulley | |
| Nut | 27 N·m |

SPECIAL TOOLS

SPECIAL TOOLS

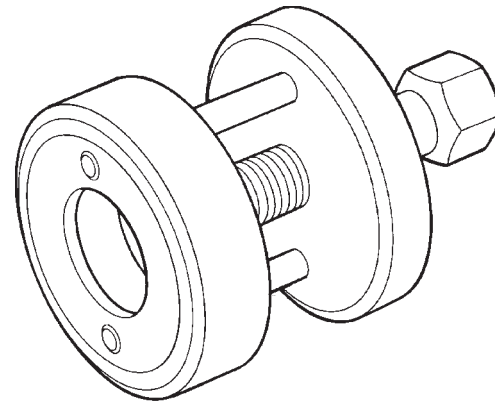

803fd6a1

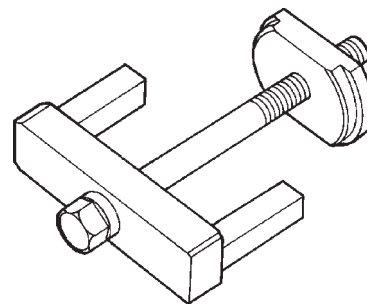
Crankshaft Pulley and Gear Remover VM. 1000A

803fd6a2

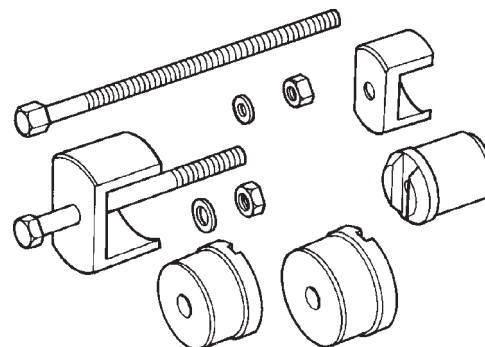
Cylinder Liner Puller VM, 1001

803fd6a3

Crankshaft Bearing Remover/Replacer VM. 1002

SPECIAL TOOLS (Continued)

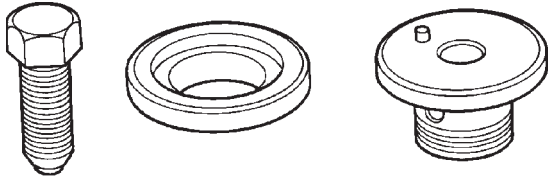

803fd6a4

Injection Pump Puller and Gear retainer VM. 1003

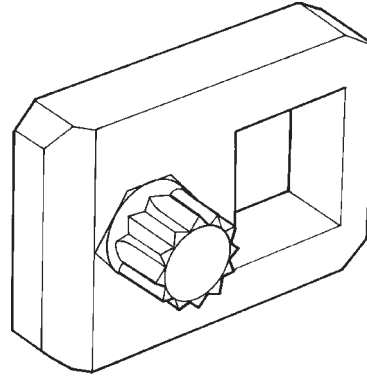

803fd6a7

Cylinder Head Bolt Wrench VM. 1006A

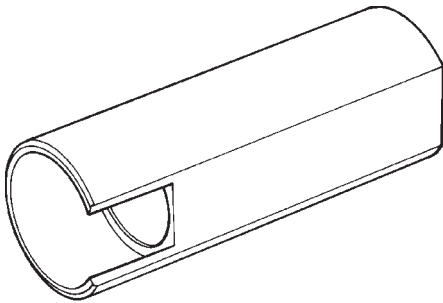

803fd6a5

Crankshaft Remover/Replacer Sleeve VM. 1004

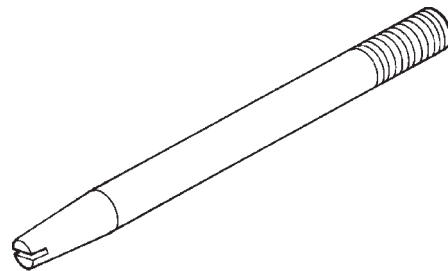

803fd6a9

Cylinder Head Guide Studs VM. 1009

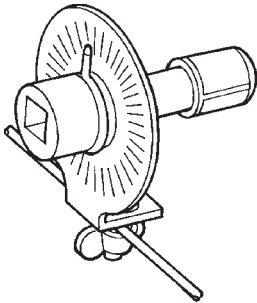

803fd6a6

Torque Angle Gauge VM. 1005

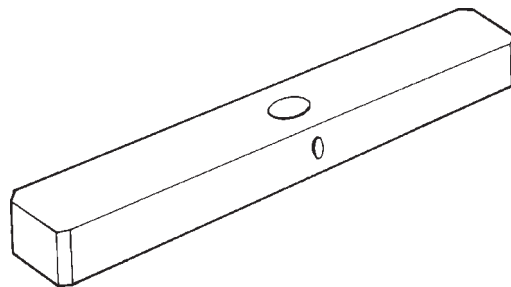

80a1aa43

Cylinder Liner Protrusion Tool VM. 1010

SPECIAL TOOLS (Continued)

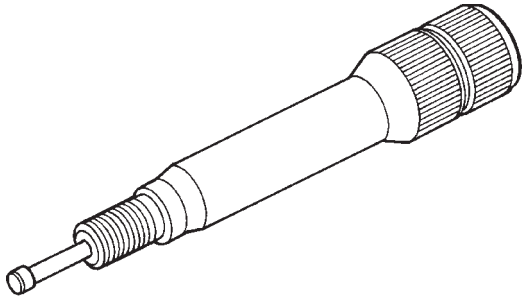

Bosch Pump Timing Adapter VM. 1011

80a1aa44

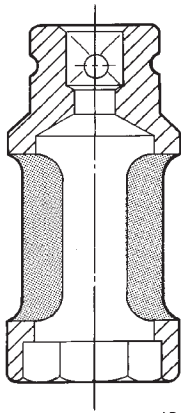
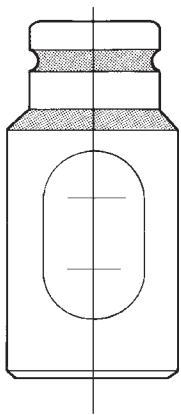

J9509-31

Injector Remover/Replacer Socket VM. 1012B

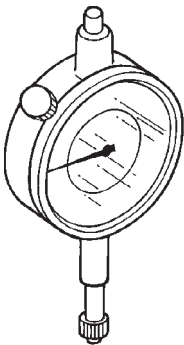

80a1aa46

Dial Indicator Gauge VM. 1013

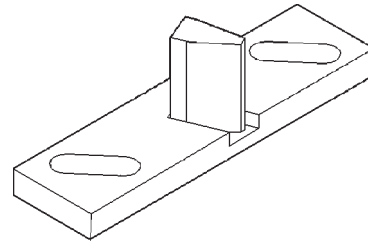

Flywheel Locking Tool VM. 1014

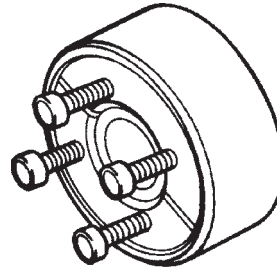

80b897ec

Timing Cover Oil Seal Replacer VM. 1015A

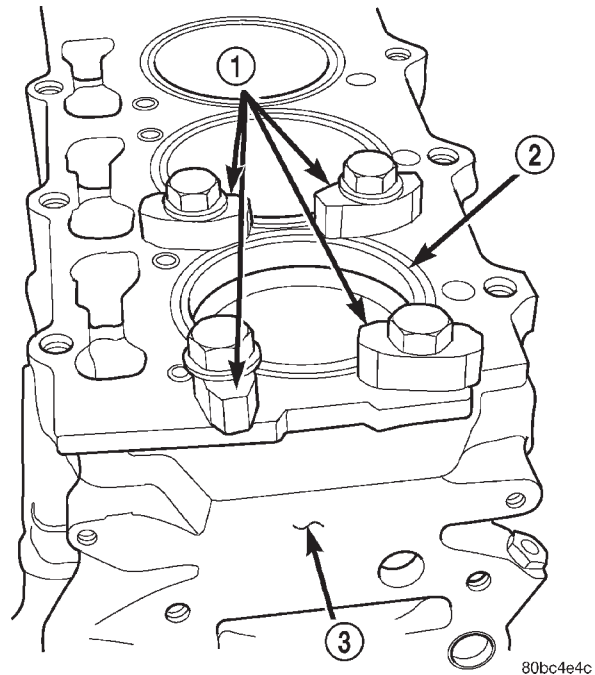

80bc4e4c

Cylinder Retainer VM. 1016

- 1 - VM.1016
- 2 - CYLINDER LINER
- 3 - CYLINDER BLOCK

SPECIAL TOOLS (Continued)

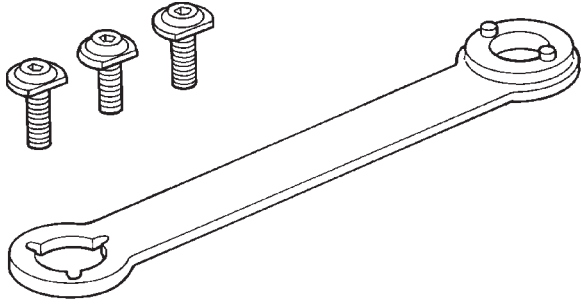

80a1aa4a

Crankshaft and Water Pump Pulley Holder VM. 1017

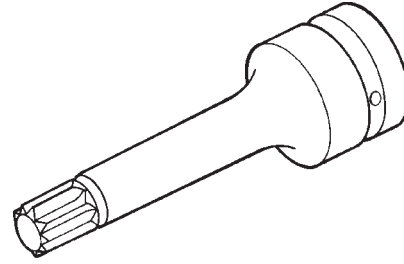

80a1aa4c

Cylinder Head Bolt Wrench M14 VM. 1019

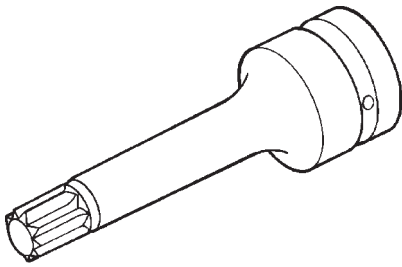

80a1aa4b

Cylinder Head Bolt Wrench M12 VM. 1018

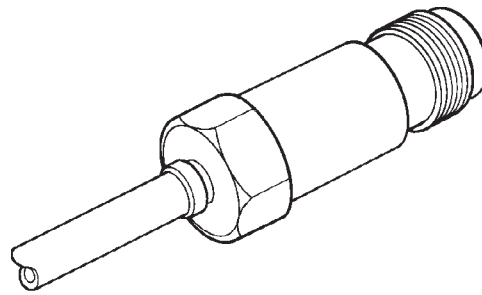

80a1aa4e

Cylinder Leakage Tester Adapter VM. 1021

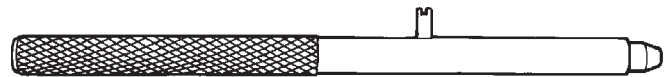

80bfe1e0

Fig. 81 Top Dead Center Tool VM. 1043

INTRODUCTION

TABLE OF CONTENTS

| | page | | page |
|--|------|---------------------------------|------|
| DESCRIPTION AND OPERATION | | FASTENER USAGE | 3 |
| VEHICLE IDENTIFICATION NUMBER | 1 | THREADED HOLE REPAIR | 3 |
| VEHICLE SAFETY CERTIFICATION LABEL | 2 | METRIC SYSTEM | 6 |
| INTERNATIONAL SYMBOLS | 2 | TORQUE REFERENCES | 6 |
| FASTENER IDENTIFICATION | 3 | | |

DESCRIPTION AND OPERATION

VEHICLE IDENTIFICATION NUMBER

The Vehicle Identification Number (VIN) plate is located on the lower windshield fence near the left A-pillar. The VIN contains 17 characters that provide data concerning the vehicle. Refer to the VIN decoding chart to determine the identification of a vehicle.

The Vehicle Identification Number is also imprinted on the:

- Body Code Plate.

- Vehicle Safety Certification Label.
- Frame rail.

To protect the consumer from theft and possible fraud the manufacturer is required to include a Check Digit at the ninth position of the Vehicle Identification Number. The check digit is used by the manufacturer and government agencies to verify the authenticity of the vehicle and official documentation. The formula to use the check digit is not released to the general public.

VEHICLE IDENTIFICATION NUMBER DECODING CHART

| POSITION | INTERPRETATION | CODE = DESCRIPTION |
|------------|-----------------------------|--|
| 1 | Country of Origin | 1 = United States |
| 2 | Make | J = Jeep |
| 3 | Vehicle Type | 4 = MPV |
| 4 | Gross Vehicle Weight Rating | F = 4001-5000 lbs. |
| 5 | Vehicle Line | F = Cherokee 4X4 (LHD) N = Cherokee 4X4 (RHD) B = Cherokee 4X2 (RHD) T = Cherokee 4X2 (LHD) |
| 6 | Series | 2 = SE 6 = Sport/Classic 7 = Limited |
| 7 | Body Style | 7 = 2dr Sport Utility 8 = 4dr Sport Utility |
| 8 | Engine | P = 2.5L Gasoline S = 4.0L Gasoline |
| 9 | Check Digit | |
| 10 | Model Year | Y=2000 |
| 11 | Assembly Plant | L = Toledo #1 |
| 12 thru 17 | Vehicle Build Sequence | |

DESCRIPTION AND OPERATION (Continued)

VEHICLE SAFETY CERTIFICATION LABEL

A vehicle safety certification label (Fig. 1) is attached to every DaimlerChrysler Corporation vehicle. The label certifies that the vehicle conforms to all applicable Federal Motor Vehicle Safety Standards. The label also lists:

- Month and year of vehicle manufacture.
- Gross Vehicle Weight Rating (GVWR). The gross front and rear axle weight ratings (GAWR's) are based on a minimum rim size and maximum cold tire inflation pressure.
- Vehicle Identification Number (VIN).
- Type of vehicle.
- Type of rear wheels.
- Bar code.
- Month, Day and Hour (MDH) of final assembly.
- Paint and Trim codes.
- Country of origin.

The label is located on the driver-side door shut-face.

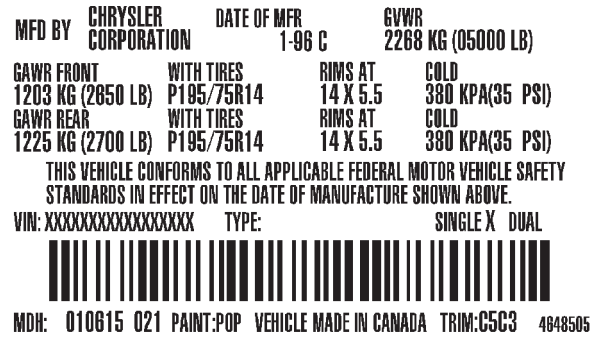

80ab36dE

























Fig. 1 Vehicle Safety Certification Label—Typical

INTERNATIONAL SYMBOLS

DESCRIPTION

The graphic symbols illustrated in the following International Control and Display Symbols Chart are used to identify various instrument controls. The symbols correspond to the controls and displays that are located on the instrument panel.

DESCRIPTION AND OPERATION (Continued)

| | | | | | |
|---|---|---|---|---|---|
|  1 |  2 |  3 |  4 |  5 |  6 |
|  7 |  8 |  9 |  10 |  11 |  12 |
|  13 |  14 |  15 |  16 |  17 |  18 |
|  19 |  20 |  21 |  22 |  23 |  24 |

80be4788

| | | | |
|----|--------------------------------------|----|----------------------------|
| 1 | High Beam | 13 | Rear Window Washer |
| 2 | Fog Lamps | 14 | Fuel |
| 3 | Headlamp, Parking Lamps, Panel Lamps | 15 | Engine Coolant Temperature |
| 4 | Turn Warning | 16 | Battery Charging Condition |
| 5 | Hazard Warning | 17 | Engine Oil |
| 6 | Windshield Washer | 18 | Seat Belt |
| 7 | Windshield Wiper | 19 | Brake Failure |
| 8 | Windshield Wiper and Washer | 20 | Parking Brake |
| 9 | Windscreen Demisting and Defrosting | 21 | Front Hood |
| 10 | Ventilating Fan | 22 | Rear hood (Decklid) |
| 11 | Rear Window Defogger | 23 | Horn |
| 12 | Rear Window Wiper | 24 | Lighter |

FASTENER IDENTIFICATION

DESCRIPTION

GRADE/CLASS IDENTIFICATION

The SAE bolt strength grades range from grade 2 to grade 8. The higher the grade number, the greater the bolt strength. Identification is determined by the line marks on the top of each bolt head. The actual bolt strength grade corresponds to the number of line marks plus 2. The most commonly used metric bolt strength classes are 9.8 and 10.9. The metric strength class identification number is imprinted on the head of the bolt. The higher the class number, the greater the bolt strength. Some metric nuts are imprinted with a single-digit strength class on the nut face. Refer to the Fastener Identification and Fastener Strength Charts.

FASTENER USAGE

WARNING: USE OF AN INCORRECT FASTENER MAY RESULT IN COMPONENT DAMAGE OR PERSONAL INJURY.

Figure art, specifications and torque references in this Service Manual are identified in metric and SAE format.

During any maintenance or repair procedures, it is important to salvage all fasteners (nuts, bolts, etc.) for reassembly. If the fastener is not salvageable, a fastener of equivalent specification must be used.

THREADED HOLE REPAIR

Most stripped threaded holes can be repaired using a Helicoil®. Follow the manufactures recommendations for application and repair procedures.

DESCRIPTION AND OPERATION (Continued)

FASTENER IDENTIFICATION

Bolt Markings and Torque - Metric

Commercial Steel Class

9.8

10.9

12.9

Bolt Head Markings

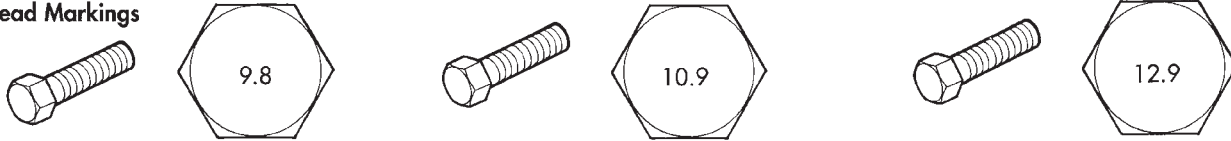

| Body Size | Torque | | | | | Torque | | | | | Torque | | | | |
|-----------|-----------|-----|----------|-----|-------|-----------|-------|----------|-------|-----|-----------|-----|----------|--|--|
| | Cast Iron | | Aluminum | | | Cast Iron | | Aluminum | | | Cast Iron | | Aluminum | | |
| | Diam. | N•m | ft-lb | N•m | ft-lb | N•m | ft-lb | N•m | ft-lb | N•m | ft-lb | N•m | ft-lb | | |
| 6 | 9 | 5 | 7 | 4 | 14 | 9 | 11 | 7 | 14 | 9 | 11 | 7 | | | |
| 7 | 14 | 9 | 11 | 7 | 18 | 14 | 14 | 11 | 23 | 18 | 18 | 14 | | | |
| 8 | 25 | 18 | 18 | 14 | 32 | 23 | 25 | 18 | 36 | 27 | 28 | 21 | | | |
| 10 | 40 | 30 | 30 | 25 | 60 | 45 | 45 | 35 | 70 | 50 | 55 | 40 | | | |
| 12 | 70 | 55 | 55 | 40 | 105 | 75 | 80 | 60 | 125 | 95 | 100 | 75 | | | |
| 14 | 115 | 85 | 90 | 65 | 160 | 120 | 125 | 95 | 195 | 145 | 150 | 110 | | | |
| 16 | 180 | 130 | 140 | 100 | 240 | 175 | 190 | 135 | 290 | 210 | 220 | 165 | | | |
| 18 | 230 | 170 | 180 | 135 | 320 | 240 | 250 | 185 | 400 | 290 | 310 | 230 | | | |

Bolt Markings and Torque Values - U.S. Customary

SAE Grade Number

5

8

Bolt Head Markings

These are all SAE Grade 5 (3) line

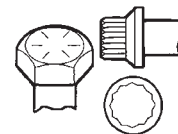

Bolt Torque - Grade 5 Bolt







Bolt Torque - Grade 8 Bolt

| Body Size | Cast Iron | | Aluminum | | Cast Iron | | Aluminum | |
|-----------|-----------|-------|----------|-------|-----------|-------|----------|-------|
| | N•m | ft-lb | N•m | ft-lb | N•m | ft-lb | N•m | ft-lb |
| 1/4 - 20 | 9 | 7 | 8 | 6 | 15 | 11 | 12 | 9 |
| - 28 | 12 | 9 | 9 | 7 | 18 | 13 | 14 | 10 |
| 5/16 - 18 | 20 | 15 | 16 | 12 | 30 | 22 | 24 | 18 |
| - 24 | 23 | 17 | 19 | 14 | 33 | 24 | 25 | 19 |
| 3/8 - 16 | 40 | 30 | 25 | 20 | 55 | 40 | 40 | 30 |
| - 24 | 40 | 30 | 35 | 25 | 60 | 45 | 45 | 35 |
| 7/16 - 14 | 60 | 45 | 45 | 35 | 90 | 65 | 65 | 50 |
| - 20 | 65 | 50 | 55 | 40 | 95 | 70 | 75 | 55 |
| 1/2 - 13 | 95 | 70 | 75 | 55 | 130 | 95 | 100 | 75 |
| - 20 | 100 | 75 | 80 | 60 | 150 | 110 | 120 | 90 |
| 9/16 - 12 | 135 | 100 | 110 | 80 | 190 | 140 | 150 | 110 |
| - 18 | 150 | 110 | 115 | 85 | 210 | 155 | 170 | 125 |
| 5/8 - 11 | 180 | 135 | 150 | 110 | 255 | 190 | 205 | 150 |
| - 18 | 210 | 155 | 160 | 120 | 290 | 215 | 230 | 170 |
| 3/4 - 10 | 325 | 240 | 255 | 190 | 460 | 340 | 365 | 270 |
| - 16 | 365 | 270 | 285 | 210 | 515 | 380 | 410 | 300 |
| 7/8 - 9 | 490 | 360 | 380 | 280 | 745 | 550 | 600 | 440 |
| - 14 | 530 | 390 | 420 | 310 | 825 | 610 | 660 | 490 |
| 1 - 8 | 720 | 530 | 570 | 420 | 1100 | 820 | 890 | 660 |
| - 14 | 800 | 590 | 650 | 480 | 1200 | 890 | 960 | 710 |

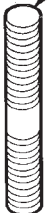
DESCRIPTION AND OPERATION (Continued)

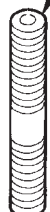
FASTENER STRENGTH

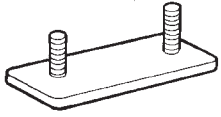
HOW TO DETERMINE BOLT STRENGTH

| | Mark | Class | | Mark | Class |
|--|---|-------|---|--|-------|
| Hexagon head bolt |  <p>Bolt head No.</p> <p>4 — 4T 5 — 5T 6 — 6T 7 — 7T 8 — 8T 9 — 9T 10 — 10T 11 — 11T</p> | | Stud bolt |  <p>No mark</p> | 4T |
| |  <p>No mark</p> | 4T | | | |
| Hexagon flange bolt w/washer hexagon bolt |  <p>No mark</p> | 4T | Welded bolt |  <p>Grooved</p> | 6T |
| Hexagon head bolt |  <p>Two protruding lines</p> | 5T | | | |
| Hexagon flange bolt w/washer hexagon bolt |  <p>Two protruding lines</p> | 6T |  | 4T | |
| Hexagon head bolt |  <p>Three protruding lines</p> | 7T | | | |
| Hexagon head bolt |  <p>Four protruding lines</p> | 8T | | | |

DESCRIPTION AND OPERATION (Continued)

METRIC SYSTEM

The following chart will assist in converting metric units to equivalent English and SAE units, or vice versa.

DESCRIPTION

The metric system is based on quantities of one, ten, one hundred, one thousand and one million.

CONVERSION FORMULAS AND EQUIVALENT VALUES

| MULTIPLY | BY | TO GET | MULTIPLY | BY | TO GET |
|---------------------------|-----------|-------------------------|----------|-----------|--------------------------|
| in-lbs | x 0.11298 | = Newton Meters (N·m) | N·m | x 8.851 | = in-lbs |
| ft-lbs | x 1.3558 | = Newton Meters (N·m) | N·m | x 0.7376 | = ft-lbs |
| Inches Hg (60° F) | x 3.377 | = Kilopascals (kPa) | kPa | x 0.2961 | = Inches Hg |
| psi | x 6.895 | = Kilopascals (kPa) | kPa | x 0.145 | = psi |
| Inches | x 25.4 | = Millimeters (mm) | mm | x 0.03937 | = Inches |
| Feet | x 0.3048 | = Meters (M) | M | x 3.281 | = Feet |
| Yards | x 0.9144 | = Meters | M | x 1.0936 | = Yards |
| mph | x 1.6093 | = Kilometers/Hr. (Km/h) | Km/h | x 0.6214 | = mph |
| Feet/Sec | x 0.3048 | = Meters/Sec (M/S) | M/S | x 3.281 | = Feet/Sec |
| mph | x 0.4470 | = Meters/Sec (M/S) | M/S | x 2.237 | = mph |
| Kilometers/ Hr. (Km/h) | x 0.27778 | = Meters/Sec (M/S) | M/S | x 3.600 | Kilometers/Hr. (Km/h) |

COMMON METRIC EQUIVALENTS

| | |
|-------------------------|-------------------------------------|
| 1 inch = 25 Millimeters | 1 Cubic Inch = 16 Cubic Centimeters |
| 1 Foot = 0.3 Meter | 1 Cubic Foot = 0.03 Cubic Meter |
| 1 Yard = 0.9 Meter | 1 Cubic Yard = 0.8 Cubic Meter |
| 1 Mile = 1.6 Kilometers | |

Refer to the Metric Conversion Chart to convert torque values listed in metric Newton- meters (N·m). Also, use the chart to convert between millimeters (mm) and inches (in.)

Refer to the Metric Conversion Chart for torque references not listed in the individual torque charts.

TORQUE REFERENCES**DESCRIPTION**

Individual Torque Charts appear at the end of many Groups. Refer to the Standard Torque Specifi-

DESCRIPTION AND OPERATION (Continued)

METRIC CONVERSION CHART

in-lbs to N•m

N•m to in-lbs

| in-lb | N•m | in-lb | N•m | in-lb | N•m | in-lb | N•m | in-lb | N•m | N•m | in-lb | N•m | in-lb | N•m | in-lb | N•m | in-lb | N•m | in-lb | N•m |
|-------|--------|-------|--------|-------|---------|-------|---------|-------|---------|-----|---------|-----|---------|------|----------|------|----------|------|----------|-----|
| 2 | .2260 | 42 | 4.7453 | 82 | 9.2646 | 122 | 13.7839 | 162 | 18.3032 | .2 | 1.7702 | 4.2 | 37.1747 | 8.2 | 72.5792 | 12.2 | 107.9837 | 16.2 | 143.3882 | |
| 4 | .4519 | 44 | 4.9713 | 84 | 9.4906 | 124 | 14.0099 | 164 | 18.5292 | .4 | 3.5404 | 4.4 | 38.9449 | 8.4 | 74.3494 | 12.4 | 109.7539 | 16.4 | 145.1584 | |
| 6 | .6779 | 46 | 5.1972 | 86 | 9.7165 | 126 | 14.2359 | 166 | 18.7552 | .6 | 5.3107 | 4.6 | 40.7152 | 8.6 | 76.1197 | 12.6 | 111.5242 | 16.6 | 146.9287 | |
| 8 | .9039 | 48 | 5.4232 | 88 | 9.9425 | 128 | 14.4618 | 168 | 18.9811 | .8 | 7.0809 | 4.8 | 42.4854 | 8.8 | 77.8899 | 12.8 | 113.2944 | 16.8 | 148.6989 | |
| 10 | 1.1298 | 50 | 5.6492 | 90 | 10.1685 | 130 | 14.6878 | 170 | 19.2071 | 1 | 8.8511 | 5 | 44.2556 | 9 | 79.6601 | 13 | 115.0646 | 17 | 150.4691 | |
| 12 | 1.3558 | 52 | 5.8751 | 92 | 10.3944 | 132 | 14.9138 | 172 | 19.4331 | 1.2 | 10.6213 | 5.2 | 46.0258 | 9.2 | 81.4303 | 13.2 | 116.8348 | 17.2 | 152.2393 | |
| 14 | 1.5818 | 54 | 6.1011 | 94 | 10.6204 | 134 | 15.1397 | 174 | 19.6590 | 1.4 | 12.3916 | 5.4 | 47.7961 | 9.4 | 83.2006 | 13.4 | 118.6051 | 17.4 | 154.0096 | |
| 16 | 1.8077 | 56 | 6.3270 | 96 | 10.8464 | 136 | 15.3657 | 176 | 19.8850 | 1.6 | 14.1618 | 5.6 | 49.5663 | 9.6 | 84.9708 | 13.6 | 120.3753 | 17.6 | 155.7798 | |
| 18 | 2.0337 | 58 | 6.5530 | 98 | 11.0723 | 138 | 15.5917 | 178 | 20.1110 | 1.8 | 15.9320 | 5.8 | 51.3365 | 9.8 | 86.7410 | 13.8 | 122.1455 | 17.8 | 157.5500 | |
| 20 | 2.2597 | 60 | 6.7790 | 100 | 11.2983 | 140 | 15.8176 | 180 | 20.3369 | 2 | 17.7022 | 6 | 53.1067 | 10 | 88.5112 | 14 | 123.9157 | 18 | 159.3202 | |
| 22 | 2.4856 | 62 | 7.0049 | 102 | 11.5243 | 142 | 16.0436 | 182 | 20.5629 | 2.2 | 19.4725 | 6.2 | 54.8770 | 10.2 | 90.2815 | 14.2 | 125.6860 | 18.5 | 163.7458 | |
| 24 | 2.7116 | 64 | 7.2309 | 104 | 11.7502 | 144 | 16.2696 | 184 | 20.7889 | 2.4 | 21.2427 | 6.4 | 56.6472 | 10.4 | 92.0517 | 14.4 | 127.4562 | 19 | 168.1714 | |
| 26 | 2.9376 | 66 | 7.4569 | 106 | 11.9762 | 146 | 16.4955 | 186 | 21.0148 | 2.6 | 23.0129 | 6.6 | 58.4174 | 10.6 | 93.8219 | 14.6 | 129.2264 | 19.5 | 172.5970 | |
| 28 | 3.1635 | 68 | 7.6828 | 108 | 12.2022 | 148 | 16.7215 | 188 | 21.2408 | 2.8 | 24.7831 | 6.8 | 60.1876 | 10.8 | 95.5921 | 14.8 | 130.9966 | 20 | 177.0225 | |
| 30 | 3.3895 | 70 | 7.9088 | 110 | 12.4281 | 150 | 16.9475 | 190 | 21.4668 | 3 | 26.5534 | 7 | 61.9579 | 11 | 97.3624 | 15 | 132.7669 | 20.5 | 181.4480 | |
| 32 | 3.6155 | 72 | 8.1348 | 112 | 12.6541 | 152 | 17.1734 | 192 | 21.6927 | 3.2 | 28.3236 | 7.2 | 63.7281 | 11.2 | 99.1326 | 15.2 | 134.5371 | 21 | 185.8736 | |
| 34 | 3.8414 | 74 | 8.3607 | 114 | 12.8801 | 154 | 17.3994 | 194 | 21.9187 | 3.4 | 30.0938 | 7.4 | 65.4983 | 11.4 | 100.9028 | 15.4 | 136.3073 | 22 | 194.7247 | |
| 36 | 4.0674 | 76 | 8.5867 | 116 | 13.1060 | 156 | 17.6253 | 196 | 22.1447 | 3.6 | 31.8640 | 7.6 | 67.2685 | 11.6 | 102.6730 | 15.6 | 138.0775 | 23 | 203.5759 | |
| 38 | 4.2934 | 78 | 8.8127 | 118 | 13.3320 | 158 | 17.8513 | 198 | 22.3706 | 3.8 | 33.6342 | 7.8 | 69.0388 | 11.8 | 104.4433 | 15.8 | 139.8478 | 24 | 212.4270 | |
| 40 | 4.5193 | 80 | 9.0386 | 120 | 13.5580 | 160 | 18.0773 | 200 | 22.5966 | 4 | 35.4045 | 8 | 70.8090 | 12 | 106.2135 | 16 | 141.6180 | 25 | 221.2781 | |

ft-lbs to N•m

N•m to ft-lbs

| ft-lb | N•m | ft-lb | N•m | ft-lb | N•m | ft-lb | N•m | ft-lb | N•m | N•m | ft-lb | N•m | ft-lb | N•m | ft-lb | N•m | ft-lb | N•m | ft-lb | N•m |
|-------|---------|-------|---------|-------|---------|-------|----------|-------|----------|-----|---------|-----|---------|-----|---------|-----|---------|-----|---------|-----|
| 1 | 1.3558 | 21 | 28.4722 | 41 | 55.5885 | 61 | 82.7049 | 81 | 109.8212 | 1 | .7376 | 21 | 15.9888 | 41 | 30.2400 | 61 | 44.9913 | 81 | 59.7425 | |
| 2 | 2.7116 | 22 | 29.8280 | 42 | 56.9444 | 62 | 84.0607 | 82 | 111.1770 | 2 | 1.4751 | 22 | 16.2264 | 42 | 30.9776 | 62 | 45.7289 | 82 | 60.4801 | |
| 3 | 4.0675 | 23 | 31.1838 | 43 | 58.3002 | 63 | 85.4165 | 83 | 112.5328 | 3 | 2.2127 | 23 | 16.9639 | 43 | 31.7152 | 63 | 46.4664 | 83 | 61.2177 | |
| 4 | 5.4233 | 24 | 32.5396 | 44 | 59.6560 | 64 | 86.7723 | 84 | 113.8886 | 4 | 2.9502 | 24 | 17.7015 | 44 | 32.4527 | 64 | 47.2040 | 84 | 61.9552 | |
| 5 | 6.7791 | 25 | 33.8954 | 45 | 61.0118 | 65 | 88.1281 | 85 | 115.2445 | 5 | 3.6878 | 25 | 18.4391 | 45 | 33.1903 | 65 | 47.9415 | 85 | 62.6928 | |
| 6 | 8.1349 | 26 | 35.2513 | 46 | 62.3676 | 66 | 89.4840 | 86 | 116.6004 | 6 | 4.4254 | 26 | 19.1766 | 46 | 33.9279 | 66 | 48.6791 | 86 | 63.4303 | |
| 7 | 9.4907 | 27 | 36.6071 | 47 | 63.7234 | 67 | 90.8398 | 87 | 117.9562 | 7 | 5.1629 | 27 | 19.9142 | 47 | 34.6654 | 67 | 49.4167 | 87 | 64.1679 | |
| 8 | 10.8465 | 28 | 37.9629 | 48 | 65.0793 | 68 | 92.1956 | 88 | 119.3120 | 8 | 5.9005 | 28 | 20.6517 | 48 | 35.4030 | 68 | 50.1542 | 88 | 64.9545 | |
| 9 | 12.2024 | 29 | 39.3187 | 49 | 66.4351 | 69 | 93.5514 | 89 | 120.6678 | 9 | 6.6381 | 29 | 21.3893 | 49 | 36.1405 | 69 | 50.8918 | 89 | 65.6430 | |
| 10 | 13.5582 | 30 | 40.6745 | 50 | 67.7909 | 70 | 94.9073 | 90 | 122.0236 | 10 | 7.3756 | 30 | 22.1269 | 50 | 36.8781 | 70 | 51.6293 | 90 | 66.3806 | |
| 11 | 14.9140 | 31 | 42.0304 | 51 | 69.1467 | 71 | 96.2631 | 91 | 123.3794 | 11 | 8.1132 | 31 | 22.8644 | 51 | 37.6157 | 71 | 52.3669 | 91 | 67.1181 | |
| 12 | 16.2698 | 32 | 43.3862 | 52 | 70.5025 | 72 | 97.6189 | 92 | 124.7352 | 12 | 8.8507 | 32 | 23.6020 | 52 | 38.3532 | 72 | 53.1045 | 92 | 67.8557 | |
| 13 | 17.6256 | 33 | 44.7420 | 53 | 71.8583 | 73 | 98.9747 | 93 | 126.0910 | 13 | 9.5883 | 33 | 24.3395 | 53 | 39.0908 | 73 | 53.8420 | 93 | 68.5933 | |
| 14 | 18.9815 | 34 | 46.0978 | 54 | 73.2142 | 74 | 100.3316 | 94 | 127.4468 | 14 | 10.3259 | 34 | 25.0771 | 54 | 39.8284 | 74 | 54.5720 | 94 | 69.3308 | |
| 15 | 20.3373 | 35 | 47.4536 | 55 | 74.5700 | 75 | 101.6862 | 95 | 128.8026 | 15 | 11.0634 | 35 | 25.8147 | 55 | 40.5659 | 75 | 55.3172 | 95 | 70.0684 | |
| 16 | 21.6931 | 36 | 48.8094 | 56 | 75.9258 | 76 | 103.0422 | 96 | 130.1586 | 16 | 11.8010 | 36 | 26.5522 | 56 | 41.3035 | 76 | 56.0547 | 96 | 70.8060 | |
| 17 | 23.0489 | 37 | 50.1653 | 57 | 77.2816 | 77 | 104.3980 | 97 | 131.5144 | 17 | 12.5386 | 37 | 27.2898 | 57 | 42.0410 | 77 | 56.7923 | 97 | 71.5435 | |
| 18 | 24.4047 | 38 | 51.5211 | 58 | 78.6374 | 78 | 105.7538 | 98 | 132.8702 | 18 | 13.2761 | 38 | 28.0274 | 58 | 42.7786 | 78 | 57.5298 | 98 | 72.2811 | |
| 19 | 25.7605 | 39 | 52.8769 | 59 | 79.9933 | 79 | 107.1196 | 99 | 134.2260 | 19 | 14.0137 | 39 | 28.7649 | 59 | 43.5162 | 79 | 58.2674 | 99 | 73.0187 | |
| 20 | 27.1164 | 40 | 54.2327 | 60 | 81.3491 | 80 | 108.4654 | 100 | 135.5820 | 20 | 14.7512 | 40 | 29.5025 | 60 | 44.2537 | 80 | 59.0050 | 100 | 73.7562 | |

in. to mm

mm to in.

| in. | mm | in. | mm | in. | mm | in. | mm | in. | mm | mm | in. | mm | in. | mm | in. | mm | in. | mm | in. | mm |
|-----|-------|-----|--------|-----|--------|-----|--------|-----|--------|-----|--------|-----|--------|-----|--------|-----|--------|-----|--------|----|
| .01 | .254 | .21 | 5.334 | .41 | 10.414 | .61 | 15.494 | .81 | 20.574 | .01 | .00039 | .21 | .00827 | .41 | .01614 | .61 | .02402 | .81 | .03189 | |
| .02 | .508 | .22 | 5.588 | .42 | 10.668 | .62 | 15.748 | .82 | 20.828 | .02 | .00079 | .22 | .00866 | .42 | .01654 | .62 | .02441 | .82 | .03228 | |
| .03 | .762 | .23 | 5.842 | .43 | 10.922 | .63 | 16.002 | .83 | 21.082 | .03 | .00118 | .23 | .00906 | .43 | .01693 | .63 | .02480 | .83 | .03268 | |
| .04 | 1.016 | .24 | 6.096 | .44 | 11.176 | .64 | 16.256 | .84 | 21.336 | .04 | .00157 | .24 | .00945 | .44 | .01732 | .64 | .02520 | .84 | .03307 | |
| .05 | 1.270 | .25 | 6.350 | .45 | 11.430 | .65 | 16.510 | .85 | 21.590 | .05 | .00197 | .25 | .00984 | .45 | .01772 | .65 | .02559 | .85 | .03346 | |
| .06 | 1.524 | .26 | 6.604 | .46 | 11.684 | .66 | 16.764 | .86 | 21.844 | .06 | .00236 | .26 | .01024 | .46 | .01811 | .66 | .02598 | .86 | .03386 | |
| .07 | 1.778 | .27 | 6.858 | .47 | 11.938 | .67 | 17.018 | .87 | 22.098 | .07 | .00276 | .27 | .01063 | .47 | .01850 | .67 | .02638 | .87 | .03425 | |
| .08 | 2.032 | .28 | 7.112 | .48 | 12.192 | .68 | 17.272 | .88 | 22.352 | .08 | .00315 | .28 | .01102 | .48 | .01890 | .68 | .02677 | .88 | .03465 | |
| .09 | 2.286 | .29 | 7.366 | .49 | 12.446 | .69 | 17.526 | .89 | 22.606 | .09 | .00354 | .29 | .01142 | .49 | .01929 | .69 | .02717 | .89 | .03504 | |
| .10 | 2.540 | .30 | 7.620 | .50 | 12.700 | .70 | 17.780 | .90 | 22.860 | .10 | .00394 | .30 | .01181 | .50 | .01969 | .70 | .02756 | .90 | .03543 | |
| .11 | 2.794 | .31 | 7.874 | .51 | 12.954 | .71 | 18.034 | .91 | 23.114 | .11 | .00433 | .31 | .01220 | .51 | .02008 | .71 | .02795 | .91 | .03583 | |
| .12 | 3.048 | .32 | 8.128 | .52 | 13.208 | .72 | 18.288 | .92 | 23.368 | .12 | .00472 | .32 | .01260 | .52 | .02047 | .72 | .02835 | .92 | .03622 | |
| .13 | 3.302 | .33 | 8.382 | .53 | 13.462 | .73 | 18.542 | .93 | 23.622 | .13 | .00512 | .33 | .01299 | .53 | .02087 | .73 | .02874 | .93 | .03661 | |
| .14 | 3.556 | .34 | 8.636 | .54 | 13.716 | .74 | 18.796 | .94 | 23.876 | .14 | .00551 | .34 | .01339 | .54 | .02126 | .74 | .02913 | .94 | .03701 | |
| .15 | 3.810 | .35 | 8.890 | .55 | 13.970 | .75 | 19.050 | .95 | 24.130 | .15 | .00591 | .35 | .01378 | .55 | .02165 | .75 | .02953 | .95 | .03740 | |
| .16 | 4.064 | .36 | 9.144 | .56 | 14.224 | .76 | 19.304 | .96 | 24.384 | .16 | .00630 | .36 | .01417 | .56 | .02205 | .76 | .02992 | .96 | .03780 | |
| .17 | 4.318 | .37 | 9.398 | .57 | 14.478 | .77 | 19.558 | .97 | 24.638 | .17 | .00669 | .37 | .01457 | .57 | .02244 | .77 | .03032 | .97 | .03819 | |
| .18 | 4.572 | .38 | 9.652 | .58 | 14.732 | .78 | 19.812 | .98 | 24.892 | .18 | .00709 | .38 | .01496 | .58 | .02283 | .78 | .03071 | .98 | .03858 | |
| .19 | 4.826 | .39 | 9.906 | .59 | 14.986 | .79 | 20.066 | .99 | 25.146 | .19 | .00748 | .39 | .01535 | .59 | .02323 | .79 | .03110 | .99 | .03898 | |
| .20 | 5.080 | .40 | 10.160 | .60 | | | | | | | | | | | | | | | | |

DESCRIPTION AND OPERATION (Continued)

TORQUE SPECIFICATIONS

SPECIFIED TORQUE FOR STANDARD BOLTS

| Class | Diameter mm | Pitch mm | Specified torque | | | | | |
|-------|----------------|-------------|-------------------|--------|------------|---------------------|--------|------------|
| | | | Hexagon head bolt | | | Hexagon flange bolt | | |
| | | | N•m | kgf-cm | ft-lbf | N•m | kgf-cm | ft-lbf |
| 4T | 6 | 1 | 5 | 55 | 48 in.-lbf | 6 | 60 | 52 in.-lbf |
| | 8 | 1.25 | 12.5 | 130 | 9 | 14 | 145 | 10 |
| | 10 | 1.25 | 26 | 260 | 19 | 29 | 290 | 21 |
| | 12 | 1.25 | 47 | 480 | 35 | 53 | 540 | 39 |
| | 14 | 1.5 | 74 | 760 | 55 | 84 | 850 | 61 |
| | 16 | 1.5 | 115 | 1,150 | 83 | — | — | — |
| 5T | 6 | 1 | 6.5 | 65 | 56 in.-lbf | 7.5 | 75 | 65 in.-lbf |
| | 8 | 1.25 | 15.5 | 160 | 12 | 17.5 | 175 | 13 |
| | 10 | 1.25 | 32 | 330 | 24 | 36 | 360 | 26 |
| | 12 | 1.25 | 59 | 600 | 43 | 65 | 670 | 48 |
| | 14 | 1.5 | 91 | 930 | 67 | 100 | 1,050 | 76 |
| | 16 | 1.5 | 140 | 1,400 | 101 | — | — | — |
| 6T | 6 | 1 | 8 | 80 | 69 in.-lbf | 9 | 90 | 78 in.-lbf |
| | 8 | 1.25 | 19 | 195 | 14 | 21 | 210 | 15 |
| | 10 | 1.25 | 39 | 400 | 29 | 44 | 440 | 32 |
| | 12 | 1.25 | 71 | 730 | 53 | 80 | 810 | 59 |
| | 14 | 1.5 | 110 | 1,100 | 80 | 125 | 1,250 | 90 |
| | 16 | 1.5 | 170 | 1,750 | 127 | — | — | — |
| 7T | 6 | 1 | 10.5 | 110 | 8 | 12 | 120 | 9 |
| | 8 | 1.25 | 25 | 260 | 19 | 28 | 290 | 21 |
| | 10 | 1.25 | 52 | 530 | 38 | 58 | 590 | 43 |
| | 12 | 1.25 | 95 | 970 | 70 | 105 | 1,050 | 76 |
| | 14 | 1.5 | 145 | 1,500 | 108 | 165 | 1,700 | 123 |
| | 16 | 1.5 | 230 | 2,300 | 166 | — | — | — |
| 8T | 8 | 1.25 | 29 | 300 | 22 | 33 | 330 | 24 |
| | 10 | 1.25 | 61 | 620 | 45 | 68 | 690 | 50 |
| | 12 | 1.25 | 110 | 1,100 | 80 | 120 | 1,250 | 90 |
| 9T | 8 | 1.25 | 34 | 340 | 25 | 37 | 380 | 27 |
| | 10 | 1.25 | 70 | 710 | 51 | 78 | 790 | 57 |
| | 12 | 1.25 | 125 | 1,300 | 94 | 140 | 1,450 | 105 |
| 10T | 8 | 1.25 | 38 | 390 | 28 | 42 | 430 | 31 |
| | 10 | 1.25 | 78 | 800 | 58 | 88 | 890 | 64 |
| | 12 | 1.25 | 140 | 1,450 | 105 | 155 | 1,600 | 116 |
| 11T | 8 | 1.25 | 42 | 430 | 31 | 47 | 480 | 35 |
| | 10 | 1.25 | 87 | 890 | 64 | 97 | 990 | 72 |
| | 12 | 1.25 | 155 | 1,600 | 116 | 175 | 1,800 | 130 |

INTRODUCTION

TABLE OF CONTENTS

| | | | |
|---|------|-------------------------------------|------|
| | page | | page |
| DESCRIPTION AND OPERATION | | E-MARK LABEL | 2 |
| VEHICLE IDENTIFICATION NUMBER | 1 | MANUFACTURER PLATE | 2 |

DESCRIPTION AND OPERATION

VEHICLE IDENTIFICATION NUMBER

DESCRIPTION

The Vehicle Identification Number (VIN) plate is located on the lower windshield fence near the left A-pillar. The VIN contains 17 characters that provide data concerning the vehicle. Refer to the VIN decoding chart to determine the identification of a vehicle.

The Vehicle Identification Number is also imprinted on the:

- Body Code Plate.
- Vehicle Safety Certification Label.
- Frame rail.

To protect the consumer from theft and possible fraud the manufacturer is required to include a Check Digit at the ninth position of the Vehicle Identification Number. The check digit is used by the manufacturer and government agencies to verify the authenticity of the vehicle and official documentation. The formula to use the check digit is not released to the general public.

VEHICLE IDENTIFICATION NUMBER DECODING CHART

| POSITION | INTERPRETATION | CODE = DESCRIPTION |
|------------|-----------------------------|---|
| 1 | Country of Origin | 1 = United States |
| 2 | Make | J = Jeep |
| 3 | Vehicle Type | 4 = MPV |
| 4 | Gross Vehicle Weight Rating | F = 4001-5000 lbs. |
| 5 | Vehicle Line | F = Cherokee 4X4 (LHD) J = Cherokee 4X4 (RHD) EXPORT N = Cherokee 4X4 (RHD) B = Cherokee 4X2 (RHD) T = Cherokee 4X2 (LHD) |
| 6 | Series/Transmission | N = 5 Speed Manual A = 3 Speed Auto B = 4 Speed Auto 4 = Sport 6 = Cherokee Country/Limited 5 = Classic |
| 7 | Body Style | 7 = 2dr Sport Utility 8 = 4dr Sport Utility |
| 8 | Engine | M = 2.5L Diesel P = 2.5L Gasoline S = 4.0L Gasoline |
| 9 | Check Digit | |
| 10 | Model Year | Y = 2000 |
| 11 | Assembly Plant | L = Toledo Assembly#1 |
| 12 thru 17 | Vehicle Build Sequence | |

DESCRIPTION AND OPERATION (Continued)

E-MARK LABEL

DESCRIPTION

An E-mark Label (Fig. 1) is located on the rear shut face of the driver's door. The label contains the following information:

- Date of Manufacture
- Month-Day-Hour (MDH)
- Vehicle Identification Number (VIN)
- Country Codes
- Regulation Number
- Regulation Amendment Number
- Approval Number

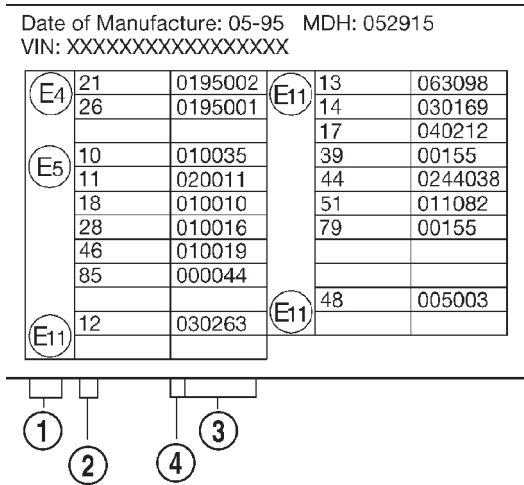

Fig. 1 E-Mark Label

- 1 - Country Code
- 2 - Regulation Number
- 3 - Approval Number
- 4 - Amendment Number

MANUFACTURER PLATE

DESCRIPTION

The Manufacturer Plate (Fig. 2) is located in the engine compartment on the radiator closure panel crossmember adjacent to the Body Code Plate. The plate contains five lines of information:

1. Vehicle Identification Number (VIN)
2. Gross Vehicle Mass (GVM)
3. Gross Train Mass (GTM)
4. Gross Front Axle Rating (GFAR)
5. Gross Rear Axle Rating (GRAR)

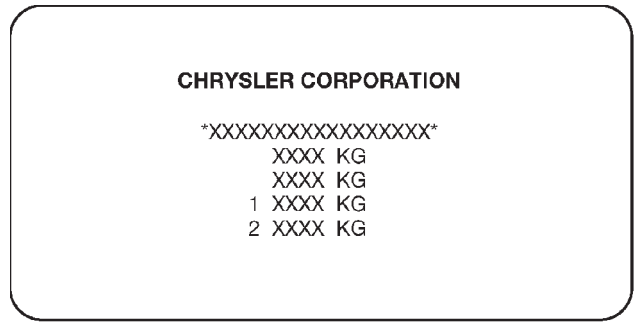

80a47179

Fig. 2 Manufacturer Plate

80a47175

GROUP TAB LOCATOR

| | | |
|-----|--|--|
| IN | Introduction | |
| INa | Introduction | |
| 0 | Lubrication and Maintenance | |
| 0a | Lubrication and Maintenance | |
| 2 | Suspension | |
| 3 | Differential and Driveline | |
| 5 | Brakes | |
| 5a | Brakes | |
| 6 | Clutch | |
| 6a | Clutch | |
| 7 | Cooling System | |
| 7a | Cooling System | |
| 8A | Battery | |
| 8B | Starting System | |
| 8Ba | Starting System | |
| 8C | Charging System | |
| 8Ca | Charging System | |
| 8D | Ignition System | |
| 8E | Instrument Panel Systems | |
| 8Ea | Instrument Panel Systems | |
| 8F | Audio Systems | |
| 8G | Horn Systems | |
| 8H | Vehicle Speed Control System | |
| 8Ha | Vehicle Speed Control System | |
| 8J | Turn Signal and Hazard Warning Systems | |
| 8K | Wiper and Washer Systems | |
| 8L | Lamps | |
| 8La | Lamps | |
| 8M | Passive Restraint Systems | |

| | | |
|-----|--------------------------------|--|
| 8N | Electrically Heated Systems | |
| 8O | Power Distribution System | |
| 8P | Power Lock Systems | |
| 8Q | Vehicle Theft/Security Systems | |
| 8Qa | Vehicle Theft/Security Systems | |
| 8R | Power Seats Systems | |
| 8S | Power Window Systems | |
| 8T | Power Mirror Systems | |
| 8U | Chime/Buzzer Warning Systems | |
| 8V | Overhead Console Systems | |
| 8W | Wiring Diagrams | |
| 9 | Engine | |
| 9a | Engine | |
| 11 | Exhaust System | |
| 11a | Exhaust System | |
| 13 | Frame and Bumpers | |
| 13a | Frame and Bumpers | |
| 14 | Fuel System | |
| 14a | Fuel System | |
| 19 | Steering | |
| 19a | Steering | |
| 21 | Transmission and Transfer Case | |
| 21a | Transmission and Transfer Case | |
| 22 | Tires and Wheels | |
| 23 | Body | |
| 24 | Heating and Air Conditioning | |
| 24a | Heating and Air Conditioning | |
| 25 | Emission Control Systems | |
| 25a | Emission Control Systems | |

Welcome to the
2000 Jeep® Cherokee
Electronic Service Manual

Click on the logo to begin

DaimlerChrysler
International Operations