

INSTRUCTION MANUAL

MODEL 05205A

PORTABLE DC HYPOT

TABLE OF CONTENTS

Specifications Page 1
General Features Page 2, 3
Calibration Instructions Page 9
Operating Instructions Page 10
Replacement Parts List
Schematic Diagram

ASSOCIATED RESEARCH, INCORPORATED
8221 North Kimball Avenue
Skokie, Illinois 60076

ASSOCIATED RESEARCH, INC.
MODEL SPECIFICATION - dc HYPOT

MODEL NUMBER: 5205

DESCRIPTION: Portable dc Hypot

PRIMARY APPLICATION: Dielectric withstand testing of rotating machinery, transformers, switchgear and cables for acceptance and routine maintenance in the field.

INPUT

Voltage: 120 volts nominal
Frequency: 60 Hz
Phase: Single
Current: 2 amperes

OUTPUT

Voltage: 0-5 KV dc continuously adjustable $\pm 2\%$
kVA: .010
Frequency: dc
Current: 2 milliamperes operating, 15 milliamperes short circuit
Duty Cycle: Continuous
Failure Detector: None; current limited against overloads

VOLTAGE CONTROL: Manually operated. No zero return interlock system.

METERING:

Kilovoltmeter: Analog -- 0-2.5/5 kV
Milliammeter: Analog -- 0-2/20/200/2000 microamperes
Range: Dual range kV meter, four range Microammeter.

TERMINATION

Input: Five foot (1.524 m), 3 conductor power cable terminated in 3 prong grounding type plug
H.V.: Receptacle with disconnectable 15 ft. (4.572 m) cable terminated in insulated clip.
Return: Metered-Bypass-Ground terminals with disconnectable 15 ft. (4.572 m) cables terminated in insulated clips.

CABINetry: Portable style, 34.3 cm x 35.56 cm x 20.3 cm (13 1/2" x 14" x 8")

WEIGHT: 27 lbs (12.25 kg)

SAFETY - Cont.

FAULT FINDING - Cont.

Because of the heavy pulse current (possibly thousands of amperes) generated with capacitance discharge equipment, it is absolutely essential that careful attention be paid to proper grounding and safety practices. The test equipment should be tied to a good earth ground with as short and heavy a connection as possible. The unused phases of a multi-phase cable and the sheath or neutral should also be tied to this same ground.

EQUIPMENT GROUNDING INSTRUCTIONS

It is absolutely essential for safety of operating personnel as well as for proper operation of the test equipment, that the equipment be effectively grounded. Effectively grounded, as defined in the national electrical code, means "..... connected to earth through a ground connection of sufficiently low impedance and having sufficient ampacity to prevent the building up of voltage which may result in undue hazard to connected equipment or to persons."

Depending on the power input requirements, some instruments may be equipped with a power input cable having a three-prong grounding type plug, a two-prong plug with grounding clip, or a three conductor cable terminating in lugs (where one lug is for ground connection). In any case an effective ground connection must be provided.

Where a three-prong grounding type plug is used, the equipment will be grounded through the ground prong provided that the receptacle itself is effectively grounded through a low impedance ground connection.

On instruments equipped with a two-prong plug and grounding clip, a three conductor line cord terminated in lugs, or where a two-prong adapter is used on a three-prong plug, the grounding clip or lead must be connected to a low impedance earth ground. For a low impedance earth ground, a continuous metallic underground water system may be used for ground connection. Where this is not available a driven ground rod may be used to provide an effective earth ground. In either case the resistance to ground of the piping system or driven ground rod should not exceed 25 ohms as required by the National Electrical Code.

Some instruments are equipped with a safety ground terminal in addition to the grounding conductor in the line cord. This terminal should be connected to an auxiliary grounding electrode, having low impedance, such as a piping system or driven ground referred to above. This terminal should be connected to ground with heavy wire.

If test equipment is being used in the field where input power is provided by a gasoline engine driven alternator, generator, or a battery operated converter, it is essential that not only the test equipment but also the metallic framework or housing of the power source be grounded.

Failure to comply with the above equipment grounding instructions could result in dangerous electrical shock to operating personnel.

SAFETY

The Test Operator must follow all accepted safety practices, proceed with caution and do all in his power to assure a safe test.

Because of the inherent dangers in any High Voltage work, special care must be taken to safeguard personnel during any testing or fault finding.

GENERAL

Regardless of the type of test to be made or fault to be found, certain preliminary steps should precede the actual test. First, open all switches and breakers to de-energize the cable or equipment and isolate the item. Using a hot stick and rubber gloves, ground all sections of the test item to insure that it is not charged.

Careful advance planning is essential to a proper and safe test. Proper test equipment, ground leads, high voltage cables, hot stick, rubber gloves and any other special tools should be assembled at the test site.

The equipment to be tested should be de-energized, *properly grounded and disconnected. Cables to be tested should be de-energized, *properly grounded, and isolated from other components such as switch gear, transformers, lightning arrestors, etc.* Both ends of a cable to be tested should be disconnected and protected to safeguard passing personnel. The conductors at the far end of a cable should be separated and taped to avoid external flash over or leakage during the test.

A man should be stationed at any point where the test item is accessible to unauthorized people and barriers should be erected. Signs should be posted that read "DANGER - HIGH VOLTAGE TEST IN PROGRESS, KEEP AWAY". Do not use terms such as "Kilovolts", "KV: or "HV" because the average person does not understand the true meaning of these terms or abbreviations.

Decide upon the proper test procedure to be followed before starting the test.

HIGH VOLTAGE TESTING

After making any test turn the High Voltage switch off and return the voltage control to zero or minimum position, check the kilovoltmeter for a zero indication (on DC test the capacitive element of the test item will hold a charge and may take a long time to discharge) and *ground the test item before disconnection. After a DC test has been performed the ground should be left on the item for at least as long as the total time high voltage was applied to prevent a voltage build up due to absorption current. It is best to leave a ground on a test item any time it is not in service or undergoing a test.

*Any time a ground is to be placed on a circuit it should first be grounded with a hot stick and rubber gloves. All circuits not in use (or connected to a guard or bypass circuit) should be grounded.

FAULT FINDING

Make an insulation resistance test on the faulted cable between the conductor and ground, shield or housing before testing on both ends of a cable to determine the condition of the fault. Consider all the factors effecting the faulted cable, such as the resistance of the fault, the age of the cable, the condition of the ground (if buried), the humidity, the voltage rating of the cable, etc. and decide on the best test method or methods to be used.

ASSOCIATED RESEARCH, INC.
MODEL SPECIFICATION - dc HYPOT

MODEL NUMBER: 5205

DESCRIPTION: Portable dc Hypot

PRIMARY APPLICATION: Dielectric withstand testing of rotating machinery, transformers, switchgear and cables for acceptance and routine maintenance in the field.

INPUT

Voltage: 120 volts nominal
Frequency: 60 Hz
Phase: Single
Current: 2 amperes

OUTPUT

Voltage: 0-5 KV dc continuously adjustable $\pm 2\%$
kVA: .010
Frequency: dc
Current: 2 milliamperes operating, 15 milliamperes short circuit
Duty Cycle: Continuous
Failure Detector: None; current limited against overloads

VOLTAGE CONTROL: Manually operated. No zero return interlock system.

METERING:

Kilovoltmeter: Analog -- 0-2.5/5 kV
Milliammeter: Analog -- 0-2/20/200/2000 microamperes
Range: Dual range kV meter, four range Microammeter.

TERMINATION

Input: Five foot (1.524 m), 3 conductor power cable terminated in 3 prong grounding type plug
H.V.: Receptacle with disconnectable 15 ft. (4.572 m) cable terminated in insulated clip.
Return: Metered-Bypass-Ground terminals with disconnectable 15 ft. (4.572 m) cables terminated in insulated clips.

CABINETSRY: Portable style, 34.3 cm x 35.56 cm x 20.3 cm (13½" x 14" x 8")

WEIGHT: 27 lbs (12.25 kg)

GENERAL FEATURES

LINE CABLE

Three conductor input cable terminated in standard three-prong grounding type plug.

HIGH VOLTAGE CABLE

Single conductor high voltage cable terminated in male connector and insulated clip for connecting item to high voltage output.

RETURN CABLES

Single conductor cables each terminated in spade lug and clip for connecting the test item to the RETURN terminals.

HIGH VOLTAGE OUTPUT RECEPTACLE

Female connector to receive the high voltage output cable connector.

POWER SWITCH/CIRCUIT BREAKER/INDICATOR

Makes or breaks all primary power (line voltage) to the instrument. The illuminated switch indicates line power is available to the high voltage control circuit and any internal assemblies.

HIGH VOLTAGE SWITCH

Operating in the primary side of the high voltage control circuit it controls the energizing and de-energizing of high voltage.

HIGH VOLTAGE INDICATOR

Red lamp indicates the high voltage control circuit is energized and high voltage is available at the output.

KILOVOLTS RANGE SWITCH

Allows selection of the full scale range of the KILOVOLT METER for more accurate setting of the output voltage.

VOLTAGE CONTROL

Permits continuous adjustment of the test voltage to the desired value from zero to maximum output of the instrument.

KILOVOLT METER

Connected directly across the output to indicate correctly the voltage actually being applied to the test item, and is therefore independent of internal regulation.

MICROAMPERES RANGE SWITCH

Operating in the electronic metering circuit, this four position selector switch provides for changing the sensitivity of the amplifier to obtain the best meter readability. The MICRO-AMPERES range indicates full scale sensitivity of the microammeter.

MICROAMMETER

The MICROAMMETER indicates the leakage current in the METERED RETURN side of the output circuit. The meter is driven by a high gain balanced bridge electronic amplifier and is electronically protected against burn-out should it be accidentally overloaded.

HIGH VOLTAGE POWER SUPPLY

The high voltage d.c. power supply uses long life silicon rectifiers. For operator safety and protection of the power supply against overloads a high reactance transformer is used. A high reactance type transformer is designed so that the output voltage will collapse should the current output exceed a given value. The chief advantage of the high reactance transformer is this inherent current limiting action which eliminates the need for a circuit breaker and prevents destruction of the item under test. Since current limiting does not depend on mechanical parts, its action is instantaneous and affords operator protection.

"METERED RETURN" AND "BYPASS RETURN SELECTOR" SWITCH AND TERMINALS

Since this instrument incorporates a low current range, provisions have been made for bypassing undesirable leakage currents around the MILLIAMMETER circuit. These undesirable currents are usually due to leakage paths between high voltage connections and isolated metallic parts near or at ground potential.

The GROUND RETURN switch in conjunction with the METERED RETURN and BYPASS RETURN terminals provides a means for directing the unwanted current around the MICROAMMETER and the desired current through the MICROAMMETER.

By connecting the return side of the specimen to the METERED RETURN switch (which grounds the BYPASS RETURN terminal) all leakages from the high voltage connection to the specimen and other unwanted leakages to ground will be directed around the MICROAMMETER. Only the specimen leakage current will flow through MICROAMMETER. By selecting METERED with the GROUND RETURN switch (which grounds the METERED RETURN terminal), the total leakage to GROUND will flow through the MICROAMMETER.

When testing a specimen that may have isolated metallic parts that provide a leakage path between the two points where the high voltage and return connections are made, the BYPASS RETURN terminal may be used as a guard circuit. If these isolated metallic parts are connected together and to the BYPASS RETURN terminal, any leakage from the high voltage point to these parts will be directed around the metering circuit.

NOTE: When using the BYPASS RETURN terminal as a guard circuit, the GROUND RETURN switch should be in the BYPASS position unless the specimen return side is earth ground. Under this condition, the GROUND RETURN switch should be in the METERED position.

On the following pages are a simplified MICROAMMETER circuit for this instrument and typical examples for connection for various types of high voltage tests.

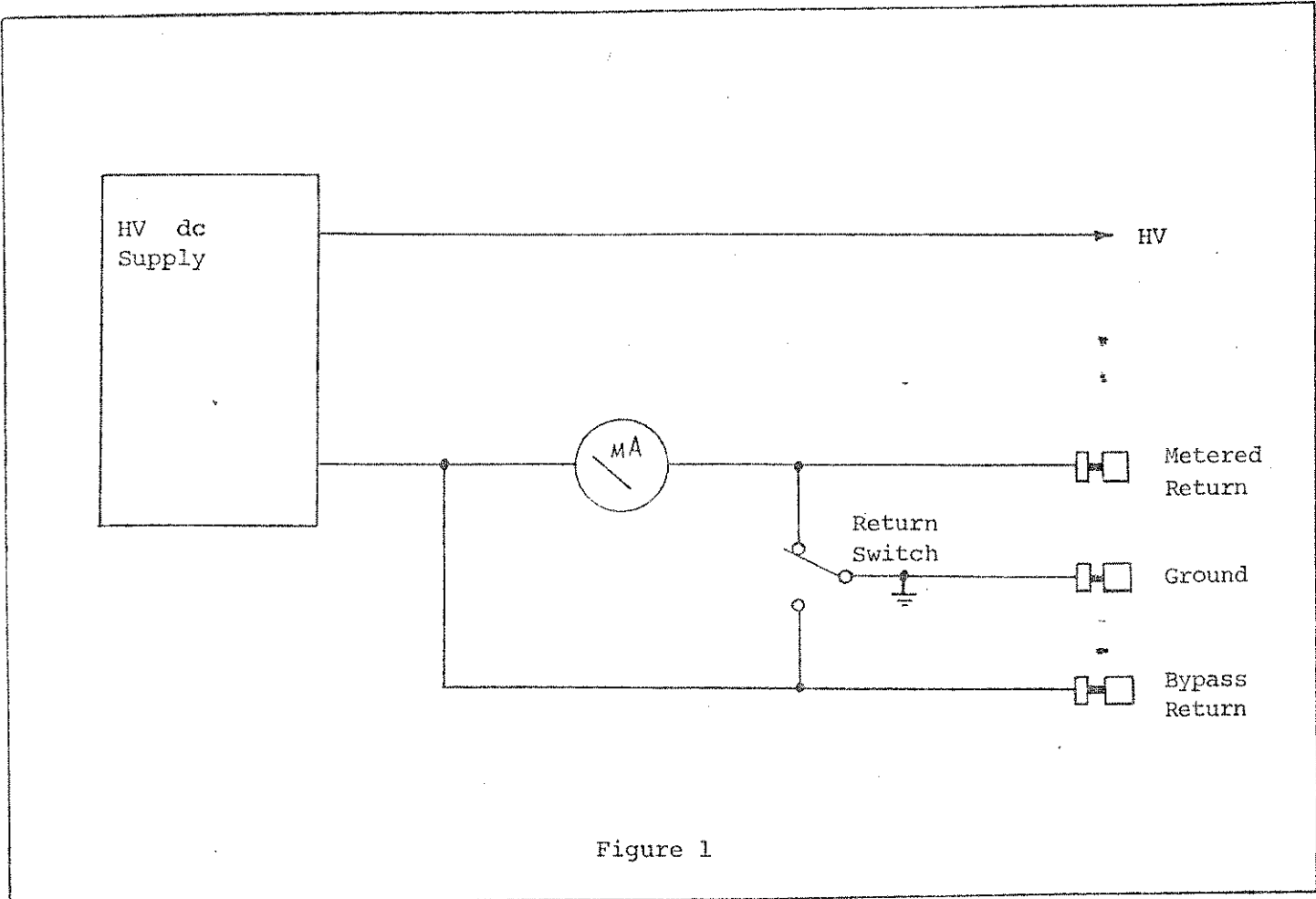
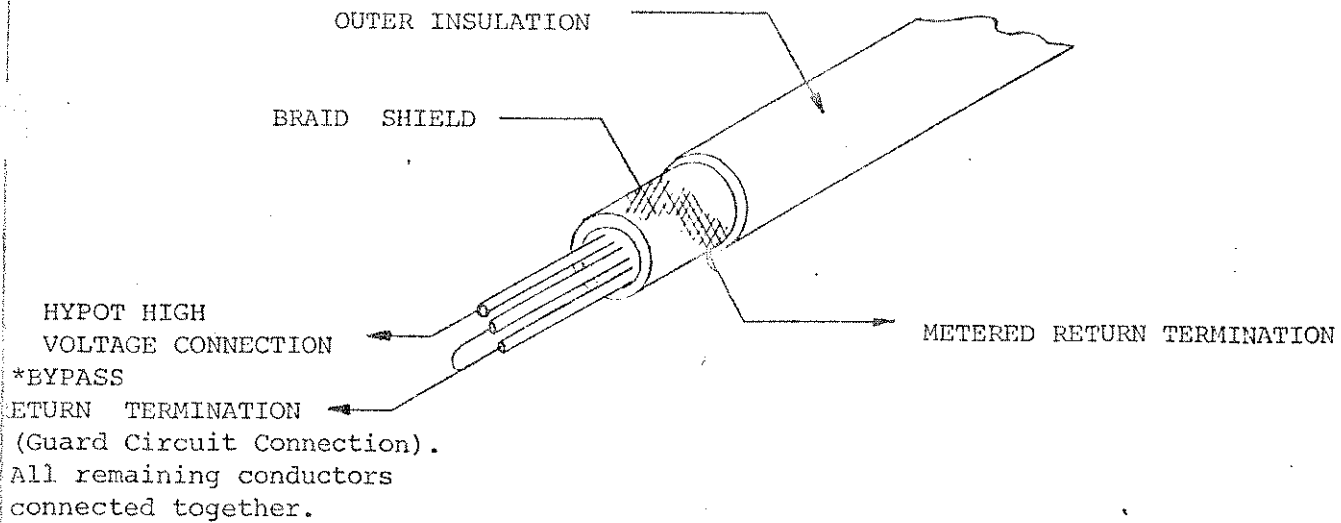

Figure 1



*Set GROUND Switch to "METERED RETURN" position. See note in Figure 3.

TESTING CABLE INSULATION BETWEEN ONE CONDUCTOR AND SHIELD

Figure 2

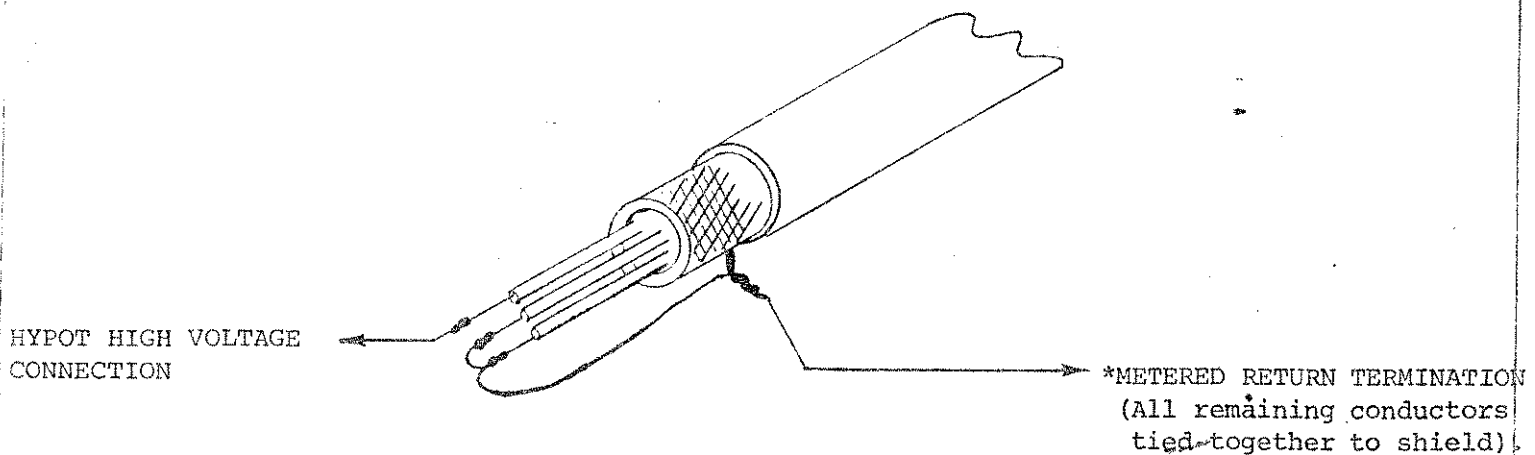

NOTE: In the various connection diagrams given here, the guard circuit may be omitted by tying the connections shown going to the "BYPASS RETURN termination" to the "METERED RETURN termination" instead. This is the difference shown by the connections in Figure 2 and Figure 3.

If this return path is grounded, set the GROUND switch to the METERED RETURN position. Total load current (leakage, corona, etc.) will be read on the meter.

If the return path is not grounded, set the GROUND switch to the BYPASS RETURN position and the effect of corona currents on the meter reading will be minimized.

TESTING CABLE INSULATION BETWEEN ONE CONDUCTOR AND ALL OTHER AND SHIELD.

Figure 3

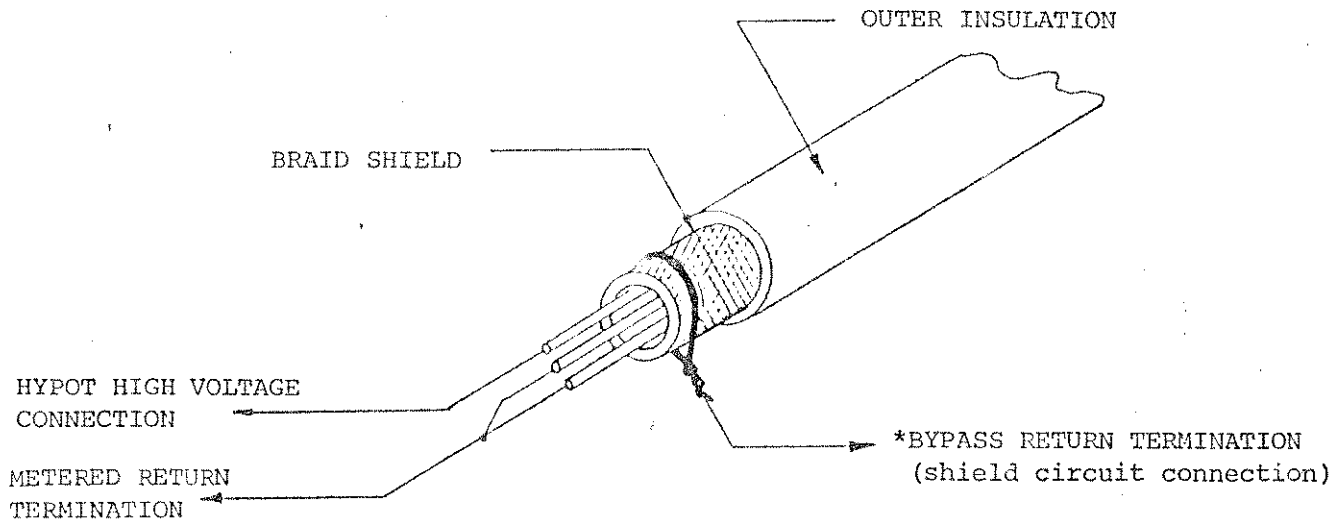

* Set ground switch to "BYPASS RETURN" position. See note in Fig. 3

TESTING CABLE INSULATION BETWEEN CONDUCTORS

Figure 4

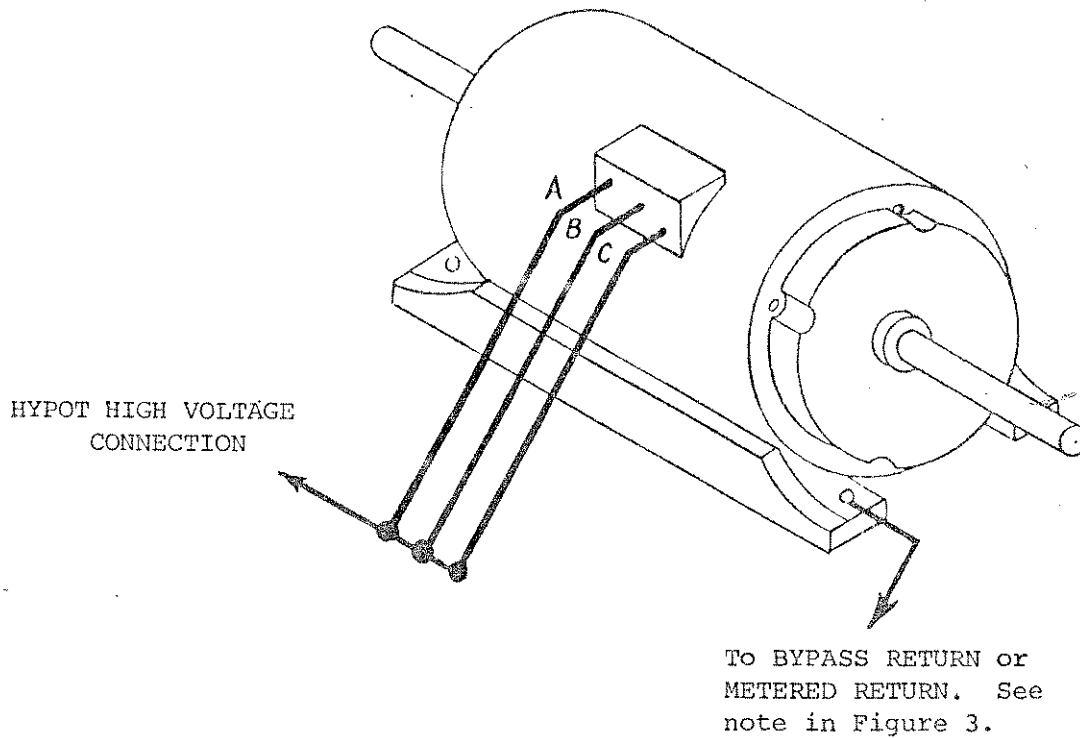

TESTING MOTOR WINDING INSULATION
ONE WINDING TO GROUNDED CORE OR CASE

Figure 5

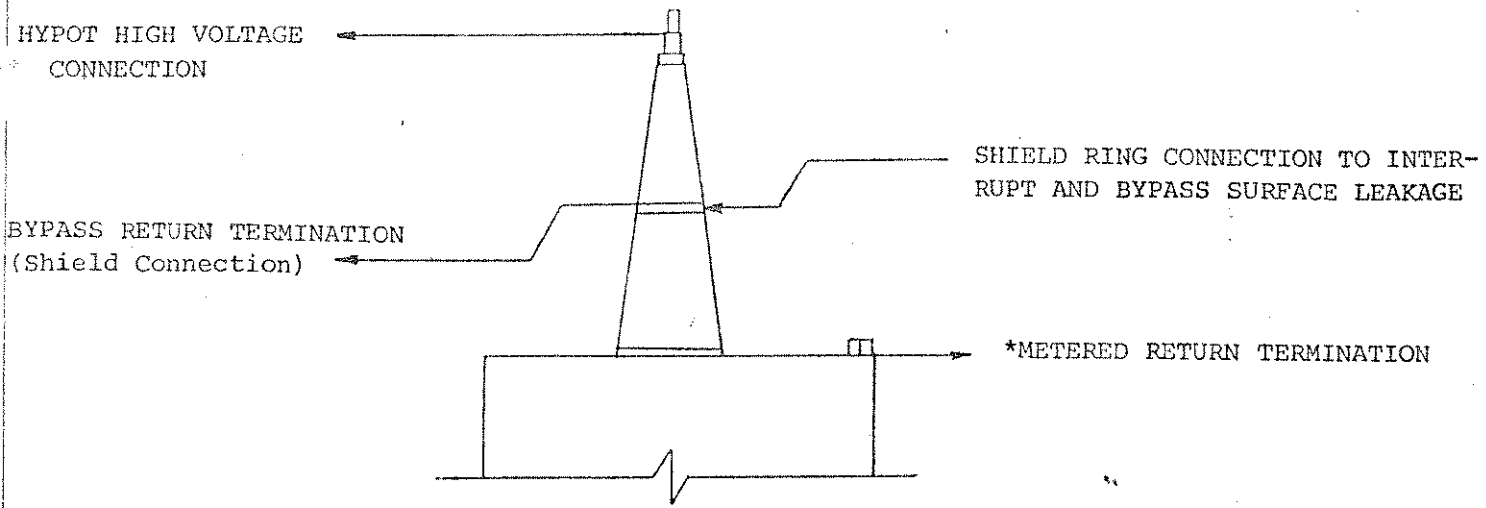

*Set GROUND switch to "METERED RETURN" position.

MEASURING BUSHING LEAKAGE (AND ELIMINATING EFFECT OF SURFACE LEAKAGE)

Figure 6

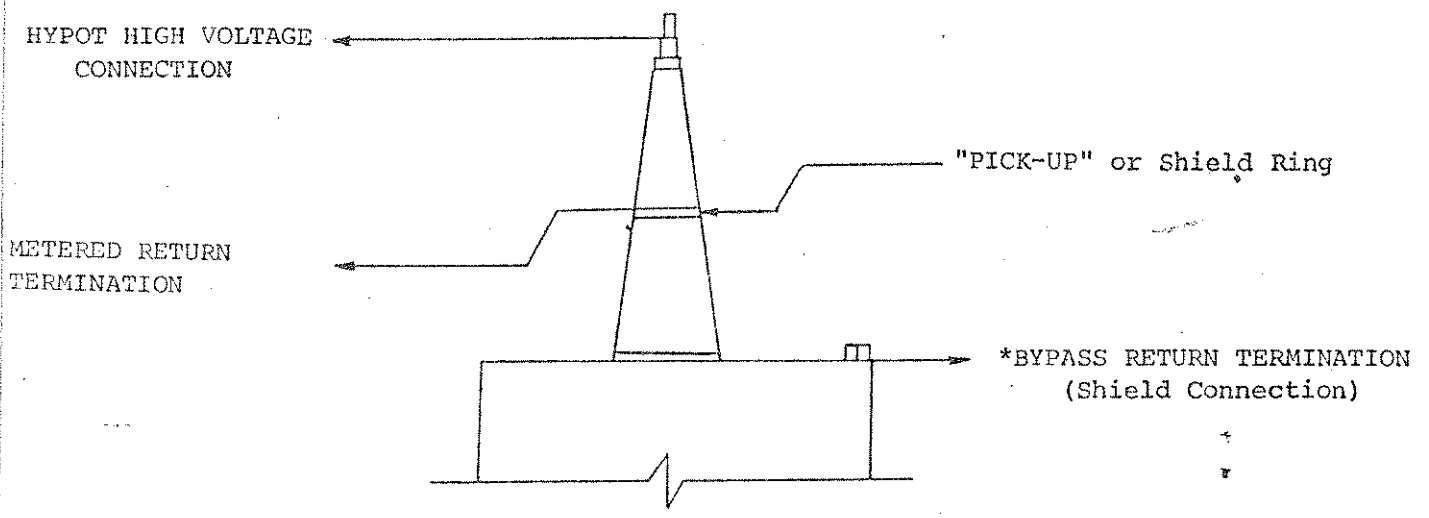

*Set GROUND switch to "BYPASS RETURN" position.

MEASURING SURFACE LEAKAGE OF A BUSHING

Figure 7

HYPOT
HIGH VOLTAGE
CONNECTION

*BYPASS RETURN TERMINATION
(Guard Circuit
connection)

METERED
RETURN
TERMINATION

*Set GROUND switch to "METERED RETURN" position. See note in Figure 3.

TESTING TRANSFORMER WINDING INSULATION
HIGH VOLTAGE WINDING TO GROUNDED CORE OR CASE

Figure 8

HYPOT
HIGH VOLTAGE
CONNECTION

METERED RETURN
TERMINATION

*BYPASS RETURN
TERMINATION
(Guard circuit
connection)

*Set GROUND switch to "BYPASS RETURN" position. See note in Figure 3.

TESTING TRANSFORMER WINDING INSULATION
HIGH VOLTAGE WINDING TO LOW VOLTAGE WINDING

Figure 9

CALIBRATION OF ELECTRONIC MICROAMMETER CIRCUIT

Recalibration is necessary whenever the electron tube, meter, or any component part of the electronic MICROAMMETER circuit is replaced. If the tube is replaced, the instrument power should be left ON for at least twenty-four hours to age the tube before proceeding with the calibration. The procedure for this calibration and replacement consists of the following steps:

REPLACEMENT INSTRUCTIONS

1. Remove the input line cord from the power source.
2. Remove the four (4) corner screws from the control panel.
3. Lift the panel and amplifier assembly from case.
4. After replacement of the component part, re-install panel assembly.

CALIBRATION INSTRUCTIONS

1. Place the POWER and HIGH VOLTAGE switches OFF, and rotate variable VOLTAGE control to its full counter-clockwise position.
2. Connect line cord to a power source as indicated on its nameplate and specification sheet.
3. Place the POWER switch ON and allow the instrument to warm up for 15 minutes.
- * 4. Place the KILOVOLTS selector switch on the LOW range.
- * 5. Set OUTPUT CURRENT switch to HIGH and OUTPUT CURRENT control to full clockwise position (MAX).

6. A resistive load with $\pm 1\%$ tolerance is required for accurate calibration of the current meter. The resistance of the load is calculated by $R = E/I$ where E is the full scale voltage on the lowest kilovolt range and I is the full scale current on the next to the lowest micro-amp range. The wattage rating of the load should be at least twice the calculated value of $E \times I$.

7. The two (2) potentiometers that control calibration are located under the white snap plugs in the side of the case.

8. Turn the ZERO ADJUST until the current meter pointer resets at ZERO.

9. Increase the output voltage to maximum full scale value on the lowest KILOVOLTS range and turn F. S. ADJUST until the current meter pointer rests at full scale. Decrease voltage to zero.

10. The MICROAMMETER is now calibrated; replace the snap plugs.

* IF PRESENT (SEE SPECIFICATIONS)

OPERATING INSTRUCTIONS

The test operator must follow all accepted safety practices, proceed with caution, and do all in his power to assure a safe test. Because of the inherent dangers in any high-voltage work, special care must be taken to safeguard personnel during any testing.

1. Place the POWER and HIGH VOLTAGE switches OFF.
2. Connect line cord to a source of power as indicated on nameplate and SPECIFICATIONS sheet. If an adaptor is used connect the ground leads to earth ground.
3. Rotate VOLTAGE ADJUST control knob fully counter-clockwise.
4. Place the POWER switch ON and allow instrument 90 seconds to warm up.
- * 5. Adjust the electronic circuit breaker.
6. Select the 2000 microamperes position with the MICROAMPERES switch.
7. Select the desired KILOVOLTS range (LOW or HIGH).
8. Connect the RETURN leads to the METERED, BYPASS and GROUND terminals and to the test item under test.
9. Plug the HIGH VOLTAGE lead into the female HIGH VOLTAGE connector on the instrument and connect it to the item to be tested.
10. Select METERED RETURN or BYPASS RETURN with the GROUND switch (see GENERAL FEATURES).
11. Operate the HIGH VOLTAGE switch to ON position.
12. Rotate the VOLTAGE control clockwise until the desired voltage is indicated on the KILOVOLTMETER.
13. The leakage current will be indicated by the MICROAMMETER. If greater sensitivity is desired for the MICROAMMETER select a lower range with the MICROAMPERES selector switch.
- * 14. If the output current exceeds the setting of the circuit breaker, high voltage will be de-energized. Return the VOLTAGE control to its full counter-clockwise position and turn the H.V. switch OFF and then ON again to re-energize the high voltage control circuit.
15. After the test is complete turn the HIGH VOLTAGE switch OFF and rotate the VOLTAGE control fully counter-clockwise.

*NOT ON ALL INSTRUMENTS (SEE SPECIFICATION SHEET).

REPLACEMENT PARTS LIST

<u>SYMBOL</u>	<u>PART NO.</u>	<u>DESCRIPTION</u>
C-1	10425	Capacitor Paper, .5 uF 600 Vac
CA	33972	Cable Assembly Return 15 Ft. Black
CA	33973	Cable Assembly Return 15 Ft. Red
CA	17337	Cable Assembly, High Voltage
CA	33975	Cable Assembly, Ground 15 Ft
CA-1	11649	Cable Assembly Input w/plug, 115 Vac
CB-1	32254	Circuit Breaker, 2P 2.5A Magnetic Lighted
I-2	14159	Indicator Assembly Red Lens
M-1,2	32931	Meter DC Current, 0-50 Microamperes
NE-1, 2	58591	Neon Lamp
R-1	58338	Resistor Fixed, 30 k, 5%, 1/2 W
R-2	57031	Resistor Fixed, 100 k, 1/2 w., 10%
R-3	18445	Resistor Fixed, 1 Meg. 1%, 1/2 w
R-4	10725	Resistor Fixed, 100 k, 1%, 1/2 W
R-5	11825	Resistor Fixed, 10 k, 1%, 1/2 W
R-6	14453	Resistor Fixed, 1 k, 1/2 w, 1%
S-2	59690	Switch Toggle, SPST
S-3	16583	Switch Rotary
S-6	16679	Switch Toggle
T-1	11654	Transformer, Var.-Auto
T-2	11147	Transformer, 5 kV
TR	11817	Terminal Post Black
TR	11818	Terminal Post Red
TR	17478	Terminal, Return, Bypass, Nickel Plated
TR-3	10304	Terminal Return

AMPLIFIER ASSEMBLY - PN 32175

C-1	10668	Capacitor, Electrolytic, 20 uF, 250 V
C-2,3	17175	Capacitor Paper
R-1	10733	Resistor Fixed, 36 k, 5%, 1/2W
R-2	14795	Resistor Fixed, 68 k, 5% 1/2 W
R-3	58343	Resistor Fixed, 2.2 Meg, 10%, 1/2 W

AMPLIFIER ASSEMBLY - PN 32175 (Cont.)

<u>SYMBOL</u>	<u>PART NO.</u>	<u>DESCRIPTION</u>
R-4,5	10514	Resistor Fixed, 2.7 k, 5%, 1/2 W
R-7	14723	Resistor Variable, 1 k, 2 W, 20%
R-8	17726	Resistor Variable, 100 k, 20%, 1/4 W
R-9	14743	Resistor Variable, 10 k, 2 W
R-10	58309	Resistor Fixed, 47k, 1/2 W
R-11	18445	Resistor Fixed, 1 Meg. 1%, 1/2 W
RT-1	14503	Rectifier, Silicon, Low Voltage
T-1	11913	Transformer, Power
V-1	15349	Tube, Vacuum, 12 Au7

AMPLIVOLT HALF WAVE - P/N - 32757

C-1	11831	Capacitor, High Voltage, Glass
CN-1	10616	Connector, High Voltage Female
R-1	16313	Resistor Fixed, 1 k, 5%, 8W
R-2	10775	Resistor Fixed, 20 Meg, 1%, 5W
RT-1	16379	Rectifier

SHUNT ASSEMBLY P/N - 30754

R-101	58148	Resistor, fixed, 453 k, 1%
R-102	17727	Resistor Variable, 250 k, 20%, 1/4 W
R-103	17726	Resistor Variable, 100 k, 20%, 1/4 W
R-104	10311	Resistor Fixed, 250 k, 1%, 1/2 W
R-105	10826	Resistor, Fixed, 800 k, 1%, 1 W

SYMBOL		IDENTIFICATION		MODEL		ONLY	
SYMBOL	P/N	ASSEMBLY	SYMBOL	P/N	ASSEMBLY		
AMPLY-1	05205A-08		R-101	58148	05205A-09		
T-2	11147	05205A-01	R-105	10826	05205A-09		
R-103	17726	05205A-09	M-1	32931	05205A-14		
R-102	17727	05205A-09					
R-104	10311	05205A-09					

*REPLACES MODEL 5220 - 5205

 <p>ASSOCIATED RESEARCH, INC. 3758 WEST BELMONT AVENUE, CHICAGO, ILLINOIS 60618</p>				TOL SCHEMATIC WIRING DIAGRAM *MODEL 05220A - 05205A DWN. CKD. <i>NWA</i> APP. SHT. 2 OF 2 B-32285	
Original Issue CHANGE	DATE 1/23/81	BY <i>EJ NWA</i>	APP. <i>NWA</i>		

10 9535

SYMBOL IDENTIFICATION			MODEL 05220A - 05205A		
SYMBOL	P/N	ASSEMBLY	SYMBOL	P/N	ASSEMBLY
AMPLV-1	05220A-08	05220A-01	R-1	58338	05220A-12
T-2	11381	05220A-01	R-2	57031	05220A-12
M-2	32931	05220A-02	CA-1	11649	05220A-12
AMPLF-1	05220A-10	05220A-02	T-1	11654	05220A-12
CA-2	05220A-05	05220A-03	S-3	16583	05220A-13
R-102	17728	05220A-09	R-3	18445	05220A-13
R-103	17727	05220A-09	R-4	10725	05220A-13
R-105	18445	05220A-09	R-5	11825	05220A-13
R-104	19023	05220A-09	R-6	14453	05220A-13
R-101	10311	05220A-09	TR-4	10304	05220A-18
I-2	14159	05220A-12	C-1	10425	05220A-21
TR-2	11817	05220A-12	NE-1, 2	58591	05220A-21
TR-1	11818	05220A-12	CN-1	10616	05220A-21
TR-3	17478	05220A-12			
S-6	16679	05220A-12			
S-2, 4	59690	05220A-12			
CB-1	32254	05220A-12			

SYMBOL IDENTIFICATION			MODEL 05205A ONLY		
SYMBOL	P/N	ASSEMBLY	SYMBOL	P/N	ASSEMBLY
AMPLV-1	05205A-08	05205A-01	R-101	58148	05205A-09
T-2	11147	05205A-01	R-105	10826	05205A-09
R-103	17726	05205A-09	M-1	32931	05205A-14
R-102	17727	05205A-09			
R-104	10311	05205A-09			

