

# Model 1040C

## PANEL METER CALIBRATOR

Section 1                      General Information

Section 2                      Operation

Section 2                      Application Notes



This manual is issued for reference only at the convenience of Arbiter Systems. Arbiter Systems has made reasonable effort to verify that all diagrams, to the best of our knowledge, are accurate as of July 1, 1991. However, due to production changes and availability of parts, these diagrams are subject to revisions and modifications. Check with Arbiter Systems at the address below for any revisions made since this publishing date.

Arbiter Systems, Inc.  
1324 Vendels Circle  
Suite 121  
Paso Robles, CA 93446  
(805) 237-3831  
(805) 238-5717  
[www.arbiter.com](http://www.arbiter.com)  
[techsupport@arbiter.com](mailto:techsupport@arbiter.com)



## **LIMITED WARRANTY**

Arbiter Systems makes no warranty, expressed or implied, on any product manufactured or sold by Arbiter Systems except for the following limited warranty against defects in materials and workmanship on products manufactured by Arbiter Systems.

Products manufactured by Arbiter Systems are guaranteed against defective materials and workmanship under normal use and service for one year from date of delivery. The responsibility of Arbiter Systems under this warranty is limited to repair or replacement, at Arbiter Systems option, of any product found to be defective. Arbiter Systems shall have no liability under this warranty unless it receives written notice of any claimed defect within the earlier of thirty days of discovery by Buyer or one year from the date of delivery. For warranty service or repair, products must be returned to a service facility designated by Arbiter Systems. Buyer shall prepay all shipping charges to Arbiter Systems and Arbiter Systems shall pay all shipping charges, duties and taxes for products returned to Buyer in a country other than the United States of America.

THE WARRANTY SET FORTH HEREIN CONSTITUTES THE ONLY WARRANTY OBLIGATIONS OF ARBITER SYSTEMS, EXPRESSED OR IMPLIED, STATUTORY, BY OPERATION OF LAW, OR OTHERWISE. ARBITER SYSTEMS DISCLAIMS ANY WARRANTY OF MERCHANTABILITY OR FITNESS FOR A PARTICULAR PURPOSE, AND BUYER EXPRESSLY WAIVES ALL OTHER WARRANTIES.

This limited warranty does not extend to any product, which has been subject to (i) improper use or application, misuse, or abuse, or operation beyond its rated capacity, or contrary to the instructions in the operation and maintenance manuals, if any (ii) accident (iii) repair or maintenance, except in accordance with the operation and maintenance manuals, if any, and any special instructions of Arbiter Systems, or (iv) modification without the prior written authorization of Arbiter Systems (whether by the substitution of nonapproved parts or otherwise).

The remedies provided herein are Buyer's sole and exclusive remedies. In no event shall Arbiter Systems be liable for direct, indirect, incidental or consequential damages (including loss of profits), whether based on contract, tort, or other legal theory.

FOR THE FASTEST POSSIBLE SERVICE, SHOULD FAULT UNDER THIS WARRANTY DEVELOP, PLEASE PROCEED AS FOLLOWS:

- 1) Notify Arbiter Systems, Inc., specifying the instrument model number and serial number and giving full details of the difficulty. Service data or instrument-return authorization will be provided upon receipt of this information.
- 2) If instrument return is authorized forward prepaid to the manufacturer. If the instrument is not covered by this warranty, an estimate will be made before the repair work begins, if requested.

1324 Vendels Circle, Suite 121, Paso Robles, CA 93446

(805) 237-3831 (800) 321-3831 FAX (805) 238-5717



# **Table of Contents**

**SECTION 1 - GENERAL INFORMATION**

**SECTION 2 - OPERATION**

**SECTION 3 - CALIBRATING METERS AND TRANSDUCERS**

# **SECTION 1**

## **GENERAL INFORMATION**





## Table of Contents

1.0	General Information .....	1-1
1.1	Introduction .....	1-1
1.2	Application .....	1-1
1.3	Technical Characteristics .....	1-1
1.4	Accessories Included.....	1-2
1.5	Options Available.....	1-2
1.6	Safety Precautions .....	1-2
1.7	Manual Changes/Updates.....	1-2
1.8	Service Information.....	1-3
1.9	Specifications .....	1-3

### Tables

Table 1.1 - Current Specifications.....	1-4
Table 1.2 - Voltage Specifications * .....	1-6
Table 1.3 - Combined Specifications * .....	1-9
Table 1.4 - General Specification .....	1-11
Table 1.5 - Supplemental Characteristics .....	1-12
Table 1.6 - Itemized Front Panel Description .....	1-15
Table 1.7 - Hand Held Unit Features .....	1-22

### Figures

Figure 1.1 - AC VOLTAGE BURDEN (VOLTAGE OUTPUT) .....	1-8
Figure 1.2 - 1040C PANEL METER CALIBRATOR (not shown actual size) .....	1-14
Figure 1.3 - HANDHELD UNIT CONTROLS .....	1-21



# Model 1040C

## Panel Meter Calibrator

### 1.0 General Information

This manual provides specifications and operating instructions for the Model 1040C Panel Meter Calibrator (hereinafter referred to as the PMC) manufactured by Arbiter Systems.

#### 1.1 Introduction

This section contains general information regarding the application, technical characteristics and specifications of the PMC.

#### 1.2 Application

The Model 1040C PMC is a “ruggedized,” portable instrument that contains precision AC/DC voltage and current sources which are suitable for in-place calibration of a wide variety of panel meters. The voltage and current sources may be operated singly for calibration of voltmeters, ammeters, and frequency meters, or simultaneously for calibration of wattmeters and power factor or phase meters. Also, two voltage outputs are provided that produce AC voltage with either 0° or 180° phase relationships for calibration of synchrosopes. Keypad controls with LED indicators, a 20-character alphanumeric display, and internal memory permit easy setup or recall of voltage, current, power, frequency and phase values. The 10 digit keypad and units keys allow entry of the exact output value desired. A rotary knob and modify keys are provided for fine adjustments.

#### 1.3 Technical Characteristics

The PMC consists of a stand alone card cage assembly that is shock mounted in a rugged, watertight aluminum case. In the center of the card cage assembly is a passive motherboard that provides the necessary daughter board and I/O interconnections. Ten plug-in daughter boards each connect to the motherboard with two, 40-pin, pin and socket connectors. The daughter boards contain all of the circuitry required to output the calibrated voltages and currents.

An extender card is available for use with any of the daughter boards to facilitate trouble-shooting. The display module has two printed circuit cards that provide the user interface through a set of function and numeric keys, indicator LED's, a rotary knob and a twenty character alphanumeric vacuum fluorescent display.

The display module is connected to the motherboard with a 34-conductor ribbon cable. A fan, high-voltage toroidal transformer and switching power supply are hard-mounted to the card cage and connected to the motherboard with pin and socket connectors. Two cables each, three meters long, are provided to facilitate connection to remotely mounted panel meters. A Hand Held Unit is included that permits remote operation of the PMC when calibrating panel meters mounted in confined locations. All functions of the 1040C including internal alignment are controllable over the General Purpose Interface Bus (GPIB) IEEE-488-1978 and IEEE-488.1.

## 1.4 Accessories Included

3 meter voltage and current test cables\*

Hand Held Unit\*

Power Cord

1040C Operation Manual

1040C Maintenance Manual\*

*\* Not Included with Utility Version*

## 1.5 Options Available

Option 03 6-meter voltage and current test cables\*

Option 04 Service Kit:

T10 Torx Drive

4 mm Allen Wrench

5 mm Allen Wrench

Display Module Extender Cable

Meter Adapters (1 set)

Option 05 3 meter Hand-Held-Unit Extension Cable

Option 06 Extended Warranty

*\* Not Included with Utility Version*

## 1.6 Safety Precautions

Observe all safety markings and instructions before beginning operation of the Model 1040C. Safety information for connection and operation is found in the appropriate places throughout this manual.

## 1.7 Manual Changes/Updates

Any changes to this manual at the time of shipment will be packaged in a separate envelope. To keep your manual as current and as accurate as possible, Arbiter Systems recommends that you periodically request the latest manual changes supplement. Please reference the manual print date and part number located on the title page when ordering. The model number and unit serial number are also requested. These supplements are available from Arbiter Systems at no charge.

## **1.8 Service Information**

Should your instrument need to be returned for factory service, please contact Arbiter System's Service Department to obtain a Return Material Authorization (RMA) number. If an instrument return is authorized, forward the instrument prepaid to Arbiter Systems. If the instrument is not covered by warranty, an estimate will be provided upon request.

## **1.9 Specifications**

Specifications for the Model 1040C are listed in Table 1.1 through Table 1.4. Supplemental characteristics are listed in Table 1.5 and an itemized front panel description is listed in Table 1.6. Table 1.7 contains characteristics of the Hand Held Unit.

**Table 1.1 - Current Specifications**

TYPE	DESCRIPTION
I.	Output, DC Current
	Range 1 <sup>1</sup> 0.10 mA to 1.05 mA
	Range 2 1.00 mA to 10.5 mA
	Range 3 10.0 mA to 105 mA
	Range 4 0.100 A to 1.05 A
	Range 5 1.00 A to 10.5 A
	DC Current Amplitude Accuracy +(0.2% of reading +0.05% of full scale)
	Compliance Voltage 12.0 V, <50 mA 3 V, >50 mA
	Overload Setting 12.5 V, <50 mA 3.5 V, > 50 mA
	Noise 0.25% rms of reading Max, 10 kHz BW
	Resolution and Setability <0.1% of reading
	Settling Time <8 seconds

<sup>1</sup> Usable to 0.025 mA but not specified

**Table 1.1 - Current Specifications (continued)**

TYPE	DESCRIPTION
II.	Output, AC Current
	Range 4
	0.1 A to 1.05 A rms
	Range 5
	1 A to 7.5 A rms
	AC Current Amplitude Accuracy
	+(0.2% of reading +0.05% of full scale) +(0.2% of reading +0.1% of full scale) on Range 5
	Compliance
	6 V rms
	Overload Setting
	6.5 V rms
	Distortion
	0.45% Max
	Frequency
	50 Hz to 75 Hz and 333.3 Hz to 500 Hz
	Frequency Accuracy
	<0.01% of reading
	Current Output Stability AC and DC
	<(0.03% of reading +0.015% of full scale); averaged 1 minute or longer
	Resolution and Setability
	<0.1% of reading
	Settling Time
	<8 seconds Max



**Table 1.2 - Voltage Specifications \***

TYPE	DESCRIPTION
I.	Output, + DC Voltage
	Range 1                      10 mV to 105 mV
	Range 2                      0.1 V to 1.05 V
	Range 3                      1 V to 10.5 V
	Range 4                      10 V to 105 V
	Range 5                      100 V to 1050 V
	+DC Voltage Amplitude      +(0.2% of reading +0.05% of full Accuracy scale)
	Burden                        15 mA on all ranges
	Overload Set Point            25 mA
	Noise                         0.25% rms of reading Max, 10 kHz BW
	Voltage Output Stability      <(0.03% of reading +0.015% of full scale); Averaged for 1 minute or longer.
	Settling Time                 <8 seconds
II.	Output, AC Voltage
	Range 3                      1.5 V rms to 15.75 V rms
	Range 4                      15 V rms to 157.5 V rms
	Range 5                      150 V rms to 750.0 V rms

*\* Utility Version Specified at Output Connectors*

**Table 1.2 - Voltage Specifications \* (continued)**

TYPE	DESCRIPTION
AC Voltage Amplitude Accuracy	AC Voltage <150 V rms      +(0.2% of reading +0.05% of full scale.) AC Voltage >150 V rms      +(0.2% of reading +0.1% of full scale).
Burden	Voltage Output <150 Vrms                      300.0 mArms >150 Vrms                      10.0 VA (See Figure 1.1) Aux. Voltage Output            Active in synchroscope mode (Aux.) Output is connected to the Voltage Output with 0° or 180° phase relationship. Total burden of both outputs not to exceed 300 mArms.
Overload Set Point	5% above rated burden
Distortion	0.45% Max
Frequency	50 Hz to 75 Hz and 333.3 Hz to 500 Hz
Frequency Accuracy	<0.01% of reading
Voltage Output Stability	<(0.03% of reading +0.015% of full scale); Averaged for 1 minute or longer.
Resolution and Setability	<0.1% of reading
Settling Time AC and DC	<8 seconds

\* *Utility Version Specified at Output Connectors*

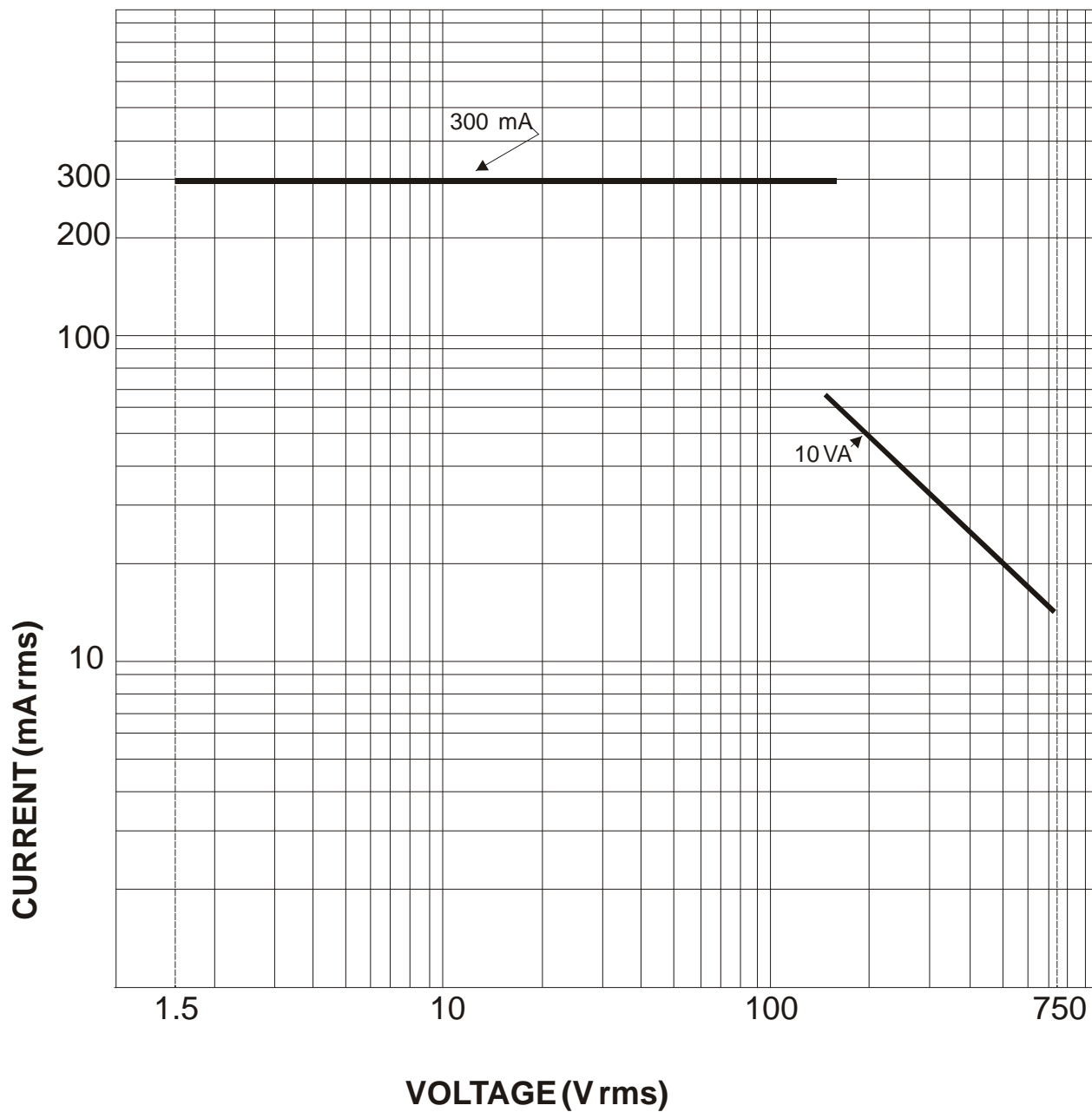

**Figure 1.1 - AC VOLTAGE BURDEN (VOLTAGE OUTPUT)**

**Table 1.3 - Combined Specifications \***

TYPE	DESCRIPTION		
I.	Output, AC Power/VARS		
	V Range	I Range	
	4	4	1.5 VA to 165 VA
	4	5	15 VA to 825 VA
	5	4	15 VA to 785 VA
	5	5	150 VA to 5625 VA
	AC Power Amplitude Accuracy, Burden, Compliance, Overload, Settling Time, Distortion, Frequency	Derived from the individual accuracies of the voltage and current outputs.	
	AC Power/VARS Output Stability	<(0.06% of reading +0.03% of full scale); averaged 1 minute or longer.	
	Phase Angle	+180° to -180°	
	Phase Accuracy	±0.33°	

*\*Utility Version Specified at Output Connectors*

**Table 1.3 - Combined Specifications \* (continued)**

TYPE	DESCRIPTION	
II.	Output, AC Phase/Power Factor	Output same as AC power
	Phase Angle Range	$+180^{\circ}$ to $-180^{\circ}$
	Phase Accuracy	$\pm 0.33^{\circ}$
	Phase Stability (RMS)	$\leq 0.2^{\circ}$ rms; averaged 1 minute or longer
	Resolution and Setability	$\leq 0.1^{\circ}$

*\*Utility Version Specified at Output Connectors*

**Table 1.4 - General Specification**

TYPE	DESCRIPTION
Supply Power	115 V rms +15%, 47 to 500 Hz, single phase
Current	0.5 amperes (Standby Mode). 3.0 amperes (Operate Mode and Maximum Output)
Cooling	Forced Air
Power Switch	The high power lead is controlled by the front panel Mounted toggle switch.
Supply Fuse	3-ampere slow blow type (3AT)
Operating Temperature Range	0°C to 55°C
Storage Temperature Range	-40°C to +75°C
Dimensions (covers in place)	38 cm X 38 cm X 28 cm 15" X 15" X 11"
Weight	17 kg (38 lbs.) net 23 kg (50 lbs.) shipping
IEEE-488	SH1, AH1, T6, L4, SR1, RL2, PP0, DC1, DT0, C0, E2

**Table 1.5 - Supplemental Characteristics**

TYPE	DESCRIPTION
Display	20-character alphanumeric vacuum fluorescent display module used to indicate output and operational status, user prompts, and diagnostic messages.
Output Mode Selection	4 Keys with LED indicators for selection of RESET, DC, 60HZ, or 400HZ
Function and Display Selection	6 keys with LED indicators for selection of VOLTAGE, CURRENT, FREQUENCY, POWER, POWER FACTOR, and PHASE display and operation.
Display Mode Selection	2 keys with LED indicators for selection of NORMAL or %DEV display modes.
Value Entry	10 digit keys, a decimal point, and a minus/backspace key for entry of the desired value for the selected function. If in Operate mode the output will revert to Standby mode only if the new value is not within the present output range.
Units Entry	4 units keys: V/A; MV/MA; W/HZ; and DEGREE/ENTER for selection of correct units following a value entry.
Value Modification	A rotary knob, increase and decrease keys allow modification of the displayed value. Modification extends only to the top and bottom of the present range.
Rotary Knob Value Modification	Clockwise rotation increases and counter-clockwise decreases the displayed value.

**Table 1.5 - Supplemental Characteristics (continued)**

TYPE	DESCRIPTION
Increase/Decrease Value Modification	UP and DOWN ARROW keys are used to increase or decrease, respectively, the displayed value. The rate of modification may be increased by depressing the UP or DOWN ARROW key and depressing the NORMAL key (or the opposite ARROW key). Successive presses of the NORMAL key (or the opposite ARROW key) continue to increase the rate of modification.
Output Control	2 keys with LED indicators select either the Standby - STBY (no output) or Operate - OPER (output active) modes.
Synchroscope Control	1 key with an LED indicator sets either 0° or 180° phase-shift between the main and aux. voltage outputs for verification of synchroscope operation. Successive presses of the SYNCHROSCOPE key will toggle the outputs between 0° and 180° as indicated on the display.
User Memory Control	3 keys control memory operation. The CLEAR key clears all user memory. The STORE key stores the displayed instrument settings sequentially into memory. RECALL sequentially recalls the stored instrument settings onto the display. The output will remain in Operate state provided the recalled function setting and range are in agreement with the previous setting. RECALL will never change the output from Standby to Operate.
Memory Capacity	50 Values: The STORE LED will be illuminated if there are any stored settings. Memory Full is indicated by a flashing STORE LED.
Warning Indicators	2 large red LED indicators warn of HIGH VOLTAGE or OVERLOAD conditions.
GPIB Indicators	4 green LED's: SRQ, RMT, LSN and TLK indicate GPIB bus activity.



Figure 1.2 - 1040C PANEL METER CALIBRATOR (not shown actual size)

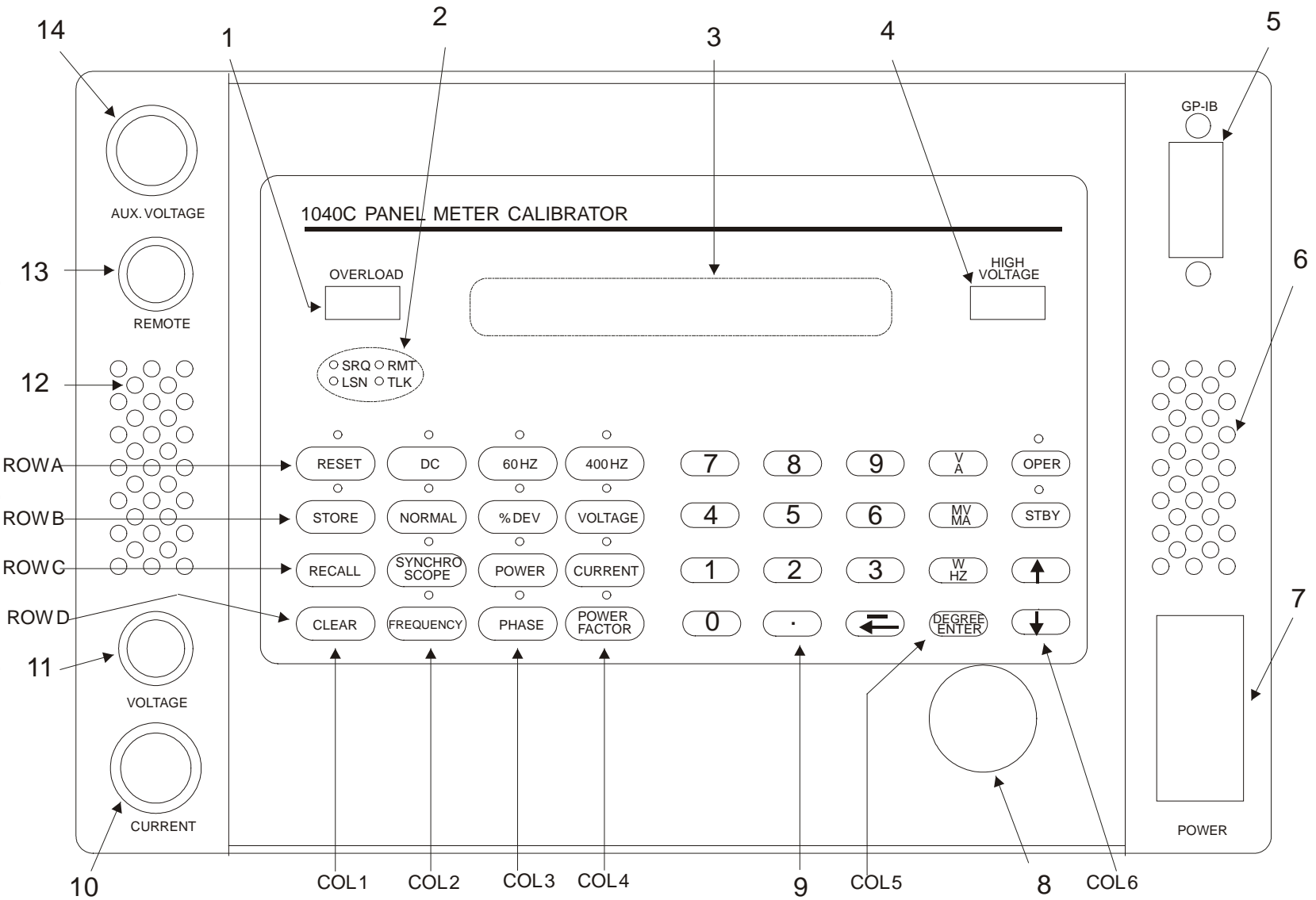

**Table 1.6 - Itemized Front Panel Description**

(See Figure 1.2)

---

FIG.1.2      CONTROLS, INDICATORS OR CONNECTORS FUNCTION

---

1	Red Overload Indicator	Indicates that the device under test (DUT) input impedance is too low for the PMC voltage output or the DUT input impedance is too high for the PMC current output. Whenever an overload occurs the output will return to Standby mode.
2	4 Green GPIB Bus Status Indicators	The Remote (RMT) LED illuminates whenever the PMC has been addressed. When the RMT LED is illuminated all user controls (except RESET) are disabled. The talk (TLK) and listen (LSN) LED's indicate the current programmed mode. The Service Request (SRQ) LED illuminates when an error or interrupt condition occurs and service is requested.
3	20 Character Alphanumeric Vacuum Fluorescent Display	Displays present output value and status for the selected function. Displays error and other user messages.
4	Red High Voltage Indicator	Flashes when the output voltage exceeds 15 VAC or 10 VDC
5	24 Pin GPIB Connector With Screw Jacks	GPIB Communications
6	Ventilation Holes	Air Outlet
7	Line Power Module	Power cord receptacle with line filter, power ON/OFF switch, and fuse.
7	Rotary Knob	Adjusts the displayed value. Clockwise rotation increases the value and counter clockwise rotation decreases the value.

**Table 1.6 - Itemized Front Panel Description (continued)**

(See Figure 1.2)

FIG. 1.2 Row, Col.	KEYS	FUNCTION
9	Keypad	Used to enter the desired value for the selected function. After a function is selected the lowest or last value will be displayed. Entering the new value on the keypad and pressing the appropriate units key may change this value. To enter a negative value, press the minus/backspace key prior to entering the desired number. Corrections may be made to the displayed value by successive presses of the minus/backspace key prior to entering the units.
10	Current Output Connector	Two pin Lemo connector with a yellow identification ring for the output of all requested currents.
11	Voltage Output Connector	Four pin Lemo connector with a red identification ring for the output of requested voltages.
12	Ventilation Holes	Air Inlet
13	Remote Connector	Sixteen-pin Lemo connector with a blue identification ring for connection to the Hand Held Unit. The RESET key should be pressed before and after connecting or disconnecting the Hand Held Unit.
14	Aux. Voltage Connector	A two-pin Lemo connector with an orange identification ring used only during synchroscope operation. The current cable may be used with the Aux. Voltage output. During synchroscope operation the Aux. Voltage and Main Voltage outputs will be the same amplitude and frequency. The phase angle between the Aux. Voltage and the Main Voltage outputs is either $0^\circ$ or $180^\circ$ , selectable by successive presses of the synchroscope key. The present phase angle is shown on the display.

**Table 1.6 - Itemized Front Panel Description (continued)**

(See Figure 1.2)

---

FIG. 1.2

Row, Col.	KEYS	FUNCTION
A1	RESET	Pressing the RESET key returns the PMC to the Reset state. The Reset state is indicated by illumination of the RESET LED and DC, 60Hz or 400Hz? on the display. The Reset state may be entered from almost every other possible state. The RESET key is the only active key during GPIB operation. Depressing RESET returns the PMC to Local mode.
A2	DC	Selects DC Operating mode and illuminates the DC LED.
A3	60 Hz	Selects 60 Hz Operating mode and illuminates the 60 HZ LED.
A4	400 Hz	Selects 400 Hz Operating mode and illuminates the 400 Hz LED.
A5	V/A	Selects the units of VOLTS or AMPS depending upon whether VOLTAGE or CURRENT output was previously selected.
A6	OPER	Selects Operate state and illuminates the OPER LED indicator. Voltage and/or current are available at the respective output connectors.
B1	STORE	Stores the present output settings in the next available memory location. The STORE LED will be illuminated whenever there are settings stored in the user memory. A flashing STORE LED indicates that all user memory locations are full.
B2	NORMAL	Selects normal display mode and illuminates the NORMAL LED. Output values are shown with standard units. If the MODIFY UP or DOWN keys are depressed at the same time the NORMAL key is pressed, the "modify rate" will increase.

---

**Table 1.6 - Itemized Front Panel Description (continued)**

(See Figure 1.2)

---

FIG. 1.2

Row, Col.	KEYS	FUNCTION
B4	VOLTAGE	Selects voltage mode and illuminates the VOLTAGE LED. If Power, Power Factor, Phase, or Synchroscope output modes have been previously selected, pressing VOLTAGE allows the user to enter or modify the voltage value without changing output modes.
B5	MV/MA	Selects the units of millivolts or milliamps depending upon whether VOLTAGE or CURRENT was previously selected.
B6	STBY	Selects Standby state and illuminates the STBY LED. No voltage or current outputs are available at the output connectors.
C1	RECALL	Sequentially recalls stored output settings from the user memory to the display. The output settings can be repeatedly recalled. Using the keypad, entering 0 followed by RECALL recalls the first stored value. A number other than 0 followed by RECALL increments the recall sequence by that number.
C2	SYNCHROSCOPE	Selects the synchroscope mode, sets the output voltage to 120.0 Volts at the selected frequency, and illuminates the SYNCHROSCOPE LED. The phase angle between the Aux. Voltage and Main Voltage outputs is displayed. The phase angle is toggled between 0° and 180° by successive presses of the SYNCHROSCOPE key.
C3	POWER	Selects Power mode and illuminates the POWER LED. Once in Power mode Power, Phase, Voltage, Current or Frequency may be selected and adjusted. Depressing the Power key with the POWER LED illuminated will alternate the display between POWER and VARS. Entering a new power level in watts will modify only the Current setting.

---

**Table 1.6 - Itemized Front Panel Description (continued)**

(See Figure 1.2)

---

FIG. 1.2

Row, Col.	KEYS	FUNCTION
C4	CURRENT	Selects current mode and illuminates the CURRENT LED. If Power, Power Factor, or Phase output modes have been previously selected, pressing CURRENT allows the user to enter or modify the current value without changing the output mode.
C5	W/HZ	Selects the units of WATTS or HERTZ depending upon whether POWER or FREQUENCY was previously selected.
C6	MODIFY UP (UP arrow)	Increases the displayed value. The value will continue to increase if the key is held down. Continuing to press this key down and depressing the NORMAL or DOWN ARROW key will increase the rate of modification.
D1	CLEAR	Clears the entire user stored instrument settings in memory.
D2	FREQUENCY	Selects Frequency-display mode, illuminates the FREQUENCY LED and allows entry or modification of the frequency value. The FREQUENCY LED is also illuminated when the 60 HZ or 400 HZ keys are pressed.
D3	PHASE	Selects Phase display mode, illuminates the PHASE LED, and allows entry or modification of the relative phase angle between the voltage and current outputs. Voltage, Current, Frequency, Power/VARS and Phase/Power Factor may all be modified while in the Phase mode.
D4	POWER FACTOR	Selects Power Factor mode, illuminates the POWER FACTOR LED and allows entry or modification of Power Factor. Voltage, Current, Frequency, Power/VARS and Phase/Power Factor may all be modified while in the Power Factor mode.

---

**Table 1.6 - Itemized Front Panel Description (continued)**

(See Figure 1.2)

---

FIG. 1.2

Row, Col.	KEYS	FUNCTION
D5	DEGREE/ENTER	Selects the units of degrees if Phase was previously selected. All numbers without units must be entered using the DEGREE/ENTER key. Changing the GPIB address on startup is an example of a number without unit that may be entered.
D6	MODIFY DOWN (DOWN arrow)	Decreases the displayed value. The value will continue to decrease if the key is held down. Continuing to press the DOWN ARROW key and depressing the NORMAL key or UP ARROW will increase the rate of modification.

---

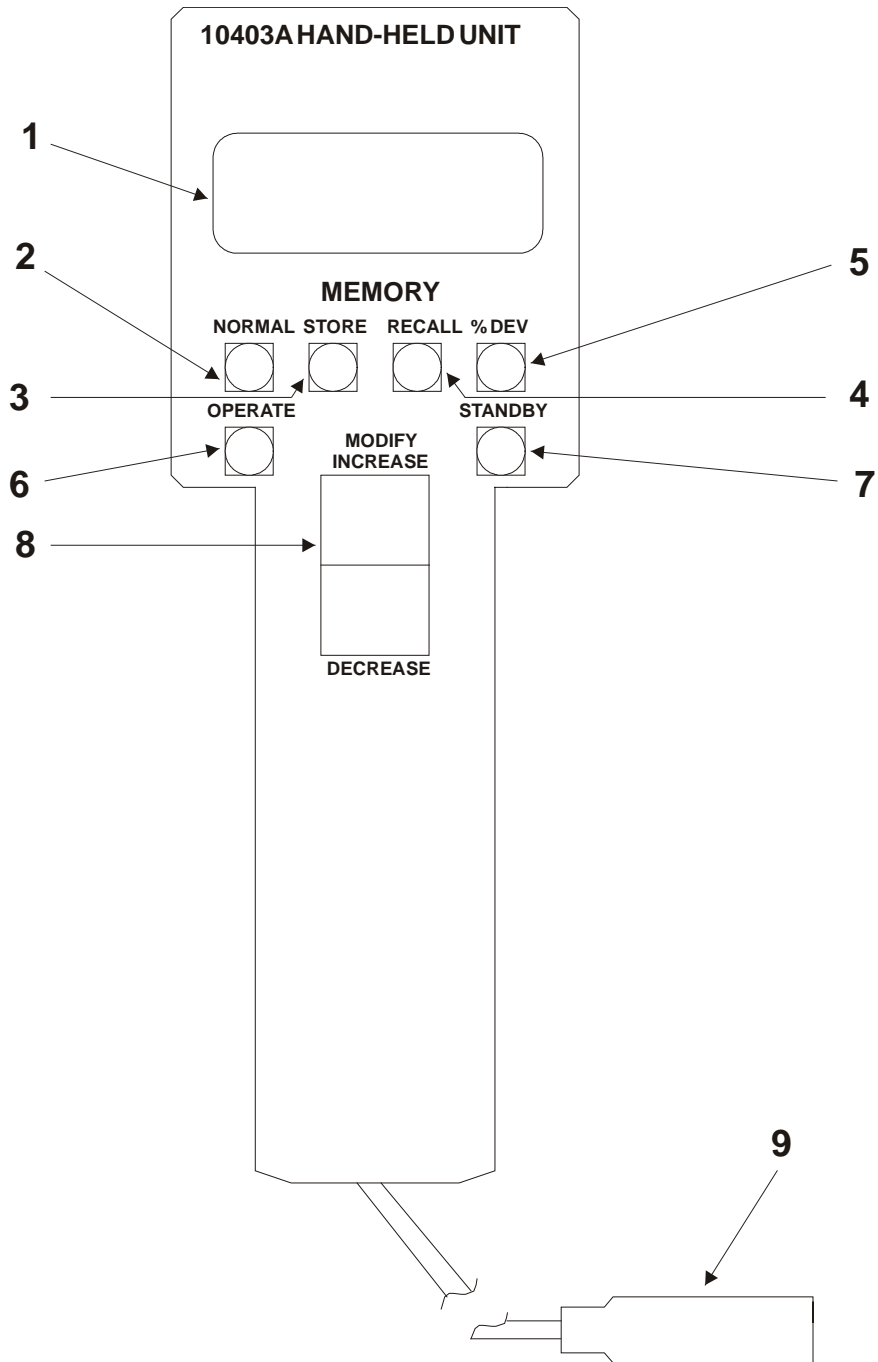

**Figure 1.3 - HANDHELD UNIT CONTROLS**



## Table 1.7 - Hand Held Unit Features

(See Figure 1.3)

FIG. 1.3	CONTROLS, INDICATORS OR CONNECTORS	FUNCTION
1	4-Digit LCD display with sign	The hand held unit (HHU) display duplicates the PMC front panel display's numeric values.
2 – 8	Pushbuttons	Duplicates and selects the corresponding function on the PMC front panel (See Table 1.2).
9	Interconnect Cable	3-meter cable with connector mates with the REMOTE connector on the PMC.

# SECTION 2

# OPERATION

## CAUTION

The PMC current and voltage outputs are designed to operate into independent, electrically isolated loads, for example, switchboard panel meters. The accuracy of the output values may be affected if the unit is connected to non-isolated loads such as some line-operated meters that induce multiground path, spurious noise or loads that interconnect in any way the voltage and current outputs.

**DO NOT connect or disconnect loads while the PMC is in Operate mode.**

**OBSERVE POLARITIES AND HIGH VOLTAGE WARNING!**



# Table of Contents

2.0	Operation.....	1
2.1	General .....	1
2.2	Unpacking .....	1
2.3	Setup.....	1
2.4	Front Panel Operation .....	2
2.4.1	General .....	2
2.4.2	Keypad .....	6
2.4.3	Display .....	6
2.4.4	Reset.....	6
2.4.5	Modify.....	7
2.4.6	Normal/Deviation.....	7
2.4.7	Memory .....	8
2.5	PMC Operating Procedures.....	8
2.5.1	Power Factor/Phase Operating Procedure .....	9
2.5.2	DC Voltage Operating Procedure.....	13
	FIGURE 2.3 – PMC CONNECTIONS FOR TESTING DC VOLTAGE OPERATION .....	13
2.5.3	AC Voltage Operating Procedure.....	14
2.5.4	DC Current Operating Procedure .....	15
2.5.5	AC Current Operating Procedure .....	16
2.5.6	AC Power Operating Procedure .....	17
2.5.7	Synchroscope Operation.....	18
2.5.8	Frequency Operating Procedure .....	19
2.6	Hand Held Unit .....	20
2.7	GPIB Operation.....	20
2.7.1	General .....	20
2.7.2	Setting the GPIB Address.....	22
2.7.3	Power On Sequence .....	22
2.7.4	Remote Programming Function Tests .....	22
2.7.5	Numbers .....	22
2.7.6	Command Codes .....	23
2.7.7	Command Sequence .....	23
2.7.7.1	Diagnostic Tests .....	23
2.7.7.2	Status Commands .....	24
2.7.8	Error Handling.....	24
2.8	Self Test Operation.....	34
2.8.1	General .....	34
2.8.2	Function Test Description .....	34
2.8.2.1	DISPLAY AND LED TEST .....	34
2.8.2.2	CONTROL FUNCTION TEST .....	34
2.8.2.2.1	ROM Test.....	35
2.8.2.2.2	RAM Test.....	35

2.8.2.2.3	Phase Test .....	35
2.8.2.2.4	A/D Test.....	35
2.8.2.3	CURRENT OUTPUT TEST.....	35
2.8.2.4	VOLTAGE OUTPUT TEST .....	35
2.8.3	Diagnostic Test Description.....	36
2.8.3.1	EXIT TESTS .....	36
2.8.3.2	DISPLAY AND LED TEST.....	36
2.8.3.3	FRONT PANEL KEY TEST.....	37
2.8.3.4	RAM/ROM & PHASE TEST.....	37
2.8.3.4.1	ROM Test .....	37
2.8.3.4.2	RAM Test .....	37
2.8.3.4.3	Phase Test .....	37
2.8.3.5	REFERENCE & ADC TEST.....	37
2.8.3.5.1	Reference Test .....	38
2.8.3.5.2	Sample and Hold Test.....	38
2.8.3.5.3	ADC Test.....	38
2.8.3.6	CURRENT MEASUREMENT TEST .....	38
2.8.3.6.1	Current Measurement Offset Test.....	38
2.8.3.6.2	DC Current Measurement Gain Test.....	38
2.8.3.6.3	AC Current Measurement Gain Test.....	38
2.8.3.6.4	Current Overload Test.....	39
2.8.3.6.5	Current Output Range Test .....	39
2.8.3.7	CURRENT SOURCE TEST.....	39
2.8.3.7.1	Minimum Output Test.....	39
2.8.3.7.2	Attenuator Test .....	39
2.8.3.7.3	Sinewave Test.....	39
2.8.3.8	VOLTAGE MEASUREMENT TEST .....	39
2.8.3.8.1	Voltage Measurement Offset Test .....	40
2.8.3.8.2	DC Voltage Measurement Gain Test .....	40
2.8.3.8.3	AC Voltage Measurement Gain Test .....	40
2.8.3.8.4	Voltage Overload Test .....	40
2.8.3.8.5	Voltage Output Range Test.....	40
2.8.3.9	VOLTAGE SOURCE TEST .....	40
2.8.3.9.1	Minimum Output Test.....	41
2.8.3.9.2	Attenuator Test .....	41
2.8.3.9.3	Sinewave Test.....	41
2.8.4	HANDHELD UNIT TESTS .....	41
2.8.4.1	DEBUG UTILITIES.....	41
2.9	Error Messages .....	43

# List of Tables

Table 2.1 - PMC Output Functions and Display Quantities	5
Table 2.2 - Power Factor/Phase Operating Procedure	10
Table 2.2 - Power Factor/Phase Operating Procedure (continued)	11
Table 2.2 - Power Factor\Phase Operating Procedure (continued)	12
Table 2.3 - HHU Status Messages	21
Table 2.4 - GPIB Command Description	25
Table 2.4 - GPIB Command Description (continued)	26
Table 2.5 - 1040C Status Message Description, Control Status (QC)	27
Table 2.5 - Control Status (QC) (continued)	28
Table 2.6 - 1040C Status Message Description, Current & Voltage	29
Table 2.7 - GPIB Error Codes	30
Table 2.8 - Routine Operation Error Codes	31
Table 2.9 - Diagnostic Tests and Error Codes	32
Table 2.9 - Diagnostic Test Error Codes (continued)	33
Table 2.10 - Error/Probable Cause/Appropriate Action	45
Table 2.10 - Error/Probable Cause/Appropriate Action (continued)	47
Table 2.10 - Error/Probable Cause/Appropriate Action (continued)	49

# List of Figures

Figure 2.1 – OPERATING SEQUENCE	3
Figure 2.2 – PMC CONNECTIONS FOR TESTING POWER FACTOR/PHASE OPERATION	9
Figure 2.3 – PMC CONNECTIONS FOR TESTING DC VOLTAGE OPERATION	13
Figure 2.4 – PMC CONNECTIONS FOR TESTING AC VOLTAGE OPERATION	14
Figure 2.5 – PMC CONNECTIONS FOR TESTING DC CURRENT OPERATION	15
Figure 2.6 – PMC COMNNECTIONS FOR TESTING AC CURRENT OPERATION	16
Figure 2.7 – PMC CONNECTIONS FOR TESTING AC POWER OPERATION	17
Figure 2.8 – PMC CONNECTIONS FOR TESTING SYNCHROSCOPE OPERATION	18
Figure 2.9 – PMC CONNECTIONS FOR TESTING FREQUENCY OPERATION	19



## 2.0 Operation

### 2.1 General

This section contains the operating procedures for the PMC. Operating Controls, Connectors and Indicators are referred to by nomenclature that appears on the Front Panel. The Front Panel Operating controls connectors and indicators for the PMC are shown in Figure 1.2.

### 2.2 Unpacking

Unpack the PMC and visually inspect for possible shipping damage. IF DAMAGE EXISTS, NOTIFY ARBITER SYSTEMS AND THE CARRIER AND RETAIN THE SHIPPING CARTON. DO NOT RETURN THE UNIT WITHOUT INSTRUCTIONS FROM ARBITER SYSTEMS.

### 2.3 Setup

The PMC is housed in a rugged weatherproof transit case. The necessary equipment for panel meter calibration should be stored inside the case. To set up the PMC for operation proceed as follows:

- 1) Remove the cover by first depressing the pressure relief button and undoing the four latches. Once the latches are completely free from the cover, the cover may be removed by lifting straight up on the handle.
- 2) The power cord, voltage cable, current cable, and Hand Held Unit are stored in the cover. Remove the power cord and any other accessories required for the calibration to be performed. With the power switch in the OFF (0) position, connect the power cord between the line module (See Fig. 1.2) and a power source having a nominal voltage of 115V rms.
- 3) Press the power switch to the ON (1) position. The display should read GPIB ADDRESS XX, the RESET, NORMAL, and STBY (and STORE, if there are previously stored user settings) LED indicators should be illuminated, and the fan should operate. The GPIB address displayed, (XX) should be between 1 and 31. If not seeing these results after applying power, difficulties may exist; the PMC should be turned off and the Self-Test Section (Sec. 2.8) should be consulted. Observing these results after applying power means that the GPIB address may now be modified (See Sec. 2.7).
- 4) After the GPIB address has been displayed for a few seconds, the PMC will begin a functional self test (See Sec. 2.8.2). If the PMC fails one of the function tests a failure message will be displayed alternately with PRESS (Down Arrow) FOR TESTS. Pressing the DOWN ARROW key will initiate the diagnostic tests (See Sec. 2.8.3). Corrective action should be taken to cure any function test failure prior to using the PMC. Once the function test has been successfully completed, the PMC will momentarily display FUNCTION TEST PASSED, then enter Reset mode and display DC, 60 Hz or 400 Hz. The function tests may be bypassed by pressing RESET.



5) The PMC is now ready to be used for meter calibration. Refer to the rest of this section for proper connections and operation.

## **2.4 Front Panel Operation**

### **2.4.1 General**

Control of the PMC is straightforward and requires pressing the keys that designate the desired operating modes, conditions, and values according to the sequences shown in Fig. 2.1. See Section 2.5 for PMC Operating Procedures. Each of the keys that represent operational status or the type of value to be entered or modified have LED indicators to show the present state of the PMC.

The alphanumeric display shows the PMC state along with prompting for user response, showing output values and displaying error messages. Table 2.1 shows the output functions of the PMC and the corresponding quantities, which can be displayed, entered, and modified. Voltage and/or current outputs are present only when the OPER key has been depressed and the OPER LED is illuminated, and are absent when the STBY LED is illuminated.

Figure 2.1 – OPERATING SEQUENCE

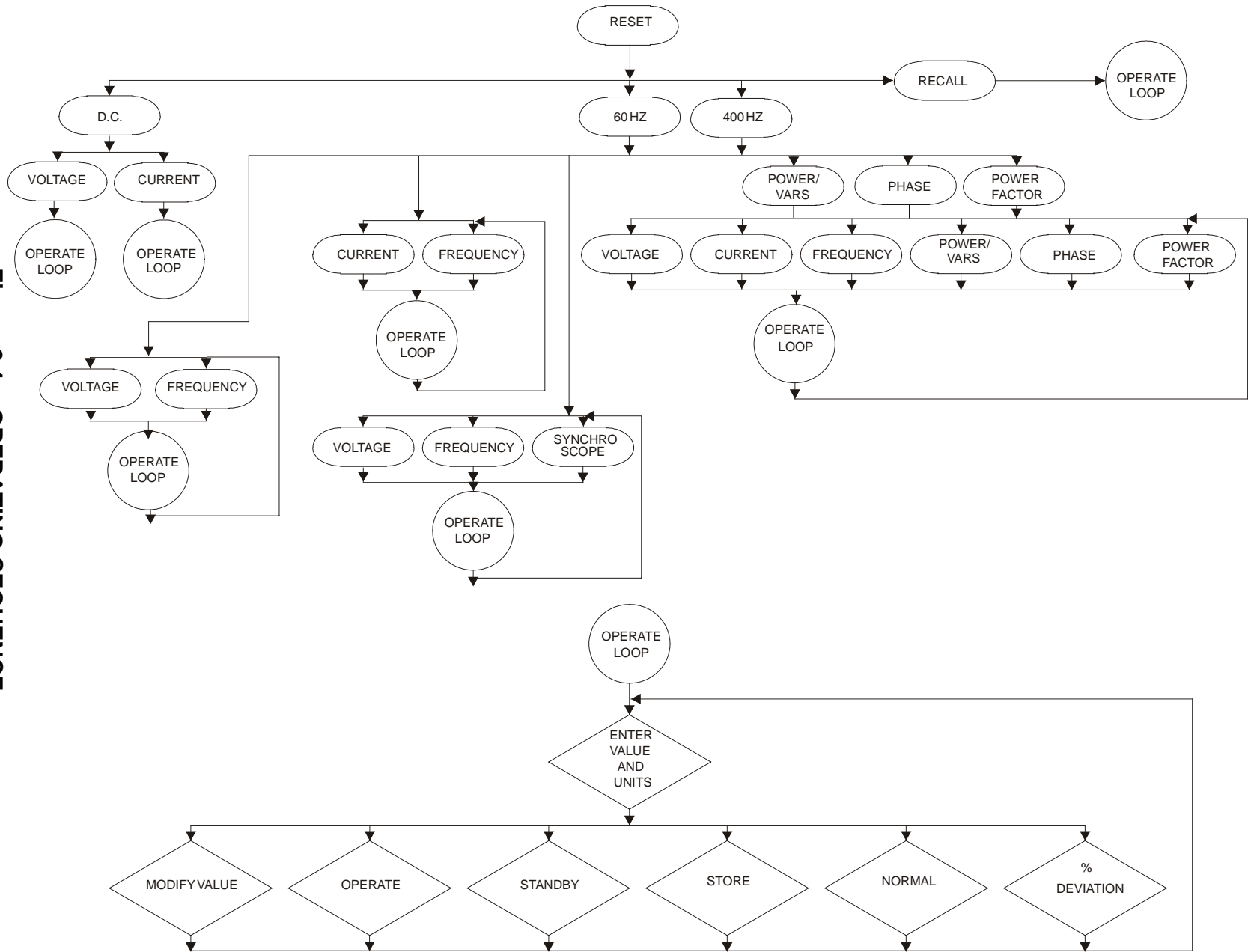



**Table 2.1 - PMC Output Functions and Display Quantities**

OUTPUT FUNCTIONS	QUANTITIES WHICH CAN BE DISPLAYED AND MODIFIED
Voltage, DC	Voltage
Voltage, AC	Voltage, Frequency
Current, DC	Current
Current, AC	Current, Frequency
Power Factor, Phase, Power	Power Factor, Phase, Voltage, Current, Frequency
AC Synchroscope	0°/180° Synchroscope, Voltage, Frequency

## 2.4.2 Keypad

The 12-key keypad (See Fig. 1.2) consists of the 10 digits, 0-9, plus a decimal point and minus/backspace key. Each keypad entry must be preceded by selection of the type of quantity to be entered and followed by selection of the desired units or the ENTER key.

The first key pressed on the keypad causes the PMC to display ENTRY=X where X represents the key depressed. Succeeding keys as depressed will add to the displayed number.

The decimal point may be placed in any position except after the last digit; i.e. there must be at least one character following the decimal point if a decimal point is entered. The minus/backspace key when used as the first entry negates the entered number. At all other times the minus/backspace key erases the single preceding entry. Successive presses of the backspace key continue to erase preceding entries until the first entry is gone.

If the PMC is in Operate mode and the value entered is within the present operating range (See Table 1.1) the output signal will change to the new output setting. If the PMC is in Operate mode and the value entered is out of the present operating range (See Table 1.1) the PMC will return to Standby mode.

## 2.4.3 Display

The PMC has a multi-purpose 20 character alphanumeric vacuum fluorescent display. The intent of the display and the LED indicators is to give the operator as much information as possible for identifying the current PMC status. The individual displayed messages are explained in each appropriate section.

In general, the display will change in response to any keystroke. In most circumstances the nomenclature on the key will appear in the appropriate location on the display. Some special display features should be noted.

A few seconds after the OPER key is depressed, a single character will appear between the type of quantity being displayed (i.e. voltage or current) and the numerical value. The characters <, =, > (output status indicator) represent whether the actual output is less than, equal to, or greater than the desired output. After waiting a few seconds for the output to settle the equal sign should be displayed.

If the desired value is modified or the output load is drastically changed the output status indicator may momentarily revert to < or >. Once the PMC is placed in Standby the output status indicator will disappear.

One other display feature is the blinking numeric value, which indicates the value has been modified below the specified limit of the present operating range. The PMC will attempt to output the requested value, however the output is not guaranteed to meet specifications. The display will also blink if the entered value is less than the lower limit of the lowest range.

## 2.4.4 Reset

The RESET function automatically occurs upon completion of the Function Test, or may be manually applied at any time by pressing the RESET key. This function removes all outputs and sets all voltage, current and phase values to zero. The display will read "DC, 60 Hz or 400 Hz?"

and the RESET, NORMAL and STBY LED's will be illuminated (the STORE LED will be illuminated if there are settings stored in the user memory).

Selecting DC, 60 Hz, 400 Hz, or the memory operations RECALL or CLEAR, are the only valid operations while in RESET mode.

### 2.4.5 Modify

Any displayed value can be modified, i.e. increased or decreased, by means of either the rotary knob, or the Modify Up or Modify Down keys. Clockwise rotation of the knob increases the output value while counterclockwise rotation decreases the output value. The rate of change of the output value is directly proportional to the speed of rotation. The Modify Up and Modify down keys offer a second means of modifying the output value. Depressing either modify key will cause the output value to change by approximately one count. Depressing the key continuously causes a steady change in the output value but at a minimum rate. The modification rate can be increased by momentary actuation of the NORMAL key or the other modify key while the present modify key is depressed. One press of the NORMAL, or the other modify key, yields a medium speed and two presses a fast speed. If at any time the modify key is released, the speed automatically reverts to slow.

The rotary knob and the Modify keys can only modify the output value, not the output range (refer to Table 1.1 and 1.2). Modification of the output value is limited to 105% of the range's upper limit (5% over range). When the value is modified below the specified lower limit of the range, the displayed value will blink. In order to change ranges, a value within the new desired range must be entered on the keypad (Section 2.4.2)

In most cases the actual output will be equal to the displayed value as the output value is modified. In some cases, such as 60 Hz Phase, if the output value is modified rapidly the actual output will lag behind the displayed value. This situation is identified by the output status indicator (See Section 2.4.3) showing either < or >.

### 2.4.6 Normal/Deviation

In the % deviation mode the PMC computes and displays the output value according to the formula:

$$\text{PMC Display Value} = \frac{(\text{METER C.P.} - \text{PMC output value}) \times 100 \%}{\text{METER F.S.}}$$

The PMC must have both the meter full-scale value (Meter F.S.) and the meter calibration point (Meter C.P.) to perform the necessary calculation.

To enable this function, press %DEV and set the PMC output value to the meter's full-scale value (it is not necessary to press OPER). The display will read **METER F.S. = XXXXX YY** where XXXXX YY represents the meter's full scale value and units.

Press %DEV again and the display will change to **METER C.P. = XXXXX YY**. Enter the meter calibration point by using the keypad, or press RECALL to retrieve a stored setting. Do not use the Modify Controls.

Press the %DEV key again to display **METER = 00.00%**. The PMC now displays the deviation from the selected calibration point in percent of meter full scale. The previous displays can be reviewed and/or changed by pressing the %DEV key.

Repeatedly press the % DEV key until the **METER = XX.XX%** is displayed again. Press OPER to initiate the output. Use the rotary knob or the modify keys to change the output level and the % deviation displayed. Do not enter a value from the keypad or use the RECALL feature. A new full scale or calibration point must be entered using the keypad or RECALL feature. Changing the full scale or calibration point resets the percent deviation to zero.

### **2.4.7 Memory**

The Memory feature is useful for storing frequently used output settings and quickly recalling them later. An output setting can be entered into the memory by simply pressing the STORE key. Illumination of the STORE LED indicates that stored values are present. Up to 50 settings can be stored. The display will flash memory store # after each entry and will continue to flash on and off if all of the memory locations have been filled.

Output settings in memory are recalled by pressing the RECALL key. The memory operates on a first in, first out (FIFO) basis. This sequence will continue whereby the first setting stored will also follow the last when recalling through all of the stored settings. Pressing the CLEAR key clears all memory settings.

The keypad may be used to help move through the stored settings. Pressing 0 then RECALL recalls the first stored setting. Entering a number other than zero and pressing RECALL recalls the output setting at that location.

## **2.5 PMC Operating Procedures**

The following procedures outline the operating steps and connections that are necessary for calibrating various categories of panel meters. A detailed example for operating a power factor meter at 120 volts, 5 amperes and 60 Hz is given in tabular form with operator actions and results listed, to help familiarize the operator with many of the operating details of the PMC. The remaining procedures are given in less detail but show the principal operating steps. All procedures follow the operating sequences shown in Figure 2.1 (See page 2-3).

### 2.5.1 Power Factor/Phase Operating Procedure

**CAUTION** - Power Factor/Phase Meter Calibrations - The following procedure employs initial output values of 120 volts and 5 amperes, at 60 Hz and 0°, 30° and 60° phase values. A full meter calibration would include other values.

The phase convention in the PMC is set by the following equations:

$$\begin{aligned} \text{Voltage:} & \quad V(t) = V_o \sin wt \\ \text{Current:} & \quad I(t) = I_o \sin (wt + \Theta) \\ \text{Power:} & \quad V_{rms} I_{rms} \cos \Theta \\ \text{VARs} & \quad V_{rms} I_{rms} \sin (-\Theta) \\ \text{Power Factor:} & \quad \cos \Theta \end{aligned}$$

Where  $\Theta$  = phase angle in degrees between voltage and current

Phase Angle	Sign of Power	Sign of VARs	Power Factor
$0 < \Theta < 90$	+	-	Lead +
$90 < \Theta < 180$	-	-	Lead -
$-180 < \Theta < -90$	-	+	Lag -
$-90 < \Theta < 0$	+	-	Lag +

Turn the PMC off, connect the PMC to a power factor or phase meter (See Fig. 2.2 below) and proceed with the steps in Table 2.2.

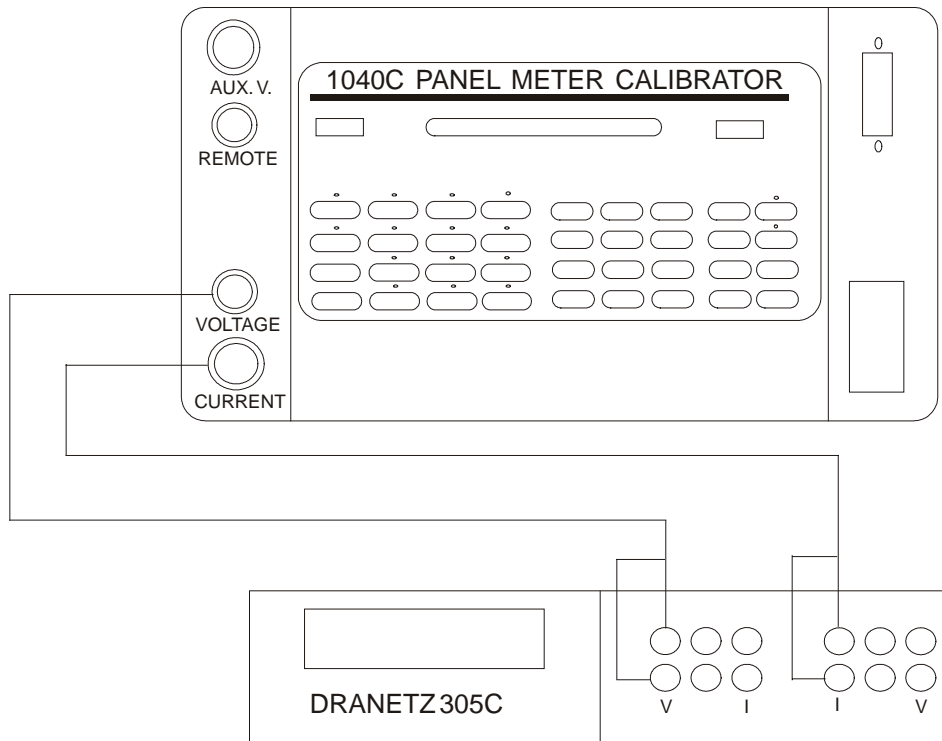

**Figure 2.2 – PMC CONNECTIONS FOR TESTING POWER FACTOR/PHASE OPERATION**



**Table 2.2 - Power Factor/Phase Operating Procedure**

STEP	OPERATOR ACTION	RESULTS
1.	Apply power to PMC	After successful completion of Function Tests the PMC will momentarily display PASSED FUNCTION TEST. The PMC will return to RESET mode and display DC, 60 Hz, or 400 Hz? The RESET, STBY, and NORMAL LED's (and the STORE LED if user settings are presently stored in the user memory) will be illuminated.
2.	Press 60 Hz	RESET LED will turn off, the 60 HZ and FREQUENCY LED's will turn on. The PMC now displays FREQUENCY 60.00 Hz. (The Frequency may now be modified or a new value entered).
3.	Press Power Factor	FREQUENCY LED will turn off, the POWER FACTOR LED will turn on and the PMC now displays POWER FACTOR 1.000 (Power Factor may now be modified or a new value entered).
4.	Press Voltage	VOLTAGE LED is illuminated and the PMC now displays VOLTAGE 15.00V (15 Volts rms is the lowest range available for Power Factor/Phase output mode).
5.	Press 1	The PMC displays ENTRY = 1
6.	Press 2	The PMC displays ENTRY = 12
7.	Press 0	The PMC displays ENTRY = 120. (The MINUS/BACKSPACE key may be used to erase incorrect entries).
8.	Press V/A	Press the unit key (V/A) to complete the entry of the voltage setting. The PMC now displays VOLTAGE 120.0 V (The voltage may now be modified using the rotary Knob or the Up/Down modify keys.).

**Table 2.2 - Power Factor/Phase Operating Procedure (continued)**

STEP	OPERATOR ACTION	RESULTS
9.	Press Current	The VOLTAGE LED will turn off, the CURRENT LED will turn on, the PMC displays CURRENT .1000A (.1 amps rms is the lowest current available for Power Factor/Phase output mode).
10.	Press 5	PMC displays ENTRY = 5
11.	Press V/A	Press the unit key V/A to complete the entry of the current setting. The PMC displays CURRENT 5.000A (The current may now be modified).
12.	Press OPER	The OPER LED will turn on, the HIGH VOLTAGE indicator will flash on and off, and a <, =, or > will appear on the display indicating the status of the output. Within the specified settling time the display should show = and the meter should read a power factor of 1.000.
13.	Press PHASE	The POWER FACTOR and CURRENT LED's will turn off, the PHASE LED will turn on, and the PMC displays PHASE 00.00°.
14.	Adjust Phase to 30°	The PMC will display PHASE 30.00° (adjustments of the output value is accomplished by either entering a new value from the keypad, Sec. 2.4.2, or using the modify controls, Sec. 2.4.5). The meter shows a lagging power factor of .8661.
15.	Press POWER FACTOR	The PHASE LED will turn off, the POWER FACTOR LED will turn on, and the PMC displays POWER FACTOR .8661.
16.	Adjust Power Factor to .4999	The PMC display POWER FACTOR .4999 (Due to the minimum phase increments some Power Factor values such as .5000 are not allowed). The meter should show .5 lag.
17.	Press PHASE	The POWER FACTOR LED will turn off, PHASE LED will turn on, and the PMC displays PHASE 60.00°.

**Table 2.2 - Power Factor\Phase Operating Procedure (continued)**

STEP	OPERATOR ACTION	RESULTS
18.	Press <b>POWER FACTOR, PHASE, POWER/VARS, FREQUENCY, VOLTAGE</b> or <b>CURRENT</b>	New values for any of these functions may be entered using the keypad or the old settings may be modified. The PMC will remain in Operate mode unless the new Voltage or Current settings entered are outside of the present operating range.
19.	Press STBY	The STBY LED will turn on, and OPER LED will turn off. No output signals will be present at the output terminals.

## 2.5.2 DC Voltage Operating Procedure

**CAUTION** - Place the PMC in Standby mode. Connect the Voltmeter to the PMC as shown in Figure 2.3 below and proceed with the following steps:

1. Press DC.
2. Press VOLTAGE.
3. Enter the desired voltage using the keypad and the unit key.
4. Press OPER.
5. MODIFY, MEMORY, or %DEV may be used.
6. Press STBY when the measurement is complete to remove the output signal.

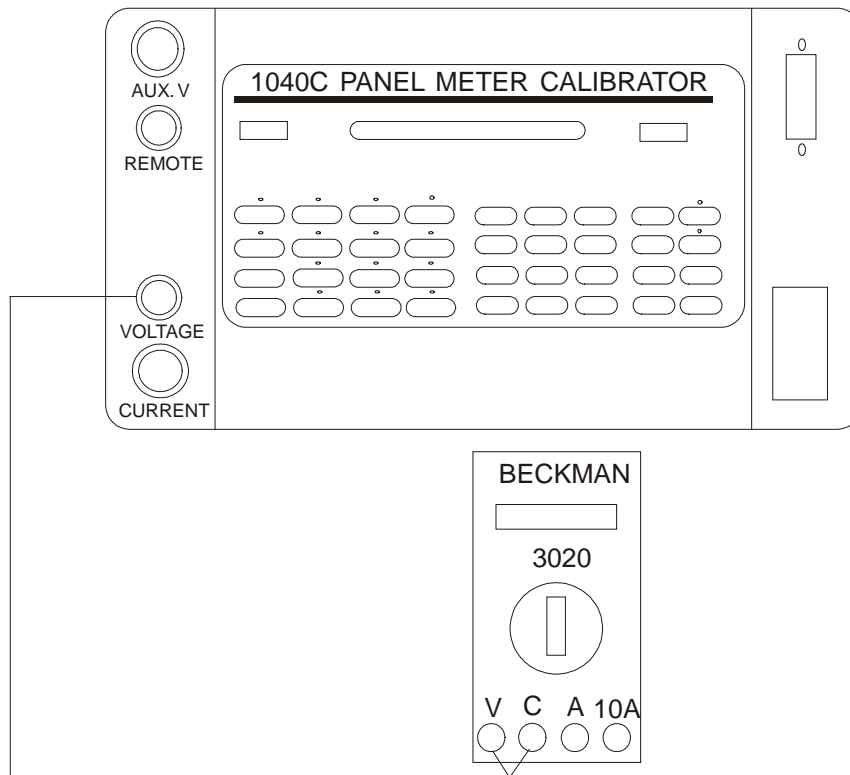
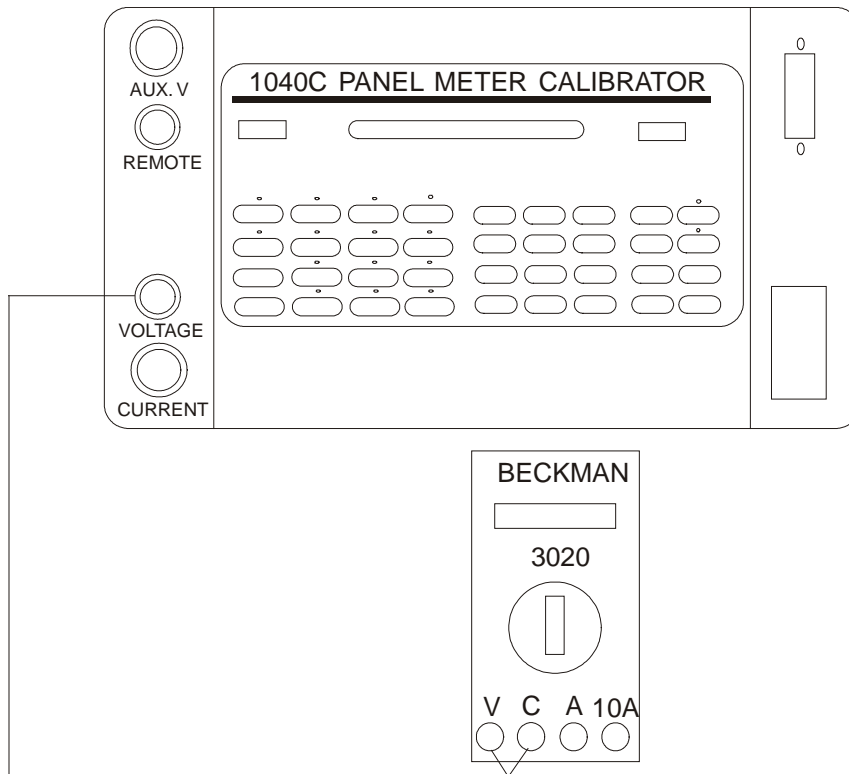

**Figure 2.3 – PMC CONNECTIONS FOR TESTING DC VOLTAGE OPERATION**

### 2.5.3 AC Voltage Operating Procedure

**CAUTION** - Place the PMC in Standby mode. Connect the Voltmeter to the PMC as shown in Figure 2.4 below and proceed with the following steps:

1. Press 60 HZ or 400 HZ.
2. Press VOLTAGE.
3. Enter the desired voltage using the keypad and units key.
4. Press OPER.
5. MODIFY, MEMORY, and %DEV may be used. The FREQUENCY or VOLTAGE may be modified.
6. Press STBY when the measurement is complete to remove the output signal.

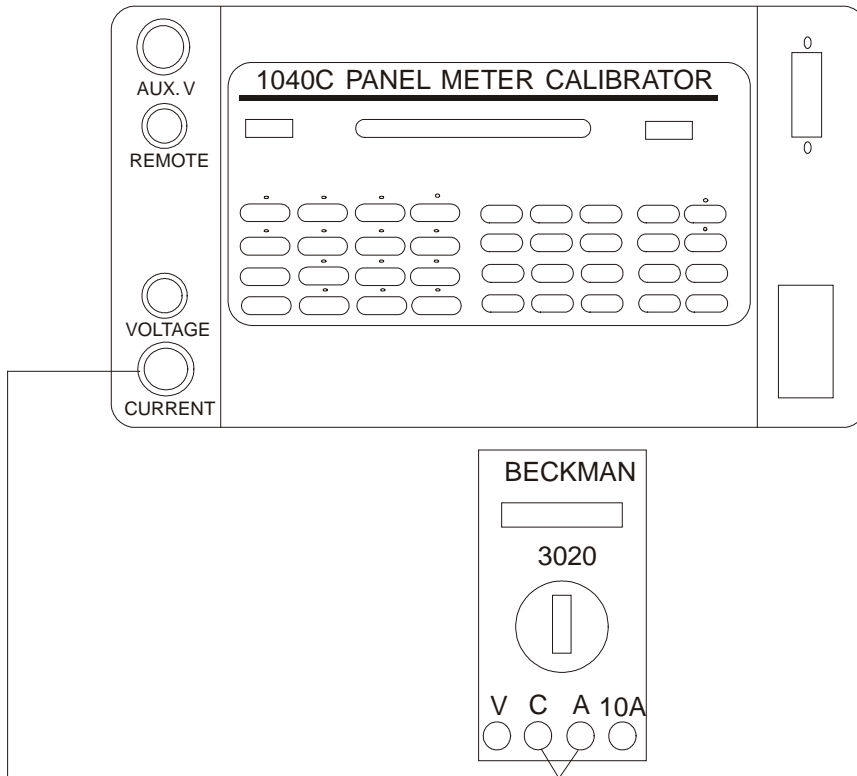

**Figure 2.4 – PMC CONNECTIONS FOR TESTING AC VOLTAGE OPERATION**

## 2.5.4 DC Current Operating Procedure

**CAUTION** - Place the PMC in Standby mode. Connect the Ammeter to the PMC as shown in Figure 2.5 below and proceed with the following steps:

1. Press DC.
2. Press CURRENT.
3. Enter desired current using the keypad and units keys.
4. Press OPER.
5. MODIFY, MEMORY, and %DEV may be used.
6. Press STBY when the measurement is complete to remove the output signal.

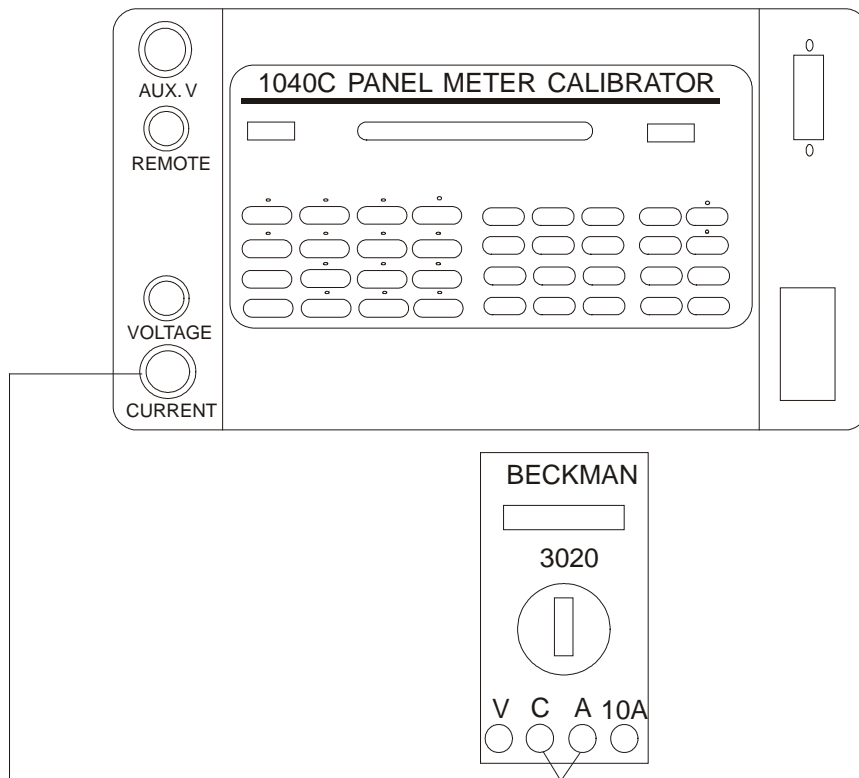

**Figure 2.5 – PMC CONNECTIONS FOR TESTING DC CURRENT OPERATION**

## 2.5.5 AC Current Operating Procedure

**CAUTION** - Place the PMC in Standby mode. Connect the Ammeter to the PMC as shown in Figure 2.6 below and proceed with the following steps:

1. Press 60 HZ or 400 HZ.
2. Press CURRENT.
3. Enter the desired current using the keypad and the unit keys.
4. Press OPER.
5. MODIFY, MEMORY, or %DEV may be used. The FREQUENCY or CURRENT may be modified.
6. Press STBY when the measurement is complete to remove the output signal.

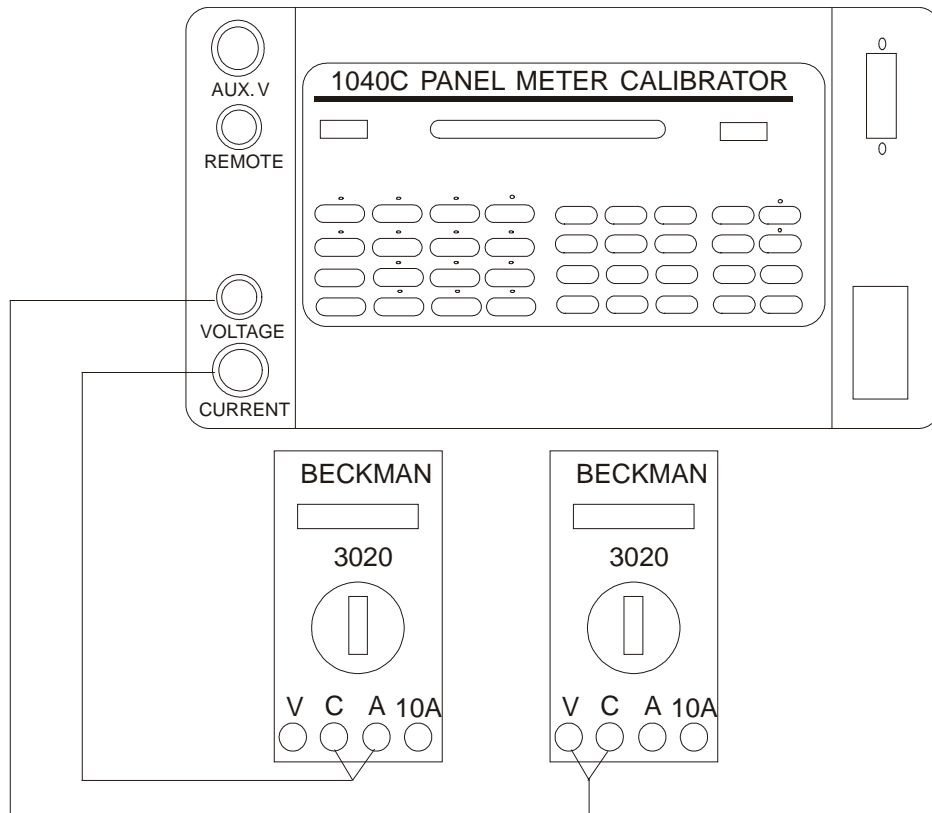

**Figure 2.6 – PMC CONNECTIONS FOR TESTING AC CURRENT OPERATION**

## 2.5.6 AC Power Operating Procedure

**CAUTION** - Place the PMC in Standby mode. Connect the Power Meter to the PMC as shown in Figure 2.7 and proceed with the following steps:

1. Press 60 HZ or 400 HZ.
2. Press POWER.
3. Press VOLTAGE.
4. Enter desired voltage using the keypad and units keys.
5. Press CURRENT.
6. Enter desired current using the keypad and units keys.
7. Press POWER. The power calculated from the entered voltage, current, and phase values will be displayed. Press POWER again and VARS will be displayed. (Modifying Power or VARS changes the current output while leaving the voltage and phase fixed.)
8. Press OPER.
9. MODIFY, MEMORY, or %DEV may be used. POWER, VARS CURRENT, VOLTAGE, PHASE, POWER FACTOR, or FREQUENCY may be modified.
10. Press STBY when the measurement is complete to remove the output signal.



**Figure 2.7 – PMC CONNECTIONS FOR TESTING AC POWER OPERATION**



## 2.5.7 Synchroscope Operation

**CAUTION** - Place the PMC in Standby mode. Connect the Synchroscope to the PMC as shown in Figure 2.8 and proceed with the following steps:

1. Press 60 HZ or 400 HZ.
2. Press SYNCHROSCOPE.
3. Press VOLTAGE.
4. The Voltage is automatically set to 120 V. The voltage may be adjusted using the modify controls or the keypad and units keys.
5. Press OPER.
6. Successive presses of the SYNCHROSCOPE key will alternate the phase relationship, between the voltage and the Aux. Voltage outputs, between 0° and 180° degrees. The present phase angle is displayed.
7. Voltage or Frequency may be modified.
8. Press STBY when the measurement is complete to remove the output signal.

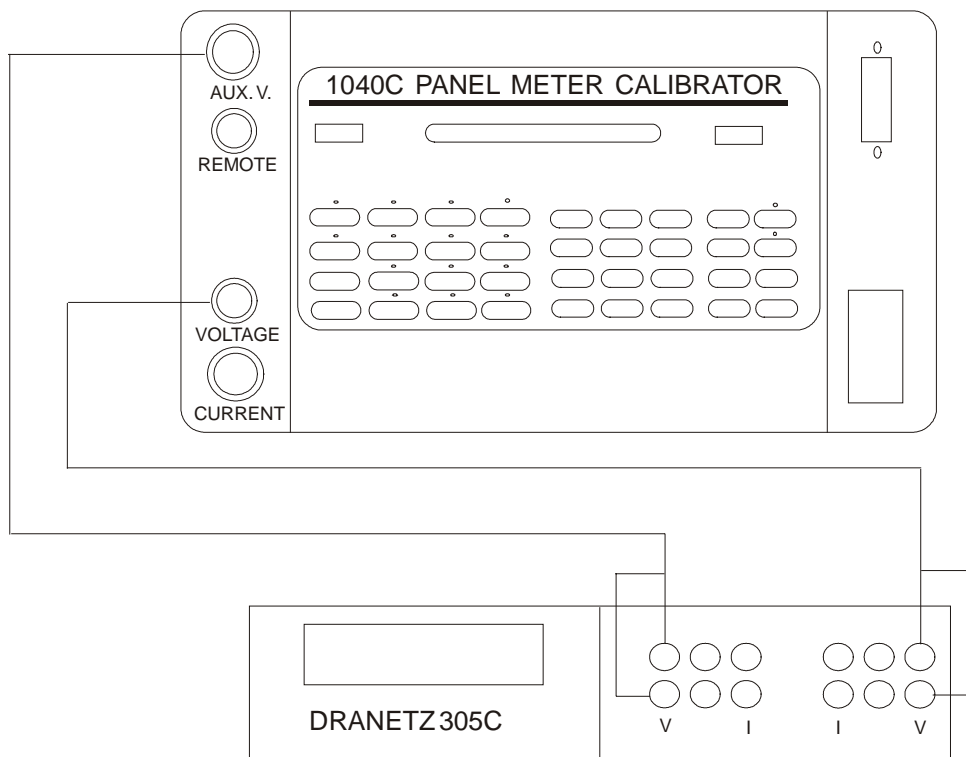
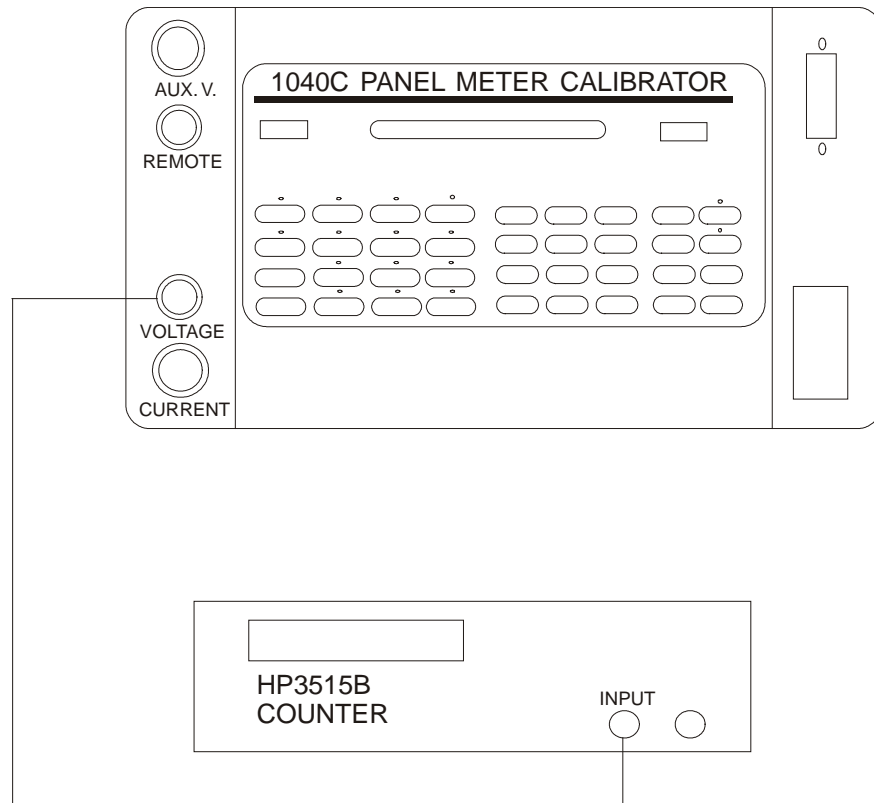

**Figure 2.8 – PMC CONNECTIONS FOR TESTING SYNCHROSCOPE OPERATION**

## 2.5.8 Frequency Operating Procedure

**CAUTION** - Place the PMC in Standby mode. Connect the Frequency Meter to the PMC as shown in Figure 2.9 and proceed with the following steps:

1. Press 60 HZ or 400 HZ.
2. Press VOLTAGE.
3. Enter the desired Voltage using the keypad and the unit key.
4. Press FREQUENCY.
5. Enter the desired Frequency using the keypad and the HZ key.
6. Press OPER.
7. MODIFY, MEMORY, or %DEV may be used. The FREQUENCY or VOLTAGE may be modified.
8. Press STBY when the measurement is complete to remove the output signal.



**Figure 2.9 – PMC CONNECTIONS FOR TESTING FREQUENCY OPERATION**

## 2.6 Hand Held Unit

The Hand Held Unit, when connected to the Remote connector on the PMC Front Panel, has controls, which duplicate controls on the PMC Front Panel. The Hand Held Unit has a 4 digit display, lighted pushbuttons and a MODIFY UP/DOWN Rocker Switch which duplicate the function of the numeric portion of the PMC display, the keys and LED indicators, and the MODIFY UP/DOWN keys, respectively.

In addition to displaying numeric values, the Hand Held Unit display uses error codes, as shown in Table 2.3, to indicate errors that are displayed in message form on the PMC display. The Hand Held Unit keys can be used interchangeably with the corresponding PMC front panel keys.

Once an output function is set up on the PMC, the Hand Held Unit may be used to alter the output; i.e. MODIFY, DEV (%), NORMAL, OPERATE or STBY. The Hand Held Unit also has pushbuttons for the STORE and RECALL functions.

## 2.7 GPIB Operation

### 2.7.1 General

The PMC has a fully functional GPIB port that provides for remote or automatic operation with a GPIB instrument controller. All functions of the PMC, except MODIFY, may be operated through GPIB commands. The PMC has the following IEEE-488 capabilities:

SH1-	Source Handshake; complete capability
AH1-	Acceptor Handshake; complete capability
T6-	Talker; Basic Taker, Serial Poll, Unaddress if MLA
L4-	Listener; Basic Listener, Unaddress if MTA
SR1-	Service Request; complete capability
RL2-	No Local Lockout (Front Panel Disabled, RESET Key active)
PP0-	Parallel Poll; no capability
DC1-	Device Clear; complete capability
DT0-	Device Trigger; no capability
C0-	Controller; no capability
E2-	Tri State (1MB/Sec max)

**Table 2.3 - HHU Status Messages**

---

DISPLAY	MESSAGE
PASS	PMC has successfully completed a functional test procedure or a circuit card test.
Er 0	Output overload.
Er 3	Measurement offset adjustment out of calibration.
Er 4	No voltage or current function set.
Er 6	Deviation cardinal value is zero.
Er 9	Defective storage EEROM.
Er 10	Calibration limit exceeded.

---

## 2.7.2 Setting the GPIB Address

The GPIB Address is set during the power on sequence using the keypad and the ENTER key. Turn on the PMC. The PMC will display GPIB ADDRESS = XX. If the desired address is displayed, press the ENTER key to begin the Self-Test Function Test. The GPIB address may only be changed while it is being displayed by entering a one or two digit address and pressing ENTER. After pressing 'ENTER' the new GPIB address is stored in non-volatile memory.

## 2.7.3 Power-On Sequence

During the Power on sequence after the GPIB ADDRESS message is displayed, the PMC will perform a Function Test. (See Section 2.8 for details.) GPIB commands are ignored during these tests. The Function Test may be bypassed by pressing RESET while the PMC displays its GPIB ADDRESS. Press RESET to return the PMC to the RESET mode. Once in the Reset mode a GPIB controller can communicate with the PMC through the GPIB port. INTERFACE CLEAR command (IFC) resets the PMC interface functions only; it does not affect the PMC operating modes.

## 2.7.4 Remote Programming Function Tests

The Function Tests may be performed remotely using the appropriate GPIB command (see Table 2.4). Upon successful completion of the Function Test, PASSED FUNCTION TEST is displayed and SRQ is asserted. The PASS code (see Sec. 2.7.7.1) is reported to the GPIB controller when the PMC is serial polled.

## 2.7.5 Numbers

The PMC accepts decimal numbers expressed as an ASCII string and if needed may contain an embedded decimal point character. The sign character (-) or optional (+) precedes the number string of up to four digits. The numeric entry string must end with a unit suffix.

For a PMC output of 5 volts the following are equivalent:

5V (LF)

+5V (LF)

5.000V (LF)

5V (CR) (LF)

For output values less than or equal to 100mV, use the MV/MA key; otherwise use the V/A key. For example to set the PMC output to -26.25 millivolts use -26.25MV, but not -.02625V. Also use .420V but not 420MV to obtain 420 millivolts on the 1 V range.

### 2.7.6 Command Codes

The PMC responds to ASCII alphanumeric command strings (capital letters only). Only one command per message is permitted, terminated with a Carriage Return (CR) and Line Feed (LF) characters or with a LF character alone. Space characters are ignored. Table 2.4 lists the available commands and the resulting PMC action.

### 2.7.7 Command Sequence

The PMC uses keystroke equivalent programming. Each front panel key has an equivalent GPIB command. GPIB commands are equivalent to those employed when the PMC is manually operated. (See the Front Panel Operation Section 2.4 for details on Front Panel Operation). The only front panel controls that are not duplicated with GPIB commands are the Modify Controls. The following command sequence is an example, which sets the PMC to 25.82 Volts output at 55.43 HZ.

---

STEP	COMMAND	RESULTS
1.	RES	Select 60 Hz Mode. This line is optional. The PMC assumes 60 Hz mode if a frequency is requested between 50 Hz and 75 Hz
2.	60 Hz	Selects 60 Hz Mode. This line is optional. The PMC assumes 60 Hz mode if a frequency is requested between 50 Hz and 75 Hz.
3.	55.43 Hz	Sets the PMC Operating Frequency to 55.43 Hz.
4.	V	Selects Voltage Output Mode. This line is optional. The PMC assumes voltage mode when a specific voltage is requested. (See next step.)
5.	25.82 V	Sets PMC for 25.82 Volts
6.	OP	Initiates output.
7.	26 V	Changes output to 26 Volts.
8.	STA	Removes output (does not alter settings).

#### 2.7.7.1 Diagnostic Tests

To run a diagnostic test, send the DTXX command where XX is the test number. Refer to the Diagnostic Test Sequence Section 2.8.3 for details. The PMC ignores interface commands while a Diagnostic Test is being performed. Upon completion of a test the PMC asserts SRQ and reports either PASS code (50) or an Error Code (see Table 2.9). To return the PMC to normal operation

after completion of a diagnostic test send Carriage Return (CR) and Line Feed (LF) characters or LF alone.

### **2.7.7.2 Status Commands**

The status of the PMC may be requested by using the Query Commands: QC, QD, QI, QV, or QM. The controller addresses the PMC to listen, sends the query command, addresses the PMC to talk and then receives the requested status data. For the QC, QI and QV commands the data is sent as ASCII strings containing 1's and 0's to denote the settings of the various PMC controls and quantities. See Table 2.5 for a description of these status items.

The PMC responds to output status command, QM, with ASCII L, H, =, or S to indicate that the output is low, high, equal to the desired setting or in the Standby mode, respectively.

### **2.7.8 Error Handling**

The PMC asserts the SRQ line when an error condition is detected and reports an error number to the controller when serial polled. Tables 2.7, 2.8 and 2.9 list the error number with corresponding conditions, and indicate the resulting state of the PMC. After corrective action is taken, the command sequence can be resumed.

**Table 2.4 - GPIB Command Description**

COMMAND	RESULT
A	Initializes Current operating mode or displays Current if in Power or Phase/Power Factor mode.
CA	Enables PMC calibration mode.
CAX	Selects calibration fraction of range with X=1, 2,3,4 or 5. 1=1/10 Range, 2=1/4, 3=1/2, 4=3/4 and 5=Top of Range.
CL	Execute MEMORY CLEAR function.
DC	Select DC Operating Mode.
DTXX	Initiates Diagnostic Test Number XX (See Sec. 2.8.3 and Table 2.9)
FT	Initiates Self Test Function Tests
HZ	Request PMC to display frequency setting.
NOR	Selects NORMAL mode.
OP	Select Operate state.
PH	Request PMC to display Phase setting.
PF	Request PMC to display Power Factor setting.
Q	Selects VARS operating mode.
QC	Query Command: Control Status (see Table 2.5).
QD	Query Command: Sends 20 ASCII string that matches the front panel alphanumeric display.
QI	Query Command: Output Current range status (see Table 2.6)
QM	Query Command: Output Signal Status (L = Low, H = High, N = Normal, S = Standby).
QV	Query Command: Output Voltage Range Status



**Table 2.4 - GPIB Command Description (continued)**

COMMAND	RESULT
REC	Execute MEMORY RECALL function
RES	Returns PMC to RESET state.
SN	Sends instrument serial number
SS0	Selects SYNCHROSCOPE output and 0°
SS180	Selects SYNCHROSCOPE output and 180°
STA	Selects STANDBY state
STO	Execute MEMORY STORE function
V	Initializes VOLTAGE Operating mode or displays Voltage if in POWER or PHASE/POWER FACTOR modes.
W	Select POWER Operating Mode
XP	Transfers Voltage and Current calibration constants power locations
XV	Sends firmware version date (ddmmmyy)
XXXXA	Set output to XXXX Amperes
± XXXCO	Adjust calibration constant by + or – XXX hundredths percent
XXXXHZ	Set output frequency to XXXXHZ
XXXXMA	Set output to XXXX Milliamps (used only on Milliamp ranges, < 100 mA)
± XXXXMV	Set output to + or – XXXX Millivolts (used only on Millivolt range, < 100 mV)
± XXXXPF	Set output to + or – XXXX Power Factor
± XXXXPH	Set output phase to + or – XXXX phase
± XXXXQ	Set output Q to + or – XXXX VARS
± XXXXV	Set output voltage to + or – XXXX Volts
± XXXXW	Set output power to + or – XXXX Watts

X = numerals 0 through 9

An embedded decimal point character may be used as necessary

**Table 2.5 - 1040C Status Message Description, Control Status (QC)**

POSITION #	DESCRIPTION
1	Normal
2	Standby
3	Synchroscope 0°
4	400 HZ
5	HZ
6	Reset
7	60 HZ
8	DC
9	Phase
10	% Deviation
11	Not used
12	Not used
13	Operate
14	Power Factor
15	Not used
16	Synchroscope 180°
17	Voltage 1
18	Memory Store 1
19	Memory Store 2
20	Power 1
21	Voltage 2
22	Current 1
23	Current 2
24	Power 2
25	Operate/Standby

**Table 2.5 - Control Status (QC) (continued)**

POSITION #	DESCRIPTION
26	Not used
27	Voltage On
28	Current On
29	Power Converter On
30	Not used
31	Not used
32	Flash Display

**Table 2.6 - 1040C Status Message Description, Current & Voltage  
Current Range (QI) and Voltage Range (QV) Status**

BIT #	CURRENT RANGE	VOLTAGE RANGE
1	1 mA	100mV
2	10 mA	1 V
3	100 mA	10 V
4	0	0
5	0	0
6	1 A	100 V
7	10 A	1000 V
8	0	0

**Table 2.7 - GPIB Error Codes**

---

SERIAL POLL RESPONSE	DESCRIPTION
64 + CODE #	Routine Operation Error CODE # (See Table 2.8 for Code #'s 0 through 10)
64 + 11	Processor Control Function Test Failure
64 + 12	Current Output Function Test Failure
64 + 13	Voltage Output Function Test Failure
64 + 14	Power Converter Function Test Failure
64 + 20	GPIB Command Entry Not Found
64 + 21	GPIB Command Value out-of-bounds
64 + 22	GPIB Command Sequence Error
64 + 30 +Error #	Diagnostic Test Failure W/ Error# (See Table 2.9 for Error#)
64 + 50	Passed Assigned Test

## Table 2.8 - Routine Operation Error Codes

(Also displayed on Hand Held Unit)

---

CODE #	DESCRIPTION
0	Output Overload
1	PMC unable to supply required output level
2	Not used
3	Measurement offset adjust error
4	Not used
5	Not used
6	Deviation cardinal point is zero
7	PMC output terminals not isolated
8	Not used
9	PMC calibration storage error
10	Calibration limit exceeded

**Table 2.9 - Diagnostic Tests and Error Codes**

TEST #	ERROR #	DESCRIPTION
01		Display and LED Test No error report (operator views display and LED's for defects).
02		Control Switch Test No error report. Operator cued to press Front Panel Buttons. Test if the button tested is inoperative, if all buttons are tested and operate, PASS message displayed (pass code is reported via GPIB if the test was requested over GPIB).
03		Processor Card Test
	1	ROM Check Sum Error
	2	RAM Check Error
	3	Phase Control Test Error
04		ADC Card Test
	1	100 mV Reference Error
	2	Sample and Hold Test Error
	3	A/D Converter Test Error
05		Current Measurement Test
	0	Measurement Offset Adjustment Error
	1	Reference Measurement Error
	2	AC Gain Measurement Error
	3	Overload Circuit Test Error
	4	1 mA. Range Measurement Error
	5	10 mA. Range Measurement Error
	6	100 mA. Range Measurement Error
	7	1 A. Range Measurement Error
	8	10 A. Range Measurement Error
	9	Current Amplifier Offset Error
06		Current Source Test
	1	Current Generator Attenuator Test Error
	2	AC Operation Failure

**Table 2.9 - Diagnostic Test Error Codes (continued)**

TEST #	ERROR #	DESCRIPTION
07		Voltage Measurement Test
	0	Measurement Offset Adjustment Error
	1	Reference Measurement Error
	2	AC Gain Measurement Error
	3	Overload Circuit Test Error
	4	100 mV Range Measurement Error
	5	1 V Range Measurement Error
	6	10 V Range Measurement Error
	7	100 V Range Measurement Error
	8	1000 V Range Measurement Error
08		Voltage Source Test
	1	Voltage Generator Attenuator Test Error
	2	AC Operation Failure
09		Hand Held Unit Test
		No error report. Operator cued to press Front Panel Buttons. Test if the button tested is inoperative, if all buttons are tested and operate, PASS message displayed (pass code is reported via GPIB if the test was requested over GPIB).



## **2.8 Self Test Operation**

### **2.8.1 General**

The PMC has two levels of built-in self-tests: a Function Test which checks for general functional characteristics and a set of Diagnostic Tests which provide for detailed fault isolation. The Function Test is performed automatically on power on and may be re-run at anytime by pressing and holding both of the modify keys (Up/Down arrows) and depressing the RESET key. Pressing the MODIFY DOWN key and depressing the RESET key will initiate the Diagnostic Tests. Terminate the Function Test or Diagnostic Tests by pressing RESET.

### **2.8.2 Function Test Description**

**NOTE** All PMC outputs must be isolated for proper Function Test Operation.

The Function Test is automatically performed during the power on sequence. The function test verifies that the major subsections of the PMC are operating. Should a fault be detected, it can be localized using the diagnostic tests (see the diagnostic test description for details, Sec. 2.8.3). It is assumed that the Z80 control processor and its associated circuitry are operable in order to perform the function test. An inoperable control processor would be immediately evident during the power on sequence by random illumination of front panel LED's and a blank or incoherent display. The PMC should be immediately switched off if this situation occurs; corrective maintenance will be required.

The following information describes the various function tests that are performed. They are listed in the order they are performed and each test references the PMC circuit subsection being tested. If a failure occurs, a FAIL message will be displayed and no further tests will be performed. Corrective maintenance must be performed before the PMC is placed in service.

#### **2.8.2.1 DISPLAY AND LED TEST**

All LED's and all elements of the alphanumeric display are illuminated during this test. The flashing STORE LED, OVERLOAD AND HIGH VOLTAGE warning indicators are also exercised. Defective LED's or display elements are easily noted for later corrective maintenance.

#### **2.8.2.2 CONTROL FUNCTION TEST**

During this test, the following key elements of the control section are tested.

1. Read Only Memory (ROM), which holds the PMC control program
2. Random Access Memory (RAM), which stores the measurement and operational data
3. Frequency generation and phase measurement counter circuitry
4. Electrically Erasable ROM (EEROM), which stores calibration and user data
5. Analog to Digital conversion circuitry (A/D).

The EEROM is not directly tested by the function test but is tested for loss or alteration of data during power on and is tested each time the reset function or calibration operations are performed. As mentioned above, it is assumed that a catastrophic fault is not present in the Z80 control

processor so that it is able to function, at least in a limited way, to perform the following control tests:

#### **2.8.2.2.1 ROM Test**

A check sum test is performed on the control ROM to verify that the control program is intact. All of the bytes for the control program, present in the ROM, are added to form a sum, which is compared with a stored value in the ROM. A FAIL message is displayed if a difference is detected.

#### **2.8.2.2.2 RAM Test**

All bytes in the RAM are exercised to verify correct operation. A FAIL message is displayed in the event a fault is detected.

#### **2.8.2.2.3 Phase Test**

The frequency generation and phase control circuitry are checked in this test. The test is restricted to the signal generation circuits and does not include operation of the AC voltage and alternating current output amplifiers. A FAIL message at the end of this test would indicate a fault in the processor phase control or frequency generation circuitry.

#### **2.8.2.2.4 A/D Test**

The analog to digital converter test measures the internal precision 100mV reference and verifies the operation of the sample and hold circuitry. A FAIL message is displayed if these tests are not correctly performed.

### **2.8.2.3 CURRENT OUTPUT TEST**

The message CURRENT TEST is displayed during the performance of the current output tests. A FAIL message is displayed if defective operation is detected.

The low current output amplifier and current measurement circuitry are tested first for correct operation. If a fault is detected, the CURRENT TEST FAIL message is displayed. The high current output amplifier is tested following successful completion of the low current test. Again, a FAIL message is displayed if a fault is detected; otherwise, the voltage function tests are performed. The low and high current tests are performed at 400 Hz in order to exercise extensive portions of the AC and DC sections of the PMC measurement circuitry.

### **2.8.2.4 VOLTAGE OUTPUT TEST**

The message VOLTAGE TEST is displayed during the performance of the voltage output tests. The low voltage DC output amplifier and voltage measurement circuitry are tested first for correct operation. If a fault is detected the VOLTAGE TEST FAIL message is displayed. The high voltage output amplifier is tested following successful completion of the low voltage test. Two voltages are tested, 100 V and 1000 V. Again, a FAIL message is displayed if a fault is detected in either of the tests; otherwise, a PASSED FUNCTION TEST message is briefly displayed signifying successful completion of the function tests. The PMC is placed in the Reset mode and DC, 60 Hz or 400 Hz is displayed. This indicates that the PMC is ready for service.

### **2.8.3 Diagnostic Test Description**

The PMC diagnostic tests are initiated if a power-on function test failure occurs or if the operator presses and holds the MODIFY DOWN key and then presses the RESET key. Upon initiation of the diagnostic tests (UP ARROW), (DOWN ARROW) & ENT for tests will be displayed. The MODIFY UP and MODIFY DOWN keys are used to cycle through the tests. Once the desired test is displayed, press ENTER to begin the test.

#### **Diagnostic Test Titles**

0. Exit Tests
1. Display and LED Test
2. Front Panel Key Test
3. RAM/ROM & Phase Test
4. Reference & ADC Test
5. Current Measure Test
6. Current Source Test
7. Voltage Measure Test
8. Voltage Source Test
9. Hand Held Unit Test
10. Debug Utilities

It is assumed that the Z80 control processor and its associated circuitry are operable in order to perform the diagnostic tests. An inoperable control processor would be immediately evident on power on by random illumination of control panel LED's and a blank or incoherent display. The PMC should be immediately switched off if this situation occurs and corrective maintenance performed to verify or replace the Z80 processor and associated power supply and support circuitry. Once correct processor operation is available the diagnostic tests can be performed to test the remaining portions of the PMC.

The following is a description of the individual menu items:

#### **2.8.3.1 EXIT TESTS**

This menu item when selected returns the PMC to Reset mode.

#### **2.8.3.2 DISPLAY AND LED TEST**

All LED's are illuminated and the flashing STORE LED is exercised. The alphanumeric matrix display is placed in a self-test mode, which displays all possible characters. The flashing OVERLOAD and HIGH VOLTAGE warning indicators are also exercised. Defective LED's or display elements are easily noted for later corrective maintenance. Depress the MODIFY UP or MODIFY DOWN key momentarily to signify pass or fail respectively and to exit this test.

### **2.8.3.3 FRONT PANEL KEY TEST**

All of the front panel PMC keys and the knob are checked for correct operation in this test. The knob check is performed first. The PMC will display the message KNOB = XXX. As the knob is rotated the number represented by XXX will cycle from 0 to 255, increasing as the knob is rotated clockwise and decreasing as the knob is rotated counter-clockwise. When the knob operation check is completed press the ENTER key to continue. During the front panel key test the name of a control key is displayed and the operator must respond by pressing the indicated key. If the control key operates correctly, the next key name is displayed; otherwise no action occurs and the test halts at this point. Corrective maintenance is required in the circuit area of the faulty key in order for the test to proceed. The key test can be terminated any time after the RESET key is tested by pressing RESET (assuming the RESET key is operable).

### **2.8.3.4 RAM/ROM & PHASE TEST**

Key elements of the control section are tested including: (1) read only memory (ROM), which holds the PMC control program; (2) random access memory (RAM), which stores measurement and operational data; (3) electrically erasable ROM (EEROM) which stores calibration and user data; and (4) frequency generation and phase control. The EEROM is not directly tested in this test routine but is tested for loss or alteration of data during power on and is tested each time the RESET function and calibration operations are performed. As mentioned above, it is assumed that a catastrophic fault is not present in the Z80 control processor so that it is able to function, at least in a limited way, to perform the control tests.

#### **2.8.3.4.1 ROM Test**

A check sum test is performed on the control ROM to verify that the control program is intact. All of the bytes for the control program, present in the ROM are added to form a sum, which is compared with a stored value in the ROM. A FAIL message is displayed if a difference is detected.

#### **2.8.3.4.2 RAM Test**

All bytes in the RAM are exercised to verify correct operation. A FAIL message is displayed if a fault is detected.

#### **2.8.3.4.3 Phase Test**

The frequency generation and phase control counter circuitry are checked in this diagnostic test. The test is restricted to the signal generation circuits and does not include operation of the PMC voltage and alternating current output amplifiers. A FAIL message at the end of this test would indicate a fault in the processor counter or frequency generation circuitry.

### **2.8.3.5 REFERENCE & ADC TEST**

The analog to digital converter (ADC) test measures the internal precision 100 mV reference and verifies the operation of the sample and hold and analog to digital conversion circuitry.

#### **2.8.3.5.1 Reference Test**

The ADC measures and compares its internal reference with the PMC's precision DC voltage reference source. The measurement is performed using the current measurement circuitry. If an out-of-bound condition exists, the measurement is repeated using the voltage measurement circuitry. If the out-of-bound condition persists, a FAIL message is displayed.

#### **2.8.3.5.2 Sample and Hold Test**

This test is performed in two steps. The precision reference is measured as described in the reference test above and the result is stored. Next, the sample and hold circuitry is placed in the hold mode, and the reference input is removed. After a period of time the reference measurement is repeated. The hold measurement and the original reference measurement values should agree within a prescribed limit in order to pass the test. A FAIL message is displayed if an unacceptable drift is detected in the hold value.

#### **2.8.3.5.3 ADC Test**

Operation of the PMC analog to digital converter (ADC) is verified by comparing the ADC's response to various known input signals. Detection of an out-of-limit measurement value results in the display indicating FAIL. If shown, corrective maintenance of the ADC circuitry is needed.

### **2.8.3.6 CURRENT MEASUREMENT TEST**

The current measurement circuitry is validated first. Each of the 5 PMC current output ranges are then exercised at the maximum current value for each range (the 10 A range is tested at 2 A). In the event of a measurement failure, the PMC DEBUG UTILITIES, (see Sec. 2.8.4.1) can be used to display measurement values and provide additional operational data for localizing a fault or for aid in setting manual adjustments.

*The following tests are performed to assess the PMC current measurement and output functions.*

#### **2.8.3.6.1 Current Measurement Offset Test**

The output of the current measurement amplifier is tested with a zero-voltage, input signal. The amplifier output must be less than a prescribed value or a FAIL message is displayed.

#### **2.8.3.6.2 DC Current Measurement Gain Test**

The PMC's precision reference is measured using the PMC's DC current measurement circuitry. The measurement amplifier's DC gain value is then compared with the expected value and a FAIL message is displayed if the difference falls outside a prescribed limit.

#### **2.8.3.6.3 AC Current Measurement Gain Test**

The PMC precision reference is measured using the AC current measurement circuitry. The AC measurement amplifier's gain value is then compared with the expected value and a FAIL message is displayed if the difference falls outside a prescribed limit.

#### **2.8.3.6.4 Current Overload Test**

The current overload test is performed in two steps. In the first step the test relay is closed and the current source is energized. A compliance measurement is performed and should be less than a prescribed limit. In the second step the test relay is opened with the current source energized and the compliance voltage measurement is repeated. The compliance voltage measured should exceed a prescribed value. A FAIL message is displayed if the test fails. NOTE: The current output connections must be open for proper operation of this test.

#### **2.8.3.6.5 Current Output Range Test**

Each of the 5 current output ranges is tested for correct output at full-scale values. The current output test relay is closed during the test to provide a current path for the output. Range 5, the 10A range, is tested at 2A. (The test relay contacts are rated at 2A.) The tests performed are the lowest DC current range (range 1) at 1 mA full scale, then range 2 at 10 mA, and range 3 at 100 mA. High current ranges, range 4 at 1 A and range 5 at 2 A for the 10 A range, are tested for correct output. This test also tests the current power converter, which supplies the high current output amplifier.

The range test current outputs are measured and compared with an expected value. If the test output value deviates from the expected value by more than a prescribed limit, a test failure message for the range is displayed and corrective maintenance is required.

#### **2.8.3.7 CURRENT SOURCE TEST**

Current waveform generation and control circuitry is tested in this series of tests. The operation of the digital to analog sinewave generator and the attenuator control circuits are exercised.

##### **2.8.3.7.1 Minimum Output Test**

The coarse and fine control attenuators, A1 and A2, are set for minimum output and the current output is measured. If the output exceeds a prescribed limit a **FAIL** message is displayed and the attenuator circuitry needs corrective maintenance.

##### **2.8.3.7.2 Attenuator Test**

To produce a prescribed set of output values the unit increments and decrements internal attenuators to check the linearity of the attenuators. A FAIL message indicates that the linearity of the control DAC is suspect and corrective maintenance is required.

##### **2.8.3.7.3 Sinewave Test**

The sinewave generator output at 60 Hz is tested. The measured output must agree with a preset value, within a prescribed limit, in order to pass the test. A FAIL message indicates that the sinewave generation ROM and DAC circuitry are suspect and in need of corrective maintenance. The high current output amplifier is not used in this test.

#### **2.8.3.8 VOLTAGE MEASUREMENT TEST**

The voltage measurement circuitry is validated first and if correct results are obtained each of the 5 voltage output ranges are exercised for correct output at the maximum output value for each

range. In the event of a measurement failure, the PMC DEBUG UTILITIES (see Sec. 2.8.4.1) can be used to display measurement values and provide additional operational data for localizing a fault or for aid in setting manual adjustments.

The following tests are performed to assess the PMC voltage measurement and output functions.

#### **2.8.3.8.1 Voltage Measurement Offset Test**

The output of the voltage measurement amplifier is tested with a zero-signal input. The amplifier output must be less than a prescribed value or a FAIL message is displayed.

#### **2.8.3.8.2 DC Voltage Measurement Gain Test**

The PMC precision reference is measured using the DC voltage measurement system. The resulting measurement amplifier DC gain value is compared with the expected value and a FAIL message is displayed if the difference falls outside a prescribed error limit.

#### **2.8.3.8.3 AC Voltage Measurement Gain Test**

The PMC precision reference is measured again using the AC voltage measurement system. The resulting measurement AC amplifier gain value is compared with the expected value and a FAIL message is displayed if the difference falls outside a prescribed error limit.

#### **2.8.3.8.4 Voltage Overload Test**

The voltage overload test is performed in two steps. First the overload input is tested with zero voltage applied to its input. The measured overload value should be less than a prescribed limit; otherwise a FAIL message is displayed. In the second step a test voltage is applied to the overload input and the overload measurement is repeated. The overload value should exceed a prescribed value for passage of the test.

#### **2.8.3.8.5 Voltage Output Range Test**

Each of the 5 voltage output ranges are tested for correct output at full-scale values. The tests are performed with DC output set to the lowest voltage range, range 1, at 100 mV, then range 2 at 1 V, range 3 at 10 V, range 4 at 100 V and range 5 at 1000 V. This test also checks the voltage power converter, which supplies the high voltage output amplifier.

The range test voltage outputs are measured and compared with an expected value. If the test output value deviates from the expected value by more than a prescribed limit then a test failure for the range is displayed and corrective maintenance is required.

#### **2.8.3.9 VOLTAGE SOURCE TEST**

Voltage waveform generation and control circuitry is tested in this series of tests. The operation of the digital to analog sinewave generator and the attenuator control circuits are exercised.

### **2.8.3.9.1 Minimum Output Test**

The coarse and fine control attenuators, A1 and A2, are set for minimum output and the voltage output is measured. If the output exceeds a prescribed limit a FAIL message is displayed and the attenuator circuitry needs corrective maintenance.

### **2.8.3.9.2 Attenuator Test**

To produce a prescribed set of output values the unit increments and decrements internal attenuators to check the linearity of the attenuators. A FAIL message indicates that the linearity of the control DAC is suspect and corrective maintenance is required.

### **2.8.3.9.3 Sinewave Test**

The sinewave generator output at 60 Hz is tested. The measured output must agree with a preset value within a prescribed limit in order to pass the test. A FAIL message indicates that the sinewave generation ROM and DAC circuitry is suspect and in need of corrective maintenance. The high voltage amplifier is not used in this test.

## **2.8.4. HANDHELD UNIT TESTS**

All of the Hand Held Unit controls are checked for correct operation in this test. The name of a control key is displayed and the operator responds by pressing the indicated key. If the control key operates correctly, the next key name is displayed; otherwise no action occurs and the test 'hangs' at this point. Corrective maintenance is required in the circuit area of the faulty key in order for the test to proceed. The PASS message is displayed when all controls operate correctly. Press the MODIFY DOWN key to return to the test menu after successful completion of the Hand Held Unit test. The test can be terminated any time by pressing RESET.

### **2.8.4.1 DEBUG UTILITIES**

This menu item contains a number of test functions, which allow the operator to view "raw" measurement data items that are critical to the operation of the PMC. Facilitate amplifier adjustments in the current and voltage measurement sections by observing the offset data while adjusting the trimmer controls. In addition, amplitude control DACs can be set by the operator to allow current and voltage outputs to be changed independent of processor feedback control. This allows the repair technician to observe operation of individual hardware items at fixed settings without interference due to processor control actions. Each voltage and current output range can be individually exercised.

Upon entry into the test, the operator is queried by the display message **CURRENT OR VOLTAGE?**

When the operator presses the CURRENT or VOLTAGE key, according to the series of tests desired, the message 'OFFSET TEST XXXXX' appears. XXXXX is the ADC reading of the output of the current or voltage measurement operational amplifier circuit with a zero input signal. The ADC reading is nominally 300 +20 when the amplifier offset is properly adjusted. If the reading does not agree the appropriate trimmer should be adjusted. Replacement of the operational amplifier may be needed if the offset cannot be adjusted to the nominal value.



Press the ENTER key when finished with the offset adjustment to proceed to the DC gain test, which is announced by the message **DC GAIN TEST XXXXX**. XXXXX is the measurement reading obtained when the precision 100-mV reference is applied to the measurement amplifier input. A reading of 14,700 +300 indicates correct DC operation.

Press the ENTER key when finished with the DC gain test to proceed to the AC gain test, which is announced by the message **AC GAIN TEST XXXXX**. XXXXX is the measurement reading obtained when the precision 100-mV reference is applied to the measurement amplifier input. A reading of 10,500 +200 for current or 6900 +200 for voltage indicates correct AC operation.

Press the ENTER key when finished to proceed to the overload test, which is announced by the message **OVERLOAD TEST XXXXX**. XXXXX is the measurement reading obtained when the output of the overload circuit is applied to the measurement amplifier input. A reading of less than 1000 indicates correct operation.

If the Current tests are being performed, the display will show **AMP OFFSET TEST XXXX** after pressing ENTER. The reading XXXX is a measurement of the output amplifier offset and should be less than 400.

Press the ENTER key when finished to proceed to the output range tests, indicated by the range messages, for example **RANGE 1 XXXXX**. XXXXX is the measurement reading obtained when the current or voltage output is applied to the measurement amplifier input. A reading of less than 700 is obtained initially. The output current or voltage is under manual control and may be adjusted up or down through the use of the MODIFY keys. The display shows the amplitude control setting while a MODIFY key is pressed. Control settings of 0 to 4095 are available and increment or decrement in steps of 100. The display reverts to the output reading when a MODIFY key is released. The output may be turned "on" or "off" by use of the OPER and STBY keys. Pressing the STBY key not only turns "off" the output but also returns the amplitude control setting to 0. The range tests are useful for observing measurement values and analog circuit performance in a static mode without the complexities of processor feedback control. Press the CURRENT or VOLTAGE key when finished with a range test to proceed to the next range.

## CAUTION

Take care not to exceed full-scale outputs for a given range. Control is entirely manual. Overload operation and processor feedback controls are disabled during the range tests. If difficulties occur press the RESET key to exit the test and return to normal operation.

The following is a table of typical values for full-scale range settings:

### Current Settings

RANGE	FULL SCALE OUTPUT	MODIFY VALUE	OUTPUT VALUE
1	1 mA	2600	15340
2	10 mA	2600	15340
3	100 mA	2500	14750
4	1 A	2600	15200
5	10 A	2600	15200

### Voltage Settings

RANGE	FULL SCALE OUTPUT	MODIFY VALUE	OUTPUT VALUE
1	100 mV	2600	15340
2	1 V	2600	15340
3	10 V	2500	14750
4	100 V	2600	15200
5	1000 V	2600	15200

Upon completion of the current output amplifier offset test, use the MODIFY UP or MODIFY DOWN keys to indicate pass or fail respectively. The operator may repeat the Debug Utilities or select other Diagnostic Tests.

### 2.9 Error Messages

The PMC displays numerous error messages to warn the operator of improper entries and setups, out-of-bound conditions, and internal faults. Along with the message display the errors are reported by code number on the Hand Held Unit display and over the GPIB. Table 2.10 lists the various error messages as seen on the display with a description, probable cause, appropriate action to be taken, and the corresponding code number. The PMC may always be returned to normal operation by pressing the RESET key.

A failure during the Function Test or one of the Diagnostic Tests is reported with FAIL appearing in the last four display locations. If a test failure persists consult a repair technician.



**Table 2.10 - Error/Probable Cause/Appropriate Action**

CODE #	DISPLAYED MESSAGES	DESCRIPTION	PROBABLE CAUSE	APPROPRIATE ACTION
0	VOLTAGE OVERLOAD	Too much current is being drawn from the voltage output. The flashing OVERLOAD light is illuminated.	<ol style="list-style-type: none"> <li>1. Voltage cable connectors shorted.</li> <li>2. Improper meter connections.</li> <li>3. Meter impedance too low.</li> <li>4. Selected voltage too high.</li> </ol>	<ol style="list-style-type: none"> <li>1. Check for proper operation with voltage cable is connected from PMC. If Error persists, an internal fault exists.</li> <li>2. Check voltage cable for isolation between banana connections.</li> <li>3. Check meter for proper input impedance.</li> </ol>
0	CURRENT OVERLOAD	The voltage at the current output went beyond the compliance limit attempting to reach the requested current. The flashing OVERLOAD light is illuminated.	<ol style="list-style-type: none"> <li>1. Current cable connections improper.</li> <li>2. Meter impedance too high.</li> <li>3. Selected current too high.</li> </ol>	<ol style="list-style-type: none"> <li>1. Check the current cable impedance.</li> <li>2. Using tested current cable, check for proper operation with cable ends shorted. If error persists, an internal fault exists.</li> <li>3. Check for proper meter connections.</li> <li>4. Check meter for proper input impedance.</li> </ol>



**Table 2.10 - Error/Probable Cause/Appropriate Action (continued)**

CODE #	DISPLAYED MESSAGES	DESCRIPTION	PROBABLE CAUSE	APPROPRIATE ACTION
1	VOLTAGE OUTPUT LOW	Unable to reach requested voltage.	Internal fault.	Consult repair technician.
1	CURRENT OUTPUT LOW	Unable to reach requested current.	Internal fault.	Consult repair technician.
3	OFFSET ADJUST ERROR	Either the voltage or current measurement amplifier needs to have its input offset voltage adjusted.	Component change or aging.	Using the Debug Routine, adjust either R13 on the Voltage Measurement card or R33 on the Current Measurement card (see Section 2.8.4.1).
7	OUTPUT NOT ISOLATED	A signal from an outside source of at least 10 Volts and 10 mA is present on the voltage or current outputs.	<ol style="list-style-type: none"> <li>1. Connection was made to a non-isolated meter.</li> <li>2. A cross connection between the voltage and current outputs exists.</li> </ol>	Disconnect one connection at a time, starting at the meter, to isolate the source.



**Table 2.10 - Error/Probable Cause/Appropriate Action (continued)**

CODE #	DISPLAYED MESSAGES	DESCRIPTION	PROBABLE CAUSE	APPROPRIATE ACTION
9	CAL. STORAGE ERROR	Whenever new calibration constants are stored a check sum is created. Upon power-up the constants are read and the check sum is verified. This error indicates the check sum verification failed.	Possible faulty component on processor card.	Turn PMC off and back on again. If problem persists consult repair technician.
10	CAL. LIMIT EXCEEDED	The calibration adjustment limit has been exceeded.	During calibration the output has been adjusted too far in one direction.	Check measurement equipment to verify calibration value. If the problem persists an internal fault is indicated - consult repair technician.
	ENTRY ERROR	An out-of-bounds value or incorrect units were input.	Incorrect key strokes.	After a few moments the error message will disappear and normal operation may continue.
	ERROR	Generic		If failure persists, consult repair technician.





## **SECTION 3 – APPLICATION NOTES**

# **CALIBRATING METERS AND TRANSDUCERS WITH THE MODEL 1040C PANEL METER CALIBRATOR**

**ARBITER SYSTEMS, INC.**  
1324 VENDELS CIRCLE, SUITE 121  
PASO ROBLES, CA 93447  
(805) 237-3831 FAX (805) 238-5717

PD0010800A 9-92

# Table of Contents

Introduction .....	1
Using the 1040C for Calibrating Single Phase Devices.....	2
A.C. Voltage .....	2
A.C. Current.....	2
A.C. Power.....	3
A.C. Frequency .....	3
Phase Angle.....	4
Power Factor .....	4
Volt-Amps and Volt-Amps Reactive.....	5
Using the 1040C for Calibrating Polyphase Devices.....	7
A.C. Voltage .....	7
A.C. Current.....	7
A.C. Power.....	7
Phase Angle.....	8
Power Factor .....	8
Volt-Amps and Volt-Amps Reactive.....	10
Calibrating Transducers Using the Null Comparison Method.....	11
Connection Diagrams.....	12
Phase, Power Factor, and VAR Convention Diagram .....	23
Appendix A: Meter Examples.....	24

# Calibrating Meters and Transducers with the Arbiter Systems 1040C Panel Meter Calibrator

## Introduction

Because of the variety of parameters involved, in-house and field calibration of meters and transducers used in the power industry has in the past required several specialized instruments. The Arbiter Systems Model 1040C Panel Meter Calibrator has incorporated all of the necessary functions into a single portable unit, designed specifically for the task. The purpose of this document is to provide a guideline for using the 1040C to calibrate commonly used meters and transducers.

The 1040C Panel Meter Calibrator is used by service and calibration professionals in the power generation and distribution fields, to measure and/or insure the accuracy of various meters and transducers used in generating facilities and substations. The instrument is also used by the U.S. Navy, to perform similar calibrations on equipment used for shipboard power generation and distribution.

The 1040C Panel Meter Calibrator can be configured to perform eight calibration functions:

- Voltage (ac and dc);
- Current (ac and dc);
- Frequency;
- Power;
- Power Factor;
- Phase;
- VARs;
- Synchroscope.

A front panel keyboard and display allow direct selection of values for all of the parameters shown above. Entered values can be further modified using a knob also located on the front panel. A percent deviation key provides a simple method of determining the percentage of error for the meter or transducer under test. An internal memory allows storage of up to 99 instrument configurations for repetitive calibration tasks. Many of the operations performed via the front panel can be duplicated using the included hand-held control unit. Devices which operate within the following ranges can be calibrated with the 1040C:

- A.C. Voltage: 1.5 Vrms to 750 Vrms.
- A.C. Current: 0.1 Arms to 7.5 Arms.
- D.C. Voltage: 0.01 Vdc to 1000 Vdc.
- D.C. Current: 0.1 mAdc to 10.5 Adc.
- Frequency: 50 Hz to 75 Hz, 333 Hz to 500 Hz.
- A.C. Power: 1.5 VA to 5625 VA.
- Power Factor: 0.0 to 1.0, lead or lag.
- Phase: +180 to -180 degrees.
- VARs: 1.5 VA to 5625 VA.
- Synchroscope: Selection between 0 and 180 degrees.

## Using the 1040C for Calibrating Single Phase Devices

### A.C. Voltage

Representative schematics are given in figure 1 for typical circuit installations of single phase ac voltage meters and transducers. Connection of these instruments to the 1040C for calibration is a very simple process, illustrated in figure 2. The 1040C current output leads are not used, and can be left disconnected. The voltage output leads should be connected to the voltage input of the meter or transducer (figures 2a, 2c). If the meter or transducer uses an external potential transformer, it must be inserted between the 1040C voltage output leads and the input voltage leads of the unit under test (see Figure 2b, 2d). The user should then select the proper operating frequency, either 60 Hz or 400 Hz, and press the "Voltage" key to put the instrument into the voltage output mode. The desired voltage should then be entered, using the keypad, followed by the appropriate units. After this is completed, pressing the "Operate" key will enable the voltage output, which will increase to the value entered. An equal sign on the front panel display indicates that the output voltage has stabilized at the desired value. The calibration procedure for the meter or transducer under test can then be performed. For more complete instructions on operation of the 1040C in the ac voltage mode, refer to section 2.5.3 of the operation manual.

### A.C. Current

Calibration of a single phase transducer or meter for ac current follows virtually the same

process as for ac voltage meters and transducers, except that only the current output of the 1040C is used, rather than only the voltage output. Representative schematics are given in figure 3 for typical circuit installations of single phase ac current meters and transducers. Connection of these instruments to the 1040C for calibration is illustrated in figure 4. The 1040C voltage output leads are not used, and can be left disconnected. The current output leads should be connected to the current input of the meter or transducer (figures 4a, 4c). If the meter or transducer uses an external current transformer, one output lead of the 1040C should be routed through the center of the current transformer and connected to the other lead (see Figure 4b, 4d). The user should then select the proper operating frequency, either 60 Hz or 400 Hz, and press the "Current" key to put the instrument into the current output mode. The desired current should then be entered, using the keypad, followed by the appropriate units. After this is completed, pressing the "Operate" key will enable the current output, which will increase to the value entered. An equal sign on the front panel display indicates that the output current has stabilized at the desired value. The calibration procedure for the meter or transducer under test can then be performed. For more complete instructions on operation of the 1040C in the ac current mode, refer to section 2.5.5 of the operation manual.

## **A.C. Power**

Typical circuit connections for single-phase ac watt meters and transducers are given in figure 5. Calibration of these types of devices requires use of both the voltage and current outputs of the 1040C. Representative calibration connection diagrams for these types of devices are given in figure 6. The 1040C voltage output leads are connected to the voltage terminals of the meter or transducer, and the 1040C current output leads are connected to the current input terminals of the meter or transducer (figures 6a and 6c). If the meter or transducer uses an external current transformer, one of the current output leads of the 1040C should be passed through the center of the current transformer, and then shorted to the other lead. If the meter or transducer uses an external potential transformer, then likewise it must be inserted between the 1040C voltage output leads and the input voltage leads of the unit under test. Refer to figures 6b and 6d for these connections. The user should then select the proper operating frequency, either 60 Hz or 400 Hz. The "Power" key should be pressed, which will place the 1040C into the power mode, enabling both the voltage and current outputs for simultaneous operation. The "Voltage" key should then be pressed, and the desired voltage entered using the keypad, followed by "V". After this, the "Current" key should be pressed and the desired current entered using the keypad, followed by "A". After this is completed, pressing the "Operate" key will enable the outputs, which will increase to the respective values entered. An equal sign on the front

panel display indicates that the current and voltage outputs, and the phase angle between them, have stabilized at the proper values. The calibration procedure for the meter or transducer under test can then be performed. The power value can be varied using the control knob or the up/down arrows, but it is important to note that it is only the current that changes; the voltage remains constant. For more complete instructions on operation of the 1040C in the ac power mode, refer to section 2.5.6 of the operation manual.

## **A.C. Frequency**

Calibration of ac frequency is another procedure that requires the use of only the 1040C voltage output. The connections are the same as for the volt meter or transducer (Figure 2). After connection, the frequency range (i.e. 60Hz, 400Hz) is selected, then "Voltage" is pressed. The operator then enters the voltage value which is appropriate for the device under test, followed by the voltage unit key. Fine adjustment of the frequency can be accomplished by first pressing the "Frequency" key, then using the adjust knob or up/down keys to select the value. A value for frequency can also be entered via the keyboard, by first pressing "Frequency", entering the value, then pressing the "Hz" key. When the "Operate" key is pressed, the voltage output will be enabled and the calibration procedure for the device under test may be performed. For more complete instructions on frequency operation of the 1040C, refer to section 2.5.8 of the operation manual.

## Phase Angle

Calibration of phase angle meters or transducers for single phase operation requires use of both the voltage and current outputs of the 1040C. The representative circuit connection diagrams for these types of devices are the same as for the ac power meters and transducers, given in figure 5. Typical connections for calibration are also the same as for ac power meters and transducers, and are given in figure 6. For calibration, the 1040C voltage output leads are connected to the voltage terminals of the meter or transducer, and the 1040C current output leads are connected to the current input terminals of the meter or transducer (figure 6a and 6c). If the meter or transducer uses an external current transformer, one of the current output leads of the 1040C should be passed through the center of the current transformer, and then shorted to the other lead. If the meter or transducer uses an external potential transformer, then likewise it must be inserted between the 1040C voltage output leads and the input voltage leads of the unit under test. Refer to figures 6b and 6d for these two types of connections. The 1040C should first be configured to operate in the ac power mode, as described in paragraph 2.5.6, and the appropriate voltage and current values should be selected. After the outputs have been enabled and the phase angle meter or transducer under test has been observed to be indicating zero, press the "Phase" button. This will allow shifting of the relative phase between the voltage and the current outputs. The desired phase angle can now be entered directly, via the keypad, and followed by the appropriate units (degrees). A negative value for phase angle corresponds to the output current lagging the output voltage. After entering the value for phase angle, the operator may adjust the value by using the control knob, or by using the "Up" or "Down"

keys. For more complete instructions on operation of the 1040C for phase angle calibrations, refer to section 2.5.1 of the operation manual.

## Power Factor

The Power Factor in a circuit is equal to the cosine of the phase angle between the voltage and the current. With this in mind, any power factor can be simulated by adjusting the phase relationship between the voltage and current, which can be accomplished quite easily with the 1040C. Two methods can be used:

- The required phase angle can be entered directly via the keypad, as described in the section on phase angle calibration;
- The power factor can be entered directly, by first pressing the "Power Factor" key, then using the adjust knob to vary the displayed power factor. This method allows entry of lead or lag power factor values without having to first calculate the corresponding phase angle.

For an illustration of the relationship between phase angle and power factor in the 1040C, refer to figure 12.

In order to accomplish power factor indication, some transducer manufacturers recommend using one of their phase angle transducers and performing a mathematical conversion on the output signal. This can be done manually, using conversion tables supplied by the manufacturer, or automatically, using a meter having cosine scaling. Typical transducer application circuit connections and calibration setup connections are usually the same as those for a phase angle, watt, or var transducer, as shown in

figures 5 and 6. Calibration can be performed using the connections in figure 6 and one of the methods outlined above, and in accordance with the transducer manufacturers recommendations.

Power factor output is also commonly available as an additional feature on single and multi-phase watt transducers. In this case, the transducer is connected in the same manner as a conventional watt transducer (refer to figures 5 and 6).

Typical applications of power factor *meters* for single-phase systems involve circuit connections which are similar, if not identical to those employed by single phase watt and var meters. In light of this, representative circuit and calibration connection diagrams for these meters are shown in figures 5 and 6. When connected per the calibration setup diagram, calibration of single-phase power factor meters can be performed using one of the methods given above, and in accordance with the meter manufacturer's recommendations. For more detailed instructions on operating the 1040C for calibration of power factor, refer to section 2.5.1 of the operation manual.

### **Volt-Amps and Volt-Amps Reactive**

Volt-Amps is the product of the rms voltage and the rms current in a circuit, without regard to the phase angle between them. Another term commonly used to describe this parameter is *apparent power*. If a separate rms ammeter and rms voltmeter were used to measure the current and voltage, respectively, and the two values were multiplied together, the result would be the apparent power. This is not an indication of the amount of work that can be done, however; if the phase angle is 90 degrees (power factor is zero), the true power available is zero.

*Volt-amps reactive* (SI unit=var) is the same as volt-amps, but with the phase angle between voltage and current factored in. Vars are a measure of the amount of power required by the reactive portion of a load, and actually represents circulating current in the circuit. Vars are calculated as the product of the RMS voltage, the RMS current, and the sine of the phase angle between the two. For an illustration of the relationship between phase angle and vars when using the 1040C, refer to figure 12.

The 1040C has a provision for displaying and modifying both volt-amps and vars; successively pressing the "Power" key during operation will first display watts, then vars, then volt-amps. The user can continue indefinitely to scroll through these three choices.

Some points of interest regarding va and var measurements:

It is important to note that unless there is a phase angle of greater than zero between voltage and current, the var value will be zero. Also, since va and var indications are sub-functions of the power mode, adjustment of these values using direct entry, the control knob, or the up/down keys affects the value by changing *only the current*, not the voltage or the phase angle. The current can only be modified to a point within the current range of the 1040C. If the necessary current exceeds this range, the display will indicate "Entry Error". Additionally, if the phase angle is set to zero and the user attempts to enter any var value other than zero, "Entry Error" will be indicated. This is because under these conditions, no value of voltage or current will produce anything other than zero vars.

Typical applications of va and var meters or transducers for single-phase systems

involve circuit connections which are similar, if not identical to those employed by single phase watt and power factor meters and transducers. Therefore, representative circuit connections and calibration connections for these devices are shown in figures 5 and 6, respectively. When connected per the

calibration setup diagram, calibration of these instruments can be performed in accordance with the meter manufacturer's recommendations. For more detailed instructions on operating the 1040C in the volt-amps and volt-amps reactive modes, refer to section 2.5.6 of the operation manual.



# Using the 1040C for Calibrating Polyphase Devices

## A.C. Voltage

Commercially available multi-phase voltage transducers frequently consist of more than one single-phase model from the manufacturers product line, repackaged into a common enclosure. In many cases, the outputs remain separate and independent. The procedure for calibration of these types of transducers is virtually identical to that of the single-phase voltage transducer. The three elements can be connected in parallel across the voltage output of the 1040C, as shown in figure 7a, provided that the combined current demand of the elements does not exceed the burden capability of the 1040C (refer to table 1.2 in the operation manual). Multiple voltmeters may also be connected to the 1040C in the same manner, as shown in figure 7b, with the same total current burden restriction.

## A.C. Current

Like their ac voltage counterparts, commercially available multi-phase current transducers frequently consist of more than one single-phase model from the manufacturers product line, repackaged into a common enclosure. In many cases, the outputs remain separate and independent. The procedure for calibration of these types of transducers is nearly identical to that of the single-phase current transducer. The three elements can be connected (in series) across the current output leads of the 1040C, as shown in figure 8a, provided that the combined voltage drop across the elements does not exceed the burden capability of the 1040C (refer to table 1.1 in the operation manual). Multiple current meters may also be connected to the 1040C in the same manner,

as shown in figure 8b, with the same total voltage burden restriction.

## A.C. Power

Power measurement in a three-phase, four-wire system requires three complete watt meters or watt transducers (each watt meter or transducer consists of one current element and one voltage element). Figure 9a shows a typical connection diagram for measurements of this type. A current sensing element is placed in series with each of the three phases, and a voltage sensing element is connected between each of the phases and the neutral wire. It is unnecessary to measure the neutral current directly, since any current flowing in the neutral conductor will be simultaneously flowing in one or more of the phases and will thus be measured.

Power measurement in a three-phase, *three*-wire system requires *two* complete watt meters or watt transducers. Figure 9b shows a connection diagram for this type of measurement. Again, the number of current elements required is equal to one less than the number of current-carrying conductors, since any current in the non-instrumented conductor must simultaneously be flowing in one or both of the others. The voltage elements are connected to the two phases having the current elements, with the common point for the voltage elements being the third phase.

Calibration of multi-element watt transducers or meters can be accomplished using the setup shown in figure 10. Basically, all of the current elements would be connected in series and placed across the current output of the 1040C, and all of the voltage elements would be connected in

parallel and placed across the voltage output of the 1040C. Again, current and potential transformers are shown for reference. Phasing of the elements is of great importance for accuracy of the calibration. All current elements should be wired the same way, and all voltage elements should be in phase. The only exception to this rule would be for 2 1/2 element transducers, which are sometimes used in order to save the cost of one potential transformer. The missing potential input is accounted for mathematically, so during calibration one of the current transformers must be reversed, and special calculations apply. When calibrating 2 1/2 element transducers, the product documentation for the device should be consulted for proper procedures.

### **Phase Angle**

Wiring connections for phase angle transducers used in three-phase systems at first glance may appear somewhat unorthodox. Typically, a single voltage element and a single current element are used. The current element is placed in series with one of the phases, or, if used, a current transformer is placed around the conductor for that phase. The voltage element is wired between the remaining two phases, sometimes employing a potential transformer. Refer to figure 11a for a typical application circuit. If the phase angle between the voltage and the current in the circuit is zero, the net voltage between the two measured phases (or the output voltage of the potential transformer) will be offset from the current measured in the third phase by 90 degrees. The two input signals are compared internally, and a dc voltage corresponding to the phase angle is output from the transducer.

Connections for use of a 1040C to calibrate this type of phase angle transducer are shown in figure 11b. The 1040C voltage

output leads are connected to the voltage terminals of the transducer, and the 1040C current output leads are connected to the current input terminals of the meter or transducer. If the transducer uses an external current transformer, one of the current output leads of the 1040C should be passed through the center of the current transformer, and then shorted to the other lead. If the meter or transducer uses an external potential transformer, then likewise it must be inserted between the 1040C voltage output leads and the input voltage leads of the unit under test. The 1040C should first be configured to operate in the ac power mode, and the appropriate voltage and current values should be selected. Next, a calibration phase angle value must be entered, keeping in mind that for indication of zero phase from the transducer output, the input voltage must be offset from the input current by 90 degrees (whether this is a lead or lag condition depends on the individual transducer manufacturer. The calibration procedure for the phase angle transducer can now be performed. For more complete instructions on operation of the 1040C for phase angle calibrations, refer to section 2.5.1 of the operation manual.

### **Power Factor**

In order to accomplish power factor indication, some transducer manufacturers recommend using one of their phase angle transducers and performing a mathematical conversion on the output signal. This can be done manually, using conversion tables supplied by the manufacturer, or automatically using a meter having cosine scaling. If a phase angle transducer is employed for this purpose, the connections will be the same as those illustrated in figure 11.

Power factor output is also commonly available as an additional feature on single and multi-phase watt transducers. In this case, the transducer is connected in the same manner as a conventional multi-phase watt transducer (refer to figure 9).

Regardless of the type of transducer or meter employed, the 1040C has a provision for direct calibration of power factor. As stated earlier in this document, the power factor in a circuit is equal to the cosine of the phase angle between the voltage and the current. With this in mind, any power factor can be simulated by adjusting the phase relationship between the voltage and current, which can be accomplished quite easily with the 1040C. Two methods can be used:

- The required phase angle can be entered directly via the keypad, as described in the section on phase angle calibration;
- The power factor can be entered directly, by first pressing the "Power Factor" key, then using the adjust

knob to vary the displayed power factor. This method allows entry of lead or lag power factor values without having to first calculate the corresponding phase angle.

Calibration of the transducer should be performed according to the instrument manufacturer's recommendations.

Typical applications of power factor *meters* for multi-phase systems involve circuit connections which are similar, if not identical to those employed by multi-phase phase angle transducers. Generally, the current is measured in one phase, and a comparison is made between it and the net voltage between the remaining two phases. Substituting a meter for the transducers shown in figure 11 will give a good indication of the type of connections necessary for typical applications and calibration.

For more detailed instructions on operating the 1040C for calibration of power factor, refer to section 2.5.1 of the operation manual.

## Volt-Amps and Volt-Amps Reactive

Refer to the single-phase volt-amps and volt-amps reactive section of this document for definitions of these parameters.

The 1040C has a provision for displaying and modifying both volt-amps and vars; successively pressing the "Power" key during operation will first display watts, then vars, then volt-amps. The user can continue indefinitely to scroll through these three choices.

Some points of interest regarding va and var measurements:

It is important to note that unless there is a phase angle of greater than zero between voltage and current, the var value will be zero. Also, since va and var indications are sub-functions of the power mode, adjustment of these values using direct entry, the control knob, or the up/down keys affects the value by changing *only the current*, not the voltage or the phase angle. The current can only be modified to a point within the current range of

the 1040C. If the necessary current exceeds this range, the display will indicate "Entry Error". Additionally, if the phase angle is set to zero and the user attempts to enter any var value other than zero, "Entry Error" will be indicated. This is because under these conditions, no value of voltage or current will produce anything other than zero vars.

Typical applications of va and var meters or transducers for multi-phase systems involve circuit connections which are similar, if not identical to those employed by multi-phase watt and power factor meters and transducers. Therefore, representative circuit connections and calibration connections for these devices are shown in figures 9 and 10, respectively. When connected per the calibration setup diagram, calibration of these instruments can be performed in accordance with the meter manufacturer's recommendations. For more detailed instructions on operating the 1040C in the volt-amps and volt-amps reactive modes, refer to section 2.5.6 of the operation manual.

## Calibrating Transducers Using the Null Comparison Method

The null comparison method is frequently recommended by transducer manufacturers, since it eliminates many of the variables that can be encountered in the course of a conventional calibration. The basic procedure for performing a null comparison calibration is as follows: The inputs of a precision standard are connected in parallel with the inputs of the transducer under test, and the appropriate source voltages and/or currents are applied. A differential meter is connected between the outputs of the precision standard and the transducer under test, and the zero and span settings of the transducer under test are adjusted until the differential meter displays zero. The advantage of this method is that since the input signals are exactly the same, the accuracy of the source (and the equipment

used to measure it) are inconsequential. The calibration accuracy is dependent only on the individual accuracies of the precision standard and of the differential meter.

Precision standards are usually available from the manufacturers of the transducers, and typically have accuracies of 0.1%. The disadvantage of using precision standards is that for each type of transducer to be calibrated, a different precision standard is required. Use of the 1040C eliminates the need for these various precision standards, since all of the necessary functions can be generated from one unit. Also, since the 1040C is a precision source and no external meters are necessary, the simplicity of the calibration procedure is about the same as that of the null comparison method.

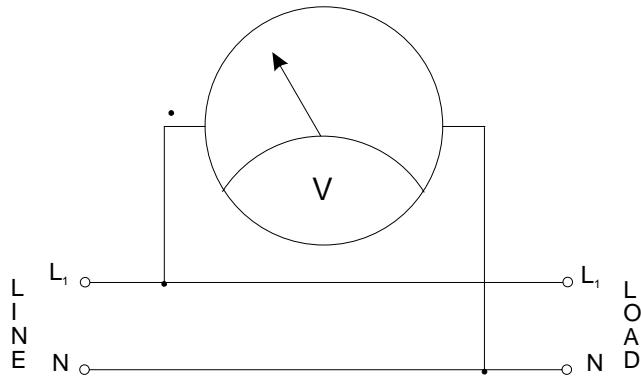

a) Voltmeter, Typical Installation, no Potential Transformer

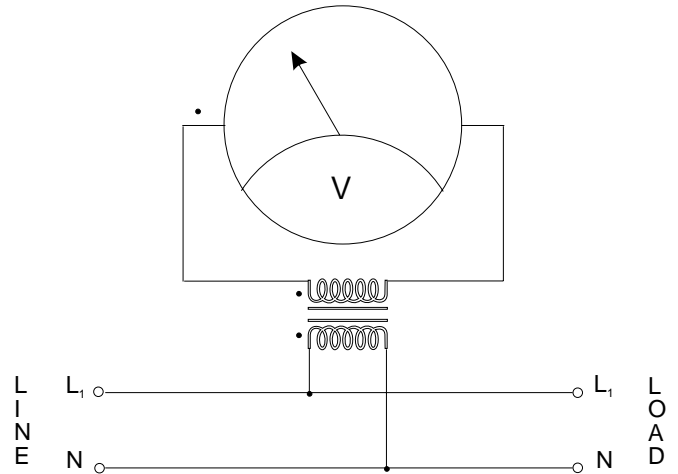

b) Voltmeter, Typical Installation, with Potential Transformer

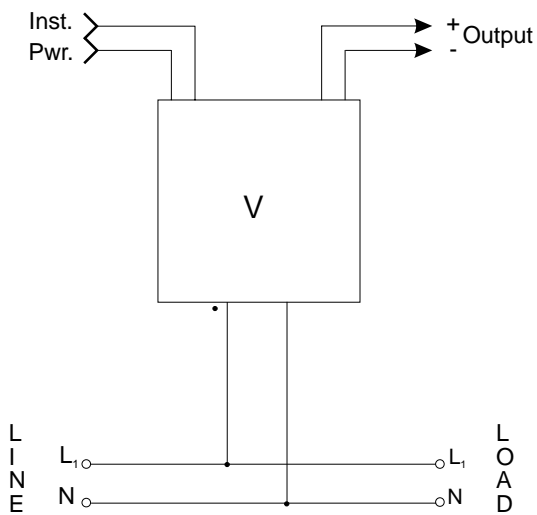

c) Voltage Transducer, Typical Installation, no Potential Transformer

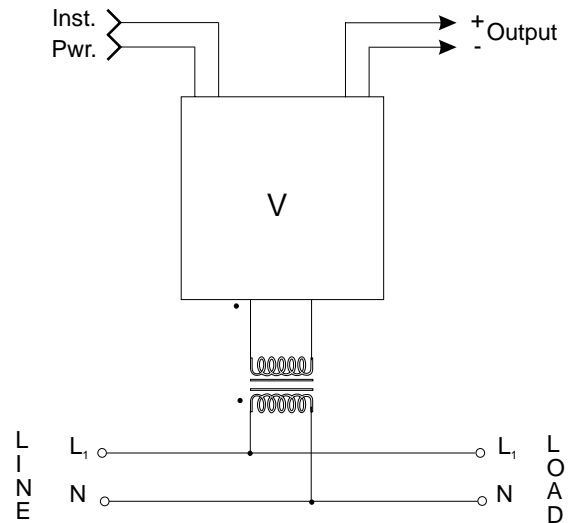

d) Voltage Transducer, Typical Installation, with Potential Transformer

**Figure 1**  
**Single-Phase Voltage Meters and Transducers,**  
**Typical Circuit Connections**

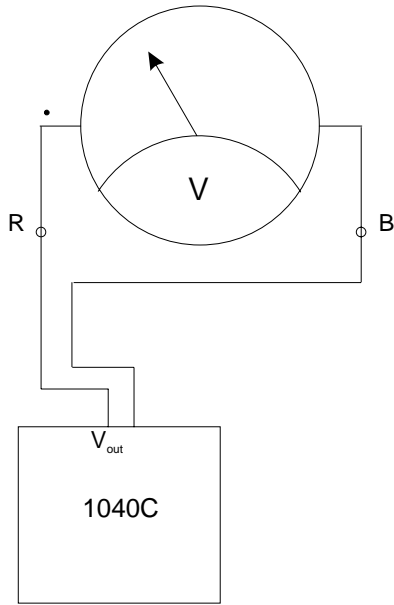

a) Voltmeter Calibration Connections, no Potential Transformer

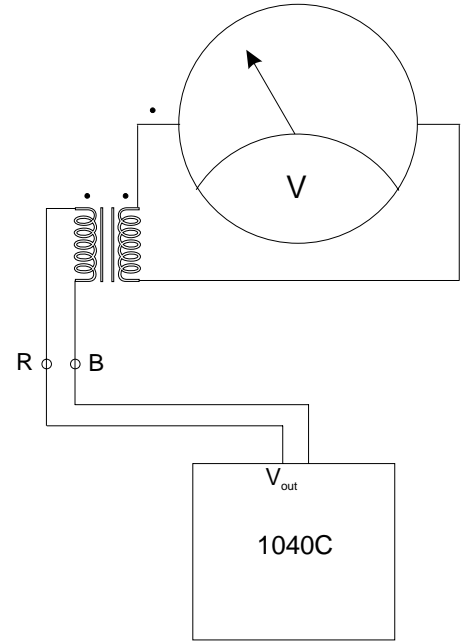

b) Voltmeter Calibration Connections, with Potential Transformer

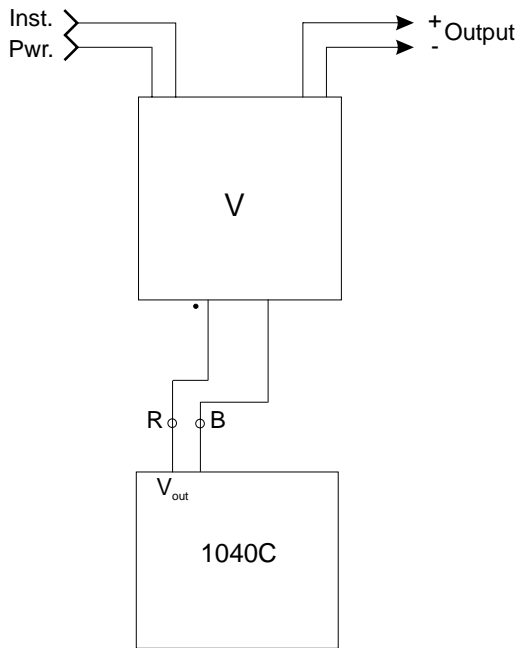

c) Voltage Transducer Calibration Connections, no Potential Transformer

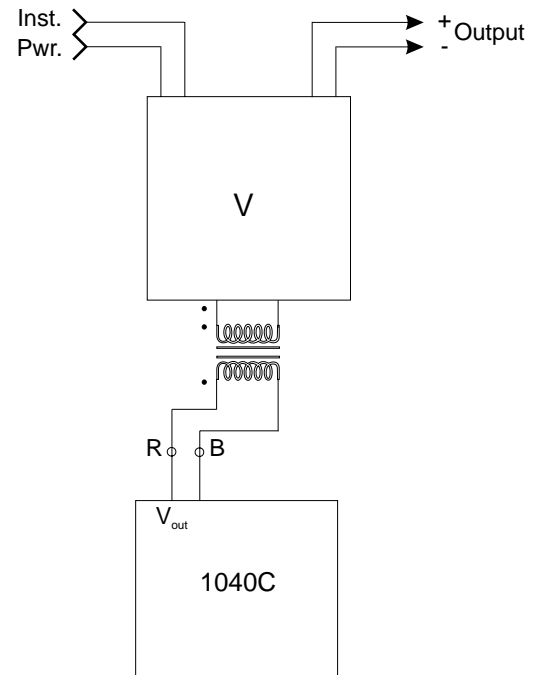

d) Voltage Transducer Calibration Connections, with Potential Transformer

**Figure 2**  
**Single-Phase Voltage Meters and Transducers,**  
**Typical Circuit Connections**

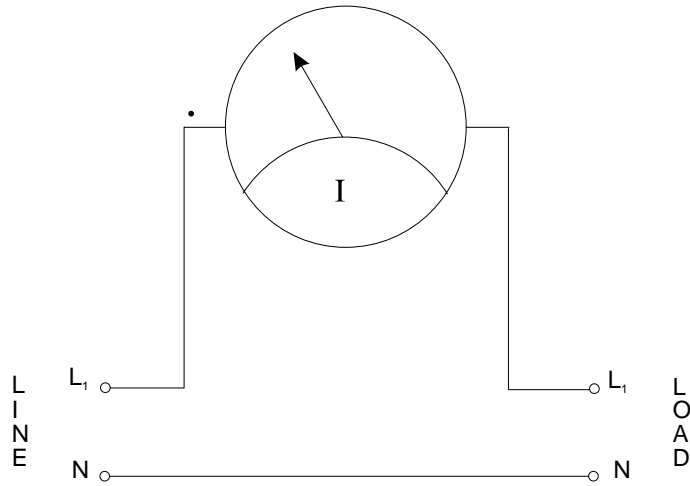

a) Current Meter, Typical Installation, no Current Transformer

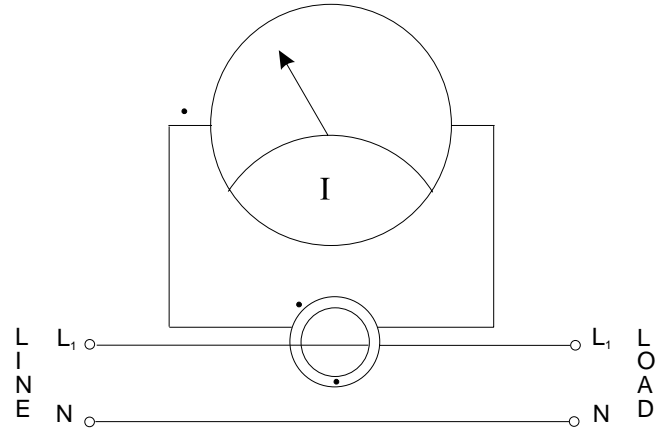

b) Current Meter, Typical Installation, with Current Transformer

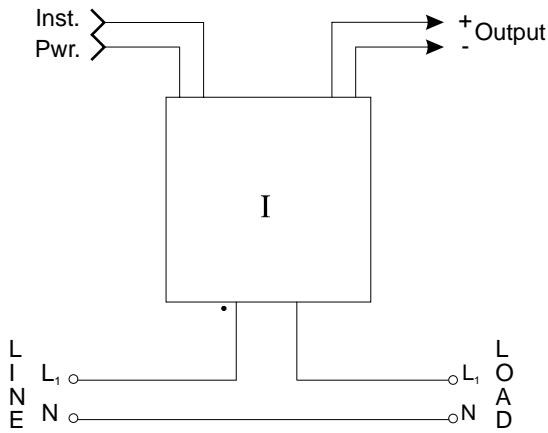

c) Current Transducer, Typical Installation, no Current Transformer

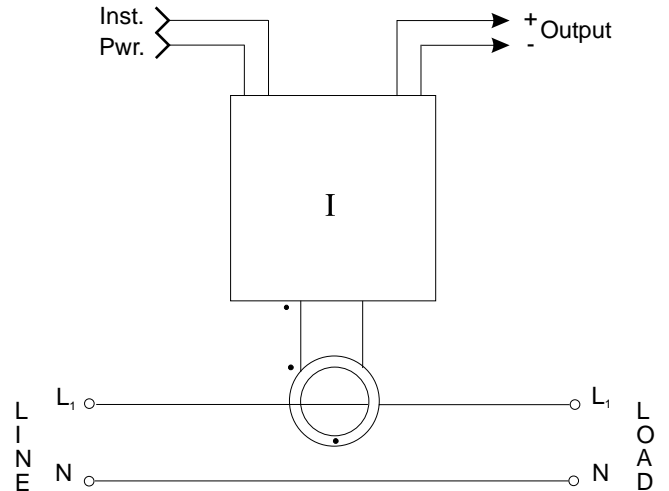

d) Current Transducer, Typical Installation, with Current Transformer

**Figure 3**  
**Single-Phase Current Meters and Transducers,**  
**Typical Circuit Connections**



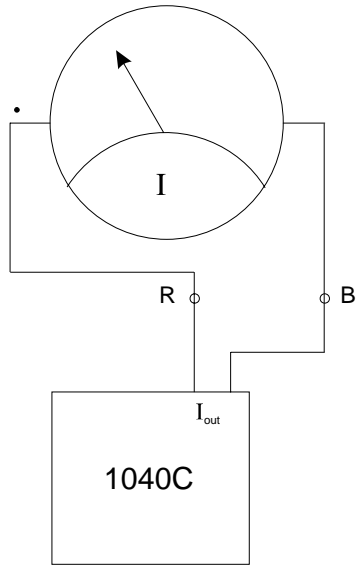

a) Current Meter Calibration Connections, no Current Transformer

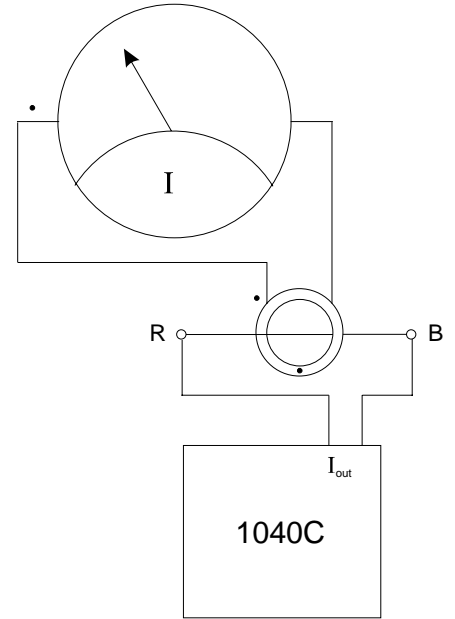

b) Current Meter Calibration Connections, with Current Transformer

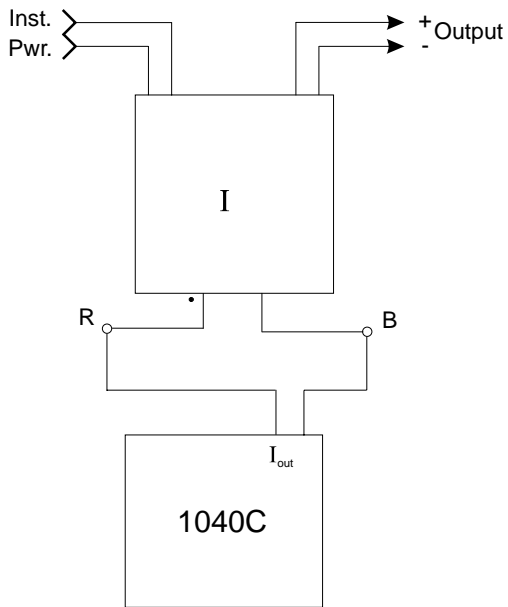

c) Current Transducer Calibration Connections, no Current Transformer

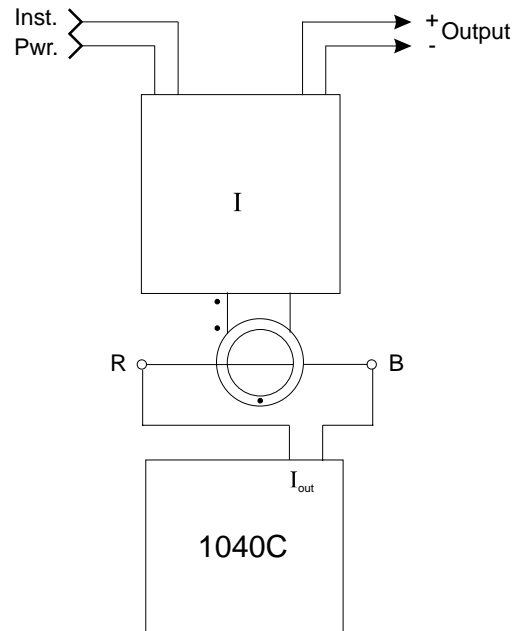

d) Current Transducer Calibration Connections, with Current Transformer

**Figure 4**  
**Single-Phase Current Meters and Transducers,**  
**Calibration Connections**

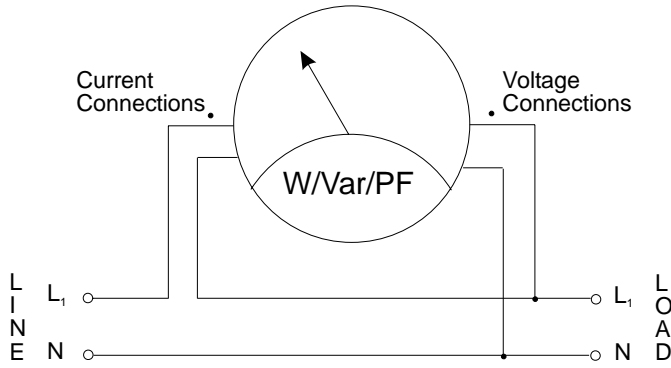

a) W/Var/PF Meter, Typical Installation, no Current or Potential Transformers

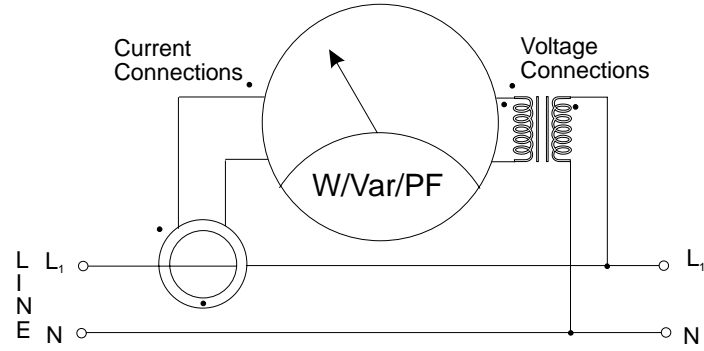

b) W/Var/PF Meter, Typical Installation, with Current and Potential Transformers

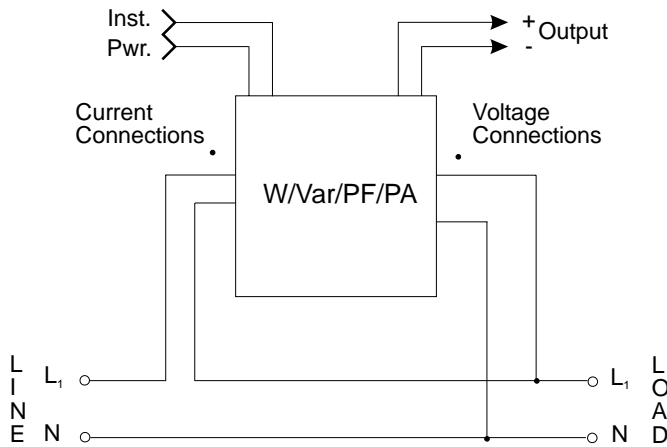

c) W/Var/PF Transducer, Typical Installation, no Current or Potential Transformers

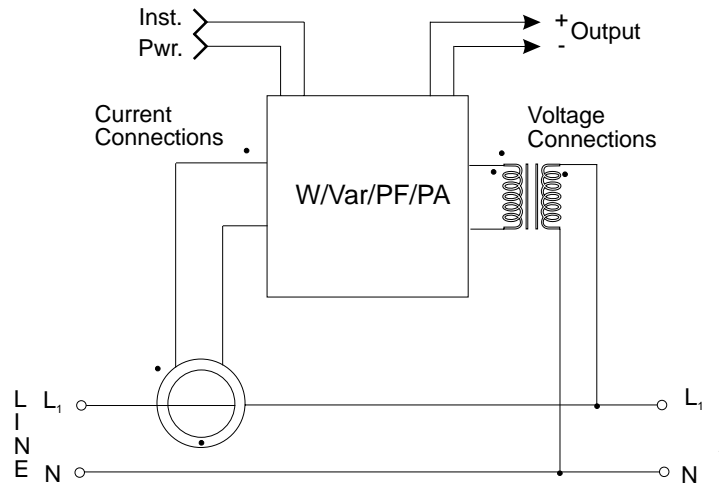

d) W/Var/PF/PA Transducer, Typical Installation, with Current and Potential Transformers

**Figure 5**  
**Single-Phase Watt, Var, or Power Factor Meters and**  
**Watt, Var, Power Factor, or Phase Transducers,**  
**Typical Circuit Connections**

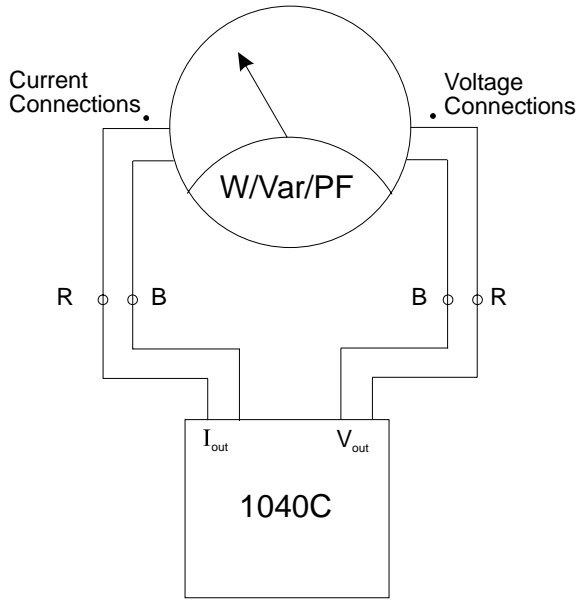

a) W/Var/PF Meter Calibration Connections, no Current or Potential Transformers

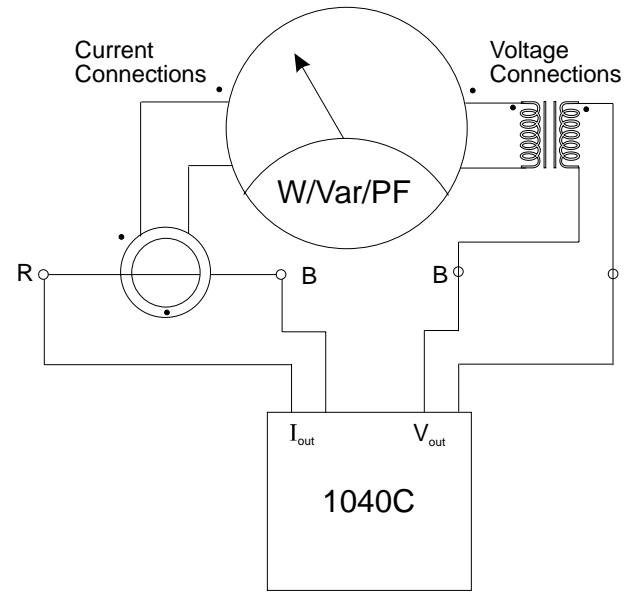

b) W/Var/PF Meter Calibration Connections, with Current and Potential Transformers

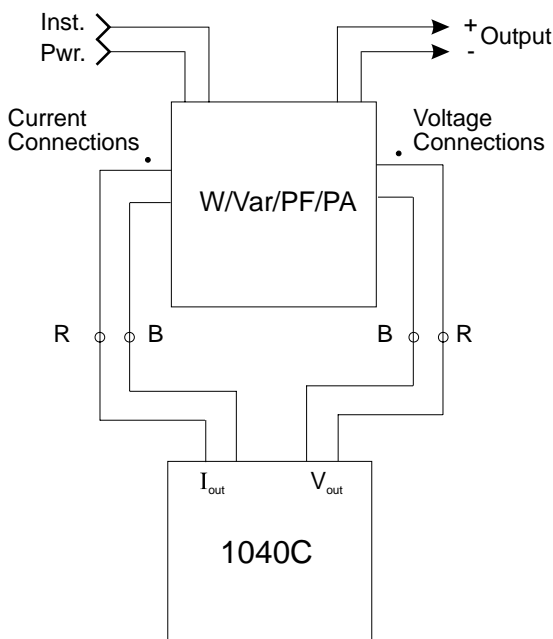

c) W/Var/PF/PA Transducer Calibration Connections, no Current or Potential Transformers

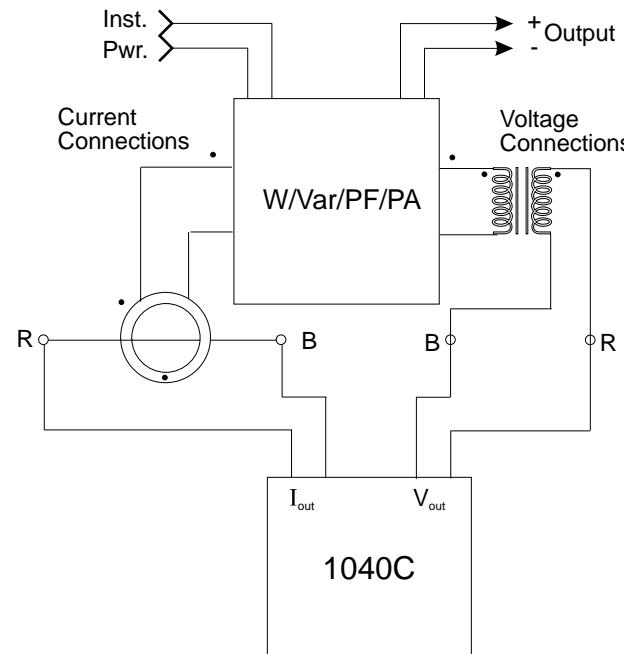

d) W/Var/PF/PA Transducer Calibration Connection with Current and Potential Transformers

**Figure 6**  
**Single-Phase Watt, Var, or Power Factor Meters and**  
**Watt, Var, Power Factor, or Phase Transducers, Calibration Connections**

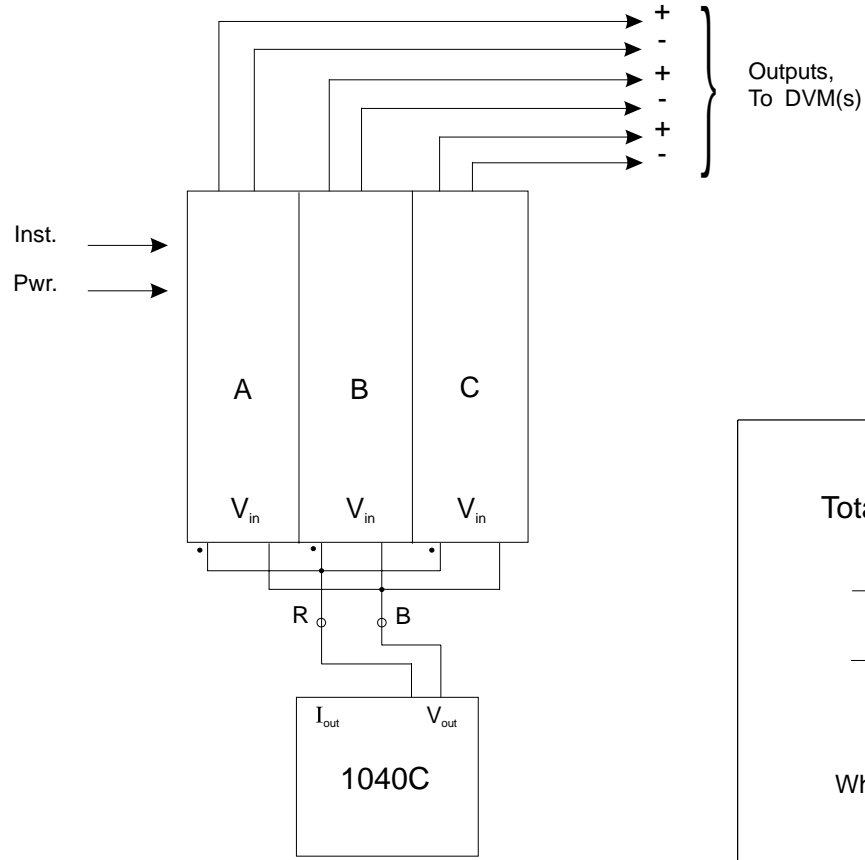

a) Transducers

Total Burden Current =

$$\frac{V}{\frac{1}{\frac{1}{Z_A} + \frac{1}{Z_B} + \frac{1}{Z_C} \dots}}$$

Where:

V= Output Voltage of 1040C

Z<sub>x</sub>= Impedance of Transducer or Meter x, at Frequency of Operation

c) Burden Calculation

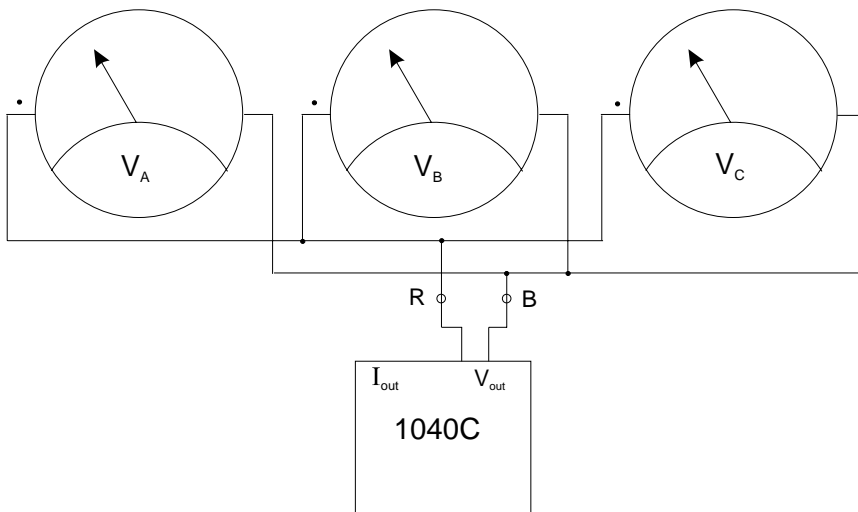

b) Meters

3-18 **Figure 7**  
**Calibration of Multiple Voltage Transducers or Meters**

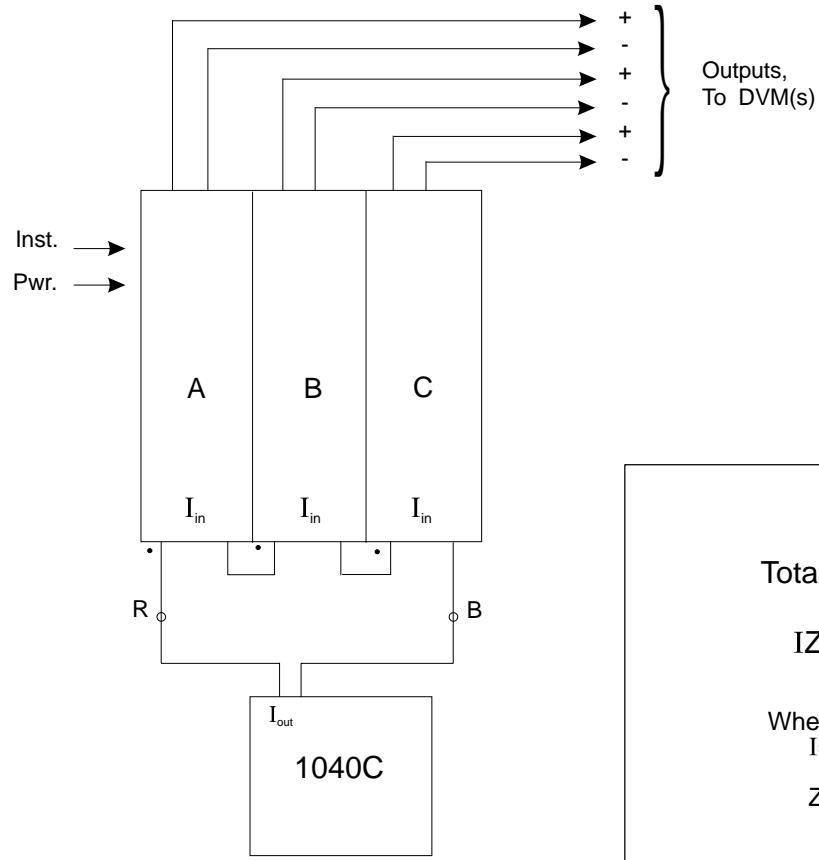

a) Transducers

Total Burden Voltage =

$$IZ_A + IZ_B + IZ_C \dots$$

Where:

$I$  = Output Current of 1040C

$Z_x$  = Impedance of Transducer x  
at Frequency of Operation

c) Burden Calculations

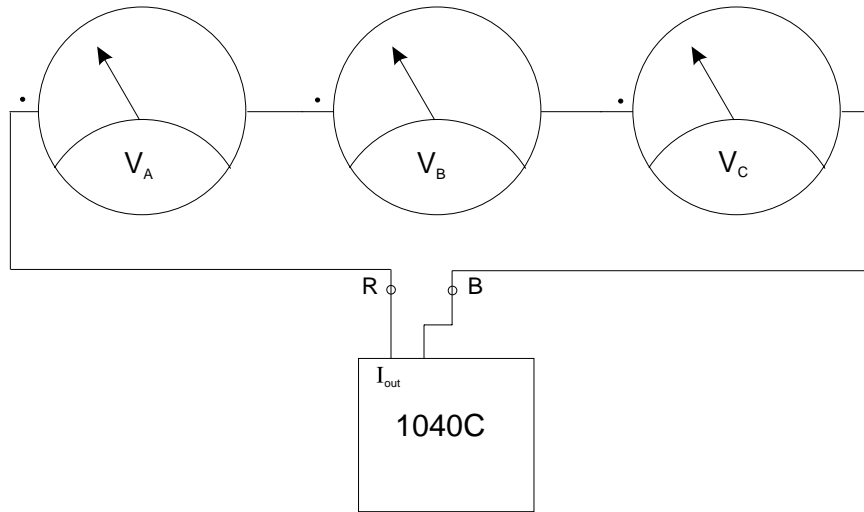

b) Meters

**Figure 8**  
**Calibration of Multiple Current Transducers or Meters**

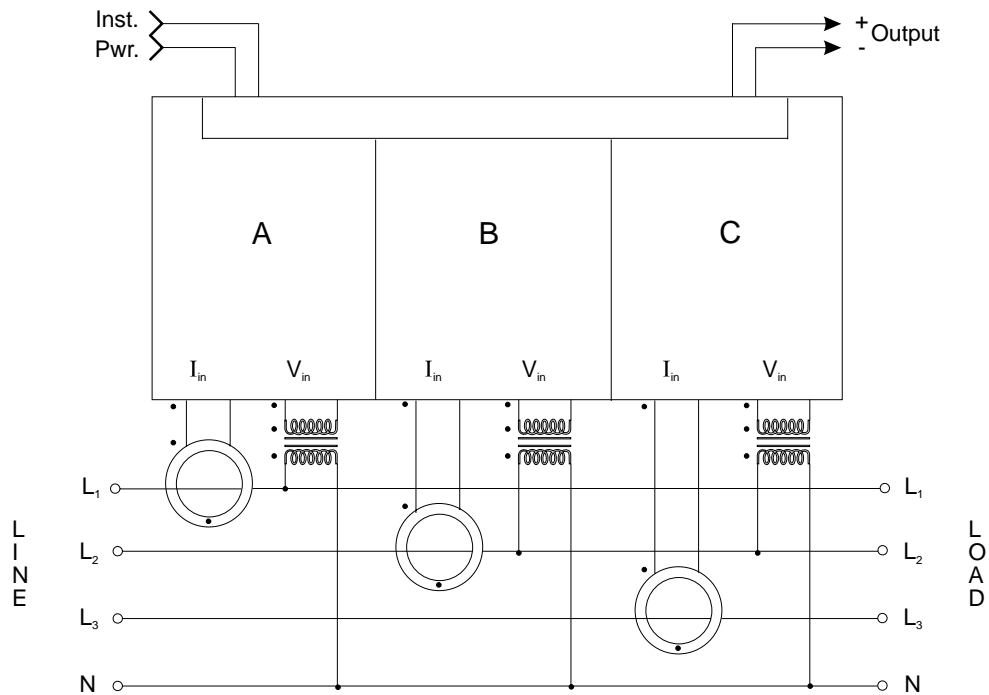

a) Circuit Connections for Power Measurement in a 3 Phase, 4 Wire System, using a 3-Element Transducer

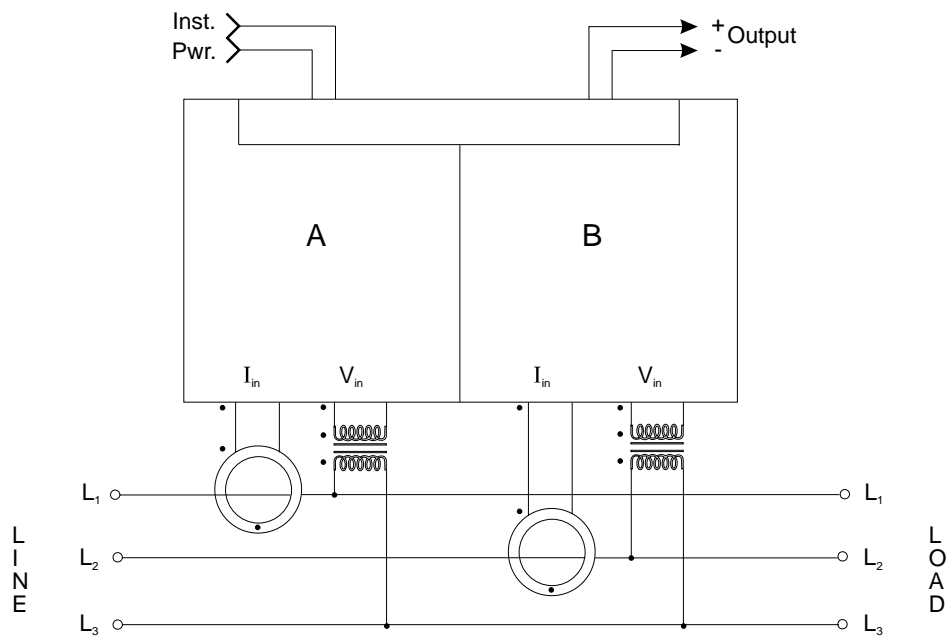

b) Circuit Connections for Power Measurement in a 3 Phase, 3 Wire System, Using a 2-Element Transducer

**Figure 9**  
**Multi-Phase Power Measurement Techniques**

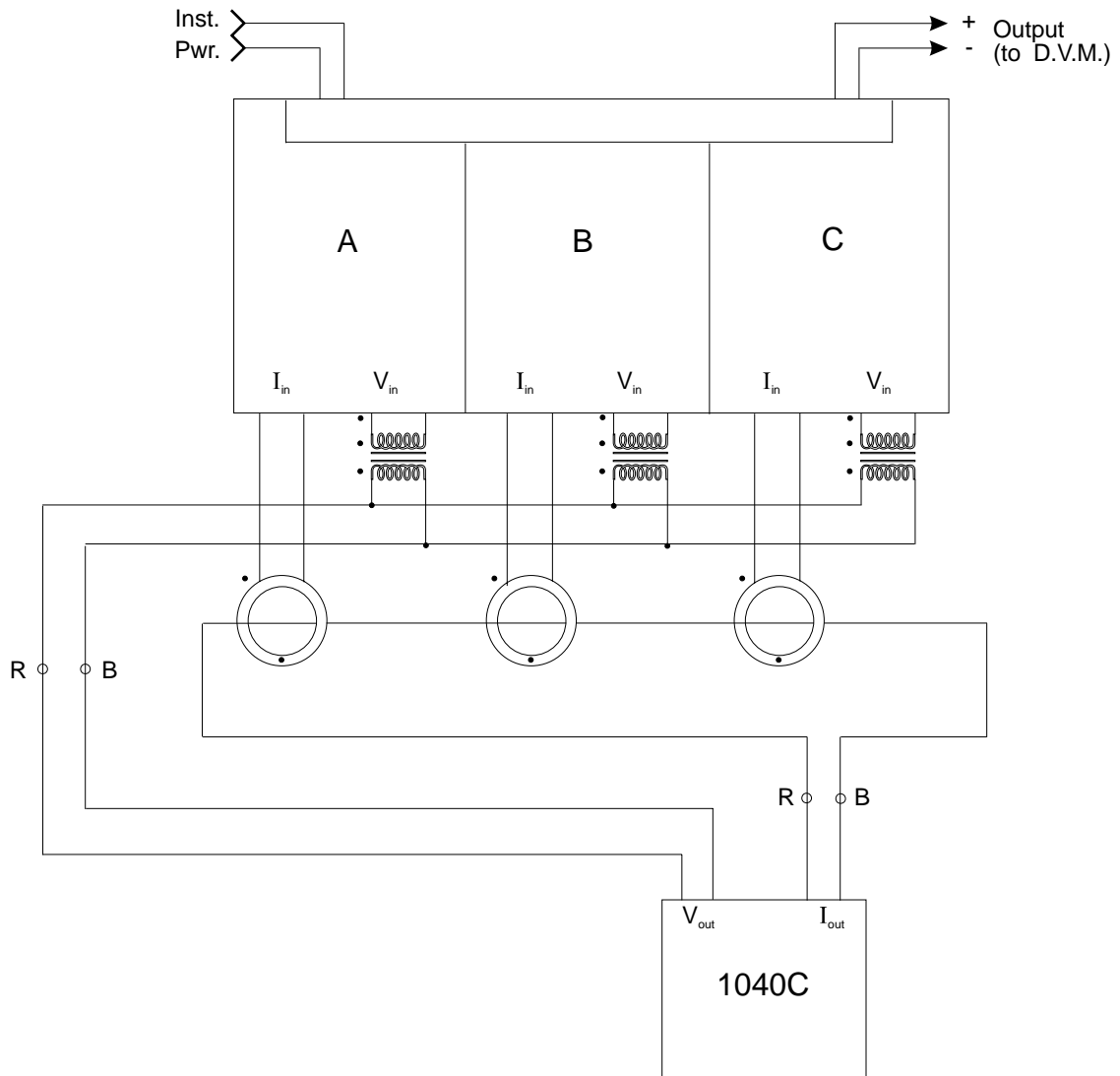

**Figure 10**  
**Calibration Connections for 3-Element Watt Transducer.**  
**Current and Potential Transformers are included for reference.**

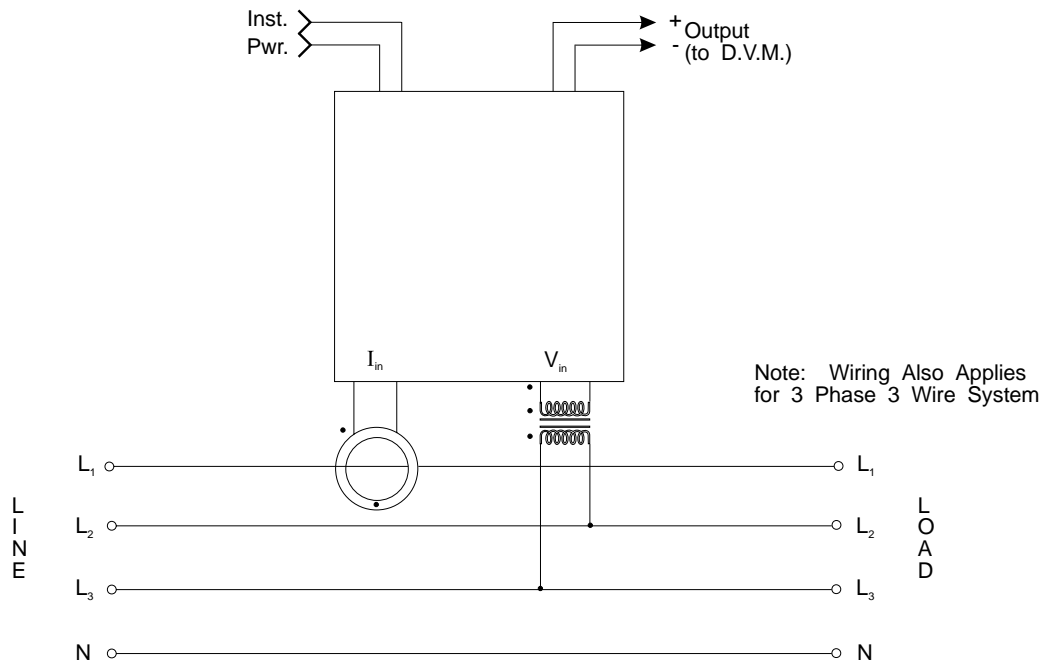

a) Typical Circuit Connections

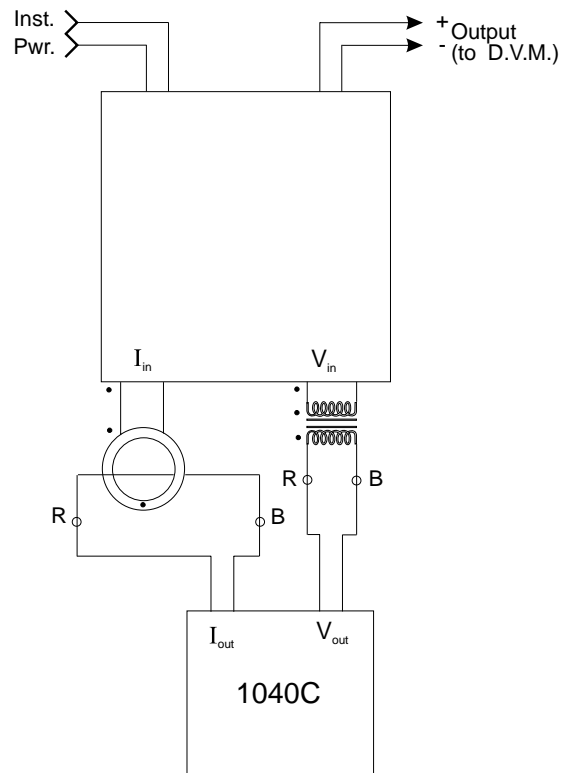

b) Typical Calibration Connections

**Figure 11**  
**Phase Angle Transducer**



### Current Leads Voltage

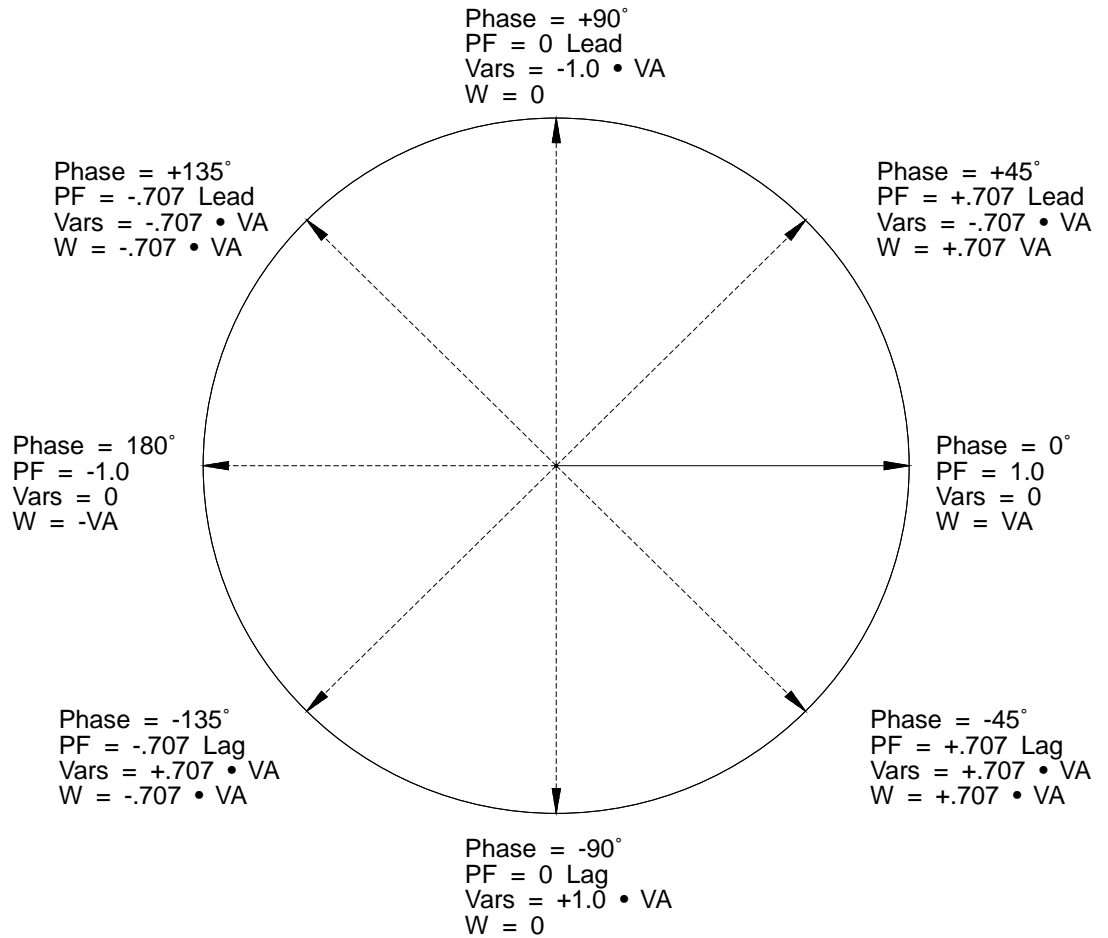

### Voltage Leads Current

### Conventions Used in the 1040C:

Power Factor = Cos  $\theta$   
 Vars = Vrms • Irms • Sin (- $\theta$ )  
 Watts = Vrms • Irms • Cos  $\theta$   
 VA = Vrms • Irms

Where:  $\theta$  (Theta) = Phase Angle between voltage and current. A negative number indicates that current is lagging voltage.

Example:

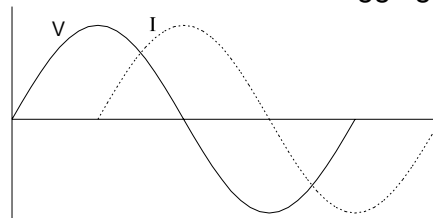

Phase Angle = -90°

**Figure 12**  
**Phase, Power Factor, and VAR Conventions**  
**Employed by the 1040C Panel Meter Calibrator**

## **Appendix A**

### **Meter Examples**

The following pages contain connection diagrams for use in calibrating various types of Yokogawa panel meters. These illustrations are for reference only; the manufacturer's data sheets should be consulted to insure proper connections.

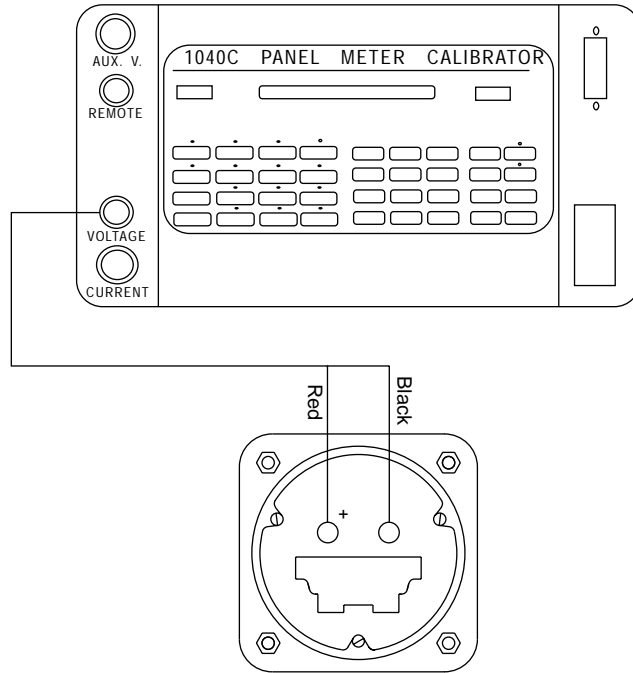

**AC VOLTMETER  
YOKOGAWA 103021**\_\_\_\_\_

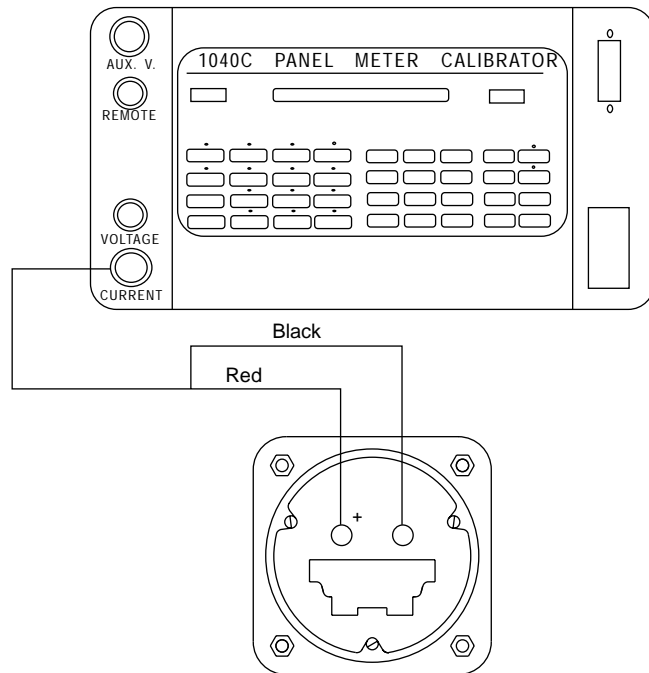

**AC AMMETER  
YOKOGAWA 103131**\_\_\_\_\_

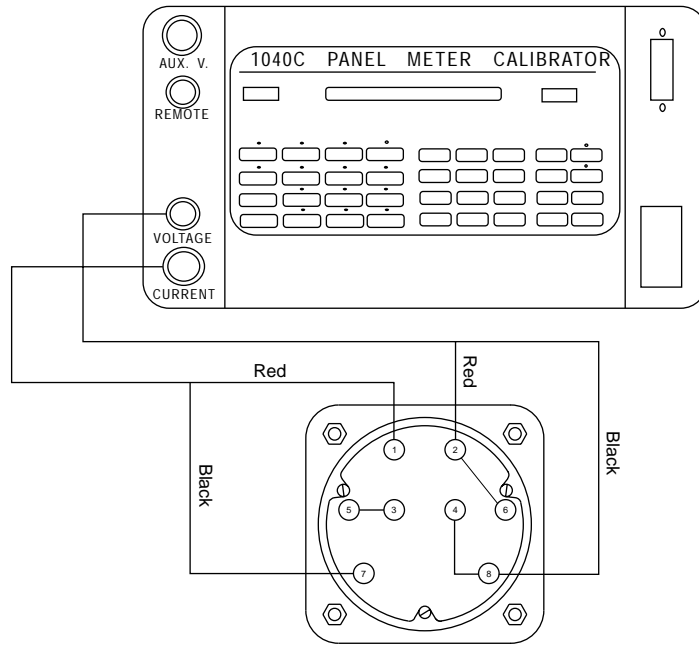

**3 WIRE, 3 PHASE WATTMETER**

**YOKOGAWA** 10322 \_\_\_\_\_  
 103712 \_\_\_\_\_

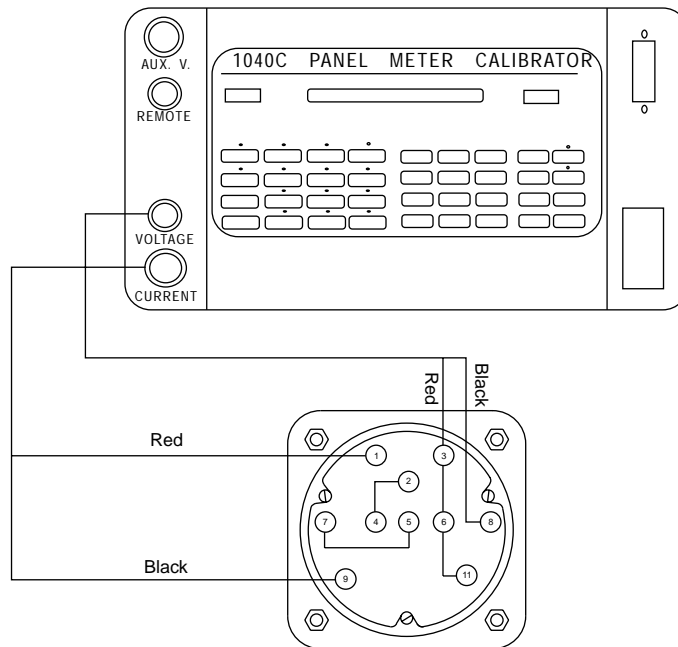

**4 WIRE, 3 PHASE WATTMETER**

**YOKOGAWA** 10325 \_\_\_\_\_  
 103732 \_\_\_\_\_

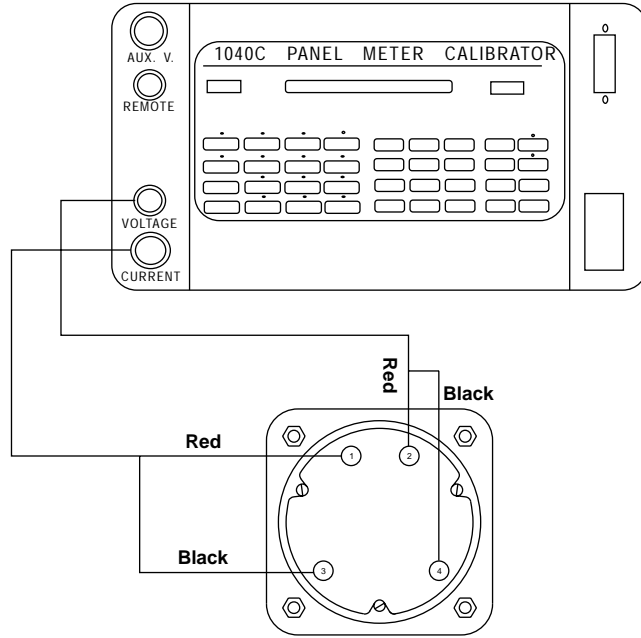

**SINGLE PHASE WATTMETER AND VARMETER**

- YOKOGAWA 10321** \_\_\_\_\_ (WATT)  
**103702** \_\_\_\_\_ (WATT)  
**10331** \_\_\_\_\_ (VAR)  
**103762** \_\_\_\_\_ (VAR)

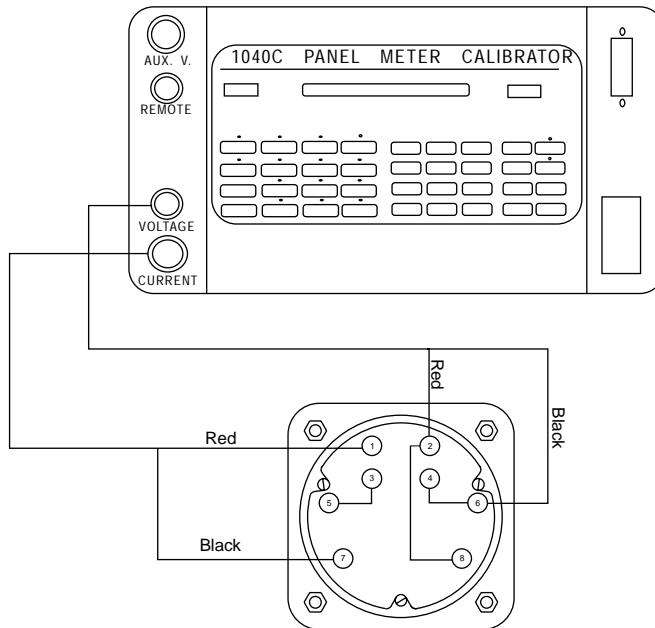

**3 WIRE, 3 PHASE VARMETER**

- YOKOGAWA 103812** \_\_\_\_\_  
**10328** \_\_\_\_\_  
**10332** \_\_\_\_\_  
**103772** \_\_\_\_\_

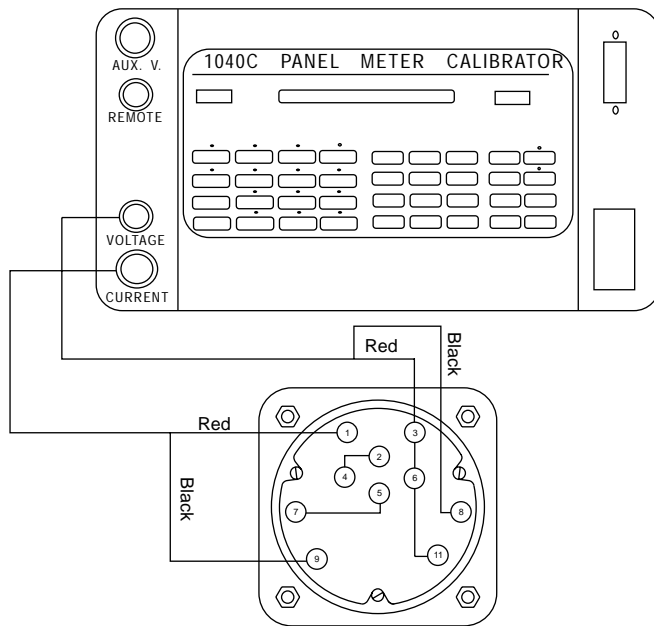

**4 WIRE, 3 PHASE, 2 1/2 ELEMENT VARMETER**

**YOKOGAWA 10329 \_\_\_\_\_**  
**103742 \_\_\_\_\_**

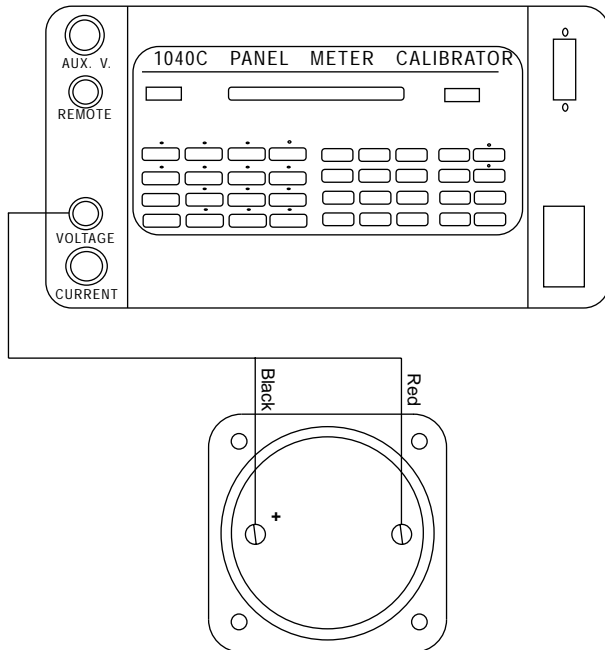

**FREQUENCY METER**  
**YOKOGAWA 103372 \_\_\_\_\_**

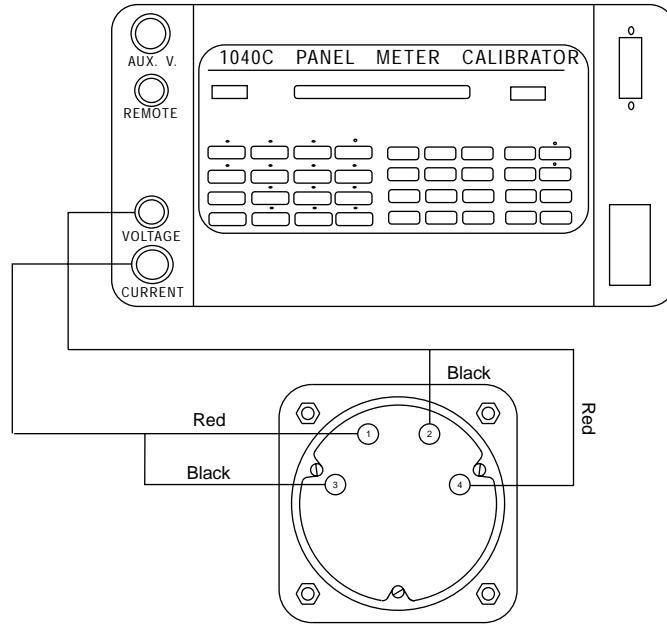

**SINGLE PHASE POWER FACTOR METER  
YOKOGAWA 103412 \_\_\_\_\_**

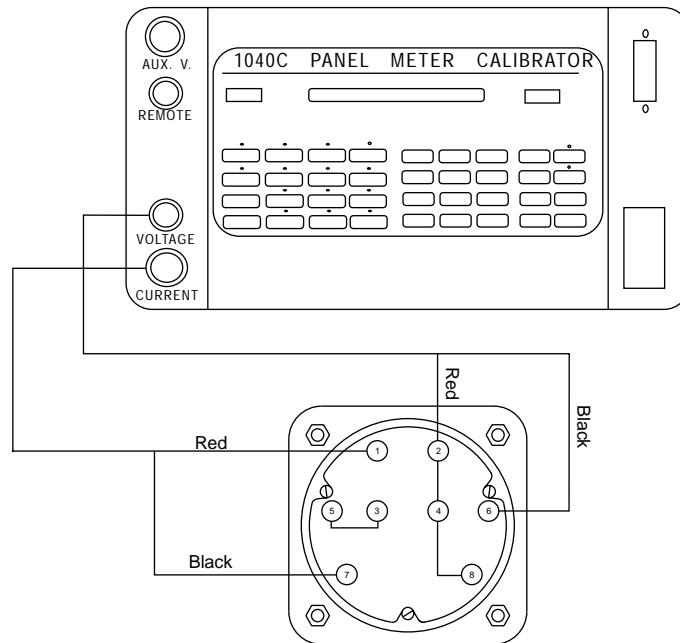

**3 PHASE POWER FACTOR METER  
FOR BALANCED SYSTEM  
YOKOGAWA 103462 \_\_\_\_\_**

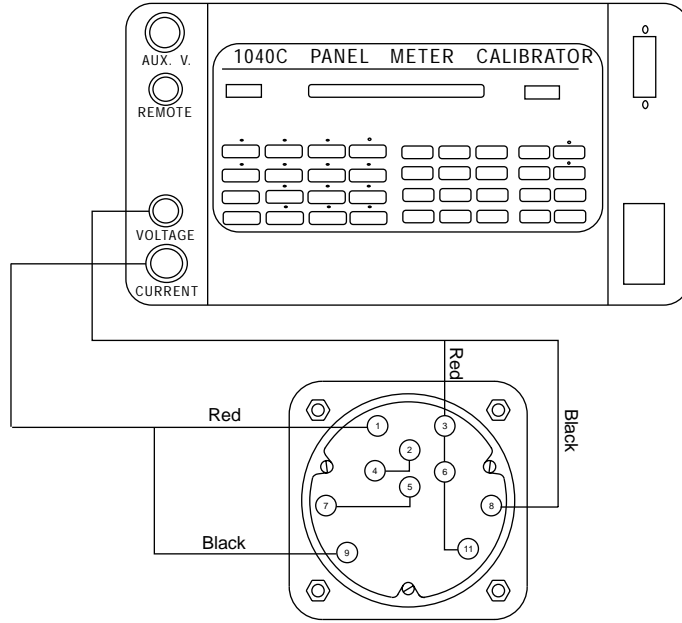

**4 WIRE, 3 PHASE POWER FACTOR METER  
YOKOGAWA 103472 \_\_\_\_\_**