

DYNA-JET

DYNAMIC MUTUAL CONDUCTANCE TUBE TESTER



INSTRUCTION MANUAL

MODEL
707

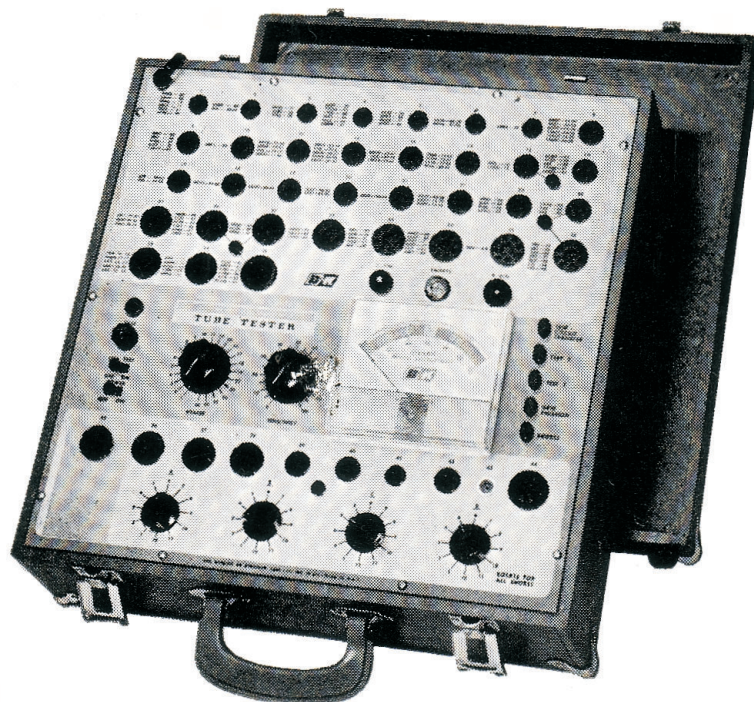

DIVISION OF DYNASCAN CORPORATION

1801 W. Belle Plaine Ave. Chicago, Illinois 60613



Dear Friend:

Congratulations on your purchase of B & K—Precision Test Equipment, and welcome to the B & K family. We hope your experience with your new test equipment will make you a lifetime B & K customer.

Your instrument is backed by more than 20 years of experience in designing and manufacturing. Our most important goal is your satisfaction. At B & K, test equipment is made to meet the demands of the field focusing on dependability and accuracy. We also concentrate on simplicity and operating ease with features that reduce the possibility of human error and speed the servicing process.

In order to determine the type of test units that are needed we have been guided by letters and reports from technicians and engineers who use the equipment daily. Our field tests and studies have helped provide better and faster service techniques. Close contact has been maintained with the manufacturers of consumer products which our test units will be checking and trouble-shooting.

Key personnel in our company cut their eye teeth in the TV service business. This is why we have more "sensitivity" for the problems and conditions under which the test equipment will be used.

B & K product designs are constantly reviewed, and refinements are made or new models developed to meet advances in our industry and to fill your needs. We set our standards high so you can be assured that the B & K test instruments you buy represent advanced design, quality construction, and dependable long-term performance at a price you can afford.

If you have any comments or thoughts about our products, or test equipment in general, I would be delighted to hear from you.

Thanks for your confidence in B & K and we look forward to serving you for a long time to come.

Sincerely,

A handwritten signature in cursive script that reads "Carl Korn". The signature is written in dark ink and is positioned below the word "Sincerely,".

**Carl Korn
President**

OPERATING INSTRUCTIONS

FOR

Model 707

DYNA-JET

DYNAMIC MUTUAL CONDUCTANCE

TUBE TESTER

B & K DIVISION OF DYNASCAN CORPORATION

1801 West Belle Plaine Avenue

Chicago, Illinois 60613

Information on your new Dyna-Jet Model 707 Tube Tester

WHAT IT WILL DO

No. 1—The Dyna-Jet Model 707 Tube Tester will check more than 99% of the TV tubes in general use. Tubes can be tested in an incredibly short time since only a minimum number of controls need be set.

No. 2—The Model 707 will provide accurate results because it checks most tubes for their Dynamic Mutual Conductance (Gm) in a true transconductance bridge. Some tubes such as diodes are checked for emission only, since this test is usually sufficient. Tube types tested in the switch section are tested in a new Dyna-Jet Emission circuit.

No. 3—Each tube is automatically checked for shorts and leakage up to 1 megohm. These tests are made between the various elements of the tube and furthermore this test is made before the Gm measurement.

No. 4—Gas, grid emission, or even obscure grid-to-cathode leakage are all disclosed by an exceptionally sensitive grid current check. This test will reveal as little as 2 or 3 microamperes of current in the grid circuit.

No. 5—Each section of a dual-section tube is checked separately. Therefore tubes can be checked and selected for balance between sections. This is convenient for selecting dual section tubes to be used in push-pull circuits.

No. 6—The Model 707 is obsolescence proof as a result of the switch section of this instrument. All of the new type sockets are included in this section of the Model 707, such as 10 pin tubes, compactrons, nuvistors, etc. Provision is also made for simple installation if a new type of socket becomes necessary.

General Information on your Dyna-Jet Model 707

TESTING TUBES FOR DYNAMIC MUTUAL CONDUCTANCE

In radio and television circuits practically all tubes (except rectifiers and diodes) are used as some type of amplifier. Even oscillator circuits (i.e.—R.F. or horizontal oscillators) are basically amplifiers with regenerative feedback. Therefore, the most important characteristic to be checked to determine how effectively any radio or TV tube will function in its circuit, is its ability to amplify. This, in turn, is governed by its mutual conductance.

The mutual conductance is the ratio of the change in the plate current that results from a small change in grid voltage.

$$G_m = \frac{\Delta I_p}{\Delta E_g}$$

where:
 ΔI_p = a change in plate signal current.
 ΔE_g = a small change in grid signal voltage.

The amplification of a circuit = $G_m R_l$. Where R_l is the equivalent load resistance of the stage.

Since R_l is constant in any circuit, we see that the amplification depends directly on the G_m of the tube.

The G_m for a given tube can be measured accurately by applying the correct amount of a.c. signal voltage to the grid and measuring the resulting a.c. plate current. This is done by means of a sensitive bridge circuit.

Measuring the mutual conductance of a tube provides the most accurate and all inclusive single test that can be made on any tube.

TESTING DUAL TRIODES AND OTHER MULTI-SECTION TUBES

Each section of a dual-section tube is checked separately and quickly by depressing a push button switch. Therefore, tubes can be checked and selected for balance between sections. This test is illustrated in Fig. 1.

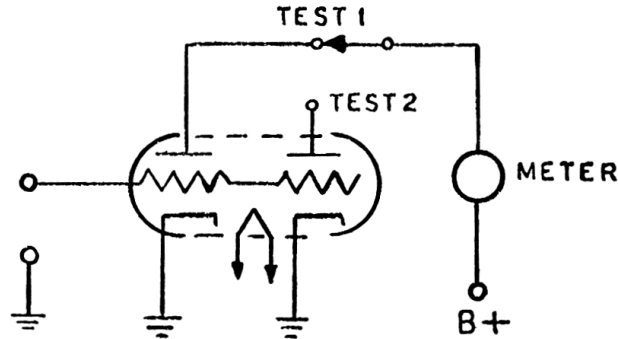

Figure 1—Each Section of Multisection Tube Tested Separately.

TESTING TUBES FOR GRID EMISSION AND GAS

The Grid Emission and Gas Test is an invaluable aid in TV servicing because it quickly picks out those tubes which can cause trouble in a.g.c., sync, I.F. amplifier, and R.F. tuner circuits.

In order to understand how a tube can have “grid emission” and “gas current” we must look into the theory of electron tubes.

There is normally some little evaporation of the cathode coating material on the grid of a tube. Some of this vapor tends to deposit on the grid and gives rise to what is known as “grid emission”, where the grid itself emits electrons and draws current commonly known as “negative grid current”. The flow of this “negative grid current” can be followed in Figure 2.

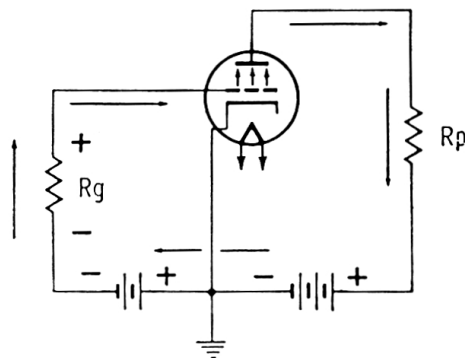

Figure 2—Negative Grid Current.

The electrons flow from the grid to the plate then back through the power supply to the grid leak resistor R_g and up to the grid again. Notice that the voltage drop across the grid leak resistor R_g is such that it causes the grid to go more positive than it normally would with no grid emission.

If a slight amount of "gas" is present in a tube some of the electrons from the cathode will collide with molecules of the gas and may knock off one or more electrons, leaving positive ions (ionization). Some of these positive ions may then strike the grid, taking an electron from the grid to form a gas molecule again. The electron flow of this "gas current" is exactly the same as it is for the "grid emission current" and can be traced on Figure 2. Notice again that the grid is made more positive by this "gas current".

Now let us see what happens if an I.F. amplifier tube in a TV set has grid emission current or gas current (negative grid current). In Figure 2 we noted that the grid would tend to go more positive if negative grid current flowed.

In Figure 3, a typical I.F. stage, we see that if there is any negative grid current, the bias voltage in that stage and other associated stages will go more positive because of the flow of current through R_1 . Making the grid more positive will drive the tubes to saturation, causing clipping or overloading.

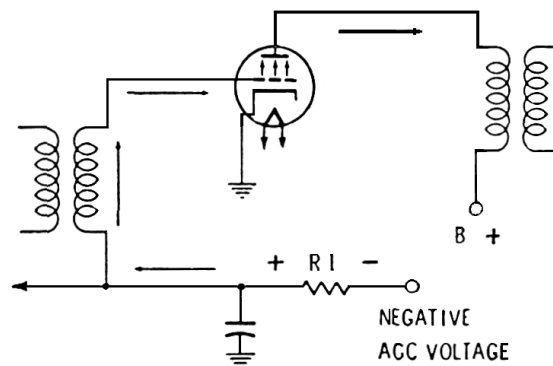

Figure 3—Typical I.F. Stage.

After detection, a video signal normally appears as shown in Figure 4. If the signal is clipped in an I.F. stage it will look like Figure 5. Now the horizontal oscillator will try to synchronize both on the blanking signal (A) and on the very black portions of the video (B). This results in pulling or snaking of the picture.

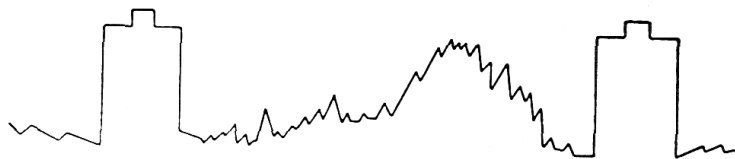

Figure 4—Normal Video and Sync Signal

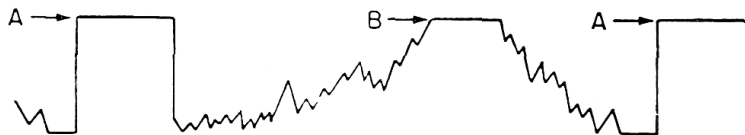

Figure 5—Overloaded or Clipped Video and Sync Signal.

To achieve this sensitive grid emission or gas test, the circuit shown in Figure 6 was employed.

The tube under test has its normal plate to grid voltage applied, but the grid is biased beyond cut-off so that no plate current flows. This bias is applied through the 5.6 megohm resistor. The same 5.6 megohm resistor is also in the grid circuit of a 6BN8 d.c. amplifier and the conditions in this tube are such that it, too, is biased just beyond cut-off. Under these conditions, no plate current flows in the 6BN8 and no reading is obtained on the meter in its plate circuit.

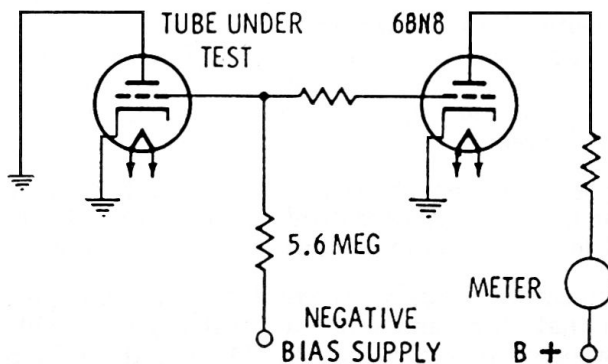

Figure 6—Grid Emission Test Circuit.

However, if the tube under test is gaseous, or its grid is contaminated with some of the cathode coating, then current will flow from grid to plate and through the 5.6 meg resistor back to the grid again. This will produce a positive voltage drop across the 5.6 meg resistor, lifting the cut-off bias on the 6BN8 and producing a meter deflection. Upon seeing this deflection, the technician immediately knows that the test tube is defective and a replacement is indicated.

SHORTS TEST

The test for shorts between elements is made to a sensitivity of approximately 1 megohm. A shorted tube will cause the neon lamp marked Shorts to glow or will cause a deflection of the meter into the reject portion of the Short Reject meter scale. *Either indication indicates shorted elements.*

LIFE TEST

Many manufacturers have found that testing tubes under reduced heater voltage conditions will give a strong indication of its probable useful life. A tube may show adequate G_m under normal test conditions; however, a reduction of 10% to 15% of heater voltage may be marked by a sharp slump in G_m reading. This slump or decay indicates that the space charge of the tube has been depleted to the point where the tube will have a short remaining useful life. While the amount of life remaining cannot be too closely estimated, you can be reasonably sure that a tube showing a sharp slump is not a good risk for continued trouble-free service.

AUTOMATIC LINE VOLTAGE COMPENSATION

Every effort has been made to make the operation of this instrument as fast and simple as possible. Toward this end, a unique patented automatic line voltage compensation has been incorporated into the tester. A voltage sensitive bridge monitors the line voltage at all times and automatically adjusts the sensitivity of the G_m bridge to compensate for these line voltage variations. This eliminates the necessity of readjusting the line voltage for different types of tubes and at different line voltages.

HOW TO OPERATE THE MODEL 707 TUBE TESTER

1. Insert line cord.
2. Turn power switch ON.
3. Set Heater Switch and Sensitivity Control as indicated in tube chart.
4. Put CIRCUIT TRANSFER push button in proper position, depending on whether the pre-wired Jet-Check section or Switch section of the tester is to be used.
5. If tube is to be tested in the Switch section, set up switches A thru D as indicated on the chart.
6. Insert tube in socket.
7. Test in sequence; Shorts, Grid Emission and Quality of tube.

Test Procedure

The Model 707 is designed for use on 105/125 volt, 50/60 cycle A.C. only. DO NOT use any other type of current. With the line cord connected to the proper type of power and with the Power Switch in the ON position, the red pilot lamp will glow.

The Model 707 Tube Tester is effectively two tube testers in one. The multiple socket or Jet-Check section tests the most commonly used tubes found in television sets. This section provides the high speed testing of tubes so necessary in home servicing of television receivers. This section is located on the upper portion of the tube tester panel.

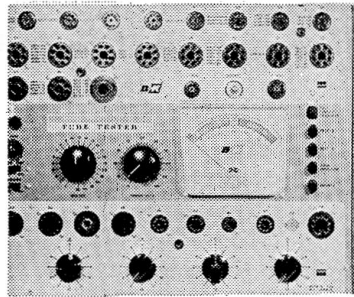

Fig. 7

The second section or Switch section is located at the bottom of the tube tester panel and has its own sockets associated with it. Included in this socket section are 2 10 pin sockets, a Nuvistor socket, and 2 Compactron sockets. The less frequently used tubes are tested in this portion of the instrument. It is also this section that protects against obsolescence.

Selection between the Jet-Check section and the Switch section is accomplished by a Circuit Transfer Switch. This switch is the top push button of the five buttons located to the right of the meter. When the button is "Up" the multiple socket or Jet-Check section of the instrument is activated. When the button is depressed and locked in the "Down" position, the Switch section of the instrument is in operation. The button is locked down by depressing the button and pushing slightly to the left. The button is released by pushing to the right. The button will then spring return to the UP position. See Fig. 7.

As an additional aid to quickly determine which section of the Model 707 is active, a neon indicator is located in the Multiple Socket panel section and another in the Switch section of the panel. See Fig. 7. The lamp that glows immediately indicates which section of the instrument is active.

SETTING UP TO TEST IN THE JET-CHECK SECTION

The most used tubes are listed beside appropriate sockets on the test panels.

On the socket panel itself, are listed only the most popular number of the tube type which is available in more than one filament voltage. For example: the 6BK5 is printed on the socket panel; however, the 12BK5, 25BK5 and 50BK5 tubes can also be tested in that same socket. The only difference in testing these tubes is that the Heater control is set to the correct filament voltage.

The setting of the Heater switch position determines the filament voltage applied to the tube under test. For example: the switch is set to 6 for 6.3 volt filament tubes, and the switch is set to 12 for 12.6 volt filament tubes, etc. This setting is usually determined by the first number of the tube designation. Thus, for a 6BK5, the heater control would be turned to 6; for a 12BK5, it would be turned to 12; and for a 25BK5, the control would be set to 25.

CAUTION: THE HEATER CONTROL MUST BE SET TO THE CORRECT FILAMENT VOLTAGE BEFORE INSERTING THE TUBE IN THE SOCKET. FAILURE TO OBSERVE THIS PRECAUTION COULD RESULT IN BURNING OUT A FILAMENT.

Since hundreds of other tube types besides those listed on the panel can be tested on the Model 707, each additional type (with socket placement and control settings) is listed in the Dyna-Jet Tube Selector Index. The test sockets are numbered 1 to 35 to aid in the quick identification of the correct socket.

The setting for the Sensitivity control is printed right next to the tube type on the socket panel. Examples: 6AU6 — 82
6U8 — 79•55

The tubes with multiple sections, such as the 6U8, have two sensitivity settings because there are two separate sections in this tube envelope. Because this type has two dissimilar sections, the sensitivity settings are different for each section, although on some types (e.g. 6SN7—78•78) the two sections are the same and therefore the sensitivity settings are the same.

When a multiple tube of dissimilar sections is tested, the Test 1 button tests the section that has the most elements and the other section will be tested with the Test 2 button.

EXAMPLE: 6U8 — 79•55

The first section tested is the pentode, and then the triode section is tested. If a type 6AT6 (triode - double diode) is to be tested, the Test 1 position will test the triode section and in the Test 2 position both diodes will be tested simultaneously.

In the case of a 5U4, the first section would be tested with the Test 1 button and the second section with the Test 2 button.

A lead, fitted with a plate cap connector and a pin plug is supplied for testing tubes having plate leads connected to caps on top of the tubes. Appropriate pin jacks are placed near the proper sockets for use with the plate lead. A line identifies each pin jack with its associated socket or sockets.

SETTING UP TO TEST WITH THE SWITCH SECTION

All tubes to be tested in the Switch section of the Model 707 are indicated by the socket number being #36 or higher, in the "Socket" column of the tube chart. Fig. 8 shows a typical listing for a tube to be tested in the Switch section of the instrument. Each of the switches is lettered and the position for each of these switches is indicated on the chart in the column under that letter. When all the switches have been set, insert the tube into the proper socket and proceed with the test. Each section of a multiple section tube is tested separately. Each section of a multiple section tube also has different switch settings. A typical listing of a multiple section tube is shown in Fig. 8. There is a common plate cap connector located between socket #39 and socket #40. This is the only plate cap connector used when testing tubes in the Switch section of the instrument.

You are now ready to proceed with the test.

TUBE TYPE	HEATER	SOCKET	SENSITIVITY				TEST POS.	
			GOOD	BAD	A	B		C
6AJ8	6	39	85		5	4	12	1
			38		5	4	12	9
6AR8	6	39	30		5	4	12	6

Figure 8—Typical Listing of Tube Types in Chart.

SHORTS TEST — JET-CHECK SECTION

A tube is tested for shorts in the Jet-Check section of the tube tester by depressing the push button labeled SHORTS located just to the right of the meter. See Fig. 7.

The neon Shorts lamp should be observed while this button is depressed. Shorts or Leakage up to 1 megohm of value between elements of the tube under test, will cause the Shorts lamp to glow. Leakage of more than 1 megohm will be indicated on the meter. If a tube causes the meter to deflect into the "Shorts-Reject" area of the meter scales, this tube has leakage in excess of 1 megohm. Any tube which causes the Shorts lamp to glow, or the meter to read into the "Shorts-Reject" area of the meter scale should be discarded immediately. It is generally desirable when making the Shorts test to lightly tap the tube to be tested in order to show up any intermittent shorts. The push button is spring-loaded and will return to the up position when released. **DO NOT GIVE FURTHER TESTS TO TUBES WHICH ARE SHORTED.**

Shorts Test — Switch Section

Insert the tube into the proper socket. It is **NOT** necessary to depress the SHORTS push button when making this test in the Switch section. A check for some inter-element shorts is made immediately upon inserting the tube into socket. If the Shorts indicator glows, the tube is defective.

To test for any other Shorts or Leakage in the tube, rotate the "D" switch through each of its positions while observing the neon Shorts indicator. If the Shorts indicator glows in any of the switch positions of switch "D", the tube should be rejected. (As the switch is rotated from one position to the next, the Shorts indicator may instantaneously flicker due to capacity discharge. This is to be ignored.) Certain tube types have more than one pin connection for a given element. Therefore, the Shorts indicator lamp may normally glow in certain positions

of switch "D", even if there is no Short in the tube. The chart will indicate where this normal Short will occur. Tubes should not be rejected for these normal Shorts.

Before proceeding with the remainder of the tests return the "D" switch to its proper position as indicated on chart.

Grid Emission and Gas Test

The tube is tested for Grid Emission, Gas Content, and extremely high resistance leakage when the Grid Emission push button is depressed. This test is used when testing tubes either in the Jet-Check section or in the Switch section of the Model 707 Tube Tester.

The result of the Gas and Grid Emission test will be observed as a deflection of the meter needle if the tube is gassy or has a contaminated grid. These conditions cause grid current to flow and since a current as low as 2 or 3 microamperes can be detected, this is a very sensitive test. A tube, although it may seem to operate normally in a receiver, should be discarded if the meter reads into the Grid Emission—Reject area of the scale during the Gas and Grid Emission test because a gassy condition usually becomes progressively worse and eventually may cause serious trouble. During the Gas Test additional inter element leakage tests are performed using the Short Lamp as the indicator. A glow of this lamp during the Gas Test indicates inter element leakage and is cause for discarding the tube. The importance of the Gas and Grid Emission tests cannot be overstressed. Case histories of hundreds of tube failures, particularly those used in R.F., I.F., and Video Amplifier stages, reveal that a substantial number were due to gas, grid emission or grid to cathode leakage. Grid to cathode leakage, caused by a high resistance leak (can be 1 megohm or higher) between the grid and cathode of the tube under test, will produce a deflection on the meter during the Gas and Grid Emission test but will not light the neon SHORTS lamp as would a low resistance leak or direct short between the grid and cathode. Grid to cathode leakage can be the source of poor picture quality, twisting, bending or pulling of the picture, vertical jitter or bounce, and sync buzz. The test circuit in Fig. 6 illustrates how the presence of grid to cathode leakage in the tube under test will produce a deflection on the meter due to the fact that enough current will flow through the 5.6 megohm resistor to make the 6BN8 tube conduct.

Quality Test

A tube is tested for Gm in the Jet-Check section when the push button marked Test 1 is depressed. This test is made if the tube has passed the Shorts and Grid Emission tests. The Sensitivity Control is set at the value listed next to the test socket, or on the chart. The condition of the tube under test will then be indicated on the "Replace?-Good" scale of the meter. Any tube not indicating Good should be replaced. If the tube under test is a multiple section tube, the Test 2 push button must be depressed to test the second section.

A tube tested in the Switch section, still must first pass the Shorts and Grid Emission test. The Sensitivity Control is set at the point indicated in the chart. Then Test 1 button is depressed to indicate the quality of the tube on the "Replace?-Good" scale of the meter. This test is a Dyna-Jet Emission test. If it is a dual section tube a second set-up of the switches must be made according to the chart and test 1 button depressed to read the quality of the section being tested. To be sure that the Circuit Transfer switch is UP for the Jet-Check section, and locked down for the Switch section. The neon indicators located in the appropriate section of the panel give immediate indications as to which section is active.

You may test a tube whose quality is so high as to cause the meter to read off scale. This is normal and does not indicate a defect of the instrument.

There are some tube types whose Gm is so low that they will not read into the Good area. These types are read on the 0-120 scale. The chart listing for the types will state the minimum reading for a good tube. Example: Tube good if it reads 40 or more.

Life Test

The Life Test switch is located just below the pilot lite. In order to initiate the Life Test, push this switch to the right and hold the switch in this position while proper test button is depressed; since it is spring loaded it will return to its normal position when released.

The Life Test will help the serviceman judge how much useful life still remains in a tube being tested. A tube may test O.K. on the Gm test but the Life test will detect whether or not it is in the process of losing its Gm.

The heater voltage is reduced by a predetermined amount when the switch is in the LIFE TEST position. The reading on the meter will drop very little (or may even rise slightly) under the reduced heater voltage conditions if the tube has sufficient reserve to continue to operate normally. If the meter reading does not drop, the tube is in excellent condition. But if the tube under test has a depleted space charge, a large drop will occur in the meter reading indicating that a replacement is warranted. A drop of 25% of the normal meter reading indicates the tube is reaching the end of its useful life.

CHART SUBSCRIPTION SERVICE

The Model 707 Tube Tester enables you to test in excess of 2200 tube types. Included in this list are voltage regulator tubes, hybrid auto radio tubes, thyratron tubes and a wide assortment of European tubes used in modern Hi Fi equipment.

In order to keep your tube chart up to date, it is recommended that you subscribe to the B & K chart mailing service at a cost of \$2.50 per year. This service will provide mailings every 90 days. These mailings are made in the months of January, April, July and October. This will mean that within 90 days of the introduction of a new tube type you will automatically have the information on how it is tested in your B & K Tube Tester.

If you do not wish to use this "4 times per year" subscription service, the latest available chart may be obtained at any time by remitting \$1.50 to the factory with the Model and Serial Number of your instrument.

SERVICE INFORMATION

All necessary voltage readings are given on the schematic. If either of the No. 55 Pilot Lamps under the Socket Panel fails, both lamps must be replaced at the same time with a No. 55 type only.

The A.C. line fuse is located on the Socket Panel. Replace only with 1 amp. fuse of the same type.

During the following adjustments push button marked "Circuit Transfer" must remain in the UP or Jet-Check position.

Shorts Sensitivity Adjustment

To adjust Short Lamp Sensitivity, connect a 1 meg. resistor from pin 2 to pin 4 of socket No. 1. Adjust R-16, while Short button is depressed, until the Short Lamp just lights. R-16 is accessible with a screwdriver from the top of the panel through the center of socket No 30. Remove resistor. Short light should then go out.

Grid Emission Sensitivity Adjustment

The sensitivity of the grid emission test circuit is adjusted at the factory so that a leakage of 25 megohms just reads in the "Grid Emission-Reject" area on the meter scale. This order of sensitivity is the level that tube manufacturers recommend, in order not to reject good tubes.

To adjust the Grid Emission Sensitivity, connect a 20 meg. resistor from pin 1 to pin 7 of socket No. 1. Adjust R-18, while the Grid Emission button is depressed, for a meter reading of 20 on the numbered scale. R-18 is accessible with a screwdriver from the top of the panel through the center of socket No. 33. Remove resistor. Meter reading should then fall to zero with nothing plugged into panel.

If you wish to make the Grid Emission test more sensitive, use a 100 meg ohm resistor in place of the 20 meg ohm resistor as stated above.

Signal Voltage Adjustment

To calibrate the instrument for the proper signal voltage, connect an A.C. VTVM to pin 1 of socket No. 1. Connect the ground lead of the VTVM to pin 2 of socket No. 1. Adjust R-20 while test 1 button is depressed, for 1.5 volts R.M.S. R-20 is accessible with a screwdriver from the top of the panel through the center of socket No. 25.

D.C. Bias Adjustment

To adjust for proper D.C. Bias, connect a 20,000 ohm/volt meter between pin 1 and pin 2 of socket No. 1. Adjust R-11 while test 1 button is depressed for -2.5 V. D.C. R-11 is located beside the 6BN8 tube on the transformer bracket.

Balance Control Adjustment

To adjust R-5, connect a 6000 ohm, 10 watt resistor from pin 5 to pin 2 of socket No. 1. Set Sensitivity Control to 100. Adjust R-5 (while test 1 button is depressed) for zero reading on tube tester meter.

R-5 is located on the rear of the transformer mounting just behind the power transformer.

WARRANTY SERVICE INSTRUCTIONS

1. Refer to the maintenance section of the instruction manual for adjustments that may be applicable.
2. Check common electronic parts such as tubes and batteries. Always check instruction manual for applicable adjustments after such replacement.
3. Defective parts removed from units which are within the warranty period should be sent to the factory prepaid with model and serial number of product from which removed and date of product purchase. These parts will be exchanged at no charge.
4. If the above mentioned procedures do not correct the difficulty, pack the product securely (preferably double packed). A detailed list of troubles encountered must be enclosed as well as your name and address. Forward prepaid (express preferred) to the nearest B&K authorized service agency.

Contact your local B&K Distributor for the name and location of your nearest service agency, or write to

Service Department
B & K DIVISION OF DYNASCAN CORPORATION
1801 W. Belle Plaine
Chicago, Illinois 60613

WARRANTY

"B & K warrants that each product manufactured by it will be free from defects in material and workmanship under normal usage and service for a period of ninety days after its purchase new from an authorized B & K distributor. Our obligation under this warranty is limited to repairing, or replacing any product or component which we are satisfied does not conform with the foregoing warranty and which is returned to our factory or our authorized service contractor, transportation prepaid, and we shall not otherwise be liable for any damages, consequential or otherwise. The foregoing warranty is exclusive and in lieu of all other warranties (including any warranty of merchantability), whether expressed or implied. Such warranty shall not apply to any product or component (i) repaired or altered by anyone other than B & K or its authorized service contractor (except normal tube replacement) without B & K's prior written approval; (ii) tampered with or altered in any way or subjected to misuse, negligence or accident; (iii) which has the serial number altered, defaced or removed; or (iv) which has been improperly connected, installed or adjusted otherwise than in accordance with B & K's instructions. B & K reserves the right to discontinue any model at any time or change specifications or design without notice and without incurring any obligation. The warranty shall be void and there shall be no warranty of any product or component if a B & K warranty registration card is not properly completed and postmarked to the B & K factory within five days after the purchase of the product new from an authorized B & K distributor."



B & K DIVISION OF DYNASCAN CORPORATION

1801 W. BELLE PLAINE AVE. • CHICAGO, ILL. 60613