

INSTRUCTION MANUAL



BK PRECISION®
MAXTEC INTERNATIONAL CORP.

MODEL 1660

Triple Output DC POWER SUPPLY



BK PRECISION®
MAXTEC INTERNATIONAL CORP.

TEST INSTRUMENT SAFETY

WARNING

Normal use of test equipment exposes you to a certain amount of danger from electrical shock because testing must sometimes be performed where exposed high voltage is present. An electrical shock causing 10 milliamps of current to pass through the heart will stop most human heartbeats. Voltage as low as 35 volts dc or ac rms should be considered dangerous and hazardous since it can produce a lethal current under certain conditions. Higher voltage poses an even greater threat because such voltage can more easily produce a lethal current. Your normal work habits should include all accepted practices that will prevent contact with exposed high voltage, and that will steer current away from your heart in case of accidental contact with a high voltage. You will significantly reduce the risk factor if you know and observe the following safety precautions:

1. There is little danger of electrical shock from the dc output of this power supply. However, there are several other possible test conditions using this power supply that can create a high voltage shock hazard:
 - a. If the equipment under test is the "hot chassis" type, a serious shock hazard exists unless the equipment is unplugged (just turning off the equipment does not remove the hazard), or the precautions of step 8 are observed.
 - b. If the equipment under test is "powered up" (and that equipment uses high voltage in any of its circuits), the power supply outputs may be floated to the potential at the point of connection. Remember that high voltage may appear at unexpected points in defective equipment. Do not float the power supply output to more than 100 volts peak with respect to chassis or earth ground.
 - c. If the equipment under test is "off" (and that equipment uses high voltage in any of its circuits under normal operation), discharge high-voltage capacitors before making connections or tests. Some circuits retain high voltage long after the equipment is turned off.
2. Use only a polarized 3-wire ac outlet. This assures that the power supply chassis, case, and ground terminal are connected to a good earth ground and reduces danger from electrical shock.
3. Don't expose high voltage needlessly. Remove housings and covers only when necessary. Turn off equipment while making test connections in high-voltage circuits. Discharge high-voltage capacitors after removing power.
4. If possible, familiarize yourself with the equipment being tested and the location of its high voltage points. However, remember that high voltage may appear at unexpected points in defective equipment.

(continued on inside rear cover)

**Instruction Manual
for**



**Model 1660
Triple Output
DC POWER SUPPLY**



BK PRECISION®

MAXTEC INTERNATIONAL CORP.

6470 W. Cortland St. • Chicago, IL 60635

TABLE OF CONTENTS

	page
TEST INSTRUMENT SAFETY	inside front cover
INTRODUCTION	1
FEATURES	3
SPECIFICATIONS	4
CONTROLS AND INDICATORS	5
General Controls And Indicators	5
4-6.5 V Supply Controls And Indicators	5
Master Supply Controls And Indicators	5
Slave Supply Controls And Indicators	7
Rear Panel Controls	8
OPERATING INSTRUCTIONS	9
Safety Precautions	9
Equipment Precautions	9
Independent Use Of "Master" Or "Slave" Supply	9
Series Tracking Operation	13
Parallel Tracking Operation	16
4-6.5 V Power Supply Operation	19
APPLICATIONS	20
General	20
Electronics Servicing	20
Electronics Manufacturing	20
Electronics Design Lab	20
Electronics Education	21
Battery Charging	21
Split Supply	21
MAINTENANCE	25
Fuse Replacement	25
Line Voltage Conversion	25
Adjustments	26
Instrument Repair Service	30
WARRANTY SERVICE INSTRUCTIONS	31
LIMITED ONE-YEAR WARRANTY	32

INTRODUCTION

The **B & K-Precision** Model 1660 Triple Output DC Power Supply is a high quality, general purpose dc power source. It provides two supplies with a 0-30 volt dc output and one with a 4-6.5 volt dc output. The 0-30 V supplies are adjustable with both coarse and fine voltage controls for precise settability and are capable of current output of 0-2 amps. The 4-6.5 V supply has a current output of 0-5 amps, allowing it to handle extensive digital logic circuitry. Two large panel-mounted LED meter displays can monitor either the output current or output voltage of each supply.

The two 0-30 volt supplies can be operated independently or in one of two tracking modes. In the series tracking mode, the Slave supply tracks the voltage of the Master supply. Maximum current setting of the two supplies can still be set independently when in the series tracking operating mode. In the series tracking mode the Master and Slave supplies are connected in series, allowing a single output of 0-60 V at up to 2 amps. In the parallel tracking mode, the two supplies are connected together in parallel, allowing a single 0-30 V output at up to 4 amps.

Both 0-30 volt supplies may be used in constant voltage or constant current applications. The crossover from constant voltage to constant current modes is smooth and automatic. LED's indicate the "CV" (constant voltage) or "CC" (constant current) mode of operation. In constant voltage applications, a current limit may be preset. When load variations cause the current to reach the preset limit, the unit then regulates output current rather than output voltage. Current limits are adjustable from 5% to 100% of maximum. In constant current applications, the maximum voltage may be preset. When load variations cause current to drop below the regulated value, the unit reverts to regulated voltage operation at the preset value.

The 4-6.5 V supply is ideal for powering digital logic circuitry. The 0-5 amp capacity

allows the supply to be used for large circuits. Built-in overload protection automatically limits to current output to a maximum of 5 amps. An indicator lights when the supply is overloaded.

The Model 1660 exhibits excellent regulation and low ripple characteristics. The circuit design incorporates a pre-regulator, which greatly reduces internal power dissipation at low output voltages.

Reverse polarity protection prevents accidental damage to the power supply from improper connection to an external voltage, and current limiting protects the equipment being powered, as well as the power supply.

The output is isolated from chassis and earth ground, which permits full flexibility of connections. When needed, the (+) or (-) polarity may be strapped to ground, or either polarity may be floated to an external voltage. Additionally, the two 0-30 volt supplies can be used as a "split supply" with two positive voltages and a common negative, two negative voltages and a common positive, or one positive, one negative, and a common. All of these configurations can be used with either matching (tracking) or differing (independent) voltages.

The features and versatility of the unit, especially the triple output and tracking features, make it an ideal general purpose power supply for engineering lab applications. It can serve as a single or multi-voltage power source, including the bias supply, for breadboard and prototype circuits and equipment. It can provide single or simultaneously varying voltages for circuit evaluation. It can provide tracking (+) and (-) voltages for evaluating differential amplifiers. It may be used as a battery eliminator, or to power individual circuit boards or cards while removed from the system. Its output can be evaluated while powering a breadboard or prototype circuit to determine the circuit's

INTRODUCTION

power supply requirements. Its laboratory quality specifications will meet most engineering laboratory requirements.

The same features that make the Model 1660 a good choice for an engineering lab also

make it a good choice for most other solid state electronic applications. These applications include service shops; industrial production testing of components, assemblies, and complete equipment; for school laboratories, and home use by electronic hobbyists.

FEATURES

TRIPLE OUTPUT

Operates as three separate power supplies. Each has floating output and is completely isolated from the other two.

ONE 4 TO 6.5 V SUPPLY

Husky 0-to-5 amp 4-to-6.5 volt supply is ideal for use with most digital logic circuitry. Adequate current capacity for extensive circuitry.

TWO 0-30 VOLT SUPPLIES

Master and Slave supply are continuously variable over 0-to-30 volt range with coarse and fine controls. Each supply has a 2 amp current capacity.

UNIQUE TRACKING FEATURE

The two 0-to-30 V supplies can be operated so that the Slave supply tracks the Master supply. Outputs can be strapped for two positive voltages with a common negative, two negative voltages with a common positive, or one positive and one negative with a neutral common.

SINGLE 0-60 V SUPPLY

Series tracking feature allows use of Master and Slave supplies as one 0-to-60 V, 2 amp supply.

SINGLE 0-30 V 4 AMP SUPPLY

Parallel tracking feature allows use of Master and Slave supply as a 0-to-30 V supply with a 4 amp current capacity (through Master output terminals).

CONSTANT VOLTAGE OR CONSTANT CURRENT

The Master and Slave supplies provide regulated dc voltage output or regulated dc

current output. Crossover is smooth and automatic.

LED DISPLAY

Two large, easy-to-read LED 3-1/2 digit displays monitor output voltage or output current of all three supplies. Use of two meters allows simultaneous current and voltage metering when use Master and Slave supplies in tracking operation. Good visibility in bright or low light. Meter allows resolution of 0.1 volt or 0.1 amp.

LABORATORY QUALITY

Excellent regulation, low ripple.

LED INDICATORS

Identify mode of operation.

PRE-REGULATOR

Limits internal dissipation for higher reliability and efficiency.

ISOLATED OUTPUT

Either polarity may be floated or grounded.

OVERLOAD PROTECTION

Fully adjustable current limiting (from 5% to 100% of maximum output current) for Master and Slave supplies protects circuit under test and the power supply.

REVERSE POLARITY PROTECTION

Prevents damage to power supply from external voltage of reverse polarity.

HOOK-UP CABLES

Supplied with three sets of red and black hook-up leads.

SPECIFICATIONS

MASTER AND SLAVE SUPPLIES

Output Voltage Range:

0 V (+0/-30 mV) to 30 V + (3% to 7%).

Output Current Limit Range:

0 A (+0/-30 mA) to 2 A +(3% to 7%).

Load Regulation (Constant Voltage):

$\leq 0.01\% + 3 \text{ mV}$.

Line Regulation 108 - 132 V (Constant Voltage):

$\leq 0.01\% + 3 \text{ mV}$.

Ripple (Constant Voltage):

$\leq 1 \text{ mV RMS}$.

Recovery Time (Constant Voltage):

$\leq 100 \mu\text{s}$.

Temp. Coefficient (Constant Voltage):

$\leq 300 \text{ ppm}/^{\circ}\text{C}$.

Load Regulation (Constant Current):

$\leq 0.2\% + 3 \text{ mA}$.

Line Regulation 108 - 132 V (Constant Current):

$\leq 0.2\% + 3 \text{ mA}$.

Ripple Current (at 108 V for Constant Current):

$\leq 3 \text{ mA RMS}$.

Tracking (Series):

$\pm 0.2\% + 10 \text{ mV}$.

Panel Meter Accuracy (Volts):

$\pm 0.5\% + 2 \text{ digits}$.

Panel Meter Accuracy (Current):

$\pm 0.5\% + 2 \text{ digits}$.

4-6.5 V SUPPLY

Output Voltage Range:

4 V $\pm 5\%$ to 6.5 V $\pm 5\%$.

Load Regulation (Constant Voltage):

$\leq 10 \text{ mV}$ (0 to 5 A load).

Line Regulation 108 - 132 V (Constant Voltage):

$\leq 10 \text{ mV}$.

Ripple And Noise:

$\leq 2 \text{ mV RMS}$.

Overvoltage Protection Threshold:

6.8 V to 7.3 V.

Panel Meter Accuracy:

Same as Master Supply Meter.

GENERAL

Power Requirements:

110/120/220/240 VAC $\pm 10\%$, 50/60 Hz.

Power Consumption (Fully Loaded):

Approximately 320 W.

Protection:

Reverse polarity protection and current limiting.

Dimensions (H x W x D):

165 x 315 x 381 mm (12.4 x 15 x 6.5").

Weight:

10 kg (22 lbs).

Accessories Supplied:

Three sets of hook-up leads, 1 red, 1 black.
Two earth ground bus straps.
Two 5A, 250V fuses (spares).
Schematic Diagram & Parts List.

Optional Accessories:

FP-10 10-amp test leads (1 red, 1 black).

CONTROLS AND INDICATORS

GENERAL CONTROLS AND INDICATORS

1. **POWER Switch.** Turns power on and off. When power is on, switch is internally illuminated to serve as a pilot light.
2. **TRACKING Mode Switches.** Two push-button switches that select **INDEPENDENT** mode, series tracking mode, or parallel tracking mode as follows:
 - a. When both switches are disengaged (out), the unit is in the **INDEPENDENT** mode and the **MASTER** and **SLAVE** power supplies are completely independent from one another.
 - b. When the left switch is engaged (in) and the right switch is disengaged (out), the unit is in the **TRACKING SERIES** mode. In this mode, maximum voltage of both supplies is set using the **MASTER VOLTAGE** controls (voltage at output terminals of the **SLAVE** supply tracks the voltage at the output terminals of the **MASTER** supply). Also, in this mode of operation the positive terminal (red) of the **SLAVE** supply is connected to the negative terminal (black) of the **MASTER** supply. This allows the two supplies to be used as one 0-to-60 volt supply.
 - c. When both switches are engaged (in), the unit is in the **TRACKING PARALLEL** mode. In this mode the **MASTER** and **SLAVE** supplies are wired together in parallel and both the maximum current and voltage are set using the **MASTER** controls. The **MASTER** and **SLAVE** outputs can be used as two individual (but tracking) power supplies or just the **MASTER** output can be used as a 0-to-30 volt supply with a 4 A capability.
3. **0-30 V/4-6.5 V Switch.** Controls **MASTER/4-6.5 V LED Display**. When this switch is in the **0-30 V** position, the LED display monitors the **MASTER** (0-30 V) supply. When this switch is in the **4-6.5 V** position, the LED display monitors the 4-6.5 V supply.
4. **A/V Switch.** Selects current or voltage metering mode for the **MASTER** 0-30 V supply or the **4-6.5 V** supply (depending on setting of **0-30 V/4-6.5 V** switch). When in the **A** (amps) position, current is read from the **MASTER/4-6.5 V LED Display**. When in the **V** (volts) position, voltage is read from the **MASTER/ 4-6.5 V LED Display**.
5. **MASTER/4-6.5 V LED Display.** Digital display indicates voltage or current at the 0-30 V **MASTER** supply or the 4-6.5 V supply (depending on the setting of the **MASTER A/V** and **0-30 V/4-6.5 V** switches).

4-6.5 V SUPPLY CONTROLS AND INDICATORS

6. **"-" Terminal (Black).** Negative polarity output terminal for 4-6.5 V supply.
7. **"+" Terminal (Red).** Positive polarity output terminal for 4-6.5 V supply.
8. **Voltage Level Control.** Adjusts output voltage for 4-6.5 V supply. Fully counterclockwise rotation adjusts output voltage to 4 V. Clockwise rotation increases voltage to a maximum of 6.5 V (full clockwise rotation).
9. **5 A OVERLOAD Indicator.** Lights when load on 4-6.5 Volt supply becomes too large.

MASTER SUPPLY CONTROLS AND INDICATORS

10. **C.C. (Constant Current) Indicator.** Red LED lights when **MASTER** supply is in the Constant Current mode. The Power

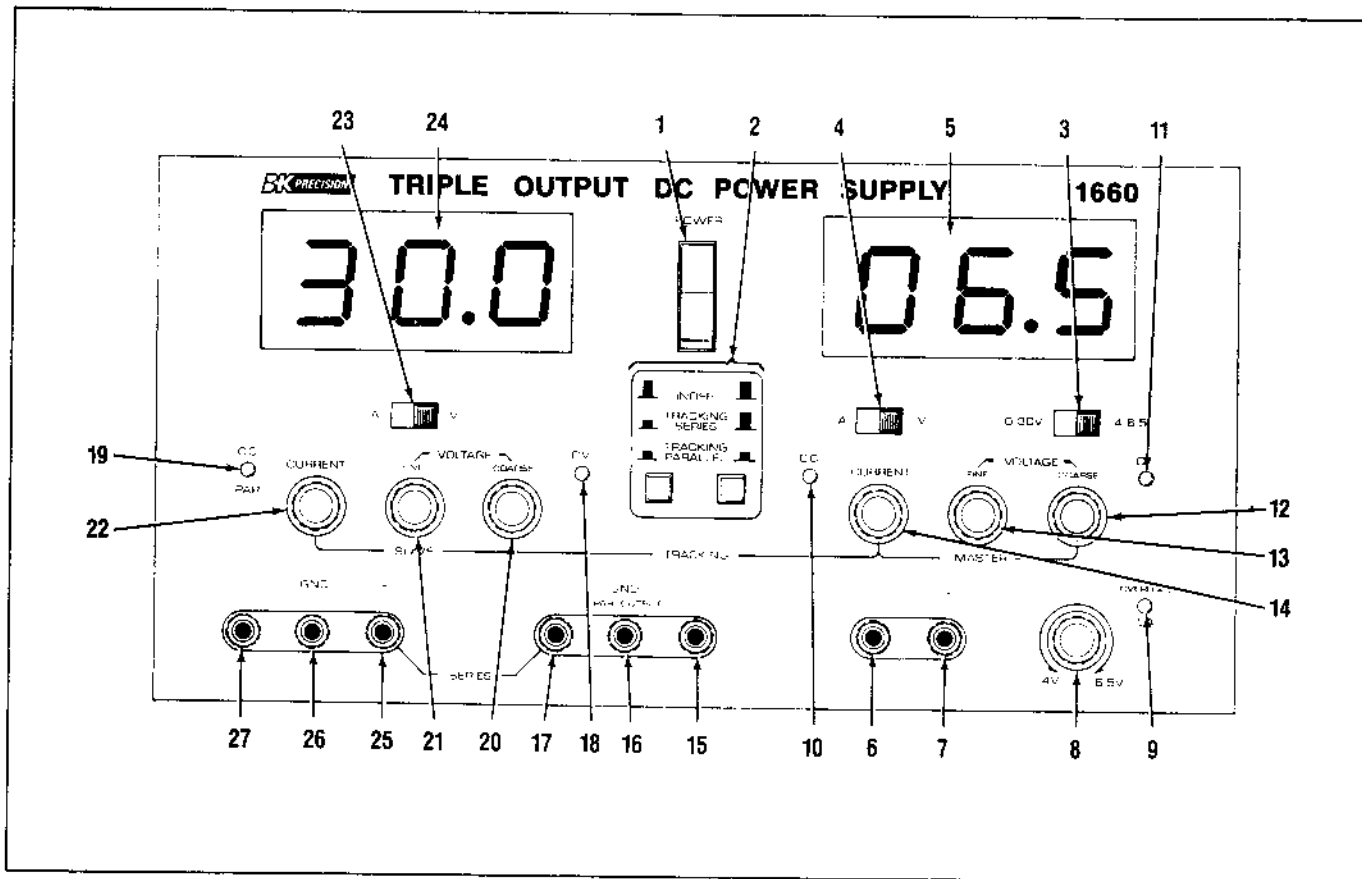

Fig. 1. Front Panel Controls And Indicators.

Supply regulates the output current at the value set by the **MASTER CURRENT** control. In the Parallel Tracking mode, when this indicator is lit, both the **MASTER** and **SLAVE** supplies are in the Constant Current mode.

mode is selected. Read the value on the **MASTER/4-6.5 V LED Display** when the voltage (V) and master (0-30 V) metering modes are selected.

11. **C.V. (Constant Voltage) Indicator.** Green LED lights when the **MASTER** supply is in the Constant Voltage mode. The Power Supply regulates the output voltage at the value set by the **MASTER VOLTAGE** controls. In either the Series or Parallel Tracking mode, when this indicator is lit, both the **MASTER** and **SLAVE** supplies are in the Constant Voltage mode.

13. **FINE VOLTAGE Control.** Fine adjustment of output voltage of the **MASTER** supply. Also functions as fine adjustment control for the maximum output voltage of the **SLAVE** supply when either parallel or series tracking mode is selected. Read the value on the **MASTER/4-6.5 V LED Display** when the voltage (V) and master (0-30 V) metering modes are selected.

12. **COARSE VOLTAGE Control.** Coarse adjustment of the output voltage of the **MASTER** supply. Also functions as coarse adjustment control for the maximum output voltage of the **SLAVE** supply when either parallel or series tracking

14. **CURRENT Control.** Adjusts current limit of **MASTER** supply in constant voltage mode. Adjusts constant current value of **MASTER** supply in constant current mode. Current can be read from the **MASTER/4-6.5 V LED Display** when the current (A) and master (0-30 V) metering modes are selected.

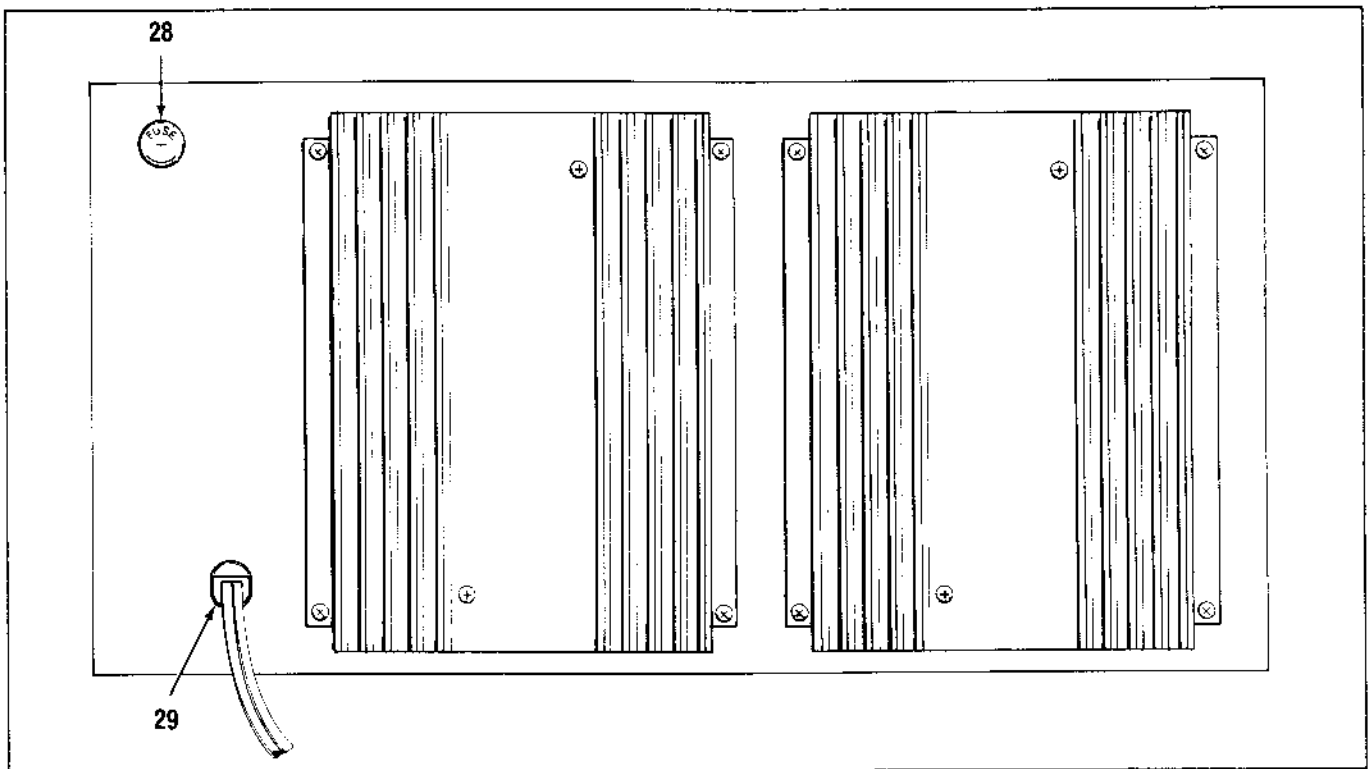

Fig. 2. Rear Panel Controls.

- | | |
|--|---|
| <p>15. "+" Terminal (Red). Positive polarity output terminal for the MASTER supply. Also serves as the positive polarity terminal for 4 A parallel and 0-to-60 V series tracking operation.</p> <p>16. GND Terminal (Green). Earth and Chassis Ground.</p> <p>17. "-" Terminal (Black). Negative polarity output terminal for the MASTER supply. Also serves as the negative polarity terminal for 4 A parallel tracking operation. In series tracking operation, this terminal is internally tied to the (+) positive terminal of the SLAVE supply.</p> | <p>19. C.C. (Constant Current)/PARALLEL Indicator. Red LED lights when SLAVE supply is in the Constant Current mode. The Power Supply regulates the output current at the value set by the SLAVE CURRENT control when in the series tracking or INDEPENDENT modes. Also lights when the TRACKING PARALLEL mode is selected.</p> <p>20. COARSE VOLTAGE Control. Coarse adjustment of the output voltage of the SLAVE supply when the INDEPENDENT mode is selected. Read the value on the SLAVE LED Display when the voltage (V) metering mode is selected.</p> <p>21. FINE VOLTAGE Control. Fine adjustment of output voltage of the SLAVE supply when the INDEPENDENT mode is selected. Read the value on the SLAVE LED Display when the voltage (V) metering mode is selected.</p> <p>22. CURRENT Control. Adjusts current limit of SLAVE supply in constant voltage mode. Adjusts constant current</p> |
|--|---|

SLAVE SUPPLY CONTROLS AND INDICATORS

18. **C.V. (Constant Voltage) Indicator.** Green LED lights when the **SLAVE** supply is in the Constant Voltage mode. The Power Supply regulates the output voltage at the value set by the **SLAVE VOLTAGE** controls.

CONTROLS AND INDICATORS

value of **SLAVE** supply in constant current mode. Current can be read from the **SLAVE LED Display** when the current (A) metering mode is selected.

23. **A/V Switch.** Selects current or voltage metering mode for the 0-30 V **SLAVE** supply. When in the **A** (amps) position, current is read from the **SLAVE LED Display**. When in the **V** (volts) position, voltage is read from the **SLAVE LED Display**.
24. **SLAVE LED Display.** Digital display indicates voltage or current at the 0-30 V **SLAVE** supply (depending on the setting of the **A/V** switch).
25. **"+" Terminal (Red).** Positive polarity output terminal for the **SLAVE** supply.

In series tracking operation, this terminal is connected to the negative terminal of the **MASTER** supply.

26. **GND Terminal (Green).** Earth and Chassis Ground.
27. **"-" Terminal (Black).** Negative polarity output terminal for the **SLAVE** supply. Also serves as the negative polarity terminal for 0-to-60 V series tracking operation.

REAR PANEL CONTROLS

28. **Fuse.**
29. **Line Cord.**

OPERATING INSTRUCTIONS

SAFETY PRECAUTIONS

CAUTION

Avoid contacting the heat sinks at the rear of the power supply. When the unit is providing large amounts of current at any or all of its outputs, the heat sinks can become very hot. Contacting the heat sinks when they are hot could result in skin burns or damage to the equipment in contact with them.

Use only a polarized 3-wire ac outlet. This assures that the power supply chassis, case, and ground terminal are connected to a good earth ground and reduces danger from electrical shock.

There may be great danger of electrical shock if the power supply output is connected to an external high voltage. Some equipment being powered may contain high voltage and present a shock hazard. Observe caution. If the power supply output is floated (referenced to a voltage rather than earth ground) turn off the power supply and the equipment under test when making connections. Never float the power supply to a potential greater than 100 volts peak with respect to earth ground.

EQUIPMENT PRECAUTIONS

Avoid using the power supply in ambient temperatures above +40° C. Always allow sufficient air space around the heat sink at the rear of the power supply for effective radiation to prevent internal heat build-up.

Although the power supply is protected against reverse polarity damage, the circuit being powered may not include such protection. Always carefully observe polarity; incorrect polarity may damage the equipment under test.

Do not exceed the voltage rating of the circuit being powered. Many transistors and integrated circuits will not withstand voltage of 30 volts.

There is no need to worry about voltage spikes or overshoot damaging the equipment under test. The voltage between the output terminals of the power supply never exceeds the preset value as the **POWER** switch is turned on or off.

INDEPENDENT USE OF "MASTER" OR "SLAVE" SUPPLY

The "**MASTER**" and "**SLAVE**" supplies each provide a 0-to-30 volt output at up to 2.0 amps. This procedure covers the use of the **MASTER** and **SLAVE** supplies only when they are used independently from one another. When used in the **INDEPENDENT** operating mode, the operating controls of the two power supplies are completely independent and either supply can be used individually or both can be used simultaneously. Basic operation is covered here. Several variations are covered in the **APPLICATIONS** section of this manual.

Hook-up

1. Disengage both **TRACKING** mode switches (both switches out) so that the power supply is in the **INDEPENDENT** operating mode.
2. Turn off the power supply and the equipment to be powered during hook-up.
3. Connect the positive polarity of the device being powered to the red (+) terminal of the power supply.

OPERATING INSTRUCTIONS

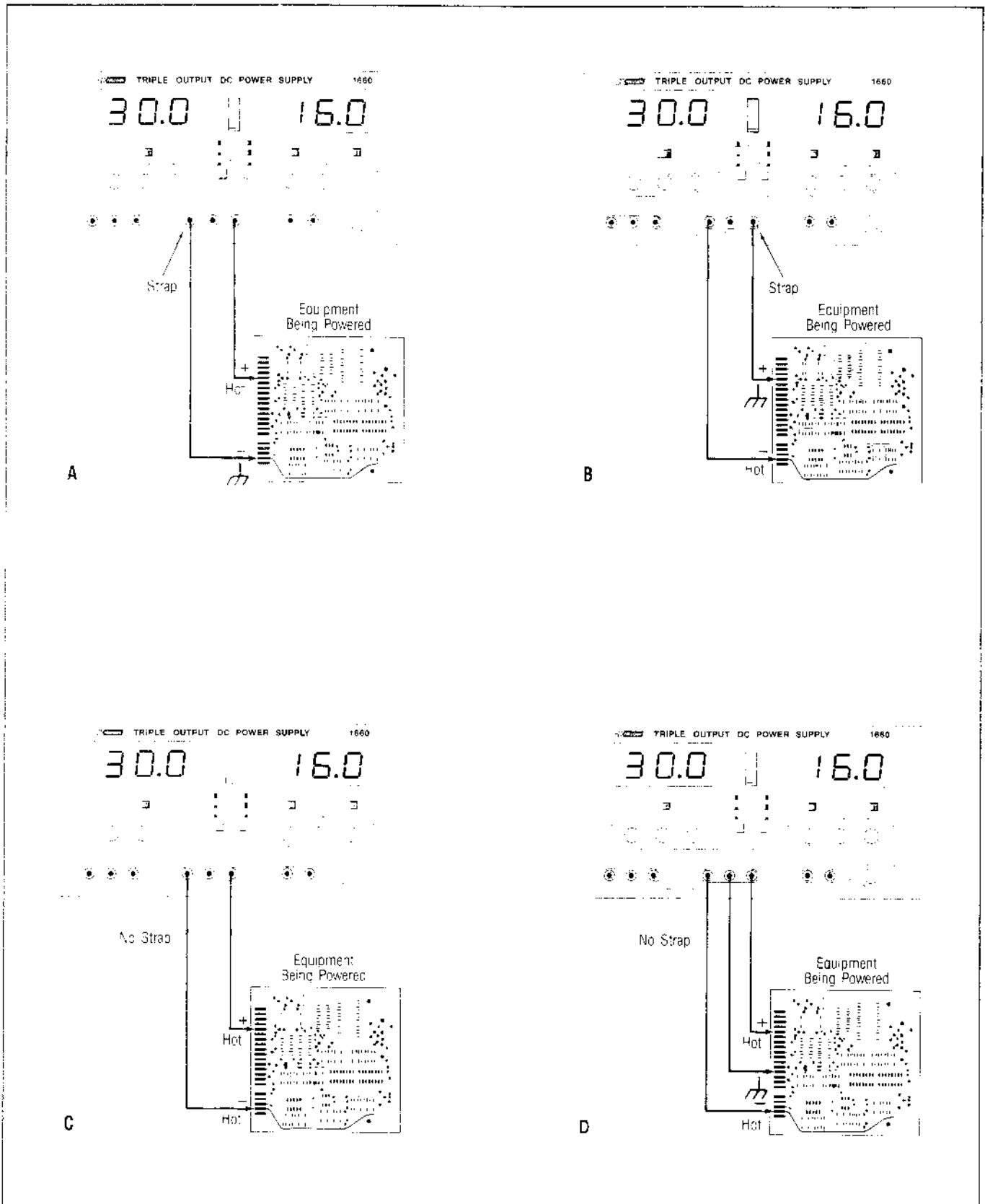

Fig. 3. Independent Operation Grounding Possibilities.

4. Connect the negative polarity of the device being powered to the black (-) terminal of the power supply.
5. Fig. 3 illustrates the grounding possibilities when used in the **INDEPENDENT** mode.
 - a. If the negative polarity of the equipment or circuit being powered is also the chassis or common, it may be grounded to earth by strapping the black (-) terminal to the green (**GND**) terminal as shown in Fig. 3A.
 - b. Similarly, the positive polarity can be grounded by strapping the red (+) terminal to the green (**GND**) terminal as shown in Fig. 3B.
 - c. If an earth ground reference is not required, the configuration of Fig. 3C may be used. The scheme in Fig. 3C should also be used where it is not known whether the chassis is common with either the positive or negative polarity.
 - d. If the chassis or common of the equipment being powered is separate from both the positive and negative polarity power inputs, use the connection shown in Fig. 3D.
6. Observe proper polarity. If the circuit being powered is not equipped with reverse polarity protection, damage to the circuit can result from reverse polarity. Use color coded hook-up leads, such as the sets supplied with the power supply, for convenience in identifying polarity, red for (+) and black for (-).
7. Make sure that the hook-up leads offer sufficient current capability and low resistance between the power supply and the circuits being powered. The hook-up leads supplied with the power supply are rated for 3 amps.

Typical Constant Voltage Operation

1. Before connecting the device to be powered to the power supply, determine the maximum safe load current for the

device to be powered and set the current limit value (see "Setting Current Limit" procedure in this section).

2. Set **FINE VOLTAGE** control to center and **COARSE VOLTAGE** control to minimum (fully counterclockwise).
3. Turn off power supply and connect it to the device to be powered (see "Hook-Up" procedure in this section).
4. Turn on **POWER** switch. The **CV** indicator should light.
5. Set the meter selection switch to the **V** position to select the voltage metering mode.
6. Increase the **VOLTAGE** setting until the LED display reads the desired value. The **FINE** control permits easier setting to a specific value.
7. Set the meter selection switch to the **A** position to select the current metering mode and note the load current on the display.

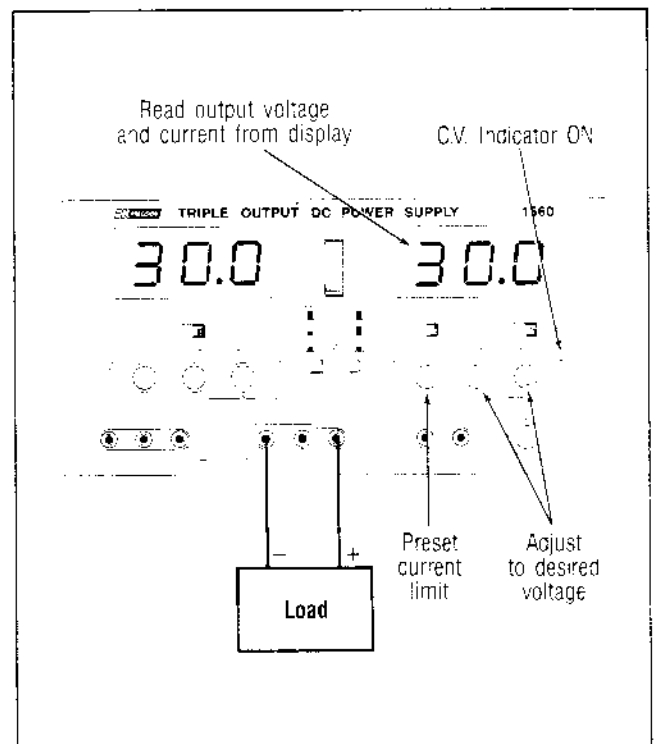

Fig. 4. Typical Constant Voltage Operation.

OPERATING INSTRUCTIONS

8. If the load current exceeds the preset current limit, the CV indicator will go off and the CC indicator will light. In this case, the power supply automatically switches to the constant current mode and further rotation of the VOLTAGE control will not increase the output voltage.

Setting Current Limit

1. Determine the maximum safe current for the device to be powered.
2. Temporarily short the (+) and (-) terminals of the power supply together with a test lead.
3. Rotate the COARSE VOLTAGE control away from zero sufficiently for the CC indicator to light.
4. Set the meter selection switch to the A position to select the current metering mode.
5. Adjust the CURRENT control for the desired current limit. Read the current value on the LED display.

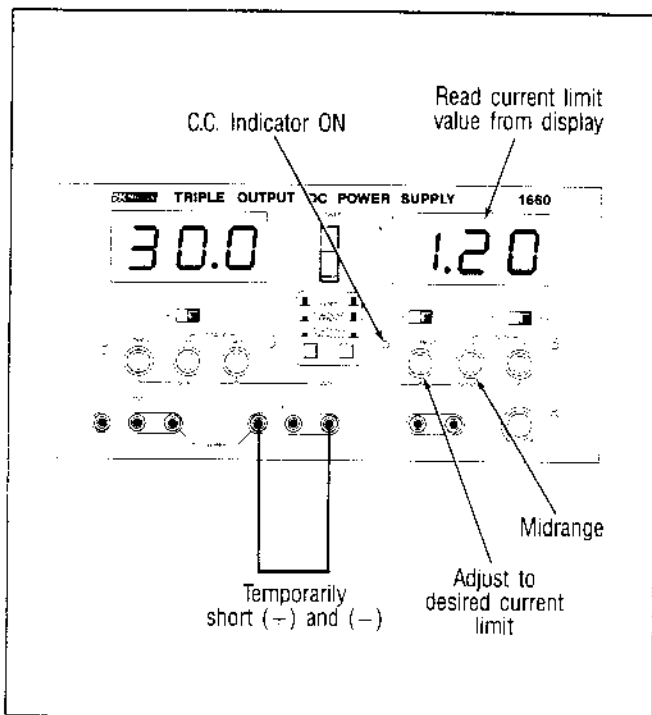

Fig. 5. Setting Current Limit.

6. The current limit (overload protection) has now been preset. Do not change the CURRENT control setting after this step.
7. Remove the short between the (+) and (-) terminals and hook up for constant voltage operation.

Typical Constant Current Operation

1. Before connecting the device to be powered to the power supply, determine the maximum safe voltage to be applied, set the meter selection switch to the V position, and set the VOLTAGE controls to obtain that voltage reading on the LED display.
2. Determine the desired constant current value.
3. Set the CURRENT control to minimum (fully counterclockwise).
4. Turn off the power supply and connect it to the device to be powered.
5. Turn on the power supply. The CC indicator should light.

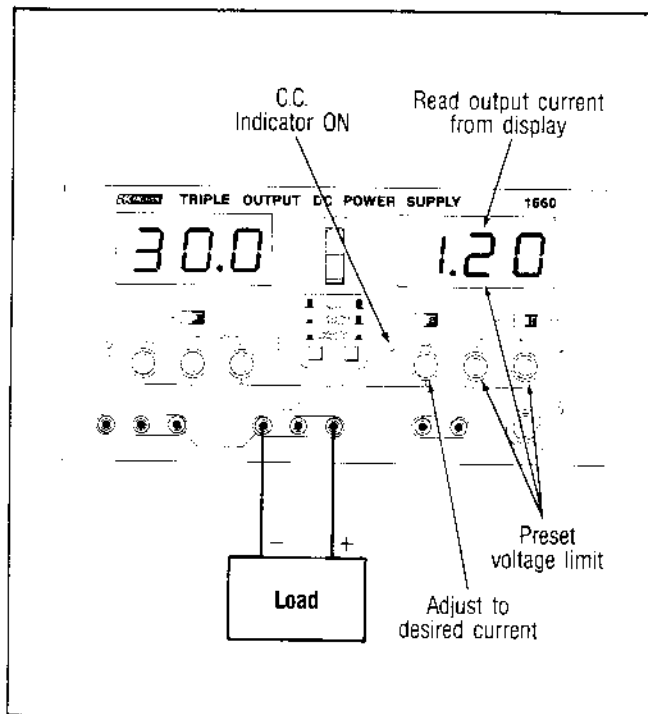

Fig. 6. Typical Constant Current Operation.

6. Set the meter selection switch to the **A** position to obtain the current metering mode.
7. Increase the **CURRENT** control setting until the desired constant current value is read on the display, or set the current limit in advance (before connecting the load) as prescribed earlier in the "Setting Current Limit" procedure
8. If the load current drops below the constant current value, the **CC** indicator will go off and the **CV** indicator will light. In this case, the power supply automatically switches to the constant voltage mode, and further rotation of the **CURRENT** control will not increase the output current.

Constant Voltage/Constant Current Characteristic

The working characteristic of this power supply is called a constant voltage/constant current automatic crossover type. This permits continuous transition from constant current to constant voltage modes in response to the load change. The intersection of constant voltage and constant current modes is called the crossover point. Fig. 7 shows the relationship between this crossover point and the load.

For example, if the load is such that the power supply is operating in the constant voltage mode, a regulated output voltage is provided. The output voltage remains constant as the load increases, up until the point where the preset current limit is reached. At that point, the output current becomes constant and the output voltage drops in proportion to further increases in load. The crossover point is indicated by the front panel LED indicators. The crossover point is reached when the **CV** indicator goes off and the **CC** indicator comes on.

Similarly, crossover from the constant current to the constant voltage mode automatically occurs from a decrease in load. A good example of this would be seen when charging a 12-volt battery. Initially, the open circuit voltage of the power supply may be preset for 13.8 volts. A low battery will place

a heavy load on the supply and it will operate in the constant current mode, which may be adjusted for a 1 amp charging rate. As the battery becomes charged, and its voltage approaches 13.8 volts, its load decreases to the point where it no longer demands the full 1 amp charging rate. This is the crossover point where the power supply goes into the constant voltage mode.

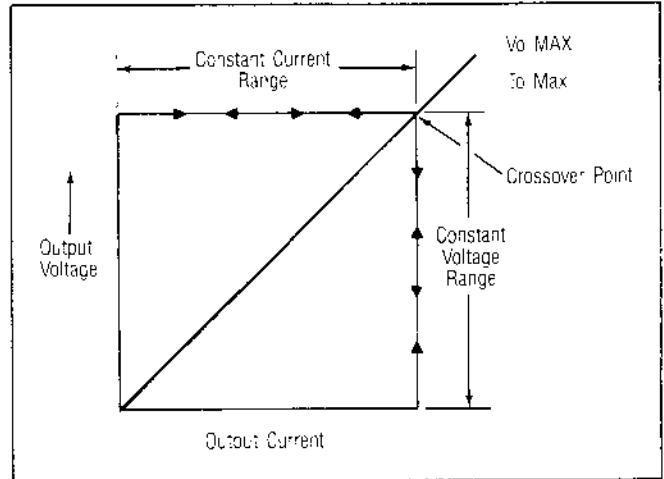

Fig. 7. Constant Voltage/Constant Current Characteristic.

SERIES TRACKING OPERATION

When the series tracking mode of operation is selected, the positive (red) terminal of the **SLAVE** supply output is internally connected to the negative (black) terminal of the **MASTER** supply. This allows the power supply to be used as a single 0-to-60 volt power supply simply by using the negative (black) terminal of the **SLAVE** supply and the positive (red) terminal of the **MASTER** supply.

In the series tracking mode, the maximum output voltage of both the **MASTER** and **SLAVE** supplies can be simultaneously varied with one control. The maximum **SLAVE** supply voltage is automatically set to the same value as the **MASTER** supply by using the **MASTER VOLTAGE** controls.

Simultaneous metering of both current and voltage can be obtained in this mode of operation by setting one of the displays for current metering and one for voltage metering.

OPERATING INSTRUCTIONS

In this case, the output voltage (across the two supplies) is actually double the displayed value. For example, if the **MASTER** display is set for voltage metering and the **SLAVE** display for current metering, the output voltage across the **MASTER** positive (red) terminal and the **SLAVE** negative (black) terminal would be double the reading on the **MASTER LED Display** (since both supplies are putting out the same voltage). The actual output current would be the value read from the **SLAVE LED Display** (since the two supplies are wired in series, current flowing through each supply must be equal).

1. Set the power supplies to the **TRACKING SERIES** mode by engaging the left **TRACKING** switch and release the right **TRACKING** switch.
2. Set the **0-30 V/4-6.5 V** switch to the **0-30 V** position the **MASTER A/V** switch to the **V** (voltage metering) position, and the **SLAVE A/V** switch to the **A** (current metering) position.
3. Set the **SLAVE CURRENT** control to the fully clockwise position. The maximum current is set using the **MASTER CURRENT** control. Follow the instructions for "Setting Current Limit" (INDEPENDENT USE OF "MASTER" OR "SLAVE" SUPPLY section of this manual) using the **MASTER CURRENT** control.

NOTE

Because the supplies are being used in series, either **CURRENT** control can be used to set maximum current. If desired, the **MASTER CURRENT** control can be rotated fully clockwise and the **SLAVE CURRENT** control can be used to adjust the maximum current value. Because current through the two supplies must be equal when they are being used in series, the lowest **CURRENT** control setting will set the maximum output current.

4. Adjust the output voltage to the desired level using the **MASTER VOLTAGE** controls (remember that the actual output

voltage is double the reading on the **MASTER LED Display**).

5. Turn off the power supply and the equipment to be powered during hook-up.
6. Connect the positive polarity of the device being powered to the red (+) terminal of the **MASTER** power supply.
7. Connect the negative polarity of the device being powered to the black (-) terminal of the **SLAVE** power supply.
8. Fig. 8 illustrates the grounding possibilities when the unit is used as a 0-to-60 volt supply.
 - a. If the negative polarity of the equipment or circuit being powered is also the chassis or common, it may be grounded to earth by strapping the black (-) terminal of the **SLAVE** supply to the green (**GND**) terminal of the **SLAVE** supply as shown in Fig. 8A.
 - b. Similarly, the positive polarity can be grounded by strapping the red (+) terminal of the **MASTER** supply to the green terminal of the **MASTER** supply as shown in Fig. 8B.
 - c. If "split supply" operation is desired, a positive and negative voltage with a center ground can be achieved by strapping the black (-) terminal of the **MASTER** supply to the green (**GND**) of the **MASTER** supply as shown in Fig. 8C. See the **APPLICATIONS** section of this manual for more information on "split supply" operation.

NOTE

If one of the supplied ground straps is to be used, only use it in one of these three ways. Connecting two ground straps could ground both the positive and negative terminals and load down the power supply, causing improper operation.

- d. If an earth ground reference is not required, the configuration of Fig. 8D may be used. The scheme in

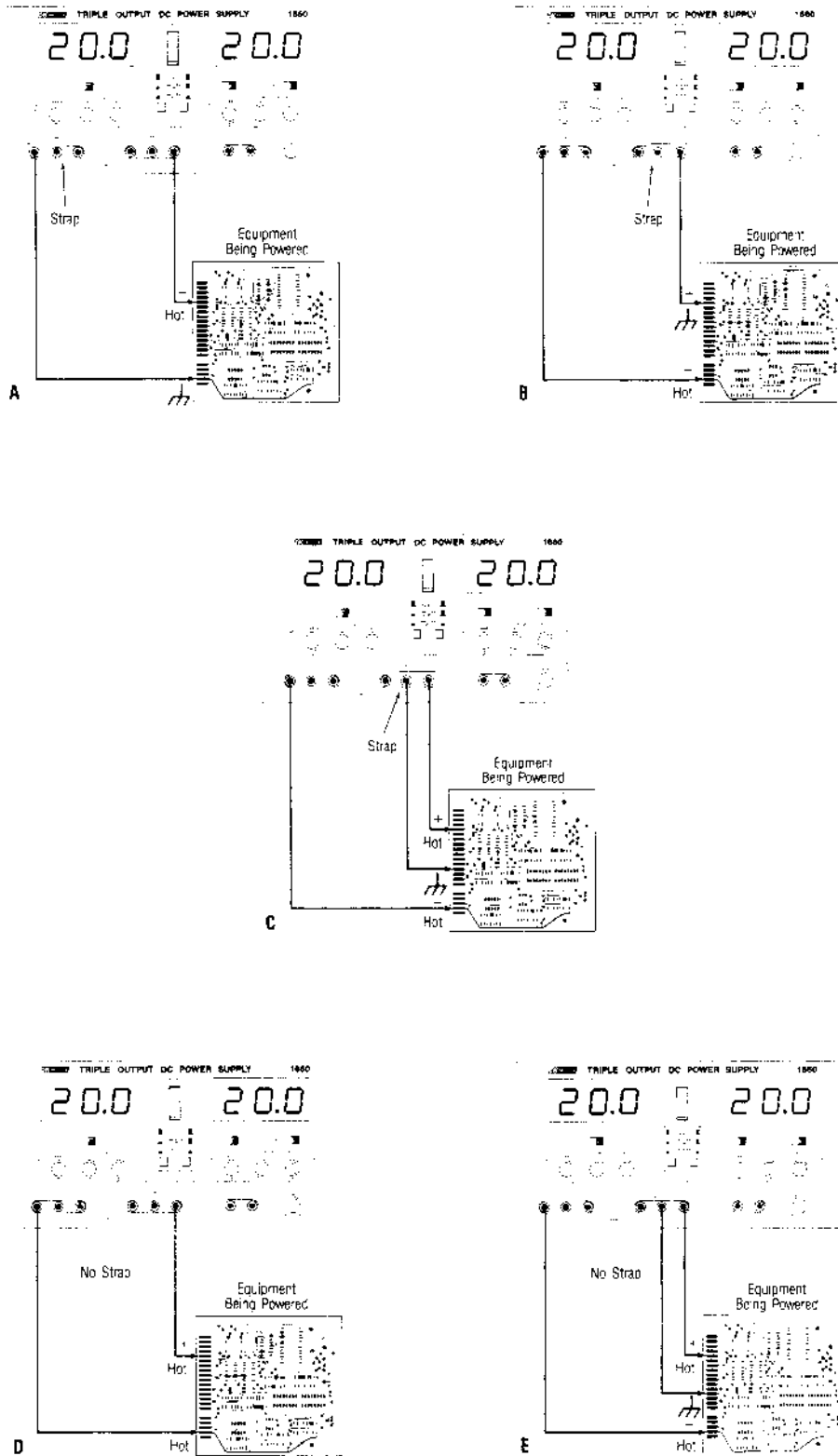

Fig. 8. Series Tracking (0-to-60 V) Operation Grounding Possibilities.

OPERATING INSTRUCTIONS

Fig. 8D should also be used where it is not known whether the chassis is common with either the positive or negative polarity.

- e. If the chassis or common of the equipment being powered is separate from both the positive and negative polarity power inputs, use the connection shown in Fig. 8E.
9. Observe proper polarity. If the circuit being powered is not equipped with reverse polarity protection, damage to the circuit can result from reverse polarity. Use color coded hook-up leads, such as the sets supplied with the power supply, for convenience in identifying polarity, red for (+) and black for (-).
10. Make sure that the hook-up leads offer sufficient current capability and low resistance between the power supply and the circuits being powered. The hook-up leads supplied with the power supply are rated for 3 amps.

PARALLEL TRACKING OPERATION

In the parallel tracking mode of operation, both supplies are strapped together (in parallel). This allows for a 0-30 V supply with a 4 amp current capability. Only the **MASTER** output terminals are used for parallel tracking operation. In the parallel tracking mode, the **SLAVE** supply output voltage and current track the **MASTER** supply output voltage and current.

1. Set the power supplies to the **TRACKING PARALLEL** mode by engaging both **TRACKING** switches.
2. Set the **0-30 V/4-6.5 V** switch to the **0-30 V** position, the **MASTER A/V** switch to the **V** (voltage metering) position, and the **SLAVE A/V** switch to the **A** (current metering) position. Output voltage will now be read from the **MASTER LED Display**. Output current is exactly double the value read from the **SLAVE LED Display** (because each supply is providing the same amount of current).
3. Because both voltage and current of the **SLAVE** supply track the **MASTER** supply,

the maximum current and voltage are set using the **MASTER** controls. Using the **MASTER** supply output jacks, follow the instructions for "Setting Current Limit" (**INDEPENDENT USE OF "MASTER" OR "SLAVE" SUPPLY** paragraph of this section). Remember that the actual current output at the **MASTER** supply output jacks is double the reading on the **SLAVE LED Display**.

4. Adjust the output voltage to the desired level using the **MASTER VOLTAGE** controls.
5. Turn off the power supply and the equipment to be powered during hook-up.
6. Connect the positive polarity of the device being powered to the red (+) terminal of the **MASTER** power supply.
7. Connect the negative polarity of the device being powered to the black (-) terminal of the **MASTER** power supply.
8. Fig. 9 illustrates the grounding possibilities when used in the **TRACKING PARALLEL** mode.
 - a. If the negative polarity of the equipment or circuit being powered is also the chassis or common, it may be grounded to earth by strapping the black (-) terminal to the green (**GND**) terminal as shown in Fig. 9A.
 - b. Similarly, the positive polarity can be grounded by strapping the red (+) terminal to the green (**GND**) terminal as shown in Fig. 9B.
 - c. If an earth ground reference is not required, the configuration of Fig. 9C may be used. The scheme in Fig. 9C should also be used where it is not known whether the chassis is common with either the positive or negative polarity.
 - d. If the chassis or common of the equipment being powered is separate from both the positive and negative polarity power inputs, use the connection shown in Fig. 9D.

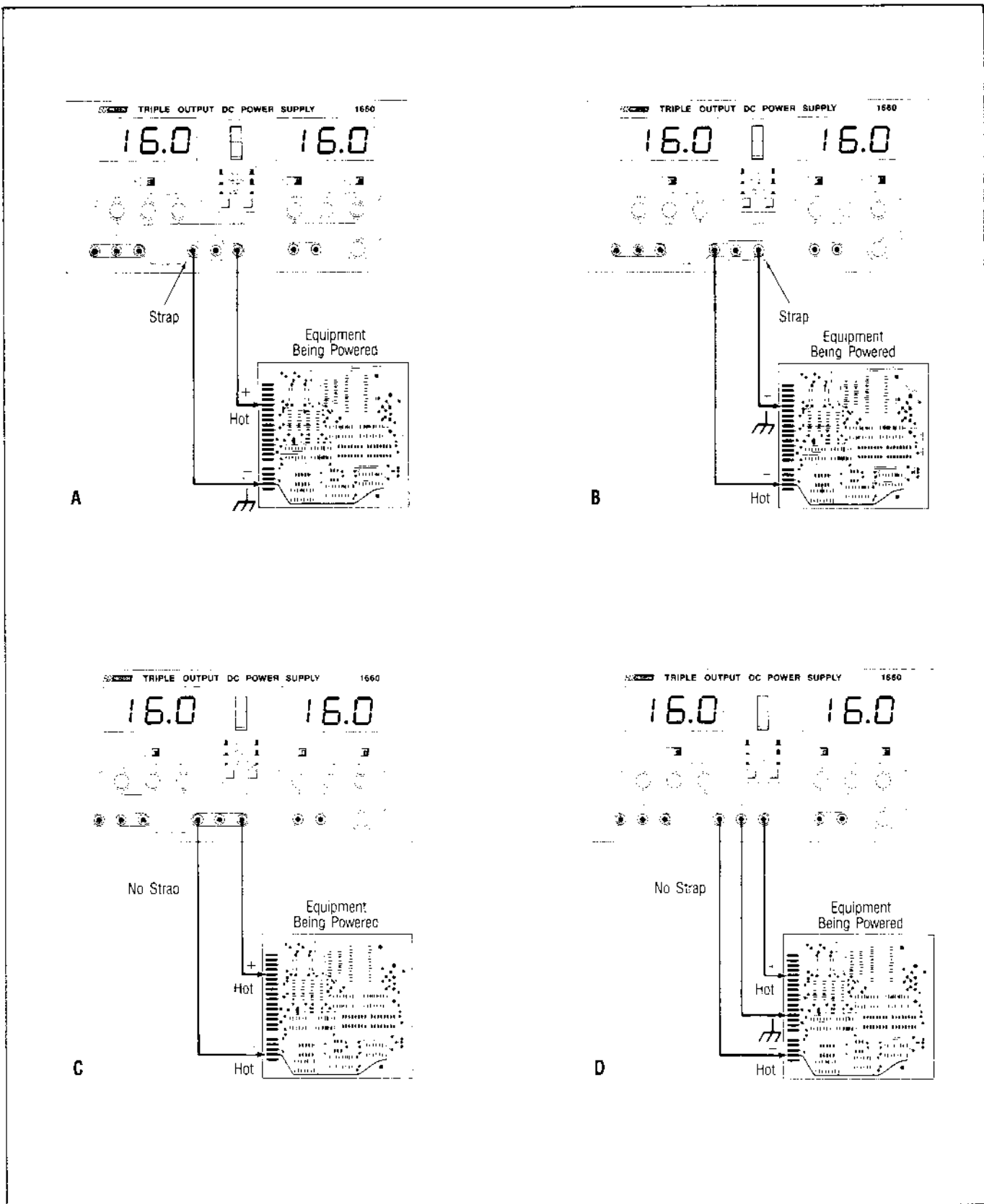

Fig. 9. Parallel Tracking Operation Grounding Possibilities.

OPERATING INSTRUCTIONS

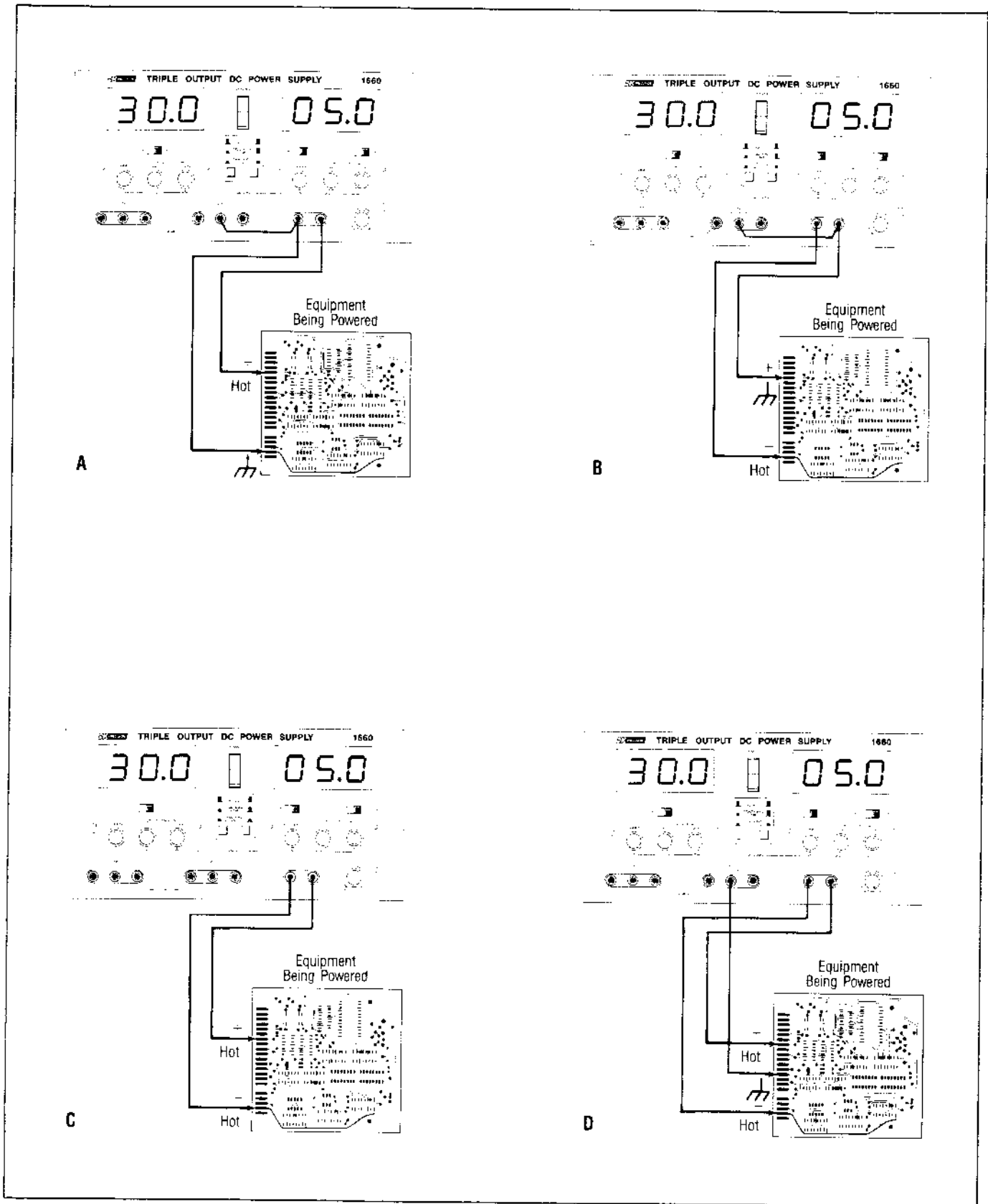

Fig. 10. Grounding Possibilities for 4-6.5 V Power Supply.

9. Observe proper polarity. If the circuit being powered is not equipped with reverse polarity protection, damage to the circuit can result from reverse polarity. Use color coded hook-up leads, such as the sets supplied with the power supply, for convenience in identifying polarity, red for (+) and black for (-).
10. Make sure that the hook-up leads offer sufficient current capability and low resistance between the power supply and the circuits being powered. The hook-up leads supplied with the power supply are rated for 3 amps. 10-amp test leads are available as an optional accessory.

4-6.5 V POWER SUPPLY OPERATION

The 4-6.5 V supply provides a 4.0 to 6.5 V DC output with a 5 amp current capacity. The supply is ideal for use with TTL circuits.

1. Set the 0-30 V/4-6.5 V switch to the 4-6.5 V position and the MASTER A/V switch to the V position. This sets the MASTER/4-6.5 V Display to show output voltage of the 4-6.5 V supply.
2. Using the Voltage Level Control to adjust the output voltage of the 4-6.5 V supply to the desired level.
3. Turn off the power supply and the equipment to be powered during hook-up.
4. Connect the positive polarity of the device being powered to the red (+) terminal of the 4-6.5 V supply.
5. Connect the negative polarity of the device being powered to the black (-) terminal of the 4-6.5 V supply.
6. Fig. 10 illustrates the grounding possibilities of the the 4-6.5 V supply.
 - a. If the negative polarity of the equipment or circuit being powered is also the chassis or common, it may grounded to earth by connecting a jumper from the black (-) terminal to either green (GND) terminal as shown in Fig. 10A.
 - b. Similarly, the positive polarity can be grounded by connecting a jumper

- between the red (+) terminal and either green (GND) terminal as shown in Fig. 10B.
- c. If an earth ground reference is not required, the configuration of Fig. 10C may be used. The scheme in Fig. 10C should also be used where it is not known whether the chassis is common with either the positive or negative polarity.
- d. If the chassis or common of the equipment being powered is separate from both the positive and negative polarity power inputs, use the connection shown of Fig. 10D.

7. Observe proper polarity. If the circuit being powered is not equipped with reverse polarity protection, damage to the circuit can result from reverse polarity. Use color coded hook-up leads, such as the sets supplied with the power supply, for convenience in identifying polarity, red for (+) and black for (-).
8. Make sure that the hook-up leads offer sufficient current capability and low resistance between the power supply and the circuits being powered. The hook-up leads supplied with the power supply are rated for 3 amps. 10-amp hook-up leads are available as an optional accessory.
9. If the red OVERLOAD indicator lights, too much load has been placed on the supply. This will cause voltage and current to drop and prevent proper operation of the 4-6.5 V supply. To correct this situation, the load on the supply must be decreased so that no more than 5 amps of current are required.

NOTE

If decreasing the load does not cause the overload indicator to turn off, the overvoltage protection circuitry has turned on. In order to return the supply to normal operation, the output voltage must be decreased (or the external voltage source must be removed) and the power must be momentarily shut off.

APPLICATIONS

GENERAL

The Model 1660 power supply has a very wide variety of applications in electrical and electronics servicing, engineering laboratories, manufacturing and testing facilities, schools, and home hobbying. The Master and Slave power supply outputs are fully adjustable from 0-to-30 volts and 0-to-2 amps and the 4-6.5 V supply is fully adjustable from 4-to-6.5 V with a current capability of 0-to-5 amps. This flexibility makes it suitable for most applications requiring a dc power source.

ELECTRONICS SERVICING

Most electronics troubleshooting and repair is performed on a test bench. This power supply can provide the dc power source to operate a module or circuit board on the test bench when it is removed from its parent equipment. It can be used to power portable, battery-operated equipment and check the effect of low battery voltage. It can power vehicular equipment such as tape players, auto sound systems, CB radios, etc. on the test bench. Parallel tracking supplies up to 4 amps, adequate surge current for most vehicular equipment.

Most automobiles and other vehicles use 12-volt electrical systems. Although the electrical system is normally referred to as a 12-volt system, actual battery voltage when fully charged is approximately 14 volts. The power supply may be set to 14 volts for servicing equipment from vehicles with 12-volt electrical systems. Some trucks use a 24-volt electrical system; bench testing of equipment from these systems should be performed at 28 volts.

Some servicing applications require the injection of a variable dc voltage for certain tests, such as checking the effect of AGC bias in a television receiver. This requires an isolated dc power supply, such as the Model

1660. The equipment being tested may contain its own power supply and operate from ac power. A dc voltage may already be present in the circuit. One polarity of the power supply output is floated to an appropriate point in the circuit, such as the emitter of a transistor. The other polarity of the power supply output is then applied to another point in the circuit, such as the base of that transistor. Varying the power supply voltage then varies the dc bias on the stage, and the effects may be noted. A series limiting resistor is often used to protect the circuits from over-dissipation.

ELECTRONICS MANUFACTURING

In electronics manufacturing facilities, the power supply is often used as a dc power source while testing and adjusting modules, subassemblies, and complete units in the production and assembly area or in the quality control area. The instrument can be used in incoming inspection as a dc power source for testing purchased components and subassemblies.

This power supply is particularly well suited for manufacturing applications because of its ease of operation and its continuous duty rating. When load current or total power dissipation are among the main characteristics to be measured, the total load current and voltage are easily displayed on the LED display. The current limit can be set so that all units which do not meet the load current specification will cause the CC indicator to light, and the unit can be rejected.

ELECTRONICS DESIGN LAB

The technician or engineer working in an engineering laboratory requires a dc power supply to power breadboard and prototype circuits. This power supply is ideal because it monitors output current and voltage, limits

current to protect the circuit, is adjustable over a wide range, and has excellent regulation and very low ripple.

Use of the instrument in an engineering laboratory is very similar to that described for servicing electronics equipment and modules, except that lower currents may be prevalent when powering individual circuits. The current limiting feature is very valuable in this application because it can protect unproven circuits from damage.

ELECTRONICS EDUCATION

The student in an electronics curriculum may use the power supply for powering equipment and circuits as previously described for all other applications. In addition, the power supply can be used in the classroom laboratory to conduct experiments in fundamental electronics. In learning Ohm's law, for example, the relationships of resistance, current, and voltage are easily demonstrated by the use of a power supply.

BATTERY CHARGING

The power supply can be used as a battery charger to restore the charge in rechargeable batteries such as lead-acid, nickel-cadmium, and some alkaline types. Refer to the battery manufacturer's charging specifications for proper voltage and current settings. Charging information is sometimes printed on the batteries. Battery charging, at least initially, requires the constant current mode of operation. Before connecting the power supply to the battery, preset the **VOLTAGE** controls to the fully charged terminal voltage specified by the battery manufacturer. Turn off the power supply while connecting the battery. Observe proper polarity and connect as for constant current operation. Adjust the **CURRENT** control for the maximum charging current specified by the battery manufacturer. (If the maximum charging current is greater than the power supply's maximum load current, set the **CURRENT** control to maximum). The **CC** indicator will light and the battery will charge at the preset current limit. As the battery approaches full charge, its terminal voltage

will approach that of the power supply output and the charging current will taper off. The power supply may automatically switch to **CV** (constant voltage) operation. When this occurs, the power supply will continue to provide a trickle charge.

SPLIT SUPPLY

Frequently, "split power supplies" are required for amplifier and other electronic circuits. The Model 1660 is ideally suited for "split power supply" operation. This supply can be configured to provide two positive voltages with a common negative, two negative voltages with a common positive, or one positive and one negative with a common ground. In addition, each of these configurations can be obtained with identical or differing voltages.

Two Identical Positive Voltages With a Common Negative

(Refer To Fig. 11)

Some electronic equipment requires two identical positive voltages with a common negative. A good example of this would be a digital car clock where there are two +12 volt inputs and a common negative. Using both supplies in the parallel tracking mode would provide the simplest hook-up and operation. This type of "split supply" operation is obtained as follows:

1. Connect a ground strap between the **MASTER** supply's negative terminal and ground.
2. Set the desired voltage and maximum current using the **MASTER VOLTAGE** and **CURRENT** controls.
3. Turn off the power supply and the equipment to be powered during hook-up.
4. Connect the positive polarity inputs of the circuit to be powered to the positive (red) terminals of the supplies and connect the common negative input of the circuit to be powered to the **MASTER** supply's negative (black) or ground (green) terminal.

APPLICATIONS

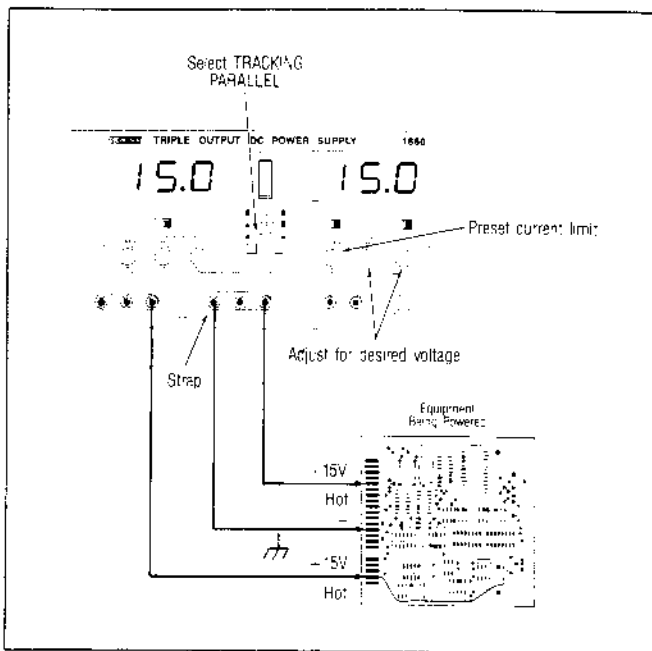

Fig. 11. Typical Hook-Up Using Two Identical Positive Voltages and a Common Negative.

Two Differing Positive Voltages With a Common Negative (Refer To Fig. 12)

Many electronic circuits require two different positive voltages with a common negative. A typical example of this would be a device that uses both TTL (+5 V) and analog (typically +15 V) circuitry. Using both supplies, two differing positive voltages with a common negative are obtained as follows:

1. Select the **INDEP**endent operating mode and set up the LED displays so that both displays monitor voltage.
2. Connect the ground straps between each supplies' negative terminal and ground.
3. Independently set the desired voltage and maximum current for the **MASTER** and **SLAVE** supplies using the **MASTER VOLTAGE** and **CURRENT** controls and the **SLAVE VOLTAGE** and **CURRENT** controls respectively.
4. Turn off the power supply and the equipment to be powered during hook-up.
5. Connect the positive polarity inputs of the circuit to be powered to the positive

(red) terminal of the supply. Connect the common negative input of the circuit to be powered to either of the supply's negative (black) or ground (green) terminal.

6. If desired, set the LED displays to monitor current.

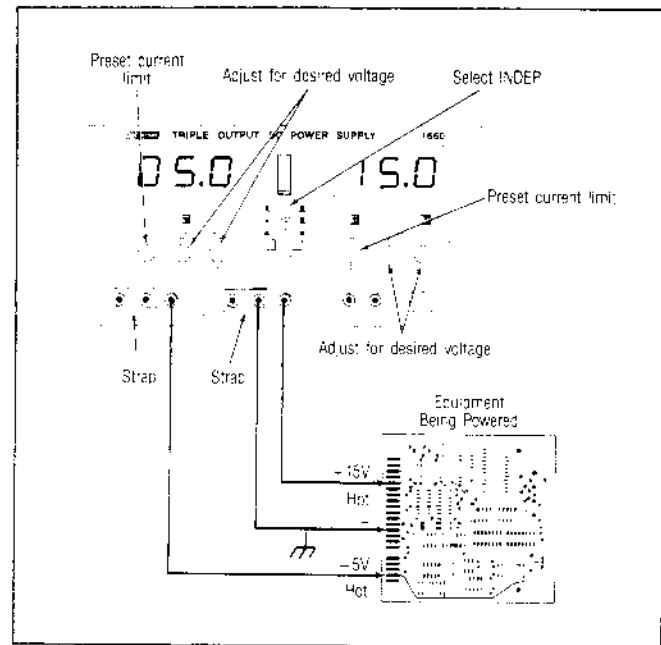

Fig. 12. Typical Hook-Up Using Two Differing Positive Voltages and a Common Negative.

Two Identical Negative Voltages With a Common Positive (Refer To Fig. 13)

When the same negative voltage is required at two points in the same circuit and a common positive is needed, perform the following:

1. Connect the ground strap between the positive terminal and the ground of the **MASTER** supply.
2. Set the desired voltage and maximum current using the **MASTER VOLTAGE** and **CURRENT** controls.
3. Turn off the power supply and the equipment to be powered during hook-up.
4. Connect the negative polarity inputs of the circuit to be powered to the negative (black) terminals of the supplies. Con-

nect the common positive input of the circuit to be powered to the **MASTER** supply's positive (red) or ground (green) terminal.

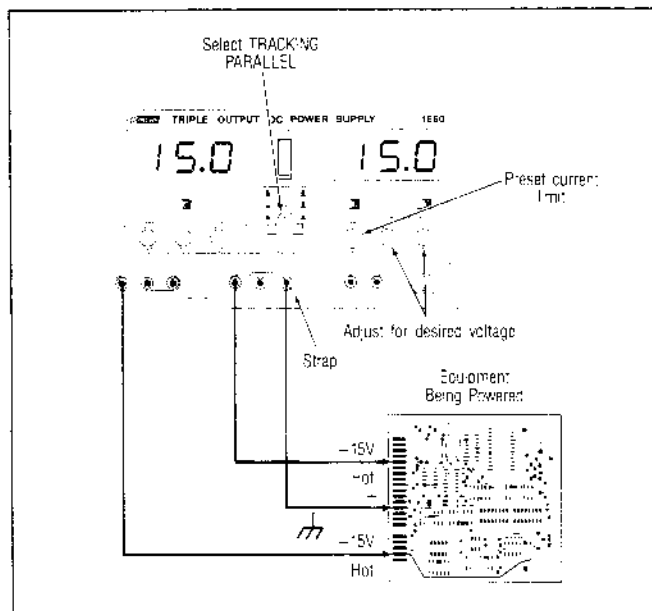

Fig. 13. Typical Hook-Up Using Two Identical Negative Voltages and a Common Positive.

Two Differing Negative Voltages With a Positive Common

(Refer To Fig. 14)

Using both supplies, two differing negative voltages with a common positive are obtained as follows:

1. Select the **INDEP**endent operating mode and set up the LED displays so that both displays monitor voltage.
2. Connect the ground straps between each supplies' positive terminal and ground.
3. Independently set the desired voltage and maximum current for the **MASTER** and **SLAVE** supplies using the **MASTER VOLTAGE** and **CURRENT** controls and the **SLAVE VOLTAGE** and **CURRENT** controls respectively.
4. Turn off the power supply and the equipment to be powered during hook-up.
5. Connect the negative polarity inputs of the circuit to be powered to the negative (black) terminals of the supplies.

Connect the common positive input of the circuit to be powered to either supplies positive (red) or ground (green) terminal.

6. If desired, set the LED displays to monitor current.

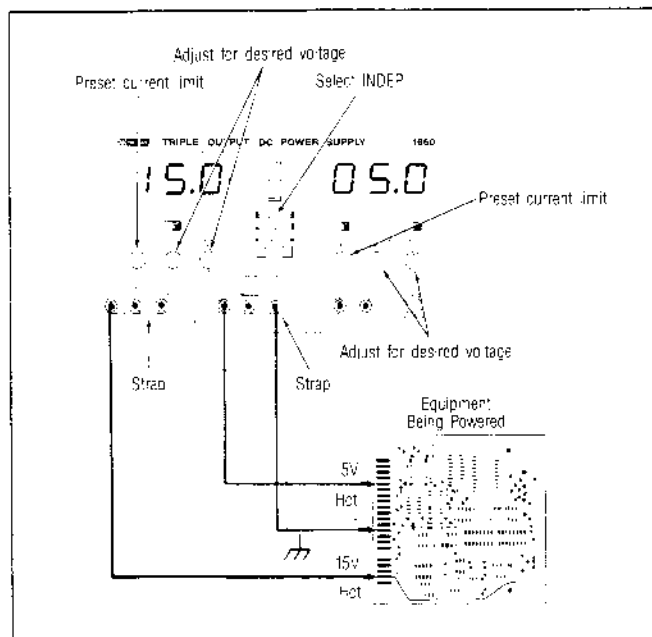

Fig. 14. Typical Hook-Up Using Two Differing Negative Voltages and a Common Positive.

Identical Positive and Negative Voltages With a Separate Common

(Refer To Fig. 15)

Another typical "split supply" application is when a circuit uses operational amplifiers (op-amps). Typically, identical positive and negative voltages are required to power op-amp circuits. Using both supplies and the series tracking mode of operation, identical positive and negative voltages with a separate common are obtained as follows:

1. Select the **TRACKING SERIES** operating mode and set up the LED displays so that at least one of the displays monitors voltage.
2. Connect the ground strap between the ground terminal and the negative terminal of the **MASTER** supply.
3. Set the desired voltage using the **MASTER VOLTAGE** controls. Independently

APPLICATIONS

- set the maximum current for the **MASTER** and **SLAVE** supplies using the **MASTER CURRENT** and **SLAVE CURRENT** controls respectively.
- Turn off the power supply and the equipment to be powered during hook-up.
 - Connect the positive polarity input of the circuit to be powered to the positive (red) terminal of the **MASTER** supply and connect the negative polarity of the circuit to the negative terminal of the **SLAVE** supply. Connect the circuit ground to the ground terminal of the **MASTER** supply.
 - If desired, set one, or both of the LED displays to monitor current. Although often balanced, there can be different load current for each of the supplies in this configuration.

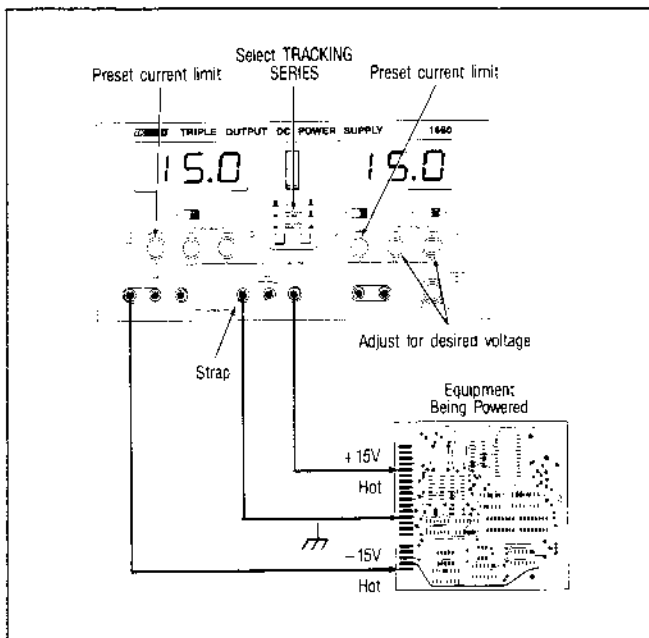

Fig. 15. Typical Hook-Up Using Identical Positive and Negative Voltages with a Separate Common.

Differing Positive and Negative Voltages With a Separate Common (Refer To Fig. 16)

Using both supplies and the independent tracking mode of operation, different positive and negative voltages with a separate common are obtained as follows:

- Select the **INDEPENDENT** operating mode and set up the LED displays to monitor voltage.
- Connect one ground strap between the ground terminal and the negative terminal of the **MASTER** supply and the other between the ground terminal and the positive terminal of the **SLAVE** supply.
- Set the desired voltage for each supply using the **VOLTAGE** controls. Set the maximum current using the **CURRENT** controls.
- Turn off the power supply and the equipment to be powered during hook-up.
- Connect the positive polarity input of the circuit to be powered to the positive (red) terminal of the **MASTER** supply and connect the negative polarity of the circuit to the negative terminal of the **SLAVE** supply. Connect the circuit ground to the ground terminal of either the **MASTER** or **SLAVE** supply.
- If desired, set the LED displays to monitor current. The load current will usually be different for each of the supplies in this configuration.

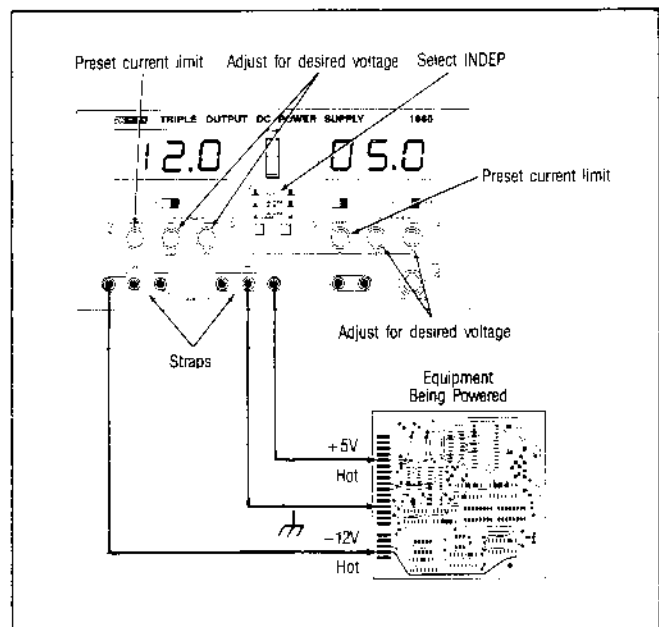

Fig. 16. Typical Hook-Up Using Differing Positive and Negative Voltages and a Separate Common.

MAINTENANCE

WARNING

The following instructions are for use by qualified personnel only. To avoid electrical shock, do not perform any servicing other than contained in the operating instructions unless you are qualified to do so.

FUSE REPLACEMENT

If the fuse blows, the switch, the LED displays, and all other indicators will not light and the power supply will not operate. The fuse should not normally open unless a problem has developed in the unit. Try to determine and correct the cause of the blown fuse, then

replace only with a fuse of the correct rating. For 110 or 120 V operation a 5 A, 250 V, 3AG fuse should be used and for 220 or 240 V operation a 2.5 A, 250 V, 3AG fuse should be used. The fuse is located on the rear panel (see Fig. 2).

LINE VOLTAGE CONVERSION

The primary winding of the power transformer is tapped to permit operation from 110, 120, 220, or 240 VAC, 50/60 Hz line voltage. Conversion from one line voltage to another is done by a simple wiring change as shown in Fig. 17.

A label on the rear panel identifies the line voltage to which the unit was factory wired.

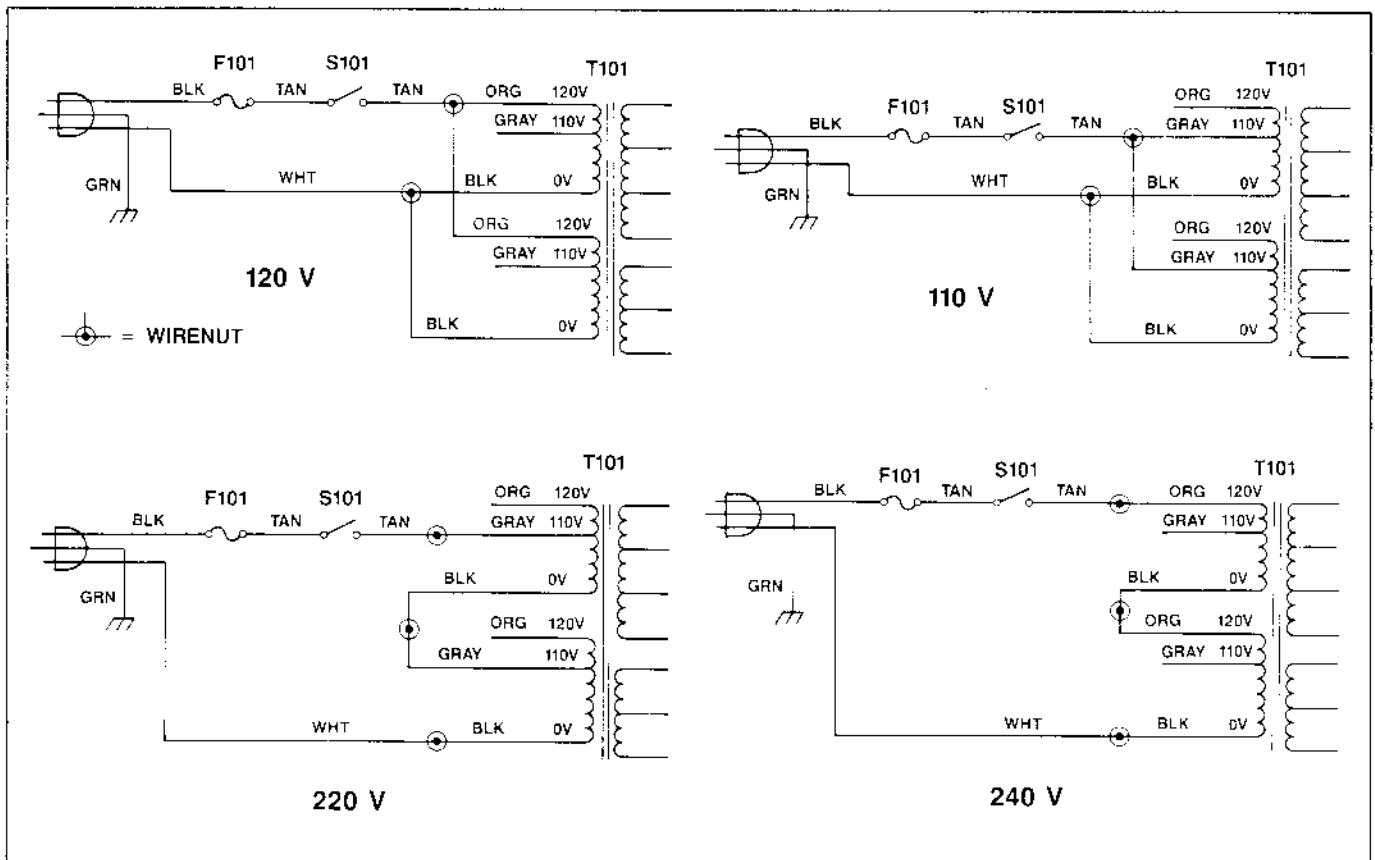

Fig. 17. Line Voltage Conversion.

MAINTENANCE

To convert to a different line voltage, perform the following procedure:

1. Make sure the power cord is unplugged.
2. Remove the case and locate the power transformer.
3. Rewire the power transformer to the desired line voltage as shown in Fig. 17. Insulate the ends of the unused transformer tap wires.
4. A change in line voltage may also require a corresponding change of fuse value. Install the correct fuse value as listed in the **FUSE REPLACEMENT** section.
5. Replace the cover.
6. Affix a label showing the correct line voltage and fuse value (if changed) for the unit after conversion. Place this label directly over the factory label.

ADJUSTMENTS

This unit was accurately adjusted at the factory before shipment. Readjustment is recommended only if repairs have been made in a circuit affecting adjustment accuracy, or if you have a reason to believe the unit is out of adjustment. However, adjustments should be attempted only if a 4-1/2 digit multimeter with an accuracy of $\pm 0.1\%$ dcV or better is available (B & K-Precision Model 2820 or equivalent).

If readjustment is required, use the following procedure. All references to left and right are correct when facing the front of the supply. Locations of the adjustments are shown in Fig. 18.

Master Supply And Master/4-6.5 V Metering Adjustments

1. Connect an accurate ($\pm 0.1\%$) external 4-1/2 digit multimeter to measure the dc voltage at the output terminals of the **MASTER SUPPLY**.
2. Disengage both **TRACKING** mode switches (both switches out) so that the

power supply is in the **INDEPENDENT** operating mode.

3. Set the **MASTER VOLTAGE** controls (both **COARSE** and **FINE**) to minimum (fully counterclockwise).
4. Adjust trimmer potentiometer VR204 on the main master circuit board (located on the right side of the supply) for a reading of $-15 \text{ mV} \pm 15 \text{ mV}$ on the multimeter.
5. Set the **MASTER VOLTAGE** controls (both **COARSE** and **FINE**) to maximum (fully clockwise).
6. Adjust trimmer potentiometer VR201 on the main master circuit board (located on the right side of the supply) for a reading as close to 31.50 volts (on the multimeter) as possible.
7. Set the **0-30 V/4-6.5 V** switch to the **0-30 V** position and the **MASTER A/V** switch to the **V** position.
8. Adjust trimmer potentiometer VR201 on the master LED display circuit board (located on the right side of the supply behind the **MASTER LED Display**) for a reading of 31.50 V on the **MASTER LED Display**.
9. Set the **0-30 V/4-6.5 V** switch to the **0-30 V** position and the **MASTER A/V** switch to the **A** position.
10. Connect the external multimeter across the **MASTER SUPPLY** output terminals to read the output current (so that the meter causes a short circuit across the terminals) and adjust the **MASTER CURRENT** control so that 2.00 amps is read on the multimeter.
11. Adjust VR601 so that the **MASTER LED Display** also reads 2.00 amps.
12. Rotate the **MASTER CURRENT** control fully clockwise (maximum).
13. Adjust VR205 on the master supply circuit board (located on the right side of the supply) to obtain an output current of 2.05 amps (read on the LED display).

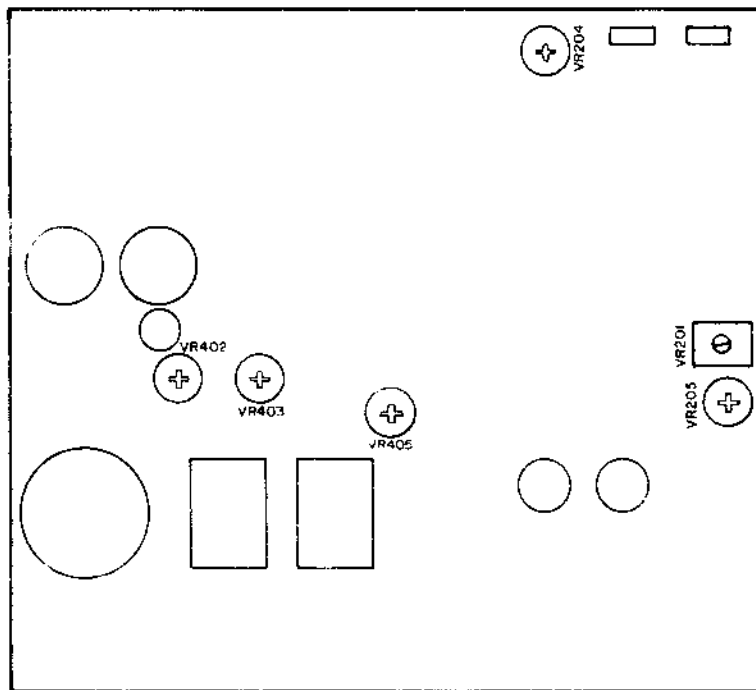

Main Master Circuit Board As Viewed From Left Side of Supply

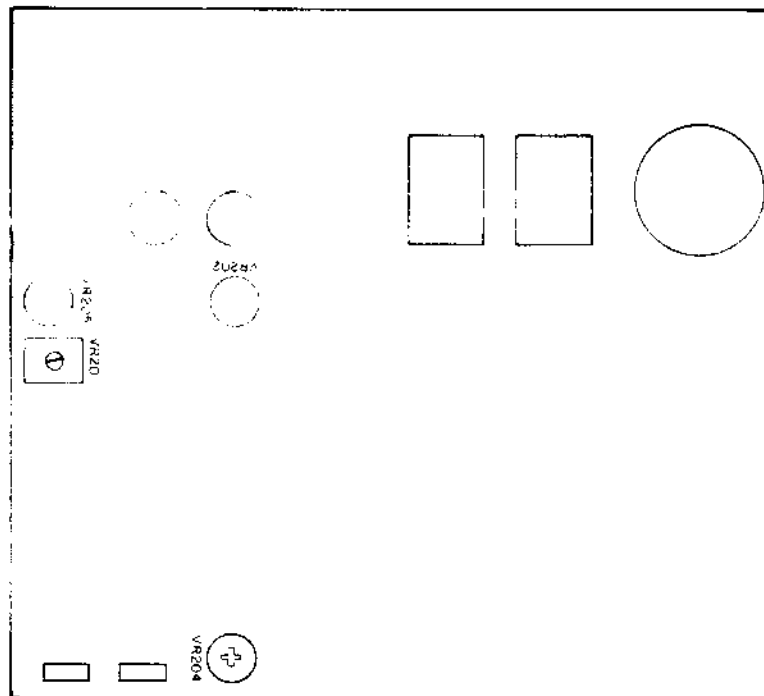

Main Slave Circuit Board As Viewed From Right Side of Supply

Fig. 18A. Location Of Adjustments (Main Circuit Boards).

MAINTENANCE

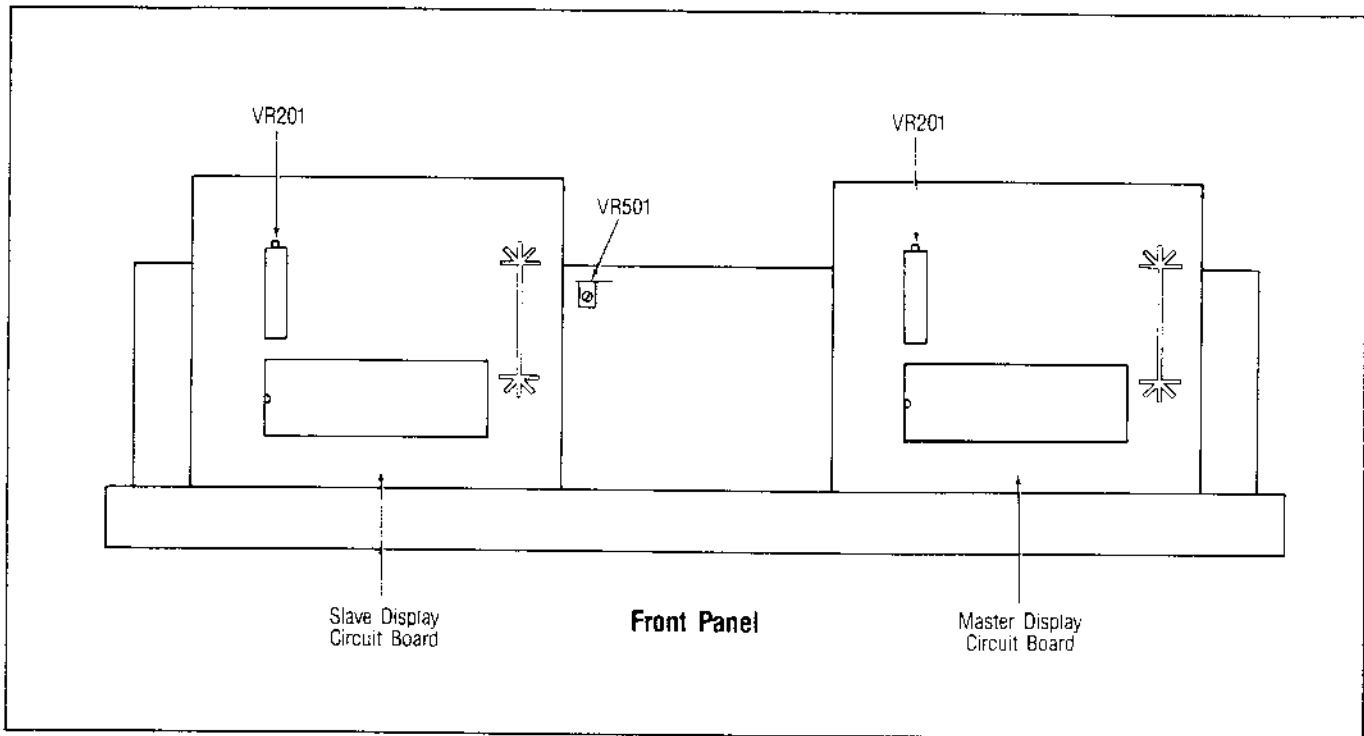

Fig. 18B. Location Of Adjustments (Metering And Tracking Boards).

14. Set the **0-30 V/4-6.5 V** switch to the **4-6.5 V** position and the **MASTER A/V** switch to the **V** position.
15. Connect the multimeter across the output terminals of the **4-6.5 V SUPPLY** to read output voltage and adjust the **4-6.5 V** voltage level control to obtain a reading of 5.00 volts on the multimeter.
16. Adjust trimmer potentiometer VR602 so that the **MASTER/4-6.5 V LED Display** reads 5.0 volts.
17. Set the **MASTER A/V** switch to the **A** position.
18. Connect a $1\ \Omega$ load (rated at 30 W or more) across the output terminals of the **4-6.5 V SUPPLY** and connect the multimeter to read the output current.
19. Adjust the **4-6.5 V** voltage level control to obtain an output of 5.00 amps (read on the multimeter).
20. Adjust trimmer potentiometer VR603 so that the **MASTER/4-6.5 V LED Display** also reads 5.00 amps.

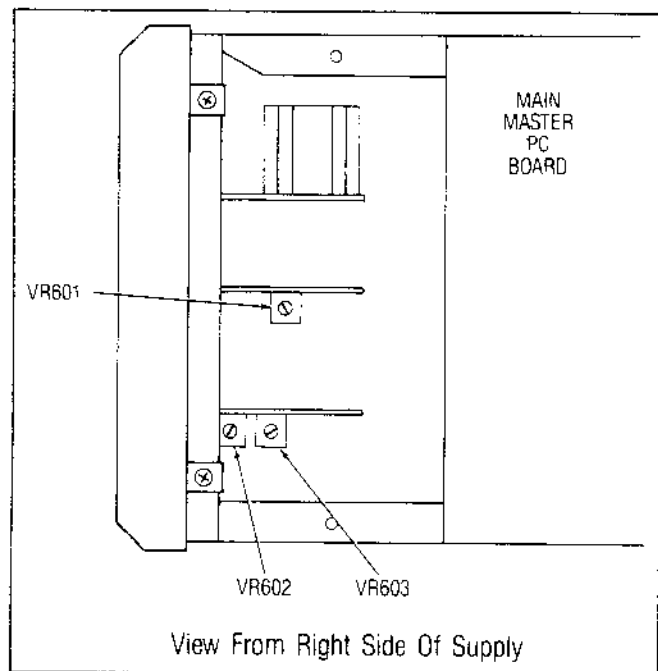

Fig. 18C. Location Of Adjustments.

Slave Supply And Metering Adjustments

1. Connect an accurate ($\pm 0.1\%$) external 4-1/2 digit multimeter to measure the dc voltage at the output terminals of the **SLAVE SUPPLY**.

2. Disengage both **TRACKING** mode switches (both switches out) so that the power supply is in the **INDEPENDENT** operating mode.
3. Set the **SLAVE VOLTAGE** controls (both **COARSE** and **FINE**) to minimum (fully counterclockwise).
4. Adjust trimmer potentiometer VR204 on the main slave circuit board (located on the left side of the supply) for a reading of $-15\text{ mV} \pm 15\text{ mV}$ on the multimeter.
5. Set the **SLAVE VOLTAGE** controls (both **COARSE** and **FINE**) to maximum (fully clockwise).
6. Adjust trimmer potentiometer VR201 on the main slave circuit board (located on the left side of the supply) for a reading as close to 31.50 volts (on the multimeter) as possible.
7. Set the **SLAVE A/V** switch to the **V** position.
8. Adjust trimmer potentiometer VR201 on the slave LED display circuit board (located on the left side of the supply behind the **SLAVE LED Display**) for a reading of 31.5 V on the **SLAVE LED Display**.
9. Set the **SLAVE A/V** switch to the **A** position.
10. Short the **SLAVE SUPPLY** output terminals together.
11. Rotate the **SLAVE CURRENT** control fully clockwise (maximum).
12. Adjust VR205 on the slave supply circuit board (located on the left side of the supply) to obtain an output current of 2.05 amps (read on the LED display).
2. Set the **SLAVE CURRENT** control to midrange and set both the **COARSE** and **FINE MASTER VOLTAGE** controls to minimum (fully counterclockwise).
3. Connect the multimeter to the **MASTER SUPPLY** outputs and measure the voltage.
4. Disconnect the multimeter from the **MASTER SUPPLY** outputs and connect it across the **SLAVE SUPPLY** outputs.
5. Adjust trimmer potentiometer VR202 on the main slave circuit board (located on the left side of the supply) to obtain the exact same reading for the **SLAVE SUPPLY** output as was present at the **MASTER SUPPLY** output (e.g., if the maximum **MASTER SUPPLY** output voltage is -15.77 mV adjust VR202 to obtain an output voltage as close to -15.77 mV at the **SLAVE SUPPLY** as possible).
6. Set the **SLAVE CURRENT** control to midrange and set both the **COARSE** and **FINE MASTER VOLTAGE** controls to maximum (fully clockwise).
7. Connect the multimeter to the **MASTER SUPPLY** outputs and measure the voltage.
8. Disconnect the multimeter from the **MASTER SUPPLY** outputs and connect it across the **SLAVE SUPPLY** outputs.
9. Adjust VR501 (located at the center of the lower front panel circuit board - behind the **POWER** and **TRACKING** switches) until the voltage read from the multimeter is the same as it was across the **MASTER** output terminals. Return the multimeter to the **MASTER** output terminals and verify that the output voltage is identical. If not, repeat this step.

4-6.5 V Supply Overload Threshold Adjustment

Slave Series Tracking Adjustment

1. Set the supply to the **TRACKING SERIES** mode by engaging the left **TRACKING** switch and releasing the right **TRACKING** switch.
1. Set the **0-30 V/4-6.5 V** switch to the **4-6.5 V** position and set the **MASTER A/V** switch to the **A** position.
2. Connect the multimeter across the **4-6.5 V** supply output terminals.

MAINTENANCE

3. Adjust the **4-6.5 V Voltage Control** to maximum (fully clockwise).
4. Adjust VR405 on the main master circuit board (located on the right side of the supply) for a reading of 6.50 ± 0.05 V on the display.
5. Adjust **4-6.5 V Voltage Control** to minimum (4 V).
6. Short R405 and VR405.
7. Preset VR404 (located on the circuit board mounted on the heat sink behind the transformer) fully clockwise.
8. Increase voltage with front panel control to approximately 7.00 V on display.
9. Slowly adjust VR404 until overvoltage circuit just activates (voltage drops approximately 1 V).
10. Use the **4-6.5 V Voltage Control** to adjust the output voltage to 5.2 volts.
11. Turn VR403 on the main master circuit board (located on the right side of the supply) fully clockwise.
12. Connect a variable load (load must be rated to handle a power of at least 30 W) across the **4-6.5 V** supply output terminals and adjust the load so that the **MASTER LED Display** shows an output current of exactly 5.35 A.
13. Adjust VR403 counterclockwise until the output voltage (read from the multimeter) drops by 5 to 6 mV.
14. Turn the **4-6.5 V Voltage Control** fully counterclockwise (minimum).
15. Turn VR402 on the main master circuit board (located on the right side of the supply) fully counterclockwise.
16. Adjust VR402 clockwise until the **5 A OVERLOAD** indicator first lights.

INSTRUMENT REPAIR SERVICE

Because of the specialized skills and test equipment required for instrument repair and calibration, many customers prefer to rely upon **B & K-Precision** for this service. We maintain a network of **B & K-Precision** authorized service agencies for this purpose. To use this service, even if the instrument is no longer under warranty, follow the instructions given in the **WARRANTY SERVICE INSTRUCTIONS** section of this manual. There is a nominal charge for instruments out of warranty.

WARRANTY SERVICE INSTRUCTIONS
(For U.S.A. and its Overseas Territories)

1. Refer to the MAINTENANCE section of your **B & K-Precision** instruction manual for adjustments that may be applicable.
2. If the above-mentioned does not correct the problem you are experiencing with your unit, pack it securely (preferably in the original carton or double-packed). Enclose a letter describing the problem and include your name and address. Deliver to, or ship PREPAID (UPS preferred in U.S.A.) to the nearest **B & K-Precision** authorized service agency (see list enclosed with unit).

If your list of authorized **B & K-Precision** service agencies has been misplaced, contact your distributor for the name of your nearest service agency, or write to:

B & K-Precision MAXTEC INTERNATIONAL CORP.
Factory Service Operations
6470 West Cortland Street
Chicago, Illinois 60635
Tel (312) 889-8870
Telex: 25-3475

Also use this address for technical inquiries
and replacement parts orders.

LIMITED ONE-YEAR WARRANTY

MAXTEC INTERNATIONAL CORP. warrants to the original purchaser that its **B & K-Precision** product, and the component parts thereof, will be free from defects in workmanship and materials for a period of one year from the date of purchase.

MAXTEC will, without charge, repair or replace, at its option, defective product or component parts upon delivery to an authorized **B & K-Precision** service contractor or the factory service department, accompanied by proof of the purchase date in the form of a sales receipt.

To obtain warranty coverage in the U.S.A., this product must be registered by completing and mailing the enclosed warranty registration card to **MAXTEC B & K-Precision**, 6470 West Cortland Street, Chicago, Illinois 60635 within fifteen (15) days from the date of purchase.

Exclusions: This warranty does not apply in the event of misuse or abuse of the product or as a result of unauthorized alterations or repairs. It is void if the serial number is altered, defaced or removed.

MAXTEC shall not be liable for any consequential damages, including without limitation damages resulting from loss of use. Some states do not allow limitation of incidental or consequential damages, so the above limitation or exclusion may not apply to you.

This warranty gives you specific rights and you may also have other rights which vary from state to state.

For your convenience we suggest you contact your **B & K-Precision** distributor, who may be authorized to make repairs or can refer you to the nearest service contractor. If warranty service cannot be obtained locally, please send the unit to **B & K-Precision** Service Department, 6470 West Cortland Street, Chicago, Illinois 60635, properly packaged to avoid damage in shipment.

B & K-Precision Test Instruments warrants products sold only in the U.S.A. and its overseas territories. In other countries, each distributor warrants the **B & K-Precision** products which it sells.

NOTES

NOTES

(continued from inside front cover)

5. Use an insulated floor material or a large, insulated floor mat to stand on, and an insulated work surface on which to place equipment; and make certain such surfaces are not damp or wet.
6. Use the time-proven "one hand in the pocket" technique while handling an instrument probe. Be particularly careful to avoid contacting a nearby metal object that could provide a good ground return path.
7. When testing ac powered equipment, remember that ac line voltage is usually present on some power input circuits such as the on-off switch, fuses, power transformer, etc. any time the equipment is connected to an ac outlet, even if the equipment is turned off.
8. Some equipment with a two-wire ac power cord, including some with polarized power plugs, is the "hot chassis" type. This includes most recent television receivers and audio equipment. A plastic or wooden cabinet insulates the chassis to protect the customer. When the cabinet is removed for servicing, a serious shock hazard exists if the chassis is touched. Not only does this present a dangerous shock hazard, but damage to test instruments or the equipment under test may result from connecting an earth ground lead of a test instrument to a "hot chassis". To make measurements in "hot chassis" equipment, always connect an isolation transformer between the ac outlet and the equipment under test. The **B & K-Precision** Model TR-110 or 1604 Isolation Transformer, or Model 1653 or 1655 AC Power Supply is suitable for most applications. To be on the safe side, treat all two-wire ac powered equipment as "hot chassis" unless you are sure it has an isolated chassis or an earth ground chassis.
9. Never work alone. Someone should be nearby to render aid if necessary. Training in CPR (cardio-pulmonary resuscitation) first aid is highly recommended.



BK PRECISION®

MAXTEC INTERNATIONAL CORP.

6470 W. Cortland St. • Chicago, IL 60635

©1988 MAXTEC INTERNATIONAL CORP.

480-585-9-001D

Printed in Taiwan, R.O.C.

B
B&K 1660

SERVICING INFORMATION



MODEL 1660

TRIPLE OUTPUT DC POWER SUPPLY

PARTS LIST

SCHEMATIC
SYMBOL

DESCRIPTION

B & K-PRECISION
PART NUMBER

MAIN CHASSIS ASSEMBLY

ELECTRICAL PARTS

C107	0.01 μ F +80/-20%, 1 kV Ceramic Capacitor	020-380-9-001
C207	100 μ F +80/-20%, 50 V Electrolytic Capacitor (Master Output, Slave Output)	022-392-9-002
C405	470 μ F +80/-20%, 16 V Electrolytic Capacitor	022-392-9-001
BD401	S10VB20 Bridge Rectifier (10 A, 200 V)	157-047-9-001
D212	1N5402 Diode (Master Output, Slave Output)	151-136-9-001
D404	1N5402 Diode (5 V Output)	151-136-9-001
Q203	2N3055 NPN Power Transistor (Master Output, Slave Output)	172-033-9-001
Q402	2N3055 NPN Power Transistor	172-033-9-001
S101	Rocker Switch, Illuminated (POWER)	093-019-9-001
S601 - 603	Slide Switch, 6 A (A-V, 0-30 V, 4-6.5 V)	084-154-9-001
F101	5 A, 250 V 3 AG Fast-Acting Fuse	191-251-3-005
	Power Transformer	065-229-9-001
	Output Terminal Jumper-Strap (2 used)	261-195-9-001
	Line Cord Strain Relief	380-001-9-001
	Line Cord	420-013-9-001
	2-Conductor Cable (3 used; J201 master, J205A master, J205A slave)	428-185-9-001
	2-Conductor Cable (master PCB J204-to-master output)	428-185-9-002
	2-Conductor Cable (slave PCB J101-to-30 volt PCB J101)	428-185-9-003
	2-Conductor Cable (master PCB J401-to-5 volt output)	428-185-9-004
	2-Conductor Cable (master PCB J402-to-D403)	428-185-9-005
	2-Conductor Cable (slave PCB J204-to-slave output)	428-185-9-006
	2-Conductor Cable (slave PCB J207-to-D210, D211)	428-185-9-007
	2-Conductor Cable (slave PCB J201-to-30 volt PCB J201B)	428-185-9-008
	3-Conductor Cable (master PCB J202-to-30 volt PCB J202A)	428-185-9-009
	3-Conductor Cable (master PCB J203-to-30 volt PCB J203A)	428-185-9-010
	3-Conductor Cable (slave PCB J202-to-30 volt PCB J202B)	428-185-9-011
	3-Conductor Cable (slave PCB J203-to-30 volt PCB J203B)	428-185-9-012
	4-Conductor Cable (30 volt PCB J601-to-master display)	428-185-9-013
	Jumper Assembly (master PCB A13-to-30 volt PCB A13)	428-185-9-014
	Test Lead Assembly (2 feet long)	523-986-9-001
	Test Lead Assembly (3 feet long)	523-985-9-001
	Fuseholder Assembly (for F101)	742-052-9-001

MECHANICAL PARTS

	Front Panel, Decorative	260-492-9-001
	Front Panel Plastic Bezel	380-599-9-002
	Display Bezel (2 used)	380-599-9-001
	Display Filter, Red (2 used)	753-040-9-001
	Knob, Pushbutton (TRACKING; 2 used)	384-090-9-001
	Knob, Control (VOLTAGE, CURRENT, etc; 7 used)	751-312-9-001
	Pushbutton Switch Bezel	380-596-9-001
	Heatsink (for Q403)	747-165-9-001
	Rear Panel Heatsink (2 used)	747-165-9-002
	Heat Sink Shield (2 used)	256-277-9-001
	Bracket, Potentiometer Mounting (2 used)	250-193-9-001
	Bracket, Display PCB Mounting (2 used)	250-271-9-001
	Holder, Display Bezel (4 used)	250-271-9-002
	Bottom Reinforcement Bracket, Left	250-271-9-003

COMPOSITE
499-375-9-001

PARTS LIST

SCHEMATIC
SYMBOL

DESCRIPTION

B & K-PRECISION
PART NUMBER

MAIN CHASSIS (Continued)

MECHANICAL PARTS (Continued)

Bottom Reinforcement Bracket, Right	250-271-9-004
Sub-Panel (Front Plate)	254-130-9-001
Side Frame (Front-to-Rear Support Brace; 2 used)	254-131-9-001
Top Cover	253-147-9-001
Bottom Cover (Chassis)	252-067-9-001
Chassis Rear Plate	262-074-9-001
Handle Grip	746-076-9-001
Steel Strap, Handle	746-076-9-002
Handle End Cap (2 used)	746-076-9-003
Foot (4 used)	381-152-9-001
3 mm Solder Lug (5 used)	724-082-9-004
3.2 x 6.5 x 0.45 mm External-Tooth Solder Lug (2 used)	744-039-9-001
Wire Nut, Large	653-122-9-001
Wire Nut, Small	653-110-9-001
3 x 6 mm ISO Flathead Phillips Machine Screw (Side Frame, S601 - 603, meter bracket; 18 used) ...	634-202-9-002
3 x 12 mm x 0.5 pitch ISO Phillips Machine Screw (Q203, Q402, Q403; 8 used)	634-202-9-003
3 x 6 mm x 0.5 pitch ISO Phillips Machine Screw (46 used)	634-237-9-001
3 x 8 mm x 0.5 pitch ISO Phillips Machine Screw (8 used)	634-238-9-001
3 x 10 mm x 0.5 pitch ISO Phillips Machine Screw (Foot Mounting; 4 used)	634-238-9-002
3 x 18 mm ISO Phillips Machine Screw (BD401 Mounting)	634-238-9-003
3 x 60 mm x 0.5 pitch Phillips Machine Screw (Internal Heat Sink-to-Bottom Chassis; 2 used)	634-238-9-004
4 x 25 mm x 0.7 pitch Phillips Machine Screw (Transformer Mounting; 4 used)	634-238-9-005
3 x 10 mm ISO Phillips Flathead Screw (Handle Mounting; 2 used)	634-238-9-006
M3 x 0.5 pitch ISO Hex Nut (16 used)	653-101-9-001
3.2 x 8 x 0.5 mm Flatwasher (8 used)	724-082-9-001
5.3 x 12 x 0.8 mm Flatwasher (4 used)	724-088-9-001
3.1 x 5.9 mm Split Lockwasher (9 used)	724-082-9-003
13.5 mm Hex Spacer (4 used)	759-197-9-001
3-Terminal Binding Post Assembly (2 used)	773-135-9-001
2-Terminal Binding Post Assembly (1 used)	773-142-9-001
Instruction Manual	480-541-9-001

MAIN PC BOARD, MASTER (Assembly 546-032-9-001)

MAIN PC BOARD, SLAVE (Assembly 546-033-9-001)

RESISTORS

MASTER SLAVE

Unlisted resistors are $\pm 5\%$, 1/4 W Carbon Film. See schematic diagram for value.

R101	4.7 k Ω $\pm 5\%$, 3 W Metal Film	011-003-5-472	X	X
R103	11.3 k Ω $\pm 1\%$, 1/4 W Metal Film	015-144-1-132	X	X
R104	10.5 k Ω $\pm 1\%$, 1/4 W Metal Film	015-144-1-052	X	X
R201	1.2 k Ω $\pm 5\%$, 1/2 W Carbon Film	002-102-5-122	X	X
R202	2 k Ω $\pm 1\%$, 1/4 W Metal Film	015-144-2-001	X	X
R203	10 k Ω $\pm 1\%$, 1/4 W Metal Film	015-144-1-002	X	X
R210	13 k Ω $\pm 1\%$, 1/4 W Metal Film	015-144-1-302	X	X
R211	30.1 k Ω $\pm 1\%$, 1/4 W Metal Film	015-144-3-012	X	X
R220	150 Ω $\pm 5\%$, 2 W Wirewound	006-002-5-151	X	X
R222	22 Ω $\pm 5\%$, 1/2 W Carbon Film	002-102-5-220	X	X
R224	1 k Ω $\pm 5\%$, 2 W Metal Film	011-002-5-102	X	X
R225A	0.3 k Ω $\pm 5\%$, 5 W Wirewound	004-221-9-001	X	X
R233, 234	2.2 k Ω $\pm 5\%$, 1/2 W Carbon Film	002-102-5-222	X	X
R401	470 Ω $\pm 5\%$, 1 W Carbon Film	002-001-5-471	X	
R402	2.37 k Ω $\pm 1\%$, 1/4 W Metal Film	015-144-2-371	X	
R403	3.01 k Ω $\pm 1\%$, 1/4 W Metal Film	015-144-3-011	X	
R405	1 k Ω $\pm 1\%$, 1/4 W Metal Film	015-144-1-001	X	
R407	0.2 Ω $\pm 5\%$, 5 W Wirewound	004-237-9-002	X	
R411	150 Ω $\pm 1\%$, 1/4 W Metal Film	015-144-1-500	X	
R412	1 k Ω $\pm 1\%$, 1/4 W Metal Film	015-144-1-001	X	
VR201, 204	2 k Ω , 100 ppm Trimmer Potentiometer	010-025-9-004	X	X
VR205	2 k Ω Trimmer Potentiometer	010-033-9-005	X	X
VR402	10 k Ω , 100 ppm Trimmer Potentiometer	010-026-9-004	X	
VR403	470 Ω , 100 ppm Trimmer Potentiometer	010-025-9-002	X	
VR405	1 k Ω Trimmer Potentiometer	008-841-9-001	X	

CAPACITORS

C102	4700 μ F +80/-20%, 63 V Radial Electrolytic	022-392-9-004	X	X
C103, 104	470 μ F +80/-20%, 35 V Radial Electrolytic	022-328-9-004	X	X

SCHEMATIC SYMBOL	DESCRIPTION	B & K-PRECISION PART NUMBER	MASTER	SLAVE
MAIN PC BOARD, MASTER, SLAVE (Continued)				
CAPACITORS (Continued)				
C105, 106	100 μ F +80/-20%, 25 V Radial Electrolytic	022-328-9-002	X	X
C201	47 μ F +80/-20%, 25 V Radial Electrolytic	022-328-9-001	X	X
C202	0.01 μ F \pm 5%, 630 V Metalized Polyester	025-262-9-004	X	X
C203	0.1 μ F \pm 5%, 100 V Metalized Polyester	025-262-9-001	X	X
C204	33 pF \pm 5%, 50 V NP0 Ceramic	031-066-9-001	X	X
C205	100 pF \pm 5%, 50 V NP0 Ceramic	031-069-9-003	X	X
C206A, 206B	4.7 μ F +80/-20%, 50 V Radial Electrolytic	022-336-9-002	X	X
C301, 302	0.01 μ F \pm 5%, 50 V Polyester	025-282-9-006	X	X
C401, 402	6800 μ F +80/-20%, 16 V Radial Electrolytic	022-398-9-001	X	
C403, 404	1000 pF +80/-20%, 25 V Ceramic	020-432-9-001	X	
C407	1000 μ F +80/-20%, 16 V Radial Electrolytic	022-350-9-001	X	
DIODES & TRANSISTORS				
BD101	S4VB40 Bridge Rectifier (4 A, 400 V)	157-047-9-002	X	X
BD102	W02M Bridge Rectifier (1 A, 200 V)	157-038-9-001	X	X
BD402	W02M Bridge Rectifier (1 A, 200 V)	157-038-9-001	X	
D201	1N751 Zener Diode (5.1 V \pm 5%, 1/2 W)	152-112-9-001	X	X
D202	1N759 Zener Diode (12.0 V \pm 5%, 1/2 W)	152-155-9-001	X	X
D203, 204	1N4148 Diode	151-038-9-001	X	X
D205	1N759 Zener Diode (12.0 V \pm 5%, 1/2 W)	152-155-9-001	X	X
D206	1N5402 Diode	151-136-9-001	X	X
D207, 208	1N4148 Diode	151-038-9-001	X	X
D209	1N752 Zener Diode (5.6 V \pm 5%, 1/2 W)	152-072-9-001	X	X
D301, 302	1N4148 Diode	151-038-9-001	X	X
D401, 405	1N4148 Diode	151-038-9-001	X	
Q101	2SA684(S) PNP Transistor	173-021-9-001	X	X
Q102	2SA1015-GR PNP Transistor	177-057-9-001	X	X
Q201	2SC1815-GR NPN Transistor	176-095-9-001	X	X
Q202	2SD8804 NPN Transistor	172-082-9-001	X	X
Q204, 205	2SC1815-GR NPN Transistor	176-095-9-001	X	X
Q206	2SA1015-GR PNP Transistor	177-057-9-001	X	X
Q301, 302	2SC1815-GR NPN Transistor	176-095-9-001	X	X
Q303	2SA1015-GR PNP Transistor	177-057-9-001	X	X
Q304, 305	2SC1815-GR NPN Transistor	176-095-9-001	X	X
Q401	2SD8804 NPN Transistor	172-082-9-001	X	
Q404	2SK30A-GR Field Effect Transistor	182-029-9-002	X	
INTEGRATED CIRCUITS				
U101	7815 Positive Voltage Regulator (15 V, 1 A; TO-220 case)	307-081-9-001	X	X
U201	TL431CLP Programmable Zener Diode	307-409-9-001	X	X
U202	741 Op-Amp	307-016-9-001	X	X
U203	301 Hi-Performance Op-Amp	307-074-9-001	X	X
U204	741 Op-Amp	307-016-9-001	X	X
U401	723 Precision Voltage Regulator	307-009-9-001	X	
U402	1458 Dual Op-Amp	307-046-9-001	X	
MISCELLANEOUS				
RL301, 302	ULD-110P Relay (24 V, 10 A)	441-050-9-001	X	X
P13	0.04" (nominal) PC Terminal	757-143-9-001	X	X
	2-Pin 0.1" PC Header (7 used)	757-144-9-002	X	X
	3-Pin 0.1" PC Header (4 used)	757-144-9-003	X	X

DISPLAY DRIVER PC BOARD, MASTER (Assembly 546-034-9-001)
DISPLAY DRIVER PC BOARD, SLAVE (Assembly 546-035-9-001)

		RESISTORS	MASTER	SLAVE
Unlisted resistors are \pm 5%, 1/4 W Carbon Film. See schematic diagram for value.				
RZ01A, 201B	495 Ω \pm 1%, 1/2 W Metal Film	013-124-9-001		X
R202	1 k Ω \pm 1%, 1/4 W Metal Film	015-144-1-001		X
R203	1 M Ω \pm 1%, 1/2 W Metal Film	015-124-1-004	X	X
R204	0.01 Ω \pm 1%, 5 W Wirewound (Shunt)	004-237-9-001		X
R205	267 Ω \pm 1%, 1/4 W Metal Film	015-144-2-670	X	X
R207	4.02 k Ω \pm 1%, 1/4 W Metal Film	015-144-4-021	X	X
R208	267 Ω \pm 1%, 1/4 W Metal Film	015-144-2-670	X	X
R210	100 k Ω \pm 1%, 1/4 W Metal Film	015-144-1-003	X	X
VR201	5 k Ω , 100 ppm Trimmer Potentiometer	010-033-9-004	X	X

PARTS LIST

SCHEMATIC SYMBOL	DESCRIPTION	B & K-PRECISION PART NUMBER		
DISPLAY DRIVER PC BOARD, MASTER, SLAVE (Continued)				
CAPACITORS				
C101	1000 μ F +80/-20%, 16 V Radial Electrolytic	022-350-9-001	X	X
C102	100 μ F +80/-20%, 16 V Radial Electrolytic	022-335-9-002	X	X
C201	0.01 μ F \pm 5%, 630 V Metalized Polyester	025-262-9-004	X	X
C202	0.1 μ F \pm 5%, 100 V Metalized Polyester	025-262-9-001	X	X
C203	100 pF \pm 5%, 50 V NP0 Ceramic.....	031-069-9-003	X	X
C204	0.22 μ F \pm 5%, 100 V Metalized Polyester.....	025-262-9-002	X	X
C205	0.47 μ F \pm 5%, 100 V Metalized Polyester.....	025-262-9-003	X	X
DIODES & TRANSISTORS				
BD101	W02M Bridge Rectifier (1 A, 200 V)	157-038-9-001	X	X
INTEGRATED CIRCUITS				
U101	7805 Positive Voltage Regulator (5 V, 1 A; TO-220 case).....	307-080-9-001	X	X
U201	7107CLP 3-1/2 Digit A/D Converter/Display Driver	308-378-9-001	X	X
U202	431CLP Programmable Zener Diode.....	307-409-9-001	X	X
MISCELLANEOUS				
	40-Pin DIP Socket (for U201)	762-017-9-001	X	X
	4-Conductor 0.1" PC Header.....	757-144-9-004	X	X
	Heatsink (for U101)	747-145-9-001	X	X
	3 x 8 mm x 0.5 pitch ISO Phillips Machine Screw (for U101 mounting)	634-202-9-001	X	X
	M3 x 0.5 pitch ISO Hex Nut (U101 mounting)	653-101-9-001	X	X
	3.2 x 8 x 0.5 mm Flatwasher (U101 mounting)	724-082-9-001	X	X
	3.1 x 5.9 mm Split Lockwasher (U101 mounting)	724-082-9-003	X	X
7-SEGMENT DISPLAY PC BOARD ASSEMBLIES (2 used) (Assembly 546-029-9-001)				
RESISTORS				
R212, 213	10 k Ω \pm 5%, 1/4 W Carbon Film.....	002-104-5-103		
DIODES & TRANSISTORS				
DS1 - 4	7-Segment Display	238-047-9-001		
Q201, 202	2SA1015-GR PNP Transistor.....	177-057-9-001		
MISCELLANEOUS				
	8-Conductor 0.1" Right-Angle Header (3 used).....	757-145-9-001		
	3-Conductor 0.1" Right-Angle Header.....	757-150-9-001		
30-VOLT CONTROL & TRACKING PC BOARD (Assembly 546-030-9-001)				
RESISTORS				
Unlisted resistors are \pm 5%, 1/4 W Carbon Film. See schematic diagram for value.				
R515	28 k Ω \pm 1%, 1/4 W Metal Film	015-144-2-802		
R601	990 k Ω \pm 1%, 1/4 W Metal Film	013-010-9-012		
R602	1 k Ω \pm 1%, 1/4 W Metal Film	015-144-1-001		
R603	0.01 Ω \pm 1%, 5 W Wirewound (Shunt).....	004-237-9-001		
R604	10 k Ω \pm 1%, 1/4 W Metal Film	015-144-1-002		
AVR203A, BVR203A	10 k Ω Potentiometer (VOLTAGE-COARSE)	008-841-9-002		
AVR203B, BVR203B	1 k Ω Dual Potentiometer (VOLTAGE-FINE)	008-841-9-003		
AVR206, BVR206	1 k Ω Potentiometer (CURRENT)	008-841-9-001		
	Tracking Adjust PCB Assembly	546-028-9-001		
VR501	5 k Ω , 100 ppm Trimmer Potentiometer for 546-028-9-001.....	010-033-9-004		
	3-Conductor 0.1" Right-Angle Header for 546-028-9-001	757-150-9-001		
VR601	2 k Ω , 100 ppm Trimmer Potentiometer.....	010-063-9-001		

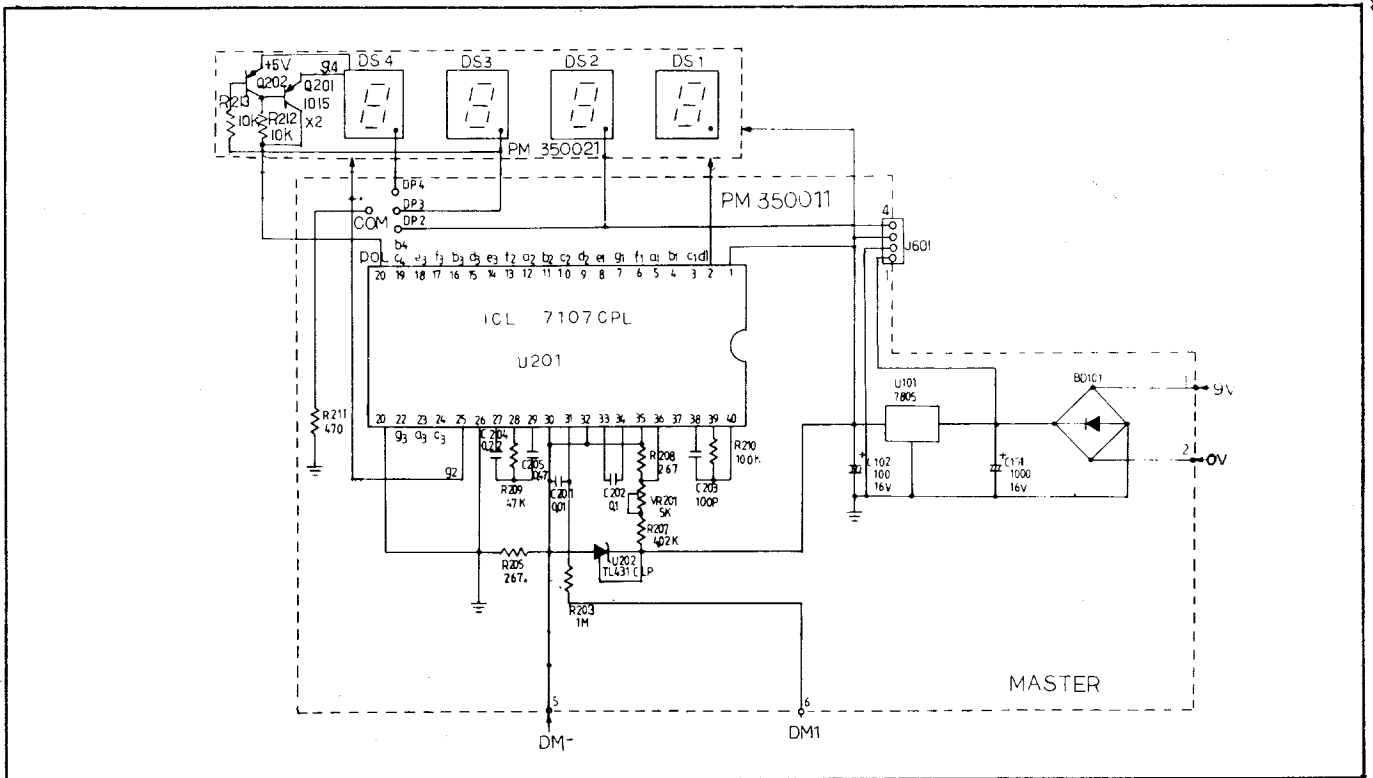

MASTER DISPLAY CIRCUIT

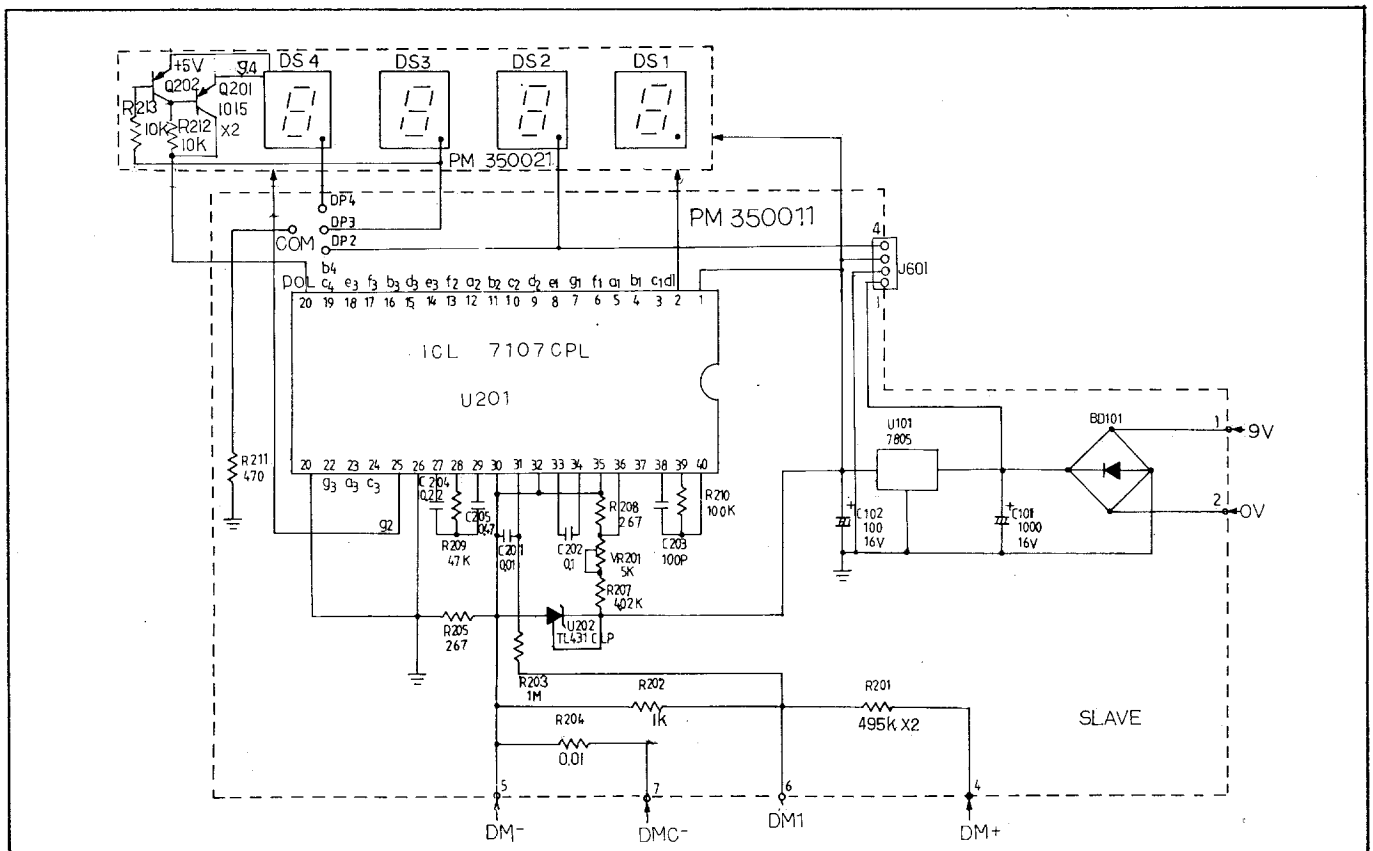

SLAVE DISPLAY CIRCUIT

SCHEMATIC SYMBOL	DESCRIPTION	B & K-PRECISION PART NUMBER
-------------------------	--------------------	--

30-VOLT CONTROL & TRACKING PC BOARD (Continued)

CAPACITORS

C503	22 μ F +80/-20%, 50 V Radial Electrolytic	022-335-9-005
------	---	---------------

DIODES & TRANSISTORS

D501-505	1N4148 Diode.....	151-038-9-001
D508-510, 610		
AD211, BD211	LED, Red (CV).....	158-102-9-001
AD210, BD210	LED, Green (CC)	158-102-9-002
Q501	2SA1015-GR PNP Transistor.....	177-057-9-001
Q502, 504, 602	2SC1815-GR NPN Transistor	176-095-9-001
Q601	2SA1015-GR PNP Transistor.....	177-057-9-001

MISCELLANEOUS

RL502-504	ULD-110P Relay (24 V, 10 A)	441-050-9-001
RL601	Relay (9 VDC Coil)	441-059-9-001
S501	Dual Pushbutton Switch Assembly (TRACKING select).....	088-181-9-001
A13	0.04" (nominal) PC Terminal.....	757-143-9-001
BJ101, 201, AJ207, BJ207	2-Conductor 0.1" Header.....	257-144-9-002
AJ202, 203, BJ202, 203	3-Conductor 0.1" Header.....	757-144-9-003
J601	4-Conductor 0.1" Header.....	757-144-9-004

**OVERVOLTAGE PROTECT/5-VOLT CONTROL PC BOARD
(Assembly 546-031-9-001)**

RESISTORS

Unlisted resistors are \pm 5%, 1/4 W Carbon Film. See schematic diagram for value.

R605	990 k Ω \pm 1%, 1/4 W Metal Film	013-010-9-012
R606	900 Ω \pm 1%, 1/4 W Metal Film	013-142-9-001
R607	0.01 Ω \pm 1%, 5 W Wirewound (Shunt).....	004-237-9-001
R608	10 k Ω \pm 1%, 1/4 W Metal Film	015-144-1-002
VR401	1 k Ω Dual Potentiometer (4 - 6.5 V Adjust).....	008-841-9-003
VR602	200 Ω Trimmer Potentiometer	010-063-9-002
VR603	2 k Ω , 100 ppm Trimmer Potentiometer.....	010-063-9-001

DIODES & TRANSISTORS

D402	1N750 Zener Diode (4.7 V \pm 5%, 1/2 W)	152-188-9-001
D403	LED, Red (OVERLOAD).....	158-102-9-001

MISCELLANEOUS

J402	2-Conductor 0.1" Header.....	757-144-9-002
J403, 404	3-Conductor 0.1" Header.....	757-144-9-003

NOTE: The following components are installed on the PC/heatsink assembly located at the rear of the bottom chassis.

R414	127 Ω \pm 1%, 1/4 W Metal Film	015-144-1-270
VR404	2 k Ω Trimmer Potentiometer	010-033-9-005
C406	2.2 μ F +80/-20%, 50 V Radial Electrolytic.....	022-392-9-003
Q403	S4008 SCR (TO-220 case)	181-017-9-001

PARTS ORDERING INFORMATION

Orders will be shipped C.O.D. unless previous open account arrangements have been made or remittance accompanies order. Advance remittance must cover handling and postage or express charges. Specify model and serial number when ordering replacement parts.

ORDER REPLACEMENT PARTS FROM:

B & K-Precision, Factory Service Operations
Maxtec International Corporation
6470 West Cortland Street
Chicago, Illinois 60635
Telephone: (312) 889-1448

SCHEMATIC DIAGRAMS

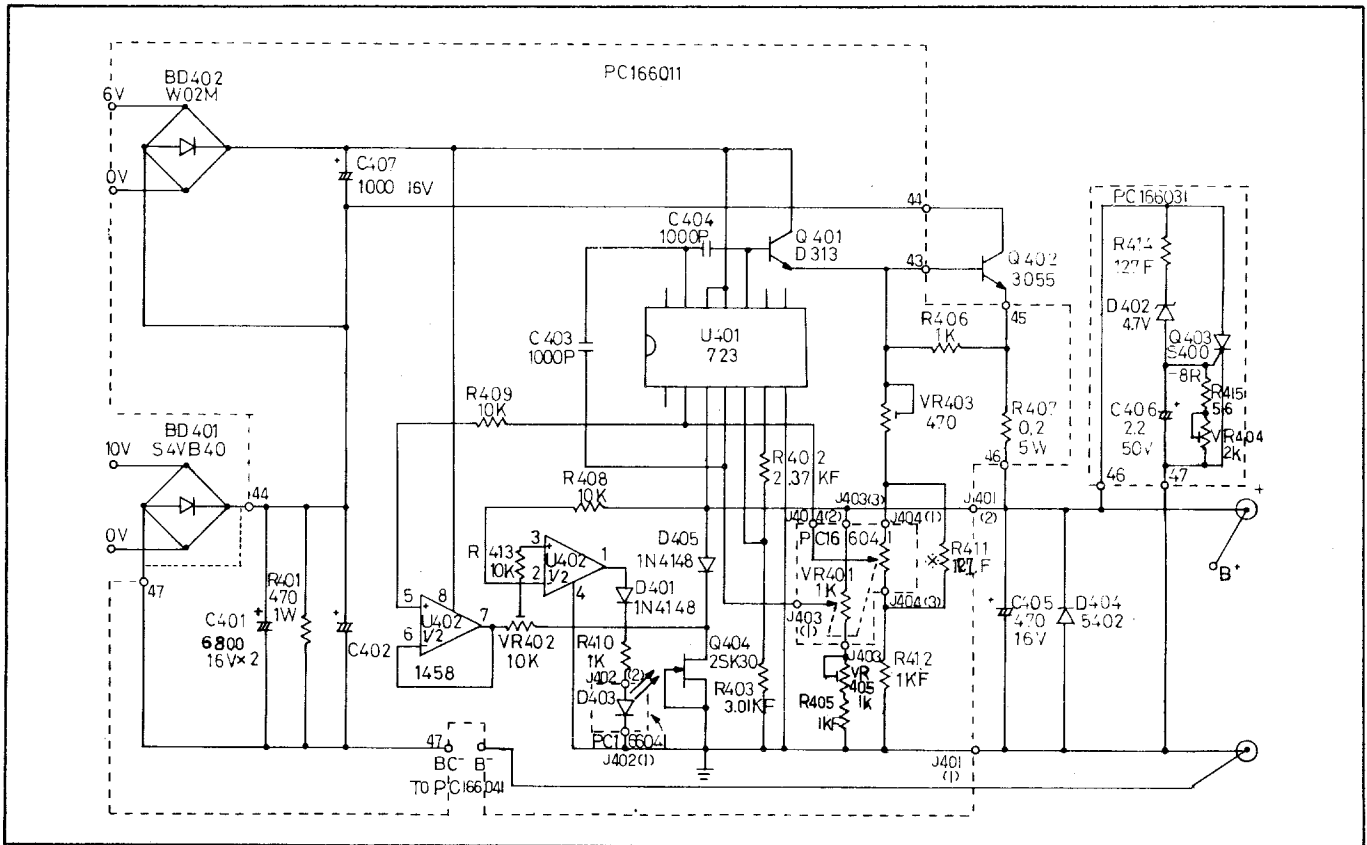

5V PCB/OVERVOLTAGE PROTECT

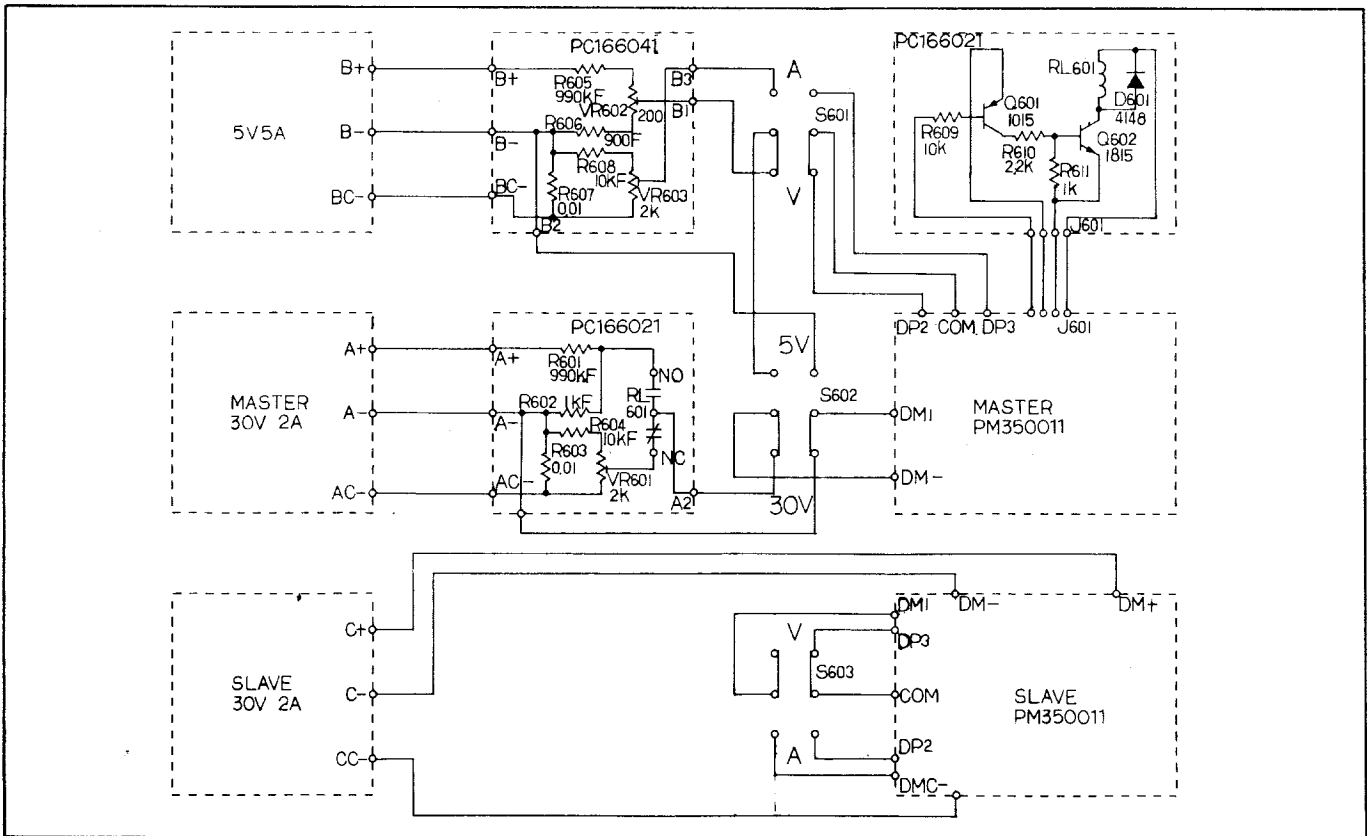

INTERCONNECT DIAGRAM

MAIN CHASSIS MASTER & SLAVE PCBs

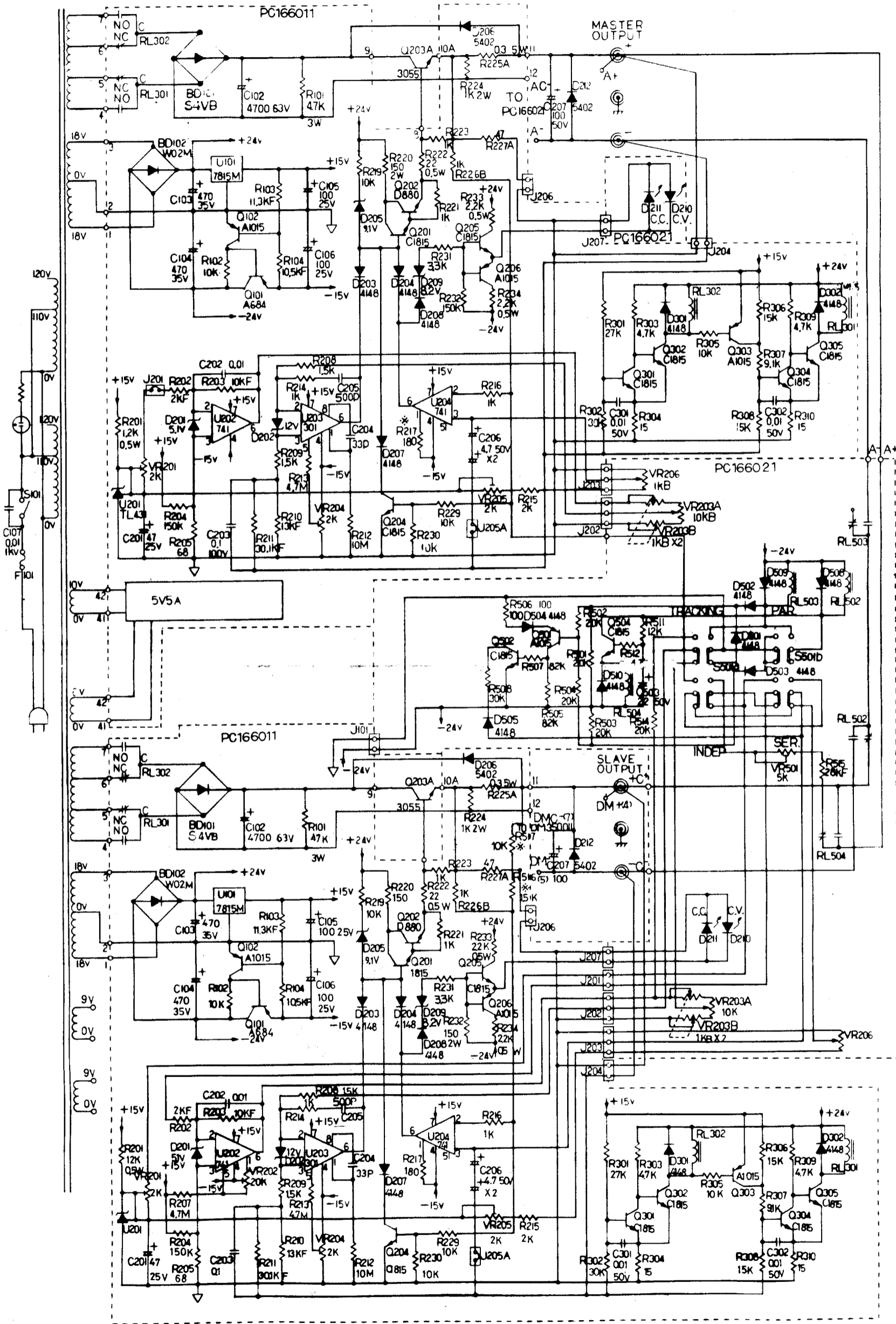

SCHEMATIC DIAGRAMS