

AVO INTERNATIONAL
510 Township Line Road
Blue Bell, PA 19422 USA
215/646-9200
1-800-723-2861
FAX: 215/643-2670



AVTM/23-IJ

Instruction Manual
AVTM 23-IJ

For the

AC High Pot Testers

Catalog Numbers: 230315, 230315-1, 230415 and 230415-1

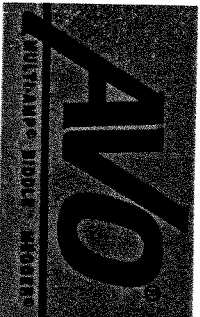

AVO INTERNATIONAL
BLUE BELL, PA 19422 • (215) 646-9200

Instruction Manual 23-1J
Biddle
AC High Pot Tester
Catalog Numbers 230315, 230315-1,
230415, 230415-1

WARNING!

- MISUSE OF THIS HIGH VOLTAGE EQUIPMENT CAN BE EXTREMELY DANGEROUS!
- READ THIS INSTRUCTION MANUAL BEFORE USING.
- SAFETY IS THE RESPONSIBILITY OF THE USER.
- EQUIPMENT TO BE TESTED MUST BE DISCONNECTED FROM POWER SUPPLY.
- ALL PERSONNEL MUST BE KEPT CLEAR OF BARE LIVE PARTS.
- FOLLOW ALL OTHER SAFETY INSTRUCTIONS.

Copyright, 1984
JAMES G. BIDDLE CO.
Blue Bell, PA 19422

TABLE OF CONTENTS

<u>SECTION</u>	<u>DESCRIPTION</u>	<u>PAGE</u>
A	INTRODUCTION	A1
B	SAFETY PRECAUTIONS	B1-B3
C	RECEIVING INSTRUCTIONS	C1
D	SPECIFICATIONS Physical Characteristics Input Input Protection Tests Performed Test Connections Description of Tests Performed Indicators Accessories	D1-D7 D1 D1 D1 D1 D2 D2-D5 D6 D6-D7
E	DESCRIPTION Control and Connector Identification	E1-E5 E1-E5
F	OPERATION Test Area Suggestions Safety Precautions Preliminary Shut Down Operating Procedure Operating Notes	F1-F6 F1 F2 F2 F2 F2 F3-F6 F6
G	APPLICATION NOTES Properties of Insulation Dielectric Withstand Test Characteristics Instructions for Setting the Leakage Sensitivity Control Notes on Dielectric Withstand Testing of 120V AC Appliances	G1-G7 G1-G3 G4-G5 G5-G6 G7



Figure 1: The Bidle Cat. No. 230315 AC High Pot Tester

TABLE OF CONTENTS (cont'd)

Section A INTRODUCTION

This instruction manual covers the operation and maintenance of Biddle portable AC High Pot Testers. Tester catalog numbers describe input and output characteristics as follows:

<u>SECTION</u>	<u>DESCRIPTION</u>	<u>PAGE</u>
H	MAINTENANCE Routine Maintenance Calibration	H1-H10 H1-H9 H9-H10
I	TROUBLESHOOTING AND REPAIR Repair Policy Troubleshooting Guide	I1-I15 I1 I1-I15
J	REPLACEABLE PARTS LIST & AC HIGH POT TESTER SCHEMATIC	J1-J8
K	WARRANTY	K1
ILLUSTRATIONS		
Figure 1.	The Cat. No. 230315 Biddle AC High Pot Tester	a
Figure 2.	Control and Connector Identification	E5
Figure 3.	Graph of Output Voltage vs. Capacitance	G4
Figure 4.	Internal View of Tester	I2
Figure 5.	AC High Pot Tester Schematic	J8

This compact, self-contained unit is a high-voltage low energy source for testing the dielectric strength of electrical insulation and continuity of the ground circuit of three wire appliances. The Tester has been designed to simplify testing procedures and to minimize hazards to the operator and to the item under test.

The tester has all the necessary characteristics of sensitivity, voltage regulation and failure detection to meet all current Underwriters Laboratories (UL) requirements for test equipment used in production line voltage - withstand testing of electrical appliances and other components.

The instructions and suggestions provided in this manual anticipate the normal use of the Tester for testing electrical insulation systems and ground circuits on motors, transformers and most line-operated electrical appliances. Dielectric withstand (high-pot) testing of electrical insulation is a valuable method for detecting assembly flaws (such as stray wire strands, etc.) and defects in marginally sound insulation which can present a hazard to the user or cause product failure during normal use. Ground wire continuity testing is used for verifying the existence of a ground circuit and finding assembly flaws (such as poor or broken connections) which can present a hazard to the user.

Section B

SAFETY PRECAUTIONS

SAFETY IS THE RESPONSIBILITY OF THE USER

WARNING!

The Tester produces voltages and currents which can cause harmful or fatal electric shock to the user or bystander during use. For your protection, follow the safety procedures in this section and, SECTION F, OPERATING PROCEDURE.

The Biddle AC High Pot Tester and the recommended operating procedures have been designed with careful attention to safety. Biddle has made formal safety reviews of the initial design and any subsequent changes. This procedure is followed for all new instruments and covers areas not included in the ANSI standard. Regardless of these efforts, it is not possible to eliminate all hazards from electrical test equipment. For this reason, every effort has been made to point out in this instruction manual the proper procedures and precautions to be followed by the user in operating the instrument. In addition, the instrument has been marked with precautionary warnings where appropriate. It is not possible to foresee every possible hazard which may occur in the great variety of applications for this Tester. It is essential that the user, in addition to following the safety rules in this manual, also carefully consider all safety aspects of the test before proceeding. To insure safe use of the Tester, do not treat it casually. Read and understand these instructions, and follow the safety rules given, paying special attention to the following areas:

1. Provide a dry test area with operator and all equipment shielded from traffic and onlookers.
2. Place the item under test out of the operators' normal reach. The item under test must be treated as a shock hazard until proven otherwise by the tests performed in accordance with the procedures given in this manual.

SAFETY PRECAUTIONS (cont'd)

3. Before conducting any test, read and understand this entire instruction manual and carefully follow the testing procedures.
4. When unskilled personnel use the Tester, they should be trained in a fixed operating routine for each test setup, and supervised by a person who fully understands the use of the Tester.
5. Maintain the Tester with a regular maintenance program.
6. The Tester and any accessories provided should not be used for any purpose except those described in this manual.
7. Safety will be enhanced if test procedures are practiced until they are completely learned before performing tests on equipment to be placed in general service.
8. Plug in the High Voltage test probe (W2) only when it is being used. Handle its clip only by the insulator; never touch the clip directly! When you are not actively performing tests, and before leaving the test area, unplug the High Voltage test probe (W2) from the Tester. When performing tests using the OUTPUT receptacle (J9), remove and store the High Voltage test probe (W2) away from the front of the Tester.
9. Connect the RETURN test probe (W1) first for any test. Connect and disconnect the item under test only when high voltage is off.
10. When connecting a cord and plug to the OUTPUT receptacle (J8), know for certain where the other end of the cord is and what it is connected to. Do not touch the cord-connected device during testing.

-B2-

SAFETY PRECAUTIONS (cont'd)

11. If you are testing an item with a three-wire grounding type line cord, always set the GROUND CHECK/BYPASS switch to the GROUND CHECK position to check the grounding circuit of the item under test.
12. Perform tests on a secure INSULATED mounting area. The insulation must isolate the item to be tested from ground and any adjacent conductors.

CAUTION!

Because there are dangerous voltages inside the case, the Tester must never be operated with the case removed. Repairs to the Tester should be made in accordance with the precautions noted in SECTION I, TROUBLESHOOTING AND REPAIR, and only by qualified personnel.

-B3-

Section C
RECEIVING INSTRUCTIONS

When your Biddle instrument arrives, check the equipment received against the packing list to ensure that all materials are included. Notify Biddle Instruments, Blue Bell, PA, of any shortage of materials.

Examine the instrument for damage received in transit. If any damage is discovered, file a claim with the carrier at once and notify Biddle Instruments or its nearest authorized sales representative. Be sure to provide a detailed description of the damages observed.

This instrument has been thoroughly tested and inspected to meet rigid inspection specifications before being shipped. It is ready for use when set up as indicated in Section F.

Section D
SPECIFICATIONS

PHYSICAL CHARACTERISTICS

Dimensions: 8 3/8" D x 9" W x 8 1/8" H (213 x 229 x 206 mm)

Weight: 12.5 lbs (5.7 kg)

Operating Temperature: 25°F to 104°F (-4°C to 40°C)

Storage Temperature: -22°F to 131°F (-30°C to 55°C)

Humidity: Operation and storage limits 5 to 95 RH.

Climate: Operation prohibited in direct rain or snow.

INPUT

120 volts $\pm 10\%$, 1A, 50/60 Hz single phase with ground (Cat. Nos. 230315 and 230415). Connection to the Tester is made via a removable 7 1/2 ft. power cord utilizing a molded PVC grounding plug PH-290B (NEMA configuration 5-15P) on one end and a molded PVC grounding connector SPH-386 on the other end.

240 volts $\pm 10\%$, 0.5A, 50/60 Hz single phase with ground (Cat. Nos. 230315-1 and 230415-1). Connection to the Tester is made via a removable 6 1/2 ft. power cord utilizing a molded PVC grounding plug PH-44 (NEMA configuration 6-15P) on one end and a molded PVC grounding connector SPH-386 on the other end.

INPUT PROTECTION

2-pole, 1 Amp, 250V, rocker handle circuit breaker.

TESTS PERFORMED

1. Tester Grounded.
2. Ground wire continuity.
3. Dielectric voltage-withstand.

SPECIFICATIONS (cont'd)

SPECIFICATIONS (cont'd)

TEST CONNECTIONS

Method 1: The item to be tested is plugged into a 3 wire receptacle (NEMA 5-20R) on the panel. A separate return test probe with alligator clip (4 feet long) is provided to connect to the metal housing of the item to be tested.

Method 2: The item to be tested is connected between the removable high voltage and return test probes with alligator clips (each 4 feet long).

DESCRIPTION OF TESTS PERFORMED

Tester Grounded

A low current (less than 0.5 mA, 120 V operation) line monitoring circuit is connected between the "HOT" side and the ground side of the incoming power line. This circuit will light a white neon lamp as soon as the Tester is connected to a correctly wired power supply. The tester grounded circuit is interlocked with the dielectric voltage-withstand test such that high voltage cannot be applied if either of the following common faults exist:

- A. Ground wire open.
- B. "HOT" and "NEUTRAL" wires interchanged (120V operation).

Ground Check

In this test 70 mA at a low compliance voltage is passed thru the ground circuit of the item under test. A green LED will light when the ground circuit has a resistance of 10 ohms or less. The ground check test is interlocked with the dielectric voltage-withstand test so that high voltage cannot be applied unless the item under test has passed the ground check test. If the item under test ground circuit resistance exceeds 15

ohms at any time during testing, high voltage will be switched off. Provision is made to bypass this portion of the test to be used; for example, when testing double insulated items, items which do not utilize the three-wire grounding type line cord, or when the test probes are used instead of the panel receptacle.

Dielectric Voltage-Withstand

In this test, a high voltage transformer supplies test voltage between the panel receptacle line connections and ground, and between the high voltage and return test probe jacks. A voltmeter indicates the test voltage. A visual and audible alarm signals when the total leakage current exceeds an adjustable preset value or when arcing occurs.

Output

0-3000 Vac continuously adjustable (Cat. Nos. 230315 and 230315-1).
0-4000 Vac continuously adjustable (Cat. Nos. 230415 and 230415-1).
Maximum short-circuit current: 12.6 mA (Electronic limitation).
Maximum capacitive load at maximum voltage:
0.011 μ F (60 Hz, 3000V, Cat. Nos. 230315 and 230315-1).
0.013 μ F (50 Hz, 3000V, Cat. Nos. 230315 and 230315-1).
0.008 μ F (60 Hz, 4000V, Cat. Nos. 230415 and 230415-1).
0.010 μ F (50 Hz, 4000V, Cat. Nos. 230415 and 230415-1).

Maximum capacitive loads are proportionally higher at reduced output voltages, (see Figure 3 in SECTION G, APPLICATION NOTES).

SPECIFICATIONS (cont'd)

Voltage Control

Manual, by adjustable autotransformer with zero-start interlock.

Mode Selection

Four pushbuttons are provided for the following:

- No. 1 One-Second test: Momentary actuation of the ONE SEC pushbutton will turn on high voltage for a minimum of 1 second, (1.3 seconds maximum), unless a failure occurs. The RESET pushbutton must be actuated or the VOLTAGE CONTROL returned to the ZERO START (RESET) position to begin initial testing or after a failure. Once the Tester is reset the One-Second test can be repeated as many times as desired.
- No. 2 Continuous test: Momentary actuation of the CONT pushbutton will turn on high voltage until the HV OFF pushbutton is actuated or a failure occurs. The RESET pushbutton must be actuated or the VOLTAGE CONTROL returned to the ZERO START (RESET) position each time high voltage is turned off or after a failure.
- No. 3 HV Off: Momentary actuation of the HV OFF pushbutton will turn high voltage off.
- No. 4 Reset: Momentary actuation of the RESET pushbutton will stop the failure signals and allow further testing.

Note: The RESET pushbutton is also a ZERO-START override. Whenever the output voltage has been preset to some value and the HV OFF pushbutton has been depressed, actuation of the RESET button will allow high voltage to be turned on to the preset value by use of the CONT or ONE SEC test pushbutton.

-D4-

SPECIFICATIONS (cont'd)

Failure Detection and Automatic Shutdown

The failure detection circuit will indicate a failure, by audible and visual alarm, and switch off high voltage within 50 ms whenever the total leakage current exceeds a preset value or arcing occurs. The leakage current trip level is adjustable between 0.3 mA $\pm 5\%$ to 12 mA $\pm 5\%$ by a front panel adjustment knob.

Metering

Rectifier type, average reading, rms calibrated.

Style: 3 1/2", zero left, analog meter with high-torque, ruggedized movement.

Range: 0-3000V (Cat. Nos. 230315 and 230315-1)
0-4000V (Cat. Nos. 230415 and 230415-1)

Accuracy: $\pm 2\%$ Full Scale.

-D5-

SPECIFICATIONS (cont'd)

SPECIFICATIONS (cont'd)

INDICATORS

- Tester Grounded: Indicates when the Tester is connected to a properly wired supply.
- Good when Lit: Indicates that the ground wire on three-wire devices is continuous with a resistance of 10 ohms or less.
- HV On: Indicates that the high voltage output is energized.
- Power: Integral part of the power switch.
Indicates that power is available to the Tester.
- Failure: Indicates that a breakdown has occurred or an excessive leakage current has been drawn by the item under test.
- Audible Alarm: Audible signal sounds when the failure lamp is lit.

ACCESSORIES

1. Cat. No. 230315-2 Removable high voltage test probe with retractile test tip (4 feet long).
2. Cat. No. 230315-3 Removable return test probe with retractile test tip (4 feet long).
3. Cat. No. 235300-1 Adapter plug to test 120 V, 50/60 Hz, 1 Phase, 15 A tools which utilize a NEMA L5-15R twist-lock plug.

4. Cat. No. 235300-2 Adapter plug to test 120 V, 50/60 Hz, 1 Phase, 20 A tools which utilize a NEMA L5-20R twist-lock Plug.
5. Cat. No. 235300-4 Adapter plug to test 120 V, 50/60 Hz, 1 Phase, 30 A tools which utilize a NEMA L5-30R twist-lock plug.

Section E DESCRIPTION

CONTROL AND CONNECTOR IDENTIFICATION

The location of controls and connectors are illustrated in Figure 2 together with the schematic reference number of the various components.

CBI: Input Circuit Breaker/Power Switch

This circuit breaker controls the power input to the Tester. It will disconnect power from the Tester if more than 1 ampere is drawn by the Tester.

DS1: Power

This indicator is an integral part of the INPUT CIRCUIT BREAKER/POWER SWITCH (CBI) and is lit when power is available to the Tester.

DS2: Failure

This indicator is lit and an audible alarm sounds when a breakdown has occurred or an excessive leakage current has been drawn by the item under test.

DS3: HV On

This indicator is lit when high voltage is available to the OUTPUT receptacle (J8) and the HIGH VOLTAGE test probe receptacle (J9).

DS4: Good When Lit

This indicator is lit when the GROUND CHECK/BYPASS switch (S5) is in the GROUND CHECK position and the ground circuit being tested (on 3-wire devices) has a resistance of 10 ohms or less.

DESCRIPTION (cont'd)

DS5: Tester Grounded

This indicator is lit when the Tester is connected to a correctly wired power supply.

NOTE: Since the current through this lamp is limited to 0.5 mA (120 V operation) this lamp will not be as bright as the other indicators.

J8: Output Receptacle

This receptacle is provided for easy connection to the item under test input cord.

J9: High Voltage Test Probe Receptacle

This receptacle accepts the HIGH VOLTAGE test probe (W2) for high voltage testing with the test probes.

J10: Return Test Probe Receptacle

The receptacle accepts the RETURN test probe (W1).

M1: Kilovoltmeter

This meter displays the voltage being applied to the item under test.

P7: Input Inlet

This inlet accepts the input power cord (W3).

R77: Leakage Sensitivity

This variable potentiometer permits the setting of the leakage current trip level between 0.3 mA and 12 mA.

-E2-

DESCRIPTION (cont'd)

S1: One Sec

This pushbutton is provided for one second high voltage testing.

S2: Cont

This pushbutton is provided for high voltage testing for any desired length of time.

S3: HV OFF

This pushbutton is provided to switch off high voltage at any time.

S4: Reset

This pushbutton is provided to stop the failure signals and allow further testing.

S5: Ground Check/Bypass Switch

This switch allows overriding the GROUND CHECK test for double insulated items or items which do not utilize the three-wire grounding type line cords.

T3: Voltage Control

This autotransformer serves as voltage control, reset, and zero start.

W1: Return Test Probe (not shown)

This lead plugs into the RETURN test probe receptacle (J10) and has two functions: When the GROUND CHECK/BYPASS switch (S5) is in the GROUND CHECK position, this lead is connected to the frame of the item under test. When the GROUND CHECK/BYPASS switch (S5) is in the BYPASS position, this lead becomes the return (Ground) lead when using the test leads for high voltage testing.

-E3-

DESCRIPTION (cont'd)

W2: High Voltage Test Probe (not shown)

This lead plugs into the HIGH VOLTAGE test probe receptacle (J9) when high voltage testing with the test probes is desired.

W3: Input Power Cord (not shown)

This cord plugs into the INPUT inlet (P7) and is provided with the proper outboard end depending on the input voltage requirement (120V or 240V).

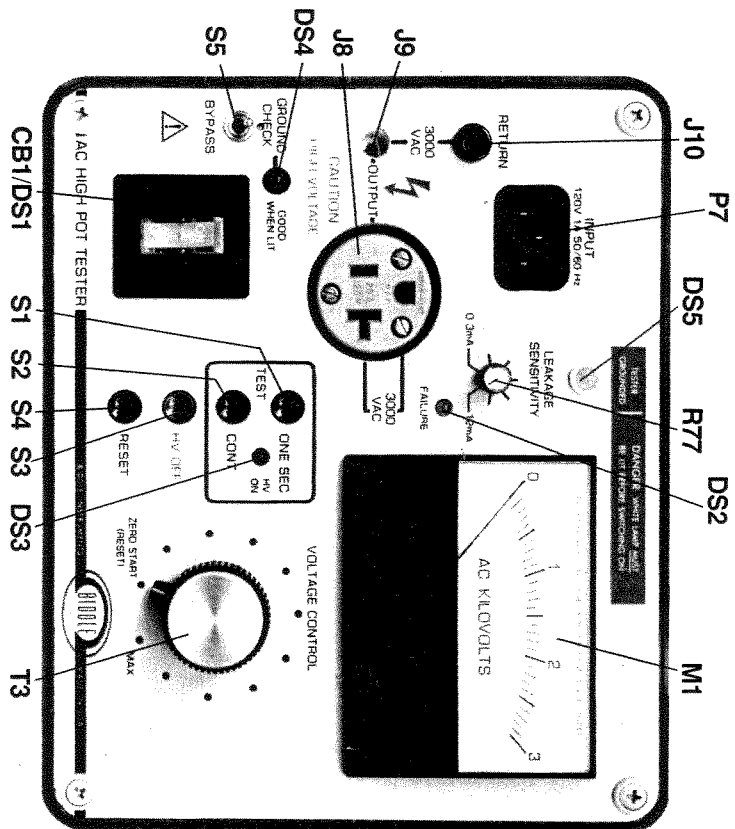

Figure 2: Control and Connector Identification

Section F OPERATION

TEST AREA

Whenever using the Tester, arrange a test area as follows:

1. Select a dry test area with the operator and all equipment shielded by suitable barriers from traffic and casual intruders.
2. Locate the Tester within 6 feet of a 3-wire GROUNDED outlet and within 4 feet of the item to be tested.
3. Place the item to be tested out of the operators' normal reach.
4. Provide a secure INSULATED mounting area for the item to be tested. The insulation must isolate the item to be tested from ground and any adjacent conductors. A rubber electrical grade insulation mat or a suitable piece of acrylic plastic or phenolic can be used as insulation if the insulation of the mounting area is in question.

CAUTION!

Arrange the work area so that the operator can reach the controls of the Tester without any danger of touching the item under test. Rubber gloves or shoes are not required, but Biddle considers their use an excellent safety practice when handling the item under test.

OPERATION (cont'd)

SUGGESTIONS

It is recommended that a sturdy wood work bench be used. A simple support may be provided to hold the entire Tester in a convenient position with the Tester case secured to the support. A location on the work bench may be arranged so that the item to be tested can be securely clamped in place and insulated from ground. Barriers are strongly recommended to prevent accidental contact with the item under test.

SAFETY PRECAUTIONS

Follow all safety precautions in SECTION B of this manual.

PRELIMINARY

Before testing begins, make a visual inspection of the item to be tested. In the case of a power tool, the housing should be wiped off and the cooling vents blown clear with compressed air. Carefully inspect the line cord for frayed wires and the plug for a cracked housing or broken pins. Review any damage report, if submitted. Repair visible defects BEFORE testing!

SHUT DOWN

1. High voltage can be removed from the item under test by setting the POWER switch (CBI) to the OFF position or by momentary actuation of the HV OFF pushbutton.
2. Make and remove all test connections only when the test voltage has been switched off as indicated in Step 1 above.

-F2-

OPERATION (cont'd)

OPERATING PROCEDURE

1. With the POWER switch (CBI) OFF, connect the INPUT POWER CORD (W3) to the Tester INPUT Inlet (P7), then plug the INPUT POWER CORD (W3) into a grounded outlet.

2. Verify that the TESTER GROUNDED Lamp (DS5) is lit.

DANGER!

IF THE TESTER GROUNDED LAMP (DS5) IS NOT LIT, DO NOT PROCEED ANY FURTHER, UNPLUG THE INPUT POWER CORD (W3) AND REFER TO SECTION I TROUBLESHOOTING AND REPAIR, OF THIS MANUAL.

3. For connecting the item under test, choose either the OUTPUT receptacle (J8) and RETURN test probe (W1) or the HIGH VOLTAGE test probe (W2) and the RETURN test probe (W1).

A. Output receptacle connection:

1. Connect the RETURN test probe (W1) to any dead metal parts of the item under test or metal foil wrapped tightly around the enclosure of the item under test.

2. Plug the item under test into the OUTPUT receptacle (J8).

WARNING!

Do not plug in the HIGH VOLTAGE test probe (W2) when using the OUTPUT receptacle (J8) for testing.

B. Test probe connection:

1. Connect the RETURN test probe (W1) to the low side of the item under test.
2. Connect the HIGH VOLTAGE test probe (W2) to the high potential side of the item under test.

-F3-

OPERATION (cont'd)

OPERATION (cont'd)

4. When using the OUTPUT receptacle (J8) for testing items with a 3-wire grounding-type line cord, set the GROUND CHECK/BYPASS switch (S5) to the GROUND CHECK position. For all other items or when using the test probes, set the GROUND CHECK/BYPASS switch (S5) to the BYPASS position.
5. Set the LEAKAGE SENSITIVITY control (R77) to the desired sensitivity setting. For details on the setting of this control, refer to "INSTRUCTIONS FOR SETTING THE LEAKAGE SENSITIVITY CONTROL" in SECTION G, APPLICATION NOTES in this manual.
6. Turn the POWER switch (CBI) ON; the rocker of the POWER switch (CBI) should light.
7. For an item which has a 3-wire grounding type line cord, the GOOD WHEN LIT lamp (DS4) should be lit.
NOTE: The GROUND CHECK/BYPASS switch (S5) must be in the GROUND CHECK position for proper testing.

WARNING!

If the GOOD WHEN LIT lamp (DS4) is not lit, set the POWER SWITCH (CBI) to the OFF position. Disconnect the item under test and repair its ground circuit BEFORE proceeding with any further testing.

For all other items or when using the test probes, the GOOD WHEN LIT lamp (DS4) should not be lit.
NOTE: The GROUND CHECK/BYPASS switch (S5) must be in the BYPASS position for proper testing.

8. Before any high voltage testing can be done, the VOLTAGE CONTROL (T3) must be in the ZERO START (RESET) position or the RESET pushbutton (S4) pressed.

9. Select the desired test, either One Second or Continuous.

A. CONTINUOUS TEST

1. Press the CONT pushbutton (S2). The HV ON lamp (DS3) will light.

WARNING!

THE TESTER IS NOW CAPABLE OF PRODUCING HIGH VOLTAGE.

2. Observing the KILOVOLTMMETER (M1) indication, raise the voltage to the desired level by clockwise rotation of the VOLTAGE CONTROL (T3) and maintain for the required time.
3. To end the test, return the VOLTAGE CONTROL (T3) to the ZERO START (RESET) position, then press the HV OFF pushbutton (S3). The HV ON lamp (DS3) will go out.

B. ONE-SECOND TEST

This test is used when testing several identical items:

1. With the item under test connected, set the voltage (by Step 9A above), but press the HV OFF pushbutton (S3) without returning the VOLTAGE CONTROL (T3) to the ZERO START (RESET) position.
2. To start a series of one-second tests, press the RESET pushbutton (S4), then press the ONE SEC pushbutton (S1) each time a test is to be performed.
3. To end a series of tests, return the VOLTAGE CONTROL (T3) to the ZERO START (RESET) position and press the HV OFF pushbutton (S3).

OPERATION (cont'd)

Section G

APPLICATION NOTES

10. Whenever the HV OFF pushbutton (S3) is pressed, the VOLTAGE CONTROL (T3) must be returned to the ZERO START (RESET) position or the RESET pushbutton (S4) pressed, to proceed with further testing.

PROPERTIES OF INSULATION

Leakage Current

11. During high voltage testing, watch for failure symptoms such as: audible alarm sounds and FAILURE Lamp (DS2) lights, or a sudden voltage drop or erratic KILOVOLTMEETER (M1) reading.

12. When the Tester detects a failure, the audible alarm sounds, the FAILURE Lamp (DS2) lights and high voltage is switched off.

To turn off the failure signals and continue testing, return the VOLTAGE CONTROL (T3) to the ZERO START (RESET) position or press the RESET pushbutton (S4).

OPERATING NOTES

High Voltage cannot be switched on unless the following interlock conditions are met:

- A. TESTER GROUNDED Lamp (DS5) must be lit.
- B. GOOD WHEN LIT Lamp (DS4) must be lit or the GROUND CHECK/BYPASS switch (S5) in the BYPASS position.
- C. VOLTAGE CONTROL (T3) in the ZERO START (RESET) position or the RESET pushbutton (S4) pressed.

All electrical insulating structures, when subjected to voltage, conduct some current. When alternating voltage is applied, this current is made up of two components: one due to conduction through or across the surface of the insulator, (the resistive) and one due to the capacitance of the structure (the capacitive). Both of these components are undesirable and are kept very small by design in new equipment. Nevertheless, some current of both types always "leaks" around or through any insulator; hence the name "leakage current". (Under some definitions, only the resistive component is called leakage, but we are following existing practice by also including the capacitive.)

Leakage current of both resistive and capacitive components increases with voltage, and generally with the size of equipment; capacitive current especially is high for items having windings (motors, transformers), or long runs of wire (wired control panels, etc). In good new equipment, the resistive component is usually much smaller than the capacitive.

Do not confuse the leakage which occurs during the Dielectric Voltage-withstand test (High Voltage Leakage) with the leakage which exists when an appliance is energized at its normal operating voltage and for which limits are specified by various safety standards, such as UL. This operating leakage is an important safety consideration, but is only indirectly related to the high voltage leakage, and it is normally much smaller. The operating leakage cannot be measured

APPLICATION NOTES (cont'd)

by a high pot tester. Ask about other Biddle instruments to measure this line-voltage leakage current. For the remainder of this section wherever the words "leakage current" are used, they should be understood to be the high voltage leakage current.

The schematic drawing below represents the leakage current paths during a Dielectric Voltage-Withstand test. In good equipment, I_R is usually much less than I_C .

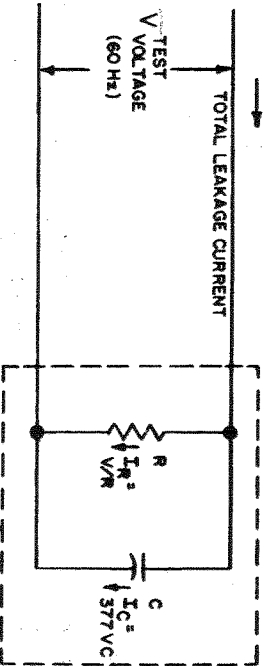

Insulation Failure

When defective insulation is subjected to a high voltage, one of two things may happen:

- Leakage current increases greatly because part of the insulation has become conductive.
- A spark jumps across an air gap which has become too short to withstand the applied voltage.

APPLICATION NOTES (cont'd)

Condition (a) may lead to (b), and (b) usually leads to a continuing "breakdown" discharge which emits light, heat, and a crackling sound, and carries as much current as the Tester will deliver, causing the detection circuit to signal a failure. Such a discharge also causes high frequency (RF) variations in the current, which is useful in detection.

Some defects which cause failure are:

- Dirt on the insulation causes increased resistive current; this may heat the surface and cause a further increase and may lead to a discharge. Moisture always aggravates this condition.
- Cracks or pinholes in insulation usually lead to a quick breakdown and discharge.
- Shortened air gap due to defective assembly may cause discharge across the gap. An example is a loose strand of wire near the frame.
- Insulation saturated with moisture may cause a large increase in either component of leakage current.

APPLICATION NOTES (cont'd)

DIELECTRIC VOLTAGE-WITHSTAND TEST CHARACTERISTICS

Output

Figure 3, a graph of output voltage vs. capacitance, shows the typical output characteristics of the Tester (both 3 kV and 4 kV models 50 and 60 Hz). For test items having capacitances outside the range of the Tester, a larger tester must be used.

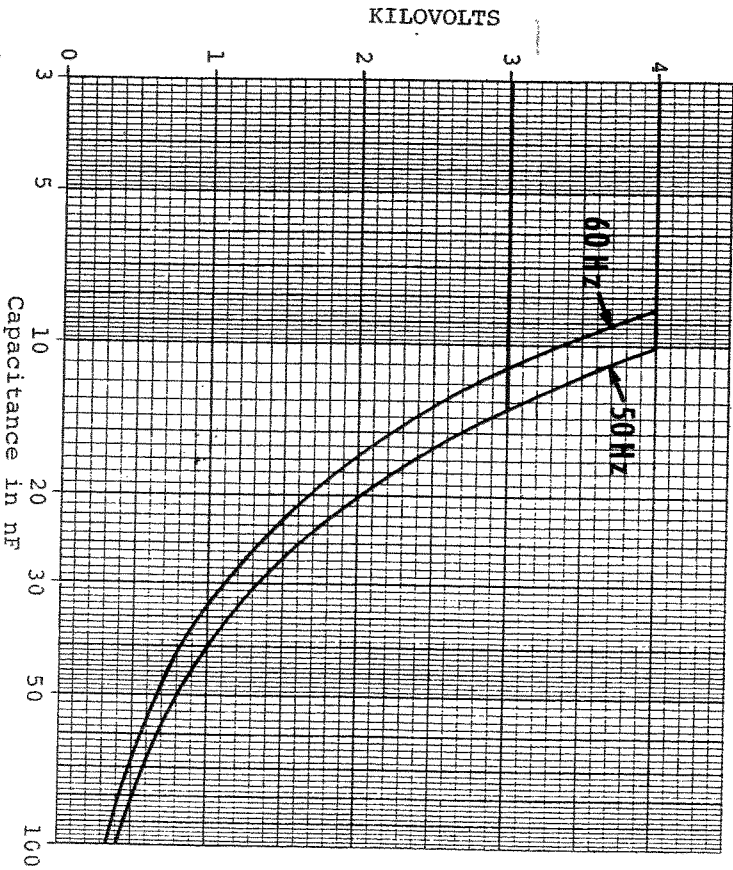

Figure 3: Typical Output Characteristics of the Biddle AC High Pot Tester.

-G4-

APPLICATION NOTES (cont'd)

Automatic Failure Detection

The Tester is equipped with a failure detection circuit which detects insulation failure in the form of excessive leakage current or an arcing fault, indicating this failure by an audible alarm and the FAILURE lamp (DS2), switching off high voltage within 50 ms. The leakage current trip level is adjustable between 0.3 mA and 12 mA by the LEAKAGE SENSITIVITY CONTROL (R77).

The operator may occasionally detect a visible or audible discharge or erratic voltmeter indication without an accompanying failure signal by the Tester. These represent borderline cases in which the discharge energy remains small and does not build up to a full breakdown. If repeated during the test period, these should be taken as signs of failure. If a signal "snap" or "pop" occurs and is not repeated, it may be due to a stray projection or dirt which has burned off, in which case the item under test may be acceptable. Such weak "pops" seldom occur at higher test voltages and with high capacitance test items. However, some complex structures such as relays and transformers may emit a more continuous buzz at high voltage; this is a very low energy "corona" discharge and generally not a sign of insulation failure.

INSTRUCTIONS FOR SETTING THE LEAKAGE SENSITIVITY CONTROL

Set the LEAKAGE SENSITIVITY control (R77) based on the capacitance of the item under test, if known, from the following details:

Capacitance of Item Unknown

If the capacitance of the item under test is unknown, always set the LEAKAGE SENSITIVITY control (R77) at the most sensitive setting, toward the 0.3 mA position (counterclockwise). This insures the best test and the maximum protection for both the operator and the item under test.

-G5-

APPLICATION NOTES (cont'd)

Low-Capacitance Items

Most items have a capacitance well below 1000 pF which implies a leakage current less than 0.3 mA when tested at 1000 to 1200 volts. In such cases the Tester can be used with the LEAKAGE SENSITIVITY control (R77) at the 0.3 mA position.

Medium to High Capacitance Items

Items having a capacitance greater than 1000 pF, and where its C-V point falls below the maximum output line in Figure 3, can be tested with the LEAKAGE SENSITIVITY control (R77) at some intermediate position between 0.3 mA and 12 mA.

Excessively High-Capacitance Items Not Testable

If the capacitance of the item is so large that its C-V point falls beyond the maximum output line in Figure 3, it is too large for the Tester to handle. This will be clear when attempting to test since even on a good appliance the voltage will not reach the desired value before a failure indication is signalled.

APPLICATION NOTES (cont'd)

NOTES ON DIELECTRIC WITHSTAND TESTING OF 120V AC APPLIANCES

Most 120V AC tools and appliances are frequently tested at 2 times working voltage + 1000 volts (1240V). Some standards call for other values of dielectric withstand voltage. Such standards are issued by many different authorities. The latest issue of the standard which applies in each particular case should be consulted. A few of the standard authorities are listed below in alphabetical order:

- American National Standards Institute (ANSI)
1430 Broadway
New York, NY 10018 USA
- Canadian Standards Association (CSA)
178 Rexdale Boulevard,
Rexdale, Ontario, Canada M9W1R3
- International Electrotechnical Commission (IEC)
1 Rue de Varembe
Geneva, Switzerland
(Copies of IEC standards can be obtained from ANSI.)
- Underwriters Laboratories, Inc. (UL)
333 Pfingsten Rd.
Northbrook, IL 60062 USA

Section H MAINTENANCE

ROUTINE MAINTENANCE

General

Certain routine checks are necessary to insure safe and correct operation of the Tester. These checks are described below. Make all of the following checks after repairs, and at regular scheduled intervals of at least once a year; more often if the set is in heavy use.

Mechanical Inspection (Exterior)

1. Visually inspect the case, noting that hinges and case lock function properly. Check for cracks in the case or lid. Inspect the condition of the handle.
2. Clean the case, panel, test probes and input power cord.
3. Inspect the panel, noting that all knobs are secure on their shafts, that all controls operate smoothly without binding and all mounting screws are tight.
4. Check the test probes for any cracks in the insulation and that the alligator clips and boot are complete.
5. Check the input power cord for any cracks in the insulation. Check the cord plugs for a cracked housing or broken pins.
6. Mechanically set the kilovoltmeter to zero.
7. Repair any defects found.

MAINTENANCE (cont'd)

Mechanical Inspection (Interior)

DANGER!

THE TESTER MUST BE DISCONNECTED FROM THE SUPPLY AND DE-ENERGIZED BEFORE REMOVING FROM CASE.

1. Remove the panel assembly from the case as follows:
 - a. Remove and set aside the four panel screws.
 - b. Carefully turn the case with the panel assembly upside down.
 - c. Slide the case off of the panel assembly.
 - d. Turn the panel assembly right side up and place on a clean dry surface.
2. Clean any accumulated dust from the interior of the case and the panel assembly.
3. Visually inspect all components and leads for defects. Repair any defects found.
4. Reinstall the panel assembly into its case and reinstall the mounting screws.

Electrical Inspection

The electrical inspection should be performed only after the mechanical inspections have been completed. Read Sections B, E, and F and follow all safety precautions before proceeding with this inspection. Before operating this Tester for the first time, read and understand this entire manual.

MAINTENANCE (cont'd)

Perform the electrical inspection as follows:

A. Setup

1. With the POWER switch (CBI) OFF, connect the INPUT POWER CORD (W3) to the Tester INPUT Inlet (P7), then plug the INPUT POWER CORD (W3) into a grounded outlet.
2. Verify that the TESTER GROUNDED Lamp (DSS) is lit.

DANGER!

IF THE TESTER GROUNDED LAMP (DSS) IS NOT LIT, DO NOT PROCEED ANY FURTHER, UNPLUG THE INPUT POWER CORD (W3) AND REFER TO SECTION I, TROUBLESHOOTING AND REPAIR OF THIS MANUAL.

3. If the TESTER GROUNDED Lamp (DSS) is lit, proceed with the following GROUND CHECK procedure:

B. Ground Check

Once Step 3 of the SETUP procedure is complete, the GROUND CHECK circuit can be checked. The following items are required:

- a. 50 Ω , 1/4 W, 5% resistor
 - b. 200 Ω , 1/4 W, 5% resistor
1. Connect the 50 Ω resistor between the RETURN test probe (W1) and the OUTPUT receptacle (J8) ground pin.
 2. Set the GROUND CHECK/BYPASS switch (SS) to the GROUND CHECK position.

MAINTENANCE (cont'd)

3. Set the POWER switch (CB1) to the ON position. The rocker of the POWER switch (CB1) should light.
4. The GOOD WHEN LIT lamp (DS4) should be lit.
5. Repeat steps 1 to 3 using the 20 Ω resistor instead of the 5 Ω resistor. The GOOD WHEN LIT lamp (DS4) should not light.
6. Disconnect the 20 Ω resistor.
7. If the GROUND CHECK circuit does not function properly, set the POWER switch (CB1) to the OFF position, unplug the Tester INPUT POWER CORD (W3) and refer to SECTION I, TROUBLESHOOTING AND REPAIR. If the GROUND CHECK circuit functions properly, proceed to the Dielectric Voltage-Withstand procedure which follows:
 - a. 1.0 M Ω , 1/4 W resistor.
 - b. 25 K Ω , 5 W resistor
 - c. stop watch
 1. Zero Start (Reset) Test
 - a. Clip the RETURN test probe (W1) to the knurl nut of the GROUND CHECK/BYPASS switch (S5). The GOOD WHEN LIT lamp (DS4) should light.
NOTE: The GROUND CHECK/BYPASS switch (S5) must be in the GROUND CHECK position for proper testing.
 - b. If the HIGH VOLTAGE test probe (W2) is connected to the Tester, disconnect it.

-H4-

MAINTENANCE (cont'd)

- c. Rotate the VOLTAGE CONTROL (T3) to the first dot above the ZERO START (RESET) position.
- d. Press the HV OFF pushbutton (S3).
- e. Press the CONT pushbutton (S2), the following should be observed:
 - HV ON lamp (DS3) should not light.
 - KILOVOLTMETER (M1) should read zero.
- f. Press the RESET pushbutton (S4).
- g. Press the CONT pushbutton (S2), the following should occur:
 - HV ON lamp (DS3) should light.
 - KILOVOLTMETER (M1) should read a few hundred volts.
- h. Press the HV OFF pushbutton (S3), the HV ON lamp (DS3) should go out.
- i. Rotate the VOLTAGE CONTROL (T3) to the ZERO START (RESET) position.
- j. Press the CONT pushbutton (S2), the following should occur:
 - HV ON lamp (DS3) should light.
 - KILOVOLTMETER (M1) should read zero.
- k. Press the HV OFF pushbutton (S3), the HV ON lamp (DS3) should go out.

-H5-

MAINTENANCE (cont'd)

2. Leakage Sensitivity Test

- a. Set the POWER switch (CB1) to the OFF position.
- b. Connect the HIGH VOLTAGE test probe (W2) to the Tester.
- c. Connect the 1.0 MΩ resistor (item a) between the HIGH VOLTAGE test probe (W2) and RETURN test probe (W1).
- d. Insulate the resistor/test probe assembly for at least 4000 V; locate the assembly to prevent accidental contact with persons.
- e. Set the LEAKAGE SENSITIVITY control (R77) to the 0.3 mA setting.
- f. Rotate the VOLTAGE CONTROL (T3) to the ZERO START (RESET) position.
- g. Set the GROUND CHECK/BYPASS switch (S5) in the BYPASS position.
- h. Set the POWER switch (CB1) to the ON position. The rocker of the POWER switch (CB1) should light.

WARNING!
DO NOT TOUCH, OR LET ANYONE ELSE TOUCH, THE RESISTOR/TEST PROBE ASSEMBLY.

- i. Press the CONT pushbutton (S2). The HV ON lamp (DS3) should light.
- j. Rotate the VOLTAGE CONTROL (T3) slowly clockwise while observing the KILOVOLTMETER (M1) indication. The FAILURE lamp (DS2) should light and the audible alarm sound around 300 volts on the KILOVOLTMETER (M1).

-H6-

MAINTENANCE (cont'd)

- k. Rotate the VOLTAGE CONTROL (T3) to the ZERO START (RESET) position.
 - l. Repeat steps a to k using the 25 KΩ resistor (item b) instead of the 1.0 MΩ resistor (item a) and set the LEAKAGE SENSITIVITY control (R77) to the 12 mA setting instead of the 0.3 mA setting.
 - m. Set the POWER switch (CB1) to the OFF position. Disconnect the 25 KΩ resistor (item b).
- ### 3. Breakdown Sensitivity Test

- a. Locate the RETURN test probe (W1) and the HIGH VOLTAGE test probe (W2) alligator clips approximately 1/16 inch apart, but not touching.
- b. Insulate the test probes for at least 4000V and locate the test probes alligator clips to prevent accidental contact with persons.
- c. Rotate the VOLTAGE CONTROL (T3) to the ZERO START (RESET) position.
- d. Set the GROUND CHECK/BYPASS switch (S5) in the BYPASS position.
- e. Set the POWER switch (CB1) to the ON position. The rocker of the POWER switch (CB1) should light.

WARNING!
DO NOT TOUCH, OR LET ANYONE ELSE TOUCH, THE TEST PROBE ALLIGATOR CLIPS.

- f. Press the CONT pushbutton (S2). The HV ON lamp (DS3) should light.

-H7-

MAINTENANCE (cont'd)

- g. Rotate the VOLTAGE CONTROL (T3) slowly clockwise while observing the KILOVOLT METER (M1) indication. The FAILURE lamp (DS2) should light and the audible alarm sound when there is an arc between the RETURN test probe (W1) and HIGH VOLTAGE test probe (W2) alligator clips.
 - h. Rotate the VOLTAGE CONTROL (T3) to the ZERO START (RESET) position.
 - i. Set the POWER switch (CB1) to the OFF position.
NOTE: If there is no arc between the test probe alligator clips, check that the spacing of the alligator clips is approximately 1/16" and repeat the test.
4. One Second Test
- a. Rotate the VOLTAGE CONTROL (T3) to the ZERO START (RESET) position.
 - b. Set the GROUND CHECK/BYPASS switch (S5) in the BYPASS position.
 - c. Disconnect the HIGH VOLTAGE test probe (W2) from the Tester.
 - d. Set the POWER switch (CB1) to the ON position. The rocker of the POWER switch (CB1) should light.
 - e. Press the ONE SEC pushbutton (S1). The HV ON lamp (DS3) should light and stay on for 1 to 1.3 seconds. Time the high voltage on period with a stop watch.
 - f. Set the POWER switch (CB1) to the OFF position.

-H8-

MAINTENANCE (cont'd)

If the Dielectric Withstand circuit does not function properly, refer to SECTION I, TROUBLESHOOTING AND REPAIR. If the Dielectric Withstand circuit does function properly and all other circuit tests have been successfully completed, the Electrical Inspection of the Tester is complete.

CALIBRATION

To perform the calibration procedure, the panel assembly must be removed from the Tester case. (Refer to MECHANICAL INSPECTION (INTERIOR) in this section for details on panel assembly removal.) An insulated screwdriver will be required for the calibration procedure. The kilovoltmeter calibration pot is located on the High Pot Tester board (A1).

NOTE: The interior of the Tester develops dangerous voltages while in operation, therefore the following calibration should only be carried out by qualified persons.

Set up the Tester according to the SET UP procedure described on page H3 BEFORE performing the calibration procedure. Once the Tester is energized DO NOT TOUCH, or let anyone else touch, any exposed parts.

The following item is required:

- a. A standard voltmeter with a 3000 volt rms range (for 3 kV Testers) or a 4000 volt rms range (for 4 kV Testers) and an overall accuracy of 0.5% or better.

Proceed as follows:

1. With the POWER switch (CB1) OFF, connect the standard voltmeter between the RETURN test probe (W1) and the HIGH VOLTAGE test probe (W2).

-H9-

MAINTENANCE (cont'd)

2. Insulate the standard voltmeter and all leads from ground and each other for at least 4000V; locate the standard voltmeter to prevent accidental contact with persons.
3. Set the GROUND CHECK/BYPASS switch (S5) in the BYPASS position.
4. Rotate the VOLTAGE CONTROL (T3) to the ZERO START (RESET) position.
5. Set the LEAKAGE SENSITIVITY control (R77) to the 0.3 mA setting.
6. Set the POWER switch (CBI) to the ON position. The rocker of the POWER switch (CBI) should light.
7. Press the CONT pushbutton (S2). The HV ON lamp (DS3) should light.
8. Rotate the VOLTAGE CONTROL (T3) slowly clockwise while observing the standard voltmeter. Set the voltage to 2 KV (for 3 KV Testers) or 3 KV (for 4 KV Testers). The KILOVOLTMMETER (M1) should also read 2 KV $\pm 2\%$ of full scale (for 3 KV Testers) or 3 KV $\pm 2\%$ of full scale (for 4 KV Testers). If there is a discrepancy, rotate the VM CAL pot (R18) using an insulated screwdriver until the standard voltmeter and the KILOVOLTMMETER (M1) agree.
9. Check several other points along the scale and be sure that they are within tolerance.
10. Once the KILOVOLTMMETER (M1) is calibrated and checked, rotate the VOLTAGE CONTROL (T3) to the ZERO START (RESET) position, press the HV OFF pushbutton (S3) and set the POWER switch (CBI) to the OFF position.
11. Unplug the INPUT POWER CORD (W3) and reinstall the panel assembly into its case. Reinstall the mounting screws.

-H10-

Section I TROUBLESHOOTING AND REPAIR

REPAIR POLICY

Biddle Instruments maintains a complete instrument repair service. Should this instrument ever require repair, we recommend it be returned to the factory for repair by our instrument specialists. When returning instruments for repair, either in or out of warranty, they should be shipped prepaid and insured, and marked for the attention of the Instrument Service Manager.

TROUBLESHOOTING GUIDE

The Tester should be completely checked for proper operation as described in SECTION H, MAINTENANCE before troubleshooting is attempted. The Tester develops dangerous interior voltages and employs printed circuit card construction, therefore, repairs must only be made by qualified persons. SECTION J, PARTS LIST identifies all components used in the Tester and gives the Biddle part number. Some of the internal components are shown in Figure 4 together with their schematic reference number. We recommend that for safety, only Biddle replacement parts be used when making repairs. Refer to the AC High Pot Tester schematic in SECTION J, REPLACABLE PARTS LIST in this manual for any required circuit details. If major problems are encountered or assistance required, contact the factory. After repairs have been made, always perform a complete inspection of the Tester as detailed in SECTION H, MAINTENANCE. A brief troubleshooting guide follows.

TROUBLESHOOTING AND REPAIR (cont'd)

TESTER GROUNDED

TROUBLESHOOTING GUIDE

PROBLEM

TESTER GROUNDED
Lamp (DS5) not lit

PROBABLE CAUSE

- No voltage at service outlet for the Tester.
- Ground wire open or ground contact of service outlet not grounded.
- "Hot" and "Neutral" wires on service outlet interchanged (120V operation).
- Defective INPUT POWER CORD (W3).
- Defective Opto-isolator (U4).
- Defective TESTER GROUNDED Lamp (DS5).

GROUND CHECK

PROBLEM

GOOD WHEN LIT Lamp (DS4) not lit with resistance of less than 10 ohm connected.

PROBABLE CAUSE

- GROUND CHECK/BYPASS switch (S5) in the BYPASS position.
- Defective GOOD WHEN LIT Lamp (DS4).
- Defective GROUND CHECK/BYPASS switch (S5).
- Defective IC (U2).
- Defective Transistor (Q5)

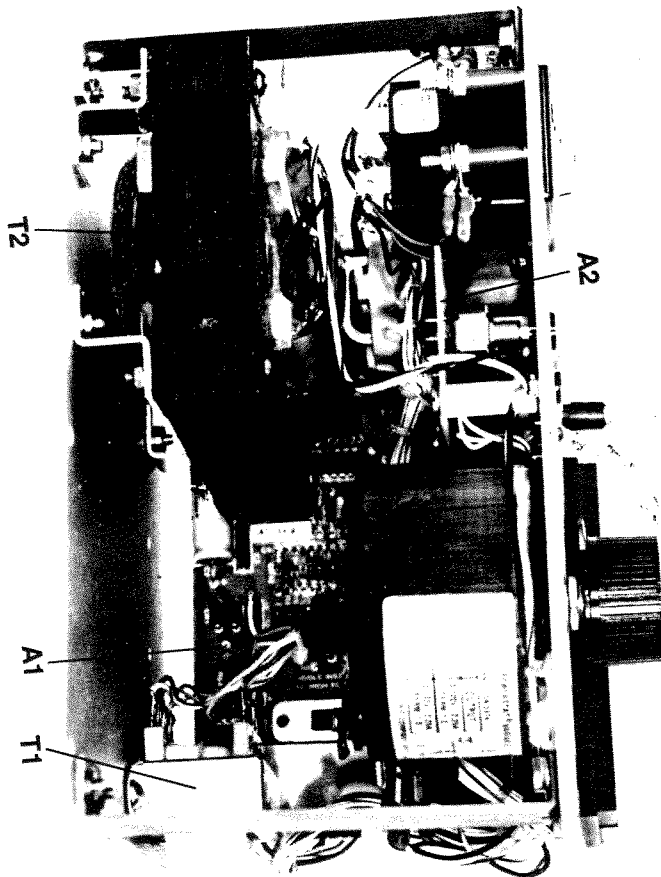

Figure 4: Internal View of Tester

TROUBLESHOOTING AND REPAIR (cont'd)

TROUBLESHOOTING GUIDE (cont'd)

DIELECTRIC WITHSTAND

PROBLEM

HV ON lamp (DS3) lit,
KILOVOLTMEETER (M1) reads zero when VOLTAGE CONTROL (T3) rotated toward the MAX position. No output voltage.
Failure indicators may occur.

PROBABLE CAUSE

- High voltage circuits internally shorted or open.

HV ON lamp (DS3) lit
KILOVOLTMEETER (M1) reads zero when VOLTAGE CONTROL (T3) rotated toward the MAX position. Output voltage present.

- Defective KILOVOLTMEETER (M1).

- Defective diode bridge (CR3).

One Second or Continuous test not functioning.
(HV ON lamp (DS3) not lit.
KILOVOLTMEETER (M1) reads zero when VOLTAGE CONTROL (T3) rotated toward the MAX position. No output voltage.
TESTER GROUNDED lamp (DS5) lit (IC U1, U4 operating)
GOOD WHEN LIT lamp (DS4) lit or GROUND CHECK/BYPASS switch (S5) in BYPASS position (IC U2, operating)).

- Defective pushbutton (S1 for One Second test, S2 for Continuous).

- Defective relay (K1).

- Defective IC (U3).

- Defective transistor (Q3, Q4, Q5).

Pressing HV OFF pushbutton (DS3) does not turn off high voltage.

- Defective pushbutton (S3)

- Defective IC (U2, U3).

- Defective transistor (Q3, Q4, Q5).

TROUBLESHOOTING AND REPAIR (cont'd)

TROUBLESHOOTING GUIDE (cont'd)

DIELECTRIC WITHSTAND

PROBLEM

FAILURE lamp (DS2) and audible alarm (LS1) not operating when a failure occurs.
High Voltage does not switch off or POWER switch (CBI) trips when failure occurs.

PROBABLE CAUSE

- Defective LEAKAGE SENSITIVITY control (R77)

- Defective IC (U1, U2, U3)

- Defective surge protector (CR4, CR5).

FAILURE lamp (DS2) and audible alarm (LS1) not operating when a failure occurs.
High Voltage switches off when failure occurs.

- Defective IC (U1, U3).

- Defective transistor (Q1, Q2).

Returning VOLTAGE CONTROL (T3) to ZERO START (RESET) position or pressing RESET pushbutton (S4) does not turn failure signals off.

- Defective opto-isolator (U5).

- Defective IC (U1, U2, U3)

- Defective RESET pushbutton (S4).

- Defective ZERO START (RESET) contact.

- Defective transistor (Q2).

Section J
REPLACEABLE PARTS LIST

<u>Schematic Symbol</u>	<u>Description</u>	<u>Biddle Part No.</u>
C1,*C11,*C20	Capacitor, .22 uF, 50V	17127-13
*C2	Capacitor, 1000 uF, 25V	23908-1
*C3	Capacitor, .01 uF, 1000V	9865-25
*C4	Capacitor, 47 uF, 20V	17132-3
*C5,*C13,*C14	Capacitor, .47 uF, 100V	19836-8
*C6-*C8,*C17	Capacitor, 1000 pF, 100V	17127-1
*C9	Capacitor, 470 pF, 1000V	7950-24
*C10	Capacitor, .047 uF, 100V	17127-2
*C12	Capacitor, .01 uF, 100V	17127-9
*C15	Capacitor, .01 uF, 630V	19836-10
*C16	Capacitor, .001 uF, 1000V	7950-12
*C19,*C22	Capacitor, .1 uF, 50V	17127-5
*C18, *C21,*C23	Capacitor, 4700 pF, 100V	17127-4
CBI	Circuit Breaker, 2 Pole, 250V, 1A	23964
*CR1, *CR3	Bridge Rectifier, VM18	22921
*CR2, *CR6 -	Diode, 1N4148	11637-40
*CR27,**CR35		

* Part of PC Board Assembly, (A1), Biddle P/N 25138
 ** Part of PC Board Assembly, (A2), Biddle P/N 25134

REPLACEABLE PARTS LIST (cont'd)

REPLACEABLE PARTS LIST (cont'd)

Schematic Symbol	Description	Biddle Part No.	Schematic Symbol	Description	Biddle Part No.
*CR4, *CR5	Transorb, 1.5KE20CA	17040-5	*L51	Alarm, AT-03	25198
DS1	Neon Part of CBI	-	M1	Kilovoltmeter (3 kv Full Scale)	19937-7
**DS2	Failure LED (yellow)	17142-1	M1	Kilovoltmeter (4 kv Full Scale)	19937-8
**DS3	HV ON LED (red)	17142	P7	Recessed Power Inlet, 250V, 6A	18305
DS4	GOOD WHEN LIT LED (green)	17142-2	*Q1-*Q5	Transistor, 2N3904	11638-62
DS5	TESTER GROUNDED NEON (white) 250V, 1/3W	4499-8	*R2, *R26, *R33, *R37, *R42, *R48, *R66	Resistor, 1M Ω , 1/4W, \pm 5% Carbon Composition	4501-508
*E1	Male Quick-Disconnect Tab	17029-1	*R3	Resistor, 33K Ω , 12/W, \pm 5% Carbon Composition	4501-186
E5, E6	Insulated Standoff	23063	*R4	Resistor, 220 Ω , 2W, \pm 5% Carbon Composition	4501-407
*E9, *E10, *E11	2-Pin Male Strip	22931-2	*R5, *R54	Resistor, 47K Ω , 1/4W, \pm 5% Carbon Composition	4501-514
*F1	Sub-miniature fuse, 1/16 A	25421-1	*R6	Resistor, 15K Ω , 1/4W, \pm 5% Carbon Composition	4501-71
J8	2-Pole, 3-Wire Grounding Receptacle 15/20A, 125V Flanged Outlet (Tested for 5 kv withstand)	23960	*R7, *R68, **R76	Resistor, 820 Ω , 1/4W, \pm 5% Carbon Composition	4501-69
J9	High Voltage Receptacle Rating 15 kv dc	25505	*R8	Resistor, 470 Ω , 1/4W, \pm 5% Carbon Composition	4501-575
J10	Return Receptacle, black nylon banana jack	9879-1			
*K1	Relay, Coil 12V dc Contact 250 VAC, 3A	25114			

* Part of PC Board Assembly (A1), Biddle P/N 25138
 ** Part of PC Board Assembly (A2), Biddle P/N 25134

* Part of PC Board Assembly (A1), Biddle P/N 25138
 ** Part of PC Board Assembly (A2), Biddle P/N 25134

REPLACEABLE PARTS LIST (cont'd)

REPLACEABLE PARTS LIST (cont'd)

Schematic Symbol	Description	Biddle Part No.	Schematic Symbol	Description	Biddle Part No.
*R9	Resistor, 430Ω, 1/4W, ±5% Carbon Composition	4501-576	*R25	Resistor, 680Ω, 1/4W, ±5% Carbon Composition	4501-66
*R10	Resistor, 10KΩ, 1/4W, ±5% Carbon Composition	4501-506	*R27, *R36	Resistor, 5.1MΩ, 1/4W, ±5% Carbon Composition	4501-540
*R11, *R23	Resistor, 681Ω, ±1%, RN55D	12398-71	*R29, *R49	Resistor, 470KΩ, 1/4W, ±5% Carbon Composition	4501-513
*R12, *R13, *R19, *R30, *R31, *R38, *R39, *R45, *R46, *R50, *R60, *R65	Resistor, 100KΩ, 1/4W, ±5%	4501-91	*R32	Resistor, 360KΩ, 1/2W, ±5% Carbon Composition	4501-536
*R14	Resistor, 10MΩ, 3W, ±1%, 6 KV	10646-17	*R34, *R35, *R40, *R41, *R43, *R67	Resistor, 510KΩ, 1/4W, ±5% Carbon Composition	4501-509
*R15	Resistor, 37.4KΩ, ±1%, RN55D	12398-19	*R28, *R44, *R47	Resistor, 200KΩ, 1/4W, ±5% Carbon Composition	4501-525
*R16	Resistor, 20KΩ, ±1%, RN55D	12398-1	*R51	Resistor, 392KΩ, ±1%, RN55D	12398-192
*R17	Resistor, 11KΩ, ±1%, RN55D	12398-176	*R52	Resistor, 2MΩ, ±1%, RN55D	12398-193
*R18	Potentiometer, 10KΩ	12340-10	*R53	Resistor, 330KΩ, 1/4W, ±5% Carbon Composition	4501-510
*R20	Resistor, 1KΩ, ±1%, RN55D	12398-16	*R55	Resistor, 150Ω, 1/4W, ±5% Carbon Composition	4501-545
*R21	Resistor, 19.6Ω, ±1%, RN55D	12398-191	*R56, *R57	Resistor, 1KΩ, 1/4W, ±5% Carbon Composition	4501-51
*R22	Resistor, 200Ω, ±1%, RN55D	12398-4	*R58	Resistor, 1MΩ, ±1%, RN55D	12398-81
*R24	Resistor, 56KΩ, 1/4W, ±5% Carbon Composition	4501-90	*R59, *R61	Resistor, 100KΩ, ±1%, RN55D	12398-27
			*R62	Resistor, 5.62KΩ, ±1%, RN55D	12398-7

* Part of PC Board Assembly (A1), Biddle P/N 25138
 ** Part of PC Board Assembly, (A2), Biddle P/N 25134

* Part of PC Board Assembly (A1), Biddle P/N 25138
 ** Part of PC Board Assembly (A2), Biddle P/N 25134

REPLACEABLE PARTS LIST (cont'd)

REPLACEABLE PARTS LIST (cont'd)

<u>Schematic Symbol</u>	<u>Description</u>	<u>Biddle Part No.</u>	<u>Schematic Symbol</u>	<u>Description</u>	<u>Biddle Part No.</u>
*R63	Resistor, 4.75K Ω , \pm 1%, RN55D	12398-155	*U2, *U3	Integrated Circuit, Quad Op Amp, LM324	25045-27
*R64	Resistor, 100K Ω , 1W, \pm 5% Carbon Composition	4501-371	*U4, *U5	Integrated Circuit, Opto-Isolator, IL-250	25257
*R67	Resistor, 4.7K Ω , 1/4W, \pm 5% Carbon Composition	4501-53	*VR1	Voltage Regulator, LM340AT	23691-5
*R69	Resistor, 2 M Ω , 1/4W, \pm 5% Carbon Composition	4501-511	W1	Return Test Probe Assembly	25136
*R70,*R71,*R72	Resistor, 22K Ω , 1/4W, \pm 5% Carbon Composition	4501-554	W2	High Voltage Test Probe Assembly	25507
**R75	Resistor, 10K Ω , 2W, \pm 5% Carbon Composition	4501-423	W3	Input Power Cord (120V Testers)	17032
**R77	Potentiometer, 50K Ω	17135-7		Input Power Cord (240V Testers)	17032-2
S1-S4	Pushbutton Switch	17137		Zero Start Contact (Mounted on T3)	23202
S5	Toggle Switch, 3PDT	12119-2		Knob (for T3)	4690-25
*S6	Line Selector Switch	18620		Knob (for R77)	25146
T1	Transformer, Primary 115/230V Secondary 16V C.T. @ 0.4A	15573-12		Case Assembly	10998
T2	High Voltage Transformer	25140		Lid Assembly	22389-4
T3	Autotransformer (120V Testers)	6408-2		Instruction Card	25144
T3	Autotransformer (240V Testers)	17787			
*U1	Integrated Circuit, Schmidt Trigger Quad NAND Gate, 4093	25045-8			
*	Part of PC Board Assembly (A1), Biddle P/N 25183		*	Part of PC Board Assembly (A1), Biddle P/N 25138	
**	Part of PC Board Assembly (A2), Biddle P/N 25134		**	Part of PC Board Assembly (A2), Biddle P/N 25134	

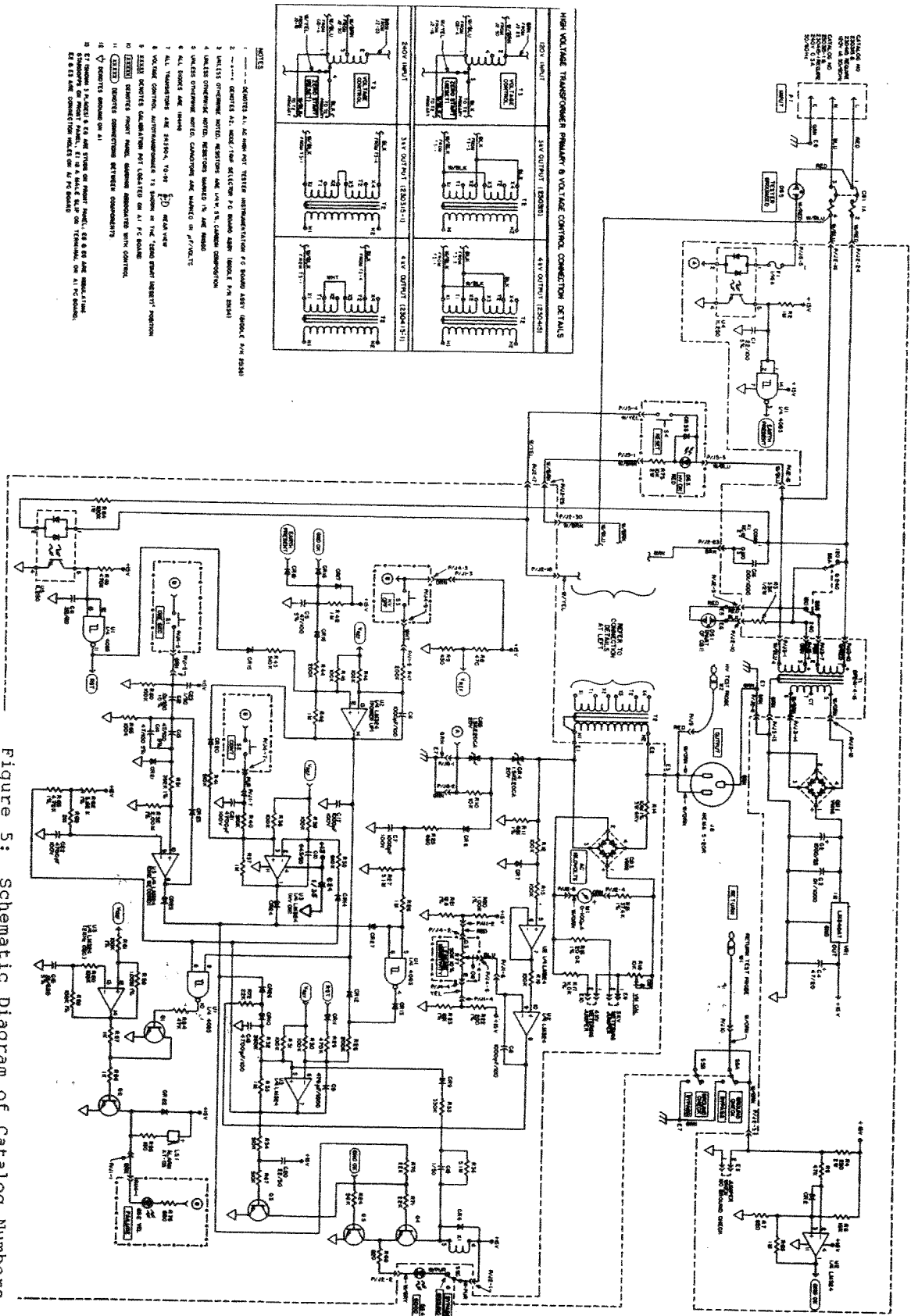

- NOTES**
1. --- denotes A.C. non-pot tester instrumentation P.C. board assembly (part of 230315)
 2. --- denotes A.C. non-pot tester instrumentation P.C. board assembly (part of 230315)
 3. --- denotes A.C. non-pot tester instrumentation P.C. board assembly (part of 230315)
 4. UNLESS OTHERWISE NOTED, RESISTORS ARE 1/4 WATT, 5% TOLERANCE COMPONENTS
 5. UNLESS OTHERWISE NOTED, CAPACITORS ARE 50V D.C. OR 50V A.C. COMPONENTS
 6. ALL POINTS ARE UNLESS OTHERWISE NOTED
 7. ALL TRANSISTORS ARE 2N4340, 100mV β MINIMUM
 8. VOLTAGE CONTROL APPROXIMATELY 1% SLOPE AT 100V PER DECADE POSITION
 9. VOLTAGE CONTROL APPROXIMATELY 1% SLOPE AT 100V PER DECADE POSITION
 10. **TESTS** INDICATES CONNECTION POINT LOCATED ON A.C. BOARD
 11. **TESTS** INDICATES CONNECTION BETWEEN COMPONENTS
 12. **TESTS** INDICATES CONNECTION BETWEEN COMPONENTS
 13. **TESTS** INDICATES CONNECTION BETWEEN COMPONENTS
 14. **TESTS** INDICATES CONNECTION BETWEEN COMPONENTS
 15. **TESTS** INDICATES CONNECTION BETWEEN COMPONENTS
 16. **TESTS** INDICATES CONNECTION BETWEEN COMPONENTS
 17. **TESTS** INDICATES CONNECTION BETWEEN COMPONENTS
 18. **TESTS** INDICATES CONNECTION BETWEEN COMPONENTS
 19. **TESTS** INDICATES CONNECTION BETWEEN COMPONENTS
 20. **TESTS** INDICATES CONNECTION BETWEEN COMPONENTS
 21. **TESTS** INDICATES CONNECTION BETWEEN COMPONENTS
 22. **TESTS** INDICATES CONNECTION BETWEEN COMPONENTS
 23. **TESTS** INDICATES CONNECTION BETWEEN COMPONENTS
 24. **TESTS** INDICATES CONNECTION BETWEEN COMPONENTS
 25. **TESTS** INDICATES CONNECTION BETWEEN COMPONENTS
 26. **TESTS** INDICATES CONNECTION BETWEEN COMPONENTS
 27. **TESTS** INDICATES CONNECTION BETWEEN COMPONENTS
 28. **TESTS** INDICATES CONNECTION BETWEEN COMPONENTS
 29. **TESTS** INDICATES CONNECTION BETWEEN COMPONENTS
 30. **TESTS** INDICATES CONNECTION BETWEEN COMPONENTS
 31. **TESTS** INDICATES CONNECTION BETWEEN COMPONENTS
 32. **TESTS** INDICATES CONNECTION BETWEEN COMPONENTS
 33. **TESTS** INDICATES CONNECTION BETWEEN COMPONENTS
 34. **TESTS** INDICATES CONNECTION BETWEEN COMPONENTS
 35. **TESTS** INDICATES CONNECTION BETWEEN COMPONENTS
 36. **TESTS** INDICATES CONNECTION BETWEEN COMPONENTS
 37. **TESTS** INDICATES CONNECTION BETWEEN COMPONENTS
 38. **TESTS** INDICATES CONNECTION BETWEEN COMPONENTS
 39. **TESTS** INDICATES CONNECTION BETWEEN COMPONENTS
 40. **TESTS** INDICATES CONNECTION BETWEEN COMPONENTS
 41. **TESTS** INDICATES CONNECTION BETWEEN COMPONENTS
 42. **TESTS** INDICATES CONNECTION BETWEEN COMPONENTS
 43. **TESTS** INDICATES CONNECTION BETWEEN COMPONENTS
 44. **TESTS** INDICATES CONNECTION BETWEEN COMPONENTS
 45. **TESTS** INDICATES CONNECTION BETWEEN COMPONENTS
 46. **TESTS** INDICATES CONNECTION BETWEEN COMPONENTS
 47. **TESTS** INDICATES CONNECTION BETWEEN COMPONENTS
 48. **TESTS** INDICATES CONNECTION BETWEEN COMPONENTS
 49. **TESTS** INDICATES CONNECTION BETWEEN COMPONENTS
 50. **TESTS** INDICATES CONNECTION BETWEEN COMPONENTS
 51. **TESTS** INDICATES CONNECTION BETWEEN COMPONENTS
 52. **TESTS** INDICATES CONNECTION BETWEEN COMPONENTS
 53. **TESTS** INDICATES CONNECTION BETWEEN COMPONENTS
 54. **TESTS** INDICATES CONNECTION BETWEEN COMPONENTS
 55. **TESTS** INDICATES CONNECTION BETWEEN COMPONENTS
 56. **TESTS** INDICATES CONNECTION BETWEEN COMPONENTS
 57. **TESTS** INDICATES CONNECTION BETWEEN COMPONENTS
 58. **TESTS** INDICATES CONNECTION BETWEEN COMPONENTS
 59. **TESTS** INDICATES CONNECTION BETWEEN COMPONENTS
 60. **TESTS** INDICATES CONNECTION BETWEEN COMPONENTS
 61. **TESTS** INDICATES CONNECTION BETWEEN COMPONENTS
 62. **TESTS** INDICATES CONNECTION BETWEEN COMPONENTS
 63. **TESTS** INDICATES CONNECTION BETWEEN COMPONENTS
 64. **TESTS** INDICATES CONNECTION BETWEEN COMPONENTS
 65. **TESTS** INDICATES CONNECTION BETWEEN COMPONENTS
 66. **TESTS** INDICATES CONNECTION BETWEEN COMPONENTS
 67. **TESTS** INDICATES CONNECTION BETWEEN COMPONENTS
 68. **TESTS** INDICATES CONNECTION BETWEEN COMPONENTS
 69. **TESTS** INDICATES CONNECTION BETWEEN COMPONENTS
 70. **TESTS** INDICATES CONNECTION BETWEEN COMPONENTS
 71. **TESTS** INDICATES CONNECTION BETWEEN COMPONENTS
 72. **TESTS** INDICATES CONNECTION BETWEEN COMPONENTS
 73. **TESTS** INDICATES CONNECTION BETWEEN COMPONENTS
 74. **TESTS** INDICATES CONNECTION BETWEEN COMPONENTS
 75. **TESTS** INDICATES CONNECTION BETWEEN COMPONENTS
 76. **TESTS** INDICATES CONNECTION BETWEEN COMPONENTS
 77. **TESTS** INDICATES CONNECTION BETWEEN COMPONENTS
 78. **TESTS** INDICATES CONNECTION BETWEEN COMPONENTS
 79. **TESTS** INDICATES CONNECTION BETWEEN COMPONENTS
 80. **TESTS** INDICATES CONNECTION BETWEEN COMPONENTS
 81. **TESTS** INDICATES CONNECTION BETWEEN COMPONENTS
 82. **TESTS** INDICATES CONNECTION BETWEEN COMPONENTS
 83. **TESTS** INDICATES CONNECTION BETWEEN COMPONENTS
 84. **TESTS** INDICATES CONNECTION BETWEEN COMPONENTS
 85. **TESTS** INDICATES CONNECTION BETWEEN COMPONENTS
 86. **TESTS** INDICATES CONNECTION BETWEEN COMPONENTS
 87. **TESTS** INDICATES CONNECTION BETWEEN COMPONENTS
 88. **TESTS** INDICATES CONNECTION BETWEEN COMPONENTS
 89. **TESTS** INDICATES CONNECTION BETWEEN COMPONENTS
 90. **TESTS** INDICATES CONNECTION BETWEEN COMPONENTS
 91. **TESTS** INDICATES CONNECTION BETWEEN COMPONENTS
 92. **TESTS** INDICATES CONNECTION BETWEEN COMPONENTS
 93. **TESTS** INDICATES CONNECTION BETWEEN COMPONENTS
 94. **TESTS** INDICATES CONNECTION BETWEEN COMPONENTS
 95. **TESTS** INDICATES CONNECTION BETWEEN COMPONENTS
 96. **TESTS** INDICATES CONNECTION BETWEEN COMPONENTS
 97. **TESTS** INDICATES CONNECTION BETWEEN COMPONENTS
 98. **TESTS** INDICATES CONNECTION BETWEEN COMPONENTS
 99. **TESTS** INDICATES CONNECTION BETWEEN COMPONENTS
 100. **TESTS** INDICATES CONNECTION BETWEEN COMPONENTS

Figure 5: Schematic Diagram of Catalog Numbers 230315, 230315-1, 230415 and 230415-1 AC High Pot Tester.

Section K
WARRANTY

All products supplied by Biddle Instruments are warranted against all defects in material and workmanship for a period of one year following shipment. Our liability is specifically limited to replacing or repairing, at our factory, defective equipment. Equipment returned to the factory for repair will be shipped prepaid and insured. The warranty does not include batteries or lamps, or where the original manufacturer's warranty shall apply. WE MAKE NO OTHER WARRANTY.

The warranty is void in the event of abuse or failure by the customer to perform specified maintenance as indicated in this manual.