

**Instruction Manual AVTM55-1J
For
Three-phase TTR®
Transformer Turns Ratio Test Set
Catalog No. 550100**

**High-voltage equipment
Read the entire manual before operating.**

**Aparato de Alto Voltaje
Antes de operar este producto lea este manual enteramente.**

**Copyright 1990
AVO INTERNATIONAL
PO Box 9007
Valley Forge, PA 19484-9007
610-676-8500**

TABLE OF CONTENTS

<u>Section</u>	<u>Title</u>	<u>Page</u>
1	Introduction	1
	Receiving Instructions	1
	General Information	1
2	Safety	3
3	Specifications	5
	Electrical	5
	Environmental	6
	Physical Data	6
	Accessories Included	6
	Optional Accessories	7
4	Controls, Indicators, and Connectors	8
5	Setup and Operation	12
	Setup	12
	Single-Phase Transformers	12
	Three-Phase Transformers	13
	Current Transformers	26
	General Procedure	30
	Operation	33
	Self-Check	33
	Operating Notes	35
	In Case of Emergency	35
	Error Messages	35
	Measurement with Printer Connected	36
6	Maintenance and Calibration	39
	Routine Maintenance	39
	Calibration	39
7	Troubleshooting and Repair	41
	Troubleshooting	41
	Repair	41
8	Replaceable Parts List	43
	Glossary	44
	Warranty	45

LIST OF ILLUSTRATIONS

<u>Figure</u>	<u>Title</u>	<u>Page</u>
1	TTR Test Set and Accessories	2
2	Control Panel	9
3	TTR Test Set, Simplified Block Diagram	10
4	Setup for Testing Single-Phase Transformer	14
5	Setup for Testing Single-Phase Autotransformer	14
6	Setup for Testing Single-Phase, Type A (Straight Design) Step Voltage Regulator	15
7	Setup for Testing Single-Phase, Type B (Inverted Design) Step Voltage Regulator	16
8	Setup for Testing Unmounted Current Transformer	27
9	Setup for Testing Taps on Multiple Tap Current Transformer	28
10	Setup for Testing BCT When Mounted on Single- Phase Two-Winding Transformer	29
11	Setup for Testing BCT When Mounted on Delta Winding of a Three-Phase Power Transformer	31
12	Setup for Testing BCT When Mounted on Wye Winding of a Three-Phase Power Transformer	32
13	Sample Printout for Single-Phase Transformers	37
14	Sample Printout for Three-Phase Transformers	38

Section 1 Introduction

Receiving Instructions

Check the equipment received against the packing list to ensure that all materials are present. Notify Biddle Instruments of any shortage. Telephone (215) 646-9200.

Examine the instrument for damage received in transit. If any damage is discovered, file a claim with the carrier at once and notify Biddle Instruments or its nearest authorized sales representative, giving a detailed description of the damage.

This instrument has been thoroughly tested and inspected to meet rigid specifications before being shipped. It is ready for use when set up as indicated in this manual.

General Information

The Three-Phase TTR[®] Test Set measures the turn ratio and excitation current of power, distribution, and instrument transformers. A -47 suffix added to the catalog number denotes a 240-V input power supply, rather than the standard 120-V supply. The test set is a portable instrument housed in a polycarbonate case with removable lid and carrying strap. A canvas carrying bag is supplied to hold the test leads, the instruction manual, and test records. Figure 1 shows the test set and accessories.

The test set can be used to test single-phase and three-phase transformers, both with and without taps. For three-phase measurements, the test set is connected to all three phases of the transformer to be tested. The internal switching arrangement then permits measurement of all phases without changing connections. This feature eliminates the need to refer to hook-up charts when testing three-phase transformers. Turn ratio and excitation current readings are displayed on digital meters on the control panel of the test set. Transformer excitation current helps to detect transformer shorted turns or an unequal number of turns connected in parallel. Error messages identify incorrect test connections or winding problems. Test results can be printed out on an optional printer installed in the lid.

Additional features include:

- Automatic balance control by high-performance microprocessor
- Turn ratio measuring range of 0.8 to 2700
- Automatic self-checking of test set calibration and operation
- Trouble-free operation in switchyards under electrostatic and magnetic interference conditions.



Figure 1: TTR[®] Test Set and Accessories

Section 2 Safety

The test set and the specimen to which it is connected are a possible source of high-voltage electrical energy and all persons making or assisting in tests must use all practical safety precautions to prevent contact with energized parts of the test equipment and related circuits. Persons actually engaged in the test must stand clear of all parts of the complete high-voltage circuit, including all connections, unless the test set is de-energized and all parts of the test circuit are grounded. Persons not directly involved with the work must be kept away from test activities by suitable barriers, barricades, or warnings.

Treat all terminals of high-voltage power equipment as a potential electric shock hazard. There is always the possibility of voltages being induced at these terminals because of proximity to energized high-voltage lines or equipment. Always disconnect test leads from power equipment before attempting to disconnect them at the test set. The ground connection must be the first made and the last removed.

This instrument operates from a single-phase power source. It has a three-wire power cord and requires a two-pole, three-terminal, live, neutral, and ground type connector. The voltage to ground from the live pole of the power source must not exceed the maximum rated operating voltage (120 V for Catalog No. 550100 and 250 V for Catalog No. 550100-47). The neutral pole must be at ground potential. Before making connection to the power source, determine that the instrument rating matches the voltage of the power source and has a suitable two-pole, three-terminal grounding type connector.

The power input plug must be inserted only into a mating receptacle with a ground contact. Do not bypass the grounding connection. Any interruption of the grounding connection can create an electric shock hazard. Determine that the receptacle is properly wired before inserting the plug.

- Safety is the responsibility of the user.
- Misuse of this high-voltage equipment can be extremely dangerous.
- The purpose of this equipment is limited to use as described in this manual. Do not use the equipment or its accessories with any device other than specifically described.
- Never connect the test set to energized equipment.
- Do not use the test set in an explosive atmosphere.
- Corrective maintenance must only be performed by qualified personnel who are familiar with the construction and operation of the test set and the hazards involved.

- Refer to IEEE 510 - 1983, "IEEE Recommended Practices for Safety in High-Voltage and High-Power Testing," for additional information.

If the test equipment is operated properly and all grounds correctly made, test personnel need not wear rubber gloves. As a routine safety procedure, however, some users require that rubber gloves be worn, not only when making connections to the high-voltage terminals, but also when manipulating the controls. Biddle Instruments considers this an excellent safety practice.

Users of equipment should note that high-voltage discharges and other sources of strong electric or magnetic field may interfere with the proper functioning of heart pacemakers. Persons with heart pacemakers should obtain expert advice on the possible risks before operating this equipment or being close to the equipment during operation.

The following specific warning and caution notices are used throughout this manual where applicable.

WARNING

Warning, as used in this manual, is defined as a condition or practice which could result in personal injury or loss of life.

CAUTION

Caution, as used in this manual, is defined as a condition or practice which could result in damage to or destruction of the equipment or apparatus under test.

Section 3 Specifications

Electrical

Input Power: 120 V, 50/60 Hz, 5A (Cat No. 550100)
240 V, 50/60 Hz, 2.5 A (Cat No. 550100-47)

Test Voltage: 120 V standard test for transformers
40 V for current transformers

Test Frequency: 50/60 Hz

Loading of Test Transformer: less than 0.2 VA

Ratio Measuring Ranges: five ranges with automatic changeover of measuring and indicating ranges.

0.8000 to 1.9999
1.9999 to 19.999
19.999 to 199.99
199.99 to 1999.9
1999.9 to 2700.0

Ratio Accuracy: 120 V: $\pm 0.1\%$ of reading (up to ratios of 1000)
40 V: $\pm 0.1\%$ of reading (up to ratios of 700)
 $\pm 0.3\%$ of reading (ratios above 700 up to 1000)

Note: NIST unable to furnish traceability on ratios above 1000.

Exciting Current Ranges: two ranges with automatic changeover of measuring and indicating ranges.

0 to 199 mA
199 to 1999 mA

Current Accuracy: $\pm(2\%$ of reading + 1 digit)

Test Modes: five-position TRANSFORMER TYPE switch and three-position PHASE switch select winding configuration and phase for both single and three-phase transformers; no need to change terminal connections; associated toggle switch selects standard or reverse winding configuration.

Metering: RATIO meter: 5 digit LCD display
MILLIAMPERES meter: 3-1/2 digit LCD display

Measuring Time: 5 to 8 s

Environmental

Operating Temperature Range: -4 to 122°F (-20 to 50°C)

Storage Temperature Range: -58 to 140°F (-50 to 60°C)

Relative Humidity: 0 to 90% noncondensing (operating)
0 to 95% noncondensing (storage)

CAUTION

Storage for extended periods of time at high temperature and relative humidity may cause degradation of the digital displays.

Physical Data

Dimensions: 20 L x 12 W x 12-1/2 in. H (51 x 30.5 x 32 cm)

Weight: 30 lb (16.5 kg)

Case: bronze colored, impact resistant, polycarbonate plastic with removable cover and adjustable webbed shoulder strap.

Accessories Included

Canvas carrying bag for test leads: 12 W x 17 H x 6 in. D (30.5 x 43 x 15 cm) with handles and adjustable shoulder strap; has pocket for instruction manual and test reports; weighs 22 lb (10 kg) including test leads.

Power supply cord, 8 ft (2.5 m)

Ground lead, 15 ft (4.6 m)

H winding test lead, 10 ft (3.1 m), single-phase connection, shielded, heavy-duty clips.

H winding test lead, 30 ft (9.2 m), three-phase connection, shielded, heavy-duty clips.

X winding test lead, 10 ft (3.1 m), single-phase connection, shielded, heavy-duty clips.

X winding test lead, 30 ft (9.2 m), three-phase connection, shielded, heavy-duty clips.

Shorting plug for external interlock receptacle.

Optional Accessories

Battery-powered printer mounts in lid of test set. The printer is programmed to print out data from both single and three-phase transformer tests. Data include instrument serial number, date, ratings, transformer under test, environmental conditions, ratios, and exciting current values.

Extra length test leads for use on EHV power transformers:

H winding test lead, 60 ft (18.3 m) three-phase
X winding test lead, 60 ft (18.3 m) three-phase
H winding test lead, 60 ft (18.3 m) single-phase
X winding test lead, 60 ft (18.3 m) single-phase

Set of extension leads (2) H and X test leads, 16.5 ft (5 m)

Separate protective interlocks with pistol grips, foot switches, or multiple permissive hardware.

Reusable, heavy duty, padded shipping and storage cases.

Three-phase TTR Calibration Standard.

Inverter, 12 V dc to 120 V ac at 0.5 A.

Section 4 Controls, Indicators, and Connectors

See Figure 2 for identification and location of test set controls, indicators, and connectors. Their function is described in the following. Figure 3 shows a simplified block diagram of the test set.

POWER - one-pole magnetic circuit breaker functions as on/off switch, controlling all power to the test set. It provides short circuit and overload protection.

TEST VOLTAGE - toggle switch selects excitation voltage for test specimen, 40 V or 120 V.

TRANSFORMER TYPE - five-position rotary switch selects winding configuration for single or three-phase transformers; may be set to 1ϕ , Δ - Δ , Δ -Y, Y-Y, or Y- Δ .

STANDARD/REVERSE - toggle switch selects standard or reverse winding configuration.

PHASE - three-position rotary switch selects individual phases for single or three-phase transformers; may be set to 1ϕ A, B, or C.

START TEST - push-button switch controls an internal relay which turns on excitation voltage, lights red TESTING indicator lamp, and starts measurement sequence.

OFF/CLEAR/PRINT - push-button switch de-energizes an internal relay which turns off excitation voltage; turns off red TESTING indicator lamp; stops measurement sequence; clears display reading; sends last measurement readings to printer; used for printing out a single-phase or three-phase report heading.

POWER - white lamp indicates when lit that the circuit breaker is on and the test set is energized.

TESTING - red lamp indicates when lit that excitation voltage is being applied to test specimen.

RATIO - five-digit LCD meter displays transformer turn ratio; also displays error messages for abnormal operating conditions.

MILLIAMPERES - three and one-half digit LCD meter displays transformer excitation current.

INTERLOCK - plug receptacle allows connection of a normally open external interlock switch.

PRINTER - plug receptacle allows connection of a printer.

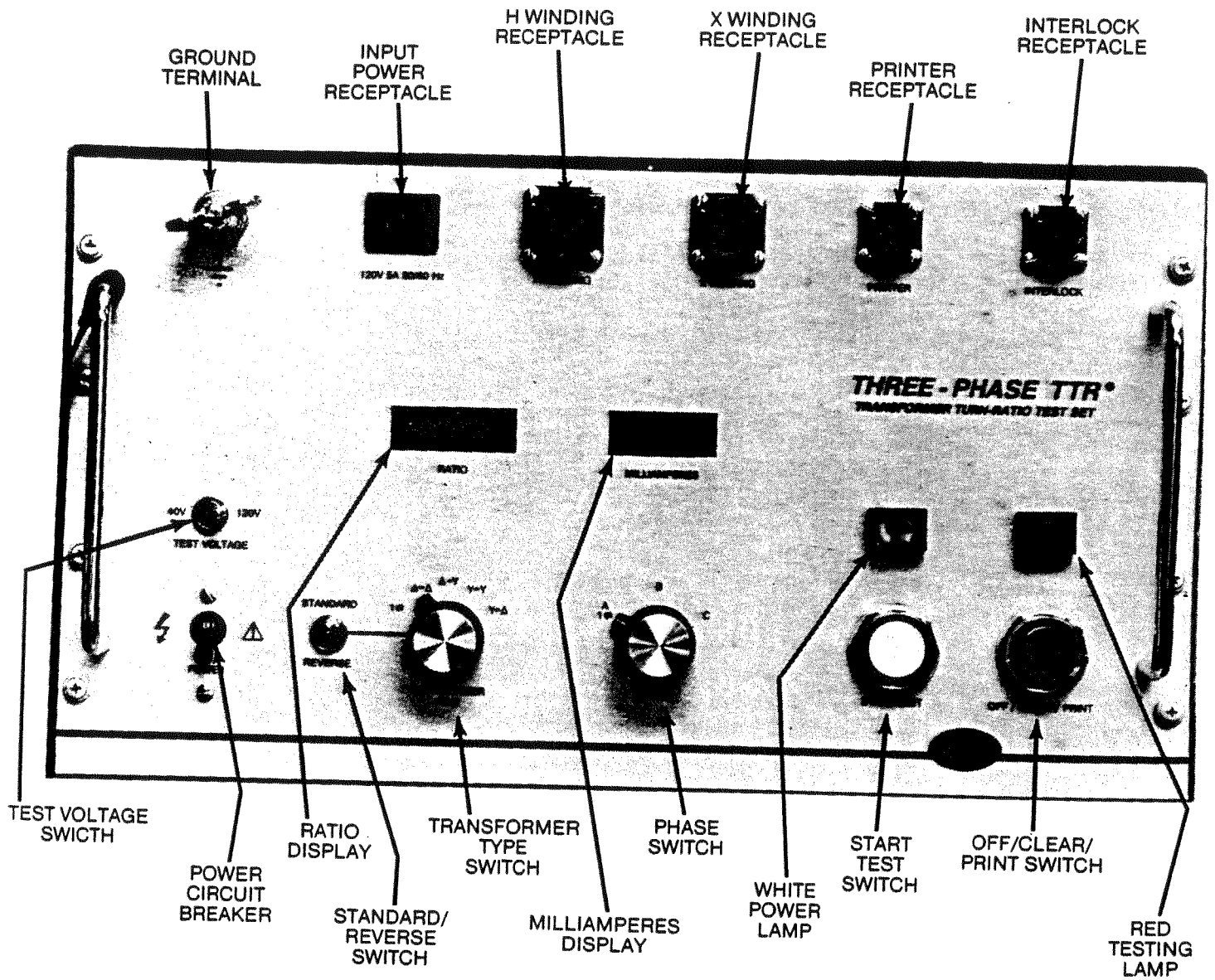

Figure 2: Control Panel

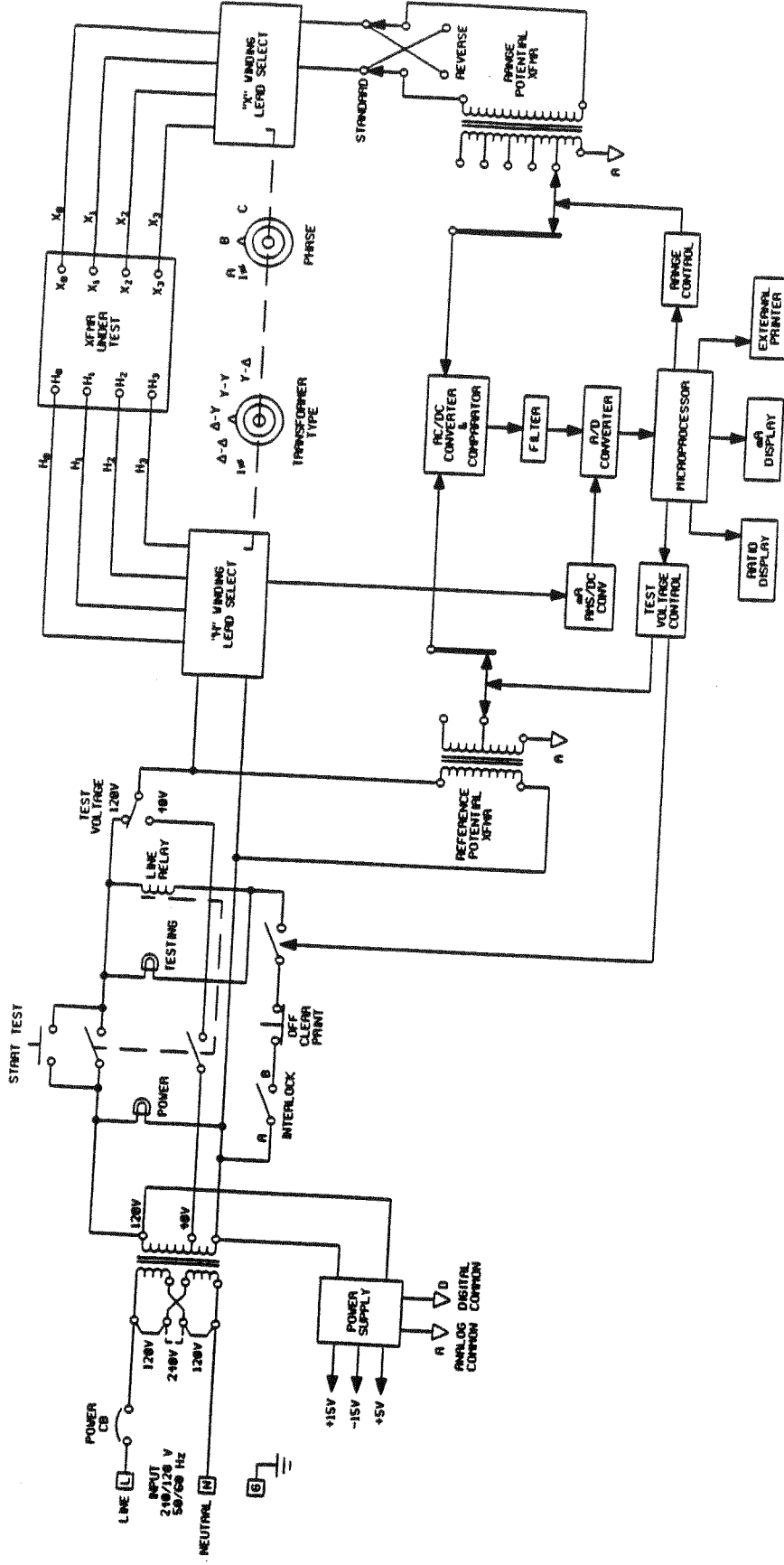

Figure 3: TTR^R Test Set Simplified Block Diagram

X WINDING - plug receptacle for connecting test leads to the low-voltage (X) winding of a transformer.

H WINDING - plug receptacle for connecting test leads to the high-voltage (H) winding of a transformer.

120V 5A 50/60 Hz or 240 V 2.5 A 50/60 Hz - input power receptacle allows connection of test set to ac power source.

Ground - this wing-nut terminal allows connection of test set to earth ground.

Section 5 Setup and Operation

Setup

When testing high-voltage transformers, caution must be used at all times and all safety precautions followed. Refer to Section 2, Safety.

WARNING

Ensure that the transformer to be tested is completely de-energized. Check every winding. Ensure that all terminals of the transformer are disconnected from line or load at the transformer. Connections to ground may be left in place.

The following connection and operation instructions pertaining to ratio, polarity, and phase relation assume that the transformer under test, connections, and terminal markings comply with the requirements of ANSI C57.12.70-1978 "American National Standards Terminal Markings and Connections for Distribution and Power Transformers." The H test leads of the test set are the exciting (high voltage) leads (40 V or 120 V).

Test sets with 220/240 V input power are energized via an internal transformer which is used for voltage reduction. Depending on whether the test set is supplied with a black, white, and green input supply cord or a brown, blue, and green/yellow supply cord, the black or brown cord lead must be connected to the live pole of the line power source and the white or blue cord lead must be connected to the neutral pole of the line power source. The green or green/yellow ground lead of the input supply cord must be connected to the protective ground (earth) contact of the input plug. These test sets, Catalog Number 550100-47, must not be energized from a power source where both poles are live.

Single-Phase Transformers

WARNING

Never interchange connections between the high and low voltage transformer terminals. Failure to observe proper connections will result in a safety hazard and may result in damage to the test set or transformer.

1. Connect the wing-nut ground terminal of the test set to a low-impedance earth ground using the 15-ft ground lead supplied.
2. Using two conductor H and X test leads, connect to the respective H and X WINDING receptacles of the test set. Make sure that the connectors (bayonet coupling) lock to the receptacle.
3. Connect the heavy-duty clips marked H1 and H2 of the test lead to the corresponding

(high-voltage winding) terminals of the transformer under test.

4. Connect the heavy-duty clips marked X1 and X2 of the test lead to the corresponding (low voltage winding) terminals of the transformer under test. Figures 4 and 5 show test setups for single-phase transformers. Figures 6 and 7 show test setups for regulators.

To test windings other than H1 - H2 and X1 - X2, ensure that the heavy-duty clip marked H1 is connected to the lower numbered terminal and H2 to the higher numbered terminal of the high-voltage winding. Similarly, X1 and X2 should be connected to the low-voltage winding. Test lead markings are as follows:

Test Lead Marking	Transformer Terminal Voltage	Heavy-Duty Clip Boot Color	Test Lead Color Band
H1	High	Red	Red
H2	High	Red	Yellow
X1	Low	Black	Red
X2	Low	Black	Yellow

Three-Phase Transformers

Setup Procedure

1. Connect the wing-nut ground terminal of the test set to a low-impedance earth ground using the 15-ft ground lead supplied.
2. Using four conductor H and X test leads, connect to the respective H and X WINDING receptacles of the test set. Make sure that the connectors (bayonet coupling) lock to the receptacles.
3. Connect the heavy-duty clips marked H0, H1, H2, and H3 of the test lead to the corresponding (high-voltage winding) terminals of the transformer under test.
4. Connect the heavy-duty clips marked X0, X1, X2, and X3 of the test lead to the corresponding (low-voltage winding) terminals of the transformer under test.

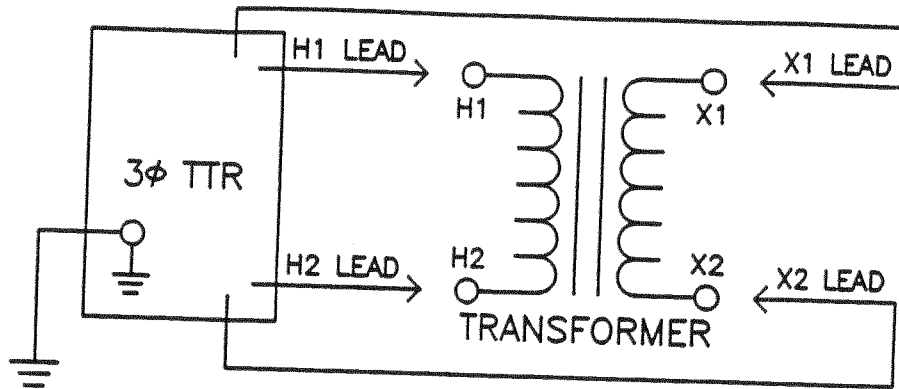

Figure 4: Setup for Testing Single-Phase Transformer

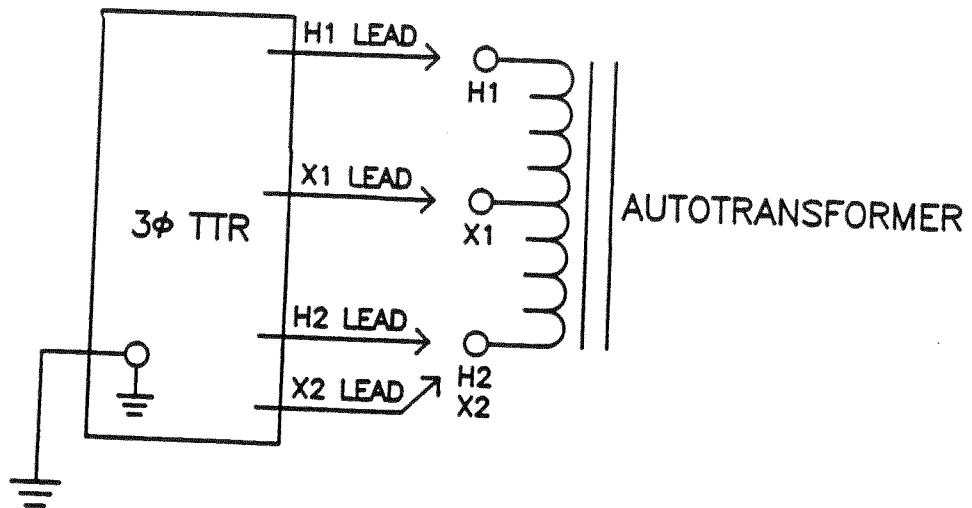

Figure 5: Setup for Testing Single-Phase Autotransformer

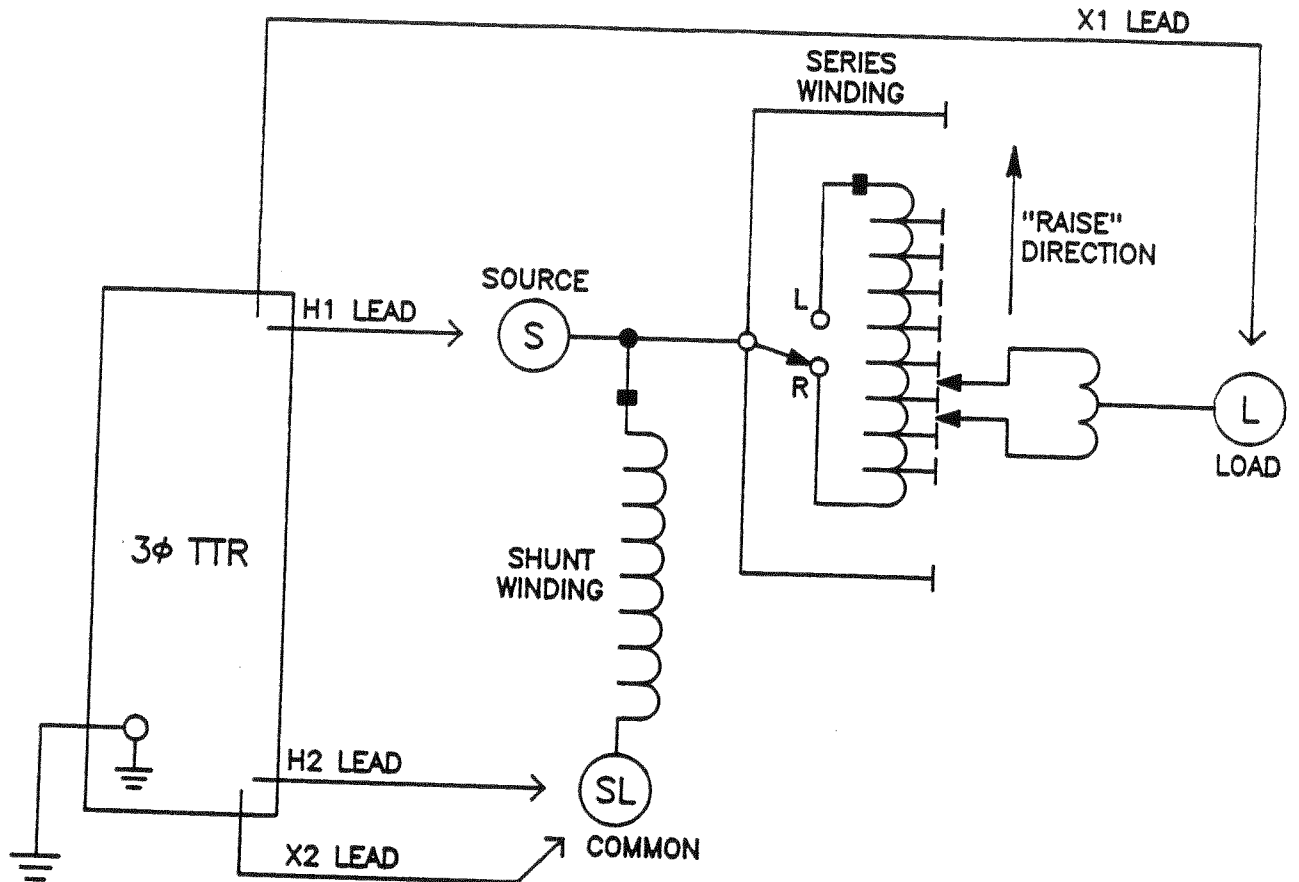

Figure 6: Setup for Testing Single-Phase, Type A (Straight Design) Step Voltage Regulator

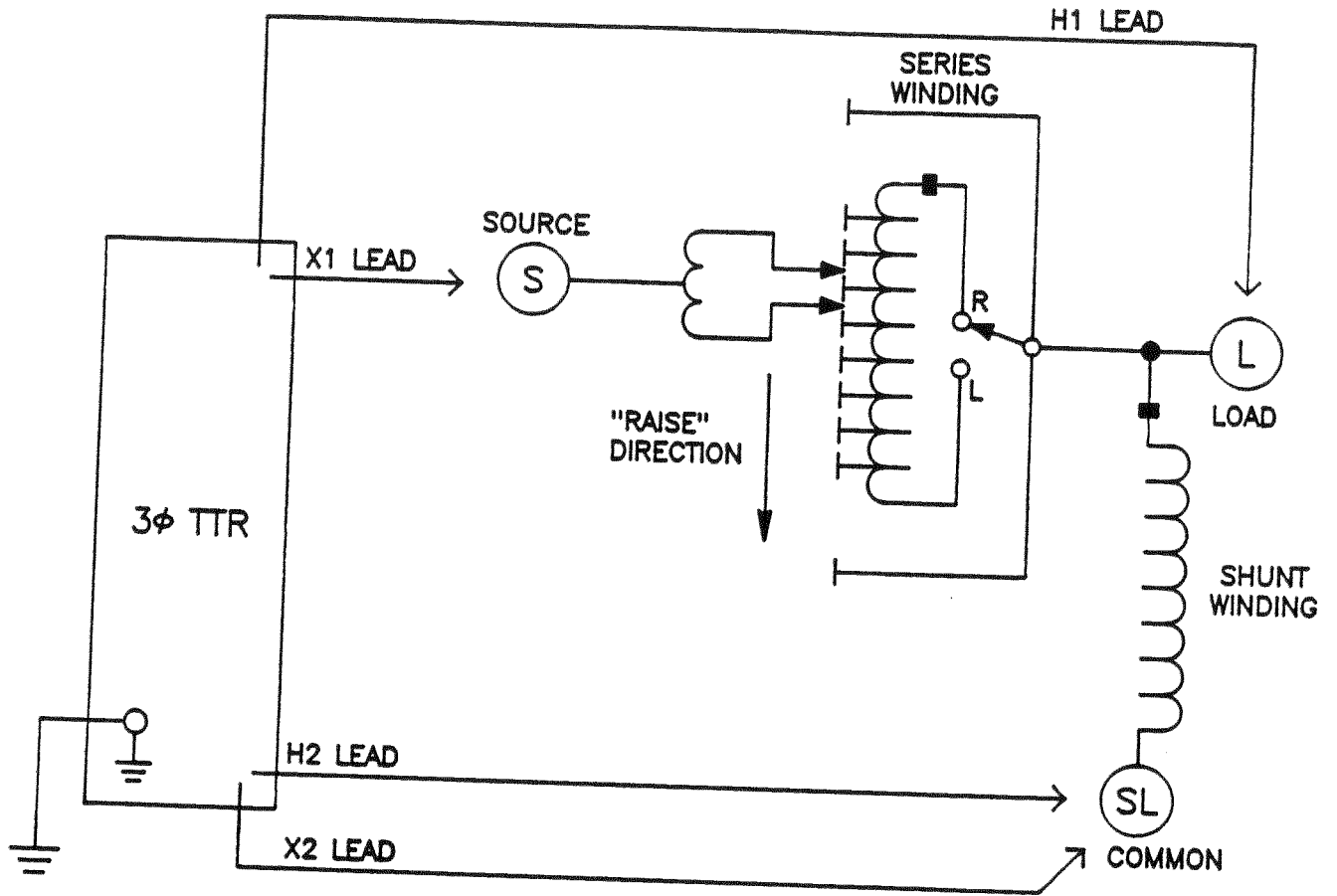

Figure 7: Setup for Testing Single-Phase, Type B (Inverted Design) Step Voltage Regulator

WARNING

Never interchange connections between the high and low voltage transformer terminals. Failure to observe proper connections will result in a safety hazard and may result in damage to the test set or transformer.

The unused H0 and X0 terminals should be kept clear of ground and personnel because it could become energized if the switches are inadvertently set in the wrong positions.

With delta connected windings, H0 or X0 is not used. With wye connected windings, a neutral connection is normally available.

Test lead markings are as follows:

Test Lead Marking	Transformer Terminal Voltage	Heavy-Duty Clip Boot Color	Test Lead Color Band
H0	Neutral		
H1	High	Red	White
H2	High	Red	Red
H3	High	Red	Yellow
		Red	Blue
X0	Neutral		
X1	Low	Black	White
X2	Low	Black	Red
X3	Low	Black	Yellow
		Black	Blue

Connections and Vector Voltage Diagrams

When testing three-phase transformers, it is necessary to understand the phase relationships, vector diagrams, and winding connection diagrams for these transformers. A detailed description of phase relationships, vector diagrams, and terminal markings is contained in specification ANSI C57.12.70 -1978, American National Standard Terminal Markings and Connections for Distribution and Power Transformers.

Table 1 shows connection diagrams for standard transformers and Table 2 for most nonstandard transformers. Match the vector diagram from the transformer nameplate to the corresponding diagram in the table, then follow the table setup instructions. The tables show the connection and winding phase relationships for each setting of the TRANSFORMER TYPE and PHASE selector switches. Tables 1 and 2 also show the relationship between the measured turn ratio and the actual line-to-line voltage ratio. The rated voltage on the high-voltage winding is represented by V_H ; V_X represents rated voltage on the low-voltage winding.

The test set is also capable of measuring the turn ratio on three-phase transformers with an inaccessible neutral point. In this case, additional jumper leads and a nonstandard test procedure must be used. Table 2 shows diagrams and setup instructions for testing this type of transformer.

Diagram 5 on Table 1 illustrates the relationship in a typical delta-wye connected transformer with accessible neutral connection point. The delta winding is the high-voltage winding and the terminals are marked H_1 , H_2 , and H_3 . The wye winding is the low-voltage winding and the terminals are marked X_0 , X_1 , X_2 , and X_3 . Now determine which windings (lines) are parallel to each other. In the diagram, winding $H_1 - H_3$ is parallel to $X_1 - X_0$, $H_2 - H_1$ is parallel to $X_2 - X_0$, and $H_3 - H_2$ is parallel to $X_3 - X_0$. All ratio measurements are made between parallel windings. The phase polarity must also be observed and is designated by the order of terminal mention, i.e., $H_1 - H_3$ is of the same phase polarity as $X_1 - X_0$. The TRANSFORMER TYPE switch should be set to STANDARD in this case.

It should be noted that the test set is also capable of measuring the turn ratio of three-phase transformers where the windings are rotated or are connected in various phase displacements from standard. Vector diagram 2 in Table 2 is an example of a typical case where the phase has been displaced 120° from that of diagram 5 in Table 1.

TABLE 1 STANDARD TRANSFORMER WINDING PHASE RELATIONSHIP

DIAG No.	TRANSFORMER TYPE		JUMPER	TTR SWITCH POSN		WINDING TESTED		MEASURED TURN RATIO	IEC VECTOR GROUP	REMARKS
	HIGH-VOLTAGE WINDING (H)	LOW-VOLTAGE WINDING (X)		XFMR TYPE	PHASE	HIGH VOLTAGE WINDING	LOW VOLTAGE WINDING			
1			—	1∅ STD	1∅	H ₁ -H ₂	X ₁ -X ₂	$\frac{V_H}{V_X}$	I10	SINGLE-PHASE TRANSFORMER
2			—	1∅ REV	1∅	H ₁ -H ₂	X ₁ -X ₂	$\frac{V_H}{V_X}$	I16	SINGLE-PHASE TRANSFORMER
3			—	Δ-Δ STD	A B C	H ₁ -H ₃ (A) H ₂ -H ₁ (B) H ₃ -H ₂ (C)	X ₁ -X ₃ (a) X ₂ -X ₁ (b) X ₃ -X ₂ (c)	$\frac{V_H}{V_X}$	Dd0	
4			—	Δ-Δ REV	A B C	H ₁ -H ₃ (A) H ₂ -H ₁ (B) H ₃ -H ₂ (C)	X ₁ -X ₃ (a) X ₂ -X ₁ (b) X ₃ -X ₂ (c)	$\frac{V_H}{V_X}$	Dd6	
5			—	Δ-Y STD	A B C	H ₁ -H ₃ (A) H ₂ -H ₁ (B) H ₃ -H ₂ (C)	X ₁ -X ₀ (a) X ₂ -X ₀ (b) X ₃ -X ₀ (c)	$\frac{V_H \cdot \sqrt{3}}{V_X}$	Dy1	
6			—	Δ-Y REV	A B C	H ₁ -H ₃ (A) H ₂ -H ₁ (B) H ₃ -H ₂ (C)	X ₁ -X ₀ (a) X ₂ -X ₀ (b) X ₃ -X ₀ (c)	$\frac{V_H \cdot \sqrt{3}}{V_X}$	Dy7	
7			—	Y-Y STD	A B C	H ₁ -H ₀ (A) H ₂ -H ₀ (B) H ₃ -H ₀ (C)	X ₁ -X ₀ (a) X ₂ -X ₀ (b) X ₃ -X ₀ (c)	$\frac{V_H}{V_X}$	Yy0	
8			—	Y-Y REV	A B C	H ₁ -H ₀ (A) H ₂ -H ₀ (B) H ₃ -H ₀ (C)	X ₁ -X ₀ (a) X ₂ -X ₀ (b) X ₃ -X ₀ (c)	$\frac{V_H}{V_X}$	Yy6	
9			—	Y-Δ STD	A B C	H ₁ -H ₀ (A) H ₂ -H ₀ (B) H ₃ -H ₀ (C)	X ₁ -X ₂ (a) X ₂ -X ₃ (b) X ₃ -X ₁ (c)	$\frac{V_H}{V_X \cdot \sqrt{3}}$	Yd1	
10			—	Y-Δ REV	A B C	H ₁ -H ₀ (A) H ₂ -H ₀ (B) H ₃ -H ₀ (C)	X ₁ -X ₂ (a) X ₂ -X ₃ (b) X ₃ -X ₁ (c)	$\frac{V_H}{V_X \cdot \sqrt{3}}$	Yd7	

TABLE 2 NONSTANDARD TRANSFORMER WINDING PHASE RELATIONSHIP

DIAG No.	TRANSFORMER TYPE		JUMPER	TTR SWITCH POSN		WINDING TESTED		MEASURED TURN RATIO	IEC VECTOR GROUP	REMARKS
	HIGH-VOLTAGE WINDING (H)	LOW-VOLTAGE WINDING (X)		XFMR TYPE	PHASE	HIGH VOLTAGE WINDING	LOW VOLTAGE WINDING			
* 1			H ₃ -H ₂ H ₁ -H ₃ H ₂ -H ₁	Δ-Δ STD	A B C	H ₁ -H ₃ (A) H ₂ -H ₁ (B) H ₃ -H ₂ (C)	X ₁ -mV (a) X ₂ -mV (b) X ₃ -mV (c)	$\frac{V_H \cdot \sqrt{3}}{V_X}$	Dy1	NO ACCESSIBLE NEUTRAL ON WYE WINDING
1a			H ₂ -H ₁ H ₃ -H ₂ H ₁ -H ₃	Δ-Δ STD	A B C	H ₁ -H ₃ (A+C) H ₂ -H ₁ (B+A) H ₃ -H ₂ (C+B)	X ₁ -X ₃ (a+c) X ₂ -X ₁ (b+a) X ₃ -X ₂ (c+b)	$\frac{V_H \cdot \sqrt{3}}{V_X \cdot 2}$	Dy1	NO ACCESSIBLE NEUTRAL ON WYE WINDING
1b			X ₃ -X ₂ X ₁ -X ₃ X ₂ -X ₁	Δ-Δ STD	A B C	H ₁ -H ₃ (A+B+C) H ₂ -H ₁ (B+A+C) H ₃ -H ₂ (C+A+B)	X ₁ -X ₃ (a+b+c) X ₂ -X ₁ (b+a+c) X ₃ -X ₂ (c+a+b)	$\frac{V_H \cdot 2}{V_X \cdot \sqrt{3}}$	Dy1	NO ACCESSIBLE NEUTRAL ON WYE WINDING
2			—	Δ-Y STD	A B C	H ₁ -H ₃ (A) H ₂ -H ₁ (B) H ₃ -H ₂ (C)	X ₃ -X ₀ (a) X ₁ -X ₀ (b) X ₂ -X ₀ (c)	$\frac{V_H \cdot \sqrt{3}}{V_X}$	Dy5	ROTATE TEST LEADS
* 3			H ₃ -H ₂ H ₁ -H ₃ H ₂ -H ₁	Δ-Δ STD	A B C	H ₁ -H ₃ (A) H ₂ -H ₁ (B) H ₃ -H ₂ (C)	X ₃ -mV (a) X ₁ -mV (b) X ₂ -mV (c)	$\frac{V_H \cdot \sqrt{3}}{V_X}$	Dy5	NO ACCESSIBLE NEUTRAL ON WYE WINDING ROTATE TEST LEADS
3a			H ₂ -H ₁ H ₃ -H ₂ H ₁ -H ₃	Δ-Δ STD	A B C	H ₁ -H ₃ (A+C) H ₂ -H ₁ (B+A) H ₃ -H ₂ (C+B)	X ₃ -X ₂ (a+c) X ₁ -X ₃ (b+a) X ₂ -X ₁ (c+b)	$\frac{V_H \cdot \sqrt{3}}{V_X \cdot 2}$	Dy5	NO ACCESSIBLE NEUTRAL ON WYE WINDING ROTATE TEST LEADS
3b			X ₂ -X ₁ X ₃ -X ₂ X ₁ -X ₃	Δ-Δ STD	A B C	H ₁ -H ₃ (A+B+C) H ₂ -H ₁ (B+A+C) H ₃ -H ₂ (C+A+B)	X ₃ -X ₂ (a+b+c) X ₁ -X ₃ (b+a+c) X ₂ -X ₁ (c+a+b)	$\frac{V_H \cdot 2}{V_X \cdot \sqrt{3}}$	Dy5	NO ACCESSIBLE NEUTRAL ON WYE WINDING ROTATE TEST LEADS
* 4			H ₃ -H ₂ H ₁ -H ₃ H ₂ -H ₁	Δ-Δ REV	A B C	H ₁ -H ₃ (A) H ₂ -H ₁ (B) H ₃ -H ₂ (C)	X ₁ -mV (a) X ₂ -mV (b) X ₃ -mV (c)	$\frac{V_H \cdot \sqrt{3}}{V_X}$	Dy7	NO ACCESSIBLE NEUTRAL ON WYE WINDING
4a			H ₂ -H ₁ H ₃ -H ₂ H ₁ -H ₃	Δ-Δ REV	A B C	H ₁ -H ₃ (A+C) H ₂ -H ₁ (B+A) H ₃ -H ₂ (C+B)	X ₁ -X ₃ (a+c) X ₂ -X ₁ (b+a) X ₃ -X ₂ (c+b)	$\frac{V_H \cdot \sqrt{3}}{V_X \cdot 2}$	Dy7	NO ACCESSIBLE NEUTRAL ON WYE WINDING
4b			X ₃ -X ₂ X ₁ -X ₃ X ₂ -X ₁	Δ-Δ REV	A B C	H ₁ -H ₃ (A+B+C) H ₂ -H ₁ (B+A+C) H ₃ -H ₂ (C+A+B)	X ₁ -X ₃ (a+b+c) X ₂ -X ₁ (b+a+c) X ₃ -X ₂ (c+a+b)	$\frac{V_H \cdot 2}{V_X \cdot \sqrt{3}}$	Dy7	NO ACCESSIBLE NEUTRAL ON WYE WINDING

TABLE 2 NONSTANDARD TRANSFORMER WINDING PHASE RELATIONSHIP

DIAG No.	TRANSFORMER TYPE		JUMPER	TTR SWITCH POSN		WINDING TESTED		MEASURED TURN RATIO	IEC VECTOR GROUP	REMARKS	
	HIGH-VOLTAGE WINDING (H)	LOW-VOLTAGE WINDING (X)		XFMR TYPE	PHASE	HIGH VOLTAGE WINDING	LOW VOLTAGE WINDING				
5			—	Δ-Y	REV	A B C	H ₁ -H ₃ (A) H ₂ -H ₁ (B) H ₃ -H ₂ (C)	X ₃ -X ₀ (a) X ₁ -X ₀ (b) X ₂ -X ₀ (c)	$\frac{V_H \cdot \sqrt{3}}{V_X}$	Dy11	ROTATE TEST LEADS
* 6			H ₃ -H ₂ H ₁ -H ₃ H ₂ -H ₁	Δ-Δ	REV	A B C	H ₁ -H ₃ (A) H ₂ -H ₁ (B) H ₃ -H ₂ (C)	X ₃ -mV (a) X ₁ -mV (b) X ₂ -mV (c)	$\frac{V_H \cdot \sqrt{3}}{V_X}$	Dy11	NO ACCESSIBLE NEUTRAL ON WYE WINDING ROTATE TEST LEADS
6a			H ₂ -H ₁ H ₃ -H ₂ H ₁ -H ₃	Δ-Δ	REV	A B C	H ₁ -H ₃ (A+C) H ₂ -H ₁ (B+A) H ₃ -H ₂ (C+B)	X ₃ -X ₂ (a+c) X ₁ -X ₃ (b+a) X ₂ -X ₁ (c+b)	$\frac{V_H \cdot \sqrt{3}}{V_X \cdot 2}$	Dy11	NO ACCESSIBLE NEUTRAL ON WYE WINDING ROTATE TEST LEADS
6b			X ₂ -X ₁ X ₃ -X ₂ X ₁ -X ₃	Δ-Δ	REV	A B C	H ₁ -H ₃ (A+B+C) H ₂ -H ₁ (B+A+C) H ₃ -H ₂ (C+A+B)	X ₃ -X ₂ (a+b+c) X ₁ -X ₃ (b+a+c) X ₂ -X ₁ (c+a+b)	$\frac{V_H \cdot 2}{V_X \cdot \sqrt{3}}$	Dy11	NO ACCESSIBLE NEUTRAL ROTATE TEST LEADS
7			—	Δ-Δ	STD	A B C	H ₁ -H ₃ (A+B+C) H ₂ -H ₁ (B+A+C) H ₃ -H ₂ (C+A+B)	X ₁ -X ₃ (a+c) X ₂ -X ₁ (b+a) X ₃ -X ₂ (c+b)	$\frac{V_H}{V_X}$	Dz0	NO ACCESSIBLE NEUTRAL
8			—	Δ-Δ	REV	A B C	H ₁ -H ₃ (A+B+C) H ₂ -H ₁ (B+A+C) H ₃ -H ₂ (C+A+B)	X ₁ -X ₃ (a+c) X ₂ -X ₁ (b+a) X ₃ -X ₂ (c+b)	$\frac{V_H}{V_X}$	Dz6	NO ACCESSIBLE NEUTRAL
9			H ₂ -H ₀ H ₃ -H ₀ H ₁ -H ₀	Y-Δ	STD	A B C	H ₁ -H ₀ (A) H ₂ -H ₀ (B) H ₃ -H ₀ (C)	X ₁ -mV (a) X ₂ -mV (b) X ₃ -mV (c)	$\frac{V_H}{V_X}$	Yy0	NO ACCESSIBLE NEUTRAL ON LOW VOLTAGE WINDING
10			X ₃ -X ₀ X ₁ -X ₀ X ₂ -X ₀	Δ-Y	STD	A B C	H ₁ -N (A) H ₂ -N (B) H ₃ -N (C)	X ₁ -X ₀ (a) X ₂ -X ₀ (b) X ₃ -X ₀ (c)	$\frac{V_H}{V_X}$	Yy0	NO ACCESSIBLE NEUTRAL ON HIGH VOLTAGE WINDING
11			—	Δ-Δ	STD	A B C	H ₁ -H ₃ (A+C) H ₂ -H ₁ (B+A) H ₃ -H ₂ (C+B)	X ₁ -X ₃ (a+c) X ₂ -X ₁ (b+a) X ₃ -X ₂ (c+b)	$\frac{V_H}{V_X}$	Yy0	NO ACCESSIBLE NEUTRAL
12			H ₂ -H ₀ H ₃ -H ₀ H ₁ -H ₀	Y-Δ	REV	A B C	H ₁ -H ₀ (A) H ₂ -H ₀ (B) H ₃ -H ₀ (C)	X ₁ -mV (a) X ₂ -mV (b) X ₃ -mV (c)	$\frac{V_H}{V_X}$	Yy6	NO ACCESSIBLE NEUTRAL ON LOW VOLTAGE WINDING

TABLE 2 NONSTANDARD TRANSFORMER WINDING PHASE RELATIONSHIP

DIAG No.	TRANSFORMER TYPE		JUMPER	TTR SWITCH POSN		WINDING TESTED		MEASURED TURN RATIO	IEC VECTOR GROUP	REMARKS
	HIGH-VOLTAGE WINDING (H)	LOW-VOLTAGE WINDING (X)		XFMR TYPE	PHASE	HIGH VOLTAGE WINDING	LOW VOLTAGE WINDING			
13			X ₀ -X ₀ X ₁ -X ₀ X ₂ -X ₀	Δ-Y REV	A B C	H ₁ -N (A) H ₂ -N (B) H ₃ -N (C)	X ₁ -X ₀ (a) X ₂ -X ₀ (b) X ₃ -X ₀ (c)	$\frac{V_H}{V_X}$	Yy6	NO ACCESSIBLE NEUTRAL ON HIGH VOLTAGE WINDING
14			—	Δ-Δ REV	A B C	H ₁ -H ₃ (A+C) H ₂ -H ₁ (B+A) H ₃ -H ₂ (C+B)	X ₁ -X ₃ (a+c) X ₂ -X ₁ (b+a) X ₃ -X ₂ (c+b)	$\frac{V_H}{V_X}$	Yy6	NO ACCESSIBLE NEUTRAL
15			—	Δ-Y STD	A B C	H ₁ -H ₃ (A+C) H ₂ -H ₁ (B+A) H ₃ -H ₂ (C+B)	X ₁ -X ₀ (a) X ₂ -X ₀ (b) X ₃ -X ₀ (c)	$\frac{V_H \cdot \sqrt{3}}{V_X}$	Yz1	NO ACCESSIBLE NEUTRAL ON WYE WINDING
* 16			H ₂ -H ₁ H ₃ -H ₂ H ₁ -H ₃	Δ-Δ STD	A B C	H ₁ -H ₃ (C+A+B) H ₂ -H ₁ (A+B+C) H ₃ -H ₂ (B+A+C)	X ₁ -X ₃ (a+c) X ₂ -X ₁ (b+a) X ₃ -X ₂ (c+b)	$\frac{V_H \cdot \sqrt{3}}{V_X \cdot 2}$	Yz1	NO ACCESSIBLE NEUTRAL
16a			X ₃ -X ₂ X ₁ -X ₃ X ₂ -X ₁	Δ-Δ STD	A B C	H ₁ -H ₃ (A+C) H ₂ -H ₁ (B+A) H ₃ -H ₂ (C+B)	X ₁ -X ₃ (a+b+c) X ₂ -X ₁ (b+a+c) X ₃ -X ₂ (c+a+b)	$\frac{V_H \cdot 2}{V_X \cdot \sqrt{3}}$	Yz1	NO ACCESSIBLE NEUTRAL
17			—	Δ-Y STD	A B C	H ₁ -H ₃ (A+C) H ₂ -H ₁ (B+A) H ₃ -H ₂ (C+B)	X ₃ -X ₀ (a) X ₁ -X ₀ (b) X ₂ -X ₀ (c)	$\frac{V_H \cdot \sqrt{3}}{V_X}$	Yz5	NO ACCESSIBLE NEUTRAL ON WYE WINDING ROTATE TEST LEADS
* 18			H ₂ -H ₁ H ₃ -H ₂ H ₁ -H ₃	Δ-Δ STD	A B C	H ₁ -H ₃ (C+A+B) H ₂ -H ₁ (A+B+C) H ₃ -H ₂ (B+A+C)	X ₃ -X ₂ (a+c) X ₁ -X ₃ (b+a) X ₂ -X ₁ (c+b)	$\frac{V_H \cdot \sqrt{3}}{V_X \cdot 2}$	Yz5	NO ACCESSIBLE NEUTRAL ROTATE TEST LEADS
18a			X ₂ -X ₁ X ₃ -X ₂ X ₁ -X ₃	Δ-Δ STD	A B C	H ₁ -H ₃ (A+C) H ₂ -H ₁ (B+A) H ₃ -H ₂ (C+B)	X ₃ -X ₂ (a+b+c) X ₁ -X ₃ (b+a+c) X ₂ -X ₁ (c+a+b)	$\frac{V_H \cdot 2}{V_X \cdot \sqrt{3}}$	Yz5	NO ACCESSIBLE NEUTRAL ROTATE TEST LEADS
19			—	Δ-Y REV	A B C	H ₁ -H ₃ (A+C) H ₂ -H ₁ (B+A) H ₃ -H ₂ (C+B)	X ₁ -X ₀ (a) X ₂ -X ₀ (b) X ₃ -X ₀ (c)	$\frac{V_H \cdot \sqrt{3}}{V_X}$	Yz7	NO ACCESSIBLE NEUTRAL ON WYE WINDING
* 20			H ₂ -H ₁ H ₃ -H ₂ H ₁ -H ₃	Δ-Δ REV	A B C	H ₁ -H ₃ (C+A+B) H ₂ -H ₁ (A+B+C) H ₃ -H ₂ (B+A+C)	X ₁ -X ₃ (a+c) X ₂ -X ₁ (b+a) X ₃ -X ₂ (c+b)	$\frac{V_H \cdot \sqrt{3}}{V_X \cdot 2}$	Yz7	NO ACCESSIBLE NEUTRAL

TABLE 2 NONSTANDARD TRANSFORMER WINDING PHASE RELATIONSHIP

DIAG No.	TRANSFORMER TYPE		JUMPER	TTR SWITCH POSN		WINDING TESTED		MEASURED TURN RATIO	IEC VECTOR GROUP	REMARKS
	HIGH-VOLTAGE WINDING (H)	LOW-VOLTAGE WINDING (X)		XFMR TYPE	PHASE	HIGH VOLTAGE WINDING	LOW VOLTAGE WINDING			
20a			X3-X2 X1-X3 X2-X1	Δ-Δ REV	A	H1-H3 (A+C)	X1-X3 (a+b+c)	$\frac{V_H \cdot 2}{V_X \sqrt{3}}$	Yz7	NO ACCESSIBLE NEUTRAL
					B	H2-H1 (B+A)	X2-X1 (b+a+c)			
					C	H3-H2 (C+B)	X3-X2 (c+a+b)			
21			—	Δ-Y REV	A	H1-H3 (A+C)	X3-X0 (a)	$\frac{V_H \cdot \sqrt{3}}{V_X}$	Yz11	NO ACCESSIBLE NEUTRAL ON WYE WINDING ROTATE TEST LEADS
					B	H2-H1 (B+A)	X1-X0 (b)			
					C	H3-H2 (C+B)	X2-X0 (c)			
* 22			H2-H1 H3-H2 H1-H3	Δ-Δ REV	A	H1-H3 (C+A+B)	X3-X2 (a+c)	$\frac{V_H \cdot \sqrt{3}}{V_X \cdot 2}$	Yz11	NO ACCESSIBLE NEUTRAL ROTATE TEST LEADS
					B	H2-H1 (A+B+C)	X1-X3 (b+a)			
					C	H3-H2 (B+A+C)	X2-X1 (c+b)			
22a			X2-X1 X3-X2 X1-X3	Δ-Δ REV	A	H1-H3 (A+C)	X3-X2 (a+b+c)	$\frac{V_H \cdot 2}{V_X \sqrt{3}}$	Yz11	NO ACCESSIBLE NEUTRAL ROTATE TEST LEADS
					B	H2-H1 (B+A)	X1-X3 (b+a+c)			
					C	H3-H2 (C+B)	X2-X1 (c+a+b)			
23			—	Y-Δ REV	A	H1-H0 (A)	X3-X1 (a+c)	$\frac{V_H}{V_X \cdot \sqrt{3}}$	Zy11	NO ACCESSIBLE NEUTRAL ON WYE WINDING ROTATE TEST LEADS
					B	H2-H0 (B)	X1-X2 (b+a)			
					C	H3-H0 (C)	X2-X3 (c+b)			
* 24			H3-H2 H1-H3 H2-H1	Δ-Δ STD	A	H1-H3 (A+B+C)	X1-X3 (a+c)	$\frac{V_H \cdot \sqrt{3}}{V_X \cdot 2}$	Zy11	NO ACCESSIBLE NEUTRAL
					B	H2-H1 (B+A+C)	X2-X1 (b+a)			
					C	H3-H2 (C+A+B)	X3-X2 (c+b)			
24a			X2-X1 X3-X2 X1-X3	Δ-Δ STD	A	H1-H3 (A+C)	X1-X3 (A+B+C)	$\frac{V_H \cdot 2}{V_X \sqrt{3}}$	Zy11	NO ACCESSIBLE NEUTRAL
					B	H2-H1 (B+A)	X2-X1 (A+B+C)			
					C	H3-H2 (C+B)	X3-X2 (A+B+C)			
25			—	Y-Δ STD	A	H1-H0 (A)	X3-X1 (a+c)	$\frac{V_H}{V_X \cdot \sqrt{3}}$	Zy5	NO ACCESSIBLE NEUTRAL ON WYE WINDING ROTATE TEST LEADS
					B	H2-H0 (B)	X1-X2 (b+a)			
					C	H3-H0 (C)	X2-X3 (c+b)			
* 26			H3-H2 H1-H3 H2-H1	Δ-Δ REV	A	H1-H3 (A+B+C)	X1-X3 (a+c)	$\frac{V_H \cdot \sqrt{3}}{V_X \cdot 2}$	Zy5	NO ACCESSIBLE NEUTRAL
					B	H2-H1 (B+A+C)	X2-X1 (b+a)			
					C	H3-H2 (C+A+B)	X3-X2 (c+b)			
26a			X2-X1 X3-X2 X1-X3	Δ-Δ REV	A	H1-H3 (A+C)	X1-X3 (A+B+C)	$\frac{V_H \cdot 2}{V_X \sqrt{3}}$	Zy5	NO ACCESSIBLE NEUTRAL
					B	H2-H1 (B+A)	X2-X1 (A+B+C)			
					C	H3-H2 (C+B)	X3-X2 (A+B+C)			

TABLE 2 NONSTANDARD TRANSFORMER WINDING PHASE RELATIONSHIP

DIAG No.	TRANSFORMER TYPE		JUMPER	TTR SWITCH POSN		WINDING TESTED		MEASURED TURN RATIO	IEC VECTOR GROUP	REMARKS
	HIGH-VOLTAGE WINDING (H)	LOW-VOLTAGE WINDING (X)		XFMR TYPE	PHASE	HIGH VOLTAGE WINDING	LOW VOLTAGE WINDING			
* 27			H ₂ -H ₁ H ₃ -H ₂ H ₁ -H ₃	Δ-Δ STD	A B C	H ₁ -H ₃ (C+A+B) H ₂ -H ₁ (A+B+C) H ₃ -H ₂ (B+A+C)	X ₁ -X ₃ (c+a+b) X ₂ -X ₁ (a+b+c) X ₃ -X ₂ (b+a+c)	$\frac{V_H \cdot \sqrt{3}}{V_X \cdot 2}$	Yd1	NO ACCESSIBLE NEUTRAL ON WYE WINDING
27a			X ₃ -X ₂ X ₁ -X ₃ X ₂ -X ₁	Δ-Δ STD	A B C	H ₁ -H ₃ (A+C) H ₂ -H ₁ (B+A) H ₃ -H ₂ (C+B)	X ₁ -X ₃ (a+c) X ₂ -X ₁ (b+a) X ₃ -X ₂ (a+b)	$\frac{V_H \cdot 2}{V_X \cdot \sqrt{3}}$	Yd1	NO ACCESSIBLE NEUTRAL ON WYE WINDING
28			—	Y-Δ STD	A B C	H ₁ -H ₀ (A) H ₂ -H ₀ (B) H ₃ -H ₀ (C)	X ₃ -X ₁ (a) X ₁ -X ₂ (b) X ₂ -X ₃ (c)	$\frac{V_H}{V_X \cdot \sqrt{3}}$	Yd5	ROTATE TEST LEADS
* 29			H ₂ -H ₁ H ₃ -H ₂ H ₁ -H ₃	Δ-Δ STD	A B C	H ₁ -H ₃ (C+A+B) H ₂ -H ₁ (A+B+C) H ₃ -H ₂ (B+A+C)	X ₃ -X ₂ (c+a+b) X ₁ -X ₃ (a+b+c) X ₂ -X ₁ (b+a+c)	$\frac{V_H \cdot \sqrt{3}}{V_X \cdot 2}$	Yd5	NO ACCESSIBLE NEUTRAL ON WYE WINDING ROTATE TEST LEADS
29a			X ₂ -X ₁ X ₃ -X ₂ X ₁ -X ₃	Δ-Δ STD	A B C	H ₁ -H ₃ (A+C) H ₂ -H ₁ (B+A) H ₃ -H ₂ (C+B)	X ₃ -X ₂ (a+c) X ₁ -X ₃ (b+a) X ₂ -X ₁ (c+b)	$\frac{V_H \cdot 2}{V_X \cdot \sqrt{3}}$	Yd5	NO ACCESSIBLE NEUTRAL ON WYE WINDING ROTATE TEST LEADS
* 30			H ₂ -H ₁ H ₃ -H ₂ H ₁ -H ₃	Δ-Δ REV	A B C	H ₁ -H ₃ (C+A+B) H ₂ -H ₁ (A+B+C) H ₃ -H ₂ (B+A+C)	X ₁ -X ₃ (c+a+b) X ₂ -X ₁ (a+b+c) X ₃ -X ₂ (b+a+c)	$\frac{V_H \cdot \sqrt{3}}{V_X \cdot 2}$	Yd7	NO ACCESSIBLE NEUTRAL ON WYE WINDING
30a			X ₃ -X ₂ X ₁ -X ₃ X ₂ -X ₁	Δ-Δ REV	A B C	H ₁ -H ₃ (A+C) H ₂ -H ₁ (B+A) H ₃ -H ₂ (C+B)	X ₁ -X ₃ (a+c) X ₂ -X ₁ (b+a) X ₃ -X ₂ (c+b)	$\frac{V_H \cdot 2}{V_X \cdot \sqrt{3}}$	Yd7	NO ACCESSIBLE NEUTRAL ON WYE WINDING
31			—	Y-Δ REV	A B C	H ₁ -H ₀ (A) H ₂ -H ₀ (B) H ₃ -H ₀ (C)	X ₃ -X ₁ (a) X ₁ -X ₂ (b) X ₂ -X ₃ (c)	$\frac{V_H}{V_X \cdot \sqrt{3}}$	Yd11	ROTATE TEST LEADS
* 32			H ₂ -H ₁ H ₃ -H ₂ H ₁ -H ₃	Δ-Δ REV	A B C	H ₁ -H ₃ (C+A+B) H ₂ -H ₁ (A+B+C) H ₃ -H ₂ (B+A+C)	X ₃ -X ₂ (c+a+b) X ₁ -X ₃ (a+b+c) X ₂ -X ₁ (b+a+c)	$\frac{V_H \cdot \sqrt{3}}{V_X \cdot 2}$	Yd11	NO ACCESSIBLE NEUTRAL ON WYE WINDING ROTATE TEST LEADS
32a			X ₂ -X ₁ X ₃ -X ₂ X ₁ -X ₃	Δ-Δ REV	A B C	H ₁ -H ₃ (A+C) H ₂ -H ₁ (B+A) H ₃ -H ₂ (C+B)	X ₃ -X ₂ (a+c) X ₁ -X ₃ (b+a) X ₂ -X ₁ (c+b)	$\frac{V_H \cdot 2}{V_X \cdot \sqrt{3}}$	Yd11	NO ACCESSIBLE NEUTRAL ON WYE WINDING ROTATE TEST LEADS

Notes to Table 1 and 2

* Indicates preferred test method when alternate method is listed for same three-phase winding connection.

Transformer terminal markings comply with requirements of C57.12.70 - 1978.

Definition of Symbol Designations

H₁, H₂, H₃: winding terminals on high-voltage side of transformer

X₁, X₂, X₃: winding terminals on low-voltage side of transformer

H₀: neutral terminal on high-voltage side of transformer

X₀: neutral terminal on low-voltage side of transformer

N: inaccessible neutral point on high-voltage side of transformer

n: inaccessible neutral point on low-voltage side of transformer

LX₁, LX₂, LX₃: three-phase TTR low-voltage test lead (X₁, X₂, X₃) connections where rotation of test leads is required

V_H: nameplate voltage rating (line-to-line) on high-voltage side of transformer

V_X: nameplate voltage rating (line-to-line) on low-voltage side of transformer

A, B, C: winding tested on high-voltage side of transformer

a, b, c: winding tested on low-voltage side of transformer

IEC Vector Group Coding: The letters indicate the three-phase winding connections; D, Y, and Z designate the high-voltage side winding; d, y, and z designate the low-voltage side winding. With D and d representing a delta connection, Y and y a wye connection, and Z and z a zigzag connection. The number indicates the phase displacement (lag) of the low-voltage winding with respect to the high voltage in units of 30 degrees. For example, 0 = 0° lag, 1 = 30° lag, 2 = 60° lag ---, 6 = 180° lag ---, 11 = 330° lag.

Current Transformers

Connections to current transformers are made backwards compared to power or potential transformers. The H terminals on the test set must be connected to the X terminals on the current transformer; and the X terminals on the test set must be connected to the H terminals on the current transformer.

WARNING

Failure to observe proper connections will result in a safety hazard and may result in damage to the test set or current transformer.

NOTE

Dots on the housing of the transformer are commonly used to identify terminals of the same polarity.

Unmounted Current Transformers

1. Connect the wing-nut ground terminal of the test set to a low-impedance earth ground using the 15-ft ground cable supplied.
2. Use two conductor H and X test leads and connect as follows and as shown in Figure 8.
3. Connect the heavy-duty clips marked H1 and H2 of the test lead to the respective X1 and X2 terminals of the current transformer.
4. Connect the heavy-duty clips marked X1 and X2 of the test lead to the respective H1 and H2 terminals of the current transformer. Ensure correct polarity.

Figure 9 shows the setup for testing the taps on a multiple tap current transformer.

Bushing Current Transformer Mounted on Single-Phase, Two-Winding Transformer

A turn-ratio test can be performed on a bushing current transformer (BCT) after it has been mounted on a circuit breaker or power transformer entrance bushing. The test can be performed without removal of the BCT from the equipment. Proceed as follows and as shown in Figure 10.

1. Use two conductor H and X test leads.
2. Short-circuit the winding on the opposite voltage side of the power transformer core, using jumper leads.
3. Connect the heavy-duty clips marked H1 and H2 of the test leads to the respective X1 and X2 terminals of the BCT.

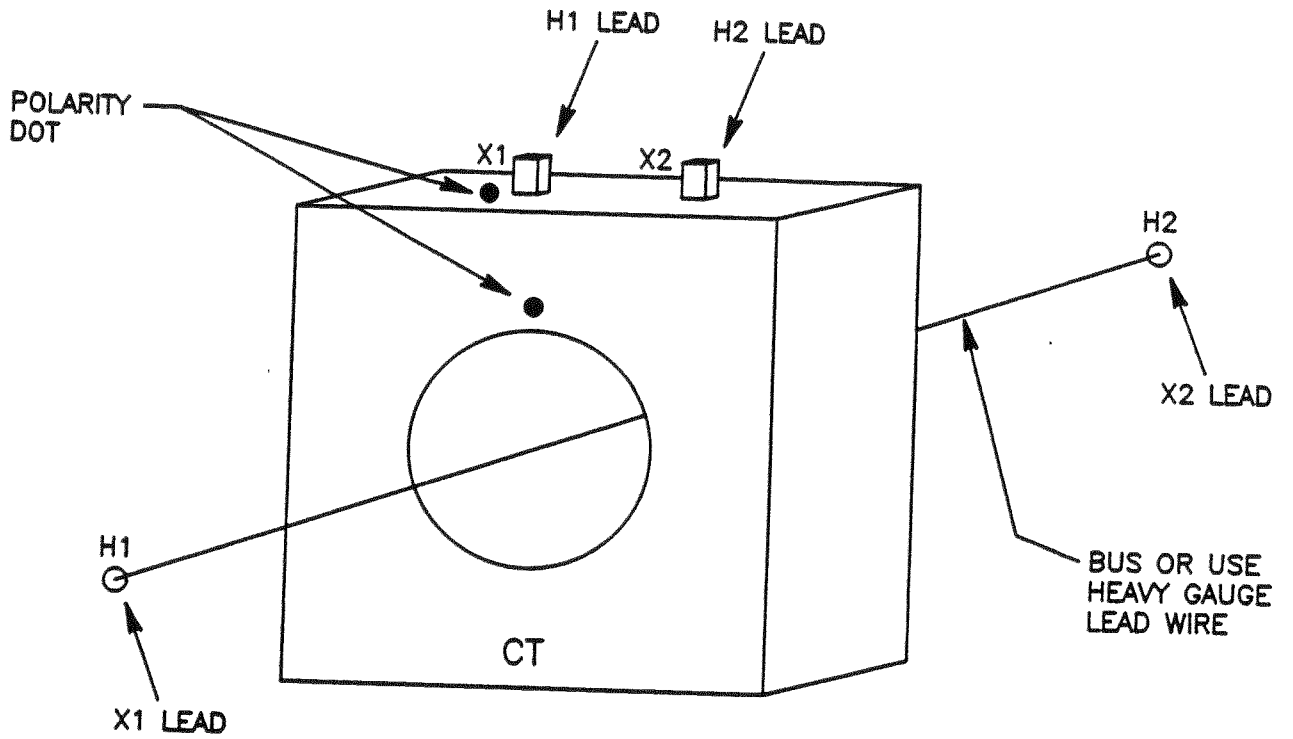

Figure 8: Setup for Testing Unmounted Current Transformer

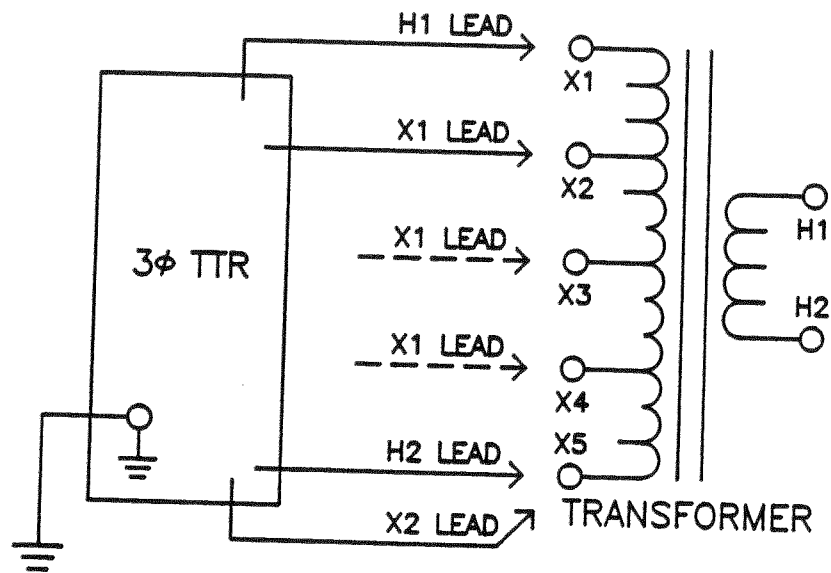

Figure 9: Setup for Testing Taps on Multiple Tap Current Transformer

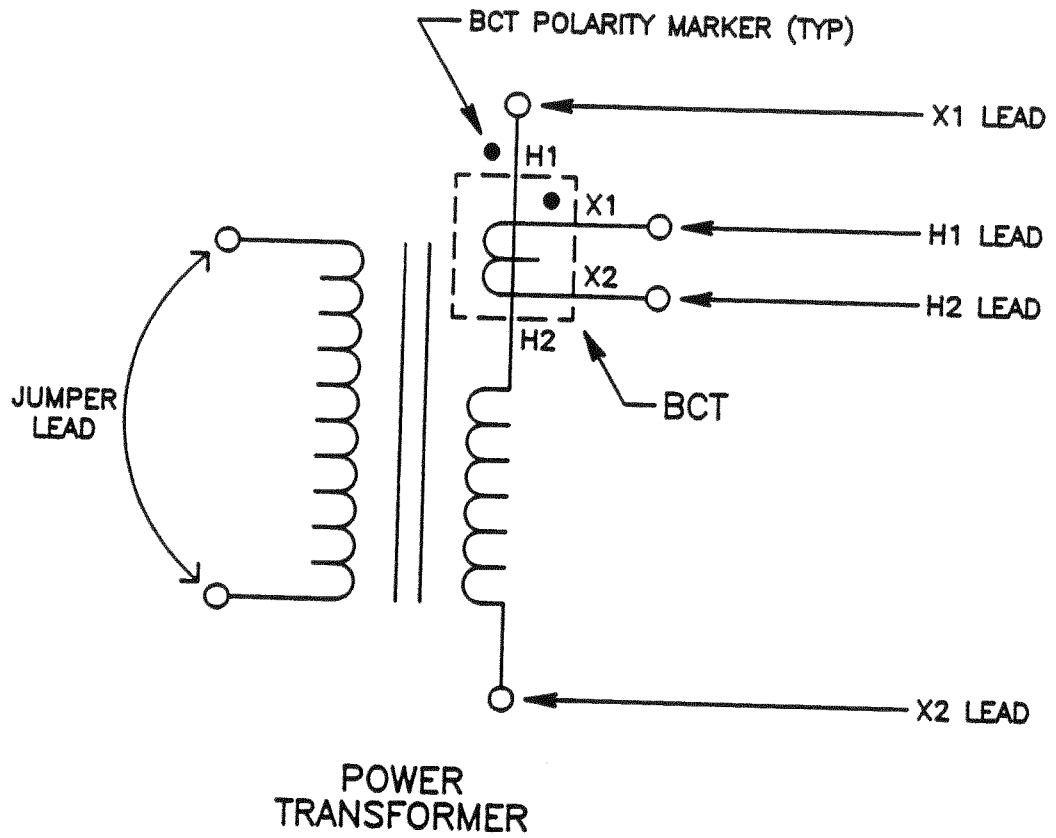

Figure 10: Setup for Testing BCT When Mounted on Single-Phase Two Winding Transformer

4. Connect the heavy-duty clip marked X1 to the power transformer terminal on which the BCT is mounted and the X2 heavy-duty clip to the terminal on the opposite side of the power transformer winding (H2 side of BCT). Check to make sure that the BCT is mounted with proper polarity with respect to power transformer entrance bushing and that connection polarities are correct.

Bushing Current Transformers Mounted on Three-Phase Transformers

A turn-ratio test can be performed on all three BCT's using a single setup. Figure 11 shows how to make the proper connections when the BCT's are mounted on a typical delta winding and Figure 12 when mounted on a typical wye winding.

1. Use four conductor H and X test leads.
2. Short-circuit all windings on the opposite voltage side of the power transformer core using jumper leads.
3. Check to make sure that all BCT's are mounted with proper polarity with respect to the power transformer entrance bushing.
Ensure that all connection polarities are correct.

General Procedure

After connecting the H and X test leads to the test set and to the transformer under test according to the preceding setup instructions, proceed as follows.

1. Insert external interlock plug into receptacle marked INTERLOCK. This plug must be wired to an external interlock switch or short-circuited with a jumper (pins A and B of interlock plug). When connection is made to an external interlock switch, it is recommended that two conductor shielded wires be used and the shield connected to pin C of the interlock plug.
2. With POWER circuit breaker switched off, plug input power cord into panel power receptacle and into 3-wire grounded power outlet.
3. Connect printer, if used, to test set PRINTER receptacle using the cable supplied with the printer. Ensure that printer DIP switch no. 6 is set to ON and all other DIP switches are set to OFF.

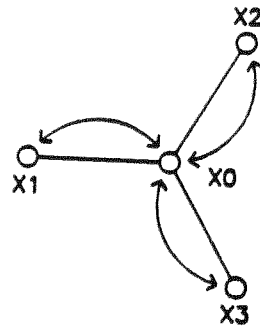
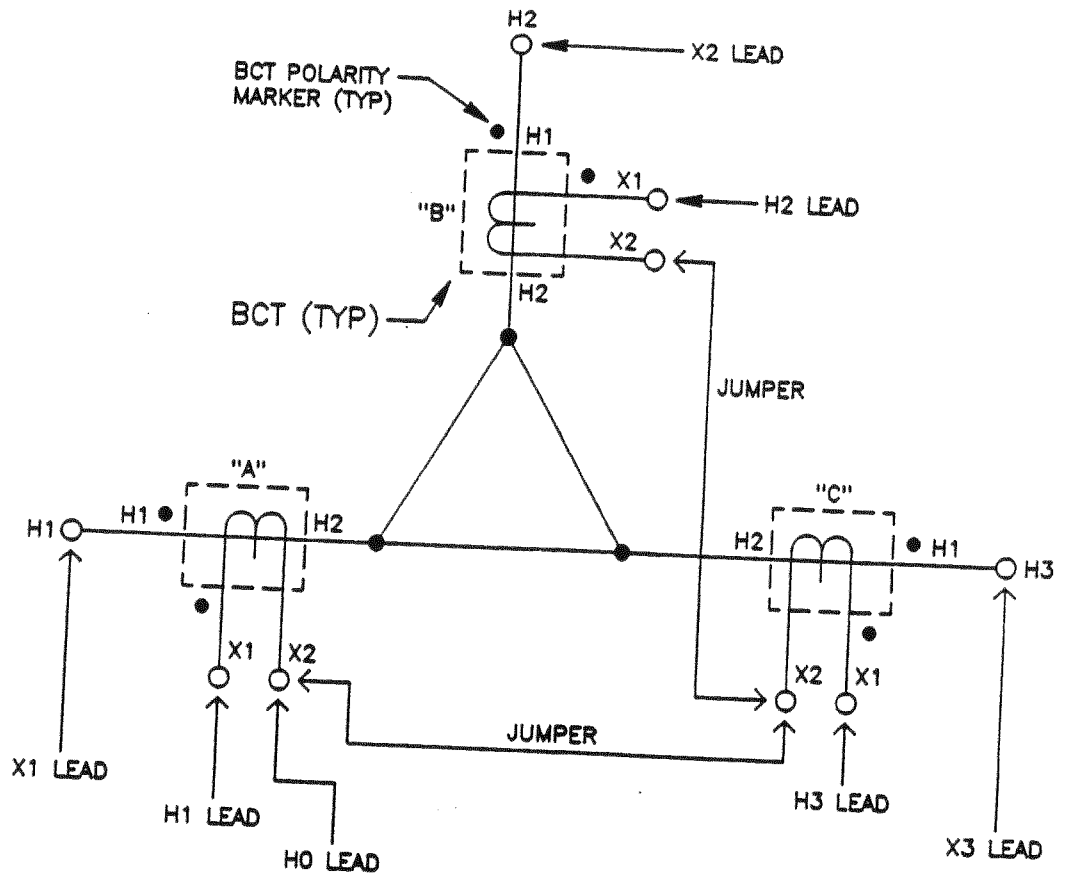

OR

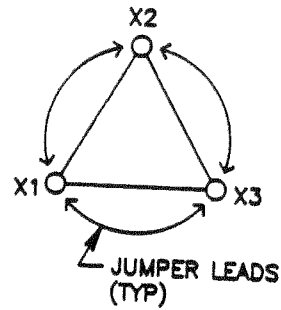

TRANSFORMER TYPE SWITCH SETTING: Y- Δ STANDARD

PHASE SWITCH SETTING:

- A: MEASURES BCT ON H1 POWER TRANSFORMER TERMINAL
- B: MEASURES BCT ON H2 POWER TRANSFORMER TERMINAL
- C: MEASURES BCT ON H3 POWER TRANSFORMER TERMINAL

Figure 11: Setup for Testing BCT When Mounted on Delta Winding of a Three-Phase Power Transformer

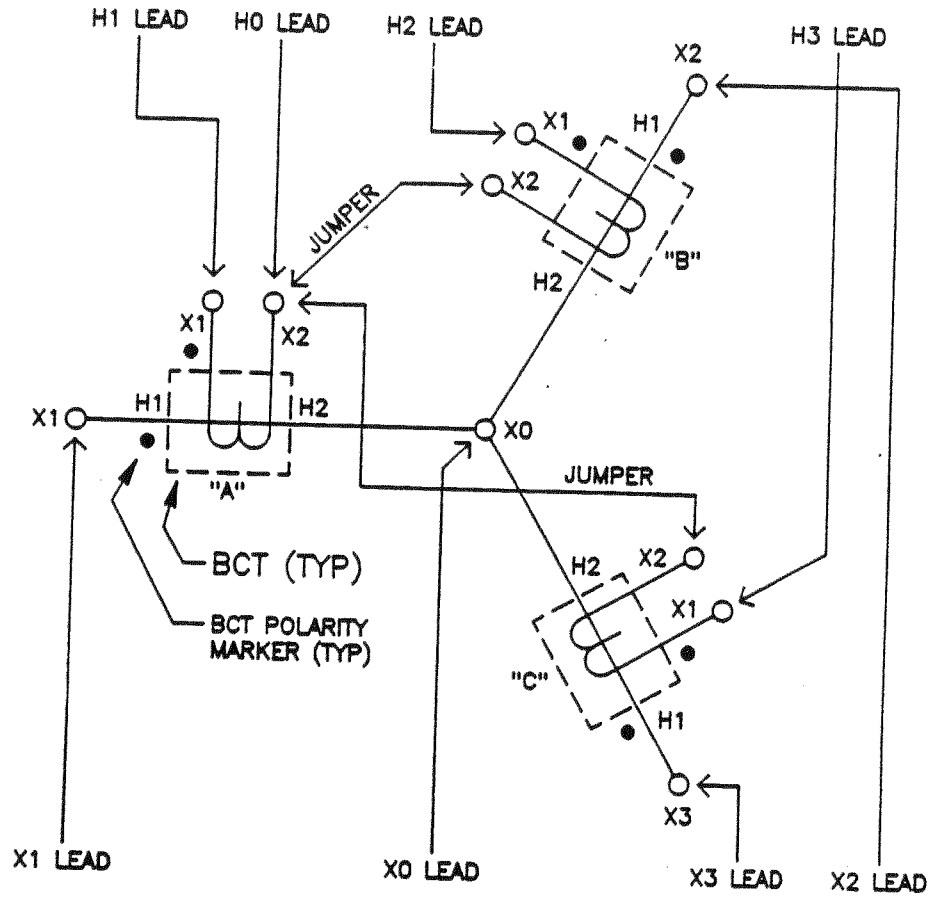
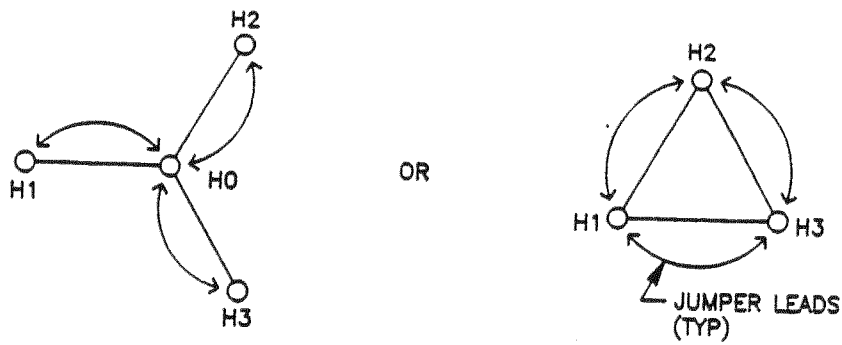

TRANSFORMER TYPE SWITCH SETTING: Y-Y STANDARD
PHASE SWITCH SETTING:
A: MEASURES BCT ON X1 POWER TRANSFORMER TERMINAL
B: MEASURES BCT ON X2 POWER TRANSFORMER TERMINAL
C: MEASURES BCT ON X3 POWER TRANSFORMER TERMINAL

Figure 12: Setup for Testing BCT When Mounted on Wye Winding of a Three-Phase Power Transformer

Operation

Proceed only after fully understanding Section 2, Safety, and setting up the test set as described. An operator who is familiar with the contents of this manual, the test setup, and the operation of the test set may follow the condensed operating procedure in the lid of the test set. The following instructions are the normal procedure for conducting a test on a transformer.

1. Close the POWER circuit breaker. The white POWER indicator lamp will illuminate.

Self-Check

The microprocessor will initially perform a self-check of the test set display, calibration, and operation. The check will start by sequentially stepping through the numeral eight (8) and decimal points in both displays. At the conclusion of a successful self-check (15 s), all zeros (0's) will appear in both displays indicating that the test set is ready to make measurements.

NOTE

In the rare event that the self-check sequence does not start by displaying all eights, switch the POWER circuit breaker off, wait approximately 5 s, then close the POWER circuit breaker.

Any failure or out-of-tolerance condition that occurs during the self-check sequence will be indicated by a blinking error message in the RATIO display.

- EE 1 - problem in microprocessor
- EE 2 - calibration error in A/D converter
- EE 3 - calibration error in D/A converter
- EE 4 - calibration error in voltage measuring circuit
- EE 5 - calibration error in mA measuring circuit
- EE 6 - calibration error in ratio measuring circuit

Pressing the OFF/CLEAR/PRINT push-button switch will terminate an error message and cause all zeros to appear in both the RATIO and MILLIAMPERES displays. The test set is now ready to make measurements in the normal manner, provided that the error is an out-of-tolerance condition rather than a component failure.

2. Turn the TRANSFORMER TYPE selector switch to the position as indicated in Table 1 or Table 2 depending on the type of transformer to be tested.

- 1 ϕ - for single-phase transformers
- Δ - Δ - for delta-delta three-phase transformers
- Δ -Y - for delta-wye three-phase transformers
- Y-Y - for wye-wye three-phase transformers
- Y- Δ - for wye-delta three-phase transformers

3. Set the STANDARD/REVERSE switch to the position as indicated in Table 1 or Table 2 (normally STANDARD).
4. Turn the PHASE selector switch to the position corresponding to the phase of the transformer to be tested. Normal initial setting is 1 ϕ /A.
1 ϕ /A - for single-phase transformers and A phase of three-phase transformers
B - for B phase of three-phase transformers
C - for C phase of three-phase transformers

CAUTION

Do not turn the TRANSFORMER TYPE or PHASE selector switches while the red TESTING indicator lamp is lit. Damage to the test set may occur because of the inductive nature of the test transformer high-voltage winding.

5. Set the TEST VOLTAGE toggle switch to the desired test voltage position. Measurements on power transformers and potential transformers should generally be made at 120 V and on current transformers at 40 V.

CAUTION

To prevent possible damage to a current transformer, always refer to the manufacturer's excitation curves for the specific type of current transformer being tested to ensure that it has sufficient core area to be excited at 40 V. In general, current transformers with ratings below 200/5 A cannot be tested with this test set.

6. Close the external interlock switch, if used.

WARNING

High voltage will be present. Treat all terminals of the transformer under test as live.

7. Press the START TEST push-button switch when ready to energize a winding. The red TESTING indicator lamp should light and the ratio and milliampere displays should blank out while the automatic balance measurement is in progress. When the balance sequence is completed (approximately 8 s), the red TESTING indicator lamp should extinguish and the ratio and milliampere values should appear in the respective displays.

The test set is ready to make the next measurement. Press the START TEST push-button switch.

NOTE

Pressing the OFF/CLEAR/PRINT push-button switch will cause all zeros to appear in both displays and the test set will be ready to make the next measurement.

8. When testing has been completed, open the external interlock switch, if used, then switch the POWER circuit breaker off. The white POWER indicator lamp and the two digital display meters should now be out.

Operating Notes

Refer to Tables 1 and 2 for transformer winding phase relationship for each setting of the TRANSFORMER TYPE and PHASE selector switches. A slight difference in ratio readings (0.05 to 0.1 percent of reading) may be expected if a comparison is made against a test set which uses the low voltage transformer winding as the exciting winding.

In Case of Emergency

Test voltage can be interrupted immediately by pressing the OFF/CLEAR/ PRINT push-button switch, opening the external interlock switch, or switching the POWER circuit breaker off.

Error Messages

The following is a list of the error messages that appear in the RATIO display for abnormal operating conditions:

- C OL Current overload. Excitation current can be reduced by using a test voltage of 40 V. A short circuit or gross overload will cause the POWER circuit breaker to trip.
- CHPOL Change polarity of the test lead connections. The test leads have either been incorrectly connected or the test transformer connections or markings do not comply with the requirements of ANSI C57.12.70-1978.
- LO Ratio value is below low range of test set (0.8).
- CH CO Check connections. This display is usually caused by an incorrect or poor connection of one of the test leads. It may also indicate that the ratio value is beyond the high range of the test set (2700:1).

NOTE

When an error message appears in the ratio display indicating an abnormal condition, it is recommended that the condition be verified by taking a repeat measurement before attempting to take any corrective action. Open connections, wrong connections, open windings, shorted windings, high resistance windings, other abnormal transformer problems, or a combination of these may cause a large deviation from normal turn ratio or indicate an unusual error message. These unusual errors may be caused by an abnormal leakage reactance or capacitive coupling within the transformer windings.

Measurement with Printer Connected

1. Close POWER circuit breaker.
2. Switch printer power ON. The printer red LED indicator lamp should light.
3. Set the TRANSFORMER TYPE, PHASE, and TEST VOLTAGE switches to the desired test position.
4. To print out a report heading, press the OFF/CLEAR/PRINT push-button switch three times. The printer will then print out the appropriate format as determined by the TRANSFORMER TYPE switch setting. See Figures 13 and 14 for sample printouts.
5. Close the external interlock switch if used.
6. Press the START TEST push-button switch when ready to energize a winding.
7. After the ratio and milliampere values appear in their respective displays, press the OFF/CLEAR/PRINT push-button switch. The printer will print out the respective readings. The readings will simultaneously be cleared from the displays and all zeros will reappear, indicating that the test set is ready to make the next measurement.

NOTE

When testing three-phase transformers, all three phase readings (A, B, and C) can be stored in the microprocessor memory. Pressing the OFF/CLEAR/PRINT push-button switch will cause the printing out of the last value measured for phase A, B, and C.

A separate manual is supplied with the printer. Refer to it for specific information about how to connect and care for the printer.

BIDDLE INSTRUMENTS
THREE PHASE TTR
CAT. NO. 550100 SERIES
TTR INSTRUMENT SER. NO. _____
TEST DATE: _____
OPERATORS NAME: _____
TRANSFORMER TYPE: SINGLE PHASE
TRANSFORMER WINDING: SINGLE PHASE
VOLTAGE RATING: _____
KVA RATING: _____
TRANSFORMER SER. NO.: _____
TEST VOLTAGE: _____
AMBIENT TEMPERATURE: _____
RELATIVE HUMIDITY: _____
COMMENTS/NOTES: _____

TAP	RATIO		MA
	12.000	STANDARD	3

TAP	RATIO		MA
	12.000	REVERSE	3

Figure 13: Sample Printout for Single-Phase Transformers

BIDDLE INSTRUMENTS
THREE PHASE TTR
CAT. NO. 550100 SERIES
 TTR INSTRUMENT SER. NO.: _____
 TEST DATE: _____
 OPERATORS NAME: _____
 TRANSFORMER TYPE: THREE PHASE
 TRANSFORMER WINDING: DELTA HIGH VOLTAGE
 DELTA LOW VOLTAGE
 VOLTAGE RATING: _____
 KVA RATING: _____
 TRANSFORMER SER. NO.: _____
 TEST VOLTAGE: _____
 AMBIENT TEMPERATURE: _____
 RELATIVE HUMIDITY: _____
 COMMENTS/NOTES: _____

TAP	PHASE A	PHASE B	PHASE C
RATIO	12.002	12.002	12.002
MA	STANDARD 3	STANDARD 3	STANDARD 3

TAP	PHASE A	PHASE B	PHASE C
RATIO	12.002	12.002	12.001
MA	REVERSE 3	REVERSE 3	REVERSE 3

Figure 14: Sample Printout for Three-Phase Transformers

Section 6 Maintenance and Calibration

Routine Maintenance

The TTR test set is sturdily constructed and requires no periodic maintenance. An occasional visual inspection and cleaning of the case, control panel, and cable assemblies is sufficient. The control panel and case can be cleaned with detergent and water. Water must not be allowed to penetrate panel holes because it may adversely effect internal components. An all-purpose spray cleaner may also be used. Polish with a soft dry cloth.

WARNING

Refer to manufacturers' precautions for handling alcohol and Xylol.

Test leads and panel receptacles can be cleaned with isopropyl or denatured alcohol applied with a clean cloth. Stubborn dirt may require cleaning with Xylol which should then be rinsed with alcohol.

Calibration

A complete performance and calibration check should be made at least once every year. This will ensure that the test set is functioning and calibrated properly over the entire measurement range. The Biddle Catalog No. 550055 Calibration Standard for Three-Phase TTR's can be used to make this check.

A simplified self-check can be performed at unity ratio. Proceed as follows:

1. Using two conductor H and X cables, connect H1 to X1 and H2 to X2.
2. Set TRANSFORMER TYPE switch to 1 ϕ , STANDARD.
3. Set PHASE switch to 1 ϕ .
4. Set TEST VOLTAGE switch to 40 V; repeat test at 120 V.
5. Perform normal self-check of test set display, calibration, and operation.

WARNING

The leads will be energized at high voltage and should be kept clear of ground and personnel.

6. Take a measurement. Readings for 40 V and 120 V should be:

RATIO: 1.0000 ± 0.0010

MILLIAMPERES: 000 to 003

Section 7 Troubleshooting and Repair

Troubleshooting

The Troubleshooting Guide, Table 3, is arranged to follow the normal sequence of self-check and operation. The table lists possible test set malfunctions which may be encountered during operation and lists possible causes. Electronic circuit repairs should not be attempted in the field. Refer to Section 8 for a list of replaceable parts.

Repair

Biddle Instruments offers a complete repair service and recommends that its customers take advantage of this service in the event of equipment malfunction. Equipment returned for repair should be shipped prepaid and insured and marked for the attention of the Repair Department. Please indicate all pertinent information including problem symptoms and attempted repairs. The catalog number and serial number of the test set should also be specified. Pack the instrument in a carton (original shipping carton if available) with adequate dunnage in accordance with best commercial practice. Seal the carton with waterproof tape.

Table 3: Troubleshooting Guide

<u>MALFUNCTION</u>	<u>POSSIBLE CAUSE</u>
White POWER lamp does not light.	-No service power -Defective line cord -POWER breaker not closed -Defective white POWER lamp
POWER breaker trips on closure.	-Short circuit in wiring -Short circuit in component
Digital displays do not light or initially display eights in both displays when white POWER lamp is lit.	-Defective displays -Defective display drivers or power source -Self-check not initialized Switch POWER breaker off, wait 5 s, close breaker -Loose connection at display printed circuit board

Table 3: Troubleshooting Guide (contd)

<u>MALFUNCTION</u>	<u>POSSIBLE CAUSE</u>
Error message EE 1 through EE 6 appears after self-check.	-Out of tolerance condition in measurement circuit;to bypass error message, press OFF/CLEAR/PRINT push button
Red TESTING lamp does not light on closure of START TEST switch.	<ul style="list-style-type: none"> -External interlock open -Defective red TESTING lamp -Defective START TEST switch -Defective power relay -Problem in measuring circuit
POWER breaker closes initially but trips when START TEST switch is pressed.	<ul style="list-style-type: none"> -Short circuit in specimen -Excitation current exceeds test set current rating -Short circuit in test leads -Short circuit in wiring -Incorrect connection of leads -Incorrect setting of TRANSFORMER TYPE switch
Error message appears in ratio display on closure of START TEST switch.	<ul style="list-style-type: none"> -Abnormal operating condition -Incorrect setting TRANSFORMER TYPE switch -Incorrect setting of phase switch -Incorrect connection of leads -Defective test leads -Problem in measuring circuit
RATIO and MILLIAMPERES readings erratic.	<ul style="list-style-type: none"> -Problem in test specimen -Defective test leads (open circuit, poor connection) -Severe abnormal transients in service power -Problem in measuring circuit
Cannot obtain printout when printer is connected.	<ul style="list-style-type: none"> -Printer power not turned on -Printer battery discharged -OFF/CLEAR/PRINT switch not pressed or pressed before a reading is stored in memory.

Section 8 Replaceable Parts List

<u>DESCRIPTION</u>	<u>VENDOR P/N</u>	<u>BIDDLE P/N</u>
Case and lid	-	25743-3
Case carrying strap	-	6580-2
Case bumper feet (3M)	SJ5023	5599-1
Instruction card	-	28684
Knob (Buckeye)	PS-125PL-2	4690-25
Wing nut (Pa. Malleable Iron)	709B	5026
Lamp POWER and TESTING (Industrial)	334	5297
Lens, white POWER	-	25302-88
Lens, red TESTING	-	25302-89
H test lead, 3 ϕ	-	28541-1
X test lead, 3 ϕ	-	28542-1
H test lead, 1 ϕ	-	28549-1
X test lead, 1 ϕ	-	28550-1
Ground lead	-	4702-5
Interlock plug	-	28552
ac line cord, 3 cond. (Belden)	17250	17032
Panel screw	-	23303-15
Canvas carrying bag for test leads	-	18313

GLOSSARY



	Use only in accordance with instruction manual.
	High-voltage warning
BCT	bushing current transformer
EHV	extra high voltage; voltage higher than 240,000 V
LCD	liquid crystal display
LED	light emitting diode
transient	a change in the steady-state condition of voltage or current, or both
TTR	transformer turn ratio; a registered trademark of Biddle Instruments
turn ratio	the ratio of the number of turns in a higher voltage winding to that in a lower voltage winding
xylol	(xylene) toxic, flammable, oily, isomeric aromatic hydrocarbons used as solvents

WARRANTY

Products supplied by Biddle Instruments are warranted against defects in material and workmanship for a period of one year following shipment. Our liability is specifically limited to replacing or repairing, at our option, defective equipment. Equipment returned to the factory must be shipped prepaid and insured. This warranty does not include batteries, lamps, or other expendable items, where the original manufacturer's warranty shall apply. We make no other warranty. The warranty is void in the event of abuse (failure to follow recommended operating procedures) or failure by the customer to perform specific maintenance as indicated in this manual.