

Instruction Manual
Power Fault Locator
PFL-1000 · PFL-4000
PFL-5000

Catalog Nos. 657100, 657400 and 657500

HIGH-VOLTAGE EQUIPMENT
Read this entire manual before operating.

APARATO DE ALTO VOLTAJE
Ante de operar este producto lea este manual enteramente.

Power Fault Locator
PFL-1000 · PFL-4000 · PFL-5000

Instruction Manual

Copyright © 2003 Megger. All rights reserved.

The information presented in this manual is believed to be adequate for the intended use of the product. If the product or its individual instruments are used for purposes other than those specified herein, confirmation of their validity and suitability must be obtained from Megger. Refer to the warranty information included at the end of this instruction manual. Specifications are subject to change without notice.

DART[®] and BIDDLE[®] are registered trademarks of Megger.

WARRANTY

Products supplied by Megger are warranted against defects in material and workmanship for a period of one year following shipment. Our liability is specifically limited to replacing or repairing, at our option, defective equipment. Equipment returned to the factory for repair must be shipped prepaid and insured. This warranty does not include batteries, lamps, or other expendable items, where the original manufacturer's warranty shall apply. We make no other warranty. The warranty is void in the event of abuse (failure to follow recommended operating procedures) or failure by the customer to perform specific maintenance as indicated in this manual.

Megger
Valley Forge Corporate Center
2621 Van Buren Avenue
Norristown, PA 19403
610-676-8500
www.megger.com

CONTENTS

| | | |
|---|--|----|
| 1 | INTRODUCTION | 1 |
| | About the PFL Power Fault Locator | 1 |
| | Upon Receipt of Product..... | 2 |
| | Safety First | 2 |
| | How to Use This Manual | 2 |
| 2 | SAFETY..... | 5 |
| | Introduction..... | 5 |
| | General Safety Precautions | 5 |
| | Safety in Using the PFL | 6 |
| | Protective Clothing | 7 |
| | Special Considerations for Personnel..... | 7 |
| | Safety Precautions for Connecting to the Power Source..... | 7 |
| | Special Grounding Considerations for Fault-Locating Systems..... | 7 |
| | Built-in Safety Features | 9 |
| 3 | SPECIFICATIONS | 11 |
| | Available Modes..... | 11 |
| | Voltage Output..... | 11 |
| | Current Output..... | 11 |
| | Energy | 12 |
| | Coupling..... | 12 |
| | Metering..... | 12 |
| | Environmental..... | 12 |
| | General | 12 |
| | Input Voltage | 13 |
| | Accessories Supplied..... | 13 |
| | Related Products | 13 |
| 4 | INSTALLATION | 15 |
| | PFL-1000 Installation..... | 15 |
| | PFL-4000 Installation..... | 16 |
| | PFL-5000 Installation..... | 16 |
| 5 | SYSTEM OVERVIEW | 17 |
| | Overview of Test Methods and Mode Selection | 17 |
| | DC Operations..... | 17 |
| | Surge Pulse Reflection and Surge Tracing Methods..... | 18 |
| | Time Domain Reflectometry (TDR) and Arc Reflection..... | 19 |
| 6 | SETTING UP THE PFL SYSTEM..... | 21 |
| | Controls and Indicators | 21 |
| | Connectors | 23 |
| | Grounding System and High-Voltage Connectors | 25 |
| | Permanent Grounds and Connections..... | 26 |

| | |
|---|-----------|
| Temporary Grounds and Connections | 28 |
| System Setup | 31 |
| Setup Procedure | 31 |
| 7 OPERATING THE PFL SYSTEM | 35 |
| Introduction | 35 |
| Changing Modes | 35 |
| Discharge Of The Cable And Shutdown | 36 |
| DC Mode | 37 |
| Arc Reflection Mode | 39 |
| Surge Mode | 43 |
| Operating Notes | 47 |
| Troubleshooting | 47 |
| Testing the System | 49 |
| 8 MAINTENANCE | 59 |
| Cleaning and Inspection | 59 |
| Repairs | 61 |
| GLOSSARY | 63 |
| Symbols on the Equipment | 63 |
| Definitions for Grounds | 63 |
| Other Terms and Acronyms | 64 |
| INDEX | 65 |

ADDENDUM: INSTRUCTIONS FOR OPTIONAL CABLE REEL ASSEMBLIES

Figures

| | |
|---|----|
| Figure 4-1: PFL-1000 Installation | 15 |
| Figure 4-2: PFL-5000 Installation | 16 |
| Figure 6-1: PFL-1000 Controls | 22 |
| Figure 6-2: PFL-4000 Controls | 22 |
| Figure 6-3: PFL-5000 Controls | 23 |
| Figure 6-4: PFL-1000 Side Panel Connectors | 24 |
| Figure 6-5: PFL-4000 Side Panel Connections | 24 |
| Figure 6-6: PFL-4000 Rear Panel Connections | 24 |
| Figure 6-7: PFL-5000 Rear Panel Connections | 25 |
| Figure 6-8: PFL-1000 Ground System Diagram, Permanent Connections | 26 |
| Figure 6-9: PFL-5000 Ground System Diagram, Permanent Connections | 27 |
| Figure 6-10: PFL-1000 Temporary Connections | 30 |
| Figure 6-11: PFL-4000 Temporary Connections | 30 |
| Figure 6-12: PFL-5000 Temporary Connections | 31 |

1

INTRODUCTION

About the PFL Power Fault Locator

Thank you for selecting an Megger product. This instrument has been thoroughly tested and inspected to meet rigid specifications before being shipped. It is ready for use when set up as described in this manual.

NOTE: *In this manual, PFL refers to the PFL-1000, 4000 and 5000. The individual models are specified as necessary.*

The BIDDLE[®] PFL Power Fault Locators are designed to locate cable faults on cables rated up to 34.5 kV ac phase-to-phase. This integrated system includes an arc reflection filter, surge generator, high potential tester, cable burner and DART[®] Analysis System in a single chassis.

NOTE: *This manual describes the PFL-1000, 4000 and 5000 and details pertinent system information. The operation of the DART Analysis System is described in Instruction Manual AVTM654000.*

The PFL operates with:

- A four-position **MODE SELECT** switch, which allows implementation of most fault location methods without the need to disconnect cables from other test equipment, thus ensuring operator safety and ease of use.
- A sturdy metal cabinet using welded construction throughout to withstand the rigors of operation in a service vehicle.
- Flexible, shielded output cable that is specially terminated for long service life and convenience.
- Many built-in and redundant safety features.

WARNING

**POTENTIAL
HAZARD**

Grounding systems and procedures described in this manual are designed specifically for BIDDLE equipment. If other manufacturers' equipment is used with the PFL, the user is responsible for verifying that the grounding and interconnections between the systems comply with each manufacturer's instructions. The user is also responsible for observing the appropriate safety precautions when working with such equipment. Incompatible grounding systems may prove hazardous.

Upon Receipt of Product

Check the equipment received against the packing list to ensure that all materials are present. Notify Megger of any shortage (tel: 610-676-8500).

Examine the instrument for damage received in transit. If you find damage, file a claim with the carrier at once. Also notify Megger or its nearest authorized sales representative, and describe the damage in detail.

Safety First

Be sure to read the safety information in Section 2 thoroughly and observe all safety precautions and recommendations. Also, before operating the PFL, be sure to read and understand the "Safety" section of the instruction manual (AVTM654000) for the DART Analysis System.

How to Use This Manual

Organization

- Description of the PFL
- Safety precautions
- Product specifications
- System overview
- Setup
- Operation
 - Procedures
 - Operating notes
 - Performance checks

- Maintenance
 - Cleaning
 - Repair
- Glossary
- Index

Typographic conventions

- Figures and tables are numbered in sequence by section
- Numbered lists show procedural steps
- Bullets list items and options
- Cautions, warnings and notes
 - Cautions alert you to possible damage to equipment
 - Warnings alert you to conditions that are potentially hazardous to people
 - Notes provide important explanation or assistance



Improper voltage levels may damage the PFL



Never assume that the test set is de-energized. Always treat exposed conductors and connections as potential electric shock hazards.

- Equipment symbols

NOTE: *This manual describes the PFL-1000, 4000 and 5000 and details pertinent system information. The operation of the DART Analysis System is described in Instruction Manual AVTM654000.*



Use only in accordance with Instruction Manual



Earth terminal. You must follow grounding procedures

Megger[®]

2

SAFETY

Introduction

Megger has designed the PFL and the recommended operating procedures with careful attention to safety. It performs formal safety reviews of the initial design and any subsequent changes to all new BIDDLE products, including the PFL. The safety review covers areas over and above those included in applicable IEC and ANSI standards.

Regardless of these efforts, it is not possible to eliminate all hazards from electrical test equipment or to foresee every possible hazard. You are therefore urged not only to follow the safety rules in this manual, but also to consider carefully all safety aspects of the test before proceeding. **Safety is the responsibility of the user.**

The design of this equipment follows safety specifications IEC 1010-1 and ANSI/ISA S82.01 and meets the requirements for Class I, Installation Category II equipment.

Megger recommends that a qualified operator attend the system at all times while it is in operation. Only qualified service personnel should replace components or make internal adjustments.

General Safety Precautions

The equipment and the cable to which the PFL connects are sources of high-voltage electrical energy. Observe the following safety precautions:

- Observe all safety warnings on the equipment. They identify areas of immediate hazard that could result in injury or death.
- Use this equipment only for the purposes described in this manual.
- Treat all terminals of high-voltage power equipment as potential electric shock hazards.
- Use all practical safety precautions to prevent contact with energized parts of the equipment and related circuits.

- Use suitable barriers, barricades, or warnings to keep persons not directly involved with the work away from test activities.
- Never connect the test equipment to energized cables.
- Do not connect to energized equipment or use in an explosive atmosphere.
- Use the grounding and connection procedures recommended in this manual.
- Observe strictly the warning and caution notices used throughout this manual (see "How to Use This Manual" on page 2).

Safety in Using the PFL

- Do not use this equipment to locate faults on direct-buried unshielded or secondary cable. Dangerously high differences in potential may be developed in the current return path.
- Do not use this equipment to locate faults on any cable that may be close enough to an energized cable to allow a burn-through of the insulation of the energized cable. Cables located in a common trench, duct or tray (for example, three-phase systems) are susceptible to burn-through.
- Do not operate the equipment without the side and top panels. Operation without these protective covers presents an electric shock hazard. Furthermore, in the event of failure, components can shatter, sending pieces of porcelain, hardware, etc. in all directions at high velocity.
- Remain at least 3 ft (0.91 m) away from all parts of the complete high-voltage circuit, including connections, unless the equipment is de-energized and all parts of the test circuit are grounded. Be aware that any voltage applied to the cable under test will be present at the remote end(s) and at any other exposed part of the cable, usually out of sight of the operator.
- Use the grounding and connection procedures illustrated in Figure 6-5, Figure 6-6, and Figure 6-7 on pages 24 and 25. Also refer to "Grounding System and High-Voltage Connectors" on page 25.
- Maintain adequate air clearances between the exposed energized conductor and any adjacent grounds to prevent sparkover. An uncontrolled sparkover can create a safety hazard.



Never assume that the test set is de-energized. Always treat exposed conductors and connections as potential electric shock hazards.

Protective Clothing

If the equipment is operated as recommended in this manual, if all safety precautions are observed, and if all grounds are correctly made, rubber gloves are not necessary. As a routine safety procedure, however, some users require that rubber gloves be worn, not only when making connections to the high-voltage terminals, but also when manipulating controls. Megger considers this an excellent safety practice.

Special Considerations for Personnel

Users of high-voltage equipment should note that high-voltage discharges and other sources of strong electric or magnetic fields may interfere with the proper functioning of heart pacemakers. Personnel using heart pacemakers should obtain expert advice on the possible risks before operating this equipment or being close to the equipment during operation.

Safety Precautions for Connecting to the Power Source

The PFL operates from a single-phase power source. It has a three-wire power cord and a two-pole, three-terminal grounding type connector (IEC). The voltage to ground from either pole of the power source must not exceed the maximum rated operating voltage, either 120 V ac or 230 V ac, depending on the system purchased. Before making connection to the power source, verify the following:

- That the instrument is suitable for the voltage of the power source.
- That the power source has a suitable two-pole, three-terminal grounding type connector.
- That the power source has a high-rupture fuse or circuit breaker rated no higher than 15/7.5 A.

The power input plug must be inserted only into a mating receptacle with a ground contact. Do not bypass the grounding connection. Any interruption of the grounding connection can create an electric shock hazard. Determine that the receptacle is correctly wired before inserting the plug.

Special Grounding Considerations for Fault-Locating Systems

High-voltage electrical impulses generated by fault locating systems and resultant current pulses create special safety problems. Large, rapidly changing currents, even across small values of impedance, can generate high voltage levels.

Ground integrity must be maintained at all times by following the instructions in this manual and using accepted industry practices for making reliable,

low-resistance ground connections capable of carrying large surge currents. For a complete description of the ground system and individual grounds, refer to Section 6, "Setting Up the PFL." For complete definitions of the grounding terms used, refer to the Glossary at the back of this manual.



The PFL should be operated only with the ground connections as described in Section 6.

The grounding scheme used in the PFL system provides two separate and distinct grounds:

1. **star ground**— This ground is designed to protect the operator by preventing a difference of potential between the PFL system and the earth in the immediate vicinity. To achieve this, the **star ground** must be connected to a good **local earth ground** of less than 5 Ω . **Star ground** is the **vehicle chassis ground**. A connection between the **PFL chassis ground** and the **vehicle chassis ground** must be made.
2. **surge ground**— This is the ground path that is designed to return the surge current directly back to the surge capacitor through the coaxial shield of the high-voltage output cable. The operator is isolated from any transient voltage rise along the **surge ground** by the insulation system in the PFL and by the insulated jacket of the high-voltage output cable.



The return lead of the output cable must not be extended because this introduces excessive impedance in the **surge ground** and could result in hazardous voltages.

Safety Ground Jumper

Treat all terminals of high-voltage power equipment as a potential electric shock hazard. Potential always exists for voltages to be induced at these terminals because of proximity to energized high-voltage lines or equipment. A **safety ground jumper** must be installed between the high-voltage conductor and ground of the cable under test (**specimen ground**). This discharges any potentially hazardous voltages in the cable under test.

Disconnecting the Test Equipment

Always disconnect test leads from the cable under test before attempting to disconnect them at the test equipment. The ground connections must be the first made and the last removed. Any interruption of the grounding connection can create an electric shock hazard.

Maintaining Safety After Test Completion

On completion of a test, even after power has been removed, energy can still be stored in the capacitor in the surge generator, in the output cable and the cable under test, and in the capacitor in the arc reflection filter section. For this reason, the PFL should be grounded after use. The PFL includes both automatic grounding and manual grounding features that will quickly reduce such stored energy to a safe, low level. Immediately after use, set the MODE SELECT switch to GROUND — this grounds the output cable. The surge capacitor is shorted automatically by the discharge resistor when not in use.



Never assume that the coaxial output cable or the cable under test is completely discharged, even after following the above procedures. Always use a **safety ground stick** to ground any conductive part of the circuit and then apply **safety ground jumpers** before touching any connections. Use a hot stick or high-voltage rubber gloves when applying **safety ground jumpers**.

Built-in Safety Features

The PFL incorporates several safety features:

- An interlock circuit to enable the operator to enclose all parts of the complete high-voltage circuit within a secure area. The interlock circuit should be used to shut off input power automatically upon unauthorized entry into the high-voltage area.
- The high-voltage output, the arc reflection filter network and surge generator are isolated from the chassis to reduce the possibility of transient voltages between the chassis ground (**star ground**) and the **local earth ground** when impulsing. This isolation reduces the possibility of current flow through other spurious paths and the possibility of damage to other equipment.
- High-voltage cable is permanently attached.
- An extra-tough jacket is provided on high-voltage output cable.

Megger.

- A special ground scheme maintains all operator accessible parts at the same potential.
- Redundant grounds provide extra protection for operator.
- Low-voltage signal cable grounds are bonded to the **PFL chassis ground** and isolated from **surge ground**.
- Operator and electronic instruments are protected by a redundant surge protection scheme.

3

SPECIFICATIONS

Available Modes

MODE SELECT switch set to ARC REFLECTION (requires cable analyzer):

Arc reflection method

Time domain reflectometry (TDR)

MODE SELECT switch set to SURGE:

Surge tracing and pinpointing

Surge pulse reflection method (requires cable analyzer)

MODE SELECT switch set to DC:

dc burn

dc proof test

Voltage Output

Surge Mode: 0 to 16 kV @ 12 μ F

Surge Interval: 2 to 10 seconds, variable (Full output voltage is not available at 2-second time interval)

DC Mode: 0 to 20 kV

Duty Cycle Continuous

Polarity: Negative with respect to ground

Current Output

DC mode:

60 mA

Megger.

Energy

Capacitance: 12 μ F
Stored Energy: 1536 Joules at 16 kV

Coupling

Arc Reflection Filter/Surge Pulse Coupler: Internally Integrated

Metering

Kilovoltmeter: 0 to 20 kV
Milliammeter: 0 to 60 mA

Environmental

Operating temperature range: -4 to 120°F (-20 to 50°C) continuous duty
Storage temperature range: -22 to 131°F (-30 to 55°C)
Elevation: 6500 ft (2000 m) max. Derate voltage at higher altitudes
Humidity: 5 to 95 percent RH noncondensing (operating and storage)
Climate: Operation is prohibited in direct rain or snow

General

PFL-1000

- Dimensions: 34H x 16W x 16H (864 x 406 x 406 mm)
- Weight: 180 (82 kg)

PFL-4000

- Dimensions: 34H x 16W x x16H in. (864 x 406 x 406 mm)
- Weight: 180 (82 kg)

PFL-5000

- Dimensions: 47.25H x 22W x 30H in. (1200 x 559 x 762 m)
- Weight: 380 (173kg)

Input Voltage

PFL-1000

- 120 V ac; 9A, 50/60 Hz
- 240 V ac or 220 V ac; 4.5 A, 50/60 Hz

PFL-4000

Specify one of the following:

- 120 V ac; 9 A, 50/60 Hz
- 240 V ac or 220 V ac; 4.5 A, 50/60Hz

PFL-5000

Specify one of the following:

- 120 Vac; 11 A; 50/60 Hz
- 230 V ac; 5.5 A; 50/60 Hz

Accessories Supplied

- One 25-ft (7.6-m) high-voltage, shielded output cable with vise-grip clamp
- One 7.5-ft (2.29-m) 3-wire, No. 16 AWG, power input cord with standard cap (IEC 320)
- Two 25-ft (7.6-m) No. 8AWG, flexible ground cables with vise-grip grounding clamps
- One 4-ft (1.2-m) No. 8 AWG, flexible ground cable
- Ground rod
- One interlock shorting plug

Related Products

- CBL125 output cable reels in a portable configuration with 125 ft (38.1 m) extension cables (Cat. No. CBL125)
- CBL125RM output cable reels on a rack-mounted assembly with 125 ft (38.1 m) extension cables for use with vehicle-mounted system configurations (Cat. No. CBL125RM)
- SD-3000 surge detector for direct buried cable (Cat. No. 653000)
- Electromagnetic surge detector for ducted and buried cable (Cat. No. 651113)
- DART Cable Analysis System (Cat. No. 654000)

Megger.

4

INSTALLATION

The PFL-1000, 4000 and 5000 each require somewhat different installations. The PFL-1000 has a compact design that allows it to fit in the tool bin of a service truck. The PFL-4000 is designed for rugged applications that demand portability in the field. The PFL-5000 is intended specifically for installation in a service vehicle.

PFL-1000 Installation

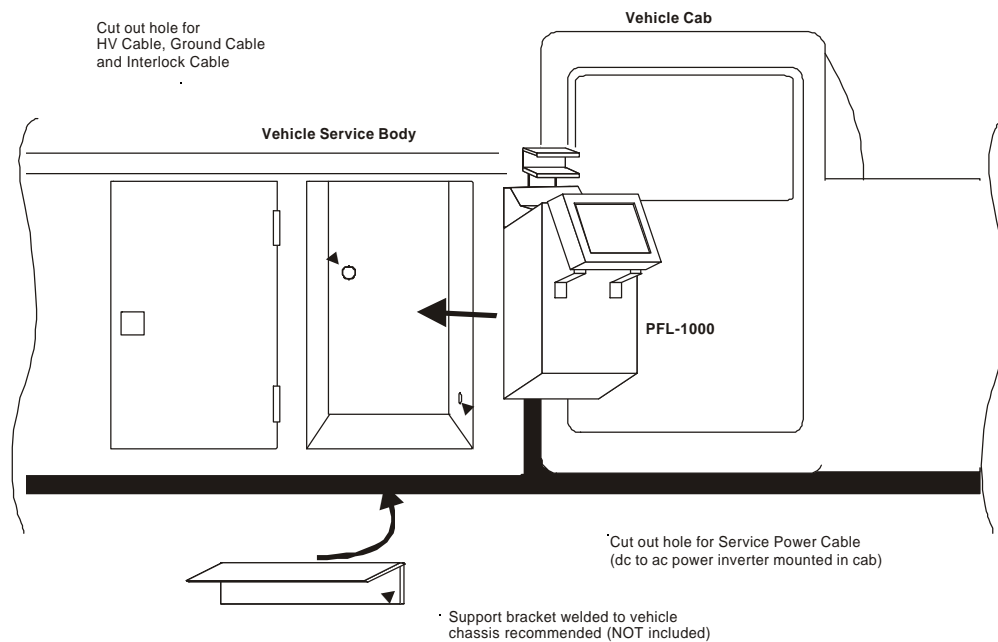

Figure 4-1: PFL-1000 Installation

Megger.

PFL-4000 Installation

The PFL-4000 is a portable unit and requires no installation.

PFL-5000 Installation

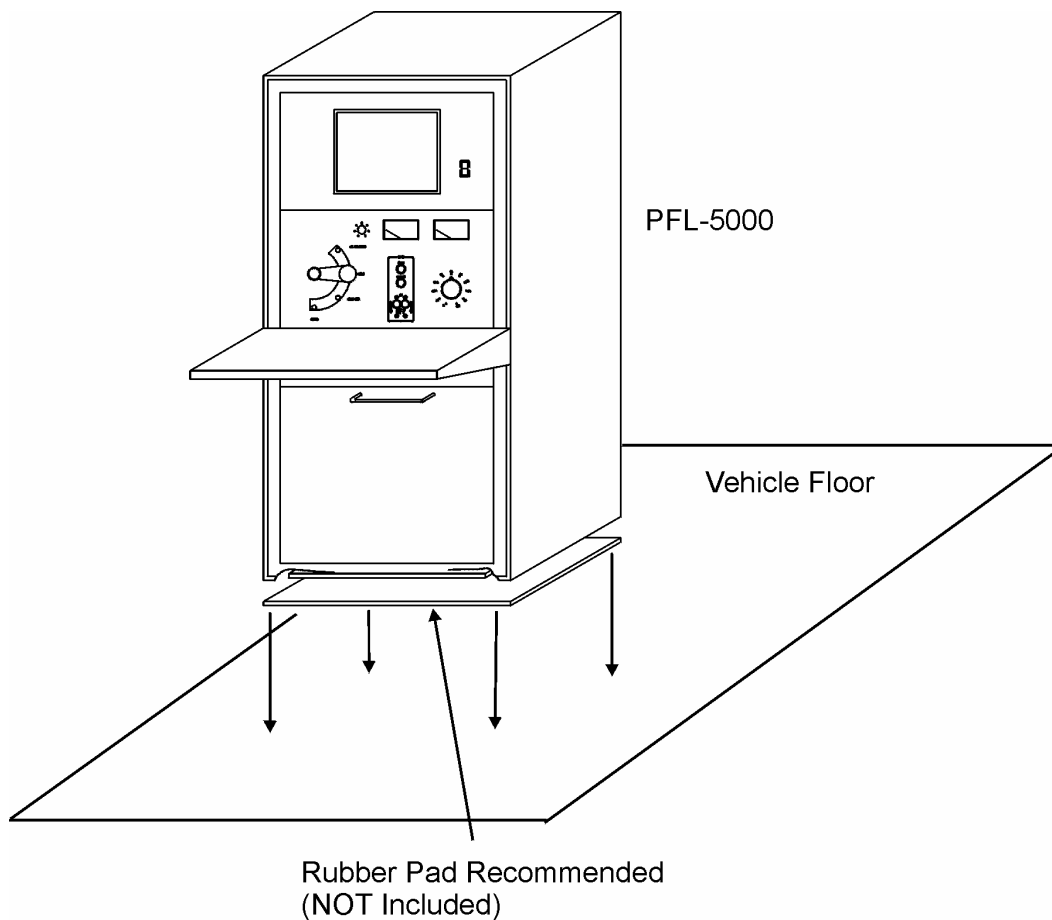

Figure 4-2: PFL-5000 Installation

5

SYSTEM OVERVIEW

Overview of Test Methods and Mode Selection

The PFL is a multifunction unit that handles all system operations. The setting of the MODE SELECT switch implements the different fault locating methods. When the switch is set to DC, the unit operates as a proof tester or dc burner. When the switch is set to SURGE, the unit operates as a surge generator. The unit also includes a current coupler, making the unit compatible with the surge pulse reflection method of fault location. When the switch is set to ARC REFLECTION, the arc reflection filter network is connected to the cable under test. In this mode, the operator can use the arc reflection or TDR methods. The following is a brief description of how the PFL systems operate for the various fault location methods.

NOTE: *When the MODE SELECT switch is set to GROUND, the surge generator and the high-voltage conductor of the output cable are physically connected to **PFL chassis ground**. The MODE SELECT switch must be moved to the GROUND position after the power is turned off.*

DC Operations

Proof Test

The *proof test* is performed to determine whether the cable insulation is good or bad. The cable under test is raised to the required voltage and held there for a prescribed period of time. If the insulation can withstand this voltage, the proof condition has been met and the cable is good. If the insulation is faulty (internal breakdown), the proof condition will not be met and additional testing will be required to locate the fault. Proof tests are effective for determining the breakdown voltage of a defective cable before fault locating.

Burn

The *burn* operation alters the electrical characteristics of the cable fault so that it will break down within the surge voltage range of the system. Burning the cable fault conditions the walls of the fault, reducing its internal resistance. The fault will then break down at a lower voltage. The lower breakdown voltage facilitates the use of other fault locating methods.

When the MODE SELECT switch is set to DC, the PFL can be used to proof the cable or burn the fault.

Surge Pulse Reflection and Surge Tracing Methods

Surge Pulse Reflection

If your PFL has the optional DART Analysis System, you can use the surge pulse reflection method to pre-locate cable faults on cables.. Then you can use surge tracing methods or the DART to pinpoint the fault. The surge pulse reflection method of fault location involves the application of a high-voltage surge to the defective cable. This surge causes the defective cable to break down and form a low impedance arc at the fault site. The electrical transient associated with the breakdown travels along the cable, reflecting back and forth between the fault and the test set. A current coupler measures the fault transient, which appears as an oscillation on the DART screen. The period of this oscillation is used to determine the distance to the fault. The surge pulse reflection method and the arc reflection method are effective for rapid localizing of high-resistance faults.

When the MODE SELECT switch is set to SURGE, the DART is connected to a current coupler.

Surge Tracing

The *surge tracing* method of fault location involves the repeated application of a high-voltage surge to the defective cable. The high-voltage surge causes a large surge current to pass through the fault, causing an acoustic emission at the fault site. The fault position along the cable is traced using detectors designed to respond to either the acoustic or electromagnetic disturbance caused by impulsing the fault. Tracing methods are effective for determining the precise location of a fault. The following Biddle surge detectors are suitable for surge tracing:

| <u>Cat. No.</u> | <u>Description</u> |
|-----------------|--|
| 653000 | SD-3000 Surge Detector (for direct buried cable) |
| 651113 | Electromagnetic Surge Detector (for ducted and buried cable) |

Time Domain Reflectometry (TDR) and Arc Reflection

TDR

The TDR method of fault location uses low-voltage pulses to identify impedance discontinuities along a defective cable. The TDR transmits a low-voltage pulse down the defective cable. This low-voltage pulse reflects back from the impedance discontinuity of the fault. The reflected pulse displays on the TDR screen as either a negative or positive reflection, depending on the fault characteristics. The reflection is used to determine the distance to the fault. This method is effective only if the cable has a low impedance fault (negative reflection) or if the cable is burned open at the fault (positive reflection).

Arc Reflection

In the arc reflection method of fault location, a high-voltage surge of long duration is applied to the defective cable. This surge causes the defective cable to break down and form a low impedance arc at the fault site. Simultaneous with the application of the high voltage, the DART transmits a low-voltage TDR pulse down the defective cable. When the low-voltage pulse arrives at the fault, it is reflected back because the arc is nearly a short circuit. The low-voltage pulses reflected from the fault display on the DART screen as a negative reflection and are used to determine the distance to the fault. The arc reflection method and the surge pulse method are effective for rapid localizing of high-resistance faults.

When the **MODE SELECT** switch is set to **ARC REFLECTION**, the surge generator supplies energy to the arc reflection filter network, and the DART is connected to the cable under test. With the surge generator turned off, the DART operates like a normal TDR on the cable under test. Refer to the instruction manual for the DART Analysis System (AVTM654000) for detailed operating instructions.

Megger[®]

6

SETTING UP THE PFL SYSTEM

Controls and Indicators

The controls and indicators on the top or front panel of the PFL are described below and illustrated in Figure 6-1, Figure 6-2 and Figure 6-3.

Power: Circuit breaker. Applies and removes input power.

HV On: Red lamp. When lit, indicates that output voltage is energized.

Line On: Amber lamp. When lit, indicates that the POWER switch is on and input power is being supplied to the system.

Mode Select: Four-position switch with ARC REFLECTION, SURGE, DC, and GROUND settings. Selects mode of operation or provides for grounding of output and impulse capacitor.

Output Voltage Control: Variable autotransformer adjusts the high-voltage output from minimum to maximum.

Surge Rate: Potentiometer adjusts repetition rate of impulse from 2 to 10 seconds.

Voltage: Meter indicates output voltage level. 0 to 20 kV.

Current: Meter indicates output current level. In DC mode, the ammeter indicates total dc current output of high-voltage supply. In SURGE mode, momentary needle deflection indicates the amount of input current required to recharge the capacitors.

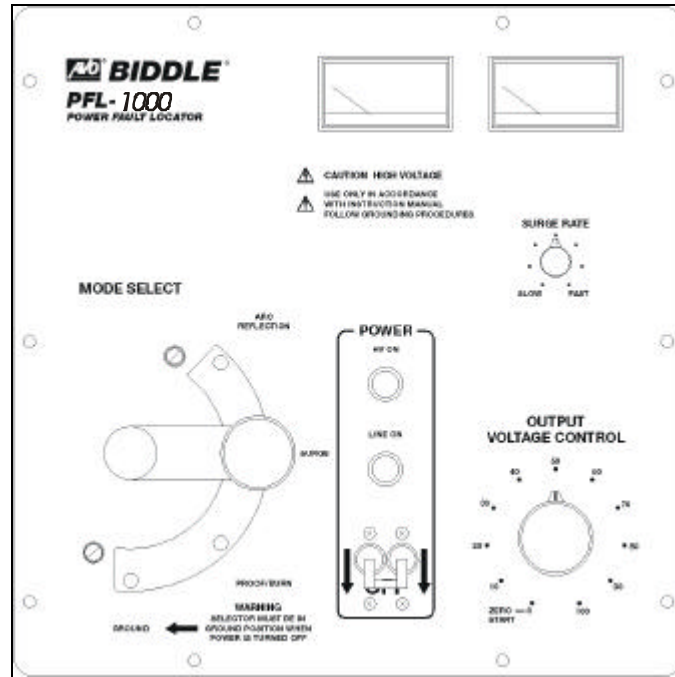

Figure 6-1: PFL-1000 Controls

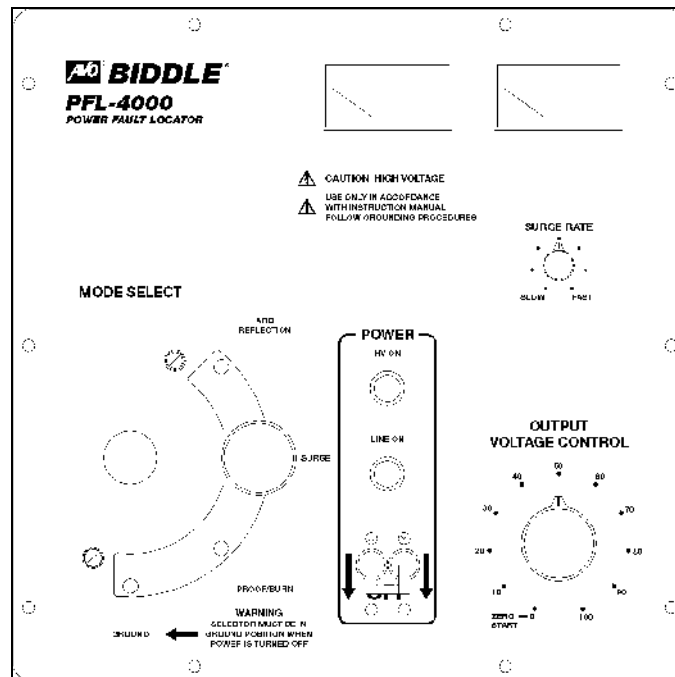

Figure 6-2: PFL-4000 Controls

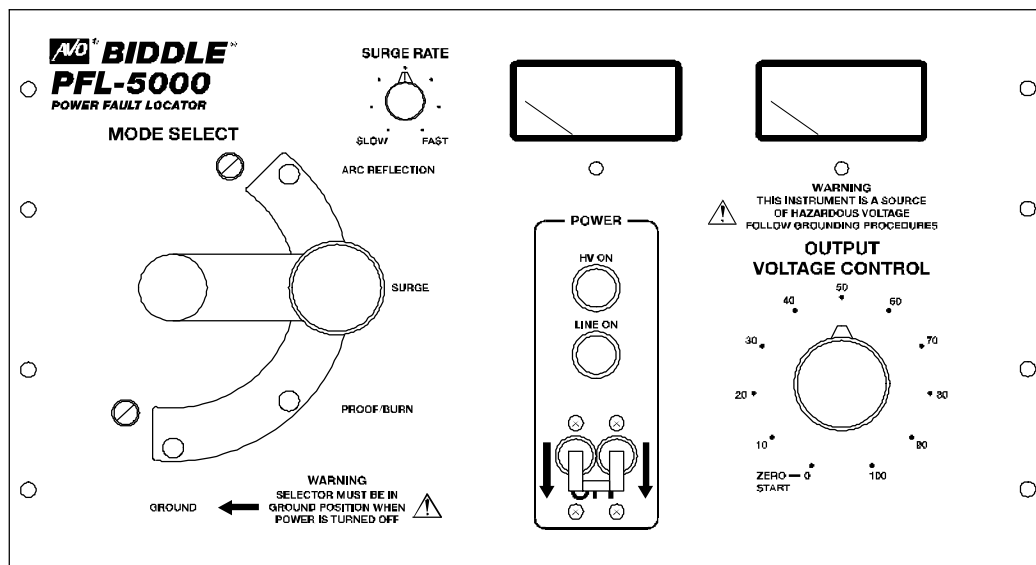

Figure 6-3: PFL-5000 Controls

Connectors

The connectors found on the side or rear panel of the PFL are described below and illustrated in Figure 6-4 through Figure 6-7.

External Interlock: Provides for connection of door interlocks and dead man switches. Connection may be made using two-wire, 18 gauge, or larger, 600 V insulated cable. A mating plug P1 is provided with a shorting wire in the event that a test area interlock is not used. Megger suggests that the customer remove the short circuit from the plug and connect the plug to a suitable test area interlock system. Construct the system so that the interlock switches are closed when the vehicle doors are closed. Run the interlock wiring as a twisted pair to minimize electromagnetic coupling into the system. Connect this interlock system to pins A and B on plug P1. When the interlock loop is opened, the test is automatically terminated.

Input Power cord with clamp: Three-conductor, 18-gauge, 9 ft, 10 in. (2.98 m), connects input power and safety grounding.

HV Output cable: Coaxial cable provides high-voltage output. The white lead is the high-voltage center conductor (red band); the black lead is the shield and surge return and is the **surge ground**.

Ground: Wing nut accepts ground cables.

Refer to the Glossary at the end of this manual for an explanation of symbols used on the system chassis.

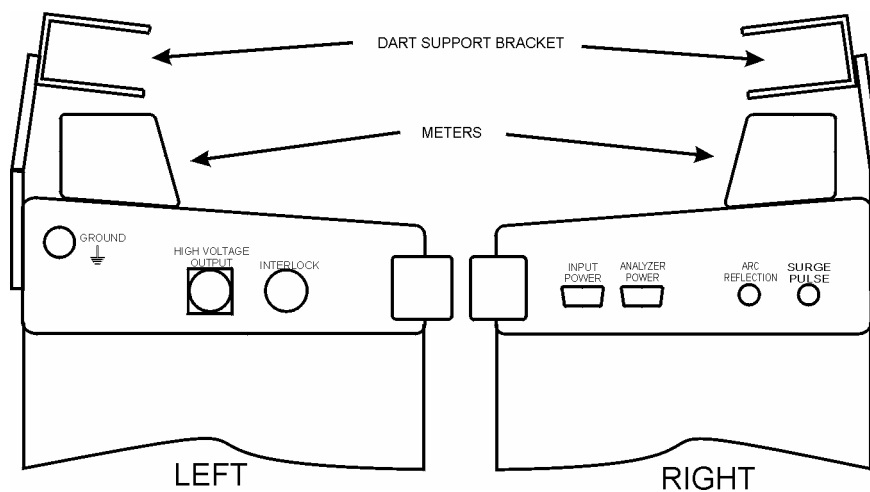

Figure 6-4: PFL-1000 Side Panel Connectors

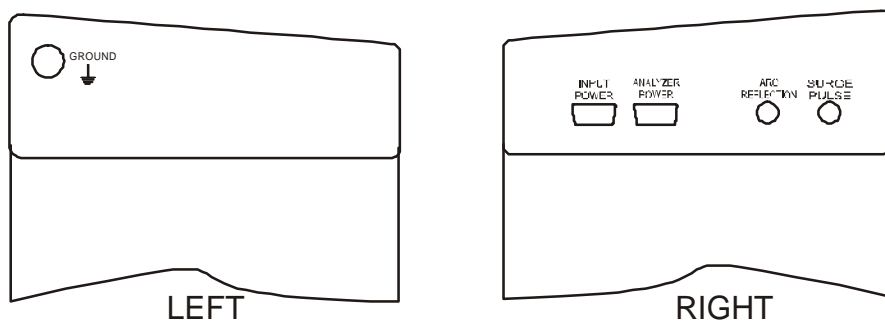

Figure 6-5: PFL-4000 Side Panel Connections

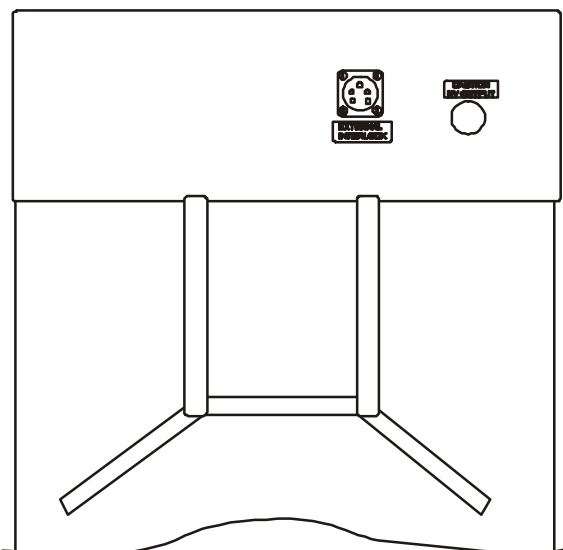

Figure 6-6: PFL-4000 Rear Panel Connections

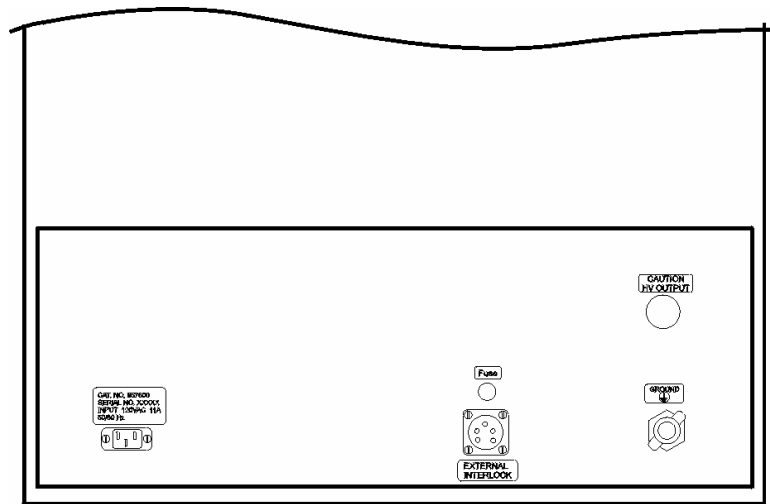

Figure 6-7: PFL-5000 Rear Panel Connections

Grounding System and High-Voltage Connectors



Grounding systems and procedures described in this manual are designed specifically for BIDDLE equipment. If other manufacturers' equipment is used with the PFL, the user is responsible for verifying that the grounding and interconnections between the systems comply with each manufacturer's instructions. The user is also responsible for observing the appropriate safety precautions when working with such equipment. Incompatible grounding systems may prove hazardous.

Safe operation requires strict adherence to the recommended grounding procedure. Simple ground connections may *appear* adequate, but they are not. Under surge conditions, the system grounds may develop hazardous voltages. To minimize the possibility of hazardous voltages occurring under all foreseeable operating conditions, be sure to use firm, low-resistance ground connections that are capable of carrying large surge currents.

The PFL system has numerous grounds. Some are permanently connected when the system is installed. Others are made each time a test is performed. The grounds are described below. Permanent grounds and connections are illustrated in Figure 6-8 and Figure 6-9. Temporary grounds and connections are illustrated in Figure 6-10 through Figure 6-12. Procedures for making the connections are provided later in this section under "System Setup."

Permanent Grounds and Connections

Star ground is the central single ground point of the system. It is the connection point for both the permanent and temporary grounds in the system. This ground point is the **vehicle chassis ground**, a connection point on the vehicle used to transport the equipment. This **star ground** should be located near the rear of the PFL chassis and connected permanently to the **PFL chassis ground**.

The **vehicle chassis ground** is permanently connected from a lug (user supplied) on the vehicle chassis to the **PFL chassis ground** when the system is installed in a vehicle. This ground connection uses the 4 ft (1.2 m) ground cable. This ground maintains the vehicle chassis at the same potential as the other accessible parts in the PFL system. The **vehicle chassis ground** is the **star ground** of the system.

Surge ground refers to any part of the high-voltage return path. The **surge ground** is the shield of the 25-ft (7.6-m) high-voltage output cable. The current in this return path can exceed 10,000 A and can be hazardous if not insulated.

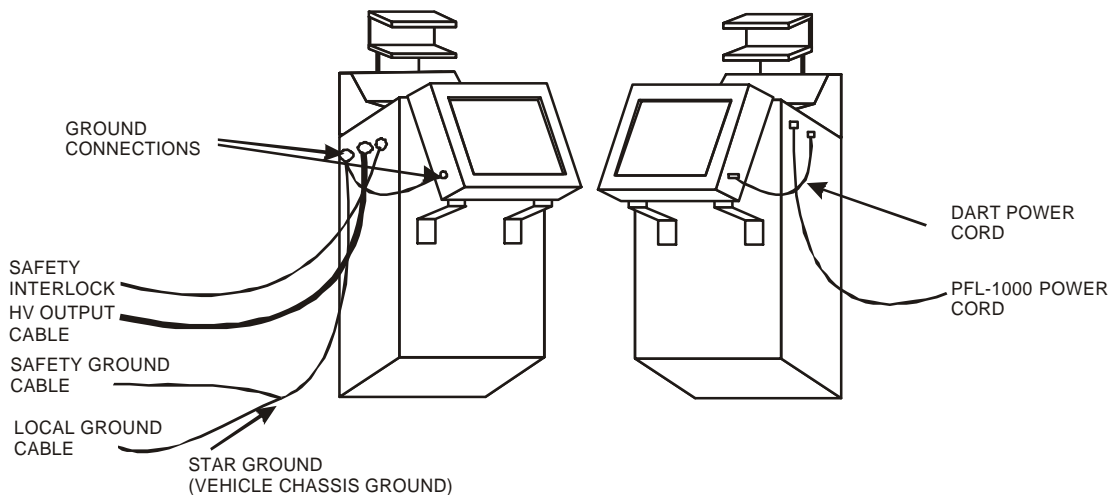

Figure 6-8: PFL-1000 Ground System Diagram, Permanent Connections

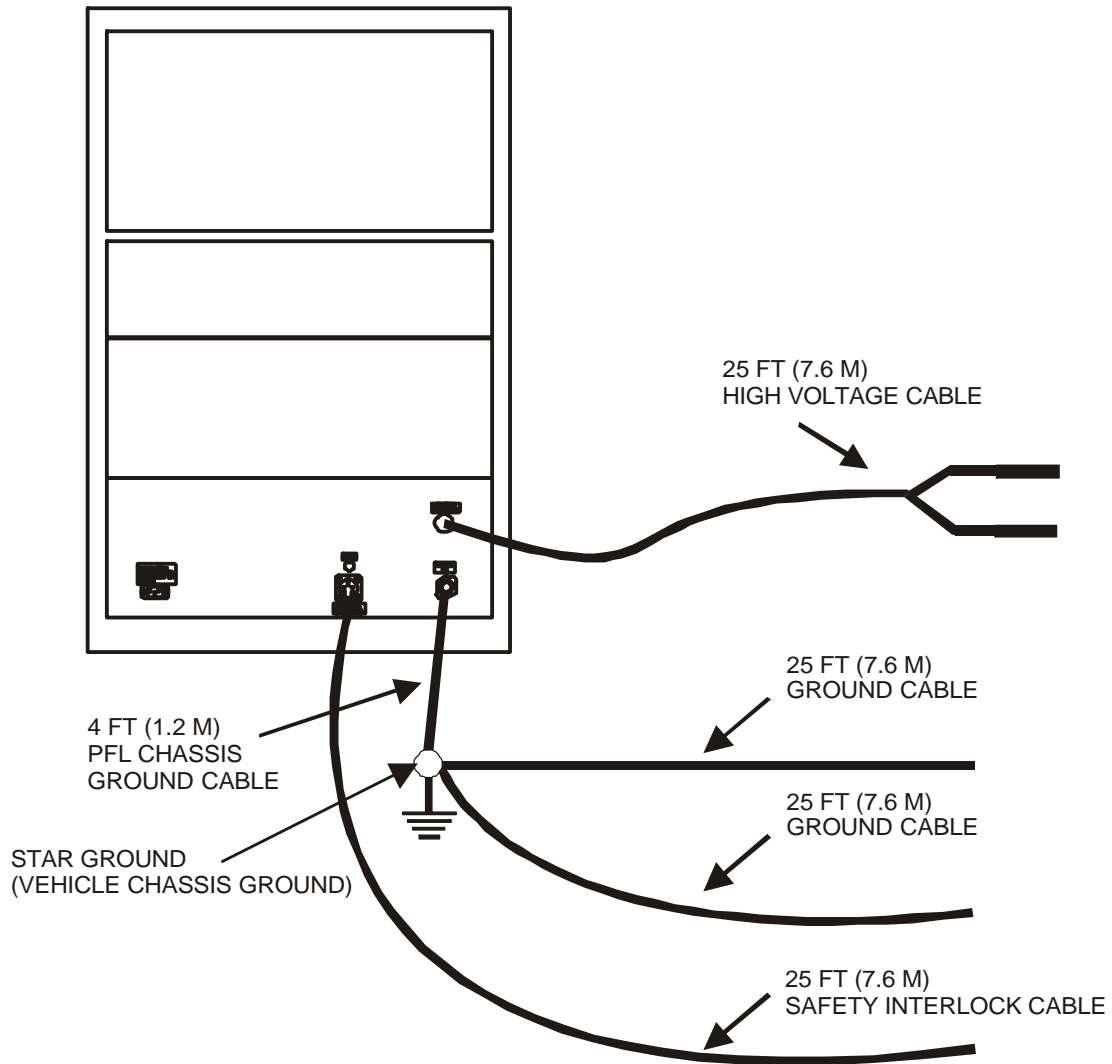

Figure 6-9: PFL-5000 Ground System Diagram, Permanent Connections

NOTE: There are no permanent grounds or connections for the PFL-4000 since it is a portable unit.

Temporary Grounds and Connections

Each time you operate the PFL system, you must make the following connections:

The **local earth ground** is a temporary driven earth ground that is connected by a clamp to one end of the 25-ft (7.6-m) ground cable. The other end of that cable is permanently connected to **star ground**. The purpose of the driven earth ground is to maintain the area surrounding the vehicle at the same potential as the vehicle. The ground should be located as near to the vehicle as practical and should have an impedance of less than 5 Ω . The **local earth ground** connection is made before each test.

The **specimen ground** is the ground conductor (shield, sheath, neutrals) of the cable under test. This ground should be bonded to earth through a driven ground with a low resistance (less than 5 Ω). It is assumed that any cable under test is inherently connected to earth through a driven ground. If the cable under test is not bonded to earth in this fashion, you must make a separate bond, which must have an impedance of less than 5 Ω .

The **safety ground** connection is formed when one end of the 25-ft (7.6 m) portion of the ground cable is connected by a clamp to the **specimen ground**. The other end of the cable is permanently connected to **star ground**. The **safety ground** is used to keep the potential of the vehicle and PFL system to remain at the potential of the **specimen ground** (system neutral). This ground carries little, if any, current. However, should a failure occur in the **surge ground** of the test system, the conductor of the **safety ground** is sized to handle the current. The connection of **safety ground** at **specimen ground** is the single point in the system where **surge ground** and the system chassis grounds are connected. It is important that **safety ground** and **surge ground** are connected at the same point. The **safety ground** connection is made before each test and the first connection made.

The **surge ground test lead** is the ground conductor (shield) of the 25-ft (7.6-m) coaxial high-voltage output cable. It is located at the same end as the **HV test lead**. The **surge ground test lead** is the black lead terminated with a vise-grip clamp, which is used to connect the **surge ground** to the **specimen ground**. The **surge ground test lead** is isolated from the other system grounds except at the **specimen ground** point. The **surge ground** provides the return path for the high-current surge pulse to the surge capacitor. The **surge ground test lead** connection is made before each test and is the second connection made.



Because dangerous voltages develop on the **surge ground** conductor, it must remain isolated from other grounds except at the **specimen ground** point. Tears or breaks in the insulating jacket of the high-voltage output cable expose the **surge ground** and pose a safety hazard to the operator.

The **HV test lead** is the high-voltage conductor of the 25-ft (7.6-m) coaxial high-voltage output cable. Located at the same end as the **surge ground** test lead, the **HV test lead** is a white lead with a red band terminated with a vise-grip clamp. It is connected to the high-voltage conductor of the cable under test. The **HV test lead** connection is made before each test and is the last connection made.

The **power ground** is the third (green/yellow) wire of the power cord that supplies system power (120/230 V ac). The **power ground** connection is made at the source of power for the system. The power cord must be connected to a power source that has a high-rupture fuse or circuit breaker with a current rating not to exceed 15/7.5 A. The ground of the power source must have a low impedance connection to earth (less than 5 Ω).

The **safety ground jumper** is a temporary ground connection that provides protection for the operator and equipment. Before connecting the system to the cable under test, the operator must use a **safety ground stick** to ground all exposed conductors and then connect a **safety ground jumper** cable from the high-voltage conductor of the cable under test to the **specimen ground**. The **safety ground jumper** is removed only during actual testing. After completion of testing, the **safety ground jumper** must be promptly replaced and remain in place until the entire test system is disconnected. The **safety ground jumper** is not supplied with the system.



If you would fail to use a **safety ground jumper** and the cable under test would accidentally become energized, operator-accessible parts of the test system could develop dangerous voltages.

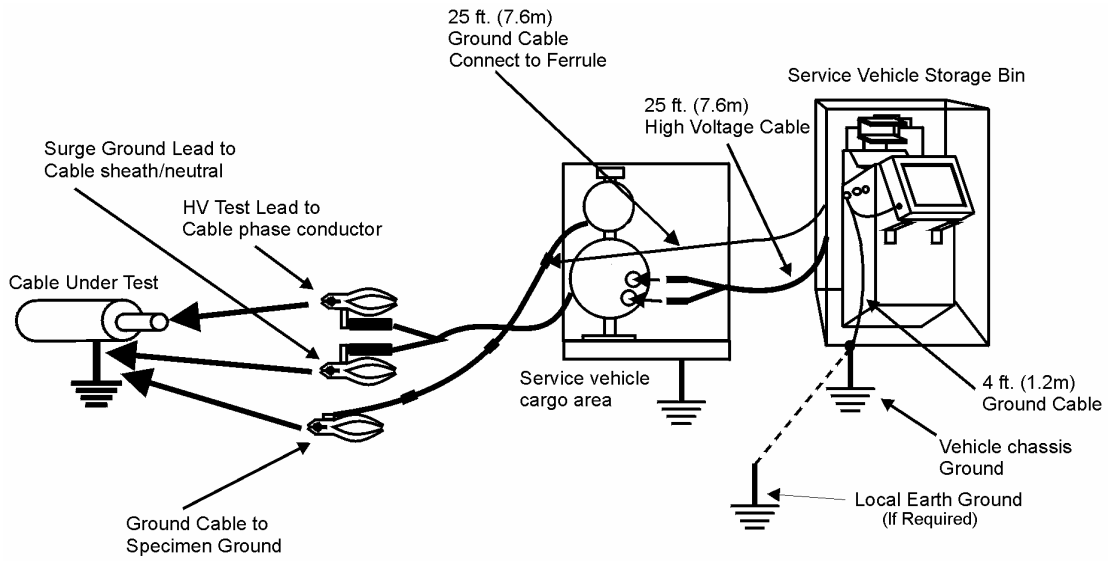

Figure 6-10: PFL-1000 Temporary Connections

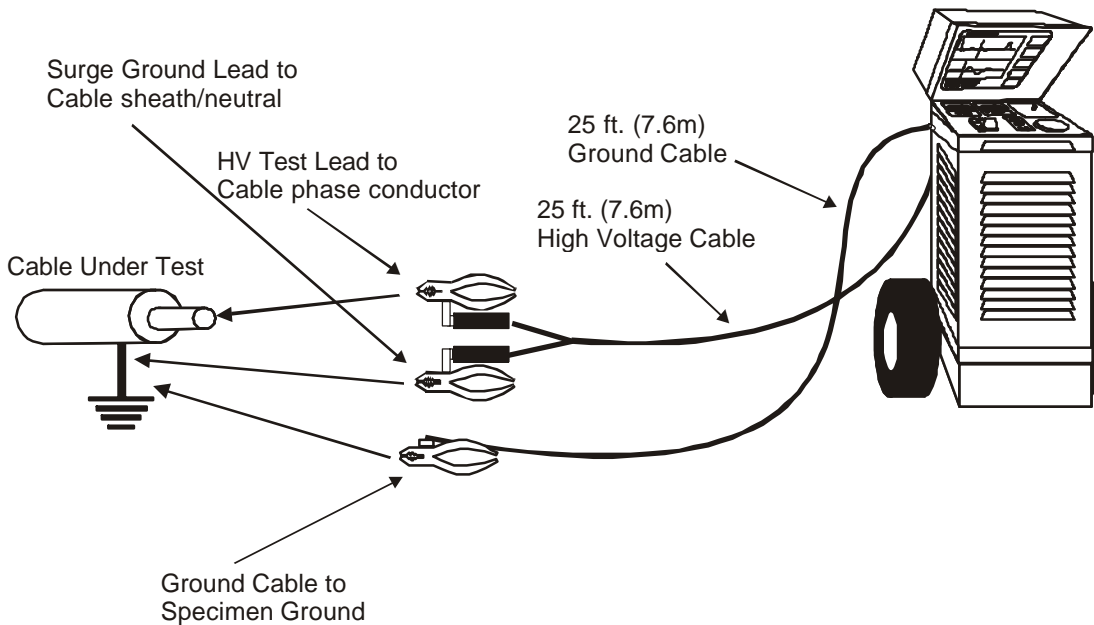

Figure 6-11: PFL-4000 Temporary Connections

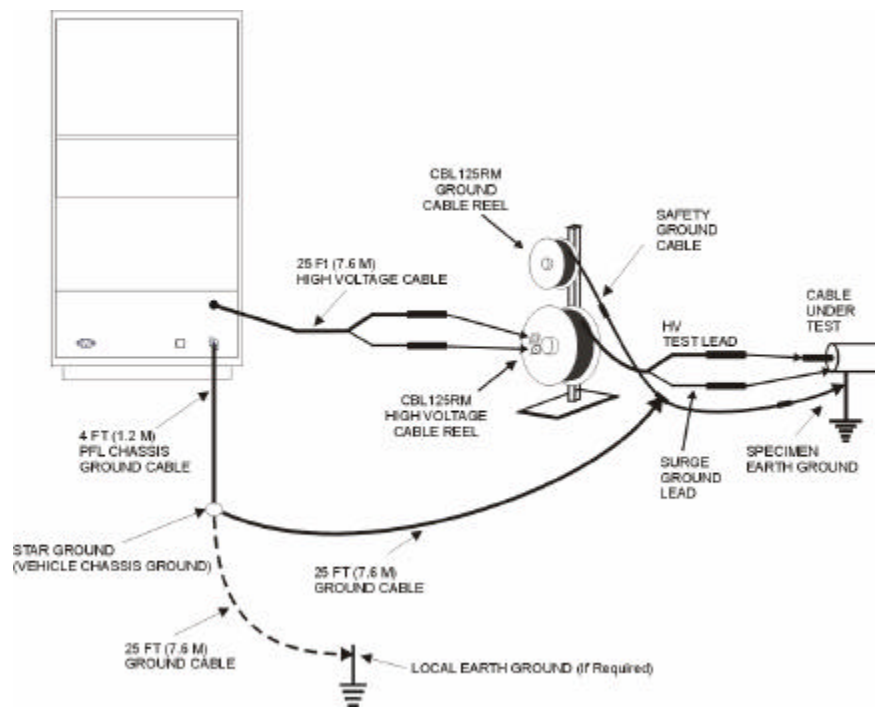

Figure 6-12: PFL-5000 Temporary Connections

System Setup

Before attempting installation and setup

- Read the "Safety" section of this manual thoroughly.
- Confirm that equipment to be tested is disconnected from power.
- Follow the recommended grounding procedures and all other safety precautions.



Misuse of high-voltage equipment is extremely dangerous. Keep personnel clear of bare live parts.

Setup Procedure



Misuse of this equipment can be extremely dangerous. Before operating, read Section 2 and all other safety descriptions contained in this manual.

To prepare the equipment for testing:

1. Observe all safety precautions and be sure all equipment is de-energized. Identify the faulted cables, obtain access to both ends, and erect barriers.
2. Discharge the cable under test by applying a ground using a **safety ground stick** (not supplied). Connect a **safety ground jumper** (not supplied) from the high-voltage conductor of the cable under test to the **specimen ground** (the ground conductor of the cable under test).

WARNING

**SHOCK
HAZARD**

Failure to apply a **safety ground jumper** to the cable under test before connecting it to the system can be extremely dangerous. Use appropriately rated high-voltage rubber gloves or a hot stick when making these connections.

3. Choose a location that meets the following conditions:
 - The vehicle can be safely parked. Set the brakes or block the wheels.
 - An electrical service suitable for the system is near the chosen location. The power source is 120/230 V ac, 50/60 Hz and has a high rupture fuse or circuit breaker with rating not to exceed 15/7.5 A.
 - A secure low-resistance ground (less than 5 Ω) is located within 20ft (6m) of the vehicle. This ground is used to maintain the surrounding area at the same potential as the test system. A driven ground called the **local earth ground** is often used.
 - The location is as dry as possible.
 - There is no flammable material stored in the vicinity.
 - The test area is adequately ventilated.
 - Suitable safety barriers are erected to protect the operator from traffic hazards and to prevent intrusion by unauthorized personnel. Warning lights are recommended.
 - Both the high-voltage conductor and the shield of the cable under test are accessible.
4. After selecting a satisfactory location, connect the **star ground** of the system to the **local earth ground** using the 25 ft (7.6 m) ground cable.
5. Verify that a connection is made between the **vehicle chassis ground** and **PFL chassis ground**.

6. Connect the **safety ground** as follows.
 - Be sure that the **specimen ground** [grounded shield (sheath, shield, neutrals) of the cable under test] connection is a secure low-resistance ground (less than 5 Ω).
 - Extend the **safety ground** cable from the PFL to the cable under test.
 - Connect the **safety ground** cable to the **specimen ground** (grounded shield of the cable under test).
7. Connect the 25-ft (7.6-m) high-voltage output cable as follows.
 - Extend the high-voltage output cable from the PFL to the cable under test.
 - Connect the **surge ground** test lead to the **specimen ground** (grounded shield of the cable under test). This is the black lead terminated with a vise-grip clamp.
 - Connect the **HV test lead** to the faulted high-voltage conductor of the cable under test. This is the white lead with red band terminated with a vise-grip clamp. Be sure that the exposed conductor and clamp are sufficiently insulated to withstand the test voltage.
8. Connect any other conductors of the cable under test to the **specimen ground**, making firm, short connections.
9. Ensure that:
 - The POWER circuit breaker on the PFL is set to OFF.
 - The MODE SELECT switch is set to GROUND.
 - The OUTPUT VOLTAGE CONTROL is set to ZERO START.
10. Remove the **safety ground jumper** applied in Step 2.
11. Connect the power input cord to the service outlet.
12. Connect to the generator as follows:

For vehicles having a motor-driven generator:

1. Make sure that the ground and neutral of the generator are securely tied to the machine frame and to the **vehicle chassis ground**. Be sure that the **vehicle chassis ground** is connected to the **PFL chassis ground**.
2. Start the motor-generator and warm up sufficiently to ensure normal stable operation.

3. Check the motor-generator voltage to ensure proper output voltage.
4. Connect the input power cord of the PFL to the generator output.



Improper voltage levels may damage the PFL.

For operation from a portable engine generator:

1. Locate the engine generator in a well-ventilated area at least 10 ft (3 m) from the test system.
2. Make certain that spare fuel is stored in a suitable safety container well away from both the portable generator and the test system.



To avoid fire, be careful when refueling a portable generator. Do not refuel the generator while it is running.

3. Provide a ground bond between the portable generator frame and a local secure low-resistance ground (less than 5 Ω). Be sure that the green neutral wire is grounded. These leads should be no longer than 25 ft (7.6 m) and should be equivalent to No. 8 AWG or larger.
4. Start the portable generator and warm up sufficiently to ensure normal stable operation.
5. Check the portable generator voltage to ensure proper output voltage.



Improper voltage levels may damage the PFL.

6. Connect the input power cord of the PFL to the generator.
7. When you have completed these procedures, you may conduct tests as described in Section 7.

7

OPERATING THE PFL SYSTEM

Introduction

The PFL is a multifunction unit that can include a DART Analysis System.

In DC Mode, the PFL operates as a proof tester or dc burner.

In SURGE Mode, the unit operates as a surge generator. Also in the SURGE Mode, if a DART Analysis System is included in the unit, an internal current coupler makes the unit compatible with the surge pulse reflection method of fault pre-location.

In ARC REFLECTION Mode, if a DART Analysis System is included in the unit, an internal filter network makes the unit compatible with the arc reflection method of fault pre-location. The low-voltage TDR capability of the DART Analysis System also can be used in ARC REFLECTION Mode.

In GROUND Mode, the high-voltage internal components and any external connected cable are connected to chassis ground.

Consult the DART Analysis System manual for detailed operating instructions and use of the DART.

Changing Modes



Never move the MODE SELECT switch on the PFL during a test. Failure to follow proper procedures for shutting down or changing modes may result in damage to the cable under test or the test system.

1. To transfer from one mode to another on the PFL, turn the **OUTPUT VOLTAGE CONTROL** fully counterclockwise. If transferring from **SURGE** or **ARC REFLECTION**, allow the unit to cycle once through a surge.
2. Turn the **LINE POWER** switch **OFF**. The red **HV ON** and amber **LINE ON** indicators will go out. This will automatically operate the discharge assembly and reduce the output voltage.
3. Wait for the high voltage to discharge to less than 1 kV, as indicated by the front panel **VOLTAGE** meter. This meter has a passive measuring circuit; it will operate normally even though the main power has been turned off. The **MODE SELECT** switch may now be moved to another position.

Discharge Of The Cable And Shutdown

When a cable becomes charged, either because the fault has failed to break down or because the cable is still partially charged from proof testing, it must be discharged before handling and before moving the **MODE SELECT** switch.

1. Turn the **OUTPUT VOLTAGE CONTROL** on the PFL fully counterclockwise. If shutting down from **SURGE** or **ARC REFLECTION** modes, allow the unit to cycle once through a surge.
2. Turn the **LINE POWER** switch **OFF**. The red **HV ON** and amber **LINE ON** indicators will go out and automatically place discharge resistors on the output load.
3. Wait for the high voltage to discharge to less than 1 kV as indicated by the **VOLTAGE** meter. This meter has a passive measuring circuit. The meter will operate normally even though power has been turned off.
4. Set the **MODE SELECT** switch to **GROUND**.

CAUTION

Unless an emergency exists, do not set the **MODE SELECT** switch of the PFL to **GROUND** with the output voltage above 1 kV. This may damage both the instrument and the cable under test.

5. With the **MODE SELECT** switch set to **GROUND**, check that the voltmeter reads zero.
6. For safety during a temporary or permanent shutdown or while making or changing connections, turn **OFF** the **POWER** circuit breaker.

7. Using a **safety ground stick**, ground all exposed high-voltage connections. Connect **safety ground jumpers** from all exposed high-voltage connections to **specimen ground**.
8. Remove the test clamps from the faulted high-voltage conductor and from the **specimen ground**, leaving the **safety ground jumper** in place to drain any relaxation charge.



To make sure that the cable is completely discharged, the temporary **safety ground jumper** should be kept in place for at least four times as long as the test voltage was applied to the cable. Use appropriately rated high-voltage rubber gloves or a hot stick when making these connections.

9. Connect the high-voltage test lead of the test system to the **surge ground** test lead for safety during storage.

DC Mode

Proof Test

Before locating a fault or after cable repairs, it is common practice to test the cable by applying a dc voltage as proof that the conductor is faulted or that the conductor will support voltage. The proof test gives an indication of the voltage required to break down the fault. You can then use the proof test breakdown voltage to select the appropriate voltage level for the arc reflection and surge pulse tests and for surge tracing.

For this test, the system is operated in the DC mode. The cable under test is raised to the required test voltage. If the cable can withstand the test voltage without any arc-over or burning for the necessary time interval, the proof condition has been met, and the cable is presumed good. If the cable fails to pass the proof test, the cable is considered faulty, and further testing is required to locate the fault(s).

Procedure

1. Ensure that you have performed the "Setup Procedure" on page 31. Remove the **safety ground jumper**.
2. Set the POWER circuit breaker on the PFL to ON. The amber LINE ON indicator will illuminate.
3. Set the MODE SELECT switch to DC.

4. Set the OUTPUT VOLTAGE CONTROL firmly to ZERO START. The red HV ON indicator will illuminate.
5. Gradually increase the OUTPUT VOLTAGE CONTROL from zero in small increments while monitoring the output voltage on the VOLTAGE meter. When the output reaches the desired level, hold that voltage for the prescribed period of time with no further adjustment of the OUTPUT VOLTAGE CONTROL. Failure is indicated by
 - inability of the VOLTAGE meter to stabilize at the desired voltage without readjustment or
 - a rapid fall-off of voltage that will not increase when the OUTPUT VOLTAGE CONTROL is increased or
 - an abnormal increase in the output current from a low value of milliamperes as monitored on the CURRENT meter.

If the proof test fails at a voltage **less** than the surge capability of the surge generator, you may:

- Stop the test to prevent further fault damage.
- Transfer to the ARC REFLECTION mode or SURGE mode to pre-locate the fault.

If the proof test fails at a voltage **greater** than the surge capability of the surge generator, you may:

- Stop the test to prevent further fault damage.
- Proceed with burn-down.
- **If further testing is required**, refer to "Changing Modes" on page 35.
- **If testing is complete**, refer to "Discharge Of The Cable And Shutdown" on page 36.

Burn-Down

In burn-down, the output voltage is increased until the cable fault breaks down. The fault resistance decreases and the current supplied by the test set increases. The objective is to cause thermal runaway, which will permanently change conditions of the fault and alter its internal resistance from high to low. This reduction in fault resistance will change the electrical characteristics of the fault so that the fault will break down at a lower voltage, and the current draw after breakdown will be greater. Then the cable fault will provide a stronger surge signal, allowing easier location of the cable fault using the arc reflection, surge pulse or surge tracing method.

NOTE: *In some instances, excessive burning is counterproductive. For some materials with low melting temperatures, excessive burning causes the material surrounding the fault to become molten. Rather than burning, the molten material begins to flow, in effect removing any charred material from the fault channel. This may have the effect of increasing the breakdown voltage.*

1. Ensure that you have performed the "Setup Procedure" on page 31. Remove the **safety ground jumper**.
2. Set the POWER circuit breaker on the PFL to ON. The amber LINE ON indicator will illuminate.
3. Set the OUTPUT VOLTAGE CONTROL firmly to ZERO START. The red HV ON indicator will illuminate.
4. Raise the OUTPUT VOLTAGE CONTROL to the desired level of voltage or current. A burn-down is accomplished by gradually increasing the OUTPUT VOLTAGE CONTROL to the proof test voltage level or until the output current develops to its maximum, then readjusting as necessary to maintain either condition until the output voltage falls below the surge voltage capability of the surge generator. At this point, you may choose to discontinue testing, or continue to reduce further the voltage across the fault.
 - **If further testing is required**, refer to "Changing Modes" on page 35.
 - **If testing is complete**, refer to "Discharge Of The Cable And Shutdown" on page 36.

Arc Reflection Mode

Locating A High-Resistance Fault

When TDR pulses are applied to the cable under test simultaneous with high voltage that exceeds the fault breakdown voltage, a low-resistance arc forms at the fault site. The TDR pulses reflected from the fault arc appear as a negative reflection on the DART screen. Although this negative reflection appears only for a fraction of a second each time the surge generator pulses the cable, the DART is able to capture and display it.

The DART has a cursor that allows the operator to measure the distance, in feet or meters, to the fault. The cursor adjustment is used to position the cursor at the leading edge of the reflection from the arc. During the arc reflection test, the cable under test has a voltage surge applied to it. Cable faults can usually be surged at any voltage that is higher than the breakdown voltage developed in the proof test or during burn-down. The output voltage is slowly raised to the test level without exceeding the recommended proof test rating of the cable.

If the output voltage is held constant and the cable fault is not breaking down, the VOLTAGE meter will promptly stabilize. This indication means the cable is charged to the applied output voltage of the test set. If the fault does not break down below limit of the surge capability of the surge generator, a burn-down procedure must be used to reduce the breakdown voltage further.

The arc reflection test may be applied directly (without prior testing) to determine whether a fault may be surged without need to burn-down. To ensure that the fault breakdown occurs with each surge, the output voltage should be raised slightly above the fault breakdown level as a minimum. In the ARC REFLECTION mode, this will not apply an over-voltage to the cable, but will increase the current through the fault. This makes it easier to capture the momentary negative reflection, during the fault arc time.

Procedure

NOTE: *For more information about the DART controls, refer to the instruction manual for the DART Analysis System. (AVTM654000)*

1. Ensure that the "Setup Procedure" on page 31 has been performed. Remove the **safety ground jumper**.
2. Set the POWER circuit breaker on the PFL to ON. The amber LINE ON indicator will illuminate.
3. Set the MODE SELECT switch on the PFL to ARC REFLECTION.
4. Set the POWER switch on the DART to ON and select the ARC mode.
5. Set the VELOCITY on the DART if a change from the default is required.
6. Set the RANGE on the DART to a distance greater than the length of the cable under test.
7. Set SAMPLE mode on the DART to CAPTURE.

8. Set the OUTPUT VOLTAGE CONTROL firmly to ZERO START. The red HV ON indicator will illuminate.

9. Raise the OUTPUT VOLTAGE CONTROL to the desired level.

If a burn-down procedure or proof test has not been performed, determine the minimum surge breakdown level of the fault as follows: increase the voltage every 20 seconds in small increments, say every 2 kV, starting at 2 kV until breakdown is observed. Once breakdown is achieved, the VOLTAGE meter will dip (momentary downward needle deflection) with each surge, indicating that there is an energy transfer with each surge from the test system to the cable. Increasing the voltage slightly above this level will enhance the display on the DART.

To surge at rated voltage or at some other limit below rated voltage, increase the voltage every 20 seconds, starting with large increments but approaching the limit gradually so as not to overshoot that point. If the fault was burned down previously, the initial breakdown usually occurs before the voltage achieved in the burn-down is reached.

If the fault fails to break down before reaching the proof test voltage level of the cable, you must use a burn-down procedure to reduce the fault breakdown voltage. Refer to "Burn-Down" on page 38.

- 10.** Once a downward reflection is observed on the DART screen, adjust the cursor until it is positioned at the front edge of the negative reflection. Read the distance to the fault at the top of the screen.
- If use of the ARC mode fails to localize the fault, use the "Surge Pulse Reflection Method" as described on page 43.
 - **If further testing is required**, refer to "Changing Modes" on page 35.
 - **If testing is complete**, refer to "Discharge Of The Cable And Shutdown" on page 36.
- 11.** Trace the path of the cable with a suitable cable route tracer and use a distance-measuring wheel to establish the pre-location site along the cable. Then pinpoint the fault location using surge tracing as described under "Surge Tracing to Pinpoint the Fault" on page 45.

Locating A Low-Resistance Fault

When the fault impedance is less than 200 Ω , the fault is considered a low-resistance fault, and TDR is usually an effective method for pre-locating the fault. TDR is also effective if the conductor or neutral is blown open.

The basic concept of TDR is easy to understand. When a pulse is transmitted down a cable, it travels along the cable at a velocity particular to that cable. When the pulse encounters a change in the characteristics of the cable (impedance discontinuity at the fault) some of the pulse energy is reflected back toward the transmitter. Measurable reflections occur when the impedance discontinuity at the fault is less than 200 Ω or if the conductor or neutral is open circuited. The reflected energy from low-resistance faults appears as negative blips on the DART screen. The reflected energy from blown-open faults appears as positive blips on the DART screen. The DART has cursors that allow the operator to measure the distance in feet (meters) to the fault.

Procedure

| |
|--|
| <p>NOTE: For more information about the DART controls, refer to the instruction manual for the DART Analysis System (AVTM654000).</p> |
|--|

1. Ensure that the "Setup Procedure" on page 31 has been performed. Remove the **safety ground jumper**.
2. Set the MODE SELECT switch on the PFL to ARC REFLECTION. High voltage is not used with this test.
3. Turn the POWER switch on the DART to ON and choose the TDR method.
4. Set VELOCITY on the DART if a change from the default is required.
5. Set the range on the DART to a distance greater than the length of the cable under test.
6. Locate the fault. Adjust the cursor until it is positioned at the beginning of the negative reflection for a low-resistance fault or at the beginning of the positive reflection for a blown-open fault. Read the distance to the fault at the top of the screen.
 - If further testing is required, refer to "Changing Modes" on page 35.

7. Trace the path of the cable with a suitable cable route tracer and measure the distance to the pre-location site along the cable route using a distance-measuring wheel.

If TDR is unsuccessful in locating the fault, use the arc reflection method as described above. Then pinpoint the fault using the method described under "Surge Tracing to Pinpoint the Fault" on page 45.

Surge Mode

Surge Pulse Reflection Method

The surge pulse method is usually an effective method for pre-locating a high-resistance fault (greater than 200 Ω) when the arc reflection method does not work effectively. The surge pulse method is related to the TDR method in that the PFL generates the pulse that produces reflections from the fault location during breakdown.

A current coupler is built into the PFL to measure the high frequencies in the transient as a series of spikes each separated by the round-trip travel time from the fault to the surge generator.

The DART has dual cursors that allow the operator to measure the distance, in feet (meters), to the fault. The cursors are adjusted to position a left and a right cursor on two consecutive reflections from the fault. The first (and possibly the second) pulse in the transient are due to the surge pulse used to energize the cable and are not related to the fault location. Therefore, the third and later pulses should be used to locate the fault.

Cable faults can usually be surged at any voltage higher than the breakdown voltage that developed in the proof test or during burn-down. The output voltage is slowly raised to the test level without exceeding the recommended proof test rating of the cable. Once breakdown is achieved, the **VOLTAGE** meter will dip (momentary downward needle deflection) with each surge, indicating that there is an energy transfer with each surge from the test system to the cable under test. In addition, at each discharge, the **CURRENT** meter will increase by 30 percent of the full scale or more and then begin to reduce as the surge capacitor becomes charged.

The surge pulse method may be applied directly (without prior testing) to determine whether you can surge a fault without the need to burn-down. To ensure that the fault breakdown occurs with each surge, raise the output voltage slightly above the fault breakdown level as a minimum.

Procedure

NOTE: *For more information about the DART controls, refer to the instruction manual for the DART Analysis System (AVTM654000).*

1. Ensure that you have performed the Setup Procedure on page 31. Remove the **safety ground jumper**.
2. Set the POWER circuit breaker on the PFL to ON. The amber LINE ON indicator will illuminate.
3. Set the MODE SELECT switch on the PFL to SURGE.
4. Set the POWER switch on the DART to ON and select the SURGE mode
5. Set the VELOCITY on the DART if a change from the default is required.
6. Set the RANGE to a distance 2 to 3 times greater than the length of the cable under test.
7. Set SAMPLE mode to CAPTURE.
8. Set the OUTPUT VOLTAGE CONTROL firmly to ZERO START. The red HV ON indicator will illuminate.
9. Raise the OUTPUT VOLTAGE CONTROL to the desired level. Do not exceed the rated surge voltage of the PFL for any extended period of time.
 - If you have not performed a burn-down procedure or proof test, determine the minimum surge breakdown level of the fault by increasing the voltage every 10 seconds in small increments (for example, every 2 kV, starting at 2 kV) until breakdown is observed. Once breakdown is achieved, the kilovoltmeter will dip (momentary downward needle deflection) with each surge, indicating an energy transfer with each surge from the test system to the cable. Increasing the voltage slightly above this level will enhance the display on the DART.
 - To surge at rated voltage or at a limit below rated voltage, increase the voltage every 20 seconds, starting with large increments but approaching the limit gradually so as not to overshoot that point. If the fault was burned down previously, the initial breakdown will usually occur before the voltage achieved in the burn-down is reached.

- If the fault fails to break down before the voltage reaches the proof test voltage level of the cable, you must use a burn-down procedure to reduce the fault breakdown voltage. (Refer to "Burn-Down" on page 38.)
- 10.** Once a transient is observed, adjust the left cursor on the DART until it is positioned at the peak of a well-defined pulse.
 - 11.** Adjust the right cursor on the DART until it is positioned at the peak of the next pulse.
 - 12.** Read the distance to the fault at the top of the DART screen.
 - If further testing is required, refer to "Changing Modes" on page 35.
 - If testing is complete, refer to "Discharge Of The Cable And Shutdown" on page 36.
 - 13.** Trace the path of the cable with a suitable cable route tracer and use a distance-measuring wheel to establish the pre-location site along the cable. Then pinpoint the fault location using the Surge Tracing method as follows.

Surge Tracing to Pinpoint the Fault

The arc reflection and surge pulse methods are referred to as *terminal* methods because they pre-locate the fault from the terminals of the cable under test. After pre-location, the operator uses a *tracing* method to locate the fault precisely. The operator traces the length of the cable under test near the pre-location site using a detector (such as the Biddle SD-3000 Surge Detector) while applying voltage surges. When a fault breaks down, it generates both electromagnetic and acoustic transients. The detector responds to these disturbances.

When the fault has a high impedance, applying a surge causes the fault to spark over. Lower impedance faults conduct the energy back through the return path. Acoustic disturbances are usually associated only with spark-over of the fault. Rapid delivery of the current through the fault also intensifies the acoustic disturbance. The **SURGE** mode is preferable to the **ARC REFLECTION** mode because the surge mode is much more effective for generating strong acoustic disturbances at the fault site. Never attempt to pinpoint a fault location with the PFL in the **ARC REFLECTION** mode.

Cable faults can usually be surged at any voltage higher than the breakdown voltage that developed in the proof test or in the burn-down. The output voltage is slowly raised to the test level without exceeding the recommended proof test rating of the cable. Once breakdown is achieved, the **VOLTAGE** meter will dip (momentary downward needle deflection) with each surge,

indicating that with each surge, there is an energy transfer from the test system to the cable. In addition, at each discharge, the **CURRENT** meter will increase by 30 percent of the full scale or more and then begin to reduce as the surge capacitor becomes charged.

If the output voltage is held constant and the cable fault is not breaking down, the **VOLTAGE** meter will promptly stabilize, indicating that the cable is charged to the applied output voltage of the test set. If the fault does not break down below limit of the surge voltage of the surge generator, a burn-down procedure must be used to reduce the fault breakdown voltage further.

The surge test may be applied directly (without prior testing) to determine whether a fault may be surged without need to burn-down. To ensure that the fault breakdown occurs with each surge, the output voltage should be raised slightly above the fault breakdown level as a minimum.

CAUTION

Be careful not too use too high a voltage, which may damage the cable under test.

In the **SURGE** mode, the applied voltage is a fast-rise step voltage. The fault breakdown does not occur at the instant that the voltage exceeds the breakdown voltage. There is a time lag, sometimes as long as 100 ms. During breakdown, transients are generated that theoretically may be four times the magnitude of the surge voltage, peak to peak.

Procedure

1. Ensure that the Setup Procedure on page 31 has been performed. Remove the **safety ground jumper**.
2. Set the **POWER** circuit breaker on the PFL to **ON**. The amber **LINE ON** indicator will illuminate.
3. Set the **MODE SELECT** switch on the PFL to **SURGE**.
4. Set the **OUTPUT VOLTAGE CONTROL** firmly to **ZERO START**. The red **HV ON** indicator will illuminate.

CAUTION

If the fault fails to break down, do not exceed the rated surge voltage of the PFL for any extended period of time. This will degrade the life of the surge capacitor.

- If you have not performed a burn-down procedure or proof test, determine the minimum surge breakdown level of the fault by increasing the voltage every 10 seconds in small increments (for example, every 2 kV, starting at 2 kV) until breakdown is observed. Once breakdown is achieved, the kilovoltmeter will dip (momentary downward needle deflection) with each surge, indicating an energy transfer with each surge from the test system to the cable.
 - To surge at rated voltage or at a limit below rated voltage, increase the voltage every 20 seconds, starting with large increments but approaching the limit gradually so as not to overshoot that point. If the fault had been burned down previously, the initial breakdown will usually occur before the final voltage is reached.
 - If the fault fails to break down before reaching the proof test voltage level of the cable, you must use a burn-down procedure to reduce the fault breakdown voltage as described under Burn-Down on page 38.
5. Pinpoint the fault by patrolling (tracing) the length of the cable near the pre-location site with an acoustic surge detector such as the SD-3000.
- If further testing is required, refer to "Changing Modes" on page 35.
 - If testing is complete, refer to "Discharge Of The Cable And Shutdown" on page 36.

Operating Notes

Troubleshooting

Megger maintains a complete repair service and recommends that its customers take advantage of this service in the event of any equipment malfunction. If the PFL fails to operate properly, the following information will be useful in determining the cause of the malfunction. Table 6-1 identifies possible equipment malfunctions and suggests the possible cause.



The PFL can produce and contain dangerous voltages. Any service or repair of this equipment should be performed only by qualified persons who are aware of high-voltage hazards and the necessary precautions routinely taken to prevent injury.

Review any trouble reports before performing work. Table 6-1 does not specifically mention wiring or hardware defects, since the possibility of those types of defects always exists and is not particular to the PFL unit.

| Table 6-1: Troubleshooting Guide | |
|---|--|
| Problem | Start circuit inoperative |
| Possible Cause | Open circuit in system interlock circuit Interlock microswitches defective MODE SELECT switch not activating microswitches OUTPUT VOLTAGE CONTROL not set firmly to ZERO START. |
| Remedy | Reset OUTPUT VOLTAGE CONTROL to ZERO START. |

| | |
|------------------------|--|
| Problem | Low or no output voltage |
| Possible cause | |
| In DC mode | Defect in high-voltage generator. Defect in high-voltage discharge assembly. Open or short circuit in high-voltage output cable. Defect in the MODE SELECT switch. |
| In SURGE mode | Defect in high-voltage discharge assembly. Open or short in input or output cable. Defect in MODE SELECT switch. |
| In ARC REFLECTION mode | Filter network capacitor shorted. Defect in high-voltage discharge assembly. Open or short in input or output cable. Defect in high-voltage resistor. Defect in MODE SELECT switch |

Testing the System

Setup

1. Erect suitable safety barriers to protect the operator from traffic hazards and to prevent intrusion by unauthorized personnel. Warning lights are recommended. Observe all safety precautions.
2. Choose a location that meets the following conditions:
 - An electrical service suitable for the system is available. The service ground wire is connected to a secure low-resistance ground (less than 5 Ω). The power source has a high-rupture fuse or circuit breaker with rating not to exceed 15/7.5 A, 120/240 V ac, 50/60 Hz.
 - A secure low-resistance ground (less than 5 Ω) is located within 20 ft (6 m) of the vehicle. A driven ground, called the **local earth ground**, is often used. This ground maintains the surrounding area at the same potential as the test system.
 - The location is as dry as possible.
 - No flammable material is stored in the vicinity.
 - The test area is adequately ventilated.
3. After you have selected a satisfactory location for the equipment, connect the **star ground** of the system to the **local earth ground** using the 25 ft (7.6 m) ground cable. This ground takes the place of the **safety ground** used in normal testing. Refer to Figure 6-9 on page 27 for details.
4. Verify that a connection is made between the **vehicle chassis ground** and **PFL chassis ground**. Refer to "Permanent Grounds and Connections" on page 26 for details.
5. Connect the output **surge ground test lead** (return lead of the high-voltage output cable with the vise-grip clamp) to the **local earth ground** (same driven ground used in Step 3).
6. Ensure that:
 - The POWER circuit breaker on the PFL is set to OFF.
 - The MODE SELECT switch is set to GROUND.
 - The OUTPUT VOLTAGE CONTROL is set to ZERO START.
7. Connect the power input cord to the service outlet.

When you have completed these procedures, you are ready to conduct the system tests as described below.

Performance Checks

You can perform the following procedures anytime to verify proper operation, either in the shop, after performing routine maintenance, or in the field, before conducting a fault locating operation. If all conditions of the following tests are met, the system is fully functional.

| | |
|---|--|
| Surge Function Test/SURGE mode | Tests the surge function of the system. |
| Surge Function Test/ARC REFLECTION mode | Tests the system in the arc reflection mode. |
| Proof Function Test | Tests the proof function of the DC mode of the system. |
| Burn Function Test | Tests the burn-down function of the DC mode of the system. |
| Arc Reflection Function Test | Tests the ARC REFLECTION mode of the system. |
| TDR Function Test | Tests the TDR mode of the system. |

Fault characteristics can vary widely or, in some cases, a fault will temporarily clear up on its own. For such unusual conditions, the performance check procedures can eliminate equipment malfunction as a possible problem and isolate fault characteristics as the problem.

Adequate clearances or blanketing between the exposed energized conductor and any adjacent grounds must be maintained to prevent spark-over. An uncontrolled spark-over can create a safety hazard.

Surge Function Test/SURGE Mode

To test the surge function of the system in the SURGE mode, perform the following procedure:

1. Ensure that you have performed the "Setup" procedures in this section.
2. Verify that **star ground** is connected to **local earth ground** and that the **surge ground** test lead is connected to **local earth ground**.

3. Connect the high-voltage test lead of the output cable to the **surge ground test lead** creating a short circuit between high-voltage and surge ground.
4. Set the POWER circuit breaker on the PFL to ON.
5. Set the MODE SELECT switch to SURGE.
6. Set the OUTPUT VOLTAGE CONTROL firmly to ZERO START. The red HV ON indicator will illuminate.
7. Slowly turn the OUTPUT VOLTAGE CONTROL fully clockwise and observe the following:
 - Between each discharge the surge capacitor charges approximately to its maximum value as indicated on the VOLTAGE meter.
 - At each discharge, the VOLTAGE meter needle swings downward and then begins to increase as the surge capacitor completes its charge.
 - In addition, at each discharge, the CURRENT meter increases to 30 percent of full scale or more and then decreases as the surge capacitor completes its charge.
8. These meter indications confirm that the surge portion of the system is operating properly. If you do not observe these indications, double-check the procedure and refer to "Table 6-2: Troubleshooting Guide" on page 48.
9. Repeat steps 1 through 10 with the RANGE SELECT switch in the 0 - 32 kV position.
10. This completes the Surge Function Test.
 - If further testing is required, refer to "Changing Modes" on page 35 to transfer to another mode.
 - If testing is complete, perform the "Discharge Of The Cable And Shutdown" procedure on page 36.

OPTIONAL Surge Function Test/SURGE Mode

To be sure a "thump" is being produced in the SURGE mode, perform the following procedure:

1. Ensure that you have performed the "Setup" procedures in this section.
2. Verify that **star ground** is connected to **local earth ground** and that the **surge ground** test lead is connected to **local earth ground**.

3. Position the high-voltage test lead in a barricaded high-voltage test area so that it is insulated from the ground or any other conductive object by a minimum of 2 ft (0.61 m) of air space.
4. Create a spark gap between the vise-grip clamps on the high-voltage output cable by adjusting the spacing between the two clamps until it is less than 0.104 in. (#38 drill). This will set the breakdown voltage to less than 8 kV.
5. Set the POWER circuit breaker on the PFL to ON. The amber LINE ON indicator will illuminate.
6. Set the MODE SELECT switch to SURGE.
7. Set the OUTPUT VOLTAGE CONTROL firmly to ZERO START. The red HV ON indicator will illuminate.
8. Slowly turn the OUTPUT VOLTAGE CONTROL clockwise until the following is observed:

CAUTION

This test will create a very loud audible sound as the energy in the capacitor discharges at the spark gap. Warn any persons in the vicinity of this possibility and provide ear protection.

- The spark gap between the vise-grip clamps of the high-voltage cable breaks down and creates an audible sound.
 - Between each discharge the surge capacitor charges to approximately its maximum value as indicated on the VOLTAGE meter.
 - At each discharge, the VOLTAGE meter needle swings downward and then begins to increase as the surge capacitor completes its charge.
 - In addition, at each discharge, the CURRENT meter increases 30 percent of full scale or more and then decreases as the surge capacitor completes its charge.
 - Do not exceed the rated surge capability of the PFL. If the spark gap fails to breakdown before 8 kV is reached, readjust the spacing.
9. The audible sound and meter indications confirm that the surge portion of the system is operating properly. If you do not get an audible “thump”, double-check the procedure and refer to the troubleshooting guide on page 48.

This completes the OPTIONAL Surge Function Test.

- If further testing is required, refer to "Changing Modes" on page 35 to transfer to another mode.

- If testing is complete, perform the "Discharge Of The Cable And Shutdown" procedure on page 36.

Surge Function Test - ARC REFLECTION Mode

To test the surge function of the system in the ARC REFLECTION mode, perform the following procedure:

- 1.** Ensure that you have performed the "Setup" procedures as described in this section.
- 2.** Verify that **star ground** is connected to **local earth ground** and that the **surge ground test lead** is connected to **local earth ground**.
- 3.** Connect the high-voltage test lead of the output cable to the **surge ground** test lead.
- 4.** Set the POWER circuit breaker on the PFL to ON. The amber LINE ON indicator will illuminate.
- 5.** Set the MODE SELECT switch to ARC REFLECTION.
- 6.** Set the OUTPUT VOLTAGE CONTROL firmly to ZERO START. The red HV ON indicator will illuminate.
- 7.** Slowly turn the OUTPUT VOLTAGE CONTROL fully clockwise and observe the following:
 - Between each discharge the surge capacitor charges to approximately its maximum value as indicated on the VOLTAGE meter.
 - At each discharge, the VOLTAGE meter needle swings downward and then begins to increase as the surge capacitor completes its charge.
 - In addition, at each discharge, the CURRENT meter increases 30 percent of full scale or more and then decreases as the surge capacitor completes its charge.
- 8.** These meter indications confirm that the surge function of the ARC REFLECTION mode is operating properly. If these indications are not observed, double-check the procedure and refer to "Table 6-2: Troubleshooting Guide" on page 48.

9. This completes the Surge Function Test for ARC REFLECTION mode.
 - If further testing is required, refer to "Changing Modes" on page 35 to transfer to another mode.
 - If testing is complete, perform the "Discharge Of The Cable And Shutdown" procedure on page 36.

Proof Function Test

To test the proof function of the DC mode of the system, perform the following procedure:

1. Ensure that the "Setup" procedures in this section have been performed.
2. Verify that **star ground** is connected to **local earth ground** and that the **surge ground** test lead is connected to **local earth ground**.
3. Position the high-voltage test lead in a barricaded high-voltage test area so that it is insulated from ground (and **surge ground**) or any other conductive object by a minimum of 2 ft (0.61 m) of air space.
4. Set the POWER circuit breaker on the PFL to ON. The amber LINE ON indicator will illuminate.
5. Set the MODE SELECT switch to DC.
6. Set the OUTPUT VOLTAGE CONTROL firmly to ZERO START. The red HV ON indicator will illuminate.
7. Slowly turn the OUTPUT VOLTAGE CONTROL fully clockwise and observe the following:
 - The VOLTAGE meter indicates the maximum proof voltage.
 - The CURRENT meter indicates less than 1 mA of leakage current.
8. These meter indications confirm that the proof testing portion of the system is operating properly. If the leakage current is excessive, make sure that the high-voltage output connector is properly insulated before performing troubleshooting and repair. If you do not observe these indications, double-check the procedure and refer to the troubleshooting guide on page 48.
9. This completes the Proof Function Test.
 - If further testing is required, refer to "Changing Modes" on page 35 to transfer to another mode.
 - If testing is complete, perform the "Discharge Of The Cable And Shutdown" procedure on page 36.

Burn Function Test

To test the burn-down function of the DC mode of the system, perform the following procedure:

1. Ensure that you have performed the "Setup" procedures in this section.
2. Verify that **star ground** is connected to **local earth ground** and that the **surge ground** test lead is connected to **local earth ground**.
3. Connect the high-voltage test lead of the output cable to the **surge ground** test lead.
4. Set the POWER circuit breaker on the PFL to ON. The amber LINE ON indicator will illuminate.
5. Set the MODE SELECT switch to DC.
6. Set the OUTPUT VOLTAGE CONTROL firmly to ZERO START. The red HV ON indicator will illuminate.
7. Slowly turn the OUTPUT VOLTAGE CONTROL fully clockwise and observe the following:
 - The VOLTAGE meter indicates less than 500 V.
 - The CURRENT meter indicates the maximum current output specified.
8. These meter indications mean the burn-down function of the system is operating properly. If these indications are not observed, double-check the procedure and refer to the troubleshooting guide on page 48.
9. This completes the Burn Function Test.
 - If further testing is required, refer to "Changing Modes" on page 35 to transfer to another mode.
 - If testing is complete, perform the "Discharge Of The Cable And Shutdown" procedure on page 36.

Arc Reflection Function Test

NOTE: For more information about the DART controls, refer to the instruction manual for the DART Analysis System (AVTM654000).

To test the ARC REFLECTION mode of the system, perform the following procedure:

1. Ensure that you have performed the "Setup" procedures in this section.
2. Verify that star ground is connected to **local earth ground** and that the **surge ground** test lead is connected to **local earth ground**.
3. Position the high-voltage test lead in a barricaded high-voltage test area so that it is insulated from the ground or any other conductive object by a minimum of 2 ft (0.61 m) of air space.
4. Create a spark gap between the vise-grip clamps on the high-voltage output cable by adjusting the spacing between the two clamps until it is less than 0.104 in. (#38 drill). This will set the breakdown voltage to less than 8 kV.
5. Set the POWER circuit breaker on the PFL to ON. The amber LINE ON indicator will illuminate.
6. Set the MODE SELECT switch to ARC REFLECTION.
7. Set the DART POWER switch to ON. Set the DART to the ARC mode.
8. Set the DART RANGE to 500 ft (150 m).
9. With the high-voltage output cable open-circuited, a positive reflection is present on the screen.
10. Set SAMPLE mode on the DART to CAPTURE.
11. Set the OUTPUT VOLTAGE CONTROL firmly to ZERO START. The red HV ON indicator will illuminate.
12. Slowly turn the OUTPUT VOLTAGE CONTROL clockwise until the following is observed:
 - The spark gap between the vise-grip clamps of the high-voltage cable breaks down.

- Between each discharge the surge capacitor charges to approximately its maximum value as indicated on the **VOLTAGE** meter.
 - At each discharge, the **VOLTAGE** meter needle swings downward and then begins to increase as the surge capacitor completes its charge.
 - In addition, at each discharge, the **CURRENT** meter increases 30 percent of full scale or more and then decreases as the surge capacitor completes its charge.
 - Do not exceed the rated surge capability of the PFL. If the spark gap fails to breakdown before 8 kV is reached, readjust the spacing.
- 13.** After the voltage necessary for breakdown is reached, increase the output voltage slightly.
- 14.** During the breakdown of the spark gap, a negative reflection is present on the screen. This is the reflection from the arc. The presence of the positive reflection that becomes negative during the arc time indicates that the arc reflection test mode of the system is operating properly. If these indications are not observed, double-check the procedure and refer to the troubleshooting guide on page 48.
- 15.** This completes the Arc Reflection Function Test.
- If further testing is required, refer to the "Changing Modes" on page 35 to transfer to another mode.
 - If testing is complete, perform the "Discharge Of The Cable And Shutdown" procedure on page 36.

TDR Function Test

NOTE: For more information about the DART controls, refer to the instruction manual for the DART Analysis System (AVTM654000).

To test the TDR mode of the system, perform the following procedure:

1. Set the MODE SELECT switch to ARC REFLECTION. High-voltage is not used with this test.
2. Position the high-voltage test lead so that it is insulated from the **surge ground test lead** and any other ground. This ensures that the output cable is open-circuited.
3. Set the POWER switch on the DART to ON. Set the DART to the TDR mode.
4. Set the DART RANGE to 500 ft (150 m).
5. With the high-voltage output cable open-circuited, you should observe a positive reflection on the screen.
6. Connect the high-voltage test lead to the **surge ground test lead**. This ensures that the high-voltage output cable is short-circuited.
7. With the high-voltage output cable short-circuited, you should observe a negative reflection on the screen.
8. The presence of the positive and negative reflections indicate that the TDR portion of the system is operating properly. If you do not observe these indications, double-check the procedure and refer to Table 6-2, "Troubleshooting." On page 48.
9. This completes the TDR Function Test.
 - If further testing is required, refer to "Changing Modes" on page 35 to transfer to another mode.
 - If testing is complete, perform the "Discharge Of The Cable And Shutdown" procedure on page 36.

8

MAINTENANCE

Cleaning and Inspection

Before performing any maintenance on the PFL, read, understand, and observe all safety precautions in Section 2, "Safety."

The PFL is constructed to withstand use normally encountered in field testing for public utilities and industrial plants. To maintain this equipment in proper condition, you should follow a planned program of routine maintenance for all major components **every six months**. In abnormally dirty areas or in difficult environments, routine maintenance may be required more often.



This is a high-voltage system that can produce and contain dangerous voltages. Any service or repair of this equipment should be performed only by qualified persons who are aware of high-voltage hazards and the necessary precautions routinely taken to prevent injury.

Before any inspection, service, or repair, the system must be completely disconnected from the power supply and from any cable under test. The MODE SELECT switch on the PFL must be set to GROUND. It must remain in this position for at least 15 minutes before access is gained to the interior.



The surge capacitors can produce and contain dangerous voltages. Any service or repair of equipment containing a surge capacitor should be performed only by qualified persons who are aware of high-voltage hazards and the necessary precautions routinely taken to prevent injury. When it is necessary to work near or touch the terminals of any of the capacitors, all terminals of the capacitor should be grounded using a **safety ground stick** and then bonded together with **safety ground jumpers**, before any connections are removed from the capacitor.

Both the high-voltage and low-voltage leads of the output cable should be bonded to **star ground**. As a safety precaution, once access to the interior of the PFL is gained and before any action is taken, the MODE SELECT switch contacts (blades and receptacles) should be bonded to **star ground**.

If company policy requires that a defect report be provided to those performing maintenance, consult this report and investigate the items noted at the appropriate point in the maintenance procedure. Inspection and maintenance should be carried out in accordance with the following steps. It is especially important to clean the impulse switch (step 10).

1. Examine all cables and permanent grounds to locate any loose or damaged terminals.
2. Inspect and clean the outer jackets of both the input and output high-voltage cables; check for breaks in these jackets.

WARNING

**SHOCK
HAZARD**

Breaks in the jackets of these cables may cause the **surge ground** to come in contact with the **star ground** resulting in dangerously high voltages on the PFL chassis and/or the vehicle chassis.

3. Check the action of the MODE SELECT switch to see that it operates freely.
4. Wipe the entire case clean and check for damage.
5. Remove the writing surface and vented filler panel from the front of the PFL. As a safety precaution, bond the terminals of the impulse capacitor to ground.
6. Check to see that all screws and nuts are tight.
7. Examine all electrical connections; check for evidence of corrosion, fracture, or burning.
8. Clean all electrical insulating supports and surfaces with a clean, dry, soft cloth. Do not use solvents or liquids. Clean, low-pressure air may be used.
9. As the cleaning proceeds, inspect all components on the protection network circuit board for burned sections or loose bonds. Check the capacitors for oil leaks.

10. Clean the impulse switch. Remove the six screws in the lid of the impulse switch. Wipe the interior of the switch with a soft dry rag; clean well around the insulation holding the electrodes. Replace the lid and tighten the six screws.
11. To reassemble the unit, carefully slide the lower module back into the PFL and replace the screws to secure the lower module. Reinstall the writing surface.
12. When work has been completed, perform the procedures detailed under "Performance Checks" beginning on page 50.

Repairs

Megger offers a complete repair and calibration service and recommends that its customers take advantage of this service in the event of any equipment malfunction.



The PFL can produce and contain dangerous voltages. Any service or repair of this equipment should be performed only by qualified persons who are aware of high-voltage hazards and the necessary precautions routinely taken to prevent injury.

1. Contact your Megger representative for instructions and a return authorization (RA) number.
2. Mark all equipment returned for repair and ship it prepaid and insured and marked for the attention of the Repair Department. Please indicate all pertinent information, including problem symptoms. The serial number and catalog number of the instrument should also be specified.

Ship to:

Megger
Valley Forge Corporate Center
2621 Van Buren Avenue
Norristown, PA 19403

Megger.

GLOSSARY

Symbols on the Equipment



Use only according to instruction manual.



Earth terminal. You must follow grounding procedures.

Definitions for Grounds

| | |
|--------------------------------------|--|
| <i>local earth ground</i> | Driven earth ground made before each test, connects to <i>star ground</i> . This ground should be less than 5Ω. |
| <i>PFL chassis ground</i> | The ground lug on the PFL. |
| <i>power ground</i> | The third (green/yellow wire) of the power cord connects at the source of power for the system. |
| <i>safety ground</i> | A temporary ground, this connection is made before each test between <i>star ground</i> , the ground stud on the reel of 125-ft (38.1-m) cable, and <i>specimen ground</i> . |
| <i>specimen ground</i> | Ground conductor (sheath) of cable under test. Assumed to be connected to the driven ground of the power system. |
| <i>star ground</i> | The central ground point of the system: <i>vehicle chassis ground</i> . |
| <i>surge ground</i> | Refers to any part of the surge current return path. It includes the <i>specimen ground</i> and the <i>surge ground</i> test lead. |
| <i>vehicle chassis ground</i> | A lug (user supplied) on the vehicle chassis that becomes <i>star ground</i> when the PFL is installed in a vehicle. |

Other Terms and Acronyms

| | |
|-------------------------------|---|
| ANSI | American National Standards Institute |
| ART | Arc reflection test |
| EPR | Ethylene propylene rubber |
| HMW | High molecular weight |
| HV test lead | Output end of the 25-ft (7.6-m) high-voltage test cable. The HV test lead is the white lead terminated with a vise-grip clamp. |
| IEEE | Institute of Electrical and Electronic Engineers |
| PILC | Paper insulated lead covered |
| safety ground jumper | Temporary connection (not supplied) made between the high-voltage conductor of the cable under test to specimen ground . |
| safety ground stick | An insulated stick (sometimes called a hot stick) with a hook type electrode connected to ground via an insulated cable. In some designs, frequently known as high-voltage discharge sticks, a resistor is connected between the electrode and the ground cable. Both are used to discharge capacitive specimens by providing a low impedance path to ground. They must be suitably rated for the voltage and capacitance of the specimen to be discharged. |
| sparkover | A disruptive discharge in the form of an arc or spark between two electrical conductors or between a conductor and earth (also called arc-over or flashover). |
| surge ground test lead | Return conductor of the 25-ft (7.6-m) high-voltage test cable. The surge ground test lead is the black lead terminated with a vise-grip clamp. |
| TDR | Time domain reflectometer. Indicates and measures reflection characteristics of a transmission system. |
| XLPE | Cross-linked polyethylene |

INDEX

- Connectors
 - high voltage, 25
 - rear panel
 - 4000, 24
 - 5000, 25
 - side panel
 - 1000, 24
 - 4000, 24
- DC operations
 - burn, 18
 - proof test, 17
- Equipment symbols, 3
- External interlock, 23
- Generators, 33
- Grounding
 - special safety problems, 7, 25
- Grounding scheme, 8
- Grounds
 - permanent, 26, 49
 - temporary, 28
- Inspection and maintenance, 60
- Performance checks, 50
- Safety precautions
 - after test completion, 9
 - disconnecting test equipment, 8
 - for connecting to the power source, 7
 - general, 5
 - grounding considerations, 7
 - in using the PFL, 6
 - protective clothing, 7
 - regarding heart pacemakers, 7
- Setup for testing, 31
- Shipping instructions, 61
- Specifications, 11, 1, 2
- Tests
 - arc reflection, 39
 - burn-down, 38
 - proof, 37
 - surge pulse reflection, 43
 - surge tracing, 45
 - system, 49
 - TDR, 42

Megger.

ADDENDUM

**Instructions for
Optional Cable Reel Assemblies
for the
PFL-1000 · PFL-4000 · PFL-5000
Power Fault Locators**

CBL125 and CBL125RM Cable Reels

Catalog Nos. CBL125 and CBL125RM

HIGH-VOLTAGE EQUIPMENT
Read this entire manual before operating.

APARATO DE ALTO VOLTAJE
Ante de operar este producto lea este manual enteramente.

CBL125 and CBL125RM Cable Reels

Optional Cable Reel Assemblies

Instruction Manual

INTRODUCTION

The CBL125 and CBL125RM cable reels are used with the PFL-1000, PFL-4000, and PFL-5000 Power Fault Locators to extend the reach of existing cables. This product comprises a high-voltage (HV) cable reel with 125 ft (38.1 m) of cable and a ground cable reel also with 125 ft (38.1 m) of cable.

SAFETY PRECAUTIONS

This information is an addendum to the AVTM657000 instruction manual. Follow all safety precautions and operating procedures included in that manual.

SPECIFICATIONS

Voltage: 20 kV dc maximum

HV cable reel containing 125 ft (38.1 m) cable

Dimensions: 9.25 x 16.5 x 19 in. (23.5 x 42 x 48 cm) (D x W x H)

Weight: 47.5 lb (21.6 kg)

Gauge: 12 AWG

Ground cable reel containing 125 ft (38.1 m) cable

Dimensions: 12 x 12 x 15 in. (30.5 x 30.5 x 38.1 cm) (D x W x H)

Weight: 26.5 lb (12 kg)

Gauge: 8 AWG



The high-voltage cable reel is part of the high-voltage circuit. Do NOT touch while energized. Shut down and ground all parts of the system before connecting or disconnecting cables.

Lethal voltages can be present at the ends of the HV output cable. Before connecting or disconnecting HV cables at the reel, ensure that the PFL MODE SELECT switch is set to GROUND, the POWER switch is set to OFF, the CBL125 or CBL125RM HV cable is disconnected from the specimen and that the ends of the HV cable have been grounded.

CONNECTING THE CBL125 CABLE REELS

Perform the following procedure to connect the CBL125 or CBL125RM cable reels. Figure 1 shows connections to the PFL-4000. Figure 2 shows connections to the PFL-5000.

1. Remove the detachable vise grips from the HV output cable of the PFL-1000, PFL-4000 or PFL-5000 by pressing the connector firmly into the receptacle to unlock the connector, then pulling the plug from the receptacle. Attach the vise grips to the output end of the CBL125 or CBL125RM HV cable by pressing the plug firmly into the receptacle.
2. Place the CBL125 or CBL125RM cable reels within 20 ft (6 m) of the PFL-1000, PFL-4000 or PFL-5000. Unreel the amount of HV cable and ground cable required to reach and connect to cable under test. Make connections as follows:
 - a. Connect the SAFETY GROUND lead to the SPECIMEN GROUND.
 - b. Connect the SURGE GROUND test lead to the SPECIMEN GROUND (grounded shield of the cable under test). This is the black lead terminated with a vise-grip clamp.



The low-voltage lead of the output cable must not be extended because this introduces excessive impedance in the SURGE GROUND and could result in hazardous voltages being present on the low-voltage lead.

- c. Connect the high-voltage test lead to the faulted conductor of the cable under test. This is the white lead with red band terminated with a vise-grip clamp. Be sure that the exposed conductor and clamp are sufficiently insulated to withstand the test voltage.
3. Attach the 25 ft (7.6 m) SAFETY GROUND cable (permanently connected to STAR GROUND) to a convenient connection ferrule on the SAFETY GROUND.
4. Plug the connectors on the 25 ft (7.6 m) HV output cable (of the cable fault locator) into the HIGH VOLTAGE and SURGE GROUND receptacles on the HV cable reel.
5. At the completion of the test, discharge the cable and shut down. Refer to the manual for the surge generator you are using for the recommended procedure.

NOTE: *To remove the HV connectors from the receptacles on the HV cable reel, firmly press the connectors into the receptacle to unlock the connector and then pull the plug from the receptacle.*

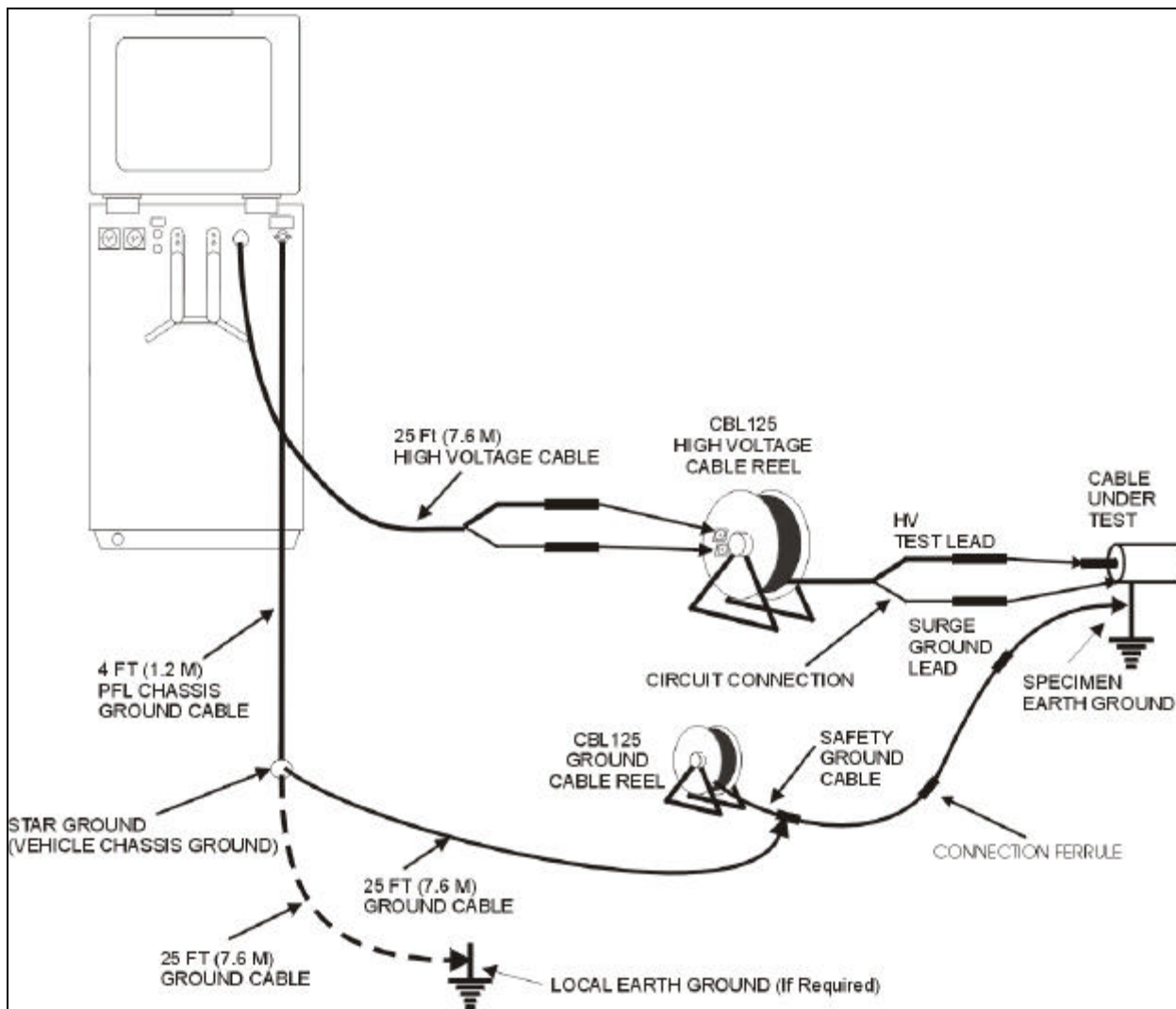

Figure 1: CBL125 Connections to PFL-4000

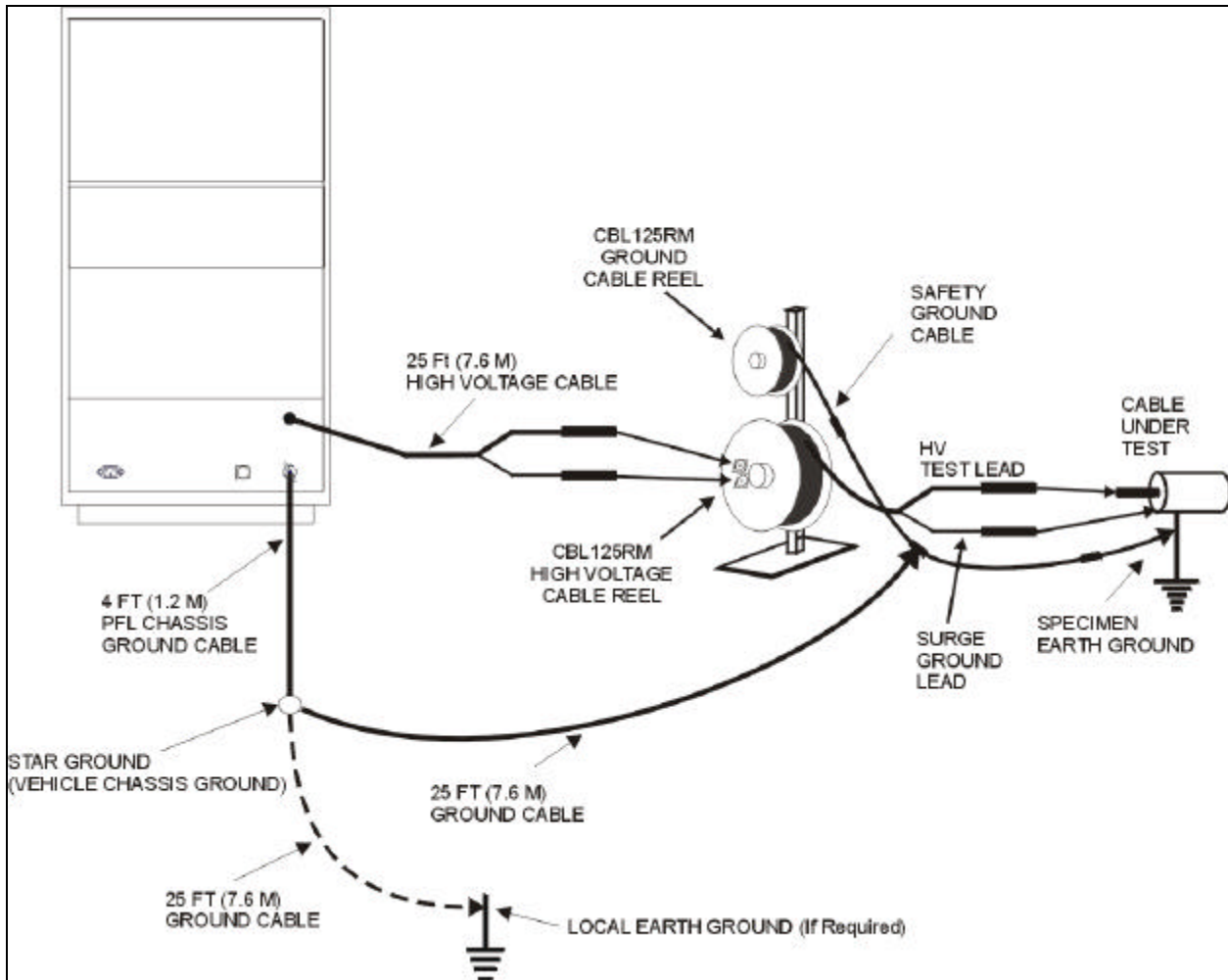

Figure 2: CBL125RM Connections to PFL-5000

Megger[®]