

AVTMTTR20
Rev. A
August 2005

**Instruction Manual AVTMTTR20
for
TTR20 Handheld TTR^â
Transformer Turn Ratio Test Set
Catalog No. TTR20**

**High-Voltage Equipment
Read the entire manual before operating.**

**Aparato de Alto Voltaje
Antes de operar este producto lea este manual enteramente.**

Megger.

2621 Van Buren Ave
Norristown, PA 19403-2329
610-676-8500

www.megger.com

TTR20 Handheld TTR^â
Transformer Turn Ratio Test Set
Instruction Manual

Copyright Notice

Copyright© 2005 by Megger. All rights reserved.

Disclaimer Notice

The information contained in this manual is believed to be adequate for the intended use of the product. If the product or its individual instrument are used for purposes other than those specified herein, confirmation of their validity and suitability must be obtained from Megger. Refer to the warranty information included at the end of this instruction manual. Specifications are subject to change without notice.

WARRANTY

Products supplied by Megger are warranted against defects in material and workmanship for a period of one year following shipment. Our liability is specifically limited to replacing or repairing, at our option, defective equipment. Equipment returned to the factory must be shipped prepaid and insured. This warranty does not include batteries, lamps, or other expendable items, where the original manufacturer's warranty shall apply. We make no other warranty. The warranty is void in the event of abuse (failure to follow recommended operating procedures) or failure by the customer to perform specific maintenance as indicated in this manual.

TABLE OF CONTENTS

1 INTRODUCTION	1
About the TTR20	1
Electrical Theory and Practice	2
Applications for the TTR20	4
Upon Receipt of the TTR20	5
Safety First	5
How to Use This Manual	5
2 SAFETY	7
Overview	7
Safety Requirements	7
Cautions and Warnings	8
3 CONTROLS & CONNECTORS	9
Overview	9
Connectors	10
4 SETUP, CONNECTIONS AND OPERATION	11
General Instructions	11
Transformers	11
Single-Phase, Two-Winding Transformers	12
Distribution Transformers with Two Secondary Windings	12
Three-Phase, Two-Winding Transformers	16
Three-Phase, Three-Winding Transformers	16
Current Transformers (CTs)	17
General Operating Procedure	20
Description of Menus and Test Screens	20
Use with the Optional Printer	23
HyperTerminal Configuration	25

5 MAINTENANCE AND TROUBLESHOOTING	27
Maintenance	27
Calibration Check	27
TTR20 Functional Test.....	28
Battery Replacement	29
Troubleshooting	30
Error Messages	31
Repair.....	33
APPENDIX A - SPECIFICATIONS	35
Electrical	35
Environmental Conditions	37
Physical Data	37
Optional Accessories	38
APPENDIX B - ORDERING INFORMATION & SPARE PARTS LIST.....	39
APPENDIX C - CONNECTIONS AND VECTOR VOLTAGE DIAGRAMS.....	41

LIST OF ILLUSTRATIONS

Figure 1-1.	TTR20 Single-Phase Test Set Block Diagram	4
Figure 3-1	TTR20 Display & Control Panel	9
Figure 3-2	TTR20 Top Side Connector Panel	10
Figure 4-1	Setup for Testing Single-Phase Transformer	13
Figure 4-2	Setup for Testing Single-Phase Autotransformer	13
Figure 4-3	Setup for Testing Single-Phase, Type A Step Voltage Regulator	14
Figure 4-4	Setup for Testing Single-Phase, Type B Step Voltage Regulator	14
Figure 4-5	Setup for Testing X1 – X2 Winding of Distribution Transformer.....	15
Figure 4-6	Setup for Testing X3 – X2 Winding of Distribution Transformer.....	15
Figure 4-7	Setup for Testing X1 – X3 Winding of Distribution Transformer.....	15
Figure 4-8	Setup for Testing Unmounted Current Transformer.....	18
Figure 4-9	Setup for Testing Taps on Multiple Tap CT.....	18
Figure 4-10	Setup for Testing BCT Mounted on Single-Phase Two-Winding Transformer.....	19
Figure 4-11	TTR20 Opening Display Screen.....	20
Figure 4-12	Start Test Screen.....	21
Figure 4-13	Test in Progress Screen.....	22
Figure 4-14	TTR20 Test Result Screen	22
Figure 4-15	Sample Test Report	23
Figure 4-16	Printer Configuration Printout	24

LIST OF TABLES

Table 5-1	Troubleshooting Guide.....	30
Table 5-2	Self-test Error Messages	31
Table 5-3	Test Error Messages.....	31
Table 5-4	Miscellaneous Message	32
Table C-1	ANSI Transformer Winding Phase Relationship.....	42
Table C-2	ANSI Transformer Winding Phase Relationship.....	44

1

INTRODUCTION

About the TTR20

The TTR20 Handheld TTR[®] Test Set is a fully automatic, self-checking, self-calibrating unit. The test set measures the turn ratio, excitation current, and phase displacement (polarity) of single- and three-phase (phase by phase) distribution transformers, as well as power, potential and current transformers. The TTR20 Handheld TTR[®] Test Set is powered by six AA-size disposable alkaline batteries. The test set is a portable instrument housed in a sturdy plastic case. A carrying case with strap and an accessory pouch is provided with the test set.

The test set can be used to test single-phase and three-phase transformers, both with and without taps in accordance with the requirements of the IEEE C57.12.90 – 1997 standards. For three-phase transformers, the test set is connected to each of the three phases of the transformer to be tested, and measurements are made on a phase by phase basis.

Turn ratio, phase displacement (polarity), and excitation current are displayed on a large LCD. Transformer excitation current helps to detect transformer shorted turns or an unequal number of turns connected in parallel. Operating condition (error) messages identify incorrect test connections, abnormal operating condition, or winding problems. Test results can be printed out on an optional printer.

Features include:

- Fully automatic operation.
- Self-checking at power-up.
- Self-calibration at each measurement.
- User-friendly, one button operation.
- Test turn ratio, excitation current, and phase displacement (polarity).

- Easy measuring of single and three phase (phase by phase) transformers, as well as potential & current transformers.
- Checking reverse test lead or winding connections at start of each test.
- External optional printer records test data.
- Three automatically selected excitation test voltages: 8 V, 1.5 V, and 0.5 V.
- Testing to ANSI standards.
- Leads marked to ANSI standards.
- Large, easy-to-read LCD shows alphanumeric data
- Meets the requirements of both the European EMC and Low Voltage Directives (CE mark).
- Trouble-free operation in switchyards under electrostatic and magnetic interference conditions.

Electrical Theory and Practice

How the TTR20 Works

The TTR20 test set provides the excitation voltage to the input of the transformer. It accurately measures both the H-side and X-side voltages to calculate turns ratio. The TTR also measures phase displacement (polarity) between primary and secondary windings of a transformer, and transformer excitation current.

Transformer Turns Ratio

Transformer Turns Ratio is the ratio of the number of turns in the high voltage winding to that in the low voltage winding. Transformer ratio can change due to several factors, including physical damage from faults, deteriorated insulation, contamination and shipping damage.

A Transformer Turns Ratio Test Set such as the TTR20 can directly measure the turns ratio of single-phase transformers as well as three-phase transformers. Deviations in these measurements will quickly indicate problems in transformer windings and in the magnetic core circuits. If a transformer ratio deviates more than 0.5 percent from the rated voltage ratio, it may not operate reliably. To measure small ratio changes such as this, the accuracy of a Megger TTR20 is needed.

Excitation Current

The TTR20 is capable of measuring exciting current by applying voltage to one of the transformer's windings. An accurate measurement of exciting current can provide information about the condition of a transformer's core. Unwanted

circulating currents, unintentional grounds or even an incipient short circuit can affect the exciting current and indicate a problem.

Transformer Polarity

Polarity of a distribution transformer becomes of interest in order to determine its proper connection within a power network. The Megger TTR20 will identify normal (in phase) and reverse polarity of the single-phase transformers.

A block diagram of TTR20 is shown in Figure 1-1. The excitation voltage oscillator applies a 55-Hz test voltage to a transformer under test. There are three test voltages: 0.5 V, 1.5 V, and 8 V used for transformer testing. Test voltage selection is based on excitation current required. The required test voltage is selected automatically.

Input and output transformer voltages are applied to conditioning circuitry. This circuitry improves signal-to-noise ratio of the test signal, and provides full voltage range of the test signals at A/D converter inputs.

A/D converter is used to convert the analog measurement signals to their digital replica. The converted output digital signals are applied to CPLD (complex programmable logic device) and then are transferred to microprocessor.

The microprocessor is the main part of the TTR test set. It provides proper timing sequence of operation, gathers and calculates the test result, and interfaces with peripherals. There are three main peripherals in the TTR20 test set: RS-232/Printer port, LCD and keypad.

DC power supply converts the primary battery voltage, six Energizer® X91 AA-alkaline batteries, 9 V (nominal), 3135 mAh nominal capacity, into the secondary DC voltages required for proper operation of the TTR20 test set.

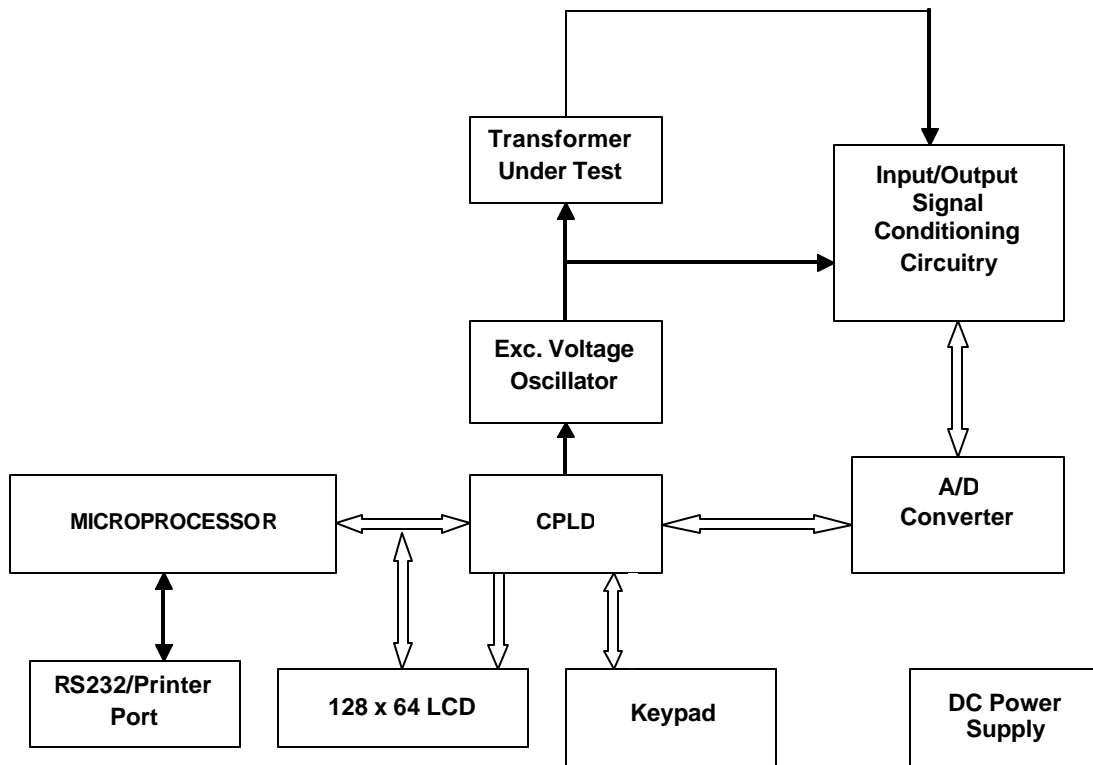

Figure 1-1. TTR20 Test Set Block Diagram

Applications for the TTR20

The proper operation of a transformer relies almost entirely on the electrical properties of its windings. To ensure continued proper operation, transformers are tested to verify that their electrical properties have not changed from design specifications. A TTR is an extremely useful instrument for testing transformer windings because it can help locate several types of problems within single- and three-phase transformers.

It is used to determine the no-load accuracy of CTs and PTs and also determine the need to further test faulty CTs and PTs.

The TTR20 applies voltage to the high-voltage winding of a transformer and accurately measures the resulting voltage from the low voltage winding. The ratio of voltages is directly proportional to turns ratio. In addition, the unit measures excitation current and polarity.

Upon Receipt of the TTR20

Check the equipment received against the packing list to ensure that all materials are present. Notify Megger of any shortage. Telephone 610-676-8500.

Examine the instrument for damage received in transit. If any damage is discovered, file a claim with the carrier at once and notify Megger or its nearest authorized sales representative, giving a detailed description of the damage.

This instrument has been thoroughly tested and inspected to meet rigid specifications before being shipped. It is ready for use when set up as indicated in this manual.

Safety First

Be sure to read the safety information in Chapter 2 thoroughly and observe all safety precautions and recommendations.

How to Use This Manual

Typographic Conventions



CAUTION

Cautions alert you to possible damage to equipment.



WARNING

Warnings alert you to conditions that are potentially hazardous to people.

NOTE: Notes provide important information.

Megger[®]

2

SAFETY

Overview

The TTR20 must be used on de-energized transformers. However, the transformer to which the test set is connected is a possible source of high-voltage electrical energy and all persons making or assisting in tests must use all practical safety precautions to prevent contact with potentially energized parts of the transformer and related circuits. Persons actually engaged in the test must stand clear of all parts of the complete high-voltage circuit, including all connections, unless the test set is de-energized and all parts of the test circuit are grounded. Persons not directly involved with the work must be kept away from test activities by suitable barriers, barricades, or warnings.

Treat all terminals of high-voltage power equipment as a potential electric shock hazard. There is always the possibility of voltages being induced at these terminals because of proximity to energized high-voltage lines or equipment. Always disconnect test leads from power equipment before attempting to disconnect them at the test set. The ground connection must be the first made and the last removed. Any interruption of the grounding connection can create an electric shock hazard.

Any repair or component replacement must be performed by qualified service personnel.

Safety Requirements

Megger has made formal safety reviews of the initial design and any subsequent changes. This procedure is followed for all new products and covers areas in addition to those included in applicable standards. Regardless of these efforts, it is not possible to eliminate all hazards from electrical test equipment. For this reason, every effort has been made to point out in this instruction manual the proper procedures and precautions to be followed by the user in operating this equipment and to mark the equipment itself with precautionary warnings where appropriate. It is not possible to foresee every hazard that may occur in the various applications of this equipment. It is therefore essential that the user, in

addition to following the safety rules in this manual, also carefully consider all safety aspects of the test before proceeding.

- Safety is the responsibility of the user.
- Follow your company safety procedures.
- Misuse of this equipment can be extremely dangerous.
- The purpose of this equipment is limited to use as described in this manual. Do not use the equipment or its accessories with any device other than specifically described.
- Never connect the test set to energized equipment.
- Do not use the test set in an explosive atmosphere.
- Corrective maintenance must only be performed by qualified personnel who are familiar with the construction and operation of the test set and the hazards involved.
- Refer to IEEE 510 - 1983, IEEE Recommended Practices for Safety in High-Voltage and High-Power Testing, for additional information.

If the test equipment is operated properly and all grounds correctly made, test personnel need not wear rubber gloves. As a routine safety procedure, however, some users require that rubber gloves be worn, not only when making connections to the high-voltage terminals, but also when manipulating the controls. Megger considers this an excellent safety practice.

Users of equipment should note that high-voltage discharges and other sources of strong electric or magnetic field may interfere with the proper functioning of heart pacemakers. Persons with heart pacemakers should obtain expert advice on the possible risks before operating this equipment or being close to the equipment during operation.

Cautions and Warnings

Warning and caution notices are used throughout this manual where applicable and should be strictly observed.

3

CONTROLS & CONNECTORS

Overview

The TTR20 is a simple, push-to-test instrument with few buttons and controls. It has no menus except for a print button.

- | | |
|-------------------------|---|
| Contrast | This knob adjusts the viewing resolution of the screen. |
| Backlight | A momentary depression of the switch will either activate or de-activate the backlight. It will remain ON for a period of three minutes without activity. |
| Power ON Switch | Press this switch to turn the TTR20 on. |
| Power OFF Switch | Press this switch to turn the TTR20 off. |
| DISPLAY SCREEN | LCD displays menus and test information. |
| KEYPAD | 4-button keypad for entering menu selections and navigating through the various screens. |

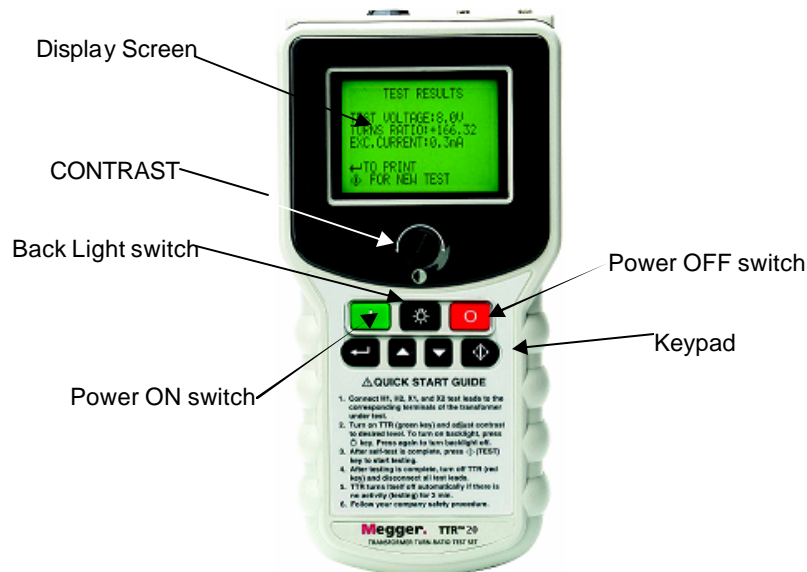

Figure 3-1 TTR20 Display & Control Panel

Connectors

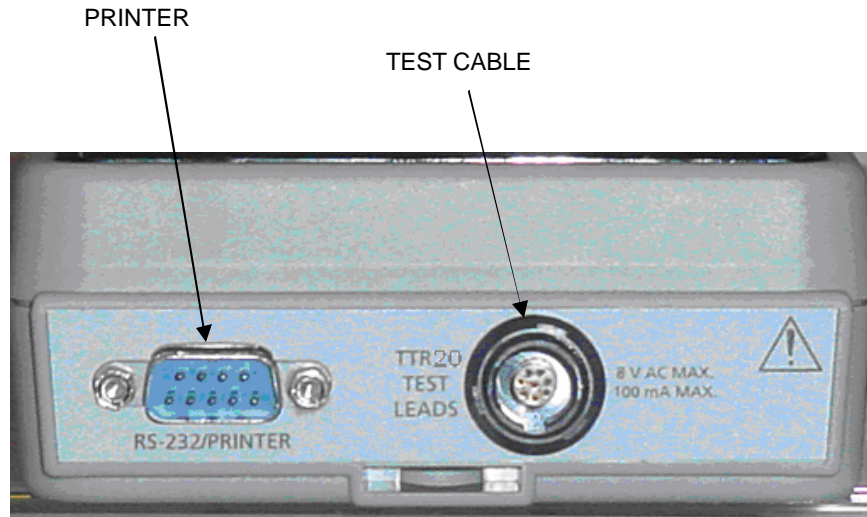

Figure 3-2 TTR20 Top Side Connector Panel

- | | |
|-----------------------|--|
| TEST CABLE | Plug receptacle for connecting test leads to the high-voltage (H) and low-voltage (X) windings of a transformer. The plug and receptacle are keyed to prevent the cable from being inserted incorrectly, and to make certain that the correct cable is used. |
| RS-232/PRINTER | A DB-9 male connector for connecting a printer or to upload data in real time to a PC (using HyperTerminal). |

4

SETUP, CONNECTIONS AND OPERATION

General Instructions

When testing high-voltage transformers, caution must be used at all times and all safety precautions followed. Read and understand all safety information contained in Section 2, Safety.

WARNING



Ensure that the transformer to be tested is completely de-energized. Check every winding. Ensure that all terminals of the transformer are disconnected from line or load at the transformer. For some transformers, connections to ground may be left in place.

Never interchange connections between the high- and low-voltage transformer terminals. Failure to observe proper connections will result in a safety hazard and may result in damage to the test set or transformer.

Check that a lead set connected is labeled for TTR20 test set operation.

The TTR20 has been designed to test a variety of transformers, such as: Single phase, Three phase (one phase at a time), CTs, PTs and Voltage Regulators.

Do not leave the TTR20 test set exposed below -20°C or above 55°C for more than 2 hours. Such conditions will lead to shortened service life of batteries.

When storing the TTR20 at temperatures below -20°C or above 55°C , remove the batteries. See *Battery Replacement* for detail.

Transformers

The setup and connection instructions pertaining to ratio, polarity, and phase relation assume that the transformer under test, connections, and terminal markings comply with the requirements of ANSI C57.12.70-1978 *American National Standards Terminal Markings and Connections for Distribution and Power Transformers*. The H leads of the test cable are the exciting leads.

The TTR20 may supply up to 100 mA of excitation current. The TTR20 will automatically select the appropriate test voltage (8 V, 1.5 V, or 0.5 V) when testing transformers.

Single-Phase, Two-Winding Transformers

Perform the following setup procedure for single-phase, two-winding transformers:

1. Connect the test lead set to the TEST CABLE receptacle of the TTR20 test set. Make sure that the connector is fully engaged into the receptacle.
2. Connect the clips marked H1 and H2 of the test lead to the corresponding (high-voltage winding) terminals of the transformer under test.
3. Connect the clips marked X1, X2 of the test lead to the corresponding (low-voltage winding) terminals of the transformer under test. Figures 4-1 and 4-2 show test setups for single-phase transformers. Figures 4-3 and 4-4 show test setups for voltage regulators.

NOTE: When properly connected, expect that polarity of the windings is normal (“+” sign is displayed in front of the turns ratio test result).

If the sign is “-”, then check the lead connections.

Distribution Transformers with Two Secondary Windings

The TTR20 may test the turn ratios of distribution transformer secondary windings (one at a time). Perform the following setup procedure for single-phase distribution transformer with two secondary windings:

1. Connect the test lead set to the TEST CABLE receptacle of the TTR20 test set. Make sure that the connector is fully engaged into the receptacle.
2. Connect the clips marked H1 and H2 of the test lead to the corresponding (high-voltage winding) terminals of the transformer under test.
3. When testing X1-X2 winding, connect, respectively, the clips marked X1 and X2 of the test lead to the X1 and X2 terminals of the transformer under test. Expect that polarity of the windings is normal (“+” sign is displayed in front of the turns ratio test result). See *Figure 4-5*.
4. When testing X3-X2 winding, connect the X1 clip to X3 transformer terminal, and connect the X2 clip to X2 transformer terminal. Expect that

polarity of the windings is reversed (“-” sign is displayed in front of the turns ratio test result). See *Figure 4-6*.

5. When testing full secondary winding (X1 – X3), connect X1 clip to X1 terminal, connect X2 clip to X3 terminal. Remove the ground connection to X2 transformer terminal before starting the test. Expect that polarity of the windings is normal (“+” sign is displayed in front of the turns ratio test result). See *Figure 4-7*.

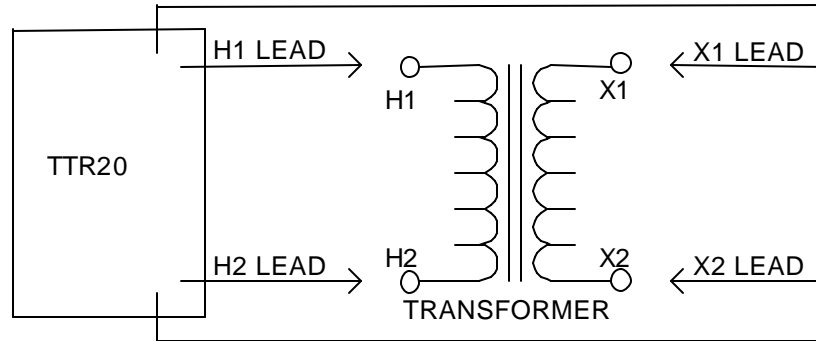

Figure 4-1 Setup for Testing Single-Phase Transformer

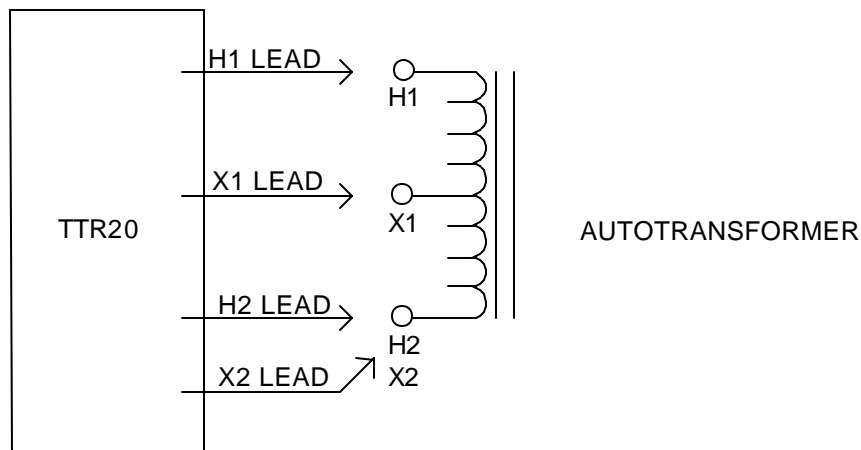

Figure 4-2 Setup for Testing Single-Phase Autotransformer

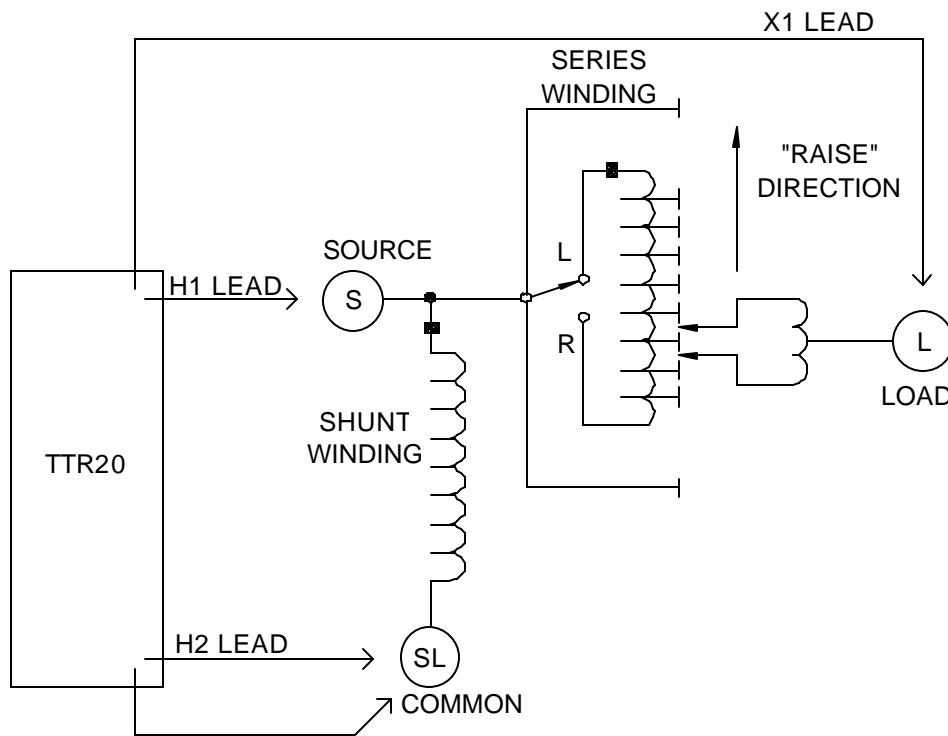

Figure 4-3 Setup for Testing Single-Phase, Type A (Straight Design) Step Voltage Regulator

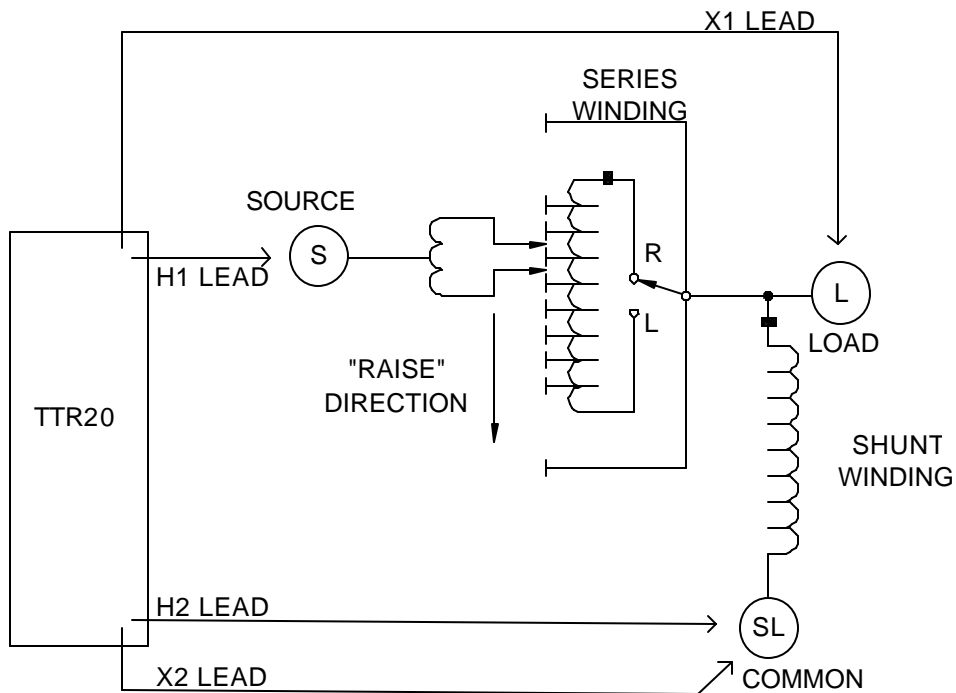

Figure 4-4 Setup for Testing Single-Phase, Type B (Inverted Design) Step Voltage Regulator

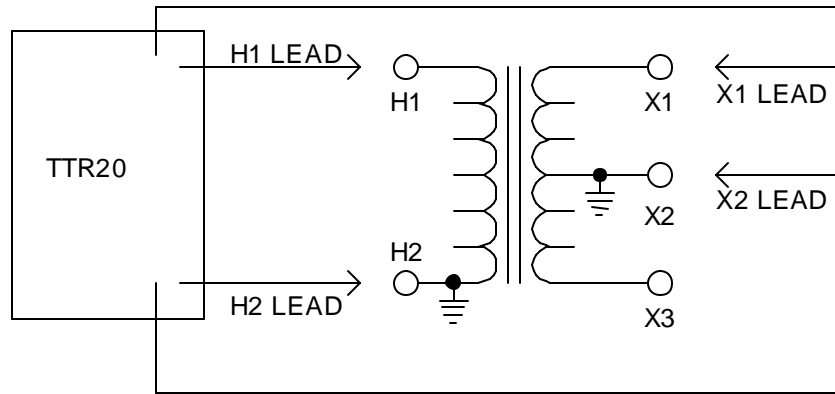

Figure 4-5 Setup for Testing X1 – X2 Winding of Distribution Transformer (H2 and X2 Grounded)

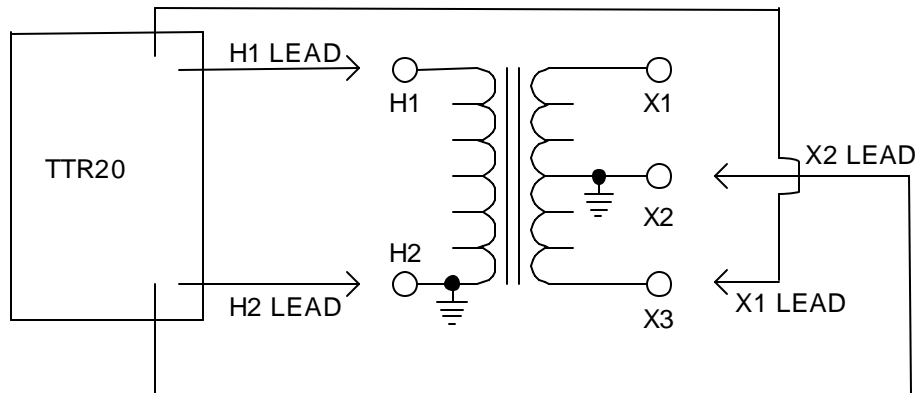

Figure 4-6 Setup for Testing X3 – X2 Winding of Distribution Transformer (H2 and X2 Grounded)

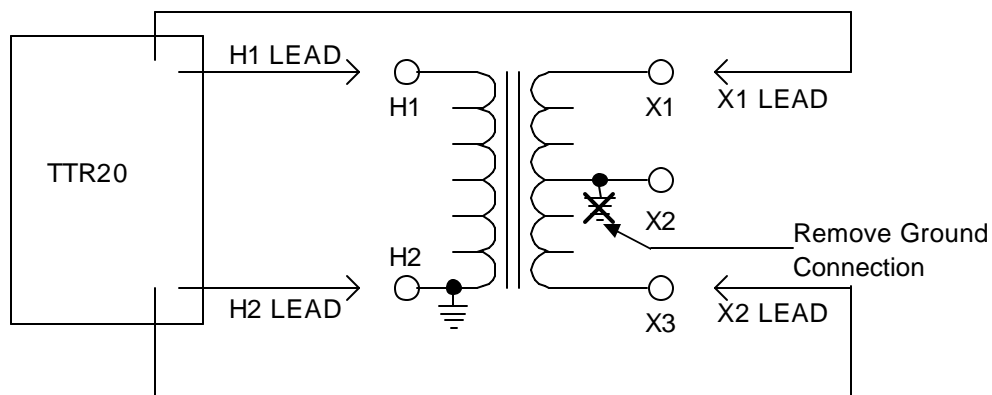

Figure 4-7 Setup for Testing X1 – X3 Winding of Distribution Transformer

Three-Phase, Two-Winding Transformers

Perform the following setup procedure for three-phase, two-winding transformers:

1. Connect the test cables to the test set.
2. Connect the clips marked H1 and H2 of the test lead to the phase being tested (high-voltage winding) terminals of the transformer under test.
3. Connect the clips marked X1 and X2 of the test lead to the phase being tested (low-voltage winding) terminals of the transformer under test.

WARNING



Never interchange connections between the high- and low-voltage transformer terminals. Failure to observe proper connections will result in a safety hazard and may result in damage to the test set or transformer.

The unused H0 and X0 terminals of the transformer should be kept clear of ground and personnel because they could become energized during the test.

With wye connected windings, a neutral connection is normally available.

Three-Phase, Three-Winding Transformers

This type of transformers has primary, secondary and tertiary windings. Primary and secondary windings are tested as a regular three-phase, two-winding transformer. To test tertiary winding, perform the following setup procedure:

1. Connect the test cables to the test set.
2. Connect the clips marked H1 and H2 of the test lead to the phase being tested (high-voltage winding) terminals of the transformer under test.
3. Connect the clips marked X1 and X2 of the test lead to the corresponding tertiary phase being tested (low-voltage winding) terminals (Y1 and Y2) of the transformer under test.

WARNING



Never interchange connections between the high- and low-voltage transformer terminals. Failure to observe proper connections will result in a safety hazard and may result in damage to the test set or transformer.

With wye connected windings, a neutral connection is normally available.

Current Transformers (CTs)

Connections to CTs are made backwards compared to power, distribution or potential transformers. The H terminals on the test lead set must be connected to the X terminals on the CT; and the X terminals on the test lead set must be connected to the H terminals on the CT.

NOTE: Dots on the housing of the transformer are commonly used to identify terminals of the same polarity.



WARNING

Failure to observe proper connections will result in a safety hazard and may result in damage to the test set or CT. Failure to observe voltage rating of low-current X winding may result in damage to the CT.

NOTES:

1. The TTR20 may supply up to 100 mA of excitation current. The TTR20 will automatically select the appropriate test voltage (8 V, 1.5 V, or 0.5 V) when testing CTs. Some current transformers with turn ratio of 50:5 and less may require more than 100 mA of excitation current when excited from 0.5 V source. These CTs can not be tested with the TTR20.
2. Expect that polarity of the windings is normal (“+” sign is displayed in front of the turns ratio test result).

Unmounted CTs

NOTE: The illustrated connection diagrams are provided as connection guides and do not suggest the physical location of the bushings / terminals of the device being tested.

Figure 4-8 shows the setup for testing unmounted current transformers.
 Figure 4-9 shows the setup for testing the taps on a multiple-tap CT.

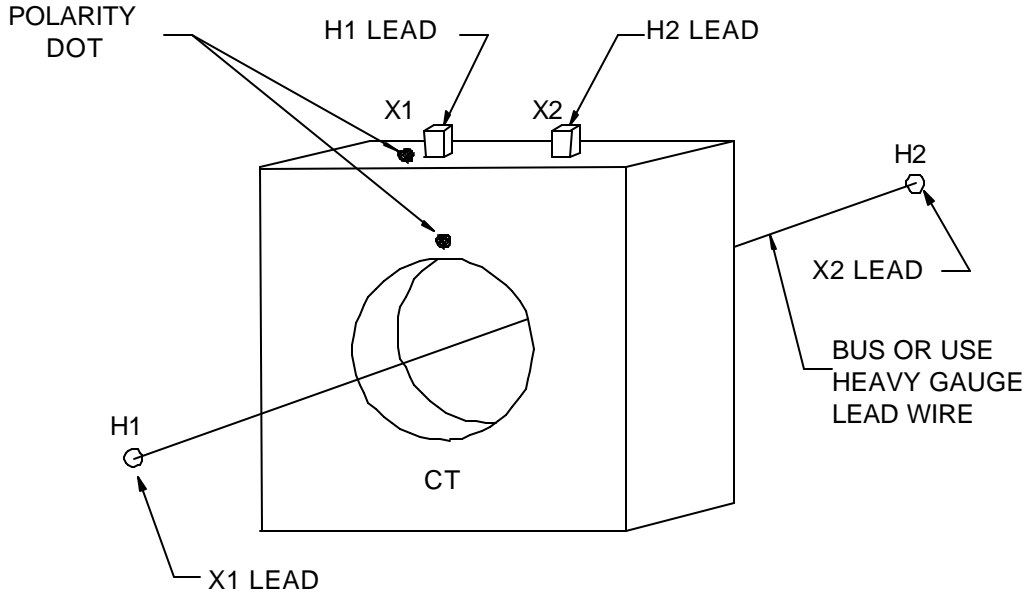

Figure 4-8 Setup for Testing Unmounted Current Transformer

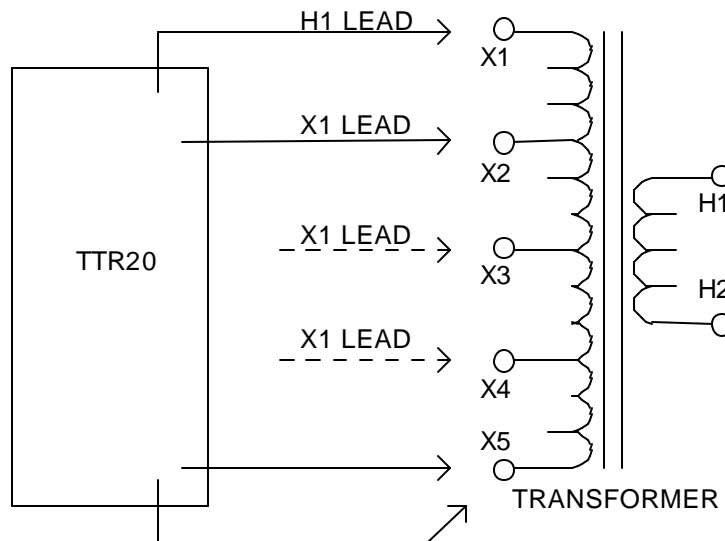

Figure 4-9 Setup for Testing Taps on Multiple Tap CT

Bushing Current Transformer (BCT) Mounted on Single-Phase, Two-Winding Transformer

A turn-ratio test can be performed on a BCT after it has been mounted on a circuit breaker or power transformer entrance bushing. The test can be performed without removal of the BCT from the equipment. Connect the TTR20 to BCT as shown in Figure 4-10.

NOTES:

1. Expect that polarity of the windings is normal (“+” sign is displayed in front of the turns ratio test result).
2. A jumper lead is not supplied with the TTR20.

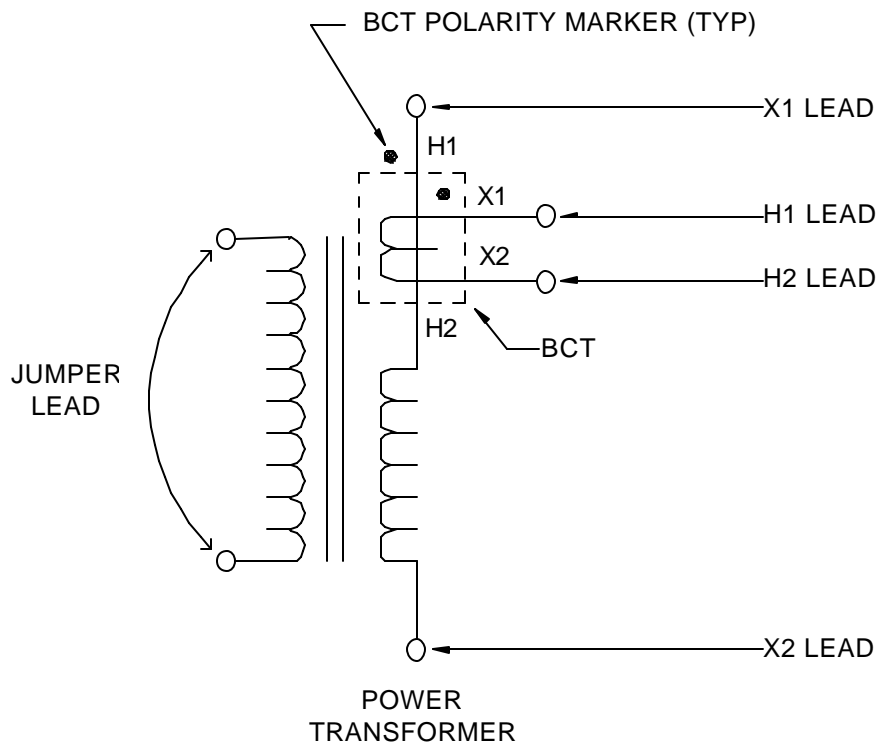

Figure 4-10 Setup for Testing BCT Mounted on Single-Phase Two-Winding Transformer

General Operating Procedure

Proceed only after reading and fully understanding Section 2, Safety, and setting up the test set as described. An operator who is familiar with the contents of this manual, the test setup, and the operation of the test set may follow the condensed operating instructions provided with the test set.

EMERGENCY SHUTDOWN
(Removal of Test Voltage from device being tested.)

Press RED KEY on the keypad to terminate test.

Description of Menus and Test Screens

Data shown on the menus and test screens in Figures 4-11 through 4-14 are for illustrative purposes only. The TTR20 test set menus and test screens are operated by using the keypad. On power up, the test set performs a self-test check, and all hardware and software variables are initialized.

Opening Display Screen

The LCD displays the opening screen (Figure 4-11) as the test set performs a diagnostic self-check of the electronics.

MEGGER
TRANSFORMER
TURN-RATIO TEST SET
TTR20
VERSION : 1.01
SELF-TEST IN PROGRESS
COPYRIGHT 2005
ALL RIGHTS RESERVED

Figure 4-11 TTR20 Opening Display Screen

If at power-up self-testing any errors are detected, one of the error messages listed in the ERROR MESSAGES section will be displayed on the screen.

If no errors are detected, the screen showing a battery charge level, in % of full charge, is displayed for 3 sec. If battery level is above 10 %, the START TEST screen (Figure 4-12) appears.

If battery level is below 10 %, the message “BATTERY LEVEL:LOW, APPR.1HR OF OPERATION REMAINING...” appears on the screen for 3 sec. A customer may continue testing of transformers. The remaining battery capacity is enough for approximately one hour of operation.

If battery level is below 5%, the message “REPLACE BATTERY! UNIT WILL TURN OFF” appears on the screen. In 10 sec. the TTR20 shuts down. Replace the batteries (six AA-size disposable alkaline batteries) before further attempting to initiate the TTR20 operation.

Start Test Screen

After a successful self-test check, the START TEST screen (Figure 4-12) appears.

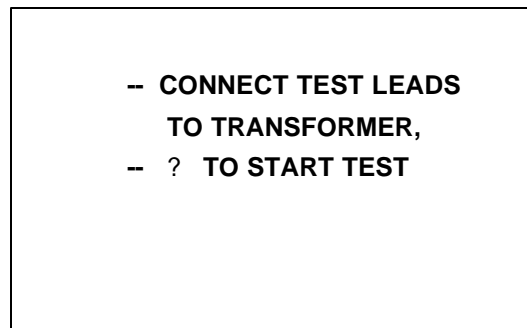

Figure 4-12 Start Test Screen

When ? is pressed on a keypad, the test starts and the TEST IN PROGRESS screen (Figure 4-13) appears.

Test in Progress Screen

Figure 4-13 shows the TEST IN PROGRESS screen.

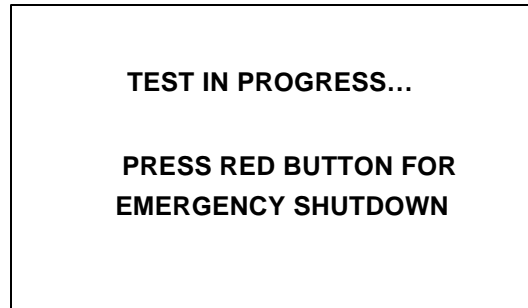

Figure 4-13 Test in Progress Screen

If during testing an abnormal condition is detected, one of the error messages listed in the ERROR MESSAGES section is displayed on the screen.

In case of emergency, press the red button on keypad. It will turn TTR20 OFF. After emergency situation is gone, turn power ON (green button) to start TTR20 operation.

Test Result Screen

At the completion of the test, the TEST RESULTS screen (Figure 4-14) appears.

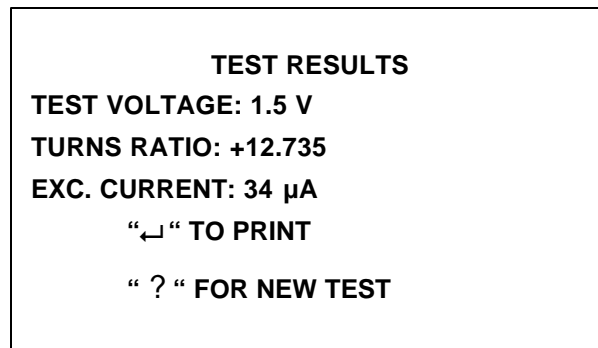

Figure 4-14 TTR20 Test Result Screen

The TEST RESULTS screen displays the test voltage used for the test, the measured turns ratio, the tested winding polarity (“+” for in phase or normal polarity, and “-” for out of phase or reversed polarity), and the tested winding excitation current.

From this screen, the test results may be printed out on the optional printer connected to RS232/PRINTER port of the TTR20.

To repeat the test or to start a new one, press the ? button on a keypad.

Use with the Optional Printer

If you are using the optional printer, plug the printer cable supplied into the RS232/PRINTER receptacle on the TTR20 test set and turn it on. A separate manual is supplied with the printer. Refer to it for specific information about how to connect, operate, and care for the printer.

NOTE: TTR20 should be turned on before turning on a printer.

Header information and test results may be printed from the test results screen

MEGGER TTR20 TRANSFORMER TURN RATIO TESTER CATALOG NO. TTR20
TRANSFORMER ID: TTR S/N: COMMENTS:
TEST RESULTS TEST VOLTAGE: 8.0 V TURNS RATIO:+69.966 EXC.CURRENT: 96.4 μ A
TEST RESULTS TEST VOLTAGE: 8.0 V TURNS RATIO:+79.966 EXC.CURRENT: 94.4 μ A

Figure 4-15 Sample Test Report

Configuration

To print a paper copy of the existing printer settings:

While holding down the "On-Line" switch, turn on the printer. The following list will print (factory default settings shown).

```
[ DIP SW setting mode ]

DIP SW-1
 1 (OFF) : Input = Serial
 2 (ON ) : Printing Speed = High
 3 (OFF) : Auto Loading = OFF
 4 (OFF) : Auto LF = OFF
 5 (OFF) : Setting Command = Disable
 6 (OFF) : Printing
 7 (ON ) :   Density
 8 (ON ) :   = 100 %

DIP SW-2
 1 (ON ) : Printing Columns = 40
 2 (OFF) : User Font Back-up = OFF
 3 (ON ) : Character Select = Normal
 4 (OFF) : Zero = Slash
 5 (ON ) : International
 6 (ON ) :   Character
 7 (ON ) :   Set
 8 (OFF) :   = U.S.A.

DIP SW-3
 1 (ON ) : Data Length = 8 bits
 2 (ON ) : Parity Setting = No
 3 (ON ) : Parity Condition = Odd
 4 (ON ) : Busy Control = H/W Busy
 5 (OFF) : Baud
 6 (ON ) :   Rate
 7 (ON ) :   Select
 8 (OFF) :   = 19200 bps

Continue ? : Push 'On-line SW'
Write ?    : Push 'Paper feed SW'

DIP SW setting complete !!
```

Figure 4-16 Printer Configuration Printout

If you want to leave the settings as they are, press the "FEED" switch.

If you need to change a setting, press the "ON LINE" switch to enter the reconfiguration mode. For each group of switches, press the "FEED" switch if all the settings are okay. Press the "ON LINE" switch if a setting needs to be changed. At an individual setting, press the "FEED" switch if it is okay and press "ON LINE" to change that setting.

HyperTerminal Configuration

The following is the HyperTerminal configuration:

Baud:	19,200
Data Bits:	8
Parity:	None
Stop Bits:	1
Flow Control:	None

Megger[®]

5

MAINTENANCE AND TROUBLESHOOTING

Maintenance

Maintenance should be performed only by qualified persons familiar with the hazards involved with high-voltage test equipment. Read and understand Section 2, Safety, before performing any service.

The TTR20 test set is sturdily constructed and requires no periodic maintenance. Routine maintenance is all that is required for the TTR test sets. Inspect the cable assemblies occasionally to ensure they are in good condition.

The appearance of the TTR test set can be maintained by occasionally cleaning the case, panel and cable assemblies. Clean the outside of the carrying case with detergent and water. Dry with a clean, dry cloth. Clean the control panel with a cloth dampened with detergent and water. Do not allow water to penetrate panel holes, because damage to components on the underside may result. An all-purpose, household spray cleaner can be used to clean the panel. Polish with a soft, dry cloth, taking care not to scratch the display screen cover. Clean the cables and mating panel receptacles with isopropyl or denatured alcohol applied with a clean cloth.

Calibration Check

A complete performance and calibration check should be made at least once every year. This will ensure that the TTR20 test set is functioning and calibrated properly over the entire measurement range. The TTR20 calibration is performed on each new or repaired unit before sending it to a customer. There is a special TTR20 final calibration procedure which requires a NIST-traceable test equipment to be used. As a result of such calibration procedure, each TTR20 may be NIST certified.

To check the TTR20 calibration at a customer site or in the field, the Megger Calibration Standard Cat.No550055 or equivalent standard should be used. To perform a quick simplified calibration check, the Megger Calibration Standard Cat.No550555 may be used. The last standard has eleven switchable turn ratio settings which cover the turns ratio range from 1:1 to 2000:1. Using these Calibration Standards will confirm proper calibration of TTR20.

TTR20 Functional Test

A customer may want to make sure that the test set is functioning properly before testing a transformer. Traditionally, for the transformer turns ratio testers, a customer performed this test by connecting H1-X1 and H2-X2 test leads. The 1:1 turns ratio was expected to be measured. Additionally, the displayed test results were interpreted as a test set calibration check.

TTR20 test set is designed and optimized for the transformer turns ratio testing. It uses a mixed analog-digital technique to provide the accurate readings of the tested transformer turns ratio. The test set measurement approach is based on high impedance input and output transformer voltage monitoring circuits. The high impedance of the monitoring circuits is optimized for the accurate transformer turns ratio testing.

When performing a TTR20 functional test, the H and X test leads interconnect the input and output monitoring circuits without a transformer being connected. Such connection cause an impedance mismatch and, as a result of the mismatch, the displayed turns ratio reading is not exactly 1:1 as it may be expected. A customer should be aware that a functional test is not a real transformer turns ratio test. Due to the intrinsic and inevitable impedance mismatching, the TTR20 functional test readings may be from 0.9980 to 1.0020. The TTR20 functional test readings do not represent the TTR20 calibration. It simply shows that the TTR20 test set circuitry functions properly. To check the TTR20 calibration, a customer should use the Calibration Standards mentioned in the Calibration section of the manual.

To perform a TTR20 functional test proceed as follows:

1. Turn TTR20 power on (green button on a keypad).
2. Connect H1 lead to X1 lead, and H2 lead to X2 lead.
3. After self-test is complete and start test screen appears, press **?** to start testing.

NOTE: This is not a 1:1 ratio calibration check due to different impedances between the instrument's H-side circuitry and X-side circuitry.



WARNING

Keep the leads, which are energized, clear of ground and personnel.

4. Turn ratio reading on the test results screen should be from +0.9980 to +1.0020.

Battery Replacement

TTR20 test set is powered up from six AA-size disposable alkaline batteries. A battery holder (contained six batteries) is installed in a battery compartment on the back side of the instrument housing. The compartment door is fixed to the housing by two screws.

To replace the batteries proceed as follows:

1. Remove the battery compartment door.
2. Lift up a battery holder from the compartment. Unplug a battery strap.
3. Replace all six batteries by the new ones. Use AA-size disposable alkaline batteries only. Observe the proper polarity of the batteries. A negative battery terminal (flat bottom portion of battery) should be placed against a battery holder spring. The batteries should be installed in series. See a battery holder for proper polarity and battery installation orientation.
4. Connect a battery strap back to the battery holder. Install the battery holder into the compartment.
5. Replace the battery compartment door and secure it with screws.
6. Turn on TTR20. It should display the opening screen, then the battery level screen. The battery level displayed depends on many factors including type of battery installed, battery manufacturing date, battery storing conditions, etc. In average, the new battery level displayed should be above 80 %.

<p>NOTE: The TTR20 is delivered with high-capacity (3135 mAh) "Titanium" batteries installed. The specified operating time of 12 hours is based on using these high-capacity batteries or equivalent.</p>
--

Troubleshooting

The Troubleshooting Guide, Table 5-1, is arranged to help you evaluate the reasons for TTR20 test set malfunction. The table lists possible TTR20 test set malfunctions which may be encountered during operation and lists possible causes. Electronic circuit repairs should not be attempted in the field. Refer to Repair section. Refer to Appendix B for a list of spare parts.

Table 5-1 Troubleshooting Guide

MALFUNCTION	POSSIBLE CAUSE
Display stays blank after POWER switch is turned on.	Battery is discharged. CONTRAST potentiometer not adjusted. Defective display or electronics.
Any error message on the screens	See ERROR MESSAGES section
Test results erratic	Defective test leads (open circuit, poor connection). Problem in test specimen (poor connection). Problem in TTR20 measuring circuit. Incorrect connection of leads. Incorrect marking of a transformer. Defective transformer.
Can not obtain printout when printer is connected.	Printer power not turned on. Printer battery discharged. Problem in TTR20 printer interface electronics. Printer cable is defective or is a null-modem cable.

Error Messages

All TTR20 error messages are divided by 3 categories: self-test error messages, test error messages, and miscellaneous error messages.

The self-test error messages may appear on the opening screen during power-up self-test procedure. The Table 5-2 below shows the messages.

Table 5-2 Self-test Error Messages

Error Message	Description of error and action required
UNIT INOPERATIVE	One of the power supply voltages is too low, or A/D converter is not working for the reference oscillator. Contact the factory for repair.
REPLACE BATTERY! UNIT WILL TURN OFF	The remaining battery capacity is less than 5 %. Unit will turn off in 10 sec. Replace all six batteries. After the batteries are replaced, continue testing.

The test error messages may appear on the screens during testing of transformer. The Table 5-3 below shows the messages.

Table 5-3 Test Error Messages

Error Message	Description of error and action required
REPLACE BATTERY! UNIT WILL TURN OFF	The remaining battery capacity is less than 5 %. Unit will turn off in 10 sec. Replace all six batteries. After the batteries are replaced, continue testing.
EXC.CURRENT TOO HIGH	Excitation current is higher than 100 mA. Check for any wrong test cable connections or transformer winding shorts.

Error Message	Description of error and action required
CHECK CONNECTIONS	<p>The test leads are not properly connected to transformer. Connect the leads properly.</p> <p>Test lead(s) is open. Contact the factory for repair.</p> <p>Transformer winding(s) is open. Fix the problem before continuing the test.</p>
CONNECTIONS REVERSED	<p>H and X test lead connections are reversed. Connect H and X test leads properly.</p>
TURN RATIO >10,000	<p>The tested turns ratio is higher than 10,000:1. Causes test to stop. Check for bad or open test lead connections.</p> <p>Transformer winding(s) is open. Fix the problem before continuing the test.</p>
TURN RATIO < 0.8	<p>The tested turns ratio is less than 0.8:1. Causes test to stop. Check for bad or shorted test lead connections.</p> <p>Transformer has a winding turn(s) shorted. Fix the problem before continuing the test.</p>
UNIT NOT CALIBRATED	<p>Tested turns ration is not calibrated. Contact factory for possible problem(s).</p>

The miscellaneous error message may appear on the screens during printing functions. The Table 5-4 below shows the message.

Table 5-4 Miscellaneous Message

Error Message	Description of error and action required
PRINT ERROR	<p>There was an error during printing a report. Try again. See <i>Table 5.1</i>. If failed, contact the factory for repair.</p>

When an error message appears on a screen indicating an abnormal operating condition, verify the condition by taking a repeat measurement before attempting

to take any corrective action. Also, refer to the Troubleshooting section for malfunctions and possible causes.

Open connections, wrong connections, open windings, shorted windings, high resistance windings, other abnormal transformer problems, or a combination of these may cause a large deviation from nominal turn ratio or indicate an unusual message. The unusual operating conditions may be caused by an abnormal leakage reactance or capacitive coupling within the transformer windings.

Repair

Megger offers a complete repair and calibration service and recommends that its customers take advantage of this service in the event of equipment malfunction. Contact your Megger representative for instructions and a return authorization (RA) number. Equipment returned for repair should be shipped prepaid and insured and marked for the attention of the Repair Department. Please indicate all pertinent information including problem symptoms and attempted repairs. The catalog number and serial number of the test set should also be specified. Pack the TTR test set, including all cables, in a carton (original shipping carton if available) with adequate dunnage in accordance with best commercial practice. Seal the carton with waterproof tape.

Ship to: Megger
 Attn: Repair Dept, RMA #
 Valley Forge Corporate Center
 2621 Van Buren Avenue
 Norristown, PA 19403 USA
 1-610-676-8500

Megger[®]

Appendix A

SPECIFICATIONS

Electrical

Type of Power

Six AA-size disposable alkaline batteries

12 hrs of continuous field operation when new Energizer® X91 batteries or equivalent (with average capacity of 3135 mAh) are used

Pollution Degree

TTR20 is designed for Pollution Degree II

Regulatory Compliance

IEC 61010-1

Environmental Protection

Dust and shower protection to IP54

Output Test Voltage and Current

3 test voltages, automatically selected: 8V rms, 1.5V rms or 0.5V rms

Test current: up to 100 mA

Test Frequency

55Hz, internally generated providing a universal 50 / 60 Hz test set.

Loading of Test Transformer

Less than 0.1 VA

Measuring Ranges

Turn ratio: 0.8:1 to 10,000:1, 5 digit resolution

Current: 0 to 100 mA, 4 digit resolution

Transformer Polarity: NORMAL (in phase) or REVERSE (out of phase)

Accuracy

Turn ratio: $\pm 0.1\%$ (0.8 to 2000)

$\pm 0.15\%$ (2001 to 4000)

$\pm 0.25\%$ (4001 to 10,000)

Current (rms): $\pm(2\%$ of reading + 1 digit)

Measurement Method

In accordance with ANSI/IEEE C57.12.90

Transformer Winding Phase Relationship

ANSI C57.12.70-1978

CEI/IEC 76-1:1993 and Publication 616:1978

Measuring Time

4 sec for turns ratio, excitation current, and phase displacement (polarity) testing.

Display

Wide temperature range LCD module, 128 x 64 dots, 21 characters by 8 lines.

Interface

Printer port:	DB-9 male connector
Cable used:	9-pin D-type connectors, standard extension female-female RS232 cable (for TTR20 to a PC connection. The cable is not included in accessory supplied); 9-pin D-type connectors, null modem female-male RS232 cable (for the optional serial printer connection. The cable is included in optional printer package)
Data exchange rate:	up to 57.6 Kbaud for the field firmware upgrading and 19.2 Kbaud for test report printing on the optional serial printer

Environmental Conditions

Operating temperature range:	-15 to 55 °C (5° to 130°F)
Storage temperature range:	-50 to 60 °C (-60° to 140°F)
Relative humidity:	to 90% noncondensing (operating) 95% noncondensing (storage)

Physical Data

Dimensions: (240 x 115 x 50 mm) (H x W x D)
9.5 x 4.5 x 1.9 in.

Weight

Test Set: 890 g (1.9 lbs.)

with Leads 1.4 kg (3.1 lbs.)

Optional Accessories

- Battery/line-powered serial thermal printer package for 120 V ac (p/n 35755-1). The package includes the thermal printer, a battery pack, an AC adapter and an interface cable.
- Battery/line-powered serial thermal printer package for 230 V ac (p/n 35755-2). The package includes the thermal printer, a battery pack, an AC adapter and interface cable.
- Lead sets for single phase transformer testing, shielded, heavy-duty clip-end terminated. The leads are marked according to ANSI Standards.
- Additional printer paper, one roll, (p/n 26999)
- USB Serial Adapter (p/n 35871) for connecting a TTR20 RS232 port to a PC USB port. The adapter is used if a PC does not have an RS232 port.
- Battery Replacement (six required) p/n 35956

Appendix B

ORDERING INFORMATION & SPARE PARTS LIST

Ordering Information

Item	Cat. No.
TTR20 Transformer Turns Ratio Test Set	TTR20
Included Accessories	
Canvas carrying bag and Accessory Pouch	55-20008
Battery (six AA-size disposable alkaline batteries included)	35956
TTR20 Lead Set, 1.8 m (6 ft)	35938
Instruction manual	AVTMTTR20

Optional Accessories

Battery/line-powered, serial, thermal-printer package, 120 V ac	35755-1
Battery/line-powered, serial, thermal-printer package, 230 V ac	35755-2
RS232 cable for connecting to a PC (for firmware upgrading)	33147-18
TTR20 Lead Set, 3.6 m (12 ft)	35942
TTR20 Lead Set, 6 m (20 ft)	36013
TTR20 Lead Set, 10 m (33 ft)	36042
Semi-hard fabric transport case	35788
Battery replacement (six required)	35956
Additional printer paper, 1 roll	26999
USB Serial adapter	35871
Certificate of calibration	CERT-NIST

Spare Parts

Item	Megger Part Number
Battery door	55-20003
Knob, CONTRAST	55-20004
Battery replacement (six required)	35956
TTR20 Lead Set, 1.8 m (6 ft)	35938
TTR20 Lead Set, 3.6 m (12 ft)	35942
TTR20 Lead Set, 6 m (20 ft)	36013
TTR20 Lead Set, 10 m (33 ft)	36042
Additional printer paper, 1 roll	26999
Battery Holder	EV22410-006

Appendix C

Connections and Vector Voltage Diagrams

Table C-1 and C-2 show winding diagrams for standard transformers and nonstandard transformers for power and distribution transformers marked in accordance with the ANSI standard.

To make a measurement on a three-phase power transformer with TTR20 test set, match the vector diagram from the transformer nameplate to the corresponding winding connection diagram from Table C-2. Then connect the TTR20 test leads to the appropriate transformer winding terminals of phase A. Put an external jumper, if required. After phase A test is complete, reconnect the test leads to phase B. Put an external jumper, if required. After phase B test is complete, reconnect the test leads to phase C. Put an external jumper, if required. Compare the measured test results to the calculated turns ratios.

NOTE. Three phase transformer may be tested in any order. For example, phase C, then phase A, and then phase B turns ratio may be tested.

The tables show the windings tested for each of the three phases. The tables also show the relationship between the measured turn ratio and the actual line-to-line voltage ratio. For the ANSI specification, the rated voltage on the high-voltage winding is represented by V_H ; V_X represents rated voltage on the low-voltage winding.

T-Type Transformers

T-type transformers represent a special type of three-phase transformers. This transformer may be tested as a single phase transformer.

To make a measurement on a T-type transformer, the jumpers indicated in Table C-1 should be applied to the appropriate terminals of the T-type transformer. The TTR20 measured turns ratio should be compared to the calculated turns ratio indicated in Table C-1.

Notes to Table C-1

1. Any connection(s) to ground/case of T-type transformer on H or X side should be removed before testing a transformer.
2. Expect that polarity of the windings is normal (“+” sign is displayed in front of the turns ratio test result)

IEC Vector Group	Winding Connection		External Jumpers	Phase tested	Winding Tested		Calculated Turn Ratio
	High-Voltage Winding (H)	Low-Voltage Winding (X)			High-Voltage Winding	Low-Voltage Winding	
T-T 0			- H ₁ -H ₂ X ₁ -X ₂	A B	H ₁ -H ₂ H ₁ -H ₃	X ₁ -X ₂ X ₁ -X ₃	$\frac{V_H}{V_X}$ $\frac{V_H}{V_X}$
T-T 30 lag			H ₂ -H ₃ X ₁ -X ₂	A B	H ₁ -H ₃ H ₂ -H ₃	X ₁ -X ₂ X ₁ -X ₃	$\frac{V_H}{V_X} \cdot \frac{\sqrt{3}}{2}$ $\frac{V_H}{V_X} \cdot \frac{2}{\sqrt{3}}$
T-T 30 lead			H ₂ -H ₃ X ₁ -X ₃	A B	H ₁ -H ₃ H ₂ -H ₃	X ₁ -X ₃ X ₂ -X ₁	$\frac{V_H}{V_X} \cdot \frac{\sqrt{3}}{2}$ $\frac{V_H}{V_X} \cdot \frac{2}{\sqrt{3}}$

Notes to Table C-2

Transformer terminal markings for distribution and power transformers marked in accordance with requirements of **American National Standard Institute, Inc (ANSI) standard C57.12.70 – 1978.**

Definition of Symbol Designations

H ₁ , H ₂ , H ₃	External terminals on HV transformer winding.
X ₁ , X ₂ , X ₃	External terminals on LV transformer winding.
H ₀	External neutral terminal on HV transformer winding.
X ₀	External neutral terminal on LV transformer winding.
*	Inaccessible neutral point on HV or LV transformer winding.
V _H	Nameplate voltage rating (line-to-line) of HV transformer winding.
V _X	Nameplate voltage rating (line-to-line) of LV transformer winding.
A, B, C	Winding tested on HV side of transformer.
a, b, c	Winding tested on LV side of transformer.

Table C-2 ANSI Transformer Winding Phase Relationship

Copyright 1999© Megger

Diag No.	IEC Vector Group	Winding Connection		Phase Tested	External Jumpers	Winding Tested		Measured Turn Ratio
		High-Voltage Winding	Low-Voltage Winding			High-Voltage Winding	Low-Voltage Winding	
1	1φ 1ph0			1φ	—	H ₁ - H ₂	X ₁ - X ₂	$\frac{V_H}{V_X}$
2	1φ 1ph6			1φ	—	H ₁ - H ₂	X ₂ - X ₁	$\frac{V_H}{V_X}$
3	Dd0			A B C	—	H ₁ - H ₃ H ₂ - H ₁ H ₃ - H ₂	X ₁ - X ₃ X ₂ - X ₁ X ₃ - X ₂	$\frac{V_H}{V_X}$
4	Dd6			A B C	—	H ₁ - H ₃ H ₂ - H ₁ H ₃ - H ₂	X ₃ - X ₁ X ₁ - X ₂ X ₂ - X ₃	$\frac{V_H}{V_X}$
5	Dyn1			A B C	—	H ₁ - H ₃ H ₂ - H ₁ H ₃ - H ₂	X ₁ - X ₀ X ₂ - X ₀ X ₃ - X ₀	$\frac{V_H \cdot \sqrt{3}}{V_X}$
6	Dyn7			A B C	—	H ₁ - H ₃ H ₂ - H ₁ H ₃ - H ₂	X ₀ - X ₁ X ₀ - X ₂ X ₀ - X ₃	$\frac{V_H \cdot \sqrt{3}}{V_X}$
7	YNyn0			A B C	—	H ₁ - H ₀ H ₂ - H ₀ H ₃ - H ₀	X ₁ - X ₀ X ₂ - X ₀ X ₃ - X ₀	$\frac{V_H}{V_X}$

Table C-2 ANSI Transformer Winding Phase Relationship

Copyright 1999© Megger								
Diag No.	IEC Vector Group	Winding Connection		Phase Tested	External Jumpers	Winding Tested		Measured Turn Ratio
		High-Voltage Winding	Low-Voltage Winding			High-Voltage Winding	Low-Voltage Winding	
8	YNyn6			A B C	—	H ₁ - H ₀ H ₂ - H ₀ H ₃ - H ₀	X ₀ - X ₁ X ₀ - X ₂ X ₀ - X ₃	$\frac{V_H}{V_X}$
9	YNd1			A B C	—	H ₁ - H ₀ H ₂ - H ₀ H ₃ - H ₀	X ₁ - X ₂ X ₂ - X ₃ X ₃ - X ₁	$\frac{V_H}{V_X \cdot \sqrt{3}}$
10	YNd7			A B C	—	H ₁ - H ₀ H ₂ - H ₀ H ₃ - H ₀	X ₂ - X ₁ X ₃ - X ₂ X ₁ - X ₃	$\frac{V_H}{V_X \cdot \sqrt{3}}$
11	Dy1			A B C	H ₃ - H ₂ H ₁ - H ₃ H ₂ - H ₁	H ₁ - H ₃ H ₂ - H ₁ H ₃ - H ₂	X ₁ - * X ₂ - * X ₃ - *	$\frac{V_H \cdot \sqrt{3}}{V_X}$
12	Dyn5			A B C	—	H ₁ - H ₃ H ₂ - H ₁ H ₃ - H ₂	X ₃ - X ₀ X ₁ - X ₀ X ₂ - X ₀	$\frac{V_H \cdot \sqrt{3}}{V_X}$
13	Dy5			A B C	H ₃ - H ₂ H ₁ - H ₃ H ₂ - H ₁	H ₁ - H ₃ H ₂ - H ₁ H ₃ - H ₂	X ₃ - * X ₁ - * X ₂ - *	$\frac{V_H \cdot \sqrt{3}}{V_X}$

Table C-2 ANSI Transformer Winding Phase Relationship

Copyright 1999© Megger

Diag No.	IEC Vector Group	Winding Connection		Phase Tested	External Jumpers	Winding Tested		Measured Turn Ratio
		High-Voltage Winding	Low-Voltage Winding			High-Voltage Winding	Low-Voltage Winding	
14	Dy7			A B C	H ₃ - H ₂ H ₁ - H ₃ H ₂ - H ₁	H ₁ - H ₃ H ₂ - H ₁ H ₃ - H ₂	* - X ₁ * - X ₂ * - X ₃	$\frac{V_H \cdot \sqrt{3}}{V_X}$
15	Dyn11			A B C	—	H ₁ - H ₃ H ₂ - H ₁ H ₃ - H ₂	X ₀ - X ₃ X ₀ - X ₁ X ₀ - X ₂	$\frac{V_H \cdot \sqrt{3}}{V_X}$
16	Dy11			A B C	H ₃ - H ₂ H ₁ - H ₃ H ₂ - H ₁	H ₁ - H ₃ H ₂ - H ₁ H ₃ - H ₂	* - X ₃ * - X ₁ * - X ₂	$\frac{V_H \cdot \sqrt{3}}{V_X}$
17	Dz0			A B C	—	H ₁ - H ₃ H ₂ - H ₁ H ₃ - H ₂	X ₁ - X ₃ X ₂ - X ₁ X ₃ - X ₂	$\frac{V_H}{V_X}$
18	Dz6			A B C	—	H ₁ - H ₃ H ₂ - H ₁ H ₃ - H ₂	X ₃ - X ₁ X ₁ - X ₂ X ₂ - X ₃	$\frac{V_H}{V_X}$
19	YNy0			A B C	H ₂ - H ₀ H ₃ - H ₀ H ₁ - H ₀	H ₁ - H ₀ H ₂ - H ₀ H ₃ - H ₀	X ₁ - * X ₂ - * X ₃ - *	$\frac{V_H}{V_X}$

Table C-2 ANSI Transformer Winding Phase Relationship

Copyright 1999© Megger

Diag No.	IEC Vector Group	Winding Connection		Phase Tested	External Jumpers	Winding Tested		Measured Turn Ratio
		High-Voltage Winding	Low-Voltage Winding			High-Voltage Winding	Low-Voltage Winding	
20	Yyn0			A B C	—	H ₁ - H ₃ H ₂ - H ₁ H ₃ - H ₂	X ₁ - X ₃ X ₂ - X ₁ X ₃ - X ₂	$\frac{V_H}{V_X}$
21	Yy0			A B C	—	H ₁ - H ₃ H ₂ - H ₁ H ₃ - H ₂	X ₁ - X ₃ X ₂ - X ₁ X ₃ - X ₂	$\frac{V_H}{V_X}$
22	YNy6			A B C	H ₂ - H ₀ H ₃ - H ₀ H ₁ - H ₀	H ₁ - H ₀ H ₂ - H ₀ H ₃ - H ₀	* - X ₁ * - X ₂ * - X ₃	$\frac{V_H}{V_X}$
23	Yyn6			A B C	—	H ₁ - H ₃ H ₂ - H ₁ H ₃ - H ₂	X ₃ - X ₁ X ₁ - X ₂ X ₂ - X ₃	$\frac{V_H}{V_X}$
24	Yy6			A B C	—	H ₁ - H ₃ H ₂ - H ₁ H ₃ - H ₂	X ₃ - X ₁ X ₁ - X ₂ X ₂ - X ₃	$\frac{V_H}{V_X}$
25	Yzn1			A B C	—	H ₁ - H ₃ H ₂ - H ₁ H ₃ - H ₂	X ₁ - X ₀ X ₂ - X ₀ X ₃ - X ₀	$\frac{V_H \cdot \sqrt{3}}{V_X}$

Table C-2 ANSI Transformer Winding Phase Relationship

Copyright 1999© Megger

Diag No.	IEC Vector Group	Winding Connection		Phase Tested	External Jumpers	Winding Tested		Measured Turn Ratio
		High-Voltage Winding	Low-Voltage Winding			High-Voltage Winding	Low-Voltage Winding	
26	Yz1			A B C	H ₃ - H ₂ H ₁ - H ₃ H ₂ - H ₁	H ₁ - (H ₃ + H ₂) H ₂ - (H ₁ + H ₃) H ₃ - (H ₂ + H ₁)	X ₁ - X ₂ X ₂ - X ₃ X ₃ - X ₁	$\frac{V_H \cdot \sqrt{3}}{V_X} \cdot \frac{\sqrt{3}}{2}$
27	Yzn5			A B C	—	H ₁ - H ₃ H ₂ - H ₁ H ₃ - H ₂	X ₃ - X ₀ X ₁ - X ₀ X ₂ - X ₀	$\frac{V_H \cdot \sqrt{3}}{V_X}$
28	Yz5			A B C	H ₃ - H ₂ H ₁ - H ₃ H ₂ - H ₁	H ₁ - (H ₃ + H ₂) H ₂ - (H ₁ + H ₃) H ₃ - (H ₂ + H ₁)	X ₃ - X ₁ X ₁ - X ₂ X ₂ - X ₃	$\frac{V_H \cdot \sqrt{3}}{V_X} \cdot \frac{\sqrt{3}}{2}$
29	Yzn7			A B C	—	H ₁ - H ₃ H ₂ - H ₁ H ₃ - H ₂	X ₀ - X ₁ X ₀ - X ₂ X ₀ - X ₃	$\frac{V_H \cdot \sqrt{3}}{V_X}$
30	Yz7			A B C	H ₃ - H ₂ H ₁ - H ₃ H ₂ - H ₁	H ₁ - (H ₃ + H ₂) H ₂ - (H ₁ + H ₃) H ₃ - (H ₂ + H ₁)	X ₂ - X ₁ X ₃ - X ₂ X ₁ - X ₃	$\frac{V_H \cdot \sqrt{3}}{V_X} \cdot \frac{\sqrt{3}}{2}$
31	Yzn11			A B C	—	H ₁ - H ₃ H ₂ - H ₁ H ₃ - H ₂	X ₀ - X ₃ X ₀ - X ₁ X ₀ - X ₂	$\frac{V_H \cdot \sqrt{3}}{V_X}$

Table C-2 ANSI Transformer Winding Phase Relationship

Copyright 1999© Megger								
Diag No.	IEC Vector Group	Winding Connection		Phase Tested	External Jumpers	Winding Tested		Measured Turn Ratio
		High-Voltage Winding	Low-Voltage Winding			High-Voltage Winding	Low-Voltage Winding	
32	Yz11			A B C	H ₃ - H ₂ H ₁ - H ₃ H ₂ - H ₁	H ₁ -(H ₃ +H ₂) H ₂ -(H ₁ +H ₃) H ₃ -(H ₂ +H ₁)	X ₁ - X ₃ X ₂ - X ₁ X ₃ - X ₂	$\frac{V_H \cdot \sqrt{3}}{V_X}$
33	ZNy5			A B C	—	H ₁ - H ₀ H ₂ - H ₀ H ₃ - H ₀	X ₃ - X ₁ X ₁ - X ₂ X ₂ - X ₃	$\frac{V_H}{V_X \cdot \sqrt{3}}$
34	Zy5			A B C	H ₃ - H ₂ H ₁ - H ₃ H ₂ - H ₁	H ₁ -(H ₃ +H ₂) H ₂ -(H ₁ +H ₃) H ₃ -(H ₂ +H ₁)	X ₃ - X ₁ X ₁ - X ₂ X ₂ - X ₃	$\frac{V_H \cdot \sqrt{3}}{V_X}$
35	ZNy11			A B C	—	H ₁ - H ₀ H ₂ - H ₀ H ₃ - H ₀	X ₁ - X ₃ X ₂ - X ₁ X ₃ - X ₂	$\frac{V_H}{V_X \cdot \sqrt{3}}$
36	Zy11			A B C	H ₃ - H ₂ H ₁ - H ₃ H ₂ - H ₁	H ₁ -(H ₃ +H ₂) H ₂ -(H ₁ +H ₃) H ₃ -(H ₂ +H ₁)	X ₁ - X ₃ X ₂ - X ₁ X ₃ - X ₂	$\frac{V_H \cdot \sqrt{3}}{V_X}$
37	Yd1			A B C	H ₃ - H ₂ H ₁ - H ₃ H ₂ - H ₁	H ₁ -(H ₃ +H ₂) H ₂ -(H ₁ +H ₃) H ₃ -(H ₂ +H ₁)	X ₁ - X ₂ X ₂ - X ₃ X ₃ - X ₁	$\frac{V_H \cdot \sqrt{3}}{V_X}$

Table C-2 ANSI Transformer Winding Phase Relationship

Copyright 1999© Megger

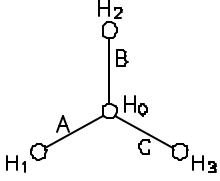
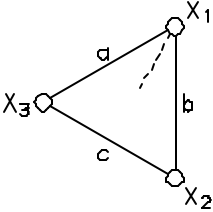
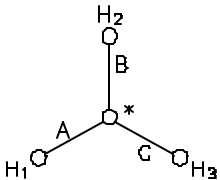
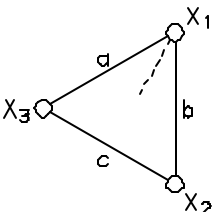
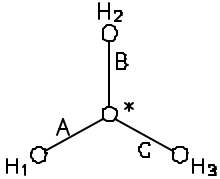
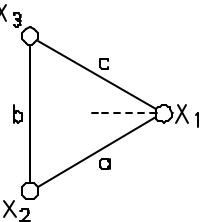
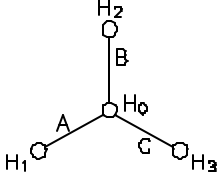
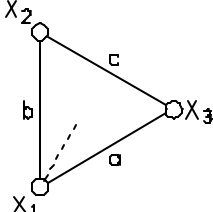
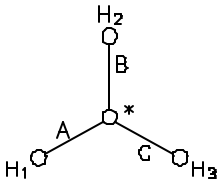
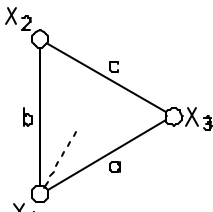
Diag No.	IEC Vector Group	Winding Connection		Phase Tested	External Jumpers	Winding Tested		Measured Turn Ratio
		High-Voltage Winding	Low-Voltage Winding			High-Voltage Winding	Low-Voltage Winding	
38	YNd5			A B C	—	H ₁ - H ₀ H ₂ - H ₀ H ₃ - H ₀	X ₃ - X ₁ X ₁ - X ₂ X ₂ - X ₃	$\frac{V_H}{V_X \cdot \sqrt{3}}$
39	Yd5			A B C	H ₃ - H ₂ H ₁ - H ₃ H ₂ - H ₁	H ₁ - (H ₃ + H ₂) H ₂ - (H ₁ + H ₃) H ₃ - (H ₂ + H ₁)	X ₃ - X ₁ X ₁ - X ₂ X ₂ - X ₃	$\frac{V_H \cdot \sqrt{3}}{V_X \cdot 2}$
40	Yd7			A B C	H ₃ - H ₂ H ₁ - H ₃ H ₂ - H ₁	H ₁ - (H ₃ + H ₂) H ₂ - (H ₁ + H ₃) H ₃ - (H ₂ + H ₁)	X ₂ - X ₁ X ₃ - X ₂ X ₁ - X ₃	$\frac{V_H \cdot \sqrt{3}}{V_X \cdot 2}$
41	YNd11			A B C	—	H ₁ - H ₀ H ₂ - H ₀ H ₃ - H ₀	X ₁ - X ₃ X ₂ - X ₁ X ₃ - X ₂	$\frac{V_H}{V_X \cdot \sqrt{3}}$
42	Yd11			A B C	H ₃ - H ₂ H ₁ - H ₃ H ₂ - H ₁	H ₁ - (H ₃ + H ₂) H ₂ - (H ₁ + H ₃) H ₃ - (H ₂ + H ₁)	X ₁ - X ₃ X ₂ - X ₁ X ₃ - X ₂	$\frac{V_H \cdot \sqrt{3}}{V_X \cdot 2}$