

EQUIPMENT MANUAL
EQUIPMENT TESTING TURNTABLE
EMCO MODELS

1060-04
1060-1.5m

1061-04
1061-1.5m

399011
Revision F

Table of Contents

Warranty

Caution/Warning

General Description

Specifications

Description of Options

Assembly Instructions

 Setting the Mechanical Limit Switches

 Setting the Controller Electronic Limit Switches

Controller Operation and Programming

Recommended Maintenance

Replacement Parts List

Cable Wire List

Appendix

 Figure 1 - Location of Mechanical Limits

 Figure 2 - Front-Panel Feature Overview

 Figure 3 - Rear-Panel Feature Overview

 Figure 4 - General Safety Considerations and
 Safety Symbols Definitions

Schematics

WARRANTY

The Electro-Mechanics Company (EMCO) warrants that our products are free from defects in materials and workmanship for a period of two years from the date of shipment. If you notify us of a defect within the warranty period, we will, at our option, either repair or replace those products which prove to be defective. If applicable, we will also recalibrate the product.

There will be no charge for warranty services performed at the location we designate. You must however, prepay inbound shipping costs and any duties or taxes. We will pay outbound shipping costs for a carrier of our choice, exclusive of any duties or taxes. You may request warranty services to be performed at your location, but it is our option to do so. If we determine that warranty service can only be performed at your location, you will not be charged for our travel related costs.

This warranty does not apply to:

1. Normal wear and tear of materials
2. Consumable items such as fuses, batteries, etc.
3. Products which have been improperly installed, maintained or used.
4. Products which have been operated outside of specifications.
5. Products which have been modified without authorization.
6. Calibration of products, unless necessitated by defects.

THIS WARRANTY IS EXCLUSIVE. NO OTHER WARRANTY, WRITTEN OR ORAL, IS EXPRESSED OR IMPLIED, INCLUDING BUT NOT LIMITED TO, THE IMPLIED WARRANTIES OF MERCHANTABILITY AND FITNESS FOR A PARTICULAR PURPOSE.

THE REMEDIES PROVIDED BY THIS WARRANTY ARE YOUR SOLE AND EXCLUSIVE REMEDIES. IN NO EVENT ARE WE LIABLE FOR ANY DAMAGES WHATSOEVER, INCLUDING BUT NOT LIMITED TO, DIRECT, INDIRECT, SPECIAL, INCIDENTAL, OR CONSEQUENTIAL DAMAGES, WHETHER BASED ON CONTRACT, TORT, OR ANY OTHER LEGAL THEORY.

Please contact our Sales Department for a Return Material Authorization Number before shipping equipment to us.

```

* * * * *
*
*           C A U T I O N
*
* CAUTION: Prior to operation of the Model 1060/1061
*           Equipment Testing Turntable, the following
*           steps must be followed:
*
*   1. Set the voltage select switch located on the rear
*       of the CONTROLLER to the proper setting.
*
*   2. Set the voltage select switch mounted on the
*       MOTOR BASE adjacent to the Control Cable
*       connection.
*
* NOTE: Voltage settings of Step 1 and 2 above should match.
*
* FAILURE TO OBSERVE THE ABOVE CAUTION CAN RESULT IN
* POSSIBLE DAMAGE TO THE MODEL 1060/1061
* AND VOID THE WARRANTY
*
* * * * *

```

FOR LABORATORY USE BY QUALIFIED PERSONNEL

POUR EMPLOI PAR LE PERSONNEL DE LABORATOIRE.

WARNING: HIGH LEAKAGE CURRENT - ENSURE PROPER GROUNDING

AVERTISSEMENT: COURANT DE FUITE ELEVE - FOURNIR UNE MISE A LA TERRE EFFICACE

WARNING: DISCONNECT SUPPLY BEFORE SERVICING

AVERTISSEMENT: COUPER L'ALIMENTATION AVANT L'ENTRETIEN ET DEPON- NAGE.

DESCRIPTION AND USE OF THE EQUIPMENT TESTING TURNTABLE

SYSTEM DESCRIPTION

The EMCO Equipment Testing Turntable is designed for use in compliance testing.

Rotation is provided by a drive system which includes an electric motor, electric brake and a drive gear reduction arrangement. Approximately 370 degrees of rotation are provided before travel is stopped by mechanically actuated limit switches, which are preset at the factory.

The base of the turntable is constructed of marine grade plywood, the platform is fabricated of either marine grade plywood covered with formica or solid 3/8" steel plate, depending on the model chosen. Both platforms are designed to provide strength and rigidity and resist degradation due to harsh environments. The drive unit is attached to the base section, as is the phenolic support and the stationary member of the center bearing.

In addition to mechanical limits, the controller has the capability to move the table a full 370 degrees of rotation as well as any smaller arc of the circle. For further explanation of controller functions and programming, see the manual section entitled "Controller Operation and Programming".

Dimensions and electrical requirements are provided in the Specifications table included in this manual.

SPECIFICATIONS

ELECTRICAL

Voltage (*)	115/230 VAC	115/230 VAC
Frequency	50 Hz	60 Hz
Max Power Input	500 VA	500 VA
Motor Horsepower	1/6	1/6
Turntable RPM	1.0	1.2

* Switch Selectable Voltage 115/230 VAC (tol: +10,-15)

MECHANICAL

1060-04

Table Diameter	4 ft (1.22 m)
Table Height	10.5 in (26.7 cm)
Load Rating (Distributed)	1000 lb (455 kg)

1060-1.5m

Table Diameter	1.5 m (4.92 ft)
Table Height	10.5 in (26.7 cm)
Load Rating (Distributed)	1000 lb (455 kg)

1061-04

Table Diameter	4 ft (1.22 m)
Table Height	9.7 in (24.7 cm)
Load Rating (Distributed)	1000 lb (455 kg)

1061-1.5m

Table Diameter	1.5 m (4.92 ft)
Table Height	9.7 in (24.7 cm)
Load Rating (Distributed)	1000 lb (455 kg)

ASSEMBLY INSTRUCTIONS

Since the unit comes with the top and bottom attached, the only assembly required is to install the unit at the place of operation, level the table by using wooden wedges and a level, then connect the cables, controller and power source.

SETTING THE MECHANICAL LIMIT SWITCHES

The mechanical limit switches are set at the factory and normally do not require setting at the customer site, only verification of full rotation. Should resetting be necessary, the procedure is described in the following pages:

Disconnect the main (AC) power to the turntable and to the controller. Remove the eight bolts which secure the rotating platform (top) to the main bearing and drive sprocket. Remove the screws which secure the motor base cover. After loosening the hold-down bolts, shift the Motor Base Assembly slightly to allow for slack in the drive chain. After removal of the motor base cover, the "CW" and "CCW" Mechanical Limit Switches, located on the Encoder Assembly, can be accessed. To set the Mechanical Limit Switches, loosen the brass cams on the encoder drive shaft with the 1/16" Allen wrench (supplied). (Refer to Figure 1.)

The "CW" limit is set by rotating the platform in a clockwise direction to 0 degrees and adjusting the brass cam above the "CW" limit switch so that the switch actuating arm is depressed (an audible "click" can be heard). Tighten the set screw on the cam, using the 1/16" Allen wrench.

The "CCW" limit is set by rotating the platform in the opposite direction approximately 370 degrees and adjusting the brass cam above the "CCW" limit switch as described above. Tighten the set screw on the cam, using the 1/16" Allen wrench.

Replace motor base cover and secure. Tighten hold-down bolts while making certain drive chain has been properly tensioned. Replace rotating platform and bolt to main bearing and drive sprocket.

Connect AC power cables to turntable and controller.

SETTING THE CONTROLLER (ELECTRONIC) LIMIT SWITCHES

Press the "CW" switch and verify that the turntable rotates clockwise. Stop the rotation by pressing the "STOP" switch. Press the "CCW" switch and verify that the turntable rotates counterclockwise. Stop the rotation by pressing the "STOP" switch.

Set the current position to 400 by using the "INC" switch: hold it down until the display reads "400". Press "CCW" switch and rotate table until the cams stop the table.

Set lower limit and current position to "0": press "DEC" until it comes to "0". Press "LOAD" then immediately press "CURRENT POSITION". If the "CURRENT POSITION" and "CCW" do not both read "0", reload and set to "0" by repeating the above procedure.

Press "CW" until the mechanical limit is reached and the table shuts off.

Note the upper limit figure (approximately 390 or 400), divide that number by 2. Press "CCW" until that number is reached.

Set "CURRENT POSITION" to 180: press "LOAD", then immediately press "CURRENT POSITION"; with the completion of this setting, table is centered and the controller electronic limits are set.

There will be 15 to 20 degrees safety factor in either direction before the table reaches the mechanical limit switches. The direction of rotation, and repeatability of position, is performed by the controller. The cams are an additional safety feature.

To verify repeatability (and insure that the cams have not slipped), select a position on the turntable and rotate in each direction to reach the clockwise and counter-clockwise limits. Then enter that preset (selected position) number. The turntable should return to the same position and the controller should display numbers within one or two degrees of the table position. Note that the number and table position can vary slightly, depending on the weight of the load placed on the table and the amount of backlash in the chain and gearbox.

CONTROLLER OPERATION AND PROGRAMMING

GENERAL DESCRIPTION

The Control Unit for the Equipment Testing Turntable, which includes a digital readout in azimuth degrees and two adjustable electronic limits, is attached to the motor unit using an eight conductor and a four conductor cable. The eight conductor cable provides power and directional control for the turntable. The four conductor cable provides position information from the turntable to the controller.

Power to the controller is applied through the filtered three pin power inlet located on the rear panel. Mains voltage selection should be made prior to connection.

The Controller is a relative position indicator. The mechanical limit switches are set at the factory, but it is important to verify that the mechanical limits are set correctly before declaring the unit operational. Refer to the section on "SETTING THE MECHANICAL LIMIT SWITCHES" in this manual if they need adjustment.

USER FRONT PANEL CONTROLS

Refer to Figure 2 for Front-Panel Feature Overview.
Refer to Figure 3 for Rear-Panel Feature Overview.

DISPLAY

The display in normal operation will display a numeral that denotes one of four programs: the current turntable position, the counter clockwise limit currently set, the clockwise limit currently set or a "display" value as entered from the "INC"/"DEC" display set switches. The display set switches are used to preset a value which can be used to set the current position, the clockwise or counter-clockwise limit. The parameter to be displayed is set by pressing the appropriate switch (i.e. Current Position, CW Limit, CCW Limit). The appropriate LED for the displayed parameter will be lit. If all three LED indicators are off, the display will follow the set switches.

To load a preset value:

1. Select the desired value by using the "Increment/Decrement" switch.
2. Depress the "Load" switch (LED lit for 2 seconds).
3. Depress the function desired:
 - "Current Position"
 - "Lower Limit"
 - "Upper Limit"
4. Value is now entered into memory.

Pressing the "INC", "DEC" switches will cancel any existing display and allow the operator to change the display to any desired value. If the switches are pressed momentarily the display value will increment/decrement by +/-1. If the given switch is held down for more than 1 second, the display will increment/decrement continuously at a fast rate to allow the operator move the value to the general range desired and then single-step the display to the desired value. The allowable range will be from -999 to 999.

If the situation ever occurs that the current table position is not within the range specified by the clockwise or counter-clockwise limits, the display will blink.

TABLE MOTION CONTROL

The table motion is controlled by the "CW", "CCW", and "STOP" switches. The function control is self-explanatory with the added explanation that the LED indicators for "CW" and "CCW" will remain lit if the table activates a mechanical limit. The current position display will obviously stop changing, thus indicating the table is mechanically stopped. If the electronic limits are exceeded or if "STOP" has been hit, the LED indicators will be extinguished.

REMOTE/LOCAL INTERFACE CONTROLS

The interface state of the instrument is indicated by the "RMT" LED indicator. When lit, the instrument is under control of the host GPIB controller; otherwise the front panel controls are active. The LOCAL switch will switch the instrument to local front panel control IF POSSIBLE (i.e. if the host controller will permit. The host may have the front panel locked out using the LLO Local Locked Out).

The ADDR LED will be lit whenever the Controller is being addressed on the GPIB.

GPIB HOST INTERFACE CONTROL

The following programming sequences list the instrument functions for the Turntable Controller.

- CW - Move table position clockwise from current position
 - CC - Move table position counter-clockwise from current position
 - ST - Stop table motion
 - CP - Set display in instrument to show current table position. Note that this sets up the display mode so that subsequent read commands will return the counter-clockwise limit value to the host controller.
 - WL - Set display in instrument to show current table clockwise limit. Note that this sets up the display mode so that subsequent read commands will return the clockwise limit value to the host controller.
 - CL - Set display in instrument to show current table counter-clockwise limit. Note that this sets up the display mode so that subsequent read commands will return the counter-clockwise limit value to the host controller.
- LD (+,-)XXX DG - Set the display to show +/-XXX degrees. (+ can be omitted). This command must be followed by a "CP", "WL", or "CL" command to load the value into the proper register.

When reading the value currently being shown in the table controller display, the meaning of this value will be whatever has been preset by a "CP", "WL" or "CL" command.

The GPIB address switch is located under the top cover panel of the control box. The address has been preset to 09.

The address switch also contains three option switches "C1", "C2" and "C3". The effect for each is as follows.

- C1- No effect
- C2- No effect
- C3- Selects between two counting modes:
 - off (preset) - controller counts from -999 +999.
 - on - controller counts from 0 to 359 then starts over at 0.

With C3 selected, the turntable can be operated as a continuous rotation turntable by removing the mechanical limits.

This is not recommended for use by inexperienced personnel.

PROGRAMMING EXAMPLE FOR THE HP-IB GPIB CONTROLLER

Reading the display:

ENTER 708; X

Loading the current position:

OUTPUT 708; "LD 123 DG CP"

A display of "E - P" indicates a power error and suggests that the electronic limits and current position should be reset.

SAMPLE LISTING

```
10  REMOTE 709
20  OUTPUT 709; "LD 15 DG CL"
30  OUTPUT 709; "LD 15 DG CP"
40  OUTPUT 709; "LD 195 DG WL"
50  OUTPUT 709; "CW"
60  WAIT 5000
70  OUTPUT 709; "ST"
80  ENTER 709; X
90  DISP X
```

RECOMMENDED MAINTENANCE

EVERY SIX MONTHS:

1. Insure that the drive chain is fairly tight: the chain should have no more than 1/2" (1cm) looseness when flexed at a point halfway between the two sprockets. Adjust the chain by loosening the 4 bolts holding the motor base to the turntable base, move the motor base in or out to the desired tension.
2. Insure that the encoder drive chain is fairly tight: the chain should have no more than 1/8" (3mm) looseness when flexed at a point halfway between the two sprockets. Adjust the chain by loosening the 2 screws holding the encoder motor base to the turntable base, move the motor base in or out to the desired tension.
3. Lubricate the drive chain and the encoder chain with a good quality chain lubricant. (Available at motorcycle or bicycle shops).
4. Check the gearbox for excessive fluid leakage; a slight film that has collected some dust is normal, puddles of fluid are not. (Note: the gearbox is lubricated and sealed at the factory and should not require servicing during it's life, under normal conditions)

EVERY 12 MONTHS:

1. Repeat the 6 month maintenance schedule and also:
2. Grease the main bearing race using a grease gun containing a good quality bearing grease. The grease fittings are located on the inside of the race, 90 degrees apart, underneath the top. Three discharges of grease from the gun in each fitting is adequate.

REPLACEMENT PARTS LIST
Model 1060/1061

Following is a partial list of common parts that are replaceable by the customer.

Contact EMCO regarding dimension specific items such as tops, etc.

Emco P/N	Description
Motor Base and Encoder	
100045	Encoder wheel
100051	Brass limit cam
101398B	Motor board assy --
630060	Roller lever switch
700004	Motor brake
700023	Motor, 100-220VAC/50-60HZ
880002	Chain, .1475 pitch
890004	Chain, .375 pitch
890005	Chain master link, .375 pitch
890012	Chain master link, .1475 pitch
101519	Encoder optical switch assembly

Interface Cable & Connectors

100071	Cable assy, 10 M, 4 & 8 pin
504014	Connector, 4 pin, male
504019	Connector, 8 pin, male
504028	Connector, 8 pin, female
504007	Receptacle, 4 pin, female
504012	Receptacle, 8 pin, male
675004	Cable, bulk, 4 conductor
675005	Cable, bulk, 8 conductor
675055	Cable clamp, 4 conductor
675053	Cable clamp, 8 conductor

Controller

100645	Chassis main board assy
100655	Main board assy
400016	Power supply 5V
400009	Battery , lead acid
480004	Fuse 1/8 A normal 3AG
480009	Fuse 1/2 A normal 3AG
480005	Fuse 1 A slow blow 3AG
480006	Fuse 5 A slow blow 3AG
890022	Mounting stub, HPiB connector
505002	Cable IEEE interconnect
505003	Header assy, 20 pin
505004	Header assy, 50 pin
504007	Receptacle, 4 pin female
504012	Receptacle, 8 pin female
505008	Cable assy, 20 pin
505009	Cable assy, 50 pin
505033	Plug, 10 pin flat
506059	Receptacle 10 pin flat
690001	Filter, feed-thru
690005	Filter, power line

Tools

960001	.0625" Allen wrench
960002	.125" Allen wrench

CABLE WIRE LIST
Model 1060/1061

CONTROL/POWER CABLE (Eight-Conductor)

POSITION	FUNCTION	WIRE COLOR
A	AC HIGH	BLACK
B	AC LOW	WHITE
C	UP/CW	ORANGE
D	DN/CCW	BROWN
E	POLARIZATION	BLUE
F*	GROUND	GREEN
G	AC HIGH (A)	RED
H	AC LOW (B)	YELLOW

* NOTE: Drain wire is connected to Pin F of the seven-pin connector on the controller end.
Shield is connected connector strain relief.

SIGNAL CABLE (Four-Conductor)

POSITION	FUNCTION	WIRE COLOR
A	+ 5 VDC	RED
B*	COMMON	BLACK
C	SIGNAL #1	GREEN
D	SIGNAL #2	WHITE

* NOTE: Drain wire is connected to Pin B of the four-pin connector on the controller end.
Shield is connected to connector strain relief.

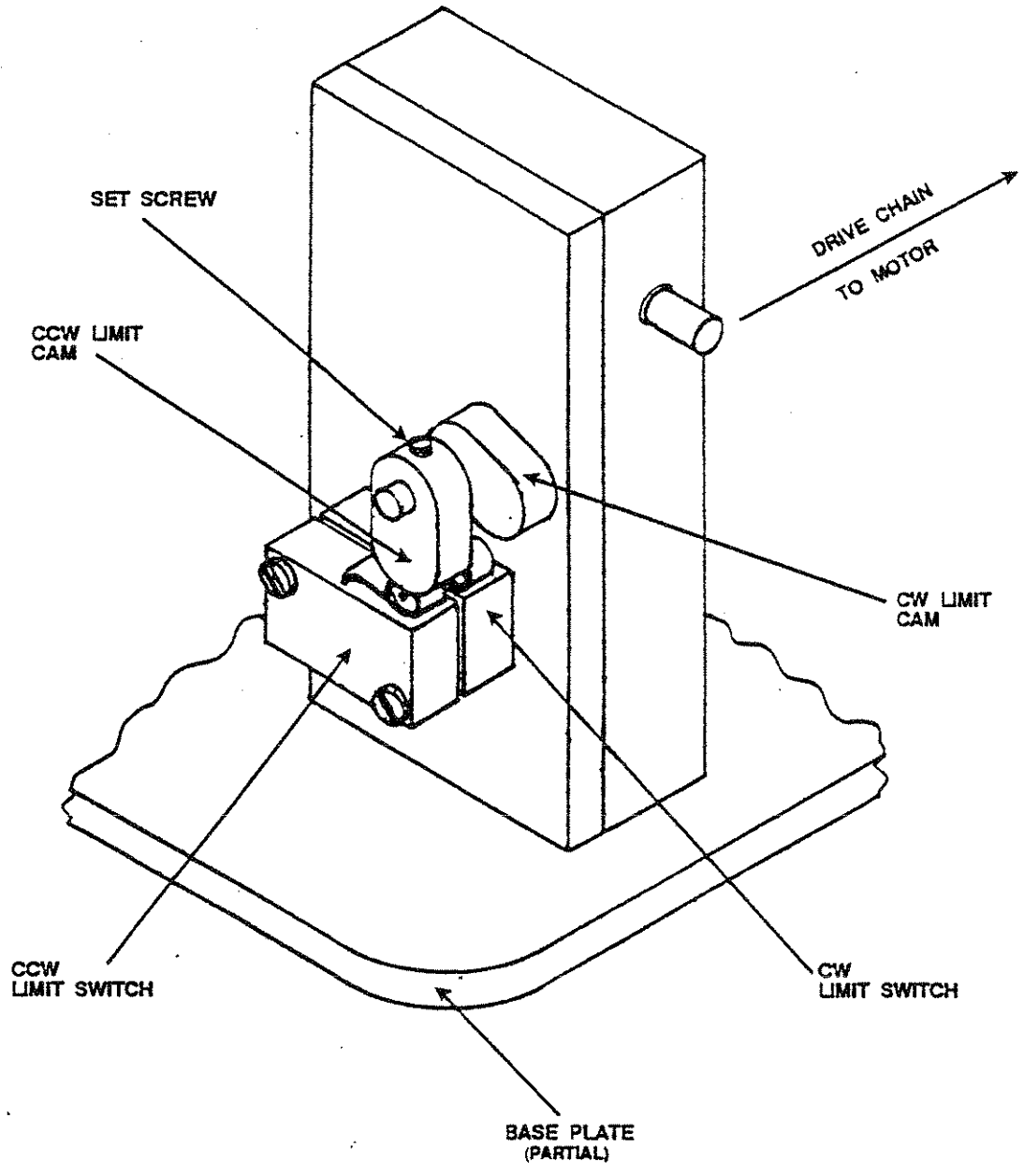

LOCATION OF MECHANICAL LIMITS
(INSIDE OF MOTOR ASSEMBLY)

FIGURE 1

CONTROLLER (1060 SERIES)

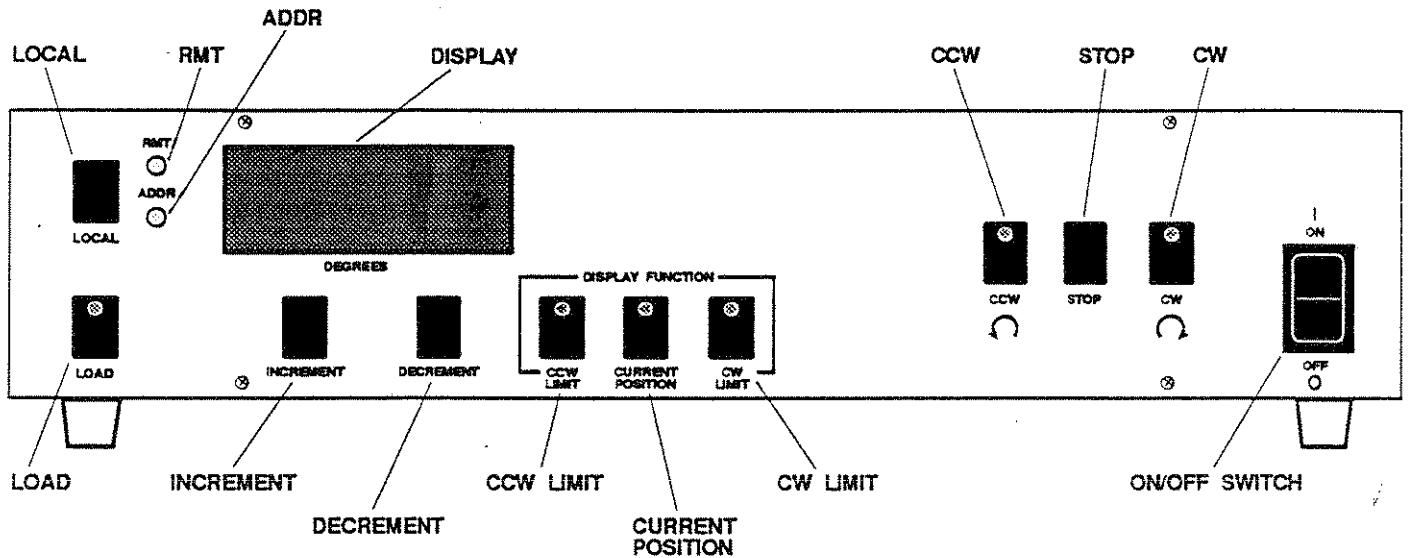

Figure 2. Front-Panel Feature Overview

The following section provides a brief description of front-panel features.

ON/OFF SWITCH	Turns the equipment on or off. The on position indicates ac power is applied to the equipment.
ADDR	LED activates (turns on) when controller is accessed by the host GRIB controller.
RMT	LED activates (turns on) when the instrument is under control of the host GPIB controller.
LOCAL	Switches the instrument to Local front-panel control (NOTE: The host controller could have the front panel locked out.).
CCW	Controls turntable motion in a counter-clockwise direction from the current position. LED remains active if turntable hits a mechanical limit. If electrical limit is exceeded or if "STOP" has been pressed, the LED will turn off.
CW	Controls turntable motion in a clockwise direction from the current position. LED remains active if turntable hits a mechanical limit. If electrical limit is exceeded or if "STOP" has been pressed, the LED will turn off.
STOP	Stops turntable motion.

CONTROLLER (1060 SERIES)

LOAD

Load is used to load a preset value. Pressing the LOAD switch turns on the LED and "arms" the loading action for approximately two seconds. During that interval, the desired function set switch, CURRENT POSITION, CCW LIMIT, or CW LIMIT, should be pressed to receive the preset value. The display mode will switch to display the parameter just loaded. If the two second "arm" interval ellapses without a load sequence being performed, or if any other switch is pressed, no loading will occur.

DISPLAY

Displays a digital readout in degrees for each of the four following functions: CURRENT POSITION, CCW LIMIT (as currently set), CW LIMIT (as currently set), and the display value as entered from the INCREMENT or DECREMENT set switch.

INCREMENT

Pressing the INCREMENT switch cancels the existing display and allows changing the display to any desired value. If switch is pressed momentarily, the display value will increment by +1. If the switch is held pressed in for more than one second, the display will increment continously at a fast rate. This allows moving value to the general range desired and then single-stepping to the desired value. Range -999 to 999.

DECREMENT

Pressing the DECREMENT switch cancels the existing display and allows changing the display to any desired value. If switch is pressed momentarily, the display value will decrement by -1. If the switch is held pressed in for more than one second, the display will decrement continously at a fast rate. This allows moving value to the general range desired and then single-stepping to the desired value. Range -999 to 999.

DISPLAY FUNCTION CCW LIMIT CURRENT POSITION CW LIMIT

The DISPLAY FUNCTION set switches (CCW LIMIT, CURRENT POSITION, and CW LIMIT) are used to preset a value which can be used to set the CCW Limit, Current Position, or CW Limit. This also activates the appropriate LED for the currently displayed parameter. If all three LEDs are inactive, the display will follow the set switches.

CONTROLLER (1060 SERIES)

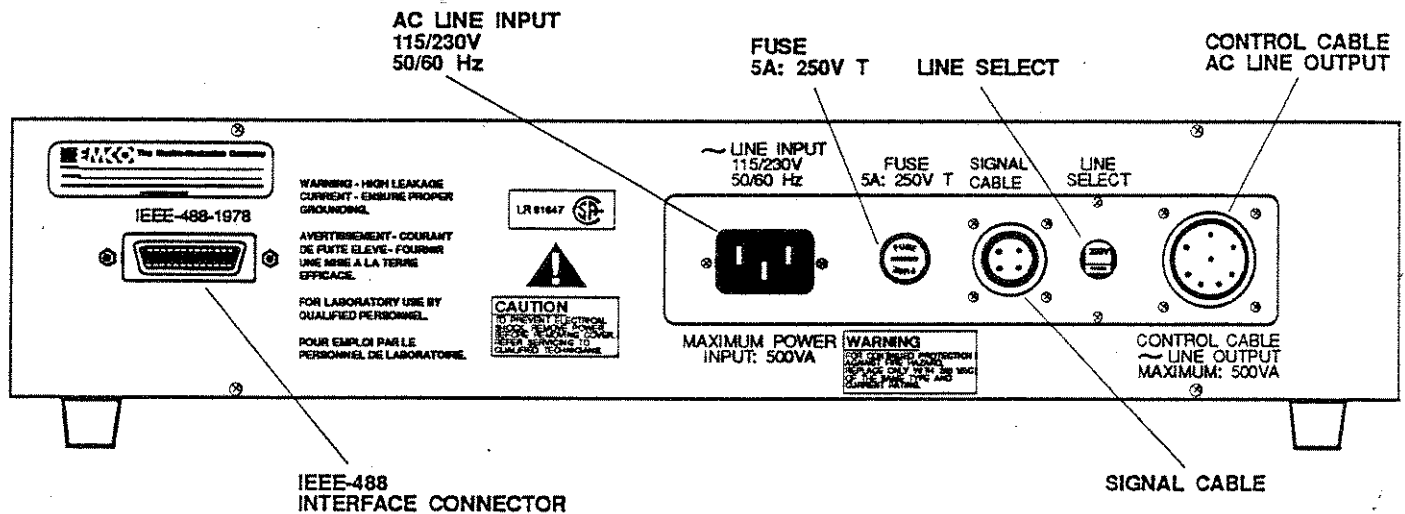

Figure 3. Rear-Panel Feature Overview

The following section provides a brief description of rear-panel features.

AC LINE INPUT

A three wire 110V power cable is included with the controller (220V power cable provided by the customer). Connect the main-power plug only into a receptacle outlet that has a protective ground contact.

WARNING - The protective earth grounding on this equipment must be maintained to provide protection from electric shock.

FUSE

A 5 amp. 250 volt slow blow 5 x 20 mm fuse is housed in a bayonet type fuse holder located next to ac line input. When replacing fuse, order EMCO part # 480019.

LINE SELECT

A line-voltage selector switch is set to the line input voltage range (115 or 230V) corresponding to the available ac voltage. A designator on the switch indicates the voltage range selected.

CONTROL CABLE AC LINE OUTPUT

An ac line output provides ac power and ac directional control signals which are used to drive the control circuits of either the turntable or mast, via an eight-conductor cable.

SIGNAL CABLE

This signal input (via a four-conductor cable) provides positional information from the encoder on the motor base and displays it as a digital readout on the controller front panel.

IEEE-488

This connector allows the interface of the controller, through the GPIB, when in remote operation only, and activates the "RMT" LED.

GENERAL SAFETY CONSIDERATIONS

WARNING

BEFORE THIS INSTRUMENT IS SWITCHED ON, make sure it has been properly grounded through the protective conductor of the ac power cable to a socket outlet provided with protective earth contact. Any interruption of the protective (grounding) conductor, inside or outside the instrument, or disconnection of the protective earth terminal could result in personal injury.



There are voltages at many points in the instrument which could, if contacted, cause personal injury. Be extremely careful. Any adjustments or service procedures that require operation of the instrument with protective covers removed should be performed only by trained service personnel.

Capacitors inside this product may still be charged even when disconnected from its power source.

CAUTION

BEFORE THIS INSTRUMENT IS SWITCHED ON, make sure its primary power circuitry has been adapted to the voltage of the ac power source. Failure to set the ac power input to the correct voltage could cause damage to the instrument when the ac power cable is plugged in.

WARNING

TO AVOID A FIRE HAZARD, only fuses with the required current rating and of the specified type (normal blow, time delay, etc.) are to be used for replacement.

SAFETY SYMBOL DEFINITIONS



REFER TO MANUAL

When product is marked with this symbol refer to instruction manual for additional information.



HIGH VOLTAGE

Indicates presence of hazardous voltage. Unsafe practice could result in severe personal injury.



PROTECTIVE EARTH GROUND (SAFETY GROUND)

Indicates protective earth terminal. Provide an uninterruptible safety earth ground from the main power source to the product input wiring terminals, power cord, or supplied power cord set.

CAUTION

HAZARD

CAUTION denotes a hazard. Included text gives proper procedures. Failure to follow instructions could result in minor personal injury and/or property damage.

WARNING

HAZARD

WARNING denotes a hazard. Included text gives proper procedures. Failure to follow instructions could result in severe personal injury and/or property damage.

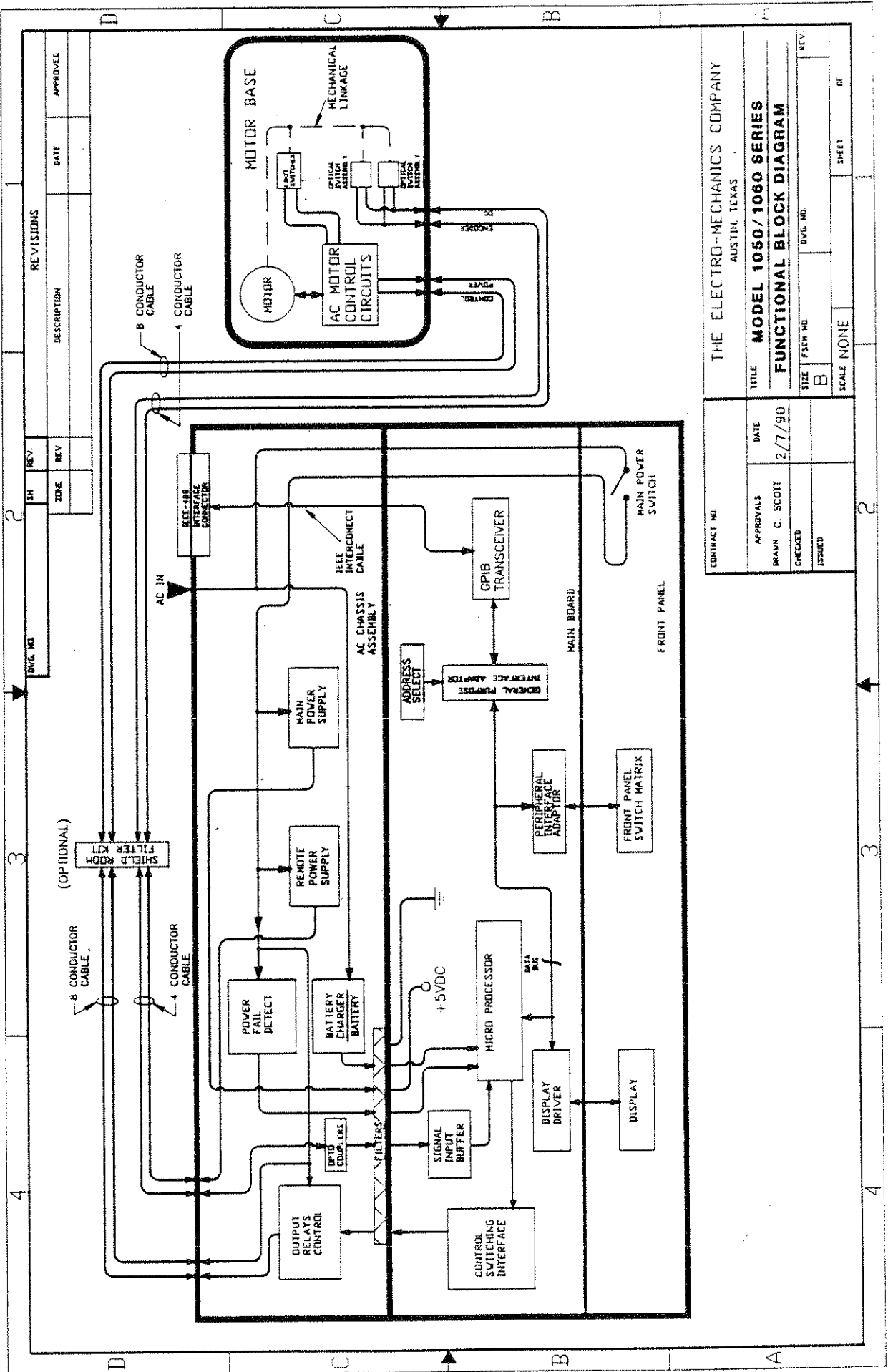

REVISIONS		DATE	APPROVED
	DESCRIPTION		

REV.	DATE	ZONE	REV.

SH	REV.

THE ELECTRO-MECHANICS COMPANY AUSTIN, TEXAS	
CONTRACT NO.	
APPROVALS	DATE
DRAWN C. SCOTT	2/7/90
CHECKED	
ISSUED	
TITLE	MODEL 1050/1060 SERIES
FUNCTIONAL BLOCK DIAGRAM	
SIZE / PCH. NO.	B /
DWG. NO.	
SCALE	NONE
SHEET	OF
2	2

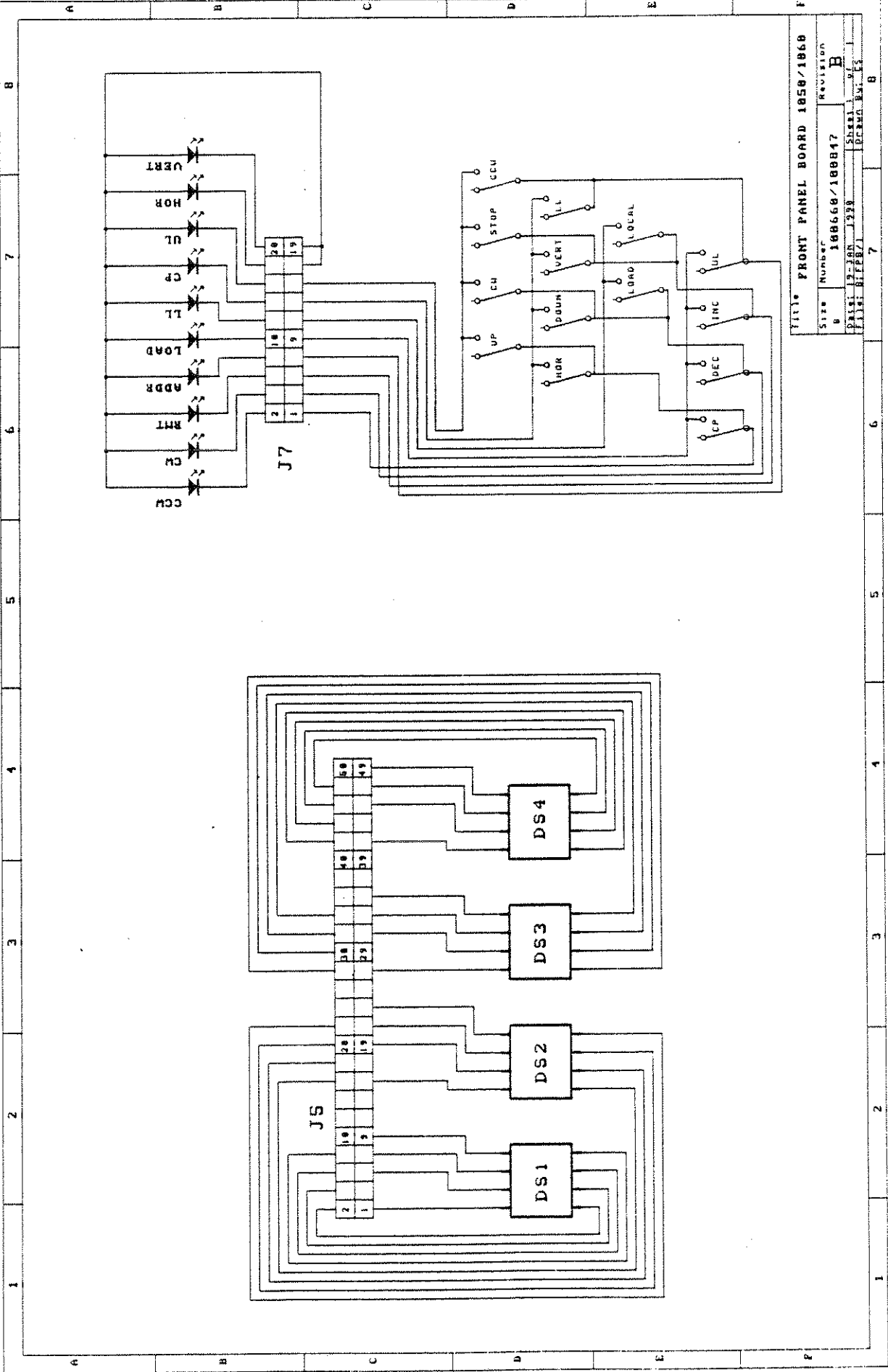

Title FRONT PANEL BOARD 1858/1868
 Size Number 18868/18817 Revision B
 Part 18868/18817 Sheet 1 of 1
 Date 11/1/58

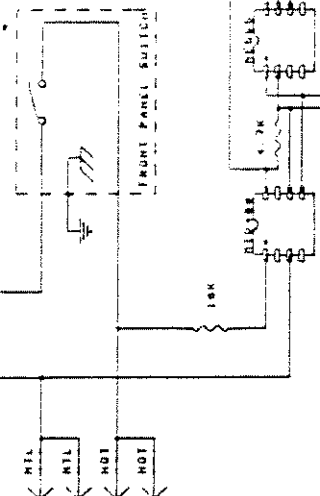
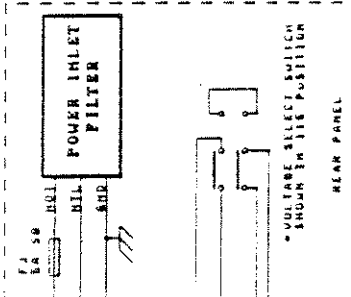
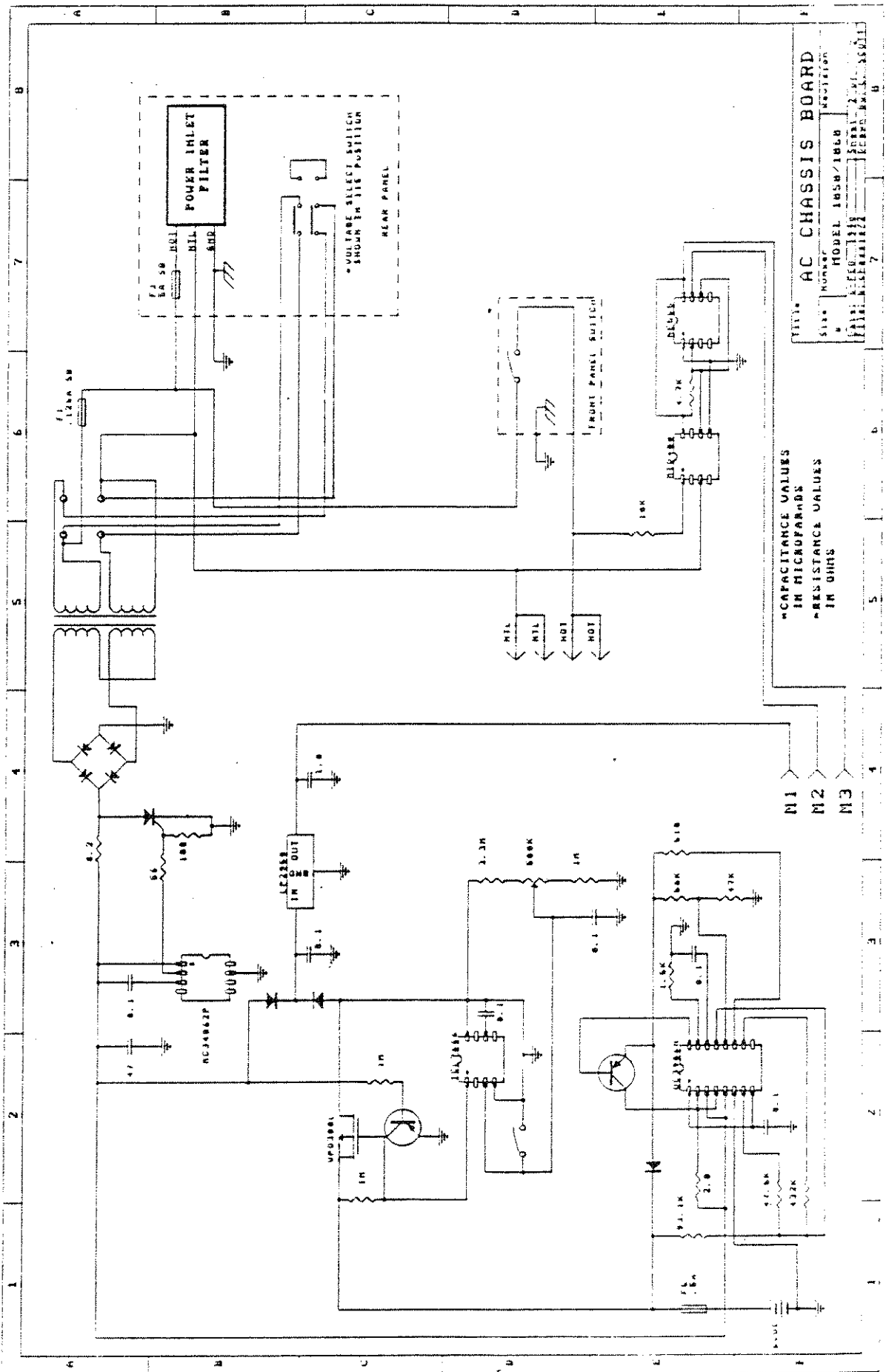

TITLE: AC CHASSIS BOARD

SIZE: NUMBER: MODEL: 1058/1060

REVISION: 7

DATE: 10/10/57

BY: [Signature]

*CAPACITANCE VALUES IN MICROFARADS

*RESISTANCE VALUES IN OHMS

N1

N2

N3

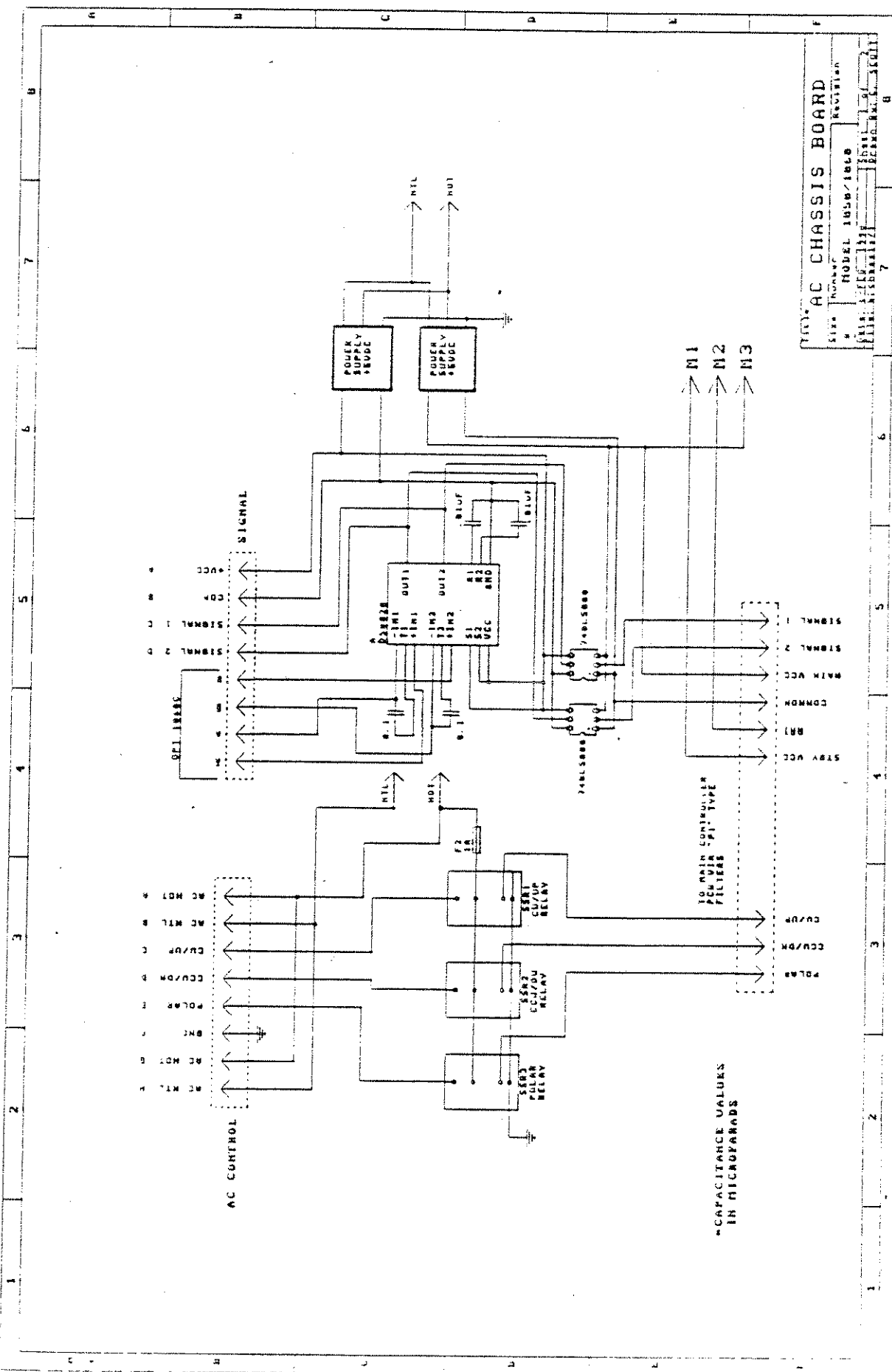

AC CHASSIS BOARD
 SIZE: MODEL 1800E/180E
 REVISION: 7
 DRAWN: M. S. SCULL
 CHECKED: M. S. SCULL
 DATE: 11/15/57

*CAPACITANCE VALUES IN MICROFARADS

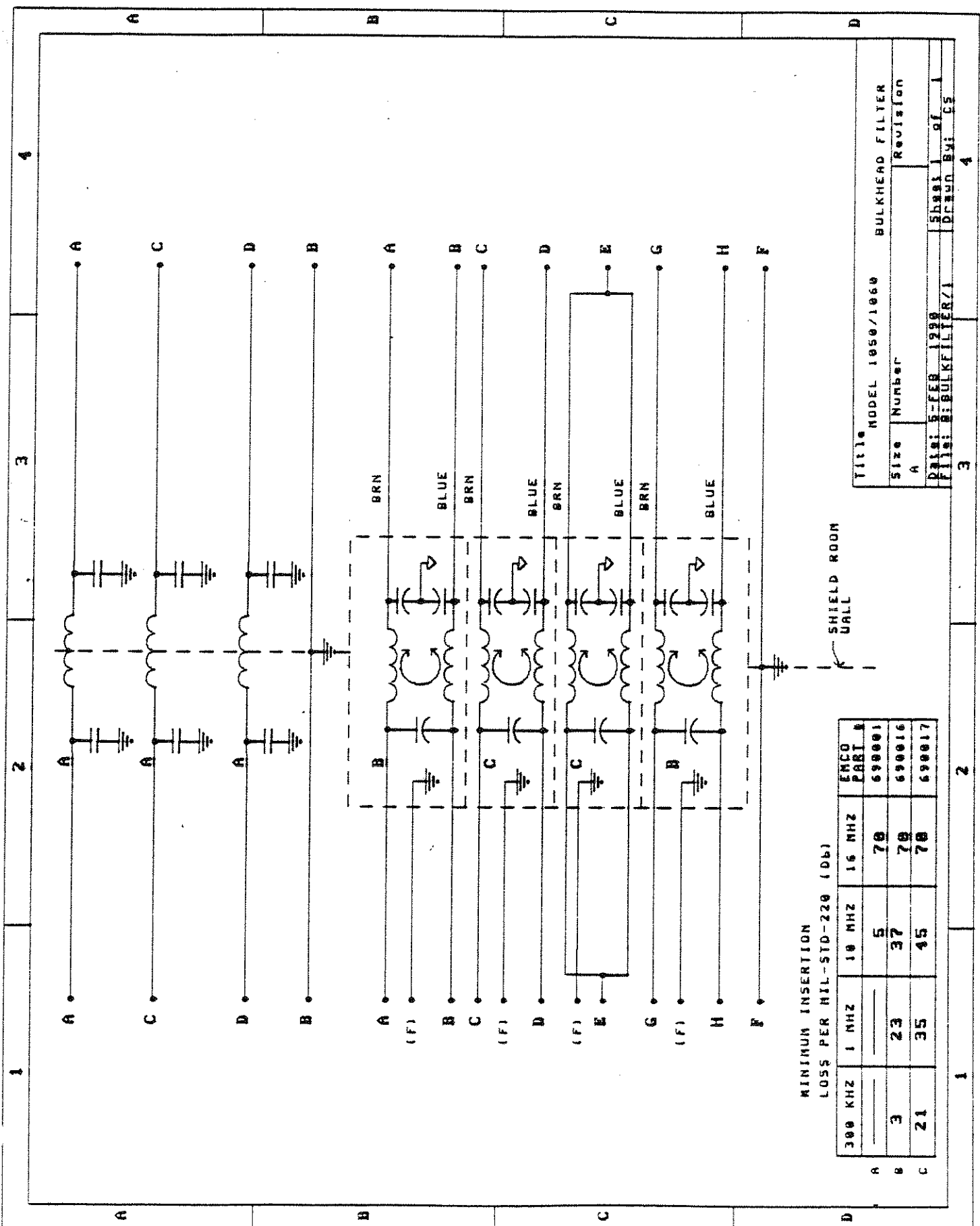

MINIMUM INSERTION LOSS PER MIL-STD-220 (DB)

300 KHZ	1 MHZ	10 MHZ	16 MHZ	EMCO PART #
A	—	5	70	690001
B	23	37	70	690016
C	21	35	70	690017

Title		MODEL 1050/1060	BULKHEAD FILTER
Size	A	Number	Revision
Date:	5-FEB-1990	Sheet	1 of 1
File:	B:BULKFILTER/1	Drawn	DAI/CS

1

2

3

4

A

B

C

D

A

B

C

D

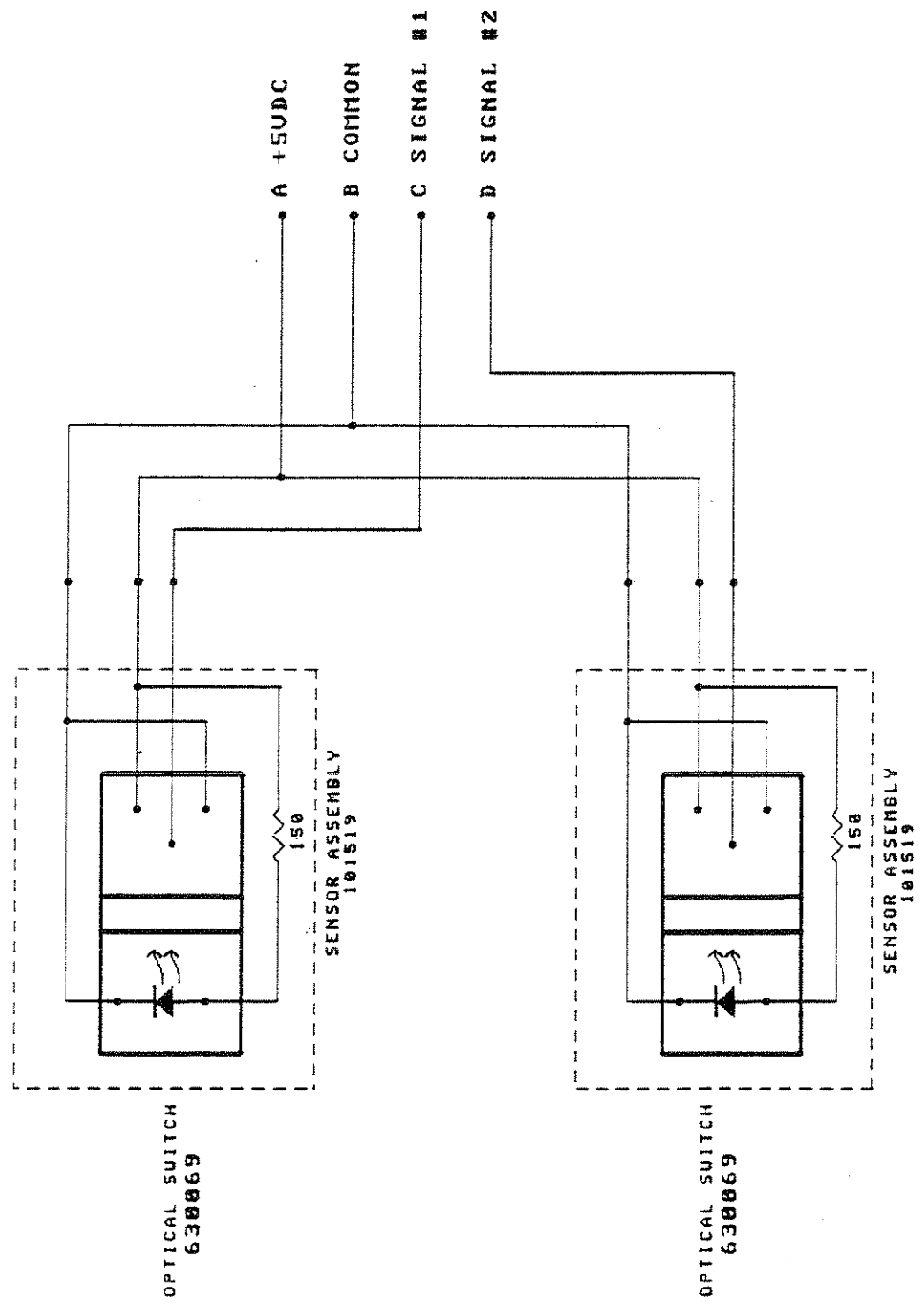

NOTE:

RESISTANCE VALUES IN OHMS

Title MODEL 1050/1060 ENCODER WIRING			
Size	Number	Revision	
A			
Date:	12-MAY 1990	Sheet 1	of 1
File:	B:ENCODER/1	Drawn By:	CS

1

2

3

4

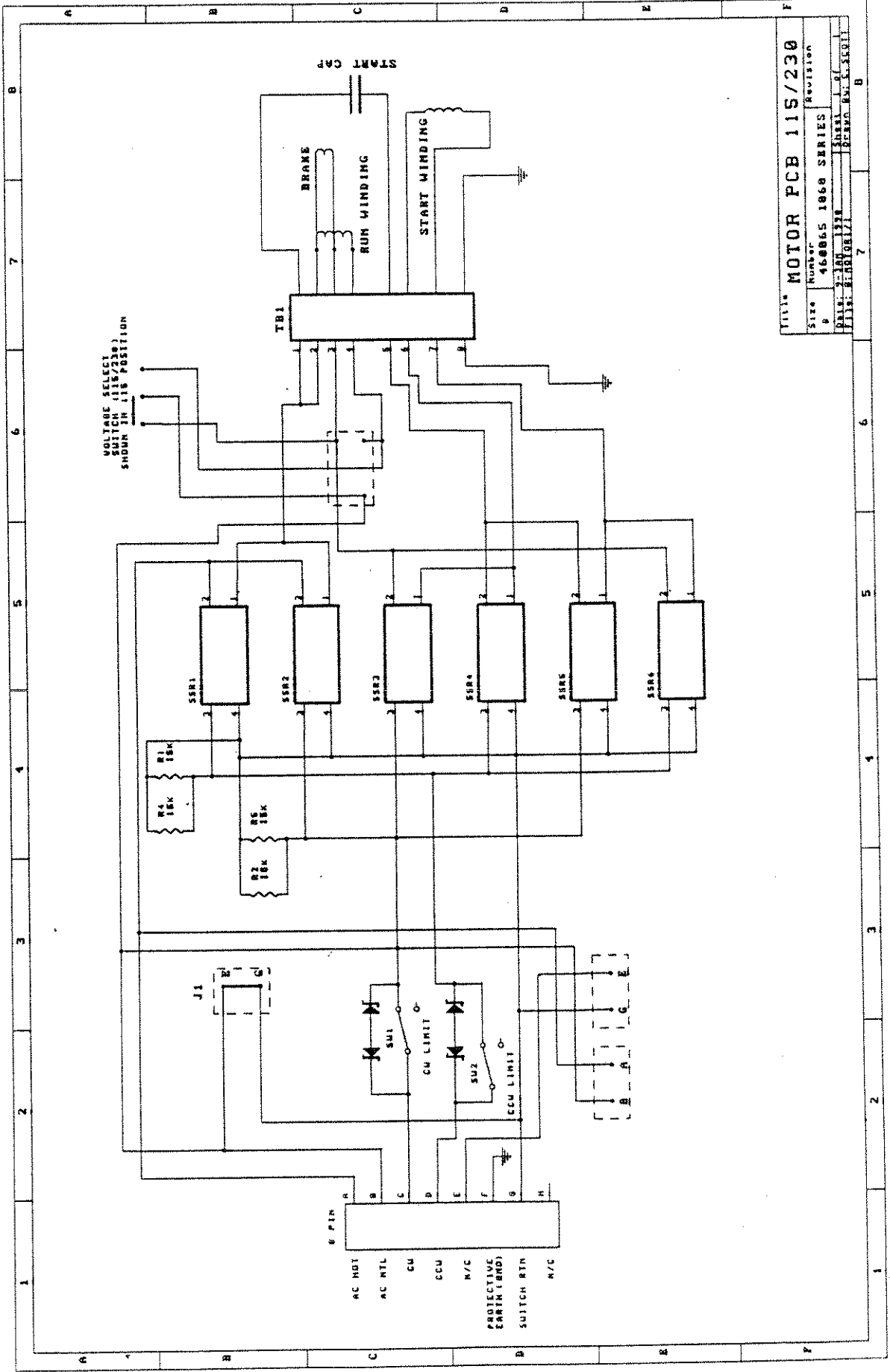

TITLE: MOTOR PCB 115/230	
Size	Number
9	460865 1860 SERIES
Revision	
1	1
DATE: 11/17/78	DESIGNER: S. SCOTT
BY: S. SCOTT	REVISION: B