



... ..

...

...

...

...

...

...

...

...

...

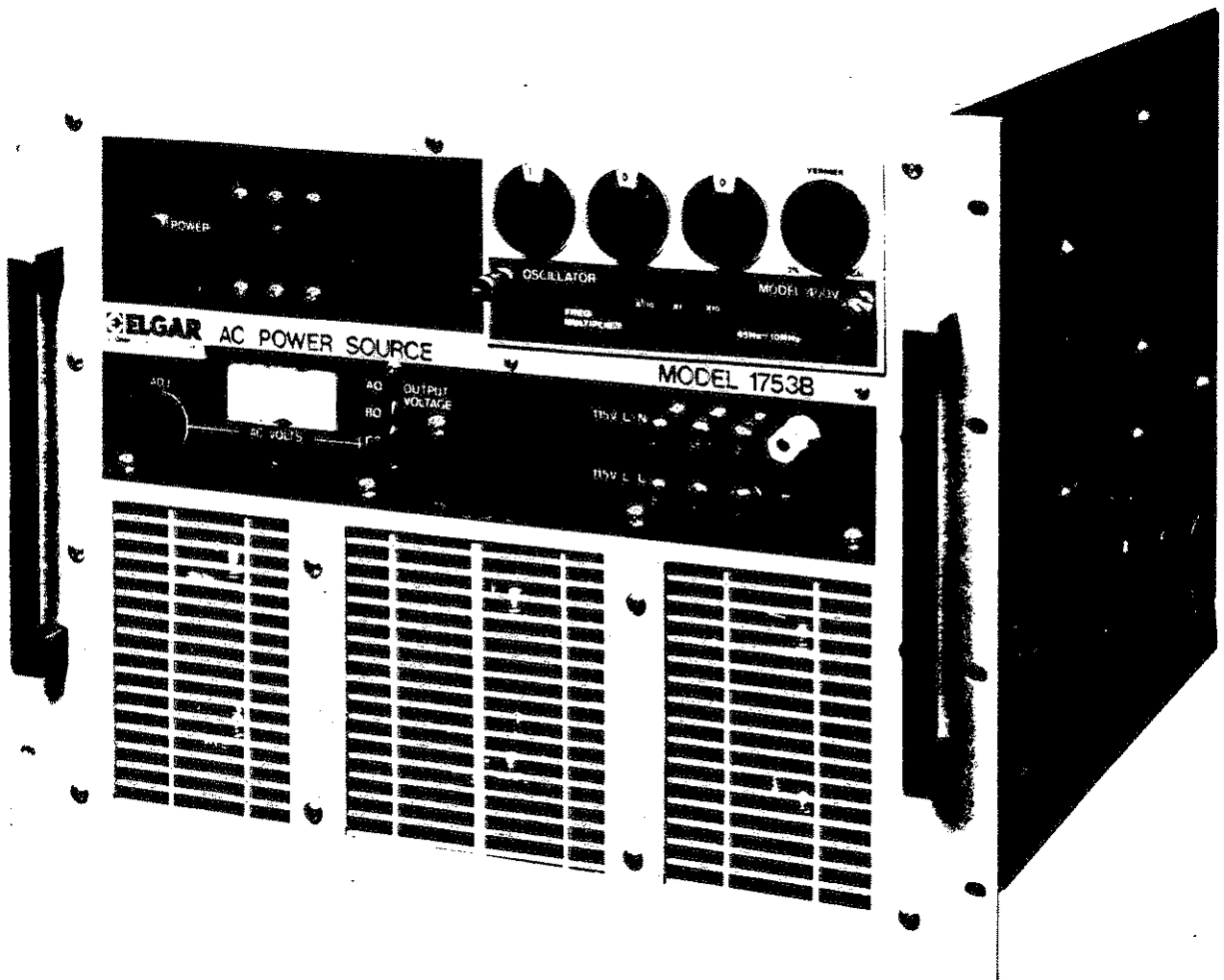

MODEL 1753B  
AC POWER SOURCE



## WARRANTY

Elgar Corporation warrants each instrument it manufactures to be free from defects in material and workmanship. The corporation's obligation under this warranty is limited to servicing the instrument and replacing defective parts. This warranty is effective for one year after delivery of the instrument to the original purchaser. Defects caused by improper operating conditions, misuse, negligence, or the alteration or removal of the nameplate, will void the warranty. Elgar Corporation shall in no circumstance be liable for any direct or consequential loss or damage of any nature resulting from the malfunction of the instrument. This warranty is effective in lieu of any or all other obligations or liabilities on the part of Elgar Corporation, its agents, or representatives.

**DO NOT RETURN THE UNIT FOR REPAIR WITHOUT AUTHORIZATION FROM ELGAR CORPORATION.** Unauthorized returns found to be within specifications will result in a \$50.00 inspection fee, plus two-way freight charges.

Unless specifically noted in the Purchase Order or Maintenance Agreement, Elgar's warranty is F.O.B. the Elgar Service Center nearest the installation site, and serviceman's travel and expenses or transportation costs will be billed to the customer at cost.



**ELGAR CORPORATION . . . THE BEST SOURCE OF POWER**  
9250 Brown Deer Road, San Diego, California 92121  
Phone 619-450-0085



## TABLE OF CONTENTS

SECTION I  
DESCRIPTION

1-1	Introduction . . . . .	1-1
1-3	General Description . . . . .	1-1
1-7	Physical Description . . . . .	1-1
1-11	Block Diagram Description . . . . .	1-1
1-14	Performance Specifications . . . . .	1-2
1-16	Output Power Derating . . . . .	1-2

SECTION II  
INSTALLATION

2-1	Introduction . . . . .	2-1
2-3	Unpacking and Receiving Inspection . . . . .	2-1
2-5	Installation Requirements . . . . .	2-1
2-7	Input Power Requirements . . . . .	2-2
2-9	Input Signal Requirements . . . . .	2-2
2-10	Installation Instructions . . . . .	2-2
2-11	Preliminary Functional Checkout . . . . .	2-3

SECTION III  
OPERATION

3-1	Introduction . . . . .	3-1
3-3	Controls and Indicators . . . . .	3-1
3-5	Operating Instructions . . . . .	3-1

SECTION IV  
THEORY OF OPERATION

4-1	Circuit Description . . . . .	4-1
4-3	Power Amplifiers . . . . .	4-1

SECTION V  
MAINTENANCE

5-1	Introduction . . . . .	5-1
5-3	Test Equipment Required . . . . .	5-1

TABLE OF CONTENTS (Continued)

5-5	Preventive Maintenance . . . . .	5-1
5-7	Corrective Maintenance . . . . .	5-2

SECTION VI  
PARTS LIST

6-1	General . . . . .	6-1
6-3	Spare Parts Ordering . . . . .	6-1

SECTION VII  
DIAGRAMS

7-1	General . . . . .	7-1/7-2
7-3	Diagrams . . . . .	7-1/7-2

LIST OF TABLES

1-1	Performance Specifications . . . . .	1-3
2-1	Input/Output Connector Data . . . . .	2-5
3-1	Model 1753B AC Power Source, Controls and Indicators . . . . .	3-3
5-1	Test Equipment Required . . . . .	5-2
5-2	Troubleshooting Chart . . . . .	5-9

LIST OF ILLUSTRATIONS

1-1	Model 1753B AC Power Source Block Diagram . . . . .	1-2
1-2	Output Power Derating . . . . .	1-4
2-1	Dimensions . . . . .	2-2
2-2	Rear Panel Power Connections . . . . .	2-3
2-3	Input Power Configuration, Model 1753B . . . . .	2-4
3-1	Model 1753B AC Power Source, Controls and Indicators . . . . .	3-2
4-1	Power Amplifier Control Circuit Board, Simplified Block Diagram . . . . .	4-2
5-1	AC Power Source, Bottom View . . . . .	5-4
5-2	Model 1753B Top View . . . . .	5-6
5-3	Model 1753B Bottom View . . . . .	5-7
5-4	Test Setup . . . . .	5-8
5-5	Shorted Heatsink Transistor Check . . . . .	5-13
7-1	Overall Schematic Model 1753A/B, 508-014-63 . . . . .	7-3/7-4
7-2	A,B,CØ Amplifier Board, Parts Layout . . . . .	7-5/7-6



## SECTION I DESCRIPTION

### 1-1. INTRODUCTION

1-2. This instruction manual has been prepared for use with the Elgar Model 1753B AC Power Source. The instructions it contains are intended for use by operators and maintenance technicians with regard to the installation, operation, adjustment, troubleshooting, and repair of the AC Power Source. The theory of operation, description, parts list, and schematics are included to aid in maintaining the Model 1753B at optimum performance.

### 1-3. GENERAL DESCRIPTION

1-4. The Model 1753B has been designed to provide three-phase output AC power at adjustable amplitudes and precise frequencies for use in test purposes, motor operation, and frequency conversion applications. The output amplitude of the AC Power Source is adjustable from 0.0 to 130 VAC line-to-line or line-to-neutral at an output frequency range of 45 Hz to 5 kHz. The output frequency is controlled by an Elgar three-phase plug-in oscillator which is available in either variable frequency or fixed frequencies with accuracies up to 0.0001%.

1-5. This AC Power Source consists of two DC power supplies which provide the internal operating voltages and three power amplifiers whose separately phased inputs are amplified, and used to drive the three tapped output transformers, thus providing nominal output up to 130 VAC line-to-line or 130 VAC line-to-neutral.

1-6. The input power to the Model 1753B is determined by the selected tap connections to the primary of the three-phase input power transformer. The input power configurations are 115 VAC or 230 VAC, line-to-line or line-to-neutral, three-phase, 47 Hz to 63 Hz. 400 Hz input power is available on a special order basis.

### 1-7. PHYSICAL DESCRIPTION

1-8. The Model 1753B is contained in a metal enclosure. The front panel has been designed to accommodate mounting the instrument in a standard 19 inch relay rack.

1-9. The Elgar plug-in oscillator module (supplied separately) mounts directly above the output voltage terminals on the front panel. Cooling air is drawn through a front-panel grill and exhausted at the rear of the enclosure. The fans used for circulating the cooling air are located on the rear panel. An input power terminal block and the output power terminal block are also located on the rear panel. A 12-pin JONES connector, next to the terminal blocks, provides for interfacing external signals and amplitude control of the AC power source.

1-10. The top and bottom covers of the power source are removable for access to the electronics housed by the enclosure. Test points, adjustment controls, and component locations are shown in Section V.

### 1-11. BLOCK DIAGRAM DESCRIPTION

1-12. A general block diagram of the Model 1753B is shown in Figure 1-1. The AC Power Source functionally consists of two DC power supplies, three power amplifiers with associated control circuitry, and three output power transformers. The DC supplies are obtained from a full wave bridge rectifier on the secondary of the input power transformer. These supplies are a nominal plus and minus 45V DC. They are used as the operating and bias voltages in the three amplifiers. The three power amplifiers are mounted on heatsink assemblies whose inputs are controlled by three plug-in amplifier circuit boards. The Elgar plug-in oscillator signals are AC coupled to the inputs of the circuit boards and determine the A, B, and C phase outputs. The amplitude of the three power amplifier signals is varied simultaneously by the front panel amplitude control potentiometer. The amplified A, B, and C phase signals are applied to the output transformers, whose secondaries are connected to the front panel binding posts and the rear panel output power terminal block.

1-13. Each power amplifier is protected against an overload or short circuit on the output. Current limit transistors clamp the input drive signals when the power amplifier currents exceed their rated level. The power amplifier recovers immediately when the short or overload is removed. Regulation circuitry consisting of AC feedback and frequency compensation is employed to provide regulation of the output signals. A thermostat located on the power amplifier heatsink assembly removes drive signal to the amplifier(s) in the event unsafe operating temperatures are incurred.

#### 1-14. PERFORMANCE SPECIFICATIONS

1-15. Specifications for the Model 1753B AC Power Source are provided in Table 1-1.

#### 1-16. OUTPUT POWER DERATING

1-17. Power at less than full rated output voltage is derated as shown in Figure 1-2.

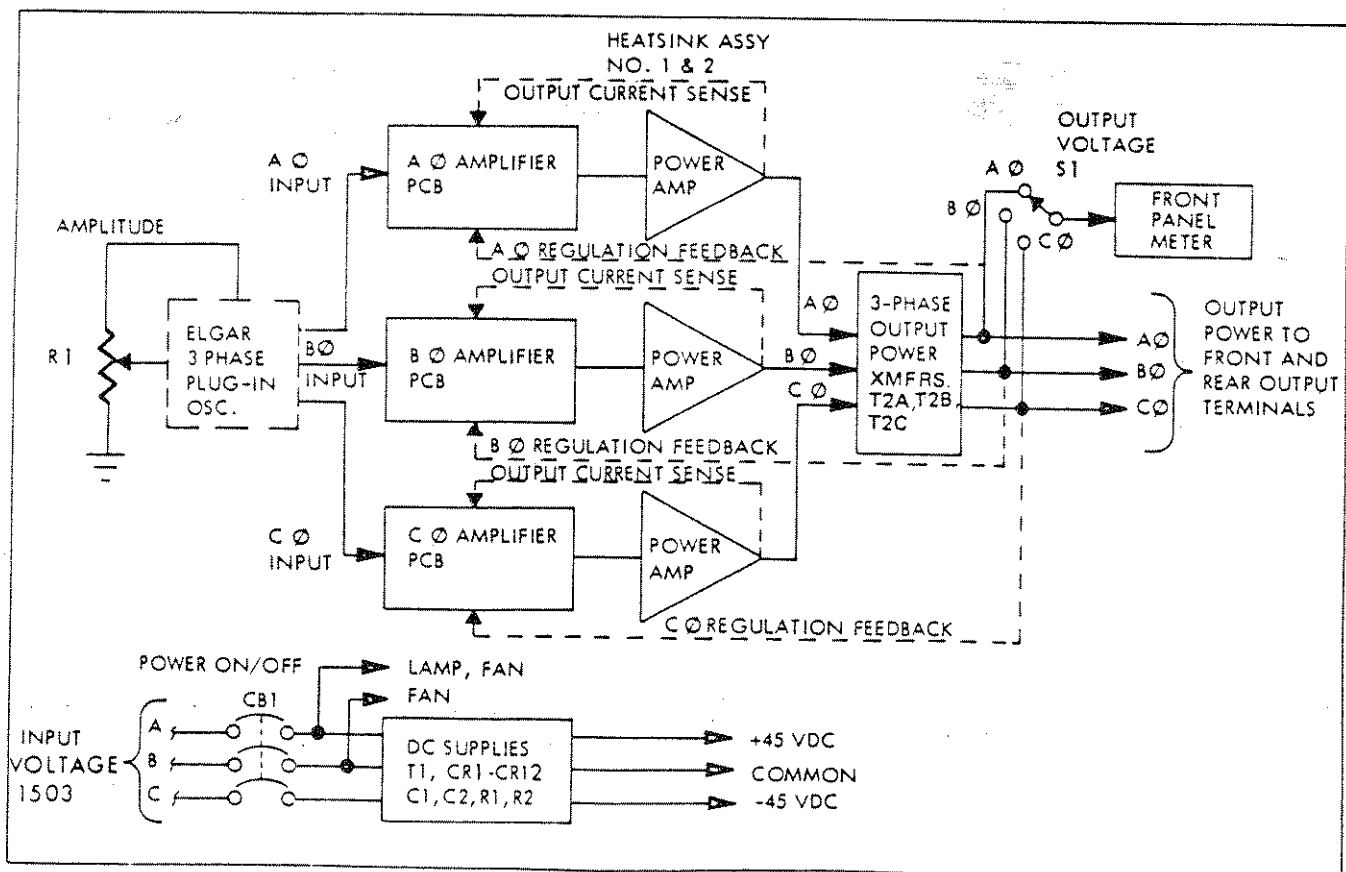

Figure 1-1. Model 1753B AC Power Source Block Diagram

Table 1-1. Performance Specifications

Output Power Per Phase	584
Load Power Factor	Unity to $\pm 0.7$
Output Voltage (Adjustable)	0-130 L-L and L-N
Output Configuration	3 wire and 4 wire isolated from ground. Any one phase or neutral may be grounded.
Output Frequency Range	45 Hz - 4 kHz at rated power
Output Distortion (Full Load)	Less than .9%
Load Regulation	Line to Neutral less than 1% Line to Line less than 1% 45 Hz - 800 Hz less than 3% 800 Hz - 5 kHz
Line Regulation	$\pm 0.25\%$ for 10% input line change
Hum and Noise	-70 db below full output
Input Power	3 phase, 115V or 230V line to line or line to neutral 47-63 Hz, 5 KVA maximum input power.
Operating Temperature Range	0 - 50°C
Weight	225 Lbs.

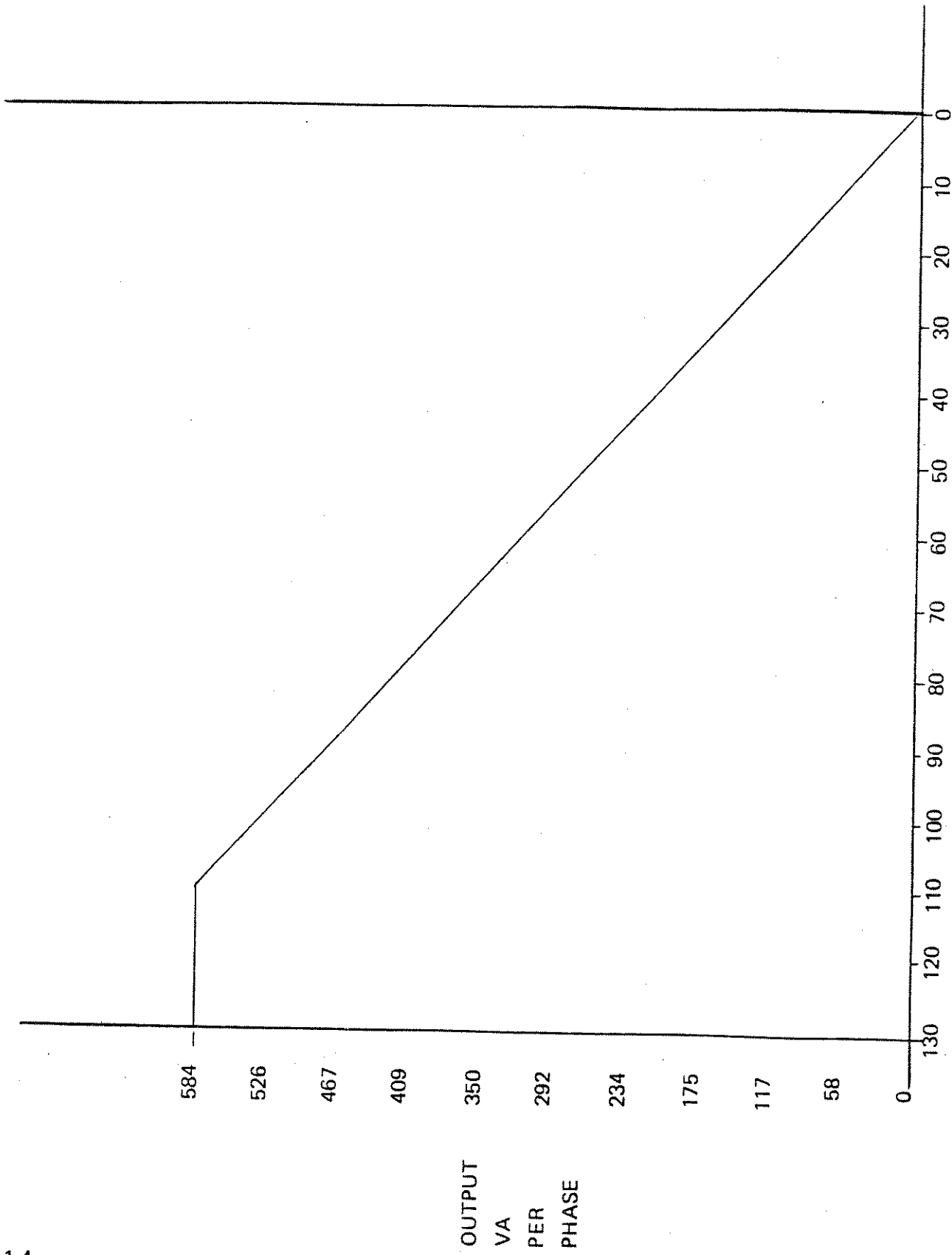

Figure 1-2. Output Power Derating

## SECTION II INSTALLATION

### 2-1. INTRODUCTION

2-2. The ELGAR AC Power Source has been calibrated and quality tested prior to shipment. The unit is therefore ready for installation and operation upon receipt. Instructions in this section must be followed to ensure proper inspection of the unit and correct installation.

### 2-3. UNPACKING AND RECEIVING INSPECTION

2-4. The AC Power Source has been packed in accordance with industrial standards for safe shipment. Upon receipt of the unit, unpack and inspect the unit as described in the following steps:

1. Make a visual inspection of the shipping container before accepting the package from the carrier. If the shipping container is damaged, describe the damage on the carrier's receipt.
2. If there is no apparent damage to the shipping container, carefully unpack the instrument and save the container and filler materials until preliminary inspection is completed.
3. Visually inspect the instrument for evidence of external damage such as chassis dents, scratches, or distortion.
4. Check front panel control and switch-circuit breaker for ease of operation.

5. Check that the front panel meter is not damaged.

6. Remove both instrument covers and verify that the three circuit boards are securely seated in their respective receptacles. Ensure the individual components are not damaged.

7. Check that the heatsinks underneath are firmly secured in place.

8. Check harness and leads for broken insulation, cracks or broken wiring.

#### NOTE

If any physical damage is evident, file a claim for concealed damage with the carrier agent and save all shipping materials for inspection. Forward a report of damage to the ELGAR Service Department, 8225 Mercury Court, San Diego, California 92111. ELGAR will provide instructions for repair or replacement of the instrument.

### 2-5. INSTALLATION REQUIREMENTS

2-6. The Elgar AC Power Source is designed for installation in a standard 19-inch instrument rack. See Figure 2-1 for mounting dimension requirements. The AC power source must be installed such that the flow of cooling air into the front panel grill and out the rear panel is not obstructed. For slide out capability the unit is equipped with

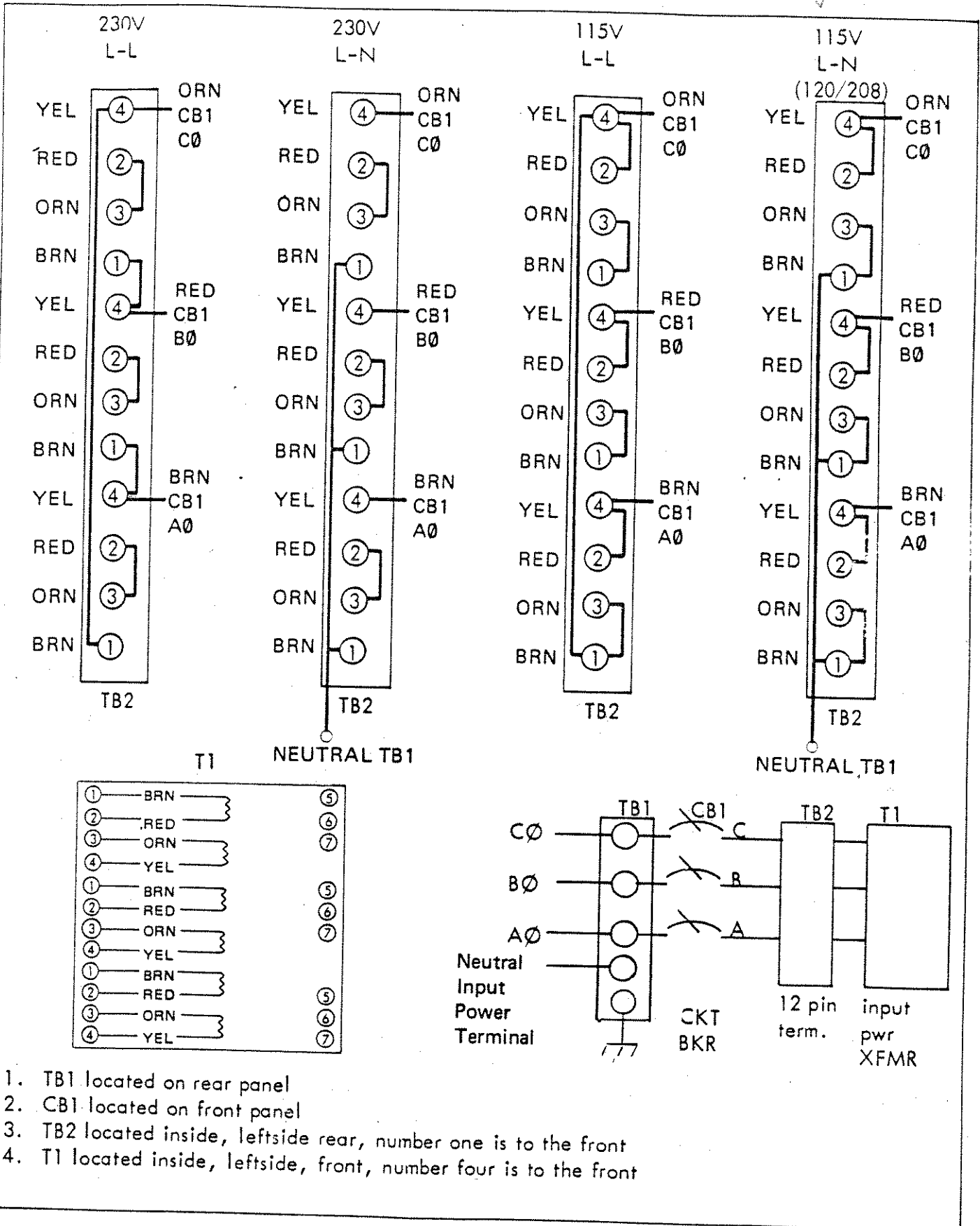

1. TB1 located on rear panel
2. CB1 located on front panel
3. TB2 located inside, leftside rear, number one is to the front
4. T1 located inside, leftside, front, number four is to the front

Figure 2-3. Input Power Configuration, Model 1753B.

Table 2-1. Input/Output Connector Data

Connector/Pin Designation	Function
J1-1	Signal Common
J1-2	B-Phase Control
J1-3	C-Phase Control
J1-4	A-Phase Control
J1-5 thru 12	Spares
J2-13	+35 VDC
J2-14	A-Phase Control
J2-15	-35 VDC
J2-16	Common
J2-21	Amplitude Control (ARM)
J2-22	Amplitude Control Excitation

NOTE: Connector J1 is jumpered according to its application. Wiring data is provided with the ELGAR unit to be used.

1. Set POWER switch-circuit breaker to ON. Observe that power on indicator lights and remains on.
2. Check that the fans on rear panel of the unit are exhausting air.
3. Set the ELGAR plug-in oscillator to desired frequency. Reference the oscillator's instruction manual for operating instructions.
4. Select position A at OUTPUT VOLTAGE selector.
5. Rotate AMPLITUDE control CW to obtain 115 VAC output at OUTPUT VOLTAGE meter. Observe that meter readout is 115 VAC for phase A output voltage.
6. Select position B at OUTPUT VOLTAGE selector and observe that B-phase output voltage is equal to phase A.
7. Select position C at OUTPUT VOLTAGE selector and observe that C-phase output voltage is equal to phase A.
8. Rotate AMPLITUDE control completely CCW and check that A, B, and C phase voltages reduce to zero volts.
9. Set POWER switch-circuit breaker to OFF. Observe that power on lamp extinguishes and fan turns off.





## SECTION III OPERATION

### 3-1. INTRODUCTION

3-2. This section contains the operating instructions for the AC Power Source. A description of the controls and indicators precedes the operating instructions.

### 3-3. CONTROLS AND INDICATORS

3-4 The controls and indicators for the Model 1753B are shown in Figure 3-1. Function of these items are included in Table 3-1.

### 3-5. OPERATING INSTRUCTIONS

1. POWER ON. Set POWER switch-circuit breaker to ON. Observe that Power Indicator lights and remains on and the fan operates.
2. FREQUENCY CONTROL. Adjust the plug-in ELGAR oscillator for desired frequencies between 45 Hz to 5 KHz. Reference the oscillator instruction manual for operating instructions.

#### NOTE

Certain ELGAR plug-in oscillators do not require the use of the front panel AMPLITUDE control and others are externally programmed. In any case, reference the respective ELGAR instruction manual.

#### CAUTION

Do not continue operation of the AC power source of the POWER switch-circuit breaker trips when power is turned on or the amplitude is increased. The AC Power Source is protected against shorts at the output terminals and recovers immediately when the short is removed. Tripping of the circuit breaker indicates that the unit requires adjustment or repair. Troubleshoot the unit as described in Section VI of the manual.

3. AMPLITUDE CONTROL. Adjust the front panel AMPLITUDE control to vary A, B, C, phase output voltages from zero to 130 VAC. Rotate the AMPLITUDE control CW to increase and CCW to decrease output voltages.
4. OUTPUT VOLTAGE MONITOR. See Figure 1-2 for output power derating when operating at less than full-rated output voltage. Select individual A, B, or C phase output voltage for readout at front panel meter by setting OUTPUT VOLTAGE selector to desired position.
5. POWER OFF. To shutdown the AC Power Source, set POWER switch-circuit breaker to OFF.

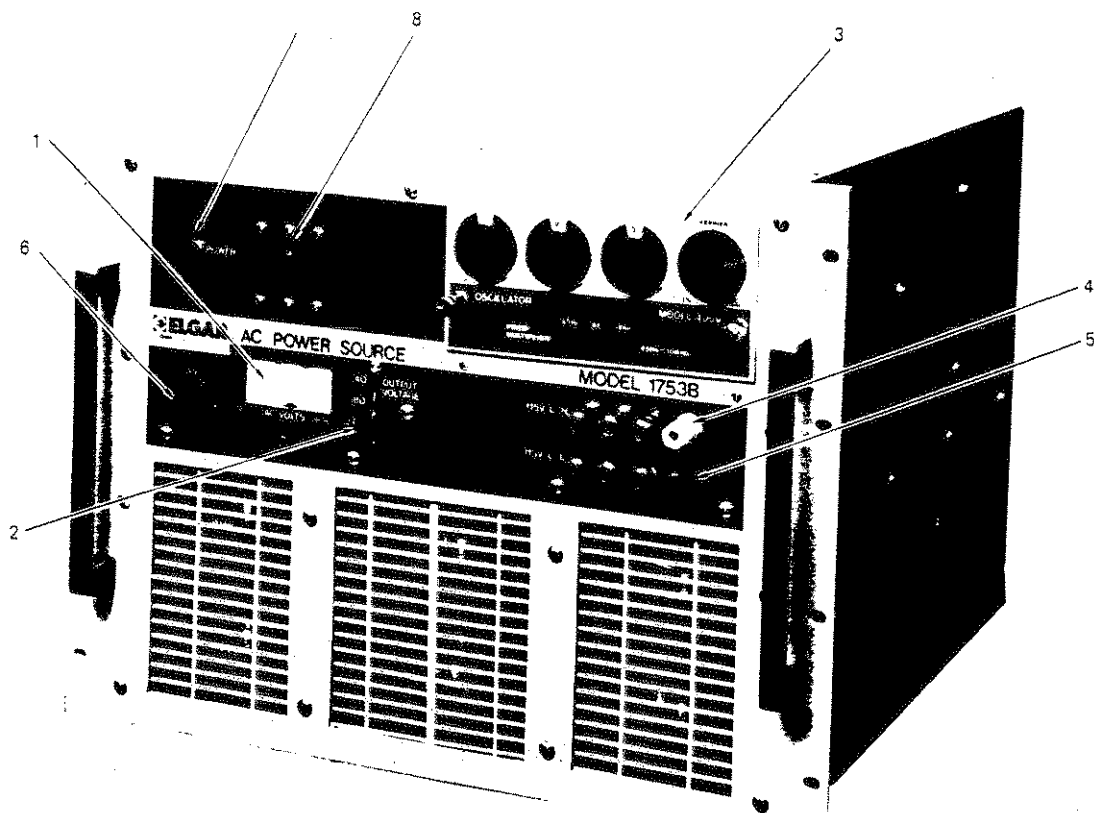

Figure 3-1. Model 1753B AC Power Source, Controls and Indicators

Table 3-1. Model 1753B AC Power Source, Controls and Indicators

INDEX NO.	NAME	FUNCTION
1	OUTPUT VOLTAGE meter	Indicates A, B, or C phase voltage at output terminals when connected by OUTPUT VOLTAGE selector.
2	OUTPUT VOLTAGE selector	Connects A, B, or C phase voltage present at output terminals to OUTPUT VOLTAGE meter
3	ELGAR plug-in oscillator	Reference oscillator instruction manual for description of controls
4	115V L-N binding posts	Provides A, B, and C phase output voltage connections to load for 115 VAC line-to-neutral operation
5	115V L-L binding posts	Provides A, B, and C phase voltage connections to load for 115 VAC line-to-line operation
6	AMPLITUDE control	Adjust zero to 130 VAC amplitude of A, B, and C phase voltages at output terminals
7	Power-on indicator	Indicates AC line input power is present in unit when POWER switch-circuit breaker is turned on. Extinguishes when AC line power is removed.
8	POWER switch-circuit breaker	Applies AC line input power to the unit. Safeguards unit by disconnecting AC line power when input current exceeds rated value of circuit breaker



## SECTION IV THEORY OF OPERATION

### 4.1. CIRCUIT DESCRIPTION

4.2. DC POWER SUPPLIES. When circuit breaker CB1 is energized, the Power On indicator DS1 lights, the fan turns on and the plus and minus 45V power supplies are energized. The DC power supplies consist of input power transformer T1, and full wave bridge rectifiers with filter capacitors and bleeder resistors. Stepped down AC line voltage at the secondary of T1 is rectified by the full wave bridge to produce plus (+) and minus(-) 45V DC across the filter capacitors. The high current DC supplies provide bias and operating voltage for the amplifiers.

4.3. POWER AMPLIFIERS. The Model 1753B AC Power Source contains three essentially identical power amplifiers for A, B, and C phases. Three input signals phase displaced  $120^\circ$  are supplied by a three phase plug-in oscillator. The amplitude of all three signals is varied simultaneously by the front panel amplitude control potentiometer R1. B and C phase output amplitudes are adjusted equal to A phase by amplitude balance potentiometers R237 and R337 located on the B and C phase plug-in amplifier boards.

4.4. The A phase input signal is AC coupled to the pre-amplifier comprised of transistors Q101, Q102, Q105, Q106 and Q107. A 12 volt zener diode CR101 is used to supply constant current to differential amplifier Q101 and Q102. The output of the differential amplifier is applied to the base of Class A driver transistor Q105. Q105 in turn furnishes drive power to Q106 and Q107. Q106 operating as an emitter follower supplies

drive signal to the upper half of the power amplifier. Phase inverted drive signal for the lower half of the power amplifier is supplied by Q107. A small amount of forward bias is established by diodes CR106-CR109 to reduce cross-over distortion in the power amplifier. Bootstrap capacitor C107 supplies additional drive during the positive conduction of the amplifier.

4.5. The power amplifier consists of series connected output transistors for amplifying the positive and negative half cycles of the sine wave output. Base drive for the respective amplifier is furnished by an emitter follower located on the respective heatsinks. Each power transistor has a .22 ohm resistor in its emitter to ensure equal current sharing of the output transistors. The sine wave output of the power amplifier is connected to the primaries of the three output transformers. At full output voltage on the secondary of the output transformer the power amplifier stage is operating at approximately 20 VRMS

4.6. A thermostat S1 located on one of the heatsink assemblies provides thermal protection for the power amplifier. If the heatsink reaches an unsafe operating temperature, due to obstructed air-flow or excessive environmental temperature, thermostat S1 closes and removes drive signals from the power amplifier. The drive signals are restored when the heatsink temperature returns to normal.

4.7. Distortion in the power amplifier is reduced by negative feedback taken across resistor R112 to the differential amplifier. Positive current feedback is used in these amplifiers to accomplish load regulation in the output transformer. This signal is developed across current transformers T3A,B,C in the

primary of the output transformers. These signals are dropped across R137 on the preamplifier. The regulation signal in all cases is applied across a regulation adjust potentiometer R110 (for A phase). This potentiometer is used to set the load regulation at frequencies up to approximately 1 KHz. Factory selected components C104 and R104 provide regulation boost at frequencies above 1 KHz.

4-8. The power amplifier is protected against overload or short circuits on the secondaries of the output transformer by current limit transistors Q103 and Q104. In the event an overload or

a short circuit is incurred on the output, current signals sampled across resistors in the power amplifier drive Q103 and Q104 into conduction clamping the drive signals to the power amplifier. The current limit thresholds are adjustable using R123 for the positive half cycle and R127 for the negative half cycle. These adjustments are factory set to initiate current limiting at slightly more than full power out.

4-9. The front panel meter is connected to read the output of any phase as selected by the output voltage switch S1.

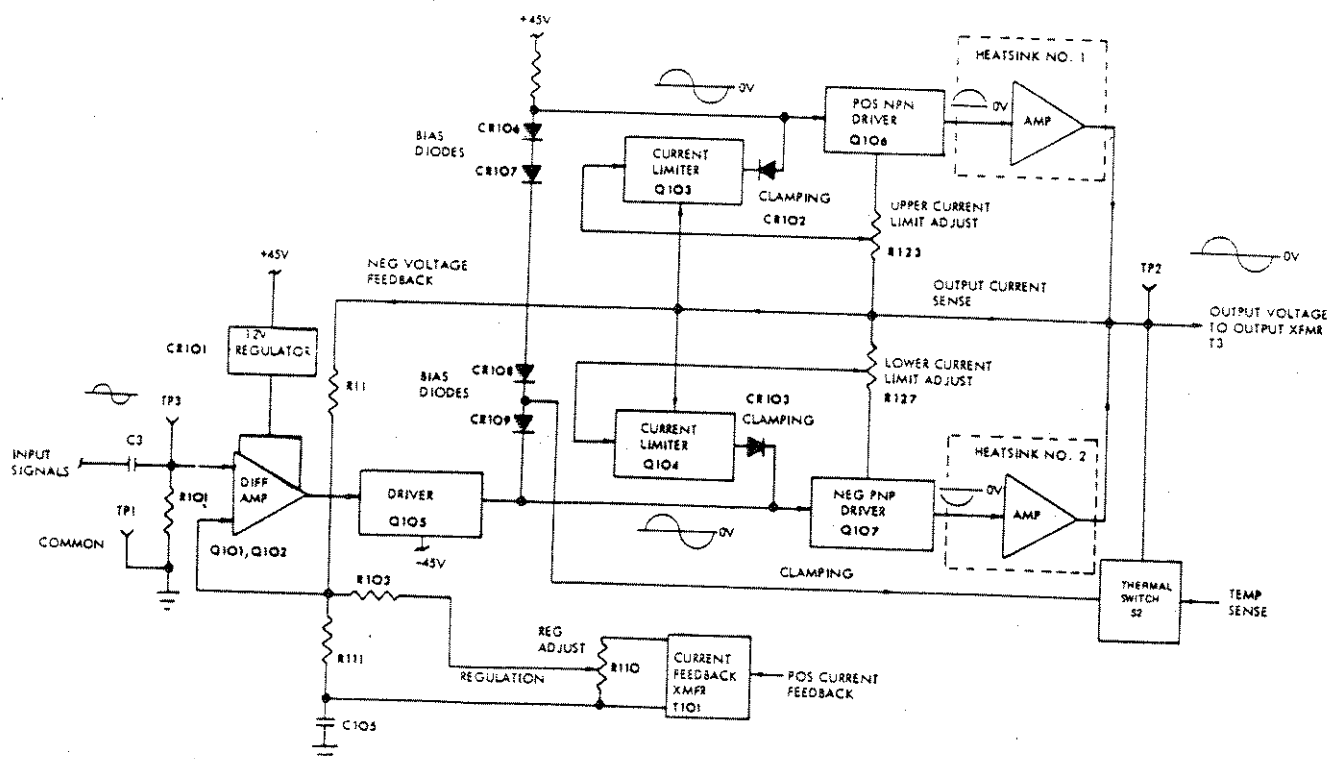

Figure 4-1. Power Amplifier Control Circuit Board, Simplified Block Diagram

## SECTION V MAINTENANCE

### 5-1. INTRODUCTION

5-2. This section contains procedures for preventive and corrective maintenance. Preventive maintenance consists of procedures for cleaning and inspecting the unit. Corrective maintenance includes checkout, troubleshooting, disassembly for repair, and adjustments. A list of special tools and test equipment required for maintenance and adjustment is also included in this section.

#### NOTE

ELGAR Corporation is not responsible for instruments returned for repair without proper ELGAR authorization. Please contact ELGAR Corporation or its authorized representative to make return shipment of the instrument. The unit should be returned to ELGAR Service Department, 8225 Mercury Court, San Diego, California 92111.

### 5-3. TEST EQUIPMENT REQUIRED

5-4. The test equipment required for maintenance and adjustment are listed in Table 5-1. Equivalent test equipment may be used.

#### WARNING

Remove power whenever performing maintenance on the unit. Failure to comply can result in serious electrical shock to person coming in contact with live voltages at exposed terminals when unit is energized.

### 5-5. PREVENTIVE MAINTENANCE

5-6. Preventive maintenance is comprised of cleaning and inspection of the unit. The AC Power Source should be cleaned and inspected at regular periodic intervals (every six months, depending on operating conditions). The top and bottom panels of the unit are removable for access to components. To clean and inspect the unit, proceed as follows:

1. Inspect circuit board parts for evidence of overheating, such as burned or distorted resistors, capacitors, and charred insulation. Replace parts suspected of damage.
2. Inspect circuit board parts for evidence of physical damage, such as broken or cracked capacitors and resistors, broken solder joints and discontinuities in circuit foil paths.
3. Inspect circuit board connectors for corrosion and obvious physical damage. Remove corrosion with clean, lint-free cloth dampened in trichlorethylene; replace circuit board assembly if damaged.
4. Inspect chassis and front panel-mounted components for broken connections, burned insulation or damaged parts.
5. Inspect transformers for evidence of overheating such as discolored insulation.
6. Inspect rear panel connector and terminal blocks for damage, such as broken wire leads, cracked insulation.

Table 5-1. Test Equipment Required

NAME	MANUFACTURER AND MODELNUMBER	CHARACTERISTICS
Multimeter	Simpson Electric Co. Model 260	20,000 ohms/volt, AC/DC/OHMS ranges
Plug-In Oscillator	ELGAR Corporation Model 403-V	Adjustable 45 Hz to 10 KHz 3-phase outputs
Differential Voltmeter	John Fluke Mfg. Co. Model 931	RMS Volts Range to 1000 VAC
Oscilloscope	Tektronix, Inc. Model 561 w/2B67 and 3A6 plug-ins	
Probe	Tektronix, Inc. Model P6028	X1 Probe
Distortion Analyzer	Hewlett-Packard, Model HP333A	
Resistance Load	Commercial	Capable of dissipating 4.84 ampere load at 120 VAC

## 5-7. CORRECTIVE MAINTENANCE

5-8. Corrective maintenance consists of check-out, troubleshooting, adjustments, and repair.

5-9. CHECKOUT. The unit should be checked after initial installation and at periodic intervals to ensure that it is operating at optimum performance. Checkout consists of the DC power circuit, regulation and distortion checks which should indicate whether the AC Power Source is operating within specifications or requires adjustment. Troubleshooting procedures are presented in paragraph 5-15, to aid in isolating suspected malfunctions in the unit.

## WARNING

High voltages dangerous to life exist in the unit when energized. AC voltages are also present at the INPUT POWER terminals at any time the power cable is connected to the line voltage. Exercise extreme caution when performing maintenance checks in the unit. Always remove power when disconnecting circuit boards, performing continuity checks or disassembling the unit.

5-10. PRELIMINARY PROCEDURES. Before applying power, perform the following preliminary procedures.



1. Set POWER switch of unit to OFF.
2. Rotate AMPLITUDE control of unit completely CCW.
3. Remove top panel of unit and remove the A, B, and C phase amplifier circuit boards.
4. Remove bottom panel of unit and disconnect the heatsink plugs. Tag the connectors to ensure proper reassembly in the unit. (See Figure 5-1.)

5-11. DC POWER CIRCUIT CHECK. To check the output of the DC supplies, proceed as follows:

1. Using multimeter, check that capacitors C1 and C2 in the unit are not shorted.
2. Apply line voltage to unit and set POWER switch on front panel to ON.
3. Using multimeter, measure +45 VDC and -45 VDC outputs of DC power circuit. The +45 VDC is the red lead at C1 and the -45 VDC is the green lead at C2. (See Figure 5-1.) Observe that the plus (+) and minus (-) 45 VDC busses are even readings of 48 VDC nominal (no load) and are within 5% (2 to 3 volts) of each other. If not, discontinue the check-out and troubleshoot the unit to correct the problem.
4. Set POWER switch of unit to OFF.

5-12. OUTPUT AMPLITUDE BALANCE CHECK AND ADJUSTMENT. The output voltage is controlled by the front-panel AMPLITUDE control (for most plug-in oscillators). The B-phase and C-phase balance potentiometers (R237 and R337) are set to give B-phase and C-phase voltages equal to the A-phase voltages. No further adjustments should be required unless the plug-in oscillator is changed. The oscillator phase-angles must be adjusted to give equal line-to-line voltages after the phase-voltage amplitudes have been balanced. Phase angle controls are located on the plug-in oscillator. If the phase voltages are set to 120V, the proper value of line-to-line voltage is 207.84V. The B-phase

angle control is used to set A-B voltage and the C-phase angle control to set the A-C voltage. To check the output and amplitude balance and adjust as needed (see Figure 5-2), proceed as follows:

1. Connect the heatsink plugs into their respective connectors.
2. Install the A, B, and C phase amplifier boards in their respective receptacles.
3. Connect rms voltmeter to A phase output terminals of the unit. Set rms voltmeter for 1000-volt range, 3%, 120 volts.
4. Set POWER switch of unit to ON.
5. Select position A on OUTPUT VOLTAGE selector and rotate AMPLITUDE control CW to increase output to 120 volts. The voltage can be read as 120 volts on the output voltage meter or null volts on the rms voltmeter.
6. Select position B on OUTPUT VOLTAGE selector. Observe that the output voltage meter reads 120 volts. Using rms voltmeter, measure B phase output voltage at terminal B of output terminals. Observe that reading is null volts. If not, adjust amplitude balance potentiometer R237 of B-phase amplifier circuit board for 120-volt output on meter (null volts on rms voltmeter).
7. Select position C on OUTPUT VOLTAGE selector. Observe that output voltage meter reads 120 volts. Using rms voltmeter, measure C phase output voltage at terminal C of output terminals. Observe that reading is null volts. If not, adjust amplitude balance potentiometer R337 of C-phase amplifier circuit board for 120-volt output on meter (or null volts on rms voltmeter).

5-13. REGULATION CHECK AND ADJUSTMENT. Upon completion of output amplitude balance adjust-

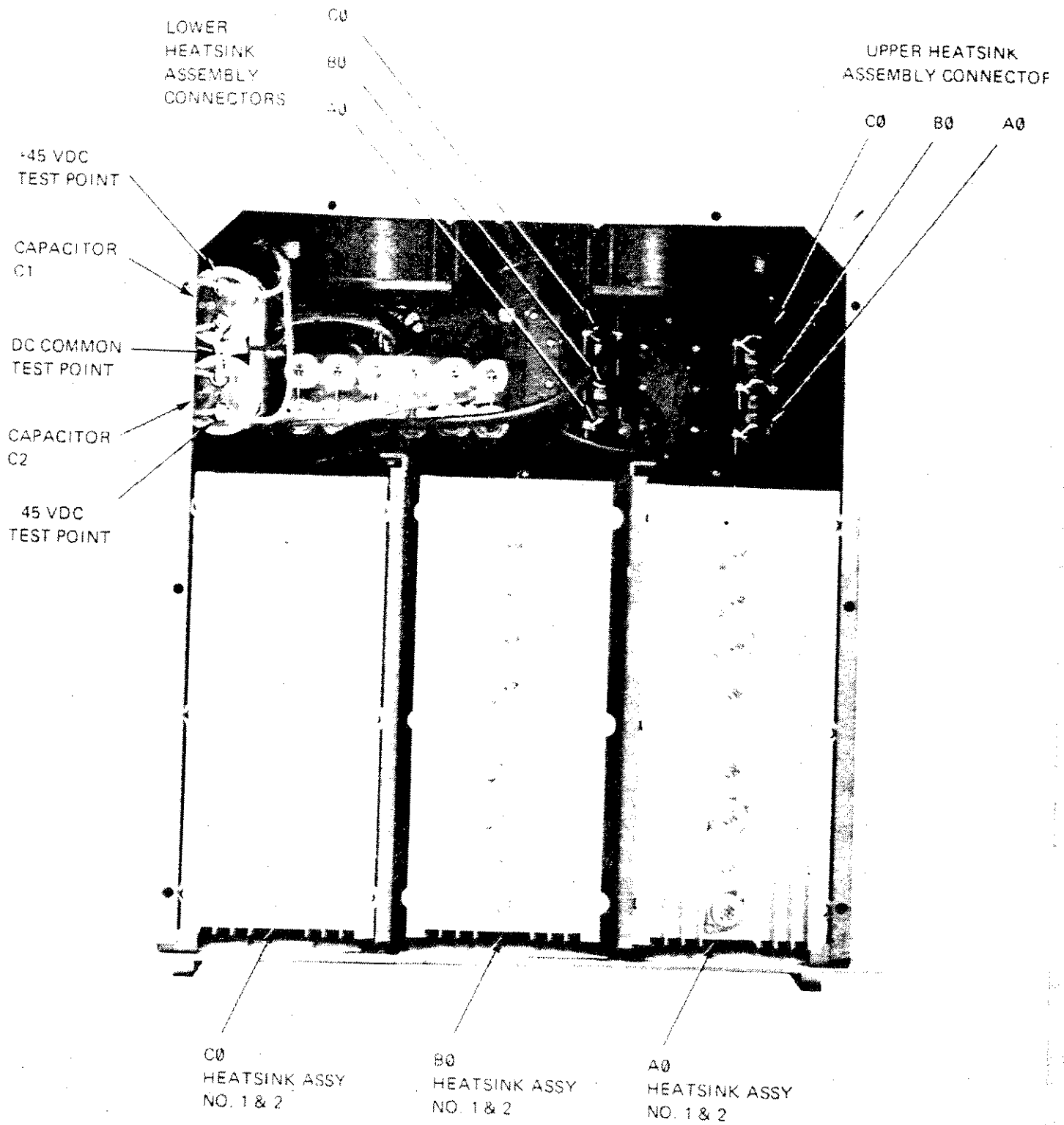

Figure 5-1. AC Power Source, Bottom View

ment, perform a regulation check and adjustment as follows:

1. Set POWER switch of unit to OFF.
2. Connect three resistive loads each capable of dissipating 4.85 amperes. (See Figure 5-3).
3. Set POWER switch of unit to ON.
4. Using rms voltmeter (set at 1000-volt range, 3%, 120 volts), measure A phase output voltage at output terminal . Observe that output is null volts on meter. If not, adjust regulation potentiometer R110 on A-phase amplifier circuit board for 120 volt output as needed.
5. Repeat step 4 to check and adjust regulation of B and C phase outputs. Use respective output terminals and regulation adjust potentiometers on the B and C phase circuit boards.
6. Set POWER switch to OFF and remove the three resistive loads.
7. Repeat the output amplitude balance checkout and adjustment in paragraph 5-12. Due to interaction between the phase regulation adjustments and the amplitude balance adjustments, it may be necessary to readjust the amplitude balance of the outputs. Repeat phase regulation and amplitude balance adjustments until no discernible difference is read on the rms voltmeter as the loads are connected.

5-14. 400-Hz DISTORTION CHECK. The distortion check may be performed at 60 Hz, 400 Hz, or 5 KHz, depending on the type plug-in oscillator used. The checks are performed identically except for changes in frequency and the specified distortion. Only one distortion check will be described as follows:

1. Set POWER switch of unit to OFF.

2. Connect resistive load to A phase output terminals.
3. Connect distortion analyzer to A phase output terminals. (See Figure 5-3).
4. Adjust input signal of plug-in oscillator to 400 Hz.
5. Set POWER switch to ON and adjust AMPLITUDE control for 120 volts output. Observe that distortion is less than 0.5% at 400 Hz.
6. Repeat steps 1 thru 5 to check distortion at B and C phase output voltages in same manner.

5-15. TROUBLESHOOTING. Troubleshooting should be accomplished only after checkout procedures indicate a malfunction. The troubleshooting procedures are presented in Table 5-2. General troubleshooting techniques are as described in the following paragraphs.

5-16. TRANSISTOR CHECK. Transistors may be checked for failure while installed on circuit boards as follows:

1. Verify power is removed from circuit.
2. Set multimeter to measure resistance with X10 OHMS scale. (Note that current supplied by various multimeters and ohmmeters varies and use ohm scale appropriate for testing transistors in the following steps.)
3. On NPN transistors, make following verifications.
  - a. With negative lead on emitter, positive lead on base, verify resistance is 100 to 300 ohms. Reverse leads and verify resistance is infinite (as read on X10 scale).
  - b. With positive lead on collector, negative lead on base, verify resistance is infinite. Reverse leads and verify resistance 100 to 300 ohms.

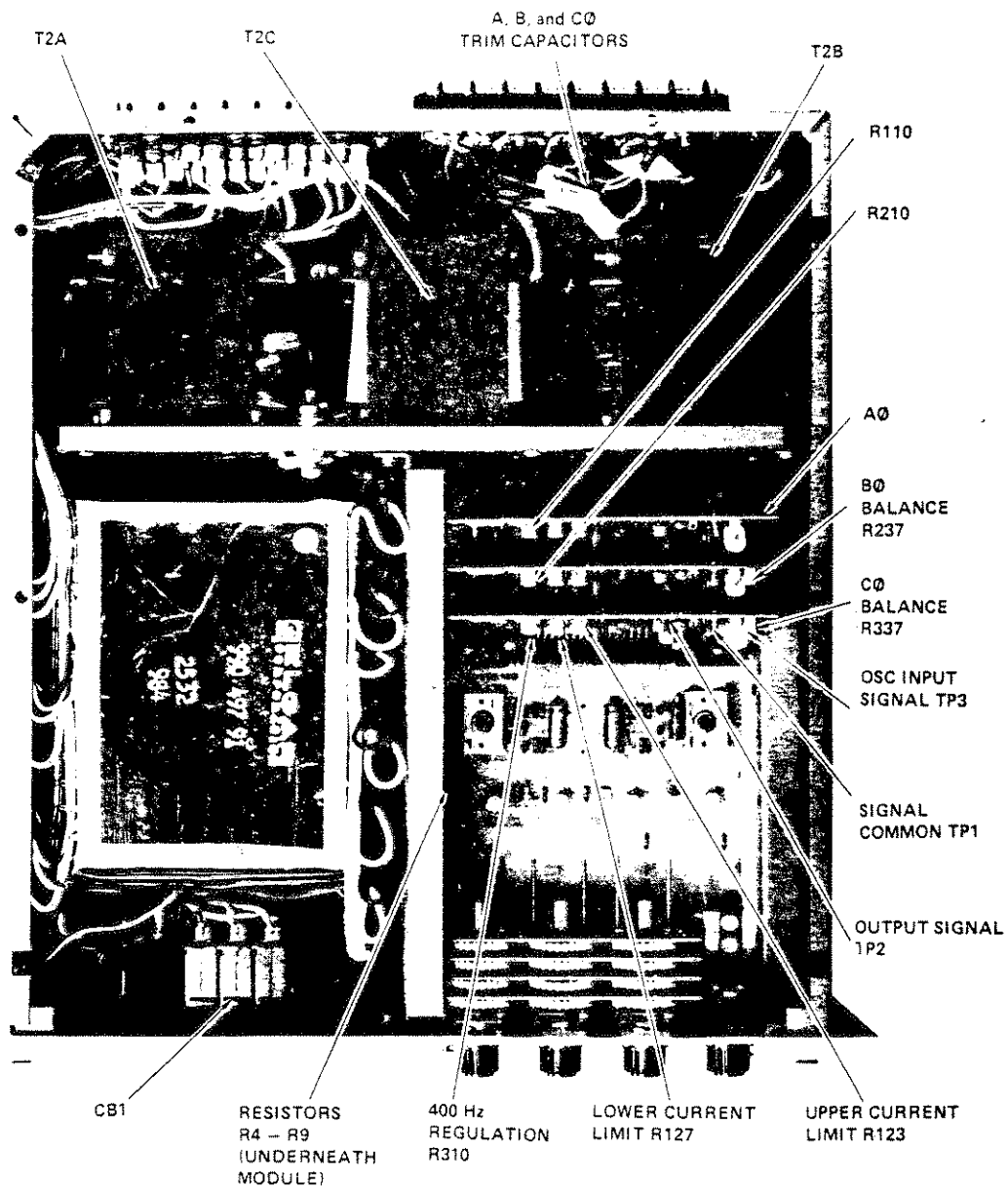

Figure 5-2. Model 1753B Top View

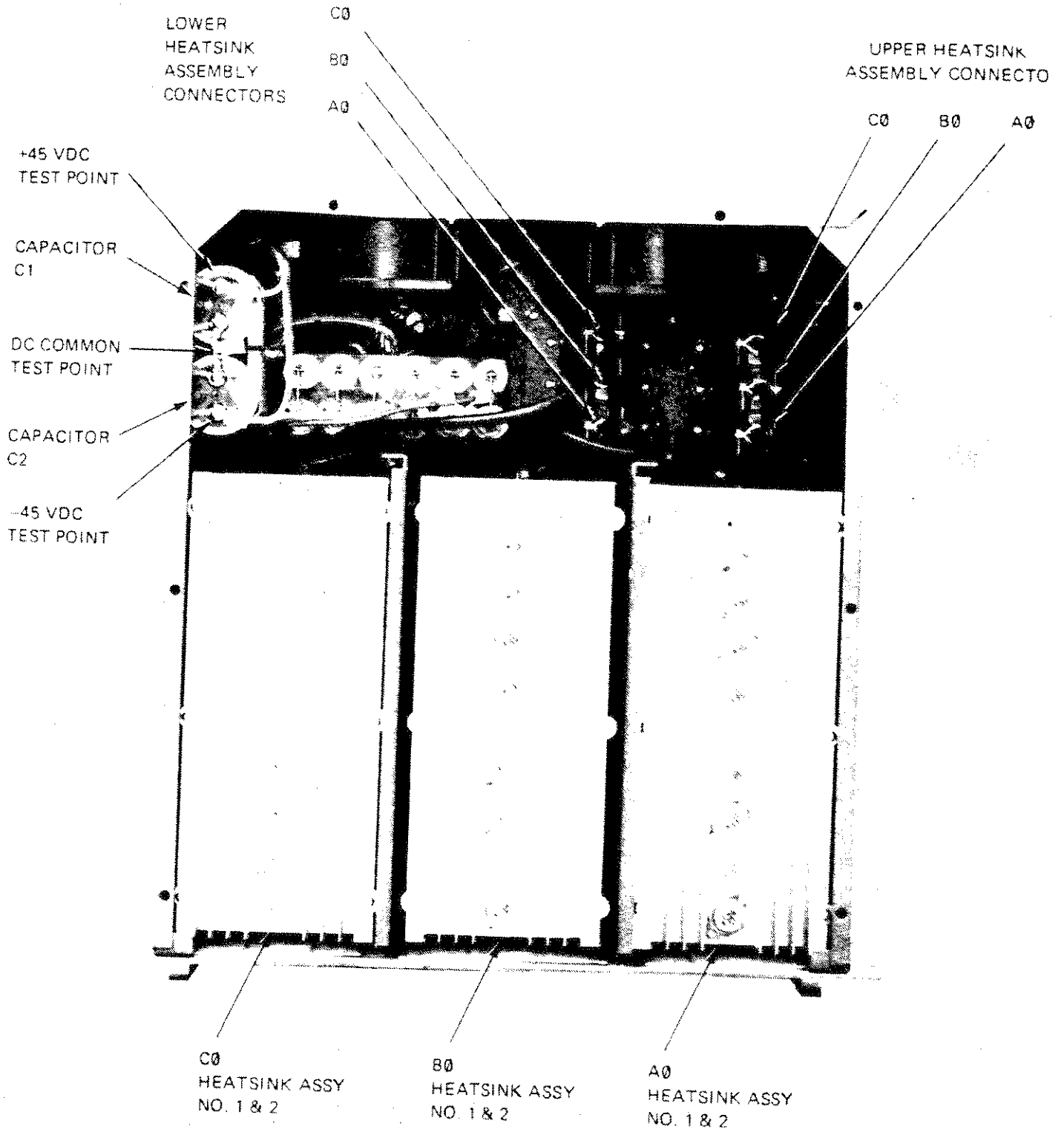

Figure 5-3. Model 1753B Bottom View

- c. With base open, verify forward and reverse resistance of emitter-collector path is infinite.

**NOTE**

PNP transistors are checked in the same manner, except that positive and negative leads are used in the reverse as described in the previous steps.

5-17. HEATSINK TRANSISTORS CHECK. If the heatsink assembly(s) are suspected of being defective, check the heatsink transistors for shorts as follows:

1. Remove power and disconnect the heatsink plugs from the unit.
2. Set multimeter to measure resistance by X 10 range. (Note that current supplied by various multimeters vary; therefore

use ohm scale appropriate for testing emitter-collector paths of transistors.)

3. Check NPN transistors in heatsink assemblies No. 1 and 2 (six heatsink assemblies total) for shorted transistors. At each heatsink plug (see Figure 5-4), connect negative lead on pin 1 and positive lead on pin 7 and verify resistance is infinite. Reverse leads and verify resistance is 100 - 300 ohms. If the multimeter reads a direct short, the transistor(s) in the heatsink is shorted and must be replaced.

4. Upon completion of repair, perform the output check of the respective phase amplifier circuit board (paragraph 5-18) to determine if the circuit board could be the cause of the shorted transistor(s). Perform the current splitting checks (paragraph 5-19) on the repaired heatsink assemblies.

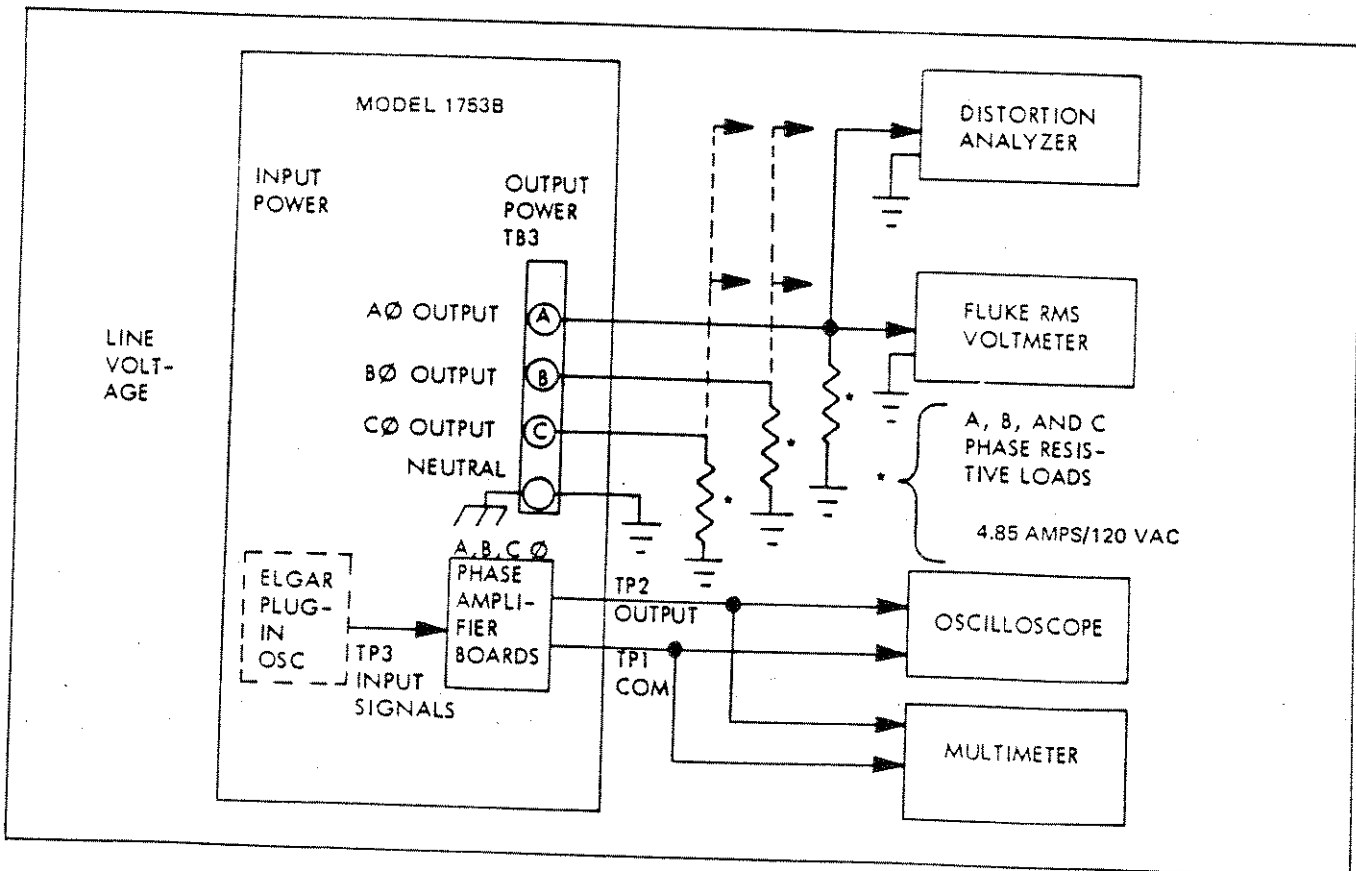

Figure 5-4. Test Setup

Table 5-2. Troubleshooting Chart

Trouble	Probable Cause	Remedy
<p>a. Power lamp fails to light when POWER switch is turned on. Fan fails to operate</p>	<ol style="list-style-type: none"> <li>1. Power cord not connected to unit</li> <li>2. Power cord not plugged into main line voltage</li> <li>3. Input power transformer connections not correct</li> <li>4. Lamp burned out</li> <li>5. Fan defective</li> <li>6. Defective switch-circuit breaker</li> </ol>	<ol style="list-style-type: none"> <li>1. Connect power cord as instructed in Section II</li> <li>2. Plug cable into AC source.</li> <li>3. Connect input power transformer as instructed in Section II.</li> <li>4. Replace defective lamp.</li> <li>5. Replace fan.</li> <li>6. Replace switch-circuit breaker CB1.</li> </ol>
<p>b. POWER switch-circuit breaker trips when turned on or when amplitude of output voltage is increased</p>	<p>Continual tripping of POWER switch-circuit breaker indicates failure of the DC supply or a power amplifier transistor in the heatsink assemblies</p>	<p>Disconnect the heatsink plugs from the unit. Set the POWER switch to ON. If it trips again, test the +45 VDC supply and filter capacitors C1 and C2 for defective components. Reference paragraph 5-11. If it does not trip, check the power transistors on the heatsink assemblies for shorts. Collector to emitter or collector to base. Reference paragraph 5-17. If heatsink transistor is shorted, check respective phase amplifier circuit board to determine if the board is the cause. Reference paragraph 5-18. Replace defective components as needed.</p>
<p>c. Front panel meter fails to indicate phase voltage selected at OUTPUT VOLTAGE switch</p>	<p>The following causes could lead to a lack of output voltage indication</p> <ol style="list-style-type: none"> <li>1. AMPLITUDE control completely CCW or defective</li> <li>2. Plug-in oscillator not properly seated or malfunctioned</li> </ol>	<p>Rotate AMPLITUDE control CW to increase output voltage to full output. Using multimeter, measure phase A, B, C voltages at output terminals. If normal, front panel OUTPUT VOLTAGE switch or meter is defective. If absent, measure signal output at TP2 of A, B, and C phase amplifiers. Using oscilloscope, observe the sine wave outputs. If normal, output transformer T2 is defective. If below normal, mea-</p>

**NOTE**

Only one circuit board and its respective heatsink assemblies should be installed at a time when accomplishing these adjustments. Before performing the following adjustments, remove the other two circuit boards and disconnect their respective heatsink assemblies.

5-21. **CURRENT LIMITS ADJUSTMENT.** To perform current limit check and adjustment, proceed as follows:

1. Set POWER switch of unit to OFF.
2. Connect resistive load capable of dissipating 584 VA across respective output terminals of phase output being adjusted (for example, connect load across terminals A and N for A phase amplifier adjustment).
3. Connect oscilloscope to output TP2 and common TP1 of phase amplifier circuit board to monitor output sine wave.
4. Set OUTPUT VOLTAGE selector to monitor respective phase voltage on front panel meter.
5. Set POWER switch of unit to ON.
6. Increase front panel AMPLITUDE control R1 in CW direction for 120 VAC output on front panel meter. Observe that sine wave output at TP2 is not clipping or oscillating. If clipping is observed, current limit adjustments must be made as described in the next procedural steps.

**NOTE**

If oscillating is observed, the amplifier circuit board must be replaced and returned to the factory for adjustment. Replacement of certain factory-selected parts (such as trim capacitors and re-

sistors) for eliminating oscillations is considered beyond the scope of customer maintenance. Notify ELGAR Corporation for authority and shipping instructions.

7. To remove clipping from upper peak of sine wave, adjust the upper current limit potentiometer R123 (see Figure 5-2) CCW only as much as necessary to remove clipping. Further adjustment CCW will permit the output transistors to deliver an unsafe amount of current.

**NOTE**

The upper and lower current limit potentiometers R123 and R127 are each adjusted such that the potentiometers are backed off slightly to a point that just eliminate clipping.

8. To remove clipping from lower peak of sine wave, adjust the lower current limit potentiometer R127 as needed.
9. Upon completion of current limit adjustment of the A, B, and C phase amplifier circuit boards, perform the output amplitude balance checkout and adjustment as instructed in paragraph 5-12.

5-22. **REPAIR AND REPLACEMENT.** Generally, if any parts are suspected of damage, they should be checked with multimeter for proper electrical values before replacement. The schematic and parts list are presented in Sections VI and VII as an aid in repairing the unit.

5-23. **CIRCUIT BOARD ASSEMBLIES.** The circuit board assemblies can either be repaired or replaced if parts or circuit board is damaged. De-energize the unit before removing any circuit board assembly. To remove circuit board, pull straight up on the circuit board, taking care not to damage circuit components. When re-installing circuit board, carefully fit edge of circuit board in guide slots and press circuit board firmly in connector. Standard circuit board repair procedures are applicable.



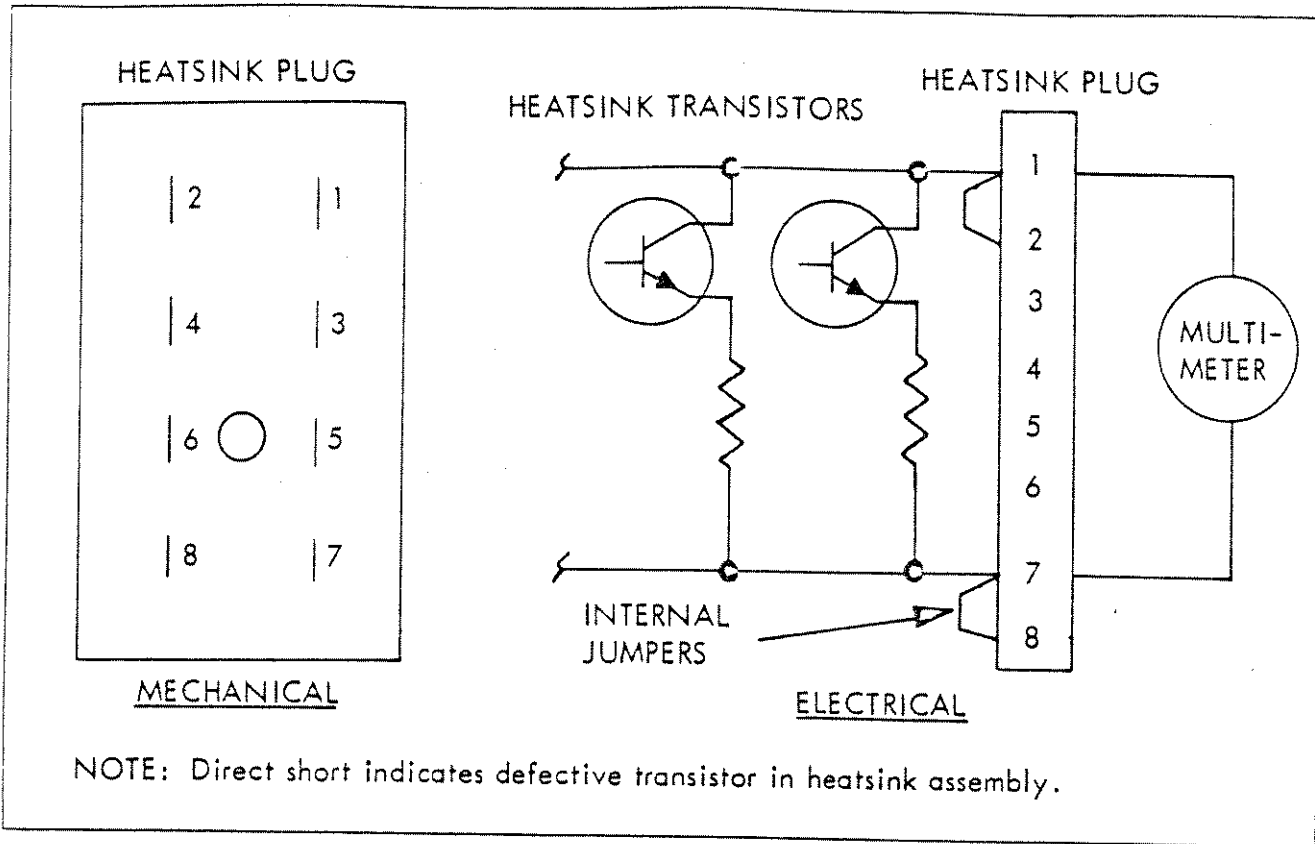

Figure 5-5. Shorted Heatsink Transistor Check

5-24. **FACTORY REPAIR.** Do not replace factory-selected parts. Should it be necessary to return an instrument to the factory for repair, please contact the ELGAR Corpora-

tion Service Department for authorization to make shipment. **DO NOT RETURN THE UNIT FOR REPAIR WITHOUT AUTHORIZATION.**



## SECTION VI PARTS LIST

### 6-1. GENERAL

6-2. This section contains a listing of all parts necessary for factory-authorized repair of the unit. Parts are located on the diagrams in Section VI and correlated on the parts list by using their reference designators. Note that trimming capacitors are factory-selected parts and their replacement is considered beyond the scope of customer maintenance.

### 6-3. SPARE PARTS ORDERING

6-4. When ordering spare parts, specify part name, part number, manufacturer, component value and rating. If complete assemblies are desired, contact ELGAR Corporation, 8225 Mercury Court, San Diego, California 92111. Specify assembly number, instrument series number and instrument name when ordering.



UPPER HEATSINK ASSEMBLY - 608-220-42

SCHEMATIC DESIGNATION	VALUE	DESCRIPTION OR TYPE	RATING	MANUFACTURER		ELGAR PART NUMBER
				NAME	PART NUMBER	
R128	22 ohm	Carbon W.W. W.W.	1/2W, 5% 5W, 5% 5W, 5%	COML	CW5-5.6 CW5-.22	802-220-05 807-5R6-05 807-R22-05
R129	5.6 ohm			Dale		
R130-R136	.22 ohm			Dale		
C113	.022 uf	Paper	200V	Sprague	142P22392	822-224-05
CR110		Diode		Westinghouse	368D	845-368-DX
Q106-Q115		Transistor		RCA	2N6259	841-625-9X
S101		Thermal Switch		Elmwood	3400	861-340-0X
LOWER HEATSINK ASSEMBLY - 608-221-42						
R137	22 ohm	Carbon W.W. W.W.	1/2W, 5% 5W, 5% 5W, 5%	COML	CW5-5.6 CW5-.22	802-220-05 807-5R6-05 807-R22-05
R138	5.6 ohm			Dale		
R139-R145	.22 ohm			Dale		
C112	.022 uf	Paper	200V	Sprague	192P22392	822-224-05
CR111		Diode		Westinghouse	368D	845-368-DX
Q116-Q123		Transistor		RCA	2N6259	841-625-9X

## PARTS COMMON TO A, B, &amp; CØ AMPLIFIER BOARDS

SCHEMATIC DESIGNATION	VALUE	DESCRIPTION OR TYPE	RATING	MANUFACTURER		ELGAR PART NUMBER
				NAME	PART NUMBER	
AØ AMP. BOARD B & CØ Amp. Bd. AØ - BØ - CØ						
R101,201,301 112,212,312	5.11K	Metal Film	1/8W, 1%	Dale	RN60C5111F	620-210-40 620-229-40
R102,202,302	FSV	Carbon	½W, 5%	COML		
R103,203,303	2.61K	Metal Film	1/8W, 1%	Dale	RN60C2611F	813-511-1F
R104,204,304	FSV					
R120,220,320	200 ohm	Carbon	½W, 5%	COML	RC20GF201J	802-201-05
R105,205,305	3.9K	Carbon	½W, 5%	COML	RC20GF392J	802-392-05
R106,206,306	4.7K	Carbon	½W, 5%		RC20GF472J	802-472-05
121,221,321, 122,222,322, 109,209,309						
R108,208,308	1.5K	Carbon	½W, 5%	COML	RC20GF152J	802-152-05
R110,210,310	1K	Potentiometer		Bourns	3059Y	819-102-05
R111,211,311	475	Metal Film	1/8W, 1%	Dale	RN60C4750F	813-475-0F
R113,213,313	FSV					
R114,214,314, 118,218,318	68 ohm	Carbon	½W, 5%	COML	RC20GF680J	802-680-05
128,228,328						
R124,224,324	15 ohm	Carbon	½W, 5%	COML	RC20GF150J	802-150-05
R115,215,315	6.2K	Carbon	½W, 5%	COML	RC20GF622J	802-622-05
R116,216,316, 119,219,319, 126,226,326, 125,225,325	100	Carbon	½W, 5%	COML	RC20GF101J	802-101-05
R123,223,323 127,227,327	10 ohm					
R117,217,317	5.6K					
C101,201,301	2 uf	Met. Mylar	½W, 5%	Bourns	3059Y	819-100-30
C102,202,302	0.022 uf	Paper	100V, 5%	IMB	RC20GF562J	802-562-05
C103,203,303	120 pf	Dip Mica	200V, 10%	ARCO	ZAZZ205J	822-205-53
C104,204,304	FSV	Paper	500V	Sprague	192P22392	822-223-05
			200V, 5%		DM15121J	820-121-05

PARTS COMMON TO A, B, & CØ AMPLIFIER BOARDS (Continued)

SCHEMATIC DESIGNATION	VALUE	DESCRIPTION OR TYPE	RATING	MANUFACTURER		ELGAR PART NUMBER
				NAME	PART NUMBER	
C105,205,305	220 uf	Tantalum	10V	Sprague	196D227X0010MA3	823-227-61
C106,206,306	.0015 uf	Cer Disc	50V, 10%	Centralab	CE152	821-152-00
C107,207,307	50 uf	Alum Elec	50V	Sprague	500D506G050DD7	824-506-71
C108,208,308	.02 uf	Cer Disc	50V, 10%	Centralab	DDM203	821-203-00
109,209,309						
C110,210,310	220 pf	Dip Mica	500V, 5%	ARCO	DM15-221J	820-221-05
C111,211,311	.0033 uf	Cer Disc	1KV, 10%	Erie	Z5V332J	821-332-00
C112,212,312	200 pf		500V, 5%	ARCO	DM15-201J	820-201-05
Q101,201,301		Transistor		Natl.	2N3810	849-381-0X
102,202,302						
Q103,203,303		Transistor		Fairchild	2N3567	835-356-7X
Q104,204,304		Transistor		Fairchild	2N3638	834-363-8X
Q105,205,305		Transistor		RCA	2N3440	837-344-0X
106,206,306						
Q107,207,307		Transistor		Motorola	2N4236	836-423-6X
CR101,201,301		Zener	12V	Motorola	1N5242	843-524-2X
AØ - CR102-CR109		Diode		Westinghouse	1N4818	845-481-8X
BØ - CR202-CR209		Diode		Westinghouse	1N4818	845-481-8X
CØ - CR302-CR309		Diode		Westinghouse	1N4818	845-481-8X
L101,201,301	150 uh			Nytronics	SWD-150	851-150-01
BØ & CØ AMPLIFIER BOARDS ONLY						
R237, R337	0-1K	Cermet		Beckman	78PR1K	819-102-30





## SECTION VII DIAGRAMS

### 7-1. GENERAL

7-2. This section contains the schematic diagrams and parts layout for the AC power source. The schematic diagram should be used to understand the theory of operation as an aid in troubleshooting the unit. Reference designators shown on schematics, correspond to reference designators shown in parts lists, where exact component values are given. Components identified as "trim" are factory-selected

parts whose values are determined at time of final checkout.

### 7-3. DIAGRAMS

- 7-4. Diagrams included in this section are as follows:
- a. AC Power Source, Schematic Diagrams
  - b. Phase Amplifier Circuit Board Assembly, Parts Layout
  - c. Typical Plug-In Oscillator Power Amplifier Interconnection



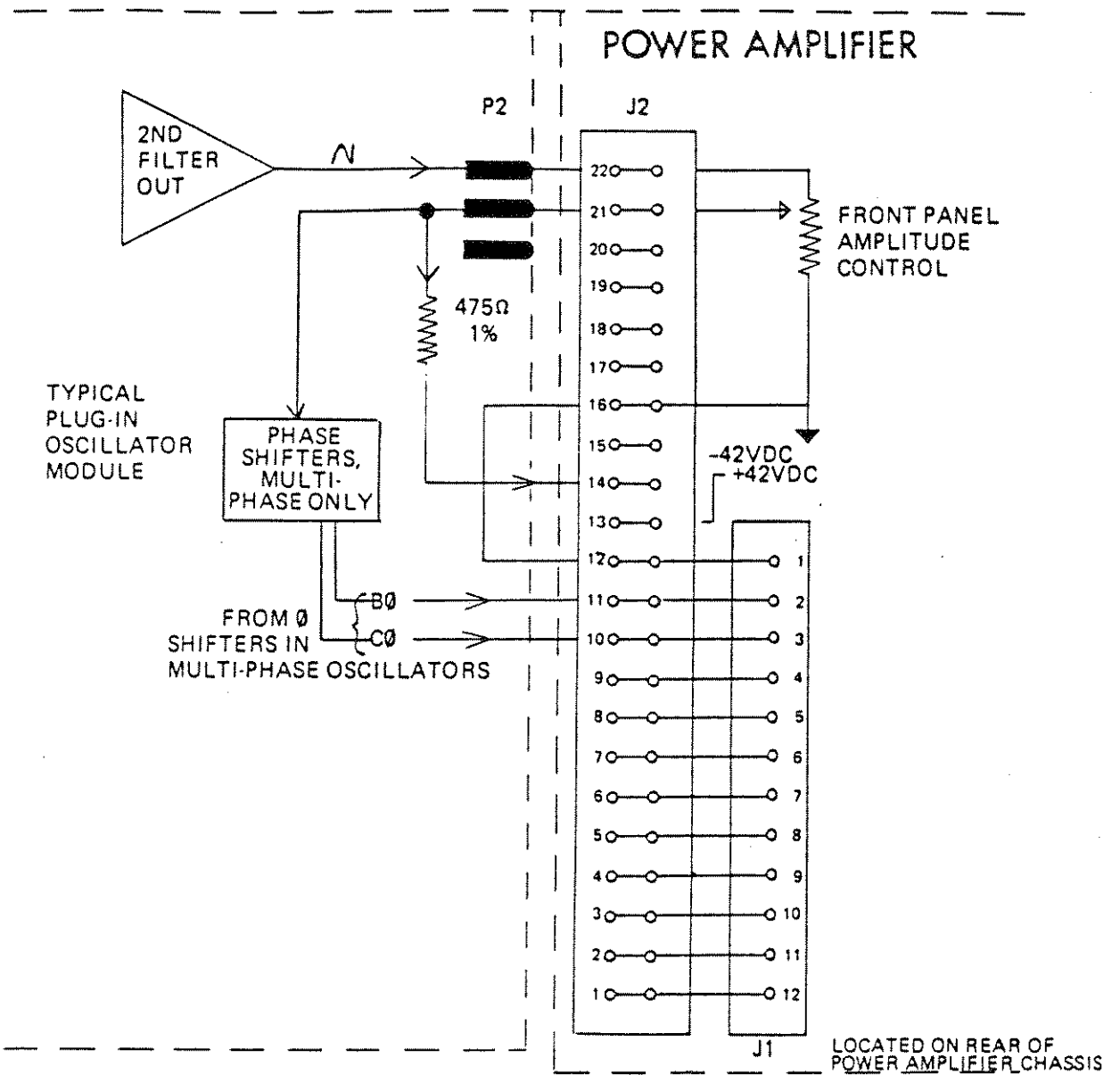

Typical Plug-in Oscillator Power Amplifier Interconnection



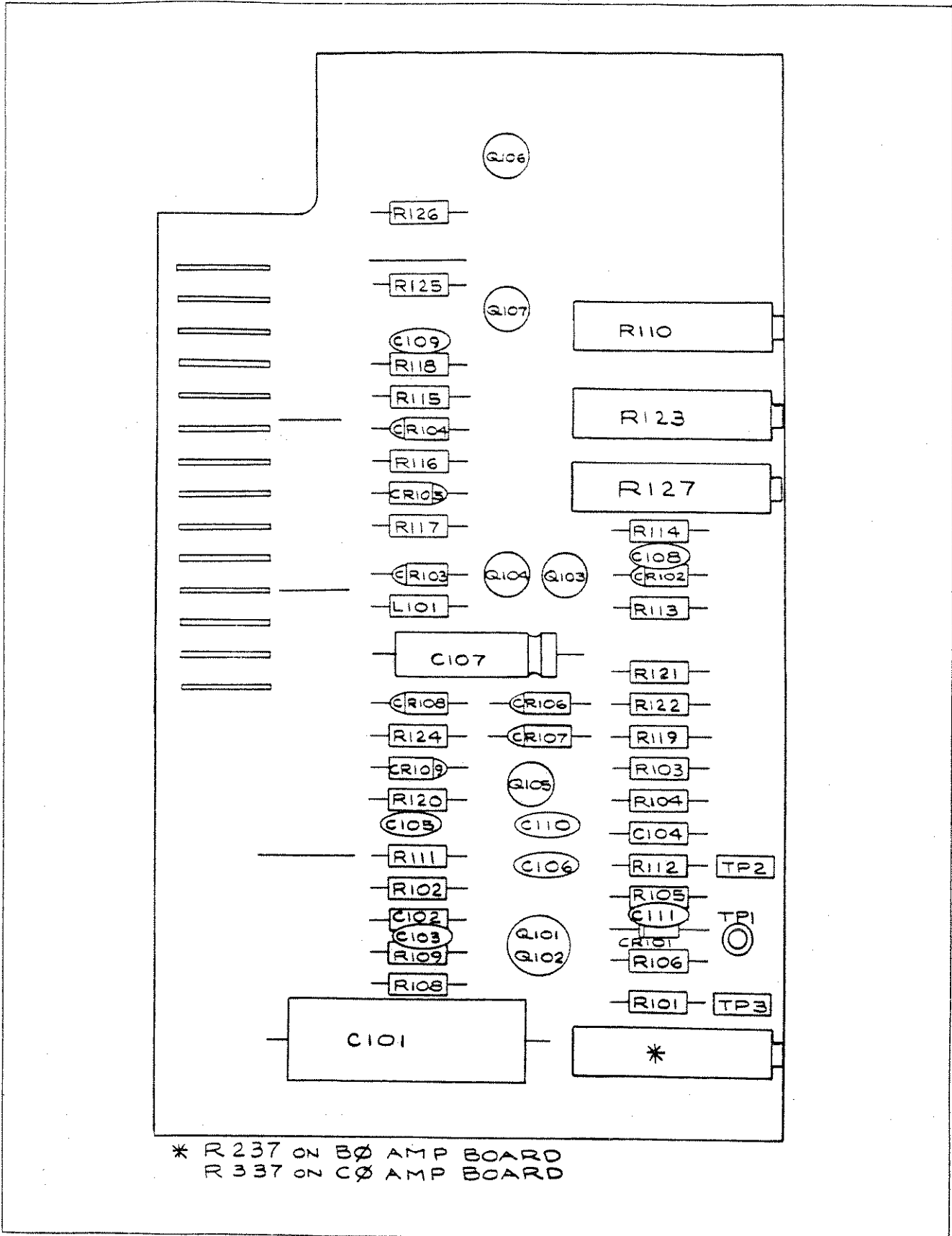

Figure 7-2. A, B, C0 Amplifier Board, Parts Layout



TABLE 1

TB1 INPUT POWER TRANSFORMER CONNECTIONS							
115 V L-L 3 WIRE (115V Δ)	TB1-1 TO TB1-2	120V L-N 4 WIRE (120/208V)	TB1-1 TO TB1-2	230V L-L 3 WIRE (230V Δ)	TB1-2 TO TB1-3	230 V L-N 4 WIRE (230/400V)	TB1-2 TO TB1-3
	TB1-3 TB1-4		TB1-3 TB1-4		TB1-6 TB1-7		TB1-6 TB1-7
	TB1-5 TB1-6		TB1-5 TB1-6		TB1-10 TB1-11		TB1-10 TB1-11
	TB1-7 TB1-8		TB1-7 TB1-8		TB1-4 TB1-5		TB1-1 TB1-9
	TB1-9 TB1-10		TB1-9 TB1-10		TB1-8 TB1-9		TB1-5 TO TB1-9
	TB1-11 TB1-12		TB1-11 TB1-12		TB1-12 TO TB1-1		
	TB1-4 TB1-5		TB1-1 TB1-9				
	TB1-8 TB1-9		TB1-5 TO TB1-9				
	TB1-12 TO TB1-1						
	CKT. BRKR 20A				CKT. BRKR 15 A		

2  
3  
4

1  
2  
3  
4  
5  
6  
7  
8  
9  
10  
11  
12  
13  
14  
15  
16  
17  
18  
19  
20  
21  
22  
23  
24  
25  
26  
27  
28  
29  
30  
31  
32  
33  
34  
35  
36  
37  
38  
39  
40  
41  
42  
43  
44  
45  
46  
47  
48  
49  
50  
51  
52  
53  
54  
55  
56  
57  
58  
59  
60  
61  
62  
63  
64  
65  
66  
67  
68  
69  
70  
71  
72  
73  
74  
75  
76  
77  
78  
79  
80  
81  
82  
83  
84  
85  
86  
87  
88  
89  
90  
91  
92  
93  
94  
95  
96  
97  
98  
99  
100